

**CONTRACTION JOINT**  
UNDOWELED - TRANSVERSE and  
UNTIED - LONGITUDINAL

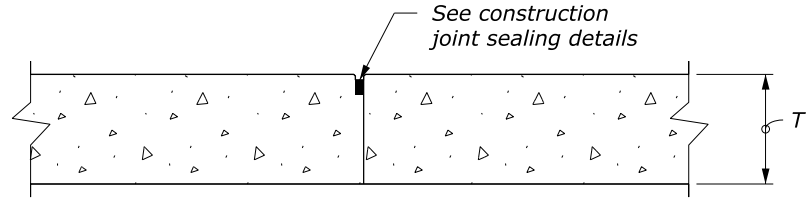

**CONSTRUCTION JOINT**  
PLAIN - TRANSVERSE or LONGITUDINAL

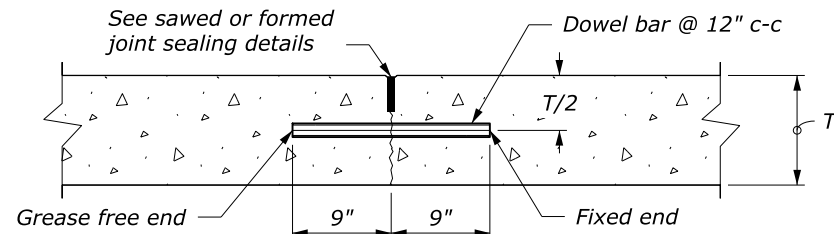

**CONTRACTION JOINT**  
DOWELED - TRANSVERSE

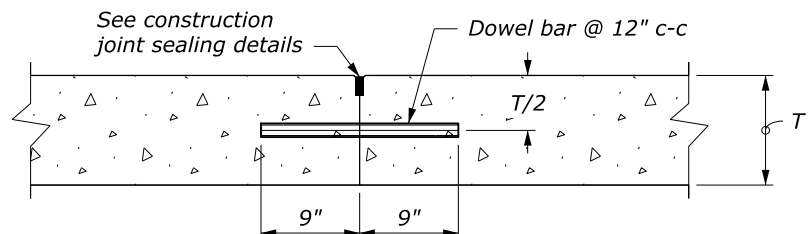

**CONSTRUCTION JOINT**  
DOWEL BUTT - TRANSVERSE

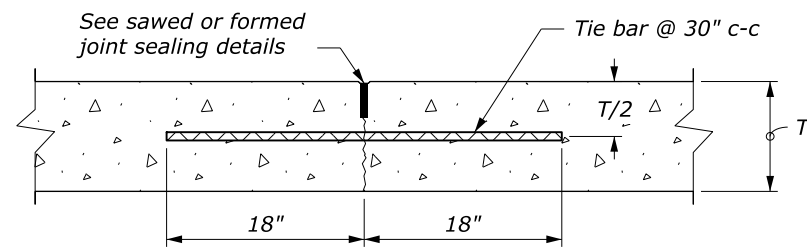

**CONTRACTION JOINT**  
TIED - LONGITUDINAL

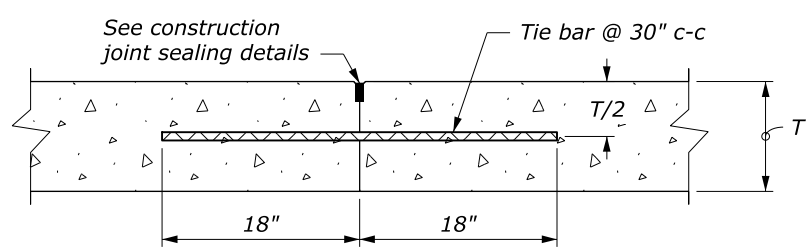

**CONSTRUCTION JOINT**  
TIED BUTT - LONGITUDINAL

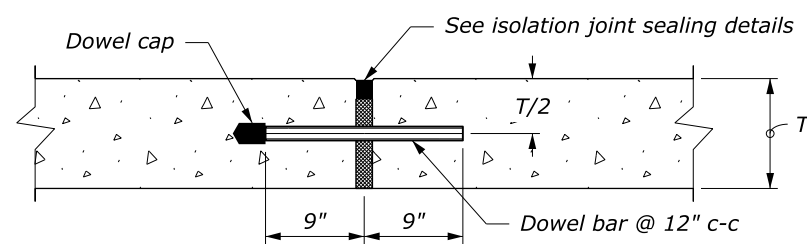

**ISOLATION/EXPANSION JOINT**  
DOWELED - TRANSVERSE

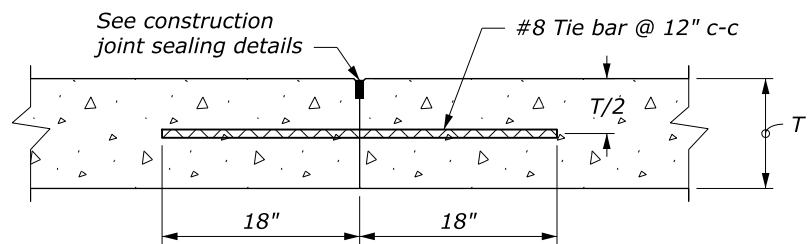

**CONSTRUCTION JOINT**  
TIED BUTT - TRANSVERSE

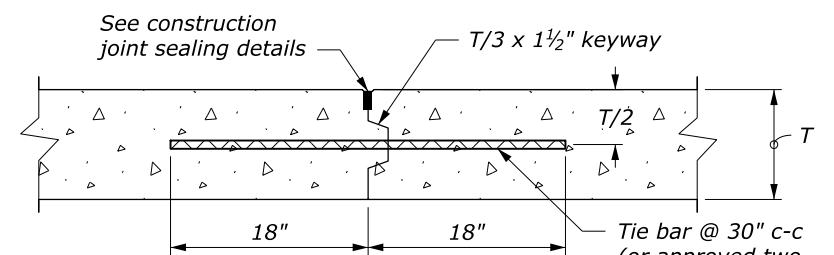

**CONSTRUCTION JOINT**  
KEYWAY - LONGITUDINAL

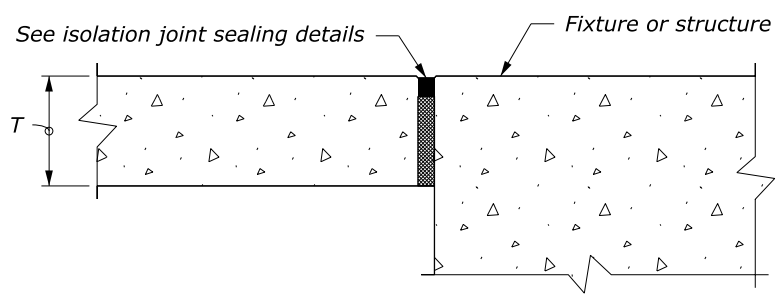

**ISOLATION JOINT**  
UNDOWELED - LONGITUDINAL

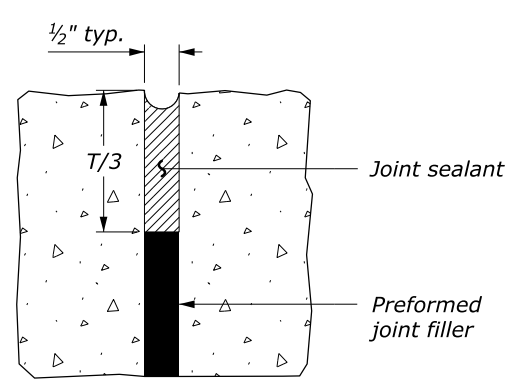

ISOLATION JOINT

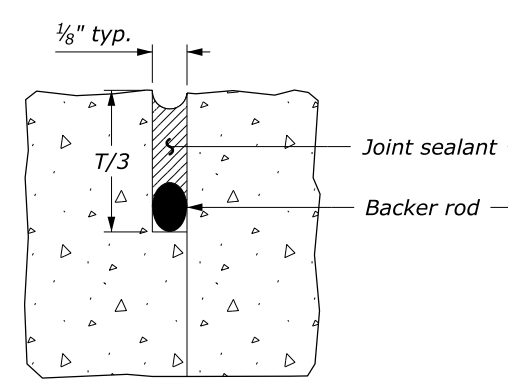

CONSTRUCTION JOINT

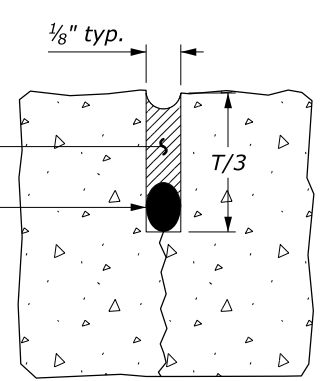

SAWED OR FORMED JOINT

**MINOR CONCRETE PAVEMENT JOINT SEALING DETAILS**

**NOTE:**

1. Use epoxy-coated material for all tie bars, dowels, and other steel used in the construction of concrete pavement.
2. Deformed reinforcing bars or hook bolts may be used for tie bars.
3. Do not place tie bars within 15 inches of transverse joints.
4. Install isolation joints when abutting a fixed structure. Use expansion joint material extending the full depth and length of the concrete surface.
5. Transverse and longitudinal construction joints are not included in the joint layout plan. Use transverse and longitudinal construction joints sparingly. Submit planned construction joint locations for approval.
6. For construction joints, if tie bars and dowels are not set into concrete during placement, drill and anchor the tie bars and dowels into the existing concrete construction with epoxy resin.
7. Maintain joint sealant shape factor of 1:1; except when silicone sealant is used maintain the width to depth shape factor of 2:1 or as recommended by sealant manufacturer.
8. See Section 712 for joint material requirements.
9. See Standards 501-1 or 502-1 for reinforcement details.

BAR SIZES		
PAVEMENT THICKNESS (T) (in)	TIE BAR	DOWEL BAR DIAMETER (in)
T ≤ 8	#5	1
8 < T ≤ 10	#5	1 1/4
10 < T ≤ 12	#6	1 1/2

U.S. DEPARTMENT OF TRANSPORTATION  
FEDERAL HIGHWAY ADMINISTRATION  
FEDERAL LANDS HIGHWAY

U.S. CUSTOMARY STANDARD

**MINOR CONCRETE PAVEMENT JOINTS**

STANDARD APPROVED FOR USE --/----

REVISED: 9/2016

STANDARD 501-2

NO SCALE