



Astrophysics Update

Astrophysics

Paul Hertz
Director, Astrophysics Division
Science Mission Directorate
[@PHertzNASA](https://twitter.com/PHertzNASA)



Astrophysics Driving Documents

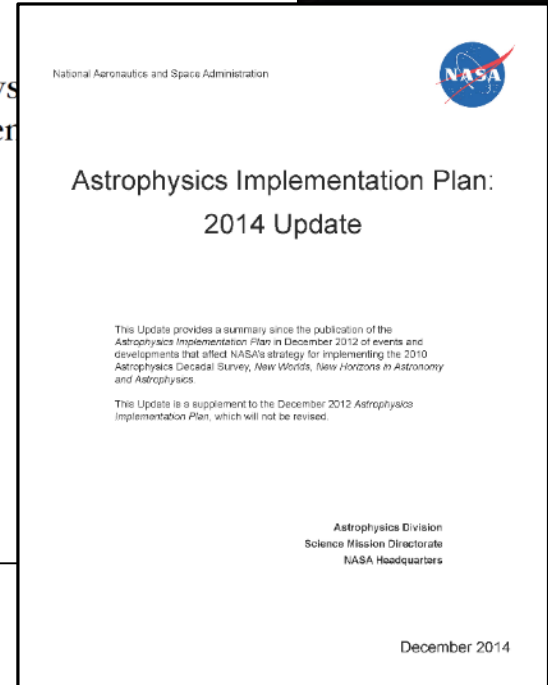
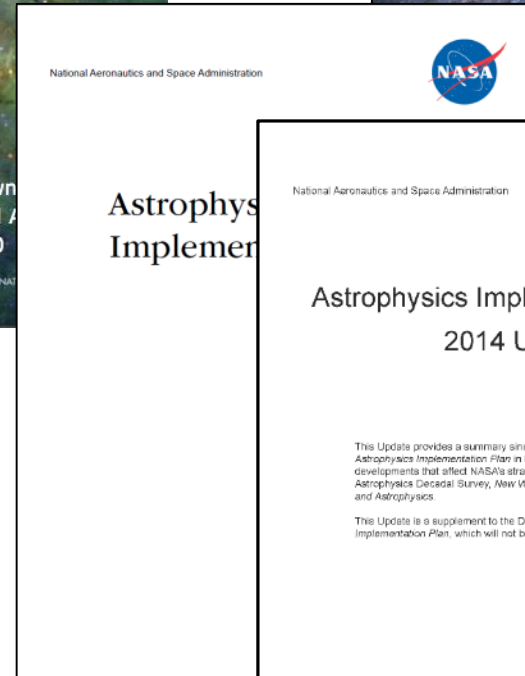
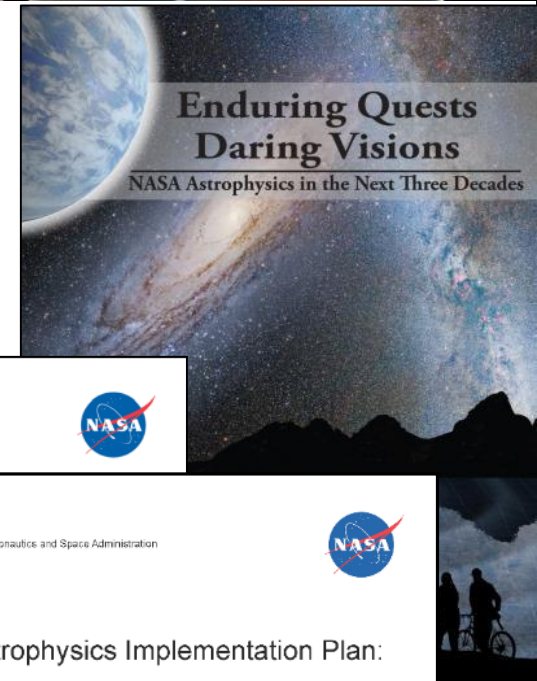

<http://science.nasa.gov/astrophysics/documents>



Astrophysics - Big Picture

- **The FY15 appropriation and FY16 budget request provide funding for NASA astrophysics to continue its programs, missions, and projects as planned**
 - The total funding (Astrophysics including JWST) is flat at ~\$1.3B through FY20
 - Fully fund JWST to remain on plan for an October 2018 launch
 - Fund continued pre-formulation and technology work leading toward WFIRST
 - Restore SOFIA to the budget with a reduction in FY15 and full funding beyond
 - Provide funding for SMD's education programs
- **The operating missions continue to generate important and compelling science results, and new missions are under development for the future**
 - Chandra, Fermi, Hubble, Kepler/K2, NuSTAR, Spitzer, Suzaku, Swift, XMM-Newton continued through FY16 (next Senior Review is Spring 2016 for FY17+)
 - SOFIA is in prime operations as of May 2014 (Senior Review is Spring 2016)
 - Missions on track for launch include LISA Pathfinder (2015), ASTRO-H (2015), NICER (2016), TESS (2017), JWST (2018), Euclid (2020)
 - WFIRST being studied, New Explorers being selected (SMEX in 2015, MIDEX in 2017), NASA joining ESA's Athena and ESA's L3 gravitational wave observatory
- **Progress being made against recommendations of the 2010 Decadal Survey**
 - Update to the Astrophysics Implementation Plan released in December 2014
 - NRC Mid Decade Review (with NSF, DOE) to begin in 2015; Jackie Hewitt (MIT) is chair
 - NASA initiating large mission concept studies for 2020 Decadal Survey

Astrophysics Missions in Development

LISA Pathfinder 11/2015

ESA-led Mission

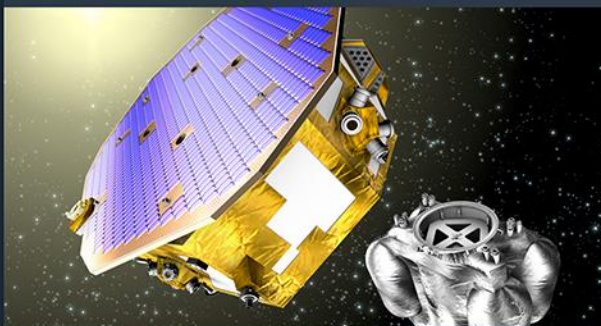

NASA supplied the ST7/Disturbance Reduction System (DRS)

ASTRO-H 11/2015
NET

JAXA-led Mission



NASA supplied the Soft X-ray Spectrometer (SXS) instrument

NICER 8/2016

NASA Mission

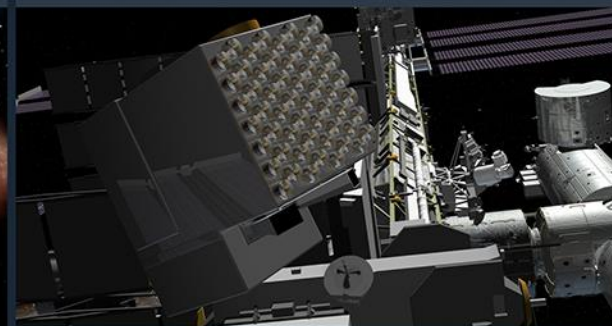

Neutron Star Interior Composition Explorer

TESS 8/2017

NASA Mission



Transiting Exoplanet Survey Satellite

JWST 10/2018

NASA Mission

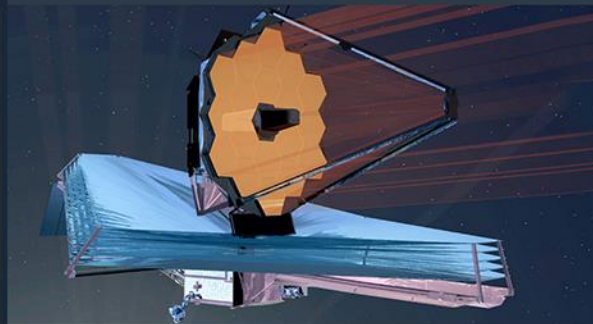

James Webb Space Telescope

Euclid 2020

ESA-led Mission

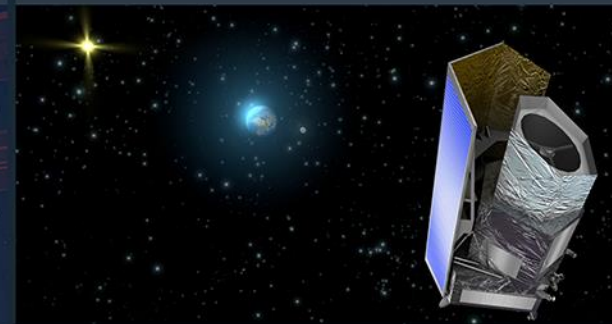

NASA is supplying the NISP Sensor Chip System (SCS)



JWST Hardware Status Updates

ISIM

- All instruments installed back into ISIM, vibration finished, acoustics test this month.

Optical Telescope Element (OTE)

- Deployable Tower Assembly installed into OTE backplane (center section, wings, backplane support fixture).
- OTE backplane preparing to ship to GSFC on August 24.
- 13 of 18 primary mirror segment assemblies shimmed for installation onto telescope backplane. All will be complete prior to arrival of backplane.

Spacecraft

- Spacecraft subsystems continue on track. Spacecraft structure completed and in testing.
- Sunshield layer 3 (delivered), 4, 5, and 2 in various stages of work.
- Cryocooler Compressor Assembly completed at NGAS, in final verification before shipping to JPL.

OTIS (OTE + ISIM)

- Optical Ground Support Equipment (OGSE) test #1 complete. All test objectives met, good practice for this Fall's OGSE #2 test.



Flight Telescope Progress



Backplane with Deployable Tower



Spacecraft Bus moving to test stand



*Flight Cryocooler Compressor Assembly
at NGAS*

JWST Simplified Schedule

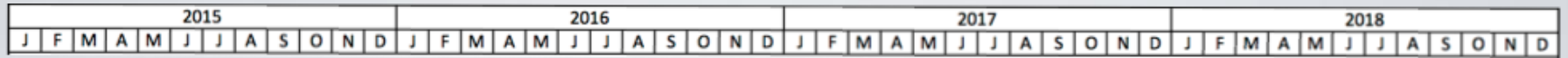

k months of project funded critical path (mission pacing) schedule reserve

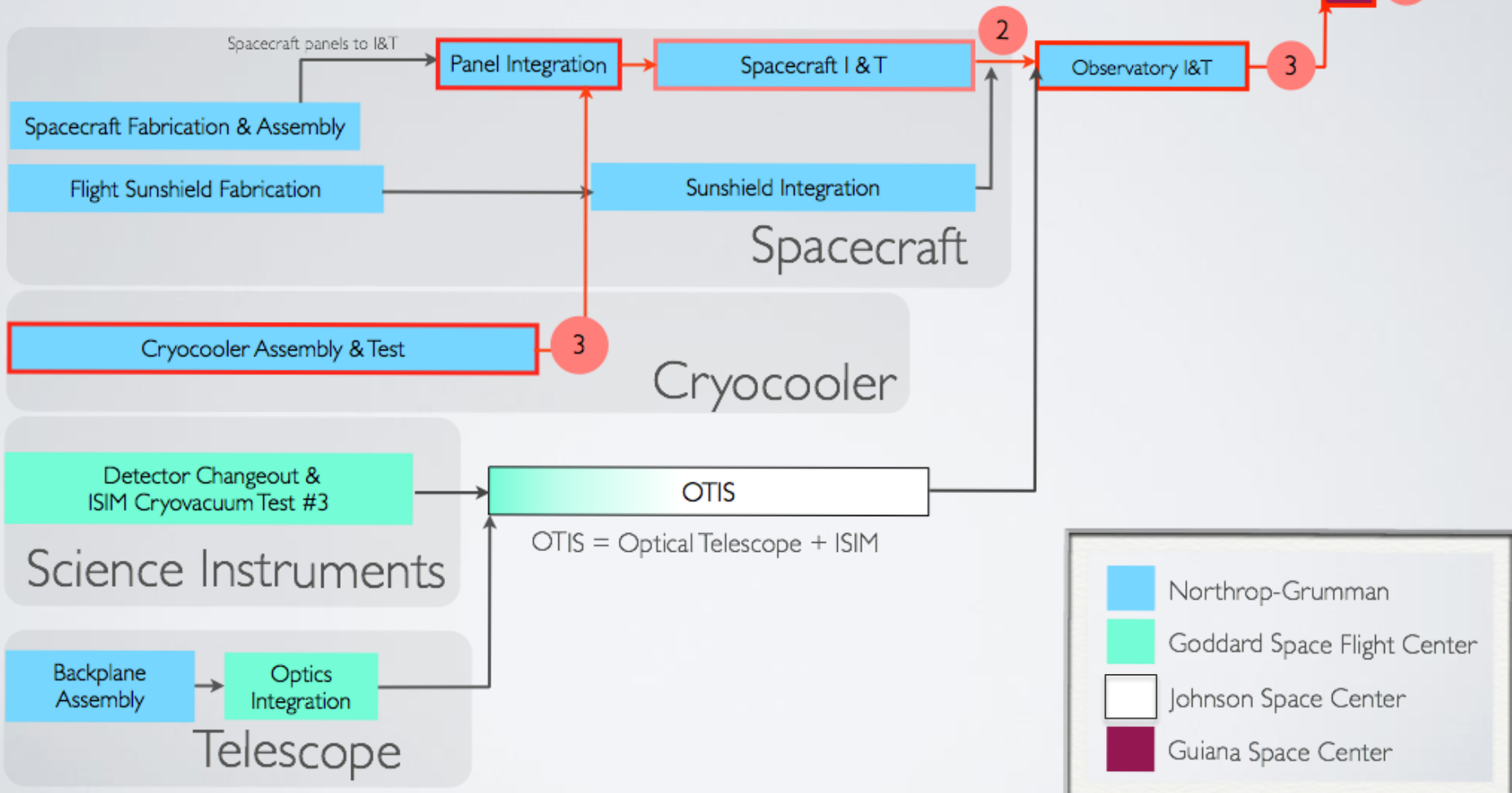

Red lines indicate critical path

	Northrop-Grumman
	Goddard Space Flight Center
	Johnson Space Center
	Guiana Space Center

Astrophysics Missions in Pre-Formulation



SMEX / MO – 2019/2020
MIDEX / MO – 2022/2023
WFIRST-AFTA – 2024/2025
Athena – 2028

all launch dates notional



WFIRST / AFTA

Widefield Infrared Survey Telescope with Astrophysics Focused Telescope Assets



Widefield Infrared Survey Telescope

Top priority of 2010 Decadal Survey

Science themes: Dark Energy, Exoplanets, Large Area Near Infrared Surveys

Mission: 2.4m widefield telescope at L2 or GEO, uses existing AFTA hardware to image 0.28 deg² at 0.8-2.0 μm

Instruments (design reference mission): Wide Field Instrument, Coronagraph Instrument

- FY15 Budget Request and FY15 Appropriation support pre-formulation of WFIRST/AFTA
- Plans support Agency/Administration decision for formulation to begin in FY16-17, subject to availability of funding.

<http://wfirst.gsfc.nasa.gov/>

CURRENT STATUS:

- Currently in pre-formulation phase.
 - Activities include technology development for detectors and coronagraph (with STMD), assessment of the 2.4m telescopes including risk mitigation, mission design trades, payload accommodation studies, and observatory performance simulations.
- Maturing key technologies by FY17.
 - H4RG infrared detectors for widefield imager.
 - Internal coronagraph for exoplanet characterization.
- WFIRST Preparatory Science is funding teams to conduct WFIRST-specific simulations and models.
- SDT report made public March 2015, and available online at wfirst.gsfc.nasa.gov
- RFI for industry engagement released July 7; expected to lead to RFP to study major elements of WFIRST hardware that could be provided
- Solicitation for members of Formulation Science Working Group (F-SWG) to be released this month



WFIRST / AFTA

Widefield Infrared Survey Telescope with Astrophysics Focused Telescope Assets

Coronagraph Technology Milestones

1	Shaped Pupil mask fabricated with reflectivity of 10^{-4} and 20 μm pixel size.	7/21/14 ✓
2	Shaped Pupil Coronagraph demos 10^{-8} raw contrast with narrowband light.	9/30/14 ✓
3	PIAACMC mask fabricated with 10^{-8} raw contrast with 10% broadband light.	12/15/14 ✓
4	Hybrid Lyot Coronagraph demos 10^{-8} raw contrast with narrowband light..	2/28/15 ✓
5	Occulting Mask Coronagraph demos 10^{-8} raw contrast with 10% broadband light.	9/15/15
6	Low Order Wavefront Sensing provides jitter sensing better than 0.4 mas rms.	9/30/15
7	Spectrograph read-out demo to have low dark current and read noise.	8/25/16
8	PIAACMC coronagraph demos 10^{-8} raw contrast with 10% broadband light.	9/30/16
9	Occulting Mask Coronagraph demos 10^{-8} raw contrast with 10% broadband light.	9/30/16

Widefield Detector Technology Milestones

1	Produce, test, and analyze 2 candidate passivation techniques in banded arrays.	7/31/14 ✓
2	Produce, test, and analyze 1 additional candidate passivation techniques in banded arrays.	12/30/14 ✓
3	Produce, test, and analyze full arrays with operability > 95%.	9/15/15
4	Produce, test, and analyze final selected recipe in full arrays demonstrating a yield > 20% with operability > 95%.	9/15/16
5	Complete environmental testing of one sensor chip assembly, as per NASA test standards.	12/1/16



FY15 Appropriation

(\$M)	2013	2014	2015	2016	2017	2018	2019
Astrophysics			\$685				
JWST			\$645				

- Provides \$77M more than the President's Budget Request for FY15
- Supports the commitment to an October 2018 launch date for JWST
- Includes \$50M for continued preformulation of WFIRST, an increase of \$36M over the Administration request and comparable to FY14
- Includes \$70M for continued SOFIA operations, an increase of \$58M over the Administration request and a reduction of \$14M (17%) from FY14
 - Directs NASA to (a) seek partners to restore SOFIA to its full level, and (b) not terminate missions without a Senior Review
- Includes \$98M for Hubble operations, an increase of \$23M over the Administration request and the same as FY14
- Includes \$38M for scientific ballooning, as requested and an increase of \$5M (15%) from FY14
- Does not specify the distribution of funding for the rest of Astrophysics, but the funding is adequate for Astrophysics to execute its program as planned in FY15.
 - Is a general reduction of \$40M from the request for the rest of Astrophysics
 - Includes support as planned in FY15 for missions under development, operating missions, SMEX AO, R&A, etc.



FY16 President's Budget Request

Outyears are notional planning from FY16 President's budget request

(\$M)	2014	2015	2016	2017	2018	2019	2020
Astrophysics*	\$678	\$685	\$689	\$707	\$750	\$986	\$1,118
JWST	\$658	\$645	\$620	\$569	\$535	\$305	\$198

- Continues preformulation of WFIRST/AFTA as the “Astrophysics Decadal Strategic Mission.”
- Grows Astrophysics Research and Analysis (including Astrophysics Data Analysis Program) from ~\$80M/yr to ~\$90M/yr in FY16.
- Supports completion of missions under development, including LPF/ST7, ASTRO-H, NICER, TESS, and Euclid.
- Enables selection of a SMEX mission and an Explorer Mission of Opportunity from the 2014 AO, and notional release of a MIDEX AO in late CY16/early FY17.
- Provides full funding for SOFIA operations and places SOFIA into the 2016 Astrophysics Senior Review.
- Plans for the 2016 Astrophysics Senior Review.
- Plans for continued Hubble operations through FY20 providing overlap with JWST.
- Plans for mission concept studies and technology development (within the three Program SR&T budgets) leading up to the 2020 Decadal Survey.

* Excludes “SMD STEM Activities” in all years.

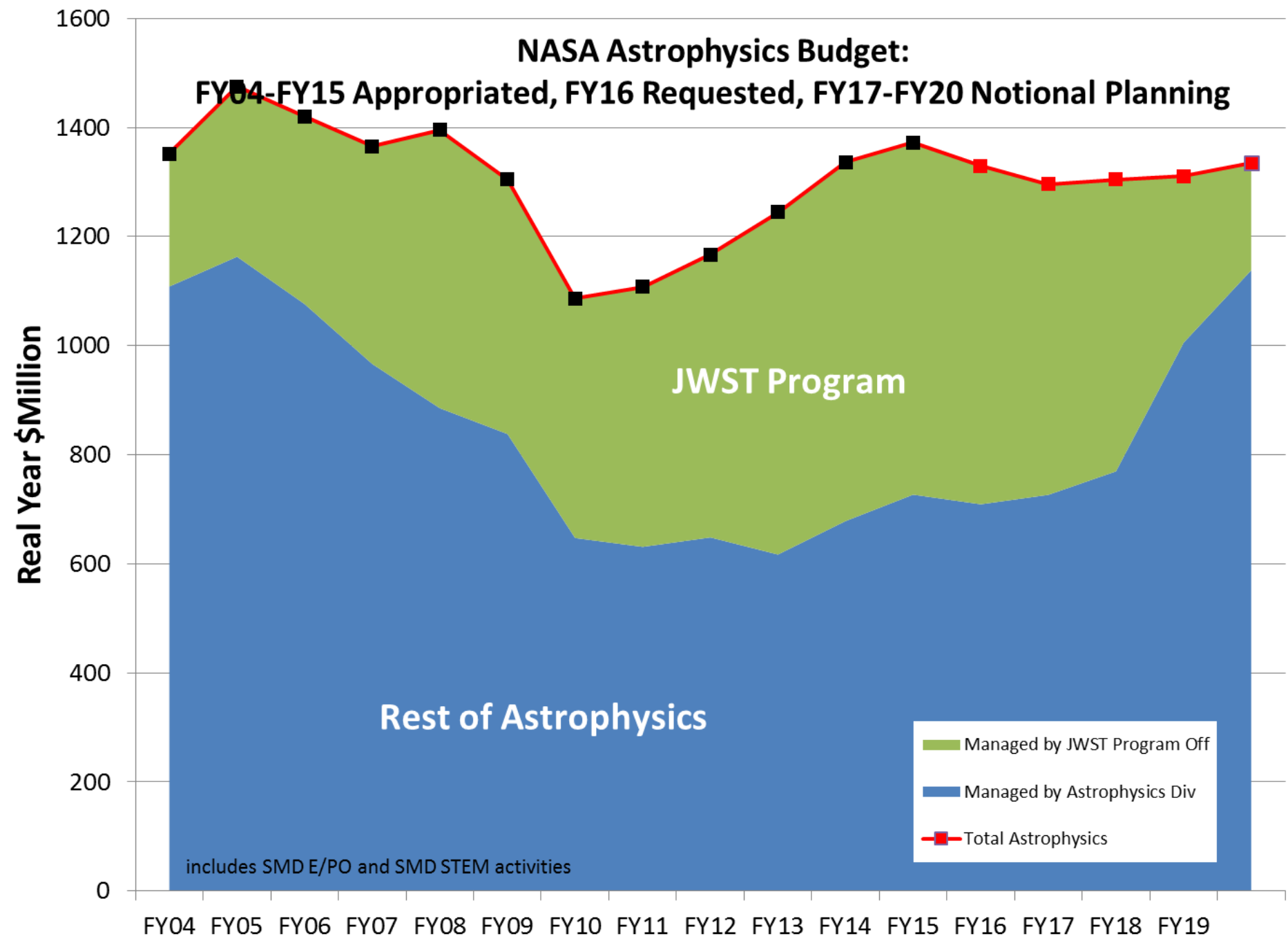



FY16 Congressional Appropriation Markups

\$M	FY15 Approp	FY16 Pres Request	FY16 House Budget	Delta House vs Request	FY16 Senate Budget	Delta Senate vs Request
Status			Appropriation passed full House		Appropriation sent from Committee to Senate	
NASA	18,010.2	18,529.1	18,529.1	0	18,289.5	-239.6
SMD	5,244.7	5,288.6	5,237.5	-51.1	5,295.0	+6.4
JWST	645.4	620.0	620.0	0	620.0	+0
Astrophysics w/ SMD Ed	726.8	709.1	735.6	+26.5		
Astrophysics w/out SMD Ed	684.8	689.1			730.6	+41.5
WFIRST	50.0	14.0	49.8	+35.8	90.0	+76.0
Hubble	98.6	97.1			98.3	+1.2
SOFIA	70.0	85.2			85.2	+0
Rest of Astroph	634.8	675.1	653.8	-21.3	653.8	-35.7
SMD Education	42.0	20.0	32.0	+12.0	42.0	+22.0



FY16 Congressional Appropriation Markups

Astrophysics Project	House Language (paraphrased)	Senate Language (paraphrased)
All	Follow the Decadal Survey	Follow the Decadal Survey
JWST	Do not overrun	Do not overrun
WFIRST	Include coronagraph; accelerate exoplanet program	Accelerate formulation start, with goal of KDP-A by January 15, 2016
Hubble		Hubble is wonderful
SOFIA	Do not put SOFIA in 2016 Senior Review	SOFIA's participation in 2016 Senior Review is only for practice
Explorers		Increase AO frequency to at least every 3 years with goal of every 2 years
Kepler		Kepler has revolutionized the pace of planet finding
SMD Education	Reallocate funds among Divisions	APD should administer SMD-wide education activities



Planning for the 2015-2016 Mid-Decade Review

- The NASA Authorization Act of 2005 requires assessments of NASA's science programs that include mid-decade reviews.
 - The Astrophysics Mid-Decade Review will be during 2015-2016
 - Study will be co-sponsored by NASA, NSF, and DOE (the Agencies)
- Given the funding circumstances that are substantially below those assumed in the Decadal Survey, the committee's review will describe:
 - The most significant scientific discoveries, technical advances, and relevant programmatic changes in astronomy and astrophysics since the Decadal Survey;
 - How well the Agencies' programs address the strategies, goals, and priorities outlined in the Decadal Survey and other NRC reports;
 - Progress toward realizing these strategies, goals and priorities; and
 - Any actions that could be taken to maximize the science return of the Agencies' programs.
- The NRC is in the process of forming the Committee.
 - Jackie Hewitt (MIT) is chair.
 - Meetings in ~August (DC), ~October (Irvine), ~December (TBD)
 - Study report requested by May 1, 2016, to inform FY18 budget formulation.



Progress Toward Decadal Survey Priorities

The NASA FY15 Appropriation, the President's FY16 Budget Request, and the notional out year budget planning guidance in the President's FY16 Budget Request, support:

Large-scale 1. WFIRST
(wide-field infrared survey telescope)

Preformulation and focused technology development for WFIRST-AFTA (a 2.4m version of WFIRST with a coronagraph) underway to enable a new start NET FY2017. Budget line established for an Astrophysics Decadal Strategic Mission.

Large-scale 2. Augmentation to Explorer Program

Astrophysics Explorers planning budget increased to support decadal cadence of AOs including SMEX AO in Fall 2014 and MIDEX AO in late 2016/early 2017.

Large-scale 3. LISA
(large GW space observatory)

Partnership discussions for ESA's L3 gravitational wave observatory; Participating in ESA-led assessment in 2014-2015; Strategic astrophysics technology (SAT) investments; Continued support of LISA Pathfinder.

Large-scale 4. IXO
(large X-ray observatory)

Partnership plans for ESA's L2 Athena X-ray observatory, Athena study phase, with U.S. participation, is underway; Strategic astrophysics technology (SAT) investments.

Medium-scale 1. New Worlds Technology Development Program

Focused technology development for a coronagraph on WFIRST-AFTA; Strategic astrophysics technology (SAT) investments; Exoplanet probe mission concept studies; Partnership with NSF to develop extreme precision Doppler spectrometer as facility instrument; Exozodi survey using NASA-developed LBTI.



Progress Toward Decadal Survey Priorities

The NASA FY15 Appropriation, the President's FY16 Budget Request, and the notional out year budget planning guidance in the President's FY16 Budget Request, support:

Medium-scale 2. Inflation Probe Technology Development Program

Balloon-borne investigations; strategic astrophysics technology (SAT) investments.

Small-scale. Research Program Augmentations

Increased annual R&A budget by 10% from FY10 to FY12 and another 10% from FY14 to FY16. Within R&A: established Theoretical and Computational Astrophysics Networks (TCAN) program with NSF; funding available for astrophysics theory; funding available for lab astrophysics; funding available for suborbital payloads.

Small-scale. Intermediate Technology development Augmentation

Strengthened competed Strategic Astrophysics Technology (SAT) program element; directed technology funding for WFIRST and other decadal priorities.

Small-scale. Future Ultraviolet-Visible Space Capability

Strategic Astrophysics Technology (SAT) investments.

Small-scale. SPICA (U.S. contribution to JAXA-led large infrared space telescope)

Not supported as a strategic contribution; candidate for Explorer Mission of Opportunity.

ASTROPHYSICS

Decadal Survey Missions

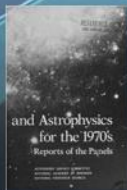

1972
Decadal
Survey
Hubble

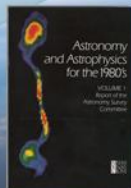

1982
Decadal
Survey
Chandra



1991
Decadal
Survey
Spitzer, SOFIA



2001
Decadal
Survey
JWST



2010
Decadal
Survey
WFIRST



Preparing for the 2020 Decadal Survey Large Mission Concepts

- Study 3-4 large mission concepts as candidate prioritized large missions
 - Science case
 - Technology assessment
 - Design reference mission with strawman payload
 - Cost assessment
- NASA Plan for Community Input
 - 2015: PAGs gather community input on selecting concepts for study
 - 2016: Appoint STDT and Center study office, STDT assesses technology
 - 2017: Fund technology development through SAT, STDT develops DRM
 - 2018: STDT submits DRM for cost assessment
 - 2019: STDT issues report and provides input to Decadal Survey
- Community workshops (incomplete list)
 - Mar 19, Joint PAG EC meeting, Baltimore
 - Jun 3-5, Far-IR workshop, Pasadena
 - Jun 13-14, ExoPAG meeting, Chicago
 - Jun 25-26, UV-Vis workshop, Greenbelt
 - Jun 29-Jul 1, High Energy workshop, Chicago
 - Aug 7, Joint PAG session @ IAU General Assembly, Honolulu



Preparing for the 2020 Decadal Survey Large Mission Concepts

The initial short list (in alphabetical order):

- **FAR IR Surveyor** – The Astrophysics Visionary Roadmap identifies a Far IR Surveyor as contributing through improvements in sensitivity, spectroscopy, and angular resolution.
- **Habitable-Exoplanet Imaging Mission** – The 2010 Decadal Survey recommends that a habitable-exoplanet imaging mission be studied in time for consideration by the 2020 Decadal Survey.
- **UV/Optical/IR Surveyor** – The Astrophysics Visionary Roadmap identifies a UV/Optical/IR Surveyor as contributing through improvements in sensitivity, spectroscopy, high contrast imaging, astrometry, angular resolution and/or wavelength coverage. The 2010 Decadal Survey recommends that NASA prepare for a UV mission to be considered by the 2020 Decadal Survey.
- **X-ray Surveyor** – The Astrophysics Visionary Roadmap identifies an X-ray Surveyor as contributing through improvements in sensitivity, spectroscopy, and angular resolution.



Preparing for the 2020 Decadal Survey Large Mission Concepts

Success statement for the Large Mission Concept Studies is defined as “Four excellent studies of implementable missions that are ready to be taken to the Decadal Survey.”

Some thoughts for the PAGs as they prepare their reports:

- The “A” in PAG is for analysis, not advocacy
- The PAG reports are not a competition
 - The STDT reports are not a competition or an AO
 - The Decadal Survey is the competition for priority in the NASA future program
- The PAG reports should not do the work of the STDTs
 - STDTs will be obligated to determine driving science requirements
 - STDTs will be free to determine DRM architecture
 - STDTs will have the time, resources, and obligation to do trade studies
- The PAG reports should not pre-populate the STDTs
 - An open and inclusive process will be used to solicit and appoint STDT members

This guidance may also be found in the White Paper that chartered these PAG studies



Preparing for the 2020 Decadal Survey Thinking about Probes

- What was done 10 years ago?
 - Origins Probes Mission Concepts (2004)
 - ROSES call for quick (~9 month) paper concept studies
 - ~9 concepts selected in 2004; total ~\$1M (\$100K average)
 - Astrophysics Strategic Mission Concepts (ASMC; 2007)
 - ROSES call for ~1 year concept studies with mission design lab run
 - ~19 ASMC concepts selected in 2007; total \$13M (\$700K average)
 - Was this effective? Efficient? Appropriately impactful?
- Possibilities this time
 - Real mission concept studies
 - Just like we are doing for large mission concepts
 - How would we select them? Where does funding come from?
 - Paper mission concept studies, with or without mission design lab run
 - Just like AMCS or Origins Probes, but limited to Probes
 - Self selected, self funded
 - Anybody can submit a white paper to the 2020 Decadal Survey
- Awaiting input from the PAG reports



Preparing for the 2020 Decadal Survey Thinking about Probes

- Suggestion for the Decadal Survey: Recommend a Probe AO
 - Similar to Planetary Science Division's New Frontiers AO
 - Recent Probe-class missions include
 - Spitzer, Fermi, Kepler
 - New Horizons, Juno, OSIRIS-REx (New Frontiers missions)
 - Community identifies to the Decadal Survey mission concepts that could plausibly be done as Probes
 - Decadal Survey prioritizes a short list of mission concepts that should be accomplished on a Probe budget for the Probe AO
 - NASA issues a Probe AO and selects a Probe proposal that is responsive in a compelling manner to Decadal Survey identified science objectives for one of the mission concepts (determined by peer review) and can be accomplished as a Probe (determined by TMC review)
- Funding allotted to Probes "slows down" the large mission(s) that follow WFIRST
- NASA Astrophysics expects to announce a path toward Probe input for the Decadal Survey by the January 2016 AAS meeting



Astrophysics Timeline

