

ADOT POST-CONSTRUCTION BEST MANAGEMENT PRACTICES MANUAL FOR WATER QUALITY



Arizona Department of Transportation

January 2016

Executive Summary and Disclaimer

The Arizona Department of Transportation (ADOT) is under an Arizona Pollutant Discharge Elimination System (AZPDES) municipal separate storm sewer system permit¹ (MS4 Permit) that requires ADOT to develop, implement, and maintain comprehensive planning procedures and control measures to reduce the discharge of pollutants to the maximum extent practicable from new development and significant redevelopment within the MS4. This manual is intended to serve as a general guidance to assist ADOT staff and consultants in understanding when and where to consider post-construction (i.e., permanent) best management practices (BMPs) for water quality in new construction and redevelopment² projects.

The manual is most applicable and useful during the planning and preliminary design phases of a highway project; incorporating design standards and maintenance requirements for post-construction BMPs. The manual is intended to educate and guide the user through important considerations including how to apply a site planning process and BMP selection criteria to prevent or minimize water quality impacts. Moreover, the manual is not necessarily inclusive of all potential project conditions or scenarios, or all key considerations that a project may require.

As of September 18, 2008, all ADOT new construction or redevelopment projects beyond 15% design shall install post-construction water quality BMPs if the project discharges to certain surface waters. In 2013, ADOT updated the post-construction stormwater program to comply with an administrative action. According to the 2015, MS4 Permit ADOT will begin implementing the program statewide. ADOT will apply this program to treat stormwater discharges when conveyances result in an outfall that is located within a quarter mile of an Outstanding Arizona Water, impaired water, or directly to another MS4. The design standards, schematics and materials specifications for the BMPs presented in this manual are subject to change. Any references to proprietary products, vendors, companies or agencies in this manual are intended as examples, reference or guidance and are not endorsed or promoted by ADOT or its authors. Users of this manual are welcomed to submit comments, suggestions, or findings of errors. This information should be addressed to: ADOTwater@azdot.gov.

¹ AZS0000018-2015. ADOT AZPDES Municipal Separate Storm Sewer System Permit

² Redevelopment is referred to as alterations of a property that change the footprint of a site or building in such a way that results in the disturbance of equal to or greater than one acre of land. The term is not intended to include such activities as exterior remodeling (ADEQ 2008).

THIS PAGE INTENTIONALLY LEFT BLANK

Table of Contents

1.0	Introduction.....	1-1
1.1	Purpose of Manual.....	1-1
1.2	Water Quality Regulations and Permits.....	1-2
1.3	ADOT’s Statewide Stormwater Permit.....	1-2
1.4	Roles and Responsibilities for Water Quality at ADOT.....	1-3
	1.4.1 Environmental Services.....	1-3
	1.4.2 Roadway Engineering.....	1-4
	1.4.3 Bridge.....	1-4
	1.4.4 Districts.....	1-4
1.5	Principles and Practices.....	1-5
	1.5.1 Non-Structural Practices.....	1-5
	1.5.2 Structural Practices.....	1-5
	1.5.3 Treatment.....	1-6
1.6	References and Resources.....	1-6
2.0	Water Quality Considerations During Project Planning and Design.....	2-1
2.1	Introduction.....	2-1
2.2	Water Quality Considerations During Project Planning.....	2-1
	2.2.1 Site-Specific Conditions.....	2-2
	2.2.2 Environmental Setting.....	2-4
	2.2.3 Climatic Conditions.....	2-5
	2.2.4 Safety.....	2-9
	2.2.5 Management.....	2-9
	2.2.6 Winter Storm Management.....	2-10
2.3	Water Quality Considerations During Project Design.....	2-10
	2.3.1 Define the Contributing Drainage Areas and Soils.....	2-11
	2.3.2 Consider Climatic Conditions.....	2-11
	2.3.3 Determine Project-Specific Hydrology.....	2-12
	2.3.4 Identify Target Pollutants and Treatment Requirements.....	2-12
2.4	References and Resources.....	2-13

List of Figures

Figure 2.1 - Site Specific Conditions.....	2-2
Figure 2.2 - Tribal Homelands in Arizona.....	2-6
Figure 2.3 - Mean Temperature in Arizona.....	2-7
Figure 2.4 - Arizona’s Average Annual Precipitation Map.....	2-8
Figure 2.5 - Management Considerations.....	2-9

List of Tables

Table 2.1 – Target Pollutants in DOT Systems.....	2-12
---	------

List of Appendices

APPENDIX A – POST-CONSTRUCTION BMP BACKGROUND INFORMATION

APPENDIX B – DESIGN CALCULATIONS, TABLES AND REFERENCES

APPENDIX C – ABBREVIATIONS, ACRONYMS AND DEFINITIONS OF TERMS

1.0 Introduction

1.0	Introduction.....	1-1
1.1	Purpose of Manual.....	1-1
1.2	Water Quality Regulations and Permits.....	1-2
1.3	ADOT Statewide Stormwater Permit	1-2
1.4	Roles and Responsibilities for Water Quality at ADOT.....	1-3
	1.4.1 Environmental Services	1-4
	1.4.2 Roadway Engineering Group.....	1-4
	1.4.3 Bridge Group.....	1-5
	1.4.4 Engineering and Maintenance Districts.....	1-5
1.5	Principles and Practices	1-5
	1.5.1 Non-Structural Practices	1-5
	1.5.2 Structural Practices.....	1-6
	1.5.3 Treatment.....	1-6
1.6	References and Resources	1-7

For purposes of this manual, post-construction best management practices (BMPs) for water quality are those facilities and features designed into highway projects to protect surface waters, and because these remain in place after construction activities have been completed, they are considered permanent controls and require long-term maintenance. With the regulatory adoption of stormwater discharge control programs in the early 1990s, post-construction BMPs are commonly used to prevent and/or mitigate potentially harmful effects of highway pollutants in stormwater runoff before it can affect water bodies downstream (FHWA, 2000). For this reason, they are now prevalently included in stormwater permits.

1.1 Purpose of Manual

Over the years, numerous structural BMPs have been developed and used by ADOT for post-construction stormwater pollution control. This manual serves to guide planners and designers, both internal and external to ADOT, in the selection, design and maintenance of post-construction BMPs that ADOT implements to comply with water quality regulatory requirements. Specifically, this manual is intended to achieve the following goals:

- Allow ADOT to meet the goals submitted to the Arizona Department of Environmental Quality (ADEQ) as part of the Statewide Stormwater Management Plan and comply with its MS4 Permit.
- Provide an overview of important factors to be considered when selecting post-construction BMPs for water quality. Selecting the most appropriate BMP(s) for specific conditions of a highway project is a critical step towards ensuring the overall effectiveness of the pollution prevention measure(s) involved.
- Offer guidance in the proper consideration of specific physical, operational, and cost (capital and maintenance) characteristics of post-construction BMPs for water quality. Proper design and implementation of a post-construction BMP demands clear understanding of the applications and limitations of the particular BMP.

1.2 Water Quality Regulations and Permits

Water quality regulations and permits are utilized by public agencies with regulatory powers for the implementation of measures to protect water bodies. This section summarizes the various federal and state water quality regulations and permits that may require permanent stormwater treatment controls to be included in ADOT highway projects.

The Federal Water Pollution Control Act of 1948 was the first major U.S. law to address water pollution. Increased public awareness and concern for controlling water pollution led to sweeping amendments of this law in 1972 and 1977. As amended, the law became widely known as the Clean Water Act (CWA). The primary goal of the CWA is to restore and maintain the chemical, physical, and biological integrity of the waters of the United States. The Water Quality Act of 1987 further amended the CWA and formed the legislative basis for all federal stormwater regulations. It required National Pollutant Discharge Elimination System (NPDES) permits (Section 402 of the CWA) for stormwater discharges from municipal separate storm sewer systems (MS4s) and select industrial activities (including construction activities disturbing one acre or more of land). In 1990, the U.S. Environmental Protection Agency (EPA) issued the details of the regulations governing stormwater discharges.

In December 2002, Arizona became the 45th state with authorization from the U.S. EPA to operate the NPDES permit program at the state level. Under the resulting Arizona Pollutant Discharge Elimination System (AZPDES) permit program, all facilities in Arizona (excluding Indian lands) that discharge pollutants from any point source into waters of the United States are required to obtain or seek coverage under an AZPDES permit.

Under section 303(d) of the CWA, states, territories, and authorized tribes are required to develop and submit to U.S. EPA for approval a list of their impaired waters, which are the surface waters that do not meet applicable water standards. The term "303(d) list" is short for the list of stream/river segments or lakes proven to be impaired. Arizona's 303(d) impaired waters list is developed by ADEQ every even-numbered year, and it effectively influences and guides the regulatory course of action for restoring and protecting the listed surface waters. Once a water body is listed as impaired, ADEQ is responsible to establish a Total Maximum Daily Load (TMDL). A TMDL is a calculation of the maximum amount of a pollutant that a water body can receive and still meet water quality standards, and an individual allocation of that load among the various sources of the pollutant.

Under Section 404 of the Clean Water Act, the United States Army Corps of Engineers (USACE) issues permits to allow discharges of dredged or fill material to waters of the United States. Projects requiring a Section 404 permit must also obtain State certification (per CWA Section 401) that the proposed activity will not contribute to or cause violations of, State and Federal water quality standards. To secure a 401 certification, site-specific post-construction BMPs for water quality may be required to address stormwater discharges during construction and operation.

1.3 ADOT's MS4 Permit

An MS4 is defined by the Code of Federal Regulations as a conveyance or system of conveyances owned by a state, city, town, or other public body, that is designed or used for collecting or conveying stormwater, and is not a combined sewer or a publicly-owned treatment works. Therefore, ADOT's roadways and highways statewide are considered MS4s and regulated under a permit-based program.

This permit authorizes ADOT to discharge stormwater and certain non-stormwater runoff to waters of the United States. The permit includes conditions that are intended to protect the quality of the receiving waters.

ADOT has developed a Statewide Stormwater Management Plan (SSWMP) that describes ADOT's program to reduce the discharge of pollutants associated with the stormwater drainage and conveyance systems that serve ADOT's highways and transportation-related properties, facilities, and activities. The plan identifies how ADOT complies with the provisions of the Arizona Pollutant Discharge Elimination System (AZPDES) stormwater program.

In addition to the SSWMP, ADOT has developed various stormwater-related manuals to provide guidance to assist staff and consultants regarding regulations and control measures. ADOT also implements construction specifications to prevent and mitigate stormwater pollution as part of the agency's overall framework for the stormwater management program. This Post-Construction BMP Manual for Water Quality augments the program by specifying treatment options for stormwater quality.

In addition to managing runoff/drainage from paved surfaces and within/across highway right-of-ways, ADOT is required by permit to manage the quality of drainage discharges from its outfalls into impaired and Outstanding Arizona Waters³. Specifically, ADOT's Statewide Stormwater Permit requires the inventory, inspection, and maintenance of post-construction BMPs in ADOT's highway system being used to protect surface waters. The permit also requires that new construction and redevelopment highway projects carefully consider and, if appropriate, incorporate post-construction BMPs to be installed for the treatment of stormwater runoff prior to discharging into surface waters.

The majority of stormwater pollution control activities conducted by ADOT are related to roadway/highway construction and maintenance activities. This manual focuses on the post-construction BMPs for water quality to be used in new construction and re-development of existing ADOT roadways and highways. This manual, along with the ADOT Erosion and Pollution Control Manual, ADOT's Stormwater Monitoring Guidance Manual for Construction Activities, the Standard Specifications for Road and Bridge Construction, the Stored Specifications, and Project Special Provisions that are incorporated into highway construction contracts, represent ADOT's complete collection of guidance and process-defining material in relation to stormwater pollution prevention technology and requirements by ADOT for construction activities.

1.4 Roles and Responsibilities for Water Quality at ADOT

Proper use of this manual requires teamwork and cooperation between several ADOT entities, including Environmental Planning, Roadway Engineering, Bridge, and Districts. This section of the manual defines general divisional roles and responsibilities regarding post-construction water quality BMP implementation and regulatory compliance.

1.4.1 Environmental Planning

Environmental Planning works closely with governmental agencies that issue environmental mandates, such as the Environmental Protection Agency and the Arizona Department of Environmental Quality.

³ Outstanding Arizona Waters or OAWs are surface waters classified by ADEQ as outstanding state water resource pursuant to the Arizona Administrative Code R18-11-112. These waters are deemed of exceptional quality, warranting special protective consideration.

Specifically, Water Resources oversees regulatory requirements on surface and groundwater for all ADOT activities. It is a goal of Water Resources to improve water quality in state waters by promoting innovative BMPs, providing effective water quality education, and facilitating cooperation between ADOT and affected stakeholders. Water Resources provides technical guidance for incorporating regulations and procedures into ADOT's Standard Specifications and project Special Provisions.

As previously mentioned, users of this manual are welcomed to submit comments, suggestions, or findings of errors. This information should be addressed to: ADOTwater@azdot.gov.

1.4.2 Roadway Engineering

Incorporating post-construction BMPs for water quality into the design engineering of a highway project (i.e., plans, specifications, and estimates) is performed primarily and/or is the responsibility of the Roadway Engineering Group in the Infrastructure Delivery and Operations Division (IDO). IDO is the division of ADOT that oversees the construction and maintenance of the state highway system. The Roadway Engineering Group is organized into the following functional sections: 1) Roadway Predesign, 2) Drainage Design, 3) Roadside Development, and 4) Roadway Design.

The Drainage Design Section within the Roadway Engineering Group provides technical expertise in the field of hydrology, hydraulics and water resources engineering associated with new development or re-development of state highway projects. Drainage Design provides a number of key services related to the proper selection, sizing, and placement of drainage features in highway projects; ranging from conducting hydrologic analysis of systems contributing to highway drainage; to conducting hydraulics analysis for design of culverts, channels, bank protection, storm drains, retention/detention basins, flow energy dissipators, and other post-construction water control structures; to conducting stream hydraulics analysis and design to mitigate stream instability, sedimentation and scour – all key roles in protecting water quality. Drainage Design is responsible to ensure the effectiveness and performance of the post-construction BMPs being used in the highway project, and that the selected features are properly described and detailed in the design documents.

1.4.3 Bridge

When a bridge is included in the highway project, then the ADOT Bridge Group is responsible for the design of that bridge. The Bridge Group is responsible to furnish bridge design, bridge construction assistance, and bridge management necessary to provide and maintain safe and functional bridges (including their drainage facilities) on Arizona highways. As part of the bridge design process, the Bridge Group is also responsible for design of the drainage from the bridge deck.

1.4.4 Districts

The Arizona highway system is divided geographically into seven Districts, including Northwest, Northcentral, Northeast, Central, Southeast, Southcentral, and Southwest. The Districts are responsible for the operation and maintenance of facilities and infrastructure systems located within the District. Once a highway project is constructed, the assets are then turned over to the District. For maintenance purposes, each District is subdivided into multiple maintenance facility locations or units to focus activities on site-specific conditions.

1.5 Principles and Practices

Roadway development and redevelopment projects can impact stormwater runoff and the quality of the downstream receiving waterbody in several ways. For example, newly constructed or modified slopes are highly susceptible to erosion, as well as new and expanded roadway surfaces increase the impermeable surface area contributing to drainage flows. In addition, common stabilization in the form of seeding and/or plantings though eventually reduce the potential for soil erosion, it may introduce pollution sources such as total suspended solids and nutrients/pesticides.

New roadways and roadway expansions may accommodate increased traffic volumes, leading to increased deposition of sediment, oils and greases, and heavy metals, among other pollutants. The contribution of pollutants by vehicular activity is dependent on many variables, including average daily traffic (ADT)⁴, traffic speed⁵, and vehicle characteristics⁶. It is important to anticipate the relative pollutant loading and types of stormwater contaminants potentially involved to properly select the post-construction BMP that is needed to adequately protect water quality.

ADOT will apply this program to treat stormwater discharges when conveyances result in an outfall that is located within a quarter mile of an Outstanding Arizona Water, impaired water, or directly to another MS4. Beginning in the planning phase of a project, the receiving water will be identified and the status of the municipal aspect will be attained. Through the project development phase, design and environmental reviews will assess program applicability. Should a water body be added to the sensitive resource list or a community become regulated and could trigger the program late in the development phase, ADOT Water Resources will assess the impacts and the planning team will determine whether post-construction treatment devices are recommended.

1.5.1 Non-Structural Practices

Impacts to water quality from the construction and operation of roadways can be minimized through various non-structural practices. Routine road sweeping and pavement maintenance have been shown to substantially reduce the concentration of suspended sediment and heavy metals in stormwater runoff. Public education and volunteer clean-up programs can reduce pollutants, by removing traffic litter and debris along the ADOT right-of-ways. While post-construction non-structural practices are highly effective to reduce stormwater pollution, they are outside of the scope of this manual, which is focused on post-construction structural BMPs.

1.5.2 Structural Practices

A structural BMP is a physical device. It is typically designed and constructed to trap or filter pollutants or to reduce runoff velocities to reduce erosion potentials or settle sediment being transported in storm flows. These structural BMPs are discussed in further detail in **Section 3.0**.

⁴ Studies have shown correlations between increased ADT and pollutant concentrations in stormwater runoff, particularly on interstates, which typically have the largest ADT.

⁵ Idling or slow moving traffic may have more time to deposit stormwater pollutants to the roadway surface, such as leaking petroleum products and other vehicle fluids. Also, frequent braking on highways increases the loading of metals and other particulates due to increased brake and tire wear.

⁶ Poorly maintained vehicles are more likely to leak and deposit oils, fluids, and other potential pollutants than well maintained vehicles.

1.5.3 Treatment

Until recent years, proper erosion control and conveyance BMPs were typically sufficient for managing stormwater quality. Treatment BMPs⁷ can operate by means of sedimentation/flotation, infiltration, filtration, and/or biological processes (Minton, 2005), as described below:

Sedimentation/flotation – A process by which gravity and buoyancy simultaneously remove sediment and attached pollutants, floatables, and dispersed petroleum products. Particles with a density greater than water settle to the bottom while constituents lighter than water (i.e. oils and floatable debris) float to the top.

Infiltration – Underlying soils serve as the treatment mechanism by filtering and adsorbing pollutants through the unsaturated soil matrix⁸. Infiltration provides other benefits, such as groundwater recharge and stormwater quantity management. Infiltration is the most common treatment mechanism along ADOT roadways.

Filtration – A unit treatment process which can consist of inert or absorptive media filtration. Inert media removes suspended solids and attached pollutants by means of physical interception as the water passes through the filter matrix. Absorptive media also removes suspended solids, but is intended to remove dissolved constituents by means of chemical attachment to media. Filtration BMPs can be custom designed and constructed or they can be purchased and installed as a pre-manufactured device.

Biological – Refers to a broad group of processes in which living organisms remove pollutants or transform them to inert constituents. Plants and trees that take up dissolved nutrients through the root system. Grasses or turf can filter suspended sediments and absorb dissolved nutrients. Microorganisms (bacteria and fungi) can use, consume, and/or degrade organic pollutants, forming inert compounds such as carbon dioxide. Biological degradation is dependent on a number of factors, including the presence of aerobic conditions, sufficient dissolved organic carbon, and the pH of the soil and stormwater.

1.6 References and Resources

Arizona Department of Environmental Quality, *Arizona Department of Transportation Statewide Permit for Discharges to Waters of the United States under the Arizona Pollutant Discharge Elimination System Program*, September 2008.

Arizona Department of Transportation (ADOT), *Erosion and Pollution Control Manual: for Highway Design and Construction*, January 25, 2005

Arizona Department of Transportation, *Statewide Stormwater Management Plan, 2005*

⁷ Treatment/Water Quality BMPs may consist of a combination of multiple treatment processes.

⁸ Note that infiltration ceases after the soil matrix becomes saturated, at which point stormwater would pond or runoff at the soil surface.

Environmental Protection Agency, *National Management Measures to Control Nonpoint Source Pollution from Urban Areas*, Publication Number U.S. EPA 841-B-05-004, November 2005, <http://www.epa.gov/owow/nps/urbanmm>

Federal Highway Administration, *Stormwater Best Management Practices in an Ultra-Urban Setting: Selection and Monitoring*, FHWA A-EP-00-002, 2000, U.S. Department of Transportation, Federal Highway Administration, Washington, DC, <http://www.fhwa.dot.gov/environment/ultraurb/index.htm>

Minton, G., *Stormwater Treatment: Biological, Chemical and Engineering Principles*, 2005

2.0 Water Quality Considerations During Project Planning and Design

2.0	Water Quality Considerations During Project Planning and Design	2-1
2.1	Introduction	2-1
2.2	Water Quality Considerations During Project Planning	2-1
2.2.1	Site-Specific Conditions	2-2
2.2.2	Environmental Setting	2-4
2.2.3	Climatic Conditions	2-5
2.2.4	Safety	2-9
2.2.5	Management	2-9
2.2.6	Winter Storm Management	2-10
2.3	Water Quality Consideration During Project Design	2-10
2.3.1	Define the Contributing Drainage Areas and Soils.....	2-11
2.3.2	Consider Climatic Conditions	2-11
2.3.3	Determine Project Specific Hydrology	2-12
2.3.4	Identify Target Pollutants and Treatment Requirements.....	2-12
2.4	References and Resources	2-13

2.1 Introduction

Water quality BMPs focus on the treatment (pollutant displacement/removal) of stormwater before discharging into surface waters, and operate by means of sedimentation, infiltration, filtration, absorption, and biological degradation. The key to effective water quality pollution prevention is selecting and applying the most appropriate BMP to the particular situation. Arizona roadways are representative of a wide range of conditions that affect the functionality and effectiveness of water quality post-construction BMPs. The improper selection of post-construction BMPs can result in costly and burdensome long-term maintenance obligations, ineffective water quality pollutant source controls, and insufficient treatment of polluted stormwater before it reaches waters of the U.S. This section describes how to evaluate and select post-construction BMPs for water quality.

2.2 Water Quality Considerations During Project Planning

The planning phase in the development of a roadway project provides the best opportunity to avoid unfavorable water quality impacts, and can greatly reduce or eliminate the selection of ineffective or unnecessary BMPs. Consider the following concepts to avoid or reduce potential impacts during project planning:

- Locate structures and bridges to reduce work in streams and minimize construction impacts.
- Acquire right-of-way easements (such as grading easements) to reduce steepness of slopes and allow for proper maintenance.
- Avoid soils or formations that will be particularly difficult to stabilize.
- Provide cut and fill slopes flat enough to allow re-vegetation and limit erosion.
- Collect and convey concentrated flows in stabilized drains and channels.

- Disturb existing slopes and other soil areas only when necessary, and retain natural vegetation where feasible.
- Utilize alternative materials or facilities to reduce future maintenance impacts on water quality.

When determining the most appropriate set of BMPs to select and implement at a site, the planner needs to consider: 1) site-specific conditions, 2) environmental setting, 3) climatic conditions, 4) safety, and 5) management. These are discussed in more detail in **Sections 2.2.1** through **2.2.5**.

2.2.1 Site-Specific Conditions

A thorough assessment of the site-specific conditions will help identify those BMPs most suitable for the location. Not all BMPs will fit site-specific conditions. For example, a BMP may require excessive maintenance or fail altogether after a short period of time if it is not suited to site-specific conditions. The different site-specific conditions that a roadway planner must consider are shown in Figure 2.1.

Right-of-Way – The contributing drainage area must be estimated in order to determine and/or design appropriate BMP storage and/or treatment volumes. In urban settings and/or where space is limited, it may be necessary to retrofit post-construction BMPs into existing structures. To accommodate the retrofit, it may be necessary for the BMP to be compact or able to be installed some distance away or be broken up into smaller units. Detention basins, for example, can either be split up into multiple, smaller “pocket basins” to accommodate the necessary volume of runoff. In contrast, in more open, rural areas, a single BMP with a larger footprint may be more cost effective yet still meet the level of treatment required. In addition, with the exception of stack interchanges, roadway footprints are predominately linear, and therefore BMPs that can accommodate linear footprints are considered advantageous for roadway transportation systems.

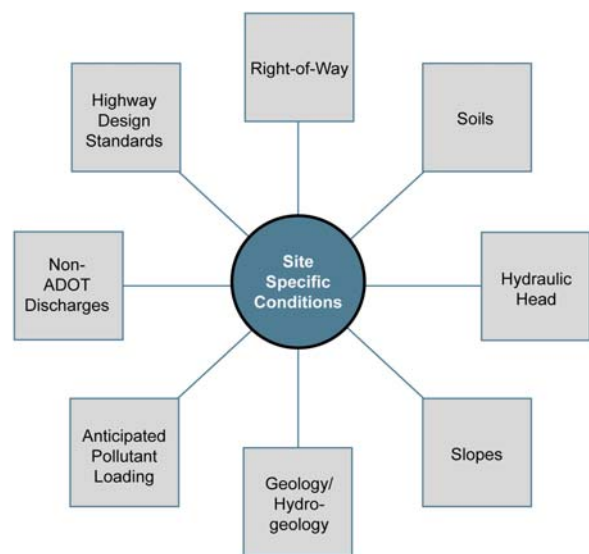

Figure 2.1 - Site Specific Conditions.
The roadway planner should consider a wide variety of site-specific conditions that can impact BMP selections and integration into a project.

Soils – The applicability and predicted functionality of several BMPs is dependent on surface and subsurface geology. For example, subsurface soils and geology need to be properly characterized for infiltration practices. Surface soil chemistry must also be considered. Soils with high organic content, for example, may have high absorptive capacity for highway pollutants such as petroleum hydrocarbon compounds.

Hydraulic Head – Most structural treatment BMPs operate under gravity flow conditions. The minimum hydraulic head must be considered in the selection of a BMP. Hydraulic head may refer to the depth of water, such as for storage and infiltration devices; or the total drop in water level for flow-through designs, such as for swales.

Slopes – The upstream slope, as well as the slope within a site is critical in evaluating the applicability of a BMP. The slopes will determine the susceptibility of a site to surface erosion and the need to implement post-construction controls to prevent elevated sediment loading. Steep slopes represent

higher erosive potential when compared to mild or flat terrain. Steep slopes can also cause breakthrough or short-circuiting of treatment BMPs if there are not sufficient velocity dissipation controls.

Geology / Hydrogeology – Certain subsurface geologic features found in various parts of Arizona, such as sinkholes, fissures, and subsidence, can form crevices and enlarged joints in the soil. Such voids in the soil can significantly impair the filtering capacity of vadose zone soil before recharged stormwater reaches groundwater. Also, the depth to groundwater can be another important criterion when selecting the appropriate BMP. The recharging of stormwater through infiltration practices may exacerbate contamination plumes that exist in a shallow aquifer below the area of infiltration. Moreover, a shallow depth to groundwater alone can substantially reduce the percolation rate of stormwater runoff from infiltration practices.

Anticipated Pollutant Loading – Predicting the anticipated pollutant type and concentration is important in selecting the appropriate BMP. Water quality requirements may also restrict the use of certain BMPs. Runoff from high density highways most likely contain elevated concentrations of total suspended and dissolved solids, petroleum hydrocarbon compounds, and metals, as well as miscellaneous litter and debris, compared to smaller, less frequently used roadways. Urbanized areas also pose a higher risk of non-stormwater discharges in roadway drainage systems. Understanding the target pollutants and the removal efficiencies required is the first step in properly defining and planning the needed post-construction water quality BMP.

Non-ADOT Discharges – ADOT roadways and drainage areas are routinely surrounded by non-ADOT drainage areas. During the design of conveyance channels, the mixing of non-ADOT and ADOT runoff should be avoided whenever possible. When runoff from all or a portion of the upstream or adjacent non-ADOT drainage area commingles with runoff from the ADOT roadway drainage area, the runoff may potentially carry pollutants from both ADOT and non-ADOT sources. In general, commingled flows are undesirable from ADOT's standpoint since BMPs must accommodate an additional pollutant load and greater runoff volume from these non-ADOT sources. When it is not practicable for external runoff to be diverted around or under an ADOT roadway (i.e. preventing it from commingling with ADOT runoff), or allowed under an encroachment permit, the treatment BMP(s) need to be designed and sized to accommodate the additional potential pollutant loading.

Highway Design Standards – ADOT is responsible for the design, construction, maintenance and operation of Arizona's State Highway System. Highway roadway design standards for construction and operation are based on applicable ADOT Roadway Design Manual and AASHTO design standards and guidelines. Design is based on factors such as type or level of access control, design speed, existing and projected design-year traffic volumes, topography and urban or rural design, and other environmental considerations and requirements. Design requirements can vary from one roadway to another based not on highway nomenclature⁹, but by consideration of design factors. Post-construction BMP design requirements, in addition to the above factors, may also affect the design of the roadway components, such as a bridge spanning over an impaired water body that cannot receive direct (considered potentially polluted) drainage discharges from the bridge.

⁹ The nomenclature for highway system operated is designated as Interstate Highways (e.g., I10), U.S. Highways (e.g., US60), and State Highways or State Routes (e.g., SR85). The highway nomenclature is based on past federal historical funding, a national numbering system in accordance to the American Association of State Highway and Transportation Officials (AASHTO) and a state numbering system.

2.2.2 Environmental Setting

Transportation projects spread across an extensive network of roadways that traverse a wide range of land uses, some considerably sensitive. The primary water quality objective during the project planning phase is to identify potential impacts to water quality to be imposed by the roadway and to develop options to avoid or minimize the potential for these impacts. Likewise during project planning, water quality considerations include identifying suitability and addressing any impacts that post-construction water quality BMPs, if required for the project, may have to the environment. The following items are specific to the Arizona roadways and must be taken into consideration when determining the appropriate BMP for the site.

Urban Areas – Typically urban areas have a higher percentage of impervious drainage areas, less available space for storage and infiltration practices, higher pollutant loading from increased traffic density, and a higher probability of illicit discharges. The 1999 Phase II Stormwater Rule requires small municipal separate storm sewer systems (MS4s) located wholly or partially in urbanized areas¹⁰, as well as small MS4s outside the urbanized areas that are designated by the permitting authority, to obtain NPDES permit coverage for their stormwater discharges. While many of the water courses in Arizona are ephemeral or intermittent, these national regulations still apply to Arizona. For an up-to-date list of the municipalities regulated by ADEQ refer to their website.

Public perception and safety concern are additional considerations in the BMP selection process within urban areas. Such concerns may include safety hazards, aesthetics, standing water, vectors, algae, and other environmental and wildlife nuisances.

Setback Distance Requirements – In both urban and rural settings, there can be several setback and zoning requirements for structures. Setback distance requirements may be in place for jurisdictional wetlands, forest conservation areas, roadways, utilities, structures, septic drain fields, and water wells. One or more of these setback requirements may exclude a potential post-construction water quality BMP from consideration or require a more complex operational configuration at a different location.

Protected Water Bodies – The selection of the appropriate BMP (or set of BMPs) becomes even more critical when the location is in close proximity to surface water bodies that are classified as impaired or Outstanding Arizona Waters (OAWs). Regulated under section 303(d) of the Clean Water Act, impaired waters are those that are too polluted or otherwise degraded to meet the water quality standards. The law requires that states, territories, and authorized tribes are required to develop lists of impaired waters, establish priority rankings for the waters on the lists, and eventually develop a Total Maximum Daily Load (TMDL) for each impaired water body. A TMDL is a calculation of the maximum amount of a pollutant that a water body can receive and still safely meet water quality standards. Outstanding Arizona Waters (OAW) are surface waters classified as an outstanding state resource water by the Director of ADEQ pursuant to the Arizona Administrative Code R18-11-112. These waters are of exceptional quality and therefore merit special consideration. Refer to the ADEQ's public website (www.azdeq.gov) for the latest list and map of the impaired waters and OAWs in Arizona.

¹⁰ The U.S. Census Bureau delineates urban areas typically after each decennial census. An urbanized area consists of densely developed territory that contains 50,000 or more people. The Census Bureau delineates UAs to provide a better separation of urban and rural territory, population, and housing in the vicinity of large places.

Federal, State, and Tribal Lands – ADOT operates under various Intergovernmental Agreements with entities such as Flood Control Districts and local municipal governments. ADOT and other state/federal agencies also have memoranda of understanding for lands under federal agency jurisdictions, such as the US Forest Service and the Arizona Bureau of Land Management. These commitments stipulate procedures for ADOT to follow when constructing or maintaining roadways on lands under the jurisdiction of another governmental entity and, subsequently, may influence or dictate the selection and implementation of post-construction BMPs. Finally, ADOT must also consult with Indian tribes and take special consideration when selecting and implementing post-construction BMPs on Indian Lands. **Figure 2-2** shows the location of all Federally-recognized tribes in Arizona.

2.2.3 Climatic Conditions

In addition to the various environmental settings listed above, ADOT roadways span a wide range of climatic zones throughout Arizona.

Annual Precipitation – Average annual precipitation is not uniform throughout Arizona. The local annual precipitation may dictate the type of erosion control measures, storage capacity and conveyance needed¹¹. Reliance on vegetative stabilization in arid areas poses additional challenges to post-construction BMP. **Figure 2-3** shows an average annual precipitation map for Arizona.

A good portion of the state also experiences severe winter conditions that result in snow accumulation during the winter period. The snow pack tends to melt fairly rapidly as warm conditions appear in early spring. Therefore, snow melt can result in water quality discharges to surface waters even when there is no measurable rainfall. Stream channels in arid regions are subject to a wide range of hydrologic, hydraulic, and sedimentary conditions. These channels often are dry or have little stream flow most of the time, and the few flows that do occur can cause substantial changes to the channel and flood plain. Floods in arid regions are often flashy in nature.

Peak Flow Reduction – The annual and seasonal precipitation considerations may also include peak flow reduction requirements. Post-construction BMPs must be able to effectively contain and/or divert water during peak flows. Precipitation volume and intensity for a given area must be evaluated in order to determine appropriate storage volume capacities. Additionally, the need for stabilized conveyance and/or interception systems and energy dissipation must be evaluated.

Temperature Extremes – Temperature extremes and associated conditions can significantly impact the performance and applicability of certain BMPs. Frozen soil can significantly reduce the efficiency of infiltration practices. Vegetative measures must be tolerant to various conditions: below freezing temperatures and de-icing salts in cold environments, and drought in hot and dry environments. Moreover, water quality BMPs must handle a higher pollutant loading during winter months; studies have shown that snow mounded along highways can accumulate pollutants and lead to elevated pollutant concentrations in snow melt runoff. Refer to **Figure 2-4** for Arizona’s Mean Temperatures.

¹¹ This does not mean that protecting and managing stormwater quality is less important or necessary in areas with less precipitation. Arid areas have extended dry periods allowing for the buildup of pollutants on roadway surfaces.

Figure 2.2 - Tribal Homelands in Arizona

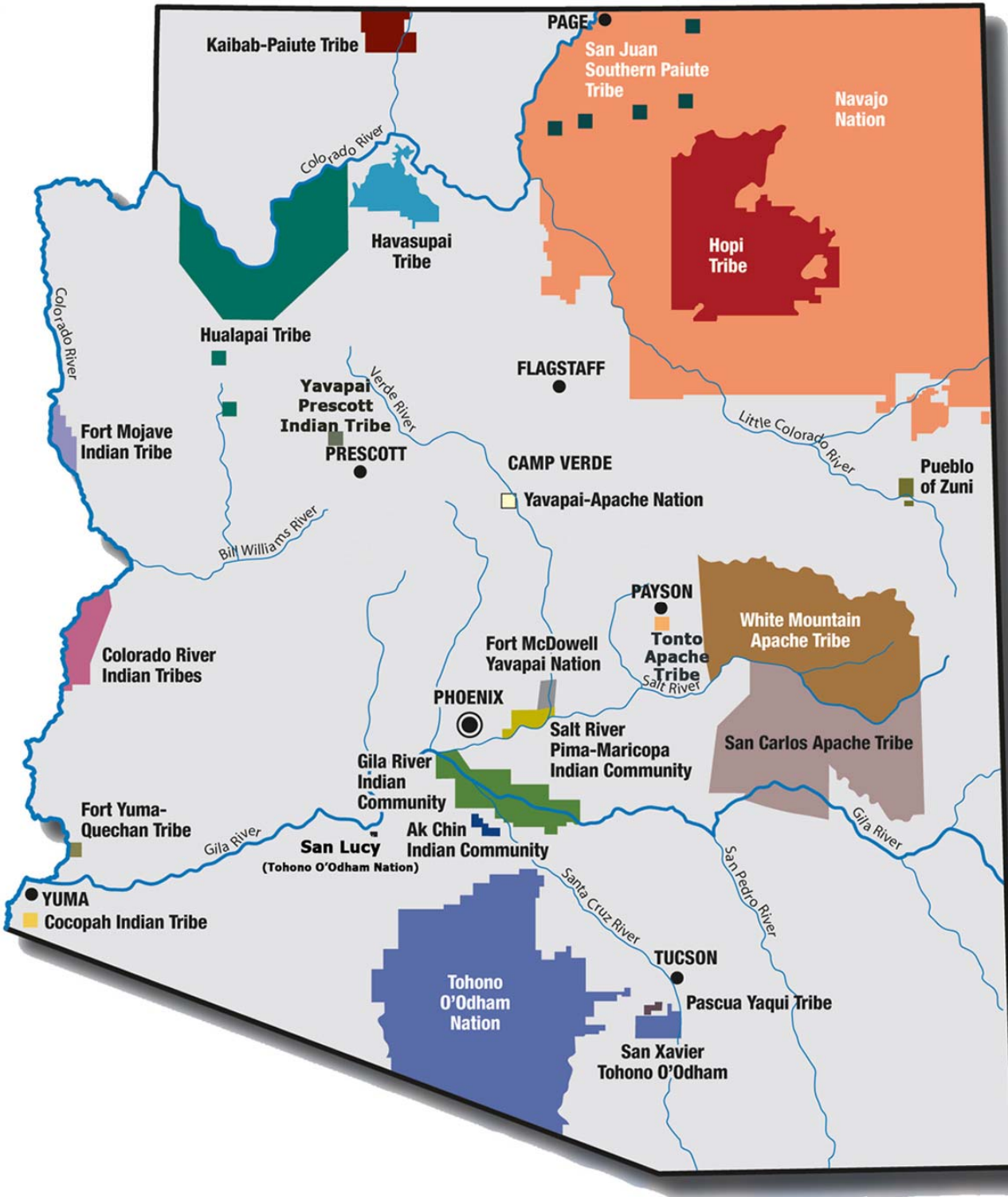

Reference: Inter Tribal Council of Arizona, Inc.

Figure 2.3 - Mean Temperature in Arizona

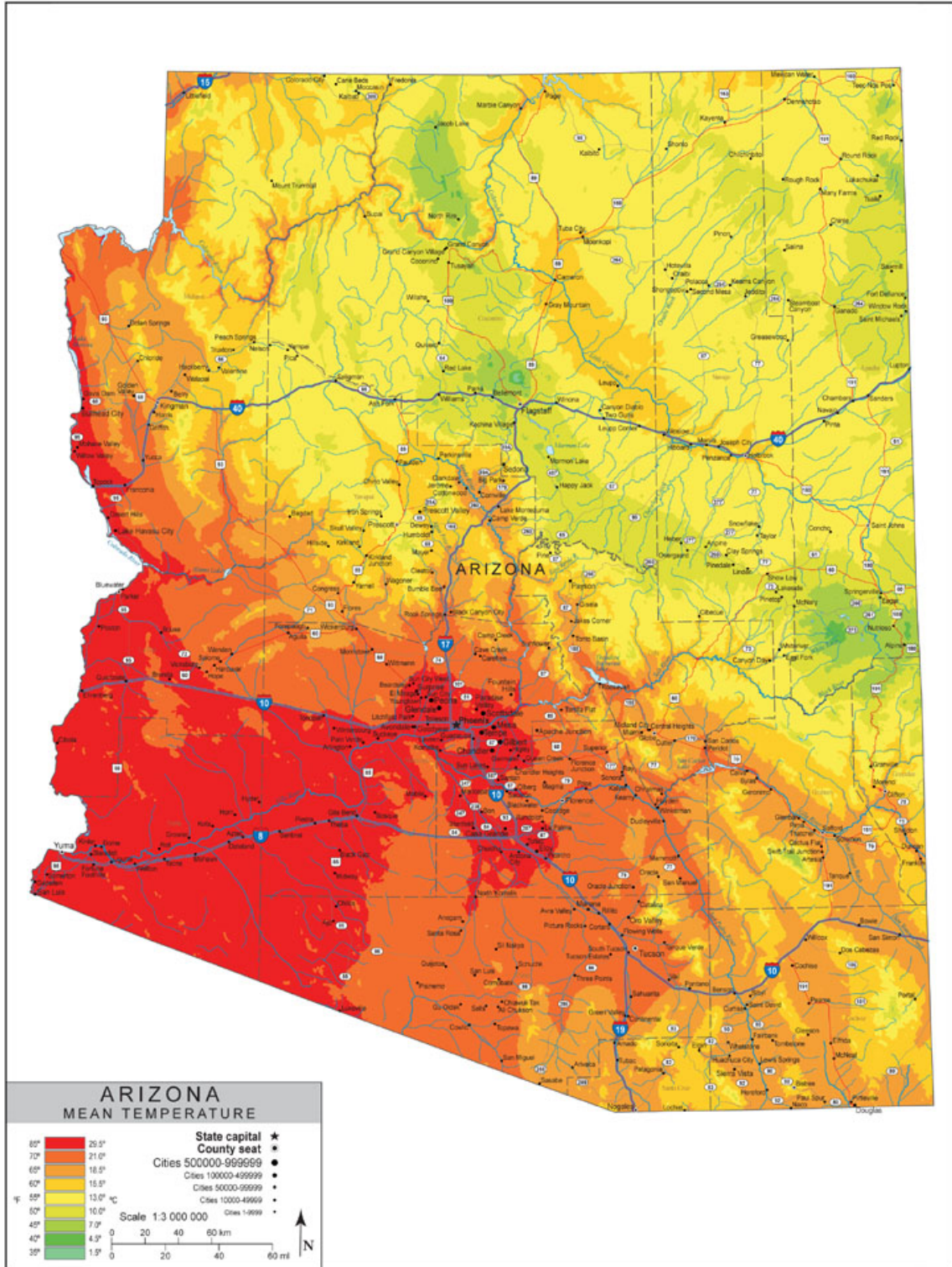
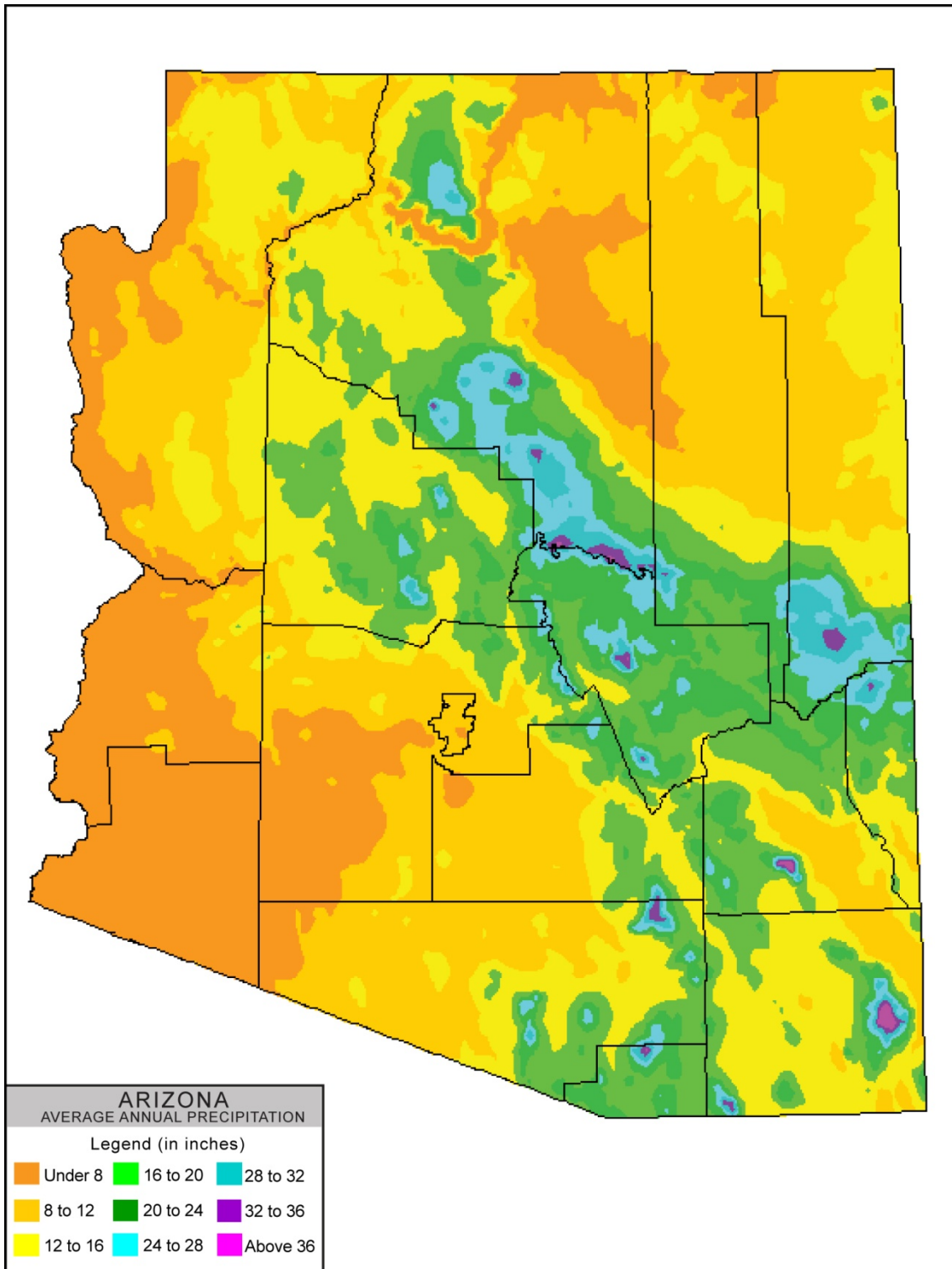

Figure 2.4 - Arizona's Average Annual Precipitation Map



Reference: Spatial Climate Analysis Service, Oregon State University.

2.2.4 Safety

ADOT’s primary focus on roadway design is ensuring public traffic safety. Post-construction BMPs are an integral component of the final roadway design and, as such, must not pose safety hazards to oncoming roadway traffic. In addition, the post-construction BMPs cannot compromise the function of roadway infrastructure. Non-traffic related safety issues from post-construction BMPs must also be considered, for example, retention basins maintain a pool of water that can pose safety hazards to nearby children, attract mosquitoes and vector-borne diseases, or be a safety hazard for staff to inspect and/or maintain.

Roadway and highway safety is a national, state and local priority. As a result, organizations such as the Federal Highway Administration (FHWA), the National Highway Traffic Safety Administration (NHTSA), the Institute of Transportation Engineers (ITE), the American Association of State Highway and Transportation Officials (AASHTO), the American Automobile Association (AAA), and other private and public organizations continue to develop and deploy resources designed to help make roadways and highways safer. Moreover, the federal transportation funding bill *Moving Ahead for Progress in the 21st Century Act* (MAP-21), which went into effect on October 1, 2012, continued the Highway Safety Improvement Program (HSIP) as a core Federal-aid program. The goal of the program is to achieve a significant reduction in traffic fatalities and serious injuries on all public roads, including non-State-owned public roads and roads on tribal lands. Proper integration in terms of safety of post-construction water quality BMPs in roadway and highway projects is paramount and should involve experts in the field of traffic and transportation safety.

2.2.5 Management

The costs and level of effort associated with installing and maintaining the post-construction BMP and the anticipated life span of the BMP must be evaluated prior to the final selection. In the event that two or more BMPs are all equally appropriate to implement based on the criteria from all of the above stages, the factors below can be used to determine more specific conditions or situations for when one BMP should be selected over another. **Figure 2.5** shows how the careful evaluation and integration of these factors help define the most effective post-construction water quality BMP.

Costs – The costs of implementing a post-construction BMP should be considered from the standpoint of planning, design, construction, inspection, and maintenance. The level of effort (and associated costs) including expertise, engineering design, and extent of labor required to plan, install, and maintain a post-construction BMP can vary greatly, ranging from the relative low cost of a simple infiltration basin to

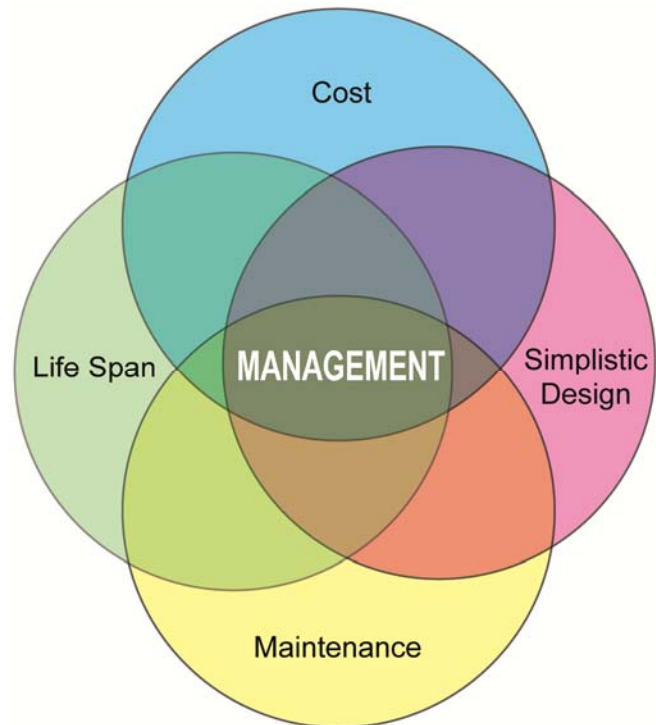

Figure 2.5 - Management Considerations
 Proper evaluation and integration of cost, simplistic design, inspection and maintenance requirements, and life span in the design of post-construction water quality BMPs ensures designing the most effective solution.

bioretention or manufactured treatment devices. In some cases, the upfront capital costs of a post-construction BMP may be negligible compared to the long term, ongoing costs for maintenance and repair.

Simplistic Designs – Post-construction BMPs need to be simplistic in design and require minimal maintenance effort and costs; while still meeting the intended water quality objectives. In comparison, localized industrial facilities, for example, can implement more specialized BMP technologies such as vortex separators, multi-chambered treatment trains, and chemical flocculation/treatment. These advanced BMPs may have high pollutant removal efficiencies, but they also require frequent inspections and close oversight, which is difficult to achieve in rural Arizona.

Inspections & Maintenance – The performance and estimated life span (discussed below) of a post-construction BMP depend largely on conducting periodic inspections and maintenance of the BMP, as appropriate. Maintenance activities vary in scope from one BMP to another, plus may involve sediment removal, vegetation management, and waste disposal. Safe access by ADOT personnel to maintain the BMP is imperative.

Life Span – Even with diligent maintenance, post-construction BMPs eventually need to be replaced. In the final selection of BMPs to implement at a site, consider that BMP life spans can range significantly. It is important to select BMPs that have similar life cycles and durations as the adjacent highway infrastructure.

2.2.6 Winter Storm Management

For ADOT, stormwater management also entails keeping highways safe and operational during winter months in regions where snow and ice can accumulate. ADOT uses a variety of winter storm management techniques, including the application of anti-icing/de-icing chemicals and abrasives. These chemicals and abrasives, which have accumulated and concentrated over the course of the winter season, become released in the melting snow/ice runoff. The roadway planner should consider the potential impacts from such winter storm management techniques and ensure that the post-construction BMPs for water quality can address these impacts.

2.3 Water Quality Considerations During Project Design

This section presents guidance for incorporating post-construction water quality BMPs in the designs of ADOT highway projects, as appropriate. During the design phase of a project, the designer may still have strong influence on minimizing potential water quality impacts, such as:

- Realignment of the roadway, while upholding safe design standards, to avoid or reduce impacts to receiving waters.
- Adjustment of the horizontal and vertical roadway alignments, without jeopardizing safe design standards, to minimize erosion from slopes.
- Minimizing cut and fill areas in the project to reduce slope lengths, particularly if the soils involved are highly erodible.

Notwithstanding, specific to water quality, the primary two objectives to achieve during project design are:

1. Complete a final determination and feasibility of the post-construction water quality BMP(s) required for the project, and

2. Develop the necessary information to design the post-construction BMP(s).

Before starting the process, the roadway designer should first assess whether post-construction BMPs are applicable to the project of interest. If it is determined that post-construction BMPs are necessary, the remaining design and decision data must be obtained. Design activities related to water quality consist of the following efforts, which are covered in more detail in **Section 2.3.1** through **Section 2.3.4**:

- Define the Contributing Drainage Areas and Soils
- Consider Climatic Conditions
- Determine Project-Specific Hydrology
- Identify Target Pollutants & Treatment Requirements

2.3.1 Define the Contributing Drainage Areas and Soils

There are many different characteristics of a project drainage area that can influence the potential to impact water quality and associated water quality controls. The physical attributes of site drainage areas may affect selection, location and design of post-construction water quality BMPs. The contributing drainage area is the up-gradient land area within which theoretically any drop of rain that falls will eventually, if not infiltrated or immobilized somehow, will make its way to the point of discharge in the project site. Drainage areas tend to be comprised of a network of drainage channels that link from smaller to larger, providing conduits for surface water runoff, more or less flowing from high elevation to low elevation perpendicular to contour (equal elevation line). The determination of drainage area allows the selection and sizing of suitable treatment controls. In addition, the percentage of the drainage area covered by pavement, concrete, or other impermeable materials significantly affects the peak flow and total volume of drainage, and ultimately the size of the BMP.

Because drainage (runoff) is what occurs when rain is not absorbed by the ground on which it falls, soil type has a significant impact on the amount of runoff produced (soil permeability). Soils are classified A through D according to their drainage potential. Group A soils absorb a lot of water and are deep, well-drained, and composed of sand or gravel. Conversely, Group D soils do not absorb as much water and have a high run-off potential, and have a layer of high clay content near the surface or are shallow soils over bedrock or other material which does not absorb water. The soil permeability rate is also used to size infiltration-based BMPs.

2.3.2 Consider Climatic Conditions

Climatic data must be known to aid in the selection and design of post-construction BMPs, such as:

Average Annual Rainfall and Distribution - this information is required for the design and specification of vegetative erosion controls. It is necessary to determine whether there is sufficient moisture naturally to maintain the vegetation in a sufficiently healthy state to serve the intended purpose or whether supplemental watering will be needed.

Design Storm – a storm whose magnitude, rate, and intensity do not exceed the design load for the post-construction water quality BMP to be designed. In other words, a specific storm event (storm duration), described in terms of the probability of occurring once within a given number of years (storm frequency), for which the BMP will be designed and built. Drainage calculations for ADOT project must follow ADOT Drainage Design Standards.

Other Climatic Factors – there are climatic conditions that could impact on the selection and design of post-construction BMPs, including humidity, evaporation, seasonal high and low temperatures, and snowpack.

2.3.3 Determine Project-Specific Hydrology

Gather additional information about the project site in order to select, locate, and design appropriate post-construction water quality BMPs. Aside from the geographical and topographical characteristics of the site, this includes the use and placement of drainage facilities to assist with the collection and conveyance of drainage flows, such as inlets, ditches/swales, channels, underground storm drains, etc. Reliance on vegetative stabilization in desert areas (where drought conditions prevail) poses additional challenges to post construction BMP effectiveness. For this effort, it is recommended that the designer use the ADOT Highway Drainage Design Manual.

2.3.4 Identify Target Pollutants and Treatment Requirements

Redevelopment and roadway expansions tend to increase traffic volumes, leading to increased loadings of sediment, petroleum hydrocarbons, trace metals, and nutrients. Table 2.1 provides a list of the most common pollutants found in DOT systems, particularly in the arid southwest. The designer must identify and focus design resources on the pollutants most likely to impact the target surface water. If the surface water is impaired, then an important target pollutant is the pollutant(s) for which the water body is impaired.

Table 2.1 – Target Pollutants in DOT Systems

Biological Constituents		
<ul style="list-style-type: none"> • Biological Oxygen Demand (BOD) • Chemical Oxygen Demand (COD) 	<ul style="list-style-type: none"> • Fecal Coliform • Total Coliform 	
Nutrients		
<ul style="list-style-type: none"> • Ammonia • Calcium • Chloride • Nitrate (NO₃ as N) 	<ul style="list-style-type: none"> • Nitrite (NO₂ as N) • Nitrogen • Sodium • Total Phosphorus 	
Trace Metals		
<ul style="list-style-type: none"> • Cadmium • Chromium • Copper 	<ul style="list-style-type: none"> • Lead • Manganese • Iron 	<ul style="list-style-type: none"> • Nickel • Zinc
Organics		
<ul style="list-style-type: none"> • Cyanide (CN) • Dissolved Organic Compounds • Particulate and dissolved Polyaromatic Hydrocarbons 	<ul style="list-style-type: none"> • Total Organic Carbon (TOC) • Total Petroleum Hydrocarbons • Total Phenols • Surfactants (detergents) 	

Detention and retention basins are common in the arid west and provide water quality benefits. Urban areas rely on these structures to settle stormwater particles and reduce peak runoff rates. Larger suspended solids can be removed effectively by gravitational sedimentation. Detention basins usually hold stormwater long enough to settle sands and larger silt particles. Detention basins are usually dry except during or after rain or snow melt. Retention basins hold stormwater for longer periods of time and allow even the fine sediments to settle to the bottom of the basin. Thus, retention basins allow for additional biological interactions that assist in improving water quality for nutrients, pathogens and metals. Both basins can be designed for a variety of storm events and purposes.

Petroleum hydrocarbons and polycyclic aromatic hydrocarbons (oil/grease, diesel fuel, gasoline) are typical stormwater pollutants in DOT systems. Short of using oil and water separators units, there are commercial materials and systems available that absorb these pollutants in stormwater runoff. A large variety of disposable products are also commercially available. Pollutant loading and volumes must be matched to the appropriate technology for effective treatment.

Trace metals comprise another common water quality pollutant from DOT systems. These can be bound to organic and inorganic particulates, or be present as a dissolved ionic species. Well-designed bioretention ponds, biofilters, and media filters can be effective in removing trace metals.

The forms and biochemical mechanisms of nutrients in stormwater render the effective treatment of these to be relatively difficult. Treatability success of nutrients, as with other complex compounds in stormwater, is highly dependent on the form and the presence of other things like bacteria, biomass, oxygen, and concentrations.

2.4 References and Resources

Highway Drainage Design Manual, Hydrology, Arizona Department of Transportation, March 1993, Report Number: FHWA-AZ93-281

Highway Drainage Design Manual, Hydraulics, Arizona Department of Transportation, January 2007

National Cooperative Highway Research Program (NCHRP), Report 565, Evaluation of Best Management Practices for Highway Runoff Control, 2006 Transportation Research Board

Project Planning and Design Guide (PPDG), CTSW-RT-10.254.03, State of California Department of Transportation (CALTRANS), July 2010

Stormwater Quality Manuals – Planning and Design Guide, Nevada Department of Transportation, January 2006

Water Quality Division webpage, www.azdeq.gov/environ/water/index.html, Arizona Department of Environmental Quality

Winter Storm Management of Arizona State Highways, Arizona Department of Transportation, October 2008

1.0 Introduction

2.0 Project Planning and Design Considerations

3.0 Post-Construction Best Management Practices

3.0	Post-Construction Best Management Practices.....	3-2
3.1	Manufactured Treatment Devices	3-3
3.2	Bioretention	3-10
3.3	Filtration Structures	3-15
3.4	Infiltration Basin	3-20
3.5	Infiltration Trench.....	3-24
3.6	Retention and Detention Basins.....	3-30
3.7	References and Resources.....	3-35

This section is intended as a technical guidance for post-construction water quality BMPs. Each BMP presented herein contains an overview of key design attributes and discussion on the appropriate applications, limitations, and specific design factors that should be considered. Also, each BMP highlights material specifications, design standards and maintenance, and inspection requirements. When applicable, design schematics are also included.

ADOT roadways can be the source of pollutants that accumulate during dry periods and are carried by stormwater from rainfall. Pollutants may originate from vehicular use including: tires, brake wear, engine fluids, as well as from non-vehicular sources such as litter and discarded trash. Those sources may also combine with dust and other accumulated materials from on site and remote sources, all becoming potential contributors. The first flush, defined as the runoff from the initial half inch of rain, typically results in the most polluted stormwater discharge form a rainfall event. Appropriate first flush containment should take into consideration the nature and sources of pollution in relation to the drainage facilities, pollutant mobility, and pollutant supply.

The post-construction water quality BMPs presented and described in this section are common stormwater drainage management systems that can adequately address first flush requirements. These BMPs focus on the displacement or removal of pollutants from stormwater, and they operate by means of sedimentation, absorption, infiltration, filtration, and biological degradation.



3.1 Manufactured Treatment Devices

DEFINITION

Manufactured water quality treatment devices include hydrodynamic (flow through) and filtration structures. Hydrodynamic structures rely on settling or separation of pollutants from stormwater runoff. These structures encourage sedimentation of particulate materials and the separation of free oil, grease, and debris. Manufactured treatment devices commonly contain screens to retain larger or floating debris. Filtration devices such as catch basin inserts are also considered.

OVERVIEW

GENERAL INFORMATION
Key design factors: <ul style="list-style-type: none"> Contributing drainage area. Identify target pollutants to remove. Footprint required for treatment device.
Maintenance needs: <ul style="list-style-type: none"> Periodic inspections per the manufacturer’s recommendation. Removal of floatable debris and trash.
Most effective when used with: <ul style="list-style-type: none"> Pretreatment (i.e. Vegetated Filter Strips or Decomposed Granite Cover).
Alternative BMPs to consider: <ul style="list-style-type: none"> Retention/detention basins (pond-in-place). Infiltration Basin or Infiltration Trench.

RATINGS*	H	M	L
Associated Costs			
Design	X		
Construction	X		
Maintenance	X		
BMP Objective			
Erosion control			X
Drainage conveyance			X
Water Quality/Treatment	X		
DOT Target Pollutants Removal			
Dissolved or suspended sediment	X		
Biological constituents	X		
Nutrients and pesticides	X		
Heavy metals	X		
Organics	X		

***Note:** Ratings are general and highly dependent on the type of device and individual manufacturer specifications.

APPROPRIATE APPLICATIONS

Manufactured systems are typically appropriate where space is limited or additional treatment is necessary. They can be also be retrofitted within existing development or redevelopment. Applications can range from catch basin inserts to oil/grit separators. Additional design considerations are described below. Manufactured treatment devices can be used online or offline to achieve storage volumes capable of containing the runoff from the design storm corresponding to ADOT’s local drainage design requirements.

LIMITATIONS

Manufactured treatment devices are limited to the manufacturer’s recommendation for appropriate applications. These devices are NOT appropriate in the following conditions:

- Rural locations where routine maintenance will be inconvenient or difficult;
- Locations where maintenance access will be limited or restricted.

DESIGN CONSIDERATIONS

Manufactured treatment devices must be installed and used in accordance with the manufacturer's specifications. Manufactured systems are usually designed for a specific flow rate or volume. Therefore, adequate overflow or bypass capacity must be designed into the drainage system to prevent downstream impacts.

Footprint/geometry – Manufactured treatment devices come in various shapes and sizes. The specific application and location will determine the type and size of unit used. Consideration of maintenance access is important and can often determine the type of device used.

Local government code – Refer to local municipal code for any local requirements, such as manhole placement and spacing for access to devices. Also, verify any applicable setback requirements from utilities, easements, and other properties.

Construction sequencing – After the system is constructed, install temporary controls around the perimeter until the project has been established to prevent excessive, premature sediment loading into the device.

Pretreatment – In areas where dense vegetation can be maintained, a vegetated buffer should be kept around the perimeter of the device for pretreatment. Otherwise, a decomposed granite cover should be used between the contributing roadway drainage area and the device.

MATERIAL SPECIFICATIONS

Material specifications will be dependent on the type of manufactured treatment device considered and specific project requirements.

DESIGN STANDARDS

Manufactured treatment devices must conform to all ADOT standards and specifications. All manufactured designs should be reviewed to ensure that the proposed system is appropriate for the project needs.

MAINTENANCE AND INSPECTION REQUIREMENTS

Inspections – All manufactured devices require regular inspection and maintenance to maximize their effectiveness. The specific maintenance requirements and schedule should be provided by the manufacturer. Maintenance frequency may vary from after any major storm to monthly. Lack of maintenance is widely acknowledged to be the most prevalent cause of failure.

Sediment and Debris Removal – Sediment and other debris collected in manufactured systems may or may not be able to be disposed of as general municipal wastes. Proper disposal methods should be confirmed prior to performing cleanouts.

Nuisance Control – Inspect areas with installed devices for standing water following each storm event and remove any stored water. The inspection and maintenance schedule outlined above should also be followed for this section.

SCHEMATICS

ADOT does not exclusively recommend the use of any manufacturer's product. The schematics in the following pages, which are from various manufactures, are provided for illustrative purposes only.

Schematic of an Example Gravity (Oil-Grit) Separator

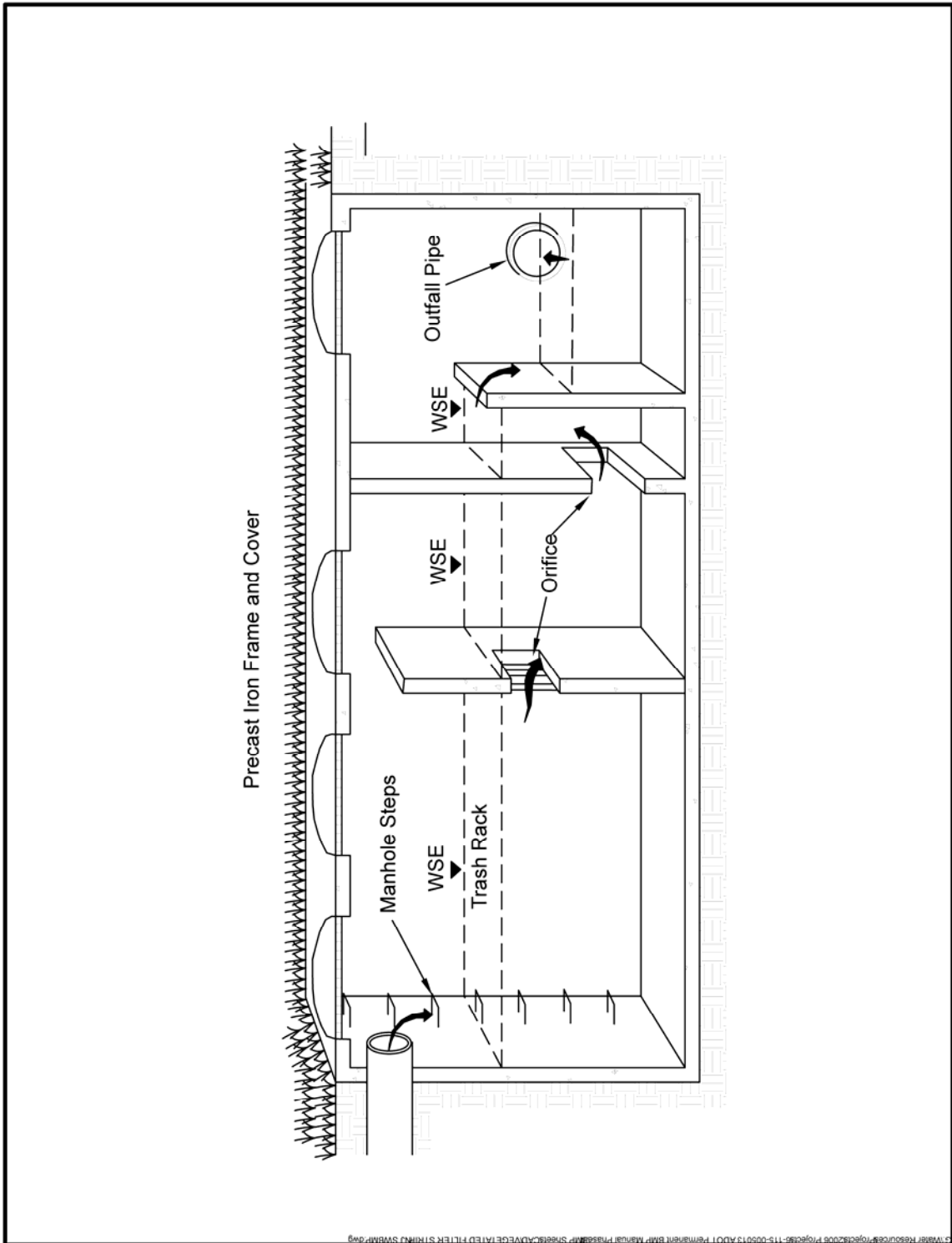

Schematic of a Hydrodynamic Device

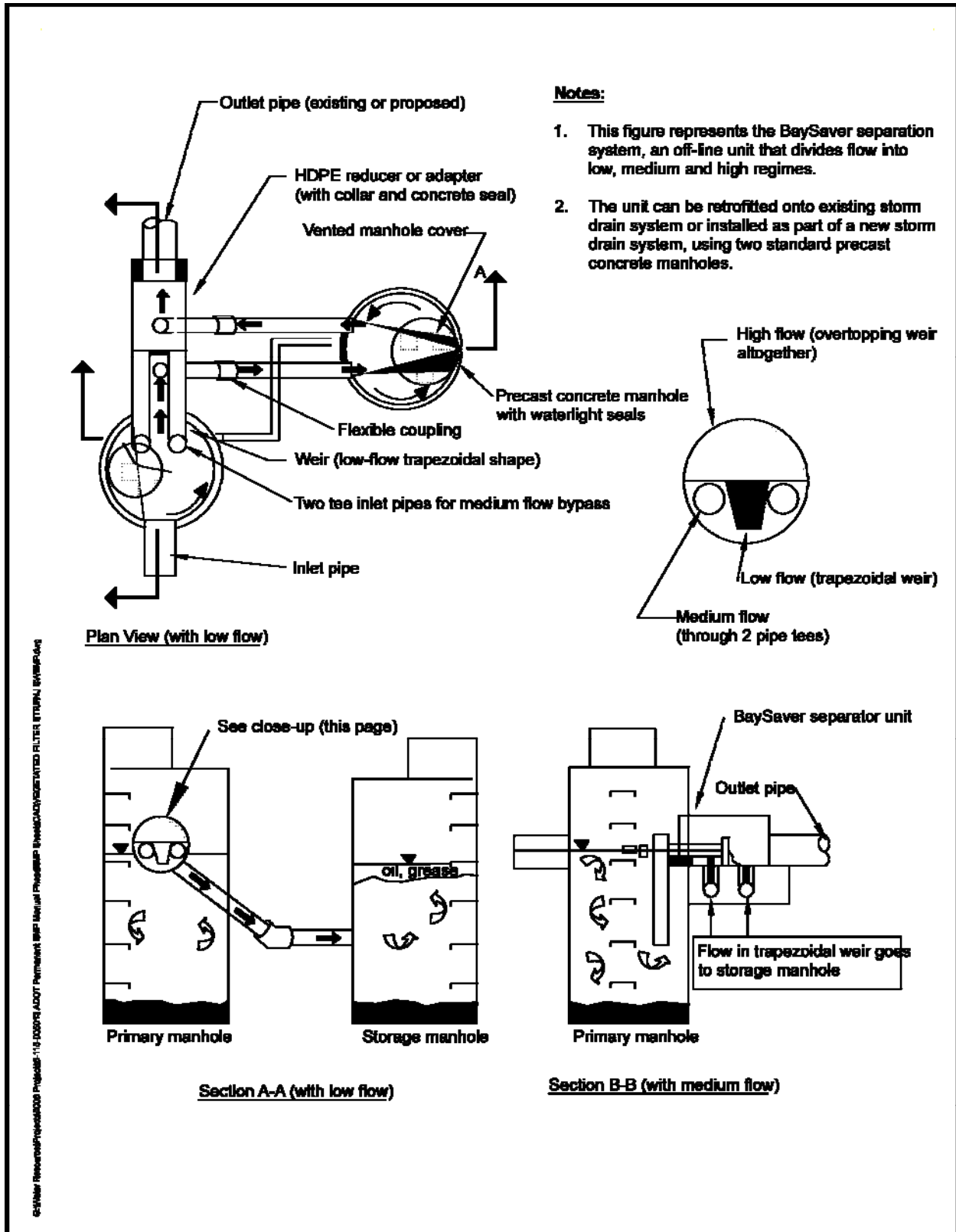

© 2008 ADOT Permanent Best Management Practices Manual, Chapter 3.0, Section 3.0.1, BaySaver

Schematic of an Oil-Water Separator with Bypass

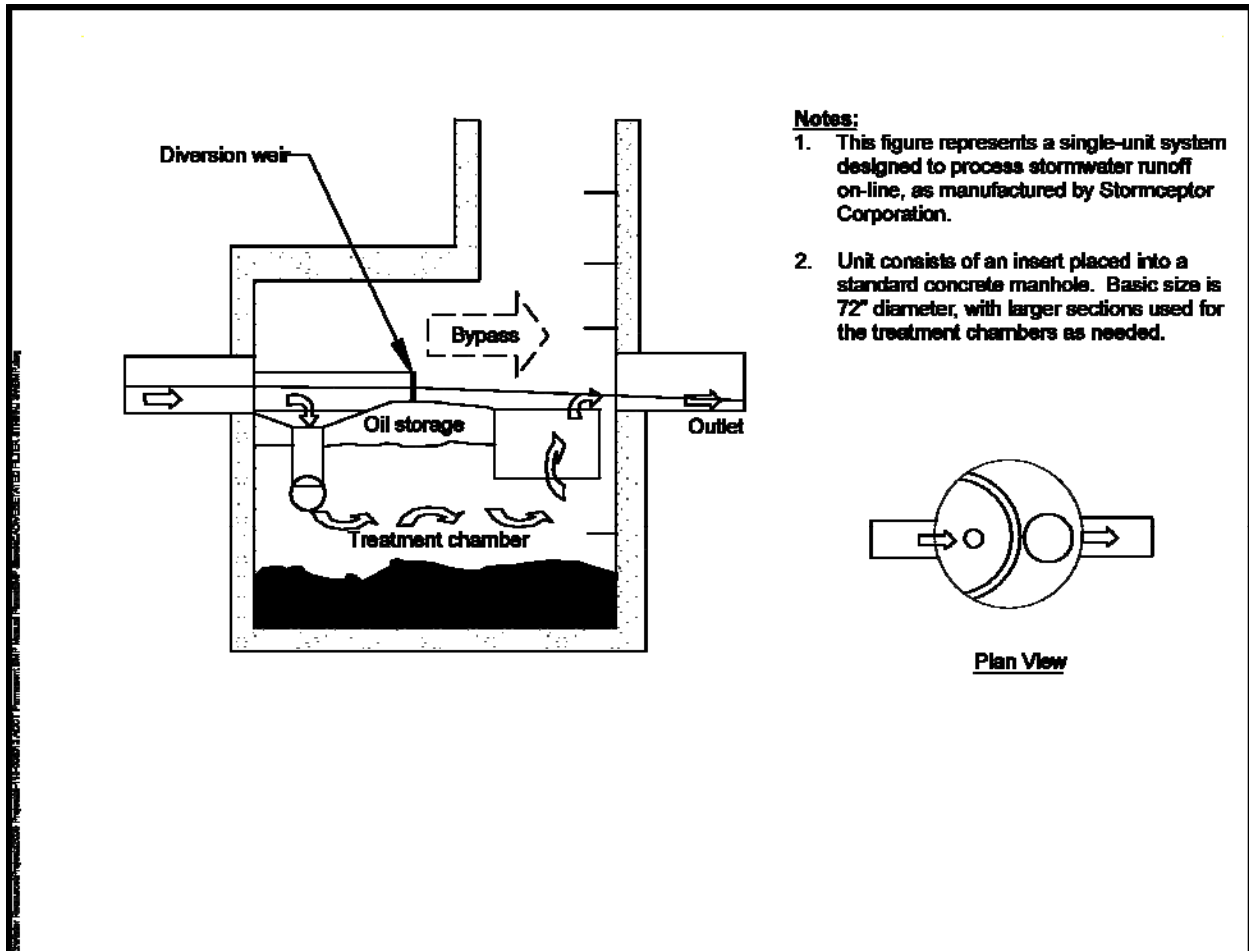

Refer to ADOT C-Standards C-15.10 to 92 for catch basin standard drawings and details and C-18.10 for manhole standard drawings.

Schematic of a Continuous Deflector Vendor Device

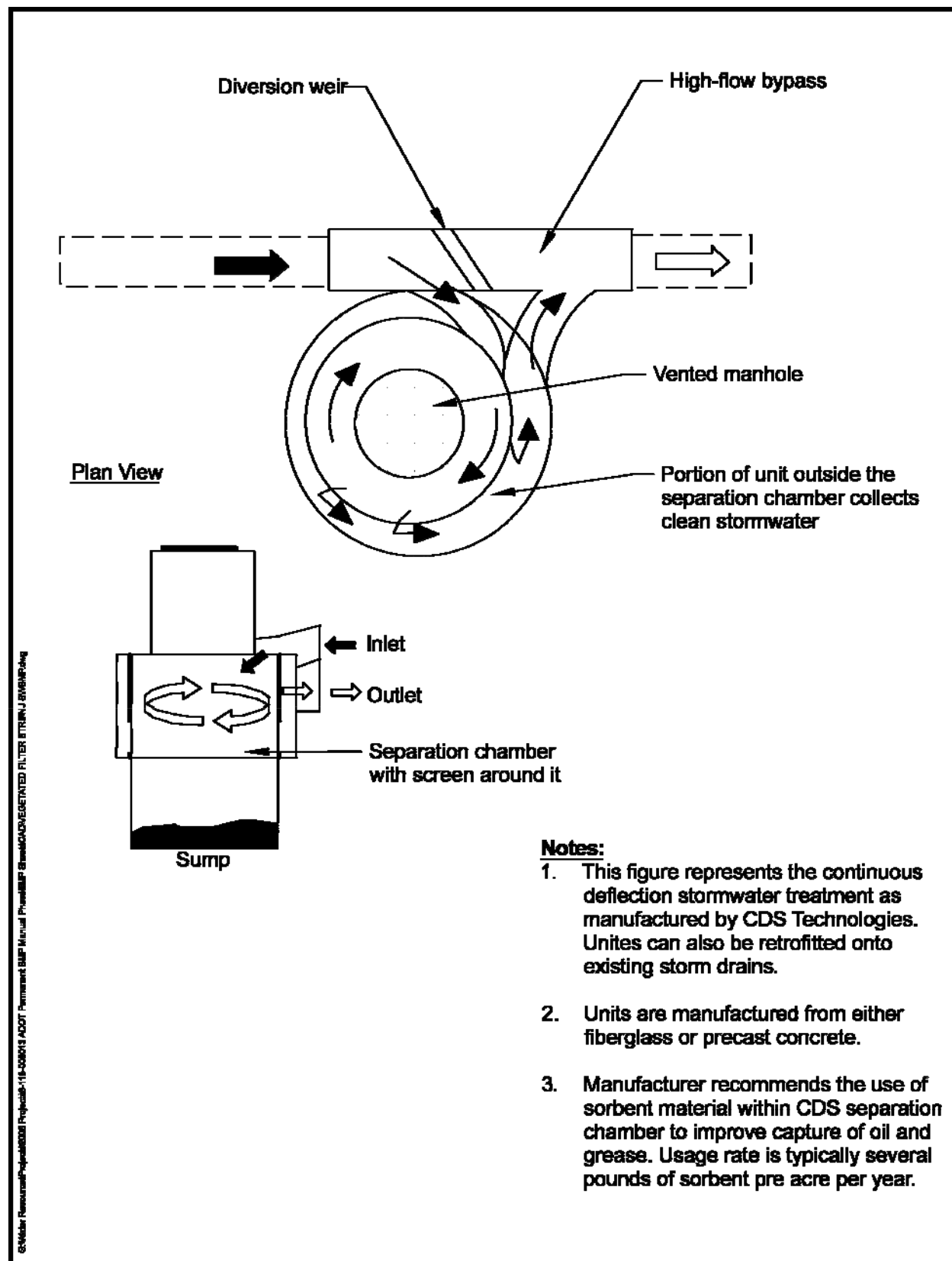

©2014 by Resources Project 20001 Project 2014-114-500014 ADOT Permanent BMP Manual. Printed on Recycled Paper. All Rights Reserved.

Schematic of a Hydrodynamic Oil Water Separator

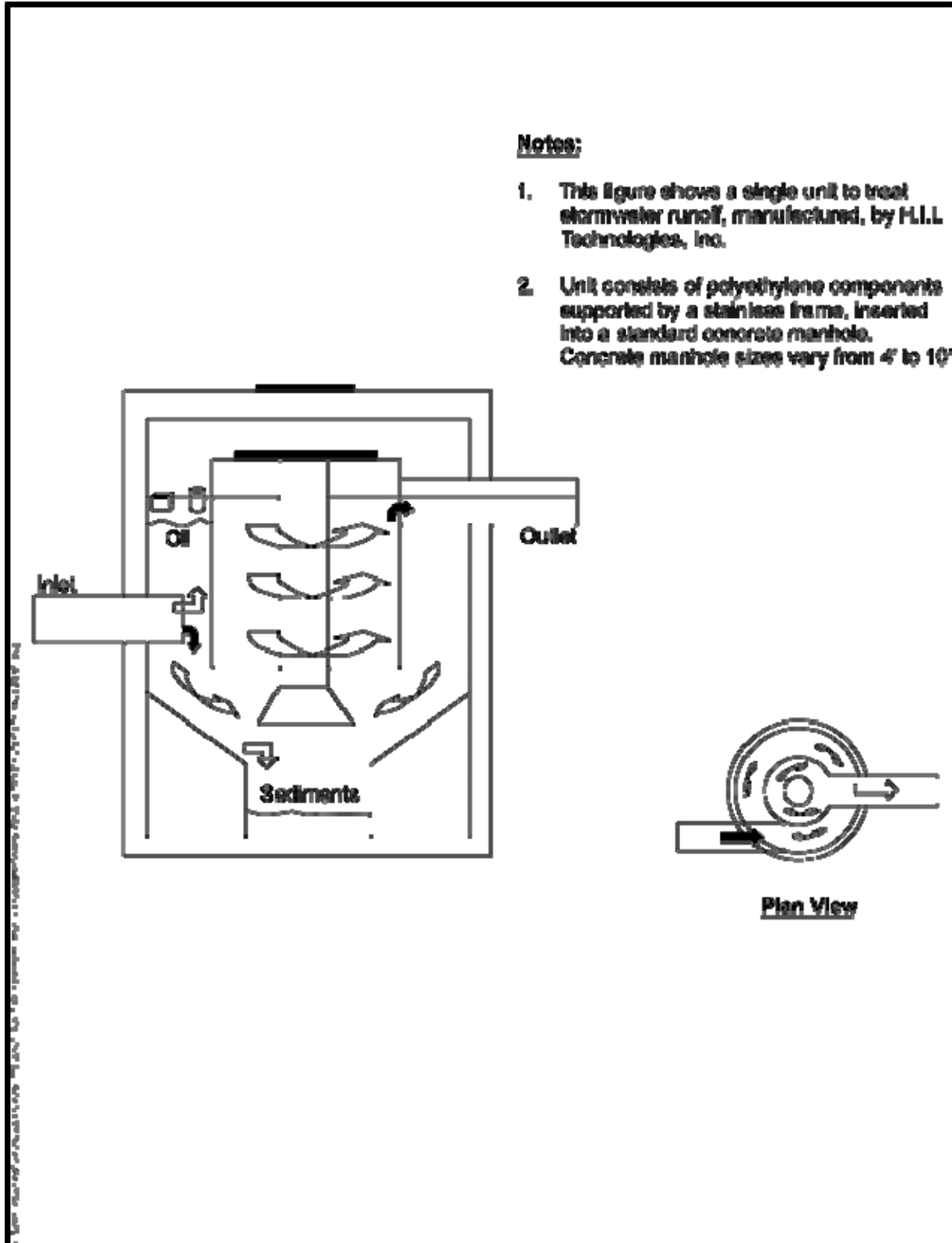

3.2 Bioretention

DEFINITION

A bioretention is an engineered structures consisting of a grass buffer strip, ponding area, organic or mulch layer, planting soil, and vegetation. An optional sand bed can also be included in the design to provide aeration and drainage of the planting soil. The filtered runoff can either be discharged through a below ground drainage system to a receiving water body, conveyance system or other BMP, or it can infiltrate to the underlying soils.

OVERVIEW

GENERAL INFORMATION
Key design factors: <ul style="list-style-type: none"> Maximum contributing drainage area of 5 acres. Typically requires 5 feet of elevation difference from inflow to outflow.
Maintenance needs: <ul style="list-style-type: none"> Periodic inspections. Repair/replace treatment area components.
Most effective when used with: <ul style="list-style-type: none"> Pretreatment (i.e. Vegetated Filter Strips or Decomposed Granite Cover).
Alternative BMPs to consider: <ul style="list-style-type: none"> Infiltration Trench or Infiltration Basin. Retention and Detention Basins.

RATINGS	H	M	L
Associated Costs			
Design		X	
Construction	X		
Maintenance		X	
BMP Objective			
Erosion control			X
Drainage conveyance			X
Water Quality/Treatment	X		
DOT Target Pollutants Removal			
Dissolved or suspended sediment	X		
Biological constituents	X		
Nutrients and pesticides		X	
Heavy metals	X		
Organics	X		

PHOTOGRAPHS



PURPOSE

A bioretention is a structural stormwater control measure that captures and temporarily stores stormwater runoff using soils and vegetation in shallow basins or landscaped areas to provide enhanced removal of dissolved stormwater pollutants, including nutrients, pesticides, organics, metals, and biological constituents.

APPROPRIATE APPLICATIONS

Bioretention is suitable for many types of development where there is a discharge (not sheet flow) within 1/4 mile of a sensitive water body. The use of bioretention is extremely flexible and can easily be incorporated into various types of new or existing landscapes including roadway median strips, along road drainage swales, and as landscaped islands in impervious or high-density environments. Refer below for additional design considerations.

LIMITATIONS

Bioretention basins are NOT appropriate in the following conditions:

- Along slopes greater than 4:1;
- Shallow groundwater (less than 4 feet below the bottom of the basin or channel) to allow proper draining; and
- Climates where soil can freeze.

DESIGN CONSIDERATIONS

Consider the following bioretention basin design factors:

Soil characteristics – If infiltration is intended for this system, ensure an infiltration rate of at least 0.5 inches per hour. Refer to geotechnical data to ensure that the permeability is sufficient at depths below the bottom of the basin. Do not locate the basin above collapsible soils. Karst areas may require a liner. If infiltration is not intended for this system, there are no restrictions on soil types.

Footprint/geometry – The total storage volume must be able to contain the runoff from the design storm corresponding to ADOT's local drainage design requirement. Offline configurations (runoff is concentrated and conveyed to another location) can be used to accommodate larger drainage areas and/or footprint geometries. Contributing drainage areas should be less than 0.5 acres for on-line systems and 5.0 acres for off-line systems.

Local government code – Refer to local municipal code for local holding and infiltration requirements, particularly the amount of time allowed for standing water. Also, verify any applicable setback requirements. Setbacks from infiltration practices are typically set for building foundations, private and public supply wells, septic systems, and downstream surface water bodies.

Basin safety and stability – Basins excavated more than 4 feet deep should be properly stabilized through benching. A geotechnical engineering analysis should be conducted to ensure side slope stability.

Construction sequencing – After the system is constructed, install temporary controls around the perimeter until the project has been established to prevent excessive, premature sediment loading into the basin.

Pretreatment – In areas where dense vegetation can be maintained, Vegetated Filter Strips should be installed along the perimeter of the infiltration basin for pretreatment. Otherwise, Decomposed Granite Cover should be used between the contributing roadway drainage area and the basin.

MATERIAL SPECIFICATIONS

Planting soil bed – shall be at least 4 feet in depth when trees are planted in the bioretention area but can be a minimum of 2 feet deep in facilities that will utilize plants other than trees. Planting soils shall consist of a sandy loam, loamy sand, or loam texture with a clay content ranging from 10 to 25%. The soil must have an infiltration rate of at least 0.5 inches per hour and a pH between 5.5 and 6.5. In addition, the planting soil must have a 1.5 to 3% organic content and a maximum 500 ppm concentration of soluble salts.

Mulch layer – must consist of 2 to 4 inches of commercially available fine shredded hardwood mulch or shredded hardwood chips.

Sand bed – must be 12 to 18 inches thick. Sand shall be clean and have less than 15% silt or clay content.

Pea gravel – for the diaphragm and curtain, when used, should be ASTM D 448 size No. 6.

Underdrain collection system – shall include a 4 to 6 inch pipe wrapped in a 6 to 8 inch gravel layer. The pipe shall have 3/8-inch perforations, spaced at 6-inch centers, with a minimum of 4 holes per row around the circumference of the pipe. The pipe spacing shall be at a maximum of 10 feet on center and a minimum grade of 0.5% must be maintained. A permeable filter fabric shall be required between the gravel layer and the planting soil bed.

DESIGN STANDARDS

General components of a bioretention area include:

- A grass filter strip (or grass channel) between the contributing drainage area and the ponding area,
- A ponding area containing vegetation with a planting soil bed,
- An organic/mulch layer,
- A gravel and perforated pipe underdrain system to collect runoff that has filtered through the soil layers (bioretention areas can optionally be designed to infiltrate into the soil – see description of infiltration trenches for infiltration criteria).
- A pea gravel diaphragm at the beginning of the grass filter strip to reduce runoff velocities and spread flow into the grass filter.
- Energy dissipation techniques will be required for contributing drainage areas that have a 6% slope or greater.

The bioretention footprint is dependent on the drainage area being treated and should be determined per the methods described in the ADOT Highway Drainage Design Manual. Adequate pretreatment and inlet protection for bioretention systems shall be provided, such as a vegetated filter strip or a decomposed granite cover. The length of the grass channel depends on the drainage area, land use, and channel slope. The minimum grassed channel length shall be 20 feet.

An overflow structure and non-erosive overflow channel must be provided to safely pass flows that exceed the storage capacity of the bioretention area to a stabilized downstream area or

watercourse. If the system is located off-line, the overflow shall be set above the shallow ponding limit. A high flow overflow system within a bioretention structure may consist of a yard drain catch basin, though any number of conventional systems could be used. The throat of the catch basin inlet located in a bioretention facility must be no more than 6 inches above the mulch layer at the elevation of the shallow ponding area.

Maintenance Access:

- A minimum 20 foot wide maintenance right-of-way or easement shall be provided from a driveway, public or private road. The maintenance access easement shall have a maximum slope of no more than 15% and shall have a minimum unobstructed drive path having a width of 12 feet, appropriately stabilized to withstand maintenance equipment and vehicles.
- The maintenance access shall be designed such that all areas of the bioretention area can be easily accessed, and shall be designed to allow vehicles to turn around.

Landscaping:

- Landscaping is critical to the performance and function of bioretention areas. A dense and vigorous vegetative cover that is appropriate for use in a bioretention area shall be established over the contributing pervious drainage areas before runoff can be accepted into the facility. When the contributing drainage area is completely or partially disturbed or unstabilized, sediment laden runoff reaching the bioretention area can clog the soils and cause the bioretention area to fail.
- In general, any vegetation used in the bioretention area should be native, resistant to drought, tolerant of pollutants, have low fertilization requirements, and be easily maintained. Grasses, shrubs, and trees are all permissible vegetation types for bioretention areas, as long as the species used meet the general guidance provided herein.

After the trees and shrubs are established, the ground cover and mulch should be established.

MAINTENANCE AND INSPECTION REQUIREMENTS

Inspections – Perform inspections regularly to confirm the system is draining within 48 hours of a storm. Static water beyond 48 hours of a storm could be indicative of an ineffective, clogged basin.

Trash and sediment removal – Trash and other miscellaneous debris should be regularly removed from the basin. The bottom sand layer may need to be replaced if water does not completely drain after 48 hours of a storm.

Nuisance Control – Inspect for standing water within 24 hours at the end of each rain event. No additional nuisance control is necessary if the infiltration basin drains properly.

SCHEMATICS

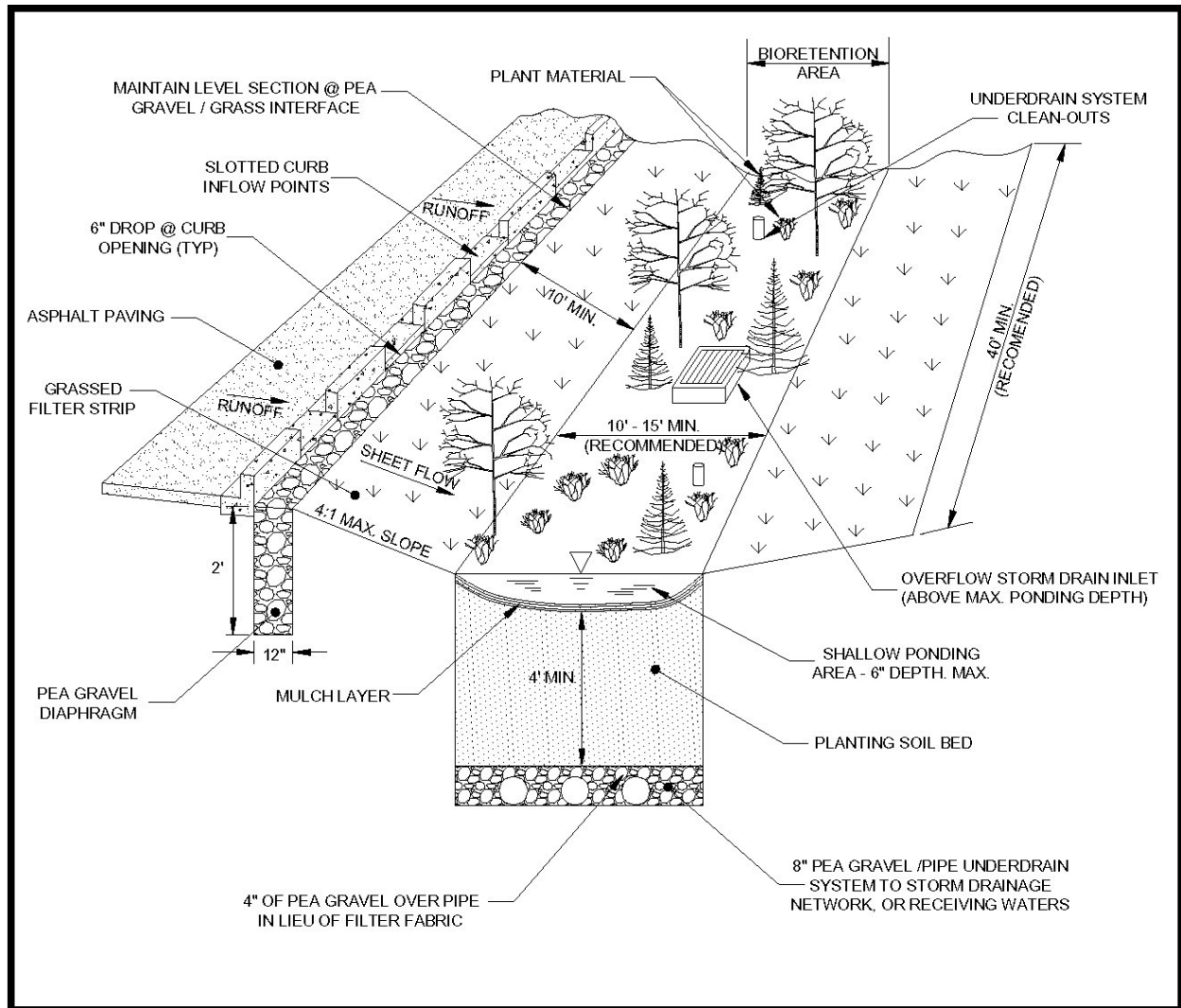

(Source: Claytor and Schueler, 1996)

3.3 Filtration Structures

DEFINITION

Stormwater filtration structures utilize a filtering media (sand, soil, gravel, peat, or compost) to remove pollutants from stormwater runoff. Filtration structures can vary in design, but should all generally comprise of the following: (a) inflow regulation that diverts a defined flow volume into the filtration system, (b) pretreatment to remove coarse sediments, (c) filter media, specific to one or more target pollutants, and (d) an outflow mechanism to discharge flows to a conveyance system or directly to a receiving water body.

OVERVIEW

GENERAL INFORMATION
<p>Key design factors:</p> <ul style="list-style-type: none"> Sediment pre-treatment must be included to prevent premature clogging. Proper selection of filter bed media, surface area, depth, and profile.
<p>Maintenance needs:</p> <ul style="list-style-type: none"> Removal of accumulated debris and replacement of exhausted filter media.
<p>Most effective when used with:</p> <ul style="list-style-type: none"> Vegetated filter strips or decomposed granite as pre-treatment.
<p>Alternative BMPs to consider:</p> <ul style="list-style-type: none"> Infiltration or storage practices. ADOT-Approved Vendor Treatment Devices.

RATINGS	H	M	L
Associated Costs			
Design	X		
Construction	X		
Maintenance	X		
BMP Objective			
Erosion control			X
Drainage conveyance			X
Water Quality/Treatment	X		
DOT Target Pollutants Removal*			
Dissolved or suspended sediment	X		
Biological constituents		X	
Nutrients and pesticides			X
Heavy metals		X	
Organics	X		

*Removal efficiencies are highly dependent on filter media and filtration structure dimensions.

PHOTOGRAPHS



PURPOSE

Filter structures are designed strictly for water quality treatment; they are not effective for handling peak storm flows. Special consideration should be given to the kind of media that is selected to target specific pollutants in the runoff.

APPROPRIATE APPLICATIONS

Due to the complexity and cost of design and construction, filtration structures should only be considered when infiltration or storage practices are not feasible (see limitations for Infiltration Trench, Infiltration Basin, and Detention and Retention Basins) and treatment is necessary (i.e. within a 1/4 mile of a regulated MS4, other stakeholder boundaries, or a sensitive water body).

LIMITATIONS

Filtration structures are NOT appropriate in the following conditions:

- If infiltration or storage practices are feasible;
- Un-stabilized areas or construction sites. No runoff should enter the filtration structure until all contributing drainage areas from the right-of-way have been stabilized; and,
- When considering an on-line treatment configurations. On-line filtration structures are located within the conveyance system and are exposed to the full range of flow events, including 100-year events. Filtration structures are most effective for specific ranges of flows. For small drainage areas (i.e. < 1.0 acre), consider using ADOT-Approved (filtration) Vendor Devices.

DESIGN CONSIDERATIONS

Consider the following design factors:

Pollutants of concern – Identifying the pollutant(s) of concern to treat in the stormwater runoff influent is important for selecting the filtration media with the associated highest removal efficiencies. Identifying the pollutants of concern is particularly important when discharging to a sensitive water body. Compare the pollutants for which the surface water body is impaired to ADOT roadway generated pollutants.

Footprint/geometry – Most filtration structures are constructed off-line where runoff is diverted from the main conveyance system. The pan area footprint or surface area of the filtration structure is dictated by the impervious cover in the upstream drainage area.

Aesthetics – Municipalities or other stakeholders (i.e. tribal lands or forest service lands) may require or prefer that filtration structures and devices not be visible to the public.

Construction sequencing – No runoff should enter the filtration structure until all contributing drainage areas from the right-of-way have been stabilized.

MATERIAL SPECIFICATIONS

Sand Filter Media – Clean AASHTO M-6 or ASTM C-33 concrete sand (0.02 to 0.04” nominal diameter).

Peat Filter Media – Uncompacted, uniform and clean peat, with an ash content < 15%, a pH range between 4.9 and 5.2 and a loose bulk density of 7.5 to 9.5 lb/ft³.

Underdrain Gravel - The underdrain gravel (0.25 to 0.75" nominal diameter) should meet AASHTO M-43 requirements.

Geosynthetic Filter Fabric – If used, the filter fabric should comply with Section 1014 of the ADOT Standard Specifications for Road and Bridge Construction.

Impermeable Liner – ASTM D 751, 412, 624 and 471.

Underdrain piping – 6" diameter schedule 40 PVC pipe. 3/8" perforations at 6" on center.

Concrete – refer to Section 601 – Concrete Structures of the ADOT Standard Specifications for Road and Bridge Construction.

DESIGN STANDARDS

A. Inflow Volume Control – Inflow regulators convey runoff from a conduit, open channel or impervious surface into the filtration structure and divert excess flow away from the system.

B. Pretreatment – Pretreatment is needed in every design to prevent coarse sediment particles from prematurely clogging the filter bed. The most common technique of pretreatment is a dry settling chamber. Geotextile screens, pea gravel diaphragms, and vegetated filter strips may also be used for additional pretreatment measures.

C. Filter Bed and Filter Media - Filter media may consist of sand, gravel, peat, grass, soil, or compost to filter target pollutants. The proper selection of filter media is important; each has different hydraulic and pollutant removal characteristics. The filter media is incorporated into the filter bed. Key properties of the filter bed are:

1. Surface area – dictated by the impervious drainage area treated and the type of media used.
2. Depth - range from 18 inches to 4 feet. Filter beds are typically shallow; most pollutants are removed in the top few inches of the filter bed.
3. Filter profile – there are a variety of filter profiles, as shown in the schematic.

D. Outflow Mechanism – Filtration structures must have a proper outflow mechanism, which is achieved by installing an impermeable liner at the bottom of the filter bed, capturing the filtered runoff through perforated pipes and discharging it to a conveyance system or directly to a receiving water body.

MAINTENANCE AND INSPECTION REQUIREMENTS

Inspections – Perform inspections regularly to confirm the filter is draining properly after a storm event. If standing water is observed after 24 hours of a storm event, the filter media is exhausted and should be replaced.

Trash and Sediment Removal – Floatable trash and debris should be removed on a routine basis.

Exhausted filter media should be replaced with new filter media (same type).

Nuisance Control – Inspect for standing water following each storm event. No additional nuisance control is necessary.

SCHEMATICS

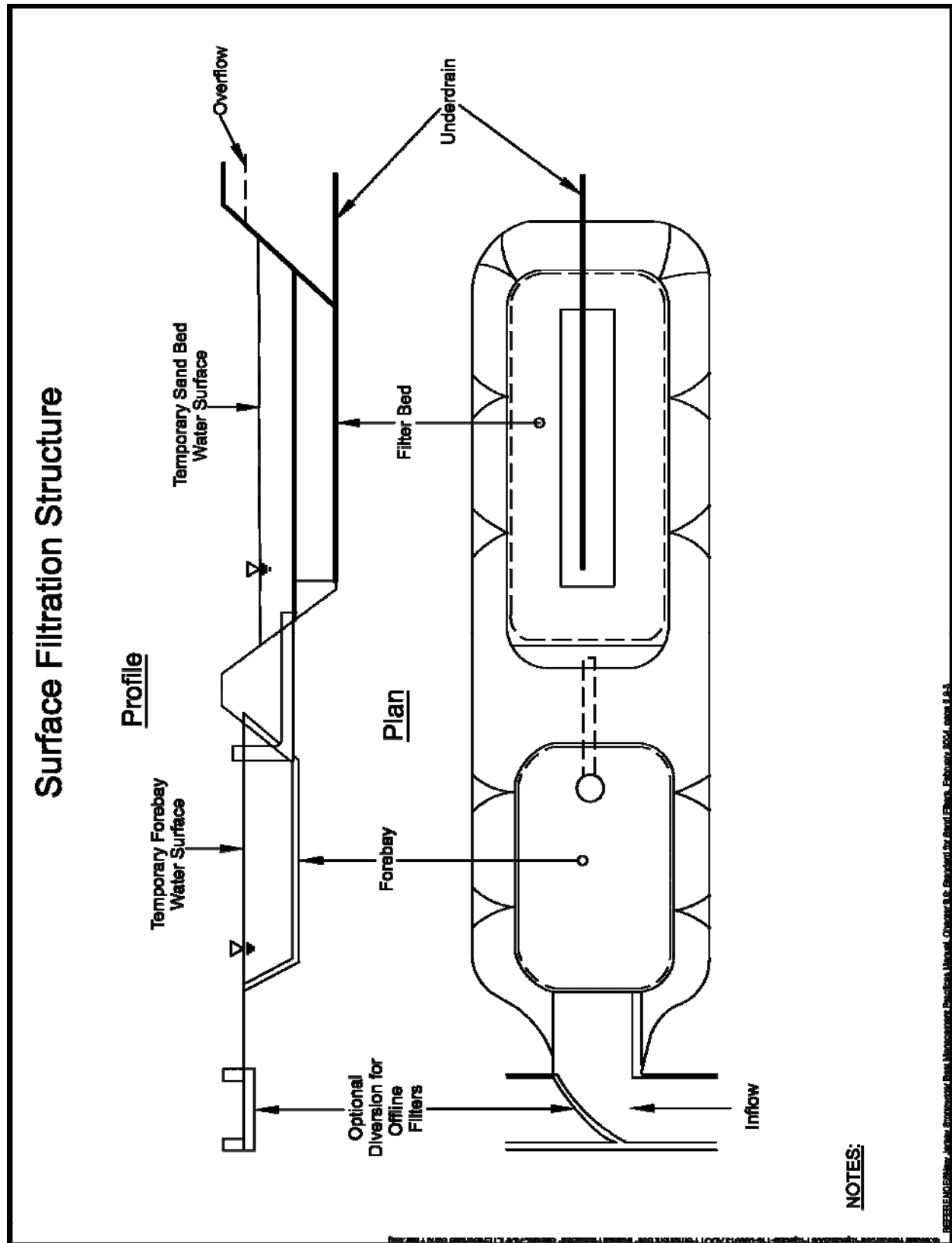

Filter Bed Cross Sections

Sand Filter with Gravel Pretreatment



Sand Filter/ Gravel Cover

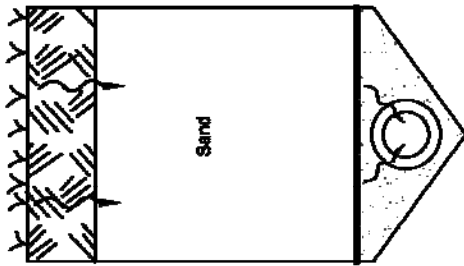

Standard Sand Filter

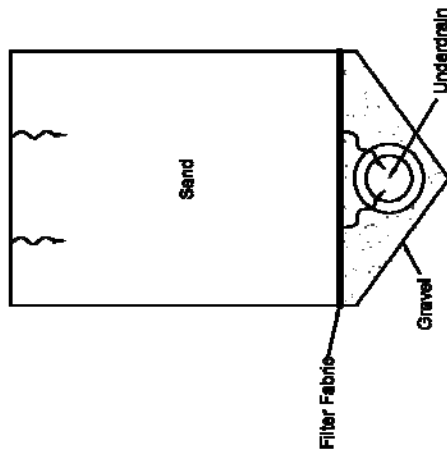

Compost Filter System

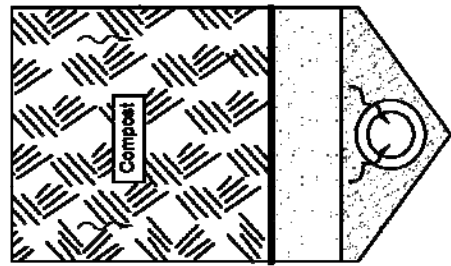

Sand Filter/ Grate Cover

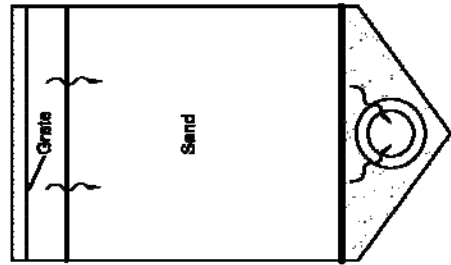

Source: www.adot.com, 2008. Figure 16-28013 ADOT Permitting BMP Manual. www.adot.com FILTER CROSS SECTION

ADOT PERMITTING BMP MANUAL CHAPTER 4, 4-362

3.4 Infiltration Basin

DEFINITION

Infiltration basins are facilities typically constructed below the roadway shoulder where the appropriate footprint is available to hold and infiltrate runoff. Infiltration basins (also known as recharge basins) are considered a treatment BMP because they can remove pollutants from surface discharges by capturing the stormwater runoff volume (typically, larger volumes than an infiltration trench) and infiltrating it directly to the soil rather than discharging it to an above-ground drainage system. Basins are excavated in most any configuration to meet footprint restrictions and can be vegetated.

OVERVIEW

GENERAL INFORMATION
Key design factors: <ul style="list-style-type: none"> Moderately to highly permeable soils needed (0.5 – 2.5 in/hr) for infiltration. Large footprint area is required in order to retain the design storm.
Maintenance needs: <ul style="list-style-type: none"> Periodic inspections of the basin surface. Removal of floatable debris and trash.
Most effective when used with: <ul style="list-style-type: none"> Pretreatment (i.e. Vegetated Filter Strips or Decomposed Granite Cover).
Alternative BMPs to consider: <ul style="list-style-type: none"> Infiltration Trench Retention/Detention Basins

RATINGS	H	M	L
Associated Costs			
Design		X	
Construction		X	
Maintenance			X
BMP Objective			
Erosion control			X
Drainage conveyance		X	
Water Quality/Treatment	X		
DOT Target Pollutants Removal			
Dissolved or suspended sediment	X		
Biological constituents	X		
Nutrients and pesticides	X		
Heavy metals	X		
Organics	X		

PHOTOGRAPHS



PURPOSE

Infiltration basins are effective in managing and treating a wide range of runoff volumes (relative to other treatment BMPs) by collecting and percolating stormwater runoff below ground surface through the surrounding and underlying native soil matrix, rather than discharging it to an above-ground drainage system.

APPROPRIATE APPLICATIONS

Infiltration basins are appropriate in areas where there is a discharge (not sheetflow) within 1/4 mile of regulated MS4s, sensitive waterbodies, or other stakeholder boundaries and the existing soils have an infiltration rate between 0.5 to 2.4 inches per hour. Refer below for additional design considerations.

LIMITATIONS

Infiltration basins are NOT appropriate in the following conditions:

- Within low permeability soils (less than 0.5 inches per hour), fill soil, compacted soil, or along slopes greater than 4:1;
- Shallow groundwater (less than 4 feet below the bottom of the basin) to allow proper draining;
- Basins require a significant footprint, relative to other treatment BMPs. If there is not sufficient footprint, consider an offline configuration at a more convenient location.

If not properly maintained, infiltration basins will prematurely clog and will result in costly maintenance. Pretreatment can help to reduce influent sediment.

In the cases where infiltration basins are not appropriate, consider implementing a Detention/Retention Basin (see Section 3.6) and the appropriate pump-out or discharge pipe infrastructure.

DESIGN CONSIDERATIONS

Consider the following infiltration basin design factors:

Soil characteristics – Ensure an infiltration rate of at least 0.5 inches per hour. Refer to geotechnical data to ensure that the permeability is sufficient at depths below the bottom of the basin. Do not locate the basin above collapsible soils.

Footprint/geometry – The total storage volume must be able to contain the runoff from the design storm corresponding to ADOT's local drainage design requirement. Offline configurations can also be designed to accommodate larger footprint geometries. The maximum depth of the infiltration basin should be 12 feet.

Local government code – Refer to local municipal code for any local holding and infiltration requirements, such as the amount of time allowed for standing water. Also, verify any applicable setback requirements. Setbacks from infiltration practices are typically set for building foundations, private and public supply wells, septic systems and downstream surface waterbodies.

Excavation practices – During construction, the excavated material from the basin may be used elsewhere on the project. During excavation, when possible, scarify the sides and bottom of the trench to correct for any smearing of the interface. Avoid compaction of the soils below the basin, whenever possible.

Basin safety and stability – Basins excavated more than 4 feet deep should be properly stabilized through benching. A geotechnical engineering analysis should be conducted to ensure the stability of the trench walls and supports.

Construction sequencing – After the basin is constructed, install temporary controls around the basin perimeter until the project has been established to prevent excessive, premature sediment loading into the basin.

Pretreatment – In areas where dense vegetation can be maintained, vegetated filter strips should be installed perimeter of the infiltration basin for pretreatment. Otherwise, decomposed granite should be used between the contributing roadway drainage area and the basin. A 6-inch sand layer at the bottom of the basin can intercept silt and debris that could potentially clog the soil underlying the basin and facilitates the cleanout of these materials.

MATERIAL SPECIFICATIONS

Soils – Minimum acceptable infiltration rate of the surrounding soil is 0.5 inches per hour.

Sand layer – Must consist of sand with a maximum 15% fines and a minimum permeability rate of 20 inches per hour.

DESIGN STANDARDS

- A. Design the basin geometry per the design criteria in Section 15.4 of the ADOT Hydraulics Manual and the allowable footprint. Use side slopes less than 4:1.
- B. Furnish a 6-inch layer of clean sand (refer to material specifications above) for the bottom of the basin.
- C. Furnish a bypass or overflow for the design check discharge.
- D. If feasible, include vehicle access to the basin for maintenance.
- E. Vegetate the sides of the basin in accordance with ADOT Standard Specifications for Road and Bridge Construction, Section 805.
- F. Observations wells should be located at the point of lowest elevation within the basin. The well design consists of a 6-inch diameter perforated stand pipe that extends the entire basin depth with a weatherproof cap to monitor water levels and sediment accumulation within the infiltration basin.

MAINTENANCE AND INSPECTION REQUIREMENTS

Inspections – Perform inspections regularly to confirm the basin is draining within 48 hours of a storm. Static water beyond 48 hours of a storm could be indicative of an ineffective, clogged basin (see trash and sediment removal).

Trash and sediment removal – Trash and other miscellaneous debris should be regularly removed from the basin. The bottom sand layer may need to be replaced if water does not completely drain after 48 hours of a storm.

Nuisance Control – Inspect for standing water within 24 hours following each storm event. No additional nuisance control is necessary if the infiltration basin drains properly.

Infiltration Basin Figure

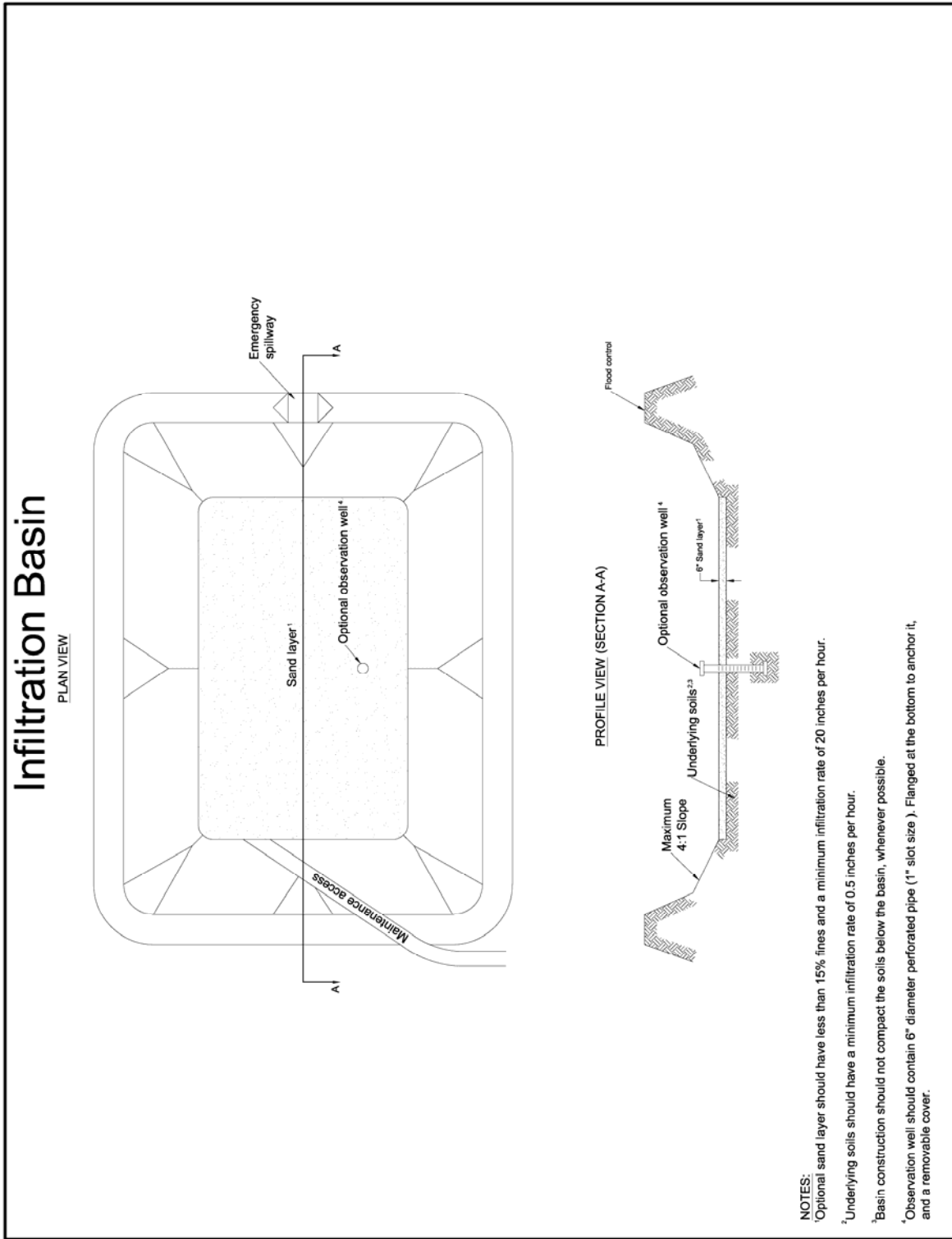

3.5 Infiltration Trench

DEFINITION

An infiltration trench is a structural BMP, constructed below ground surface, within the median and/or below a shoulder of relatively flat stretches of roadway. It is considered a treatment BMP because it can remove pollutants from surface discharges by capturing stormwater runoff volume and allowing it to infiltrate directly into the soil (through the bottom and the sides of the trench) rather than discharging it to an above-ground drainage system. Infiltration trenches are excavated, lined with a geotextile fabric (optional), and backfilled with aggregate.

OVERVIEW

GENERAL INFORMATION
Key design factors: <ul style="list-style-type: none"> Moderately to highly permeable soils needed (0.5 – 2.5 in/hr). Most effective when used with sediment pretreatment to prevent premature clogging.
Maintenance needs: <ul style="list-style-type: none"> Periodic inspections of trench surface and its observation well. Removal of floatable debris and trash.
Most effective when used with: <ul style="list-style-type: none"> Pretreatment (i.e. vegetated filter strips or decomposed granite).
Alternative BMPs to consider: <ul style="list-style-type: none"> Infiltration Basin Bioretention

RATINGS	H	M	L
Associated Costs			
Design		X	
Construction		X	
Maintenance			X
BMP Objective			
Erosion Control			X
Drainage conveyance		X	
Water Quality/Treatment	X		
DOT Target Pollutants Removal			
Dissolved or suspended sediment		X	
Biological constituents	X		
Nutrients and pesticides	X		
Heavy metals	X		
Organics	X		

PHOTOGRAPHS



PURPOSE

Infiltration trenches are effective in managing and treating drainage by collecting and percolating stormwater runoff below ground surface through the surrounding and underlying native soil matrix, rather than discharging it to an above-ground drainage system.

APPROPRIATE APPLICATIONS

Infiltration trenches are appropriate in relatively flat areas where sheetflow discharges from roadway surfaces occur. They are particularly effective within regulated MS4s or other stakeholder boundaries, including discharges within 1/4 mile of sensitive water bodies in Arizona.

LIMITATIONS

Infiltration trenches are NOT appropriate where the following conditions occur:

- Within low permeability soils (less than 0.5 inches per hour), fill soil, compacted soil, or along slopes greater than 4:1; and
- Shallow groundwater (less than 4 feet below the trench bottom) to allow proper draining.
- Areas with high sediment loading (i.e. unstabilized construction sites).

If not properly designed and/or maintained, infiltration trenches may prematurely clog. This will result in costly maintenance (removal and replacement of the aggregate matrix). Pretreatment measures are required to reduce potential influent sediment.

DESIGN CONSIDERATIONS

Consider the following infiltration trench design factors:

Soil characteristics – Ensure an infiltration rate of at least 0.5 inches per hour. Refer to geotechnical data to ensure that the permeability is sufficient at depths below the bottom of the trench. Do not locate the trench above collapsible soils.

Footprint/geometry – The total trench storage volume must be able to contain the runoff from the design storm corresponding to ADOT's local drainage design requirement. Offline configurations can also be designed to accommodate larger footprint geometries. The maximum depth of the infiltration trench should be 12 feet.

Local government code – Refer to municipal code for any local holding and infiltration requirements, such as the amount of time allowed for standing water. Also, verify any applicable setback requirements from infiltration systems. Setbacks from infiltration systems are typically designated for building foundations, private and public supply wells, septic systems, and downstream surface waterbodies.

Excavation practices – Trenches are best constructed with a backhoe to the desired depth. The excavated material may be used elsewhere on the project. During excavation, when possible, scarify the sides and bottom of the trench to correct for any smearing of the interface.

Trench safety and stability – Trenches over 4 feet deep should be properly stabilized with a trench box and/or other trench supports. Refer to the Occupational Safety and Health Administration (OSHA) trench safety standards: 29 CFR 1926.650, 651, and 652. A geotechnical engineering analysis should be conducted to ensure the stability of the trench walls and supports.

Earthen partitions – To minimize the impacts of the ground surface slope (longitudinal to the trench), the trench design can include earthen partitions to shorten trench lengths. The earthen partitions should be wide enough to prevent collapse into the subsequent trench.

Construction sequencing – After the trench is constructed, install temporary controls around the trench perimeter until the pretreatment measure has been established to prevent excessive, premature sediment loading into the trench.

Pretreatment – In areas where dense vegetation can be maintained, vegetated filter strips should be installed on the sides of the infiltration trench for pretreatment measure. Otherwise, decomposed granite cover should be used between the contributing roadway drainage area and the infiltration trench.

MATERIAL SPECIFICATIONS

Soils – Minimum acceptable infiltration rate of surrounding soil is 0.5 inches per hour.

Aggregate Fill – The aggregate fill in the trench should be clean (washed of fines), 1.5 to 2.5 inches in diameter, and have a void space of approximately 40%. Specify as Class 6 Aggregate of the ADOT Standard Specifications for Road and Bridge Construction.

Geosynthetic Filter Fabric – A geosynthetic filter fabric can be used to line the sides of the trench to prevent soil piping. It can also be used 2 to 6 inches from the top of the trench to prevent sediment from passing into the underlying aggregate in areas with particularly high sediment loading. Note, however, that filter fabric will likely necessitate more frequent maintenance. If used, the filter fabric should comply with the ADOT Standard Specifications for Road and Bridge Construction.

DESIGN STANDARDS

- A. Design the trench geometry based on the runoff volume per unit length of roadway. The drainage area should include the contributing width of roadway and the subsequent pretreatment (vegetated filter strip or decomposed granite cover). Deep and narrow infiltration trenches are most efficient (3 to 4 feet wide and 3 to 12 feet deep) because they provide more static pressure head.
- B. Once the design depth has been established, an additional 6 inches can be excavated and filled with clean sand at the trench bottom. The sand will absorb the impact from the overlying aggregate fill so that the underlying soil is not compacted.
- C. Observation wells should be located at the downgradient end of the infiltration trench. The well design consists of a 6-inch diameter perforated stand pipe that extends the entire trench depth with a weatherproof cap to monitor water levels and sediment accumulation within the infiltration trench. Label the trench depth on the monitor well cap.
- D. Provide pretreatment whenever possible using a vegetated filter strip where dense vegetation can be maintained. Otherwise, decomposed granite cover should be used between the contributing roadway drainage area and the infiltration trench.

MAINTENANCE AND INSPECTION REQUIREMENTS

Inspections – Trained ADOT Maintenance personnel should perform regular inspections to confirm the trench is draining within 24 hours. Trash and debris should be regularly removed from the trench surface. Two critical aspects to monitor are draining capacity and sediment accumulation, which should be evaluated as follows:

- After 24 hours of a design (significant) storm event, evaluate whether the trench has drained. Drop a groundwater sounder in the observation well and record the depth of static water (if any) below the ground surface. Static water could be indicative of an ineffective (clogged) trench and maintenance may be required.
- To evaluate sediment accumulation, the trench must be completely drained and dry. Feed a tape measure to the bottom of the observation well until the tape hits the well bottom and record the depth at the top edge of the well. Compare this depth to the total well depth. Sediment accumulation is the difference between the original well depth and the measured depth.

Sediment Removal – If ADOT decides that the infiltration trench was effective and that a new infiltration trench should be reconstructed, sediment should be removed after the depth of sediment accumulation has reached the slope of the trench; refer to the Infiltration Trench schematic. Sediment can be removed from the trench by removing the aggregate, screening out the accumulated sediment and other debris, reconstructing the trench with the clean aggregate.

Nuisance Control – Inspect for standing water at the end of each storm event. No additional nuisance control is necessary if the infiltration trenches drain properly.

SCHEMATICS

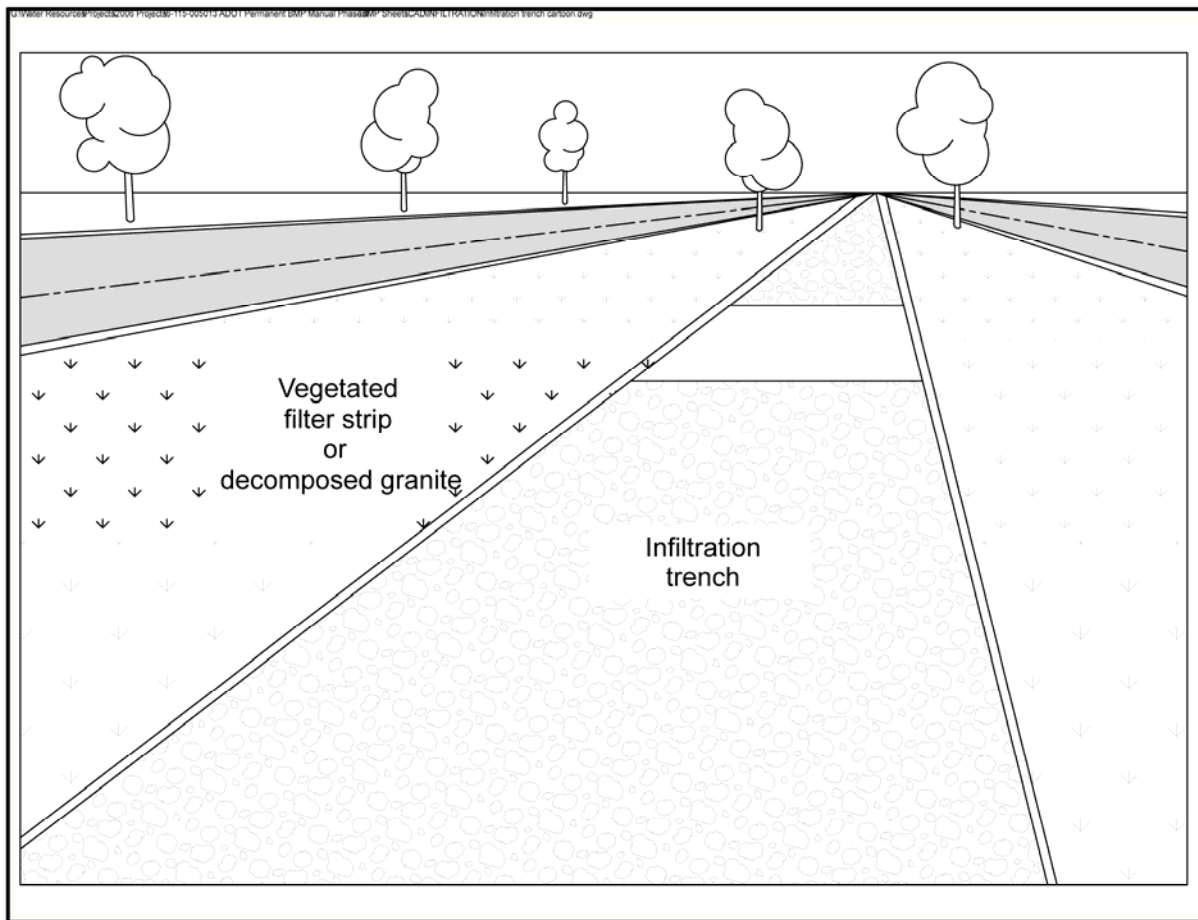

Infiltration Trench (Profile View)

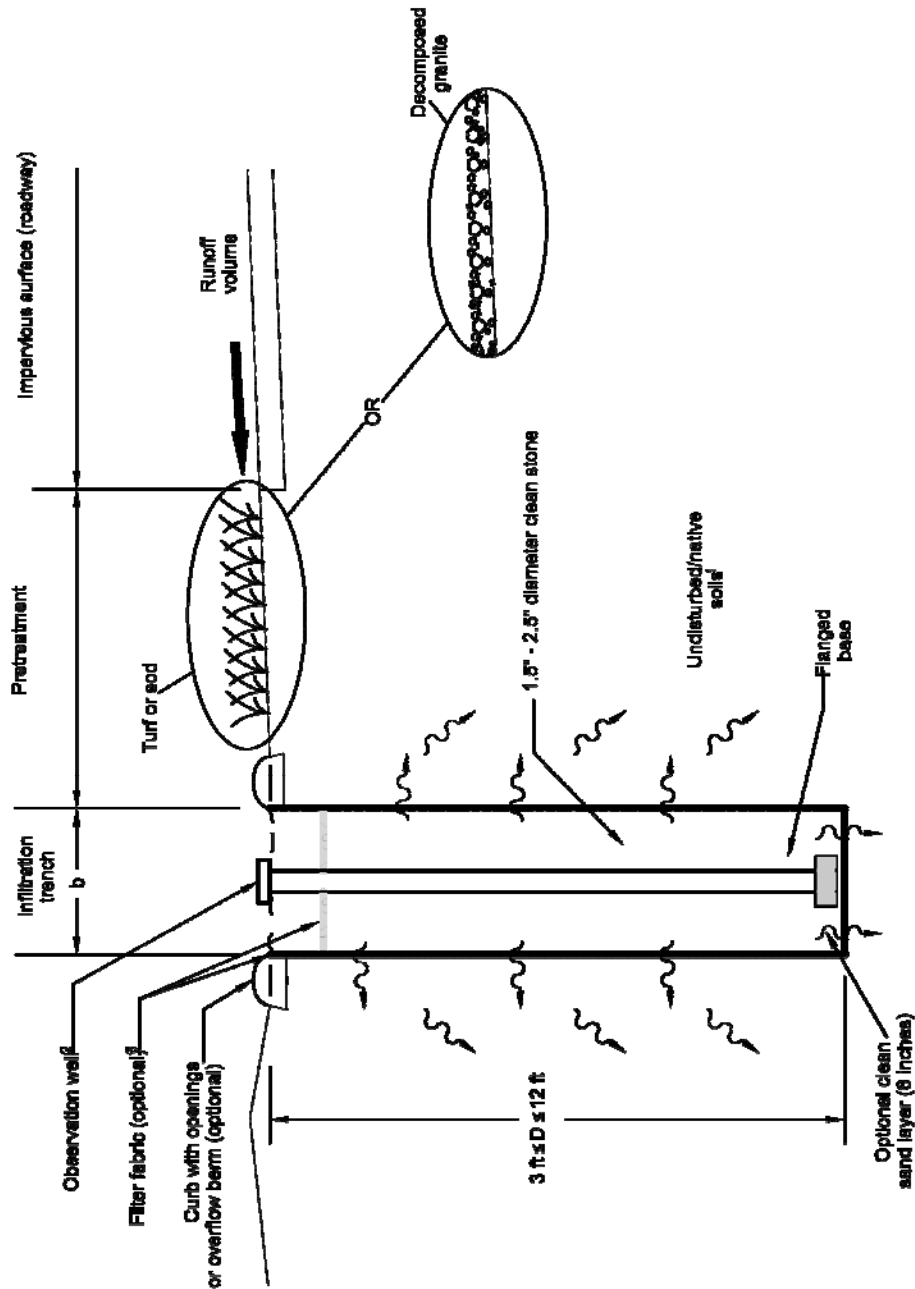

- NOTES:**
- ¹Maximum infiltration rate of surrounding/ underlying soils should be 0.8 inches per hour.
 - ²Observation well should contain 6" diameter perforated pipe (1" slot size), flanged at the bottom to anchor it, and a removable cover.
 - ³The filter fabric can be folded over 6" from the top of the trench and completed with aggregate fill for additional pre-treatment.

Not to scale

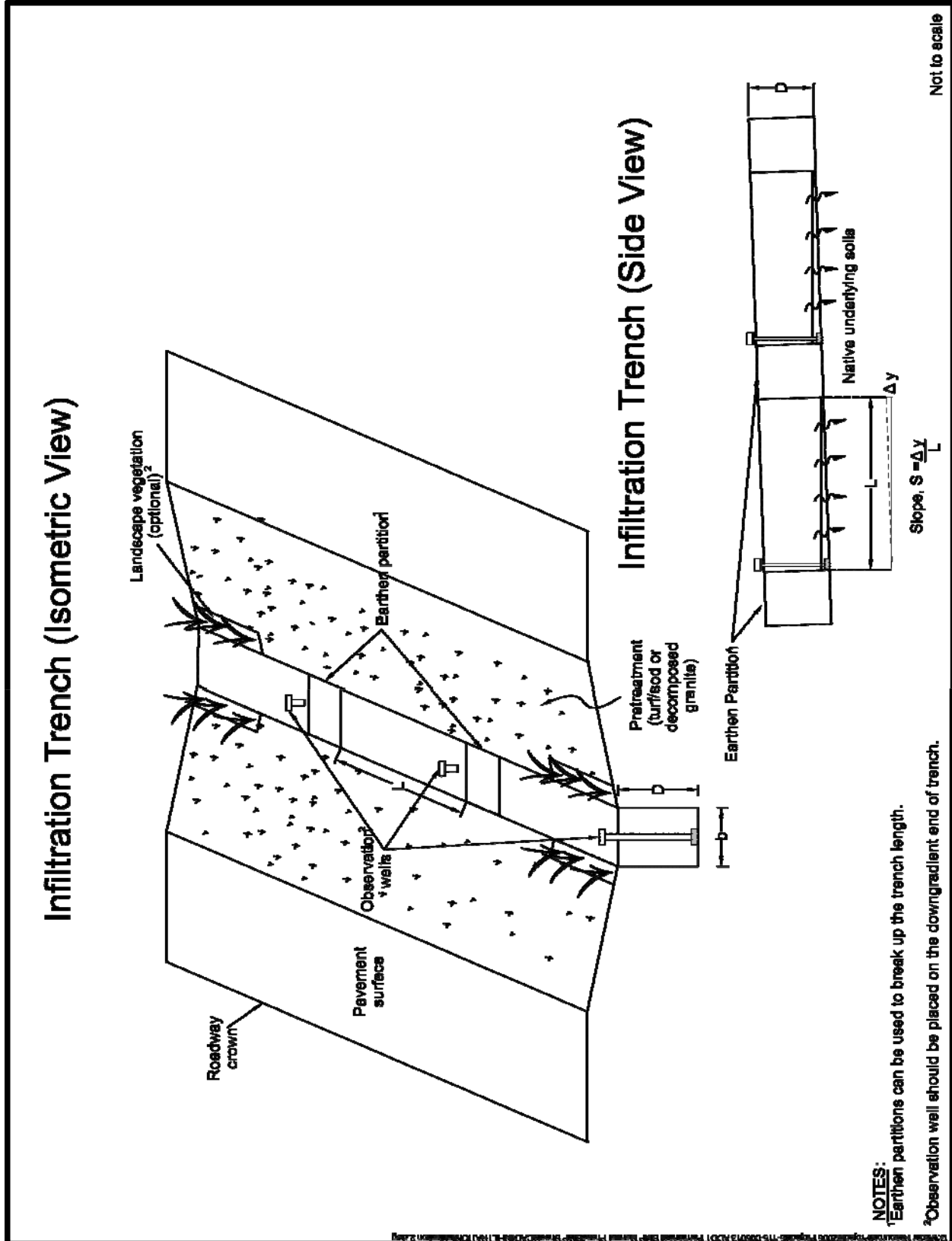

3.6 Retention and Detention Basins

DEFINITION

Retention and detention basins are facilities typically constructed below the roadway shoulder where the appropriate footprint is available to hold runoff, and are also referred to as pond-in-place practices. Retention and detention basins are excavated in most any configuration to meet footprint restrictions and can be vegetated. The difference between retention and detention is explained further in the Purpose section below.

OVERVIEW

GENERAL INFORMATION
<p>Key design factors:</p> <ul style="list-style-type: none"> • A sediment forebay or equivalent upstream pretreatment must be provided. • Typical minimum length:width ratio is 1.5:1.
<p>Maintenance needs:</p> <ul style="list-style-type: none"> • Periodic inspections of the sediment forebay, outlet structure, spillway, and vegetation. • Removal of floatable debris/trash and sediment.
<p>Most effective when used with:</p> <ul style="list-style-type: none"> • Pretreatment (i.e. Vegetated Filter Strips or Decomposed Granite Cover).
<p>Alternative BMPs to consider:</p> <ul style="list-style-type: none"> • Infiltration Basin • Filtration Structures

RATINGS	H	M	L
Associated Costs			
Design		X	
Construction			X
Maintenance			X
BMP Objective			
Erosion control		X	
Drainage conveyance	X		
Water Quality/Treatment	X		
DOT Target Pollutants Removal			
Dissolved or suspended sediment	X		
Biological constituents	X		
Nutrients and pesticides		X	
Heavy metals		X	
Organics	X		

PHOTOGRAPHS



PURPOSE

Retention and detention basins can manage and treat a wide range of runoff volumes (relative to other treatment BMPs). Retention and detention basins are both intended to mitigate stormwater runoff quantity and quality. They differ by their intended function, as described below:

- Retention Basin – a structural BMP that impounds all stormwater flows from a design storm until the storm has passed. A retention basin is considered a treatment BMP because it can remove suspended pollutants through settling and being slowly released.
- Detention Basin – a structural BMP that impounds stormwater for a set period of time sufficient to reduce the peak discharge. Similar to retention, a detention basin is considered a treatment BMP because it can remove suspended pollutants through settling, before the water is slowly released to a receiving waterbody, conveyance, or other BMP.

APPROPRIATE APPLICATIONS

Retention and detention basins are appropriate in areas where there is a discharge (not sheet flow) within 1/4 mile of regulated MS4s, sensitive water bodies, or other stakeholder boundaries; plus the existing soils are not suitable for infiltration.

LIMITATIONS

Retention and detention basins are **NOT** appropriate in the following conditions:

- Do not locate retention or detention basins on unstable slopes or slopes greater than 4:1;
- Basins require a significant footprint relative to other treatment BMPs. If there is not a sufficient footprint, consider an offline configuration at a more convenient location; and
- Retention and detention basins have the potential for thermal impacts/downstream warming.

DESIGN CONSIDERATIONS

Consider the following detention and retention basin design factors:

Soil characteristics – Underlying soils of hydrologic group “C” or “D” are typically adequate to maintain a permanent pool. Retention and detention basins constructed in group “A” soils and some group “B” soils require a pond liner. Evaluation of underlying soils should be based upon an actual subsurface analysis and permeability tests.

Footprint/geometry – The total storage volume must be able to contain the runoff from the design storm corresponding to ADOT’s local drainage design requirement. Offline configurations can also be designed to accommodate larger footprint geometries. As a rule of thumb, a footprint of approximately 2 to 3% of the contributing drainage area is typically required for most retention basins.

Local government code – Refer to local municipal code for local storage requirements and the amount of time allowed for standing water. Also, verify any applicable easement or setback requirements. Setbacks from pond-in-place practices are typically set for building foundations, private and public supply wells, septic systems, and downstream surface waterbodies.

Excavation practices – During construction, the excavated material from the basin may be used elsewhere on the project.

Basin safety and stability – Basins excavated more than 4 feet deep should be properly stabilized through benching. A geotechnical engineering analysis must be conducted to ensure the stability of the side slopes.

Construction sequencing – Temporary desilting basins and/or sediment traps (see Section 5.3.3 of the ADOT Erosion and Pollution Control Manual) can be converted into permanent detention or retention basins, where appropriate, after construction has been completed.

Pretreatment – In areas where dense vegetation can be maintained, vegetated filter strips should be installed along the perimeter of the basin for pretreatment. Otherwise, decomposed granite cover should be used between the contributing roadway drainage area and the basin.

DESIGN STANDARDS

Consider the following design factors:

- Design the basin geometry per the design criteria in the ADOT Highway Drainage Design Manual and the allowable footprint;
- Furnish a bypass or overflow for the design event discharge;
- Whenever feasible, include vehicle access to the basin for maintenance;
- Vegetate the sides of the basin in accordance with ADOT Standard Specifications for Road and Bridge Construction.

MAINTENANCE AND INSPECTION REQUIREMENTS

Inspections – After significant storm events (usually half inch or more), inspect for bank stability, signs of erosion, and damage to outlet structures. Look for signs of pollution such as oil sheens, discolored water, or odors; and measure sediment accumulation.

Trash and sediment removal - Trash and other miscellaneous debris should be regularly removed from the basin.

Structural repairs – Repair damage to the basin outlet structures, embankments, control gates, valves, or other mechanical devices. Repair undercut or eroded areas.

Nuisance Control – Inspect for standing water after a significant storm event. Check for undesirable or invasive vegetation growth. No additional nuisance control is necessary if the basin drains and evaporates properly.

SCHEMATICS

Standard Retention Basin

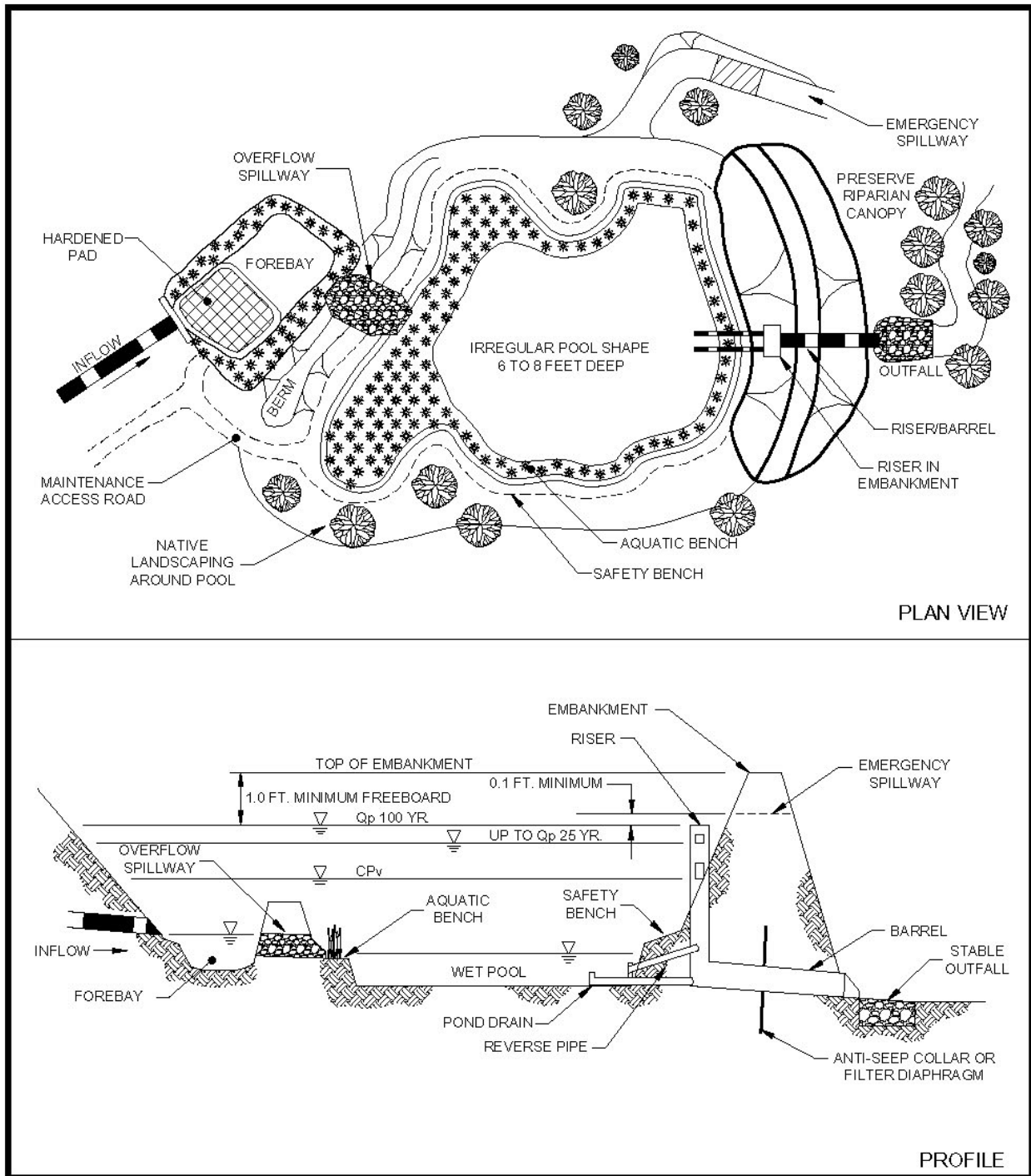

(Source: adapted from CWP, 2005)

Dry Extended Detention Basin

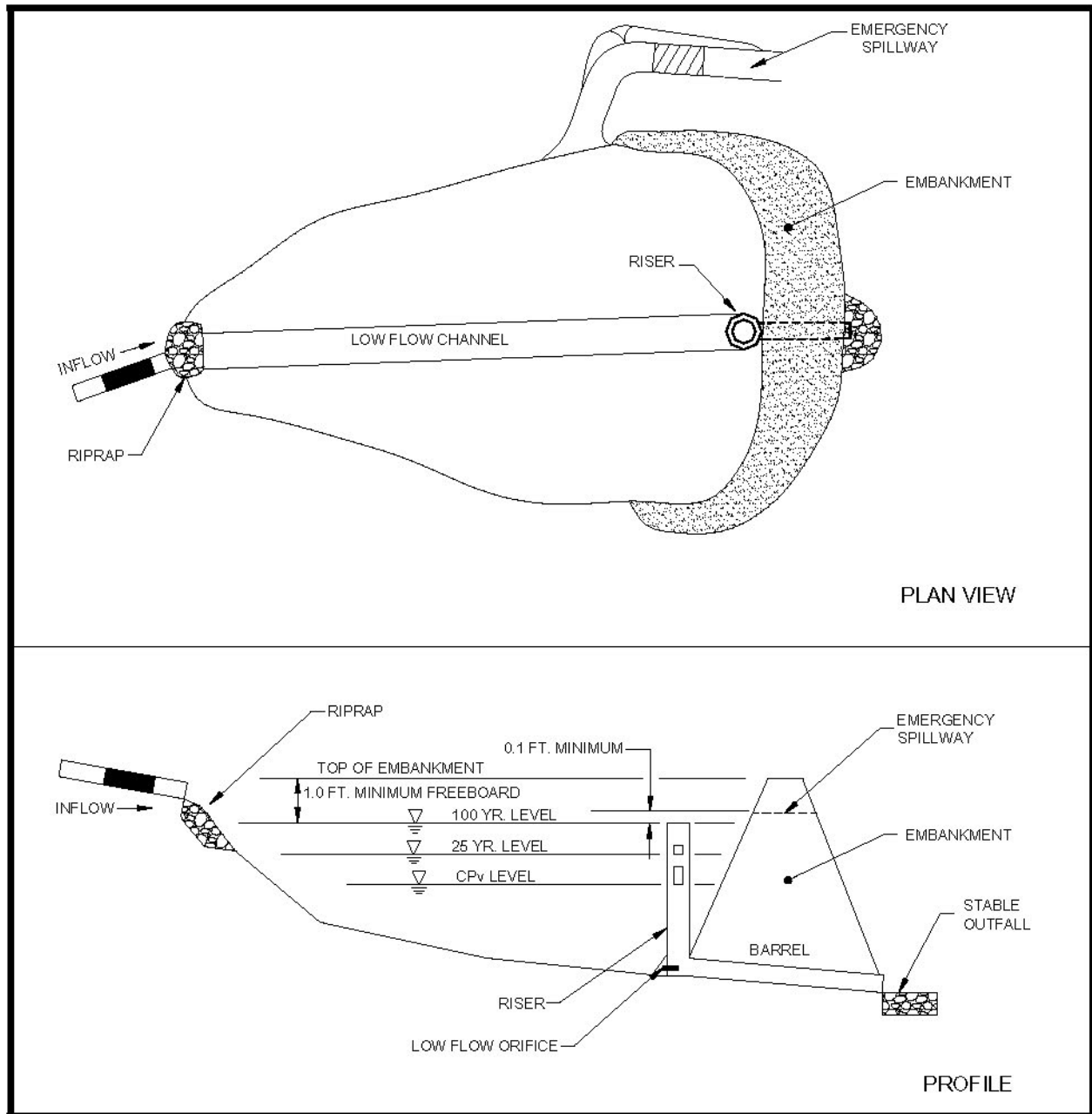

(Source: adapted from CWP, 2005)

3.7 References and Resources

Arizona Department of Environmental Quality, Antidegradation Implementation Procedures, draft April 2008.

Arizona Department of Transportation, Bridge Design Guidelines

Arizona Department of Transportation, Bridge Hydraulics Guidelines

Arizona Department of Transportation, Construction Manual, August 2009

Arizona Department of Transportation, Construction Standard Drawings C-15.10 to 92

Arizona Department of Transportation, draft Water Quality Protection Issues and Recommendations for Discharges from External Entities into ADOT's Stormwater Conveyance System, May 2006.

Arizona Department of Transportation, Erosion and Pollution Control Manual: for Highway Design and Construction, February 1, 2005

Arizona Department of Transportation, Federal Highway Administration, Arizona Bureau of Land Management, Memorandum of Understanding No. AZ-931-0309, April 2003.

Arizona Department of Transportation, Federal Highway Administration, Arizona Bureau of Land Management, Memorandum of Understanding No. AZ-931-0309 – Amendment #1, January 2005.

Arizona Department of Transportation, Federal Highway Administration, Arizona Bureau of Land Management, Memorandum of Understanding No. AZ-931-0309 – Amendment #2, March 2006.

Arizona Department of Transportation, Federal Highway Administration, United States Forest Service, Memorandum of Understanding Regarding the Construction, Operation and Maintenance of Highways in Arizona Crossing National Forest System Lands, MOU No. 06-MU-11031600-013, October 2005.

Arizona Department of Transportation, Highway Drainage Design Manual, Hydrology, March 1993, Report Number: FHWA-AZ93-281

Arizona Department of Transportation, Highway Drainage Design Manual, Hydraulics, January 2007

Arizona Department of Transportation, Roadway Design Guidelines, May 2012

Arizona Department of Transportation, Maintenance and Facilities Best Management Practices (BMP) Manual, 2010

Arizona Department of Transportation, Office of Environmental Services, Natural Resources Management Group, Winter Storm Management Environmental Overview and Operations Manual, October 2008, www.azdot.gov/Highways/NResources/Winter_Storm_Management.asp

Arizona Department of Transportation, Standard Specifications for Road and Bridge Construction, 2008.

Arizona Department of Transportation (ADOT), Statewide Stormwater Management Plan, March 2010

Arizona Department of Transportation (ADOT), Stormwater Monitoring Guidance Manual for Construction Activities, September 2009

Arizona Department of Transportation (ADOT), Stormwater Monitoring Guidance Manual for MS4 Activities, July 2009

Arizona Department of Transportation (ADOT), Stormwater Monitoring Guidance Manual for Industrial Activities, July 2009

California Department of Transportation (Caltrans), State of California Department of Transportation, Storm Water Treatment BMP New Technology Report, SW-04-069.04.02, April 2004.

California Department of Transportation (Caltrans), Storm Water Quality Handbooks: Project Planning and Design Guide, April 2003.

California Department of Transportation (Caltrans), Storm Water Treatment BMP New Technology Report, SW-04-069.04.02, April 2004.

Center for Watershed Protection, Inc., Stormwater Manager's Resource Center (SMRC)

Clar, M., B.J. Barfield, and S. Yu, Considerations in the Design of Treatment Best Management Practices to Improve Water Quality. EPA 600/R-03/103.

Colorado Department of Transportation, CDOT MS4 Permit: New Development and Redevelopment Stormwater Management Program, February 2004.

Federal Highway Administration, Pollutant Loadings and Impacts from Highway Stormwater Runoff, Volume I: Design Procedure, FHWA-RD88-006, U.S. Department of Transportation, Federal Highway Administration, Washington, DC, April 1990.

Federal Highway Administration, Storm Water Best Management Practices in an Ultra-Urban Setting: Selection and Monitoring. FHWA A-EP-00-002.

GeoSyntec Consultants, Urban Drainage and Flood Control District and Urban Water Resources Council of ASCE (GeoSyntec and ASCE), Urban Stormwater BMP performance monitoring: a guidance manual for meeting the national stormwater BMP database requirements, EPA 821/B-02/001, U.S. Environmental Protection Agency, Office of Water, Washington DC, 2002.

Minton, G., Stormwater Treatment: Biological, Chemical and Engineering Principles, 2005

National Risk Management Research Laboratory, Considerations in the Design of Treatment Best Management Practices to Improve Water Quality, EPA 600/R-03/103, U.S. Environmental Protection Agency, Office of Research and Development, Washington DC, September 2002.

Ohio Department of Transportation, Division of Highway Operations, Office of Structural Engineering, Hydraulic Section, Location and Design Manual, Volume 2, Drainage Design Procedures, Chapter 1100, January 2006.

APPENDIX A
POST-CONSTRUCTION BMP BACKGROUND INFORMATION

THIS PAGE INTENTIONALLY LEFT BLANK

Water Quality or Treatment BMP	Area Typically Served (acres)	Percent of Site Area Required for BMP (%)	Configuration	Soils	Minimum Hydraulic Head (ft)	Maximum Upstream Slopes (%)	Fracturing Geology Present	Minimum Depth to Groundwater	Total Suspended Solids (TSS)	Materials	Total Phosphorous (TP)	Total Nitrogen (TN)	Total Petroleum Hydrocarbons (TPH)	Safety	References(s)
Manufactured Treatment Devices	< 1	None	Offline/Online	Independent	1-2	N/A	N/A	N/A	20-40	<10	<10	<10	N/A	Good	FHWA, 2000 NJDA, et al., 2000
Bioretention	1.0 – 4.0	4-10	Offline/Online	Independent, when equipped with an underdrain system	2-4	5	Impermeable liner required	2 feet	75-80	75-80	50-60	50	75	Good	FHWA, 2000 CDOT, 2004 NJDA, et al., 2000
Filtration Structures	2-5	2-3	Offline	Independent	1-8	6-10	Impermeable liner required if not lined with concrete	2 feet	70-95	20-90	27-80	25-70	N/A to 90	Good	FHWA, 2000 NJDA, et al., 2000
Infiltration Basin	2-20	2-4	Offline	Dependent	3-4	15	Not practical due to sinkhole formation	2-5 feet	75-99	50-90	50-70	45-70	75	Good	FHWA, 2000 NJDA, et al., 2000
Infiltration Trench	2-4	2-4	Offline/Online	Dependent	3-8	15	Not practical due to sinkhole formation	2-5 feet	75-99	75-99	50-75	45-70	75	Good	FHWA, 2000 NJDA, et al., 2000
Retention and Detention Basins	>20	10-20	Offline/Online	Independent	3-8	15	Impermeable liner and geologic tests required	2-4 feet, if aquifer is contaminated	45-98	25-90	20-95	10-60	N/A	Poor, unless fenced, to Fair	CDOT, 2004 NRML, 2002 FHWA, 2000 NJDA, et al., 2000

¹Removal efficiencies are based on the references cited.

²There are other pollutants (not included in the table) equally important to consider from transportation systems, such as litter and traffic details.

Water Quality or Treatment BMP	Urban Areas	Setback Requirements	Sensitive Waterbodies	Sensitive Wildlife Habitats	References
Manufactured Treatment Devices.	<ul style="list-style-type: none"> Water quality inlets can fit inside drain lets; ideal for bridges and ultra urban settings. 	<ul style="list-style-type: none"> N/A 	<ul style="list-style-type: none"> Ideal for online treatment on bridges over sensitive waterbodies. 	<ul style="list-style-type: none"> No information for these BMPs specifically related to sensitive wildlife habitats. 	<p>NJDA, et al., 2000 Clar, et al., 2003 FHWA, 2000 NRML, 2002</p>
Bioretention	<ul style="list-style-type: none"> Standing water is a safety concern for children nearby. Standing water may breed mosquitoes during the warmer months, posing a public health concern. Standing water may become eutrophic. Space may be limited in ultra-urban settings (see columns 2 and 3) 	<ul style="list-style-type: none"> Any storage devices that discharge to a coldwater stream should be placed offline from the outfall to the stream. Install storage devices and infiltration basin/trench in a flat area; it may need to be placed off-line to accommodate the BMP footprint. Move all infiltration devices 100 feet from drinking water wells; all other BMPs must be 50 feet away. 	<ul style="list-style-type: none"> May release water with a temperature above temperature of the receiving coldwater streams. 	<ul style="list-style-type: none"> No information for these BMPs specifically related to sensitive wildlife habitats. No information for these BMPs specifically related to sensitive wildlife habitats. 	
Retention and Detention Basins					
Infiltration Basin	<ul style="list-style-type: none"> Space may be limited in ultra-urban settings (see columns 2 and 3) 	<ul style="list-style-type: none"> Structural BMPs (excluding vegetation) should be > 25 feet from a streambank. Structural BMPs (excluding vegetation) should be > 25 feet from jurisdictional wetlands. 	<ul style="list-style-type: none"> Ideal BMP for sensitive waterbodies if all runoff is collected and infiltrated. 		
Infiltration Trench		<ul style="list-style-type: none"> Structural BMPs (excluding vegetation) should be > 25 feet of the critical root zone of state protected tree species. Structural BMPs (excluding vegetation) should be > 50 feet from the edge of a septic drain system. 	<ul style="list-style-type: none"> Can provide relatively advanced water treatment for a discharge to a sensitive waterbody when infiltration is not practicable (see column 9 in Table 3). 		
Filtration Structures	<ul style="list-style-type: none"> Underground filters are often well suited for urban settings. 				

Table A.3: Climatic Conditions

Water Quality or Treatment BMP	Peak flow reduction	Temperature Extremes	
		Cold Climate	Arid and Semi-Arid Climates
Manufactured Treatment Devices.	<ul style="list-style-type: none"> No peak flow reduction. 	<ul style="list-style-type: none"> None 	<ul style="list-style-type: none"> None
Bioretention	<ul style="list-style-type: none"> Low to moderate; 40% reduction in the total runoff volume (influent to effluent). 	<ul style="list-style-type: none"> Protect inlet/outlet pipes Use large diameter (> 8 in) gravel in underdrain of outfall protection Provide ice storage volume Use freeze and salt tolerant vegetation 	<ul style="list-style-type: none"> Minor modifications may be necessary.
Retention and Detention Basins	<ul style="list-style-type: none"> Ideally suited for peak flow reduction and flood control. Retention and detention ponds may increase the risk of downstream flooding in some cases. 		<ul style="list-style-type: none"> Acceptable in arid and semi-arid areas.
			<ul style="list-style-type: none"> Preferred in arid and acceptable in semi-arid areas.
Infiltration Basin	<ul style="list-style-type: none"> Moderate; when designed with sufficient capacity, all runoff collected is infiltrated. 	<ul style="list-style-type: none"> Monitor groundwater for chlorides and do not allow infiltration if chlorides are a concern for the groundwater in the area. Increase soil permeability requirements Use a 20 foot minimum setback between the road subgrade and the BMP structure. 	<ul style="list-style-type: none"> Soil limitations often exist in arid areas.
Infiltration Trench			
Filtration Structures	<ul style="list-style-type: none"> None to low peak flow reduction. 	<ul style="list-style-type: none"> Reduced filtration occurs during cold weather Underground filters are only effective if placed below the frost line. Peat/compost (organic) media is ineffective during cold weather and may become impervious if frozen. 	<ul style="list-style-type: none"> Preferred in both arid and semi-arid areas. Arid area filters require greater pretreatment.



Water Quality or Treatment BMP	Costs		Maintenance	Effective Life (years)	References
	Capital	O&M			
Manufactured Treatment Devices.	Low - Moderate	Moderate - High	High; Frequent cleanouts	10 - 50	FHWA, 2000 CDOT, 2004 NRML, 2002
Bioretention	Moderate	Low	Mowing/plant replacement	5-20	
Retention and Detention Basins	Moderate-High	Low	Moderate; annual inspection and debris removal	20-50	
Infiltration Basin	Moderate	Moderate	High; sediment and debris removal from the surface	5-10, before deep tilling is required	
Infiltration Trench	Moderate -High	Moderate	High; sediment and debris removal from the top	10-15	
Filtration Structures	Moderate-High	Moderate-High	High; biannual to annual media removal	5-20	

BMP	Description	Treatment mechanism	Advantage	Critical Limitations
Manufactured Treatment Devices	Vendor treatment devices include trapping catch basins and oil/grit separators that prompt sedimentation of particulate materials with sorbed oil and the separation of free oil. WQIs also contain screens to retain larger or floating debris. WQIs can also include coalescing units to help promote oil/water separation.	Filtration and adsorption	Highly effective for trapping litter, oil, and grease.	<ul style="list-style-type: none"> • Sediment can be resuspended in vendor treatment devices and released to surface waters. • Standing water in vendor treatment devices is breeding ground for mosquitoes.
Bioretention	A combination of a (1) vegetated buffer strip, (2) ponding area, (3) organic mulch layer, (4) planting soil bed, (5) sand bed, and (6) surrounding plants.	Sedimentation, filtration, adsorption, and biodegradation.	Ideally suited for impervious areas and widely applicable to different climatic zones. Can be very effective for removing fine sediments, trace metals, nutrients, bacteria and organics.	<ul style="list-style-type: none"> • Not recommended for upstream slopes greater than 20%; • Not suitable for aquifers less than 6 feet; • Pretreatment is necessary to avoid clogging; • Not suitable in climates where soil can freeze; • Bioretention BMPs can attract mosquitoes and other environmental nuisances.
Filtration Structures	Systems that may consist of a pretreatment basin, water storage reservoir, flow spreader, sand, and under-drain piping. Liners can be installed if the treated runoff is not allowed to infiltrate to groundwater. Structures can be constructed above or below ground with a sand or peat moss media.	Filtration and absorption	<ul style="list-style-type: none"> • Filters are useful in high density, impervious drainage areas. • High removal efficiencies for suspended solids. • In addition to the benefits of surface sand filters, underground filters can be placed below the right of way when space is limited. 	<ul style="list-style-type: none"> • Pretreatment required to prevent filter media from clogging. • Requires complete stabilization of upstream drainage area.
Infiltration Basin	An open surface pond that collects stormwater from impervious areas and infiltrates water to the subsurface; requires highly permeable soils for efficient recharge.	Sedimentation of particulate pollutants and filtration through native soil strata.	<ul style="list-style-type: none"> • Theoretically, infiltration achieves 100% removal of dissolved and colloidal pollutants to surface waterbodies. • Flood attenuation, reduction of peak flows • Eliminates downstream bank erosion 	<ul style="list-style-type: none"> • High failure rates due to improper siting, design, and lack of maintenance, especially when no pretreatment is included. • Clogging likely under high suspended solid loading; • Not suitable below steep slopes; • Possible groundwater contamination or exacerbation; violation of Aquifer Protection Permit (APP) standards. • Requires complete stabilization of upstream drainage area.
Infiltration Trench	An excavated trench lined with aggregate. Stormwater infiltrates through the sides and the bottom of the trench.	Sedimentation of particulate pollutants and filtration through native soil strata.	In addition to the benefits of an infiltration basin, trenches can have a linear footprint.	<ul style="list-style-type: none"> • Requires complete stabilization of upstream drainage area.
Retention and Detention Basins	A dry or wet pond that impounds stormwater and allows suspended pollutants to settle. They may or may not permanently retain water.	Predominately sedimentation of particulate pollutants and biodegradation.	<ul style="list-style-type: none"> • Can perform in both arid and cold environments. • Can limit downstream bank erosion. • May have high aesthetic value. • Retention basins improve treatment, flood attenuation, and reduce peak flows. 	<ul style="list-style-type: none"> • Not suitable for drainage areas less than 10 acres. • Potential for clogging outlets and sediment resuspension (if not properly maintained). • Discharges from dry detention basins may be warmer than the temperature of receiving surface waterbody (heat sink effect). • Can not be placed on steep or unstable slopes and require a base flow or supplemental source of water to maintain ponded water level. • Improper design of retention basins can result in stratification and release of nutrients and metals.

Water Quality and Treatment		
BMP	Upfront Construction Costs¹	Annual Maintenance Costs¹
Infiltration Basin	\$0.55/ft ³ of storage	\$0.04/ft ³ of storage
Infiltration Trench	\$4.36/ft ³ of storage	\$0.04/ft ³ of storage
Bioretention	\$6.83/ft ³ of storage	N/A
Filtration Structures	\$2.63/ft ³ of storage	N/A
Manufactured Treatment Devices	\$2,200 each	\$164 each
Retention and Detention Basins	\$0.55/ft ³ of storage	\$0.009 – \$0.08/ft ³ of storage (retention)
		\$0.008 – \$0.33/ft ³ of storage (detention)

Notes:

¹ Unit costs are very approximate and should only be used for comparison and informational purposes. Do not use these costs for construction cost estimates.

² N/A – Unit cost data is either not available or is not an appropriate measurement of costs for the BMP.

THIS PAGE INTENTIONALLY LEFT BLANK

APPENDIX B
DESIGN CALCULATIONS, TABLES AND REFERENCES

THIS PAGE INTENTIONALLY LEFT BLANK

Appendix B

Design Calculations, Tables and References

DESIGN CALCULATIONS

Water Quality Volume Calculation

$$WQv = T(P * A * Cq) / 12$$

where:

WQv = Water Quality Volume (Ac-ft)

T = Treatment Percent

P = Precipitation

A = Contributing Drainage Area to an outfall (acres)

$Cq = 0.858i^3 - 0.78i^3 + 0.774i + 0.04$

i = impervious area divided by the total area

Treatment Percent

$$Treatment = [(Aix * 20) + (Ain * 100)] / (Aix + Ain)$$

where:

Treatment = Treatment percent

Aix = Existing impervious area (acrea)

Ain = New impervious area (acres)

Bioretention Cell Sizing

$$A = WQv * D / [3600 * K * T * (h + D)]$$

where:

WQv = Water Quality volume

T = Drain time of the cell

K = permeability of the soil

A = Top surface area of the trench

D = Depth of the planting soil

h = Maximum height of water above the cells top layer of the WQv

Infiltration Trench

$$Lt = 43560 * WQv / (3600 * K * T * (b+2D) + 0.4 [D^2 + (b * D)])$$

where:

WQv = Water Quality volume

T = Drain time through the sides of the trench, 24 hours

K = permeability of the surrounding soil (ft/sec)

D = Trench Depth

b = Bottom width of the trench (ft)

Infiltration Basin (invert area)

$$A = (WQv * S.F. * 12) / (k * t)$$

where:

A = area of invert of the basin (acres)

WQv = Water Quality volume

S.F. = Safety Factor of 1.5

k = Infiltration Rate (in/hr)

t = Drawdown time of 48 hours

Infiltration Basin (depth)

$$D = WQv / A$$

where:

A = area of invert of the basin

WQv = Water Quality volume

D = Required depth of the basin

REFERENCES

Arizona Department of Transportation, Highway Drainage Design Manual, Hydraulics, January 2007

Arizona Department of Transportation, Roadway Design Guidelines, May 2012

California Department of Transportation, (CALTRANS), Storm Water Quality Handbooks: Project Planning and Design Guide, Appendix A: Approved Design Pollution Prevention BMPs and Appendix B: Approved Treatment BMPs, April 2003.

Ohio Department of Transportation, Division of Highway Operations, Office of Structural Engineering, Hydraulic Section, ODOT Storm Water BMP Updates, January 24, 2006.

THIS PAGE INTENTIONALLY LEFT BLANK

APPENDIX C
ABBREVIATIONS, ACRONYMS AND DEFINITION OF TERMS

THIS PAGE INTENTIONALLY LEFT BLANK

Appendix C

Abbreviations, Acronyms, and Definition of Terms

Acronym/Term	Definition
303(d) List:	Under Section 303(d) of the 1972 Clean Water Act, states, territories and authorized tribes are required to develop a list of water quality limited segments. These waters on the list do not meet water quality standards, even after point sources of pollution have installed the minimum required levels of pollution control technology. The law requires that these jurisdictions establish priority rankings for water on the lists and develop action plans, called as Total Maximum Daily Loads (TMDLs) to improve water quality.
AASHTO:	Association of State Highway and Transportation Officials
ADEQ:	Arizona Department of Environmental Quality
ADOT:	Arizona Department of Transportation
ADWR:	Arizona Department of Water Resources
Bank:	The lateral boundary of a stream confining water flow. The bank on the left side of a channel looking downstream is called the left bank, etc.
Bank Protection:	Revetment, or other armor protecting a bank of a stream from erosion, includes devices used to deflect the forces of erosion away from the bank.
Base Flow:	The flow contribution to a creek by groundwater. During dry periods, base flow constitutes the majority of stream flow.
Basin:	Earthen systems, usually below ground, capable of retaining or detaining runoff.
Best Management Practice:	Structural devices or nonstructural practices that are designed to prevent pollutants from entering into stormwater flows, to direct the flow of stormwater or to treat polluted stormwater flows.
Bioretention:	Engineered facilities consisting of a grass buffer strip, ponding area, organic or mulch layer, planting soil, and vegetation. An optional sand bed can also be included in the design to provide aeration and drainage of the planting soil. The filtered runoff can either be discharged through an underdrain system to a receiving waterbody, conveyance system or other BMP, or it can infiltrate to the underlying soils. They can be configured in an on-line and off-line configuration.
Bridge Drainage System:	Infrastructure that conveys runoff from the bridge deck. This may include channeling water through gutters to either end of the bridge

	for short bridge spans or immediately off of the deck through scuppers or closed conduit systems. Inlet drain systems may function either by gravity or in combination with a pumping system.
Capacity:	The effective stormwater carrying ability of a drainage structure. Generally measured in cubic feet per second.
Catch Basin	A drainage structure that collects water. May be either a structure where water enters from the side or through a grate inlet
CFR:	Code of Federal Regulations
Channel:	The space above the bed and between banks occupied by a stream.
Check Dam:	A temporary dam across a swale or gully to reduce gully erosion, or placed bank to bank downstream from a headcut; often used in series. A small dam generally placed in steep ditches for the purpose of reducing the velocity in the ditch.
Chemical Oxygen Demand:	A test used to indirectly measure the amount of organic compounds in water.
Concentrated Flow:	Drainage that has accumulated into a single narrow width, with greater velocity than sheetflow.
Concentration:	Mass per unit volume of a pollutant.
Conduit:	Any channel or pipe for directing the flow of water.
Construction Project:	Installation of a new roadway or expansion of an existing roadway, not otherwise considered maintenance or a safety/emergency project.
Conveyance:	Any natural or man-made channel or pipe in which concentrated water flows.
Culvert Structure:	A closed conduit or underpass, other than a bridge, that allows water to drain from and pass under a roadway. Culverts must be designed with proper inlet/outlet protection and headwalls.
Debris:	Any material including floating woody material and other trash, suspended sediment, or bed load moved by a flowing stream.
Decomposed Granite:	Granite rock, ranging from ¼" to 2" nominal diameter, used for drains, erosion control, and a temporary driving surface.
Design Storm:	That particular storm that contributes runoff that drainage facilities were designed to handle. This storm is selected for design on the basis of its probability of exceedance or average recurrence interval.
Detention/ Retention Basin:	Facilities typically constructed below the roadway shoulder where the appropriate footprint is available to hold runoff, and are also referred to as pond-in-place practices. Retention and detention basins are excavated in most any configuration to meet footprint restrictions and can be vegetated.

Diversion Dike:	Embankment to confine or control water, often built along the banks of a river to prevent overflow of lowlands; a levee.
Discharge:	A release or flow of stormwater or other substance from a conveyance or storage container.
Dissipate:	Expend or scatter harmlessly, as of energy of moving water.
Ditch:	Small artificial channel, usually unlined.
Drainage:	(1) The process of removing surplus ground or surface water by artificial means. (2) The system by which the waters of an area are removed. (3) The area from which waters are drained; a drainage basin.
Drainage Area:	Portion of the earth's surface upon which falling precipitation flows to a given location.
Drainage System:	Usually a system of underground conduits and collector structures that flows to a single point of discharge.
Easement:	Right to use the land of others.
Embankment:	Soil surface adjacent to a stream, lake, or body of water where the soil elevation adjacent to the water is higher than the water level; usually referred to as the bank.
Energy Dissipater:	A structure for the purpose of slowing the flow of water and reducing the erosive forces present in any rapidly flowing body of water.
Erosion Control Blankets:	A protective blanket or soil stabilization mat installed to reduce soil erosion by wind or water. Erosion control blankets usually consist of photodegradable mesh filled with straw, excelsior, coconut fiber, wood fiber, or jute.
Excavation:	The process of removing earth, stone, or other materials.
Fecal Coliform:	Bacteria that indicate the presence of sewage contamination of a waterway and the possible presence of other pathogenic organisms.
Fertilizer:	Any of a large number of natural or synthetic compounds including organic material, nitrogen, phosphorus, and potassium, applied to the soil to promote its plant growth capabilities.
FHWA:	Federal Highway Administration
Filter Bed:	Filter consisting of a layer of sand or gravel for filtering water
Filter Structures:	Structures that utilize a filtering media (sand, soil, gravel, peat, or compost) to remove pollutants from stormwater runoff. Filtration structures can vary in design, but should all generally comprise of the following: (a) inflow regulation that diverts a defined flow volume into the filtration system, (b) pretreatment to remove coarse sediments,

	(c) filter media, specific to one or more target pollutants, and (d) an outflow mechanism to discharge flows to a conveyance system or directly to a receiving water body.
Filter Fabric:	Textile of relatively small mesh or pore size that is used to (a) allow water to pass through while keeping sediment out (permeable), or (b) prevent both runoff and sediment from passing through (impermeable).
First Flush	The initial half (0.5) inch of runoff from a storm event. The first flush of runoff, typically contains the highest concentration of pollutants.
Flow:	A term used to define the movement of water, silt, sand, etc.; discharge; total quantity carried by a stream.
Footprint Area:	The plan view or surface area that a structure occupies.
Gabion:	Baskets (usually made of wire) filled with rock or broken pieces of concrete, used for building erosion control structures.
Geosynthetic:	Manufactured (inorganic/organic) fabric material.
Geotextile:	Textiles in the traditional sense, but consist of synthetic fibers rather than natural ones. Thus biodegradation is not a problem. These synthetic fibers are made into a flexible, porous fabric by standard weaving machinery or are matted together in a random, or nonwoven, manner. The fabric performs at least one of five discrete functions separation, reinforcement, filtration, drainage or as a moisture barrier when impregnated.
Girders:	A beam, as of steel, wood, or reinforced concrete, used as a main horizontal support in a building or bridge.
Grading:	The cutting and/or filling of the land surface to a desired slope or elevation.
Gradient:	See definition for "Slope"
Gravel:	Soil particles ranging from 1/5 inch to 3 inches in diameter.
Grout:	A thin, coarse mortar poured into various narrow cavities, as masonry joints or rock fissures, to fill them and consolidate the adjoining objects into a solid mass.
"H":	High rating (in terms of Costs, BMP Objective, and DOT Target Pollutants Removal)
Head:	Represents an available force equivalent to a certain depth of water. This is the motivating force in effecting the movement of water. The height of water above any point or plane of reference. Used also in various compound expressions, such as energy head, entrance head, friction head, static head, pressure head, lost head, etc.

Heavy Metals:	Any metallic chemical element that has a relatively high density and is toxic or poisonous at low concentrations. Examples of heavy metals include mercury (Hg), cadmium (Cd), arsenic (As), chromium (Cr), thallium (Tl), and lead (Pb).
Hydraulic:	Pertaining to water in motion and the mechanics of the motion.
Hydrologic:	Pertaining to the cyclic phenomena of waters of the earth; successively as precipitation, runoff, storage and evaporation, and quantitatively as to distribution and concentration.
Impaired Waterbody:	A waterbody (e.g., stream reaches, lakes, water body segments) with chronic or recurring monitored violations of the applicable numeric and/or narrative water quality criteria established to protect its set of designated uses.
Impervious Surface:	Artificial surfacing of a soil surface to resist erosion or scour. Impervious cover can consist of soil cement (a dry mix of sand, cement and admixtures, compacted to the required density); shotcrete (mortar or concrete applied, pneumatically, through a hose); grouted riprap (rock voids filled with concrete grout); concrete slope pavement (cast-in-place or pre-cast and place concrete monolithic armor) and grouted fabric slope pavement (sand-cement mortar, injected between two layers of double-woven fabric).
Impervious Channel:	A rigid facing for a drainage swale, ditch, or channel that is typically constructed out of concrete or grouted riprap for minimal infiltration and erosion.
Inlet:	An entrance into a ditch, storm sewer, or other waterway.
Inlet Protection:	A decomposed granite cover or riprap surface surrounding a storm drain inlet, culvert, spillway, channel, or other BMP structure. It can also refer to slots or screens to prevent floatable debris from entering a culvert or a storm drain system.
Infiltration Basin:	Facilities typically constructed below the roadway shoulder where the appropriate footprint is available to hold and infiltrate runoff. Infiltration basins (also known as recharge basins) are considered a treatment BMP because they can remove pollutants from surface discharges by capturing the stormwater runoff volume (typically, larger volumes than an infiltration trench) and infiltrating it directly to the soil rather than discharging it to an above-ground drainage system. Basins are excavated in most any configuration to meet footprint restrictions and can be vegetated.
Infiltration Trench:	Constructed below ground surface, within the median and/or below a shoulder of relatively flat stretches of roadway. It is considered a treatment BMP because it can remove pollutants from surface discharges by capturing stormwater runoff volume and allowing it to infiltrate directly into the soil (through the bottom and the sides of the trench) rather than discharging it to an above-ground drainage system. Infiltration trenches are excavated, lined with a geotextile fabric (optional), and backfilled with aggregate.

Karst Geology:	Refers to subsurface geologic features found in various parts of Arizona, including sinkholes, fissures and subsidence can form crevices and enlarged joints in the soil.
“L”:	Low rating (in terms of Costs, BMP Objective, and DOT Target Pollutants Removal)
Level Spreader:	A device used to spread out stormwater runoff uniformly over the ground surface as sheet flow (i.e., not through channels). The purposes of level spreaders are to prevent concentrated erosive flows from occurring and to enhance infiltration.
Loam:	Soil composed of a mixture of sand, clay, silt, and organic matter.
“M”:	Medium rating (in terms of Costs, BMP Objective, and DOT Target Pollutants Removal)
Median Cable Barrier:	A flexible traffic barrier that is ideally suited for use as a retrofit design in existing relatively wide and flat medians to prevent cross-over crashes.
Mulch:	A natural or artificial layer of plant residue or other materials covering the land surface which conserves moisture, holds soil in place, aids in establishing plant cover, and minimizes temperature fluctuations.
Municipal Separate Storm Sewer System (MS4):	All separate storm sewers defined as “large,” “medium,” or “small” municipal separate storm sewer systems or any municipal separate storm sewers on a system-wide or jurisdiction-wide basis as determined by the Director under 18-9-C902(A)(1)(g)(i) through (iv). [A.A.C. R18-9-A901(23)]
Not Attaining Waterbody:	A surface water for which: (1) a TMDL has been completed and approved by EPA, but the water standards are not yet attained, (2) other pollution control requirements are expected to result in the attainment of water quality standards by the next regularly scheduled listing cycle, or (3) the impairment is not related to pollutant loading, but is caused by pollution (e.g., hydromodification).
Nuisance Control:	Control and/or eradication of vectors and pests, including mosquitoes, insect larvae, and rodents.
Nutrients:	A substance that provides nourishment for growth or metabolism. Plants absorb nutrients mainly from the soil in the form of minerals and other inorganic compounds.
Oil Sheen:	A thin, glistening layer of oil on water.
Open Channel:	Any conveyance in which water flows with a free surface.
Organic:	Involving organisms or the products of their life processes.
OSHA:	Occupational Safety and Health Administration

Outfall:	The point, location, or structure where wastewater or drainage discharges from a sewer pipe, ditch, or other conveyance to a receiving body of water.
Outlet Protection:	Outlet protection consists of loose or grouted riprap placed at the outlet ends of culverts, conduits, spillways, or channels to reduce erosion along the soil interface and at the toe of concrete and metal structures.
Outstanding Waterbody:	Defined by ADEQ as waters of exceptional recreational or ecological significance because of unique attributes, including but not limited to geology, flora, fauna, water quality, and/or aesthetic values, or waters that sustain threatened or endangered species. Refer to the current ADEQ list.
Permeability:	The property of soils that permits the passage of any fluid. Permeability depends on grain size, void ratio, shape and arrangement of pores.
Pervious Channel Lining:	A pervious channel lining is typically a vegetated or rock-lined (non-grouted) swale, ditch, or channel that allows some infiltration in addition to providing a means for conveyance.
Pesticides:	A chemical used to control/eradicate pests, especially invasive insect and plant species.
pH:	An expression of the intensity of the basic or acidic condition of a waterbody. pH is calculated as the negative log of the hydronium (H ₃ O ⁺) concentration present within the natural waterbody (i.e. the higher the pH, the lower the concentration of hydronium ions present.). The measurement range for pH is between 1 (very acidic) to 14 (very basic or alkaline), and neutral pH is defined as 7. Natural waters usually have a pH between 6.5 and 8.5.
Pollutant:	Fluids, contaminants, toxic wastes, toxic pollutants, dredged spoil, solid waste, substances and chemicals, pesticides, herbicides, fertilizers and other agricultural chemicals, incinerator residue, sewage, garbage, sewage sludge, munitions, petroleum products, chemical wastes, biological materials, radioactive materials, heat, wrecked or discarded equipment, rock, sand, cellar dirt and mining, industrial, municipal and agricultural wastes or any other liquid, solid, gaseous or hazardous substances. [A.R.S. § 49-201(29)]
Precipitation:	Discharge of atmospheric moisture as rain, snow, or hail, measured in depth of fall or in terms of intensity of fall in unit time.
Pretreatment:	Robust displacement of pollutants (typically suspended sediment) in stormwater prior to reaching a water quality/treatment BMP.
Rainfall Harvesting:	The practice of collecting and storing rainwater for use in irrigation or any application where surface or groundwater resources would traditionally be consumed. Rainwater harvesting also acts as a retention/detention practice from a stormwater management perspective.

Retaining Wall:	A wall structure, built along soil slopes ranging from vertical to the angle of repose.
Retention Basin:	A structural BMP that impounds all stormwater flows from a design storm until the storm has passed. A retention basin is considered a treatment BMP because it can remove suspended pollutants through settling and being slowly released.
Retrofit:	The modification of stormwater management systems in developed areas through the construction of wet ponds, infiltration systems, wetland plantings, stream bank stabilization, and other BMP techniques for improving water quality. A retrofit can consist of the construction of a new BMP in the developed area, the enhancement of an older stormwater management structure, or a combination of improvement and new construction.
Revegetation:	Reestablishing vegetative cover on ground that has been disturbed, such as a construction site.
Revetment:	A stone or concrete facing to sustain an embankment.
Riprap:	A controlled placement of erosion-resistant ground cover of large, loose, angular stone with a geotextile or granular underlining.
Roadway:	Infrastructure for vehicles to use to travel from one point to another. Roadways include interstates, highways, freeways, on-ramps, off-ramps, intersections, bridges, tunnels under the jurisdiction of ADOT
Roadway Maintenance Project:	Repair or reconditioning to an existing roadway that does not include expansion or new construction activity.
Roadway Safety or: Emergency Project	Roadway construction project that is given higher priority or expedited schedule due to increased potential safety hazards to the public.
Rock Mulch:	Rock mulch typically has a nominal diameter of less than 3 inches and is used for pipe inlet and outlet protection and headwall and wingwall erosion control.
Runoff:	That portion of precipitation, snowmelt, or irrigation water that runs off the land into streams or other surface water. It can carry pollutants from the air and land into the receiving waters.
Scuppers:	An opening for draining off water, as from a floor or the roof of a building.
Sedimentation:	The process of depositing soil particles, clays, sands, or other sediments that were picked up by runoff.
Sediments:	Soil, sand, and minerals washed from land into water usually after rain, that pile up in reservoirs, rivers, and harbors, destroying fish-nesting areas and holes of water animals and clouding the water so that needed sunlight might not reach aquatic plants. Careless

farming, mining, and building activities will expose sediment materials, allowing them to be washed off the land after rainfalls.

Sediment Forebay:	A pretreatment mechanism, installed prior to basins and infiltration/filtration structures.
Seed Mix:	The application of native vegetation seeds to a previously disturbed soil surface, seeding can be mixed with fiber, fertilizers, mulch, or stabilizing emulsions to enhance the seed germination.
Sensitive Waterbody:	See definition for "Impaired" or "Outstanding Waterbody". See also definition for "Not Attaining Waterbody".
Sheet Flow:	The portion of precipitation that moves initially as overland flow in very shallow depths before eventually reaching a stream channel.
Shotcrete:	Mortar or concreate applied pneumatically through a hose.
Slope Modification:	Slope modification practices may include mini benches, terraces, serrations, stair-steps, or track-marks on the face of the slope. Existing and new slopes should also be flattened to the lowest extent possible, whenever feasible, to reduce erosive runoff velocities and increase infiltration time.
Soil:	The unconsolidated mineral and organic material on the immediate surface of the earth that serves as a natural medium for the growth of land plants.
Spillway:	Spillways drain roadway surface runoff through an open channel down an embankment or side slope. Spillways must be designed with proper riprap inlet/outlet protection and headwalls.
Storage:	Detention, or retention of water for future flow, naturally in channel and marginal soils or artificially in reservoirs.
Storm Drain:	A slotted opening leading to an underground pipe or an open ditch for carrying surface runoff.
Stormwater:	Runoff, snow melt runoff, and surface runoff and drainage; rainfall that does not infiltrate the ground or evaporate because of impervious land surfaces but instead flows onto adjacent land or watercourses or is routed into drain/sewer systems.
Subsoil:	The bed or stratum of earth lying below the surface soil.
Surface Water:	All water naturally open to the atmosphere (rivers, lakes, reservoirs, streams, wetlands impoundments, seas, estuaries, etc.); also refers to springs, wells, or other collectors which are directly influenced by surface water.
Suspended Solids:	Organic or inorganic particles that are suspended in and carried by the water. The term includes sand, silt, and clay particles as well as solids in wastewater.

Swale:	A vegetated channel; can be either “wet” or “dry”. Wet swales can temporarily store water and can act as a linear and shallow wetland treatment system. Dry swales have an underlying filterbed and eliminate standing water.
Tackifier:	A material used to bond seed to the soil surface. It is commonly used as an additive for hydro-seeding mixtures.
TDS:	Total Dissolved Solids
TMDL:	Total Maximum Daily Load
Transport:	To carry solid material in a stream in solution, suspension, saltation, or entrainment.
Treatment:	Displacement and removal of undesirable pollutants from stormwater.
TSS:	Total Suspended Solids
Turbidity:	A measure of the amount of material suspended in water. Increasing the turbidity of the water decreases the amount of light that penetrates the water column. High levels of turbidity are harmful to aquatic life.
Turf Reinforced Mats:	A combination of vegetation and a geosynthetic material used to prevent soil erosion due to stormwater runoff. The mat can be made from such material as polypropylene, nylon, and polyvinyl chloride, and is used to enhance vegetative root and stem development.
Vadose Zone:	The region between the water table and the land surface, where the moisture content is typically unsaturated. The soil pore space is a combination of moisture and air.
Velocity:	The rate of motion of objects or particles, or of a stream of particles.
Vegetative Filter Strip:	Vegetated Filter Strips (VFSs) are typically long but relatively narrow areas of natural (undisturbed) or planted vegetation (ground cover, sod, or grasses). They are used to retard stormwater runoff and consequently settle or trap sediment and other pollutants; hence protecting surface waterbodies or adjacent, downslope properties. They are designed for overland sheet flow and are often well suited to provide pretreatment to other best management practices (BMPs), such as infiltration, filtration, or storage practices.
Wire-tied Rock:	A wire mesh structure, filled with rock, that can be constructed in the form of wire-tied rock mattresses or gabions. In wire-tied rock mattress designs, the individual wire mesh units are laid end-to-end and side-to-side to form a mattress layer along the channel bed or side slope. Generally, the depth is much smaller than the width or length. Gabions, in contrast, are typically rectangular or trapezoidal in shape. The depths are approximately the same as the widths and are stacked vertically.