

Technical guidelines of an ice rink

Chapter 3

3.1 General introduction

Ice rink facilities share all the same concerns: energy usage, operating costs and indoor climate. Ice rink design and operation are totally unique and differ in many ways from standard buildings. Thermal conditions vary from -5°C on the ice surface to $+10^{\circ}\text{C}$ in the stand and $+20^{\circ}\text{C}$ in the public areas like dressing rooms and offices. High humidity of indoor air will bring on corroding problems with steel structures, decay in wooden structures and indoor air quality problems like fungi and mould growth etc. Obviously there are special needs to have technical building services to control the indoor climate and energy use of an ice-rink facility. Advanced technology can reduce energy consumption by even 50 % and thus decrease operating costs in existing and proposed ice rink facilities while improving the indoor climate.

Energy costs and concern about the environment sets high demands for the technical solutions, without effective solutions the operational (energy, maintenance, replacement) costs will increase and short service life time of such a system is expected from the environmental point of view. Potentially a lot of savings can be made if the facilities are got operating as energy-efficiently as possible. This will require investment in energy-saving technology and in raising energy awareness on the part of ice rink operators.

The basic technical elements of a well-working facility are:

- Insulated walls and ceiling
- Efficient refrigeration plant
- Mechanical ventilation
- Efficient heating system
- Air dehumidification

1) Insulated walls and ceiling makes it possible to control the indoor climate regardless of the outdoor climate. In an open-air rink the operation is conditional on the weather (sun, rain, wind) and the running costs are high. Depending of the surroundings there might also be noise problems with the open-air rink – traffic noise may trouble the training or the slamming of the pucks against the boards may cause noise nuisance to the neighbourhood. Ceiling only construction helps to handle with sun and rain problems but may bring about maintenance problems in the form of “indoor

rain”: humid air will condensate on the cold inner surface of the ceiling and the dripping starts. The ceiling is cold because of the radiant heat transfer between the ice and the ceiling i.e. the ice cools down the inner surface of the ceiling. Though there are technical solutions to minimize the indoor rain problem (low emissive coatings) the ceiling only solution is still subjected to weather conditions and high running costs.

- 2) The refrigeration plant is needed to make and maintain ice on the rink.** Refrigeration plant includes the compressor(s), the condenser(s), the evaporator(s), and rink pipes. The heat from the rink is “sucked” by the compressor via the rink pipes and the evaporator and then released to the surrounding via the condenser. The heat from the condenser can be used to heat the ice rink facility and thus save considerably energy and money. Refrigeration plant is the main energy consumer in the ice rink facility. Compressors, pumps and fans needed in the refrigeration system are normally run by electricity and their electricity use may cover over 50 % of the total electricity use of an ice rink facility.
- 3) Mechanical ventilation is necessary to be able to control the indoor air quality and thermal as well as humidity conditions inside the ice rink.** Ventilation is needed both in the public spaces (dressing rooms, cafeteria, etc.) and in the hall. If you ever have visited a dressing room when the ventilation is off you will realize the necessity of the proper ventilation; the stink of the outfit of the hockey players is unthinkable. Inadequate ventilation will cause also health problems in the hall. To be energy-efficient air renewal must be well controlled. This means that the ice rink enclosure should be airtight so that there are no uncontrollable air infiltration through openings (doors etc.) and roof-to-wall joints. Air infiltration will increase energy consumption during the warm and humid seasons related to refrigeration and dehumidification and during the cold seasons this is associated with space heating. This leads us to the fourth basic demand: the ice rink facility must be heated. Unheated ice rink is freezing cold even in warm climates and humidity control of the air becomes difficult.

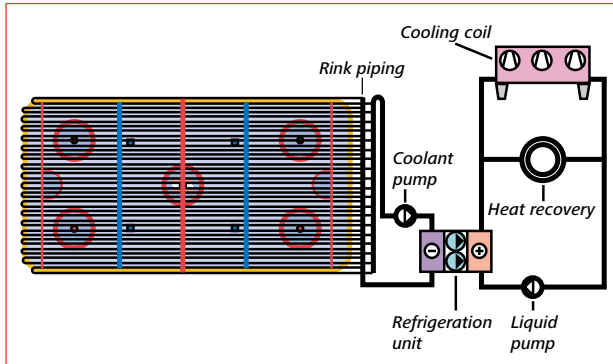

Figure 1. Refrigeration plant, indirect cooling system.

Energy consumption is in the key role when speaking of the life cycle costs and above all the environmental load of the facility during its life cycle. The key to the effective utilization of the energy resources in new as well as in retrofit and refurbishment projects is in the consciousness of the energy-sinks and the various parameters affecting the energy consumption.

The construction, plant system and operation define the energy consumption of an ice rink. The construction characteristics are the heat and moisture transfer properties of the roof and walls, as well as air infiltration through cracks and openings in the building envelope. The structure of the floor is also important from the energy point of view. Plant characteristics include the refrigeration, ventilation, dehumidification, heating, lighting and ice maintenance systems. The operational characteristics are the length of the skating season, air temperature and humidity, ice temperature, supply air temperature and fresh air intake of the air-handling unit as well as the control- and adjustment parameters of the appliances. Figure 3 shows the energy spectrums of typical training rinks and figure 4 illustrates the energy flows of a typical small ice rink.



- 4) Ventilation offers also a means to heat the ice rink. Heating the ice rink with air necessitates the use of re-circulated air and that the ventilation unit is equipped with heating coil(s). Remarkable energy-savings can be achieved when using waste heat of the refrigeration process to warm up the air.
- 5) The dehumidification plant is needed in well-working facility to dry the rink air. Excess moisture in indoor air will cause corrosion of metal structures, rotting of wooden structures, fungi and mould growth, increased energy consumption and ice quality problems.

Insulated exterior envelope

- Enables to build an ice rink anywhere in the world
- Air tight envelope to avoid moisture problems

Heating

- Maintains acceptable thermal conditions
- Use heat recovered from the refrigeration plant (condenser heat) as much as possible

Mechanical ventilation

- Provides good indoor air conditions
- Demand-controlled ventilation saves money and energy

Dehumidification

- Dehumidification prevents moisture problems (fog, soft ice, damages to the building)
- Dry ventilation air before entering the building

Refrigeration plant

- Needed to make and maintain ice
- Pay attention to the energy efficiency of the plant (high COP)

Figure 2. The construction, plant system and operation define energy consumption of an ice rink.

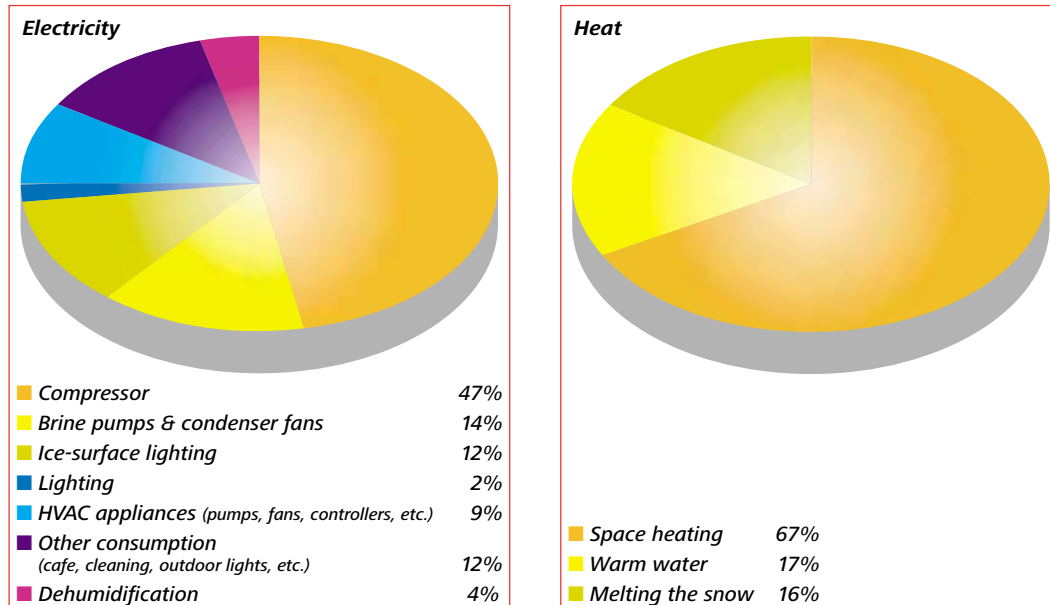

Figure 3. Main electricity and heat consumption components of a typical training facility.

In an ideal situation the heating demand of the ice rink is totally covered with recovered heat from the refrigeration process. In practice extra heat is still needed to cover the needs of hot tap water and heating peaks. Moreover a backup

heating system is needed to meet the heating demands when the compressors are not running for example during dry floor events (concerts, shows, meetings, etc.).

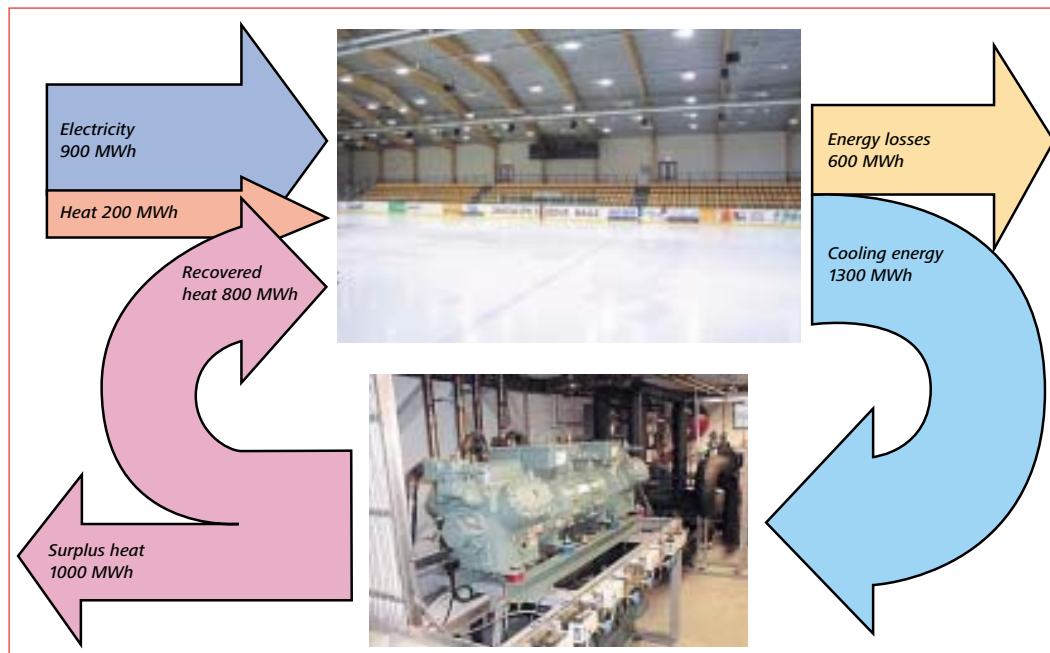

Figure 4. While producing cold, the "ice plant" provides heat that can be utilized in space heating and hot water production. Still there is a great deal of extra heat that could be made good use of for example in a nearby indoor swimming pool.

3.2 Sizing the ice rinks

There are several ways to classify ice sport venues and in this manual the definition will be done on the basis of fixed seating capacity, size of the food service supply and multi-purpose possibilities.

Therefore the sizing of the ice sport venues are divided into three categories as follow:

- Small ice rinks with seating capacity up to 2000
- Medium size ice arenas between 2000 and 6000 seats with some multi-purpose features
- Modern multi-purpose ice arenas with over 6000 fixed seats with a wide scale catering offer and many possibilities for multi-purpose use

Small ice rinks can be done without any fixed seating or any foodservice capability, although the modern small ice rinks are without exception also concentrating on getting additional revenues through special hospitality programs.



Figure 5. Small ice rink, capacity less than 2000 seats.



Figure 6. Multi-purpose arena, capacity over 8000 seats.

It is strongly recommended that the first studies for a new ice rink will be done on a so called modular base, which allows in later years possibilities for optional enlargements. These later modifications could be like an additional ice pad, enlarged spectator stand or a restaurant.

In order to make the optional features possible for later realization, the designer team should take into consideration some technical features like:

- Sizing of refrigeration unit
- Main structural support system, where for example the columns and foundations on one side of the building are from beginning planned to take later on extra load from additional structures
- Envelope structure, like external walls, should be at least partly removable

In this manual we are only concentrating on a small ice rink by defining an IIHF prototype ice rink with about 500 fixed seating and a small restaurant.

3.3 IIHF prototype definition

Minimum required space, IIHF prototype ice rink

In a small ice rink there is a minimum space needed for following use:

- at least one standard IIHF ice pad, size of 30 m x 60 m surrounded by a dasher board and glass protection with 1,5 m minimum space outside of the dasher board
- four dressing rooms incl. toilets, showers and lockers for personal items
- two coach rooms
- referees and linesmen dressing room incl. toilet and shower
- two drying rooms
- entrance hall, ticketing
- medical room
- equipment service room (skate sharpening, stick storage etc.)
- storage space
- technical room for mechanical and electrical system
- tribune for 500 spectators
- public toilets
- small restaurant

Required minimum space for each type of room in a IIHF prototype ice rink:

Room	Surface area nett	Typical surface texture		
		Flooring (water proof)*	Ceiling	Wall finishing
Main hall - Dasher board with surrounding	2100 m ²	Painted concrete slab	Metal sheet of roofing	Outside walls, painted
Small restaurant	132 m ²	wooden surfacing	Wood lining	Painted brick walls or concrete
Players dressing room (4 x)	30 m ²	8 mm rubber surfacing *	Wood lining	Painted brick walls or concrete
Referees and lines-men room	18 m ²	8 mm rubber surfacing *	Wood lining	Painted brick walls or concrete
Drying room (2 x)	4 m ²	Painted concrete slab	Concrete (underneath)	Painted brick walls or concrete
Medical room	15 m ²	8 mm rubber surfacing *	Plasterboard	Painted brick walls or concrete
Equipment service room	8 m ²	Painted concrete slab	Concrete (underneath)	Painted brick walls or concrete
Technical room	50 m ²	Painted concrete slab *	Metal sheet of roofing	Plasterboard
Ice resurfacing machine	50 m ²	Painted concrete slab *	Metal sheet of roofing	Painted brick walls or concrete
Coat-rack for public ice skating	20 m ²	2 mm plastic surfacing	Metal sheet of roofing	Plasterboard
Dressing rooms for public ice skating (2 x)	10 m ²	8 mm rubber surfacing *	Wood lining	Painted brick walls or concrete
Entrance hall, ticketing	70 m ²	ceramic tile floor	Plasterboard	Plasterboard
Office	20 m ²	2 mm plastic surfacing	Plasterboard	Plasterboard

This requires a total building surface area of 3700 m².

3.4 Materials and structural systems for an ice rink

First of all, most important to know about ice rinks and ice arenas are to understand their different features compare to any other kind of buildings. These special features are due to:

- High inside temperature differences in same indoor climate from -4 °C to +24 °C, where at the same time these internal climate zones must be controlled and stay stable
- Differences in indoor climate also cause humidity problems that must be under control
- Air tightness is more important feature of the building envelope than thermal insulation
- Large glazing of the facade should be avoided due to energy costs by operating the facility and the most optimised ice rink could be done by a fully closed casing

However, like in all other kind of buildings, there are structural possibilities for almost all kinds of systems with numerous materials. Main structural systems used for the ice rinks and arenas are normally:

- Arched girders
- Grids with mast columns
- Frameworks

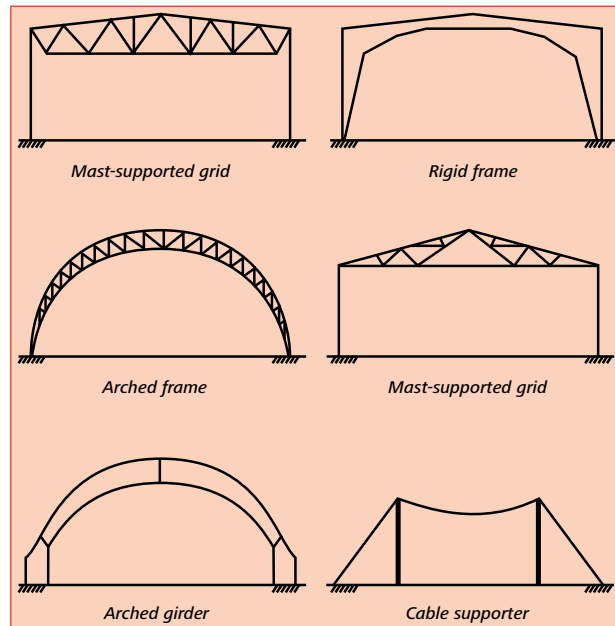

Figure 7. Structural systems.

Below you will find existing examples of small rinks with these different roof structures.

Hartwall Jaffa Arena Training Rink Eura, Finland

Facts

- Building year: 2000
- Building area: 2520 m² (70 x 26 m)
- Ice pad size: 58 x 28 m
- Seats: 400
- Skating season: 8 months (August–March)
- Ice charge: 44–72 €/hour
- Personnel: 2
- Heating consumption: 710 MWh/year
- Electricity consumption: 710 MWh/year
- Water consumption: 2200 m³/year



Layout

The layout of the rink is simple, the stand and the players boxes are on the opposite sides of the rink, four dressing rooms are at the end of the hall. On top of the dressing rooms there are office rooms, lecture room and cafeteria. The space under the spectator seat is used as storage. Technical room is placed in a separate container outside of the rink.

Structures

The rigid frame structure of the rink is made of glue laminated timber. The roofing and the walls are made of polyurethane elements. To improve the energy efficiency of the rink the air tight polyurethane elements are equipped with low emissivity coating laminated on the indoor surface of the elements. The elements have also acoustic dressing which improves the acoustic atmosphere of the rink. The facades are made of bricks and profiled metal sheets.

Training Rink Hämeenkyrö, Finland

Facts

- Building year: 1997
- Building area: 2590 m² (68 x 38 m)
- Ice pad size: 58 x 28 m
- Seats: 600
- Skating season: 8.5 months
- Ice charge: 59–104 € / hour
- Personnel: 1–2
- Heating consumption: 395 MWh/year
- Electricity consumption: 490 MWh year
- Water consumption: 1100 m³/year



Layout

The four dressing rooms with showers are under the seat along the long side of the hall. At the other end of the hall there is a cafeteria and a training room.

Structures

The arched girder structure of the rink is made of glue laminated timber. The roofing and the walls are made of polyurethane elements. To improve the energy efficiency of the rink the air tight polyurethane elements are equipped with low emissivity coating laminated on the indoor surface of the elements. The elements have also acoustic dressing which improves the acoustic atmosphere of the rink. The facades are made of profiled metal sheets, clapboard and lime bricks.

Monrepos Arena Training Rink Savonlinna, Finland

Facts

- Building year: 1999
- Building area: 2420 m² (67 x 36 m)
- Ice pad size: 58 x 28 m
- Seats: 400
- Skating season: 12 months
- Ice charge: – summer 59– 83 € / hour
– other time 38–73 € / hour
- Personnel: 3
- Heating consumption: 760 MWh/year
(76 m³ oil)
- Electricity consumption: 720 MWh/year
- Water consumption: 3500 m³/year



Layout

Four of the six dressing rooms with showers are under the seat along the long side of the hall and the other two dressing rooms at the end of the hall. On top of these two dressing rooms there are office rooms, lecture room, cafeteria, TV stand and air conditioner. Technical room (refrigeration unit) is placed in a separate container outside of the rink.

Structures

The mast-supported grid constructure of the rink is made of glue laminated timber. The roofing and the walls are made of polyurethane elements. To improve the energy efficiency of the rink the air tight polyurethane elements are equipped with low emissivity coating laminated on the indoor surface of the elements. The elements have also acoustic dressing which improves the acoustic atmosphere of the rink. The facades are made of profiled metal sheets.

In this manual we will concentrate on a structural system of a grid supported by columns and the materials for this structural system can be divided into four main categories:

- Steel structures
- Wood structures
- Reinforced concrete structures
- Mix material structures of steel, wood and/or concrete

Materials and structural system

Steel support	Wood support	Reinforced concrete	Mix material combinations
<ul style="list-style-type: none"> + long span length + global availability + pre-fab system + cost - corroding - fire protection - maintenance 	<ul style="list-style-type: none"> + long span length + non corroding + pre-fab system + fire protection - global availability - cost - maintenance - decaying 	<ul style="list-style-type: none"> + global availability + non corroding + pre-fab system + fire protection - cost - beam span length - acoustic feature - flexibility in use 	<ul style="list-style-type: none"> + long span length + fire protection + pre-fab system + cost - corroding - decaying - cost - maintenance

Figure 5. Material features of main supporters.

If the idea of a modular system is found possible and reasonable, the best flexibility in use with either steel or wood frame structures. However through careful and skilled engineering the later changes of the supporting structure are also possible with all other materials and systems.

In the design phase all structural capabilities of the building for later enlargement should be defined in combination with the size of the plot, traffic situation and possible changes in the surrounding.

By becoming aware of the special features of an ice rink, there are several possibilities to optimise the ice rink construction costs that will also lower the later operational costs.

3.4.1 Structural system as used in the IIHF prototype

The roof structure consists of steel trusses supported each by two concrete columns. At support points the bottom boom of the truss bears on an elastomeric bearing pad bolted to the supporting concrete column. The whole roof structure of steel (see roofing 3.3.2) is floating on top of the concrete framework. The concrete columns are mounted ridged to the concrete foundations.

Regarding to the region of the planned new ice rink, the horizontal loads of the roof structure, like snow are highly affecting when choosing the most economical structural system. If the snow loads are not remarkable, the steel trusses could easily cost efficiently be spanned over the spectator stand and the dashed board, using the span length like 40 to 45 meters and concrete column raster of 6 to 8 meters. A minimum free space between the ice surface and the bottom of steel trusses should be at least 6 meters.

In order to avoid serious problems with humidity, like corrosion etc. the mechanical and electrical plant must be equipped with a dehumidification system.

3.4.2 Envelope, roofing

The main function of an ice rink envelope is air tightness and not particularly thermal insulation. The envelope structure can be done most efficiently to fulfil only that one main characteristic.

Most used roofing structures consist of following layers:

- Profiled, load bearing steels sheets
- Vapour barrier
- Thermal insulation (10 cm to 15 cm rock wool)
- Water insulation

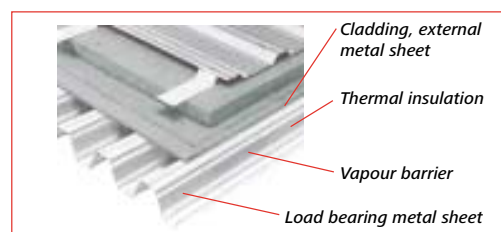

Figure 6. Typical roof structure.

3.4.3 Envelope, walls

The outside wall structure of an ice rink is commonly also based on the idea of air tightness and the simplest walling is done by using different metal sheet panels. These panels are simple, pre-fabricated sandwich elements, that have inside a core of thermal insulation of rock wool or polyurethane and both sides covered with metal sheets.

These panels also allow later changes of the envelope very easily and with rather low additional costs.

These metal sheet panels are delivered with a long range of length up to 8 meters each, in large scale of different colours and surface treatment. A harmful aspect by using these metal sheet panels is a rather poor resistance against mechanical exertion like hits of the hockey pucks inside or vandalism.

Therefore it is recommended to use in a lower partition of outside wall sandwich elements of concrete and replace them over 2.5 meter height with metal sheet panels.

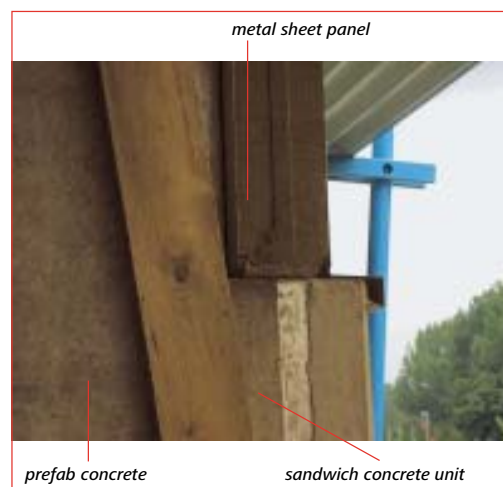

Figure 8. Typical wall structure.

3.4.4 Ice pad structure

Perhaps the most special structure in an ice rink is the ice pad. The ice pad consists of ground layers below the pad, thermal insulation, piping and pad itself. New technologies have made possible the use of new materials and technical solutions in these structures, where at the same time the energy efficiency and construction costs could be optimised.

The most common surfacing materials is:

- Concrete

However sand surface is cheapest and fairly energy economical because of the good heat transfer characteristics but the usability is limited to ice sports. Asphalt surfaces are suitable for some special needs, for example in the case that the facility is used for tennis off the ice sport season. Asphalt is cheaper than concrete but the refrigeration energy requirement is higher.

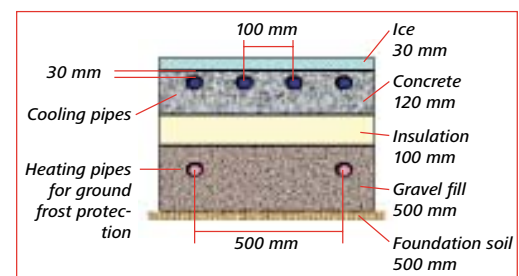

Figure 9. Typical ice pad construction.

Rink pipe material (plastic/metal) and space sizing are questions of optimisation of investments vs. energy. The cooling pipes are mounted quite near the surface, in a concrete slab the mounting depth is normally 20–30 mm and the mounting space between the pipes is 75–125 mm. The rink pipes are connected to the distribution and collection mains, which are laid along the rink short or long side outside the rink. Rink pipes are laid in U-shape and they are mounted to the surfacing layer by simply binding the pipes directly to the concrete reinforcement or to special rails.

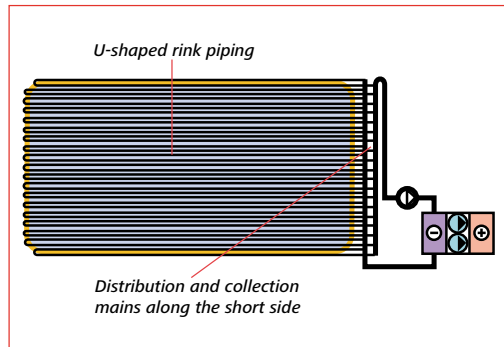

Figure 10. Collectors along the short side of the ice rink.

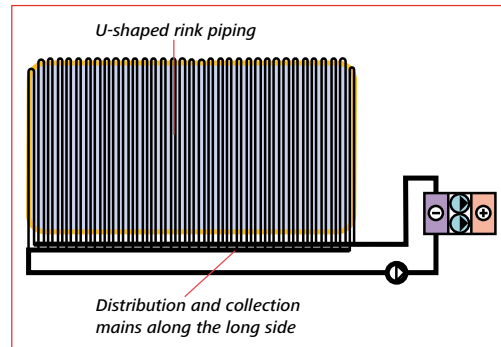

Figure 11. Collectors along the long side of the ice rink.



Figure 12. Plastic rink piping connections to the distribution and the collection mains (thermally insulated).

3.5 Mechanical and electrical plant

The effective utilization of the energy resources has become an important aspect in the design of new facilities. There are many different energy conservation measures that can be incorporated in the planning stage. In planning the hardware configuration and construction of an ice rink, it is important to consider the types of activities, special requirements and interest of the various user groups in question. Table 1 summarises the main indoor air design values, which can be used in designing technical building services. It is important to set these values already in the pre-design stage in order to control the demands.

Action	Air temperature of the rink space °C		Ice temperature, °C	Max. relative humidity of the rink space (%)	Min. fresh air intake l/s/occupant
	Rink (at 1.5 m height)	Tribune (operative)			
Hockey					
- game	+6	+10.+15	-5	70	4...8 / spectator
- training	+6	+6. +15	-3	70	12 / player
Figure					
- competition	+12	+10.+15	-4	70	4...8 / spectator
- training	+6	+6. +15	-3	70	12 / skater
Other	+18	+18	-	-	8 / person

Indoor air design values for small ice rink (rink space).

3.5.1 Refrigeration plant

Refrigeration plant is fundamental to the ice-rink facility. Much used, but true, phrase is that the refrigeration unit is the heart of the ice rink. Almost all of the energy-flows are connected to the refrigeration process in one way or another. It is quite normal that the electricity consumption of the refrigeration system accounts for over 50 % of the total electricity consumption and the heat loss of the ice can be over 60 % of the total heating demand of an ice rink.

In the design stage, when choosing the refrigeration unit one has to consider the economics, energy usage, environment, operation, maintenance and safety.

The design of the refrigeration plant can be either so-called direct or indirect system. In a direct system the rink piping works as the evaporator, whereas an indirect system is comprised of separate evaporator (heat exchanger) and the ice pad is indirectly cooled by special coolant in closed circulation loop. The energy efficiency of the direct system is in general better than the efficiency of the indirect system. On the other hand the first cost of the direct system is higher than that of the indirect system. Moreover indirect systems can't be used with for example ammonia in several countries because of health risks in the case of refrigerant leaks. Table 2 summarises the advantages and disadvantages of the different systems.

Direct system

- + Energy efficiency
- + Simple

- Not possible with certain refrigerants (ammonia)
- Installation costs
- Need of professional skills in design and in installing

Indirect system

- + Use of factory made refrigeration units
- + Small refrigerant filling (environmentally positive)
- + Suitable to any refrigerant

- Lower energy efficiency than with direct system

Features of direct and indirect refrigeration plant.

In most cases the refrigeration plant comprises the refrigerant circuit refrigerates an indirect system i.e. the floor by a closed brine circuit rather than directly. The refrigerant used in the compressor loop should be environmentally accepted, for example natural substances like ammonia (NH_3) and carbon dioxide (CO_2) or HFC refrigerants such as R134a, R404A and R407A. The tendency is to favour in natural substances of HFCs. In choosing the refrigerant the country-specific regulations must be taken into account. The operational aspect is to equip the compressor with reasonable automation, which enables demand-controlled running of the system. In addition, the safety factors should be incorporated in the design of the machine room.

From the energy point of view it is a matter of course that the compressor unit should be as efficient as possible, not only in the design point but also under part-load conditions.

When estimating the energy economy of the system it is essential to focus on the entire system and not only on one component alone. The refrigeration plant is an integral part of the ice rink, Figure 12.

Design and dimensioning aspects

The refrigeration plant is dimensioned according to cooling load and the required evaporation and condenser temperatures. For a standard single ice rink approximately 300–350 kW of refrigeration capacity is adequate.

The refrigeration capacity is normally sized according to the heat loads during the ice making process. The dimensioning cooling load during the freezing period is comprised of the following components:

- Cooling the ice pad construction down to the operating temperature in required time. Needed cooling capacity depends on the temperature of the structures at the beginning of the freezing and the required freezing time (normally 48 hours).
- Cooling the temperature of the flooded water to the freezing temperature ($0\text{ }^\circ\text{C}$) and then freezing the water to form the ice and to cool the temperature of the ice to the operating temperature. The freezing capacity depends on the temperature of the water, the operating temperature of the ice and the required freezing time (48 hours).
- Heat radiation between the rink surface and the surrounding surfaces. Cooling capacity depends on the surface temperatures during the freezing period.
- Convective heat load between the rink surface and the air. Cooling capacity depends on the air and rink surface temperatures both the air stream velocity along the rink surface during the freezing period.
- Latent heat of the condensing water vapour from the air to the rink surface. Cooling capacity

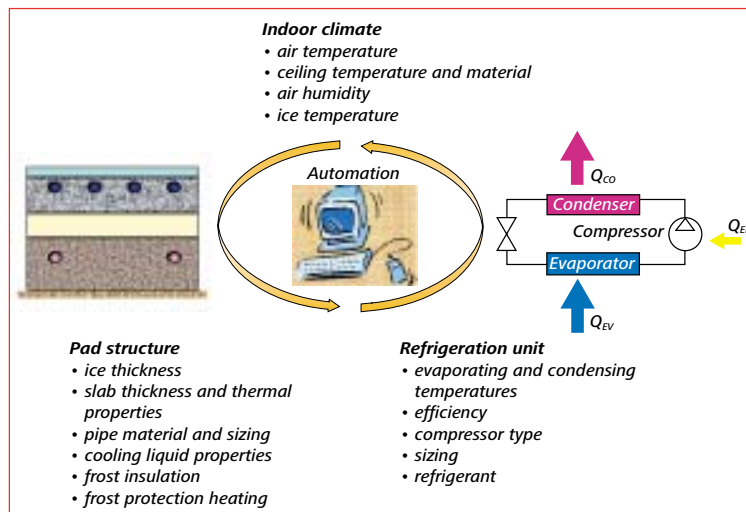

Figure 12. Refrigeration unit and related energy flows.

depends on the air humidity (water vapour pressure) and the surface temperature of the rink during the freezing period.

- Radiation heat load on rink surface during the freezing period (lights etc.).
- Pump-work of the coolant pump.

3.5.1.1 Refrigeration unit

Refrigeration unit is comprised of many components: compressor(s), evaporator, condenser, and expansion valve and control system.

The function of the compressor is to keep the pressure and temperature in the evaporator low enough for the liquid refrigerant to boil off at a temperature below that of the medium surrounding the evaporator so that heat is absorbed. In the compressor the vapour is raised to high pressure and high enough temperature to be above that of the cooling medium so that heat can be rejected in the condenser. After the condensation the liquid refrigerant is throttled in the expansion valve back to the pressure of the evaporator. In other words the compressor "pumps"



Figure 13. Two screw compressors.

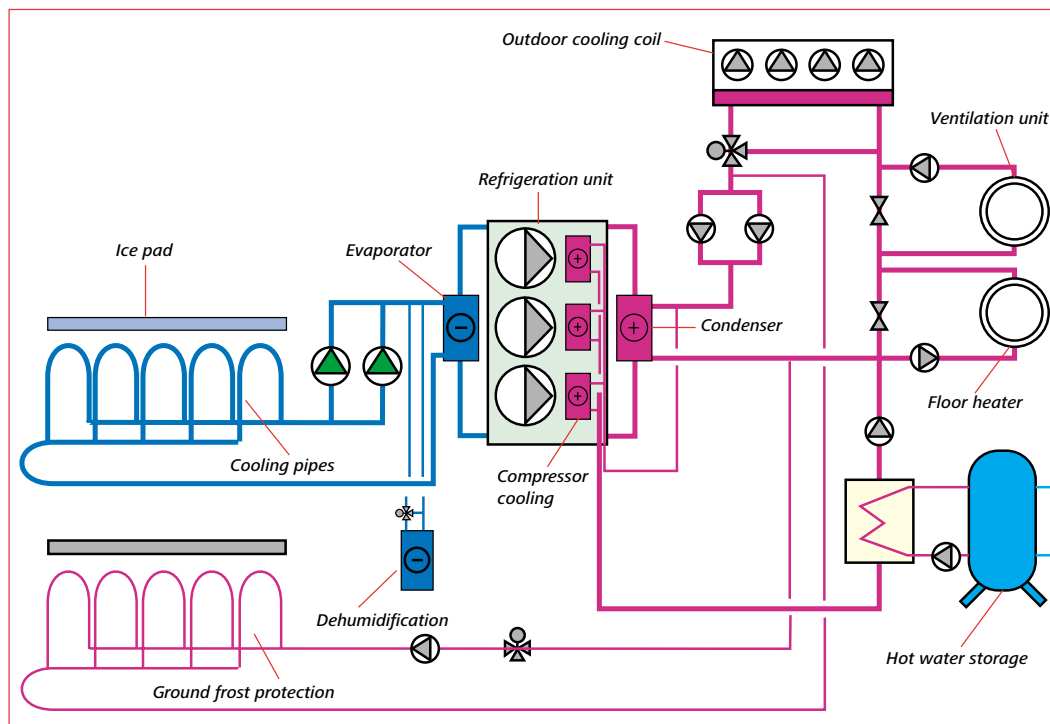

Figure 14. Refrigeration plant with heat recovery: preheating of hot water, floor heating and air heating.

heat from the rink to the surroundings, which is similar process to a normal fridge.

There are different types of refrigeration compressors on the market of which reciprocating compressors and screw compressors are the most common types. In most cases the compressors are electric driven. The refrigeration unit consists normally of at least 2 compressors to guarantee flexible and economical use of the unit.

3.5.1.2 Ice pad

Another interesting aspect in the energy-chain is the heat resistance between the ice and the brine, which has effect on the energy consumption. The underlying energy-thinking in the heat resistance is, the bigger the resistance is the lower the brine and evaporation temperature of the compressor should be in order to produce the same cooling effect as with smaller resistance. The lower the evaporation temperature is the bigger the power need of the compressor. Heat resistance consists of five different parameters: (1) the so-called surface resistance of the ice surface, which is a combination of ceiling radiation and convection as discussed earlier. (2) Heat resistance of the ice, mainly dependent on the ice thickness. (3) Likewise the ice, the concrete slab or any other surfacing material constitutes heat resistance based on the thickness of the layer and the heat conductivity of the material involved. (4) Pipe material and pipe spacing in the floor. (5) Surface resistance between the pipe and fluid.

The function of secondary coolants is to transfer heat from the rink to the evaporator in the refrigeration unit. The profile of the perfect coolant would be: environmentally friendly, non-toxic, low pumping costs, high efficiency (good heat transfer characteristics), and non-corrosive,

cheap and practical. Quite a variety of coolants are in use, table 2 summarize the most common of them.

In the construction of the ice pad the ground frost insulation and in some cases ground heating is necessary (condenser waste-heat can be used for heating). Ground frost will build up also in warm climates where frost normally is not a problem. If the ground is frost-susceptible and the frost may cause uneven frost heave of the ice pad. The pad will be damaged by the frost and frost heave makes it more difficult to maintain the ice and will impede the utilisation of the facility to other sports (tennis, basketball) over the ice-free period. Moreover, un-insulated pad increases energy consumption of the refrigeration.

3.5.2 Air conditioning

It is highly recommended to use mechanical ventilation in ice rink facilities to ensure healthy and safe indoor air conditions. The air-handling unit(s) provides fresh air to the ice rink and other premises and it is also used for heating purposes and even to dehumidify the ice rink air. Fresh air intake is necessary to maintain good air quality. Air quality is affected by the emissions of the people, the building materials and the ice resurfacers especially when the resurfacer is run by combustion engine (gas or gasoline).

The building is divided into two thermal zones: the ice rink and the public areas. The simplest and safe way is to equip the facility with two ventilation units, one for the rink area and one for the public areas.

The energy-saving factor in ventilation can be found in the demand-controlled fresh-air intake and in optimising the airflow rates according to the needs for minimizing the fan power.

Secondary coolant	Remarks
Glycols • Ethylene glycol • Propylene glycol	High pumping costs, low efficiency, easy to handle
Salts • calcium chloride (CaCl ₂)	Low pumping costs, high efficiency, unpractical
Formats • Potassium formats • Potassium acetates	Low pumping costs, high efficiency, corrosive, expensive

Secondary coolants.

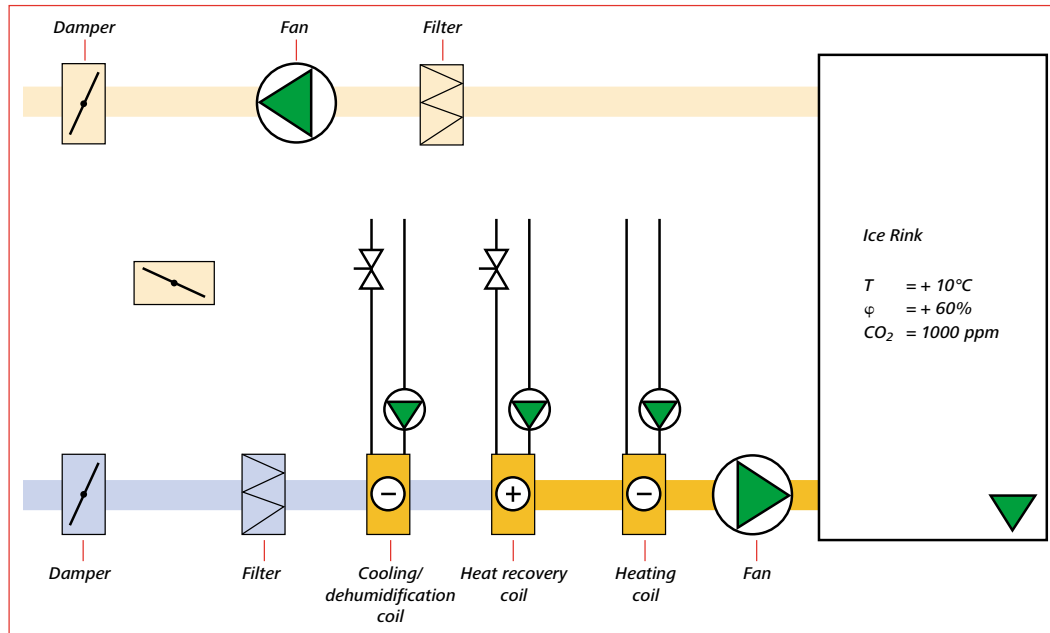

Figure 15. Schematic diagram of an ice rink air-conditioning system with dehumidification and heat recovery coils.

3.5.3 Dehumidification

The moisture loads are due to the occupants (skaters, audience), outdoor air moisture, evaporating floodwater of the ice resurfacing and combustion driven ice resurfacer. The biggest moisture load is the water content of the outdoor air which enters the ice rink through ventilation and as uncontrolled air infiltration leakage through openings (doors, windows), cracks and interstices in constructions caused by pressure effects during operation.

Excess air humidity increases the risk of rot growth on wooden structures and corrosion risk of metals thus shortening the service lifetime of the construction components and materials, which means increased maintenance costs. High humidity levels cause also indoor air problems by enabling the growth of mould and fungus on the surfaces of the building structures. In the following tables maximum allowable ice rink air humidity rates are presented to avoid indoor air problems and depraving of constructions.

There are two primary ways to remove moisture from the air: cool the air below its dew point to condense the water vapour, or pass the air over a material that absorbs (chemical dehumidification) water.

Ice rink air temperature, °C	Maximum relative air humidity, %
5	90
10	80
15	70
20	60

Air temperature and humidity criteria to avoid fog.

	Temperature, °C	Relative humidity, %
Rot	50–5	>90–95
Mould	55–0	>75–95

Air temperature and humidity criteria for rot and mould damages of wooden structures.

Temperature, °C	Relative humidity, %
>0	>80

Corrosion criteria for metals.

Systems that cool the air below its dew point use normally mechanical refrigeration. Air is passed over a cooling coil causing a portion of the moisture in the air to condense on the coils' surface and drop out of the airflow. Cooling coil can also be integrated in the ventilation unit and in the ice refrigeration circuit.

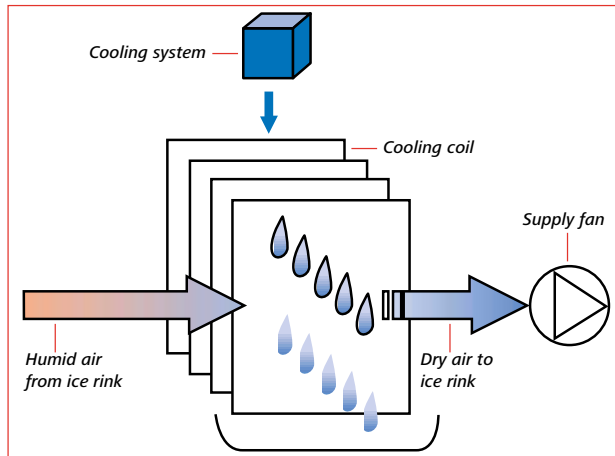

Figure 16. Condensing dehumidification process.

Chemical dehumidification is carried out through the use of absorbent materials, which are either solids or liquids that can extract moisture from the air and hold it.

Desiccant dehumidification system, figure 14, consists of a slowly rotating disk, drum or wheel that is coated or filled with an absorbent (often silica gel). Moist air is drawn into the facility and passed across one portion of the wheel where the desiccant absorbs moisture from the air. As the wheel slowly rotates, it passes through a second heated air stream. Moisture that was absorbed by the desiccant is released into the heated air, reactivating the desiccant. The warm moist air is then exhausted from the facility.

3.5.4 Heating

Heating system is needed to maintain comfortable thermal conditions for both the players and the audience. Heating is also advantageous in controlling the humidity of the ice rink in

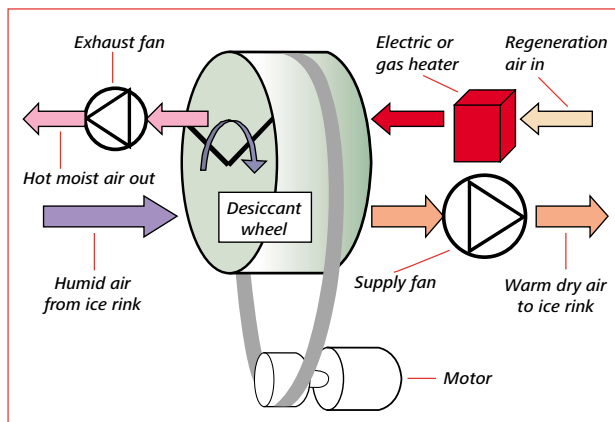

Figure 17. Desiccant dehumidification process.

order to avoid fog and ceiling dripping problems. Moreover heat is needed for hot water production (ice resurfacing, showers), and in some cases for melting waste-ice that is the consequence of the ice resurfacing process.

Waste-heat recovery

Compressor waste-heat recovery can cover almost all of the heating demand of a training rink in most operating situations. When designing the heat recovery system, the relatively low temperature level should be taken into account. The temperature level of the waste heat is normally around 30–35 °C, small portion of the waste heat, so-called super heat, can be utilized at a higher temperature level. Waste heat can be utilized in the heating of the resurfacing water, in the heating of the rink, heating the fresh air, to pre-heat the tap water and to melt the snow and ice slush of the resurfacing process.

3.5.5 Electric system

Electricity is needed to run the facility: in the refrigeration, in lighting, in air conditioning, in cafeteria etc. Electrical installation comprises a distribution and transformer central. Emergency lighting and guide lights must work also on occasions of power cuts. Emergency power can be supplied by diesel-fuelled generators or by battery back-up system. In most cases it is worthwhile avoiding the reactive power by capacitive compensation.

Lighting

Lights are traditionally grouped according to their operational principle to incandescence and burst illuminates. In general incandescent lamps are suitable only to general lighting (except maybe the halogen lamps). Characteristics to incandescent lamps are high demand for electricity compared to the illumination, short service lifetime, good colour rendering and good controllability. Burst illuminates feature high efficiency, long service lifetime but poor controllability.

Recently, many products have been developed that may be incorporated at the design stage. One such a product is the compact fluorescent lamp, which can be used instead of incandescent lamps. The superiority of the fluorescent lamps is a result of high-luminous efficacy (more

Type	Applicability	Power range	Life	
Compact fluorescent lamps	General lighting	5–55 W	8000–12 000 h	Good energy efficiency
Standard fluorescent lamps	General lighting	30–80 W	20 000 h	Good energy efficiency
	Rink lighting			
Metal halide lamps	Rink lighting	35–2000 W	6000–20 000 h	Good for rink lighting
High pressure sodium lamps	Rink lighting	50–400 W	14 000–24 000 h	Poor colour rendering
Induction lamps	Rink lighting	55–165 W	60 000 h	Long life, expensive (so far)
Halogen lamps	Special lighting	20–2000 W	2000–4000 h	Excellent colour rendering, good dimming capabilities

Available lamps for ice rink facility.

light per watt) and long life expectancy compared with the standard incandescent lamps. The electronic ballast connected with the standard fluorescent lamp technology will decrease the operating cost 25 % compared with standard systems. The use of occupancy sensors to automatically shut lights off and on is a sure way of reducing electrical use. The ice-surface lighting system is advantageous to design such that the illumination can be changed flexibly according to the need.

3.5.6 Acoustics and noise control

Minimum acoustical quality of an ice rink should enable clear and understandable speaking even amplified spoken words and music. Therefore environmental acoustics must also be included in the design process. The importance of the acoustics is emphasized in multi purpose rinks. The most significant acoustical parameter is the reverberation time, which should be low enough (< 3 s). Too high background noise level caused by ventilation and compressors (inside) or traffic (outside) has also negative effects on the acoustical indoor environment. In some cases it is also necessary to take into account the noise caused by the ice rink facility to its surroundings. Outdoor condenser fans and even the sounds of an ice hockey game may cause disturbing noise.

3.5.7 Building automation and information systems

Modern automation systems enable demand-controlled operation of different systems, such as ventilation rates, ice rink air temperature and humidity, ice temperature, etc. An automation system enables functional and economical use of the different systems of the ice rink. Besides these traditional benefits of the building energy management system, there are other functions

that can be emphasized such as information and security systems, Figure 7.

3.5.8 Water and sewer system

Water is needed in showers, toilets, and cafeterias, cleaning and as flood and ice resurfacing water etc. Warm water system must be equipped with re-circulation to ensure short waiting times of warm water and to prohibit the risk of bacterial growth. Because of the legionella risk

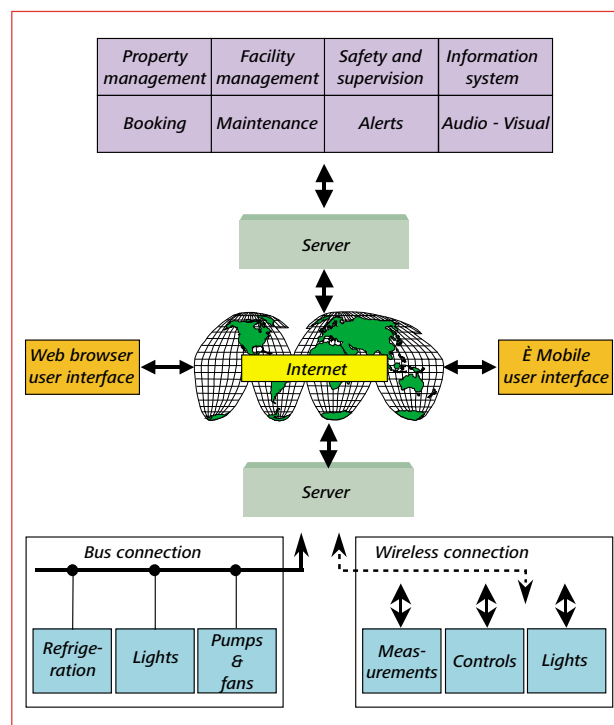

Figure 18. Advanced information and automation systems of an ice rink.

the hot water must be heated at least up to +55 °C. Waste-heat from the refrigeration plant can be utilized to lower the energy consumption of hot water for example to heat the resurfacing water and to pre-heat the hot water.

In the sewer system of an ice rink there are two special systems to be taken care of, namely the rink melted water drainage and the melting pit of waste-ice. Surface water drains for melted water from ice defrosting is required outside and around the rink.

3.6 Energy consumption optimisation

Energy consumption of the refrigeration unit is subjected to the heat loads of the ice. Ceiling radiation is generally the largest single component of the heat loads. Other ice heat-load components are: the convective heat load of the ice rink air temperature, lighting, ice maintenance, ground heat, humidity condensing from the air onto the ice, and pump-work of the cooling pipe network.

The amount of heat radiated to the ice is controlled by the temperatures of the ceiling and ice surface and by proportionality factor called emissive. Materials that are perfect radiators of heat would have an emissive of 1, while materials that radiate no heat would have an emissive of 0. In new facilities, using low-emissive material in the surface of the ceiling can reduce the ceiling radiation. Most building materials have an emissive rate near 0.9. The most common low-emissive material used in ice rinks is aluminium foil. It is the low emissive property (emissive as low as 0.05) of the aluminium foil facing the ice that makes this system so effective. Moreover, the low-emissive surface reduces heating demand and improves the lighting conditions of the rink.

The temperature level of the ice rink air has a significant effect on both the electricity consumption of the refrigeration unit and on the heating energy need. The higher the air temperature is, the warmer the ceiling is, which increases the ceiling radiation as well as the convective heat load of the ice. The convective heat load is relative to the temperature difference between the air temperature and ice-surface temperature and the air velocity above the ice. The most effective way to reduce convective heat load is to keep the ice temperature as high as possible and the air temperature as low as possible.

The other operational parameters, besides the ice rink air temperature, which affects the electricity consumption of the compressor and the heating energy consumption is the ice temperature and ice thickness. Rising of 1°C of the ice temperature gives 40-60 MWh savings in electricity and 70-90 MWh savings in heating per year in year-round operation. The thickness of the ice tends to increase in use. Increasing ice thickness brings about higher electricity consumption of the refrigeration unit and makes the maintenance of the ice more difficult. Recommended ice thickness is about 3 centimetres. The thickness of the ice must be controlled weekly in order to maintain the optimal thickness.

Ice resurfacing is one of the highest heat loads of the ice after the ceiling radiation and convection. This load, imposed by the resurfacing of ice with flood water in the range of 30 °C to 60 °C and 0.4 to 0.8 m³ of water per one operation, can account for as much as 15 % of the total refrigeration requirements. A lower floodwater volume and temperature should be used so reducing the refrigeration electrical use and the cost of heating the water.

The humidity of the ice rink air tends to condense on the cold ice surface. This phenomenon is mainly dependent on the outdoor air conditions and can be overcome by dehumidification of the ice rink air. Condensation is normally not so important from the energy consumption point of view. Instead, humidity problems may occur from a dripping ceiling or as fog above the ice. Humidity problems are one indication of the possible moisture damage in the structures and thus must be taken seriously.

Lighting forms a radioactive heat load on the ice, which is relative to the luminous efficacy of the lamps.

Warm soil under the floor is a minor heat load on the refrigeration, which can be dealt with sufficient insulation between the soil and the cooling pipes.

The system pump-work is a heat load on the refrigeration system due to the friction in the cooling pipes and in the evaporator. Pump-work is affected by the cooling liquid used (there are several alternatives), pipe material and hydraulic sizing of the pipe network and the evaporator.

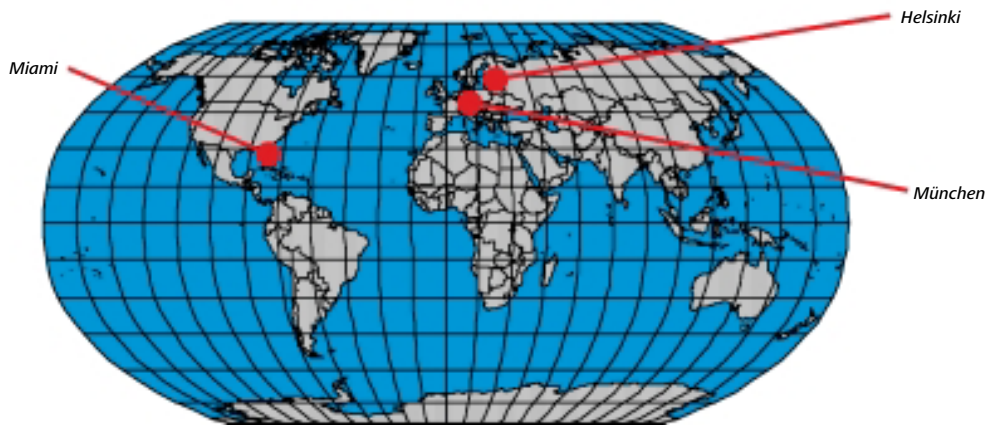

Figure 19. Studied ice rink locations: Helsinki (Finland), Munich (Germany) and Miami (USA).

3.6.1 Case studies of energy consumption

Energy consumption of a standard small ice rink depends mainly on the thermal conditions both inside (air and ice temperature) and outside (climate). In the following the effect of climatic conditions on the energy consumption of a standard ice rink facility is studied. The differences of the energy consumption, both electricity and heating, between the same prototype ice rink is studied in three locations: Helsinki (Finland), Munich (Germany) and Miami (USA). The technical description of the prototype ice rink is given in the previous section.

1. Electric energy consumption

The electric energy consumption of the ice rink consists of ice refrigeration, rink lighting, air conditioning and heating systems (fans and pumps), public space lighting, different appliances, cleaning etc. The refrigeration process consumes some half of the total electricity use of a small ice rink. In warm and humid conditions the dehumidification of the rink air plays also a big role in the energy consumption. The electricity consumption of the dehumidification system depends on the selected system: desiccant dehumidifiers consume mainly heat energy,

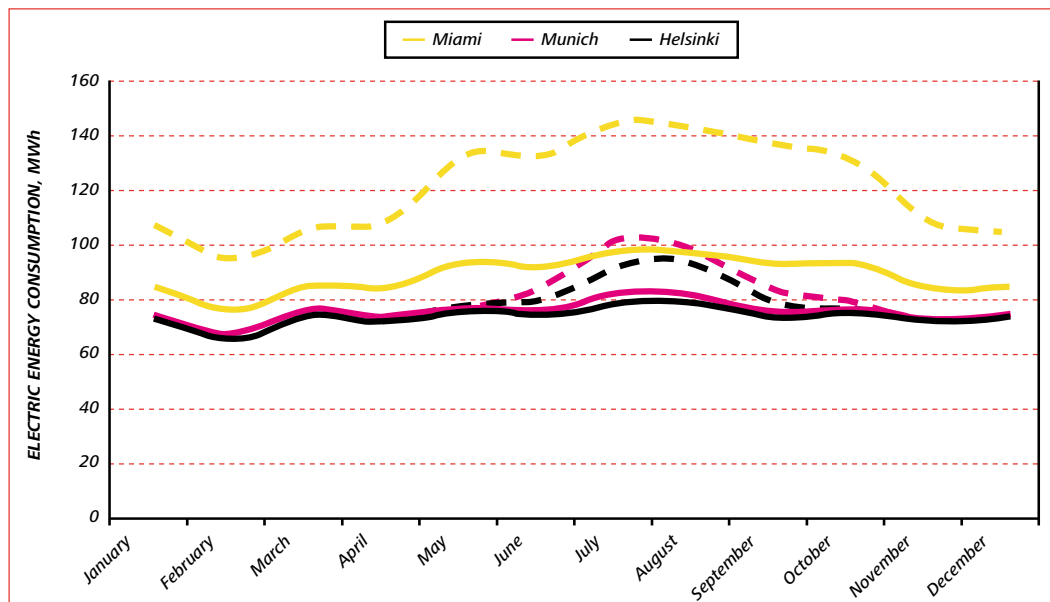

Figure 20. Electric energy consumption of the ice rink facility with (dashed lines) and without dehumidification. In the case of the dehumidification the ice refrigeration system is supposed to be used for the dehumidification.

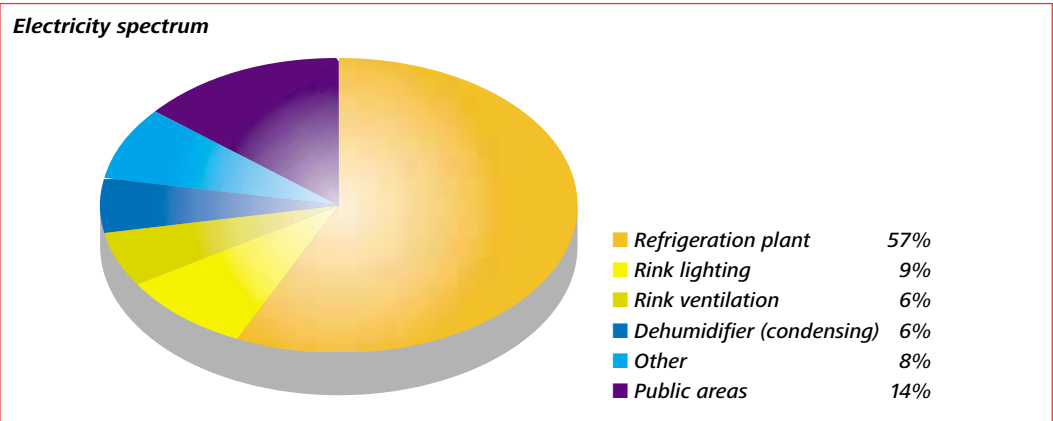

Figure 21. Electric consumption spectrum of the prototype ice rink in Munich. Annual electricity consumption is 960 MWh with mechanical dehumidification (900 MWh without dehumidification).

which can be produced with gas or some other fuel but also electricity is possible, mechanical dehumidifiers (separate heat pump or ice refrigeration system) use usually electricity.

2. Heating energy consumption

Heating energy need is the sum of the heating need of the ventilation and infiltration air as well as the cooling effect of the ice and the conductive heat flows through the exterior envelope. The heat loads of the occupants, lights and other equipment are taken into account when determining the heating energy need of the ice arena. In many cases the waste ice (slush) of the ice resurfacing process must be

melted in a special melting pit before draining it and melting requires also heating. In some cases the waste ice can be just driven outside or even be re-used for example to build ski tracks. Depending of the climatic conditions the heat flows can be either negative or positive. For example in Miami the outdoor climate is so hot all around the year that the ventilation, air infiltration and conductive heat flows heat the ice rink space and actually the only cooling load is the

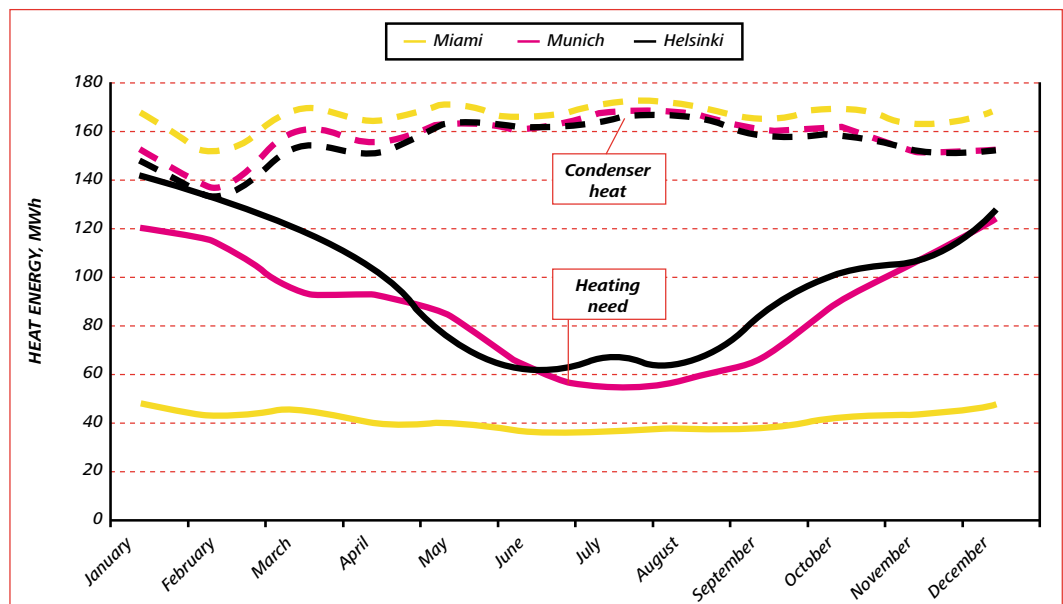

Figure 22. Heating energy need of the ice rink and heat from the refrigeration condensers (dashed lines) in different climates (Miami, Munich and Helsinki).

Energy spectrum of heating need

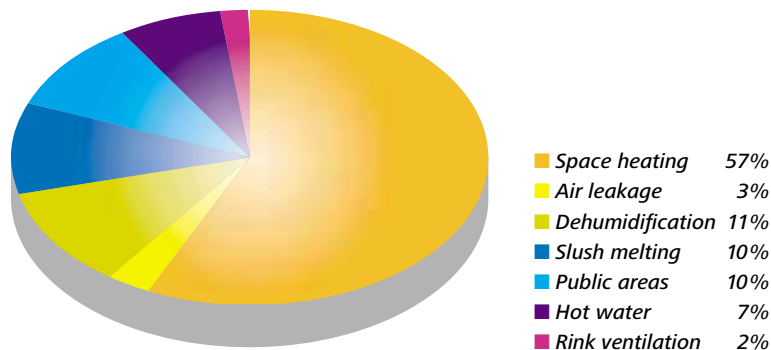

Figure 23. Spectrum of heating energy need of the prototype ice rink in Munich. Annual heating need is 1100 MWh. Most of the heating need can be covered by free condenser heat of the ice refrigeration.

ice. The cooling effect of the ice is still bigger than the heat loads and thus the rink must be heated even in Miami.

The ice refrigeration produces continuously large amount of heat and this heat can be utilized in heating: directly to space heating and supply air heating, pre-heating of hot water for ice resurfacing and showers, slush melting, ground heating (frost protection) under the ice pad and in the dehumidification processes. Condenser energy can save a great portion of the annual heating costs.

3. Dehumidification

The local weather conditions determine the dehumidification need and this affects also the energy use of the facility. This can be seen in figure x, where the moisture removal need is much higher in Miami where the climate is hot and humid compared to the colder and drier climates in Munich and in Helsinki. The dehumidification need is also affected by the ventilation need, air tightness of the building envelope and moisture load of the occupants.

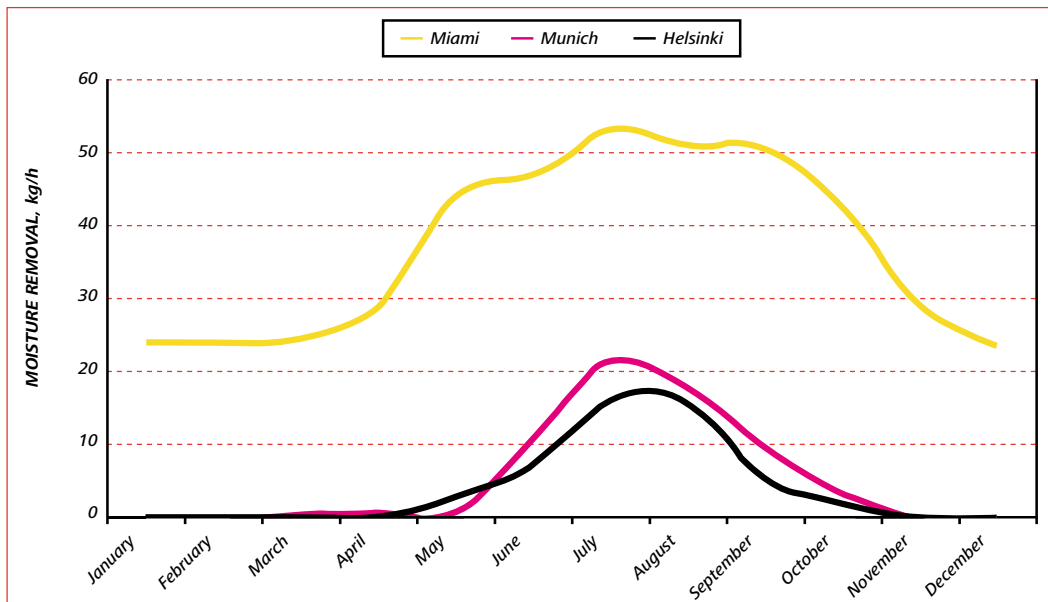

Figure 24. Moisture removal of the dehumidification system in order to maintain the required indoor air conditions (temperature +10°C and relative humidity 65%).

4. Water consumption

Water consumption is formed of the ice resurfacing water and sanitary water. Shower and toilet use dominate sanitary water consumption. In some cases treated water is used for cooling the condensers of the ice refrigeration plant. This is the case especially during the summer operation even in cold climates. Direct use of treated water should be avoided as far as possible for this purpose because of high operation costs.

Greenhouse gas emissions g/m ² , CO ₂ eq	Acidifying emissions g/m ² , CO ₂ eq
3 000 000	7500

Environmental loads of an ice rink in Finland based by life cycle analysis (LCA) of the rink (50 years) excluding transport.¹

3.7 Environmental effects

Most of the environmental loads and impacts of an ice rink during its life cycle are due to the transport and the energy (electricity and heat) and water use. It is impossible to give exact or general figures of the loads for example because of the variety of energy production profiles in each case. In the following some results of the environmental load calculations in Finland are given.

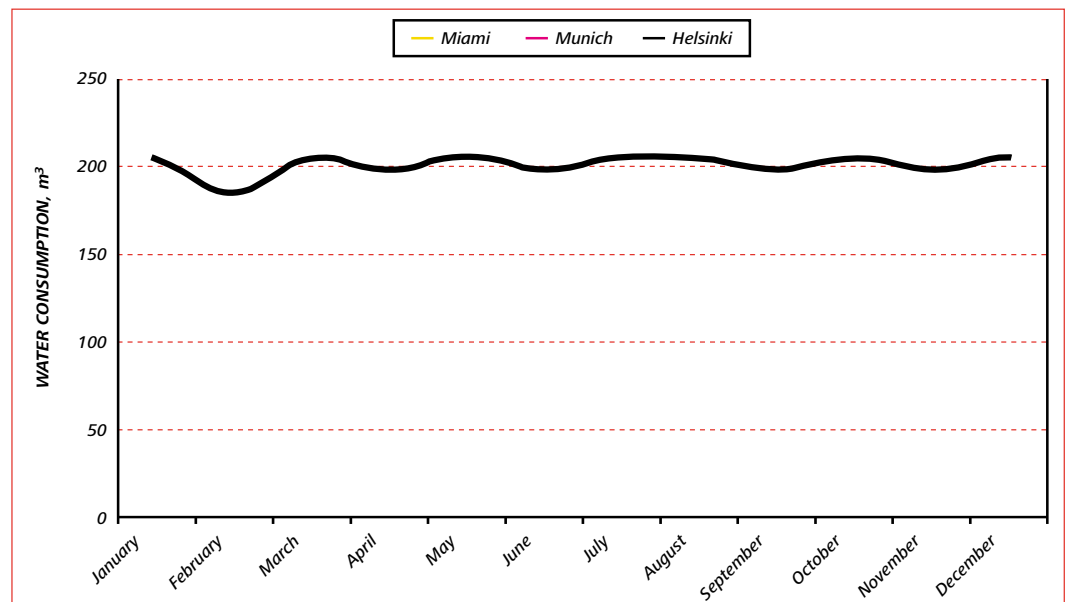

Figure 25. Water consumption including the ice resurfacing water and sanitary water without the possible condenser flush water of the ice refrigeration. Water consumption rate is the same for all the studied three cases. Annual water consumption is 2500 m³.

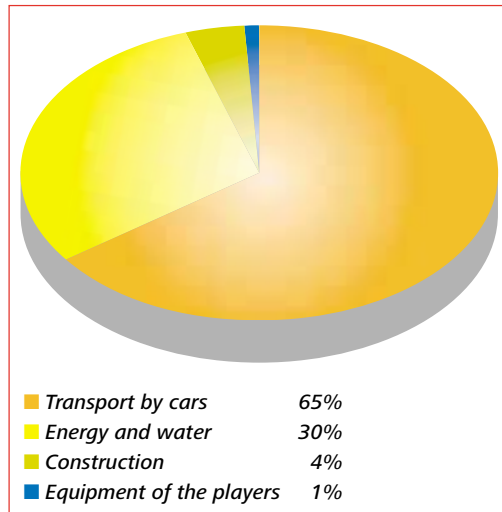

Figure 26. An example of the use of the natural resources of a junior ice hockey team in Finland based on MIPS calculation. MIPS - material input per service, kg/active skating hour.²

In the analysed case 91% of the greenhouse gas emissions and 74% of the acidifying emissions were due to energy usage during the life cycle (50 years).¹

The ecology of an ice rink can be improved by

- Using reusable and renewable materials and components in construction
- Minimizing the energy use (heat recovery, efficient appliances, renewable energy sources)
- Minimizing the distance between the rink and the users (town planning)
- Enabling public transport (storerooms for the equipment by the rink)

¹ Vaahterus T., Saari A. Environmental Loads of a Finnish indoor training ice-skating rink in the Context of LCA. Helsinki University of Technology, Publications 194, Espoo 2001. ISBN 951-22-5465-4, ISSN 1456-9329. (In Finnish).

² Kiekko-Nikkarit Ry.