

Roadmap

for Agriculture Biomass Feedstock Supply
in the United States



November 2003



Report Documentation Page

*Form Approved
OMB No. 0704-0188*

Public reporting burden for the collection of information is estimated to average 1 hour per response, including the time for reviewing instructions, searching existing data sources, gathering and maintaining the data needed, and completing and reviewing the collection of information. Send comments regarding this burden estimate or any other aspect of this collection of information, including suggestions for reducing this burden, to Washington Headquarters Services, Directorate for Information Operations and Reports, 1215 Jefferson Davis Highway, Suite 1204, Arlington VA 22202-4302. Respondents should be aware that notwithstanding any other provision of law, no person shall be subject to a penalty for failing to comply with a collection of information if it does not display a currently valid OMB control number.

1. REPORT DATE NOV 2003	2. REPORT TYPE N/A	3. DATES COVERED -	
4. TITLE AND SUBTITLE Roadmap for Agriculture Biomass Feedstock Supply in the United States		5a. CONTRACT NUMBER	
		5b. GRANT NUMBER	
		5c. PROGRAM ELEMENT NUMBER	
6. AUTHOR(S)		5d. PROJECT NUMBER	
		5e. TASK NUMBER	
		5f. WORK UNIT NUMBER	
7. PERFORMING ORGANIZATION NAME(S) AND ADDRESS(ES) U.S. Department of Energy 1800 Independence Ave., SW Washington, DC 20585		8. PERFORMING ORGANIZATION REPORT NUMBER	
9. SPONSORING/MONITORING AGENCY NAME(S) AND ADDRESS(ES)		10. SPONSOR/MONITOR'S ACRONYM(S)	
		11. SPONSOR/MONITOR'S REPORT NUMBER(S)	
12. DISTRIBUTION/AVAILABILITY STATEMENT Approved for public release, distribution unlimited			
13. SUPPLEMENTARY NOTES The original document contains color images.			
14. ABSTRACT			
15. SUBJECT TERMS			
16. SECURITY CLASSIFICATION OF:			17. LIMITATION OF ABSTRACT
a. REPORT unclassified	b. ABSTRACT unclassified	c. THIS PAGE unclassified	UU
			18. NUMBER OF PAGES 104
			19a. NAME OF RESPONSIBLE PERSON



Roadmap

for Agriculture Biomass Feedstock Supply in the United States

The Biomass Roadmap was sponsored by the U.S. Department of Energy, Office of Energy Efficiency and Renewable Energy, Biomass Program.

Product Disclaimer

References herein to, or depictions of, any specific commercial product, process, or service by trade name, trademark, manufacturer, or otherwise, does not necessarily constitute or imply its endorsement, recommendation, or favoring by the U.S. Government, or any agency thereof.

November 2003



Table of Contents

Executive Summary	5
1. Roadmap Background and Overview	7
1.1 Stakeholder Involvement and Benefit	10
1.2 United States Bioenergy Vision and Feedstock Supply	11
1.3 Strategic Goals and Associated Industry Performance Targets	13
1.4 Roadmap Organization and Top Priority R&D Needs	15
1.5 Key Partners for Feedstock Goals Include USDA and DOE	17
2. Production	19
2.1 Current Technical Situation	21
2.2 Performance Targets	23
2.3 Technical Barriers	24
2.4 Research and Development Needs	24
2.5 Research and Development Priorities	26
3. Harvesting and Collection	31
3.1 Current Technical Situation	33
3.2 Performance Targets	35
3.3 Technical Barriers	36
3.4 Research and Development Needs	36
3.5 Research and Development Priorities	40
4. Storage	43
4.1 Current Technical Situation	45
4.2 Performance Targets	46
4.3 Technical Barriers	48
4.4 Research and Development Needs	50
4.5 Research and Development Priorities	51
5. Preprocessing	55
5.1 Current Technical Situation	58
5.2 Performance Targets	59
5.3 Technical Barriers	60
5.4 Research and Development Needs	63
5.5 Research and Development Priorities	63
6. System Integration	67
6.1 Current Technical Situation	70
6.2 Performance Targets	71
6.3 Technical Barriers	72
6.4 Research and Development Needs	74
6.5 Research and Development Priorities	75
7. Transportation	79
8. Appendices	83
Appendix A – Grouped Colloquies R&D Need Statements	85
Appendix B – Grouped Sustainability Workshop R&D Need Statements	93
Appendix C – FACA Roadmap R&D Need Statements	97
Appendix D – Contributors and Authors	99



Executive Summary

The Biomass Research and Development Technical Advisory Committee set forth a goal that biomass will supply 5% of the nation's power, 20% of transportation fuels, and 25% of chemicals by 2030. These combined goals are approximately equivalent to 30% of the current petroleum consumption. The benefits of a robust biorefinery industry supplying this amount of domestically produced power, fuels, and products is considerable, including decreased demand for imported oil, revenue to the depressed agriculture industry, and revitalized rural economies. A consistent supply of high quality, low cost feedstock is vital in achieving this goal. This biomass roadmap defines the research and development path towards supplying the feedstock needs of the biorefinery and achieving the important national goals set for biomass.

In order to meet these goals, the biorefinery industry must be more sustainable than the systems it will replace. Sustainability hinges on the economic profitability for all participants, environmental impact of every step in the process, and social impact of the product and its production. In early 2003, a series of colloquies were held to define and prioritize the research and technology development needs towards supplying the feedstock needs of the biorefinery in a sustainable manner. These colloquies involved participants and stakeholders in the feedstock supply chain including growers, transporters, equipment manufacturers, and processors as well as environmental groups and others with a vested interest in assuring the sustainability of the biorefinery. From this series of colloquies, four high level strategic goals were set for the feedstocks area:

- Biomass Availability – By 2030 1 billion dry tons of lignocellulosic feedstock are needed annually to achieve the power, fuel, and chemical production goals set by the Biomass Research and Development Technology Advisory Committee
- Sustainability – Production of the 1 billion dry tons annually must be done in a sustainable manner
- Feedstock Infrastructure – An integrated feedstock supply system must be developed and implemented that can supply the feedstock needs of the biorefinery at the cost, quality, and consistency performance targets that have been set
- System Profitability – Economic profitability and sustainability need to be assured for all required participants in the feedstock supply system.

For each step in the biomass supply process (production, harvesting and collection, storage, preprocessing, system integration, and transportation), this roadmap addresses the current state of the technology, performance targets, barriers, and R&D priorities towards overcoming the barriers and achieving the performance targets. Crop residue biomass is an attractive starting feedstock that shows the best near-term promise for utilization as biorefinery feedstocks. Because crop residue is a byproduct of grain production, it is currently abundant, underutilized, and low cost. Corn stover and cereal straw are the two most abundant crop residue biomass sources available in the U.S., therefore, this roadmap focuses primarily on the research and technology development needs towards using these biomass sources as viable biorefinery feedstocks. However, achieving the 1 billion dry ton goal will require the utilization of other biomass sources such as dedicated energy crops. The research and technology needs identified in this roadmap to develop the required integrated feedstock supply system will need to accommodate these other sources of biomass in the long term.

1. Roadmap Background and Overview

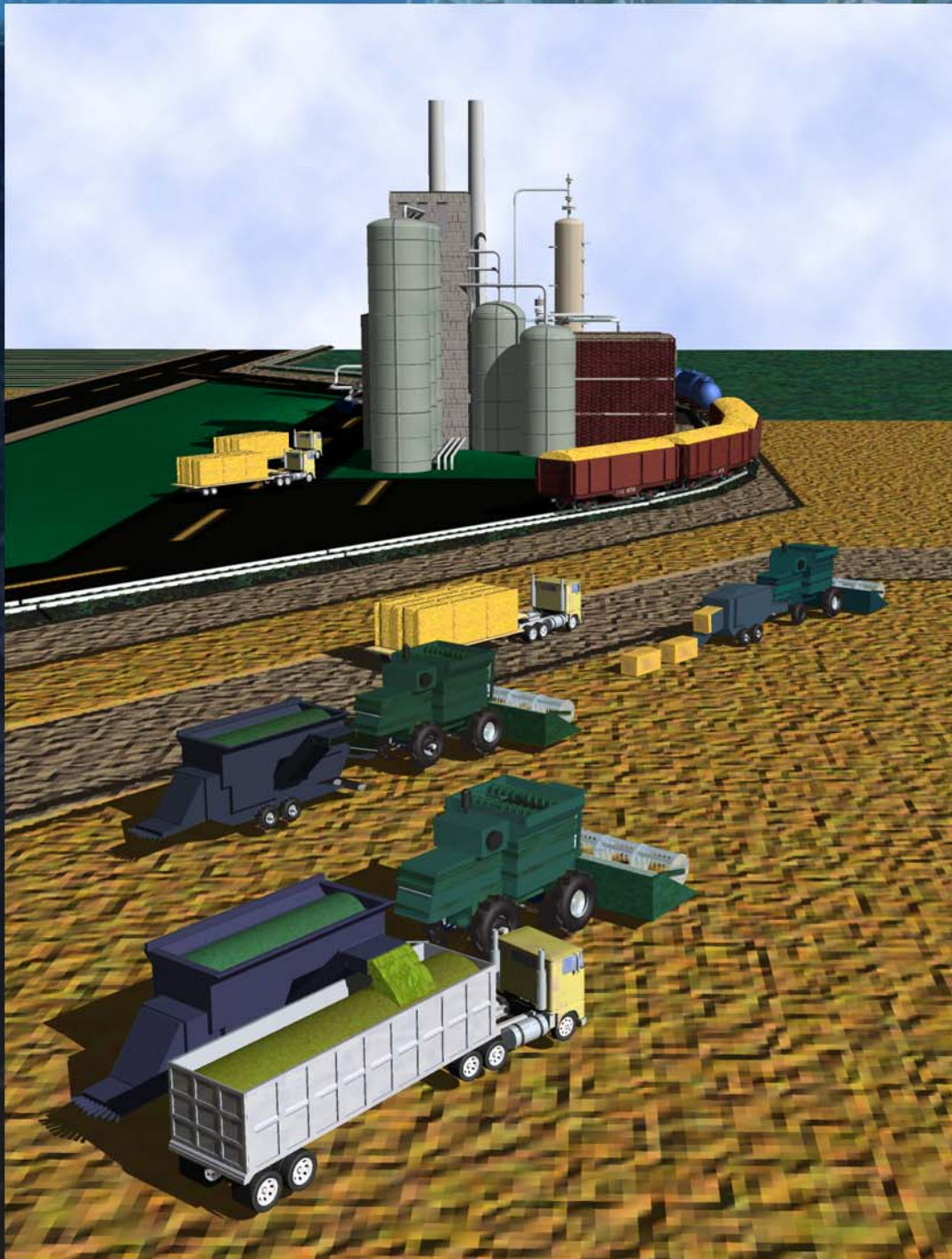



1. Roadmap Background and Overview

Biomass is a sustainable feedstock for energy products that could potentially enrich the future of the United States and the world. This roadmap focuses on the feedstock supply of lignocellulosic biomass, such as corn stover, straw, or wood, that can be converted into energy products (i.e., fuels, chemicals, and power) through sugar or syngas platforms. These products have traditionally been produced from petroleum. Lignocellulosic biomass is the nonstarch, fibrous part of plant material that is inherently moist and lightweight. The sugar platform hydrolyzes biomass into its component sugar molecules and then ferments the sugars into energy products; the syngas platform breaks down biomass into carbon, hydrogen, and oxygen elements and then uses basic chemistry to synthesize these elements into energy products. Although some biorefinery processes, such as paper and corn mills, already use biomass rather than petroleum feedstocks, there is currently no guarantee they will maintain sustainability nor benefit all stakeholders. Yet if sustainability issues are addressed, the benefits of collecting, storing, and transporting biomass to processing facilities, as well as using biorefinery co-products such as feeds and fertilizers in the agricultural system, will have positive economic, environmental, and social impacts. These

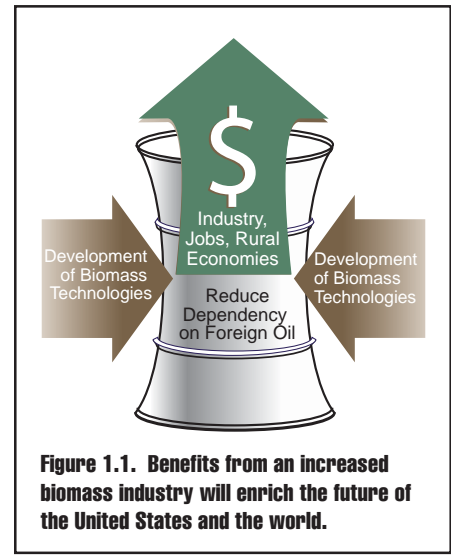

Figure 1.1. Benefits from an increased biomass industry will enrich the future of the United States and the world.

benefits include a decreased demand for imported oil, additional revenue for the depressed agriculture industry, new jobs, and revitalized rural economies (see Figure 1.1).

In order for a lignocellulosic biomass refining industry to be successful, the biorefinery and the associated feedstock supply system must be more sustainable than the fossil fuel based energy system it is replacing. Such sustainability is comprised of three components:

- Economic viability for all participants in the value chain
- Acceptable environmental impact of the products from cradle to grave
- Positive social impact of the product and its production.

The purposes of this roadmap are to define a research and development (R&D) path forward and to express the methods and infrastructure necessary to supply agricultural lignocellulosic feedstocks to biorefineries for producing



What is a Biorefinery?

A biorefinery processes biomass into value added product streams. These can range from biomaterials to fuels such as ethanol and fuel gases, or key intermediates for the production of chemicals and other materials. Biorefineries are based on a number of processing platforms using mechanical, thermal, chemical, and biochemical processes.



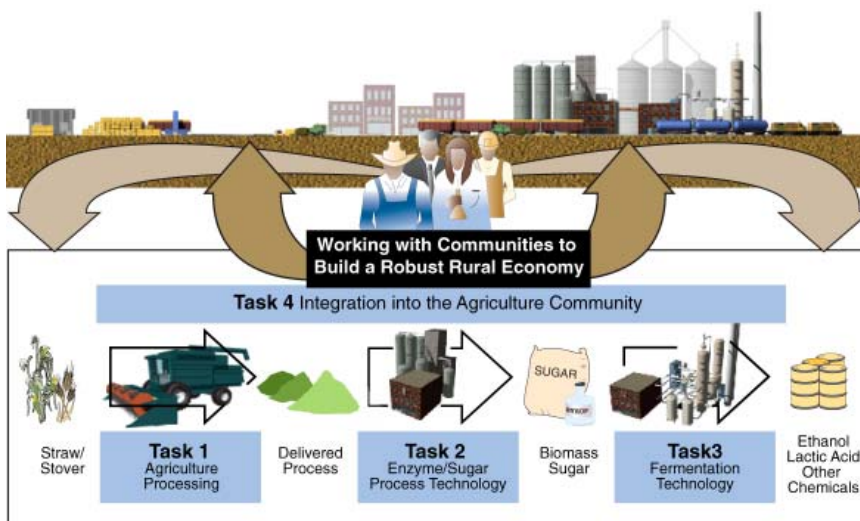

Figure 1.2. Stakeholder involvement ensures successful integration of sustainable feedstock supply technologies and systems into rural communities.

biobased fuels, power, and products. This document is designed to build upon the groundwork laid in the “Vision for Bioenergy and Biobased Products in the United States” and the “Roadmap for Biomass Technologies in the United States,” which were prepared for the United States Department of Energy (DOE) by the Biomass Research and Development Technical Advisory Committee (TAC). The R&D needs and priorities discussed in this document represent the collective input of stakeholders directly involved in the agricultural feedstock value chain including growers, equipment suppliers, transporters, and processors, as well as input from indirectly involved stakeholders including public R&D organizations, universities, educators, traditional agriculture industry sectors, environmental advocacy groups, states, and rural communities. As these stakeholders become more involved, the benefits to everyone involved increase (see Figure 1.2).

1.1 Stakeholder Involvement and Benefit

In early 2003, a series of colloquies and workshops were held by the various stakeholders to outline and define R&D needs and directions for lignocellulosic feedstock supply. The attendees focused primarily on corn and cereal straw crop residues, while recognizing that the resultant biomass supply technologies and infrastructure must ultimately accommodate energy crops and other sources of biomass. The input provided by the many different perspectives has been combined and prioritized in this roadmap according to the highest impact on the sustainable, cost-effective supply of biomass feedstock and biorefining industry.

The continued involvement of and benefit to all stakeholder groups in this system are critical to the success of this roadmap (i.e., stakeholders need to agree that the R&D meets their respective needs). Growers and processors are the primary owners and operators of the feedstock supply system and will ultimately be responsible for the sustainable economic and environmental operation of the system. Their investments into this roadmap will directly impact technology development and product lines, while the commercial technology products and systems that are produced will ultimately be purchased and used by these same stakeholders. The equipment manufacturers are arguably equal in importance to the growers and processors as they are the group

that will actually integrate the technologies and build the commercial biomass feedstock system that will be operated by the grower and processor groups. Due to the high level of uncertainty and risk in developing this new biorefining industry, industry access to and partnerships with DOE national laboratories, U.S. Department of Agriculture (USDA) laboratories, and universities will be essential for solving the technical gaps and understanding the sustainability issues of greatest concern. These public R&D groups will also prove useful in bringing nontraditional expertise from other industry sectors (i.e., mining, nuclear, oil, and chemical), thereby providing new approaches and solutions to seemingly insurmountable problems.

Transportation and feedstock guarantees are critical issues for the biomass processing industry. Therefore, involving the transportation and brokering industry that traditionally deals with forage and other large volume/tonnage agriculture commodities is also necessary. In addition, transportation equipment, laws, and infrastructure are likely the least flexible component of the feedstock system (i.e., we must use what is available), so involving this group while defining requirements and influencing rule and policy changes will greatly affect technology selections throughout the feedstock supply system. Finally, the states/communities and nongovernmental organizations represent the people and environmental resources that will be most affected by this new biomass refining system. While these groups are not responsible for building this feedstock system, their support and “buy-in” to the technological, environmental, and business solutions are essential for success. As such, environmental sustainability and economic profitability are key measures of performance throughout this roadmap document.

- **Biopower** – Biomass consumption in the industrial sector will increase at an annual rate of 2% through 2030, increasing from 2.7 quads in 2001 to 3.2 quads in 2010, 3.9 quads in 2020, and 4.8 quads in 2030. Moreover, biomass consumption in electric utilities will double every 10 years through 2030. Combined, biopower will meet 4% of total industrial and electrical generator energy demand in 2010 and 5% in 2020.
- **Biobased Transportation Fuels** – Transportation fuels from biomass will increase significantly from 0.5% of U.S. transportation fuel consumption in 2001 (0.147 quads) to 4% of transportation fuels consumption in 2010 (1.3 quads), 10% in 2020 (4.0 quads), and 20% in 2030.
- **Biobased Products** – Production of chemicals and materials from biobased products will increase substantially from approximately 12.5 billion pounds, or 5% of the current production of target U.S. chemical commodities in 2001, to 12% in 2010, 18% in 2020, and 25% in 2030.

1.2 United States Bioenergy Vision and Feedstock Supply

The “Vision for Bioenergy and Biobased Products in the United States” sets forth the goal that by 2030 biomass will supply 5% of the nation’s power, 20% of transportation fuels, and 25% of chemicals (see Figure 1.3). These combined goals are approximately equivalent to 30% of the current petroleum consumption.

From a feedstock supply perspective, it is important to determine how much biomass is needed to meet the 2030 goals. Considering average conversions of standard lignocellulose biomass, 1 billion dry tons of lignocellulosic feedstock is required annually to supply the projected biobased industry in 2030. It is estimated that roughly 2 billion dry tons of biomass are currently produced annually in the U.S. in the form of crop, forest, and mill residues and livestock and municipal wastes (see Figure 1.4). Forest residues produced from traditional forest product industries have and will continue to produce about 200 million dry tons of forest residue biomass per year. This biomass resource is the primary source of bioenergy today. Significant additional forest supplies could result from thinning forests for fire hazard reduction. Though forest residues represent the largest total volume, sustainability and economic concerns (i.e., harvesting, endangering species, and disturbing public lands) call into question the reliability of these residues

Figure 1.3. U.S. bioenergy and bioproducts vision goals.

for further large-scale development. As a result, crop residues are the most likely high volume lignocellulosic feedstocks to be available as a new large-scale biomass source for development in the near term. A portion of these crop residue biomass resources will provide sufficient feedstock to expand the biorefining industry, achieve the bioenergy vision's 2010 goals, and to a great extent achieving the 2020 goals. With an established and profitable feedstock infrastructure and biorefining industry, existing biomass resources (i.e., urban and forest residues) can be used more effectively and dedicated crops (i.e., switchgrass and fast growing trees) can be developed and established, all of which will be required to satisfy the 1 billion dry ton feedstock target by 2030.

Since the initial focus is on using stover and straw to achieve the near term bioenergy vision objectives, this roadmap primarily addresses efficiently and cost-effectively harvesting, collecting, storing, preprocessing, and transporting these crop residues, with minimal or positive crop production impacts (see Figure 1.5). However, fundamental infrastructure solutions must be applicable to all or multiple biomass feedstocks.



Figure 1.5. Initial focus is on using stover and straw.

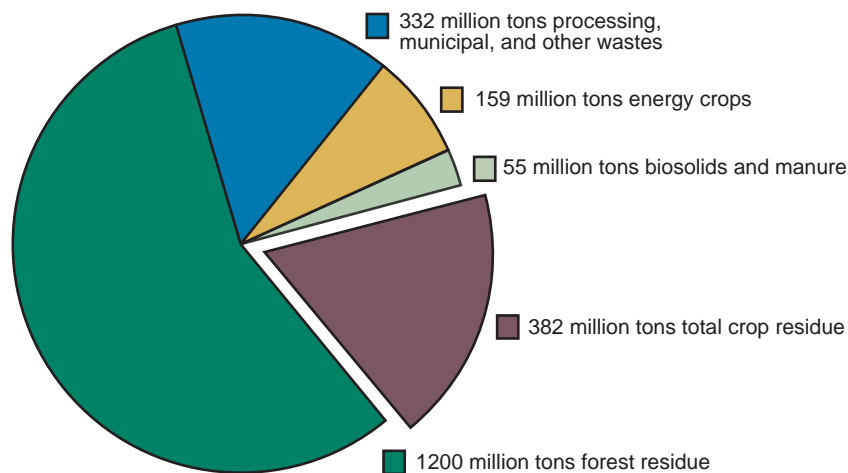

Arthur D. Little. 2001. "Aggressive Growth in the Use of Bioderived Energy and Products in the United States by 2010." Reference 71038. Final Report.

Figure 1.4. Of the estimated 382 million tons of crop residues, 150 million tons could be collected with development of feedstock supply infrastructure technologies that address environmental and economic sustainability concerns.

Several challenges must be addressed while establishing such a large feedstock infrastructure. For example, no single agriculture or forest product commodity even approaches the 1 billion dry ton scale. Corn, which is one of the largest U.S. commodities, makes up only about 280 million dry tons per year. On a tonnage basis, the proposed biorefining industry would be 3.5 times larger than the U.S. corn industry. This underscores the critical importance of a feedstock supply infrastructure to the emerging biofuels and bioproducts industry. While improvements in processing technology and the development of new and innovative chemicals and products from biomass will undoubtedly advance the biobased industry toward the vision

goals, the lack of a large-scale guaranteed supply of feedstock could limit the biobased industry to niche markets.

Several general priority R&D areas for feedstock production are outlined in the “Roadmap for Biomass Technologies in the United States.” These include:

- “Biotechnology, genetics and plant physiology for improved feedstocks,
- Optimize agronomic practices, including land use availability and soil sustainability, and
- Optimized logistics for collecting, storing and combining (i.e., blending) feedstocks.”

This feedstock roadmap builds upon the biomass technologies roadmap by expanding the priority R&D area of “feedstock handling” into a technical R&D roadmap of far greater detail that can be used as a guide for developing biorefinery feedstock supply technologies for the future.

1.3 Strategic Goals and Associated Industry Performance Targets

The overarching goal of this roadmap is to achieve a \$30/dry ton cost of feedstock delivered to a biorefinery at the prescribed megaton scale. This feedstock cost supports producing lignocellulosic sugars at about \$.07/lb in order to be economically competitive with sugars produced from starch grain or other starch based sources. Determining an accurate current cost for feedstocks is difficult because existing biomass markets are not at the scale of the biorefinery. In addition, for any given geographic area, the amount and quality of feedstock biomass economically available for a biorefinery varies depending on annual growing conditions, the amount that needs to be left in the field for sustainability and other purposes, the efficiency of harvest, the transportation infrastructure, and post harvest losses associated with storing and handling.

Current estimates for the delivered cost of biomass feedstocks at the scale of the biorefinery, factoring in all these variabilities, are approximately \$50 - \$55/dry ton, which includes a modest \$10/dry ton return to the biomass producer. Figure 1.6 shows how the research and technology development outlined in this roadmap lays out a viable path for reducing this cost to the target \$30/dry ton delivered.

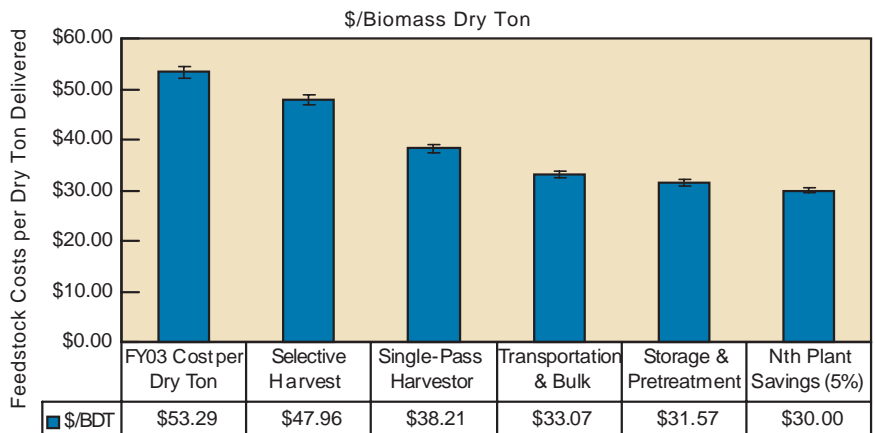

Figure 1.6. Research and technology development pathway towards achieving feedstock price target.

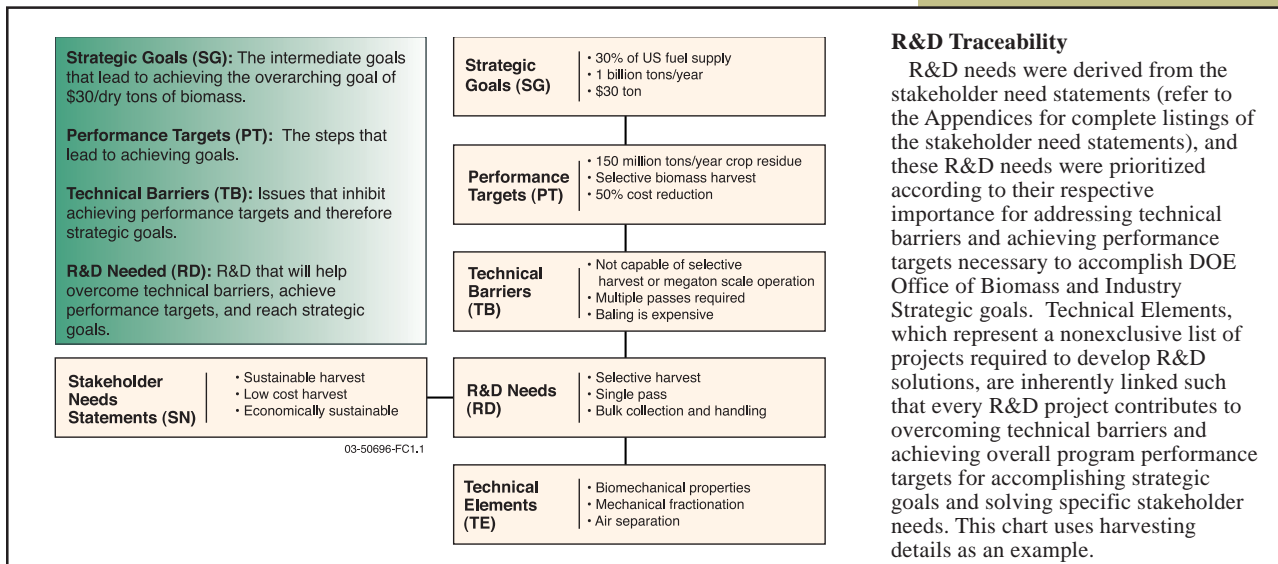

Table 1.1. Alignment of strategic goals with industry-wide performance targets.

Strategic Goals	Industry Wide Performance Targets
SG1 Biomass Availability	<ul style="list-style-type: none"> • SG1.1 Accelerate annual development of 1 billion tons of available lignocellulosic biomass resources for fuels and chemicals by <ul style="list-style-type: none"> - Developing technologies and systems to begin and then increase sustainable utilization of crop residue biomass resources to work towards meeting the 2010 vision goals for bioenergy and bioproduct - Expanding the diversity of available and potential biomass resources including processing wastes, forest resources, energy crops, etc., to meet 2020 and 2030 vision goals. • SG1.2 Create the technologies and systems that allow the widespread production and supply of biomass feedstock and resources to reduce the risk of reliance on single or few contract feedstock suppliers.
SG2 Sustainability	<ul style="list-style-type: none"> • SG2.1 Minimize net impact of biomass production and utilization on the environment. • SG2.2 Enhance environmental resources and the productive capacity of the enterprise level production system for different climates and cropping systems. • SG2.3 Improve net energy balance of biomass production, harvesting, collection, and handling.
SG3 Feedstock Infrastructure	<ul style="list-style-type: none"> • SG3.1 Increase efficiency of utilizing standard transportation equipment and infrastructure with respect to safety per local laws and labor agreements. • SG3.2 Define and achieve feedstock composition and quality throughout the system. • SG3.3 Demonstrate cost-effective storage systems for megaton quantities of wet and dry biomass. • SG3.4 Minimize required farm level capital investments and enterprise impacts of harvest and collection systems. • SG3.5 Increase biomass value with every process step of the feedstock chain.
SG4 System Profitability	<ul style="list-style-type: none"> • SG4.1 Define life cycle value of crop residue to the production enterprise. • SG4.2 Improve over all system efficiency and profitability by integrating value-add processes throughout the feedstock system. • SG4.3 Improve enterprise level economics for sustainable technologies and practices to reduce or eliminate the need for subsidies and/or incentive payments.

03-50696-T1.1

The strategic goals of this roadmap are aligned into four categories that address separate, but interconnected requirements of the feedstock supply chain:

- Biomass availability
- Sustainability
- Infrastructure
- System profitability.

Developments in these categories are necessary in each step of the feedstock supply chain to develop a feedstock supply infrastructure that can handle 1 billion dry tons annually by 2030, while producing a profit for each party involved in the supply chain from grower to processor. The strategic goal categories, with their associated industry-wide performance targets, are shown in Table 1.1.

1.4 Roadmap Organization and Top Priority R&D Needs

Although conversion and product use technologies are not included in this roadmap, processing technologies represent the bulk of the technical performance characteristics of a biomass feedstock. Growers that produce grain and/or dedicated energy crops will be the primary biomass feedstock suppliers of crop residues. Thus growers and processors form the backbone of the industry and are primarily responsible for adopting the technologies and practices that will contribute to achieving long-term industry goals. The remaining stakeholders will provide technologies, services, and support to the feedstock supply operation.

This roadmap is organized by supply system industry segment and the primary grower-oriented feedstock production and supply steps (see Figure 1.7). It presents detailed performance targets, technical barriers, R&D needs, and R&D priorities for each feedstock production and supply industry segment including:

- Production
- Harvest and collection

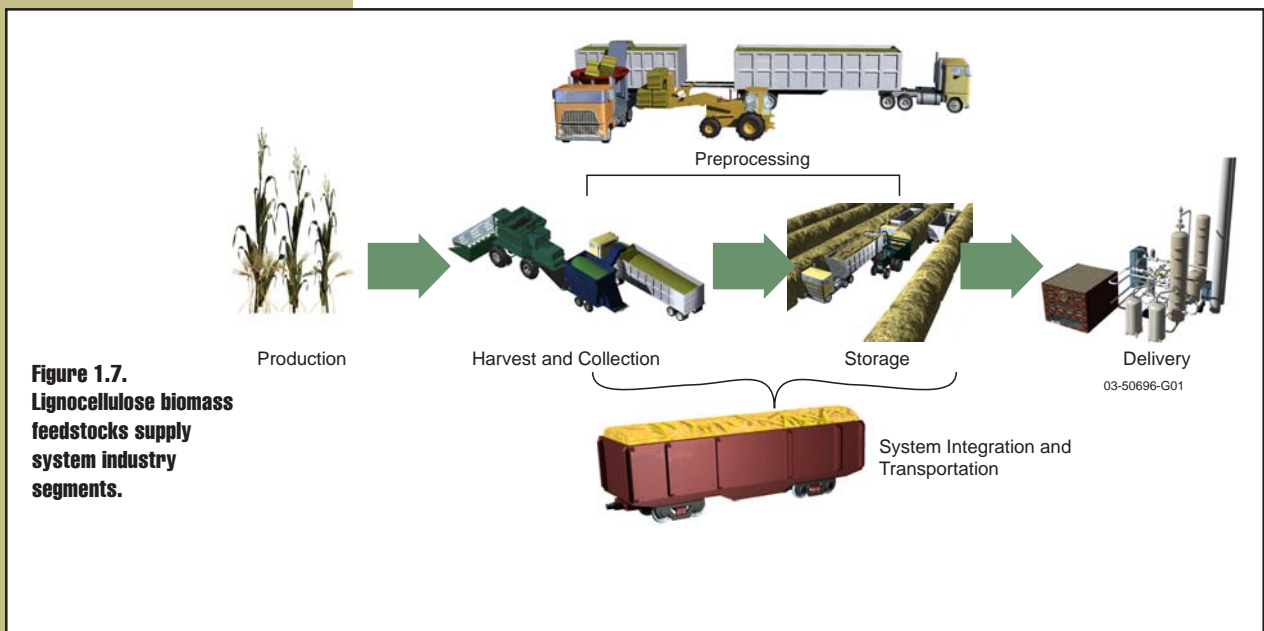

- Storage
- Preprocessing
- System integration
- Transportation.

The areas of R&D needed within each of these feedstock production and supply industry segments are shown in Table 1.2. These R&D areas represent technological needs that offer significant opportunity for the industry to develop an adequate and reliable biomass supply, ensure that the natural resource base can sustainably support the intensified production demands, develop the infrastructure for a large-scale biomass industry, and ensure the economic viability of the industry at both the individual enterprise level and at the national and global scale.

Feed Stock Industry Segments	Areas of R&D
Production	<ul style="list-style-type: none"> • Resource Assessment • Sustainability/Agronomics • Plant Science/Agronomics
Harvesting and Collection	<ul style="list-style-type: none"> • Selective Harvest for Sustainability • Single Pass Harvesting and Collection • Bulk Harvesting and Collection
Storage	<ul style="list-style-type: none"> • Feedstock Quality and Monitoring • Dry Storage Systems • Wet Storage Systems
Preprocessing	<ul style="list-style-type: none"> • Biomass Material Properties • Biomass Physical State Alteration • Biomass Bulk Material Handling
Systems Integration	<ul style="list-style-type: none"> • Subsystem Specifications • Overall Integration • Market and Policy
Transportation	<ul style="list-style-type: none"> • Integrated Systems for the Utilization of Existing Infrastructure

Table 1.2. Key areas of R&D needed for feedstocks production and supply.

03-50696-T1.2

1.5 Key Partners for Feedstock Goals Include USDA and DOE

The U.S. stands to reap significant benefits from a robust biorefinery industry that can convert abundant crop residue and other biomass sources to domestically produced fuels and products, benefits such as a decreased demand for imported oil, additional revenue for the depressed agriculture industry, new jobs, and revitalized rural economies. A cost-effective, sustainable harvest and collection of crop residue biomass is critical to the success of this industry. However, as with any new industry, a few issues need to be addressed such as, a biobased industry will require new infrastructure from stakeholders that may not want to build new infrastructure without an existing market; processors want a guaranteed supply of low-cost, high-quality biomass over the long term before committing to build a biorefinery; and similarly, growers and equipment manufacturers want a reliable market and dependable prices prior to investing in producing the required quantities of biomass feedstock.

Plant sciences and agronomy are key R&D elements required for achieving the 1 billion dry ton target. The expertise of the USDA in production, agronomy, and plant sciences is essential for achieving biomass feedstock supply goals. In addition, the biomass technologies roadmap and this roadmap identify a need for DOE in industrial science and engineering to solve many feedstock infrastructure issues that directly affect supply, sustainability, and profitability (see Figure 1.8). USDA and DOE will need to interface with each other to achieve the 1 billion dry ton goal.

DOE's participation and support of the R&D needs identified in this roadmap are crucial in allowing the biorefinery concept to move forward and realize potential benefits. Continued sponsorship will enable research to develop and demonstrate the necessary biomass harvest and collection technologies and methods. DOE leadership and resources are also needed in sponsoring public/private partnerships of growers and equipment manufacturers working in tandem with the processors to commercialize and implement the necessary harvesting and collection technologies and methods to meet the biorefinery industry needs.

Although the collective benefits to the nation as a whole are considerable, the benefit to any individual grower or equipment manufacturer does not justify the resources and risk required. As such, DOE's sponsorship of public/private partnerships is absolutely critical. Investments in cost shared partnerships and research at the national laboratories, USDA laboratories, and universities are necessary to develop the science and technology base as well as address important knowledge gaps.

Figure 1.8. The Bioenergy Vision 2010 milestone will be primarily achieved by the application of DOE industrial science and engineering to solve infrastructure development issues related to the utilization of readily available crop residues and other forms of biomass.

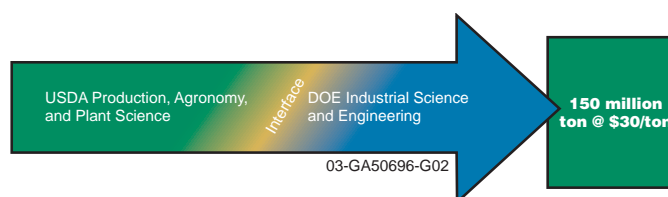

DOE resource assessments confirm sufficient biomass for the first 30 to 150 plants (i.e., about 150 million tons).

The infrastructure needs the ability to deliver biomass to the biorefinery at the \$30 price target.

2. Production





2. Production

Sustainability is a requirement for all new biobased technologies. Environmental sustainability is generally not a significant issue when using processing wastes like corn fiber, rice hulls, or sugarcane bagasse, which materials have already been removed from farm fields and often represent a disposal problem for food processors. These may be the preferred feedstocks used in the first biorefineries. Feedstock sustainability is a factor, however, for all feedstock supply systems that involve producing biomass crops or collecting agricultural or forestry residues.

This section focuses on research priorities for meeting the near-term needs of deploying early technology. These R&D activities address technical barriers related to resource assessment and sustainability. This roadmap also summarizes recommendations for long-range research in plant sciences, agronomics, and sustainability, especially those identified in the roadmap for biomass technologies in the U.S. It assumes that the detailed planning for such research will be carried out in the relevant basic plant sciences research programs of the DOE Office of Science and USDA and in the applied plant and soil sciences R&D programs of the USDA (see Figure 2.1).



Figure 2.1. Long-range research is needed in plant sciences to improve biomass quality and quantity.

2.1 Current Technical Situation

Biomass now contributes about 200 million dry tons annually to the nation's energy supply, primarily from wood residues. Increasing the annual contribution to 1 billion dry tons will require new biomass supplies and new uses for existing biomass resources. Industries that already have biomass supply infrastructures – such as wet and dry corn mills and pulp and paper mills – can reduce the need for new feedstock sources by more fully using all components of their existing feedstocks. New biorefineries, however, need new region-specific feedstocks and supply systems to ensure reliable supplies of high-quality, low-cost biomass. The major existing and potential biomass resources have been estimated at national, state, and sometimes county levels. Estimates from the various studies, however, are difficult to compare and combine because of embedded differences in geographic coverage, time frame, costing methodology, and assumptions about availability and competing uses.

Forest and industrial wood residues, including logging residues, bark, other mill residues, and spent pulping liquors, are the source of most biomass energy consumed today. The forest products industry has a harvesting and processing infrastructure for wood, and continually seeks higher-value uses for mill residues. Residue availability is determined by production levels of wood products and by the economics of alternative uses. Under certain ecological, financial, and policy conditions, the supply of forest harvesting residues could be increased. Thinning forests to reduce fire hazards, a potentially significant new source of biomass, is the subject of major environmental and cost studies by the U.S. Forest Service (see Figure 2.2).



Urban wood residues from tree trimmings, construction, and demolition make a small contribution to biomass energy today. These resources tend to be used where tipping fees are high. Other urban wastes sometimes considered for bioenergy include grass clippings and newspapers. Alternate markets for these include mulches and paper recycling.

Other industry residues include the by-products of grain and food processing industries. These resources are small in total amount but are already collected and potentially readily available. Issues include the proprietary nature of the resource information, and possible competition from other new uses for the same resources.



Figure 2.2. Biomass can be obtained from natural, residential, commercial, and industrial sources.

Agricultural residues are the largest available lignocellulosic biorefinery feedstock resource. Current production is concentrated where grain is grown, in the Midwest and Great Plains. Researchers have concluded that, within limits, residue removal can be sustainable and crop residues could be an additional revenue source for farmers. Ongoing research is needed in identifying conditions under which residues can be removed without increasing erosion or reducing soil productivity. The research results still need to be applied to the development of decision-making tools for on-farm application. The task of developing new harvest equipment capable of removing specific components of residue creates a need to understand the implications of differential residue removal on erosion, carbon, and nutrient cycling.

Dedicated biomass crops include grasses and short-rotation trees. Grasses are widely planted for forage and conservation purposes. New varieties that produce sustained high biomass yields with relatively low nutrient inputs have already been developed. The deep roots, perennial nature, and high nutrient-use efficiencies of some warm-season grasses increase the probability of dependable yields. Short-rotation tree crops are being used commercially for fiber and in a few locations as dedicated biomass crops for bioenergy demonstration projects. New varieties and culture techniques offer the capability for high yield, sustainable production systems similar to grasses. The ongoing genetic sequencing of poplars is making available information and tools to design woody crops with desired feedstock characteristics.

2.2 Performance Targets

The targets for production research and analysis activities that can contribute to achieving the overall biomass feedstock industry goals and performance targets described earlier in this roadmap are grouped into three areas in Table 2.1. The first area, biomass availability, includes defining and documenting feasible scenarios for the development of feedstock resources. The targets specify resource levels that can support the expansion of biobased industries at rates that meet the targets defined in the U.S. vision for bioenergy and bioproducts through the year 2030. The second area, sustainability, addresses short-term targets that will facilitate the translation of research data into decision-making tools for on-farm use by producers, and longer-term targets that assess the regional- and watershed-level effects of biomass production on water quality and water use. The third area, profitability, includes targets that integrate feedstock production and conversion technologies to improve overall system efficiencies.

Table 2.1. Production performance targets.

<p>PT1 Biomass Availability</p>	<ul style="list-style-type: none"> • PT1.1 By 2005, resource data with national coverage for all significant biomass resources is up-to-date, documented, and readily accessible via the Internet. • PT1.2 By 2010, production systems are defined and demonstrated for the sustainable collection of 100 million dry tons yr of crop residues. • PT1.3 By 2020, production systems are defined and demonstrated for the sustainable collection of 600 million dry tons of biomass feedstocks. • PT1.4 By 2030, production systems are defined and demonstrated for the sustainable collection of 1 billion tons per year of biomass feedstocks.
<p>PT2 Sustainability</p>	<ul style="list-style-type: none"> • PT2.1 By 2010, sustainable practices and management decision tools for collecting crop residues are defined for multiple regions. • PT2.2 By 2010, the regional environmental benefits of biomass production have been identified and quantified. • PT2.3 By 2010, environmentally sustainable production systems and management decision support tools are developed for dedicated biomass crops and the information is made available for farmer/industry use. • PT2.4 By 2020, new crops are significantly more efficient (i.e., higher grain and/or biomass yields per land, water and nutrient use) per unit of input.
<p>PT3 System Profitability</p>	<ul style="list-style-type: none"> • PT3.1 Improved feedstock quality reduces processing costs. • PT3.2 Genetically improved and environmentally acceptable feedstocks increase the dollar value of biobased products. • PT3.3 Reliable feedstock supply data reduce the costs and risks in locating sites for biorefineries.

03-50696-01T2.1

2.3 Technical Barriers

The biomass production area covers the R&D activities related to the sustainable production of biomass for bioenergy and bioproducts. The technical barriers addressed by this work are grouped into three areas:

- Resource availability
- Sustainability and agronomics
- System profitability.

Crop residues appear to be the lowest-cost feedstock option for the initial development of biorefineries. In the longer term, biomass supplies can be increased by using other sources, including municipal wastes, forest residues, and energy crops. Estimates of current and potential future feedstock resources provide support for a variety of policy and industrial development activities. Feedstock supply data (current and projected) are important in shaping the design of competitive biorefineries and in formulating the strategy needed for supplying an industry capable of effecting a significant reduction in our dependence on foreign oil.

Producers approach collecting, or not collecting, crop residues as a business decision. The technical barriers associated with making such decisions include incomplete information on the costs and benefits of adding residue collection to their crop management systems. Costs related to crop production include issues also related to sustainability, especially the near- and long-term effects on soil quality and crop productivity.

In the long term, plant sciences research can increase the profitability of biorefineries by producing biomass resources that are more uniform, produce higher product yields, and/or cost less than the process. In general, increasing yields and increasing the efficiency of using inputs are effective ways of reducing the costs of producing biomass that can be applied to any crop. For maximum impact, it is likely that research to change the chemical composition or physical form of the biomass will be designed to improve feedstocks for specific conversion processes.

Major technical, institutional, and policy barriers that are drivers for production research and analysis are summarized in Table 2.2. These barriers are currently limiting efforts in achieving the performance targets listed above.

2.4 Research and Development Needs

The R&D needed to achieve the performance targets can be organized into three major areas:

- Biomass supply forecasts and analysis
- Sustainability and agronomics
- Basic plant sciences (i.e., genomics and plant physiology).

Biomass Supply Forecasts

Biomass supply forecasts comprise developing projections for the prices and quantities of biomass resources available to support biorefineries. Activities will involve developing and applying modeling tools that integrate available resource databases from USDA with new data from plant sciences, sustainability, and

Table 2.2. Production technical barriers.

	Performance Targets Addressed
TB1 Resource Availability	
<ul style="list-style-type: none"> • TB1.1 There are no periodic national surveys of lignocellulosic biomass production, current estimates of feedstock resources are limited in scope, and they do not consider how major technological advances in production technologies will impact biomass availability. • TB1.2 Uncertainty about the amount, price, quality, and year-round reliability of feedstock resources is a barrier to stimulating bioindustry development. • TB1.3 Existing data on the environmental effects of feedstock production are not adequate to support life cycle analysis of bioenergy systems. • TB1.4 The production of biomass feedstocks will ultimately be limited by competition for finite land and water resources. • TB1.5 Physical and chemical characteristics of feedstocks vary by source, by year, and by season, increasing processing costs. • TB1.6 There is inadequate information on plant biochemistry as well as inadequate genomic and metabolic data on many potential biomass crops. 	<p>PT1.1, PT1.2, PT1.3, PT1.4, PT3.3</p> <p>PT1.1, PT1.2, PT1.3, PT1.4, PT3.3</p> <p>PT1.1, PT2.1, PT2.2, PT2.3, PT2.4</p> <p>PT2.3, PT2.4</p> <p>PT1.1, PT2.2, PT2.4, PT3.2</p> <p>PT3.1, PT3.2</p>
TB2 Sustainability	
<ul style="list-style-type: none"> • TB2.1 Farmers are concerned about long-term effects on soil and crop productivity, return on investment when collecting residues, and lack of data and tools to support on-farm decisions about residue collection. Research has not addressed the potential differences between returning whole-crop residues and specific fractions of crop residues. • TB2.2 The regional- and/or watershed-level effects of biomass feedstock production on water flows, water quality, biodiversity, and crop productivity have not been addressed. • TB2.3 Genetic modification of dedicated crops for improved characteristics may create risks to native populations of related species. 	<p>PT1.2, PT2.1, PT2.2</p> <p>PT2.2, PT2.3, PT2.4</p> <p>PT3.2</p>
TB3 System Profitability	
<ul style="list-style-type: none"> • TB3.1 System profitability is highly sensitive to crop inputs and yields, residue collection rates, and effects on other farming operations. • TB3.2 Genetic modification of commodity crops to improve residue characteristics may affect grain values. 	<p>PT2.1, PT2.4, PT3.2</p> <p>PT2.4, PT3.2</p>

03-50696-02T2.2

agronomic research (see Table 2.3). Applications include projecting biomass costs and supplies, defining delivered costs and relating them to the size of the biomass-using facility, and providing input data for life cycle assessments. The resource forecasts inform the energy projection, policy and planning, and results reporting activities of DOE. They also support industries and other organizations directly involved in the development of biorefineries. Because biomass supplies and competing uses change with time, and availability and costs change as collection and transportation technologies advance, this area includes periodic updates of all feedstock types. In addition, since existing resource data are frequently requested for a range of uses, this will also include making resource forecasts and projections accessible in an efficient, web-based format.

Sustainability and Agronomics

Although it is assumed that USDA and universities will be performing the research and developing the detailed R&D priorities and technical elements, the R&D needs identified in the colloquies and workshops for the sustainability and agronomics area are described in this roadmap (see Table 2.3). Coordination between research on harvest technologies and agronomics and sustainability will be important, especially for systems that collect and return specific residue fractions. There is no information on the effects of new in-field fractionation technologies on soils, though changing the average physical and chemical characteristics of collected biomass will also change the characteristics of the returned biomass, which can be expected to have some effects on soil processes and crop production. For all harvesting systems, cost is closely correlated to the amount of biomass collected per acre of land, making assumptions about sustainable collection rates critical to feedstock cost as new technologies allow greater control over residue removal and return.

Plant Sciences

Plant sciences research is a long-term effort that can potentially make significant contributions to the overall efficiencies of advanced biorefineries, and to the suite of bioproducts they produce. It is assumed that the USDA and the DOE's Office of Science will perform the basic plant sciences research needed to support biorefinery development. This roadmap lists the major R&D needs in the area of plant sciences, specifically those identified in the "Roadmap for Biomass Technologies in the United States" (see Table 2.3). However, it is assumed that detailed R&D plans will be developed by the organizations supporting the research, and plant sciences R&D, like sustainability R&D, are not included in later sections of this document.

2.5 Research and Development Priorities

Research needs were selected as top priority needs based on their relevance to the DOE Office of Biomass goals. Table 2.4 details key technical elements for the biomass supply forecast and analysis activity, which falls within the scope of the DOE's Office of Biomass Programs. They are:

- Develop forecasts of biomass supplies
- Maintain a web-based biomass resource database
- Detail a long-term vision for developing biomass supplies
- Support total system techno-economic and life cycle analysis.

Table 2.3. Production R&D needs.

Term of Priority Impact			Technical Barriers Addressed
RD1 Resource Assessment			
		R&D Need	
Top	N	RD1.1 Develop biomass supply forecasts and perform analysis activities in support of life cycle assessment, techno economic analysis, and defining the steps necessary to produce 1 billion tons/year of biomass per year in a sustainable manner.	TB1.3
High	N	RD1.2 Develop biomass feedstocks supply data relevant to diverse user needs.	TB1.2, TB1.5
RD2 Sustainability/Agronomics			
		R&D Need	
Top	N	RD2.1 Develop data on carbon and nutrient flows in biomass feedstock production to support life cycle assessment and to establish requirements for system sustainability, and to support development of on-farm decision-making tools.	TB2.1
Top	N	RD2.2 Develop data on the effects of fractionating biomass feedstocks at harvest to support life cycle analysis, equipment development, and to establish requirements for system sustainability.	TB1.3, TB2.1
High	M	RD2.3 Develop data and information on the effects of biomass feedstock production on water quality and water use, including landscape- and watershed-scale studies, to support life cycle analysis and to establish requirements for system sustainability.	TB1.3, TB2.2
Medium	M	RD2.4 Quantify other environmental debits and credits of biomass production as needed for life cycle assessment.	TB1.3
RD3 Plant Science/Agronomics			
		R&D Need	
Top	L	RD3.1 Develop plant varieties and optimize associated agronomic practices for sustainable biomass feedstock production.	TB3.1, TB3.2
High	L	RD3.2 Improve the technical understanding of plant biochemistry and enzymes and develop the ability to engineer enzymes within desired crops.	TB2.3, TB3.2
Medium	L	RD3.3 Develop the chemical and chemical/biological pathways necessary to improve the energy density and chemical characteristics of delivered feedstocks for efficient storage and processing.	TB2.3
			03-GA50696-03T2.3

Term of Impact = N: Near-term (within 3 years) M: Mid-term (within 10 years) L: Long-term (>10 years)

Table 2.4 also provides additional details on the risks, payoffs, and expected time frames for results from R&D on each of the high-priority areas for biomass supply forecasts and analysis. Top research needs in sustainability and plant sciences areas are listed in the table, but because these research areas are outside the current scope of the DOE program it is assumed that the key technical elements associated with them will be defined by the organizations or agencies performing the research.

Table 2.4. Production R&D priorities.

R&D Priority – RD1.1	Develop biomass supply forecasts and perform analysis activities in support of life cycle assessment, techno economic analysis, and defining the steps necessary to produce 1 billion tons/year of biomass per year in a sustainable manner.
Key Technical Elements	<p>TE1 Develop documented forecasts of biomass supplies from current crops and from potential feedstock production systems, including costs, quantities, and locations.</p> <p>TE2 Develop and maintain a documented, web-based resource database.</p> <p>TE3 Produce a journal paper describing a vision for how biomass resources can be developed capable of supplying to 1 billion tons of biomass per year on a sustainable basis.</p> <p>TE4 Support total system techno-economic analysis led by conversion researchers and developers.</p> <p>TE5 Support total system life cycle assessments with feedstock production data.</p>
Technical Barriers Addressed	TB1.1, TB1.2, TB1.3
Performance Targets Addressed	PT1.1,PT1.2, PT1.3, PT1.4, PT2.1, PT2.2, PT2.3, PT2.4, PT3.3
Risk	Low – The risk is low because the necessary background data are available, and similar analyses have been done successfully in the past
Benefit to Strategic Goals	<ul style="list-style-type: none"> • Increase in credibility of resource estimates. • High quality information on quantity, price, location, and quality of biomass residues important to near-term bioenergy implementation. • Development of a methodology that can be easily used to update estimates. • Good feedstock supply curve estimates could help DOE and USDA in establishing priorities for type and locations for cooperation on relevant projects or research. • Development of a common vision on resource availability.
Term of Impact	Near-term
Stakeholders Needs Addressed	SN1.1, SN1.5, SN1.10, SN1.13, SN11.14, SN12.2, SN13.3, SN13.5, SN18.5, SN19.1, SN19.4

R&D Priority – RD2.1	Develop data on carbon and nutrient flows in biomass feedstock production to support life cycle assessment and to establish requirements for system sustainability, and to support development of on-farm decision-making tools.
Key Technical Elements	This research is outside the scope of DOE's OBP. It is assumed that the programs within USDA or other DOE offices that are responsible for performing the research will develop the key technical elements.
Technical Barriers Addressed	TB1.3, TB1.4, TB2.1
Performance Targets Addressed	PT1.1, PT1.2, PT2.1, PT2.2, PT2.3, PT2.4
Risk	Medium – The technical risk is moderate because information will be required before long-term studies can be completed. The technical risk increases with the degree of extrapolation over space and time.
Benefit to Strategic Goals	<ul style="list-style-type: none"> • Documented data inputs for quantification of life cycle benefits of biobased systems. • Increased public support for biobased energy systems. • Increase in types and amounts of biomass feedstocks generally accepted as sustainable or "green."

Term of Impact	Near-term – Results from existing DOE-USDA studies on corn residue. New studies will yield mid- and long-term results.
Stakeholders Needs Addressed	SN1.8, SN2.6, SN11.14, SN13.2, SN13.6, SN13.7, SN14.5, SN16.3, SN16.9,

R&D Priority – RD2.2	Develop data on the effects of fractionating biomass feedstocks at harvest to support life cycle analysis, equipment development, and to establish requirements for system sustainability.
Key Technical Elements	This research is outside the scope of DOE's OBP. It is assumed that the programs within USDA or other DOE offices that are responsible for performing the research will develop the key technical elements.
Technical Barriers Addressed	TB1.3, TB2.1
Performance Targets Addressed	PT1.1, PT1.2, PT2.3, PT2.4
Risk	Low - The technical risk in this research is low except when short-term and site-specific results must be extrapolated to long-term effects and to different sites.
Benefit to Strategic Goals	<ul style="list-style-type: none"> • More efficient harvesting systems that improve soil quality and ensure sustainability. • Documented data inputs for quantification of life cycle benefits of biobased systems.
Term of Impact	Near-term - Pilot plot-scale can begin immediately. Field-scale tests would be coordinated with schedule for equipment trials.
Stakeholders Needs Addressed	SN1.8, SN2.1, SN2.2, SN2.3, SN2.4, SN2.5, SN2.6, SN2.7, SN2.9, SN2.11, SN2.13, SN2.14, SN2.15, SN2.16, SN2.17, SN2.18, SN2.19, SN11.5, SN14.5, SN16.3, SN16.9, SN18.2, SN19.3

R&D Priority – RD3.1	Develop plant varieties and optimize associated agronomic practices for sustainable biomass feedstock production.
Key Technical Elements	This research is outside the scope of DOE's OBP. It is assumed that the programs within USDA or other DOE offices that are responsible for performing the research will develop the key technical elements.
Technical Barriers Addressed	TB1.4, TB1.5, TB3.1, TB3.2
Performance Targets Addressed	PT1.1, PT2.1, PT2.2, PT2.3, PT2.4, PT3.2
Risk	Medium-High – The greatest risk comes from the fact that the research is outside the DOE scope, and therefore outside DOE's control.
Benefit to Strategic Goals	<ul style="list-style-type: none"> • By increasing the amount of biomass produced per unit area, and reducing the inputs required, this research increases the potential energy, economic, and environmental benefits of bioenergy and biobased products.
Term of Impact	Long-term
Stakeholders Needs Addressed	SN2.20, SN11.14, SN12.4, SN12.5, SN17.1, SN17.2, SN17.3, SN17.4, SN19.2, SN19.5

3. Harvesting and Collection





3. Harvesting and Collection

Harvesting and collection technologies are the first step in the feedstock infrastructure process. The primary goal is to harvest, collect, and remove the biomass from the field in a sustainable, cost-effective manner.

Harvesting and collection must be considered in the context of the overall feedstock supply infrastructure. For instance, harvesting and collection methods and technologies have significant impacts on storage, transportation, and preprocessing. Additionally, sustainability concerns such as soil compaction as well as the portions of the biomass left in the field for erosion control must be considered and addressed.

Currently agriculture crops such as corn, wheat, and barley are grown for the grain, thus harvest and collection technologies have been developed and optimized for grain harvest. Both the infrastructure and grower familiarity exist with equipment such as combines, grain carts, grain trucks, and other equipment that comprise grain harvesting and collection. Therefore, in order to meet the biomass price targets of the biorefinery, biomass harvesting and collection technologies will need to be compatible with existing harvest equipment.

3.1 Current Technical Situation

Currently crop residues, corn stover and cereal straw, are harvested, collected, and used in the livestock and dairy industries, as well as some specialty applications such as hydromulch. The current harvest and collection method is a three or four step process (see Figure 3.1). First, a combine harvests the grain and discharges the biomass in a windrow behind the combine. Second, a baler towed by a tractor picks up the windrow, packages the biomass in a bale, and discharges the bale when baler capacity is reached (typically 1,000 to 1,300 dry lb for large balers). Third, a tractor picks up the bales and hauls them field side.

Crop residue biomass harvesting and collection in this manner is inadequate to meet the feedstock performance targets of the biorefinery for several reasons. Crop residue biomass harvest using this approach introduces a significant amount of dirt and rock contamination into the feedstock by dropping it in the soil and picking it back up. The multiple passes across the field in the current

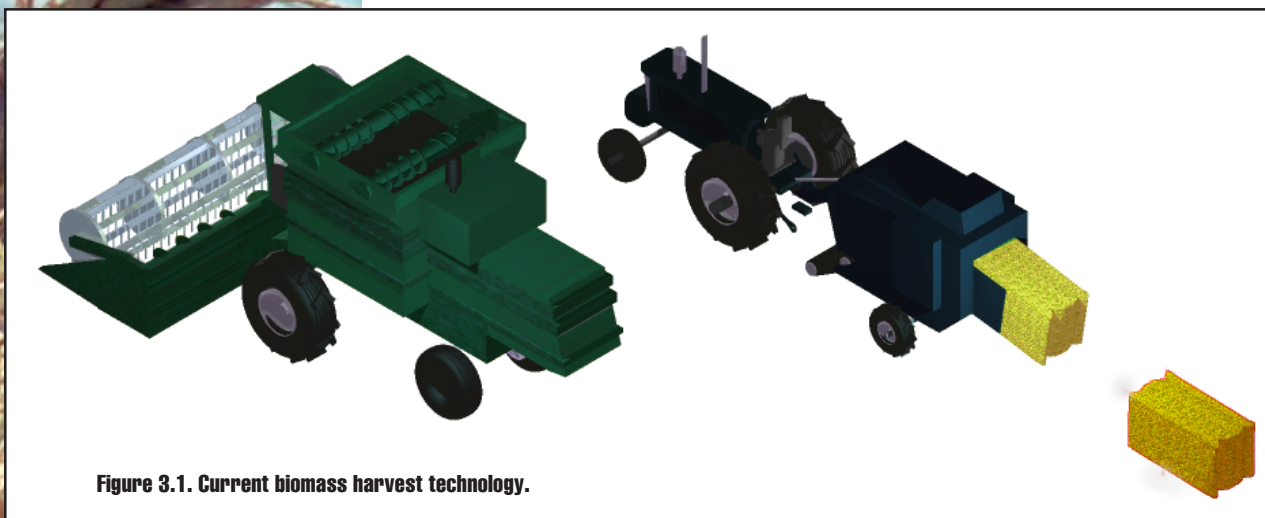

Figure 3.1. Current biomass harvest technology.



system add costs by requiring additional dedicated equipment and labor and increase soil compaction, making minimum or no-till agronomic practices more difficult to implement when the biomass is harvested in this manner. Numerous studies have shown that minimum or no-till practices are highly desirable for maintaining soil carbon levels when crop residue biomass is harvested.

The continuous harvest of crop residue biomass to meet the needs of the biorefinery on the national and local scale will demand that sustainable biomass harvest technologies be developed and implemented. The goal of sustainable harvest for the biorefinery is to maximize the amount of residue that can be removed for use as biorefinery feedstocks while adhering to sustainability guidelines. Crop residue biomass, whether it be corn stover or cereal straw, is composed of many components such as stalks or stems, leaves, sheaths, husks, cobs, awns, and other minor components. Certain components of the biomass are more valuable than others to be left on the field to address sustainability and erosion concerns; this varies depending on climate and growing conditions and the crop. Selective harvest technologies that have the ability to leave the components and the amounts of the residue most desired for sustainability and erosion concerns and harvest only the remaining portions of the residue will be more sustainable than current approaches. Additionally, since selective harvest will maximize the sustainability benefits of what is left in the field, this approach holds the promise of maximizing the amount of residue that can be removed in a sustainable manner.

The development of a single-pass harvester capable of selective biomass harvest shows promise for meeting the availability, sustainability, quality, and price performance targets for biorefinery feedstocks. As shown in Figure 3.2, this equipment would selectively harvest specified components of the biomass to be used for biorefinery feedstocks in a single pass, simultaneously harvesting the biomass with the grain. This equipment could help address important sustainability needs by leaving the required percentages and biomass components required by soil health and erosion constraints. In addition, other potential benefits of single pass biomass and grain harvest include reduced soil compaction, making biomass harvest more compatible with minimum or no-till practices and reduced costs and energy use.

Bales are also problematic for the biorefinery. Although bales are well developed technology and work well for the livestock industry, they are not well suited for the large-scale needs of the biorefinery. Bales are expensive to make, have low bulk density as compared to other dry industrial feedstocks, require separate power equipment such as loaders or forklifts to load and unload, and are difficult to handle at the large scale of the biorefinery. Bulk collection systems need to be designed and developed to overcome the limitations of the bale system at the large scale.

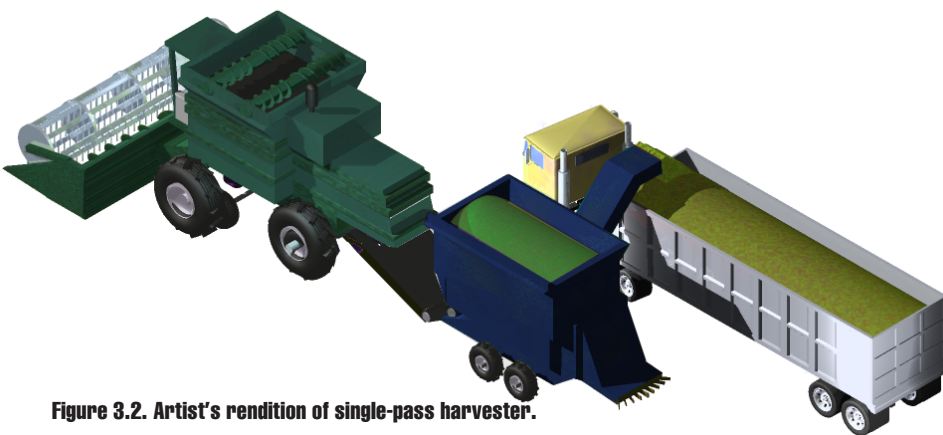

Figure 3.2. Artist's rendition of single-pass harvester.

3.2 Performance Targets

The economics of the biorefinery present some significant challenges for feedstocks. The biomass must be plentiful on a nation-wide basis, yet its availability must be concentrated on a local basis. Since its low bulk density precludes transportation over large distances. It must be low cost, of consistent quality, and harvested and collected in a sustainable manner while being removed from the field in a short harvest window to not negatively impact other farming operations.

Table 3.1. Harvesting and collection performance targets.

<p>PT4 Biomass Availability</p>	<ul style="list-style-type: none"> • PT4.1 Technologies and methods need to be developed to harvest and collect 150 Million tons/year of crop residue biomass nationally with a 50% cost reduction when compared to current technologies. • PT4.2 Biomass harvest and collection technologies can handle bulk crop residue biomass at the megaton scale.
<p>PT5 Sustainability</p>	<ul style="list-style-type: none"> • PT5.1 Selective biomass harvest systems are developed by 2010 that can be tailored to address site-specific sustainability and economic concerns. • PT5.2 Single-pass harvesting systems consume less fuel and reduce total energy demands of biomass harvest and collection by 33% over current multi-pass systems. • PT5.3 Single-pass, selective biomass harvesting systems reduces by 50% soil compaction and erosion associated with the biomass harvest, and these systems are compatible with no-till cropping systems by 2010.
<p>PT6 Feedstock Infrastructure</p>	<ul style="list-style-type: none"> • PT6.1 Specialized equipment needed for optimized grain and biomass harvest systems are minimized as well as associated capital equipment costs (i.e., Less machinery does the grain and biomass harvest for 50% less cost than current harvest, mow, rake, and bale machinery processes). • PT6.2 Single pass stover and straw harvest has no negative impact on the grain harvest. • PT6.3 Biomass selective harvest can be accomplished in single-pass over the field by 2010. • PT6.4 Biomass harvest equipment reduces soil and other contaminant by 90% or more by 2010. • PT6.5 By 2020, advances in single pass harvester technology allows significant value-added on-harvester biomass feedstock preprocessing. • PT6.6 By 2020, single pass grain/biomass harvesters can harvest grain and biomass from multiple crops. • PT6.7 Harvesting equipment must operate in an optimal mode for both biomass (<1% loss and soil contamination) and grain (<1% loss/damage).
<p>PT7 System Profitability</p>	<ul style="list-style-type: none"> • PT7.1 Costs to harvest and collect the crop residue biomass need to be reduced by 50% over current technologies. • PT7.2 Biomass harvest and collection technologies and methods must be profitable both the equipment manufacturer and the grower.

These objectives put considerable demands on biomass harvest and collection technologies and methods. Harvest and collection technologies must be able to handle biomass in large volumes at low cost, and the systems must have broad nationwide applicability but be readily adaptable to meet the needs of specific crops and areas. The performance targets for the harvesting and collection area that make these objectives achievable are presented in Table 3.1.

3.3 Technical Barriers

Crop residue biomass is an attractive starting feedstock for the biorefinery because of its high availability and current underutilization. Additionally, since it is a byproduct of grain production, the grain crop covers primary production costs. However, many significant barriers exist that must be addressed. The technical barriers for harvest and collection are shown in Table 3.2 and are grouped into three technology areas:

- Sustainable biomass harvest
- Single pass harvest
- Bulk harvesting and collection systems.

Although some crop biomass harvesting and collection currently occurs on a limited basis, harvesting and collection of biomass on the scale required, while meeting quality and price targets, for a national biorefinery industry is essentially a new endeavor. As with any new endeavor, significant challenges and opportunities exist. Achieving the performance targets for this area in the desired time frame will require an accelerated research and development program. Feedstock costs and quality have a significant impact on the overall economics of the biorefinery. Meeting the \$30/ton price target at the quality levels required by the biorefinery, while making this an economically sustainable venture for all parties involved in the feedstock supply chain, represents a significant challenge. Clearly there is a need for enabling research as well as public/private technology development and implementation partnerships to address these technical barrier areas and achieve the performance targets set for the harvesting and collection area.

3.4 Research and Development Needs

To meet the performance targets set for the harvest and collection area, biomass harvest and collection equipment must address long-term sustainability issues associated with biomass harvest such as soil health and erosion concerns. It must be robust and tailorable to specific crops and site-specific concerns. In addition, it must produce a clean, high-quality, consistent feedstock; have minimal impact on soil compaction; require low energy and labor inputs; and be low-cost. To accomplish these significant performance targets within the desired time scale will require an accelerated research and technology development effort that involves research at national laboratories and universities and integrated demonstrations involving growers, equipment manufacturers, and processors. The R&D needed to achieve this can be organized into the same three areas:

- Sustainable biomass harvest
- Single pass harvest
- Bulk harvesting and collection systems.

Table 3.2. Harvesting and collection technical barriers.

	Performance Targets Addressed
TB4 Selective Harvest for Sustainability	
<ul style="list-style-type: none"> • TB4.1 Current crop harvesting machinery is unable to selectively harvest desired components of biomass and address the soil carbon and erosion sustainability constraints. • TB4.2 Lack of feedstock specifications and standards against which to engineer harvest equipment, technologies, and methods. • TB4.3 Biomass variability places high demands and functional requirements on biomass harvesting equipment and are not currently addressed. • TB4.4 Lack of methods to optimally control operational performance of multi-component harvesting equipment. • TB4.5 Site specific quantifiable data is needed on the value of the residue left in the field for sustainability (i.e., impact to farming operations, yields, crop rotations, etc.) versus value to the grower as a biorefinery feedstock. • TB4.6 Lack of data on how residue removal could potentially negatively or positively impact no-till operations in certain areas. 	<p>T5.1, PT6.2</p> <p>PT6.5</p> <p>PT6.6</p> <p>PT6.7</p> <p>PT5.1, PT5.3</p> <p>PT5.3</p>
TB5 Single Pass Harvest	
<ul style="list-style-type: none"> • TB5.1 Current biomass harvest methods require multiple passes across the field, which causes soil compaction and high fuel, and labor usage. • TB5.2 Current harvest and collection technologies and methods do not produce clean feedstock. The process of picking up the windrow behind the combine also picks up high amounts of dirt and rocks. • TB5.3 Small margins only allow for a minimal capital outlay from growers for new specialized equipment, which translates to very small margins for equipment manufacturers. • TB5.4 Grain harvest occurs during a short window in which the additional complexity of the biomass harvest could have negative impacts. • TB5.5 Site or region specific definitive data is needed on what percentages and portions of the biomass should be left on the field for soil health and erosion concerns. • TB5.6 Lack of data on soil compaction associated with biomass harvest and collection. 	<p>PT5.2, PT5.3, PT6.3, PT7.2</p> <p>PT6.4</p> <p>PT6.1, PT7.2</p> <p>PT6.2</p> <p>PT5.1, PT5.3</p> <p>PT5.3</p>
TB6 Bulk Harvesting and Collection Systems	
<ul style="list-style-type: none"> • TB6.1 Current crop residue biomass harvesting and collection technologies and methods are inadequate (i.e., not designed for handling many million of tons) to meet the 150 million-ton/year collection capability goal by 2010. • TB6.2 Current biomass collection, handling and transport methods, which are bale based, are primarily designed to meet the needs of the livestock and dairy industry and are inadequate to meet the large low-cost biomass needs of the biorefinery. • TB6.3 Current methods of harvesting and collection biomass are too costly. • TB6.4 Biorefinery feedstock price targets combined with costs of current technologies and methods only allow a very small margin for growers. 	<p>PT4.1, PT4.2</p> <p>PT4.1, PT4.2, PT7.1</p> <p>PT7.1, PT7.2</p> <p>PT6.2, PT7.2</p>

03-50696-01T3.2

Sustainable Biomass Harvest

Maintaining soil carbon levels for soil health and reducing soil erosion losses to wind and/or rain dictate that certain percentages and components of the biomass are left on the field. The different percentages and components that must be left vary depending on soil type, climate, and agronomic practices. Biomass harvesting and collection technologies and methods are needed that can meet these sustainability requirements by selectively harvesting the portions and percentages of the biomass acceptable for removal. They must be adjustable to meet site-specific needs, able to handle different biomass and crop types, and be low cost. In addition, sustainable harvest equipment must be developed for a variety of crops and various moisture levels (see Table 3.3).

Single Pass Harvest

The sustainable selective biomass harvest systems must be capable of single-pass simultaneous harvest of the grain and biomass. Whether the grain and biomass are separated in the field or at field-side depends on the specific crop, moisture content, and end use. No till or minimum till practices can allow significantly higher amounts of biomass to be removed while still meeting soil carbon and erosion constraints. Single pass biomass harvest systems can reduce soil compaction and make biomass harvest compatible with no or minimum till agronomic practices. Additionally, single pass biomass harvest can reduce the cost of biomass harvest and facilitate achieving the biorefinery feedstock price targets. Of utmost importance to the grower is that these sustainable selective biomass harvest systems not have negative impact on other important farming operations (see Table 3.3).

Bulk Harvesting and Collection Systems

Current bale based systems for collecting and handling biomass have many significant drawbacks including low bulk density, high dirt and rock contamination, high per unit cost, and significant handling and storage issues at the large scale. These issues combine to make it unlikely that biorefinery feedstock performance targets can be achieved with current bale based systems. Fortunately bulk collection and handling systems offer significant potential toward overcoming this limitations and achieving the biorefinery feedstock performance targets. A critical component to the viability of bulk systems is the ability to harvest, collect, and remove biomass from the field in a large-scale bulk mode. Research and technology development need to be conducted on developing bulk biomass harvesting and collection technologies and methods. Since there will most likely be a transition period from existing bale systems to the bulk systems, the newly developed bulk handling systems will need to be compatible with existing bale based systems (see Table 3.3).

Table 3.3. Harvesting and collecting R&D needs.

Priority	Term of Impact	R&D	Technical Barriers Addressed
RD4 Selective Harvest for Sustainability			
Top	M	RD4.1 Develop the biomass separation techniques necessary for development of a harvester capable of biomass selective harvest.	TB4.3, TB4.4, TB5.5
High	N	RD4.2 Develop economic data/models to determine what separations should be done in the field versus at latter stage handling steps to economically maximize biomass quality and optimize cropping system sustainability.	TB4.5, TB4.6, TB5.5
High	M	RD4.3 Develop biomass quality assurance and quality control specification for engineering requirements to guide in-field equipment designs.	TB4.2
Medium	N	RD4.4 Develop autonomous intelligent control systems for multi-component selective harvest equipment.	TB4.3, TB4.4
Low	M	RD4.5 Develop in-field technologies that add value to the biomass crop and further improve system sustainability and economics.	TB4.1
RD5 Single Pass Harvesting and Collection			
Top	N	RD5.1 Develop biomass harvest and collection technology that simultaneously harvest the biomass with the grain in a single pass to minimize soil compaction to make biomass harvest compatible with no or minimum till agronomic practices, and to minimize costs.	TB4.5, TB5.1, TB5.2, TB5.3, TB5.6, TB6.1
High	M	RD5.2 Integrate biomass harvesting and collection equipment and methods with the entire farming operation to ensure economic sustainability.	TB4.5, TB5.4, TB6.4
RD6 Bulk Harvesting and Collection Systems			
Top	N	RD6.1 Develop crop residue biomass bulk handling, collection methods and equipment and transport and operational scenarios that reduce equipment and operational costs by 50%, compared to conventional baling systems. These systems should minimize dirt and rock contamination and have no negative impact on grain harvest or soil compaction.	TB4.1, TB5.2, TB5.3, TB6.1, TB6.2, TB6.3, TB6.4
Medium	N	RD6.2 Develop bulk handling and collection technologies for the range of biomass variability that optimize the utilization of locally available transportation infrastructure.	TB4.3, TB6.1
Low	M	RD6.3 Investigate innovative equipment designs such as vacuum pickup and biomass compaction following the combine or doing away with the combine entirely.	TB6.1
			03-50696-01T3.3

Term of Impact = N: Near-term (within 3 years) M: Mid-term (within 10 years) L: Long-term (>10 years)

3.5 Research and Development Priorities

Although all the R&D needs presented in Table 3.3 are important in achieving performance goals, three major needs have emerged as high priority for the harvesting and collection area. Focusing resources and efforts in these areas will provide the most benefit towards achieving the performance targets set for the harvesting and collection area. These three areas are:

- Develop sustainable biomass selective harvest technologies necessary for achieving biomass availability goals in a sustainable manner
- Develop single pass biomass harvest technologies that minimize soil compaction and costs and make biomass harvest more compatible with no or minimum till agronomic practices that also significantly reduce dirt and rock contamination of the feedstock.
- Develop bulk biomass harvesting and collection systems capable of operating at the megaton scale and achieving the biorefinery feedstock price targets.

Table 3.4. Harvesting and collection R&D priorities.

R&D Priority – RD4.1	Develop the biomass mechanical fractionation and air stream separation techniques necessary for development of a harvester capable of biomass selective harvest.
Key Technical Elements	<p>TE6 Develop and evaluate biomass mechanical fractionation techniques.</p> <p>TE7 Develop and evaluate air stream separation of the different components of the biomass.</p> <p>TE8 Engineer mechanical fractionation and air stream separation for implementation on a harvester.</p> <p>TE9 Design, build and evaluate prototype selective biomass harvesters.</p>
Technical Barriers Addressed	TB4.1, TB4.2, TB4.3, TB4.4, TB5.5
Performance Targets Addressed	PT5.1, PT5.3, PT6.2, PT6.5, PT6.6, PT6.7
Risk	High – Because of the complexity of the several new techniques that must be developed the risk is high.
Benefit to Strategic Goals	<ul style="list-style-type: none"> • Necessary for long-term sustainability. • Increase amounts of biomass available in a sustainable manner. • Increased yields. • Higher quality feedstocks.
Term of Impact	Mid-term
Stakeholders Needs Addressed	SN4.1, SN4.2, SN4.4, SN4.6, SN4.12, SN7.1, SN7.2, SN7.6, SN7.7, SN12.7, SN15.2, SN18.3
R&D Priority – RD5.1	<p>Develop biomass harvest and collection technology that simultaneously harvest the biomass with the grain in a single pass to minimize soil compaction to make biomass harvest compatible with no or minimum till agronomic practices, and to minimize costs.</p> <p>TE10 Develop single-pass concepts and perform conceptual evaluation.</p>
Key Technical Elements	<p>TE11 Define selective and bulk harvest interface requirements for single pass harvest.</p> <p>TE12 Engineer, build test and optimize prototypes and document performance.</p>

Technical Barriers Addressed	TB4.5, TB5.1, TB5.2, TB5.3, TB5.6, TB6.1
Performance Targets Addressed	PT4.1, PT4.2, PT5.1, PT5.2, PT5.3, PT6.1, PT6.3, PT6.4, PT7.2
Risk	Medium to High – Many individual technologies for single pass harvesting are available today, however, as more unit operations are combined into a single machine/operation, the complexity and cost of machinery dramatically increases.
Benefit to Strategic Goals	<ul style="list-style-type: none"> • Decreased cost of biomass harvest. • Decreased soil compaction making biomass harvest compatible with no or minimum till agronomic practices. • Decreased energy and labor demand.
Term of Impact	Near-term
Stakeholders Needs Addressed	SN1.9, SN1.12, SN2.3, SN4.2, SN4.3, SN4.6, SN4.9, SN9.1, SN9.2, SN9.3, SN9.6, SN11.1, SN11.7, SN11.11, SN15.1, SN18.3

R&D Priority – RD6.1	Develop crop residue biomass bulk handling, collection methods and equipment and transport and operational scenarios that reduce equipment and operational costs by 50%, compared to conventional baling systems. These systems should minimize dirt and rock contamination and have no negative impact on grain harvest or soil compaction.
Key Technical Elements	<p>TE13 Evaluate bulk collection systems as an alternative to baling.</p> <p>TE14 Perform baseline analysis of existing crop residue biomass harvesting equipment and document inadequacies.</p> <p>TE15 Define interfaces for feedstock feed requirements for both sugars and syngas conversion platforms.</p> <p>TE16 Perform chopping shredding and grinding studies to determine optimum grind size.</p> <p>TE17 Research densification, transportation and storage issues and interfaces.</p>
Technical Barriers Addressed	TB4.1, TB5.2, TB5.3, TB6.1, TB6.2, TB6.3, TB6.4
Performance Targets Addressed	PT4.1, PT4.2, PT5.1, PT6.1, PT6.2, PT6.4, PT7.1, PT7.2
Risk	Medium – Evaluation and definition of the systems is of less risk, but the greatest risk is meeting the cost reduction goal.
Benefit to Strategic Goals	<ul style="list-style-type: none"> • Decreased harvesting and collection costs. • Lower transportation costs by increasing the bulk density. • Better long-term biomass storage. • Better quality feedstock formatted as desired by processors. • Increased safety at biorefinery site by reducing dust and fire hazards associated with grinding biomass on site.
Term of Impact	Near-term
Stakeholders Needs Addressed	SN1.2, SN1.5, SN1.9, SN1.12, SN4.3, SN4.6, SN4.7, SN4.8, SN4.11, SN8.2, SN8.5, SN9.3, SN10.6, SN11.1, SN11.2, SN11.8, SN15.1

03-50696-08T3.4a.ai

4. Storage





4. Storage

Storage systems that are environmentally acceptable, safe, and provide the required supply of quality feedstock are critical components of a sustainable biomass conversion industry. These storage systems may store the feedstock in a wet form or dry form depending on the feedstock material, environmental conditions, geography, and/or processing use. Equally critical is integrating storage systems with other elements of the feedstock supply chain. Storage costs increase feedstock costs. Processing methods and yields can be altered by compositional and other changes that occur in feedstock during storage. Storage and supply methods are linked since supply methods must be able to deal with the feedstock as it emerges from storage to eliminate additional preprocessing steps.

Storage systems are needed that can mitigate and balance issues that arise from the competing need for a low-cost, high-density, high-yielding, perishable feedstock that is harvested only in the fall and must be stored for as many as two years. Little infrastructure currently exists for non-bale storage systems, but to be capable of supplying a low-cost feedstock, biorefinery storage systems cannot require significant new infrastructure. Thus, developing cost-effective storage systems that consistently supply biorefinery feedstocks will require creative approaches and will not likely result in a single universal solution.

4.1 Current Technical Situation

A dry bulk storage system, the existing agricultural bale system, was developed to supply forage and bedding materials to small and medium scale livestock operations and has been adapted for corn stover with only limited success. A biorefinery must process as much as 1 million tons of lignocellulosic biomass annually and may need to have an inventory of at least half that much to smooth bumps in the supply curve, depending on the source and type of biomass and the distances the biomass must be transported. This storage volume requirement would be much greater than any bale system has been designed for (see Figure 4.1). At this 1 million-ton scale, the economics of storing bales would likely be unfavorable. Other options need to be considered.

Presently, agricultural residues such as corn stover are typically windrowed and air-dried in the field to 15-35% moisture before baling. If this moisture level is not attained or the bales become wet from rain or humidity, biomass decomposes due to microbial activity of microbes naturally in the biomass.

Figure 4.1. Current bale technology is not designed for the tremendous amount of feedstock required to annually supply biorefineries.



Heat generation from microbial activity can lead to a series of chemical reactions that could potentially cause fires and result in significant feedstock losses. Pelletizing or granulizing biomass and storing it in protected storage is an effective means of addressing these issues. The pellets are also less combustible because their density is higher and their surface area is reduced. Unfortunately, the current cost of pelletizing technologies is too high, as much as \$15/dry ton. Systems and technologies exist for bulk handling ground feedstocks and can likely be used for dry bulk biomass with the appropriate formatting and handling systems.

The other storage system alternative is wet bulk storage. A potentially effective though untested strategy to minimize microbial degradation of crop residues in storage is eliminating oxygen from the storage system via ensiling. Ensiling is well developed for storing wet green forage in bunkers or sealed containers such as bags, wrapped bales, or silos. Wet green forage contains free sugars and assimilable nitrogen, which are necessary for this method to be effective. In contrast, senescent lignocellulose (not actively growing when harvested) contains few free sugars and little assimilable nitrogen. Ensiling has been used successfully to store sweet sorghum and sugar cane bagasse (which contain free sugars), sometimes with added molasses. Ensiling large, water-saturated bulk piles, if constructed and maintained at low cost, is a potential solution to the problem of feedstock stability in storage.

Feedstock source, availability, and geographical location will ultimately determine the best-suited storage system for a given biorefinery or market. It is likely that certain situations may warrant hybrid bulk storage systems that incorporate elements of both wet and dry bulk methods. Similarly, staged harvesting strategies where greener biomass is stored for shorter time periods and dryer biomass is stored for longer time periods may be favored in some circumstances. Finally, it is possible that a cost-effective biomass conversion economy may require that lignocellulosic feedstock be traded in bulk as a commodity (see Figure 4.2), in which case maintaining feedstock quality in storage would be necessary to define a lignocellulose feedstock “grading” system to determine commodity end-use and market.

4.2 Performance Targets

Table 4.1 presents the performance targets for storage. These targets define improvements needed in storage technologies for biorefinery feedstocks that will significantly impact attaining the strategic goals. These targets must be achieved without significantly increasing infrastructure requirements, feedstock quality, or economic competitiveness.



Figure 4.2. Commodity feedstocks are almost exclusively handled in bulk. Bulk storage and handling of biomass feedstocks may be necessary for cost-effective feedstocks supply to biorefineries.

Biomass storage systems must be able to accommodate many different sources of feedstocks to support the national goal of 1 billion dry tons of feedstock annually by 2030. The new storage systems should be low capital, low-labor, bulk systems that maintain and perhaps help to define the standards and specifications for trading and evaluating biomass. Blending feedstock to meet these specifications should be considered.

Table 4.1. Storage performance targets.

<p>PT8 Biomass Availability Profitability</p>	<ul style="list-style-type: none"> • PT8.1 Storage systems are flexible enough by 2010 to accommodate the myriad of different biomass sources needed. • PT8.2 Processor standards and specifications define a feedstock grading scale by 2020 that is used for valuation of feedstock stored in various ways.
<p>PT9 Sustainability</p>	<ul style="list-style-type: none"> • PT9.1 Storage systems have no negative impact on water and air quality. • PT9.2 Safety standards for storage systems are developed by 2010 to minimize risk of worker injury. • PT9.3 By 2020, storage systems can be taken out of service temporarily or permanently without generating environmental problems.
<p>PT10 Feedstock Infrastructure</p>	<ul style="list-style-type: none"> • PT10.1 Cost-effective outside bulk storage of biomass for up to two years in arid and humid climates, meeting processor- or market-defined average composition and quality standards both when the biomass enters and when it emerges from storage. • PT10.2 Storage systems can maintain or improve feedstock quality as defined by processor standards and specifications by 2010. • PT10.3 Cost-effective field storage-monitoring systems for fermentable carbohydrates and water content sufficiently accurate to track compositional losses are available by 2010 and are applicable to crop biomass entering, stored in, and emerging from storage. • PT10.4 Infrastructure and resources required for storage are minimized by 2020.
<p>PT11 System Profitability</p>	<ul style="list-style-type: none"> • PT11.1 Storage systems add minimally to overall feedstock costs so that the overall economics are favorable for a wide range of end products by 2020. • PT11.2 Storage systems allow maximum flexibility in the use of the feedstock by 2030. • PT11.3 Storage systems cost-effectively improve the density of the feedstock by at least a factor of 2.5 times as compared to bales. • PT11.4 Storage systems and compositional stability attained by 2020 allow feedstock valuation based on a common scale such as potential yields of fermentable sugars from the biomass.

03-50696-09T4.1

A significant fraction of feedstock costs arises from the cost of packaging biomass for transportation and storage. An unconventional storage system that reduces this cost may require bulk storage, different formatting, or packaging. As this requirement is linked with several other R&D areas, quantitatively determining the infrastructure requirements for wet and dry storage systems is critical. Finally, storage systems and practices must be developed that allow sustainable supply and operation for the most efficient and lowest cost biorefinery feedstocks.

4.3 Technical Barriers

To develop storage systems that achieve the performance targets, solutions must be developed for several technical barriers, shown in Table 4.2. These have been grouped into three areas:

- Feedstock quality and monitoring
- Dry storage systems
- Wet storage systems.

The technical barriers presented within these technology areas generally address important crosscutting issues for both dry and wet storage. For example, feedstock composition and quality monitoring are important regardless of whether dry or wet storage is used, but the issues in developing and implementing such systems will not always be the same for dry versus wet storage systems. Similarly, basic barriers exist that crosscut both dry and wet storage, such as the effects of storage on biomass composition and the infrastructure required to implement such systems. Finally, some environmental and sustainability considerations will be similar for dry and wet storage systems while others will be different.

There is a lack of information on feedstock variations and its compositional and biological diversity, which limits the development of storage systems. In addition, the lack of real-time, passive, noninvasive, compositional measurement tools and sensors makes it difficult to define meaningful standards that can be used during selling, storing, and processing. This lack of processor standards and specifications for feedstocks leads to biomass use in niche markets only.

Dry bulk storage systems are closer to realization than wet systems, primarily because dry bulk handling and storage have been developed for a wide variety of feedstocks across many industries (i.e., grain, ore, and coal). But for these dry bulk storage systems there are still a number of biomass-specific issues to be worked out (e.g., dry bulk storage systems are known to be expensive and possibly have unacceptable fire risk), as well as infrastructure requirements regarding feedstock location, format, and climate to consider. Wet storage, in contrast, is not developed as well as dry storage and will require additional R&D. Thus, there are a greater number of barriers to wet storage development. For both wet and dry systems, engineering analyses and information on storage requirements and yield losses as functions of feedstock-specific factors are critical to providing systems and defining infrastructure for stable storage. A lack of processor specifications on the allowable effects of feedstock preservation on processing makes it difficult to determine the type of storage systems to be used and limits the use of storage systems to reduce processor costs.

4.4 Research and Development Needs

The barriers to developing cost-effective lignocellulosic biomass storage can be overcome through integrated research, engineering development, design, and

Table 4.2. Storage technical barriers.

	Performance Targets Addressed
TB7 Feedstock Quality and Monitoring	
<ul style="list-style-type: none"> • TB7.1 Lack of information on physical, chemical, microbiological, and post-harvest physiology variations in feedstocks arising from differences in variety, geographical location, and harvest time. • TB7.2 Lack of passive, noninvasive analytical tools and sensors for real-time compositional measurements for most lignocellulosic feedstocks. • TB7.3 Lack of processor standards and specifications for feedstocks. • TB7.4 Lack of specifications on the allowable effects of feedstock preservation on processing. 	<p>PT8.1, PT10.1, PT10.2</p> <p>PT8.2, PT10.1, PT10.2, PT10.3, PT11.4</p> <p>PT8.2, PT10.1, PT10.2, PT10.3, PT11.2, PT11.4</p> <p>PT10.1, PT10.2, PT11.4</p>
TB8 Dry Storage Systems	
<ul style="list-style-type: none"> • TB8.1 Lack of engineering analyses of unconventional dry storage methods, including centralized versus distributed systems. • TB8.2 Lack of information on storage requirements, yield losses, and infrastructure for packaged and bulk year-round dry storage systems as a function of feedstock source, climate, and harvest time relative to the grain harvest. • TB8.3 Lack of cost-effective densification technologies and knowledge regarding the effect of storage methods on feedstock density. • TB8.4 Lack of information on dry bulk storage system emissions, potential pest, disease and other risks, and their short- and long-term effects on the environment as well as the material in storage. • TB8.5 Lack of infrastructure requirements for large-scale dry bulk storage and the associated impacts on worker safety. 	<p>PT8.1, PT10.1, PT10.4, PT11.3</p> <p>PT8.1, PT10.1, PT10.2, PT10.4</p> <p>PT11.3</p> <p>PT9.1, PT9.2, PT9.3</p> <p>PT9.2</p>
TB9 Wet Storage Systems	
<ul style="list-style-type: none"> • TB9.1 Lack of engineering analyses of wet storage methods, year-round storage and supply of wet biomass, and centralized versus distributed wet storage systems. • TB9.2 Lack of information on storage requirements and yield losses for wet storage, as a function of feedstock source, climate, and harvest time relative to the grain harvest. • TB9.3 Lack of information on whether pretreatment in storage can or should be performed and its value to processors. • TB9.4 Lack of information on the physical and chemical requirements of biomass and storage water requirements necessary for the engineering design of wet storage systems tailored to different feedstocks, climates and biorefinery processes. • TB9.5 Lack of information on potential wet storage system emissions, pest, disease and other risks and their short and long-term effects on the environment. • TB9.6 Lack of infrastructure requirements for large-scale wet storage and the associated impacts on worker safety. 	<p>PT8.1, PT10.1, PT10.4</p> <p>PT8.1, PT10.1, PT10.2</p> <p>PT10.2, PT11.4</p> <p>PT9.1, PT10.2, PT11.1</p> <p>PT9.1, PT9.2, PT9.3</p> <p>PT9.2</p>

03-50696-10T4.2

demonstration activities. The R&D needed to achieve the performance targets for storage can be aligned with the same three areas:

- Feedstock quality and monitoring
- Dry storage systems
- Wet storage systems.

The R&D needs for these areas are presented in Table 4.3. Because dry storage systems are currently better developed than wet storage systems, the term of impact for dry storage systems is shorter term (near-term), while wet storage R&D needs generally will have mid-term impacts since more initial research is needed.

Table 4.3. Storage R&D needs.

Term of Priority Impact		R&D Need	Technical Barriers Addressed
RD7 Feedstock Quality and Monitoring			
Top	N	RD7.1 Develop valuation parameters for biorefinery feedstocks as a commodity or based on fermentable carbohydrates.	TB7.1, TB7.2, TB7.3
High	M	RD7.2 Develop passive, noninvasive analytical tools and sensors for real-time compositional analysis of significant lignocellulosic feedstocks.	TB7.1, TB7.2
High	N	RD7.3 Develop and standardize tests for the physical processing characteristics defining feedstock quality.	TB7.1, TB7.2
Medium	M	RD7.4 Define the composition and quality of feedstock for specific processes or specified end-uses (i.e., processing, soil sustainability, feed).	TB7.3, TB7.4
RD8 Dry Storage Systems			
Top	N	RD8.1 Develop designs and equipment infrastructure for dry storage, and evaluate the variability of feedstock chemical, biological, and harvest-related parameters and their effect on yield losses in dry bulk storage systems.	TB7.1, TB7.2, TB7.4, TB8.1, TB8.2, TB8.3, TB8.4, TB8.5
High	N	RD8.2 Investigate potential disease and pest problems in the dry bulk storage of feedstock material.	TB8.1, TB8.4
RD9 Wet Storage Systems			
Top	M	RD9.1 Develop designs and equipment infrastructure for wet storage, and evaluate the variability of feedstock chemical, biological, and harvest-related parameters and their effect on yield losses in wet storage systems.	TB7.1, TB7.2, TB7.4, TB9.1, TB9.2, TB9.4, TB9.5
High	M	RD9.2 Determine societal and environmental impacts and regulations regarding potential disease, pest, odor, and other emissions resulting from the transport and storage of wet feedstock.	TB7.1, TB9.1, TB9.2, TB9.3, TB9.4, TB9.5, TB9.6
High	M	RD9.3 Evaluate methods for reducing water usage in wet storage, and the production and disposition of possible wastewater streams or emissions.	TB9.1, TB9.2, TB9.4, TB9.5
Medium	M	RD9.4 Evaluate pretreatment and other value-add modifications to feedstock while stored in wet systems.	TB7.3, TB7.4, TB9.3

03-50696-11T4.3

Term of Impact = N: Near-term (within 3 years) M: Mid-term (within 10 years) L: Long-term (>10 years)

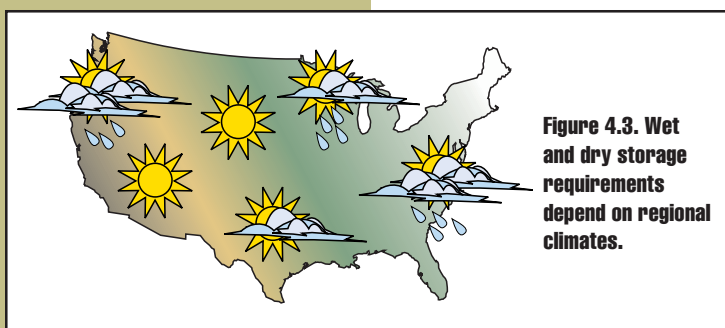

Figure 4.3. Wet and dry storage requirements depend on regional climates.

Lignocellulosic biomass is geographically distributed in areas with widely differing climates. Variations in biomass compositions and other important parameters are largely unknown, and current analytical tools are insufficient to cost-effectively determine variations in incoming feedstock in real-time, as well as feedstock in storage. Consistent feedstock valuation is impossible unless standards and specifications are developed for biorefinery feedstocks.

Both wet and dry storage system requirements and yield losses can vary with feedstock location and harvest time (see Figure 4.3). In addition, the infrastructure requirements for bulk storage methods are largely undefined for biomass, depending on the format. Since there may be different economies of scale associated with infrastructure and transportation costs depending on feedstock and location, storage scale and distribution will likely limit the feedstock supply area and the allowable biorefinery size. Without knowledge of these requirements, choice of storage systems and the overall economics of biomass use are hampered.

Little work has been done to determine potential emissions, runoff, groundwater contamination, dust, mold, odor control, fire, explosion hazards, and other potential problems with wet and dry bulk storage systems. It is unknown how much water is required for wet storage systems or such a systems' potential to impact the environment. Both minimal infrastructure and larger systems present greater potential for significant risks to worker injury. Finally, it is unknown whether potential pest/disease problems exist for either wet or dry storage methods.

4.5 Research and Development Priorities

While all of the research needs play important roles in achieving the storage performance targets and contributing to overall targets and strategic goals, it is critical that the top six R&D priorities are initiated as quickly as possible. These priorities have large effects on attaining the performance targets in the necessary timeframe. In addition, beginning these activities as soon as possible aligns their completion with near-term needs in currently funded Office of the Biomass Program demonstration projects. The six top priorities are:

- Develop valuation parameters for biorefinery feedstocks as a commodity or based on fermentable carbohydrates
- Develop passive, noninvasive analytical tools and sensors for real-time compositional analysis of significant lignocellulosic feedstocks
- Evaluate the variability of feedstock chemical, biological, and harvest-related parameters that affect the applicability of storage methods
- Evaluate feedstock yield losses in wet and dry storage systems in various climates
- Develop scalable, low-labor, and easy to use designs and equipment infrastructure for wet and dry storage
- Determine societal and environmental impacts and regulations on transporting and storing feedstock in various systems.

The key technical elements, technical barriers, performance targets, technical risks, timeframe for completion, benefits to strategic goals, and the necessary interfaces and partners for successful completion are presented for each priority in Table 4.4.

Table 4.4 Storage R&D priorities.

R&D Priority – RD7.1	Develop valuation parameters for biorefinery feedstocks as a commodity or based on fermentable carbohydrates.
Key Technical Elements	<p>TE19 Develop method to predict the chemical and microbiological variability of corn stover and cereal straw entering storage as a function of feedstock, environmental, harvest time, and harvest method.</p> <p>TE20 Work with manufacturers in the various biomass markets to define feedstock specifications that crosscut all the markets.</p>
Technical Barriers Addressed	TB7.1, TB7.2, TB7.3
Performance Targets Addressed	PT8.1, PT8.2, PT8.2, PT10.1, PT10.2, PT10.3, PT11.2, PT11.4
Risk	High – Currently no infrastructure exists, and additional uses of the stored feedstock have not been identified.
Benefit to Strategic Goals	<ul style="list-style-type: none"> • Providing a basis for valuation and commodity trading of fresh and stored biomass contributes to availability and profitability. • Standardization opens trading to new markets for stored biomass.
Term of Impact	Near-term
Stakeholders Needs Addressed	SN3.4, SN3.7, SN3.8, SN3.9, SN3.10, SN3.12, SN3.17, SN5.2, SN10.3, SN18.4

R&D Priority – RD8.1	Develop designs and equipment infrastructures for dry storage, and evaluate the variability of feedstock chemical, biological, and harvest-related parameters and their effect on yield losses in dry bulk storage systems.
Key Technical Elements	<p>TE21 Determine feedstock moisture variability with crop, location and time harvested.</p> <p>TE22 Determine additions (acids, water repellents) that extend the storage life of dry storage.</p> <p>TE23 Determine dry matter losses from dry storage piles due to chemical, physical, and microbiological factors.</p> <p>TE24 Assess the use of preservation using non-traditional techniques such as ionizing radiation and traditional/new preservatives to prevent spoilage.</p> <p>TE25 Test pilot-scale dry storage systems in varied locations and climates.</p> <p>TE26 Determine the required equipment, costs, benefits, and limitations of transportation of feedstock stored by dry bulk methods.</p> <p>TE27 Develop a computational process model to predict requirements for dry bulk storage based on feedstock, location, collection time after harvest, etc.</p> <p>TE28 Determine the preferred form for feedstock within dry bulk storage systems.</p>
Technical Barriers Addressed	TB7.1, TB7.2, TB7.4, TB8.1, TB8.2, TB8.3, TB8.4, TB8.5
Performance Targets Addressed	PT8.1, PT8.2, PT9.1, PT9.2, PT9.3, PT10.1, PT10.2, PT10.3, PT10.4, PT11.3, PT11.4
Risk	Low - Methods and equipment are well developed and can be assessed in a reasonably short time. Design and infrastructure requirements reasonably well understood.

Benefit to Strategic Goals	<ul style="list-style-type: none"> • A comprehensive accounting of requirements for dry storage aid in more rapid assessment of infrastructure needs for design and implementation. • Bulk handling of dry feedstocks eliminates the need for expensive packaging and makes more biomass potentially available due to this flexibility. • Provides critically needed estimates of the allowable feedstock variation. • Choices of stable storage system depending on climate and feedstock will allow more feedstock to be utilized. • Provides information to balance trade-offs within storage and among the feedstock supply chain elements.
Term of Impact	Near-term
Stakeholders Needs Addressed	SN5.1, SN5.2, SN5.6, SN5.7, SN5.8, SN5.10, SN5.14, SN8.6

R&D Priority – RD9.1	Develop designs and equipment infrastructure for wet storage, and evaluate the variability of feedstock chemical, biological, and harvest-related parameters and their effect on yield losses in wet storage systems.
Key Technical Elements	<p>TE29 Determine feedstock moisture and microbial load variability with crop, location and time harvested.</p> <p>TE30 Assess feedstock microbial community structure and how it changes with time after harvest.</p> <p>TE31 Determine additions that must be made to allow stable wet storage.</p> <p>TE32 Determine dry matter and carbohydrate losses from wet storage systems due to chemical, physical, and microbiological factors.</p> <p>TE33 Determine the effects of chemical, physical and biological changes during wet storage on processing of feedstock.</p> <p>TE34 Determine the required equipment, costs, benefits, and limitations of transportation of feedstock stored by wet methods.</p> <p>TE35 Determine the preferred form for feedstock within wet storage systems.</p>
Technical Barriers Addressed	TB7.1, TB7.2, TB7.4, TB9.1, TB9.2, TB9.4, TB9.5
Performance Targets Addressed	PT8.1, PT8.1, PT8.2, PT9.1, PT9.2, PT9.3, PT10.1, PT10.2, PT10.2, PT10.3, PT10.4, PT11.1, PT11.4
Risk	Medium – Biomass silage storage for livestock is well developed, but engineering studies that expand these systems to the scale and type(s) of biomass needed for the biorefining industry are critical to success.
Benefit to Strategic Goals	<ul style="list-style-type: none"> • A comprehensive accounting of requirements for wet storage aid in more rapid assessment of infrastructure needs for design and implementation. • Provides critically needed estimates of the allowable feedstock variation for wet storage. • Choices of stable storage system depending on climate and feedstock will allow more feedstock to be utilized. • Provides information to balance trade-offs within storage and among the feedstock supply chain elements.
Term of Impact	Mid-term
Stakeholders Needs Addressed	SN3.14, SN5.1, SN5.1, SN5.3, SN5.4, SN5.4, SN5.5, SN5.8, SN5.9, SN5.11, SN5.12, SN5.12, SN5.13, SN5.13, SN5.14, SN5.14, SN5.15, SN5.15, SN8.6

5. Preprocessing



5. Preprocessing

Biomass, when harvested, is characterized by its low density; varying and often high moisture content; and varying size, shape, density, and chemical makeup of its differing parts. Biomass may also be contaminated with dirt and other undesirable foreign materials that adversely affect the biorefining quality. Preprocessing treatments are designed to improve biomass handling, transport, and storability (see Figure 5.1). Preprocessing can also add value by making biomass more fit for final conversion to fuels, power, and chemicals. Potential preprocessing treatments include:

- Cleaning
- Separating and sorting
- Mixing/blending
- Controlling moisture
- Physical state alteration and/or densifying
- Partially chemically or biochemically treating.

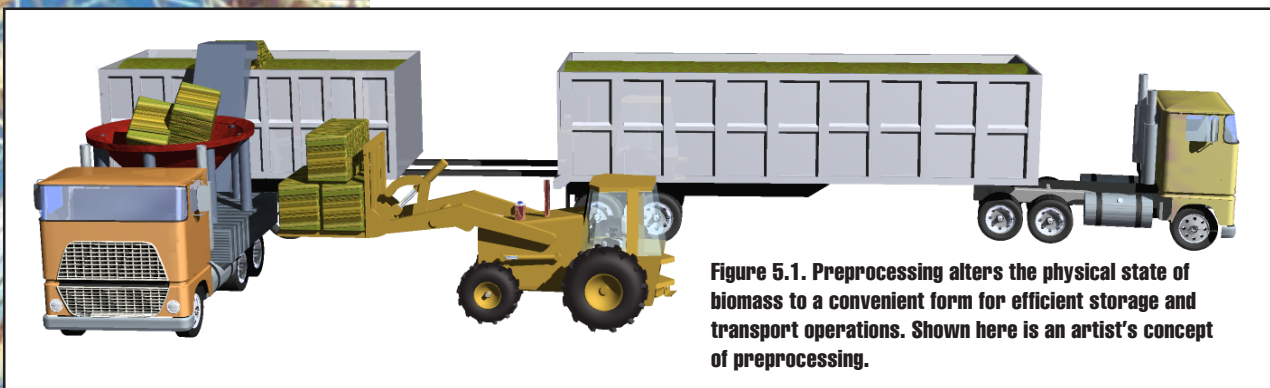

Figure 5.1. Preprocessing alters the physical state of biomass to a convenient form for efficient storage and transport operations. Shown here is an artist's concept of preprocessing.

Cleaning is usually the first operation in post harvest operations. The objective is to remove dirt and other undesirable contaminants that have been mixed with biomass during harvest and subsequent handling operations.

Separating and sorting consists of operations that segregate components of plant material based on shape, size, or density. These operations commence during harvest when grain and straw are separated. Separation can also take place during later processes for producing a more uniform product.

Mixing and blending operations involve bringing two or more of the same or differing materials together for the purpose of preparing a mixture with improved biomass characteristics.

Controlling moisture, either in the field or at a central location, deals with changing the moisture content of the biomass. Drying operations may be used to reduce the moisture of biomass, or water may be added to increase moisture. In either method, the goal is to change the moisture content of the biomass to levels that are safe for long-term storage or final processing.

Physical state alteration and densifying is any operation that changes the physical state and/or reduces the volume of a given mass of biomass. This size reduction can increase the unit density of biomass, resulting in a smaller space required for storage and transportation. Plant material that is fibrous and leafy is

difficult to handle in its original form, making physical state alteration and/or size reduction a desirable operation (see Figure 5.2).

Partially chemically or bio-chemically treating biomass at or near the source of its production could potentially reduce the overall cost of biomass conversion technologies.

Preprocessing may consist of one or more of these treatments. For example, reducing size to increase density and ease of handling may be the only desirable operation for preparing the material as a feedstock for biorefinery. Chopped, ground, and granulated biomass can have bulk properties and flowability characteristics similar to grains, flours, and slurried materials, thus allowing the use of more conventional equipment for handling, transporting, and storing biomass feedstocks. Additionally it gives biorefineries the ability to mix and blend feedstock from a variety of sources to meet physical and chemical specifications for efficient and predictable conversions. Also, partial chemical and biochemical treatments on farm or at storage sites may be desirable to further improve processability of the biomass.

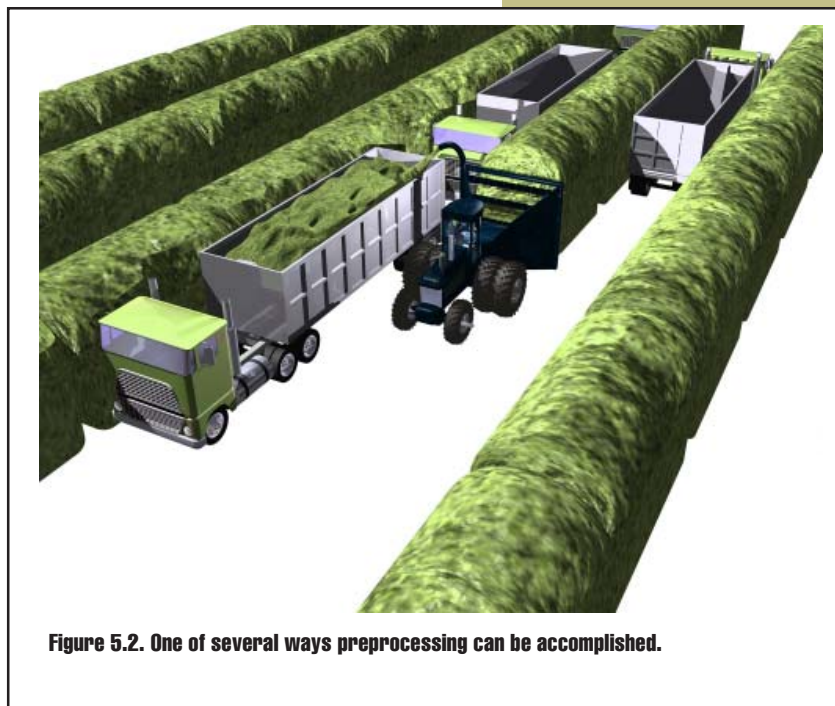

Figure 5.2. One of several ways preprocessing can be accomplished.

5.1 Current Technical Situation

The critical moisture content for safely storing most low moisture agricultural products is less than 15%. Typical moisture content of corn stover ranges from 35-50% while corn is at about 25% moisture at harvest. Small grains and their straw are typically at 12-14% moisture at harvest. Untimely rain or snow during harvest seasons may raise moisture levels even higher. The moisture content of the crop residue biomass can be more greatly affected by geography and climate than by crop type. Midwestern and Eastern regions of the U.S. must be capable of handling high-moisture biomass for both straw and stover. The dry climate of the western U.S. is conducive to dry, or low-moisture, biomass feedstock sources. Therefore, it is imperative to determine how the weather affects moisture content levels in various field conditions as well as how those levels affect various preprocessing treatments in the context of the overall feedstock system.

Several physical properties impact crop handling including stalk diameter, moisture content, resistance to shear and bending, toughness, elasticity, and compressibility. Biomass is categorized according to physical characteristics, specifically stalk diameter, dryness, and mechanical properties. Approximately 80% of the dry matter of mature plants consists of highly lignified cell wall material, which in turn affects the mechanical properties of the biomass. For example, corn stover is categorized as dry, thick, hard stalks with high shear and bending resistance, qualities that make it unsuitable for compacting in its untreated form.

Low bulk density, 4-6 lb/ft³, is a fundamental characteristic of loose biomass in its raw form. Bulk density is increased to 8-10 lb/ft³ when ground to 1/8 in. Bulk density can be increased to 20-30 lb/ft³ by chopping and compacting biomass to form pellets. Dense biomass requires less area and volume to store and transport than loose biomass. Ground and/or pelletized biomass flows like cereal grains and can use the existing well-developed handling infrastructure for grains. Ground biomass can also be slurried for handling with conventional slurry pumping systems. Baling also increases bulk density to roughly 8-12 lb/ft³. Baling and bale handling systems are well-developed technology and may continue to be used for some feedstock applications. However, when considering very large-scale refining operations (i.e., 1 million tons or more), the loading and unloading systems and the cost of baling would need to be improved substantially in order for these technologies to be economically viable.

5.2 Performance Targets

Successfully commercializing the biorefinery concept demands a stable supply of high quality biomass feedstock in large quantities at competitive prices. Most cellulosic feedstock is widely distributed in loose form and needs to be collected, packaged, shipped or stored (preferably in bulk), and transported to conversion facilities. Table 5.1 shows the performance targets for preprocessing technologies that deal with inherent challenges associated with biomass (i.e., low bulk density, high moisture content, and variability in yield and quality).

Preprocessing increases the availability of biomass which will help realize the target quantity of 1 billion tons annually. A well-developed understanding of the physical properties and variability of biomass will accelerate research and development in new equipment and processes while minimizing risks associated with innovations. The resulting biomass supply enterprise will be sustainable in terms of environmental footprint and economic viability. The technologies will treat and upgrade the biomass quality and quantity in terms of size, form, density, and storability.

5.3 Technical Barriers

One or more of the following characteristics complicate the delivery of high-quality, low-cost biomass to a conversion plant:

- Low bulk density
- Spoilage and/or difficulty in handling due to improper moisture
- Variability in physical and chemical characteristics
- Geographical and seasonal variations in biomass
- Conflicting demands on labor and machines at harvest
- Combustibility
- Competition regarding soil fertility
- Local regulations on storage and transport
- Sensitivity to price structure for companion products and farm commodities.

Table 5.1. Preprocessing performance targets.

<p>PT12 Biomass Availability</p>	<ul style="list-style-type: none"> • PT12.1 Preprocessing treatments will upgrade low quality and diverse sources of biomass to a higher value commodity like feedstock (i.e., uniform size, consistent composition, and predictable quality). • PT12.2 Innovative post harvest preprocessing increase the total biomass availability at least 35%, by enabling effective storage systems for seasonal biomass sources and making formerly unusable biomass sources or components usable.
<p>PT13 Sustainability</p>	<ul style="list-style-type: none"> • PT13.1 Preprocessing technologies inserted throughout the feedstock supply system improve energy and natural resource use efficiency by reducing biomass losses and the resulting waste streams, increasing transportation and handling efficiencies, and enabling the utilization use of wasted biomass resources.
<p>PT14 Feedstock Infrastructure</p>	<ul style="list-style-type: none"> • PT14.1 Preprocessing technologies produce a biomass resource with the bulk properties and flowability characteristics similar to grains, flours, and slurried materials such that it can be handled with traditional high-volume conveyance, pneumatics, and pumping material handling systems. • PT14.2 Develop the data and understanding on the fundamental physical and material properties of biomass, which information will enable equipment manufacturers to invest in the development of new equipment and processes for biomass preprocessing systems.
<p>PT15 System Profitability</p>	<ul style="list-style-type: none"> • PT15.1 Biomass preprocessing operations become local value-added enterprises that create manufacturing activities distributed throughout rural America. • PT15.2 Development material properties engineering data on biomass reduces risks associated with developing new equipment, accelerates new equipment development, and enables new equipment designs that reduce preprocessing operations (i.e., grinding, sorting, drying, and pelleting) cost by 50-60%.

03-50696-13T5.1

To develop preprocessing systems that achieve the performance targets, solutions must be developed for several technical barriers, shown in Table 5.2, which are grouped into three areas:

- Biomass material properties
- Biomass physical state alteration (i.e., grinding, densification, and blending)
- Biomass bulk material handling.

These categories address uncertainties in biomass properties but also highlight several limitations within the existing infrastructure that could interfere with meeting the targeted biomass quantities. For example, the most optimal form for processed biomass depends on safety and storage considerations as well as on conversion requirements.

Table 5.2. Production performance targets.

	Performance Targets Addressed
TB10 Biomass Material Properties	
<ul style="list-style-type: none"> • TB10.1 Lack of data on mechanical, thermal, and physical properties of biomass. • TB10.2 Incomplete information on functional moisture relations on quality and physical properties for biomass as affected by crop variability and climatic conditions during harvest and post harvest operations. • TB10.3 Lack of data on biomass quality and physical property characteristics for optimum conversion. • TB10.4 Lack of methods and instruments for measuring physical and biomechanical properties of biomass. 	<p>PT12.2, PT14.1, PT14.2, PT15.2</p> <p>PT12.1, PT12.2, PT14.1, PT14.2, PT15.2</p> <p>PT12.1, PT13.1, PT14.1, PT14.2, PT15.2</p> <p>PT14.2, PT15.2</p>
TB11 Biomass Physical State Alteration (i.e., grinding, densification, and blending)	
<ul style="list-style-type: none"> • TB11.1 High levels of impurities foul downstream preprocessing and processing systems. • TB11.2 Variability of biomass requires a wider range of equipment designs and capacities. • TB11.3 Harvest season for most crop-based lignocellulosic biomass is short, especially in northern climates, thus requiring preprocessing system that facilitate stable biomass storage as well as year round feedstock delivery to the biorefinery. • TB11.4 Existing biomass preprocessing infrastructure is tailored for higher value animal feeds. 	<p>PT12.2, PT13.1, PT15.1</p> <p>PT12.1, PT12.2, PT14.1, PT15.1, PT15.2</p> <p>PT12.2, PT13.1, PT15.1, PT15.2</p> <p>PT12.2, PT13.1, PT15.1, PT15.1, PT15.2</p>
TB12 Biomass Bulk Material Handling	
<ul style="list-style-type: none"> • TB12.1 High capital and operating costs (energy and power) for the existing package-based (i.e., bales, stacks, and pellets) equipment and facilities. • TB12.2 Low density and fibrous nature of lignocellulosic biomass make the biomass handling and transportation expensive. 	<p>PT12.2, PT13.1, PT15.1, PT15.1, PT15.2</p> <p>PT13.1, PT14.1, PT15.1, PT15.2</p>

03-50696-14T5.2

5.4 Research and Development Needs

Wide-ranging challenges facing biomass development require time and multi-institutional resources. Each of these research components has a significant effect on just-in-time delivery of feedstock to biorefineries. For example, researching biomass material properties will lead to developing equipment for grinding, sorting, and cleaning. Table 5.3 prioritizes preprocessing research and development topics.

Table 5.3. Preprocessing R&D needs.

Term of Priority Impact		R&D Need	Technical Barriers Addressed
RD10 Biomass Material Properties			
Top	M	RD10.1 Develop physical properties of dry and wet biomass and the application of these properties to harvest, storage, and transport as well as to post harvest operations such as size reduction, sorting, drying, densification, blending, etc.	TB10.1, TB10.3, TB10.4
High	M	RD10.2 Develop data and functional relations for moisture in biomass and the dependence of moisture on the surrounding environment (temperature, relative humidity, precipitation, etc.). Apply moisture relations to large scale preprocessing and handling of biomass.	TB10.2, TB10.3, TB10.4
RD11 Biomass Physical State Alteration (i.e., grinding, densification, and blending)			
Top	N	RD11.1 Develop in-the-field selection systems and post harvest equipment to clean and sort wet and dry biomass and to reduce particle size that increases density, and produces a clean flowable bulk material.	TB10.1, TB10.2, TB11.1, TB11.2, TB11.3, TB11.4, TB12.1
High	N	RD11.2 Develop physical state alteration systems, blending systems and strategies for smoothing out feedstock variations arising from different sources of feedstock and to meet feedstock quality specifications set by a biorefinery.	TB10.3, TB11.2
Medium	N	RD11.3 Improve the existing low-cost packaging systems (i.e., compressed piles, bales, bundles and stacks), and develop low capital and operating costs equipment for pelletizing biomass.	TB11.1, TB11.4
Low	M	RD11.4 Develop moisture control using high temperature drying including using biomass as source of heat.	TB10.2, TB11.2
Low	L	RD11.5 Develop distributed processing systems to convert biomass to intermediate chemicals immediately after collection, including on-combine preprocessing and first stage biorefinery pretreatments (i.e., processing plant on wheels).	TB10.1, TB11.3
RD12 Biomass Bulk Material Handling			
Top	N	RD12.1 Investigate bulk handling (i.e., conveyance, pneumatic, and slurry pumping) of biomass preprocessed into a bulk flowable form, and assess the placement of single or multiple preprocessing systems in the feedstock supply chain (i.e., on-combine, pre-transport and pre-storage) to maximize the benefits of preprocessing physical state changes for handling, transport and storage.	TB10.1, TB10.2, TB11.3, TB12.1, TB12.2
Low	L	RD12.2 Investigate the feasibility of a biomass slurry pipeline for handling and transferring biomass from the point of production to the refining facilities.	TB10.1, TB12.1, TB12.2 03-50696-15T5.3

Term of Impact = N: Near-term (within 3 years) M: Mid-term (within 10 years) L: Long-term (>10 years)

Preprocessing variable and moist biomass is expected to be a major challenge for safe and efficient harvest, storage, transport, and post harvest handling. The moisture content of stover could be 10 to 20% higher than the corn moisture content at the time of harvest. Unfortunately, the time of the year and crop conditions do not always provide suitable conditions for field drying. Finding ways to reduce the suitable level of moisture content in biomass for dry storage methods and/or developing effective preprocessing treatments to facilitate wet storage methods is critical to the eventual success of the biorefinery industry.

Biomass generally comes from the fibrous part of the plant material and thus it is inherently lightweight and low in density. Transporting and storing it in its loose form is costly. Current densification methods, like grinding and pressing operations, are too costly and energy consuming. Thus topics of important R&D are developing optimal physical state alteration technologies that will allow biomass to be efficiently handled, stored, transported, and ultimately converted to fuels and chemicals. Preprocessing technologies should also create from the wide-diversity of biomass sources a delivered feedstock of consistent uniformity and physical form.

5.5 Research and Development Priorities

While all preprocessing research needs play an important role in achieving biomass supply targets, three R&D priorities have the greatest potential to enable the industry to realize its vision:

- Develop physical engineering properties of biomass and their application to cleaning, densifying, and managing moisture
- Develop preprocessing technologies and equipment to clean and sort wet and dry biomass and to reduce particle size that increases density and produces a clean flowable bulk material
- Investigate bulk handling of biomass (i.e., conveyance, pneumatic, and slurry pumping).

The key technical elements, technical barriers, performance targets, technical risks, timeframe for completion, benefits to strategic goals, and the necessary interfaces and partners for successful completion are presented for each priority in Table 5.4.

Table 5.4. Preprocessing R&D priorities.

R&D Priority – RD10.1	Develop physical properties of dry and wet biomass and the application of these properties to harvest, storage, and transport as well as to post harvest operations such as size reduction, sorting, drying, densification, blending, etc.
Key Technical Elements	<p>TE36 Develop biomechanical (shear and normal stresses) and other physical properties of biomass as solid particles and en-mass.</p> <p>TE37 Develop controlled tests for time-temperature-moisture and quality relations for biomass during storage.</p> <p>TE38 Develop flow characteristics of whole, chopped, ground and granulated (cubes and pellets) biomass.</p> <p>TE39 Develop dielectric properties for biomass.</p> <p>TE40 Develop relations for moisture adsorption and desorption isotherms and thermal properties of biomass.</p>
Technical Barriers Addressed	TB10.1, TB10.3, TB10.4
Performance Targets Addressed	PT12.1, PT12.2, PT13.1, PT14.1, PT14.2, PT15.2
Risk	Medium technical risk – Fundamental material properties will have clear objectives, detailed research methodology, and rigorous scientific analysis, but biomechanics and rheological properties are directly related to complex plant growth and development phenomenon that require a significant research effort.
Benefit to Strategic Goals	<ul style="list-style-type: none"> • The data will assist in controlling and managing the existing equipment and processes to run more efficient. • The availability of data and models to manufacturers reduces development time and costs.
Term of Impact	Mid-term
Stakeholders Needs	SN3.1, SN3.5, SN3.7, SN6.9, SN10.3, SN10.5, SN10.7, SN10.9, SN17.5, SN18.4

R&D Priority – RD11.1	Develop in-the-field moisture control/selection systems and post harvest equipment to clean and sort wet and dry biomass and to reduce particle size that increases density, and produces a clean flowable bulk material.
Key Technical Elements	<p>TE41 Develop low cost size reduction technologies for high and low moisture biomass.</p> <p>TE42 Develop separation and sorting equipment based on physical properties of biomass – mechanical, aerodynamics, optical properties, etc.</p> <p>TE43 Optimize power and energy used for the existing and new preprocessing equipment, including densification equipment.</p> <p>TE44 Develop pilot scale equipment for chopping, grinding, slurry milling, separation, and other preprocessing steps, and field-test these equipment/systems. The system can be used for evaluated novel processes and biomass types and species.</p>
Technical Barriers Addressed	TB10.1, TB10.2, TB11.1, TB11.2, TB11.3, TB11.4, TB12.1

03-GA50696-16t5.4

Performance Targets Addressed	PT12.1, PT12.2, PT13.1, PT14.1, PT14.2, PT15.1, PT15.2
Risk	High technical risk - As a fibrous material, biomass may not be as easily preprocessed as materials rich in starch and protein, and development of new or modification of existing equipment requires considerable capital investment.
Benefit to Strategic Goals	Grinding, sorting, and densification increase the density of biomass improves the quality of biomass and reduces storage, handling and transportation costs.
Term of Impact	Near-term
Stakeholders Needs Addressed	SN3.1, SN3.7, SN3.19, SN4.1, SN4.2, SN4.3, SN4.4, SN4.5, SN4.6, SN4.7, SN4.10, SN6.9, SN7.3, SN7.4, SN9.4, SN9.5, SN10.2, SN11.11

R&D Priority – RD12.1	Investigate bulk handling (i.e., conveyance, pneumatic, and slurry pumping) of biomass preprocessed into a bulk flowable form, and assess the placement of single or multiple preprocessing systems in the feedstock supply chain (i.e., on-combine, pretransport, and prestorage) to maximize the benefits of preprocessing physical state changes for handling, transporting, and storing.
Key Technical Elements	<p>TE45 Investigate the feasibility of slurry pumping transport and its economic and environmental implications.</p> <p>TE46 Develop mechanical and pneumatic conveying systems for fluidized bulk biomass.</p> <p>TE47 Investigate multiphase flow (solid and fluid) phenomena for ground biomass.</p> <p>TE48 Develop an engineering economic analysis of compression methods for bulk biomass material in large bulk modules and their cost advantages on granulated biomass.</p>
Technical Barriers Addressed	TB10.1, TB10.2, TB11.3, TB12.1, TB12.2
Performance Targets Addressed	PT12.1, PT12.2, PT13.1, PT14.1, PT14.2, PT15.1, PT15.2
Risk	Medium – Bulk handling systems are well known and used today, and of lower risk. Integration of multiple preprocessing systems is of higher risk because of lack of experience in the system.
Benefit to Strategic Goals	Safe, easy, and low cost handling and transport of biomass.
Term of Impact	Near-term
Stakeholders Needs Addressed	SN1.2, SN1.6, SN1.9, SN1.12, SN6.18, SN10.1, SN10.2, SN10.5, SN10.6, SN11.1, SN11.2

03-50696-16T5.4

6. System Integration





6. System Integration

The most critical component of a successful biorefinery is a secure and reliable feedstock supply. Ample feedstock should be available to biorefineries at the appropriate time and at competitive prices without safety, environmental, or regulatory setbacks. System integration across the whole of the feedstock supply system, from the processor, through the harvesting and collection, to storage and transport, addresses the seasonal nature of biomass production and the complex interactions that must occur between producers, processors, transporters, and the local community. The supplier expects to make a consistent profit; the feedstock processor expects adequate and secure supply, low cost, and uniform quality; and the community, as a whole, expects the benefits of an environmentally friendly, domestically produced fuel supply.

Developing a consistent, economically viable feedstock supply system requires addressing and optimizing diverse harvesting, storage, preprocessing, and transportation scenarios. The logistics for biomass feedstocks involve geographically dispersed and varied material, time dependent maturity and yield, a short time window for collection, and competitive demands on resources. Feedstock supply system simulation models can be used as powerful cost saving optimization and analytical tools to evaluate the techno-economic viability of several biomass supply options while factoring in variability. An optimized network of harvesting and collection, storage, and transportation infrastructure is the key to the viability of the biorefinery. Adding supply scenarios into an integrated feedstock supply system model will lead to a higher level decision support platform that can provide critical information necessary for designing and operating biorefinery feedstock supply systems.

Because biomass quantities, prices, and transportation costs will vary with location, it is critically important to capture geographic specificity in resource information. Given the variability that exists in biomass supplies, a standardized approach for feedstock supply systems will not work for all biomass types, in all conditions, and in all regions of the country. Instead biomass supply systems will need to be tailored and optimized for the site-specific set of



Figure 6.1. The supplier, processor, and the community, as a whole, expect the benefits of an environmentally friendly, domestically produced fuel supply.

conditions. System simulation models and market barrier analyses will provide very useful information and tools toward this end.

6.1 Current Technical Situation

To meet the needs of the biorefinery, an integrated feedstock supply system must be developed. For some processes, such as biomass harvesting, new technology is most likely needed and will need to be developed near term. For other processes, such as transportation, development of new technologies is not realistic in the time period required; therefore the feedstock supply systems must be built around existing transportation technologies and infrastructure. Other than a few integrated forest-related industries that benefit from a highly organized biomass supply chain, the low demand on other biomass sources has not warranted the development of robust, integrated biomass supply systems. System integration analyses and modeling tools will be highly valuable in integrating the various feedstock supply system process steps and guiding the overall design of the integrated biorefinery feedstock supply system.

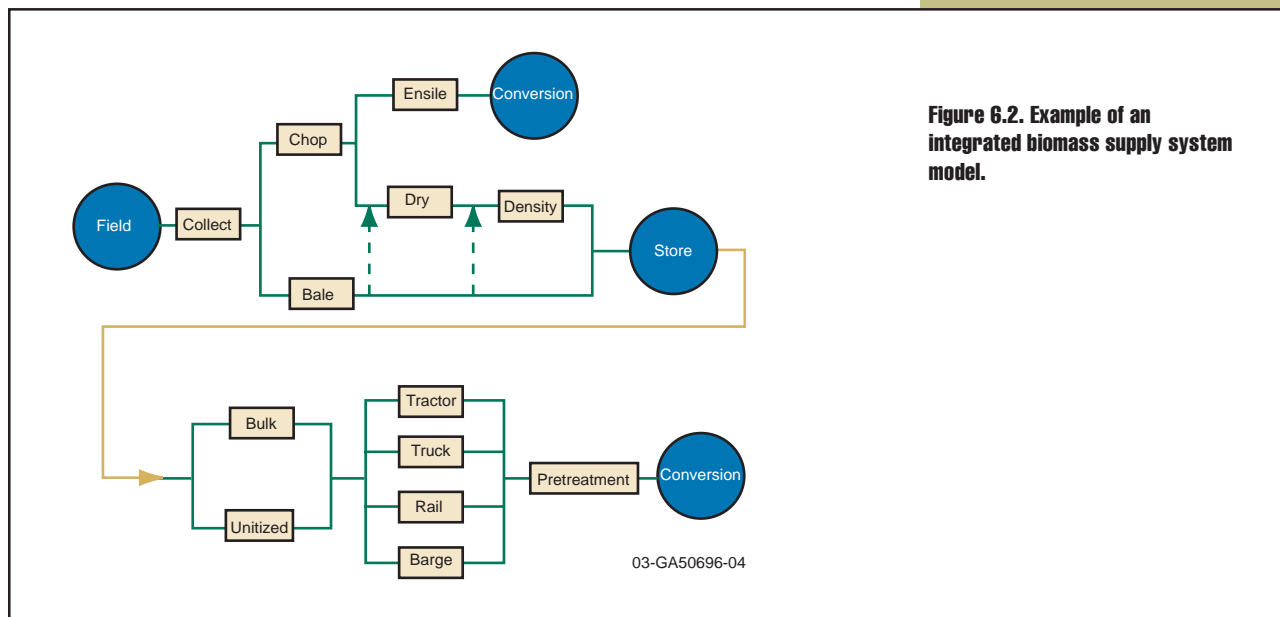

Figure 6.2. Example of an integrated biomass supply system model.

Figure 6.2 illustrates the envisioned flow of biomass from the field to a biorefinery. After harvesting and collection, the material is preprocessed to ease storage and transport. Several scenarios exist for the delivery of the preprocessed biomass to the biorefinery. In one scenario, wet biomass may be ensiled in large piles and shipped gradually to the conversion facility. In other scenarios biomass may be packaged, stored, and transported. The best possible scenario is dependent on factors such as climate, moisture content of biomass, and local factors.

An entire feedstock supply system model is needed to determine optimized scenarios dependent on these factors. This model will require performance data for various equipment and processes used in collecting, storing, and transporting biomass. Climate and biological data that describe the availability and characteristics (e.g., moisture content) of the biomass at any given time are also required. Finally, biomass quality requirements, processor demand schedules, transportation options as a function of location, and storage options will be needed for model input. Much of this information will be available to the model as the elements of this roadmap are implemented.

Additionally, to support policy planning and understanding of market development, a variety of national-level biomass supply analyses need to be developed. A few of this type of analysis have been done, but policy makers and the public desire more information on this type for making decisions that affect the feedstock supply system for the biorefinery.

6.2 Performance Targets

Given the large economies of scale of biorefineries, a typical-sized biorefinery may require as many as 1 million tons/year of biomass supplied at a constant rate year round. Delivering this volume of biomass requires knowing where and when the biomass is available and the optimal configuration of the feedstock supply system. Transportation is a critical interface element of the feedstock supply system and represents a significant fraction of feedstock costs. The model will need to track the biomass mix and available means of transport, such as water, rail, and pipeline, to meet the biorefinery feedstock transport needs at the lowest cost. Safety of persons and the environment are also paramount and need to be integrated into the analysis.

Table 6.1 shows performance targets for systems integration. Since the primary system integration activity is optimizing technical and economic

Table 6.1. System integration performance targets.

PT16 Biomass Availability	<ul style="list-style-type: none"> • PT16.1 Analysis tools are sufficiently developed to rigorously assess feedstock infrastructure by 2010 that would be needed to attain 150M tons/year of crop residues in a sustainable manner.
PT17 Sustainability	<ul style="list-style-type: none"> • PT17.1 Complete integrated LCA analyses have been performed by 2010 for biorefinery feedstock supply systems to supply 150M tons/year of crop residues. • PT17.2 Safety standards exist by 2010 for the handling of 150M tons of crop residues annually by various methods. • PT17.3 Feedstock infrastructure system has been optimized to obtain the maximum possible fossil fuel displacement by 2020.
PT18 Feedstock Infrastructure	<ul style="list-style-type: none"> • PT18.1 Analysis tools and process models are developed sufficiently to rigorously assess and integrate options for feedstock harvest, collection, transportation, storage, and preprocessing of 150M tons/year of crop residues in a sustainable manner by 2010. • PT18.2 System models exist that can assess the cost and benefits of alternative means of bulk transportation such as rail, pipelines, etc. by 2010.
PT19 System Profitability	<ul style="list-style-type: none"> • PT19.1 Detailed system and process models are available for prediction of integrated system profitability by 2010. • PT19.2 Local, State, and National policies are developed and instituted that are supportive to biomass technology and market development by 2010.

03-50696-17T6.1

outcomes through modeling and facilitating policy development, the targets will by necessity have to reflect the hoped for outcomes of using these tools. The development of a validated robust system simulation model will support targets on biomass quantities, sustainability, feedstock infrastructure, and profitability of the system. Similarly, optimal feedstock supply and transportation networks will contribute greatly to the viability of an integrated feedstock supply system for the biorefinery.

6.3 Technical Barriers

To develop adequate feedstock supply system integration, solutions to several technical barriers must be developed. These technical barriers can be divided into three general categories:

- Subsystem specifications
- Overall integration
- Market and policy.

Subsystem specification barriers refer to those barriers that hinder developing cost-effective and widely applicable harvest, collection, storage, preprocessing, and transportation subsystems. Overall integration refers to establishing integrated feedstock supply systems. Market and policy barriers include regulations and liabilities that affect the availability of biomass feedstocks. For example, competitive demands for land and biomass resources are considered a type of market barrier. Table 6.2 displays the barriers to feedstocks supply systems integration categorized by the three categories listed above.

In spite of impressive progress in systems modeling tools, the challenge remains to apply these advanced modeling tools to specific cases. The necessary data and individual process models do not currently exist to create an integrated feedstock supply system model. Operational aspects of machinery in the field depend upon speeds and process efficiencies that vary widely from one field to the next and from one crop to another. The management of harvest operations depends largely on human management decisions, for which modeling may not be feasible. A time lapse exists between deploying new equipment in the field and the availability of operational and cost data. A credible systems analysis of supply logistics cannot be conducted unless reliable data are available.

Current transportation equipment is generally designed for high-density/high-value material, while biomass is generally neither. Biomass could be processed to make it denser or equipment could be modified to better suit biomass characteristics. In addition, the seasonal nature of biomass must be dealt with in terms of equipment use and availability. Rail systems or barging may be an attractive alternative because of its larger load volume and weight capacities compared to trucks, however, there are institutional barriers, such as changing loaded rail cars from one rail company to another, and waterway access that must be addressed if rail or barges are to be a viable transportation option.

Some of the market barriers relate specifically to transportation issues. For truck transportation, weight and size limits vary by state and time of year. Some tractors are designed for higher speeds, but this may exceed state maximum allowed speed. The sugar cane, wood chip (for pulping), and beet industries store large quantities of biomass, but many areas where biomass will be produced and stored do not have experience storing such quantities. There are liability questions as well as potential health and safety issues with moving and

Table 6.2. System integration technical barriers.

	Performance Targets Addressed
TB13 Subsystem Specifications	
<ul style="list-style-type: none"> • TB13.1 Lack of data and relationships between machine performance and the variability of physical characteristics of biomass. • TB13.2 Lack of analyses of existing transportation technologies and how they can be used in the near term to sustainable supply 150 M tons of crop residues annually. • TB13.3 Safety and environmental issues associated with transporting and handling huge quantities of biomass have not been addressed. 	<p>PT16.1</p> <p>PT16.1, PT17.3</p> <p>PT17.2</p>
TB14 Overall Integration	
<ul style="list-style-type: none"> • TB14.1 Lack of data on variability of biomass resources and how this variability affects shelf life and processing yields. • TB14.2 Sustainability analyses are suspect due to lacking and sometimes inconsistent data. • TB14.3 Existing transportation infrastructures, regulations and labor agreements limit transportation options and these vary by region. • TB14.4 Existing biomass collection, handling and transport systems are not designed for the large-scale needs of the biorefinery. • TB14.5 Feedstock infrastructure has not yet been solidified as to what is needed for various locations, climates, feedstocks, storage methods, etc. 	<p>PT16.1</p> <p>PT17.1</p> <p>PT17.1</p> <p>PT17.1</p> <p>PT18.1, PT19.1</p>
TB15 Market & Policy	
<ul style="list-style-type: none"> • TB15.1 Local, State and Federal regulations concerning weight and dimension of biomass loads constrain transportation options. • TB15.2 The use of biomass for production of fuels and chemicals from lignocellulose has not been demonstrated to be cost effective at a significant scale. • TB15.3 Lack of sufficient political awareness of the biorefinery concept hinders development and implementation of the needed incentives programs. • TB15.4 Lack of support at the grass roots from the agricultural community because commercial viability of cellulosic biomass to bioenergy and bioproducts has not been demonstrated. 	<p>PT18.2</p> <p>PT17.3, PT19.2</p> <p>PT19.2</p> <p>PT19.2</p> <p>03-50696-18T6.2</p>

storing large quantities. The lack of predictions on future competitive demands for biomass for forage, fiber, and multiple new bioproducts and between biofuels and biopower could have a paralyzing effect on the implementation of biomass projects. While no predictions will ever be precise, analyses can begin to provide information on market risks and facilitate the development of risk minimization strategies.

6.4 Research and Development Needs

The barriers to the development of the integrated feedstock supply can be overcome through integrated R&D activities. The R&D needed to achieve the performance targets for systems integration can be aligned with the barrier areas above. Table 6.3 displays the R&D needs.

In order to meet the national goal of 150 million tons of crop residues/year, integrated feedstock supply systems will need to be developed to handle multiple sources of different types of biomass in multiple sets of conditions. Feedstock supply system simulation and modeling tools that can be used as design tools to guide the design of site-specific feedstock supply systems for individual biorefineries must be developed to account for this variability.

Table 6.3. System integration R&D needs.

Priority	Term of Impact	R&D Need	Technical Barriers Addressed
RD13 Subsystem Specifications			
Top	M	RD13.1 Comprehensive techno-economic, life cycle analyses, and process models are needed on new and existing feedstock supply infrastructure subsystems including production, harvesting and collection, storage, transportation and preprocessing interconnected with conversion pathway options.	TB13.1, TB13.2, TB13.3, TB14.1, TB14.2, TB14.3, TB14.4, TB14.5, TB15.1, TB15.2, TB15.3, TB15.4
Medium	N	RD13.2 Assess the costs associated with the use of densification systems and how these systems affect processing.	TB15.1
RD14 Overall Integration			
Top	M	RD14.1 Develop a feedstock supply system simulation tool that can be used to determine optimal feedstock supply system elements, including the tradeoffs between using multiple crops to extend biomass supply period vs. storage requirements, while accounting for interdependencies, existing transportation infrastructure, trade-offs, and variability.	TB13.1, TB13.2, TB14.1, TB14.2, TB14.3, TB14.4, TB14.5
High	N	RD14.2 Develop a framework for selecting and matching optimal transportation networks with various combinations of feedstock supply system elements.	TB15.1
High	N	RD14.3 Assess the safety and standardization issues associated with the feedstock supply chain including transportation.	TB13.3
RD15 Market & Policy			
Top	N	RD15.1 Identify market and policy barriers associated with establishment of the feedstock supply system on both national and local scales.	TB14.2, TB14.5, TB15.1
High	N	RD15.2 Work with producers, processors, and government to determine the necessary framework and data necessary to support policy development.	TB15.3
Medium	N	RD15.3 Identify sites with high potential for reasonably priced feedstock supplies due to feedstock availability, transport options and supportive state and local policies; target these sites for demonstration projects.	TB15.3 03-50696-19T6.3

Term of Impact = N: Near-term (within 3 years) M: Mid-term (within 10 years) L: Long-term (>10 years)

Additionally, analysis work must be performed to identify the market, regulatory land use, and other issues that must be considered when developing site-specific feedstock supply systems.

Feedstock supply simulation models will need to be developed to account for the interdependencies of the process steps and variability. The feedstock supply system will involve many highly interrelated process steps. The logistics and processes performed in one step will have significant implications in other steps. For instance, the cost driver to handle and transport the feedstock in bulk form will have major implications on harvesting, collecting, and storing. Additionally, the effects of biomass type, climate, moisture levels, transportation infrastructure and options, and regional variability issues must be accounted for. The model will need to make it possible to conduct sensitivity or risk analyses on how variations in input and resources affect the output in terms of labor, machine, cost, and energy requirements. Once it has been developed and validated, the feedstock supply simulation model will provide a powerful design and decision support tool to assist in designing and evaluating site-specific integrated feedstock supply systems.

Significant market and policy barriers on both national and local scales need to be overcome (i.e., regulatory, policy, economic, and labor rules; restrictions and competing desires for land use; and environmental, regional, and system specific issues that exist towards establishing the biorefinery industry). It is critically important that these barriers be identified early so that they can be addressed. Several types of analyses are required and must be linked to support identification of these barriers. These include life cycle analyses, technoeconomic analyses, and evaluations of competition for resources and land. The research and analyses should also be directed towards developing organizational structures for biomass acquisition and supply systems for enabling smaller producers to participate in a biomass supply enterprise.

6.5 Research and Development Priorities

Developing feasible and sustainable feedstock supply systems for collecting biomass and transporting it to conversion facilities requires a thorough analysis of highly interrelated activities and numerous combinations of options. Individual process steps in the feedstock supply system can be modeled mathematically and used to develop a simulation tool. This provides a valuable tool for designing site-specific feedstock supply systems while minimizing costs. The optimization problem will be subject to constraints stemming from competing resources, competing uses of biomass, fire and safety regulations, weight limit rules, and many other obstacles.

The development of low cost, high volume feedstock supply systems for the biorefinery is critical. Inherent characteristics of high moisture content for most biomass, low bulk density, and seasonality of supply must be dealt with. An integrated simulation model of biomass supply systems is a complex undertaking with a moderate amount of technical risk. However, it will provide a management and decision-making tool for a biorefinery to allow optimal resource decisions for equipment and other capital, labor, and energy. Table 6.4 shows the R&D priorities.

Table 6.4 . System integration R&D priorities.

R&D Priority – RD13.1	Comprehensive techno-economic, life cycle analyses, and process models are needed on new and existing feedstock supply infrastructure subsystems including production, harvesting and collection, storage, transportation and preprocessing interconnected with conversion pathway options.
Key Technical Elements	<p>TE49 Assess transportation options for wet and dry feedstock of varying formats.</p> <p>TE50 Determine the required equipment, costs, benefits, and limitations of transportation of feedstock stored using by wet and dry methods.</p> <p>TE51 Investigate mass and load dimensions of various transport equipment.</p> <p>TE52 Investigate relations between the biomass form (wet or dry chop, baled, pelleted) and transport equipment.</p> <p>TE53 Process modeling of each separate supply system subsystem, in tandem with design and development efforts.</p>
Technical Barriers Addressed	TB13.1, TB13.2, TB13.3, TB14.1, TB14.2, TB14.3, TB14.4, TB14.5, TB15.1, TB15.2, TB15.3, TB15.4
Performance Targets Addressed	PT16.1, PT17.1, PT17.2, PT17.3, PT18.1, PT18.2, PT19.1, PT19.2
Risk	Low – All subsystems are defined and modeling of similar integrated systems has been successful.
Benefit to Strategic Goals	<ul style="list-style-type: none"> • Provide optimized estimates of the requirements and costs of various permutations of system subsystems for use in TEA & LCA Provide decision-making tool for system linkages.
Term of Impact	Mid-term
Stakeholders Needs Addressed	SN1.2, SN1.3, SN1.5, SN1.10, SN5.4, SN5.9, SN6.3, SN6.4, SN6.5, SN6.11, SN6.14, SN7.4, SN8.2, SN8.3, SN8.5, SN8.6, SN8.7, SN8.10, SN8.11, SN8.12, SN8.14, SN10.1, SN11.4, SN11.9, SN11.12, SN13.2, SN13.8, SN14.1, SN18.5

R&D Priority – RD14.1	Develop a feedstock supply system simulation tool that can be used to determine optimal feedstock supply system elements, including the tradeoffs between using multiple crops to extend biomass supply period vs. storage requirements, while accounting for interdependencies, existing transportation infrastructure, trade-offs, and variability.
Key Technical Elements	<p>TE54 Access sustainability, storage, and biomass characterization data, including variability, to support analyses.</p> <p>TE55 Develop biomass availability and characteristics database(s) including maturity date, biomass yield, harvest duration, and traditional biomass use.</p> <p>TE56 Perform comprehensive TEA and LCA of production and of individual supply system elements including both existing and new technology.</p> <p>TE57 Perform comprehensive integrated TEA and LCA of the entire feedstock supply system, including transportation, accounting for system interdependencies and trade-offs.</p> <p>TE58 Develop or identify a computational simulation model and use it, together with the TEA and LCA analyses, to simulate the feedstock supply system.</p>

Technical Barriers Addressed	TB13.1, TB13.2, TB14.1, TB14.2, TB14.3, TB14.4, TB14.5
Performance Targets Addressed	PT16.1, PT17.1, PT17.3, PT18.1, PT19.1
Risk	Low to Medium – Modeling the complex tradeoffs among multiple feedstock supplies increases model complexity and risk that the models will be broadly applicable.
Benefit to Strategic Goals	<ul style="list-style-type: none"> • Increased confidence in the profitability of biobased enterprises. • Allay producer and environmental advocacy groups' concerns on sustainability. • Provide information for policy development support.
Term of Impact	Mid-term
Stakeholders Needs Addressed	SN2.12, SN6.1, SN6.2, SN6.3, SN6.4, SN6.5, SN6.6, SN6.8, SN6.9, SN6.11, SN6.12, SN6.13, SN6.14, SN6.16, SN6.17, SN7.4, SN8.1, SN8.2, SN8.5, SN8.6, SN8.11, SN10.1, SN10.2, SN11.4, SN14.3, SN15.3, SN18.5

R&D Priority – RD15.1	Identify market and policy barriers associated with establishment of the feedstock supply system on both National and local scales.
Key Technical Elements	<p>TE59 Evaluate competition for land and biomass resources by linking biomass resource models with agricultural demand models.</p> <p>TE60 Assess the regional differences of the economics associated with different geographical locations and growing conditions.</p> <p>TE61 Identify regulatory and liability issues with existing transportation options. Estimate and compare regional economic impacts and job creation for different feedstock supply systems.</p> <p>TE62 Investigate optimal enterprise structures (who does what) for feedstock supply systems.</p>
Technical Barriers Addressed	TB14.2, TB14.5, TB15.1
Performance Targets Addressed	PT17.1, PT18.1, PT18.2, PT19.1
Risk	Low - The feedstock supply system, though widespread and geographically variable, will be very much a part of and similar to the current food, feed and fiber agriculture production and supply system.
Benefit to Strategic Goals	<ul style="list-style-type: none"> • Obtain grass-roots and governmental support. • Improve profitability.
Term of Impact	Near-term
Stakeholders Needs	SN6.3, SN8.1, SN8.3, SN13.1, SN13.2, SN13.4, SN13.6, SN13.8, SN14.1, SN14.4

03-50696-20T6.4

7. Transportation





7. *Transportation*

Transportation is a key segment of the biomass feedstock supply system industry. It was discussed at each feedstock colloquy meeting to the extent that 10% of the recorded stakeholder input deals directly with transportation issues. There was general agreement that the current way existing transportation options are utilized for biomass are neither the most efficient nor effective, however, the solution to this issue does not include a separate grouping of R&D needs for developing a unique biomass transportation infrastructure. Instead, each of the previous section's R&D needs encompasses R&D for improving utilization of existing transportation options.

The transportation infrastructure is a fixed constraining requirement for the biomass feedstock supply system. Biomass may be transported by truck on existing roads or by trains and barges on existing rail networks and waterways (see Figure 7.1). No matter the method, existing transportation technologies must be used. Developing new transportation technologies just for biomass is unfeasible due to the size and multiple use nature of the existing infrastructure. In addition, current methods of transportation have set limitations such as weight and size of loads. Highway overpasses cannot be raised, railcars are already sized for multiple uses, and traffic control systems are already in place and must be accepted.

Although the transportation equipment, laws, and infrastructure are the least flexible segment of the feedstock supply system, many researchable transportation related issues have been identified regarding developing, selecting, and



Figure 7.1. The biomass feedstock supply system must use the existing transportation network and local transportation options.



integrating harvesting, storing, preprocessing, and other technologies. Each technology must take advantage of and optimize the use of the diversity of existing transportation options that might be locally available. As such, research in production, harvesting and collection, storage, preprocessing, and systems integration includes performance targets, technical barriers, and R&D needs to achieve significant improvements in the utilization of the existing transportation infrastructure for biomass.

Appendices





Appendix A – Grouped Colloquies R&D Need Statements

Critical issues for supplying biomass feedstocks over the next three to ten years were discussed in seven colloquies held across the country between March and May of 2003. The purpose of these colloquies was to solicit the information necessary to develop the feedstock roadmap.

The colloquies included six to twelve participants, each a stakeholder in a position to influence the future of the industry. Participants generally had a broad knowledge of the issues, with in-depth expertise in one or more of the key areas. They represented the following segments:

- Corn and wheat growers
- Ag equipment manufacturers
- Potential biomass processors
- Environmental NGOs
- Farm group NGOs
- States/communities
- USDA/Univ/national labs
- Biomass processors.

Below is a comprehensive list of the list of the research and technology development needs identified in these seven colloquies that were used to develop this roadmap.

Stakeholder Need Statement	Addressed by R&D Priority
SN1: General Economics	
SN1.1: Need research into how the whole process will be funded.	RD1.1
SN1.2: Questions about making the collection and transportation economical.	RD6.1, RD6.2, RD12.1, RD13.1, RD13.2
SN1.3: Need research into the economics hauling distances, storage facilities, and preprocessing.	RD6.2, RD13.1, RD13.2
SN1.4: Questions about the high cost to the grower in time, equipment depreciation, capital costs to produce the feedstock, and there doesn't seem to be the incentive to the grower to cover these costs.	RD15.3
SN1.5: Need research into the economics of the scale of the operations that are needed to make this a viable operation.	RD1.1, RD6.1, RD13.1
SN1.6: Questions about the cost of new equipment to the grower.	RD4.4, RD12.1
SN1.7: Questions about utilization levels of the equipment and the reliability of the harvesting equipment.	RD4.4
SN1.8: Need research into the value to the farmer of leaving the straw in the field or removing the straw from the field.	RD2.1, RD2.2, RD2.3, RD2.4
SN1.9: Questions about the cost to design and analyze the changes/impacts to harvesting equipment to meet different needs.	RD5.1, RD6.1, RD12.1
SN1.10: Need research into the development of smaller processing plants with smaller capital costs including transportation and other infrastructure needs.	RD1.1, RD13.1
SN1.11: Need research into the impact on the economics of the whole process when the large volume of material needed comes into play.	RD5.2, RD14.2
SN1.12: Questions about the higher costs to handle the grain as a result of harvesting the stover (i.e., having to go and collect the grain from the separation site).	RD5.1, RD5.2, RD6.1, RD12.1
SN1.13: Need research into the regional differences of the economics associated with different geographical locations and growing conditions.	RD1.1, RD2.4, RD13.2, RD14.2



Stakeholder Need Statement

Addressed by
R&D Priority

SN2: Sustainability	
SN2.1: Need research into what are the long-term consequences of harvesting this material?	RD2.2, RD2.3, RD2.4
SN2.2: Questions about the crop residue left after harvesting as a key component of sustainable farming in highly erodible areas.	RD2.2, RD2.4
SN2.3: Need research into the impact of harvesting the feedstock on the sustainability of the field and how to reduce those impacts (e.g., one-pass).	RD2.2, RD2.4, RD5.1
SN2.4: Need research into the soil consequences of removing the byproduct.	RD2.2, RD2.4
SN2.5: Need research on what we should be leaving behind in the fields. (Research using modeling, virtual research, and field studies.)	RD2.2, RD2.4
SN2.6: Can we capture value in the biomass that lies around after the grain harvest?	RD2.1, RD2.2, RD2.3, RD2.4
SN2.7: Questions about what parts or amount of stover that needs to be left in the field to meet sustainability and economic needs.	RD2.2, RD2.4
SN2.8: Need research into no-till and the impact no-till will have on sustainability and erosion protection (erosion control, soil conservation, carbon sequestration, environmental quality etc.).	RD2.3, RD2.4
SN2.9: Need research into the effect of residue removal in soil biota, soil moisture, temperature, and crop yield affects.	RD2.2, RD2.4
SN2.10: Need research into the geographic differences for sustainability that will impact intelligent harvesting machines ability to deal with selective harvesting and other concepts.	RD4.2, RD4.4
SN2.11: Need research to develop guidelines for residue removal rates.	RD2.2, RD2.4
SN2.12: Questions about the amount of the surface area for the feedstock.	RD14.1, RD14.2
SN2.13: Need research into the affects (above and below the ground) of no tilling and how this will impact biomass harvesting requirements.	RD2.2
SN2.14: Need research into the benefit or detriment of the removal of straw/stover in relation to the farming practice.	RD2.2
SN2.15: Need research into what part of the biomass we want to collect? Do we need to collect all of it?	RD2.2
SN2.16: Questions about the need to replace the stover normally left in the field is a lot of work and expense that will impact the ability or desire of the grower to provide feedstock.	RD2.2
SN2.17: Need research into the amount of biomass that can be taken off the field and what biomass needs to be left in the field.	RD2.2
SN2.18: Need research into the geographic, topographic and climatic differences in byproduct removal and processing between locations.	RD2.2, RD2.4
SN2.19: Need research into the benefits and conditions for no-till operations.	RD2.2
SN2.20: Need research into the interaction of cover crops and the byproduct removal with the research stratified on a regional or local basis.	RD3.1
SN3: Feedstock Composition and Quality	
SN3.1: The simpler the feedstock form coming into the processor the better.	RD7.2, RD10.1, RD11.1
SN3.2: Questions about the value of the cobs and other parts of the stover to other processors.	RD7.4
SN3.3: The number and kinds of contaminates in the feedstock.	RD4.3, RD7.2, RD7.4, RD11.2
SN3.4: Need research into the composition and quality of the feedstock needed for a specific process.	RD4.3, RD7.1, RD7.2, RD7.4, RD11.2
SN3.5: Need research into the best form of delivering the corn stover.	RD4.3, RD7.2, RD7.4, RD10.1, RD14.3
SN3.6: Need research into monitoring the quality and consistency of the feedstock (what to monitor and how to monitor it).	RD4.3, RD7.2, RD7.4
SN3.7: Questions about the fineness of the feedstock coming out of the harvesting equipment.	RD4.3, RD7.1, RD7.2, RD7.3, RD7.4, RD10.1, RD11.1
SN3.8: Compensation to the grower based on the composition of the feedstock.	RD7.1, RD7.2, RD7.3, RD7.4

03-50696-22Ta2

Stakeholder Need Statement

Addressed by
R&D Priority

SN3.9: Need research into the composition of the feedstock coming into the process and its affects on processing and storage.	RD4.3, RD7.1, RD7.2, RD7.4, RD11.2, RD11.4
SN3.10: Need research into the optimal sugar contents of the feedstock material at different times.	RD7.1, RD7.2, RD7.4, RD11.2
SN3.11: Need research into developing tests for straw quality.	RD7.2, RD7.3
SN3.12: Questions about the moisture content of the material.	RD7.1, RD7.2, RD7.3, RD11.4
SN3.13: Which of the individual stover components is important and of value to the processor or to other end product processors?	RD11.2
SN3.14: Need research into other enzymes that may be economically used at harvesting or storage.	RD3.2, RD9.1, RD9.4
SN3.15: Concerned with the amount of water in the stover and the cost this adds to either the grower or the processor.	RD7.2, RD11.4
SN3.16: Need research into the elimination or reduction of the lignin content of the feedstock. Low lignin content will be value added to the processor.	RD4.5, RD11.5
SN3.17: Need research into the marketability of cobs.	RD7.1
SN3.18: Need research into the stover content of corn impacted by drought.	RD11.2
SN3.19: Need research into the weight of the cob as part of the stover.	RD11.1, RD11.2
SN4: Harvesting Equipment	
SN4.1: Questions about being able to alter the harvesting machine to differentiate between the different parts of the feedstock.	RD4.1, RD4.5, RD11.1
SN4.2: Need research into selective harvest, multi-component, intelligent machines that can take into account the sustainability needs of the field.	RD4.1, RD4.4, RD4.5, RD5.1, RD5.2, RD11.1
SN4.3: Need research into the R&D of new or modified equipment to respond to the whole biomass feedstock system.	RD5.1, RD5.2, RD6.1, RD11.1
SN4.4: Need research into modifying the combine to separating the material and leaving the low quality material in the field or material needed for precision farming guidelines.	RD4.1, RD4.2, RD11.1
SN4.5: Capability of the combine to automatically adjust to conditions without operator intervention.	RD4.4, RD11.1
SN4.6: Questions about the need for specialized harvesting equipment.	RD4.1, RD4.4, RD5.1, RD6.1, RD11.1
SN4.7: Need research into the use of alternative harvesting machines that go beyond the current technology.	RD4.2, RD4.4, RD4.5, RD6.1, RD6.3, RD11.1
SN4.8: Questions about the size and configuration of the harvesting equipment for ease of use and impact on the field.	RD6.1
SN4.9: Need research to address the one-pass and the equipment needs to make it economical to all.	RD5.1, RD5.2
SN4.10: Need research into a combine that would chop material small enough, deposit it, so it could then be picked up by a vacuum truck following along behind the harvester.	RD6.3, RD11.1
SN4.11: Need research into improving the chaff capacity of the harvesting equipment.	RD6.1, RD6.2
SN4.12: Need the ability to adjust the height of the stalk remaining.	RD4.1, RD4.2
SN5: Storage	
SN5.1: Need research into the differences of dense bails vs. wet storage or other storage methods.	RD8.1, RD9.1, RD9.1, RD9.4
SN5.2: Need research into the single pass storage of the 1/8-inch particle in the field.	RD7.1, RD8.1
SN5.3: Potential issue with the cost of a capital expense for wet storage of the stover.	RD9.1, RD9.4
SN5.4: Need research into the cost, benefits, or limitations of hauling material stored using water storage method.	RD9.1, RD9.1, RD13.1
SN5.5: Need research into the affect of degradation of the straw on the processing of the straw at the processing plant.	RD8.2, RD9.1, RD9.4
SN5.6: Need research into storage of the straw.	RD8.1, RD8.2
SN5.7: Need research into ways to improve storage options.	RD8.1, RD11.2

03-50696-23Ta3

Stakeholder Need Statement

Addressed by
R&D Priority

SN5.8: Need research into how the feedstock will change over time as it is in storage.	RD7.3, RD8.1, RD9.1, RD9.4, RD11.2
SN5.9: Need research into the equipment and economics of hauling and handling of wet storage material.	RD9.1, RD12.2, RD13.1
SN5.10: Need research into the material loss from piling the straw at central locations.	RD8.1, RD8.2
SN5.11: Need research into the amount of water needed by a specific process or storage option.	RD7.3, RD9.1, RD9.3, RD9.4, RD11.4
SN5.12: Need research into the acid content of wet storage material and the impact on the processing of that wet storage material into the final product.	RD7.3, RD9.1, RD9.1, RD9.4
SN5.13: Need research into the smell produced by wet straw storage systems.	RD9.1, RD9.1, RD9.2
SN5.14: Need research into potential disease problems in the storage of feedstock material.	RD7.3, RD8.1, RD8.2, RD9.1, RD9.1, RD9.2, RD11.2
SN5.15: An issue with the water requirements of the wet storage and pre-processing needs.	RD9.1, RD9.1, RD9.2, RD9.3, RD9.4, RD11.4, RD12.2
SN6: Transportation	
SN6.1: Need research into the transportation of 1/8-inch product and how it will react to transportation techniques and equipment.	RD14.1
SN6.2: Need research into the existing network of coops, transportation and the existence of feedstock to supply a processing plant.	RD6.2, RD14.1, RD14.2, RD15.3
SN6.3: Questions about the size of the harvesting collection area per a transportation node.	RD13.1, RD13.2, RD14.1, RD14.2, RD15.1
SN6.4: Questions about the distance of the haul from the collection point to the processing point.	RD13.1, RD14.1
SN6.5: The volume of feedstock collected per a transportation node.	RD13.1, RD13.2, RD14.1, RD14.2
SN6.6: Location of collection points to main rail lines verses use of a branch line.	RD14.1
SN6.7: Use of standard rail cars verses the need for specialized rail cars.	RD14.2
SN6.8: Need research into reducing the costs of packaging and transport of the straw.	RD6.2, RD14.1
SN6.9: Questions about the form (dry, liquid, gas) of the material being transported.	RD10.1, RD10.2, RD11.1, RD12.2, RD14.1
SN6.10: Standardization of the feedstock product moved by rail.	RD11.2
SN6.11: Need research into how far dry material can be hauled to storage or pre-processing sites.	RD13.1, RD14.1
SN6.12: Need research into the economics of truck hauling and what are the requirements to make the hauling efficient.	RD13.2, RD14.1, RD15.2
SN6.13: Need research into the type of trucks and trailers (new purchase or conversion) that are needed and into the economics (cost) of the hauling.	RD14.1
SN6.14: Questions about the number and location of pre-processing facilities in relation to transportation nodes.	RD13.1, RD14.1
SN6.15: Questions about the availability of large rail cars that can accommodate stover.	RD14.2
SN6.16: Need research into the economics of rail verses truck hauling (including equipment utilization levels and logistics).	RD14.1
SN6.17: Need research into the liability of shipping of dry bales, either by truck or by rail, and how to modify the shipping process to reduce the liability.	RD14.1
SN6.18: Need research into an air-lock system to unload chopped straw.	RD12.1
SN7: Separations	
SN7.1: Questions about what can be done in the field verses what can be done someplace else.	RD4.1, RD4.2

03-50696-21Ta1

Stakeholder Need Statement

Addressed by
R&D Priority

SN7.2: Need research into the different ways of separating the material in the field (one pass) or bringing all the material into the plant.	RD4.1, RD4.2
SN7.4: Need research into pre-treatment in a distributed system coupled with the storage and transport system.	RD11.1
SN7.5: Questions about separating the grain out in a high quality that is not degraded by the feedstock harvest needs (treat the corn grain gently).	RD11.1, RD13.1, RD14.1
N7.6: Questions about the number of separations that the harvesting equipment has to do or the number of times the feedstock has to be manipulated.	RD4.2
SN7.7: Need research into harvesting the entire corn stock and doing something different with the stock and the grain.	RD4.1, RD4.2
SN7.8: Questions about mechanical separation of the lignin in the field.	RD4.1, RD4.2
SN8: Whole Systems Analysis	
SN8.1: Questions about a harvesting system to optimize the soil compaction, fuel costs, quality, time and risk to the grower.	RD5.2, RD14.1, RD15.1, RD15.2
SN8.2: Need research into how can the collection process be integrated with the whole biomass feedstock process.	RD4.2, RD6.1, RD13.1, RD14.1, RD15.2
SN8.3: Need research into the whole system of the feedstock operation.	RD13.1, RD13.2, RD15.1
SN8.4: Questions about the net energy loss of the entire process.	RD15.2
SN8.5: Need research into optimizing the logistics of handling the product from the combine into the stack, and then into the processing plant.	RD4.2, RD6.1, RD13.1, RD13.2, RD14.1
SN8.6: The processor doesn't want to store a whole years worth of feedstock. Are interested in only a several day supply. Will need a steady stream of material.	RD8.1, RD9.1, RD11.2, RD13.1, RD14.1
SN8.7: Need research into the interaction of biomass processing, sustainability, and economic components.	RD13.1
SN8.8: Preprocessing has to be considered in context of the entire life cycle (system view).	RD11.5
SN8.9: Need research into the production and disposition of possible wastewater streams.	RD12.2
SN8.10: Need research into the net energy profile of the process and the environmental impacts of the process (distributed vs. large scale processing plants).	RD13.1, RD15.2
SN8.11: Need research into the sustainability profile of the final product and the practices used in the process chain.	RD13.1, RD14.1
SN8.12: Need to understand the feedbacks in the cycle.	RD13.1, RD13.2, RD14.2, RD15.2
SN8.13: Need research into the impact of an increase in the use of fossil fuel used in the process on the economics of the operations to the grower, hauler, and processor.	RD15.2
SN8.14: Questions about putting a processing plant in a location and then draw a circle around the plant to determine how much biomass will need to be collected to make the plant viable.	RD13.1, RD14.2
SN9: One-pass	
SN9.1: Need research into the benefits of one-pass harvest and what one-pass harvest entails.	RD5.1
SN9.2: Questions about one pass harvesting taking the standing crop, grain and all.	RD4.2, RD5.1
SN9.3: Need research into a single pass that eliminates contaminates (rocks and other things) during the harvesting operation so that the straw never touched the ground.	RD5.1, RD6.1
SN9.4: Need research into other ways, other than one-pass, of removing dirt from stover.	RD6.3, RD11.1
SN9.5: Need research into eliminating contaminates (e.g., soil) in the harvesting of byproducts.	RD6.3, RD11.1
SN9.6: Need research into the comparison of multiple passes with smaller equipment verses one pass with a larger machine.	RD5.1
SN10: Preprocessing	
SN10.1: Questions about distance of the pre-processing plant from the harvesting field.	RD12.1, RD13.1, RD14.1, RD14.2
SN10.2: Is there some interim processing that can be done to make the shipping more economical?	RD11.1, RD12.1, RD14.1

03-50696-25Ta5

Stakeholder Need Statement

Addressed by
R&D Priority

SN10.3: Need research into pretreatment to provide a more consistent product.	RD7.1, RD9.4, RD10.1, RD10.2, RD11.2
SN10.4: Need research into how to economically un bale and rehydrate the feedstock.	RD11.3
SN10.5: Need research into the cost of processing bales verses processing chopped material.	RD10.1, RD10.2, RD11.3, RD12.1
SN10.6: Unbaled products are difficult to handle. This is one of the biggest problems that needs to be addressed.	RD6.1, RD12.1
SN10.7: Need research into economically baling or cubing feedstock.	RD10.1, RD10.2
SN10.8: Need research into adding water to cubes and the cost of doing this.	RD9.4, RD10.2
SN10.9: Need research into pelletizing straw as opposed to chopping the straw.	RD10.1
SN11: Farming Operation	
SN11.1: Need research into designing or developing a farming operation and equipment where residue capture is part of the whole integrated operation.	RD5.1, RD5.2, RD6.1, RD12.1
SN11.2: Questions about the time the grower is in the field harvesting.	RD5.2, RD6.1, RD12.1
SN11.3: Need research into the logistics of the byproduct so that it does not interfere with the primary grain product.	RD5.2
SN11.4: Questions about storing huge quantities of material. That puts a big load on the infrastructure.	RD13.1, RD14.1
SN11.5: Potential issue with a conflict between no-till operations and the removal of the stover.	RD2.2, RD4.2, RD5.2
SN11.6: Need research into any negative social or environmental impacts of a specific storage or processing method.	RD15.3
SN11.7: Need research into how the feedstock operation will enhance the application of no-tillage operations.	RD5.1, RD5.2
SN11.8: The window of opportunities for harvesting stover are getting smaller not larger. Because of the constraints on the quality of the stover it may be difficult for the farmer to harvest when needed.	RD5.2, RD6.1
SN11.9: Questions about the willingness of the grower to hire-out the harvesting activities to others.	RD5.2, RD13.1
SN11.10: Need research into more and varied crop rotations.	RD2.4
SN11.11: Need research into widening the harvesting window.	RD5.1, RD11.1
SN11.12: Questions about harvesting when the forage is ready to harvest and the storage problem created by this limited window opportunity.	RD13.1
SN11.13: Need research into the timeliness of harvesting based on geographical differences.	RD5.2, RD14.2
SN11.14: Issue with the nature or requirements of the cropping system used by the grower.	RD1.1, RD1.2, RD2.1, RD3.1
SN12: Miscellaneous	
SN12.1: Need research into types of feedstock other than stover or straw.	RD2.4
SN12.2: Need research into utilizing stuff that is already available and then look at the use of stover at a future time.	RD1.1
SN12.3: Research needs to focus on straw in the near term and move to stover in the long-term research.	RD2.4
SN12.4: Need research into enhancing the straw product through genetic enhancement.	RD3.1
SN12.5: Need research into possible genetic engineering possibilities of the feedstock.	RD3.1, RD3.2, RD3.3
SN12.6: Need research into the gasification of the lignin and possible uses for that material, including bioconversion.	RD6.3, RD11.5
SN12.7: Continue the INEEL research on separating the nodes and other material in the wheat harvester.	RD4.1
SN12.8: Need research into gasification bioconversion.	

03-50696-26Ta1





Appendix B – Grouped Sustainability Workshop R&D Need Statements

In 1999, the USDA Agricultural Research Service (ARS), and DOE, determined that understanding the sustainability of collecting corn stover was relevant to both of their missions and jointly planned a project on the implications of removing corn stalks (stover) from production fields. The project, “Implications of Using Corn Stalks as a Biofuel Source,” added residue removal experiments to existing ARS corn production studies. It began in September 1999 and included literature reviews and field and laboratory studies designed to last through five growing seasons. By early 2003, a major review of the technical literature was complete, initial results were emerging from the research projects, and participants had begun to identify areas with remaining questions.

In 2000, the DOE’s National Renewable Energy Laboratory (NREL) began a life cycle assessment of producing ethanol from corn stover using it as a vehicle fuel. One of the first steps in the assessment was soliciting stakeholder input on goals and scope for the study. Stakeholder input was gathered in May 2000 at a workshop held at the Iowa State University’s Wallace Foundation Learning Center. At that time, a promise was made that the stakeholders would be invited to a follow-on meeting to review and discuss results of the project. By early 2003, a preliminary report on the life-cycle assessment was complete and ready for such a review.

In May 2003, the ARS and DOE held a second workshop at the Wallace Foundation Learning Center. This workshop was designed to serve two purposes. The first was to provide a forum, promised in 2000, for reviewing and discussing the NREL’s life cycle assessment of fuel ethanol from corn stover. The second was to solicit input from involved workshop participants on research and technology development needs for the development of this roadmap predominantly for the production section and to identify important sustainability needs and concerns.

Stakeholder Need Statement

Addressed by
R&D Priority

SN13: Analysis/Assessment

SN13.1: Analyze effects of residue collection on erosion and identify production systems that would ensure erosion does not increase with residue collection.	RD15.1
SN13.2: Develop a simple tool for estimating the economic and environmental sustainability of residue harvesting, incorporating relevant studies.	RD2.1, RD2.4, RD5.2, RD13.1, RD15.1
SN13.3: Set forth a long term national vision for the development of sustainable biomass resources that shows how residues fit with other potential biomass resources.	RD1.1, RD14.2, RD14.3, RD15.2, RD15.3
SN13.4: Optimize crop production systems that include residue collection in terms of farm income over entire rotation.	RD2.4, RD5.2, RD15.1
SN13.5: Analyze the potential impacts of new hybrid varieties with differing grain:residue ratios on the economics and sustainability of crop production system and on the economics and sustainability of ethanol production.	RD1.1
SN13.6: Develop an analysis system that integrates dynamic modeling and experimental work to enhance fundamental understanding of soil sustainability and sustainable biomass harvesting.	RD2.1, RD2.4, RD15.1, RD15.3
SN13.7: Develop tools that are better follow nutrients in the life cycle.	RD2.1

03-50696-27Tb1



Stakeholder Need Statement

Addressed by
R&D Priority

SN13.8: Ensure all analysis systems are flexible enough to be applied to other residues, crops, and products.	RD1.2, RD2.4, RD13.1, RD14.2, RD14.3, RD15.1
SN14: Education/Information	
SN14.1: Engage growers in planning communication efforts and decision tools to ensure the resulting products are relevant and useful.	RD5.2, RD13.1, RD15.1, RD15.3
SN14.2: Review the reasons for conflicting information on energy balances for ethanol, including the estimates and assumptions behind the science.	RD15.2
SN14.3: Use the web to disseminate information, including information on the energy balance of ethanol.	RD14.1
SN14.4: Create information products tailored to specific stakeholder groups (growers, policymakers, environmental organizations, city dwellers, etc.).	RD15.1, RD15.2
SN14.5: Develop accessible information for growers that synthesizes current understanding of the sustainability of harvesting residues.	RD1.2, RD2.1, RD2.2, RD15.2
SN15: Equipment	
SN15.1: Design cost-effective harvest equipment that reduces the number of passes over field, separates plant components, and controls the types and amounts of residues left in the field.	RD5.1, RD6.1
SN15.2: Develop the capability to control the return of plant components to the field.	RD4.1, RD4.2, RD4.5
SN15.3: Incorporate results from environmental and economic analysis into design criteria for crop fractionation.	RD14.1
SN16: Production/Management	
SN16.1: Understand the role that different components of the residue have on sustainability by crop and regions.	RD2.4
SN16.2: Need to reevaluate "T" and develop criteria for acceptable soil loss rates.	RD2.4
SN16.3: Need to develop data on long-term effects by maintaining, for 5 more years, USDA residue removal studies.	RD2.1, RD2.2, RD2.3, RD2.4
SN16.4: Need to develop management systems that optimize soil, air, water quality, and economic returns.	RD2.3
SN16.5: Understand the potential for breeding crops to enhance residue production to optimize total system economics and sustainability.	RD3.2, RD3.3
SN16.6: Need to understand genetic variability of plant components (roots, stem, grain, leaves, cobs, etc.) by quantity and chemistry.	RD3.3
SN16.7: Need to track C in the production systems ñ carbon may in future have direct value for sequestration in soil.	RD2.4, RD3.3
SN16.8: Need to design systems that are neutral or positive to grain production.	RD3.3
SN16.9: Need to link manure management into residue harvesting systems.	RD2.1, RD2.2, RD2.3, RD2.4, RD5.2

03-50696-28Tb2





Appendix C – FACA Roadmap R&D Need Statements

In December of 2002, the Biomass Research and Development Technical Advisory Committee, which represents experts from wide-ranging backgrounds relevant to biomass resources, technologies and markets, developed a roadmap for biomass technologies in the United States. This roadmap focused in three main areas: feedstock production, processing and conversion, and product uses and distribution. Following is the comprehensive list of feedstock research and technology needs identified by this group that was also used as input in developing this roadmap.

Stakeholder Need Statement	Addressed by R&D Priority
SN17: FACA-Biotechnology and Plant Physiology	
SN17.1: Improve the technical understanding of plant biochemistry and enzymes and develop the ability to engineer enzymes within desired crops.	RD3.1, RD3.2
SN17.2: Increased knowledge of the metabolic pathways that lead to lignins, proteins, and other plant components is needed.	RD3.1, RD3.2, RD3.3
SN17.3: Research is needed to produce crops with desirable traits for both edible and industrial uses.	RD3.1, RD3.2, RD3.3
SN17.4: Research is needed on the fundamental structure of lignocellulosic materials including the chemistry of its cell wall structures, transport properties, and genetic potential.	RD3.1, RD3.2, RD3.3
SN17.5: Research should also include development and testing of cost-effective preconversion treatment processes to increase energy- and chemical-density of raw materials at the point of harvest.	RD10.1, RD11.2
SN18: FACA- Agronomic Practices	
SN18.1: Research must evaluate methods to ensure the availability of land for producing the biomass feedstocks necessary to vision goals.	RD1.2, RD2.4
SN18.2: This (agronomic practices to assure soil sustainability) includes research to ensure proper maintenance of soil nutrients and to identify methods to reduce or eliminate erosion.	RD2.1, RD2.2, RD2.3, RD2.4
SN18.3: Improved processes for collecting materials that ensure soil sustainability should be identified and developed as part of best management practices for agricultural harvesting processes.	RD4.1, RD5.1
SN18.4: Research efforts should lead to agricultural and forestry production methods that contribute to maximizing yields of biobased feedstocks that have desired characteristics.	RD7.1, RD7.2, RD7.3, RD7.4, RD10.1, RD10.2
SN18.5: Analysis of the feedstock production stage of the biomass life cycle is needed to better understand and evaluate the economics of biomass resources as well as carbon cycles and other environmental costs and benefits.	RD1.1, RD2.1, RD13.1, RD14.1
SN19: FACA-General Feedstock Needs or Issues	
SN19.1: Environmentally sound biomass resources are those for which life cycle assessments demonstrate their desirability.	RD1.1, RD2.1
SN19.2: Scientific methods to produce and prepare plants and residues so that they meet specifications for end-use applications are needed.	RD3.1, RD3.2, RD3.3
SN19.3: Agronomic practices must be improved to increase efficiency and reduce the cost of biomass feedstock production and delivery, and to ensure crop sustainability.	RD2.1, RD2.2, RD2.3, RD2.4
SN19.4: Research into the agronomic, economic, and environmental impacts of harvesting lignocellulosic material must be established to ensure that these materials have beneficial life-cycle impacts.	RD1.1, RD1.2, RD2.1, RD2.3
SN19.5: Improved methods for verifying the safety as well as the societal and environmental benefits of genetically engineered plants are needed.	RD3.1, RD3.2, RD3.3



03-50696-29Tc1



Appendix D – Contributors and Authors

Colloquy and Workshop Contributors:

Charles A. Abbas, Archer Daniels Midland Company
Susan Andrews, USDA Natural Resources Conservation Service
Leslie Backer, North Dakota State University
David A. Barker, Shell Global Solution (US) Inc.
Tim Bodin, Cargill
George Boody, Land Stewardship Project
James Bowman, Eastern Idaho Economic Development Council
Mike Bruer, National Association of Wheat Growers
Ron Buckhalt, USDA Agricultural Research Service
Jon Chiappe, Southwestern Oklahoma State University
Daren Coppock, National Association of Wheat Growers
Patricia Dailey, Idaho Wheat Commission
Robert R. Dorsch, DuPont Bio-Based Materials
James L. Easterly, Easterly Consulting
Francis Epplin, Oklahoma State University
Donald C. Erbach, USDA Agricultural Research Service
Warren Formo, National Corn Growers Association
Daniel Frohberg, Ag/Biosystemes Engineering
Gene Fynboh, National Corn Growers Association
Mark Gaede, National Association of Wheat Growers
Mark Gage, National Association of Wheat Growers
Gordon Gallup, National Association of Wheat Growers
Clark Gerstacker, National Corn Growers Association
Richard Glass, National Corn Growers Association
David A. Glassner, Cargill Dow, LLC
Harold Gortner, Vermeer Manufacturing Company
Duane Grant, Grant 4-D Farms
Jeff Greavu, Cargill
Gregory Guenther, National Corn Growers Association
Kevin Halstead, Grain Processing Corp.
Marvin Hankins, Southwestern Oklahoma State University
Susan Hennessey, DuPont Central Research & Development
Brent Hessing, Idaho Ethanol, LLC
James R. Hettenhaus, Chief Executive Assistance, Inc.
John Hickman, John Deere Technology Center
Kipp Hicks, Eastern Idaho Economic Development Council
Maurice Hladik, Iogen Corporation
Andy Hoffman, Tate & Lyle North America
Ray Huhnke, University of Oklahoma
Scott Jackson, A. Scott Jackson Trucking Co.
Steven C. Johnson, Idaho Grain Producers Association

Dennis Keiser, Intrepid Technology & Resources, Inc.
Robert J. Kelly, The Burlington Northern and Santa Fe Railway Company
David W. Kmoch, John Deere Combine Worldwide Products
David Kolsrud, CORN-er Stone Farmers COOP
Charles Kubert, Environmental Law & Policy Center
Al Kurki, National Center for Appropriate Technology
Mike Lawson, National Association of Wheat Growers
Dave Loos, Illinois Department of Commerce and Community Affairs
James R. Lucas, CNH Global N.V.
Grant MacNeill, AGCO Corporation
Larry Matlack, Stinger Limited
Don McCool, USDA Land Management and Water Conservation Research Service
Scott McGarraugh, Texas State FSA Office
Lyle Miller, National Association of Wheat Growers
Ray W. Miller, DuPont Bio-Based Materials
Vance Morey, University of Minnesota
David Morris, Institute for Local Self-Reliance
Richard Nelson, Kansas State University
Quang Nguyen, Abengoa Bioenergy
Dick Nicolai, South Dakota State University
Jeri Neal, Iowa State University
Pete Nowak, University of Wisconsin
Norm Olson, BECON
Steve Pickett, Pickett Equipment
Fran Pierce, Washington State University
Graeme Quick, Iowa State University
Edward Rall, USDA Farm Service Agency
Thomas Richard, Iowa State University
Rick Rigel, City of Imperial
Denise Ritcher, National Corn Growers Association
Rodney Roof, Farmrail System, Inc.
Gerson Santos-Leon, Abengoa Bioenergy
Tom Schechinger, Iron Farms/BMAP
Steve Scott, National Corn Growers Association
Hosein Shapouri, USDA Office of the Chief Economist
Scott A. Shearer, University of Kentucky
Rene Shunk, National Corn Growers Association
John Skorburg, American Farm Bureau
Peter F. Smith, USDA Natural Resources Conservation Service
John R. Smylie, Association of Equipment Manufacturers (AEM)
Lyle Stephens, American Society of Agriculture Engineers/Deere & Co.
Douglas Stokke, Idaho State University
Andy Talbott, OXBO Corporation
Paul Titterton, GATX Rail

Vince Tomlonovic, Hiniker, Co.
Gerald Tumbleson, National Corn Growers Association
Jay Van Roekel, Vermeer Manufacturing Company
Doug Van Thorre, Biorefining Inc.
Gary Wagner, A.W.G. Farms, Inc.
Paul J. Weimer, USDA-Agricultural Research Service
Gary K. Welch, Williams Bio-Energy
Carol Werner, Environmental and Energy Study Institute
Bryan Whipple, The Amalgamated Sugar Company LLC
Sandra Wright, National Corn Growers Association
Robert Wooley, Cargill Dow, LLC
Bill Yearous, Renewable Fuels, LLC

Contributing Authors:

Janet H. Cushman, Oak Ridge National Laboratory
James L. Easterly, Easterly Consulting
Donald C. Erbach, U.S. Department of Agriculture, Agricultural Research Service
Thomas D. Foust, Idaho National Engineering and Environmental Laboratory
J. Richard Hess, Idaho National Engineering and Environmental Laboratory
James R. Hettenhaus, Chief Executive Assistance, Inc.
Reed L. Hoskinson, Idaho National Engineering and Environmental Laboratory
John J. Sheehan, National Renewable Energy Laboratory
Shahabaddine Sokhansanj, Oak Ridge National Laboratory
Sam Tagore, U.S. Department of Energy
David N. Thompson, Idaho National Engineering and Environmental Laboratory
Anthony Turhollow, Oak Ridge National Laboratory
Lynn L. Wright, Oak Ridge National Laboratory

Graphics Design:

Shaun C. Eames, Idaho National Engineering and Environmental Laboratory
Allen J. Haroldsen, Idaho National Engineering and Environmental Laboratory

Document Editing:

Tonya A. Charles, Idaho National Engineering and Environmental Laboratory

Web Addresses: www.bioproducts-bioenergy.gov/publications.asp
www.osti.gov/bridge

Program Contact

Douglas Kaempf

Acting Program Manager, Office of Biomass

U.S. Department of Energy, Energy Efficiency and Renewable Energy

1000 Independence Ave. S.W.

Washington, DC 20585

Phone: (202) 586-5264

Fax: (202) 586-5010

E-mail: douglas.kaempf@ee.doe.gov

Feedstock Research Lead

Sam Tagore

U.S. Department of Energy, Energy Efficiency and Renewable Energy, Office of Biomass

U.S. Department of Energy, EE13

1000 Independence Ave. S.W.

Washington, DC 20585

Phone: (202) 586-9210

Fax : (202) 586-5879

E-mail: sam.tagore@ee.doe.gov

Technical Leads

J. Richard Hess

Idaho National Engineering and Environmental Laboratory

P.O. Box 1625, MS 2210

Idaho Falls, ID 83415-2210

Phone: (208) 526-0115

Fax: (208) 526-0690

E-mail: jrh@inel.gov

Thomas D. Foust

Idaho National Engineering and Environmental Laboratory

P.O. Box 1625, MS 2210

Idaho Falls, ID 83415-2210

Phone: (208) 526-0147

Fax: (208) 526-0690

E-mail: foustd@inel.gov

Lynn L. Wright, Shahabaddine Sokhansanj

Oak Ridge National Laboratory

Bldg. 1059, MS 6422

Oak Ridge, TN 37831-6422

Phone: (865) 574-7378

Fax: (865) 576-8143

E-mail: wrightll@ornl.gov

Document Number:
DOE/NE-ID-11129 Rev 0