

<https://www.epa.gov/beach-tech/submitting-data-epa#notify>



Beach Notification Database User Guide (For Notification Schema v2.4)

Contract Number GS-35F-4797H

Task Order # 1518

TDD 10.02 eBeaches

Version 2.2.4

October 26, 2016

Table of Contents.....	i
List of Exhibits.....	iii
Revision Log	v
Changes from v2.2.1.....	vi
1 Introduction	1
1.1 Document Purpose.....	1
2 How to Submit Data	2
2.1 Submit Data via CDX.....	2
2.2 Detailed XML Processing Notes	4
3 How to Understand the XML Submission	6
3.1 Elements in the XML Schema and XML Files	6
3.1.1 Organization Information	7
3.1.2 Person Information	14
3.1.3 Beach Information	20
3.1.4 Beach Attribute Information	24
3.1.5 Beach Activity Information	36
3.1.6 Activity Deletion Form	44
3.1.7 Beach Role Information	44
3.1.8 Beach Coordinate Information	47
3.1.9 Year Completion Indicators	51
3.1.10 Beach Procedure Information (Local Action Decision Procedure)	53
3.1.11 Header Information	55
3.2 Use of Effective Date and Status Indicator Data Elements	59
4 How to Decode the Error Messages	60
4.1 System Generated Error Messages.....	60
4.2 Common Causes of Error Messages	63
4.3 Oracle Generated Error Messages	67
5 How to Understand Beaches that are Similar Points of Access	67
6 Appendix A—Schema Graphics	69
7 Appendix B—Example XML File.....	79
8 Appendix C—Procedure Type Codes (Local Action Decision Procedure)	86
9 Appendix D—Water Body Codes	91
10 Appendix E—Horizontal Collection	92

11	Appendix F—Addition Notifications.....	95
12	Appendix G—Pollution Source Identification	99
13	Appendix H—Data Entry Forms	104
14	Appendix I—Summary Reports	108
15	Appendix J—CDX Web Messages	114
16	Appendix K—Activity Deletion Process	121

List of Exhibits

Exhibit 2-1 Custom Data Submission Steps	2
Exhibit 2-2 Data Transfer Diagram	4
Exhibit 3-1 Organization Information Schema	8
Exhibit 3-2 Person Information Schema	15
Exhibit 3-3 Beach Information Schema	21
Exhibit 3-4 Beach Attribute Information Schema	25
Exhibit 3-5 Beach Activity Information Schema	37
Exhibit 1-6 Activity Deletion Form Schema	44
Exhibit 3-7 Beach Role Information Schema	47
Exhibit 3-8 Beach Coordinate Information Schema	51
Exhibit 3-9 Organization Information Schema	54
Exhibit 3-10 Beach Procedure Information Schema	56
Exhibit 3-11 Header Information Schema	58
Exhibit 4-1 PRAWN Error Messages	60
Exhibit 4-2 Common Error Messages	63
Exhibit 6-1 Beach Data Submission	69
Exhibit 6-2 Organization Detail	70
Exhibit 6-3 Organization Person Detail	71
Exhibit 6-4 Beach Name Detail	72
Exhibit 6-5 Beach Activity Detail	74
Exhibit 6-6 Beach Role Detail	75
Exhibit 6-7 Beach Coordinate Detail	76
Exhibit 6-8 Beach Procedure Detail (Local Action Decision Procedure)	77
Exhibit 6-9 Year Completion Indicators	78
Exhibit 8-1 Procedure Type Codes (Local Action Decision Procedure)	87
Exhibit 9-1 Water Body Name	91
Exhibit 9-2 Water Body Type	91
Exhibit 10-1 Horizontal Collection Method Name	92
Exhibit 10-2 Horizontal Collection Reference Datum Name	94
Exhibit 11-1 Example Notification XML Document	96
Exhibit 11-2 Custom XML Generation	97
Exhibit 12-1 Access Database	100
Exhibit 12-2 XML Schema	102

Exhibit 13-1 Forms	104
Exhibit 13-2 Main Menu	105
Exhibit 13-3 Return to Main Menu	107
Exhibit 14-1 Reports	108
Exhibit 14-2 Beach Actions	109
Exhibit 14-3 Beach Attributes	110
Exhibit 14-4 Beach Monitoring Frequency	111
Exhibit 14-5 Possible Pollution Sources	112
Exhibit 14-6 Possible Pollution Sources (<i>cont.</i>)	113

Revision Log

Date	Version No.	Description	Author	Reviewer	Review Date
7/21/10	2.2.1	Added Appendix J CDX Messages	E.Richards		
12/23/11	2.2.2	Added XML Schema changes introduced in v2.2	E.Richards	C.Kilgore	
11/01/15	2.2.3	Added XML Schema changes introduced in v2.3	C. Stevenson		
8/9/16	2.2.4	Added XML Schema changes introduced in v2.4 Added Activity deletion process Added Partial Day Functionality	C. Stevenson		

Changes from v2.2.1

Page #	Description
7	3.1.1 - New State Contact details in the Organization Information section.
10	Notes on submitting an Organization's website information.
12	New State Contact data elements.
14	3.1.2 - Notes on assigning Beach Contacts.
22	New Water Body Names.
24	Effective Year Examples
25	New Swim Season Start/End Date requirements.
26	Swim Day Attribute
29	New ALGAE Pollution Source domain value.
29	New Beach Website data element.
30	New Dormant Beach data element.
30	New Reporting Frequency data elements.
30	New Beach Criterion data elements (WQS).
35	New Activity Stop Date notes.
36	New ALGAE Reason Type domain value.
38	Partial Day Value
44	3.1.6 Activity Deletion Form
53	4.1 - New PRAWN Error Messages pertaining to Beach Criterion data.
56	4.2 - New Trouble Shooting Tips for the Beach Criterion data.
63	New State Contact details.
66	New Reporting Frequency details.
66	New Dormant Beach detail.
66	New Beach Criterion details (WQS).
66	New Beach Website detail.
72	Additional XML example data.
81	Appendix D - New Water Body Names.
98	Minor changes to the Beach Actions report.
99	Minor changes to the Beach Attributes report.
100	Minor changes to the Beach Monitoring Frequency report.
101	Minor changes to the Possible Pollution Sources report.
130	Appendix K – Activity Deletion Process

1 Introduction

1.1 Document Purpose

The purpose of this document is to introduce representatives from state (includes tribal and territorial) beach programs to the **PR**ogram tracking, beach **A**dvisories, **W**ater quality standards, and **N**utrients (PRAWN) database. All state beach program and notification (advisory and closing) data will be stored in PRAWN. In particular, this guide is intended for officials from State beach programs, the EPA's Beaches program, and any database administrators in charge of a state database.

The document can be used to explain the following about beach data submissions to EPA:

- **Chapter 2** — explanation on how data is transferred from the originator (in most cases State Beach programs) through CDX to the EPA. Details about the transfers are separated into a second subsection for a more technical audience.
- **Chapter 3** — explanation of the data that needs to be submitted to EPA and how that data should be formed within the XML document. Each section of the XML schema is explained in detail, and a specific section is devoted to explaining the use of the effective date and status indicator elements.
- **Chapter 4** — explanation of the errors that the PRAWN database will produce due to logic and/or technical errors in the path between the creation of the XML document and the loading of data into PRAWN.

If you are responsible for submitting beach data, and you have not been registered to use the EPA systems identified below, please contact [Bill Kramer](mailto:kramer.bill@epa.gov) (kramer.bill@epa.gov); 202-566-0385. You will be asked to provide contact information, to which we will add your WQX ORG_ID and send on to CDX and WQX/STORET to complete your credentials. Once you receive your passwords, begin preparing for data submission, by reading the instructions at: <https://www.epa.gov/beach-tech/submitting-data-epa>

If you are using the EPA provided Access database and intend on submitting the xml file through the exchange network click here for instructions: https://www.epa.gov/sites/production/files/2014-09/documents/ebeaches_ensc.pdfh

If you do not use the EPA provided Access database to submit notification data to PRAWN, this Guide may still provide useful examples. Also see the schema development documents at: <http://www.exchangenetwork.net/data-exchange/beach-notification/>

2 How to Submit Data

States that need to submit Beach information to EPA need to take advantage of EPA’s Central Data exchange (CDX) initiative to submit their data through a website.

2.1 Submit Data via CDX

The Central Data eXchange (CDX) is an Office of Environmental Information (OEI) initiative to provide a single point of entry for incoming data into EPA. CDX will maintain a set of web pages where, once registered, States can log in and upload data files to EPA. Additional information on CDX and the Exchange Network can be found at: <http://www.epa.gov/cdx>.

Beginning on the upper left side, the object labeled “State Database” starts the flow of information and can be followed through to the “PRAWN Database”.

Exhibit 2-2 describes how data can be submitted from a State database to EPA’s PRAWN database via CDX. Beginning on the upper left side, the object labeled “State Database” starts the flow of information and can be followed through to the “PRAWN Database”.

Exhibit 2-2. For information on how to create a custom data submission, please see Exhibit 11-2. The following table describes the steps involved in the process:

Exhibit 2-1 Custom Data Submission Steps

State Steps	CDX Automated Steps	PRAWN Automated Steps
1. Register in 3 places: A) Register with CDX via the CDX HelpDesk. Send an email to epacdx@csc.com or call 888-890-1995 B) Register any new beaches with the EPA to create a unique EPA Beach ID for each beach in the state. C) Register water quality stations in WQX submissions (http://www.epa.gov/storet/wqx.html)		
2. Create an XML document containing the appropriate data (see Chapter 3 for the data to be included) using a local copy of the schema.		
3. Upload the XML document from a local State computer to CDX via CDX’s website: https://cdx.epa.gov/SSL/cdx/login.asp		
	4. Archive the file and validate the XML document against the schema. If errors are found, send a CDX error log to the State user; otherwise, skip to Step 6.	

State Steps	CDX Automated Steps	PRAWN Automated Steps
5. Visit MyCDX Inbox for error/success log messages. If a CDX error log is received, go back to Step 2 and fix the errors.		
	6. Once the XML document passes validation, add the header information and transfer the XML document to the PRAWN XML Parser.	
		7. Validate the XML document against the business rules. If errors are found, create an error log to CDX; otherwise, skip to Step 10.
	8. If a PRAWN error log is created, pass it along to the State.	
9. Make a second visit to MyCDX Inbox. If a PRAWN error log is received, go back to Step 2 and fix the errors.		
		10. When the XML file is received that passes the business rules, parse the data into the database and create a success log.
	11. If a PRAWN success log is created, pass it along to the State.	

Beginning on the upper left side, the object labeled “State Database” starts the flow of information and can be followed through to the “PRAWN Database”.

Exhibit 2-2 Data Transfer Diagram

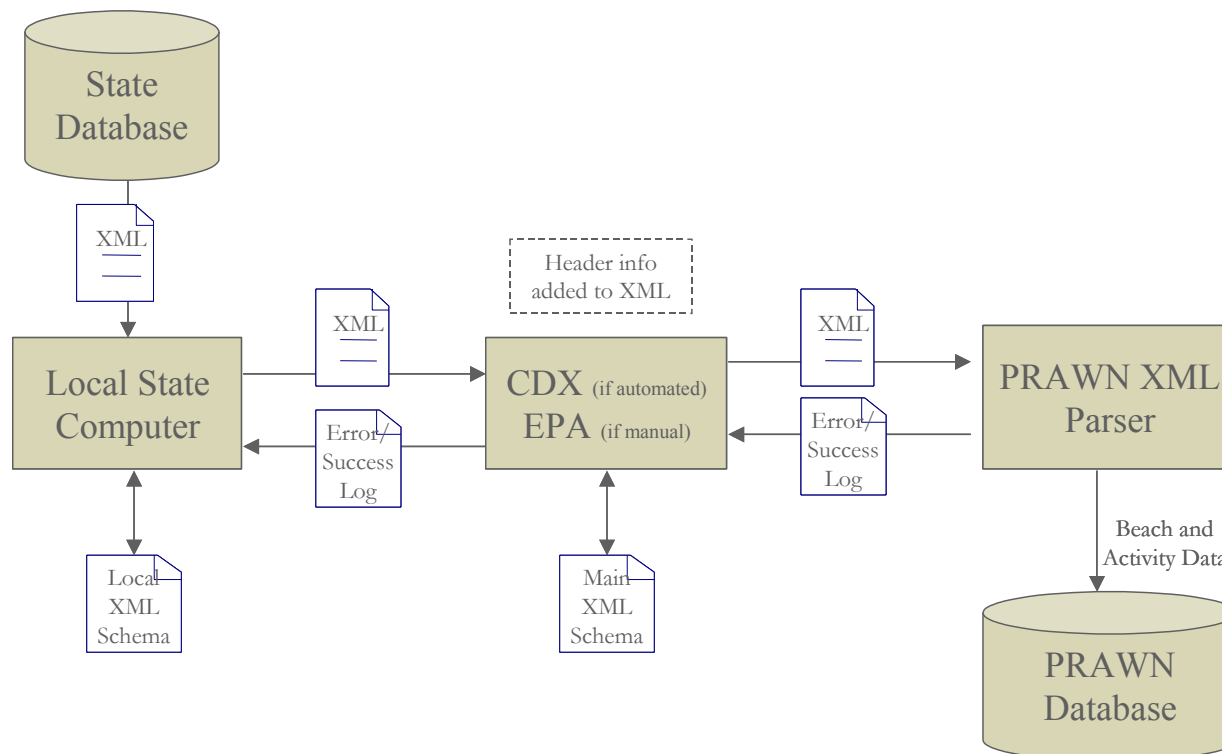

2.2 Detailed XML Processing Notes

The following technical notes support the processes described in the previous two sections of this chapter:

- Empty tags, such as “<OrganizationCode></OrganizationCode>” or “<OrganizationCode/>”, will not be accepted.
- If the XML submission passes the validation routine, information about the submission will be inserted into the following four XML tags: SubmissionIdentifier, SubmittingAgencyIdentifier, SubmittingUserIdentifier, and SubmissionDate. These four tags are enclosed in tags labeled HeaderInformation. The HeaderInformation tag must appear second in the file, after the BeachDataSubmission tag.

- When the XML load process is complete, any errors will be written to an error file with the same name, with a .log extension instead of the .xml extension.

Some notes about using the access database:

If, after opening a form, the "Return to Main Menu" option is not displayed due to screen size, resolution settings, etc, place your cursor in a field and hit tab. The cursor will eventually move down to the "Return to Main Menu" option and bring it into view

There are several views you can use to fill in data. We recommend using the "Form" view but if you are entering large amounts of data or are using a spreadsheet with collected data, you may want to use the "Table" view.

Both views can be selected from the drop down menu on the left side of the screen, above the form list:

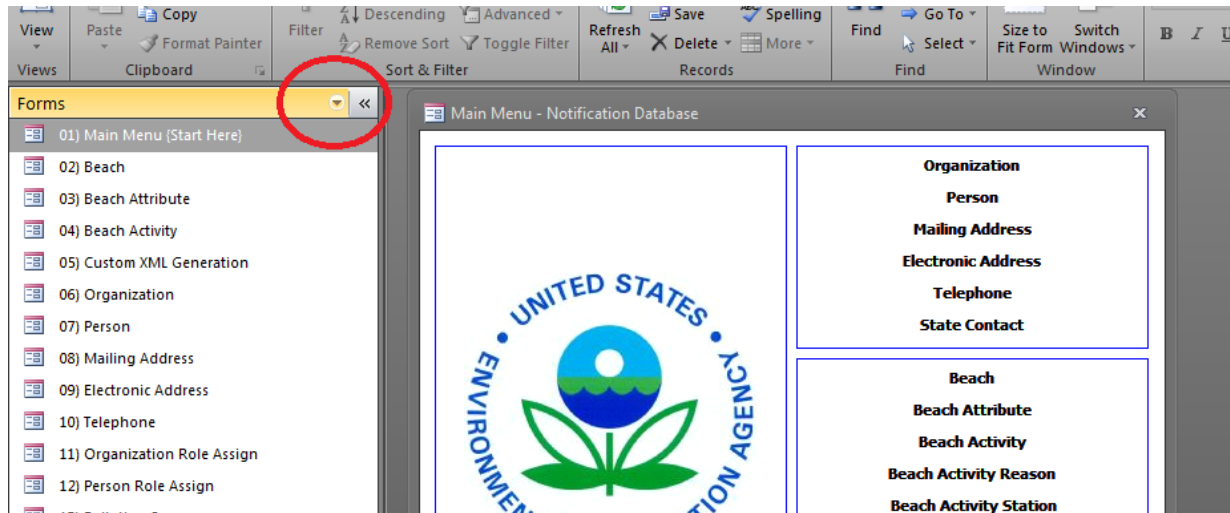

Once you have entered data, or if you make any changes to existing data, it's a good idea to click the "Next record" button at the bottom of the form to make sure your data gets committed to the database.(See Appendix H for more information on using forms)

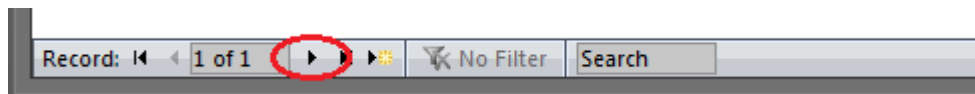

3 How to Understand the XML Submission

This chapter describes the XML data files and the associated XML schema to be used for the PRAWN database.

3.1 Elements in the XML Schema and XML Files

The XML schema for the data submissions to PRAWN provides a template for the XML files to be submitted. This schema describes the data elements to be included in the XML document and is also used to validate it. Files are accepted or rejected based on their conformity to the schema.

A graphical version of this schema is provided in Appendix A and an example XML document is provided in Appendix B of this document. Please refer to these appendices when creating an XML document.

This section contains descriptions of the data elements in the PRAWN XML Schema. For each table in the following sections, the following information is provided:

- Data Element: The name of the data element stored in the XML data file.
- XML Tag Name: The XML key associated with the data element.
- XML Data Type: The XML data type for this element.
- Length: The maximum length for the data element for character and numeric data types.
- Access Table Mapping: This value is where the information is coming from in the access database. The naming convention is `TABLE.COLUMN_NAME`
 - Eg `ORGANIZATION.NAME` = Data will be from the `ORGANIZATION` table and in the column called `NAME`.
- Req'd (Y/N): This value indicates if the column is required in the XML data file. Please note that empty tags such as `<OrganizationCode></OrganizationCode>` or `<OrganizationCode/>` will not be accepted when the element is not required.
- Comments: Additional comments related to the XML data element.

For questions on the conventions and formats used in the schema, reference the Exchange Network's *XML Schema Design Rules and Conventions*¹.

¹ The Exchange Network's *XML Schema Design Rules and Conventions* can be found here: http://www.exchangenetwork.net/dev_schema/drc.htm

3.1.1 Organization Information

The organization information section of the XML submission contains data related to the organizations involved in the Beach Act Grant Program, such as organization code, organization name, organization description, and contact information. These data elements will be included in the XML file when organization data needs to be added or updated in the PRAWN database.

Some of this information is also included in the “State Contact” list is located on the EPA’s beach web page.

<http://ofmpub.epa.gov/apex/beamcon2/f?p=beamcon2:50:22359276278849:::::>

Multiple State Contacts can be submitted for one organization. To submit updates for the State Contact list, include the State Contact XML elements listed in the following table in this section.

To submit Local Beach-level contact information see §3.1.7, and Exhibit 3.6.

All XML elements in this section are located in the following position on the XML element hierarchy—“BeachDataSubmission/OrganizationDetail”.

Exhibit 3-1 Organization Information Schema

Data Element	XML Tag Name	XML Data Type	Req'd (Y/N)	Length	Access Table Mapping	Comment
Organization Identifier Example: 987654321098	OrganizationIdentifier	STRING	Y	12	ORGANIZATION.ID, PERSON.FK_ORGANIZATION_ID, MAILING_ADDRESS.FK_ORGANIZATION_ID, ELECTRONIC_ADDRESS.FK_ORGANIZATION_ID, BEACH_ORGANIZATION_ROLE_ASSIGN.FK_ORGANIZATION_ID	An organization refers to the entity associated with a Notification submitted to PRAWN. The type of entity is noted in the 'Organization Type Code' field. EPA will maintain a list of valid Organization Identifiers for all organizations that are stored in the PRAWN database. These identifiers must be unique, as they will be used to update organization-level data.
Organization Type Code Example: STATE_AGENCY	OrganizationNameDetail /OrganizationTypeCode	STRING	Y	12	ORGANIZATION.ORGANIZATION_CODE	This value must be set to one of the following: STATE_AGENCY (State Agency) EPA (U.S. EPA) PUB_INT_GRP (Public Interest Group) LOCAL_GOV (Local Government) PRIVATE (Private Company) OW (U.S. EPA Office of Water) OW_DIV (U.S. EPA Office of Water Division) OW_BRANCH (U.S. EPA Office of Water Branch) This value is required if any organization name information is included in the XML data file.
Organization Name Example: Maine Department of Environmental Protection	OrganizationNameDetail /OrganizationName	STRING	Y	60	ORGANIZATION.NAME	This value is required if any organization name information is included in the XML data file.
Organization Description Text Example: Maine DEP	OrganizationNameDetail /OrganizationDescriptionText	STRING	N	255	ORGANIZATION.DESCRPTION	
Organization Abbreviation Text Example: MDEP	OrganizationNameDetail /OrganizationAbbreviationText	STRING	N	30	ORGANIZATION.ABBREVIATION	

Data Element	XML Tag Name	XML Data Type	Req'd (Y/N)	Length	Access Table Mapping	Comment
Organization Mailing Address Type Code Example: MAILING	OrganizationMailingAddressDetail/MailingAddressTypeCode	STRING	Y	12	MAILING_ADDRESS.MAILING_ADDRESS_CODE	This value must be set to one of the following: SHIPPING (Shipping Address) MAILING (Mailing Address) OTHER (Other Address) This value is required if any organization mailing address information is included in the XML data file.
Organization Mailing Address Street Line 1 Text Example: 14 Main Rd.	OrganizationMailingAddressDetail/MailingAddressStreetLine1Text	STRING	Y	100	MAILING_ADDRESS.LINE_1	This value is required if any organization mailing address information is included in the XML data file.
Organization Mailing Address Street Line 2 Text Example: Suite 4	OrganizationMailingAddressDetail/MailingAddressStreetLine2Text	STRING	N	100	MAILING_ADDRESS.LINE_2	
Organization Mailing Address Street Line 3 Text Example: Building 12	OrganizationMailingAddressDetail/MailingAddressStreetLine3Text	STRING	N	100	MAILING_ADDRESS.LINE_3	
Organization Mailing Address City Text Example: Augusta	OrganizationMailingAddressDetail/MailingAddressCityName	STRING	Y	50	MAILING_ADDRESS.CITY	This value is required if any organization mailing address information is included in the XML data file.
Organization Mailing Address State Code Example: ME	OrganizationMailingAddressDetail/StateCode	STRING	Y	2	MAILING_ADDRESS.STATE_POSTAL_CODE	This value is required if any organization mailing address information is included in the XML data file. This value must be a valid 2-character State Postal Code.

Data Element	XML Tag Name	XML Data Type	Req'd (Y/N)	Length	Access Table Mapping	Comment
Organization Mailing Address Zip Code Example: 04333	OrganizationMailingAddressDetail/AddressPostalCode	STRING	Y	12	MAILING_ADDRESS.ZIP_CODE	This value is required if any organization mailing address information is included in the XML data file. This value must be in one of the following numeric formats: ##### or #####-####
Organization Mailing Address Effective Date Example: 2003-01-01T00:00:00	OrganizationMailingAddressDetail/MailingAddressesEffectiveDate	DATE	Y		MAILING_ADDRESS.EFFECTIVE_DATE	This value is required if any organization mailing address information is included in the XML data file. The date should be entered in the XML file in the following format: YYYY-MM-DDTHH:MI:SS This value should be set to the date on which the mailing address information became effective or will become effective. **Please see Section 3.2 Use of Effective Date and Status Indicator Data Elements for more information.
Organization Mailing Address Status Indicator Example: ACTIVE	OrganizationMailingAddressDetail/MailingAddressesStatusIndicator	STRING	Y	8	MAILING_ADDRESS.STATUS	This value is required if any organization mailing address information is included in the XML data file. This value must be set to "ACTIVE" or "INACTIVE". **Please see Section 3.2 Use of Effective Date and Status Indicator Data Elements for more information.

Data Element	XML Tag Name	XML Data Type	Req'd (Y/N)	Length	Access Table Mapping	Comment
Organization Electronic Address Type Code Example: URL	OrganizationElectronicAddressDetail/ElectronicAddressTypeCode	STRING	Y	12	ELECTRONIC_ADDRESS.ELECTRONIC_ADDRESS_CODE	This value must be set to one of the following: EMAIL (E-mail) URL (URL) OTHER (Other) This value is required if any organization electronic address information is included in the XML data file. **Please use the URL code to submit electronic address information pertaining to an Organization's website.
Organization Electronic Address Text Example: http://www.maine.gov/dep/blwq/beach.htm	OrganizationElectronicAddressDetail/ElectronicAddressText	STRING	Y	255	ELECTRONIC_ADDRESS.ADDRESS	This value is required if any organization electronic address information is included in the XML data file.
Organization Electronic Address Effective Date Example: 2003-01-01T00:00:00	OrganizationElectronicAddressDetail/ElectronicAddressEffectiveDate	DATE	Y		ELECTRONIC_ADDRESS.EFFECTIVE_DATE	This value is required if any organization electronic address information is included in the XML data file. The date should be entered in the XML file in the following format: YYYY-MM-DDTHH:MI:SS This value should be set to the date on which the electronic address information became effective or will become effective. Please see Section 3.2 Use of Effective Date and Status Indicator Data Elements for more information.
Organization Electronic Address Status Indicator Example: ACTIVE	OrganizationElectronicAddressDetail/ElectronicAddressStatusIndicator	STRING	Y	8	ELECTRONIC_ADDRESS.STATUS	This value is required if any organization electronic address information is included in the XML data file. This value must be set to "ACTIVE" or "INACTIVE". Please see Section 3.2 Use of Effective Date and Status Indicator Data Elements for more information.

Data Element	XML Tag Name	XML Data Type	Req'd (Y/N)	Length	Access Table Mapping	Comment
Organization Telephone Type Code Example: VOICE	OrganizationTelephoneDetail/TelephoneTypeCode	STRING	Y	12	TELEPHONE.TELEPHONE_CODE	This value must be set to one of the following: FAX (Fax) VOICE (Voice) PAGER (Pager) CELL (Cellular/Mobile) OTHER (Other) This value is required if any organization telephone information is included in the XML data file.
Organization Telephone Number Example: 207-287-3901	OrganizationTelephoneDetail/TelephoneNumberText	STRING	Y	12	TELEPHONE.TELEPHONE_NUMBER	This value is required if any organization telephone information is included in the XML data file. This value must be in the following alphanumeric format: XXX-XXX-XXXX
Organization Telephone Effective Date Example: 2003-01-01T00:00:00	OrganizationTelephoneDetail/EffectiveDate	DATE	Y		TELEPHONE.EFFECTIVE_DATE	This value is required if any organization telephone information is included in the XML data file. The date should be entered in the XML file in the following format: YYYY-MM-DDTHH:MI:SS This value should be set to the date on which the telephone information became effective or will become effective. **Please see Section 3.2 Use of Effective Date and Status Indicator Data Elements for more information.
Organization Telephone Status Indicator Example: ACTIVE	OrganizationTelephoneDetail/StatusIndicator	STRING	Y	8	TELEPHONE.STATUS	This value is required if any organization telephone information is included in the XML data file. This value must be set to "ACTIVE" or "INACTIVE". **Please see Section 3.2 Use of Effective Date and Status Indicator Data Elements for more information.
State Contact First Name Example: Jane	ContactFirstName	STRING	Y	50	ORGANIZATION.STATE_CONTACT_FIRST_NAME	This value represents the first name of the State contact.

Data Element	XML Tag Name	XML Data Type	Req'd (Y/N)	Length	Access Table Mapping	Comment
State Contact Last Name <i>Example: Smith</i>	ContactLastName	STRING	Y	50	ORGANIZATION.STATE_CONTACT_LAST_NAME	This value represents the last name of the State contact.
State Contact Agency Name <i>Example: Department of Health</i>	ContactAgencyName	STRING	Y	60	ORGANIZATION.STATE_CONTACT_AGENCY	This value represents the name of State contact's agency.
State Contact Telephone <i>Example: 703-321-4466</i>	ContactTelephoneNumberText	STRING	Y	12	ORGANIZATION.STATE_CONTACT_TELEPHONE_NUMBER	This value must be in the following alphanumeric format: XXX-XXX-XXXX
State Contact Electronic Address Text <i>Example: Hardy.Tom@epa.gov</i>	ContactElectronicAddressText	STRING	Y	255	ORGANIZATION.STATE_CONTACT_ELECTRONIC_ADDRESS	This value represents the electronic address information of the State contact.

3.1.2 Person Information

The person information section of the XML submission contains data related to the people associated with the beaches overseen by the National BeachProgram. Examples of this data include person identifier code, name, title, and contact information. These data elements will be included in the XML file when person data needs to be added or updated in the PRAWN database.

In the XML schema, each person is affiliated with exactly one organization. However, each organization can be associated with many people.

All XML elements in this section are located in the following position on the XML element hierarchy—
“BeachDataSubmission/OrganizationDetail/OrganizationPersonDetail”.

If assigning beach contacts please specify PUBLIC (Public Contact) as the beach role. Reference Section 3.1.7, [Exhibit 3.6](#) on assigning beach roles.

Exhibit 3-2 Person Information Schema

Data Element	XML Tag Name	XML Data Type	Req'd (Y/N)	Length	Access Table Mapping	Comment
Person Identifier <i>Example: JOSM</i>	PersonIdentifier	STRING	Y	12	PERSON.ID, BEACH_PERSON_ROLE_ASSIGN.FK_PERSON_ID, ELECTRONIC_ADDRESS.FK_PERSON_ID, MAILING_ADDRESS.FK_PERSON_ID, TELEPHONE.FK_PERSON_ID	Submitting organizations will need to maintain a list of valid Person Identifiers for all people that are stored in the PRAWN database. These identifiers must be unique within each organization, as they will be used to update organization-level data (for example, with an organization there can only be 1 person identified as "JOSM", but there could be another person identified as "JOSM" in another organization).
Person Status Indicator <i>Example: ACTIVE</i>	PersonNameDetail/PersonStatusIndicator	STRING	Y	8	PERSON.ACTIVE	This value if required if any person name information is included in the XML data file. This value must be set to "ACTIVE" or "INACTIVE".
Person First Name <i>Example: John</i>	PersonNameDetail/First Name	STRING	Y	50	PERSON.FIRST_NAME	This value if required if any person name information is included in the XML data file.
Person Last Name <i>Example: Smith</i>	PersonNameDetail/Last Name	STRING	Y	50	PERSON.LAST_NAME	This value if required if any person name information is included in the XML data file.
Person Middle Initial <i>Example: S</i>	PersonNameDetail/PersonMiddleInitial	STRING	N	2	PERSON.MIDDLE_INITIAL	The two characters in the 'Person Middle Initial' can be used as needed by the submitting state. For example, if there are two people within a given organization called 'Bob A Smith', using the second letter of the Middle Name as the second letter of the 'Person Middle Initial' can be a valuable method used to differentiate between the two. Or, a period can be inserted after the first letter. Or, the second space can be left blank.
Person Suffix <i>Example: Jr.</i>	PersonNameDetail/NameSuffixText	STRING	N	5	PERSON.SUFFIX	

Data Element	XML Tag Name	XML Data Type	Req'd (Y/N)	Length	Access Table Mapping	Comment
Person Title <i>Example: Mr.</i>	PersonNameDetail/NamePrefixText	STRING	N	60	PERSON.TITLE	
Person Mailing Address Type Code <i>Example: SHIPPING</i>	PersonMailingAddressDetail/MailingAddressTypeCode	STRING	Y	12	MAILING_ADDRESS.MAILING_ADDRESS_CODE	This value must be set to one of the following: <ul style="list-style-type: none"> SHIPPING (<i>Shipping Address</i>) MAILING (<i>Mailing Address</i>) OTHER (<i>Other Address</i>) This value is required if any person mailing address information is included in the XML data file.
Person Mailing Address Street Line 1 Text <i>Example: 14 Main Rd.</i>	PersonMailingAddressDetail/MailingAddressStreetLine1Text	STRING	Y	100	MAILING_ADDRESS.LINE_1	This value is required if any person mailing address information is included in the XML data file.
Person Mailing Address Street Line 2 Text <i>Example: Suite 4</i>	PersonMailingAddressDetail/MailingAddressStreetLine2Text	STRING	N	100	MAILING_ADDRESS.LINE_2	
Person Mailing Address Street Line 3 Text <i>Example: Building 12</i>	PersonMailingAddressDetail/MailingAddressStreetLine3Text	STRING	N	100	MAILING_ADDRESS.LINE_3	
Person Mailing Address City Text <i>Example: Augusta</i>	PersonMailingAddressDetail/MailingAddressCityName	STRING	Y	50	MAILING_ADDRESS.CITY	This value is required if any person mailing address information is included in the XML data file.
Person Mailing Address State Code <i>Example: ME</i>	PersonMailingAddressDetail/StateCode	STRING	Y	2	MAILING_ADDRESS.STATE_POSTAL_CODE	This value is required if any person mailing address information is included in the XML data file. This value must be a valid 2-character State Postal Code.

Data Element	XML Tag Name	XML Data Type	Req'd (Y/N)	Length	Access Table Mapping	Comment
Person Mailing Address Zip Code <i>Example: 04333</i>	PersonMailingAddressDetail/AddressPostalCode	STRING	Y	12	MAILING_ADDRESS.ZIP_CODE	This value is required if any person mailing address information is included in the XML data file. This value must be in one of the following numeric formats: <ul style="list-style-type: none"> ■ ##### or <ul style="list-style-type: none"> ■ #####-####
Person Mailing Address Effective Date <i>Example: 2003-01-01T00:00:00</i>	PersonMailingAddressDetail/MailingAddressEffectiveDate	DATE	Y		MAILING_ADDRESS.EFFECTIVE_DATE	This value is required if any person mailing address information is included in the XML data file. The date should be entered in the XML file in the following format: YYYY-MM-DDTHH:MI:SS This value should be set to the date on which the mailing address information became effective or will become effective. Please see Section 3.2 Use of Effective Date and Status Indicator Data Elements for more information.
Person Mailing Address Status Indicator <i>Example: ACTIVE</i>	PersonMailingAddressDetail/MailingAddressStatusIndicator	STRING	Y	8	MAILING_ADDRESS.STATUS	This value is required if any person mailing address information is included in the XML data file. This value must be set to "ACTIVE" or "INACTIVE". Please see Section 3.2 Use of Effective Date and Status Indicator Data Elements for more information.

Data Element	XML Tag Name	XML Data Type	Req'd (Y/N)	Length	Access Table Mapping	Comment
Person Electronic Address Type Code <i>Example: EMAIL</i>	PersonElectronicAddressDetail/ElectronicAddressTypeCode	STRING	Y	12	ELECTRONIC_ADDRESS.ELECTRONIC_ADDRESS_CODE	This value must be set to one of the following: <ul style="list-style-type: none"> EMAIL (<i>E-mail</i>) URL (<i>URL</i>) OTHER (<i>Other</i>) This value is required if any person electronic address information is included in the XML data file.
Person Electronic Address Text <i>Example: Smith.Bob@maine.gov</i>	PersonElectronicAddressDetail/ElectronicAddressText	STRING	Y	255	ELECTRONIC_ADDRESS.ADDRESS	This value is required if any person electronic address information is included in the XML data file.
Person Electronic Address Effective Date <i>Example: 2003-01-01T00:00:00</i>	PersonElectronicAddressDetail/ElectronicAddressEffectiveDate	DATE	Y		ELECTRONIC_ADDRESS.EFFECTIVE_DATE	This value is required if any person electronic address information is included in the XML data file. The date should be entered in the XML file in the following format: YYYY-MM-DDTHH:MI:SS This value should be set to the date on which the electronic address information became effective or will become effective. Please see Section 3.2 Use of Effective Date and Status Indicator Data Elements for more information.
Person Electronic Address Status Indicator <i>Example: ACTIVE</i>	PersonElectronicAddressDetail/ElectronicAddressStatusIndicator	STRING	Y	8	ELECTRONIC_ADDRESS.STATUS	This value is required if any person electronic address information is included in the XML data file. This value must be set to "ACTIVE" or "INACTIVE". Please see Section 3.2 Use of Effective Date and Status Indicator Data Elements for more information.

Data Element	XML Tag Name	XML Data Type	Req'd (Y/N)	Length	Access Table Mapping	Comment
Person Telephone Type Code <i>Example: CELL</i>	PersonTelephoneDetail/ TelephoneTypeCode	STRING	Y	12	TELEPHONE.TELEPHONE_TYPE_CODE	This value must be set to one of the following: <ul style="list-style-type: none"> ■ FAX (<i>Fax</i>) ■ VOICE (<i>Voice</i>) ■ PAGER (<i>Pager</i>) ■ CELL (<i>Cellular/Mobile</i>) ■ OTHER (<i>Other</i>) This value is required if any person telephone information is included in the XML data file.
Person Telephone Number <i>Example: 207- 287-1111</i>	PersonTelephoneDetail/ TelephoneNumberText	STRING	Y	12	TELEPHONE.TELEPHONE_NUMBER	This value is required if any person telephone information is included in the XML data file. This value must be in the following alphanumeric format: <ul style="list-style-type: none"> ■ XXX-XXX-XXXX
Person Telephone Effective Date <i>Example: 2003-01-01T00:00:00</i>	PersonTelephoneDetail/ EffectiveDate	DATE	Y		TELEPHONE.EFFECTIVE_DATE	This value is required if any person telephone information is included in the XML data file. The date should be entered in the XML file in the following format: YYYY-MM-DDTHH:MI:SS This value should be set to the date on which the telephone information became effective or will become effective. Please see Section 3.2 Use of Effective Date and Status Indicator Data Elements for more information.
Person Telephone Status Indicator <i>Example: ACTIVE</i>	PersonTelephoneDetail/ StatusIndicator	STRING	Y	8	TELEPHONE.STATUS	This value is required if any person telephone information is included in the XML data file. This value must be set to "ACTIVE" or "INACTIVE". Please see Section 3.2 Use of Effective Date and Status Indicator Data Elements for more information.

3.1.3 Beach Information

The Beach Information section of the XML submission contains data, such as beach name, beach description, state code, and county code, related to the beaches overseen by the National Beach Program. These data elements will be included in the XML file when beach information needs to be added or updated in the PRAWN database.

All XML elements in this section are located in the following position on the XML element hierarchy—“BeachDataSubmission/BeachDetail”.

Exhibit 3-3 Beach Information Schema

Data Element	XML Tag Name	XML Data Type	Req'd (Y/N)	Length	Access Table Mapping	Comment
Beach Identifier <i>Example: ME234898</i>	BeachIdentifier	STRING	Y	8	BEACH.ID, BEACH_ACTIVITY.FK_BEACH_ID, BEACH_PROCEDURE_ASSIGN.FK_BEACH_ID, BEACH_PERSON_ROLE_ASSIGN.FK_BEACH_ID, BEACH_ORGANIZATION_ROLE_ASSIGN.FK_BEACH_ID, BEACH_LATITUDE_LONGITUDE_COORDINATE.FK_BEACH_ID, ACTIVITY_DELETE.FK_BEACH_ID	EPA maintains a list of valid Beach Identifiers for all beaches that are stored in the PRAWN database. Each new identifier must be registered with EPA before it can be submitted. These identifiers must be unique, as they will be used to update beach-level data. *Send request for new Beach ID to ebeaches@cgifederal.com CC: Bill Kramer: Kramer.Bill@epa.gov and your Regional Beach Coordinator
Beach Name <i>Example: Sandy Beach Point</i>	BeachNameDetail/ProgramInterestName	STRING	Y	60	BEACH.NAME	This value is required if any beach name information is included in the XML data file.
Beach Description Text <i>Example: Rocky, big waves, no pollution</i>	BeachNameDetail/ProgramInterestDescriptionText	STRING	Y	255	BEACH.DESCRPTION	This value is required if any beach name information is included in the XML data file.
Beach Comment Text <i>Example: A nice place to surf</i>	BeachNameDetail/ProgramInterestCommentText	STRING	N	255	BEACH.COMMENT	This is an optional field that can be used to store other information about the particular beach that is not included in an official description.
Beach State Code <i>Example: ME</i>	BeachNameDetail/ProgramInterestStateCode	STRING	Y	2	BEACH.STATE_POSTAL_CODE	This value is required if any beach name information is included in the XML data file. This value must be a valid 2-character State Postal Code.

Data Element	XML Tag Name	XML Data Type	Req'd (Y/N)	Length	Access Table Mapping	Comment
Beach FIPS County Code <i>Example: 23001</i>	BeachNameDetail/ProgramInterestFIPSCountyCode	STRING	Y	5	BEACH.FIPS_COUNTY	This value is required if any beach name information is included in the XML data file. This value must be a valid 5 digit code representing a county, as assigned by the Federal Information Processing Standards Publications (FIPS). The first two digits represent the state, while the last three digits represent the specific county. FIPS county codes can be found at http://www.itl.nist.gov/fipspubs/codes/states.htm
Water Body Name Code <i>Example: ATLANTIC</i>	BeachNameDetail/WaterBodyNameCode	STRING	N	12	BEACH.WATERBODY_NAME	This value can be chosen from a list in Appendix D. Any Jurisdiction in a Great Water Body, is required to submit waterbody names.
Water Body Type Code <i>Example: OPEN_COAST</i>	BeachNameDetail/WaterBodyTypeCode	STRING	N	12	BEACH.WATERBODY_TYPE	If Water Body Name (above) is NOT assigned to INLAND, this value must be set to one of the following: <ul style="list-style-type: none"> ■ OPEN_COAST (Open Coast) ■ SND_BY_INLT (Sound, Bay, or Inlet) If Waterbody Name (above) IS assigned to INLAND, this value must be set to one of the following: <ul style="list-style-type: none"> ■ STILL_WATER (Still Water) ■ FLOW_WATER (Flowing Water) Any Jurisdiction in a Great Water Body, is required to submit waterbody names.

Data Element	XML Tag Name	XML Data Type	Req'd (Y/N)	Length	Access Table Mapping	Comment
Beach Accessibility Type <i>Example: PUB_PRV_ACC</i>	BeachNameDetail/BeachAccessibilityDetail/BeachAccessibilityType	STRING	Y	12	BEACH.ACCESS_TYPE	This value is required if any beach name information is included in the XML data file. The value must be set to one of the following: <ul style="list-style-type: none"> ■ PUB_PUB_ACC (<i>Public Beach with Public Access</i>) ■ PRV_PRV_ACC (<i>Private Beach with Private Access</i>) NOTE: if BAB not Y, do not include <ul style="list-style-type: none"> ■ PUB_PRV_ACC (<i>Public Beach with Private Access</i>) ■ PRV_PUB_ACC (<i>Private Beach with Public Access</i>)
Beach Accessibility Comment <i>Example: Public Property at the end of a road.</i>	BeachNameDetail/BeachAccessibilityDetail/BeachAccessibilityComment	STRING	N	255	BEACH.ACCESS_COMMENT	This is an optional field that can be used to store other information about the beach access that is not included in an official description.

3.1.4 Beach Attribute Information

The beach attribute section of the XML submission contains data related to beach information that may change over time, such as beach extent (length), swim season length, and monitoring frequency.

States should submit one ‘Beach Attribute Detail’ section each year for each beach [with revisions or deletions and/or at least updated effective year](#).

Effective year examples:

- To submit data for the 2016 season, set the effective year to 2016.
- To change (overwrite) data for a prior specific year (e.g., 2015); change the data, but keep the effective year (i.e., 2015).
- To change prior year data going forward (e.g., beach status – to change from active (2015 and before) to dormant (2016), submit the status as dormant, but with an effective year of 2016. BEACON will then show both the active status for the prior years, and the current status as dormant until the status is changed again.

All XML elements in this section are located in the following position on the XML element hierarchy—“BeachDataSubmission/BeachDetail/BeachAttributeDetail”.

When a new beach ID is created, data will not show up in BEACON until beach attribute data is submitted. In the Access Beach Notification database, fill out: Form 02 Beach Data Entry, Form 03 Beach Attribute, and Form 16 Latitude Longitude Coordinate Entry and submit the resulting xml to PRAWN. Once the data has been submitted, users should see that data show up in BEACON within 4 to 24 hours.

Exhibit 3-4 Beach Attribute Information Schema

Data Element	XML Tag Name	XML Data Type	Req'd (Y/N)	Length	Access Table Mapping	Comment
Attribute Effective Year Example: 2006	AttributeEffectiveYear	STRING	Y	4	BEACH_ATTRIBUTE.EFFECTIVE_YEAR	This value is required if any beach attribute information is included in the XML data file. Attribute Effective Year is appended to each of the beach extent, swim season, and monitoring frequency records in PRAWN to distinguish the change over time. This value must be updated every year, even if the subsequent attribute information does not change, in order to verify the correct information for a beach.
Beach Extent Length Measure Example: 5	BeachExtentDetail/ExtentLengthMeasure	NUMBER	Y	14	BEACH_ATTRIBUTE.EXTENT_LENGTH	This value is required if any beach name information is included in the XML data file. This value is the numeric equivalent of the length of a beach, along with the units of measure below.
Beach Extent Length Unit of Measure Example: MI	BeachExtentDetail/ExtentUnitOfMeasureCode	STRING	Y	12	BEACH_ATTRIBUTE.EXTENT_UNITS	This value must be set to one of the following: MI (Miles) FT (Feet) YDS (Yards) M (Meters) KM (Kilometers) This value is required if any beach name information is included in the XML data file.

Data Element	XML Tag Name	XML Data Type	Req'd (Y/N)	Length	Access Table Mapping	Comment
Swim Season Start Date Example: 1/1/2007	BeachSwimSeasonLengthDetail/SwimSeasonStartDate	DATE	Y	n/a	BEACH_ATTRIBUTE. SWIM_SEASON_START_DATE	<p>The Swim Season Start Date and Swim Season End Date are required if any beach name information is included in the XML data file. Beach Season Length is calculated, and Beach Season Unit of Measure are optional to include, but if a beach is not open everyday between start and end dates, you can also enter the number of open days, in Beach Season Length, below.</p> <p>This value is the date the beach swim season starts for the year.</p>
Swim Season End Date Example: 12/31/2007	BeachSwimSeasonLengthDetail/SwimSeasonEndDate	DATE	Y	n/a	BEACH_ATTRIBUTE. SWIM_SEASON_END_DATE	<p>The Swim Season Start Date and Swim Season End Date are required if any beach name information is included in the XML data file. Beach Season Length and Beach Season Unit of Measure are optional to include. For example, if a beach is not open everyday between start and end dates, you can set the number of open days.</p> <p>This value is the date the beach swim season ends for the year.</p>
Swim Day	BeachSwimSeasonLengthDetail/SwimSeasonDayMeasure	Number	N	2	BEACH_ATTRIBUTE.SWIM_DAY	<p>This is the period of time (in hours) that the beach is open per day during the swim season. It will be used to calculate Advisories and closures with a greater precision.</p> <p>For example, if a beach is open for 8 hours and an advisory occurs for 4 hours, the time the beach is under advisory for swimming will calculate at 50% as opposed to 17% for a full 24 hr day.</p>

Data Element	XML Tag Name	XML Data Type	Req'd (Y/N)	Length	Access Table Mapping	Comment
Beach Season Length Example: 150	BeachSwimSeasonLengthDetail/SwimSeasonLengthMeasure	NUMBER	N	14	BEACH_ATTRIBUTE.SWIM_SEASON_LENGTH	<p>The Swim Season Start Date and Swim Season End Date are required if any beach name information is included in the XML data file. Beach Season Length and Beach Season Unit of Measure are optional to include. For example, if a beach is not open everyday between start and end dates, you can set the number of open days.</p> <p>This value is the numeric equivalent of the amount of time in a swim season, along with the units of measure below.</p>
Beach Season Unit of Measure Example: DAYS	BeachSwimSeasonLengthDetail/SwimSeasonUnitOfMeasureCode	STRING	N	12	BEACH_ATTRIBUTE.SWIM_SEASON_UNITS	<p>This value must be set to one of the following:</p> <ul style="list-style-type: none"> DAYS (Days) WEEKS (Weeks) MONTHS (Months) <p>The Swim Season Start Date and Swim Season End Date are required if any beach name information is included in the XML data file. Beach Season Length and Beach Season Unit of Measure are optional to include. For example, if a beach is not open everyday between start and end dates, you can set the number of open days.</p>

Data Element	XML Tag Name	XML Data Type	Req'd (Y/N)	Length	Access Table Mapping	Comment
Swim Season Monitoring Frequency Example: 10	MonitoringFrequencyDetail/SwimSeasonFrequencyMeasure	NUMBER	Y	14	BEACH_ATTRIBUTE.SWIM_MONITOR_FREQ	<p>This value is required if any beach attribute information is included in the XML data file. This value is the numeric equivalent of the frequency of monitoring performed during the designated Swim Season, as defined in the previous tags. The Swim Season Monitoring Frequency corresponds to the units of measure below.</p> <p>If monitoring is not performed on the beach during the swim season, please enter a 0 (zero) for this value.</p> <p>At end of season before submitting data, check to see if there was any WQ data and or advisories during the year, and mark monitoring status accordingly.</p>
Off Season Monitoring Frequency Example: 2	MonitoringFrequencyDetail/OffSeasonFrequencyMeasure	NUMBER	Y	14	BEACH_ATTRIBUTE.OFF_MONITOR_FREQ	<p>This value is required if any beach attribute information is included in the XML data file. This value is the numeric equivalent of the frequency of monitoring performed outside of the designated Swim Season, as defined in the previous tags. The Off Season Monitoring Frequency corresponds to the units of measure below.</p> <p>If monitoring is not performed on the beach during the off season, please enter a 0 (zero) for this value.</p>

Data Element	XML Tag Name	XML Data Type	Req'd (Y/N)	Length	Access Table Mapping	Comment
Monitoring Frequency Unit of Measure Example: PER_WEEK	MonitoringFrequencyDetail/MonitoringFrequencyUnitOfMeasureCode	STRING	Y	12	BEACH_ATTRIBUTE.MONITOR_FREQ_UNITS	This value must be set to one of the following: PER_DAY (Per Day) PER_WEEK (Per Week) PER_MONTH (Per Month) PER_YEAR (Per Year) This value is required if any beach attribute information is included in the XML data file. This value corresponds to both the Swim Season and Off Season Monitoring Frequencies. For example, if the Swim Season Monitoring Frequency Measure is 10, and the Units are PER_WEEK, the frequency reads "The beach is monitored 10 times per week during the swim season."
Monitored Irregularly Indicator Example: Y	MonitoredIrregularly	BOOLEAN	Y	1	BEACH_ATTRIBUTE.MONITORED_IRREGULARLY	This value is required if any beach attribute information is included in the XML data file. This should be "Y" if the beach is monitored irregularly and "N" if not monitored irregularly (or monitored at all).
Monitored Irregularly Comment	MonitoredIrregularlyComment	Text	N	255	BEACH_ATTRIBUTE.MONITORED_IRREGULARLY_COMMENT	Any comments the about the regularity of the monitoring.
Pollutions Sources Indicator Example: Y	NoPollutionSourcesIndicator	BOOLEAN	Y	1	POLLUTION_SOURCES	This should be "Y" if there are any possible pollution sources impacting the beach, at least during the season. This should be "N" if pollution sources were investigated and none were found. Note, see Appendix G for more information on populating data for pollution sources.
Pollutions Sources Investigated Indicator Example: Y	PollutionsSourcesUninvestigatedIndicator	BOOLEAN	Y	1	POLLUTION_SOURCES_INVESTIGATED	This should be "Y" if the beach pollution sources have been investigated and "N" otherwise. Note, see Appendix G for more information on populating data for pollution sources.

Data Element	XML Tag Name	XML Data Type	Req'd (Y/N)	Length	Access Table Mapping	Comment
Advisory Reporting Frequency	AdvReportingFrequencyDetail/ AdvReportingFrequencyMeasure	Number	N	4	BEACH_ATTRIBUTE.ADV_REPORT_FREQ	This value is required if any beach attribute information is included in the XML data file. This value is the numeric equivalent of the frequency of advisory reporting to EPA performed during the designated Swim Season, as defined in the previous tags. The Swim Season Advisory Reporting Frequency corresponds to the units of measure below. If Advisory Reporting is not performed on the beach during the swim season, please enter a 0 (zero) for this value.
Advisory Reporting Frequency Units	AdvReportingFrequencyDetail/ AdvReportingFrequencyUnitOfMeasureCode	String	N	255	BEACH_ATTRIBUTE.ADV_REPORT_FREQ_UNITS	This value must be set to one of the following: PER_DAY (Per Day) PER_WEEK (Per Week) PER_MONTH (Per Month) PER_YEAR (Per Year) This value is required if any beach attribute information is included in the XML data file including a 0 (zero) for frequency.

Data Element	XML Tag Name	XML Data Type	Req'd (Y/N)	Length	Access Table Mapping	Comment
Beach Pollution Source Code Example: SEWER_LINE	BeachPollutionSourceDetail/BeachPollutionSourceCode	STRING	Y	12	BEACH_POLLUTION.POLLUTION_SOURCE	<p>This value must be set to at least one of the following:</p> <ul style="list-style-type: none"> AGRICULTURAL (Agricultural Runoff) ALGAE (Algae Sources) BOAT (Boat Discharge) CAFO (Concentrated Animal Feeding Operation) CSO (Combined Sewer Overflow) POTW (Publicly-Owned Treatment Works) RUNOFF (Non-storm Related/Urban/Dry weather runoff) SEPTIC (Septic System Leakage) SEWER_LINE (Sewer Line Leak/Break/Blockage) SSO (Sanitary Sewer Overflow) STORM (Storm Related/Wet-Weather Runoff) WILDLIFE (Wildlife) UNKNOWN (Unknown) OTHER (Other-Specify in Description Field) TBD (To Be Determined - Use this value in one of the following two cases: <ul style="list-style-type: none"> 1. Beach with no reported activities or investigation. 2. When a beach has an activity but a source has not been determined and an investigation is planned.) <p>This data element is designed to allow states to store pollution sources impacting a given beach during the beach season when actions are being posted. These may include "possible" sources, identified by a citable study or attributed to by a credible person or entity; even if not confirmed to a level suitable for use in a court of law.</p> <p>**Note that submitting a beach with no potential pollution sources is identical to saying that no pollution sources are known to impact that beach.</p>

Data Element	XML Tag Name	XML Data Type	Req'd (Y/N)	Length	Access Table Mapping	Comment
Beach Pollution Source Description	BeachPollutionSourceDetail/BeachPollutionSourceDescription	STRING	N	255	BEACH_POLLUTION.POLLUTION_COMMENT	<p>This is an optional field that can be used to store other information about the beach pollution source that is not included in an official description. Or names of additional sources</p> <p>This field can also specify the species of Algae, see STORET Biological names standard.</p> <p>http://www.epa.gov/storet/links.html</p>
Beach Website URL	BeachWebsite	Text	N	255	BEACH_ATTRIBUTE.BEACH_WEBSITE	<p>This value represents the URL State's can use to specify the website page of a beach or state website that lists beach sites. Please include http:// when entering your data.</p>
Beach Tier Ranking <i>Example: 2</i>	BeachTierRanking	NUMBER (0-9)	Y	1	BEACH_ATTRIBUTE.BEACH_TIER	<p>This value is required if any beach attribute information is included in the XML data file.</p> <p>The ranking system for this value is set by individual states, so the ranges may differ (e.g., State A may have tiers 1 and 2, while State B may have tiers 1, 2, and 3)</p> <p>States with no tier system should enter a value of '1' for all beaches.</p>
Beach Act Beach Indicator <i>Example: Y</i>	BeachActBeachIndicator	BOOLEAN	Y	1	BEACH_ATTRIBUTE.BEACH_ACT_BEACH	<p>This value is required if any beach attribute information is included in the XML data file.</p> <p>This should be "Y" if the beach qualifies as a BEACH Act beach and "N" otherwise. If "N" it should not be submitted to EPA</p>

Data Element	XML Tag Name	XML Data Type	Req'd (Y/N)	Length	Access Table Mapping	Comment
Beach Reporting Status <i>Example: Dormant</i>	BeachDormantIndicator	STRING	N	1	BEACH_ATTRIBUTE.BEACH_DORMANT	<p>This should be "Active" if the beach is normally managed to report actions, and or monitoring results.</p> <p>This should be "Dormant" if the beach is normally managed and or monitored but is not expected to be used by the public and not managed to report actions or monitored for at least a year/season.</p> <p>If the beach is normally not managed and monitored, but is used by the public, set the status to "Non-reporting" (NR)</p> <p>If the beach was normally managed and or monitored but not expected to be used by the public (deactivated) for longer, than a year, ask EPA to set the historical flag to "Y".</p>
Monitoring Reporting Frequency <i>Example: 3</i>	ReportingFrequencyMeasure	NUMBER	N	14	BEACH_ATTRIBUTE.REPORT_FREQ	<p>This value is the numeric equivalent of the frequency of monitoring reporting to EPA performed during the year. The Reporting Frequency corresponds to the units of measure below.</p> <p>If monitoring reporting is not being done on the beach report the frequency as 0 and set the dormant flag to "Y" or "NR".</p> <p>If the monitoring reporting is not determined please enter 0.</p>

Data Element	XML Tag Name	XML Data Type	Req'd (Y/N)	Length	Access Table Mapping	Comment
Monitoring Reporting Frequency Unit of Measure Example: PER_WEEK	ReportingFrequencyUnitOfMeasureCode	STRING	N	12	BEACH_ATTRIBUTE.REPORT_FREQ_UNITS	<p>This value must be set to one of the following:</p> <p>PER_DAY (Per Day) PER_WEEK (Per Week) PER_MONTH (Per Month) PER_YEAR (Per Year)</p> <p>This value corresponds to the Reporting Frequency. For example, if the Reporting Frequency Measure is 1, and the Units are PER_WEEK, the frequency reads "The beach is reported once per week during the year."</p> <p><i>This value is required if any beach attribute information is included in the XML data file including a 0 (zero) for frequency.</i></p>
(WQS Criteria) Indicator Name <i>Example: ECOLI</i>	IndicatorName	STRING	Y	12	BEACH_CRITERION.INDICATOR_NAME	<p>This value must be set to one of the following:</p> <p>ENTERO (Enterococci) FECAL (Fecal Coliform) TOTAL (Total Coliform) ECOLI (E. coli) OTHER (Other-Please specify in the Description field)</p> <p>This value is designed to allow states to notify the BEACON user under which conditions a beach activity occurs. Multiple criterion entries may be included for a single beach.</p>
(WQS Criteria) Water Type Name <i>Example: MARINE</i>	WaterTypeName	STRING	Y	12	BEACH_CRITERION.WATER_TYPE_NAME	<p>This value must be set to one of the following:</p> <p>MARINE FRESH BOTH</p> <p>This value represents the water type used in reporting the criterion data.</p>

Data Element	XML Tag Name	XML Data Type	Req'd (Y/N)	Length	Access Table Mapping	Comment
(WQS Criteria) Measure Type Name <i>Example: SSM</i>	MeasureTypeName	STRING	Y	12	BEACH_CRITERION.MEASURE_TYPE_NAME	This value must be set to one of the following: GM (Geometric Mean – 30 Day) If GM is other than 30 day so note in “Criterion Comment” below SSM (Single Sample Maximum) CFU (Colony Forming Units) STV (Statistical Threshold Value) qPCR (Quantitative Polymerase Chain Reaction) CCE (Computed Cell Equivalents) BNT (Beach Notification Threshold) OTHER (Other) This value represents the measure type used in reporting the criterion data. Multiple measure type names may exist for a single indicator.
(WQS Criteria) Measure Value <i>Example: 35</i>	MeasureValue	NUMBER	Y	14	BEACH_CRITERION.MEASURE_VALUE	This value is the numeric measure representing the criterion data, along with the units of measure below.
(WQS Criteria) Measure Unit Code <i>Example: CFU/100ml</i>	MeasureUnitCode	STRING	Y	12	BEACH_CRITERION.MEASURE_UNIT_CODE	This value is the string unit code representing the criterion data.
(WQS Criteria) Criterion Comment	CriterionComment	STRING	Y	200	BEACH_CRITERION.CRITERION_COMMENT	This value can contain information on your BNT, a string of characters or a URL to a document that explains the local advisory and closure action decision procedures.

3.1.5 Beach Activity Information

The beach activity section of the XML submission contains data related to beach advisories and closures, [including un-monitored beaches](#), such as activity type code, activity name, activity description text, and activity reason. These data elements will be included in the XML file when activity or closure information needs to be added to the PRAWN database. Since activities require a start and stop date, [A place holder can be used if the actual stop date is unavailable. Use the following timestamp to submit the stop date in a later submission: 1900-01-01T00:00:00](#)

[If the blank timestamp is used, please see Section 3.1.6 and Appendix K for removal and updating Activities when the correct stop date is determined.](#)

If the activity crosses a calendar year, stop it at the end of the year and start a continuation at the beginning of the next year.

States should submit one ‘Beach Activity Detail’ section per any one of the Activity Type Codes. Multiple ‘Beach Activity Detail’ sections can appear under one ‘Beach Detail’ section.

All XML elements in this section are located in the following position on the XML element hierarchy—
“BeachDataSubmission/BeachDetail/BeachActivityDetail”.

A note on activity submissions:

- Because it is possible for multiple activities to overlap on portions of the same beach, it is not possible to determine if duplicate activities have been submitted. For this reason, it is ***critically important*** that State users track those activities that have been previously submitted; submitting an activity twice *will* result in a duplicate activity in PRAWN. [Should an activity be submitted multiple times, see Appendix K for activity deletion process in the case of duplicate activities](#)
- Simultaneous or overlapping activities can cause the % days under an activity to be >100%. Consider merging these into one longer or combined activity.

Exhibit 3-5 Beach Activity Information Schema

Data Element	XML Tag Name	XML Data Type	Req'd (Y/N)	Length	Access Table Mapping	Comment
Activity Type Code Example: CLOSURE	ActivityTypeCode	STRING	Y	12	BEACH_ACTIVITY.ACTIVITY_CODE	This value must be set to one of the following: CONTAM_ADV (Contamination Advisory) CLOSURE (Closure) PERM_CLOSURE (Permanent Closure) RAIN_ADV (Rain Advisory) This value is required if any beach activity information is included in the XML data file. States should submit one 'Beach Activity Detail' section per any one of the above activities. Activity Type Code and Activity Name are related in so far as the Activity Name can be used to keep track of the various activity types by assigning a local name to the various activities. There is not an Identifier in this portion of the data submission to aid in this endeavor.
Activity Name Example: Closure 34	ActivityName	STRING	Y	60	BEACH_ACTIVITY.NAME	This value is required if any beach activity information is included in the XML data file. Activity Type Code and Activity Name are related in so far as the Activity Name can be used to keep track of the various activity types by assigning a local name to the various activities. There is not an Identifier in this portion of the data submission to aid in this endeavor.
Activity Actual Start Date Example: 2002-04-12T02:00:00	ActivityActualStartDate	DATE	Y		BEACH_ACTIVITY.ACTUAL_START_DATE	This value is required if any beach activity information is included in the XML data file. The date should be entered in the XML file in the following format: YYYY-MM-DDTHH:MI:SS

Data Element	XML Tag Name	XML Data Type	Req'd (Y/N)	Length	Access Table Mapping	Comment
Activity Actual Stop Date Example: 2002-04-16T06:30:00	ActivityActualStopDate	DATE	Y		BEACH_ACTIVITY.ACTUAL_STOP_DATE	<p>The date should be entered in the XML file in the following format: YYYY-MM-DDTHH:MI:SS</p> <p>This should be the last date that use of the beach is restricted. E.G., if the activity ends on June 15th but before the beach opens, it would not effect beach use so you can use the date of June 14. As the stop date.</p> <p>**Note a place holder can be used if the actual stop date is unavailable. Use the following timestamp to submit the stop date in a later submission: 1900-01-01T00:00:00</p> <p>If the blank timestamp is used, please see Appendix K for removal and updating Activities when the correct stop date is determined..</p>
Partial Day Amount (in Hours)	ActivityPartialDayAmount	Number	Y	2	BEACH_ACTIVITY.PARTIAL_DAY_AMOUNT	<p>Partial Day Amount refers to the amount of time an activity occurs if it last less than a full day. This value is used in conjunction with the Swim Day field on the Beach Attribute form.</p> <p>Value will be calculated as a percentage of total time the beach is open per day. Example: If beach is open for 10 hours a day, Swim Day will equal 10. If an advisory or closure only occurs for 2 of the hours the beach is open, Partial Day Amount will equal 2. The calculated advisory time will be 20%. (2 hours/10 total open hours)</p> <p>When using Partial Day, the actual start date and actual end date must be the same. If advisory or closure occurs over two days, the form must be filled out for both days.</p>

Data Element	XML Tag Name	XML Data Type	Req'd (Y/N)	Length	Access Table Mapping	Comment
Activity Reason Type Example: ELEV_BACT	ActivityReasonDetail/ActivityReasonType	STRING	Y	60	BEACH_ACTIVITY_REASON.T YPE (BEACH_ACTIVITY_REASON.C LASS = 'REASON')	This value must be set to at least one of the following: ELEV_BACT (Monitoring that revealed elevated bacteria levels) RAINFALL (Preemptive-Rainfall) SEWAGE (Preemptive-Sewage discharge or spill) CHEM_OIL (Preemptive-Chemical or oil discharge or spill) MODEL (Model prediction) POLICY (Policy dictates action) OTHER (Other-Please specify in the Description field) MODEL_VB (Virtual Beach) This value is required only if beach activity information AND beach activity reason information is included in the XML data file. The Beach Activity Reason Type field is used to supply information regarding the reason for the activity denoted in the Activity Type Code field. Any number of Reason Detail sections may be submitted (consecutively in the XML file) to associate many reasons to a single activity. **Note that activities with Type 'ELEV_BACT' must submit at least one Monitoring Station Identifier in Form 19) Beach Activity Station
Activity Reason Description Text Example: Exceeded Water Quality Standards	ActivityReasonDetail/ActivityReasonDescriptionText	STRING	N	255	BEACH_ACTIVITY_REASON.D ESCRPTION (BEACH_ACTIVITY_REASON.C LASS = 'REASON')	The Beach Activity Reason Description field is used to supply additional information regarding the reason for the activity denoted in the Activity Type Code field.

Data Element	XML Tag Name	XML Data Type	Req'd (Y/N)	Length	Access Table Mapping	Comment
Activity Source Type Example: CSO	ActivitySourceDetail/ActivitySourceType	STRING	Y	60	BEACH_ACTIVITY_REASON.T YPE (BEACH_ACTIVITY_REASON.C LASS = 'SOURCE')	This value must be set to at least one of the following: AGRICULTURAL (Agricultural Runoff) ALGAE (Algae Sources) BOAT (Boat Discharge) CAFO (Concentrated Animal Feeding Operation) CSO (Combined Sewer Overflow) POTW (Publicly-Owned Treatment Works) RUNOFF (Non-storm Related/Urban/Dryweather runoff) SEPTIC (Septic System Leakage) SEWER_LINE (Sewer Line Leak/Break/Blockage) SSO (Sanitary Sewer Overflow) STORM (Storm Related/Wet-Weather Runoff) WILDLIFE (Wildlife) UNKNOWN (Unknown) OTHER (Other-Specify in Description Field) This data element is required only if beach activity information AND beach activity source information is included in the XML data file. The Beach Activity Source Type field is used to supply information regarding the source of the activity denoted in the Activity Type Code field. Note, see Appendix G for more information on populating data for pollution sources.
Activity Source Description Text Example: Visible from CSO	ActivitySourceDetail/ActivitySourceDescriptionText	STRING	N	255	BEACH_ACTIVITY_REASON.D ESCRIPTION (BEACH_ACTIVITY_REASON.C LASS = 'SOURCE')	The Beach Activity Source Type field is used to supply additional information regarding the source of the activity denoted in the Activity Type Code field. The comment field can also specify the species of Algae, see STORET Biological names standard. http://www.epa.gov/storet/links.html

Data Element	XML Tag Name	XML Data Type	Req'd (Y/N)	Length	Access Table Mapping	Comment
Activity Indicator Type Example: PREEMPT	ActivityIndicatorDetail/ ActivityIndicatorType	STRING	Y	60	BEACH_ACTIVITY_REASON.T YPE (BEACH_ACTIVITY_REASON.C LASS = 'INDICATOR')	This value must be set to one of the following: PREEMPT (Preemptive) ENTERO (Enterococci) TOTAL_COL (Total Coliform) FECAL_COL (Fecal Coliform) ECOLI (E. coli) RATIO (Total/Fecal Ratio) OTHER (Other-Please specify in the Description field) This value is required only if beach activity information AND beach activity indicator information is included in the XML data file. The Beach Activity Indicator Type field is used to supply information regarding the indicator for the activity denoted in the Activity Type Code field.
Activity Indicator Description Text Example: To avoid more actions	ActivityIndicatorDetail/ ActivityIndicatorDescriptionText	STRING	N	255	BEACH_ACTIVITY_REASON.D ESCRPTION (BEACH_ACTIVITY_REASON.C LASS = 'INDICATOR')	This value is required only if beach activity information AND beach activity indicator information is included in the XML data file.

Data Element	XML Tag Name	XML Data Type	Req'd (Y/N)	Length	Access Table Mapping	Comment
Activity Monitoring Station ID Example: 21MEBCH Station 1	ActivityMonitoringStationIdentifier	STRING	N	65	BEACH_ACTIVITY_STATION.STATION_ID	This value corresponds to the combination of a valid, pre-registered STORET organization ID and the valid, pre-registered STORET station ID that impacted the activity. The two IDs must be joined together with a "pipe" (" ") character (e.g., 'OrgID StationID'). Any number of Monitoring Station IDs may be submitted (consecutively in the XML file) to associate many stations to a single activity. This value is required if the Activity Reason Type is 'ELEV_BACT'. If monitoring frequency is > 0, a value is required.
Activity Description Text Example: The lifeguards closed the beach	ActivityDescriptionText	STRING	N	255	BEACH_ACTIVITY.DESCRPTION	This is an optional field that can be used to describe anything about the activity itself. An example might be, "The lifeguards closed the beach."
Activity Comment Text Example: The police were not present	ActivityCommentText	STRING	N	255	BEACH_ACTIVITY.COMMENT	This is an optional field that can be used to store other information about the particular activity. An example might be, "The police were not present."
Activity Start Measure Example: 2	ActivityExtentDetail/ActivityExtentStartMeasure	NUMBER	N	14	BEACH_ACTIVITY.EXTENT_START_MEASURE	This value is the numeric equivalent of the location or mile marker where the length of affected beach begins. The activity extent length (below) is added to the activity start measure to understand the exact extent of beach that was affected by the activity. For example, a start measure of 2 with an extent length of 5 and a unit of measure code of mi means the activity affected the beach from mile marker 2 to mile marker 7.

Data Element	XML Tag Name	XML Data Type	Req'd (Y/N)	Length	Access Table Mapping	Comment
Activity Extent Length Measure Example: 5	ActivityExtentDetail/ActivityExtentLengthMeasure	NUMBER	Y	14	BEACH_ACTIVITY.EXTENT_LENGTH	This value is required only if any beach activity information AND any beach activity extent information is included in the XML data file. See Activity Start Measure (above) for an explanation of the use of this value.
Activity Unit of Measure Code Example: MI	ActivityExtentDetail/ActivityUnitOfMeasureCode	STRING	Y	12	BEACH_ACTIVITY.EXTENT_UNIT_OF_MEASURE	This value must be set to one of the following: MI (Miles) FT (Feet) YDS (Yards) M (Meters) KM (Kilometers) This value is required only if any beach activity information AND any beach activity extent information is included in the XML data file.

3.1.6 Activity Deletion form

A new feature of Version 2.2.4 is the ability for users to delete existing activities through an xml submission. Using the following form, users will be able to export xml that will remove duplicate or erroneous activities from the PRAWN database. For further instructions on this process, see appendix K--Activity Deletion Process.

Exhibit 3-7 Activity Deletion Form Schema

Data Element	XML Tag Name	XML Data Type	Req'd (Y/N)	Length	Access Table Mapping	Comment
ActivityCode Number Ex: 123456	ActivityDeleteDetail/ActivityCodeNumber	STRING	Y	12	ACTIVITY_DELETE.ACTIVITY_CODE_NUMBER	This number can be found in BEACON in the Beach Actions (Advisories and Closures Report) See Appendix K for use.

3.1.7 Beach Role Information

The beach role section of the XML submission allows submitting states to provide data related to the Organization and/or Person performing roles for a given beach. This section includes data elements, such as beach role type code, organization identifier, and person identifier. These data elements will be included in the XML file when beach role information needs to be added or updated in the PRAWN database.

All XML elements in this section are located in the following position on the XML element hierarchy—`“BeachDataSubmission/BeachDetail/BeachRoleDetail”`.

Exhibit 3-6 Beach Role Information Schema

Data Element	XML Tag Name	XML Data Type	Req'd (Y/N)	Length	Access Table Mapping	Comment
Beach Role Type Code Example: LOCAL	BeachRoleTypeCode	STRING	Y	12	BEACH_ORGANIZATION_ROLE_ASSIGN.ORG_ROLE_CODE, BEACH_PERSON_ROLE_ASSIGN.PERSON_ROLE_CODE	<p>People/organizations are assigned a role on a beach via the 'Beach Role Type Code' field.</p> <p>For beach/organization assignments, this value must be set to one of the following:</p> <ul style="list-style-type: none"> LOCAL (Lead Local Agency) STATE (Lead State Agency) CONTRACTOR (Contractor) SUBCONTRACT (Subcontractor) RESPONDENT (Respondent) DETERM_AUTH (Determination Authority) ISSUAN_AUTH (Issuance Authority) REOPEN_AUTH (Reopening Authority) LAB (Laboratory) COLLECTOR (Sample Collector) ANALYZER (Sample Analyzer) OTHER (Other) UNKNOWN (Unknown) <p>For beach/person assignments, this value must be set to one of the following:</p> <ul style="list-style-type: none"> STATE (Lead State Contact) LOCAL (Lead Local Contact) COLLECTOR (Sample Collector)

Data Element	XML Tag Name	XML Data Type	Req'd (Y/N)	Length	Access Table Mapping	Comment
<i>Beach Role Type Code (cont.)</i>						ANALYZER (Sample Analyzer) RESPONDENT (Respondent) TECHNICAL (Technical Contact) <ul style="list-style-type: none"> PUBLIC (Public Contact) DETERM_AUTH (Determination Authority) ISSUAN_AUTH (Issuance Authority) REOPEN_AUTH (Reopening Authority) INFO_TECH (Information Technology Authority) This value is required if any beach role information is included in the XML data file.
Beach Role Organization Identifier Example: 987654321098	BeachRoleOrganizationIdentifier	STRING	Y	12	BEACH_ORGANIZATION_ROLE_ASSIGN.FK_ORGANIZATION_ID, PERSON.FK_ORGANIZATION_ID	A beach is associated with an organization via this field. To do so, enter the Organization Identifier in the Beach Role Organization Identifier field. This value must correspond to a valid Organization Identifier in the XML file or in the PRAWN database.
Beach Role Person Identifier Example: 123456789012	BeachRolePersonIdentifier	STRING	N	12	BEACH_PERSON_ROLE_ASSIGN.FK_PERSON_ID	A beach can be associated with a person via this field. To do so, enter the Person Identifier in the Beach Role Person Identifier field in addition to entering the Organization Identifier in the Beach Role Organization Identifier field. The Beach Role Person Identifier must correspond to a valid Person Identifier in the XML file or in the PRAWN database.

Data Element	XML Tag Name	XML Data Type	Req'd (Y/N)	Length	Access Table Mapping	Comment
Beach Role Effective Date Example: 2003-01-01T00:00:00	BeachRoleEffectiveDate	DATE	Y		BEACH_ORGANIZATION_ROLE_ASSIGN.EFFECTIVE_DATE, BEACH_PERSON_ROLE_ASSIGN.EFFECTIVE_DATE	This value is required if any beach role information is included in the XML data file. The date should be entered in the XML file in the following format: YYYY-MM-DDTHH:MI:SS This value should be set to the date on which the beach role information became effective or will become effective. Please see Section 3.2 Use of Effective Date and Status Indicator Data Elements for more information.
Beach Role Status Indicator Example: ACTIVE	BeachRoleStatusIndicator	STRING	Y	8	BEACH_ORGANIZATION_ROLE_ASSIGN.STATUS, BEACH_PERSON_ROLE_ASSIGN.STATUS	This value is required if any beach role information is included in the XML data file. This value must be set to "ACTIVE" or "INACTIVE". Please see Section 3.2 Use of Effective Date and Status Indicator Data Elements for more information.

3.1.8 Beach Coordinate Information

The beach coordinate section of the XML submission allows submitting states to provide data related to the end points of a given beach. This section includes data elements, such as latitude measure, longitude measure, source map scale, horizontal collection method name, and horizontal coordinate reference system datum name. These data elements will be included in the XML file when beach coordinate information needs to be added or updated in the PRAWN database.

Exhibit 3-7 Beach Coordinate Information Schema

Data Element	XML Tag Name	XML Data Type	Req'd (Y/N)	Length	Access Table Mapping	Comment
Latitude Measure Example: 34.141592	LatitudeMeasure	NUMBER	Y	6-8	BEACH_LATITUDE_LONGITUDE_COORDINATES.START_LATITUDE BEACH_LATITUDE_LONGITUDE_COORDINATES.END_LATITUDE	The measure of the angular distance on a meridian north or south of the equator. Signed Decimal Latitude with positive values north of the Equator.
Longitude Measure Example:- 74.141592	LongitudeMeasure	NUMBER	Y	6-9	BEACH_LATITUDE_LONGITUDE_COORDINATES.START_LONGITUDE BEACH_LATITUDE_LONGITUDE_COORDINATES.END_LONGITUDE	The measure of the angular distance on a meridian east or west of the prime meridian. Signed Decimal Longitude with negative values west of Greenwich.
Source Map Scale Numeric Example: 12500	SourceMapScaleNumeric	NUMBER	C	14	BEACH_LATITUDE_LONGITUDE_COORDINATES.SOURCE_MAP_SCALE	The number that represents the relative distance on the ground for one unit of measure on the map or photo. This field is mandatory only when the Horizontal Collection Method Name used is INTERPOLATION MAP.
Horizontal Collection Method Name Example: INTERPOLATION-MAP INTERPOLATION-SATELLITE GPS	HorizontalCollectionMethodName	STRING	Y	150	BEACH_LATITUDE_LONGITUDE_COORDINATES.REF_HORIZONTAL_COLLECTION_METHOD_NAME	The name that identifies the method used to determine the latitude and longitude coordinates for a point on the earth.
Horizontal Coordinate Reference System Datum Name Example: NAD27 NAD83	HorizontalCoordinateReferenceSystemDatumName	STRING	Y	6	BEACH_LATITUDE_LONGITUDE_COORDINATES.REF_HORIZONTAL_REFERENCE_DATUM_NAME	The name that describes the system used in determining the latitude and longitude coordinates.

Data Element	XML Tag Name	XML Data Type	Req'd (Y/N)	Length	Access Table Mapping	Comment
Description Example: Short Description.	BeachCoordinateDescriptionText	STRING	N	255	BEACH_LATITUDE_LONGITUDE_COORDINATES.DESCRPTION	This is an optional field that can be used to store other information about the particular beach's coordinates.

3.1.9 Year Completion Indicators

The Year Completion Indicators section of the XML submission allows submitting states to notify the EPA when they have finished submissions for the year. This section includes data elements, such as Notification Data Complete Indicator, Monitoring Data Complete Indicator, and Location Data Complete Indicator. These data elements will be included in the XML file when states wish to notify that the EPA that they have finished submitting data for the year.

NOTE: To generate a submission with the Notification Access database with year completion information, you can now use the Custom XML Generation form. This includes end of year completion information with your normal xml submission. There are no tables to fill out to generate this submission.

All XML elements in this section are located in the following position on the XML element hierarchy—`“BeachDataSubmission/YearCompletionIndicators/”`.

Exhibit 3-8 Organization Information Schema

Data Element	XML Tag Name	XML Data Type	Req'd (Y/N)	Length	Access Table Mapping	Comment
Completion Year Example: 2007	CompletionYear	NUMBER	N	4	N/A	This value is required if any year completion data is included in the XML data file. This value indicates what year the data has been submitted for. This can be created using the End Of Year Submission Generation form.
Notification Data Completion Indicator Example: Y	NotificationDataCompletionIndicator	BOOLEAN	N	N/A	N/A	This value indicates whether or not the Notification data has all been submitted for the calendar year. This can be created using the End Of Year Submission Generation form.
Monitoring Data Completion Indicator Example: Y	MonitoringDataCompletionIndicator	BOOLEAN	N	N/A	N/A	This value indicates whether or not the Monitoring data has all been submitted for the calendar year. This can be created using the End Of Year Submission Generation form.
Location Data Completion Indicator Example: Y	LocationDataCompletionIndicator	BOOLEAN	N	N/A	N/A	This value indicates whether or not the Location data has all been submitted for the calendar year. This can be created using the End Of Year Submission Generation form.

3.1.10 Beach Procedure Information (Local Action Decision Procedure)

The beach procedure section of the XML submission contains data related to the procedures used by beaches for monitoring, notification, issuance, and reopening. This section includes data elements, such as procedure type code (See Appendix C for a list of valid codes), procedure description text, and procedure identifier. These data elements will be included in the XML file when beach procedure information needs to be added or updated in the PRAWN database.

All XML elements in this section are located in the following position on the XML element hierarchy—
“BeachDataSubmission/BeachDetail/BeachProcedureDetail”.

Exhibit 3-9 Beach Procedure Information Schema

Data Element	XML Tag Name	XML Data Type	Req'd (Y/N)	Length	Access Table Mapping	Comment
Procedure Type Code Example: IA_RADIO	ProcedureTypeCode	STRING	Y	12	PROCEDURE.PROCEDURE_CODE	This value must be set to a valid procedure type code. See Appendix C for a list of valid codes. This value is required if any beach procedure information is included in the XML data file. (Local Action Decision Procedure)
Procedure Description Text Example: Announce the advisory on the local radio station	ProcedureDescriptionText	STRING	Y	255	PROCEDURE.DESCRPTION	This value is required if any beach procedure information is included in the XML data file.
Procedure Identifier Example: 675849302019	ProcedureIdentifier	STRING	Y	12	PROCEDURE.ID	Submitting organizations will need to maintain a list of valid Procedure Identifiers for all procedures that are stored in the PRAWN database. These identifiers must be unique within each organization, as they will be used to update organization-level data. (For example, with an organization there can only be 1 procedure identified as "AB123", but there could be another procedure identified as "AB123" in another organization.)
Procedure Beach Identifier Example: ME234898	ProcedureBeachIdentifier	STRING	Y	12	BEACH_PROCEDURE_ASSIGN.FK_BEACH_ID	This value must correspond to EITHER a valid Beach Identifier and/or a valid Program Interest Identifier in the XML file or in the PRAWN database. Any number of Procedure Beach Identifiers may be submitted (consecutively in the XML file) to associate many beaches and/or program interests to a single procedure.

3.1.11 Header Information

The header information section of the XML file contains information regarding the data submission, such as submission date, submitting user, and submitting agency. **These keys should not be included in the XML file submitted by the submitting agency.** Instead, once an XML file has been successfully submitted to CDX, these XML keys will be added to the file by the CDX web application.

All XML elements in this section are located in the following position on the XML element hierarchy—
“BeachDataSubmission/HeaderDetail”.

Exhibit 3-10 Header Information Schema

Data Element	XML Tag Name	XML Data Type	Req'd (Y/N)	Length	Access Table Mapping	Comment
Submitting Agency Identifier Example: KYDEP	SubmittingAgencyIdentifier	STRING	Y	12		This key will be inserted into the file by the CDX web application. The list of valid Submitting Agency Identifiers will be maintained as part of the CDX registration process.
Submitting User Identifier Example: BSMITH	SubmittingUserIdentifier	STRING	Y	12		This key will be inserted into the file by the CDX web application. The list of valid Submitting User Identifiers will be maintained as part of the CDX registration process.
Submission Identifier Example: 111111111111	SubmissionIdentifier	STRING	Y	12		This key will be inserted into the file by the CDX web application. This value will uniquely identify each submission and will be generated by the CDX web application.
Submission Date Example:2003-01-01T00:00:00	Submission Date	DATE	Y			This key will be inserted into the file by the CDX web application. The date should be entered in the XML file in the following format: YYYY-MM-DDTHH:MI:SS

3.2 Use of Effective Date and Status Indicator Data Elements

The Effective Date and Status Indicator data elements are used to set the effective dates in the PRAWN database for mailing addresses, electronic addresses, telephone numbers, beach/person roles, and beach/organization roles. For each of these types of data, the PRAWN database tracks the Start Date and Stop Date. For example, the database may track that a fax telephone number was valid starting on January 1, 2001. If this telephone number was updated and the new fax number was valid on July 1, 2001, a new record is added in the database with a Start Date of July 1, 2001 and the same date is added as the Stop Date for the previous telephone number. To set this information correctly, the XML schema uses two data elements—Effective Date and Status Indicator—with mailing address, electronic address, telephone, beach/person role, and beach/organization role data. Furthermore, the user must specify the appropriate Type Code value (e.g., “FAX”, “VOICE”, etc. for telephone number) so that the correct address, telephone number, beach/person role, or beach/organization role is updated.

To update these types of data, these three data elements should be populated as follows:

- To update an address, electronic address, telephone number, beach/person role assignment, or beach/organization assignment, the Effective Date and Status Indicator fields should be set as follows:
 - Effective Date should be set to the date on which the new address, telephone number, or assignment will become valid.
 - Status Indicator should be set to “ACTIVE”.
 - Type Code should be set to the type of information to be updated. (For example, this might be set to “STATE” for BeachRoleTypeCode.)
 - This will update the Stop Date for the current data and will create a new record with the updated data and the associated Start Date.
- To indicate that an address, electronic address, telephone number, beach/person role assignment, or beach/organization assignment is no longer valid and there is no replacement data, the Effective Date and Status Indicator fields should be set as follows:
 - Effective Date should be set to the date on which the address, telephone number, or assignment will become invalid.
 - Status Indicator should be set to “INACTIVE”.
 - Type Code should be set to the type of information to be updated. (For example, this might be set to “SHIPPING” for MailingAddressTypeCode.)

This will update the Stop Date for the current data but will not create a new record, since there is no new data.

4 How to Decode the Error Messages

This chapter provides detailed information regarding the error messages that may be produced during data transfer. This chapter assumes that the XML submission has passed XML schema validation before being processed by the data loading software.

4.1 System Generated Error Messages

This section describes system generated error messages associated with the validation and loading of National Beach Program data to the PRAWN database. The following table details the specific error codes and messages that may be produced during data loading and provides a short description of each error and appropriate corrective actions. It should be noted that error messages will be followed by XML tag value(s) to describe the location in the XML document where the error occurred. For instance, the error message ‘OrganizationName is required for adding/editing an Organization’ would be followed by the text ‘[OrganizationIdentifier = X]’ where ‘X’ is the identifier for the Organization where the error occurred.

All errors encountered during the processing and loading of an XML data submission will be written to an Error Log File that can be sent to CDX and used for reporting feedback to data submitters. In addition to PRAWN system generated errors, Oracle specific error messages will also be written to this file (see Section 4.3 for more information).

Exhibit 4-1 PRAWN Error Messages

Error Code	Error Message	Description/Corrective Action
BCH-0101	OrganizationIdentifier must be unique for adding an Organization to the PRAWN system. [OrganizationIdentifier = 'X']	All new Organization records must have a previously unused value for Organization Identifier in the PRAWN system. Confirm that you are using the assigned OrganizationIdentifier.
BCH-0102	OrganizationIdentifier not found in the PRAWN system. [OrganizationIdentifier = 'X']	You are attempting to edit a record that does not exist. Please confirm that you have entered the correct Organization Identifier for the record you are attempting to edit or change OrganizationTransactionType to add if you wish to create a new Organization record.
BCH-0103	OrganizationTypeCode is invalid. [OrganizationIdentifier = 'X'; OrganizationTypeCode = 'X']	A value unknown to the PRAWN system has been submitted for OrganizationTypeCode. Please see Chapter 3 for a list of valid values.
BCH-0201	PersonIdentifier must be unique within an Organization. [OrganizationIdentifier = 'X'; PersonIdentifier = 'X']	All new Person records must have a value for Person Identifier that is previously unused by the referenced Organization in the PRAWN system.
BCH-0202	PersonIdentifier not found within the specified Organization. [OrganizationIdentifier = 'X'; PersonIdentifier = 'X']	You are attempting to edit a record that does not exist within the specified Organization. Please confirm that you have entered the correct Person Identifier for the record you are attempting to edit or change PersonTransactionType to add if you wish to create a new Person record.
BCH-0301	MailingAddressTypeCode is invalid. [OrganizationIdentifier = 'X'; MailingAddressTypeCode = 'X']	A value unknown to the PRAWN system has been submitted for MailingAddressTypeCode. Please see Chapter 3 for a list of valid values.

Error Code	Error Message	Description/Corrective Action
BCH-0302	MailingAddressStateCode is invalid. [OrganizationIdentifier = 'X'; MailingAddressStateCode = 'X']	MailingAddressStateCode must be a valid 2-digit State Postal Code (such as CA for California). Confirm that you are using a valid state code.
BCH-0303	MailingAddressZipCode is invalid. [OrganizationIdentifier = 'X'; MailingAddressZipCode = 'X']	Provide a MailingAddressZipCode in one of the following numeric formats: ##### or #####-####
BCH-0401	ElectronicAddressTypeCode is invalid. [OrganizationIdentifier = 'X'; ElectronicAddressTypeCode = 'X']	A value unknown to the PRAWN system has been submitted for ElectronicAddressTypeCode. Please see Chapter 3 for a list of valid values.
BCH-0501	TelephoneNumber is invalid. [OrganizationIdentifier = 'X'; TelephoneNumber = 'X']	Provide a TelephoneNumber in one of the following alphanumeric formats: XXX-XXX-XXXX
BCH-0502	TelephoneTypeCode is invalid. [OrganizationIdentifier = 'X'; TelephoneTypeCode = 'X']	A value unknown to the PRAWN system has been submitted for TelephoneTypeCode. Please see Chapter 3 for a list of valid values.
BCH-0601	ProgramInterestStateCode is invalid. [BeachIdentifier = 'X'; ProgramInterestStateCode = 'X']	ProgramInterestStateCode must be a valid 2-digit State Postal Code (such as CA for California). Confirm that you are using a valid state code.
BCH-0602	BeachIdentifier must be unique for adding a Beach to the PRAWN system. [BeachIdentifier = 'X']	All new Beach records must have a previously unused value for Beach Identifier in the PRAWN system. Confirm that you are using the assigned 8-digit BeachIdentifier.
BCH-0603	BeachIdentifier registered but not previously submitted to the PRAWN system. [BeachIdentifier = 'X'; BeachNameTransactionTypeCode = 'X']	You are attempting to edit a record that does not exist. Please confirm that you have entered the correct Beach Identifier for the record you are attempting to edit or change Beach Transaction Type Code to add if you wish to create a new Beach record.
BCH-0604	BeachIdentifier not registered with EPA. [BeachIdentifier = 'X']	You are attempting to submit notification data for a beach with an identifier that has not been assigned by EPA. Contact your EPA beach coordinator for the appropriate beach identifier.
BCH-0605	ProgramInterestFIPSCountyCode is invalid. [BeachIdentifier = 'X'; ProgramInterestFIPSCountyCode = 'X']	ProgramInterestFIPSCountyCode must be valid 5-digit FIPS County Code. Confirm that you are using a valid code, and that it matches the two letter State code submitted as ProgramInterestStateCode.
BCH-0606	WaterBodyNameCode cannot be combined with WaterBodyTypeCode. [BeachIdentifier = 'X'; WaterBodyNameCode = 'X'; WaterBodyTypeCode = 'X']	The Waterbody Name Code submitted for the beach must correspond to an acceptable Waterbody Type Code. Please see Chapter 3 for acceptable matches (e.g., a Name of INLAND may only have a Type of STILL_WATER or FLOW_WATER).
BCH-0607	Beach Extent/Swim Season/Monitoring Frequencies already defined for the year on beach. [BeachIdentifier = 'X'; AttributeEffectiveYear = 'X']	The Beach Attribute information (Beach Extent/Swim Season/Monitoring Frequencies/Beach Tier/Pollution Source) you have submitted already exists for that particular beach, for that particular year. Please either revise the Attribute Effective Date to the appropriate year, or contact the EPA Beach program manager to ensure the proper information is stored in the PRAWN system.
BCH-0608	IndicatorName is invalid. [BeachIdentifier = 'X']	A value unknown to the PRAWN system has been submitted for IndicatorName. Please see Chapter 3 for a list of valid values.

Error Code	Error Message	Description/Corrective Action
BCH-0609	WaterTypeName is invalid. [BeachIdentifier = 'X']	A value unknown to the PRAWN system has been submitted for WaterTypeName. Please see Chapter 3 for a list of valid values.
BCH-0610	MeasureTypeName is invalid. [BeachIdentifier = 'X']	A value unknown to the PRAWN system has been submitted for MeasureTypeName. Please see Chapter 3 for a list of valid values.
BCH-0611	MeasureUnitCode is invalid. [BeachIdentifier = 'X']	A value unknown to the PRAWN system has been submitted for MeasureUnitCode. Please see Chapter 3 for a list of valid values.
BCH-0701	ActivityTypeCode is invalid. [BeachIdentifier = 'X'; ActivityName = 'X'; ActivityTypeCode = 'X']	A value unknown to the PRAWN system has been submitted for ActivityTypeCode. Please see Appendix B for a list of valid values.
BCH-0702	ActivityMonitoringStationIdentifier not found in the STORET system. [BeachIdentifier = 'X'; ActivityName = 'X'; ActivityMonitoringStationIdentifier = 'X']	You are attempting to submit a monitoring station ID that has not been registered with STORET. Check the validity of the Station ID and if valid, ensure it has been registered as a monitoring station in STORET. Contact your EPA beach coordinator for further information.
BCH-0703	Activities with elevated bacteria (ELEV_BACT) as reasons must have at least one valid STORET Station ID. [BeachIdentifier = 'X'; ActivityName = 'X']	You are attempting to report a notification activity based on elevated bacteria levels without submitting a valid STORET Station ID. Each activity with a Reason Type Code of 'ELEV_BACT' must have at least one Monitoring Station ID.
BCH-0704	Activity Reason/Source/Indicator Description must be included if Activity Reason/Source/Indicator Code is OTHER. [BeachIdentifier = 'X'; ActivityName = 'X']	You are attempting to submit either a Reason, a Source, or an Indicator for an activity labeled with type 'OTHER' without submitting a description for the Reason, Source, or Indicator.
BCH-0705	ActivityActualStartDate year does not match year of ActivityActualStopDate. [BeachIdentifier = 'X'; ActivityName = 'X'; ActivityActualStartDate = 'X'; ActivityActualStopDate = 'X']	You are attempting to submit an Activity that is spanning multiple years. Activities may only be submitted for one year at a time. Should an activity actually go on for more than one year, it is required that the initial activity end on December 31st 11:59:59pm of the current year and a new activity start again on January 1st 12:00:00am of the next year.
BCH-0706	ActivityActualStopDate occurs prior to ActivityActualStartDate. [BeachIdentifier = 'X'; ActivityName = 'X'; ActivityActualStartDate = 'X'; ActivityActualStopDate = 'X']	You are attempting to submit an Activity whose stop date occurred before it was started. Please correct the dates so the stop date is after the start date.
BCH-0801	BeachRoleTypeCode is invalid. [BeachIdentifier = 'X'; BeachRoleOrganizationIdentifier = 'X'; BeachRoleTypeCode = 'X']	A value unknown to the PRAWN system has been submitted for BeachRoleTypeCode. Please see Chapter 3 for a list of valid values.
BCH-0802	BeachRoleOrganizationIdentifier not found in the PRAWN system. [BeachIdentifier = 'X'; BeachRoleOrganizationIdentifier = 'X']	You are attempting to associate a role with an Organization that does not exist in the PRAWN system. Please confirm that you have entered the correct Organization Identifier and that the information for that Organization has been previously submitted and successfully processed by the PRAWN system.
BCH-0803	BeachRolePersonIdentifier not found in the PRAWN system. [BeachIdentifier = 'X'; BeachRoleOrganizationIdentifier = 'X'; BeachRolePersonIdentifier = 'X']	You are attempting to associate a role with a person that does not exist in the PRAWN system. Please confirm that you have entered the correct Person Identifier and that the information for that Person has been previously submitted and successfully processed by the PRAWN system.

Error Code	Error Message	Description/Corrective Action
BCH-0804	BeachRolePersonIdentifier cannot be assigned a role on a beach without a role assignment for the person's parent organization on the same beach. [BeachIdentifier = 'X'; BeachRoleOrganizationIdentifier = 'X'; BeachRolePersonIdentifier = 'X']	You are attempting to associate a Person with a Beach without having associated that Person's Organization to the beach. Please check that the Organization Role Information precedes the Person Role Information in the XML file.
BCH-0901	ProcedureIdentifier must be unique for adding a Procedure to the PRAWN system. [ProcedureIdentifier = 'X']	All new Procedure records must have a value for Procedure Identifier that is previously unused by the referenced Organization in the PRAWN system. To update an existing Procedure, including assigning more beaches to the Procedure, change the ProcedureTypeCode to 'EDIT'.
BCH-0902	ProcedureIdentifier not found in the PRAWN system. [ProcedureIdentifier = 'X']	You are attempting to edit a record that does not exist. Please confirm that you have entered the correct Procedure Identifier for the record you are attempting to edit or change ProcedureTransactionType to add if you wish to create a new Procedure record.
BCH-0903	ProcedureTypeCode is invalid. [ProcedureIdentifier = 'X'; ProcedureTypeCode = 'X']	A value unknown to the PRAWN system has been submitted for ProcedureTypeCode. Please see Chapter 3 for a list of valid values.
BCH-0904	ProcedureBeachIdentifier not found in the PRAWN system. [ProcedureIdentifier = 'X'; ProcedureBeachIdentifier = 'X']	You are attempting to associate a procedure with a beach that does not exist in the PRAWN system. Please confirm that you have entered the correct Beach Identifier and that the information for that Beach has been previously submitted and successfully processed by the PRAWN system.

4.2 Common Causes of Error Messages

When troubleshooting an error log returned by the PRAWN system, please refer to the following chart for help with some of the most common errors (full-text error messages can be found in section 4.3). If the error is not resolved following the suggestions below, please contact ebeaches@cgifederal.com.

Exhibit 4-2 Common Error Messages

Error Code	Troubleshooting Tip	Page(s)
BCH-0101	Please check the value of the OrganizationNameTransactionTypeCode tag (ORGANIZATION.TRANSACTION in the Notification Access Database). Generally, this error occurs if the related OrganizationId already exists in PRAWN and has been submitted with an OrganizationNameTransactionTypeCode of ADD.	N/A
BCH-0102	Please check the value of the OrganizationNameTransactionTypeCode tag (ORGANIZATION.TRANSACTION in the Notification Access Database). Generally, this error occurs if the related OrganizationId does not yet exist in PRAWN and has been submitted with an OrganizationNameTransactionTypeCode of EDIT.	N/A
BCH-0103	Please check the value of the OrganizationTypeCode tag (ORGANIZATION.ORGANIZATION_CODE in the Notification Access Database). Generally, this error is the result of a misspelling in of one of the valid values used to indicate Organization Type (most often 'STATE_AGENCY' is input instead of 'STATE_AGNCY', which is the correct value). Please see Chapter 3 for additional information.	8

Error Code	Troubleshooting Tip	Page(s)
BCH-0201	Please check the value of the PersonNameTransactionTypeCode tag (PERSON.TRANSACTION in the Notification Access Database). Generally, this error occurs if the related PersonId already exists in PRAWN and has been submitted with an PersonNameTransactionTypeCode of ADD.	N/A
BCH-0202	Please check the value of the PersonNameTransactionTypeCode tag (PERSON.TRANSACTION in the Notification Access Database). Generally, this error occurs if the related PersonId does not yet exist in PRAWN and has been submitted with an PersonNameTransactionTypeCode of EDIT.	N/A
BCH-0301	Please check the value of the MailingAddressTypeCode tag (MAILING_ADDRESS.MAILING_ADDRESS_CODE in the Notification Access Database). Generally, this error is the result of a misspelling in of one of the valid values used to indicate Mailing Address Type. Please see 3 for additional information.	9, 16
BCH-0302	Please check the value of the MailingAddressStateCode tag (MAILING_ADDRESS.STATE_POSTAL_CODE in the Notification Access Database). Generally, this error is the result of a misspelling in of one of the valid values used to indicate the correct state. Please confirm that a valid state code is being used.	9, 16
BCH-0303	Please check the value of the MailingAddressZipCode tag (MAILING_ADDRESS.ZIP_CODE in the Notification Access Database). Generally, this error is the result of an incorrectly formatted Zip Code. The correct formats are either '#####' (ZIP) or '#####-####' (ZIP+4). Please see 3 for additional information.	10, 17
BCH-0401	Please check the value of the ElectronicAddressTypeCode tag (ELECTRONIC_ADDRESS.ELECTRONIC_ADDRESS_CODE in the Notification Access Database). Generally, this error is the result of a misspelling in of one of the valid values used to indicate Electronic Address Type Please see Chapter 3 for additional information.	11, 18
BCH-0501	Please check the value of the TelephoneNumber tag (TELEPHONE.TELEPHONE_NUMBER in the Notification Access Database). Generally, this error is the result of an incorrectly formatted telephone number. The correct format is 'XXX-XXX-XXXX'. Please see Chapter 3 for additional information.	12, 19
BCH-0502	Please check the value of the TelephoneTypeCode tag (TELEPHONE.TELEPHONE_CODE in the Notification Access Database). Generally, this error is the result of a misspelling in of one of the valid values used to indicate Telephone Type. Please see Chapter 3 for additional information.	12, 19
BCH-0601	Please check the value of the ProgramInterestStateCode tag (BEACH.STATE_POSTAL_CODE in the Notification Access Database). Generally, this error is the result of a misspelling in of one of the valid values used to indicate the correct state. Please confirm that a valid state code is being used.	21
BCH-0602	Please check the value of the BeachNameTransactionTypeCode tag (BEACH.TRANSACTION in the Notification Access Database). Generally, this error occurs if the related BeachId already exists in PRAWN and has been submitted with a BeachNameTransactionTypeCode of ADD.	N/A
BCH-0603	Please check the value of the BeachNameTransactionTypeCode tag (BEACH.TRANSACTION in the Notification Access Database). Generally, this error occurs if the related BeachId has been registered with the EPA, but has not yet been submitted to PRAWN, and has been submitted with a BeachNameTransactionTypeCode of EDIT.	N/A

Error Code	Troubleshooting Tip	Page(s)
BCH-0604	Please check the value of the BeachIdentifier tag (BEACH.ID in the Notification Access Database). Generally, this error occurs if the related BeachId has not yet been registered with the EPA, or has been misspelled in the submission.	21
BCH-0605	Please check the value of the ProgramInterestFIPSCountyCode tag (BEACH.FIPS_COUNTY in the Notification Access Database). Generally, this error is the result of a misspelling in the standard 5-digit FIPS County Code. Please confirm that the correct FIPS Code is being used.	22
BCH-0606	Please check the value of the WaterBodyNameCode tag (BEACH.WATERBODY_NAME in the Notification Access Database) and the WaterBodyTypeCode tag (BEACH.WATERBODY_TYPE in the Notification Access Database). Generally, this error is the result of a misspelling in of one of the valid values used to indicate Water Body Name or Water Body Type. Please see Appendix D in the Beach Notification Data User Guide for additional information.	22
BCH-0607	Please check the value of the appropriate tag: ExtentLengthMeasure (BEACH_ATTRIBUTE.EXTENT_LENGTH in the Notification Access Database), SwimSeasonLengthMeasure (BEACH_ATTRIBUTE.SWIM_SEASON_LENGTH in the Notification Access Database), SwimSeasonFrequencyMeasure (BEACH_ATTRIBUTE.SWIM_MONITOR_FREQ in the Notification Access Database), OffSeasonFrequencyMeasure (BEACH_ATTRIBUTE.OFF_MONITOR_FREQ in the Notification Access Database) for the related year (AttributeEffectiveYear, BEACH_ATTRIBUTE.EFFECTIVE_YEAR in the Notification Access Database). Beach Attribute data (Beach Extent/Swim Season/Monitoring Frequencies) has already been submitted for this calendar year. If this is incorrect, or you have questions, please contact eBeaches@cgifederal.com.	25, 27, 29
BCH-0608	Please check the value of the IndicatorName tag (BEACH_ATTRIBUTE_CRITERON.INDICATOR_NAME in the Notification Access Database). Generally, this error is the result of a misspelling in of one of the valid values used to indicate Indicator Name. Please check Chapter 3 for additional information.	3-18
BCH-0609	Please check the value of the WaterTypeName tag (BEACH_ATTRIBUTE_CRITERON.WATER_TYPE_NAME in the Notification Access Database). Generally, this error is the result of a misspelling in of one of the valid values used to indicate Water Type Name. Please check Chapter 3 for additional information.	3-18
BCH-0610	Please check the value of the MeasureTypeName tag (BEACH_ATTRIBUTE_CRITERON.MEASURE_TYPE_NAME in the Notification Access Database). Generally, this error is the result of a misspelling in of one of the valid values used to indicate Measure Type Name. Please check Chapter 3 for additional information.	3-18
BCH-0611	Please check the value of the MeasureUnitCode tag (BEACH_ATTRIBUTE_CRITERON.MEASURE_UNIT_CODE in the Notification Access Database). Generally, this error is the result of a misspelling in of one of the valid values used to indicate Measure Unit Code. Please check Chapter 3 for additional information.	3-18
BCH-0701	Please check the value of the ActivityTypeCode tag (BEACH_ACTIVITY.ACTIVITY_CODE in the Notification Access Database). Generally, this error is the result of a misspelling in of one of the valid values used to indicate Activity Type. Please check Chapter 3 and Appendix B in the Beach Notification Data User Guide for additional information.	37
BCH-0702	Please check the value of the ActivityMonitoringStationIdentifier tag (BEACH_ACTIVITY_STATION.STATION_ID in the Notification Access Database). Generally, this error occurs if the related StationId has not been properly formatted ("OrgId StationId"), has not yet been registered with STORET, or has been misspelled in the submission.	42

Error Code	Troubleshooting Tip	Page(s)
BCH-0703	Please check the value of the ActivityMonitoringStationIdentifier tag (BEACH_ACTIVITY_STATION.STATION_ID in the Notification Access Database). Generally, this error occurs if the related StationId has been omitted, but has also been known to occur if a BCH-0702 error (incorrectly formatted StationId) has occurred in the same submission.	42
BCH-0704	If the ActivityReasonType (BEACH_ACTIVITY_REASON.TYPE in the Notification Access Database where BEACH_ACTIVITY_REASON.CLASS = Reason), ActivitySourceType (BEACH_ACTIVITY_REASON.TYPE in the Notification Access Database where BEACH_ACTIVITY_REASON.CLASS = Source), or ActivityIndicatorType (BEACH_ACTIVITY_REASON.TYPE in the Notification Access Database where BEACH_ACTIVITY_REASON.CLASS = Indicator) are equal to OTHER, the corresponding description field must be filled in.	39, 40, 41
BCH-0705	The ActivityActualStartDate (BEACH_ACTIVITY.ACTUAL_START_DATE in the Notification Access Database) year does not match the ActivityActualStopDate (in the Notification Access Database) year. Activities can only occur during one calendar year. In the event that an event does cross into another year, it must be split into two activities, one for each year.	37
BCH-0706	ActivityActualStartDate (BEACH_ACTIVITY.ACTUAL_START_DATE in the Notification Access Database) occurs after the ActivityActualStopDate (in the Notification Access Database). The order of these dates must be reversed in order to achieve a successful submission.	37
BCH-0801	Please check the value of the BeachRoleTypeCode tag (BEACH_ORGANIZATION_ROLE_ASSIGN.ORG_ROLE_CODE and BEACH_PERSON_ROLE_ASSIGN.PERSON_ROLE_CODE in the Notification Access Database). Generally, this error is the result of a misspelling in of one of the valid values used to indicate Beach Role Type. Please check Chapter 3 in the Beach Notification Data User Guide for additional information.	47
BCH-0802	Please check that the OrganizationIdentifier (ORGANIZATION.ID in the Notification Access Database) has already been submitted to PRAWN. Generally this error occurs if the Organization in question does not already exist in PRAWN, but has also been known to occur if BCH-0101, BCH-0102, and/or BCH-0103 errors (related OrganizationIds) have occurred in the same submission.	8
BCH-0803	Please check that the PersonIdentifier (PERSON.ID in the Notification Access Database) has already been submitted to PRAWN. Generally this error occurs if the Person in question does not already exist in PRAWN, but has also been known to occur if BCH-0201 and/or BCH-0202 errors (related PersonIds) have occurred in the same submission.	15
BCH-0804	Please check the order of the Organization and Person assignments on a given beach. Persons cannot be assigned a role on a beach until the Organization they belong to has been assigned a role on that beach.	48
BCH-0901	Please check the value of the ProcedureTransactionTypeCode tag (PROCEDURE.TRANSACTION in the Notification Access Database). Generally, this error occurs if the related ProcedureId already exists in PRAWN and has been submitted with an ProcedureTransactionTypeCode of ADD.	N/A
BCH-0902	Please check the value of the ProcedureTransactionTypeCode tag (PROCEDURE.TRANSACTION in the Notification Access Database). Generally, this error occurs if the related OrganizationId does not yet exist in PRAWN and has been submitted with an ProcedureTransactionTypeCode of EDIT.	N/A

Error Code	Troubleshooting Tip	Page(s)
BCH-0903	Please check the value of the ProcedureTypeCode tag (PROCEDURE.PROCEDURE_CODE in the Notification Access Database). Generally, this error is the result of a misspelling in of one of the valid values used to indicate Procedure Type. Please see Appendix C in the Beach Notification Data User Guide for additional information.	56
BCH-0904	Please check to be sure that the BeachId listed in the ProcedureBeachIdentifier tag (BEACH_PROCEDURE_ASSIGN.FK_BEACH_ID in the Notification Access Database) has been entered into PRAWN. Generally, this error occurs if the related BeachId has not yet been submitted to PRAWN, but an association between a procedure and the related BeachId has been submitted.	56

4.3 Oracle Generated Error Messages

In addition to error messages generated by the PRAWN system, it is also possible that Oracle specific errors may occur during XML processing. These errors would most likely be associated with the administration and maintenance of the Oracle database instance (for example, exceeding the allocated table space size). Oracle specific errors will be captured by the XML data loading software and reported in the Error Log File together with the PRAWN system generated errors. Oracle specific errors will be prefixed with the text 'Oracle Error:' and will contain the error message number and text produced by the Oracle database at the time the error occurred.

5 How to Understand Beaches that are Similar Points of Access

This chapter provides detailed information regarding similar points of access. This chapter assumes that the XML submission has passed XML schema validation before being processed by the data loading software.

1. Enter Beach Information and Beach Attribute Information prior to Beach Extent Length, go to step 2.
2. Is this entry a SPA? If yes, you may enter an actual length that does not exceed: 100 ft. If no go to step 3.
3. Enter Beach Extent Length (note: a separate length will be calculated from your L/L data as indexed to the RAD to enable mapping and for allotment formula calculations.)
4. Enter Swim Season Monitoring Frequency and so on.

6 Appendix A—Schema Graphics

This appendix provides a graphical representation of the Beaches Notification v2.0 XML Schema. The figures that follow offer an expanded view of each of the four major sections that comprise a Beach Data Submission (Organization Detail, Person Detail, Beach Detail, and Beach Procedure Detail).

- Dashed lines represented optional elements, solid lines represent mandatory elements.
 - Please note: Empty tags (e.g., <BeachIdentifier></BeachIdentifier>) for optional elements cannot appear in the XML file.
- The figures 0..∞ and 1..∞ mean that the field may be repeated, as long as the repetitions are next to each other, as many times as the user wishes.
 - For example, a user may submit as many BeachDetail sections as necessary in a single file.
 - 1..∞ means that there must be at least one field included and 0..∞ means the field is entirely optional.
- A + sign at the end of the box means more elements exist under that element.

Exhibit 6-1 Beach Data Submission

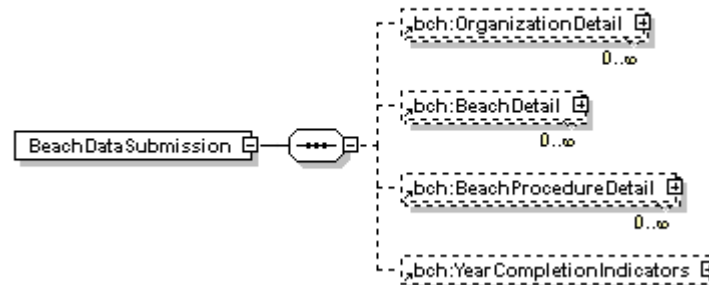

Exhibit 6-2 Organization Detail

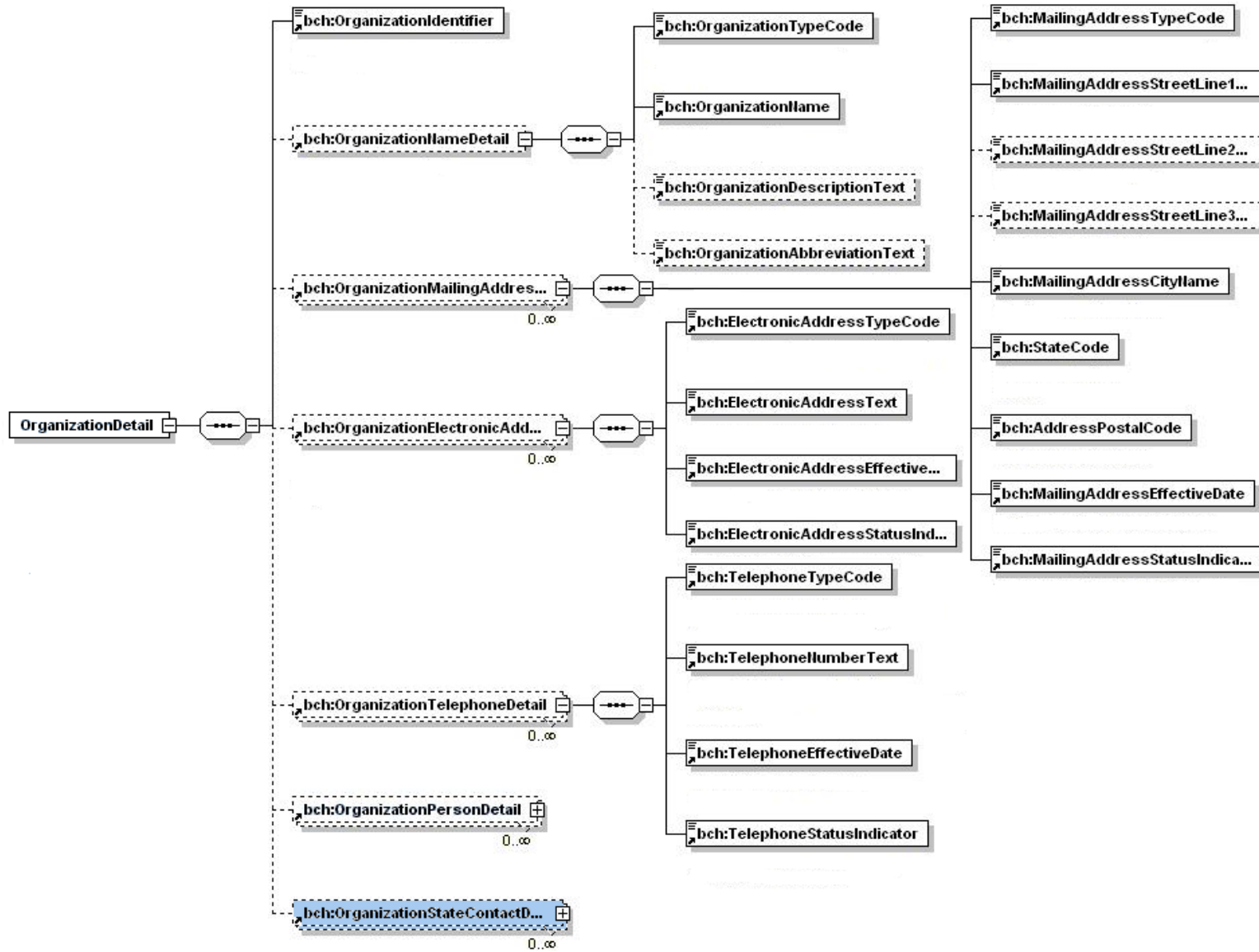

Exhibit 6-3 Organization Person Detail

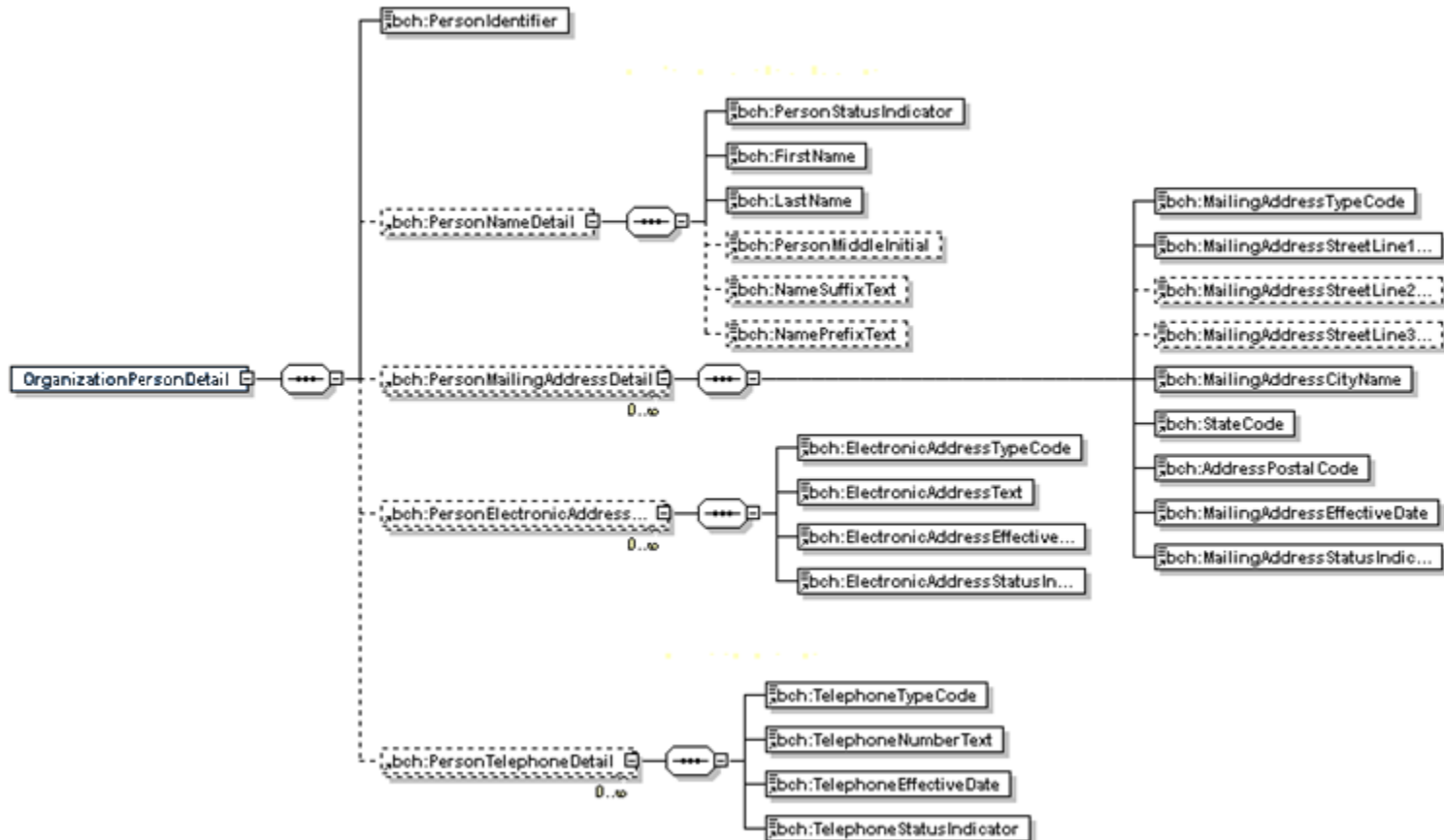

Exhibit 6-4 Beach Name Detail

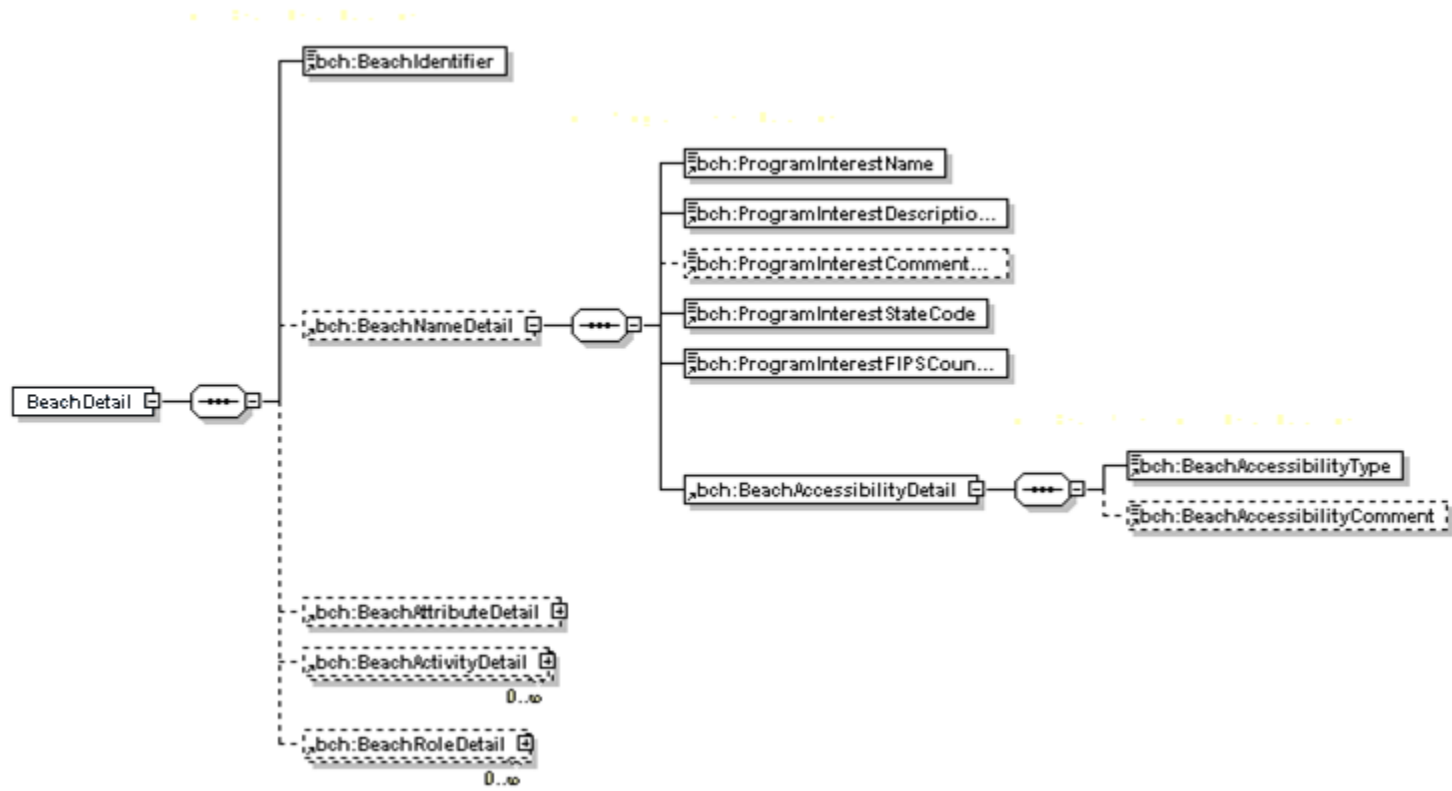

Exhibit 6-5 Beach Attribute Detail

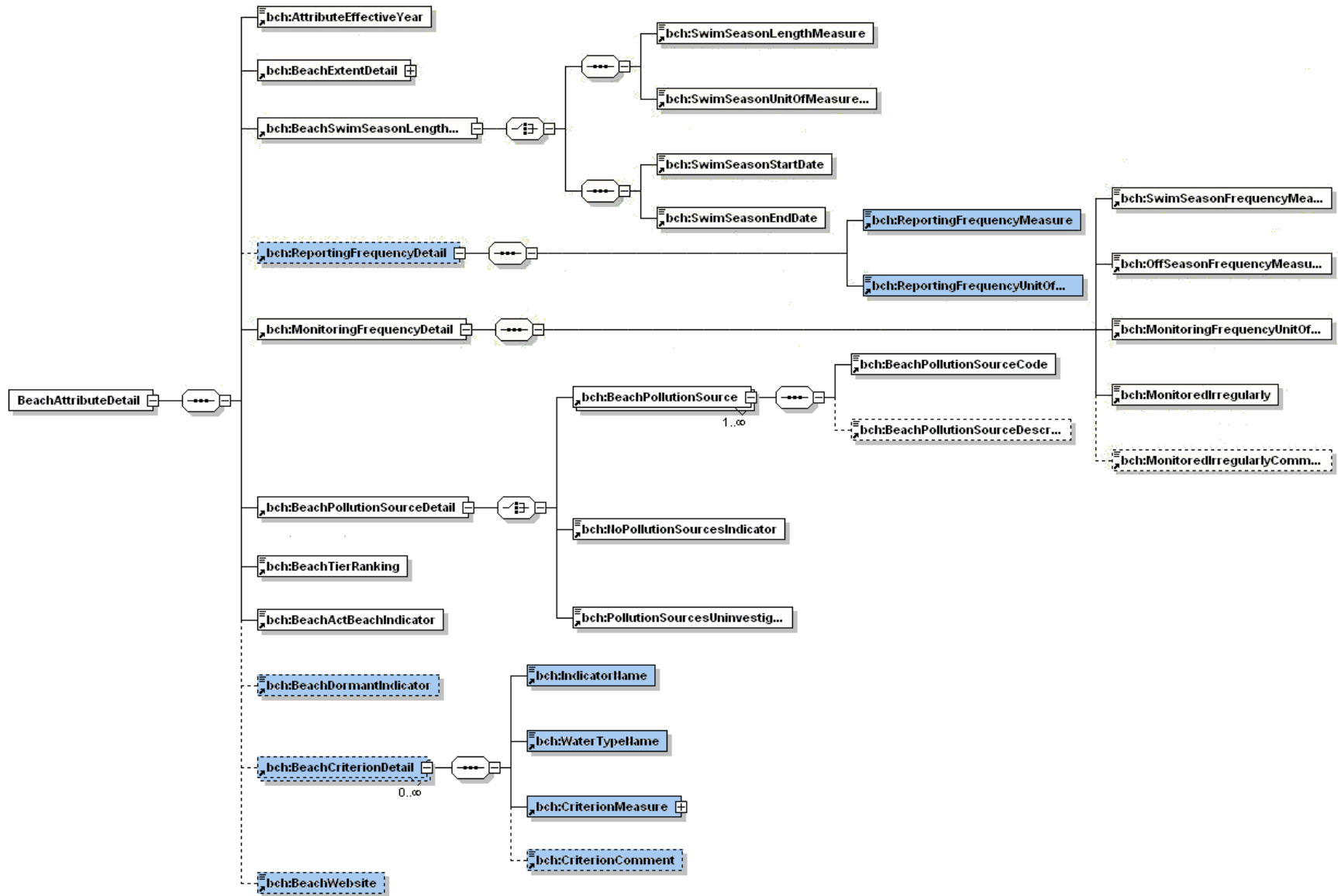

Exhibit 6-5 Beach Activity Detail

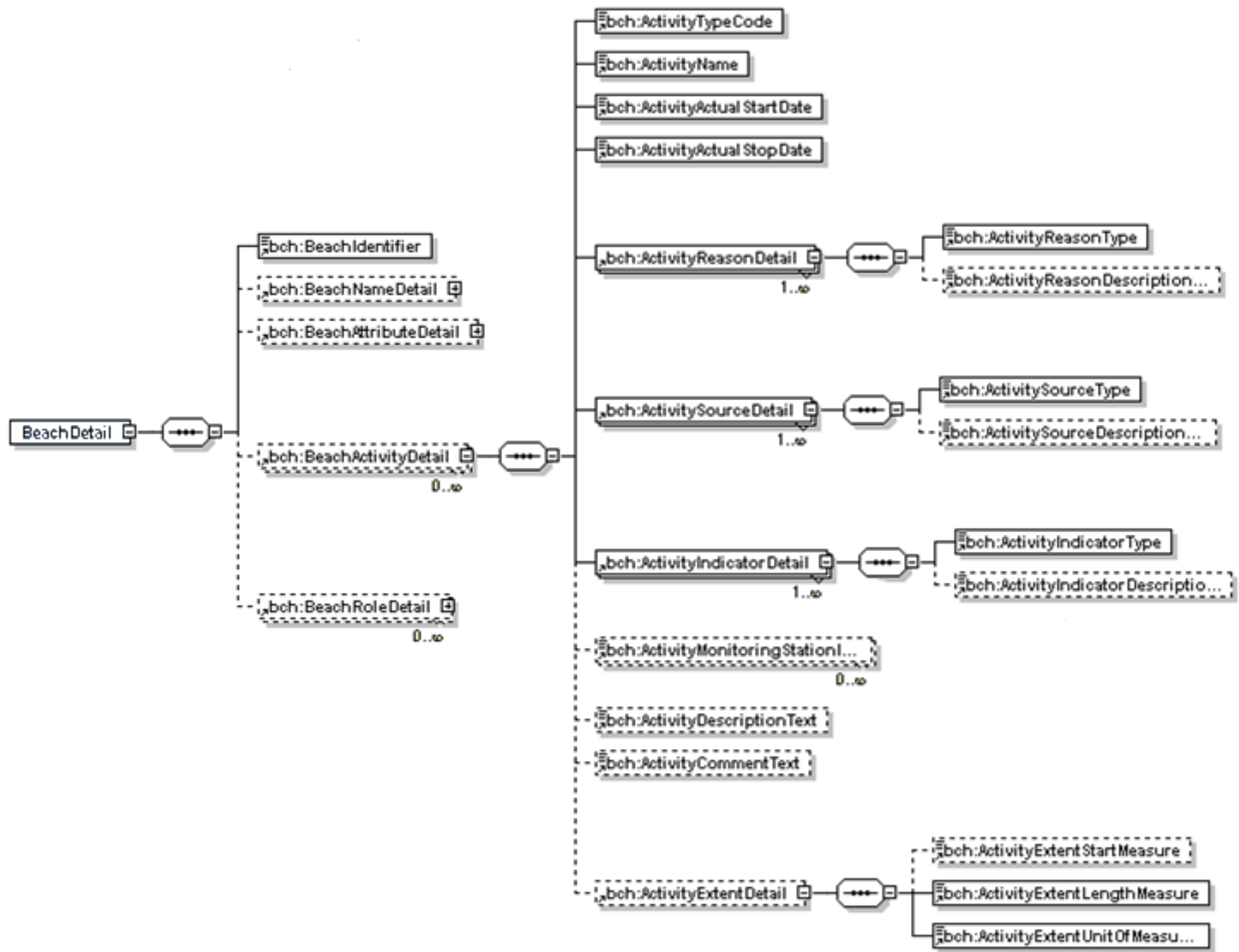

Exhibit 6-6 Beach Role Detail

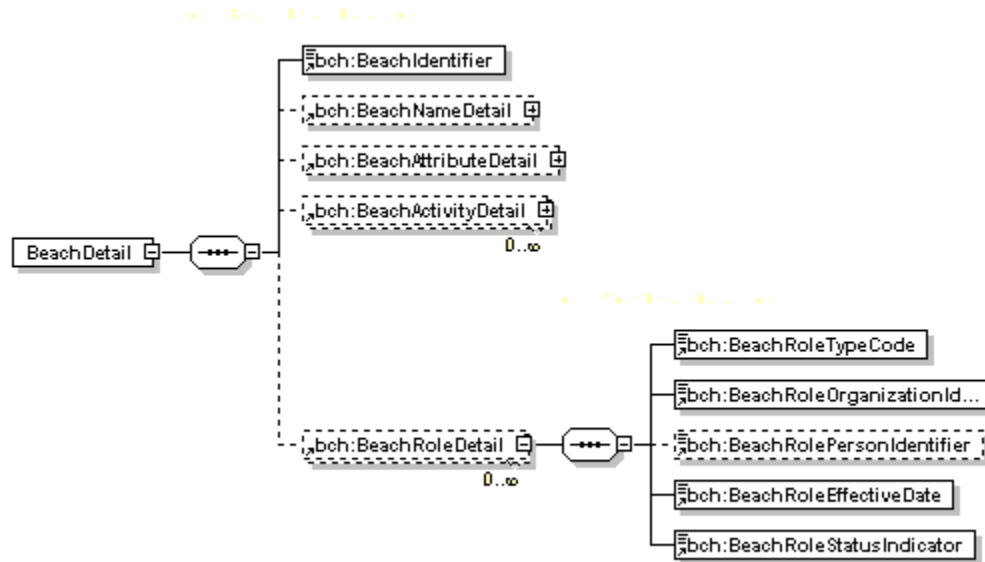

Exhibit 6-7 Beach Coordinate Detail

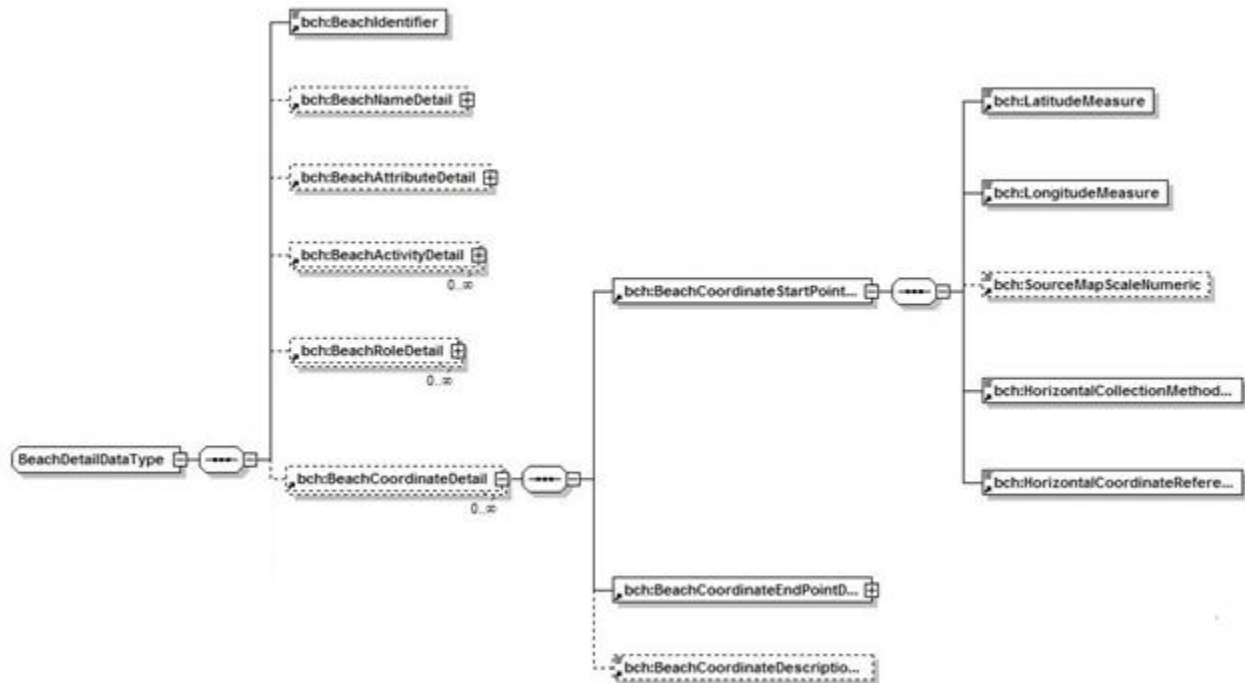

Exhibit 6-8 Beach Procedure Detail

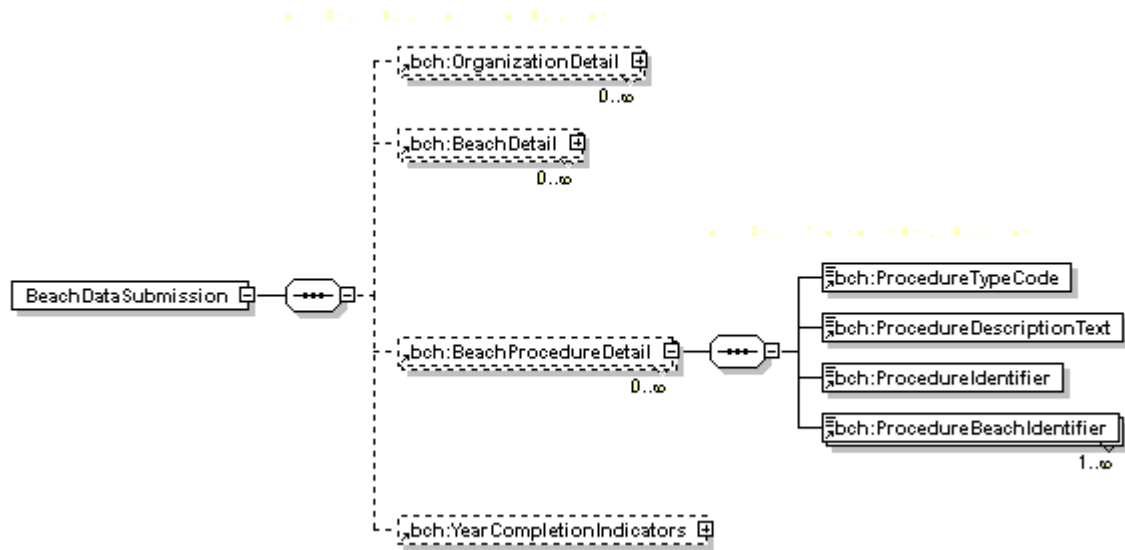
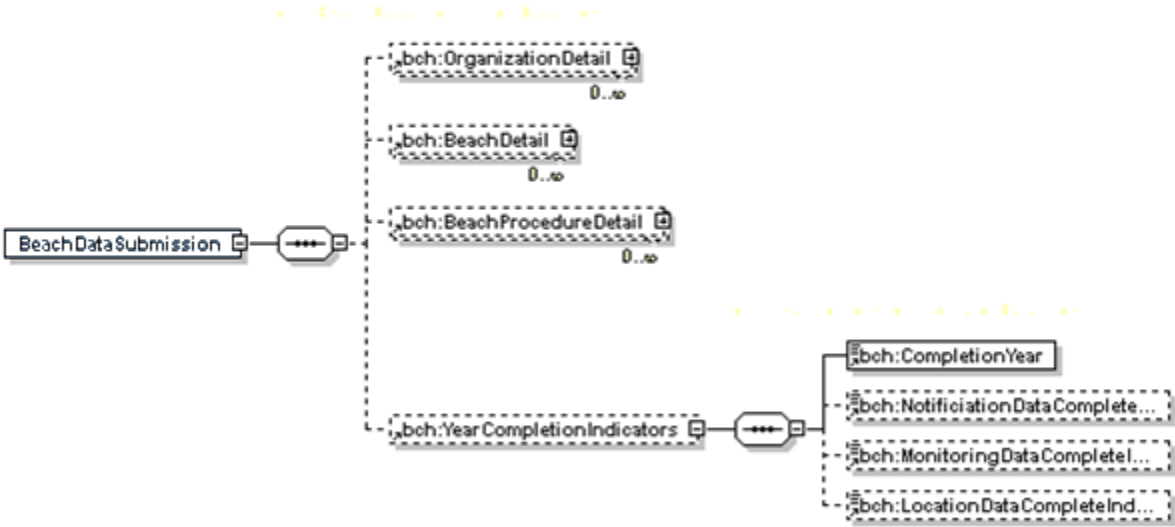

Exhibit 6-9 Year Completion Indicators



7 Appendix B—Example XML File

The following is text from an example XML file that would be sent to PRAWN from a “State”. The file appears with spacing to provide a more clear view of the data. The spacing is not required or standard.

Example xml tag with data: `<xmlTag> Data entered by user. </xmlTag> >2349fwe</`

Only the black font text between the blue xml tags will be submitted to PRAWN.

Green text represents a comment or xml code that will not be read by the xml parser. In the example below, comments are used to show an alternative or optional section of code.

In the sample xml file, version changes are denoted in red.

```
<?xml version="1.0"?>
<BeachDataSubmission xsi:schemaLocation="http://www.exchangenetwork.net/schema/BEACHES/2 index.xsd"
xmlns="http://www.exchangenetwork.net/schema/BEACHES/2" xmlns:xsi="http://www.w3.org/2001/XMLSchema-
instance">
<OrganizationDetail>
  <OrganizationIdentifier>2349fwe</OrganizationIdentifier>
  <OrganizationNameDetail>
    <OrganizationTypeCode>PRIVATE</OrganizationTypeCode>
    <OrganizationName>Tested</OrganizationName>
    <OrganizationDescriptionText>Testeddesc</OrganizationDescriptionText>
    <OrganizationAbbreviationText>TD</OrganizationAbbreviationText>
  </OrganizationNameDetail>
  <OrganizationMailingAddressDetail>
    <MailingAddressTypeCode>MAILING</MailingAddressTypeCode>
    <MailingAddressStreetLine1Text>123 Long Drive</MailingAddressStreetLine1Text>
    <MailingAddressStreetLine2Text>Suite 534</MailingAddressStreetLine2Text>
    <MailingAddressStreetLine3Text>The Last Stop</MailingAddressStreetLine3Text>
    <MailingAddressCityName>Testerville</MailingAddressCityName>
    <StateCode>VA</StateCode>
    <AddressPostalCode>45387</AddressPostalCode>
    <MailingAddressEffectiveDate>2002-05-05T12:00:00-05:00</MailingAddressEffectiveDate>
    <MailingAddressStatusIndicator>ACTIVE</MailingAddressStatusIndicator>
  </OrganizationMailingAddressDetail>
  <OrganizationElectronicAddressDetail>
    <ElectronicAddressTypeCode>EMAIL</ElectronicAddressTypeCode>
```

```

    <ElectronicAddressText>my@my.com</ElectronicAddressText>
    <ElectronicAddressEffectiveDate>2001-01-01T00:00:00</ElectronicAddressEffectiveDate>
    <ElectronicAddressStatusIndicator>ACTIVE</ElectronicAddressStatusIndicator>
</OrganizationElectronicAddressDetail>
<OrganizationTelephoneDetail>
    <TelephoneTypeCode>VOICE</TelephoneTypeCode>
    <TelephoneNumberText>123-456-7890</TelephoneNumberText>
    <TelephoneEffectiveDate>2001-01-01T00:00:00-05:00</TelephoneEffectiveDate>
    <TelephoneStatusIndicator>ACTIVE</TelephoneStatusIndicator>
</OrganizationTelephoneDetail>
<OrganizationPersonDetail>
    <PersonIdentifier>9e8ef7</PersonIdentifier>
    <PersonNameDetail>
        <PersonStatusIndicator>ACTIVE</PersonStatusIndicator>
        <FirstName>Johnny</FirstName>
        <LastName>Jones</LastName>
        <PersonMiddleInitial>J</PersonMiddleInitial>
        <NameSuffixText>Jr</NameSuffixText>
        <NamePrefixText>Mr.</NamePrefixText>
    </PersonNameDetail>
    <PersonMailingAddressDetail>
        <MailingAddressTypeCode>MAILING</MailingAddressTypeCode>
        <MailingAddressStreetLine1Text>830 My Drive</MailingAddressStreetLine1Text>
        <MailingAddressStreetLine2Text>Suite 223</MailingAddressStreetLine2Text>
        <MailingAddressStreetLine3Text>The last row</MailingAddressStreetLine3Text>
        <MailingAddressCityName>The Big House</MailingAddressCityName>
        <StateCode>VA</StateCode>
        <AddressPostalCode>27886</AddressPostalCode>
        <MailingAddressEffectiveDate>2001-01-01T12:00:00-05:00</MailingAddressEffectiveDate>
        <MailingAddressStatusIndicator>ACTIVE</MailingAddressStatusIndicator>
    </PersonMailingAddressDetail>
    <PersonElectronicAddressDetail>
        <ElectronicAddressTypeCode>EMAIL</ElectronicAddressTypeCode>
        <ElectronicAddressText>agnes.flemming@vdh.virginia.gov</ElectronicAddressText>
        <ElectronicAddressEffectiveDate>2001-01-01T12:00:00-
05:00</ElectronicAddressEffectiveDate>
        <ElectronicAddressStatusIndicator>ACTIVE</ElectronicAddressStatusIndicator>
    </PersonElectronicAddressDetail>
    <PersonTelephoneDetail>
        <TelephoneTypeCode>VOICE</TelephoneTypeCode>
        <TelephoneNumberText>617-254-0845</TelephoneNumberText>

```

```

        <TelephoneEffectiveDate>2001-01-01T00:00:00</TelephoneEffectiveDate>
        <TelephoneStatusIndicator>ACTIVE</TelephoneStatusIndicator>
    </PersonTelephoneDetail>
</OrganizationPersonDetail>
<OrganizationStateContactDetail>
    <ContactNameDetail>
        <ContactFirstName>Johnny</ContactFirstName>
        <ContactLastName>Jones</ContactLastName>
    </ContactNameDetail>
    <ContactAgencyName>Tested</ContactAgencyName>
    <ContactTelephoneNumberText>617-254-0845</ContactTelephoneNumberText>
    <ContactElectronicAddressText>my@my.com</ContactElectronicAddressText>
</OrganizationStateContactDetail>
</OrganizationDetail>
<OrganizationDetail>
    <OrganizationIdentifier>394e785</OrganizationIdentifier>
    <OrganizationNameDetail>
        <OrganizationTypeCode>LOCAL_GOV</OrganizationTypeCode>
        <OrganizationName>testing</OrganizationName>
        <OrganizationDescriptionText>testingdesc</OrganizationDescriptionText>
        <OrganizationAbbreviationText>T</OrganizationAbbreviationText>
    </OrganizationNameDetail>
    <OrganizationPersonDetail>
        <PersonIdentifier>foi34e0</PersonIdentifier>
        <PersonNameDetail>
            <PersonStatusIndicator>ACTIVE</PersonStatusIndicator>
            <FirstName>Chris</FirstName>
            <LastName>Johnson</LastName>
            <NamePrefixText>Manager</NamePrefixText>
        </PersonNameDetail>
    </OrganizationPersonDetail>
<OrganizationPersonDetail>
    <PersonIdentifier>JH</PersonIdentifier>
    <PersonNameDetail>
        <PersonStatusIndicator>ACTIVE</PersonStatusIndicator>
        <FirstName>Jill</FirstName>
        <LastName>Holander</LastName>
    </PersonNameDetail>
    <PersonElectronicAddressDetail>
        <ElectronicAddressTypeCode>EMAIL</ElectronicAddressTypeCode>
        <ElectronicAddressText>my@my.com</ElectronicAddressText>

```

```

        <ElectronicAddressEffectiveDate>2001-01-01T00:00:00</ElectronicAddressEffectiveDate>
        <ElectronicAddressStatusIndicator>ACTIVE</ElectronicAddressStatusIndicator>
    </PersonElectronicAddressDetail>
</OrganizationPersonDetail>
</OrganizationDetail>
<BeachDetail>
    <BeachIdentifier>AK162093</BeachIdentifier>
    <BeachNameDetail>
        <ProgramInterestName>Demo Beach</ProgramInterestName>
        <ProgramInterestDescriptionText>For Demonstration</ProgramInterestDescriptionText>
        <ProgramInterestCommentText>Delete this record.</ProgramInterestCommentText>
        <ProgramInterestStateCode>NV</ProgramInterestStateCode>
        <ProgramInterestFIPSCountyCode>21000</ProgramInterestFIPSCountyCode>
        <WaterBodyNameCode>ATLANTIC</WaterBodyNameCode>
        <WaterBodyTypeCode>OPEN_COAST</WaterBodyTypeCode>
        <BeachAccessibilityDetail>
            <BeachAccessibilityType>PUB_PUB_ACC</BeachAccessibilityType>
            <BeachAccessibilityComment>Test Comment.</BeachAccessibilityComment>
        </BeachAccessibilityDetail>
    </BeachNameDetail>
    <BeachAttributeDetail>
        <AttributeEffectiveYear>2002</AttributeEffectiveYear>
        <BeachExtentDetail>
            <ExtentLengthMeasure>28.45</ExtentLengthMeasure>
            <ExtentUnitOfMeasureCode>MI</ExtentUnitOfMeasureCode>
        </BeachExtentDetail>
        <BeachSwimSeasonLengthDetail>
            <SwimSeasonStartDate>2001-05-01</SwimSeasonStartDate>
            <SwimSeasonEndDate>2001-09-30</SwimSeasonEndDate>
            <SwimSeasonDayMeasure>8</SwimSeasonDayMeasure>
        </BeachSwimSeasonLengthDetail>
        <!-- Although discouraged, BeachSwimSeason is also allowed to be in the form
    <BeachSwimSeasonLengthDetail>
        <SwimSeasonLengthMeasure>3</SwimSeasonLengthMeasure>
        <SwimSeasonUnitOfMeasureCode>MONTHS</SwimSeasonUnitOfMeasureCode>
        <SwimSeasonDayMeasure>8</SwimSeasonDayMeasure>
    </BeachSwimSeasonLengthDetail-->
        <ReportingFrequencyDetail>
            <ReportingFrequencyMeasure>3</ReportingFrequencyMeasure>
            <ReportingFrequencyUnitOfMeasureCode>PER_MONTH</ReportingFrequencyUnitOfMeasureCode>
        </ReportingFrequencyDetail>

```

```

<AdvReportingFrequencyDetail>
  <AdvReportingFrequencyMeasure>5</AdvReportingFrequencyMeasure>
  <AdvReportingFrequencyUnitOfMeasureCode>PER_YEAR</AdvReportingFrequencyUnitOfMeasureCode>
</AdvReportingFrequencyDetail>
<MonitoringFrequencyDetail>
  <SwimSeasonFrequencyMeasure>3</SwimSeasonFrequencyMeasure>
  <OffSeasonFrequencyMeasure>1</OffSeasonFrequencyMeasure>
  <MonitoringFrequencyUnitOfMeasureCode>PER_WEEK</MonitoringFrequencyUnitOfMeasureCode>
  <MonitoredIrregularly>true</MonitoredIrregularly>
  <MonitoredIrregularlyComment>This beach is also monitored whenever there is heavy
rain.</MonitoredIrregularlyComment>
</MonitoringFrequencyDetail>
<!--
<MonitoringFrequencyDetail>
  <MonitoredIrregularly>true</MonitoredIrregularly>
</MonitoringFrequencyDetail>
-->
<BeachPollutionSourceDetail>
  <!--
  <NoPollutionSourcesIndicator>true</NoPollutionSourcesIndicator>
  And/or
  <PollutionSourcesUninvestigatedIndicator>true</PollutionSourcesUninvestigatedIndicator>
  And/or-->
  <BeachPollutionSource>
    <BeachPollutionSourceCode>CSO</BeachPollutionSourceCode>
    <BeachPollutionSourceDescription>Comment for CSO</BeachPollutionSourceDescription>
  </BeachPollutionSource>
  <BeachPollutionSource>
    <BeachPollutionSourceCode>POTW</BeachPollutionSourceCode>
    <BeachPollutionSourceDescription>Comment for POTW</BeachPollutionSourceDescription>
  </BeachPollutionSource>

</BeachPollutionSourceDetail>
<BeachTierRanking>3</BeachTierRanking>
<BeachActBeachIndicator>true</BeachActBeachIndicator>
<BeachDormantIndicator>true</BeachDormantIndicator>
<BeachCriterionDetail>
  <IndicatorName>ENTEROCOCCI</IndicatorName>
  <WaterTypeName>MARINE</WaterTypeName>
  <CriterionMeasure>
    <MeasureTypeName>GM</MeasureTypeName>

```

```

                <MeasureValue>35</MeasureValue>
                <MeasureUnitCode>CFU/100ml</MeasureUnitCode>
            </CriterionMeasure>
            <CriterionComment>Notes</CriterionComment>
        </BeachCriterionDetail>
        <BeachWebsite>www.state.va/beachid</BeachWebsite>
    </BeachAttributeDetail>
    <BeachActivityDetail>
        <ActivityTypeCode>CLOSURE</ActivityTypeCode>
        <ActivityName>Demo Activity 1</ActivityName>
        <ActivityActualStartDate>2002-01-01T08:30:00</ActivityActualStartDate>
        <ActivityActualStopDate>2003-01-01T23:59:59</ActivityActualStopDate>
        <ActivityPartialDayAmount>4</ActivityPartialDayAmount>
        <ActivityReasonDetail>
            <ActivityReasonType>ELEV_BACT</ActivityReasonType>
            <ActivityReasonDescriptionText>Demo Description</ActivityReasonDescriptionText>
        </ActivityReasonDetail>
        <ActivitySourceDetail>
            <ActivitySourceType>SEWER_LINE</ActivitySourceType>
            <ActivitySourceDescriptionText>Shut her down Clancy, she's pumpin'
mud!</ActivitySourceDescriptionText>
        </ActivitySourceDetail>
        <ActivityIndicatorDetail>
            <ActivityIndicatorType>OTHER</ActivityIndicatorType>
            <ActivityIndicatorDescriptionText>Demo Description 2</ActivityIndicatorDescriptionText>
        </ActivityIndicatorDetail>
        <ActivityMonitoringStationIdentifier>NV004|rs001</ActivityMonitoringStationIdentifier>
        <ActivityMonitoringStationIdentifier>NV004|rs002</ActivityMonitoringStationIdentifier>
        <ActivityDescriptionText>Demo activity description</ActivityDescriptionText>
        <ActivityCommentText>Demo</ActivityCommentText>
        <ActivityExtentDetail>
            <ActivityExtentStartMeasure>4</ActivityExtentStartMeasure>
            <ActivityExtentLengthMeasure>16</ActivityExtentLengthMeasure>
            <ActivityExtentUnitOfMeasureCode>MI</ActivityExtentUnitOfMeasureCode>
        </ActivityExtentDetail>
    </BeachActivityDetail>
    <BeachRoleDetail>
        <BeachRoleTypeCode>COLLECTOR</BeachRoleTypeCode>
        <BeachRoleOrganizationIdentifier>2349fwe</BeachRoleOrganizationIdentifier>
        <BeachRolePersonIdentifier>SD</BeachRolePersonIdentifier>
        <BeachRoleEffectiveDate>2001-01-01T00:00:00</BeachRoleEffectiveDate>
    </BeachRoleDetail>

```

```

    <BeachRoleStatusIndicator>ACTIVE</BeachRoleStatusIndicator>
  </BeachRoleDetail>
<BeachRoleDetail>
  <BeachRoleTypeCode>ANALYZER</BeachRoleTypeCode>
  <BeachRoleOrganizationIdentifier>394e785</BeachRoleOrganizationIdentifier>
  <BeachRoleEffectiveDate>2006-01-01T00:00:00</BeachRoleEffectiveDate>
  <BeachRoleStatusIndicator>ACTIVE</BeachRoleStatusIndicator>
</BeachRoleDetail>
<BeachRoleDetail>
  <BeachRoleTypeCode>ANALYZER</BeachRoleTypeCode>
  <BeachRoleOrganizationIdentifier>394e785</BeachRoleOrganizationIdentifier>
  <BeachRolePersonIdentifier>JH</BeachRolePersonIdentifier>
  <BeachRoleEffectiveDate>2001-01-01T00:00:00</BeachRoleEffectiveDate>
  <BeachRoleStatusIndicator>ACTIVE</BeachRoleStatusIndicator>
</BeachRoleDetail>
</BeachDetail>
<BeachDetail>
  <BeachIdentifier>AK177449</BeachIdentifier>
  <BeachNameDetail>
    <ProgramInterestName>test</ProgramInterestName>
    <ProgramInterestDescriptionText>test</ProgramInterestDescriptionText>
    <ProgramInterestCommentText>test</ProgramInterestCommentText>
    <ProgramInterestStateCode>NV</ProgramInterestStateCode>
    <ProgramInterestFIPSCountyCode>21000</ProgramInterestFIPSCountyCode>
    <WaterBodyNameCode>ATLANTIC</WaterBodyNameCode>
    <WaterBodyTypeCode>OPEN_COAST</WaterBodyTypeCode>
    <BeachAccessibilityDetail>
      <BeachAccessibilityType>PUB_PUB_ACC</BeachAccessibilityType>
      <BeachAccessibilityComment>Test Comment.</BeachAccessibilityComment>
    </BeachAccessibilityDetail>
  </BeachNameDetail>
  <BeachRoleDetail>
    <BeachRoleTypeCode>TESTOR</BeachRoleTypeCode>
    <BeachRoleOrganizationIdentifier>394e785</BeachRoleOrganizationIdentifier>
    <BeachRolePersonIdentifier>foi34e0</BeachRolePersonIdentifier>
    <BeachRoleEffectiveDate>2001-01-01T00:00:00</BeachRoleEffectiveDate>
    <BeachRoleStatusIndicator>ACTIVE</BeachRoleStatusIndicator>
  </BeachRoleDetail>
  <BeachCoordinateDetail>
    <BeachCoordinateStartPointDetail>
      <LatitudeMeasure>34.141592</LatitudeMeasure>

```

```

        <LongitudeMeasure>-74.141592</LongitudeMeasure>
        <SourceMapScaleNumeric>12500</SourceMapScaleNumeric>
        <HorizontalCollectionMethodName>INTERPOLATION-MAP</HorizontalCollectionMethodName>
    <HorizontalCoordinateReferenceSystemDatumName>NAD27</HorizontalCoordinateReferenceSystemDatumName>
    </BeachCoordinateStartPointDetail>
    <BeachCoordinateEndPointDetail>
        <LatitudeMeasure>36.564398</LatitudeMeasure>
        <LongitudeMeasure>-44.124812</LongitudeMeasure>
        <SourceMapScaleNumeric>12500</SourceMapScaleNumeric>
        <HorizontalCollectionMethodName>INTERPOLATION-MAP</HorizontalCollectionMethodName>
    <HorizontalCoordinateReferenceSystemDatumName>NAD27</HorizontalCoordinateReferenceSystemDatumName>
    </BeachCoordinateEndPointDetail>
    <BeachCoordinateDescriptionText>Short description.</BeachCoordinateDescriptionText>
</BeachCoordinateDetail>
</BeachDetail>
<BeachProcedureDetail>
    <ProcedureTypeCode>DA_ASES_RISK</ProcedureTypeCode>
    <ProcedureDescriptionText>Our Procedure to Assess Risk</ProcedureDescriptionText>
    <ProcedureIdentifier>PRESS_RELEASE</ProcedureIdentifier>
    <ProcedureBeachIdentifier>AK162093</ProcedureBeachIdentifier>
    <ProcedureBeachIdentifier>AK162093</ProcedureBeachIdentifier>
</BeachProcedureDetail>
<YearCompletionIndicators>
    <CompletionYear>2008</CompletionYear>
    <NotificationDataCompleteIndicator>true</NotificationDataCompleteIndicator>
    <MonitoringDataCompleteIndicator>true</MonitoringDataCompleteIndicator>
    <LocationDataCompleteIndicator>true</LocationDataCompleteIndicator>
</YearCompletionIndicators>
</BeachDataSubmission>

```

8 Appendix C—Procedure Type Codes

Due to the large number of Procedure Type codes, this appendix provides a separate table to explain the acceptable codes. See Section 3.1.4 for a description of when to use these codes in the XML schema.

For most codes, the naming convention is XY_NAME where X is R (REOPEN), D (DETERM), or I (ISSUE) and Y is A (Advisory), C (Closing), or B (Both a Closing and an Advisory). The exceptions to this rule are the MO and OT prefixes where MO stands for MONITOR and OT stands for OTHER.

Exhibit 8-1 Procedure Type Codes

Code	Name	Description
DA_ASES_RISK	DETERMINE ADVISORY: Assess risk	Assess risks to potential swimmers
DA_ASES_SICK	DETERMINE ADVISORY: Asses sickness	Assess number of complaints of sickness
DA_DIS_AGENCY	DETERMINE ADVISORY: Discuss with agencies	Discuss situation with other agencies
DA_PRECAUTN	DETERMINE ADVISORY: Precautionary	Perform a precautionary closing in response to hazardous discharges
DA_PREEMPTVE	DETERMINE ADVISORY: Preemptive	Compare conditions to preemptive closing criteria
DA_WTR_STAND	DETERMINE ADVISORY: Compare with water standards	Compare bacterial concentrations with water quality standards to determine whether standards are exceeded
DA_W_Q_MONTR	DETERMINE ADVISORY: Water quality monitoring	Perform water quality modeling
DB_ASES_RISK	DETERMINE COMBINED: Assess risk	Assess risks to potential swimmers
DB_ASES_SICK	DETERMINE COMBINED: Asses sickness	Assess number of complaints of sickness
DB_DIS_AGENCY	DETERMINE COMBINED: Discuss with agencies	Discuss situation with other agencies
DB_PRECAUTN	DETERMINE COMBINED: Precautionary	Perform a precautionary closing in response to hazardous discharges
DB_PREEMPTVE	DETERMINE COMBINED: Preemptive	Compare conditions to preemptive closing criteria
DB_WTR_STAND	DETERMINE COMBINED: Compare with water standards	Compare bacterial concentrations with water quality standards to determine whether standards are exceeded
DB_W_Q_MONTR	DETERMINE COMBINED: Water quality monitoring	Perform water quality modeling
DC_ASES_RISK	DETERMINE CLOSING: Assess risk	Assess risks to potential swimmers
DC_ASES_SICK	DETERMINE CLOSING: Asses sickness	Assess number of complaints of sickness
DC_DIS_AGENCY	DETERMINE CLOSING: Discuss with agencies	Discuss situation with other agencies
DC_PRECAUTN	DETERMINE CLOSING: Precautionary	Perform a precautionary closing in response to hazardous discharges
DC_PREEMPTVE	DETERMINE CLOSING: Preemptive	Compare conditions to preemptive closing criteria
DC_WTR_STAND	DETERMINE CLOSING: Compare with water standards	Compare bacterial concentrations with water quality standards to determine whether standards are exceeded
DC_W_Q_MONTR	DETERMINE CLOSING: Water quality monitoring	Perform water quality modeling
IA_BEACH	ISSUE ADVISORY: Post at Beach	Post advisory or closing at the beach
IA_DIF_AGENCY	ISSUE ADVISORY: Different Agency(ies)	Provide announcement to other government agency(ies)

IA_INTERNAL	ISSUE ADVISORY: Internal Agency	Provide announcement to internal agency staff
IA_INTERNET	ISSUE ADVISORY: Post on Internet	Post advisory or closing on the Internet
IA_NEWSPAPER	ISSUE ADVISORY: Newspaper article	Publish advisory or closing in local newspaper
IA_PHONE	ISSUE ADVISORY: Provide phone line	Provide results on hotline/water quality information/result phone line
IA_PHYS_ISOL	ISSUE ADVISORY: Physical Isolation	Physically isolate contaminated area (e.g., block access, fence off area)
IA_RADIO	ISSUE ADVISORY: Radio announcement	Have advisory or closing announced on local radio station
IA_RESP_PRSN	ISSUE ADVISORY: Notify responsible person	Notify owner/manager/operator/lifeguards of results
IA_TV_ANNCE	ISSUE ADVISORY: TV announcement	Have advisory or closing announced on local TV station
IB_BEACH	ISSUE COMBINED: Post at Beach	Post advisory or closing at the beach
IB_DIF_AGENCY	ISSUE COMBINED: Different Agency(ies)	Provide announcement to other government agency(ies)
IB_INTERNAL	ISSUE COMBINED: Internal Agency	Provide announcement to internal agency staff
IB_INTERNET	ISSUE COMBINED: Post on Internet	Post advisory or closing on the Internet
IB_NEWSPAPER	ISSUE COMBINED: Newspaper article	Publish advisory or closing in local newspaper
IB_PHONE	ISSUE COMBINED: Provide phone line	Provide results on hotline/water quality information/result phone line
IB_PHYS_ISOL	ISSUE COMBINED: Physical Isolation	Physically isolate contaminated area (e.g., block access, fence off area)
IB_RADIO	ISSUE COMBINED: Radio announcement	Have advisory or closing announced on local radio station
IB_RESP_PRSN	ISSUE COMBINED: Notify responsible person	Notify owner/manager/operator/lifeguards of results
IB_TV_ANNCE	ISSUE COMBINED: TV announcement	Have advisory or closing announced on local TV station
IC_BEACH	ISSUE CLOSING: Post at Beach	Post advisory or closing at the beach
IC_DIF_AGENCY	ISSUE CLOSING: Different Agency(ies)	Provide announcement to other government agency(ies)
IC_INTERNAL	ISSUE CLOSING: Internal Agency	Provide announcement to internal agency staff
IC_INTERNET	ISSUE CLOSING: Post on Internet	Post advisory or closing on the Internet
IC_NEWSPAPER	ISSUE CLOSING: Newspaper article	Publish advisory or closing in local newspaper
IC_PHONE	ISSUE CLOSING: Provide phone line	Provide results on hotline/water quality information/result phone line
IC_PHYS_ISOL	ISSUE CLOSING: Physical Isolation	Physically isolate contaminated area (e.g., block access, fence off area)
IC_RADIO	ISSUE CLOSING: Radio announcement	Have advisory or closing announced on local radio station
IC_RESP_PRSN	ISSUE CLOSING: Notify responsible person	Notify owner/manager/operator/lifeguards of results
IC_TV_ANNCE	ISSUE CLOSING: TV announcement	Have advisory or closing announced on local TV station
MO_BEACH	Post at Beach	Post results at beach
MO_DIF_AGENCY	Different Agency	Provide results to different agency staff for evaluation
MO_INTERNAL	Internal Agency	Provide results to internal agency staff for evaluation
MO_INTERNET	Post on article	Post results on the Internet
MO_NEWSPAPER	Newspaper article	Publish results in local newspaper
MO_ON_REQUEST	Provide on request	Provide results to anyone on request
MO_PHONE	Provide phone line	Provide results on hotline/water quality information/results/phone line
MO_RADIO	Radio announcement	Have results announced on local radio station
MO_RESP_PRSN	Notify responsible person	Notify owner/manager/operator/lifeguards of results
MO_TV_ANNCE	TV announcement	Have results announced on local TV station
OT_OTHER	Other	Other
RA_ASES_RISK	REOPEN ADVISORY: Assess risks	Assess risks to potential swimmers
RA_ASES_SICK	REOPEN ADVISORY: Assess sickness	Assess number of complaints of sickness
RA_BEACH	REOPEN ADVISORY: Post at beach	Post announcement at the beach
RA_DIF_AGENCY	REOPEN ADVISORY: Discuss with agencies	Discuss situation with other agencies

RA_INTERNAL	REOPEN ADVISORY: Agency	Provide announcement to agency staff
RA_INTERNET	REOPEN ADVISORY: Post on Internet	Post reopening on the Internet
RA_LOCAL_GOV	REOPEN ADVISORY: Local government	Provide announcement to local government staff
RA_NEWSPAPER	REOPEN ADVISORY: Newspaper article	Publish reopening in local newspaper
RA_PHONE	REOPEN ADVISORY: Provide phone line	Provide results on hotline/water quality information/result phone line
RA_PHYS_ISOL	REOPEN ADVISORY: Remove physical isolation	Remove physical barriers set when closed
RA_RADIO	REOPEN ADVISORY: Radio announcement	Have reopening announced on local radio station
RA_RESAMPLE	REOPEN ADVISORY: Resample	Resample and compare bacterial concentrations with water quality standards to determine whether levels are below
RA_RESP_PRSN	REOPEN ADVISORY: Notify responsible person	Notify owner/manager/operator/lifeguards of results
RA_STD_RAIN	REOPEN ADVISORY: Standard rain reopening	Reopen after a set number of days following rainfall
RA_TV_ANNCE	REOPEN ADVISORY: TV announcement	Have reopening announced on local TV station
RB_ASES_RISK	REOPEN COMBINED: Assess risks	Assess risks to potential swimmers
RB_ASES_SICK	REOPEN COMBINED: Assess sickness	Assess number of complaints of sickness
RB_BEACH	REOPEN COMBINED: Post at beach	Post announcement at the beach
RB_DIF_AGENCY	REOPEN COMBINED: Discuss with agencies	Discuss situation with other agencies
RB_INTERNAL	REOPEN COMBINED: Agency	Provide announcement to agency staff
RB_INTERNET	REOPEN COMBINED: Post on Internet	Post reopening on the Internet
RB_LOCAL_GOV	REOPEN COMBINED: Local government	Provide announcement to local government staff
RB_NEWSPAPER	REOPEN COMBINED: Newspaper article	Publish reopening in local newspaper
RB_PHONE	REOPEN COMBINED: Provide phone line	Provide results on hotline/water quality information/result phone line
RB_PHYS_ISOL	REOPEN COMBINED: Remove physical isolation	Remove physical barriers set when closed
RB_RADIO	REOPEN COMBINED: Radio announcement	Have reopening announced on local radio station
RB_RESAMPLE	REOPEN COMBINED: Resample	Resample and compare bacterial concentrations with water quality standards to determine whether levels are below
RB_RESP_PRSN	REOPEN COMBINED: Notify responsible person	Notify owner/manager/operator/lifeguards of results
RB_STD_RAIN	REOPEN COMBINED: Standard rain reopening	Reopen after a set number of days following rainfall
RB_TV_ANNCE	REOPEN COMBINED: TV announcement	Have reopening announced on local TV station
RC_ASES_RISK	REOPEN CLOSING: Assess risks	Assess risks to potential swimmers
RC_ASES_SICK	REOPEN CLOSING: Assess sickness	Assess number of complaints of sickness
RC_BEACH	REOPEN CLOSING: Post at beach	Post announcement at the beach
RC_DIF_AGENCY	REOPEN CLOSING: Discuss with agencies	Discuss situation with other agencies
RC_INTERNAL	REOPEN CLOSING: Agency	Provide announcement to agency staff
RC_INTERNET	REOPEN CLOSING: Post on Internet	Post reopening on the Internet
RC_LOCAL_GOV	REOPEN CLOSING: Local government	Provide announcement to local government staff
RC_NEWSPAPER	REOPEN CLOSING: Newspaper article	Publish reopening in local newspaper
RC_PHONE	REOPEN CLOSING: Provide phone line	Provide results on hotline/water quality information/result phone line
RC_PHYS_ISOL	REOPEN CLOSING: Remove physical isolation	Remove physical barriers set when closed
RC_RADIO	REOPEN CLOSING: Radio announcement	Have reopening announced on local radio station
RC_RESAMPLE	REOPEN CLOSING: Resample	Resample and compare bacterial concentrations with water quality standards to determine whether levels are below
RC_RESP_PRSN	REOPEN CLOSING: Notify responsible person	Notify owner/manager/operator/lifeguards of results
RC_STD_RAIN	REOPEN CLOSING: Standard rain reopening	Reopen after a set number of days following rainfall

RC_TV_ANNCE	REOPEN CLOSING: TV announcement	Have reopening announced on local TV station
-------------	---------------------------------	--

9 Appendix D—Water Body Codes

This Appendix provides a separate table to explain the acceptable water body codes for name and type.

Exhibit 9-1 Water Body Name

Code	Description
ATLANTIC	Atlantic Ocean
PACIFIC	Pacific Ocean
GULF_MEXICO	Gulf of Mexico
LAKE_SUPR	Lake Superior
LAKE_MCHGN	Lake Michigan
LAKE_HURON	Lake Huron
LAKE_ERIE	Lake Erie
LAKE_ONTR	Lake Ontario
INLAND	Inland (not a BAB, do not send to EPA)
LNG_ISL_SND	Long Island Sound
CHSPK_BAY	Chesapeake Bay

Exhibit 9-2 Water Body Type

Code	Description
OPEN_COAST	Open Coast
SND_BY_INLT	Sound, Bay, or Inlet
STILL_WATER	Still Water
FLOW_WATER	Flowing Water (not Beach Act waters do not send to EPA)

10 Appendix E—Horizontal Collection

This appendix provides a list of valid domain values for Horizontal Collection Method Name and Horizontal Collection Reference Datum Name.

Exhibit 10-1 Horizontal Collection Method Name

NAME	DESCRIPTION
Address Matching-House Number	The geographic coordinate determination method based on address matching-house number
Address Matching-Block Face	The geographic coordinate determination method based on address matching-block face
Address Matching-Street Centerline	The geographic coordinate determination method based on address matching-street centerline
Address Matching-Nearest Intersection	The geographic coordinate determination method based on address matching-nearest intersection
Address Matching-Primary Name	The geographic coordinate determination method based on address matching-primary name
Address Matching-Digitized	The geographic coordinate determination method based on address matching-digitized
Address Matching-Other	The geographic coordinate determination method based on address matching-other
Census Block-1990-Centroid	The geographic coordinate determination method based on census block-1990-centroid
Census Block/Group-1990-Centroid	The geographic coordinate determination method based on census/group-1990-centroid
Census Block/Tract-1990-Centroid	The geographic coordinate determination method based on census/tract-1990-centroid
Census-Other	The geographic coordinate determination method based on census-other
GPS Carrier Phase Static Relative Position	The geographic coordinate determination method based on GPS carrier phase static relative positioning technique
GPS Carrier Phase Kinematic Relative Position	The geographic coordinate determination method based on GPS carrier phase kinematic relative positioning technique
GPS Code (Pseudo Range) Differential	The geographic coordinate determination method based on GPS code measurements (pseudo range) differential (DGPS)
GPS Code (Pseudo Range) Precise Position	The geographic coordinate determination method based on GPS code measurements (pseudo range) precise positioning service
GPS Code (Pseudo Range) Standard Position (SA Off)	The geographic coordinate determination method based on GPS code measurements (pseudo range) standard positioning service (SA Off)
GPS Code (Pseudo Range) Standard Position (SA On)	The geographic coordinate determination method based on GPS code measurements (pseudo range) standard positioning service (SA On)

NAME	DESCRIPTION
Interpolation-Map	The geographic coordinate determination method based on interpolation-map
Interpolation-Photo	The geographic coordinate determination method based on interpolation-photo
Interpolation-Satellite	The geographic coordinate determination method based on interpolation-satellite
Interpolation-Other	The geographic coordinate determination method based on interpolation-other
Loran C	The geographic coordinate determination method based on Loran C
Public Land Survey-Quarter Section	The geographic coordinate determination method based on public land survey quarter of a section
Public Land Survey-Section	The geographic coordinate determination method based on public land survey section
Classical Surveying Techniques	The geographic coordinate determination method based on classical surveying techniques
Zip Code-Centroid	The geographic coordinate determination method based on zipcode-centroid
Unknown	The information is not known
GPS-Unspecified	Global Positioning Method, with unspecified parameters
GPS, With Canadian Active Control System	GPS Code Measurements (pseudo range) Standard Positioning Service Corrected using Canadian Active Control System
Interpolation-Digital Map Srce (Tiger)	The geographic coordinate determination method is based on a digital map source (TIGER)
Interpolation-Spot	The geographic coordinate determination method uses SPOT (Système Probatoire d'Observation de la Terre), a French-owned satellite launched in 1984
Interpolation-MSS	The geographic coordinate determination method is based on the use of a Multi-Spectral Scanner (MSS)
Interpolation-TM	The geographic coordinate determination method is based on the use of a Thematic Mapper (TM)
Public Land Survey-Eighth Section	The geographic coordinate determination method is based on a public land survey, an eighth of a section
Public Land Survey-Sixteenth Section	The geographic coordinate determination method is based on a public land survey, a sixteenth of a section
Public Land Survey-Footing	The geographic coordinate determination method is based on a public land survey footing
Zip+4 Centroid	The center of an area defined by the 5-digit ZIP code and its 4-digit geographic segment extension
Zip+2 Centroid	The center of an area defined by the 5-digit ZIP code and its 2-digit geographic segment extension

Exhibit 10-2 Horizontal Collection Reference Datum Name

NAME	DESCRIPTION
NAD27	North American Datum 1927
NAD83	North American Datum 1983
OTHER	Other
UNKWN	Unknown
AMSMA	American Samoa Datum
ASTRO	Midway Astro 1961
GUAM	Guam 1963
JHNSN	Johnson Island 1961
OLDHI	Old Hawaiian Datum
PR	Puerto Rico Datum
SGEOR	St. George Island Datum
SLAWR	St. Lawrence Island Datum
SPAUL	St. Paul Island Datum
WAKE	Wake-Eniwetok 1960
WGS72	World Geodetic System 1972
WGS84	World Geodetic System 1984

11 Appendix F—Addition Notifications

One feature of the notification schema is that users can submit activities over time as they happen, rather than being forced to submit them all at once. The primary Notification XML element is comprised of three main sub-elements:

- OrganizationDetail, containing information related to the organizations involved in the Beach Act Grant Program.
- BeachDetail, containing information related to the beaches overseen by the National Beach Program.
- BeachProcedureDetail, contains information related to the procedures used by beaches for Monitoring, Notification, issuance, and reopening.

An XML document containing additional activities needs only contain a portion of the BeachDetail element.

The BeachDetail element contains information on specific beaches, including the BeachId, name data, attribute data, activity data, and role data. During the initial submission (or initial submission for a given beach), all required information in the BeachDetail element must be included. During subsequent submissions (to add activities to specific beaches) only the activity data should be included*. This activity data falls under the BeachDetail sub-element, BeachActivityDetail.

Exhibit 11-1 is an example Notification XML document containing two activities for the beach TX259473. Note that additional activities for TX259473 would be added by inserting additional BeachActivityDetail elements to the existing BeachDetail element. Activities on additional beaches would be added through the addition of BeachDetail elements.

* Beach Name data can be updated in the subsequent Notification XML submissions. This is accomplished through the inclusion of the BeachNameDetail element (see the Beach Notification User's Guide, sections 3.1.3 to 3.1.4).

Exhibit 11-1 Example Notification XML Document

```
<BeachDataSubmission xsi:noNamespaceSchemaLocation="BeachesNotification.xsd"
xmlns:xsi="http://www.w3.org/2001/XMLSchema-instance">
<BeachDetail>
  <BeachIdentifier>TX259473</BeachIdentifier>
  <BeachActivityDetail>
    <ActivityTypeCode>CONTAM_ADV</ActivityTypeCode>
    <ActivityName>Advisory</ActivityName>
    <ActivityActualStartDate>2003-12-23T09:27:00</ActivityActualStartDate>
    <ActivityActualStopDate>2003-12-23T09:27:00</ActivityActualStopDate>
    <ActivityPartialDayAmount>4</ActivityPartialDayAmount>
    <ActivityReasonDetail>
      <ActivityReasonType>ELEV_BACT</ActivityReasonType>
      <ActivityReasonDescriptionText>1367 cfu</ActivityReasonDescriptionText>
    </ActivityReasonDetail>
    <ActivitySourceDetail>
      <ActivitySourceType>UNKNOWN</ActivitySourceType>
    </ActivitySourceDetail>
    <ActivityIndicatorDetail>
      <ActivityIndicatorType>ENTERO</ActivityIndicatorType>
    </ActivityIndicatorDetail>
    <ActivityMonitoringStationIdentifier>21TXBCH|NUE030</ActivityMonitoringStationIdentifier>
  </BeachActivityDetail>
<BeachActivityDetail>
  <ActivityTypeCode>CONTAM_ADV</ActivityTypeCode>
  <ActivityName>Advisory</ActivityName>
  <ActivityActualStartDate>2003-11-14T16:10:00</ActivityActualStartDate>
  <ActivityActualStopDate>2003-11-14T04:10:00</ActivityActualStopDate>
  <ActivityReasonDetail>
    <ActivityReasonType>ELEV_BACT</ActivityReasonType>
    <ActivityReasonDescriptionText>119 cfu</ActivityReasonDescriptionText>
  </ActivityReasonDetail>
  <ActivitySourceDetail>
    <ActivitySourceType>UNKNOWN</ActivitySourceType>
  </ActivitySourceDetail>
  <ActivityIndicatorDetail>
    <ActivityIndicatorType>ENTERO</ActivityIndicatorType>
  </ActivityIndicatorDetail>
  <ActivityMonitoringStationIdentifier>21TXBCH|NUE034</ActivityMonitoringStationIdentifier>
</BeachActivityDetail>
</BeachDataSubmission>
```

</BeachDetail>
</BeachDataSubmission>

Previously, users of the PRAWN Notification Access database were unable to generate valid XML files for these additional, interim submissions. With the addition of the Custom XML Generation macro, users now have more control over which data to include in individual submissions.

Exhibit 11-2 Custom XML Generation

XML Generation

Activity Start Date
Jan 2008
Selected Start Date: 1/1/2008

Sun	Mon	Tue	Wed	Thu	Fri	Sat
30	31	1	2	3	4	5
6	7	8	9	10	11	12
13	14	15	16	17	18	19
20	21	22	23	24	25	26
27	28	29	30	31	1	2
3	4	5	6	7	8	9

Activity Stop Date
Sep 2008
Selected Stop Date: 9/5/2008

Sun	Mon	Tue	Wed	Thu	Fri	Sat
31	1	2	3	4	5	6
7	8	9	10	11	12	13
14	15	16	17	18	19	20
21	22	23	24	25	26	27
28	29	30	1	2	3	4
5	6	7	8	9	10	11

Include Beach Data?
 Include Beach Name Data?
 Include Beach Attributes?
 Include Beach Activities?
 Include Beach Role Data?
 Include Beach Coordinate Data?
 Include Org./Person Data?
 Include Procedure Data?
 Include Completion Data?
 Notification Data Submitted?
 Monitoring Data Submitted?
 Location Data Submitted?

Year: 2008

File Name/Path?:

This form allows a user to choose which of the three main data sub-elements to submit, as well as which sections of the BeachDetail element (Names, Attributes, Activities, and Roles) should be included. The calendars allow a user to narrow down the Activities to a specific timeframe. If the BeachActivityDetail element is not included in a submission, the calendars become inactive.

To generate a custom file, simply follow these steps:

1. Open the Notification Access Database.

-
2. From the 'Macros' window, select the 'Custom XML Generation' macro.
 3. Once the Custom XML Generation macro is started, a screen (Exhibit 11-2) will be presented.
 4. Select which data should be included in the Notification XML submission by checking or un-checking the boxes in the center of the windows.
 - a. Note that the calendars allow for the selection of activities within a specific date range. If activities are not included in a given submission, these calendars will be inactive.
 5. Click the "Browse..." button to select a name and location for the Notification XML submission.
 6. Once the selections have been made, click the "Go!" button to generate a Notification XML submission with the selected data.
 7. A message will display with details of the file generation, along with confirmation that the Notification XML submission was generated successfully.

A note on activity submissions:

- Because it is possible for multiple activities to overlap on portions of the same beach, it is not possible to determine if duplicate activities have been submitted. For this reason, it is ***critically important*** that State users track those activities that have been previously submitted; submitting an activity twice *will* result in a duplicate activity in PRAWN. Should an activity be submitted multiple times, see Appendix K for activity deletion process in the case of duplicate activities

12 Appendix G—Pollution Source Identification

This appendix provides logical tables of how to enter data concerning pollution sources for both the Access database and XML schema.

NOTE: All references to “pollution sources” are only “POSSIBLE sources” – see Page 24 of User Guide.

Notification Access Database (Revised to avoid double negatives in Schema’s Boolean logic, will be translated back to schema in XML)

Exhibit 12-1 Access Database

	BEACH_ATTRIBUTE	(Beach – all activities)	(Activity specific)	
Example Case	[POLLUTION_SOURCES] Is it possible that there are pollution sources for the beach? Y/N	[POLLUTION_SOURCES_INVESTIGATED] Have the pollution sources been investigated for the beach? Y/N	BEACH_POLLUTION [POLLUTION_SOURCE]	BEACH_ACTIVITY_REASON
1a. No Activity - No Investigation Done. “May or may not be sources”	[Y] Because no investigation was done the schema uses “Y” in this case to indicate that there may be sources, but they are unknown	[N] It is unknown whether or not pollution sources exist for this beach because they were not investigated - no pollution sources are to be listed in the [BEACH_POLLUTION] table.	UNKNOWN or TBD (Intend to do an investigation but has not been done yet)	Leave Blank
1b. No Activity – Investigation Done – No Sources Identified (Rare)	[N] Investigated, but no sources found (rare) “N” will make the schema force a “Y” into [POLLUTION_SOURCES_INVESTIGATED]	[Y] If no pollution sources were found, i.e.: POLLUTION_SOURCES] = [N] The schema is set to assume that the pollution sources were investigated.	UNKNOWN or TBD (Intend to investigate further but has not been done yet)	Leave Blank

	BEACH_ATTRIBUTE	(Beach – all activities)	(Activity specific)	
1c. No Activity – Investigation Done – Sources Identified	[Y] Investigated and sources found	[Y] It is known that pollution sources exist for this beach because they were investigated and listed in the [BEACH_POLLUTION] table	List all identified for that beach, even though no activity that year and, if applicable, UNKNOWN and or TBD (Intend to investigate further but has not been done yet)	Leave Blank
2a. Activity Reported - No Investigation Done. “May or may not be sources”	[Y] Because no investigation was done the schema uses “Y” in this case to indicate that there may be sources, but it is unknown	[N] It is unknown whether or not pollution sources exist for this beach because they were not investigated and no pollution sources were listed in the [BEACH_POLLUTION] table.	UNKNOWN and or TBD (Intend to do an investigation but has not been done yet)	‘UNKNOWN’
2b. Activity Reported – Investigation Done – Sources Unidentified “May or may not be sources”	[Y] Because there were no sources found, the schema uses “Y” in this case to indicate that there may be sources, but they are unknown.	[Y] It is known that pollution sources exist for this beach because there was an activity. However, although there was an investigation, the sources were not identifiable at the time of the investigation.	List all identified for that beach or at least UNKNOWN and, if applicable, TBD (Intend to do an investigation but has not been done yet)	‘UNKNOWN’

	BEACH_ATTRIBUTE	(Beach – all activities)	(Activity specific)	
2c. Activity Reported – Investigation Done – Sources Identified	[Y] Investigated and sources found	[Y] It is known that pollution sources exist for this beach because they were investigated and listed in the [BEACH_POLLUTION] table	List all identified for all activities at that beach and, if applicable, UNKNOWN and or TBD (Intend to investigate further but has not been done yet)	List all identified for that activity

XML Schema (Boolean Logic with Double Negatives)

Exhibit 12-2 XML Schema

Example Case	Beach Attribute	Beach Pollution	Beach Activity Reason
1a. No Activity - No Investigation Done. “May or may not be sources”	NoPollutionSourcesIndicator = ‘false’ PollutionSourcesUninvestigatedIndicator = ‘true’ if no investigation done	BeachPollutionSourceCode = ‘UNKNOWN’ Or BeachPollutionSourceCode = ‘TBD’	Leave Blank
1b. No Activity – Investigation Done – No Sources Identified (Rare)	NoPollutionSourcesIndicator = ‘true’ investigated but no sources found	BeachPollutionSourceCode = ‘UNKNOWN’ Or BeachPollutionSourceCode = ‘TBD’ Or Leave Blank	Leave Blank
1c. No Activity – Investigation Done – Sources Identified	NoPollutionSourcesIndicator = ‘false’ investigated and sources found PollutionSourcesUninvestigatedIndicator = ‘false’ investigation done	BeachPollutionSourceCode = list all identified for that beach, even though no activity that year	Leave Blank

<p>2a. Activity Reported - No Investigation Done.</p> <p>“May or may not be sources”</p>	<p>NoPollutionSourcesIndicator = ‘false’</p> <p>PollutionSourcesUninvestigatedIndicator = ‘true’ if no investigation done</p>	<p>BeachPollutionSourceCode = ‘UNKNOWN’</p> <p>Or</p> <p>BeachPollutionSourceCode = ‘TBD’</p>	<p>ActivityReasonType = ‘UNKNOWN’</p>
<p>2b. Activity Reported – Investigation Done – Sources Unidentified</p> <p>“May or may not be sources”</p>	<p>NoPollutionSourcesIndicator = ‘false’ investigated and sources found</p> <p>PollutionSourcesUninvestigatedIndicator = ‘false’ investigation done</p>	<p>BeachPollutionSourceCode = ‘UNKNOWN’</p>	<p>ActivityReasonType = ‘UNKNOWN’</p>
<p>2c. Activity Reported – Investigation Done – Sources Identified</p>	<p>NoPollutionSourcesIndicator = ‘false’ investigated and sources found</p> <p>PollutionSourcesUninvestigatedIndicator = ‘false’ investigation done</p>	<p>BeachPollutionSourceCode = list all identified for all activities at that beach</p>	<p>ActivityReasonType = List All Identified for that activity</p>

13 Appendix H—Data Entry Forms

Forms have been added to ease the data entry process; however, it is still possible to copy and paste records directly into the tables. To access the data entry forms, click the Forms tab.

Exhibit 13-1 Forms

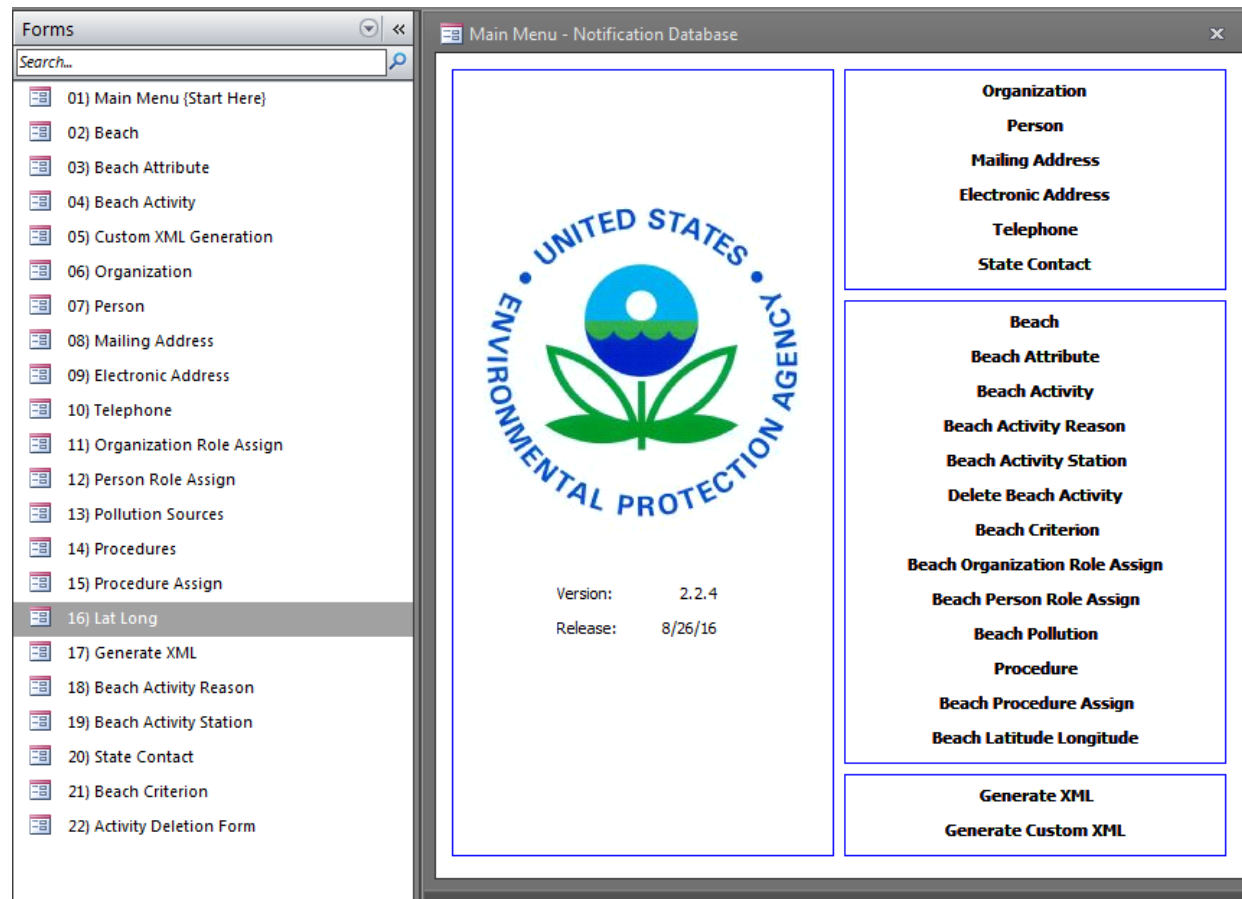

The main menu lists forms in the order of entry. For example organization data should be entered before beach data.

Exhibit 13-2 Main Menu

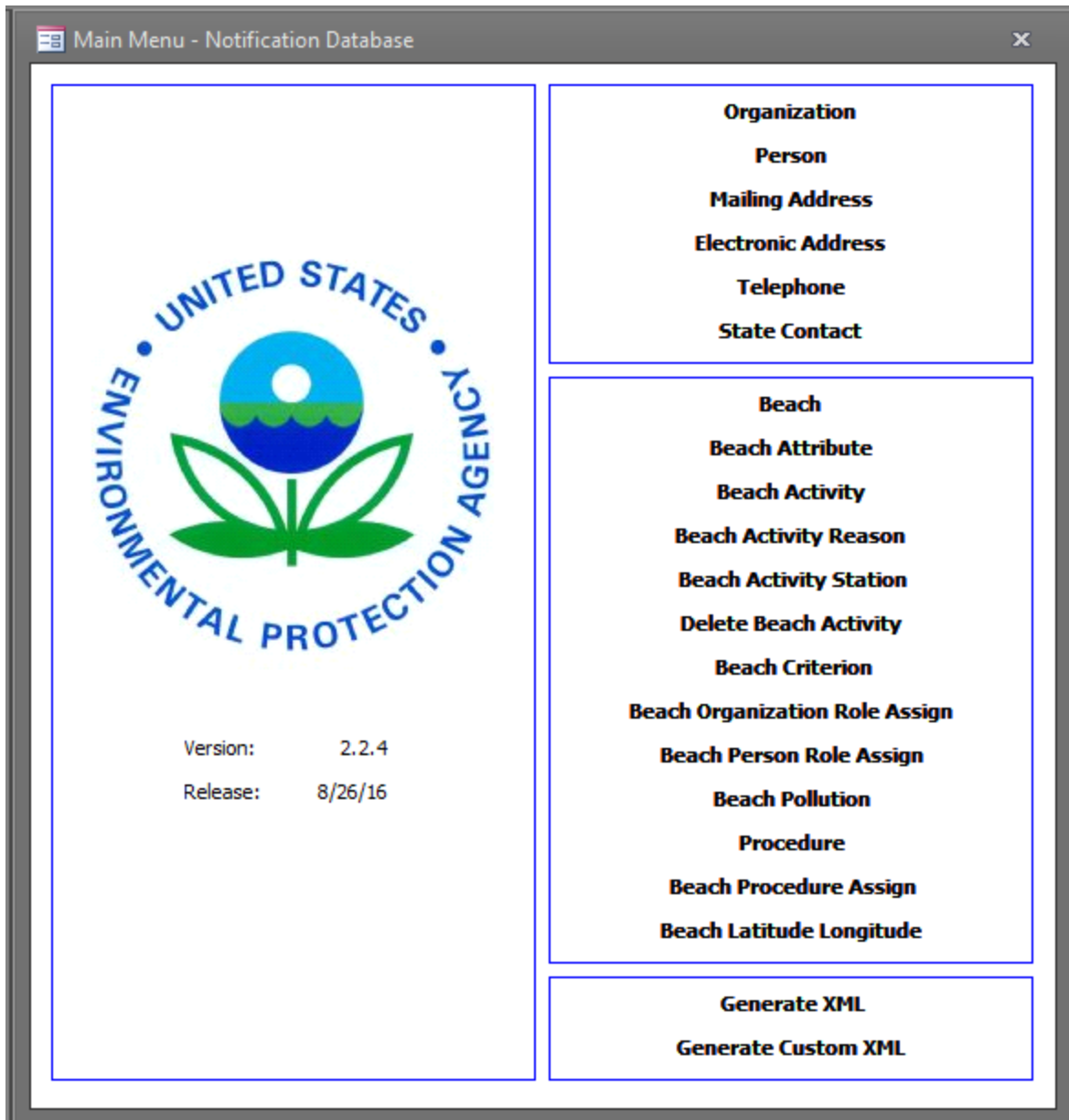

On each data entry form there is a Return to Main Menu button. Use this button to navigate back to the Main Menu form.

Exhibit 13-3 Return to Main Menu

The screenshot shows a web-based data entry form titled "Beach Data Entry Form". The form contains the following fields and values:

- Beach ID**: CN392116
- Name**: Sunny Beach
- Description**: Shadyville's Sunniest Beach
- Comment**: PACIFIC
- State Code**: CN
- FIPS County Code**: 99001
- Access Type**: PUB_PUB_ACC
- Access Comment**: (empty)
- Waterbody Name**: Pacific Ocean
- Waterbody Type**: Still Water
- Send to EPA**: N

Below the form fields is a button labeled "Return to Main Menu".

At the bottom of the form, there is a footer area with the following text:

- * **Data elements in bold are required.**
- ** For further information please reference the user guide or contact ebeaches@cgifederal.com
- [Click here for the user guide.](#)

The bottom of the window shows a navigation bar with the text "Record: 1 of 2", "No Filter", and a "Search" button.

14 Appendix I—Summary Reports

Summary Reports have been added to assist in the QA process. To access the summary reports, select reports from the menu on the left.

Exhibit 14-1 Reports

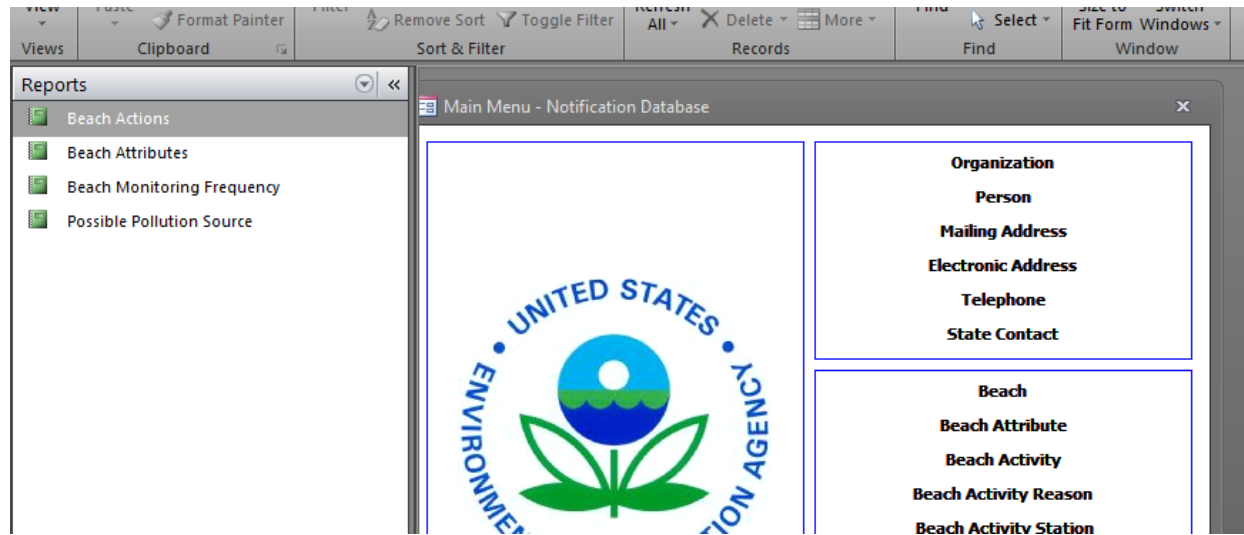

Exhibit 14-2 Beach Actions

Beach Actions

Beach ID	Beach Name	Activity Type	Action Start Date	Action Stop Date	No. of Days	Action Reason	Action Indicator	Action Source
					Under			
<hr/>								
CN392116	Sunny Beach	POSTING	6/25/2014 6:38:00 AM	6/25/2014 11:06:00 PM	0	ELEV_BACT	ENTERO	STORM
CN392116	Sunny Beach	PERM_CLOSURE	9/24/2014 5:00:00 AM	11/11/2014 9:46:00 PM	48	ELEV_BACT	ENTERO	STORM
CN392116	Sunny Beach	CLOSURE	10/28/2014 10:15:00 AM	10/28/2014 6:25:00 PM	0	ELEV_BACT	ENTERO	STORM
CN392116	Sunny Beach	CLOSURE	3/28/2014 2:00:00 AM	7/2/2014 2:35:00 AM	96	CHEM_OIL	RATIO	BOAT
CN599204	Shady Beach	CONTAM_ADV	12/7/2014 10:30:00 AM	12/8/2014 8:00:00 PM	1	ELEV_BACT	ENTERO	STORM
CN599204	Shady Beach	CONTAM_ADV	11/23/2014 6:50:00 PM	11/30/2014 7:45:00 PM	7	ELEV_BACT	ENTERO	STORM
CN599204	Shady Beach	CONTAM_ADV	11/16/2014 3:05:00 AM	11/16/2014 3:45:00 AM	0	ELEV_BACT	ENTERO	STORM
CN599204	Shady Beach	CONTAM_ADV	10/26/2014 10:20:00 AM	11/2/2014 2:00:00 PM	7	RAINFALL	ENTERO	STORM

Exhibit 14-3 Beach Attributes

Beach Attribute

Beach ID	Beach Name	Beach Act Beach	Beach Ownership/ Beach Accessibility	Beach Tier	Start Latitude	Start Longitude	End Latitude	End Longitude
CN392116	Sunny Beach	YES	PUB_PUB_ACC	1	YES	YES	YES	YES
CN599204	Steady Beach	YES	PRV_PRV_ACC	1	YES	YES	YES	YES

Exhibit 14-4 Beach Monitoring Frequency

Beach Monitoring Frequency

Beach ID	Beach Name	Swim Season Length	Swim Season Length Units	Swim Season Monitoring Frequency	Swim Season Monitoring Frequency Units	Off Season Monitoring Frequency	Off Season Monitoring Frequency Units
CN392116	Sunny Beach	7	MONTHS	1	PER_YEAR	1	PER_YEAR
CN599204	Shady Beach	12	WEEKS	1	PER_DAY	0	PER_DAY

Exhibit 14-5 Possible Pollution Sources

**The pollution source report takes up twice as many pages due to the number of columns it displays.

Exhibit 14-6 displays the other half of the report.

Possible Pollution Sources

Beach ID	Beach Name	Pollution Sources Investigated	Pollution Sources	Run Off	Storm	Agricultural	Boat	CAFO	CSO	SSO	POTW
CN599204	Shady Beach	Y	Y	NO	NO	NO	NO	NO	NO	NO	NO
CN599204	Shady Beach	Y	Y	NO	NO	NO	NO	NO	NO	NO	NO
CN599204	Shady Beach	Y	Y	NO	NO	NO	NO	NO	NO	NO	NO
CN599204	Shady Beach	Y	Y	NO	NO	NO	NO	NO	NO	NO	YES

Exhibit 14-6 Possible Pollution Sources (cont.)

Possible Pollution Sources (cont.)

Beach ID	Beach Name	Pollution Sources Investigated	Pollution Sources	Sewer Line	Septic	Wildlife	Other	Unknown
CN599204	Shady Beach	Y	Y	NO	NO	NO	NO	YES
CN599204	Shady Beach	Y	Y	NO	NO	NO	NO	NO
CN599204	Shady Beach	Y	Y	YES	NO	NO	NO	NO
CN599204	Shady Beach	Y	Y	NO	NO	NO	NO	NO

15 Appendix J—CDX Web Messages

See: https://www.epa.gov/sites/production/files/2014-09/documents/ebeaches_ensc.pdf for more detailed explanations.

You will only receive one email per submission:

Completed

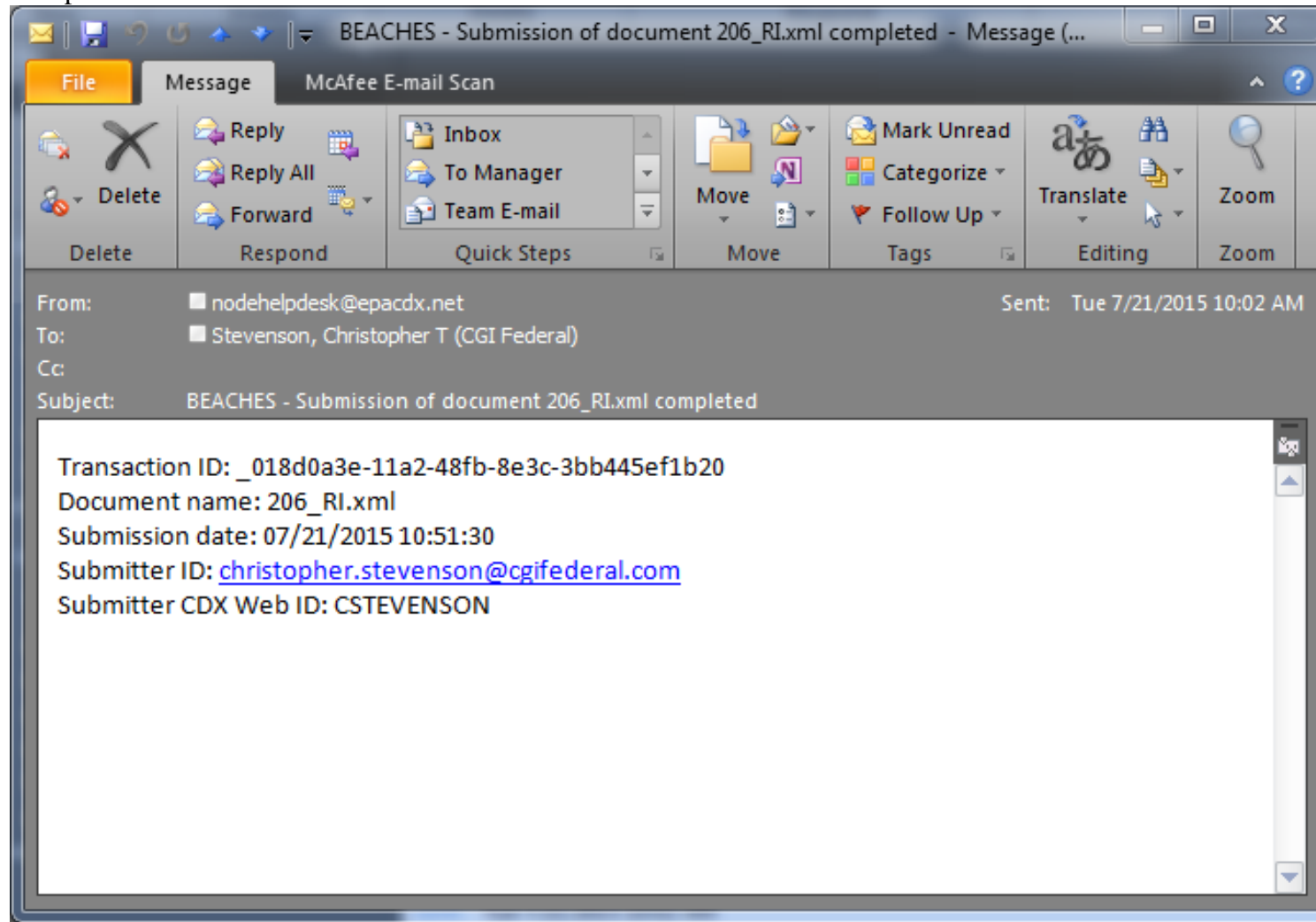

Or Failed:

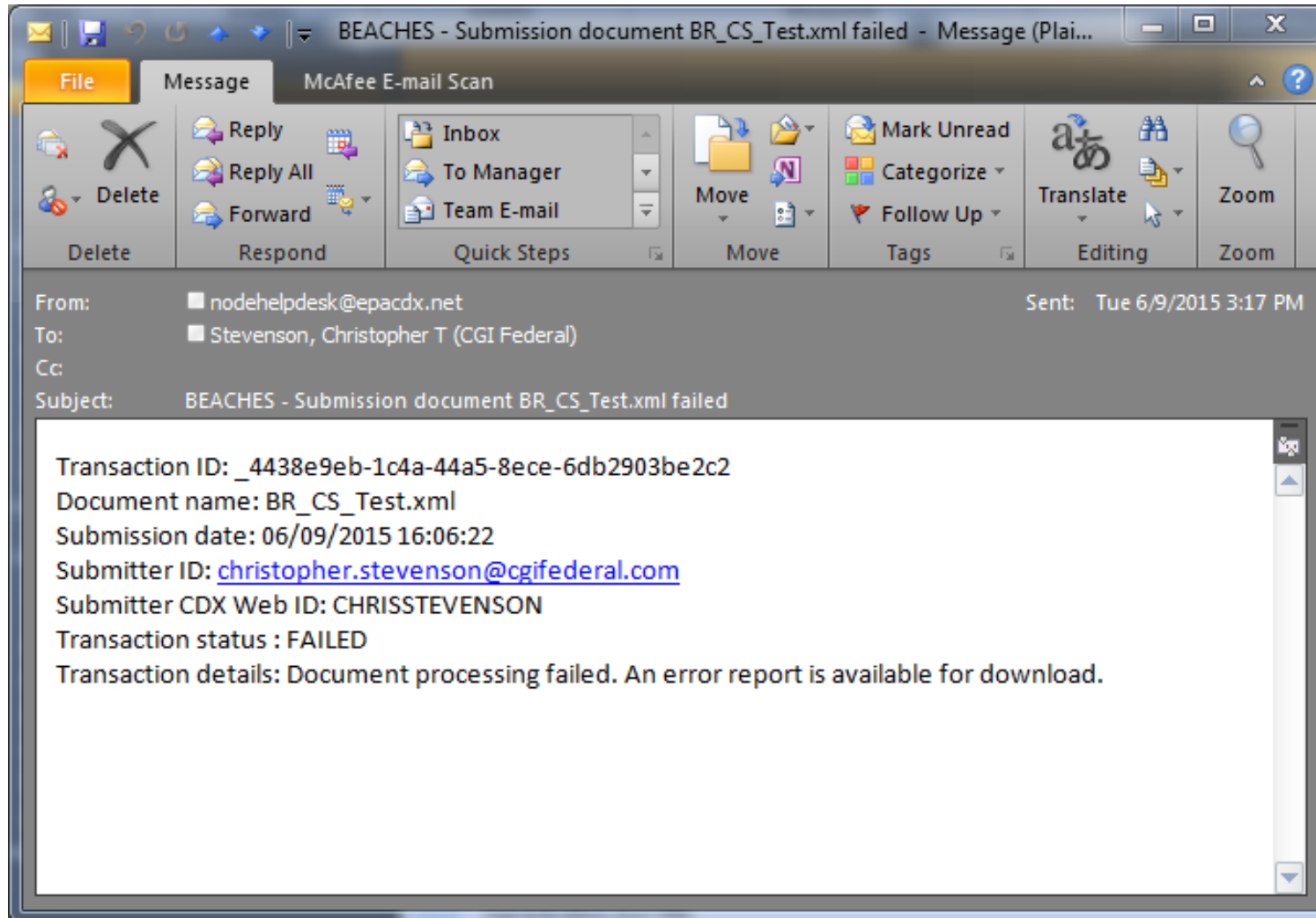

Users would download the error message(s) associated with a submission by selecting the “Download a document” radio button and select the “Continue” button.

Environmental Information
exchange Network

SERVICES CENTER

My Profile | Help | Contact Us | Logout

Home | My Services Center | Exchange Network Services | News & Data Channels | My Quick Links ▼

Use either the **Step-by-Step** OR **Express** approach to send, get, or download information from the Exchange Network:

CHOOSE

Guide Me Step-by-Step (recommended for novice users)

Step 1: Choose the Type of Transaction to Perform

- Send information to a system on the Exchange Network
- Get information that is stored on the Exchange Network
- Download a document from the Exchange Network. You must know the [Transaction ID](#) or [Document ID](#) to perform a download

Continue

Express Request (recommended for advanced users)

Search for a Service by Keyword

Search

OR

Browse our entire Services Directory

Browse Services Directory

After selecting “Continue” you will be directed to the Guide Me Step-by-Step page. Select the “.NGNProd2.0” as the node and “BEACHES” as the dataflow. Select the “Continue” button to be directed to Step 3.

The screenshot displays the 'Exchange Network SERVICES CENTER' interface. The user is logged in as 'christopher.stevenson@cgifederal.com'. The main navigation bar includes 'Home', 'My Services Center', 'Exchange Network Services', and 'News & Data Channels'. Below this, there are links for 'My EPA Activity' and 'My Channels'. The 'My Services' section is active, showing a 'Download Document' form. The form has two dropdown menus: 'Select a Node' with 'NGNProd2.0' selected and 'Select a DataFlow' with 'BEACHES' selected. There are two input fields for 'Enter Transaction ID' and 'Enter Document ID', with an 'OR' label between them. A 'GET DOCUMENT(S)' button is at the bottom right of the form.

Enter the transaction ID and select “GET DOCUMENT(S)” to obtain the documents associated with the entered transaction ID.

The screenshot displays the 'Exchange Network SERVICES CENTER' interface. At the top, there is a navigation bar with links for 'My Profile', 'Help', 'Contact Us', and 'Logout'. Below this is a secondary navigation bar with buttons for 'Home', 'My Services Center', 'Exchange Network Services', and 'News & Data Channels', along with a 'My Quick Links' dropdown menu. The main content area is divided into two columns. The left column is titled 'Guide Me Step-by-Step (recommended for novice users)' and shows 'Step 3: Enter Transaction ID'. It includes instructions: 'You must know either the Transaction ID or the Document ID associated with this document before you can download it.' There are two input fields: one for 'Enter Transaction ID (multiple documents may be associated with a single Transaction ID):' containing the value '_ee7d7b8b-edda-466-a7af-c4dfc3e6213f', and another for 'Enter Document ID:'. Below these fields are two buttons: a green 'Back' button and a dark green 'GET DOCUMENT(S)' button. The right column is titled 'Your Progress with this Transaction:' and shows a checklist: 'Step 1: Select a Transaction Type' (checked), 'Step 2: Select a Node' (checked), and 'Step 3: Enter Transaction ID' (not checked).

Below shows an example of the downloaded error report.

```
<return xmlns='http://exchangenetwork.net/schemas/validator/1.1/validatorEx.xsd'>
  <transactionId>_4be68143-eede-4207-b87e-7b11ab892997</transactionId>
  <validationType>schema</validationType>
  <processStatus>Finished</processStatus>
  <documentStatus>Invalid</documentStatus>
  <timeStamp>2012-01-30T21:23:15Z</timeStamp>
  <results>The document,d:\SOAPServer\DataFolder\_4be68143-eede-4207-b87e-7b11ab8929970.unzipped\CNMI Beach Monitoring 2011.xml, contains the following error(s):

  Error at line 3 column 1063517 : The element 'ActivityDescription' in namespace 'http://www.exchangenetwork.net/schema/wqx/1' has invalid child element 'Activity:

  Error at line 3 column 1067722 : The element 'ActivityDescription' in namespace 'http://www.exchangenetwork.net/schema/wqx/1' has invalid child element 'Activity:

  Error at line 3 column 1071929 : The element 'ActivityDescription' in namespace 'http://www.exchangenetwork.net/schema/wqx/1' has invalid child element 'Activity:
```

Below shows an example of a successful processing report.

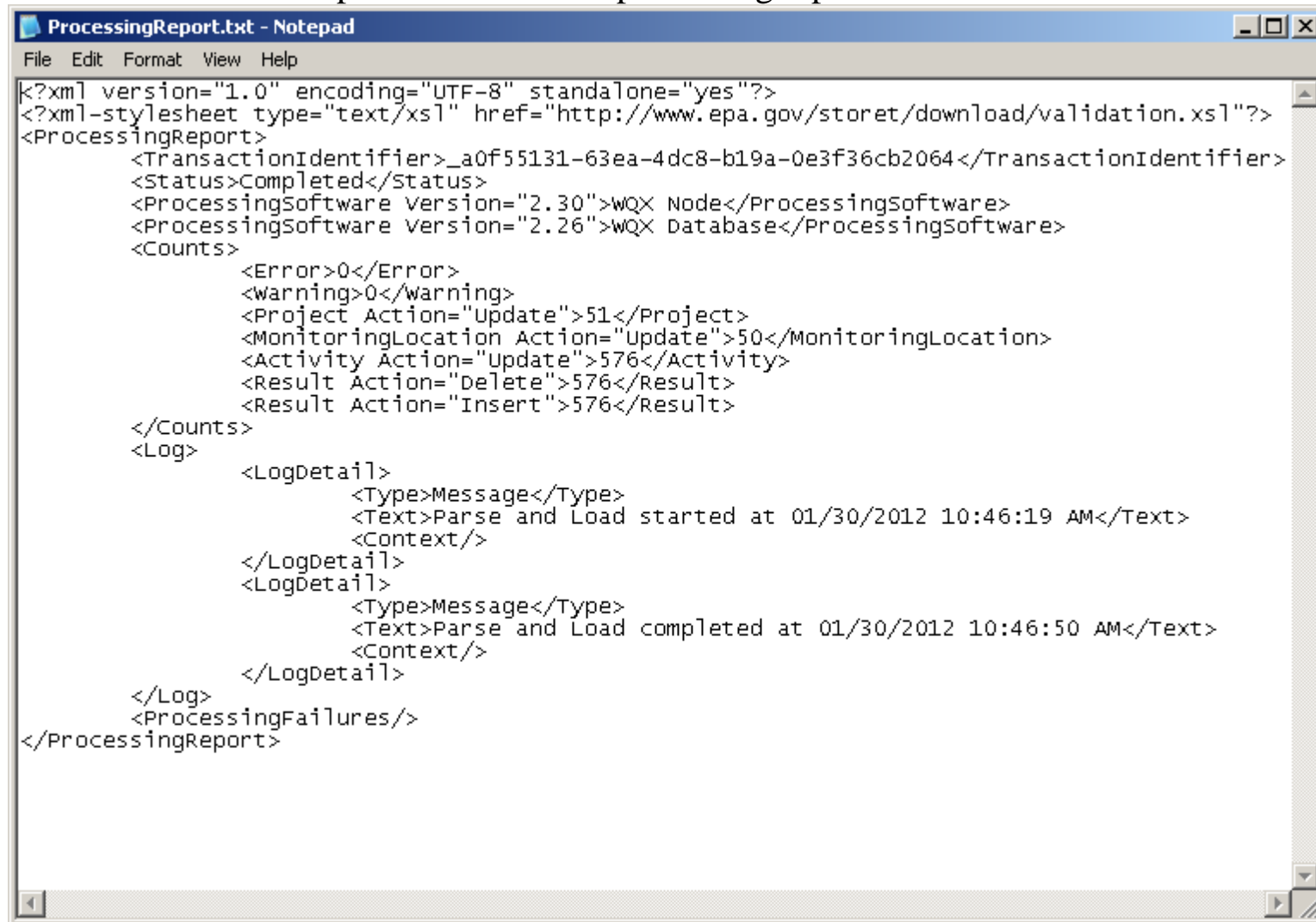

```
ProcessingReport.txt - Notepad
File Edit Format View Help
<?xml version="1.0" encoding="UTF-8" standalone="yes"?>
<?xml-stylesheet type="text/xsl" href="http://www.epa.gov/storet/download/validation.xsl"?>
<ProcessingReport>
  <TransactionIdentifier>_a0f55131-63ea-4dc8-b19a-0e3f36cb2064</TransactionIdentifier>
  <Status>Completed</Status>
  <ProcessingSoftware Version="2.30">WQX Node</ProcessingSoftware>
  <ProcessingSoftware Version="2.26">WQX Database</ProcessingSoftware>
  <Counts>
    <Error>0</Error>
    <Warning>0</Warning>
    <Project Action="Update">51</Project>
    <MonitoringLocation Action="Update">50</MonitoringLocation>
    <Activity Action="Update">576</Activity>
    <Result Action="Delete">576</Result>
    <Result Action="Insert">576</Result>
  </Counts>
  <Log>
    <LogDetail>
      <Type>Message</Type>
      <Text>Parse and Load started at 01/30/2012 10:46:19 AM</Text>
      <Context/>
    </LogDetail>
    <LogDetail>
      <Type>Message</Type>
      <Text>Parse and Load completed at 01/30/2012 10:46:50 AM</Text>
      <Context/>
    </LogDetail>
  </Log>
  <ProcessingFailures/>
</ProcessingReport>
```

16 Appendix K—Activity Deletion Process

To manually delete a single activity, users will need to get the activity code from the Beach Actions (Advisories and Closures) report in BEACON as well as the Beach ID. The Beach ID is on the top the report, circled in red and the activity code can be found in the column labeled “Activity ID”:

State : CN, County : TEST, Year : 2014, Beach Id: CN392116											
Beach Name	Beach Status	Reported	Activity ID	Monitoring Station ID	Action Type	Action Start Date	Action End Date	Action Duration Days	Action Reasons	Action Indicator	Action Possible Source
Sunny Beach	Non-Reporting	Y	463900	Sunny Station 1	Posting	JUN-25-2014	JUN-25-2014	1	ELEV_BACT	ENTERO	STORM
Sunny Beach	Non-Reporting	Y	455815	Sunny Station 1	Closure	OCT-28-2014	OCT-28-2014	1	ELEV_BACT	ENTERO	STORM
Sunny Beach	Non-Reporting	Y	455817	Sunny Station 1	Posting	JUN-25-2014	JUN-25-2014	1	ELEV_BACT	ENTERO	STORM
Sunny Beach	Non-Reporting	Y	456378	Sunny Station 1	Closure	OCT-28-2014	OCT-28-2014	1	ELEV_BACT	ENTERO	STORM
Sunny Beach	Non-Reporting	Y	456380	Sunny Station 1	Posting	JUN-25-2014	JUN-25-2014	1	ELEV_BACT	ENTERO	STORM
Sunny Beach	Non-Reporting	Y	456386	Sunny Station 1	Closure	OCT-28-2014	OCT-28-2014	1	ELEV_BACT	ENTERO	STORM
Sunny Beach	Non-Reporting	Y	456388	Sunny Station 1	Posting	JUN-25-2014	JUN-25-2014	1	ELEV_BACT	ENTERO	STORM
Sunny Beach	Non-Reporting	Y	456394	Sunny Station 1	Closure	OCT-28-2014	OCT-28-2014	1	ELEV_BACT	ENTERO	STORM

Once the user has both the Beach ID and the Activity code for the Activity to be deleted, enter them into the access database in Form 22 – Activity Deletion Form. Once the Beach ID and the Activity ID are entered, follow the same process as submitting data (new and revised activities can be included in the current submission), export the xml from Form 17- Genrate XML, and submit the exported file to the ENSC.

If there are a large number of activities to delete, users may find it easier to enter the Beach ID’s and Activity ID’s through the table view in the access database. See page 5 of this user guide, “Some notes about using the access database:” for instructions on accessing and using table view.

BEACON has a download feature that can export large amounts of data that can be then be used to copy and paste data into Access table view.

Select “Download” from the Actions menu of the Beach Actions (Advisories and Closures) report:

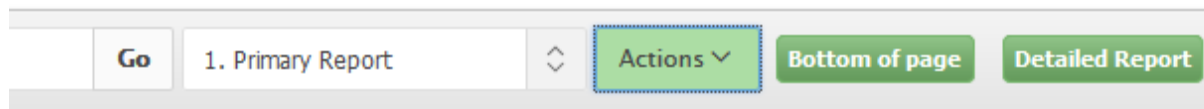

Then choose “.CSV” from the download menu. The data will then be opened in an excel spreadsheet.

CN	TEST	2014	CN392116	Sunny Bea	Non-Repc	Y		456378	Sunny Sta		OCT-28-20	OCT-28-20
CN	TEST	2014	CN392116	Sunny Bea	Non-Repc	Y		456380	Sunny Sta	Posting	JUN-25-20	JUN-25-20
CN	TEST	2014	CN392116	Sunny Bea	Non-Repc	Y		456386	Sunny Sta		OCT-28-20	OCT-28-20
CN	TEST	2014	CN392116	Sunny Bea	Non-Repc	Y		456388	Sunny Sta	Posting	JUN-25-20	JUN-25-20
CN	TEST	2014	CN392116	Sunny Bea	Non-Repc	Y		456394	Sunny Sta		OCT-28-20	OCT-28-20
CN	TEST	2014	CN392116	Sunny Bea	Non-Repc	Y		456396	Sunny Sta	Posting	JUN-25-20	JUN-25-20
CN	TEST	2014	CN392116	Sunny Bea	Non-Repc	Y		456435	Sunny Sta		OCT-28-20	OCT-28-20
CN	TEST	2014	CN392116	Sunny Bea	Non-Repc	Y		456437	Sunny Sta	Posting	JUN-25-20	JUN-25-20
CN	TEST	2014	CN392116	Sunny Bea	Non-Repc	Y		456443	Sunny Sta		OCT-28-20	OCT-28-20
CN	TEST	2014	CN392116	Sunny Bea	Non-Repc	Y		456445	Sunny Sta	Posting	JUN-25-20	JUN-25-20
CN	TEST	2014	CN392116	Sunny Bea	Non-Repc	Y		456451	Sunny Sta		OCT-28-20	OCT-28-20
CN	TEST	2014	CN392116	Sunny Bea	Non-Repc	Y		456453	Sunny Sta	Posting	JUN-25-20	JUN-25-20

From this point the best way to proceed would be to get the data into two columns, one for the Beach ID and one for the Activity ID. One method would be to delete everything from the spreadsheet except the Beach ID column and the Activity ID column:

	A	B	C	D	E	F	G	H	I	J
187				CN392116					456386	
188				CN392116					456388	
189				CN392116					456394	
190				CN392116					456396	
191				CN392116					456435	
192				CN392116					456437	
193				CN392116					456443	
194				CN392116					456445	
195				CN392116					456451	
196				CN392116					456453	

Next, delete the empty columns between the columns with data:

	A	B	C	D
187	CN392116	456386		
188	CN392116	456388		
189	CN392116	456394		
190	CN392116	456396		
191	CN392116	456435		
192	CN392116	456437		
193	CN392116	456443		
194	CN392116	456445		
195	CN392116	456451		
196	CN392116	456453		
197	CN392116	456459		
198	CN392116	456461		
199	CN392116	456467		
200	CN392116	456469		

Then select the data to be pasted, copy it to the clipboard, and open up the access database to the Activity Delete table. Once the Activity Delete table is opened, users will need to select both the BEACH ID column and the ACTIVITY ID column of the table before trying to paste the existing data:

ID	FK_BEACH_ID	ACTIVITY_CODE_NUMBER	Click to Add
(New)		0	

When the columns are selected, choose paste (Control-v) and accept the prompt to paste “x” amount of records and then follow the usual xml export process to completion.