

PB91208199



## NOAA Technical Memorandum NMFS-F/NEC-82

This TM series is used for documentation and timely communication of preliminary results, interim reports, or special purpose information, and has not received complete formal review, editorial control, or detailed editing.

# Response of the Habitat and Biota of the Inner New York Bight to Abatement of Sewage Sludge Dumping Third Annual Progress Report -- 1989

Anne L. Studholme<sup>1</sup>, Merton C. Ingham<sup>2</sup>, and Anthony Pacheco<sup>1</sup>, Editors

<sup>1</sup>Sandy Hook Lab., National Marine Fisheries Serv., Highlands, NJ 07732

<sup>2</sup>Narragansett Lab., National Marine Fisheries Serv., Narragansett, RI 02882

### U. S. DEPARTMENT OF COMMERCE

Robert A. Mosbacher, Secretary

National Oceanic and Atmospheric Administration

John A. Knauss, Administrator

National Marine Fisheries Service

William W. Fox, Jr., Assistant Administrator for Fisheries

Northeast Fisheries Center

Woods Hole, Massachusetts

February 1991

REPRODUCED BY:  
U.S. Department of Commerce  
National Technical Information Service  
Springfield, Virginia 22161

**NTIS**



## TABLE OF CONTENTS

Acknowledgement .....	iv
12-Mile Dumpsite Study Participants .....	iv
Executive Summary .....	v
Introduction .....	1
Background .....	1
Development of the Study .....	2
Sampling Strategy .....	3
Results and Discussion .....	3
Physical Oceanography.....	4
<i>M.C. Ingham, Principal Investigator</i>	
Circulation: Current Meter Observations .....	4
<i>J. Manning</i>	
Hydrography: Temperature/Salinity Profiles .....	7
<i>D. Mountain</i>	
Sediment Resuspension .....	9
<i>W. Davis, Principal Investigator</i>	
Sediment Erosion Studies .....	10
<i>W. Davis</i>	
Microbial Sludge Indicators .....	12
<i>W. Davis and W. Watkins</i>	
Sediment Transport Model Development .....	12
<i>W. Davis</i>	
Sediment Transport .....	15
<i>R. Bopp, Principal Investigator</i>	
Water and Sediment Chemistry .....	18
<i>A. Draxler, Principal Investigator</i>	
Sediment Biogeochemistry .....	18
<i>A. Draxler, L. Arlen, T. Finneran, and R. Bruno</i>	
Sediment Trace Metals .....	22
<i>V. Zdanowicz, S. Leftwich, T. Finneran, and E. Leimburg</i>	
Sediment Metabolism .....	26
<i>W. Phoel, Principal Investigator</i>	
Seabed Oxygen Consumption .....	26
<i>W. Phoel, K. Sharack, A. Fanning, and S. Fromm</i>	
Near-Bottom Water Chemistry .....	30
<i>W. Phoel, B. May, R. Waldhauer, S. Fromm, and C. Zetlin</i>	
Total Plankton Respiration.....	31
<i>W. Phoel, B. May, and P. Fournier</i>	
Benthic Macrofauna .....	32
<i>R. Reid, Principal Investigator, S.A. Fromm, D. Jeffress, J. Vitaliano, A. Frame, and D. Radosh</i>	
Fish and Megainvertebrates .....	33
<i>S. Wilk, Principal Investigator</i>	
Species Composition, Distribution, and Abundance .....	33
<i>S. Wilk, A. Pacheco, R. Pikanowski, D. McMillan, L. Stehlik, and B. Phelan</i>	
Winter Flounder and American Lobster Pathology .....	48
<i>A. Pacheco and J. Rugg</i>	
Migrations of Winter Flounder .....	49
<i>B. Phelan</i>	
Contaminants in Biota: Trace Organic Compounds in Winter Flounder and American Lobster ....	53
<i>A. Draxler, Principal Investigator, and A. Deshpande</i>	
References Cited .....	53
Appendix: Publications and Presentations Resulting from the 12-Mile Dumpsite Study .....	56

## ACKNOWLEDGEMENT

Appreciation for preparation of this report is owed to all the contributors, but special thanks are due to C. Noonan for patiently and expertly typing the numerous drafts.

### 12-MILE DUMPSITE STUDY PARTICIPANTS

#### NOAA/ NATIONAL MARINE FISHERIES SERVICE

##### Northeast Fisheries Center

###### Environmental Processes Division

R. Murchelano, Chief

###### Physical Oceanography Branch

M. Ingham, Chief

###### Fishery Oceanography Investigation

D. Mountain, Chief

J. Manning

###### Chemical Processes Branch

J. O'Reilly, Chief

###### Environmental Chemistry Investigation

A. Draxler, Chief

V. Zdanowicz

A. Deshpande

R. Waldhauer

P. Fournier

T. Finneran

S. Leftwich

L. Arlen

M. Yin

E. Leimburg

###### Coastal Dynamics Investigation

W. Phoel, Chief

S. Fromm

K. Sharack

B. May

A. Fanning

C. Zetlin

R/V *Kyma*

F. Farwell, Master

S. Kingsley

###### Environmental Assessment Branch

A. Studholme, Chief

###### Environmental Analysis Investigation

S. Wilk, Chief

A. Pacheco

F. Steimle

R. Pikanowski

B. Phelan

L. Stehlik

D. McMillan

J. Rugg

###### Benthos Investigation

R. Reid, Chief

A. Frame

C. MacKenzie

D. Radosh

S. A. Fromm

D. Jeffress

J. Vitaliano

##### Southeast Fisheries Science Center

###### Beaufort Laboratory

R. Ferguson

##### U.S. ENVIRONMENTAL PROTECTION AGENCY

###### Environmental Research Laboratory, Narragansett, RI

W. Davis

###### Region II, Edison, NJ

I. Katz

##### U.S. FOOD & DRUG ADMINISTRATION, Davisville, RI

W. Watkins

J. Gaines

##### NEW JERSEY DEPARTMENT OF ENVIRONMENTAL PROTECTION

###### Office of Science and Research

R. Tucker, Director

F. Moser

P. Hauge

##### LAMONT-DOHERTY GEOLOGICAL OBSERVATORY

R. Bopp

## EXECUTIVE SUMMARY

In 1986, the Northeast Fisheries Center initiated a study to document changes in living marine resources and their habitats during and following cessation of sewage sludge dumping at the 12-mile dumpsite in the New York Bight (NYB). This summary highlights findings from the last 18 months of the field work (1988-89), focusing on changes at three intensively sampled stations: NY6 - heavily degraded, R2 - enriched, and NY 11 - a reference area assumed to be the least influenced by sludge dumping.

1. Current meters, deployed 1 m above the bottom in the NYB Apex from May 1987 through June 1989, indicated that currents at subtidal frequencies are highly coherent with wind, especially at sites within the Hudson Shelf Valley (HSV). During the summer, the most intense bottom flow events (36 cm/s maximum) were in a southward (down-valley) direction driven by occasional episodes of eastward winds. During the winter, the persistent westward winds often became strong enough to sustain bottom flow in a northward (up-valley) direction (54 cm/s maximum).
2. Repeated hydrographic surveys indicated an exchange of bottom water in the dumpsite area in a one-week period, associated most likely with flow events up and down the HSV.
3. Erodibility and sludge-marker studies along the HSV indicated short-term storage of sludge in the Christiaensen Basin followed by resuspension events probably coinciding with wind-driven currents. An exponential down-valley decline in the erodibility and sludge markers (chemical contaminants and *Clostridium* spores) was demonstrated, but station depth and HSV width governed deposition and subsequent resuspension potential. A predictable relationship between grain size and erodibility was demonstrated, permitting development of erosion models based on shear, grain size, and porosity values.
4. Measurement of fallout (Cesium-137) and natural (Beryllium-7) radionuclides in sediment cores indicated that the highest rates of net accumulation of fine-grained particles (a few centimeters per year) in the study area occur along the axis of the HSV up to several kilometers down valley from the dredge spoil and former sewage sludge disposal sites. This suggests resuspension of disposed material and down-valley transport.

The dominance of DDT over DDD in surface particulate matter samples indicates that resuspension and Hudson-Raritan discharge were only minor sources of these compounds to the surface waters. Based on analysis of samples from the shelf break, it is conjectured that the DDT contamination of surface waters in the vicinity of the dumpsites is dominated by regional

inputs derived from fine coastal aerosol transport during spraying of DDT prior to the domestic ban in 1972. The dominance of DDD over DDT in the near-bottom, suspended-particle sample is evidence of resuspension.

The high concentration of 2,3,7,8-TCDD (dioxin) found in sediment samples between the sludge and dredge dumpsites was probably derived from the disposal of material dredged from the lower Passaic River and Newark Bay.

5. Consumption of oxygen by the seabed is used as a measure of benthic community metabolism to understand energy flow and carbon cycling at the sediment-water interface in aquatic ecosystems. Stations not under the influence of sludge dumping maintained seabed oxygen consumption (SOC) rates of about 15 ml O<sub>2</sub>·m<sup>-2</sup>·h<sup>-1</sup>, and these rates did not change with the cessation of dumping. The stations under the influence of dumping maintained very high rates of SOC, especially during summer months. As dumping was phased out, the SOC rates at these stations declined to the "NYB Apex background levels" of the stations not under the influence of dumping.
6. In 1989, dissolved oxygen (DO) concentrations in water near the seabed reached 2.5 mg/l (77 μM), the lowest value since the beginning of sludge volume reductions in 1986. Dissolved oxygen minima at NY6 had not been below about 4 mg/l (125 μM) during 1986-88; however, before reductions, values below 0.5 mg/l (15 μM) were observed in summers of 1983-85. The 1989 minimum is within the range predicted for this study and probably reflects a general lowering of DO levels throughout the Apex due to water-column processes which are unrelated to sludge dumping.
7. Biologically labile carbon concentrations in surface sediments in 1989 at NY6 and R2 were the lowest observed during the study. Sediment labile carbon content decreased from about 165 μmole/cm<sup>3</sup> in 1984-87 to about 55 μmole/cm<sup>3</sup> in 1989. This is consistent with predictions from a model of sediment biogeochemistry. Concentrations at NY6 continue to be higher than those at NY11 and R2. However, the remaining difference between NY11 and R2 appears to be largely the result of differential input of phytoplankton carbon.
8. Redox potential in surface sediments at NY6 and R2 has generally increased since 1986 when sludge input was reduced to 30 percent of precessation dumping. The amplitude of seasonal cycles has also diminished. This trend continued in 1989, with the observation of the highest values during the study and a convergence in values among the three areas. These trends also followed predictions based on a model of sediment biochemistry.
9. Acid-soluble sulfide concentrations in surface sediments at NY6 and R2 were lower in 1989 than in

previous years, continuing the decline first evident in 1988.

10. Metal contamination of surface sediments did not change appreciably at NY11 or R2 during the phaseout and for a year following cessation of dumping (July 1986 - December 1988). Sediment contamination at NY6 was severe throughout the phaseout, but within a month of complete cessation, significant reductions occurred in surface-sediment metal levels.
11. Preliminary analyses of data on bottom-living invertebrates from the three replicate stations during the summers of 1986-89 indicate that the numbers of crustacean, molluscan, and total species have increased. There were greater increases at those stations presumably influenced by sludge (NY6 and R2) than in the reference area (NY11); this may be an indication of the recovery of the altered areas. The pollution-indicator polychaete, *Capitella* sp., which had usually been very abundant while dumping was ongoing, was scarce in the summers of 1988 and 1989. Amphipod crustaceans, considered more pollution sensitive, were abundant at NY6 in June 1989 (18 months after cessation), but were rare again later in the summer.
12. Little skate and Atlantic rock crab ranked first in biomass of demersal fish and invertebrate megafauna, respectively, for all years at all replicate stations. Little skate made up to 92 percent of the summer demersal fish biomass. Winter flounder ranked second, and in the last year of study constituted about a quarter of the demersal fish biomass at R2 and NY6 from October to January. Increases in fish biomass during the post-dumping surveys were due primarily to spiny dogfish, probably a reflection of a general offshore increase in numbers of elasmobranchs rather than to any changes in dumping. In part, due to the transient nature of the finfish species and their seasonal occurrence, it appears that cessation of dumping has not had any measurable effect on finfish over the short-term. Dominance of elasmobranchs has tended to mask any effects on teleosts; species analyses remain to be tested statistically.
13. From gross pathology observations of winter flounder, there were apparent reductions in the incidence of finrot, cysts, *Glugea*, and lymphocystis at all three replicate stations after 1986-87. No changes in the incidence of somatic anomalies, bentfin, or ambicoloration were detected. In the post-dumping period, a chitinoclasia incidence of about 20 percent occurred in American lobster; five percent were severe infections, the rest were lighter infections.
14. Analyses for organic contaminants in hepatic tissues of winter flounder and American lobster collected from the vicinity of NY6 during and after the cessation of dumping revealed two statistically significant results. Within each sampling period: (1) concentrations of polychlorinated biphenyls (PCBs) in both flounder and lobster from nearer NY6 were higher than in those animals collected from the reference area; and (2) lobster values were higher than those for flounder.
15. Over 7,000 winter flounder were tagged during the study. Some 3,000 were released in and around the dumpsite, the remainder in Sandy Hook and Raritan Bays. About three percent were recovered, a few from as far as Nantucket Shoals. Results suggest the river systems associated with Sandy Hook Bay support a population that returns yearly during the spawning season. There was some indication that intermixing takes place among winter flounder populations in New Jersey, the 12-mile dumpsite, and Long Island, New York, indicating that these populations may be less discrete than described previously.

## INTRODUCTION

In July 1986, the Environmental Processes Division (EPD) of the Northeast Fisheries Center (NEFC), National Marine Fisheries Service (NMFS), National Oceanic and Atmospheric Administration (NOAA), proposed and initiated a study to document changes in living marine resources and their habitats during and following cessation of sewage sludge dumping at the 12-mile dumpsite in the New York Bight (NYB) (Environmental Processes Division 1988). The current report summarizes the preliminary findings from the second half of the field survey (January 1988 through September 1989), during which no sludge was dumped at the site.

The following sections within the "Introduction" are excerpted from the Second Annual Report (Environmental Processes Division 1989) to serve as a frame of reference for current program results.

## BACKGROUND

Since 1924, sewage sludge from some 200 sewage treatment plants in the New York Metropolitan Area was dumped at a site in the NYB approximately 12 nautical miles from Sandy Hook (Figure 1).

Although the number of municipalities using this site declined over time, the volume of sludge dumped increased as waste treatment facilities were upgraded. In 1974, approximately  $4.2 \times 10^6$  wet tons were dumped, while by 1983, the volume had almost doubled, reaching  $8.3 \times 10^6$  wet tons (Figure 2; Santoro 1987). The volumes dumped during the early 1980s were larger than at any other sludge dumpsite in the world (Norton and Champ 1989).

Although the dumpsite is in a somewhat dispersive area with little evidence of sludge accumulation, in 1970 the U.S. Food and Drug Administration (FDA) closed an area within a radius of 11 km of the 12-mile dumpsite to commercial shellfish harvesting after finding elevated levels of coliform bacteria in sediment and shellfish (Figure 1; Verber 1976). Additionally, indications that sewage sludge dumped at the site was the major source of sewage-related contaminants in the adjacent Christiaensen Basin and Hudson Shelf Valley (HSV) led the U.S. Environmental Protection Agency (EPA) to deny further applications for dumping after December 1981 (Erdheim 1985; Santoro 1987).

Following unsuccessful litigation by New York and New Jersey to continue use of the 12-mile dumpsite, in April 1985, EPA essentially closed the site by denying requests for its redesignation (U.S. Environmental Protection Agency 1985) and selecting Deepwater Dumpsite 106 as the alternate location. EPA adopted a schedule to phase out use of the 12-mile dumpsite beginning in early 1986, and all dumping was discontinued by the end of 1987 (Figure 3; Santoro 1987).

Since little is known about the recovery of dumpsites, discontinuation of the use of this site has provided marine scientists an opportunity to determine the response of this

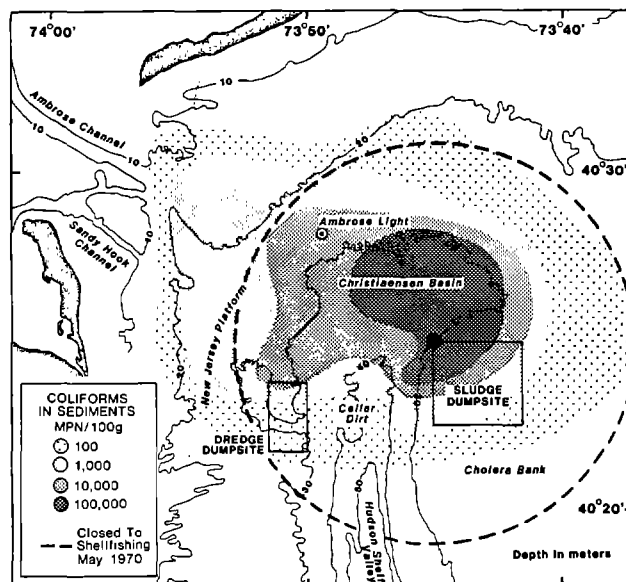

Figure 1. Location of the 12-mile dumpsite, dredge materials dumpsite, and area closed to commercial shellfishing in the NYB (after Verber 1976).

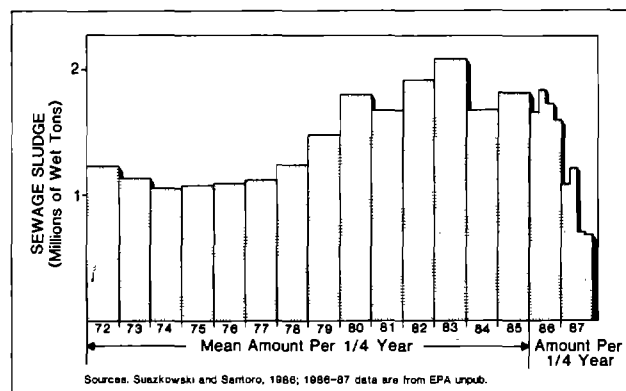

Figure 2. Estimated volumes of sewage sludge dumped in the NYB [annual means for 1972-85; quarterly totals for 1986-87 (after Swanson *et al.* 1985; Santoro 1987)].

area to the removal of a major waste loading. Beginning in the summer of 1986, EPD developed and initiated a study in which biological, chemical, and physical oceanographic approaches are integrated to document changes in living marine resources and their habitats (Environmental Processes Division 1988).

Results will document the response and extent of recovery of the site and its environs, which will provide information useful for:

1. Defining when and if the area can be reopened for shellfishing;
2. Assessing the changes in distribution and abundance of resource species in the vicinity of the site;
3. Determining probable sediment resuspension and transport of associated sludge components out of the Christiaensen Basin;

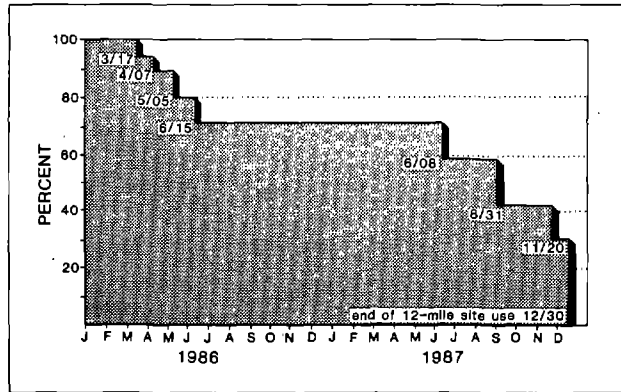

Figure 3. Phaseout schedule for sewage sludge dumping at the 12-mile dumpsite (after Santoro, pers. comm.<sup>1</sup>).

4. Quantifying the response of the area to the changes in pollutant loading in a way which will permit the use of this information for predicting response rates for other proposed temporary dumpsites; and
5. Evaluating the management decision made by EPA to divert the dumping of sewage sludge to Deepwater Dumpsite 106.

### DEVELOPMENT OF THE STUDY

Several factors had to be considered in the development of a practical and efficient study. The first relates to the long history of environmental degradation in the area which precludes the use of predumping conditions as a baseline. Data from the first year's sampling, during which the volume of sludge dumped was reduced by 30 percent (Figure 3; Santoro 1987), serve as a "baseline" and assessment of changes will be based on comparisons of this baseline with later sampling. Other information collected from as far back as the late 1960s does exist as well for several of the variables under study and will also be used to assess changes.

A second difficulty pertains to the separation of pollutant effects from various sources. It is estimated that on average, 16 percent of the contaminant load in the NYB Apex is traceable to sewage sludge, with most contributed by the Hudson-Raritan plume (27 percent), and to dredged material which is dumped on the western edge of the Christiaensen Basin (Figure 1; Stanford and Young 1988). Nevertheless, by conducting synoptic surveys and initiating the study before a significant curtailment of dumping occurred, evaluation of the effects of abatement should be possible. Possible changes may include the following:

1. Dispersion of sewage sludge and cleansing of the Christiaensen Basin will be influenced by local windfield conditions and resultant changes in bottom-water circulation in the upper HSV.

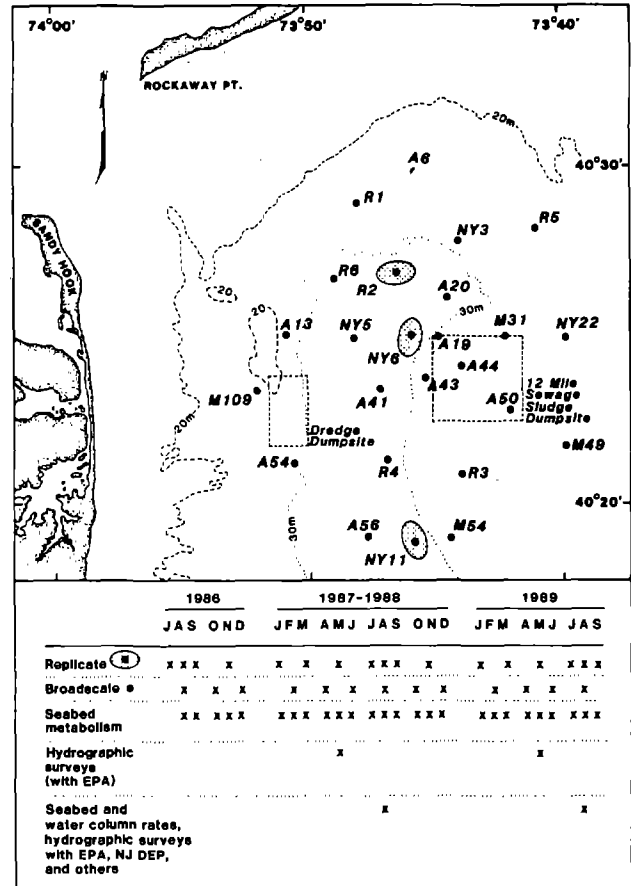

Figure 4. Replicate, broadscale, and seabed metabolism stations (also Figure 44) and survey schedule of the 12-mile dumpsite study.

2. Changes in water and sediment chemistry should occur, including reduction of sediment trace metals in sludge depositional areas. However, concentrations of certain organic compounds (e.g., PCBs) may be more stable. Seabed oxygen consumption and nutrient regeneration rates should be reduced as benthic community metabolism and organic loading decrease.
3. Microbial concentrations should be reduced and bacteria indicative of sewage contamination should decrease to acceptable levels and permit shellfish beds to be reopened for harvesting.
4. In areas which are presently heavily polluted, numbers of benthic macrofaunal species should increase; populations of *Capitella capitata*, an opportunistic polychaete found in disturbed areas, should decrease.
5. While dumping continues, abundance, distribution, and species composition of finfish and invertebrate communities should differ among areas which are bathymetrically similar, but represent a gradient of sludge influence. Following cessation of dumping and expected shifts in sediment contaminants and benthic forage species, these spatial differences should be reduced.

<sup>1</sup> Personal communication from E. Santoro, EPA, New York, NY 10278.)



Table 1. Variables measured during the 12-mile dumpsite study

Habitat		Biota
Water	Sediment	
Bottom water	Chemistry	Resource species
Dissolved oxygen (R,B) <sup>1</sup>	Heavy metals (R,B)	Distribution/abundance (R,B)
Temperature (R,B)	Organic contaminants (R,B)	Diet (R)
Salinity (R,B)	Sulfide, pH profiles (R)	Winter flounder
pH (R,B)	Redox potential (R,B)	Red hake
Sulfide (R,B)	Sediment BOD <sup>2</sup> (R)	Silver hake
Nutrients (R,B)	Chlorophyll pigments (R,B)	American lobster
Turbidity (R,B)	Total organic carbon (R,B)	Gross pathology (R)
Water column	Characteristics	Winter flounder
Temperature	Grain size (R,B)	American lobster
Salinity (CTD)	Erodibility	Tissue organics (R)
Oxygen	Rates	Winter flounder
Current measurements (moored meters)	Seabed oxygen consumption	American lobster
	Sedimentation	Migration (tagging) (B)
		Winter flounder
		American lobster
		Benthos
		Macrofauna abundance/diversity (R,B)
		Meiofauna abundance/diversity (R,B)
		Bacteria - sediments
		Fecal & total coliform (R)
		<i>C. perfringens</i> (R)
		<i>Vibrio</i> spp. (R)
		Total count (R)
		Bacteria - shellfish

<sup>1</sup>R = replicate survey; B = broadscale survey.

<sup>2</sup>BOD = biological oxygen demand.

## SAMPLING STRATEGY

The study is developed around two complementary sampling series: (1) a replicate survey; and (2) a broadscale survey, each conducted in alternate months, except for August when both are conducted to monitor rapid changes likely to occur at that time of year (Figure 4; Environmental Processes Division 1988).

In the replicate survey, repeated measurements (n=8) for most variables (Table 1) are made at three stations (Figure 4) which are similar bathymetrically and for which historical data exist, but which represent different levels of sewage sludge accumulation and effects. The most heavily degraded, NY6, is located approximately 1.6 km down-slope from the corner of the dumpsite where the heaviest dumping has occurred; it is thought to have the greatest accumulation of sludge constituents. A second station, R2, is about 3.4 km north of the dumpsite on the north edge of the Christiaensen Basin. Benthic communities in this area are presumably "enriched" with a high biomass of tolerant, though not necessarily pollutant-indicator, species. The third replicate station, NY11, is nearly 10 km south-southwest of the dumpsite center on the eastern shoulder of

the HSV. It is considered to be the least polluted of the three sites, with the lowest concentrations of sediment contaminants and with benthic macrofauna typical of upper shelf valley sediments.

The broadscale survey consists of single, nonreplicated bimonthly measurements made every other month at 25 stations covering most of the inner NYB and including all major habitat types. Station selection was based on considerations of bathymetry, known distribution of contaminants, patterns of environmental variables, dumping and dispersion patterns of sewage sludge, and existing historical benthic data. To add to our data base for interpreting the effects of sludge abatement, we collaborate with several agency and university researchers.

## RESULTS AND DISCUSSION

Results presented in this year's progress report will focus on findings from the three replicate stations; *i.e.*, the "heavily degraded" NY6, "enriched" R2, and the "reference" station, NY11, concentrating on the post-dumping period from January 1988 through September 1989.

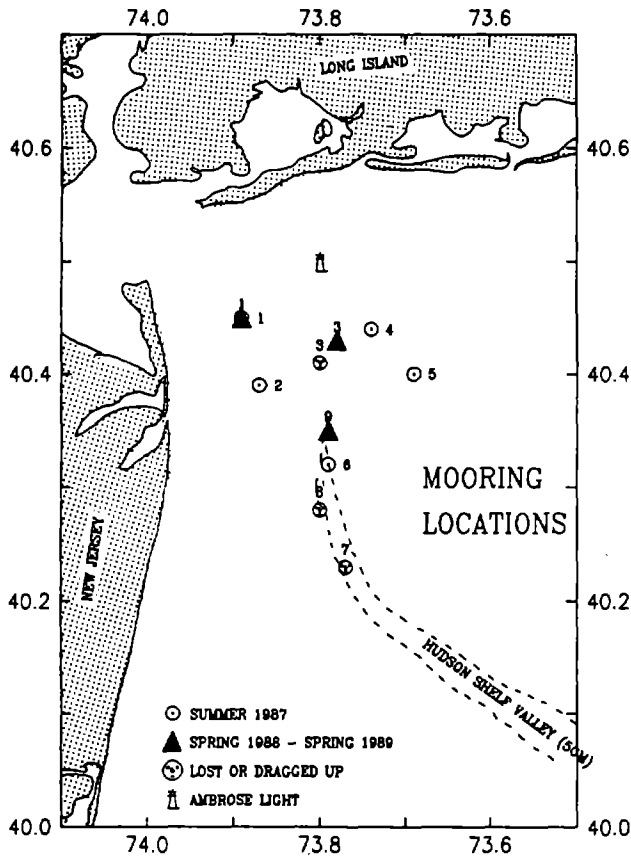

Figure 5. Current meter mooring locations in the NYB, including all deployment periods.

## PHYSICAL OCEANOGRAPHY

*M.C. Ingham, Principal Investigator*

Oceanographic and meteorological conditions in the NYB are expected to be significant factors in the degree to which, and rate at which, changes may occur at the dump-site and surrounding areas. As hypothesized at the beginning of the study (Environmental Processes Division 1988), "The cleansing of sewage sludge from the Christiaensen Basin will be accomplished by episodic down-valley transport of sludge which can be related to windfield conditions." The physical oceanographic studies of the NYB are designed to address this hypothesis.

### Circulation: Current Meter Observations

*J. Manning*

Current meters were deployed 1 m above the bottom at seven locations in the NYB Apex (Figure 5) during various periods from May 1987 through June 1989 (Figure 6). The meters (vector-averaging current meters) sampled current speed and direction, as well as temperature, at 7.5-minute

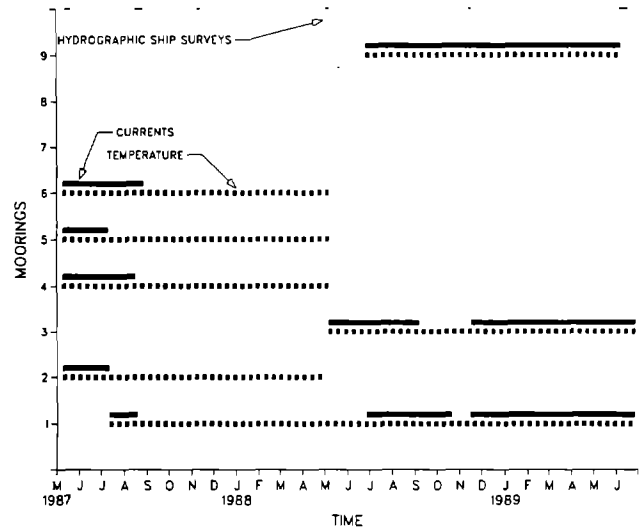

Figure 6. Data coverage over time for all mooring sites.

intervals. Due to fish-trawling activity and biofouling, some records contained as little as one month of good data. Taken together, however, they adequately sampled both summer and winter conditions.

Hourly average wind velocities, collected at Ambrose Light Tower, were obtained from the National Climatic Data Center (1987 and 1988) and the National Oceanographic Data Center (1989, on order). Daily average Hudson River discharge records, collected at Green Island, New York, were obtained from the U.S. Geological Survey (USGS). Wave height records, collected at NOAA buoys 44002 and 44004, were obtained from the National Climatic Data Center.

Basic statistics for the entire deployment period are listed in Table 2. The mean, standard deviation, and extremes at each site are listed for both the eastward/westward and northward/southward velocities. The maximum flow is shown to be an order of magnitude or more greater than the mean and, sometimes, in the opposite direction. At mooring #6, for example, the mean flow was to the north at about 1 cm/s, but the maximum flow was recorded to the south at 36 cm/s.

Distributions of current speed and direction are plotted for most deployments in Figure 7. The frequency of vector speeds (the right-hand panels) peaks at a tidally-driven 10 cm/s and drops off to a small percentage at >20 cm/s. In terms of sediment resuspension and transport, it is this small percentage of >20 cm/s flow that is potentially important. Channelized flow, particularly for the sites within the HSV, is depicted by peaks in the directionality at about 180° and 360° which represent down-valley and up-valley flow, respectively.

Since we are most interested in the low-frequency storm events that may resuspend and transport bottom sediment, current meter records were filtered to remove the diurnal and semidiurnal tides. In order to demonstrate the

Table 2. Basic current meter statistics

Mooring #	Depth (m)	Location		Period of Usable Data		Current Velocity (cm/s)							
		Lat. (°)	Long. (°)	Start Date	Stop Date	Eastward				Northward			
						Stand. Mean	Dev.	Max.	Min.	Stand. Mean	Dev.	Max.	Min.
1A	20	40.46	73.89	07/11/87-08/18/87	0.8	5.	29.	-18.	-0.3	6.	38.	-24.	
1B				06/27/88-10/10/88	-0.3	9.	26.	-25.	-1.2	12.	32.	-24.	
1C				11/16/88-06/26/89	-1.0	7.	28.	-28.	1.2	11.	31.	-33.	
2	22	40.39	73.87	05/09/87-07/08/87	-2.0	7.	18.	-21.	-2.2	9.	21.	-27.	
3A	36	40.43	73.80	05/06/88-08/31/88	-1.0	5.	15.	-17.	0.2	8.	23.	-18.	
3B				11/16/88-06/26/89	-0.7	6.	16.	-27.	5.1	10.	45.	-23.	
4	27	40.44	73.74	05/09/87-08/16/87	0.4	7.	19.	-23.	-0.4	6.	18.	-22.	
5	26	40.40	73.74	05/09/87-07/09/87	-1.0	6.	21.	-17.	-2.6	8.	18.	-27.	
6	53	40.32	73.79	05/09/87-08/27/87	-0.1	6.	10.	-10.	1.1	9.	30.	-36.	
9	44	40.35	73.79	06/26/88-06/07/89	-0.7	4.	13.	-30.	4.1	13.	54.	-50.	

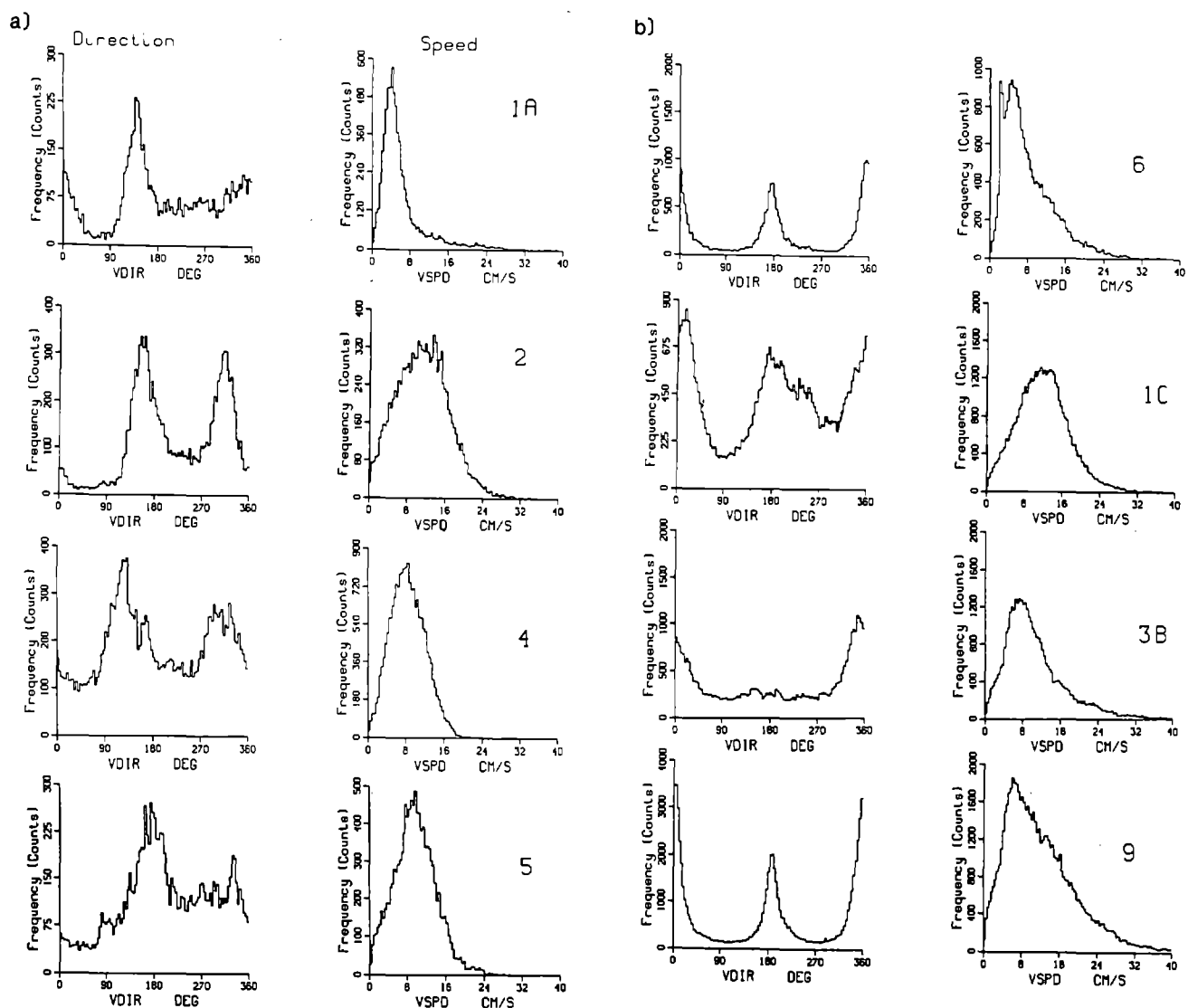

Figure 7. Distribution of direction and vector speed measured at: (a) sites 1, 2, 4, and 5; and (b) sites 6, 1C, 3B, and 9. The code "1A, 1C, and 3B" refers to the particular deployment period as defined in Table 2.

effect of this filter, the raw hourly data, the filtered data, and difference of the two are plotted in Figure 8 for a segment of along-valley flow at mooring #6. The filter has the effect of smoothing over a 33-hour period, but successfully retains the low-frequency events. The spectra before and after filtering are plotted in Figure 9 for the entire mooring #6 record. The peak at tidal frequency is eliminated successfully by the filter. Subsequent analysis of current vs. wind refers to the filtered data set.

Time series of the low-pass-filtered, bottom current observations for the first and second deployment periods are plotted in Figures 10 and 11, respectively. Westward[+]/eastward[-] wind, the dominant forcing function, is plotted in the top panels. For the summer of 1987 (Figure 10), the channelized flow of the deeper HSV site is depicted by the north/south (along-valley) orientation of the lowermost stick plot. Large events, for example, on May 21, 1987, indicating strong, down-valley flow, are apparent at the other sites (2, 4, and 5), but in a less intense, multidirectional sense. For May 1988 through June 1989 (Figure 11), the time axis is compressed, but the current magnitudes are drawn at the same scale so that the more intense flows, particularly during the winter period, are readily apparent. The largest events during this second-year deployment are directed up-valley in the winter and appear to persist for several days. Examples of this persistent up-valley flow can be seen at all three moorings around December 1, 1988, and February 8, 1989.

A transfer function (H) was calculated to model the subtidal flow (V) as a linear response to an input forcing function (X):

$$V(f) = H(f)X(f)$$

where f represents frequency. H(f) is nonzero only at frequencies for which the input (X) and the output (V) are significantly coherent. Transforming this into the time domain, this becomes

$$v(t)_p = h * x$$

where  $v_p$  is the predicted current, h is a response function (inverse Fourier transform of H), \* is a convolution, and x is input to the system. Wind velocity and river flow can be tested as inputs.

Table 3 includes the coherence, gain, and phase between the eastward/westward wind recorded at Ambrose Light Tower and the northward/southward flow at all sites for the first-year deployment only. Values are listed for low-frequency (<0.5 cycles per day) current only because higher-frequency relationships were not significant (see Figure 12, mooring #6, for example). Coherence estimates indicate that nearly 80 percent of the low-frequency current variability is explained by the wind. Gain factors range from 0.13 at mooring #1 to 0.78 at mooring #6, indicating that the wind forcing is several times more efficient at the deeper HSV site. Phase factors range from 0 to 37 degrees,

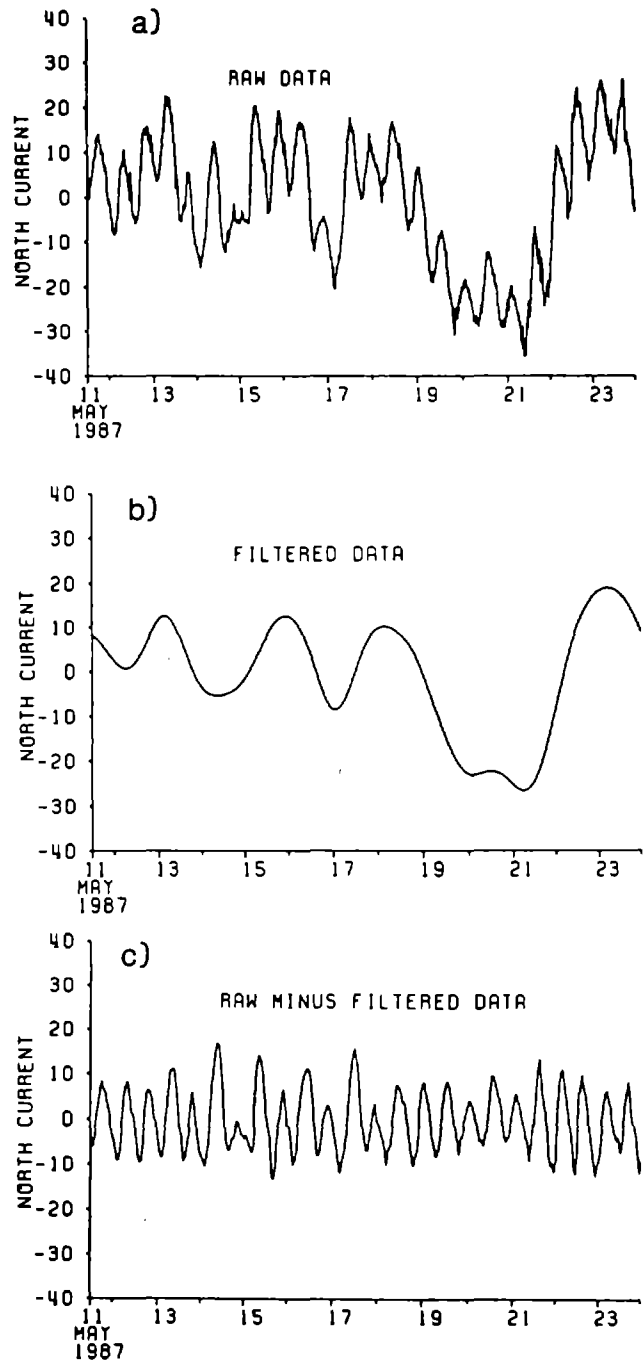

Figure 8. Demonstration of low-pass filtering operation: (a) the raw northward/southward velocity recorded at mooring #6; (b) the same data after they had been run through the PL33 filter (see text); and (c) the difference between the two, or the high-frequency oscillations (primarily tides) that have been filtered out.

indicating that there is a quick setup time ranging from 0 to 15 hours between the wind and current velocity (given a mean period of four days). Similar estimates for both higher and lower frequencies should be available as soon as the 1989 wind record is received and the longer, second-year deployment record can be analyzed. When these additional estimates are made, and if they are statistically

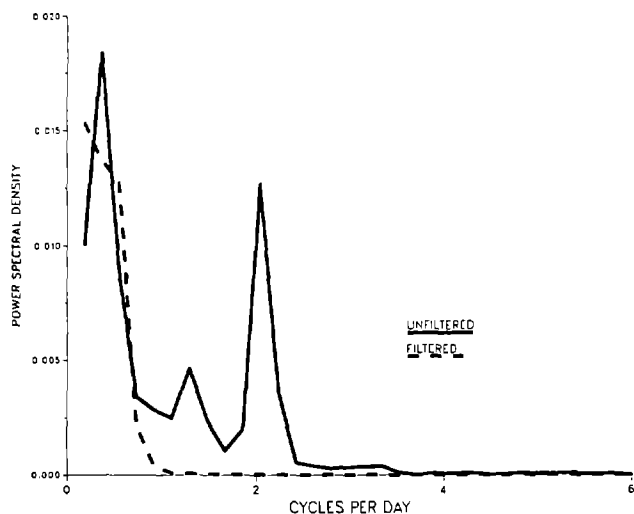

Figure 9. Demonstration of low-pass filtering operation in the frequency domain. Solid line shows the peak in power spectral density at the diurnal (one cycle per day) and semidiurnal (two cycles per day) frequencies that are eliminated from the autospectra of filtered data (dotted line).

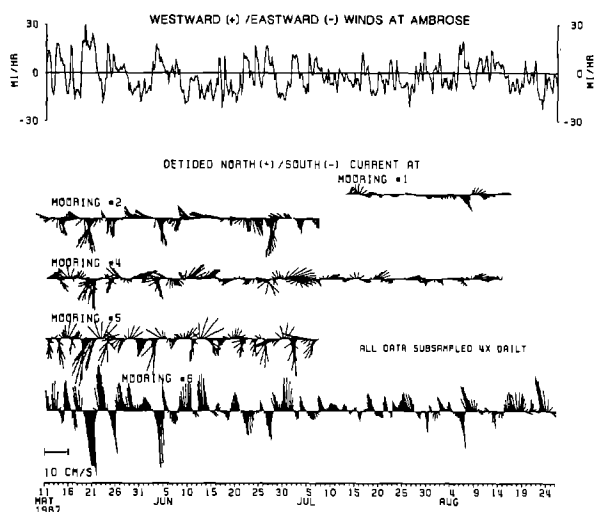

Figure 10. Current vectors for the first-year deployment (stick plots) and the simultaneous westward/eastward wind from Ambrose Light Tower (top panel), all subsampled four times daily. Period runs from May 11, 1987, to August 26, 1987.

significant, we may then calculate response functions in order to infer current speed from the wind.

Improvements might be made to the model when additional inputs are included. Simply adding a north/south component of the wind may increase the hindcasting capability. The river discharge may be an important factor in density-driven current, especially for those sites within the range of the Hudson-Raritan plume.

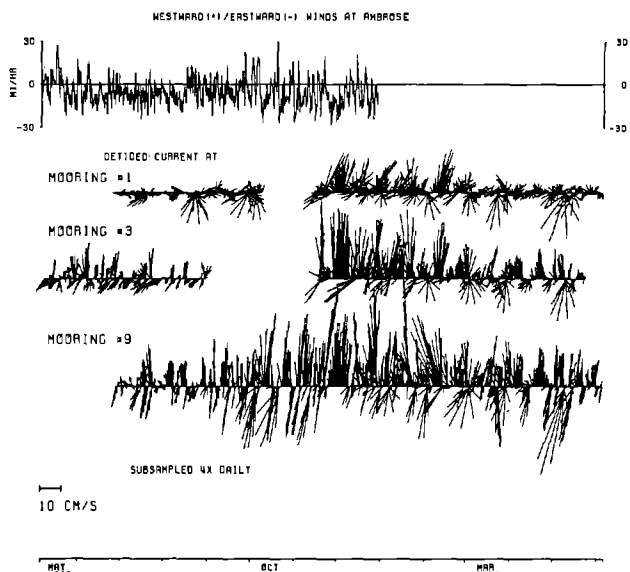

Figure 11. Current vectors for the second-year deployment (stick plots) and the simultaneous westward/eastward wind from Ambrose Light Tower (top panel), all subsampled four times daily. Period runs from May 6, 1988, to June 7, 1989.

Determining the physical forces governing bottom flow, however, is only the first step in a multiphased project to estimate sediment transport in and around the 12-mile dumpsite. The proposed analysis plan is given in Figure 13. After the first phase is complete, the unfiltered tidal velocities and estimated orbital wave velocities, both important resuspension mechanisms, need to be combined with low-frequency bottom current records in an empirical bottom stress model. Several empirical models such as that by Grant and Madsen (1979) are available and may be applied to give a first-order approximation of resuspension and transport potential. Once the results of grain size/type analyses have been completed by the NMFS's Sandy Hook Laboratory and the estimates on sediment erodibility vs. stress are available from the Particle Entrainment Simulator (PES) tests (see Davis, this report), an estimate of sediment transport over time can then be calculated.

## Hydrography: Temperature/Salinity Profiles

### D. Mountain

Temperature and salinity profiles through the water column have been made from May 1987 through September 1989. Summaries from the first and second years of the study are reported in Quarterly Reports VIII and XI<sup>2</sup>.

During the third year of the study, two oceanographic survey cruises of the inner New York Bight were conducted. The first cruise was *Delaware II* 89-04 (June 6-18, 1989), and the second was *Oregon II* 89-05 (August 11-22, 1989).

<sup>2</sup> Unpublished documents available from A. Studholme, NMFS, Highlands, NJ 07732.

Table 3. East/west wind - north/south current relationship averaged over 2-10 day cycles

Mooring Number	Coherence		Transfer Function				Observation Period (days)
	Estimate	Significance Level	Gain	Confidence Interval	Phase (°)	Confidence Interval	
1A	0.73	0.53	0.13	0.07	29.	27.	27
2	0.81	0.38	0.33	0.01	37.	14.	49
4	0.79	0.41	0.29	0.10	9.	16.	88
5	0.78	0.36	0.49	0.15	0.	14.	55
6	0.81	0.41	0.78	0.26	3.	15.	88

On each survey, hydrographic measurements were made using a SeaBird Electronics Model SBE-9 CTD (conductivity/temperature/depth) profiling instrument. The data are recorded internally in the instrument during each cast and downloaded afterwards to a computer. At most stations, a water sample was obtained at the bottom of the cast using a Niskin bottle and messenger. The salinities of these water samples were determined after the cruise, using a Guildline Model 8400 Autosal. From these values, a quality-control correction for the CTD-measured salinity was determined and applied to all of the salinity values for the cruise. The accuracies of these measurements are at least  $\pm 0.02^\circ\text{C}$  and  $\pm 0.02$  PSU (practical salinity units).

After the cruise, the data for each cast were averaged in depth intervals of one decibar (approximately 1 m). Only the down-cast data were used, unless an obvious problem existed, and then the up-cast values were used.

Horizontal contour maps of the surface and bottom temperature and salinity values were generated for each survey. A volumetric temperature and salinity (T/S) analysis also was performed on each survey to identify the changes between surveys. This analysis technique estimates the volume of water which has particular temperature and salinity properties. The T/S diagrams in this report have a minimum salinity value of 27.00 PSU and may omit a few very low salinity observations.

The first survey during the *Delaware II* 89-04 cruise occurred during June 7-10, 1989 (Figure 14). Surface and bottom temperature (Figure 15) and salinity (Figure 16) distributions are shown for this survey. Similar results for the second survey (Figure 17) are also shown (Figures 18 and 19).

The volumetric T/S distributions for the two surveys are compared in Figure 20. In the first survey, a large portion of the volume occurred in a relatively narrow temperature and salinity range and represented the cooler, saltier waters below the thermocline. The warmer and fresher water in and above the thermocline occurred over a wider range of values, but represented a relatively small volume of water. In the second survey, the volumetric distribution was more bimodal, and the low-salinity water evident in the first survey had largely disappeared.

Subtracting the second survey's volumetric distribution from that of the first survey indicates the changes in

water properties which occurred between the surveys. The result is shown in Figure 21. The open symbols represent positive volumes, *i.e.*, more volume of that T/S type in the first survey than in the second. The solid symbols represent negative volumes, *i.e.*, more volume in the second survey. The squares represent the areas of largest change, together accounting for 75 percent of the total change. The circles are areas of smaller change and together account for the remaining 25 percent of the volume change.

The water property changes shown in Figure 21 indicate that a large volume of relatively warm water with salinity of 31.0-32.0 PSU was present during the second survey and that it was not the result of any mixing of the waters present in the first survey. Instead, it must be water that entered the region between the surveys. Comparison of the original station data indicates that this water was located at the northern part of the region near Long Island and likely entered from the east. The water properties found near Long Island in the first survey were found along the New Jersey shore in the second. The implication is that there was a counterclockwise movement of water around the northern and western sides of the survey region. A comparison of the water properties observed in the HSV on the two surveys (Figure 22) indicates that little change occurred there between the surveys. An analysis of the current meter data obtained in the HSV during this period should be able to indicate if changes in the up/down-valley flow pattern contributed to the water property changes observed between the two oceanographic surveys.

A grid of stations covering the inner NYB was completed during August 12-22, 1989, on the *Oregon II* 89-04 cruise. The station locations (Figure 23), surface and bottom temperature distributions (Figure 24), and salinity distributions (Figure 25) are shown for the first survey. About one half of the stations were occupied on a second survey (Figure 26) on this cruise. Surface and bottom temperature distributions (Figure 27) and salinity distributions (Figure 28) are also presented for this partial survey. Due to the relatively low density of stations in the second survey and the fact that the surveys were immediately consecutive, a direct comparison of the two surveys (as done with the first cruise) was not made.

The highest bottom salinities (>32.5 PSU) during the first survey were observed within enclosed contours at the

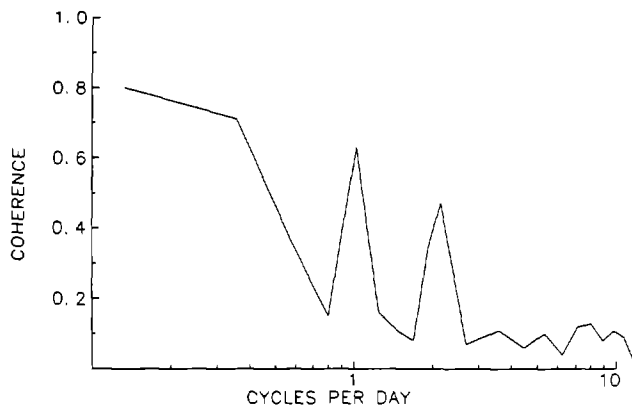

Figure 12. Coherence of the northward/southward current at mooring #6 with the eastward/westward wind at Ambrose Light Tower as a function of frequency.

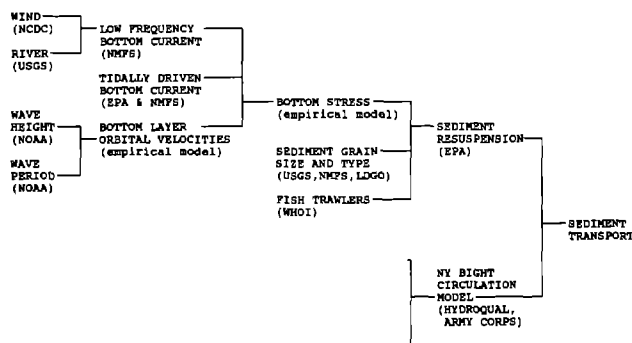

Figure 13. Work plan for preparing estimates of sediment transport.

northern end of the HSV (Figure 25b). This high-salinity water does not appear to extend eastward beyond the sampling area, and may represent a dense water parcel advected up the shelf valley from a deeper, more offshore part of the shelf. This water had largely disappeared by the second survey (Figure 28b) and may have moved down the shelf valley and out of the survey region. A more detailed analysis of the water properties and a better understanding of the up/down-valley flow events from the current meter analysis may help to clarify this event.

A volumetric T/S diagram of the first August survey is shown in Figure 29. The August sampling covered a smaller area than in June, so that the total volume in Figure 29 is less than in Figure 20. The changes in water properties between the first survey in June and the first survey in August are shown in Figure 30, using the same volumetric T/S technique and symbols as in Figure 21. Throughout the water column, the waters in August were warmer and somewhat lower in salinity than in June. Also, a larger portion of the water volume was in and above the thermocline in August.

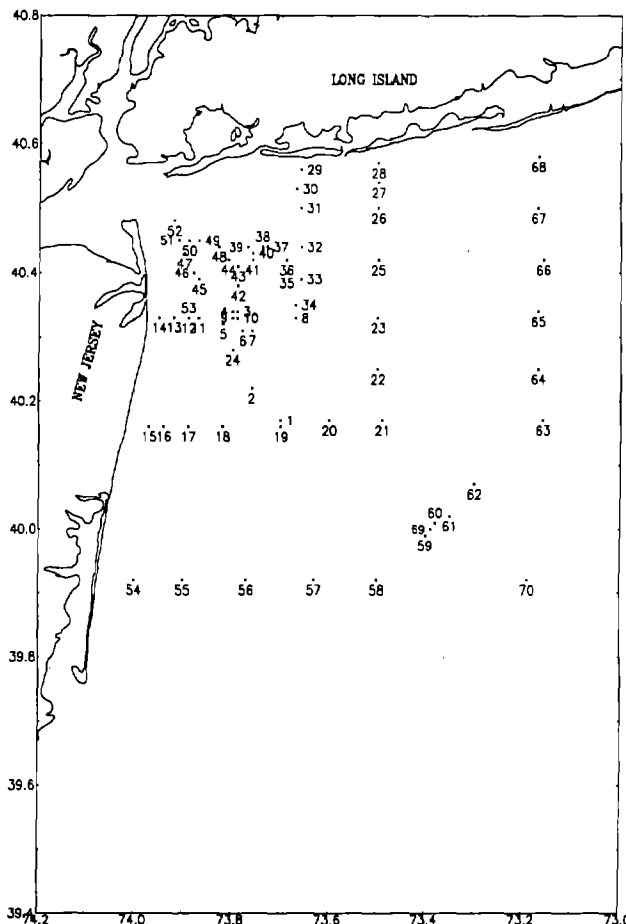

Figure 14. Station locations during the first survey of the inner NYB on cruise *Delaware II* 89-04, June 7-10, 1989.

## SEDIMENT RESUSPENSION

*W. Davis, Principal Investigator*

Scientists from the EPA's Environmental Research Laboratory in Narragansett, Rhode Island, have conducted annual cruises (1987, 1988, and 1989) to determine the fate of the sewage sludge found in the upper HSV following closure of the dumpsite in December 1987. The fate of the fine-grained material was to be assessed by determining erodibility patterns of surficial sediments (experimental resuspension with respect to shear) and related patterns in sediment sludge indicators (chemistry and microbiology of surficial sediments).

The final cruise in the study area was made June 6-18, 1989, on the *Delaware II* to survey erodibility, chemistry, and microbiology of sediments one-and-one-half years following cessation of sludge disposal on December 31, 1987. The cruise surveyed a sediment transect of the inner NYB, the HSV, and the Hudson Canyon (Figure 31).

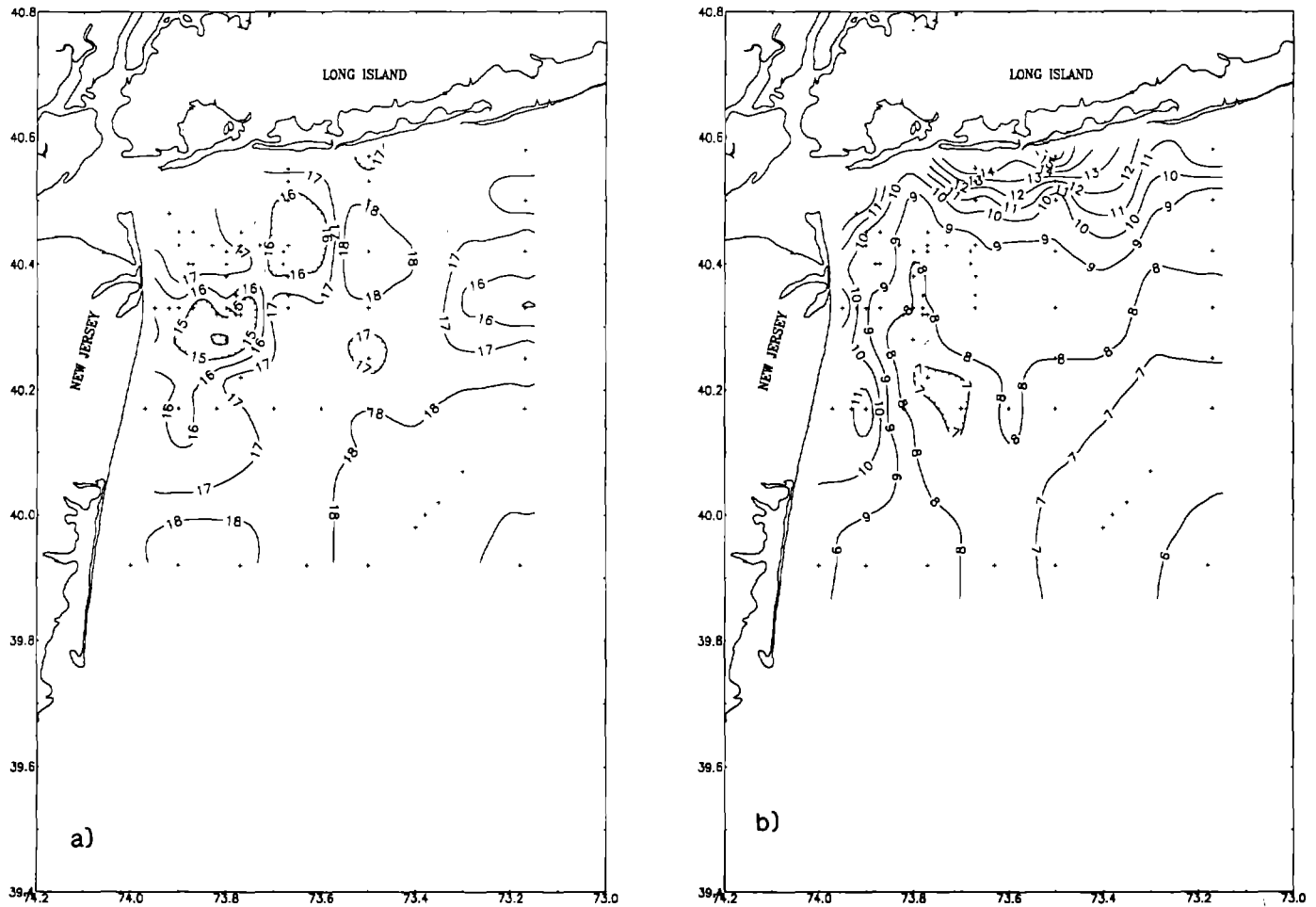

Figure 15. Surface (a) and bottom (b) temperature ( $^{\circ}\text{C}$ ) during the first survey of the inner NYB on cruise *Delaware II* 89-04, June 7-10, 1989.

Grab samples were taken for chemistry (metals, PCBs, and coprostanol), microbiology (*C. perfringens* spores), and physical erosion tests. Cores were subjected to physical stress using the PES, and resulting resuspension was quantified as resuspension rates as a function of applied shear (Lavelle and Davis 1987). All erodibility experiments were performed aboard the *Delaware II*. Sediment chemistry will be performed by the Chemistry Branch of the EPA's Environmental Research Laboratory in Narragansett, Rhode Island, and will be reported at a later time. Spore analyses were performed by Dr. William Watkins at the FDA laboratory in Quonset Point, Rhode Island.

## Sediment Erosion Studies

*W. Davis*

Deposited sewage sludge forms an anoxic, silt-only sediment of high water content. A combination of processes such as winnowing, post-storm deposition, scouring, and bed-load transport results in sediment with both re-

gional and sludge qualities. Thus, sewage-sludge-contaminated sediments possess a greater-than-expected silt fraction. The original grain size in the Christiaensen Basin in 1924 prior to sludge disposal at the 12-mile dumpsite is speculated to have been sand with a transition to sandy silt in the upper-middle HSV, and finally reversing toward sand in the lower Valley (Figure 31). The description of this transect sediment prior to closing the dumpsite in 1987 represents near-steady state that existed during sludge disposal. High variation in upper HSV-Christiaensen Basin surficial sediment indicates month-to-month patterns of sludge accumulation and sudden mass resuspension events. Cruise results in 1988 and 1989 indicate a transition to a new steady state.

Prior to and after cessation of sludge disposal, sediment-sludge conditions were partially characterized using experimental erosion studies. Site sediment was collected undisturbed and subjected to an experimentally applied shear (ranging from 2 to 5  $\text{dyn}/\text{cm}^2$ ) to simulate site resuspension energy associated with bottom currents ranging between 20 and 75  $\text{cm}/\text{s}$  or with equivalent turbulence from wave action. Resuspension values are estimates if that specific shear value occurred at the seabed.



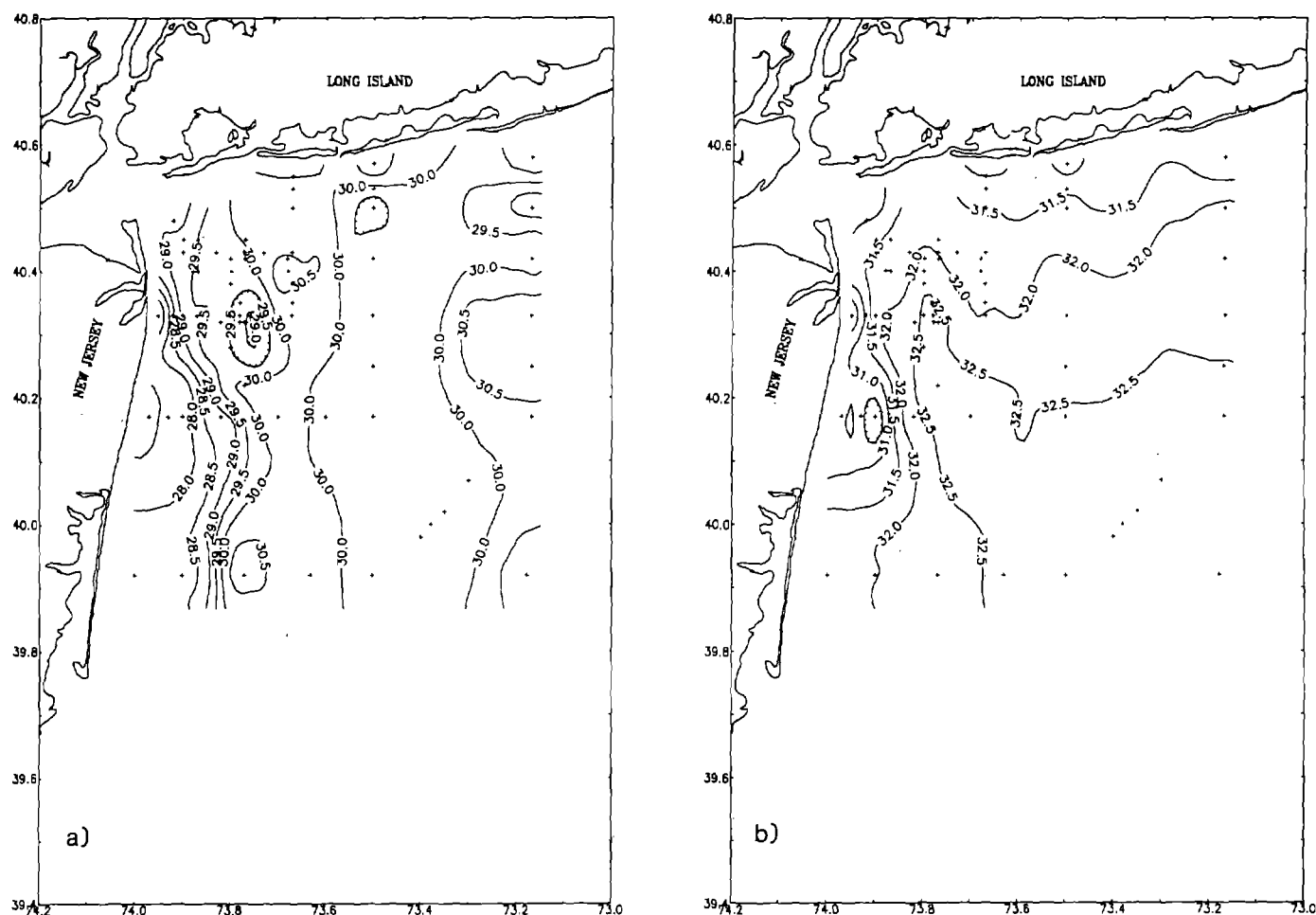

Figure 16. Surface (a) and bottom (b) salinity (PSU) during the first survey of the inner NYB on cruise *Delaware II* 89-04, June 7-10, 1989.

The final processed data for the three-year assessment of sediment erodibility along the Christiaensen Basin-HSV transect (Figure 31) are summarized in Figures 32a-f. Resuspension data for representative stations (median replicate response) along this transect are presented for 1987 (pre-cessation, Figures 32a,b) and for 1988 and 1989 (post-cessation, Figures 32c-f). Each data set is labeled with the station (e.g., AL-39; see Figure 31 for location), the cruise year (e.g., -87), and the number of the replicate experiment which exhibited the median response (e.g., -2). Each erosion experiment is expressed as resuspension [g (dry sediment)/m<sup>2</sup> (seabed)] with respect to time (up to 60 minutes) and applied shear (2, 3, 4, and 5 dyn/cm<sup>2</sup>). Thus, each curve estimates the quantity of sediment resuspended as a function of time and level of shearing (simulated environmental resuspension energy). The slope at any point on the curve is identical to the instantaneous resuspension rate (g·m<sup>-2</sup>·s<sup>-1</sup>).

Prior to cessation, NY6 was found occasionally to consist entirely of sludge (>25-cm grab depth). This condition (e.g., March 1987) was characterized by black, watery silt, covered with *Beggiotoa* spp., and was found to be highly erodible. On other occasions, NY6 was charac-

terized by a stable, anoxic, and homogeneous silty sand (e.g., September 1987). Intermediate conditions were just as likely (e.g., October 1986). The temporal trend strongly suggests that NY6 rapidly accumulates sludge during calm periods and may possibly lose that reservoir during storm events. Since cessation (December 1987), NY6 has gradually lost its anoxic silt to become an aerobic sand with a minor silt fraction (1988), and a well-sorted sand with just trace silt (1989). The early part of this "loading-unloading" trend is summarized in Figure 33.

Other stations possessing sludge-contaminated sediment are located generally along a transect bisecting the Christiaensen Basin and continuing down the axis of the HSV. The Basin stations showed the major temporal fluctuations in sediment character discussed above. After cessation, the Basin shifted to sand-silt and the upper HSV shifted to de-watered silt. The sediment character varied along the transect from a consistent sludge reservoir in the upper HSV (anoxic silt with high water content), gradually shifting to silt-clay and eventually sand-silt, and finally sand with a minor silt fraction at the base of the HSV (by AL-21). Sediment erodibility along the HSV transect (Figure 34) shows peak values (mostly sludge or other silts)

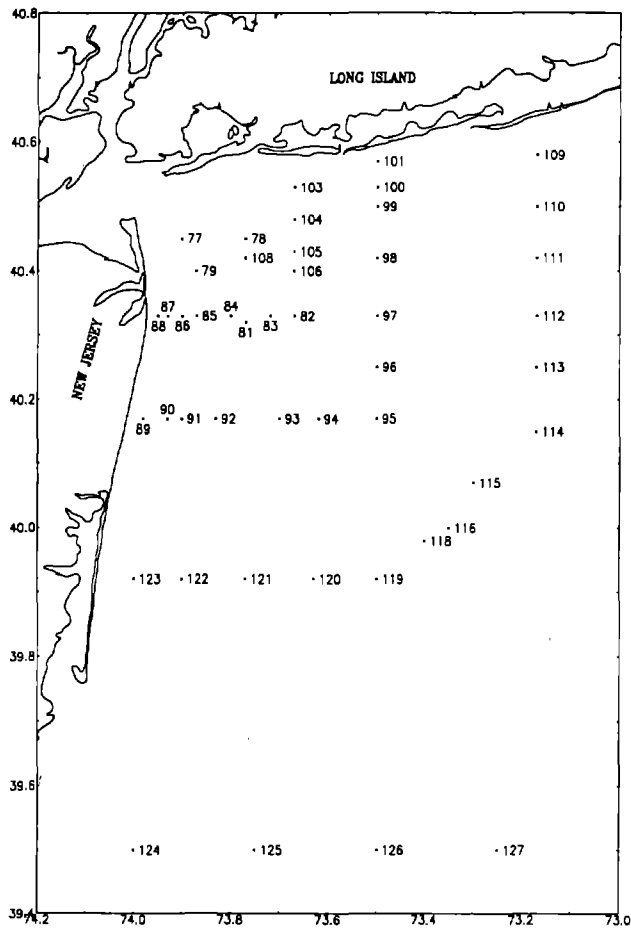

Figure 17. Station locations during the second survey of the inner NYB on cruise *Delaware II* 89-04, June 15-17, 1989.

at station AL-39. A sharp drop in depth just up-valley and a widening of the channel probably result in an area of greater deposition and less resuspension energy. During the 1988 cruise (six months following complete cessation), this station was 25 percent as erodible as in 1987, and one year later (1989), AL-39 was 10 percent of 1987 values (total resuspension at 5 dyn/cm<sup>2</sup> went from 4 to 1 to 0.4 kg/m<sup>2</sup>). Down-valley erodibility decreased similarly to AL-31, while no consistent year-to-year changes occurred at AL-21 or below. Sediments up-valley from AL-39 were highly variable, resulting from a combination of periodic sludge accumulation (highest erosion values), its loss during storms, and a confounding influence of settled dredged sediment at the six-mile site.

## Microbiological Sludge Indicators

*W. Davis and W. Watkins*

*Clostridium perfringens* spore concentrations are probably stable sludge markers (Cabelli and Pedersen 1982) and

were therefore used to estimate sludge contamination in Hudson sediments (e.g., Christiaensen Basin, HSV, and Hudson Canyon) and to infer transport of sludge-contaminated sediment following cessation of sludge disposal. Sediment spore concentrations were enumerated using the Most Probable Number (MPN) method by the FDA.

Surveys of the Hudson Channel were made during early summer of 1987, 1988, and 1989 to establish presumably peak levels (1987) and to track a potential decline. The 1982 survey (Cabelli and Pedersen 1982) was used to approximate dumping steady-state levels, because the 1987 sediment collection was lost. The assumption of peak levels similar to the 1982 survey is reasonable (cf. Figure 2), but cannot be verified.

Spore concentrations in Hudson Channel sediments are summarized (Figure 35) for 1982 (Cabelli and Pedersen 1982) and for 1988 and 1989 (Davis and Watkins, unpublished<sup>3</sup>). The 1982 survey indicated a logarithmic decrease in spores with distance down the Channel and may represent steady-state sediment contamination after many years of sludge disposal. Sludge disposal was reduced gradually to zero by December 1987. A survey, conducted approximately six months after complete cessation, showed a complex distribution indicating: (1) a 10<sup>2</sup> decrease in spores in the Christiaensen Basin and upper HSV, (2) a graded change to an order of magnitude decrease in the middle Valley, and (3) a gradual merging to 1982 background values at the base of the Valley. One year later (June 1989), the down-channel trend showed: (1) a similar decrease in the Christiaensen Basin (10<sup>2</sup> decrease); (2) an unusual rise to 1982 levels at the Christiaensen Basin-HSV transition; (3) an abrupt decrease to 1988 levels in the upper HSV; and (4) a graded change similar in the middle Valley to 1988, except that spore concentrations there were once again at about 1982 levels.

Changes in the Hudson Channel spore distribution following cessation suggest certain possibilities: (1) shallow stations in the Christiaensen Basin may lose their sludge markers rapidly due to greater resuspension activity (a shift toward silty sand or sand supports this contention); (2) the upper HSV, while of similar depth, has lost much less of its spore reservoir; and (3) a depth-related down-valley decline in spore concentration continues, but with a shifting baseline.

The higher values along the transect in 1989 from the upper HSV to the deep end might be caused by inputs at the dredge spoil dumpsite which is located just west of the Valley. Phoel (this report) has shown a rebound in oxygen demand values similar to the spore concentration rebound.

## Sediment Transport Model Development

*W. Davis*

With the completion of the 12-mile dumpsite study, it appears feasible to map the major variables of fine-particle

<sup>3</sup> Unpublished data available from W. Davis, EPA, Narragansett, RI 02882.

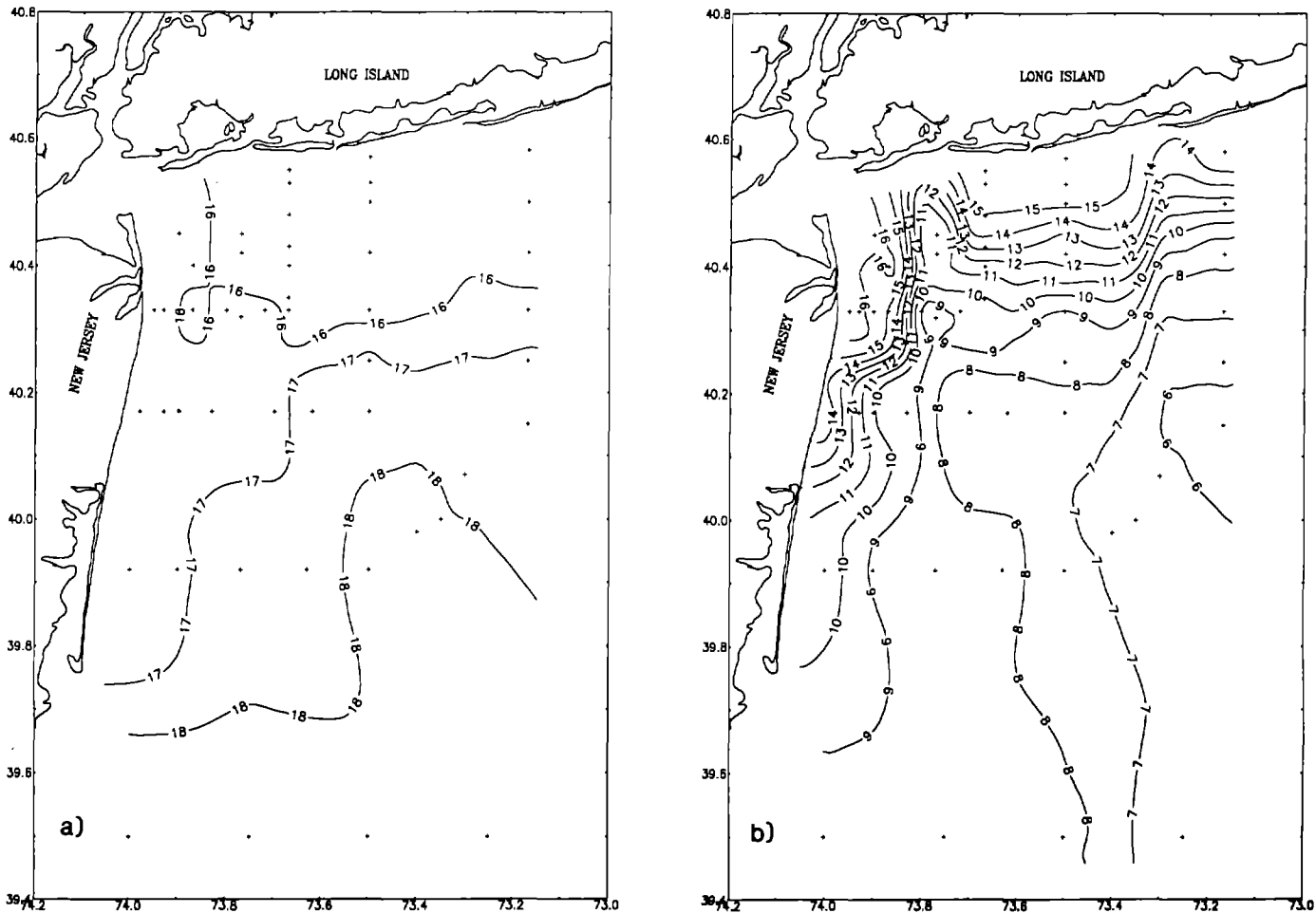

Figure 18. Surface (a) and bottom (b) temperature ( $^{\circ}\text{C}$ ) during the second survey of the inner NYB on cruise *Delaware II* 89-04, June 15-17, 1989.

transport: (1) sediment grain size, (2) bottom currents, and (3) benthic erodibility. The interaction of these data bases is being used to develop a predictive model of sediment resuspension.

This study of sediment erodibility or resuspension potential originated as an empirical assessment of erosion as a function of applied stress and station location (e.g., NY6). The hypothesis is that sediment erosion rate as a function of applied shear ( $\text{Tau}$  in  $\text{dyn}/\text{cm}^2$ ) is predictable from some measure of grain size and sediment water content (Lavelle and Davis 1987; Keith *et al.* 1990):

$$E = f[\text{Tau}, \text{Grain Size}, \text{Water Content}].$$

The quantitative formulation of these relationships was developed in two steps. First, a wide variety of sediments were empirically tested for erodibility, measured for sand, silt, clay and water content (percent), and evaluated for mean grain size, sorting, skewness, and kurtosis (method of moments calculation). The second step in model development was to determine best-fit polynomial equations of correlates between erosion results and

sediment grain and water content qualities (Pearson product-moment correlation statistic). A typical result for one such analysis (e.g., the  $3 \text{ dyn}/\text{cm}^2$  erosion test) is:

$$E = -.054 - .02(\text{MNGR}) + .010(\text{VAR}) - .032(\text{SORT}) \\ + .011(\text{MOD}) + .001(\text{SND}) - .001(\text{WAT}),$$

where six input variables (mean grain size, variance, sorting, mode, sand content, and water content) accounted for 71 percent of variance in erodibility data ( $\text{g}\cdot\text{m}^{-2}\cdot\text{s}^{-1}$ ). A general equation may eventually take the form:

$$E = b(\text{Tau}) + a(d\text{MNGR} - \text{MDGR}) + g(\text{SORT}) \\ + i(\text{SAND}, \text{SILT}) + j(\text{WATER}).$$

Further, it is widely hypothesized that bioturbation strongly influences the shear-erodibility relationship, affecting the  $\text{Tau}$ - $E$  value, by changing surficial sediment water content (Davis and Means 1986). An important exception involves interface barriers to erosion such as created by tube mats (e.g., *Ampelisca* sp.). Wide-scale application of a model predicting erodibility is possible by

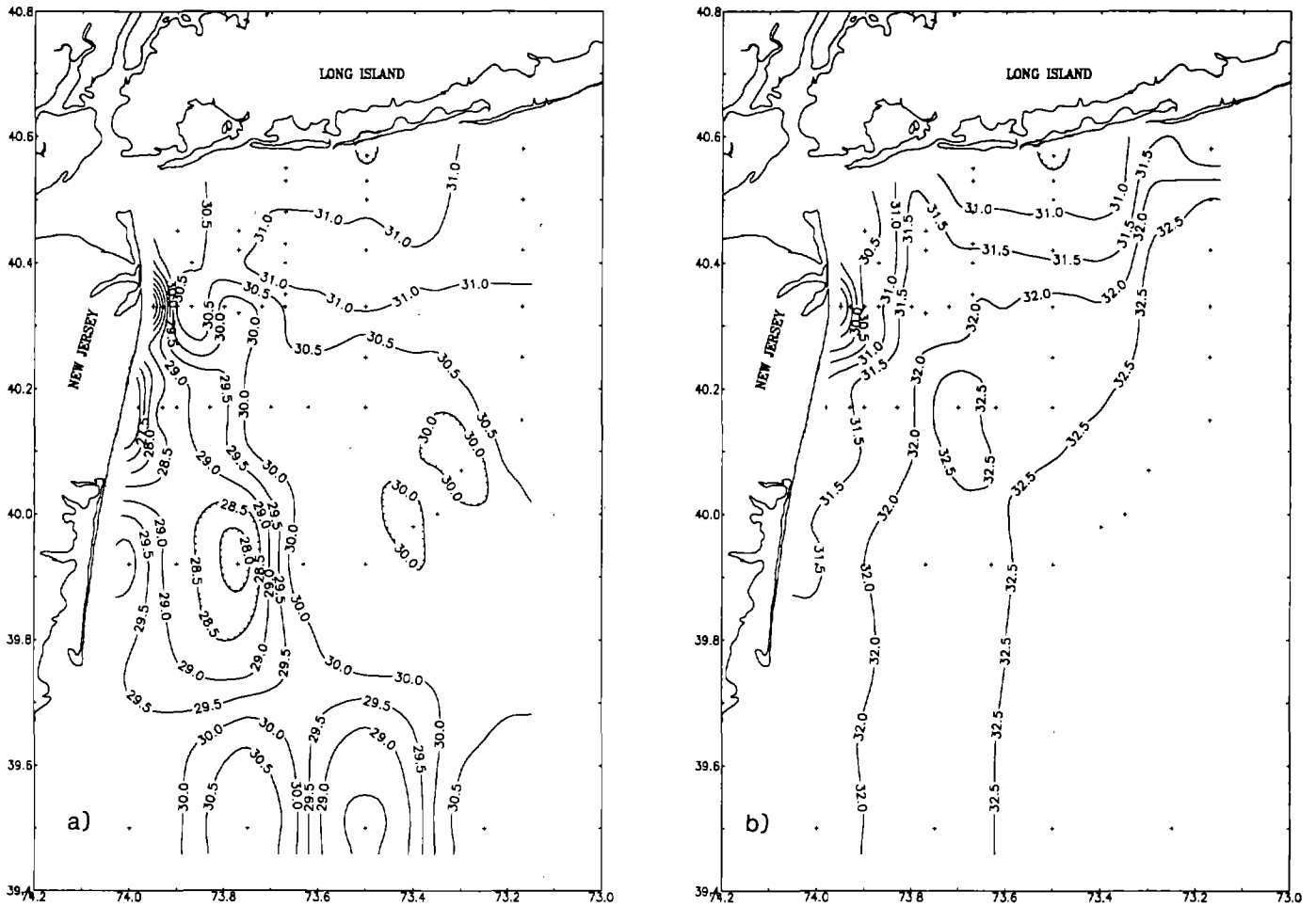

Figure 19. Surface (a) and bottom (b) salinity (PSU) during the second survey of the inner NYB on cruise *Delaware II* 89-04, June 15-17, 1989.

applying the model to existing NOAA and USGS grain-size maps.

Our erosion study results indicate that changes in sediment structure (grain size, porosity, and biological cohesion) have occurred in the HSV. The changes may be consistent with resuspension and redistribution of contaminated particulates along the axis of the HSV, but stronger conclusions are probable when sediment chemistry and current meter data are analyzed. Long-term changes in the sludge-sediment reservoir will be the result of a complex interaction of various transport processes such as particle flux and in-sediment mixing (bioturbation).

There are still certain problems which should be solved for successful completion of this portion of the study, and other efforts should be undertaken to utilize more fully the information obtained including:

1. A sidescan sonar survey of the inner NYB using a newly acquired digital system (EG&G, Inc.; Sea Beam Lab, Graduate School of Oceanography, University of Rhode

Island) which would provide a “photograph” of the NYB bottom (relief, grain size). This effort would also produce a high-density bathymetric map.

2. Bottom shear values (e.g., wave-pressure records) are required at dispersive (sandy) and depositional sites.
3. Collection and integration (mapping) of existing grain size as an index of transport mechanisms (deposition, resuspension, chemical reservoirs) and as “ground truth” for the sidescan sonar map.
4. Chemical analyses of sediment at some stations which will provide an independent estimate of change in the sediment-sludge reservoir.

A map data base of study results will express chemical reservoirs or sources (sludge-contaminated sediment, dredge material disposal site), sinks (depositional zones), transport pathways, and biotic exposures. The proposed map would also support key objectives of the NYB restoration plan (e.g., shellfish bed restoration) and help identify conflicting uses.

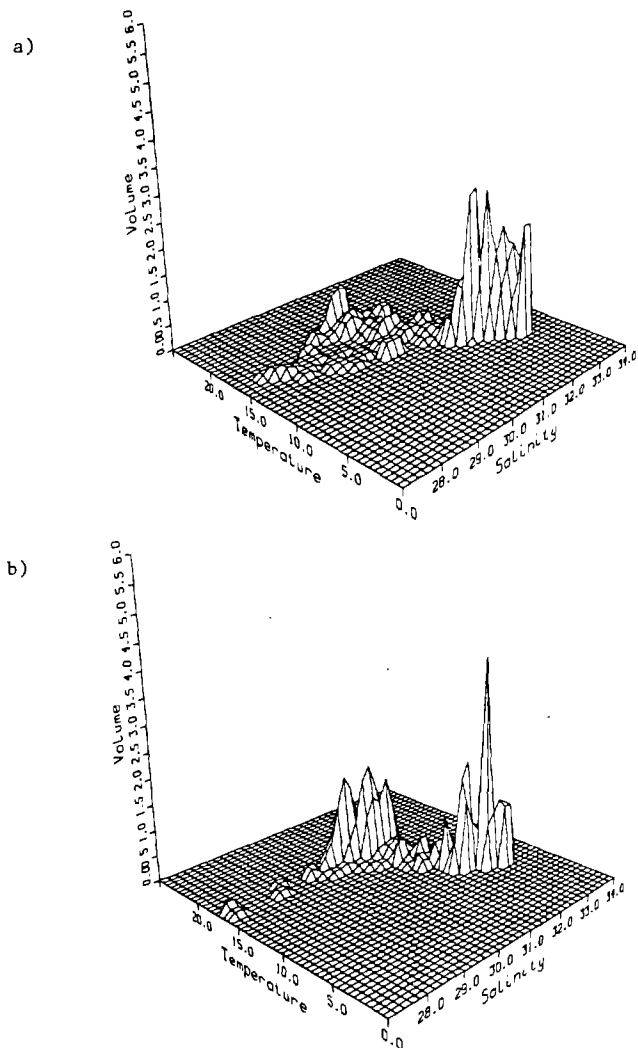

Figure 20. Volumetric temperature/salinity diagram for (a) the first and (b) the second surveys on cruise *Delaware II* 89-04.

## SEDIMENT TRANSPORT

*R. Bopp, Principal Investigator*

Investigators from Columbia University's Lamont-Doherty Geological Observatory are conducting collaborative studies with EPD to determine net sediment and pollutant accumulation rates in the region of the 12-mile dumpsite and along the axis of the HSV to the shelf break. Net sediment accumulation rates are determined from the distribution of the fallout radionuclide, Cesium-137, in sediment cores. In areas of rapid deposition, the Cesium-137 penetration depth indicates the net accumulation since about 1954 when significant global fallout first occurred. The other major part of this study involves collection of gram-sized, suspended-matter samples using an *in situ* pump and filtering apparatus. Analyses of these samples provide a direct measurement of pollutants actively being transported in the water column.

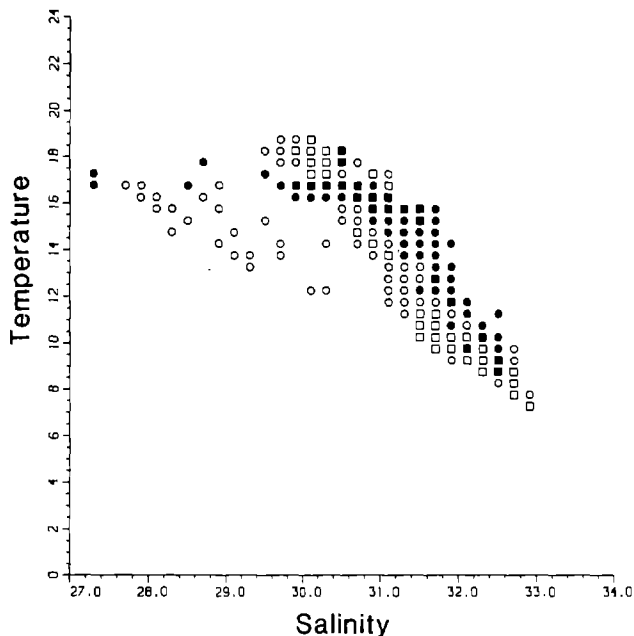

Figure 21. The difference in water properties between the first and second surveys on cruise *Delaware II* 89-04. The open symbols indicate more volume of that T/S type existed in the first survey than in the second. The solid symbols indicate more volume in the second survey. The squares represent the areas of largest change, together accounting for 75 percent of the total change. The circles are areas of smaller change and together account for the remaining 25 percent of the volume change.

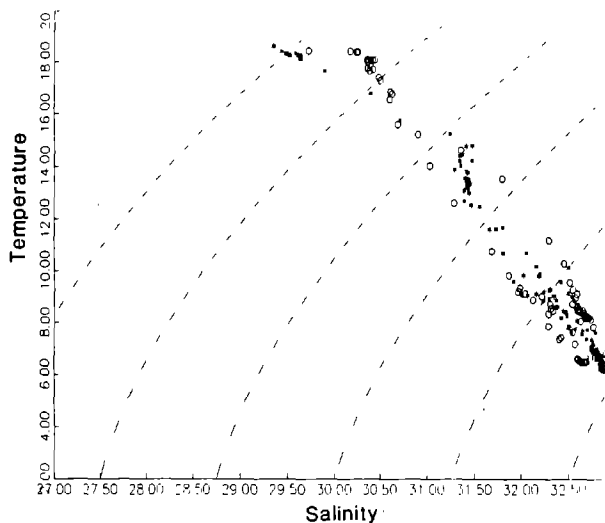

Figure 22. Temperature/salinity diagram for observations in the HSV during the first ("O") and second ("\*") surveys on cruise *Delaware II* 89-04.

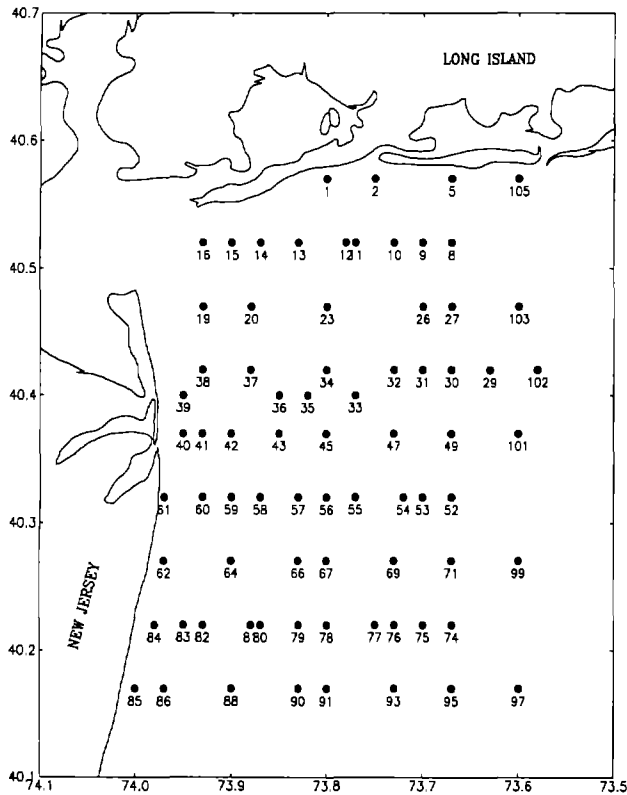

Figure 23. Station locations during the first survey of the inner NYB on cruise *Oregon II* 89-04, August 12-22, 1989.

Figure 36 shows Cesium-137 penetration depths (net accumulation since 1954) in cores from the vicinity of the dumpsite. Most striking is the rapid accumulation (several centimeters per year) observed at A56, in the axis of the HSV. This rapid sedimentation suggests significant recent particle transport to this site, perhaps from the dumpsites. We have also cored at eight other sites further down the HSV and found Cesium-137 penetration depths ranging from about 6 to about 30 cm. From analysis of these samples, we will be able to determine pollutant accumulation rates along the HSV, the major depositional area of this region.

Table 4 lists pp'-DDT and pp'-DDD data from the suspended-matter samples collected in August 1987. Our original hypothesis was that DDT/DDD ratios in such samples should range between approximately 0.05 (characteristic of resuspended dredge spoils and sewage sludge) and 0.40 (characteristic of Hudson-Raritan discharge) (Table 5). This was the case only for the Sandy Hook Buoy G1 surface sample (F1099) and the site A54 deep sample (F1098). The much higher ratios in the other samples indicate that F1098 is dominated by resuspension, and F1099, because of its location, contains both resuspension and discharge components. Also, the data from the other samples imply another source of DDT-derived compounds highly enriched in DDT relative to DDD (*i.e.*, having had no significant exposure to anaerobic conditions). It should

Table 4. Results of DDT analyses of suspended-matter samples collected in August 1987

Sample	pp'-DDT (ppb)	pp'-DDD (ppb)	DDT/DDD
F1094 (surface) Long Branch station 3	12.6±1.9	9.7±1.3	1.3
F1095 (surface) Long Branch station 5	12.6±2.5	9.5±1.6	1.3
F1096 (surface) A56	12.5±4.1	4.6±1.9	2.8
F1097 (surface) A54	20.0±4.0	6.0±1.5	3.3
F1098 (deep) A54	4.8±0.7	14.0±1.5	0.3
F1099 (surface) Sandy Hook Buoy G1	2.2±0.4	24.6±2.6	0.1

Note: All samples were corrected for blanks. Error estimates were based on analytical precision (±10 percent) and variation of procedural blanks.

Table 5. Characteristic pp'-DDT/pp'-DDD ratios

Type of Sample	Ratio
Samples representative of dredge spoils:	
New York Harbor sediment (30 samples, average)	<0.02
Newark Bay sediment (14 samples, average)	0.07
Suspended-particle samples representative of Hudson-Raritan discharge:	
Raritan Bay (GFF 1055 <sup>1</sup> , 1981)	0.63
New York Harbor (GFF 1060 <sup>1</sup> , 1981)	0.22
Arthur Kill (GFF 1057 <sup>1</sup> , 1981)	0.19
Newark Bay (F1049 <sup>1</sup> , 1985)	0.22
Shelf-break samples (atmospheric input?):	
Aerobic core tops containing the integrated input (low net-accumulation cores):	
EN123 BC E6 (0.0-1.0 cm)	23
EN123 BC E6 (1.0-2.0 cm)	24
EN123 BC E4 (1.0-1.5 cm)	13
EN123 BC E4 (2.0-2.5 cm)	18
Sediment trap samples (SEEP I & MASAR)	1.6-5.4

<sup>1</sup> Lamont-Doherty Geological Observatory Control No.

be noted that the high ratios of DDT/DDD result primarily from higher concentrations of pp'-DDT and indicate significant isolation of the surface waters at these sites from resuspension and Hudson-Raritan discharge contaminant inputs.

High DDT/DDD ratios are also characteristic of aerobic sediment and sediment trap samples from the shelf break that we have recently analyzed as part of another project (Table 5). We suggest that the source of this contamination was aerial spraying of DDT in the 1950s and 1960s for gypsy moth and mosquito control and transport as

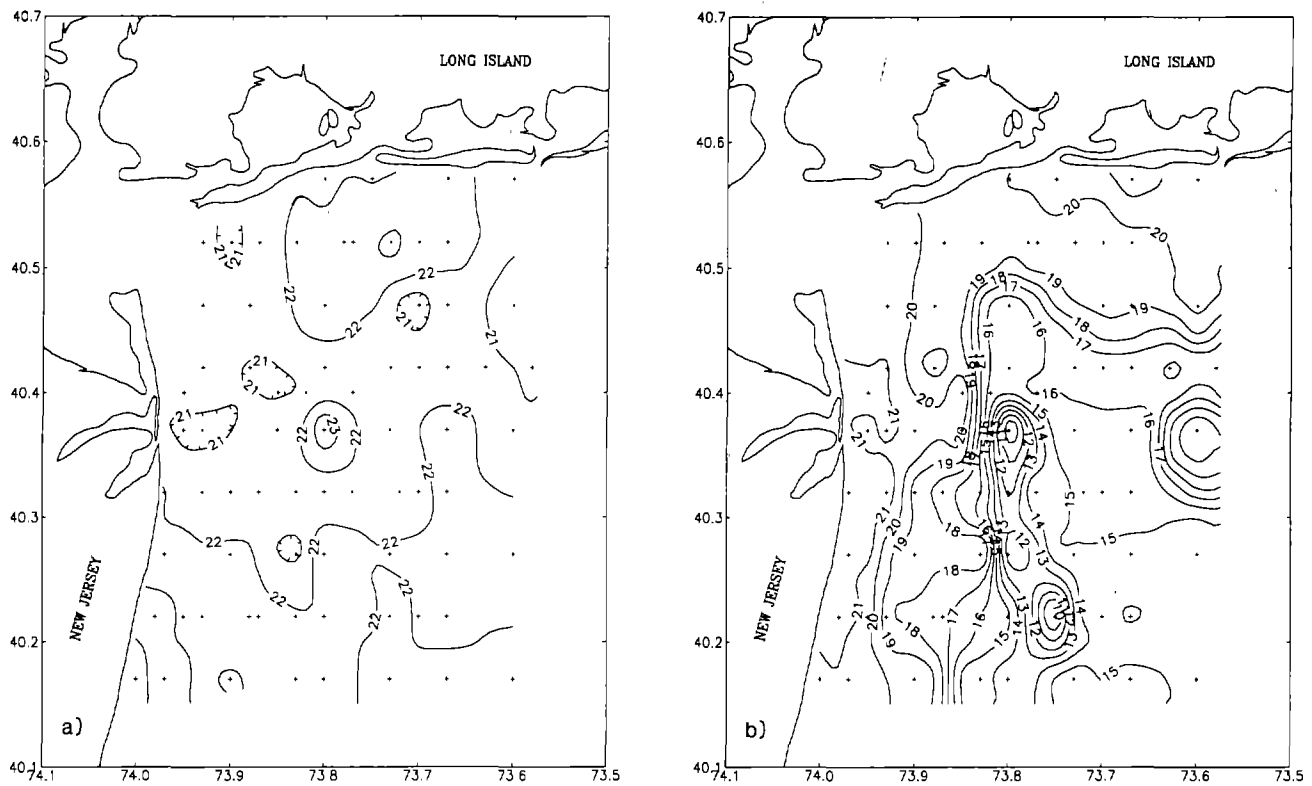

Figure 24. Surface (a) and bottom (b) temperature ( $^{\circ}\text{C}$ ) during the first survey of the inner NYB on cruise *Oregon II* 89-04, August 12-22, 1989.

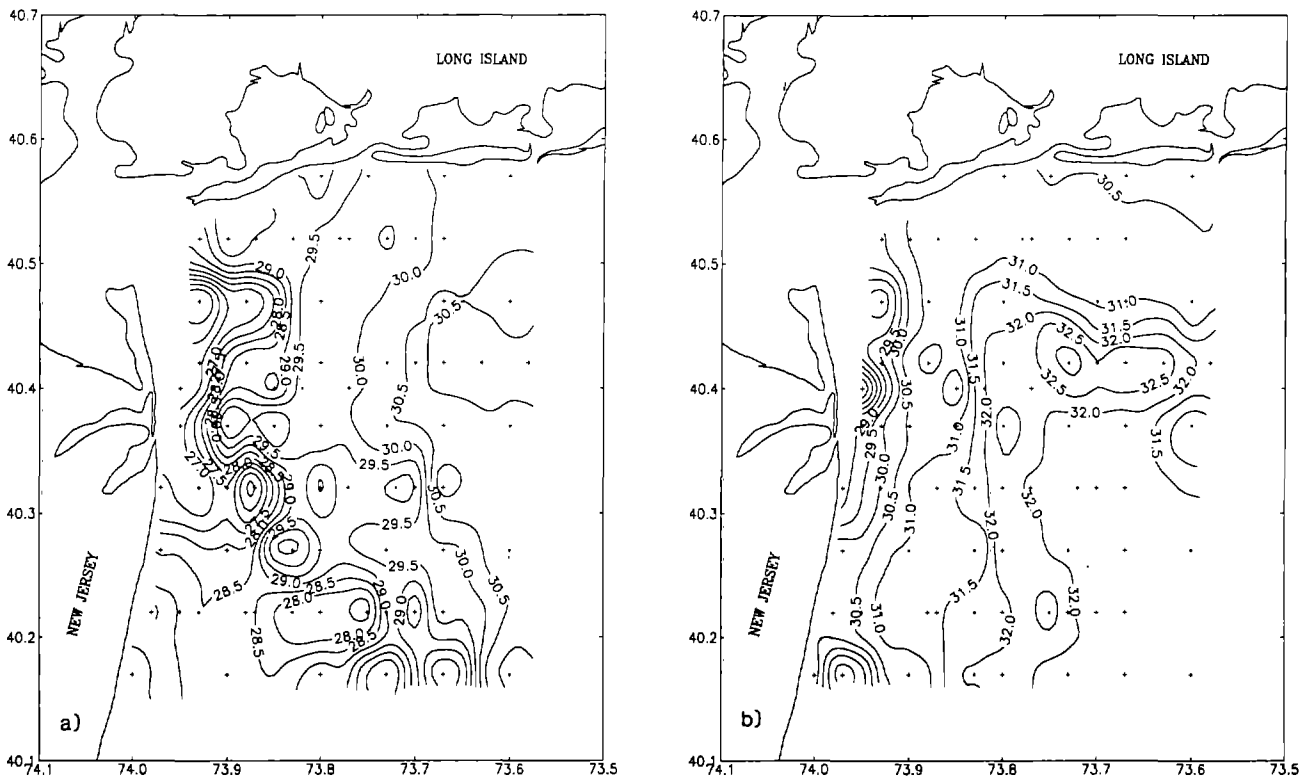

Figure 25. Surface (a) and bottom (b) salinity (PSU) during the first survey of the inner NYB on cruise *Oregon II* 89-04, August 12-22, 1989.

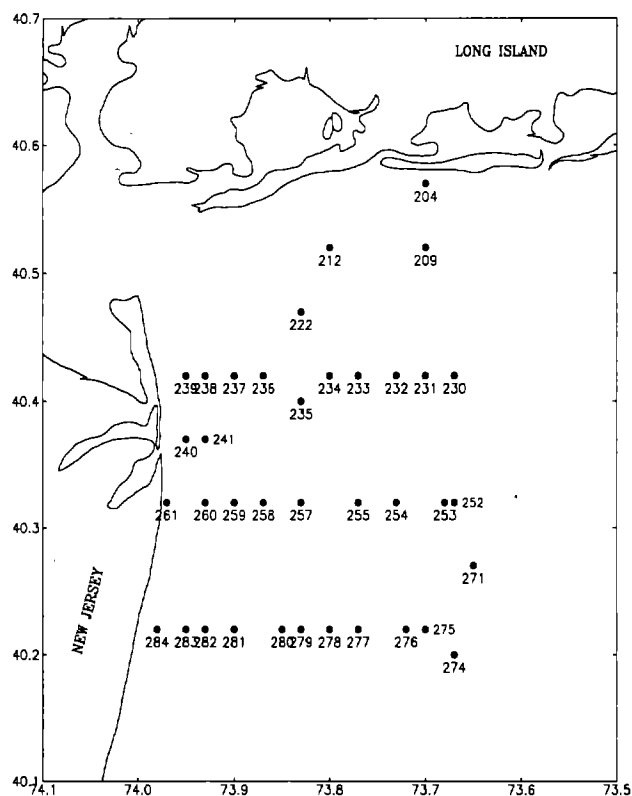

Figure 26. Station locations during the second survey of the inner NYB on cruise *Oregon II* 89-04, August 12-22, 1989.

fine aerosol particles. This implies a long (decades) residence time of DDT in shelf waters. A significant contribution from this source would also explain the high DDT/DDD ratios observed in our nearshore suspended-matter samples. Although the interpretation has been altered, the DDT/DDD ratio remains a powerful tracer in the nearshore and shelf environment. For example, further study could produce estimates of the residence time of particle-reactive pollutants in the water column. Applied to a more specific problem, particle samples from near Deepwater Dumpsite 106 could be analyzed for evidence of the impact of sewage sludge dumping (*i.e.*, lowered DDT/DDD ratios).

A few of our samples have also been analyzed for chlorinated dioxins at the laboratory of Dr. Michael Gross of Nebraska University. Post-1954 deposition at site A41 averaged 400 parts per trillion 2,3,7,8-TCDD. This significant contamination is much higher than levels that we observe in New York Harbor sediments. We suggest that the ultimate source of this contamination is past industrial discharges to the lower Passaic River from the 80 Lister Avenue facility, a major source of 2,3,7,8-TCDD. Working with New Jersey Department of Environmental Protection, we have traced this contamination through Newark Bay and adjacent waters. The appearance of high levels of 2,3,7,8-TCDD at A41 probably results from the disposal of sediments from the lower Passaic and Newark Bay at the

dredge spoil disposal site. Additional samples are currently being analyzed for chlorinated dioxins.

During the summer of 1990, we will complete the analyses for PCB, chlordane, and DDT-derived compounds on approximately 20 sediment core samples. All of our samples are archived and could be used in future analyses for other persistent pollutants including trace metals and polycyclic aromatic hydrocarbons.

## WATER AND SEDIMENT CHEMISTRY

*A. Draxler, Principal Investigator*

Significant changes were expected in the chemistry of the water and sediments in and around the dumpsite following cessation of dumping. This report will focus on changes in sediment biogeochemistry and heavy-metal concentrations.

### Sediment Biogeochemistry

*A. Draxler, L. Arlen, T. Finneran, and R. Bruno*

Three sediment variables (labile carbon, redox potential, and acid-soluble sulfide) indicate that extensive changes have occurred in the sediment chemistry over the course of the study.

Prior to the cessation of dumping in December 1987, the baseline concentration of biologically labile carbon in surface sediments (Figure 37) was about 165  $\mu\text{mole}/\text{cm}^3$  (1984-87) at replicate station NY6. By 1989, two years after cessation, the concentration of labile carbon in the sediment had decreased to 55  $\mu\text{mole}/\text{cm}^3$ , about one-third the earlier value. In 1988, baseline values were intermediate at about 100  $\mu\text{mole}/\text{cm}^3$  and trending downward. Surmounting the baseline concentrations were spikes that are attributable to inputs of labile carbon to the sediment from: (1) preformed labile carbon from sewage sludge dumping, and (2) settled primary production from the water column. Labile carbon concentrations at station NY6 continued to be higher than those at NY11 and R2 in 1989, probably due to the transformation of refractory carbon stored in the sediment into labile carbon. The remaining differences between NY11 and R2 in 1989 appear to be the result of differential input of phytoplankton primary production carbon. Preliminary measurements of chlorophyll *a* pigments in sediments from 1987 to 1989 follow the labile carbon data closely.

Redox potential in surface sediments appears to have responded to the decrease in biologically labile carbon which serves as fuel for heterotrophic activity (Figure 38). Redox potential, in the sense summarized by Whitfield (1969), is used as the key chemical variable in this study. It is an extensive variable that indicates the potential of the



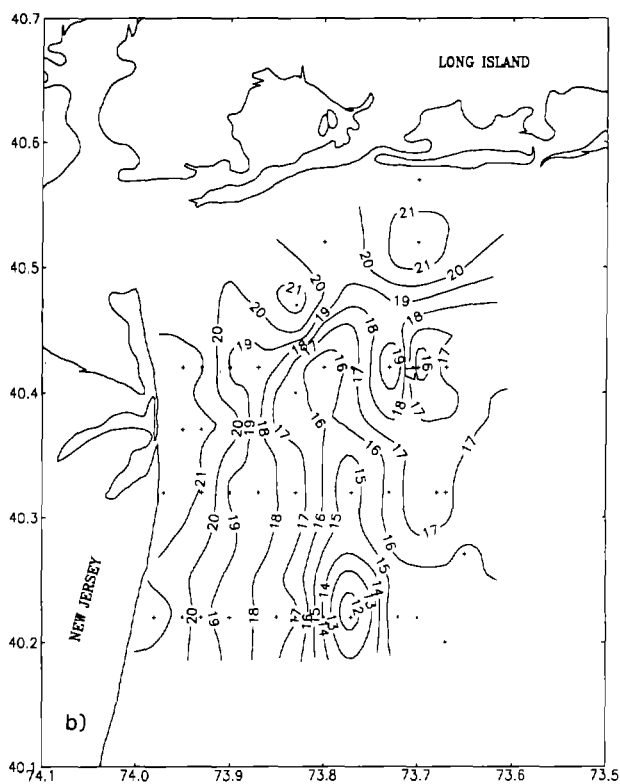
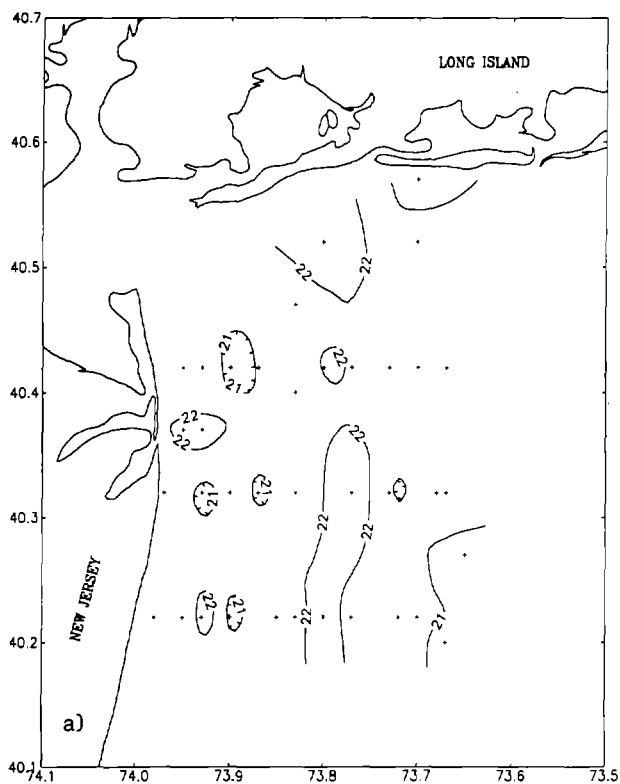

Figure 27. Surface (a) and bottom (b) temperature ( $^{\circ}\text{C}$ ) during the second survey of the inner NYB on cruise *Oregon II* 89-04, August 12-22, 1989.

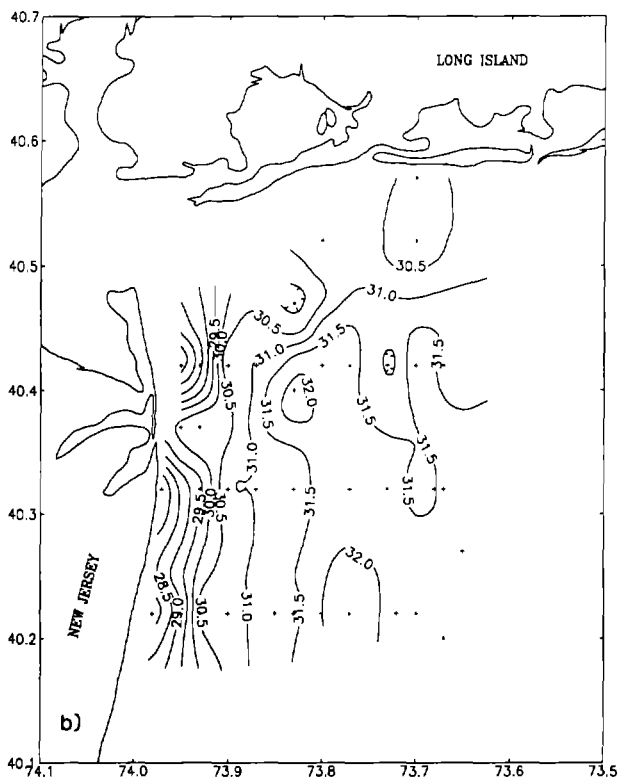
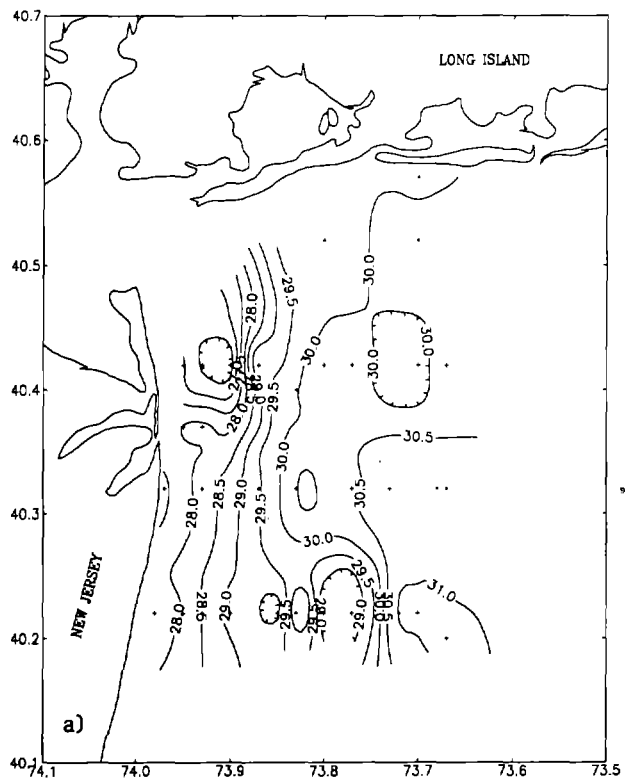

Figure 28. Surface (a) and bottom (b) salinity (PSU) during the second survey of the inner NYB on cruise *Oregon II* 89-04, August 12-22, 1989.

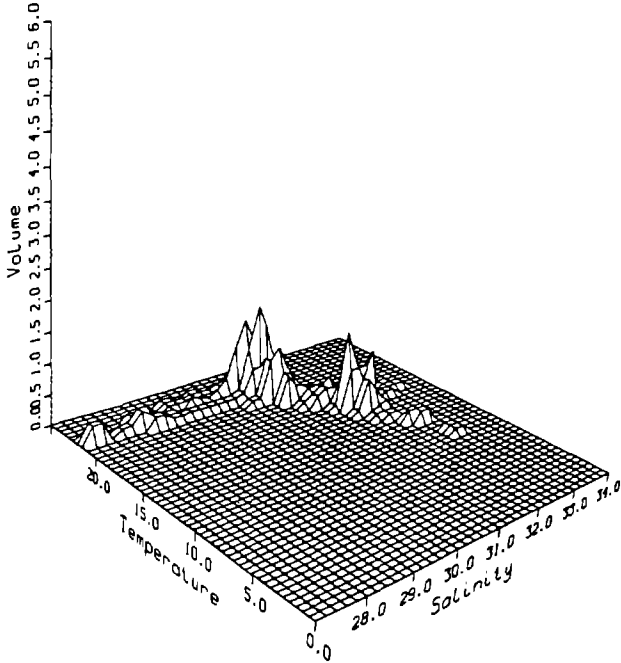

Figure 29. A volumetric temperature/salinity diagram for the observations made during the first survey on cruise *Oregon II 89-04*.

chemical species present in a matrix to give up or take up electrons, and functions as an index that can be compared to animal behavior over the period of dumping and during ecosystem response.

The amplitude of the seasonal redox cycles has diminished markedly over the course of the study. In the period 1983 to 1985<sup>4</sup>, long intervals of reducing conditions (to -150 mV) were regular features of the sediment biogeochemistry. Since 1986 when sludge input was reduced to 70 percent of pre-cessation dumping, redox potential at replicate stations NY6 and R2 has generally increased. This trend continued through 1989, with the observation of the highest values of the study. This was accomplished by further decreases in differences among the three reference stations. Both of these trends (reduced labile carbon and increased redox potential) are consistent with predictions drawn from a model of sediment biogeochemistry (Draxler 1988).

One measurable result of the increase in sediment redox condition is seen in the sediment acid-soluble sulfide (SASS) data (Figure 39). Concentrations of SASS in surface sediments at replicate stations R2 and NY6 (Figure 39a,b) were lower in 1989 than in previous years, continuing the decline first evident in 1988. No change in concentrations was evident in deeper (3-10 cm) sediment strata.

A second apparent result of reduced sediment labile carbon and the accompanying rise in redox potential was increased bottom water dissolved oxygen (DO) concentrations. In 1989, the minimum DO concentration at NY6 reached 77  $\mu\text{M}$  (2.5 mg/l), the lowest value since the begin-

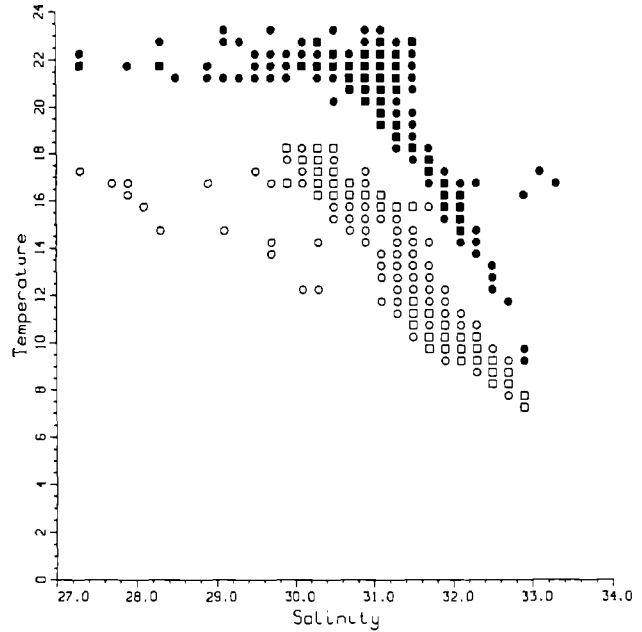

Figure 30. The difference in water properties between the first survey in June and the first survey in August. Open symbols indicate more volume of that T/S type existed in the earlier survey; the solid symbols indicate more volume in the latter survey. The squares represent the areas of largest change, together accounting for 75 percent of the total change. The circles are areas of smaller change and together account for the remaining 25 percent of the volume change.

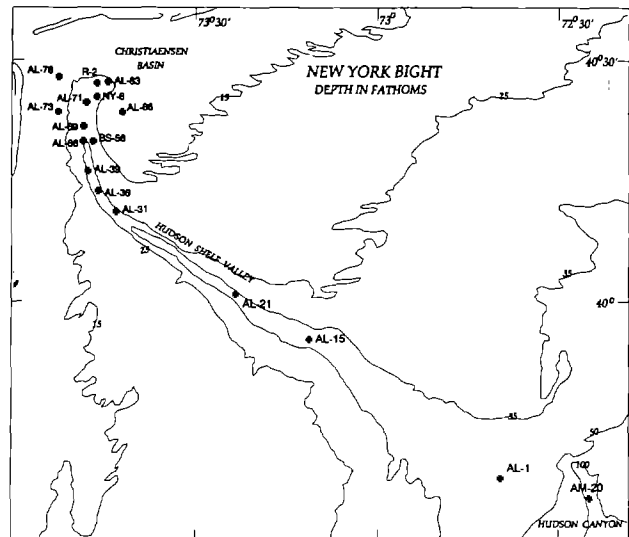

Figure 31. Map of the NYB showing sampling transect along the axis of the Christiaensen Basin-HSV-Hudson Canyon.

<sup>4</sup> Although values for 1985 were lost in a laboratory fire, a description of the main events [onset of reducing conditions (0 mV) and time of seasonal minimum] survived.

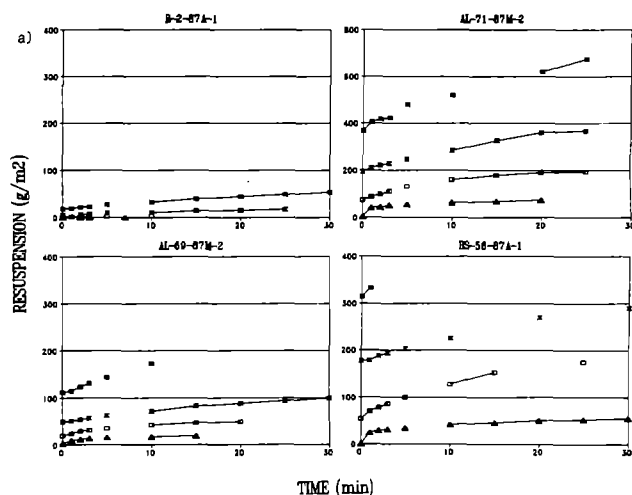

Figure 32a. Resuspension rates for stations R-2, AL-69, AL-71, and BS-56 during 1987 in  $\text{dyn/cm}^2$  as a function of applied shear (closed triangle = 2  $\text{dyn/cm}^2$ , open square = 3  $\text{dyn/cm}^2$ , hourglass = 4  $\text{dyn/cm}^2$ , and closed square = 5  $\text{dyn/cm}^2$ ) and which of the three replicate experiments exhibited the median response. Given for each panel are station (e.g., R-2; see Figure 31), year (i.e., -87), and replicate number of median response (i.e., -1, -2, or -3). The 1987 survey was made in two cruises which are indicated by -87M for May, or -87A for August.

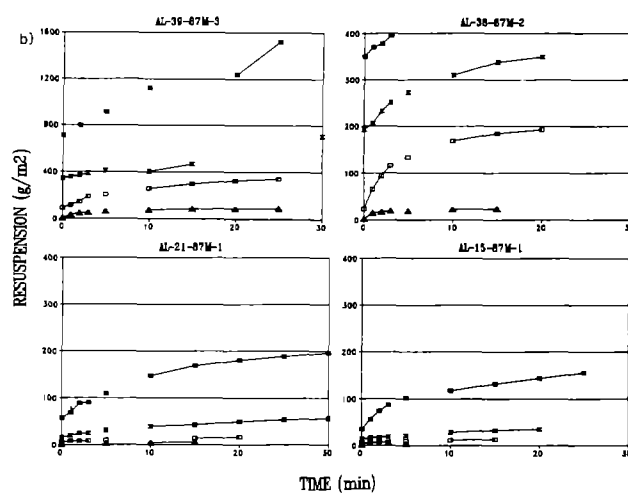

Figure 32b. Resuspension rates for stations AL-39, AL-36, AL-21, and AL-15 during 1987 in  $\text{dyn/cm}^2$  as a function of applied shear (closed triangle = 2  $\text{dyn/cm}^2$ , open square = 3  $\text{dyn/cm}^2$ , hourglass = 4  $\text{dyn/cm}^2$ , and closed square = 5  $\text{dyn/cm}^2$ ) and which of the three replicate experiments exhibited the median response. Given for each panel are station (e.g., AL-39; see Figure 31), year (i.e., -87), and replicate number of median response (i.e., -1, -2, or -3). The 1987 survey was made in two cruises which are indicated by -87M for May, or -87A for August.

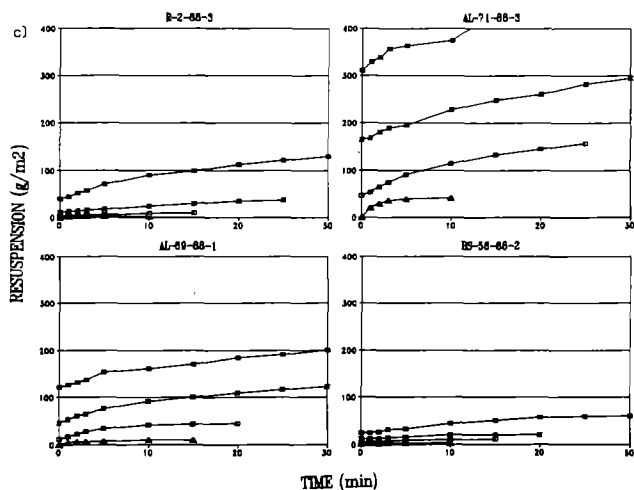

Figure 32c. Resuspension rates for stations R-2, AL-69, AL-71, and BS-56 during 1988 in  $\text{dyn/cm}^2$  as a function of applied shear (closed triangle = 2  $\text{dyn/cm}^2$ , open square = 3  $\text{dyn/cm}^2$ , hourglass = 4  $\text{dyn/cm}^2$ , and closed square = 5  $\text{dyn/cm}^2$ ) and which of the three replicate experiments exhibited the median response. Given for each panel are station (e.g., R-2; see Figure 31), year (i.e., -88), and replicate number of median response (i.e., -1, -2, or -3).

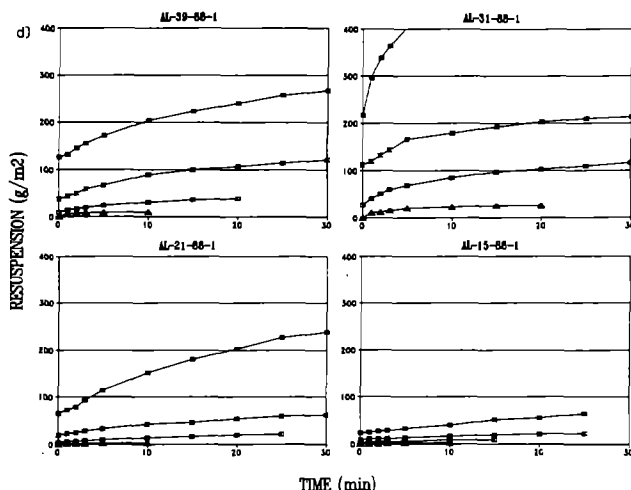

Figure 32d. Resuspension rates for stations AL-39, AL-31, AL-21, and AL-15 during 1988 in  $\text{dyn/cm}^2$  as a function of applied shear (closed triangle = 2  $\text{dyn/cm}^2$ , open square = 3  $\text{dyn/cm}^2$ , hourglass = 4  $\text{dyn/cm}^2$ , and closed square = 5  $\text{dyn/cm}^2$ ) and which of the three replicate experiments exhibited the median response. Given for each panel are station (e.g., AL-39; see Figure 31), year (i.e., -88), and replicate number of median response (i.e., -1, -2, or -3).

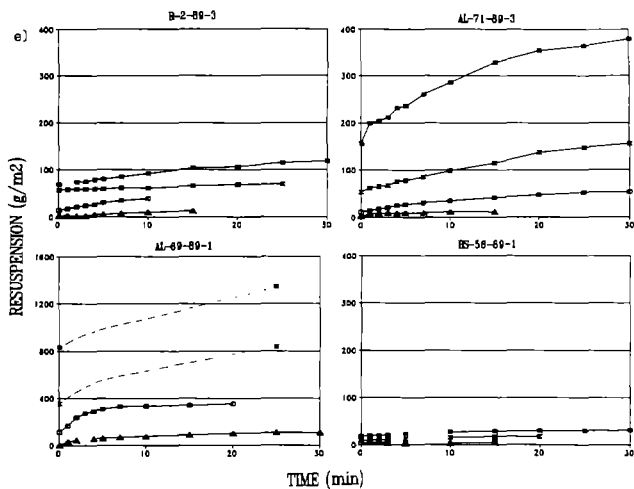

Figure 32e. Resuspension rates for stations R-2, AL-69, AL-71, and BS-56 during 1989 in  $\text{dyn/cm}^2$  as a function of applied shear (closed triangle = 2  $\text{dyn/cm}^2$ , open square = 3  $\text{dyn/cm}^2$ , hourglass = 4  $\text{dyn/cm}^2$ , and closed square = 5  $\text{dyn/cm}^2$ ) and which of the three replicate experiments exhibited the median response. Given for each panel are station (e.g., R-2; see Figure 31), year (i.e., -89), and replicate number of median response (i.e., -1, -2, or -3).

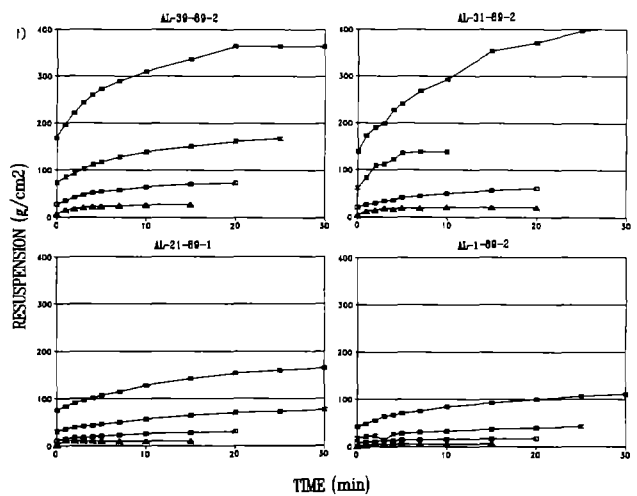

Figure 32f. Resuspension rates for stations AL-39, AL-31, AL-21, and AL-1 during 1989 in  $\text{dyn/cm}^2$  as a function of applied shear (closed triangle = 2  $\text{dyn/cm}^2$ , open square = 3  $\text{dyn/cm}^2$ , hourglass = 4  $\text{dyn/cm}^2$ , and closed square = 5  $\text{dyn/cm}^2$ ) and which of the three replicate experiments exhibited the median response. Given for each panel are station (e.g., AL-39; see Figure 31), year (i.e., -89), and replicate number of median response (i.e., -1, -2, or -3).

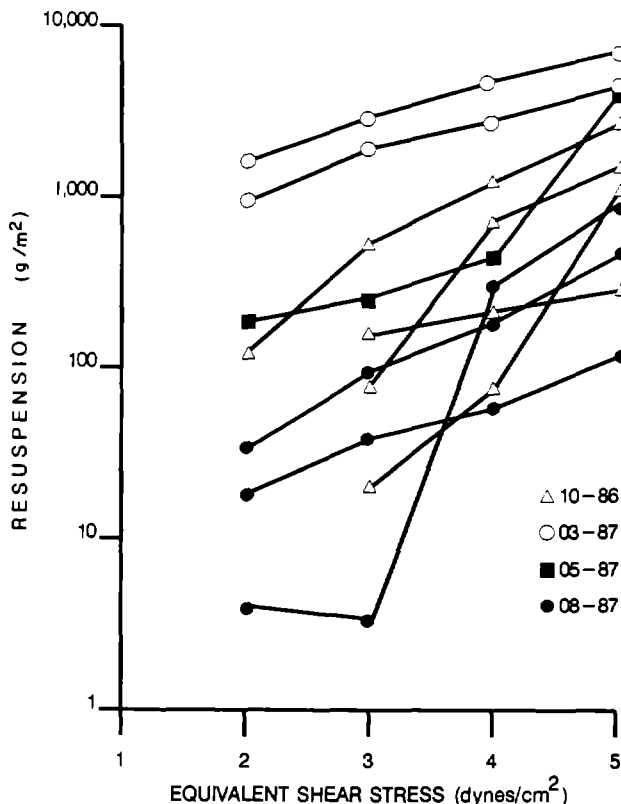

Figure 33. Erosion response at NY6 during various cruises (month-year) expressed as cumulative resuspension ( $\text{g/m}^2$ ); each value is an estimate of steady state of curves in Figure 32 (resuspension over time).

ning of sludge volume reductions in 1986. DO minima at NY6 had not been below about 125  $\mu\text{M}$  (4  $\text{mg/l}$ ) during 1986-88. Before reductions in sludge dumping, values below 15  $\mu\text{M}$  (0.5  $\text{mg/l}$ ) were observed in summers of 1983-85 in near-bottom waters. Based on the increased sediment redox potential and the reduced labile carbon and SOC (see W. Phoel, this report), it appears that the mechanism of bottom water DO regulation has shifted from being controlled predominantly by sediment processes to being controlled predominantly by water-column processes. Sediment processes will continue to play a role, but not to the extent as when there were three sources of sediment labile carbon (labile sewage sludge, refractory sewage sludge, and phytoplankton). The 1989 minimum is within the range predicted (Hypothesis #11) in the plan for this study (Environmental Processes Division 1988) and probably reflects a general broadscale lowering of DO levels throughout the Apex during 1989 due to water-column processes.

### Sediment Trace Metals

V. Zdanowicz, S. Leftwich, T. Finneran, and E. Leimburg

Sediment samples collected at the three replicate stations between July 1986 and December 1988 have been analyzed for concentrations of chromium, copper, nickel,

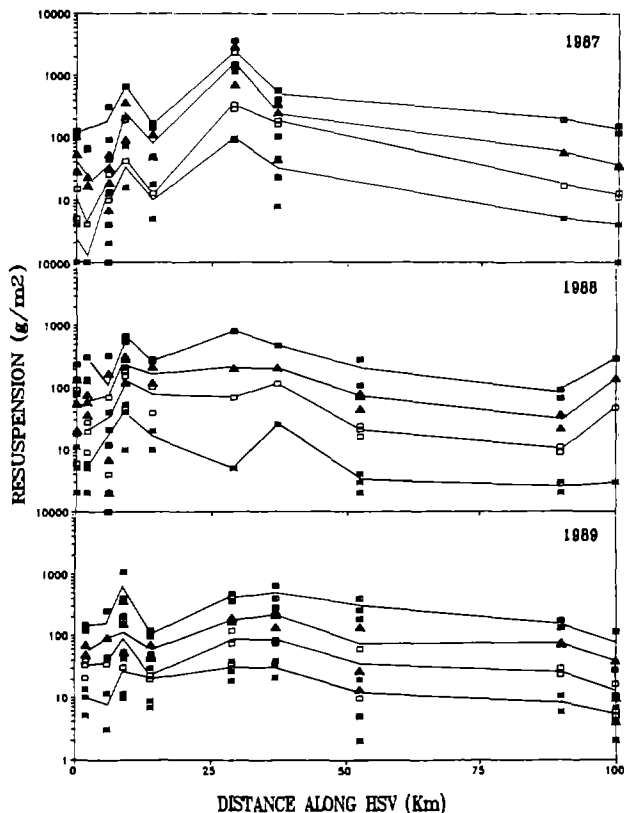

Figure 34. Erosion response of stations along the HSV for 1987 (pre-cessation), 1988, and 1989. Resuspension ( $g/m^2$ ) is total sediment resuspended by end of experiment for grid oscillation frequencies calibrated to 2 (asterisk), 3 (open square), 4 (triangle), and 5 (square with X)  $dyn/cm^2$ .

lead, zinc, and iron. The first five metals are contaminants associated commonly with sewage sludge; iron is generally associated with fine-grained sediment. The rate of sludge dumping (waste volume) from July 1986 to May 1987 was 70 percent of pre-cessation rate, declined from 70 to 30 percent from May to December, 1987, and was zero by January 1988.

Two sediment strata were investigated, the surface (0-1 cm) and buried (4-5 cm) layers. Surface samples were used to assess the most recent inputs of metals at each station, and, in conjunction with buried sediment samples, to provide information on the vertical distribution of contaminants in the sediment column. Vertical chemical distributions illustrate the depositional history of the sediment at a site.

Distributions of zinc and iron at each of the replicate stations are shown in Figures 40-42. The zinc distribution is representative of the distributions of the contaminant metals, while the iron distribution is distinct from the others. Vertical lines appear where major changes in dumping volume occurred. For convenience, the three time periods delineated by the vertical lines will be referred

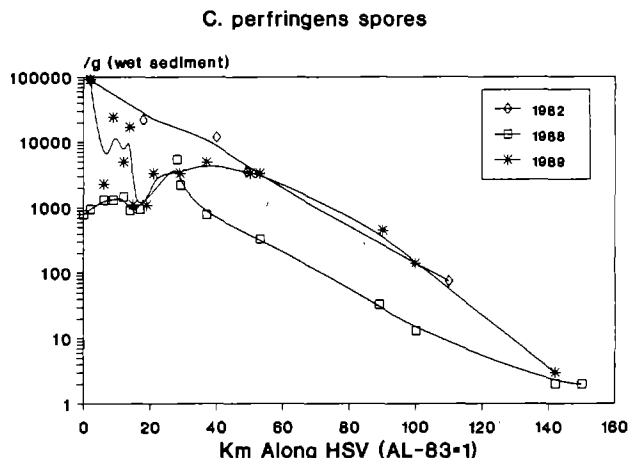

Figure 35. Trends in *Clostridium perfringens* spores along the Christiaensen Basin-HSV transect prior to (Cabelli and Pederson 1982), and after (1988-89), cessation in sludge disposal.

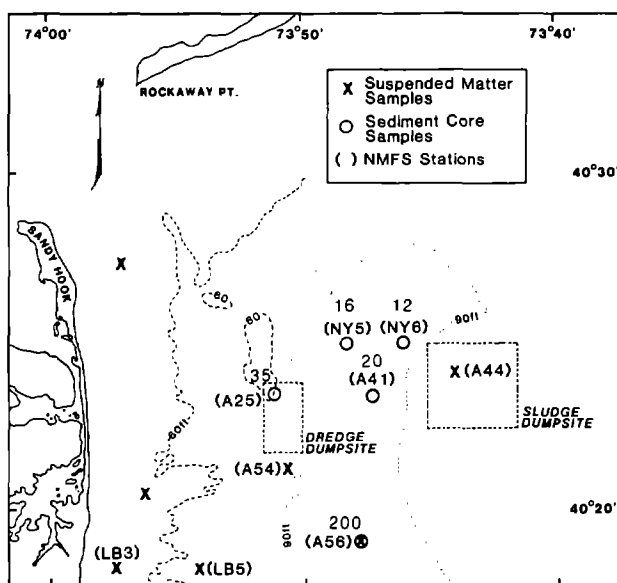

Figure 36. Cesium-137 penetration depths (cm) in sediment cores from the vicinity of the dumpsites. Suspended-particle sampling sites (Table 4) are indicated with an asterisk.

to as the 70-percent period (left), the phaseout period (middle, stepped reduction from 70 to 30 percent) and the cessation, or post-dumping, period (right).

Overall, highest contaminant metal concentrations were found in surface sediment at station NY6 (Figure 40) during the 70-percent and phaseout periods. Metal concentrations in buried sediment at NY6 were next highest during that time, sometimes exceeding levels in surface sediment during the phaseout period. After cessation, metal levels in surface sediment had generally declined to levels similar to those in the buried layer. Lowest metal concentrations were found at station NY11 (Figure 41) where concentra-

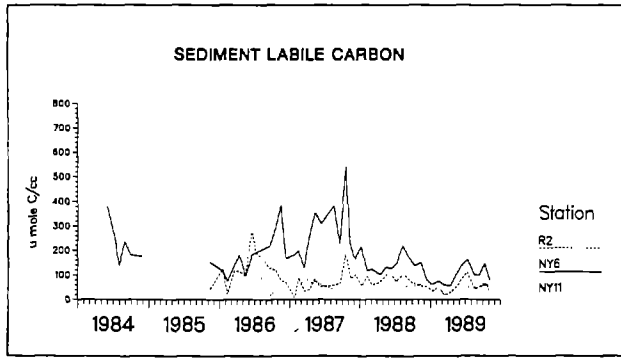

Figure 37. Biologically labile carbon in surface sediments at the three replicate stations.

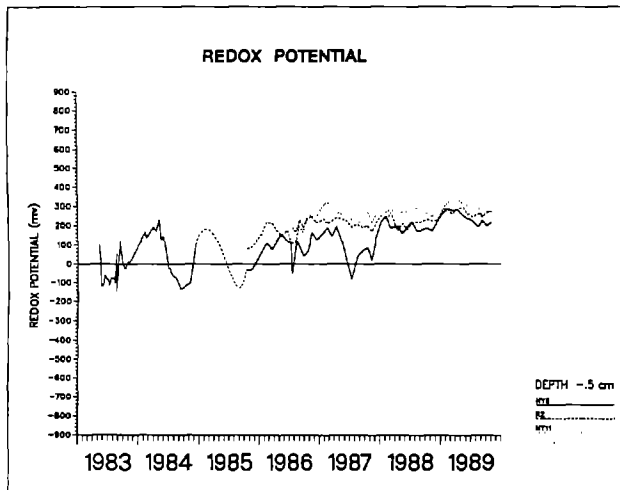

Figure 38. Mean redox potential values (mV), for the three replicate stations recorded at a depth of 0.5 cm.

tions were similar in both layers. Concentrations at R2 were intermediate (Figure 42), with metal levels in the buried layer higher than in the surface layer.

At station NY6, which was directly affected by sludge dumping, metal concentrations indicate that sediment in both layers was contaminated (e.g., zinc, Figure 40). However, the level of contamination was highest in surface sediment during the 70-percent and phaseout periods. Using ANOVA ( $\alpha = 0.05$ ) to compare different time intervals, metal concentrations observed during the 70-percent and phaseout periods were indistinguishable, while concentrations measured after cessation were significantly lower. That is, metal concentrations were similarly high during periods of active dumping, regardless of reductions in volume, including December 1987 when dumping volume had been reduced to approximately 30 percent of maximum. In contrast, contaminant metal concentrations in buried sediment were lowest during the 70-percent period, highest during the phaseout period, and intermediate thereafter. Iron concentrations were higher in surface sediment than in

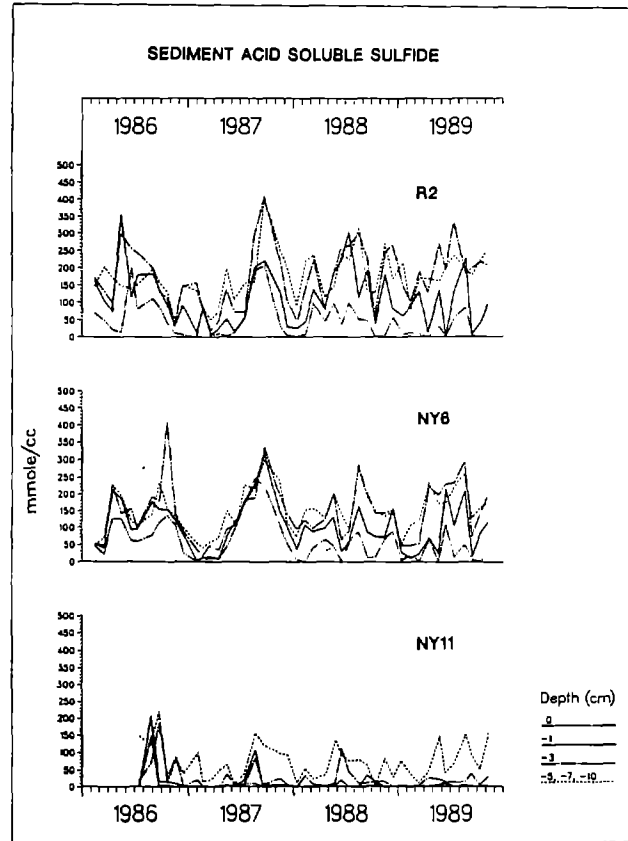

Figure 39. Acid-soluble sulfide (m mole/cm<sup>3</sup>) measured in the upper 10 cm of sediment at the three replicate stations: (a) R2, (b) NY6, and (c) NY11.

buried sediment during the 70-percent period, but were similar in the two sediment layers thereafter.

At station NY11, metal levels in both sediment layers were similarly low (e.g., zinc, Figure 41), and remained relatively constant irrespective of dumping volumes, confirming the assumption that this area is not affected directly by dumping. No significant differences in metal concentrations were detected. The increased contaminant concentrations observed in March and April 1987 in surface sediment were accompanied by a disproportionately lower increase in iron levels, suggesting the transient presence of material relatively enriched in contaminants. The increase observed in November 1988 in the contaminant levels in buried sediment was also accompanied by a disproportionately low increase in the iron concentration, suggesting that a stratum was sampled that contained material enriched in contaminants.

At station R2, levels of all six metals were higher in the buried layer than in the surface layer. In a comparison of time periods, concentrations of copper, nickel, and zinc in

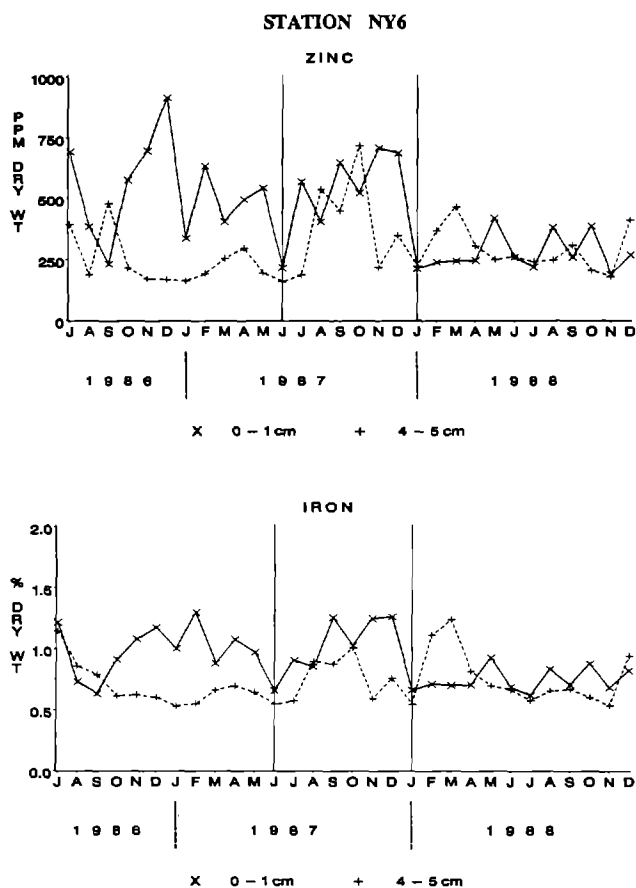

Figure 40. Concentrations of zinc and iron at station NY6.

buried sediment were higher during the phaseout period and after cessation than during the 70-percent period. In surface sediment, concentrations of all five contaminant metals, including zinc (Figure 42), were higher during the phaseout period and after cessation than during the 70-percent period. Iron levels in each layer were indistinguishable during all three periods (Figure 42). Higher iron levels in the buried layer suggest that this sediment layer contained more fine-grained materials than the surface layer. Ratios of contaminant metals to iron (not shown) also were higher in buried sediment than in surface sediment, indicating higher contaminant enrichment in buried sediment.

At individual stations, metal distributions were qualitatively similar and concentrations were highly correlated. At NY6 ( $n = 180$ ), correlation coefficients ( $r$ ) were  $\geq 0.91$  among the contaminant metals, and were 0.83-0.86 for iron with the other metals. At R2 ( $n = 180$ ),  $r$  values were  $\geq 0.89$ , except for lead which had correlation coefficients of 0.72-0.79 with the other metals. At NY11 ( $n = 180$ ), correlation coefficients were  $\geq 0.94$ . When all stations were considered together, however, the contaminant metals remained highly correlated ( $n = 540$ ,  $r \geq 0.94$ ), but none was highly correlated with iron ( $n = 540$ ,  $r \leq 0.56$ ).

This is reflected in the results of principal-components analysis performed using the entire data set ( $n = 540$ )

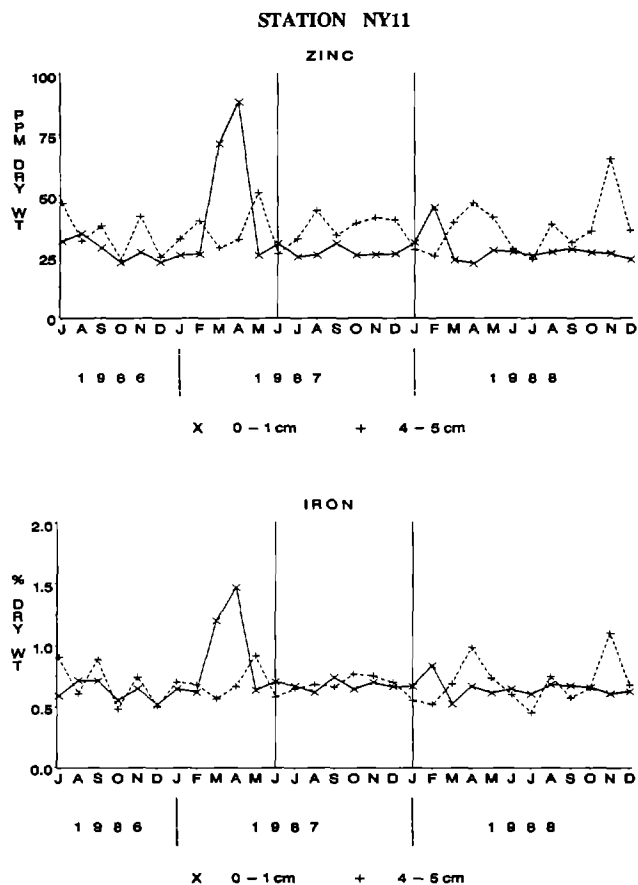

Figure 41. Concentrations of zinc and iron at station NY11.

(Figure 43). Factor 1, the X-axis (85 percent of data variability), represents the contaminant metals chromium, copper, nickel, lead, and zinc, while factor 2, the Y-axis (12 percent of data variability), represents iron (an indicator of fine-grained sediments), whose concentration is independent of the other metals. The group of points labeled "A" is derived from concentrations found in surface and buried sediment at stations NY11 and R2, while the group labeled "B" is derived from concentrations found in surface and buried sediment at station NY6. The relationship between contaminants and iron can be interpreted as indicating that conditions at NY11 and R2 are closer to natural, unpolluted conditions than those at NY6. At NY6, sediments contained far higher contaminant levels than expected from the levels of iron (fine sediment) present.

Of interest are the magnitude and statistical significance of the decrease in sediment contaminant metal levels at NY6 since the complete cessation of sludge dumping. It is equally important to note that no significant differences in contaminant concentrations were observed during any phase of reduction of sludge volume. That is, even a reduction to 30 percent of maximum was insufficient to produce a decrease in sediment contamination. In addition, the observed differences occurred in January 1988, within one month of complete cessation, indicating fairly rapid response by the system to the removal of contaminant inputs.

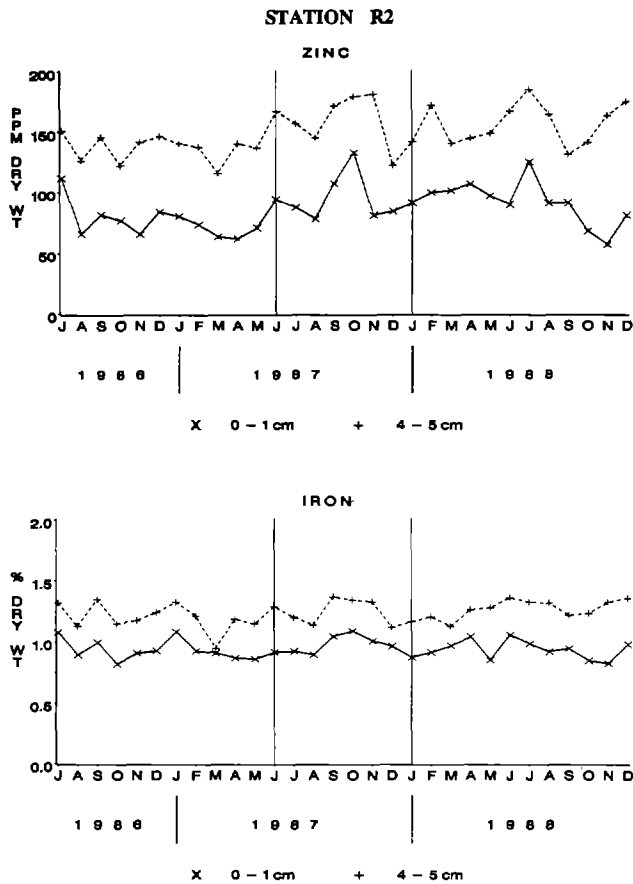

Figure 42. Concentrations of zinc and iron at station R2.

Also of interest are findings at R2 and NY11. Concentrations of sediment metals at NY11 have been relatively constant and low in all samples analyzed, except for the increased concentrations observed in March and April 1987 and November 1988, mentioned earlier. This suggests that this station is not influenced by sludge dumping, except for aperiodic transport to this site of enriched material, possibly of sludge origin. In contrast, R2 metal levels were more variable than those at NY11 and appear to have increased slightly during the final phaseout of sludge dumping and after complete cessation.

Finally, principal-components analysis suggests that some similarities exist between stations NY11 and R2, while NY6 is different from both. However, metal distributions and correlations show that each of these stations is influenced by separate geochemical mechanisms governing the introduction and incorporation of contaminants into the seafloor.

### SEDIMENT METABOLISM

*W. Phoel, Principal Investigator*

Consumption of oxygen by the seabed and water column has been used as a measure of benthic community

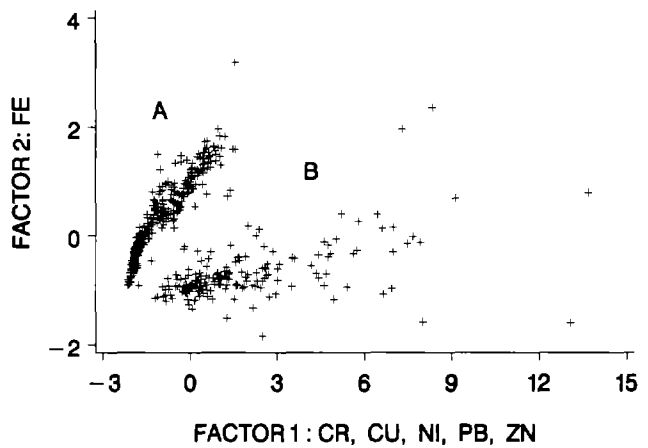

Figure 43. Principal-components analysis of metal concentrations at replicate stations.

metabolism to understand energy flow and carbon cycling in marine ecosystems (Environmental Processes Division 1989). Oxygen consumption processes by the seabed and water column, coupled with the physical dynamics of the system, can cause oxygen depletion, often resulting in hypoxia or anoxia. Seabed oxygen demand measurements are also used to indicate the oxidation of organic matter and the effect of pollution on benthic communities. Understanding these rates and processes is important for considerations of use and management of natural resources and protection of the marine ecosystem.

Between 1974 and 1985, various parameters were sampled aperiodically at six stations on an east-to-west transect across the northern extent of the 12-mile dumpsite and Christiaensen Basin (Figure 44). Since 1985, these stations have been occupied monthly. Measurements of seabed oxygen consumption (*i.e.*, seabed oxygen demand) (Phoel 1983), total plankton respiration (TPR) (Robertson 1983), benthic nutrient regeneration, benthic sulfide production, DO concentrations (Robertson 1983), salinity, temperature, and ambient nutrient concentrations were made at these stations. Also collected were samples for total organic carbon, particulate organic carbon, sediment grain size, chlorophyll pigments, and water-column photometry.

### Seabed Oxygen Consumption

*W. Phoel, K. Sharack, A. Fanning, and S. Fromm*

Since June 1988, the mean SOC rates at station 30, which is located 2.3 km east of the designated dumpsite area, have exhibited no significant response to changes in the quantity of sludge dumped. The SOC rates have remained at 12-18 ml O<sub>2</sub>·m<sup>-2</sup>·h<sup>-1</sup> (Figure 45a; the volume of sludge dumped depicted on each figure indicates the total amount dumped in the site per year, not the amount dumped



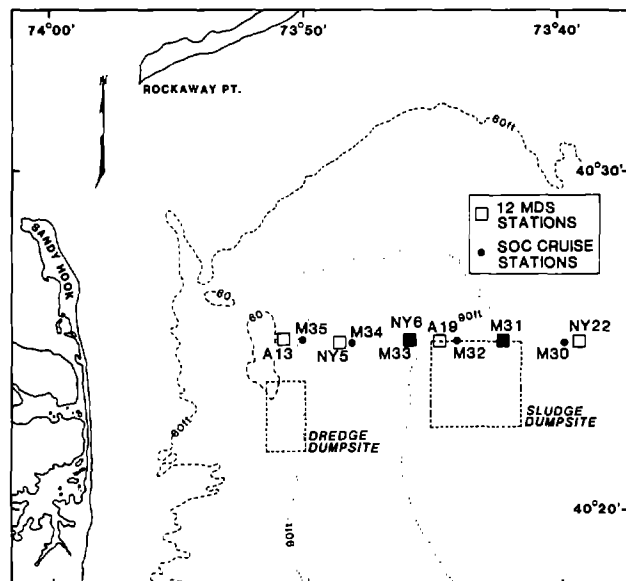

Figure 44. Location of stations occupied for measurement of SOC and other parameters.

at each station). This range is close to those measured at other stations with similar sandy sediments under coastal influence, both within and outside the NYB. Figure 45b indicates that SOC rates did not increase significantly with increasing temperature from spring through summer. This suggests that benthic metabolism at this station is carbon limited.

Station 31 has sediments similar to station 30, but is 0.5 km inside the dumpsite's eastern boundary and therefore received some input of sludge (Figure 44). Figure 46 confirms observations reported previously (Environmental Processes Division 1989) that SOC rates declined significantly between 1985 and 1987, and remained at that level through the summer of 1988. Subsequent study (through September 1989) indicates that SOC is being maintained at a relatively constant rate (mean  $\sim 15 \text{ ml O}_2 \cdot \text{m}^{-2} \cdot \text{h}^{-1}$ ).

As reported previously (Environmental Processes Division 1989), the relatively large decrease in SOC rates apparent between 1985 and 1986 is probably due to the early cessation of sludge dumping by Nassau County, New York (March-June 1986). Nassau County was the exclusive dumper in the northeast corner of the dumpsite. In effect, the majority of sludge reaching station 31 was halted by mid-1986, and the SOC rates apparently reflected this change.

From 1985 through 1987, SOC rates increased seasonally with increasing temperatures. After dumping ceased and anthropogenically derived carbon was no longer supplied to the system, benthic metabolism rates ceased to have high peaks during the summer seasons (Figure 46b).

The station in the dumpsite which received most of the dumped sludge is station 32 (Figure 47a,b), which is located in the northwest corner of the site (Figure 44).

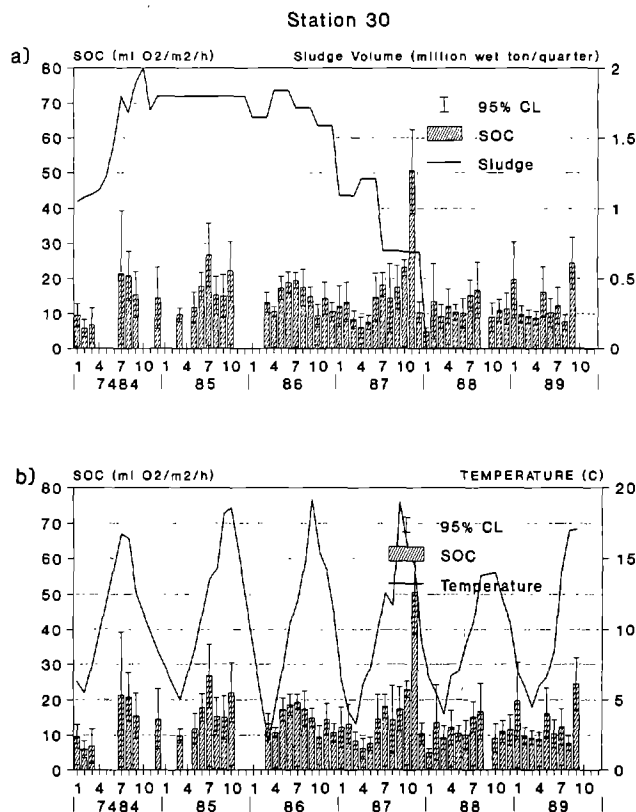

Figure 45. SOC measured at station 30 (see Figure 44) in relation to: (a) monthly volume of sewage sludge dumped, and (b) seasonal changes in temperature. Historical data measured from 1974 to 1984 are depicted as monthly means over the "7484" portion of the X-axis.

Although the sediments at station 32 are sandy and somewhat similar to those of stations 30 and 31, the mean SOC rates reflect the high organic input and historically were consistently higher than stations 30 and 31. As stated previously (Environmental Processes Division 1989), the decline in the SOC rates at station 32 was precipitous after the phaseout of dumping began. As dumping continued to decline, the rates approached "Apex background" levels ( $\sim 15 \text{ ml O}_2 \cdot \text{m}^{-2} \cdot \text{h}^{-1}$ ) and continued at this level through September 1989 (Figure 47a).

Before the phaseout of dumping began, the SOC rates were very responsive to seasonal increases in temperature. After dumping stopped, however, higher summer bottom-water temperatures did not elicit exaggerated SOC rates (Figure 47b).

Station 33 (NY6), which lies on the eastern slope of the Christiaensen Basin, just outside of the western boundary of the dumpsite, receives large inputs of organic material from the dumpsite (Figures 44 and 48). The sediments were soft black mud, typical of stations in the Christiaensen Basin. The graphical representation (Figure 48a) of SOC rates and volume of sludge dumped, supports the earlier conclusion that the extremely high rates of SOC measured in 1985 decreased to "Apex background" levels ( $\sim 15 \text{ ml O}_2 \cdot \text{m}^{-2} \cdot \text{h}^{-1}$ ) by 1988 (Environmental Processes Division

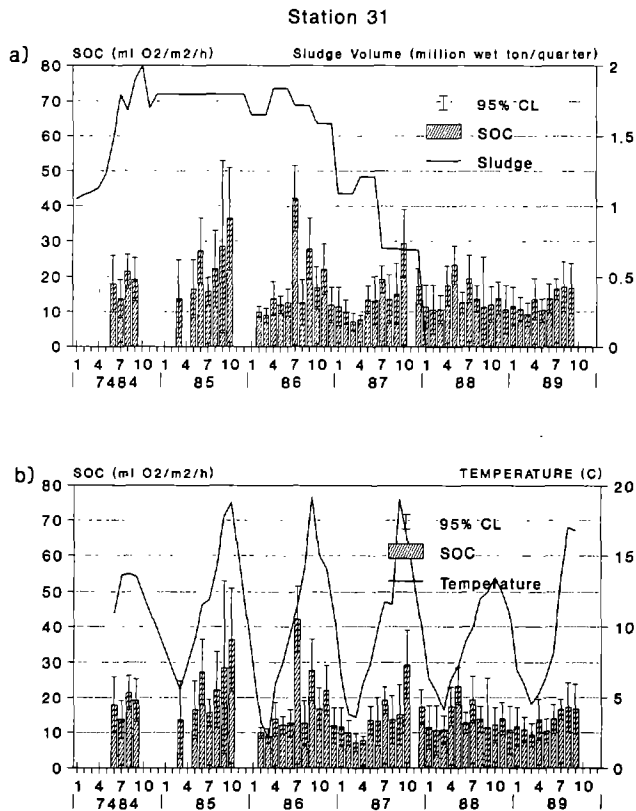

Figure 46. SOC measured at station 31 (see Figure 44) in relation to: (a) monthly volume of sewage sludge dumped, and (b) seasonal changes in temperature. Historically, data measured from 1974 to 1984 are depicted as monthly means over the "7484" portion of the X-axis.

1989). They remained at this level through September 1989.

Unlike stations 30, 31, and 32, station 33 maintained extremely high SOC rates even when bottom-water temperatures were low. After dumping had stopped, SOC rates stabilized at  $\sim 15\text{-}20\text{ ml O}_2\cdot\text{m}^{-2}\cdot\text{h}^{-1}$  and responded minimally to the seasonal fluctuations in bottom-water temperature (Figure 48b). Qualitative observations made in handling the sediments, and by remotely-operated-vehicle videotape, revealed that the sediments had become harder and more sandy after dumping stopped.

In the center of the Christiaensen Basin and at the greatest depth, station 34 receives not only sewage sludge, but a variety of other natural and anthropogenic inputs to its muddy sediments (Figure 44). As reported previously (Environmental Processes Division 1989), SOC rates are lower than those measured to the east (station 33) or to the west (station 35). Data from June 1988 through September 1989 showed a reduction in SOC rates that was minimal (Figure 49a).

The trend of benthic metabolism followed bottom-water temperatures throughout the study period (Figure 49). Unlike SOC rates at the other stations, which declined in response to temperature changes after dumping stopped,

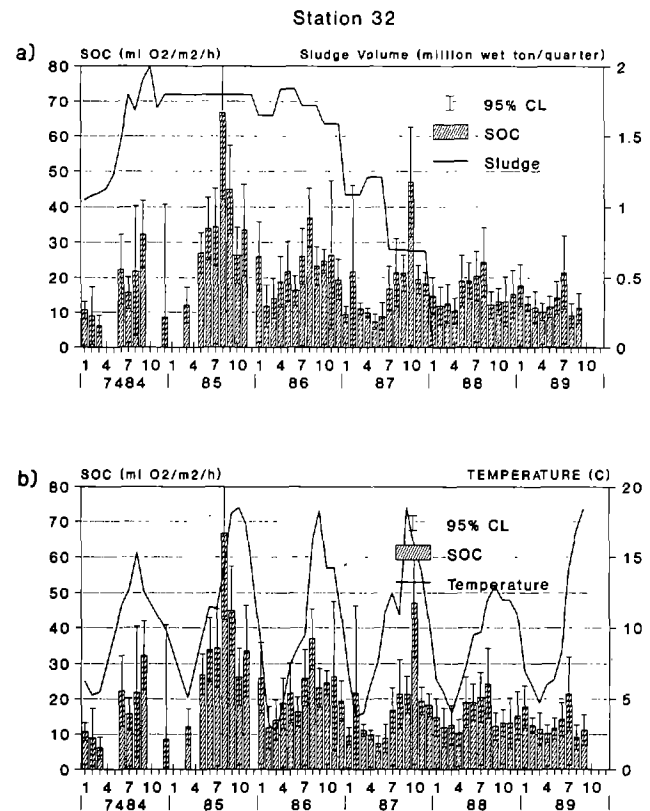

Figure 47. SOC measured at station 32 (see Figure 44) in relation to: (a) monthly volume of sewage sludge dumped, and (b) seasonal changes in temperature. Historically, data measured from 1974 to 1984 are depicted as monthly means over the "7484" portion of the X-axis.

the rates at station 34 continued to respond. This indicates that the sediments are not carbon limited, even though the carbon at this site may be more refractory.

Station 35 is located on the western side of the Christiaensen Basin, upslope from station 34, and 7.5 km west of the sewage sludge dumpsite (Figure 44). Due to its location, it is unlikely that it is influenced greatly by sewage sludge dumping. Station 35 is, however, quite near and downslope from the dredge spoils dumpsite, from which it probably receives an unknown amount of contaminated sediments. SOC rates declined significantly between 1986 and 1987 (Figure 50a). This decrease from an annual mean of  $\sim 32$  to  $\sim 19\text{ ml O}_2\cdot\text{m}^{-2}\cdot\text{h}^{-1}$  is, however, more likely due to the 75-percent decrease in dredge spoil dumping between 1985 and 1986 than to the phaseout of sewage sludge dumping. During the summer of 1989, SOC rates increased to levels measured in 1985 and 1986, substantiating the indication that the cessation of sewage sludge dumping was not responsible for the lowered rates in 1987 and 1988.

Rates of benthic metabolism responded to seasonal bottom-water temperature fluctuations in 1985, 1986, and 1989, but not in 1987 and 1988 (Figure 50b). This is interpreted to indicate that the sediments were carbon limited in 1987 and 1988 when dredge spoil dumping was

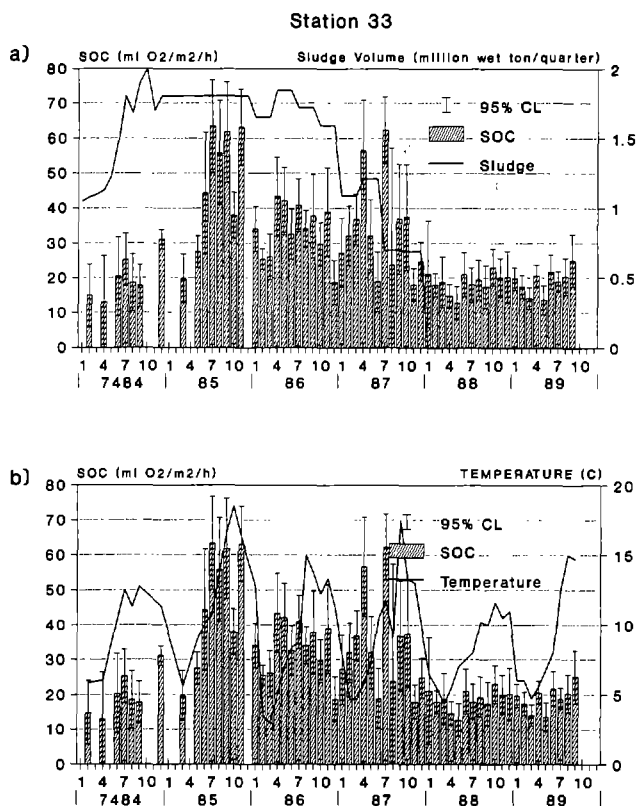

Figure 48. SOC measured at station 33 (see Figure 44) in relation to: (a) monthly volume of sewage sludge dumped, and (b) seasonal changes in temperature. Historical data measured from 1974 to 1984 are depicted as monthly means over the "7484" portion of the X-axis.

limited, but not in the other years when a larger quantity of dredge spoils was being dumped.

Correlation coefficients of mean annual SOC rates on mean annual wet tons of sludge dumped for each station from 1985 through 1988 have been reported previously (Environmental Processes Division 1989). The stations in the Christiaensen Basin with mud sediments had higher correlation coefficients ( $r = 0.90, 0.92, \text{ and } 0.85$  for stations 33, 34, and 35, respectively) than the stations with sand bottoms ( $r = 0.64, 0.66, \text{ and } 0.71$  for stations 30, 31, and 32, respectively). The correlation coefficients should be viewed with caution, however, as only four means were used in each station calculation and factors other than sewage sludge dumping may be influencing the SOC rates (as indicated above for station 35).

To define the relationship between SOC and volume of sludge dumped, we analyzed these data on a monthly basis until dumping ceased. The correlation coefficients derived from mean monthly SOC rates on calculated monthly wet tons of sewage sludge (*i.e.*, annual sewage sludge volume in wet tons divided by 12 months) were poor at best: correlation coefficients for the sandy stations 30, 31, and 32 were  $-0.10, 0.14, \text{ and } 0.23$ , respectively. For muddy stations 33, 34, and 35,  $r = 0.28, 0.13, \text{ and } 0.39$ , respectively.

These weak correlation coefficients indicate either

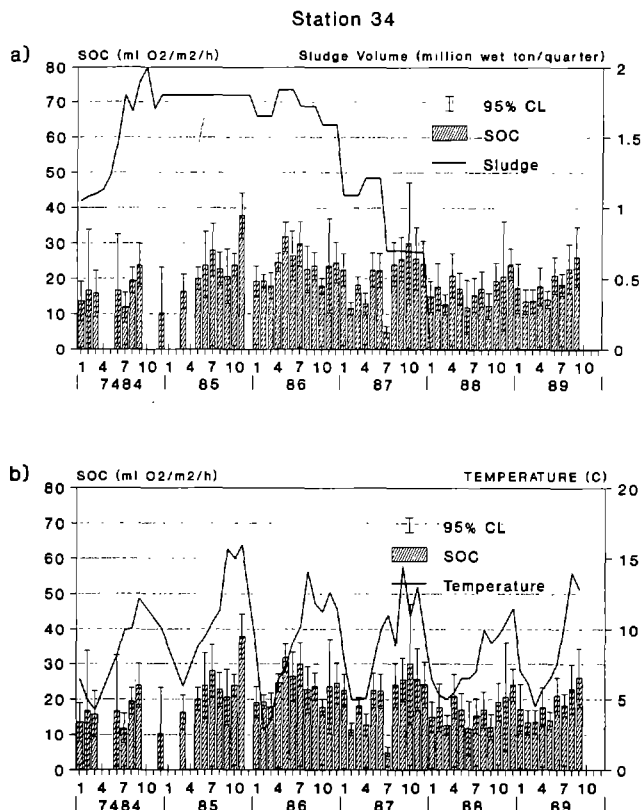

Figure 49. SOC measured at station 34 (see Figure 44) in relation to: (a) monthly volume of sewage sludge dumped, and (b) seasonal changes in temperature. Historical data measured from 1974 to 1984 are depicted as monthly means over the "7484" portion of the X-axis.

that changes in SOC rates are due to influences other than volume of sewage sludge (*e.g.*, temperature), or the derivation of monthly volumes of sewage sludge by dividing the annual volume by 12 is inappropriate. The strong correlation coefficients derived for mean annual SOC rates and volume of sewage sludge support the latter explanation. Acquisition of sewage sludge dumping data (*e.g.*, volumes and compositional characteristics) from EPA files may permit necessary reduction and interpretation for further refinement of statistical models relating rates of dumping to rates of SOC.

In the Second Annual Report (Environmental Processes Division 1989), it was postulated that further investigations into the SOC rates of these stations should indicate that either: (1) the rates continue to decrease over time to some "natural NYB Apex background" level, or (2) they do not decline further and the present rates are the background levels for this ecosystem (Environmental Processes Division 1989). SOC data acquired from June 1988 through September 1989 indicate that there has been no further decline in SOC rates at any station. With the exception of station 33, which was slow to respond, all the other stations reached their respective background level in 1987 when an average of 4.0-million wet tons of sewage sludge was still being dumped. This suggests that perhaps seabed metabolism in the Christiaensen Basin can endure the impact of

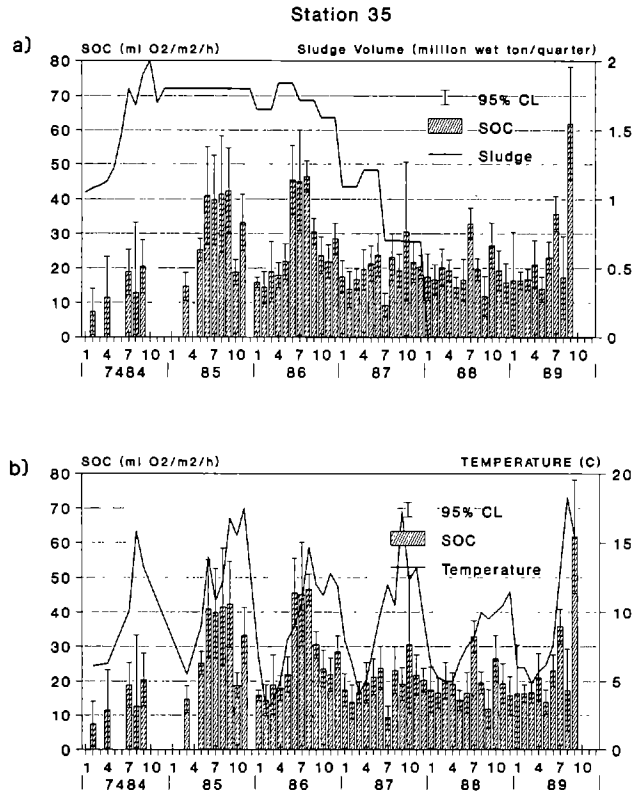

Figure 50. SOC measured at station 35 (see Figure 44) in relation to: (a) monthly volume of sewage sludge dumped, and (b) seasonal changes in temperature. Historical data measured from 1974 to 1984 are depicted as monthly means over the "7484" portion of the X-axis.

this amount of sludge with no increase in sediment oxygen consumption levels above "Apex background levels." Further evaluation of this finding will require more detailed information on the change in biological oxygen demand of particulate matter in sludge dumped over the time course of SOC measurements.

### Near-Bottom Water Chemistry

*W. Phoel, B. May, R. Waldhauer, S. Fromm, and C. Zetlin*

Water samples, collected 0.5 m above the bottom, have been analyzed for nitrite ( $\text{NO}_2^-$ ), nitrate ( $\text{NO}_3^-$ ), ammonium ( $\text{NH}_4^+$ ), phosphate ( $\text{PO}_4^{3-}$ ), and reactive silicate ( $\text{SiO}_4^{4-}$ ).

Nitrite is an intermediate oxidation state of nitrogen both in the oxidation of ammonia to nitrate and in the reduction of nitrate. Nitrite concentrations ranged from 0.0 to 3.5  $\mu\text{M/l}$  during the study. Figure 51a indicates a variable pattern of nitrite concentration at station 30, with no obvious changes with relation to the cessation of dumping. At station 31 (Figure 51b), nitrite concentrations were

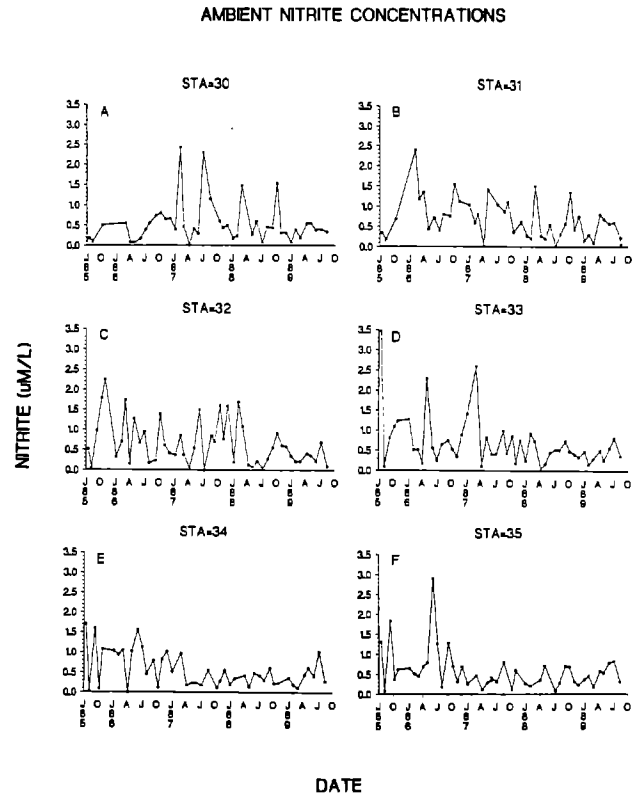

Figure 51. Concentrations ( $\mu\text{M/l}$ ) of nitrite measured at 0.5 m depth at: (a) station 30, (b) station 31, (c) station 32, (d) station 33, (e) station 34, and (f) station 35 from July 1985 through August 1989.

also variable and showed no clear response to the cessation of dumping. Nitrite concentrations at station 32 (Figure 51c), on the other hand, declined and became less variable about three months after dumping had ceased and continued through the completion of the study. Station 33 exhibited lower concentrations of nitrite both during and after the phaseout of dumping (Figure 51d). Nitrite concentrations at station 34 (Figure 51e) showed minimal response to the cessation of dumping. Measurements at station 35 suggest that there were lowered amounts of nitrite during and after the phaseout; however, due to its location, it is difficult to ascribe the reduction of nitrate to nitrite to the cessation of sewage sludge dumping.

Nitrate is generally the dominant form of oxidized nitrogen in coastal bottom waters and is often considered to be a growth-limiting nutrient for many photosynthetic autotrophs. Nitrate concentrations ranged from 0.0 to 10.3  $\mu\text{M/l}$  during the study, and, in general, were about twice as high as nitrite concentrations. There was no indication at any station that nitrate concentrations responded to the cessation of dumping. Nitrate concentrations measured at stations 30 and 31 (Figure 52a,b) were generally lower than concentrations at stations 32-35 (Figure 52c-f), and were

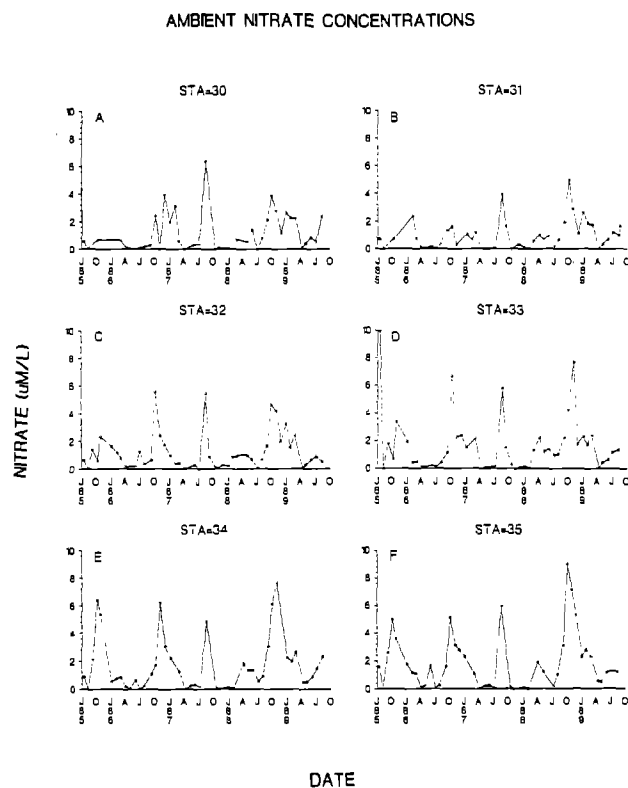

Figure 52. Concentrations ( $\mu\text{M/l}$ ) of nitrate measured at 0.5 m depth at: (a) station 30, (b) station 31, (c) station 32, (d) station 33, (e) station 34, and (f) station 35 from July 1985 through August 1989.

more variable with time. The concentrations at stations 32-35 showed more of a periodicity, with very low concentrations from about March-May, except in 1988 when there was less of a decline.

Ammonium concentrations ranged from 0.0 to 9.0  $\mu\text{M/l}$  during the study, and concentrations appeared extremely variable over time (Figure 53a-f). Preliminary analyses suggest that concentrations measured at stations 32-35 were higher before dumping ceased than after. Often, high concentrations of nitrate were observed associated with low ammonia concentrations. This probably indicated that efficient oxidation of ammonia was occurring.

Phosphate concentrations ranged from 0.18 to 3.3  $\mu\text{M}$  per liter over the course of the study for stations 30-35 (Figure 54a-f). At stations 30, 33, 35, and perhaps 31, phosphate concentrations appeared to have increased after the cessation of dumping.

Silicate concentrations ranged from 0.46 to 18.0  $\mu\text{M}$  per liter and were quite variable over the course of the study. Preliminary interpretations of values from stations 30-35 (Figure 55a-f) suggest that the cessation of sewage sludge dumping had no effect on ambient silicate concentrations.

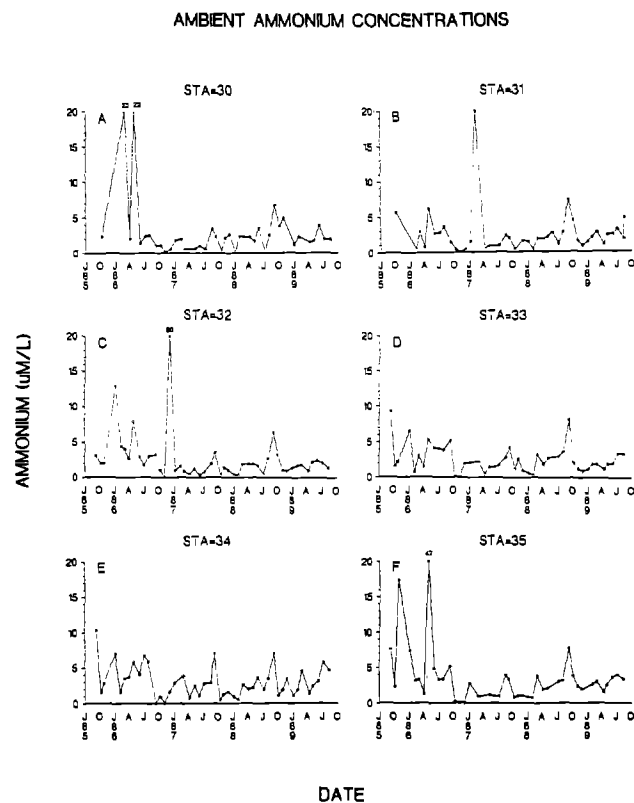

Figure 53. Concentrations ( $\mu\text{M/l}$ ) of ammonium measured at 0.5 m depth at: (a) station 30, (b) station 31, (c) station 32, (d) station 33, (e) station 34, and (f) station 35 from July 1985 through August 1989.

Total oxidized nitrogen ( $\text{NO}_2 + \text{NO}_3$ ) concentrations and total nitrogen ( $\text{NO}_2 + \text{NO}_3 + \text{NH}_4$ ) concentrations are presented for stations 30-35 (Figure 56a-f). No interpretations have been made of these data.

## Total Plankton Respiration

*W. Phoel, B. May, and P. Fournier*

Preliminary analyses of TPR rates measured between June 1989 and September 1990 confirm the results described previously that TPR rates in water collected from 0.1 to 0.5 m off bottom have not responded to the cessation of dumping as we had hypothesized (Environmental Processes Division 1989). The preliminary TPR data at stations 30-35 (Figure 57a-f) indicate high and variable rates 0.1 m off bottom, and lower but still variable rates 0.5 m off bottom. Only at station 33 (Figure 57d) is there a suggestion of lowered rates 0.5 m off bottom after dumping ceased. DO concentrations in ml/l show seasonal variation (Figure 57a-f), but, on this scale at least, no response to the cessation of sewage sludge dumping.

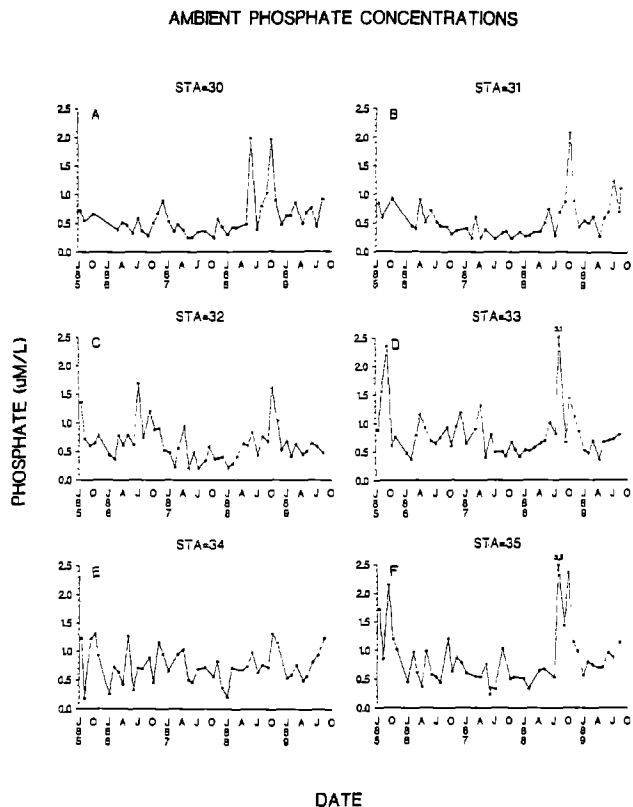

Figure 54. Concentrations ( $\mu\text{M/l}$ ) of phosphate measured at 0.5 m depth at: (a) station 30, (b) station 31, (c) station 32, (d) station 33, (e) station 34, and (f) station 35 from July 1985 through August 1989.

Bottom-water DO concentrations and temperatures are presented for stations 30-35 (Figure 58a-f). As expected, DO was generally negatively correlated with seasonally oscillating temperatures. Concentrations of DO at sandy stations 30 and 31 showed no response to the cessation of dumping (Figure 58a,b). Station 32 showed a minor response prior to the phaseout when DO levels reached a minimum of between 3 and 4 ml/l (Figure 58c). During and after phaseout, minimum DO concentrations were always above 4 ml/l.

The deeper and organically enriched stations, 33-35 (Figure 58d-f), all had minimum DO concentrations lower than stations 30-32 (Figure 58a-c) and were more responsive to the cessation of dumping. Station 33 had minimum DO concentrations between 2 and 3 ml/l before cessation and between 3 and 4.7 ml/l during and after phaseout (Figure 58d). Minimum DO concentrations at station 34, before phaseout began, were in the range of 1.8-2.0 ml/l (Figure 58e). During and after phaseout, minimum DO concentrations were in the range of 3-4 ml/l. At station 35, the substantial increase in minimum DO concentrations, during and after cessation, was somewhat unexpected because we had perceived this station to be affected minimally by sludge dumping and quite affected by dredge spoil dumping (Figure 58f). Minimum DO concentrations measured in 1989, however, indicate values equivalent to

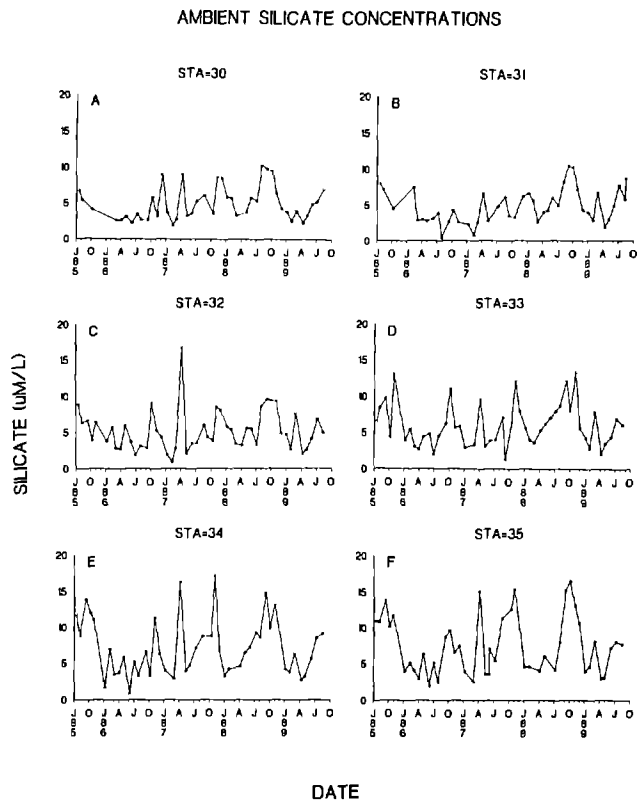

Figure 55. Concentrations ( $\mu\text{M/l}$ ) of silicate measured at 0.5 m depth at: (a) station 30, (b) station 31, (c) station 32, (d) station 33, (e) station 34, and (f) station 35 from July 1985 through August 1989.

those measured before phaseout. That the cessation of sludge dumping is the causative agent for the higher minimum values of DO concentrations is difficult to suggest based on these preliminary data. However, the decreased rates of SOC in 1987 and 1988 probably resulted in the higher bottom-water DO concentrations measured during those years.

## BENTHIC MACROFAUNA

*R. Reid, Principal Investigator, S.A. Fromm, D. Jeffress, J. Vitaliano, A. Frame, and D. Radosh*

As indicated previously (Environmental Processes Division 1989), changes in the structure of benthic assemblages may be a useful indicator of biological effects of cessation of sewage sludge dumping. Efforts have concentrated on completing processing of the three samples collected in alternate months from the center of each replicate station (NY6, R2, and NY11), with additional processing planned for samples collected at those station centers during the broadscale cruises. Data from these latter collections will provide monthly measurements and strengthen analysis of trends at the study's three central points. This preliminary analysis examines trends over summer



### Total Plankton Respiration

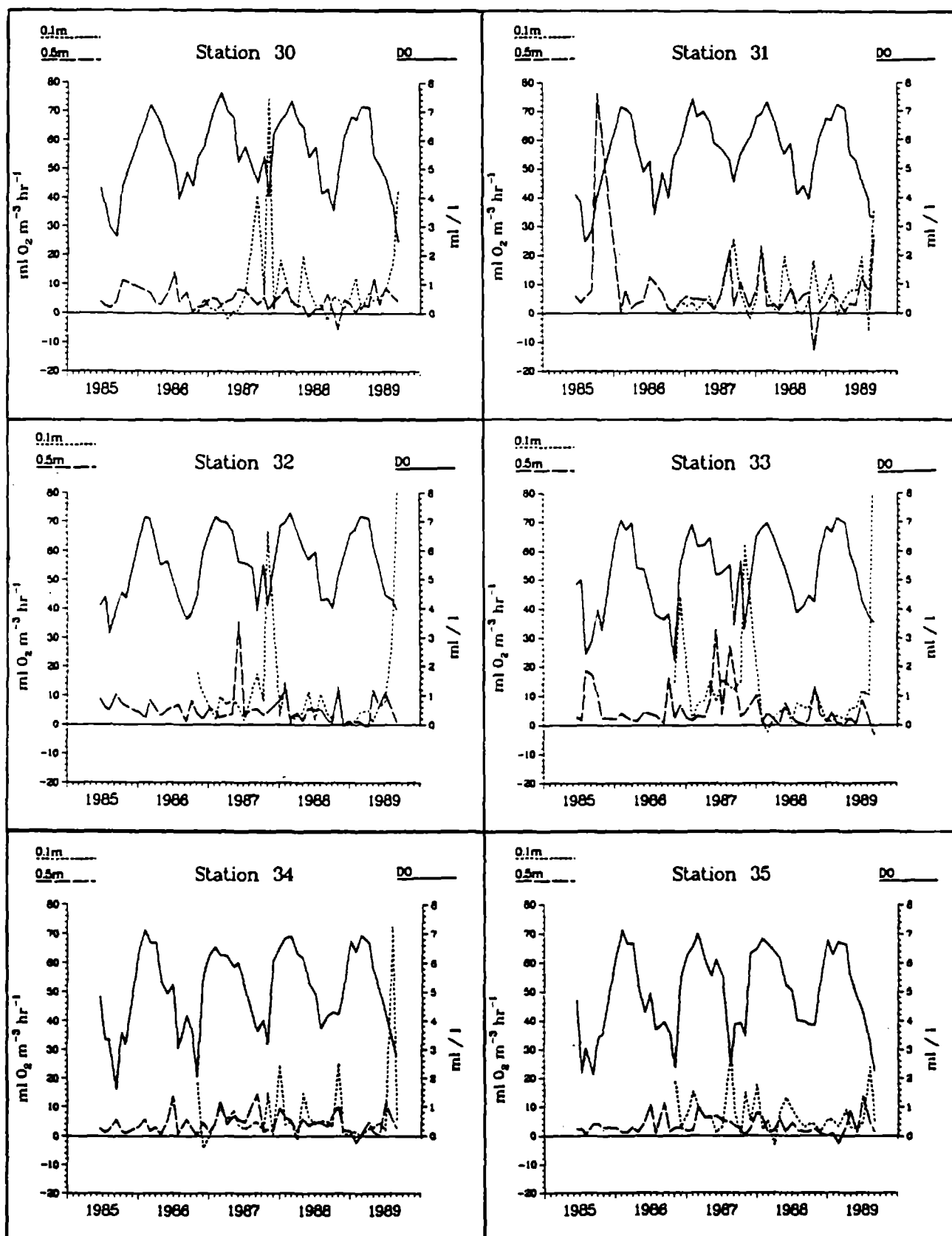

Figure 57. TPR rates measured at 0.1-m (...) and 0.5-m (---) depths and concentrations (ml/l) of DO (DO---) at: (a) station 30, (b) station 31, (c) station 32, (d) station 33 (NY6), (e) station 34, and (f) station 35.



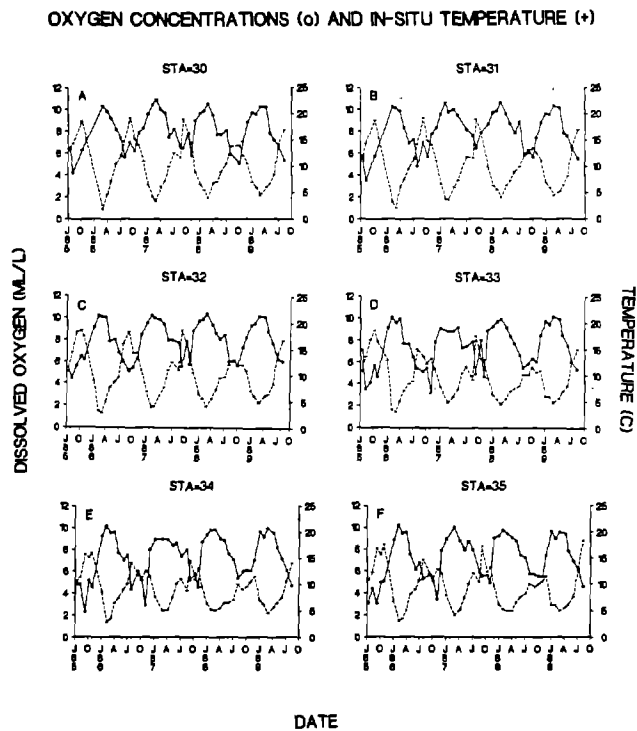

Figure 58. Bottom-water DO concentrations (ml/l[\*]) and *in situ* temperature (°C[+]) measured at: (a) station 30, (b) station 31, (c) station 32, (d) station 33, (e) station 34, and (f) station 35.

structure of finfish and megainvertebrate communities would differ significantly among the three replicate sites prior to the cessation of dumping; and (2) following the cessation of dumping and demonstrated shifts in sediment contaminants and benthic forage species, the abundance and distribution of finfish and megainvertebrates at the most polluted sites would be similar to the relatively cleaner reference stations (Environmental Processes Division 1988).

The characterization of the fish and megainvertebrate (shellfish/crustacean) communities during the phaseout and cessation of dumping is drawn from data from sampling at the three replicate stations, R2, NY6, and NY11. The data were obtained from a series of standard net tows; the gear and techniques used have been described previously (Environmental Processes Division 1988). The similarities and differences of species composition at the three stations, seasonal patterns of species distribution, dominance hierarchy, and relative biomass from 168 trawl catches at each of the three stations comprise this characterization.

The three replicated series available for comparison each represent data from seven surveys, each set of which includes catches from November, January, March, May, July, August, and September for 1986-87 (Table 6), 1987-88 (Table 7), and 1988-89 (Table 8). For purposes of grouping by season, the discussions of each species are referenced by seasonal sets, October-January, February-May, and June-September. In all cases, biomass estimates are expressed as weight (kg) per standard tow. Total

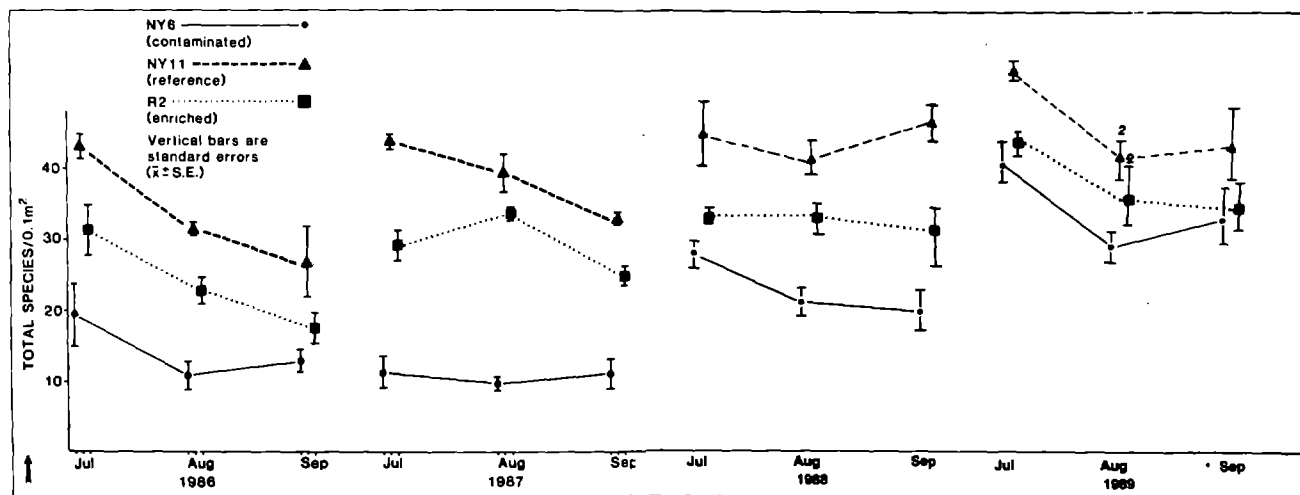

Figure 59. Means and standard errors for number of species (S) per 0.1 m<sup>2</sup> for replicate grabs 1-3 from each replicate station. Where indicated above error bars, only two grabs analyzed.

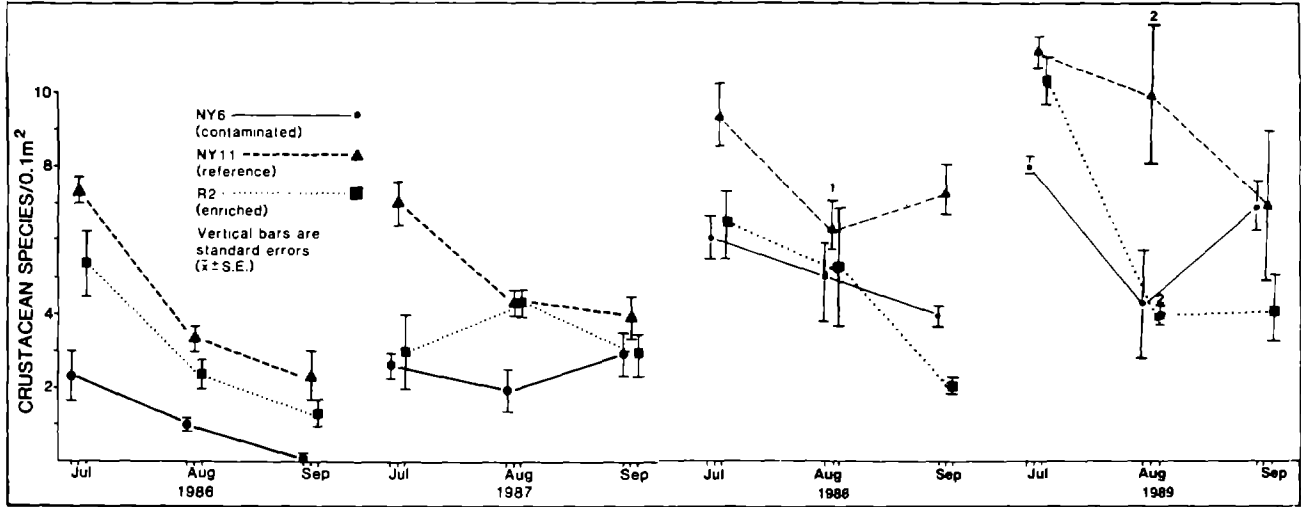

Figure 60. Means and standard errors for numbers of crustacean species per 0.1 m<sup>2</sup> for replicate grabs 1-3 from each replicate station. Where indicated above error bars, only two grabs analyzed.

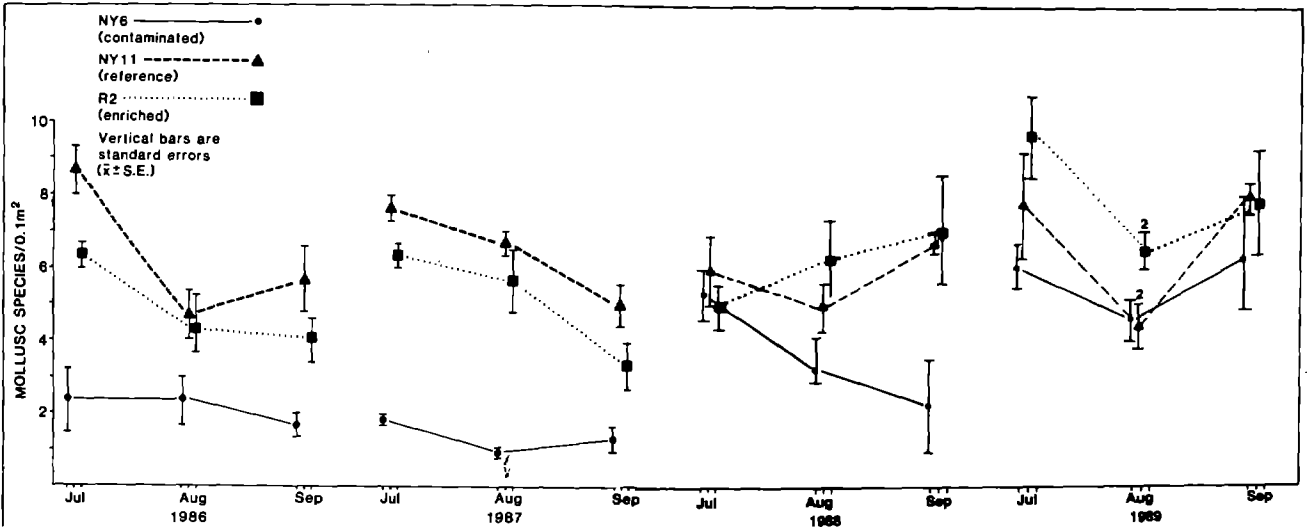

Figure 61. Means and standard errors for numbers of mollusc species per 0.1 m<sup>2</sup> for replicate grabs 1-3 from each replicate station. Where indicated above error bars, only two grabs analyzed.

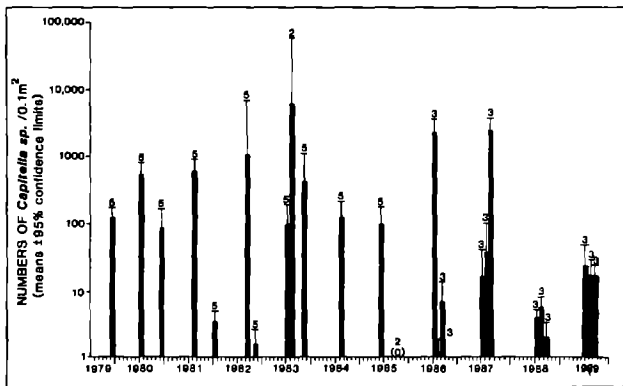

Figure 62. Means and 95-percent confidence limits for numbers of *Capitella* sp. per 0.1 m<sup>2</sup> at NY6 from 1979 to 1989. Numbers of samples analyzed are given above confidence limits.

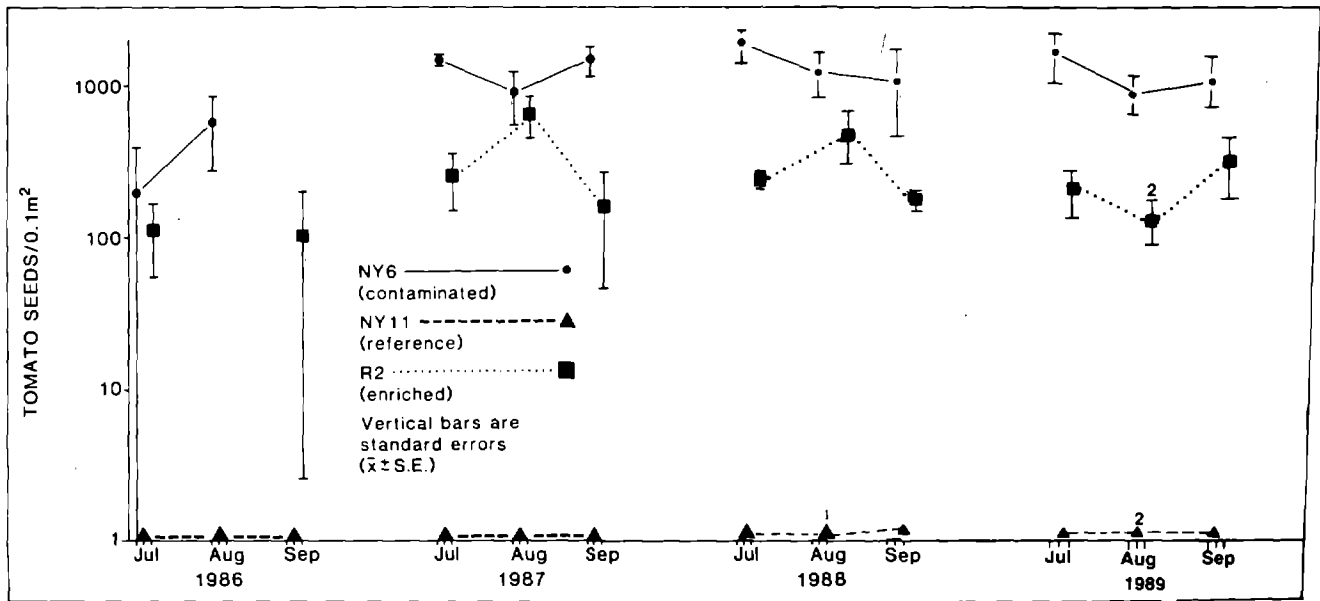

Figure 63. Means and standard errors for numbers of tomato seeds per 0.1 m<sup>2</sup> for replicate grabs 1-3 from each replicate station.

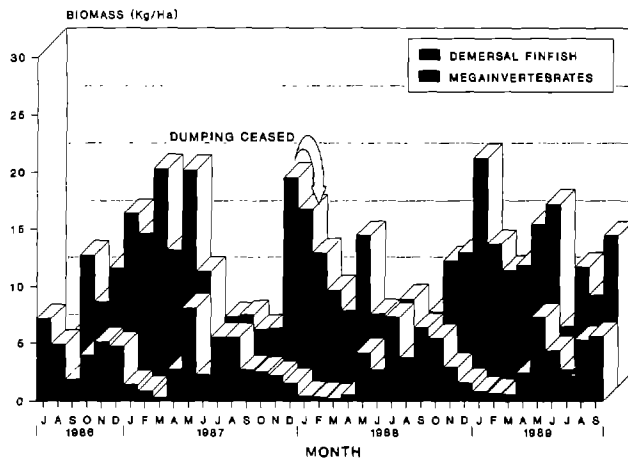

Figure 64. Biomass (kg/ha) of demersal finfish and megainvertebrates collected at all stations (replicate and broadscale) prior to and following cessation of dumping at the 12-mile dumpsite.

seasonal biomass for subsets of finfish and invertebrate types are summarized by years (Table 9).

Some consistencies throughout the study are evident. Demersal fish, as expected, always constituted the group with greatest biomass except in 1989 when an influx of spiny dogfish enhanced the semipelagic category (Table 9). Of the megainvertebrates trawled, crustaceans dominated in all years and time sets. Biomass of demersal fish was generally three times that of crustaceans and was invariably greatest in October through January, and least in June through September (Figure 64). Although the ranking of demersal finfish and megainvertebrate biomass varied

among years and species, little skate and Atlantic rock crab were consistently predominant at all stations (Table 10).

#### *Little Skate (Raja erinacea)*

From 1986 to 1989, there appears to be a slight reduction in the percent occurrence of little skate in relation to the total demersal finfish biomass from October to May at R2, and February to May at NY6 (Table 11). No distinct change in the percent of little skate is obvious at NY11. During the summer, this species makes up the majority of demersal finfish biomass at all three stations (Table 11). Although there was some variability over time, in general, biomass was relatively consistent at all stations (Figure 65).

#### *Winter Flounder (Pseudopleuronectes americanus)*

Seasonal biomass of winter flounder increased slightly at R2 and NY6 from October through January during the last two years of the study (Table 12, Figure 66). From October to May, the weight per tow was least at NY11. Similarly, the percentage of winter flounder in the demersal finfish biomass increased during the fall at R2 and to a lesser degree at NY6. The spring percentages are remarkably similar among years at R2.

The variation in winter flounder biomass among seasons and years (Figure 66) is probably a feature related to the species' normal inshore-offshore migrations from estuarine spawning grounds in the spring to nearshore post-spawning feeding areas from late spring through the warmer months.

Table 6. Finfish and megainvertebrate species composition, biomass, and numbers recorded from each of the three replicate stations. Sampling dates are from November 1986 through September 1987. Weights (kg) and numbers are normalized to a 1-km tow. (Occ. = occurrence)

Species	Station R2 (56 tows)				Station NY6 (56 tows)				Station NY11 (56 tows)						
	Occ.	Wt./Tow	Occ./Tow	No./Tow	Occ.	Wt./Tow	Occ./Tow	No./Tow	Occ.	Wt./Tow	Occ./Tow	No./Tow			
<b>Finfish</b>															
Alewife	5	0.09	0.01	1.4	0.1	11	0.26	0.05	2.3	0.5	6	0.32	0.03	3.8	0.4
Atlantic herring	8	2.79	0.40	16.9	2.4	8	1.53	0.22	9.9	1.4	4	14.64	1.05	96.8	6.9
Atlantic mackerel	0	0.00	0.00	0.0	0.0	0	0.00	0.00	0.0	0.0	1	0.25	0.00	1.7	0.0
Atlantic silverside	0	0.00	0.00	0.0	0.0	0	0.00	0.00	0.0	0.0	1	0.04	0.00	0.8	0.0
Black sea bass	0	0.00	0.00	0.0	0.0	1	0.31	0.01	1.0	0.0	2	0.21	0.01	0.8	0.0
Blueback herring	4	0.26	0.02	5.0	0.4	2	1.78	0.06	25.2	0.9	0	0.00	0.00	0.0	0.0
Bluefish	0	0.00	0.00	0.0	0.0	1	0.60	0.01	0.9	0.0	0	0.00	0.00	0.0	0.0
Butterfish	26	0.55	0.25	19.0	8.8	29	0.33	0.17	21.8	11.3	12	0.04	0.01	1.4	0.3
Clearnose skate	1	1.38	0.02	0.8	0.0	0	0.00	0.00	0.0	0.0	2	1.09	0.04	0.9	0.0
Cunner	6	0.30	0.03	2.0	0.2	14	0.72	0.18	5.3	1.3	4	1.28	0.09	10.8	0.8
Fourspot flounder	18	0.86	0.28	4.7	1.5	19	0.54	0.18	3.1	1.0	30	0.41	0.22	2.4	1.3
Goosefish	7	0.41	0.05	1.0	0.1	16	0.55	0.16	1.2	0.3	5	3.35	0.30	1.1	0.1
Gulfstream flounder	3	0.06	0.00	1.1	0.1	17	0.11	0.03	2.7	0.8	10	0.16	0.03	4.2	0.8
Haddock	1	0.04	0.00	0.8	0.0	8	0.05	0.01	1.1	0.2	5	0.04	0.00	1.7	0.2
Hickory shad	2	0.06	0.00	0.8	0.0	1	0.04	0.00	0.8	0.0	0	0.00	0.00	0.0	0.0
Little skate	55	8.63	8.48	19.2	18.9	43	3.84	2.95	9.3	7.1	49	5.09	4.45	12.4	10.8
Longhorn sculpin	4	0.29	0.02	0.8	0.1	4	0.42	0.03	1.0	0.1	1	0.78	0.01	1.6	0.0
Northern kingfish	1	0.08	0.00	0.8	0.0	0	0.00	0.00	0.0	0.0	0	0.00	0.00	0.0	0.0
Northern puffer	0	0.00	0.00	0.0	0.0	1	0.09	0.00	0.9	0.0	0	0.00	0.00	0.0	0.0
Northern searobin	7	0.16	0.02	1.3	0.2	4	0.07	0.00	0.9	0.1	4	0.07	0.00	1.6	0.1
Ocean pout	20	4.66	1.66	11.4	4.1	18	0.99	0.32	2.8	0.9	13	1.93	0.45	2.3	0.5
Planehead filefish	0	0.00	0.00	0.0	0.0	0	0.00	0.00	0.0	0.0	3	0.06	0.00	0.8	0.0
Red hake	26	0.90	0.42	6.7	3.1	37	1.73	1.14	9.8	6.5	8	0.29	0.04	2.4	0.3
Rough scad	0	0.00	0.00	0.0	0.0	1	0.04	0.00	0.9	0.0	0	0.00	0.00	0.0	0.0
Round herring	0	0.00	0.00	0.0	0.0	2	0.47	0.02	33.8	1.2	0	0.00	0.00	0.0	0.0
Scup	7	0.23	0.03	8.7	1.1	9	0.30	0.05	12.3	2.0	9	0.17	0.03	10.0	1.6
Sea raven	3	0.33	0.02	1.0	0.1	1	1.11	0.02	1.6	0.0	6	0.35	0.04	0.9	0.1
Silver hake	29	0.49	0.25	3.8	2.0	31	0.74	0.41	5.4	3.0	17	0.32	0.10	3.6	1.1
Smooth dogfish	4	3.12	0.22	1.4	0.1	3	3.88	0.21	1.7	0.1	0	0.00	0.00	0.0	0.0
Spiny dogfish	6	7.91	0.85	1.8	0.2	2	4.72	0.17	1.6	0.1	1	10.31	0.18	2.7	0.0
Spotted hake	3	0.32	0.02	1.8	0.1	3	0.21	0.01	2.4	0.1	3	0.17	0.01	0.9	0.0
Striped searobin	4	0.21	0.01	1.2	0.1	3	0.12	0.01	1.2	0.1	2	0.18	0.01	0.9	0.0
Summer flounder	6	0.30	0.03	0.8	0.1	10	0.55	0.10	1.6	0.3	12	0.56	0.12	2.0	0.4
Tautog	0	0.00	0.00	0.0	0.0	0	0.00	0.00	0.0	0.0	1	0.78	0.01	1.6	0.0
Windowpane	16	0.54	0.15	1.6	0.4	19	0.32	0.11	1.5	0.5	13	0.37	0.09	1.3	0.3
Winter flounder	47	1.42	1.19	5.6	4.7	48	1.48	1.27	6.6	5.7	43	0.87	0.67	3.7	2.8
Winter skate	3	1.80	0.10	2.3	0.1	0	0.00	0.00	0.0	0.0	1	0.37	0.01	0.9	0.0
Yellowtail flounder	5	0.55	0.05	1.8	0.2	8	0.84	0.12	2.2	0.3	15	0.60	0.16	1.6	0.4
<b>FINFISH SUBTOTAL</b>			<b>14.60</b>		<b>49.2</b>		<b>8.00</b>		<b>45.7</b>			<b>8.16</b>		<b>29.7</b>	

Table 6. Continued.

Species	Station R2 (56 tows)					Station NY6 (56 tows)					Station NY11 (56 tows)				
	Occ.	Wt./Occ.	Wt./Tow	No./Occ.	No./Tow	Occ.	Wt./Occ.	Wt./Tow	No./Occ.	No./Tow	Occ.	Wt./Occ.	Wt./Tow	No./Occ.	No./Tow
<b>Invertebrates</b>															
American lobster	13	0.49	0.11	1.5	0.4	28	0.85	0.43	3.0	1.5	22	0.61	0.24	1.5	0.6
Atlantic rock crab	53	5.52	5.23	52.1	49.4	49	4.04	3.53	27.8	24.3	48	1.56	1.34	10.3	8.8
Hermit crab (unclass.)	21	0.11	0.04	1.8	0.7	11	0.11	0.02	1.5	0.3	2	0.13	0.00	0.9	0.0
Horseshoe crab	20	3.59	1.28	1.9	0.7	20	1.98	0.71	1.3	0.5	4	2.72	0.19	1.6	0.1
Jonah crab	15	0.27	0.07	1.7	0.5	20	0.33	0.12	2.3	0.8	9	0.09	0.01	1.0	0.2
Lady crab	3	0.06	0.00	1.2	0.1	2	0.05	0.00	0.9	0.0	0	0.00	0.00	0.0	0.0
Longfin squid	30	0.91	0.49	24.8	13.3	26	0.50	0.23	18.5	8.6	27	0.75	0.36	16.2	7.8
Moon snail (unclass.)	2	0.27	0.01	1.7	0.1	0	0.00	0.00	0.0	0.0	1	0.33	0.01	0.8	0.0
Northern shortfin squid	5	0.75	0.07	16.1	1.4	9	0.67	0.11	17.5	2.8	5	0.33	0.03	13.2	1.2
Ocean quahog	0	0.00	0.00	0.0	0.0	0	0.00	0.00	0.0	0.0	1	0.27	0.00	0.9	0.0
Spider crab (unclass.)	2	0.38	0.01	0.8	0.0	1	0.04	0.00	1.7	0.0	0	0.00	0.00	0.0	0.0
Starfish (unclass.)	29	0.08	0.04	3.7	1.9	18	0.07	0.02	3.3	1.1	49	0.25	0.22	7.4	6.5
<b>INVERTEBRATE SUBTOTAL</b>			<b>7.36</b>		<b>68.3</b>			<b>5.17</b>		<b>39.9</b>			<b>2.41</b>		<b>25.2</b>
<b>TOTAL</b>			<b>21.95</b>		<b>117.4</b>			<b>13.17</b>		<b>85.6</b>			<b>10.58</b>		<b>54.9</b>

Table 7. Finfish and megainvertebrate species composition, biomass, and numbers recorded from each of the three replicate stations. Sampling dates are from November 1987 through September 1988. Weights (kg) and numbers are normalized to a 1-km tow. (Occ. = occurrence)

Species	Station R2 (56 tows)				Station NY6 (56 tows)				Station NY11 (56 tows)						
	Occ.	Wt./Occ.	Wt./Tow	No./Occ.	No./Tow	Occ.	Wt./Occ.	Wt./Tow	No./Occ.	No./Tow	Occ.	Wt./Occ.	Wt./Tow	No./Occ.	No./Tow
<b>Finfish</b>															
Alewife	9	0.16	0.03	2.6	0.4	5	0.13	0.01	1.5	0.1	2	0.04	0.00	1.9	0.1
American shad	4	0.04	0.00	1.5	0.1	1	0.05	0.00	1.0	0.0	1	0.04	0.00	0.8	0.0
Atlantic herring	4	0.21	0.01	1.5	0.1	6	0.39	0.04	1.8	0.2	1	0.15	0.00	1.5	0.0
Atlantic menhaden	0	0.00	0.00	0.0	0.0	1	0.16	0.00	0.8	0.0	0	0.00	0.00	0.0	0.0
Bigeye	0	0.00	0.00	0.0	0.0	0	0.00	0.00	0.0	0.0	1	0.04	0.00	0.9	0.0
Black sea bass	4	0.15	0.01	0.7	0.1	3	0.25	0.01	0.8	0.0	2	0.12	0.00	0.8	0.0
Blueback herring	2	0.06	0.00	1.5	0.1	0	0.00	0.00	0.0	0.0	4	0.11	0.01	4.0	0.3
Bluefish	1	0.04	0.00	0.8	0.0	0	0.00	0.00	0.0	0.0	0	0.00	0.00	0.0	0.0
Butterfish	31	0.65	0.36	24.3	13.5	32	0.31	0.18	12.4	7.1	16	0.16	0.05	8.5	2.4
Conger eel	0	0.00	0.00	0.0	0.0	0	0.00	0.00	0.0	0.0	1	0.08	0.00	0.8	0.0
Cunner	6	0.32	0.03	1.9	0.2	13	3.30	0.77	12.2	2.8	6	2.59	0.28	17.2	1.8
Fourspot flounder	26	0.88	0.41	4.5	2.1	28	1.00	0.50	5.1	2.6	32	0.47	0.27	3.0	1.7
Goosefish	3	5.46	0.29	0.8	0.0	6	0.65	0.07	0.8	0.1	7	2.02	0.25	0.9	0.1
Gulfstream flounder	23	0.05	0.02	1.5	0.6	28	0.06	0.03	2.2	1.1	24	0.07	0.03	3.2	1.4
Haddock	8	0.07	0.01	1.7	0.2	8	0.06	0.01	1.0	0.1	3	0.04	0.00	0.8	0.0
Inquiline snailfish	0	0.00	0.00	0.0	0.0	1	0.04	0.00	0.9	0.0	0	0.00	0.00	0.0	0.0
Lined seahorse	3	0.05	0.00	0.9	0.0	0	0.00	0.00	0.0	0.0	0	0.00	0.00	0.0	0.0
Little skate	54	5.34	5.15	11.7	11.2	53	4.50	4.26	11.7	11.1	47	4.48	3.76	13.0	10.9
Longhorn sculpin	7	0.34	0.04	1.1	0.1	2	0.23	0.01	0.7	0.0	2	0.26	0.01	0.8	0.0
Northern scarobin	1	0.04	0.00	0.9	0.0	3	0.05	0.00	1.1	0.1	0	0.00	0.00	0.0	0.0
Ocean pout	16	4.48	1.28	10.3	2.9	12	0.72	0.15	1.2	0.3	11	4.93	0.97	5.7	1.1
Pollock	1	0.09	0.00	0.9	0.0	0	0.00	0.00	0.0	0.0	0	0.00	0.00	0.0	0.0
Red hake	43	0.43	0.33	4.0	3.0	32	0.34	0.19	5.1	2.9	14	0.06	0.01	1.0	0.3
Scup	13	0.94	0.22	9.7	2.3	11	0.75	0.15	7.4	1.5	10	0.95	0.17	11.6	2.1
Sea raven	1	0.16	0.00	0.8	0.0	0	0.00	0.00	0.0	0.0	4	0.88	0.06	1.5	0.1
Silver hake	36	0.21	0.13	3.9	2.5	30	0.35	0.19	8.6	4.6	37	0.12	0.08	3.8	2.5
Smallmouth flounder	0	0.00	0.00	0.0	0.0	0	0.00	0.00	0.0	0.0	1	0.05	0.00	2.1	0.0
Smooth dogfish	1	1.91	0.03	0.8	0.0	0	0.00	0.00	0.0	0.0	1	3.45	0.06	0.8	0.0
Spiny dogfish	8	10.70	1.53	6.4	0.9	7	19.94	2.49	12.8	1.6	6	4.08	0.44	2.6	0.3
Spotted hake	8	0.20	0.03	1.2	0.2	6	3.83	0.41	1.0	0.1	1	0.05	0.00	1.0	0.0
Striped searobin	2	0.27	0.01	1.7	0.1	3	0.12	0.01	1.3	0.1	2	0.05	0.00	0.9	0.0
Sturgeon (unclass.)	0	0.00	0.00	0.0	0.0	1	4.63	0.08	0.8	0.0	0	0.00	0.00	0.0	0.0
Summer flounder	2	0.95	0.03	2.5	0.1	9	0.37	0.06	1.0	0.2	3	0.44	0.02	0.8	0.0
Tautog	0	0.00	0.00	0.0	0.0	0	0.00	0.00	0.0	0.0	1	0.28	0.01	1.4	0.0
Weakfish	1	0.04	0.00	0.8	0.0	1	1.08	0.02	0.8	0.0	0	0.00	0.00	0.0	0.0
Windowpane	23	0.73	0.30	5.7	2.4	33	0.91	0.54	5.6	3.3	16	0.32	0.09	1.7	0.5
Winter flounder	55	2.20	2.16	13.3	13.1	55	1.50	1.47	8.3	8.1	50	0.81	0.73	4.1	3.6
Winter skate	4	0.43	0.03	1.2	0.1	4	3.24	0.23	0.8	0.1	7	2.44	0.30	1.7	0.2
Yellowtail flounder	13	0.06	0.01	1.3	0.3	33	0.15	0.09	2.9	1.7	34	0.20	0.12	2.5	1.5
<b>FINFISH SUBTOTAL</b>			<b>12.48</b>		<b>56.7</b>			<b>11.98</b>		<b>49.9</b>			<b>7.73</b>		<b>31.3</b>

Table 7. Continued.

Species	Station R2 (56 tows)					Station NY6 (56 tows)					Station NY11 (56 tows)				
	Occ.	Wt./Occ.	Wt./Tow	No./Occ.	No./Tow	Occ.	Wt./Occ.	Wt./Tow	No./Occ.	No./Tow	Occ.	Wt./Occ.	Wt./Tow	No./Occ.	No./Tow
<b>Invertebrates</b>															
American lobster	28	0.41	0.21	1.5	0.8	31	0.62	0.34	2.1	1.2	14	0.34	0.08	1.3	0.3
Atlantic rock crab	50	6.26	5.59	81.0	72.3	45	2.34	1.88	28.4	22.8	49	1.65	1.45	19.2	16.8
Blue crab	1	0.13	0.01	0.8	0.0	1	0.04	0.00	0.8	0.0	0	0.00	0.00	0.0	0.0
Bristled longbeak shrimp	6	0.06	0.01	3.2	0.3	1	0.04	0.00	1.7	0.0	1	0.04	0.00	0.8	0.0
Hermit crab (unclass.)	16	0.05	0.01	1.2	0.4	6	0.07	0.01	0.9	0.1	3	0.06	0.00	0.8	0.0
Horseshoe crab	15	3.59	0.96	2.0	0.5	8	1.52	0.22	0.9	0.1	0	0.00	0.00	0.0	0.0
Jonah crab	13	0.25	0.06	1.7	0.4	16	0.23	0.07	1.6	0.5	9	0.08	0.01	1.0	0.2
Lady crab	5	0.05	0.00	0.9	0.1	4	0.05	0.00	0.9	0.1	0	0.00	0.00	0.0	0.0
Longfin squid	29	0.27	0.14	8.6	4.4	27	0.15	0.07	6.7	3.3	29	0.36	0.18	19.8	10.3
Moon snail (unclass.)	0	0.00	0.00	0.0	0.0	4	0.06	0.00	0.8	0.1	3	0.14	0.01	0.8	0.0
Ocean quahog	0	0.00	0.00	0.0	0.0	0	0.00	0.00	0.0	0.0	1	0.46	0.01	0.9	0.0
Spider crab (unclass.)	1	0.22	0.00	1.1	0.0	1	0.04	0.00	0.8	0.0	0	0.00	0.00	0.0	0.0
Starfish (unclass.)	53	0.20	0.19	8.3	7.9	25	0.05	0.02	1.6	0.7	55	0.49	0.48	16.1	15.9
<b>INVERTEBRATE SUBTOTAL</b>			<b>7.18</b>		<b>87.2</b>			<b>2.61</b>		<b>28.8</b>			<b>2.23</b>		<b>43.5</b>
<b>TOTAL</b>			<b>19.66</b>		<b>143.9</b>			<b>4.59</b>		<b>78.7</b>			<b>9.96</b>		<b>74.8</b>

Table 8. Finfish and megainvertebrate species composition, biomass, and numbers recorded from each of the three replicate stations. Sampling dates are from November 1988 through September 1989. Weights (kg) and numbers are normalized to a 1-km tow. (Occ. = occurrence)

Species	Station R2 (56 tows)					Station NY6 (56 tows)					Station NY11 (56 tows)				
	Occ.	Wt./Occ.	Wt./Tow	No./Occ.	No./Tow	Occ.	Wt./Occ.	Wt./Tow	No./Occ.	No./Tow	Occ.	Wt./Occ.	Wt./Tow	No./Occ.	No./Tow
<b>Finfish</b>															
Alewife	1	0.16	0.00	1.6	0.0	2	0.13	0.00	2.7	0.1	1	0.04	0.00	0.9	0.0
American shad	0	0.00	0.00	0.0	0.0	2	0.24	0.01	0.8	0.0	0	0.00	0.00	0.0	0.0
Atlantic cod	1	0.23	0.00	0.8	0.0	0	0.00	0.00	0.0	0.0	1	1.36	0.02	0.8	0.0
Atlantic herring	6	0.69	0.07	4.7	0.5	6	1.22	0.13	6.8	0.7	1	0.38	0.01	3.0	0.1
Black sea bass	3	0.23	0.01	0.8	0.0	1	1.14	0.02	1.3	0.0	3	0.05	0.00	0.8	0.0
Blueback herring	1	0.04	0.00	0.7	0.0	0	0.00	0.00	0.0	0.0	0	0.00	0.00	0.0	0.0
Butterfish	34	0.88	0.53	64.5	39.2	31	0.81	0.45	64.6	35.8	27	1.20	0.58	85.0	41.0
Cunner	7	0.68	0.08	6.1	0.8	21	0.73	0.27	4.5	1.7	7	1.34	0.17	6.4	0.8
Fourspot flounder	26	0.74	0.35	4.5	2.1	32	1.48	0.84	8.7	5.0	30	0.35	0.19	2.6	1.4
Goosefish	4	4.56	0.33	0.9	0.1	8	0.81	0.12	1.3	0.2	3	1.14	0.06	0.8	0.0
Gulfstream flounder	10	0.05	0.01	1.4	0.2	26	0.06	0.03	2.1	1.0	16	0.05	0.01	1.8	0.5
Haddock	2	0.04	0.00	0.8	0.0	0	0.00	0.00	0.0	0.0	0	0.00	0.00	0.0	0.0
Lined seahorse	1	0.04	0.00	0.8	0.0	0	0.00	0.00	0.0	0.0	0	0.00	0.00	0.0	0.0
Little skate	56	7.56	7.56	16.1	16.1	51	5.57	5.07	14.2	12.9	51	6.43	5.86	16.7	15.2
Longhorn sculpin	10	0.18	0.03	1.1	0.2	3	0.09	0.01	0.9	0.1	1	0.09	0.00	0.9	0.0
Northern puffer	0	0.00	0.00	0.0	0.0	0	0.00	0.00	0.0	0.0	1	0.06	0.00	1.1	0.0
Northern searobin	4	0.04	0.00	1.2	0.1	3	0.07	0.00	1.9	0.1	3	0.05	0.00	1.2	0.1
Ocean pout	20	4.75	1.70	10.2	3.6	17	1.03	0.31	3.5	1.1	19	3.92	1.33	5.3	1.8
Red hake	29	0.89	0.46	6.2	3.2	25	1.02	0.46	7.3	3.3	11	0.61	0.12	5.9	1.2
Rock gunnel	0	0.00	0.00	0.0	0.0	1	0.08	0.00	0.8	0.0	0	0.00	0.00	0.0	0.0
Sand lance (unclass.)	0	0.00	0.00	0.0	0.0	0	0.00	0.00	0.0	0.0	1	0.04	0.00	0.8	0.0
Scup	12	1.21	0.26	36.5	7.8	13	1.88	0.44	55.1	12.8	10	0.18	0.03	6.8	1.2
Sea raven	1	0.04	0.00	0.8	0.0	4	0.75	0.05	0.9	0.1	4	0.40	0.03	0.8	0.1
Silver hake	44	1.07	0.84	7.8	6.1	39	1.41	0.98	11.4	8.0	19	0.51	0.17	3.9	1.3
Smooth dogfish	3	2.69	0.14	0.9	0.0	2	4.13	0.15	1.4	0.0	0	0.00	0.00	0.0	0.0
Spiny dogfish	8	11.72	1.67	8.7	1.2	10	56.25	10.04	42.9	7.7	11	37.69	7.40	23.2	4.6
Spotted hake	11	0.27	0.05	2.5	0.5	13	0.34	0.08	3.3	0.8	8	0.53	0.08	5.2	0.7
Striped searobin	0	0.00	0.00	0.0	0.0	1	0.25	0.00	1.3	0.0	0	0.00	0.00	0.0	0.0
Summer flounder	2	0.75	0.03	1.2	0.0	0	0.00	0.00	0.0	0.0	0	0.00	0.00	0.0	0.0
Tautog	1	0.58	0.01	1.2	0.0	0	0.00	0.00	0.0	0.0	1	0.15	0.00	0.8	0.0
Windowpane	23	0.31	0.13	1.7	0.7	27	0.37	0.18	2.2	1.1	12	0.22	0.05	1.3	0.3
Winter flounder	50	2.00	1.79	9.6	8.6	53	2.32	2.19	12.4	11.8	41	0.87	0.64	4.0	2.9
Winter skate	5	3.93	0.35	1.4	0.1	4	1.59	0.11	1.5	0.1	3	4.25	0.23	2.5	0.1
Yellowtail flounder	26	0.43	0.20	3.3	1.5	30	1.12	0.60	7.8	4.2	27	0.81	0.39	3.6	1.7
<b>FINFISH SUBTOTAL</b>			<b>16.62</b>		<b>93.0</b>			<b>22.55</b>		<b>108.3</b>			<b>17.38</b>		<b>75.1</b>



Table 8. Continued.

Species	Station R2 (56 tows)					Station NY6 (56 tows)					Station NY11 (56 tows)				
	Occ.	Wt./Occ.	Wt./Tow	No./Occ.	No./Tow	Occ.	Wt./Occ.	Wt./Tow	No./Occ.	No./Tow	Occ.	Wt./Occ.	Wt./Tow	No./Occ.	No./Tow
<b>Invertebrates</b>															
American lobster	25	0.69	0.31	2.4	1.1	48	1.60	1.37	5.7	4.9	41	1.40	1.02	4.3	3.1
Atlantic rock crab	55	3.22	3.16	32.4	31.8	44	2.40	1.89	22.3	17.5	50	1.70	1.52	17.4	15.5
Blue crab	1	0.19	0.00	0.9	0.0	2	0.13	0.00	0.8	0.0	0	0.00	0.00	0.0	0.0
Bristled longbeak shrimp	0	0.00	0.00	0.0	0.0	0	0.00	0.00	0.0	0.0	1	0.04	0.00	0.8	0.0
Hermit crab (unclass.)	18	0.07	0.02	1.3	0.4	12	0.07	0.01	1.2	0.3	1	0.05	0.00	1.0	0.0
Horseshoe crab	18	3.86	1.24	2.7	0.9	13	1.49	0.35	1.0	0.2	1	1.96	0.03	0.9	0.0
Jonah crab	22	0.29	0.11	1.8	0.7	29	0.44	0.23	2.9	1.5	12	0.25	0.05	1.6	0.3
Lady crab	4	0.10	0.01	1.8	0.1	1	0.09	0.00	0.9	0.0	0	0.00	0.00	0.0	0.0
Longfin squid	37	0.55	0.37	19.2	12.7	30	0.49	0.26	24.5	13.1	34	0.55	0.33	19.4	11.8
Moon snail (unclass.)	1	0.09	0.00	0.9	0.0	0	0.00	0.00	0.0	0.0	1	0.10	0.00	1.0	0.0
Northern shortfin squid	0	0.00	0.00	0.0	0.0	0	0.00	0.00	0.0	0.0	1	0.04	0.00	0.9	0.0
Ocean quahog	1	0.04	0.00	0.8	0.0	0	0.00	0.00	0.0	0.0	0	0.00	0.00	0.0	0.0
Sea scallop	1	0.09	0.00	0.9	0.0	0	0.00	0.00	0.0	0.0	1	0.05	0.00	0.5	0.0
Spider crab (unclass.)	4	0.34	0.02	1.1	0.1	1	0.45	0.01	0.9	0.0	1	0.05	0.00	1.0	0.0
Starfish (unclass.)	23	0.07	0.03	2.8	1.2	36	0.07	0.04	2.5	1.6	51	0.48	0.43	12.6	11.5
<b>INVERTEBRATE SUBTOTAL</b>			<b>5.27</b>		<b>49.0</b>			<b>4.16</b>		<b>39.2</b>			<b>3.40</b>		<b>42.4</b>
<b>TOTAL</b>			<b>21.90</b>		<b>142.0</b>			<b>26.71</b>		<b>147.4</b>			<b>20.78</b>		<b>117.5</b>

Table 9. Seasonal biomass (kg/tow) per replicate station from 1986 through 1989

Category of Organism	Year	October-January			February-May			June-September		
		R2	NY6	NY11	R2	NY6	NY11	R2	NY6	NY11
Demersal finfish	86-87	17.4	9.1	9.1	13.9	12.1	6.3	9.1	2.4	5.9
	87-88	14.1	16.8	14.0	9.1	6.4	4.1	9.1	6.1	4.7
	88-89	13.2	12.0	10.9	16.6	14.0	9.3	13.3	10.2	8.5
Semipelagic finfish	86-87	3.7	1.1	0.7	0.2	0.2	0.1	0.6	0.6	0.*
	87-88	6.4	8.9	1.4	0.1	0.4	0.5	0.2	0.1	0.*
	88-89	5.9	34.9	25.2	1.1	0.7	0.8	0.9	1.1	1.3
Pelagic finfish	86-87	0.7	0.3	0.*	0.7	0.4	3.7	0.0	0.1	0.0
	87-88	0.*	0.1	0.*	0.*	0.*	0.0	0.*	0.0	0.0
	88-89	0.0	0.*	0.0	0.3	0.5	0.*	0.0	0.0	0.0
Crustaceans	86-87	6.2	3.4	2.0	6.4	6.4	2.6	7.4	4.6	1.1
	87-88	3.9	1.2	1.0	3.4	2.2	1.2	10.7	3.6	2.2
	88-89	4.0	2.0	1.6	6.6	4.7	2.1	4.3	4.5	3.4
Mollusks	86-87	1.1	0.7	0.2	0.2	0.*	0.2	0.5	0.3	0.6
	87-88	0.1	0.1	0.1	0.2	0.*	0.2	0.2	0.1	0.3
	88-89	0.5	0.1	0.1	0.1	0.*	0.2	0.5	0.5	0.6
Echinoderms	86-87	0.*	0.1	0.2	0.*	0.*	0.1	0.1	0.*	0.3
	87-88	0.2	0.*	0.2	0.*	0.*	0.2	0.3	0.*	0.9
	88-89	0.1	0.*	0.4	0.*	0.*	0.5	0.*	0.1	0.4

Note: 0.\* = value <0.05.

Table 10. Ranking of demersal finfish and megafaunal invertebrate biomass per replicate station and sampling year<sup>1</sup>

Species	1986-87			1987-88			1988-89		
	R2	NY6	NY11	R2	NY6	NY11	R2	NY6	NY11
<b>Demersal fish</b>									
Little skate	1	1	1	1	1	1	1	1	1
Ocean pout	2	5	3	3	6	2	3	5	2
Winter flounder	3	2	3	2	2	3	2	2	3
Red hake	4	3	-	5	4-5	-	4	4	6
Fourspot flounder	5	6	4	4	4-5	4	5	6	5
Silver hake	6	4	5	6	3	6	-	-	-
Yellowtail flounder	-	-	6	-	-	5	6	3	4
<b>Invertebrates</b>									
Atlantic rock crab	1	1	1	1	1	1	1	1	1
Horseshoe crab	2	2	4	2	2	-	2	3	4
Longfin squid	3	4	2	4	4	2	3	4	3
American lobster	4	3	3	3	3	3	4	2	2

<sup>1</sup>For purposes of comparison, the pelagic and semipelagic categories will not be considered here because of the inability of the bottom trawl gear to sample such fish semiquantitatively.

Table 11. Seasonal mean biomass (kg) per tow and percentage of demersal finfish biomass for little skate, *Raja erinacea*, per replicate station and sample year

Year	October-January			February-May			June-September		
	R2	NY6	NY11	R2	NY6	NY11	R2	NY6	NY11
<b>Mean Biomass per Tow (kg)</b>									
86-87	12.8	4.5	4.8	4.9	3.8	3.7	8.0	1.3	4.7
87-88	6.8	7.6	7.8	1.8	1.1	1.2 <sup>1</sup>	6.3	4.1	2.8 <sup>1</sup>
88-89	4.8	5.2	4.9 <sup>1</sup>	3.3	2.1	4.8 <sup>1</sup>	12.2	7.0	7.3 <sup>1</sup>
<b>Percentage of Demersal Finfish Biomass</b>									
86-87	73.5	49.4	52.7	35.2	31.4	58.7	87.9	54.1	79.7
87-88	48.2	45.2	55.7	19.7	17.2	29.3 <sup>1</sup>	69.2	67.2	35.7 <sup>1</sup>
88-89	36.4	43.3	44.9 <sup>1</sup>	19.9	15.0	51.6 <sup>1</sup>	91.7	68.6	85.8 <sup>1</sup>

<sup>1</sup>Post-dumping period.

Table 12. Seasonal mean biomass (kg) per tow and percentage of demersal finfish biomass for winter flounder, *Pseudopleuronectes americanus*, per replicate station and sample year

Year	October-January			February-May			June-September		
	R2	NY6	NY11	R2	NY6	NY11	R2	NY6	NY11
<b>Mean Biomass per Tow (kg)</b>									
86-87	1.8	1.3	0.9	1.7	2.0	0.4	0.4	0.7	0.7
87-88	3.5	1.6	0.4	1.4	1.9	0.8 <sup>1</sup>	0.7	1.1	1.9 <sup>1</sup>
88-89	3.8	2.7	0.9 <sup>1</sup>	1.8	2.1	0.6 <sup>1</sup>	0.7	0.9	0.5 <sup>1</sup>
<b>Percentage of Demersal Finfish Biomass</b>									
86-87	10.5	14.7	9.4	12.2	16.5	6.8	4.8	74.6	6.4
87-88	24.8	9.8	3.1	15.3	30.3	19.7 <sup>1</sup>	8.0	17.2	41.1 <sup>1</sup>
88-89	29.1	22.5	8.2 <sup>1</sup>	11.1	14.9	6.4 <sup>1</sup>	5.3	8.4	5.9 <sup>1</sup>

<sup>1</sup>Post-dumping period.

Table 13. Seasonal mean biomass (kg) per tow and percentage of demersal finfish biomass for ocean pout, *Macrozoarces americanus*, per replicate station and sample year

Year	October-January			February-May			June-September		
	R2	NY6	NY11	R2	NY6	NY11	R2	NY6	NY11
<b>Mean Biomass per Tow (kg)</b>									
86-87	1.3	0.6	1.0	4.5	0.5	0.6	0	0	0
87-88	1.1	0.2	2.7	3.4	0.3	0.7 <sup>1</sup>	0	0	0 <sup>1</sup>
88-89	1.1	0.4	2.9 <sup>1</sup>	4.9	0.6	1.8 <sup>1</sup>	0	0	0 <sup>1</sup>
<b>Percentage of Demersal Finfish Biomass</b>									
86-87	7.4	6.6	11.0	32.7	4.3	9.0	-	-	-
87-88	7.7	1.3	19.4	37.4	5.0	16.6 <sup>1</sup>	-	-	-
88-89	7.9	3.7	26.7 <sup>1</sup>	29.4	4.6	18.8 <sup>1</sup>	-	-	-

<sup>1</sup>Post-dumping period.

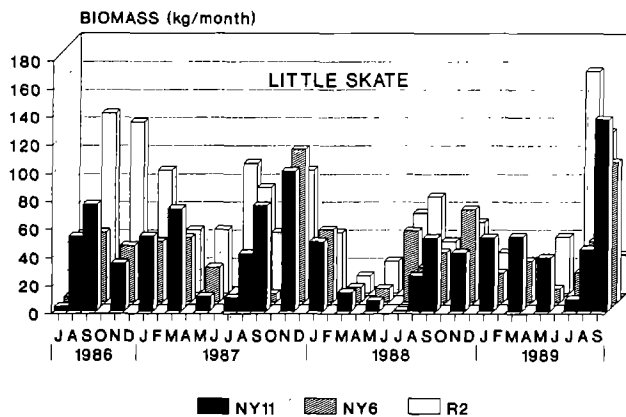

Figure 65. Seasonal biomass (kg) of little skate, *Raja erinacea*, collected at the three replicate stations from July 1986 through September 1989.

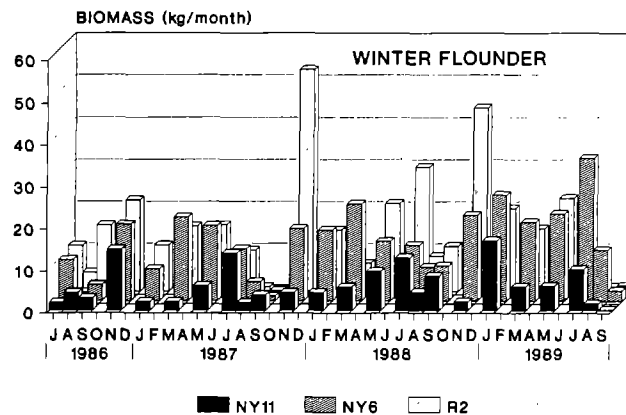

Figure 66. Seasonal biomass (kg) of winter flounder, *Pseudopleuronectes americanus*, collected at the three replicate stations from July 1986 through September 1989.

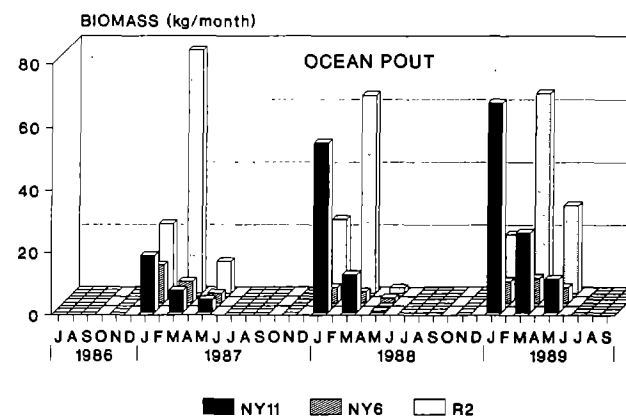

Figure 67. Seasonal biomass (kg) of ocean pout, *Macrozoarces americanus*, collected at the three replicate stations from July 1986 through September 1989.

**Ocean Pout (*Macrozoarces americanus*)**

Ocean pout is a cool-water demersal finfish and is available in the study area only from October to May (Table 13, Figure 67). There is no evidence from either the data or the literature of extensive migrations, but observations indicate that ocean pout regularly congregate around rough bottom where eggs are laid and guarded, and this behavior probably accounts for their unavailability in summer. The percentage of finfish biomass due to ocean pout was essentially similar among years except at NY11 where the fraction increased over the three years (Table 13). They were less common at NY6.

**Red Hake (*Urophycis chuss*)**

Red hake are a ubiquitous species of the demersal fish community, collected predominately from November through May (Figure 68). Biomass was generally greater at R2 and NY6 (highest). There was no clear trend among the three years, although the greatest biomass was collected at NY6 in February through May 1987. The species ranked from fourth to sixth in weight during the study, but only surpassed 10 percent of demersal finfish biomass at NY6 in fall 1986 and winter 1987.

**Fourspot Flounder (*Paralichthys oblongus*)**

Fourspot flounder are a persistent, relatively inconsequential member of the demersal finfish community. Their occurrence from May to September consisted mostly of juveniles which ventured into deeper waters with falling temperatures. There was no real change in their biomass during the three years, and they were always least available at NY11 (Figure 69). They generally ranked from fourth to sixth among stations and years during the study, only exceeding 10 percent of demersal finfish biomass at NY6 during February to May of 1988 and 1989.

**Silver Hake, (*Merluccius bilinearis*)**

This species showed a regular early peak biomass in January followed by a peak in May (Figure 70). Biomass was generally least at NY11 with fish occurring only sporadically in all areas during summer and fall. The greatest catches in weight occurred at R2 and NY6 during May 1989 (Figure 70). It is conjectured that trawl escapement has biased the ability to quantify adequately the relative abundance of silver hake. The species ranked from third to less than sixth during the study.

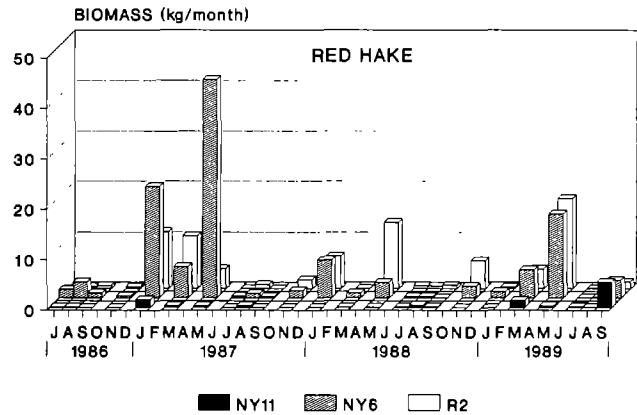

Figure 68. Seasonal biomass (kg) of red hake, *Urophycis chuss*, collected at the three replicate stations from July 1986 through September 1989.

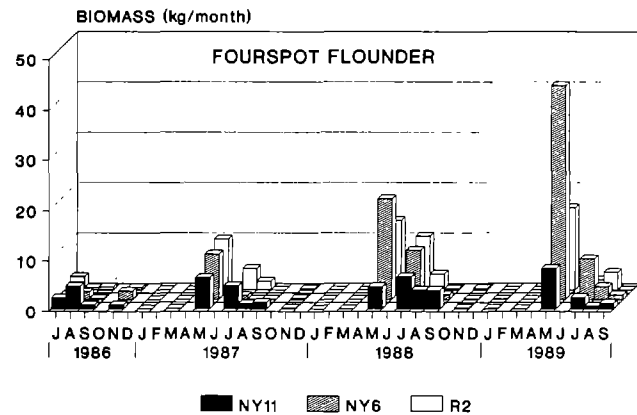

Figure 69. Seasonal biomass (kg) of fourspot flounder, *Paralichthys oblongus*, collected at the three replicate stations from July 1986 through September 1989.

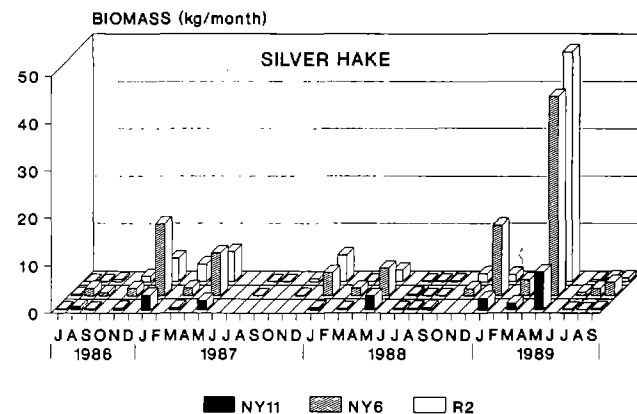

Figure 70. Seasonal biomass (kg) of silver hake, *Merluccius bilinearis*, collected at the three replicate stations from July 1986 through September 1989.

Table 14. Seasonal mean biomass (kg) per tow and annual percentage of total finfish biomass for spiny dogfish, *Mustelus canis* (values not in parentheses), and for smooth dogfish, *Squalus acanthius* (values in parentheses), per replicate station and sample year

Year	October-January			February-May			June-September		
	R2	NY6	NY11	R2	NY6	NY11	R2	NY6	NY11
<b>Mean Biomass per Tow (kg)</b>									
86-87	3.0	0.6	0.6	(0.1)	(0.1)	0.0	(0.4)	(0.4)	0.0
87-88	5.4	8.4	1.2	0.0	0.4	0.3/	(0.1)	0.0	0.0 <sup>1</sup>
88-89	5.0	34.6	25.2 <sup>1</sup>	0.9	0.6	0.8 <sup>1</sup>	0.3	0.3	0.0 <sup>1</sup>
<b>Percentage of Total Finfish Biomass</b>									
86-87	8.2			5.0			2.4		
87-88	53.2			57.8			57.0		
88-89	62.7			71.7			78.7		

<sup>1</sup>Post-dumping period.

MEAN BOTTOM TEMPERATURE (C)

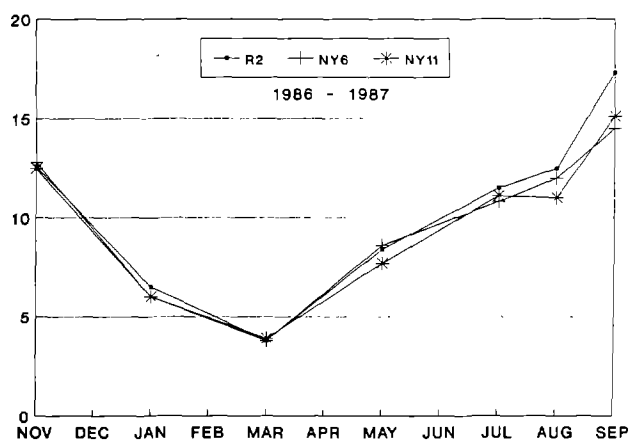

Figure 71a. Mean bottom temperatures (°C) at replicate stations R2 (-.-), NY6 (-+-), and NY11 (-\*-) from November 1986 through September 1987.

MEAN BOTTOM TEMPERATURE (C)

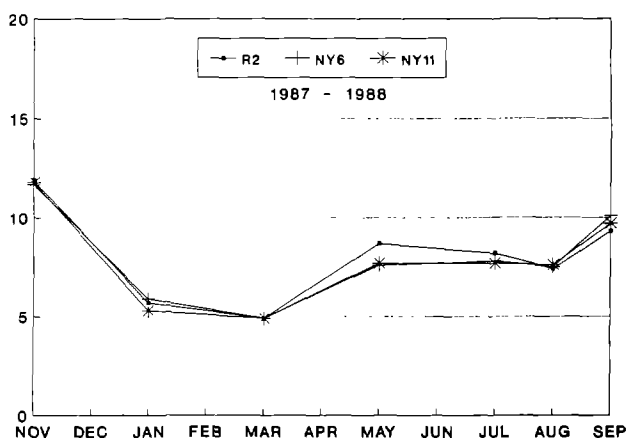

Figure 71b. Mean bottom temperatures (°C) at replicate stations R2 (-.-), NY6 (-+-), and NY11 (-\*-) from November 1987 through September 1988.

MEAN BOTTOM TEMPERATURE (C)

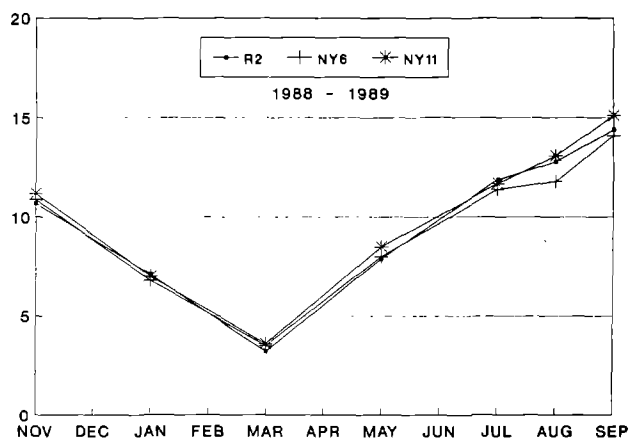

Figure 71c. Mean bottom temperatures (°C) at replicate stations R2 (-.-), NY6 (-+-), and NY11 (-\*-) from November 1988 through September 1989.

### Spiny Dogfish (*Mustelus canis*) and Smooth Dogfish (*Squalus acanthius*)

Both spiny and smooth dogfish are categorized as semipelagic, and the unusual abundance of spiny dogfish from October to January 1988-89 must be considered in interpreting trends of total fish biomass (Table 14). The influx of spiny dogfish is probably unrelated to any dump-site effect and is more likely a response to hydrographic differences or other parameters. Bottom temperature plots (Figures 71a,b,c) indicate that the lowest summer temperatures (nearly 5°C below the two other years) were recorded in 1988, with March 1989 the coldest month of the three-year survey. Most of the biomass increase in the last two

years was due to the catch of spiny dogfish, and this increase may be a reflection of general increases in elasmobranch populations in offshore waters.

### Atlantic Rock Crab (*Cancer irroratus*)

Atlantic rock crab was the most ubiquitous megainvertebrate; however, abundance was reduced regularly in winter (Figure 72). Of the four age groups sampled in the catch, ages I and II were by far the most abundant. The largest catch by weight was taken at R2 and NY6 (Table 15, Figure 72).

In summary, while the hypotheses identified on changes

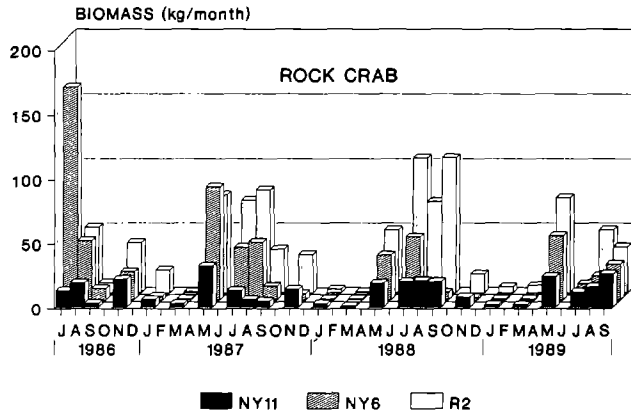

Figure 72. Seasonal biomass (kg) of Atlantic rock crab, *Cancer irroratus*, collected at the three replicate stations from July 1986 through September 1989.

in distribution and abundance of fish and megainvertebrates remain to be tested statistically, it would appear that cessation of dumping has not had any measurable effect on either, in part due to the dominance of the elasmobranchs.

### Winter Flounder and American Lobster Pathology

A. Pacheco and J. Rugg

Observations of winter flounder, *Pseudopleuronectes americanus*, from the trawl collections of the replicate series were continued in order to determine and record systematically the incidence of overt pathology. The hypothesis to be tested states that there would be a significant decrease in incidence of fin erosion, ulcerations, parasitism, tumors, and skeletal anomalies as a result of reduction in environmental degradation during the interval of study (Environmental Processes Division 1988). The 1989 observations generally indicated the lowest incidence in the 12-mile-dumpsite survey series for finrot, cysts, and *Glugea* (Table 16). Lymphocystis, essentially a warm-temperature phenomenon, was not adequately measured during the abbreviated 1986 observations, hence measured reductions of incidence are based on 1987 levels. The incidence of bentfin and ambicoloration, somatic anomalies from early life stages, did not change.

All American lobsters, *Homarus americanus*, trawled in the broadscale collections were examined for signs of shell disease, tagged, and released. In addition, lobster pots were baited and set to provide a larger sample size. Totals of catch and incidence of chitinoclasia (shell disease) are summarized for two years (Table 17). Diseased lobsters were classified by degree of severity--Type I were infected with obvious necrotic lesions and Type II showed small infection spots.

There was considerable consistency in the catch-by-gear ratio, sex ratio, and total incidence of disease between

Table 15. Seasonal mean biomass (kg) per tow and percentage of total crustacean biomass for Atlantic rock crab, *Cancer irroratus*, per replicate station and sample year

Year	October-January			February-May			June-September		
	R2	NY6	NY11	R2	NY6	NY11	R2	NY6	NY11
Mean Biomass (kg) per Tow									
86-87	3.5	1.5	1.5	4.3	4.8	1.9	7.0	4.1	0.9
87-88	1.8	0.3	0.9	2.4	1.8	1.1 <sup>1</sup>	10.3	3.0	2.1 <sup>1</sup>
88-89	1.2	0.2	0.5 <sup>1</sup>	4.1	2.7	1.4 <sup>1</sup>	3.8	2.5	2.3 <sup>1</sup>
Percentage of Total Crustacean Biomass									
86-87	56.4	44.1	75.0	67.2	73.8	73.1	94.6	89.1	81.8
87-88	46.2	40.0	90.0	60.0	78.3	92.0 <sup>1</sup>	96.3	83.3	95.4 <sup>1</sup>
88-89	30.0	10.0	31.2 <sup>1</sup>	62.1	57.4	66.7 <sup>1</sup>	88.4	55.6	62.2 <sup>1</sup>

<sup>1</sup>Post-dumping period.

Table 16. Annual incidence (percent) of pathological conditions of winter flounder, *Pseudopleuronectes americanus*, collected at the three replicate stations during 1986-89

Condition	Year	Station		
		R2	NY6	NY11
Finrot	1986	1.8	2.2	3.9
	1987	0.3	0.7	1.1
	1988	0.3	0.6	0.0
	1989	0.0	0.1	0.0
Cysts	1986	2.7	8.7	3.0
	1987	3.7	4.1	3.7
	1988	1.0	1.0	0.9
	1989	0.6	0.1	0.0
Lymphocystis	1986	0.0	0.0	0.0
	1987	0.8	3.0	1.2
	1988	0.4	0.1	0.5
	1989	0.2	0.2	0.0
Bentfin	1986	1.8	3.0	3.9
	1987	1.6	1.9	3.3
	1988	2.2	2.3	2.4
	1989	1.0	1.9	0.3
Ambicoloration	1986	0.5	0.0	0.0
	1987	0.7	0.4	2.6
	1988	0.4	1.3	1.4
	1989	3.5	2.7	2.5
<i>Glugea</i>	1986	1.0	0.0	0.0
	1987	6.7	2.1	0.4
	1988	1.8	2.6	3.8
	1989	1.2	0.8	0.6
Numbers sampled	1986	201	85	56
	1987	385	356	161
	1988	816	577	233
	1989	286	585	178
	1986-89	1688	1603	628

Table 17. Incidence (percent) of shell disease (chitinoclasia) in American lobsters, *Homarus americanus*, from the 12-mile dumpsite collections for 1988-89

	1988		1989	
	No.	Percent	No.	Percent
Total catch	785		1020	
	<b>Catch by gear</b>			
Pot	371	47.3	394	38.6
Trawl	414	52.7	626	61.4
	<b>Catch by sex</b>			
Male	502	63.9	630	61.8
Female	269	34.3	390	38.2
Indeterminate	14	1.8	-	-
	<b>Incidence by type</b>			
Type I	46	5.8	40	3.9
Type II	113	14.4	135	13.2
	<b>Incidence by type, sex, and gear</b>			
Type I				
Male				
Pot	1		3	
Trawl	10		13	
Female				
Pot	24		5	
Trawl	11		19	
Type II				
Male				
Pot	14		60	
Trawl	14		24	
Female				
Pot	65		12	
Trawl	19		29	
Indeterminate	1			

years. Pot selectivity for larger specimens resulted in a higher catch of small lobsters in the trawl. Their greater rate of molt resulted in a lower percentage of disease observations from that gear. Analysis of incidences by size is planned.

## Migrations of Winter Flounder

### B. Phelan

Winter flounder, *Pseudopleuronectes americanus*, have been tagged since July 1986 as one part of the 12-mile dumpsite study to determine the extent of movement by these migratory demersal fish between the dumpsite and surrounding areas. The hypothesis tested is that winter flounder using the dumpsite area comprise a significant portion of the Sandy Hook-Raritan Bay population.

An encoded Petersen disc tag was used to tag all winter flounder longer than 180 mm collected during the broadscale surveys. Tagged fish were released immediately near the capture sites. In a complementary study, trawling was conducted in Sandy Hook and Raritan Bays to obtain winter flounder for tagging and release in those estuarine areas.

A total of 7,346 tagged winter flounder were released from July 1986 through August 1989 (3,245 at the dumpsite, 4,101 in the bays). Of the total, 206 tags were returned. The overall return rate was 2.8 percent with the majority (163) returned from bay areas (Table 18).

From bay releases, most of the tag returns (90) came from the confluence of the Navesink and Shrewsbury Rivers from March to May (Table 18). Generally, returns were from fish at large less than two months and recaptured within 4 km of the release site. An aggregation of winter flounder occurs in the rivers during the spawning season at which time they are fished heavily by recreational fishermen as they forage after prespawn fasting (Tyler 1971).

A fifth of the returns from the riverine confluence area, however, were from fish at large for over 300 days and recaptured within 4 km of the release site. This indicates that fish tend to return each year to the same spawning area. This type of return pattern was also evident in Sandy Hook-Raritan Bay where some fish were captured within 10 km of the release point after 300 days at large (Table 18). Most early tagging studies of winter flounder (Lobell 1939; Perlmutter 1947; Saila 1961; Howe and Coates 1975), as well as more recent ones (Northeast Utilities Service Company 1986; Powell 1989; Black *et al.* 1988; Scarlett 1988), provide similar evidence of a return to natal waterways to spawn.

Many winter flounder recaptured in bay areas had been originally captured and tagged at the dumpsite, following the generally accepted pattern of winter migration inshore to spawn (Figure 73). Tag returns from fish tagged at the dumpsite came from a variety of locations north and west of the release site (*i.e.*, Shark River, New Jersey, and Great Bay, New York) and were not limited to any one estuarine system (Table 19). Several fish released from the dumpsite exhibited movements beyond those normally associated with seasonal migrations. Recaptures were made in Long Island Sound, Montauk, Block Island, and Nantucket Shoals (Figure 74).

The offshore spring migration pattern into deeper, cooler waters was seen in fish returned from the ocean and in other estuaries of southern New Jersey and New York (Figure 73, Table 19). Spring movements may not be limited to ocean passage as adult winter flounder are frequently found in deep channels of estuaries during warm months (Lobell 1939; Wilk *et al.* 1977).

Most returns (86 percent) came from recreational fishermen, followed by research trawls (9 percent) and commercial fishermen (5 percent). The small return rate from the commercial sector is probably related to a general disinterest or suspicion of scientific surveys, an obvious

Table 18. Winter flounder, *Pseudopleuronectes americanus*, tag returns from fish captured and released in the Sandy Hook-Raritan Bay area, July 1986 - August 1989

Length (cm)	Sex	Tagging Date (and Location)	Recapture Date	Recapture Location	Days at Large
<b>Bays To Ocean</b>					
32.5	F	27 Mar 87 (B6)	7 Apr 87	Ocean: Long Branch, NJ	11
37.1	F	11 Mar 87 (B9)	3 May 87	Ocean: Sandy Hook, NJ	53
24.5	F	13 Jan 89 (B6)	11 Apr 89	Hudson River (Battery), NY	57
22.3	M	23 Mar 88 (B5)	28 Nov 88	Shark River, NJ	220
31.5	F	25 Apr 89 (B6)	28 Jan 90	Shark River, NJ	278
19.5	?	19 Jan 89 (B6)	25 Jun 90	West Nantucket Island, MA	521
<b>Bays To Long Island</b>					
32.4	F	16 Mar 88 (B5)	7 May 88	Merrick Bay, LI	52
28.2	M	22 Mar 88 (B6)	21 May 88	Freeport, LI	60
24.0	F	11 Mar 87 (B9)	12 May 87	Rockaway Inlet, LI	62
24.9	F	5 Jan 87 (B11)	2 May 87	Jamaica Bay, LI	120
39.2	F	30 Dec 86 (B8)	17 Jul 87	Reynolds Channel, LI	201
23.7	F	2 Jun 87 (B6)	15 Sep 88	Shinnecock Bay, LI	571
24.5	F	16 Mar 88 (B5)	6 Apr 89	Jamaica Bay, LI	396
26.8	F	24 Aug 88 (B6)	26 Mar 89	Jamaica Bay, LI	227
28.3	M	24 Aug 88 (B4)	20 Apr 89	Merrick Bay, LI	242
25.5	M	23 Feb 89 (B9)	26 Aug 89	Jones Inlet, LI	184
26.4	F	19 May 88 (B7)	21 May 89	Reynolds Channel, LI	367
19.5	F	22 Jun 88 (B6)	12 Nov 89	East Rockaway Inlet, LI	508
26.1	M	19 Jan 89 (B6)	8 May 90	Jamaica Bay, LI	474
<b>Within-Bay Movements</b>					
27.0	F	2 Jun 87 (B9)	5 Jun 87	Sandy Hook Bay	3
29.4	F	11 Mar 87 (B9)	13 Apr 87	Lower Bay	33
29.0	M	27 Mar 87 (B6)	5 May 87	Lower Bay	39
29.7	M	11 Mar 87 (B9)	25 Apr 87	Sandy Hook Bay	45
38.2	F	30 Dec 86 (B11)	12 Apr 87	Sandy Hook Bay	103
37.1	?	27 Mar 87 (B9)	6 Aug 87	B6	132
33.5	F	22 Mar 88 (B11)	27 Nov 88	Sandy Hook Bay	250
31.8	M	24 Mar 88 (B6)	9 Apr 89	East Reach Channel	381
22.0	M	9 Apr 87 (B2)	7 Apr 89	Great Kills, Staten Island	367
22.4	M	13 Apr 88 (B2)	11 Apr 89	East Reach Channel	393
21.3	F	22 Mar 88 (B6)	12 Apr 89	Great Kills, Staten Island	386
31.7	M	13 Dec 88 (B6)	9 Apr 89	East Reach Channel	117
33.3	F	23 Feb 89 (B8)	11 Apr 89	Princes Bay, Staten Island	47
30.0	F	13 Feb 89 (B6)	12 Apr 89	Lower Bay	58
32.4	F	23 Feb 89 (B11)	30 Apr 89	Sandy Hook Bay	66
36.0	F	9 Apr 87 (B2)	5 Apr 89	East Reach Channel	727
31.5	M	25 Apr 89 (B2)	21 May 89	Old Orchard Shoal	26
38.8	F	10 Mar 89 (B6)	7 May 89	Earle Naval Pier, Sandy Hook Bay	58
29.7	F	24 Mar 88 (B9)	14 Apr 90	Hoffman Island	751
28.7	F	23 Feb 89 (B6)	14 Apr 90	Lower Shrewsbury River, NJ	415
20.8	F	19 Jan 89 (B6)	14 Apr 90	Arthur Kill	450
21.9	M	29 Jan 88 (B6)	23 Apr 90	Raritan Bay	814
32.3	M	21 Mar 89 (B11)	22 Apr 90	Earle Naval Pier, Sandy Hook Bay	397
26.2	F	20 Mar 87 (B5)	9 Nov 88	Earle Naval Pier, Sandy Hook Bay	600
<b>Bays To Rivers</b>					
20.0	F	31 Aug 88 (B6)	22 Mar 90	Shrewsbury River, NJ	232
32.9	M	20 Nov 86 (B9)	26 Mar 87	Lower Shrewsbury River, NJ	126
32.4	F	23 Dec 86 (B9)	29 Mar 87	Navesink River, NJ	96
32.9	M	20 Nov 86 (B9)	9 Apr 87	Lower Shrewsbury River, NJ	140
30.1	?	3 Nov 86 (B9)	11 Apr 87	Lower Shrewsbury River, NJ	290
25.7	M	28 Aug 87 (B6)	9 Mar 88	Lower Shrewsbury River, NJ	194



Table 18. Continued.

Length (cm)	Sex	Tagging Date (and Location)	Recapture Date	Recapture Location	Days at Large
<b>Bays To Rivers (Continued)</b>					
25.5	F	11 Mar 87 (B9)	9 May 88	Lower Shrewsbury River, NJ	60
25.9	M	13 Apr 88 (B6)	27 Mar 89	Lower Shrewsbury River, NJ	348
21.6	F	22 Jun 88 (B6)	3 Apr 89	Lower Shrewsbury River, NJ	285
29.3	M	19 May 88 (B6)	28 Mar 89	Shrewsbury River, NJ	313
32.5	F	22 Mar 88 (B8)	11 Apr 89	Lower Shrewsbury River, NJ	385
38.7	F	28 Oct 86 (B6)	15 Nov 86	Navesink River, NJ	18
26.5	F	13 Apr 88 (B6)	17 Apr 89	Lower Shrewsbury River, NJ	399
25.1	M	23 Feb 89 (B6)	7 Apr 90	Lower Shrewsbury River, NJ	408
32.6	M	10 Mar 89 (B6)	21 Apr 90	Navesink River, NJ	407
24.2	M	21 Mar 89 (B6)	27 Apr 90	Shrewsbury River, NJ	96
<b>Within-River Movements (Navesink and Shrewsbury Rivers)</b>					
24.4	F	11 Mar 87 (B5)	2 Apr 87	Lower Shrewsbury River, NJ	22
19.8	M	6 Mar 87 (B5)	13 Mar 87	Lower Shrewsbury River, NJ	7
25.7	M	6 Mar 87 (B5)	13 Mar 87	Lower Shrewsbury River, NJ	7
18.6	M	13 Mar 87 (B5)	20 Mar 87	Lower Shrewsbury River, NJ	7
22.1	M	6 Mar 87 (B5)	20 Mar 87	Lower Shrewsbury River, NJ	14
23.0	M	13 Mar 87 (B5)	9 Apr 87	Lower Shrewsbury River, NJ	27
20.0	M	6 Mar 87 (B5)	11 Apr 87	Lower Shrewsbury River, NJ	36
19.3	M	6 Mar 87 (B5)	12 Apr 87	Lower Shrewsbury River, NJ	37
19.8	M	6 Mar 87 (B5)	29 Mar 87	Lower Shrewsbury River, NJ	23
25.5	M	20 Mar 87 (B5)	10 Apr 87	Lower Shrewsbury River, NJ	21
23.3	M	13 Mar 87 (B5)	24 Mar 87	Lower Shrewsbury River, NJ	11
32.5	M	20 Mar 87 (B5)	26 Apr 87	Lower Shrewsbury River, NJ	37
18.3	M	13 Mar 87 (B5)	15 Apr 87	Lower Shrewsbury River, NJ	33
29.7	M	6 Mar 87 (B5)	22 Mar 87	Lower Shrewsbury River, NJ	16
21.6	M	13 Mar 87 (B5)	27 Apr 87	Lower Shrewsbury River, NJ	45
22.8	F	20 Mar 87 (B5)	25 Apr 87	Lower Shrewsbury River, NJ	36
29.6	M	6 Mar 87 (B5)	1 May 87	Lower Shrewsbury River, NJ	56
27.8	F	13 Mar 87 (B5)	20 Mar 87	Lower Shrewsbury River, NJ	7
26.6	M	6 Mar 87 (B5)	25 Mar 87	Lower Shrewsbury River, NJ	19
23.5	M	6 Mar 87 (B5)	26 Mar 87	Lower Shrewsbury River, NJ	20
23.5	M	6 Mar 87 (B5)	29 Mar 87	Shrewsbury River, NJ	23
20.3	M	6 Mar 87 (B5)	27 Mar 87	Lower Shrewsbury River, NJ	21
23.3	M	13 Mar 87 (B5)	18 Mar 87	Lower Shrewsbury River, NJ	5
24.6	M	6 Mar 87 (B5)	10 Apr 87	Lower Shrewsbury River, NJ	35
30.8	F	16 Mar 88 (B5)	23 Mar 88	Lower Shrewsbury River, NJ	7
25.3	M	16 Mar 88 (B5)	23 Mar 88	Lower Shrewsbury River, NJ	7
28.8	M	16 Mar 88 (B5)	19 Mar 88	Lower Shrewsbury River, NJ	3
32.0	M	20 Mar 87 (B5)	10 Mar 88	Lower Shrewsbury River, NJ	356
32.0	M	10 Mar 88 (B5)	18 Mar 88	Navesink River, NJ	8
24.3	M	13 Mar 87 (B5)	12 Mar 88	Lower Shrewsbury River, NJ	365
22.7	M	13 Mar 87 (B5)	14 Mar 88	Lower Shrewsbury River, NJ	367
28.2	M	20 Mar 87 (B5)	13 Mar 88	Lower Shrewsbury River, NJ	359
29.4	M	11 Mar 87 (B5)	28 Mar 88	Lower Shrewsbury River, NJ	383
26.3	F	16 Mar 88 (B5)	24 Mar 88	Lower Shrewsbury River, NJ	8
23.0	M	16 Mar 88 (B5)	26 Mar 88	Lower Shrewsbury River, NJ	10
32.4	F	16 Mar 88 (B5)	27 Mar 88	Lower Shrewsbury River, NJ	11
27.2	F	16 Mar 88 (B5)	24 Mar 88	Lower Shrewsbury River, NJ	8
28.0	M	6 Mar 87 (B5)	3 Apr 88	Shrewsbury River, NJ	394
24.3	M	20 Mar 87 (B5)	2 Apr 88	Lower Shrewsbury River, NJ	379
20.0	M	13 Mar 87 (B5)	1 Apr 88	Lower Shrewsbury River, NJ	385

Table 18. Continued.

Length (cm)	Sex	Tagging Date (and Location)	Recapture Date	Recapture Location	Days at Large
<b>Within-River Movements (Navesink and Shrewsbury Rivers)</b>					
22.3	M	13 Mar 87 (B5)	11 Apr 88	Lower Shrewsbury River, NJ	395
28.8	F	16 Mar 88 (B5)	6 Apr 88	Lower Shrewsbury River, NJ	21
25.7	F	16 Mar 88 (B5)	30 Mar 88	Lower Shrewsbury River, NJ	14
37.4	F	23 Mar 88 (B5)	31 Mar 88	Navesink River, NJ	4
30.7	M	16 Mar 88 (B5)	29 Mar 88	Lower Shrewsbury River, NJ	13
21.4	F	16 Mar 88 (B5)	1 Apr 88	Lower Shrewsbury River, NJ	16
24.4	F	16 Mar 88 (B5)	29 Mar 88	Lower Shrewsbury River, NJ	13
26.6	F	16 Mar 88 (B5)	30 Mar 88	Lower Shrewsbury River, NJ	14
19.8	M	16 Mar 88 (B5)	2 Apr 88	Lower Shrewsbury River, NJ	17
27.5	F	16 Mar 88 (B5)	1 Apr 88	Lower Shrewsbury River, NJ	16
26.6	F	16 Mar 88 (B5)	30 Mar 88	Lower Shrewsbury River, NJ	14
23.1	M	16 Mar 88 (B5)	27 Mar 88	Lower Shrewsbury River, NJ	11
22.8	F	16 Mar 88 (B5)	30 Mar 88	Lower Shrewsbury River, NJ	14
21.5	F	16 Mar 88 (B5)	1 Apr 88	Lower Shrewsbury River, NJ	16
29.3	F	23 Mar 88 (B5)	30 Mar 88	Shrewsbury River, NJ	7
35.8	?	16 Mar 88 (B5)	10 Apr 88	Lower Shrewsbury River, NJ	24
21.2	M	13 Mar 87 (B5)	12 Mar 88	Lower Shrewsbury River, NJ	365
27.0	M	23 Mar 88 (B5)	24 Mar 88	Shrewsbury River, NJ	1
37.6	F	16 Mar 88 (B5)	22 Apr 88	Lower Shrewsbury River, NJ	37
22.0	F	16 Mar 88 (B5)	31 Mar 88	Shrewsbury River, NJ	15
27.2	F	16 Mar 88 (B5)	12 Feb 89	Shrewsbury River, NJ	333
19.1	F	16 Mar 88 (B5)	28 Mar 89	Lower Shrewsbury River, NJ	377
21.5	F	27 Mar 89 (B5)	3 Apr 89	Lower Shrewsbury River, NJ	7
25.6	M	27 Mar 89 (B5)	3 Apr 89	Lower Shrewsbury River, NJ	7
25.5	F	16 Mar 88 (B5)	2 Apr 89	Lower Shrewsbury River, NJ	382
26.8	M	27 Mar 89 (B5)	2 Apr 89	Lower Shrewsbury River, NJ	6
24.3	F	16 Mar 88 (B5)	2 Apr 89	Lower Shrewsbury River, NJ	382
30.8	F	27 Mar 88 (B5)	29 Mar 89	Lower Shrewsbury River, NJ	2
20.4	M	16 Mar 88 (B5)	28 Mar 89	Lower Shrewsbury River, NJ	377
29.7	F	27 Mar 89 (B5)	1 Apr 89	Lower Shrewsbury River, NJ	5
29.0	M	27 Mar 89 (B5)	1 Apr 89	Lower Shrewsbury River, NJ	5
33.1	M	27 Mar 89 (B5)	1 Apr 89	Lower Shrewsbury River, NJ	5
26.6	F	27 Mar 89 (B5)	3 Apr 89	Lower Shrewsbury River, NJ	7
26.6	M	27 Mar 89 (B5)	9 Apr 89	Lower Shrewsbury River, NJ	13
20.9	F	23 Mar 88 (B5)	14 Apr 89	Lower Shrewsbury River, NJ	2
25.6	M	3 Apr 89 (B5)	14 Apr 89	Lower Shrewsbury River, NJ	11
23.3	M	3 Apr 89 (B5)	14 Apr 89	Lower Shrewsbury River, NJ	11
27.4	M	3 Apr 89 (B5)	14 Apr 89	Lower Shrewsbury River, NJ	12
30.3	M	5 Apr 89 (B5)	12 Apr 89	Lower Shrewsbury River, NJ	7
28.0	F	5 Apr 89 (B5)	15 Apr 89	Lower Shrewsbury River, NJ	10
25.2	M	5 Apr 89 (B5)	8 Apr 89	Lower Shrewsbury River, NJ	3
27.0	F	20 Mar 87 (B5)	19 Apr 89	Navesink River, NJ	761
28.8	F	16 Mar 89 (B5)	20 Apr 89	Navesink River, NJ	35
24.0	F	16 Mar 88 (B5)	20 Apr 89	Navesink River, NJ	400
20.4	M	27 Mar 89 (B5)	10 Apr 89	Lower Shrewsbury River, NJ	14
24.8	M	27 Mar 89 (B5)	10 Apr 89	Lower Shrewsbury River, NJ	14
23.4	M	27 Mar 89 (B5)	10 Apr 89	Lower Shrewsbury River, NJ	14
32.2	M	3 Apr 89 (B5)	14 Apr 89	Lower Shrewsbury River, NJ	11
25.6	M	5 Apr 89 (B5)	9 Apr 89	Lower Shrewsbury River, NJ	4
27.6	F	27 Mar 89 (B5)	8 Apr 89	Lower Shrewsbury River, NJ	12
25.3	M	5 Apr 89 (B5)	8 Apr 89	Lower Shrewsbury River, NJ	3
27.8	M	27 Mar 89 (B5)	9 Apr 89	Lower Shrewsbury River, NJ	13
27.9	M	5 Apr 89 (B5)	10 Apr 89	Lower Shrewsbury River, NJ	5
29.8	F	27 Mar 89 (B5)	11 Apr 89	Lower Shrewsbury River, NJ	15
26.5	M	5 Apr 89 (B5)	14 Apr 89	Lower Shrewsbury River, NJ	9

Table 18. Continued.

Length (cm)	Sex	Tagging Date (and Location)	Recapture Date	Recapture Location	Days at Large
26.3	F	27 Mar 89 (B5)	14 Apr 89	Lower Shrewsbury River, NJ	18
27.8	M	27 Mar 89 (B5)	14 Apr 89	Lower Shrewsbury River, NJ	18
27.5	F	27 Mar 89 (B5)	11 Nov 89	Lower Shrewsbury River, NJ	229
26.0	M	3 Apr 89 (B5)	15 Apr 89	Shrewsbury River, NJ	12
23.5	F	27 Mar 89 (B5)	21 Mar 90	Lower Shrewsbury River, NJ	12
32.2	M	23 Mar 88 (B5)	18 Apr 90	Shrewsbury River, NJ	756
25.7	M	5 Apr 89 (B5)	27 Apr 90	Lower Shrewsbury River, NJ	387

nonresponse from illegal trawlers in the bay and principal offshore trawling areas north and east of the dumpsite area. Because of these biases, the returns are not adequate to quantify the Sandy Hook-Raritan contributions to the dumpsite, but returns do provide evidence of extensive movements from fish utilizing dumpsite habitats and support findings from other winter flounder mark-recapture studies (Klein-MacPhee 1978).

Furthermore, indications are that intermixing takes place among winter flounder populations in New Jersey, the 12-mile sewage sludge dumpsite, and Long Island, New York, thus indicating that these populations may be less discrete than described previously.

## CONTAMINANTS IN BIOTA: TRACE ORGANIC COMPOUNDS IN TISSUES OF WINTER FLOUNDER AND AMERICAN LOBSTER

A. Draxler, Principal Investigator, and A. Deshpande

One of the working hypotheses proposed at the start of the study was that levels of organic contaminants in gut contents of winter flounder, *Pseudopleuronectes americanus*, and American lobster, *Homarus americanus*, would decrease following cessation of dumping, but body-burden levels would not shift since species are seasonal migrants (Environmental Processes Division 1988). Early in the study, it was decided that changes in contaminant levels are best detected by analysis of hepatic tissue in these species.

The concentrations of polychlorinated biphenyls (PCBs) and polynuclear aromatic hydrocarbons (PAHs), along with other anthropogenic contaminants, have been found to be higher in the sediment of the Christiaensen Basin (Figure 1) near waste dumpsites than at surrounding stations (Boehm 1982). In order to determine whether these organic contaminants might be entering resource species and the times in the seasonal cycles that this might occur, hepatic tissues were taken from winter flounder and lobster. Specimens were collected in spring (1987) and fall (1987, 1988) to cover pre- and post-spawning conditions at various times after the cessation of dumping at stations NY6 and NY11. Two composites from each successful

sampling were analyzed for PCBs and PAHs. Composites consisted of five randomly allocated winter flounder livers or three lobster hepatopancreases.

Data for pentachlorobiphenyls (as representative PCB congener analytes) and total polychlorinated biphenyls are given in Table 20. Two statistically significant results were obtained for each sampling period: (1) concentrations of PCBs in both flounder and lobster from nearer the dumpsite (station NY6) were higher than those from the reference area (station NY11), and (2) lobster PCB values were higher than those for winter flounder. In most composites, PAHs were below the detection limits of the method employed. The concentrations of 2,3,7,8-tetrachlorodibenzodioxin (TCDD) and 2,3,7,8-tetrachlorodibenzofuran (TCDF) were below the detection limit in all samples. A report on all these results is in press (Draxler *et al.*, in press).

## REFERENCES CITED

- Black, D.E., D.K. Phelps, and R.L. Lapan. 1988. The effect of inherited contamination on egg and larval winter flounder, *Pseudopleuronectes americanus*. *Mar. Environ. Res.* 25: 45-62.
- Boehm, P. 1982. Organic contaminants (PCBs, polynuclear aromatic hydrocarbons and coprostanol) in sediments. Pages 32-36 in R.N. Reid *et al.*, eds. Contaminants in New York Bight and Long Island Sound sediments, and contaminant effects on benthos, summer 1980. *NOAA Tech. Mem. NMFS-F/NEC-16*.
- Cabelli, V.J., and D. Pedersen. 1982. The movement of sewage sludge from the New York Bight dumpsite as seen from *Clostridium perfringens* spore densities. Pages 995-999 in Oceans '82 conference record. Marine Technology Society, Washington, D.C.
- Davis, W.R., and J.C. Means. 1989. A developing model of benthic-water contaminant transport in bioturbated sediment. Pages 215-226 in K.L. Ekowski *et al.*, eds. Proceedings of the 21st European Marine Biology Symposium, Gdansk, Poland, Sept. 14-19, 1986. Polish Academy of Sciences - Institute of Oceanography, Sopot, Poland.
- Draxler, A.F.J. 1988. A model of sediment biogeochemistry at the sewage sludge accumulation site for 1983-89.

Table 19. Winter flounder, *Pseudopleuronectes americanus*, tag returns from fish captured and released in the area of the 12-mile dumpsite, July 1986 - August 1989

Length (cm)	Sex	Tagging Date	Recapture Date	Recapture Location	Days at Large
<b>Dumpsite to Bays and Rivers</b>					
21.0	?	18 Jul 86	13 Apr 87	Lower Bay	275
32.0	F	21 Dec 87	18 Mar 88	Lower Shrewsbury River	90
26.3	F	27 Jan 87	? Apr 87	Lower Bay	108
36.6	F	10 Jun 87	1 May 88	Lower Bay	326
31.0	F	27 Oct 88	9 Apr 89	Lower Bay	164
30.2	M	9 Dec 88	10 Apr 89	Lower Shrewsbury River	122
28.3	F	22 Dec 88	15 Apr 89	Lower Bay	114
29.9	M	9 Dec 87	29 Apr 89	Lower Bay	142
18.2	M	18 Feb 87	28 Apr 89	Lower Shrewsbury River	800
<b>Dumpsite To Long Island, New York</b>					
27.0	?	17 Oct 86	27 Mar 87	Jones Inlet, LI	161
24.0	F	9 Dec 87	12 Dec 87	Jones Inlet, LI	3
23.0	F	14 Apr 87	27 Mar 88	Seaford, LI	348
26.5	F	9 Jun 87	29 Mar 88	Jamaica Bay, LI	294
24.6	F	21 Dec 87	9 Apr 88	Sheepshead Bay, LI	110
26.7	M	9 Dec 87	20 Apr 88	Jamaica Bay, LI	133
29.7	F	22 Dec 87	9 May 88	South Oyster Bay, LI	139
23.8	F	19 Oct 87	25 Oct 88	Reynolds Channel, LI	342
27.5	F	11 Oct 88	25 Mar 89	Jamaica Bay, LI	165
27.3	F	26 Apr 88	29 Mar 89	Baldwin Bay, LI	337
25.5	F	21 Dec 87	14 Apr 89	Massapequa, LI	115
24.7	F	10 Feb 89	13 May 89	Shinnecock Bay, LI	92
31.8	F	21 Dec 87	1 May 90	Sheepshead Bay, LI	862
28.8	F	8 Jun 88	9 May 90	Jones Beach, LI	700
<b>Dumpsite to Other Locations</b>					
24.0	F	15 Apr 87	28 May 87	Ocean off Rockaway, LI	43
27.0	?	15 Apr 87	13 Jul 87	South off Martha's Vineyard, MA	104
27.5	F	18 Feb 87	23 Oct 87	Nantucket Shoals	247
26.8	F	25 Feb 87	8 May 87	Montauk, LI	72
25.9	F	25 Feb 87	8 Aug 87	Ocean Off Shinnecock, LI	164
28.8	F	21 Dec 87	9 May 88	Long Island Sound	140
24.9	F	29 Jan 88	19 May 88	Ocean Off Shinnecock, LI	111
22.6	F	22 Feb 88	24 Nov 88	Ocean off Jones Inlet, LI	276
27.5	M	7 Dec 87	8 Dec 87	Ambrose Light	1
25.9	F	11 Feb 88	30 Dec 88	A6/NY3	323
34.6	M	15 Apr 87	10 Feb 89	NY6	667
31.5	F	10 Jun 88	20 Apr 89	Shark River, NJ	314
25.4	F	8 Feb 88	22 May 89	A56	469
35.0	M	13 Feb 89	1 May 89	Ocean off Coney Island, NY	77
27.5	F	7 Feb 89	29 May 89	Ocean off Fire Island, NY	111
22.5	F	6 Feb 89	11 May 89	SW of Block Island, RI	94
32.9	F	21 Dec 88	1 Jun 89	Ocean off Rockaway Beach, LI	162
24.7	F	7 Feb 89	12 Jun 89	Ocean off Fire Island, NY	111
27.7	F	10 Feb 89	3 Mar 90	East of Block Island, RI	386
35.0	?	13 Feb 90	8 Jan 90	South Martha's Vineyard	329
29.2	?	10 Feb 89	22 Jun 90	South of Block Island, RI	497

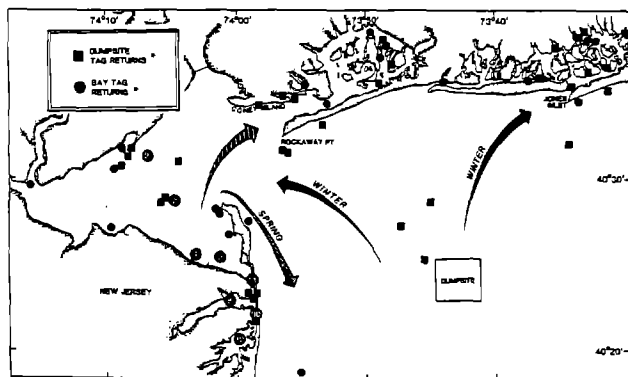

Figure 73. Winter flounder, *Pseudopleuronectes americanus*, tag returns indicating spring (stippled arrow), winter (solid arrow), and Long Island (striped arrow) migrations. \*Each symbol represents one return unless indicated by an inscribed number.

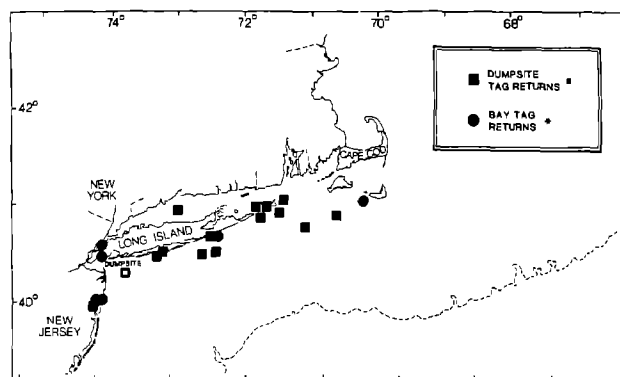

Figure 74. Winter flounder, *Pseudopleuronectes americanus*, tag returns showing long distance recapture location. \*Each symbol represents one return unless indicated by an inscribed number.

[Nat. Mar. Fish. Serv.,] *Sandy Hook Lab. Rep.* 88-03. 31 pp.

Draxler, A.F.J., P. Hauge, and A.D. Deshpande. In press. Organic contaminants in hepatic tissues of lobster and flounder at the New York Bight "12-mile" sewage sludge dumpsite: 1987-88. *NOAA Tech. Mem. NMFS-F/NEC. Environmental Processes Division.* 1988. A plan for study: response of the habitat and biota of the inner New York Bight to abatement of sewage sludge dumping. *NOAA Tech. Mem. NMFS-F/NEC-55.* 34 pp.

Environmental Processes Division. 1989. Response of the habitat and biota of the inner New York Bight to abatement of sewage sludge dumping: second annual progress report -- 1988. *NOAA Tech. Mem. NMFS-F/NEC-67.* 47 pp.

Erdheim, E. 1985. United States marine waste disposal policy. Pages 421-460 in B.H. Ketchum *et al.*, eds. *Wastes in the ocean*, vol. 6: nearshore waste disposal. Wiley-Interscience, New York.

Grant, W.G., and O.S. Madsen. 1979. Combined wave and current interaction with a rough bottom. *J. Geophys. Res.* 84(C4): 1797-1808.

Howe, A.B., and P.G. Coates. 1975. Winter flounder movements, growth, and mortality off Massachusetts. *Trans. Amer. Fish. Soc.* 104: 13-29.

Keith, D.J., W.R. Davis, and J.F. Paul. 1990. Sediment erodibility in Narragansett Bay, Rhode Island; a method of predicting sediment-chemical reservoir dynamics: final report. [U.S. Environ. Protect. Agency,] *Narragansett Environ. Res. Lab. Contrib.* No. 1112. 58 pp.

Klein-MacPhee, G. 1978. Synopsis of biological data for the winter flounder, *Pseudopleuronectes americanus* (Walbaum). *NOAA Tech. Rep. NMFS Circ.* 414. 43 pp.

Lavelle, J.W., and W.R. Davis. 1987. Measurements of benthic sediment erodibility in Puget Sound, Washington. *NOAA Tech. Mem. ERL PMEL-72.* 32 pp.

Lobell, M.J. 1939. A biological survey of the salt waters of Long Island, 1938. Report on certain fishes. Winter

Table 20. Concentrations ( $\mu\text{g}/\text{kg}$  wet weight) of pentachlorobiphenyls and total polychlorinated biphenyls in hepatic tissue of winter flounder, *Pseudopleuronectes americanus*, and American lobster, *Homarus americanus*, from replicate stations NY6 and NY11

Season	Year	Flounder		Lobster	
		NY6	NY11	NY6	NY11
<b>Pentachlorobiphenyls</b>					
Spring	1987	410.5	253.0	-	549.0
Fall	1987	199.9	-	721.5	624.5
Fall	1988	267.5	-	340.5	284.0
<b>Total Polychlorinated Biphenyls</b>					
Spring	1987	936.7	610.1	-	1430.6
Fall	1987	435.0	-	1952.8	1546.0
Fall	1988	616.3	-	858.7	699.5

flounder (*Pseudopleuronectes americanus*). Pages 63-96 in 28th Annu. Rep. N.Y. Conserv. Dept., Part I, Suppl. 14.

Northeast Utilities Service Company. 1986. Winter flounder population studies. In Annual report (1985): monitoring the marine environment of Long Island Sound at Millstone Nuclear Power Station, Waterford, CT. 69 pp.

Norton, M.G., and M.A. Champ. 1989. The influence of site-specific characteristics on the effects of sewage sludge dumping. Pages 161-183 in D.W. Hood *et al.*, eds. *Oceanic processes in marine pollution*, vol. 4: scientific monitoring strategies for ocean waste disposal. Robert E. Krieger Co., Malabar, Fla.

Pearce, J.B. 1971. Indicators of solid waste pollution. *Mar. Pollut. Bull.* 2(1): 11.

Perlmutter, A. 1947. The blackback flounder and its fishery in New England and New York. *Bull. Bingham Oceanogr. Collect. Yale Univ.* 11(2): 1-92.

- Phoel, W.C. 1983. Rate measurement of benthic oxygen consumption and nutrient regeneration. Sect. 14 in Working group information and responses to NOAA's quality assurance survey for biological rate measurements, vol. III. Available from National Marine Fisheries Service, P.O. Box 428, Highlands, NJ 07732.
- Powell, J.C. 1989. Winter flounder tagging study, 1986-1988 with comments on movements. *R.I. Div. Fish Wildl. Res. Ref. Doc. 89-3. 13 pp.*
- Robertson, C.N. 1983. Quality assurance: total plankton respiration. Sect. 2 in Working group information and responses to NOAA's quality assurance survey for biological rate measurements, vol. III. Available from National Marine Fisheries Service, P.O. Box 428, Highlands, NJ 07732.
- Saila, S.B. 1961. A study of winter flounder movements. *Limnol. Oceanogr.* 6: 292-298.
- Santoro, E. 1987. Status report: phaseout of ocean dumping of sewage sludge in the New York Bight apex. *Mar. Pollut. Bull.* 18(6): 278-280.
- Scarlett, P.G. 1986. Life history investigations of marine fish: occurrence, movements, food habits and age structure of winter flounder from selected New Jersey estuaries. *N.J. Dept. Environ. Protect. Tech. Ser.* 86-20. 46 pp.
- Stanford, H.M., and D.R. Young. 1988. Pollutant loadings to the New York Bight apex. Pages 745-751 in Oceans '88 conference record. Marine Technology Society, Washington, D.C.
- Swanson, R.L., M.A. Champ, T. O'Connor, P.K. Park, J. O'Connor, G.F. Mayer, H.M. Stanford, E. Erdheim, and J. Verber. 1985. Sewage sludge dumping in the New York Bight apex: a comparison with other proposed ocean dump sites. Pages 461-488 in B.H. Ketchum *et al.*, eds. Wastes in the ocean, vol. 6: nearshore waste disposal. Wiley-Interscience, New York.
- Tyler, A.V. 1971. Surges of winter flounder, *Pseudopleuronectes americanus*, into the intertidal zone. *J. Fish. Res. Bd. Can.* 28: 1727-1732.
- U.S. Environmental Protection Agency. 1985. Ocean dumping notice of final determination to deny petitioners to redesignate the 12-mile site. *Fed. Regist.* 50: 14336-14340. Apr. 11, 1985.
- Verber, J.L. 1976. Safe shellfish from the sea. Pages 433-441 in M.G. Gross, ed. Middle Atlantic continental shelf and the New York Bight. *Amer. Soc. Limnol. Oceanogr. Spec. Symp.* 2.
- Whitfield, M. 1969.  $E_p$  as an operational parameter in estuarine studies. *Limnol. Oceanogr.* 14: 547-558.
- Wilk, S.J., W.W. Morse, D.E. Ralph, and T.R. Azarovitz. 1977. Fishes and associated environmental data collected in the New York Bight, June 1974 - June 1975. *NOAA Tech. Rep. NMFS SSRF-716.* 53 pp.

---

## APPENDIX: PUBLICATIONS AND PRESENTATIONS RESULTING FROM

---

### THE 12-MILE DUMPSITE STUDY

#### PUBLICATIONS

##### 1987

Environmental Processes Division. 1987. Response of the habitat and biota of the inner New York Bight to abatement of sewage sludge dumping: progress report, July 1986 - June 1987. Unpublished report available from National Marine Fisheries Service, P.O. Box 428, Highlands, NJ 07732.

Studholme, A.L. 1987. Phaseout and closure of the 12-mile sewage sludge dumpsite: a case study on ecosystem response, Pages 68-92 in Proceedings of the 7th International Ocean Disposal Symposium, Wolfville, N.S., Sept. 21-25, 1987. Environment Canada, Ottawa, Ont.

##### 1988

Environmental Processes Division. 1988. A plan for study: response of the habitat and biota of the inner New York Bight to abatement of sewage sludge dumping. *NOAA Tech. Mem. NMFS-F/NEC-55.* 34 pp.

##### 1989

Environmental Processes Division. 1989. Response of the habitat and biota of the inner New York Bight to abatement of sewage sludge dumping: second annual progress report -- 1988. *NOAA Tech. Mem. NMFS-F/NEC-67.* 47 pp.

##### 1990

Reid, R. 1990. Responses of habitats and biota of the inner New York Bight to abatement of sewage sludge dumping -- progress report. Pages 491-504 in M.T. Southerland and K. Swetlow, eds. Conference proceedings on Cleaning Up Our Coastal Waters: an Unfinished Agenda, Manhattan College, Bronx, N.Y., Mar. 12-14, 1990. U.S. Environ. Protect. Agency Contract. Rep. No. 68-C8-0052.

##### 1991

Studholme, A.L., M.C. Ingham, and A. Pacheco. 1991. Response of the habitat and biota of the inner New York Bight to abatement of sewage sludge dumping: third annual progress report -- 1989. *NOAA Tech. Mem. NMFS-F/NEC-82.*

## MAJOR PRESENTATIONS

### 1987

- Reid, R. 1987. Recovery of the New York Bight sewage sludge dumpsite: plan of study. Paper presented at Conference on Water Quality Problems in the Hudson-Raritan Estuarine System, Ramapo, N.J., Apr. 1987.
- Studholme, A.L. 1987. Phaseout and closure of the 12-mile sewage sludge dumpsite: a case study on ecosystem response. Paper presented at 7th International Ocean Disposal Symposium, Wolfville, N.S., Sept. 21-25, 1987.

### 1988

- Davis, W.R., J.F. Paul, H.A. Walker, and M.C. Ingham. 1988. Fate of sewage sludge contaminated sediment in the New York Bight Hudson-Shelf Valley. Paper presented at [American Geophysical Union - American Society of Limnologists and Oceanographers] Ocean Sciences Meeting, New Orleans, La., Jan. 1988. [Abstract: *EOS* 68(50), Dec. 15, 1987.]
- Ferguson, R.L., W.R. Davis, A.F.J. Draxler, and F.R. Jacobsen. 1988. Erodability of benthic bacteria in wastewater sludge-enriched coastal sediments. Paper presented at [American Geophysical Union - American Society of Limnologists and Oceanographers] Ocean Sciences Meeting, New Orleans, La., Jan. 1988. [Abstract: *EOS* 68(50), Dec. 15, 1987.]
- McMillan, D. 1988. The abatement of sewage sludge dumping at the 12-mile dumpsite. Poster presented at Fourth Northeast Fisheries Center Research Conference, Point Judith, R.I., Feb. 23-25, 1988.
- Phoel, W.C. 1988. 12-mile dumpsite recovery study. Paper presented at C.W. Post College Sigma Xi Scientific Honor Society Meeting, Brookville, N.Y., Jan. 1988.
- Reid, R. 1988. Responses of the inner New York Bight sewage sludge dumpsite to phaseout of sludge disposal. Paper presented at American Fisheries Society Mid-Atlantic Chapter Meeting, Highlands, N.J., Sept. 1988.
- Valdes, B.A. 1988. A study of winter flounder movements in the New York Bight. Poster presented at Fourth Northeast Fisheries Center Research Conference, Point Judith, R.I., Feb. 23-25, 1988.

### 1989

- Mountain, D. 1989. Bottom currents in the vicinity of the 12-mile dumpsite. Paper presented at Middle Atlantic Bight Physical Oceanography and Meteorology Workshop, Gloucester Point, Va., Nov. 1989.
- Pacheco, A.L., and J. Rugg. 1989. Incidence of disease in winter flounder (*Pseudopleuronectes americanus*) col-

lected during the 12-mile dumpsite recovery study. Paper presented at Workshop on Winter Flounder Biology, Mystic, Conn., Dec. 5-6, 1989.

- Phoel, W. 1989. Seabed metabolism aspects of 12-mile dumpsite recovery study. Paper presented at New York Water Pollution Control Association Environmental Science Forum, New York, N.Y., Jan. 11, 1989.
- Phoel, W. 1989. Seabed metabolism aspects of 12-mile dumpsite recovery study. Paper presented at New Jersey Division of Water Resources Meeting, Trenton, N.J., Mar. 21, 1989.
- Pikanowski, R.A. 1989. Experimental design of 12-mile dumpsite recovery study -- an overview. Paper presented at Workshop on Winter Flounder Biology, Mystic, Conn., Dec. 5-6, 1989.
- Reid, R. 1989. Phased cessation of sewage sludge dumping in the inner New York Bight: benthic macrofauna responses. Paper presented at Benthic Ecology Meeting, Solomons, Md., Mar. 17-19, 1989.
- Valdes, B.A. 1989. A study of winter flounder movements in the New York Bight. Paper presented at Workshop on Winter Flounder Biology, Mystic, Conn., Dec. 5-6, 1989.
- Wilk, S.J., R.A. Pikanowski, A.L. Pacheco, D.G. McMillan, and L.L. Stehlik. 1989. Distribution, relative abundance and size-age composition of winter flounder (*Pseudopleuronectes americanus*) collected during the 12-mile dumpsite recovery study. Paper presented at Workshop on Winter Flounder Biology, Mystic, Conn., Dec. 5-6, 1989.

### 1990

- Mountain, D. 1990. Bottom currents in the vicinity of the 12-mile dumpsite. Paper presented at Middle Atlantic Bight Physical Oceanography & Meteorology Workshop, Woods Hole, Mass., Oct. 1990.
- Mountain, D. 1990. Bottom currents in the vicinity of the 12-mile dumpsite. Paper presented at American Geophysical Union Spring '90 Meeting, Baltimore, Md., May 1990.
- Phoel, W. 1990. 12-mile dumpsite recovery study. Paper presented at NOAA Seminar, Silver Spring, Md., Sept. 1990.
- Reid, R. 1990. Responses of habitats and biota of the inner New York Bight to abatement of sewage sludge dumping -- progress report. Paper presented at Cleaning Up Our Coastal Waters: An Unfinished Agenda, Bronx, N.Y., Mar. 12-14, 1990.
- Valdes, B.A. 1990. Winter flounder tag return problems. Paper presented at Enhancing Catch/Tag-and-Release Fishing in the Northeast Region: Issues, Concerns, Potential, Woods Hole, Mass., Apr. 27-28, 1990.

f

f