



Quadrennial Technology Review-2015

Chapter 3: Enabling Modernization of Electric Power Systems

Update to the Electricity Advisory Committee

Akhlesh Kaushiva

June 29, 2015



QTR 2015 Chapter Outline

Intro.

1. Energy System Goals and Challenges
 2. Energy Systems and Strategies
-

Assessments

- 3. Enabling Modernization of Electric Power Systems**
 4. Advancing Clean Electric Power Technologies
 5. Increasing Efficiency of Buildings Systems and Technologies
 6. Innovating Clean Energy Technologies in Advanced Manufacturing
 7. Advancing Systems and Technologies to Produce Cleaner Fuels
 8. Advancing Clean Transportation and Vehicle Systems and Technologies
 9. Enabling Capabilities for Science and Energy RD3
-

Integrated Analysis

10. Approaches to Integrated Analysis
11. Action Agenda and Conclusions

DRAFT FOR DISCUSSION



The Electricity Infrastructure Landscape

- The objective has been to provide reliable and affordable electricity to power the national economy – “Obligation to Serve”
- More than 3,000 entities that own and operate the system:
 - 19,000 power plants
 - 55,000 transmission substations
 - 476,000 miles of high voltage lines
 - 6 million miles of distribution lines
- 145 million customers across the country
- Thousands of jurisdictional entities, e.g. municipal, state and federal
- Evolved over a period of time as the needs changed, yet using the same core design concepts

DRAFT FOR DISCUSSION



Electricity is the Largest Proportion of U.S. Energy Use



Estimated U.S. Energy Use in 2013: ~97.4 Quads

DRAFT FOR DISCUSSION

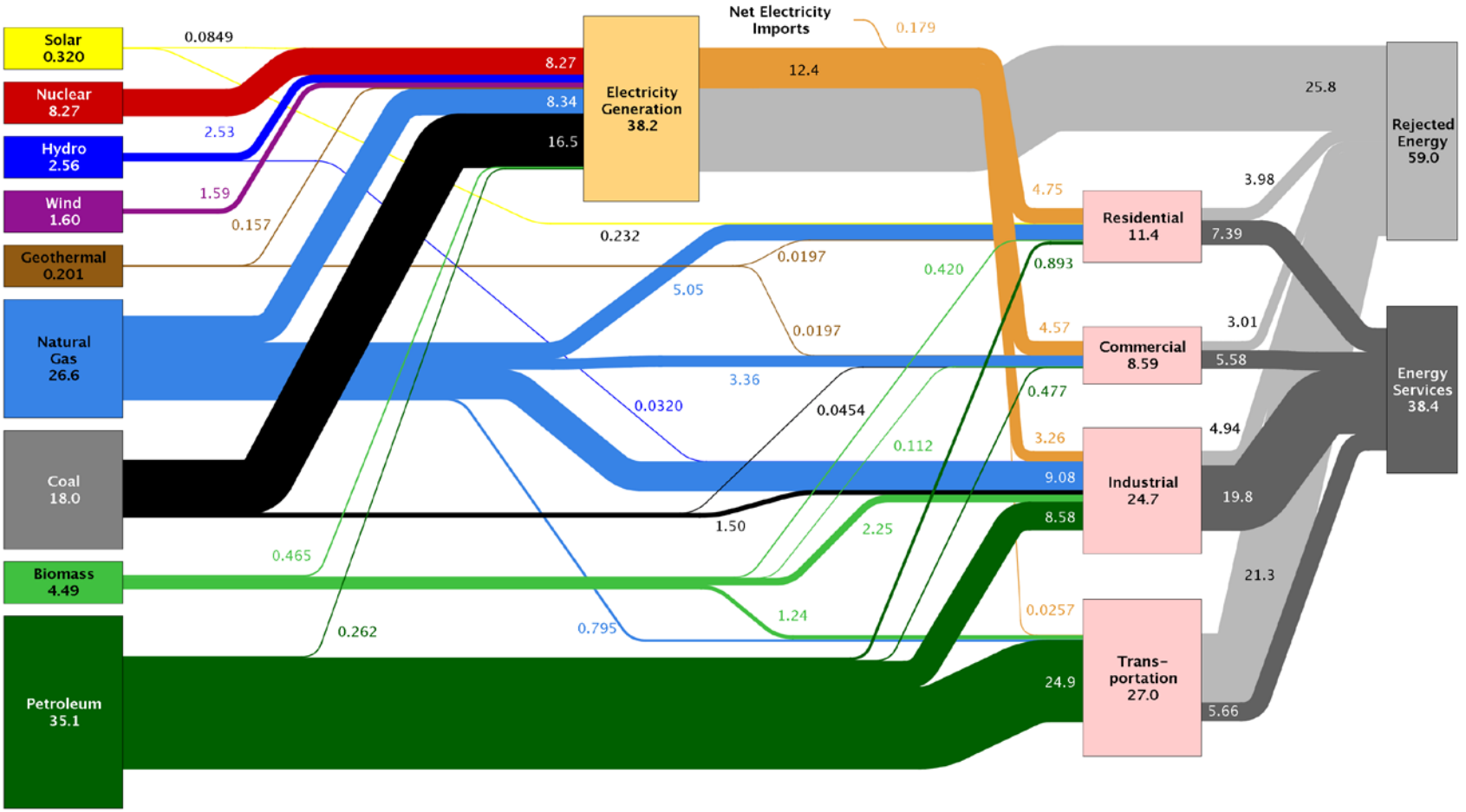

Source: LLNL 2014. Data is based on DOE/EIA-0035(2014-03), March, 2014. If this information or a reproduction of it is used, credit must be given to the Lawrence Livermore National Laboratory and the Department of Energy, under whose auspices the work was performed. Distributed electricity represents only retail electricity sales and does not include self-generation. EIA reports consumption of renewable resources (i.e., hydro, wind, geothermal and solar) for electricity in BTU-equivalent values by assuming a typical fossil fuel plant "heat rate." The efficiency of electricity production is calculated as the total retail electricity delivered divided by the primary energy input into electricity generation. End use efficiency is estimated as 65% for the residential and commercial sectors 80% for the industrial sector, and 21% for the transportation sector. Totals may not equal sum of components due to independent rounding. LLNL-MI-410527



Drivers of Electricity System Transformation

- **Changing mix and characteristics of electricity generation sources**
 - Large central station plants to many smaller and sometimes variable generators
 - Locational variation of energy resources
- **Changing demand (loads) in retail electricity markets**
 - Adoption of more energy-efficient end-use technologies
 - Growing consumer participation and broader electrification
- **Integration of smart grid technologies for managing complex power systems**
 - Availability of advanced technologies that can better manage progressively challenging loads
- **Growing expectations for a resilient and responsive power grid**
 - Frequent and intense weather events
 - Cyber and physical attacks

DRAFT FOR DISCUSSION



The Future Grid Is a Change from the Present

DRAFT FOR DISCUSSION

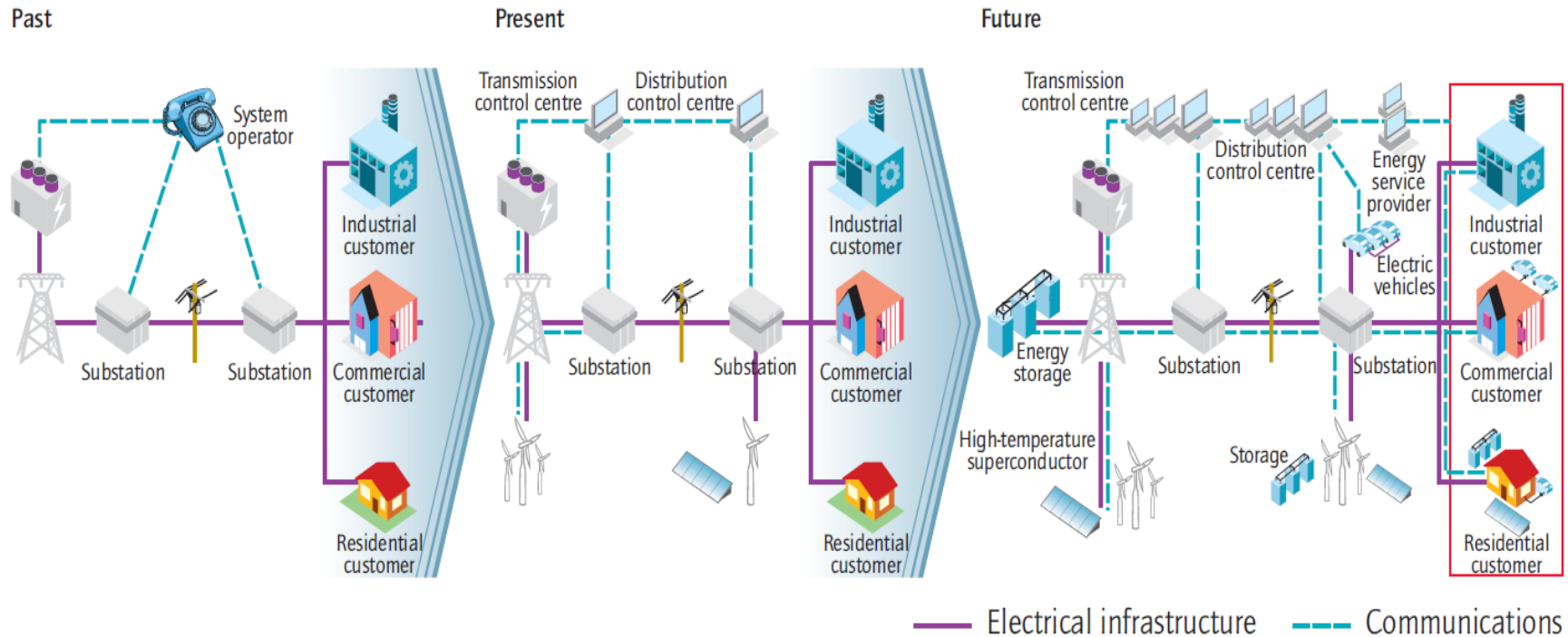

- Central stations currently provide stability while integrating renewables, market operations are expanding, and some consumer sensing and distribution control exists
- The future is a fully integrated communication and electrical system
 - Interoperability across the system is essential
 - Maintaining system stability will require visibility at very low levels in some areas and quick and secure communication across the system



The QTR Identifies Key Research Themes

DRAFT FOR DISCUSSION

- Operating the future grid will require significantly improved visibility, quick and secure communications, and improved models and controls to take actions to maintain system stability and performance
- Active coordination of distributed energy resources is a fundamental change that requires a new architecture to achieve interoperability across the system
- A new generation of components based on material advancements will enable and derive benefit from the grid's new structure

Drivers of change

Integration of digital devices for managing power systems

Changing mix of electricity supply

Expectations and needs for greater reliability and resilience

Customer participation in electricity markets

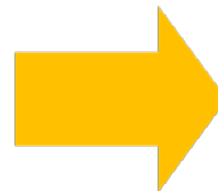

RD3 themes

Sensing and communications for power systems

Modeling, computation, and controls

Materials and manufacturing for power electronic devices



Control Systems – Transmission & Distribution (Observability)

- Benefits
 - Improved visibility into system and asset conditions can increase the efficiency, reliability, and resilience of the system
- Key Challenges
 - Computational capabilities and methods are not fast enough to support more dynamic and stochastic operations
 - Large data streams are not effectively analyzed or integrated into applications
 - Little visibility into distribution systems

DRAFT FOR DISCUSSION

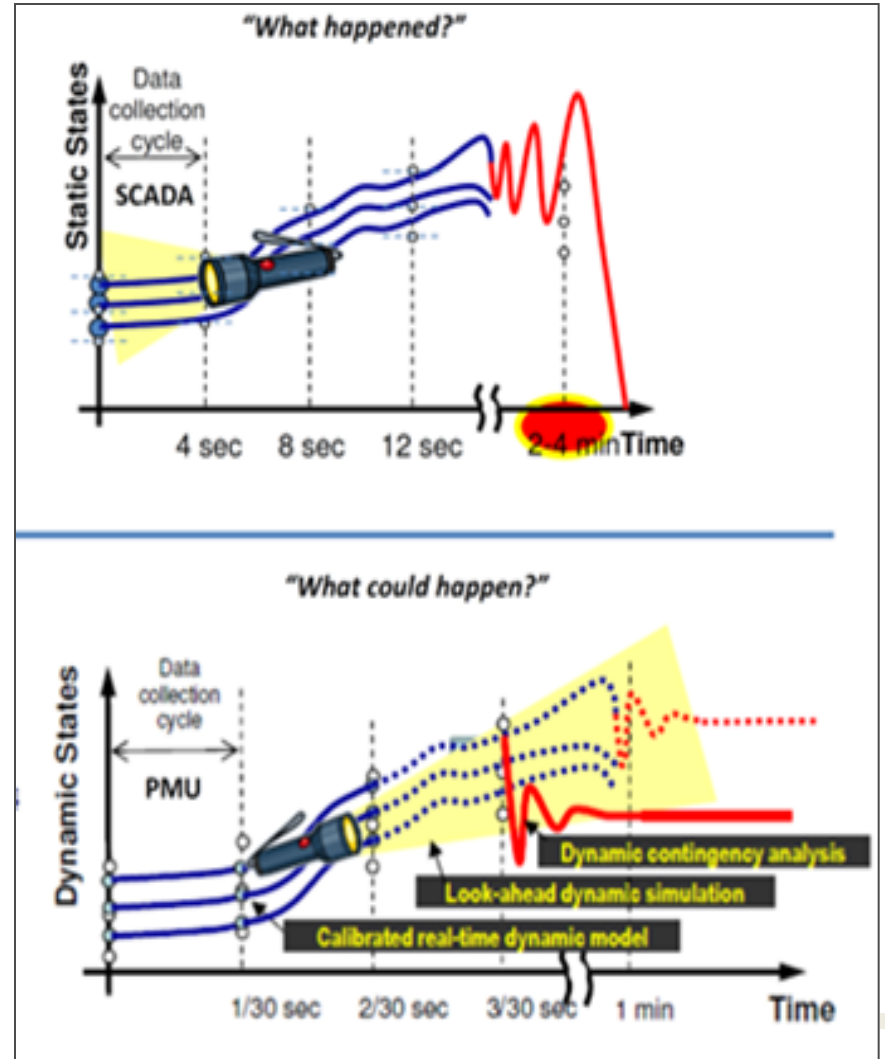
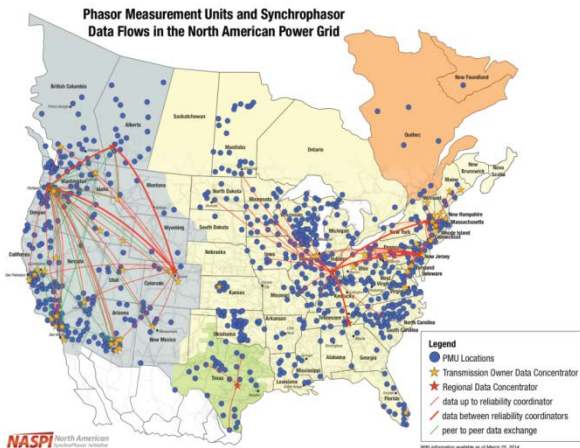



Control Systems – Transmission & Distribution (Controllability)

- Benefits
 - Enhanced controls can improve the power quality, efficiency, reliability, and resilience of the system and support the integration of variable renewables
 - Enables consumer participation, supporting innovation and new products and services
- Key Challenges
 - Management and coordination of the large number of control points (~10,000x) will require innovative and scalable control approaches
 - Control of distributed assets and resources will need to be coordinated across the distribution system and up to the transmission system

DRAFT FOR DISCUSSION

Estimated Number of Nodes/Control Points per Entity Type for Transactive Energy

Entity Type	Number of Nodes
Regional	< 20
Control Area	~200
Distribution	~1500
Market Participant	~500
Supply	~10,000
Building	~150,000,000

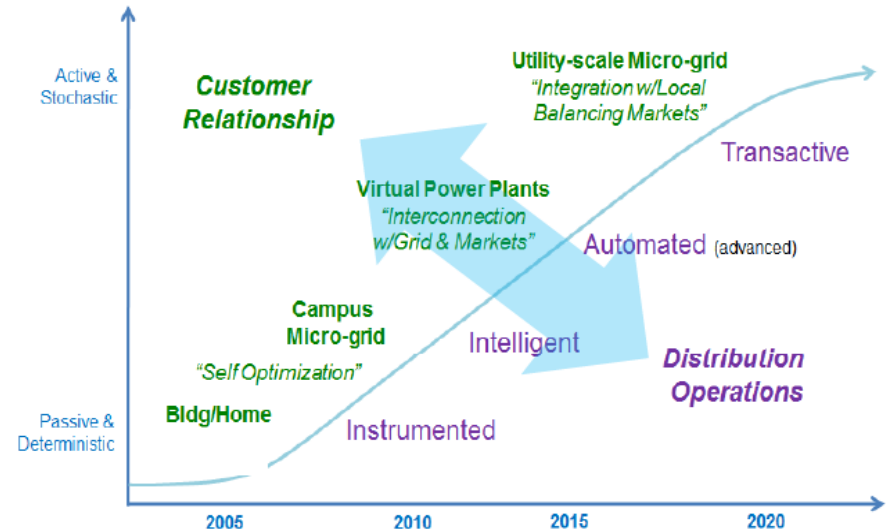

Source: GridWise Transactive Energy Framework, GridWise Architecture Council, January 2015



Transmission & Distribution Components

- Benefits
 - New grid components and control capabilities can help optimize dispatch, increase asset utilization, and reduce system congestion to save money
- Key Challenges
 - Advances in solid state devices and other materials are foundational for next-generation components that are high-performance and cost-effective
 - Experience with advanced system designs and components are limited and few testing facilities exist to explore full control capabilities

DRAFT FOR DISCUSSION

Technology	Capabilities	Opportunities
Solid State Transformers	Enables segmentation of the grid and hybrid configurations; two-way flow	Fundamental design and material improvements
Power Flow Controllers	Optimizes power flows and improves grid stability	Cost reductions and integration with system operations
Advanced Protection Devices	Isolates parts of the system quickly and protects expensive assets	Fundamental design and material improvements; manufacturing
Cables and Conductors	Reduces conduction losses and increases throughput	Design and material improvements; manufacturing



Distributed Energy Resources

DRAFT FOR DISCUSSION

- Benefits
 - Customer-sited technologies can be a cost effective option for the provision of power system services (e.g., demand response, voltage support, or frequency regulation)
 - Improved capabilities of distributed energy resource supports their integration
 - Integrated systems can improve local reliability and resiliency
- Key Challenges
 - DERs are designed for their primary function (lighting, heating, cooling, pumping, etc.)
 - Limited communication, control, and local intelligence are embedded for interaction with utilities and operators
 - Characterization of the various resources is need to inform integration and use
 - Integrated systems can have an impact on a building level, in a local area, or on a regional scale, requiring improved protections

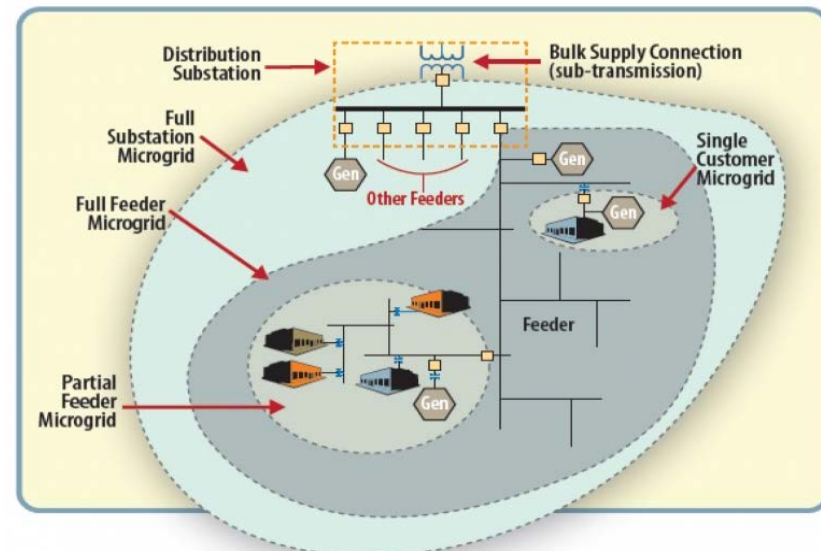
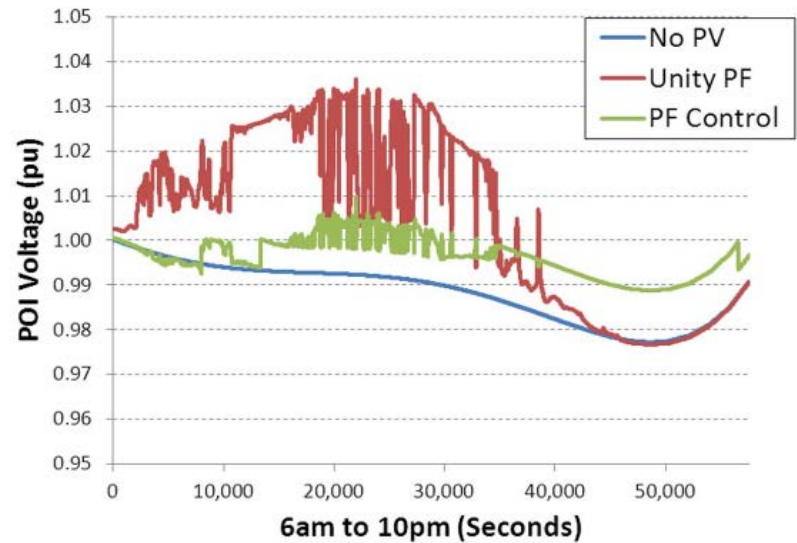



Electrical Energy Storage

DRAFT FOR DISCUSSION

- Benefits
 - Energy storage is a game changer, enabling increased system flexibility to fully utilize renewable resources
 - Defers costly generation, transmission, and distribution investments and optimizes assets
 - Can provide emergency power during outage events
- Key Challenges
 - Limited options exist for bulk power management technologies
 - Reliability and safety concerns exist with newer technologies
 - Limited utility experience and modeling capabilities with storage
 - Costs for the full system will need to come down dramatically

Operational Uses for Energy Storage

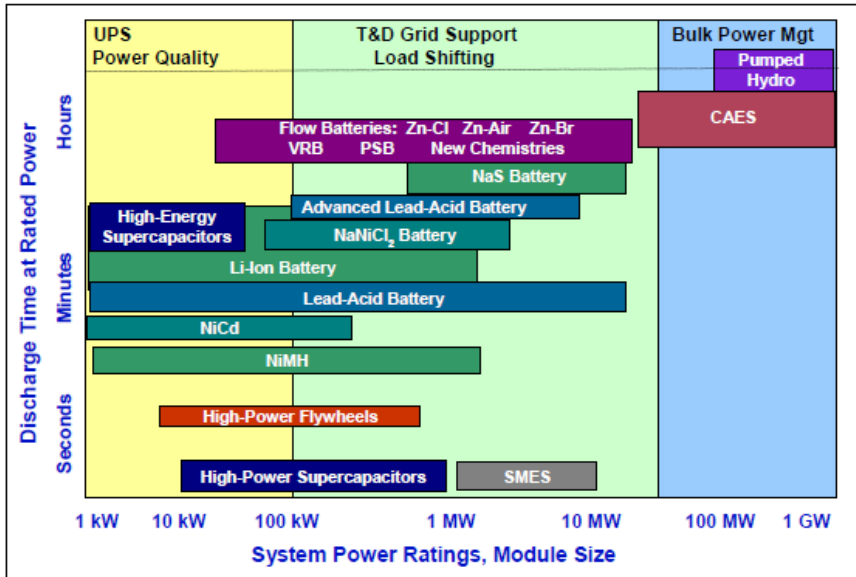

Cost Components of Batteries

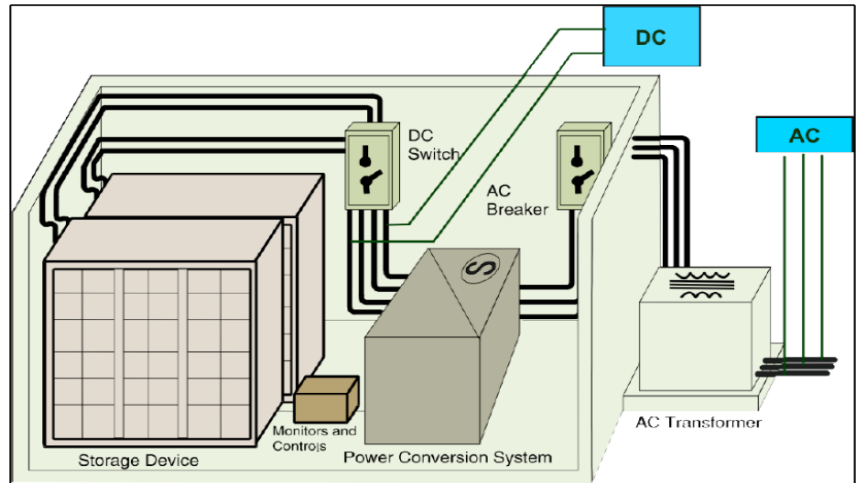



Planning Tools

- Benefits
 - The ability to examine all system aspects, including architectures, controls, new devices, security, communications, and interdependencies will improve decision making
- Key Challenges
 - Current tools and models are domain-specific (e.g., long-range planning, production cost, dynamics, transmission, distribution) with limited fidelity and interoperability
 - Decisions and phenomena relevant to the grid span various timescales, geographic scales, with large degrees of uncertainty
 - Well documented use-cases (with assumptions), accessible databases, and accurate models are also needed

DRAFT FOR DISCUSSION

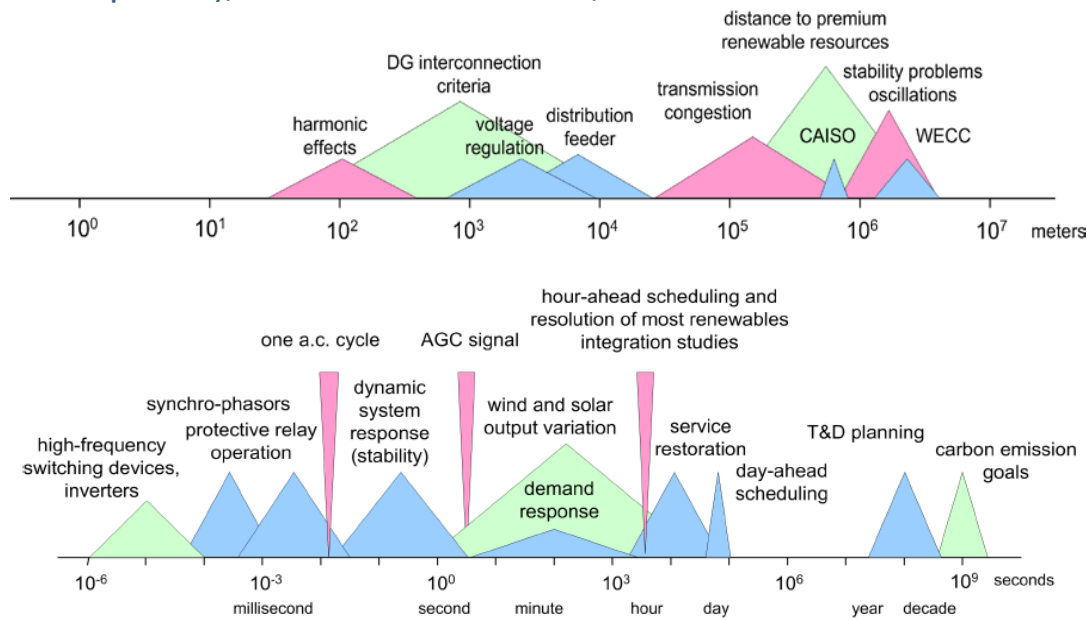
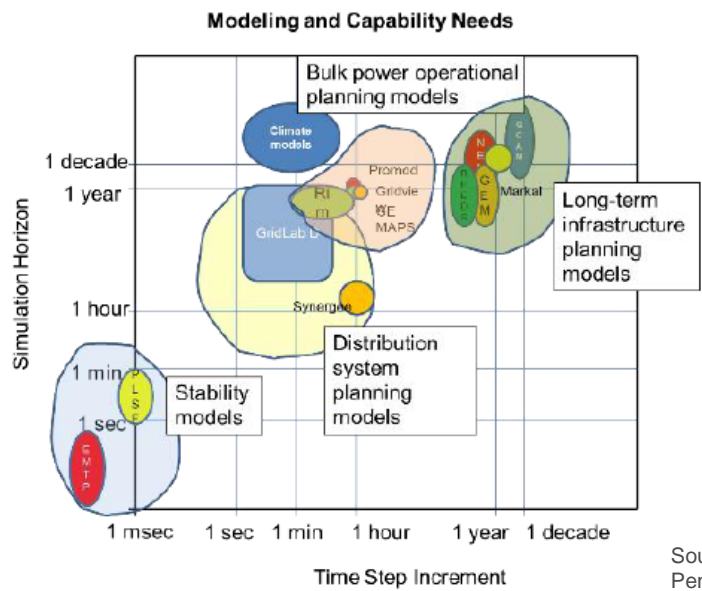

Source: Alexandra von Meier, "Challenges to the Integration of Renewable Resources at High System Penetration," California Institute for Energy and Environment (2014).



Physical and Cyber Security

DRAFT FOR DISCUSSION

- Benefits
 - Improvements in security technologies can make the grid resilient to all-hazards
 - Help reduce the societal cost of outages, accelerate the time to restore power, and minimize impact on consumers
- Key Challenges
 - Legacy systems and components were not designed with security in mind
 - Threats are constantly evolving and changing, getting more sophisticated
 - The integration of information and communication technologies with the power system is forming a tightly coupled cyber-physical system
 - System restoration requires the coordination of numerous resource, physical and human

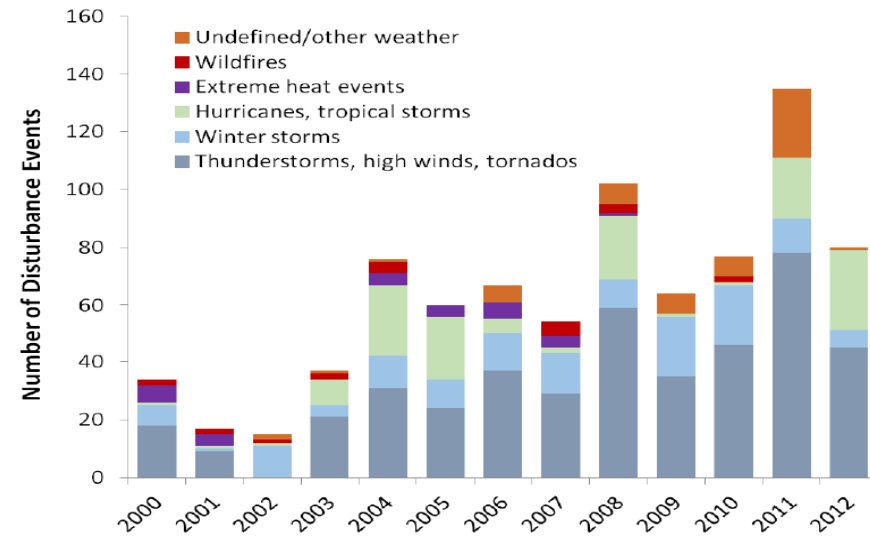
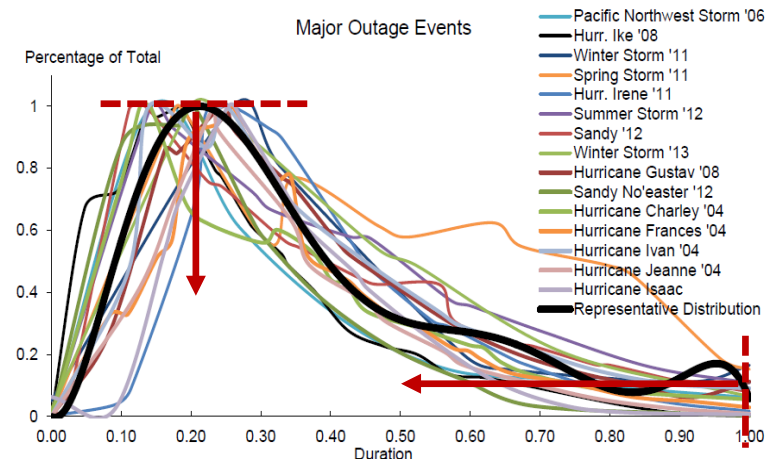

Figure 28. Weather-related grid disruptions, 2000-2012

Data source: DOE 2013b



Source: Department of Energy, Office of Electricity Delivery and Energy Reliability



Conclusion – Advancements Across the Electric Power System Are Needed

- Integration of IT and electrical systems enables system operators to “close the loop”, which is a fundamental change in the system
- Operating the future grid will require significantly improved visibility into the grid and improved models and controls to take actions to maintain system stability and performance
- A new generation of components – from transformers to batteries - is needed that take full advantage of the grid’s new structure and to exploit capabilities to create value
- The area experiencing the most radical change is the distribution system
- Planners and decision makers will require a new generation of tools to support the change
- Security – cyber and physical - is becoming ever more critical

DRAFT FOR DISCUSSION



Representative R&D Opportunities

DRAFT FOR DISCUSSION

Grid Design and Interoperability

- Development, analysis, and refinement of grid architecture, designs, and associated structures
- Standards to ensure interoperability between various resources and with controls systems

Control Systems for Transmission and Distribution

- Development of advanced software, models, and visualization tools utilizing high-speed data from phasor measurement units and other sensors to provide robust “real-time” monitoring, control, detection, and mitigation of system conditions
- New distribution-level technologies and tools to interpret and visualize data, predict conditions, and enable faster control to ensure reliability and safety
- Innovative control approaches to coordinate and manage distributed resources in conjunction with transmission system operations



Representative R&D Opportunities (continued)

DRAFT FOR DISCUSSION

Transmission and Distribution Components	<ul style="list-style-type: none">• Material innovations for high power, high frequency, and high reliability grid applications, including wide band gap semiconductors• Component designs, topologies, and systems based on solid-state devices that lead to higher performance, increased reliability, and lower costs
Distributed Energy Resources	<ul style="list-style-type: none">• Advanced “smart” technologies (e.g., loads, generators, electric vehicles) with embedded local intelligence, communication, and control capabilities• Controllers for integrated systems such as smart buildings and microgrids
Electrical Energy Storage	<ul style="list-style-type: none">• Materials research to lower costs, increase energy density, increase capacity, improve performance, and reduce lifetime impacts, including disposal• Full system designs that address costs (e.g., subsystem, installation, and integration) along with round-trip efficiencies, cycle life, depth-of-discharge, ramp rates, and safety• Solid state control systems to better integrate storage in the grid



Representative R&D Opportunities (continued)

DRAFT FOR DISCUSSION

Planning Tools

- High-fidelity models, tools, and simulators that are user-friendly and accessible to decision-makers
- Common framework for modeling and co-simulation of tools from disparate technical domains (e.g., power flow, communications, markets)

Physical and Cyber Security

- Tools for non-traditional contingency planning and situational awareness of the security posture, both cyber and physical
- Resilient and adaptive control systems that can survive an incident while sustaining critical functions
- Innovative technologies to assess system trust, identify and eradicate embedded malware, and techniques to validate security of supply chain