



# Fort Gordon, Georgia Installation Design Guide

"Community of Excellence"





# Fort Gordon

## Army Installation Design Guide

### Fort Gordon Georgia



**U.S. Army Signal Center  
and Fort Gordon**



**U.S. Army Garrison  
Fort Gordon, Georgia**



**PREPARED BY:  
Directorate of Public Works  
Fort Gordon, Georgia**

**OCTOBER 2008**



# Fort Gordon

## Army Installation Design Guide

### **Table of Contents:**

**SECTION ES: Executive Summary**

**SECTION 1: Introduction**

**SECTION 2: Process and Implementation**

**SECTION 3: Design Guide and Analysis Criteria**

**SECTION 4: Installation Profile**

**SECTION 5: Visual Themes and Zones**

**SECTION 6: Improvement Projects**

**SECTION 7: Site Planning Design Standards**

**SECTION 8: Building Design Standards**

**SECTION 9: Circulation Design Standards**

**SECTION 10: Landscape Design Standards**

**SECTION 11: Site Elements Design Standards**

**SECTION 12: Force Protection Design Standards**

**OCTOBER 2008**



# Fort Gordon

## **Army Installation Design Guide**

### **Appendices**

[APPENDIX A – Design Team IDG Checklist](#)

[APPENDIX B - Project Requirements Checklist](#)

[APPENDIX C - Interior Design Review Checklist](#)

[APPENDIX D - Sustainable Design](#)

**D.1 What is Sustainable Design?**

**D.2 Sustainable Design and Development**

**D.3 Sustainability and the Federal Government**

**D.4 Army Standards**

**D.5 References**

[APPENDIX E - LEED Checklist](#)

[APPENDIX F - Landscape Maintenance Schedule](#)

[APPENDIX G - Prioritized Improvements Projects List](#)

[APPENDIX H - Self-Help Project Checklist](#)

[APPENDIX I - Interior Finishes Standards](#)

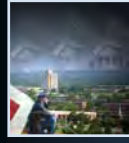
**I.1 Flooring**

**I.2 Base**

**I.3 Walls**

**I.4 Ceilings**

**OCTOBER 2008**



# Fort Gordon

**I.5 Countertops**

**I.6 Doors**

**I.7 Lighting**

## **APPENDIX J - Interior Furnishings Standards**

**J.1 Furniture Finishes**

**J.2 Furniture & Textile Construction**

**J.3 Conventional Furniture**

**J.4 Systems Furniture**

**J.5 Children's Furniture**

**J.6 Accessories**

**J.7 Restrooms & Locker Rooms**

**J.8 Signage**

**J.9 Railings**

## **APPENDIX K - Exterior Materials Chart**

- **Support Operations (Signal Center Barracks and Admin.**

**Visual Theme**

- **Industrial Facilities Visual Theme**
- **Community Center Visual Theme**
- **Medical Center Visual Theme**
- **Gates Visual Theme**



# Fort Gordon

## APPENDIX L - Exterior Color Chart

- North Industrial Visual Zone
- Signal Center Barracks and Administration Visual Zone
- USAR / National Guard Visual Zone
- South Industrial Visual Zone
- Community Center Visual Zone
- Signal Center HQ, Admin. And Academic Facility Visual Zone “Traditional Core”
- Medical Center Visual Zone

## APPENDIX M - Historic Preservation Guidelines

### **M.1 Introduction**

M.1.1 Military Planning and Design

### **M.2 Historic Preservation Regulations**

### **M.3 Rehabilitation of Historic Properties**

M.3.1 New Work

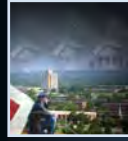
M.3.2 Treatment of Historic Fabric

M.3.3 Standards for Historic Preservation Projects

M.3.4 Guidelines for Historic Preservation Projects

### **M.4 Army Standards**

### **M.5 References**



# Fort Gordon

## APPENDIX N - Housekeeping Rules

### **N.1 Housekeeping Rules**

N.1.1 General

N.1.2 Public Spaces

## APPENDIX O - Plant Palette

## APPENDIX P - DA Facilities Standardization Program

### Centers Of Standardization

## APPENDIX Q - Standards & References

**Q.1 Section 7, Site Planning**

**Q.2 Section 8, Buildings**

**Q.3 Section 9, Circulation**

**Q.4 Section 10, Landscape**

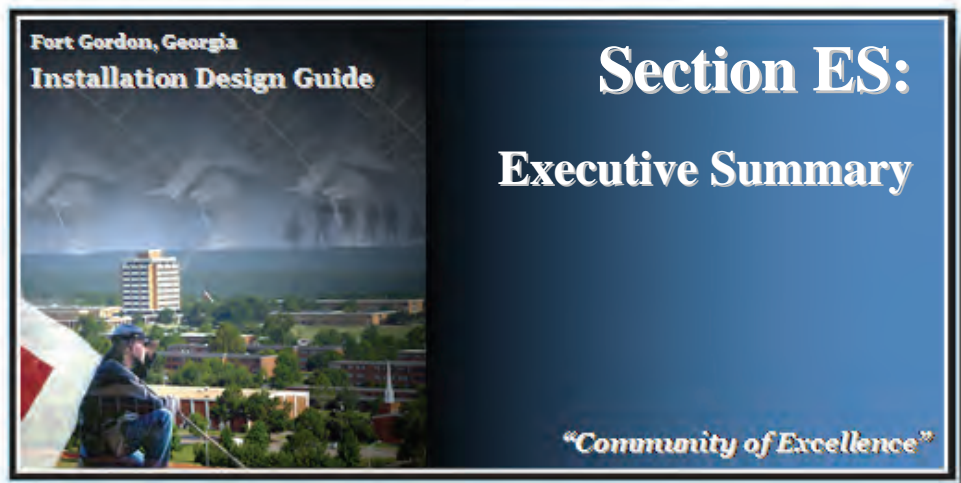
**Q.5 Section 11, Site Elements**

**Q.6 Section 12, Force Protection**

**Q.7 Appendix D, Sustainable Design**

**Q.8 Appendix M, Historic Preservation**

**Acknowledgements**



**Authority.** The Commander's Guide Army Installation Standards published 1 October 2002 gave initial senior Army leadership direction. The Army Installation Design Standards establishes the Army standards for installation design as directed by the Secretary of the Army and the Chief of Staff, Army. The Model Army Installation Design Guide used in the development of the Fort Gordon Installation Design Guide was published 3 May 2004

## ES.1 INTRODUCTION

An efficient, harmonious, and visually compatible environment is conducive to attracting and retaining skilled and motivated personnel. The Fort Gordon Installation Design Guide (IDG) provides direction for improving the visual quality on Fort Gordon and also serves as a tool for implementing the goal and vision of creating an "Community of Excellence" that fosters pride and commitment to the Army professional military way of life.

This document is the Executive Summary of the Fort Gordon Installation Design Guide (IDG or "Guide"). As a synopsis of the Guide it provides an overview of the existing conditions and command policies that relate to the design and management of facilities and grounds at Fort Gordon.





## ES.2 BACKGROUND

**ES.2.1** The *Army Installation Design Standards* follows the concept established in the Joint Service *Unified Facilities Criteria Installation Design* manual.

**ES.2.2** Research was conducted to incorporate into Army standards the best practices from other organizations such as the Air Force, Navy, AAFES, GSA, National Park Service, Federal Highway Administration, and various city and county governments, and associations.

**ES.2.3** Existing Army Installation Design Guides were also reviewed for their application of procedures, examples, and benchmarks for IDG implementation Army-wide.

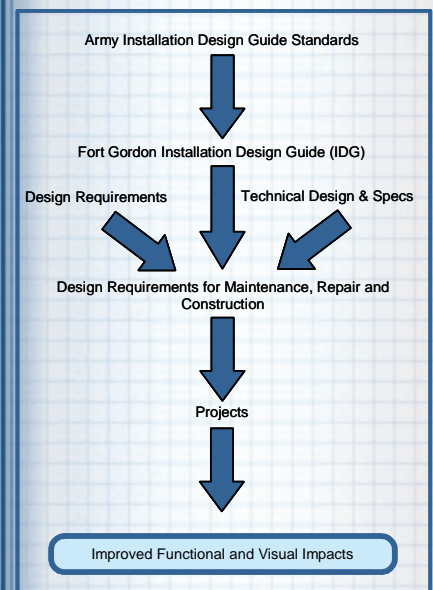
## ES.3 PURPOSE OF THE INSTALLATION DESIGN GUIDE

The IDG provides guidance on standardizing the visual effects for the exterior of new and renovated facilities as well as the surrounding land. It also provides measures on improving the total environmental and visual quality of the installation (Fig. ES.1).

Visual quality is dependent upon the visual appearance of the layout and physical components of Fort Gordon. The IDG serves as a comprehensive planning tool for articulating the Installation's short-range and long-range master planning vision. Once a design standard is prepared and adopted, it is used for design decisions for all new construction, renovation, maintenance, and repair projects.

The IDG was developed utilizing a process of analysis, planning, design, and implementation. This process includes the following steps.

- Set Goals and Objectives
- Collect Base Data
- Conduct Visual and Spatial Surveys
- Define Visual Themes and Zones
- Prepare Functional Analysis
- Define Visual and Spatial Assets and Liabilities
- Prepare Recommendations for Projects to Improve Visual and Spatial Impacts



**Fig. ES.1 – Purpose of IDG**



The IDG includes standards and general guidelines for site planning; architectural character, colors and materials; vehicular and pedestrian circulation; and landscape elements, including plant material, outdoor seating, signage, lighting and utilities. The design guidelines incorporate sustainable design, quality of design, antiterrorism, low maintenance, life cycle costing, historical and cultural considerations, durability, safety and compatibility.

#### ES.4 STAKEHOLDERS

This IDG is to be used by all individuals involved in the decision making process for design, construction, and maintenance of facilities (Fig. ES.2):



Fig. ES.2 – A Diagram of the Guide’s Primary Stakeholders

The primary stakeholders and users include the following:

- Installation Commander and staff
- Garrison Commander and staff
- U.S. Army Corps of Engineers, Savannah District
- Customers and other users of installation infrastructure
- Consulting planners, architects, engineers, and landscape architects (working on installation projects)
- Maintenance personnel

- Contractors employed by the Operations and Maintenance Division

The ultimate success of the IDG depends on the commitment of all stakeholders to fully implement the guide, and on the proper education of installation staff about the existence and purpose of the Guide.

## **ES.5 ORGANIZATION OF THE IDG**

**ES.5.1** Improvements to the quality of development and the use of sustainable design and development practices have a direct impact on the efficiency and effectiveness of the installation. These measures affect mission performance and the quality of life for those who live and work on or visit Fort Gordon.

The IDG is organized to facilitate the preparation and execution of projects to improve the visual image of the installation and to ensure that design conforms to Army standards, including sustainability requirements.

The IDG Sections are as briefly described below:

- **Section 1 “Introduction”**
- **Section 2 “The Installation Design Guide Process and Implementation”** describes how the IDG plays a part when initiating any maintenance, repair, renovation or new construction project and how to use the IDG as a resource.
- **Section 3 “Design Guide Analysis Criteria”** discusses specific goals and objectives promoted by the Fort Gordon IDG, the visual elements that are addressed by the IDG and the design principles employed in analyzing the current and desired state of the installation.
- **Section 4 “Installation Profile”** details the regional setting, natural environment and existing land use on Fort Gordon.
- **Section 5, “Visual Themes and Zones”** analyzes the design theme of Fort Gordon and breaks it down into a set of visual zones. Assets, liabilities and recommendations are described for each zone.
- **Section 6 “Improvement Projects”** provides a consolidated list of recommendations to correct the visual



**Fort Gordon Aerial**



and functional liabilities identified for each visual zone. It also includes improvement projects developed by the installation to accomplish the recommendations.

- **Section 7 “Site Planning Design Standards”** discusses what factors and requirements must be considered in selecting and planning a building site.
- **Section 8 “Buildings Design Standards”** discusses what factors and requirements must be considered in building design.
- **Section 9 “Circulation Design Standards”** discusses what factors and requirements must be considered in the design of roads, parking lots and the pedestrian circulation system.
- **Section 10 “Landscape Design Standards”** discusses what factors and requirements must be considered in landscape design.
- **Section 11 “Site Elements Design Standards”** discusses what factors and requirements must be considered in the selection and location of site elements.
- **Section 12 “Antiterrorism Design Standards”** discusses what factors and requirements must be considered for all infrastructure that may affect antiterrorism efforts.

## ES.6 IDG METHODOLOGY

**ES.6.1** The IDG provides standards and guidelines to installation decision makers, contracted and in-house planning and design professionals, installation maintenance personnel, and others.

**ES.6.2** The following paragraphs present an overview of the steps involved in developing an installation specific IDG. The IDG promotes a sense of arrival, functional compatibility, visual order, enhances site assets, relates the natural and man-made environment, and achieves consistent architectural themes throughout the installation.



### Step 1. Installation Profile

Initially an installation profile is created in which the installation setting, existing land use, and proposed land use are detailed to include all applicable sub installations.

### Step 2. Visual Surveys

The first survey establishes the visual zones and themes of the installation. The second survey documents the liabilities and assets within each visual zone.

### Step 3. Visual Zones and Themes

Information gathered is recorded and used to delineate visual zones. Zones with similar visual characteristics are grouped together to form a broader category called themes. Visual characteristics define a "look and feel" of an area together with the dominant features that define its image. Typical visual characteristics include unique buildings, vehicular and pedestrian corridors, functional use, natural features, and spatial relationships (Fig. ES.3).

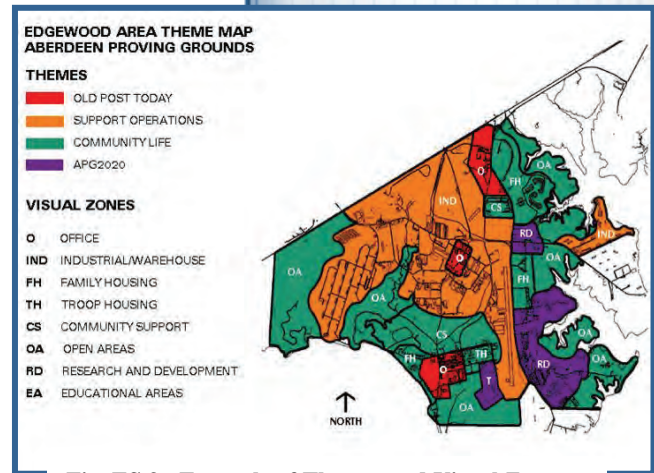


Fig. ES.3 - Example of Themes and Visual Zones

### Step 4. Assets and Liabilities

Each visual zone is then defined for its assets and liabilities. Subsequently, a functional analysis is prepared.

### Step 5. Recommendations

Recommendations are developed to address the liabilities identified and to enhance the assets noted in accordance with Army standards and the IDG goals and objectives. Recommendations are in the form of specific projects that are utilized to prepare a prioritized projects list for approval by the installation Real Property Planning Board.

## ES.7 RESPONSIBILITIES

As directed by the Secretary of the Army and the Chief of Staff, Army and approved by the Army Installation Management Board of Directors, the following responsibilities are established:



**ES.7.1 Assistant Chief of Staff for Installation Management (ACSIM):**

- Establish Army facility standards and approve deviations from the standards.
- Approve Army Installation Design Standards Implementation Plan.
- Approve Army Installation Design Standards Investment Strategy.

**ES.7.2 Director, Installation Management Command (IMCOM):**

- Develop and implement the Army Installation Design Standards Implementation Plan.
- Develop and implement the Army Installation Design Standards Investment Strategy.
- Ensure compliance with the Army Installation Design Standards.
- Maintain an electronic newsletter for communicating changes in standards.

**ES.7.4 Garrison Commander:**

- Maintain and provide IDG compliance for Fort Gordon.
- Chair Real Property Planning Board (RPPB).
- Enforce IDG standards.
  - **The Directorate of Public Works (DPW)** supports the Garrison Commander and Staff by performing the following tasks;
    - Developing the IDG.
    - Defining and communicating the responsibilities of other organizations in implementing the IDG.
    - Ensuring that the processes needed for IDG implementation have been established, implemented and maintained.



**U.S. Army Installation  
Management Command**

- Conducting Planning and Design Charrettes in accordance with the Director of IMCOM memoranda identified above.

**1.8.1.4 Senior Commander:**

- Review and approve IDG.

**1.8.5 Commanders / Directors of Tenant Organizations:**

- Participate in installation Real Property Planning Board.
- Participate in design and planning charrettes.
- Determine project functional requirements.
- Participate in design reviews.

**ES.7.5 U.S. Army Corps of Engineers, Savannah District:**

- Provide planning, design and construction support to Fort Gordon.

**ES.7.6 Consulting Planners, Architects, Engineers and Landscape Architects:**

- Use the IDG for planning and design to make Army standard designs conform to the Fort Gordon master plan for exterior appearance called “Southern Vernacular.”

**Fort Gordon**  
Fort Gordon



**The Fort Gordon Senior Commander Reviews and Approves the IDG.**



**“ONE TEAM”**



## 1.1 PURPOSE

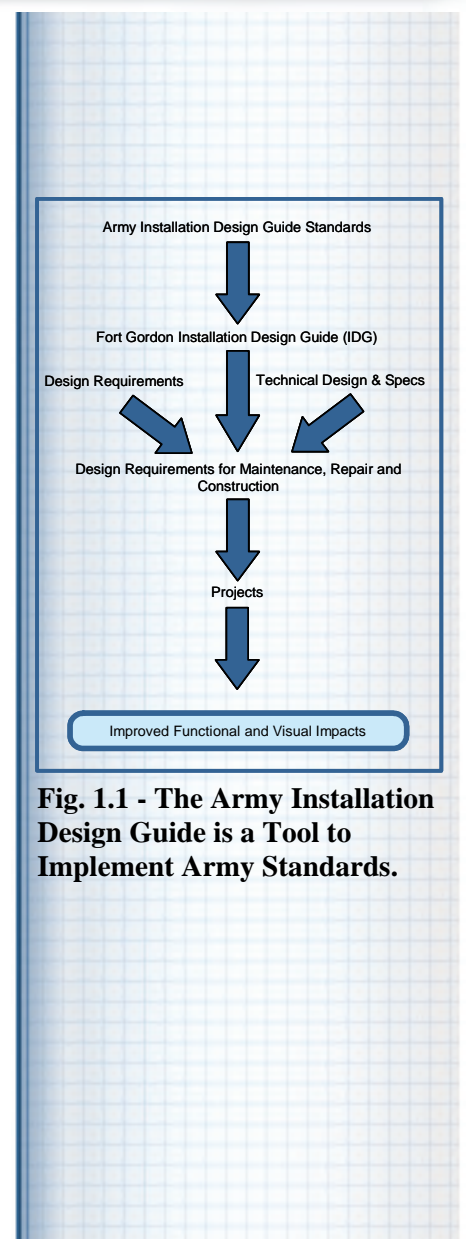
**1.1.1** A military installation conveys a visual image established by its architectural and historical character, arrangement of facilities, circulation patterns, and features in the landscape. This image can be clear, orderly, logical and attractive; or cluttered, confused, and unattractive.

**1.1.2** The purpose of the Installation Design Guide (IDG) is to provide design guidance for standardizing and improving the quality of the total environment of the installation. (Fig. 1.1). It also includes provisions for maintenance and repair requirements on the installation. Improvements to the quality of development and the use of sustainable design and development practices have a direct impact on the efficiency and effectiveness of the installation. These measures affect mission performance and the quality of life for those who live and work on or visit Fort Gordon.

**1.1.3** The IDG includes standards and general guidelines for the design issues of site planning; architectural character, colors and materials; vehicular and pedestrian circulation; and landscape elements, including plant material, seating, signage, lighting, and utilities. The design guidelines incorporate sustainable design, quality of design, anti-terrorism, low maintenance, historical and cultural considerations, durability, safety, and compatibility.

## 1.2 GOAL

The goal of the IDG is to provide a clear, comprehensive approach to establish and maintain a positive visual imagery throughout the installation and implement appropriate standards. This is accomplished by providing a systematic development process that



**Fig. 1.1 - The Army Installation Design Guide is a Tool to Implement Army Standards.**



is defined through description, analysis, synthesis, and implementation.

### 1.3 OBJECTIVES

The objectives of the IDG are:

- To provide a set of general design standards and guidelines that define color, materials, style, signage, and other aspects of design for all visual elements surveyed.
- To provide standards and guidelines for the selection of materials for new construction, renovation, maintenance and repair projects.
- To provide guidance for accomplishing sustainable development. [See Appendix D.](#)
- To provide a structured methodology for establishing projects to improve the visual imagery of the installation.
- To provide guidance to integrate ATFP standards.

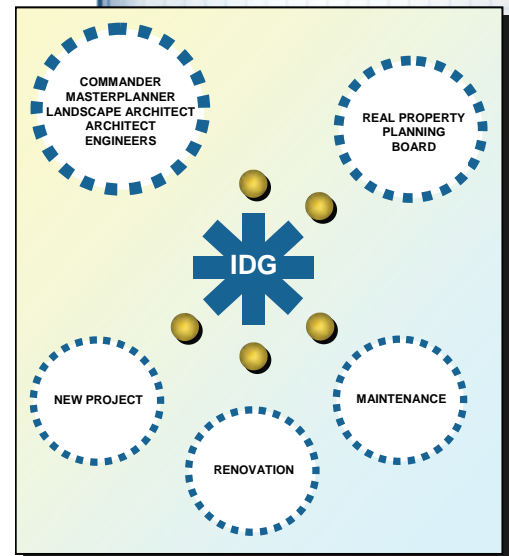
### 1.4 AUDIENCE

**1.4.1** The IDG is to be used by all individuals involved in decision-making, design, construction, and maintenance of facilities (Fig.1.2). The primary users include the following:

- Senior Commander
- Garrison Commander
- Installation facility planning and design personnel
- Installation facility maintenance personnel
- Installation Management Agency and Region
- U.S. Army Corps of Engineers project managers, design, and construction staff
- Consulting Planners, Architects, Engineers, Interior Designers, and Landscape Architects
- Supporting agencies such as AAFES, DeCA, DoDDS, MEDCOM, tenants, etc.



**A Military Installation Conveys a Visual Image Established by its Architectural and Historical Character.**



**Fig. 1.2 - Design Guide Audience**



- National Guard

**1.4.2** The ultimate success of the IDG is dependent upon the commitment of the above individuals and organizations working as a team to apply the Army standards.

## **1.5 ORGANIZATION**

- This Army Installation Design Guide is organized to facilitate the preparation and execution of projects to improve the visual image on the installation and ensure design conforms to Army standards to include sustainability.
- Sections 2 and 3 discuss the process, use, and implementation of the IDG.
- Section 4 establishes the installation profile. The installation setting, existing land use, and future land use are detailed.
- Section 5 addresses the development of installation visual themes and zones. It lists visual themes and zones, specifies assets and liabilities of each zone, and offers recommendations.
- Section 6 provides a list of prioritized improvement projects. All projects are addressed in terms of existing conditions, design concept, cost estimate, funding and maintenance impact, and site plan where applicable.
- Sections 7 through 12 discuss the six design components that provide the categories used for review and analysis during the visual inventory of the installation. The visual impressions of each zone are categorized according to these six design components.

## **1.6 WHEN TO USE THE ARMY INSTALLATION DESIGN GUIDE**

**1.6.1** This IDG provides installation-specific design data. The general design concepts, recommendations, and standards addressed herein are applicable to all Army installations. This document will be used as a reference to acquire recommendations and Army standards on the design of all facilities, new roads, road widening, parking, sidewalks and other pedestrian paths, bicycle paths, Access Control Points (ACP), site furnishing selection and placement, signage selection and placement, lighting selection and placement, utility corridor selection, and utilities. Clearing of plant

materials and planting of new plant materials will be based upon the guidance herein.

## **1.7 MAINTAINING THE ARMY INSTALLATION DESIGN GUIDE**

**1.7.1** Since the IDG is a "living document", keeping it up-to-date and accurate will ensure its continued usefulness. Therefore, it will become necessary to revise it as mission, budget, standards, and other conditions generate new planning and design requirements and in response to facility user feedback.

**1.7.2** In accordance with AR 210-20, Master Planning for Army Installations, the installation Real Property Planning Board (RPPB) is the adjudicating body for the Army Installation Design Guide at the installation level. Violations and variances from standards will be reviewed and adjudicated by the RPPB. The Senior Commander will chair an Installation Planning Board (IPB) to review and approve the RPPB's actions.

**1.7.3** The Fort Gordon DPW Master Planning Staff is responsible for maintaining the Installation Design Guide.

## **1.8 RESPONSIBILITIES**

**1.8.1** As directed by the Secretary of the Army and the Chief of Staff, Army and approved by the Army Installation Management Board of Directors the following responsibilities are established:

### **☐ Assistant Chief of Staff for Installation Management (ACSIM):**

- Establish Army facility standards and approve deviations from the standards.
- Approve Army Installation Design Standards Implementation Plan.
- Approve Army Installation Design Standards Investment Strategy.

### **☐ Director, Installation Management Command (IMCOM):**

- Develop and implement the Army Installation Design Standards Implementation Plan.



**Fort Gordon DPW Master Planning maintains IDG.**



**ACSIM Establishes Army Facility Standards and Approves Deviations from the Standards.**

- Develop and implement the Army Installation Design Standards Investment Strategy.
- Ensure compliance with the Army Installation Design Standards.
- Maintain electronic newsletter for communicating changes in standards.

**☐ Senior Commander:**

- Review and approve IDG.

**☐ Garrison Commander:**

- Develop the installation's IDG.
- Chair Real Property Planning Board (RPPB).
- Enforce IDG standards.

**☐ Commanders / Directors of Tenant Organizations:**

- Participate in installation Real Property Planning Board.
- Participate in design and planning charrettes.
- Determine project functional requirements.
- Participate in design reviews.

**Fort Gordon**  
Fort Gordon



**The Fort Gordon Senior  
Commander Reviews and  
Approves the IDG.**



**U.S. Army Installation  
Management Command**

## 1.9 SUSTAINABLE DESIGN AND DEVELOPMENT

**1.9.1** Practicing the principles of sustainable design in the planning, design, construction, and operation of infrastructure and facilities is a smart business practice. Protecting our natural resources and reducing our impact on the natural environment is achievable when we create high-performance, healthy (Fig. 1.3), energy efficient (Fig. 1.2), and safe buildings.

**1.9.2** The Integrated Design Process. Critical to the success of sustainable design and development is the organization and commitment of the team to engage in the Integrated Design Process. To effect change in building design and operation, the project delivery process itself must become a collaborative effort to integrate design strategies among all disciplines and all players in the project delivery process. Integrated design demands a more inclusive team, working closer together than is traditionally the case. Future building users and facility managers must be invited to join architects, engineers, and planners in developing the vision and goals for new facilities. (Adapted from the HOK Guidebook to Sustainable Design)

**1.9.3** [Appendix D, Sustainable Design](#), discusses the sustainable design concept and its application to Army projects. [Paragraph D.3](#) discusses the Sustainable Project Rating Tool (SPiRiT) developed by the U.S. Army Corps of Engineers (USACE). Per the [Assistant Secretary of the Army \(Installation & Environment\) Sustainable Design and Development Memorandum](#) and the [Assistant Chief of Staff for Installation Management \(ACSIM\) endorsement of Sustainable Design and Development](#) initiative, the SPiRiT rating system will be used by design professionals in all new construction, additions, or renovation of Army facilities for rating sustainability.

**1.9.3.1** The SPiRiT document ([Appendix E](#)) was derived from the U.S. Green Building Council LEED 2.0 (Leadership in Energy and Environmental Design) Green Building Rating System.

**1.9.3.2** Army Rating Standard.

**1.9.3.2.1** The SPiRiT rating of "Silver" is the standard for all FY06 MILCON vertical construction projects currently under design (as of March 18, 2003). For all other FY06 and future-year MILCON projects, the minimum SPiRiT rating requirement is "Gold". See [Assistant Secretary of the Army memorandum Subject: Sustainable Design and Development Requirements, dated 18 March 2003](#).



**1.3 - Energy Efficient Lighting  
Contributes to Sustainability**



**1.2 - CO2 Measurements  
Measure Indoor Air Quality  
Assisting in Creating a Healthy  
Environment**



**1.9.4** Further information on sustainable design can be obtained at the following websites:

[Assistant Chief of Staff for Installation Management, Sustainable Design and Development Website](#) This site provides information on the following topics: documentation and references; sustainable process, tools, products and materials; Sustainable Design and Development Training; and links to various sustainable design and development informational website.

U.S Army Corps of Engineers, Engineering Research and Development Center, Construction Engineering Research Laboratory (CERL), [Sustainable Design and Development Website](#).

[Whole Building Design Guide \(WBDG\)](#) This site provides comprehensive and current information on sustainable design strategies and technologies.

## **1.10 ARMY STANDARDS**

**1.10.1** Army Standards and References are included in the last two paragraphs of the following sections and appendices: Section 7, Site Planning Design Component; Section 8, Buildings Design Component; Section 9, Circulation Design Component; Section 10, Landscape Design Component; Section 11, Site Element Design Component; Section 12, Force Protection Design Component; Appendix D, Sustainable Design; and Appendix M, Historic Preservation Guidelines.

### Links

[Go to Section 2](#)

[Go to Table of Contents](#)



## 2.1 INTRODUCTION

Military installations are hometowns (Fig 2.1) for many of our military families, resources for many veterans and retirees, and an integral part of the surrounding communities. The Army Installation Design Guide (IDG – Fig. 2.2) provides direction for achieving a sense of community, order, tradition, and pride on our installations. This section provides a brief overview of the IDG developmental process and methodology detailed in [Unified Facilities Criteria \(UFC\) 2-600-01, Installation Design](#).

## 2.2 THE DESIGN GUIDE PROCESS

**2.2.1** The IDG includes a process for analysis, planning, design, and implementation. This process includes the following steps:

**2.2.1.1 Setting Goals and Objectives.** The installation develops a set of goals and objectives that address the visual requirements of the installation. The goals and objectives provide a pre-determined image that helps create a visually pleasing and optimally functional environment (Fig. 2.3).

**2.2.1.2 Conduct Visual and Spatial Surveys.** Two visual surveys are performed in the preparation of the IDG. The first survey establishes the visual zones and themes of the installation. The second survey documents the assets and liabilities within each visual zone. [Chapter 5 of UFC 2-600-01](#) details the method for conducting the installation visual survey.



**Fig. 2.1 – Reflect a Hometown Feel**



**Fig. 2.2 – Fort Gordon installation Design Guide**

### 2.2.1.3 Establish Visual Zones and Themes

- The Information gathered during the first survey is used to establish the visual zones of the installation. The visual zones are delineated by the visual characteristics of an area defined as the "look and feel" of an area together with the dominant features that help define its image (Fig. 2.4). A functional analysis of each zone organizes the visual impressions and assesses their functional relationships to determine the visual character and unifying motif. Typical visual characteristics include unique buildings, vehicular and pedestrian corridors, functional use, natural features, and spatial relationships.
- Visual zones with similar characteristics are then grouped together to form a broader category called themes (Fig. 2.5). Example themes include, community life theme, operations support theme, buffer/open space theme, and industrial theme.

**2.2.1.4 Determine Assets and Liabilities.** The second survey a visual zone inventory is conducted. During the survey each visual zone is analyzed for specific visual impacts. The objective of the inventory is to define the visual assets and liabilities within the visual zone.

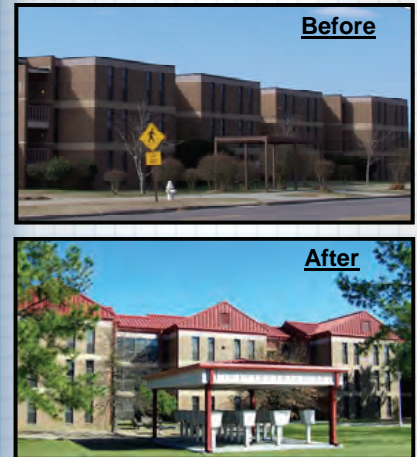
- **Assets.** Assets are positive visual elements, design elements, or features that enhance the surroundings, either visually or functionally.
- **Liabilities.** Liabilities are negative visual elements, design elements, or features that detract from the visual image or functionality of the surroundings. Liabilities should be corrected through appropriate design measures and are the basis for recommendations for improvement.

### 2.2.1.5 Recommendations and Implementation Plan

The assessment of each visual zone includes recommendations to correct liabilities and where desired to enhance assets. The recommendations are in the form of specific projects and are described in detail Section 6, Improvement Projects of the IDG.

### 2.2.2 Design Components

The following six design components, described in sections 7 through 12, provide guidelines and standards from which to conduct the visual zone review and analysis.



**Fig. 2.3 – Goals and Objectives must address Visual Requirements. (Fort Gordon Barracks Upgrade Program)**

Orange	Signal Center HQ, Admin. & Schoolhouse Zone
Pink	North Industrial / Maintenance Zone
Light Blue	South Industrial / Maintenance Zone
Dark Blue	Medical Center Zone
Green	Signal Center Barracks and Admin. Zone
Red	Community Center Zone
Purple	USAR / Ga National Guard Zone
Brown	NSA Ga Complex Zone
Yellow	Open Areas (Green Space)
Grey	Residential Housing (RCI)

**Fig. 2.4 – Fort Gordon Visual Zones**

- VISUAL THEMES -	
Orange	SIGNAL CENTER HQ "TRADITIONAL CORE"
Green	SUPPORT OPERATIONS
Red	COMMUNITY LIFE
Light Blue	INDUSTRIAL
Dark Blue	MEDICAL CENTER
Brown	NSA/CSS GA

**Fig. 2.5 – Fort Gordon Visual Themes**



Section 7, [Site Planning](#)

Section 8, [Buildings](#)

Section 9, [Circulation](#)

Section 10, [Landscape](#)

Section 11, [Site Elements](#)

Section 12, [Force Protection](#)

**2.2.3 Design Principles.** The visual inventory and analysis requires an understanding of basic design principles. These design principles are discussed in [Section 3, paragraph 3.4](#).

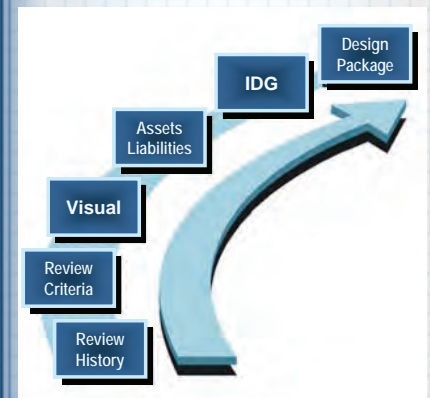
**2.2.4 Visual Elements.** The basic design principles are used to define the visual elements described in [Section 3, paragraph 3.5](#). The assessment and classification of visual elements follows basic design principles describing "good" (positive visual elements) and "not so good" (negative visual elements) design.

## 2.3 USING THE DESIGN GUIDE

**2.3.1** Use this IDG in determining the general design and construction considerations inherent in the preparation of project plans. The IDG provides design guidelines and Army-wide design standards intended to be used in all maintenance, repair, renovation, and new construction projects. The IDG applies to all projects, regardless of the funding source.

**2.3.2** The following steps illustrate how the design guide is used for the preparation of plans for new construction, renovation, maintenance and repair projects on the installation (Fig. 2.6):

- **Step 1:** Review the Installation Profile information included in this IDG ([Section 4](#)).
- **Step 2:** Review the IDG analysis criteria information ([Section 3](#)) including design goals and objectives, visual elements, and design principles.
- **Step 3:** Review the applicable references, guidelines, and standards of the design components. These include site planning, buildings, circulation, landscaping, site elements, and force protection and are discussed in Sections 7 through 12 respectively.



**Fig. 2.6 – Using the Design Guide**

- **Step 4:** Review the information and description of the installation themes in [Section 5, paragraph 5.2](#).
- **Step 5:** Select the zone where the project will be located from [Section 5, Visual Themes and Zones](#). Review the assets, liabilities, and recommendations for that zone.
- **Step 6:** Select the appropriate guidelines or standards from the design components addressed in Sections 7 through 12.
- **Step 7:** Assemble all materials gathered in steps 1 through 5 above.

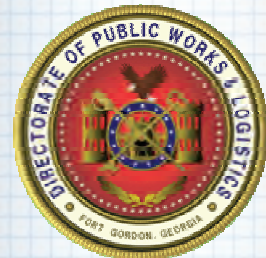
## 2.4 IMPLEMENTATION

### 2.4.1 IDG Review and Approval

- Master Planner will review the IDG prior to submission to the Senior Commander.
- Installation Commanders / Directors of Tenant Organizations will review the IDG prior to submission to the Garrison Commander.
- Garrison Commander will review the IDG prior to submission to Installation Management Command (IMCOM) Regional Director.
- IMCOM Regional Director will approve the IDG and Prioritization Projects Lists, as designated by Headquarters (HQ), IMCOM. They will also review requests for IDS waivers or changes submitted by garrison commander and forward to HQ IMCOM with recommendations.

### 2.4.2 The Garrison Commander maintains and provides IDG compliance for Fort Gordon.

- For the IDG to work optimally as a management tool, it is essential that the Master Planner or designated representative establish an understanding of the IDG among the parties concerned with its use. This can best be established at the RPPB level where all installation principles are represented. The Directorate of Public Works (DPW) staff Master Planner or designated representative shall insure that the guidelines and requirements of the IDG are readily available to, and understood by, all parties



**Essential that Master Planner Establishes Installation-wide Understanding of IDG.**



**The Garrison Commander is the Final Authority in Enforcement of IDG Guidelines and Standards.**



involved in the design of new facilities, design of additions or alterations to existing facilities, or maintenance.

- The Master Planner or designee, acting in support of the RPPB, is the first level reviewer of projects (SRM, MCA, and NAF to include Design Build) and other requests for actions that involve compliance with IDG guidelines and standards.
- The Garrison Commander, supported and advised by the RPPB, is the final authority in enforcement of the IDG guidelines and standards.
- The Installation Planning Board chaired by the Senior Commander, will monitor development of the installation planning process and provide guidance to other installation boards and the Garrison Command for areas such as:
  - Strategic Planning
  - Real Property Planning
  - Range Planning
  - Communications Planning

### 2.4.3 Project Approval

**2.4.3.1** Project requests to include a 4283 shall be submitted to the DPW or equivalent and will include the required Design Team IDG Checklist discussed below.

**2.4.3.2** Design Team IDG Checklist.

- The Design Team IDG Checklist is to be completed by the design team to assure the guidelines and standards have been considered in the design process. The Design Team IDG Checklist is provided in [Appendix A](#).
- The Designer of Record or Design Agent shall provide a copy of the completed checklist to the Master Planner, together with a signed certification statement with each design submittal. The checklist along with concept site plans and elevations for each design submittal shall be provided to the Master Planner for review. If the Master Planner or designated representative concurs, the plan and the signed checklist are forwarded to the RPPB for final approval.

- The accepted checklist shall become a part of the project record files.

#### **2.4.4 Self-help Projects and Occupant Purchased and Installed Site Furnishings and Features Projects.**

#### **2.4.5 Request for Waiver**

**2.4.5.1** A request of waiver from the Design Guide Checklist ([Appendix A](#)) will be submitted to the Master Planning office for approval by the RPPB.

**2.4.5.2** A request for waiver from the Army standards shall be submitted to the Assistant Chief of Staff for Installation Management for approval.

#### **2.4.6 Checklists (optional)**

##### **2.4.6.1 Projects Requirements Checklist (Optional)**

It is recommended that this checklist be used as a pre-design planning tool for initiating projects and to present a functional description of the project at MILCON [Planning Charrettes](#) and [Design Charrettes](#). The checklist can assist participants of the charrettes in project formulation and documentation. By the nature of the planning process all the data on the forms will not be completed, however, the form should be completed to the greatest extent possible prior to the charrettes. The checklist can also be used to document the results of the planning or design charrettes. The Projects Requirement Checklist is provided at [Appendix B](#).

##### **2.4.6.2 Interior Design Review Checklist (Optional)**

It is recommended that the Interior Design Review Checklist be used during review of a Request for Proposal (RFP) submission or an AE or in-house design prior to solicitations. The Interior Design Review Checklist is provided at [Appendix C](#).

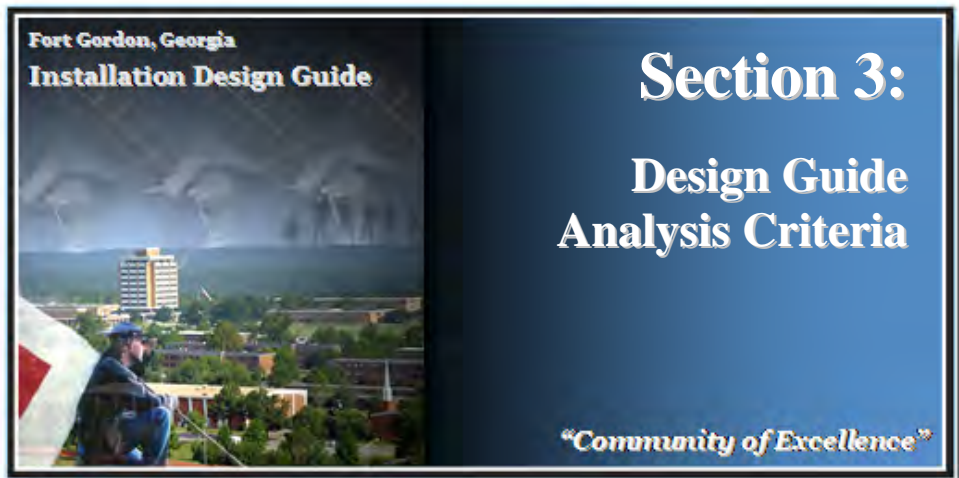
**2.4.7** The requirement to use the IDG as a design tool in all facility planning, design, and construction should be included in the Request for Proposals on new projects, Scopes of Work for new projects, and maintenance agreements.



#### **Links**

[Go to Section 3](#)

[Go to Table of Contents](#)



### 3.1 INTRODUCTION

**3.1.1** The Army Installation Design Guide process depends upon the development of visual goals and objectives and the identification of visual elements. Goals and objectives provide the desired visual context of the installation (Fig. 3.1).

**3.1.2** Basic design principles are used to assess, define, and classify visual elements. This assessment becomes the design criteria used to determine the visual character of the installation. These design criteria are used for design decisions in the review of existing visual context and determination of project recommendation.

The existing image of Fort Gordon is determined by the broad flat ridge upon which the cantonment lies, the open, sparse tree cover, and a strict, rectilinear street pattern that is reinforced by a repetitive placement of the many structures of the Installation. The architecture is generally featureless and the grounds present a somewhat undesirable design quality with many makeshift, home made features. There is little to remind the viewer that this is a major educational setting or a viable, highly specialized community.

The notable image makers or landmarks of the Installation include; Signal Towers, Darling Hall, and Eisenhower Medical Center Buildings; the major open spaces of Barton Field, Myer Mall Plaza area, and the School green along Chamberlain Avenue; and the well defined spatial arrangement of the major land uses. These elements are to be enhanced.



**Fig 3.1 – Trainee Barracks Upgrade Program Visual Goal**

## 3.2 REAL PROPERTY VISION, GOALS, AND OBJECTIVES

### 3.2.1 Real Property Vision

The Real Property Vision, incorporating elements of all other related installation planning initiatives, sets the course for the installation's real property development for the next 25 years.

Very little of the 'Old' Fort Gordon is of an appropriate design quality to be included as a standard in these design guidelines. The intended image features a standard architectural style, an increase in the Landscaping and Tree Cover, and a strengthening of the major open spaces, entry sequences and high visibility areas of the Installation. The well defined land uses and circulation systems provide a strong framework for development that is to be reinforced with; an improved series of standard design elements, unifying systems of signage, landscaping, site furnishings and lighting; and an increased emphasis on the major open spaces which now exist.

The few existing buildings which come close to the intended style and forms for the Installation include the Soldier Service Center (Darling Hall), the Trainee Barrack Complexes, the Post Exchange, Freedom Park Elementary School, the Consolidated Fire Station (Fig. 3.2), and the Consolidated Brigade and 35<sup>th</sup> Signal Brigade Maintenance Facility / Motor pools.

Signal Towers, and neighboring Classroom Buildings comprise the Signal Center HQ, Admin. and Schoolhouse Zone (Fig. 3.3). The architectural style within this zone; featuring Fort Gordon's most notable landmark Signal Towers; does characterize the intended style and form of the Fort Gordon "Traditional Core" which it represents. These buildings present a consistent architectural theme producing a visually cohesive campus.

The design or adaptation of plans for new structures on the Installation are to reflect a high quality, professional image of a well run, efficient organization. There will be a continuity of design which will require a uniform set of standards but at the same time enough variety to distinguish between Land Use Zones and prevent a repetitive look. These guidelines are intended to set those standards.

New buildings or renovations on the Installation will be of an architectural character reflective of the regional, Southern Vernacular, but are to interpret that style in a contemporary and



**Fig. 3.2 – Fort Gordon Consolidated Fire Station**



**Fig. 3.3 – Fort Gordon Signal Center "Traditional Core"**

fresh manner. Many of the recent buildings are a mix of contemporary styles, several are quite attractive, but they rarely reflect the regional style. As existing structures are renovated, they are to be brought into character with new buildings so that, in time there will be a common look or feel for Fort Gordon.

Buildings that are inconsistent with this look will not be permitted. New designs must strictly avoid being different just for the sake of being different. Currently fashionable architectural styles, such as the "Post Modern" are to be avoided in favor of a more conservative and fundamental contemporary look (Fig. 3.4); dignified, never relying on tricks for visual interest. To strengthen this uniform image, common materials and colors have been made standard and are to be used throughout the Installation (Fig. 3.5) and at any remote locations attached to Fort Gordon.

The single most common material will be the use of a limited range of brick types and colors. The standard brick types are common to the region, have historical precedents, are energy efficient, and have low maintenance requirements but they also will carry the image of stability, strength and endurance. These same brick types are to be used in site elements such as walls and paving to help unify the Installation.

The second most common material is to be the liberal use of a standing seam metal roof as an entire roofing system or on larger flat, built up roofed structures as accent features to define entry areas, stair wells or attached structures.

Glazing is to generally be recessed under broad eaves supported by columns or pilasters to create covered walks, and to affect solar shading.

Some finished concrete or stucco like panels or banding will be permitted, again to delineate important building features and as accent elements. The use of a very limited set of accent colors or tiles is also to be allowed to add visual interest.

The application of these standard materials is intended to guide the design toward a uniform architecture, not to restrict their innovative or creative use, to provide an environment of high visual quality at Fort Gordon.

The highest visibility areas of the Installation are to be given the strongest consideration.



**Fig. 3.4 – Although sometimes appealing, fashionable architectural styles, such as the "Post Modern", are to be avoided**



**Fig. 3.5 – Similar Exterior Building Materials and Colors Strengthen Installation's Uniform Visual Image**



### 3.2.2 Real Property Goals and Objectives

To create a visual appearance at Fort Gordon that projects the stated vision, a series of goals must be achieved. A logical progression in accomplishing these goals will reduce the time required to reach the desired image. Therefore, they will be presented in an order that will maximize the impact of each.

Some goals will be short term and cosmetic in nature, but will have highly visible impacts, and some will be the more costly and time consuming to achieve. No single goal is most important, because the failure of any one can seriously disrupt the entire vision by becoming the focus of attention. Each goal will have specific objectives taken from the visual improvement priorities. Some objectives will be quickly achieved and others will address planning and layout situations years in the making. All goals will require ongoing commitments to maintain the vision of Fort Gordon, once they have been achieved.

### 3.2.3 Goals

#### **Project a strong sense of entry (Fig. 3.6):**

Project a strong sense of entry into the Installation by being particularly sensitive to any projects that directly or indirectly impact the entry drives from Gates 1, 2, and 5 into the Installation. Also, in the planning and design of each such project, the design is to be compatible with or significantly up-grade the visual appearance of existing conditions.

- The use of standard entry signs and a uniform sign system at Gates 1, 2, 3, and 5.
- The use of an increased level of landscaping and improved landscape and turf maintenance practices along all entry drives and major roadways.
- The screening or removal of unsightly elements along principal entry drives.
- The use of a uniform architecture at each gatehouse that is compatible with the recommended Installation-wide architecture.
- A program to standardize site elements and relocate visible utility system elements along principal entry drives.



**Fig. 3.6 – A Strong sense of entry to the Installation is expressed at the Fort Gordon main gate**



- The establishment of green parkway entry drives from Gates 1, 2, and 5 into the Installation proper that sets back new buildings.

**Establish a strong graphic image (Fig. 3.7):**

Establish a strong graphic image through the strict adherence to the Fort Gordon Installation Design Guide. Non-conforming and unnecessary elements will be cause for the rejection of a design proposal.

- The Installation-wide use of uniform traffic control, information and identification signs mounted on a well designed, uniform, easily assembled and versatile mounting system.
- The removal of existing temporary, homemade, non-standard signs.
- The provision of uniform and appropriate spaces for the display of unit colors, insignia and morale slogans.
- The control of existing and future architectural signs.
- A uniform street and pavement striping program.
- The redesign and construction of intersections and locations on the Installation that are confusing or congested and a general reorganization of the traffic circulation system.

**Improve the quality of the landscaping (Fig. 3.8):**

Improve the quality of the landscaping through the increased use of standard plant materials, and minimum maintenance designs. Planting designs are to consider likely maintenance requirements, screening capabilities, and the level of visibility the materials will receive.

- A review and improvement of current maintenance practices.
- A rescheduling of maintenance efforts to increase the level of care given to high visibility and heavily used sites.
- An improved turf establishment and maintenance program.
- A program that makes standard plant materials available to housing areas residents.



**Fig. 3.7 – Darling Hall Presents a strong, positive Graphic Image**



**Fig. 3.8 – Native plants are to be used to visually relate developed areas to the natural environment.**



- The general re-landscaping of all high visibility roadways, open spaces and buildings.
- An active use of plant material to screen unsightly views and buildings and to define and organize visual open space.
- The establishment of an effective erosion control system using landscape materials as well as hard engineering applications.

**Reduce the general clutter (Fig. 3.9):**

Reduce the general clutter on the grounds by screening, removing and prohibiting design features and elements in the landscape that are unsightly, unneeded, or of a utilitarian design. The use of non-standard design elements and items of a low design quality will not be permitted. All projects are to provide for the removal or replacement of all non-standard design elements within the 'Limit of Work' designation of the site plan.

- The establishment of a uniform architecture, color scheme; and exterior materials policy.
- A program to bury highly visible overhead wires and utilities within the Cantonment area.
- The removal of dilapidated buildings, fences, equipment and other abandoned or unsightly elements.
- An overall reduction of signs and sign posts through actual removal or consolidation of messages onto multi-purpose standards.
- The screening and landscaping of parking areas.
- The relocating or screening of all dumpsters and building service areas on the Installation.
- The removal of pedestrian control devices, and non-standard fences.
- The replacement of Installation-wide site furnishings and standardization of individual unit outdoor lounge areas.
- The removal or consolidation of the various storage and utility buildings on the Installation.
- The elimination of open drainage.
- The removal of inappropriate items from building facades, such as utilities, graphics, awnings, signs, lights and other extraneous items.



**Fig. 3.9 – Prohibited, non-standard site elements must be removed**



**Establish a master tree canopy and wind break program:**

Establish a master tree canopy and wind break program that is to generally improve the tree cover in the cantonment area of the Installation (Fig. 3.10). All projects are to provide for the planting of approved trees as a major part of the landscape requirements of that project. Existing trees are to be protected through imaginative and sound siting and design and by following the established procedures for protection during construction. All trees within the 'Limit of Work' designation are to be considered for such protection and for horticultural renovation as part of that project.

- The renovation and rehabilitation of diseased or stressed trees in the main cantonment area, particularly for trees in prominent locations or of high scenic value.
- The removal of those trees beyond salvage.
- A ban on parking under established trees or groves of trees in unimproved (unpaved) or undesignated areas.
- The subsoiling and aeration of compacted soils under existing trees and the establishment of turf or ground cover in these areas.
- An active tree fertilizing and spraying program.
- The planned introduction of standard, native trees in areas of high visibility, sparse tree cover, and wind break protection.
- The stipulation that a percentage of new building budgets be earmarked from tree plantings.

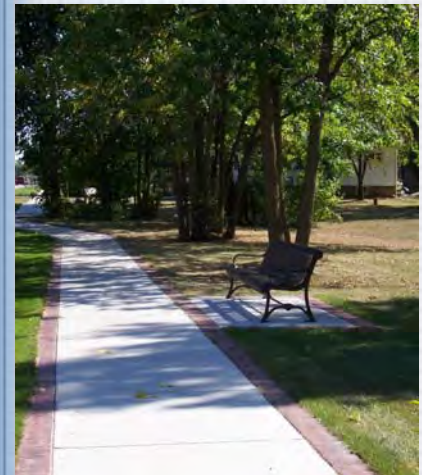
**To establish a system of circulation and open spaces:**

To establish a system of open spaces that will compliment and connect the existing open spaces now on the Installation. Existing and proposed recreational grounds both for active and passive use are to be visually and physically joined to this system.

- The redesign and landscaping of the three major existing spaces on the Installation, Barton Field, the connecting mall to Signal Towers (Myer Mall), and the school parade ground North of Chamberlain Avenue.
- The creation and improvement of important focal points within the open space system, such as a monument plaza at reviewing stand area.



**Fig. 3.10 – Desired result of master tree canopy program**



**Fig. 3.11 – Walkways connecting existing open spaces**

- The improvement of Signal Towers plaza and adjacent flag array area.
- The improvement of highly visible Heritage Park to include new landscaping, tree planting, benches, walkway lighting, entrance signage, and quality uniform markers at static displays.
- The use of standard outdoor lighting to define open spaces.
- The creation of “Downtown” Park with athletic fields, tennis courts, walking trails, walkway lighting, lawn area, playground, and outdoor seating; easily accessible from housing areas, and connected by use of paved sidewalk / bicycle lane system (Figures 3.12 and 3.13).
- The use of setbacks in relation to building heights for streets, parking or adjacent buildings.
- The redesign and improvement of recreation facility spaces particularly in playground areas.
- The creation of entry drive parkways at Gates 1, 2, and 5 that visually deliver the viewer to the main Cantonment area.
- The creation of Installation-wide pedestrian and bike systems located away from the street and road system wherever possible (Fig. 3.11).
- A program to develop small, passive and active parks in the community facilities areas such as the Post Exchange, PXtra and proposed “Downtown” Community Center.

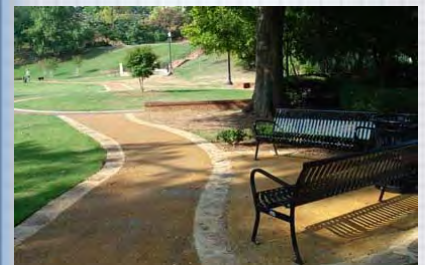
**Establish Area Design Plans (ADP’s):**

Establish Area Design Plans (ADP’s) for selected spaces with each being a part of the larger Installation but having distinctive boundaries and character. These areas are; the Dwight D. Eisenhower Army Medical Center Complex (DDEAMC), the “Traditional Core” School House/Signal Towers Complex north of Chamberlain Avenue, the Signal Center Barracks and Administration Area, the “Downtown” Community Center Facilities Complex (Fig. 3.14), the NSA GA Complex, each of the housing areas, the Industrial Park Areas near Gate 3, and the Reserve Center / GA National Guard Area.

- The identification of functional ADP’s as part of a master development plan.
- The removal or screening of nonconforming buildings in each designated “small area”.



**Fig. 3.12 – Proposed youth ball fields in “Downtown” Community Park**



**Fig. 3.13 – Proposed “Downtown” Park (casual space) vision**



**Fig. 3.14 – Proposed Chapel will be cornerstone of “Downtown” Community Center ADP**



- The use of a uniform architecture in areas of like function.
- A consolidation of facilities by land use zone such as industrial areas.
- The creation of points of focus such as a green space, courtyard, display, or other landmark.

### **Establish an Installation-wide organization of space:**

Establish an Installation-wide organization of space by consolidating compatible Land Uses, and establishing a hierarchy of roads and paths. Each project is to consider the immediate and the long-term effect it will have on the visual quality of each ADP and of the Installation as a whole. Will it fit the character of the area and does it belong at that location. Projects that are not compatible or which disrupt a viable system such as open space or roadways will not be permitted.

- The consolidation of Installation administration functions in a central dominant location.
- The creation of a hierarchy of roads and paths.
- The creation of a Installation-wide, comprehensive parking system.
- The designation of a permanent open space system designed to feature major buildings and landmarks.
- Planning for expected future build-ups that often leave nonconforming structures in central and high visibility areas.
- The definition of visual areas through the use of landscaping and screening to accentuate nodes and desirable vistas.
- Highlighting “Small Area” entries through improved signage and landscaping.
- Standardizing the level of treatment for entries to like facilities, through landscaping and signage.

### 3.2.4 Objectives

#### **Plan and develop facilities that maximize operational support for an Expeditionary Army at War (Fig. 3.15):**

- Incorporate public health, safety, and welfare in facilities planning.
- Maximize functional, operational, and spatial relationships among facilities.
- Consolidate and centralize operationally and functionally related facilities and activities.
- Promote compatible development.
- Promote efficient traffic circulation that addresses vehicle and pedestrian flow.

#### **Direct an orderly and effective long-range development that supports Army restationing and growth:**

- Document comprehensive procedures for translating mission into policies, programs, and specific projects for on-post facilities and systems.
- Reuse existing space and facilities for current missions, and new facilities for new missions.
- Always use approved development plans when selecting sites for facilities.
- Optimize space and infrastructure through cluster development.

#### **Support the needs of individual soldiers and families by designing and providing facilities that achieve community (Fig. 3.16):**

- Use principles of urban design to achieve a sense of community.
- Co-locate community facilities that promote a positive use of free time and physical activity.



**Fig. 3.15 – Maximize operational support of an Expeditionary Army at War**



**Fig. 3.16 – Support needs of individual soldiers and families**



- Consider pedestrian orientation, bicycling, and public transportation options.
- Develop state-of-the-art community facilities to ensure soldiers and their families live and work in an environment that supports all aspects of life.

**Promote a harmonious relationship between the installation and the local community:**

- Consider adjacent land uses, both existing and planned, and engage in joint land use compatibility planning.
- Engage joint transportation planning for mutually beneficial gate and roadway access improvements.
- Partner with the community to avoid and reduce encroachment.
- Promote community development compatible to training areas to avoid operational restrictions while protecting surrounding communities.
- Identify partnering opportunities [i.e. Public Private Ventures (PPVs and Enhanced Use Leasing (EUL)].

**Respect the Environment (Fig. 3.17):**

- Protect and encourage wise use of natural and manmade resources.
- Make the National Environmental Policy Act (NEPA) an integral part of the master planning process.
- Embrace sustainability principles to improve Fort Gordon's installation footprint.

**Create a framework integrating Real Property Master Planning components with other installation wide planning processes:**

- Compare ranges and training plans to cantonment area plans to ensure future military training needs are met.
- Ensure Fort Gordon plans meet the real property



**Fig. 3.17 – Respect and Protect the Environment**

requirements and are accurately documented in the Capital Investment Strategy, Real Property Inventory, and Tabulation of Existing and Required Facilities.

- Package comprehensive mission plans and programs into Area Development Plans that are supported by RPMP and ongoing installation initiatives.
- Maintain a comprehensive set of planning principles that guide holistic planning.
- Annually update the Real Property Master Plan Digest.
- Update the Capital Investment Strategy (CIS).
- Update/Maintain the Installation Design Guide (IDG).
- Educate, publicize, and make Master Plan documents more accessible (Fig 3.18).
- Encourage compliance of real property master plan guidance.

### 3.3 IDENTIFICATION AND CLASSIFICATION OF VISUAL ELEMENTS

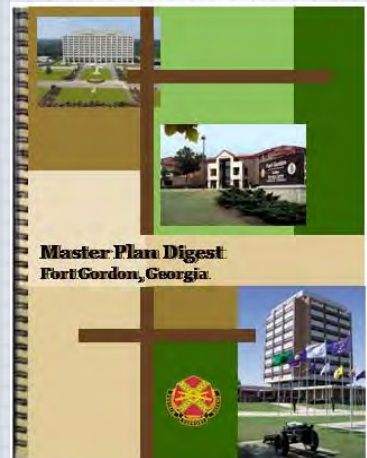
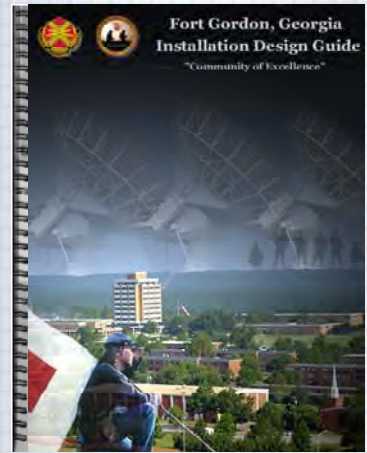
**3.3.1** Basic design principles define visual elements and assess their character.

**3.3.2** The assessment and classification of visual elements follows basic design principles describing "good" and "not so good" design. Their assessment becomes the design criteria used to determine the visual character of the installation.

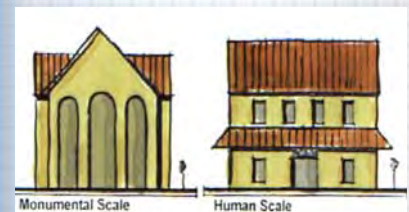
### 3.4 DESIGN PRINCIPLES

The visual inventory and analysis requires an understanding of basic design principles. The primary principles are:

- **Scale** - The proportional relationship of humans to their spatial environment. The scale should result in a comfortable relationship for the user and will vary as space, size and activities vary (Fig. 3.19).



**Fig 3.18 – Document Fort Gordon Master Plan Components**



**Fig 3.19 – Monumental & Human Scale**



- **Form** - The size and shape of mass. Individual forms should be designed to complement one another and the environment.
- **Function** – The use of a space or an area. Function is gauged by the degree to which the space works for its intended purpose.
- **Color** – All elements of the visual environment have color. The use and arrangement of colors greatly determine the visual impact of all elements.
- **Texture** – All elements of the visual environment have texture. The use and blending of textures greatly impact the visual environment.
- **Unity** – All elements of the visual environment should blend to complement one another (Fig. 3.21). Repetition of scale, form, color, and texture results in a unified visual impression.
- **Framing** – All views include a ground plane, side planes, and overhead plane. The relationship of planes changes as the individual moves through the environment.
- **Axis** – An axis is a linear progression of space connecting two or more dominant features.
- **Terminus** – A terminus is the end of an axis and is typically defined by a dominant feature such as a building (Fig. 3.20).
- **Balance** – Visual elements are composed to be symmetrical or asymmetrical. In either case, visual elements should be sized and located to provide visual balance (Fig. 3.22).
- **Sustainability** - Practicing the principles of sustainable design in the planning, design, construction, and operation of infrastructure and facilities is a smart business practice ([See Appendix D](#)).

## Fort Gordon



**Fig 3.20 – Mall or Parade Ground Axis with Building as Terminus**



**Fig. 3.21 – All Elements of the visual environment should blend to complement one another. (Permanent Party Barracks)**



**Figure 3.22 – Symmetrical Elements (DDEAMC)**

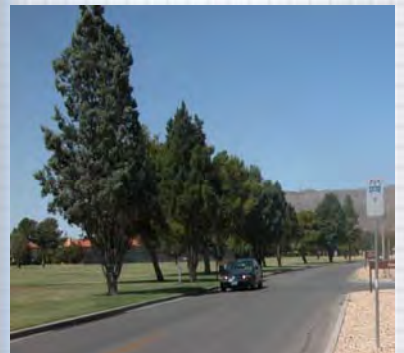
### 3.5 VISUAL ELEMENTS

The visual elements, described below, elements include manmade and natural features and their inter-relationship. This Army Installation Design Guide provides guidance on how to recognize the visual impacts of the installation and how to improve upon them if warranted.

- **Natural Characteristics** - Regional and site characteristics that have been preserved and enhanced as a part of the installation.
- **Edges and Boundaries** - Linear elements such as walls, fences, or trees create separation of use and activities.
- **Buildings and Structures** - Typically the most dominant features of an installation. Their location and design characteristics determine the primary visual image.
- **Activity Nodes** - Centers of activity that attract people on a daily basis (Fig. 3.23).
- **Landmarks** - Visually or historically prominent features such as towers, statues, static displays, or buildings that provide identity and orientation of place.
- **Entrances and Gates** - Provide the first and last impression of the installation.
- **Circulation System** - Includes streets, railroad tracks, trails, sidewalks, parking lots, driveways, delivery areas, and bicycle paths. The circulation system utilizes a large amount of space and creates significant visual impact.
- **Trees and Other Vegetation** - Trees and other vegetation frame views, provide visual screens, shade, color, and interest in the installation.
- **Street Trees** - Street trees soften, complement, and define the road hierarchy, and improve the overall visual quality of the installation (Fig. 3.24).
- **Views and Vistas** - Scenic and attractive views and vistas should be enhanced. Unattractive views should be screened (Fig. 3.25).



**Fig. 3.23 – Freedom Park Gazebo is Important Activity Node**



**Fig. 3.24 - Street Trees Improve the Overall Visual Quality of the Installation**

- **Open Spaces** - Open space areas create visual impact and can be designed to either separate or integrate adjacent uses.
- **Signage** - A coordinated installation signage plan, addressing both exterior and interior signage, should be developed to facilitate circulation and provide useful information.
- **Utility Corridors** - Utilities should be in corridors and unsightly above ground utilities minimized.
- **Other Elements** - Visual elements other than those above may occur within an installation and should be noted.

## Fort Gordon Fort Gordon



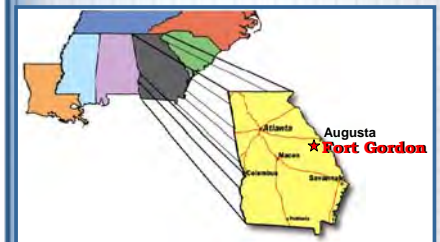
**Fig. 3.25 – Unobstructed vista looking south from Chamberlain Avenue**



## 4.1 SETTING

### 4.1.1 Regional Setting

Fort Gordon encompasses approximately 55,600 acres in east central Georgia. Fort Gordon's central installation is located at approximately latitude 33°20'N, longitude 82°15'W. The majority of the installation and the entire cantonment area lie within Richmond County, with a small portion of the training area in Jefferson, Columbia, and McDuffie counties (Figure 4-5). Fort Gordon is located approximately 145 miles east of Atlanta, Georgia and approximately 115 miles northwest of Savannah, Georgia. Augusta, Georgia is the nearest urban center and is located approximately 9 miles northeast of the installation. Fort Gordon is bound to the north by U.S. Highway 78, on the east and south by U.S. Highway 1, and on its western perimeter by U.S. Highway 221. Interstate 20 (I-20), located 2 miles north of the installation, and Interstate 520 (Bobby Jones Expressway, I-520), located 2 miles east of Gate One, provide access to the installation. There are no public roads or highways on the installation.



**Fort Gordon Location Map**

### 4.1.2 History of the Installation

Fort Gordon was established in December of 1941 as Camp Gordon and was originally constructed as a Triangle Division Camp. The first building, constructed as a set of two on base, was number 2050. The Post was originally laid out on formal grids north and south of a massive parade ground known today as Barton Field. The Post administrative functions were located

as the focal point at the east end of this large space. This mall was designed for the parade of the armored units originally stationed there. The camp was commissioned for active duty and charged with preparing American servicemen for war in Europe. Temporary wooden barracks were vigorously constructed almost overnight to house the trainees. This initial rush construction was completed by the middle of 1942 and some of these structures still exist today.

Fort Gordon's history contains a variety of command assignments and changes in the military service roles based on both the shifting tides of American obligations and position of the military throughout the world. The Signal Corps was established at Camp Gordon in 1948 and in 1956, the installation became Fort Gordon. In June of 1962, after several reorganizations, all activities at Fort Gordon were combined under the Southeastern Signal School.

The skyline of Fort Gordon changed dramatically from 1964 to 1975. The Southeastern Signal School complex, enlisted men's barracks, and the medical complex with barracks were all built during this period. Many of the WWII era "white" buildings were removed to make way for these modern permanent structures, but the original street layout and plan were virtually left intact. The Signal Tower (Fig. 4.1) was built during this period and was located north of Barton Field about half way down its massive length. This single building is the dominant landmark of the Post and has become the major image generator for Fort Gordon.

Since June 1986, Fort Gordon has been the U.S. Signal Corps home, responsible for providing and maintaining information systems and communication networks. The Signal Corps training center's primary purpose is to conduct specialized instruction for all Signal Corps military and civilian personnel. Marine Corps, Army, Navy, Air Force, and multinational personnel also train at Fort Gordon. These organizations conduct operations in theater level, multi-disciplined intelligence; force projection; electronic warfare; and information-warfare operations that support the Army's U.S. Central Command and other deploying forces.

Fort Gordon is currently home to the National Security Agency/Central Security Service Georgia (NSA/CSS Georgia), part of the Department of Defense (DoD), and is comprised of Army, Air Force, Marine Corps, and Navy staff. They provide a variety of intelligence services supporting the U.S. Central



**Camp Gordon During World War II**



**Old Post Headquarters Building.**



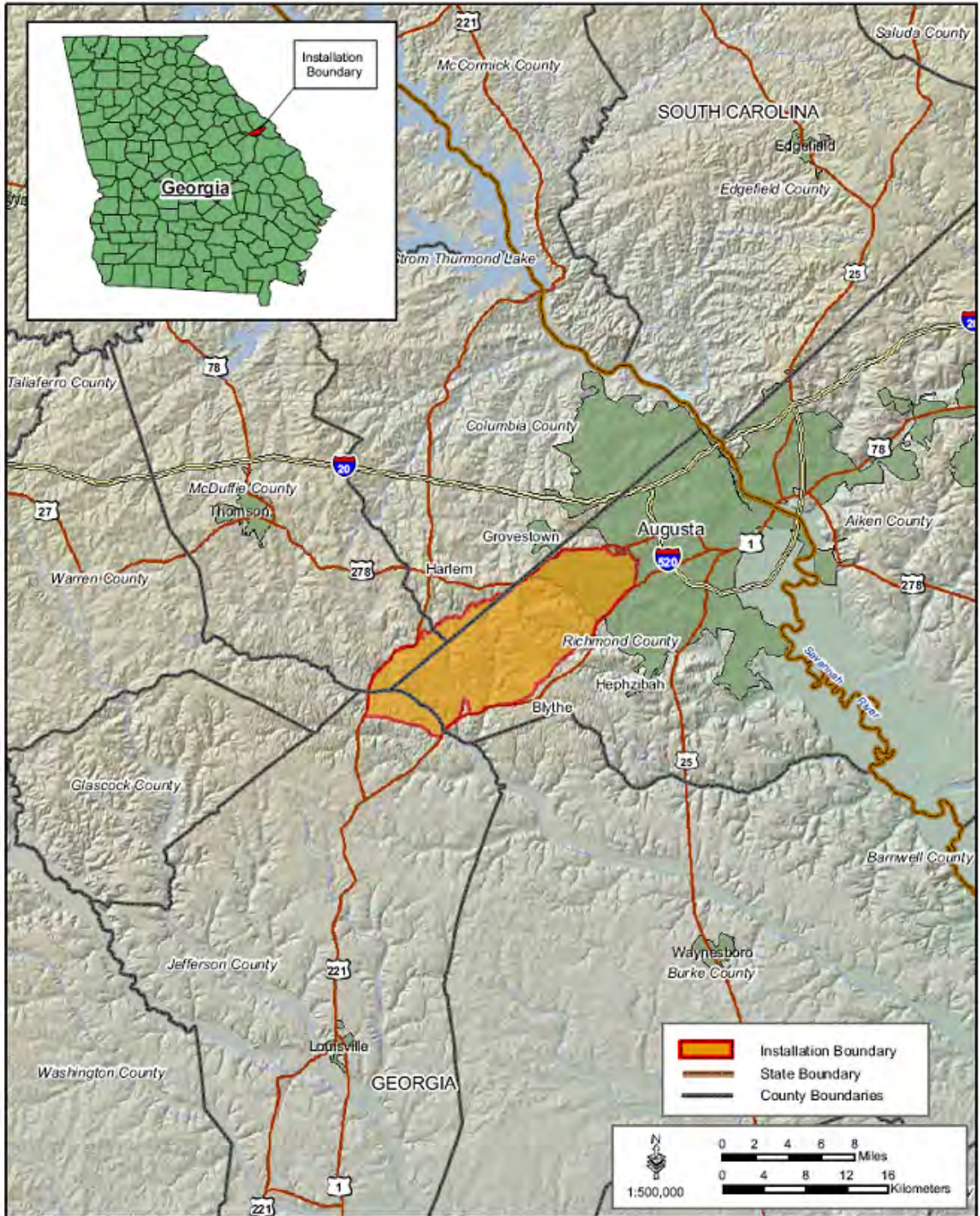
**Fig. 4.1 –Signal Towers**

Command, the U.S. European Command, and the U.S. Special Operations Command.

# Fort Gordon

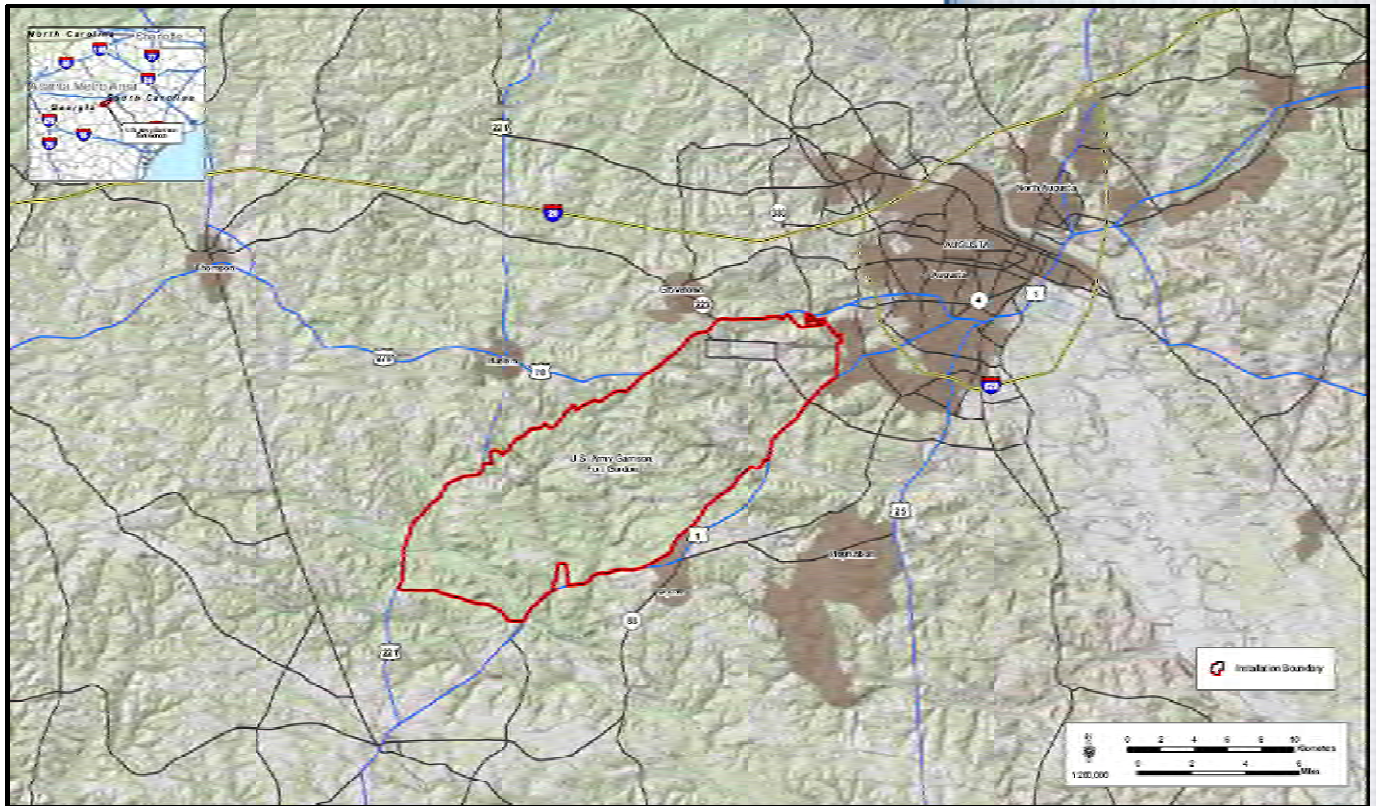


### Fort Gordon Location Map





### Major Transportation Routes Serving Fort Gordon



## 4.2 ENVIRONMENTAL SETTING

### 4.2.1 Endangered Species Management Component (ESMC)

As part of the 5-year review and update of the Integrated Natural Resources Management Plan (INRMP), Fort Gordon revised the Ecosystem-based Endangered Species Management Plan (EESMP) and prepared an Endangered Species Management Component (ESMC). The ESCM guides natural resources management on Fort Gordon and will be implemented as part of the INRMP. The ESCM was prepared in accordance with the revised 2003 red-cockaded woodpecker (RCW, *Picoides borealis*) Recovery Plan (U.S. Fish and Wildlife Service [USFWS] 2003) and the Army's 2007 Management Guidelines for Red-Cockaded Woodpecker (RCW) (Fig. 4.2) on Army Installations (2007 Guidelines, Army 2007). The ESCM adjusted population goals, objectives, and management requirements originally set forth in the EESMP and 2001 INRMP. The objective of the ESCM is to conserve Federally threatened and endangered species as required by the Endangered Species Act (ESA) of 1973, as amended, while preserving training readiness and other mission requirements of Fort Gordon. Section 7 of the ESA requires Fort Gordon to carry out a program for the conservation of Federally protected species. Federal properties are required to employ all methods and procedures necessary to bring Federally protected species to the point where ESA measures are no longer necessary. The RCW is the only Federally threatened or endangered species that is a resident of Fort Gordon, therefore, the RCW is the focus of the ESCM. However, the ESCM does provide guidance for target species other than the RCW on Fort Gordon.

As part of the ESCM, Fort Gordon established approximately 24,300-acre Habitat Management Unit (HMU) for the RCW. Based on the size of the HMU Fort Gordon's installation population goal (IPG) is 122 potential breeding groups. The IPG reflects Fort Gordon's contribution to the Regional Recovery Goal, as outlined in the revised 2003 RCW Recovery Plan (USFWS 2003). Fort Gordon's long-term goal is to establish 40 active clusters (Fiscal Years 2025 through 2035); however the short-term goal is 20 active clusters by the Fiscal Year 2013. RCW clusters in the HMU would be protected from military training. A total of 25 recruitment clusters would be provisioned and five existing recruitment clusters would be activated as part of the Proposed Action. The proposed recruitment clusters are shown in Figure 4.3. The location and priority of recruitment is also provided in Table 4-1.



**Fig 4.2 – red-cockaded woodpecker (RCW, *Picoides borealis*)**





Fig. 4-3: Current and Planned Managed RCW Cluster Locations, Fort Gordon, Georgia

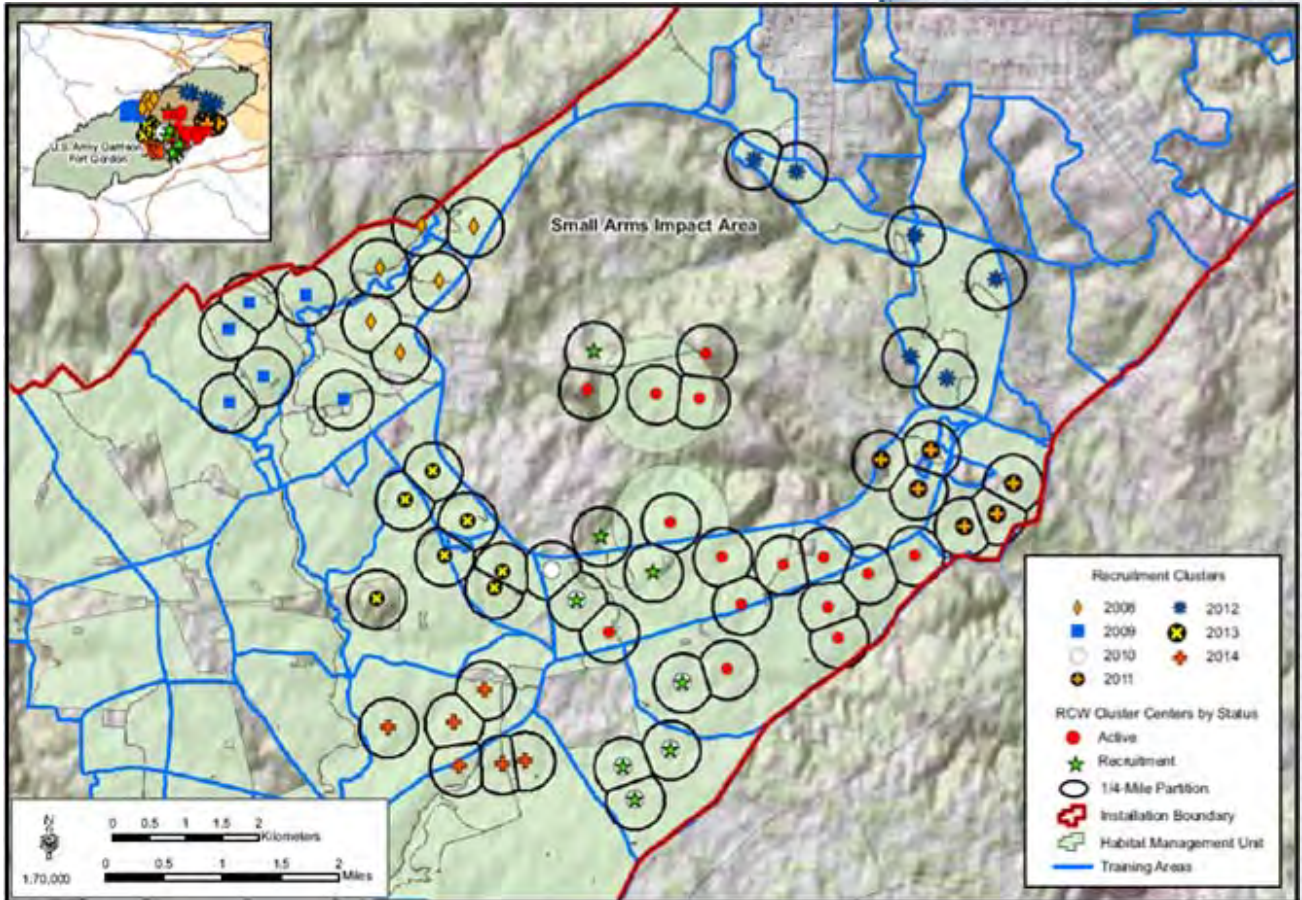




Table 4-1: RCW Recruitment Cluster Priority and Location

Calendar Year	Fiscal Year	Training Areas
2008	2009	18,26,27
2009	2010	26,27
2010	2011	21, 22,23
2011	2012	20,19
2012	2013	14, 15
2013	2014	24,25,29,30
2014	2015	31

#### 4.2.2 Species at Risk (SAR)

The Army Species at Risk (SAR) Policy and Implementing guidance (15 September 2005) requires all Army installations to manage for those SAR identified in the guidance memorandum (Army 2005). The Army’s policy is to manage SAR proactively in order to prevent Endangered Species Act (ESA) listing that could severely degrade military readiness. Listing of any SAR pursuant to the ESA could significantly impact the military missions at one or many Army installations. Therefore, proactive measures to prevent the listing of a SAR and the conservation of SAR on Army installations benefit both the Army and SAR. Two SARs, gopher tortoise (*Gopherus polyphemus*) (Fig. 4.3) and Pickering morning glory (*Stylisma pickeringii* var. *pickeringii*) (Fig. 4.4) , inhabit Fort Gordon and require special management consideration to prevent further degradation of the species or its habitat which could result in listing under the ESA. The Army’s management policy and implementation guidance was developed during the implementation phase of the 2008 Integrated Natural Resources Management Plan (INRMP); therefore, management for SAR would be implemented as part of the revised and updated INRMP.



Fig 4.3 – gopher tortoise (*Gopherus polyphemus*)

#### 4.2.3 Integrated Training Area Management (ITAM)

Traditionally, Army installations maintained separate programs for forestry management, fish and wildlife management, erosion control, training area maintenance, and agricultural leases. There was no long-range approach to integrating land management activities with training and testing missions. The Army developed Integrated Training Area Management (ITAM) as a comprehensive approach to land management on all Army installations. However, the 2001 Integrated Natural Resources Management Plan (INRMP) did not integrate the ITAM program into natural resources



© Jim Stasz  
Fig 4.4 – Pickering morning glory (*Stylisma pickeringii* var. *pickeringii*)

management. The revised and updated 2008 INRMP provides consideration for ITAM and natural resources programs and training requirements are closely coordinated between the Directorate of Plans, Training, Mobilizations and Safety's ITAM Coordinator and the Directorate of Public Works, Environmental Branch.

#### 4.2.4 Topography

Fort Gordon is located along the fall line between the Lower Piedmont and Upper Coastal Plains physiographic provinces (Figure 4.7). In this zone of transition, the topography ranges from the gentle undulating sand hills of the south and middle sections, to areas of steep slopes and near-bluffs adjacent to some of the streams, which are characteristically small and bordered by heavy hardwood swamp areas. The elevation of Fort Gordon ranges between 221 ft and 561 ft above mean sea level (msl), and the majority of the land area (35,852 acres) is between 378 ft and 489 ft above msl.

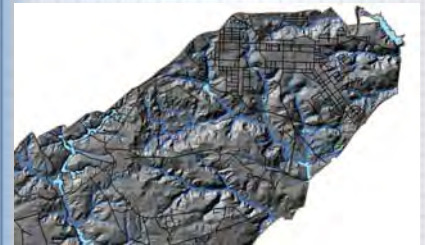
#### 4.2.5 Geology

Most of Fort Gordon is situated within the Coastal Plain physiographic province; however the extreme northeast corner of the installation is situated on the fringe of the Piedmont physiographic province. Sedimentary rock of the region is composed primarily of two formations, the Barnwell Group formed during the Eocene Epoch and the Gailard Formation of the Oconee Group of the Cretaceous Period (Fort Gordon 2007). Geologic components associated with the Gaillard formation include quartz and arkosic sands imbedded in kaolin.

One geologic feature, the Belaire Fault Line, traces southwest to northeast on the east side of the installation in the cantonment area (Fort Gordon 2007). This is an approximate location, and this fault is not considered active. Fort Gordon is considered to be in a USGS Seismic Zone 2. Zone 2 is a region of moderate seismic activity based on the known distribution of damaging earthquakes. No earthquake epicenters have ever been recorded at Fort Gordon; however, Columbia County had three earthquakes recorded in January 2005.

#### 4.2.6 Soils

Fort Gordon is located within an area that produces a substantial portion of the world's commercial kaolin. Extensive mining and exploration in the Fort Gordon area indicates a high probability of



**Fig 4.7 – Fort Gordon Map Displaying Topography (Utilizing "Hill Shade" Modeling Technique)**

substantial kaolin deposits on the installation. In Jefferson County, a 1,450-acre site has been selected on the installation as an area that could be potentially mined for Kaolin (Fort Gordon 2008). Additionally, there is an abundance of sand and clay deposits on the installation and there are active and inactive borrow pits scattered throughout (Fig. 4.8).

#### 4.2.7 Climate

Fort Gordon has a humid subtropical climate. The Installation experiences mild winters and a humid summer. The average high temperature for the summer months is 90.6 °F (32.6 °C); the average low temperature is 67.8 °F (19.9 °C). The average high temperature for the winter months is 58.9 °F (14.9 °C); the average low temperature is 34.4 °F (1.3 °C).

#### 4.2.8 Surface Waters

The borders of Fort Gordon encompass five separate watersheds (Table 4-2) and none of the watersheds are entirely within the installation (GADNR 2008b). Three of the five streams are in non-attainment for criteria pollutants. Section 303(d) of the CWA requires that states develop a list of waters not meeting water quality standards or not supporting their designated uses (Water Quality Inventory Integrated Report Section 305(b) and 303(d) Reports). As seen in Table 3-3 below, three streams that flow through the installation are impaired for fecal coliforms. They are not supporting the primary contact recreation (swimming) and secondary contact recreation (boating) designated uses. The suspected causes of impairment include urban runoff and nonpoint source pollution (NPS) from a unknown source (Brier Creek and Headstall Creek) (GADNR 2008b).

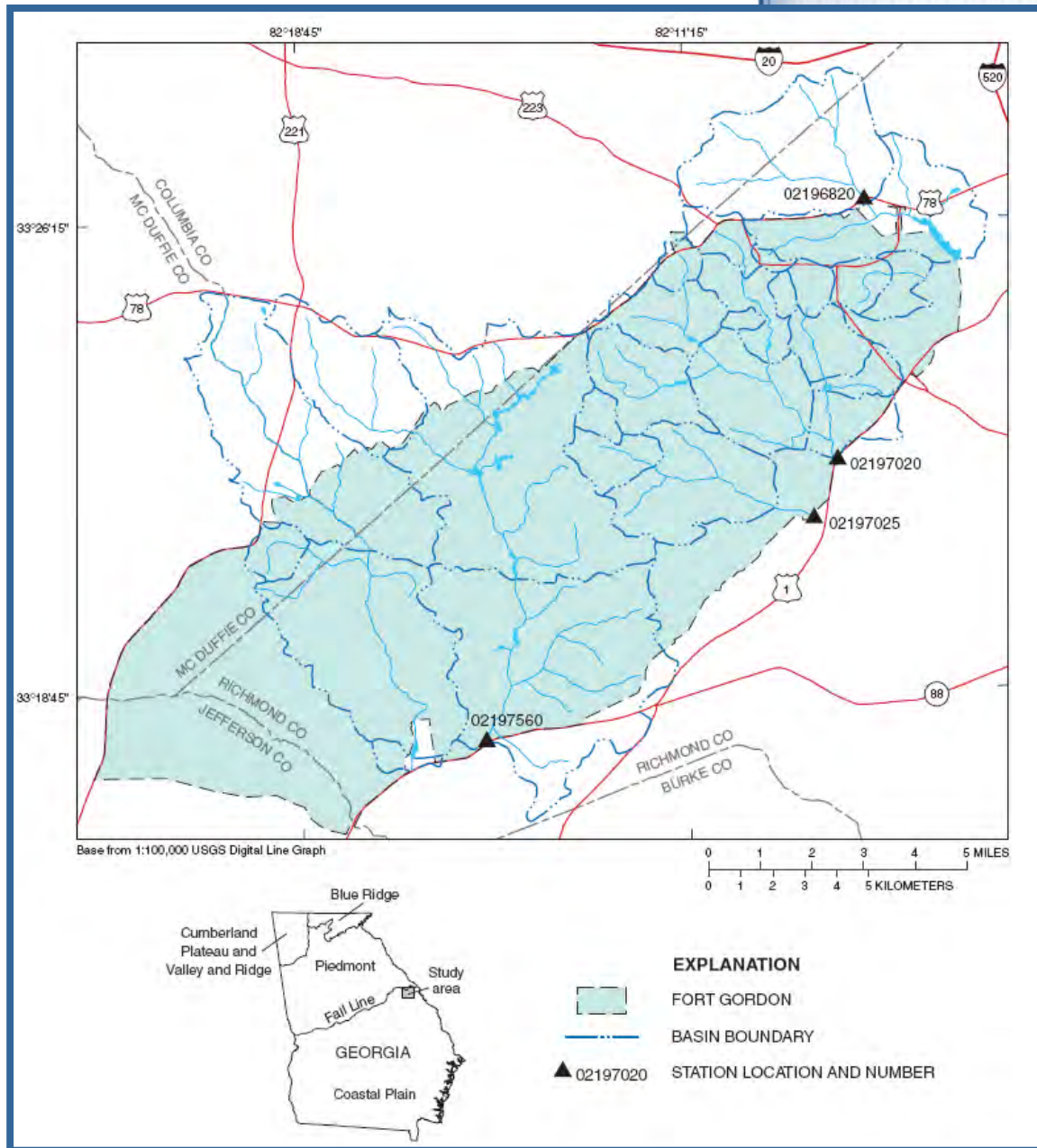
**Table 4-2 Watersheds Occurring on Fort Gordon**

<b>Watershed</b>	<b>Area (acres)</b>	<b>303(d) Listed Impairment</b>	<b>Suspected Cause of Impairment</b>
Butler Creek	3,840	Fecal Coliforms	Urban Runoff
Spirit Creek	19,200	Fecal Coliforms	Urban Runoff
Sandy Run	13,440	None	None
Boggy Gut	11,520	None	None
Brier Creek and Headstall Creek	12,800	Fecal Coliform	Nonpoint Source

Source: GADNR 2008b



**Fig 4.8 – Fort Gordon Borrow Pit**



**Streamflow stations, Fort Gordon**

Recent water quality monitoring studies in urban areas have shown that the highest pollutant loading and concentrations usually occur during rainfall events in the first runoff of rain, commonly referred

to as the "first flush" (Louisiana Department of Environmental Quality 2000). Impervious surface area such as streets, parking lots, and rooftops, is increased in urban areas. As precipitation falls on urban areas, it picks up contaminants from the air, littered and dirtied streets and sidewalks, petroleum residues from automobiles, exhaust, herbicides, pesticides, and sediments from construction sites. Brier Creek is in non-attainment, however, the sources of pollution have not been quantified or qualified (GADNR 2008b). NPS pollution can originate from a number of land uses such as agriculture, urban, forestry, and natural systems contribute to the loading of chemical, mineral, and biological elements to the waterways. Hydro-modification affects the transport of water through the stream networks and often reduces the capacity of riparian zones to retain sediments on the streambank. Residential sewage from faulty septic systems also contributes to the nutrient and organic loadings to waterways.

Additional detailed information regarding surface waters is provided in the current approved INRMP, and is incorporated herein by reference (Fort Gordon 2008).

#### **4.2.9 Groundwater**

Fort Gordon is located in the Coastal Plain hydrogeologic province of Georgia, whose principle groundwater source is the Southeastern Coastal Plain aquifer system. This aquifer is composed of interbedded sand and clay of Cretaceous age and locally includes sand and clay of early Tertiary age. Typical yields in this area range from 29,000 to 72,000 gallons per day. Studies of groundwater quality indicate the groundwater is quite acidic (Fort Gordon 2001). Additional detailed information is provided in the current approved INRMP, and is incorporated herein by reference (Fort Gordon 2008) – See Map (Fig. 4.9).

#### **4.2.10 Wetlands**

Wetlands are defined as “those areas that are inundated or saturated by surface or groundwater at a frequency and duration sufficient to support, and that under normal circumstances do support, a prevalence of vegetation typically adapted for life in saturated soil conditions” (CFR 33, Part 328.3[b]). Approximately 4,395 acres of wetlands occur on Fort Gordon (2008) – See Map (Fig. 4.9).



**Tributary stream to Butler Creek, Fort Gordon**



Fig. 4.9 Surface Water on Fort Gordon

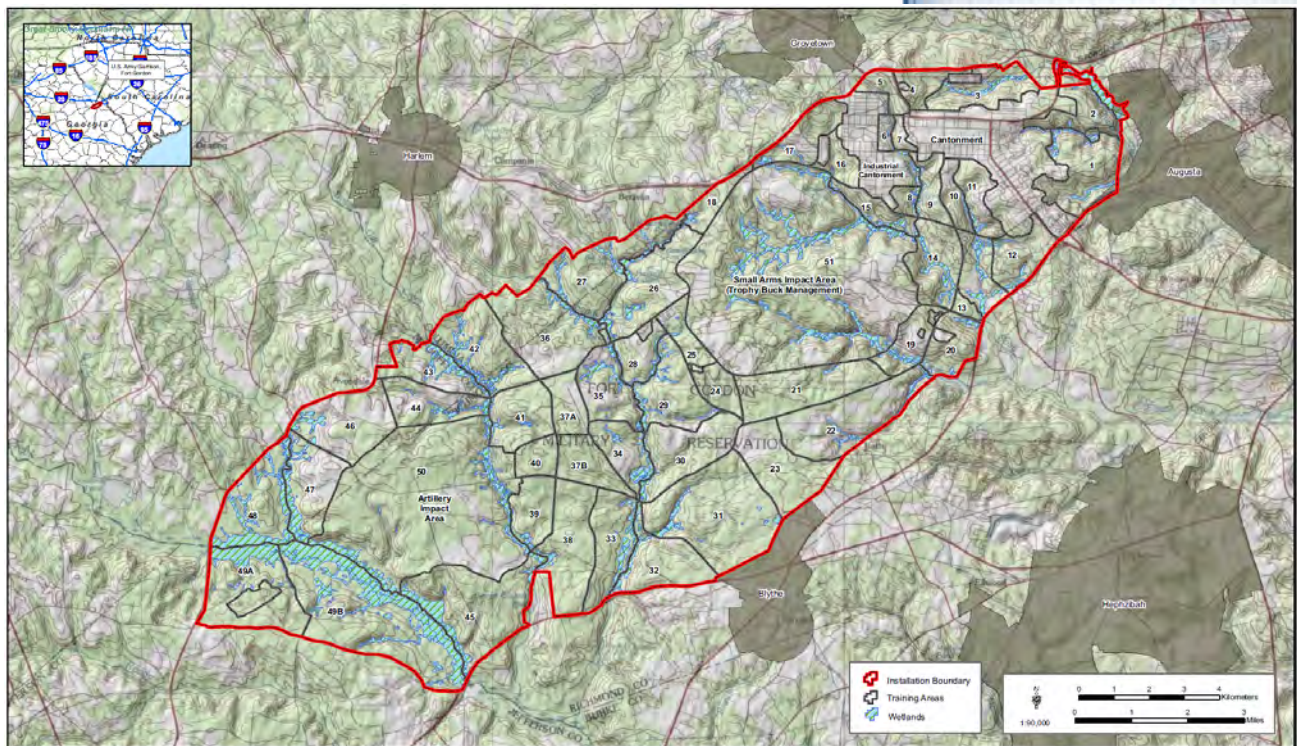
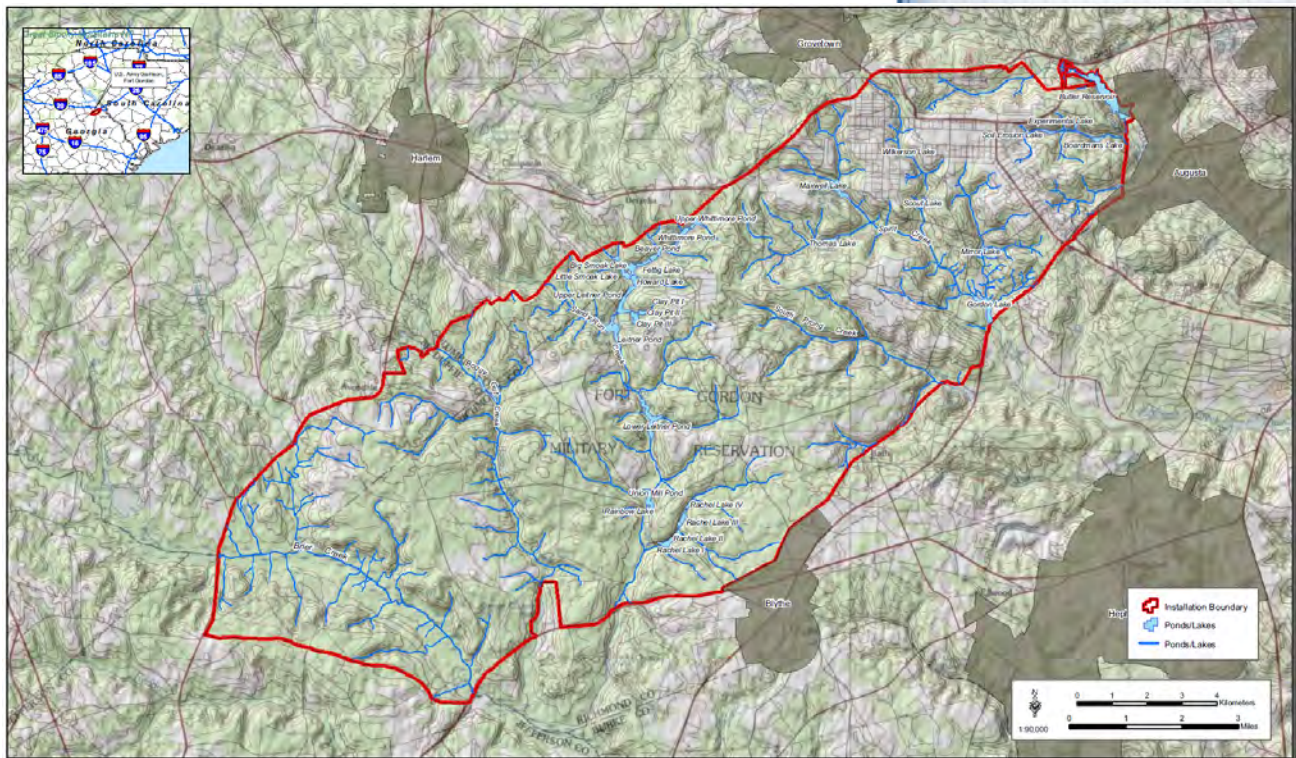


Fig. 4.10 Fort Gordon Wetlands

#### 4.2.11 Vegetation

The Sand Hills is a region of pine and mixed pine-hardwood habitat along with rich, productive drainage bottoms (Fig. 4.11). Historically a longleaf pine community dissected by sluggish backwater stream, seeps, swamps, and pocosins inhabited the region and large expanses of Fort Gordon (Fort Gordon 2007). Land use changes and the subsequent regeneration of other pine species (e.g., slash and loblolly pine) within longleaf sites have reduced the coverage of the longleaf pine community throughout its natural range. Most of the existing tree and shrub communities common to Fort Gordon can be grouped into nine major forest types. These are Natural Pine, Pine Plantation, Pine-Scrub Oak, Pine-Hardwood, Scrub Oak, Bottomland Hardwood, Hardwood Pine, Streamside Forest, and Grassland communities. Additional detailed information regarding the soils on the installation is available in the current approved INRMP, and is incorporated herein by reference (Fort Gordon 2008).

#### 4.2.12 Wildlife

A variety of wildlife species inhabit Fort Gordon and they are dispersed throughout the various habitats on the installation. It is estimated that approximately 34 species of mammals, 136 species of birds, 55 species of fish, and 60 species of reptiles and amphibians inhabit Fort Gordon (Fort Gordon 2001). Additional detailed information regarding wildlife on the installation is available in the current approved INRMP, and is incorporated herein by reference (Fort Gordon 2008).

#### 4.2.13 Threatened and Endangered Species

Target species for the purpose of this plan refers to Federally endangered or threatened species, species of concern, state listed species, and state tracked species. A total of 17 animals (five birds, two mammals, six reptiles and amphibians, and four fishes) and 11 plant species listed as either threatened, endangered, or species of concern by the USFWS or the State of Georgia are known to occur on Fort Gordon. (Table 4-3) list these species, their status and describes each species' optimum habitat requirement for survival.

Since 2001, Fort Gordon has been using an ecosystem-based approach to manage target species and human land use needs. The ecosystem management principles and guidelines for Fort Gordon are established in the policy directive for the Implementation of



**Fig. 4.11 - Sand hill and Long Leaf Pines**



**Fig. 4.12 - American Kestrel**



**Fig 4.13 - Wood stork© Helsaple Studios**



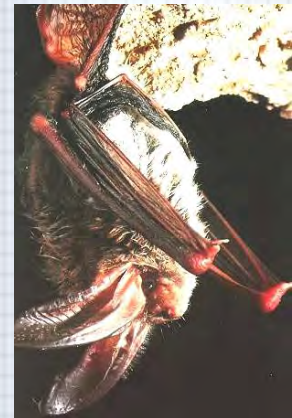
Ecosystem Management in the Department of Defense (DoD 1994).

The USFWS maintains the list of threatened and endangered species that are protected by the ESA. The ESA provides Federal protection for all species designated as endangered or threatened and provides a means to conserve their ecosystems.

Federally listed species that occur on Fort Gordon include the RCW (endangered) and wood stork (*Mycteria americana* [endangered]). The RCW (Fig 4.14) is the only Federally listed species known to reside on Fort Gordon. The wood stork (Fig. 4.13) is a transient species that has been observed foraging and roosting on the installation, but is not known to nest on the installation. Therefore, an individual management plan has not been developed for the wood stork and none is required under the ESA. Additional detailed information concerning threatened and endangered species is provided in the current approved INRMP, and is incorporated herein by reference (Fort Gordon 2008).



**Fig 4.14 - Red-cockaded woodpecker© USFWS**



**Fig 4.15 – Rafinesque Big-Eared Bat**



**Fig 4.16 – Southern Hognose Snake**

**Table 4-3. Target Species Known to Occur on Fort Gordon**

Common Name	Scientific Name	Status		Description of Habitat
		Federal	State	
<b>Birds</b>				
Bachman's sparrow	<i>Aimophila aestivali</i>	SC	R	Abandoned fields with scattered shrubs, pines, or oaks.
Southeastern American kestrel (Fig. 4.12)	<i>Falco sparverius paulus</i>	SC	R	Breed in open or partly open habitats with scattered trees and in cultivated or urban areas.
Migrant loggerhead shrike	<i>Lanius ludovicianus migrans</i>	SC	Tr	Open wood, field edges.
Wood stork	<i>Mycteria americana</i>	E	E	Primarily feed in fresh and brackish wetlands and nest in cypress or other wooded swamps.
Red-cockaded woodpecker	<i>Picoides borealis</i>	E	E	Nest in mature pine with low understory vegetation; forage in pine and pine hardwood stands.
<b>Mammals</b>				
Southeastern bat	<i>Myotis austroriparius</i>	SC	Tr	Caves used for hibernating, maternity colonies, and summer roost.
Rafinesque's big eared bat (Fig. 4.15)	<i>Corynorhinus rafinesquii</i>	SC	R	Buildings in forested regions.
<b>Reptiles and Amphibians</b>				
Gopher tortoise	<i>Gopherus polyphemus</i>	SC	T	Well-drained, sandy soils in forest and grassy area, associated with pine overstory.
American alligator	<i>Alligator mississippiensis</i>	T	NL	Marshes, swamps, rivers, farm ponds, and lakes. Nest in shallow, heavily vegetated secluded areas.
Southern hognose snake (Fig. 4.16)	<i>Heterodon simus</i>	SC	T	Open, sandy woods, fields, and floodplains.
Florida pine snake	<i>Pituophis melanoleucus mugitus</i>	SC	Tr	Arid pinelands, sandy areas, and dry mountain ridges.
Dwarf waterdog	<i>Necturus punctatus</i>	NL	Tr	Sluggish streams with substrate of leaf litter or woody debris.
Eastern tiger salamander	<i>Ambystoma t. tigrinum</i>	NL	Tr	Isolated wetlands, pine dominated uplands, and open fields.
<b>Fish</b>				
Bluebarred pygmy sunfish	<i>Elassoma okatie</i>	NL	E	Heavily vegetated creeks, sloughs, and roadside ditches.
Savannah darter	<i>Etheostoma fricksium</i>	NL	Tr	Shallow creeks with moderate current with sandy or gravel bottoms.
Sawcheek darter	<i>Etheostoma serriferum</i>	NL	Tr	Sluggish streams and swamps with sand or mud.
Sandbar shiner	<i>Notropis scepcticus</i>	R	NL	Large streams to medium-sized rivers.
<b>Plants</b>				
Sandy-woods chaffhead	<i>Carphophorus bellidifolius</i>	NL	Tr	Sandy scrub.



Table 4-3 (continued)

Common Name	Scientific Name	Status		Description of Habitat
		Federal	State	
Rosemary	<i>Ceratiola ericoides</i>	NL	T	Driest, openly vegetated, scrub oak sandhills and river dunes with deep white sands of the Kershaw soil series.
Atlantic white cedar	<i>Chamaecyparis thyoides</i>	NL	R	Wet sandy terraces along clear streams and in acidic bogs.
Pink ladyslipper	<i>Cypripedium acaule</i>	NL	U	Upland oak-hickory pine forest.
Sandhill gay-feather	<i>Liatris secunda</i>	NL	Tr	Fall line sandhills.
Carolina bogmint	<i>Macbridea carolina</i>	SC	R	Bogs, marshes, and alluvial woods.
Indian olive	<i>Nestronia umbellula</i>	SC	R	Dry open upland forest of mixed hardwood and pine.
Sweet pitcher plant	<i>Sarracenia rubra rubra</i>	NL	T	Acid soils of open bogs, sandhill seeps, Atlantic white cedar swamps, and wet savannahs.
Carolina pink	<i>Silene caroliniana</i>	NL	Tr	Granite outcrops and sandhills near the Ogeechee and Savannah Rivers.
Pickering morning glory	<i>Stylisma pickeringii</i> var. <i>pickeringii</i>	SC	T	Coarse white sands on sandhills near the Fall line and on a few ancient dunes along the Flint and Ohoopsee rivers.
Silky camelia	<i>Stewartia malacodendron</i>	NL	R	Steepheads, bayheads, and edge of swamps.

Fort Gordon 2008

Key : E = Endangered, SC = Species of Concern, NL = Not Listed, U = Unusual, T = Threatened, R = Rare, Tr = Tracked

#### 4.2.14 Cultural Resources

Currently there are no sites on the installation that are listed in the National Register of Historic Places (NRHP). However, 1120 prehistoric and historic archaeological sites have been located on the installation of these 167 are potentially eligible for the NRHP. As funds become available these sites are being further tested to assist in making final eligibility determinations. A majority of the prehistoric sites are located adjacent to water features such as drainages. Many of the historic sites are homesteads that were

razed after the Army purchased the land and relic mill sites (Fig. 4.17).

There are 61 historic cemeteries that preceded the establishment of Fort Gordon. Many of these cemeteries are still in use and maintained by the Fort Gordon. One cemetery of particular interest is the prisoner-of-war (POW) cemetery located near Gate 2 (Fig. 4.18). Several German POWs and one Italian POW who died while in captivity from 1944 through the end of World War II were buried at this cemetery. The National Historic Preservation Act specifically excludes most cemeteries from consideration for listing on the Register (Fort Gordon 2001).



**Fig 4.17 – Leitner Mill**



**Fig 4.18 – POW Cemetery near Fort Gordon Gate 2**

Based on information collected in the 2005 Historic Building Survey, the Georgia State Historic Preservation Officer (SHPO) determined that the Fort Gordon Woodworth Library (Fig. 4.19) is exceptionally important and eligible for listing in the National Register of Historic Places (NRHP) under Criterion C as an excellent example of modern architecture known as new formalism, which was popular in the United States in the 1960s. The library, which was built in 1966, meets NRHP Criteria Consideration G for resources less than 50 years of age because buildings in the new formalism style were seldom built in Georgia, and few survive unaltered (Figs 4.20 and 4.21).



**Fig 4.19 – Fort Gordon Woodworth Library**



**Fig 4.20 – Library Interior has survived unaltered**



**Recent Photo – Library Interior**

**1966 Photo – Library Interior**

**Fig 4.21 – Library Kitchen / Break Room has survived unaltered**



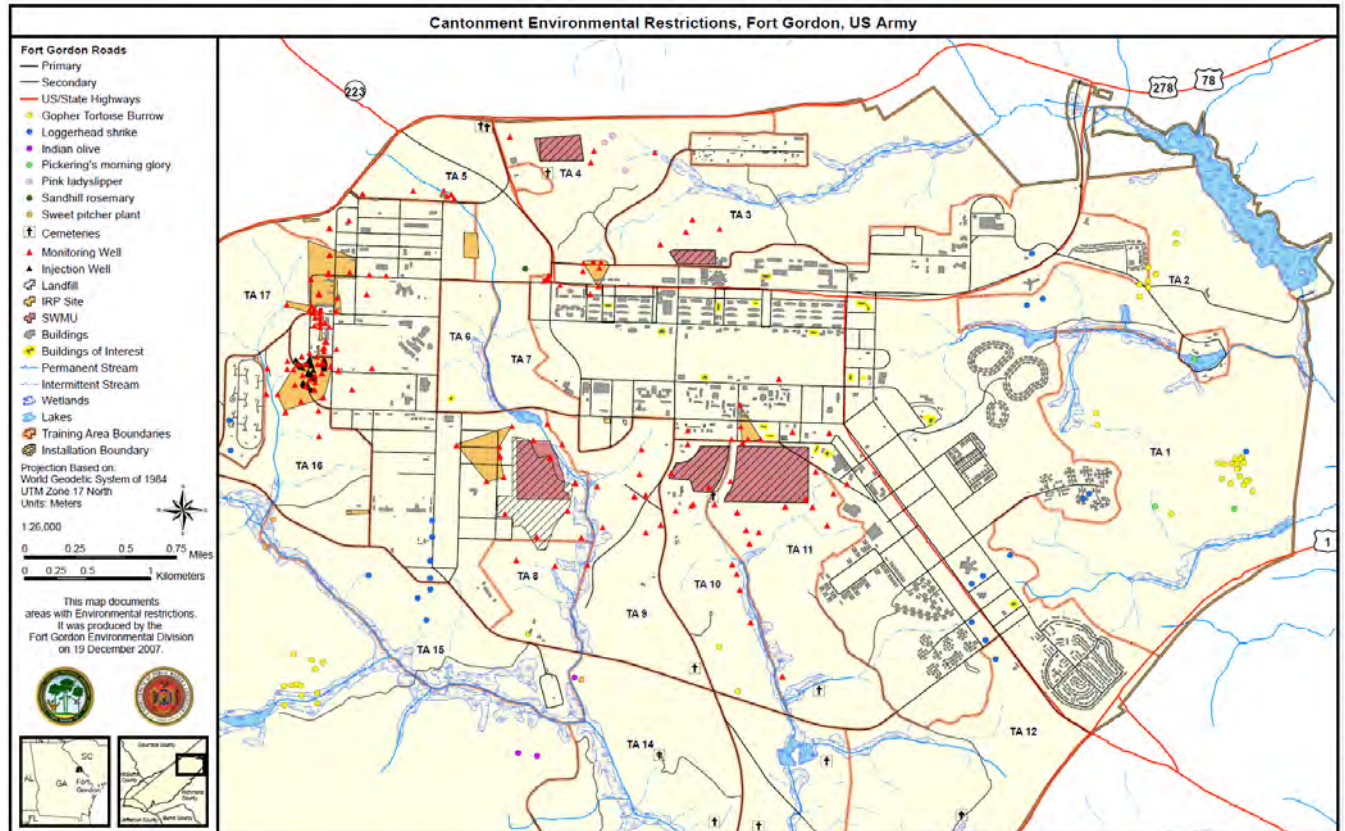
**Recent Photo – Library Kitchen**

**1967 Photo – Library Kitchen**

Of the buildings included in the 2005 Historic Building Survey, 43 of them will need to be reevaluated for their eligibility to the NRHP when they reach 50 years old. Included in those that need to be reevaluated are the 17 buildings that make up the Signal School. The Signal School, built between 1966-1973, has retained its exterior integrity and will need to be evaluated for eligibility as a historic district. Its master plan was developed in the mid-1960s by Aeck Associates of Atlanta, which designed several significant buildings in the Atlanta Metropolitan Area.



**4.2.17 Contaminated Areas: (See Constraints Map – Fig. 4.22)**



**Fig. 4.22 – Fort Gordon Constraints Map**

**4.2.15 Solid Waste Management**

Fort Gordon operates one active solid waste landfill on the installation. This facility accepts non-hazardous demolition debris from the installation. Other solid waste is disposed of at the Richmond County landfill under contract. Woody debris from ground maintenance is disposed of on-post at the mulch pit located in Training Area 17.

**4.2.16 Noise**

Fort Gordon’s noise emissions typically originate from four sources: transportation, timber operations, artillery fire and small arms fire (Figures 4.23 and 4.24). The equipment used in timber operations (e.g. skidders, tractors, loaders, etc.) can create noise



**Fig 4.23 – Small Arms Artillery Training**

impacts above acceptable levels (65 dBA). This increase in noise levels is temporary and baseline conditions return at the completion of the activities. Timber harvesting and site preparation activities are typically located in remote portions of the installation away from the cantonment and other developed areas. Additionally, these types of activities are currently conducted as part of the ecosystem-based management implemented on Fort Gordon. These activities do not result in adverse impacts to the noise environment in the region.

#### 4.2.18 Air Quality

The U.S. Environmental Protection Agency (USEPA) established National Ambient Air Quality Standards (NAAQS) for specific pollutants determined to be of concern with respect to the health and welfare of the general public. Ambient air quality standards are intended to protect public health and welfare and are classified as either "primary" or "secondary" standards. The major pollutants of concern, or criteria pollutants, are carbon monoxide, sulfur dioxide, nitrogen dioxide, ozone, particulate matter less than 10 micrometers (PM-10), and lead (Figures 4.25 thru 4.27). NAAQS represent the maximum levels of background pollution that are considered safe, with an adequate margin of safety, to protect the public health and welfare. The NAAQS are included in Table 4-4.

Areas that do not meet these NAAQS standards are called non-attainment areas; areas that meet both primary and secondary standards are known as attainment areas. The Federal Conformity Final Rule (40 CFR Parts 51 and 93) specifies criteria or requirements for conformity determinations for Federal projects. The Federal Conformity Rule was first promulgated in 1993 by USEPA, following the passage of Amendments to the CAA in 1990. The rule mandates that a conformity analysis must be performed when a Federal action generates air pollutants in a region that has been designated a non-attainment or maintenance area for one or more NAAQS standard.

Fort Gordon is located in Richmond County which is within the Georgia Air Quality Control Region. USEPA has classified Richmond County as in attainment for NAAQS; however, USEPA is currently reassessing the region's air quality to consider reclassification of Richmond County as being in non-attainment for ozone. The non-attainment determination has not been implemented at the time of printing of this SEA nor is there any schedule for the non-attainment determination. However,



**Fig 4.24 – Helicopter Transport**



**Fig 4.25 – Generator**



**Fig 4.26 – Boiler Stacks**



**Fig 4.27 – Paint Booth**

GADNR, Environmental Protection Division in a 26 June 2007 correspondence limited open burning in Richmond County (GADNR 2007). The open burning rule became enforceable on 1 May 2005 and is enforceable during the summer months (ozone season) from 1 May through 30 September. The control measure prohibits burning vegetation for the purpose of weed abatement, disease and pest prevention. Operations at Fort Gordon air emissions are covered under a Georgia Part 70 Operating Permit (9711-245-0021-V-01-0).



**Table 4-4. National Ambient Air Quality Standards**

POLLUTANT	STANDARD VALUE	STANDARD TYPE
<b>Carbon Monoxide (CO)</b>		
8-hour average	9ppm (10mg/m <sup>3</sup> )*	P
1-hour average	35ppm (40mg/m <sup>3</sup> )*	P
<b>Nitrogen Dioxide (NO<sub>2</sub>)</b>		
Annual arithmetic mean	0.053ppm (100µg/m <sup>3</sup> )*	P and S
<b>Ozone (O<sub>3</sub>)</b>		
8-hour average	0.08ppm (157µg/m <sup>3</sup> )*	P and S
1-hour average	0.12ppm (235µg/m <sup>3</sup> )*	P and S
<b>Lead (Pb)</b>		
Quarterly average	1.5µg/m <sup>3</sup>	P and S
<b>Particulate&lt;10 micrometers (PM-10)</b>		
Annual arithmetic mean	50µg/m <sup>3</sup>	P and S
24-hour average	150µg/m <sup>3</sup>	P and S
<b>Particulate&lt;2.5 micrometers (PM-2.5)</b>		
Annual arithmetic mean	15µg/m <sup>3</sup>	P and S
24-hour average	65µg/m <sup>3</sup>	P and S
<b>Sulfur Dioxide (SO<sub>2</sub>)</b>		
Annual average mean	0.03ppm (80µg/m <sup>3</sup> )	P
24-hour average	0.14ppm (365µg/m <sup>3</sup> )	P
3-hour average	0.50ppm (1300µg/m <sup>3</sup> )	S

Key: P= Primary  
S= Secondary

Source: USEPA 2006.

ppm = parts per million  
mg/m<sup>3</sup> = milligrams per cubic meter of air  
µg/m<sup>3</sup> = micrograms per cubic meter of air

\* Parenthetical value is an approximate equivalent concentration



## 4.2 EXISTING LAND USE

### 4.2.1 Fort Gordon Land Use

Land use at Fort Gordon is a function of training that results from installation missions. Training activities can be divided into two broad categories: classroom and field training. These activities are largely conducted by units under one of six U.S. Army Major Command (MACOM) groups: the U.S. Army Signal Center and School under TRADOC; tenant units under MEDCOM, NETCOM and INSCOM; reserve units under the U.S. Army Reserve Command; and National Guard units under the U.S. Army National Guard.

Fort Gordon is also home to the National Security Agency/Central Security Service Georgia (NSA/CSS Georgia), part of the Department of Defense (DoD),

Land use for Army Installations has been standardized into the following categories:

- Administration - Headquarters, offices, records, office supplies, etc.
- Airfield - Runways, operations buildings, maintenance, navigation aids, etc.
- Community Facilities - Commercial and service facilities.
- Family Housing - Housing, support, and recreational facilities.
- Green Space - Safety and secure areas, easements, waters, wetlands, etc.
- Industrial - Manufacturing and utility plants, waste disposal, etc.
- Maintenance - Facilities and shops for all types of equipment.
- Medical - Inpatient and outpatient medical and dental care.
- Outdoor Recreation - Athletic and recreational facilities.

Fort Gordon's land use includes approximately 55,590 acres; 5,590 acres of which comprise the cantonment, 13,000 acres comprise the impact areas, and 37,000 acres comprise on-post maneuver and training areas (Map\_4). The installation is subdivided into 49 training areas, 2 restricted impact areas, a main cantonment and an industrial cantonment. Individual and unit (up to battalion size) training are conducted in these areas by the various units. Training consists primarily of advanced individual signal training and unit employment of tactical communications/electronics operations. There is also limited artillery, demolition and airborne troop training on the installation.



**Fig 4.28 – Training, maneuver and exercise areas generally occur in the southwestern end of the installation**

Training, maneuver and exercise areas within the reservation boundaries generally occur in the southwestern end of the installation (Fig. 4-28). Several lakes and ponds are scattered among the woodlands and open areas. This portion of the installation supports abundant wildlife habitats. Peripheral land uses are those of farming, woodlands, houses and several small trailer parks on the western end of the installation.

Mechanized training occurred historically and is currently restricted to reserve use. Heavy training impacts on Fort Gordon have been limited to two principal areas. The Small Arms Impact Area (SAIA), approximately 7,500 acres, encompasses 14 active firing ranges. Heavy artillery detonation occurs in the Artillery Impact Area (AIA).

With over 52,000 acres of commercial woodland and unimproved grounds, Fort Gordon has an abundant outdoor recreation resource base varying from forested habitats to forested wetland habitats and open water resources. Existing outdoor recreation areas provide opportunities for camping, picnicking, horseback riding, swimming, hiking, boating, and fishing (Figures 4.29,30,31).

In addition, forest management has been a major land-use on Fort Gordon. Ninety-two percent of the installation is in forest cover, of which 46,145 acres are managed (reforestation, timber and pine straw harvesting, prescribed burning, etc.).

There are 30 reservoirs located on Fort Gordon totaling 435.7 acres. The largest are Butler Reservoir (82 acres), Gordon Lake (37 acres), Leitner Pond (29 acres), Lower Leitner Pond (25 acres), and Upper Leitner Pond (24 acres).

Transportation is another major land use. Ground transportation at the installation is provided through a network of paved (primary roads), unpaved, (secondary roads), and woodland access roads (tertiary roads). The road network includes 92.4 miles of paved roads, 67 miles of unpaved roads, and 610 miles of one and one-half lane earthen permanent firebreaks and woodland access roads.



**Fig 4.29 – Fort Gordon Kid’s Fishing Derby**



**Fig 4.30 – Dove Hunting**



**Fig 4.31 – Deer Hunting Opportunities**

## 4.2.2 Fort Gordon Visual Zones

The visual character of Fort Gordon is comprised of major image zones, landmarks/reference points, visual edges, significant views, and architectural features. A visual inventory performed, along with other data collected, provided identifiable areas or visual zones. These visual zones and the design elements within them provide the framework for how Fort Gordon is perceived.

Each zone is defined by the architectural style, activity, and function that occur in a given area. Ten (10) major visual zone classifications have been identified at Fort Gordon. These include: Signal School HQ and Academic Facility Zone, North & South Industrial Zones, Medical Center Zone, Signal Center Barracks and Admin Zone, Community Center Zone, USAR / GA National Guard Zone, NSA GA Complex Zone, Housing (RCI) Zone, and Open Areas (Greenspace) Zones.

See Section 5 for Visual Zone and Theme Analysis and Maps.  
[\(Link\)](#)





## 5.1 INTRODUCTION

**5.1.1** Visual themes and zones are determined after performing the two surveys mentioned in [paragraph 2.2](#). These surveys were conducted using existing installation maps, visual inspection, interviews, questionnaires, and photographs to record impressions of visual and spatial impacts. The data captured was used to define the visual themes and zones of the installation. Figure 5.1 presents a graphical portrayal of the of the installation's visual zones and themes.

**The Flag Array and Plaza at Signal Towers assist in illuminating the structure's positive impression and designation as Fort Gordon's most prominent visual image.**

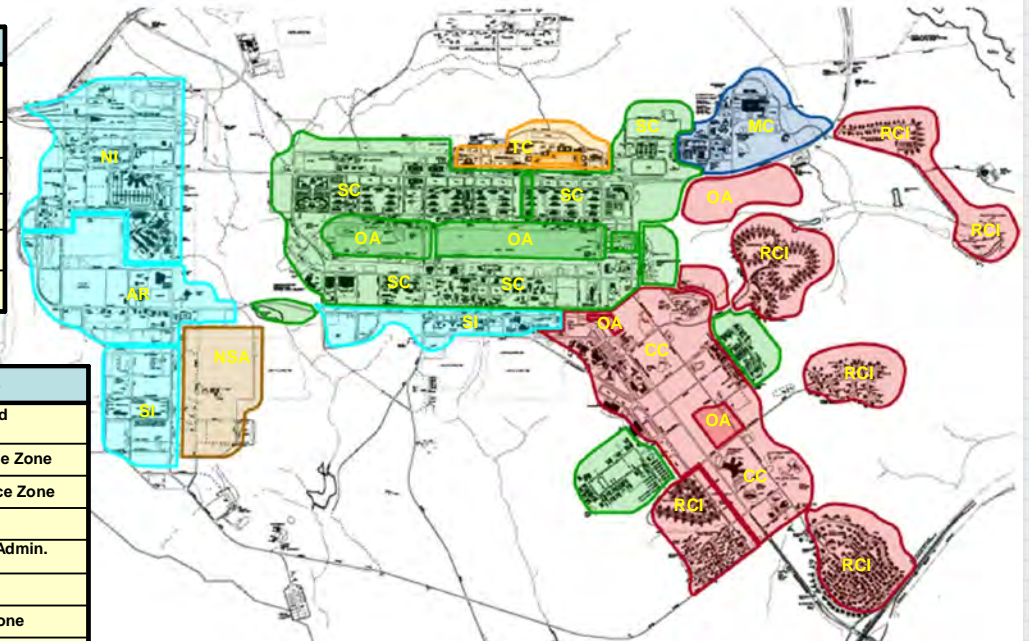




Fig. 5.1 Fort Gordon Visual Themes Map

- VISUAL THEMES -	
	SIGNAL CENTER HQ "TRADITIONAL CORE"
	SUPPORT OPERATIONS
	COMMUNITY LIFE
	INDUSTRIAL
	MEDICAL CENTER
	NSA/CSS GA

- VISUAL ZONES -	
TC	Signal Center HQ, Admin. and Academic Facility Zone
NI	North Industrial / Maintenance Zone
SI	South Industrial / Maintenance Zone
MC	Medical Center Zone
SC	Signal Center Barracks and Admin. Zone
CC	Community Center Zone
AR	USAR / GA National Guard Zone
NSA	NSA GA Complex Zone
RCI	Residential Housing (RCI)
OA	Open Areas



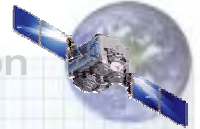
## 5.2 VISUAL THEMES

5.2.1 Visual themes create a perception of unification within the installation (Fig. 5.2). These themes create design consistency that provides orientation and a "sense of place".

5.2.2 Visual themes are generalized groupings of visual zones that provide the same general use and visual characteristics. Visual themes include broad scale activities that occur on the installation. These activities typically include similar design and layout characteristics. Table 5-1 shows the theme/visual zone relationship throughout the installation.

Fig 5.2 – Visual Themes create a perception of unification.





**TABLE 5- 1 VISUAL THEME/ZONE RELATIONSHIP**

SIGNAL CENTER HQ "TRADITIONAL CORE" THEME	SUPPORT OPERATIONS THEME	COMMUNITY LIFE THEME	INDUSTRIAL THEME	MEDICAL CENTER THEME	NSA / CSS GA THEME
Signal Center HQ, Admin. and Schoolhouse Visual Zone	Signal Center Barracks and Admin. Visual Zone	Community Center Visual Zone	USAR / GA National Guard Visual Zone	Medical Center Visual Zone	NSA/CSS GA Visual Zone
Open Area Visual Zone	Open Areas Visual Zone	Open Areas Visual Zone	North Industrial / Maintenance Visual Zone		
		Residential Housing Visual Zone	South Industrial / Maintenance Visual Zone		

### 5.3 VISUAL ZONES

**5.3.1** Visual zones are areas within the installation that include similar visual characteristics (Map – Fig. 5.3). Visual characteristics define a "look and feel" of an area together with the dominant features that define its image. Typical visual characteristics include unique buildings, vehicular and pedestrian corridors, natural features, and spatial relationships.

**5.3.2** The following paragraphs present a functional analysis of each of the visual zones. This analysis includes a description of the visual character, a visual analysis map, assets, liabilities, and recommendations for each zone.

**5.3.3** The visual analysis maps graphically illustrate the features and constraints that affect the visual character of the zone.

**5.3.4** Assets and liabilities are determined according to the following criteria: installation visual goals and objectives ([Section 3, para 3.2](#)), design principles ([Section 3, para 3.4](#)) and visual elements ([Section 3, para 3.5](#)) in relationship to the six design components described in Sections 7 through 12 of this Army Installation Design Guide.

**5.3.5** Recommendations are made to correct the liabilities or enhance the assets. These recommendations are used to generate projects that are listed in [Section 6, Improvement Projects](#).

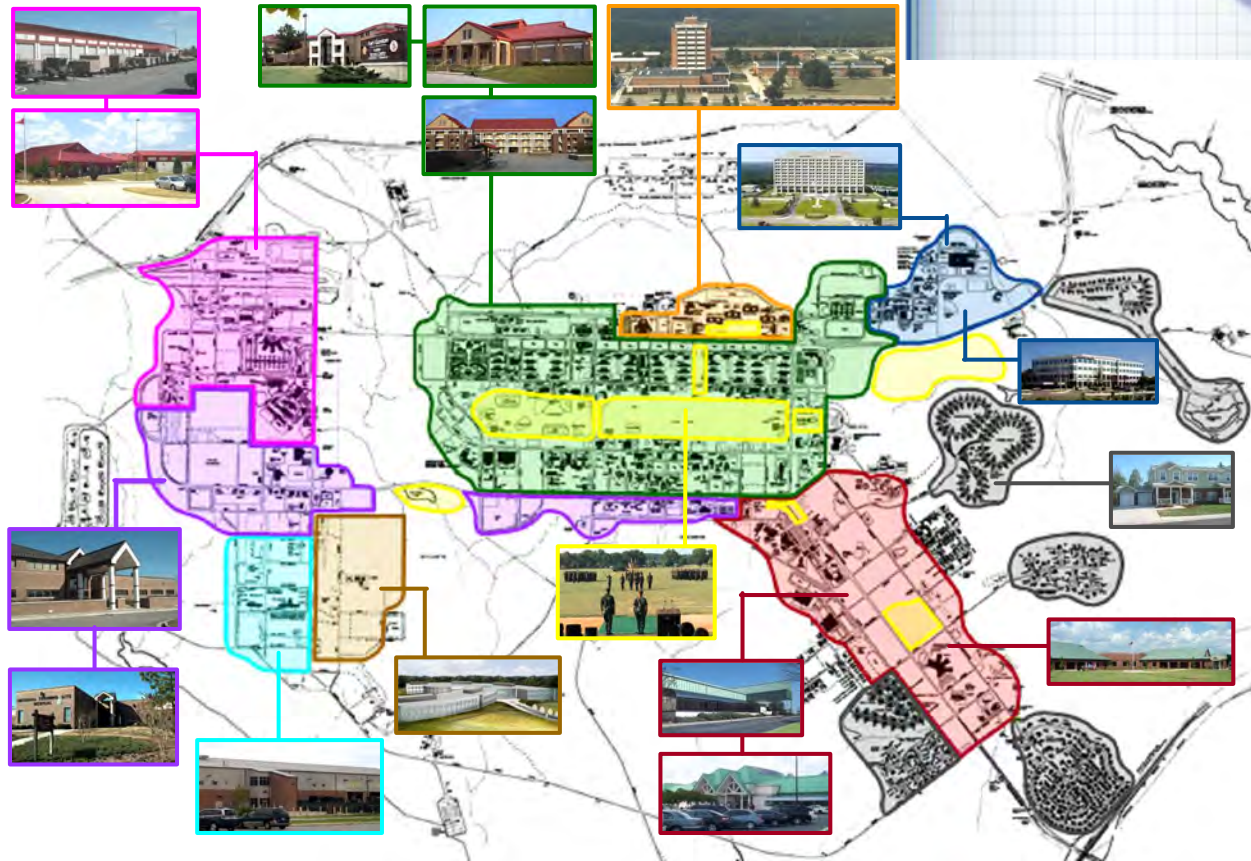


Fig. 5.3 Fort Gordon Visual Zones Map

Orange	Signal Center HQ, Admin. & Schoolhouse Zone
Pink	North Industrial / Maintenance Zone
Cyan	South Industrial / Maintenance Zone
Blue	Medical Center Zone
Green	Signal Center Barracks and Admin. Zone
Red	Community Center Zone
Purple	USAR / Ga National Guard Zone
Brown	NSA Ga Complex Zone
Yellow	Open Areas (Green Space)
Light Yellow	Residential Housing (RCI)

## 5.4 COMMUNITY CENTER VISUAL ZONE

### 5.4.1 Visual Character:

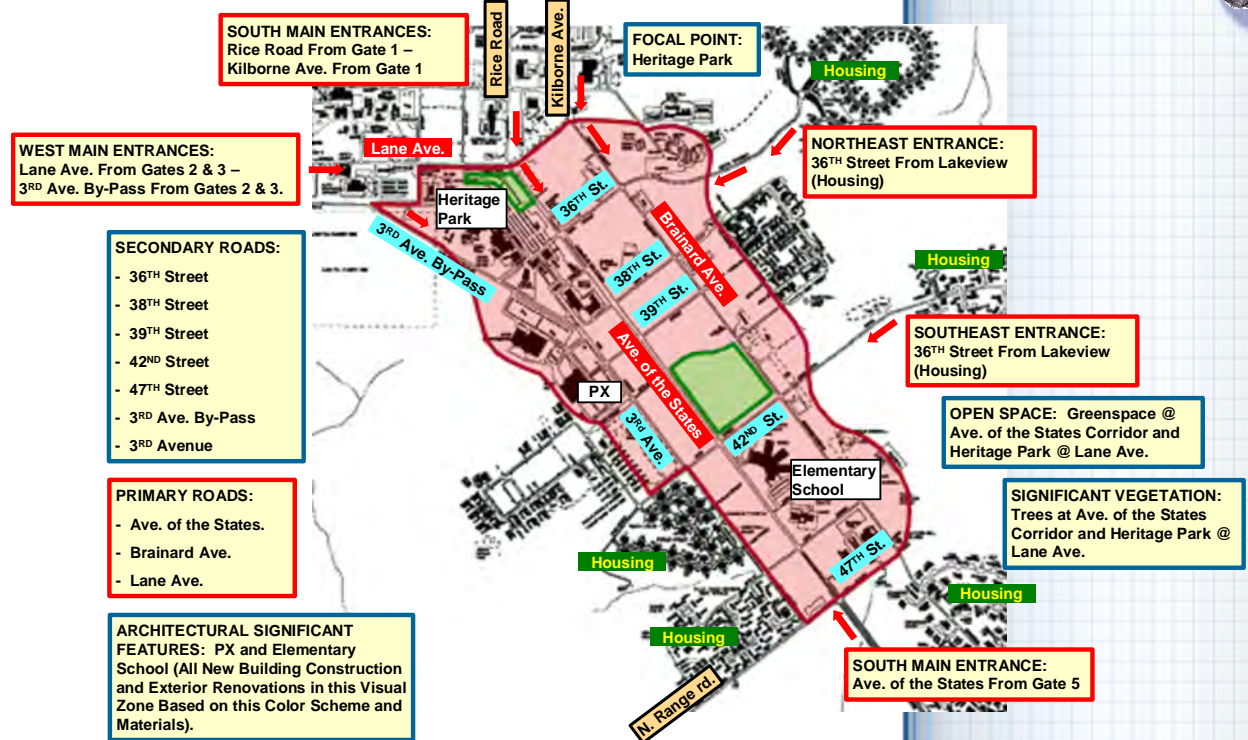
The primary community/commercial area for Fort Gordon; This Zone also serves as a transition zone between the Administration / Troop Housing areas and the Residential Housing areas. The architectural design image of this district is dominated by the modern Post Exchange Building (Fig. 5.4), and Freedom Park Elementary School.

Visual Analysis Map Figure 5.5 (Next Page)



Fig 5.4– Fort Gordon Post Exchange

## 5.4.2 Visual Analysis Map (Community Center) – Fig. 5.5



## 5.4.3 Assets

**Facility Siting** – Location of community support facilities such as schools (Fig. 5.6), child development centers, and shopping areas in relation to the neighborhood residential areas that they primarily serve has been well planned and works well functionally, enjoying high visibility and access. Area is also centrally located between Troop Housing and neighborhood residential areas.

**New Structures** - Recent construction utilizes brick as a historical building material and maintains a building scale which is compatible with human scale. The use of brick is recommended because of its sustainability. Brick is extremely durable, reduces maintenance costs, and is produced locally.

**Heritage Park (Fig. 5.7)** – The under-developed park has potential to become significant visual feature due to its’ prime location at Community Center entrance “Gateway”.

**Developable Acreage** – There’s ample, relatively flat developable acreage available within the Community Center boundary.



**Fig 5.6 – Freedom Park Elementary School**



**Fig 5.7 – Heritage Park**



#### 5.4.4 Liabilities

**Architecture** - Incompatible aluminum prefabricated building additions and a lack of consistency in exterior finish materials and color palette prevents cohesion with respect to Visual Zone identity (Fig. 5.8).

**Pedestrian/Bikeway Connection** - Fort Gordon has made progress in the construction of walkways, but there is no pedestrian and bicycle paths that interconnect housing and schools. This system should be expanded to link all community facilities with the neighborhoods and barracks they serve. Fort Gordon's generous setbacks and right-of-ways allow for a pedestrian /bikeway system to interconnect primary activity areas throughout the installation.

**Downtown Community Center Park** - There is no true Community Park or usable passive outdoor use areas for social and/or recreational activities. Centrally located park with ball fields / concession area, running tracks, lighted walking trails, lawn area, benches, playground, tennis & basketball courts, and parking is imperative (Fig. 5.9).

**Maintenance** - Being poorly maintained and having a utilitarian, cluttered look (Fig. 5.10).

**Utilities** - Overhead utility lines produce visual clutter and detract from architectural character of buildings.

### 5.5 SIGNAL CENTER BARRACKS AND ADMIN. VISUAL ZONE

#### 5.5.1 Visual Character:

This Visual Zone includes troop housing, community and commercial services, troop administration, open/green space, recreation, warehouse, mess halls and vehicle maintenance areas. Darling Hall's material and color scheme sets the standard for the entire Visual Zone (Fig. 5.11).  
Visual Analysis Map (Next Page)



**Fig 5.8 – Incompatible building additions**



**Fig 5.9 – Available acreage for much needed Community Park**



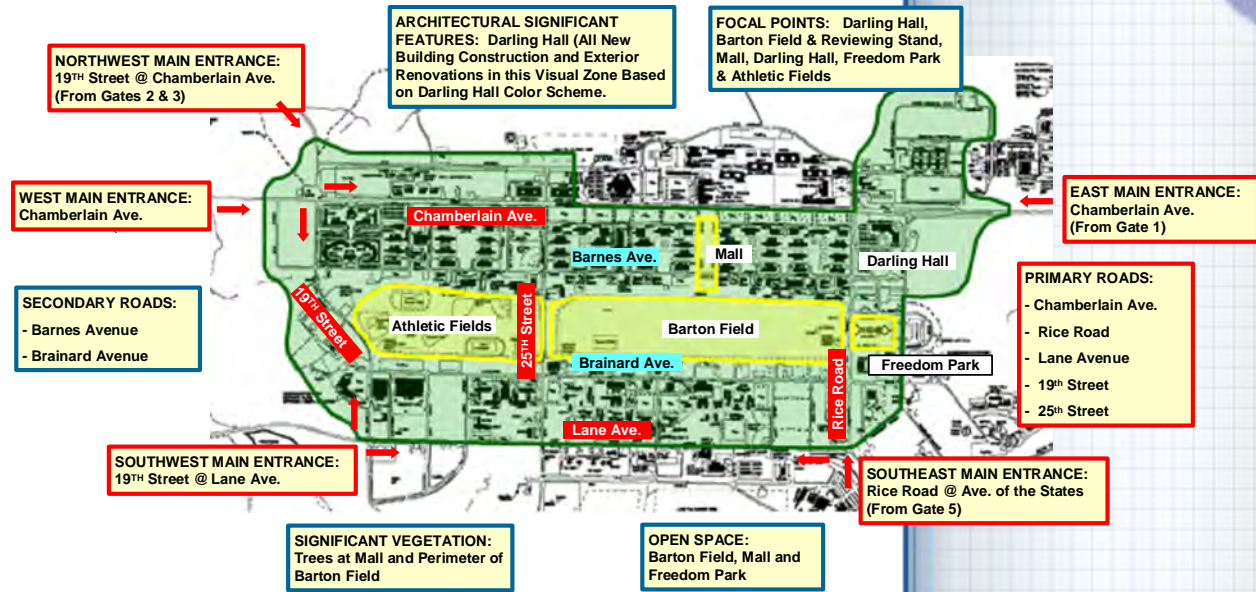
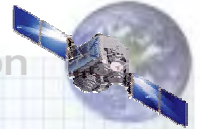
**Fig 5.10 – Cluttered appearance at highly visible location**



**Fig 5.11 – Darling Hall**

## 5.4.2 Visual Analysis Map

# Fort Gordon



## 5.5.3 Assets

**Identity** - The Zone is easily recognizable by its older architecture (use of flat roofs), and newer styles utilizing standing-seam metal roofs and a warmer color palette (Fig. 5.12).

**Site Design** - The functional relationship between administration, barracks and common areas provide for optimal pedestrian circulation; providing areas of daily activity.

**Accessibility** - The Zone is easily accessible with four major roads serving as boundaries for, troop housing, administration and community support land uses.

**Functional Relationships** - Site layout and orientation of land uses to one another provides for efficient utilization of space. Barton Field connects visually dissimilar buildings and ties together different areas of the entire space (Fig. 5.13).

**Visibility** – The Zone is the location of involvement by the largest number of persons on the Installation, giving it a high level of visibility.



**Fig 5.12 – Newer style buildings with warm color palette**



**Fig 5.13 – Centrally located Barton Field connects visually dissimilar buildings**

## 5.5.4 Liabilities

**Common Areas** - Courtyards and plazas are stark, cold, un-vegetated, and visually unappealing.

**Site Elements / Clutter** - Having many non-standard, make shift site elements; often placed with no consideration to siting, aesthetics, standards, or providing an appropriate setting for intended campus-like setting (Figures 5.14 thru 5.17).

**Landscaping** - Area is poorly landscaped

**Erosion Control** - Some areas are experiencing erosion problems. Corrective measures must be implemented.

**Insufficient Parking spaces** - Having inadequate or poorly located parking creates a poor visual impression.

**Rhythm** - Uniform building heights promote an industrial look. An overall lack of architectural details promotes a poor image.

**Walkways** - Area has unorganized, insufficient and poorly designed paved walk systems. As a result, a number of unpaved dirt paths have scarred the campus.

**Visual Vulnerability** - Due to the lack of screening and buffering, the Zone is highly visible and visually vulnerable when viewed from the primary corridors.

**Storage buildings** - Many non-standard storage buildings are located on (or near) primary corridors throughout the Zone creating a negative visual impact.

**Misc. Barriers** - Placement of a variety of unsightly makeshift force protection and pedestrian control devices has created a negative visual impact.

**Vehicular/Pedestrian Conflicts** – There is a serious conflict between vehicular and pedestrian circulation (Notably along Chamberlain Avenue).

Additionally, the generous width of pedestrian sidewalks (high-temp trench covers) provides adequate space for automobiles to drive into courtyard areas not intended for vehicular traffic. The



**Fig 5.14 – Non standard site elements**



**Fig 5.15 – Non standard site elements creating cluttered appearance**



**Fig 5.16 – Make shift landscape features distracting from intended overall campus-like setting.**



**Fig 5.17 – Non standard signage and site elements**

result creates potential circulation conflicts and provides a poor visual image for these pedestrian-oriented areas.

**Utilities** - Overhead utility lines produce visual clutter and detract from architectural character of buildings.



## 5.6 SIGNAL CENTER HQ, ADMIN. AND ACADEMIC FACILITIES VISUAL ZONE “TRADITIONAL CORE”

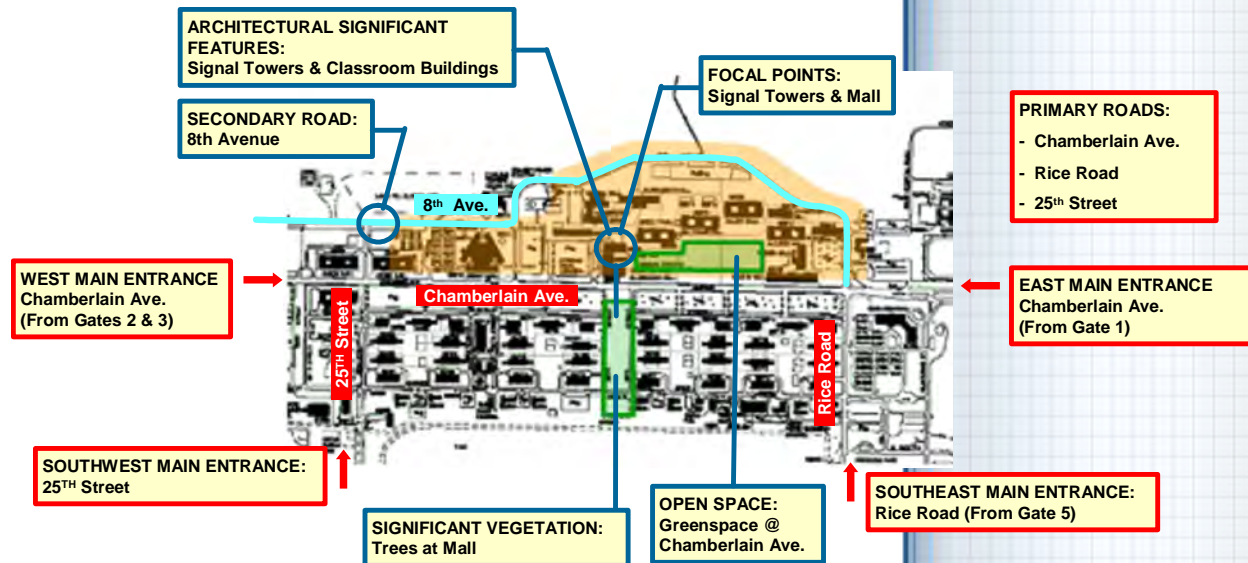
### 5.6.1 Visual Character:

The Traditional Core Zone is the administrative center of Fort Gordon which includes Signal Towers. “Traditional Core” is reflective of Beaux- Arts design principles such as symmetry, axis, and preserved green spaces. Visually, it is a compact district composed of the Signal School HQ, administrative and instructional facilities. This area offers an excellent opportunity to establish a high visibility central core for the Post (Fig. 5.18).



**Fig 5.18 – Signal Towers and Academic Facilities comprise the Fort Gordon “Traditional Core” Zone.**

### 5.6.2 Visual Analysis Map



### 5.6.3 Assets

**Architecture** - Strong architectural features dominated by cast-in-place concrete columns and brick facades aid in the development of the strong image (providing a sense of arrival and entry) that this zone demands.

**Site Planning** - Planning principles incorporating orderly designed walkways create a “campus” atmosphere within the “Traditional Core” Zone.

**Landmarks** – The prominent structure (Signal Towers – Fig. 5.19) and the Instructional Facilities share similar architectural characteristics. This further enhances the unified visual theme.

**Plaza/Courtyard (Signal Towers)** - A flag plaza celebrates the zone’s rich history and provides opportunities to accentuate focal points and create a cohesive visual link.

### 5.6.4 Liabilities

**Landscaping** - Area is poorly landscaped

**Site Elements** – Absence of markers identify the rich history that Signal Towers represents, benches, additional walkways and landscaping.

**Utilities** - Overhead utility lines produce visual clutter and detract from architectural character of buildings.

## 5.7 NORTH INDUSTRIAL / MAINTENANCE VISUAL ZONE

### 5.7.1 Visual Character:

This Zone consists of warehouse storage, vehicle maintenance facilities, Administration and supplemental utility buildings and structures (Fig. 5.20). The balance of land is undeveloped forest. Some permanent vegetative buffer areas exist on the undeveloped land. Architecturally, the Zone consists of large-scale, industrial-style buildings made of metal, brick and concrete block with clerestory glass inserts. Pre-engineered metal construction buildings at the motor pool make up the balance of this Zone.

Visual Analysis Map (Next Page)

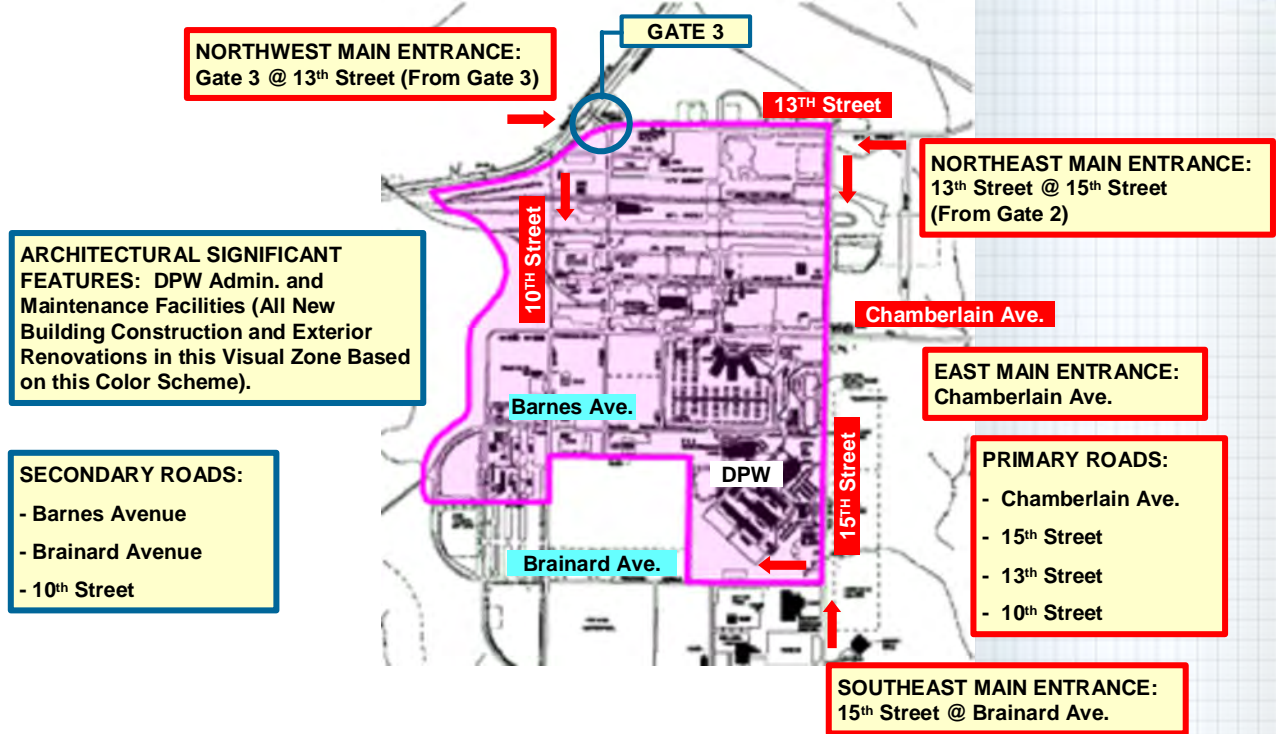


**Fig 5.19 – Signal Towers is Fort Gordon’s most prominent visual feature**



**Fig 5.20 – Unified Building exterior colors dominate visual zone – Public Works Admin. Building and Maintenance Facilities**

## 5.7.2 Visual Analysis Map



## 5.7.3 Assets

**Siting** - Large industrial buildings are grouped together to minimize impact on the surrounding environment (Fig. 5.21).

**Buffers** - The North Industrial District maintains a sufficient buffer and is remotely sited so that it has little impact on surrounding Zones.

**Recent Construction** - Site planning and design considerations such as parking layout, unified building color schemes, and entry features have been successfully implemented (Fig. 5.22).

**Architecture** - Low building heights throughout the Zone help integrate architecture with site. The earthtone color palette and brick exteriors make the Zone easily identifiable.

**Screening** - Many good examples of screened parking lots and motor pools can be found in this Zone.



**Fig 5.21 – Large industrial buildings are grouped together.**



**Fig 5.22 – Successful integration of architecture and site**

**Access** - Being fenced and secure with few points of entry or interaction with the community at large that require increased landscaping.

#### 5.7.4 Liabilities

**Erosion Control** - Areas within the district experiencing erosion problems which need to have corrective action taken.

**Maintenance** - Some of the older buildings are in disrepair, providing a poor visual image. Some buildings are also difficult to maintain and are energy inefficient (Fig. 5.23).

**Road Condition** – Road “wear & tear” due to frequent use by large / heavy vehicles has deteriorated road surface and edge (Fig. 5.24).

**Blights** - Having an over abundance of unused industrial spaces / structures, and concrete slabs due to the earlier historical Installation uses.

### 5.8 SOUTH INDUSTRIAL / MAINTENANCE VISUAL ZONE

#### 5.8.1 Visual Character:

This Zone consists of warehouse storage, vehicle maintenance facilities, Administration and supplemental utility buildings and structures (Fig. 5.25). The balance of land is undeveloped forest. Some permanent vegetative buffer areas exist on the undeveloped land. Architecturally, the Zone consists of large-scale, industrial-style buildings made of metal, brick and concrete block with clerestory glass inserts. Pre-engineered metal construction buildings at the motor pool make up the balance of this Zone.

Visual Analysis Map (Next Page)



**Fig 5.23 – Some older building create poor visual image**

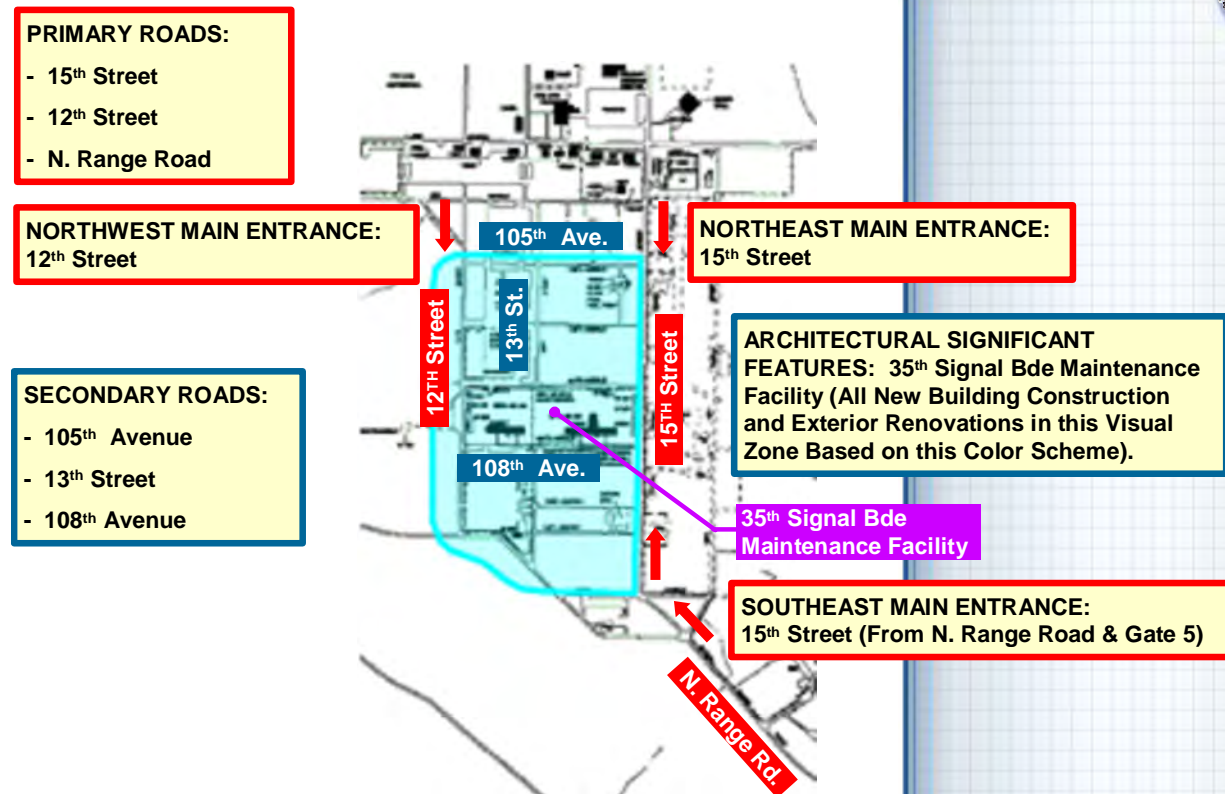


**Fig 5.24 – Deteriorated road surfaces**



**Fig 5.25 – 35<sup>th</sup> Signal Brigade Maintenance Facility and Motor Pool**

## 5.8.2 Visual Analysis Map



## 5.8.3 Assets

**Siting** - Large industrial buildings are grouped together to minimize impact on the surrounding environment.

**Buffers** - The North Industrial District maintains a sufficient buffer and is remotely sited so that it has little impact on surrounding Zones.

**Recent Construction** - Site planning and design considerations such as parking layout, seating walls, some landscaping, unified building color schemes, and entry features have been successfully implemented.

**Architecture** - Low building heights throughout the Zone help integrate architecture with site. The earthtone color palette and brick exteriors make the Zone easily identifiable (Fig. 5.26).

**Screening** - Many good examples of screened parking lots and motor pools can be found in this Zone.



**Fig 5.26 – Facilities within zone have unified color and theme**



**Access** - Being fenced and secure with few points of entry or interaction with the community at large that require increased landscaping.

### 5.8.4 Liabilities

**Erosion Control** - Areas within the district experiencing erosion problems which require corrective action.

**Maintenance** - Some of the older buildings are in disrepair, providing a poor visual image (Fig. 5.27). Some buildings are also difficult to maintain and are energy inefficient.

**Road Condition** – Road “wear & tear” due to frequent use by large / heavy vehicles has deteriorated road surface and edge.

**Blights** - Having an over abundance of unused industrial spaces / structures, and concrete slabs due to the earlier historical Installation uses (Fig. 5.28).

## 5.9 USAR / GA NATIONAL GUARD VISUAL ZONE

### 5.9.1 Visual Character:

This Zone consists of Administration Buildings, warehouse storage, vehicle maintenance facilities, and supplemental utility buildings and structures. The balance of land is undeveloped forest. Some permanent vegetative buffer areas exist on the undeveloped land. Architecturally, the Zone contains Administrative and industrial-style buildings made of metal, brick and concrete block. Pre-engineered metal construction buildings at the motor pools make up the balance of this Zone. Visually, it is a compact district dominated by the Reserve Center and Regional Training Site Medical (RTS MED) Buildings (Fig. 5.29).

Visual Analysis Map (Next Page)



**Fig 5.27 – Some older buildings in disrepair**



**Fig 5.28 – Over abundance abandoned concrete foundations overgrown parking lots**



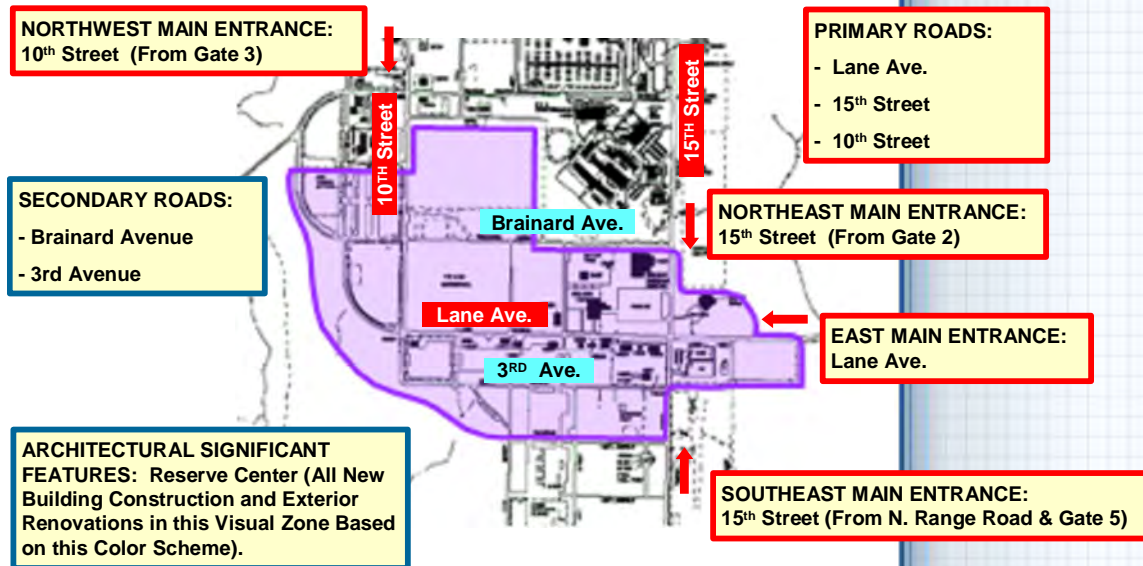
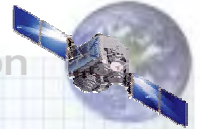
**Regional Training Site Medical (RTSMED)**



**United States Army Reserve Center**

**Fig 5.29 – Primary Facilities within zone have unified color palette**

## 5.9.2 Visual Analysis Map



## 5.9.3 Assets

**Recent Construction** - Site planning and design considerations such as parking layout, pedestrian-scale lighting, seating walls, landscaping, and entry features have been successfully implemented

**Architecture** – Existing strong architectural features aid in the development of image and provide a sense of arrival and entry (Fig. 5.30).



Fig 5.30 – Strong architectural entry features

## 5.9.4 Liabilities

**Erosion Control** - Areas within the district experiencing erosion problems which need to have corrective action taken.

**Visual Vulnerability** - Virtually the entire Zone is visually vulnerable due to a lack of screening and buffering.

**Road Condition** – Road “wear & tear” due to frequent use by large / heavy vehicles has deteriorated road surface and edge (Fig. 5.31).



Fig 5.31 – Deteriorated road surfaces

## 5.10 MEDICAL CENTER VISUAL ZONE

### 5.10.1 Visual Character:

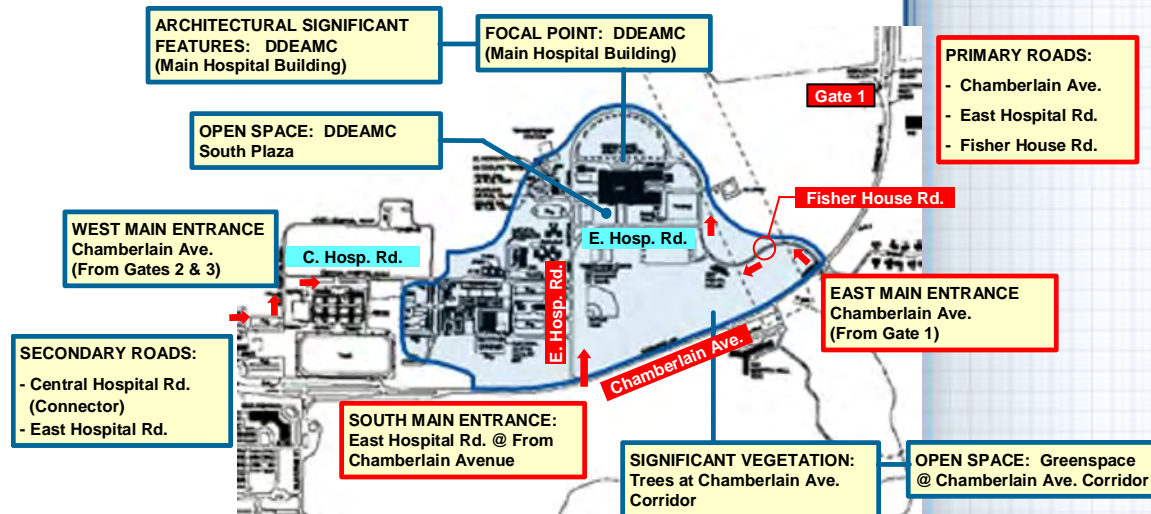
The Dwight D. Eisenhower Medical Center (DDEAMC) dominates this Visual Zone (Fig. 5.32).

The Southeast Region Medical Command, the Southeast Region Dental Command, the Southeast Region Veterinary Command, Eisenhower Army Medical Center (a teaching hospital), Considered a mission partner on Fort Gordon is the [Dwight D. Eisenhower Army Medical Center](#) (DDEAMC), home of the Southeast Regional Medical Command (SERMC) as well as a dental laboratory. The facility treats active duty military and their families, as well as many of the military retiree community in the [Central Savannah River Area](#). Under SERMC, the hospital is responsible for military hospital care from Kentucky to Puerto Rico.



Fig 5.32 – Dwight D. Eisenhower Medical Center (DDEAMC)

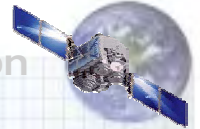
### 5.10.2 Visual Analysis Map



### 5.9.3 Assets

**Landmarks** – The prominent structure, Eisenhower Army Medical Center, is an important Fort Gordon landmark of monumental scale that dominates the visual character of the Medical Center Visual Zone.

**Potentially Pedestrian Friendly:** Entire Zone is compact; allowing the possibility to connect related functions with the construction of new pedestrian walkways.



**Utilities** - All existing utilities are buried in this area eliminating negative image of unsightly overhead wiring.

#### 5.9.4 Liabilities

**Available Acreage** - The Medical Center Visual Zone is virtually land-locked and contains limited acreage for expansion. All future major construction must be vertical, multi-story.

**Architecture** - Incompatible aluminum prefabricated buildings and a lack of consistency in exterior finish materials and color palette prevents cohesion with respect to Visual Zone identity.

**Traffic Circulation** - Limited vehicular access and egress problems require corrective action; Primarily at intersection of Chamberlain Avenue and Fisher House Road.

**Parking** - Entire Zone has insufficient, inadequate and poorly located parking.

**Visual Vulnerability** - Due to the lack of screening and buffering, some visually negative areas within the Zone are highly visible when viewed from Fort Gordon's primary corridor (Chamberlain Avenue).

### 5.11 NSA / CSS GA VISUAL ZONE

#### 5.11.1 Visual Character:

NSA/CSS GA Complex is currently under construction. Architecture consist of a high-tech, modern architectural style with expansive window walls, pre-fab concrete panels on steel frame construction (Fig. 5.33).

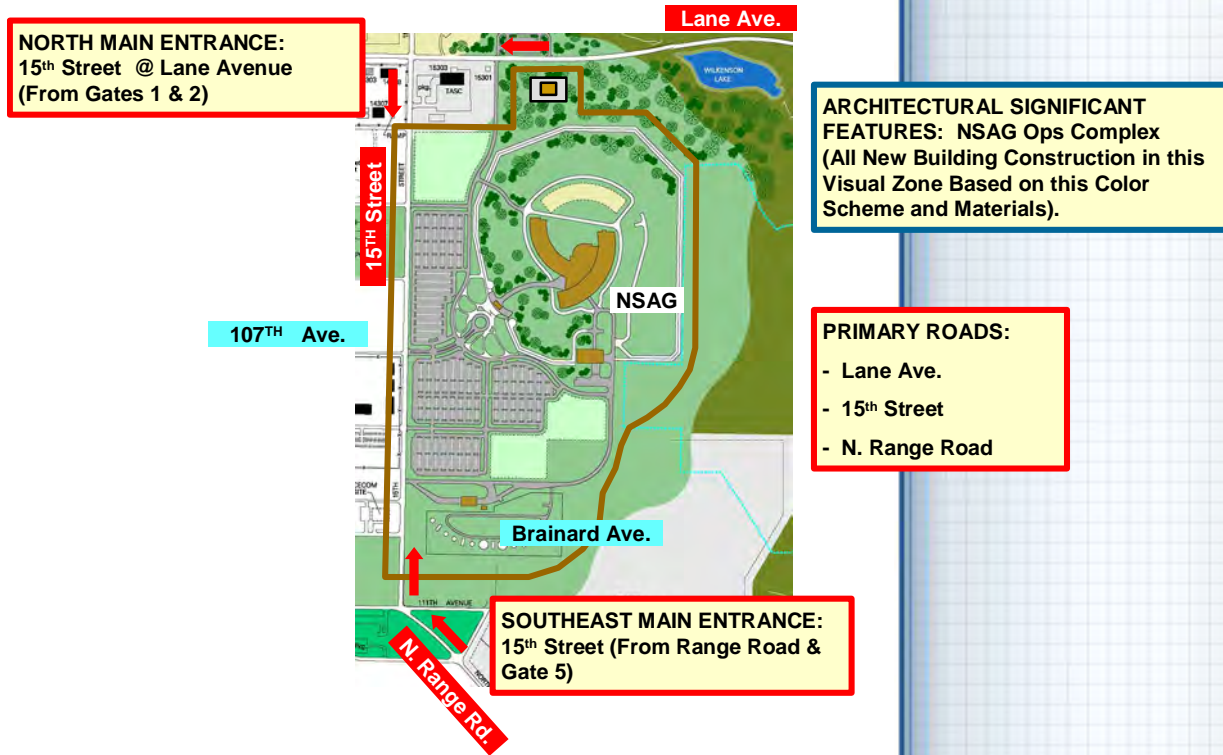
Landscaping features and site elements will be consistent with primary structures' modern architectural style.

Visual Analysis (Fig. 5.34) – Next Page



**Fig 5.33 – Pre-construction rendering of NSA/CSS GA Operations Center**

### 5.11.2 Visual Analysis Map (Fig. 5.34)



### 5.11.3 Assets

**Architecture** – (Currently under Construction) – Will be architecturally impressive state-of-the-art facility.

**Available Acreage** – Adequate acreage for expansion is available.

#### **HOUSING ZONE (RCI):**

The Housing Zone is divided into six separate areas: Boardman Lake, Maglin Terrace, McNair Terrace, Lakeview Terrace, Olive Terrace, and Gordon Terrace. The Housing District consists of both single family and multi-family unit dwellings. Family units range from one to two-story configurations. Materials throughout the Housing District include brick (Fig. 5.35), and horizontal aluminum siding. Building colors are natural earthtone values. A significant contribution to the overall image is the prevalent gable roof configuration. The roof style promotes a cohesive image and provides a sense of continuity to the architectural fabric.



**Fig 5.35 – Brick is the predominant exterior building material**

**Assets:**

**New Construction** – New homes are currently being constructed, and existing homes are being completely renovated.

**Functional Relationships** - Schools and community facilities are conveniently located near neighborhoods.

**Neighborhood Recreation Areas** - Neighborhood parks and open spaces offer residents an easily accessible area for play and relaxation (Fig. 5.37).

**Sidewalks** - Pedestrian walkways within housing areas offer a safe alternative to roadway walking or jogging (Fig. 5.36).

**Kiosks** - Neighborhood entry signage/kiosks is consistent in design and offers easily identifiable information relating to each housing area.

**Architecture** - Brick is a predominant exterior material providing years of low maintenance care.

**Liabilities:**

**Views** - Unscreened views of the backside of housing promote a very poor visual image. Chainlink fences in backyards become catchall outdoor storage areas.

**On-Street Parking** - Inadequate parking in older housing areas create a cluttered image, and presents a poor visual image.

**OPEN SPACES:**

**Assets:**

**Formal spaces** - (Heritage Park & Myer Mall) could be the location of central visual features such as memorials, foundations and sculptures.

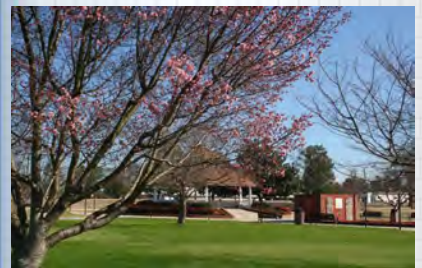
**Social gathering space** - The Gazebo/Bandstand at Freedom Park possesses the character of an outdoor "room" presenting the potential for a variety of human activity (Fig. 5.38).



**Fig 5.36 – Pedestrian walkways present throughout new housing developments**



**Fig 5.37 – Neighborhood Recreation Area**



**Fig 5.38 – Freedom Park offers a variety of human activities**

**Functional connection** - Barton Field connects visually dissimilar buildings and tie together different areas of the whole place.

**Visibility** - Several open spaces are highly visible (Fig. 5.39).

**Siting** - Having a number of excellent, well located spaces (Barton Field, Myer Mall, Heritage park, Freedom Park, Wilkenson Lake, and the natural vista near intersection of Chamberlain and Kilborne Avenues)

**Liabilities:**

**Under developed** - Having some very strong formal spaces that have not been developed to anywhere near their capacity as important image makers for the Installation (Heritage Park, Myer Mall south of Chamberlain at Signal Tower).

**Encroachment** - Having been encroached upon over the years by a variety of uses.

**Misuse of acreage** - Being thought of as unused space and available for development.

**Landscaping** - Being poorly landscaped.

**Over development** - Being poorly organized and cluttered (Freedom Park). Also inappropriate vinyl fencing distracts from formal space.

**Green space** - Lacking well developed, passive use areas, and small human scale spaces.

**Maintenance issues** - Being subjected to unskilled, 'force account' maintenance efforts.

**Design quality** - Having recreation facilities of low design and maintenance quality.



**Fig 5.39 – Natural vista looking South from Chamberlain Ave.**



## 6.1 INTRODUCTION

**6.1.1** Section 6 consists of projects generated from the liabilities presented in the visual zone analysis section starting at [paragraph 5.4](#). The projects may consist of enhancement of a single visual element or improvement of an area that includes a variety of visual elements. Depending on the project scope and cost, the projects could include: Military construction (MILCON), Host Nation programs, Nonappropriated-funded (NAF), Other Procurement, Army (OPA) and maintenance and repair, local minor construction, and self-help. Each improvement project is described and cost-estimated in enough detail to place each project within the appropriate project list or annual work plan, in an appropriate Fiscal Year, within the statutorily correct funding program. Projects require a Capital Investment Strategy.

**6.1.2** The paragraphs below discuss each project at length and includes existing conditions, project description, design concept, cost estimate, primary and alternate recommended funding sources, photographs, sketches and maintenance impact as applicable.

**6.1.3** [Appendix G](#) of this Army Installation Design Guide, the Prioritized Improvement Projects List, records information on each project and prioritizes them in accordance with the installation goals and objectives stated in [paragraph 3.2](#), Goals, Objectives and Recommendations. The appendix is an interactive form and designed to be altered as circumstances effecting the prioritization scheme change.





## 6.3 TRAINEE BARRACKS UPGRADE PROGRAM (TBUP)

**6.3.1 Existing Conditions:** The architectural character of the buildings included in the Trainee Barracks Upgrade Program (TBUP) are 1960s era contemporary/modern single to multi-story structures, with flat roofs (Fig. 6.1). The typical exterior materials are brick masonry and aluminum frame windows, with some variations in brick and accent colors. In most cases the designs have relied upon mechanical, energy intensive methods for cooling and heating. They have not been responsive to the hot humid climate of the region.

The “Rolling-Pin” barracks buildings have received many upgrades over the years, but do not currently meet the Army Advanced Individual Trainee (AIT) standard. The exterior appearance of the barracks is virtually unchanged from its’ original form.

The other buildings included in the program; Brigade HQ, Battalion HQs, COFs and DFACs are of similar construction, appearance, and ineffective utility systems as barracks.

### 6.3.2 Project Description:

- Renovate (18) Rolling Pin Barracks @ 190 spaces each (Fig. 6.2)
- Renovate (1) Bde HQ Building (Exterior and Interior), upgrade utilities. Provide for ADA accessibility. Provide new roof.
- Renovate (8) Existing Five Bay Admin buildings (Exterior and Interior), upgrade utilities. Provide new roof.
- Renovate (4) Bn HQ Buildings (Exterior and Interior), upgrade utilities. Provide for ADA accessibility. Provide new roof.
- Renovate (4) Dining Facilities. Expand Dining Area, and reconfigure serving, operational areas. Upgrade utilities and provide new roof.



**Fig 6.1 – Exist Typical Rollin-Pin Barracks**



**Fig 6.2 –Rendering of Typical Rollin-Pin Barracks (TBUP)**

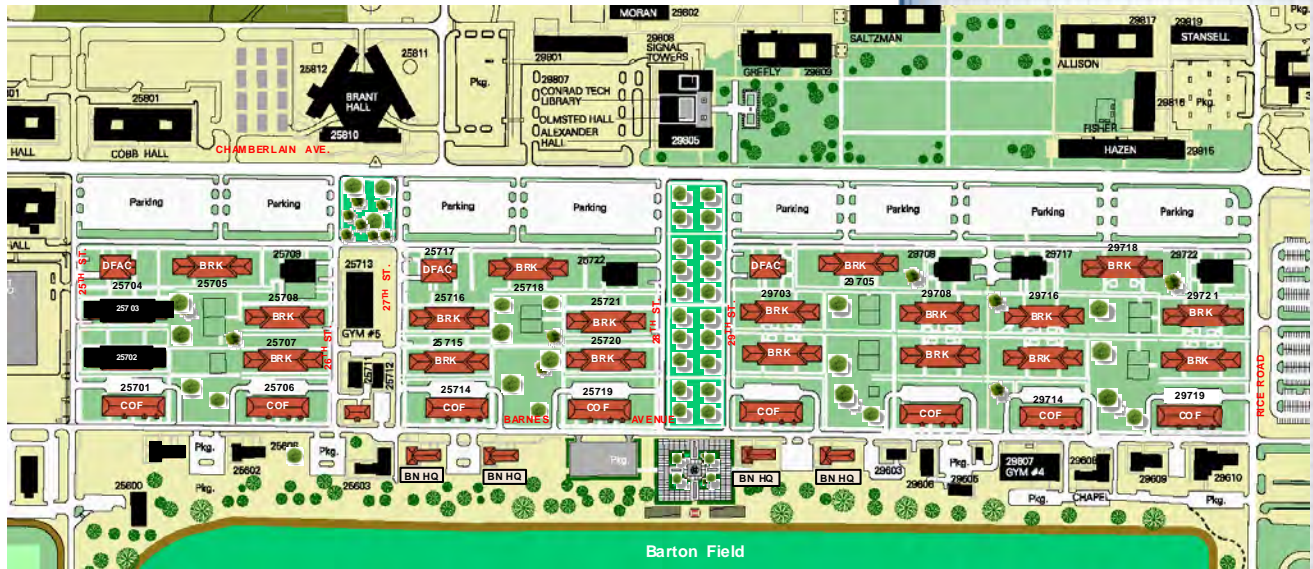


**Fig 6.3 – Rendering depicting unified visual image of Trainee Barracks Campus (TBUP)**

**6.3.3 Design Concept:** Utilize same color scheme and materials for each building creating unified visual image (Fig. 6.3). Provide new walkways and decorative post-top lighting establishing pedestrian friendly, campus-like setting.



**TBUP Site Plan Map**



**6.4 LANDSCAPING (TBUP AREA)**

**6.4.1 Existing Conditions:** Current landscaping is inadequate, and does not present the desired visual image of a “Campus-like” setting.

The entire area is currently undergoing a major facility upgrade; the (Trainee Barracks Upgrade Program – TBUP). The TBUP will address new landscaping in each “Quad” as the project progresses.

**6.4.2 Project Description (Fig. 6.4):**

- Remove all dead or diseased trees and shrubs.
- Remove non-standard landscape and site elements.
- Provide low maintenance groundcover.
- Provide low maintenance native trees and shrubs.
- Provide new walkways as needed.
- Provide new walkway lighting.
- Provide new standard site elements, benches, tables, etc.



**Fig 6.4 – Desired appearance of typical TBUP ‘Quad’**

**6.5 ESTABLISH NEW STANDARD SIGNAGE TO ACCOMMODATE UNIT “DISPLAY OF COLORS” IN TRAINEE BARRACKS AREA.**

**6.5.1 Existing Conditions:** Use of non-standard, make shift signs and site elements; often placed with no consideration to siting and aesthetics, has created an inappropriate setting for intended campus-like setting (Fig. 6.5).

**6.5.2 Project Description:** Create unique, professionally rendered 4 x 6 ft. signs (on standard sized metal canvas with metal posts) displaying individual Unit colors, crest, motto, etc. (Fig. 6.6). Locate all new signs near barracks entrance(s) along major walkways. All non-standard site elements to be removed.



**Fig 6.5 – Non Standard Signage and Site Elements**



**Fig 6.6 – Rendering Depicting Proposed (Unit Designed) Standard Sign Displaying Unit Colors, Crest, and Motto.**

## 6.6 BARRACKS UPGRADE PROGRAM (BUP)

**6.6.1 Existing Conditions:** The architectural character barracks included in the Barracks Upgrade Program (BUP) are 1970s era contemporary/modern three-story, brown-brick VOLAR type structures, with flat roofs (Fig. 6.7). In most cases the designs have relied upon mechanical, energy intensive methods for cooling and heating. They have not been responsive to the hot humid climate of the region.

The barracks buildings have received many upgrades over the years, but do not currently meet the Army's one-plus-one standard. The exterior appearance of the barracks is virtually unchanged from its' original form.

**6.6.2 Project Description:** Upgrade VOLAR barracks consistent with guidance from the Office of the Assistant Chief of Staff for Installation Management (OACSIM) to the Army's one-plus-one standard and improve the quality of life for the soldier. Upgrades includes new doors & windows, plumbing, bathroom fixtures, electrical, standing seam metal roof system, and bring communications up to DoD standards, etc. (Fig. 6.8).

**6.6.3 Design Concept:** Utilize same color scheme and materials for each building creating unified visual image. Provide new walkways and decorative post-top lighting establishing pedestrian friendly, campus-like setting.



**Fig 6.7 – Exist VOLAR Barracks**



**Fig 6.8 –VOLAR Barracks Post BUP renovation**

## 6.7 INITIATE ACADEMIC BUILDING UPGRADE PROGRAM

**6.7.1 Existing Conditions:** The buildings that make up the Signal School represent an important part of Fort Gordon's history. The consolidation of the Signal School at Fort Gordon in 1964 led to the need to construct new classrooms and administration space. The Signal School buildings utilize cast-in-place concrete columns with a cast-in-place concrete two-way joist system without beams (waffle-flat plate construction) floor/roof system, and concrete block wall system with brick that was quite popular in urban areas in the late 1960s (Fig. 6.9). The significance of these buildings lies in their role not only in the communications training of the school but also in representing the physical infrastructure changes the installation went through when it became the Home of the Signal School. Thus, earning its designation as the Fort Gordon Traditional Core.

**General Instructional Buildings (GIB):** Fort Gordon has 398,000 SF of GIB. These facilities were constructed starting in the late 1960's, and do not have adequate power in the classrooms for the new training equipment. Lighting levels in the classrooms and hallways is insufficient, and the heating and cooling in these facilities is inadequate. Power circuits are overloaded resulting in lost training time due to frequent power outages.

### 6.7.2 Project Description:

- Interior and exterior renovation. Upgrade plumbing, HVAC and Electrical.
- Enclose interior courtyards if additional space requirement dictates
- Provide new roofing at Academic Buildings. No standing Seam Metal Roofing will be utilized in this area (Zone).
- Provide new windows, frames and metal panels matching Signal Towers (Typical all Classroom Buildings).
- Connect Academic Buildings with Covered Walkways Matching Colonnade at Signal Towers.

**6.7.3 Design Concept:** Signal Tower is Fort Gordon's most identifiable feature, we should preserve its status as the hub of the Signal Center HQ, Admin Visual Zone, or

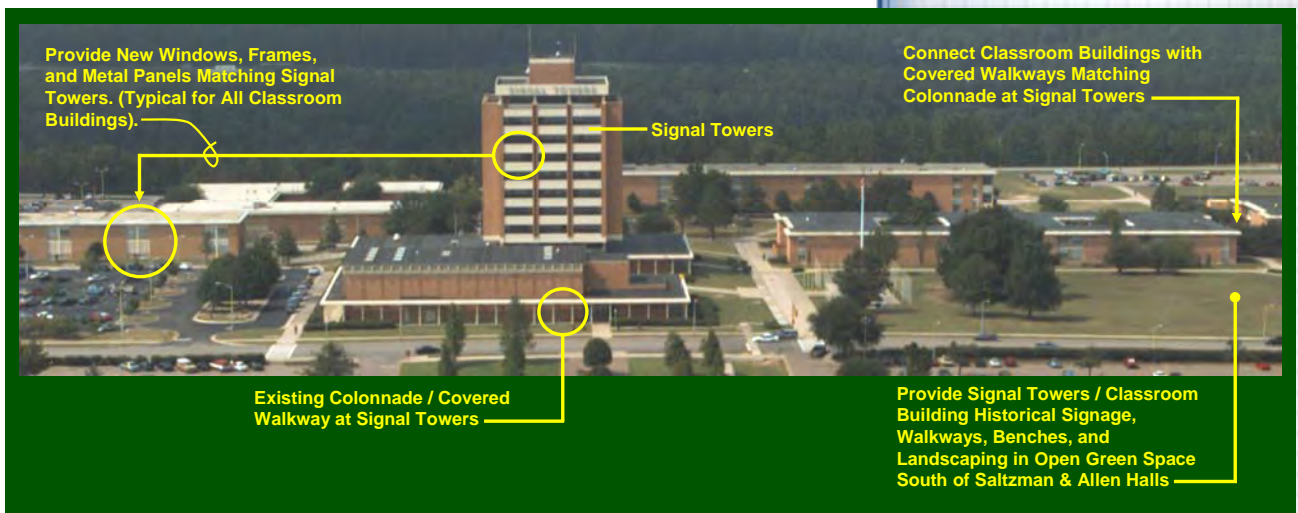


**Fig 6.9 – U.S. Army Signal School at Fort Gordon**



Signal Center “Traditional Core”. Therefore , it becomes paramount that the support buildings (Academic Buildings) surrounding Signal Tower keep their architectural integrity intact.

Project will not surround Signal Tower with metal, ‘red roofs’. That will only distract from the building’s significance, and degrade the area’s “Traditional Core” designation”. The concept is to incorporate the most distinguishable characteristics of Signal Tower, and incorporate those qualities in the academic building facades. Most noticeable, new windows matching Signal Towers, and covered walkways with colonnades between the buildings (Fig. 6.10).



**Fig 6.10 –Renovate Academic Building exteriors incorporating most distinguishable characteristics of Signal Towers**

## 6.8 SIGNAL CENTER CORRIDOR RENOVATION

**6.8.1 Existing Conditions:** The Signal Center Corridor describes the green space North of Chamberlain Avenue within the Signal Center School / Administrative area. The sparse, non-descript space presents an unremarkable image; not befitting the space shared by Fort Gordon's most prominent landmark, Signal Towers.

**6.8.2 Project Description:** The Signal Center Corridor Project Description is as follows:

- Provide 4 ft. high black aluminum fencing with 5 ft. high brick columns at walkway openings along Chamberlain Avenue (Fig. 6.13).
- Provide Signal Center entry signs at East and West entrances (Fig. 6.11).
- Provide cobra head street lights at Chamberlain Avenue and Breckenridge Post-top light fixtures along walkways within greenspace area
- Provide landscaping and benches within greenspace area (Fig. 6.12).



**Fig 6.11 – Proposed Entry Signage at East & West Entrances**



**Fig 6.12 – Typical Bench within Greenspace**



**Proposed Signal Center Corridor Plan**



**Fig 6.13 – Typical Black Aluminum Fencing and Brick Columns**

## 6.9 RELOCATE OVERHEAD UTILITIES TO UNDERGROUND

**6.9.1 Existing Conditions:** Unsightly overhead utility lines are visible throughout the Fort Gordon cantonment area. Many of the lines run immediately adjacent to major roads and entrance corridors. This condition has created a negative Installation-wide visual impact.

The Fort Gordon street lighting system presents an unorganized, inconsistent appearance. Lighting is substandard; utilizing several different light fixture types. Additionally, there is currently no established pedestrian walkway lighting system.

**6.9.2 Project Description:** All overhead utility lines within the cantonment area will be relocated underground. All utility poles will be removed, and new light poles and fixtures erected throughout the cantonment area. The five phase project duration is FY08 thru FY13 (Fig. 6.14).

**6.9.3 Maintenance Impact:** Utility service provider will be responsible for all maintenance.

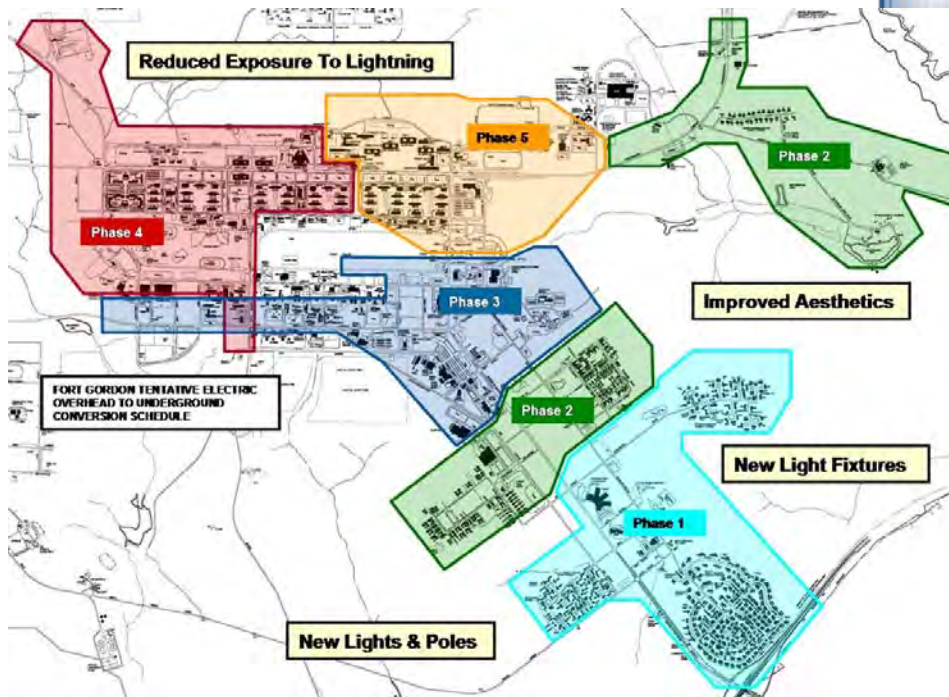


Fig 6.14 –Utilities Overhead to Underground Location map





**Fig 6.14 – Rendering depicting proposed Street Light System at Avenue of the States**

## **6.10 INITIATE PHASED INSTALLATION-WIDE LANDSCAPING PLAN**

**6.10.1 Existing Conditions:** Fort Gordon; having soils of very low fertility; being in an exposed and harsh climate situation; in many cases being improperly maintained; using plants that are non-standard and poorly suited in their various applications; has led to noticeable erosion and plant loss.

Fort Gordon soils are also high in sand content and very susceptible to said erosion when disturbed; the grounds tend to lose their turf cover under moderate foot traffic in areas where hard surface walks are not available (Many such dirt paths are visible on the Installation); eroding and washing onto walks and depositing heavy silt loads into the storm drain system.

**6.10.2 Project Description:** Initiate phased, low maintenance, sustainable, Installation-wide landscaping plan.

- Review mowing and turf management techniques
- Review overall landscape maintenance techniques
- Review overall tree maintenance techniques



**Fig 3.X – Initiate active use of native plant material to screen unsightly views**

- Establish a limited irrigation program for high visibility and prominent turf/shrub areas (Fig. 6.16).
- Establish high quality turf along principal entry drives and at primary destinations (Fig. 6.15).
- Increase level of landscaping and turf maintenance practices along all entry drives, major roadways and primary destinations.
- Establish a program to improve appearance of and landscape the bus shelters
- Initiate active use of plant material to screen unsightly views and buildings and to define and organize visual open space.
- Establish an effective erosion control system using native landscape materials as well as hard engineering applications.

**Establish a Master Tree Canopy / Wind Break Program:**

- Rehabilitate diseased or stressed trees in the main cantonment area, particularly for trees in prominent locations or of high scenic value.
- The removal of those trees beyond salvage.
- A ban on parking under established trees or groves of trees in unimproved (unpaved) or undesignated areas.
- Initiate sub-soiling and aeration of compacted soils under existing trees and the establishment of turf or ground cover in these areas.
- Initiate an active tree fertilizing and spraying program.
- Introduce standard, native trees in areas of high visibility, sparse tree cover, and wind break protection.
- Stipulate that a percentage of new building budgets be earmarked from tree plantings.



**Fig 6.15 – Establish high quality turf along principal entry drives**



**Fig 6.16 – Introduce standard native trees in areas of high visibility**

## 6.11 COMPLETE DEVELOPMENT OF “DOWNTOWN” FORT GORDON COMMUNITY CENTER PLAN (MAP FIG. 6.21)

**6.11.1 Existing Conditions:** The existing Fort Gordon Community Center has no definition. It’s primarily a group of community facilities with no visible bond or connection. Available acreage exist within the area; allowing the opportunity to unite the disconnected structures into a unified, pedestrian friendly Community Center.

### 6.11.2 Project Description:

- **Proposed Major Projects**

- New Chapel Complex (Fig. 6.18)
- New 40-Lane Bowling Center (Fig. 6.19)
- New Library / Media Center (Fig. 6.17)
- New Physical Fitness Center
- New (Casual Dining) Restaurant

- **On-going Projects / Initiatives**

- Relocate Overhead Utilities to Underground
- Establish centrally located Community Center Park with ball fields / concession area, running tracks, lighted walking trails, lawn area, benches, playground, tennis & basketball courts. (Fig. 6.20)
- Renovate Heritage Park

- **Proposed Initiatives**

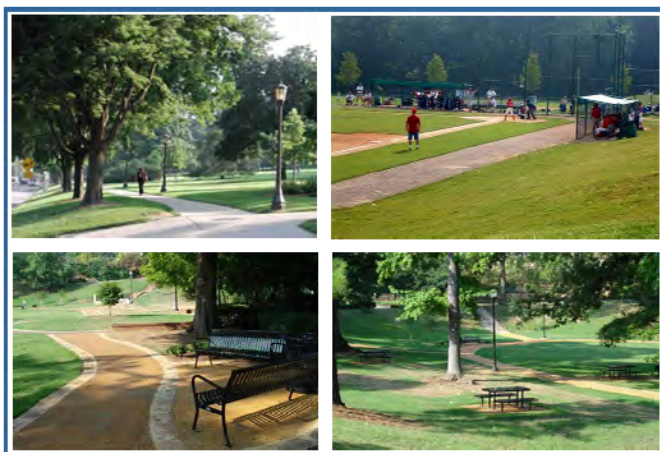
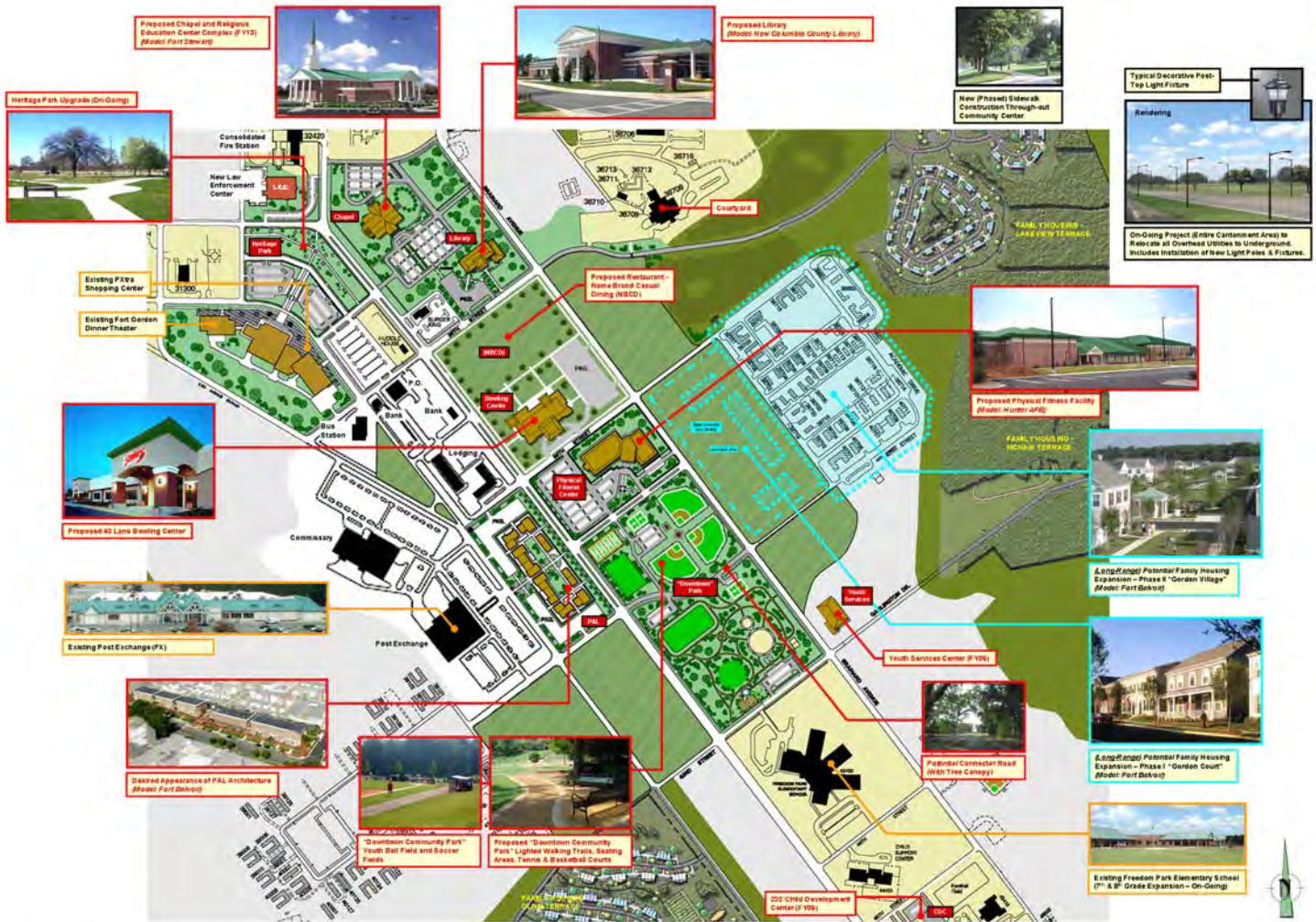
- Create system of walkways / Bikeways linking all community facilities with the neighborhoods and barracks they serve.
- Initiate Low Maintenance, sustainable landscaping plan.



**Fig 6.17 – Design Model for Proposed  
Library / Media Center**



**Fig 6.21 – Map of Proposed “Downtown” Community Center**



**Fig. 6.20 – Images Representing Vision of Proposed “Downtown” Community Park**



**Fig. 6.19 – Design Model for Proposed 40 Lane Bowling Center**



Fig. 6.18 – Proposed Chapel / Religious Education Center will be Cornerstone of “Downtown” Community Center



Proposed Site: Chapel and Religious Education Center



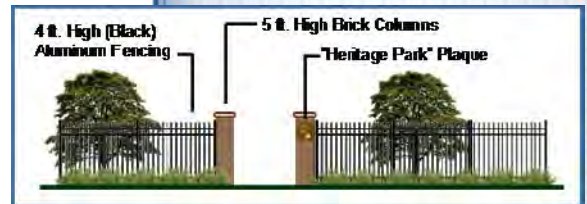
Fig. 6.18 – Architectural Rendering of Proposed Chapel

**6.12 PROJECT: Initiate project to renovate all Fort Gordon Formal Spaces, i.e. Heritage Park, Myer Mall, and Plaza at Barton Field Reviewing Stand.**

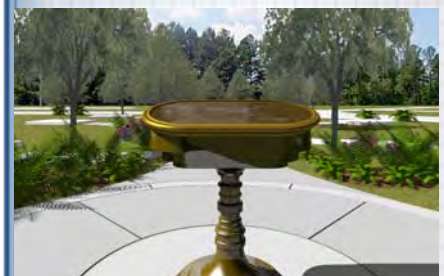
**6.12.1 Existing Conditions:** Fort Gordon has some very strong formal open spaces that have not been developed to their capacity as important image makers for the Installation. These areas receive the same low level of landscape design and grounds maintenance that surrounding areas receive.

**6.12.2 Project Description (HERITAGE PARK):**

- Provide Landscaping (Native Trees and Shrubs).
- Provide Benches and Trash receptacles.
- Provide Standard Breckenridge Post-top Walkway Lights.
- Provide 4 ft. High Black Aluminum Fencing at North and East Perimeter. Provide 5' High Brick Columns at Park Entrances. Install Bronze "Heritage Park" Plaque on Column at Main Entrance (Intersection of Lane Avenue and Avenue of the States), and on Column at South Entrance (Figures 6.23).
- Provide "Camp Gordon – Established 1941" Map on New Pedestal at Circular Walkway in Park Center. (Fig. 6.22)
- Provide New Pad-mounted Markers at Static Displays.



**Fig. 6.23 – Heritage Park – Proposed Black Aluminum Fencing with Brick Columns**



**Fig. 6.22 – "Camp Gordon" Map on Pedestal at Park Center**



**Fig. 6.21 – Heritage Park Propose Site Plan**



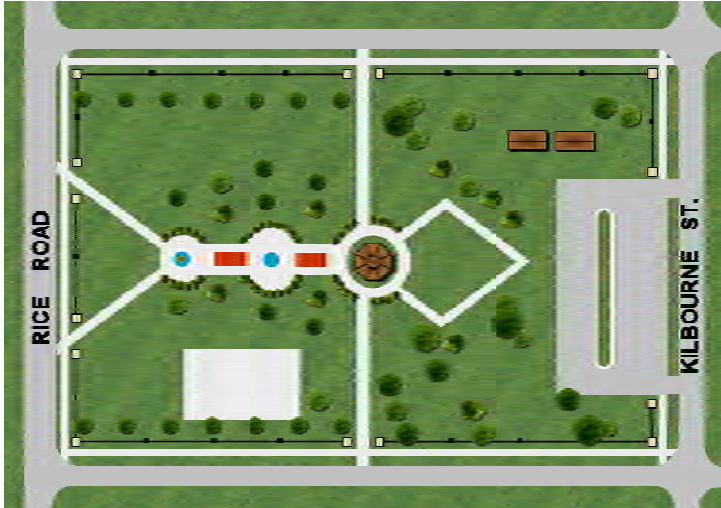
**Fig. 6.23 – "Heritage Park" Plaque on Column at Entrances**



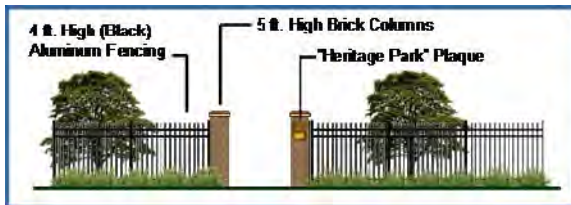
**6.12.3 Project Description (FREEDOM PARK – Fig. 6.24):**

- Provide Standard Breckenridge Post-top Walkway Lights.
- Replace Existing White Vinyl “Corral Type” Perimeter Fencing with 4 ft. High Black Aluminum Fencing.

Provide 5’ High Brick Columns at Park Entrances. Install Bronze “Freedom Park” Plaque on Column at Main Entrances on Rice Road (Fig. 6.25 and 6.26).



**Fig. 6.24 – Freedom Park Site Plan**



**Fig. 6.26 – Freedom Park – Proposed Black Aluminum Fencing with Brick Columns**



**Existing Freedom Park Photograph**



**Fig. 6.25 – “Freedom Park” Plaque on Column at Entrances**

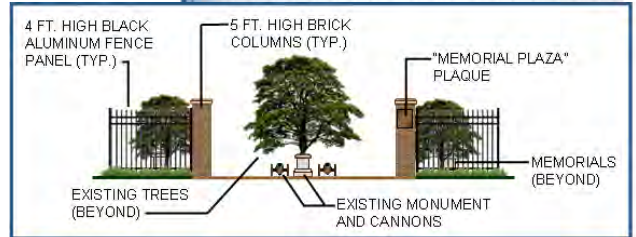
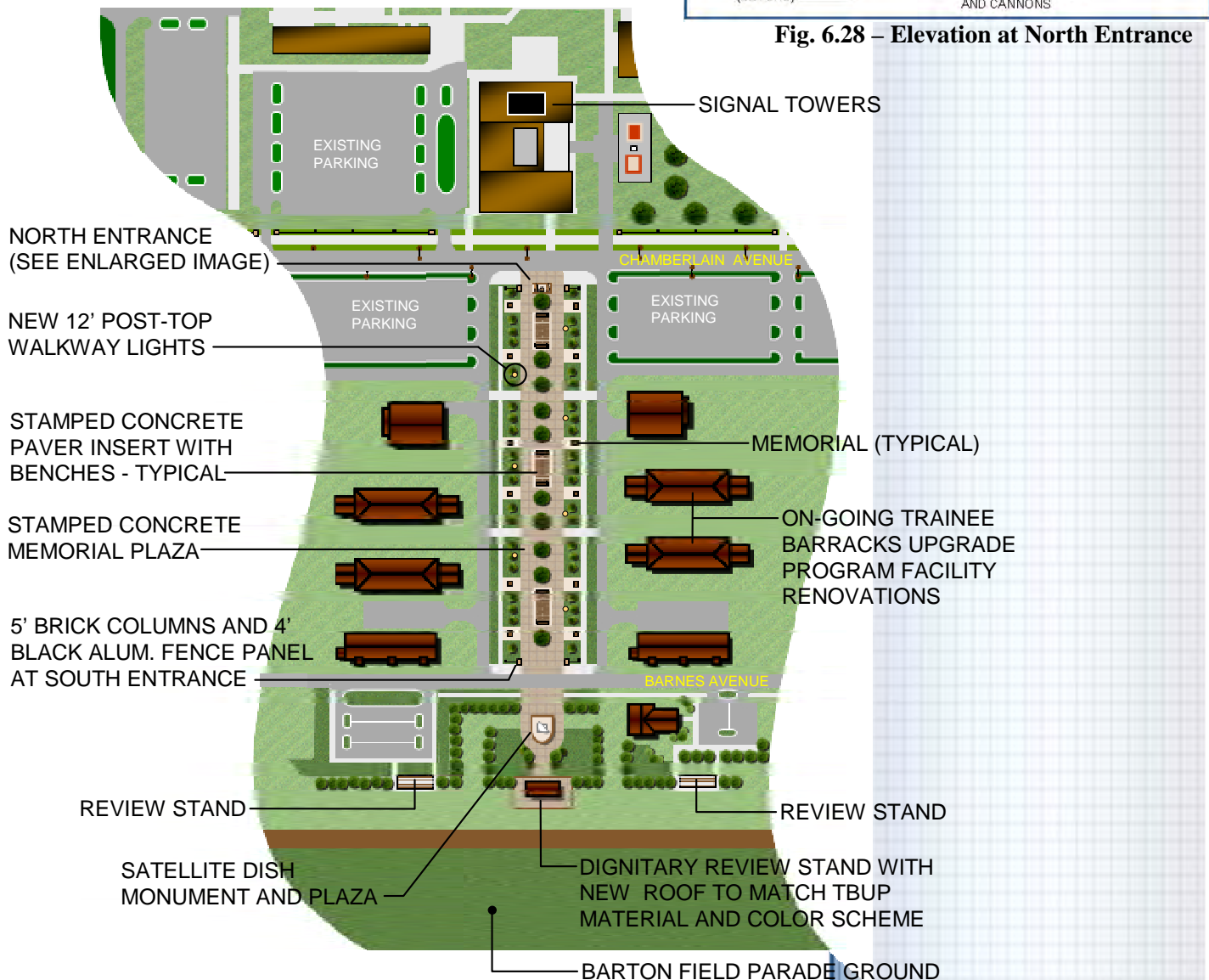
**6.12.4 Project Description (MYER MALL & REVIEWING STAND PLAZA – Figures 6.27 and 6.28):**

- Provide Additional Landscaping (Native Trees and Shrubs).
- Provide Stamped Concrete Plaza with Reflecting Pools.
- Provide Standard Breckenridge Post-top Walkway Lights.
- Provide 5’ High Brick Columns at Myer Mall Entrances.

- Renovate Existing Reviewing Stand.
  - Provide New Metal Roof System (“Terra Cotta” color to match on-going, adjacent TBUP renovation projects).
  - Paint all railings and trim to match TBUP renovation projects.
- Provide New Walkways and landscaping North of Reviewing Stand Area; Creating Plaza with Centrally Located Satellite Dish Monument.



**Fig. 6.27 – “Memorial Plaza” Proposed Site Plan**



**Fig. 6.28 – Elevation at North Entrance**



**6.13 PROJECT:** Continue Program to Replace all non-standard building identification signage with IDG approved standard sign. Non-standard signs will be replaced due to deterioration of existing sign or tenant relocation. (Mandated IDS compliant building address inclusion required on all new signs – Fig. 6.29).

**6.13.1 Existing Conditions:** Several Building Identification Signs within the cantonment area have deteriorated beyond repair and must be replaced with Standard Fort Gordon Building Identification Signs. Many other signs are non-standard, and must be replaced with conforming signage.

**6.14 PROJECT:** Provide New Pedestrian Walkways / Bicycle Paths linking residential housing, troop housing and Community Center. All new or repaired walkways / Bicycle Paths must conform to the Fort Gordon Installation Design Guide. (Fig. 6.30)

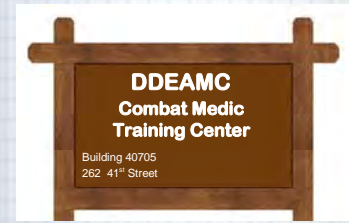
**6.14.1 Existing Conditions:** Fort Gordon has well defined functional spaces, but lacks adequate pedestrian connectors or walkways.

**6.15 PROJECT:** Initiate phased project to remove all abandoned concrete slabs and asphalt from Cantonment area.

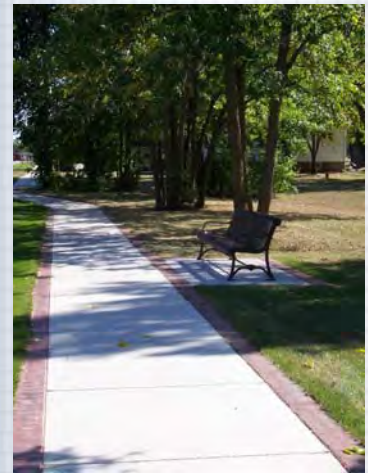
**6.15.1 Existing Conditions:** The Fort Gordon cantonment area is littered with abandoned concrete slabs. The situation was (primarily) created when parking lots and sidewalks were deserted when the facilities they served were demolished.

**6.16 PROJECT:** Initiate phased project to repair or remove all unsightly, neglected, and discarded fencing within Cantonment area. All new or repaired fencing must conform to the Fort Gordon Installation Design Guide.

**6.16.1 Existing Conditions:** Non-standard fencing and screening elements within the Fort Gordon Cantonment Area has created an Installation-wide negative visual image.



**Fig. 6.29 – Fort Gordon Standard Bldg. Identification Sign.**

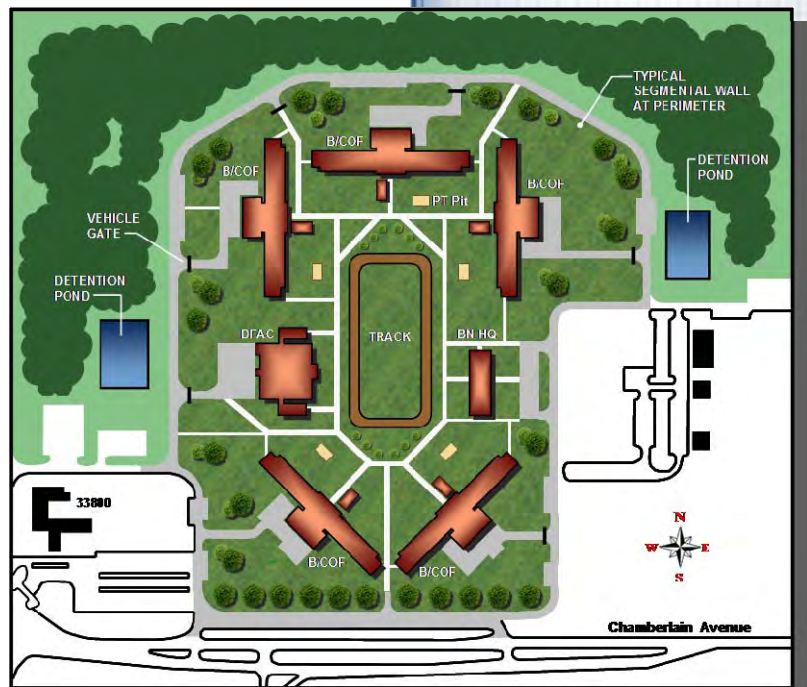


**Fig. 6.30 – Walkways connecting existing open spaces**



## 7.1 INTRODUCTION

**7.1.1** Site Planning is the process of arranging an external physical environment in complete detail to include the structures, circulation patterns, and other elements that form the built environment. The site planning and design process is used to develop a project that fulfills facility requirements and creates the optimal relationship with the natural site (Fig. 7.1). See [Unified Facilities Criteria \(UFC\) 3-210-06FA, Design: Site Planning and Design](#) for detailed guidance on site planning to include program analysis, site analysis, site verification, and concept development. This TM also discusses site design guidelines, describes the steps in the site planning process, and contains examples of various sketches/diagrams developed in support of these steps.



**Fig. 7.1 – Programmed New AIT Barracks Complex Site Plan**

Also see [TI 800-01, Design Criteria, Chp. 3, Site Planning and Design Criteria](#). Environmental documentation will be prepared prior to site selection to support the construction activity in accordance [AR 200-2, Environmental Effects of Army Actions](#).

**7.1.2** The site planning component provides the spatial arrangement of the installation. (Fig. 7.1) The installation master plan provides information that forms the foundation for site planning. The master plan is a mechanism for ensuring that individual projects are sited to meet overall installation requirements. [AR 210-20, Master Planning for Army Installations](#), and the [Master Planning Instructions \(MPI\)](#), provide additional information concerning the master plan.



**Fig. 7.2 – Fort Gordon Real Property master Plan Map**

**7.1.3** The other five design components are dependent upon site planning for their location and spatial relationships. The other five components are identified below and discussed in Sections 8-12.

- [Section 8 - Buildings Design Standards](#)
- [Section 9 - Circulation Design Standards](#)
- [Section 10 - Landscape Design Standards](#)
- [Section 11 - Site Elements Design Standards](#)
- [Section 12 - Force Protection Design Standards](#)

## 7.2 SITE PLANNING OBJECTIVES

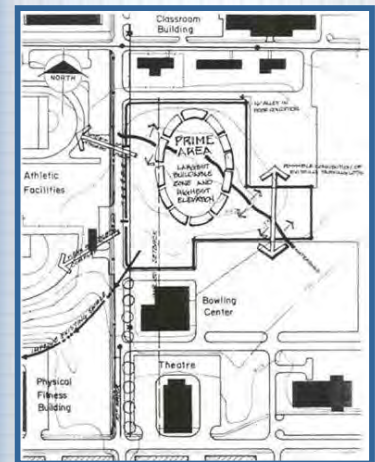
**7.2.1** The goal of site planning for the installation is to produce an attractive, sustainable development. Sustainability requires the built environment to be designed and constructed to preserve and enhance the natural environment. Manmade facilities are designed as a part of the environment to minimize negative environmental impacts. General site planning techniques resulting in sustainable development are cost efficient because they conserve energy and reduce construction and maintenance cost. Typical site planning objectives include the following.

- Preserve natural site features such as topography, hydrology, vegetation, and tree cover.
- Locate facilities with consideration of climatic conditions such as wind, solar orientation, and microclimate.
- Preserve the natural site by molding development to fill around existing land forms and features. This development approach minimizes extensive earthwork, preserves existing drainage patterns, and preserves existing vegetation.
- Plan for facilities to be clustered to preserve land and reduce construction cost. Clustering should occur on the flattest land areas. Room for expansion should be provided. When clustering facilities Force Protection measures must be considered.

## 7.3 SITE PLANNING CONSIDERATIONS

**7.3.1** The primary “fit” of the development to its environment is initially determined by the site analysis and subsequent site planning. The determination of primary issues that provide basic location and organization of spatial relationships are determined during the site planning (Fig. 7.3).

**7.3.2 Accessibility.** Any building or facility used only by able-bodied personnel need not be accessible to the disabled. Nevertheless, when feasible and appropriate, seek to incorporate accessibility measures into the design since the facility use may change over time (military exclusion is provided by [UFAS 4.1.4 \(2\)](#)). All other structures or facilities must meet the standards of the [Americans with Disabilities Act Accessibility Guidelines \(ADAAG\)](#) and the [Uniform Federal Accessibility Standards](#).



**Fig. 7.3 – Site Opportunity and Constraint Plan**

[\(UFAS\)](#), with the most stringent standards applied in the event of conflicting guidelines. (See [AR 420-70](#), Chapter 2, Para 2.8). This includes the avoidance of site barriers through the use of curb cuts, ramps, handrails, and grade-level entrances to avoid site barriers. Provide designated handicapped parking spaces in all major parking lots and drop-off zones for persons with mobility impairments. Modify existing structures for handicapped accessibility whenever possible, especially community facilities that are most likely to be used by families, veterans or visitors.

**7.3.3 Environmental.** Environmental issues to consider in the preparation of a site plan include any action or proposal that has a detrimental affect on a site area's land, water, or air quality (Fig. 7.4). The location of facilities on land that results in minimal disturbance to the existing topography, vegetation, and drainage patterns greatly reduces the negative impact on the environment. It is the Garrison Commanders responsibility to ensure that all National Environmental Policy Act (NEPA) documentation is started before the site selection process, as this process feeds the 1391 process.

**7.3.3.1** NEPA requires that an Environmental Impact Statement (EIS) be submitted to the U. S. Environmental Protection Agency (EPA) for major projects that may significantly effect the environment. The EPA reviews and responds to filed impact statements. Information pertaining to Environmental Impact Statements and their submission can be found at the following EPA websites.

- [Environmental Impact Statement \(EIS\)](#)
- [Submitting Environmental Impact Statements \(EISs\)](#)

**7.3.3.2** Federal law requires that prior to the undertaking of activities which effect the nation's waterways, described as "navigable waters of the United States" and "waters of the United States" to include wetlands, a permit must be acquired. Information regarding statutory, administrative, and judicial matters, including general regulatory policy, definitions of "waters of the United States" and "navigable waters", and processing of permits can be obtained at the following Corps of Engineers website.

- [Statutory, Administrative, and Judicial Materials](#)

**7.3.3.3** Include procedures for mitigating environmental concerns in the early stages of project development. To the



**Fig. 7.4 – Development Should Have Minimal Disturbance to Existing Topography**

maximum extent possible avoid siting development or individual buildings in environmentally sensitive areas. The installation master plan environmental overlay should be reviewed prior to the development for areas designated as threatened and endangered species habitat areas.

## 7.4 SITE PLANNING DESIGN CRITERIA

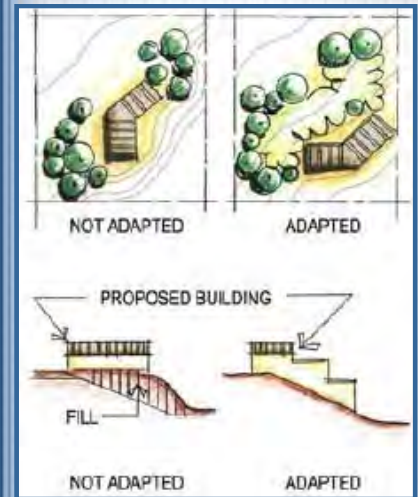
**7.4.1** The site planning component of installation design comes first in the design process and determines the general location of the other components. Consequently, site planning must consider the criteria for architectural design, circulation, landscape architecture, site elements, and force protection. Site planning criteria is divided into two categories, natural conditions and manmade conditions. Each is discussed separately in the following paragraphs. These criteria are to be utilized for the assessment of the visual and spatial impacts of site planning.

## 7.5 NATURAL CONDITIONS

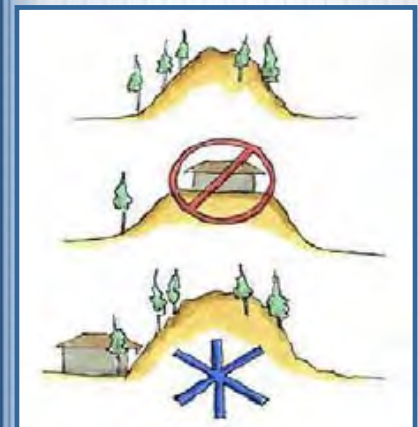
**7.5.1 Topography.** The natural terrain is a major determinant of the layout and form of the installation. Fort Gordon is located along the fall line between the Lower Piedmont and Upper Coastal Plains physiographic provinces. In this zone of transition, the topography ranges from the gentle undulating sand hills of the south and middle sections, to areas of steep slopes and near-bluffs adjacent to some of the streams, which are characteristically small and bordered by heavy hardwood swamp areas. The elevation of Fort Gordon ranges between 221 ft and 561 ft above mean sea level (msl), and the majority of the land area (35,852 acres) is between 378 ft and 489 ft above msl.

The following guidelines should be used to maintain the natural topography of the installation (Figs. 7.5 and 7.6).

- Maintain natural ground slopes and elevations.
- Align roadways and buildings along topographic lines.
- Locate facilities that have expansive ground coverage on relatively flat terrain.
- Use moderately sloping areas for buildings with less ground coverage area.
- Avoid development on steep slopes.



**Fig. 7.5 – Accommodate Natural Conditions**



**Fig. 7.6 Develop Around Natural Landforms**

- Avoid development in natural drainage ways and flood plains.
- Provide a reasonable balance of cut and fill.

**7.5.2 Hydrology.** Fort Gordon is located in the Coastal Plain hydrogeologic province of Georgia, whose principle groundwater source is the Southeastern Coastal Plain aquifer system. This aquifer is composed of interbedded sand and clay of Cretaceous age and locally includes sand and clay of early Tertiary age. Typical yields in this area range from 29,000 to 72,000 gallons per day. Studies of groundwater quality indicate the groundwater is quite acidic (Fort Gordon 2001). Additional detailed information is provided in the 2001 EA and is incorporated herein by reference (Fort Gordon 2001).

The site planning team will consider the following hydrologic concerns for natural drainage corridors, floodplains, and waterways during the site planning process.

- Preserve and maintain natural drainage areas and floodplains.
- Limit development in floodplains to open spaces and recreation uses.
- Preserve rivers, lakes, streams, or other waterways, and incorporate them into the design layout (Fig. 7.7).

**7.5.3 Climate.** Fort Gordon has a humid subtropical climate. The Installation experiences mild winters and a humid summer. The average high temperature for the summer months is 90.6 °F (32.6 °C); the average low temperature is 67.8 °F (19.9 °C). The average high temperature for the winter months is 58.9 °F (14.9 °C); the average low temperature is 34.4 °F (1.3 °C).

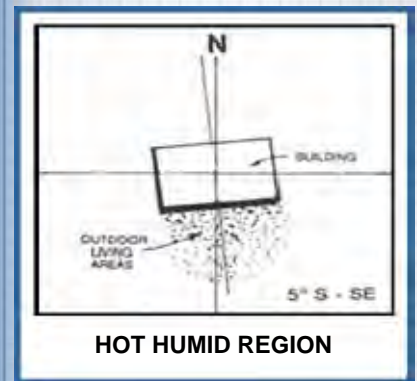
The installation will be designed in response to local climatic conditions to provide a more comfortable environment, and reduce the demands for heating and cooling (Fig. 7.8).

- Design and site development to minimize solar heat gain and promote air movement and cross ventilation.

**7.5.4 Views and Vistas.** The installation will be design to preserve and enhance scenic and other attractive views and vistas, and to screen unattractive views and vistas. Visual extensions



**Fig 7.7 – Tributary stream to Butler Creek, Fort Gordon**



**Fig. 7.8 - Building oriented for passive solar heating and cooling**



**Fig. 7.9 – Preserve Attractive Views and Vistas**

through open spaces provide a sense of orientation, relief, and enjoyment (Fig. 7.9).

**7.5.5 Vegetation.** The Sand Hills is a region of pine and mixed pine-hardwood habitat along with rich, productive drainage bottoms. Historically a longleaf pine community dissected by sluggish backwater stream, seeps, swamps, and pocosins inhabited the region and large expanses of Fort Gordon (Fort Gordon 2007) (Fig. 7.10). Land use changes and the subsequent regeneration of other pine species (e.g., slash and loblolly pine) within longleaf sites have reduced the coverage of the longleaf pine community throughout its natural range. Most of the existing tree and shrub communities common to Fort Gordon can be grouped into nine major forest types. These are Natural Pine, Pine Plantation, Pine-Scrub Oak, Pine-Hardwood, Scrub Oak, Bottomland Hardwood, Hardwood Pine, Streamside Forest, and Grassland communities.

The installation will be designed to protect and preserve existing native vegetation. This preservation reduces maintenance and enhances sustainability. A preferred plant matrix ([Appendix O, Plant Palette](#)) is included in this Army Installation Design Guide. (Also, see [Section 10 – Landscape Design Component](#)).

## 7.6 MANMADE SITE CONDITIONS

**7.6.1** The site plan provides the locations of the manmade development that will occur on site. It establishes the spatial relationships as well as the relationships between manmade and existing natural features. Manmade site conditions include all development on the installation to include buildings, roadways, parking lots, walkways, walls, fences, utilities, and other facilities. Buildings, roadways, parking lots and above ground utilities are the primary manmade visual determinants.

**7.6.2** The following site planning guidelines will be used in the visual and spatial review of the installation:

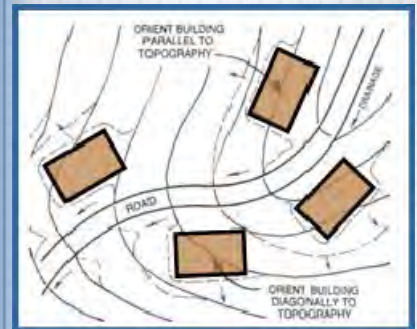
- Cluster buildings to reduce impact on the natural environment, and reduce roadways and utility corridors needed to serve the development, however, at the same time giving full consider to antiterrorism and force protection requirements.



**Fig. 7.10 – Sand Hill and Long Leaf Pines**



- Locate large buildings in relatively flat areas to reduce the cut and fill and preserve the natural vegetation and drainage and orient to topography (fig. 7.11).
- Minimize solar heat gain for cooling and maximize solar heat gain and retention for heating.
- Site buildings with consideration for the microclimate conditions of the site that result in variances in wind or light because of adjacent land forms, structures, or trees.
- Orient outdoors pedestrian areas for most comfortable exposure.
- Utilize lighter colored building surfaces exposed to the sun and darker colors on recessed surfaces to absorb radiation.
- Orient windows according to impact of climatic conditions.
- Locate development on leeward side of hills.
- Design and locate roads to provide a hierarchy of traffic carrying capacities.
- Locate roads to blend with topography and vegetation.
- Design and locate parking lots to minimize visual impact of broad expanses of pavement and vehicles. (Fig. 7.12)
- Design and locate pedestrian walkways and bicycle paths to fit the physical environment, and provide a comfortable pedestrian experience, limiting conflicts with vehicular traffic.
- Locate trees and shrubs to buffer harsh natural conditions.
- Deciduous material provides for sun in the winter and shade in the summer. Evergreen material provides windbreaks for cold north winds.
- Design and locate site elements to blend with and enhance the physical environmental.



**Fig. 7.11 - Orient Buildings and Roads to Topography**



**Fig. 7.12 Screen Parking Areas to Minimize Negative Visual Impact**

- Force Protection requirements should be designed and located to blend with the physical environment.



## 7.7 ARMY STANDARDS

7.7.1 The cited Army Standards shall be met.

- [Unified Facilities Criteria \(UFC\) 3-210-06FA, Design: Site Planning and Design](#)
- [Americans with Disabilities Act Accessibility Guidelines \(ADAAG\)](#)
- [Uniform Federal Accessibility Standards \(UFAS\)](#)

## 7.8 REFERENCES

7.8.1 The following references are provided for guidance.

- [Unified Facilities Criteria \(UFC\) 2-600-01, Installation Design, Chap 7](#)
- [Unified Facilities Criteria \(UFC\) 3-400-01, Design: Energy Conservation](#)
- [Unified Facilities Criteria \(UFC\) 3-210-01A Design: Area Planning, Site Planning, and Design,](#)
- [Unified Facilities Criteria \(UFC\) 3-230-15FA, Design: Subsurface Drainage Facilities for Airfields and Heliports](#)
- [Unified Facilities Criteria \(UFC\) 3-230-16FA, Design: Drainage and Erosion Control Structures for Airfields and Heliports](#)
- [Unified Facilities Criteria \(UFC\) 3-230-17FA , Design: Drainage for Areas Other than Airfields](#)
- [Unified Facilities Criteria \(UFC\) 3-230-18FA, Design: General Provisions and Geometric Design for Roads, Streets, Walks, and Open Storage Areas](#)
- [Unified Facilities Criteria \(UFC\) 3-260-02, Design: Pavement Design for Airfields](#)

- [Unified Facilities Criteria \(UFC\) 3-250-01FA, Design: Pavement Design for Roads, Streets, Walks and Open Storage Areas](#)
- [Army Regulation \(AR\) 200-2, Environmental Effects of Army Actions](#)
- [Technical Instructions \(TI\) 800-01, Design Criteria](#)
- [Technical Instructions \(TI\) 801-02, Family Housing](#)
- [Master Planning Instructions \(MPI\)](#)
- [Whole Building Design](#)

**Fort Gordon**  
**Fort Gordon**



Links

[Go to Section 8](#)

[Go to Table of Contents](#)



## 8.1 INTRODUCTION

**8.1.1** The design character of an installation's buildings affect the installations overall image (Fig. 8.1). The visual analysis of buildings and related structures helps define visual zones and themes and is an important part of an installation's assets and liabilities assessment.

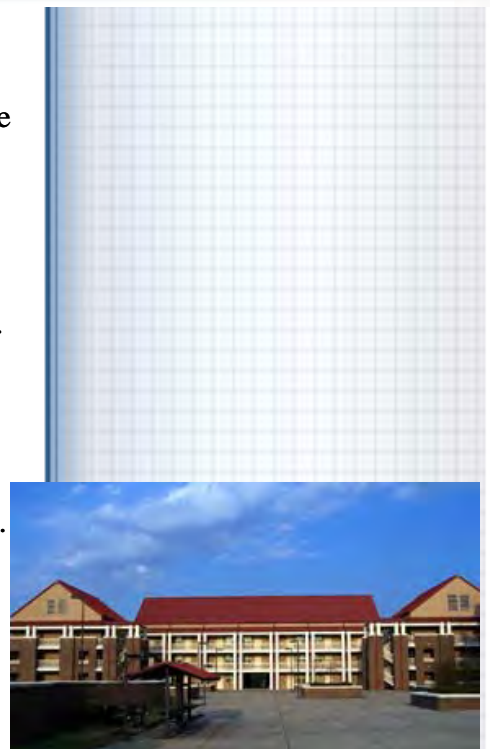
**8.1.2** The building design component encompasses the character of the buildings as well as the arrangement of buildings to one another and to their environment. In general, use architectural style, materials, and colors indigenous to the region. The preservation of historically and culturally significant structures adds to an installation's character and provides a sense of heritage.

**8.1.3** The visual analysis of structure also includes concern for accessibility, use of materials, placement of entrances, incorporation of additions and renovations, the incorporation of plazas and courtyards, interior design and the appropriateness and quality of building maintenance.

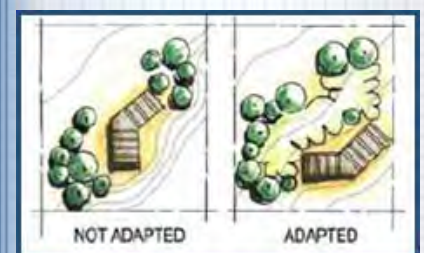
**8.1.4** This section provides the objectives and visual determinants that should be utilized to identify and assess the building design quality of the installation. The section also provides standards and guidance pertaining to the development and maintenance of the various interiors and exteriors of buildings on the installation.

## 8.2 BUILDING OBJECTIVES

**8.2.1** Sustainability. The architectural style of existing and future buildings should reflect and reinforce the sustainability of the installation. Sustainable design reduces construction and



**Fig. 8.1 – The design character of an installation's buildings affect the installations overall image**



**Fig. 8.2 – Adapt Building Design to Site Conditions**

maintenance cost and conserves energy through proper construction and materials selection. See [Appendix D](#) for a more complete discussion on Sustainable Design.

## **8.2.2 Building Design Objectives:**

**8.2.2.1** Adapt building designs to natural site conditions (Fig 8.2).

**8.2.2.2** Design buildings in clusters to preserve land and reduce construction and maintenance costs (Fig. 8.3).

**8.2.2.3** Develop a coherent architectural style that results in the blending of new and old structures. However, when considering historical buildings one should be able to differentiate between the historic fabric and the new material.

**8.2.2.4** Design buildings to include more floors in a vertical structure that results in a smaller footprint and more efficiently utilizes limited installation land areas.

**8.2.2.5** Combine multiple activities in one building to reduce the number of buildings required and more efficiently utilize limited installation land areas.

**8.2.2.6** Design multiple use facilities with the capability to quickly change interior layouts to accommodate changing requirements.

**8.2.2.7** Sustainability in the design and construction of buildings includes incorporating time-proven building designs that are indigenous to the region. Indigenous design elements should be utilized in the design of new buildings

Use indigenous construction materials and practices that require less energy to produce and transport and may be recycled at the end of their usefulness.

**8.2.2.8** Locate windows to maximize natural light, ventilation and outward views.

**8.2.2.9** Consider adaptive reuse of buildings once their initial use is no longer required.



**Fig. 8.3 - Design buildings in clusters to preserve land and reduce cost**

## 8.3 ARCHITECTURAL CHARACTER

**8.3.1** The character of installation architecture varies according to the use of the structure and when it was built. This use and age variation can result in character incompatibilities.

**8.3.2** The difference in character may also result when the designer ignores the character and scale of adjacent buildings or uses an imitative technique unsuccessfully.

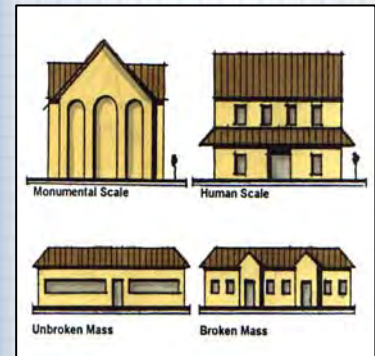
**8.3.3** The coordination of structural character on an installation provides a consistent and coherent “sense of order” and “sense of place”. This relationship of design comes from using compatible scales, massing, form, color, texture, materials, and fenestration. These design techniques can be utilized in the visual review and analysis of the installation. They are further explained below:

**8.3.3.1 Scale.** Scale refers to the size of a building facade in relation to humans. Buildings that include predominant vertical facades, which dwarf the individual, are defined as monumental in scale. Buildings with more horizontal facades designed to relate more to the size of the human figure are defined as human scale (Fig. 8.4). The scale of most buildings on installations should be more human than monumental. All new construction should be compatible in scale with adjacent buildings. Monumental architectural design is typically utilized for more ceremonial buildings, such as worship centers, headquarters complexes, and hotel facilities. These buildings make use of large, glazed areas at entrances and oversized fenestration elements to create a scale appropriate to the building’s use. Scale and relief should be provided through roof form, fenestration, building articulation and landscape plantings.

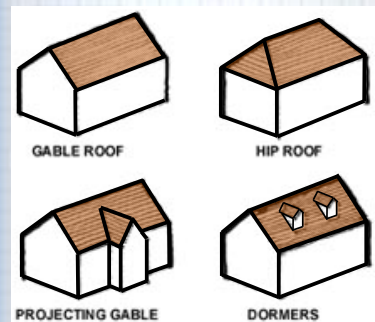
**8.3.3.2 Massing.** Massing refers to the overall bulk or volume of a building or buildings (Fig. 8.4). The size and proportion of the individual buildings in a grouping of buildings should be designed to be proportionally compatible with the adjacent structures.

**8.3.3.3 Form.** The form of a building is determined by its size, mass, shape and proportions. The use of similar building forms provides continuity to the installation architectural impact. The result is a more aesthetically pleasing environment.

The shape and proportion of a building’s elevation and roof are basic form-giving characteristics that are important in relating a new building to its setting (Fig. 8.5). In general, a rectilinear form



**Fig. 8.4 – Structure Scale and Massing**



**Fig. 8.5 – Roof Styles Within Each Visual Zone should be Complementary.**



**Fig. 8.6 - Color and Form Contribute to a Sense of Place**

sited with its long axis extending northeast to southwest is the most energy efficient form and orientation.

Predominant roof forms at Fort Gordon include gable and flat roofs.

**8.3.3.4 Color.** The use of a color scheme that is consistent throughout the installation, where possible, results in a continuity of buildings and contributes to a sense of place (Fig. 8.6). However, color schemes throughout the installation often vary according to the visual zone and visual theme in which the structure is located.

**8.3.3.5 Texture.** The use of materials of similar texture in buildings helps to provide visual continuity for the installation

**8.3.3.6 Materials.** The use of the same materials in the exterior finish and trim of buildings helps provide visual continuity.

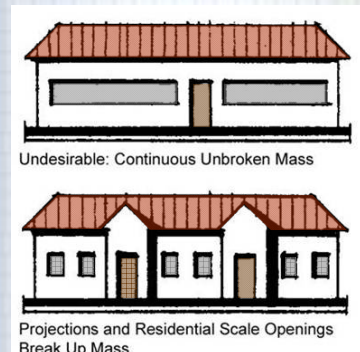
**8.3.3.7 Fenestration.** Building fenestration includes features such as doors, windows, and building decoration details. These features should be similar in arrangement, design, size, and proportion for architectural compatibility and visual consistency and continuity (Fig. 8.7).

**8.3.3.8 Climatic Conditions.** Sustainable buildings should be oriented to reduce solar heat gain as much as possible. This can be partially achieved by siting the building with its long axis extending northwest to southwest. Reduction of solar gain is most important on the south and west facing walls that the sun impacts from late morning until late afternoon (Fig. 8.8). Roof overhangs or porches on south and west exposures should be designed to shade windows in summer, but allow penetration by the lower winter sun.

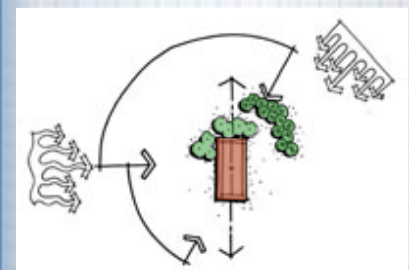
The amount of glass on the facades facing south and west should be limited. Concentrating glass areas on the east facade, which receives morning sunlight, and the north, which receives no direct but ample indirect sunlight, will control solar heat gain while admitting natural light. The use of natural light to illuminate building interiors enhances sustainability by reducing energy consumption (Fig. 8.9).

Windows shall consist of insulated glass systems to further reduce energy use by reducing mechanical heating and cooling loads.

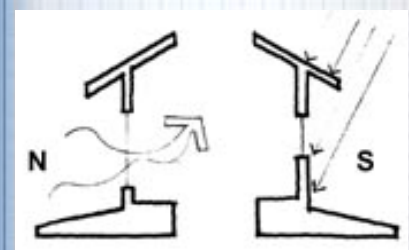
Barracks and other facilities where people live shall have windows that are operable. Retail facilities and other buildings that include



**Fig. 8.7 - Fenestration breaks up mass**



**Fig. 8.8 - Control of Solar Heat Gain is Optimized by Proper Building Orientation**



**Fig. 8.9 - North Facade Captures Indirect Light with Large Windows / South Facade Utilizes Roof Overhangs and Small Windows to Control Direct Heat and Light**

large window areas should face north of east. In addition reducing direct solar heat gain, this will minimize glare when exiting these buildings.

Deciduous trees help to shade the summer sun, but will admit light and heat when they have lost their leaves during the winter (Fig. 8.10).

## 8.4 BUILDING ENTRANCES

**8.4.1** A defined entrance is essential for any building regardless of function or importance. A defined entrance creates an obvious entry point that is an integral architectural element of the building. (Fig. 8.11).

**8.4.2** The entrance to a building should be in a prominent location and should be oriented toward the primary adjacent public spaces such as a courtyard, lawn, parking lot, or street.

**8.4.3** The details of an entrance should be designed to provide continuity with other entrances to the building and the entrances of adjacent buildings.

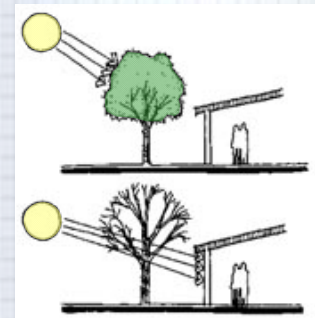
**8.4.4** Entrances may be grouped formally into three categories: flush, projected, and recessed.

Flush entrances maintain the continuity of a wall's surface and can be, if desired, deliberately obscured. Projected entrances announce their function and provide shelter. Recessed entrances also provide shelter and carry forward a portion of exterior space into the interior of the building.

## 8.5 SERVICE AREAS

**8.5.1** Service areas, such as loading docks and trash dumpsters, should be screened from the views of primary use areas such as entrances, courtyards, gathering areas, streets, and parking lots.

**8.5.2** Service areas should be screened as an enclosure by using walls and landscaping. Screen walls should be between six and eight feet high and should be in harmony with the adjacent building (Fig. 8.12).



**Fig. 8.10 - Deciduous Trees Provide Shade from Summer Sun While Allowing Heat Gain During Winter Months**



**Fig. 8.11 - Prominent Entrance at Reserve Center**



**Fig. 8.11 - Entrance at Darling Hall is Well Defined.**



**8.5.3** Trash and garbage collection areas must be located a minimum of 25 meters (82 feet) from troop billeting, family housing areas (containing more than 12 units), and stand-alone retail facilities. They will be placed a minimum of 10 meters (33 feet) from all other inhabited structures ([UFC 4-010-01](#), Table B-1).

## 8.6 BUILDING ACCESSIBILITY

**8.6.1** All structures or facilities, other than the exceptions mentioned below, must meet the [Americans with Disabilities Act Accessibility Guidelines \(ADAAG\)](#) and the [Uniform Federal Accessibility Standards \(UFAS\)](#) accessibility standards. The more stringent standards apply in the event of conflicting guidelines (Fig. 8.13).

**8.6.1.1** Any building or facility that is specifically restricted by occupancy classification to use only by able-bodied personnel during the expected useful life of the building or facility need not be accessible (military exclusion is provided by [UFAS 4.1.4 \[2\]](#)), but accessibility is recommended since the intended use of the facility may change with time.

**8.6.1.2** In particular, the following facilities need not be designed to be accessible: unaccompanied personnel housing, closed messes, vehicle, and aircraft maintenance facilities.

## 8.7 SEISMIC POLICY

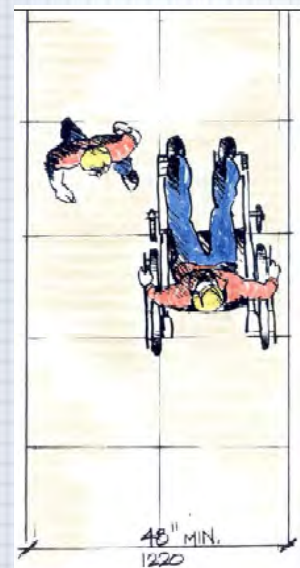
**8.7.1** The minimum performance objective for Army facilities is Substantial Life-Safety. To ensure compliance, seismic evaluations and mitigation of unacceptable seismic risks shall be performed. Higher levels of seismic protection for mission essential facilities will be considered in the evaluation.

**8.7.2** Seismic evaluation. Guidance for the seismic evaluation of existing facilities is given in [TI 809-05, \*Seismic Design Evaluation and Rehabilitation for Buildings\*](#). Buildings will have a seismic evaluation performed when:

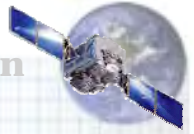
- A change in the building's use causes a change in the occupancy category, as defined in [TI 809-04, \*Seismic\*](#)



**Fig. 8.12 - Plants and Berms in Service Area Presents a Positive Visual Image**



**Fig. 8.13 - Facilities Must Meet UFAS Standards**



Design for Buildings, to a category of greater importance (lower category number).

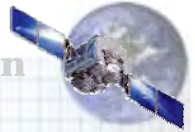
- A project is planned which causes the capacity of the structural system or components to be reduced to 90 percent or less of original stability and strength.
- A project will significantly extend the facility's useful life or will significantly increase the facility's value and the cost exceeds 50 percent of the current replacement value.
- A facility is damaged or is deemed to be an exceptionally high risk to occupants or to the public.

**8.7.3** Exceptions to Seismic Evaluations. Existing facilities are exempt from seismic evaluation if:

- The original design was done according to the provisions of the 1982 or later edition of [TM 5-809-10](#), or the 1988 or later edition of TM 5-809-1.
- Replacement is scheduled within 5 years.
- The facility is intended only for minimal human occupancy, and occupied by persons for a total of less than 2 hours a day.
- The facility is a one or two family dwelling, two stories or less, located in zone 1 or 2, as shown in [TM 5-809-10](#).
- The gross area is less than 3000 square feet (275 square meters). Mitigation of unacceptable seismic risks. If the seismic evaluation determines that the facility does not meet Substantial Life-Safety or higher performance standards, as appropriate, unacceptable seismic risks will be mitigated. Rehabilitation will be performed in accordance with [TI 809-05](#).

**8.7.4** New Facilities or Additions or Extension of Existing Facilities.

**8.7.4.1** New facilities and additions or extension of existing facilities will be designed to provide the level of seismic protection required by [TI 809-04](#).



## 8.8 SECURITY

The DoD Force Protection Construction Standards and Guidance Regulations must be complied with for all development at Fort Gordon.

Additional general design considerations include:

- Minimize the number of exterior openings at or below grade, and protect openings against unauthorized entry.
- Provide sufficient space in entry areas for security personnel, sign-in desks, credential readers, personnel identification equipment, and detection equipment.
- Protect all utilities and control panels from unauthorized access and interruption.

Design elevators, stairways, and automated locking mechanisms so that security is not compromised during emergency evacuations

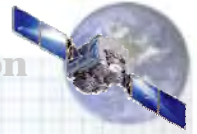
## 8.9 HISTORIC ARCHITECTURE

**8.9.1** The visual integrity of historic buildings or districts on the installation will be preserved and protected. The Army's management of historic properties is pursuant to the duties and responsibilities established by Congress under the National Historic Preservation Act (NHPA). The NHPA also created the National Register of Historic Places as the official listing of the nation's historic properties considered worthy of preservation. When working with historic properties the Army uses the following three categories:

**8.9.1.1 Historic Buildings or Structures.** These are significant buildings or structures, which are listed in or eligible for listing in the National Register of Historic Places.

**8.9.1.2 Historic District.** A distinct group of buildings, structures, or landscapes that possesses significance and are listed in or eligible for listing in the National Register.

**8.9.1.3 National Historic Landmarks.** Buildings, structures, or landscapes listed in the National Register, but also recognized as nationally significant. National Historic Landmarks can either be listed individually or as a district.



#### **8.9.1.4 Historic Preservation**

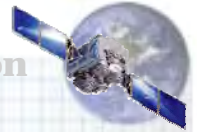
Preserving integrity of historic buildings encompasses aspects of design, maintenance, and repair. The replacement of deteriorated building elements, or the rehabilitation and adaptive reuse of an entire building can significantly affect the architectural character and appearance of both a building and its surrounding district. Therefore, these changes must be done in a manner that is sensitive to the architectural design of the building.

The National Park Service has developed the Secretary of the Interior's Standards for preservation, rehabilitation, restoration, and reconstruction projects. The Standards address issues as diverse as building materials, building elements, building interiors, building site, setting (district/neighborhood), and special considerations, such as additions, energy conservation, handicapped accessibility, and fire/life safety.

The Secretary of the Interior Standards serve as a guide to all staff members working with historic buildings and structures. These standards provide guidance for maintenance, repair, alteration and demolition of historic structures.

#### **The Secretary of the Interior's guidelines on historic preservation include the following:**

- A property will be used as it was historically, or be given a new use that maximizes the retention of distinctive materials, features, spaces, and spatial relationships. Where a treatment and use have not been identified, a property will be protected and, if necessary, stabilized until additional work may be undertaken.
- The historic character of a property will be retained and preserved. The replacement of intact or repairable historic materials or alteration of features, spaces, and spatial relationships that characterize a property will be avoided.
- Each property will be recognized as a physical record of its time, place, and use. Work needed to stabilize, consolidate, and conserve existing historic materials and features will be physically and visually compatible, identifiable upon close inspection, and properly documented for future research.
- Changes to a property that have acquired historic significance in their own right will be retained and preserved.



- Distinctive materials, features, finishes, and construction techniques or examples of craftsmanship that characterize a property will be preserved.
- The existing condition of historic features will be evaluated to determine the appropriate level of intervention needed. Where the severity of deterioration requires repair or limited replacement of a distinctive feature, the new material will match the old in composition, design, color, and texture.
- Chemical or physical treatments, if appropriate, will be undertaken using the gentlest means possible. Treatments that cause damage to historic materials will not be used.
- New additions, exterior alterations, or related new construction will not destroy historic materials, features, and spatial relationships that characterize the property. The new work shall be differentiated from the old and will be compatible with the historic materials, features, size, scale and proportion, and massing to protect the integrity of the property and its environment (Fig. 8.14).
- New additions and adjacent or related new construction will be undertaken in such a manner that, if removed in the future, the essential form and integrity of the historic property and its environment would be unimpaired.



**Fig. 8.14 – Renovation /Additions should be Compatible**

**8.9.2** For further guidance use [Army Regulation 200-4](#) and [Department of the Army Pamphlet 200-4](#). Specific requirements and recommendations for the treatment of historic properties are available in the National Park Service's [Secretary of the Interior's Standards for the Treatment of Historic Properties](#). A working awareness of historic preservation policies and procedures followed by the Army Corp of Engineers can be found in the [Technical Instruction \(TI\) 800-01, Design criteria, Chp. 16, Preservation of Historic Structures](#).

**8.9.3** See [Appendix M, Historic Preservation Guidelines](#).

## **8.10 RENOVATIONS AND ADDITIONS**

When existing buildings are renovated or additions are constructed, the architectural character of the renovation or addition should be compatible with the architectural character of the existing building and the adjacent buildings (Fig. 8.X). This

compatibility includes the use of materials, color, shape, size, scale, and massing in the addition or renovation that blends with the architectural character of the existing structure. However, when renovating or adding to historical buildings one should be able to differentiate between the historic fabric and the new material.

## 8.11 PLAZAS AND COURTYARDS

Plazas and courtyards can be located as part of the primary entrance to a building, or as an extension of non-primary entrance areas to the outside (Fig. 8.15). Wide, paved entrance plazas need vehicular barriers.

## 8.12 BUILDING MAINTENANCE

Buildings designed and constructed to incorporate sustainable design criteria should minimize life cycle, energy and maintenance costs through proper selection of forms, materials, and construction details.

## 8.13 INTERIOR DESIGN

**8.13.1** Introduction. Inhabited spaces, that require the selection of furnishings or equipment, should be designed by professional interior designers. Interior design impacts the functioning and productivity of people. People spend the majority of their time inside, working, eating, sleeping, and relaxing. The productivity, comfort, and safety of the personnel living, working, or relaxing in the facilities they inhabit is directly related to the quality of interior design provided within the facility.

**8.13.2** Interior design is required on building construction and renovation projects regardless of the funding source. General interior design guidance and interior design guidance for medical facilities and family housing is provided at the following websites.

- General Guidance. [Design Guide \(DG\) 1110-3-122, Design Guide for Interiors.](#)
- Medical Facilities. Interior design guidance for medical facilities is furnished in [Unified Facilities Criteria \(UFC\) 4-510-01, Design: Medical Military Facilities.](#)
- Family Housing. Interior design for family housing will be in accordance with [Technical Instruction \(TI\) 801-02, Family Housing.](#)

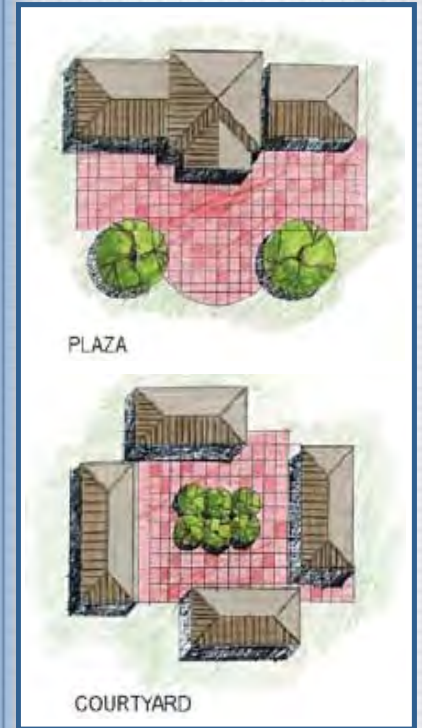


Fig. 8.15 – Plazas and Courtyards

**8.13.3** [Engineering Regulation \(ER\) 1110-345-122, \*Engineering and Design, Interior Design\*](#), defines projects that require interior design, design requirements and responsibilities of participants, and methods and funding for execution of interior design. For cost estimating see [Air Force Interior Design Guides, Chap. 3, Cost Estimating Guide](#).

### 8.13.4 Space Planning.

**8.13.4.1** Space planning is the basic building block of the facilities program for administration and operational facilities. [Army Regulation \(AR\) 405-70, \*Utilization of Real Property\*](#) (Appendix D) provides numerical planning allowances and addresses the quantities for programming space for personnel and equipment.

**8.13.4.2** Space planning takes into consideration the following; who will be using a space, how this space will be used, what activities will take place there, and the interaction of other people in the building. Professionally trained interior designers are best at gathering the required information to formulate a space utilization plan.

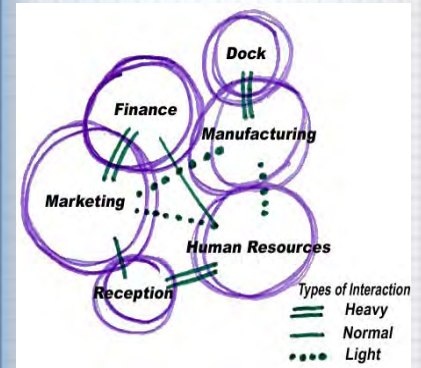
**8.13.4.2.1 Bubble Diagrams.** Bubble diagrams show the working relationship of one group to another (Fig 8.16). They do not represent a space plan or floor plan, but the relationship of organizations to one another. The adjacency requirements for individuals, user groups, and support functions to accomplish the product of service provided is analyzed. Bubble diagrams assist in organizing an existing facility as well as a new facility.

**8.13.4.2.2 Blocking Diagram.** An extension of the bubble diagram is the block diagram. The blocking diagram is made more regular and is for fit inside the proposed floor plan (Fig. 8.17).

**8.13.4.2.3** The next step in the process is the development of the actual space plan. The layout of the space plan is detailed to the workstation level.

### 8.13.5 Electrical and Communications.

**8.13.5.1** Electrical. Electrical power supply in the United States is available in a number of configurations, the most common of which are 120/240 volt single-phase three wire, 120/208 volt 3-phase 4-wire, and 277/480 volt 3-phase 4 wire.



**8.16 - A typical Bubble Diagram Indicating Group Relationships**



**8.17 - A Typical Blocking Diagram Demonstrating The Fit Into The Floor Plan**

**8.13.5.1.1** Design standards for interior electrical systems are found in [Unified Facilities Criteria \(UFC\) 3-520-01, Interior Electrical Systems](#). Compliance with this UFC is mandatory for the design of interior electrical systems. This UFC:

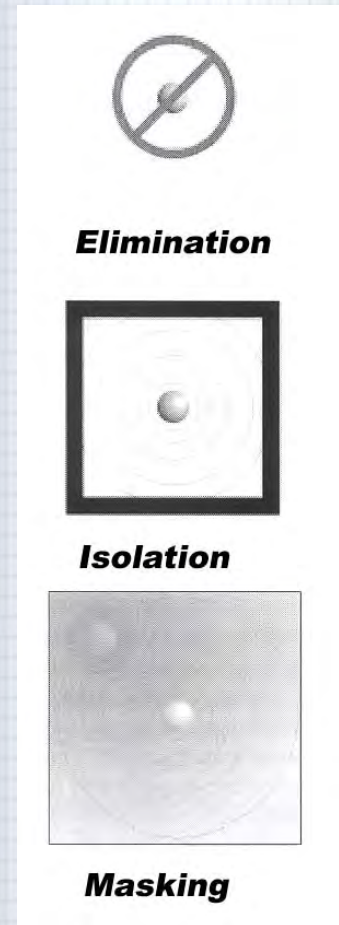
- Establishes criteria for the design of interior electrical systems.
- Establishes system-level design criteria.
- Establishes facility-level criteria for interior electrical systems,
- Provides a starting point for determining the applicable design criteria for a facility.

**8.13.5.1.2** Facilities outside the United States must comply with the applicable host nation standards; refer to [Technical Manual 5-688, Foreign Voltages and Frequencies Guide](#), for additional information.

**8.13.5.2 Communications.** Communications systems handle the transport of telephone and data networks (e.g. video, multi-media, teleconferencing, data transfer, facsimile transmission, and voice conversation).

**8.13.5.2.1** The design criteria for interior wiring of communications and information system is found in the Installation Information Infrastructure Architecture (I3A) Design and Implementation Guide. This guide shall be used as the basis for designing both the premises distribution system (inside plant) and the outside plant cable distribution system for all new construction and renovation projects. The Installation Information Infrastructure Architecture (I3A) Design and Implementation Guide is Appendix A of [U.S. Army Corps of Engineers engineering technical letter \(ETL\) 1110-3-502, Telephone and Network Distribution System Design and Implementation Guide](#).

**8.13.5.3 Distribution.** Distribution of electrical and electronic systems through a building is generally accomplished through branched distribution. A central chase or trunk will run the length or height of the facility, then horizontal distribution systems run from a central connection closet to the end user. This distribution may be overhead or underfoot, in many instances it is a combination of the two (Fig. 8.X).



**Fig. 8.18 - Control Noise Sources**



### 8.13.6 Color.

**8.13.6.1** Color plays an important role in the design of interior environments. Color has a large impact on how we feel and behave in a space. Its quality affects emotions directly and immediately. Successful interior designs harmonize form, space, light, and color.

**8.13.6.2** Information on color and light, optical effects, basic color theory, color schemes, and applying color in facilities can be found in Corps of Engineers, [Design Guide \(DG\) 1110-3-122](#), [Design Guide for Interiors](#), Chap. 3, Light and Color and in the Air Force Interior Design Guides, Chap. 9, Color Principles, [Part 1](#) and [Part 2](#).

### 8.13.7 Acoustics.

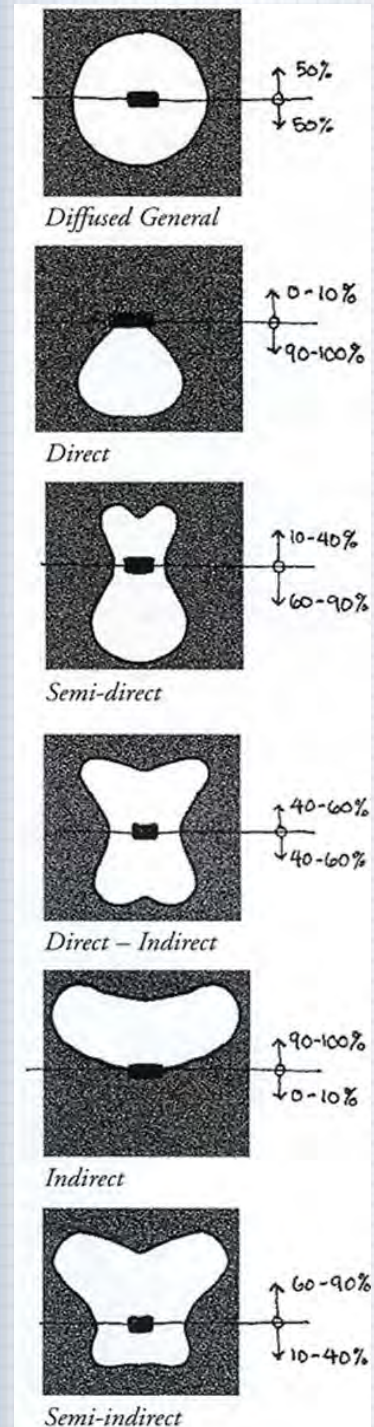
**8.13.7.1** Acoustics as an environmental variable significantly impacts the human impression of an interior environment. Productivity, speech intelligibility, privacy, safety, positive user attitude and response, and environmental comfort all depend on proper acoustic design. The interior designer is concerned with reducing unwanted noise and preserving desirable sound in a space. Sound can be controlled in the following three ways: eliminate the source, isolate the source, i.e. provide a barrier between the user and the source or mask the offending sound (Fig. 8.18).

**8.13.7.2** A discussion of the dynamics and control of acoustics can be found in the [Design Guide \(DG\) 1110-3-122](#), [Design Guide for Interiors](#), Chap. 5.

### 8.13.8 Interior Lighting.

**8.13.8.1** Lighting will be designed with the work activities being performed in mind. Always supplement overhead lighting with task lighting and use architectural lighting in entrances, corridors, waiting rooms, and other spaces to light artwork and provide interest.

**8.13.8.2** For Army installation buildings to achieve a high quality lighting environment, lighting equipment/systems selected must satisfy both performance and aesthetics (Fig 8.19). Factors for consideration in this selection are based on the following: lumens per watt, color temperature, color rendering index, life and lumen maintenance, availability, switching, dimming capability, and cost.



**Fig. 8.19 - Typical Distribution of Light**

**8.13.8.3** Lighting design approaches and lighting applications can be found in the following publications:

- [Technical Instructions \(TI\) 811-16, \*Lighting Design; Design Guide for Interiors, DG 1110-3-122\* Chp. 5](#)
- [Air Force Interior Design Guides, Chp. 10](#)
- [Unified Facilities Criteria \(UFC\) 3-520-01, \*Interior Electrical Systems\*, Appendix F.](#)

**8.13.8.4** Lighting Maintenance, Types, and Problem Solving. Information on lighting maintenance, types, and lamp troubleshooting is found in [TM 5-683, \*Electrical Interior Facilities, Chp. 9\*](#).

**8.13.9 Finishes.** Interior finish standardization is important for administrative and financial reasons. Standardization presents a unifying element throughout all buildings that is more cost effective, efficient, and easy to maintain.

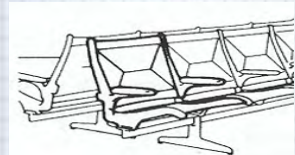
**8.13.10 Installation Finishes Standards.** Installation finishes standards are found in [Appendix I, \*Interior Finishes Standards\*](#) of this guide.

**8.13.11 Furnishings.** Furnishings are elements added to a building for utility or ornamentation following construction. These include furniture such as chairs, desks, sofas, and tables and also cabinetry, window treatments, signage, accessories, art, and plants (Fig. 8.21). When selecting furnishings for an interior environment, care should be taken to include their design as an integral part of the overall concept and to ensure coherency between architecture, materials, furniture, art, and signage. The following paragraphs discuss the various furnishings components and give guidance on the programming, acquisition, functionality, and maintenance of the various components.

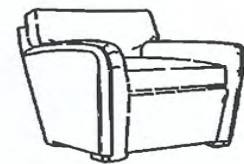
**8.13.11.1 Furniture.** Furniture systems are a wide range of furniture types comprised of components to create a custom designed work environment to meet specific functional needs. Furniture includes seating and case goods. Case goods are furniture elements constructed from box-like components. These include desks credenzas, file cabinets, etc. (Fig. 8.20) Case goods fall under two major categories: conventional and modular. Conventional case goods are delivered as pre-assembled, ready-to-use products. Modular case goods are manufactured as separate



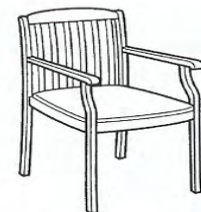
**Fig. 8.20 - Conventional Case goods**



Multiple seating



Lounge seating



Side chair



Desk/conference chair

**Fig. 8.21 - Contract Seating, Various Chair Classes**

pieces that may be grouped into a number of different arrangements.

**8.13.11.1.1 Systems Furniture.** Systems furniture is ergonomically designed to meet a variety of conditions and requirements (Fig. 8.22). Careful planning is critical during the initial stages of designing new systems furniture layouts. Power and communications requirements must be determined and planned so they are available at the locations where they are needed. Provisions for furniture systems electrical and data requirements must be made a part of the construction documents. See [paragraphs 8.13.5.1.1 and 8.13.5.2.1](#) for interior design standards for electrical and communications wiring respectively. Surface mounted conduit and power poles are unsightly and should be avoided.

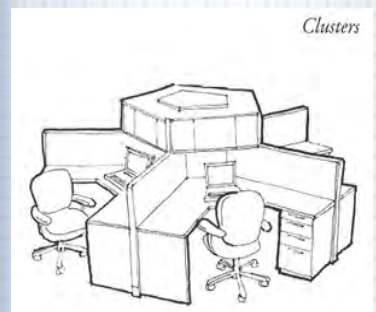
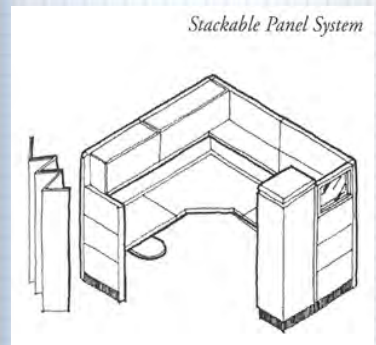
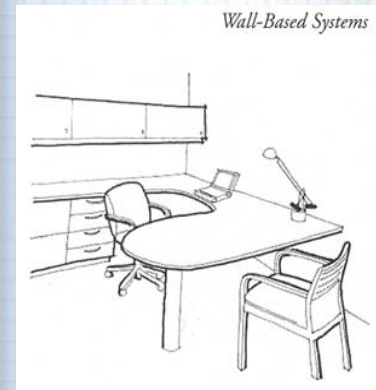
**8.13.11.1.2** For a detailed discussion on the Army Interior Design Process (planning and programming, procurement, and design services) and Planning for Administrative Work Environments (data collection, analysis, space planning, layout, design coordination, documentation, and implementation) see Appendix A and Appendix B of [Design Guide for Interiors, DG 110-3-122](#) respectively.

**8.13.11.1.3 Budgeting for Furniture Systems.** Furniture systems represent a significant percentage of a project. Furniture systems are O&M funded and should be included in the project scope along with such items as built-in casework. Furniture systems are listed on the DD Form 1391 as a non-add entry in Block 9 for "Equipment Provided for Other Appropriations". In Block 12b, the furniture systems should be as an O&M funded item, the fiscal year the funds are requested, and the line item cost. Accessories can amount for a significant portion of the furniture systems package and should be budgeted with the basic system components.

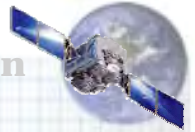
#### **8.13.11.1.4 Systems Furniture Design Guidelines.**

##### **8.13.11.1.4.1 General.**

- During the initial planning of new systems furniture, consider the condition and appearance of existing paint, wall coverings, carpet, and base of the area.
- When planning the location of office equipment and break areas, do not place heat generating devices, such as coffee makers or copiers, near a thermostat.



**Fig. 8.22 - Systems Furniture**



- Circulation paths should be clear and easy to navigate.
- Topics that should be considered when designing new systems furniture layouts include:
  - Function of the office
  - Adjacencies of personnel and activities
  - Meeting and conference room requirements
  - Individual storage needs
  - Areas for common use office equipment such as the copier and fax
  - Reception area with waiting and guest seating space
  - Special furniture or needs of a particular office, such as drafting tables or extra storage space
  - Communications equipment
  - Task lighting, daylight, and ambient lighting
  - Special security requirements
  - Budget constraints
  - Flexibility to allow future changes
  - Schedules of design, delivery, and installation
  - Air conditioning
  - Acoustic performance requirements

#### **8.13.11.1.4.2 Panels.**

- Full height panels should be used only in areas with a specific need for increased privacy or separation, such as conference rooms, break areas, and certain private offices.
- Provide glass panels in corners and at windows to open up the space and allow natural light to filter into the center of the space.

- Provide access panels in the systems furniture to allow for communications connection.
- Panels should generally not exceed 66 inches in height in an open office area. Taller panels cut off air circulation, block views and natural light, and create a closed-in feeling.
- The location and use of taller panels must be carefully planned and coordinated because they can interfere with the proper functioning of air conditioning diffusers, fire sprinklers and smoke detectors, lighting fixtures, switches, thermostats, and sensors.
- Panels should not block service access to mechanical, electrical, or telephone equipment.
- Do not install panels in front of windows, as they will block natural light for the entire area. Panels installed perpendicular to windows should be installed at a window mullion.

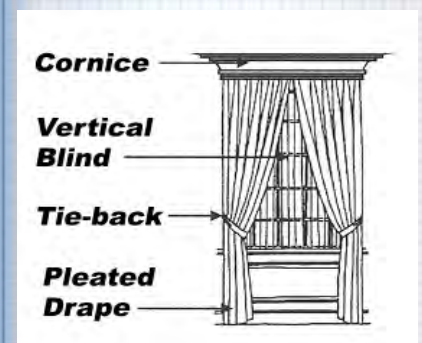
#### **8.13.11.1.4.3 Color and Texture.**

- To maintain a professional atmosphere, the style and types of systems furniture should be consistent throughout the area.
- The materials and colors of the panels and chairs should be durable. They should be heavy-duty and stain resistant.
- The fabric on the systems furniture panels should harmonize with the overall building color scheme.

#### **8.13.11.2 Window Treatments.**

**8.13.11.2.1** Window treatments serve many purposes in an interior environment. They provide privacy, light and sun control, reduced energy consumption, and decreased sound transmission. The type of treatment, as well as the type of material used, will determine the effective of the treatment in and give instance. The following should be taken into consideration when selecting fabric type:

- Sheer or semi-sheer fabrics will provide minimum privacy, shade, and energy conservation.



**Fig. 8.23 - Window Treatments Should Complement the Interior Space**

- Heavy, opaque fabric and hard treatments should be used only where total light exclusion is required.
- Full, soft treatments will absorb more sound than hard treatments.

**8.13.11.2.2** Window treatments should complement and support the interior design of a space (Fig. 8.23). Window treatments also conceal architectural defects, or change the apparent size, shape, and character of a room. Consider the following factors when making a window treatment selection:

- Light control requirements
- Architectural style
- Historical context

**8.13.11.3 Signage.**

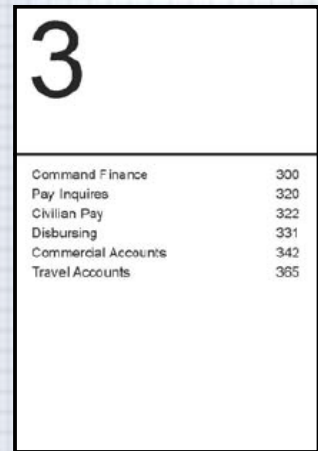
**8.13.11.3.1** Signage may be informational, directional, or regulatory. Informational signage provides the user with information and includes room or area labels, bulletin boards, menus, artwork descriptions, and emergency information. Directional signage directs circulation and provides orientation. It includes entry directories, directional arrows, and maps. The purpose of regulatory signage is control: providing prohibitions, warnings, emergency instructions, and use restrictions (Fig. 8.24).

**8.13.11.3.2** Interior signage is covered in detail in [Technical Manual \(TM\) 5-807-10, Signage](#). The manual includes graphics for the following: directional, identification signs, information, and pictograms.

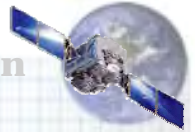
**8.13.11.4 Accessories.**

**8.13.11.4.1** Accessories may be either functional or decorative. Whatever the purpose, accessories serve to make a room appear inviting and personal (Fig. 8.25).

**8.13.11.4.2 Functional Accessories.** These accessories include letter trays, coat racks, lamps, product displays, magazine racks, brochure racks, and message boards. This group of accessories should be selected for utilitarian aspects as well as aesthetic qualities that may contribute to the total design concept. Repetitive elements can act as unifiers and help tie the accessories to the design theme.



**Fig. 8.24 - Directional Sign Directs Circulation**



**8.13.11.4.3 Decorative Accessories.** Decorative accessories are objects such as artwork and plants.

**8.13.11.5 Art.** The preparation of artwork to be displayed and positioned in an interior space involves many important decisions. The designer must work closely with the user to determine placements that are satisfactory for both functional and visual composition. Some of the factors to be taken into consideration in the selection of are:

- Quality (posters, prints, original art),
- Subject matter,
- Medium (photography, paper, oil, etc.),
- Size,
- Placement,
- Method of display (permanent collection or rotating program),
- Lighting, and
- Integration with design scheme.

#### **8.13.11.6 Plants.**

**8.13.11.6.1** Plants add color, texture, and variety of form and shape to the interior. They bring a natural element to an interior space. They are used for focal points, screen, and for psychological effect. Increasingly, plants are being incorporated into the interior environment for the health and well-being of the user, as well as enrichment of the space.

**8.13.11.6.2** When selecting plants, their light, water, and temperature needs, continuing care requirements, and ease of replacement must all be considered. Also, the types and amount of light the space has (direct or indirect) daylight, fluorescent, or incandescent must be considered. Plants should not be positioned such that their location presents a problem when watering.

**8.13.11.6.3** Detailed information on interior planting to include design considerations (light requirements, temperature, atmosphere considerations, and planters), plant maintenance, and a listing of



**Fig. 8.25 - Decorative Accessories Can Add a Sense of Uniqueness**

recommended plants can be found at the following web locations (Air Force Interior Design Guides, Chapter 8):

- [Design Considerations](#)
- [Maintenance](#)
- [Recommended Plant List](#)

**8.13.12 Unified Facilities Guide Specifications.** See the "Division 12 - Furnishings" section on the [Construction Criteria Base](#) website for Unified Facilities Guide Specifications for furnishings.

**8.13.13 Installation Furnishings Standards.** Installation furnishings standards are found in [Appendix J, Interior Furnishings Standards](#) of this guide.

**8.13.14 Interior Operations Policies.** To preserve the quality of facilities, operations policy is set between the user and the installation management. The user is responsible for preserving the visual appearance of the facility, and installation management is responsible for providing maintenance needed to preserve facility quality. Interior operations policies address the following issues (See [Appendix N, Housekeeping Rules \(Example\)](#)):

- Housekeeping responsibilities.
- Policy to prevent and eliminate visual clutter.
- Carpet cleaning, repair, and replacement policy.
- Height restrictions for partitions and furniture.
- Policy on buildings modifications including: partitions, painting, window treatment, HVAC, lighting, and the installation of communications and electric wiring.
- Maintenance of directories and signage.
- Smoking and eating locations.
- Procurement information on matching or compatible furniture.
- Policy on personalization and plants.





**8.13.15 Interior Appearance Policy.** The following are Army standards to follow.

- Keep work areas cleared of clutter. Cleanup, throw away.
- Avoid hanging things in the work area. Find another way to refer to organization charts, personnel listings, and calendars, other than having them hung on walls or partitions except framed artwork, diplomas, awards, etc.
- Notes and references hung on partition walls should be kept below the height of the partitions. Some things may be mounted on the partitions by hooking into the metal supports between the partitions, but not by hooking into the fabric.
- Anything not contributing to the overall décor of the work area should be put in a drawer or on a shelf behind a closed door.
- Do not overwhelm the work area décor with an excess of plants or personal artifacts.
- Thin out your files.
- Keep walkways into work areas open and free of clutter. Do not store things on the floor, or on top of shelves, or partitions.
- Office chiefs should consider the overall office appearance and visual contrasts between work areas.
- Be sure that anything you do in your work area contributes to color coordination, rather than detracts from it.
- Keep vacant workstations and common areas clean. Do not use them as a dumping area for things you do not know what to do with.



## 8.14 EXTERIOR BUILDING MATERIALS AND COLOR

### 8.14.1 Exterior Building Materials.

**8.14.1.1** Building materials make a major contribution to the scale, color, texture, and character of a military installation. A limited palette of durable, low maintenance materials should be used that, while encouraging a variety of expression, provides a cohesive and consistent architectural character through the installation and within each visual zone. Material should reflect the function of a building, and its hierarchy within the installation.

- Use the following guidelines when selecting exterior building materials.
- Choose materials for their longevity and maintenance characteristics.
- Use materials with integral colors - avoid painting exterior colors.
- Use installation standard colors for exterior walls. Add accent colors sparingly. Accent colors can be used in recesses and to accent certain portions of a buildings façade.
- Use pre-finished material where possible - gutters, window frames, doorframes, etc.
- Use blended colors on pitched roofs.

**8.14.2** The list of building materials applicable to the Fort Gordon Visual Zones is found in [Appendix K, Exterior Materials Charts](#). The Visual Zone areas are described and illustrated in the following paragraphs and [Section 5](#) further discusses them.

**8.14.2.1 Signal Center HQ, Admin. and Academic Building Visual Zone.** This Visual Zone is the administrative center of Fort Gordon which includes Signal Towers. “Traditional Core” is reflective of Beaux- Arts design principles such as symmetry, axis, and preserved green spaces. Visually, it is a compact district composed of the Signal School HQ, administrative and instructional facilities (Fig. 8.26). This area offers an excellent opportunity to establish a high visibility central core for the Post.



**Fig 8.26 – Signal Towers and Instructional Facilities comprise the Fort Gordon “Traditional Core” Zone.**

**8.14.2.2 North Industrial / Maintenance Visual Zone.** This Zone consists of warehouse storage, vehicle maintenance facilities, Administration and supplemental utility buildings and structures. The balance of land is undeveloped forest. Some permanent vegetative buffer areas exist on the undeveloped land. Architecturally, the Zone consists of large-scale, industrial-style buildings made of metal, brick and concrete block with clerestory glass inserts (Figs. 8.27 thru 8.29). Pre-engineered metal construction buildings at the motor pool make up the balance of this Zone.



**Fig 8.28 – Maintenance Facility – North Industrial Visual Zone**



**Fig 8.29 – Maintenance Facility and Admin. – North Industrial Visual Zone**

**8.14.2.3 South Industrial / Maintenance Visual Zone.** This Zone consists of warehouse storage, vehicle maintenance facilities, Administration and supplemental utility buildings and structures (Fig. 8.30). The balance of land is undeveloped forest. Some permanent vegetative buffer areas exist on the undeveloped land. Architecturally, the Zone consists of large-scale, industrial-style buildings made of metal, brick and concrete block with clerestory glass inserts. Pre-engineered metal construction buildings at the motor pool make up the balance of this Zone.

**8.14.2.4 Medical Center Visual Zone.** The Dwight D. Eisenhower Medical Center (DDEAMC) dominates this Visual Zone (Fig. 8.31). The Southeast Region Medical Command, the Southeast Region Dental Command, the Southeast Region Veterinary Command, Eisenhower Army Medical Center (a teaching hospital), Considered a mission partner on Fort Gordon is the [Dwight D. Eisenhower Army Medical Center](#) (DDEAMC), home of the Southeast Regional Medical Command (SERMC) as well as a dental laboratory. The facility treats active duty military and their families, as well as many of the military retiree community in the [Central Savannah River Area](#). Under SERMC, the hospital is responsible for military hospital care from Kentucky to Puerto Rico.



**Fig 8.27 – Unified Building exterior colors dominate visual zone – Public Works Admin. Building and Maintenance Facilities – North Industrial Visual Zone**



**Fig 8.30 – Maintenance Facility – South Industrial Zone**



**Fig 8.30 – Maintenance Facility – South Industrial Zone**



**Fig 8.31 – Dwight D. Eisenhower Medical Center (DDEAMC)**

**8.14.2.5 Signal Center Barracks and Admin. Visual Zone.**

This Visual Zone includes troop housing, community and commercial services, troop administration, open/green space, recreation, warehouse, mess halls and vehicle maintenance areas. (Figures 8.32 thru 8.34)



**Fig 8.33 – Trainee Barracks Upgrade Program (Currently Under Construction)**



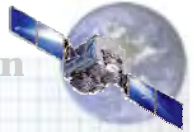
**Fig 8.34 – Recently Constructed Facilities within the Zone Offer a Warm Color palette.**

**8.14.2.6 Community Center Visual Zone.** The primary community/commercial area for Fort Gordon; This Zone also serves as a transition zone between the Administration / Troop Housing areas and the Residential Housing areas. The architectural design image of this district is dominated by the modern Post Exchange Building, and Freedom Park Elementary School (Figures 8.35 and 8.36).



**Fig 8.36 – Fort Gordon Post Exchange**

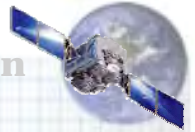
**Fort Gordon**  
Fort Gordon



**Fig 8.32 – The Darling Hall Material and Color scheme is the model palette for this Visual Zone.**



**Fig 8.35 – Freedom Park Elementary School**



**8.14.2.7 USAR / GA National Guard Visual Zone.** This Zone consists of Administration Buildings, warehouse storage, vehicle maintenance facilities, and supplemental utility buildings and structures. The balance of land is undeveloped forest. Some permanent vegetative buffer areas exist on the undeveloped land. Architecturally, the Zone contains Administrative and industrial-style buildings made of metal, brick and concrete block. Pre-engineered metal construction buildings at the motor pools make up the balance of this Zone. Visually, it is a compact district dominated by the Reserve Center and Regional Training Site Medical (RTS MED) Buildings (Fig 8.37).



**Fig 8.37 – Primary Facilities Within this Zone have Unified Material and Color Palette.**

**8.14.2.8 NSA/CSS GA Complex Visual Zone.**

**The NSA/CSS GA Complex is currently under construction (Fig. 8.38).**

**Fig 8.38 – Architectural Rendering NSA/CSS GA Complex (Currently Under Construction)**



**8.14.2.9 Residential Housing Visual Zone (RCI).** The Housing Zone is divided into six separate areas: Boardman Lake, Maglin Terrace, McNair Terrace, Lakeview Terrace, Olive Terrace, and Gordon Terrace. The Housing Zone consists of both single family and multi-family unit dwellings. Family units range from one to two-story configurations. Materials throughout the Housing District include brick, and horizontal aluminum siding. Building colors are natural earthtone values (Fig. 8.39). A significant contribution to the overall image is the prevalent gable roof configuration. The roof style promotes a cohesive image and provides a sense of continuity to the architectural fabric.



**Fig 8.39 – Typical Single Family Homes**

**8.14.2.10 Open Space Visual Zone**

Fort Gordon contains a number of excellent, well located spaces (Barton Field, Myer Mall, Heritage Park, Freedom Park, and Wilkenson Lake (to name a few). Barton field is centrally located, and is the Installations' most prominent Open Space (Fig. 8.40). The Gazebo/Bandstand at Freedom Park and Stage Cover at Barton Field both possess the character of an outdoor "room" presenting the potential for a variety of human activity (Figs. 8.41 and 8.42).



**Fig 8.41 – Freedom Park**



**Fig 8.40 – Centrally located Barton Field is Fort Gordon's most Prominent Open Space.**



**Fig 8.42 – Stage Cover at Barton Field**

### 8.14.3 Exterior Building Color.

**8.14.3.1** Color charts have been developed for specific geographical areas giving consideration to climate, geography, culture, facility function, historical context, architectural character, etc. (Fig. 8.43). Color changes will be implemented during normally scheduled paint cycles (see [Appendix L, Exterior Color Charts](#)).

**8.14.3.2** Color is closely linked to the appropriate selection of exterior building materials and is a critical design element in relating adjacent buildings and creating a compatible visual environment within an installation.

**8.14.3.3 Historic Buildings.** Repaint the building or structure to match the existing colors or colors that can be documented to have been used on that building.

### 8.15 KEY FACILITY TYPES STANDARDIZATION

**8.15.1** The Assistant Chief of Staff for Installation Management (ACSIM) establishes Army facility standards and approves deviations from the standards.

#### 8.15.2 Residential Communities Initiative.

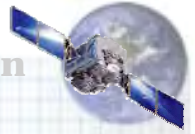
**8.15.2.1** The intent of the Residential Communities Initiative (RCI) is to improve the housing for military families by providing quality housing that is built in attractive neighborhoods.

**8.15.2.2** The Military Housing Privatization Initiative (MHPI) legislation allows developers to build housing to local standards. In those areas where local standards do not meet the quality of life requirements of soldiers, the Community Development and Management Plan (CDMP) process allows a negotiated determination of those standards. To ensure a uniform level of quality throughout RCI, Headquarters, Department of the Army has developed a "[Quality Standards for New and Replacement Residential Communities Initiative \(RCI\) Family Housing](#)" to be used as reference points during CDMP preparation.

**8.15.2.3** All RCI projects planned or under design will meet the "Gold" SPiRiT rating (as of 18 March 2003). See [Assistant Secretary of the Army Memorandum Subject: Sustainable Design and Development Requirements, dated 18 March 2003](#).



**Fig.8.43 - The Geographical Areas for Exterior Colors**



**8.15.3** Department of the Army (DA), Facilities Standardization Program.

**8.15.3.1** Under the DA Facilities Standardization program, standard design packages are developed for facility types that are repetitively designed and constructed at Army installations. These design packages are developed to the definitive design level (10%-15%) and once approved are mandatory for Army MILCON.

**8.15.3.2** Currently, there are thirty one (31) DA standard design packages. Headquarters, U.S. Army Corps of Engineers has established eight (8) Centers of Standardization to develop and maintain the definitive and design packages. See [Appendix P, DA Facilities Standardization Program Centers of Standardization](#) for a list of the various centers and the facility type assigned to each center. ([Centers of Standardization](#) homepage.)

**8.15.3.2.1** Army Chapel Design Standards are complete and approved. See [The Army Standard for Chapel Construction – January 2004](#) and Memorandum for Record, subject: [The Army Standards for Chapels](#), dated 21 January 2004.

**8.15.4** Unaccompanied Personnel Housing (Army Barracks Modernization Program).

**8.15.4.1** The Army's Barracks Modernization Program is based upon a whole community approach providing modernized private living and sleeping areas for soldiers as well as a more functional work environment. This is being realized with the construction and renovation of barracks, and associated Company Operations Facilities (COF), Battalion Headquarters (BN HQ) and Brigade Headquarters BDE HQ), and Dining Facilities (DEFAC). For a detailed discussion of the Army Barracks Modernization Program see the [Army Barracks Master Plan](#). The Army Barracks Master Plan only includes requirements for activity duty permanent party soldiers' barracks.

**8.15.4.2** Army Barracks Standards. The Army Barracks Modernization Program design criteria gives commanders and contractors the direction to incorporate best business practices around a modular floor plan. The [Army Barracks Master Plan, Appendix I, Army Barracks Standards](#), promotes barracks with an appropriate balance between private and common areas. The Vice Chief of Staff of the Army (VCSA) specified the “New Army Barracks Construction Criteria” in his [Memorandum Subject: New Barracks Construction Criteria, dated 11 July 2002](#) in which he strongly endorsed the new standards. The criteria was further



revised in [Memorandum Subject: Revised Barracks Construction Criteria, dated 1 May 2003](#) which makes the following four changes to the Army Barracks Standards:

- Establishes the two-bedroom/one bath module as the standard module;
- Requires installation of a stove or cook top;
- Requires laundries in the barracks; and
- Eliminates the separate soldier community building.

See the above memorandum for detailed guidance.

#### **8.15.4.3 Furnishings.**

**8.15.4.3.1** Acquisition of new furnishings is planned and accomplished in concert with the facility design and construction schedule so that delivery of the new furnishings coincides with the beneficial occupancy date (BOD).

**8.15.4.3.2** The U.S. Army Interior Design Manual (IDM) for Single Soldiers provides guidance to help furniture managers prepare order packages. The manual uses standard Army furniture specifications; i.e. medium oak wood furnishings or acceptable wood/steel alternatives; construction and fabric specification, and specific information for authorized items of furniture. The manual also contains standard living/sleeping room arrangements, and SCB plans with color schemes. The manual includes information on waiver requirements, the procurement process, order forms, and final inspection checklist.

**8.15.4.4** Construction design criteria for COFs, BBN HQ buildings, BDE buildings, and DEFAC facilities can be viewed on the web at [ProjNet](#).

#### **8.15.5 Army Lodging.**

**8.15.5.1** The Army Lodging Standards promote economies in serving the Army traveler, but not at the expense of quality or service. The standards define the facilities and the level of service the Army traveler should expect.

**8.15.5.2** The following standards provide the level of service that a guest should expect when they travel to an Army installation. That expected level of service should be consistent



from installation to installation. The following documents provide the service, operations, and facilities standards for Army Lodging.

- [Army Lodging Standards for Service](#)
- [Army Lodging Standards for Operations](#)
- [Army Lodging Standards for Facilities](#)

**8.15.6** Morale, Welfare, and Recreation (MWR) Branded Theme Operations.

**8.15.6.1** The U.S. Army Community and Family Support Center (CFSC) through its Theme Operations, offers comprehensive theme packages pertaining to restaurants and entertainment centers. The packages are customized to the installation.

**8.15.6.2** CFSC will conduct an assessment for market viability, provide architectural designs, and other promotional items. Information on the CFSC Branded Theme Operations to include how to get a theme operation, management support, and food service support is located on the CFSC website at the [Army Brand Theme Operations Home Page](#).

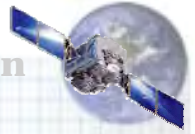
**8.15.7** Range Standards.

**8.15.7.1** The Army Sustainable Range Program (SRP), proponent is HQDA Office Deputy Chief of Staff Operations, ODCSOPS/G3 (DAMO-TRS), phone number (703) 692-6410. To contact SRP technical support call (256) 895-1535 or e-mail [RTPL@HND01.usace.army.mil](mailto:RTPL@HND01.usace.army.mil).

**8.15.7.2** The SRP develops and manages standard designs for Army Ranges in accordance with AR 210-21 and Training Circular 25-8 Army Training Ranges. The Range Standards are available on the following web pages.

- Design Manual for Remoted Target Systems (RETS) Ranges, [CEHCN 1110-1-23 Manual](#).
- [Revised Range Design/Construction Interface Standards](#).
- Unexploded Ordinance Considerations in the Planning, Design, and Construction of Ranges, [Supplement to CEHNC 1110-1-23 Manual](#).





## 8.16 PHYSICAL SECURITY REQUIREMENTS

To assure the required physical measures are met the installation Provost Marshall or Physical Security Officer will be coordinated with during the planning, design, and construction of all construction projects. ([AR 190-13, \*The Army Physical Security Program\*](#), Para 1-26) See [Section 12, Force Protection](#) for a more detailed discussion regarding Antiterrorism measures.

## 8.17 SALE AND OUTLEASE OF ARMY ASSETS

**8.17.1** In an effort to offset some of the impacts of constrained resources, the Army has implemented initiatives that improve cost effectiveness and efficiency of installation operations. To the extent permitted by law, funds that become available as a result of these initiatives are retained by, or returned to, garrison commanders.

**8.17.2** The Office of the Assistant Secretary of the Army for Financial Management and Comptroller (OASA (FM&C)) has developed the "[Sales and Outlease of Army Assets - Installation Guide](#)" to assist garrison commanders in using the sales and outlease program. The guide provides an overview of major policies, procedures, and responsibilities pertaining to the following three major initiatives of the program:

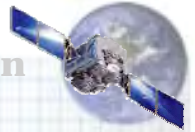
- Sale of Real Property;
- Outlease of Real Property; and
- Outlease of Personal Property.

The guide provides hyperlinks to Sale and Outlease governing regulations and legal and informational references.

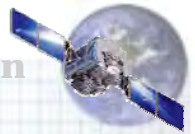
## 8.18 ARMY STANDARDS

**8.18.1** The cited Army Standards shall be met.

- [Army Regulation \(AR\) 420-70, \*Buildings and Structures\*](#)
- [Unified Facilities Criteria \(UFC\) 3-520-01, \*Interior Electrical Systems\*](#)
- [Unified Facilities Criteria \(UFC\) 4-010-01, \*DoD Minimum Antiterrorism Standards for Buildings\*](#)



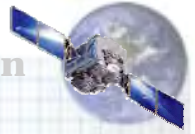
- [Americans with Disabilities Act Accessibility Guidelines \(ADAAG\)](#)
- [Uniform Federal Accessibility Standards \(UFAS\)](#)
- [Secretary of the Interior's Standards for the Treatment of Historic Properties](#)
- [U.S. Army Corps of Engineers Engineering Technical Letter \(ETL\) 1110-3-502, Telephone and Network Distribution System Design and Implementation Guide](#)
- [Standards of Seismic Safety for Existing Federally Owned and Leased Buildings](#)
- [Army Barracks Master Plan, Appendix I, Army Barracks Standards](#)
- [Memorandum Subject: Revised Barracks Construction Criteria, dated 1 May 2003](#)
- [Quality Standards for New and Replacement Residential Communities Initiative \(RCI\) Family Housing](#)
- [Army Lodging Standards](#)
- Design Manual for Remoted Target Systems (RETS) Ranges, [CEHCN 1110-1-23 Manual](#)
- Unexploded Ordinance Considerations in the Planning, Design, and Construction of Ranges, [Supplement to CEHNC 1110-1-23 Manual](#)
- [Revised Range Design/Construction Interface Standards](#)



## 8.19 REFERENCES

8.19.1 The following references are provide for guidance.

- [Army Regulation \(AR\) 190-13, \*The Army Physical Security Program\*](#)
- [Army Regulation \(AR\) 200-1, \*Environmental Protection and Enhancement\*](#)
- [Army Regulation \(AR\) 200-2, \*Environmental Effects of Army Actions\*](#)
- [Army Regulation \(AR\) 200-4, \*Cultural Resources Management\*](#)
- [Army Regulation \(AR\) 405-45, \*Real Property Inventory Management\*](#)
- [Army Regulation \(AR\) 405-70, \*Utilization of Real Property\*](#)
- [Unified Facilities Criteria \(UFC\) 2-600-01, \*Installation Design, Chap 8\*](#)
- [Unified Facilities Criteria \(UFC\) 1-200-01, \*Design: General Building Requirements, 31 July 2002\*](#)
- [Unified Facilities Criteria \(UFC\) 4-510-01, \*Design: Medical Military Facilities\*](#)
- [Unified Facilities Criteria \(UFC\) 3-400-01, \*Design: Energy Conservation\*](#)
- [Engineering Regulation \(ER\) 1110-345-122, \*Engineering and Design, Interior Design\*](#)
- [Department of the Army Pamphlet \(DA PAM\) 200-4, \*Cultural Resources Management\*](#)
- [U.S. Army Corps of Engineers, Design Guide \(DG\) 1110-3-122, \*Design Guide for Interiors\*](#)
- [Department of Defense \(DoD\) Interior Design Website](#)
- [Technical Instructions \(TI\) 800-01, \*Design Criteria\*](#)



- [Technical Instructions \(TI\) 809-04, \*Seismic Design for Buildings\*](#)
- [Technical Instructions \(TI\) 809-05, \*Seismic Design Evaluation and Rehabilitation for Buildings\*](#)
- [Technical Instructions \(TI\) 811-16, \*Lighting Design\*](#)
- [Technical Manual \(TM\) 5-683, \*Electrical Interior Facilities\*](#)
- [Technical Manual \(TM\) 5-688, \*Foreign Voltage and Frequencies Guide\*](#)
- [Technical Manual \(TM\) 5-809-10/Navy NAVFAC P-355/Air Force AFM 88-3, Chap 13, \*Seismic Design for Buildings\*](#)
- [Technical Manual \(TM\) 5-809-10-2/Navy NAVFAC P-355.2/Air Force AFM 88-3, Chap 13, Sec B, \*Seismic Design Guidelines for Upgrading Existing Buildings\*](#)
- [Army Barracks Master Plan](#)
- [Air Force Sustainable Facilities Guide](#)
- [Air Force Interior Design Guides](#)
- Office of the Assistant Secretary of the Army for Financial Management and Comptroller (OASA (FM&C)) [Sales and Outlease of Army Assets - Installation Guide](#)
- [Assistant Chief of Staff for Installation Management, Sustainable Design and Development Website](#)
- U.S Army Corps of Engineers, Engineering Research and Development Center, Construction Engineering Research Laboratory (CERL), [Sustainable Design and Development Website](#)
- [U.S. Army Corps of Engineers Engineering Technical Letter \(ETL\) 1110-3-502, Telephone and Network Distribution System Design and Implementation Guide](#)
- [Whole Building Design Guide](#)

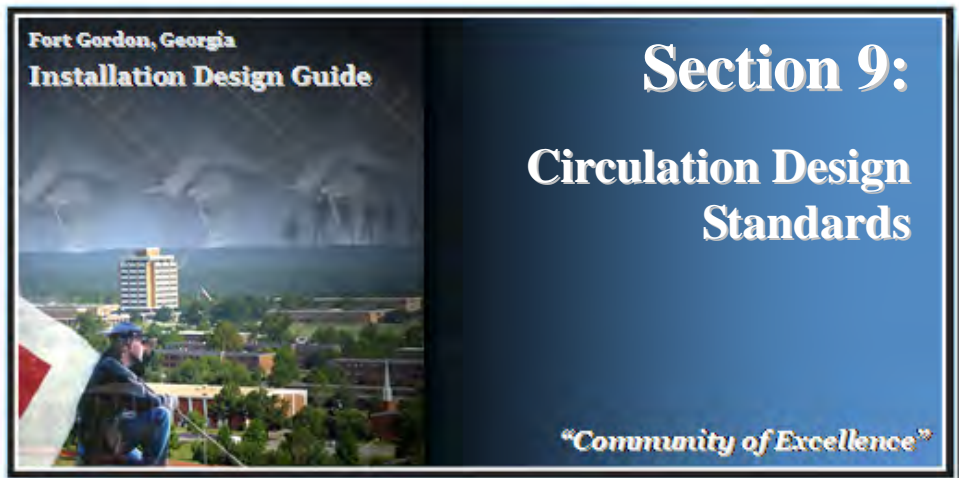
- Unified Facilities Guide Specifications (UFGS), "Division 12 - Furnishings", [Construction Criteria Base](#)
- [Engineering and Construction Bulletins](#)



Links

[Go to Section 9](#)

[Go to Table of Contents](#)



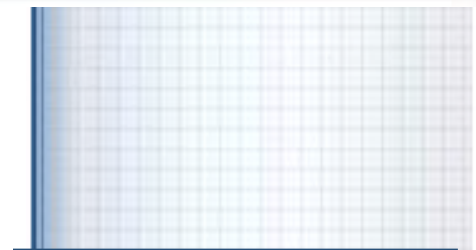
## 9.1 INTRODUCTION

**9.1.1** The image of Fort Gordon is greatly determined by the design and location of roadways, walkways, entrances (Fig. 9.1), and parking lots. The primary roadway system and parking lots utilize considerable amounts of land and are a visually dominant element of the installation. The location of primary circulation elements is presented in [Section 7, Site Planning](#). This section discusses the details of circulation design and impacts.

**9.1.1.1** The key to a good circulation system lies in the development of good vehicular/pedestrian traffic flow patterns and convenient parking arranged to provide the most efficient and safe environment for Fort Gordon personnel and visitors (Fig. 9.2). The circulation component of this guide is used to assess the circulation elements and is used to help identify specific characteristics that provide visual zone and theme identity and improvement projects.

Circulation planning, design, and management involves the collection of data, including pedestrian and vehicular traffic volumes; parking demands; traffic speeds; and street and intersection capacities. This information is used in the determination of present and future hardscape needs. The campus circulation system is divided into categories (Primary, Secondary, and Tertiary) based upon traffic volumes and uses. This system of hierarchy ensures that both existing and future pedestrian and roadway systems can accommodate traffic demands and solve circulation problems.

This section provides the criteria, guidelines, and standards for



**Fig. 9.1 – Fort Gordon Entrance at Gate 1**



**Fig. 9.2 – Circulation System Design Should Accommodate Pedestrian and Vehicular Traffic Demands**



determining circulation system functional relationships and design. The section covers roadways, entrance gates, parking, service and drop-off areas, walkways, bikeways, and methods of traffic calming. This section also addresses methods for mitigating the visual impact of parking and other vehicle use areas.

**9.1.2** The circulation system provides a primary vantage point from which all installations are viewed. Safe and efficient vehicular movement results in better orientation and contributes to the development of a positive environment for installation personnel and visitors. The circulation component is used to assess the circulation elements of Fort Gordon and identify specific characteristics that provide visual zone and theme identity.



**Fig. 9.3 – Sustainable Circulation System Promotes Energy Conservation**

**9.1.3** Roadways, pedestrian walkways, and bicycle trails will be designed to provide a hierarchy of circulation design and carrying capacity. Functionally, a hierarchical network can be created that separates incompatible types of traffic. This separation of traffic promotes sustainability because it results in more efficient energy consumption (Fig. 9.3).

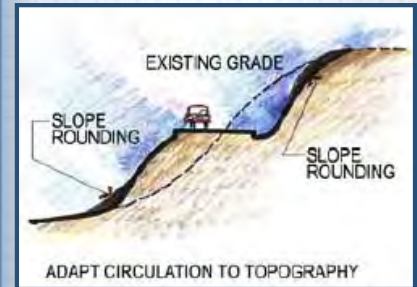
## **9.2 CIRCULATION OBJECTIVES**

The goal for the circulation system on the installation is to establish a sustainable system that promotes aesthetic appeal, environmental preservation, and energy conservation while providing safe and efficient circulation (Fig. 9.4). The objectives below should be followed to achieve a sustainable circulation system:



**Fig. 9.4 – Effective Roadway, Pedestrian Walkway, and Bicycle Trail Design Provide Safe and Efficient Circulation**

- Provide circulation that meets force protection requirements and promotes and enhances public health and safety.
- Provide a system of circulation that results in improved vehicular and pedestrian circulation, reduces maintenance costs, and presents a more pleasing appearance.
- Provide a system that includes hierarchies of vehicular and pedestrian traffic flow with minimal conflicts.
- Adapt the circulation system that relates to the natural contours of the land in order to minimize grading and destruction of the natural environment (Fig. 9.5). Within developed areas, planting, screening, setbacks, and other techniques can be used to visually integrate roads with the use areas that they serve.
- Improve the existing circulation network for expansion, safety, wayfinding, and appearance.
- Close unnecessary streets that are under utilized and provide opportunities to create “super blocks.”
- Promote the use of curbs and gutters to enhance the installation’s appearance by preventing street and parking lot edges from eroding, keep vehicles off grass and other improved areas, and control drainage. See Figure 9.2c. The installation will include curbs and gutters in future streets and parking lot construction.
- Visually reinforce the circulation hierarchy through design, planting, signage, and lighting, promoting a more attractive visual experience and sense of orientation (Fig. 9.6).
- Provide circulation systems that meet existing and future capacity, are efficient, and are designed to current traffic engineering standards.



**Fig. 9.5 – Adapt Circulation to Natural Contours of the Land**



**Fig. 9.6 – Street Trees Visually Reinforce the Circulation Hierarchy and Promote an Attractive Visual Experience**



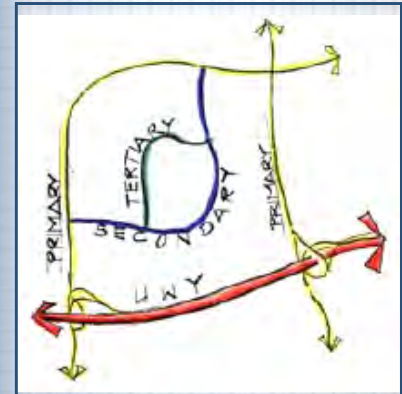
### 9.3 ROADWAY HIERARCHY

**9.3.1** The roadway network of Fort Gordon should functionally and visually reflect a logical hierarchy of traffic circulation. The network should separate types of traffic by function and volume, ranging from through traffic to local traffic. The visual character of each segment of the network should appropriately convey its role and function within the overall network. The basic network is classified as follows in terms of the type, character, and appearance of the road (Fig. 9.7).

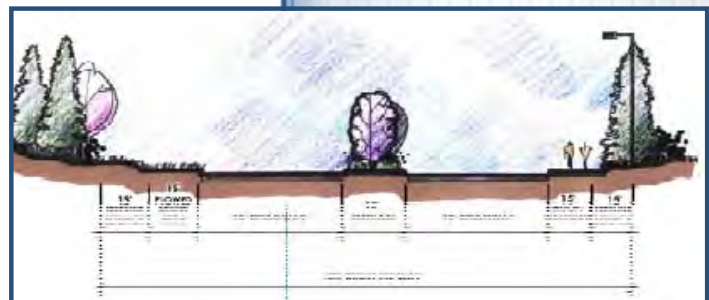
**9.3.1.1 Highways.** Fort Gordon’s main entrance is located at the intersection of US 78 (Gordon Highway) and Jimmie Dyess Parkway.

Highways provide primary high-speed traffic access to, around, or through a military installation. The design includes:

- Continuous, relatively straight or large radii curvilinear alignments that carry high-speed through-traffic movement between major activity centers within a region.
- A minimum of two lanes on each direction typically divided by a median or median divider.
- Alignments that border lane use areas rather than bisect them, and green space buffers between the road and adjacent uses.
- Controlled access onto the road.
- Either grade-separated or at grade channelized intersections with traffic signal controls.
- Shoulders for emergency stopping but strict prohibition of on-street parking.
- Street signing, lighting, and planting that reflects the high-speed nature of traffic movement.



**Fig. 9.7 – Roadway Hierarchy**



**Fig. 9.8 – Typical Primary Roadway**

**9.3.1.2 Primary Roadways.** These are arterial routes that connect major activity centers, provide the primary access through the installation, and provide the means by which most people view



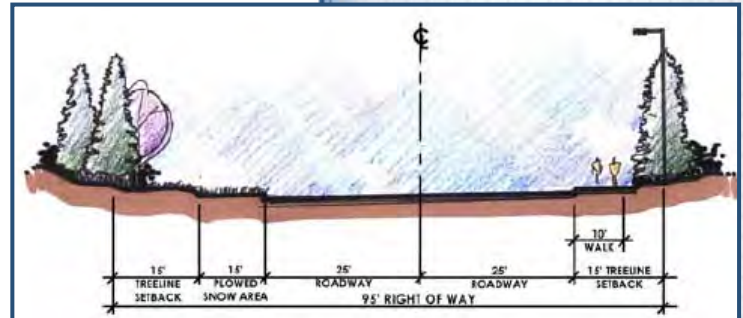
the installation (Fig. 9.8). These roadways often traverse the entire installation and carry the heaviest volume of traffic that results in high speed and high visibility corridors. Direct access to this type of road should be restricted to crossing at major intersections. Primary roadways are designated as boulevards in urban areas and as avenues in rural and suburban areas.

Design characters include:

- Typical right-of-way of 80 to 120 feet. This includes roadway pavement with curb and gutter; median; stormwater piping; underground utility corridors; landscape planting areas, pedestrian walkways, and/or combination walkway-bikeways; roadway and pedestrian light standards; and right-of-way fencing or landscape screen depending on adjacent land use.
- Continuous, through-traffic alignments that are relatively straight or large-radii curvilinear to handle moderate to heavy traffic.
- Alignments that form the boundary between different land uses are preferable to alignments that transect a land use zone.
- One or more moving lanes in each direction typically divided by a median.
- Controlled access and a minimum of curb cuts limited to entranceways to major facilities or building groups.
- At-grade intersections with signal controls.
- On-street parking prohibited.
- Medians, street lighting, signing, and planting that enforces the moderate- to-high speed nature and importance of the road.

Due to existing site constraints, many primary roadways at Fort Gordon are undivided, two lane roads with a minimal 80 foot right-of-way.

**9.3.1.3 Secondary Roadways.** Secondary roadways serve as connectors between primary roads and tertiary roads and typically connect primary roads to adjacent land use zones (Fig. 9.9). Secondary roads accommodate moderate to slow traffic speeds with one moving lane in each direction. On-street parking should be prohibited and left-turn lanes provided at intersections with primary roads.



**Fig. 9.9 – Typical Secondary Roadway**

Design characteristics include:

- Continuous through-traffic alignment between primary roads, either straight or curvilinear based upon the design speed topography and land pattern.
- Direct access to abutting property.
- A maximum of two moving traffic lanes in each direction, either undivided or a boulevard with planted median.
- On-street parking generally prohibited.
- Sidewalk separated from the road by a planting strip.
- Street lighting, signing, and planting that reflects the moderate-to-slow speed nature of traffic and the character of the land use area they are in (Fig. 9.10).
- Curbs, gutters, and sidewalks provided in all cantonment area and other residential areas with densities greater than two dwelling units per acres.



**Fig. 9.10 - Improved, Visually Appealing Streetscape**

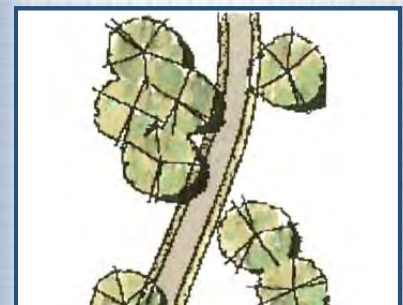
**9.3.1.4 Tertiary Roadways.** Tertiary roadways provide access to individual facilities, parking and service areas. They are designed to handle low speed, low volumes of traffic, with one lane in each direction. Tertiary roadways make use of “T” intersections and cul-de-sacs to reduce through traffic, promote safety, and limit noise impacts from truck traffic (Fig. 9.11).



**Fig. 9.11 – Typical Tertiary Roadway with Walkway**

Design characteristics include:

- Typical right-of-way of 40 to 65 feet. This generally includes roadway pavement, stormwater piping, underground utility corridors, landscape planting areas, walkways, and roadway light standards
- Alignments designed to discourage through-traffic.
- Alignments are relatively short straight or curvilinear keeping with topography, land use, and slow speed nature of traffic (Fig. 9.12).
- Generally a maximum of two moving traffic lanes, one in each direction.
- On-street parking allowable on an infrequent overflow basis by the addition of a parallel parking lane or bay.
- Pedestrian walkways may be limited to only side, depending upon need.
- Street lighting, signing, and planting in character with slow speed nature of traffic and the land use area within which the road is located.



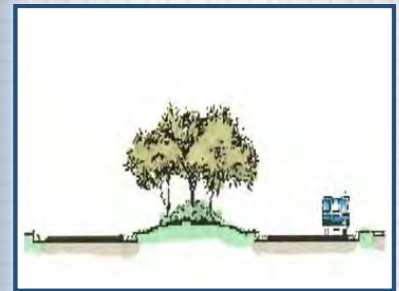
**Fig. 9.12 - Tertiary Street Plan**

**9.3.1.5 Cul-de-sacs.** Cul-de-sacs are short dead-end tertiary streets located primarily in residential areas (Fig. 9.13). They connect at one end to a tertiary or secondary street and have a turnaround at the other end, providing direct access to a abutting property while preventing through traffic.

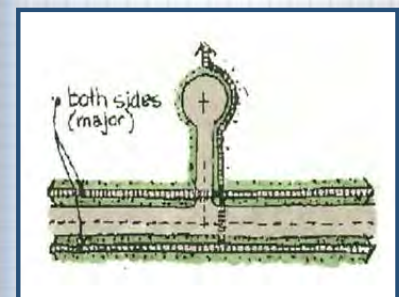
Design characters include:

- Short, straight, or curvilinear alignment to serve abutting property (Fig. 9.14).
- Generally a maximum of two traffic lanes, one in each direction.
- Generally a maximum length of 600 feet, or less, except in areas where terrain and low density justify a longer length.
- Turnarounds must include a diameter to accommodate fire and garbage trucks.
- Turnarounds can be either symmetrical or offset.
- Turnarounds should have center planting islands to reduce the expanse of paved area.
- Overflow parking can be provided on street in parking bays or within center of turnarounds.
- Sidewalks, if any, are generally limited to one side of the road.
- Street lighting, signing, and planting is character with the slow speed nature of traffic and the land use area being served.

**9.3.1.6 Tactical vehicle trails** provide alternative access for armored vehicles and other vehicles utilized in combat readiness training. They are recommended for installations with high use of armored vehicles to enhance the movement of the vehicles and reduce traffic congestion on the other installation roadways. These trails provide one lane access for vehicles between motor pools and maneuver areas. It is recommended that these trails be hard surfaced within developed areas with concrete of a thickness to withstand the weight of armored vehicles. The hard service will



**Fig. 9.13 - Cul-de-sac Section - May Incorporate Plantings**



**Fig. 9.14 - Cul-de-sac Plan**

reduce dust pollution. These trails should be designed to provide as direct access as possible while minimizing crossings with primary, secondary, or tertiary roads. All crossings with the other roadway systems should be paved with concrete to support the weight of the vehicles and clearly marked with signage.

#### 9.4 ROADWAY SETBACKS

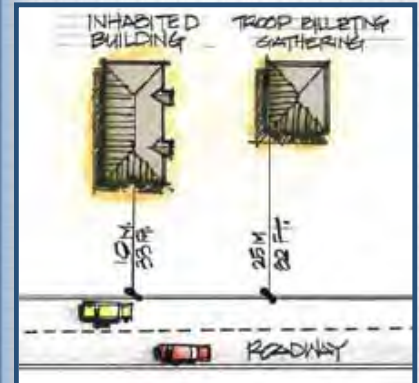
Department of Defense Antiterrorism standards state that all inhabited buildings within a controlled perimeter will be setback a minimum of 10 meters (33 feet) from roadways, and that troop billeting and primary gathering spaces shall be setback a minimum of 25 meters (82 feet) from roadways. Inhabited buildings not within a controlled perimeter the minimum setback distance is 25 meters (82 feet) and for primary gathering places and troop facilities the minimum distance is 45 meters (148 feet). (Fig. 9.15) (See, [Unified Facilities Criteria \(UFC\) 4-010-01, DoD Minimum Antiterrorism Standards for Buildings](#), Table B-1).

#### 9.5 ROADWAY SYSTEM DESIGN

**9.5.1** The location and design of new circulation system alignments as well as improvements to the existing system should be prepared to promote development sustainability. They should be designed to minimize impacts, relieve driver monotony, and provide a positive visual experience for the user, without compromising safety. The following design techniques should be applied to circulation system design.

**9.5.2** Blend Circulation With Natural Landform. The horizontal and vertical alignment of roads, walkways, and bikeways should minimize landform disturbance and blend with the natural setting (Fig. 9.17).

- Minimize cut and fill by avoiding steeping terrain and aligning roadway, walkway, or bicycle system to cross slopes diagonally or parallel to the contours rather than perpendicular to the contours.
- Mold cut and fill slopes to blend into the natural landform (Fig. 9.16).
- Blend road drainage ditches, swales, or channels into the natural landform.



**Fig. 9.15 - Antiterrorism Roadway Setbacks Within a Controlled Perimeter**



**Fig. 9.16 – Build Circulation Into Natural Landform**



- Use cluster development wherever possible to limit the lengths and required intersections of roadway and other circulation system elements and to preserve land. Consideration should be given to meeting antiterrorism requirements when developing cluster type facilities.
- Minimize pedestrian, railroad, and bikeway crossings of highway, primary, and secondary roads.
- Use natural topographic conditions to create grade separated pedestrian, railroad, and bikeway road crossings wherever possible especially on highways and primary roads.

**9.5.3 Adapt Circulation to Preserve Vegetation.** Design roads, walkways, and bike paths to minimize disturbance to existing vegetation, encourage re-vegetation in disturbed areas, and reduce the visual impact of landscape disturbance.

**9.5.3.1** Align roads through open areas rather than forested areas.

**9.5.3.2** Minimize cut and fill to reduce the limits of clearing.

**9.5.3.3** Clear only for sight distances rather than uniform right-of-way clearing.

**9.5.3.4** Utilize tree wells or retaining walls to preserve specimen trees or significant vegetation areas.

**9.5.3.5** Provide optimum conditions for re-vegetation by following proper planting and maintenance techniques.

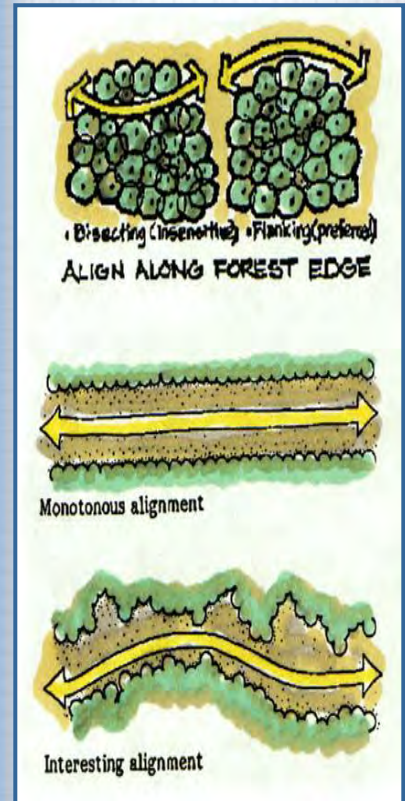
**9.5.3.6** Restore vegetation to disturbed areas using naturalistic plantings of native plant material.

**9.5.4 Minimize Adverse Impacts on Adjacent Land Uses.**

**9.5.4.1 Air Pollution.** Locate roadway alignments to minimize the impact of traffic-emitted pollutants on adjacent development. This can be accomplished by the following:

**9.5.4.1.1** Locate roads adjacent to land uses that are minimally affected by traffic-emitted air pollutants.

**9.5.4.1.2** Reduce the impact of traffic-emitted pollutants on more sensitive land use areas by locating the roadways downwind and/or



**Fig. 9.17 – Roadway Alignment**



**Fig. 9.18 – Landscape and Berms Buffer Air and Noise Pollution**

providing planted buffers. Tactical vehicle trails should be hard surfaced to reduce dust pollution.

**9.5.4.2 Noise Pollution.** Design and locate roadways to reduce the impact of traffic noise on adjacent development.

**9.5.4.2.1** Roads should be physically separated from sensitive land uses including residential, medical, education, recreation, administration, religious, library, community, or child care facilities.

**9.5.4.2.2** Utilizing noise abatement techniques such as berms, sound barrier walls, and plant material to reduce noise levels (Fig. 9.18).

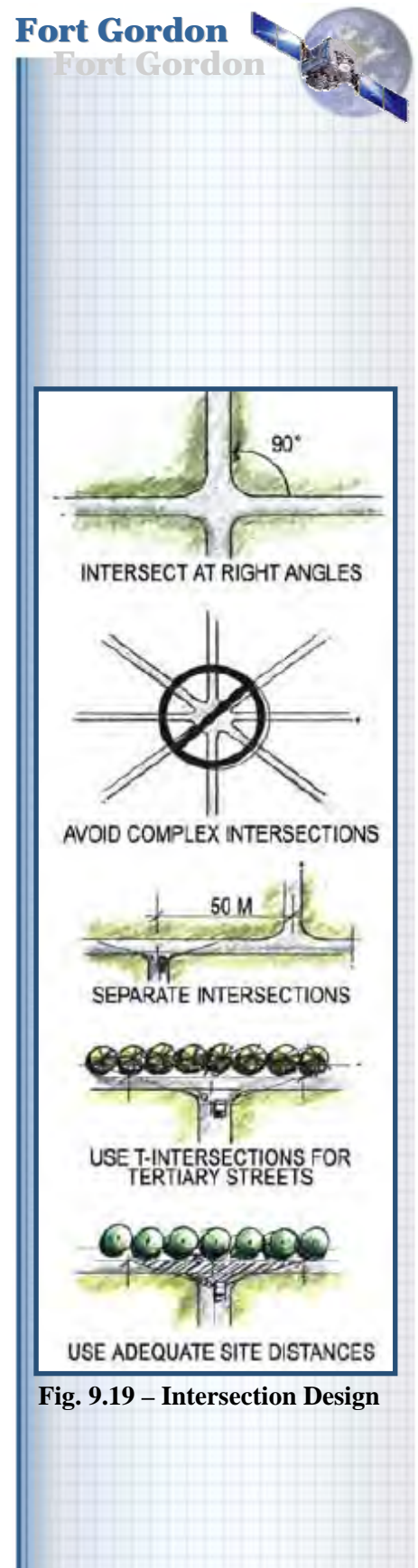
**9.5.4.2.3** Reroute truck and tank traffic to roadways adjacent to less noise sensitive land uses. Tracked vehicle traffic should, ideally, be routed to a system of tank trails that are totally separate form corridors used by wheeled traffic vehicles.

## 9.6 INTERSECTIONS

**9.6.1** Intersections are the most dangerous areas of the installation circulation system. They should be planned or improved to provide safe and efficient traffic flow for both pedestrian and vehicular traffic.

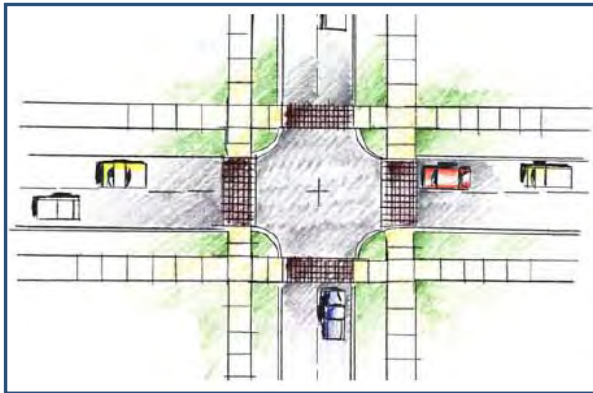
The following design techniques should be used to plan or improve intersections (Fig. 9.19):

- All roadways should intersect at right angles (90 degrees), although 85-95 degrees is acceptable.
- Avoid dangerous, complex intersections of more than two streets intersecting at one point or offset intersections.
- Eliminate intersections that are in close proximity to one another. They should be no closer than a minimum distance of 30 meters (100 feet).
- Use T-intersections for tertiary road intersections with secondary or primary roads to reduce conflict and promote safety.



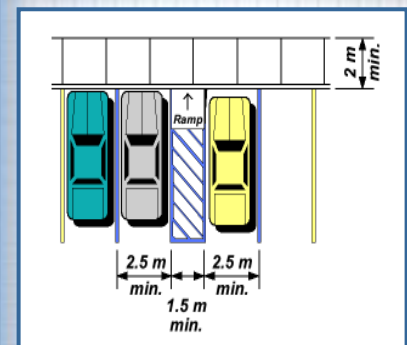


- Provide turning lanes at all intersections along primary roads to eliminate interference with through traffic flow.
- Minimize intersections along primary roads to reduce points of conflict and increase safety. Existing intersections with secondary and tertiary streets can be eliminated by the use of cul-de-sacs with traffic routed along parallel streets to primary and secondary streets.



**Fig. 9.20 – Increase Crosswalk Safety by Using Different Paving Surfaces**

- Include adequate sight distances to meet minimum standard requirements at all intersections. The location from where the driver is waiting to cross or enter a traffic lane to a point 23 meters (75 feet) down the centerline to the right and the left forms the sight triangle.
- Minimize pedestrian and bicycle intersections with primary streets.
- Provide crosswalks at all intersections where necessary, marked with paint or vinyl strips or identified with a different paving surface (Fig. 9.20).
- Provide pedestrian access to persons with disabilities in accordance with the [Americans with Disabilities Act Accessibility Guidelines \(ADAAG\)](#) and the [Uniform Federal Accessibility Standards \(UFAS\)](#). In the event of a conflict the most stringent standards will be applied (Fig. 9.21).
- Create local service drives or access roads to parallel highways and primary roads to provide access to properties



**Fig. 9.21 - Accessible Parking Space**



fronting the primary road avoiding a direct curb cut from the primary road to each individual property.

- Intersections between railroad track and high-speed roads must be signaled, well marked and have a smooth transition. All other road crossings must be well marked and have clear line of sight down the tracks.

## 9.6.2 Intersection Design Criteria

A comprehensive intersection design criteria which includes types, design controls, and elements design improvements is located at the following website: [Better Military Traffic Engineering, MTMCTEA Pamphlet 55-17, Chapter 2.](#)

## 9.7 ENTRANCE GATES

**9.7.1** The location and design of the installation entrance gates is a primary component of the installation circulation system. Entrance gates must be designed to be functional, while providing security protection not only for the installation itself, but also for personnel and others waiting to be admitted to the installation. Gates should also be designed as a visual amenity to provide an aesthetically pleasing entrance to and exit from the installation.

With well-designed entry control facilities, an image can be created that conveys a commitment to facilities excellence, the importance of the mission that lies within, and a determination to see it through. This section provides guidance on the appropriate configuration and design of perimeter entry control facilities. See Section 12, Force Protection, [paragraph 12.8](#) for information on the design standards for installation gates.

### 9.7.1 Gate Categories

Entry Control Facilities (ECFs) are classified based on the intended function and anticipated usage of the ECF. The five use classifications are outlined in Table 9.22. The use classification is determined based on the traffic volume, hours of operations, and FPCON considerations.



**Table 9.22 – Entry Control Facility Classifications and Functions**

Use Classification	Traffic Volume	Operational Hours	FPCON Considerations	Preferred Operation
Primary	Heavy/ Moderate	24/7 Open continuously	Open thru FPCON Delta	Vehicle registration/visitor pass capacity. Closed to trucks and deliveries. Regular operations, visitors with authorization. Could also be designated as truck and delivery gate.
Secondary	Moderate to Heavy	Regular hours, closed at times	Potentially closed at or above FPCON Charlie	Regular operations, visitors with authorization. Could also be designated as truck and delivery gate.
Limited Use	Low	Only opened for special purposes	Closed at most times	Tactical vehicles, HAZMAT, special events, etc.
Pedestrian Access	Low	14/7 Open continuously	Potentially closed at or above FPCON Charlie	Personnel only. Could be located near installation housing areas, near schools, or as part of a Main or Primary gate.

### 9.7.2 Gate Design

The first line of defense at Fort Gordon is its perimeter. Providing necessary security at the perimeter, including entry control facilities, will allow “life as normal” within the installation to the maximum extent possible.

The entry gate must be designed to impart an immediate impression of professionalism and commitment to facilities excellence and to convey the Army’s commitment to protection and safety of its personnel.

A poorly designed gate contributes to congestion, accidents, wasted energy, inaccessibility, and off-installation impacts. Factors to consider in designing gates includes security level, traffic volumes and classification, roadway class, speed, and the distance from other intersections and major roadways. Entrance gates often become bottlenecks and cause traffic delays during peak travel periods.

The following steps can be used to remedy the problem:

- Ensure that share-ride and staggered duty-hour programs have been implemented to maximum extent possible so that gate entrance design requirements will be reduced to a



minimum.

- Ensure sufficient lanes exist to handle peak traffic flow.
- Locate the checkpoints a minimum 300 feet from an intersection to reduce vehicle conflicts and sight distance problems.
- Provide turnouts to get visitor or other stopping traffic out of the way.
- Have a map or directory station available for visitors.
- Canopies should be provided to protect the entry controllers from the elements (minimum 4.41 meters clear height) and to provide a platform for area and task lighting.
- Provide visitor center for visitors requiring passes or consider provision of a separate gate for truck inspections and passes.

### **9.7.3 Entry Control Facility Function**

ECFs serve as the entry point for all personnel, visitors, and deliveries to Army installations. The objective of ECF is to prevent unauthorized access and maximize vehicular traffic flow. Priorities in the design of an ECF are:

- Security – The first priority of an ECF is to maintain perimeter security, which is the first physical line of a “defense in depth” strategy and a legal line of demarcation.
- Safety – ECFs must have a working environment that is both safe and comfortable for security forces personnel. Security forces safety includes provisions for personal protection against attacks, snipers, and errant drivers. Special consideration must be given to climate, location, and orientation.
- Capacity – The ECF must maximize vehicular traffic flow to eliminate undue delays that would affect Fort Gordon operations while maintaining vigilance against acts of terrorism.



- Image –The ECF must be designed to impart an immediate impression of professionalism and commitment to facilities excellence and to convey the Army’s commitment to the protection and safety of Army personnel.

#### **9.7.4 Entry Control Facility Plan Review**

Future development plans for new ECFs should be coordinated with the Security Forces, DPW, surrounding Community Planning Offices, and State and local highway agencies to ensure development plans will accommodate future highway approach queuing modifications necessitated by increased demand or revised security measures. The Headquarters Department of the Army, Office of the Provost Marshal General, Operations Branch (DAPM-OPS) in coordination with the Protective Design and Electronic Security Centers of Expertise developed standards for Army Access Control Points (ACP). [Standard Definitive Design for Access Control Points, Dec. 2004.](#)

#### **9.7.5 Antiterrorism Setback Requirements**

Comply with the requirements of Unified Facilities Criteria [UFC 4-010-01, DoD Minimum Antiterrorism Standards for Buildings](#), for all new ECF construction and renovation projects. Installations have attempted to slow both inbound and outbound gate traffic using numerous devices. The most commonly used device is temporary concrete barriers, which is used to accomplish the speed reduction as well as reduce the threat of unauthorized entry. However, use of these barriers often results in geometric constraints and unsafe conditions for the innocent motorist. They are also unsightly.

#### **9.7.6 Traffic Calming**

Traffic calming is needed on inbound and outbound roadways to control vehicle speed and slow incoming vehicles before they reach the gate so that Security Forces personnel have adequate time to respond to unauthorized activities. This includes provisions for restricting traffic flow approaching the ID check area during increased threat-cons.

Traffic calming is the use of physical measures to address speeding and high-volume, cut-through traffic. Generally, traffic calming measures are not appropriate on higher speed and higher volume streets such as arterial roadways. Traffic



calming measures may be appropriate on: local residential streets, collector streets with predominantly residential land uses, and arterial roads within a commercial area (40 mph posted speed limit or less). Appropriate traffic calming measures include: roundabouts, drop-in or retractable bollards and road spikes (to cause serpentine traffic flow), swing gates, speed humps, and raised crosswalks. The MTMCTEA safety bulletin establishes criteria regarding traffic calming; [Traffic Engineering & Highway Safety Bulletin, Traffic Calming](#).

### 9.7.7 Capacity

Design capacity is the maximum volume of traffic that a gate would be able to serve without an unreasonable level of congestion occurring. Capacity is used at the design level in assessing the adequacy of gates to serve current and future traffic demands. Vehicles arriving at a gate faster than they can be processed cause congestion. MTMCTEA have collected significant data, which has established new criteria regarding capacity and processing rates at gates. The MTMCTEA bulletin supplement has established criteria regarding capacity, design, and processing rates at gates; [Traffic Engineering & Highway Safety Bulletin, Gates Revisited](#).

### 9.7.8 Signage

Signing is a common deficiency noted at many installations; conflicting sign messages, too many signs, or non-standard signing. All regulatory signs should conform to Federal Highway Administration's (FHWA) Manual on [Uniform Traffic Control Devices \(MUTCD\)](#). All informational type signing that is not necessary outside the installation should be moved inside the installation boundary. A consistent signing plan should be in place on all gate approaches, refer to [Section 11.4](#).

Variable message signs, which give information on local events or distinguished visitors, are not recommended at ECF locations. However, if used, the signs should be located inside the installation and at least 200 feet beyond the ID check area.

### 9.7.9 Lighting

Lighting is extremely important for safety and processing activities in gate areas. The following are some guidelines to consider:



- Multiple fixtures per pole are more economical and efficient for area coverage.
- Use low-level, directed (from behind guard) lighting for ID processing (5 to 10-foot candles).
- Use 400-watt High-Pressure Sodium (HPS) lamps on gate approaches and at processing points.
- Use Metal Halide or Deluxe HPS lamps at inspection areas.
- Require a color rendition index of 65 (measure of color distinction). This criterion is critical at inspection areas.

## 9.8 PARKING REQUIREMENTS

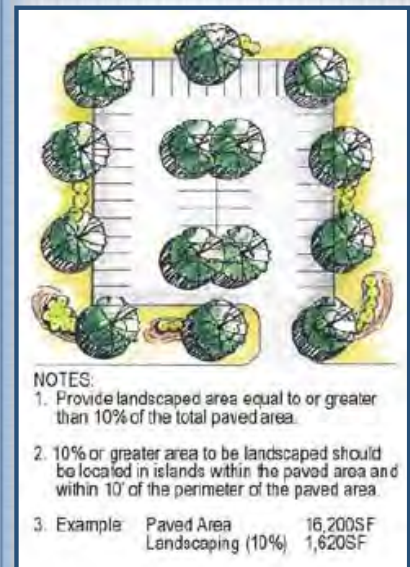
**9.8.1** The total quantity of parking in any one location will vary with the needs of the facility. The following are general considerations considering parking requirements.

- All parking lots will be accessible to persons with disabilities in accordance with the requirements of the [UFAS, paragraph 4.1.1\(5\)\(a\)](#). If parking spaces are provided for employees or visitors, or both, then accessible spaces shall be provided in conformance with the required minimum number of accessible spaces shown in Figure 9.23.
- For initial planning and programming, allocate 400 square feet of parking lot area per car. The total provides adequate minimum space for the parking spaces, access drives, and planting islands that make up a parking lot. This allocation is not withstanding tactical military vehicles.
- Minimize parking space requirements of a facility by selecting a site that will allow the sharing of parking with related activities.
- Small parking lots are usually preferable to large lots because they enhance the visual environment by increasing the percent of landscaped area to paved area and allow more conformance to natural topography.



Total spaces in parking area	Required minimum number of accessible spaces
1 to 25	1
26 to 50	2
51 to 75	3
76 to 100	4
101 to 150	5
151 to 200	6
201 to 300	7
301 to 400	8
401 to 500	9
501 to 1000	2% of total
1001 and up	20 plus 1 for each 100 over 1000

**Fig. 9.23 - Required Minimum Number of Accessible Parking Spaces**



**Fig. 9.24 - Provide Islands With Trees to Soften Visual Expanse**

- The monotony of large parking areas can be altered by the use of designs such as curvilinear parking or the introduction of large planting islands (Fig. 9.25).
- Promote means of access other than vehicular by providing alternative means of access such as walkways and bikeways.



**Fig. 9.25 – Landscaping Mitigates Visual Impact of Parking**

## 9.9 PARKING LOT LOCATION AND DESIGN

**9.9.1** Parking areas can be designed and enhanced to provide a more pleasing impact and a more comfortable physical experience for the user. The following design techniques should be used to create more aesthetically pleasing, physically comfortable parking lots.

- Locate parking lots between and behind buildings to reduce the visual impact from the circulation system.
- Locate parking lots on relatively level areas to avoid excessive cut and fill.
- Design parking lots to be efficient in the design and placement of access drives and parking spaces. All drives providing direct access to parking spaces should provide spaces on both sides of the drive.
- Provide planting areas at the ends of all rows of parking spaces. Provide islands with trees within the main parking lot to soften the visual expanse of the parking lot, provide shade and/or wind breaks (Fig. 9.24).



**Fig. 9.26. – Trees /Berms / Walls Screen Parking Lot**



- Use natural topography and existing trees to visually screen parking areas from adjacent facilities and other parking bays (Figs. 9.26).
- Design parking lots to preserve significant existing trees. Provide a planting area around the tree that is large enough to allow water to the root system.
- On street parking along primary and some secondary streets should be avoided because it reduces the vehicular carrying capacity of the street, is visually unattractive, and is unsafe.
- Parking lots should be paved with concrete, asphalt, or other paving material.
- Parking structures, both below grade and above grade, provide for greater parking capacity in densely developed areas where available land is scarce. Parking structures are expensive, but they provide a number of benefits including efficient land use, reduced visual impact and protection of vehicles from inclement weather (Fig. 9.27). If parking structures are built they shall be designed to meet antiterrorism requirements.



**Fig. 9.27 - Parking Structures are Desirable but Expensive - Consider AT/FP Standards in Planning**

**9.9.2 Parking Area Design Guide.** A comprehensive parking area design guide which includes siting, parking area types, geometry (parallel, perpendicular, angled), access, and maintenance consideration is located at the following website: [U. S. Air Force Landscape Design Guide, Section 14, Parking Areas.](#)





**9.9.3 Planning Future Parking Facilities.**

Future parking needs can be determined by developing parking generation rates. These parking rates can be developed by simply relating the parking demand to an existing similar facility. When establishing parking rates, existing facility characteristics such as employment, population, or floor space should be evaluated. The following guidelines can be used for planning purposes to help in determining the number of parking spaces for non-organizational vehicles authorized for select facilities. However, these are general criteria and should be used in conjunction with Army facility design criteria and project specific criteria. See Table 9.28.

<b>RULE-OF-THUMB GENERATION RATES FOR SELECTED LAND USES<sup>1</sup></b>	
<b>Land Use</b>	<b>Parking Requirement</b>
Administration Building	75 percent of assigned personnel
Bank	2.0 – 2.5 per 1,000 sq.ft. GFA <sup>2</sup>
Barracks:	
Officers	1.1 per person
Enlisted	0.9 per person
Commissary	13 per 1,000 sq.ft. of sales area
Community Center	7 per 1,000 sq.ft. GFA
Hospital	(.62 x P + .21 x O) spaces, where: P = all personnel working within the facility on a continual basis. O = Average daily outpatient load for the peak month.
<sup>1</sup> = Data provided by Institute of Transportation Engineers and research conducted by MTMC. <sup>2</sup> = Gross Floor Area (GFA)	

**Table 9.28 – Parking Generation rates**

**9.9.4 Antiterrorism Setback Requirements.**

Parking lots within a controlled perimeter shall be located a minimum of 10 meters (33 feet) from inhabited structures, and 25 meters (82 feet) from troop billeting and primary gathering structures. Parking lots without a controlled perimeter shall be located a minimum of 25 meters (82 feet) from inhabited structures, and 45 meters (148 feet) from troop billeting and primary gathering areas (UFC 4-010-01, Table B-1). Designated parking for family housing located within secured perimeters with access control is excluded from the 25-meter (82 feet) setback requirement.

## 9.10 SERVICE AREAS

Facilities that require pickup and deliveries should have a service area that allows for easy access to a loading dock exclusively for service vehicles. These areas should be designed to provide direct, easy access for vehicles and not conflict with railroad operations (Fig. 9.29). They should be screened from public view to reduce negative visual impacts. Service areas shall meet all antiterrorism requirements.

## 9.11 DROP-OFF AREAS

Facilities that include a high percentage of persons arriving by vehicle should include a vehicle drop-off area for users. Included are buildings such as headquarters, child development centers, schools, dining facilities, and clubs. Antiterrorism standards state that the access drive must be clearly defined and marked and that their intended use is clear to prevent parking of vehicles in those areas and that drop-off lanes will not be located under any inhabited portion of a building (UCF 4-010-01, para B-1.4) It is recommended that physical barriers be used to define the area. These barriers may include curbing, planters, or other barriers together with signage to identify and restrict access. The driveway shall be configured so that vehicles can be restricted during times of high alert. Access to the driveway shall be located outside the standoff area with the initial approach parallel to the building, or a barrier must be directed to prevent direct vehicular movement toward the building (Fig. 9.30).

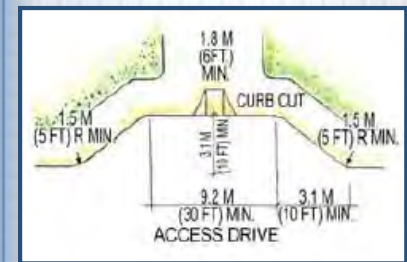
## 9.12 WALKWAYS AND PEDESTRIAN CIRCULATION

**9.12.1** Walkways provide connections for pedestrians between buildings and ancillary facilities such as parking lots and other areas. Well designed and located pedestrian walkways also provide a desirable alternative to total dependence on motor driven vehicles (Fig. 9.31).

**9.12.2** The goal is to encourage the use of walkways as an alternative means of circulation. Pedestrian walkways should be designed and located to provide a comfortable, enjoyable experience for the user. The use of walkways within the installation promotes development sustainability by conserving energy, reducing air pollution, and decreasing the land requirement for parking. These walkways as well provide a means to increase physical fitness.



**Fig. 9.29 - Typical Loading Area**



**Fig. 9.30 - Typical Drop Off Area**



**Fig. 9.31 - Promote Means of Access Other Than Vehicular. Provide Walkways and Bikeways**

**9.12.3** In order to achieve this goal the following objectives must be met:

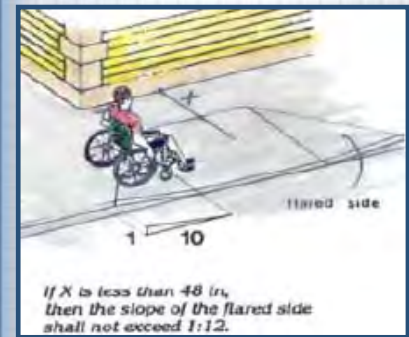
- Provide walkways that are designed at a pedestrian scale to be comfortable and pleasant.
- Provide safe and secure pedestrian facilities that are separate from vehicular and railroad traffic.
- Provide amenities for pedestrians.
- Provide accessibility to all users, including physically impaired or challenged persons. All street and driveway crossings shall be ramped (Fig. 9.32), marked, and accessible to persons with disabilities in accordance with requirements of the UFAS. See the following UFAS paragraphs for the respective standards: [Curb Ramps, paragraph 4.7](#); [Ramps, paragraph 4.8](#); [Stairs, paragraph 4.9](#).
- Provide links to major attractions and generators of pedestrian traffic.
- Provide design consistency throughout the walkway and be well drained.

**9.12.4 Walkway Network Hierarchy.** Sidewalks are classified to conform to the hierarchy roadway system - Primary walkways, secondary walkways, and tertiary walkways. Non- roadway oriented sidewalks should be sized and placed where people will use them rather than creating worn “shortcut” paths. Railroad track crossing should be avoided, but where necessary, they should be well marked and have good line of sight. Walkways through railroad track ballast should be maintained with small, well-drained rock.

#### **9.12.4.1 Primary Walkways.**

**9.12.4.1.1** Primary walkways (Fig. 9.33) should be placed along both sides of primary roadways, wherever possible, within the cantonment areas. These walkways are also used for high volume pedestrian routes to facilities and should be designed along axis lines relating to adjacent building entries, plazas, or streets. They should be paved with concrete, brick, or other pavers.

**9.12.4.1.2** Primary walkways should be sized to accommodate anticipated pedestrian use. They should have a minimum width of



**Fig. 9.32 - Ramps Must Be Provide Per UFAS Standards**

1.8 meters (6 feet), and a maximum width should be 3-3.5 meters (10-12 feet) in high use areas (Fig. 9.36).



**Fig. 9.33 – Typical Primary Walkways**

#### **9.12.4.2 Secondary Walkways.**

**9.12.4.2.1** Secondary walkways (Fig. 9.34) should be provided along one or both sides of secondary and tertiary streets. They are designed to carry moderate volumes of pedestrians between activity centers and housing areas. They should provide access to building entrances, plaza areas, or streets. They should be paved with concrete, brick, or other pavers.

**9.12.4.2.2** These walkways should be sized to accommodate anticipated pedestrian use, but not less than 1.2 meters (4 feet), and a maximum of 3-3.5 meters (10 - 12 feet) in high use areas (Fig. 9.36).



**Fig. 9.34 – Typical Secondary Walkways**



**9.12.4.3 Tertiary Walkways.**

**9.12.4.3.1** Tertiary walkways (Fig. 9.35) provide pedestrian walkways in recreational and scenic areas for casual walking and hiking. They can be paved with concrete or bituminous asphalt or constructed with woodchips. The layout of the walkway should have a meandering and curvilinear alignment. Paved walkways should have a minimum width of 1.2 meters (4 feet). Wood chip trails should have a minimum width of 1 meter (3 feet) (Fig. 9.36). Where paths are designated for use by bicyclists and pedestrians, these widths should be increased an additional three feet for each bike lane.



**Fig. 9.XX – Typical Tertiary Walkways**

**9.12.5 Combination Walkway-Bikeway.**

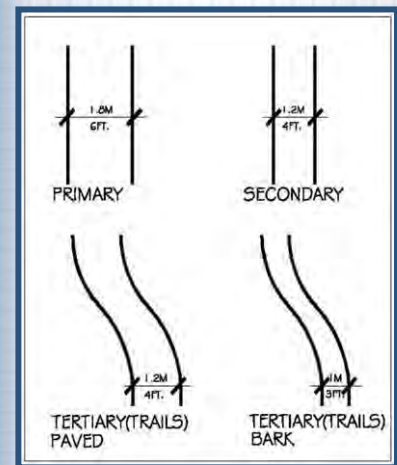
Where walkways are designated for use by bicyclists and pedestrians, these widths should be increased an additional 3 feet for each bike lane.

**9.12.5 Troop Running Trails.**

Troop running trails should be provided for soldiers both in and out of formation. The width should 4.5-5 meters (approximately 15 feet) to provide the width necessary for four soldiers abreast with a cadence caller. Primary, secondary, and tertiary walkways can be designed to provide this function.

**9.12.6 Troop Movement Paths.**

In locations where troops need to move four (4) abreast; for example, troops marching in formation between classrooms,



**Fig. 9.36 – Minimum Walkway Widths**



barracks/dinning hall facilities, a hard surface walkway of adequate width should be provided.

### 9.12.7 Site Amenities at Walkways.

**9.12.7.1** Utilize site furnishings to reinforce the walkway system hierarchy (Fig. 9.37). Provide directional and informational signage, where appropriate. Locate site furnishings, such as benches, tables, waste receptacles, drinking fountains, and signage in response to travel distance and traffic volume.

**9.12.7.2** Site furnishings should be placed at regular intervals along walkways, parallel to the walk and facing the flow of pedestrian traffic. Incorporate adequate provisions for the handicapped into site amenities (Fig. 9.38).

### 9.12.8 Landscaping at Walkways.

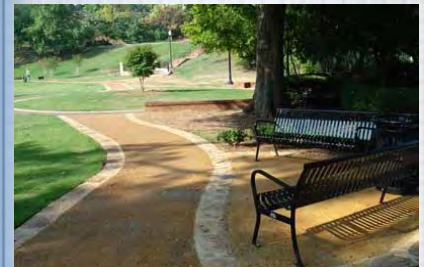
Use a combination of canopy and ornamental trees along sidewalks to provide shade, define the path, provide visual interest, and discourage the creation of “shortcuts”. Utilize evergreen buffer plantings to screen harsh winds and undesirable views. Discourage the use of flowering/fruit bearing trees and shrubs along walkways because of threat of insects or other problems.

## 9.13 BIKEWAYS

**9.13.1** The use of bicycles as alternatives to the automobile has become more acceptable to installation personnel This trend is encouraged as a method of reducing the automobile vehicle trips within the installation and reduce the need for greater carrying capacity. Also, cycling is a popular recreation activity that is enhanced by the availability of a safe and well planned system of bike trails.

**9.13.2** A bikeway system should provide direct routes between primary traffic and destination within the installation. This network should be continuous and minimize conflicts between bikes, pedestrians, and vehicles. Bikeways should be planned and designed according to the classifications that define the level of separation they maintain from roadways and walkways. The ideal solution for the development of bikeways is to physically separate them from both roadways and walkways.

**9.13.3** Bikeways are design according to the following classifications:



**Fig. 9.37 – Place Landscape and Site Furnishings Along Walkways**



**Fig. 9.38 – Incorporate Adequate Provisions for the Handicapped Into Site Amenities**



**9.13.3.1 Class I Bikeway.** A Class I Bikeway is intended for the exclusive use of bicycles. While it may parallel a roadway, it is physically separated by distance or a vertical barrier (Fig. 9.39). Class I Bikeway considerations include:

- A class I Bikeway provides the safest and most efficient means of bicycle travel and is the preferred option for bikeway development.
- Crossing of a Class I Bikeway by pedestrians, train, or automobile should be minimized.
- If a Class I Bikeway does not closely parallel a roadway, it should be designed to provide appropriate bikeway gradient and curvature.
- Class I Bikeways require the greatest amount of space and advance planning to reserve land and assure appropriate routing.
- Railroad crossings should be well marked, with proper operating signals and clear sighting down the tracks. Road crossing transitions should be smooth and well drained.

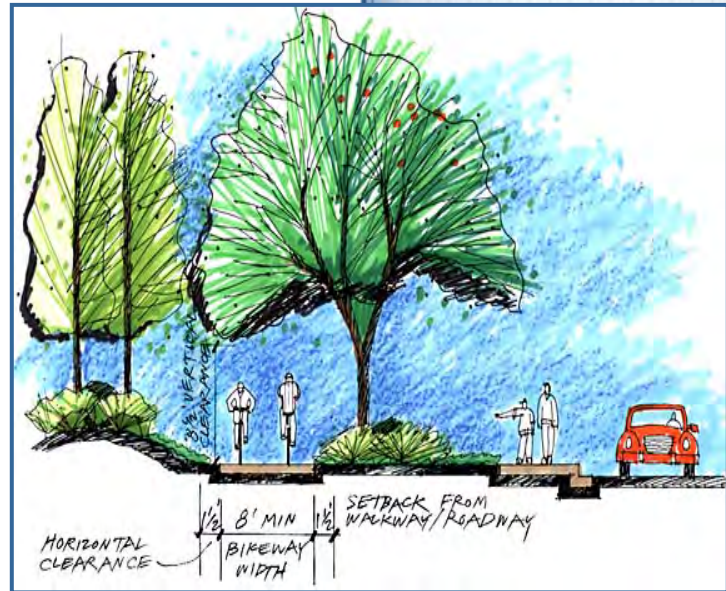


Fig. 9.39 - Class I Bikeway

**9.13.3.2 Class II Bikeways.** A Class II Bikeway shares the right-of-way with a roadway or walkway. It is indicated by a bikeway pictograph on the pavement and a continuous strip on the pavement or separated by a continuous or intermittent curb or other low barrier (Fig. 9.40). Class II Bikeway considerations include:

- Because some separation is provided for bicycle travel, a Class II Bikeway provides some level of safety for the bicyclist and pedestrian.

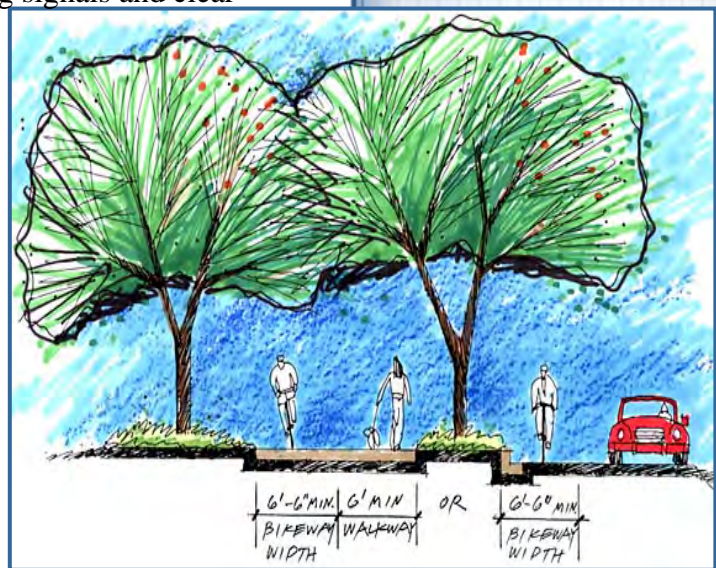


Fig. 9.40 - Class II Bikeway



- While crossing by pedestrians or automobiles are discouraged, they are not as controllable as they are on a Class I Bikeway because the Class II Bikeway is adjacent to the walkway or roadway.
- Because Class II Bikeways are tied to the adjacent roadway or walkway, route selection is important to maintain appropriate bikeway gradient and curvature.
- Class II Bikeways generally require less space than Class I Bikeways because they follow the alignment of and share the right-of-way with a roadway or walkway.

**9.13.3.3 Class III Bikeways.** A Class III Bikeway shares the right-of-way with a roadway or walkway. It is not indicated by a continuous strip on the pavement or separated by any type of barrier, but it is identified as a bikeway with signs (Fig. 9.41). Class III Bikeway considerations include:

- Because no separated is provided, there is a higher potential for safety conflicts between automobiles and bicycles and between bicycles and pedestrians.
- Class III Bikeways provide continuity within the bikeway network and designate preferred shared routes to minimize potential conflicts. To maintain safety for bicyclist and pedestrians, Class III Bikeways should be developed, if possible, only where automobile and pedestrian traffic is moderate to light.
- Because Class III Bikeways share the roadway or walkway, route selection is important to maintain appropriate bikeway gradients and curvature.
- Class III Bikeways require the least space because they share the pavement with a roadway or walkway.

**9.13.4 General Guidelines.**

- Wherever possible, provide a designated right-of-way for bike traffic, separate from



Fig. 9.41 - Class III Bikeway

vehicular and pedestrian routes.

- Locate bikeway crossings away from vehicular intersections with crossings marked on the street pavement.
- When separate bicycle right-of-ways are not feasible, designate bikeway lanes with paint on the right-hand side of roadways.
- Bikeways should never share undesignated space with roadways except at crossings.

**9.13.5 Bikeway Furnishings.** Encourage use of the bicycle system by making trails visually attractive and providing pedestrian amenities in appropriate locations. Provide site furnishings such as benches, tables, waste receptacles, drinking fountains, and signage along paths. Location of these amenities should be in response to travel distance and traffic volume.

**9.13.6 Bicycle Storage.** Provide bicycle storage racks in areas that can be visually supervised and in close proximity to building entrances, high activity areas, major workplaces, and recreational facilities, while avoiding conflicts with pedestrian circulation. Bicycle storage areas should be covered, especially at barracks, and easily accessible to building entrances (Fig. 9.42).

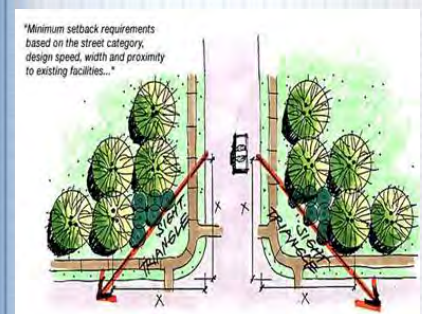
**9.13.7 Landscaping.** Use a combination of canopy and ornamental trees along bicycle paths for shade, route definition, and visual interest. Provide evergreen buffers to screen harsh winds and undesirable views.

**9.13.8 Crosswalks.** Provide crosswalks at all intersections of roads and walkways/bikeways. When laying out the crosswalk, consider the following:

- Extend walk's paving across the road in heavily used areas. Raised crosswalks eliminate the need for curb ramps in sidewalks.
- Provide a clear line of sight for motorist and pedestrians. Do not plant in sight lines. Walkways should meet the road at 90 degree angles (Fig 9.43).
- Adequate light should be provided.
- Provide barrier-free access at all intersections or used raised crosswalks.



**Fig. 9.42 - Bicycle Storage Should Be Covered**



**Fig.9.43 - Adequate Sight Lines Give Pedestrians an Unobstructed View of Crosswalks**



**9.13.9 Walkway and Bikeway Lighting Design.** Roadway lights and building exterior lights can serve also as walkway and bikeway lights. Maximum use will be made of multi-purpose lighting systems. Paragraph 10.4 of [Technical Manual \(TM\) 5-811-1, Electric Power Supply and Distribution](#) directs the following walkway and bikeway lighting standards.

**9.13.9.1 Intensities.** Values are dependent upon whether walkways and bikeways are adjacent to roadways or are isolated from vehicular traffic.

**9.13.9.1.1 Adjacent to Roadways.** Walkways and bikeways will be illuminated to not less than one-half the maintained illumination required for adjacent roadways. Areas having in grade, such as stairs and ramps, will require special treatment. Crosswalks in the middle of the block will be illuminated to 1.5 to 2 times the normal roadway lighting level.

**9.13.9.1.2 Remote from Roadways.** Walkways and bikeways remote from roadways will have a minimum of 5 lux (.5 foot-candle) average illumination measured in 10-foot levels. Pedestrian tunnels will have 40 lux (4.0 foot-candles), stairways will have 6 lux (0.6 foot-candles), and overpasses will have 3 lux (0.3 foot-candles) illumination.

**9.13.9.2 Pole design.** Where pole mounted lights illuminate only walkways or bikeways, shorter poles are most suitable, but luminaire height will not be less than 10 feet. Construction will be such as to minimize vandalism by use of break-resistant lenses, tamperproof screws, and sturdy poles.

**9.13.10 Signs.** The federal Manual of Uniform Traffic Control Devices (MUTCD) provides standards signs and markings for bicycle lanes and related bicycle facilities. See the [MUTCD, Chapter 9](#) and any applicable amendments for traffic controls for bicycle facilities standards (Fig. 9.44).

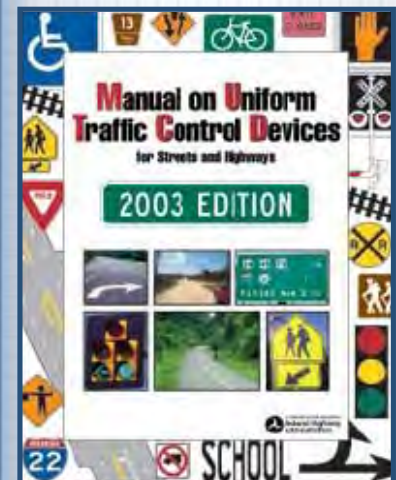


Fig. 9.44 – Manual on Uniform Traffic Control Devices

## 9.14 ARMY STANDARDS

**9.14.1** The cited Army Standards shall be met.

- [Army Regulation \(AR\) 420-72, Transportation Infrastructure and Dams](#)



- [Unified Facilities Criteria \(UFC\) 3-210-02, Design: POV Site Circulation and Parking](#)
- [Unified Facilities Criteria \(UFC\) 3-230-18FA, Design: General Provisions and Geometric Design for Roads, Streets, Walks, and Open Storage Areas](#)
- [Unified Facilities Criteria \(UFC\) 3-260-02, Design: Pavement Design for Airfields](#)
- [Technical Manual \(TM\) 5-811-1/Air Force AFJMAN 32-1080, \*Electric Power Supply and Distribution\*](#)
- [Technical Manual \(TM\) 5-850-2/Air Force AFJMAN 32-1046, \*Railroad Design and Rehabilitation\*](#)
- [Manual For Railway Engineering](#)
- [Unified Facilities Criteria \(UFC\) 4-010-01, \*DoD Minimum Antiterrorism Standards for Buildings\*](#)
- [Americans with Disabilities Act Accessibility Guidelines \(ADAAG\)](#)
- [Uniform Federal Accessibility Standards \(UFAS\)](#)
- [Manual of Uniform Traffic Control Devices \(MUTCD\)](#)

## 9.15 REFERENCES

9.15.1 The following references are provided for guidance.

- [Unified Facilities Criteria \(UFC\) 2-600-01, \*Installation Design, Chap 9\*](#)
- [U.S. Air Force, \*Landscape Design Guide, Parking Area\*](#)
- [U.S. Air Force, \*Landscape Design Guide, Walkways and Bikeways\*](#) (Provides a comprehensive walkways and bikeways planning guide including sections on paving materials and gradients and curvature data).
- [Chicago's Bike Lane Design Manual](#) (Provides a comprehensive series of technical drawings and design specifications for bike lanes).

Links

[Go to Section 10](#)

[Go to Table of Contents](#)



## 10.1 INTRODUCTION

**10.1.1** The Landscape Design Standards includes the selection, placement, and maintenance of plant material on Fort Gordon. Landscape plantings provide a simple and cost effective enhancement to the general appearance of the installation.

The visual image of Fort Gordon is defined not just by architectural character and site organization, but also by an attractive, organized landscape design. Identification of visual zones within the installation can benefit from development of landscape designs that address the objectives in this section. Preservation and creation of open space, and traditional space, and the visual enhancement of dominant features on Fort Gordon can be achieved through successful implementation of landscape principles.

The presence of plant material on Fort Gordon greatly enhances the visual character and environmental quality of the installation. Preservation of existing high-quality trees within the installation, the creation and use of the landscape palette, (Appendix O), and improved maintenance programs will add visual appeal to the environment and establish a higher value to the installation.

Plantings add an element of human scale to open spaces and can be used functionally to screen undesirable views, buffer winds, reinforce the hierarchy of the circulation system, or provide a visual transition between dissimilar land uses (Fig. 10.2).



**Fig. 10.2 - Use native Plants to Improve Visual Quality**



**Fig. 10.2 – Human Scale**

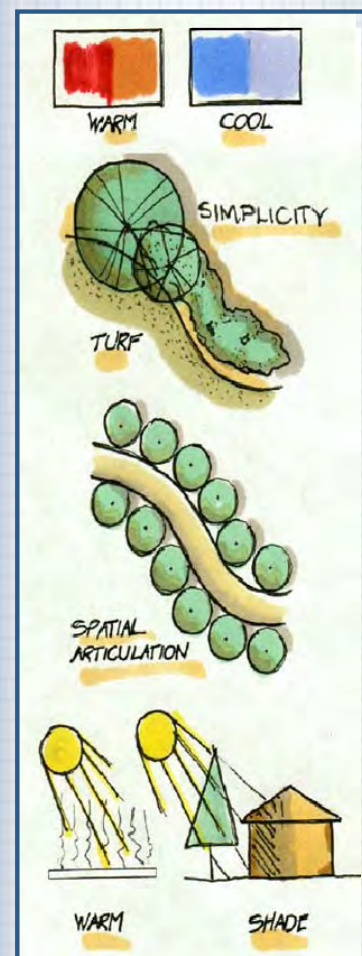
## 10.2 LANDSCAPE OBJECTIVES

**10.2.1** The overall objective of the use of plant material within the installation is to improve the physical and psychological well being of the people who live and work on the installation. This is achieved through the following objectives:

- Preserve and enhance civic open space (Fig. 10.3), focal points, and architectural features through proper placement of selected native trees, forest lands, and detailed planting features such as shrubs and groundcovers. Shape open space to accent an architectural feature and to create interest.
- Improve the overall visual quality of Fort Gordon through the use of selected native and other adapted plant material (Fig. 10.1) to create a sense of place within the installation, frame views and vistas, accent key facilities and entrances, and provide pleasing visual and sensory experiences.
- Improve the circulation system of pedestrian walkways, roadways and bikeways by reinforcing and defining the system with plant material.
- Define a standard by which landscape plant material is used to screen undesirable views or structures, buffer non-compatible land uses, and establish scale to open spaces and built structures.
- Minimize maintenance operations through the use of mass plantings, better organized landscape developments, and a greater use of native material.
- Minimize the appearance of landscape clutter created by the heavy pruning of individual shrubs making more “broad brush” landscape gestures.
- Establish a standard plant palette to enhance force protection measures, as well as incorporate force protection requirements into the landscape design.
- Enhance Antiterrorism capabilities.



**Fig. 10.3 – Accent Open Space**



**Fig. 10.4 - Principles of Design Illustrated**



## 10.3 PRINCIPLES OF LANDSCAPE DEVELOPMENT

**10.3.1** Creation of a quality landscape design is based on the following artistic principles which should be applied in the development of all landscape designs: (Fig. 10.4).

- **Unity.** The selection and placement of plant material can be used to blend, screen, and soften incompatible architectural or other unattractive visual impacts. Plant material as a unifying element can be placed in front of a building or view to frame and enhance the visual impact.
- **Harmony.** The aesthetic integration of diverse elements results in harmony. Within a design, harmony can be accomplished through the use of site amenities of a similar style and character, as well as a community of indigenous and compatible plant material.
- **Line.** As part of the landscape design, the creation of lines should be pleasing and proportionate. Lines are expressed through paths, walls, fences, and planting masses. In a landscape composition, lines will direct the movement or sight to a particular area of interest. The use of a strong axis line in a design should be used sparingly as it invokes the need for a strong focal point at the termination of the axis (Fig. 10.5). Most successful designs using this approach can be seen in large formal settings where the axis is reinforced with proportional planting designs. Figure 10.6 shows the use of a bent axis in the same context as the strong axis. The bent axis is more successful when used in proportion to smaller scale buildings.
- **Balance.** Plant material can be selected and placed to provide visual equilibrium or balance through the use of either a symmetrical or asymmetrical planting scheme. Symmetrical plantings are generally more formal while asymmetrical plantings are informal.
- **Contrast.** Plant material can be selected and placed to provide differences in size and shape that add interest to the environment. Plants can be located to provide a backdrop for other plants such as a hedge behind a bed of annuals or perennials.
- **Variety.** Variety is created by introducing different forms or



Fig. 10.5 – Strong Axis



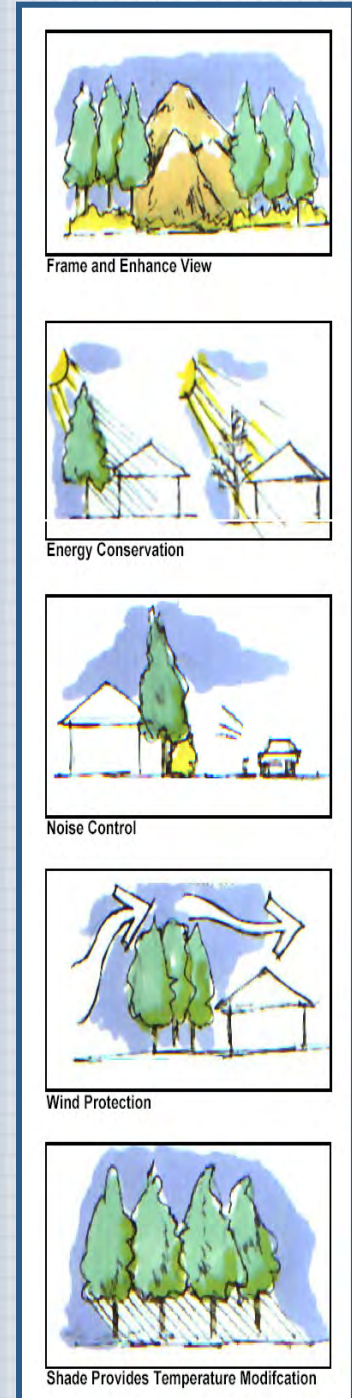
Fig. 10.6 – Bent Axis

types of elements. Too little variety leads to monotony. Introducing too many elements can create a chaotic, unmanageable environment. A fine balance between extremes produces a pleasant sense of unity in the landscape design.

- **Repetition.** Repetition is achieved by massing or grouping individual plants or site amenities. Repetitive elements in the landscape reflect or amplify architectural geometry and can improve the connection between indoor and outdoor space.
- **Color and Texture.** Plants can be selected and placed to provide visual interest according to their color and texture. Colors are classified as either warm (red, orange, yellow) or cool (violet, blue, green). Texture is classified as either coarse or fine.
- **Simplicity.** Landscape plans should be broad and simple in form to limit excessive maintenance. Plant material should be grouped in beds with simple edges that are easy to mow. Small turf areas should be avoided because of the difficulty of mowing. The use of annuals should be minimal because of the high maintenance involved.
- **Ultimate Effect.** The landscape plan should be prepared with consideration for the mature size of all plants. The spacing of all material should utilize nursery industrial standards for mature material to account for spread as well as height. The ultimate height of the material should also be considered in relation to windows and other visual concerns.
- **Spatial Articulation.** Plants can be selected and placed to create enclosed spaces or to separate spaces from one another. They can also be used to direct people by visually defining and reinforcing patterns of movement. The degree of enclosure, separation, or movement is dependent upon the density, form, and type of plants used.

## 10.4 SUSTAINABLE LANDSCAPE DEVELOPMENT

**10.4.1** The use of plant material on Fort Gordon promotes the sustainability of the development (Fig. 10.7). Trees, shrubs, groundcover, and vines provide aesthetic appeal as well as



**Fig. 10.7 – Plant Material Promotes Sustainability**

preservation of fauna and flora, energy conservation, climate modification, erosion control, air purification, and noise abatement.

## 10.5 LANDSCAPE DESIGN GUIDELINES

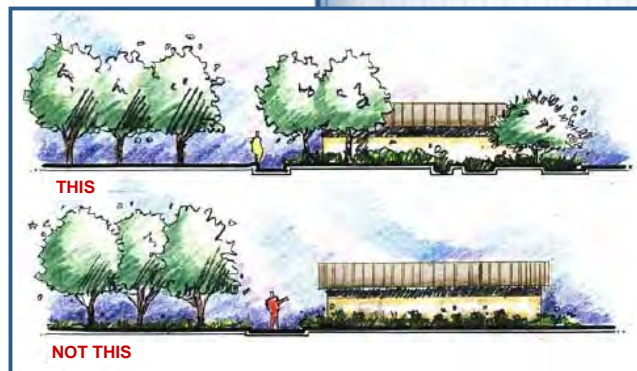
**10.5.1** Proposed plantings must be reviewed to ensure that site conditions (soil, topography, adjacent uses, and architecture) and climatic criteria (sun, shade, and moisture requirements) are considered in the desired plant design and selection (i.e., form, texture, color, size). The uses and users of the site must also be considered. Landscape planting plans should be approved by qualified personnel to provide quality assurance and promote design consistency within each visual zone.

**10.5.2** The following paragraphs present landscaping guidelines for the various locations of plant material use.

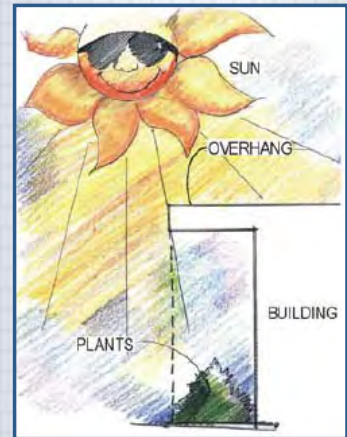
**10.5.2.1 Foundation Planting.** Foundation planting provides a green background for additional plantings, adds scale and character to the building, helps to integrate the building with its surroundings, screens HVAC and other utilities, and helps create a sense of arrival. When developing foundation plantings plans consideration should be given to force protection measures. A thorough knowledge of plant material characteristics and force protection requirements is needed. Figures 10.8 thru 10.10 illustrate the importance of foundation plantings in relation to building structures.

Accent should be given to entry points for pedestrian interest and as part of a wayfinding system to identify key points on Fort Gordon.

**Fig. 10.10 – Foundation Planting**



Use the architecture and function of the building to evaluate the planting design and selection of plant material. Identify key pedestrian corridors and linkages to adjacent buildings and land uses.



**Fig. 10.8 – Avoid Plantings Under Building Overhangs**



**Fig. 10.9 – Energy Conservation**



Incorporation of mass plantings and accent shrubs at key points simplify the design and improve maintenance procedures. The proper design and installation of planting beds to eliminate weeds and other invasive plants is key to successful foundation plantings. See Figures 10.11 and 10.12.

Use trees along walkways to frame the corridor and to accent design elements of the landscape and building. Allow space for mature growth and development of root systems. Careful consideration should be given to the use of large trees specifically for this reason. Consider using tree groupings to frame or accent walkways and streetscapes as shown in Figure 10.13.

Consideration should also be given to tree selections that do not promote insect infestation. Trees that bear fruits and flowers attracting nesting birds should be carefully located.

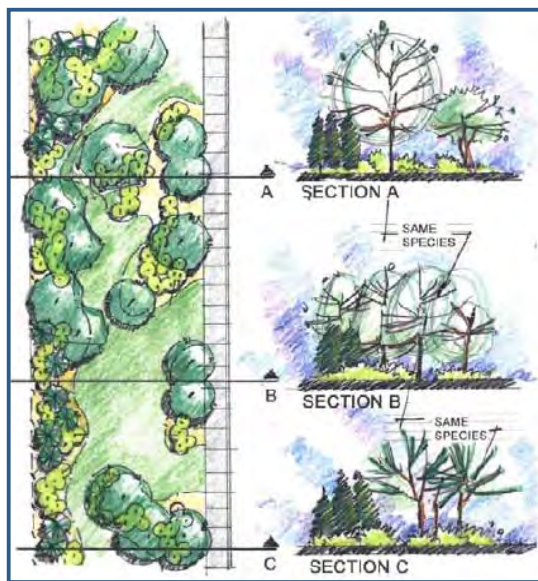


Fig. 10.13 – Tree Group Sections

### 10.5.2.2 Screening (Fig. 10.14).

**10.5.2.2.1 Windscreens.** Use a combination of evergreen and deciduous trees to provide windbreak protection from prevailing winds. Windbreak plantings should be irregular in form, rather than straight and evenly spaced, in order to provide more effective wind control and to visually blend with the natural character of the installation.

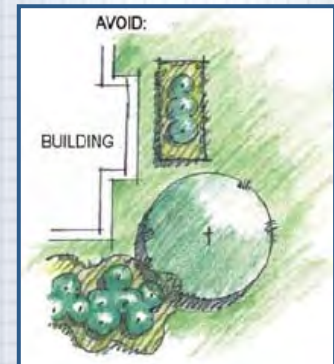


Fig. 10.11 – Avoid Small Planting Areas

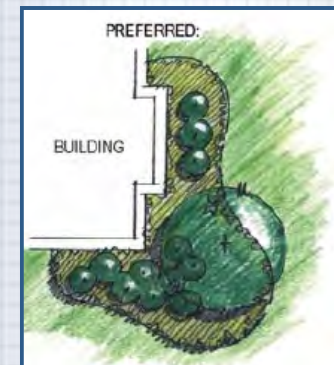


Fig. 10.12 – Prefer Mass Planting Areas

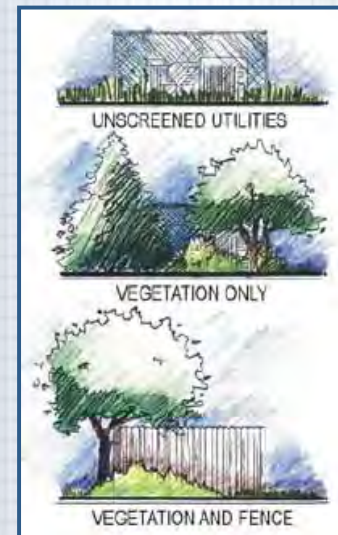
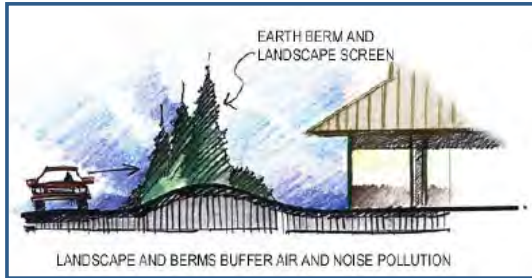


Fig. 10.14 – Screening Types

**10.5.2.2 Screening of Dumpsters.** Landscape planting should be used to supplement wood fence and masonry wall dumpster enclosures (Fig. 10.15).

**10.5.2.3 Buffer Planting.** Use a mixture of evergreen and deciduous trees and shrubs to visually separate land uses and to help separate visual zones (Fig. 10.16).

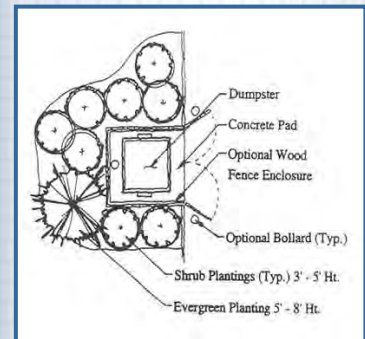


**Fig. 10.16 - Buffering**

**10.5.2.4 Open Space Planting.** Enhance open space areas with planting. Use a mix of evergreen, deciduous, and flowering trees. Plant the same kind of trees in massive groupings to impact the vast open areas (Fig. 10.17).

**10.5.2.5 Street Trees.** Street tree plantings should be used to reinforce vehicular hierarchy, orient and direct traffic, upgrade views, and to visually de-emphasize on-street parking. Also, in the design of a street tree planting, separate plant species may be used to identify distinctive details or areas of the installation, for example, a particular land use relationship, historical district, community area, or other similar entity.

- Use formal street trees in single rows to visually reinforce primary and secondary roads. Use regularly spaced and uniformly shaped deciduous trees to provide a regimented appearance (Figures 10.18 and 10.19).
- Use informal groupings of street trees along tertiary routes. Utilize medium size deciduous trees to screen on-street parking along roadways. Set trees 1 to 2 meters (3 to 6 feet) from the back of curbs. Spacing should be uniform, except where curb cuts interrupt regular spacing.
- As a general rule, street trees should be deciduous species, resistant to salt and root pressure, and should have a 10' to 12' high clearance between the street pavement and branch height to allow adequate clearance for pedestrian and vehicle traffic to pass unimpeded by lower branches.



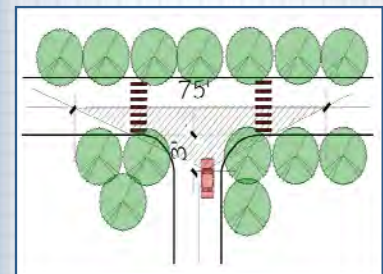
**Fig. 10.15 - Screen Dumpsters**



**Fig. 10.17 - Enhance Open Spaces with Plantings**



**Fig. 10.18 – Use Formal Street Trees in Single Rows**



**Fig. 10.19 – Use Street Trees to Visually Reinforce Roadway Hierarchy**

- The street tree layout should be coordinated with the layout of proposed street lighting.
- Appropriate plant heights should be used within sight triangles to ensure safe views from intersections.
- Weeping trees should not be used in locations where they may hang over the roadway or block views.

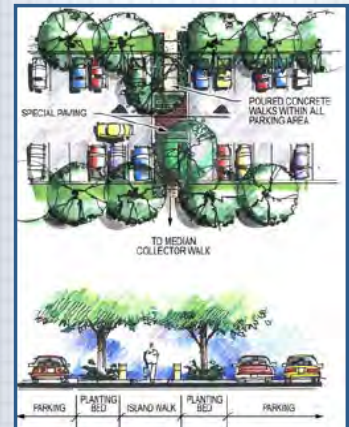
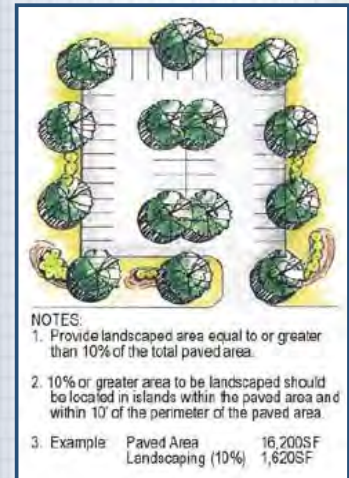
**10.5.2.6 Parking Lot Planting.** Parking lots are often the least attractive elements on a military installation. The use of landscape plant material and earth berms can greatly improve the appearance of these areas as well as help define circulation and reduce heat gain during summer months (Fig. 10.20).

- Use shade tree plantings at parking lots to reduce glare and moderate ambient air temperatures on the lot. Optimum spacing of parking lot shade trees is 10 to 12 meters (35 to 40 feet) on center.
- Choose trees and shrubs that require minimum maintenance and will not litter the parking area with leaves, fruit, or nuts.
- Consider sight distances near entrances and exits when selecting and placing plant material.
- Select trees, shrubs, and ground covers that can withstand harsher conditions, such as sun, glare, heat, and reduced water supply.
- Use a mix of evergreen and deciduous plant material to screen parking areas from adjacent uses.

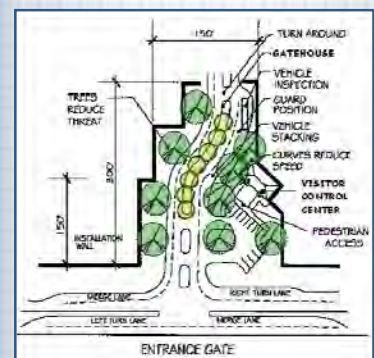
**10.5.2.7 Environmental Control Planting.** When properly placed, plants can provide environmental benefits, as well as address visual concerns.

**10.5.2.7.1** Use deciduous trees and shrubs at courtyards, buildings and along streets to provide shade, moderate temperatures and reduce glare during the summer months while allowing solar exposure in the winter.

**10.5.2.7.2** Locate deciduous plantings on the southeast and southwest corner of buildings or courtyards to mitigate solar



**Fig. 10.20 - Provide Parking Lot Planting to Reduce Heat Gain**



**Fig. 10.21 - Landscaping at Entrance Gates will Meet AT/FP Requirements**

radiation and glare due to heat build-up and lower sun angles in the mid-morning and late afternoon hours.

**10.5.2.7.3** Use mixed massings of deciduous shrubs and evergreen trees and shrubs to provide sound control along primary and secondary roads.

**10.5.2.8 Image Planting.** The image of the installation is formed by the visual impressions that exist within the installation. The primary locations of highly visible images are the main gate, along primary circulation systems, and at areas of high concentrations of people. Features such as signs, statues, static displays, and other primary visual images can be improved by the use of trees, shrubs, and ground cover.

**10.5.2.9 Entrances to the Installation.** The entrances and streetscapes into the installation are areas to place landscaping that will develop a strong visual image and provide visual interest during the year. The entrance to the installation creates the first visual impression for the visitor (Fig. 10.22). Open space adjacent to the entrance should be preserved to create an image of grandeur and to serve as an announcement of arrival.

**10.5.2.9.1** The landscape materials and planting areas should be proportional in scale to the hierarchy of the street on which they are located.

**10.5.2.9.2** Landscaping must be integrated with the Force Protection requirements of Section 12. Low shrubs, groundcover, annual/perennial plants and canopy trees provide seasonal interest as well as maintain views required to ensure force protection measures. Large evergreen trees are discouraged in these locations because they may obstruct sightlines and impact the need for force protection. Adequate lines of sight must be maintained for guard personnel to observe vehicular and pedestrian traffic approaching the gate (Fig. 10.21).

**10.5.2.10 Zeroscaping.** Where appropriate, to conserve water and lower maintenance consider zeroscaping.

**10.5.2.11 Xeriscap.** Xeriscap is the conservation of water and energy through creative and adaptive landscape design. Xeriscap landscapes provide attractive solutions that save money, water, and maintenance. The following website provides guidance on specific design principles of the xeriscap design process and xeriscap design application:



**Fig. 10.22 Fort Gordon's Main Entrance**

**Plant Categories**

**Cultural Characteristics**

[Growth Rate-Rapid](#)

[Growth Rate-Medium](#)

[Growth Rate-Slow](#)

[Disease/Pest Resistance](#)

**Environmental Characteristics**

[Acidic Soil Tolerant](#)

[Alkaline Soil Tolerant](#)

[Dry Soil Tolerant](#)

[Moist Soil Tolerant](#)

[Poor/Rocky Soil Tolerant](#)

[Salt Tolerant](#)

[Shade Tolerant](#)

[Summer Wind Tolerant](#)

[Urban Condition Tolerant](#)

**Ornamental Characteristics**

[Blue Flowers](#)

[Ornamental Bark](#)

[Ornamental Fruit](#)

**Fig. 10.23 – Plant Categories**

- [USAF Landscape Design Guide, Xeriscape.](#)



## 10.6 PLANT MATERIAL SELECTION

**10.6.1** Trees, shrubs, ground cover and turf are the major elements of a planting composition. Basic plant selection criteria should consider creating a unified composition utilizing native materials for low maintenance and sustainability, avoiding incompatible colors, textures and forms, and matching the appropriate plant to the land use, situation, and environmental condition.

**10.6.2** The ability of plant material to provide lasting benefit is dependent upon the plant's hardiness and its appropriateness to the site use. Major factors affecting plant hardiness are soil type and organic content, temperature, moisture and light. These climatic conditions can be modified to an extent by specific site conditions, such as wind protection, solar orientation, and planting design, to create microclimates.

**10.6.3** Selecting appropriate plants for a given condition is only one aspect of planting design. Compositional arrangement to provide texture variety and to accent site and building features is another. The selection and composition of a planting design requires an understanding of each plant's characteristics, form, and environmental needs as well as how each plant can relate to and complement other plants in the design. Plants are used in four basic design categories (Fig 10.23):

- Canopy
- Barrier
- Screen (or Baffle)
- Groundcover

## 10.7 PLANT PALETTE AND PLANT CATEGORIES

**10.7.1** The plant palette and categories are designed to help the designer choose the best plant for each particular set of design requirements. The plants that appear on the palette and in the categories were selected for their hardiness and their ability to survive in this geographical area. To use them effectively, the design requirements must be well defined for the specific site.

### **Plant Categories Cont.**

#### **Ornamental Characteristics**

[Pink/Purple Flowers](#)

[Red/Crimson Flowers](#)

[White/Cream Flowers](#)

[Yellow/Orange Flowers](#)

[Yellow/Orange/Red Fall Color](#)

#### **Functional Characteristics**

[Erosion Control/Bank Stabilizer](#)

[Foundation Plants](#)

[Large Hedges \(+25'\)](#)

[Medium Hedges \(10-20'\)](#)

[Low Hedges \(4-10'\)](#)

[Naturalizing/Conservation](#)

[Park Trees](#)

[Large Street Trees \(+35'\)](#)

[Small Trees \(15-35'\)](#)

[Thorny Plants](#)

**Fig. 10.23 – Plant Categories Continued**

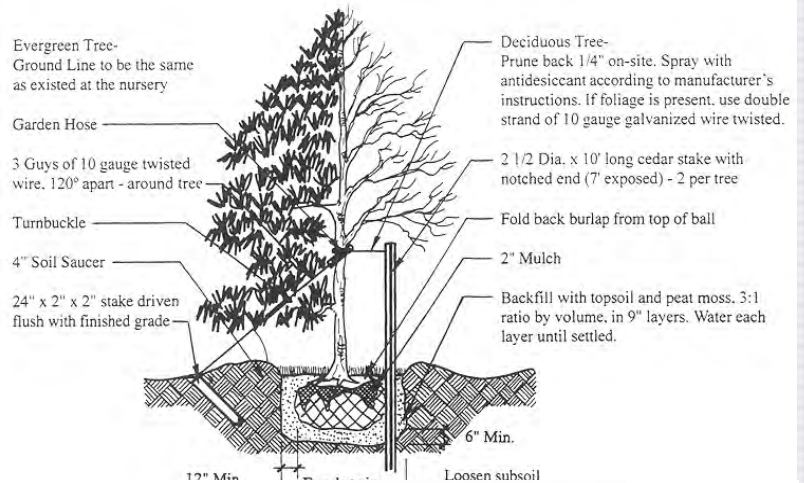


## 10.7.2 The Plant Palette.

10.7.2.1 A select group of plant materials has been divided into the following six categories:

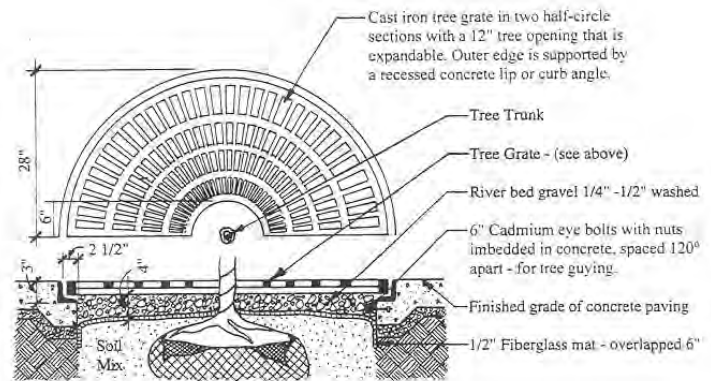
- deciduous trees
- coniferous trees
- deciduous shrubs
- coniferous shrubs
- broadleaf evergreen shrubs
- groundcover and vines

10.7.2.2 On the palette, the plants appear in alphabetical order by their botanical name, followed by their common name, design characteristics, cultural information, recommended use, and miscellaneous notes. The plant palette is presented in a matrix format in [Appendix O](#).



## 10.7.3 The Plant Categories.

10.7.3.1 Plants from the plant palette with similar characteristics have been cataloged in the Plant Categories (Fig. 10.23). These characteristics could be cultural (e.g., upright, narrow form), environmental (e.g., shade tolerant), ornamental (e.g., red fall color), or functional (e.g., screening plant). Characteristics include: Cultural Conditions (mature height and spread, form and growth rate, disease and pest resistance), Environmental Conditions (sun/shade, pH range, soil moisture required, and wind/sun), and Ornamental Characteristics (flower color, autumn color, fruit color, and/or summer leaf color).



**Fig. 10.24 - Install Plant Material According to Industrial Standards**

**10.7.3.2** Each category describes a list of plants that share a similar quality. For example, materials that are shade tolerant would be placed in the Shade Tolerant group under the "Environmental Conditions" heading. To further explain the Categories, under the "Environmental Conditions" heading, in the Shade Tolerant group, all shade tolerant deciduous trees would be listed under "Deciduous Trees"; all shade tolerant Coniferous trees would be listed under "Coniferous Trees"; and so on.

**10.8 PLANT MATERIAL INSTALLATION**

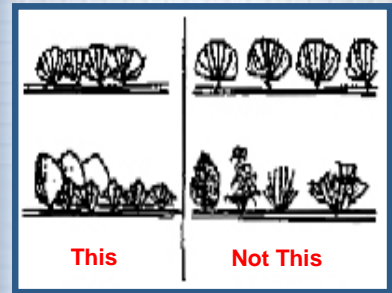
**10.8.1** A key step in assuring successful planting is to select plants of the highest quality. Plant material should be of the size, genus, species, and variety to comply with the recommendations and requirements of the "American Standard for Nursery Stock" ANSI Z60.1 (Fig. 10.24).

**10.8.2** As part of the design process and prior to plant installation, review the installation's Master Plans, Basic Information Maps, or As Built Drawings for utility locations and verify with the Directorate of Public Works or equivalent.

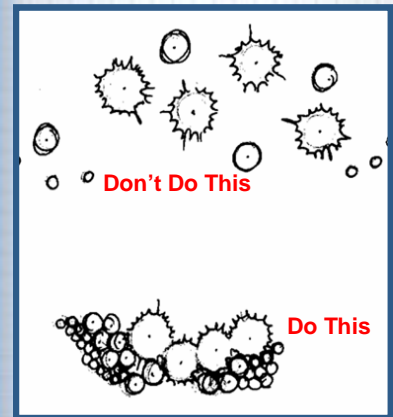
**10.8.3** The planting and establishment of trees, shrubs, ground covers, and vines is detailed in [TM 5-803-13](#), Chapter 3.

**10.8.4 General Guidelines for Plant Installation.**

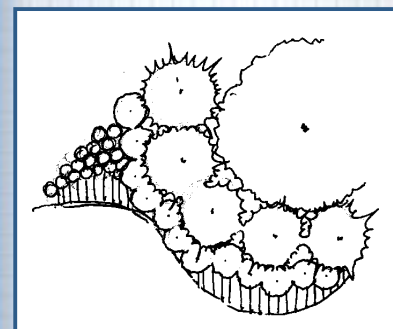
- At planting time, thin plants by removing one-third of the vegetative material.
- Spray all evergreens with an antidesiccant within 24 hours of planting.
- Water all plants thoroughly during the first 24-hour period after planting.
- Site all plants and stakes plumb.
- Space plants according to their mature size (Fig. 10.25).
- Install plant materials in groups for greater impact (Fig. 10.26).
- Installation of Lawn Areas.
- Installation techniques for turf are detailed in [Unified Facilities Criteria \(UFC\) 3-210-05FA, Design: Landscape](#)



**Fig. 10.25 – Space Plants According to their Mature Size**



**Fig. 10.26 – Grouped Plants Have Greater Impact**



**Fig. 10.27 – Group Plants in Mulched Beds to Reduce Maintenance**

[Design and Planting Criteria](#), Chapter 4. The details include site evaluation, site preparation, selection of turf, and maintenance requirements (Fig. 10.27).

## 10.9 MAINTENANCE OF PLANT MATERIAL

**10.9.1** The ease of maintenance should be one of the primary goals when considering the success of any planting design.

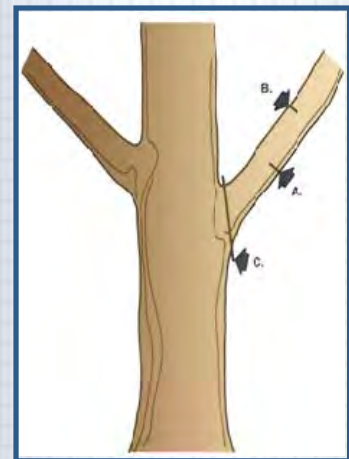
**10.9.2 Pruning.** In general plant material should be allowed to conform to its natural shape. This practice allows the plant to mature in a health manner, and saves the time and energy required for trimming. The pruning of trees and shrubs is done to maintain overall plant health, direct plant growth, maintain a desired shape, and increase flower or fruit development.

### 10.9.2.1 Pruning Shrubs.

- Do not prune shrubs flat across the top.
- Prune branches yearly on thick-branched shrubs and at the base of the shrub.
- When pruning deciduous shrubs prune shrub stems as close to the ground as possible and shrub branches as close to the stem as possible.
- When "thinning out" deciduous shrubs prune about one-third of all branches where they meet their main stem.

### 10.9.2.2 Pruning Trees.

- Remove a large limb by making three cuts as follows:
- Make the first cut at the bottom of the branch 12-24" from the branch attachment (Cut A, Fig 10.28).
- Make the second cut on the top of the branch within 1" of the undercut (Cut B, Fig 10.28).
- Make the final cut just beyond the outer portion of the branch collar (Cut C, Fig 10.28). The first two cuts were necessary to remove the weight of the branch to allow cut #3 to be clean without ripping the bark.
- Never cut the central leader of the tree.



**Fig. 10.28 - Proper Tree Pruning Procedures**

- Coniferous evergreens trees should be pruned, during the spring, by snipping off new growth. Avoid geometrically shaping plant material while pruning.

### 10.9.3 Mulching.

- Use mulch around the base of plant material to provide for greater moisture and help inhibit the growth of weeds and grasses. Mulch should be maintained at a depth of two (2) to four (4) inches.
- The best time to mulch for water conservation is in the late spring. Apply mulch immediately to new fall plantings.

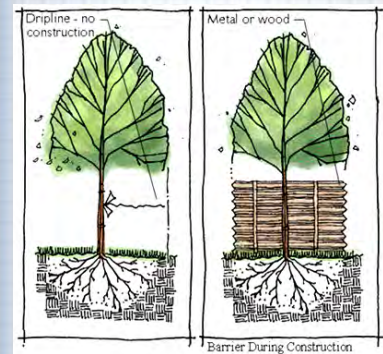
**10.9.4 Ground Cover Maintenance.** Although ground covers do not require pruning, they may be periodically dug up in the spring or fall for propagation and to prevent overcrowding in their beds.

**10.9.5 Landscape Maintenance Schedule.** The general objective of a landscape maintenance schedule is to ensure an orderly and efficient care of the grounds. The landscape maintenance schedule included in the Army Installation Design Guide ([See Appendix F](#)) identifies times throughout the year when specified maintenance should be undertaken. Use of the landscape maintenance schedule will improve all aspects of landscape on the installation. Materials and supplies can be ordered in a timely fashion, manpower needs can be calculated and anticipated, and a correlation between the level of maintenance and appropriate cost can be derived.

## 10.10 TREE PROTECTION AND PRESERVATION

**10.10.1** Existing urban trees and forest should be preserved if they are in good health. Construction should be planned to provide for the preservation of significant trees.

**10.10.2** During the clearing and construction process, trees should be protected from damage. Construction barricades should be erected to protect the existing trees to be preserved. The barricades should be no closer to the trunk of the tree than one-half the distance from the trunk to the drip line. Existing trees that cannot be preserved should be considered for transplanting to a different location on site or to a different site.



**Fig 10.29 - Construct a Barrier at Drip Line During Construction to Maintain Grade**

**10.10.3** Changes in the grade of the soil around trees can cause extensive root damage and eventually death of the tree. To prevent damage to the tree, it is important to maintain the existing grade for least the size of the threes canopy (the drip line) (Fig. 10.29).

## 10.11 ANTI-TERRORISM/FORCE PROTECTION CONSIDERATIONS

**10.11.1** The presence of vegetation on an installation can have both beneficial and detrimental impacts on security. The selection and placement of landscape plant material on Army installations is an integral element in the provision of protective measures to reduce the threat of terrorism.

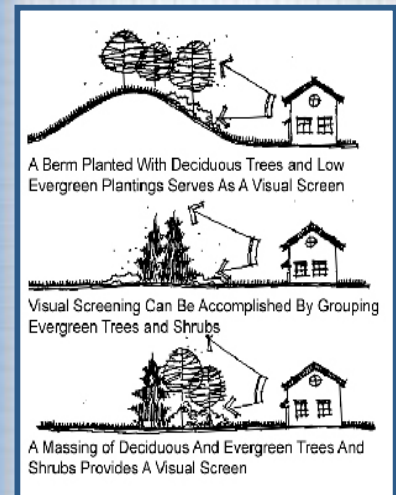
**10.11.2** Proper selection and placement of trees and shrubs can be utilized to provide visual screening without creating concealment for covert activity. The landscape architect responsible for tree placement should work closely with installation force protection experts to design a landscape plan that provides visual screening without compromising Antiterrorism measures (Fig. 10.30).

**10.11.3** The plant material must allow building occupants to see out, but must not allow outside forces to monitor interior activity. The landscape architect should incorporate the following aspects into the design:

- Avoid conditions within 10 meters (33 feet) of inhabited structures that permit concealment of aggressors or obscure the view of objects or packages 150-millimeters (6 inches) in height from the view of security personnel. This results in the placement of shrubs and trees that are loose rather than dense in growth habit and possess multiple small stems rather than a single trunk that will obscure a 150 mm (6 inch) package.
- Vegetation groupings provide reduction of blast effect.
- Plant material selection and placement shall minimize potential hiding places for bombs and aggressors.
- Provide vegetation screens for play areas and outdoor recreation areas to obscure from off-installation view.
- Use trees to obscure sight lines of on-installation buildings from off-installation buildings (Fig. 10.31).



**Fig. 10.30 – Establish a Visual Barrier in Perimeter Setback**



**Fig. 10.31 – Use Trees to Obscure Sight Lines**



## 10.12 ARMY STANDARDS

10.12.1 The cited Army Standards shall be met.

- [Army Regulation \(AR\) 420-70, Buildings and Structures](#)
- [Unified Facilities Criteria \(UFC\) 3-210-05FA, Design: Landscape Design and Planting Criteria](#)
- [Technical Manual \(TM\) 5-630, Natural Resources Land Management](#)
- American Standard for Nursery Stock, ANSI Z60.1
- Overseas (Host Nation Standards)

## 10.13 REFERENCES

10.13.1 The following references are provided for guidance.

- [Unified Facilities Criteria \(UFC\) 2-600-01, Installation Design, Chap 10](#)
- [USAF Landscape Design Guide](#)
- C. Brickell and D. Joyce. Pruning and Training, 1996.

Links

[Go to Section 11](#)

[Go to Table of Contents](#)



## 11.1 INTRODUCTION

**11.1.1** Site elements include all visual elements of the installation that are considered utilitarian in use (Fig. 11.1). These elements include the following four categories of utilitarian amenities:

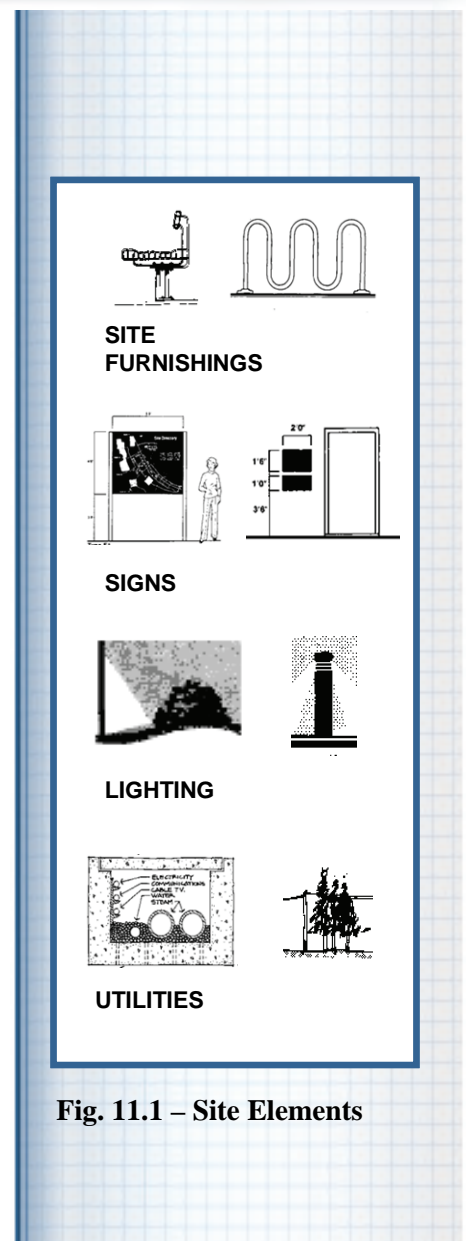
- Site Furnishings
- Signs
- Lighting
- Utilities

**11.1.2** The four sub-components provide dominant visual impacts within the installation. The specific site element features and equipment should, to the extent possible, reflect the local or regional design standards. This allows for ease of maintenance and blending into the local community. The four sub-components and their visual impacts are discussed in detail in this chapter.

**11.1.3** Overseas installations should reflect consideration of local design standards.

## 11.2 SITE ELEMENT OBJECTIVES

The site element plans for existing and future installation use should be prepared and the site elements selected to enhance the sustainability of the installation. To this end, site elements should meet the following objectives:



**Fig. 11.1 – Site Elements**

- Provide site elements that are appropriate to their intended function.
- Establish a coordinated system of site elements that provide consistency and continuity throughout the installation to convey a sense of organization (Fig. 11.2).
- The design and location of the various site elements should express an image, character, and scale appropriate to the installation.
- Design and locate all site elements to meet AT/FP requirements.
- Use recycled/salvaged materials wherever possible.
- Minimize maintenance and repair through the use of efficient products that are vandal-proof.
- Minimize negative visual impacts of all utility systems (Fig.11.3).
- Minimize environmental impacts of all utility systems.

### 11.3 SITE FURNISHINGS

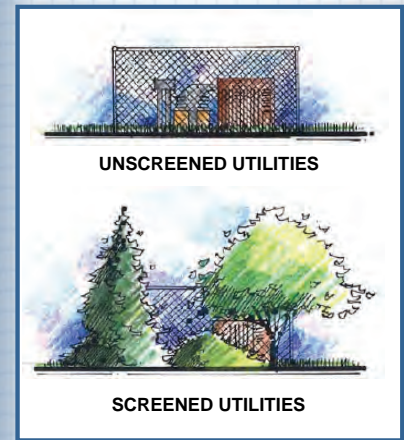
**11.3.1** Site furnishings include all of the utilitarian outdoor amenities found on an installation. These outdoor furnishings should be located in coordinated clusters to provide areas of multi-furnishing amenities (Fig. 11.4), and avoid the haphazard proliferation of furniture elements around the installation. All furnishings shall be accessible to, and usable by, persons with disabilities, in accordance with the requirements of the [Americans with Disabilities Act Accessibility Guidelines \(ADAAG\)](#) and the [Uniform Federal Accessibility Standards \(UFAS\)](#), with the most stringent standards to apply in the event of conflicts.

**11.3.2** Site furnishings include the following:

- Seating
- Tables
- Telephone Booths



**Fig. 11.2 – Establish a coordinated system of site elements**



**Fig. 11.3 - Negative and Positive Visual Impacts**



**Fig. 11.4 – Provide areas of multi-furnishing amenities**



- Shelters
- Kiosks
- Walls and Fences
- Trash Receptacles
- Dumpsters
- Flagpoles
- Movable Planters
- Bicycle Racks
- Tree Grates
- Bollards
- Play Equipment
- Mailboxes
- Monuments, Memorials, Military Equipment Static Displays
- Drinking Fountains

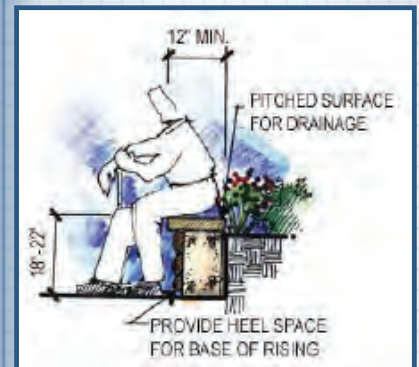
**11.3.3 Seating.** Seating includes benches and walls, as well as tables and movable chairs (Fig. 11.6).

**11.3.3.1 Benches.**

- **Bench Location.** Benches should be located in areas of high pedestrian use, and arranged to encourage socialization within a pleasant outdoor setting. This includes pedestrian nodes along primary walkways, at major building entryways, courtyards, and at bus stops.
- **Bench Sitting.** Benches should be sited on concrete pads adjacent to walkways. Provide proper clearance around benches, a minimum 2'0" setback from adjacent sidewalks and a minimum of 5'0" between front of bench and any stationary obstacle. Provide appropriate planting treatment for visual definition and seasonal shade.



**Fig. 11.5 - Trellis and Vines Provide Shelter**



**Fig. 11.6 - Retaining Wall/Seating**

### 11.3.3.2 Bench Design: (Trainee Barracks Areas)

#### Visual Zones:

- North Industrial Zone
- South Industrial Zone
- Family Housing (RCI) Zone

**11.3.3.2.1** Metal benches with backs are appropriate for the informal gathering, resting, and waiting uses characteristic of the Fort Gordon Trainee Barracks areas (Fig. 11.7). Benches shall be a contoured style, durable and maintenance-free; constructed of black thermoplastic-coated, expanded metal with black powder-coated galvanized steel legs. Standard bench size shall be 6'-0" long. In-ground mounting is recommended. Benches in this Trainee Barracks Area will be Barco Products Co., Winfield Comfort Bench (Model B6WBWINGS), or equal. Bench dimensions should meet specifications presented in the [Technical Manual \(TM\) 5-803-5, Installation Design Manual](#), Fig. 2.5, page 8. Wall mounted benches will be similar in style and color to free standing benches.

### 11.3.3.1.4 Bench Design: (Permanent Party Barracks Areas)

#### Visual Zones:

- USAR National Guard Zone
- Signal Center Barracks and Admin Zone
  - \* Except Trainee Barracks Area
- Community Center Zone
- Signal Center Schoolhouse Zone
- Medical Center Zone

**11.3.3.1.4.1** Wood benches with backs are appropriate for the informal gathering, resting, and waiting uses characteristic of the Fort Gordon Permanent Party Barracks areas (Fig. 11.8). Benches shall be a contoured style, durable and maintenance-free constructed of 2 1/2" x 2 1/2" faux cedar colored recycled plastic members with wood grain finish. Standard bench size shall be 6'-



**Fig. 11.7 – Typ. Fort Gordon Trainee Barracks Area Bench**



**Fig. 11.8 – Typ. Fort Gordon Permanent Party Barracks Area Bench**

0" long. Bench supports shall be heavy-duty with powder-coated black steel frame. In-ground mounting is recommended. Benches in this Trainee Barracks Area will be Barco Products Co., Silhouette (Model KSPB6PG), or equal. Bench dimensions should meet specifications presented in the [Technical Manual \(TM\) 5-803-5, Installation Design Manual](#), Fig. 2.5, page 8. Wall mounted benches will be similar in style and color to free standing benches.

### 11.3.3.1.5 Bench Design: (Park Settings / Open Spaces)

#### Visual Zones:

- Parks and Open Spaces

**11.3.3.1.5.1** These wood benches with backs are appropriate for the formal and informal gathering, resting, and casual uses characteristic of Fort Gordon Park Areas (Fig. 11.9). Benches shall be durable and maintenance-free constructed of a patented 2nd Site Systems (or equal) faux maple colored 100% recycled plastic lumber. Standard bench size shall be 6'-0" long. Bench supports shall be heavy-duty with powder-coated black steel frame. In-ground mounting is recommended. Benches in park like settings will be Victor Stanley, Inc. Homestead Series (Model 28), or equal. Bench dimensions should meet specifications presented in the [Technical Manual \(TM\) 5-803-5, Installation Design Manual](#), Fig. 2.5, page 8.

### 11.3.3.2 Seating Walls.

**11.3.3.2.1 Seating Walls Location.** Wherever possible, seating should be incorporated into planter boxes or retaining walls, particularly at building entrance area. Seating walls should be integrated into the overall area design and the pedestrian circulation system.

**11.3.3.2.2 Seating Wall Design.** Seating walls should generally be between 18" and 22" high, and 12" to 18" wide and constructed of textured concrete or brick in a manner to complement or match the materials of the adjacent buildings (Fig. 11.10).

**11.3.3.3 Tables.** Locate tables together with seating that is oriented to the user needs of socializing, relaxing, or eating in less formal spaces with a pleasant setting and attractive view.



**Fig. 11.9 – Typ. Fort Gordon Bench at Park Setting / Open Spaces**



**Fig. 11.10 – Typical Seating Wall**

**11.3.3.3.1 Table Location.** Small groupings of tables in high visibility areas should be placed within proximity of recreation or food service facilities. These groupings should be located on hard pavement areas adjacent to walkways. Pavement should be constructed of exposed aggregate or broom finish concrete. Incorporate tree plantings and overhead trellis structures within these areas to provide shade and spatial definition (Fig. 11.5).

**11.3.3.3.2 Table Design: (Trainee Barracks Areas)**

**Visual Zones:**

- North Industrial Zone
- South Industrial Zone
- Family Housing (RCI) Zone

**11.3.3.3.2.1** Metal tables are appropriate for the informal gathering, eating, and casual uses characteristic of the Fort Gordon Trainee Barracks areas (Fig. 11.11). Tables shall be durable and maintenance-free, constructed of black thermoplastic-coated expanded steel with black powder-coated 4" sq galvanized steel pedestal mount in-ground frame. Size shall be 46" dia (Octagon) x 31" h with seating capacity of 8 adults. Tables in Trainee Barracks Areas will be Barco Products Co., (Model T46OCTROLPDS), or equal.

**11.3.3.3.3 Table Design: (Permanent Party Barracks Areas)**

**Visual Zones:**

- USAR National Guard Zone
- Signal Center Barracks and Admin Zone
  - \* Except Trainee Barracks Area
- Community Center Zone
- Signal Center Schoolhouse Zone
- Medical Center Zone

**11.3.3.3.3.1** Wood tables are appropriate for the informal gathering, eating, and casual uses characteristic of the Fort Gordon



**Fig. 11.11 – Typ. Fort Gordon Trainee Barracks Area Table**



**Fig. 11.12 – Typ. Fort Gordon Permanent Party Barracks Area Table**

Permanent Party Barracks areas (Fig. 11.12). Tables shall be durable and maintenance-free, constructed of faux cedar colored recycled plastic members with woodgrain finish. Standard table shall be pedestal in-ground mount. Size shall be 48” sq x 29” h with seating capacity of 8 adults. Bench supports shall be heavy-duty with powder-coated black steel frame. Tables in Park Areas will be Barco Products Co., (Model 07BM1334), or equal.

**11.3.4 Telephone Booths.** Telephone booths should be incorporated into building architecture, utilizing building recesses and overhangs, or integrated into bus or other shelters. Provide a minimum 3’0” clearance between booths and the edge of walkways. All service line wiring should be underground or concealed. Booths should be equipped with lighting for nighttime use. In sheltered areas, use standard wall-mounted phone enclosures.

**11.3.5 Shelters.**

There are many different types of shelters on military installations. Shelters are provided for those in areas where people congregate to socialize or eat such as in courtyards or picnic areas.

**11.3.5.1 Picnic Shelters.**

**11.3.5.1.1 Picnic Shelter Location.** Picnic shelters should be strategically located and sized for shared use to discourage the proliferation of small shelters scattered throughout the installation.

**11.3.5.1.1.2 Picnic Shelter Design.** Picnic shelters can be open on all sides. The minimum size should be 20 feet square with a minimum 8-foot vertical clearance.

The typical Fort Gordon Picnic Shelter shall be Natural Structures, “White Mountain Series”, or equal (Fig. 11.13). Rectangular shape recommended. Standing seam metal roof required; color dependant on location (Visual Zone). Shelter size dependant on requirement.

The typical Fort Gordon Gazebo shall be Natural Structures, “White Mountain Series” (Model 98-HEX016-8T), or equal (Fig. 11.14). Standing seam metal roof required; color dependant on location (Visual Zone). Gazebo size dependant on requirement.

**11.3.5.2 Kiosks**

**11.3.5.2.1 Kiosks Location.**



**Fig. 11.13 – Typ. Fort Gordon Picnic Shelter / Pavilion**



**Fig. 11.14 – Typ. Fort Gordon Gazebo**

Kiosks can be used as information centers at pedestrian nodes within the town center. Provide kiosks only where they are needed on a concrete base adjacent to walkways. Allow a minimum of 3' clearance on all sides.

### 11.3.5.2.2 Kiosks Design.

Kiosk design should blend compatibly with other site furnishings and with the architectural character of the zone in terms of form, scale, and materials. A similar design treatment should be established for kiosks and shelters.

The typical Fort Gordon Kiosk shall be Natural Structures, "Sentinel Mountain Series" (Model 98-102), or equal (Fig. 11.15). Standing seam metal roof required; color dependant on location (Visual Zone). Kiosk size 12' x 12'.

### 11.3.5.3 Bus Shelters.

#### 11.3.5.3.1 Bus Shelter Location.

Bus shelters should be located at major facilities along the bus route such as Commissary/Post Exchange areas, barracks areas, Hospital, and Library. Bus stops should relate to major pedestrian walkways, and be placed on concrete pads. Provide a minimum 3'0" clearance between shelters and the edge of walks.

#### 11.3.5.3.2 Bus Shelter Design.

Bus shelters should provide protection from wind, rain, and sun with an overhead roof with enclosure on three sides. Side enclosures should be a transparent, unbreakable type material to allow for adequate visibility. Bus shelter design typically should be simple and consistent throughout the post, matching the existing units in terms of materials, scale, and detail. Shelter design should have similar character as that for kiosks and vending machine shelters. Bus shelters should have a minimum size of 5' by 8' with a minimum height of 6'-6" from floor to underside of roof. The shelters should include an integral bench, trash receptacle, and ashtray. Fort Gordon Bus Shelters shall be "Easy Rack" Prefabricated Bus Stop Shelters, or equal (Fig. 11.16).



Fig. 11.15 – Typ. Fort Gordon Kiosk



Fig. 11.16 - Bus Shelters Enclosures Should Allow For Adequate Visibility



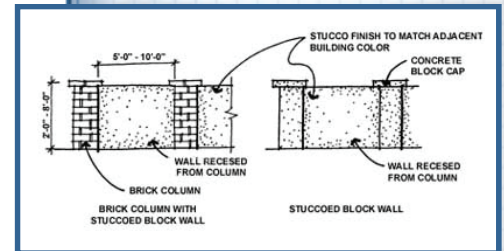
**11.3.6 Walls and Fences.**

**11.3.6.1 Location and Use.**

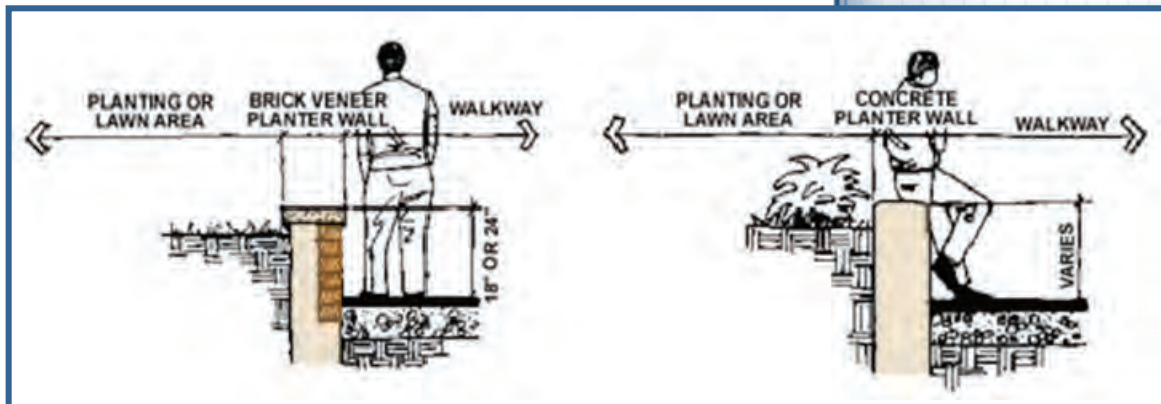
Walls and fencing should be used to provide visual screening, define pedestrian plaza areas, wind screening, pedestrian and vehicular control, security, and to retain soil. The design of walls and fences should fulfill their function in harmony with the character and appearance of their setting.

**11.3.6.2 Walls.**

Low walls should be used to define pedestrian court areas and provide informal seating. Screening walls can be used where appropriate to screen building service areas. Walls adjacent to walkways should be free of any projections, such as signs or drain pipes that would pose a hazard to passing pedestrians. Construction of walls should incorporate either brick to match adjacent buildings, with stone or concrete cap (Fig. 11.17), or concrete with a textured finish and stone or concrete cap. Retaining walls may be constructed of brick, native stone, versa-lock modular stone with a light tan finish, or concrete block with a light tan stucco finish, concrete block planters, or other appropriate material (Fig. 11.18). Walls used to screen service areas or trash enclosures should incorporate landscape plantings to help reduce the negative visual impact of these areas.



**Fig. 11.17 – Brick and Stucco Walls should be Compatible with Adjacent Architecture**



**Fig. 11.18 - Seat Wall Finishes and Veneer Treatment should Complement Adjacent Architecture**



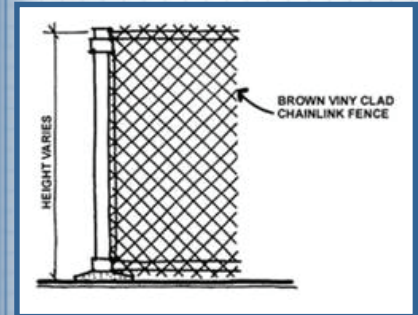
### 11.3.6.3 Fences.

Fences should be utilized for screening of service areas and site utilities, particularly dumpsters. Screen fencing should consist of square tubular metal posts and rails with vertical wood fence boards. All fence posts should be securely anchored with concrete footings. All metal posts and framework should be painted standard dark brown and wood fencing should be western cedar.

Brown vinyl-coated fencing is recommended for use in all high visibility areas (Fig. 11.19). (Note: Except for Formal Spaces and Parks). Hardware shall be stainless steel to prevent rust.

Delgard maintenance free black ornamental aluminum fencing, (or equal) shall be used at all Parks and Formal Spaces. “Black Commercial Tahoe” with ball caps style, (or equal) is preferred (Fig. 11.20).

Chain link fences should be screened with trees and shrubs. Dark Brown mesh fabric is to be used when maximum screening is desired. The use of chain link fence should be held to a minimum in the cantonment area. Three strands of barbed wire across the top of the fence are optional and should be added if required for security measures.



**Fig. 11.19 - Brown Vinyl Clad Fencing Is Recommended In Most Areas of High Visibility**



**Fig. 11.20 – Fort Gordon Parks and Formal Space fencing**

### 11.3.7 Trash Receptacles.

#### 11.3.7.1 Trash Receptacle Location.

Trash containers should be highly visible and accessible for effective litter control. Containers should be located conveniently along walkways, near major pedestrian intersections, near building entrances and near seating and eating areas. Antiterrorism/force protection requirements restrict the location of dumpsters to a minimum of 10 meters (33 feet) from inhabited buildings and 25



meters (82 feet) from billeting and primary gathering areas (*Unified Facilities Criteria (UFC) 4-010-01, DoD Minimum Antiterrorism Standards for Buildings*, Table B-1).



### 11.3.7.2 Trash Receptacle Design.

Container should be of a design that is compatible and in harmony with other site furnishings.

### 11.3.7.3 Trash Receptacle Type: (Trainee Barracks Areas)

#### Visual Zones:

- North Industrial Zone
- South Industrial Zone
- Family Housing (RCI) Zone

**11.3.7.3.1** Trash receptacles in the Trainee Barracks Areas shall be durable and maintenance-free; constructed of black onyx powder-coated expanded metal with protective zinc finish. Trash receptacle shall have 32 gallon capacity with black dome lid and liner. Size shall be 21.75" dia x 43.25" h. Trash receptacles in Trainee Barracks Areas will be Barco Products Co., (Model 08JA1297), or equal (Fig. 11.21).



**Fig. 11.21 – Typ. Fort Gordon Trainee Barracks Area Trash Receptacle**

### 11.3.7.4 Trash Receptacle Design: (Permanent Party Barracks Areas)

#### Visual Zones:

- USAR National Guard Zone
- Signal Center Barracks and Admin Zone
  - \* except Trainee Barracks Area
- Community Center Zone
- Signal Center Schoolhouse Zone
- Medical Center Zone



**Fig. 11.22 – Typ. Fort Gordon Permanent Party Barracks Area Trash Receptacle**

**11.3.7.4.1** Trash receptacles in the Trainee Barracks Areas shall be durable and maintenance-free; constructed of heavy-gauge, galvanized fire-safe steel frames with 100% recycled polyethylene slats (cedar color). Size shall be 23" dia x 36" h .Trash receptacles in Trainee Barracks Areas will be Barco Products Co., (Model UH55), or equal (Fig. 11.22).

**11.3.7.5 Trash Receptacle Design: (Park Settings / Open Spaces)**

**Visual Zones: - Parks and Open Spaces**

**11.3.7.5.1** Trash receptacles in the Park Areas shall be durable and maintenance-free; constructed of heavy-gauge, black powder-coated steel frames utilizing patented 2nd Site Systems (or equal) faux maple colored 100% recycled plastic slats. Size shall be 23" dia x 36" h with 36 gallon capacity. Trash receptacles in Park Areas will be Victor Stanley, Inc. Greensites Series (Model RTH-36 with Dome Lid), or equal (Fig. 11.23).

**11.3.8 Dumpsters.**

**11.3.8.1 Dumpster Location.**

The location of dumpsters can have a significant visual impact and should be addressed as part of an overall building design and incorporated in site planning. To the greatest extent possible, incorporate dumpster placement into areas screened with walls, fencing, or plant material (Fig. 11.24). Avoid locating dumpsters along major circulation or use areas. Dumpsters should be directly accessible by way of a paved service drive or parking lot with adequate overhead clearance for collection vehicles.

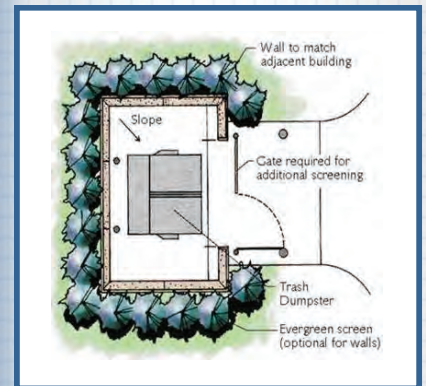
Antiterrorism/force protection requirements restrict the location of dumpsters to a minimum of 10 meters (33 feet) from inhabited buildings and 25 meters (82 feet) from billeting and primary gathering areas ([Unified Facilities Criteria \(UFC\) 4-010-01, DoD Minimum Antiterrorism Standards for Buildings](#), Table B-1).

**11.3.8.2 Dumpster Site Design.**

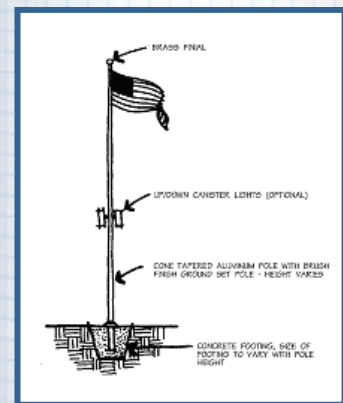
Incorporate plantings to buffer the visual impact of screen walls. Walls or fencing should be a maximum 6' in height. Provide a minimum 3' clearance on each side between screen walls and dumpsters to allow adequate pedestrian and truck access. All dumpsters should be placed on concrete pads with aprons large enough to encompass the bearing points of the service vehicle.



**Fig. 11.23 – Typ. Fort Gordon Parks and Open Spaces Trash Receptacle**



**Fig. 11.24 – Enclose Dumpsters with Walls, Fences, or Plantings and Place on Concrete Pad**



**Fig. 11.25 – Standard Flagpole**

### 11.3.9 Flagpoles.

The standard flagpole for Fort Gordon will be tapered mill finish aluminum, fitted with a gold anodized finish “ball” finial (Figure 11.25). The mounting detail should be simple with a concrete base flush at grade. A concrete pad should be used when poles are located in lawn areas. In plaza areas, flagpole locations and mounting detail should be integrated into the paving pattern. Flagpoles should include lighting and may be accented with planting beds around the base of the flagpole.

### 11.3.10 Planters.

**11.3.10.1** Movable pre-cast concrete planters may be used outside building entrances to provide seasonal color and interest and function as security threat barriers (Fig. 11.28). Planters should be located so they block uninterrupted vehicular access to a building, but not so they excessively impede pedestrian movement. Several planters of various sizes should be grouped together to produce an aesthetically pleasing display.

#### 11.3.10.2 Planter Sizes and Design:

**11.3.10.2.1** Planters used throughout the Fort Gordon cantonment area shall be concrete with steel reinforcement built to meet or exceed any industry standard for strength and durability. All concrete planters shall come with drain holes for proper drainage. Concrete planters at Fort Gordon shall be Petersen Mfg. Co., Inc. Aurora Series (Model A – Round or Square), or equal (Fig. 11.26). Size and configuration will depend on application. Color shall be Sand Tan Etch (or equal).

### 11.3.11 Bicycle Racks.

Bicycle racks should be provided at key destination locations. They should be located on a concrete surface where they will not impede pedestrian movement or block building entrances.

A ribbon type tubular aluminum bike rack with an anodized black finish is the Fort Gordon standard (Fig. 11.28). Bicycle storage areas near barracks should be covered.

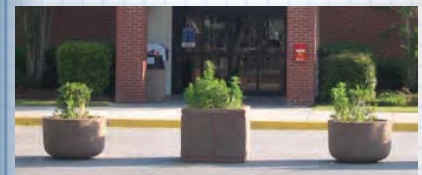
The recommended standard rack is available from Barco Products in stainless steel. Other manufacturers may be selected, provided design and quality are equal to the recommended product.



**Fig. 11.26 – Typ. (Round) Fort Gordon Concrete Planter**



**Fig. 11.26 – Typ. (Square) Fort Gordon Concrete Planter**



**Fig. 11.27 – A concrete barrier planter should be attractive, as well as effective in blocking vehicles.**



**Fig. 11.28 – Typ. Fort Gordon Alum. Bicycle Rack**

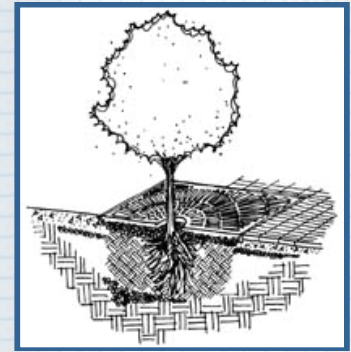
### 11.3.12 Tree Grates.

Use anodized aluminum tree grates when installing trees in formal paved areas such as courtyards, entry areas or plazas (Fig. 11.29). Grates allow air and water to pass through them to the root system over a large area without impeding foot traffic.

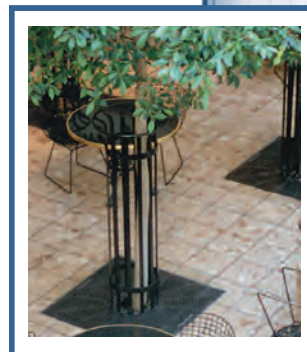
Sizes may vary from three feet to seven feet depending upon specific project use. Inner grates can be removed as the tree grows.

Alternatives to tree grates, that should be used in less formal locations, include laying brick on sand or installing washed gravel at the base of a tree and removing material as the tree grows. Care should be taken to install brick flat and/or true to conditions around it to minimize tripping.

The recommended tree grates are available from Neenah Foundry Company. Other manufacturers that provide products manufactured from recycled materials may be selected, provided design and quality are equal to the recommended product (Fig. 11.30).



**Fig. 11.29 - Tree Grates Provide an Attractive Solution for Incorporating Trees in Paved Plazas**



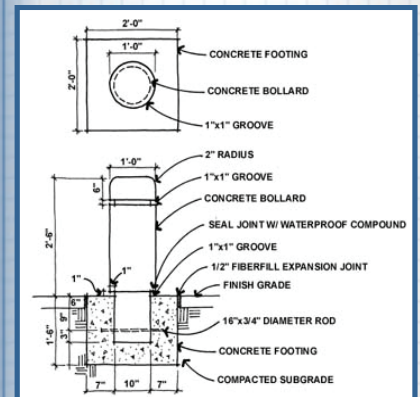
**Fig. 11.30 – Typ. Fort Gordon Tree Grate**

### 11.3.13 Bollards.

Bollards can effectively be used to control traffic or separate pedestrians from vehicular traffic, or as decorative elements at an entry, courtyard, or plaza (Fig. 11.31).

Small chains, ropes and other temporary barriers should be removed or replaced with more permanent bollard solutions.

Use concrete bollards at important arrival zones, such as auto drop-off zones and at any place where conflicts occur between pedestrians and autos. Bollards with removable chains shall be used in situations where vehicular access is required. In park and recreational areas where a more naturalistic effect is desired, the use of a recycled wood bollard is recommended.



**Fig. 11.31 - Concrete Bollards should be Used in Areas of High Pedestrian and Vehicular Use**



### 11.3.13.1 Bollard Types:

**11.3.13.1.1** The Fort Gordon Installation-wide **Bollard** standard for use in residential and commercial settings is Petersen Mfg. Co., Inc. (Model SQB-12), or equal (Fig. 11.32). Size of bollard is 12" x 12" x 30". Color shall be Sand Tan Etch (or equal).

**11.3.13.1.2** The Fort Gordon Installation-wide **Lighted Bollard** standard for use in residential and commercial settings is Petersen Mfg. Co., Inc. (Model SQB-11L), or equal (Fig. 11.33). Size of bollard is 11" x 11" x 41". Color shall be Sand Tan Etch (or equal).



**Fig. 11.32 – Typical Fort Gordon Bollard**



**Fig. 11.33 – Typical Fort Gordon Lighted Bollard**

### 11.3.14 Playgrounds/Tot Lots.

**11.3.14.1** The playgrounds and tot lots within the installation should use equipment that is consistent throughout the installation or that meets specific criteria of materials, color, and design (Fig. 11.34).

#### 11.3.14.2 Playground Planning and Design.

Guidance for planning and designing unsupervised outdoor play areas that meet child safety and child development requirements is found in [Unified Facilities Criteria \(UFC\) 3-210-04, Design: Children's Outdoor Play Areas](#). The guidance given in this publication meets the needs of children with and without disabilities.

#### 11.3.14.3 Playground Inspection and Maintenance.



**Fig. 11.34 - Playgrounds and Tot Lots meet Specific Criteria of Materials, Color, and Design Throughout the Installation**

A play area inspection and maintenance program for Child Development Centers can be found in [Technical Manual \(TM\) 5-663, Child Development Center, Play Area Inspection and Maintenance Program](#).

#### 11.3.14.4 Recalled and Banned Playground Equipment.

For updates on banned or recalled playground equipment consult the [Consumer Product Safety Commission Press Releases and Recalls](#) web site.

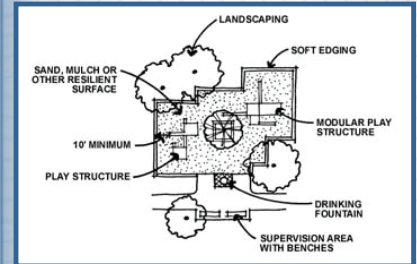
#### 11.3.14.5 Fort Gordon Playgrounds.

Playgrounds should be located in close proximity to schools, child development centers, parks and other recreational areas. There should be a wide variety of equipment which is designed for child skill development and imaginative play (Fig. 11.35), such as climbing structures, balance beams, wheels and fortresses. Drinking fountains should be provided at each playground. A soft resilient play surface shall be maintained within the play area to prevent serious injury (Fig. 11.36). All areas should be landscaped or existing trees preserved to provide shade and limit heat buildup on play equipment. Landscape materials that have thorns and those that are poisonous are to be avoided around play areas. Seating for adult observation shall also be provided. Recycled materials should be utilized whenever possible.

#### 11.3.15 Mailboxes.

**11.3.15.1** All mailboxes should be located in close proximity to the facility they serve. However, when locating mailboxes consider the potential for the site element being used as a container for the concealment of explosive, etc. Consider Antiterrorism/force protection requirements for locating similar container types i.e. trash receptacles which are located a minimum of 10 meters (33 feet) from inhabited buildings and 25 meters (82 feet) from billeting and primary gathering areas ([Unified Facilities Criteria \(UFC\) 4-010-01, DoD Minimum Antiterrorism Standards for Buildings](#), Table B-1).

**11.3.15.2** The location should be coordinated with the Postal Services.



**Fig. 11.35 - Design Playgrounds to Accommodate Children of All Ages**



**Fig. 11.36 - An example of play equipment for the two to five year old age group.**

**11.3.15.3** If group mailboxes are required, provide central locations for them adjacent to hard-surface walkways but not to impede pedestrian movement.

**11.3.16 Monuments, Memorials, and Military Equipment Static Displays.**

**11.3.16.1** Monuments and static displays should be carefully designed and placed in prominent locations to serve as visual focal points within the installation (Fig. 11.37). Static displays of equipment should be consolidated in one location to create a central museum or exhibition facility within the installation.

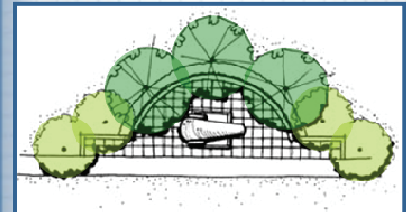
**11.3.16.2** Memorials will conform to the guidance set forth in [Army Regulation \(AR\) 1-33, Memorial Programs](#).

**11.3.17 Drinking Fountains.**

Outdoor drinking fountains should not be provided, except to support larger playgrounds, outdoor recreation facility complexes, and outlying recreation areas if convenient to a potable water supply line. Steps should be provided for children and the [Americans with Disabilities Act Accessibility Guidelines \(ADAAG\)](#) and [Uniform Federal Accessibility Standards \(UFAS\)](#) standards meet.

**11.4 SIGNS**

**11.4.1** Signs are used to visually communicate information. They are highly visible features that should be attractive and compatible with their surroundings. Careful consideration must be given to what a sign says, how it is said, its visual appearance and organization, its location, structural support system, and relation to other signs within the installation (Fig. 11.38). Standardized signage systems facilitate movement, provide a sense of orientation, and reinforce standards of excellence. Signage creates a unifying element throughout the installation that visually ties the installation themes together and builds a reference and continuity that translates into confidence and reassurance when traveling throughout the installation. The creation of a coordinated signage system will enhance Fort Gordon's visual image and improve the efficiency of movement. The standards to apply for signage color, type, and sizing is found in [Technical Manual \(TM\) 5-807-10, Signage](#).



**Fig. 11.37 - Military Displays should be Appropriately Designed and Located in a Park-like Setting to Become an Integral Part of the Installation. Displays Limited to Brigade Headquarters or Higher Command.**



**Fig. 11.38 – Signage Reflects the Importance of the Activity Relative to the Installation**

The following criteria provides recommendations for the design and location of all signs at Fort Gordon. Signs not in compliance with these guidelines are not permitted unless approved by the DPW.

**11.4.2 Sign System Characteristics.** There are several basic design characteristics that, by serving to convey necessary information clearly and attractively, are an integral part of any successful signage system.

**11.4.2.1 Simplicity.** An effective strategy provides only needed information, avoids redundancy, and eliminates over-signing with resultant clutter and visual confusion. Sign messages must be clear, simple, and easy for motorists to process quickly.

**11.4.2.2 Continuity.** It is essential that the system be applied uniformly and consistently throughout the entire installation. The importance of consistent implementation extends from the larger issues of sign type and size down to accurate color continuity and matching typestyles.

**11.4.2.3 Visibility.** Sign location is a very important ingredient within the system. Signs must be located at significant decision points and oriented to provide clear sight lines for the intended user. Close coordination of locations with respect to landscaping, utilities, adjacent signage, and various other street design elements is important to ensure long-term maximum visibility.

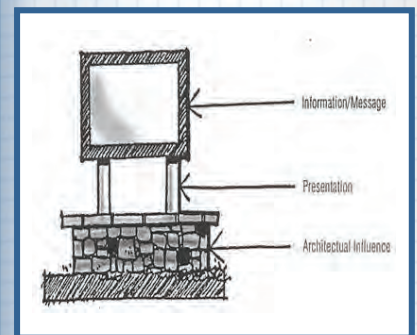
**11.4.2.4 Legibility.** Sign typestyle, line spacing, color, and size all combine to create the crucial design characteristics of legibility. This aspect of sign design should take into consideration users such as motorist, pedestrians, or bicyclists, and the relative travel speed at which each type of user will be traveling when viewing the signs.

**11.4.3 Vocabulary-Communications.**

**11.4.3.1** A common language has been created for establishing a signing system. The different components that create the sign package have been named and referred to within the total signing system.

**11.4.3.2** The creation of a "signing language" helps generate a unified bond within sign types that make up a signing family (Fig. 11.39).

- Reference



**Fig. 11.39 - Signing Language Helps Establish A Signing System**





- Information/Message
- Presentation
- Architectural Influence
- Graphic Architecture

**11.4.4 Visual Hierarchy.**

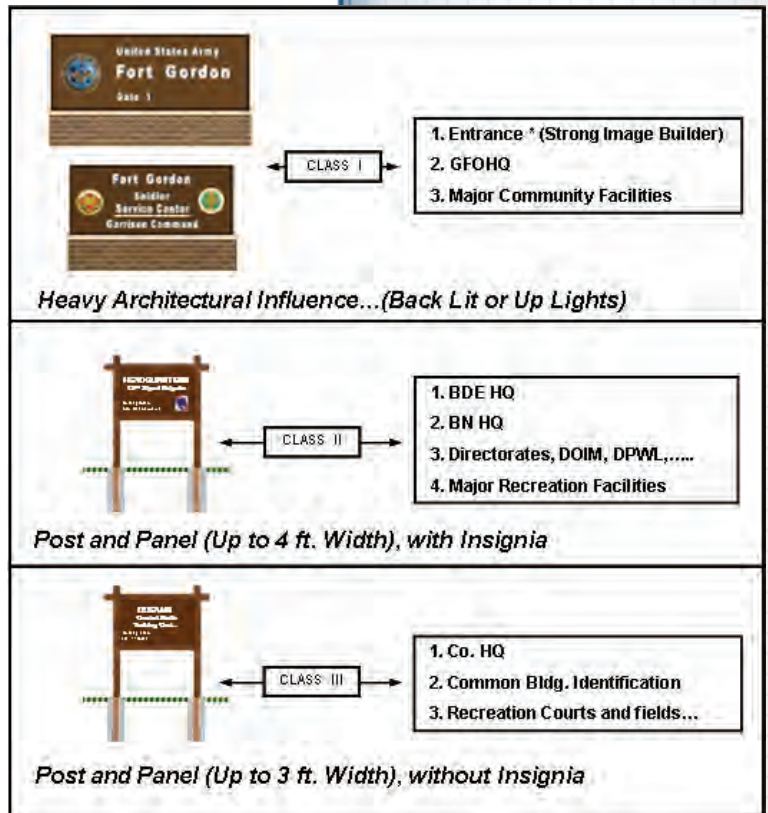
**11.4.4.1** The entire signing system must communicate, through a range of sign and typestyle sizes, the relative importance of the individual activity that the sign identifies. The system should follow a logical progression from a point of origin to the desired destination (Fig. 11.40).

**11.4.4.2** A stated ranking method supports the visual standard of hierarchy within the signing system. Signs can be organized within assigned classes with emphasis on the function and image of the installation.

**11.4.4.3** Within each class, the level of architectural influence evokes the importance of the sign to the installation. This is also critical to the idea of progression. The importance of a sign must be presented in its size and level of detail.

**11.4.4.4** As individuals move closer to their destination on the installation, the scale of the sign becomes progressively smaller and the level of the message more detailed.

**Fig. 11.40 - Signs Can Be Organized Into Classes Within The Visual Hierarchy**





## 11.4.5 Types of Signs.

### 11.4.5.1 Information / Identification Signs.

These are signs that identify entrances to the installation, areas within the installation, major tenants, buildings, and organizational or functional components. They identify a location, and greet the visitor to that location. They should be compatible in scale and character with the architecture and also blend with the natural surroundings (Fig. 11.41). Building Identification Signs will use street addresses.

**These signs are designed to include the following:**

#### 11.4.5.1.1 Typeface: Lettering is self-adhesive backing material.

- Building Title: Helvetica Medium, Upper and lower case
- Building Numbers: Helvetica regular
- Building Addresses: Helvetica Medium, Upper and lower case

#### 11.4.5.1.2 Color:

- Panel: Dark Brown
- Lettering: White
- Post: Dark Brown
- Exposed panel backs and edges: Dark Brown
- All paint: Semi gloss

#### 11.4.5.1.3 Materials:

- Panel: Double-face 1/8" thick aluminum  
Dimensions: 36" x 24"
- Post: 4" x 4" Cedar
- Foundation: Concrete pier or direct burial

### 11.4.5.2 Building Identification.



**Fig. 11.41 – Typical Class III Fort Gordon Bldg. identification Sign with street address**

ABCDEFGHIJKLMN  
OPQRSTUVWXYZ

**Use Helvetica Type Style Font on all Signage  
Unless an Approved Alternative is Noted**

**11.4.5.2.1 Street Addresses.** The addressing procedures prescribed in [DoD 4525.8-M, DoD Official Mail Manual](#) are mandatory for use by all DoD components. DoD 4525.8-M, Chapter 3 prescribes the following:

All DoD addresses shall be assigned so they are compatible with the United States Postal Services automated delivery point sequencing (C3.3).

The DoD installation is responsible for assigning city-style, street address on the installation (C3.3.2.2).

Street addresses shall be assigned and used even though a DoD activity may deliver the mail to the addressee (C3.3.2.2.1).

Only geographically locatable civilian-style street address (such as 4102 Cindy Avenue, Fig. 11.42) shall be used (C3.3.2.2.4).

Installations shall not use one street address for the entire installation and then use secondary unit designators such as "Building 123" to designate the delivery addresses on the installation (C3.3.2.2.5).

Addresses such as "Building 123 Roberts Street" are not a valid address format and shall not be used (C3.3.2.2.6).

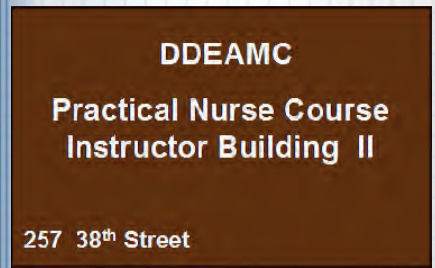
### **11.4.5.3 Brigade, Battalion and Company Headquarters Signs.**

TM 5-807-10 must be followed for any specifics not covered here.

#### **Notes:**

- All figures and paragraphs referenced in the following can be found in TM 5-807-10.
- Building numbers as described in TM 5-807-10 **will not** be placed on building identification signs
- Building addresses will be placed on all building identification signs where the building numbers were once placed.

**Military headquarters identification signs consist of four types:**



**Fig. 11.42 – Use of Street Addresses On All Building Identification Sign**



- Sign type B1, installation headquarters sign, identifies the central administration of the installation.
- Sign type B2, command, division and brigade headquarters sign.
- Sign type B3, battalion headquarters sign.
- Sign type B4, headquarters building entrance sign, identifies the building entrance for all levels of authority. In addition, type B4 is used to identify a unit headquarters that has a special entry point other than the main entrance of a building.

Graphics appear on both sides of these signs, since they are placed perpendicular to the road and can be viewed by traffic moving in both directions.

#### 11.4.5.3.1 Headquarters Facilities.

Sign **Type B1** signs are used to identify the headquarters facilities of each installation. When the headquarters of a command or division level organization is located in the same facility as the installation headquarters, the unit name is placed below the installation name. In addition, the authorized insignia of the command or division level unit is located to the left of the unit name.

(1) Colors. White letters and numbers on standard brown background; full-color insignia.

(2) Sign grid specifications.

(a) *Dimensions.* 3ft-6in. H x 8ft-0in. W.

(b) *Message.* Installation name - upper and lower case Helvetica medium, 6-inch capital letter height, centered in top grid. Average line length-21 characters per line. "Headquarters" - upper and lower case Helvetica bold, 6-inch capital letter height, centered below Installation name. Average line length - 24 characters per line. Command or division level name - upper and lower case Helvetica medium, 4-inch capital letter height, centered below "Headquarters". Average line length - 27 characters per line.

(c) *Building address.* Upper and lower case Helvetica

medium, 4-inch capital letter height, flush left.

(d) *Insignia.* Authorized military insignia, 12-inch maximum height x 9-inch maximum width, flush left and centered.

### 11.4.5.3.2 Brigade Headquarters.

Sign Type B2 signs are used to identify the headquarters facilities of command, division and brigade level organizations. The authorized shoulder sleeve insignia or distinctive unit insignia for each command or division is located in the bottom right grid of the sign. Brigade level organizations show the name of the command or division under which each serves below the unit name, and display the command or division insignia to the left of the unit name. Only one headquarter unit is identified per sign. (Fig. 11.43)

Names or titles of individuals shall not be displayed on Brigade level organization signs

(1) Colors. White letters and numbers on standard brown background; full-color insignia (Fig. 11.43).

(2) Sign grid specifications.

(a) *Dimensions.* 3ft-6in. H x 5ft-0in. W.

(b) *Message.* "HEADQUARTERS" - upper case Helvetica bold, 4-inch letter height, top centered. Average line length -25 characters per line. Unit name-upper and lower case Helvetica bold, 4-inch capital letter height, centered below "HEADQUARTERS". Average line length-17 characters per line.

(c) *Building address.* Upper and lower case Helvetica medium, 3-inch capital letter height, flush left bottom.

(d) *Insignia.* Authorized military insignia, 12-inch maximum height x 9-inch maximum width, flush right bottom. (Fig. 11.43)

### 11.4.5.3.3 Battalion Headquarters.

Sign Type B3 signs are used to identify the headquarters facilities of battalion level organizations. The name of the command or division under which each serves is shown below the unit name.

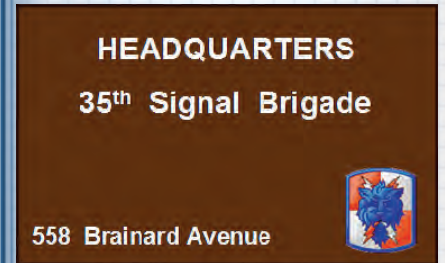


Fig. 11.43 – Example Brigade Headquarters Sign

The authorized branch color(s) of the unit is located flush left center of the sign. Battalion headquarters signs shall display the command or division level organizational insignia in the lower right corner. If more than one (1) battalion headquarters is located in a specific building all unit names will be displayed on one (1) sign. (Fig. 11.44)

Names or titles of individuals shall not be displayed on Battalion level unit signs

(1) Colors. White letters and numbers on standard brown background; full-color symbol (Fig. 11.44).

(2) Sign grid specifications.

(a) *Dimensions.* 3ft-0in. H x 4ft-0in. W.

(b) *Message.* "HEADQUARTERS" - upper case Helvetica bold, 4-inch letter height, top centered. Average line length - 22 characters per line. Unit name-upper and lower case Helvetica bold, 4-inch capital letter height, centered below "HEADQUARTERS". Average line length -20 characters per line.

(c) *Symbol.* 7 - inch square overall "white" field with 1-inch border in secondary branch color. Battalion insignia / symbol centered within "white" field, flush left centered. (Fig. 11.44)

(d) *Building address.* Upper and lower case Helvetica medium, 3 - inch capital letter height, flush left.

#### 11.4.5.3.4 Company Headquarters.

Most company operations facilities contain more than one company headquarters unit. When more than one company Headquarters unit is located in a specific building all units will be listed on an individual sign. Sign specifications are as follows:

- **Facilities with one (1) company headquarters unit:**

Type C4 signs. Insignias, branch colors, unit mottos, names or titles of individuals are not to be displayed on company level unit signs. The name of the command or division under which each serves is shown below the unit name.



Fig. 11.44 – Example Battalion Headquarters Sign

(1) Colors. White letters and numbers on standard brown background.

(2) Sign grid specifications.

(a) Dimensions. 3ft-0in. H x 4ft-0in. W.

(b) Message. Facility and unit name-upper and lower case Helvetica medium, 3-inch capital letter height, flush left. Average line length-25 characters per line.

(c) Building address. Upper and lower case Helvetica medium, 3-inch capital letter height, flush left.

- **Facilities with more than one (1) company headquarters unit:**

Type C2 signs. Sign Type C2 will be used with the extended grid specifications listed below. The name of the command or division under which each serves is shown below the unit name.

Insignias, branch colors, unit mottos, names or titles of individuals are not to be displayed on company level unit signs (Fig. 11.45).

(1) Colors. White letters and numbers on standard brown background.

(2) Sign grid specifications.

(a) Dimensions. 3ft-0in. H x 4ft-0in. W.

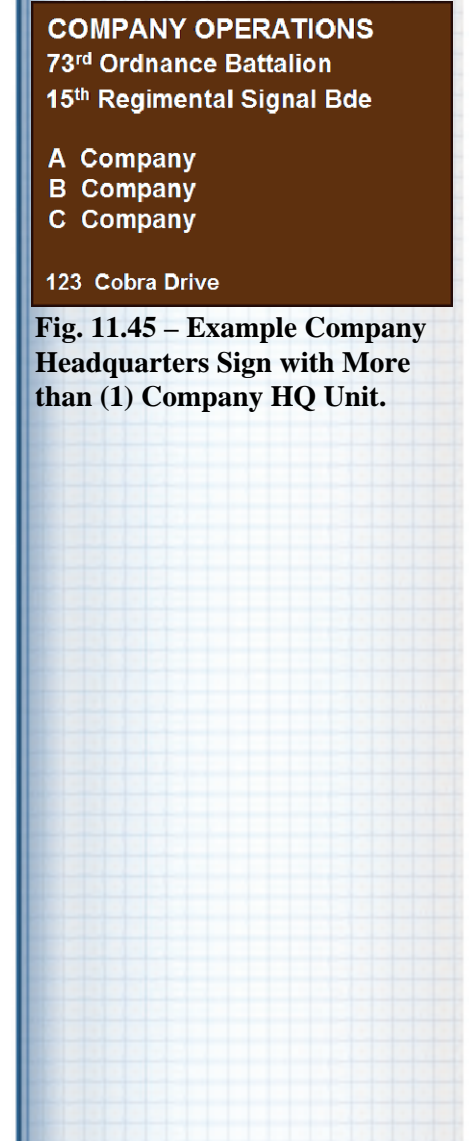
(b) Message. Unit facility and name - upper and lower case Helvetica medium 4-inch capital letter height, flush left. Average line length-19 characters per line. Sub-service name-upper and lower case Helvetica regular, 3-inch capital letter height, flush left. Average line length-30 characters per line. (Fig. 11.45)

(c) Building address. Helvetica regular, 4-inch number height, flush left.

(3) Extended sign grid specifications.

(a) Dimensions. 4ft-0in. H x 5ft-0in. W.

(b) Message. Military unit name-upper and lower case Helvetica medium, 4-inch capital letter height, flush left. Average line length - 19 characters per line. Sub-unit name-upper and lower case Helvetica regular, 3-inch capital letter height, flush left. Average line length-30 characters per line. (Fig. 11.45)



**Fig. 11.45 – Example Company Headquarters Sign with More than (1) Company HQ Unit.**

(c) Building address. Helvetica regular, 4-inch number height, flush left.

**Exceptions to Stated Regulations.** If companies or detachments are co-located in the same facility with battalion or higher headquarters units, all units will be listed on the facility identification sign of the type associated with the highest echelon unit.

#### 11.4.5.4 Housing Areas.

- The sign should be complimentary to the architectural setting of the housing area and approved by the installation Real Property Planning Board.
- Housing numbers should be placed on the curb in front of the respective house and on the house where lighting will effectively light the numbering.

#### 11.4.5.5 Installation Identification Signs.

- Installation identification signs name the installation and display the official US Army plaque (Fig. 11.46). The designation "United States Army" must appear at the top of the sign in accordance with [AR 420-70](#), para 2-7h. Every installation entrance shall have an installation identification sign displaying only the US Army plaque, with the words "United States Army, Fort Gordon, and gate name as indicated in "Figure 11.47 - Installation Entrance Signs". The placement of Senior Mission Commander logo, unit crest, and other installation identification signs, monuments, or displays shall be located inside the installation beyond the cleared area of the Access Control Point (ACP) of entry. When used service-wide, these signs convey a uniform image of strength and stability to the public. Emblems, branch colors, unit mottos, names, and titles of individuals are not to be displayed.

- Installation identification signs consist of three types:
  - Sign type A1, main entrance sign, identifies the principal visitor entrance.



Fig. 11.46 – U.S. Army Plaque

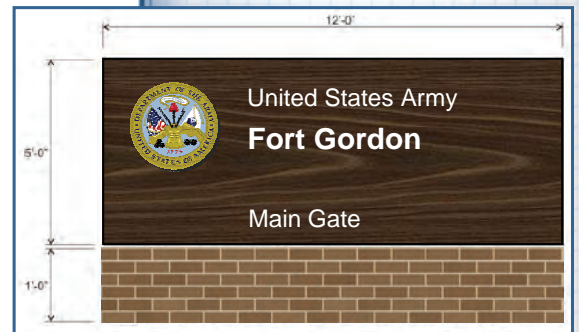


Fig. 11.47 - Installation Entrance Signs



- Sign type A2, secondary entrance sign, identifies entry points with relatively high volumes of visitor traffic.
- Sign type A3, limited access entry gate signs, identifies entry points with limited public access.
- See Technical Manual (TM) 5-807-10, Signage, paragraph 3-3, for sign specifications and paragraph 3-11 for sign placement guidelines.

#### 11.4.5.6 Street Signs.

Street name identification signs should be designed with the same lettering, color, and materials as other information signs (Fig. 11.46).

#### 11.4.5.7 Wheeled Electrical Signs.

Wheeled electrical signs will have an attractive presentation. Temporary landscape elements should be used whenever possible. The siting of this type of sign will be approved by the RPPB. No sign of this type will be left in place for longer than six (6) months. After which time, the sign will be removed or turned into a permanent sign.

#### 11.4.5.8 Directional Signs.

Place directional signs in central locations and at major decision points along circulation routes. These signs guide the motorist or pedestrian in, around, and out of the installation (Fig. 11.47). The legibility and placement of these signs, as well as the ordering of information, is critical to their effectiveness. Messages will be grouped in the following order according to their arrow direction: forward, left, and right. In addition, placement of the message on the sign panel is determined by the arrow direction. Destinations forward and left are listed first and have flush left messages. Destinations right are listed next and have flush right messages. The arrow is centered in the space between the message and the edge of the sign. Prioritize destinations to be listed by giving the highest priority to the destinations that are most often sought by people new to the garrison or that serve as highly visible landmarks on the garrison. Those who live or work on the garrison or who visit frequently do not need the degree of help required by a first time or infrequent visitor. These signs are designed to include the following:

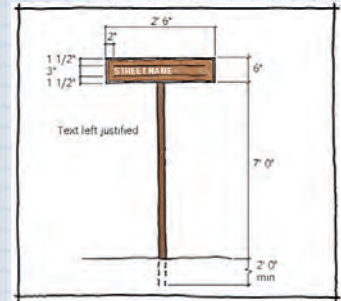


Fig. 11.46 - Typical Street Signs

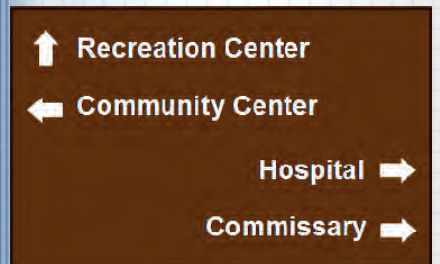


Fig. 11.47 - Directional Sign

**11.4.5.8.1 Typeface:** Lettering is self-adhesive backing material.

- Helvetica Medium upper and lower case

**11.4.5.8.2 Arrow:**

- Place at end indicating direction.
- Stroke width: Helvetica Medium cap

**11.4.5.8.3 Color:**

- Panel: Dark Brown
- Lettering: White
- Post: Dark Brown
- Exposed panel backs and edges: Dark Brown
- All paint: Semi gloss

**11.4.5.8.4 Materials:**

- Panel: Double-face 1/8" thick aluminum
- Post: 4" x 4" Cedar
- Foundation: Concrete pier or direct burial

**11.4.5.9 Regulatory Signs.**

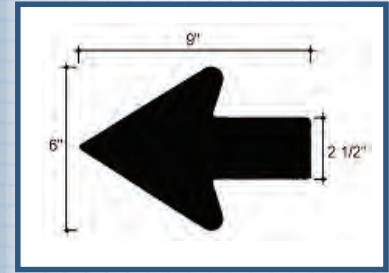
These signs provide the rules for travel and parking on the installation. They include speed signs, turning and lane use signs, warning signs, parking control signs, etc. (Figs. 11.48 and 11.49)). Related to these signs are pavement markings and traffic signals. These signs are designed to include the following:

**11.4.5.9.1 Typeface:** Lettering is self-adhesive backing material.

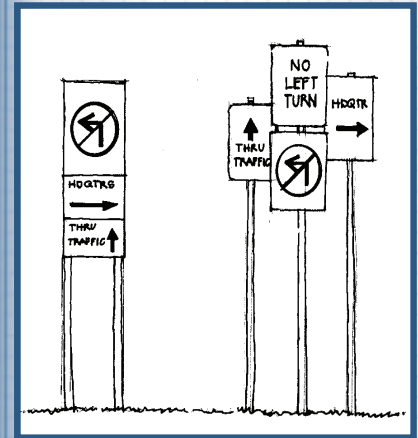
- Helvetica Medium upper and lower case

**11.4.5.9.2 Color:**

- Panel: Dark Brown



**Typical Arrow For Use On All Destination Signs**



**Fig. 11.48 – Sign should be Simple, Legible, and Combined**

- Lettering: White
- Post: Dark Brown
- Exposed panel backs and edges: Dark Brown
- All paint: Semi gloss

#### 11.4.5.9.3 Materials:

- Panel: Double-face 1/8" thick aluminum
- Post: Steel Pipe
- Foundation: Concrete pier or direct burial

#### 11.4.5.10 Traffic Control Signs.

**11.4.5.10.1 CONUS Installations.** National highway standards will be used for signs to regulate vehicular traffic on CONUS installation ([AR 420-72, Transportation Infrastructure and Dams](#), Para 2-15f). These standards are described in the [Manual of Uniform Traffic Control Devices \(MUTCD\)](#). Also see [MTMC Pamphlet 55-14, Traffic Engineering for Better Signs and Markings](#). This pamphlet clarifies existing standards and provides definite guidelines for installation officials to conform to the MUTCD. These standards shall be used installation wide to include installation Access Control Points.

**11.4.5.10.2 OCONUS Installations.** OCONUS installation streets and roads are to be considered extensions of the road system of the host nation and shall use traffic control device standards and criteria of the host nation ([AR 420-72, Transportation Infrastructure and Dams](#), Para 2-15e).

**11.4.5.11 Prohibitory (Warning) Signs.** This category of signage is intended to maintain security and safety on the installation perimeter and at other specific secure areas. These signs notify visitors of restrictions, as well as other security procedures. The guidelines for design, fabrication, and placement of warning signs are found in [Technical Manual \(TM\) 5-807-10, Signage](#), para 3-9.

#### 11.4.5.12 Electronic Exterior Signs

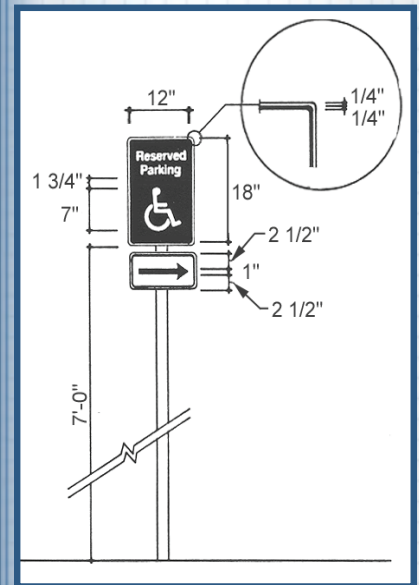


Fig. 11.49 – Regulatory Sign

All exterior flashing signs, traveling lights, or signs animated by lights of changing degrees of intensity or color are prohibited.

#### 11.4.6 Sign Placement

Placement of signs differs according to the type of sign and the specific site constraints. The following guidelines apply to placement of the majority of signs.

Do not place more than one sign at any location. Traffic rules are the exception to this rule (Fig. 11.50).

Place signs in areas free of visual clutter and landscape materials.

Place signs in locations that allow enough time for the user to read and react to the message.

Signs should not be placed to block sight lines at intersections.

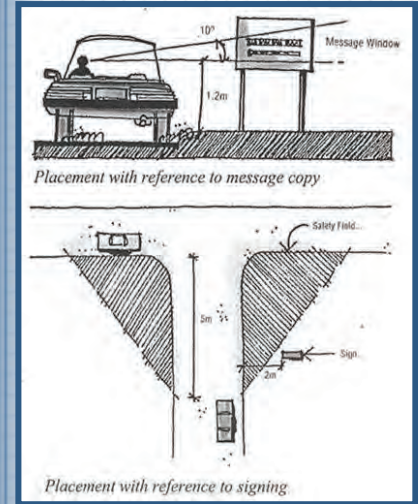
Place signs approximately 1.2 meters (4 feet) above ground level to be within 10 degrees the driver's line of vision. Provide proper placement to avoid a hazard to children.

#### 11.4.7 Sign System Typography.

**11.4.7.1 Military Emblems.** The Army has a rich tradition of military heraldry. Military emblems are an important part of the soldiers' identity and the emblems have been carefully crafted over the years to express unit pride and unique history and function of the unit. The care and use of organizational emblems in a signage system can add visual interest as well as build pride and a sense of history. However, the overuse of miscellaneous emblems can lead to clutter and a dilution of their importance. Colors for military emblems must be in accordance with the Institute of Heraldry.

**11.4.7.2 Department of the Army Plaque.** The plaque should be displayed on installation identification signage to emphasize the heritage and professionalism of the United States Army. The design of the plaque must be in accordance with [Army Regulation \(AR\) 840-1](#), [Department of the Army Seal](#), and [Department of the Army Emblem and Branch of Service Plaques](#), and must be reproduced in full color.

**11.4.7.3 Insignia.** The use of branch insignia, shoulder sleeve insignia, coat of arms and/or distinctive insignia on headquarters signs is permitted (Fig. 11.51). All military emblems must appear in full color. Motivational symbols or motifs will not be used.



**Fig. 11.50 - Placement Is Critical To Ensure Easy Readability**



**Fig. 11.51 - The use of branch insignia on Type B2 and B3 signs is permitted, i.e., Brigade and Battalion HQ signs**

### 11.4.8 Reduce Visual Clutter.

**11.4.8.1** Over-signing detracts from a uniform sign system and if left uncontrolled will eventually destroy the integrity of the system.

**11.4.8.2** Clutter creates confusion and ineffectiveness. Often motorists and pedestrians are confused by the bombardment of messages that have no relationship to each other, or the communication is on such a minimal level that the sign serves no purpose (Fig. 11.52).

### 11.4.9 Location Maps (Fig. 11.53).

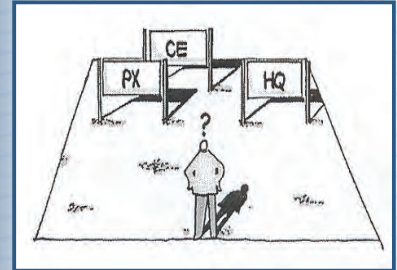
**11.4.9.1** The location map is an integral element of an installation entrance. The location map display provides information and sense of place to the viewer. The design and construction should be of compatible architectural materials found throughout the installation.

**11.4.9.2** The location map should contain the following characteristics within the design.

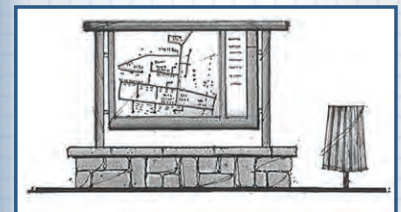
- Plexiglas covered map for protection
- Architectural compatible materials used for the base
- Paved walk-up area
- Litter receptacle
- Provide parking adjacent
- Provide current takeaway maps

### 11.4.10 GENERAL SIGN PROVISIONS

This section regulates all Fort Gordon exterior signs and interior signs positioned for exterior observance. Signs should be used only as necessary. Visual Clutter causes confusion and creates



**Fig. 11.52 - Visual Clutter Causes Confusion**



**Fig. 11.53 - Location Maps Provide a Sense of Place**



**Acceptable Symbology Commonly used as Signage Graphics**

ineffectiveness. It detracts from a uniform sign system, and if left uncontrolled will eventually destroy the integrity of the system.

Signs not specifically outlined in this IDG are not authorized unless approved by the Garrison Commander.

**11.4.10.1 General sign provisions include the following:**

- a) Redundant, unreadable, and outdated signs should be moved.
- b) DPW approval is required prior to installing, painting, remodeling, relocating, or expanding any sign.
- c) No approval is required to perform normal maintenance and repair of a conforming sign or to change a message on a sign or marquee specifically designed for this purpose.
- d) Public safety signs not exceeding two square feet do not require site approval. Examples include emergency telephone, restroom, and underground utilities.
- e) Street signs, not located in state rights-of-ways, do not require site approval.
- f) Signs conforming to previous regulations, but not conforming to this guide, will be removed and replaced.
- g) All signs will either be pre-manufactured from materials meeting or exceeding the EPA required minimum recycled content or fabricated by DPW. Low quality and “homemade” signs are prohibited.
- h) Any sign that is mechanically animated (i.e., revolves, rotates, or moves in any way) is prohibited.
- i) Locate signs where they are visible and unobstructed.
- j) Signs will not indicate names of individuals (commander, first sergeant, OIC, manager, etc.).
- k) Sign wording shall be brief and limited to essential information. Words may be abbreviated if the message remains easily understood.
- l) Commercial symbols are allowed only on MWR / PPV signs, Burger King, etc.





- m) Signs generally are not landscaped; however, if ornamental planting occurs in the vicinity of the sign, locate the sign in the planting bed.
- n) Temporary signs do not require landscaping; changeable signs are not considered temporary.
- o) Any exposed lighting tubes, strings of lights, spotlights, or any illumination that causes direct glare upon an unrelated building are prohibited.
- p) Any flashing signs, traveling lights, or signs animated by lights of changing degrees of intensity or color are prohibited.
- q) Signs may be lit by remote lamps or backlit where nighttime identification is required such as at clubs, shopping areas, and post entry points.
- r) Traffic signs will follow guidelines in the Federal Highway Administration's "Standard Alphabets for Highway Signs and Pavement Markings" standards.
- s) Nonconforming signs shall not be enlarged, repaired, reconstructed, changed, including wording or graphics changes, except to comply.
- t) Signs itemized in this section shall be placed at the appropriate buildings regardless of its real property category, unless specified otherwise.
- u) No signs shall interfere with or confuse traffic or other aspects of safe driving conditions through use of improper wording, graphics, location, size, shape, or color.

#### **11.4.10.1.1 Billboards**

Use billboards at parade fields only. Any other sign that directs attention to a business attraction, or entertainment conducted at a location other than the premises where the sign is located, must be combined with other signs of similar character or type and requires specific site and design approval by DPW.

#### **11.4.10.1.2 Banners**

Limited to a maximum of 3-foot by 25-foot fabric material. Banners mounted on or attached to buildings, structures, and utility

poles must have DPW site approval. Sign display period limited to 30 days.



#### **11.4.10.1.3 Directional Signs**

Use these signs only for facilities frequented by non-Fort Gordon personnel. Typical examples, include post exchange, commissary, contracting, hospital, information center, and museum. These are to be located only on major thoroughfares. Use the Federal Highway Administration's "Standard Alphabets for Highway Signs and Pavement Markings" standards.

#### **11.4.10.1.4 Historic Facilities**

Upon approval from Cultural Resources, historical plaques may be used for any facility properly listed on the State or National Register of Historic Places.

#### **11.4.10.1.5 Memorialized Facilities**

Upon approval of the Memorialization Board, special facilities may be identified.

#### **11.4.10.1.6 Parking Lot Signs**

These signs include handicapped, General Officer, Command Sergeant Major, Mayor, Military Vehicle, Mother with Child, and Visitor spaces.

No reserve parking signs, besides those already mentioned, are allowed for any commanding officer, noncommissioned officer, or executive officer. No "Permit Parking Only" signs are authorized.

#### **11.4.10.1.7 Portable Signs**

These signs are prohibited. Portable is defined as signs designed to be transported from one location to another, with or without wheels or trailer, and typically have a changeable message area.

#### **11.4.10.1.8 Residential Business Signs**

These signs are prohibited. Examples include home day-care identification.

#### **11.4.10.1.9 Restricted Area Signs**

Use when authorized by the Provost Marshal. Sign color will be brown 20059.





#### **11.4.10.1.11 Supplemental Building / Structures Signs**

These signs are prohibited. Examples include paint or storage shed and kiosk or shelter identification. Safety/Warning signs specifically associated with a supplemental building/structures are allowed.

#### **11.4.10.1.12 Advertisement / Business Announcement**

One sign per location not exceeding 20 square feet. Examples include "Grand Opening", "Under New Management" and similar announcements. Sign display period limited to 30 days and only once per year per vendor.

#### **11.4.10.1.13 Construction Signs**

One sign per location not exceeding 32 square feet.

#### **11.4.10.1.14 Official Notices, Fairs, and Special Programs**

Two per building or location and/or two per intersection. Sign display period limited to 30 days.

#### **11.4.10.1.16 Seasonal Displays**

Displays not advertising a product, service, or entertainment require no DPW approval and will be treated as temporary signs.

#### **11.4.10.2 Sign Mounting and Location**

Locate identification signs typically at building entrances and/or other parts of the building visible from the main access street. Building signs should be visible from the main circulation paths to the building (vehicular or pedestrian).

#### **11.4.10.3 When signs are mounted on buildings, the following requirements shall apply:**

- a) No sign may be mounted on the outside of the door, except small signs (one square foot or less) that indicate required use of an alternate entrance.
- b) Signs such as "Escort Required" or changeable signs are not permitted.

- c) No sign may be attached or mounted to roofs and parapets.
- d) No sign shall be painted or applied directly onto the surface of a building.
- e) No permanent signs shall obstruct any window, door, fire escape, ladder, or opening intended for light, air, or egress.
- f) No temporary sign in windows or glass walls is allowed to cover more than 20 percent of the glass area. Temporary sign display may not exceed 30 days.
- g) No signs shall interrupt the vertical and horizontal features of the facade.
- h) No sign may be tacked, posted, painted, or otherwise affixed to site elements such as sheds, trees, or structures.
- i) No sign may be attached to utility poles except for pole identification or warning.
- j) In no case may signs be closer than 18 inches to the curb line. A minimum clear height of 3 feet 6 inches above the ground is required.





## 11.5 LIGHTING

**11.5.1** Lighting is a functional requirement of installations that also impacts the visual environment. The installation lighting system conveys a sense of order and organization. There are five primary types of lighting on military installations. They are:

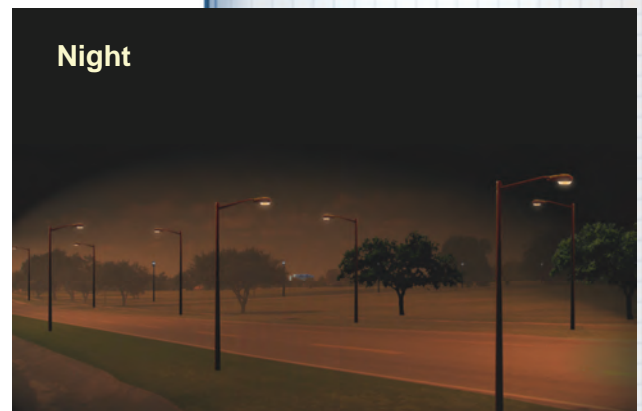
- Roadway Lighting
- Pedestrian Lighting
- Parking Lot Lighting
- Outdoor Architectural Lighting
- Security Lighting

**11.5.2** The primary visual problem that exists with exterior lighting on most military installations has been the lack of overall coordination of a lighting system (Fig. 11.54).

**11.5.3** A lighting system provides the proper type of lighting for different lighting requirements and locations. A system is composed of six primary components – fixtures, light height, type of pole, light spacing, type of lamp, and level of intensity of lamp.

**11.5.4** The proper type of lighting for various locations is shown in the (Figure 11.X – Lighting Design Matrix)

**11.5.5** All lighting should be located or designed to prevent undesirable spillover of light into other areas. Spotlights in particular should be aimed or screened to prevent glare that could blind motorists or pedestrians or light sleeping areas.



**Fig. 11.54 – Example of Coordinated Lighting System (Fort Gordon Rendering)**

Table 11.55 Light Design Matrix



LIGHT DESIGN MATRIX		TYPICAL AREAS OF USE																		
		Entry Gates	Primary Roadways	Secondary Roadways	Tertiary Roadways	Primary Walkways/Bikeways	Secondary Walkways/Bikeways	Tertiary Walkways/Bikeways	Courtyards	Playgrounds	Ball fields	Basketball Courts	Tennis Courts	Buildings	Landscaping	Fence Parameters	Signs & Monuments	Large Parking Lots	Small Parking Lots	Training areas
LAMP	Incandescent													•						
	Halogen	•	•																	
	Mercury Vapor		•	•	•	•	•		•	•	•	•	•		•					
	Florescent																			
	Metal Halide		•	•	•	•	•		•	•	•	•	•	•	•		•			
	High Pressure Sodium	•	•							•	•	•	•			•		•	•	•
LEVEL	Lux (lx)		20	15	10	10	2		50		200	200	50							
	Foot-candles (fc)		2	1.4	0.9	0.9	0.2		5		10	20	5.6			0.2		1	1	1
HEIGHT	40' Max	•							•					•	•	•		•		
	25' Max	•				•	•	•						•	•				•	
	15' Max			•	•															
	Varies		•							•	•	•	•				•			•
FIXTURE	Cutoff		•	•	•													•	•	
	Utility	•														•				•
	Bollard																			
	Spot												•				•			
	Wall Mount																			
POLE	Metal		•	•	•													•	•	
	Wood															•				
SPACED	120' Max		•	•	•											•		•		
	90' Max																		•	
	Varies													•			•			•

### 11.5.6 Light Fixtures.

**11.5.6.1** A lighting fixture is the frame or housing for holding the lamp in position and for protecting it from damage. Light fixtures should be selected and located to maintain the minimum foot-candle requirements for safety and security purposes. Beyond that, aesthetic considerations should take precedence.

**11.5.6.2** Lighting fixtures are grouped into five general categories as defined below. Figure 11.56 includes examples of four of the categories.

#### 11.5.6.2.1 Cutoff Lighting.

Refers to the large shoebox-shaped fixtures placed on tall poles and used to illuminate streets and parking lots. They are designed to cut off light traveling to the top and sides of the fixtures, concentrating it down onto the parking lot. The fixtures reduce the spillover of light where it is not wanted.

#### 11.5.6.2.2 Utility Lighting.

Refers to simple, inexpensive fixtures that are used in industrial areas of low visibility.

#### 11.5.6.2.3 Bollard Lighting.

Refers to fixtures that are mounted on or in a short post to illuminate pedestrian areas. They can also be used as physical barriers between pedestrian and vehicular traffic.

#### 11.5.6.2.4 Spot lighting.

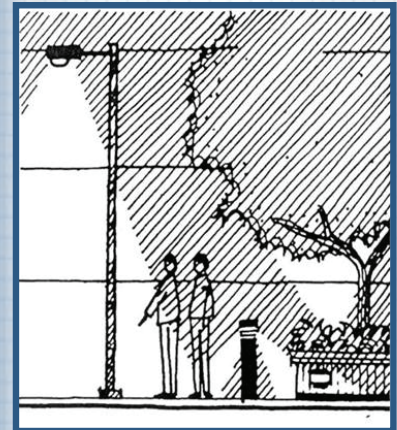
Refers to high intensity fixtures that concentrate light into a narrow beam and are used to highlight signs and other important objects. Spotlights should be screened by landscaping or other methods so they are inconspicuous during the day.

#### 11.5.6.2.5 Wall-Mounted Lighting.

Refers to fixtures attached to the wall of a building or a wall bordering a walkway or stairway.

### 11.5.7 Light Poles

**11.5.7.1** The light fixture size should be proportional to the intended pole height.







**Fig. 11.56 – Example of Cutoff, Bollard, Wall and Spot Lighting**



**Fig. 11.57 – Pole Height Determined by Function**



**11.5.7.2 Fort Gordon Light Pole and Fixture Standards**

<b>Fort Gordon Standard Light Fixture Types</b>	
	<p><b>MPB BRECKENRIDGE</b></p> <p><b>Mounting Height: 16 ft. Roadway 12 ft. Walkway</b></p> <p>Colonial styling with cast aluminum housing and spun top, finial, prismatic refractor and black powder coat finish.</p>
	<p><b>OVZ COBRA</b></p> <p><b>Mounting Height: 30 ft. Roadway</b></p> <p>Cast aluminum roadway luminaire with anodized aluminum reflector, prismatic refractor and Bronze powder coat finish.</p>
	<p><b>Mongoose® Off-Road Light Fixture and Pole</b></p> <p><b>Mounting Height: 35 ft. Roadway</b></p> <p>400W, high pressure sodium. High tilt, 27 to 45°. Wide roadway distribution with prismatic refractor. Vertical tenon mounting. Terminal block, NEMA decal 1 x 1 and NEMA Twist-off Photo-control receptacle. Dark Bronze finish.</p>
	<p><b>GMA MEDIUM GALLERIA</b></p> <p><b>Mounting Height: Varies</b></p> <p>Contemporary square parking lot luminaire with formed aluminum housing, anodized aluminum reflector, tempered convex glass lens and bronze powder coat finish.</p>

**11.5.8 Light Fixtures and Poles.**

Light poles should be consistent and provide uniformity throughout the installation. The pole height shall be determined by their intended function as shown below (Fig. 11.57).

**11.5.9 Lamp Characteristics.**

Selection of a lamp involves evaluating its optical control, efficiency, lamp color rendition, lamp life, cost, and maintenance.

The following is a summary of the characteristics of typical lamp types.

**11.5.9.1 Incandescent**

- Superior color rendition
- Inexpensive
- Good optical control
- Short life span
- Lowest efficiency

**11.5.9.2 High Pressure Sodium**

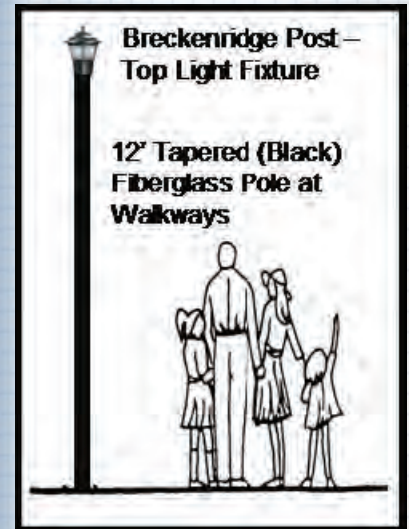
- Poor color rendition
- Broad application
- Low maintenance
- Superior optical control
- Superior life span
- Excellent efficiency
- Expensive

**11.5.9.3 Low Pressure Sodium**

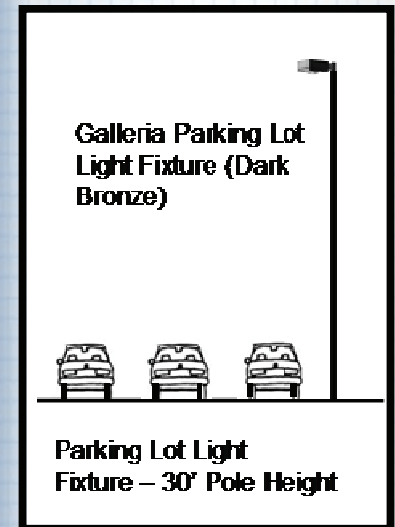
- Poor color rendition
- Good efficiency
- Superior life span
- Expensive

**11.5.9.4 Fluorescent**

- Good color rendition
- Poor optical control
- Good life span



**Typ. Fort Gordon Walkway Light Fixture**



**Typ. Fort Gordon Parking Lot Light Fixture**

- Good efficiency in mild climates
- Produces glare

#### **11.5.9.5 Metal Halide**

- Superior color rendition
- Superior optical control
- Efficiency better than mercury vapor but poorer than pressure sodium.
- Expensive

#### **11.5.9.6 Mercury Vapor**

- Good color rendition
- Good foliage lighting
- Good life span
- Good efficiency
- Inexpensive





## 11.6 UTILITIES

**11.6.1** Utility systems provide the basic infrastructure of power, communication, water, and sewer services necessary for the operation of the installation. Utilities play a key role in the visual quality on an installation. Their primary impact on the visual quality is the result of the clutter of overhead utility lines and poorly designed storm drainage systems.

**11.6.2** The visual and environmental impact of utilities should be minimized on the installation (Fig. 11.58). Also, the systems should be designed to minimize maintenance and repair. The result is a more sustainable utility system that will promote the overall sustainability of the installation. The primary components of the utility system and recommendations for their location and design are included below.

### 11.6.3 Overhead Transmission Lines

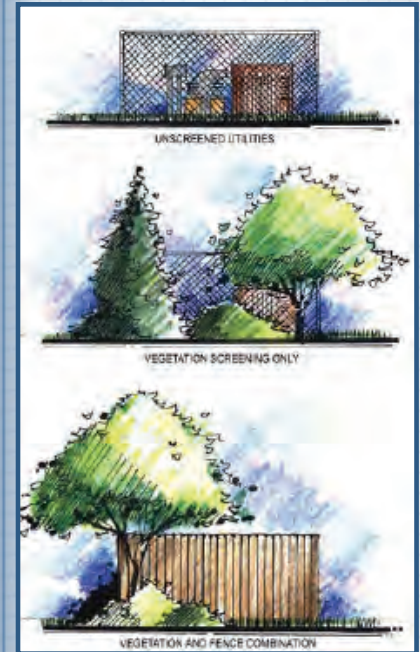
**11.6.3.1** Unsightly overhead utilities should be relocated underground wherever possible to reduce negative visual impacts, and reduce maintenance and repair requirements. Underground utilities are also desirable for protection from terrorist or other enemy attack. When underground locations are not possible, the negative visual impacts should be minimized by using the following design techniques:

#### 11.6.3.2 Overhead Transmission Lines Location.

Overhead transmission lines should be aligned along edges of land use areas to avoid dividing an area and creating gaps or unusable areas. They should conform to natural landforms that can be utilized to screen them from public view. Hills should be crossed obliquely rather than at right angles. Alignments along hillcrests or steep grades should be avoided.

#### 11.6.3.2 View Screening.

Minimize long views or silhouette views of overhead transmission lines from along roads and other public viewing areas. Avoid the “tunnel effect” of long, straight, uninterrupted views along the alignment by clearing vegetation only within the right-of-way that threatens the overhead lines. Jog the alignment at road crossings and periodically undulate and feature plant materials along the edges of the right-of-way.



**Fig. 11.58 - Screen Existing Utilities to Decrease Visual Impact**

### 11.6.4 Distribution Lines.

Power distribution lines should also be located underground to minimize negative visual impact, reduce maintenance, and protect from terrorist or other enemy attack. If overhead, they should be located out of view from main public visibility areas or screened to be as unobtrusive as possible (Fig. 11.59). Avoid alignments of overhead lines along major circulation corridors. Use minor streets, alleyways, rear lot lines, and vegetation or topography that provide screening and minimize visual impact. Minimize the number of poles and pole height, and use poles that blend into their surroundings to reduce visual impact. Poles should also be multi-functional for power, telephone, cable television, street lighting, etc., to reduce visual clutter.

### 11.6.5 Substations and Transformers.

Substations and transformers should be designed and located to minimize their visual impact and be compatible with the character of their setting. Substations are best located in industrial use areas rather than in major public circulation areas. They should be screened from public view by using plant material, berms, and walls.

### 11.6.6 Sewer and Water.

**11.6.6.1** All sewer and water lines should be underground.

**11.6.6.2** Sewage treatment facilities should be located 1,250 ft. (0.38 Km) distance and in a downwind direction from all inhabited facilities.

**11.6.6.2** Treatment facilities should be screened from view of major roads and other installation facilities by plant material, berms, walls, and fences.

**11.6.6.3** A water storage tank that has visual strength in its form can be used as a focal point or identifying landmark that can provide a sense of orientation within the installation.

**11.6.6.4** Fire hydrants should be highly visible and free of any screening. They shall be nutmeg brown in color with luminous paint. Caps shall indicate tested water pressure (Fig. 11.60).



**Fig. 11.59 - Well-placed trees and shrubs of the appropriate types reduce the visibility of distribution lines.**



**Fig. 11.60 - Fire Hydrants Shall be Nutmeg Brown. Caps Shall Indicate Tested Water Pressure**



## 11.6.7 Storm Drainage

**11.6.7.1** Installation storm drainage systems should be appropriate to the character of development they serve. Storm drainage systems in densely developed areas require curbs, gutters, and underground lines. Storm drainage systems in low-density areas can utilize drainage swales and ditches that are contoured to be compatible with the natural landform. Where retention ponds are required, they should be designed to appear as a natural amenity that is part of the natural contour of the land, rather than a square or rectangular hole in the ground. Retention ponds that are designed to be dry most of the time can be utilized for recreational purposes or as open space. In either case, the areas should be designed to conform to the natural contours of the land.

**11.6.7.2** Large hard surfaced parking lots should have covered drainage at the entry to prevent water draining into adjacent streets.

## 11.7 ARMY STANDARDS

**11.7.1** The cited Army Standards shall be met.

- [DoD 4525.8-M, DoD Official Mail Manual](#)
- [Army Regulation \(AR\) 420-49, Utility Services](#)
- [Army Regulation \(AR\) 420-70, Buildings and Structures](#)
- [Army Regulation \(AR\) 420-72, Transportation Infrastructure and Dams](#)
- [Americans with Disabilities Act Accessibility Guidelines \(ADAAG\)](#)
- [Uniform Federal Accessibility Standards \(UFAS\)](#)
- [Technical Manual \(TM\) 5-807-10, Signage](#)
- [Manual of Uniform Traffic Control Devices \(MUTCD\)](#)
- [MTMC Pamphlet 55-14, Traffic Engineering for Better Signs and Markings](#)
- [Unified Facilities Criteria \(UFC\) 4-010-01, DoD Minimum Antiterrorism Standards for Buildings](#)

## 11.8 REFERENCES

11.8.1 The following references are provided for guidance.

- [Unified Facilities Criteria \(UFC\) 2-600-01, Installation Design, Chap 11](#)
- [Unified Facilities Criteria \(UFC\) 3-210-04, Design: Children's Outdoor Play Areas](#)
- [Army Regulation \(AR\) 1-33, Memorial Programs](#)
- [Army Regulation \(AR\) 840-1, Department of the Army Seal, and Department of the Army Emblem and Branch of Service Plaques](#)
- [Technical Manual \(TM\) 5-663, Child Development Center, Play Area Inspection and Maintenance Program](#)
- [Technical Manual \(TM\) 5-803-5, Installation Design Manual](#)

**Fort Gordon**  
Fort Gordon



Links

[Go to Section 12](#)

[Go to Table of Contents](#)



## 12.1 INTRODUCTION

**12.1.1** Accommodating the need for security and antiterrorism is a significant concern for all military facilities design. The security and antiterrorism requirements must be integrated into the total project. Design of protective elements should seek to visually enhance and complement the design of a facility. Site elements such as fences, courtyards, screen walls, swales, berms, planters, and retaining walls can be used effectively for facility protection. These design elements should be designed to provide visual harmony with the main facility, producing architectural compatibility through consistent use and application of materials, forms, and colors.



**Entrance Corridor to Fort Gordon Main Gate and Entry Control Facility**

**12.1.2** Final design decisions to meet security and antiterrorism requirements and resolve conflicts will require coordination among the design disciplines and appropriate functional areas to include land planners, landscape architects, architects, intelligence personnel, security personnel, Force Protection Officer, facility users, and engineers. The designers must work to balance force protection requirements with all other requirements that impact design and development. These include the [Americans with Disabilities Act Accessibility Guidelines](#) (ADAAG), the [Uniform Federal Accessibility Standards](#) (UFAS), [National Fire Protection Codes](#) (NFPA), and all applicable local building codes and ordinances. The design team will also consult security personnel to determine whether portions of the design documents are subject to access limitations.



**Decorative Wall Beyond Installation Main Gate**

**12.2 BUILDING SITING AND DESIGN STANDARDS**

**12.2.1** A primary concern for Army installations throughout the world is the threat of terrorist attack. To minimize the likelihood of mass casualties from terrorist attacks against DoD personnel in the buildings in which they work and live DoD has developed the [Unified Facilities Criteria \(UFC\) 4-010-01, DoD Minimum Antiterrorism Standards for Buildings](#). See Figure 12.1



**Fig. 12.1 – Elements of Minimum Protection for Site Design**

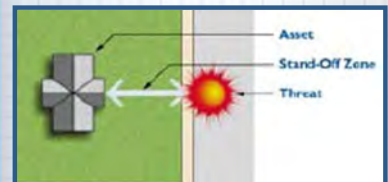
**12.2.1.1** UFC 4-010-01 establishes the minimum building antiterrorism standards for all DoD components.

- Mandatory DoD minimum antiterrorism standards for new and existing inhabited buildings are contained in Appendix B.
- Mandatory DoD minimum antiterrorism standards for expeditionary and temporary structures are contained in Appendix D.
- Additional recommended measures for new an existing, inhabited buildings are contained in Appendix C.

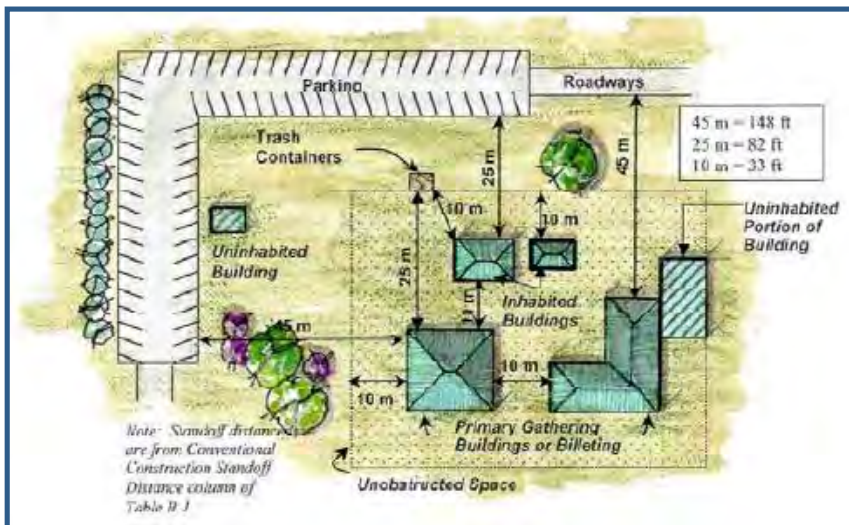
Implementation of the mandatory standards is obligatory for all new construction regardless of the funding source. These standards apply to FY 2004, and all subsequent fiscal years, for projects involving new construction and major renovations for inhabited structures. The standards will be reviewed before any site planning or design is initiated.

**12.2.1.2 Minimum Standoff Distances and Separation for Buildings (Concept – Fig. 12.2):**

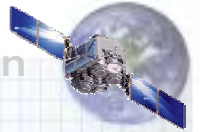
- The minimum standoff distances and separation for new and existing buildings are found in Table B-1 of [UFC 4-010-01](#). See Figures 12.3 and 12.4



**Fig. 12.2 – Concept of Stand-Off Distance**

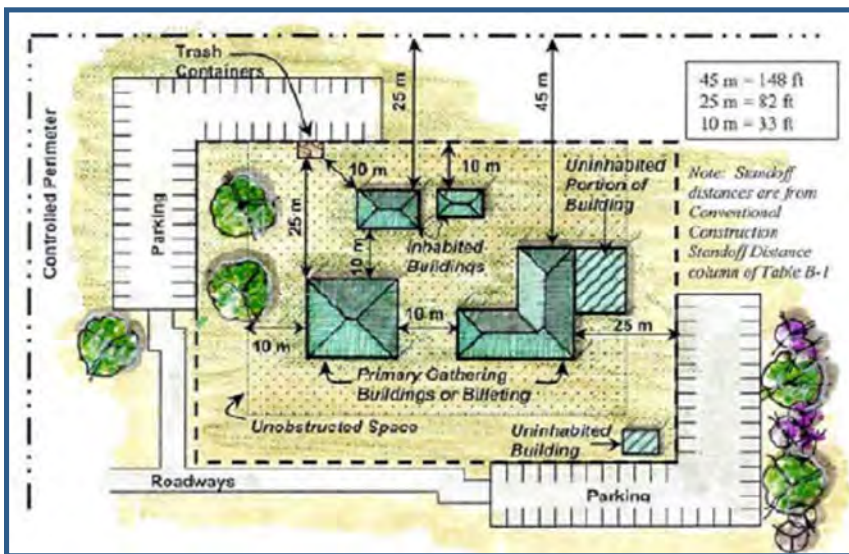


**Fig. 12.3 – Criteria for Stand-Off Distances and Building Separation – No Controlled Perimeter**



**Fig. 12.4 – Criteria for Stand-Off Distances and Building Separation – Controlled Perimeter**

- The minimum standoff distances and separation for expeditionary and temporary structures are found in Table D-1 of [UFC 4-010-01](#). See Figure 12.5



**Fig. 12.5 –Stand-Off Distances for Expeditionary and Temporary Structures**

**12.2.1.3** The DoD minimum standards, when applicable, may be supplemented by more stringent force protection building standards to meet specific threats inherent in the geographical area where the



facility is to be constructed. Those additional requirements may be established by either standards for specific Combatant Commanders or based on Risk and/or Threat Analysis.

**12.2.1.4** When the minimum standoff distances can not be achieved because land is unavailable, the standards allow for building hardening to mitigate blast effects. Costs and requirements for building hardening will be addressed in the DoD Security Engineering Manual. (See para 12.2.2 below for information regarding the DoD Security Engineering Manual).

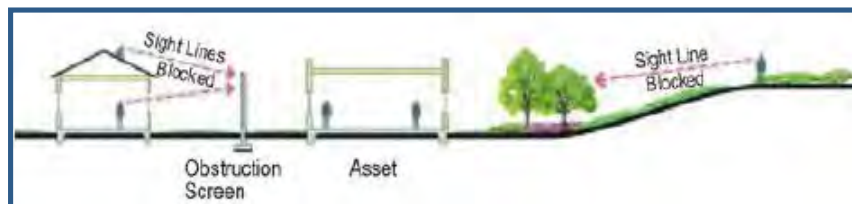
**12.2.2 Implementing Design Guidance.** Additional guidance on applying the antiterrorism standards is found in [UFC 4-010-02, DoD Minimum Antiterrorism Standards for Buildings](#).

**12.2.2.1 Website Access for Military and Government Users.** This is a password protected website. To enter the site you must be accessing the site from either a ".mil" or ".gov" address. Upon initial entry, you will be prompted with instructions on how to acquire your password.

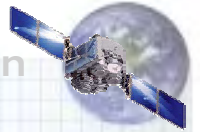
**12.2.2.2 Website Access for Non Military and Government Users.** Currently, the Protective Design Center is developing a procedure for e-mailing the network administrator to receive procedures to enter the site. If upon initial entry into the site there are no instructions on this procedures, contact the [Protective Design Center](#) (CENWO-ED-S) at (402) 221-3151 for instructions.

**12.2.3 Orientation of Buildings on a Site.** The following will be given consideration when determining the orientation of a building.

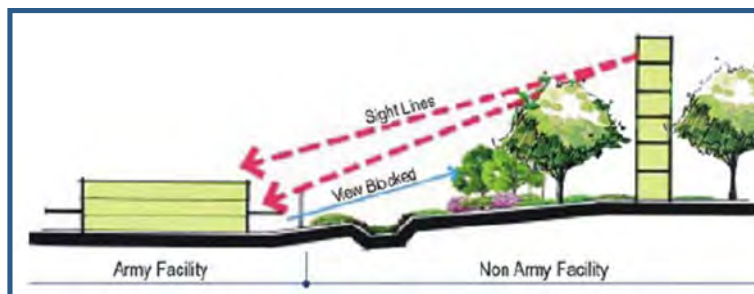
- Deny aggressors a clear "line of sight" to the facility from on or off the installation where possible. Protect the facility against surveillance by locating the protected facility outside of the range or out of the view of vantage points. See Figure 12.6



**Fig. 12.6 –Deny Aggressors a Clear “Line of Sight” to Installation Assets from On or Off Post**



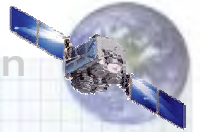
- Protect against attack by selecting perimeter barriers to block sightlines such as obstruction screens, trees, or shrubs. Non-critical structures or other natural or man-made features can be used to block sightlines.
- Provide passive vehicle barriers to keep Stationary Vehicle Bombs (SVBs) at distance from the asses (high curbs, low berms, shallow ditches, and landscape materials).
- Create "defensible space" by positioning facilities to permit building occupants and police to clearly monitor adjacent areas.
- If roads are nearby, orient building so there are no sides parallel to vehicle approach routes.
- Design vehicular flow to minimize vehicle bomb threats, avoid high-speed approach into any critical or vulnerable area.
- Avoid siting the facility adjacent to high surrounding terrain, which provides easy viewing of the facility from nearby non-military facilities. See Figure 12.7



**Fig. 12.7 –Avoid Siting Facilities Adjacent to High Surrounding Terrain**

## 12.3 FENCING

**12.3.1** Fences are used as protective measures against project-specific threats. They are most appropriately used to define boundaries and to deter penetration of a secure area. A fence will assist in controlling and screening authorized access to a secured area.



Fences also serve the purposes listed below:

- As a platform for the Intrusion Detection System.
- As a screen against explosive projectiles.
- To stop moving vehicles if they are reinforced to do so.

**12.3.2** Plants with tall growth habits and/or large mature growth will be located well away from security fences.

## **12.4 LANDSCAPE CONSIDERATIONS**

**12.4.1** Landscaping guidelines for buildings should not be ignored because of standoff distances. The landscape design should enhance the overall attractiveness of the facility while still providing or enhancing the objective level of security level of security.

**12.4.2** Establish clear zones along both sides of security fencing. Vegetation in the clear zone should not exceed four inches in height. (DoD 0-2000.12-H, *Protection of DoD Personnel and Activities Against Acts of Terrorism and Political Turbulence*, Appendix EE, Table EE-4). For additional information consult [FM 19-30](#). This document gives guidance on physical security and barriers.

**12.4.3** Strategically locate trees and planters to prevent penetration of an attack vehicle into the secure area perimeter.

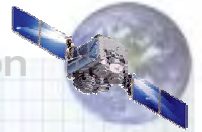
**12.4.4** Vegetative groupings and earth sheltering berms provide inherent blast effect reduction from external blast forces.

**12.4.5** Plant material that can provide concealment will not be used adjacent to high security structures or fence lines.

**12.4.6** Use dense, thorn-bearing plant material to create natural barriers to deter aggressors.

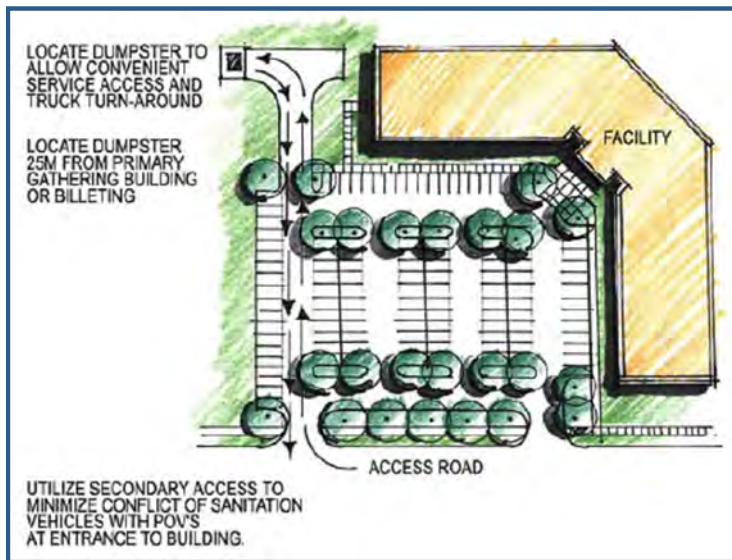
**12.4.7** Screen play and outdoor recreation areas from public (off-installation) view.

**12.4.8** Designers need to balance the need for signs that identify, locate, and direct residents and supported personnel to installation assets, versus the need to discourage and frustrate hostile intelligence gathering and access. One method of achieving this



balance could be to direct people to a community support or information center to obtain directions to high security activities.

**12.4.9** Place trash containers as far away from the facility as possible. Antiterrorism/force protection requirements restrict the location of dumpsters to a minimum of 10 meters (33 feet) from inhabited buildings and 25 meters (82 feet) from billeting and primary gathering areas ([Unified Facilities Criteria \[UFC\] 4-010-01, DoD Minimum Antiterrorism Standards for Buildings](#), Table B-1). See Figure 12.8

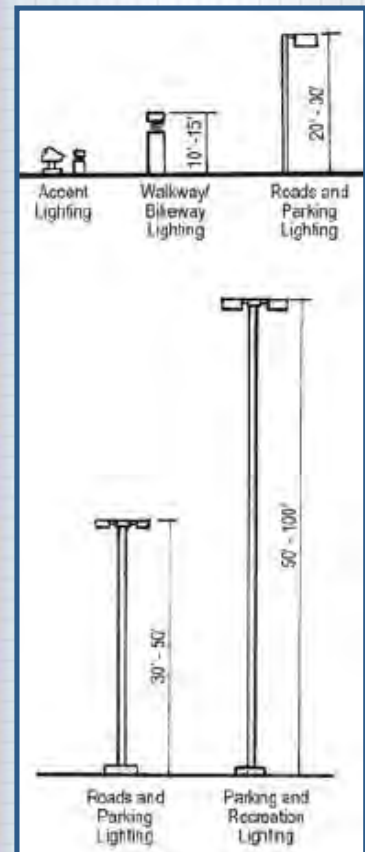


**Fig. 12.8 –Locate Trash Dumpsters 10 Meters From Inhabited Buildings**

**12.4.10** Unobstructed Space. Ensure that vegetation and site features within 10 meters (33 feet) of inhabited buildings do not conceal form observation objects of 150mm (6 inches) in height. ([UFC 4-010-01](#), Appendix B, Para B-1.3). This does not preclude landscaping within the unobstructed space, but it will affect the design and may affect plant selection.

## 12.5 LIGHTING

Lighting systems for security operations provide illumination for visual and closed-circuit television (CCTV) surveillance of boundaries, sensitive inner areas, and entry points. When CCTV is used as part of security operations, the lighting system will be coordinated with the CCTV system. The specific installation environment and the intended use determines lighting system requirements. Often two or more types of lighting systems are used



**Fig. 12.9 – Lighting Creates a deterrent**

within a single area (Fig. 12.9). Guidance on the use of security lighting may be obtained from [TM 5-811-1, Electrical Power Supply and Distribution](#).

## 12.6 BERMS

**12.6.1** Use of berms for force protection can fulfill one of more of the following functions (Fig. 12.10).

- Define boundaries of property or boundary limits.
- Provide a barrier to moving vehicles.
- Hinder pedestrian movement.
- Intercept projectiles.
- Obstruct lines of sight.

**12.6.2** Berms used to block lines of sight or projectiles must be high enough to achieve those objectives or may be combined with landscaping or other construction elements. Detailed design guidance is contained in Army Technical Manual (TM) 5-853-3/AFMAN 32-1071, Vol. 3, *Security Engineering Final Design*.

**NOTE:** This Army Technical Manual is a "For Official Use Only" document and is not accessible on the Army Corps of Engineers publications website. A copy of the manual can be acquired by ordering it through your standard publications account.

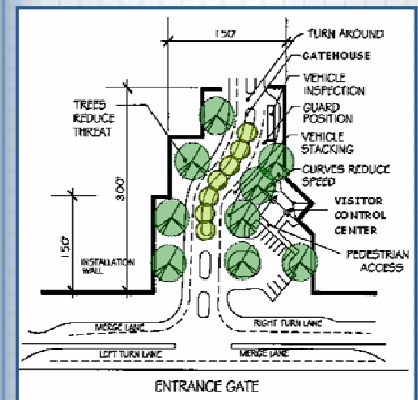
## 12.7 GATES AND ENTRANCES [ACCESS CONTROL POINTS (ACP)]

**12.7.1** Installation entry points are key components in the force protection security program. The most effective entrances accommodate the functions of observation, detection, inspection, access control, and disablement of hostile personnel and vehicles, while containing the vehicles and pedestrians until access is granted. These areas are one of the most important installation features in the creation of a sense of arrival for both installation personnel and visitors. It is important that these areas present a positive public image (Fig. 12.11).

**12.7.2** The Headquarters Department of the Army, Office of the Provost Marshal General, Operations Branch (DAPM-OPS) in coordination with the Protective Design and Electronic Security Centers of Expertise developed standards for Army Access



**Fig. 12.10 – Berms can serve many Force Protection functions**



**Fig. 12.11 – Conceptual Entrance Gate to Meet AT/FP Requirements**

Control Points (ACP). [Standard Definitive Design for Access Control Points, Dec. 2004.](#)

**12.7.2.1 Canopies for ACPs.** ACPs will have a canopy, which will cover the full width of incoming lanes at the Guard Booth. The canopy shall have a minimum clearance of 14.5 feet and shall have a minimum length of 50 feet. Supporting structure of roof will consist of columns sized and located to create peripheral vision for the guards with minimal obstructions. Lighting will provide a minimum of 10 ft-candles with a Color Rendition Index of 65. Measures will be taken to protect the canopy from the threat of an over-height vehicle.

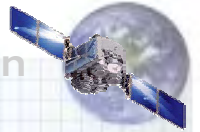
**12.7.2.2** [The Interim Army Standard for Canopies at Army Installation Access Points, Feb. 2004.](#)

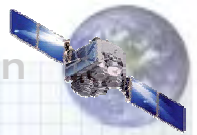
### **12.7.3 Physical Security Equipment.**

**12.7.3.1** The Product Manager, Physical Security Equipment (PM-PSE) under DoD Directive 3324.3 is assigned the mission of developing, fielding, and supporting Physical Security Equipment (PSE) throughout its life cycle for the Army, Joint Services, and other Government agencies.

**12.7.3.2** The DoD Directive assigns specific areas of responsibility which include: interior PSE, Command and Control Systems, security lighting, force protection systems, barrier and systems, and interior and exterior robotics. Physical security may dictate that CCTV cameras with recording capabilities may be required at entrance gates. Physical security may dictate that CCTV cameras with recording capabilities may be required at entrance gates. The PM-FPS homepage and the DA-approved equipment Blank Purchase Agreements (BPAs) are listed below.

- [Product Manager - Physical Security Equipment Homepage](#)
- [DA-approved PSE Equipment Blanket Purchase Agreements \(BPAs\)](#)





**12.8 ENTER PARAGRAPHS PERTAINING TO AREA SPECIFIC STANDARDS. (GET THIS INFORMATION FROM DPTMS DURING REVIEW).**

**12.9 ARMY STANDARDS**

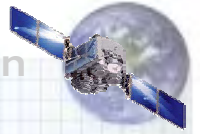
**12.9.1** The cited Army Standards shall be met.

- [Unified Facilities Criteria \(UFC\) 4-010-01, DoD Minimum Antiterrorism Standards for Buildings](#)
- [Unified Facilities Criteria \(UFC\) 4-010-10, DoD Minimum Antiterrorism Standoff Distances for Buildings](#). (This document is a "For Official Use Only (FOUO)" publication. Users may contact the Point of Contact posted at the noted website for inquires regarding this document).
- [Uniform Federal Accessibility Standards \(UFAS\)](#)
- [Americans with Disabilities Act Accessibility Guideline \(ADAAG\)](#)
- [DoD Instruction 2000.16, DoD Antiterrorism Standards](#)

**12.10 REFERENCES**

**12.10.1** The following references are provided for guidance.

- [Unified Facilities Criteria \(UFC\) 2-600-01, Installation Design, Chap 12](#)
- DoD Handbook 2000.12-H, *Protection of DoD Personnel and Activities Against Acts of Terrorism and Political Turbulence*, February 1993 (This Handbook is a "For Official Use Only (FOUO)" publication. Users may contact the Point of Contact posted at the following website to obtain a copy of the Handbook). <http://www.dtic.mil/whs/directives/corres/html/o200012h.htm>
- Army Regulation (AR) 525-13, The Army Force Protection Program (Available only through the [Army Knowledge Online](#) web portal).



- UFC 4-010-02, *DoD Security Engineering Manual*, (This document is in draft form. See the [Security Engineering Working Group](#) website).
- U.S. Air Force, [Installation Force Protection Guide](#): (Contains information on installation planning, engineering design, and construction techniques that will preclude or minimize the effect of a terrorist attack).
- Technical Manuals/Air Force Manual series TM 5-853/AFMAN) 32-1071, Security Engineering, 3 volume series: (Volumes 2 and 3 are "For Official Use Only [FOUO]" and are not available on the Army Corps of Engineers publications website. A copy of the manuals can be acquired via your standard publications account. The three volumes cover, Project Development, Concept Design, and Final Design respectively).

Links

[Go to Appendix A](#)

[Go to Table of Contents](#)





# Fort Gordon, Georgia Installation Design Guide

"Community of Excellence"



## U.S. Army Signal Center and Fort Gordon



## U.S. Army Garrison Fort Gordon, Georgia



**PREPARED BY:**  
**Directorate of Public Works**  
**Fort Gordon, Georgia**

**OCTOBER 2008**



# Fort Gordon, Georgia Installation Design Guide

"Community of Excellence"

## Appendices





# Fort Gordon

## **Army Installation Design Guide**

### **Appendices**

[APPENDIX A – Design Team IDG Checklist](#)

[APPENDIX B - Project Requirements Checklist](#)

[APPENDIX C - Interior Design Review Checklist](#)

[APPENDIX D - Sustainable Design](#)

**D.1 What is Sustainable Design?**

**D.2 Sustainable Design and Development**

**D.3 Sustainability and the Federal Government**

**D.4 Army Standards**

**D.5 References**

[APPENDIX E - LEED Checklist](#)

[APPENDIX F - Landscape Maintenance Schedule](#)

[APPENDIX G - Prioritized Improvements Projects List](#)

[APPENDIX H - Self-Help Project Checklist](#)

[APPENDIX I - Interior Finishes Standards](#)

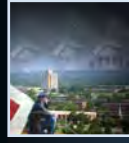
**I.1 Flooring**

**I.2 Base**

**I.3 Walls**

**I.4 Ceilings**

**OCTOBER 2008**



# Fort Gordon

**I.5 Countertops**

**I.6 Doors**

**I.7 Lighting**

## **APPENDIX J - Interior Furnishings Standards**

**J.1 Furniture Finishes**

**J.2 Furniture & Textile Construction**

**J.3 Conventional Furniture**

**J.4 Systems Furniture**

**J.5 Children's Furniture**

**J.6 Accessories**

**J.7 Restrooms & Locker Rooms**

**J.8 Signage**

**J.9 Railings**

## **APPENDIX K - Exterior Materials Chart**

- **Support Operations (Signal Center Barracks and Admin.**

**Visual Theme**

- **Industrial Facilities Visual Theme**
- **Community Center Visual Theme**
- **Medical Center Visual Theme**
- **Gates Visual Theme**



# Fort Gordon

## APPENDIX L - Exterior Color Chart

- North Industrial Visual Zone
- Signal Center Barracks and Administration Visual Zone
- USAR / National Guard Visual Zone
- South Industrial Visual Zone
- Community Center Visual Zone
- Signal Center HQ, Admin. And Academic Facility Visual Zone “Traditional Core”
- Medical Center Visual Zone

## APPENDIX M - Historic Preservation Guidelines

### **M.1 Introduction**

M.1.1 Military Planning and Design

### **M.2 Historic Preservation Regulations**

### **M.3 Rehabilitation of Historic Properties**

M.3.1 New Work

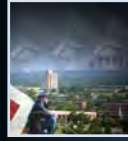
M.3.2 Treatment of Historic Fabric

M.3.3 Standards for Historic Preservation Projects

M.3.4 Guidelines for Historic Preservation Projects

### **M.4 Army Standards**

### **M.5 References**



# Fort Gordon

## APPENDIX N - Housekeeping Rules

### **N.1 Housekeeping Rules**

N.1.1 General

N.1.2 Public Spaces

## APPENDIX O - Plant Palette

## APPENDIX P - DA Facilities Standardization Program

### Centers Of Standardization

## APPENDIX Q - Standards & References

**Q.1 Section 7, Site Planning**

**Q.2 Section 8, Buildings**

**Q.3 Section 9, Circulation**

**Q.4 Section 10, Landscape**

**Q.5 Section 11, Site Elements**

**Q.6 Section 12, Force Protection**

**Q.7 Appendix D, Sustainable Design**

**Q.8 Appendix M, Historic Preservation**

**Acknowledgements**



## **APPENDIX A – DESIGN TEAM IDG CHECKLIST**

A Design Team IDG Checklist should be completed for all projects that impact the appearance of an Army Installation. The Master Planner shall provide the checklist to all teams designing new facilities; additions or renovations to existing facilities; or maintenance on the installation. The Design Team IDG Design Checklist is to be completed by the design team to assure the guidelines and standards have been considered and complied with in the design process and by the Master Planner in project review.

The Designer of Record or Design Agent will provide a copy of the completed checklist, together with a signed certification statement with each design submittal [10% (pre-concept), 35%, 60%, and 90%] for each MILCON project. The Designer of Record will complete the checklist and verify compliance in the space provided. In the case of Design Build, all agents, i.e., the Corps of Engineers, NAF, AAFES, Host Nation, tenants, etc. shall have the prospective design build contractors submit a completed IDG Checklist as part of their proposal. The completed checklist will be provided to the Master Planner for review with concurrence or denial. Upon a determination of concurrence by the Master Planner, the plan and checklist with signatures will then be provided to the Real Property Planning Board for final acceptance or denial. The accepted checklist will become a part of the project record files.

If plans are denied for non-compliance at the installation or command level (where applicable) of review, an explanation of the denial will be provided to the Designer of Record. The plan and checklist can be resubmitted with revisions as indicated in the explanation of denial.

## INSTALLATION DESIGN GUIDE (IDG) COMPLIANCE CHECKLIST

### 1. Project Title and Description

Title:

---

Description:

---

---

### 2. Project Justification:

---

---

### 3. Sustainable Design

a. Has the LEED™ checklist been attached? (If not, obtain completed checklist.)

b. Does the project meet or exceed LEED™ Silver level? ("Silver" is the standard for all FY07 MILCON vertical construction projects currently under design (as of March 18, 2003). For all other FY06 and future-year MILCON projects the minimum LEED™ rating requirement is "Gold.")

Yes \_\_\_\_ Review project as submitted.

No \_\_\_\_ Return submittal to design team for revisions to meet LEED™ requirements.

### 4. Site Planning

a. Was a site plan prepared for the proposed project utilizing the IDG Design Process included in Sections 2, 3, and 5 of the IDG?

Yes \_\_\_\_ No \_\_\_\_

b. Does the site plan include Site Planning Design Component guidelines of the IDG?

Yes \_\_\_\_ No \_\_\_\_

c. Does the site plan meet AT/FP requirements identified in Section 12 of the IDG?

Yes \_\_\_\_ No \_\_\_\_

d. Designer Comments on Site Planning

---

---

e. Does Site Planning comply with IDG? If not, provide justification.



---

---

f. Does Site Planning meet approved installation master plan siting compliance?

Yes \_\_\_\_\_ No \_\_\_\_\_ If not, provide justification.

---

---

g. Has NEPA been initiated for the construction effort in accordance with AR 200-2?

Yes \_\_\_\_\_ No \_\_\_\_\_

h. Has airspace criteria been considered relative to airfield accident potential zones?

Yes \_\_\_\_\_ No \_\_\_\_\_

**5. Buildings**

a. Does the building exterior design meet the Building Design objectives defined in the IDG?

Yes \_\_\_\_\_ No \_\_\_\_\_

b. Is the exterior building designed to meet the Structural Characteristics defined in the IDG?

Yes \_\_\_\_\_ No \_\_\_\_\_

c. If the project is a renovation or addition, does the proposed renovation or addition meet IDG building design and structural characteristics?

Yes \_\_\_\_\_ No \_\_\_\_\_

d. If the project is a renovation or addition to a historic building, does the renovation or addition maintain the design integrity of the original building or meet Historical Approval Agencies' requirements for any deviations?

Yes \_\_\_\_\_ No \_\_\_\_\_

e. Does the building exterior design meet AT/FP requirements (if applicable)?

Yes \_\_\_\_\_ No \_\_\_\_\_

f. Designer Comments on exterior Building Design:

---

---

g. Does building design comply with IDG? If not, provide justification.

---

---

**6. Circulation**

a. If the project includes roadway construction, does the proposed plan meet Federal highway and/or local guidelines defined in the IDG?

Yes \_\_\_\_\_ No \_\_\_\_\_

b. If the project includes roadway construction, does the proposed plan meet AT/FP roadway setback requirements defined in the IDG?

Yes \_\_\_\_\_ No \_\_\_\_\_

c. If the project includes roadway construction, does the proposed plan include applicable Roadway Alignment and Intersection guidelines defined in the IDG?

Yes \_\_\_\_\_ No \_\_\_\_\_

d. If the project is an entrance gate, does the proposed plan include Entrance Gate guidelines and standards defined in the IDG?

Yes \_\_\_\_\_ No \_\_\_\_\_

e. If the project includes parking, does the proposed plan meet the Parking Lot Location/Design guidelines defined in the IDG?

Yes \_\_\_\_\_ No \_\_\_\_\_

f. If the project includes pedestrian circulation, does the proposed plan meet the Walkways and Pedestrian Circulation Guidelines in the IDG?

Yes \_\_\_\_\_ No \_\_\_\_\_

g. If the project includes bicycle circulation, does the proposed plan meet the Bikeway Guidelines in the IDG?

Yes \_\_\_\_\_ No \_\_\_\_\_

h. Designer Comments on Circulation Design:

---

---

i. Does Circulation Design comply with IDG? If not, provide justification.

---

---

**7. Plant Material**

a. All projects for new construction should include the planting of trees shrubs and/or groundcover. Does the proposed planting plan include a project plan?

Yes \_\_\_\_\_ No \_\_\_\_\_

c. Does the proposed planting plan meet AT/FP requirements defined in the IDG?

Yes \_\_\_\_\_ No \_\_\_\_\_

d. Does the proposed planting plan include plant material recommended in the selected Plant Palette Matrix included in the IDG?

Yes \_\_\_\_\_ No \_\_\_\_\_

e. Designer Comments on Landscape Design:

---

---

f. Does Landscape Design comply with IDG? If not, provide justification.

---

---

**8. Site Elements**

a. If the project includes Site Furnishings, does the proposed plan follow the guidelines in the IDG?

Yes \_\_\_\_\_ No \_\_\_\_\_

b. If the project includes Signs, does the proposed plan meet the Signs standards in the IDG?

Yes \_\_\_\_\_ No \_\_\_\_\_

c. If the project includes exterior Lighting, does the proposed plan meet the exterior Lighting guidelines defined in the IDG?

Yes \_\_\_\_\_ No \_\_\_\_\_

d. Will all power and other distribution lines be located underground?

Yes \_\_\_\_\_ No \_\_\_\_\_

e. Will all substations and transformers be designed as to be screened from view?

Yes \_\_\_\_\_ No \_\_\_\_\_

f. Will all sewer and water lines be located underground?

Yes \_\_\_\_\_ No \_\_\_\_\_

g. Are all storm drain systems designed to meet the guidelines defined in the IDG?

Yes \_\_\_\_\_ No \_\_\_\_\_

h. If the project includes Communications requirement, does the proposed plan follow the guidelines defined in the IDG?

Yes \_\_\_\_\_ No \_\_\_\_\_

i. Designer Comments on Site Elements Design:

---

---

j. Does Site Elements Design comply with IDG? If not, provide justification.

---

---

**9. Antiterrorism (Security)**

a. Have installation boundary setbacks been included?

Yes \_\_\_\_\_ No \_\_\_\_\_

b. Have building setbacks from roads, parking, other buildings been included?

Yes \_\_\_\_\_ No \_\_\_\_\_

c. Do site plans and landscape plans include the criteria outlined for AT/FP.

Yes \_\_\_\_\_ No \_\_\_\_\_

d. Designer Comments on AT/FP Compliance:

---

---

e. Does AT/FP Design comply with IDG? If not, provide justification.

---

---

I hereby certify that the information provided is in compliance with the guidelines of the installation or applicable IDG, except as justified as non-compliance.

---

\_\_\_\_\_  
Designer of Record  
Date

Concur \_\_\_\_ Deny \_\_\_\_ Explanation of denial is attached.

---

\_\_\_\_\_  
IDG Coordinator  
Date

Accept \_\_\_\_ Deny \_\_\_\_ Explanation of denial is attached.

---

\_\_\_\_\_  
Command Review (Where Applicable)



## PROJECT REQUIREMENTS CHECKLIST

For Completion by Installation Personnel for Use in Preparation of the Request for Proposals (RFP).

**PROJECT** \_\_\_\_\_ **LOCATION** \_\_\_\_\_

**DPW/DIS POC** \_\_\_\_\_ **PH#** \_\_\_\_\_

**ADDRESS:** \_\_\_\_\_

\_\_\_\_\_

**E-MAIL** \_\_\_\_\_

**DATE CHECKLIST COMPLETED** \_\_\_\_\_ **BY** \_\_\_\_\_

When completing this form it is important to remember that it is the responsibility of the installation to resolve any conflicts between the different “users” (i.e. DPCA, DPW, etc.) about wants, needs, etc. The A/E that prepares the RFP must have the specific guidance contained herein to get you what you want. If there is information you wish to provide that is not specifically requested or you are unable to make your desires clear within the confines of this checklist, then add those comments at the end. Overseas installations consider compliance with Host Nation codes.

## 1.0 GENERAL INFORMATION

### A. Maps and plans available: (Provide copies with completed checklist)

#### 1. Basic Information Maps (BIMs): (List Drawing Numbers)

(Maps should be provided in Spatial Data Standards (SDS) compatible GIS format whenever possible.)

- Site topography
- Site Sanitary Sewer
- Site Storm Sewer
- Site Electrical
- Site Water
- Site Plan Extract - from RPMP (Future Development Site Plan)
- Other
- Project Location Plans
- Area Map
  - a) Site Map

#### 2. Aerial Photograph (Preferred to Topographic)

#### 3. USGS Map

#### 4. Project Siting Plan (Proposed)

#### 5. Environmental

- a) Jurisdictional wetlands designation
- b) Other historical concerns:

### B. Project Building Plans: (If renovation/addition or prior design, provide available information and plans)

- |               |                    |
|---------------|--------------------|
| 1. Foundation | 7. Electrical      |
| 2. Basement   | 8. Mechanical      |
| 3. Floor      | 9. Plumbing        |
| 4. Structural | 10. Site Utilities |
| 5. Roof       | 11. Specifications |
| 6. Elevations | 12. Other          |

### C. Applicable Codes and Standards:

List all known applicable codes and regulations. Generally, NAF construction will not follow Federal or Military Specifications.

Department of Defense (DoD) Governing criteria is [UFC 1-200-01, Design: General Building Requirements, 31 July 2002](#)

Local Building Codes:

State and County Codes:

Environmental Regulations:

Installation Regulations:

Cultural Regulations:

Other:

National Fire Protection Codes (NFPA), [UFC 3-600-01, Design: Fire Protection Engineering for Facilities, 17 April 2003](#)

## 1.1 TEMPORARY FACILITIES AVAILABLE TO THE CONTRACTOR

### A. Facilities available to contractor during construction:

1. General Site Plan has been annotated to show limits of construction site: \_\_\_\_\_ Yes, \_\_\_\_\_ No. If the contractor requires the use of additional area, he must obtain written approval from the Contracting Officer.
2. Construction Office available: \_\_\_\_\_ Yes, \_\_\_\_\_ No.
3. Covered materials storage available: \_\_\_\_\_ Yes, \_\_\_\_\_ No.
4. Uncovered materials storage available: \_\_\_\_\_ Yes, \_\_\_\_\_ No.

**NOTE:** Security of construction site and materials is the Contractor's responsibility.

5. Select fill borrow areas, spoil areas, sanitary fill and haul routes are shown on attached Installation map: \_\_\_ Yes, \_\_\_\_\_ No.

List any restrictions or notes on the use of those areas:

**NOTE:** Disposition of scrap and salvageable materials resulting from construction is the responsibility of the contractor unless otherwise noted and agreed.

### B. Utilities available to contractor during construction:



1. Potable Water: \_\_\_\_ Yes, \_\_\_\_ No; Metering required: \_\_\_\_ Yes, \_\_\_\_ No;  
Cost \$ \_\_\_\_\_ per \_\_\_\_\_.
2. Non-Potable Water (Irrigation, Machine Washing, etc.): \_\_\_\_ Yes, \_\_\_\_ No;  
Metering required: \_\_\_\_ Yes, \_\_\_\_ No; Cost \$ \_\_\_\_\_ per \_\_\_\_\_.
3. Electricity: \_\_\_\_ Yes, \_\_\_\_ No; Metering required: \_\_\_\_ Yes, \_\_\_\_ No;  
Cost \$ \_\_\_\_\_ per \_\_\_\_\_.
4. Natural gas: \_\_\_\_ Yes, \_\_\_\_ No; Metering required: \_\_\_\_ Yes, \_\_\_\_ No;  
Cost \$ \_\_\_\_\_ per \_\_\_\_\_.
5. Sanitary sewer: \_\_\_\_ Yes, \_\_\_\_ No

**NOTE:** Utilities used at the construction may be metered and/or charged to the contractor. The rate schedule for utilities will be provided as part of this completed checklist and shall be the basis by which the installation will bill the utility usage. Installation of temporary meters, where required, and temporary tie-ins to the utility systems shall be the responsibility and at the cost of the contractor.

## 1.2 DEMOLITION REQUIREMENTS

### Facilities for demolition, relocation, or retention.

Provide description, size, type construction, and location of any existing facilities on the site that must be demolished, relocated or retained. Consider all structures, foundations, pavements, communications, and utilities (whether active or abandoned). Consider demolition hazards (i.e. lead, asbestos, etc.). Every effort shall be made by the installation to ensure compliance with the clean site policy. Provide the date when the clean site will be available. Recycle building demolition and debris material when ever possible.

## 1.3 PAVING REQUIRMENTS

### A. Parking area (s) required: \_\_\_\_ Yes, \_\_\_\_ No.

1. Location and brief description:
2. Number of parking spaces for passenger vehicles: \_\_\_\_\_

(including \_\_\_\_\_ spaces for the handicapped).

3. Type of pavement: \_\_\_\_\_
4. Perimeter of parking area (s) to have concrete curb: \_\_\_\_\_ Yes, \_\_\_\_\_ No.
5. Striping of parking spaces required: \_\_\_\_\_ Yes, \_\_\_\_\_ No.
  - a) Width of stripes: \_\_\_\_\_
  - b) Type of paint to be used: \_\_\_\_\_
1. Special signage required: \_\_\_\_\_
2. Concrete wheel stops required: \_\_\_\_\_ Yes, \_\_\_\_\_ No.
3. Handicapped ramps/depressed curbs required: \_\_\_\_\_ Yes, \_\_\_\_\_ No.

**B. Service road (s) required: \_\_\_\_\_ Yes, \_\_\_\_\_ No.**

1. Location: \_\_\_\_\_
2. Type pavement: \_\_\_\_\_
3. Concrete curbing required on both sides of road: \_\_\_\_\_ Yes, \_\_\_\_\_ No.
4. Minimum roadway width: \_\_\_\_\_ Feet \_\_\_\_\_.

List any other special paving considerations or needs: \_\_\_\_\_  
\_\_\_\_\_  
\_\_\_\_\_  
\_\_\_\_\_

**C. Sidewalks required: \_\_\_\_\_ Yes, \_\_\_\_\_ No.**

1. Type of paving material: \_\_\_\_\_
2. Location: \_\_\_\_\_
3. Minimum width: \_\_\_\_\_
4. Minimum thickness shall be 4" with welded wire fabric.

**D. Concrete dumpster pads required: \_\_\_\_\_ Yes, \_\_\_\_\_ No.**

1. Number of pad (s): \_\_\_\_\_ each. See note below.

2. Size of each pad: \_\_\_\_\_ feet by \_\_\_\_\_ feet.
3. Provide bumper stops at rear of pads: \_\_\_\_\_ Yes, \_\_\_\_\_ No.
4. Provide architectural screening of pads: \_\_\_\_\_ Yes, \_\_\_\_\_ No.

Type: \_\_\_\_\_

**NOTE:** Building orientation or design may eliminate need for screening. Screening shall be in accordance with the Army Installation Design Guide (IDG).

#### 1.4 UTILITIES SERVICE REQUIREMENTS

**A. Electrical Service: Meter required: \_\_\_\_\_ Yes, \_\_\_\_\_ No,**

Type: \_\_\_\_\_

1. Type system to be installed: \_\_\_\_\_ underground, \_\_\_\_\_ aerial.
2. Type transformer (s) to be installed: \_\_\_\_\_ Pole mtd., \_\_\_\_\_ Pad mtd.,

**NOTE:** Screen in accordance with Army Installation Design Guide (IDG).

3. Available Voltage: \_\_\_\_\_
4. Location of tie-in point: \_\_\_\_\_

**B. Water Service: Meter required: \_\_\_\_\_ Yes, \_\_\_\_\_ No.**

1. Size and location of tie-in point: \_\_\_\_\_
2. Additional fire hydrant (s) required: \_\_\_\_\_

**C. Sanitary Sewer Service: Size and location of tie-in point: \_\_\_\_\_**

\_\_\_\_\_

**D. Storm Drainage:**

1. Design for \_\_\_\_\_ year occurrence.
2. Type System: \_\_\_\_\_ Surface,  
\_\_\_\_\_ Underground

3. Location of tie-in point for existing underground storm drainage system if incorporated in contractor design: See Site Plan.

**E. Gas Service: \_\_\_\_\_Natural, \_\_\_\_\_Propane;**

Meter required: \_\_\_\_\_Yes, \_\_\_\_\_No.

1. For Heating: \_\_\_\_\_Yes, \_\_\_\_\_No.
2. For domestic hot water: \_\_\_\_\_Yes, \_\_\_\_\_No.
3. For laundry dryers: \_\_\_\_\_Yes, \_\_\_\_\_No.
4. For kitchen equipment: \_\_\_\_\_Yes, \_\_\_\_\_No.
5. Size and location of tie-in point: \_\_\_\_\_

**NOTE:** Contractor (Offeror) shall be responsible to determine that all of the existing service utilities are of sufficient capacity to accommodate all of the design loads for this total facility. Should a Contractor (Offeror) determine that one or more of the existing service utilities are not adequate to accommodate the Contractor's (Offeror's) design loads for this total facility, then the Contractor (Offeror) shall submit with his initial and any subsequent proposal (Best & Final Offer), the requirements, design data and the price for increasing the capacity of each existing service utility system or for providing a new service utility system. Design loads for this facility shall be calculated in accordance with the criteria specified in this Request for Proposals (RFP), with the most stringent criteria governing. The responsibility for verification and field location of any and all information provided in the RFP and on any attached or enclosed drawings, or other documents shall be and is the responsibility of the Contractor (Offeror).

**F. Coordination and Notification Required for Utilities Tie-in:**

1. Point of contact for coordination: \_\_\_\_\_  
Tel. \_\_\_\_\_ Email \_\_\_\_\_
2. Road Closing:
  - a) Can both lanes be closed to traffic: \_\_\_\_\_Yes, \_\_\_\_\_No.
  - b) Maximum time road can be closed:
  - c) Can road be closed over a holiday or weekend: \_\_\_\_\_Yes, \_\_\_\_\_No.

3. Minimum notification time required for utilities outages and road closing:

- a) Electric Power: \_\_\_\_\_working days.
- b) Water: \_\_\_\_\_working days.
- c) Gas: \_\_\_\_\_working days.
- d) Steam: \_\_\_\_\_working days.
- e) Central AC lines: \_\_\_\_\_working days.
- f) Roads: \_\_\_\_\_working days.

**NOTE:** Enclose underground primary electrical service in concrete from the new utility tie-in points to the pad mounted transformer and/or mechanical room panel boxes. Provide one spare conduit for each service sealed at both ends. The conduit may be PVC provided it conforms to NFPA 70, current edition.

**NOTE:** If existing sidewalk, curbs, gutters, or paving are disturbed or removed during construction, the paving or concrete must be replaced by the Contractor.

**NOTE:** At overseas installations, utility work must meet Host Nation codes. Notably, in Europe utilities connections shall comply with the supplier's local codes. Contractors in Europe shall meet local utilities provider's conditions.

**G. Coordination and Notification Required for Railroad Track Work:**

1. Point of contact for coordination: \_\_\_\_\_

Tel. \_\_\_\_\_ Email \_\_\_\_\_

2. Road Closing:

a) Can both lanes of traffic be closed: \_\_\_\_\_ Yes, \_\_\_\_\_  
No.

b) Maximum time road can be closed:

c) Can road be closed over a holiday or weekend: \_\_\_\_\_ Yes,  
\_\_\_\_\_ No.

3. Railroad Track Closing:

- a) Can track be closed to traffic: \_\_\_\_\_ Yes, \_\_\_\_\_ No.
  - b) Maximum time track can be closed: \_\_\_\_\_
  - c) Can track be closed over holiday of weekend: \_\_\_\_\_ Yes, \_\_\_\_\_ No.
4. Minimum notification time required for railroad track and road closing:
- a) Railroad track:     working days.
  - b) Road:                working days.
5. Are used track components to be sorted and properly stored: \_\_\_  
Yes, \_\_\_\_\_  
No.
6. Are samples, ultra-sonic inspections, temperature recordings, and certificates to be submitted for ties, rail track components, or ballast: \_\_\_\_\_  
Yes, \_\_\_\_\_ No.
7. Are RAILER markings and reporting required: \_\_\_\_\_ Yes, \_\_\_\_\_  
No.
8. Are there special radio or communication requirements: \_\_\_\_\_ Yes,  
\_\_\_\_\_ No.

**NOTE:** If existing sidewalk, curbs, gutters, drainage, ballast, or paving are disturbed or removed during construction, the paving, drainage, ballast, or concrete must be replaced by the Contractor.

**1.5 ARCHITECTURAL AND STRUCTURAL BUILDING DESIGN REQUIREMENTS**

- A. Seismic Design Zone:** \_\_\_\_\_. Structural design shall be in accordance with codes specified in the RFP.
- B. Basic wind speed:** \_\_\_\_\_ mph.
- C. Ground Snow Load:** \_\_\_\_\_ PSF (Plus code live load).
- D. Maximum Frost Penetration:** \_\_\_\_\_ inches.
- E. Heat Transmission: “U” Factors:**

1. Walls: \_\_\_\_\_.
2. Floor (slab-on-grade) at perimeter foundation wall: \_\_\_\_\_.
3. Floor over ventilated crawl spaces: \_\_\_\_\_.
4. Ceiling and/or roofs: \_\_\_\_\_.

**F. Roof:**

1. Minimum pitch: \_\_\_\_\_
2. Type: \_\_\_\_\_
3. Scuppers and drains are required: \_\_\_\_\_ Yes, (If a parapet type roof is proposed); . No.
4. Gutters and downspouts: \_\_\_\_\_ Yes, \_\_\_\_\_ No, Type: \_\_\_\_\_
5. Drainage carry off: \_\_\_\_\_ Splash Blocks; or \_\_\_\_\_  
Underground drainage system (internal roof drains not permitted.)
6. Access to roof: \_\_\_\_\_.

**NOTES:** Catwalks to and around rooftop HVAC units and other equipment are required (Cary tread or equal). Where possible, architectural screening of visible rooftop equipment is required.

**G. Site Conditions:**

1. Environmental Assessment required: \_\_\_\_\_ Yes, \_\_\_\_\_ No.  
Completion Date: \_\_\_\_\_.  
EIS Required: \_\_\_\_\_ Yes, \_\_\_\_\_ No.  
Completion Date: \_\_\_\_\_.  
(Provide copies of actions to date.)
2. Cultural Resources Compliance Completed: \_\_\_\_\_ Yes, \_\_\_\_\_ No.
3. Site Conditions:  
Topographical feature description: \_\_\_\_\_  
\_\_\_\_\_  
\_\_\_\_\_

---

Confirm or identify subterranean hazards:

Fill area  
Old foundations  
Unexploded ordnance  
Existing/abandoned utility line  
Tunnels/mines  
Other

4. Soil investigation data available: \_\_\_\_ Yes, \_\_\_\_ No.

At project location: \_\_\_\_ Yes, \_\_\_\_ No.

Other:

5. Soil bearing capacity: \_\_\_\_\_ PFS. Actual test \_\_\_\_\_,  
Assumed \_\_\_\_\_.

**NOTE:** The successful Offeror shall be responsible for accomplishing additional necessary testing to verify soil characteristics at the site and design of the foundation system to meet these requirements.

**H. Building Exterior:** Brick: \_\_\_\_ Yes, \_\_\_\_ No.

Other: \_\_\_\_\_

**NOTE:** Where brick is required, the exterior walls shall be finished with face brick with through body integral color and shall match the brick currently in place in Building No's \_\_\_\_\_.

**NOTE:** The final floor plan as designed by Offerors shall include all functional areas outlined subsequently in this section. Gross building areas shall not exceed that specified in the RFP, including the mechanical room.

**I. Barrier Free Requirements:** (Where applicable) as minimum, \_\_\_\_\_ guest units shall be barrier free.

**NOTE:** Where required, "Barrier Free Requirements" shall be designed and constructed to provide for the Physically Handicapped (interior and exterior), in accordance with [Uniform Federal Accessibility Standards \(UFAS\)](#) and the [Americans with Disabilities Act Accessibility Guidelines \(ADAAG\)](#).

**J. Kickplates required on interior wood doors:** \_\_\_\_ Yes, \_\_\_\_ No.



**K. Approximate total maximum occupancy:**

- 1. Female: Adults \_\_\_\_\_ Children \_\_\_\_\_
- 2. Male: Adults \_\_\_\_\_ Children \_\_\_\_\_
- 3. TOTAL: \_\_\_\_\_

Comments: \_\_\_\_\_  
\_\_\_\_\_  
\_\_\_\_\_  
\_\_\_\_\_

**L. Landscape Requirements:**

List any special requirements:

**NOTE:** Offerors will provide a Landscaping Plan for the project area as required in the RFP. Surface area disturbance and tree removal will be minimized. Trees determined to be retained will be incorporated in the Landscaping Plan. Landscaping shall refer to the planting of trees, shrubs, plants, etc. and shall not be associated with establishment of turf as defined below. Trees, shrubs, plants, etc. shall be guaranteed for a period of one (1) year from time of planting.

**M. Establishment of Turf:**

**N. Soil Poisoning:** For termite protection is \_\_\_\_\_, is not \_\_\_\_\_ required.

**NOTE:** It will be the Contractor's responsibility to protect all existing turf and landscaping affected by the construction and to replace any turf or landscaping that has been damaged, for the term of the contract.

**O. Paint Color:**

List standard paint colors:

**P. Finishes:**

List standard finishes:

**1.6 ELECTRICAL DESIGN REQUIREMENTS**

**A. Exterior lighting:**

1. Parking area (s) lighting required: \_\_\_\_\_ Yes, \_\_\_\_\_ No.

- a) Type of lighting: \_\_\_\_\_ High Pressure Sodium  
\_\_\_\_\_ Low Pressure Sodium  
\_\_\_\_\_ Mercury  
\_\_\_\_\_ Halogen  
\_\_\_\_\_ Other

b) Average Intensity: \_\_\_\_\_ foot candles per sq. yd.  
with a uniformity ratio of 4:1 \_\_\_\_\_, Other \_\_\_\_\_.  
(Avg. to min.)

c) Type pole: \_\_\_\_\_.

d) Special mounting requirements:

e) Switching:

- Type: \_\_\_\_\_ Manual  
\_\_\_\_\_ Clock 7 day 7 day  
\_\_\_\_\_ Astronomical  
\_\_\_\_\_ Photo Electric  
\_\_\_\_\_ Combination of above as  
indicated.  
\_\_\_\_\_ Other

2. Exterior building lighting required: \_\_\_\_\_ Yes, \_\_\_\_\_ No.

- a) Type of lighting: \_\_\_\_\_ High Pressure Sodium  
\_\_\_\_\_ Low Pressure Sodium  
\_\_\_\_\_ Mercury  
\_\_\_\_\_ Halogen

- \_\_\_\_\_ Other
- b) Average Intensity: \_\_\_\_\_ foot candles per sq. yd.
- c) To be mounted on the building structure: \_\_\_\_\_ Yes, \_\_\_\_\_ No.
- d) Switching:
- 1) Type: \_\_\_\_\_ Manual
- \_\_\_\_\_ Clock 7 day 7 day
- \_\_\_\_\_ Astronomical
- \_\_\_\_\_ Photo Electric
- \_\_\_\_\_ Combination of above as indicated.
- \_\_\_\_\_ Other
- 2) Location: \_\_\_\_\_.
- 3) Lighting for plumbing and electrical chases required:
- \_\_\_\_\_ Yes, \_\_\_\_\_ No.

**NOTE:** All electrical wiring (exterior and interior) shall be copper.

**B. Outside weather proof receptacles:** shall be installed every \_\_\_\_\_ feet along the building exterior. Outside weather proof receptacles should be RCD (GFCI) protected.

**NOTE:** The building shall have emergency light fixtures and exit lights in accordance with NFPA requirements. Both shall have battery powered back-up, charge level meters and test buttons.

**C. Electromagnetic Shielding:**

List any electromagnetic shielding requirements.

**D. Standby/Backup Power Requirements:**

List and standby/backup power requirements.

## 1.7 MECHANICAL/PLUMBING DESIGN REQUIREMENTS

### A. Heating design data:

1. Below is the outside dry bulb temperature that is equaled or exceeded 97 ½ percent of the time, on the average, during the coldest 3 consecutive months (Dec., Jan., and Feb.). Heating design shall be based on the dry bulb temperature equaled or exceeded 97 ½ percent of the time.
  - a) Dry bulb temperature: \_\_\_\_\_.
  - b) Wind velocity: \_\_\_\_\_.
  - c) Degree days: \_\_\_\_\_.
2. Interior design temperatures: 68 degrees.

### B. Air conditioning design data:

1. Outside dry bulb and wet bulb temperatures that are equaled or exceeded 2 ½ percent of the time, on the average, during the warmest 4 consecutive months (Jun. thru Sep.) are given below. Air conditioning design shall be based on the 2 ½ percent dry bulb, wet bulb temperature.
  - a) Dry bulb temperature: \_\_\_\_\_.
  - b) Wet bulb temperature: \_\_\_\_\_.
2. Interior design temperatures: \_\_\_\_\_.
  - a) Dry bulb temperature: \_\_\_\_\_.
  - b) Wet bulb temperature: \_\_\_\_\_.

**C. Heating and air conditioning system:** shall be designed to provide a relative humidity of 50% + 10% or -10%.

**D. Mechanical Systems:** Economy cycle. The air conditioning system except where room fan coil units are located, if located where the winter design dry bulb temperature is 35 degrees F (97 ½% basis) or less, shall be designed so that 100% outside air may be used in the system during those cool weather periods when the outside air temperature is sufficiently low to provide all the cooling needed, or reduce the load on the air conditioning refrigeration equipment. Use of the economy cycle in areas above 358 F

shall be provided when it can be clearly shown that use of the economy cycle is cost effective.

**E. Install humidity control override:** \_\_\_\_\_Yes, \_\_\_\_\_No.

**F. Automatic timer controls required for:**

1. Heating System: \_\_\_\_\_Yes, \_\_\_\_\_No.
2. Air Conditioning System: \_\_\_\_\_Yes, \_\_\_\_\_No.

**G. Heating and Air Conditioning Source:**

1. Self contained plant: \_\_\_\_\_Heat, \_\_\_\_\_AC.
2. Supply lines from central plant: \_\_\_\_\_Heat, \_\_\_\_\_AC.
3. Purchased heat: \_\_\_\_\_

**H. Low profile roof mounted HVAC units are permissible:**\_\_\_\_\_Yes, \_\_\_\_\_No.

**I. Automatic timer controls required for:**

1. Heating System: \_\_\_\_\_Yes, \_\_\_\_\_No.
2. Air Conditioning System: \_\_\_\_\_Yes, \_\_\_\_\_No.

**J. Heating fuel to be used:**

Fuel: \_\_\_\_\_Natural gas, \_\_\_\_\_#2 Fuel oil,  
\_\_\_\_\_Propane.

**K. Dual fuel heating plant required:** \_\_\_\_\_Yes, \_\_\_\_\_No.

Primary Fuel \_\_\_\_\_, Secondary Fuel\_\_\_\_\_.

**L. Outside air supply intake:** to close when building is unoccupied:

\_\_\_\_\_Yes, \_\_\_\_\_No.

**M. Outside air supply intake:** to close when building is unoccupied:

\_\_\_\_\_Yes, \_\_\_\_\_No.

**N. Type heating and air conditioning filters required:**

( ) Permanent ( ) Throw away

**O. Covers and locks:** required on interior utilities controls: \_\_\_\_\_Yes, \_\_\_\_\_No.

**P. Plumbing Design Data:**

1. Exterior hose bibs: Minimum of \_\_\_\_\_ each with ¾” hose connection on building exterior.

a) Frost protection required: \_\_\_\_\_ Yes, \_\_\_\_\_ No.

b) Removable cutoff handles required: \_\_\_\_\_ Yes,  
\_\_\_\_\_ No.

2. Interior hose bibs: See Functional Requirements

3. Grease trap (s) required: \_\_\_\_\_ Yes, \_\_\_\_\_ No.

Location (s):

4. Commodes shall be floor mounted flush valve type.

5. Lift station required: \_\_\_\_\_ Yes, \_\_\_\_\_ No.

6. Hot water heater (s) required: \_\_\_\_\_ Yes, \_\_\_\_\_ No.

a) Energy source: \_\_\_\_\_ Natural gas, \_\_\_\_\_  
#2 Fuel oil.

b) Required minimum temperature: \_\_\_\_\_

c) System: \_\_\_\_\_

**NOTE:** All domestic water piping below grade shall be type K copper. All domestic water piping above grade shall be either type L copper in accordance with appropriate codes. All joints shall be soldered with 95/5 Tin/Antimony solder. The entire potable water system shall be lead free. Vent piping shall be schedule 40 galvanized steel or DWV weight copper.

7. Provide a minimum of \_\_\_\_\_ floor drain (s) in the laundry and mechanical room.

8. Insulate all water pipes (hot & cold) above slab: \_\_\_\_\_ Yes, \_\_\_\_\_ No.

**NOTE:** The domestic hot and cold water piping below grade shall be kept to a minimum, and below the frost line if located outside the building perimeter.

9. All domestic water pipes (hot & cold) shall be stenciled HW or CW. If pipes have been insulated then the pipe insulation shall also be stenciled.

10. Provide grease interceptor: \_\_\_\_\_ Yes, \_\_\_\_\_ No.

Location: \_\_\_\_\_

11. Provide a water filtration system: \_\_\_\_\_ Yes, \_\_\_\_\_ No.

Location: \_\_\_\_\_

Type: \_\_\_\_\_

12. Other plumbing considerations or requirements:

## 2.0 MINIMUM REQUIREMENTS FOR RESTROOMS

The following criteria are for minimal requirements only and may be superseded in quantities and/or finishes, providing that changes are an upgrading of the minimal requirements.

### A. General: MALE and FEMALE

<u>ITEM</u> <u>REQUIREMENTS</u>	<u>QUANTITY</u>	<u>SPECIAL</u>
Lavatory	_____	
Commode	_____	
Faucets	_____	chrome finish.
Expose pipes/valves	_____	chrome finish.
Pipe penetrations	_____	chrome finish
escutcheons.		
Clean outs	_____	chrome covers.
Mirrors	_____	mech. wall fasteners.
		Lighting
Floor drain	_____	each restroom.
Hose bib	_____	under lavatory in each
restroom.		
Wall finish		ceramic tile to 5' height
Ceiling		moisture resistant DW.
Floors		ceramic tile w/ceramic tile
base, or		
base.		quarry tile w/quarry tile
Toilet Partitions	_____	Tile shall be MUD-SET.
urinals.		at all commodes and
		overhead braced w/door
bumpers		
		baked enamel w/skirts.
Skirts	_____	18" stainless steel.
		watertight top edge.
Duplex receptacle	_____	GFCI type over vanity.

Paper towel dispenser with trash receptacle	_____	recessed in wall.
Hand dryer	_____	over each lavatory.
Soap dispenser	_____	liquid pump.
Toilet paper dispenser	_____	each commode stall.
Ash receptacle	_____	recessed, each restroom.

**B. Specific: WOMENS**

Sanitary napkin disposal	_____	each commode stall.
Sanitary napkin disposal operated.	_____	each restroom, coin

**C. Specific: MENS**

Urinal	_____	porcelain wall mounted w/stainless steel part.
--------	-------	---

**NOTE:** Each restroom shall be designed and constructed with provisions for the handicapped and shall conform to the latest edition of the National Standard Plumbing Code and the Uniform Federal Accessibility Standards published in the Federal Register, August 7, 1984 (Current Edition).

**3.0 FIRE PROTECTION REQUIREMENTS**

**A. Sprinkler system required: \_\_\_\_\_ Yes, \_\_\_\_\_ No.**

1. Type system to be installed: \_\_\_\_\_ Wet, \_\_\_\_\_ Dry.
2. Complete coverage throughout the structure: \_\_\_\_\_ Yes, \_\_\_\_\_ No.  
If no, describe proposed system, layout, etc.:
3. Exterior siamese connections are required.

**B. Detection System:**

1. Smoke detectors required: \_\_\_\_\_ Yes, \_\_\_\_\_ No.

**NOTE:** Radium type shall not be used.

2. Heat detectors required: \_\_\_\_\_ Yes, \_\_\_\_\_ No.  
(Rate of Rise Heat Detectors shall not be permitted.)

**NOTE:** When smoke and heat detectors are specific, full coverage of the building is required. In addition, heat detectors are also to be installed in conjunction with potential fire producing equipment such as furnaces, electric motors, etc. All detection devices shall be spaced and installed in accordance with manufacturer's specifications and the latest edition of the NFPA in effect at the time of installation. Heat detectors



shall be set to trigger at 1358 F. The heat and smoke detectors shall be the combination type. The smoke detection unit shall alarm locally and the heat detection unit shall alarm the facility and transmit the alarm to the fire department via a dedicated telephone line or appropriate transmission media, i.e. radio transmission equipment. Automatic cutoff of air handling equipment is required when smoke or heat detectors, sprinkler systems, or any other automatic/manual fire alarm suppression system are activated.

**C. Manually Activated Fire Alarm System:** installed in accordance with the latest edition of the NFPA in effect at the time of installation, is required. Also provide manual pull stations at the ends of the building. The pull stations shall be tied into a central panel box that will signal the fire department via a dedicated telephone line or appropriate transmission media, i.e. radio transmission equipment.

**D. Special fire suppression system (s) required:** \_\_\_\_ Yes, \_\_\_\_\_ No.

Describe type, location, and justification:

**E. Fire extinguishers (manually operated) are required.**

1. Government furnished: \_\_\_\_\_Yes, \_\_\_\_\_No.
2. Quantity and locations shall be based upon building design, NFPA, requirements, and coordinated with Installation's fire department.
3. Recessed cabinet mounted: \_\_\_\_\_Yes, \_\_\_\_\_No.

**NOTE:** The Contractor (Offeror) shall furnish and install the recessed fire extinguisher cabinets. The cabinets shall be at a minimum 24 1/2" tall, 7" deep and 8 1/2" wide w/glass doors.

**F. All interior finish materials shall be per NFPA standards and [UFC 3-600-01, Design: Fire Protection Engineering for Facilities, 17 April 2003.](#)**

**G. Water supply lines: for the sprinkler system shall be black steel pipe.**

**H. The installation's standard fire alarm panels shall be specified for ease of maintenance and sustainability.**

**I. Emergency Lighting Requirements:**

## 4.0 SECURITY REQUIREMENTS

### A. Building physical security:

1. Intrusion detection system required: \_\_\_\_\_ Yes, \_\_\_\_\_ No.
  - a) Type system to be installed.
  - b) Desired location of detectors:
  - c) Exterior door alarm requirements:
  - d) Exterior window alarm requirements:
2. Duress alarm system (s) required: \_\_\_\_\_ Yes, \_\_\_\_\_ No.
  1. Type system to be installed.
  2. Location (s):

### B. Safe (s) required: \_\_\_\_\_ Yes, \_\_\_\_\_ No.

1. Type and Number:
2. Size:
3. Location (s):
4. Secure to building: \_\_\_\_\_ Yes, \_\_\_\_\_ No, if yes, how:
5. Connect to main intrusion alarm system: \_\_\_\_\_ Yes, \_\_\_\_\_ No.

**C. Remote transmission of the intrusion alarm system:** to the installations master system required: . Yes, \_\_\_\_\_ No. If yes, provide and install the transmitter, all conduit, wiring, hookups from the intrusion alarm devices to the transmitter, as well as all exterior underground conduit, required wiring, panel boxes and all other ancillary equipment to bring the system to the existing communication transmission lines. The final connection at the communication line will be made by the government. All systems proposed shall be compatible with the existing system (s) installed at the installation. Point of coordination is Provost Marshall's Physical Security Officer. Specify the installation's standard intrusion alarm system if required.

### D. Keying requirements:

1. Rooms requiring card readers:
2. Rooms requiring cipher locks:

3. Rooms requiring individual keys:
4. Rooms requiring master keys:
5. Exterior keying requirements:
6. At least six (6) keys shall be provided for each lock. An additional twelve (12) sub master and six (6) master keys shall be provided.
7. The Offeror shall provide fifty (50) key blanks in addition to the above keying requirements.

**E. All exterior doors shall have irremovable hinge pins.**

**F. Panic hardware shall be in accordance with NFPA requirements.**

**G. Hardened secure area (s) required: \_\_\_\_\_ Yes, \_\_\_\_\_ No**

Location (s):

**H. Fencing Requirements:**

1. Location:
2. Type and height:
3. Gate requirements:

**I. Antiterrorism Requirements:**

1. Blast resistant windows:
2. Setbacks:
3. Barriers:
4. Others:

**J. Risk/Threat Analysis Requirements:**

1. ***Installation:*** Fill in unclassified pieces of risk/threat analysis.

2.

3.

## 5.0 COMMUNICATIONS REQUIREMENTS

**A. Intercom system required: \_\_\_\_\_ Yes, \_\_\_\_\_ No.**

Give a brief description of the requirements for the system:

**B. Music/Paging system required: \_\_\_\_\_ Yes, \_\_\_\_\_ No.**

Give a brief description of the requirements for the system:

**C. Telephone system required: \_\_\_\_\_ Yes, \_\_\_\_\_ No.**

Location:

Type:

Pay telephone required: \_\_\_\_\_ Yes, \_\_\_\_\_ No. If required, unit (s) will be wall hung. Contractor shall run wire and conduit from pay phone outlets to the main panel. Phones to be provided by Contractor.

**NOTE:** Contractor shall provide all conduit, wire, junction boxes and pull wires for the telephone system as required. Hookup of the telephone system will be performed by the Contractor. The Contractor shall coordinate all the telephone requirements with the installation's Directorate of Public Works (DPW) office and the local telephone company to determine requirements and provide space for communication equipment, panels, etc., in the mechanical room of where otherwise designed.

The basic telephone system shall be the "Centrax System" as provided by: \_\_\_\_\_

They system functions shall include the following:

1. Direct in dialing, with restrictions on receiving collect calls.
2. Direct out dialing to local exchange number only.
3. Restrictions on placing chargeable calls outside the local exchange, except for calls charged to credit card or calls made with the charges reversed.

**D. Television system required: \_\_\_\_\_ Yes, \_\_\_\_\_ No.**

1. The technical and installation requirements of the television system shall be coordinated with \_\_\_\_\_ the local cable television provider.
2. Locations/number of internal outlets:
3. Wiring and grounding shall be in accordance with the National Electric Code.

**E. Mass Notification System** (Required per [UFC 4-010-01](#), Standard 23: for New Inhabited Buildings and for Existing Buildings (Primary Gathering and Billeting), also for Existing Buildings, Recommended for all Inhabited Buildings)

Type of Mass Notification System Required:

## **6.0 SIGNAGE REQUIREMENTS**

(Excluding those required by NFPA and OSHA)

**D. Interior signage:**

**E. Exterior Signage:**

All exterior signage shall conform with the Army Installation Design Guide and Post Wide Paint/Exterior Finish Standards and color charts.

## **7.0 OTHER COMMENTS**



## APPENDIX C – INTERIOR DESIGN REVIEW CHECKLIST

The following checklist is optional and is designated for use on major projects.

**INTERIOR DESIGN REVIEW CHECKLIST**

**1. INSTALLATION** \_\_\_\_\_ **PROJECT** \_\_\_\_\_ **DATE** \_\_\_\_\_

**JOB DESCRIPTION** \_\_\_\_\_

**BUILDING No.** \_\_\_\_\_ **BUILDING COST\$** \_\_\_\_\_

**EVALUATOR** \_\_\_\_\_ **FURNISHING COST\$** \_\_\_\_\_

**USING AGENCY CO-ORDINATOR** \_\_\_\_\_ **PHONE#** \_\_\_\_\_

**DESIGNER** \_\_\_\_\_ **PHONE#** \_\_\_\_\_

---

ITEM	YES	NO	N/A
------	-----	----	-----

**2. Is the interior design integral to the facility design?**

-Interior Design is specified by the using agency.

-Scope of work includes building related interior design.

-Scope of work includes furniture related interior design.

-Design incorporates Installation Design criteria

-DPW representative was a member of Pre-selection and/or Selection Boards.

**Pre-selection member:** \_\_\_\_\_

**Selection member:** \_\_\_\_\_

**3. Was the designer provided interior design criteria?**

-Designed Guide for Interiors DG 11100-3-122.

-Design Guide for facility type designed.

-Installation Design Guide

**4. The design has been reviewed and the following are acceptable?**

For building related interior design?

**5. Does the interior design address the following functions?**

-Statement of Design Objective

- Sketches
- Color Board
- Furniture Plan
- Exterior Materials and Finishes
- Graphic Design
- Hand Drawn Sketches
- Digital Image Files (JPG, BMP, etc.)
- 3D Model
- Animation (AVI, etc.)
- Interior Design Finish Schedule
- Government Furnished Material List

### **Items for Installation of Furniture and Accessories**

- Pre-design Evaluation:
- Maintenance Data
- Floor Systems
- Electrical Equipment and Task/Supplemental

### Lighting

- Interior Element Specification
- Cost Estimates
- Maintenance and Repair
- New Work
- Equipment-in-place and Furnishings

### **For furniture related interior design**

- Typical furniture layout
- Furnishing, fabrics and finishes board



- Furnishings plan
- Sketch perspectives
- Colored rendering
- Photographs
- Catalog Cuts
- Furnishing illustration sheets
- Furnishing placement lists
- Furnishing order forms
- Furnishing contract specifications

**6. Construction and installation phase** -Positive first impression is created -Coordinated color scheme, interior reflecting exterior - Area & shape of spaces match function & support mission - Furnishings support function of space -Creative use of interior design spaces -Retained designer to review and approve contractor submittals -Retained designer to oversee the installation of furnishings -Color boards were required and reviewed -Interior Appearance policy is implemented Describe actions taken to ensure quality interior design to all negative responses on an attached sheet. Maintain a copy of this interior design review checklist and all negative responses in the DPW project file. I hereby certify that the information provided is in compliance with the guidelines of the installation or applicable IDG, except as justified as non-compliance.

**Designer of Record**

**Date**

Concur \_\_\_\_\_ Deny \_\_\_\_\_, Explanation of denial is attached.

**Master Planner**

**Date**

Accept \_\_\_\_\_ Deny \_\_\_\_\_, Explanation of denial is attached

**Command Review (Where Applicable)**

**Date**



## APPENDIX D – SUSTAINABLE DESIGN

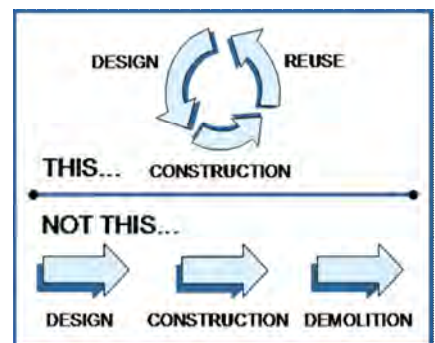
### D.1 What is Sustainable Design?

**D.1.1** Sustainable design and development is an integrated approach to planning, designing, building, operating, and maintaining facilities in a collaborative and holistic manner among all stakeholders (Fig. D.1). It is a systematic process and engineering practice with how to do it guidance, checklist, tools, and scoring systems. Sustainable design integrates the decision making across the installation, basing every decision on the greatest long-term benefits and recognizing the interrelationship of installation actions with the natural environment. In the content of Fort Gordon, sustainable design is the design, construction, operation, and reuse/removal of the built environment in an environmentally and energy efficient manner (Fig. D.2). The basic objectives of sustainability are:

- Reduce the consumption of energy, land, materials, water, and other non-renewable resources.
- Minimize the waste of energy, land, materials, water, and other limited resources.
- Protect the natural environment that is the source of all resources.
- Create livable, healthy, and fiscally productive manmade environments for existing and future generations.



**Fig. D.1 – Sustainable design is demonstrated in this site plan by extensive green space**



**Fig. D.2 – Sustainable Design Process**

**D.1.2** Designing for sustainability ultimately increases quality of life through better resource protection and use. The design process must incorporate a change in mind-set that embraces less consumptive lifestyles. This mind-set change must include global interdependence, stewardship of the environment, social responsibility, and economic viability. The new design mind-set must change from the traditional approach to recognize the impacts of every design choice on natural and cultural resources and on local, regional, and global environments.

## **D.2 SUSTAINABLE DESIGN AND DEVELOPMENT**

**D.2.1** Practicing the principles of sustainable design in the planning, design, construction, and operation of infrastructure and facilities is a smart business practice. Protecting our natural resources and reducing our impact on the natural environment is achievable when we create energy efficient (Fig. D.3), healthy (Fig. D.4), high-performance (Fig. D.5), and safe buildings.

**D.2.2** The Integrated Design Process. Critical to the success of sustainable design and development is the organization and commitment of the team to engage in the Integrated Design Process. To effect change in building design and operation, the project delivery process itself must become a collaborative effort to integrate design strategies among all disciplines and all players in the project delivery process. Integrated design demands a more inclusive team, working closer together than is traditionally the case. Future building users and facility managers must be invited to join architects, engineers, and planners in developing the vision and goals for new facilities. (Adapted from the HOK Guidebook to Sustainable Design)

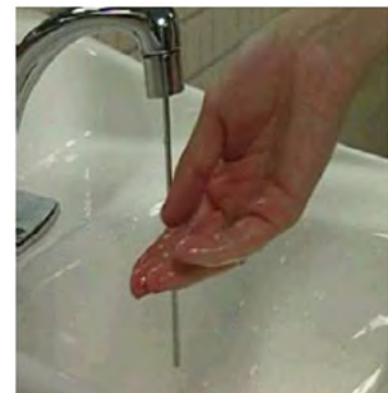
**D.2.3** This appendix discusses the sustainable design concept and its application to Army projects. Paragraph D.3 discusses the “Leadership in Energy and Environmental Design” (LEED) Green Building Rating System developed by the U.S. Green Building Council. To comply with the [Assistant Chief of Staff for Installation Management \(ACSIM\) endorsement of Sustainable Design and Development](#) initiatives, the LEED Rating System will be used for all projects funded FY08 and later. Because the planning and design process for projects anticipated for funding in FY08 is initiated many months in advance of funding, Fort Gordon has adopted use of the LEED Rating System.



**Fig. D.3 – Energy Efficient Lighting Contributes to Sustainability**



**Fig. D.4 – CO2 Measurements of Indoor Air Quality Assisting in Creating a Healthy**



**Fig. D.5 – Efficient Water Usage Contributes to a High Performance Facility**

As stated on the Green Building Council website, the LEED Green Building Rating System (a trademarked system) is the nationally accepted benchmark for the design, construction, and operation of high performance green buildings. LEED gives building owners and operators the tools they need to have an immediate and measurable impact on their buildings' performance. LEED promotes a whole-building approach to sustainability by recognizing performance in five key areas of human and environmental health: sustainable site development, water savings, energy efficiency, materials selection and indoor environmental quality. The minimum LEED 2.2 rating requirement is "Silver".

The LEED checklist ([Appendix E, LEED Checklist](#)) is from the U.S. Green Building Council LEED 2.2 (Leadership in Energy and Environmental Design) Green Building Rating System.

**D.2.4** Further information on sustainable design can be obtained at the following websites:

- [Assistant Chief of Staff for Installation Management, Sustainable Design and Development Website](#) This site provides information on the following topics: documentation and references; sustainable process, tools, products and materials; Sustainable Design and Development Training; and links to various sustainable design and development informational website.
- U.S Army Corps of Engineers, Engineering Research and Development Center, Construction Engineering Research Laboratory (CERL), [Sustainable Design and Development Website](#).
- [Whole Building Design Guide \(WBDG\)](#) This site provides comprehensive and current information on sustainable design strategies and technologies.



**Fig. D.6 – Sustainable Design Principles**

### **D.3 SUSTAINABILITY AND THE FEDERAL GOVERNMENT**

**D.3.1** The Federal Government has led the nation in the energy efficient, resource-conserving building design, construction, and operation. Executive Order (EO) 13123, "Greening the Government through Efficient Energy Management", was issued June 3, 1999. This Order establishes that sustainable design principles shall be applied to all Federal projects in order to reduce

pollution and other environmental costs associated with facility construction, operation, and eventual decommissioning. The principles of sustainable design for Federal Agencies established by EO 13123 include siting, design, and construction, as follows (Fig. D.6):

- Site - Optimize site potential.
- Energy – Minimize nonrenewable energy consumption.
- Materials – Use environmentally preferable products.
- Water – Protect and conserve water.
- Indoor Environmental Quality – Enhance indoor environmental quality.
- Facility Delivery – Holistic delivery of facility.
- O&M – Optimize operational and maintenance practices.
- Future Missions – Functional life of facility and support systems.

#### **D.4 ARMY STANDARDS**

The cited Army Standards shall be met.

#### **D.5 REFERENCES**

The following references are provided for guidance.

- [Assistant Chief of Staff for Installation Management, Sustainable Design and Development Website](#)
- U.S Army Corps of Engineers, Engineering Research and Development Center, Construction Engineering Research Laboratory (CERL), [Sustainable Design and Development Website](#)
- [Air Force Sustainable Facilities Guide](#)
- [Whole Building Design Guide](#)



## APPENDIX E– SPiRiT

[Appendix E.pdf](#)



[Appendix E Checklist.pdf](#)

Use this worksheet as a tool for determining the potential LEED™-NC score for a project. For new projects, photocopy this sheet for planning discussions, and use it for tracking potential points. Points that end up in the question mark category can be moved in either direction when making a final decision about whether to pursue them. For additional details, please refer to the following website: <http://www.usgbc.org>.



## APPENDIX F – LANDSCAPE MAINTENANCE SCHEDULE

[Landscape Maintenance Schedule.xls](#)



## APPENDIX G – PRIORITIZED IMPROVEMENTS PROJECTS LIST

See List (Next Page)



**PRIORITIZED IMPROVEMENTS PROJECT LIST**

**INSTALLATION: FORT GORDON**

**DPW or EQUIVALENT - MASTER PLANNER**

**NAME:**

**PHONE:**

**ADDRESS:**

**EMAIL:**

<b>Priority No.</b>	<b>Project Title</b>	<b>Recommended Funding Source</b>	<b>Alt. Funding Source</b>	<b>Cost Estimate</b>	<b>IDG Para Number</b>	<b>Point of Contact</b>
1.						
2.						
3.						
4.						
5.						
6.						
7.						
8.						
9.						
10.						
11.						
12.						
13.						
14.						
15.						
16.						
17.						
18.						
19.						



## **APPENDIX H – SELF-HELP PROJECTS CHECK LIST**

This checklist references items that are critical to the plans review process and the eventual outcome of the Fire Final Acceptance Inspection. This is a partial list only and should not be construed to be all inclusive of fire or building codes and standards. The developer and his agents should be well versed in these applicable codes and standards.

All Self Help Projects must be submitted on a [DA Form 4283](#) Work request accompanied by a Bill of Materials (BOM) detailing all materials required to complete the project. (i.e. sheetrock, nails, plaster, etc.)

The following represents items which should be considered by occupants of facilities, when a renovation is being planned:

### **SELF HELP RENOVATION CHECKLIST**

#### **H1. DETERMINE PURPOSE OF RENOVATION**

H1.1. Upgrade of existing use

H1.1.2. Renovation needed for space utilization

H1.1.3. Renovation needed for change/increase or decrease in mission

#### **H2. DETERMINE SPECIFICS OF RENOVATION REQUIRED**

##### **H.2.1 Work Request #**

##### **H.2.1.1. Walls, Finish Desired:**

- (1) Sheetrock, with texture
- (2) Vinyl Coated Sheetrock
- (3) Paneling, Wainscoting
- (4) Paint
- (5) Other

**H.2.1.2. Doors/Hardware, Type and Style:**

- (1) Hollow Core
- (2) Solid Core
- (3) Panel
- (4) Bi-Fold
- (5) Sliding
- (6) Screen (Single or Double)
- (7) Steel/Metal
- (8) Other
- (9) Passage Locks
- (10) Key Locks and Keys
- (11) Dead Bolts
- (12) Cipher
- (13) Panic Bar
- (14) Mailbox Locks/Keys

**H.2.1.3. Trim, Walls/Floors/Ceiling:**

- (1) Base Shoe
  - 1.1 Vinyl/Rubber
  - 1.2 Wood (Type of Wood)
- (2) Chair Rails (Type of Wood)
- (3) Picture Rails
- (4) Door Trim

4.1 Sanitary Casing

4.2 Detailed Casing

(5) Finish

5.1 Stained

5.2 Painted

**H.2.1.4. Electrical Light Switches/Duplex Receptacles.**

(1) 15 AMP - Most Office Equipment/ Computers

(2) 20 AMP - Copier/Special Equipment

(3) Ground Fault Interrupters - Safety

(4) Voltage (110V, 220V, etc

**H.2.1.5. Light Fixtures.**

(1) Florescent

(2) Incandescent

(3) Emergency

(4) Other

**H.2.1.6. Modular Furniture Hook-Ups.**

**H.2.1.7. Ceilings**

(1) Sheetrock Textured/Painted

(2) Grid, Drop Ceiling

**H.2.1.8. Flooring.**

(1) Tile

(2) Vinyl Sheet Goods

(3) Carpet/Carpet Squares

(4) Other

**H.2.1.9. Cabinetry**

(1) Wall Mounted

(2) Base Units, Floor Mounted

#### **H.2.1.10. Windows.**

- (1) Blinds (Self Help)
- (2) Draperies (Self Help)
- (3) Insulated
- (4) Tinted

#### **H.2.1.11. Heating and Ventilation**

- (1) Radiators/Fin Tube
- (2) Forced Air
- (3) Swamp Cooler
- (4) Other

#### **H.2.1.12. Security**

- (1) Special Locks
- (2) Vaults
- (3) Window Screening
- (4) Fencing
- (5) Alarm Sensors
- (6) Cages (Supply)

#### **H.2.1.13. Furnishings**

- (1) Free Standing
- (2) Built-In
- (3) Modular

#### **H.2.1.14. Bathrooms**

- (1) Tile/Marlite Panels
- (2) Sinks/Lavatories/Water closets/Urinals
- (3) Mirrors
- (4) Paper Towel/Toilet Roll Dispensers
- (5) Soap Dispensers

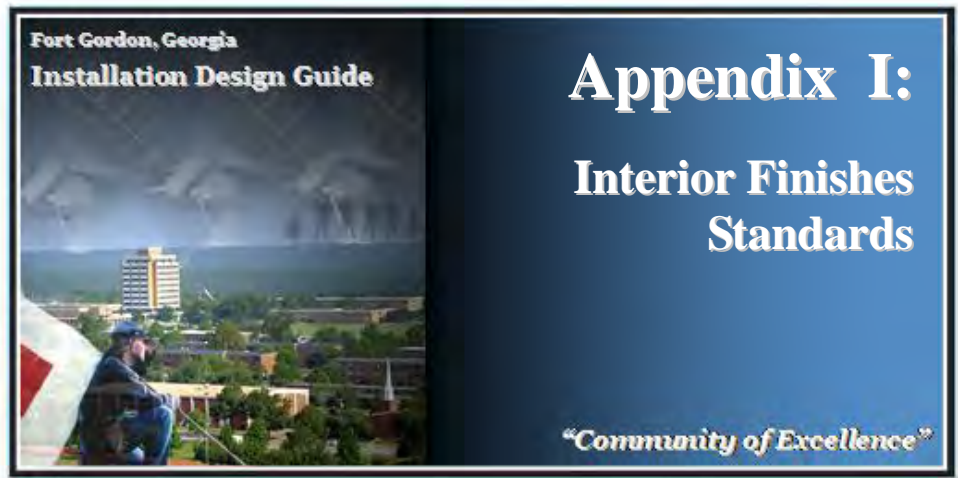
- (6) Stall Dividers
- (7) Exhaust Fans
- (8) Commodes
- (9) Towel Racks/Hooks
- (10) Plumbing/Hardware
- (11) Handicap Bars/ Stalls/ Access
- (12) Other

**H.2.1.15. General**

- (1) Fire Detection/Escapes
- (2) Physically Impaired
- (3) Signage (Exterior/ Interior/ Directional/Parking)
- (4) Phones (Conduit)
- (5) Parking (Paving/Striping)
- (6) Computer Conduit
- (7) Storage Closets
- (8) Break Areas
- (9) Landscaping
- (10) Gazebos
- (11) Running Trails
- (12) Volleyball, Basketball Courts
- (13) PT Areas/Structures

All renovation projects should result in complete and usable facilities when completed.

The above listings are not intended to be all inclusive, but should be used as a guide for use in preliminary planning of renovation of facilities.



## APPENDIX I – INTERIOR FINISHES STANDARDS

### 1.1 FLOORING

#### 1.1.1 CARPET

Use the standard field carpet in all typical office areas. Accent carpet and carpet borders are to be used in officer suites, conference rooms, corridors, and lobbies. The accent carpet or a carpet border may be used in other areas if approved by the [DPW](#).

A minimum of 6' of walk off carpet is to be used at all doors accessing the exterior where carpet is used inside the door. Walk off mats are to be used at all exterior doors where a material other than carpet is used inside the door.

Provide 5% minimum overstock for future modifications.

##### 1.1.1.1 Guidance, Warranties, and Requirements

All carpet must meet standards specified in [UFGS 096800, Carpet](#).

LEED™ provides credits in the Material and Resources as well as the Indoor Environment Quality categories for sustainable options that could be relevant to carpet and adhesive selection. More details on sustainable carpet selection are provided below in Section I.1.1.4 Sustainability.

##### 1.1.1.2 Type/Size Requirements

24" square carpet tiles are preferred.

6' or 12' rolled goods are acceptable in low traffic areas like office and conference areas.

### **1.1.1.3 Quality Considerations**

Different height carpets next to each other are generally inappropriate; proper preparation and consideration must be given to resolve this prior to installation.

Brand name continuous nylon fibers will wear better and provide more resilience than those made from polyester, acrylic, or olefin fibers.

Staple fibers are not allowed.

### **1.1.1.4 Sustainability**

Whenever possible, sustainable carpet materials must be used. Sustainable properties of carpet that should be considered are:

Recycled content: either industrial waste and/or post consumer waste.

Recyclability of the product at the end of its life.

Yarn fiber type and dye method.

Proper cushion/padding material will extend the carpet life.

Expected life cycle for carpet as a whole.

Reduction or absolution of toxic chemicals, VOCs, and pollutant emissions.

### **1.1.1.5 Cushions/Padding**

All carpet shall have an attached cushion/padding such as on carpet tiles or cushion/padding should be added to 12' rolled goods.

All carpet shall meet all ADA requirements. Maximum pile thickness shall not be more than ½" thick.

### **1.1.1.6 Use and Selection**

See charts in the Interior portion of Section 8 for locations and instances where carpet is an acceptable flooring material.

Carpet on stairs is not recommended. Other more durable material should be used, i.e., rubber treads.

### **1.1.1.7 Solid Colored Carpet**

Solid color carpeting is to be used sparingly. If solid color carpet is installed, it should be installed so the "hand" is always in the same direction. Solid color carpet can be used as an accent or border carpet. If an entire room of solid colored carpet is to be installed rolled goods are preferred over carpet tiles.



### **1.1.1.8 Pattern Selection**

Patterned carpets are preferred. Patterns help to “mask” soiling in traffic areas. Use only patterned carpets with distinguishable designs and patterns. Patterned carpet should be multi-colored with three or more colors, not just shades of the same color.

### **1.1.2 VINYL COMPOSITION TILE (VCT)**

See charts in the Interior portion of Section 8 for locations and instances where VCT is an acceptable flooring material. VCT may be used in some locations that have occasional wet areas, have very high people and equipment traffic, or require constant cleaning. VCT installations should be designed with limited patterns and borders. A standard 12”x12”x1/8” tile is to be used. Provide 5% minimum overstock for future modifications.

Do not use VCT in:

Areas where multiple seams are a clean-up problem.

Clean rooms.

Laboratories.

Childcare centers.

Kitchens.

#### **1.1.2.1 Adhesives**

See the manufacturer’s recommended adhesive for the substrate the material is being installed over. Typically, a water-resistant adhesive is used. Adhesives that reduce or omit the use of toxic chemicals, VOCs, and pollutant emissions are preferred. Note that LEED™ provides credits that could be relevant.

#### **1.1.2.2 Installation**

Tiles shall be quarter turned on all VCT installation applications.

Verify that concrete slabs comply with [ASTM F 710](#) and are clean and free to curing compounds, sealers, hardeners, and other materials that would interfere with bonding adhesive.

Apply five coats of acrylic floor polish allowing proper curing time between coats before moving furniture and equipment onto floor.

### **1.1.3 SHEET VINYL**

See charts in the Interior portion of Section 8 for locations and instances where sheet vinyl is an acceptable flooring material. Sheet vinyl shall be a commercial grade product when used in a commercial facility. All seams shall be welded. Provide 5% minimum overstock for future modifications.

Sheet vinyl that reduces or omits the use of toxic chemicals, VOCs, and pollutant emissions are preferred.

### **1.1.4 PORCELAIN TILE**

See charts in the Interior portion of Section 8 for locations and instances where porcelain tile is an acceptable flooring material. All tile floors shall have tile base. Tiles are excellent for durability and low maintenance. Minimize using tile with smooth glossy finishes for floors, as they tend to be very slippery. Instead, they may be used as an accent tile in limited quantities. Provide 5% minimum overstock for future modifications.

#### **1.1.4.1 Sizes**

Use large tiles where possible to limit grout lines for easier maintenance. However, maximum size should be 8" x 8" because of potential for building movement. Smaller tiles will tend to be easier to replace if needed.

#### **1.1.4.2 Finish Texture**

Interior tile finish texture should not be too rough. This creates cleaning problems and shall be avoided. Do not use a tile with grooves or ridges that are too deep. Dirt becomes trapped, making cleaning difficult. Make sure all tiles used in wet areas, or at entrances that can be wet, meet the proper slip resistance for the use.

#### **1.1.4.3 Meet ADA and OSHA**

All tiles used in flooring applications shall be slip resistant:

0.50 COF for walkway surfaces.

#### **1.1.4.4 Grout**

Select colors that will hide dirt the best for the tile selected. The grout will always darken with use. The grout line should be smallest as possible to avoid staining and fallout of grout material over time. Sealing grout after curing is recommended for easier maintenance.

### **1.1.5 WOOD**

See charts in the Interior portion of Section 8 for locations and instances where wood is an acceptable flooring material. There are numerous types of hardwoods

that are appropriate for flooring installations. New, more sustainable woods shall be considered, such as bamboo or cork. Finish stain colors are to be oak, walnut, cherry, or mahogany. Provide 3% minimum overstock for future modifications.

Wood that has been sustainably and/or locally grown and harvested is preferred.

### **1.1.6 SEAMLESS EPOXY**

See charts in the Interior portion of Section 8 for locations and instances where seamless epoxy is an acceptable flooring material. Seamless epoxy flooring shall be used in spaces where cleanliness is very important. Because this material is impervious and does not have seams, it is perfect for areas where chemicals and other materials are used and potentially spilled. Slip resistant surfaces can be specified. Pour the flooring up the walls at least 4" to provide an integral seamless base.

Epoxy that reduces or omits the use of toxic chemicals, VOCs, and pollutant emissions are preferred.

### **1.1.7 RUBBER**

See charts in the Interior portion of Section 8 for locations and instances where rubber is an acceptable flooring material. Rubber flooring typically comes in tiles much like VCT. There are, however, rubber sheet options. Consistent colors and types should be used throughout a facility. Rubber flooring has a better acoustical value than hard tile surfaces but is not quite as good as carpet is. The appropriate sealant should be used for easier maintenance. Rubber flooring can be a sustainable product as some types are made of recycled products. Provide 5% minimum overstock for future modifications.

Rubber that reduces or omits the use of toxic chemicals, VOCs, and pollutant emissions are preferred.

Rubber flooring is:

Durable.

Comfortable under foot.

Naturally slip-resistant.

Easy to install.

Easy to maintain.

### **1.1.7.1 Basic Type**

The commonly used rubber flooring comes in many different patterns, colors, and textures. Some examples are: solid, speckled, marbled patterns, and smooth, hammered, slate textures.

### **1.1.7.2 Heavy Duty Type**

Is typically used for fitness center weight/workout rooms and heavy machinery areas. There are rubber flooring products designed specifically for weight rooms, aerobics, and other high impact applications. These products are typically interlocking tiles.

## **1.1.8 STAINED/SEALED CONCRETE**

### **1.1.8.1 Chemically Stained or Colored**

See charts in the Interior portion of Section 8 for locations and instances where stained/sealed concrete is an acceptable flooring material. Chemically stained concrete is a cost effective and attractive way to finish high-use floor areas like lobbies, corridors, locker rooms, casual snack bar areas, and patio spaces. Stained concrete may be scored or stamped to create a design.

Concrete that reduces or omits the use of toxic chemicals, VOCs, and pollutant emissions are preferred.

### **1.1.8.2 Unfinished (Sealed)**

An unfinished floor typically needs to be sealed so that it is cleanable, especially if the space is used on a daily basis.

## **1.2 BASE**

### **1.2.1 RUBBER**

See charts in the Interior portion of Section 8 for locations and instances where rubber base is an acceptable material. Rubber base is the standard base material for most facilities. Use a 4" coved base for all flooring types. The profile is a flared concave radius on the bottom edge. There are many new styles of rubber base that can be used for more specialized facilities and spaces such as a rubber base profile that resembles a wood base. These types of profiles can be used in dormitories, lodging facilities, clubs, and other places that need a more decorative finish yet require the durability and maintenance of a rubber project. Provide 3% minimum overstock for future modifications.

### **1.2.2 TILE**

See charts in the Interior portion of Section 8 for locations and instances where tile base is an acceptable material. Tile base is to be used with all tile floors - no

exceptions. Coved styled tile is to be used. If there is not a cove style available, a straight bullnosed base is acceptable. Straight base with wall tile should not have a bullnose top edge. Provide 3% minimum overstock for future modifications.

### **1.2.3 WOOD**

See charts in the Interior portion of Section 8 for locations and instances where wood base is an acceptable material. Provide 3% minimum overstock for future modifications. Wood base is recommended for upgraded areas such as: executive suites, clubs, lodging. The wood species and finish/stain shall be the same as the other wood in the room/space. If wood base is to be painted, use a MPI Gloss Level 5 paint.

### **1.2.4 SHEET VINYL**

See charts in the Interior portion of Section 8 for locations and instances where sheet vinyl base is an acceptable material. Sheet vinyl base can be used as an integral cove base with sheet vinyl flooring installations. Cant strips are required at all floor-to-wall transitions. Use a metal 'J' molding termination strip at the top of the material on the wall. Provide 5% minimum overstock for future modifications.

### **1.2.4 CARPET**

See charts in the Interior portion of Section 8 for locations and instances where carpet base is an acceptable material. Carpet base is only allowed in high visibility facilities such as lodging facilities and clubs. The top of the base should be finished by binding the edge or an appropriate invisible top cap. Provide 5% minimum overstock for future modifications.

## **1.3 WALLS**

Wall finishes that reduce or omit the use of toxic chemicals, VOCs, and pollutant emissions are preferred.

### **1.3.1 PAINT & COATINGS**

#### **1.3.1.1 General**

See charts in the Interior portion of Section 8 for locations and instances where paint is an acceptable finish. Epoxy paint is to be used in all moist/damp areas such as kitchens, restrooms, laundry rooms, pools, and medical rooms. Epoxy paint is to have a MPI Gloss Level 5. All interior paint used is to be lead free and shall have no Volatile Organic Content (VOC) or low VOCs. Provide 3% minimum overstock for future modifications.

Note: estimate approximately 300 sq. ft. per gallon of paint.

### **1.3.1.2 Gloss Levels**

The Master Painters Institute (MPI), [www.paintinfo.com/mpi/approved/sheen](http://www.paintinfo.com/mpi/approved/sheen), gloss levels are the standard that shall be specified, submitted, and used for all interior paints.

### **1.3.1.3 Basic Solid Paint**

Basic wall paint is to be used on all walls throughout facilities except where sprayed, speckled paint is used/appropriate. Basic paint is also to be used on doors, doorframes, and gypsum ceilings. Painted designs and patterns can be painted in facilities such as fitness centers, indoor pools, clubs, and bowling alleys. Painted designs are not to be used in office/administrative and lodging type facilities. Painted accent walls can be used to break up a space or add some color without adding costs in all types of facilities.

### **1.3.1.4 Interior Multi-Color Speckled Paint**

Speckled paint simulates wall covering. Its intended use is to break up large/long wall paces by bringing in multiple colors and a visual texture. Provide 3% minimum overstock and directions/tools needed for patching and future modifications.

### **1.3.1.5 Paint at Barracks**

Painting of barracks rooms require submission of a DA Form 2765-1, with a list of materials and colors required.

Painting from floor to ceiling is allowed as long as proper safety precautions are followed.

### **1.3.1.6 Spot Painting**

Material for spot painting of buildings interiors (other than family housing) may be purchased with a DA Form 2765-1. Submit form prior to proceeding to the Supply Warehouse.

All other self-help paint projects requiring LESS THAN 5 GALLONS (1 gal = 300 sq ft.) must be submitted to the Troop Construction Branch.

### **1.3.1.7 Large Scale Painting**

For large painting projects, submit a DA Form 4283, Facilities Engineering Work Request to DPW, Work Management Section, Building 14500. Only paint issued by DPW can be used.

Required attachments to the DA Form 4283 are sketches, sizes, measurements, directions, colors, and suggested quantities.

No painting of facilities, other than indicated above in I.1 SPOT PAINTING, interior or exterior will be allowed without DPW approval.

### **1.3.1.8 Authorized Paint Colors**

The authorized paint colors on Fort Gordon are as follows:

Walls: Sandstone, off white (one accent wall per room) is permitted.

Corridors and Dayrooms: Sandstone.

Trim and Doors: mocha brown (dark brown if building has dark brown window casings (trim).

Stairwells: Bamblewood.

Ceilings: off white.

## **1.3.2 WALLCOVERINGS – PAPER/VINYL**

### **1.3.2.1 General**

See charts in the Interior portion of Section 8 for locations and instances where wall coverings are an acceptable finish. Wall coverings can be used for visual interest, soil hiding, enhancing design characteristics, and coordinating an overall color scheme. All types of wall coverings (vinyl, fabric, or acoustical) are to be selected for each specific situation depending on functional and durability requirements. Many companies are providing products with recycled content and these should be used wherever possible. Type II vinyl is to be used in all locations. Do not install wall coverings over concrete block, even if using a liner sheet. Provide 5% minimum overstock for future modifications.

Do not use wall coverings in the following facilities:

Fitness centers.

Child/youth centers.

Most office spaces.

### **1.3.2.2 Fire Code Requirements**

[ASTM E84](#).

Flame spread not more than 25.

Smoke developed not more than 50.

### **1.3.3 WALLCOVERINGS - FABRIC/TEXTILE**

See charts in the Interior portion of Section 8 for locations and instances where wall coverings are an acceptable finish. Fabric wall covering is hard to maintain and clean and should only be used in specialized areas. Therefore, use shall be considered with the function of the space. Never use fabric/textile wall coverings in high traffic spaces like corridors. Because nail holes are very noticeable and unpatchable, careful consideration shall be taken when deciding what is being hung on the wall. Many companies are providing products with recycled content and these should be used where possible. Provide 5% minimum overstock for future modifications.

### **1.3.4 ACOUSTICAL WALL PANEL**

There are various types of acoustical panels available and they vary in appearance and level of sound dampening. Panels are usually fabric wrapped and can be very basic or used as an accent. Perforated metal panels with acoustical material behind are also available. Acoustical wall panels can be used in auditoriums, fitness centers, education/ training room, conference rooms, large mess type dining halls, projection rooms, executive areas, and large open lobbies. The shape of the panel, the panel configuration, and/or the fabric used to cover the panel can all be used as a design element within the space.

### **1.3.5 WALL TILE**

#### **1.3.5.1 General**

See charts in the Interior portion of Section 8 for locations and instances where wall tile is an acceptable finish. Tile is to be used behind water fountains, in high use areas such as fitness centers or clinics, and in wet areas in the restrooms (behind water closets, urinals, and at countertops). Use tile sizes that minimize grout joints. A cove piece should be used as a base wherever wall tile meets the floor. All wall tile is to be installed over a waterproof substrate such as cementous backer board, or Duraock. Provide 5% minimum overstock for future modifications.

#### **1.3.5.1 Restrooms**

It is preferred that wall tile is to be used behind toilets and urinals and not on all walls. A tile wainscot at 42" A.F.F. is acceptable in most restroom locations. Some specific restrooms may need to be fully tiled. Showers stalls are to be fully tiled. Light switches are to be installed so the bottom of the plate is just above the top wall tile (switches must meet ADA requirements above all). If the wainscot is too high to allow this, the tile is to be installed surrounding the plate only at the points necessary.



### **1.3.6 WOOD PANELING**

See charts in the Interior portion of Section 8 for locations and instances where wood paneling is an acceptable finish. High-quality, custom-paneled spaces can create a rich and sophisticated atmosphere associated with status and success. The warmth of wood is also comfortable and relaxing. Possible locations for the use of wood paneling are executive private dining rooms, officer club dining rooms, and top administrative conference rooms. Wood-like pressboard paneling is unacceptable. Hardwoods are to be used and paneling is to have a Class A fire rating. Provide 5% minimum overstock for future modifications.

### **1.3.7 STONE OR BRICK**

Stone and brick can be used as interior finishes in entry lobbies and on fireplaces in clubs and lodging facilities. These materials are low maintenance and can help tie the interior spaces to the exterior design of the building. These materials can also add an interesting design element to the interior spaces.

## **1.4 CEILINGS**

Ceiling finishes that reduce or omits the use of toxic chemicals, VOCs, and pollutant emissions are preferred.

### **1.4.1 GYPSUM**

See charts in the Interior portion of Section 8 for locations and instances where gypsum board is an acceptable ceiling. Gypsum ceilings can be used as accent soffits and as bulk heads to break up suspended acoustical tile ceilings. Coved or special ceiling details can be created for spaces such as conference rooms. Gypsum ceilings should also be provided in areas where cleanliness is an issue, such as restrooms. The finish texture is to be smooth and all ceilings are to be painted with a minimum MPI gloss level 3. Ceiling color is to be a 'ceiling white' which provides maximum light reflection.

### **1.4.2 SUSPENDED ACOUSTICAL TILE**

See charts in the Interior portion of Section 8 for locations and instances where suspended acoustical tile is an acceptable ceiling. Acoustical tile is to be the primary ceiling material for most facilities. The tile is set in a suspended grid system. This type of system provides easy access to the space above the ceiling. Provide 5% minimum overstock for future modifications.


Standard color: white.

Required size: 24" x 48" tiles for all new installations with a reveal for a 24" x 24" look, similar to an Armstrong second look tile.

Edge: angled regular.

Material:

Mineral based panels.

Recycled content options shall be considered first 

Pattern/Texture:

Minimal directional pattern.

Light to fine texture.

Preferred to be consistent throughout the base.

Suspension System: Typically, grid to be the same color as tiles.

Standard tee color: white.

Material/Finish: steel with baked white enamel.

### **1.4.3 METAL OR SPECIAL CEILINGS**

Metal or special ceiling systems may be used in high visibility areas or as accents, if planned and designed carefully. Provide 5% minimum overstock for future modifications.

This is appropriate for:

Public areas

Common areas

Conference rooms.

Executive suites.

Clubs.

Gyms.

### **1.4.4 NON-PERFORATED ACOUSTICAL TILE**

May be used in kitchens or other wet areas or where easy clean up of ceiling tile is required. Provide 5% minimum overstock for future modifications.

### **1.4.5 OTHER**

All other ceiling mounted accessories: grills, speakers, smoke detectors, etc. to be white.

## **1.5 COUNTERTOPS**

Countertops and cabinets that reduce or omit the use of toxic chemicals, VOCs, and pollutant emissions are preferred.

### **1.5.1 GENERAL CABINET AND COUNTERTOP CRITERIA**

Cabinet door/drawer material can be laminate or wood. The type of material is to be determined per location and use of the cabinetry. Wood is preferred for upper executive areas. Toe kicks are required and are to be faced with rubber base unless the facility is not using rubber base. Drawers and doors are to have pulls. All restroom sinks are to be installed with a counter. No wall mounted sinks are to be used. No vanity cabinets are to be installed under restroom sinks because they create clutter and gather trash.

The countertops shall have an overhang and apron in the front. Backsplashes are required at all locations where water is or could be present.

### **1.5.2 MATERIAL TYPES - COUNTERTOPS**

Solid surface is a durable and attractive material that is the preferred at all locations. Use an integral backsplash at wet areas. Sinks installed in solid surface countertops should be under counter mounted.

Laminate is acceptable for most facilities and locations. A gloss finish is not allowed. Use an integral backsplash at wet areas.

## **1.6 DOORS**

Doors that reduce or omit the use of toxic chemicals, VOCs, and pollutant emissions are preferred, as are wood doors that are sustainably and/or locally grown and harvested or made of recycled content.

### **1.6.1 GENERAL**

Door styles are to be consistent throughout a facility. Wood is the preferred material. Style, wood, and finish should be consistent within a facility. Door hardware is to be of a consistent material and finish throughout as well. Hardware requirements shall be coordinated for various specialty doors like sound rated doors and fire rated doors. Kick plates are necessary at all medium to heavy use doors. Provide windows in doors where required by use of space and code.

Doors with an Energy Star® rating are also preferable.

### **1.6.2 FIRE CODE REQUIREMENTS**

Where permanently mounted folding or movable partitions divide a room into smaller spaces, doors shall be added in the partition or next to the partition to maintain proper egress requirements when the partition is closed.

### **1.6.3 MATERIAL TYPE**

#### **1.6.3.1 Wood**

On double doors to be stained, wood graining shall match. The grain is to match in intensity and design -no exceptions. Flush, solid core wood doors shall be used in locations where appearance of such doors is to be of stain grade, hardwood veneer, stain color per project, and finished with a clear coat. Hollow core doors may be used only when so directed.

Finish options:

Stained – Oak veneer.

Painted - use [MPI Gloss Level 5](#).

#### **1.6.3.2 Metal**

Metal doors are to be used at interior locations subject to above normal humidity, dampness, or damage. SCIF 3 and secured doors may be required to be metal per force protection requirements. Doors fabricated of stainless steel, aluminum or other special materials shall be used at interior locations (i.e., sterilizing rooms, wash racks, etc.) subject to excessive humidity or dampness.

Finish options:

Painted - use [MPI Gloss Level 5](#).

#### **1.6.3.3 Hardware**

Locksets are to be Best Locks, Series 4000, 7 tumbler removable cores with master key to match existing. Lever are to be used per ADA. Keying by Post Contractor

## **1.7 LIGHTING**

### **1.7.1 GENERAL**

In the work environment, people tend to have more job satisfaction if they have some contact with natural light through windows, skylights, atriums, and the use of full spectrum light sources. When properly designed and effectively integrated with the electric lighting system, daylighting can offer significant energy savings by offsetting a portion of the electric lighting load. A related benefit is the reduction in cooling system capacity because the electric lighting operates less, lowering a significant component of internal gains. See [Appendix D](#) for more daylighting information. A lighting system made up of layers of ambient light, task light, and accent light improves the visual comfort in a space, as well as reduces the amount of lighting energy used. Accented interest can be achieved with coves, soffits, up-lighting, recessed fixtures, or with wall mounted fixtures such as sconces rather

than just the typical 2' x 2' fluorescent fixtures. In every case, energy consumption shall be considered in the design and energy consumption minimized by using the most energy efficient fixtures and materials that will satisfy the design requirements. Lower light levels with appropriate task lighting should be considered. LEED™ provides credits in Sustainable Sites, Energy and Atmosphere, and Indoor Environmental Quality categories for sustainable options that could be relevant to lighting and lighting controls selection.

Corridor lighting needs to be carefully planned to avoid accentuating the length of the corridor. Lighting shall not create heavy shadowing, but will have both ambient and accent type lighting.

Dimming shall be provided in most areas. Use a 10-5% capability for general use, lower for conference rooms. Turn knob dimming switches are not allowed. A slide switch with an on/off button is preferred.

### **1.7.2 LAMP USE GUIDANCE**

Detailed guidance on lighting selection and use can be found in [Appendix D](#).

Incandescent: Do not use except in special situations.

Tungsten: Only for important accent areas such as art. Try not to use since they are high maintenance.

Mercury: Not encouraged.

Fluorescent: Use as much as possible.

Metal Halide: Use for outdoors. Use for high ceiling garages or hangars.

High Pressure Sodium (HPS): Outdoors only.

Induction: Outside only. Use in place of metal halide or High Pressure Sodium (HPS).

### **1.7.3 INCANDESCENT**

Use incandescent lighting for lamps, vanity lights, wall sconces. Energy efficient fixtures and/or fluorescent bulbs are preferred and should be considered to replace incandescent lamps.

Exceptions may be for:

Dining rooms.

Lodging rooms.

Food preparation areas.

Housing.

Vanity sinks and mirrors in restrooms.

Used incandescent bulbs in areas where true color rendition is important.

#### **1.7.4 FLUORESCENT**

There are now many different styles of bulbs that will suit various needs and different types of fixtures. All 2' x 2' or 2' x 4' fixtures will have 2" square parabolic lenses. Do not use acrylic. T-8 lights should be used in lieu of T-12.

Finishes:

Housing to be white baked enamel steel.

Lens to be semi-specular, clear anodized aluminum.

#### **1.7.5 SPECIALTY**

Specialty fixtures such as decorative pendants, display/art spotlights, wall sconces, etc. can be used to add interest and break up the lighting patterns in a space.

### **I.8 RESTROOMS**

#### **I.8.1 TOILET PARTITIONS**

Standard stalls are to be 36" wide minimum, doors are to swing out of the stall, and each stall shall have a hook on the inside of the door. Handicapped stalls are to meet all ADA requirements. Floor mounted partition systems are preferred. Toilet partitions are to be Solid plastic by Santana or approved equal.

#### **I.8.2 URINALS**

Solid plastic urinal screens shall be provided at all urinal locations. Urinals shall be wall mounted at the appropriate height. At least one urinal in each restroom shall meet ADA requirements if ADA requirements are required. Waterless urinals should be considered in all cases.

#### **I.8.3 FLUSH VALVES**

All flush valves are to be electronic, infrared or motion sensor operated. They shall not be battery powered and shall be exposed not concealed within the walls. Flush valves shall have a manual option and will have a turn off switch for cleaning.

#### **I.8.4 FAUCETS**

All faucets are to be electronic, infrared or motion sensor operated and shall incorporate a turn off switch for cleaning. Sensors shall not be battery powered. Adjustable faucets shall have instant hot water capability.



## **APPENDIX J – INTERIOR FURNISHINGS STANDARDS**

### **J.1 FURNITURE FINISHES**

#### **J.1.1 WOOD**

Possibly catalyzed lacquer. This is a new type of product that looks like wood with the durability of laminate or better.

#### **J.1.2 METAL**

All to be electrostatically painted.

#### **J.1.3 LAMINATE**

High-pressure plastic laminate with a common thickness of 0.050” thick used for both vertical and horizontal applications.

A postforming type, 0.040” thick, is manufactured so it can be heated and bent to a small radius.

#### **J.1.4 GLASS**

Shall be appropriate thickness for intended use.

Appropriate use:

Occasional table inlay.

Table tops.

Desk tops to protect the wood.

Use felt or rubber tabs between tabletop and glass.



## **J.2 FURNITURE AND TEXTILE CONSTRUCTION**

### **J.2.1 FURNITURE**

Materials selected for furniture should contain low-emitting bonding adhesives and should be constructed from rapidly renewable materials, recovered materials, or sustainably harvested materials. Furniture construction can be separated into two categories: wood and metal.

#### **J.2.1.1 Wood**

Wood furniture is either made of softwoods that are evergreens, or hardwoods that are deciduous. Softwoods are used for residential grade furniture and are not recommended for the majority of Army facilities. Hardwoods are used to construct seating frames, base cabinetry, and solid furniture. Hardwoods make good surface finishes. Veneers are thin sheets of wood that are glued to base materials, then stained and finished. Premium pieces should be veneered on both sides of each board for stability. These pieces can be very decorative depending on the placement of veneers.

#### **J.2.1.2 Metals**

Metals are often used for office furniture. These metals include steel, aluminum, and alloys. Steel is strong, but will rust if not properly treated with a plating or painting process. Stainless steel is very expensive and used only in areas where high durability is required. Aluminum is not as strong, but does not rust. The finishes on metal furniture should not chip, which almost always lead to rust and corrosion.

Metal is measured by the gauge - the smaller the gauge, the thicker the sheet. For example, an 8 gauge sheet is much thicker than a 16 gauge sheet. The connections of metal furniture are either welded or bolted.

### **J.2.2 TEXTILES**

When selecting fabrics, there are several factors to consider; color, durability, price, fire resistance, and fiber type. There are natural fibers and artificial fibers. The most common natural fibers for textiles are wool, mohair, cotton, silk, and linen. The most common synthetics are polyester, acrylics, nylons, polyurethane, polyvinyl chloride, olefin, and rayon.

There are several treatments that can enhance the performance of textiles. Antibacterial and mildew resistance treatments protect against the growth of mold and mildew. Anti-static treatments aid in reducing static electricity. Fireproofing, fire-retardant, and flame resistance treatments help fabric to resist ignition, slow flame spread, and provide fireproofing.

## **J.3 CONVENTIONAL FURNITURE**

### **J.3.1 SEATING**

Numerous types of seating are included with conventional furniture, including operational, stationary chairs, and several types of lounge seating.

#### **J.3.1.1 Operational Seating**

The awareness of ergonomics is important when choosing task chairs. Five prong base chairs with casters are suggested to provide excellent stability and mobility. Casters should be composed of dual hard wheels for use on carpet, and single soft wheels for use on hard flooring surfaces. Chair arms should be replaceable or removable in the field. Molded plastic arms, used for most applications, are easier to maintain; upholstered arms tend to soil easily with high use. Adjustable arms are required for intensive use by computer operators. Chair frames should be finished in chrome or a powder coated epoxy. Wood based chairs are more expensive and may be chosen for executive use.

#### **J.3.1.2 Stationary Chairs**

Stationary chairs with four posted legs are suggested. These chairs are not often moved since they are used as office side chairs or perimeter seating in conference rooms. Sled based chairs offer sliding motions when scooting in and out from under tables and desks. Provide appropriate chair glides for either carpet or hard floor surfaces. Clear glides are preferred on hard floor surfaces since black glides tend to leave marks. Seating used in dining facilities and cafeterias should have "wipe-out channels" or chair backs that are spaced from their seats for ease of cleaning.

#### **J.3.1.3 Lounge Seating**

Lounge seating is defined as fully upholstered seating for lobbies, waiting areas, lounge areas, and private executive offices. All internal frame parts should be kiln-dried hardwoods. All exposed parts should be cut from #1 common or better grade hardwood with uniform grain and color uniformity. Frame joints should be carefully fitted and secured with dowels. Frames must be reinforced and corner block mitered to fit securely. Each seat foundation is to be 8-1/2 gauge sinuous wire springs clinched to insulated tie wires and strapped to tie rails and back post. Back construction should be 11 gauge wire spring construction stretched between top and bottom spring rails and secured with double staples. The spring system should be covered with noise free insulating fabric and stapled to the frame on all sides. Seats are to be cushioned with 1.80 lbs density polyurethane foam with 32 lbs of construction. Each seat cushion should be wrapped with resin treated polyester fiber to give a smooth, even finish. Chair backs and cushions should be 1.10 lbs density polyurethane foam with 20 lbs for back compression and 35 lbs for arm compression.

Backs and arms should be topped with blended fiber battings for smooth, even appearances. All units should be constructed to allow for field reupholstering and repair. Upholstery patterns should be marked on the vertical and horizontal for uniform pattern. Upholstery should be treated with soil retardants. Waiting area seating for medical facilities should accommodate children, pregnant women, the elderly, heavy or tall people, and the physically weak. All seating should have arms for ease in and out of seated positions. Chair seats shall be firm, level with the floor, and not at a decline toward the backs of the chairs.

### **J.3.2 SEATING TYPES**

#### **General office spaces**

Desk chair.

#### **Group level office spaces**

Desk chair.

Side chairs.

#### **Command level spaces**

Desk chair.

Side chair.

#### **Waiting and Break areas**

Lounge seating

Waiting room chairs.

#### **Conference rooms.**

Command level spaces.

Smaller conference rooms.

Stacking chairs.

### **J.3.3 FUNCTION**

Furniture selection will depend on the function of the space and how much flexibility is required. A very important feature to consider when purchasing any furniture item is the warranty. Research how each manufacturer deals with their warranties and response time, and use the warranties if problems arise. Avoid altering furniture without the manufacturer's guidance or assistance to prevent voiding warranties.

### **J.3.4 FLEXIBILITY**

Flexible furniture design is an essential element of efficient facility planning while accommodating dynamic requirements. Designers must keep in mind how functions may evolve, and which furnishings may require future modifications. Rapid technological advancements often demand upgraded equipment, power, and communication requirements. The elements of pure design, including structural expression, suitability of materials, harmonious visual and tactile features, and classic furnishings, will always remain the foundation of good design. Designers should avoid trendy or dated finishes and design features. Furnishings should incorporate creative but not extreme designs, reflect quality but not opulence, and be capable of being updated to accommodate changes in functions.

Modular furniture is similar to systems furniture except that all work surfaces are floor supported rather than panel supported. It is also referred to as automatic data processing (ADP) or electronic data processing (EDP) furniture. Modular furniture is comprised of components that are usually field replaceable or field reupholstered. For example, a user can replace a damaged arm rather than a whole chair on site without taking the chair out of commission.

### **J.3.5 MAINTENANCE**

When making selections, designers must consider product performance and longevity of appeal, as well as initial costs. As the appeal of finish materials degrades, users want to replace them; therefore, products that keep their appearance and shape longer are better choices even when initial costs are higher.

Durable designs and finishes pass the "test of time." Designers must be concerned with material durability and wearability while considering budget restrictions. Selections of quality materials and products must also be appropriate to the function and level of use of each facility.

Some general examples for selecting furniture are:

Use clear chair glides on hard floor surfaces to avoid marks on the flooring.

Chairs in dining facilities should have "wipe out channels" or a separate seat or back.

All fabrics should be treated with a soil retardant finish.

A 100 percent Trevira fabric should be used for draperies to meet fire standards and allow machine washing.

The use of easily maintained finishes is critical. While certain finishes may provide excellent durability, designers must give serious consideration to maintaining the appeal of materials. It is critical that designers be familiar with finishes that wear well and require low maintenance.

### **J.3.6 TABLES AND COUNTERTOPS**

The undersides of table tops may not be less than 28 inches from floors, while table tops for sitting applications are not to exceed 30 inches from floors. The height of tables for standing applications is not to exceed 36 inches from the floor.

Each table top should be constructed of one piece unless the table length is too long to fit in a doorway and, therefore, must be shipped in two or more pieces. Core materials must meet or exceed strength requirements for commercial standards. Particle board must have a minimum density of 48 lbs. per cubic foot. Cores must be sanded from top to bottom leaving smooth edges. Laminates or veneers must be glued uniformly and evenly to ensure adhesion and stability. Applied edging must be mitered, and all wood edges must be hardwood. Laminate tops are to be used with vinyl edging, self-edging, or solid wood edging. Wood veneer tops are appropriate for conference rooms and executive areas.

All bases must be appropriately sized to their tops and be equipped with leveling glides. All metal bases should be finished in powder coatings.

Wood tops are preferred for all tables in conference rooms, briefing rooms, and break rooms. The wood finish of tables should be coordinated with wood selected for the doors and trim in the area. Plastic laminate tops are acceptable in break rooms, colors to match cabinetry in the area. Conference tables should be sized to appropriately accommodate the size of function required in the room. Always provide side seating along the walls for extra people.

### **J.3.7 FREESTANDING OFFICE FURNITURE - CASEGOODS**

Freestanding office furniture includes desks, credenzas, computer tables, executive "u" units, and bookcases.

Metal casegoods with laminate work surfaces should meet the standards and construction of systems furniture, yet they are floor supported (freestanding). Wood veneers should be edged with hardwoods, and all units should have glides for leveling.

Desk tops should be equipped with two grommets (two inches minimum in diameter) to allow for electrical cords. Location of grommets will vary depending on application. Work surface tops with rolled/soft edges are preferred to a straight edge for comfort. Drawers must use full extension, stop action progressive slides with precision ball bearing, and no metal-to-metal connection for smooth, quiet operation. Dovetail construction should be used on all corners. All drawers should be able to receive dividers and accommodate other filing options needed. Drawers should also be lockable and keyed alike, within each workstation, with removable cylinders for re-keying.

### **J.3.8 TEMPORARY LIVING FACILITIES AND DORMITORIES - CASEGOODS**

Furniture for these spaces include: headboards, bed frames, night stands, wardrobes, units with drawers or open shelves, TV armoires, desks, writing tables, dressers, chests, mirrors, end tables, coffee tables, various types of seating/hide-a-beds, dining tables, computer accessibility, etc.

All furniture should be constructed of solid wood veneers, hardwood solids, or five-ply lumber-core with wood veneers. The suggested wood for all solid parts and veneers should be northern red oak or equal durable hardwood. The finished product can be treated and stained for the desired look. Particle board and cardboard are not acceptable. Back pieces must be equal to the sides in thickness, or a minimum of 1/4" inch.

Drawer fronts, doors, desk tops, and other components should be removable and replaceable on site. This extends the life of a product by changing individual damaged parts, rather than ordering an entire new unit.

The dry construction method, with metal-to-metal connections, is the preferred method of construction. This method creates a stronger, more durable casegood; glue joints tend to fail. Screws, hinges, etc., should be concealed or inserted into the lumber for a clean, high quality look. Units held together only with glue and staples are unacceptable.

Dove-tail joinery should be used as drawer joints. Drawer pulls should be flush or recessed for furniture that is highly used. This prevents the pulls from being knocked off, or pulled off. Drawer bottoms should sit in grooves and the drawer sides should be reinforced. Epoxy coated metal drawer slides with nylon bearing rollers with automatic stop features are suggested. TV armoires and shelving units should have grommet holes in the backs in which to run electrical and telephone cords. All large units should come with leveling glides.

### **J.3.9 FILING CABINETS**

Metal filing cabinets should be manufactured with rolled metal that is seamless on three sides and rounded at the corners for a smooth finish. When wood file cabinets are appropriate, use veneer surfaces and hardwood edges. An interlock system is required on drawers so that only one drawer will extend at one time. Drawers should have ball-bearing suspension systems with anti-rebound devices, and drawer pulls should be recessed so they do not get knocked off or get in the way of traffic.

All lateral files should have front-to-back and side-to-side filing options. Cabinets should be flexible to allow for fixed shelves on five high units, or roll-out shelves and drawers. All units should be equipped with glides or leveling devices to ensure drawers or doors open properly. Color should be electrostatically applied at the factory.

## **J.4 systems furniture**

Most office systems furniture layouts rely heavily or exclusively on square component shapes and orthogonal space layouts. The introduction of curved panels, panels placed at different angles, and panel windows provide physical and visual relief, helping to break-up the "boxy" maze of repetitive spaces. Locations appropriate for these treatments include corner panels at beginnings and ends of series of panels, at intersections of circulation aisles, and at workstations that are visible from reception areas. Glazed, fire-rated panels offer privacy without confinement and should be integrated into overall interior landscapes. Acrylic window panels are unacceptable as they exceed flame and smoke development requirements.

Acoustical performance ratings should be based upon workstation designs. While the sound transmission class (STC) and noise reduction coefficient (NCR) ratings contribute to overall acoustical performance, the acoustical role of panels is relatively minimal in the overall environment when compared to sound absorptive properties of other finish surfaces such as carpet and acoustical ceiling tiles. In addition, panel hung components greatly reduce the quantity of acoustical contributing area.

### **J.4.1 GENERAL OFFICE SPACES**

The systems furniture layouts shown below are recommendations only.

#### **J.4.1.1 Secretarial/General Office Worker**

6x8 cubical (48sf) complying with the general office space furnishing schemes.

#### **J.4.1.2 Supervisor**

8x8 cubical (64sf) complying with the general office space furnishing schemes. Cubical may have a visitor chair.

#### **J.4.1.3 Engineer and Element Chief**

10x10 cubical (100sf) complying with the general office space furnishing schemes. Cubical to have a visitor chair.

#### **J.4.1.4 Group Level Executive Staff**

10x15 cubical (partial or full height walls) or hard walled office (150sf) if approved. Furnishings must comply with the group level schemes. Cubical to have at least two visitors chairs.

#### **J.4.1.5 Commander**

18x10 hard walled office (180sf) with conference area. Systems furniture or casegoods can be used in these offices. Furnishings must comply with the command level schemes. The entire commander's suite may incorporate the command level furnishings.

#### **J.4.1.6 Bull Pen and Teaming Arrangements**

These are examples of various bull pen and teaming arrangements that can be used. These kinds of arrangements are typically used in spaces with general office worker offices. These bull pen and teaming arrangements can help save square footage in the overall design by combining common circulation spaces. These types of spaces shall follow the general office furnishing standards.

### **J.5 CHILDREN'S FURNITURE**

Children's furniture should be very durable and scaled down to child size. Most manufactures of children's lines will offer scaled down furniture primarily for preschoolers and first graders, and junior sized furniture for children eight to twelve years of age. Once a child reaches age seven or eight, they will prefer to sit in "grown up" furniture when given a choice.

### **J.6 ACCESSORIES**

#### **J.6.1 ARTWORK AND BULLETIN BOARDS**

##### **J.6.1.1 Artwork**

Artwork should be used to enhance all areas, including lobbies; waiting rooms; general office areas; corridors; conference rooms; break rooms; restaurants and cafeterias; lodging; and recreational areas. Create themes for artwork throughout facilities and follow established standards for matting, framing, and displaying. Facilities with multiple floors can have varied themes from floor to floor as long as there are smooth transitions between each theme. Avoid suggestive or controversial subjects when choosing artwork. All hanging artwork must be attached to walls so that each piece is straight and aligned. Consider using security locks on artwork that could easily be pilfered.

##### **J.6.1.2 Bulletin Boards**

Bulletin boards and tackboards should be provided in common areas to display notices and announcements. These boards should coordinate with signs and other adjacent buildings' finishes. Avoid taping literature to walls, doors, or windows. This is unprofessional and tape creates a tacky film that may harm surfaces.



## **J.7 RESTROOMS AND LOCKER ROOMS**

### **Soap Dispensers**

Bobrick B-306 Trimline Series Soap Dispenser

Satin-finish stainless steel or equal

### **Paper Towel Dispenser**

Bobrick B-4362 Contura Series

Satin-finish stainless steel or equal

### **Waste Receptacles**

Bobrick B-43644 Contura Series

Satin-finish stainless steel or equal

### **Toilet Tissue Dispenser**

Bobrick B-386 Classic Series Multi-roll partition mount

Satin-finish stainless steel or equal

### **Sanitary Napkin Disposal**

B-4354 Contura Series partition mounted

Satin-finish stainless steel or equal

### **Recessed Napkin/Tampon Vendor**

Bobrick B-352 25 Recessed

Satin-finish stainless steel or equal

All other finishes at restrooms shall be stainless steel.

Waterless urinals may be used in larger public restrooms only.

Toilet partitions should be solid plastic equal to "Santana" products and should be floor mounted.

## **J.8 SIGNAGE**

- All interior signage is to meet the criteria set forth in [UFC 3-120-01](#).
- Font - Helvetica medium or Helvetica regular.
- Allowable Font Heights - 1/2", 3/4", 1", 1-1/2", 2", 3", 4", & 6".
- The signage must be coordinated with the selected interior color scheme.
- Signs should be in an aluminum frame that is dark brown with interchangeable inserts.

## **J.9 RAILINGS**

All railings, interior and exterior, should have a galvanized or anodized finish.



## APPENDIX K – EXTERIOR MATERIALS CHARTS

(Exterior Materials Charts – Next Page)



# EXTERIOR MATERIALS CHART

## SUPPORT OPERATIONS (Signal Center Barracks and Admin.)

Building Design Element		Permitted Material Type	Notes
Walls	Base (primary) material	Brick	
		CMU, wainscot	
	Secondary Material	Pre-cast concrete sills and trim	
Roof	Sloped areas	Standing seam metal	
	"Flat" areas	Light colored reflective membrane	
Fenestration	Doors	Aluminum storefront at entries	
		Steel insulated core	
	Overhead Doors	Steel insulated core; pre-finished	
	Door & Window Frames	Aluminum or steel and glass	
	Storm window or sash	Aluminum or steel and glass	
	Window	1" insulated tinted exterior	1
Trim Items	Fascia	Metal, factory pre-finished	
	Soffit	Metal, factory pre-finished	
	Gutters and D.S.	Metal, factory pre-finished	
	Awnings and canopies	Metal framework with fabric	
	Stair or balcony railings, balusters and related trim/accessories	Galvanized steel with factory finish	
	Handrails	Galvanized steel with factory finish	
	Fire escapes	Galvanized steel with factory finish	
	Grilles and louvers	Painted metal or aluminum	

	Coping	Metal factory pre-finished	
		Precast concrete	
	Roof ventilators	Galvanized metal, painted at sloped roofs	
Related Site Structures	Courtyard enclosure walls, retaining walls, fences, dumpster enclosures	Brick and/or CMU to match building, metal slats for gates	
	Porch crawl space enclosure	CMU or pre-finished metal panel	

NOTES	
<b>Note 1</b>	See force protection requirements for laminated glazing
<b>Note 2</b>	"No-maintenance finish" = anodized aluminum, powder coated steel, baked enamel on steel, Kynar coated steel. Where applicable and coordinated with the design.



# EXTERIOR MATERIALS CHART

## INDUSTRIAL FACILITIES VISUAL THEME

Building Design Element		Permitted Material Type	Notes
Walls	Base (primary) material	CMU, wainscot minimum 4'-0" above the ground	1
		Metal, pre-finished metal panel siding	
	Secondary Material	Precast concrete sills and trim	
Roof	Sloped areas	Standing seam metal	
	"Flat" areas	Light colored reflective membrane	
Fenestration	Doors	Aluminum storefront at entries	
		Steel insulated core	
	Storm Doors	Aluminum or steel and glass	
	Door & Window Frames	Aluminum or Steel	
	Storm window or sash	Aluminum or Steel	
	Window	1" insulated glass	2
Trim Items	Fascia	Metal, factory pre-finished	
	Soffit	Metal, factory pre-finished	
	Gutters and D.S.	Metal, factory pre-finished	
	Awnings and canopies	Metal framework with fabric	
	Stair or balcony railings, balusters and related trim/accessories	Aluminum or galvanized steel	
	Handrails	Aluminum or galvanized steel	

	Fire escapes	Aluminum or galvanized steel	
	Grilles and louvers	Painted steel or aluminum	
	Coping	Metal, pre-finished	
	Roof ventilators	Galvanized metal, paint at sloped roofs	
Related Site Structures	Courtyard enclosure walls, retaining walls, fences, dumpster enclosures	CMU pillars with metal slats between	
	Porch crawl space enclosure	CMU	

NOTES	
Note 1	<b>Brick may be utilized on Facilities with substantial Administration function</b>
Note 2	<b>See force protection requirements for laminated glazing</b>



## EXTERIOR MATERIALS CHART

### COMMUNITY CENTER VISUAL THEME

Building Design Element		Permitted Material Type	Notes
Walls	Base (primary) material	Brick,	1
		CMU, in combination with Brick as an accent material	
	Secondary Material	CMU, banding, wainscot, columns	
		Precast concrete, sills and trim	
Pre-finished metal panel, fascia and accents			
Roof	Sloped areas	Standing seam metal	
	"Flat" areas	Light colored reflective membrane	
Fenestration	Doors	Aluminum storefront at entries	
		Steel insulated core	
	Storm Doors	Aluminum or steel and glass	
	Door & Window Frames	Aluminum or steel and glass	
	Storm window or sash	Aluminum or steel and glass	
	Window	1" insulated tinted exterior	2
Trim Items	Fascia	Metal, factory pre-finished	
	Soffit	Metal, factory pre-finished	
	Gutters and D.S.	Galvanized metal, factory pre-finished	
	Awnings and canopies	Metal framework with fabric	
	Stair or balcony railings, balusters and related trim/accessories	Aluminum or galvanized steel with factory no-maintenance finish	3



	Handrails	Aluminum or galvanized steel with factory no-maintenance finish	3
	Fire escapes	Galvanized steel with factory no-maintenance finish	3
	Grilles and louvers	Painted metal or aluminum	
	Coping	Pre-cast concrete	
		Metal, factory pre-finished	
Roof ventilators	Galvanized metal, painted at sloped roof		
Related Site Structures	Courtyard enclosure walls, retaining walls, fences, dumpster enclosures	Combination of Brick and CMU that matches the adjacent facility	
	Porch crawl space enclosure	Brick	

NOTES	
Note 1	<b>Brick to cover majority of each façade on Facilities visually exposed in high traffic areas.</b>
Note 2	<b>See force protection requirements for laminated glazing.</b>
Note 3	<b>"No-maintenance finish" = anodized aluminum, powder coated steel, baked enamel on steel, Kynar coated steel. Where applicable and coordinated with the design.</b>



## EXTERIOR MATERIALS CHART

### MEDICAL CENTER VISUAL THEME

Building Design Element		Permitted Material Type	Notes
Walls	Base (primary) material	Brick, Conc. Panels, Metal Panels	2,3
		CMU wainscot	
	Secondary Material	Metal, pre-finished fascia	
		Pre-cast concrete, sills and trim	
Roof	Sloped areas	Standing seam metal	
	"Flat" areas	Light colored reflective membrane	4
Fenestration	Doors	Aluminum storefront at entries	
		Steel insulated core	
	Storm Doors	Aluminum or steel and glass	
	Door & Window Frames	Aluminum or steel	
	Storm window or sash	Aluminum or steel	
	Window	1" insulated glass	1
Trim Items	Fascia	Metal, factory pre-finished	
	Soffit	Metal, factory pre-finished	
	Gutters and D.S.	Metal, factory pre-finished	
	Awnings and canopies	Metal framework with fabric	
	Stair or balcony railings, balusters and related trim/accessories	Aluminum or galvanized steel with factory no-maintenance finish	5

	Handrails	Aluminum or galvanized steel with factory no-maintenance finish	5
	Fire escapes	Aluminum or galvanized steel with factory no-maintenance finish	5
	Grilles and louvers	Painted metal or aluminum	
	Coping	Precast concrete	
		Metal, factory pre-finished	
	Roof ventilators	Galvanized metal, paint at sloped roofs	
<b>Related Site Structures</b>	Courtyard enclosure walls, retaining walls, fences, dumpster enclosures	Brick and/or CMU to match adjacent structures	
	Porch crawl space enclosure	CMU	

<b>NOTES</b>	
<b>Note 1</b>	<b>See force protection requirements for laminated glazing</b>
<b>Note 2</b>	<b>Pre-fabricated concrete panels in combination with CMU wainscot at major construction HQ, Admin, Clinical, or Lab Projects</b>
<b>Note 3</b>	<b>Brick and / or Metal Siding in combination with CMU wainscot at minor construction Projects</b>
<b>Note 4</b>	<b>Flat Roof at Major Construction Projects</b>
<b>Note 5</b>	<b>"No-maintenance finish" = anodized aluminum, powder coated steel, baked enamel on steel, Kynar coated steel. Where applicable and coordinated with the design.</b>



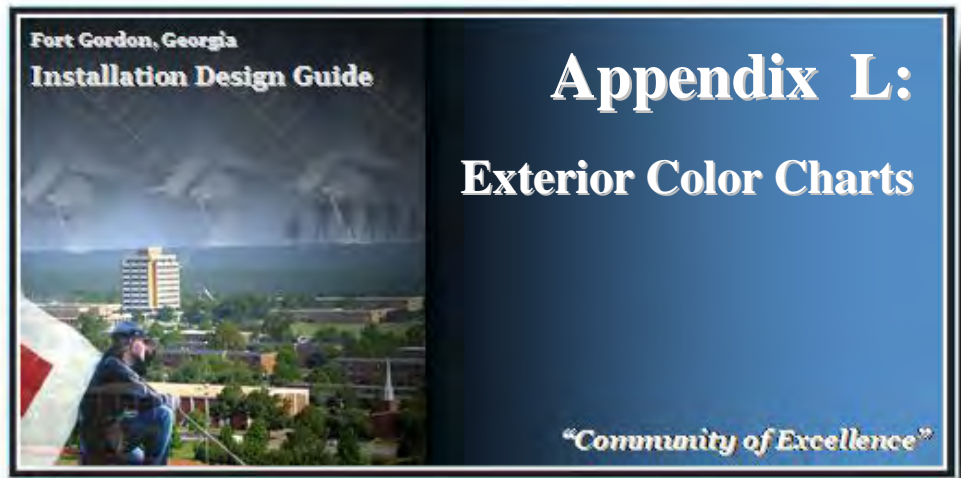
## EXTERIOR MATERIALS CHART

### GATES VISUAL THEME

Building Design Element		Permitted Material Type	Notes
Walls	Base (primary) material	Brick	
		CMU	
	Secondary Material	Metal Structure Frame, painted	
		Precast concrete, sills and trim	
Roof	Sloped areas	Standing seam metal	
	"Flat" areas	Light colored reflective membrane	
Fenestration	Doors	Aluminum storefront at entries	
		Steel insulated core	
	Storm Doors	Aluminum or steel and glass	
	Door & Window Frames	Aluminum or steel and glass	
	Storm window or sash	Aluminum or steel and glass	
	Window	1" insulated tinted exterior	1
Trim Items	Fascia	Metal, factory pre-finished	
	Soffit	Metal, factory pre-finished	
	Gutters and D.S.	Galvanized metal, factory pre-finished	
	Awnings and canopies	Metal framework with fabric	
	Handrails	Aluminum or galvanized steel with factory no-maintenance finish	

	Grilles and louvers	Painted metal or aluminum	
	Coping	Pre-cast concrete	
		Metal, factory pre-finished	
	Roof ventilators	Galvanized metal, painted at sloped roof	
Related Site structures	Courtyard enclosure walls, retaining walls, fences, dumpster enclosures	Primary material: CMU Secondary material: Architectural Concrete	
	Porch crawl space enclosure	Match primary CMU	

NOTES	
Note 1	See force protection requirements for laminated glazing
Note 2	
Note 3	












## APPENDIX L – EXTERIOR COLOR CHARTS



## EXTERIOR COLOR CHART

### VISUAL ZONE: North Industrial

Bldg. Design Element		Required Color Standard	Color Sample	Notes
Walls	Base (primary) material	CMU, Sand		
	Secondary Material	Pre-finished metal panels, Surrey Brown		1
		Pre-cast concrete sills and trim Light Sand		2
Roof	Sloped areas	Standing seam metal, AMS Terra Cotta		3,4
	"Flat" areas	Light colored reflective membrane, White		
Fenestration	Doors	Aluminum storefront at entries, Dark Bronze or Clear		5
		Steel insulated core, Dark Bronze		5
	Overhead Doors	Steel insulated core; pre-finished, Dark Sand		
	Door & Window Frames	Aluminum or steel and glass, Alum: Dark Bronze or Clear Steel: Dark Bronze		5
	Storm window or sash	Aluminum or steel and glass, Alum: Dark Bronze or Clear Steel: Dark Bronze		5
	Window	1" insulated tinted exterior, Light Bronze		
Trim Items	Fascia	Metal, factory pre-finished, Match sloped metal roof – RMS Terra Cotta		3,4
	Soffit	Metal, factory pre-finished, Match sloped metal roof – RMS Terra Cotta		3,4

	Gutters and D.S.	Metal, factory pre-finished, Match sloped metal roof – RMS Terra Cotta		3,4
	Awnings, Shelters and canopies	Metal, factory pre-finished, Match sloped metal roof – RMS Terra Cotta		3,4
	Stair or balcony railings, balusters and related trim/accessories	Galvanized steel with factory finish, Dark Bronze		5
	Handrails	Galvanized steel with factory finish, Dark Bronze		5
	Fire escapes	Galvanized steel with factory finish, Dark Bronze		5
	Grilles and louvers	Painted galvanized metal, Color match adjacent wall material		
	Coping	Painted galvanized metal, match roof color		3,4
	Roof ventilators	Galvanized metal, painted to match roof color, Unpainted galvanized at flat roofs		3,4
<b>Related Side Structures</b>	Courtyard enclosure walls, retaining walls, fences, dumpster enclosures	CMU: Sand		
	Porch crawl space enclosure	CMU or pre-finished metal panel, CMU: Sand, Metal Panel: Surrey Brown		










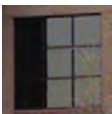






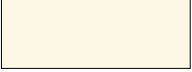






<b>NOTES: North industrial</b>	
<b>Note 1</b>	Surrey Brown color to match vertical siding at Building 13700
<b>Note 2</b>	Light Sand color to match trim at Building 19733
<b>Note 3</b>	Terra Cotta color to match metal roof system at Building 21715
<b>Note 4</b>	Major Construction with HQ and substantial admin to have “Colonial Red” color metal roof system in this Zone.
<b>Note 5</b>	Dark Bronze color to match door and window frames at Building 33720



## EXTERIOR COLOR CHART

### VISUAL ZONE: Signal Center Barracks and Administration

Bldg. Design Element		Required Color Standard	Color Sample	Notes
Walls	Base (primary) material	Brick: 2.0 GreyStone		1
	Secondary Material	Ext. Insulation Finish System (EIFS): Beige		2
		Pre-cast concrete sills and trim, Light Sand		3
Roof	Sloped areas	Standing seam metal, AMS Terra Cotta		4
	"Flat" areas	Light colored reflective membrane, White		
Fenestration	Doors	Aluminum storefront at entries, Dark Bronze or Clear		5
		Steel insulated core, Dark Bronze		5
	Overhead Doors	Steel insulated core; pre-finished, Dark Sand		
	Door & Window Frames	Aluminum or steel and glass, Alum: Dark Bronze or Clear Steel: Dark Bronze		5
				
	Storm window or sash	Aluminum or steel and glass, Alum: Dark Bronze or Clear Steel: Dark Bronze		5
Window	1" insulated tinted exterior, Light Bronze			
Trim Items	Fascia	Metal, factory pre-finished, Match sloped metal roof – RMS Terra Cotta		4








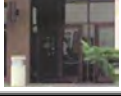





	Soffit	Metal, factory pre-finished, Match sloped metal roof – RMS Terra Cotta		4
	Gutters and D.S.	Metal, factory pre-finished, Match sloped metal roof – RMS Terra Cotta		4
	Awnings, Shelters, and canopies	Metal, factory pre-finished, Match sloped metal roof – RMS Terra Cotta		4
	Stair or balcony railings, balusters and related trim/accessories	Galvanized steel with factory finish, Light Sand		3
	Handrails	Galvanized steel with factory finish, Dark Bronze		5
	Fire escapes	Galvanized steel with factory finish, Dark Bronze		5
	Grilles and louvers	Painted galvanized metal, Color match adjacent wall material		
	Coping	Painted galvanized metal, match roof color		4
	Roof ventilators	Galvanized metal, painted to match roof color, Unpainted galvanized at flat roofs		4
	<b>Related Side Structures</b>	Courtyard enclosure walls, retaining walls, fences, dumpster enclosures	Brick: 2.0 GreyStone, or CMU: Dark Sand	
Porch crawl space enclosure		Brick: 2.0 GreyStone		1











<b>NOTES: Signal Center Barracks and Administration</b>	
<b>Note 1</b>	Brick color to match Building 33720 "Darling Hall"
<b>Note 2</b>	Beige color to match EIFS at Building 19733
<b>Note 3</b>	Light Sand color to match trim at Building 19733
<b>Note 4</b>	Terra Cotta color to match metal roof system at Building 21715
<b>Note 5</b>	Dark Bronze color to match door and window frames at Building 33720



## EXTERIOR COLOR CHART

### VISUAL ZONE: USAR / National Guard

Bldg. Design Element		Required Color Standard	Color Sample	Notes
Walls	Base (primary) material	Brick: 2.0 GreyStone		1
	Secondary Material	Ext. Insulation Finish System (EIFS): Beige		2
		Pre-cast concrete sills and trim Light Sand		3
Roof	Sloped areas	Standing seam metal, Dark Bronze		4
	"Flat" areas	Light colored reflective membrane, White		
Fenestration	Doors	Aluminum storefront at entries, Dark Bronze or Clear		4
		Steel insulated core, Dark Bronze		4
	Overhead Doors	Steel insulated core; pre-finished, Dark Sand		
	Door & Window Frames	Aluminum or steel and glass, Alum: Dark Bronze or Clear Steel: Dark Bronze		4
				
	Storm window or sash	Aluminum or steel and glass, Alum: Dark Bronze or Clear Steel: Dark Bronze		4
	Window	1" insulated tinted exterior, Light Bronze		
Trim Items	Fascia	Metal, factory pre-finished, Match sloped metal roof – Dark Bronze	 	4
	Soffit	Metal, factory pre-finished, Match sloped metal roof – Dark Bronze		4










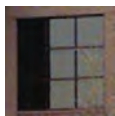
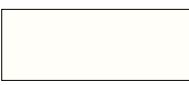

	Gutters and D.S.	Metal, factory pre-finished, Match sloped metal roof – Dark Bronze		4
	Awnings, Shelters, and canopies	Metal, factory pre-finished, Match sloped metal roof – Dark Bronze	 	4
	Stair or balcony railings, balusters and related trim/accessories	Galvanized steel with factory finish, Dark Bronze		4
	Handrails	Galvanized steel with factory finish, Dark Bronze		4
	Fire escapes	Galvanized steel with factory finish, Dark Bronze		4
	Grilles and louvers	Painted galvanized metal, Color match adjacent wall material		
	Coping	Painted galvanized metal, match roof color		4
	Roof ventilators	Galvanized metal, painted to match roof color, Unpainted galvanized at flat roofs		4
<b>Related Side Structures</b>	Courtyard enclosure walls, retaining walls, fences, dumpster enclosures	Brick: 2.0 Grey Stone, or CMU: Dark Sand		
	Porch crawl space enclosure	Brick: 2.0 GreyStone		1

<b>NOTES: USAR / National Guard</b>	
<b>Note 1</b>	Brick color to match Building 33720 "Darling Hall"
<b>Note 2</b>	Beige color to match EIFS at Building 19733
<b>Note 3</b>	Light Sand color to match trim at Building 19733
<b>Note 4</b>	Dark Bronze color to match metal roof system at Building 14401
<b>Note 5</b>	Dark Bronze color to match door and window frames at Building 14401












## EXTERIOR COLOR CHART

### VISUAL ZONE: South Industrial

Bldg. Design Element		Required Color Standard	Color Sample	Notes
Walls	Base (primary) material	Brick, Olde Red Blend		1
	Secondary Material	Pre-finished metal panels, Light Tan		2
		Pre-cast concrete sills and trim, Light Tan		2
Roof	Sloped areas	Standing seam metal roof, Light Tan		3
	"Flat" areas	Light colored reflective membrane, White		
Fenestration	Doors	Aluminum storefront at entries, Dark Bronze or Clear		4
		Steel insulated core, Dark Bronze		4
	Overhead Doors	Steel insulated core; pre-finished, Medium Sand		
	Door & Window Frames	Aluminum or steel and glass, Alum: Dark Bronze or Clear Steel: Dark Bronze		4
				
	Storm window or sash	Aluminum or steel and glass, Alum: Dark Bronze or Clear Steel: Dark Bronze		4
	Window	1" insulated tinted exterior, Light Bronze		
Trim Items	Fascia	Metal, factory pre-finished, Match sloped metal roof – Light Tan		3
	Soffit	Metal, factory pre-finished, Match sloped metal roof – Light Tan		3











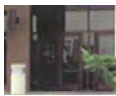



	Gutters and D.S.	Metal, factory pre-finished, Dark Bronze		4
	Awnings, Shelters and canopies	Metal, factory pre-finished, Match sloped metal roof – Light Tan		3
	Stair or balcony railings, balusters and related trim/accessories	Galvanized steel with factory finish, Dark Bronze		4
	Handrails	Galvanized steel with factory finish, Dark Bronze		4
	Fire escapes	Galvanized steel with factory finish, Dark Bronze		4
	Grilles and louvers	Painted galvanized metal, Color match adjacent wall material		
	Coping	Painted galvanized metal, match roof color		3
	Roof ventilators	Galvanized metal, painted to match roof color, Unpainted galvanized at flat roofs		3
<b>Related Side Structures</b>	Courtyard enclosure walls, retaining walls, fences, dumpster enclosures	CMU: Dark Sand		
	Porch crawl space enclosure	CMU or pre-finished metal panel, CMU: Dark Sand, Metal Panel: Insignia White		







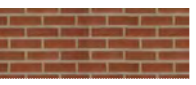
<b>NOTES: South Industrial</b>	
<b>Note 1</b>	Brick color to match 35 <sup>th</sup> Signal BDE maintenance Facility
<b>Note 2</b>	Pre-finished metal panel color to match 35 <sup>th</sup> Signal BDE maintenance Facility
<b>Note 3</b>	Light Tan color to match metal roof system at 35 <sup>th</sup> Signal BDE maintenance Facility
<b>Note 4</b>	Dark Bronze color to match door and window frames at 35 <sup>th</sup> Signal BDE maintenance Facility
<b>Note 5</b>	Medium Sand color to match overhead door at 35 <sup>th</sup> Signal BDE maintenance Facility



## EXTERIOR COLOR CHART

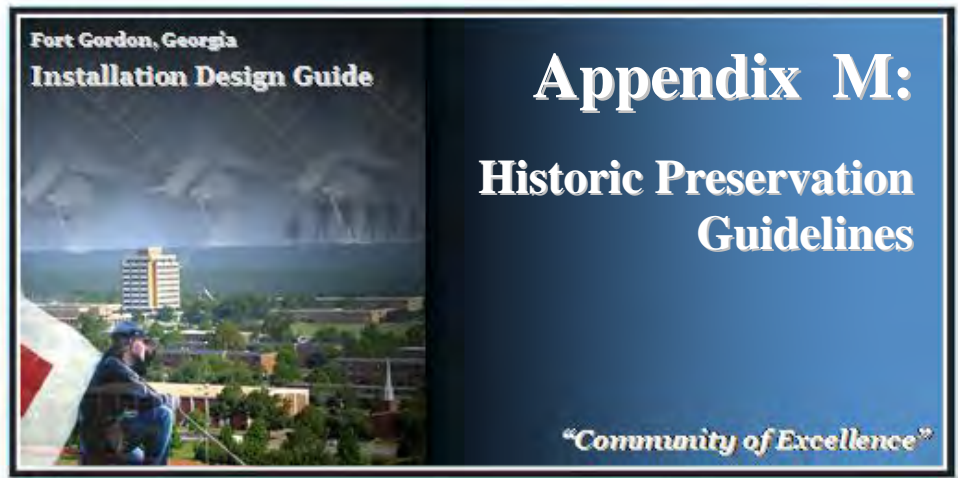
### VISUAL ZONE: Community Center

Bldg. Design Element		Required Color Standard	Color Sample	Notes
Walls	Base (primary) material	Brick: Southern Red		1
	Secondary Material	CMU: Light Sand or (EIFS): Antique White	 	
		Pre-cast concrete sills and trim, Antique White		
Roof	Sloped areas	Standing seam metal, Deep Green		4
	"Flat" areas	Light colored reflective membrane, White		
Fenestration	Doors	Aluminum storefront at entries, Dark Bronze or Clear		5
		Steel insulated core, Dark Bronze		5
	Overhead Doors	Steel insulated core; pre-finished, Dark Sand		
	Door & Window Frames	Aluminum or steel and glass, Alum: Dark Bronze or Clear Steel: Dark Bronze		5
				
	Storm window or sash	Aluminum or steel and glass, Alum: Dark Bronze or Clear Steel: Dark Bronze		5
	Window	1" insulated tinted exterior, Light Bronze		
Trim Items	Fascia	Metal, factory pre-finished, Match sloped metal roof – Deep Green		4

	Soffit	Metal, factory pre-finished, Match sloped metal roof – Deep Green		4
	Gutters and D.S.	Metal, factory pre-finished, Antique White or Deep Green depending on Building Function.	 	6
	Awnings, Shelters, and canopies	Metal, factory pre-finished, An Deep Green		4
	Stair or balcony railings, balusters and related trim/accessories	Galvanized steel with factory finish, Dark Bronze		5
	Handrails	Galvanized steel with factory finish, Dark Bronze		5
	Fire escapes	Galvanized steel with factory finish, Dark Bronze		5
	Grilles and louvers	Painted galvanized metal, Color match adjacent wall material		
	Coping	Painted galvanized metal, match roof color		4
	Roof ventilators	Galvanized metal, painted to match roof color, Unpainted galvanized at flat roofs		4
<b>Related Side Structures</b>	Courtyard enclosure walls, retaining walls, fences, dumpster enclosures	Brick: Southern Red, or CMU: Light Sand	 	1
	Porch crawl space enclosure	Brick: Southern Red		1

<b>NOTES: Community Center</b>	
<b>Note 1</b>	Brick color to match Building 43400 "Freedom Park Elementary School"
<b>Note 2</b>	Light Sand color to match CMU at Building 33720 "Darling Hall Entrance"
<b>Note 3</b>	Antique White color to match trim at Building 38200
<b>Note 4</b>	Deep Green color to match metal roof system at Building 43400
<b>Note 5</b>	Dark Bronze color to match door and window frames at Building 33720
<b>Note 6</b>	Proposed Chapel and Library to have Antique White Gutters and Downspouts

COLOR SAMPLE



## **APPENDIX M – HISTORIC PRESERVATION GUIDELINES**

### **M.1 INTRODUCTION**

#### **M.1.1 MILITARY PLANNING AND DESIGN**

Most of the history and literature about the military does not deal with the topic of Army facility planning and design processes. However, to plan for the future development of an Army installation, it is necessary to go back and attempt to understand what has taken place there in the past.

In the development of its policies, the Army had to deal with the question of how buildings relate to one another by both use and layout and by architectural characteristics. At least in its earliest phases, this development was not always a conscious formulation of policy as much as it was the immediate response to a given situation.

### **M.2 HISTORIC PRESERVATION REGULATIONS**

The Army's management of historic properties is pursuant to the duties and responsibilities established by Congress under the National Historic Preservation Act (NHPA) of 1966 and its subsequent amendments. This act committed Federal agencies to a program of identification and protection of historic properties on the land they own. The NHPA established the Advisory Council on Historic Preservation (ACHP) to "advise the President and the Congress on matters relating to historic preservation; [and to] recommend measures to coordinate activities of Federal, State, and local agencies." (16 U.S.C. 470j)

Created by the National Register of Historic Places (NHPA), its official listing of the nation's historic and cultural resources include "districts, sites, buildings,

structures, and objects significant in American history, architecture, archaeology, engineering, and culture." (16 U.S.C.470a) The NHPA encourages the identification and evaluation of publicly and privately owned properties to determine eligibility for listing on the National Register, and promotes preservation management plans as well as compatible use of eligible properties.

In order to comply with the intent of the law, the NHPA has established procedural steps that Federal agencies must follow. Section 106 of the NHPA requires that: "the head of any Federal agency having direct or indirect jurisdiction over a proposed Federal or federally assisted undertaking in any State and the head of any Federal department or independent agency having authority to license any undertaking shall, prior to the approval of the expenditure of any Federal funds on the undertaking or prior to the issuance of any license, as the case may be, take into account the effect of the undertaking on any district, site, buildings, structure, or object that is included in or eligible for inclusion in the National Register. The head of any such Federal agency shall afford the Advisory Council on Historic Preservation established under Title II of this Act a reasonable opportunity to comment with regard to such undertaking." (16 U.S.C. 470f)

Pursuant to its authority in overseeing the nation's historic preservation programs, the Department of the Interior has developed regulations which provide a set of acceptable standards for work on properties listed in or eligible for listing in the National Register. The Secretary of the Interior's Standards and Guidelines for Archeology and Historic Preservation act as a guide to the Advisory Council and State Historic Preservation Offices in their procedural review of Federal undertakings. These guidelines should also act as standards for all Federal agencies as they commence planning for any undertaking, which has the potential to trigger Section 106 review, thus assuring that all proposed projects would meet Advisory Council and NHPA requirements.

Federal agencies must comply with the NHPA by following a series of steps detailed in 36 CFR 800. The Army further explains its policies and procedures in [Army Regulation \(AR\) 200-4, Cultural Resources Management](#) and [Department of the Army Pamphlet \(DA PAM\) 200-4, Cultural Resources Management](#). This Installation Design Guideline is intended to be used in conjunction with the above regulations as well as with the Fort Gordon Integrated Cultural Resources Management Plan (ICRMP).

The recently developed Army Alternate Procedures (AAP) provide a new method for managing historic properties. The AAP, a streamlined approach to Section 106 of the National Historic Preservation Act, now allows installations to manage historic properties programmatically rather than on a project-by-project review. These procedures also enable installations to leverage existing Army and DoD program requirements while internally managing historic properties in a more efficient and cost effective manner.

## **M.3 REHABILITATION OF HISTORIC PROPERTIES**

Design and renovation guidelines for historic districts, such as those within Fort Carson are of necessity much broader than design guidelines for single structures. Such guidelines must not only address the appropriate architectural image (style, material, etc.) for proposed new buildings, they must also address how a proposed action within the historic district will impact the integrity of the original design intent of the given historic area.

Alternate procedures (AAP) provide a new method for managing historic properties. The AAP, a streamlined approach to Section 106 of the National Historic Preservation Act, now allows installations to manage historic properties programmatically rather than through a project-by-project consultation process. These procedures also enable installations to leverage existing Army and DoD program requirements while internally managing historic properties in a more efficient and cost effective manner.

### **M.3.1 NEW WORK**

New work shall **not** conflict with the existing architectural character. For example, it should not:

- Be larger in mass or taller than the existing historic structures.
- Be of a color or material that conflicts visually with the predominant historic material used in the area.
- Destroy the historic fabric of any existing structures or landscape features, which are essential character defining elements within the district.
- Destroy the spatial relationship between or among historic buildings designed as a grouping. This includes the regular spacing of buildings within a group, as well as views from one to the other or into the grouping as a whole.

New work shall seek to enhance and protect the historic quality and existing resources. For example:

- Conduct a survey to examine the level of use of existing facilities prior to determining the need for new construction.



- Follow the Standards and Guidelines for Historic Preservation as recommended by the Secretary of the Interior.

New work shall provide necessary modern conveniences as unobtrusively as possible. For example, it should:

- Locate new construction so that it does not destroy the configuration and relationship between existing buildings.
- Scale new buildings down so as to minimize their visual impact.
- Place parking to the rear of historic buildings.
- Landscape parking areas and modern mechanical equipment to screen them from view.

New work shall gradually eliminate existing intrusions. For example, it should:

- Demolish structures designated as intrusions on the National Register Inventory when they are no longer needed.
- Restore buildings that have been altered by inappropriate color schemes, replacement windows, porch enclosures, etc.

### **M.3.2 TREATMENT OF HISTORIC FABRIC**

The most effective way to preserve historic properties is to keep them in use and to consistently maintain them. When buildings and grounds are consistently used for their intended purposes and regular maintenance is conducted, there is rarely a need for extensive preservation work. Only when they are misused, underused, or left vacant for long periods of time does large-scale rehabilitation become necessary. It follows that if a regular maintenance program is put into effect once a property has been appropriately renovated, another major rehabilitation will rarely be required.

### **M.3.3 STANDARDS FOR HISTORIC PRESERVATION PROJECTS**

#### **M.3.3.1 Compatible Use of Historic Sites and Structures**

Every reasonable effort should be made to use a historic structure or site for its originally intended purpose or to provide a compatible use. The use should be compatible in the sense that it involves minimal alteration to the property and/or

has no adverse effect upon its historic integrity. Use of the site and structure should be regulated to prevent alterations that are potentially damaging to historic fabric and/or cultural context.

#### **M.3.3.2 Retention of Character Defining Features**

Distinguishing stylistic or character defining features and examples of skilled craftsmanship should not be destroyed, altered, or removed from a historic site or structure. All such fabric should be treated with sensitivity and preserved in its original context and form.

#### **M.3.3.3 Treatment of Deteriorated Historic Fabric**

Deteriorated historic fabric should be repaired rather than replaced whenever possible. When replacement is unavoidable, new material, whether man-made or natural, should match the existing fabric in composition, design, color, texture, and other visual/structural qualities.

#### **M.3.3.4 Documentation of Missing Historic Elements**

Replacement of missing historic elements should be based on the accurate duplication of features known to have existed and substantiated by historic pictorial and/or physical evidence and not on conjecture, nor simply on the example of similar treatment found on other structures or sites of the same period or region.

#### **M.3.3.5 Retention of Historic Alterations**

Changes to a historic structure or site, which have occurred over the course of time, may provide evidence of important social or cultural processes. As such, they should be respected and their potential significance carefully evaluated.

#### **M.3.3.6 Unacceptable Alterations**

Historic sites and structures should be recognized as products of their own time and as part of an important cultural process. Alterations that have no historical basis, or that destroy the authenticity of the place, are discouraged.

#### **M.3.3.7 Acceptable Alterations and Additions**

When possible, alterations and new additions to historic structures or sites should be done in such a manner as to leave the essential form and integrity unimpaired.

#### **M.3.3.8 Contemporary Design in a Historic Context**

Contemporary design for additions to existing historic sites or districts should not be discouraged if such design is compatible with the massing, proportions, scale, materials, color, views, and general contextual relationships of the place.

### **M.3.3.9 Surface Cleaning Methods**

Surface cleaning of structures or buildings should be undertaken with the gentlest possible means, and only when cleaning is essential to the preservation of the buildings. Cleaning methods, such as sand blasting, which could damage historic material or speed their deterioration, are discouraged.

### **M.3.3.10 Archaeological Resources**

All treatment work, which potentially affects surface or sub-surface pre-historic or historic archaeological resources, should be coordinated with an archaeologist.

### **M.3.3.11 Historic Preservation and Maintenance**

The guidelines contained within this IDG are general in nature. The IDG must be utilized in conjunction with the Installation ICRMP.

## **M.3.4 GUIDELINES FOR HISTORIC PRESERVATION PROJECTS**

### **M.3.4.1 Roof Guidelines**

- Preserve existing historic roofing. Repair and patch with matching materials.
- All roofs should receive an annual inspection. Repair and patch all materials as needed and clean out all gutters and drains.
- When full replacement of the roof becomes necessary, replace or restore with historic materials.
- Roof details. Retain and/or maintain all existing chimneys, ventilators, vents, louvers, and decorative elements such as brackets, dentils, and cornices. When possible, restore missing decorative elements.

### **M.3.4.2 Wall Guidelines**

#### **Limestone and brick masonry.**

- Clean only when necessary, using the gentlest possible means.
- Repair or replace deteriorated or missing units as needed.

#### **Stucco.**

- Repair damaged or deteriorated stucco.
- Repaint only when necessary with appropriate color based on analysis of historic paint.

## **Wood.**

- Retain or repair wood siding. Where replacement is necessary, match existing clapboards in width and species.
- Repaint only as need to maintain moisture protection.
- Use color scheme based on analysis of existing paint layers.

### **M.3.4.3 Porch Guidelines**

- Retain or maintain existing original porches.
- Remove historically inappropriate porches.
- Where possible, restore original porches that have been removed or enclosed.

### **M.3.4.4 Window Guidelines**

- In most historic districts or buildings, windows constitute a highly visible design element, as they make up a large percentage of façades.
- If building an addition or altering the building, maintain height configuration of windows.
- Retain window size and fenestration pattern when replacing windows or altering the building.
- If replacing windows, preserve frame material or use historically accurate reproductions. Avoid replacing original frames with aluminum frames.
- Restore historic windows where non-historic replacement windows have been used.
- The window manufacturing industry can replicate and/or reproduce most types and sizes of windows to match existing historic windows. In many cases, matching replacement windows are available as stock items.

### **M.3.4.5 Door Guidelines**

- Although not usually as visually overpowering as windows, main entrance doorways are also important façade details. As a design element, decorative doors have stylistic features that belong to the particular era for which they were designed.
- Retain or maintain existing historic doors.

- If replacing doors, preserve frame material or use historically accurate reproductions.
- If building an addition or altering the building, maintain the size of the door opening.
- Restore all main entranceways by reinstalling appropriate frames.

#### **M.3.4.6 Color Guidelines**

- If historic buildings must be repainted before an accurate color scheme is developed, a very conservative approach should be followed. Repaint to match the existing colors or use colors that can be documented to have been used on that building.
- Utilize a qualified historic paint color specialist for an inventory and analysis of the paint layer sequences for all building groupings.
- Establish a rotating schedule for the painting and cleaning of each building.

#### **M.3.4.7 Painting Guidelines**

- Do not undertake a paint job until any problems with leaking water have been solved. All gutters and downspouts should be repaired and be in good operating condition.
- Only repaint when existing coat is no longer performing, as excessive coats of paint create a thick film that obscures detail.

#### **M.3.4.8 Handicap and Safety Access Guidelines**

As a general rule, buildings listed in or determined eligible for listing in the National Register may receive special consideration for meeting safety and accessibility requirements. Any modifications required to bring a historic structure in compliance with safety and accessibility codes should be carefully planned and undertaken so that they do not adversely affect the design of main entrances or principal façades.

- Where possible, avoid alterations to the main façade and principal doorways.
- Place or install new ramps, lifts, and any added fire escapes on secondary building façades preferably to the side or rear of the building.
- Locate new doorways at the rear or side of the building.

- Required protective railings on ramps, stairs, steps, and lifts should match existing porch railings.

#### **M.3.4.9 Mechanical Equipment Guidelines**

In many cases within historic districts, mechanical equipment is located outside the building. When historic structures are renovated and mechanical systems are upgraded, equipment placement should be planned in order to make the least visual impact.

- Where possible, locate mechanical equipment within the building.
- Screen necessary surface equipment with vegetation.
- When large groups of buildings are upgraded as one project, consider the use of a remote system in which to house mechanical equipment.

#### **M.3.4.10 Guidelines for Additions**

In general, additions should follow all of the guidelines for new construction within historic districts; but, because their proximity makes the potential for damage to historic fabric even greater, there are additional principles that should be followed.

- Avoid changes that impact primary façades.
- Note that some highly visible freestanding buildings may not have a secondary façade, and thus additions are not advisable.
- Scale down additions to make the least visual impact.
- Design should establish a clear and obvious difference between the existing historic structure and the new addition.

#### **M.3.4.11 Force Protection**

These guidelines should be used in conjunction with the [UFC 4-010-01, DoD Minimum Antiterrorism Standards for Buildings](#) and the Force Protection Design Standards of this Installation Design Guide.

### **M.4 ARMY STANDARDS**

- [Army Regulation \(AR\) 200-4, Cultural Resources Management.](#)

- [Department of the Army Pamphlet \(DA PAM\) 200-4, Cultural Resources Management.](#)
- [The Secretary of the Interior's Standards for the Treatment of Historic Properties.](#)

## **M.5 REFERENCES**

- [Advisory Council on Historic Preservation.](#)
- [United States Army Environmental Center](#)



## APPENDIX N – HOUSEKEEPING RULES (EXAMPLE)

The following set of housekeeping rules consist of a list of general and public rules that are applicable to the administrative office work areas throughout the installation. Organizations should make every effort to assure that all personnel are familiar with the facilities housekeeping rules. An organized, well kept working area that is neat and clean contributes to the visual harmony of the work area and fosters work efficiencies.

Below is a sample of housekeeping rules. Fort Gordon should modify as appropriate when used for various buildings.

### N.1 HOUSEKEEPING RULES FOR (ENTER NAME OF ORGANIZATION)

#### N.1.1 GENERAL

**Alterations.** Employees shall not mark, paint, drill, damage, string wires within, or in any way deface any part of the building. Employees will not install or permit the installation of any awnings, shades, Mylar films, or num filters on windows. Employees will not obstruct, alter, or in any way impair the efficient operation of the heating, ventilating, air conditioning, electrical, fire safety, or lighting systems, nor shall the employee tamper with or change the setting of any thermostat or temperature control valve in the building. Employees shall not cover or block air ducts or vents.

**Cleanliness.** Employees shall exercise his/her best efforts to keep workstations and common areas, i.e., hallways, corridors, team rooms, etc., clean and free from rubbish. No employee shall cause any unnecessary labor due to carelessness or indifference in the preservation of good order and cleanliness. It is highly recommended that employees use covered cups



when transporting liquids to and from the coffee bars. Employees shall not bring any substance into the building that might add an undue burden to the cleaning or maintenance of the premises or the building.

**Carpet.** Carpet stains and/or damage should be reported to (enter Point of Contact (POC)).

**Energy Conservation.** Turn off systems furniture lighting, conference room lights, private office lights, and equipment, etc. when not in use, especially at the end of the day. During non-business hours, employees shall limit the use of lighting and equipment to areas occupied.

**Lighting.** Do not adjust or move any overhead lighting fixtures or fixtures within workstations. Lighting within workstations may not be without written approval by (enter POC). One desktop personal lamp may be placed in a workstation.

**Vertical Blinds.** Blinds are to be left down at all times. Only the wands will be used for adjustments. Items will not be placed/stored on windowsills other than small plants as covered above.

**Signage.** No signs, advertisements, or notes shall be painted or affixed on or to any window, door, restroom, conference/team room, or other part of the building unless approved by (enter POC). Bulletin boards will be installed in each of the coffee bars for posting of unofficial material.

**Vehicles.** Employees shall not bring bicycles into the office environment.

**Air Sprays.** Since many people are sensitive to various air sprays, their use is discouraged.

**Maintenance.** All requests for maintenance on workstations, chairs, carpeting should be reported to (enter POC).

## **N.1.2 PUBLIC SPACES**

**Eating in Work Areas.** Eating in work areas can contribute to pest infestation and an unsightly appearance. If eating at your desk, please ensure trash is discarded daily. Perishable food items should not be stored in the employee's work area. Perishable foods are to be kept refrigerated.

**Appliances** (e.g., heaters, refrigerators, microwaves, coffee pots).  
Refrigerators and microwaves are not permitted in work areas. One personal fan, not to exceed 8" in diameter may be placed in a workstation. Exceptions to accommodate health problems may be submitted to (enter POC).

**Centralization.** Copiers, faxes, scanners, printers, etc. will be centralized and networked to the maximum extent possible. Personal office equipment will be provided on an exception basis only.

**Office Accessories.** All office equipment and other devices of any electrical or mechanical nature shall be placed on an area of the work surface that best accommodates the prevention/elimination of any vibration, noise, or annoyance to others. Employees shall not construct, maintain, use, or operate any equipment or machinery that produces music, sound, noise, pictures, or lighting that is audible or visible beyond their workstation.

**Office Wall Mountings.** Only framed items will be hung on walls. No artwork or other displays may be placed or hung on fixed or temporary walls/partitions, other than in private offices without approval by (enter POC). The use of tape, pushpins, or other devices to affix items to walls is prohibited.

**Plants.** Plants must be contained within workstations and not affixed in any way to the workstation, partitions, floors, or ceiling as outlined in the guidance detailed elsewhere in this document. Small plants that do not interfere with the normal operation of window blinds may be placed on windowsills.

**Speakerphones.** The use of speakerphones is restricted to when absolutely necessary. Concerted efforts must be made to utilize team rooms when speakerphone conversations are required.

**Trash.** The janitorial contractor will discard only items in wastebaskets or items clearly labeled "TRASH." Do not place trash in the corridors, hallways, stairwells, or other common areas.

**Workstation Reconfiguration.** Workstations will not be reconfigured, modified, or altered in any way by the occupant.

**Workstation Guidelines.** Every employee shall make a concerted effort to keep workstations clean, uncluttered, and professional in appearance. Avoid placing papers and other "hard copy" materials on the wall of the workstation and avoid the accumulation of excessive pictures, cartoons, and mementos. The storage of papers, boxes, and files on floors is prohibited. Materials are not to be hung on the outside panels of workstations.

**Above the Panels.** Nothing will be placed above the panel height of the workstations or hung from the ceiling. Nothing will be stacked on the tops of flipper doors, map files, filing cabinets, towers, etc.

**Cabling.** No temporary cabling for electrical, information technology, or communications is allowed. Requests for alterations must be submitted to

(enter POC). This prohibition includes extension cords; surge protectors are allowed. Wiring is to be contained in cable trays and off the floors.

**Care of Furniture and Furniture Systems.**

**Laminate Surfaces.** To clean laminate tops, wash with a soft cloth and a solution of mild detergent and warm water. Rinse thoroughly and dry with a soft cloth.

**Steel and Painted Metal Surfaces.** Panel trim, panel poles, painted flipper doors, and other parts of flipper doors should be cleaned with a soft cloth soaked in detergent and warm water. Rinse thoroughly and dry.

**Fabric.** For information on how to remove spots from panels and workstation flipper doors, contact (enter POC).



## APPENDIX O – PLANT PALETTE

### RECOMMENDED PLANTS FOR FORT GORDON

#### [TREES \(Evergreen\)](#)

#### [TREES \(Deciduous\)](#)

#### [SHRUBS \(Spreading Evergreen\)](#)

#### [SHRUBS \(Deciduous\)](#)

The X rating system is used industry wide to identify water efficient plants. X (Xeriscape) rated plants require about 1 inch (ET) of water per week. XX rated plants require about 1/2" (ET) of water per week. XXX rated plants require about 1/2" (ET) of water every 2 weeks. Generally, XXX plants can survive, after establishment (1 to 2 years) on average available precipitation. XX rated plants, planted properly and in good sites also will do well with available precipitation. Mature X rated plants can survive on available precipitation, although the survival margin is much less. However, during Drought, XXX plants have the highest survival rates. It is imperative that these plants be grouped according to their X rating. Irrigation at the appropriate rate is recommended for all X, XX and XXX planting.

### **Plant Palette Tables Currently Being Developed**



## **APPENDIX P – CENTERS OF STANDARDIZATION**

**DA Facilities Standardization Program  
Centers of Standardization (See Table – Next Page)**

The following U.S. Army Corps of Engineer Centers of Standardization locations are responsible for the standardization of the respective facility types. Addresses and telephone numbers are provided.

**DA Facilities Standardization Program  
Centers of Standardization**

<b>ASSIGNED CENTER</b>	<b>FACILITY TYPE</b>
<p><u><a href="#">U.S. Army Engineering and Support Center, Huntsville</a></u>            Attn: CEHNC-ED-CS-A and IS            P.O. Box 1600            Huntsville AL 35807            Telephone: 256-895-1673/1672/1535</p>	<p><u>Child Development Center- Infant/Toddler</u>  <u>Child Development Center Playground</u>  <u>Child Development Center-6 to 10 Years Old</u>  <u>Physical Fitness Facilities</u>  <u>Fire Station</u>  <u>Hazardous Material Storage Facility</u>  <u>Outdoor Sports Facility</u>  <u>Close Combat Tactical Trainer</u>  <u>Military Operations Urban Terrain (MOUT) Facility</u>  <u>Training Range</u>  <u>Youth Activity Center</u></p>
<p><u><a href="#">U.S. Army Engineer District, Louisville</a></u>            ATTN: CENWO-ED-DG/PM-M            803 Front Street            Norfolk, VA 23510            Telephone: (757) 441-7702</p>	<p><u>Army Reserve Center/National Guard Armory</u>  <u>Bowling Center (RFP)</u></p>
<p><u><a href="#">U.S. Army Engineer District, Norfolk</a></u>            ATTN: CENAO-TS-EA            803 Front Street            Norfolk, VA 23510  <b>Telephone: 757-441-7702</b></p>	<p><u>Classroom 21</u>  <u>Criminal Investigation Facility (CIDC)</u>  <u>Enlisted Personnel Dining Facility</u>  <u>Family Housing (RFP)</u>  <u>General Instruction Building</u>  <u>Information Systems Facility</u>  <u>Troop Issue Subsistence Activity Facility (TISA)</u></p>

<p><b><u>U.S. Army Engineer District, Omaha</u></b>  ATTN: CENWO-ED-DG/PM-M  215 North 17th Street  Omaha, NE 68102  <b>Telephone: 402-221-4552/4434</b></p>	<p><u>Army Chapel</u>  <u>Chapel Family Life Center</u>  <u>Religious Education Facility</u>  <u>Small Site Chapel</u></p>
<p><b><u>U.S. Army Engineer District, Sacramento</u></b>  ATTN: CESPKE-ED-M  1325 J Street  Sacramento, CA 95814  <b>Telephone: 916-557-7412</b></p>	<p><u>Brigade/Battalion HQ</u>  <u>Two Story Battalion HQ</u></p>
<p><b><u>U.S. Army Engineer District Savannah</u></b>  ATTN: CESAS-EN-E  P.O. Box 889  Savannah, GA 31402  <b>Telephone: 912-652-5212</b></p>	<p><u>Company Operations Facility</u>  <u>Military Entrance Processing Station</u>  <u>(MEPS)</u>  <u>Tactical Equipment Maintenance</u>  <u>Facility (TEMF)</u>  Unaccompanied Enlisted Personnel  Housing (UEPH)  <u>New &amp; Modernization</u></p>
<p><b><u>U.S. Army Engineer District, Seattle</u></b>  4735 E. Marginal Way  Seattle, WA 98124  <b>Telephone:</b></p>	<p><u>Central Issue Facility</u>  <u>General Purpose Warehouse</u></p>
<p><b><u>U.S. Army Engineer District, Tulsa</u></b>  ATTN: CESWT-EC-D  1645 S. 101ST East Avenue  Tulsa, OK 74128  <b>Telephone: 918-669-7033</b></p>	<p><u>One Station Unit Training (OSUT)</u>  <u>Barracks</u>  <u>Advanced Individual Training (AIT)</u>  <u>Barracks</u>  <u>Base Combat Trainee (BCT)</u>  <u>Unaccompanied Officer Quarters</u>  <u>Unaccompanied Officer Quarters,</u>  <u>Transient</u></p>



## APPENDIX Q – STANDARDS AND REFERENCES

**Include in FINAL DRAFT**