

DROIGSA-08-0021  
INTERGOVERNMENTAL SERVICE AGREEMENT  
BETWEEN THE  
UNITED STATES DEPARTMENT OF HOMELAND SECURITY  
U.S. IMMIGRATION AND CUSTOMS ENFORCEMENT  
AND  
Town of Farmville

---

This Intergovernmental Service Agreement ("Agreement") is entered into between United States Department of Homeland Security Immigration and Customs Enforcement ("ICE"), and the Town of Farmville ("Service Provider") for the detention and care of aliens ("detainees"). The term "Parties" is used in this Agreement to refer jointly to ICE and the Service Provider.

**FACILITY LOCATION:**

The Service Provider shall provide detention services for detainees at the following institution(s):

**Town of Farmville**  
116 North Main Street  
Farmville, Virginia 23901

The following constitute the complete agreement:

- INTERGOVERNMENTAL SERVICE AGREEMENT (IGSA)
- PROPOSAL, DATED \_\_\_\_\_ (Incorporated by reference)
- ATTACHMENT 1--STATEMENT OF WORK
- ATTACHMENT 2--QUALITY CONTROL PLAN
- ATTACHMENT 3--QUALITY ASSURANCE SURVEILLANCE PLAN (w/ PRS, CDR and PMT)
- ATTACHMENT 4--STAFFING PLAN
- ATTACHMENT 5--LABOR STANDARDS
- ATTACHMENT 6--WAGE DETERMINATION Number \_\_\_\_\_ Dated \_\_\_\_\_

**IN WITNESS WHEREOF**, the undersigned, duly authorized officers, have subscribed their names on behalf of the Town of Farmville and Department of Homeland Security, U.S. Immigration and Customs Enforcement.

**ACCEPTED:**

U.S. Immigration and Customs Enforcement

Jerald Neveleff  
Contracting Officer

Print Name: Jerald Neveleff  
Date: 15 Sept 08

**ACCEPTED:**

Town of Farmville

Gerald J. Spates  
Town Manager

Print Name: GERALD J. SPATES  
Date: 9/9/08

## Article I. Purpose

- A. **Purpose:** The purpose of this Intergovernmental Service Agreement (IGSA) is to establish an Agreement between ICE and the Service Provider for the detention and care of persons detained under the authority of Immigration and Nationality Act, as amended. All persons in the custody of the ICE are "Administrative Detainees". This term recognizes that ICE detainees are not charged with criminal violations and are only held in custody to assure their presence throughout the administrative hearing process and to assure their presence for removal from the United States pursuant to a lawful final order by the Immigration Court, the Board of Immigration Appeals or other Federal judicial body.
- B. **Responsibilities:** This Agreement sets forth the responsibilities of ICE and the Service Provider. The Agreement states the services the Service Provider shall perform satisfactorily to receive payment from ICE at the rate prescribed in Article I, C.
- C. **Guidance:** This is a fixed rate agreement, not a cost reimbursable agreement, with respect to the detainee day rate. The detainee daily rate is \$TBD. ICE shall be responsible for reviewing and approving the costs associated with this Agreement and subsequent modifications utilizing all applicable federal procurement laws, regulations and standards in arriving at the detainee day rate.

## Article II. General

- A. **Funding:** The obligation of ICE to make payments to the Service Provider is contingent upon the availability of Federal funds. ICE will neither present detainees to the Service Provider nor direct performance of any other services until ICE has the appropriate funding. Orders will be placed under this Agreement when specific requirements have been identified and funding obtained. Performance under this Agreement is not authorized until the Contracting Officer issues an order, in writing. The effective date of the Agreement will be negotiated and specified in an order to this Agreement by the Contracting Officer. This Agreement is neither binding nor effective unless signed by the Contracting Officer. Payments at the approved rate will be paid upon the return of the signed Agreement by the authorized Local Government official to ICE.
- B. **Subcontractors:** The Service Provider shall notify and obtain approval from the Contracting Officer if it intends to house detainees in a facility other than the Facility named in this Agreement. If either that facility or any future facility is operated by an entity other than the Service Provider, ICE shall treat the entity as a subcontractor to the Service Provider. The Service Provider shall obtain the Contracting Officer's approval before subcontracting the detention and care of detainees to another entity. The Contracting Officer has the right to deny, withhold, or withdraw approval of the proposed subcontractor. Upon approval by the Contracting Officer, the Service Provider shall ensure that any subcontract includes all provisions of this Agreement, and shall provide ICE with copies of all subcontracts. All payments will be made to the Service Provider. ICE will not accept invoices from, or make payments to a subcontractor.
- C. **Consistent with Law:** This is a firm fixed rate agreement, not cost reimbursable agreement. This Agreement is permitted under applicable statutes, regulation, policies or

judicial mandates. Any provision of this Agreement contrary to applicable statutes, regulation, policies or judicial mandates is null and void and shall not necessarily affect the balance of the Agreement.

- D. **Use of Service Provider's Policies and Procedures:** The Contracting Officer shall approve Service Provider's policies and procedures for use under this Agreement. Upon approval, the Service Provider can use its policies and procedures in conjunction with the detention standards mandated under this Agreement.
- E. **Notification and Public Disclosure:** No public disclosures (i.e. press releases, press conferences) regarding this IGSA shall be made by the Service Provider or any of its contractors or subcontractors without the review and approval of such disclosure by ICE Public Affairs and express permission granted by the ICE Contracting Officer.

### **Article III. Covered Services**

Below are the general requirements under this Agreement. Specific requirements for the services under this Agreement are stated in the attached Statement of Work. See Attachment 1.

- A. **Bedspace:** The Service Provider shall provide male/female beds on a space available basis. The Service Provider shall house all detainees as determined within the Service Provider's classification system.
- B. **Basic Needs:** The Service Provider shall provide detainees with safekeeping, housing, subsistence, medical and other services in accordance with this Agreement. In providing these services, the Service Provider shall ensure compliance with all applicable laws, regulations, fire and safety codes, policies and procedures. If the Service Provider determines that ICE has delivered a person for custody who is under the age of eighteen (18), the Service Provider shall not house that person with adult detainees and shall immediately notify the Contracting Officer's Technical Representative (COTR).
- C. **Interpretive Services:** The Service Provider shall make special provisions for non-English speaking, handicapped or illiterate detainees. ICE will reimburse the Service Provider for the actual costs associated with providing commercial written or telephone language interpretive services. Upon request, ICE will assist the Service Provider in obtaining translation services. The Service Provider shall provide all instructions verbally either in English or the detainees' language, as appropriate, to detainees who cannot read. The Service Provider shall include the actual costs that the Service Provider paid for such services on its monthly invoice. Except in emergency situations, the Service Provider shall not use detainees for translation services. If the Service Provider uses a detainee for translation service, it shall notify ICE within 24 hours of the translation service.
- D. **Escort and Transportation Services:** The Service Provider will provide, upon request and as scheduled by the Contracting Officer's Technical Representative (COTR) or Contracting Officer (CO), necessary escort and transportation services for detainees to and from designated locations. Escort services will be required for escorting detainees to court hearings; escorting witnesses to the courtroom and any escort services as requested by an ICE judge during proceedings. Escort and transportation services shall also include

providing all such air and/or ground transportation services as may be required to transport detainees securely and in a timely manner. Transportation and/or escort services may be required to transport detainees from the Facility to and from a medical facility for outpatient care. During all transportation activities, at least one (1) transportation officer shall be of the same sex as the detainees being transported. The Service Provider shall use a communications system that has direct and immediate contact with all transportation vehicles. Transportation and escort services shall be provided in the most economical and efficient manner. The Service Provider personnel provided for these services shall be of the same qualifications, receive training, complete the same security clearances, and wear the same uniforms as those personnel provided for in other areas of this Agreement. The Statement of Work shall provide specific escort and transportation services unique for this Agreement.

E. **Guard Services:** The Service Provider agrees to provide stationary guard services on demand by the COTR or Contracting Officer and shall include, but are not limited to, escorting and guarding detainees to medical or doctor's appointments, hearings, ICE interviews, and any other location requested by the COTR. Qualified personnel employed by the Service Provider will perform such services. The Service Provider agrees to augment such practices as may be requested by ICE to enhance specific requirements for security, detainee monitoring, visitation, and contraband control. Public contact is prohibited unless authorized in advance by the COTR or Contracting Officer. The Service Provider shall be authorized to provide at least two (2) officers for each remote post, as directed by the COTR or Contracting Officer.

F. **Medical Services:** The Statement of Work shall provide specific medical service requirements unique to this Agreement. Regardless of the unique requirements for this contract, the Service Provider shall provide the following services regarding medical care of detainees:

- 1) The Service Provider shall provide for medical screening of every detainee upon arrival at the Facility performed by health care personnel or health trained personnel.
- 2) Medical coverage at the Facility shall be no less than twenty-four (24) hours per day, seven (7) days per week.
- 3) The Service Provider shall provide the detainees written instructions for gaining access to health care services. Procedures shall be explained to all detainees in the detainees' native language, and orally to detainees' who are unable to read. The detainee shall similarly be provided instructions and assistance in personal hygiene, dental hygiene, grooming and health care. It shall be made routinely available.
- 4) The Service Provider shall provide to all detainees a written policy and defined procedure to require that detainee's written health complaints are solicited and delivered to the medical facility for appropriate follow-up. Written policy and defined procedure shall require that health care complaints are responded to and that sick call, conducted by health care personnel or health trained personnel is available to detainees daily. If a detainee's custody status precludes attendance at sick call, arrangements shall be made to provide sick call services in the place of the detainee's detention. A minimum of one sick call shall be conducted daily.

USPHS reserves the right to conduct triage and sick call in the place of the detainee's detention.

- 5) The Service Provider shall provide and maintain basic first aid kits throughout the Facility. First aid kits shall be available at all times to allow quick access.
- 6) The Service Provider shall provide security with a minimum of a staff of one at all times. When detainees are housed in the infirmary, a security guard shall be posted to the unit 24 hours a day, seven days a week. The Service Provider shall coordinate and escort detainees to the medical clinic for sick call, appointments and pill line.
- 7) When communicable or debilitating physical problems are suspected, the detainee shall be separated from the detainee population, and immediately notify USPHS staff. Behavioral problems (detainee who is not diagnosed as psychotic) and suicide observation will be the responsibility of the Service Provider.

#### **Article IV. Receiving and Discharging Detainees**

- A. **Required Activity:** The Service Provider shall receive and discharge detainees only to and from properly identified ICE personnel or other properly identified Federal law enforcement officials with prior authorization from DHS/ICE. Presentation of U.S. Government identification shall constitute "proper identification." The Service Provider shall furnish receiving and discharging services twenty-four (24) hours per day, seven (7) days per week. ICE shall furnish the Service Provider with reasonable notice of receiving and discharging detainees. The Service Provider shall ensure positive identification and recording of detainees and ICE officers. The Service Provider shall not permit medical or emergency discharges except through coordination with on-duty ICE officers.
- B. **Restricted Release of Detainees:** The Service Provider shall not release detainees from its physical custody to any persons other than those described in Paragraph A of Article IV for any reason, except for either medical, other emergency situations, or in response to a federal writ of habeas corpus. If a detainee is sought for federal, state, or local proceedings, only ICE may authorize release of the detainee for such purposes. The Service Provider shall contact the COTR immediately regarding any such requests.
- C. **Service Provider Right of Refusal:** The Service Provider retains the right to refuse acceptance or request removal of any detainee exhibiting violent or disruptive behavior, or of any detainee found to have a medical condition that requires medical care beyond the scope of the Service Provider's health care provider. In the case of a detainee already in custody, the Service Provider shall notify ICE and request removal of the detainee from the Facility. The Service Provider shall allow ICE reasonable time to make alternative arrangements for the detainee.
- D. **Emergency Evacuation:** In the event of an emergency requiring evacuation of the Facility, the Service Provider shall evacuate detainees in the same manner, and with the same safeguards, as it employs for persons detained under the Service Provider's authority. The Service Provider shall notify the Contracting Officer and COTR within two (2) hours of evacuation.

#### **Article V. ICE National Detention Standards**

- A. The Service Provider is required to house detainee and perform related detention services in accordance with the most current edition of the ICE National Detention Standards found within the ICE Detention Operations Manual. This manual can be found at <http://www.ice.gov/partners/dro/opsmanual/index>. ICE Inspectors will conduct periodic inspections of the facility to assure compliance with the ICE National Detention Standards.
- B. The Service Provider shall certify to the Contracting Officer and COTR that its personnel have completed all training as required by the ICE Detention Operations Manual, the Service Provider's own manual (if it is approved for use by the Contracting Officer), and any additional training as required in any manuals or detention standards referenced in this Agreement.

#### **Article VI. No Employment of Unauthorized Aliens**

Subject to existing laws, regulations, Executive Orders, and addenda to this Agreement, the Service Provider shall not employ aliens unauthorized to work in the United States. Except for maintaining personal living areas, detainees shall not be required to perform manual labor.

#### **Article VII. Period of Performance**

This Agreement shall become effective upon the date of final signature by the ICE Contracting Officer and the authorized signatory of the Service Provider and will remain in effect for a period not to exceed sixty (60) months, unless terminated in writing, by either party. Either party must provide written notice of intentions to terminate the agreement, 60 days in advance of the effective date of formal termination, or the Parties may agree to a shorter period under the procedures prescribed in Article X.

#### **Article VIII. Inspections**

The Facility and Provider's services shall be inspected in accordance with the following procedures:

- A. Definitions. "Services," as used in this clause, includes services performed, workmanship, and material furnished or utilized in the performance of services.
- B. The Provider shall provide and maintain an inspection system acceptable to the Government covering the services under this agreement. Complete records of all inspection work performed by the Provider shall be maintained and made available to the Government during contract performance and for as long afterwards as the agreement requires.
- C. The Government has the right to inspect and test all services called for by the agreement, to the extent practicable at all times and places during the term of the agreement. The Government shall perform inspections and tests in a manner that will not unduly delay the work.

- D. If the Government performs inspections or tests on the premises of the Provider or a subcontractor, the Provider shall furnish, and shall require subcontractors to furnish, at no increase in agreement price, all reasonable facilities and assistance for the safe and convenient performance of these duties.
- E. If any of the services do not conform to agreement requirements, the Government may require the Provider to perform the services again in conformity with agreement requirements, at no increase in agreement amount. When the defects in services cannot be corrected by re-performance, the Government may (1) require the Provider to take necessary action to ensure that future performance conforms to agreement requirements and (2) reduce the agreement price to reflect the reduced value of the services performed.
- F. If the Provider fails to promptly perform the services again or to take the necessary action to ensure future performance in conformity with agreement requirements, the Government may (1) by contract or otherwise, perform the services and charge to the Provider any cost incurred by the Government that is directly related to the performance of such service or (2) terminate the agreement for default.

#### **Article IX. Inspection Reports**

- A. **Inspection Report:** The Inspection Report stipulates minimum requirements for fire/safety code compliance, supervision, segregation, sleeping utensils, meals, medical care, confidential communication, telephone access, legal counsel, legal library, visitation, and recreation. The Service Provider shall allow ICE to conduct inspections of the facility, as required, to ensure an acceptable level of services and acceptable conditions of confinement as determined by ICE. No notice to the Service Provider is required prior to an inspection. ICE will conduct such inspections in accordance with the Inspection Report. ICE will share findings of the inspection with the Service Provider's facility administrator. The Inspection Report will state any improvements to facility operation, conditions of confinement, and level of service that will be required by the Service Provider.
- B. **Possible Termination:** If the Service Provider fails to remedy deficient service ICE identifies through inspection, ICE may terminate this Agreement without regard to the provisions of Articles VII and X.
- C. **Share Findings:** The Service Provider shall provide ICE copies of facility inspections, reviews, examinations, and surveys performed by accreditation sources.
- D. **Access to Detainee Records:** The Service Provider shall, upon request, grant ICE access to any record in its possession, regardless of whether the Service Provider created the record, concerning any detainee held pursuant to this Agreement. This right of access shall include, but is not limited to, incident reports, records relating to suicide attempts, and behavioral assessments and other records relating to the detainee's behavior while in the Service Provider's custody. Furthermore, the Service Provider shall retain all records where this right of access applies for a period of two (2) years from the date of the detainee's discharge from the Service Provider's custody.

## **Article X. Modifications and Disputes**

- A. **Modifications:** Actions other than those designated in this Agreement will not bind or incur liability on behalf of either Party. Either Party may request a modification to this Agreement by submitting a written request to the other Party. A modification will become a part of this Agreement only after the ICE Contracting Officer and the authorized signatory of the Service Provider have approved the modification in writing.
- B. **Disputes:** The ICE Contracting Officer and the authorized signatory of the Service Provider will settle disputes, questions and concerns arising from this Agreement. Settlement of disputes shall be memorialized in a written modification between the ICE Contracting Officer and authorized signatory of the Service Provider. In the event a dispute is not able to be resolved between the Service Provider and the ICE Contracting Officer, the ICE Contracting Officer will make the final decision. If the Service Provider does not agree with the final decision, the matter may be appealed to the ICE Head of the Contracting Activity (HCA) for resolution. The ICE HCA may employ all methods available to resolve the dispute including alternative dispute resolution techniques. The Service Provider shall proceed diligently with performance of this Agreement pending final resolution of any dispute.

## **Article XI. DETAINEE DAY RATE and ADJUSTMENT to the DAY RATE**

- A. **Detainee Day Rate:** In consideration for the Service Provider's performance under this Agreement, ICE shall make payment to the Service Provider for each detainee accepted and housed by the Service Provider. This "detainee day rate" is a per diem rate for the support of one Detainee per day and shall include the day of arrival but not the day of departure.
- B. The detainee day rate is TBD.
- C. The Service Provider, by execution of this Agreement, certifies that the pricing established under this agreement is in compliance with OMB Circular A-87 and includes only allowable costs of performance under this agreement.
- D. **Basis for Price Adjustment:** A firm fixed price with economic adjustment provides for upward and downward revision of the stated Per Diem based upon cost indexes of labor and operating expenses, or based upon the Service Provider's actual cost experience in providing the service.
- E. ICE shall reimburse the Service Provider at the fixed detainee day rate shown on the cover page of the document, Article I. (C). The Parties may adjust the rate twelve (12) months after the effective date of the agreement and no sooner than every twelve (12) months. The Parties shall base the cost portion of the rate adjustment on the principles of allowability and allocability as set forth in OMB Circular A-87, federal procurement laws, regulations, and standards in arriving at the detainee day rate. The request for adjustment shall be submitted on an ICE Jail Services Cost Statement. If ICE does not receive an official request for a detainee day rate adjustment that is supported by an ICE Jail Services Cost Statement, the detainee day rate as stated in this Agreement will control.



- F. ICE reserves the right to audit the actual and/or prospective costs upon which the rate adjustment is based. All rate adjustments are prospective. As this is a fixed rate agreement, there are no retroactive adjustment(s).
- G. Guard and transportation services shall be denoted as separate items on submitted invoices. ICE agrees to reimburse the Service Provider for actual stationary guard services provided at a negotiated rate of \$24.28. Transportation mileage reimbursable rates will be commensurate with current applicable federal travel allowance rates. Any additional operational costs will be reimbursed at the negotiated rate identified in the task order (HSCEDM-08-F-IG064). The additional items shall also be billed as separate line items until modified in the task order.

## Article XII. Enrollment, Invoicing, and Payment

- A. Enrollment in Electronic Funds Transfer: The Service Provider shall provide ICE with the information needed to make payments by electronic funds transfer (EFT). Since January 1, 1999, ICE makes all payments only by EFT. The Service Provider shall identify their financial institution and related information on Standard Form 3881, Automated Clearing House (ACH) Vendor Miscellaneous Payment Enrollment Form. The Service Provider shall submit a completed SF 3881 to ICE payment office prior to submitting its initial request for payment under this Agreement. If the EFT data changes, the Service Provider shall be responsible for providing updated information to the ICE payment office.
- B. Invoicing: The Service Provider shall submit an original itemized invoice containing the following information: the name and address of the facility; the name of each ICE detainee; detainee's A-number; specific dates of detention for each detainee; the total number of detainee days; the daily rate; the total detainee days multiplied by the daily rate; an itemized listing of all other charges; and the name, title, address, and phone number of the local official responsible for invoice preparation. For stationary guard services, the itemized monthly invoice shall state the number of hours being billed, the duration of the billing (times and dates) and the name of the detainee(s) that was guarded. The Service Provider shall submit monthly invoices within the first ten (10) working days of the month following the calendar month when it provided the services, to:

Department of Homeland Security  
ATTN: Immigration and Customs Enforcement  
Contracting Officer's Technical Representative (COTR)  
2675 Property Avenue  
Fairfax, Va. 22031  
Phone: 703-285 (b)(2)Low  
Fax: 703-285 (b)(2)Low

- C. Payment: ICE will transfer funds electronically through either an Automated Clearing House subject to the banking laws of the United States, or the Federal Reserve Wire Transfer System. The Prompt Payment Act applies to this Agreement. The Prompt Payment Act requires ICE to make payments under this Agreement the thirtieth (30<sup>th</sup>) calendar day after the ICE Deportation office receives a complete invoice. Either the date

on the Government's check, or the date it executes an electronic transfer of funds, shall constitute the payment date. The Prompt Payment Act requires ICE to pay interest on overdue payments to the Service Provider. ICE will determine any interest due in accordance with the Prompt Payment Act.

#### **Article XIII. Government Furnished Property**

- A. **Federal Property Furnished to the Service Provider:** ICE may furnish Federal Government property and equipment to the Service Provider. Accountable property remains titled to ICE and shall be returned to the custody of ICE upon termination of the Agreement. The suspension of use of bed space made available to ICE is agreed to be grounds for the recall and return of any or all government furnished property.
- B. **Service Provider Responsibility:** The Service Provider shall not remove ICE property from the facility without the prior written approval of ICE. The Service Provider shall report any loss or destruction of any Federal Government property immediately to ICE.

#### **Article XIV. Hold Harmless and Indemnification Provisions**

- A. **Service Provider Held Harmless:** ICE shall, subject to the availability of funds, save and hold the Service Provider harmless and indemnify the Service Provider against any and all liability claims and costs of whatever kind and nature, for injury to or death of any person(s), or loss or damage to any property, which occurs in connection with or is incident to performance of work under the terms of this Agreement, and which results from negligent acts or omissions of ICE officers or employees, to the extent that ICE would be liable for such negligent acts or omissions under the Federal Tort Claims Act, 28 USC 2691 *et seq.*
- B. **Federal Government Held Harmless:** The Service Provider shall save and hold harmless and indemnify federal government agencies to the extent allowed by law against any and all liability claims, and costs of whatsoever kind and nature for injury to or death of any person or persons and for loss or damage to any property occurring in connection with, or in any way incident to or arising out of the occupancy, use, service, operation or performance of work under the tenets of this Agreement, resulting from the negligent acts or omissions of the Service Provider, or any employee, or agent of the Service Provider. In so agreeing, the Service Provider does not waive any defenses, immunities or limits of liability available to it under state or federal law. The Service Provider agrees to hold harmless and indemnify DHS/ICE and its officials in their official and individual capacities from any liability, including third-party liability or worker's compensation, arising from the conduct of the Service Provider and its employees during the course of transporting detainees on behalf of ICE.
- C. **Defense of Suit:** In the event a detainee files suit against the Service Provider contesting the legality of the detainee's incarceration and/or immigration/citizenship status, ICE shall request that the U.S. Attorney's Office, as appropriate, move either to have the Service Provider dismissed from such suit, to have ICE substituted as the proper party defendant; or to have the case removed to a court of proper jurisdiction. Regardless of the decision on any such motion, ICE shall request that the U.S. Attorney's Office be responsible for the defense of any suit on these grounds.

- D. **ICE Recovery Right:** The Service Provider shall do nothing to prejudice ICE's right to recover against third parties for any loss, destruction of, or damage to U.S. Government property. Upon request of the Contracting Officer, the Service Provider shall, at ICE's expense, furnish to ICE all reasonable assistance and cooperation, including assistance in the prosecution of suit and execution of the instruments of assignment in favor of ICE in obtaining recovery.

#### **Article XV. IGSA/Financial Records**

- A. **Retention of Records:** All IGSA and financial records including, but not limited to, supporting documents, statistical records, and other records, pertinent contracts, or subordinate agreements under this Agreement shall be retained by the Service Provider for three (3) years after the expiration of the Agreement for purposes of federal examinations and audit. If any litigation, claim, negotiation, audit, or other action involving the records has been started before the expiration of the three (3) year period, the records must be retained until completion of the action and resolution of all issues which arise from it or until the end of the regular three (3) year period, whichever is later.
- B. **Access to Records:** ICE and the Comptroller General of the United States, or any of their authorized representatives, shall have the right of access to any pertinent books, documents, papers or other records of the Service Provider or its sub-contractors, which are pertinent to the award, in order to make audits, examinations, excerpts, and transcripts. The rights of access must not be limited to the required retention period, but shall last as long as the records are retained.
- C. **Delinquent Debt Collection:** ICE will hold the Service Provider accountable for any overpayment, or any breach of this Agreement that results in a debt owed to the Federal Government. ICE shall apply interest, penalties, and administrative costs to a delinquent debt owed to the Federal Government by the Service Provider pursuant to the Debt Collection Improvement Act of 1982, as amended.

#### **Article XVI. Detainee Telephone Services (DTS)**

- A. The **PROVIDER** shall provide detainees with reasonable and equitable access to telephones as specified in ICE National Detention Standards on Telephone Access. Telephones shall be located in an area that provides for a reasonable degree of privacy and a minimal amount of environmental noise during phone calls.
- B. If authorized to do so under applicable law, the **PROVIDER** shall monitor and record detainee conversations. If detainee telephone conversations can be monitored under applicable law, the **PROVIDER** shall provide notice to detainees of the potential for monitoring. However, the **PROVIDER** shall also provide procedures at the facility for detainees to be able to place unmonitored telephone calls to their attorneys.
- C. Telephone rates shall not exceed the dominant carrier tariff rate and shall conform to all applicable federal, state, and local telephone regulations.

- D. The ICE designated DTS Contractor will be the exclusive provider of detainee telephones for this facility. The DTS Contractor shall be allowed to install vending debit machines and shall receive 100 percent of all revenues collected by sale of prepaid debit services. The DTS Contractor shall be responsible for furnishing all inventory and supply of prepaid debit cards to the PROVIDER. The DTS Contractor shall be responsible for the costs incurred for installation of the equipment, any monthly telephone charges incurred from the operation of DTS, and the maintenance and operation of the system. The PROVIDER will not be entitled to any commissions, fees, or revenues generated by the use of the DTS or the detainee telephones.
- E. The PROVIDER shall inspect telephones for serviceability, in accordance with ICE policies and procedures. The PROVIDER will notify the COTR or ICE designees of any inoperable telephones.

**Article XVII. Maintain Institutional Emergency Readiness**

- A. The Service Provider shall submit an institutional emergency plan that will be operational prior to start of the Agreement. The plan shall receive the concurrence of the Contracting Officer prior to implementation and shall not be modified without the further written concurrence of the Contracting Officer.
- B. The Service Provider shall have written agreements with appropriate state and local authorities that will allow the Service Provider to make requests for assistance in the event of any emergency incident that would adversely affect the community.
- C. Likewise, the Service Provider shall have in place, an internal corporate nation-wide staff contingency plan consisting of employees who possess the same expertise and skills required of staff working directly on this agreement. At the discretion of ICE, these employees would be required to respond to an institutional emergency at the Facility, when necessary.
- D. The emergency plans shall include provisions for two or more disturbance control teams. Protective clothing and equipment for each team member and 30 percent of all additional facility staff members shall be provided by the Service Provider, and maintained in a secure location outside the secure perimeter of the facility.
- E. Any decision by ICE or other federal agencies to provide and/or direct emergency assistance will be at the discretion of the Government. The Service Provider shall reimburse the Government for any and all expenses incurred in providing such assistance.
- F. The Contracting Officer and COTR shall be notified immediately in the event of all serious incidents. Serious incidents include, but are not limited to the following: activation of disturbance control team(s); disturbances (including gang activities, group demonstrations, food boycotts, work strikes, work-place violence, civil disturbances/protests); staff use of force including use of lethal and less-lethal force (includes inmates in restraints more than eight hours); assaults on staff/inmates resulting in injuries requiring medical attention (does not include routine medical evaluation after the incident); fights resulting in injuries requiring medical attention; fires; full or partial lock down of the facility; escape; weapons discharge; suicide attempts; deaths; declared

or non-declared hunger strikes; adverse incidents that attract unusual interest or significant publicity; adverse weather (e.g., hurricanes, floods, ice/snow storms, heat waves, tornadoes); fence damage; power outages; bomb threats; central inmate monitoring cases admitted to a community hospital; witness security cases taken outside the facility; significant environmental problems that impact the facility operations; transportation accidents (i.e. airlift, bus) resulting in injuries, death or property damage; and sexual assaults.

- G. Attempts to apprehend the escapee(s) shall be in accordance with the Emergency Plan, which should comply with ICE Detention Operations Manual regarding Emergency Plans.
- H. The Service Provider shall submit to the COTR a proposed inventory of intervention equipment (weapons, munitions, chemical agents, electronics/stun technology, etc.) intended for use during performance of this Agreement. Prior to the start of this Agreement, the Contracting Officer shall approve the intervention equipment. The approved intervention equipment inventory shall not be modified without prior written concurrence of the Contracting Officer.
- I. The Service Provider shall obtain the appropriate authority from state or local law enforcement agencies to use force as necessary to maintain the security of the institution. The use of force by the Provider shall at all times be consistent with all applicable policies of ICE Detention Operations Manual regarding Use of Force.

## **XVIII. Security Requirements**

### **A. GENERAL**

The Department of Homeland Security (DHS), U.S. Immigration and Customs Enforcement (ICE), Office of Professional Responsibility, Personnel Security Unit (DHS-ICE-OPR-PSU, hereinafter OPR-PSU) has determined that performance of the tasks as described in IGSA (Contract) \_\_\_\_\_ requires that the Service Provider (Contractor, subcontractor(s), vendor(s), etc. (herein known as Service Provider) have access to ICE detainees, and that the Service Provider will adhere to the following and shall expressly incorporate this provision into any and all Subcontracts or subordinate agreements issued in support of this Agreement .

### **B. SUITABILITY DETERMINATION**

ICE-OPR-PSU shall have and exercise full control over granting, denying, withholding or terminating unescorted government facility and/or access to ICE detainees, as well as, when applicable, sensitive Government information access for Service Provider employees, based upon the results of a background investigation.

ICE-OPR-PSU may, as it deems appropriate, authorize and make a favorable entry on duty (EOD) decision based on preliminary security checks. The favorable EOD decision would allow the Service Provider employees to commence work temporarily prior to the completion

of the full investigation. The granting of a favorable EOD decision shall not be considered as assurance that a full employment suitability authorization will follow as a result thereof.

The granting of a favorable EOD decision or a full employment suitability determination shall in no way prevent, preclude, or bar the withdrawal or termination of any such access by ICE-OPR-PSU, at any time during the term of the IGSA. No employee of the Service Provider shall be allowed to EOD and/or access facilities or ICE detainees without a favorable EOD decision or suitability determination by OPR-PSU. No employee of the Service Provider shall be allowed unescorted access to a Government facility without a favorable EOD decision or suitability determination by OPR-PSU. Service Provider employees assigned to the IGSA not needing access to ICE detainees or recurring access to DHS-ICE facilities will not be subject to security suitability screening.

Suitability criteria as detailed in ICE Policy Directives that will exclude applicants from consideration to perform under this agreement include, but not limited to:

- Felony convictions, or a conviction for any crime that involves violence
- Conviction of a sex crime
- Offense/s involving a child victim
- Pattern of arrests, without convictions, that brings into question a person's judgment and reliability to promote the efficiency and integrity of the ICE mission.
- Intentional falsification and/or omission of pertinent personal information
- Drug and/or Alcohol Abuse
- Personal conduct to include failure to pay just debts

The process for suitability determination includes, but is not limited to, criminal, employment, citizenship, residential and financial records checks and reviews.

### C. BACKGROUND INVESTIGATIONS

IGSA Service Provider employees (to include applicants, temporaries, part-time and replacement employees) under the contract, needing access to ICE detainees, shall undergo a position sensitivity analysis based on the duties each individual will perform on the contract. The results of the position sensitivity analysis shall identify the appropriate background investigation to be conducted. Background investigations will be processed, managed and conducted under direction of OPR-PSU.

In those cases where prospective IGSA Service Provider employees already have a security clearance issued by the Defense Industrial Security Clearance Office (DISCO), that was granted using an appropriate background investigation, reciprocity may apply in that those prospective employees may not be required to submit complete security packages, as the clearance issued by DISCO may be accepted.

Prospective Service Provider employees without adequate security clearances issued by DISCO shall submit the following completed forms to the Personnel Security Unit through the COTR, no less than 45 days before the starting date of the IGSA (contract), or 45 days prior to the expected entry on duty of any employees, whether a replacement, addition, subcontractor employee, or vendor:

Standard Form 85P, "Questionnaire for Public Trust Positions"  
Form will be submitted via e-QIP (electronic Questionnaires for  
Investigation Processing)  
FD Form 258, "Fingerprint Card" (2 copies)  
Foreign National Relatives or Associates Statement  
DHS 11000-9, "Disclosure and Authorization Pertaining to Consumer Reports Pursuant  
to the Fair Credit Reporting Act"  
Drug Questionnaire  
Alcohol Questionnaire

Details regarding the required forms will be provided by ICE-OPR. Only complete packages will be accepted by OPR-PSU. Specific instructions on submission of packages will be provided by OPR-PSU.

**PLEASE NOTE:** Unless an applicant has resided in the US for three of the past five years, with few exceptions such as military or other federal service overseas, the Government may not be able to complete a satisfactory background investigation. In such cases, OPR-PSU retains the right to deem an applicant as ineligible due to insufficient background information.

#### D. SUITABILITY – RETROACTIVE EFFECT

Employees of the Service Provider(s) who have not been previously investigated as described under the Background Investigations section, above, must be scheduled not later than six months after implementation of this IGSA. Employees of the Service Provider(s) may continue to work while the investigation is in progress.

#### E. CONTINUED ELIGIBILITY

If a prospective Service Provider employee is found to be ineligible for access to Government facilities or information, the COTR will advise the Service Provider that the employee shall not continue to work or to be assigned to work under the contract.

The OPR-PSU may require drug screening for probable cause at any time and/ or when the contractor independently identifies, circumstances where probable cause exists.

The OPR-PSU may require reinvestigations when derogatory information is received and/or every 10 years.

ICE-OPR reserves the right and prerogative to deny and/ or restrict the facility and information access of any Service Provider employee whose actions are in conflict with the standards of conduct as detailed in 5 CFR 2635 and 5 CFR 3801, or whom ICE-OPR-PSU determines to present a risk of compromising ICE standards and conduct, including sensitive Government information, to which he or she would have access under this contract.

The Service Provider will report any adverse information coming to their attention concerning contract employees under the IGSA to OPR-PSU through the COTR. Reports based on rumor or innuendo should not be made. The subsequent termination of employment of an employee does not obviate the requirement to submit this report. The

report shall include the employees' name and social security number, along with the adverse information being reported.

OPR-PSU must be notified of all terminations/ resignations within five days of occurrence.

If applicable, the Service Provider will return any expired ICE-DRO owned employee identification cards and/or building passes, or those of employees terminated and/or removed from the IGSA to the COTR within five (5) workdays. If an identification card or building pass is not available to be returned, a report must be submitted to the COTR, referencing the pass or card number, name of individual to whom issued, the last known location and disposition of the pass or card. The COTR will return the identification cards and building passes to the responsible ID Unit.

#### **F. EMPLOYMENT ELIGIBILITY**

The Service Provider must agree that each employee working on this IGSA will have a Social Security Card issued and approved by the Social Security Administration.

The Service Provider shall be responsible to the Government for acts and omissions of his own employees and for any Subcontractor(s) and their employees.

ICE-DRO has determined that employment on this IGSA (Contract) shall be limited to U.S. Citizens, Lawful Permanent Residents and Conditional Permanent Residents.

Subject to existing law, regulations and/ or other provisions of this IGSA, illegal or undocumented aliens will not be employed by the Service Provider, or with this IGSA. Service Provider will ensure that this provision is expressly incorporated into any and all Subcontracts or subordinate agreements issued in support of this IGSA.

#### **G. SECURITY MANAGEMENT**

The Service Provider shall appoint a senior official to act as the Corporate Security Officer. The individual will interface with the OPR-PSU through the COTR on all personnel security matters and if applicable, information security matters.

The COTR and OPR-PSU shall have the right to inspect the procedures, methods, and facilities utilized by the Service Provider in complying with the security requirements under this contract. Should the COTR determine that the Service Provider is not complying with the security requirements of this contract, the Service Provider will be informed in writing by the Contracting Officer of the proper action to be taken in order to effect compliance with such requirements. Copies of these communications by both the

Contracting Officer and the Service Provider shall be provided to OPR-PSU.

#### **H. INFORMATION TECHNOLOGY SECURITY**

Should the scope of the work change to require IGSA Service Provider personnel to access DHS-ICE IT systems, DHS IT Management Directives preclude routine access to any DHS



ICE IT systems, to include those utilized by ICE-DRO, by Non-U.S. citizens, including Lawful Permanent Residents (LPRs).

The following computer security requirements apply to both Department of Homeland Security (DHS) operations and to the former Immigration and Naturalization Service operations (FINS). These entities are hereafter referred to as the Department.

#### I. INFORMATION TECHNOLOGY SECURITY CLEARANCE

When sensitive government information is processed on Department telecommunications and automated information systems, the Contractor agrees to provide for the administrative control of sensitive data being processed and to adhere to the procedures governing such data as outlined in *DHS IT Security Program Publication DHS MD 4300.Pub. or its replacement*. Contractor personnel must have favorably adjudicated background investigations commensurate with the defined sensitivity level.

Contractors who fail to comply with Department security policy are subject to having their access to Department IT systems and facilities terminated, whether or not the failure results in criminal prosecution. Any person who improperly discloses sensitive information is subject to criminal and civil penalties and sanctions under a variety of laws (e.g., Privacy Act).

#### XIX. Accreditation

The Service Provider will have eighteen (18) months from commencement of this Agreement to become ACA accredited. The Service Provider shall, within nine (9) months from the date this facility becomes operational, formally apply for accreditation to the American Correctional Association. The Service Provider shall provide the Contracting Officer with written proof of such application to ICE within five (5) days of the application. The Service Provider shall provide the Contracting Officer with written proof of its accreditation within five (5) days of notification of its accreditation.

#### XX. Quality Control

- A. The Service Provider shall establish and maintain a complete Quality Control Program (QCP) acceptable to the Contracting Officer ("CO"), in consultation with the Contracting Officer's Technical Representative ("COTR") to assure the requirements of this Agreement are provided as specified in the Performance Requirement Summary (PRS)—Attachment 3.

The QCP shall:

1. Be implemented prior to the start of performance.
2. Provide quality control services that cover the scope of the IGSA and implement proactive actions to prevent non-performance issues.

- B. A complete QCP addressing all areas of agreement performance shall be submitted to the COTR no later than 30 days after the Agreement effective date. All proposed changes to the QCP must be approved by the Contracting Officer. The Service Provider shall submit a resume of the proposed individual(s) responsible for the QCP to the CO for approval. The Service Provider shall not change the individual(s) responsible for the QCP without prior approval of the Contracting Officer.
- C. The QCP shall include, at a minimum:
1. Specific areas to be inspected on either a scheduled or unscheduled basis and the method of inspection.
  2. Procedures for written and verbal communication with the Government regarding the performance of the Agreement.
  3. Specific surveillance techniques for each service identified in the Agreement and each functional area identified in the PRS.
  4. The QCP shall contain procedures for investigation of complaints by the Service Provider and Government staff and feedback to the Government on the actions taken to resolve such complaints.
- D. A file of all inspections, inspection results, and any corrective action required, shall be maintained by the Service Provider during the term of this Agreement. The Service Provider shall provide copies of all inspections, inspection results, and any corrective action taken to the COTR and Contracting Officer.
- E. Failure by the Service Provider to maintain adequate quality control can result in monetary deductions based upon the schedule of deductions incorporated herein.

#### **XXI. Contracting Officer's Technical Representative**

The Contracting Officer's Technical Representative (COTR) shall be designated by the Contracting Officer. When and if the COTR duties are reassigned, an administrative modification will be issued to reflect the changes. This designation does not include authority to sign contractual documents or to otherwise commit to, or issue changes, which could affect the price, quantity, or performance of this Agreement.

#### **XXII. Labor Standards and Wage Determination**

- A. The Service Contract Act, 41 U.S.C. 351 et seq., Title 29, Part 4 Labor Standards for Federal Service Contracts, is here by incorporated into this Agreement at Attachment 5. These standards and provisions are included in every contract over \$2,500, or in an indefinite amount, that is entered into by the United States, the principal purpose of which is to furnish services through the use of service employees.

**B. Wage Determination:** Each service employee employed in the performance of this Agreement shall be paid not less than the minimum monetary wages and shall be furnished fringe benefits in accordance with the wages and fringe benefits determined by the Secretary of Labor or authorized representative, as specified in any wage determination attached to this Agreement at Attachment 6.

\*\*\*\*\*  
END OF DOCUMENT  
\*\*\*\*\*

<b>AMENDMENT OF SOLICITATION/MODIFICATION OF CONTRACT</b>		1. CONTRACT ID CODE	PAGE OF PAGES 1 2
2. AMENDMENT/MODIFICATION NO. P00001	3. EFFECTIVE DATE 09/22/2008	4. REQUISITION/PURCHASE REQ. NO.	5. PROJECT NO. (If applicable)
6. ISSUED BY ICE/Detent Mngt/Detent Contracts-DC Immigration and Customs Enforcement Office of Acquisition Management 425 I Street NW, Suite 2208 Washington DC 20536	CODE ICE/DM/DC-DC	7. ADMINISTERED BY (If other than item 6) ICE/Detent Mngt/Detent Contracts-DC Immigration and Customs Enforcement Office of Acquisition Management 425 I Street NW, Suite 2208 Washington DC 20536	CODE ICE/DM/DC-DC
8. NAME AND ADDRESS OF CONTRACTOR (No, street, county, State and ZIP Code) FARMVILLE TOWN OF P O BOX 368 FARMVILLE VA 239010368		(x) 9A. AMENDMENT OF SOLICITATION NO.	9B. DATED (SEE ITEM 11)
CODE 0401562180000 FACILITY CODE		X 10A. MODIFICATION OF CONTRACT/ORDER NO. DROIGSA-08-0021/	10B. DATED (SEE ITEM 11) 09/22/2008

**11. THIS ITEM ONLY APPLIES TO AMENDMENTS OF SOLICITATIONS**

The above numbered solicitation is amended as set forth in Item 14. The hour and date specified for receipt of Offers  is extended,  is not extended. Offers must acknowledge receipt of this amendment prior to the hour and date specified in the solicitation or as amended, by one of the following methods: (a) By completing Items 8 and 15, and returning \_\_\_\_\_ copies of the amendment; (b) By acknowledging receipt of this amendment on each copy of the offer submitted; or (c) By separate letter or telegram which includes a reference to the solicitation and amendment numbers. FAILURE OF YOUR ACKNOWLEDGEMENT TO BE RECEIVED AT THE PLACE DESIGNATED FOR THE RECEIPT OF OFFERS PRIOR TO THE HOUR AND DATE SPECIFIED MAY RESULT IN REJECTION OF YOUR OFFER. If by virtue of this amendment you desire to change an offer already submitted, such change may be made by telegram or letter, provided each telegram or letter makes reference to the solicitation and this amendment, and is received prior to the opening hour and date specified.

**12. ACCOUNTING AND APPROPRIATION DATA (If required)**

See Schedule

**13. THIS ITEM ONLY APPLIES TO MODIFICATION OF CONTRACTS/ORDERS. IT MODIFIES THE CONTRACT/ORDER NO. AS DESCRIBED IN ITEM 14.**

CHECK ONE	A. THIS CHANGE ORDER IS ISSUED PURSUANT TO: (Specify authority) THE CHANGES SET FORTH IN ITEM 14 ARE MADE IN THE CONTRACT ORDER NO. IN ITEM 10A.
X	B. THE ABOVE NUMBERED CONTRACT/ORDER IS MODIFIED TO REFLECT THE ADMINISTRATIVE CHANGES (such as changes in paying office, appropriation date, etc.) SET FORTH IN ITEM 14, PURSUANT TO THE AUTHORITY OF FAR 43.103(b).
	C. THIS SUPPLEMENTAL AGREEMENT IS ENTERED INTO PURSUANT TO AUTHORITY OF:
	D. OTHER (Specify type of modification and authority)

**E. IMPORTANT:** Contractor  is not,  is required to sign this document and return 1 copies to the issuing office.

**14. DESCRIPTION OF AMENDMENT/MODIFICATION (Organized by UCF section headings, including solicitation/contract subject matter where feasible.)**

DUNS Number: 040156218  
 FIELD POC: Craig Raine 703-285 (b)(2)Low  
 Paul Picone 703-285 (b)(2)Low  
 Program POC: Elena Smyly 202-732 (b)(2)Low  
 M.J. Bates 202-732 (b)(2)Low  
 OAQ POC: Jerald Neveleff, Contracting Officer, 202-616 (b)(2)Low  
 Arnold Casterline, Contract Specialist, 202-514 (b)(2)Low

The purpose of this modification is to change ARTICLE I: Section C: The detainee daily rate is TBD. To: The detainee daily rate is \$62.83. This will also modify ARTICLE XI:  
 Continued ...

Except as provided herein, all terms and conditions of the document referenced in Item 9A or 10A, as heretofore changed, remains unchanged and in full force and effect.

15A. NAME AND TITLE OF SIGNER (Type or print) GERALD J. SPATERS TOWN MGR	16A. NAME AND TITLE OF CONTRACTING OFFICER (Type or print) Jerald H. Neveleff
15B. CONTRACT OFFEROR 	16B. UNITED STATES OF AMERICA 
16C. DATE SIGNED 9/24/08	16C. DATE SIGNED 25 Sept 08

NSN 7540-01-152-8070  
 Previous edition unusable

STANDARD FORM 30 (REV. 10-83)  
 Prescribed by GSA  
 FAR (48 CFR) 53.243

**CONTINUATION SHEET**

REFERENCE NO. OF DOCUMENT BEING CONTINUED  
DROIGSA-08-0021//P00001

PAGE OF  
2 2

NAME OF OFFEROR OR CONTRACTOR  
FARMVILLE TOWN OF

ITEM NO. (A)	SUPPLIES/SERVICES (B)	QUANTITY (C)	UNIT (D)	UNIT PRICE (E)	AMOUNT (F)
	Section B: The detainee day rate is TBD. To: The detainee day rate is \$62.83.  After completion and approval of the facility, another Task Order will be issued with funding for the bed days. Period of Performance: 09/22/2008 to 09/30/2009				

**ORDER FOR SUPPLIES OR SERVICES**

PAGE OF PAGES

1 3

**IMPORTANT: Mark all packages and papers with contract and/or order numbers.**

1. DATE OF ORDER 09/15/2008	2. CONTRACT NO. (If any) DROIGSA-08-0021	6. SHIP TO:		
3. ORDER NO. HSCEDM-08-F-IG064		4. REQUISITION/REFERENCE NO. FDG08FARM		
5. ISSUING OFFICE (Address correspondence to) ICE/Detention Mngt/Detention IGSA's Immigration and Customs Enforcement Office of Acquisition Management 425 I Street NW, Suite 2208 Washington DC 20536		a. NAME OF CONSIGNEE  ICE Detention & Removal		
		b. STREET ADDRESS Immigration and Customs Enforcement 801 I Street, NW Suite 900		
		c. CITY Washington	d. STATE DC	e. ZIP CODE 20536

7. TO:		f. SHIP VIA		
a. NAME OF CONTRACTOR FARMVILLE TOWN OF		8. TYPE OF ORDER		
b. COMPANY NAME		<input type="checkbox"/> a. PURCHASE <input checked="" type="checkbox"/> b. DELIVERY		
c. STREET ADDRESS P O BOX 368		REFERENCE YOUR:  Please furnish the following on the terms and conditions specified on both sides of this order and on the attached sheet, if any, including delivery as indicated.		
d. CITY FARMVILLE		e. STATE VA	f. ZIP CODE 239010368	

9. ACCOUNTING AND APPROPRIATION DATA See Schedule		10. REQUISITIONING OFFICE ICE Detention & Removal		
--	--	--	--	--

11. BUSINESS CLASSIFICATION (Check appropriate box(es))					12. F.O.B. POINT
<input type="checkbox"/> a. SMALL	<input type="checkbox"/> b. OTHER THAN SMALL	<input type="checkbox"/> c. DISADVANTAGED	<input type="checkbox"/> g. SERVICE-DISABLED VETERAN-OWNED	Destination	
<input type="checkbox"/> d. WOMEN-OWNED	<input type="checkbox"/> e. HUBZone	<input type="checkbox"/> f. EMERGING SMALL BUSINESS			

13. PLACE OF		14. GOVERNMENT B/L NO.		15. DELIVER TO F.O.B. POINT ON OR BEFORE (Date)		16. DISCOUNT TERMS	
a. INSPECTION Destination	b. ACCEPTANCE Destination			Multiple		(b)(2)Low	

17. SCHEDULE (See reverse for Rejections)

ITEM NO. (a)	SUPPLIES OR SERVICES (b)	QUANTITY ORDERED (c)	UNIT (d)	UNIT PRICE (e)	AMOUNT (f)	QUANTITY ACCEPTED (g)
	DUNS Number: 040156218 Field office POC: Phillis Chapman 703-285- (b)(2)Low Craig Raine 703-285- (b)(2)Low Program POC: Elena Smyly 202-732- (b)(2)Low Continued ...					

18. SHIPPING POINT		19. GROSS SHIPPING WEIGHT		20. INVOICE NO.		17(h) TOTAL (Cont. pages)
21. MAIL INVOICE TO:						
SEE BILLING INSTRUCTIONS ON REVERSE	a. NAME Department of Homeland Security				\$968,000.00	17(i) GRAND TOTAL
	b. STREET ADDRESS (or P.O. Box) Citizenship & Immigration Services 2675 Prosperity Avenue Suite 300					
	c. CITY Fairfax		d. STATE VA	e. ZIP CODE 22031-4906		

22. UNITED STATES OF AMERICA BY (Signature)			23. NAME (Typed) Jerald H. Neveleff TITLE: CONTRACTING/ORDERING OFFICER		
--	--	--	---	--	--

**ORDER FOR SUPPLIES OR SERVICES  
SCHEDULE - CONTINUATION**

PAGE OF PAGES

2      3

**IMPORTANT:** Mark all packages and papers with contract and/or order numbers.

DATE OF ORDER	CONTRACT NO.	ORDER NO.
09/15/2008	DROIGSA-08-0021	HSCEDM-08-F-IG064

ITEM NO. (A)	SUPPLIES/SERVICES (B)	QUANTITY ORDERED (C)	UNIT (D)	UNIT PRICE (E)	AMOUNT (F)	QUANTITY ACCEPTED (G)
	M.J. Bates 202-732- (b)(2)Low  OAO POC: Jerald Neveleff, Contracting Officer, 202-616- (b)(2)Low Arnold Casterline, Contract Specialist, 202-514- (b)(2)Low  This is a Task Order for the Farmville transportation in support of the Washington field office. Accounting Info:  (b)(2)Low  Period of Performance: 09/15/2008 to 03/14/2009					
0001	Adult Alien Detainees Bed day rate (TBD)  Delivery: 30 Days After Award		EA	0.00	0.00	
0002	Transportation Guard hourly rate Product/Service Code: S206 Product/Service Description: GUARD SERVICES  Delivery: 09/15/2008	18615.9967	HR	24.28	451,996.40	
0003	Dispatcher for Transportation Product/Service Code: S206 Product/Service Description: GUARD SERVICES  Delivery: 09/15/2008	1040	HR	25.00	26,000.00	
0004	Director of Transportation Product/Service Code: S206 Product/Service Description: GUARD SERVICES  Delivery: 09/15/2008	1040	HR	40.12	41,724.80	
0005	Transportation Initiation Charges  Delivery: 09/15/2008	6	MO	2,112.00	12,672.00	
0006	Estimated mileage for six months of Continued ...	744627	EA	0.585	435,606.80	

TOTAL CARRIED FORWARD TO 1ST PAGE (ITEM 17(H))

**ORDER FOR SUPPLIES OR SERVICES  
SCHEDULE - CONTINUATION**

PAGE OF PAGES

3 3

**IMPORTANT:** Mark all packages and papers with contract and/or order numbers.

DATE OF ORDER CONTRACT NO.

09/15/2008 DROIGSA-08-0021

ORDER NO.

HSCEDM-08-F-IG064

ITEM NO. (A)	SUPPLIES/SERVICES (B)	QUANTITY ORDERED (C)	UNIT (D)	UNIT PRICE (E)	AMOUNT (F)	QUANTITY ACCEPTED (G)
	transportation. Approximately 744,627 miles @ .585 per mile is \$435,606.80  Delivery: 09/15/2008  The total amount of award: \$968,000.00. The obligation for this award is shown in box 17(i).					

TOTAL CARRIED FORWARD TO 1ST PAGE (ITEM 17(H))



**TITLE 29--LABOR****PART 4 LABOR STANDARDS FOR FEDERAL SERVICE CONTRACTS--Table of Contents**

## Subpart A Service Contract Labor Standards Provisions and Procedures

## Sec. 4.6 Labor standards clauses for Federal service contracts exceeding \$2,500.

The clauses set forth in the following paragraphs shall be included in full by the contracting agency in every contract/Inter-Governmental Service Agreement (IGSA) entered into by the United States or the District of Columbia, in excess of \$2,500, or in an indefinite amount, the principal purpose of which is to furnish services through the use of service employees:

(a) Service Contract Act of 1965, as amended: This contract/IGSA is subject to the Service Contract Act of 1965 as amended (41 U.S.C. 351 et seq.) and is subject to the following provisions and to all other applicable provisions of the Act and regulations of the Secretary of Labor issued there under (29 CFR part 4).

(b) (1) Each service employee employed in the performance of this Contract/IGSA by the contractor or any subcontractor shall be paid not less than the minimum monetary wages and shall be furnished fringe benefits in accordance with the wages and fringe benefits determined by the Secretary of Labor or authorized representative, as specified in any wage determination attached to this contract.

(2) (i) If there is such a wage determination attached to this Contract/IGSA, the contracting officer shall require that any class of service employee which is not listed therein and which is to be employed under the Contract/IGSA (i.e., the work to be performed is not performed by any classification listed in the wage determination), be classified by the contractor so as to provide a reasonable relationship (i.e., appropriate level of skill comparison) between such unlisted classifications and the classifications listed in the wage determination. Such conformed class of employees shall be paid the monetary wages and furnished the fringe benefits as are determined pursuant to the procedures in this section.

(ii) Such conforming procedure shall be initiated by the contractor prior to the performance of contract/IGSA work by such unlisted class of employee. A written report of the proposed conforming action, including information regarding the agreement or disagreement of the authorized representative of the employees involved or, where there is no authorized representative, the employees themselves, shall be submitted by the contractor to the contracting officer no later than 30 days after such unlisted class of employees performs any Contract/IGSA work. The contracting officer shall review the proposed action and promptly submit a report of the action, together with the agency's recommendation and all pertinent information including the position of the contractor and the employees, to the Wage and Hour Division, Employment Standards Administration, U.S. Department of Labor, for review. The Wage and Hour Division will approve, modify, or disapprove the action or render a final determination in the event of disagreement

within 30 days of receipt or will notify the contracting officer within 30 days of receipt that additional time is necessary.

(iii) The final determination of the conformance action by the Wage and Hour Division shall be transmitted to the contracting officer who shall promptly notify the contractor of the action taken. Each affected employee shall be furnished by the contractor with a written copy of such determination or it shall be posted as a part of the wage determination.

(iv) (A) The process of establishing wage and fringe benefit rates that bears a reasonable relationship to those listed in a wage determination cannot be [[Page 41]] reduced to any single formula. The approach used may vary from wage determination to wage determination depending on the circumstances. Standard wage and salary administration practices, which rank various job classifications by pay grade pursuant to point schemes or other job factors may, for example, be relied upon. Guidance may also be obtained from the way different jobs are rated under Federal pay systems (Federal Wage Board Pay System and the General Schedule) or from other wage determinations issued in the same locality. Basic to the establishment of any conformable wage rate(s) is the concept that a pay relationship should be maintained between job classifications based on the skill required and the duties performed.

(B) In the case of a Contract/IGSA modification, an exercise of an option or extension of an existing contract, or in any other case where a contractor succeeds a Contract/IGSA under which the classification in question was previously conformed pursuant to this section, a new conformed wage rate and fringe benefits may be assigned to such conformed classification by indexing (i.e., adjusting) the previous conformed rate and fringe benefits by an amount equal to the average (mean) percentage increase (or decrease, where appropriate) between the wages and fringe benefits specified for all classifications to be used on the Contract/IGSA which are listed in the current wage determination, and those specified for the corresponding classifications in the previously applicable wage determination. Where conforming actions are accomplished in accordance with this paragraph prior to the performance of Contract/IGSA work by the unlisted class of employees, the contractor shall advise the contracting officer of the action taken but the other procedures in paragraph (b) (2) (ii) of this section need not be followed.

(C) No employee engaged in performing work on this Contract/IGSA shall in any event be paid less than the currently applicable minimum wage specified under section 6(a) (1) of the Fair Labor Standards Act of 1938, as amended. (v) The wage rate and fringe benefits finally determined pursuant to paragraphs (b)(2)(i) and (ii) of this section shall be paid to all employees performing in the classification from the first day on which Contract/IGSA work is performed by them in the classification. Failure to pay such unlisted employees the compensation agreed upon by the interested parties and/or finally determined by the Wage and Hour Division retroactive to the date such class of employees commenced Contract/IGSA work shall be a violation of the Act and this contract. (vi) Upon discovery of failure to comply with paragraphs (b)(2)(i) through (v) of this section, the Wage and Hour Division shall make a final determination of conformed classification, wage rate,

and/or fringe benefits which shall be retroactive to the date such class of employees commenced Contract/IGSA work.

(3) If, as authorized pursuant to section 4(d) of the Service Contract Act of 1965 as amended, the term of this Contract/IGSA is more than 1 year, the minimum monetary wages and fringe benefits required to be paid or furnished there under to service employees shall be subject to adjustment after 1 year and not less often than once every 2 years, pursuant to wage determinations to be issued by the Wage and Hour Division, Employment Standards Administration of the Department of Labor as provided in such Act.

(c) The contractor or subcontractor may discharge the obligation to furnish fringe benefits specified in the attachment or determined conformably thereto by furnishing any equivalent combinations of bona fide fringe benefits, or by making equivalent or differential payments in cash in accordance with the applicable rules set forth in subpart D of 29 CFR part 4, and not otherwise.

(d) (1) In the absence of a minimum wage attachment for this contract, neither the contractor nor any subcontractor under this Contract/IGSA shall pay any person performing work under the Contract/IGSA (regardless of whether they are service employees) less than the minimum wage specified by section 6(a)(1) of the Fair Labor Standards Act of 1938. Nothing in this provision shall relieve the contractor or any subcontractor of any other obligation under [[Page 42]] law or Contract/IGSA for the payment of a higher wage to any employee.

(2) If this Contract/IGSA succeeds a contract, subject to the Service Contract Act of 1965 as amended, under which substantially the same services were furnished in the same locality and service employees were paid wages and fringe benefits provided for in a collective bargaining agreement, in the absence of the minimum wage attachment for this Contract/IGSA setting forth such collectively bargained wage rates and fringe benefits, neither the contractor nor any subcontractor under this Contract/IGSA shall pay any service employee performing any of the Contract/IGSA work (regardless of whether or not such employee was employed under the predecessor contract), less than the wages and fringe benefits provided for in such collective bargaining agreements, to which such employee would have been entitled if employed under the predecessor contract, including accrued wages and fringe benefits and any prospective increases in wages and fringe benefits provided for under such agreement. No contractor or subcontractor under this Contract/IGSA may be relieved of the foregoing obligation unless the limitations of Sec. 4.1b(b) of 29 CFR part 4 apply or unless the Secretary of Labor or his authorized representative finds, after a hearing as provided in Sec. 4.10 of 29 CFR part 4 that the wages and/or fringe benefits provided for in such agreement are substantially at variance with those which prevail for services of a character similar in the locality, or determines, as provided in Sec. 4.11 of 29 CFR part 4, that the collective bargaining agreement applicable to service employees employed under the predecessor Contract/IGSA was not entered into as a result of arm's-length negotiations. Where it is found in accordance with the review procedures provided in 29 CFR 4.10 and/or 4.11 and parts 6 and 8 that some or all of the wages and/or fringe benefits contained in a predecessor contractor's collective bargaining agreement are substantially at variance with those which prevail for

services of a character similar in the locality, and/or that the collective bargaining agreement applicable to service employees employed under the predecessor Contract/IGSA was not entered into as a result of arm's-length negotiations, the Department will issue a new or revised wage determination setting forth the applicable wage rates and fringe benefits. Such determination shall be made part of the Contract/IGSA or subcontract, in accordance with the decision of the Administrator, the Administrative Law Judge, or the Administrative Review Board, as the case may be, irrespective of whether such issuance occurs prior to or after the award of a Contract/IGSA or subcontract. 53 Comp. Gen. 401 (1973). In the case of a wage determination issued solely as a result of a finding of substantial variance, such determination shall be effective as of the date of the final administrative decision.

(e) The contractor and any subcontractor under this Contract/IGSA shall notify each service employee commencing work on this Contract/IGSA of the minimum monetary wage and any fringe benefits required to be paid pursuant to this contract, or shall post the wage determination attached to this contract. The poster provided by the Department of Labor (Publication WH 1313) shall be posted in a prominent and accessible place at the worksite. Failure to comply with this requirement is a violation of section 2(a) (4) of the Act and of this contract.

(f) The contractor or subcontractor shall not permit any part of the services called for by this Contract/IGSA to be performed in buildings or surroundings or under working conditions provided by or under the control or supervision of the contractor or subcontractor which are unsanitary or hazardous or dangerous to the health or safety of service employees engaged to furnish these services, and the contractor or subcontractor shall comply with the safety and health standards applied under 29 CFR part 1925.

(g) (1) The contractor and each subcontractor performing work subject to the Act shall make and maintain for 3 years from the completion of the work records containing the information specified in paragraphs (g) (1) (i) through (vi) of this section for each employee subject to the Act and shall make them available for inspection [[Page 43]] and transcription by authorized representatives of the Wage and Hour Division, Employment Standards Administration of the U.S. Department of Labor:

(i) Name and address and social security number of each employee.

(ii) The correct work classification or classifications, rate or rates of monetary wages paid and fringe benefits provided, rate or rates of fringe benefit payments in lieu thereof, and total daily and weekly compensation of each employee.

(iii) The number of daily and weekly hours so worked by each employee.

(iv) Any deductions, rebates, or refunds from the total daily or weekly compensation of each employee.

(v) A list of monetary wages and fringe benefits for those classes of service employees not included in the wage

determination attached to this Contract/IGSA but for which such wage rates or fringe benefits have been determined by the interested parties or by the Administrator or authorized representative pursuant to the labor standards clause in paragraph (b) of this section. A copy of the report required by the clause in Paragraph (b) (2) (ii) of this section shall be deemed to be such a list.

(vi) Any list of the predecessor contractor's employees which had been furnished to the contractor pursuant to Sec. 4.6(1)(2).

(2) The contractor shall also make available a copy of this Contract/IGSA for inspection or transcription by authorized representatives of the Wage and Hour Division.

(3) Failure to make and maintain or to make available such records for inspection and transcription shall be a violation of the regulations and this contract, and in the case of failure to produce such records, the contracting officer, upon direction of the Department of Labor and notification of the contractor, shall take action to cause suspension of any further payment or advance of funds until such violation ceases.

(4) The contractor shall permit authorized representatives of the Wage and Hour Division to conduct interviews with employees at the worksite during normal working hours.

(h) The contractor shall unconditionally pay to each employee subject to the Act all wages due free and clear and without subsequent deduction (except as otherwise provided by law or Regulations, 29 CFR part 4), rebate, or kickback on any account. Such payments shall be made no later than one pay period following the end of the regular pay period in which such wages were earned or accrued. A pay period under this Act may not be of any duration longer than semi-monthly.

(i) The contracting officer shall withhold or cause to be withheld from the Government prime contractor under this or any other Government Contract/IGSA with the prime contractor such sums as an appropriate official of the Department of Labor requests or such sums as the contracting officer decides may be necessary to pay underpaid employees employed by the contractor or subcontractor. In the event of failure to pay any employees subject to the Act all or part of the wages or fringe benefits due under the Act, the agency may, after authorization or by direction of the Department of Labor and written notification to the contractor, take action to cause suspension of any further payment or advance of funds until such violations have ceased. Additionally, any failure to comply with the requirements of these clauses relating to the Service Contract Act of 1965, may be grounds for termination of the right to proceed with the Contract/IGSA work. In such event, the Government may enter into other contracts or arrangements for completion of the work, charging the contractor in default with any additional cost.

(j) The contractor agrees to insert these clauses in this section relating to the Service Contract Act of 1965 in all Subcontracts subject to the Act. The term contractor as used in these clauses in any subcontract shall be deemed to refer to the subcontractor, except in the term Government prime contractor.

(k)(1) As used in these clauses, the term service employee means any person engaged in the performance of this Contract/IGSA other than any person employed in a bona fide executive, administrative, or professional capacity, as those terms are defined in part 541 of title 29, Code of Federal Regulations, as of July [(Page44)) 30, 1976, and any subsequent revision of those regulations. The term service employee includes all such persons regardless of any contractual relationship that may be alleged to exist between a contractor or subcontractor and such persons.

(2) The following statement is included in contracts pursuant to section 2(a) (5) of the Act and is for informational purposes only:

The following classes of service employees expected to be employed under the Contract/IGSA with the Government would be subject, if employed by the contracting agency, to the provisions of 5 U.S.C. 5341 or 5 U.S.C. 5332 and would, if so employed, be paid not less than the following rates of wages and fringe benefits:

Employee class	wage-fringe benefit
GS-05	\$13.83 (As of Dec 07)
GS-07	\$17.83 (As of Dec 07)

Search current rates at <http://www.opm.gov/oca/08tables/>

(1)(1) If wages to be paid or fringe benefits to be furnished any service employees employed by the Government prime contractor or any subcontractor under the Contract/IGSA are provided for in a collective bargaining agreement which is or will be effective during any period in which the Contract/IGSA is being performed, the Government prime contractor shall report such fact to the contracting officer, together with full information as to the application and accrual of such wages and fringe benefits, including any prospective increases, to service employees engaged in work on the contract, and a copy of the collective bargaining agreement. Such report shall be made upon commencing performance of the contract, in the case of collective bargaining agreements effective at such time, and in the case of such agreements or provisions or amendments thereof effective at a later time during the period of Contract/IGSA performance, such agreements shall be reported promptly after negotiation thereof.

(2) Not less than 10 days prior to completion of any Contract/IGSA being performed at a Federal facility where service employees may be retained in the performance of the succeeding Contract/IGSA and subject to a wage determination which contains vacation or other benefit provisions based upon length of service with a contractor (predecessor) or successor (Sec. 4.173 of Regulations, 29 CFR part 4), the incumbent prime contractor shall furnish to the contracting officer a certified list of the names of all service employees on the contractor's or subcontractor's payroll during the last month of Contract/IGSA performance. Such list shall also contain anniversary dates of employment on the Contract/IGSA either with the current or predecessor contractors of each such service employee. The contracting officer shall turn over such list to the successor contractor at the commencement of the succeeding contract.

(m) Rulings and interpretations of the Service Contract Act of 1965, as amended, are contained in Regulations, 29 CFR part 4.

(n) (1) By entering into this contract, the contractor (and officials thereof) certifies that neither it (nor he or she) nor any person or firm who has a substantial interest in the contractor's firm is a person or firm ineligible to be awarded Government contracts by virtue of the sanctions imposed pursuant to section 5 of the Act.

(2) No part of this Contract/IGSA shall be subcontracted to any person or firm ineligible for award of a Government Contract/IGSA pursuant to section 5 of the Act.

(3) The penalty for making false statements is prescribed in the U.S. Criminal Code, 18 U.S.C. 1001.

(o) Notwithstanding any of the clauses in paragraphs (b) through (m) of this section relating to the Service Contract Act of 1965, the following employees may be employed in accordance with the following variations, tolerances, and exemptions, which the Secretary of Labor, pursuant to section 4(b) of the Act prior to its amendment by Public Law 92-473, found to be necessary and proper in the public interest or to avoid serious impairment of the conduct of Government business:

(1) Apprentices, student-learners, and workers whose earning capacity is impaired by age, physical, or mental deficiency or injury may be employed at wages lower than the minimum wages otherwise required by section 2(a) (1) or [[Page 45]]

(2) (b) (1) of the Service Contract Act without diminishing any fringe benefits or cash payments in lieu thereof required under section 2(a) (2) of that Act, in accordance with the conditions and procedures prescribed for the employment of apprentices, student-learners, handicapped persons, and handicapped clients of sheltered workshops under section 14 of the Fair Labor Standards Act of 1938, in the regulations issued by the Administrator (29 CFR parts 520, 521, 524, and 525).

(3) The Administrator will issue certificates under the Service Contract Act for the employment of apprentices, student-learners, handicapped persons, or handicapped clients of sheltered workshops not subject to the Fair Labor Standards Act of 1938, or subject to different minimum rates of pay under the two acts, authorizing appropriate rates of minimum wages (but without changing requirements concerning fringe benefits or supplementary cash payments in lieu thereof), applying procedures prescribed by the applicable regulations issued under the Fair Labor Standards Act of 1938 (29 CFR parts 520, 521, 524, and 525).

(4) The Administrator will also withdraw, annul, or cancel such certificates in accordance with the regulations in parts 525 and 528 of title 29 of the Code of Federal Regulations.

(p) Apprentices will be permitted to work at less than the predetermined rate for the work they perform when they are employed and individually registered in a bona fide apprenticeship program

registered with a State Apprenticeship Agency which is recognized by the U.S. Department of Labor, or if no such recognized agency exists in a State, under a program registered with the Bureau of Apprenticeship and Training, Employment and Training Administration, U.S. Department of Labor. Any employee who is not registered as an apprentice in an approved program shall be paid the wage rate and fringe benefits contained in the applicable wage determination for the journeyman classification of work actually performed. The wage rates paid apprentices shall not be less than the wage rate for their level of progress set forth in the registered program, expressed as the appropriate percentage of the journeyman's rate contained in the applicable wage determination. The allowable ratio of apprentices to journeymen employed on the Contract/IGSA work in any craft classification shall not be greater than the ratio permitted to the contractor as to his entire work force under the registered program.

(q) Where an employee engaged in an occupation in which he or she customarily and regularly receives more than \$30 a month in tips, the amount of tips received by the employee may be credited by the employer against the minimum wage required by Section 2(a)(1) or 2(b)(1) of the Act to the extent permitted by section 3(m) of the Fair Labor Standards Act and Regulations, 29 CFR Part 531. To utilize this provision:

(1) The employer must inform tipped employees about this tip credit allowance before the credit is utilized;

(2) The employees must be allowed to retain all tips (individually or through a pooling arrangement and regardless of whether the employer elects to take a credit for tips received);

(3) The employer must be able to show by records that the employee receives at least the applicable Service Contract Act minimum wage through the combination of direct wages and tip credit;

(4) The use of such tip credit must have been permitted under any predecessor collective bargaining agreement applicable by virtue of section 4(c) of the Act.

(r) Disputes concerning labor standards. Disputes arising out of the labor standards provisions of this Contract/IGSA shall not be subject to the general disputes clause of this contract. Such disputes shall be resolved in accordance with the procedures of the Department of Labor set forth in 29 CFR parts 4, 6, and 8. Disputes within the meaning of this clause include disputes between the contractor (or any of its subcontractors) and the contracting agency, the U.S. Department of Labor, or the employees or their representatives. (The information collection, recordkeeping, and reporting requirements contained in this section have been approved by the Office of Management and Budget under the following numbers:

[[Page 46]]

- Paragraph	OMB control number
(b)(2) (i)--(iv).....	1215-0150
(e).....	1215-0150
(g)(1) (i)--(iv).....	1215-0017
(g)(1) (v), (vi).....	1215-0150



(1) (1), (2)..... 1215-0150  
(q) (3)..... 1215-0017

---

[48 FR 49762, Oct. 27, 1983; 48 FR 50529, Nov. 2, 1983, as amended at  
61 FR 68663, Dec. 30, 1996]







D	W	M	Q	K.	DETENTION STANDARDS	Rating A/D/R	Corrective Action Required / Comments	Due Date
					Detainees in SMUs may shave and shower three times weekly and receive other basic services (laundry, hair care, barbering, clothing, bedding, linen) on the same basis as the general population			
				L.	The facility administrator (or designee) visits each SMU daily			
				M.	A health care provider visits every detainee in a SMU at least 3x week, and detainees are provided any medications prescribed for them			
				N.	Detainees in the SMU are offered at least one hour of recreation per day, scheduled at a reasonable time, at least five days per week. Where cover is not provided to mitigate inclement weather, detainees are provided weather-appropriate equipment and attire			
					<b>29. Staff-Detainee Communication</b>			
				A.	Housing unit rounds conducted daily by security staff.			
				B.	Housing unit rounds conducted daily by Deportation Staff			
				C.	Detainee requests answered within 72 hours			
				D.	ICE SDC visit schedules are posted in housing unit			
				E.	Request forms are available to detainees			
				F.	There is a secure box available for detainees to place requests in for ICE staff that is checked on a daily basis			
				G.	Unannounced ICE staff housing unit visits occur weekly			
				H.	Visiting staff observe, document and communicate current climate and conditions of confinement			
					<b>30. Suicide Prevention and Intervention</b>			
				A.	The facility has a written suicide prevention and intervention program approved and signed by the health			













## Town of Farmville – ICE Facility

### TRANSPORTATION WORK ASSIGNMENT

NAMES: \_\_\_\_\_

DATE: \_\_\_\_\_

HOURS: \_\_\_\_\_

MILEAGE: \_\_\_\_\_

DESCRIPTION: \_\_\_\_\_

\_\_\_\_\_

\_\_\_\_\_

\_\_\_\_\_

I \_\_\_\_\_ CERTIFY THAT THE

HOURS ON THIS SHEET ARE ACCURATE AND CORRECT.

TIME OF DEPARTURE \_\_\_\_\_ TIME OF RETURN \_\_\_\_\_

SIGNATURE: \_\_\_\_\_

SUPERVISOR'S SIGNATURE: \_\_\_\_\_

DATE: \_\_\_\_\_

**DHS/ICE/DRO—DEDICATED IGSA  
QUALITY ASSURANCE SURVEILLANCE PLAN (QASP)  
for IGSA NUMBER DROIGSA-08-0021**

## **1. INTRODUCTION**

The Government's Quality Assurance Surveillance Plan (QASP) is based on the premise that the service provider, and not the Government, is responsible for the day-to-day operation of the facility and all the management and quality control actions required to meet the terms of the contract. The role of the Government in quality assurance is to ensure performance standards are achieved and maintained. The service provider is required to develop a comprehensive program of inspections and monitoring actions and to document its approach in a Quality Control Plan (QCP). The service provider's QCP, upon approval by the Government, will be made a part of the resultant agreement.

This QASP is designed to provide an effective surveillance method to monitor the service provider's performance relative to the requirements listed in the agreement. The QASP illustrates the systematic method the Government (or its designated representative) will use to evaluate the services the service provider is required to furnish.

This QASP is based on the premise the Government must validate that the service provider is complying with DRO-mandated quality standards in operating, maintaining, and repairing detention facilities. Performance standards address all facets of detainee handling, including safety, health, legal rights, facility and records management, etc. Good management by the service provider and use of an approved QCP will ensure that the facility is operating within acceptable quality levels.

## **2. DEFINITIONS**

**Performance Requirements Summary (Attachment 1):** The Performance Requirements Summary (PRS) communicates what the Government intends to qualitatively inspect. The PRS is based on the American Correctional Association (ACA) Standards for Adult Local Detention Facilities (ALDF) and Immigration And Customs Enforcement (ICE) National Detention Standards (NDS). The PRS identifies performance standards grouped into nine functional areas, and quality levels essential for successful performance of each requirement. The PRS is used by the Government (or its designated representative) when conducting quality assurance surveillance to guide them through the inspection and review processes.

**Functional Area:** A logical grouping of performance standards.

**Contracting Officer's Technical Representative (COTR):** The COTR interacts with the service provider to inspect and accept services/work performed in accordance with the technical standards prescribed in the agreement. The Contracting Officer issues a written memorandum that appoints the COTR. Other individuals may be designated to assist in the inspection and quality assurance surveillance activities.

**Performance Standards:** The performance standards are established in the ICE Office Of Detention And Removal (DRO) NDS and contained in the Detention Operations Manual, at <http://www.ice.gov/partners/dro/opsmanual/index.htm>, as well as the ACA standards for ALDF. Other standards may also be defined in the agreement.

**Measures:** The method for evaluating compliance with the standards.

**Acceptable Quality Level:** The minimum level of quality that will be accepted by the Government in order to meet the performance standard.

**Withholding:** Amount of monthly invoice payment withheld pending correction of a deficiency. See Attachment 1 for information on percentage of invoice amount that may be withheld for each functional area. Funds withheld from payment are recoverable (See Sections 6 and 7) if the COTR and Contracting Officer confirm resolution/correction, and should be included in the next month's invoice.

**Deduction:** Funds may be deducted from a monthly invoice for an egregious act or event, or if the same deficiency continues to occur. The service provider will be notified immediately if such a situation arises. The Contracting Officer in consultation with the Program Office will determine the amount of the deduction. Amounts deducted are not recoverable.

### **3. QUALITY CONTROL PLAN:**

As a part of its agreement with the Government, the service provider is required to develop, implement, and maintain a Quality Control Plan (QCP) that illustrates the methods it will use to review its performance to ensure it conforms to the performance requirements. (See Attachment 1 for a summary list of performance requirements.) Such reviews are performed by the service provider in order to validate its operations, and assure the Government that the services meet the performance standards.

The service provider's QCP should include monitoring methods that ensure and demonstrate its compliance with the performance standards. This includes inspection methods and schedules that are consistent with the regular reviews conducted by DRO. The reports and other results generated by the service provider's QCP activities should be provided to the COTR as requested.

The frequency and type of the service provider's reviews should be consistent with what is necessary in order to ensure compliance with the performance standards, but no less frequent than what is described in the Government's monitoring instrument/worksheets (See Attachment 3).

The service provider is encouraged not to limit its inspection to only the processes outlined in the Government's standard; however, certain key documents must be produced by the provider to assure the Government that the services meet the performance standards. Some of the documentation that must be generated and made available to the COTR for inspection is listed below. The list is intended as illustrative and is not all-inclusive. The service provider must develop and implement a program that addresses the specific requirement of each standard and the means it will use to document compliance.

- Written policies and procedures to implement and assess operational requirements of the standard
- Documentation and record keeping to ensure ongoing operational compliance with the standards (e.g.; inventories, logbooks, register of receipts, reports, etc.)
- Staff training records
- Contract discrepancy reports (CDRs)
- Investigative reports
- Medical records
- Records of investigative actions taken
- Equipment inspections
- System tests and evaluation

#### **4. METHODS OF SURVEILLANCE**

The Government will inspect the service provider's facility and operations using worksheets it developed for this purpose. All facilities will be subject to an annual full facility review using the procedures outlined in the Detention Management Control Program (DMCP) as well as the ACA Standards for Adult Local Detention Facilities (ALDF). The Government's annual full facility reviews will use the monitoring instruments embedded in the standards.

Facilities with 500 beds or more have an on-site COTR and/or designees who will perform regular and more frequent inspections using the worksheet in Attachment 3. This worksheet, which distills some 600 review areas included in the standards, will help the COTR or designee assess overall performance, by reviewing specific items within the 9 functional areas on a daily, weekly, monthly, and/or quarterly basis. Both annual and routine inspections will include a review of the service provider's QCP activities including the reports and results generated by them.

The COTR or designee will evaluate the service provider's performance by (a) conducting site visits to assess the facility and detainee conditions, (b) reviewing documentation, and (c) interviewing the service provider's personnel and/or detainees. NOTE: For day-to-day activities, the Government will conduct its surveillance using the worksheets created for this purpose, along with the Contract Deficiency Reports (CDRs; See Attachment 2) and the "Contract Performance Monitoring Tool" set forth in Attachment 3. Where ICE/DRO standards are referenced for annual review purposes, the "Monitoring Instruments" and "Verification Sources" identified in the DRO standard will be used.

**4.1 Site Visits:** Site visits are used to observe actual performance and to conduct interviews to determine the extent of compliance with performance standards, and to ensure any noted defects are effectively addressed and corrected as quickly as possible. Sites with 500+ beds will have an on-site COTR designee. Routine reviews may involve direct observation of the service provider personnel performing tasks, interacting with detainees and other staff members, and/or reviewing documentation that demonstrates compliance with the DRO standards. On-site inspections may be performed by the ICE COTR or by other parties designated as representatives of ICE.

Inspections may be planned (e.g., annual inspections and the regular inspections identified in Attachment 3) or ad-hoc.

**4.2 Ad-Hoc:** These inspections are unscheduled and will be conducted as a result of special interests arising from routine monitoring of the service provider's QCP, an unusual occurrence pertaining to the agreement or other ICE concerns. These inspections may also be used as a follow-up to a previous inspection. Inspection findings will be provided to the service provider as appropriate.

When visiting a site, either the COTR or a designated third party may conduct their own inspections of service provider performance activities, or accompany the service provider's designated Quality Control Inspector (QCI) on scheduled inspections. The COTR may also immediately inspect the same area as soon as the QCI has completed the quality control inspection to determine if any surveillance areas were overlooked. The COTR may also inspect an area prior to the QCI and compare results. The COTR will record all findings; certain deficiencies noted will be provided in writing and must be corrected within a reasonable amount of time (See Attachment 2).

**4.3 Review of Documentation:** The service provider must develop and maintain all documentation as prescribed in the performance standards (e.g., post logs, policies, and records of corrective actions). In addition to the documentation prescribed by the standards, the service provider must also develop and maintain documentation that demonstrates the results of its own inspections as prescribed in its QCP. The COTR will review both forms of documentation to affirm that the facility conditions, policies/procedures, and handling of detainees all conform to the performance standards stated herein. When reviewing the service provider's documentation, the Government may review 100% of the documents, or a representative sample. Documentation may be reviewed during a site visit, or at periodic points throughout the period of performance.

**4.4 Interviews and Other Feedback:** The COTR will interview key members of the service provider's staff, detainees and other Government personnel to ascertain current practices and the extent of compliance with the performance standards.

## **5. FUNCTIONAL PERFORMANCE AREAS AND STANDARDS**

To facilitate the performance review process, the required performance standards are organized into nine functional areas. Each functional area represents a proportionate share (i.e., weight) of the monthly invoice amount payable to the service provider based on meeting the performance standards. Payment withholdings will be based on these percentages and weights applied to the overall monthly invoice.

ICE may, consistent with the scope the agreement, unilaterally change the functional areas and associated standards affiliated with a specific functional area. The Contracting Officer will notify the service provider at least 30 calendar days in advance of implementation of the new standard(s). If the service provider is not provided with the notification, adjustment to the new standard must be made within 30 calendar days after notification. If any change affects pricing,

the service provider may submit a request for equitable price adjustment in accordance with the "Changes" clause. ICE reserves the right to develop and implement new inspection techniques and instructions at any time during performance without notice to the service provider, so long as the standards are not more stringent than those being replaced.

## 6. FAILURE TO MEET PERFORMANCE STANDARDS

Performance of services in conformance with the PRS standards is essential for the service provider to receive full payment as identified in the agreement. The Contracting Officer may take deductions against the monthly invoices for unsatisfactory performance documented through surveillance of the service provider's activities gained through site inspections, reviews of documentation (including monthly QCP reports), interviews and other feedback. As a result of its surveillance, the service provider will be assigned the following rating relative to each performance standard:

Rating	Description
Acceptable	Based on the measures, the performance standard is demonstrated.
Deficient	Based on the measures, compliance with most of the attributes of the performance standard is demonstrated/observed with some area(s) needing improvement. There are no critical areas of unacceptable performance
At-Risk	Based on the performance measures, the majority of a performance standard's attributes are not met.

Using the above standards as a guide, the Contracting Officer will implement adjustments to the service provider's monthly invoice as prescribed in Attachment 1.

Rather than withholding funds until a deficiency is corrected, there may be times when an event or a deficiency is so egregious that the Government *deducts* (vs. "withholds") amounts from the service provider's monthly invoice. This may happen when an event occurs, such as sexual abuse, when a particular deficiency is noted 3 or more times without correction, or when the service provider has failed to take timely action on a deficiency about which he was properly and timely notified. The amount deducted will be consistent with the relative weight of the functional performance area where the deficiency was noted. The deduction may be a one-time event, or may continue until the service provider has either corrected the deficiency, or made substantial progress in the correction.

Further, a deficiency found in one functional area may tie into another. If a detainee escaped, for example, a deficiency would be noted in "Security and Control," but may also relate to a deficiency in the area of "Administration and Management."

## 7. NOTIFICATIONS

- (a) Based on the inspection of the service provider's performance, the COTR will document instances of deficient or at-risk performance (e.g., noncompliance with the standard) using the CDR located at Attachment 2. To the extent practicable, issues should be resolved

informally, with the COTR and service provider working together. When documentation of an issue or deficiency is required, the procedures set forth in this section will be followed.

- (b) When a CDR is required to document performance issues, it will be submitted to the service provider with a date when a response is due. Upon receipt of a CDR, the service provider must immediately assess the situation and either correct the deficiency as quickly as possible or prepare a corrective action plan. In either event, the service provider must return the CDR with the action planned or taken noted. After the COTR reviews the service provider's response to the CDR including its plan/remedy, the COTR will either accept plan or correction or reject the correction/plan for revision and provide an explanation. This process should take no more than one week. The CDR should not be used as a substitute for quality control by the service provider.
- (c) The COTR and CO, in addition to any other designated ICE official, shall be notified immediately in the event of all emergencies. Emergencies include, but are not limited to the following: activation of disturbance control team(s); disturbances (including gang activities, group demonstrations, food boycotts, work strikes, work-place violence, civil disturbances/protests); staff use of force including use of lethal and less-lethal force (includes inmates in restraints more than eight hours); assaults on staff/inmates resulting in injuries requiring medical attention (does not include routine medical evaluation after the incident); fights resulting in injuries requiring medical attention; fires; full or partial lock down of the facility; escape; weapons discharge; suicide attempts; deaths; declared or non-declared hunger strikes; adverse incidents that attract unusual interest or significant publicity; adverse weather (e.g., hurricanes, floods, ice/snow storms, heat waves, tornadoes); fence damage; power outages; bomb threats; central inmate monitoring cases admitted to a community hospital; witness security cases taken outside the facility; significant environmental problems that impact the facility operations; transportation accidents (airlift, bus, etc.) resulting in injuries, death or property damage; and sexual assaults. Note that in an emergency situation, a CDR may not be issued until an investigation has been completed.
- (d) If the COTR concludes that the deficient or at-risk performance warrants a withholding or deduction, the COTR must include the CDR in its monthly report to DRO Headquarters, with a copy to the Contracting Officer. The CDR must be accompanied by the COTR's investigation report and written recommendation for any withholding. If contractual action including a withholding or deduction is appropriate, DRO headquarters will forward the CDR and supporting information to the Contracting Officer for action. The Contracting Officer will consider the COTR's recommendation and forward the CDR along with any relevant supporting information to the service provider in order to confirm or further discuss the prospective cure, including the Government's proposed course of action. As described in section 7 above, portions of the monthly invoice amount may be withheld until such time as the corrective action is completed, *or* a deduction may be taken
- (e) Following receipt of the service provider's notification that the correction has been made, the COTR may re-inspect the facility. Based upon the COTR's findings, he will recommend that the Contracting Officer continue to withhold a proportionate share of the payment until the



correction is made, or accept the correction as final and release the full amount withheld for that issue.

- (f) If funds have been withheld and either the Government or the service provider terminates the agreement, those funds will not be released. The service provider may only receive withheld payments upon successful correction of an instance of non-compliance. Further, the service provider is not relieved of full performance of the required services hereunder; the agreement may be terminated upon adequate notice from the Government based upon any once instance, or failure to remedy deficient performance, even if a deduction was previously taken for any inadequate performance.
- (g) The COTR will maintain a record of all open and resolved CDRs.

#### **8. DETAINEE/MEMBER OF PUBLIC COMPLAINTS:**

The detainee and the public are the ultimate recipients of the services identified in this agreement. Any complaints made known to the COTR will be logged and forwarded to the service provider for remedy. Upon notification, the service provider will be given a pre-specified number of hours after verbal notification from the COTR to address the issue. The service provider will submit documentation to the COTR regarding the actions taken to remedy the situation. If the complaint is found to be invalid, the service provider will document its findings and notify the COTR.

#### **9. ATTACHMENTS**

- 1 Performance Requirements Summary
- 2 Contract Discrepancy Report
- 3 Performance Monitoring Tool

**QUASP Attachment 1**  
**Performance Requirements Summary**

FUNCTIONAL AREA/ WEIGHT	PERFORMANCE STANDARD	PERFORMANCE MEASURE	METHOD OF SURVEILLANCE	ACCEPTABLE QUALITY LEVEL	WITHHOLDING CRITERIA	
<b>Administration and Management (10%)</b>  (Addresses facility policy development, internal inspection and reviews, detainee records, administration and orientation, personal property and monies, release and accommodations for the disabled)	Accommodations for the Disabled, 4-ALDF-6B-04, 4-ALDF-6B-07	Performance measures are reflected in the monitoring instrument that accompanies each standard or in the supplemental performance monitoring tool issued by the COIR	<ul style="list-style-type: none"> <li>Annual review of facility using Detention Management Control Program (DCMP) procedures and based upon the performance standard</li> <li>Periodic reviews in accordance with the contract performance monitoring tool (see attached)</li> <li>Monthly review of corrective action plan results.</li> <li>Ad-hoc reviews as needed</li> <li>Review of service provider's quality control program monitoring reports</li> <li>CDRs</li> </ul>	Performance fully complies with all elements of standard at a level no less than acceptable (see Section 7 of the QASP)	A rating of Deficient on any three of the standards will result in a 10% withholding in the monthly invoiced per-diem day rate until compliance with the standard is established.	
	Contractor Quality Control/ Assurance Program (Contract) 4-ALDF-7D-02					
	Admission and Release/Orientation (ICE Standard) ( <a href="http://www.ice.gov/doclib/partners/dro/opsmanual/admiss.pdf">http://www.ice.gov/doclib/partners/dro/opsmanual/admiss.pdf</a> )					
	Detainee Records/ Detention Files (ICE Standard) ( <a href="http://www.ice.gov/doclib/partners/dro/opsmanual/DetentFiles.pdf">http://www.ice.gov/doclib/partners/dro/opsmanual/DetentFiles.pdf</a> )					
	Detainee Handbook (ICE Standard) ( <a href="http://www.ice.gov/doclib/partners/dro/opsmanual/handbk.pdf">http://www.ice.gov/doclib/partners/dro/opsmanual/handbk.pdf</a> )					
	Internal Inspections and/or Reviews/ Detention Management & Control Program (ICE Standard)					
Funds & Personal Property (ICE Standard) ( <a href="http://www.ice.gov/doclib/partners/dro/opsmanual/fundprop.pdf">http://www.ice.gov/doclib/partners/dro/opsmanual/fundprop.pdf</a> )						
Policy Development and Monitoring 4-ALDF-7D-06						

FUNCTIONAL AREA/ WEIGHT	PERFORMANCE STANDARD	PERFORMANCE MEASURE	METHOD OF SURVEILLANCE	ACCEPTABLE QUALITY LEVEL	WITHHOLDING CRITERIA
<p><b>Health Care (15%)</b> (Addresses overall access to routine, chronic health care, mental health, emergency health and dental services provided by the institution)</p>	Communicable Disease 4-ALDF-4C-14	Performance measures are reflected in the monitoring instrument that accompanies each standard or in the supplemental performance monitoring tool issued by the COTR	<ul style="list-style-type: none"> <li>Annual review of facility using Detention Management Control Program (DCMP) procedures and based upon the performance standard</li> <li>Periodic reviews in accordance with the attached performance monitoring tool</li> <li>Monthly review of corrective action plan results.</li> <li>Ad-hoc reviews as needed</li> <li>CDRs</li> </ul>	Performance fully complies with all elements of standard at a level no less than acceptable (see Section 7 of the QASP)	A rating of Deficient on any two of the standards will result in a 15% withholding in the monthly invoiced per-diem day rate until compliance with the standard is established.  A rating of At-Risk on any of the standards will result in a 15% withholding in the monthly invoiced per-diem day rate until compliance with the standard is established.
	Detainee Hunger Strikes (ICE Standard) ( <a href="http://www.ice.gov/doclib/partners/dro/opsmanual/hunger.pdf">http://www.ice.gov/doclib/partners/dro/opsmanual/hunger.pdf</a> ) Experimental Research 4-ALDF-4D-18 Medical, Dental, and Appraisals/Medical Care (ICE Standard) ( <a href="http://www.ice.gov/doclib/partners/dro/opsmanual/medical.pdf">http://www.ice.gov/doclib/partners/dro/opsmanual/medical.pdf</a> ) Suicide Prevention (ICE Standard) ( <a href="http://www.ice.gov/doclib/partners/dro/opsmanual/suicprev.pdf">http://www.ice.gov/doclib/partners/dro/opsmanual/suicprev.pdf</a> ) Terminal Illness, Advanced Directives and Death (ICE Standard) ( <a href="http://www.ice.gov/doclib/partners/dro/opsmanual/terminal.pdf">http://www.ice.gov/doclib/partners/dro/opsmanual/terminal.pdf</a> )				

FUNCTIONAL AREA/ WEIGHT	PERFORMANCE STANDARD	PERFORMANCE MEASURE	METHOD OF SURVEILLANCE	ACCEPTABLE QUALITY LEVEL	WITHHOLDING CRITERIA
<p align="center"><b>Security and Control (25%)</b></p> <p>(Addresses post orders, permanent logs, security features, security inspections, control of contraband, detainee searches, detainee accountability, use of force, non-routine use of restraints, tool and equipment control, detainee discipline, supervision for special housing, contingency and emergency plans.)</p>	Detainee Searches 4-ALDF-2C-01-06	Performance measures are reflected in the monitoring instrument that accompanies each standard or in the supplemental performance monitoring tool issued by the COTR	<ul style="list-style-type: none"> <li>Monthly review of corrective action plan results.</li> <li>Ad-hoc reviews as needed</li> <li>CDRs</li> <li>Review of service provider's quality control program monitoring reports and output data</li> </ul>	Performance fully complies with all elements of standard at a level no less than acceptable (see Section 7 of the QASP)	A rating of Deficient on any two of the standards will result in a 15% withholding in the monthly invoiced per-diem day rate until compliance with the standard is established.
	Detainee Accountability & Supervision / Population Counts (ICE Standard) ( <a href="http://www.ice.gov/doclib/partners/dro/opsmanual/popula.pdf">http://www.ice.gov/doclib/partners/dro/opsmanual/popula.pdf</a> )	Annual review of facility using Detention Management Control Program (DCMP) procedures and based upon the performance standard		A rating of Deficient on any three of the standards will result in a 25% withholding in the monthly invoiced per-diem day rate until compliance with the standard is established.	A rating of At-Risk on any of the standards will result in a 25% withholding in the monthly invoiced per-diem day rate until compliance with the standard is established.
	Use of Force (ICE Standard) ( <a href="http://www.ice.gov/doclib/partners/dro/opsmanual/useoffor.pdf">http://www.ice.gov/doclib/partners/dro/opsmanual/useoffor.pdf</a> )	Periodic reviews in accordance with the contract performance monitoring tool (see attached)			
	Detainee Transfers (ICE Standard) ( <a href="http://www.ice.gov/doclib/partners/dro/opsmanual/detTransStdfinal.pdf">http://www.ice.gov/doclib/partners/dro/opsmanual/detTransStdfinal.pdf</a> )				
	Tool and Equipment Control (ICE Standard) ( <a href="http://www.ice.gov/doclib/partners/dro/opsmanual/toolcont.pdf">http://www.ice.gov/doclib/partners/dro/opsmanual/toolcont.pdf</a> )				
	Weapon Control 4-ALDF-2B-04, 4-ALDF-2B-08, 4-ALDF-7B-14				
	Detainee Discipline (ICE Standard) ( <a href="http://www.ice.gov/doclib/partners/dro/opsmanual/discip.pdf">http://www.ice.gov/doclib/partners/dro/opsmanual/discip.pdf</a> )				
	Special Management Unit- Administrative Segregation (ICE Standard) ( <a href="http://www.ice.gov/doclib/partners/dro/opsmanual/smu_admin.pdf">http://www.ice.gov/doclib/partners/dro/opsmanual/smu_admin.pdf</a> )				

FUNCTIONAL AREA/ WEIGHT	PERFORMANCE STANDARD	PERFORMANCE MEASURE	METHOD OF SURVEILLANCE	ACCEPTABLE QUALITY LEVEL	WITHHOLDING CRITERIA
	<p>Special Management Unit-Disciplinary Segregation (ICE Standard) (<a href="http://www.ice.gov/doclib/partners/dro/opsmanual/smu_dis.pdf">http://www.ice.gov/doclib/partners/dro/opsmanual/smu_dis.pdf</a>)</p> <p>Contingency/Emergency Plan (ICE Standard) (<a href="http://www.ice.gov/doclib/partners/dro/opsmanual/emeege.pdf">http://www.ice.gov/doclib/partners/dro/opsmanual/emeege.pdf</a>)</p> <p>Hold Rooms in Detention Facilities (ICE Standard) (<a href="http://www.ice.gov/doclib/partners/dro/opsmanual/holdrm.pdf">http://www.ice.gov/doclib/partners/dro/opsmanual/holdrm.pdf</a>)</p> <p>Control of Contraband (ICE Standard) (<a href="http://www.ice.gov/doclib/partners/dro/opsmanual/contra.pdf">http://www.ice.gov/doclib/partners/dro/opsmanual/contra.pdf</a>)</p> <p>Post Orders (ICE Standard)(<a href="http://www.ice.gov/doclib/partners/dro/opsmanual/postord.pdf">http://www.ice.gov/doclib/partners/dro/opsmanual/postord.pdf</a>)</p> <p>Permanent Logs 4- ALDF-2A-11</p> <p>Security Features (ICE Standard) (<a href="http://www.ice.gov/doclib/partners/dro/opsmanual/keylock.pdf">http://www.ice.gov/doclib/partners/dro/opsmanual/keylock.pdf</a>)</p> <p>Security Inspections and/or Reviews (ICE Standard) (<a href="http://www.ice.gov/doclib/partners/dro/opsmanual/secinsp.pdf">http://www.ice.gov/doclib/partners/dro/opsmanual/secinsp.pdf</a>)</p> <p>Sexual Assault 4-ALDF- 4D-22-8</p>				

FUNCTIONAL AREA/ WEIGHT	PERFORMANCE STANDARD	PERFORMANCE MEASURE	METHOD OF SURVEILLANCE	ACCEPTABLE QUALITY LEVEL	WITHHOLDING CRITERIA
<b>Food Service (10%)</b> (Addresses basic sanitation and adequacy of varied meals and special diets provided to detainees)	Transportation (Land Transportation) (ICE Standard) ( <a href="http://www.ice.gov/doclib/partners/dtro/opsmanual/transp.pdf">http://www.ice.gov/doclib/partners/dtro/opsmanual/transp.pdf</a> ) Weapons Control 4- ALDF-2B-04, 4-ALDF- 2B-08, 4-ALDF-7B-14				
	Environmental Health & Safety (ICE Standard) ( <a href="http://www.ice.gov/doclib/partners/dtro/opsmanual/envirom.pdf">http://www.ice.gov/doclib/partners/dtro/opsmanual/envirom.pdf</a> ) Food Service Standards (ICE Standard) ( <a href="http://www.ice.gov/doclib/partners/dtro/opsmanual/FoodService.pdf">http://www.ice.gov/doclib/partners/dtro/opsmanual/FoodService.pdf</a> )	Performance measures are reflected in the monitoring instrument that accompanies each standard or in the supplemental performance monitoring tool issued by the COTR	<ul style="list-style-type: none"> <li>Annual review of facility using Detention Management Control Program (DCMP) procedures and based upon the performance standard</li> <li>Periodic review in accordance with the attached performance monitoring tool</li> <li>Monthly review of corrective action plan results.</li> <li>Ad-hoc reviews as needed</li> <li>CDRs</li> </ul>	Performance fully complies with all elements of standard at a level no less than acceptable (see Section 7 of the QASP)	A rating of Deficient on any the standards will result in a 10% withholding in the monthly invoiced per-diem day rate until compliance with the standard is established.  A rating of At-Risk on any of the standards will result in a 10% withholding in the monthly invoiced per-diem day rate until compliance with the standard is established.

FUNCTIONAL AREA/ WEIGHT	PERFORMANCE STANDARD	PERFORMANCE MEASURE	METHOD OF SURVEILLANCE	ACCEPTABLE QUALITY LEVEL	WITHHOLDING CRITERIA
<p><b>Staff and Detainee Communication (2.5%)</b> (Addresses methods of communicating with detainees, detention/correctional staff training in diversity, and the detainee grievance process)</p>	<p>Detainee Grievances (ICE Standard) (<a href="http://www.ice.gov/doclib/partners/dro/opsmanual/griev.pdf">http://www.ice.gov/doclib/partners/dro/opsmanual/griev.pdf</a>)</p>	<p>Performance measures are reflected in the monitoring instrument that accompanies each standard or in the supplemental performance monitoring tool issued by the COIR</p>	<ul style="list-style-type: none"> <li>Annual review of facility using Detention Management Control Program (DCMP) procedures and based upon the performance standard</li> <li>Periodic reviews in accordance with the attached performance monitoring tool</li> <li>Monthly review of corrective action plan results.</li> <li>Ad-hoc reviews as needed</li> <li>CDRs</li> </ul>	<p>Performance fully complies with all elements of standard at a level no less than acceptable (see Section 7 of the QASP)</p>	<p>A rating of Deficient on any two of the standards will result in a 2.5% withholding in the monthly invoiced per-diem day rate until compliance with the standard is established.</p>
<p>Diversity Training 4-ALDF-6A-08, 4-ALDF-7B-10</p> <p>Staff Detainee Communication (ICE Standard) (<a href="http://www.ice.gov/doclib/partners/dro/opsmanual/Staff_Detainee_Communication.pdf">http://www.ice.gov/doclib/partners/dro/opsmanual/Staff_Detainee_Communication.pdf</a>)</p>	<p>Performance measures are reflected in the monitoring instrument that accompanies each standard or in the supplemental performance monitoring tool issued by the COIR</p>	<ul style="list-style-type: none"> <li>Annual review of facility using Detention Management Control Program (DCMP) procedures and based upon the performance standard</li> <li>Periodic reviews in accordance with the attached performance monitoring tool</li> <li>Monthly review of corrective action plan results.</li> <li>Ad-hoc reviews as needed</li> <li>CDRs</li> </ul>	<p>Performance fully complies with all elements of standard at a level no less than acceptable (see Section 7 of the QASP)</p>	<p>A rating of At-Risk on any of the standards will result in a 2.5% withholding in the monthly invoiced per-diem day rate until compliance with the standard is established.</p>	
<p><b>Safety and Sanitation (10%)</b> (Addresses the adequacy of fire safety programs, the control of dangerous materials, the general facility environment (including air quality, noise levels, and sanitation and hygiene programs), the adequacy of clothing and bedding, and from infectious diseases)</p>	<p>Environmental Health &amp; Safety (ICE Standard) (<a href="http://www.ice.gov/doclib/partners/dro/opsmanual/ehs/ehsfrom.pdf">http://www.ice.gov/doclib/partners/dro/opsmanual/ehs/ehsfrom.pdf</a>)</p> <p>Clothing and Bedding (ICE Standard) (<a href="http://www.ice.gov/doclib/partners/dro/opsmanual/clothing.pdf">http://www.ice.gov/doclib/partners/dro/opsmanual/clothing.pdf</a>)</p>	<p>Performance measures are reflected in the monitoring instrument that accompanies each standard or in the supplemental performance monitoring tool issued by the COIR</p>	<ul style="list-style-type: none"> <li>Annual review of facility using Detention Management Control Program (DCMP) procedures and based upon the performance standard</li> <li>Periodic reviews in accordance with the attached performance monitoring tool</li> <li>Monthly review of corrective action plan results.</li> <li>Ad-hoc reviews as needed</li> <li>CDRs</li> </ul>	<p>Performance fully complies with all elements of standard at a level no less than acceptable (see Section 7 of the QASP)</p>	<p>A rating of Deficient on any two of the standards will result in a 10% withholding in the monthly invoiced per-diem day rate until compliance with the standard is established.</p> <p>A rating of At-Risk on any of the standards will result in a 10% withholding in the monthly invoiced per-diem day rate until compliance with the standard is established.</p>

FUNCTIONAL AREA/ WEIGHT	PERFORMANCE STANDARD	PERFORMANCE MEASURE	METHOD OF SURVEILLANCE	ACCEPTABLE QUALITY LEVEL	WITHHOLDING CRITERIA
<p align="center"><b>Services and Programs (10%)</b> (Addresses detainee security classification, religious practices, work assignments, availability of exercise programs, access to legal materials, access to legal representation, access to a telephone, the handling of detainee mail and other correspondence, and visitation privileges)</p>	Access to Legal Material (ICE Standard) ( <a href="http://www.ice.gov/doclib/partners/dro/opsmanual/legal.pdf">http://www.ice.gov/doclib/partners/dro/opsmanual/legal.pdf</a> )	Performance measures are reflected in the monitoring instrument that accompanies each standard or in the supplemental performance monitoring tool issued by the COIR	<ul style="list-style-type: none"> <li>Annual review of facility using Detention Management Control Program (DCMP) procedures and based upon the performance standard</li> <li>Periodic reviews in accordance with the attached performance monitoring tool</li> <li>Monthly review of corrective action plan results.</li> <li>Ad-hoc reviews as needed</li> <li>CDRs</li> </ul>	Performance fully complies with all elements of standard at a level no less than acceptable (See section 7 of the QASP)	A rating of Deficient on any two of the standards will result in a 10% withholding in the monthly invoiced per-diem day rate until compliance with the standard is established.
	Classification, Review, and Housing (ICE Standard) ( <a href="http://www.ice.gov/doclib/partners/dro/opsmanual/classif.pdf">http://www.ice.gov/doclib/partners/dro/opsmanual/classif.pdf</a> )				
	Detainee Mail & Correspondence (ICE Standard) ( <a href="http://www.ice.gov/doclib/partners/dro/opsmanual/corrcsp.pdf">http://www.ice.gov/doclib/partners/dro/opsmanual/corrcsp.pdf</a> )				
	Group Legal Representation (ICE Standard) ( <a href="http://www.ice.gov/doclib/partners/dro/opsmanual/grplegal.pdf">http://www.ice.gov/doclib/partners/dro/opsmanual/grplegal.pdf</a> )				
	Marriage Requests (ICE Standard) ( <a href="http://www.ice.gov/doclib/partners/dro/opsmanual/marreq.pdf">http://www.ice.gov/doclib/partners/dro/opsmanual/marreq.pdf</a> )				
	Non-Medical Emergency Escorted Trips (ICE Standard) ( <a href="http://www.ice.gov/doclib/partners/dro/opsmanual/escort.pdf">http://www.ice.gov/doclib/partners/dro/opsmanual/escort.pdf</a> )				
	Recreation (ICE Standard) ( <a href="http://www.ice.gov/doclib/partners/dro/opsmanual/recreat.pdf">http://www.ice.gov/doclib/partners/dro/opsmanual/recreat.pdf</a> )				



FUNCTIONAL AREA/ WEIGHT	PERFORMANCE STANDARD	PERFORMANCE MEASURE	METHOD OF SURVEILLANCE	ACCEPTABLE QUALITY LEVEL	WITHHOLDING CRITERIA
<p><b>Workforce Integrity (15%)</b> (Addresses the adequacy of the detention/correctional officer hiring process, staff training and licensing/certification and adequacy of systems to report and address staff misconduct)</p>	<p>Religious Practices (ICE Standard) (<a href="http://www.ice.gov/doclib/partners/dro/opsmanual/colofh.pdf">http://www.ice.gov/doclib/partners/dro/opsmanual/colofh.pdf</a>) Telephone Access (ICE Standard) (<a href="http://www.ice.gov/doclib/partners/dro/opsmanual/teleacc.pdf">http://www.ice.gov/doclib/partners/dro/opsmanual/teleacc.pdf</a>) Voluntary Work Program (ICE Standard) (<a href="http://www.ice.gov/doclib/partners/dro/opsmanual/work.pdf">http://www.ice.gov/doclib/partners/dro/opsmanual/work.pdf</a>) Visitation Privileges (ICE Standard) (<a href="http://www.ice.gov/doclib/partners/dro/opsmanual/visit.pdf">http://www.ice.gov/doclib/partners/dro/opsmanual/visit.pdf</a>)</p>	<p>Performance measures are reflected in the monitoring instrument that accompanies each standard or in the supplemental performance monitoring tool issued by the COTR</p>	<ul style="list-style-type: none"> <li>Annual review of facility using Detention Management Control Program (DCMP) procedures and based upon the performance standard</li> <li>Periodic reviews in accordance with the attached contract performance monitoring tool</li> <li>Monthly review of corrective action plan results.</li> <li>Ad-hoc reviews as needed</li> <li>CDRs</li> </ul>	<p>Performance fully complies with all elements of standard at a level no less than acceptable (See section 7 of the QASP)</p>	<p>A rating of Deficient on any three of the standards will result in a 15% withholding in the monthly invoiced per-diem day rate until compliance with the standard is established.</p> <p>A rating of At-Risk on any of the standards will result in a 15% withholding in the monthly invoiced per-diem day rate until compliance with the standard is established.</p>
	<p>Staff Background and Reference Checks (Contract) 4-ALDF-7B-03 Staff Misconduct 4-ALDF-7B-01 Staffing Pattern Compliance within 10% of required (Contract) 4-ALDF-2A-14 Staff Training, Licensing, and Credentialing (Contract) 4-ALDF-4D-05, 4-ALDF-7B-05, 4-ALDF-7B-08</p>				

FUNCTIONAL AREA/ WEIGHT	PERFORMANCE STANDARD	PERFORMANCE MEASURE	METHOD OF SURVEILLANCE	ACCEPTABLE QUALITY LEVEL	WITHHOLDING CRITERIA
<p align="center"><b>Detainee Discrimination (2.5%)</b> (Addresses the adequacy of policies and procedures to prevent discrimination against detainees based on their gender, race, religion, national origin, or disability)</p>	<p>Discrimination Prevention 4-ALDF-6B-02-03</p>	<p>Performance measures are reflected in the monitoring instrument that accompanies each standard or in the supplemental performance monitoring tool issued by the COIR</p>	<ul style="list-style-type: none"> <li>• Annual review of facility using Detention Management Control Program (DCMP) procedures and based upon the performance standard</li> <li>• Periodic reviews in accordance with the attached performance monitoring tool (see attached)</li> <li>• Monthly review of corrective action plan results.</li> <li>• Ad-hoc reviews as needed</li> <li>• CDRs</li> </ul>	<p>Performance fully complies with all elements of standard at a level no less than acceptable (see Section 7 of the QASP)</p>	<p>A rating of Deficient on the standards will result in a 2.5% withholding in the monthly invoiced per-diem day rate until compliance with the standard is established.</p> <p>A rating of At-Risk on any of the standards will result in a 2.5% withholding in the monthly invoiced per-diem day rate until compliance with the standard is established.</p>

## QUASP Attachment 2 - Contract Discrepancy Report

CONTRACT DISCREPANCY REPORT		1. CONTRACT NUMBER	
<b>Report Number:</b>		<b>Date:</b>	
2. TO: (Contractor and Manager Name)		3. FROM: (Name of COTR)	
<b>DATES</b>			
CONTRACTOR NOTIFICATION	CONTRACTOR RESPONSE DUE BY	RETURNED BY CONTRACTOR	ACTION COMPLETE
4. DISCREPANCY OR PROBLEM <i>(Describe in Detail: Include reference in PWS / Directive: Attach continuation sheet if necessary.)</i>			
5. SIGNATURE OF CONTRACTING OFFICER'S TECHNICAL REPRESENTATIVE (COTR)			
6. TO: (COTR)		7. FROM: (Contractor)	
8. CONTRACTOR RESPONSE AS TO CAUSE, CORRECTIVE ACTION AND ACTIONS TO PREVENT RECURRENCE. ATTACH CONTINUATION SHEET IF NECESSARY. <i>(Cite applicable Q.A. program procedures or new A.W. procedures.)</i>			
9. SIGNATURE OF CONTRACTOR REPRESENTATIVE			10. DATE
11. GOVERNMENT EVALUATION OF CONTRACTOR RESPONSE/RESOLUTION PLAN: <i>(Acceptable response/plan, partial acceptance of response/plan, rejection: attach continuation sheet if necessary)</i>			
12. GOVERNMENT ACTIONS <i>(Payment withholding, cure notice, show cause, other.)</i>			
<b>CLOSE OUT</b>			
CONTRACTOR NOTIFIED	NAME AND TITLE	SIGNATURE	DATE
COTR			
CONTRACTING OFFICER			

# QUASP Attachment 3 – Performance Monitoring Tool

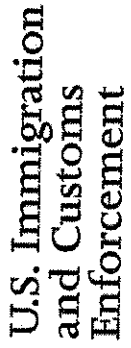

Detention and Removal Operations  
 Performance Monitoring Tool  
 Facility Name: \_\_\_\_\_ Month/Year: \_\_\_\_\_

Frequency	DEVIATION STANDARD	Rating A/D/R	Corrective Action Required / Comments	Due Date
D	<b>1. Admission and Release</b>			
W	A. ICE information is available for initial classification			
M	B. Medical screening taking place within timeframes			
O	C. Inventory detainee personal effects			
	D. Detainee funds accountability in place for admin/release			
	E. All visual searches documented and are not routine in procedure			
	F. Appropriate clothing and bedding issued			
	G. Orientation material in English, Spanish or most prevalent second language			
	<b>2. Detainee Classification System</b>			
	A. All detainees classified appropriately upon arrival			
	B. Reassessment and reclassification process in place			
	C. Housing assignments are based upon classification			
	D. Work assignments are based upon classification system			
	E. Detainees are assigned color coded uniforms/wrist bands to reflect classification level			
	<b>3. Contraband</b>			
	A. Policy in place for handling contraband			
	B. Contraband disposed of properly and documented			
	C. Facility staff make a concerted effort to control			





D	W	M	Q	DEFENTION STANDARDS	Rating A/D/R	Corrective Action Required/ Comments	Due Date
				<b>10. Non-Medical Emergency Escorted Trips</b>			
			A.	The Field Office Director considers and approves, on a case-by-case basis, trips to visit an immediate family member in accordance with standards			
				<b>11. Security Inspections</b>			
			A.	Staff are required to conduct security check of assigned areas			
			B.	All visitors officially recorded in a visitor log book			
			C.	Front entrance staff inspect ID of everyone entering/exiting			
			D.	Maintain a log of all incoming and departing vehicles			
			E.	Housing unit searches occur at irregular times			
			F.	Area searches documented in log book			
			G.	Daily/Monthly fence checks completed and logged			
			H.	Facility administrator or designee and department heads visit housing units and activity areas weekly			
			I.	Officers monitor all vehicular traffic entering and leaving the facility			
			J.	The facility has a written policy and procedures to prevent the introduction of contraband into the facility or any of its components			
			K.	Security officer posts located in or immediately adjacent to detainee living areas to permit officers to see or hear and respond promptly to emergency situations. Personal contact and interaction between staff and detainees is required and facilitated			
			L.	Daily procedures include: perimeter alarm system tests; physical checks of the perimeter fence; documenting the results			

D	W	M	Q	DETENTION STANDARDS	Rating A/D/R	Corrective Action Required/ Comments	Due Date
			M.	Tools being taken into the secure area of the facility are inspected and inventoried			
				<b>12. Food Service</b>			
			A.	Appropriate security measures for sharps are in place			
			B.	Appropriate food temperatures are maintained for both hot and cold food			
			C.	Food Service department maintained at a high level of sanitation			
			D.	Detainees receive safety and appropriate equipment training prior to beginning work in department			
			E.	A minimum of two hot meals served daily			
			F.	Facility has a standard 35 day cycle menu			
			G.	A registered dietician conducts nutritional analysis			
			H.	All menu changes documented			
			I.	Common fare menu for authorized detainees			
			J.	Weekly inspections conducted and documented			
				<b>13. Funds and Personal Property</b>			
			A.	Inventory personal property/funds is maintained			
			B.	Funds/valuables documented on receipt			
			C.	Detainees property searched for contraband			
			D.	Staff forward arriving detainees medication to medical staff			
			E.	Detainee funds are deposited into the cash box			
			F.	Staff secure every container used to store property with a tamper-proof numbered strap			
			G.	Quarterly audits of detainee baggage & luggage are conducted, verified, and logged			
D	W	M	Q	DETENTION STANDARDS	RATING A/D/R	Corrective Action Required/ Comments	Due Date











## **Town of Farmville – ICE Facility: DROISA-08-0021**

**May 9, 2008**

### **Quality Control Plan**

#### **PURPOSE**

To develop and implement a Quality Control Plan which will ensure compliance with all required Town of Farmville—ICE Facility quality standards and the ICE standards to be monitored under the Government's Quality Assurance Surveillance Plan.

#### **POLICY**

It is the policy of the Town of Farmville—ICE Facility to ensure all applicable standards, polices and procedures are adhered to.

- A. The Town of Farmville—ICE Facility will adopt, adapt and/or establish procedures that will meet or exceed the objective represented by each of the 38 Detention Standards outlined in the QUASP Attachment 3—Performance Monitoring Tool.

#### **PROCEDURES**

The Town of Farmville—ICE Facility will establish policies and procedures that will govern the facility.

- A. These policies and procedures will meet or exceed the minimum standards required by the Department of Homeland Security and the Department of Immigration and Customs Enforcement.
- B. A designated employee(s) will be responsible for the compliance of such policies and procedures.
  1. The enforcement of these practices will be considered the Quality Control Plan.

#### **Quality Control Plan**

- A. All policies and procedures will be reviewed on an annual basis by the Quality Control Officer and other designated staff.
- B. The COO (Senior Member of Management) at the Town of Farmville—ICE Facility will meet quarterly with the Quality Control Officer to ensure that all policies and procedures are enforced.
  1. All policies and procedure plans will comply with the Town of Farmville—ICE Facility standards of confidentiality, accountability, review and revision.

- C. The Quality Control Officer will maintain a cooperative relationship with ICE and will share information with his/her ICE "counterpart" and coordinate planning to interact with him/her accordingly.
- D. The QCO will train and brief the staff in the implementation and enforcement of the policies and procedures.
- E. The QCO will tap into the expertise of all Department Heads during the review process.
  - 1. This inclusive process will ensure that all departments have input into the plan.
  - 2. It will also ensure the compliance of all standards and improve the quality of service to the detainee residents and the DHS—ICE.
- F. The QCO will update the policy and procedure plans, as often as is necessary, to keep them current.
  - 1. All revisions recommended by the QCO will be forwarded to the Town of Farmville—ICE Facility's COO (Senior Member of Management) for approval.

### Staff Actions

The enforcement of the Quality Control Plan will allow staff members to improve the quality of the detainee's care and improve the chance of deflecting detainee unrest, if the staff:

- A. Discusses the set Quality Control Plan, as well as policies, procedures and programs, at all staff meetings and during on-going interaction during work hours.
- B. Always acts in a manner that treats detainees fairly and impartially.
- C. Consistently follows and enforces the established policies and procedures.

### Confidentiality

Every Quality Control Plan will include a statement prohibiting unauthorized Plan disclosure. This applies equally to the development stages to the finished Quality Control Plan.

- A. The staff will not discuss any aspects of a Quality Control Plan anywhere within hearing distance of a detainee and visitor.

### Plan Details

Detail plans for each of the 38 Detention Standards (outlined in the QUASP Attachment 3—Performance Monitoring Tool) will be complete once the contract is awarded and forwarded to ICE for review within two weeks of the contract being signed.

DEPARTMENT OF HOMELAND SECURITY (DHS)  
IMMIGRATION AND CUSTOMS ENFORCEMENT (ICE)  
OFFICE OF DETENTION AND REMOVAL (DRO)

REQUEST FOR PROPOSAL--ICE Detainee Services

STATEMENT OF WORK

Date: 4/02/2008

FACILITY LOCATION

**Town of Farmville**  
116 North Main Street  
Farmville, Virginia 23901

**I. Performance:**

The **PROVIDER** is required, in units housing U.S. Immigration and Customs Enforcement (ICE) detainees, to perform in accordance with the most current editions of the ICE National Detention Standards, American Correctional Association (ACA) Standards for Adult Local Detention Facilities (ALDF), and Standards Supplement, Standards for Health Services in Jails, latest edition, National Commission on Correctional Health Care (NCCHC). Some ACA standards are augmented by ICE policy and/or procedure. In cases where other standards conflict with ICE Policy or Standards, ICE Policy and Standards prevail. ICE Inspectors will conduct periodic inspections of the facility to assure compliance of the aforementioned standards.

**II. Anticipated Start Of Performance: TBD**

**III. Exclusivity:**

The **CONTRACTOR** or **PROVIDER** agrees that the facility is to be for the exclusive use of ICE and its detainee population. No other agency will be allowed to use the facility to house its detainees, prisoners, or inmates without prior approval of the Contracting Officer with input from the Contracting Officer's Technical Representative. If given approval, a separate bed day rate shall be negotiated with the other agency and ICE shall not be responsible for payment related to beds used by another agency. The other agency will be separately invoiced for the beds it uses. The duration of the use of beds will be determined on a case by case basis.

**IV. Armed Transportation Service:**

A. Transportation service shall include the following:

1. The **PROVIDER** shall provide all such ground transportation services as may be required to transport detainees securely, in a timely manner, to locations as directed by the COTR or designated ICE Official. When **PROVIDER** employees are not providing transportation services, the

**PROVIDER** shall assign the employees to supplement security duties within the Facility to assist ICE as directed by the COTR or designated ICE official. However, the primary function of these Service Provider employees is transportation. Duties as directed by the COTR utilizing these employees shall not incur any additional expense to ICE.

2. The **PROVIDER** shall assign, at a minimum, two person teams of transportation officers on a daily basis distributed throughout a twenty-four (24) hour period seven (7) days a week including weekends and holidays. The COTR shall approve the number of teams assigned to any shift or period of time in order to meet the needs of ICE transportation requirements.
3. The **PROVIDER** shall furnish suitable vehicles in good condition, approved by the Government, to safely provide the required transportation services per facility as listed below. The **PROVIDER** shall comply with all federal and state laws with regard to inspections, licensing, and registration for all vehicles used for transportation.
4. Nothing in this agreement shall restrict the **PROVIDER** from acquiring additional vehicles as deemed necessary by the **PROVIDER** at no cost to the Government. The **PROVIDER** shall not allow employees to use their privately owned vehicles to transport detainees. The **PROVIDER** shall furnish vehicles equipped with interior security features (such as, but not limited to: door lock controls, window locks, a wire cage with acrylic panel between the driver seat and the rear passenger seats) and be in accordance with ICE National Detention Standards including physical separation of detainees from guards. The **PROVIDER** shall provide the interior security specification of the vehicles to ICE for review and approval prior to installation.
5. In the event of transportation services involving distances that exceed a standard eight (8) hour workday to complete, the **PROVIDER** shall be reimbursed for related costs of lodging and meals commiserate with the U.S. General Services Administration rates for such within the geographical area of occurrence. Any incurred overtime pay for such services will be reimbursed at the applicable Department of Labor overtime rate for the transportation officer position incorporated within this agreement. The **PROVIDER** shall comply with ICE transportation standards related to the number of hours the **PROVIDER** employee may operate a vehicle. Overnight lodging resulting from transportation services shall be approved in advance by the COTR or designated ICE official.
6. All transportation shall be accomplished in the most economical manner.

7. The **PROVIDER** shall, upon order of the COTR, or upon his own decision in an urgent medical situation with notification to the COTR immediately thereafter, transport a detainee to a hospital location. An officer(s) shall keep the detainee under supervision 24 hours per day until the detainee is ordered released from the hospital, or at the order of the COTR. The **PROVIDER** shall then return the detainee to the Facility.
8. The **PROVIDER** personnel provided for the above services shall be of the same qualifications, receive the same training, complete the same security clearances, and wear the same uniforms as those **PROVIDER** personnel provided in the other areas of this agreement. Transportation officers shall have the required state licenses for commercial drivers with the proper endorsement limited to vehicles with Automatic Transmission and the state DMV Medical Certification.
9. During all transportation activities, at least one transportation officer shall be the same sex as the detainee(s). Questions concerning guard assignments shall be directed to the COTR for final determination.
10. All transportation Detention Officers shall be armed in the performance of these duties.
11. The COTR may direct the **PROVIDER** to transport detainees to miscellaneous locations.
12. When the COTR provides documents to the **PROVIDER** concerning the detainee(s) to be transported and/or escorted, the **PROVIDER** shall deliver these documents only to the named authorized recipients. The **PROVIDER** shall ensure the material is kept confidential and not viewed by any person other than the authorized recipient.
13. The **PROVIDER** shall establish a fully operational communication system compatible with ICE communication equipment that has direct and immediate contact with all transportation vehicles and post assignments. Upon demand, the COTR shall be provided with current status of all vehicles and post assignment employees.
14. Failure of the **PROVIDER** to comply fully with the detainee(s) departure as pre-scheduled shall result in the **PROVIDER** having deductions made for non-performance.



B. ANTICIPATED TRANSPORTATION ROUTES

The following transportation routes/destinations are anticipated requirements for this agreement. The following requirements are **one way routes**; these routes (mile approximations) are not all inclusive and should not be limited to the following:

<i>Legend</i>	<i>Daily = 2 times plus per week; Weekly = 2 or less per week; Periodic = as required</i> <i>Mileage = One Way</i>		
<b>Mileage From Farmville, VA</b>	<b>Locations</b>	<b>City</b>	<b>Frequency</b>
	<b>Field Offices</b>		
164	Detention and Removal Office	Fairfax	Daily
121	Detention and Removal Office	Harrisonburg	Weekly
153	Detention and Removal Office	Norfolk	Daily
65	Detention and Removal Office	Richmond	Daily
100	Detention and Removal Office	Roanoke	Weekly
	<b>JPATS/DOCC Destinations</b>		
173	Dulles International Airport	Washington, DC	Periodic
289	Harrisburg International Airport	Harrisburg, PA	Weekly
69	Richmond International Airport	Richmond	Proposed weekly
143	Piedmont Triad International Airport	Greensboro, NC	Proposed weekly
455	Stewart Detention Center	Stewart, GA	Periodic
266	York Detention Center	York, PA	Weekly
	<b>Jails</b>		
162	Alexandria City Jail	Alexandria	Daily
166	Arlington County Jail	Arlington	Daily
120	Augusta Correctional Center	Craigsville	Daily
180	Bland Correctional Center	Bland	Daily
59	Brunswick Correctional Center	Lawrenceville	Daily
22	Buckingham Correctional Center	Dillwyn	Daily
85	Central Virginia Regional Jail	Orange	Daily
145	Chesapeake City Jail	Chesapeake	Daily
96	Coffeewood Correctional Center	Coffeewood	Daily
170	DC Jail (Central Detention, Central Treatment)	Washington, DC	Daily
47	Deep Meadow Correctional Center	State Farm	Daily
22	Dillwyn Correctional Center	Dillwyn	Daily
48	Dinwiddie Correctional Unit	Church Road	Daily
160	Fairfax County Jail	Fairfax	Daily
67	FCI Petersburg - Camp - Virginia	Petersburg	Daily
67	FCI Petersburg - Low - Virginia	Petersburg	Daily
67	FCI Petersburg - Medium - Virginia	Petersburg	Daily

<b>Mileage From Farmville, VA</b>	<b>Locations</b>	<b>City</b>	<b>Frequency</b>
92	Green Rock Corr Center (New 06/2007)	Chatham	Daily
74	Greensville Correctional Center	Jarratt	Daily
138	Hampton City Jail	Hampton	Daily
136	Hampton Roads Regional Jail	Portsmouth	Daily
124	Haynesville Correctional Center	Haynesville	Daily
64	Henrico County Jail	Richmond	Daily
48	James River Correctional Center	State Farm	Daily
59	Lawrenceville Correctional Center	Lawrenceville	Daily
169	Loudoun County Jail	Leesburg	Daily
53	Mecklenburg Correctional Center	Boydton	Daily
116	Middle Peninsula Regional Jail	Saluda	Daily
141	Newport News City Jail	Newport News	Daily
141	Norfolk City Jail	Norfolk	Daily
194	Northampton County Jail	Eastville	Daily
115	Northern Neck Regional Jail	Warsaw	Daily
190	Northwestern Regional ADC	Winchester	Daily
19	Nottoway Correctional Center	Burkeville	Daily
79	Pamunkey Regional Jail	Hanover	Daily
67	Petersburg City Jail	Petersburg	Daily
0	Piedmont Regional Jail	Farmville	Daily
140	Portsmouth City Jail	Portsmouth	Daily
48	Powhatan Correctional Center	State Farm	Daily
156	Prince William/Manassas Regional Jail	Manassas	Daily
126	Rappahannock Regional Jail	Stafford	Daily
296	Red Onion State Prison	Pound	Daily
67	Richmond City Jail	Richmond	Daily
73	Riverside Regional Jail	Hopewell	Daily
122	Rockingham/Harrisonburg Regional Jail	Harrisonburg	Daily
155	St. Brides Correctional Center	Chesapeake	Daily
77	Sussex County Jail	Sussex	Daily
155	Virginia Beach City Jail	Virginia Beach	Daily
46	Virginia Correctional Center for Woman	Goochland	Daily
121	Western Tidewater Regional Jail	Suffolk	Daily
29	Appomattox County Jail	Appomattox	Daily to Weekly
52	Chesterfield County Jail	Chesterfield	Daily to Weekly
111	Culpeper County Jail	Culpepper	Daily to Weekly
135	Fauquier County Jail	Warrenton	Daily to Weekly
100	Roanoke City Jail	Roanoke	Daily to Weekly
158	Shenandoah County Jail	Woodstock	Daily to Weekly
119	Virginia Peninsula Regional Jail	Williamsburg	Daily to Weekly
89	Danville City Jail	Danville	Weekly
108	Franklin County Jail	Rocky Mount	Weekly
120	Gloucester County Jail	Gloucester	Weekly

<b>Mileage From Farmville, VA</b>	<b>Jails</b>	<b>City</b>	<b>Frequency</b>
119	Henry County Jail	Martinsville	Weekly
155	Indian Creek Correctional Center	Chesapeake	Weekly
30	Lunenburg Correctional Center	Victoria	Weekly
100	Middle River Regional Jail	Staunton	Weekly
153	New River Valley Regional Jail	Dublin	Weekly
103	Peumansend Creek Regional Jail	Bowling Green	Weekly
111	Roanoke County Jail	Salem	Weekly
94	Southampton Correctional Center	Capron	Weekly
204	Marion Treatment Center	Marion	Weekly to Periodic
310	USP Lee - Virginia	Jonesville	Weekly to Periodic
225	Accomack County Jail	Accomac	Periodic
59	Albemarle/Charlottesville Regional Jail	Charlottesville	Periodic
135	Alleghany County Regional Jail	Covington	Periodic
60	Amherst County Jail	Amherst	Periodic
72	B.R.R.J. - Bedford County ADC	Bedford	Periodic
47	B.R.R.J. - Campbell County ADC	Rustburg	Periodic
50	B.R.R.J. - Lynchburg City Jail	Lynchburg	Periodic
58	B.R.R.J.A. - Halifax County ADC	Halifax	Periodic
53	Baskerville Correctional Center	Baskerville	Periodic
103	Botetourt Correctional Center	Troutville	Periodic
108	Botetourt County Jail	Fincastle	Periodic
247	Bristol City Jail	Bristol	Periodic
60	Brunswick County Jail	Lawrenceville	Periodic
59	Brunswick Work Center for Women	Lawrenceville	Periodic
90	Caroline Correctional Unit #2	Hanover	Periodic
52	Central Virginia Correctional Unit #13	Chesterfield	Periodic
26	Charlotte County Jail	Charlotte Court House	Periodic
87	Cold Springs Correctional Unit #10	Greenville	Periodic
87	Cold Springs Work Center	Greenville	Periodic
88	Danville City Jail Farm	Danville	Periodic
992	Deerfield Correctional Center	Capron	Periodic
60	Dinwiddie County Jail	Dinwiddie	Periodic
65	Fluvanna Correctional Center for Women	Troy	Periodic
74	Greenville Work Center	Jarratt	Periodic
58	Halifax Correctional Unit #23	Halifax	Periodic
124	Haynesville Correctional Unit #17	Haynesville	Periodic
48	James River Work Center	State Farm	Periodic
265	Keen Mountain Correctional Center	Oakwood	Periodic
141	Lancaster County Jail	Lancaster	Periodic
123	Martinsville City Jail	Martinsville	Periodic
51	Mecklenburg County Jail	Boydton	Periodic
66	Medical College of Virginia	Richmond	Periodic

Mileage From Farmville, VA	Jails	City	Frequency
136	Montgomery County Jail	Christiansburg	Periodic
131	Newport News City Jail Farm	Newport News	Periodic
19	Nottoway Work Center	Burkeville	Periodic
132	Page County Jail	Luray	Periodic
150	Patrick County Jail	Stuart	Periodic
130	Patrick Henry Correctional Unit #28	Ridgeway	Periodic
92	Pittsylvania County Jail	Chatham	Periodic
152	Pulaski Correctional Center	Dublin	Periodic
123	Rappahannock County Jail	Washington	Periodic
93	Rockbridge Regional Jail	Lexington	Periodic
47	Rustburg Correctional Unit #9	Rustburg	Periodic
109	Southampton County Jail	Courtland	Periodic
94	Southampton Pre-Release and Work Center for Women	Capron	Periodic
94	Southampton Work Center for Men	Capron	Periodic
79	Southside Regional Jail	Emporia	Periodic
288	Southwest Virginia Regional Jail	Hayso	Periodic
236	Southwest Virginia Regional Jail Authority - Abingdon	Abingdon	Periodic
291	Southwest Virginia Regional Jail Authority - Duffield	Duffield	Periodic
219	Southwest Virginia Regional Jail Authority - Tazewell	Tazewell	Periodic
91	Sussex I State Prison	Waverly	Periodic
91	Sussex II State Prison	Waverly	Periodic
219	Tazewell Correctional Unit #31	Tazewell	Periodic
310	USP Lee - Camp -Virginia	Jonesville	Periodic
294	Wallens Ridge State Prison	Big Stine Gap	Periodic
139	Warren County Jail	Front Royal	Periodic
275	Wise Correctional Unit	Coeburn	Periodic

**V. Guard Services:**

- A. The **PROVIDER** agrees to provide stationary guard services on demand by the COTR and shall include, but not limited to, escorting and guarding detainees to medical or doctor's appointments, hearings, ICE interviews, and any other remote location requested by the COTR. Qualified detention officer personnel employed by the **PROVIDER** under its policies, procedures, and practices will perform such services. The **PROVIDER** agrees to augment such practices as may be requested by ICE to enhance specific requirements for security, detainee monitoring, visitation, and contraband control. Public contact is prohibited unless authorized in advance by the COTR.
- B. The **PROVIDER** shall be authorized two (2) officers for each such remote location, unless at the direction of the COTR or designated Agency official as additional officers are required.

- C. The itemized monthly invoice for such stationary guard services shall state the number of hours being billed, the duration of the billing (times and dates) and the names of the detainees that were guarded. Such services shall be denoted as a separate item on submitted invoices. ICE agrees to reimburse the **PROVIDER** for actual stationary guard services provided at a negotiated rate.

**VI. Medical Services:**

- A. The **PROVIDER** shall be responsible for the provision of health care services for ICE detainees at the facility.
- B. In the event of an emergency, the **PROVIDER** shall proceed immediately with necessary medical treatment. In such event, the **PROVIDER** shall notify ICE immediately regarding the nature of the transferred detainee's illness or injury and type of treatment provided.
- C. The **PROVIDER** shall ensure that all health care service providers utilized for ICE detainees hold current licenses, certifications, and/or registrations with the State and/or City where they are practicing. The **PROVIDER** shall retain a registered nurse to provide health care and sick call coverage unless expressly stated otherwise in this Agreement. In the absence of a health care professional, non-health care personnel may refer detainees to health care resources based upon protocols developed by the United States Public Health Service (USPHS) Division of Immigration Health Services (DIHS). Healthcare or health trained personnel may perform screenings.
- D. The **PROVIDER** shall ensure that onsite medical and health care coverage as defined below is available for all ICE detainees at the facility for twenty-four (24) hours per day, seven (7) days per week. The **PROVIDER** shall ensure that its employees solicit each detainee for health complaints and deliver complaints in writing to the medical and health care staff.
- E. The **PROVIDER** shall furnish onsite health care under this Agreement. The **PROVIDER** shall not charge any ICE detainee an additional fee or co-payment for medical services or treatment provided at the **PROVIDER'S** facility. The **PROVIDER** shall ensure that ICE detainees receive no lower level of onsite medical care and services than those it provides to local inmates. Onsite health care services shall perform initial medical screening (inclusive of the skin test/PPD) within the first twenty-four (24) hours of arrival to the facility, sick call coverage, provision of over-the-counter medications, treatment of minor injuries (e.g. lacerations, sprains, and contusions), treatment of special needs and mental health assessments. A full medical screening must be done within the first 14 days of detainee arrival. Detainees with chronic conditions shall receive prescribed treatment and follow-up care. Arrival screening shall include at a minimum TB symptom screening, planting of the Tuberculin; skin Test (PPD), and recording the history of past and present illnesses (mental and physical).

- F. If the **PROVIDER** determines that an ICE detainee has a medical condition which renders that person unacceptable for detention under this Agreement, (for example, contagious disease, condition needing life support, uncontrollable violence), the **PROVIDER** shall notify ICE. Upon such notification, the **PROVIDER** shall allow ICE reasonable time to make the proper arrangements for further disposition of that detainee.
- G. The DIHS acts as the agent and final health authority for ICE on all off-site detainee medical and health related matters. The relationship of the DIHS to the detainee equals that of physician to patient. The **PROVIDER** shall release any and all medical information for ICE detainees to the DIHS representatives upon request, except where prohibited by federal or state law or regulation. The **PROVIDER** shall solicit DIHS approval before proceeding with non-emergency, off-site medical care (e.g. off site lab testing, eyeglasses, cosmetic dental prosthetics, and dental care for cosmetic purposes). The **PROVIDER** shall submit supporting documentation for non-routine, off-site medical/health services to DIHS. For medical care provided outside the facility, the DIHS may determine that an alternative medical provider or institution is more cost-effective or more aptly meets the needs of ICE and the detainee. ICE may refuse to reimburse the **PROVIDER** for non-emergency medical costs incurred that were not pre-approved by the DIHS. The **PROVIDER** shall send requests for pre-approval for non-emergency off-site care to:

United States Public Health Service  
Division of Immigration Health Services  
1220 L Street, NW, PMB 468  
Washington, DC 20005-4018  
Phone: (703) 541-2155  
Fax: (202) 318-0080

- H. The **PROVIDER** is to notify all medical providers approved to furnish off-site health care of detainees to submit their bills in accordance with instructions provided to:

BCE Emergis  
DIHS Claims  
P.O. Box 10250  
Gaithersburg, MD 20898-0250  
Phone: (888) 383 (b)(2)Low  
Fax: (888) 383 (b)(2)Low

- I. The **PROVIDER** shall furnish twenty-four (24) hour emergency medical care and emergency evacuation procedures. In an emergency, the **PROVIDER** shall obtain the medical treatment required to preserve the detainee's health. The **PROVIDER** shall have access to an off site emergency medical provider at all times. The Health Authority of the **PROVIDER** shall notify the DIHS Managed Care Coordinators, ICE Health Services, 1220 L Street, NW, PMB 468,

Washington, DC, 20005-4018, phone (888) 718-8947, fax (202) 318-0080, as soon as possible, and in no case more than seventy-two (72) hours after detainee receipt of such care. The Health Authority will obtain pre-authorization from the DIHS Managed Care Coordinator for service(s) beyond the initial emergency situation.

- J. The **PROVIDER** shall allow DIHS Managed Care Coordinators reasonable access to its facility for the purpose of liaison activities with the Health Authority and associated Service Provider departments.
- K. The **PROVIDER** and all medical providers approved to furnish off-site health care of detainees shall submit their bills to:

BCE Emergis  
DIHS Claims  
P.O. Box 10250  
Gaithersburg, MD 20898-0250  
Phone: (888) 383- (b)(2)Low  
Fax: (888) 383 (b)(2)Low

- L. The ICE and PHS may refuse to reimburse the **PROVIDER** for non-emergency medical costs incurred that were not pre-approved by the DIHS.
- M. The **PROVIDER** agrees to accept and provide for the secure custody, care, and safekeeping of detainees in accordance with the State, and local laws, standards, policies, procedures, or court orders applicable to the operations of the facility.
- N. The **PROVIDER** agrees to provide ICE detainees with the same level of medical care and services as provided to non-ICE detainees as part of the per diem rate. This rate includes:
- On-site sick call (when provided by on-site staff);
  - Medication (over the counter/non-legend and routine drugs and medical supplies);
  - Escort/security services for transport to/from emergency or non-emergency health care services as either an in-patient or out-patient.

## VII. ICE Physical Plant Requirements

### A. ICE Office Space

The **PROVIDER** shall refer to ICE Design Standards for specific office and workstation sizes and specific furnishing requirements for a 1000 bed facility. The Standards include but are not limited to the following:

1. A total of 34 offices and 46 workstations as outlined below:

- a. 1 Office - Assistant Field Office Director GS-1801-14
- b. 1 Office - Officer in Charge GS-1801-14
- c. 1 Office - Assistant Officer in Charge GS-1801-14
- d. 1 Office - Intelligence Officer GS-1801-14
- e. 1 Office - Chief Immigration Enforcement Agent GS-1801-13
- f. 4 Offices - Supervisory Detention & Deportation Officers GS-1801-13
- g. 16 Offices - Deportation Officers GS-1801-12
- h. 2 Offices - Supervisory Immigration Enforcement Agents GS-1801-11
- i. 26 Workstations - Immigration Enforcement Agents GS-1801-5/7/9
- j. 2 Offices - Supervisory Deportation Assistant, GS-1802-09
- k. 16 Workstations - Detention & Removal Assistants GS-1802-07
- l. 1 Office - Mission Support Specialist GS-0301-9/11/12
- m. 2 Offices - Contracting Officer's Technical Representative, GS-1102-09
- n. 1 Office - Intelligence Research Specialist GS-1801-09
- o. 1 Office - Training Officer GS-1801-11
- p. 2 Workstations - Mission Support Assistant GS-0301-5/7
- q. 1 Workstation - Receptionist
- r. 1 Workstation - OIC Secretary
- s. 1 Workstation - Records Tech
- t. 1 Workstation - Mail/File Clerk
- u. File rooms (see Standards for size and quantity)
- v. Conference rooms adjacent to or within ICE area (see Standards for size and quantity)
- w. Employee break rooms (see Standards for size and quantity)
- x. IT computer support rooms must be provided through out ICE space per the specifications. Including specialized requirements for climate control of IT equipment rooms for PHS, EOIR and ICE office area.
- y. Actual location, layout, configuration, and size of rooms will be determined during the final design phase.

#### B. OPLA Space

The **PROVIDER** shall refer to ICE Design Standards for specific office and workstation sizes and specific furnishing requirements for a 1000 bed facility. All furniture and case goods shall be furnished by the service provider in accordance with ICE Design Standards. The Standards include but are not limited to the following:

- 1. 1 Office - Deputy Chief Counsel (see Standards for size)
- 2. 12 Offices - Assistant Chief Counsel (see Standards for size)
- 3. 4 Workstations - Legal Technicians (see Standards for size)
- 4. 1 Workstation - Mail/File Clerk



5. Office support space must be provided per the ICE/OPLA Design Standards.
6. OPLA Space

#### C. EOIR Space

The **PROVIDER** shall refer to ICE/EOIR Design Standards for specific office and workstation sizes and specific furnishing requirements for a 1000 bed facility. All furniture and case goods shall be furnished by the service provider in accordance with ICE Design Standards. The Standards include but are not limited to the following:

1. 5 - Courtrooms and accompanying office and support space as per the EOIR Design Standards for a 1000 bed facility. The office space is per the EOIR Design Standards. Each courtroom should have the capability to hold live court as well as hold video tele-conferencing court. All furniture and case goods shall be furnished by the service provider in accordance with ICE Design Guide and specifications.
2. 15 - Hard walled offices (see Standards for size)
3. 15 - Workstations (see Standards for size)
4. Visitation space must be provided to meet the ACA and NDS standards.
5. Separate entrance for judges required with complete security system and access to parking lot. Must be ADA compliant.
6. EOIR Support Space must be provided per the EOIR Design Standards.

#### D. Health Services

Healthcare services will be provided by the **PROVIDER**.

#### E. Facility Requirements for Infectious Disease Screening

The Service Provider will ensure that there is adequate space and equipment to provide medical intake screening including a TB screening chest x-ray within the intake processing area. In order to prevent the spread of airborne infectious disease or cross contamination of zones within the facility, the HVAC system in the Intake Screening Area will be constructed to exhaust to the exterior and prevent air exchange between the intake screening area and any other area within the facility.

#### F. Infectious Disease Screening

In order to prevent the transmission of Tuberculosis (TB) to the resident population of a detention facility, the Service Provider will perform TB screening as part of the a routine infectious disease screening within 12 hours of detainee admission and obtain documented clearance of transmissible disease before the detainee is assigned to a housing unit or is transferred from the intake processing area. A screening chest x-ray will be performed by a trained and qualified health care provider and interpreted by a credentialed radiologist. Detainees will remain isolated from the rest of the facility population (remain in the intake screening

area) until the chest x-ray report is obtained and the interpretation verifies that the detainee is free of infectious TB (turnaround time for chest x-ray interpretation should be 4 hours or less). Detainees who are found to be infected or where there is a possibility that they are infected will be assigned to a respiratory isolation unit until treatment or further testing is done and the detainee is no longer infectious.

#### G. Teleradiology Service Provider

1. The Detention Service Provider shall use the services of the ICE Teleradiology Service Provider (ITSP). The cost of the equipment; maintenance of the equipment; training of staff; arrangements for interpretation of the x-rays by credentialed radiologists; and transmission of data to and from the Detention Facility are provided by the ITSP and charged directly to ICE. The Service Provider shall coordinate with the ITSP to ensure adequate space is provided for the equipment, connectivity and electrical services are installed, immediate 24/7 access to equipment for service and maintenance by ITSP technicians is granted, a teleradiology coordinator is appointed and available for training by the ITSP, and medical staff is available to perform the screening exams and receive reports. The teleradiology coordinator may be a nurse or nurse practitioner and collateral duty of the appointed staff (it is not necessary to appoint a full time coordinator if the volume of work does not support a full time employee).
2. Teleradiology equipment requires high voltage power to accommodate x-ray equipment, specifications will be provided by ICE.

#### H. Processing Area

1. Expansion required in this area includes the need to accommodate processing varying numbers of detainees for intake and out-processing, i.e., large buses transport of up to 100 detainees.
2. Processing area must be designed to process male and/or female detainees as required in high frequency rates and varying numbers, i.e., a busload up to 100 detainees at one time.

#### I. Furniture

All furniture and case goods shall be furnished by the service provider in accordance with ICE Design Guide and specifications, which include ICE support space and all operational components which include EOIR, OPLA and DIHS space as required in accordance with the ICE Design Standards.

#### J. ICE IT Equipment

ICE will provide and install IT equipment in office spaces for ICE personnel only, to include computer workstations and screens, printers and fax machines. All

infrastructure, cabling, and interfacing equipment shall be provided by the Service Provider at time of construction.

**NOTE:** ICE IT system must be a complete, independent and physically separate system from the Service Provider's IT system. The system shall serve all operational components: ICE, OPLA, and DIHS. EOIR shall have a separate system within EOIR IT space as per the EOIR Design Standards.

#### K. Communication Equipment

The service provider shall purchase, install and maintain a complete and operating communication system, which includes but is not limited to: cabling, fiber optics, patch panels, landing blocks, circuits, PBX and voice mail, phone sets and other supporting infrastructure and supporting system in compliance with ICE specifications. Separate billing to ICE must be established on all reoccurring service fees for communications and IT. Systems shall be installed specifically for ICE use.

**NOTE:** ICE communication system must be a complete, independent and physically separate system from the Service Provider communication system, and billed separately. The system shall serve all operational components: ICE, OPLA, and DIHS. EOIR shall have a separate system within EOIR IT space as per the EOIR Design Standards.

Service Provider see attached SOW for phone system details.

#### VIII. Detainee Work Program:

1. Detainee labor shall be used in accordance with the detainee work plan developed by the **PROVIDER**, and will adhere to the ICE National Detention Standard on Detainee Voluntary Work Program. The detainee work plan must be voluntary, and may include work or program assignments for industrial, maintenance, custodial, service, or other jobs. The detainee work program shall not conflict with any other requirements of the contract and must comply with all applicable laws and regulations.
2. Detainees shall not be used to perform the responsibilities or duties of an employee of the **PROVIDER**. Detainees shall not be used to perform work in areas where sensitive documents are maintained (designated ICE workspace). Custodial/janitorial services to be performed in designated ICE work space will be the responsibility of the **PROVIDER**.
3. Appropriate safety/protective clothing and equipment shall be provided to detainee workers as appropriate. Detainees shall not be assigned work that is considered hazardous or dangerous. This includes, but is not limited to, areas or

assignments requiring great heights, extreme temperatures, use of toxic substances, and unusual physical demands.

4. The **PROVIDER** shall supply sufficient Detention Officers to monitor and control detainee work details. Unless approved by the COTR, these work details must be within the security perimeter.
5. It will be the sole responsibility of ICE to determine whether a detainee will be allowed to perform on voluntary work details and at what classification level. All detainees shall be searched when they are returned from work details.

**IX. Law Library:**

The **PROVIDER** shall provide secure space within the secure perimeter, either a dedicated room or a multipurpose room for books and materials to provide a reading area "Law Library" - in accordance with the ICE National Detention Standards on the Access to Legal Materials.

**X. Training:**

Employees shall not perform duties under this agreement until they have successfully completed all initial training and the COTR receives written certification from the **PROVIDER**.

**A. General Training Requirements**

1. All employees must have the training described in the ACA Standards and in this section. Any remuneration (pay) due PROVIDER employees in accordance with Department of Labor regulations for any training time is the responsibility of the PROVIDER. The PROVIDER shall provide the required refresher courses or have an institution acceptable to the COTR to provide the training. Failure of any employee to complete training successfully is sufficient reason to disqualify him or her from duty.
2. All new Detention Officers will receive 54 hours of basic training, not to include firearms and 40 hours of on-the-job training prior to entering on duty. The **PROVIDER'S** Training Officer will be responsible for administering an on-the-job training program for new employees. A senior Detention Officer, at all times during this latter 40-hour period, must accompany the Detention Officers. The **PROVIDER'S** Training Officer shall send a copy of the documentation to the COTR upon successful completion of the employee's on-the-job training.
3. In addition, after completion of the first 94 hours of training, the **PROVIDER** has 60 days to complete an additional 40 hours of training. During the remainder of the first year on duty, the officer will have an additional 40 hours of training for a total of 174 hours within the first year of employment. The training program must directly relate to the employee's assigned position and

afford application of necessary job skills. Training site shall be provided by the **PROVIDER** at no cost to the Government.

a. Basic Training Subjects:

1. Employees must complete the following list of basic training subjects. The course title is followed by the estimated hours of training for that subject.

a. In-service Orientation/Social Diversity	2 HRS
b. Counseling Techniques/Suicide Prevention	2 HRS
c. Conduct/Duties/Ethics and Courtroom Demeanor	2 HRS
d. Bomb Defense and Threats	1 HR
e. Telephone Communications/Radio Procedures	1 HR
f. Fire and other Emergency Procedures	2 HRS
g. Treatment and Supervision of Detainees	2 HRS
h. ICE Use of Force Policy	2 HRS
i. Security Methods/Key Control/Count	1 HR
j. Procedures/Observational Techniques	4 HRS
k. EEO/Sexual Harassment	2 HRS
l. Detainee Escort Techniques	1 HR
m. ICE Paperwork/Report Writing	2 HRS
n. Detainee Searches/Detainee Personal Property	4 HRS
o. Property/Contraband	2 HRS
p. Detainee Rules and Regulations	2 HRS
q. First Aid*	4 HRS
r. Cardiopulmonary resuscitation (CPR)*	4 HRS
s. Blood-borne Pathogens*	2 HRS
t. Self Defense	8 HRS
u. Use of Restraints	6 HRS
v. Firearm Training	**
w. Sexual Abuse/Assault Prevention & Intervention*	2 HRS
x. National Detention Standards	2 HRS

\* Critical Training Subjects

\*\* Firearm Training for Required Armed Detention Services in accordance with state licensing requirements. **PROVIDER** shall certify proficiency every quarter.

b. Refresher Training

1. Every year the **PROVIDER** shall conduct 40 hours of Refresher Training for all Detention Officers including Supervisory Detention Officers. Refresher training shall consist of these critical subjects listed above and a review of basic training subjects and others as approved by ICE.
2. The **PROVIDER** shall coordinate recertification in CPR and First Aid with the ICE training staff. This training shall be provided at no cost to the Government. Annually, upon completion, the **PROVIDER** shall provide documentation of refresher training to the COTR.
3. In addition to the refresher training requirements for all Detention Officers, supervisors must receive refresher training relating to supervisory duties.

c. On-the-Job Training

1. After completion of the minimum of 54 hours basic training, all Detention Officers will receive an additional 40 hours of on-the-job training at specific post positions. This training includes:
  - a. Authority of supervisors and organizational code of conduct.
  - b. General information and special orders.
  - c. Security systems operational procedures.
  - d. Facility self-protection plan or emergency operational procedures.
  - e. Disturbance Control Team training.

d. Training During Initial 60 Day Period

The **PROVIDER** shall provide an additional 40 hours of training for Detention Officers within 60 days after completion of first 94 hours of training. The **PROVIDER** shall provide the training format and subjects, for approval by the COTR and CO, prior to the commencement of training.

e. Basic First Aid and CPR Training

1. All members of the **PROVIDER'S** security staff shall be trained in basic first aid and CPR. They must be able to:
  - a. Respond to emergency situations within four minutes.
  - b. Perform cardiopulmonary resuscitation (CPR).
  - c. Recognize warning signs of impending medical emergencies.
  - d. Know how to obtain medical assistance.
  - e. Recognize signs and symptoms of mental illness.

- f. Able to administer medication;
- g. Know the universal precautions for protection against blood-borne diseases.

## B. Supervisory Training

1. All new Supervisory Detention Officers assigned to perform work under this agreement must successfully complete a minimum of 40 hours of formal supervisory training provided by the **PROVIDER** prior to assuming duties. This training is in addition to mandatory training requirements for Detention Officers. Supervisory training shall include the following management areas:

- a. Techniques for issuing written and verbal orders 2 HRS
- b. Uniform clothing and grooming standards 1 HR
- c. Security Post Inspection procedures 2 HRS
- d. Employee motivation 1 HR
- e. Scheduling and overtime controls 2 HRS
- f. Managerial public relations 4 HRS
- g. Supervision of detainees 4 HRS
- h. Other company policies 4 HRS

Additional classes are at the discretion of the PROVIDER with the approval of the COTR.

The PROVIDER shall submit documentation to the COTR, to confirm that each supervisor has received basic training as specified in the basic training curriculum.

## C. Proficiency Testing

The PROVIDER shall give each Detention Officer a written examination consisting of at least 25 questions after each classroom-training course is completed. The PROVIDER may give practical exercises when appropriate. The COTR shall approve the questions before the PROVIDER can administer the examination. To pass any examination, each officer must achieve a score of 80% or better. The PROVIDER must provide the COTR with the eligible Detention Officer's completed exam before the Detention Officer may be assigned to duties under the agreement. Should an employee fail the written test on the initial attempt, he or she shall be given additional training by the PROVIDER and be given one additional opportunity to retake the test. If the employee fails to complete and pass the test the second time, the PROVIDER shall remove the employee from duties on this agreement.

## D. Certified Instructors

Certified instructors shall conduct all instruction and testing. A state or nationally recognized institution shall certify instructors unless otherwise approved in writing by the COTR. Certifications of instructors may be established by documentation of past experience in teaching positions or by successful completion of a course of training for qualifying personnel as instructors. The COTR must approve the instructor prior to the training course.

E. Training Documentation

1. The **PROVIDER** shall submit a training forecast and lesson plans to the COTR or ICE designee, on a monthly basis, for the following 60-day period. The training forecast shall provide date, time, and location of scheduled training and afford the COTR observation/evaluation opportunity.
2. The **PROVIDER** shall certify and submit the training hours, type of training, date and location of training, and name of the instructor monthly for each employee to the COTR or ICE designee.

XI. Notification and Public Disclosures:

There shall be no public disclosures regarding this agreement made by the **PROVIDER** (or any subcontractors) without review and approval of such disclosure by ICE Public Affairs and express permission granted by the ICE Contracting Officer. The Government considers such information privileged or confidential until award of the agreement.

**XII. Establish and Maintain Program for Prevention of Sexual Abuse/Assault:**

The **PROVIDER** shall develop and implement a comprehensive sexual abuse/assault prevention and intervention program. This program shall include training that is given separately to both staff and detainees, in accordance with the Prison Rape Elimination Act (PREA).

**XIII. Business Permits and Licenses:**

The **PROVIDER** must obtain all required permits and licenses by the date of agreement award. The **PROVIDER** must (depending on the state's requirements) be licensed as a qualified security service company in accordance with the requirements of the district, municipality, county, and state in which ICE work site(s) is/are located. Throughout the term of this agreement, the **PROVIDER** shall maintain current permits/business licenses and make copies available for Government Inspection. The **PROVIDER** shall comply with all applicable federal, state, and local laws and all applicable Occupational Safety and Health Administration (OSHA) standards.



#### **XIV. Firearms / Body Armor:**

##### **A. Firearms Requirements**

1. The **PROVIDER** shall provide new firearms and maintain sufficient licensed firearms and ammunition to equip each armed Detention Officer and armed supervisor(s) with a licensed weapon while on duty. Firearms maybe re-issued to new replacement employees throughout the life of the agreement as long as the firearm is in serviceable condition.
2. Personal firearms shall not be used. A licensed gunsmith, in writing, shall certify all firearms safe and accurate.
3. Firearms shall be standard police service-type, semi-automatic capable of firing hollow-point ammunition that meets the recommendations of the firearms manufacturer. Ammunition will be factory load only – no reloads. Ammunition will be replaced every year.
4. The **PROVIDER** shall provide sufficient ammunition for each armed Detention Officer, including uniformed contract supervisor(s); they shall be issued three full magazines.
5. The **PROVIDER** shall account for all firearms and ammunition daily.
6. If any weapons or ammunition are missing from the inventory, the COTR shall be notified immediately.
7. All firearms shall be licensed by the State.
8. Firearms will be inspected. This shall be documented by the Warden/Facility Director.
9. Loading, unloading, and cleaning of the firearms shall only take place in designated areas.
10. The firearms shall be cleaned and oiled as appropriate to ensure optimum operating conditions.
11. Firearms shall be carried with the safety on, if applicable, with a round in the chamber.
12. The **PROVIDER** shall maintain appropriate and ample supplies of firearms' upkeep and maintenance equipment (cleaning solvents, lubricating oil, rods, brushes, patches, and other normal maintenance tools).
13. The **PROVIDER** shall provide a complete listing of licensed firearms by serial numbers and by each safe location to the COTR prior to beginning performance under this agreement.
14. These lists shall be kept current through the terms of the agreement and posted within each firearms safe.
15. The **PROVIDER** shall obtain and maintain on file appropriate State and municipality permits and weapons permits for each officer.

16. A copy of this permit shall be provided to the COTR at least three working days prior to the anticipated assignment date of any individual.
17. The **PROVIDER** shall ensure that his/her employees have all permits and licenses in their possession at all times while in performance of this agreement.
18. The **PROVIDER** shall provide safes/vaults for storage of firearms and ammunition, for each location where firearms are issued or exchanged, which meet agency requirements and are approved for the storage of firearms and ammunition.
19. The COTR is responsible for approving the proposed safes/vaults prior to usage. **PROVIDER** supervisors and guards shall make accurate receipt and return entries on a Firearms and Equipment Control Register.
20. Except when issuing or returning ammunition or firearms, each safe/vault shall remain locked at all times.
21. The **PROVIDER** shall be responsible for having the combination of each safe/vault changed at least once every six months, or more often if circumstances warrant.
22. The **PROVIDER** certifies firearms training to the COTR.
23. The **PROVIDER** shall certify proficiency every quarter.
24. The **PROVIDER** shall provide an ICE approved intermediate weapon(s).

#### B. Body Armor Requirements

1. The **PROVIDER** shall provide body armor to all armed Detention Officers and armed supervisor(s).
2. Body armor shall be worn while on armed duty.
3. The body armor shall meet all requirements as set forth in the ICE Firearms Policy.
4. The **PROVIDER** shall procure replacement body armor if the body armor becomes unserviceable, ill-fitting, worn/damaged, or at the expiration of service life.
5. All armed Detention Officers and armed supervisors need to be made aware of the health risks associated with the wearing of body armor in high heat/high humidity conditions and/or during strenuous exertion. When Detention Officers and supervisors are required to wear body armor, they shall be provided opportunities to rehydrate and remove the body armor as necessary.
6. The use of personally owned body armor is not authorized.

**XVI. FEDERAL GOVERNMENT QUALITY ASSURANCE**

A. The Government's Quality Assurance Program (QASP) is based on the premise that the provider, and not the Government, is responsible for management and quality control actions to meet the terms of the agreement. The QASP procedures recognize that the provider is not a perfect manager and that unforeseen and uncontrollable problems do occur. Good management and use of an adequate Quality Control Plan will allow the facility to operate within acceptable quality levels.

B. Each phase of the services rendered under this agreement is subject to inspection both during the Provider's operations and after completion of the tasks.

C. When the Provider is advised of any unsatisfactory condition(s), the contractor shall submit a written report to the Contracting Officer addressing corrective/preventive actions taken. The QASP is not a substitute for quality control by the Provider.

D. The COTR may check the Provider's performance and document any noncompliance, however, only the Contracting Officer may take formal action against for unsatisfactory performance.

E. The Government may reduce the invoice or otherwise withhold payment for any individual item of nonconformance observed. The Government may apply various inspection and extrapolation techniques (i.e., 100 % surveillance, random sampling, planned sampling, unscheduled inspections, etc.) to determine the quality of services and the total payment due.

F. FAILURE TO PERFORM REQUIRED SERVICES. The rights of the Government and remedies described in this section are in addition to all other rights and remedies set forth in this agreement. Any reductions in the invoice shall reflect the agreement's reduced value resulting from the failure to perform required services.

\*\*\*\*\*  
END OF DOCUMENT  
\*\*\*\*\*



**Town of Farmville—ICE Facility: DROISA-08-0021**  
**May 9, 2008**

**Staffing Post Plan**

**PURPOSE**

To establish guidelines for staffing needs within the Town of Farmville—ICE Facility, by department, to ensure adequate coverage is provided to operate the Facility at maximum efficiency. To provide coverage for time off to allow staff job training, personal time off, and unexpected absenteeism.

**POLICY**

It is the policy of the Town of Farmville—ICE Facility to ensure that the facility is being managed and supported by a well trained staff at all times. The planned staffing levels will ensure all requirements for the safety and security of the detainees is met on a daily basis and will allow for training and planned as well as unplanned absenteeism.

**PROCEDURES**

The Town of Farmville-ICE Facility will utilize the following work schedule to operate the facility.

**Administration**

- A. **Split Shifts** are worked by the Receptionist and the Induction Assistant.
  - 1. For these positions, one employee works Sunday to Thursday, and the other employee works Tuesday to Saturday.
  - 2. The overlap during the middle of the week allows for training, personal time off, and administrative coverage in other areas of the facility if needed.
- B. **Work Week**
  - 1. The Administration's routine work week will be Monday to Friday for the Department Head, HR Training Supervisor, HR Administrative Assistant and Life Skills Coach.

- a. These individuals may switch a day during the week for a Saturday or Sunday, if work with the detainee is required during the weekend.
  - b. The Department Head is always on call.
2. See the attached "Shift Staffing Report" for more details on the Administration's work week.

### Security

- A. Split Shifts are worked by the Watch Commander, Security Supervisors, Officers and Stationary Guards.
- B. Work Week
  1. A routine Monday to Friday work week is the norm for the Department Head, but this individual is always on call.
  2. See the attached "Shift Staffing Report" for more details on the Security's work week.

### Medical

- A. Split Shifts are worked by the Shift LPNs and the Shift Certified Nursing Assistants.
- B. Work Week
  1. A routine Monday to Friday work week is the norm for the Department Head, Doctor and LPN supervisor.
    - a. The Department Head and the Doctor are always on call.
  2. See the attached "Shift Staffing Report" for more details on the Medical's work week.

### Support

- A. Maintenance Staff works a regular weekly schedule as well as Split Shifts.
  1. Maintenance Staff on the 'Day Shift' typically Monday to Friday but may switch days if weekend work provides a better opportunity for repairs.
  2. The Evening shift staff works a 'split week' to provide coverage during the weekend.
- B. A routine Monday to Friday work week is the norm for the Department Head, Maintenance Supervisor and Grounds Keepers.
  1. These individuals may work on weekends, if needed.
    - a. The Department Head is always on call.
- C. The Kitchen Staff works a split shift, as does the Kitchen Supervisor.
- D. Work Week
  1. The attached "Shift Staffing Report" will provide details on the Support Staff's work week.

Accounting and IT Support

- A. A routine Monday to Friday work week is the norm for the CFO and Accounting Staff and IT Staff, but these individuals may work weekends when needed.
  - a. The Accountants provide back up to each other and provide coverage while the each other is out of the office.
  - b. The IT staff provides back up for each other and provides coverage while the each other is out of the office.

Director of Facilities Management

- A. A routine Monday to Friday work week is the norm for the Director of Facilities Management, but this individual may work weekends, when needed.

Director of Communications

- A. A routine Monday to Friday work week is the norm for the Director of Communications, but this individual may work weekends, when needed.

# The Town of Farmville- ICE Facility

## Organization Structure

### Job Titles and Description of Duties

Department	Position	Duties
	Chief Operations Officer Quality Control Officer	Ultimate responsibility for Compliance to ICE Guidelines, Operations and Financial Issues related to operating the facility Chief compliance officer responsible for developing and monitoring quality control for all areas of facility
Administration	Dept. Head - Administration Receptionist Induction Agent/Video Coordinator Records Clerk Commissary Clerk Life Skills Coach HR- Training Supervisor HR- Admin Assistant	Responsible for daily administrative and operations duties and serves as immediate supervisor for Dept Heads Responsible for welcoming guest, residents and assist with other administrative task Responsible for induction paperwork for detainees and coordination/operation of video conferencing when needed Responsible for tracking all individual records for the detainees including funds they bring to site as well as time as a detainee Responsible for commissary sales and inventory tracking of supplies for the commissary Plan and supervise recreational activities for residents. Work with Local groups to provide life skill programs Responsible for development and implementation of training programs as well as required certification Responsible for daily guidance on HR issues and assist other administrative positions
Security	Dept. Head- Security Shift Watch Commander Shift Supervisor Shift Officers Stationary Guards	Responsible for oversight of security staff and stationary guards Supervise Supervisors and fill in for Supervisors as needed. Supervise Officers and fill in for Officers as needed Immediate supervision of detainees Immediate supervision of detainees during transportation or other offsite trips
Medical	Dept. Head Doctor LPN Supervisor Shift LPN Shift Certified Nursing Assistant	Responsible for all phases of medical support for facility Provide medical treatment to residents Provide supervision to Shift LPN and fill in for any nursing position if necessary Provide leadership and support to Certified Nursing Assistants as they provide health care to residents Provide medical treatment to residents as directed by Physician and LPNs
Support Services	Dept. Head - Support Services Kitchen Manager Kitchen Supervisor Kitchen Staff Maintenance Supervisor Maintenance Workers Grounds Keeper Housekeeping	Responsible for Food Services and maintenance of the facility and grounds Plan menus, order food and supervise kitchen staff Supervise kitchen staff in absence of Kitchen Manager Prepare and serve meals to residents, 3 meals per day. Supervise maintenance workers and ensure physical plant is operating at top efficiency Repair items as needed Maintain grounds and assist Maintenance as needed General cleaning of building's interior
Accounting and IT	CFO Accountant IT System and Desk Top support	Responsible for all accounting duties and financial reporting needs of the government Responsible for daily accounting duties related to AR, AP and monthly/annual financial reporting Provide network and desk top support
Facilities Management	Director	Responsible for facilities maintenance, upgrades and expansion
Community Relations	Director	Responsible for all external communication and government relations

The Town of Farmville- ICE Facility  
 Organization Structure  
 Staffing Post Plan

Salaries based on www.Salary.com for Farmville, Va.

See Detail work schedule in Volume I, Attachment VI - Staffing

Department	Position	Total Compliment	Work Days/wk	Split Shifts Yes	Weekends On Call Yes	Annual Salary	Hourly Rate if applicable	Labor Standards	Labor Std. Classification
	Chief Operations Officer	1	5		Yes	150,000.00			
	Quality Control Officer	1	5		Yes	75,000.00			
Administration									
	Dept. Head - Administration	1	5		Yes	80,000.00			
	Receptionist	3	5			29,499.00	14.18	13.94	Receptionist
	Induction Agent/Video Coordinator	5	5	Yes		35,670.00	17.15	17.12	General Clerk III
	Records Clerk	2	5			35,670.00	17.15	17.12	General Clerk III
	Commissary Clerk	3	5			35,670.00	17.15	17.12	General Clerk III
	Life Skills Coach	2	5		Yes	45,391.00	21.82		
	HR- Training Supervisor	1	5		Yes	55,611.00	26.74		
	HR- Admin Assistant	1	5		Yes	48,621.00	23.38	18.46	
Security									
	Dept. Head- Security	1	5		Yes	75,000.00			
	Shift Watch Commander	6	5	Yes		45,000.00	21.63	15.66	Corrections Officer
	Shift Supervisor	12	5	Yes		37,000.00	17.79	15.66	Corrections Officer
	Shift Officers	60	5	Yes		32,000.00	15.38	12.79	Guard II
	Stationary Guards	30	5	Yes		32,000.00	15.38	12.79	Guard II
Medical									
	Dept. Head	1	5		Yes	75,000.00			
	Doctor	1	5		Yes	179,975.00			
	LPN Supervisor	1	5		Yes	39,086.00	18.79	17.37	LPN II
	Shift LPN	6	5	Yes		39,086.00	18.79	15.48	LPN II
	Shift Certified Nursing Assistant	16	5	Yes		26,014.00	12.51	10.61	Nursing Assistant III
Support Services									
	Dept. Head - Support Services	1	5		Yes	75,000.00			
	Kitchen Manager	1	5		Yes	48,193.00	23.17		
	Kitchen Supervisor	4	5	Yes		34,234.00			
	Kitchen Staff	12	5	Yes		21,164.00	10.18	9.72	Food Service Worker
	Maintenance Supervisor	1	5		Yes	54,705.50	26.30		
	Maintenance Workers	5	5	Yes	Yes	35,387.00	17.01	17.94	General Maintenance Worker
	Grounds Keeper	2	5		Yes	29,170.00	14.02	10.63	Laborer - Grounds Maintenance
	Housekeeping	8	5	Yes		21,166.00	10.18	10.06	Janitor
Accounting and IT									
	CFO	1	5		Yes	90,000.00			
	Accountant	2	5		Yes	53,913.00	25.92	16.33	Accounting Clerk III
	IT System and Desk Top support	2	5		Yes	66,837.00	32.13	27.62	Computer Analyst II
Facilities Management									
	Director	1	PT			50,000.00			
Community Relations									
	Director	1	PT			25,000.00			
	<b>TOTAL</b>	<b>195</b>							



# Town of Farmville - ICE Facility

Staffing Post Plan- per Shift

## ADMINISTRATION

Day Shift           8AM -4PM  
 Evening Shift      4PM-12AM  
 Night Shift         12AM-8AM

### DAY SHIFT

#### Team A

Position	Sunday	Monday	Tuesday	Wednesday	Thursday	Friday	Saturday
Receptionist	X	1	1	1	1	1	X
Receptionist	X	X	1	1	1	1	1
Receptionist							
Induction Agent	X	1	1	1	1	1	X
Induction Agent	1	1	1	1	1	X	X
Records Clerk	X	1	1	1	1	1	X
Records Clerk	X	1	1	1	1	1	X
Commissary Clerk	X	1	1	1	1	1	X
Commissary Clerk	X	1	1	1	1	1	X
Commissary Clerk	X	1	1	1	1	1	X
<b>Total Team A</b>	<b>1</b>	<b>8</b>	<b>9</b>	<b>9</b>	<b>9</b>	<b>8</b>	<b>1</b>

#### Team B

Position	Sunday	Monday	Tuesday	Wednesday	Thursday	Friday	Saturday
Receptionist	1	1	1	1	1	X	X
Induction Agent							
Induction Agent	X	X	1	1	1	1	1
Records Clerk							
Commissary Clerk							
<b>Total Team A</b>	<b>1</b>	<b>1</b>	<b>2</b>	<b>2</b>	<b>2</b>	<b>1</b>	<b>1</b>
<b>Total Shift</b>	<b>2</b>	<b>9</b>	<b>11</b>	<b>11</b>	<b>11</b>	<b>9</b>	<b>2</b>

### EVENING SHIFT

#### Team A

Position	Sunday	Monday	Tuesday	Wednesday	Thursday	Friday	Saturday
Receptionist							
Induction Agent	1	1	1	1	1	X	X
Induction Agent							
Records Clerk							
Commissary Clerk							
<b>Total Team A</b>	<b>1</b>	<b>1</b>	<b>1</b>	<b>1</b>	<b>1</b>	<b>0</b>	<b>0</b>

**Team B**

<u>Position</u>	<u>Sunday</u>	<u>Monday</u>	<u>Tuesday</u>	<u>Wednesday</u>	<u>Thursday</u>	<u>Friday</u>	<u>Saturday</u>
Receptionist							
Induction Agent	X	X	1	1	1	1	1
Induction Agent							
Records Clerk							
Commissary Clerk							
<b>Total Team A</b>	0	0	1	1	1	1	1
<b>Total Shift</b>	1	1	2	2	2	1	1

**NIGHT SHIFT****Team A**

<u>Position</u>	<u>Sunday</u>	<u>Monday</u>	<u>Tuesday</u>	<u>Wednesday</u>	<u>Thursday</u>	<u>Friday</u>	<u>Saturday</u>
Receptionist							
Induction Agent							
Induction Agent							
Records Clerk							
Commissary Clerk							
<b>Total Team A</b>	0	0	0	0	0	0	0

**Team B**

<u>Position</u>	<u>Sunday</u>	<u>Monday</u>	<u>Tuesday</u>	<u>Wednesday</u>	<u>Thursday</u>	<u>Friday</u>	<u>Saturday</u>
Receptionist							
Induction Agent							
Induction Agent							
Records Clerk							
Commissary Clerk							
<b>Total Team A</b>	0	0	0	0	0	0	0
<b>Total Shift</b>	0	0	0	0	0	0	0
<b>TOTAL STAFF</b>	3	10	13	13	13	10	3

# Town of Farmville - ICE Facility

Staffing Post Plan- per Shift

SECURITY DEPARTMENT

(b)(2)High, (b)(7)e

Team B

(b)(2)High, (b)(7)e

# Town of Farmville - ICE Facility

Staffing Post Plan- per Shift

## MEDICAL DEPARTMENT

Day Shift            8AM -4PM  
 Evening Shift       4PM-12AM  
 Night Shift          12AM-8AM

### DAY SHIFT

#### Team A

Position	Sunday	Monday	Tuesday	Wednesday	Thursday	Friday	Saturday
Doctor	X	1	1	1	1	1	X
LPN Supervisor	X	1	1	1	1	1	X
LPN	1	1	1	1	1	X	X
LPN							
Certified Nursing Assistant	1	1	1	1	1	X	X
Certified Nursing Assistant	1	1	1	1	1	X	X
Certified Nursing Assistant	1	1	1	1	1	X	X
Certified Nursing Assistant							
<b>Total Team A</b>	<b>4</b>	<b>6</b>	<b>6</b>	<b>6</b>	<b>6</b>	<b>2</b>	<b>0</b>

#### Team B

Position	Sunday	Monday	Tuesday	Wednesday	Thursday	Friday	Saturday
Doctor							
LPN Supervisor							
LPN	X	X	1	1	1	1	1
LPN							
Certified Nursing Assistant	X	X	1	1	1	1	1
Certified Nursing Assistant	X	X	1	1	1	1	1
Certified Nursing Assistant	X	X	1	1	1	1	1
Certified Nursing Assistant							
<b>Total Team B</b>	<b>0</b>	<b>0</b>	<b>4</b>	<b>4</b>	<b>4</b>	<b>4</b>	<b>4</b>
<b>Total Shift</b>	<b>4</b>	<b>6</b>	<b>10</b>	<b>10</b>	<b>10</b>	<b>6</b>	<b>4</b>

### EVENING SHIFT

#### Team A

Position	Sunday	Monday	Tuesday	Wednesday	Thursday	Friday	Saturday
Doctor							
LPN Supervisor							
LPN	1	1	1	1	1	X	X
LPN							
Certified Nursing Assistant	1	1	1	1	1	X	X
Certified Nursing Assistant	1	1	1	1	1	X	X
Certified Nursing Assistant	1	1	1	1	1	X	X
Certified Nursing Assistant							
<b>Total Team A</b>	<b>4</b>	<b>4</b>	<b>4</b>	<b>4</b>	<b>4</b>	<b>0</b>	<b>0</b>

**Team B**

<u>Position</u>	<u>Sunday</u>	<u>Monday</u>	<u>Tuesday</u>	<u>Wednesday</u>	<u>Thursday</u>	<u>Friday</u>	<u>Saturday</u>
Doctor							
LPN Supervisor							
LPN	X	X	1	1	1	1	1
LPN							
Certified Nursing Assistant	X	X	1	1	1	1	1
Certified Nursing Assistant	X	X	1	1	1	1	1
Certified Nursing Assistant	X	X	1	1	1	1	1
Certified Nursing Assistant							
<b>Total Team B</b>	<b>0</b>	<b>0</b>	<b>4</b>	<b>4</b>	<b>4</b>	<b>4</b>	<b>4</b>
<b>Total Shift</b>	<b>4</b>	<b>4</b>	<b>8</b>	<b>8</b>	<b>8</b>	<b>4</b>	<b>4</b>

**NIGHT SHIFT****Team A**

<u>Position</u>	<u>Sunday</u>	<u>Monday</u>	<u>Tuesday</u>	<u>Wednesday</u>	<u>Thursday</u>	<u>Friday</u>	<u>Saturday</u>
Doctor							
LPN Supervisor							
LPN	1	1	1	1	1	X	X
LPN							
Certified Nursing Assistant	1	1	1	1	1	X	X
Certified Nursing Assistant	1	1	1	1	1	X	X
Certified Nursing Assistant							
<b>Total Team A</b>	<b>3</b>	<b>3</b>	<b>3</b>	<b>3</b>	<b>3</b>	<b>0</b>	<b>0</b>

**Team B**

<u>Position</u>	<u>Sunday</u>	<u>Monday</u>	<u>Tuesday</u>	<u>Wednesday</u>	<u>Thursday</u>	<u>Friday</u>	<u>Saturday</u>
Doctor							
LPN Supervisor							
LPN	X	X	1	1	1	1	1
LPN							
Certified Nursing Assistant	X	X	1	1	1	1	1
Certified Nursing Assistant	X	X	1	1	1	1	1
Certified Nursing Assistant							
<b>Total Team B</b>	<b>0</b>	<b>0</b>	<b>3</b>	<b>3</b>	<b>3</b>	<b>3</b>	<b>3</b>
<b>Total Shift</b>	<b>3</b>	<b>3</b>	<b>6</b>	<b>6</b>	<b>6</b>	<b>3</b>	<b>3</b>
<b>TOTAL STAFF</b>	<b>11</b>	<b>13</b>	<b>24</b>	<b>24</b>	<b>24</b>	<b>13</b>	<b>11</b>

# Town of Farmville - ICE Facility

Staffing Post Plan- per Shift

## SUPPORT SERVICES-MAINTENANCE

Day Shift            8AM -4PM  
 Evening Shift       4PM-12AM  
 Night Shift         12AM-8AM

### DAY SHIFT

#### Team A

Position	Sunday	Monday	Tuesday	Wednesday	Thursday	Friday	Saturday
Maintenance Supervisor	X	1	1	1	1	1	X
Maintenance Worker	X	1	1	1	1	1	X
Maintenance Worker	X	1	1	1	1	1	X
Maintenance Worker -Admin	X	1	1	1	1	1	X
Grounds Keeper	X	1	1	1	1	1	X
Grounds Keeper	X	1	1	1	1	1	X
Housekeeping	X	1	1	1	1	1	X
Housekeeping		1	1	1	1	X	X
Housekeeping- Admin	X	1	1	1	1	1	X
<b>Total Team A</b>	<b>1</b>	<b>9</b>	<b>9</b>	<b>9</b>	<b>9</b>	<b>8</b>	<b>0</b>

#### Team B

Position	Sunday	Monday	Tuesday	Wednesday	Thursday	Friday	Saturday
Maintenance Supervisor							
Maintenance Worker							
Maintenance Worker							
Grounds Keeper							
Grounds Keeper							
Housekeeping							
Housekeeping	X	X	1	1	1	1	1
<b>Total Team B</b>	<b>0</b>	<b>0</b>	<b>1</b>	<b>1</b>	<b>1</b>	<b>1</b>	<b>1</b>
<b>Total Shift</b>	<b>1</b>	<b>9</b>	<b>10</b>	<b>10</b>	<b>10</b>	<b>9</b>	<b>1</b>

### EVENING SHIFT

#### Team A

Position	Sunday	Monday	Tuesday	Wednesday	Thursday	Friday	Saturday
Maintenance Supervisor							
Maintenance Worker							
Maintenance Worker		1	1	1	1	X	X
Grounds Keeper							
Grounds Keeper							
Housekeeping		1	1	1	1	X	X
Housekeeping							
Housekeeping- Admin	X	1	1	1	1	1	X
Housekeeping- Admin	X	1	1	1	1	1	X
<b>Total Team A</b>	<b>2</b>	<b>4</b>	<b>4</b>	<b>4</b>	<b>4</b>	<b>2</b>	<b>0</b>

**Team B**

<u>Position</u>	<u>Sunday</u>	<u>Monday</u>	<u>Tuesday</u>	<u>Wednesday</u>	<u>Thursday</u>	<u>Friday</u>	<u>Saturday</u>
Maintenance Supervisor							
Maintenance Worker			1	1	1	1	1
Maintenance Worker	X	X					
Grounds Keeper							
Grounds Keeper							
Housekeeping			1	1	1	1	1
Housekeeping	X	X					
<b>Total Team B</b>	<b>0</b>	<b>0</b>	<b>2</b>	<b>2</b>	<b>2</b>	<b>2</b>	<b>2</b>
<b>Total Shift</b>	<b>2</b>	<b>4</b>	<b>6</b>	<b>6</b>	<b>6</b>	<b>4</b>	<b>2</b>

**NIGHT SHIFT****Team A**

<u>Position</u>	<u>Sunday</u>	<u>Monday</u>	<u>Tuesday</u>	<u>Wednesday</u>	<u>Thursday</u>	<u>Friday</u>	<u>Saturday</u>
Maintenance Supervisor							
Maintenance Worker							
Maintenance Worker							
Grounds Keeper							
Grounds Keeper							
Housekeeping							
Housekeeping							
<b>Total Team A</b>	<b>0</b>	<b>0</b>	<b>0</b>	<b>0</b>	<b>0</b>	<b>0</b>	<b>0</b>

**Team B**

<u>Position</u>	<u>Sunday</u>	<u>Monday</u>	<u>Tuesday</u>	<u>Wednesday</u>	<u>Thursday</u>	<u>Friday</u>	<u>Saturday</u>
Maintenance Supervisor							
Maintenance Worker							
Maintenance Worker							
Grounds Keeper							
Grounds Keeper							
Housekeeping							
Housekeeping							
<b>Total Team B</b>	<b>0</b>	<b>0</b>	<b>0</b>	<b>0</b>	<b>0</b>	<b>0</b>	<b>0</b>
<b>Total Shift</b>	<b>0</b>	<b>0</b>	<b>0</b>	<b>0</b>	<b>0</b>	<b>0</b>	<b>0</b>
<b>TOTAL STAFF</b>	<b>3</b>	<b>13</b>	<b>16</b>	<b>16</b>	<b>16</b>	<b>13</b>	<b>3</b>



# Town of Farmville - ICE Facility

Staffing Post Plan- per Shift

## SUPPORT SERVICES-KITCHEN

**3:00 AM to 11:00 AM**

**Team A**

Position	Sunday	Monday	Tuesday	Wednesday	Thursday	Friday	Saturday
Kitchen Manager							
Kitchen Manager							
Kitchen Staff Supervisor	1	1	1	1	1	X	X
Kitchen Staff	1	1	1	1	1	X	X
Kitchen Staff	1	1	1	1	1	X	X
Kitchen Staff							
<b>Total Team A</b>	<b>3</b>	<b>3</b>	<b>3</b>	<b>3</b>	<b>3</b>	<b>0</b>	<b>0</b>

**Team B**

Position	Sunday	Monday	Tuesday	Wednesday	Thursday	Friday	Saturday
Kitchen Manager							
Kitchen Manager							
Kitchen Staff Supervisor	X	X	1	1	1	1	1
Kitchen Staff	X	X	1	1	1	1	1
Kitchen Staff	X	X	1	1	1	1	1
Kitchen Staff							
<b>Total Team B</b>	<b>0</b>	<b>0</b>	<b>3</b>	<b>3</b>	<b>3</b>	<b>3</b>	<b>3</b>
<b>Total Shift</b>	<b>3</b>	<b>3</b>	<b>6</b>	<b>6</b>	<b>6</b>	<b>3</b>	<b>3</b>

**5:00 AM to 1:00 AM**

**Team A**

Position	Sunday	Monday	Tuesday	Wednesday	Thursday	Friday	Saturday
Kitchen Manager							
Kitchen Manager							
Kitchen Staff Supervisor							
Kitchen Staff							
Kitchen Staff	1	1	1	1	1	X	X
Kitchen Staff	1	1	1	1	1	X	X
<b>Total Team A</b>	<b>2</b>	<b>2</b>	<b>2</b>	<b>2</b>	<b>2</b>	<b>0</b>	<b>0</b>

**Team B**

Position	Sunday	Monday	Tuesday	Wednesday	Thursday	Friday	Saturday
Kitchen Manager							
Kitchen Manager							
Kitchen Staff Supervisor							
Kitchen Staff	X	X	1	1	1	1	1
Kitchen Staff	X	X	1	1	1	1	1
Kitchen Staff							
<b>Total Team B</b>	<b>0</b>	<b>0</b>	<b>2</b>	<b>2</b>	<b>2</b>	<b>2</b>	<b>2</b>
<b>Total Shift</b>	<b>2</b>	<b>2</b>	<b>4</b>	<b>4</b>	<b>4</b>	<b>2</b>	<b>2</b>

7:00 AM to 3:00 AM

**Team A**

Position	Sunday	Monday	Tuesday	Wednesday	Thursday	Friday	Saturday
Kitchen Manager	X	1	1	1	1	1	X
Kitchen Manager							
Kitchen Staff Supervisor							
Kitchen Staff							
<b>Total Team A</b>	<b>0</b>	<b>1</b>	<b>1</b>	<b>1</b>	<b>1</b>	<b>1</b>	<b>0</b>

**Team B**

Position	Sunday	Monday	Tuesday	Wednesday	Thursday	Friday	Saturday
Kitchen Manager							
Kitchen Manager							
Kitchen Staff Supervisor							
Kitchen Staff							
<b>Total Team B</b>	<b>0</b>	<b>0</b>	<b>0</b>	<b>0</b>	<b>0</b>	<b>0</b>	<b>0</b>
<b>Total Shift</b>	<b>0</b>	<b>1</b>	<b>1</b>	<b>1</b>	<b>1</b>	<b>1</b>	<b>0</b>

11:00 AM to 7:00 AM

**Team A**

Position	Sunday	Monday	Tuesday	Wednesday	Thursday	Friday	Saturday
Kitchen Manager							
Kitchen Manager							
Kitchen Staff Supervisor	1	1	1	1	1	X	X
Kitchen Staff	1	1	1	1	1	X	X
Kitchen Staff	1	1	1	1	1	X	X
Kitchen Staff							
<b>Total Team A</b>	<b>3</b>	<b>3</b>	<b>3</b>	<b>3</b>	<b>3</b>	<b>0</b>	<b>0</b>

**Team B**

Position	Sunday	Monday	Tuesday	Wednesday	Thursday	Friday	Saturday
Kitchen Manager							
Kitchen Manager							
Kitchen Staff Supervisor	X	X	1	1	1	1	1
Kitchen Staff	X	X	1	1	1	1	1
Kitchen Staff	X	X	1	1	1	1	1
Kitchen Staff							
<b>Total Team B</b>	<b>0</b>	<b>0</b>	<b>3</b>	<b>3</b>	<b>3</b>	<b>3</b>	<b>3</b>
<b>Total Shift</b>	<b>3</b>	<b>3</b>	<b>6</b>	<b>6</b>	<b>6</b>	<b>3</b>	<b>3</b>
<b>TOTAL STAFF</b>	<b>8</b>	<b>9</b>	<b>17</b>	<b>17</b>	<b>17</b>	<b>9</b>	<b>8</b>

REGISTER OF WAGE  
DETERMINATIONS  
UNDER THE SERVICE  
CONTRACT ACT

By direction of the  
Secretary of Labor

Shirley Division of  
F. Wage  
Ebbesen Determinations  
Director

U.S. DEPARTMENT OF  
LABOR

EMPLOYMENT  
STANDARDS  
ADMINISTRATION  
WAGE AND HOUR  
DIVISION

WASHINGTON, D.C.  
20210

Wage  
Determination 2008-0334  
No.:

Revision No.: 1

Date of Last  
Revision: 09/26/2008

State: Virginia

Area: Virginia County of Cumberland

---

Employed on U.S. Department of Homeland Security contract (IGA) for prisoner detention services between United States Immigration and Customs Enforcement and Prisoner Operations Division, Cumberland County Town of Farmville, VA.

The wage rates and fringe benefits paid by above company are hereby adopted as prevailing.

NOTE: Under Section 2(b)(1) of the Service Contract Act no employees shall be paid less than the minimum wage specified by Section 6(a)(1) of the Fair Labor Standards Act; \$6.55 per hour, effective July 24, 2008.

---

**\*\* UNIFORM ALLOWANCE \*\***

If employees are required to wear uniforms in the performance of this contract (either by the terms of the Government contract, by the employer, by the state or local law, etc.), the cost of furnishing such uniforms and

maintaining (by laundering or dry cleaning) such uniforms is an expense that may not be borne by an employee where such cost reduces the hourly rate below that required by the wage determination. The Department of Labor will accept payment in accordance with the following standards as compliance:

The contractor or subcontractor is required to furnish all employees with an adequate number of uniforms without cost or to reimburse employees for the actual cost of the uniforms. In addition, where uniform cleaning and maintenance is made the responsibility of the employee, all contractors and subcontractors subject to this wage determination shall (in the absence of a bona fide collective bargaining agreement providing for a different amount, or the furnishing of contrary affirmative proof as to the actual cost), reimburse all employees for such cleaning and maintenance at a rate of \$3.35 per week (or \$.67 cents per day). However, in those instances where the uniforms furnished are made of "wash and wear" materials, may be routinely washed and dried with other personal garments, and do not require any special treatment such as dry cleaning, daily washing, or commercial laundering in order to meet the cleanliness or appearance standards set by the terms of the Government contract, by the contractor, by law, or by the nature of the work, there is no requirement that employees be reimbursed for uniform maintenance costs.

**Stevens, Richard P**

---

**From:** Wyatt-Powell, Wendie M  
**Sent:** Monday, March 24, 2008 2:57 PM  
**To:** Neveleff, Jerald  
**Cc:** Jenkins, John E; Erickson, Susan D  
**Subject:** Farmville County  
**Importance:** High  
**Attachments:** FDG08FARM\_Farmville VA.pdf

Attached is the G-514 other documents will follow.

*Wendie Wyatt-Powell*

Detention Acquisition Support Unit  
Detention Management Division  
Office of Detention and Removal  
U.S. Immigration and Customs Enforcement  
US Department of Homeland Security  
202-732  
202-732 (b)(2)Low

Warning: This document is UNCLASSIFIED//FOR OFFICIAL USE ONLY (U//FOUO). It contains information that may be exempt from public release under the Freedom of Information Act (5 U.S.C. 552). It is to be controlled, stored, handled, transmitted, distributed, and disposed of in accordance with DHS policy relating to FOUO information and is not to be released to the public or other personnel who do not have a valid "need-to-know" without prior approval of an authorized DHS official. No portion of this report should be furnished to the media, either in written or verbal form.

**REQUISITION — MATERIALS-SUPPLIES-EQUIPMENT**

SEE INSTRUCTIONS ON REVERSE

1. NUMBER  
FDG08FARM

2. DATE  
20-MAR-2008

3. ACTIVITY SYMBOL  
See Attachment A

4. TO: NAME AND ADDRESS — PROCUREMENT SECTION (OR STOREROOM)  
GSA - ITACQ CENTER  
1800 F STREET, NW  
WASHINGTON, DC 20405

5. FROM: NAME AND ADDRESS — REQUISITIONER  
IMMIGRATION AND CUSTOMS ENFORCEMENT  
DETENTION AND REMOVAL  
RM 315 ATTENTION PHYLLIS CHAPMAN  
2675 PROSPERITY AVENUE  
FAIRFAX, VA 22031

STOCK NUMBER	DESCRIPTION OF ARTICLE (MAKE, MODEL, TYPE, SIZE, COLOR, MFG, ETC)	QUANTITY	UNIT	COST		ACTION CODE
				UNIT PRICE	AMOUNT	
6	7	8	9	10	11	12
	BED SPACE, GUARD SERVICE AND TRANSPORTATION COSTS FOR THE PERIOD OF 9/1/2008 THRU 9/30/2008 FOR DETENTION FACILITY LOCATED IN FARMVILLE, VA	1	EA	2,416,980 00	2,416,980 00	

**Justification:**  
ADDED JAIL SPACE FOR NEW FACILITY IN FARMVILLE, VA

**Recommended Vendor:**  
No Recommended Vendor

13. SIGNATURE OF APPROVING OFFICIAL

14. TITLE OF APPROVING OFFICIAL

*Phyllis Chapman (A)*

24. SIGNATURE OF FUNDING OFFICIAL

*Phyllis Chapman* P.D.CHAPMAN

25. TITLE OF FUNDING OFFICIAL

*Mission Support Specialist*

15. TOTAL 2,416,980 00

16. KEY TO ACTION CODE

S	SUBSTITUTE ITEM	2	CANCELLED—NOT STOCKED
B	BACK ORDERED	3	CANCELLED—NOT ABLE TO IDENTIFY
D	PURCHASED FOR DIRECT SHIPMENT	0	OTHER—AS INDICATED
1	CANCELLED—STOCK EXHAUSTED		

PROCUREMENT SECTION (OR STOREROOM)

17. DATE RECEIVED	19. PURCHASE ORDER
18. APPROVED	DATE NUMBER

I CERTIFY THAT THE ABOVE ARTICLES -- COLUMNS 3, 9 AND 12 - HAVE BEEN RECEIVED.

20. LOCATION	21. DATE	22. SIGNATURE	23. TITLE
--------------	----------	---------------	-----------

# Form G-514

## REQUISITION - MATERIALS-SUPPLIES-EQUIPMENT

### Activity Symbols ATTACHMENT A

REQUISITION NUMBER: **FDG08FARM**

PROJECT	TASK	FUND	PROGRAM	ORGANIZATION	OBJECT	UDF	AMOUNT
				(b)(2)Low			<b>\$2,416,980.00</b>

**INDEPENDENT GOVERNMENT COST ESTIMATE**

**FARMVILLE, VA**

**PERIOD OF PERFORMANCE - JULY 1, 2008 - SEPTEMBER 30, 2008**

**Per Diem Rate By Number of Beds**

**1000 Beds: \$80.00**

<u>Number of Detainee Beds</u>	<u>Person Days</u>	<u>* Rate</u>	<u>Total</u>
92 Days X 1000 Beds	\$ 92,000.00	\$ 80.00	\$ 7,360,000.00
____ Days X _____ Beds	\$ -		\$ -

**SUBTOTAL: \$ 7,360,000.00**

<u>Stationary Guard Services</u>	<u>Estimated Number of Hours</u>	<u>Hourly Rate</u>	<u>Total</u>
	200	\$ 30.00	\$ 6,000.00

**SUBTOTAL: \$ 6,000.00**

Transportation

**SUBTOTAL: \$ 75,000.00**

**TOTAL ESTIMATED COST = \$ 7,441,000.00**

\* Note: the Rate (or per diem rate), with the exception of stationary guard services, is inclusive of costs such as fringe benefits, overhead, materials, vendor direct costs, general and administrative costs, profit, etc. Guard services are billed as a separate item.

*Instructed to Fund 2,416,980.00 by  
M.J. Bates on 3/21/08*



**Stevens, Richard P**

---

**From:** Wyatt-Powell, Wendie M  
**Sent:** Monday, March 24, 2008 2:58 PM  
**To:** Neveleff, Jerald  
**Cc:** Washington, John W; Jenkins, John E; Erickson, Susan D  
**Subject:** Farmville County Additional Documents  
**Importance:** High  
**Attachments:** RCA STATEMENT OF WORK March 14 08.doc; Farmville IGCE March08.xls

*Wendie Wyatt-Powell*

Detention Acquisition Support Unit  
Detention Management Division  
Office of Detention and Removal  
U.S. Immigration and Customs Enforcement  
US Department of Homeland Security  
202-732-  
202-732- (b)(2)Low

Warning: This document is UNCLASSIFIED//FOR OFFICIAL USE ONLY (U//FOUO). It contains information that may be exempt from public release under the Freedom of Information Act (5 U.S.C. 552). It is to be controlled, stored, handled, transmitted, distributed, and disposed of in accordance with DHS policy relating to FOUO information and is not to be released to the public or other personnel who do not have a valid "need-to-know" without prior approval of an authorized DHS official. No portion of this report should be furnished to the media, either in written or verbal form.



**ICE OFFICE OF DETENTION AND REMOVAL  
DETENTION ACQUISITION SUPPORT UNIT  
REQUEST FOR CONTRACT ACTION**

***STATEMENT OF WORK***

**FACILITY LOCATION:**

**Immigration Centers of America**  
401 Water Work Road LLC  
Farmville, Virginia 23909

**ANTICIPATED START OF PERFORMANCE: July 1, 2008**

**PERFORMANCE:**

The **PROVIDER** is required, in units housing ICE detainees, to perform in accordance with the most current editions of the **ICE National Detention Standards, American Correctional Association (ACA) Standards for Adult Local Detention Facilities (ALDF)**, and **Standards Supplement, Standards for Health Services in Jails, latest edition, National Commission on Correctional Health Care (NCCHC)**. Some ACA standards are augmented by ICE policy and/or procedure. In cases where other standards conflict with DHS/ICE Policy or Standards, DHS/ICE Policy and Standards prevail. ICE Inspectors will conduct periodic unscheduled inspections of the facility to assure compliance of the aforementioned standards. In addition, the Provider shall provide full and complete cooperation for any request or investigation conducted by the Government.

The **PROVIDER** will have eighteen (18) months from commencement of this agreement to become ACA accredited. The **PROVIDER** shall, within nine (9) months from the date this facility becomes operational, to formally apply for accreditation to the American Correctional Association. The **PROVIDER** shall furnish written proof of such application to ICE within five (5) days of the application.

**PERIOD OF PERFORMANCE:**

This Agreement shall become effective upon the date of final signature by ICE and the **PROVIDER** and remain in effect indefinitely unless terminated in writing, by either party. Either party must provide written notice of intention to terminate the agreement, 120 days in advance of the effective date of formal termination.

**EXCLUSIVITY:**

The **CONTRACTOR** or **SERVICE PROVIDER** agrees that the facility is to be for the exclusive use of ICE and its detainee population. No other agency will be allowed to use the facility to house its detainees, prisoners, or inmates without prior approval of the Contracting Officer with input from the Contracting Officer's Technical Representative. If given approval, a separate bed day rate shall be negotiated with the other agency and ICE shall not be responsible for payment related to beds used by another agency. The other agency will be separately invoiced for the beds it uses. The duration of the use of beds will be determined on a case by case basis.

**ARMED TRANSPORTATION SERVICES:**

The **PROVIDER** shall provide all such ground transportation services as may be required to transport detainees securely, in a timely manner, to locations as directed by the COTR or designated ICE official. When officers are not providing transportation services, the **PROVIDER** shall assign the employees to supplement security duties within the facility to assist ICE as directed by the COTR or designated ICE official. However, the primary function of these officers is transportation. Duties as directed by the COTR utilizing these officers should not incur any additional expenses to the Government.

The **PROVIDER** shall assign, at a minimum, two person teams of transportation officers on a daily basis distributed throughout a twenty-four (24) hour period seven (7) days a week including weekends and holidays. The COTR shall approve the number of teams assigned to any shift or period of time in order to meet the needs of ICE transportation requirements.

The **PROVIDER** shall furnish suitable vehicles in good condition, approved by the Government, to safely provide the required transportation services per facility as listed below. The **PROVIDER** shall comply with all federal and state laws with regard to inspections, licensing, and registration for all vehicles used for transportation.

Nothing in this agreement shall restrict the **PROVIDER** from acquiring additional vehicles as deemed necessary by the **PROVIDER** at no cost to the Government. The **PROVIDER** shall not allow employees to use their privately owned vehicles to transport detainees. The **PROVIDER** shall furnish vehicles equipped with interior security features in accordance with ICE National Detention Standards including physical separation of detainees from guards. The **PROVIDER** shall provide the interior security specification of the vehicles to ICE for review and approval prior to installation. Vehicles furnished by the **PROVIDER** shall be equipped with interior security features such as, but not limited to: door lock controls, window locks, a wire cage with acrylic panel between the driver seat and the rear passenger seats, and provide physical separation of detainees from Detention Officers.

In the event of transportation services involving distances that exceed a standard eight (8) hour workday to complete, the **PROVIDER** shall be reimbursed for related costs of lodging and meals commiserate with the U.S. General Services Administration rates for such within the geographical area of occurrence. Any incurred overtime pay for such services will be reimbursed at the applicable Department of Labor overtime rate for the transportation officer position incorporated within this agreement. The **PROVIDER** shall comply with ICE transportation standards related to the number of hours the **PROVIDER** employee may operate a vehicle. Overnight lodging resulting from transportation services shall be approved in advance by the COTR or designated ICE official.

All transportation shall be accomplished in the most economical manner.

The **PROVIDER** personnel provided for the above services shall be of the same qualifications, receive the same training, complete the same security clearances, and wear the same uniforms as those **PROVIDER** personnel provided in the other areas of this agreement. Transportation officers shall have the required state licenses for commercial drivers with the proper endorsement limited to vehicles with Automatic Transmission and the state DMV Medical Certification.

During all transportation activities, at least one officer shall be the same sex as the detainee. Questions concerning officer assignments shall be directed to the COTR for final determination.

All transportation Detention Officers shall be armed in the performance of these duties.

The **PROVIDER** shall, upon order of the COTR, or upon his or her own decision in an urgent medical situation, transport a detainee to a hospital location. An officer, or officers, shall keep the detainee under constant supervision 24 hours per day until the detainee is ordered released from the hospital, or at the order of the COTR. The **PROVIDER** shall then transport the detainee to the detention site.

The COTR may direct the **PROVIDER** to transport detainees to unspecified, miscellaneous locations.

When the COTR provides documents to the **PROVIDER** concerning the detainee(s) to be transported and/or escorted, the **PROVIDER** shall deliver these documents only to the named authorized recipients. The **PROVIDER** shall ensure the material is kept confidential and not viewed by any person other than the authorized recipient.

The **PROVIDER** shall establish a fully operational communication system compatible with ICE communication equipment that has direct and immediate contact with all transportation vehicles and post assignments. Upon demand, the COTR shall be provided with current status of all vehicles and post assignment employees.

Failure of the **PROVIDER** to comply fully with the detainee(s) departure as pre-scheduled shall result in the **PROVIDER** having deductions made for non-performance.

The following transportation routes/destinations are anticipated requirements for this agreement. The following requirements are **one way routes**; these routes (mile approximations) are not all inclusive and should not be limited to the following:

<i>Legend</i>	<i>Daily = 2 times plus per week; Weekly = 2 or less per week; Periodic = as required Mileage = One Way</i>		
<b>Mileage From Farmville, VA</b>	<b>Locations</b>	<b>City</b>	<b>Frequency</b>
	<b>Field Offices</b>		
164	Detention and Removal Office	Fairfax	Daily
121	Detention and Removal Office	Harrisonburg	Weekly
153	Detention and Removal Office	Norfolk	Daily
65	Detention and Removal Office	Richmond	Daily
100	Detention and Removal Office	Roanoke	Weekly
	<b>JPATS/DOCC Destinations</b>		
173	Dulles International Airport	Washington, DC	Periodic
289	Harrisburg International Airport	Harrisburg, PA	Weekly
69	Richmond International Airport	Richmond	Proposed weekly
143	Piedmont Triad International Airport	Greensboro, NC	Proposed weekly
455	Stewart Detention Center	Stewart, GA	Periodic
266	York Detention Center	York, PA	Weekly
	<b>Jails</b>		
162	Alexandria City Jail	Alexandria	Daily
166	Arlington County Jail	Arlington	Daily
120	Augusta Correctional Center	Craigsville	Daily
180	Bland Correctional Center	Bland	Daily
59	Brunswick Correctional Center	Lawrenceville	Daily
22	Buckingham Correctional Center	Dillwyn	Daily
85	Central Virginia Regional Jail	Orange	Daily
145	Chesapeake City Jail	Chesapeake	Daily
96	Coffeewood Correctional Center	Coffeewood	Daily
170	DC Jail (Central Detention, Central Treatment)	Washington, DC	Daily
47	Deep Meadow Correctional Center	State Farm	Daily
22	Dillwyn Correctional Center	Dillwyn	Daily
48	Dinwiddie Correctional Unit	Church Road	Daily
160	Fairfax County Jail	Fairfax	Daily
67	FCI Petersburg - Camp - Virginia	Petersburg	Daily
67	FCI Petersburg - Low - Virginia	Petersburg	Daily

67	FCI Petersburg - Medium - Virginia	Petersburg	Daily
92	Green Rock Correctional Center (New 06/2007)	Chatham	Daily
74	Greensville Correctional Center	Jarratt	Daily
138	Hampton City Jail	Hampton	Daily
136	Hampton Roads Regional Jail	Portsmouth	Daily
124	Haynesville Correctional Center	Haynesville	Daily
64	Henrico County Jail	Richmond	Daily
48	James River Correctional Center	State Farm	Daily
59	Lawrenceville Correctional Center	Lawrenceville	Daily
<b>Mileage From Farmville, VA</b>	<b>Locations</b>	<b>City</b>	<b>Frequency</b>
169	Loudoun County Jail	Leesburg	Daily
53	Mecklenburg Correctional Center	Boydton	Daily
116	Middle Peninsula Regional Jail	Saluda	Daily
141	Newport News City Jail	Newport News	Daily
141	Norfolk City Jail	Norfolk	Daily
194	Northampton County Jail	Eastville	Daily
115	Northern Neck Regional Jail	Warsaw	Daily
190	Northwestern Regional ADC	Winchester	Daily
19	Nottoway Correctional Center	Burkeville	Daily
79	Pamunkey Regional Jail	Hanover	Daily
67	Petersburg City Jail	Petersburg	Daily
0	Piedmont Regional Jail	Farmville	Daily
140	Portsmouth City Jail	Portsmouth	Daily
48	Powhatan Correctional Center	State Farm	Daily
156	Prince William/Manassas Regional Jail	Manassas	Daily
126	Rappahannock Regional Jail	Stafford	Daily
296	Red Onion State Prison	Pound	Daily
67	Richmond City Jail	Richmond	Daily
73	Riverside Regional Jail	Hopewell	Daily
122	Rockingham/Harrisonburg Regional Jail	Harrisonburg	Daily
155	St. Brides Correctional Center	Chesapeake	Daily
77	Sussex County Jail	Sussex	Daily
155	Virginia Beach City Jail	Virginia Beach	Daily
46	Virginia Correctional Center for Woman	Goochland	Daily
121	Western Tidewater Regional Jail	Suffolk	Daily
29	Appomattox County Jail	Appomattox	Daily to Weekly
52	Chesterfield County Jail	Chesterfield	Daily to Weekly
111	Culpeper County Jail	Culpepper	Daily to Weekly
135	Fauquier County Jail	Warrenton	Daily to Weekly
100	Roanoke City Jail	Roanoke	Daily to Weekly
158	Shenandoah County Jail	Woodstock	Daily to Weekly
119	Virginia Peninsula Regional Jail	Williamsburg	Daily to Weekly

89	Danville City Jail	Danville	Weekly
108	Franklin County Jail	Rocky Mount	Weekly
120	Gloucester County Jail	Gloucester	Weekly
119	Henry County Jail	Martinsville	Weekly
155	Indian Creek Correctional Center	Chesapeake	Weekly
30	Lunenburg Correctional Center	Victoria	Weekly
100	Middle River Regional Jail	Staunton	Weekly
153	New River Valley Regional Jail	Dublin	Weekly
103	Peumansend Creek Regional Jail	Bowling Green	Weekly
<b>Mileage From Farmville, VA</b>	<b>Locations</b>	<b>City</b>	<b>Frequency</b>
111	Roanoke County Jail	Salem	Weekly
94	Southampton Correctional Center	Capron	Weekly
204	Marion Treatment Center	Marion	Weekly to Periodic
310	USP Lee - Virginia	Jonesville	Weekly to Periodic
225	Accomack County Jail	Accomac	Periodic
59	Albemarle/Charlottesville Regional Jail	Charlottesville	Periodic
135	Alleghany County Regional Jail	Covington	Periodic
60	Amherst County Jail	Amherst	Periodic
72	B.R.R.J. - Bedford County ADC	Bedford	Periodic
47	B.R.R.J. - Campbell County ADC	Rustburg	Periodic
50	B.R.R.J. - Lynchburg City Jail	Lynchburg	Periodic
58	B.R.R.J.A. - Halifax County ADC	Halifax	Periodic
53	Baskerville Correctional Center	Baskerville	Periodic
103	Botetourt Correctional Center	Troutville	Periodic
108	Botetourt County Jail	Fincastle	Periodic
247	Bristol City Jail	Bristol	Periodic
60	Brunswick County Jail	Lawrenceville	Periodic
59	Brunswick Work Center for Women	Lawrenceville	Periodic
90	Caroline Correctional Unit #2	Hanover	Periodic
52	Central Virginia Correctional Unit #13	Chesterfield	Periodic
26	Charlotte County Jail	Charlotte Court House	Periodic
87	Cold Springs Correctional Unit #10	Greenville	Periodic
87	Cold Springs Work Center	Greenville	Periodic
88	Danville City Jail Farm	Danville	Periodic
992	Deerfield Correctional Center	Capron	Periodic
60	Dinwiddie County Jail	Dinwiddie	Periodic
65	Fluvanna Correctional Center for Women	Troy	Periodic
74	Greensville Work Center	Jarratt	Periodic
58	Halifax Correctional Unit #23	Halifax	Periodic

124	Haynesville Correctional Unit #17	Haynesville	Periodic
48	James River Work Center	State Farm	Periodic
265	Keen Mountain Correctional Center	Oakwood	Periodic
141	Lancaster County Jail	Lancaster	Periodic
123	Martinsville City Jail	Martinsville	Periodic
51	Mecklenburg County Jail	Boydton	Periodic
66	Medical College of Virginia	Richmond	Periodic
136	Montgomery County Jail	Christiansburg	Periodic
131	Newport News City Jail Farm	Newport News	Periodic
19	Nottoway Work Center	Burkeville	Periodic
<b>Mileage From Farmville, VA</b>	<b>Locations</b>	<b>City</b>	<b>Frequency</b>
132	Page County Jail	Luray	Periodic
150	Patrick County Jail	Stuart	Periodic
130	Patrick Henry Correctional Unit #28	Ridgeway	Periodic
92	Pittsylvania County Jail	Chatham	Periodic
152	Pulaski Correctional Center	Dublin	Periodic
123	Rappahannock County Jail	Washington	Periodic
93	Rockbridge Regional Jail	Lexington	Periodic
47	Rustburg Correctional Unit #9	Rustburg	Periodic
109	Southampton County Jail	Courtland	Periodic
94	Southampton Pre-Release and Work Center for Women	Capron	Periodic
94	Southampton Work Center for Men	Capron	Periodic
79	Southside Regional Jail	Emporia	Periodic
288	Southwest Virginia Regional Jail	Hayso	Periodic
236	Southwest Virginia Regional Jail Authority - Abingdon	Abingdon	Periodic
291	Southwest Virginia Regional Jail Authority - Duffield	Duffield	Periodic
219	Southwest Virginia Regional Jail Authority - Tazewell	Tazewell	Periodic
91	Sussex I State Prison	Waverly	Periodic
91	Sussex II State Prison	Waverly	Periodic
219	Tazewell Correctional Unit #31	Tazewell	Periodic
310	USP Lee - Camp -Virginia	Jonesville	Periodic
294	Wallens Ridge State Prison	Big Stine Gap	Periodic
139	Warren County Jail	Front Royal	Periodic
275	Wise Correctional Unit	Coeburn	Periodic

### **GUARD SERVICES:**

The **PROVIDER** agrees to provide stationary guard services on demand by the COTR and shall include, but not limited to, escorting and guarding detainees to medical or



doctor's appointments, hearings, ICE interviews, and any other remote location requested by the COTR. Qualified detention officer personnel employed by the **PROVIDER** under its policies, procedures, and practices will perform such services. The **PROVIDER** agrees to augment such practices as may be requested by ICE to enhance specific requirements for security, detainee monitoring, visitation, and contraband control. Public contact is prohibited unless authorized in advance by the COTR.

The **PROVIDER** shall be authorized one officer for each such remote location, unless at the direction of the COTR or designated Agency official as additional officers are required.

The itemized monthly invoice for such stationary guard services shall state the number of hours being billed, the duration of the billing (times and dates) and the names of the detainees that were guarded. Such services shall be denoted as a separate item on submitted invoices. ICE agrees to reimburse the **PROVIDER** for actual stationary guard services provided at a negotiated rate.

#### **MEDICAL SERVICES:**

The **PROVIDER** shall be responsible for the provision of health care services for ICE detainees at the facility.

In the event of an emergency, the **PROVIDER** shall proceed immediately with necessary medical treatment. In such event, the **PROVIDER** shall notify ICE immediately regarding the nature of the transferred detainee's illness or injury and type of treatment provided.

The **PROVIDER** shall ensure that all health care service providers utilized for ICE detainees hold current licenses, certifications, and/or registrations with the State and/or City where they are practicing. The **PROVIDER** shall retain a registered nurse to provide health care and sick call coverage unless expressly stated otherwise in this Agreement. In the absence of a health care professional, non-health care personnel may refer detainees to health care resources based upon protocols developed by the United States Public Health Service (USPHS) Division of Immigration Health Services (DIHS). Healthcare or health trained personnel may perform screenings.

The **PROVIDER** shall ensure that onsite medical and health care coverage as defined below is available for all ICE detainees at the facility for at least eight (8) hours per day, seven (7) days per week. The **PROVIDER** shall ensure that its employees solicit each detainee for health complaints and deliver complaints in writing to the medical and health care staff.

The **PROVIDER** shall furnish onsite health care under this Agreement. The **PROVIDER** shall not charge any ICE detainee an additional fee or co-payment for medical services or treatment provided at the **PROVIDER'S** facility. The **PROVIDER** shall ensure that ICE detainees receive no lower level of onsite medical care and services than those it provides to local inmates. Onsite health care services shall include arrival screening within twenty-four (24) hours of arrival to the facility, sick call coverage,

provision of over-the-counter medications, treatment of minor injuries (e.g. lacerations, sprains, and contusions), treatment of special needs and mental health assessments. Detainees with chronic conditions shall receive prescribed treatment and follow-up care. Arrival screening shall include at a minimum TB symptom screening, planting of the Tuberculin; skin Test (PPD), and recording the history of past and present illnesses (mental and physical).

If the **PROVIDER** determines that an ICE detainee has a medical condition which renders that person unacceptable for detention under this Agreement, (for example, contagious disease, condition needing life support, uncontrollable violence), the **PROVIDER** shall notify ICE. Upon such notification, the **PROVIDER** shall allow ICE reasonable time to make the proper arrangements for further disposition of that detainee.

The DIHS acts as the agent and final health authority for ICE on all off-site detainee medical and health related matters. The relationship of the DIHS to the detainee equals that of physician to patient. The **PROVIDER** shall release any and all medical information for ICE detainees to the DIHS representatives upon request, except where prohibited by federal or state law or regulation. The **PROVIDER** shall solicit DIHS approval before proceeding with non-emergency, off-site medical care (e.g. off site lab testing, eyeglasses, cosmetic dental prosthetics, and dental care for cosmetic purposes). The **PROVIDER** shall submit supporting documentation for non-routine, off-site medical/health services to DIHS. For medical care provided outside the facility, the DIHS may determine that an alternative medical provider or institution is more cost-effective or more aptly meets the needs of ICE and the detainee. ICE may refuse to reimburse the **PROVIDER** for non-emergency medical costs incurred that were not pre-approved by the DIHS. The **PROVIDER** shall send requests for pre-approval for non-emergency off-site care to:

United States Public Health Service  
Division of Immigration Health Services  
1220 L Street, NW, PMB 468  
Washington, DC 20005-4018  
Phone (b)(2)Low  
Fax:

The **PROVIDER** is to notify all medical providers approved to furnish off-site health care of detainees to submit their bills in accordance with instructions provided to:

BCE Emergis  
DIHS Claims  
P.O. Box 10250  
Gaithersburg, MD 20898-0250  
Phone (b)(2)Low  
Fax:

The **PROVIDER** shall furnish twenty-four (24) hour emergency medical care and emergency evacuation procedures. In an emergency, the **PROVIDER** shall obtain the medical treatment required to preserve the detainee's health. The **PROVIDER** shall have access to an off site emergency medical provider at all times. The Health Authority of the **PROVIDER** shall notify the DIHS Managed Care Coordinators, ICE Health Services, 1220 L Street, NW, PMB 468, Washington, DC, 20005-4018, phone (888) 718-8947, fax (202) 318-0080, as soon as possible, and in no case more than seventy-two (72) hours after detainee receipt of such care. The Health Authority will obtain pre-authorization from the DIHS Managed Care Coordinator for service(s) beyond the initial emergency situation.

The **PROVIDER** shall allow DIHS Managed Care Coordinators reasonable access to its facility for the purpose of liaison activities with the Health Authority and associated Service Provider departments.

The **PROVIDER** and all medical providers approved to furnish off-site health care of detainees shall submit their bills to:

BCE Emergis  
DIHS Claims  
P.O. Box 10250  
Gaithersburg, MD 20898-0250  
Phone (b)(2)Low  
Fax: (

The ICE and PHS may refuse to reimburse the **PROVIDER** for non-emergency medical costs incurred that were not pre-approved by the DIHS.

The **PROVIDER** agrees to accept and provide for the secure custody, care, and safekeeping of detainees in accordance with the State, and local laws, standards, policies, procedures, or court orders applicable to the operations of the facility.

The **PROVIDER** agrees to provide ICE detainees with the same level of medical care and services as provided to non-ICE detainees as part of the per diem rate. This rate includes:

- On-site sick call (when provided by on-site staff);
- Medication (over the counter/non-legend and routine drugs and medical supplies);

Escort/security services for transport to/from emergency or non-emergency health care services as either an in-patient or out-patient.

## **ICE PHYSICAL PLANT REQUIREMENTS:**

### **MINIMUM REQUIREMENTS FOR A 1000 BED FACILITY**

#### **ICE Office Space**

Refer to ICE Design Standards for specific office and workstation sizes and specific furnishing requirements for a 1000 bed facility. The Standards include but are not limited to the following:

- A total of 34 offices and 46 workstations as outlined below:
- 1 Office - Assistant Field Office Director GS-1801-14
- 1 Office - Officer in Charge GS-1801-14
- 1 Office - Assistant Officer in Charge GS-1801-14
- 1 Office - Intelligence Officer GS-1801-14
- 1 Office - Chief Immigration Enforcement Agent GS-1801-13
- 4 Offices - Supervisory Detention & Deportation Officers GS-1801-13
- 16 Offices - Deportation Officers GS-1801-12
- 2 Offices - Supervisory Immigration Enforcement Agents GS-1801-11
- 26 Workstations - Immigration Enforcement Agents GS-1801-5/7/9
- 2 Offices - Supervisory Deportation Assistant, GS-1802-09
- 16 Workstations - Detention & Removal Assistants GS-1802-07
- 1 Office - Mission Support Specialist GS-0301-9/11/12
- 2 Offices - Contracting Officer's Technical Representative, GS-1102-09
- 1 Office - Intelligence Research Specialist GS-1801-09
- 1 Office - Training Officer GS-1801-11
- 2 Workstations - Mission Support Assistant GS-0301-5/7
- 1 Workstation - Receptionist
- 1 Workstation - OIC Secretary
- 1 Workstation - Records Tech
- 1 Workstation - Mail/File Clerk
- File rooms (see Standards for size and quantity)
- Conference rooms adjacent to or within ICE area (see Standards for size and quantity)
- Employee break rooms (see Standards for size and quantity)
- IT computer support rooms must be provided through out ICE space per the specifications. Including specialized requirements for climate control of IT equipment rooms for PHS, EOIR and ICE office area.
- Actual location, layout, configuration, and size of rooms will be determined during the final design phase.

### **OPLA Space**

Refer to ICE Design Standards for specific office and workstation sizes and specific furnishing requirements for a 1000 bed facility. All furniture and case goods shall be furnished by the service provider in accordance with ICE Design Standards. The Standards include but are not limited to the following:

- 1 Office – Deputy Chief Counsel (see Standards for size)
- 12 Offices – Assistant Chief Counsel (see Standards for size)
- 4 Workstations - Legal Technicians (see Standards for size)
- 1 Workstation - Mail/File Clerk
- Office support space must be provided per the ICE/OPLA Design Standards.

### **EOIR Space**

Refer to ICE/EOIR Design Standards for specific office and workstation sizes and specific furnishing requirements for a 1000 bed facility. All furniture and case goods shall be furnished by the service provider in accordance with ICE Design Standards. The Standards include but are not limited to the following:

- 5 - Courtrooms and accompanying office and support space as per the EOIR Design Standards for a 1000 bed facility. The office space is per the EOIR Design Standards. Each courtroom should have the capability to hold live court as well as hold video tele-conferencing court. All furniture and case goods shall be furnished by the service provider in accordance with ICE Design Guide and specifications.
- 15 - Hard walled offices (see Standards for size)
- 15 - Workstations (see Standards for size)
- Visitation space must be provided to meet the ACA and NDS standards.
- Separate entrance for judges required with complete security system and access to parking lot. Must be ADA compliant.
- EOIR Support Space must be provided per the EOIR Design Standards.

### **Health Services**

Healthcare services will be provided by the **PROVIDER**.

### **Facility Requirements for Infectious Disease Screening**

The Service Provider will ensure that there is adequate space and equipment to provide medical intake screening including a TB screening chest x-ray within the intake processing area. In order to prevent the spread of airborne infectious disease or cross contamination of zones within the facility, the HVAC system in the Intake Screening Area will be constructed to exhaust to the exterior and prevent air exchange between the intake screening area and any other area within the facility.

### **Infectious Disease Screening**

In order to prevent the transmission of Tuberculosis (TB) to the resident population of a detention facility, the Service Provider will perform TB screening as part of the a routine infectious disease screening within 12 hours of detainee admission and obtain documented clearance of transmissible disease before the detainee is assigned to a housing unit or is transferred from the intake processing area. A screening chest x-ray will be performed by a trained and qualified health care provider and interpreted by a credentialed radiologist. Detainees will remain isolated from the rest of the facility population (remain in the intake screening area) until the chest x-ray report is obtained and the interpretation verifies that the detainee is free of infectious TB (turnaround time for chest x-ray interpretation should be 4 hours or less). Detainees who are found to be infected or where there is a possibility that they are infected will be assigned to a respiratory isolation unit until treatment or further testing is done and the detainee is no longer infectious.

### **Teleradiology Service Provider**

The Detention Service Provider shall use the services of the ICE Teleradiology Service Provider (ITSP). The cost of the equipment; maintenance of the equipment; training of staff; arrangements for interpretation of the x-rays by credentialed radiologists; and transmission of data to and from the Detention Facility are provided by the ITSP and charged directly to ICE. The Service Provider shall coordinate with the ITSP to ensure adequate space is provided for the equipment, connectivity and electrical services are installed, immediate 24/7 access to equipment for service and maintenance by ITSP technicians is granted, a teleradiology coordinator is appointed and available for training by the ITSP, and medical staff is available to perform the screening exams and receive reports. The teleradiology coordinator may be a nurse or nurse practitioner and collateral duty of the appointed staff (it is not necessary to appoint a full time coordinator if the volume of work does not support a full time employee).

## **ADDITIONAL MINIMUM REQUIREMENTS**

### **Processing Area**

- Expansion required in this area includes the need to accommodate processing varying numbers of detainees for intake and out-processing, i.e., large buses transport of up to 100 detainees.
- Processing area must be designed to process male and/or female detainees as required in high frequency rates and varying numbers, i.e., a busload up to 100 detainees at one time.
- Teleradiology equipment requires high voltage power to accommodate x-ray equipment, specifications will be provided by ICE.

### **Furniture**

All furniture and case goods shall be furnished by the service provider in accordance with ICE Design Guide and specifications, which include ICE support space and all operational components which include EOIR, OPLA and DIHS space as required in accordance with the ICE Design Standards.

### **ICE IT Equipment**

ICE will provide and install IT equipment in office spaces for ICE personnel only, to include computer workstations and screens, printers and fax machines. All infrastructure, cabling, and interfacing equipment shall be provided by the Service Provider at time of construction.

**NOTE:** ICE IT system must be a complete, independent and physically separate system from the Service Provider's IT system. The system shall serve all operational components: ICE, OPLA, and DIHS. EOIR shall have a separate system within EOIR IT space as per the EOIR Design Standards.

### **Communication Equipment**

The service provider shall purchase, install and maintain a complete and operating communication system, which includes but is not limited to: cabling, fiber optics, patch panels, landing blocks, circuits, PBX and voice mail, phone sets and other supporting infrastructure and supporting system in compliance with ICE specifications. Separate billing to ICE must be established on all reoccurring service fees for communications and IT. Systems shall be installed specifically for ICE use.

**NOTE:** ICE communication system must be a complete, independent and physically separate system from the Service Provider communication system, and billed separately. The system shall serve all operational components: ICE, OPLA, and DIHS. EOIR shall have a separate system within EOIR IT space as per the EOIR Design Standards.

Service Provider see attached SOW for phone system details.

### **DETAINEE TELEPHONE SERVICES:**

The **PROVIDER** shall provide detainees with reasonable and equitable access to telephones as specified in ICE National Detention Standards on Telephone Access. Telephones shall be located in an area that provides for a reasonable degree of privacy and a minimal amount of environmental noise during phone calls.

If authorized to do so under applicable law, the **PROVIDER** shall monitor and record detainee conversations. If detainee telephone conversations can be monitored under applicable law, the **PROVIDER** shall provide notice to detainees of the potential for monitoring. However, the **PROVIDER** shall also provide procedures at the facility for detainees to be able to place unmonitored telephone calls to their attorneys.

Telephone rates shall not exceed the dominant carrier tariff rate and shall conform to all applicable federal, state, and local telephone regulations.

The ICE designated DTS-IV vendor will be the exclusive provider of detainee telephones for this facility. The DTS-IV contractor shall be allowed to install vending debit machines and shall receive 100 percent of all revenues collected by sale of prepaid debit

services. The DTS-IV provider shall be responsible for furnishing all inventory and supply of prepaid debit cards to the **PROVIDER**. The DTS-IV provider shall be responsible for the costs incurred for installation of the equipment, any monthly telephone charges incurred from the operation of DTS-IV, and the maintenance and operation of the system. The **PROVIDER** will not be entitled to any commissions, fees, or revenues generated by the use of the DTS-IV or the detainee telephones.

The **PROVIDER** shall inspect telephones for serviceability, in accordance with ICE policies and procedures. The **PROVIDER** will notify the COTR or ICE designees of any inoperable telephones.

#### **MANAGE A DETAINEE WORK PROGRAM:**

1. Detainee labour shall be used in accordance with the detainee work plan developed by the **PROVIDER**, and will adhere to the ICE National Detention Standard on Detainee Voluntary Work Program. The detainee work plan must be voluntary, and may include work or program assignments for industrial, maintenance, custodial, service, or other jobs. The detainee work program shall not conflict with any other requirements of the contract and must comply with all applicable laws and regulations.

2. Detainees shall not be used to perform the responsibilities or duties of an employee of the **PROVIDER**. Detainees shall not be used to perform work in areas where sensitive documents are maintained (designated ICE workspace). Custodial/janitorial services to be performed in designated ICE work space will be the responsibility of the **PROVIDER**.

3. Appropriate safety/protective clothing and equipment shall be provided to detainee workers as appropriate. Detainees shall not be assigned work that is considered hazardous or dangerous. This includes, but is not limited to, areas or assignments requiring great heights, extreme temperatures, use of toxic substances, and unusual physical demands.

The **PROVIDER** shall supply sufficient Detention Officers to monitor and control detainee work details. Unless approved by the COTR, these work details must be within the security perimeter.

4. It will be the sole responsibility of ICE to determine whether a detainee will be allowed to perform on voluntary work details and at what classification level. All detainees shall be searched when they are returned from work details.

#### **LAW LIBRARY:**

The **PROVIDER** shall provide secure space within the secure perimeter, either a dedicated room or a multipurpose room for books and materials to provide a reading area "Law Library" - in accordance with the ICE National Detention Standards on the Access to Legal Materials.



**TRAINING:**

Employees shall not perform duties under this agreement until they have successfully completed all initial training and the COTR receives written certification from the **PROVIDER**.

**A. General Training Requirements**

All employees must have the training described in the ACA Standards and in this section. Any remuneration (pay) due **PROVIDER** employees in accordance with Department of Labor regulations for any training time is the responsibility of the **PROVIDER**. The **PROVIDER** shall provide the required refresher courses or have an institution acceptable to the COTR to provide the training. Failure of any employee to complete training successfully is sufficient reason to disqualify him or her from duty.

All new Detention Officers will receive 54 hours of basic training, not to include firearms and 40 hours of on-the-job training prior to entering on duty. The **PROVIDER'S** Training Officer will be responsible for administering an on-the-job training program for new employees. A senior Detention Officer, at all times during this latter 40-hour period, must accompany the Detention Officers. The **PROVIDER'S** Training Officer shall send a copy of the documentation to the COTR upon successful completion of the employee's on-the-job training.

In addition, after completion of the first 94 hours of training, the **PROVIDER** has 60 days to complete an additional 40 hours of training. During the remainder of the first year on duty, the officer will have an additional 40 hours of training for a total of 174 hours within the first year of employment. The training program must directly relate to the employee's assigned position and afford application of necessary job skills. Training site shall be provided by the **PROVIDER** at no cost to the Government.

**1. Basic Training Subjects**

Employees must complete the following list of basic training subjects. The course title is followed by the estimated hours of training for that subject.

- a. In-service Orientation/Social Diversity 2 HRS
- b. Counseling Techniques/Suicide Prevention 2 HRS
- c. Conduct/Duties/Ethics and Courtroom Demeanor 2 HRS
- d. Bomb Defense and Threats 1 HR
- e. Telephone Communications/Radio Procedures 1 HR
- f. Fire and other Emergency Procedures 2 HRS
- g. Treatment and Supervision of Detainees 2 HRS
- h. ICE Use of Force Policy 2 HRS

i. Security Methods/Key Control/Count	1 HR
j. Procedures/Observational Techniques	4 HRS
k. EEO/Sexual Harassment	2 HRS
l. Detainee Escort Techniques	1 HR
m. ICE Paperwork/Report Writing	2 HRS
n. Detainee Searches/Detainee Personal Property	4 HRS
o. Property/Contraband	2 HRS
p. Detainee Rules and Regulations	2 HRS
q. First Aid*	4 HRS
r. Cardiopulmonary resuscitation (CPR)*	4 HRS
s. Blood-borne Pathogens*	2 HRS
t. Self Defense	8 HRS
u. Use of Restraints	6 HRS
v. Firearm Training	**
w. Sexual Abuse/Assault Prevention & Intervention*	2 HRS
x. National Detention Standards	2 HRS

\* *Critical Training Subjects*

\*\* *Firearm Training for Required Armed Detention Services in accordance with state licensing requirements. PROVIDER shall certify proficiency every quarter.*

## 2. Refresher Training

Every year the **PROVIDER** shall conduct 40 hours of Refresher Training for all Detention Officers including Supervisory Detention Officers. Refresher training shall consist of these critical subjects listed above and a review of basic training subjects and others as approved by ICE.

The **PROVIDER** shall coordinate recertification in CPR and First Aid with the ICE training staff. This training shall be provided at no cost to the Government. Annually, upon completion, the **PROVIDER** shall provide documentation of refresher training to the COTR.

In addition to the refresher training requirements for all Detention Officers, supervisors must receive refresher training relating to supervisory duties.

### **3. On-the-Job Training**

After completion of the minimum of 54 hours basic training, all Detention Officers will receive an additional 40 hours of on-the-job training at specific post positions. This training includes:

- a. Authority of supervisors and organizational code of conduct.
- b. General information and special orders.
- c. Security systems operational procedures.
- d. Facility self-protection plan or emergency operational procedures.
- e. Disturbance Control Team training.

### **4. Training During Initial 60 Day Period**

The **PROVIDER** shall provide an additional 40 hours of training for Detention Officers within 60 days after completion of first 94 hours of training. The **PROVIDER** shall provide the training format and subjects, for approval by the COTR and CO, prior to the commencement of training.

### **5. Basic First Aid and CPR Training**

All members of the **PROVIDER'S** security staff shall be trained in basic first aid and CPR. They must be able to:

- a. Respond to emergency situations within four minutes.
- b. Perform cardiopulmonary resuscitation (CPR).
- c. Recognize warning signs of impending medical emergencies.
- d. Know how to obtain medical assistance.
- e. Recognize signs and symptoms of mental illness.
- f. Able to administer medication;
- g. Know the universal precautions for protection against blood-borne diseases.

### **B. Supervisory Training**

All new Supervisory Detention Officers assigned to perform work under this agreement must successfully complete a minimum of 40 hours of formal supervisory training provided by the **PROVIDER** prior to assuming duties. This training is in addition to mandatory training requirements for Detention Officers. Supervisory training shall include the following management areas:

1. Techniques for issuing written and verbal orders	2 HRS
2. Uniform clothing and grooming standards	1 HR
3. Security Post Inspection procedures	2 HRS
4. Employee motivation	1 HR
5. Scheduling and overtime controls	2 HRS
6. Managerial public relations	4 HRS
7. Supervision of detainees	4 HRS
8. Other company policies	4 HRS

Additional classes are at the discretion of the **PROVIDER** with the approval of the COTR.

The **PROVIDER** shall submit documentation to the COTR, to confirm that each supervisor has received basic training as specified in the basic training curriculum.

### **C. Proficiency Testing**

The **PROVIDER** shall give each Detention Officer a written examination consisting of at least 25 questions after each classroom-training course is completed. The **PROVIDER** may give practical exercises when appropriate. The COTR shall approve the questions before the **PROVIDER** can administer the examination. To pass any examination, each officer must achieve a score of 80% or better. The **PROVIDER** must provide the COTR with the eligible Detention Officer's completed exam before the Detention Officer may be assigned to duties under the agreement. Should an employee fail the written test on the initial attempt, he or she shall be given additional training by the **PROVIDER** and be given one additional opportunity to retake the test. If the employee fails to complete and pass the test the second time, the **PROVIDER** shall remove the employee from duties on this agreement.

### **D. Certified Instructors**

Certified instructors shall conduct all instruction and testing. A state or nationally recognized institution shall certify instructors unless otherwise approved in writing by the COTR. Certifications of instructors may be established by documentation of past experience in teaching positions or by successful completion of a course of training for qualifying personnel as instructors. The COTR must approve the instructor prior to the training course.

### **E. Training Documentation**

The **PROVIDER** shall submit a training forecast and lesson plans to the COTR or ICE designee, on a monthly basis, for the following 60-day period. The training forecast shall

provide date, time, and location of scheduled training and afford the COTR observation/evaluation opportunity.

The **PROVIDER** shall certify and submit the training hours, type of training, date and location of training, and name of the instructor monthly for each employee to the COTR or ICE designee.

**Notification and Public Disclosures:**

There shall be no public disclosures regarding this agreement made by the **PROVIDER** (or any subcontractors) without review and approval of such disclosure by ICE Public Affairs and express permission granted by the ICE Contracting Officer. The Government considers such information privileged or confidential until award of the agreement.

**Establish and Maintain Program for Prevention of Sexual Abuse/Assault:**

The **PROVIDER** shall develop and implement a comprehensive sexual abuse/assault prevention and intervention program. This program shall include training that is given separately to both staff and detainees, in accordance with the Prison Rape Elimination Act (PREA).

**Business Permits and Licenses:**

The **PROVIDER** must obtain all required permits and licenses by the date of agreement award. The **PROVIDER** must (depending on the state's requirements) be licensed as a qualified security service company in accordance with the requirements of the district, municipality, county, and state in which ICE work site(s) is/are located. Throughout the term of this agreement, the **PROVIDER** shall maintain current permits/business licenses and make copies available for Government Inspection. The **PROVIDER** shall comply with all applicable federal, state, and local laws and all applicable Occupational Safety and Health Administration (OSHA) standards.

**Firearms / Body Armor:**

**Firearms Requirements**

- a. The **PROVIDER** shall provide new firearms and maintain sufficient licensed firearms and ammunition to equip each armed Detention Officer and armed supervisor(s) with a licensed weapon while on duty. Firearms may be re-issued to new replacement employees throughout the life of the agreement as long as the firearm is in serviceable condition.
- b. Personal firearms shall not be used. A licensed gunsmith, in writing, shall certify all firearms safe and accurate.
- c. Firearms shall be standard police service-type, semi-automatic capable of firing hollow-point ammunition that meets the recommendations of the firearms

manufacturer. Ammunition will be factory load only – no reloads. Ammunition will be replaced every year.

- d. The **PROVIDER** shall provide sufficient ammunition for each armed Detention Officer, including uniformed contract supervisor(s); they shall be issued three full magazines.
- e. The **PROVIDER** shall account for all firearms and ammunition daily.
- f. If any weapons or ammunition are missing from the inventory, the COTR shall be notified immediately.
- g. All firearms shall be licensed by the State.
- h. Firearms will be inspected. This shall be documented by the Warden/Facility Director.
- i. Loading, unloading, and cleaning of the firearms shall only take place in designated areas.
- j. The firearms shall be cleaned and oiled as appropriate to ensure optimum operating conditions.
- k. Firearms shall be carried with the safety on, if applicable, with a round in the chamber.
- l. The **PROVIDER** shall maintain appropriate and ample supplies of firearms' upkeep and maintenance equipment (cleaning solvents, lubricating oil, rods, brushes, patches, and other normal maintenance tools).
- m. The **PROVIDER** shall provide a complete listing of licensed firearms by serial numbers and by each safe location to the COTR prior to beginning performance under this agreement.
- n. These lists shall be kept current through the terms of the agreement and posted within each firearms safe.
- o. The **PROVIDER** shall obtain and maintain on file appropriate State and municipality permits and weapons permits for each officer.
- p. A copy of this permit shall be provided to the COTR at least three working days prior to the anticipated assignment date of any individual.
- q. The **PROVIDER** shall ensure that his/her employees have all permits and licenses in their possession at all times while in performance of this agreement.
- r. The **PROVIDER** shall provide safes/vaults for storage of firearms and ammunition, for each location where firearms are issued or exchanged, which meet agency requirements and are approved for the storage of firearms and ammunition.
- s. The COTR is responsible for approving the proposed safes/vaults prior to usage. **PROVIDER** supervisors and guards shall make accurate receipt and return entries on a Firearms and Equipment Control Register.

- t. Except when issuing or returning ammunition or firearms, each safe/vault shall remain locked at all times.
- u. The **PROVIDER** shall be responsible for having the combination of each safe/vault changed at least once every six months, or more often if circumstances warrant.
- v. The **PROVIDER** certifies firearms training to the COTR.
- w. The **PROVIDER** shall certify proficiency every quarter.
- x. The **PROVIDER** shall provide an ICE approved intermediate weapon(s).

### **Body Armor Requirements**

- a. The **PROVIDER** shall provide body armor to all armed Detention Officers and armed supervisor(s).
- b. Body armor shall be worn while on armed duty.
- c. The body armor shall meet all requirements as set forth in the ICE Firearms Policy.
- d. The **PROVIDER** shall procure replacement body armor if the body armor becomes unserviceable, ill-fitting, worn/damaged, or at the expiration of service life.
- e. All armed Detention Officers and armed supervisors need to be made aware of the health risks associated with the wearing of body armor in high heat/high humidity conditions and/or during strenuous exertion. When Detention Officers and supervisors are required to wear body armor, they shall be provided opportunities to rehydrate and remove the body armor as necessary.
- f. The use of personally owned body armor is not authorized.

**INDEPENDENT GOVERNMENT COST ESTIMATE**

**FARMVILLE, VA**

**PERIOD OF PERFORMANCE - SEPTEMBER 1, 2008 - SEPTEMBER 30, 2008**

**Per Diem Rate By Number of Beds**

**1000 Beds: \$80.00**

<u>Number of Detainee Beds</u>	<u>Person Days</u>	<u>* Rate</u>	<u>Total</u>
30 Days X 1000 Beds	\$ 30,000.00	\$ 80.00	\$ 2,400,000.00
Days X Beds	\$ -		\$ -
		<b>SUBTOTAL:</b>	<b>\$ 2,400,000.00</b>

<u>Stationary Guard Services</u>	<u>Estimated Number of Hours</u>	<u>Hourly Rate</u>	<u>Total</u>
	200	\$ 30.00	\$ 6,000.00
		<b>SUBTOTAL:</b>	<b>\$ 6,000.00</b>

Transportation **SUBTOTAL: \$ 10,980.00**

**TOTAL ESTIMATED COST = \$ 2,416,980.00**

\* Note: the Rate (or per diem rate), with the exception of stationary guard services, is inclusive of costs such as fringe benefits, overhead, materials, vendor direct costs, general and administrative costs, profit, etc. Guard services are billed as a separate item.



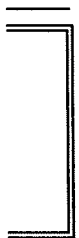

—

0

—

**0**

—

0

**0**

**0**

**0**

of all  
e

**Stevens, Richard P**

---

**From:** Wyatt-Powell, Wendie M  
**Sent:** Monday, March 24, 2008 2:59 PM  
**To:** Neveleff, Jerald  
**Cc:** Washington, John W; Jenkins, John E; Erickson, Susan D  
**Subject:** Farmville County Design Standards  
**Importance:** High  
**Attachments:** Phone PBX system 500-1000.pdf; CDF - EOIR Design Standards 3-20-07.pdf; CDF - HS Design Standards 3-11-05.pdf; CDF - ICE Design Standards - 5-14-07.pdf; INS Armory Design Standards\_2000 2 4.pdf

*Wendie Wyatt-Powell*

Detention Acquisition Support Unit  
Detention Management Division  
Office of Detention and Removal  
U.S. Immigration and Customs Enforcement  
US Department of Homeland Security  
202-732  
202-732 (b)(2)Low

Warning: This document is UNCLASSIFIED//FOR OFFICIAL USE ONLY (U//FOUO). It contains information that may be exempt from public release under the Freedom of Information Act (5 U.S.C. 552). It is to be controlled, stored, handled, transmitted, distributed, and disposed of in accordance with DHS policy relating to FOUO information and is not to be released to the public or other personnel who do not have a valid "need-to-know" without prior approval of an authorized DHS official. No portion of this report should be furnished to the media, either in written or verbal form.



## SCOPE OF WORK PRIVATE BRANCH EXCHANG (PBX)/PHONE SYSTEM

### Section 1 GENERAL INFORMATION

**Organization:** This Performance Work Statement (PWS) identifies and defines the tasks required for the Department of Homeland Security (DHS) Immigration and Customs Enforcement (ICE).

**Background:** The Department of Homeland Security (DHS) Immigration and Customs Enforcement (ICE), Office of Detention and Removal Operations (DRO) is opening a new adult Detention Facility or adding bed space to an existing facility. This facility will meet the DRO requirements for housing 500 to 1000 additional detainees. The telephone system will serve users in a number of different parts of the complex. The appropriate tie cables will be installed by others.

**Objective:** The successful contractor shall purchase, install, program and test a Nortel Communications Server 1000 telephone system with an integrated voice mail for Immigration and Customs Enforcement (ICE). **The installed system shall be equipped with redundant processors and shall be capable of expansion beyond two hundred (200) users.** The DHS/ICE offices requirement is for this telephone system to support the local office with PRI service from the Local Exchange Carrier (LEC).

#### 1.1 Scope of Work

The contractor must provide all personnel, equipment, tools, materials, supervision, and other items and services necessary to perform the procurement and installation of a complete and operating system.



# U.S. Immigration and Customs Enforcement

U.S. Department of Homeland Security

The service provider will be responsible for providing testing and training of the telephone system the service provider must perform to the requirements as defined in this document.

## 1.2.1 Employee Training

The service provider shall be responsible for all related instructor, equipment, and materials necessary to support all end user training. The Contractor shall provide DHS / ICE with a hard copy of all applicable commercial operating manuals and training materials for the new telephone switch, instruments, and user manuals for all Voice Mail Systems users. The Contractor shall provide end user training for approximately seventy-five (75) personnel. The training shall last approximately one hour. The training shall be conducted on live sets and shall address all the features of the telephone set and associated voicemail system. The vendor shall plan on classes of approximately ten (10) to twelve (12) students. The training shall be performed by an instructor qualified and certified by the equipment manufacture. The instructor must be approved by DHS/ICE prior to the commencement of the training. Although a majority of the training will be conducted during normal working hours (8 AM to 4 PM Monday thru Friday), the vendor shall plan on conducting one training class during the 4 PM to 11PM shift and one class between the hours of 12 midnight and 6 AM. The government shall arrange for the training to occur between 9 PM and 2 AM. This time will allow the vendor to conduct training for three groups of end users.

The contractor shall also train a minimum of one (1) and as many as two (2) staff members in the basic administration of the telephone and voice mail system. This training shall include, but is not limited to, PBX and voice mail system login, resetting voice mail passwords, changing caller ID on a telephone instrument or in the voice mail system. This training shall occur after the system is operational and shall be performed on the installed system.

## 2.2 Technical Definitions

**2.2.1 DHS- Department of Homeland Security**

**2.2.2 ICE- Immigration and Customs Enforcement**

**2.2.3 FOD- Field Office Director-**This office oversees all issues related to the detention, housing and deportation/removal of individuals who have been apprehended. This office also works closely with the OPLA staff to prosecute cases on behalf of the United States government.

**2.2.4 DRO-Detention and Removal-**This office reports to the FOD. The DRO is responsible for the detention and removal of those individuals apprehended in the United States illegally.

**2.2.5 OPLA-Office of the Principal Legal Advisor-**The OPLA is comprised of legal staff and they are responsible for preparing/presenting the government's case against individuals who have entered the United States illegally. They are responsible for presenting the government's case in hearings before an Immigrations Judge.

**2.2.6 EOIR-Executive Office of Immigration Review-** This office is responsible for providing the judges and courtrooms for the immigration hearings. These judges are specially trained on immigration issues and oversee the hearing on behalf of the government.

**2.2.7 End User Training-**This training is for the end user of the telephone system.

**2.2.8 Instructor Led Training-**Instructor led training is that training usually provided by a telephone system manufacturer or a manufacturer certified training corporation. This training is for the government staff and is a more in depth training on the telephone and voicemail system administration. The training is provided at the training corporation's facility and is not to be confused with End User Training.

### 3.1.1 Government-Furnished Materials

There will not be any Government-Furnished Materials for this project.



### **3.1.2 Local Exchange Carrier**

The government will provide all telephone services required to meet the performance criteria of this contract. The telephone service required to meet the objective of this contract will be identified by the government representative. These identified telephone services will be installed prior to or during the beginning phase of the contract period. The contractor will work with the Local Exchange Carrier to ensure all requested telephone services are connected to the PBX and operating within accepted industry standards. In the case where telephone services are not required to be connected to the Phone System, the contractor will ensure that the services are terminated at the appropriate wall outlet.

## **SECTION 4 CONTRACTOR-FURNISHED ITEMS AND SERVICES**

### **4.1 General Information**

4.2.1 The service provider is responsible for the procurement, installation, programming, and testing of a Nortel Communications Server 1000 Private Branch Exchange (PBX). This system shall have the capacity to accommodate at least two hundred and fifty (250) digital, seventy - five (75) analog devices and three (3) PRI's. **The vendor shall include the system admin. terminal, keyboard, mouse (if applicable) and a printer for the PBX and the voice mail system.**

4.2.2 The service provider is responsible for the procurement, installation, programming, and testing of an integrated voice mail system of the same manufacturer/ brand as the PBX. The voice mail system shall have the ability to accommodate two hundred (250) users and approximately six (6) auto attendants.

4.2.3 The service provider is responsible for the procurement, installation and testing of one hundred and sixty (160) Model 3903 digital telephone instruments. Color shall be black.

4.2.4. The service provider is responsible for the procurement, installation and testing of thirty (30) Model 3904 digital telephone instruments. Color shall be black

4.2.5 The service provider is responsible for the procurement, installation and testing of ten (10) Model 3902 telephone instruments. Color shall be black.

4.2.6 The service provider is responsible for the procurement, installation and testing of fifteen (15) key based expansion modules with foot stands.

4.2.7 The service provider is responsible for the procurement installation and testing of sixteen (16) conference room telephones (Polycom) with external microphones (do not quote Premiere sets).

4.2.8 The service provider is responsible for the procurement, installation and testing of four (4) wireless 2.4 or 5.8 GHZ telephone instruments (Panasonic).

4.2.9 The service provider is responsible for the procurement, installation and testing of fifteen (15) wireless headsets with over the head/over the ear capability (Plantronics).

4.2.10 The service provider is responsible for the procurement, installation and testing of twenty (20) two pair telephone mounting cords (cord from the jack to the telephone), which shall be twenty-five (25) feet in length.

4.2.11 The service provider is responsible for the procurement, installation and testing of sufficient digital line cards to support two hundred (200) digital instruments.



## U.S. Immigration and Customs Enforcement

U.S. Department of Homeland Security

4.2.12 The service provider is responsible for the procurement, installation, program and testing of sufficient analog line cards to support sixty (60) analog devices.

4.2.13 The service provider is responsible for the procurement and installation of forty-eight (48) port Cat 5e patch panels. These panels shall be mounted in a 19" rack provided by others.

4.2.14 The service provider is responsible for all labor and materials to terminate all system tails on 110 blocks.

4.2.15 The service provider is responsible for all labor and materials to run a tie cable from a second 110 block to the patch panels.

4.2.16 The service provider is to provide two hundred and forty (260) Cat 5e patch cords. These patch cords shall be approximately seven (7) feet in length and shall be white in color for digital and green for analog.

4.2.17 The service provider is responsible for the procurement, installation and testing of a Music-on-Hold system that is similar to a CD/Digital Player. This system shall come complete with at least one EZ listening or light classical music CD with all royalty and licensing fees included.

4.2.18 The service provider is responsible for the procurement, installation, testing and program of three (3) PRI cards. One of the three PRI cards will be used to connect to the facility operator's phone system via a copper tie cable using a standard T-1 protocol. Provide labor and materials to connect the ICE phone system via PRI card to the service provider's telephone system. Vendor is to provide the appropriate circuit card for the system and the labor to program a unified dial plan for the system. ***These requirements are for the DHS/ICE/DRO phone system only. The service provider's phone system requirements are not addressed in this document.***

4.2.19 The system shall be configured with all hardware and software necessary to provide an additional layer of password security and still perform remote maintenance via a dial up line (i.e. Teltronics SEBII or equivalent). A second non-secure modem does not meet this requirement.

4.2.20 The system shall come equipped with a Universal Power Supply (UPS) that provides emergency power for up to two hours at peak usage. The CSU/DSU(s) shall be connected to this UPS.

4.2.21 The service provider is responsible to provide all labor and material to wall mount ten (10) telephone instruments. This installation shall include the correct length line cord such that there is no exposed line cord when the instrument is mounted on the wall.

4.2.22. The service provider is responsible for the procurement, installation of a two or four post 19" rack. The rack base shall be mounted to the floor and secured at the top of the rack with a standard 12" ladder rack. The entire telephone system shall be mounted in this rack. At a minimum, the following components shall be mounted in the rack: PBX, Voice mail system. UPS, system administration terminals for the PBX and voice mail system. The system admin printer(s) need not reside in the enclosure.

4.2.23 The service provider is responsible for the procurement, installation and program testing of a Power Failure Transfer Unit (PFTU). This device shall reside in the PBX and shall be capable of transferring approximately five (5) analog business lines and bypass the switch in the event of a power failure at the site.

### SECTION 5 SPECIFIC TASKS



# U.S. Immigration and Customs Enforcement

U.S. Department of Homeland Security

## 5.1 General Information

The objective of this task is for the service provider to purchase, install, and test a Nortel Communication Server 1000 telephone system with an integrated voicemail system for the Immigration and Customs Enforcement (ICE). The DHS/ICE offices requirement is for this telephone system to support the local office with PRI service from the Local Exchange Carrier (LEC).

The Department of Homeland Security currently terminates all voice and data station cables on patch panels. We terminate all four pair of each voice and data connection such that the jacks may be used interchangeably for either voice or data. The termination for the switch shall be as follows. All system tails shall be terminated on 110 style blocks. A second 110 block shall be mounted in close proximity to the 110 block on which the system tails were terminated. This second 110 block shall connect to the patch panels specified in Section 4.2.12 via a tie cable. Vendor shall bid labor and materials to perform all terminations for the 110 style blocks as well as labor to terminate the tie cable between the second 110 block and the patch panels.

All work is expected to meet the applicable portions of the ICE Structured Cabling Standards (Version 5.1) and/or industry standards for installation, labeling, testing, training and documentation (hand written labels on telephone sets are specifically prohibited).

The final implementation plan must be furnished by the service provider and approved by the COR before installation begins.

**The Contractor shall obtain any necessary permits.**

## 5.2 Perform Equipment Installation Services

### 5.2.1 Installation

5.2.1.1 All switch tails shall be routed across 12" ladder rack and terminated on 19" rack mounted patch panels. All digital and analog system ports, (either active or not) shall be terminated in a similar manner on CAT 5e patch panels. Each system port shall be terminated to its own patch panel port and labeled accordingly.

5.2.1.2 The service provider shall be responsible for all cross connects, including patch cords, from the dial tone demarcation point to the existing riser/tie cables, to the PBX. The service provider is also responsible for ensuring dial tone is carried through all cross connects, including patch cords, from the PBX to the existing riser/tie cables, horizontal cabling termination patch panels and to the desk top telephone instrument.

### 5.2 Warranty Repairs

5.2.1 The service provider shall be responsible for a minimum warranty period of 12 months (new parts and labor) from the date of final acceptance.

5.2.2 The service provider shall submit in response to this PWS, a copy of the warranty with detailed instructions indicating the step by step procedures to be used to replace the equipment covered under the system warranty.

## 5.3 Maintenance Service Agreement

5.3.1 The service provider shall also include maintenance for 12 months starting after the 12 month warranty period terminates followed by **(1) option year** priced individually. The pricing for the one year



options shall be broken out separately from the cost of the system.

5.3.2 The service provider shall provide step by step procedures for this Maintenance Service Agreement (MSA) for the PBX and voice mail system.

5.3.3 The MSA based on 24 X 7 X 365 coverage on all aspects of the PBX and voicemail systems including the coverage of major and minor alarms. Please refer to Attachment 2 for the details pertaining to this maintenance service agreement.

## **SECTION 6 APPLICABLE PUBLICATIONS AND FORMS**

Publications and forms that apply to the PWS are listed below. The publications and forms have been designated as either mandatory or informational. The contractor is obligated to follow those publications and use those forms designated as mandatory to the extent specified in other sections of this PWS. The contractor must be guided by those publications or use those forms designated as informational to the extent necessary to accomplish requirements in this PWS. All publications and forms listed must be provided by the government at the start of the contract.

### **6.1 Publications**

#### **6.1.1 Informational Publications**

6.1.1.1 Federal Acquisition Regulation (FAR) Part 37.104 titled "Personal Services Contract, this task order is not being used to procure personal services which are prohibited by the aforementioned publication.

6.1.1.2 Section 508 of the Rehabilitation Act of 1973 (29 U.S.C. 794d), All electronic and information technology (EIT) identified in this PBSOW, shall comply with Section 508 of the Rehabilitation Act of 1973 (29 U.S.C. 794d), and the Architectural and Transportation Barriers Compliance board Electronic and Information Technology (EIT) Accessibility Standards (36CFR Part 1194); unless an agency exception to this requirement exists. 36 CFR 1194 implements Section 508 of the Rehabilitation Act of 1973, as amended, and is viewable at <http://www.accessboard.gov/sec508/508standards.htm-Part1194>.

6.1.1.2a The service provider shall indicate for each line item in the schedule whether each product or service is compliant or noncompliant with the accessibility standards at 36 CFR 1194. Further, the proposal must indicate where full details of compliance can be found (e.g., vendor's website or other exact location).

#### **6.1.2 Mandatory Publications**

6.1.2.1 ICE Structured Cable Plant Standard (Version 5.1) available upon award of contract.

6.1.2.2 ICE Telephone Site Survey Form (attachment 1)

6.1.2.3 ICE Project Data Sheet (attachment 2)

The following will be evaluated and given either a pass or fail assessment:

- The service provider shall contained sufficient detail to prove that the proposed solution meets all DHS / ICE requirements.
- All features of the system and the station equipment are listed and explained.





# U.S. Immigration and Customs Enforcement

U.S. Department of Homeland Security

---

- The brochures, technical manuals, and other information needed for understanding and management of the proposed system, Voice Mail, telephone instruments and ancillary devices are provided.

1.2 Unless otherwise specified in the agreement, the service provider is responsible for the performance of all installation inspections for conformance with the service providers prepared and Government accepted Installation. The service provider shall document all test results and provide an electronic copy and a hard copy to the Government. The service provider shall anticipate no more than one failure related to the Government furnished connectivity to the system or location.

2.2 There will be a One hundred percent inspection of all devices installed.

## **Technical Exhibit 2 – Maps and Work area layouts (floor plans)**

Floor plans will be available upon installation start.



# U.S. Department of Homeland Security

U.S. Immigration and Customs Enforcement

Office of Detention and Removal Operations

## CONTRACT DETENTION FACILITY

---

# DESIGN STANDARDS

for EXECUTIVE OFFICE FOR IMMIGRATION REVIEW

March 20, 2007



**U.S. DEPARTMENT OF HOMELAND SECURITY**  
U.S. Immigration and Customs Enforcement  
Office of Detention and Removal Operations

**CONTRACT DETENTION FACILITY**  
**Design Standards** for

---

**Executive Office for Immigration Review**

---

*Immigration and Customs Enforcement (ICE) is a component of the U.S. Department of Homeland Security (DHS). ICE brings a unified and coordinated focus to the enforcement of federal immigration laws, customs laws, and air security laws. ICE brings to bear all of the considerable resources and authorities invested in it to fulfill its primary mission: to detect vulnerabilities and prevent violations that threaten national security.*

*As an Operational Division of ICE, the Office of Detention and Removal Operations (DRO) is responsible for public safety and national security by ensuring the departure from the United States of all removable aliens and by enforcing the Nation's immigration laws.*

*Because of increasing demands on Service resources, ICE/DRO personnel must be able to share information rapidly and efficiently in order to succeed in fulfilling the Service mission.*

*In addition to this document, which establishes the EOIR Court Design Standards, other documents are being developed that provide additional related information for planning and design of Contract Detention Facilities (CDF).*

---

*The U.S. Department of Homeland Security gratefully acknowledges the participation and input of the following individuals:*

---

**U.S. Immigration and Customs Enforcement - Office of Detention and Removal Operations**

Dalton D. Lilly, *Chief of Acquisition and Support*

**U.S. Department of Justice - Executive Office for Immigration Review**

Mary Jane Graul, *Chief, Space and Facilities Management Staff*

Zlatko Jovanovic, *Deputy Chief, Space and Facilities Management Staff*

**Performa, Inc.**

David A. Robillard, *President - Performa's Governmental/Justice Team*

Paul DeLeeuw, NCARB, *Strategic Planner*

Scott Woehr, *Strategic Planner*





# Table of Contents

	<b>Page</b>
<b>1. INTRODUCTION</b> .....	1.1
- Project Statement	
- Design Standards Purpose	
- Design Standards Organization	
<b>2. ORGANIZATIONAL REQUIREMENTS</b> .....	2.1
- EOIR Court Background	
- EOIR Court Function	
- EOIR Court Organization	
<b>3. OPERATIONAL REQUIREMENTS</b> .....	3.1
- CDF Operational Model	
- EOIR Court Operational Units	
- EOIR Court Staff Positions	
- EOIR Court Staff Forecasts	
<b>4. FUNCTIONAL REQUIREMENTS</b> .....	4.1
- EOIR Court Space Requirements	
1.0 Court Unit Requirements	
2.0 Administrative Unit Requirements	
3.0 Common Support Unit Requirements	
- Technical Requirements	
<b>5. APPENDIX</b> .....	5.1
- Reference Publications	
- Acronyms and Abbreviations	





## 1. INTRODUCTION

Project Statement  
Design Standards Purpose  
Design Standards Organization





## Project Statement

### PROJECT INTENT

The U.S. Department of Homeland Security (DHS) and Immigration and Customs Enforcement (ICE) are responsible for detaining those who have entered the United State illegally or violated their immigration status. Facilities used by DHS/ICE for detention are called Service Processing Centers (SPC's) or Contract Detention Facilities (CDF's). The purpose of these facilities is to provide a place of detention for aliens who are taken into custody pending completion of their deportation case or pending release.

It is the intent of this project and Design Standards to develop a set of planning and design standards from which Contract Detention Facilities are built. The operational components within a CDF are derived from categorizing the personnel groups and service activities of a CDF. The level of securing required determines how the components are organized. The side bar to the right lists the main operational components within a CDF and for each their functional areas. This report establishes the planning and design guidelines for one of the court/interface components called the Executive Office for Immigration Review (EOIR) Court.

### EXECUTIVE OFFICE FOR IMMIGRATION REVIEW

The Executive Office for Immigration Review (EOIR) is part of the Department of Justice (DOJ) and oversees the immigration courts. The EOIR Court determines if an alien will be granted permission to reside in the U.S. The EOIR Court component is located within the court interface zone of the CDF complex and includes courtrooms, and work areas.

### CDF Operational Components

#### **Office Components**

Normal office setting for administrative and public functions of the CDF. (They are located outside the secure perimeter.)

- Lobby
- Public Visitation
- Deportation
- INS Court Attorneys
- SPC Administration
- Staff Services & Training
- LANS

#### **Detainee Living Components**

Located inside the secure perimeter they are used by the detainees during their normal daily routine.

- Security Command
- Housing
- Commissary
- Recreation
- Law Library/Recreational Library
- Food Service Dining

#### **Court and Public/Detainee/Interface Components**

This component includes the EOIR Court work area and courtroom space.

#### **- EOIR Court**

- Attorney/Contact Visiting

#### **Service Components**

Service functions for the CDF detainee population. They are typically placed in a secure area because detainees require frequent access to them or are given work details in these components.

- Mailroom
- Processing
- Visiting
- Health Services
- Food Service Preparation
- Laundry
- Detainee Work/Industries

#### **Facility Support Components**

These elements support the facility but do not provide direct services to the detainees and may be located outside the secure perimeter.

- Warehouse and Supply
- Maintenance
- Central Utility Plant

**EXAMPLE: Contract Detention Facility**



EOIR Floor Plan

CDF Site Plan



## Design Standards Purpose

### PURPOSE OF THE DESIGN STANDARDS

The EOIR Court Design Standards (hereafter referred to as the Standards) contains criteria and concepts for the planning and design of the EOIR Court. The standards contain the *organizational*, *operational*, and *functional* requirements for the EOIR Court Component.

The purpose of the Standards, is to establish operational directions and architectural relationships for future EOIR Court spaces. The decisions made and policies adopted during the development of the Standards are intended to provide direction and guidance during the planning and design of existing and future Contract Detention Facilities, bringing standardization to the facilities as well as reducing the amount of effort and time required to design, construct and activate facilities.

### USERS OF THE DESIGN STANDARDS

This document is intended for all individuals involved in the planning and design of a CDF facility, including architects and engineers, EOIR staff, DHS/ICE staff located at Headquarters, Regional, and District offices assigned to Detention and Removal, Engineering Design and Construction, and any other DHS agencies involved. This document is intended to communicate ICE/EOIR requirements to other service providers providing design, construction, and facility management services.

### APPLICATION OF THE DESIGN STANDARDS

The architectural information contained in the EOIR Court Design Standards should be viewed as ICE/EOIR policy applicable to the design of all CDF facilities. It is intended to provide to the user clear guidance on project requirements, conceptual solutions, and specific technical details. The information is intended to focus the user on meeting ICE/EOIR needs, to educate regarding design of EOIR Court facilities, and to establish design performance conditions as well as to provide design solutions.

The requirements in the Standards are generic in nature. Specific applications such as the mission of the proposed facility, site conditions, ability to receive

service support from local communities and other institutions, and climactic differences must be considered.

The EOIR Court Design Standards provide instructions that must be met, alternative acceptable solutions, and design issues the user should consider. For instructions that must be met, the user shall comply and provide final designs that meet these instructions. Alternative acceptable solutions provide the user with flexible choices to react to variations unique to the specific project. Issues being considered help the user understand the context of the problem and the needs of ICE and the EOIR Court.

The Design Standards are meant to be used as a guideline for the layout of the EOIR Court. Design decisions must be coordinated through EOIR Space and Facilities Management Staff (SFMS) and the ICE/DRO Facilities Management Unit. A review process will be established at the inception of each project and at the 30/60/90 percent design phases. EOIR SFMS and ICE/DRO OFM will provide approvals after each stage. EOIR will provide final approvals from the EOIR Office of the Chief Immigration Judge (OCIJ) and Office of the Director (OD).

Any deviations from the design standards must be approved by EOIR SFMS and ICE/DRO OFM.





## Design Standards Organization

### ORGANIZATION OF THE EOIR COURT DESIGN STANDARDS

The EOIR Court Design Standards are organized to provide conceptual and technical information in a structured manner.

The Design Standards document is organized for ease of use. The Standards are organized into five sections. Each section is designed to stand alone so it may be extracted for use in the planning and design process.

The side bar to the right briefly outlines the contents of each section of this document.

### DESIGN STANDARDS DEVELOPMENT PROCESS

The design standards documented herein have been developed by selected representatives from ICE/DRO and EOIR.

The Standards Development Team, reviewed and evaluated existing EOIR standards documents and assessed existing Service Processing Centers and Contract Detention Facilities noting advantages and disadvantages of each EOIR layout.

The goal of the new standards is to enhance the organizational, operational, and functional efficiencies within an EOIR Court unit and to enhance its relationship to all of the other CDF components.

### Design Standards Contents

#### **Section 1. Introduction**

The Introduction identifies the overall function of a CDF and discusses the purpose and organization of the Design Standards.

#### **Section 2. Organizational Requirements**

This section of the Standards discusses the history of EOIR Court how it is organized within the Department of Justice (DOJ) as well as within a CDF.

#### **Section 3. Operational Requirements**

This section of the Standards discusses the physical relationships of EOIR Court within a CDF and between the EOIR Court Units. Staff positions are identified and correspond per the number of detainee beds.

#### **Section 4. Functional Requirements**

This section of the Standards discusses the spaces needed for each EOIR Court Unit and corresponding technical requirements (i.e. functional description, room or area photograph, space plan, material, and equipment list).

#### **Section 5. Appendix**

This section of the Standards contains a listing of reference publications and acronyms/abbreviations.

### Design Standards Report Contents



Project Statement  
Design Standards Purpose  
Design Standards Organization

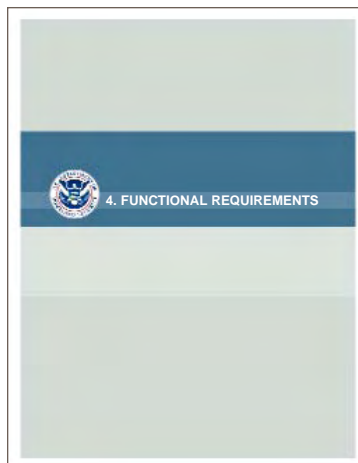

EOIR Court Space Requirements  
1.0 Court Unit Requirements  
2.0 Administrative Unit Requirements  
3.0 Common Support Unit Requirements



EOIR Court Background  
EOIR Court Function  
EOIR Court Organization



Reference Publications  
Acronyms and Abbreviations



CDF Operational Model  
EOIR Court Operational Units  
EOIR Court Staff Positions  
EOIR Court Staff Forecasts



## 2. ORGANIZATIONAL REQUIREMENTS

EOIR Court Background  
EOIR Court Function  
EOIR Court Organization



## EOIR Court Background

### OVERVIEW

The Executive Office for Immigration Review (EOIR) is an administrative tribunal that presides over all trial and appellate cases involving charges of immigration violations. On behalf of the Attorney General, EOIR exercises authority to interpret and administer Federal immigration laws and regulations through Immigration court proceedings, appellate reviews, and administrative hearings in certain types of immigration-related cases.

The Executive Office for Immigration Review (EOIR) was created on January 9, 1983, through an internal Department of Justice (DOJ) reorganization which combined the Board of Immigration Appeals (BIA or Board) with the Immigration Judge function previously performed by the former Immigration and Naturalization Service (INS), now part of the U.S. Department of Homeland Security.

### MANDATE AND MISSION

EOIR's mandate is to provide a fair, expeditious, and uniform interpretation and application of immigration law. This is accomplished through various adjudicative functions including immigration hearings; appellate review of decisions in immigration matters; and hearings pertaining to employment discrimination, document fraud, and employer sanctions. The purpose of these proceedings is to provide a process through which individuals can defend themselves against Government charges, complaints, denials of benefits, or through which they can seek relief from penalties imposed on or against them.

EOIR's mission is:

***To provide for the fair, expeditious and uniform interpretation and application of immigration law.***

Headed by a Director who reports to the Deputy Attorney General, EOIR carries out its mission through three main organizational components: The Board of Immigration Appeals (BIA); the Office of the Chief Immigration Judge (OCIJ); and the Office of the Chief Administrative Hearing Officer (OCAHO). Except for immigration courts located throughout the country, all component, management and support functions of EOIR are located at its headquarters in Falls Church, VA, just outside Washington, D.C.



U.S. Department of Justice Organization Chart

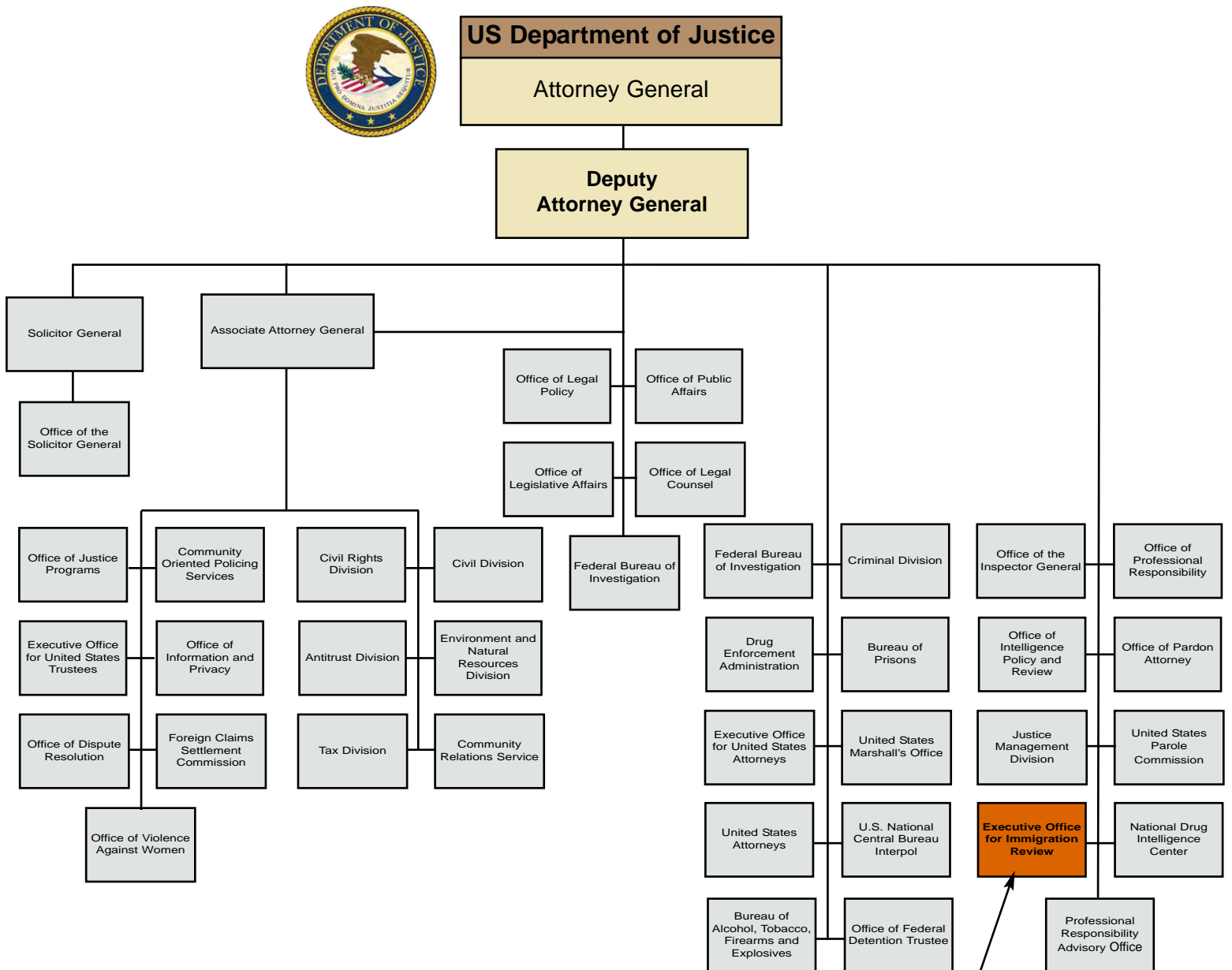

Executive Office for Immigration Review (EOIR)



## EOIR Court Function

### FUNCTION

EOIR is responsible for adjudicating immigration cases under authority from the Attorney General. In conducting immigration court proceedings, appellate reviews, and administrative hearings EOIR interprets and administers immigration laws. EOIR consists of three primary components - Office of Chief Immigration Judge, the Board of Immigration Appeals and the Office of the Chief Administrative Hearing Officer. EOIR is separate from the Office of Special Counsel for Immigration-Related Unfair Employment Practices in the DOJ Civil Rights Division and the Office of Immigration Litigation in the DOJ Civil Division.

The most common type of proceeding before EOIR is a removal hearing at an EOIR Court. In these hearings, DHS charges and must prove that an alien is in the United States unlawfully and should be removed. EOIR does not have jurisdiction over an alien's cases unless DHS files charging documents with EOIR.

If DHS charges an alien with an immigration law violation, it serves the alien with a charging document, known as a Notice to Appear, ordering the individual to appear before an Immigration Judge. The Notice to Appear is filed with the Immigration Court having jurisdiction over the alien, and advises the alien of the nature of the proceedings, the alleged acts that violated the law, the right to obtain legal representation at no expense to the Government, and the consequences of failing to appear at scheduled hearings.

The issue of removal from the United States is often only the first step in the process because the outcome of many hearings depends on the decision regarding relief from removal. Immigration law provides relief from removal to some aliens who meet specific eligibility criteria. To qualify for relief, aliens must prove that they are eligible. Relief can include asylum, voluntary departure, cancellation of removal, or remedies provided by immigration law.

Another common proceeding is the bond redetermination hearing for aliens who are detained by DHS but have pending immigration hearings with EOIR. Eligible aliens can ask an Immigration Judge to reduce the amount of bond set by DHS, or set a bond if DHS has determined that no bond should be set.

Once a case is completed, if the alien or DHS disagrees with the Immigration Judge's decision, either party or both parties may appeal the decision to the BIA, which is the final decision-maker on "discretionary relief" decisions. ("Discretionary relief" is a type of relief where, even though the alien may meet the requirements, the Immigration Judge has the discretion to determine whether the relief is granted.)

In some instances, if the alien disagrees with the BIA's ruling, the alien may appeal the decision to the Federal court system. In rare instances, if DHS disagrees with the BIA's ruling, the case may be referred ("certified") to the Attorney General for review.

The organizational chart on page 2.5 illustrates the three agencies present within a CDF and their respective responsibilities.

### CDF Organization Chart

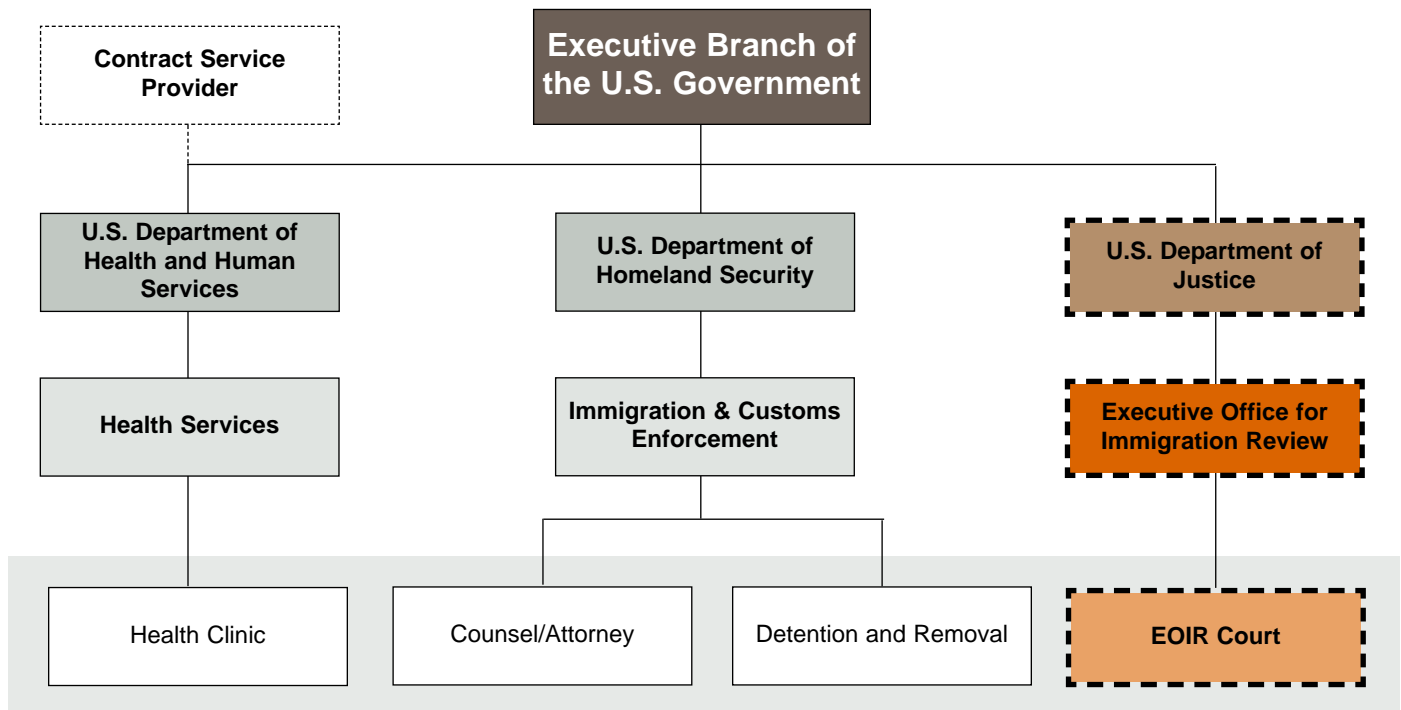

Three agencies are present within the CDF: Detention and Removal Operations (DRO), [Executive Office for Immigration Review \(EOIR\)](#) and Health Services (HS). These groups' respective areas of responsibility are:

1. Detention and Removal Operations (DRO) is responsible for managing the detainees, presenting cases for deportation and executing deportations.
2. [Executive Office for Immigration Review \(EOIR\)](#) is part of the Department of Justice and is responsible for conducting the court hearings.
3. Health Services (HS) is part of the Department of Health and Human Services and is responsible for providing health services.

*NOTE: In some instances Health Services are provided through Contract Detention Service Providers.*



## **EOIR Court Organization**

### **EOIR COURT ORGANIZATION**

The EOIR Court is organized into three units;

- 1.0 Court Unit
- 2.0 Administrative Unit
- 3.0 Common Support Unit

The units are managed by the EOIR Court Administrator. Immigration Judges are assigned to Courtrooms and manage the court proceedings with support from the Administrative Support Unit.

The Court Administrator manages staff that work in support of the courts with the exception of the Immigration Judges. The Court Administrator also controls the Master Hearing Schedule and day-to-day administrative operations for EOIR.

The diagram on page 2.7 illustrates the organizational structure of the EOIR Court.

### **FUNCTION**

EOIR within the CDF is responsible for proceedings providing a process through which individuals can defend themselves against Government charges, complaints, denials of benefits, or through which they can seek relief from penalties imposed on or against them to the full extent of the law. EOIR Courts are provided within CDF to provide expeditious processing of aliens charged without having to move them to locations remote from where they are currently held.

**EOIR Organizational Chart**

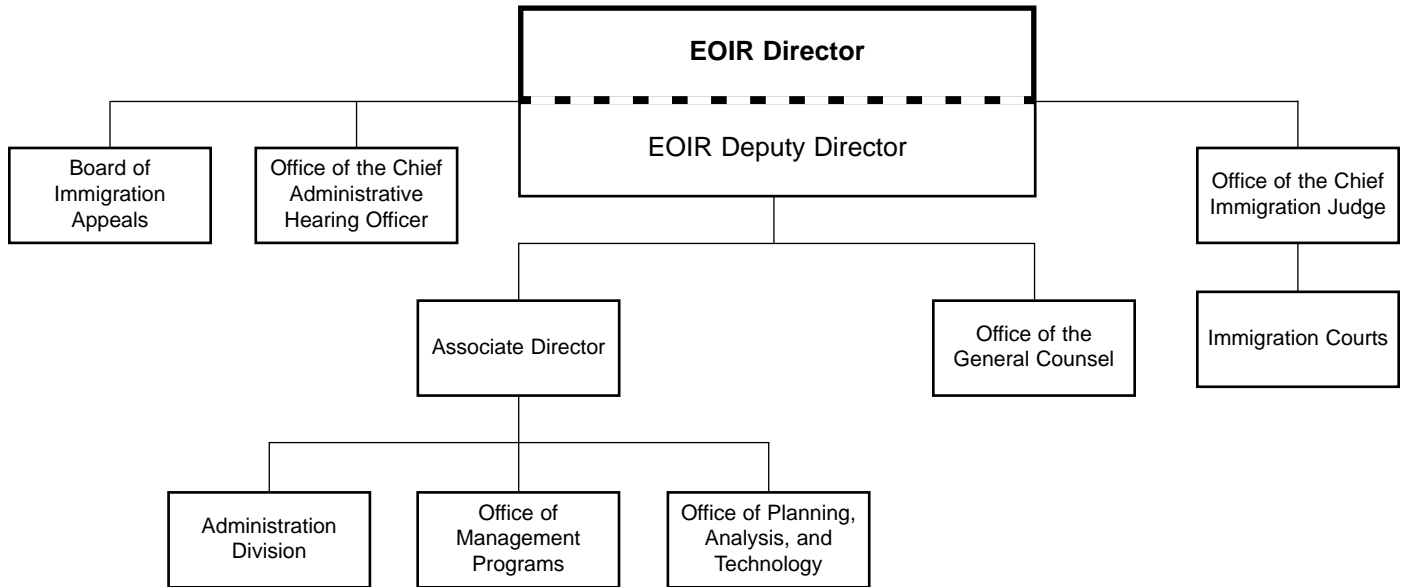

**EOIR Court Organizational Chart**

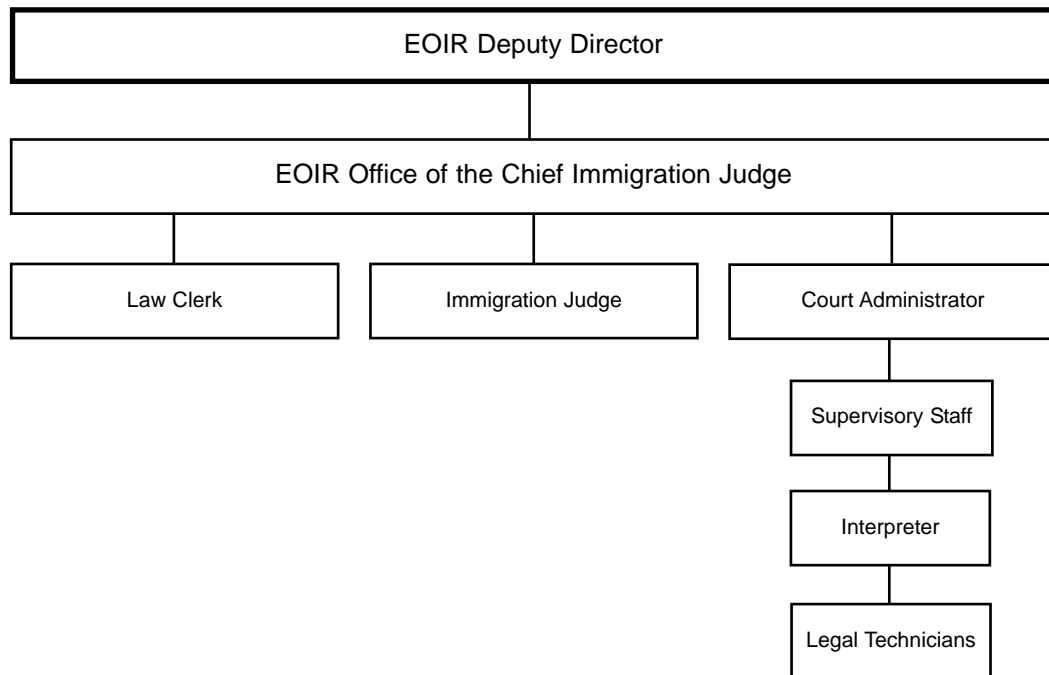



### 3. OPERATIONAL REQUIREMENTS

CDF Operational Model  
EOIR Court Operational Units  
EOIR Court Staff Positions  
EOIR Court Staff Forecasts



## CDF Operational Model

### CDF MISSION

Contract Detention Facility (CDF) is responsible for providing expeditious resolution of aliens that have been charged with violations of United States Immigration, Civil or Criminal law. For this reason, EOIR assigns Immigration Judges to each CDF where they conduct on and off site hearings. In most cases the process begins with DHS filing charges against an alien respondent and represents the Government in seeking the respondent's removal from the United States. Detainees awaiting arraignment are held in Housing Units until proceedings are completed.

### THE EXECUTIVE OFFICE FOR IMMIGRATION REVIEW

The EOIR consists of work area and courtroom space, and is an interface area between the court personnel, the Deportation staff, the public, and detainees under restraint. It requires a secure area demised from the rest of the CDF. The purpose of a distinct secure perimeter for the EOIR courtroom is twofold: (1) to allow general public to enter without going through the secure perimeter of the main facility; and (2) to ensure a secure perimeter for an area where detainees are present. Detainees who have attended proceedings in the court component and may have come in contact with individuals from the public should be searched prior to returning to other secure zones. Public attending hearings or proceedings should be given a secure screening prior to admission.

### PUBLIC ACCESS GROUP

Components that require public access must be adjacent to and open to the public lobby. This includes the Administration, Deportation, the EOIR Court, and Visiting. Other components that have direct adjacency requirements with these must also be included in this arrangement. These additional components include the DHS Attorneys, Staff Training and Services, and Central Control. This public access group includes components within the non-secure and public interface security zones. The primary secure perimeter must separate public access groups from others. In a multi-story facility, this group should be located on the ground floor for direct public access.

### SECURITY ZONES

The secure zones of the facility correspond to the degree of detainee and public access required in the components. The Court/Interface Zone should be in its own secondary secure perimeter, contiguous with but separate from the main facility primary secure perimeter. Access will be by hardened commercial grade doorways, with special controls for general and emergency egress. The perimeter barriers, electronic controls, and procedures should be at the same level as the other secondary secure perimeters.

### CDF Operational Zones

#### **Office Zone**

Normal office setting for administrative and public functions of the CDF. (They are located outside the secure perimeter.)

- Lobby
- Public Visitation
- Deportation
- CDF Administration
- Staff Services & Training
- LANS

#### **Detainee Living Zone**

Located inside the secure perimeter they are used by the detainees during their normal daily routine.

- Security Command
- Housing
- Commissary
- Recreation
- Law Library/Recreational Library
- Food Service Dining

#### **Court/Interface Zone**

This component includes the EOIR Court work area and courtroom space.

- **EOIR Court**
- Detainee Visitation

#### **Service Zone**

Service functions for the CDF detainee population. They are typically placed in a secure area because detainees require frequent access to them or are given work details in these components.

- Processing
- Health Services
- Food Preparation
- Commissary
- Laundry

#### **Facility Support Zone**

These elements support the facility but do not provide direct services to the detainees and may be located outside the secure perimeter.

- Warehouse and Supply
- Maintenance
- Central Utility Plant

### CDF Facility Model

(b)(2)High







## EOIR Court Operational Units

### EOIR COURT ORGANIZATIONAL MODEL

The EOIR Court consists of three operational units.

- 1.0 Court Unit
- 2.0 Administrative Unit
- 3.0 Common Support Unit

*The description for each unit is provided in the sidebar to the right.*

Public access to the EOIR Court is gained through the waiting area and is directly accessed from the CDF Public Lobby. All official court business, internal department access, deliveries, and visitors to EOIR Court come through the Public Lobby. The Courtrooms are located for secure and controlled access by Judges, EOIR staff, the public, and detainees.

### EOIR COURT WORKFLOW

The EOIR Court is located in the Court Interface Zone immediately adjacent to the Public Lobby and near the ICE Attorney's Office. There shall be a separate exterior Judge/Staff entrance for EOIR from staff parking with designated parking spaces for the Judges. Detainees are escorted into the Courtroom(s) through a secure corridor from either a Holding Room or directly from Housing. Visitors and Attorneys access the Courtrooms through the same secure corridor as detainees. Corridor traffic is regulated by CDF guards. Traffic in the Public/Detainee corridor will need to be monitored for segregating traffic to and from the Courtrooms. The Judges access the Courtrooms from the EOIR suite through a secure door behind the Judges bench.

### EOIR COURT ADJACENCIES

Deportation, Administration, EOIR Court, and Visiting should be adjacent to the public entrance and lobby to allow public access without requiring entry any further into the facility. Due to the presence of the detainees, the entrance to the EOIR Court must have security measures. The EOIR staff members are located adjacent to the courtrooms. Outside individuals attending EOIR Court functions must be admitted to the Court. The DHS attorneys must be located next to Deportation for access to records. The attorneys interact with EOIR and should be placed adjacent to this function.

The diagram on page 3.5, illustrates the adjacencies needed between the three EOIR units as well as critical workflow patterns and security check points.

### EOIR Unit Descriptions

#### 1.0 Court Unit

The Courts Unit consist of courtrooms, vestibules and secure corridors. A separate secure corridor is provided for visitors and aliens. A Judge's secure corridor is provided for ease of access from inside the EOIR suite.

#### 2.0 Administrative Unit

The Administrative Unit consists of the Judges Chambers, staff offices, workstations and work areas. Included in this unit are enclosed offices and open work areas. Open work areas are fixed low partitions central to the unit. This unit should be adjacent to the Courts Unit.

#### 3.0 Common Support Unit

The Common Support Unit consists of all the service functions used by EOIR Staff in completion of their mission. Included with this are public waiting areas, conference and equipment spaces, file and storage rooms. Common support should be located with ease of access to the Administrative Unit and Courts Unit.

### EOIR Court Facility Organizational Diagram

(b)(2)High



## EOIR Court Staff Positions

### STAFF AND ACTIVITIES

The work activities of EOIR Court include preparing and hearing cases and administration of EOIR affairs. Staff involved in these activities include: EOIR Judge(s), a Court Administrator and support staff. (For planning purposes 3.5 support staff are assigned per judge.)

Participants within EOIR Court hearings include: the EOIR Judge, and interpreter/legal tech., Court Attorneys, detainee defendant and his/her attorney(s), witnesses, and public viewing. The EOIR Court does not conduct jury trials. Detainees, in groups of individuals, may be present in the Courtroom at one time.

### STAFF DESCRIPTIONS

The following describes the roles and responsibilities for each of the staff positions within the EOIR Court Unit.

#### Immigration Judge

An immigration judge presides at formal hearings to determine issues arising in removal and other immigration proceedings. An Immigration Judge presides over cases involving claims of persecution in which an alien applies to the Immigration for asylum. Immigration Judges also hear cases involving the rescission of adjustment of status for aliens who had previously been adjusted to that of a permanent resident, and cases involving departure control to determine whether the departure of an alien from the United States may be prejudicial to the interest of the United States. Immigration Judges hear custody determination cases when an alien is arrested by the Department of Homeland Security which initially sets the amount of bond and conditions for an alien's release and an Immigration Judge may reduce the amount of bond or rule that the alien be released upon their own recognizance. Immigration Judges regulate the course of hearings, rule on all objections, motions, procedural issues, requests for continuances and receive the testimony of witnesses and other evidence.

Immigration Judges may issue subpoenas to compel an appearance by a witness for a hearing or the production of documents. Immigration Judges hear oral arguments, and may receive and consider briefs prior to a decision. At the conclusion of the hearing, the Immigration Judge issues a decision on the issues of the proceeding. This decision is final unless appealed to the Board of Immigration Appeals in Removal Proceedings (other types of proceedings are not appealable to the Board.) In most cases, a permanent verbatim record of the entire proceedings is kept and a transcript is certified in case of an appeal. Immigration Judges have the authority to order an alien removed from the United States or to grant relief from removal such as asylum, cancellation of removal, waivers of removal and adjustment of status.

#### Attorney Advisor - Judicial Law Clerk

A Judicial Law Clerk assists the Immigration Judges in preparing for immigration hearings, in drafting of facts and conclusions of law. A Law Clerk drafts recommendations on proposed orders and decisions for a case, and examines formal filings to make sure they meet the legal and procedural requirements of the court.

#### **Court Administrators**

The Court Administrator for an Immigration Court is the chief management resource in the court and sometimes a region. A Court Administrator exercises delegated authority for planning and directing the work of court staff to ensure that Immigration Judges are provided support services to conduct immigration hearings. A Court Administrator administers a court management program to include supervising the processing of charging documents that are filed by the Department of Homeland Security, and the processing of motions, applications for relief, briefs and appeals from the initial creation of the Record of Proceeding to the final disposition of the matter. A Court Administrator creates and maintains the court's calendaring docket and is responsible for managing the court's hearing notice system to provide notice to all parties, and for monitoring case related actions.

#### **Legal Technicians**

Legal Technicians provide direct legal support assistance to the Immigration Court in support of the hearing process. Legal Technicians receive, examine and process charging documents and create a Record of Proceeding for each case that comes before an Immigration Court. Legal Technicians provide hearing notices to the parties of an immigration case. Legal Technicians perform the duties of court clerks during Master Calendar hearings where a legal assistant will prepare for immigration hearings by posting calendars and providing the immigration judge with the Records of Proceeding for that day's docket of cases. Legal Technicians call cases to hearing; receive filings in court from the parties to a hearing which include applications for relief, briefs or motions. Legal Technicians also receive calls and visitors, process correspondence, and coordinate hearing room and the hearing logistics for the transportation of detained aliens who are heard at Immigration Courts and for an Immigration Court's Institutional Hearing Program. Legal Technicians also perform administrative duties as required such as assisting with procurement of supplies for a court, administering time and attendance and creating travel vouchers.

#### **Interpreters**

The Interpreters in Immigration Courts perform a full range of interpretations from one or more languages into English for the Immigration Judges, aliens, attorneys and alien representatives during all types of immigration proceedings (master calendar hearings, individual calendar hearings and bond hearings). Interpreters also serve as a language advisor and expert for an Immigration Court, advising judges on language services at the court. Immigration Court interpreters translate the full range of legal, technical, and general material and information received or issued by the Immigration Court. Interpreters also assist the court in other activities such as processing, maintaining Records of Proceeding and electronic data and perform a variety of administrative functions to support court operations.



## **EOIR Court Staff Forecasts**

### **STAFF FORECASTS**

The EOIR Court staff is organized into three functional units. The Staff Requirements matrix shown on page 3.9, illustrates the number of staff assigned to each unit based on the number of detainee beds at the CDF. The numbers illustrate a general rule and may vary based on the operational model used at the specific detention facility. In all cases the staffing must be verified and approved by the OCIJ and OD.

### **STAFF ASSIGNMENTS**

The EOIR Court staff may serve in several functional areas within the court facility. The matrix also illustrates which EOIR unit the staff member may be assigned.

EOIR Court Staff Forecasts

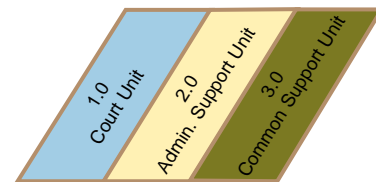

1.0 COURT UNIT

**No Permanently Assigned Staff**  
Staffed only when court is in session

2.0 ADMINISTRATIVE UNIT

Immigration Judge  
Court Administrator  
Law Clerk  
Supervisory Staff  
Support Staff

Subtotal

3.0 COMMON SUPPORT UNIT

**No Permanently Assigned Staff**  
Support Staff (Reception)

(b)(2)High

P = Primary Role  
S = Secondary Role  
B = Business 8am-5pm  
M-F = Monday through Friday

NOTE: The numbers of Judges forecasted is based on the high-end of the bed forecast.



## 4. FUNCTIONAL REQUIREMENTS

- EOIR Space Requirements Summary
- 1.0 Court Unit Requirements
- 2.0 Administrative Unit Requirements
- 3.0 Common Support Unit Requirements
- Technical Requirements



## Space Requirements Summary

### SPACE IDENTIFICATION

The space requirements for the EOIR Court were developed by interviewing with ICE/EOIR and staff representatives. They were developed as a tool for delineation of EOIR Court space needs based on the number of detainees housed within a CDF.

The size of a CDF is determined by the number of staff and detainees served as well as specific functional requirements. There may, however, be variations to its requirements depending on operations and specific types of available staff.

The chart to the right lists the spaces needed to support the EOIR mission. The spaces are categorized by the three operating units. The diagram illustrates a prototype layout for an 800-1000 bed CDF.

### Planning Assumptions

- (1) Supervisory Legal Technician per (4) Legal Technicians/Clerks
- (1) Supervisory Interpreter per (4) or more Interpreters under the supervision of a Court Administrator
- (1) Judge per courtroom for each 200 beds
- 5' wide corridor for Judge's secure corridor
- (15) file cabinets per Judge at 12 sf per cabinet
- Printer workstations = number of courtrooms + 1 X 65 sf
- Waiting room = 100 sf + 75sf per Court Room
- Supervisory Staff = 1:4 Support Staff
- (3.5) Support Staff per (1) Judge
- Circulation is determined by these factors:
  - 30% for all spaces through 175 sf
  - 20% to 176 sf through 600 sf
  - 10% to 600 sf



**EOIR Court Layout : 800-1000 Beds**

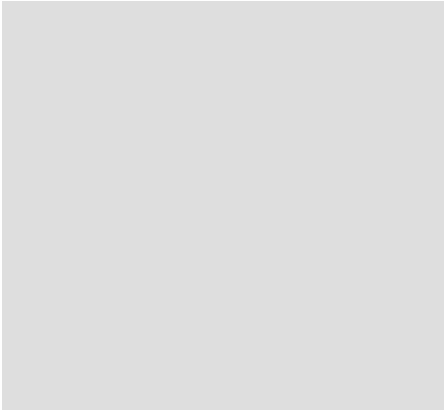
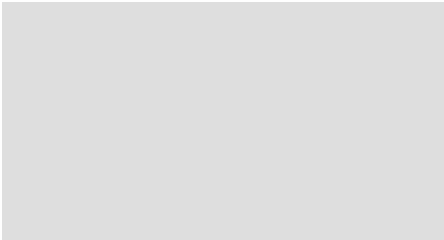

(b)(2)High



## Space Requirements Summary

### SPACE FORECAST MATRIX

The Space Requirements Summary Matrix on the following page, identifies the spaces needed for each of the three EOIR Court Units. The matrix is also designed to forecast these needs for five planning scenarios, they include:

1. <200 beds
2. 200 - 400 beds
3. 400 - 600 beds
4. 600 - 800 beds
5. 800 - 1000 beds

The bed ranges were determined to best represent the capacity range for existing and planned detainee populations.

For each planning scenario, the following information is provided:

- # of Users is the number of persons (staff or detainees) in a given space.
- # of Spaces is the quantity of a given space.
- Space Size NSF is the net square feet or size of a given space.
- Total Size NSF is the number of spaces or quantity of a space times it's NSF or size.

### SPACE CALCULATIONS

The total Net Square Footage is the sum of all net areas of the spaces listed. This number is multiplied by a Net Usable Factor (1.30) (an industry factor based on facility type and utilization efficiency) to determine Usable Square Footage. The Net Usable Area is multiplied by a usable Gross factor (1.05) to determine the Total Gross Square Foot for the EOIR Court Space Requirements.

### DEFINITIONS

#### **Net Square Footage (NSF)**

Total clear floor area within a given room, excluding walls, corridors, mechanical equipment rooms, shafts, stairs, and chases.

#### **Usable Square Footage (USF)**

Total floor area including mechanical and electrical equipment rooms general circulation spaces including corridors, stairs, and elevator shafts.

#### **Gross Square Footage (GSF)**

Total building area measured from outside face of exterior walls.

# Space Requirements Summary

ID #		EOIR Components and Spaces		SPACE FORECAST MODEL: BY NUMBER OF DETAINEE BEDS																				Comments
				Current				200 - 400 Beds				400 - 600 Beds				600 - 800 Beds				800 - 1,000 Beds				
				# of Users	# of Spaces	Space Size NSF	Total Size NSF	# of Users	# of Spaces	Space Size NSF	Total Size NSF	# of Users	# of Spaces	Space Size NSF	Total Size NSF	# of Users	# of Spaces	Space Size NSF	Total Size NSF	# of Users	# of Spaces	Space Size NSF	Total Size NSF	
DOJ Planning Standard																								
1.0		COURT UNIT																				1 Judge/Courtroom for each 200 beds 5' wide corridor by width of Courtroom 5' wide corridor by width of Courtroom		
1.1		Courtroom																						
1.2		Courtroom Sub-Lobby																						
1.3		Judges Corridor																						
1.4		Detainee Sally-Port																						
1.5		Public Sally-Port																						
		Subtotal Courts NSF																						
2.0		ADMINISTRATIVE UNIT																				Reception cubicle may be manned by Legal Tech or Interpreter		
2.1		Immigration Judge Chambers																						
2.2		Court Administrator Office																						
2.3		Law Clerk Office																						
2.4		Supervisory Office																						
		Supervisory Legal Tech Office																						
		Supervisory interpreter Office																						
2.5		Support Work Station (incl. Recpt.)																						
		Legal Tech Workstation																						
		Interpreter Workstation																						
2.6		Supervisory Interpreter Office																						
		Subtotal Administrative NSF																						
3.0		Common Support Unit																				Table and 4 chairs in room adjacent to Waiting Area  15 file cabinets per Judge at 12 SF per file  If needed, designer to confirm with overall layout Number of Courtrooms + 1 x 65 sf		
3.1		Conference Room																						
3.2		Pro Bono Room																						
3.3		Copier/Mail Room																						
3.4		File Room																						
3.5		Computer (ADP) Room																						
3.6		Break Room																						
3.7		Staff Restroom (1 Male, 1 Female)																						
3.8		Janitor Closet																						
3.9		Printer Workstation																						
3.10		Supply Room																						
		Subtotal Common Support NSF																						
		Total NSF																						
		Net Usable Factor (NUF)																						
		Total Usable Area (TUA x NUF)																						
		Usable Gross Factor (UGF)																						
		Total Gross Area (TGA x UGF)																						

(b)(2)High

## 1.0 COURT UNIT REQUIREMENTS

- Function
- Workflow Patterns
- Room Data Sheets



## 1.0 Court Unit - Function

### FUNCTION STATEMENT

The Court Unit is responsible for conducting Master and Merit Hearings.

#### Master Calendar Hearings

These hearings are for arraignment-like purposes only. The charges against each detainee are read and he/she is asked to admit or deny the charges. Also each detainee is asked if they concede removability. Detainees are advised of eligibility for types of relief and the cases are scheduled to an individual hearing, several, based on the request for relief.

#### Merit Hearings

Immigration Judges have jurisdiction to consider applications for various forms of discretionary or mandatory relief, including applications for asylum, adjustment of status, cancellation of removal, and waivers of inadmissibility. The decisions are administratively final unless appealed or certified to the Board of Immigration Appeals.

### Design Criteria

#### Critical Issues

- ✓ Courtrooms need to be grouped together for ease of access by security, aliens, Judges, attorneys, EOIR Court staff, and the public.
- ✓ Because of the need for visitor access to the Court rooms, and the need to maintain security, it is desirable for Courtrooms to be located adjacent to the main CDF Public Entry lobby/waiting area.
- ✓ Access to the Courtrooms by visitors and detainees is through the same secure corridor. Controlled visual access to this corridor for both types of traffic will require timed flow.
- ✓ The Court Unit will accommodate all classifications of detainees: Low, Medium and High Risk Populations.
- ✓ All visitors must enter the Main Public Lobby before entering the EOIR Court Unit.
- ✓ All detainees will be escorted to the EOIR Court Unit.
- ✓ The EOIR Court Unit does not conduct jury trials.

#### Special Requirements

- ✓ Due to the nature of the proceedings, courtrooms must be acoustically isolated from background and equipment noise.
- ✓ The Judge's access to the courtroom(s) is through a separate secure corridor opposite the courtroom sub-lobby. The Judge enters the courtroom from behind the Bench. The Bench is on a raised platform or dais and shall be provided with ramp access from the Judges secure corridor per ADAAG standards.
- ✓ A Judges secure corridor shall be accessed from the EOIR Court and be near the Judge Chambers.
- ✓ Courtrooms shall not contain any exterior windows.

#### Space Requirements

- 1.0 COURT UNIT**
- 1.1 Courtroom
- 1.2 Courtroom Secure Corridor
- 1.3 Judges Secure Corridor
- 1.4 Detainee Sally-port
- 1.5 Public Sally-port
- 1.6 Courtroom Storage Room

### 1.0 Court Unit : Organizational Diagram

(b)(2)High



## **1.0 Court Unit - Critical Workflow Patterns**

### **INTRODUCTION**

The diagrams on the following page (p4.9) illustrate some of the most critical workflow issues and patterns of the Court Unit.

## 1.0 Court Unit : Critical Workflow Patterns

(b)(2)High





## 1.0 Court Unit - Room Data Sheet

### 1.1 COURTROOM

#### Function

The Courtroom is used for both Master Calendar Hearings and individual Merit Hearings. It is the largest space within EOIR and the center for legal proceedings. The Courtroom Dais is a raised platform for the Judges Bench.

The Courtrooms must provide seating for approximately thirty to thirty-five (30-35) people. The Courtroom will have varying numbers of individuals at each proceeding to include the Immigration Judge, Legal Technician, Interpreter, Trial Attorney, respondent, respondent Attorney, respondent family and friends, witnesses and observers.

Pew seating is provided for the visitors, tables for Attorneys and Detainees, Witness Stand, Interpreter Station and Clerks Station are the primary types of furniture within the Courtroom.

#### Video Proceedings

Where there are limitations, some Courtrooms may be equipped to conduct remote hearings using video technology. Future development of the Courtroom standard may be modified to better accommodate remote operation using video and digital technology.

All courtrooms shall be wired for televideo proceedings, via ISDN. The number of courtrooms to be used for televideo will be determined at a later date. Once determined, the ISDN lines shall be activated.



Photograph

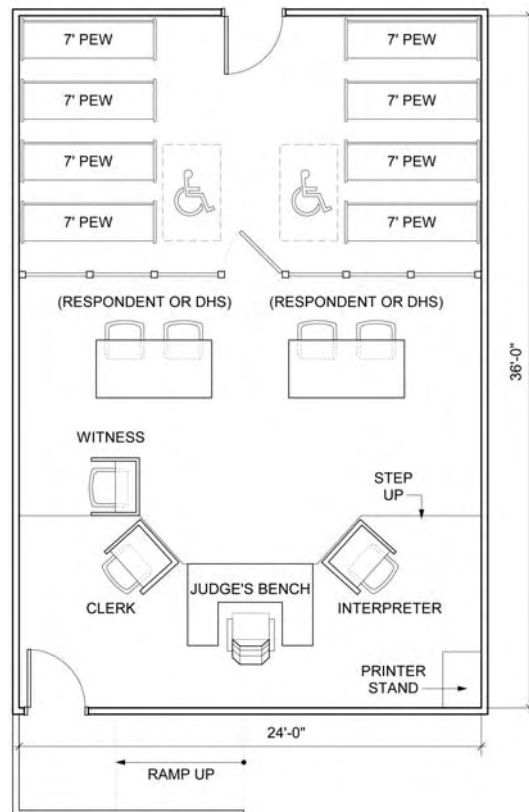

Floor Plan (864 nsf)

## 4. FUNCTIONAL REQUIREMENTS

### 1.1 SYSTEMS MATRIX

<b>Walls</b>	<b>Floors</b>	<b>Ceiling</b>	<b>Doors</b>	<b>Hardware</b>	<b>Glazing</b>
See Appendix - Section 5 - for Finish Schedule	See Appendix - Section 5 - for Finish Schedule	ACT - 10' high	3'x6'8" Solid Core Wd	See Schedule Below	N/A
<b>Plumbing</b>	<b>HVAC</b>	<b>Lighting</b>	<b>Power</b>	<b>Security</b>	<b>Communications</b>
N/A Avoid plumbing piping above ceiling	Stand alone A/C Unit AHU mounted outside Courtroom for sound isolation - High Volume Low Velocity Diffusers No transfer grills	Recessed Parabolic Fluorescent remotely switched. Emergency lighting connected to back-up generator.	Receptacles NEMA 5-20R 125v/20A, 3 wire Single Phase	See Schedule Below Duress alarm button below Judges Bench	See Schedule Below Run Telephone/Data in 1" dia. floor conduit for future addn'l. cable runs.

### 1.1 FURNITURE - EQUIPMENT - HARDWARE SCHEDULE

<b>ID</b>	<b>Item</b>	<b>Vendor*</b>	<b>Style</b>	<b>Model #</b>	<b>Qty.</b>
<b>FURNITURE</b>					
F	Waste Receptacle				2
F	Pew 7'-0" (custom built)	UNICOR		EOIR7PEW	TBD
F	Pew 6'-0" (custom built)	UNICOR		EOIR6PEW	TBD
F	Interpreter Station (custom built)	UNICOR		EOIR CLERK	1
F	Judges Bench (custom built)	UNICOR		EOIRBENCH	1
F	Clerk Station (custom built)	UNICOR		EOIRCLERK	1
F	Witness Stand (custom built)	UNICOR		EOIRSTAND	1
F	Attorneys Tables	UNICOR	Symphony	S7236-02-WN	2
F	Printer Stand	UNICOR	Baritone	BT3524MCWWN	1
F	Attorney Chair	Trinity Furniture	Walnut	7110-00-584-6490	4
F	Clerk Chair	UNICOR	Budget (Black)	ZZUST2032-3601	1
F	Witness Chair	UNICOR	Budget (Black)	ZZUST2032-3601	1
F	Interpreter Chair	UNICOR	Budget (Black)	ZZUST2032-3601	1
F	Immigration Judges Chair	UNICOR	Queen Anne	WVC1211WN	1
	or	UNICOR	Overture	FC-HB-VG-UG-SM-S-C-04	1
F	AV Stand w/Casters	KLOG	Medium Oak	MLCT-75	1
<b>EQUIPMENT</b>					
Bl	Floor Mounted Telephone Outlet			RJ45	1
Bl	Floor Mounted Microphone Outlet, Male			XLR	4
Bl	Floor Mounted Microphone Outlet, Female			XLR	4
Bl	Microphone Jumper - Extension cables		Include Connectors	XLR (1 Male/1 Female)	4
Bl	Female Outlet for Speaker Phone			RJ11	4
Bl	Outlet for Soundstation Microphone			RJ9	4
Bl	Female Outlet to Connect Console			RJ45	4
Bl	Observers Rail with Gate and Hardware				1
Bl	Floor Mounted Data Outlet			RJ45	5
Bl	Floor Mounted Electrical Outlet			Duplex	8
Bl	Wall Mounted Electrical Outlet			Duplex	4
Bl	Wall Mounted Data Outlet			RJ45	3
Bl	Emergency Lighting				1
Bl	Wall Mounted ISDN Hook-up			RJ45	3
<b>HARDWARE</b>					
Bl	Public Entry Door Closer	LCN	w/Hold Open	LCN 4040	1
Bl	Duress Alarm System	Radionics or Ademco		D7212B or 50P	1
Bl	Public Entry Door Lockset				1
Bl	Public Entry Door Offset Hinges (Swing Away)				3
Bl	Door Floor Stops				2
Bl	Judges Entry Door Closer	LCN		LCN 4040	1
Bl	Judges Entry Door Cipher Lock	Trilogy		DL 2700	1
Bl	Judges Entry Door Deadbolt Lock	Schlage Lockset		B680	1
Bl	Judges Entry Door Peaphole	Ives	190 degree	Ives 698	1
Bl	Judges Door - Non-removable hinge pins	Site Specific			3
Bl	Door Sweep - Automatic retracting inset				2
Bl	Door Sound Seal				2

\* Vendor names are listed as a point of reference for equipment specs. Equal products by other manufactures can be used.

\*\* Lockset to be determined based on CDF facility requirements. Where an existing facility is being modified, new hardware shall be compatible with existing preference is for electronic keyless entry - via card readers or cipher locks. Each system must provide for key override.





# 1.0 Court Unit - Room Data Sheet

## 1.1 COURTROOM - TECHNICAL SPECIFICATIONS

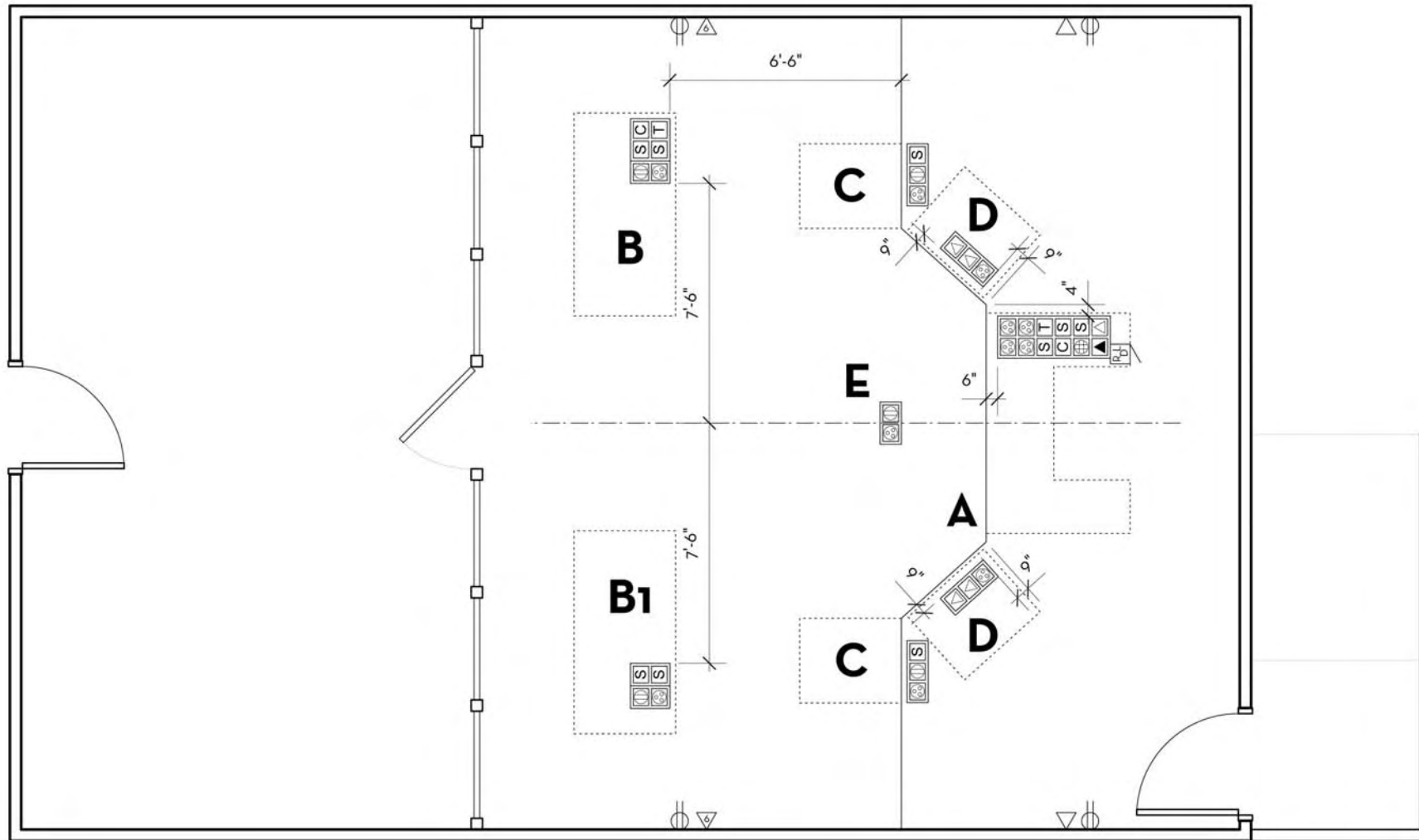

### SYMBOL LEGEND

	FLOOR MOUNTED TELEPHONE OUTLET - RJ45		FLOOR MOUNTED DUPLEX 110V OUTLET
	FLOOR MOUNTED DATA OUTLET - RJ45		FLOOR MOUNTED QUADRUPLEX 110V OUTLET
	RJ11 - FEMALE OUTLET FOR ANALOG PHONE LINE TO PLUG IN SOUNDSTATION PREMIER SATELLITE CONSOLE SPEAKER PHONE.		WALL MOUNTED TELEPHONE OUTLET - RJ45
	RJ9 - OUTLET FOR SOUNDSTATION MICROPHONE		WALL MOUNTED DATA OUTLET - RJ45
	RJ45 - FEMALE OUTLET TO CONNECT THE SOUNDSTATION PREMIER CONSOLE TO SOUNDSTATION PREMIER SATELLITE		WALL MOUNTED DUPLEX 110V OUTLET
	FLOOR MOUNTED MICROPHONE CONNECTOR - XLR (FEMALE)		
	FLOOR MOUNTED MICROPHONE CONNECTOR - XLR (MALE)		

### TECHNICAL NOTES

- A** Recessed Floor Box in DAIS/Platform
- One (1) Female Data Outlet for Computer Network (RJ45)
  - One (1) Female Phone Outlet for Judges Phone (RJ45)
  - One (1) Female Phone Outlet for Speaker Phone (Analog RJ9)
  - One (1) Female Outlet to connect to the Soundstation Premier to Soundstation Satellite (RJ45)
  - Three (3) Female Outlets for External Microphone to Speaker Phone (RJ9)
  - Four (4) Male 3-XLR Connectors to connect Microphone to Recorder
  - One (1) Fourplex Electrical Outlet
- B** Recessed Floor Box at Atty. Table
- One (1) Female Phone Outlet for Speaker Phone (Analog RJ9)
  - One (1) Female Outlet to connect to the Soundstation Premier to Soundstation Satellite (RJ45)
  - Two (2) Female Outlets for External Microphone to Speaker Phone (RJ9)
  - One (1) Female 3-XLR Connectors to connect Microphone to Recorder
  - One (1) Duplex Electrical Outlet
- B1** Recessed Floor Box at Atty. Table
- Two (2) Female Outlets for External Microphone to Speaker Phone (RJ9)
  - One (1) Female 3-XLR Connectors to connect Microphone to Recorder
  - One (1) Duplex Electrical Outlet
- C** Recessed on the Face of the DAIS
- One (1) Female Outlets for External Microphone to Speaker Phone (RJ9)
  - One (1) Female 3-XLR Connectors to connect Microphone to Recorder
  - One (1) Duplex Electrical Outlet
- D** Recessed Floor Box in DAIS/Platform
- Two (2) Female Data Outlets for Computer Network (RJ45)
  - One (1) Duplex Electrical Outlet
- E** Recessed in the Center of the face of the DAIS
- One (1) Female 3-XLR Connectors to connect Microphone to Recorder
  - One (1) Duplex Electrical Outlet



1.0 Court Unit - Room Data Sheet

1.1 COURTROOM - RAILING DETAILS

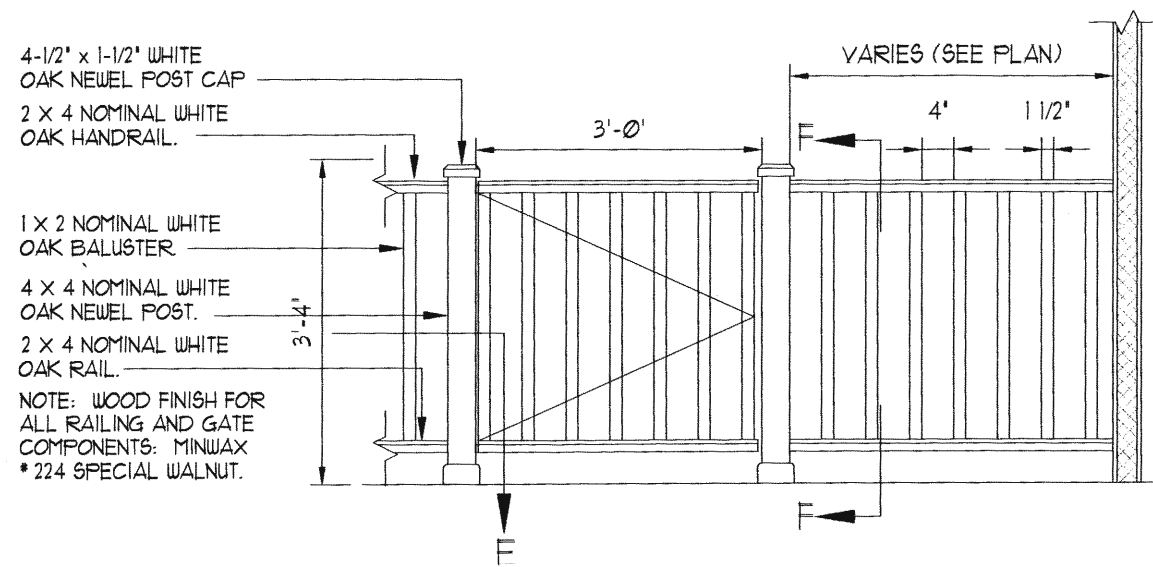

RAIL ELEVATION

SCALE: 1/2" = 1'-0"

DOOR STOP WITH SILENCER

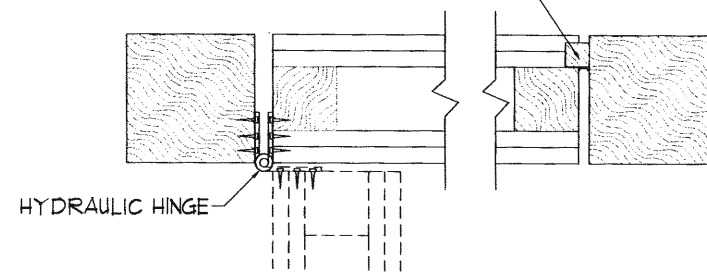

HINGE SECTION E-E

NTS

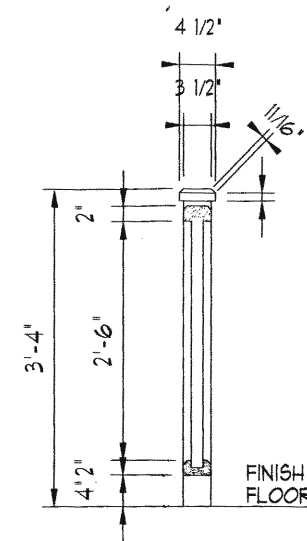

RAIL SECTION F-F

SCALE: 1/2" = 1'-0"

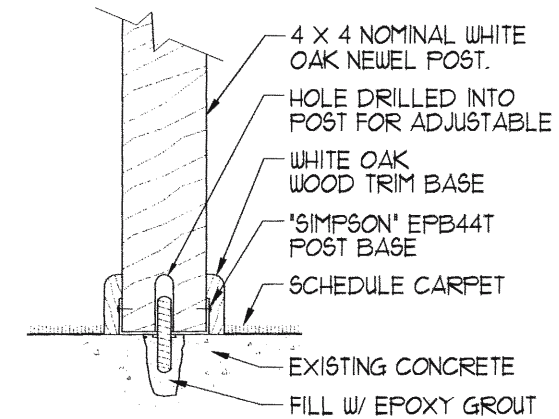

BASE @ NEWEL POST

SCALE: 1-1/2" = 1'-0"

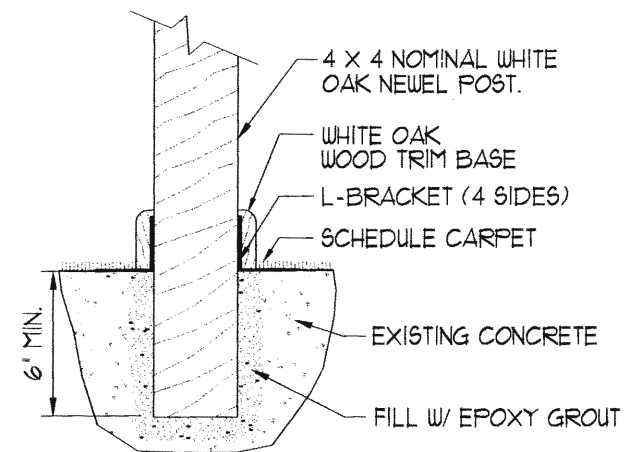

MAIN POST DETAIL

SCALE: 1-1/2" = 1'-0"



## 1.0 Court Unit - Room Data Sheet

### 1.1 COURTROOM - DOOR SECURITY

(b)(2)-High



## 1.0 Court Unit - Room Data Sheet

### 1.1 COURTROOM - DAIS DETAIL

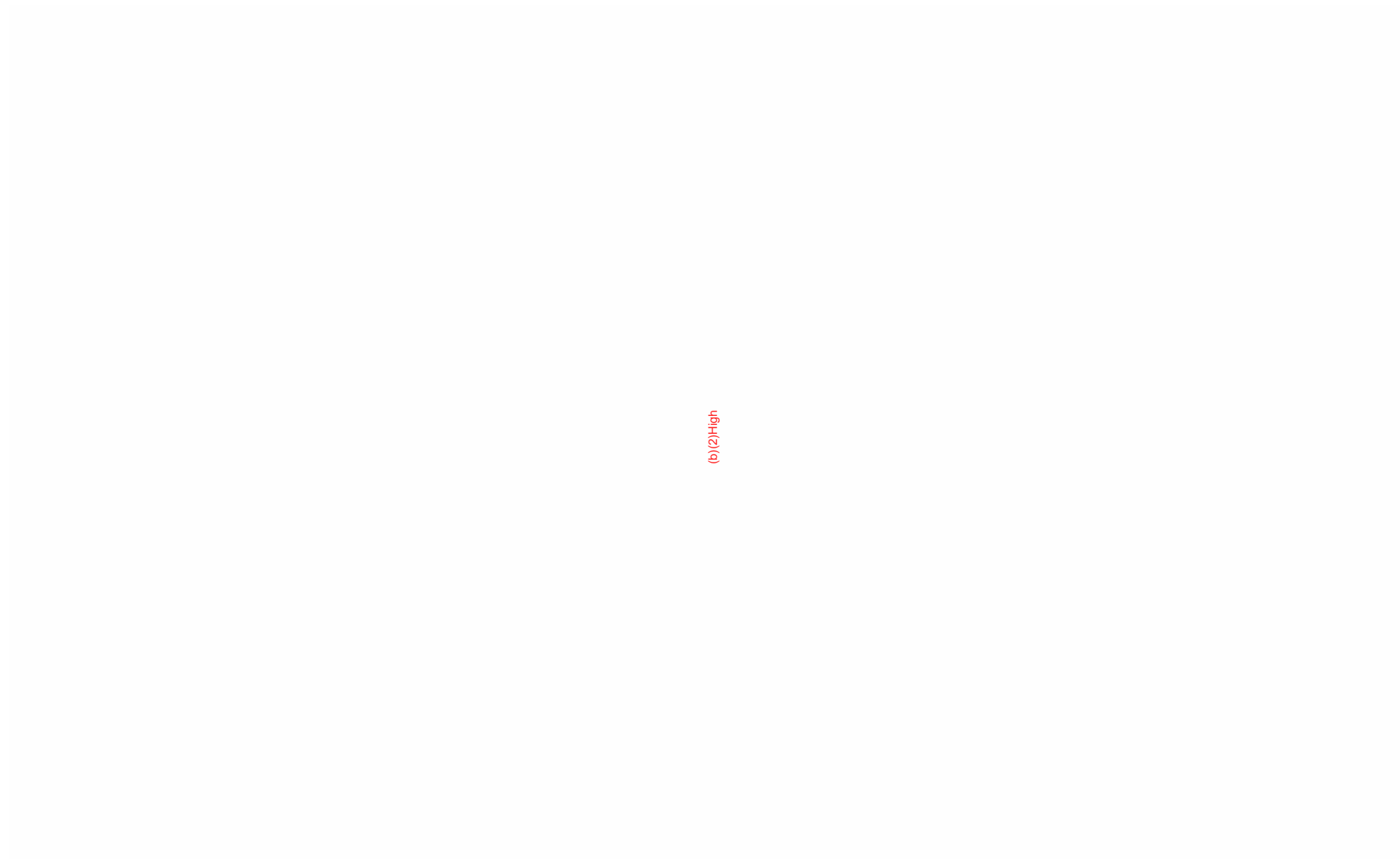

(b)(2) High



## 1.0 Court Unit - Room Data Sheet

### 1.2 COURTROOM SUB-LOBBY

#### Function

The Courtroom Secure Corridor is used to provide access to the Courtrooms by the Public/Visitors, and detainees. Pedestrian sally-ports are located at opposite ends of the corridor to monitor the flow of pedestrian traffic entering and leaving the courtrooms.

The Courtroom Sub-Lobby is used for visitor/public and alien access to the Courtroom. It is essentially a corridor leading from the Public Lobby/Waiting Room at one end and the detainee Housing Units/Holding Rooms on the opposite end.

Security controls are incorporated to make sure that there is not any cross traffic of detainees and the public when entering the Sub-Lobby. This may be accomplished through the installation of a vestibule or secure air lock at the Public end of the corridor.

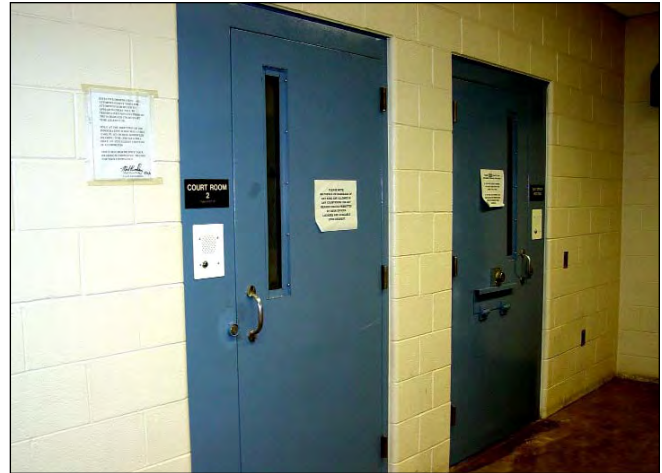

Photograph

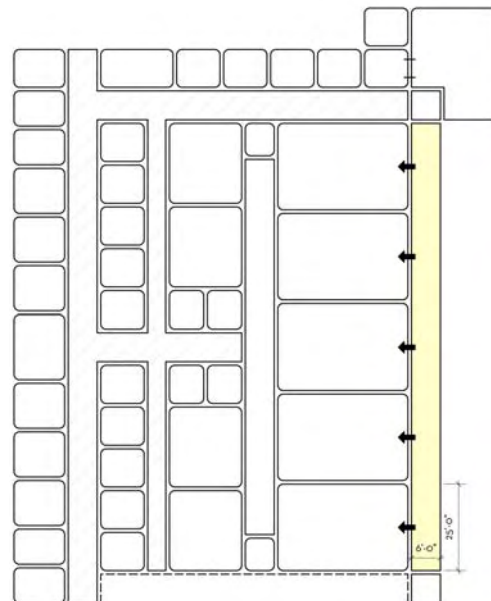

Floor Plan (150 nsf per Courtroom)







## 1.0 Court Unit - Room Data Sheet

### 1.3 JUDGES CORRIDOR

#### Function

One corridor is required for each courtroom to provide separate and secured access to and from the hearing. This ensures that the Immigration Judges and other court personnel do not have to pass through waiting areas or the seating area of the hearing room to reach the bench. In case of an emergency, the staff can escape from the hearing room through the door immediately behind the Judge's Bench. The security system then locks the door to the corridor to provide safe egress.

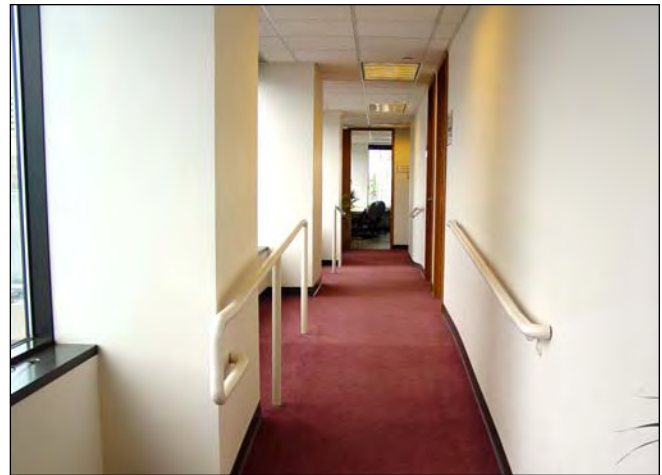

Photograph

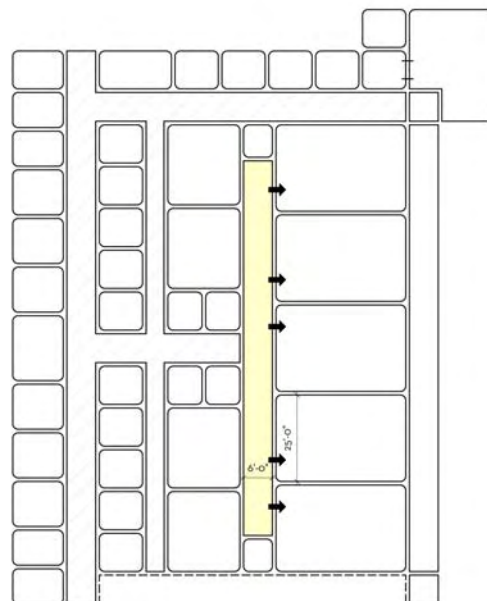

Floor Plan (150 nsf per Courtroom)







1.0 Court Unit - Room Data Sheet

1.3 JUDGES SECURE CORRIDOR - RAMP ELEVATION

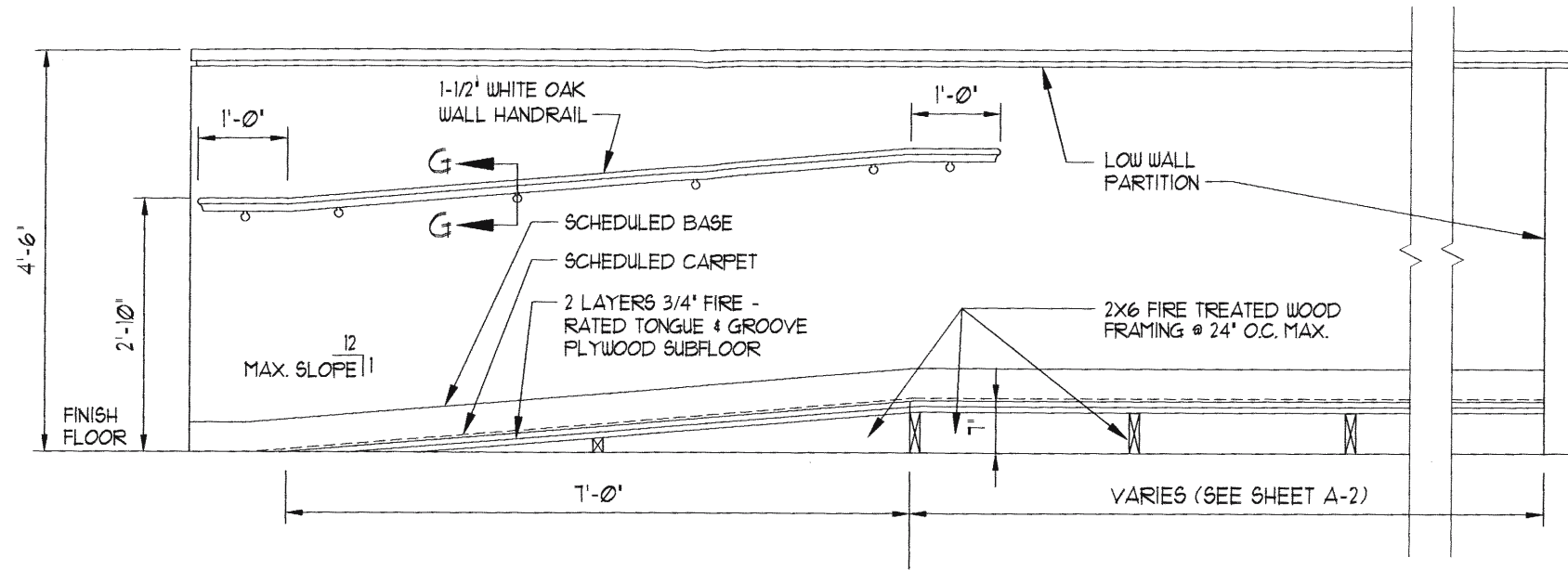

HANDRAIL ELEVATION @RAMP-LOW WALL  
SCALE: 1/2" = 1'-0"

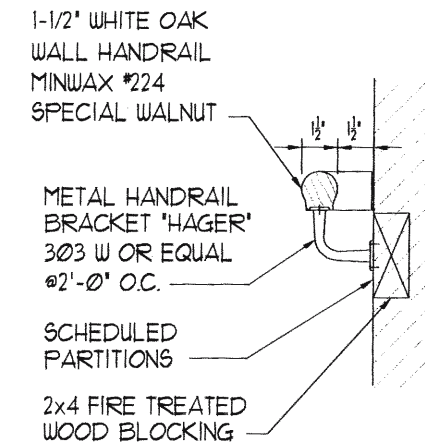

HANDRAIL @ WALL - SECTION G-G  
SCALE: 1-1/2" = 1'-0"

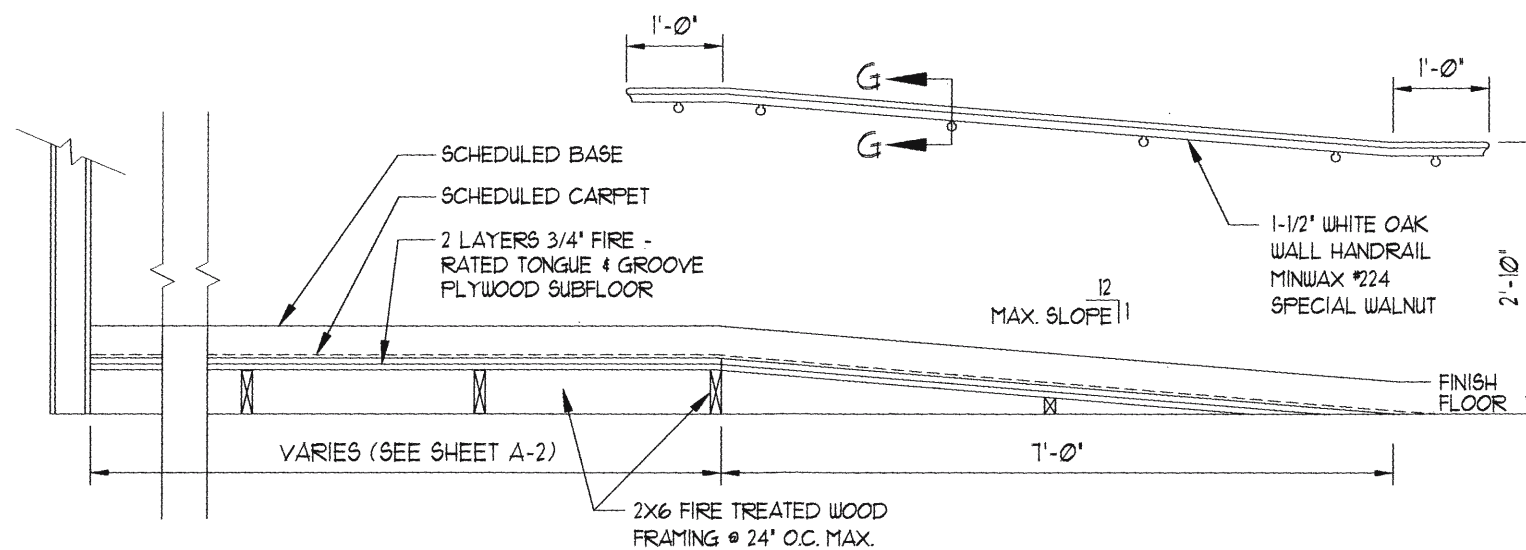

HANDRAIL ELEVATION @RAMP  
SCALE: 1/2" = 1'-0"





## 1.0 Court Unit - Room Data Sheet

### 1.4 DETAINEE SALLYPORT

#### Function

The Detainee Sallyport is located at the end of the Public/Detainee Secure Corridor which leads to the EOIR Courtrooms. Its function is to control detainees movement to and from the EOIR Courtrooms. Detainees would remain within the Detainee Sallyport if any members of the public are present in the Public/Detainee Secure Corridor. Detainees will be accompanied by a CDF officer during this process.

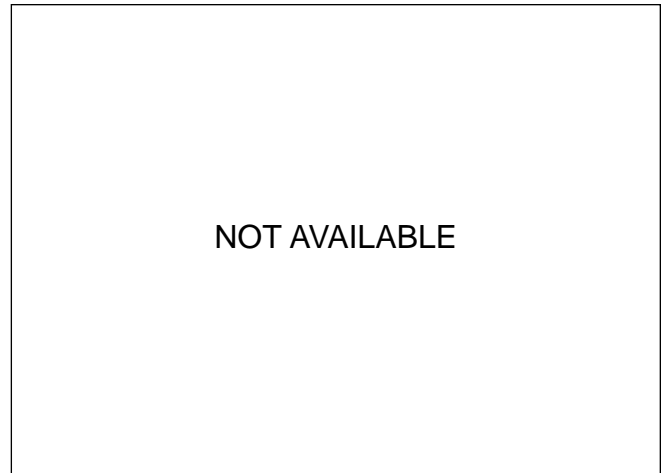

Photograph

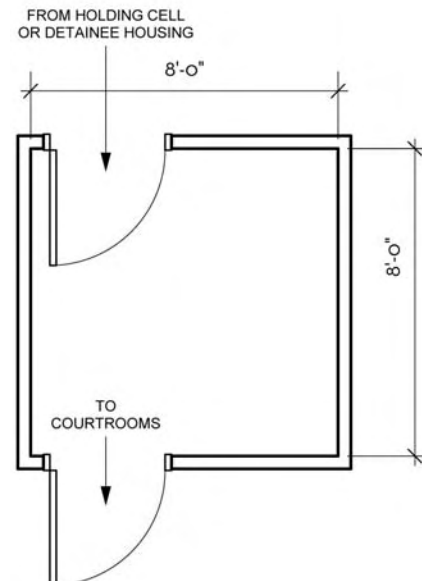

Floor Plan (64 nsf)

**1.4 SYSTEMS MATRIX**

<b>Walls</b>	<b>Floors</b>	<b>Ceiling</b>	<b>Doors</b>	<b>Hardware</b>	<b>Glazing</b>
See Appendix - Section 5 - for Finish Schedule	See Appendix - Section 5 - for Finish Schedule	ACT - 8' High	Security	See Schedule Below	N/A
<b>Plumbing</b>	<b>HVAC</b>	<b>Lighting</b>	<b>Power</b>	<b>Security</b>	<b>Communications</b>
N/A	Typical	Recessed Fluorescent	N/A	See Schedule Below	Site Specific

**1.4 FURNITURE - EQUIPMENT - HARDWARE SCHEDULE**

<i>ID</i>	<i>Item</i>	<i>Vendor*</i>	<i>Style</i>	<i>Model #</i>	<i>Qty.</i>
<b>FURNITURE</b>					
N/A					
<b>EQUIPMENT</b>					
N/A					
<b>HARDWARE</b>					
BI	Electronic Access Reader	Site Specific			
BI	Door Floor Stops	Site Specific			
BI	Public Door - Non-removable hinge pins	Site Specific			
BI	Door Sound Seal	Site Specific			
BI	Door Sweep - Automatic retracting inset	Site Specific			

\* Vendor names are listed as a point of reference for equipment specs. Equal products by other manufactures can be used.  
 \*\* Lockset to be determined based on CDF facility requirements. Where an existing facility is being modified, new hardware shall be compatible with existing preference is for electronic keyless entry - via card readers or cipher locks. Each system must provide for key override.





## 1.0 Court Unit - Room Data Sheet

### 1.5 PUBLIC SALLYPORT

#### Function

The Public Sallyport is located at the end of the Public/Detainee Secure Corridor which leads to the EOIR Courtrooms directly adjacent to the Main Public Lobby. Its function is to control the public movement to and from the EOIR Courtrooms. The public would remain within the Public Sallyport if any detainees have been cleared to enter the Public/Detainee Secure Corridor. The public will be escorted to the courtrooms by a CDF officer.

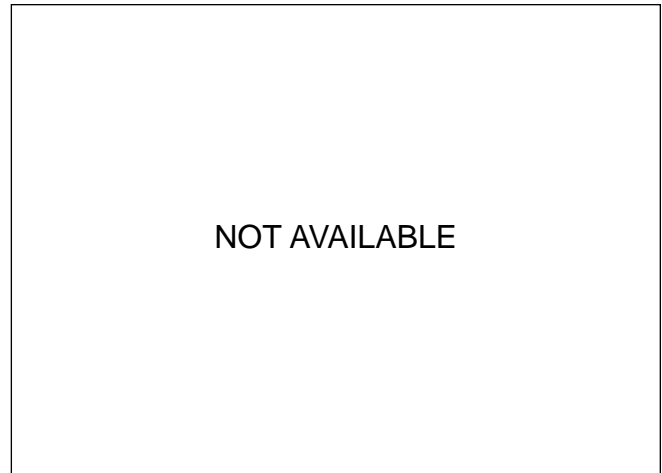

Photograph

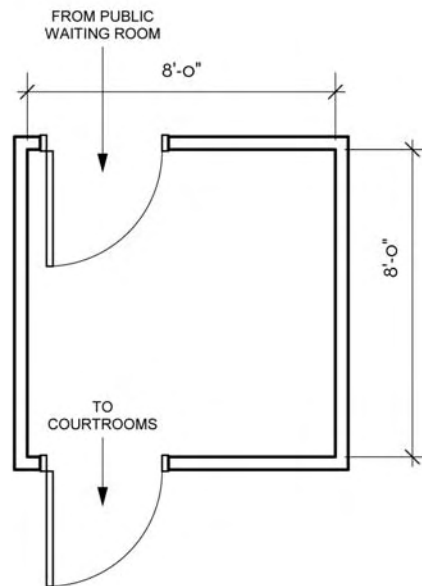

Floor Plan (64 nsf)





## 2.0 ADMINISTRATIVE UNIT REQUIREMENTS

- Function
- Workflow Patterns
- Room Data Sheets



## 2.0 Administrative Unit - Function

### FUNCTION STATEMENT

The function of the Administrative Unit includes leading court proceedings, managing records of proceedings, recording, printing, and filing of documents.

The Court Administrator manages the operations including scheduling and staff. The Immigration Judges conduct hearings and arraignments with assistance from the support staff.

In a typical proceeding a charge is filed by DHS against a detainee being held at the CDF. The charge is filed with EOIR in the form of a written document and is received at the receptionist area. Then, the document is sent to the Court for schedule determination, and transferred to the Judge for the hearing. Once the hearing is completed the record of the proceedings is printed and the recorded information is transferred/stored in the File Room.

### Design Criteria

#### *Critical Issues*

- ✓ All support work areas shall be adjacent to each other
- ✓ The Judges Chambers shall be located near the support staff
- ✓ The Main Entry into EOIR shall be off of the main CDF lobby/waiting area.
- ✓ The Administrative Unit staff members need to be located adjacent to the courtrooms.

#### *Special Requirements*

Consideration shall be made to provide natural light to both private offices and general office areas.

#### *Space Requirements*

##### **2.0 ADMINISTRATIVE UNIT**

- 2.1 Immigration Judge Chambers
- 2.2 Court Administrator Office
- 2.3 Law Clerk Office
- 2.4 Supervisory Legal Technician Office
- 2.5 Support Work Station
- 2.6 Supervisory Interpreter Office

## 2.0 Administrative Unit : Organizational Diagram

(b)(2)High



## **2.0 Administrative Unit - Critical Workflow Patterns**

### **INTRODUCTION**

The diagrams on the following page (p4.29) illustrate some of the most critical workflow issues and patterns of the Administrative Unit.

2.0 Administrative Unit : Critical Workflow Patterns

1. "CENTER CONTROL"

The Court Administrator coordinates activities for the EOIR Court Unit. For ease of coordination, the Court Administrator Office shall be central to all functions within the Unit.

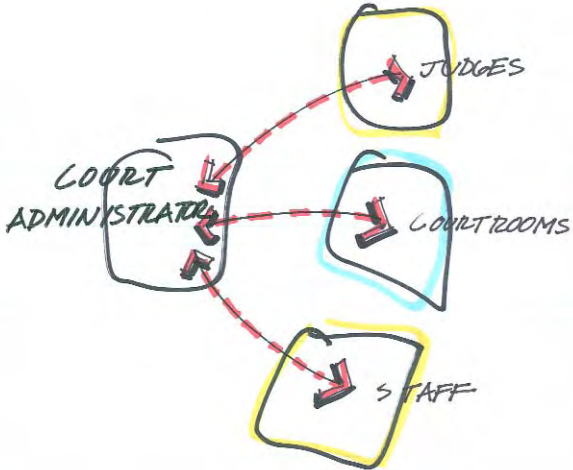

2. "STAFF CONNECTIVITY"

The EOIR Judges are assisted by the support staff. Direct and immediate access to staff is desirable.

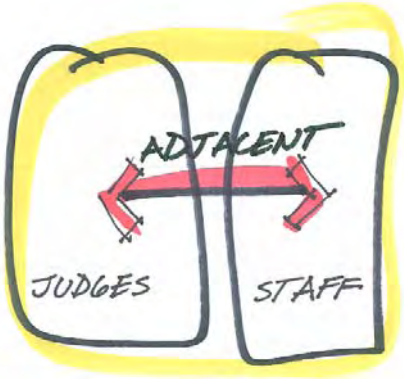

3. "CONTROLLED PUBLIC PENETRATION"

The EOIR Court Suite is a secure area. All public/visitor entry into the EOIR Court Suite shall begin at the Public Lobby and be contained within an EOIR Reception Area. No public/visitors are allowed into the EOIR Court Suite with the exception of the courtrooms.

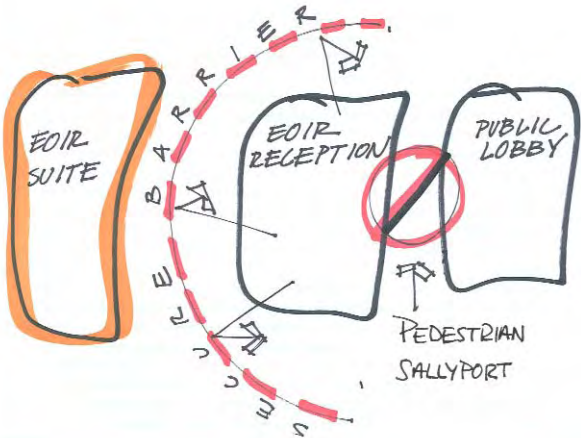





## 2.0 Administrative Unit - Room Data Sheet

### 2.1 IMMIGRATION JUDGE CHAMBERS

#### Function

The Immigration Judge Chambers is the primary office for the Immigration Judge and shall be located in close proximity to the courtroom.

#### Judges activities include :

- ✓ Holding hearings
- ✓ Analyzing evidence
- ✓ Making legal judgement
- ✓ Issuing appropriate legal action
- ✓ Rendering a decision

Immigration Judges are responsible for conducting judicial proceedings and act independently in their decision-making capacity; their decisions are administratively final, unless appealed or certified to the Board of Immigration Appeals. The Judges conduct hearings concerning the removal of illegal aliens throughout the United States. Through its Criminal Alien Institutional Hearing Program, OCIJ currently has programs coordinated and in place in all 50 states, including Puerto Rico, the District of Columbia, and selected municipalities and Bureau of Prison facilities to adjudicate the immigration status of alien inmates incarcerated by Federal, State, and municipal correctional authorities as a result of convictions for criminal offenses. Judges report directly to the Office of the Chief Immigration Judge.



Photograph

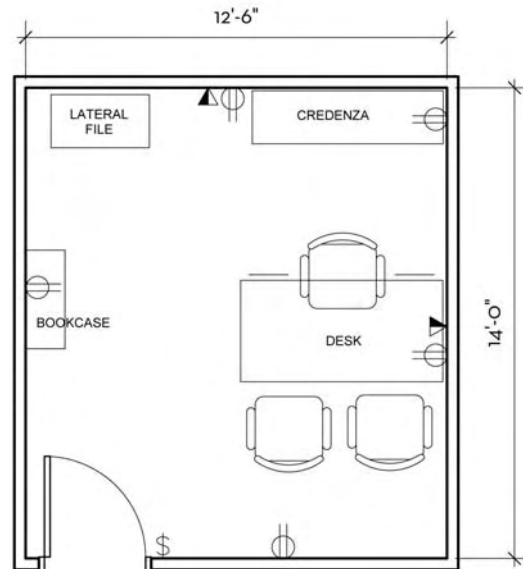

Floor Plan (175 nsf)

## 4. FUNCTIONAL REQUIREMENTS

### 2.1 SYSTEMS MATRIX

<i><b>Walls</b></i>	<i><b>Floors</b></i>	<i><b>Ceiling</b></i>	<i><b>Doors</b></i>	<i><b>Hardware</b></i>	<i><b>Glazing</b></i>
See Appendix - Section 5 - Finish Schedule	See Appendix - Section 5 - Finish Schedule	ACT - 8' High	Solid Core Wood	See Schedule Below	Exterior Windows
<i><b>Plumbing</b></i>	<i><b>HVAC</b></i>	<i><b>Lighting</b></i>	<i><b>Power</b></i>	<i><b>Security</b></i>	<i><b>Communications</b></i>
N/A	Typical	Recessed Fluorescent	110v Duplex	N/A	Telephone and Data - 2 Walls

### 2.1 FURNITURE - EQUIPMENT - HARDWARE SCHEDULE

<i><b>ID</b></i>	<i><b>Item</b></i>	<i><b>Vendor*</b></i>	<i><b>Style</b></i>	<i><b>Model #</b></i>	<i><b>Qty.</b></i>
<b>FURNITURE</b>					
F	Desk	UNICOR	Symphony	S-7236-01-WN	1
F	Credenza (Kneespace) or (Double Door)	UNICOR	Symphony	S-6820-09-WN	1
F	Bookcase (4-shelf, open)	UNICOR	Symphony	S-6820-01-WN	1
F	Bookcase (4-shelf, glass doors)	UNICOR	Symphony	S-3520-12-WN	1
F	Lateral File (Two Drawer) or (Four Drawer)	UNICOR	Baritone	BT3515BC4SHGWN	1
F	Lateral File (Two Drawer) or (Four Drawer)	UNICOR	Symphony	S-3520-09-WN	1
F	Desk Chair (High back/Panel Arms) or (Ergonomic/Mid back)	UNICOR	Symphony	S-3520-10-WN	1
F	Desk Chair (High back/Panel Arms) or (Ergonomic/Mid back)	UNICOR	Soprano	WVC6222WN-7540	1
F	Side Chair	UNICOR	Overture	FC-MB-VG-UG-SM-S-C-04	1
F	Waste Receptacle	UNICOR	Soprano	WVC6120-WN-7612	2
F	Waste Receptacle				1
<b>EQUIPMENT</b>					
N/A					
<b>HARDWARE</b>					
BI	Door Hardware Lockset**		Classroom Function		1

\* Vendor names are listed as a point of reference for equipment specs. Equal products by other manufactures can be used.  
 \*\* Lockset to be determined based on CDF facility requirements. Where an existing facility is being modified, new hardware shall be compatible with existing preference is for electronic keyless entry - via card readers or cipher locks. Each system must provide for key override.



## 2.0 Administrative Unit - Room Data Sheet

### 2.2 COURT ADMINISTRATOR OFFICE

#### Function

The Court Administrator manages the day to day operation of EOIR Court Unit including staffing. The Court Administrator is responsible for the following:

- ✓ Administrative management of operations
- ✓ Scheduling hearings
- ✓ Management of support staff



Photograph

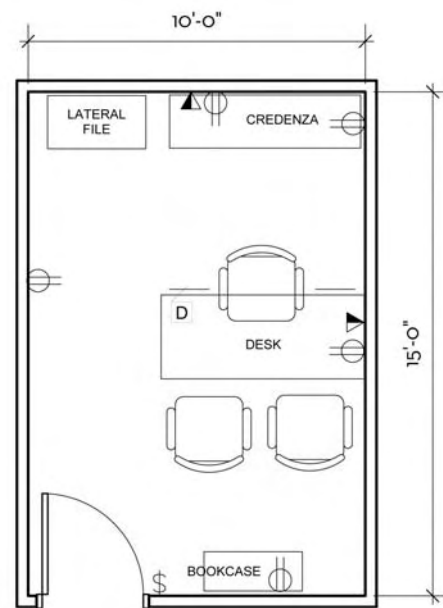

Floor Plan (150 nsf)

# 4. FUNCTIONAL REQUIREMENTS

## 2.2 SYSTEMS MATRIX

<i>Walls</i>	<i>Floors</i>	<i>Ceiling</i>	<i>Doors</i>	<i>Hardware</i>	<i>Glazing</i>
See Appendix - Section 5 - Finish Schedule	See Appendix - Section 5 - Finish Schedule	ACT - 8' High	Solid Core Wood	See Schedule Below	Exterior Windows
<i>Plumbing</i>	<i>HVAC</i>	<i>Lighting</i>	<i>Power</i>	<i>Security</i>	<i>Communications</i>
N/A	Typical	Recessed Fluorescent	110v Duplex	N/A	Telephone and Data - 2 Walls

## 2.2 FURNITURE - EQUIPMENT - HARDWARE SCHEDULE

<i>ID</i>	<i>Item</i>	<i>Vendor*</i>	<i>Style</i>	<i>Model #</i>	<i>Qty.</i>
FURNITURE					
F	Desk	UNICOR	Symphony	S-7236-01-WN	1
F	Credenza (Kneespace)	UNICOR	Symphony	S-6820-09-WN	1
F	or (Double Door)	UNICOR	Symphony	S-6820-01-WN	1
F	Bookcase (4-shelf, open)	UNICOR	Symphony	S-3520-12-WN	1
F	Lateral File (Two Drawer)	UNICOR	Symphony	S-3520-09-WN	1
F	or (Four Drawer)	UNICOR	Symphony	S-3520-10-WN	1
F	Desk Chair (High back/Panel Arms)	UNICOR	Classic Ergo	WP8007-BLK-3501 (Ebony 3501)	1
F	Side Chair	UNICOR	Soprano	WVC6120-WN-7612	2
F	Waste Receptacle				
EQUIPMENT					
N/A					
HARDWARE					
BI	Door Hardware Lockset**		Classroom Function		1

\* Vendor names are listed as a point of reference for equipment specs. Equal products by other manufactures can be used.  
 \*\* Lockset to be determined based on CDF facility requirements. Where an existing facility is being modified, new hardware shall be compatible with existing preference is for electronic keyless entry - via card readers or cipher locks. Each system must provide for key override.



## 2.0 Administrative Unit - Room Data Sheet

### 2.3 LAW CLERK OFFICE

#### Function

The Law Clerk Office is a private office. This position is non-supervisory and provides direct support to the Immigration Judge. The Law Clerks are responsible for the following:

- ✓ Supporting the Immigration Judge in case preparation
- ✓ Conducting research for the Immigration Judge



Photograph

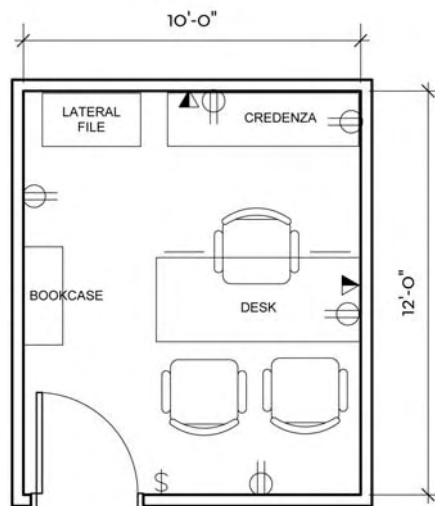

Floor Plan (120 nsf)

## 4. FUNCTIONAL REQUIREMENTS

### 2.3 SYSTEMS MATRIX

<i>Walls</i>	<i>Floors</i>	<i>Ceiling</i>	<i>Doors</i>	<i>Hardware</i>	<i>Glazing</i>
See Appendix - Section 5 - Finish Schedule	See Appendix - Section 5 - Finish Schedule	ACT - 8' High	Solid Core Wood	See Schedule Below	Exterior Windows
<i>Plumbing</i>	<i>HVAC</i>	<i>Lighting</i>	<i>Power</i>	<i>Security</i>	<i>Communications</i>
N/A	Typical	Recessed Fluorescent	110v Duplex	N/A	Telephone and Data - 2 Walls

### 2.3 FURNITURE - EQUIPMENT - HARDWARE SCHEDULE

<i>ID</i>	<i>Item</i>	<i>Vendor*</i>	<i>Style</i>	<i>Model #</i>	<i>Qty.</i>
FURNITURE					
F	Desk	UNICOR	Symphony	S-7236-01-WN	1
F	Credenza (Kneespace)	UNICOR	Symphony	S-6820-09-WN	1
	or (Double Door)	UNICOR	Symphony	S-6820-01-WN	1
F	Bookcase (4-shelf, open)	UNICOR	Symphony	S-3520-12-WN	1
F	Lateral File (Two Drawer)	UNICOR	Symphony	S-3520-09-WN	1
	or (Four Drawer)	UNICOR	Symphony	S-3520-10-WN	1
F	Desk Chair (High back/Panel Arms)	UNICOR	Classic Ergo	WP8007-BLK-3501 (Ebony 3501)	1
F	Side Chair	UNICOR	Soprano	WVC6120-WN-7612	2
F	Waste Receptacle				1
EQUIPMENT					
N/A					
HARDWARE					
BI	Door Hardware Lockset**		Latchset		1

\* Vendor names are listed as a point of reference for equipment specs. Equal products by other manufactures can be used.  
\*\* Lockset to be determined based on CDF facility requirements. Where an existing facility is being modified, new hardware shall be compatible with existing preference is for electronic keyless entry - via card readers or cipher locks. Each system must provide for key override.



## 2.0 Administrative Unit - Room Data Sheets

### 2.4 SUPERVISORY LEGAL TECHNICIAN OFFICE

#### Function

The Supervisory Legal Technician supervises and provides administrative and court support. The Supervisory staff is responsible for the following:

- ✓ General staff administrative functions
- ✓ One to One supervision, work assignment(s), scheduling and consultation



Photograph

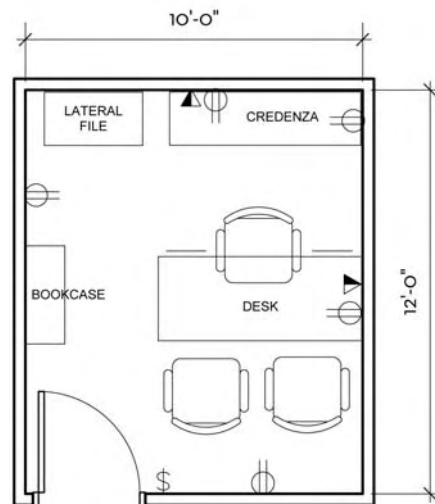

Floor Plan (120 nsf)

# 4. FUNCTIONAL REQUIREMENTS

### 2.4 SYSTEMS MATRIX

<i><b>Walls</b></i>	<i><b>Floors</b></i>	<i><b>Ceiling</b></i>	<i><b>Doors</b></i>	<i><b>Hardware</b></i>	<i><b>Glazing</b></i>
See Appendix - Section 5 - Finish Schedule	See Appendix - Section 5 - Finish Schedule	ACT - 8' High	Solid Core Wood	See Schedule Below	Exterior Windows
<i><b>Plumbing</b></i>	<i><b>HVAC</b></i>	<i><b>Lighting</b></i>	<i><b>Power</b></i>	<i><b>Security</b></i>	<i><b>Communications</b></i>
N/A	Typical	Recessed Fluorescent	110v Duplex	N/A	Telephone and Data - 2 Walls

### 2.4 FURNITURE - EQUIPMENT - HARDWARE SCHEDULE

<i><b>ID</b></i>	<i><b>Item</b></i>	<i><b>Vendor*</b></i>	<i><b>Style</b></i>	<i><b>Model #</b></i>	<i><b>Qty.</b></i>
<b>FURNITURE</b>					
F	Desk	UNICOR	Symphony	S-6830-01-WN	1
F	Credenza (Kneespace)	UNICOR	Symphony	S-6820-09-WN	1
	or (Double Door)	UNICOR	Symphony	S-6820-01-WN	1
F	Bookcase (4-shelf, open)	UNICOR	Symphony	S-3520-12-WN	1
F	Lateral File (Two Drawer)	UNICOR	Symphony	S-3520-09-WN	1
	or (Four Drawer)	UNICOR	Symphony	S-3520-10-WN	1
F	Desk Chair (High back/Panel Arms)	UNICOR	Classic Ergo	WP8007-BLK-3501 (Ebony 3501)	1
F	Side Chair	UNICOR	Soprano	WVC6120-WN-7612	2
F	Waste Receptacle				1
<b>EQUIPMENT</b>					
N/A					
<b>HARDWARE</b>					
BI	Door Hardware Lockset**		Classroom Function		1

\* Vendor names are listed as a point of reference for equipment specs. Equal products by other manufacturers can be used.  
 \*\* Lockset to be determined based on CDF facility requirements. Where an existing facility is being modified, new hardware shall be compatible with existing preference is for electronic keyless entry - via card readers or cipher locks. Each system must provide for key override.





## 2.0 Administrative Unit - Room Data Sheet

### 2.5 SUPPORT WORKSTATION

#### Function

The Support Workstation consisting of low fixed gypsum board partitions. This area houses clerks, legal technicians, the receptionist and interpreters. Depending on the layout of the partitions - the individual workstation may have a left or right handed "L"-shaped desk. Also within this area are shared printers. One of the workstations will function as the Receptionist and may be occupied by a Legal Technician or Interpreter.

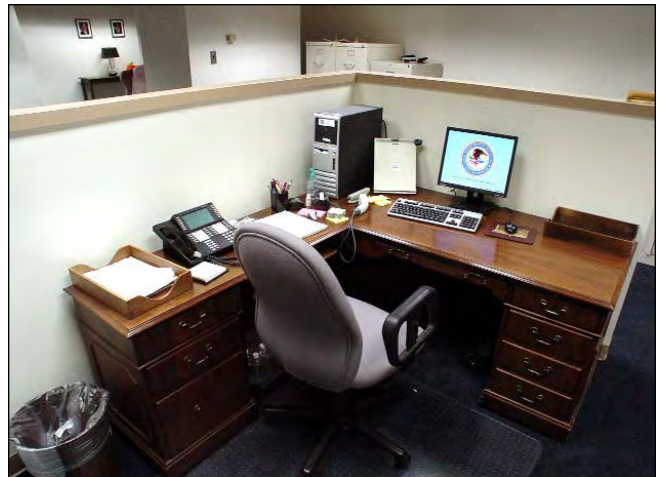

Photograph

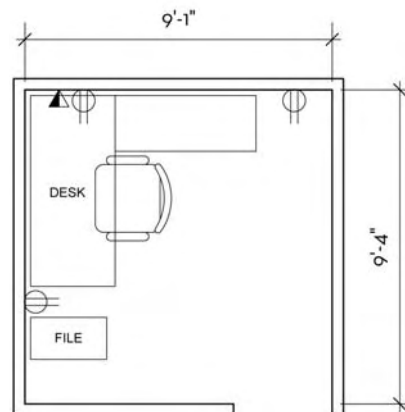

Floor Plan (85 nsf)

## 4. FUNCTIONAL REQUIREMENTS

### 2.5 SYSTEMS MATRIX

<b>Walls</b>	<b>Floors</b>	<b>Ceiling</b>	<b>Doors</b>	<b>Hardware</b>	<b>Glazing</b>
See Appendix - Section 5 - Finish Schedule  Full Security Partition in Receptionist Area	See Appendix - Section 5 - Finish Schedule	ACT - 8' High	Solid Core Wood	See Schedule Below	Ballistic - Reception Only
<b>Plumbing</b>	<b>HVAC</b>	<b>Lighting</b>	<b>Power</b>	<b>Security</b>	<b>Communications</b>
N/A	Typical	Recessed Fluorescent	110v Duplex - All 54" H Partitions	See Schedule Below	Telephone and Data - All 54" H Partitions

### 2.5 FURNITURE - EQUIPMENT - HARDWARE SCHEDULE

<b>ID</b>	<b>Item</b>	<b>Vendor*</b>	<b>Style</b>	<b>Model #</b>	<b>Qty.</b>
<b>FURNITURE</b>					
F	"L" Desk Right Return	UNICOR	Symphony	S-68R9-01-WN	TBD
F	"L" Desk Left Return	UNICOR	Symphony	S-68L9-01-WN	TBD
F	File Cabinet (2-drawer, letter size)	UNICOR	Putty	312P	1
F	Desk Chair (High Back/Adj.)	UNICOR	Classic Ergo	WP8007-BLK-3501	1
F	File Compressor	UNICOR		CIVISCF	1 Drawer
F	Waste Receptacle				
<b>EQUIPMENT</b>					
N/A					
<b>HARDWARE</b>					
N/A					
<b>RECEPTION WINDOW</b>					
<b>FURNITURE</b>					
F	"L" Desk Right Return, or	UNICOR	Symphony	S-68R9-01-WN	1
F	"L" Desk Left Return	UNICOR	Symphony	S-68L9-01-WN	1
F	File Cabinet (2-drawer, letter size)	UNICOR	Putty	312P	1
F	Desk Chair (High Back/Adj.)	UNICOR	Classic Ergo	WP8007-BLK-3501	1
<b>EQUIPMENT</b>					
BI	Ballistic Transaction Window	Armortex		SSTW-10	1
<b>HARDWARE</b>					
BI	Duress Alarm Button				1
BI	2-way Communicator	Haven Technologies		SC-300	1
BI	Closer, Door	LCN		4040	1
BI	Speaker - Glass Mounted	ARMORTEX		SSBRS-7	1
BI	Electronic Keypad	Radionics or Ademco	Vista	D1225 or 6139	1
BI	Electronic Door Release				1
BI	Peephole (190 degrees)	IVES		698	1
BI	Cypher Lock	Trilogy		DL2700	1
BI	Door Buzzer			BZ-24	1

\* Vendor names are listed as a point of reference for equipment specs. Equal products by other manufacturers can be used.

\*\* Lockset to be determined based on CDF facility requirements. Where an existing facility is being modified, new hardware shall be compatible with existing preference is for electronic keyless entry - via card readers or cipher locks. Each system must provide for key override.



## 2.0 Administrative Unit - Room Data Sheets

### 2.6 SUPERVISORY INTERPRETER OFFICE

#### Function

The Supervisory Interpreter Staff supervises interpreters and provides administrative and court support. The Supervisory Interpreter is responsible for the following:

- ✓ General staff administrative functions
- ✓ One to One supervision, work assignment(s), scheduling and consultation



Photograph

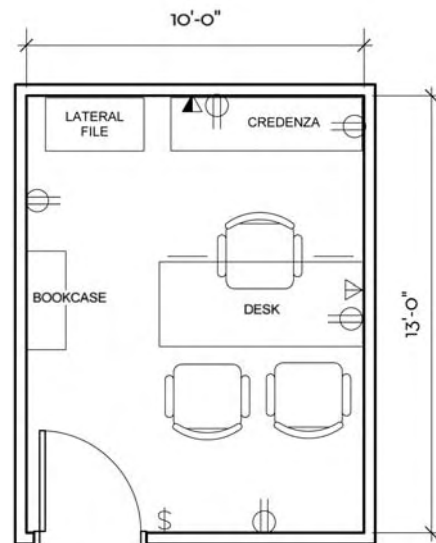

Floor Plan (130 nsf)





### **3.0 COMMON SUPPORT UNIT REQUIREMENTS**

- Function
- Workflow Patterns
- Room Data Sheets



### 3.0 Common Support Unit - Function

#### FUNCTION STATEMENT

The Common Support Unit contains the space which help support the daily roles and responsibilities of the EOIR Court staff. As such, the spaces should be located in a centralized location for easy access.

Design Criteria
<b>Critical Issues</b>
✓ The Common Support Unit should be centrally located for easy staff access.
<b>Special Requirements</b>
✓ The Common Support Unit houses a secure File Room, Computer Room and work areas requiring special equipment data and power requirements.
✓ The Waiting Room is separated from a Reception Work Station by a Ballistic Transaction Window installed in a secure partition.
<b>Space Requirements</b>
<b>3.0 COMMON SUPPORT UNIT</b>
3.1 Conference Room
3.2 Pro Bono Room
3.3 Copier/Mail Room
3.4 File Room
3.5 Computer (ADP) Room
3.6 Break Room
3.7 Staff Restrooms
3.8 Janitor Closet
3.9 Printer Workstation
3.10 Supply Room

### 3.0 Common Support Unit : Organizational Diagram

(b)(2)High





## **3.0 Common Support Unit - Workflow Patterns**

### **INTRODUCTION**

The diagrams on the following page (p4.47) illustrate some of the most critical workflow issues and patterns of the Common Support Unit.

### 3.0 Common Support Unit : Critical Workflow Patterns

#### 1. "CENTRAL SUPPORT"

The support functions shall be located centrally for ease of access between the judges and administrative staff moving between the courtrooms, administrative and support spaces.

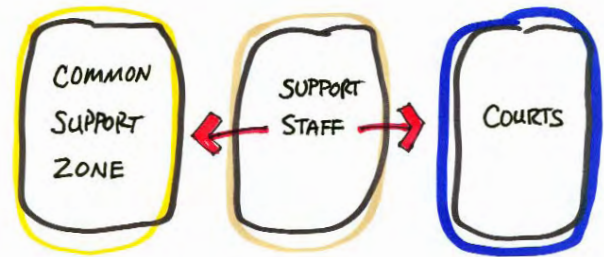



## 3.0 Common Support Unit - Room Data Sheet

### 3.1 CONFERENCE ROOM

#### Function

The Conference Room is provided in each EOIR Court suite and will increase in size proportionate to the number of courtrooms/staff. The conference room is used for the following:

- ✓ Meetings
- ✓ Conferences
- ✓ Intermittent training

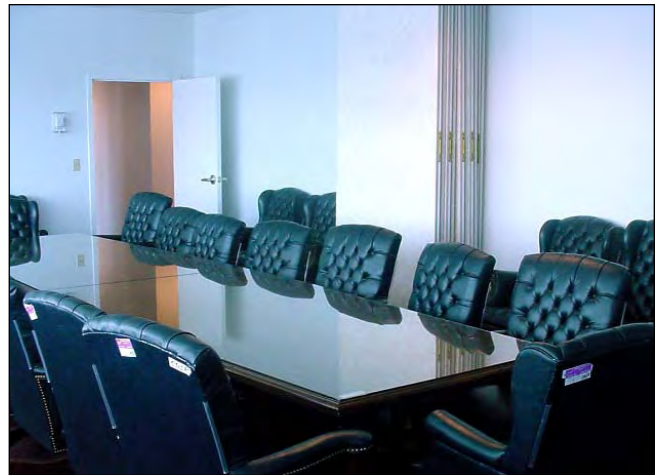

Photograph

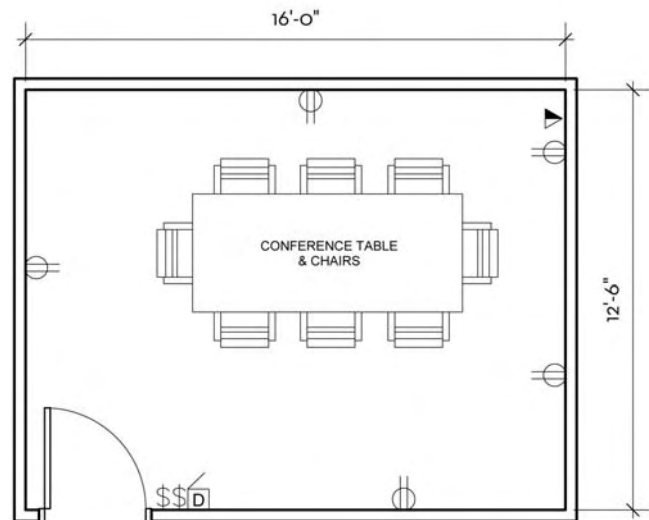

Floor Plan (Size determined by number of courtrooms)

## 3.1 SYSTEMS MATRIX

<b>Walls</b>	<b>Floors</b>	<b>Ceiling</b>	<b>Doors</b>	<b>Hardware</b>	<b>Glazing</b>
See Appendix - Section 5 - Finish Schedule	See Appendix - Section 5 - Finish Schedule	ACT - 8' High	Solid Core Wood	See Schedule Below	190 Degree Peephole in Door
<b>Plumbing</b>	<b>HVAC</b>	<b>Lighting</b>	<b>Power</b>	<b>Security</b>	<b>Communications</b>
N/A	Typical	Recessed Fluorescent	110v Duplex - 6	Duress Alarm Button - 110V	Telephone and Data

## 3.1 FURNITURE - EQUIPMENT - HARDWARE SCHEDULE

<i>ID</i>	<i>Item</i>	<i>Vendor*</i>	<i>Style</i>	<i>Model #</i>	<i>Qty.</i>
FURNITURE					
F	Table 12'	UNICOR	Symphony	S-14448-03-WN	TBD
F	Table 10'	UNICOR	Symphony	S-12048-03-WN	TBD
F	Table 8'	UNICOR	Symphony	S-964201-WN	TBD
F	Chairs	UNICOR	Minuet	WVC7232-BLK-7612	TBD
F	Waste Receptacle				1
EQUIPMENT					
NA					
HARDWARE					
BI	Door Peephole - 190 Degrees	Ives		698	1
BI	Lockset				1
BI	Duress Alarm - Wall Mounted				1

\* Vendor names are listed as a point of reference for equipment specs. Equal products by other manufacturers can be used.  
 \*\* Lockset to be determined based on CDF facility requirements. Where an existing facility is being modified, new hardware shall be compatible with existing preference is for electronic keyless entry - via card readers or cipher locks. Each system must provide for key override.



## 3.0 Common Support Unit - Room Data Sheet

### 3.2 PRO BONO ROOM

#### Function

The Pro Bono Room is used by private counsel representing a respondent on a pro bono basis and who require meeting time prior to a scheduled hearing. The room shall be located adjacent and accessible to the Waiting Room to preclude entrance into EOIR Court's secure area.



Photograph

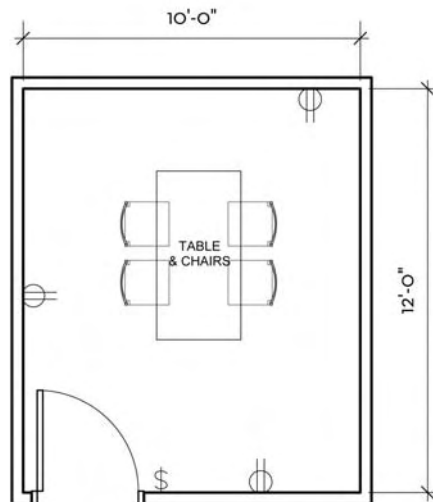

Floor Plan (120 nsf)





## 3.0 Common Support Unit - Room Data Sheet

### 3.3 COPIER/MAIL ROOM

#### Function

The Copier/Mail Room is used for mass printing for Courtroom proceedings and record-keeping, mail receipt, processing and distribution for EOIR Court staff. The Copier/Mail Room will contain the following as a minimum:

- ✓ One photocopier
- ✓ One shredder
- ✓ Fax
- ✓ Postage meter
- ✓ Mail center
- ✓ Form sorter



Photograph

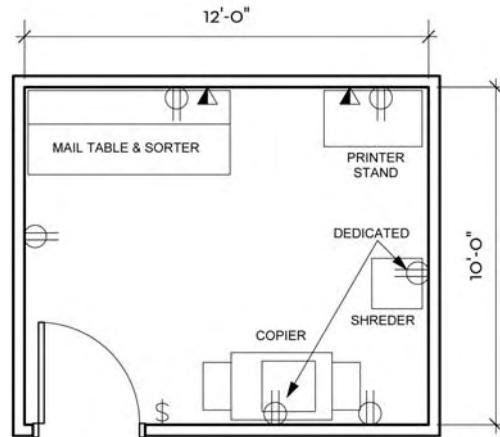

Floor Plan (120 nsf)

# 4. FUNCTIONAL REQUIREMENTS

## 3.3 SYSTEMS MATRIX

<i><b>Walls</b></i>	<i><b>Floors</b></i>	<i><b>Ceiling</b></i>	<i><b>Doors</b></i>	<i><b>Hardware</b></i>	<i><b>Glazing</b></i>
See Appendix - Section 5 - Finish Schedule	See Appendix - Section 5 - Finish Schedule	ACT - 8' High	Solid Core Wood	See Schedule Below	N/A
<i><b>Plumbing</b></i>	<i><b>HVAC</b></i>	<i><b>Lighting</b></i>	<i><b>Power</b></i>	<i><b>Security</b></i>	<i><b>Communications</b></i>
N/A	Typical	Recessed Fluorescent	TBD Based on Dedicated Equipment Circuits	N/A	Fax, Mail Machine, Telephone and Data - 2 Analog Lines Required

## 3.3 FURNITURE - EQUIPMENT - HARDWARE SCHEDULE

<i><b>ID</b></i>	<i><b>Item</b></i>	<i><b>Vendor*</b></i>	<i><b>Style</b></i>	<i><b>Model #</b></i>	<i><b>Qty.</b></i>
FURNITURE					
F	Mail Table	Charnstrom	Putty/Walnut	A987W	1
F	Mail Table Sorter	Charnstrom	Putty	P787	1
F	Waste Receptacle				1
EQUIPMENT					
BI	Copier	DOJ			1
BI	Postage Meter	DOJ			1
BI	Shredder	DOJ			1
BI	Fax Machine	DOJ			1
HARDWARE					
BI	Lockset		Building Standard Latchset		1

\* Vendor names are listed as a point of reference for equipment specs. Equal products by other manufactures can be used.  
 \*\* Lockset to be determined based on CDF facility requirements. Where an existing facility is being modified, new hardware shall be compatible with existing preference is for electronic keyless entry - via card readers or cipher locks. Each system must provide for key override.





## 3.0 Common Support Unit - Room Data Sheet

### 3.4 FILE ROOM

#### Function

The File Room is used to secure files. The size of the File Room will vary proportionately to the number of courtrooms. The worktable is for use by a support staff in closing out/retiring files. The Case File Room shall be in close proximity to the Administrative Staff.

#### Following are functional uses of the Case File Room:

- ✓ Storage of court case records
- ✓ Completion of case closeout files



Photograph

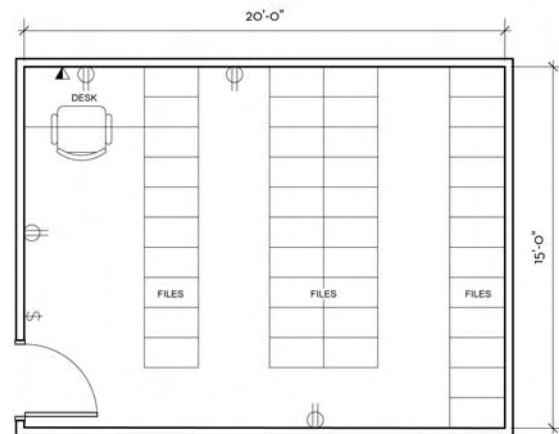

Floor Plan (Size determined by number of courtrooms)





## 3.0 Common Support Unit - Room Data Sheet

### 3.5 COMPUTER (ADP) ROOM

#### Function

The Computer (ADP) Room is used for termination of network cabling into EOIR Court server equipment. Termination occurs in the LAN within a "Patch Panel".

#### The following are Computer Room functions:

- ✓ Computer cabling terminations
- ✓ Main server equipment location
- ✓ Computer cabling terminations

#### Critical Requirements

- ✓ 3/4 ton split air conditioning unit (ACU) with remote condenser, that operates 24/7/365. The ACU will have the capacity to control both temperature and humidity



Photograph

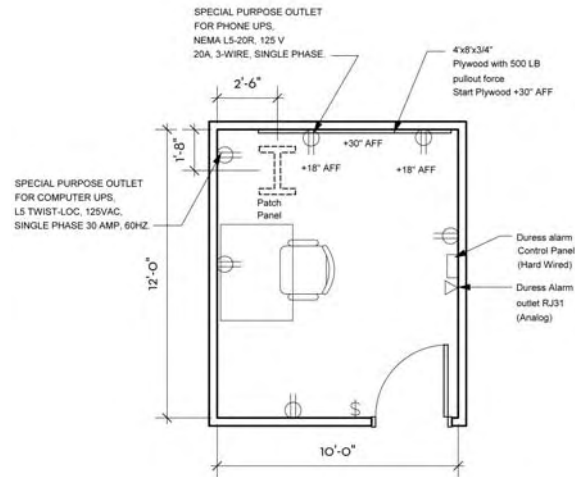

Floor Plan (120 nsf)





## 3.0 Common Support Unit - Room Data Sheet

### 3.6 BREAK ROOM

#### Function

The Break Room is used for staff food storage and preparation and for staff lunch/coffee breaks. A small table is provided for seating of up to four people.

In addition, to the use by employees during regular working hours, there is an ongoing requirement for individuals that may be required to work after hours and weekends. The size/number of Break Rooms will be proportional to the number of courtrooms, with one Break Room per floor in those Immigration Courts that are on multiple floors. A refrigerator will be provided in each Break Room

#### Following are functional uses of the Break Room:

- ✓ Lunch room
- ✓ Storage of food and drinks
- ✓ Employee Breaks



Photograph

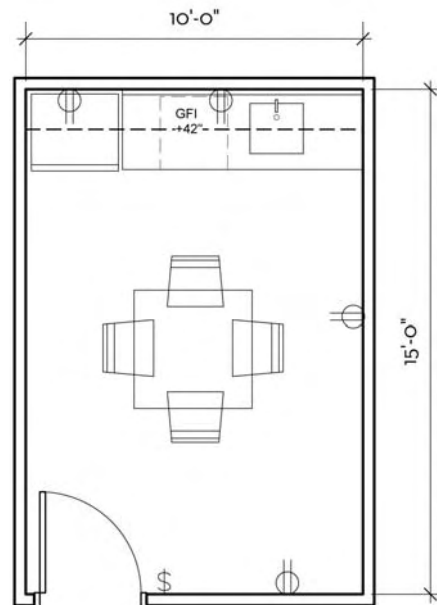

Floor Plan (150 nsf)

**3.6 SYSTEMS MATRIX**

<i><b>Walls</b></i>	<i><b>Floors</b></i>	<i><b>Ceiling</b></i>	<i><b>Doors</b></i>	<i><b>Hardware</b></i>	<i><b>Glazing</b></i>
See Appendix - Section 5 - Finish Schedule	See Appendix - Section 5 - Finish Schedule	ACT - 8' High	Solid Core Wood	See Schedule Below	N/A
<i><b>Plumbing</b></i>	<i><b>HVAC</b></i>	<i><b>Lighting</b></i>	<i><b>Power</b></i>	<i><b>Security</b></i>	<i><b>Communications</b></i>
Faucet & Sink w/Disposal	Typical w/Air Exhaust	Recessed Fluorescent	110v Duplex - GFI	Small Appliance Dedicated 20 amp Circuit	N/A

**3.6 FURNITURE - EQUIPMENT - HARDWARE SCHEDULE**

<i><b>ID</b></i>	<i><b>Item</b></i>	<i><b>Vendor*</b></i>	<i><b>Style</b></i>	<i><b>Model #</b></i>	<i><b>Qty.</b></i>
FURNITURE					
F	Seating	UNICOR		MXPLNAPY-CH-BL	4
F	Table	UNICOR		R04242TA1XAJBB	1
F	Waste Receptacle (Mid-size)				2
EQUIPMENT					
Bl	Upright Refrigerator/Freezer		White (18 c.u.)		1
Bl	Base Cabinets, 6 LF Total				1
Bl	Wall Cabinets, 6 LF Total				1
Bl	Counter Top, 6 LF Total				1
Bl	Air Exhaust System (200 CFM)	Penn Zepher		Z-10	1
Bl	Faucet & Sink w/Disposer		Stainless Steel		1
HARDWARE					
Bl	Latchset				

\* Vendor names are listed as a point of reference for equipment specs. Equal products by other manufactures can be used.  
 \*\* Lockset to be determined based on CDF facility requirements. Where an existing facility is being modified, new hardware shall be compatible with existing preference is for electronic keyless entry - via card readers or cipher locks. Each system must provide for key override.



## 3.0 Common Support Unit - Room Data Sheet

### 3.7 STAFF RESTROOMS

#### Function

The Staff Restrooms are single use rooms located within the EOIR court suite so that staff and Judges do not have to leave the secure EOIR Court suite to access restroom facilities.



Photograph

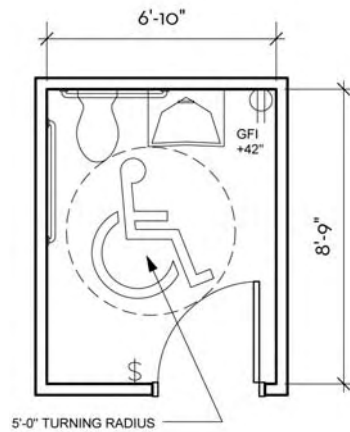

Floor Plan ( 56 nsf)

## 4. FUNCTIONAL REQUIREMENTS

### 3.7 SYSTEMS MATRIX

<i><b>Walls</b></i>	<i><b>Floors</b></i>	<i><b>Ceiling</b></i>	<i><b>Doors</b></i>	<i><b>Hardware</b></i>	<i><b>Glazing</b></i>
See Appendix - Section 5 - Finish Schedule	See Appendix - Section 5 - Finish Schedule	ACT - 8' High	Solid Core Doors	See Schedule Below	N/A
<i><b>Plumbing</b></i>	<i><b>HVAC</b></i>	<i><b>Lighting</b></i>	<i><b>Power</b></i>	<i><b>Security</b></i>	<i><b>Communications</b></i>
Fixture Water and Waste Lines	Toilet Exhaust	Recessed Fluorescent	110v Duplex - GFI	N/A	N/A

### 3.7 FURNITURE - EQUIPMENT - HARDWARE SCHEDULE

<i><b>ID</b></i>	<i><b>Item</b></i>	<i><b>Vendor*</b></i>	<i><b>Style</b></i>	<i><b>Model #</b></i>	<i><b>Qty.</b></i>
FURNITURE					
N/A					
EQUIPMENT					
By Owner	Toilet - Flush Valve	***			1
By Owner	Lavatory - Wall Mounted	***			1
By Owner	Grab Bars	***			2
By Owner	Toilet Paper Dispenser	***			1
By Owner	Toilet Seat Cover Protector Dispenser	***			1
By Owner	Semi-recessed Paper Towel/Waste Receptacle	***			1
By Owner	Soap Dispenser	***			1
By Owner	Feminine Napkin Disposal Unit (Women's Restroom)	***			1
By Owner	Wall Mirror	***			1
HARDWARE					
By Owner	Lockset	***	Push Button/Privacy		1

\* Vendor names are listed as a point of reference for equipment specs. Equal products by other manufactures can be used.  
 \*\* Lockset to be determined based on CDF facility requirements. Where an existing facility is being modified, new hardware shall be compatible with existing preference is for electronic keyless entry - via card readers or cipher locks. Each system must provide for key override.  
 \*\*\* Item provide by owner as part of CDF build-out.





### 3.0 Common Support Unit - Room Data Sheet

#### 3.8 JANITOR CLOSET

**Function**

A janitor's closet with a mop sink and room for storage of cleaning products and equipment will be located within the EOIR Court suite.



Photograph

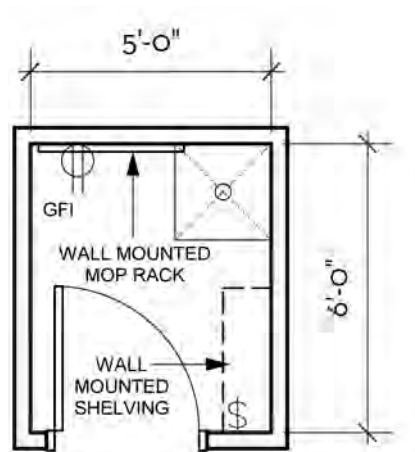

Floor Plan ( 30 nsf)





### 3.0 Common Support Unit - Room Data Sheet

#### 3.9 PRINTER WORKSTATION

**Function**

A Printer Workstation is a dedicated space for document printing and management of print files. The size of the Printer Workstation is proportionate to the number and Courtrooms served.



Photograph

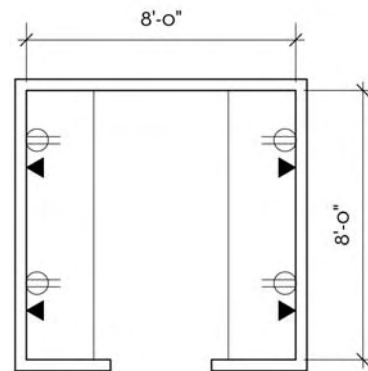

Floor Plan (64 nsf, Qty. determined by No. of courtrooms)





## 3.0 Common Support Unit - Room Data Sheet

### 3.10 SUPPLY ROOM

#### Function

The Supply Room is used to stock boxes of copier paper, supply cabinets, blank transcription tapes, standard forms and stacked boxed files.



Photograph

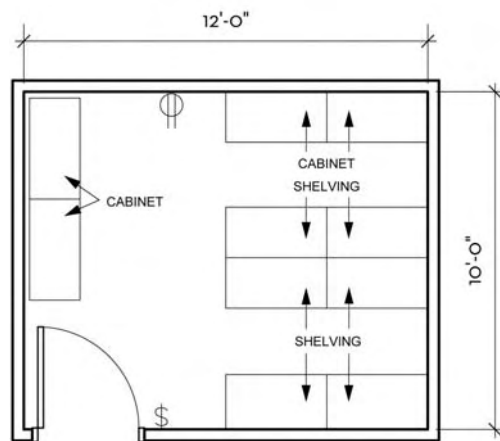

Floor Plan (Size determined by number of courtrooms)





## TECHNICAL REQUIREMENTS





## Technical Requirements

### HANDICAPPED ACCESSIBILITY

Accommodations for the handicapped shall be provided in accordance with the Uniform Federal Accessibility Standards (UFAS), which identifies standards for complying with accessibility provisions contained in the Architectural Barriers Act, 42 U.S.C. 4251-4157, and/or applicable local codes, regulations and laws.

### FIRE PROTECTION AND LIFE SAFETY

Fire Protection and Life Safety requirements shall be in accordance with local statutes. Notwithstanding this provision, the requirements shall comply with National Fire and Protection Association, National Fire Codes, Occupational Safety and Health Administration standards, and applicable local and/or national codes.

### ELECTRICAL

The installation of two isolated ground duplex outlets with a limit of four isolated ground outlets per circuit shall be provided per 125 square feet of space. For each position, there shall be one quadruplex outlet (or equivalent). All power wiring shall be in floor, wall, or ceilings. No power poles are allowed. Panelboards shall have spare circuit spaces, which shall be defined by EOIR with each space request.

One electrical closet per 10,000 square feet shall be provided with sufficient ventilation. Notwithstanding this provision, a minimum number and location of outlets required by local and/or national codes shall be adhered to.

### COMPUTER LAN REQUIREMENTS

For each workstation, individual data cabling (Cat6, 8-wire twisted pair plenum rated) shall be provided. Cable drops will originate at each workstation location marked on the provided floor plan with a single 8-pin, RJ45 jack (pin-out configuration: 1,2;3,6;4,5;7,8) and will terminate and be hard wired into the back of a patch panel that meets TIA/EIA-568B Category 6 standards in the computer room. The patch panel shall be installed in a floor-mounted upright distribution rack. Each end to be clearly marked to uniquely identify each cable in the computer room and each cable at the workstation location. All cable runs to be tested for Category 6 certification. Each cable run will be supplied with a 10'-0" Cat6 patch cord at the workstation location and a 3'-0" Cat6 patch cord at the patch panel location in the computer room.

The computer room will be provided with three (duplex) NEMA L5-20R receptacles (orange), 125 Volt, 20 Amp, 3-wire single phase, individual branch circuits with isolated ground; four (duplex) standard 20A and one (duplex) NEMA L5-30R twist-lock receptacle (orange), 125 Volt, 20 Amp, 3-wire single phase, individual branch circuit with isolated ground for Uninterruptible Power Source (UPS). Also, three analog phone lines shall be provided.

The computer room shall have a package ¾ ton, split air conditioning unit (ACU) with remote condenser, which will operate 24 hours a day. The ACU will have the capability to control both temperature and humidity.

### MECHANICAL

Mechanical requirements shall be provided in accordance with the American Society of Heating, Refrigeration and Air-Conditioning Engineers (ASHRAE) Handbook and Standards.

### PHYSICAL SECURITY

Physical security guidelines have been established for EOIR to afford an adequate level of uniform protection. Each guideline is designed to achieve a separate security objective. All guidelines are mutually inclusive and the absence of any component, will result in a security vulnerability. These guidelines include the following:

#### Public Access Control

Agency requires contiguous space. Space will be accessible to the public while providing adequate security measures, due to the highly sensitive and critical filing and archiving system and for increased personnel security. Unique building siting and/or security issues and concerns may also preclude building occupancy.

Courts shall be located in buildings where visitors are required to pass through a public access control (PAC) point or screening area comprised of a guard(s), a magnetometer, and/or X-ray equipment. Emergency exits shall be accessible to the public.

**Employee Entrances:** Consideration shall be given to establishing one or more separate employee entrances.

### Perimeter Security

Perimeter Security is the outer security boundary which surrounds the secured area, and provides the first level of control and protection. The perimeter security guidelines will contain the following minimum components:

**Site Perimeter:** The perimeter of the CDF property shall be delineated by a minimum 6 feet (1800 mm) high non-secure chain link fence with single barbed wire outrigger, or in an urban setting, a 6' (1800 mm) high concrete masonry fence to block views. This fencing is intended to clearly identify the limitations of the property to the general public. Appropriate fence-mounted signage shall identify US Government Property and specify the penalties for crossing the fence without authorization. A buffer zone of 200 feet (61 meters) shall be provided between the perimeter fence and the primary facility perimeter in order to diminish visual contact between the public and secure sides. In urban areas, where the buffer zone or a separate site perimeter is not attainable, other measures for the security and protection of the facility must be considered. At the site perimeter, maintain openings in the chain link fence for vehicular site access.

**Pedestrian Sallyport:** Where separate pedestrian access through the primary facility perimeter is provided, gates shall be interlocked and under CCTV surveillance from the central control room. The interlocked gates shall be operated from the central control room.

**Walls:** Slab to slab walls; either cinder block with drywall or plaster finish, or metal stud with drywall and fiberglass insulation.

The wall surrounding the Ballistic Transaction Window (BTW) will be reinforced with 9-11 gauge steel mesh lathe. Ballistic-rated walls may be considered where appropriate.

#### **Wall Construction:**

**"High" security walls** shall be constructed using one of the following methods:

Concrete masonry unit walls shall be a minimum nominal 8" (200 mm) wide units reinforced with #4 (No. 13 metric) vertical reinforcing bar at 8" (200 mm) on center. All cells of concrete masonry units shall be fully grouted with 3,000 psi (21 Mpa) grout.

Precast concrete panel walls shall be a minimum nominal 4" (100 mm) wide, minimum strength of

5,000 psi (35 Mpa) and reinforced with minimum W4 (MW26) welded wire fabric at 4" (100 mm) on center in both directions, conforming to ASTM A185. Cast-in-place concrete walls shall be a minimum 6" (150 mm) wide, minimum strength of 3,000 psi (21 Mpa) reinforced with #4 (No. 13 metric) reinforcing bars at 8" (200 mm) on center in one direction. Cast-in-place concrete walls that are less than 6" (150 mm) wide, but no less than 4" (100 mm) wide shall have a minimum strength of 5,000 psi (35 Mpa) reinforced with W4 (MW26) welded wire fabric at 4" (100 mm) on center in both directions.

Steel wall panels shall be 0.093 in. (12 gage) minimum thickness A-60 galvanized steel conforming to ASTM A 653-CS requirements. All structural or stiffening members shall be 0.058 in. (16 gage) minimum thickness A-60 galvanized steel conforming to ASTM A 653-LFQ requirements. All structural tubing shall be 0.115 in. (11 gage) minimum thickness steel conforming to ASTM A 653-CS and ASTM A-525, G-90 galvanized requirements.

**"Medium" security walls** shall be constructed using one of the following methods:

Concrete masonry unit walls shall be a minimum nominal 8" (200 mm) wide units reinforced with #4 (No. 13 metric) vertical reinforcing bar at 16" (400 mm) on center. All cells of concrete masonry units shall be fully grouted with 3,000 psi (21 Mpa) grout.

Precast concrete panel walls shall be a minimum nominal 4" (100 mm) wide, minimum strength of 5,000 psi (35 Mpa) and reinforced with minimum W4 (MW26) welded wire fabric at 4" (100 mm) on center in both directions, conforming to ASTM A185.

Cast-in-place concrete walls shall be a minimum 6" (150 mm) wide, minimum strength of 3,000 psi (21 Mpa) reinforced with #4 (No. 13 metric) reinforcing bars at 8" (200 mm) on center in one direction. Cast-in-place concrete walls that are less than 6" (150 mm) wide, but no less than 4" (100 mm) wide shall have a minimum strength of 5,000 psi (35 Mpa) reinforced with W4 (MW26) welded wire fabric at 4" (100 mm) on center in both directions.

Steel wall panels shall be 0.093 in. (12 gage) minimum thickness A-60 galvanized steel conforming to ASTM A 653-CS requirements. All structural or stiffening members shall be 0.058 in. (16 gage) minimum thickness A-60 galvanized steel conforming to ASTM A 653-LFQ requirements. All



## Technical Requirements

structural tubing shall be 0.115 in. (11 gage) minimum thickness steel conforming to ASTM A 653-CS and ASTM A-525, G-90 galvanized requirements.

**“Low” security walls** shall be constructed using one of the following methods:

Concrete masonry unit walls shall be a minimum nominal 6” (150 mm) wide units. All cells of concrete masonry units shall be fully grouted with 3,000 psi (21 Mpa) grout.

Gypsum wallboard walls (partitions) shall be a minimum 5/8” (16 mm) thick gypsum wall board on galvanized steel mesh panels 0.048” (1.2 mm) thick, 41 lbs/sf (200 kg/m) on each side of minimum 20 gauge metal studs at 16” (400 mm) on center. “High”, “medium”, and “low” security walls must be constructed continuously from a security floor to a secure ceiling. The secure ceiling may be either a secure roof deck or a cap of secure construction built below the roof deck in high bay areas. The continuity of the secure wall construction must be maintained by tying the wall reinforcing into the secure floor and ceiling construction. When this cannot be accomplished, a continuous #4 (No. 13) reinforcing bar shall be cast no more than 1 ½” (38 mm) from the edge of the concrete unit where it meets other concrete or masonry members.

### **Roofing / Ceiling Construction:**

**“High” security roof/ceiling** construction shall be constructed of the following:

Cast-in-place concrete slabs shall be a minimum of 6” (150 mm) thick, 3,000 psi (21 Mpa) concrete with #4 (No. 13 metric) reinforcing bars at 8” (200 mm) on center in one direction. Cast-in-place concrete slabs that are less than 6” (150 mm) thick, but no less than 4” (100 mm) thick shall have a minimum strength of 5,000 psi (35 Mpa) reinforced with W4 (MW26) welded wire fabric at 4” (100 mm) on center in both directions.

Composite metal deck shall be a minimum of 4” (100 mm) total depth, 3,000 psi (21 Mpa) concrete, #4 (No. 13 metric) bars 8” (200 mm) on center in one direction. Prestressed concrete tees or hollow core slabs shall have a concrete topping to give adequate cover for #4 (No. 13 metric) bars 8” (200 mm) on center in one direction.

Solid concrete planks shall have #4 (No. 13 metric) reinforcing bars at 8” (200 mm) on center in one direction. No concrete topping is required.

Metal acoustical ceiling panel shall be maximum security double skin metal 0.125” (3.2 mm) thick with perforations.

Metal roof decks shall be a minimum of 12 gauge. No additional reinforcing is required, however the deck must be securely tied to the “high” security walls.

**“Medium” security roof/ceiling** construction shall be constructed of the following:

Cast-in-place concrete slabs shall be a minimum of 6” (150 mm) thick, 3,000 psi (21 Mpa) concrete with #4 (No. 13 metric) reinforcing bars at 16” (400 mm) on center in one direction. Cast-in-place concrete slabs that are less than 6” (150 mm) thick, but no less than 4” (100 mm) thick shall have a minimum strength of 5,000 psi (35 Mpa) reinforced with W4 (MW26) welded wire fabric at 4” (100 mm) on center in both directions.

Composite metal deck shall be a minimum of 4” (100 mm) total depth, 3,000 psi (21 Mpa) concrete, #4 (No. 13 metric) bars 16” (400 mm) on center in one direction.

Prestressed concrete tees or hollow core slabs shall have a concrete topping to give adequate cover for #4 (No. 13 metric) bars 16” (400 mm) on center in one direction.

Solid concrete planks shall have #4 (No. 13 metric) reinforcing bars at 16” (400 mm) on center in one direction. No concrete topping is required.

Metal acoustical ceiling panel shall be maximum security double skin metal 0.125” (3.2 mm) thick with perforations.

Metal roof decks shall be a minimum of 12 gauge. No additional reinforcing is required, however the deck must be securely tied to the “medium” security walls.

**“Low” security roof/ceiling** construction shall be constructed of the same level of security as “Medium” security described above.

### Reception Areas

**Ballistic Transaction Windows:** A ballistic transaction window (BTW), with a Level 3 ballistic rating (.44 Magnum) and incorporating a Natural Voice Channel and/or the indicated Level 3-rated center speech device, will be installed in immigration Court reception areas. Larger windows will be incorporated in larger courts.

**The Wall** surrounding the BTW will be reinforced with 9-11 gauge steel mesh lath. Ballistic-rated walls may be considered where appropriate.

**The Door** leading from the reception area and/or waiting room into the staff area (generally, adjacent to the BTW) will be of solid wood construction and incorporate a keyed lockset. The door will also incorporate hardware which will enable the receptionist to remotely unlock the door by pressing a button at or near the reception desk. It shall also include a door closer and a peephole

### Courtrooms

**Doors:** All doors will be of solid wood construction.

Doors leading from public space (i.e., waiting rooms, reception areas, and corridors, etc.) into courtrooms will incorporate keyed locking hardware and will remain locked when courtrooms are not in use. Interior doors leading from the courtrooms into the staff areas will be fitted with automatic door closers, Trilogy combination locks with no key bypass, door viewers (model to be specified by the EOIR Security Office), and a single throw deadbolt lock (unless prohibited by local codes) on the staff side of the door. The door frame will be provided with electric strike controlled by a timer.

**Rail:** A 3'-4" (or 40") high wood rail will separate the visitors' seating area from the judge's and attorney's area. The rail will incorporate a single-swing gate which swings away from the judge's bench towards the visitors' area.

**Judges' Benches:** Where feasible, judges' benches will be placed at least twelve (12) feet from the respondent(s).

**Emergency Lighting:** Emergency lights will be installed in all courtrooms. The lights will be incorporated into the building's electrical system and have battery back-up capability.

**Duress Alarm System (DAS):** Each court will be provided a DAS connected to the main CDF control room and to on-site security personnel (i.e., Detention and Deportation Officers). Upon Court occupancy of the space, the contractor must provide the Court with an Operator's Instruction Manual, and provide on-site training session on the system's operation.

The DAS performs two critical functions:

1. It alerts the court's staff and the designated monitoring facilities to a security situation within the court; and
2. When incorporated into the Electronic Door Release System (EDRS), it provides the judges/staff a means to expeditiously evacuate the courtroom during an emergency situation without having to use the combination lock on the interior courtroom door.

The DAS consists of the following components:

1. Duress buttons: One (1) fixed duress button each at the reception area desk or within the immediate area), the Court Administrator's desk, conference room, and at each judge's bench. Only the duress buttons affixed on the judges' benches (when tied into the EDRS) will automatically secure the door upon exit or is timed out. These doors will remain locked at all times.

There shall be the installation and wiring of a fully operational duress system, which, when activated, will summon an immediate armed response and engage ceiling mounted strobe lights. Duress system components are as follows:

1. Panic buttons shall be cylinder slide, no noise; alarm reset with key operation.
2. Controller shall be Radionics #D7212B or equivalent.
3. Electronic keypad shall be Radionics #D1255 or equivalent.
4. Strobe lights shall be SECO-LARM SL-126 ceiling/wall mount or equivalent.
5. Wiring shall be steel shield or conduit, 18-22 gauge, four conductor, copper.



## Technical Requirements

Where appropriate, locking hardware will be keyed or coded (as in card swipe) to permit access by building management and engineering personnel during an emergency situation, (e.g., flooding, power outages, fire, etc.) The keyed locks will also allow authorized members of the building's cleaning staff after-hours access to the court's space.

Distribution of keys (or key cards) to court space shall be limited and a log maintained for accountability purposes. Spare keys shall be secured in a locked key cabinet, inside the Computer Room.

**Detention Hollow Metal Doors and Frames:** All doors and frames that occur as openings in "High", "Medium", and "Low" security walls shall be detention type and comply with the Technical Specifications Section 11191 "Security Metal Doors and Frames" and Section 11199 – "Detention and Non-detention Door and Hardware Schedule" in Part C. The following secure construction types shall match specific hollow metal grades by the Hollow Metal Manufacturers Association (HMMA): Secure Construction Type HMMA "High" Grades 1 "Medium" Grade 2 "Low" Grade 3 have the capability to disengage the electric strikes on the interior courtroom doors. This feature will permit the judges, in the event of an emergency, to open the door without having to use the combination lock. EOIR Security Office will specify portable (wireless) duress buttons where appropriate.

2. Indicator panel (keypad): Shall be installed at or near the receptionist's desk/area, programmed to display which button (zone) is activated and emit a low audible alarm (e.g., beeping sound) which can be heard in the immediate area of the panel. Alarm signals shall not be audible throughout court space nor be emitted from remote or external sounder(s)/horn(s).

3. Strobe lights: Number and locations will be determined by the EOIR Security Office. Lights will activate when any of the duress buttons are pressed.

The judge's private entrance/exit door in each courtroom will be equipped with a push button lock, viewport, deadbolt and an Electronic Door Release System (EDRS) incorporated into the duress alarm system (the duress button will activate the EDRS).

The system will require an electric strike, a momentary switch and a power supply at each

courtroom door. The panic button, which will be "hardwired" to the alarm system, will require an additional set of wires leading to the power supply and the electric strike. A timer must be added so the door will remain "unlocked" until the staff exit. EDRS system components are as follows:

1. Electronic strike shall be Rutherford #7114 or equivalent.
2. Momentary switch shall be Ace II Switch Locks # 4073-70DDC.
3. Power supply shall be Securitron #BPS-12-3 or equivalent.
4. Timer shall be Securitron #TM-8.
5. Deadbolt shall be Schlage #B680 or equivalent.
6. Viewport shall be Ives #698 or equivalent.

Door from waiting area into agency administrative area to be equipped with an electric door strike with remote release button to be accessible by the receptionist in the main work area. An electronic signal shall be located at the reception window. Components are as follows:

1. Electric strike shall be Rutherford Model 7114 (or equivalent) with BZ-24 buzzer.
2. Momentary switch, Ace II switch Locks Model #4073-70DDC or equivalent.
3. Power supply, Securitron Model BPS-12-3 or equivalent.

**Electronic Door Release System (EDRS):** Each interior door leading from the courtroom into the staff area will be fitted with an EDRS which will be incorporated into, and work in conjunction with, the courtrooms' duress buttons. When a duress button in a courtroom is activated (pressed), the EDRS will allow the judge/staff to effect a rapid exit from the courtroom by disengaging the electric strike on the interior courtroom door, thereby eliminating the need for the staff to press the code numbers on the door's combination lock. Button activation will also signal the appropriate monitoring facility, and/or on-site security staff (where available), activate the court's internal strobe light system, and initiate a low audible signal at the court's duress alarm panel.

The EDRS, which will work in conjunction with the door's specified locking hardware (Trilogy combination lock), will require an electric strike (Rutherford Model 7114 or equivalent) and momentary switch (Ace II Model #4073-70DDC or equivalent) at each courtroom door, while using the existing button specified for the court's duress alarm system. The button, which will be "hardwired" to the alarm system, will require an additional set of wires

leading to a power supply (Securitron Model BPS-12-3 or equivalent) and the electric strike. A timer (Securitron Model TM-8) must be added so the electric strike remains "disengaged" for no longer than fifteen (15) seconds allowing the staff sufficient time to exit. After the staff opens the door to exit the courtroom the electric strike will "re-engage" (a Door Position Switch (relay) allowing the electric strike to re-engage when the door is opened) and the door, when closed, will remain locked until the duress alarm system is reset. To further secure the staff area, a deadbolt lock (Schlage Model B680 or equivalent) will be installed on each courtroom door. The lock will be engaged after the staff enters the area.

The Statement of Work shall read as follows:

"When pressed, duress buttons installed in the courtrooms shall simultaneously disengage the electric strike only on the respective interior courtroom door, activate alarms at the appropriate on-site security, activate the court's internal strobe light system, and initiate a low audible signal at the court's duress alarm panel (keypad). A timer shall keep the electric strike disengaged until the door opens, at which time the timer will immediately shut-down so that the electric strike re-engages and door is automatically secured when closed or the door is automatically secured after the preset timer time expires. The timer shall not be set for more than fifteen (15) seconds. Once closed, the courtroom door will remain secured and the duress button will not be able to disengage the electric strike (a second time) until the threat situation is nullified and the duress system is reset."

### Other Office Areas

**ADP Rooms:** The doors of ADP rooms will be secured with a push button (Trilogy) lock, as specified by the EOIR Security Office.

**File Rooms:** To control access, the room shall have ceiling high walls and the door will be secured with a lock as specified by the EOIR Security Office.

**Restrooms:** Restrooms shall be incorporated within court staff areas, one male and one female minimum. Doors to restrooms located outside court space shall be secured by locking hardware as specified by the EOIR Security Office, and incorporate a key bypass for building management access.

**Evacuation Routes:** Floor plans and/or maps of evacuation routes for bomb threats, fires and other emergencies shall be strategically posted within office areas.

**Windows:** A Category-2 (.08 mil) shatter-resistant film (clear or reflective) shall be applied to the interior side of all exterior windows (e.g., courtrooms, judges' chambers, administrative areas) in court spaces.

Windows of courts located in close proximity of public/private public roads/streets shall be comprised of Level III rated ballistic resistant glass. Street level windows may have to be protected with steel grillwork or metal screening.

### Safety Systems

Safety systems shall be designed to meet the minimum requirements specified by the Occupational Safety and Health Administration (OSHA), for safe emergency egress. These requirements shall be coordinated with CDF facility security and safety requirements. This system includes the following.

1. Panic release bars installed on all main entrance doors and stairwell doors that sound audible alarm when opened, as per Security Specifications.
2. Electronic door strikes that are used on fire egress doors are designed to fail-safe (unlock) in the event of a power failure or emergency.
3. Fail-safe capability on selected door locks are to work in conjunction with smoke and fire alarms in those instances where emergency egress is restricted without such a configuration.
4. The use of fire certified or safety approved products install in the office (e.g., fire resistant doors and draperies.)

### Communication Closet Specifications (MDF and RWC)

Typically communications closets house common equipment required to support both voice and data connectivity to workstations. Communication closets/rooms are typically centrally located on the floor, and adhere to the ANSI/TIA/EIA specifications for cable lobe lengths (e.g. maximum cable from closet to workstation will not exceed 100 meters, end-to-end). Closets/rooms shall be vertically stacked, with a sufficient number of sleeves interconnecting each closet. All wiring centers shall



## Technical Requirements

comply with or support the following specifications and requirements:

### **General Requirements**

The space shall be environmentally temperate, convenient, and professional looking.

The communication closets must have sufficient infrastructure required to support the variety of communication services provided to ICE and contractor staff. Typically this includes items such as conduits, cable trays, building grounding system, etc.

Communications closets shall be designed for growth, and flexibility supporting new technologies without the need for major room modifications and rearrangements.

### **Environmental**

Room shall be dust free with positive air pressure where possible and meet Federal guidelines for specified material to reduce airborne contaminants caused by off gassing.

Ceilings shall be finished with similar drop tiles used throughout the floor.

Overhead lighting sufficient to provide 80 candle feet measured five feet above the finished floor, is to be switched controlled and is not to be connected to communications equipment circuits.

Care must be taken to avoid structural columns, ductwork, other building structures, which would restrict the functionality of the space.

Ceiling space above communications closets shall be open and clear of major Heating, Ventilation, and Air Conditioning (HVAC) systems and ductwork, including major motors, elevator motors, generators, or equipment that induce excessive EMI an/or RFI to communications equipment or systems.

Room temperature must be maintained between 65 and 85 degrees Fahrenheit, with a relative humidity range of 20 to 60 percent. When heat-generating equipment placed into communication closets, maintaining environmental parameters is essential, thus avoiding down time due to equipment failures caused by equipment overheating. Where the building HVAC is insufficient to maintain these parameters a standalone HVAC system shall be considered to maintain these environmental ranges for 24 hour, 7 days a week (24/7) schedule.

Where no dedicated HVAC system is required for plenum air return buildings, there shall be a minimum of two diffusers for fresh HVAC air intake, with a minimum of two air return vents, vented door and a positive air flow maintained. Buildings without air return systems shall provide clean air 24/7. Additionally, rooms without dedicated HVAC systems shall have continuous airflow 24/7.

### **Construction**

Closets regardless of their function shall be 120 sf. However, minimum communications closet shall never be less than specified in the applicable ANSI/TIA/EIA specifications. ICE typical closet minimum size shall be no less than 80 square feet, whereas the recommended size is calculated by the ANSI/TIA/EIA specifications

Door locks for all communications rooms will conform to local security requirements

Door must be a minimum 36 inches wide by 80 inches high. The door shall swing out to facilitate equipment installation and provide maximum space utilization by allowing higher density equipment designs and configurations without the concern of lost space due to door travel.

Floor shall be rated to withstand 100 pounds per square foot and shall be covered with appropriate tile or linoleum. Carpets are not acceptable in communications closets.

Each communications closet shall have a minimum of 2 separate 120 Volt @ 20A circuits installed for cable plant electronics. Preferred outlets are the National Electrical Manufacturers Association (NEMA) - 20 5 quad receptacles. Outlets shall be installed at heights that adhere to the building electrical codes, typically 18 inches above finished floor. Additional circuits may be required as equipment density is increased.

A certified electrical ground and buss shall be installed into each closet for communications equipment grounding and be connected to a dedicated building ground, that is compliant with the ANSI/TIA/EIA 607.

For both the Medium Density Fiberboard (MDF), a pre-treated, fire-rated, plywood backboard (3/4 inches by 4 feet by 8 feet sheets) shall be fastened properly to the wall for riser cable control.

All cable shall be neatly tie-wrapped and anchored every 3 feet on the backboard.

ICE occupied floors that are contiguous, with stacked closets, shall have a minimum of two 4-inch shelves between closets for ICE Data and Voice cables. Additional sleeves will be required for the building voice riser system. Where ICE data and voice cables must pass through communications closets not controlled by ICE or the US government, mechanical protection must be provided. Thin wall ridged conduit will be sufficient for this requirement.





## 5. APPENDIX

Reference Publications

Acronyms and Abbreviations

Room Finish Schedule



## Reference Publications

### REFERENCE DOCUMENTS

The Offeror (Contractor) will conform their facility design to the following standards, at a minimum, plus any additional applicable standards that may be pertinent to the location where the facility is intended to be built. The Offeror will be solely responsible for complying with these standards and code requirements. Failure of ICE to identify particular construction code standards that are pertinent to a particular site will not relieve the Offeror of the responsibility of meeting those criteria.

American Correctional Association (ACA)

Standards for Adult Local Detention Facilities  
3rd Addition

American Correctional Association (2002 Standards  
Supplement)

International Building Code, 2003

National Fire Protection Association

Life Safety Code 101, current edition

U.S. Department of Justice  
Immigration and Naturalization Service (Legacy)  
Service Processing Center Design Guide

Joint Commission on Accreditation of Healthcare  
Organizations (JCAHO)

National Commission on Correctional Healthcare  
(NCCHC)

Occupation, Safety and Health Association (OSHA)

ICE Detention Standards

USICE Structured Cable Plant Standard

ANSI/TIA/EIA - 526-14, Optical Power Loss  
Measurement of Installed Multimode Fiber Cable Plant  
- OFSTP-14

ANSI/TIA/EIA - 568-B.1, Commercial Building  
Telecommunications Cabling Standard Part 1: General  
Requirements

ANSI/TIA/EIA - 568-B.2, Commercial Building  
Telecommunications Cabling Standard Part 2: Balanced  
Twisted-Pair Cabling Components

National Electrical Code (NEC)

ANSI/TIA/EIA - 568-B.3, Commercial  
Telecommunications Cabling Standard Part 3: Optical  
Fiber Cabling Components

ANSI/TIA/EIA - 568-A, Commercial Building Standard  
for Telecommunications Pathways and Space

ANSI/TIA/EIA - 598, Optical Fiber Cable Color Coding

ANSI/TIA/EIA - 606-A, Administration Standard for  
Telecommunications Infrastructure of Commercial  
Building

ANSI/TIA/EIA - 607, Commercial Building Grounding  
and Bonding Requirements for Telecommunications

ANSI/TIA/EIA - 758, Customer-Owned Outside Plant  
Telecommunications Cabling Standard

### RELATED DOCUMENTS

Uniform Federal Accessibility Standards, 1988

Americans with Disabilities Act (ADA), Title III

American Society for Testing and Materials,  
current standards

Underwriters Laboratories, Inc.

American National Standards Institute, Inc.

National Association of Architectural Metal  
Manufacturers

Hollow Metal Manufacturers Association,  
Standard 863-96

H.P. White Laboratory, Inc. HPW-TP-0500.02

WMFL Physical Attack Test

**ACRONYMS AND ABBREVIATIONS**

ACA	American Correctional Association	manuf.	manufacturer
ADA	Americans with Disabilities Act	ME	medical Equipment
AHSA	Assistant Health Services Administrator	MRT	Medical Records Technician
BOP	Bureau of Prisons	NCCHC	National Commission on Correctional Health Care
BP	blood pressure	NEC	National Electrical Code
BI	built-in	NFPA	National Fire Protection Association
CCTV	closed circuit television	NP/PA	Nurse Practitioner/Physicians Assistant
CD	Clinical Director	NSF	Net Square Feet
CDF	Contract Detention Facility	OSHA	Occupational, Safety and Health Administration
IBC	International Building Code	OTC	over-the-counter medications
CBP	Customs and Border Protection	P	primary
DHS	U.S. Department of Homeland Security	PA	public address system
DOJ	Department of Justice	PDT	Project Development Team
DRO	Detention and Removal Office	PI	performance improvement
EOIR	Executive Office for Immigration Review	pk	package
F	furniture	S	secondary
Fab.	Fabricators	SHU	Secured Housing Unit
FDA	U.S. Food and Drug Administration	SPC	Service Processing Center
Flr.	floor	SSU	Short Stay Unit
GFI	ground fault interrupter	TB	tuberculosis
GSF	Gross Square Feet	RHIA	Registered Health Information Administrator
HCP	Health Care Program	RN	Registered Nurse
H.M.	hollow metal	TBD	to be determined
HS	Health Services	USF	Usable Square Feet
HSA	Health Services Administration	USPHS	United States Public Health Service
Ht.	height	VCT	vinyl composition tile
HVAC	heating, ventilation and air conditioning	w/	with
ICE	Bureau of Immigration and Customs Enforcement	Wt.	weight
IGSA	Inter-governmental service agreements		
INS	(Legacy) Bureau of Immigration and Naturalization Services		
DIHS	Division of Immigration Health Services		
HHS	U.S. Department of Health and Human Services		
HRSA	Health Resources Services Administration		
JCAHO	Joint Commission on Accreditation of Healthcare Organizations		
LAN	local area network		
Lav.	lavatory		
LVN	Licensed Vocational Nurse		
qt.	quart		



## Room Finish Schedule

### FINISH SCHEDULE FOR NEW CDF's

Product	Location	Manufacturer	Color/Style	Number	Name	Finish	Notes
Paint	All Spaces	Duron		CW003W	Mysterious	Eggshell	
Paint	Courtroom	Duron		8505D	Bluecoat	Eggshell	Only on wall behind IJ Bench
Stain	Wood Cap	Minwax		224	Special Walnut	-	
Carpet	Throughout	Bentley	Bond Street RC	8BS4506301	Cove Road 888630	-	Direct Glue-Down
VCT	ADP, Break, File & Waiting Room	Mannington	Brushwork	702	Granito	-	
Base Molding	All spaces other than courtrooms	Roppe	-	748	Steel Gray	-	4", vinyl
Base Molding	Courtroom	Johnsonite	-	MW-40-F	Black	-	4 1/4" Millwork Reveal Profile
Wall Covering	Waiting Room	Muraspec	Regalia	GS-6147	Lunar	-	Type II, 20 oz.
Counter	Break Room	Nevamar	-	LD-6-1T	Black Lodestone	Textured	ARP Surface
Cabinets	Break Room	Nevamar		S-6-475	Sandpiper	Textured	
Ceramic Tile	Restroom Walls	Dal-Tile	Almond	135	-	Semi-Gloss	4 1/4" x 4 1/4", 5 foot high
Ceramic Tile	Restroom Walls	Dal-Tile	Denim	DH69	-	Semi-Gloss	4 1/4" x 4 1/4", 2 accent rows



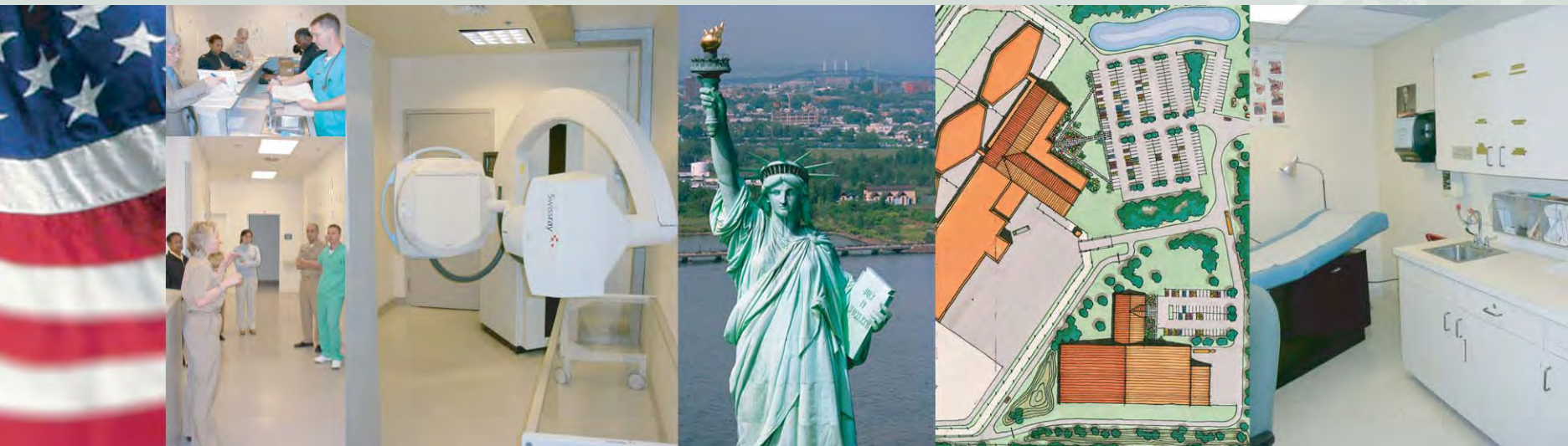

U. S. Department of Homeland Security  
Immigration and Customs Enforcement

**CONTRACTOR OWNED/CONTRACTOR OPERATED FOR  
HEALTH SERVICES DESIGN STANDARDS**

March 11, 2005



**U.S. Department of Homeland Security**  
IMMIGRATION & CUSTOMS ENFORCEMENT

**Health Services**

---

DESIGN STANDARDS

March 11, 2005





# Table of Contents

	<b>Page</b>
1. INTRODUCTION.....	1.1
2. ORGANIZATIONAL REQUIREMENTS .....	2.1
3. FUNCTIONAL REQUIREMENTS.....	3.1
4. SPACE REQUIREMENTS .....	4.1
5. DEPARTMENTAL REQUIREMENTS.....	5.1
6. APPENDIX .....	6.1





## 1. INTRODUCTION

Health Services (HS)  
- *History and Mission*

Health Services (HS)  
- *Design Standards*



## Health Services

### HISTORY

The Immigration and Naturalization Service, now known as the Department of Homeland Security (DHS)/Bureau of Immigration and Customs Enforcement (ICE), has had a relationship with the United States Public Health Service (PHS) dating from 1891, when the Immigration Act authorized the PHS to examine and quarantine immigrants at Ellis Island. Today, that historic link is maintained by an interagency agreement between ICE and the Division of Immigration Health Services (DIHS), an agency of the PHS, and its parent organizations the Department of Health and Human Services (DHHS), Health Resources Services Administration (HRSA), Bureau of Primary Health Care (BPHC).

### MISSION

The mission of the DIHS is to protect America by providing primary health care and public health services in support of immigration law enforcement. This mission is accomplished through a comprehensive delivery system that emphasizes disease screening and preventive health services and incorporates the provision of high quality, necessary and appropriate medical, dental, and mental health services in a cost-effective manner. Each DIHS medical facility operates in adherence to nationally established ICE Detention Management Standards for health care, as well as the standards of the National Commission on Correctional Health Care (NCCHC), the Joint Commission on Accreditation of Healthcare Organizations (JCAHO), and the American Correctional Association (ACA).

### FUNCTION

The DIHS has experienced phenomenal growth in recent years. That growth has accompanied the increased detainee population that followed changes in U.S. immigration law enacted by Congress in 1996. As recently as 1995, health care to detainees was provided almost exclusively between the hours of 8 AM and 5 PM, Monday through Friday, in eight medical facilities located in Services Processing Centers (SPC). At that time, the average detained population barely exceeded 5,000 per day.

DIHS medical staff currently provide direct services to an average daily detained population of well over 20,000 individuals, 24 hours a day, seven days a week, in fourteen DIHS medical facilities nationwide, located in ICE Service Processing Centers, Staging Facilities, and Contract Detention Facilities (CDF).



Health Check at Ellis Island - Early 1900's



Port Isabel Service Processing Center Groundbreaking - 2004

Administration Organization - HS within U.S. Department of Health and Human Services

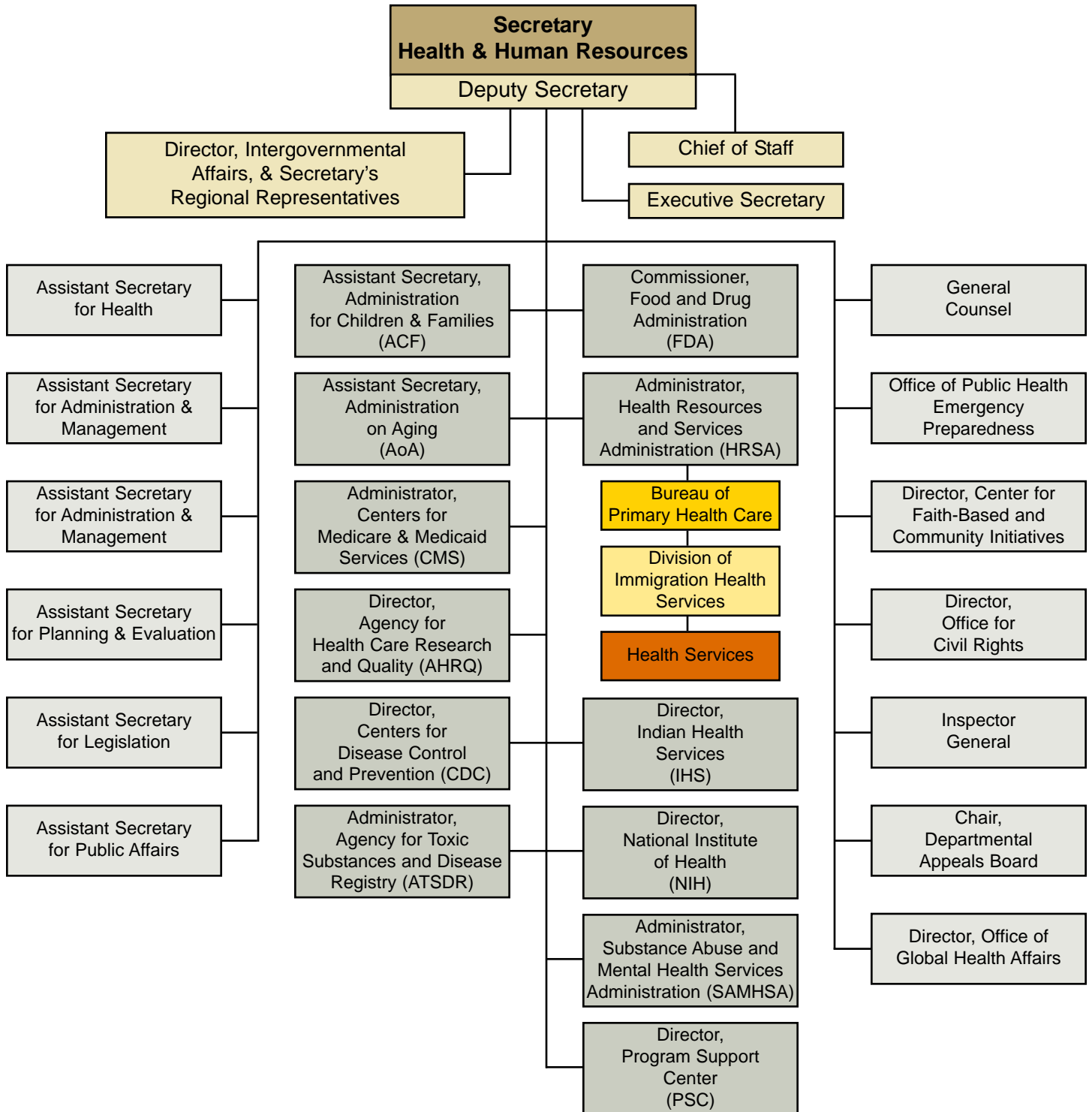



## Health Services (cont.)

Five of the facilities have inpatient Short Stay Units. One additional medical facility, Pearsall in Texas, is scheduled to open in 2005. Based on the increasing detainee population it is anticipated that ICE will continue to expand bed capacity by opening new facilities as needed. The rapid increase in the detained population of the late 1990s far exceeded occupancy limits of existing ICE facilities. Inter-governmental service agreements (IGSAs) between ICE and various local and county governmental entities were expanded in scope and number to provide bed space in their jails for ICE detainees. As hundreds of IGSAs were enacted, the need to strengthen controls and accountability measures for the expenditure of health care funds was recognized. DIHS answered the challenge by forming the Managed Care Branch.

The Managed Care Branch was composed of a cadre of health care professionals (PHS officers), who established a mechanism for IGSA facilities to request approval for health services to detainees. These Managed Care "Coordinators" operated from an established set of principles and criteria whereby requested services would be individually considered and authorization would be granted or denied. A network of providers was developed. Contracts, memorandums of agreement, or other blanket purchase agreements were established to maximize return on health care dollars expended.

The Managed Care Branch has continued on a track of development and refinement with automation, information technology applications, and sub-contracting (ongoing) network development and claims adjudication processes. Claims reimbursement is based upon the provisions of Title 18 (18 U.S.C. 4006b) except where there is a blanket purchase agreement with a given provider or vendor. The Veterans Administration Financial Center in Austin, Texas currently pays claims.

The DIHS' value to ICE is enhanced by the newly created responders. This corps of deployable DIHS uniformed officers are available to assist with mass migration influxes, staging operations, and evacuation drills. This has proven invaluable on numerous occasions in recent years, including Tinian (Northern Mariana Islands), the Florida Keys, Guatemala, metropolitan New York City, the U.S./Mexican border, and the Port of San Diego.

An even more recent development has been the formal establishment of the DIHS Aviation Medicine Program. Some DIHS officers have successfully completed the U.S. Air Force's Aviation Medicine Academy at Brooks Air Force Base, Texas, creating a highly skilled cadre of health professionals to assist ICE with the removal of individuals to their countries of origin when medication or sedation is required.



Health Inspection Aboard a Ship, Coast of Guatemala - 2003



Commonwealth of Northern Mariana Islands, Tinian - 1999

Administration Organization - HS within Service Processing Center

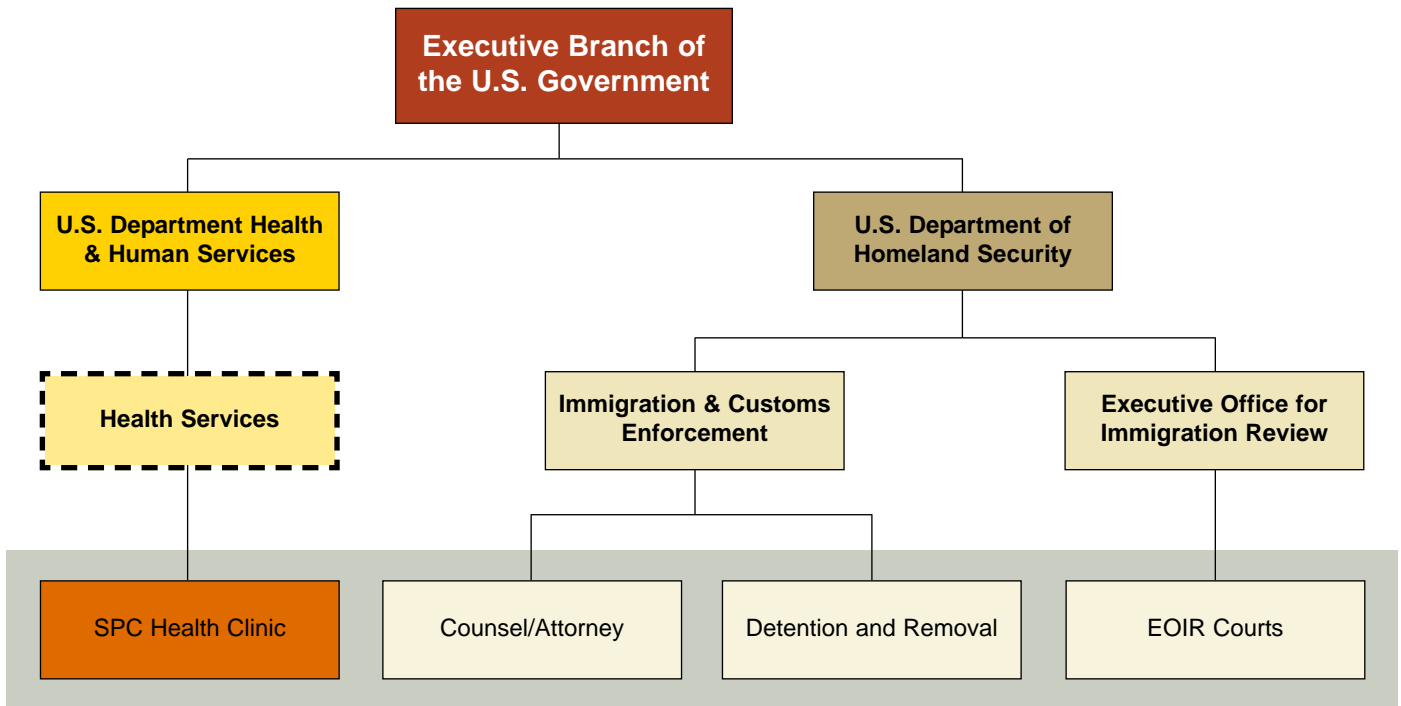

Three agencies are present within the SPC: Detention and Removal Operations (DRO), Executive Office of Immigration and Review (EOIR) and Health Services (HS). These groups' respective areas of responsibility are:

1. Detention and Removal Operations (DRO), which is responsible for managing the detainees, presenting cases for deportation and executing deportations.
2. Executive Office of Immigration Review (EOIR), which is part of the Department of Justice, is responsible for conducting the court hearings.
3. Health Services (HS), which is part of the Department of Health and Human Services, is responsible for providing health services.



## Health Services Design Standards

### DESIGN STANDARDS PURPOSE

The intent of the HS Design Standards is to provide uniform guidelines for the planning and design of new and renovated health services facilities, whether DRO owned and operated or contractor owned and operated. This document should be used as a tool for designers and DIHS staff as they plan, program, design, and build HS facilities. It provides general recommendations that should be used and adopted to fit the specific ICE mission at the location of the planned facility. The standards contained within this document should be continually upgraded as HS organizational, operational, and functional philosophies change and as new technologies become available.

### DESIGN STANDARDS DEVELOPMENT PROCESS

The design standards documented herein have been developed by selected representatives of ICE and DIHS. The standards development team evaluated existing HS standards and existing HS facilities with the intent of developing HS standards that will enhance their organizational, operational, and functional efficiencies within an HS unit.

### DESIGN STANDARDS DOCUMENT

The design standards document is organized for ease of use. The standards are organized into six sections. Each section is designed to stand alone so it may be extracted for use in the planning and design process.

The chart to the right briefly outlines the contents of each section of this document.

#### Report Sections

##### **1. Introduction**

The Introduction includes Health Services history, mission and the purpose of the Standards with a brief description of each section.

##### **2. Organizational Requirements**

This section includes the HS organization, staff forecasts, and roles/responsibilities. A staffing model illustrates the number of staff by position based on detainee population. It also illustrates the type of space based on staff function.

##### **3. Functional Requirements**

This section diagrams basic functional relationships of HS within the overall Service Processing Center (SPC) or Contract Detention Facility (CDF), and relationships among the four components within a HS Unit.

##### **4. Space Requirements**

The rationale for determining the size of a facility is dependent on the number of detainees held. The number of staff is predicated on the number of detainees and the services offered. Size of facilities are determined by the number of staff and detainees served as well as specific functional requirements of the Service Processing Center (SPC) or CDF. The space analysis is based on four capacity levels of detainee population. These were determined to be representative population levels based on DHS input. Detainee population levels were defined as <200, 200-450, 450-900, and 900-2000. As a general rule, functional spaces within PHS units are similar for each range in detainee population. There may, however, be configuration variations depending on operations and clinical staff mix.

##### **5. Departmental Requirements**

This section contains detailed information for each of the four components which makes up the HS unit. For each component you will find its organizational model/concept, critical workflow patterns, and room data sheets.

##### **6. Appendix**

This section contains a listing of reference publications and standards as well as two existing HS case studies.



Health Services (HS)  
- *History and Mission*

Health Services (HS)  
- *Design Standards*



Health Services (HS)  
- *Space Requirements Spreadsheet*



Health Services (HS)  
- *Organization*

Health Services (HS)  
- *Organizational Requirements*



Health Services (HS)  
- *Space Components*

1.0 *Administration and Common Support*

2.0 *Medical Intake and Processing*

3.0 *Ambulatory Care Unit*

4.0 *Short Stay Unit (Infirmary)*



Health Services (HS)  
- *Inter-Departmental Adjacencies*

Health Services (HS)  
- *Intra-Departmental Adjacencies*



Reference Publications

Health Services (HS)  
- *Case Studies*



## 2. ORGANIZATIONAL REQUIREMENTS

Health Services (HS)  
- *Organization*

Health Services (HS)  
- *Staff Requirements*





## HS Organization

### HEALTH SERVICES ORGANIZATION

There are two basic staff organizational components within Health Services as illustrated on the following page. The components are managed by the Health Services Administrator and Clinical Director. The Health Services Administrator oversees the general day-to-day operations of Health Services, while the Clinical Director oversees the clinical operations including Dental and Mental Health Services.

### HEALTH SERVICES COMPONENTS

The Health Services unit is comprised of four functional units. These are the Administrative and Common Support Unit, Medical Intake Unit, Ambulatory Care Unit, and Short Stay Unit. The organizational charts on page 2.3 illustrate the interaction between staff and functional unit.

The Health Services Administrator (HSA) manages staff that work in all four units. Staff under HSA management includes the Assistant HSA and Medical Records Technicians, Pharmacist and Pharmacy Technician that are housed in the Administrative and Common Support Unit, Licensed Vocational Nurses (LVN) and Registered Nurses (RN) who work part time in the Medical Intake Unit and part time in the Short Stay Unit and the Nurse Manager who resides in the Short Stay Unit.

The Clinical Director manages clinical professional staff that works in three of the four units. Included are the Clinical Director and Administrative Assistant who work in the Administrative and Common Support Unit, Physicians, Dentists, Mental Health provider along with their assistants, and Nurse Practitioners who work in Ambulatory Care Unit. Physicians, Nurse Practitioners and Physicians Assistants and the Mental Health provider also work in the Short Stay Unit where they provide in-patient services.

### FUNCTION

The SPC or CDF is responsible for the health and welfare of individuals in its custody. This responsibility mandates the provision of medical staff to provide care to detainees at the SPC/CDF in accordance with the Immigration and Naturalization Service Health Care Program (INS HCP) Policy Manual and in compliance with accreditation standards.

A medical clinic is located within the SPC/CDF to provide the necessary health care and treatment. Non-elective medical care not available at the SPC/CDF, but deemed necessary by the health authority, will be referred to outside sources.

### STAFF & ACTIVITIES

Mental and Health services are provided by commissioned officers of the U.S. Health Services (PHS) augmented by local contract staffing. A Clinical Director or designated health authority is responsible for the provision of health services to the detainees. Health services staff should include physicians, mid-level practitioners, nurses, mental health professionals, and a pharmacist. Other medical staff such as x-ray technicians may be added as needed.

Activities in the Health Care Unit may vary depending on the SPC/CDF size. All Health care Units are staffed 24/7 to provide intake screening and to respond to emergencies. However, at smaller SPC/CDF facilities, certain activities as routine sick call may not happen every day. At larger facilities, the clinic is typically open every day. Detainees may sign up for sick call daily and have their requests responded to during clinic operation hours. Emergencies are responded to immediately. Triage or sick call can also be conducted in a medical screening area located within each housing unit.

When detention services are provided through a contract facility, the Contractor normally provides health care services for the detainees.

Arrangements are normally made with nearby hospitals or other facilities for all health services (medical and psychiatric) that cannot be appropriately provided for within the facility. These services could include Emergency Room services, caring for severe physical conditions like quadriplegia and caring for violent mentally ill patients.

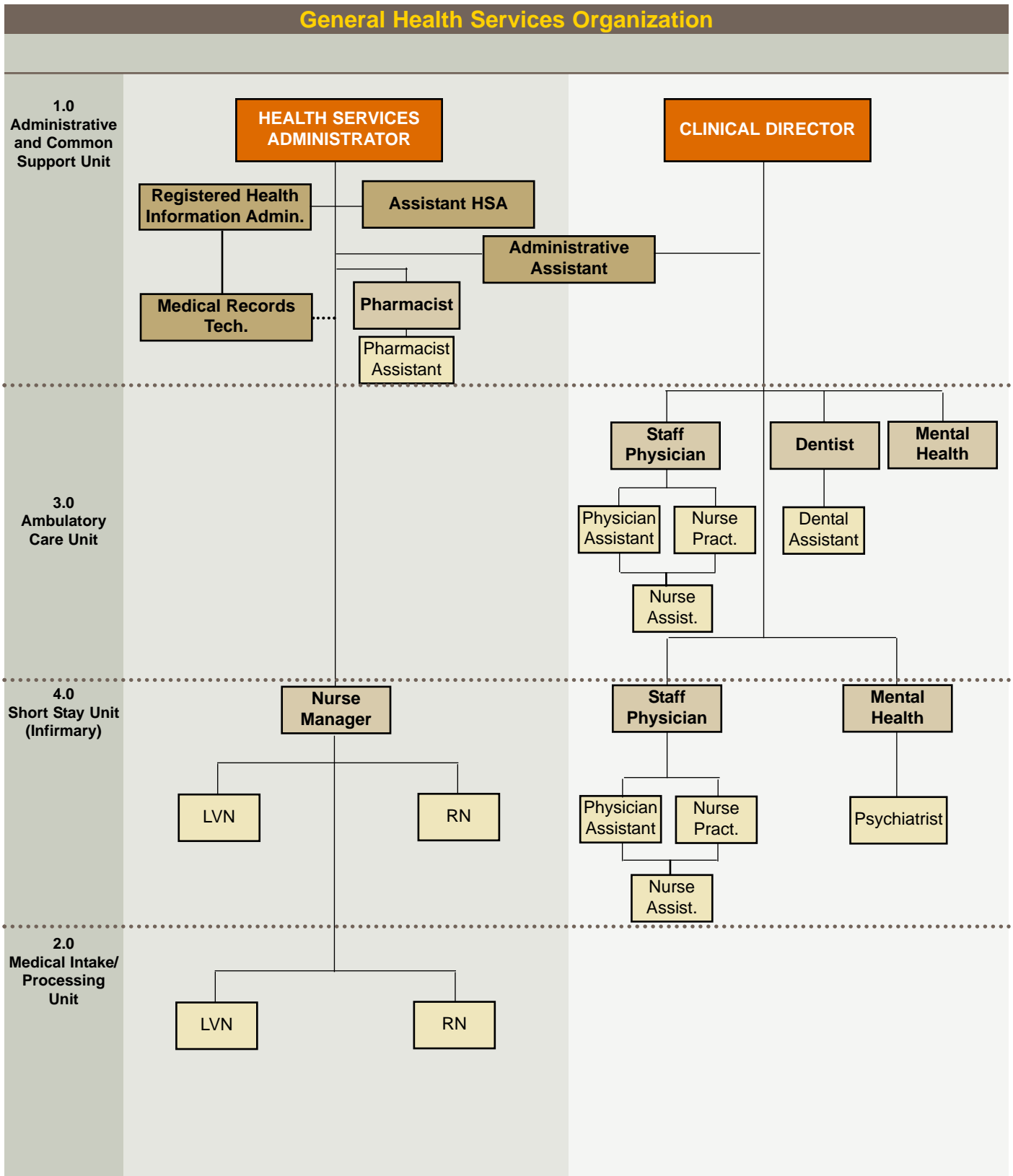



## HS Staff Requirements

### STAFF FORECASTS

The Health Services staff is organized into four functional components. The Staff Requirements matrix shown below illustrates the number of staff assigned to each component based on the number of detainees served at the SPC or CDF. The numbers illustrate a general rule and may vary based on the operational model used at the specific detention facility. In all cases the staffing must be verified by management for the specific hours and mix of clinical personnel.

### STAFF ASSIGNMENTS

The Health Services staff may serve several functional areas within the facility. The matrix below also illustrates to which HS component the staff member is assigned.

### STAFF DESCRIPTIONS

The chart on the following page contains a listing of all the staff positions by component. For each position, key roles/responsibilities are identified.

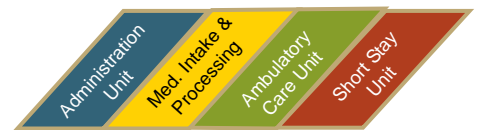

#### 1.0 ADMINISTRATIVE and COMMON SUPPORT UNIT

- a. Clinical Director (CD)
- b. Health Services Administrator (HSA)
- c. Assistant HSA
- d. Reg. Health Information Admin. (RHIA)
- e. Administrative Assistant
- f. Medical Records Technician (MRT)
- i. Pharmacist
- j. Pharmacist Technician

**Subtotal**

#### 2.0 MEDICAL INTAKE/PROCESSING UNIT

- a. No permanent assigned staff

#### 3.0 AMBULATORY CARE UNIT

- a. Staff Physician
- b. Nurse Practitioner/Physician's Assist.
- c. Registered Nurse
- d. Licensed Vocational Nurse
- e. Dentist
- f. Dental Assistant
- g. Mental Health Provider
- h. Psychiatrist

**Subtotal**

#### 4.0 SHORT STAY UNIT

- a. Nurse Manager (in SSU's Only)

**Subtotal**

P = Primary  
 S = Secondary

(b)(2)High

### HS Staff Descriptions by Component

#### 1.0 Administrative and Common Support Unit

- a. Clinical Director (CD)**
  - ✓ Serves as the on-site medical authority
  - ✓ Develops and coordinates all aspects of health care delivery at the SPC/CDF
- b. Health Services Administrator (HSA)**
  - ✓ Provides administrative oversight for clinic
- c. Assistant Health Services Administrator (AHSA)**
  - ✓ Provides an administrator trainee position
  - ✓ Provides primary support for HSA
  - ✓ Oversees of day-to-day operations of clinic
- d. Registered Health Information Administrator (RHIA)**
  - ✓ Professional management of health information and supervises Medical Records Technicians
- e. Administrative Assistant**
  - ✓ Provides administrative support to the HSA/CD

#### Common Support

- f. Medical Records Technician**
  - ✓ Performs clerical work in support of the care and treatment given to patients including maintaining patient medical records in a SPC/CDF
  - ✓ Sets patient appointments
  - ✓ Performs QC checks on medical records
  - ✓ Inputs data entry of lab reports
  - ✓ Consultation (from ancillary sources)
- g. Pharmacist**
  - ✓ Fills, labels, and dispenses prescription medications based on physician instructions
  - ✓ Manages inventory and orders/stocks pharmacy
  - ✓ Screens all medication orders for harmful interactions
  - ✓ Educates staff and detainees on medication use
- h. Pharmacist Technician**
  - ✓ Performs all duties related to preparation and dispensing of medical orders
  - ✓ Conducts inventory.

#### 2.0 Medical Intake and Processing Unit

*There are no permanent positions assigned to this unit. Temporary staff is available when needed from the Ambulatory Care Unit.*

- a. Registered Nurse/Licensed Vocational Nurse (part time)**
  - ✓ Conducts general health screening of intake detainees
  - ✓ Completes chest x-ray
  - ✓ Collects urine and blood sample - submits to Lab
  - ✓ Inputs data entry for medical record including lab reports
  - ✓ Clears detainee for processing to housing or requests further treatment or isolation

#### 3.0 Ambulatory Care Unit

- a. Staff Physician**
  - ✓ Provides direct medical, mental health care, and infirmary care (in-patient) to detainees including examination, diagnosis, and treatment
  - ✓ Emergency care of patients
- b. Nurse Practitioner/Physician's Assistant**
  - ✓ Provides direct care to detainees per guidelines
  - ✓ Performs medical histories and physical exams on detainees
  - ✓ Carries out all orders directed by physician
- c. Registered Nurse**
  - ✓ Provides direct primary nursing care to detainees in ambulatory care and Secured Housing Unit (SHU) settings
  - ✓ Takes medical histories and performs physical exams
  - ✓ Conducts triage and screening of detainees during sick call
  - ✓ Refers medical problems to physician
- d. Licensed Vocational Nurse**
  - ✓ Provides primary nursing care under the direction of an RN or physician or NP/PA
  - ✓ Performs screenings and digital TB chest screening
- e. Nursing Assistant**
  - ✓ Assists Nursing in providing basic nursing care
- f. Dentist**
  - ✓ Provides full range of direct dental services to ICE detainees located at detention facility
- g. Dental Assistant**
  - ✓ Provides assistance to the Dentist during exams and operations
- h. Mental Health Provider**
  - ✓ Provides limited range of mental health services to include screening, group counseling, and case management
- i. Psychiatrist**
  - ✓ Provides full range of psychiatric treatment of ICE detainees
  - ✓ Prescribes medication

#### 4.0 Short Stay Unit

- a. Nurse Manager**
  - ✓ Generally classified as a Registered Nurse
  - ✓ Oversees Short Stay Infirmary on a day to day basis.
  - ✓ Manages nurse staff and activities in Medical Intake and Processing, Common Support, Ambulatory Care, and Short Stay Units



### 3. FUNCTIONAL REQUIREMENTS

Health Services (HS)  
- *Inter-Departmental Adjacencies*

Health Services (HS)  
- *Intra-Departmental Adjacencies*



## Inter-Departmental Adjacencies

### SERVICE PROCESSING CENTER/CONTRACT DETENTION FACILITY

Service Processing Centers and Contract Detention Facilities (SPC/CDF) are detention facilities where DHS detains those who have entered the United States illegally or violated their immigration status. The purpose of this facility is to provide a place of detention for aliens who are taken into custody pending completion of their deportation case, released on their own recognizance, or pending release. The SPC's purpose is not for punishment, correction, or reformation, nor is the SPC used to confine direct street arrests. Federal and state prisoners may, however be held in SPC facilities.

DHS uses SPC's/CDF's to process and detain apprehended aliens who are illegally in the United States, regardless of whether the alien entered the United States illegally or entered legally but subsequently violated the terms of their visa. All detained individuals are transferred from other institutions or facilities to the SPC/CDF. Legal processing of detainees and determination of custody status is done prior to arrivals at the SPC/CDF.

### SECURITY ZONES

The secure zones of the facility correspond to the degree of detainee and public access required in the components. General zones within the facility include the following:

- Office Zone
- Court/Interface Zone
- Detainee Living Zone
- Service Zone
- Facility Support Zone

### HEALTH SERVICES LOCATION

The medical facility should be located within the primary secure perimeter in a secure zone restricted from general detainee access. The medical facility should have its own secure perimeter to restrict unauthorized individuals from having access to medications, instruments, and supplies stored in the clinic. The pharmacy must also have a secure perimeter to prevent unauthorized individuals from obtaining medications.

The medical facility should be located on the ground floor to minimize vertical movement during medical emergencies. Corridors and exit ways leading to the facility exterior must be large enough for ambulance equipment, wheelchairs, and gurneys.

### SPC/CDF Operational Components

#### **Office Components**

Normal office setting for administrative and public functions of the SPC/CDF. (They are located outside the secure perimeter.)

- Lobby
- Public Visitation
- Deportation
- SPC Administration
- Staff Services & Training

#### **Detainee Living Components**

Located inside the secure perimeter they are used by the detainees during their normal daily routine.

- Security Command
- Housing
- Commissary
- Recreation
- Law Library/Recreational Library
- Food Service Dining

#### **Court/Interface Components**

This component includes the EIOR Courts work area and courtroom space.

- EIOR Courts
- Detainee Visitation

#### **Service Components**

Service functions for the SPC/CDF detainee population. They are typically placed in a secure area because detainees require frequent access to them or are given work details in these components.

- Processing
- **Health Services**
- Food Preparation
- Laundry

#### **Facility Support Components**

These elements support the facility but do not provide direct services to the detainees and may be located outside the secure perimeter.

- Warehouse and Supply
- Maintenance
- Central Utility Plant

**SPC/CDF Organizational Model**

Site Perimeter (Rural Settings Only)

(b)(2)High

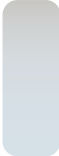



## Intra-Departmental Adjacencies

### HEALTH SERVICES

The Service Processing Center (SPC)/Contract Detention Facility (CDF) is responsible for the health and welfare of individuals in its custody. This responsibility mandates the provision of medical staff to provide care to detainees at the SPC in accordance with the Immigration and Naturalization Service Health Care Program (INS HCP) Policy Manual and in compliance with accreditation standards.

A medical clinic is located within the SPC/CDF to provide the necessary health care and treatment. Non-elective medical care not available at the SPC/CDF, but deemed necessary by the health authority, will be referred to outside sources. The HS unit is organized into four functional components described to the right and illustrated on the following page.

### HEALTH SERVICES LOCATION

The Health Services Unit must be located inside the secure perimeter and have a close adjacency to the Segregation Unit and Intake/Processing Unit. The unit will have secure access to the Vehicle Sally-Port for emergency transport of ill detainees to medical services outside the SPC/CDF. Access to a nurse triage room adjacent to, or within, the housing units for sick call, medication administration and other medical activities is required to minimize detainee movement.

Detainees are admitted to the Health Services area for health related issues either from initial intake screening, when an incident occurs with an existing detainee through sick call, or due to accident or trauma.

### HEALTH SERVICES ORGANIZATION

The conceptual diagram on the following page illustrates the critical intradepartmental adjacencies for Health Services. Access to the facility occurs in two locations. One is from the general detainee intake and processing area, the other is from detainee housing. Detainees being processed for initial admission to the detention facility will enter Medical Intake for health screening. During this process the detainee is returned to a holding cell in Intake and Processing. The second access is for resident detainees who are being examined or treated for illnesses or health related incidents. They are brought into the facility from housing and are placed in holding cells where they are scheduled for examination and treatment (Ambulatory Care or Short Stay) by the Nurse Coordinator. Adjacent to both

Ambulatory Care and the Short Stay Units, the Administrative and Common Support Unit is a secure area segregated from detainee movement yet directly accessible from Ambulatory Care. A central control vestibule is located between the four functional units. Located in this vestibule is a Security Guard and Nurse Coordinator who monitor and control detainee movement.

#### Functional Components

##### **1.0 Administrative and Common Support Unit**

The Administrative and Common Support Unit houses the management and staff offices, records storage, medical storage, pharmacy and support space. It should have direct access to the Ambulatory Care Unit and contain a separate secure entrance for HS staff.

##### **2.0 Medical Intake and Processing Unit**

General Intake and Processing is a function administered by U.S. Immigration and Customs Enforcement (ICE) for detainees being admitted to the SPC/CDF. Part of processing a detainee involves screening the detainees for health related issues. These procedures are conducted in the Medical Intake Unit of Health Services. Included is detection of communicable diseases and any physical conditions requiring medical attention. Screening includes x-raying intake detainees. Detainees suspected of having tuberculosis or other highly contagious diseases are sent directly to holding cells and transported to a hospital for isolation and treatment. Detainees with other communicable diseases are sent to the Isolation Medical cells within the Short Stay Unit (Infirmary) for processing. Due to the need for health screening to take place during the general intake process, this function needs to be in close proximity to the Health Service area within the SPC/CDF.

##### **3.0 Ambulatory Care Unit**

The Ambulatory Care Unit is the center for detainee sick call and administration of outpatient health care. This unit is essentially a clinic containing nurse triage, medical and dental exam rooms, laboratories, and pharmacy. One entrance to the Ambulatory Care Unit is for detainees entering from housing/triage and the other entry is from detainee general intake/processing. The Ambulatory Care Unit is connected directly to the Short Stay Unit (Infirmary) and Administrative and Common Support Unit.

##### **4.0 Short Stay Unit (Infirmary)**

The Short Stay Unit houses the primary functions for the treatment of detainees that need inpatient services. The unit includes a nurse station, clean and soiled utilities, and individual patient rooms complete with showers and toilets. The Short Stay Unit contains patient Isolation Medical Cells.



Health Services Organizational Model



(b)(2)High



## 4. SPACE REQUIREMENTS

Health Services (HS)  
- *Space Requirements Summary*



## Space Requirements Summary

### SPACE FORECAST MATRIX

The space requirement for Health Services (HS) were developed through interviews with HS/ICE staff representatives. They were developed as a tool for delineation of space needs based on the number of detainees housed within a SPC/CDF.

Size of facilities are determined by the number of staff and detainees served as well as specific functional requirements of the SPC/CDF. There may, however, be variations depending on operations and specific types of clinical staff available.

The Space Requirement's Matrix on the following page is organized by individual space description. The space descriptions and corresponding area (net square footage) are organized vertically (by row) into the four functional components housed within a typical HS unit. They are: 1.0-Administrative Unit, 2.0-Medical Intake Unit, 3.0-Ambulatory Care Unit, and 4.0-Short Stay Unit (Infirmary).

The matrix is organized horizontally into separate columns representing four ranges of detainee population. These population ranges include: less than 200 detainees, 200-450 detainees, 450-900 detainees, and 900-2000 detainees. The detainee ranges were determined to best represent the capacity range for existing and planned detainee populations and the relative operations, services provided and associated functional space. The matrix on the following page is comprised of the following components:

**Item Number:** *Sequential numbering system related to the unit type*

**HS Components & Spaces:** *Room names*

**Current Space Standards:** *The Space Standards are square footage areas for specific functional space. They are based on the National Commission on Correctional Health Care (NCCHC) facility standards .*

**Capacity:** *Number of persons (staff and detainees) in a given space*

**Units:** *Number of spaces*

**Unit NSF:** *Net Square Footage for a given space*

**Total NSF:** *Total Net Square Footage = Number of units (spaces) x Unit Net Square Footage*

### SPACE CALCULATIONS

The total Net Square Footage is the sum of all net areas of the spaces listed. This number is multiplied by a Net Usable factor (1.55) (an industry factor based on facility type and utilization efficiency) to determine Usable Square Footage. The Net Usable Area is multiplied by a usable Gross factor (1.05) to determine the Total Gross Square Foot for the HS Space Requirement.

#### **Net Square Footage (NSF)**

Total clear floor area within a given room, excluding walls, corridors, mechanical equipment rooms, shafts, stairs, and chases.

#### **Usable Square Footage (USF)**

Total floor area including mechanical and electrical equipment rooms, general circulation spaces including corridors, stairs, and elevator shafts.

#### **Gross Square Footage (GSF)**

Total of building area measured from outside face of exterior walls.



### Space Requirements Matrix

Item#	HS COMPONENTS AND SPACES	SPACE FORECAST MODELS BY NUMBER OF DETAINEE BEDS																COMMENTS	
		Current Space Standard	Less than 200 Detainee Beds				200-450 Detainee Beds				450-900 Detainee Beds				900-2000 Detainee Beds				
			Capacity	Units	Unit NSF	Total NSF	Capacity	Units	Unit NSF	Total NSF	Capacity	Units	Unit NSF	Total NSF	Capacity	Units	Unit NSF		Total NSF
<b>1.0 ADMINISTRATION and COMMON SUPPORT UNIT</b>																			Registered Health Info. Administrator Private Office w/ window to MRT work area
1.1	Medical Records Administrator Office																		Private Office
1.2	Health Services Administrator (HSA) Office																		Private Office
1.3	Clinical Director (CD) Office																		Private Office
1.4	Assistant HSA Office																		Private Office
1.5	Administrative Ass't Workstation																		Workstation
1.6	Work Area																		Open area for document scanner, cabinets, etc.
1.7	Multi Purpose Room																		Lunchroom, cabinets; sink; bookcases; reference, conference, computers
<b>Common Support Spaces</b>																			
1.8	Medical Records Technician (MRT) Workstation																		Workstation w/in medical records room
1.9	Medical Records Room																		Directly adjacent to MRT's; going paperless
1.10	LAN Room																		
1.11	Pharmacy																		
1.12	Pharmacy Supply Room																		Pill cart storage area
1.13	Ambulatory Medical Supply Room																		W/ locked cabinet
1.14	Medical Laboratory																		
1.15	Janitor Closet																		
1.16	Staff Toilet/Locker Room																		1 Staff toilet in 200 detainee facility
1.17	Biohazard Waste / Storage Room																		Constant exhaust, seamless floor, spill containment
<b>Subtotal Administration and Common Support Unit</b>																			
<b>2.0 MEDICAL INTAKE and PROCESSING UNIT</b>																			
2.1	Intake Screening Room																		
2.2	Teleradiology Room (X-Ray)																		
<b>Subtotal Intake/Processing Unit</b>																			
<b>3.0 AMBULATORY CARE UNIT</b>																			
3.1	Exam Room																		
3.3	Detainee Holding Area (Waiting)																		Provide 1 toilet behind partial height privacy partition in each holding cell
3.4	Detainee Toilet																		
3.5	Dental Office																		Part of "Dental Clinic" - group dental components
3.6	Dental Exam Room (Operatory)																		Part of "Dental Clinic"
3.7	Dental Lab																		Part of "Dental Clinic" - group dental components
3.8	Dental Mechanical Room																		Part of "Dental Clinic" - group dental components
3.9	Mental Health Room																		Psychiatric, psychological or social worker (CSW)
3.10	Nurse Coordinator Room																		BP, wt, ht etc.
3.11	Urgent Care Room																		
3.12	Telemedicine Machine Room																		
3.13	Guard Station																		
<b>Subtotal Ambulatory Care Unit</b>																			
<b>4.0 SHORT STAY UNIT (Infirmiry)</b>																			
4.1	4 bed ward - See Comments																		Used in medical/mental referral centers replaced by universal ward room
4.2	2 bed ward - See Comments																		Used in medical/mental referral centers replaced by universal ward room
4.3	Single bed room - See Comments																		Used in medical/mental referral centers replaced by universal ward room
4.4	Mental Health Ward																		Requirement dependant on ICE HQ
4.5	Suicide Observation Room																		May double as a Time-out Room
4.6	Safety Cell																		rubber room
4.7	Respiratory Isolation Room w/ Vestibule																		Universal ward room - Negative pressure; bed against wall; w/ combo + shower
4.8	Nurse Manager's Office																		
4.9	Nurses Station w/ Security Officer																		
4.10	Detainee Shower/Tub Room																		w/ roll-in shower & tub
4.11	Medication Prep Room																		
4.12	Kitchenette																		w/ nurses station
4.13	Physical Therapy Room																		Requirement Dependent on ICE HQ
4.14	Infirmiry Supply Room																		wheel chairs, crutches etc. + med. Supplies
4.15	Soiled Linen Room																		w/ slop sink
4.16	Clean Linen Room																		
4.17	Janitor's Closet																		
4.18	Staff Toilet																		
4.19	Day Room																		
<b>Subtotal Short Stay Unit (Infirmiry)</b>																			
<b>Total NSF</b>																			
Net Usable Factor																			
Total Usable Area (USF)= NSF x Net Usable Factor																			
Usable Gross Factor																			
<b>Total Gross Area=USF x Usable Gross Factor</b>																			

(b)(2) High



## 5. DEPARTMENTAL REQUIREMENTS

- 1.0 Administrative and Common Support Unit
- 2.0 Medical Intake/Processing Unit
- 3.0 Ambulatory Care Unit
- 4.0 Short Stay Unit (Infirmary)



## 1.0 ADMINISTRATIVE and COMMON SUPPORT UNIT



## Administrative and Common Support Unit - Functional Adjacencies

### 1.0 ADMINISTRATIVE AND COMMON SUPPORT UNIT

The Administrative and Common Support Unit contains the Administrative Offices, Medical Records Storage and Common Support Space for Public Health Services. Common Support areas include those areas that are shared between Administrative, Ambulatory Care and Short Stay functions and are Central to all three. The Administrative and Common Support Unit has direct access to the Ambulatory Care Unit. The Refer to the diagram on page 5.5.

#### Administrative and Common Support Unit

##### *Critical Issues*

- ✓ Administrative Unit should be segregated from direct detainee access
- ✓ Administrative Unit should have direct access to the Ambulatory Care Unit.

##### *Special Requirements*

The Administrative and Common Support Unit should be contained in a secured area separated from detainee flow. It is desirable for offices to be located on exterior walls for natural daylight. It should be immediately accessible from the main entry vestibule and contain centralized access to support functions used by both Ambulatory Care and Short Stay Units. Several functions are centrally located common support for both Ambulatory Care and Short Stay Units. These functions include Medical Records, Medical Supply Medical Laboratory and Pharmacy. The Pharmacy and Medical Records should contain secure, pass-through windows accessed from the main vestibule outside of the secure Administrative and Common Support Unit corridor. Direct access from Administrative and Common Support shall be provided to Ambulatory Care and where possible into the Short Stay Unit. All doors accessing the Administrative and Common Support Unit must be secured. The walls separating the Administrative and Common Support Unit from other functions in the facility must be secure construction. The Pharmacy, Pharmacy Storage and Medical Supply rooms must be of secure construction.

##### *Space Requirements*

#### **1.0 ADMINISTRATIVE UNIT**

- 1.1 Medical Records Administrator Office
- 1.2 Health Services Administrator (HSA) Office
- 1.3 Clinical Director (CD) Office
- 1.4 Assistant HSA Office
- 1.5 Administrative Assistant Workstation
- 1.6 Work Area
- 1.7 Multi Purpose Room

#### **Common Support Area**

- 1.8 Medical Records Technician (MRT) Workstation
- 1.9 Medical Records Room
- 1.10 LAN Room
- 1.11 Pharmacy
- 1.12 Pharmacy Supply Room
- 1.13 Ambulatory Medical Supply Room
- 1.14 Medical Laboratory
- 1.15 Janitor Closet
- 1.16 Staff Toilet/Locker Room
- 1.17 Biohazard Waste/Storage Room

2.0 ADMINISTRATIVE AND COMMON SUPPORT UNIT ORGANIZATIONAL MODEL

(b)(2)High





## Administrative and Common Support Unit - Concepts

### INTRODUCTION

In order to delineate Administrative Common Support Unit operational imperatives, the following diagrams describe and diagram the relationships between HS staff, detainees and specific processes.

#### 1. Centralized Secure Functions

Three functional areas have been identified as needing special secure construction. These are the Pharmacy and Pharmacy Storage, Medical Supply Storage, and the Administration area. Since all three of these areas serve both Ambulatory Care and the Short Stay Infirmary, they should be located central to these functions with secure entry away from detainee circulation corridors. The diagram illustrates how these functions may be collocated.

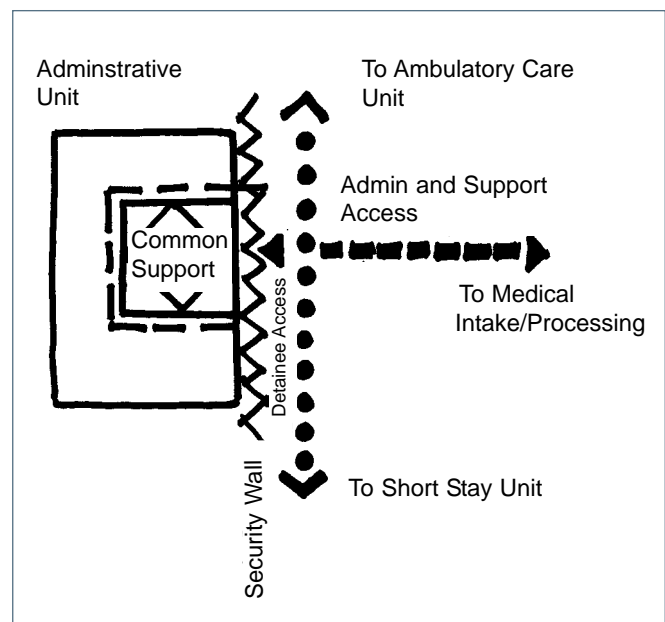

#### 2. Segregated/Isolated Flow between Detainee and Staff

The concept of isolation and segregation of flow illustrates how detainee and staff circulation patterns may be organized to minimize conflict and maintain a hierarchy in access and help to further define the location of secured spaces.

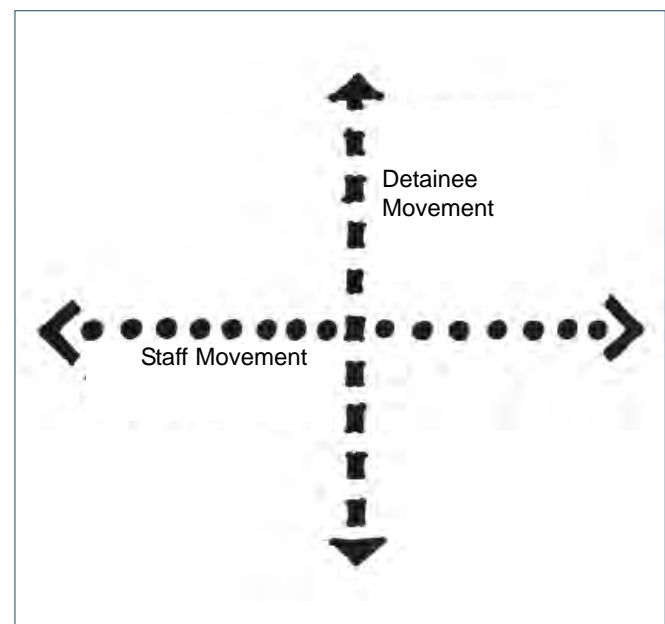



## Administrative and Common Support Unit - Space Materials and Room Data Sheets

### ROOM DATA SHEETS

The following provides specific data regarding the rooms located within the Administrative and Common Support Unit of Health Services. Each room data sheet includes the following information:

- ✓ Functional Description
- ✓ Representative Photograph
- ✓ Room Floor Plan
- ✓ Isometric
- ✓ Space Materials Matrix
- ✓ Room Equipment Matrix



### SYMBOL LEGEND

- BI** - Built-in
- F** - Furniture
- ME** - Medical Equipment



## Administrative and Common Support Unit - Room Data Sheet

### 1.1 MEDICAL RECORDS ADMINISTRATIVE OFFICE

The Medical Records Administrative Office is a private office for the Medical Records Administrator. The function of the Medical Records Administrator is to manage the recording and storage of detainee medical records. It is important for this space to be near the Medical Records Room. This office should have visual access to the medical technician workstations.



Photo

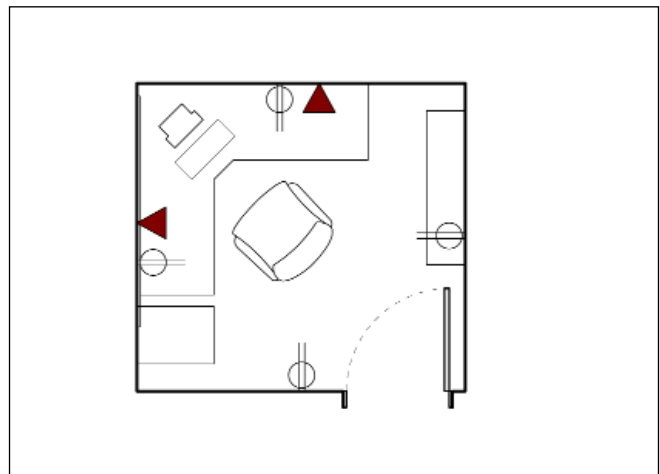

Floor Plan (100 nsf)

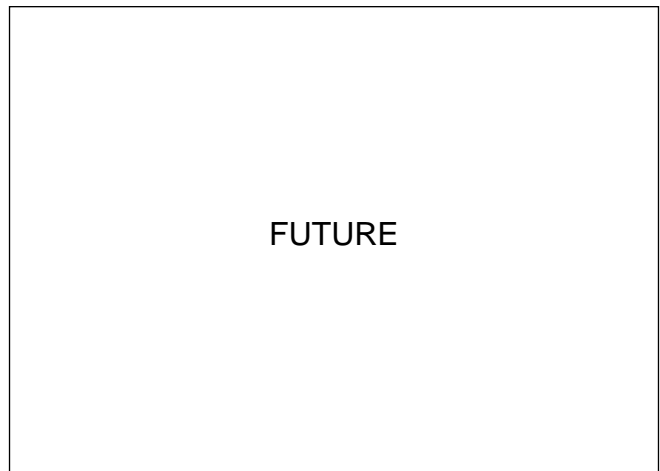

Isometric





## Administrative and Common Support Unit - Room Data Sheet

### 1.2 HEALTH SERVICES ADMINISTRATOR (HSA) OFFICE

The office of Health Services Administrator (HSA) is a private office located within the Administrative Unit. The office should provide seating for meeting with one to three visitors.

#### Administrative activities include :

- ✓ Planning, budget management, travel
- ✓ Answer correspondence: written, electronic, phone and fax
- ✓ Employee counseling
- ✓ Storage of files: projects, employees' health and leave records, etc...
- ✓ Assists in the maintenance of facility accreditation (ACA, NCCHC, JCAHO)
- ✓ Coordinates implementation of policy and procedures.
- ✓ Mentors junior officers



Photo

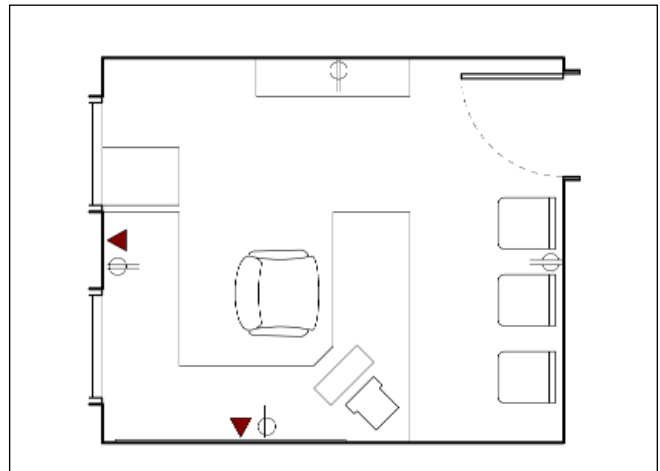

Floor Plan (120 nsf)

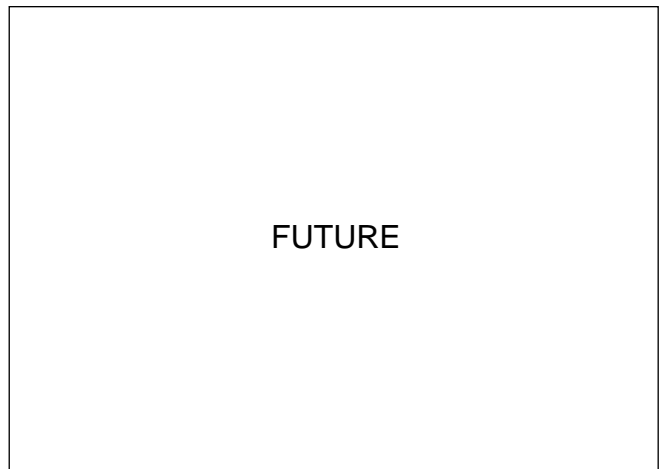

Isometric





## Administrative and Common Support Unit - Room Data Sheet

### 1.3 CLINICAL DIRECTOR (CD) OFFICE

The office of the Clinical Director is similar to the HSA office. The responsibility of the Clinical Director is oversight of Medical, Dental and Mental Health services. In some cases this office is located in Ambulatory Care Unit to be close to these clinical functions.

#### Clinical Director functions include the following:

- ✓ Administrative activities like planning.
- ✓ Answer correspondence: written, electronic, phone and fax.
- ✓ Coordinates daily clinical operations, consults\ and mentor clinical staff.
- ✓ Peer review on charts daily
- ✓ Directs patient care.
- ✓ Evaluate of charts for compliance with local operational policies/procedures.
- ✓ Assists in the maintenance of facility accreditation.
- ✓ Reviews medical competency of staff and provide in-services.
- ✓ Assumes medical care of difficult medical cases.
- ✓ Mentors junior officers.
- ✓ Assumes medical care of difficult medical cases.
- ✓ Mentors junior officers.

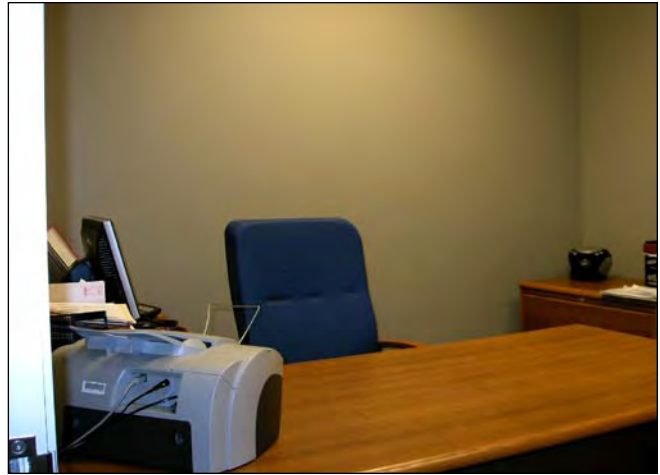

Photo

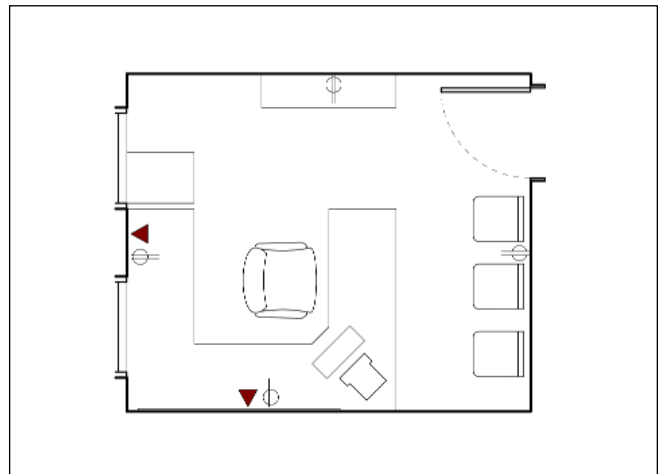

Floor Plan (120 nsf)

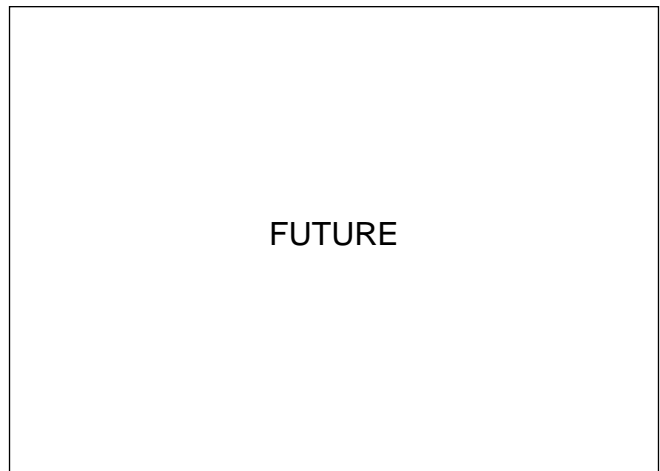

Isometric







## Administrative and Common Support Unit - Room Data Sheet

### 1.4 ASSISTANT HSA OFFICE

The Assistant HSA position is the primary support of the HSA and should be located in a private office near HSA office.

**Assistant HSA functions include the following:**

- ✓ Performs administrative activities
- ✓ Answers correspondence: written, electronic, phone and fax
- ✓ File maintenance and retrieval, archiving documents, records and correspondence. Maintenance of credential files
- ✓ Assists with staffing issues and or day to day operation of the clinic.
- ✓ Assists in the management of the operating budget
- ✓ Assists in the maintenance of facility accreditation

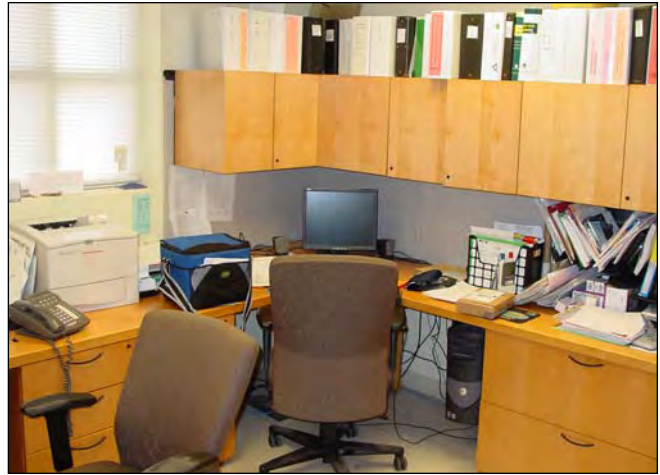

Photo

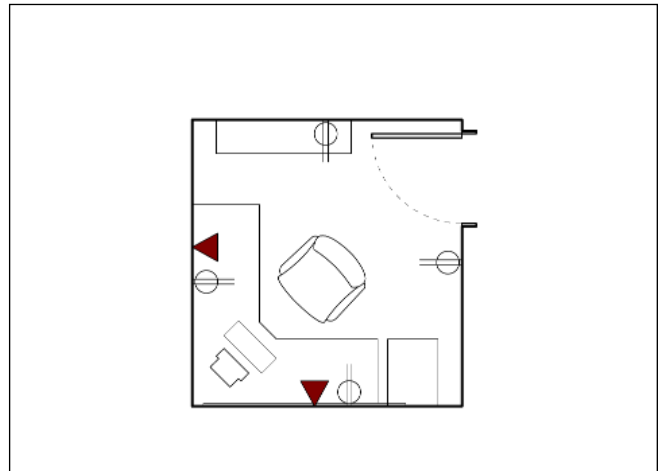

Floor Plan (100 nsf)

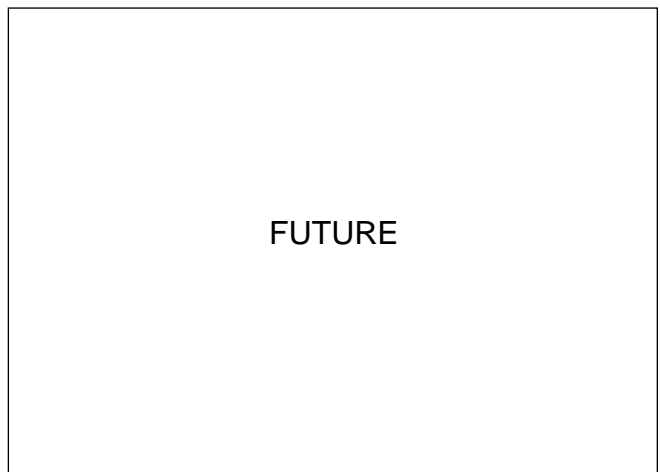

Isometric





## Administrative and Common Support Unit - Room Data Sheet

### 1.5 ADMINISTRATIVE ASSISTANT WORKSTATION

The Administrative Assistant provides direct support for HSA and Clinical Director. This workstation should be located with direct access to both the HSA and Assistant HSA offices.

#### Administrative activities include :

- ✓ Provides clerical support to HSA and CD
- ✓ Answer correspondence: written, electronic, phone and fax
- ✓ Completes filing and storage



Photo

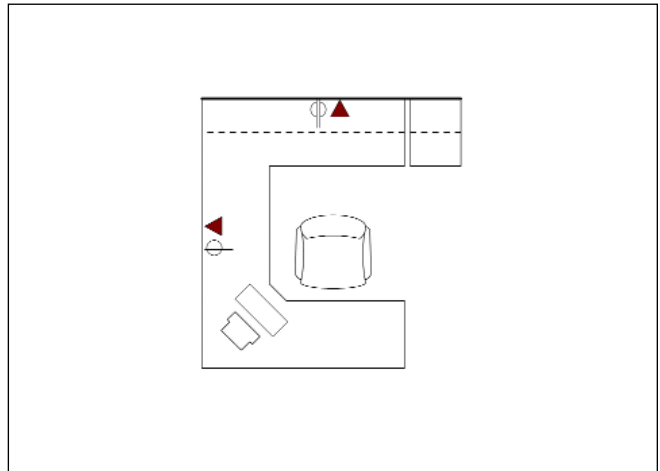

Floor Plan (64 nsf)

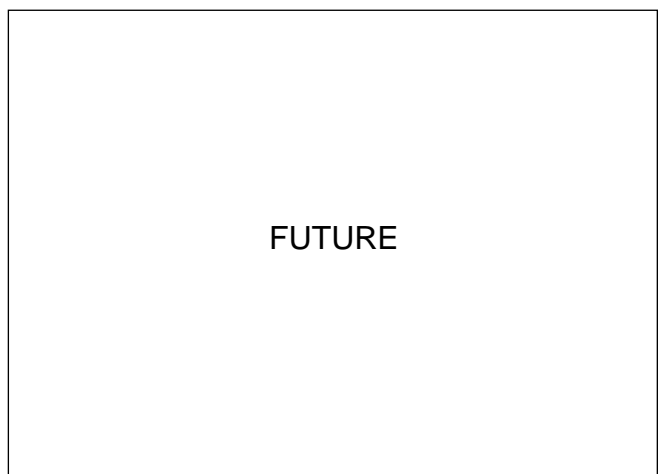

Isometric





## Administrative and Common Support Unit - Room Data Sheet

### 1.6 WORK AREA

The Work Area is essentially an open work station with document scanner, workstation and cabinets for use by administrative staff. It should be located close to Medical Records and Medical Records Technicians.

**The Work Area includes the following functions:**

- ✓ Location of fax, shredder, cabinets.
- ✓ Storage of stationary supplies.



Photo

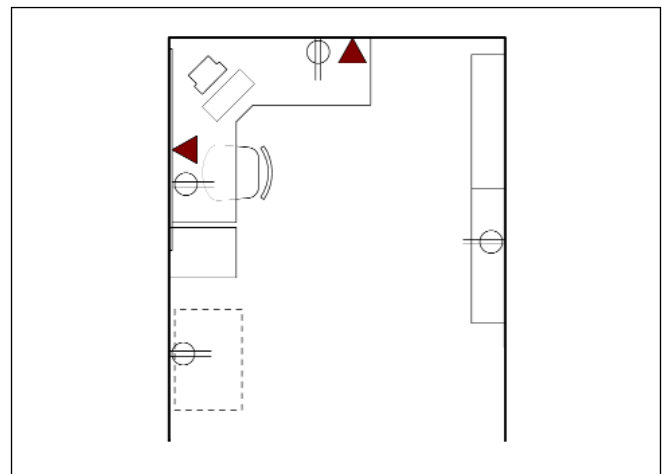

Floor Plan (120 nsf)

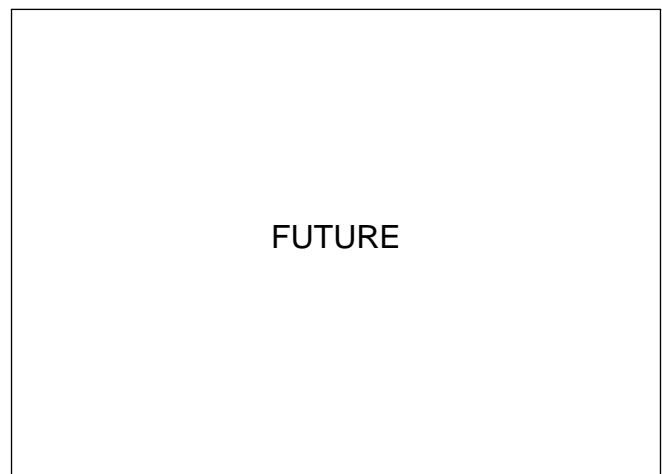

Isometric





## Administrative and Common Support Unit - Room Data Sheet

### 1.7 MULTI PURPOSE ROOM

The Multi-Purpose Room is a conference and training space located in the Administrative Unit. It contains a kitchenette with sink, reference materials and bookshelves. This room may be used as a break/lunch room.

The Multi-Purpose Room includes the following functions:

- ✓ General staff meeting
- ✓ Staff Training
- ✓ Food preparation
- ✓ Break/Lunch



Photo

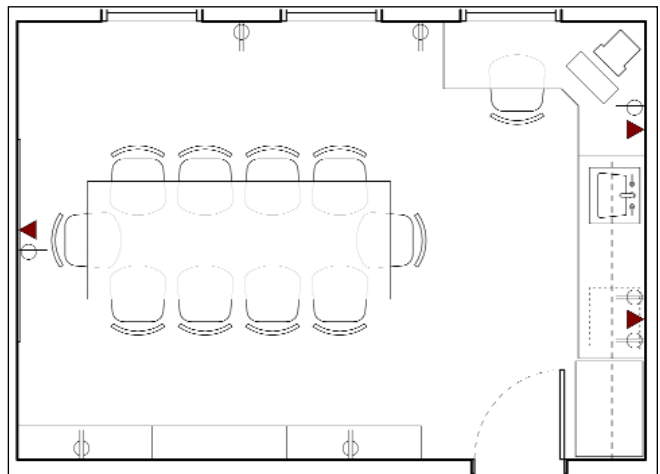

Floor Plan (150 - 400 nsf)

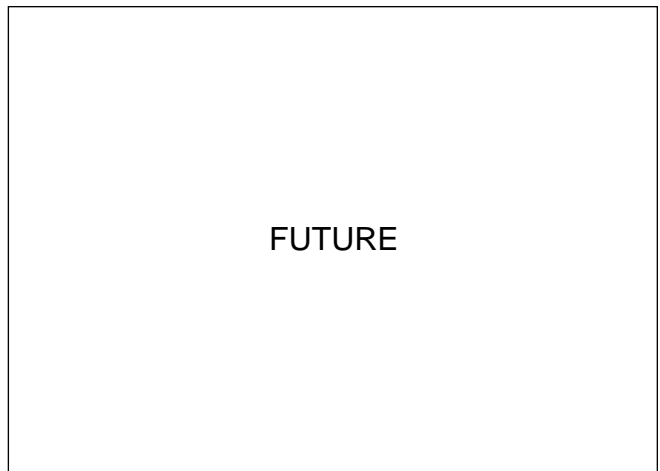

Isometric







## Administrative and Common Support Unit - Room Data Sheet

### 1.8 MEDICAL RECORDS TECHNICIAN (MRT) WORKSTATION

The Medical Records Technicians occupy workstations located within the Medical Records Room or directly outside the door.

#### MRT include the following functions:

- ✓ Clerical work: print labels, make copies, answer the phone
- ✓ Enters all new arrivals into the system
- ✓ Schedules appointments
- ✓ Compiles charts
- ✓ Reviews charts as they come back to medical records for signatures, completed notes and labels placed on all forms
- ✓ Files completed charts
- ✓ Pulls charts for Sick Call and Physical exams
- ✓ Pulls charts upon request for peer review or studies
- ✓ Compiles charts for transfer
- ✓ Collects and file routing slips
- ✓ Conducts quarterly chart audits for completeness of medical records
- ✓ Pulls inactive charts and file
- ✓ Faxes Medical Hold list to detention and deportation staff daily
- ✓ Conducts other clinics to request information, reports, release of information for continuation of care
- ✓ Conducts other clinics to request information, reports, release of information for continuation of care



Photo

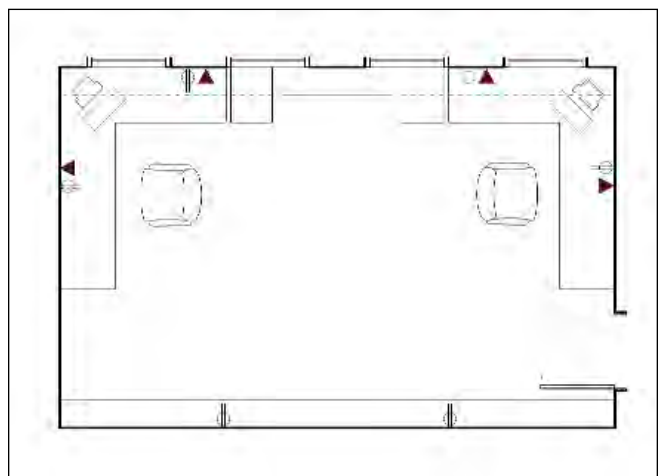

Floor Plan (64 - 256 nsf)

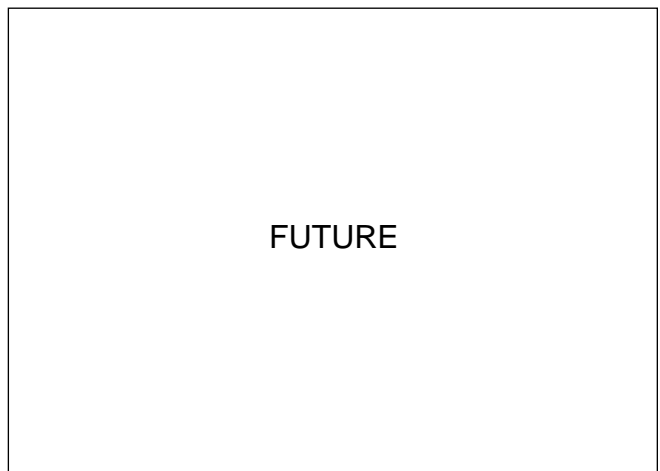

Isometric





## Administrative and Common Support Unit - Room Data Sheet

### 1.9 MEDICAL RECORDS ROOM

The Medical Records Room is a secure and fire rated room with direct access to MRT workstations. One consideration in the planning of this room is the need for technology in the development of electronic documentation. In the new model technology may reduce the need for a Medical Records Room.

#### Medical Records includes the following functions:

- ✓ Enters all new arrivals into the system.
- ✓ Makes copies of forms needed for the charts.
- ✓ Storage of patient's charts, inactive and active charts.
- ✓ Storage all routing slips.
- ✓ Schedules outside referrals, release of information, PI reports
- ✓ Refers medical holds, supply orders, schedule sick-call appointments.
- ✓ Conducts medical record review, filing and data entry.
- ✓ Archiving records, medical record storage.
- ✓ In some locations is used for: Nursing stations, lunch room, Clinical Directors work station.



Photo

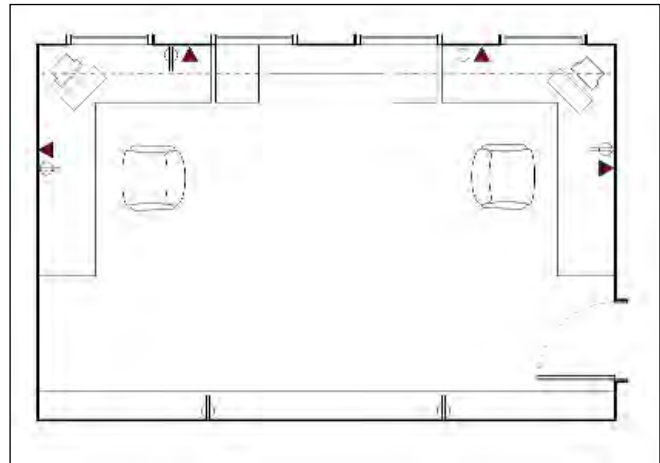

Floor Plan (100 nsf)

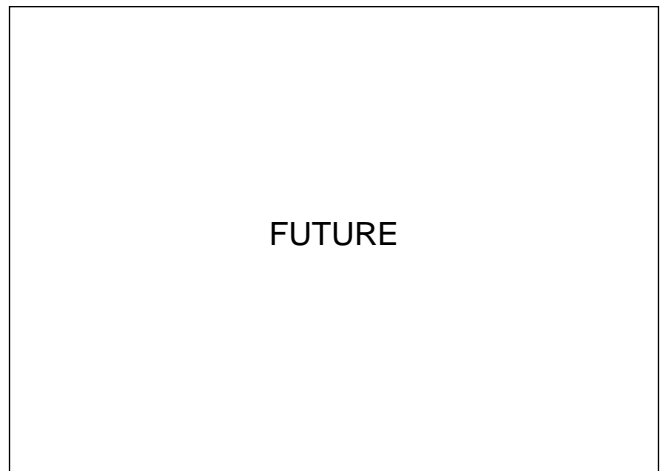

Isometric





## Administrative and Common Support Unit - Room Data Sheet

### 1.10 LAN ROOM

The Local Area Network (LAN) Room is a secure space for computer servers that is located within the acceptable range for length of runs of fiber-optic cabling.

**The LAN Room includes the following functions:**

- ✓ Contains the server for DIHS network systems
- ✓ Used to store server supplies and electronic supplies



Photo

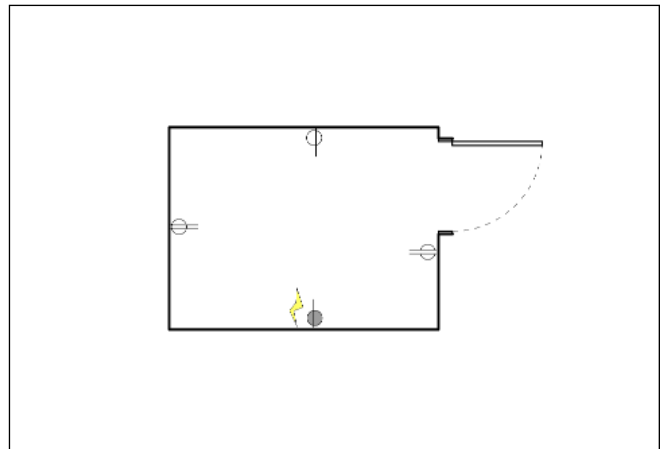

Floor Plan (48 nsf)

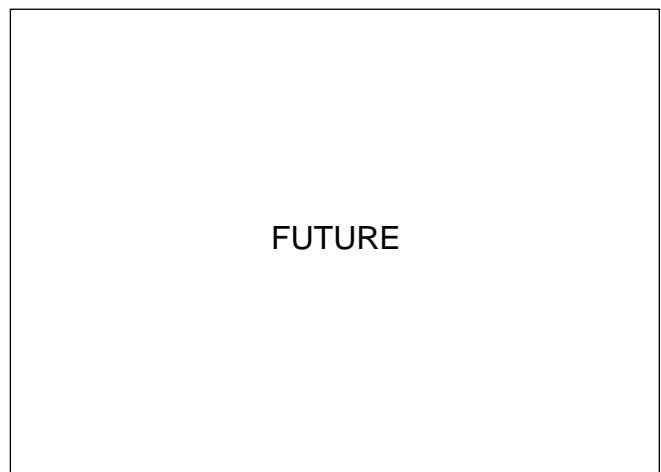

Isometric





## Administrative and Common Support Unit - Room Data Sheet

### 1.11 PHARMACY

The Pharmacy is a secure room centrally located to Ambulatory Care and Short Stay Units within the Common Support area. The primary purpose of the Pharmacy is for the control and dispensing of medications to HS staff. A secure window is located with access to the main corridor for dispensing pharmaceuticals.

#### The following are functional uses of the Pharmacy:

- ✓ Performs administrative duties
- ✓ Order, fill store pharmaceutical supplies
- ✓ Maintains pharmacy inventory
- ✓ Storage of controlled medications and maintain control logs
- ✓ Storage of pharmaceutical supplies in refrigerator
- ✓ Refills night cart for expired drugs
- ✓ Maintains sharps inventory. Maintain control logs
- ✓ Prints and distributes medication renewal list.
- ✓ Files Rx for inpatient/ambulatory care
- ✓ In some facilities with limited office space is used as the pharmacist's office
- ✓ Should have a private area for patient counseling
- ✓ Handsink with hot and cold water
- ✓ Pass through window for dispensing medicines



Photo

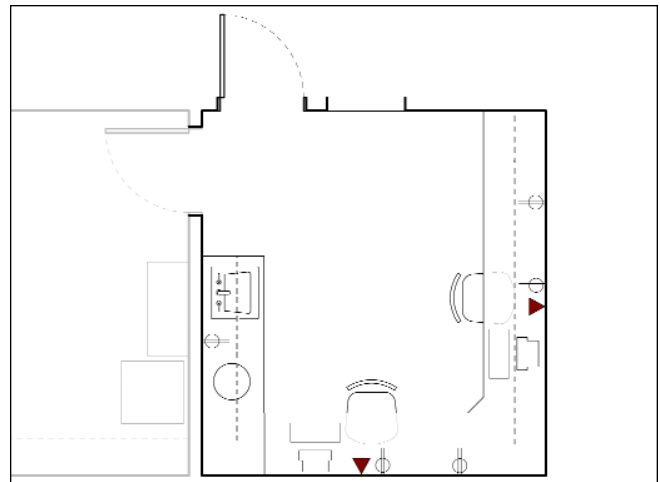

Floor Plan (150 - 250 nsf)

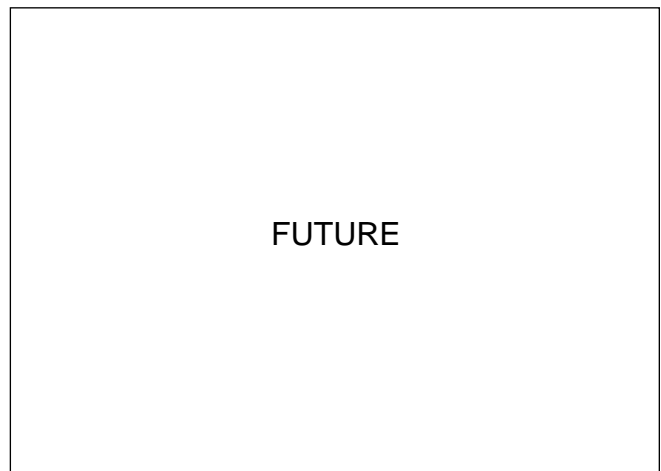

Isometric







## Administrative and Common Support Unit - Room Data Sheet

### 1.12 PHARMACY SUPPLY ROOM

The Pharmacy Supply Room is a secure room with direct access to the Pharmacy.

**The following are functional uses of the Pharmacy Supply Area:**

- ✓ Storage of bulk pharmacy items like: cases of Ensure, Maalox, various OTCs, prescriptions vials, bottles, lids, etc.
- ✓ Storage of non-formulary medications and medications rarely used.
- ✓ Has a cart for restocking the night cabinet and another cart for use when delivering supplies to the various clinic areas.
- ✓ This room contains all the medication supplies, syringes, vials, etc.
- ✓ Storage of controlled medications.



Photo

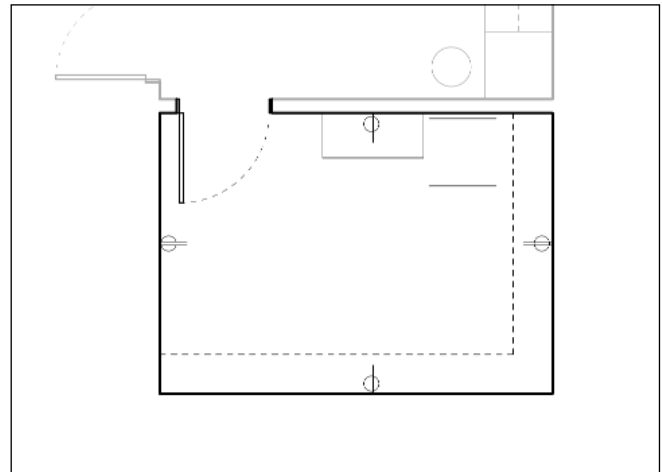

Floor Plan (100 - 200 nsf)

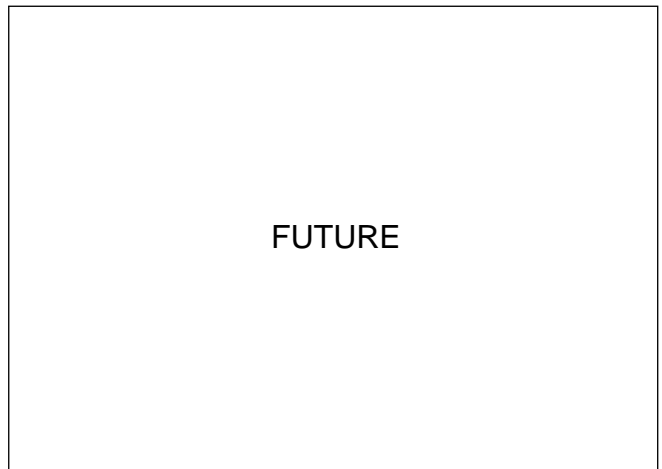

Isometric





## Administrative and Common Support Unit - Room Data Sheet

### 1.13 AMBULATORY MEDICAL SUPPLY ROOM

The Ambulatory Medical Supply Room is for storage of medical equipment necessary for the treatment of detainees. Examples of items to be stored in this room are - crutches, splints and wheelchairs.



Photo

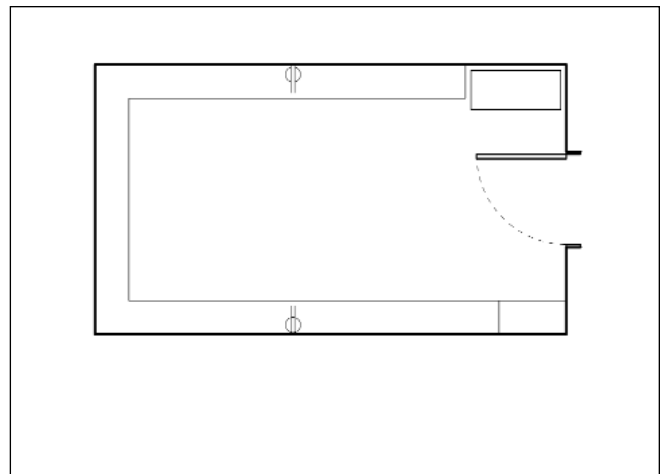

Floor Plan (100 - 120 nsf)

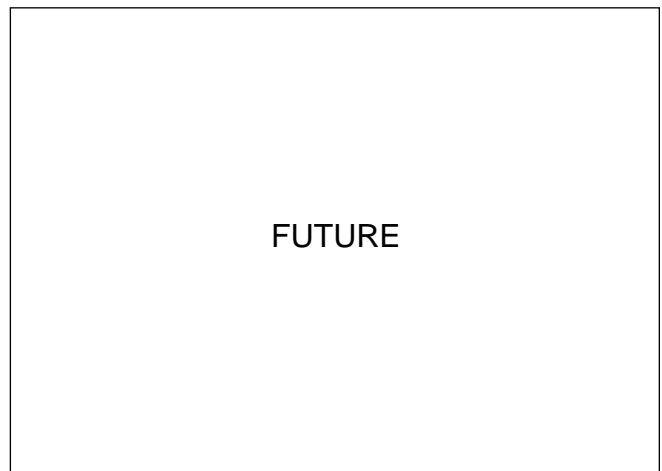

Isometric





## Administrative and Common Support Unit - Room Data Sheet

### 1.14 MEDICAL LABORATORY

The Medical laboratory is used for testing and analysis of bodily fluids and cultures in health diagnosis. It contains freezer storage and technical equipment necessary for the completion of these analyzes. The Medical laboratory contains upper and lower storage cabinets with laboratory stone counters and sinks.

#### Following are functional uses of the Medical Laboratory:

- ✓ Collection of laboratory specimens: blood, stool, urine
- ✓ Storage of laboratory supplies
- ✓ Hand washing and eye washing stations
- ✓ Refrigeration equipment for specimen preservation - monitors temperatures twice a day
- ✓ Sharp containers and store Bio-hazardous supplies
- ✓ Provides storage space for sharps inventory
- ✓ Used for teaching detainees to perform self-care (blood sugar checks, administering insulin, and drawing up medications)



Photo

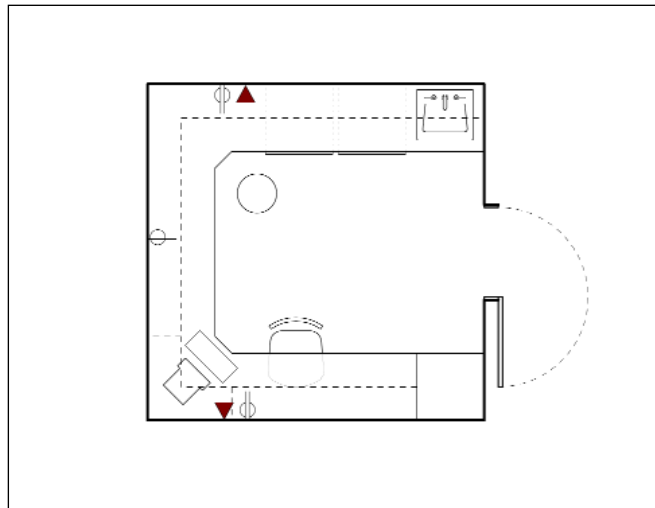

Floor Plan (100 nsf)

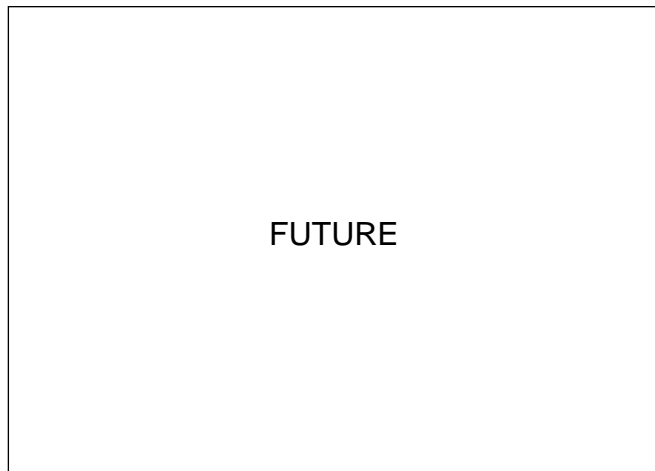

Isometric

**1.14 SPACE MATERIAL MATRIX**

<i>Walls</i>	<i>Floors</i>	<i>Ceiling</i>	<i>Doors</i>	<i>Hardware</i>	<i>Glazing</i>
Secure 1	VCT	Acoustic Tile	Custom H.M.	Mechanical Detention	

<i>Plumbing</i>	<i>HVAC</i>	<i>Lighting</i>	<i>Power</i>	<i>Elec./Security</i>	<i>Communications</i>
Sink	Vent Hood		Per Equip. Manuf.	Intrusion Detection, PA	Telephone, LAN

**1.14 SPACE EQUIPMENT MATRIX**

	ITEM	VENDOR	MODEL	QUANTITY
BI	Casework, locking, with small sink, under counter drawers and overhead storage			1
BI	Paper Towel Dispenser, roll, wall mount			1
BI	Liquid Soap Dispenser, wall mount			1
BI	Eyewash station, Faucet Mount	GSA	6523161	1
BI	Water Purifier System	Government Scientific Source		1
ME	Chair, Phlebotomy, UMF 8672	Moore Medical	70618	1
ME	Centrifuge, tabletop (for blood)	Moore Medical	72071	1
ME	Stool, provider, rolling	Midmark	195	1
ME	Glucometer	Moore Medical	97100	1
ME	Sharps container with glove dispenser, wall mount	GSA	UMISWM310001H	1
ME	Wastebasket, biohazard, Step on, metal, red	GSA	URI-ST12EPLRD	1
ME	Wastebasket, step-on, metal, White	GSA	URI-ST12EPLRD	1
ME	Clock, Wall	GSA	SET1164	1
ME	Telephone with Speakerphone			
ME	Computer			1
ME	Printer for lab labels			1
ME	Refrigerator-Freezer, undercounter, locking	Jewett		1
ME	Thermometer, refrig, digital	Tech Instrumentation	A150Q	1
ME	Storage Cabinet, Metal, 2 door, Locking	Staples	796615	1



## Administrative and Common Support Unit - Room Data Sheet

### 1.15 JANITOR'S CLOSET

The Janitor's Closet should be adequately sized for a mop sink and potentially a hot water heater. Space should also be provided for storage of soap, detergents and other cleaning products. Included in the Janitor's Closet will be mop hangers, floor sink, germicidal soap and paper towel dispenser.



Photo

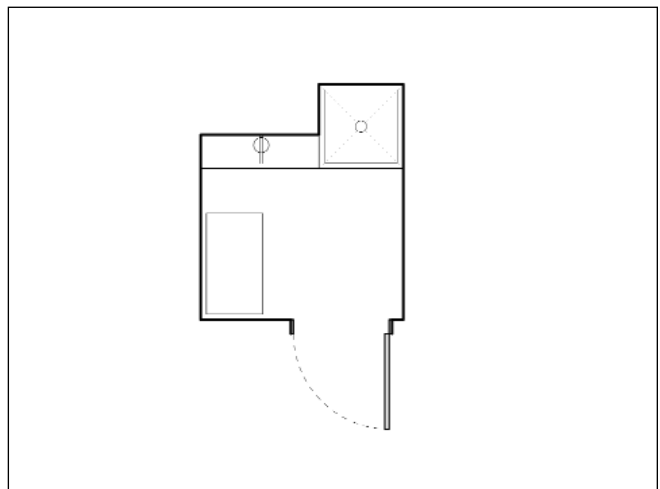

Floor Plan (100 nsf)

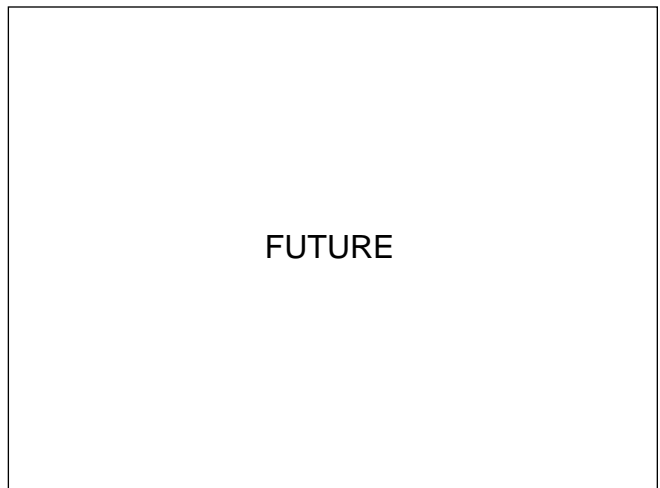

Isometric

FUTURE







## Administrative and Common Support Unit - Room Data Sheet

### 1.16 STAFF TOILET/LOCKER ROOM

The Staff Locker Rooms provide space for staff to store personal property. One each Toilet/Locker Room combination should be provided for men and women. Housed with the lockers should be staff toilets and showers. Location of the staff Locker Room should be central to Ambulatory Care and Short Stay Units.



Photo

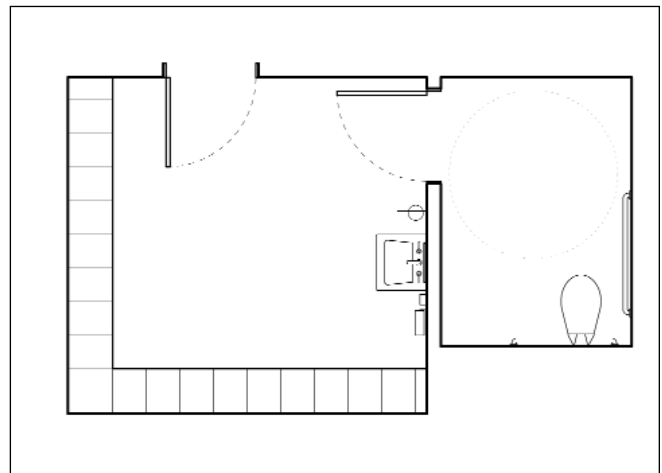

Floor Plan (120 - 160 nsf)

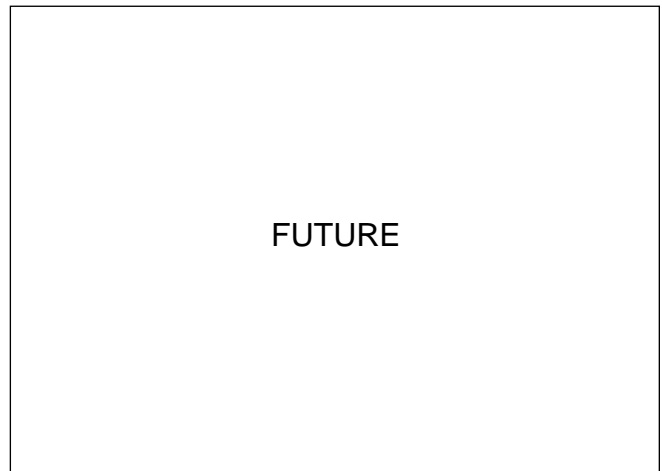

Isometric





## Administrative and Common Support Unit - Room Data Sheet

### 1.17. BIOHAZARD WASTE (CLOSET)/STORAGE ROOM

The Bio-hazardous Waste Storage Room is a secured room used for the storage of waste. This room should have a separate ventilation system



Photo

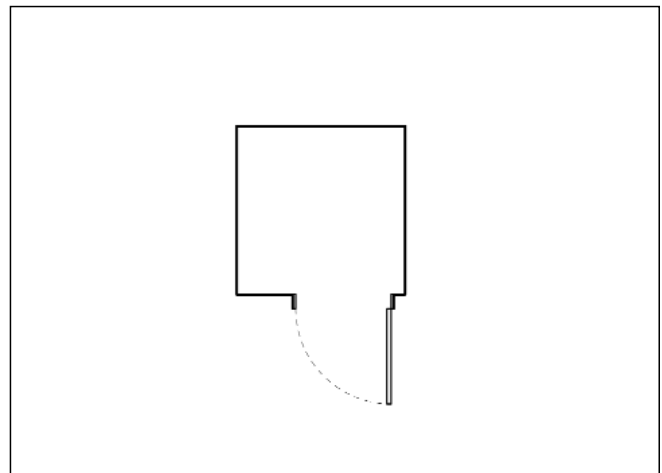

Floor Plan (25 nsf)

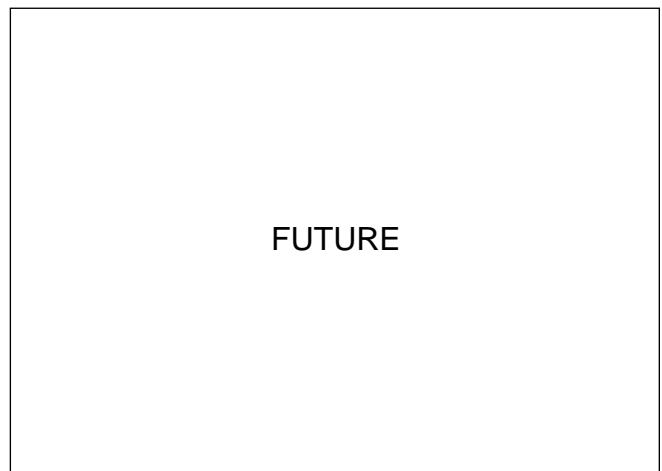

Isometric





## 2.0 MEDICAL INTAKE/PROCESSING UNIT



## Medical Intake/Processing Unit - Function

### 2.0 MEDICAL INTAKE/PROCESSING UNIT

The Medical Intake/Processing Unit for Health Services includes detainee health screening for general health and communicable diseases. This includes Tuberculosis screening by chest x-ray. Of primary importance in HS screening is the segregation of detainees being x-rayed from those in Ambulatory Care. A segregation vestibule is provided to separate the two functions. Off of this vestibule are holding cells and the Teleradiology (x-ray) Room. Refer to the diagram on page 5.35.

#### ACCESS TO CARE

Detainee access to care may occur at different times during the duration of their stay at a Service Processing Center. This may occur during detainee processing, sick call or if an incident occurs requiring immediate medical attention (urgent care). Refer to page 5.35 for workflow diagrams.

#### DETAINEE PROCESSING

Detainees begin their health screening at the time of initial Intake and Processing for admission into the SPC/CDF. They arrive at a Vehicle Sally Port and are escorted into the processing area. During processing the detainee is given a brief physical exam to check height, weight, blood pressure, heart and lungs (vitals). They are brought into the HS secure vestibule where they are placed in a holding cell while awaiting x-ray. Detainees are x-rayed to determine if they have lung disease (tuberculosis). While x-rays are processed and evaluated, detainees are held in waiting/holding rooms in the SPC/CDF Intake and Processing area. If tests are negative and there are no other health concerns the detainee is released to complete intake.

If the detainee tests positive to a serious disease or displays other conditions requiring emergency medical attention, he/she is escorted back to the vehicle Sally Port for ambulance transport to a hospital.

If the detainee has a medical condition that is not an emergency, he/she is admitted to the HS Ambulatory care Unit for further examination and treatment.

If the detainee is suspected of a communicable illness, he/she is immediately admitted to a room with appropriate isolation capabilities in either the Short Stay Unit (Infirmary) or the Special Housing Unit. The Special Housing Unit is used for detainees that are incarcerated for capital offenses or are a threat to staff or other inmates.

### Medical Intake/Processing Unit

#### Critical Issues

- ✓ Provide enclosed vestibule for intake/processing.
- ✓ Intake teleradiology and holding should be off of a vestibule with shared access to SPC/CDF Intake and Processing. This will provide segregation of detainees with potential communicable diseases from those in Ambulatory Care and Intake.
- ✓ HS screening should be located in the general SPC/CDF Intake and Processing Area
- ✓ Detainee Holding Cells should be located with access to the enclosed vestibule for holding detainees while they await x-ray results

#### Special Requirements

The Medical Intake Unit houses two health Screening Rooms and a Teleradiology Room. The Teleradiology Room shall contain an observation window and be built using lead-shielded construction. The Teleradiology Room is accessed from a secure vestibule that acts as an air lock between Ambulatory Care and general Intake and Processing. Detainees being admitted to the detention facility are x-rayed as part of the general health screening process to detect potential respiratory diseases. Once x-ray procedure is completed, the detainee is held in secure holding rooms inside of general Intake and Processing until they are assigned to a Housing Unit. The Teleradiology Room is also used for inpatient and outpatient diagnostics. There should be direct access to Medical Intake from the central vestibule.

#### Space Requirements

### 2.0 MEDICAL INTAKE UNIT

- 2.1 Screening Room
- 2.2 Teleradiology Room (X-ray)

2.0 MEDICAL INTAKE/PROCESSING UNIT WORKFLOW PATTERN

Intake Screening Workflow Pattern (a new detainee arrives at the facility)

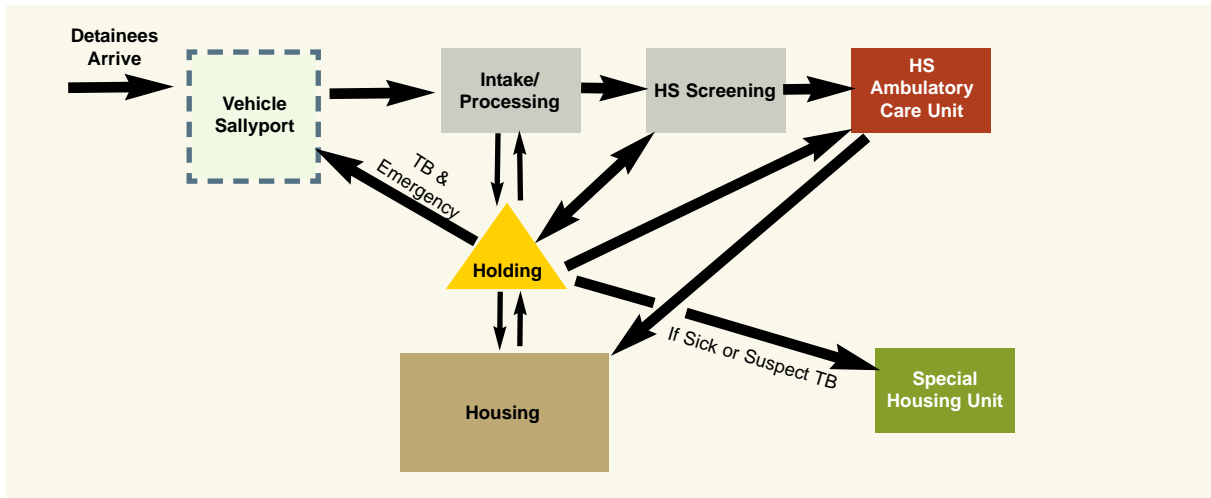

2.0 MEDICAL INTAKE/PROCESSING UNIT ORGANIZATIONAL MODEL

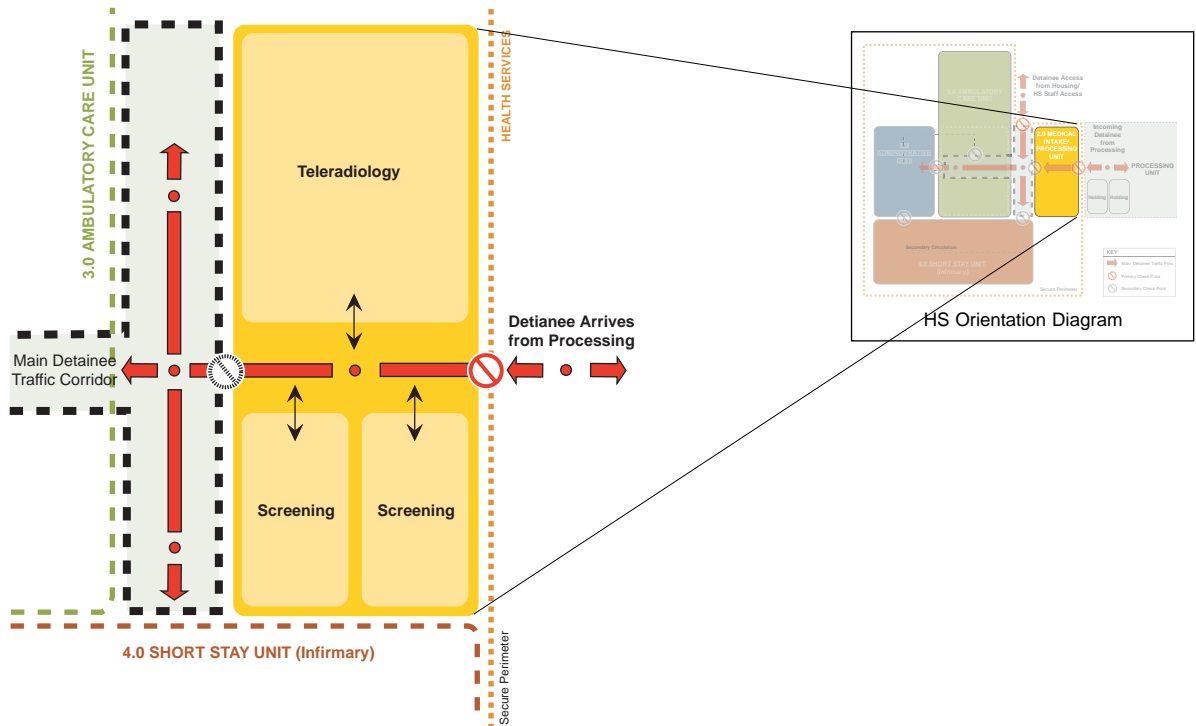



## Medical Intake/Processing Unit - Concepts

### INTRODUCTION

In order to delineate Medical Intake and Processing operational imperatives, the following workflow diagram illustrates the relationships between HS staff, detainees and specific processes.

#### 1. Medical Intake

The intake process for health services begins when a detainee is in the general processing for admittance to the detention facility. Detainees are screened for contagious respiratory diseases through x-ray testing. When detainees are brought into the intake area, they are placed in holding cells. Each detainee is escorted from the general holding cell into the medical screening room where they are interviewed, vital signs are checked and a general health screening is completed. Detainees are taken to Teleradiology where they are x-rayed. While awaiting medical evaluation of x-rays, the detainee is sent back to general holding. It may take up to four hours until the patient is medically cleared and sent to a housing unit or referred to respiratory isolation.

The concept is to provide a secure vestibule that acts as an air lock between Detention Intake and Ambulatory Care. Two screening rooms are located off this vestibule with teleradiology located directly across this vestibule.

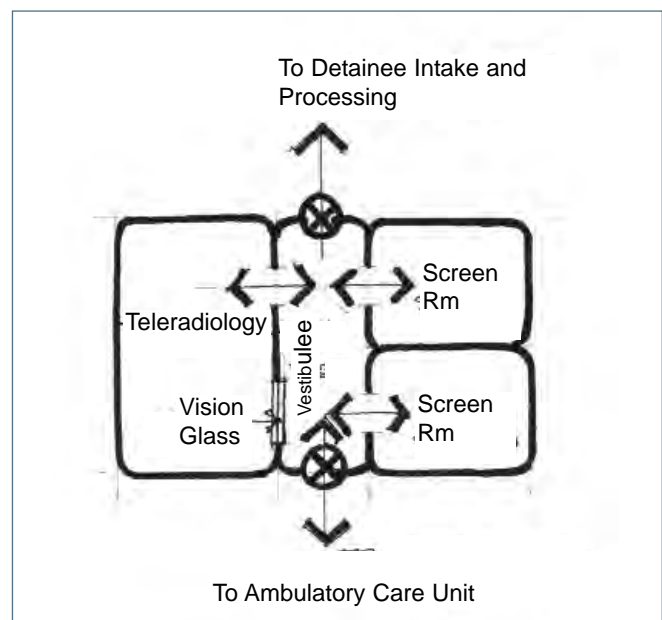





## Medical Intake/Processing Unit - Room Data Sheets

### ROOM DATA SHEETS

The following provides specific data regarding the rooms located within the Medical Intake/Processing Unit of Health Services. Each room data sheet includes the following information:

- ✓ Functional Description
- ✓ Representative Photograph
- ✓ Room Floor Plan
- ✓ Isometric
- ✓ Space Materials Matrix
- ✓ Room Equipment Matrix

### SYMBOL LEGEND



**BI** - Built-in

**F** - Furniture

**ME** - Medical Equipment





## Medical Intake/Processing Unit - Room Data Sheet

### 2.1 INTAKE SCREENING ROOM

The Intake Screening Rooms are where detainees are initially screened for potential health issues during detainee processing at the Service Processing Center. The rooms are used by health practitioners to record and analyze basic health (weight, height, heart, blood pressure). It is important to note that screening rooms should be located off of the entry Vestibule and across from the Teleradiology Room.

#### Intake Screening includes the following functions:

- ✓ Part of the health evaluation involves completion and analysis of a chest x-ray
- ✓ Hand washing station
- ✓ Screening for physical examinations
- ✓ Recording vital signs, weight, and visual acuity
- ✓ Sick call and sick call triage
- ✓ Medication administration, patient and staff education
- ✓ Also may be used by nursing to perform work on collateral duties.



Photo

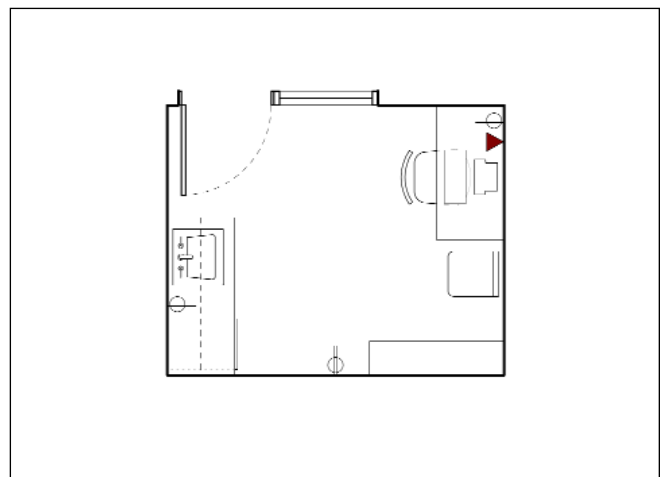

Floor Plan (100 nsf)

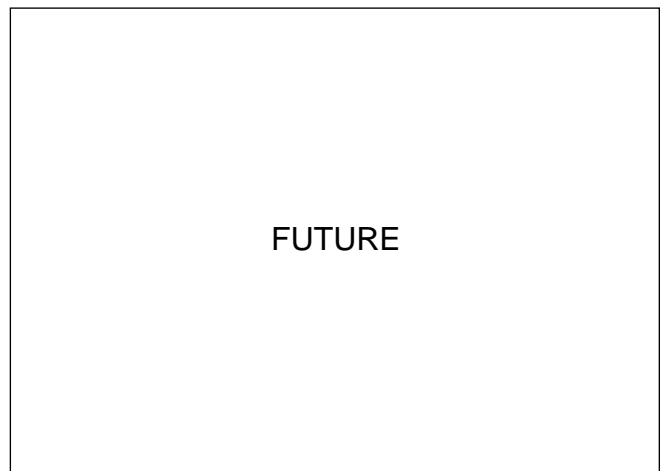

Isometric

**2.1 SPACE MATERIAL MATRIX**

<i>Walls</i>	<i>Floors</i>	<i>Ceiling</i>	<i>Doors</i>	<i>Hardware</i>	<i>Glazing</i>
Masonry	VCT	Acoustic Tile	Standard H.M.	Builders Hardware	Glass Clad Polycarbonate - Level 2
<i>Plumbing</i>	<i>HVAC</i>	<i>Lighting</i>	<i>Power</i>	<i>Elec./Security</i>	<i>Communications</i>
Lavatory					Telephone, Speaker, LAN

**2.1 SPACE EQUIPMENT MATRIX**

	ITEM	VENDOR	MODEL	QUANTITY
BI	Paper Towel Dispenser, wall mount, roll			1
BI	Liquid Soap Dispenser, wall mount			1
BI	Eyewash station, Faucet Mount	GSA	6523161	1
BI	HEPA air filtration or UV light for room			1
BI	Air exhaust fan to exterior			1
F	Workstation, with lower drawers and upper storage, locking	Unicor	Bravo	1
F	Chair, rolling	Unicor	Bravo	1
F	Chair, patient	Unicor	Bravo	1
F	Stool, provider, rolling	Midmark	195	1
F	File cabinet, 4 drawer, locking			1
F	Storage Cabinet, Metal, 2 door, Locking	Staples	796615	1
ME	Exam Light, Halogen, rolling	Welch Allyn	LS-150 with mobile castor base	1
ME	Sundry Jars, plastic	Moore Medical	65227	1
ME	BP Cuff Manual	Moore Medical	66306	1
ME	Glucometer	Moore Medical	97100	1
ME	Oto-Ophthalmoscope, Welch-Allyn, wall mount,		AD451	1
ME	Scale, Patient w height	Health o meter	32150	1
ME	Sharps container with glove dispenser, wall mount	GSA	UMISWM310001H	1
ME	Stethoscope	Welch Allyn	5079-135	1
ME	Thermometer, electronic	Welch Allyn	Sure-Temp 678	1
ME	Vital Sign monitor w/pulse ox	Welch Allyn	52NTP-E1	1
ME	Wastebasket, biohazard, Step on, metal, red	GSA	URI-ST12EPLRD	1
ME	Wastebasket, step-on, metal, White	GSA	URI-ST12EPLRD	1
ME	Hammer, reflex ( non metallic handle)			
ME	Privacy Screen, 3 panel, rolling	United Metal Fabricator	8425 with 860 curtain	1
ME	Thermometer, refrig. Monitor, digital	Tech Instrumentation	A150Q	1
ME	Clock, Wall	GSA	SET1164	1
ME	Telephone with Speakerphone			1
ME	Computer			1
ME	Printer			1
ME	Refrigerator-Freezer, undercounter, locking	Jewett		1



## Medical Intake/Processing Unit - Room Data Sheet

### 2.2 TELERADIOLOGY ROOM (X-ray)

The Teleradiology Room is located within the Health Services area and should be accessed off of a secure vestibule that separates processed detainees (in Ambulatory Care Unit) from the general SPC/CDF Processing Area. The primary function of the Teleradiology Room is for taking digital x-rays and storing the x-ray equipment.



Photo

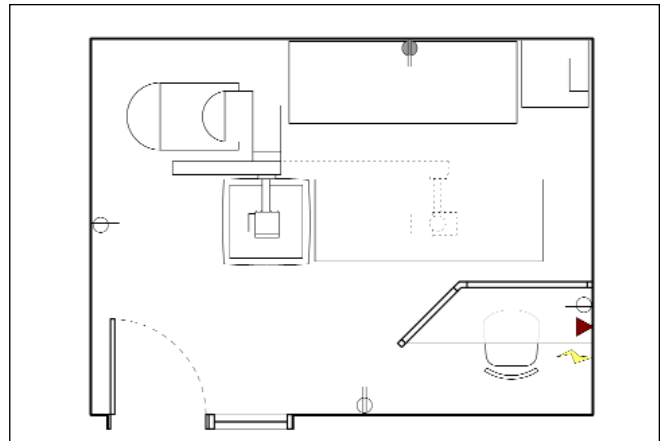

Floor Plan (150 nsf)

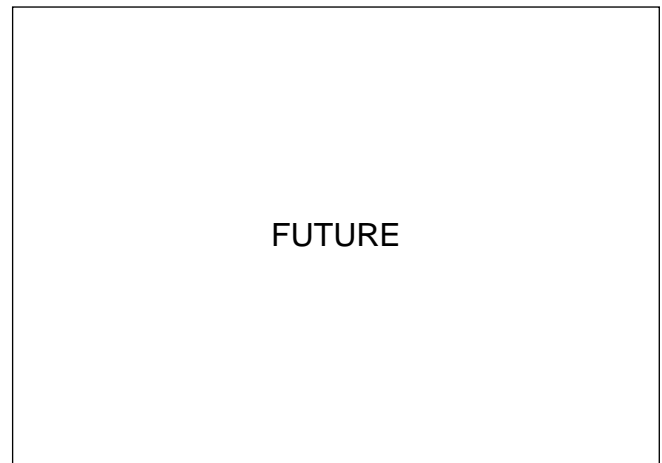

Isometric





## 3.0 AMBULATORY CARE UNIT



## Ambulatory Care Unit - Functional Adjacencies

### 3.0 AMBULATORY CARE UNIT

The Ambulatory Care Unit is the primary "outpatient clinic" for the SPC/CDF. It includes Medical Exam Rooms, Dental Exam (Operator), Laboratories, and Trauma Room. It is here where detainees are brought from sick call and when a health incident requiring medical treatment occurs. Indirect access to the Ambulatory Care Unit from housing includes detainee holding and access to the Sally Port for transfer out should a major emergency require outside medical attention. Direct access is provided from SPC/CDF Intake and Processing through the health screening vestibule. Refer to the diagram on page 5.47.

### AMBULATORY CARE PROCESSING

Detainees entering the Ambulatory Care Unit have access from Housing area and are first place into a secure holding(waiting) area. They are then seen by a nurse who takes vital signs. The patient is then examined by a physician or mid-level provider as appropriate.

### EMERGENCY CARE

In the case of a medical emergency, a medical response team goes to the location of the incident and either waits for the ambulance or transports the patient to medical. Refer to diagram below.

Emergency Care Diagram

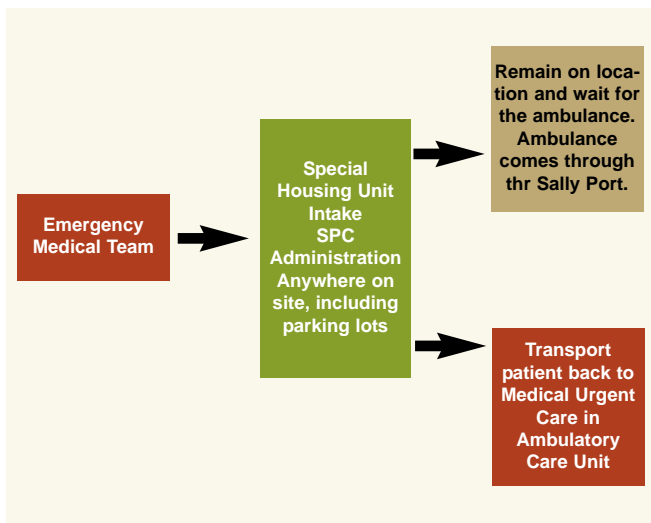

### Ambulatory Care Unit

#### Critical Issues

- ✓ Ambulatory Care should be adjacent to yet separated by doors from Short Stay Infirmary with two ways of access
- ✓ Ambulatory Care should have outside access from Intake and Processing for intake screening and from Housing for sick call.

#### Special Requirements

The Ambulatory Care Unit must be organized for ease of flow and surveillance. The Nurse Coordinator, acting as "gatekeeper" for detainee flow is the front line staff member who conducts initial triage and assigns detainees to their respective exam rooms. Wait/Hold rooms, located across from the Nurse Coordinator are where detainees awaiting medical examination and outpatient treatment are held. Wait/Hold rooms must contain vision glazing for security. Each hold room houses detainees that are schedule within one hour of arrival. The hold rooms may be used for detainee segregation based on criminal classification or gender. It may be desirable to have different sized Wait/Hold rooms based on the detainee profile. There is also a security guard centrally located with visual access to the Exam Rooms, Wait/Hold Rooms and vestibule. The Urgent Care treatment room should be located close to the entrance from Housing for ease of access. Common Support functions that serve the Ambulatory Care Unit should be located within easy access.

#### Space Requirements

### 3.0 AMBULATORY CARE UNIT

- 3.1 Exam Room
- 3.2 Detainee Waiting Area (Holding)
- 3.3 Detainee Toilet
- 3.4 Dental Office
- 3.5 Dental Exam Room (Operator)
- 3.6 Dental Lab
- 3.7 Dental Mechanical Room
- 3.8 Mental Health Room
- 3.9 Nurses Coordinator Room
- 3.10 Urgent Care Room
- 3.11 Telemedicine Machine Room
- 3.12 Guard Station



### 3.0 AMBULATORY CARE UNIT WORKFLOW PATTERN

Ambulatory Care Services Diagram (a resident detainee requires care)

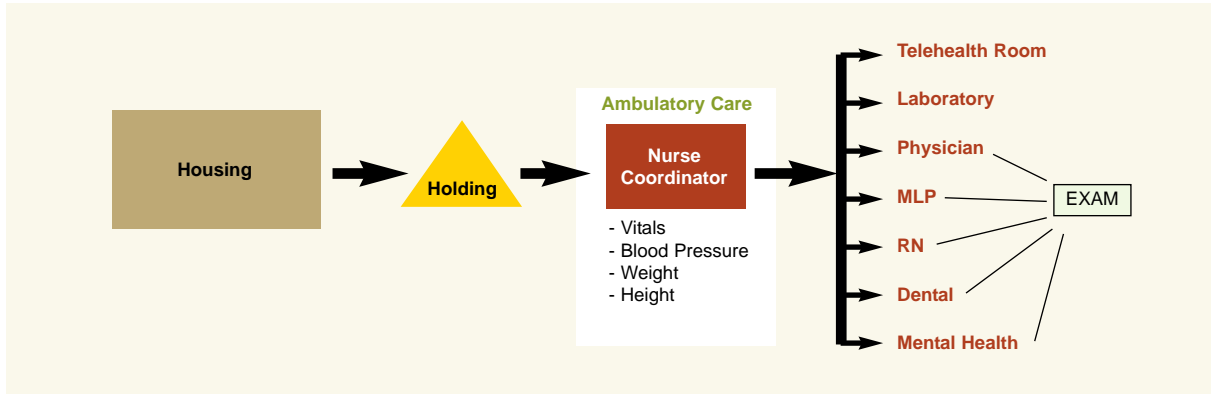

### 3.0 AMBULATORY CARE UNIT ORGANIZATIONAL MODEL

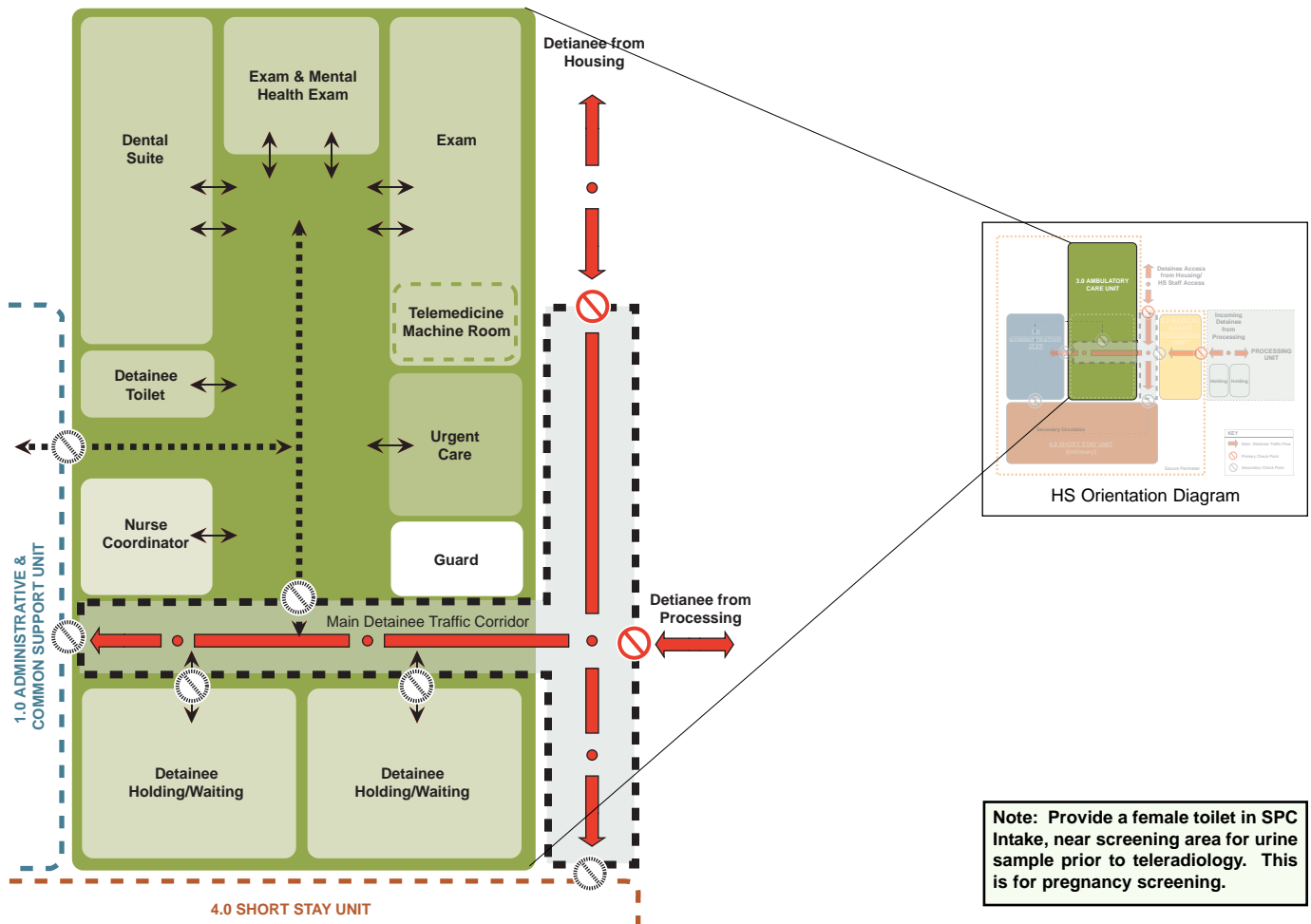



## Ambulatory Care Unit - Concepts

### INTRODUCTION

In order to delineate operational imperatives for Ambulatory Care Unit functions, the following workflow diagrams describe and diagram the relationships between HS staff, detainees and specific processes.

#### 1. Waiting/Holding Areas

When a resident detainee is admitted to health services from the Housing Pod, they are brought into a sally port and immediately escorted to a Waiting/Holding Room. The Waiting/Holding Room is sized based on the number of detainees that can be examined in a one hour period. The Waiting/Holding Rooms are on one side of the Sally Port so that there is no visual access between the rooms.

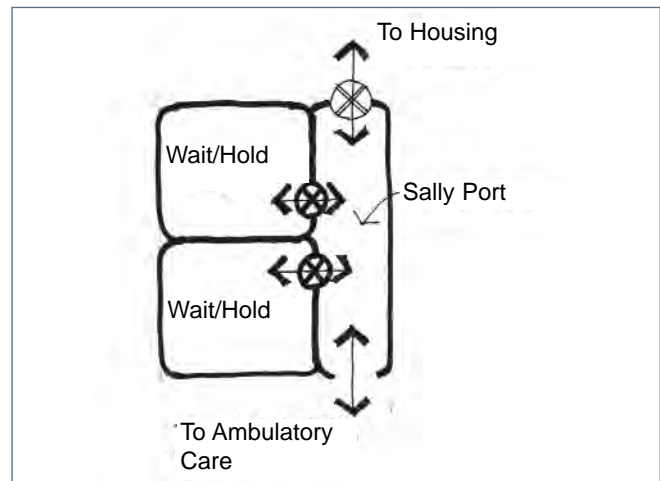

#### 2. Satellite Nurse Triage

In order to improve detainee health services by limiting the handling/movement of detainees from housing into the health services facility the following has been suggested:

Create a small Nurse Triage Room within the Housing pods.

This localized health services will provide for initial sick call screening, medications/pill line and for setting up appointments for doctor visit at a future date.

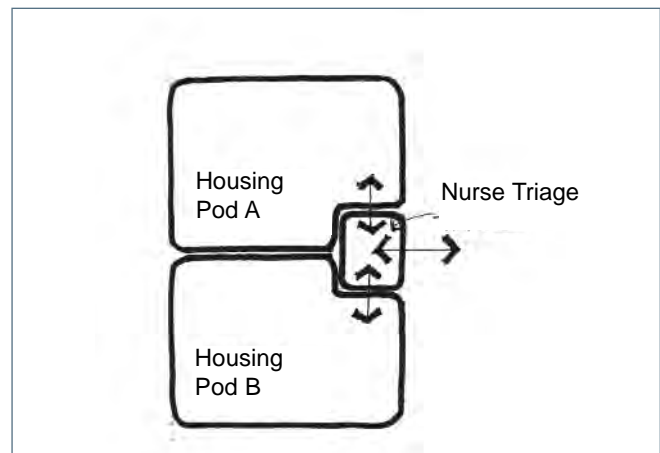

#### 3. Visual Access

A security guard station should be positioned near the entrance from the Sally Port into Ambulatory Care such that there are clear lines of site to all Medical Exam Rooms. The security guard is responsible for monitoring all detainee movement within Ambulatory Care.

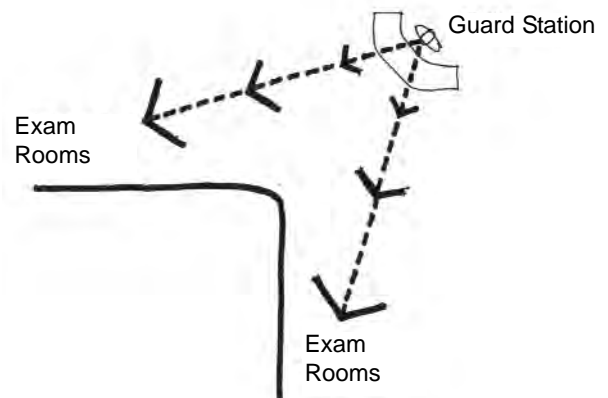

## 5. DEPARTMENTAL REQUIREMENTS

### 4. Security Surveillance

The nurse coordinator is the gate-keeper for detainees awaiting examination. The Nurse/Coordinator is responsible for initial preliminary examination of resident detainees. Detainees are each brought into the Nurse Coordinators room for initial health screening and then escorted to an Exam Room. A physician or NP completes the examination and the detainee is sent to Short Stay Unit or is escorted back to the Waiting/Holding room for eventual release to Housing.

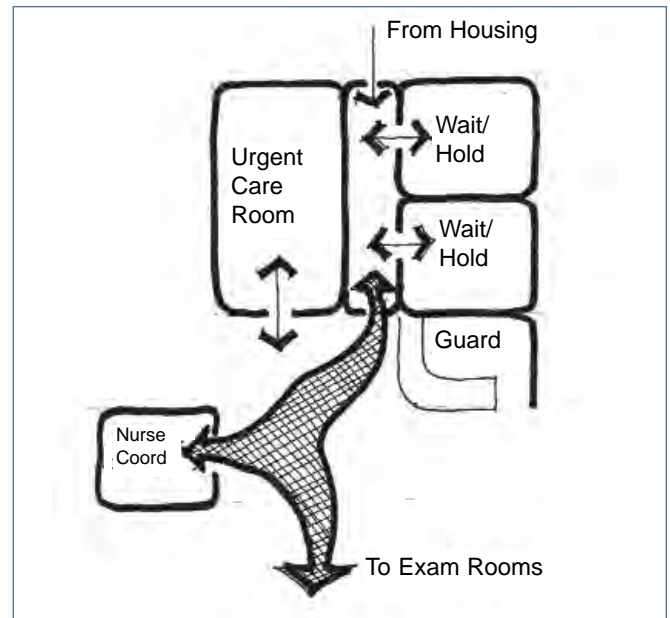

### 5. Dental Suite

The Dental suite includes a Dental Office, Exam Room and Laboratory. Entrance to the suite is off of a corridor into the Exam Room. The Dental office and Laboratory flank the Dental Exam Room. There is no corridor access to the Laboratory or Office. They are both accessed from the dental Exam Room.

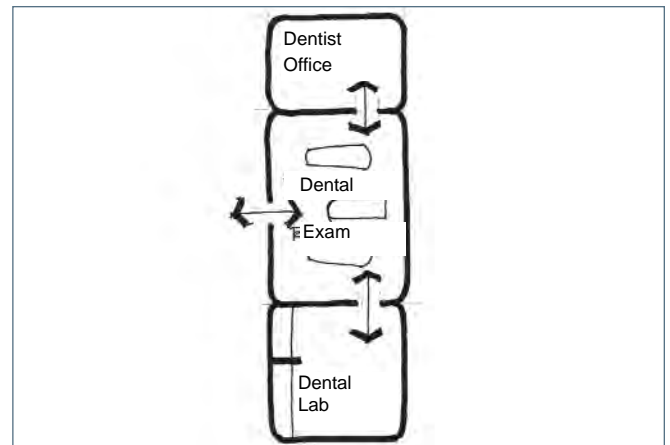

### 6. Dental Laboratory

The Dental Laboratory is used for specific functions. These include dental model-making and equipment sterilization. Sterilization is a clean function and Modeling/casting is a "dirty" function. These functions are located at either end of a laboratory counter.

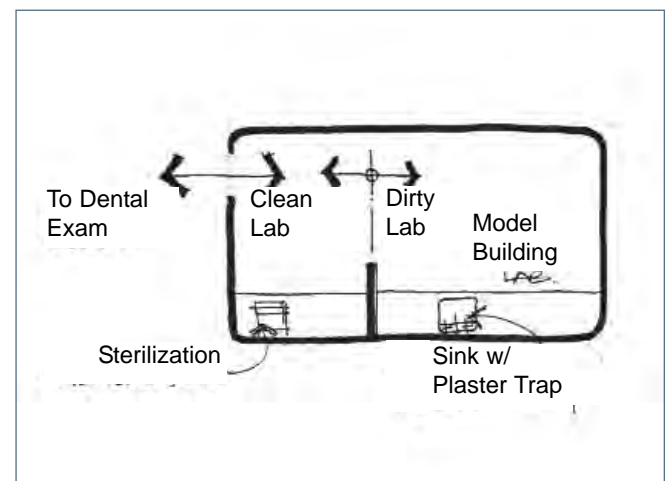



## Ambulatory Care Unit - Room Data Sheets

### ROOM DATA SHEETS

The following provides specific data regarding the rooms located within the Ambulatory Care Unit of Health Services. Each room data sheet includes the following information:

- ✓ Functional Description
- ✓ Representative Photograph
- ✓ Room Floor Plan
- ✓ Isometric
- ✓ Space Materials Matrix
- ✓ Room Equipment Matrix

### SYMBOL LEGEND

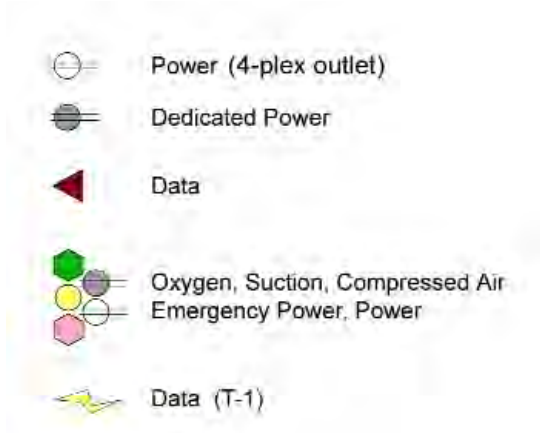

**BI** - Built-in

**F** - Furniture

**ME** - Medical Equipment



## Ambulatory Care Unit - Room Data Sheet

### 3.1 EXAM ROOM

The Examination Rooms are used by physicians and health care practitioners to complete general physical/medical examinations and health treatment. The Exam Rooms contain the same type of equipment found in a general medical clinic for out-patient exam and treatment. Each room contains a small sink with cabinetry and treatment table.

#### Exam Room functions are as follows:

- ✓ Hand washing station
- ✓ Conducts a physical exam or obtain a medical history from a detainee in privacy
- ✓ Used by PA and RN for examination/treatment, triage, wound care, sick call evaluations
- ✓ Staff Consultations, Physical Exams and evaluations
- ✓ Procedures, IV fluids/ Monitoring, MD consultation
- ✓ Computer work, chronic and acute care clinics
- ✓ Splinting/ace wraps. Minor injury treatment
- ✓ Assessing and treating scheduled patients
- ✓ Administration of medications and patient education provided related to medications administration
- ✓ Follow-up Chronic (hypertension, diabetes) and sick care referrals
- ✓ Phone call coordination with local and outside sources.
- ✓ Provides counseling and patient education
- ✓ Reviews daily charts, lab results and medication refills
- ✓ In small facilities this room is also used by the Social Worker and the Psychiatrist



Photo

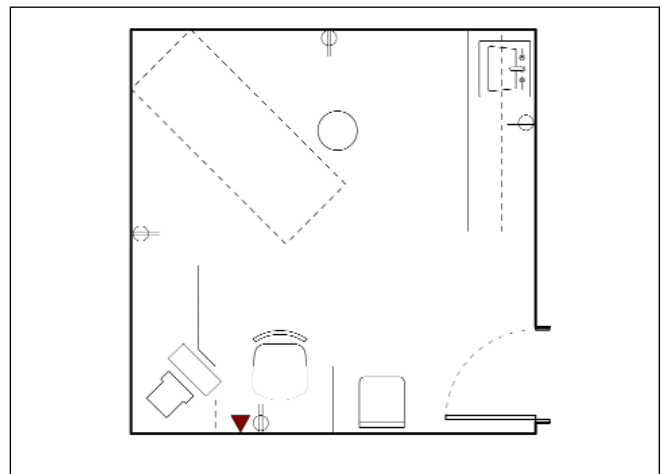

Floor Plan (100 nsf)

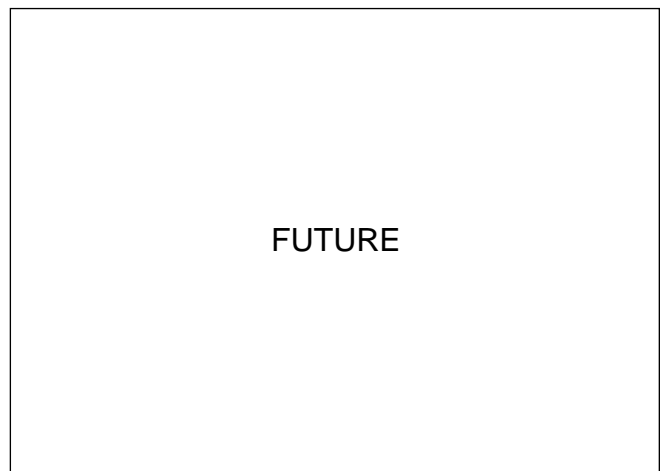

Isometric Plan

**3.1 SPACE MATERIAL MATRIX**

<i>Walls</i>	<i>Floors</i>	<i>Ceiling</i>	<i>Doors</i>	<i>Hardware</i>	<i>Glazing</i>
Secure 1	VCT	Acoustic Tile	Detention H.M.	Mechanical Detention	
<i>Plumbing</i>	<i>HVAC</i>	<i>Lighting</i>	<i>Power</i>	<i>Elec./Security</i>	<i>Communications</i>
Lavatory		Exam Light	GFI Outlets		Telephone, LAN

**3.1 SPACE EQUIPMENT MATRIX**

	ITEM	VENDOR	MODEL	QUANTITY
BI	Casework with small sink, under counter drawers and overhead storage			1
BI	Paper Towel Dispenser, roll, wall mount			1
BI	Liquid Soap Dispenser, wall mount			1
BI	Eyewash station, Faucet Mount	GSA	6523161	1
F	Workstation, with lower drawers and upper storage, locking	Unicor	Bravo	1
ME	Examination Table with storage, roll paper, left & right hand	Midmark	304	1
ME	Chair, rolling, provider	Unicor	Bravo	1
ME	Chair, patient	Unicor	Bravo	1
ME	Hammer, reflex, plastic, Taylor or Queen Square	US Neurologicals		1
ME	Oto-Ophthalmoscope, wall mount,	Welch Allyn	767 System (79510)	1
ME	Thermometer, electronic	Welch Allyn	Sure-Temp 678	1
ME	Sphygmomanometer, Manual, hand held	Moore Medical	66306	1
ME	Sphygmomanometer, Wall mount	Welch Allyn	767 (7670-01CB)	1
ME	Sphygmomanometer, MERCURY			
ME	Glucometer	Moore Medical	97100	1
ME	Mayo Instrument Stand, foot pedal adjust, 16x21 tray	UMF	SS8311	1
ME	Stool, provider, rolling	Midmark	195	1
ME	Sharps container with glove dispenser, wall mount	GSA	UMISWM310001H	1
ME	Stethoscope	Welch Allyn	5079-135	1
ME	Exam Light, Halogen, rolling	Welch Allyn	LS-150 with mobile	1
ME	Wastebasket, biohazard, Step on, metal, red	GSA	URI-ST12EPLRD	1
ME	Wastebasket, step-on, metal, White	GSA	URI-ST12EPLRD	1
ME	Privacy Screen, 3 panel, rolling	United Metal Fab.	8425 with 860 curtain	1
ME	Clock, Wall	GSA	SET1164	1
ME	Telephone with Speakerphone			
ME	Computer			1
ME	Sundry Jars, plastic	Moore Medical	65227	1



## Ambulatory Care Unit - Room Data Sheet

### 3.2 DETAINEE HOLDING AREA (WAITING)

The Detainee Holding/Waiting Area is a secure multi-person room for temporary holding of detainees that are awaiting medical treatment. There is a waiting area for male and female detainees. Each holding/Waiting area includes a combo toilet/lavatory unit with partial height privacy wall.

- ✓ Initial contact area
- ✓ Used for detainees awaiting appointments
- ✓ Hold detainees who are waiting to be seen by a provider
- ✓ Provides detainees access to educational materials for multiple conditions
- ✓ Contains a water fountain, a hand-sink and a toilet
- ✓ Provides a Security Officer Desk (log book and phone available)



Photo

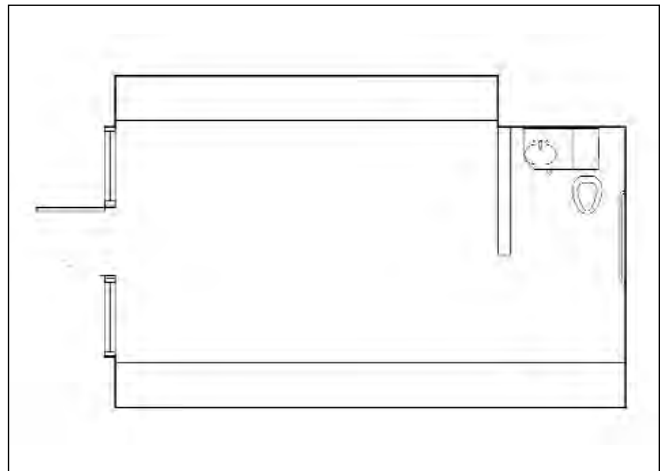

Floor Plan (250 nsf - capacity 10)

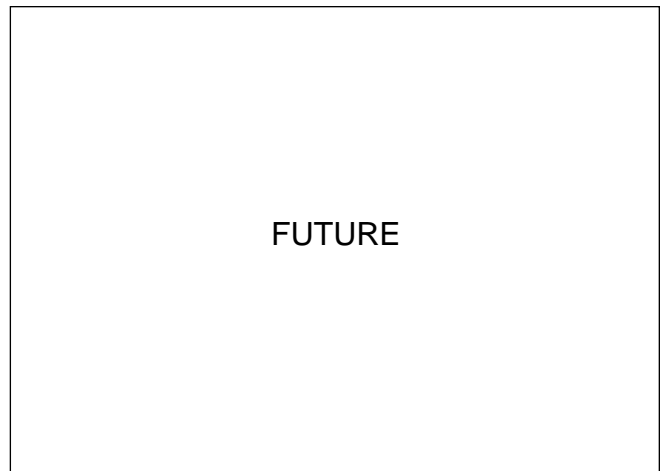

Isometric

**3.2 SPACE MATERIAL MATRIX**

<i>Walls</i>	<i>Floors</i>	<i>Ceiling</i>	<i>Doors</i>	<i>Hardware</i>	<i>Glazing</i>
Secure 1	Sealed Concrete	Secured Ceiling	Detention H.M.	Electro-Mech. Detention	Glass-clad polycarbonate Lev 2
<i>Plumbing</i>	<i>HVAC</i>	<i>Lighting</i>	<i>Power</i>	<i>Elec./Security</i>	<i>Communications</i>
Toilet,Lav,Drinking	Secure	Maximum	No Outlets	Door Control, Intercom	
Fountain, Flr. Drain	Diffuser	Security Fixture		Audio Monitoring, PA, CCTV	

**3.2 SPACE EQUIPMENT MATRIX**

	ITEM	VENDOR	MODEL	QUANTITY
BI	Benches, sitting, permanent mount			1
BI	Toilet,sink, drinking fountain combo, metal, security			1
BI	Partial privacy wall screening toilet, 4 ft high			1
BI	Hand dryer, Electric, wall mount, high security			1
BI	Negative Pressure airflow			1
BI	Floor drain			1
BI	TV/VCR (behind security glazing), speaker projecting sound into room			1
BI	Window, security, large, looking into room			1





## Ambulatory Care Unit - Room Data Sheet

### 3.3 DETAINEE TOILET (SPECIMEN COLLECTION)

A single use detainee toilet is located near entrance to the Ambulatory Care Unit. It is used for collection of urine samples for urinalysis testing. The Detainee Toilet should be located adjacent to the Medical Laboratory with a secure “lazy susan” type through-wall sample transfer for ease of handling specimens.



Photo

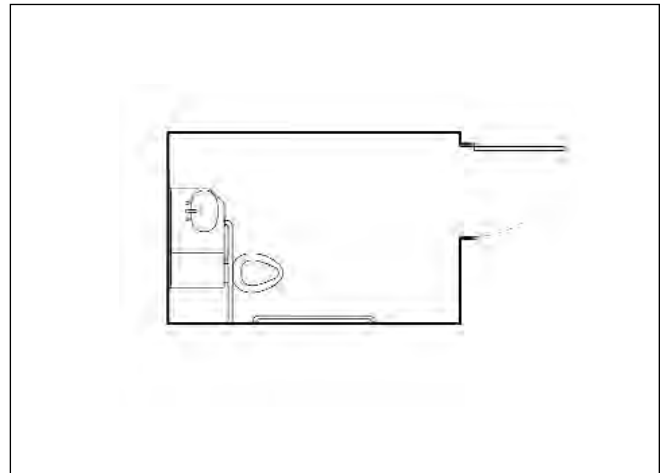

Floor Plan (49 nsf)

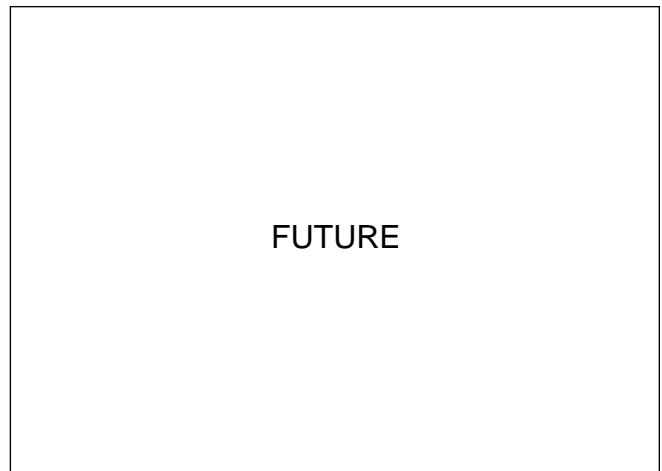

Isometric





## Ambulatory Care Unit - Room Data Sheet

### 3.4 DENTAL OFFICE

The Dental Office should be located (in the dental suite) near the Dental Exam Room(s) and Dental Laboratory for efficiency of the dental operations. The Dental Office is a private office with room for one visitor.

**Following are functional uses of the Dental Office:**

- ✓ Answers correspondence: written, electronic, phone and fax
- ✓ Coordinates daily clinical operations, consults and mentor clinical staff
- ✓ Peer review on charts daily
- ✓ Used for administrative purposes
- ✓ Evaluation of charts for compliance with local operational policies/procedures
- ✓ Assists in the maintenance of facility accreditation
- ✓ Storage of clean dental scrubs and lab coats
- ✓ Dental library



Photo

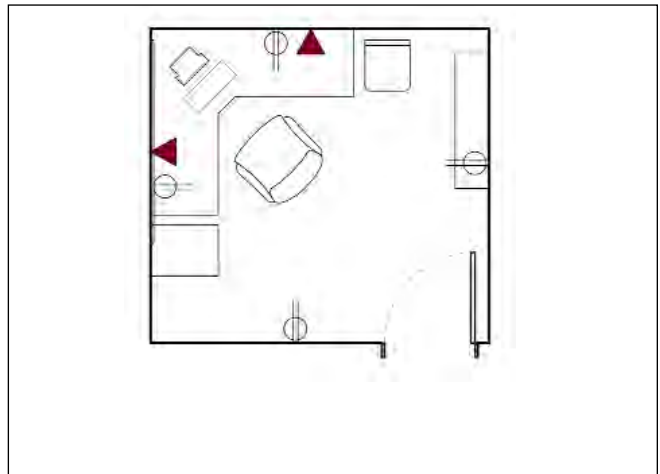

Floor Plan (100 nsf)

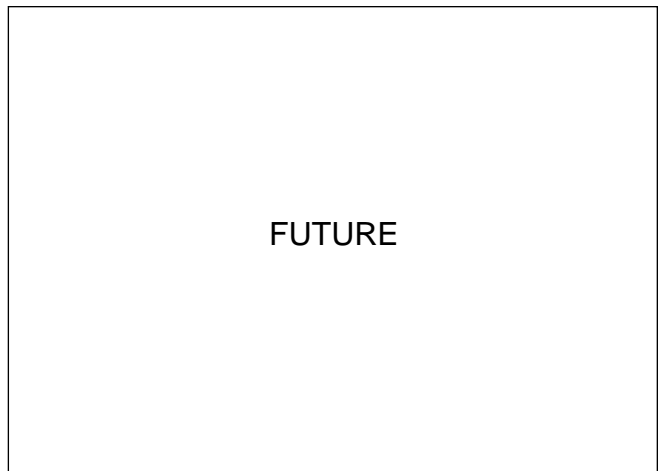

Isometric





## Ambulatory Care Unit - Room Data Sheet

### 3.5 DENTAL EXAM ROOM (OPERATORY)

The Dental Exam Room or Dental Operatory contains all the equipment for dental examination and treatment including dental chair, dental vacuum, water and air. The Dental Exam Room may hold one or more dental chairs depending on detainee population and staffing. The Dental Exam Room is the central functional area within the dental suite.

#### Following are function uses and characteristics of the Dental Exam Room:

- ✓ Dental Sick call/Dental Triage
- ✓ Dental exams/treatment.
- ✓ Routine and surgical extractions
- ✓ Biopsies, cleaning
- ✓ Maintains dental instrument count, needle count, X-rays, storage for dental supplies
- ✓ Computer work
- ✓ Open wound repair and Staff dental training

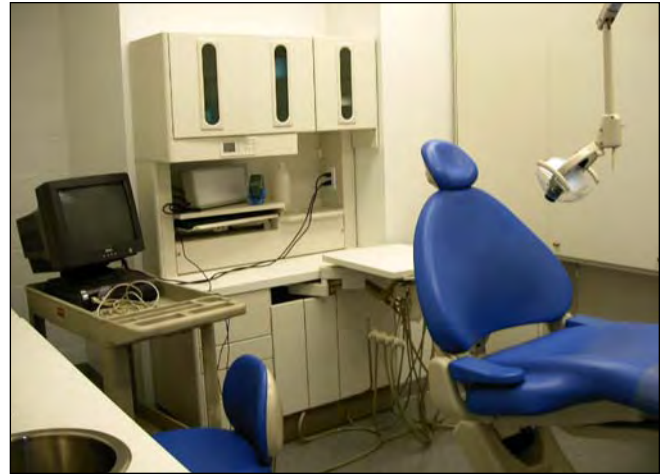

Photo

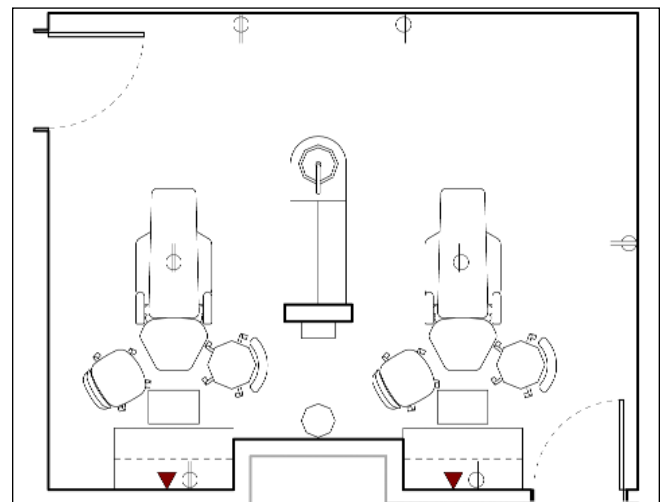

Floor Plan (140 nsf)

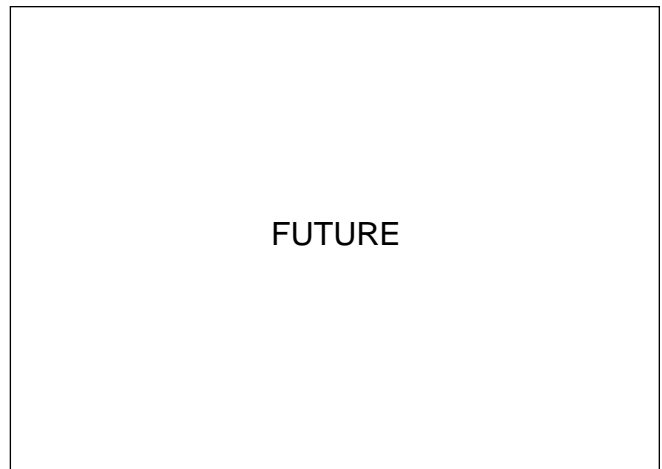

Isometric

## 5. DEPARTMENTAL REQUIREMENTS

### 3.5 SPACE MATERIAL MATRIX

<i>Walls</i>	<i>Floors</i>	<i>Ceiling</i>	<i>Doors</i>	<i>Hardware</i>	<i>Glazing</i>
Secure 1	VCT	Acoustic Tile	Custom H.M.	Mechanical Detention	
<i>Plumbing</i>	<i>HVAC</i>	<i>Lighting</i>	<i>Power</i>	<i>Elec./Security</i>	<i>Communications</i>
Sink			Per Equip. Manuf	Intrusion Detection	Telephone(Speaker) LAN

### 3.5 SPACE EQUIPMENT MATRIX

ITEM	VENDOR	MODEL	QUANTITY
ME Operatory Chair	ADEC	Cascade 1040	2
ME 12 O'clock Treatment Console	ADEC	Preference 5580	2
ME Delivery Unit	ADEC	Cascade 3181	2
ME Accessory Console	ADEC	Preference 5631.44	1
ME Center Console	ADEC	Preference 5543.SB	1
ME Track-Mount Single Light	ADEC	Preference Mounted Light 28-1461	2
ME Doctor's Stool	ADEC	Cascade 1601	2
ME Assistant's Stool	ADEC	Cascade 1626	2
ME Intraoral x-ray	GENDEX	GX-770	1
ME Digital Radiography System	Schick Technologies		1
ME Dental Dell mini tower			1
ME CDR DICOM Software			1
ME Sensor size 2			1
ME Universal Holder Set-size2			1
ME USB remote			1
ME USB Remote Cable (5 meter)			1
ME USB CAM Kit			1
ME USB Cam Cable (5 m)			1
ME Universal Viewer, Slim Line, Des /Wall	HS	313-2507	1
ME Curing Light, Optilux	HS	549-7284	1
ME Apron, Adult	HS	100-4339	1
ME Apron Hanger	HS	100-3530	1
ME Steel Step-On Can, 32 qt	HS	545-5228	1
ME Safety Glasses	HS	100-7382	5
ME Glove Dispenser		100-6182	1
ME Cavitron SPS, Dentsply	HS	167-3341	1
ME In-Room Sharps Disposal System	HS	666-3672	1
ME XCP Instrument it	HS	189-4148	1
ME Disposable XCP Bite Bloc s, 100/box	HS	189-1585	1
ME Maxiclens Soap, Qt	HS	431-0032	2
ME Hand Pump for Maxiclens Soap	HS	431-1478	2
ME Light Handle Covers, "T"	HS	100-9864	2
ME Pro-Barrier Tube Sox	HS	991-5498	2



## Ambulatory Care Unit - Room Data Sheet

### 3.5 DENTAL EXAM ROOM

ITEM	VENDOR	MODEL	QUANTITY
ME X-Ray Covers	HS	101-6507	2
ME Push Button Low Speed Angles		772-6728	2
ME Hurricaine Gel Topical Anesthetic	HS	916-6726	2
ME Lidicaine HCL 2%, w/ Epi 1:100	HS	856-8483	15
ME Carbocaine HCL 3%, Plain	HS	856-0233	4
ME Marcaine HCL .5%, w/ Epi 1:200	HS	856-7407	2
ME Aspirating Syringe, CW type	HS	100-9808	10
ME On-Gard Recapper	HS	658-7851	2
ME College Pliers #317	HS	600-8348	10
ME Explorer/Probe #23/CP-12	HS	600-7165	15
ME Mirror #5 Front Surface/Cone Soc et	HS	600-0452	15
ME Mirror, Handle Cone Soc et	HS	600-0781	15
ME Tofflemire Retainer, Universal,Getz	HS	112-5550	5
ME Tofflemire Bands #1, .002,(36/ ),Getz	HS	112-3267	25
ME Amalgam Well	HS	100-1803	2
ME Amalgamator,ProMix,Dentsply/Caul	HS	222-4105	1
ME Wizard Wedges, Assorted	HS	112-4713	2
ME Articulating Paper, Thin	HS	100-2876	10
ME Endo-Ray II, 2/pk		733-0816	1
ME Absorbent Points, Assorted, 15-40		101-2534	10
ME Absorbent Points, Assorted, 45-80		101-5685	5
ME Bibs, DriGuard, 500/case	HS	100-9276	2
ME Bib Holder	HS	100-8229	2
ME 2" x 2" Gauze, non- sterile, 5000/case	HS	100-8608	1
ME Tray Covers, 1000/box	HS	101-1309	1
ME Evacuator Tips, High Volume, 50/bag	HS	100-4568	10
ME Saliva Ejectors, 100/bag	HS	100-5205	10
ME Surg-O-Vac Tips, .25", 25/pk	HS	889-0061	4
ME Cotton Pellet Dispenser	HS	754-7183	1
ME Cotton Roll Dispenser	HS	754-8598	1
ME Sundry Jars, Glass, 5/set	HS	100-4641	1
ME High Speed Handpiece, Midwest Tradition, Push Button, Non-fiber optic	HS	772-4247	6
ME Slow Speed Handpiece Motor, Midwest, Rhino XP Single Speed		772-3510	2
ME Slow Speed Handpiece Straight Attachment		772-5813	2

## 5. DEPARTMENTAL REQUIREMENTS

ITEM	VENDOR	MODEL	QUANTITY
ME Slow Speed Handpiece Ball Bearing Contra Angle Attachment, Latch Type		772-2941	2
ME Slow Speed Handpiece Contra Angle Sheath		772-1553	2
ME Midwest Plus Handpiece Maintenance System		772-4268	1
ME High Speed Handpiece, Midwest Tradition, Push Button, Fiberoptic		772-7345	6
ME Slow Speed Handpiece, Midwest Shorty Two Speed w/ Straight Attachment		772-7194	2
ME Slow Speed Handpiece Contra Angle Sheath		772-1553	2
ME Midwest Plus Handpiece Maintenance System		772-4268	1
ME Cavitron Inserts, 30K TFI-10 Straight	HS	167-4055	3
ME Floss Dispenser, Steel	HS	555-0406	1
ME Floss J & J (110 yds)	HS	555-9882	3





## Ambulatory Care Unit - Room Data Sheet

### 3.6 DENTAL LAB

The Dental Laboratory is used for preparation of materials needed for dental operations and periodontal appliances and devices. The Lab should be adjacent to the Dental Exam Rooms (in the dental suite) for efficiency of operations.

**The following are Dental Lab functions:**

- ✓ Utilized for sanitation of dental supplies and storage of dental supplies.
- ✓ Sterilization of dental equipment (Autoclave).
- ✓ Fabrication of lab models, denture repairs.
- ✓ Storage of chemicals and flammable cabinet.
- ✓ Performs machinery and equipment maintenance.



Photo

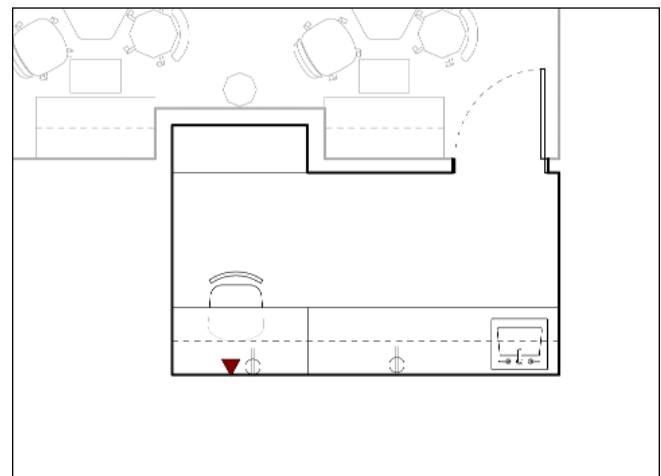

Floor Plan (80 nsf)

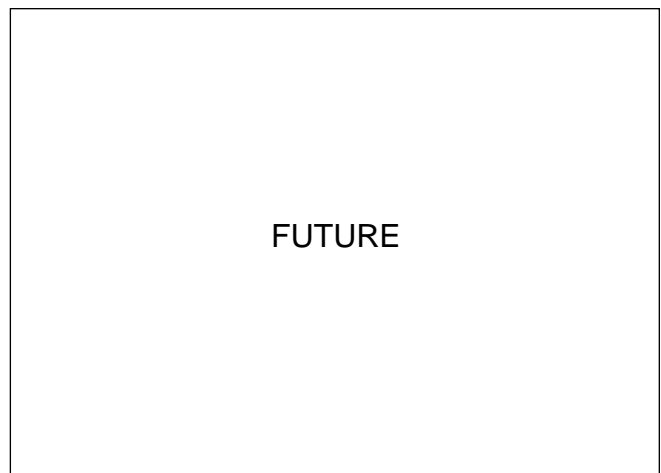

Isometric

### 3.6 SPACE MATERIAL MATRIX

<i>Walls</i>	<i>Floors</i>	<i>Ceiling</i>	<i>Doors</i>	<i>Hardware</i>	<i>Glazing</i>
Secure 1	VCT	Acoustic Tile	Custom H.M.	Mechanical Detection	
<i>Plumbing</i>	<i>HVAC</i>	<i>Lighting</i>	<i>Power</i>	<i>Elec./Security</i>	<i>Communications</i>
Sink			Per Medical Equip. Manufacturer	Intrusion Detection, PA Duress Alarm	Telephone, LAN

### 3.6 SPACE EQUIPMENT MATRIX

	ITEM	VENDOR	MODEL	QUANTITY
ME	Refrigerator, under counter			1
ME	Flammable Storage Cabinet	Justrite	4 gallon	1
ME	M9 Ultraclave Sterilizer	Sullivan-schein	386-1150	1
ME	Perio-Pro III Air Techniques Developer with Daylight Loader	HS	698-6096	1
ME	SciCan Statim 2000 Autoclave		138-8030	1
ME	Ultrasonic Cleaner	HS	100-6879	1
ME	Ultrasonic Cleaner Accessory Kit	HS	100-7900	1
ME	Daylight Loader	HS	698-7485	1
ME	Ezee Ieen 2.5 Water Distiller	HS	551-9685	1
ME	Ezee Ieen Cartridge Refill	HS	551-6714	2
ME	Model Trimmer	Buffalo	1/2 HQ, 10"	1
ME	Digipex III Apex Locator, Pulp Tester		923-2193	1
ME	Model Trimmer, Buffalo, 1/3 HP		365-6944	1
ME	Plaster Trap - Disposable	Buffalo	TRAP-EZE 5 Ga	1
ME	Rapid Access Developer & Fixer, Set	HS	111-0626	3
ME	D-Speed Film, Periapical Sz #2, 150/box	HS	100-7066	2
ME	D-Speed Film, Bitewing Sz #3, 100/box	HS	100-6107	2
ME	J & J Microtouch Gloves, Med, Box	HS	555-5324	10
ME	J & J Microtouch Gloves, Lg, Box	HS	555-5326	10
ME	J & J Barrier Mas , Tie-on, Box of 4	HS	555-6051	4
ME	C-Cl r Disposable Lens Cl ning Station	HS	101-1617	2
ME	Maxicide Plus, Qt	HS	101-5796	8
ME	All Rap 4" x 6", Cl r	HS	127-3240	2
ME	Dispenser for All Rap	HS	127-5189	1
ME	Tytin Amalgam, Double Spill, 600 mg Reg Set		123-3531	3
ME	Tytin Amalgam, Single Spill, 400 mg Reg Set		123-1421	3
ME	Monoject Needles, long 1 1/4", Yellow	HS	194-9460	5
ME	Monoject Needles, short 3/4", Blue	HS	194-5141	5
ME	Point 4 Optimized Particle Composite System	HS	123-7115	1
ME	Excavator #17	HS	600-3748	10
ME	Excavator #23	HS	600-6209	10
ME	Amalgam Carrier, Med/Large	HS	600-3316	5
ME	Amalgam Plugger # 1/2	HS	600-9295	10
ME	Amalgam Plugger # 0/1	HS	600-9517	10



## Ambulatory Care Unit - Room Data Sheet

### 3.7 DENTAL MECHANICAL ROOM

The Dental Mechanical Room contains the mechanical systems for generating dental air (compressor) vacuum, storage and chemical cabinet. This room should be located near the Dental Exam area for ease of access.



Photo

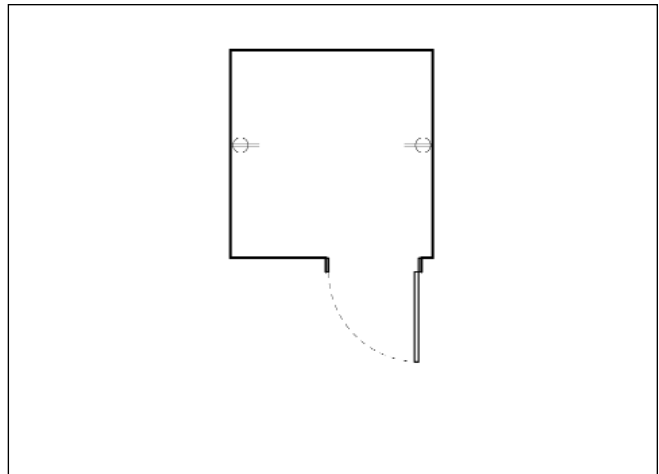

Floor Plan (25 nsf)

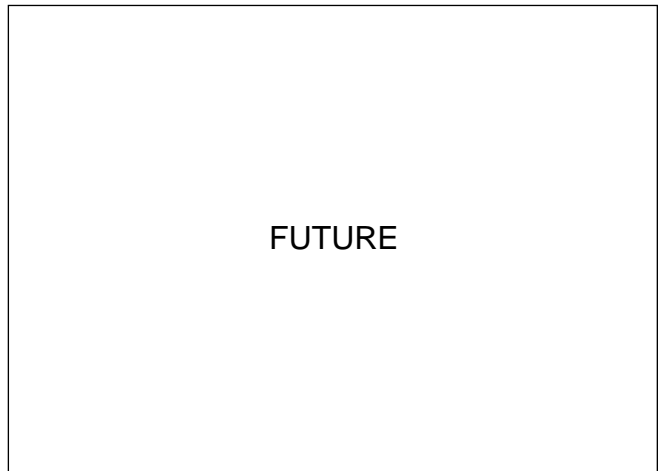

Isometric





## Ambulatory Care Unit - Room Data Sheet

### 3.8 MENTAL HEALTH ROOM

The Mental Health Room is a clinical exam room for Mental Health practitioner use in meeting with detainees requiring mental health treatment.

Following are functional uses of the Mental Health Room:

- ✓ Mental Health Screening, Diagnostic
- ✓ Interviews, Psychological Testing (if applicable), Psychotherapy, and Psychological services
- ✓ Consults psychiatrists and other mental health professionals
- ✓ Observation point for non-violent, non-aggressive detainee awaiting mental health services
- ✓ Daily living of mentally detainee, i.e., detainees unable to attend to activities of daily living or adequately care for themselves in population
- ✓ Provides educational activities, recreational therapy, and occupational therapy



Photo

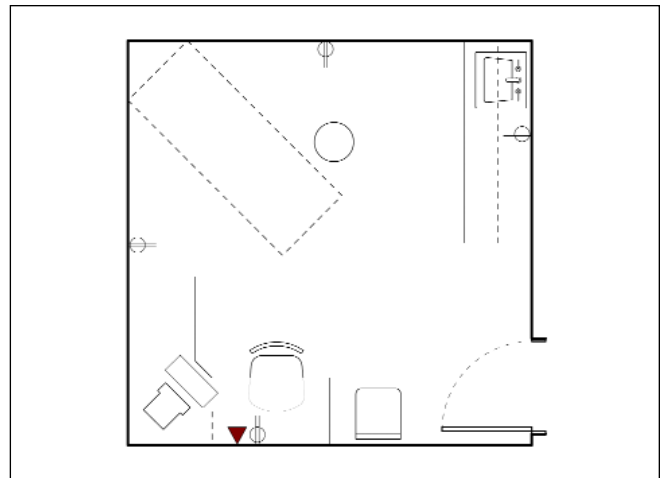

Floor Plan (100 nsf)

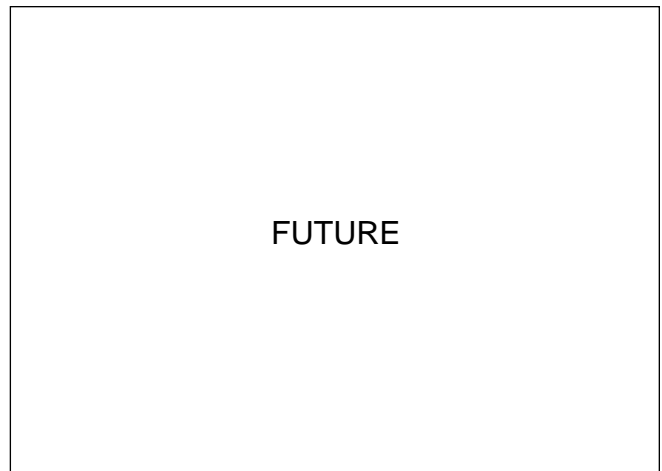

Isometric





## Ambulatory Care Unit - Room Data Sheet

### 3.9 NURSE COORDINATOR ROOM

The Nurse Coordinator Room is an open workstation area for management of detainees that are seeking admission into the Ambulatory Care Unit, or need OTC medication. In this space the Nurse Coordinator completes initial screening of patients being admitted for medical treatment. The Nurse Coordinator assigns patients to specific Exam Rooms and is the “gatekeeper” for Ambulatory Care.

In the past, this space was commonly used as a nurse triage area. In the new model, nurse triage is to be set up in the Housing Unit so that detainees do not have to be escorted to the Ambulatory Care Unit unless necessary.

#### Following are functional uses of the Medical Triage Area:

- ✓ Used to route all patients that are scheduled to be seen in the clinic
- ✓ Charts for clinic appointments are housed in this area.
- ✓ Triage of walk-in appointments
- ✓ Vital signs are performed on scheduled appointments and patient is routed to providers
- ✓ Communication center for all ambulatory clinic activities



Photo

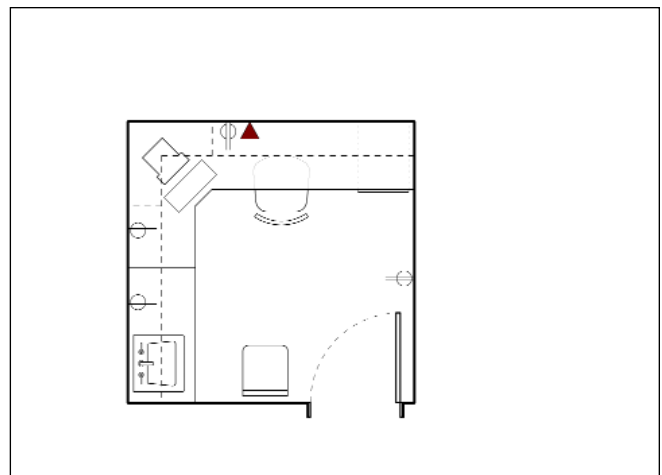

Floor Plan (100 nsf)

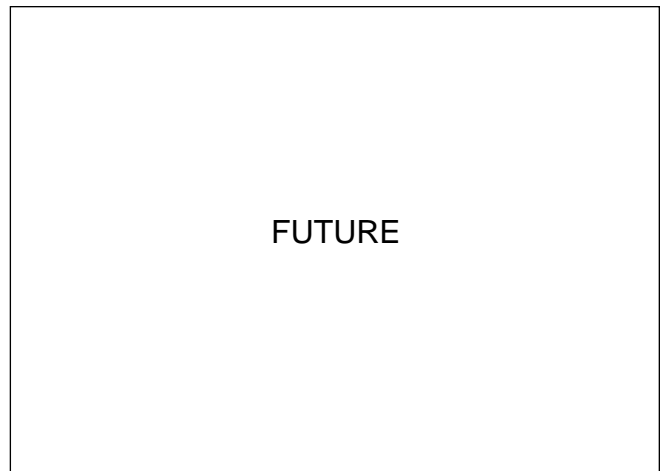

Isometric

**3.9 SPACE MATERIAL MATRIX**

<i>Walls</i>	<i>Floors</i>	<i>Ceiling</i>	<i>Doors</i>	<i>Hardware</i>	<i>Glazing</i>
Secure 1	VCT	Acoustic Tile	Detention H.M.	Mechanical	Detention Glass-clad polycarbon-
<i>Plumbing</i>	<i>HVAC</i>	<i>Lighting</i>	<i>Power</i>	<i>Elec./Security</i>	<i>Communications</i>
Lavatory			GFI Outlets	PA, Duress Alarm	Telephone, LAN

**3.9 SPACE EQUIPMENT MATRIX**

	ITEM	VENDOR	MODEL	QUANTITY
BI	Sink, handwashing			1
BI	Paper Towel Dispenser, roll, wall mount			1
BI	Liquid Soap Dispenser, wall mount			1
BI	Eyewash station, Faucet Mount	GSA	6523161	1
F	Desk/Workstation/Counter	Unicor	Bravo	2
F	Chair, rolling	Unicor	Bravo	2
F	Chair, patient	Unicor	Bravo	2
F	File cabinet, 4 drawer, locking			1
F	Storage Cabinet, Metal, 2 door, Locking	Staples	796615	1
ME	Vital Sign monitor w/pulse ox	Welch Allyn	52NTP-E1	1
ME	Oto-Ophthalmoscope, desktop hand held, with charger	Welch Allyn		1
ME	Thermometer, electronic	Welch Allyn	Sure-Temp 678	1
ME	Scale, Patient w height	Health o meter	32150	2
ME	Hammer, reflex, plastic, Taylor or Queen Square	US Neurologicals		1
ME	Stool, provider, rolling	Ritter	195-001	1
ME	BP Cuff Manual	Moore Medical	66306	1
ME	Glucometer	Moore Medical	97100	1
ME	Sharps container with glove dispenser, wall mount	GSA	UMISWM31000	1
ME	Stethoscope	Moore Medical	66256	1
ME	Wastebasket, biohazard, Step on, metal, red	GSA	URI-ST12EPLR	1
ME	Wastebasket, step-on, metal, White	GSA	URI-ST12EPLR	1
ME	Privacy Screen, 3 panel, rolling	United Metal Fab.	8425 with	1
ME	Eye Test Chart, Illiterate	Moore Medical	8503	2
ME	Clock, Wall	GSA	SET1164	1
ME	Telephone with Speakerphone			
ME	Computer			1
ME	Refrigerator, under counter, locking			
ME	Thermometer, refrig, digital	Tech Instrumentati	A150Q	1





## Ambulatory Care Unit - Room Data Sheet

### 3.10 URGENT CARE ROOM

The Urgent Care Room is an emergency treatment room for detainees with urgent/trauma related issues. This room should be located near the entrance from Housing and have easy access to the vehicle sally port for ambulance transfer to outside emergency care providers.

#### Following are functional uses of Urgent Care Room:

- ✓ Used for treatment of trauma, minor surgery and casting
- ✓ Houses emergency equipment: crash cart, oxygen, nebulizer, defibrillator, AED, medical supplies, medical instruments, EKG
- ✓ Used for treatment of urgent medical needs, stabilization, and minor invasive procedures
- ✓ Also used for procedures requiring privacy like pelvic exams, and dressing changes
- ✓ Could be used for stabilization of patients after anxiety attacks or suffering emotional distress
- ✓ Overhead lighting and gurney essential equipment



Photo

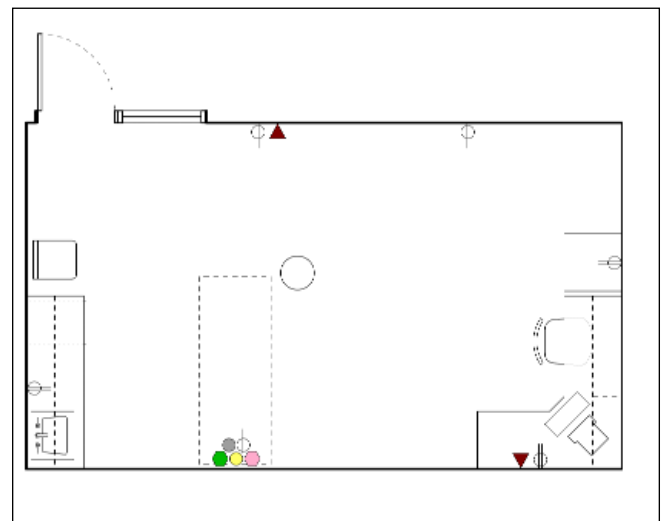

Floor Plan (250 nsf)

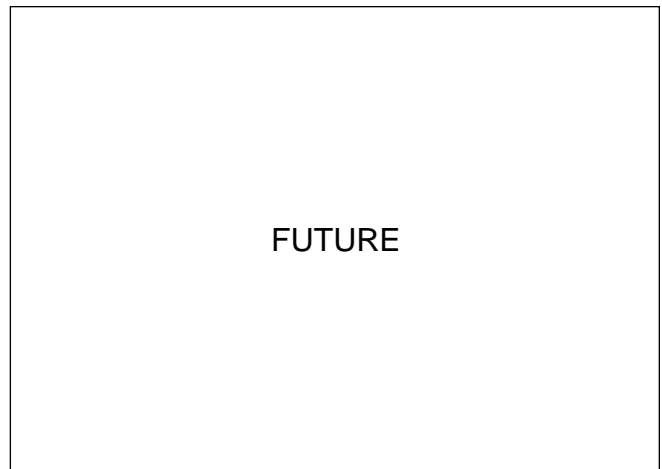

Isometric

**3.10 SPACE MATERIAL MATRIX**

<b>Walls</b>	<b>Floors</b>	<b>Ceiling</b>	<b>Doors</b>	<b>Hardware</b>	<b>Glazing</b>
Secure 1	VCT	Acoustic Tile	Detention H.M. Oversized for gurney	Mechanical Detention	
<b>Plumbing</b>	<b>HVAC</b>	<b>Lighting</b>	<b>Power</b>	<b>Elec./Security</b>	<b>Communications</b>
Lavatory		Exam Light,Ceiling Hung by ICE	GFI Outlets		Telephone, LAN

**3.10**

	ITEM	VENDOR	MODEL	QUANTITY
BI	Casework (like El Centro) with small sink, locking under counter drawers and overhead storage			1
BI	Paper Towel Dispenser, roll, wall mount			1
BI	Liquid Soap Dispenser,wall mount			1
BI	Eyewash station, Faucet Mount	GSA	6523161	1
BI	Emergency Shower, ceiling mount with drain			1
BI	Headwall Chase w/ oxygen, Suction			1
F	Chair, rolling	Unicor	Bravo	1
F	Chair, patient	Unicor	Bravo	1
ME	Carts, rolling, equipment			
ME	Vital Sign monitor w/pulse ox (with cart)	Welch Allyn	52NTP-E1	1
ME	Oto-Ophthalmoscope, Welch-Allyn, wall mnt,	Welch Allyn	767 System (79510)	1
ME	Thermometer, electronic	Welch Allyn	Sure-Temp 678	1
ME	AED Machine, "Quick grab unit" for emergency response	Cardiac Science	G-3 Series	1
ME	Zoll Defibrillator/Monitor	Zoll	M Series	1
ME	Zoll Battery Charger W extra battery	Zoll	for M Series	1
ME	EKG Machine, 12 lead on 1 sheet paper with rolling cart			1
ME	EKG Battery charger with Batteries			1
ME	Pump, IV Infusion, 1-Line with Stand	Baxter	Flo-Gard 6201: Cat. #2M8063	1
ME	Fetal Doppler FD1	Moore Medical	44677	1
ME	Backboard	Moore Medical	62918	2
ME	Transporter, mobile, model 35-A	Goldenhour Medical	FM35A	1
ME	Gurney, triage, positions changes/movements*	Alliance Medical	Ferno Model 35-A	1
ME	"Code clock"			1
ME	Sphygmomanometer, Wall mount	Welch Allyn	767 (7670-01CB)	1
ME	Light, Exam, Ceiling,	Burton	124522	1
ME	Light, Exam, rolling, Halogen	Welch Allyn	LS-150 with mobile castor base	1
ME	Stretcher, Treatment, Emergency	Stryker	Renaissance 1231	1
ME	Nebulizer, electric	Moore Medical	45873	1
ME	Aspirator	Gomco	405 with 01-10-0814 cart	1
ME	Mayo Instrument Stand, foot pedal adjust, 16x21 tray	UMF	SS8311	1



## Ambulatory Care - Room Data Sheet

### 3.10 SPACE EQUIPMENT MATRIX

ITEM	VENDOR	MODEL	QUANTITY
ME Crash Cart	Health Care Logistics	5391	1
ME Hammer, reflex, plastic, Taylor or Queen Sq.	US Neurologicals		1
ME Large "Go Bag"			1
ME AED Starter Kit	Cardiac Science	for G-3 Series	1
ME Light, UV (Woods) with Magnifier, UV & white light		316030	
ME Stool, provider, rolling	Midmark	195	1
ME BP Cuff Manual	Moore Medical	66306	1
ME Welch Allyn Direct Plug in Handle	Welch Allyn	71000-A	2
ME Glucometer	Moore Medical	97100	1
ME Scale, Patient w height	Health o meter	32150	1
ME Sharps container with glove dispenser, wall mount	GSA	UMISWM310001H	1
ME Stethoscope	Welch Allyn	5079-135	1
ME Wastebasket, biohazard, Step on, metal, red	GSA	URI-ST12EPLRD	1
ME Wastebasket, step-on, metal, White	GSA	URI-ST12EPLRD	1
ME Blanket, Gurney			2
ME Privacy Screen, 3 panel, rolling	United Metal Fab.	8425 with 860 curtain	1
ME Drill, Fingernail (two speed cordless multipro 770)	Moore Medical	73283	1
ME Irrigator, Ear	Moore Medical	69253	1
ME Saw, cast	American Orthopaedic		1
ME Cast Spreader, Moore German	Moore Medical	14653	1
ME Clock, Wall	GSA	SET1164	1
ME Telephone with Speakerphone			
ME Computer			1
ME Illuminator, Film, 2-Bank Surface	Carr Corp	2WS	1
ME IV Stand	Moore Medical	41113	1
ME Hamper, Linen, Foot Pedal Operation			1
ME Backboard Straps	Moore Medical	48333	4
ME Backboard head blocks	Moore Medical	66049	1
ME Kickbucket, Removeable Pail w/frame	Pedigo Products	P-1020-SS	1
ME Oxygen tank, D, Aluminum	Armstrong Medical	DV-91T	1
ME Oxygen tank cart, 2 wheel	Armstrong Medical	DV-99H	1
ME Oxygen Regulator, 0-25 lpm	Armstrong Medical	DV-330	1
ME Sundry Jars, plastic	Moore Medical	65227	1



## Ambulatory Care Unit - Room Data Sheet

### 3.11 TELEMEDICINE MACHINE ROOM

The Telemedicine Machine Room is an examination and treatment room that has video teleconferencing capabilities for remote access to specialist physicians in the diagnosis and treatment of detainees.



Photo

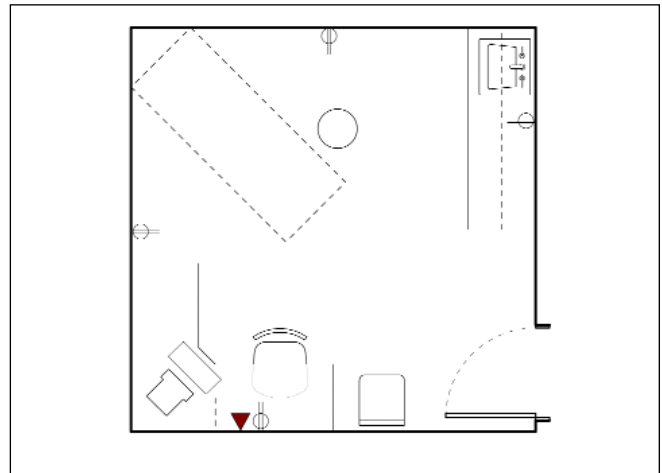

Floor Plan (100 nsf)

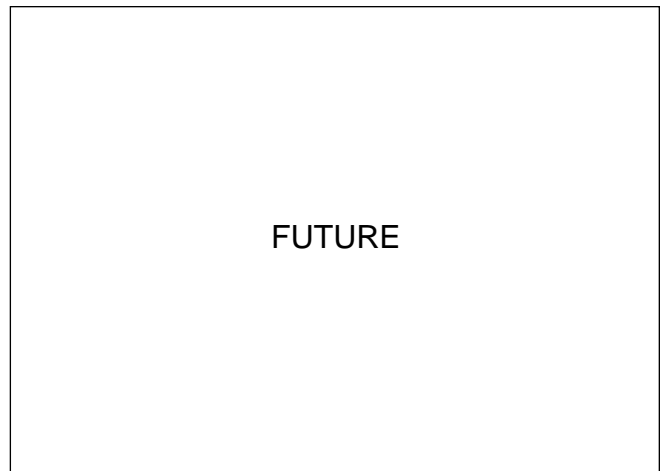

Isometric

**3.11 SPACE MATERIAL MATRIX**

<i>Walls</i>	<i>Floors</i>	<i>Ceiling</i>	<i>Doors</i>	<i>Hardware</i>	<i>Glazing</i>
Secure 1	VCT	Acoustic Tile	Detention H.M.	Mechanical Detention	
<i>Plumbing</i>	<i>HVAC</i>	<i>Lighting</i>	<i>Power</i>	<i>Elec./Security</i>	<i>Communications</i>
Lavatory		Exam Light	GFI Outlets		Telephone, LAN

**3.11 SPACE EQUIPMENT MATRIX**

	ITEM	VENDOR	MODEL	QUANTITY
BI	Lighting, color corrected for medical videoconferencing			
BI	Walls painted "Telemedicine Blue"			
BI	Casework with small sink, under counter drawers and overhead storage			1
BI	Paper Towel Dispenser, roll, wall mount			1
BI	Liquid Soap Dispenser, wall mount			1
BI	Eyewash station, Faucet Mount	GSA	6523161	1
F	Workstation, with lower drawers and upper storage, locking	Unicor	Bravo	1
F	Chair, rolling, provider	Unicor	Bravo	1
F	Chair, patient	Unicor	Bravo	1
F	File cabinet, 4 drawer, locking	Unicor	Bravo	1
ME	Medical Videoconferencing System	DIANA Associates		1
ME	Exam Light, Halogen, rolling	Welch Allyn	LS-150 with mobile castor base	1
ME	Examination Table with storage	Midmark	304	1
ME	Stool, provider, rolling	Midmark	195	1
ME	Sphygmomanometer, Manual, hand held	Moore Medical	66306	1
ME	Sphygmomanometer, Wall mount	Welch Allyn	767 (7670-01CB)	1
ME	Oto-Ophthalmoscope, Welch-Allyn, wall mount,		AD451	1
ME	Sharps container with glove dispenser, wall mount	GSA	UMISWM310001H	1
ME	Stethoscope	Welch Allyn	5079-135	1
ME	Wastebasket, biohazard, Step on, metal, red	GSA	URI-ST12EPLRD	1
ME	Wastebasket, step-on, metal, White	GSA	URI-ST12EPLRD	1
ME	Hammer, reflex	Taylor	1115	1
ME	Privacy Screen, 3 panel, rolling	United Metal Fab.	8425 with	1
ME	Mayo Instrument Stand, foot pedal adjust, 16x21 tray	UMF	SS8311	1
ME	Clock, Wall	GSA	SET1164	1
ME	Telephone with Speakerphone			
ME	Computer			1
ME	Sundry Jars, plastic	Moore Medical	65227	1
ME	Illuminator, Film, 2-Bank Surface	Carr Corp	2WS	1



## 4.0 SHORT STAY UNIT



## Short Stay Unit (Infirmary) - Functional Adjacencies

### 4.0 SHORT STAY UNIT (INFIRMARY)

The Short Stay Unit is a treatment area for detainees requiring nurse supervised overnight care. It houses treatment rooms with showers and toilets as well as several isolation rooms for detainees with communicable illnesses. The Short Stay Unit has direct access to and from the Ambulatory Care unit.

#### SICK CALL PROCESSING

Sick call occurs when a housed detainee requests medical service. A staff nurse conducts periodic sick call visits to the housing unit for detainees in the nurse triage area of the housing pod. It is here that initial requests are reviewed and acted upon. Medications may also be administered in this area. Detainees needing to be seen in the clinic are taken there or scheduled for an appointment where a determination of need for additional medical service is made. This process involves the three basic medical responses listed below.

#### Non-Medical Concern

If there appears to be no health issue the detainee is reverted to the appropriate section of the housing unit.

#### Medical Concern - OTC Medication

The condition of the detainee is assessed and over the counter medications may be distributed. The detainee is released back to housing.

#### Referral

If the initial evaluation indicated that the detainee is ill, or needs to see a provider, he/she is sent to either the Ambulatory Care Unit, Short Stay Unit (SSU), Special Housing Unit (SHU), or escorted to the hospital by ambulance from the vehicle Sally Port.

### Short Stay Unit (Infirmary)

#### Critical Issues

- ✓ Provide two access points from Ambulatory Care for entry of detainees from initial Intake and from Sick Call entries.
- ✓ Provide complete visual access to all rooms from nurse call station.
- ✓ Locate Respiratory Isolation Rooms closest to the intake areas in Ambulatory Care.

#### Special Requirements

The Short Stay Unit should have direct access from the central vestibule. A central Nurse Station should be located where there is unobstructed visual access to patient Ward Rooms. It is desirable for each ward room to contain a shower and combo unit. Soiled and Clean Utility Rooms should be easily accessed for Ward Room maintenance. A Day Room with secured exterior recreation yard should be provided.

#### Space Requirements

#### 4.0 SHORT STAY UNIT (INFIRMARY)

- 4.1 4-Bed Ward (in medical/mental referral centers)
- 4.2 2-Bed Ward (in medical/mental referral centers)
- 4.3 Single Bed Room (in medical/mental referral centers)
- 4.4 Mental Health Ward
- 4.5 Suicide Observation Room
- 4.6 Safety Cell
- 4.7 Respiratory Isolation Room w/Vestibule (universal)
- 4.8 Nurse Manager's Office
- 4.9 Nurses Station (w/Security Officer)
- 4.10 Detainee Shower/Tub Room
- 4.11 Medication Preparation Room
- 4.12 Kitchenette
- 4.13 Physical Therapy Room
- 4.14 Infirmary Supply Room
- 4.15 Soiled (Utility) Linen Room
- 4.16 Clean (Utility) Linen Room
- 4.17 Janitor's Closet
- 4.18 Staff Toilet
- 4.19 Day Room

### 4.0 SHORT STAY UNIT (INFIRMARY) WORKFLOW PATTERN

Sick Call Triage Diagram

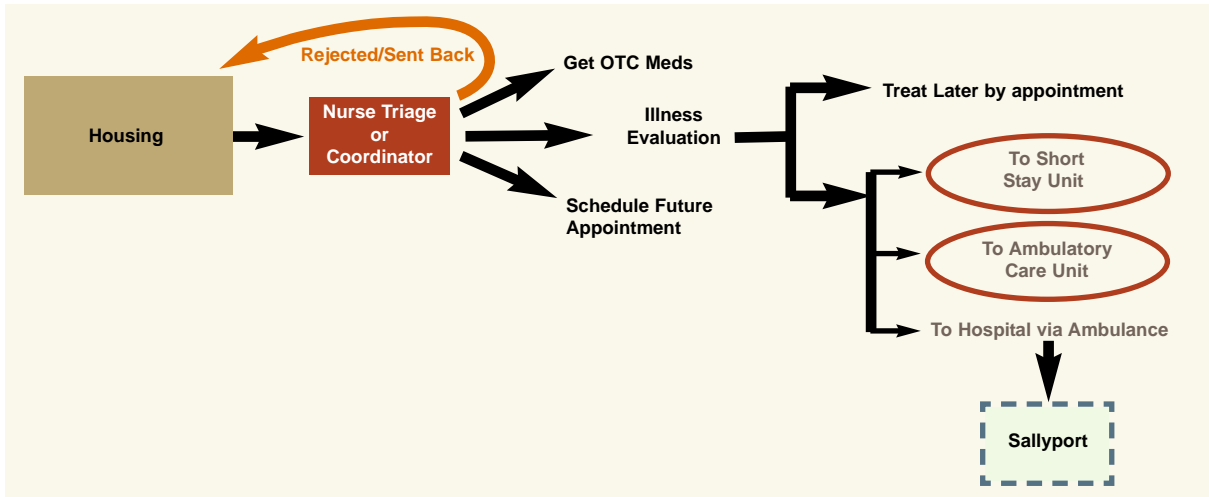

### 4.0 SHORT STAY UNIT (INFIRMARY) ORGANIZATIONAL MODEL

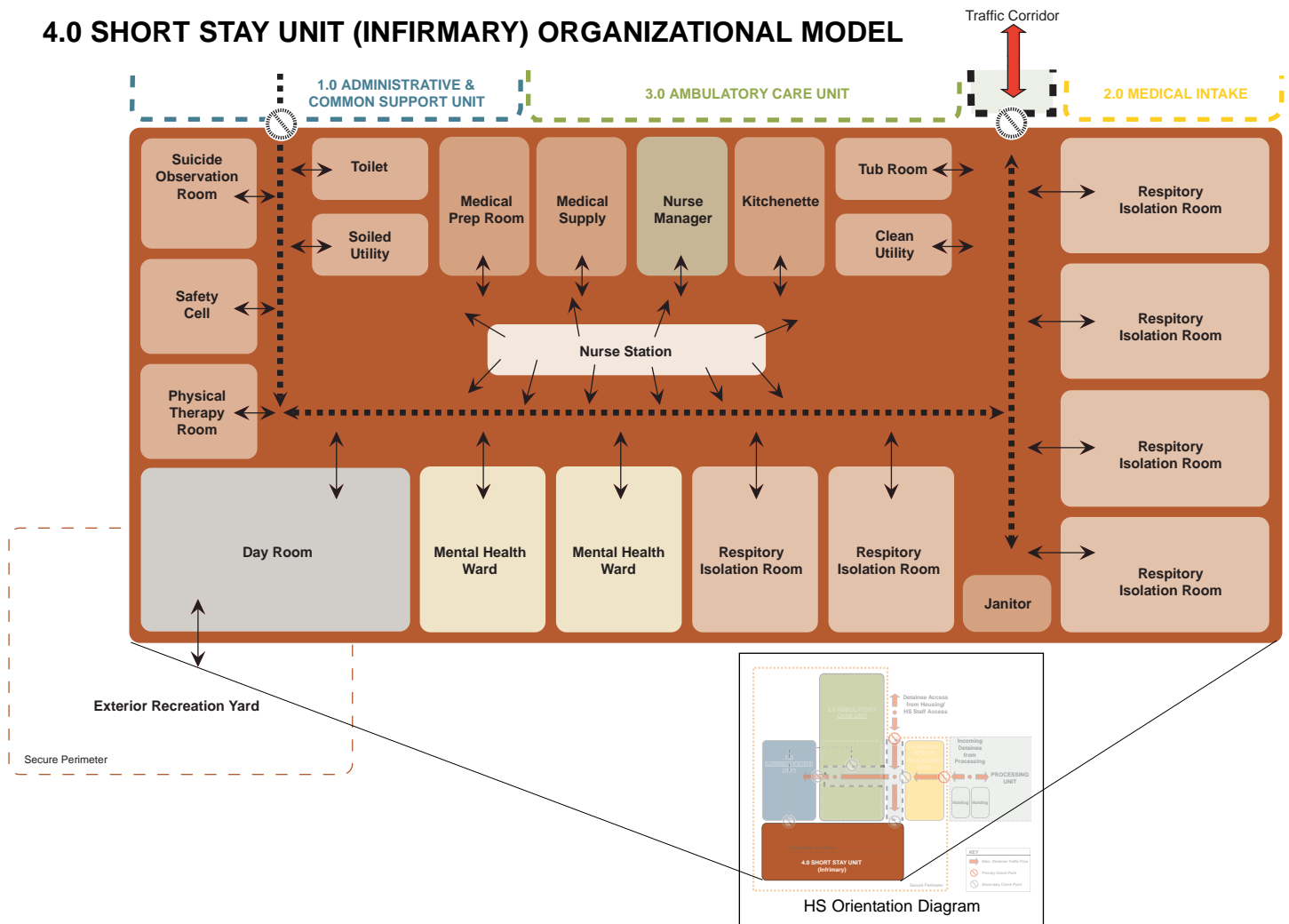





## Short Stay Unit (Infirmary) - Concepts

### INTRODUCTION

In order to delineate operational imperatives for Short Stay functions, the following workflow diagrams describe and diagram the relationships between HS staff, Detainees and specific processes.

#### 1. Indirect Visual Access

Ward Rooms should be configured such that no two are directly across from each other.

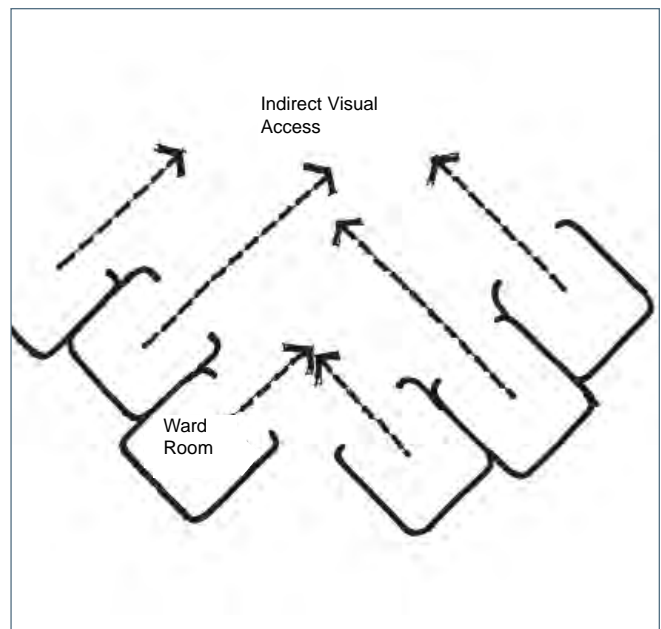

#### 2. Respiratory isolation Vestibule

Create a vestibule with access into two separate isolation cells. The vestibule will have two primary functions:

To create an air lock to prevent the spread of contagious respiratory disease

To provide a place for nurses to quarantine their potentially contaminated clothing items and wash hands.

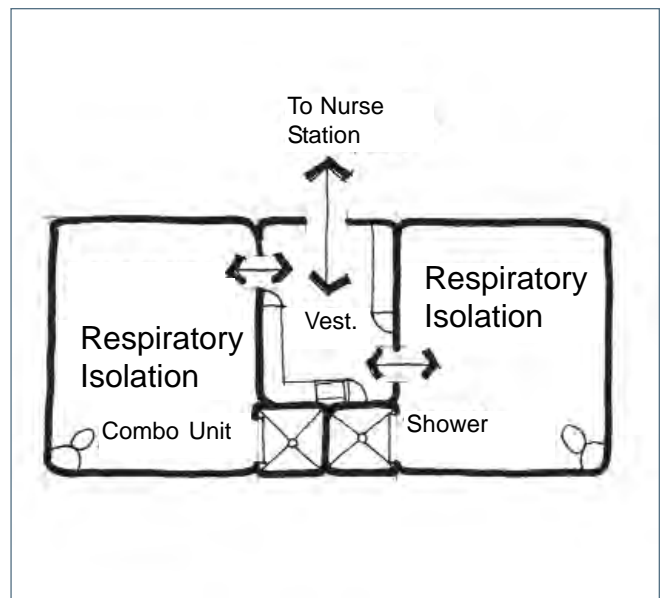

**3. Unobtrusive Shared Maintenance Closets**

Plumbing chases should be planned for ease of access by Maintenance personnel from outside of the detainee area.

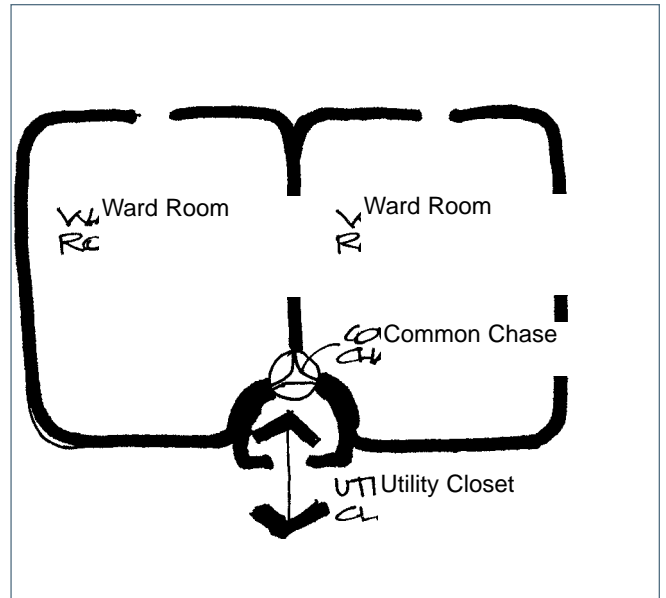



## D. Short Stay Unit (Infirmary) - Room Data Sheets

### ROOM DATA SHEETS

The following provides specific data regarding the rooms located within the Short Stay Unit of Health Services. Each room data sheet includes the following information:

- ✓ Functional Description
- ✓ Representative Photograph
- ✓ Room Floor Plan
- ✓ Isometric
- ✓ Space Materials Matrix
- ✓ Room Equipment Matrix

### SYMBOL LEGEND



**BI** - Built-in

**F** - Furniture

**ME** - Medical Equipment



## Short Stay Unit (Infirmary) - Room Data Sheet

### 4.1 4-BED WARD

The 4-Bed Ward is used for medical and mental referral center detainees requiring overnight stays for illness and supervised observation. In the new HS model Short Stay Unit, universal respiratory isolation rooms will be developed as the standard room creating more flexibility in detainee care.

#### Following are functional uses of the 4-Bed Ward:

- ✓ Utilized by short stay unit patients
- ✓ Screening for physical examinations
- ✓ Recording vital signs, weight, and visual acuity
- ✓ Sick call and sick call triage



Photo

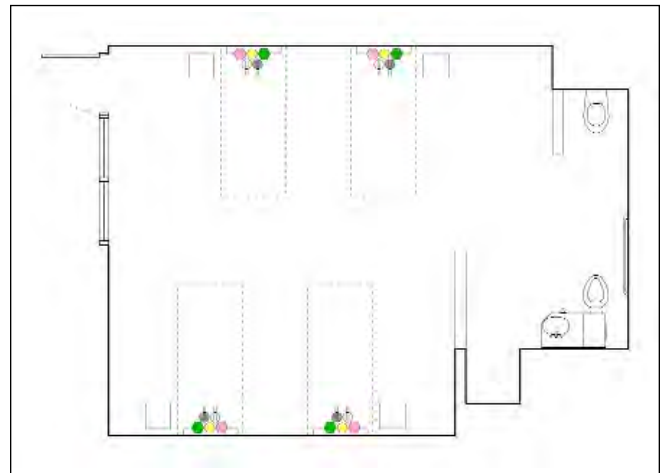

Floor Plan (320 nsf)

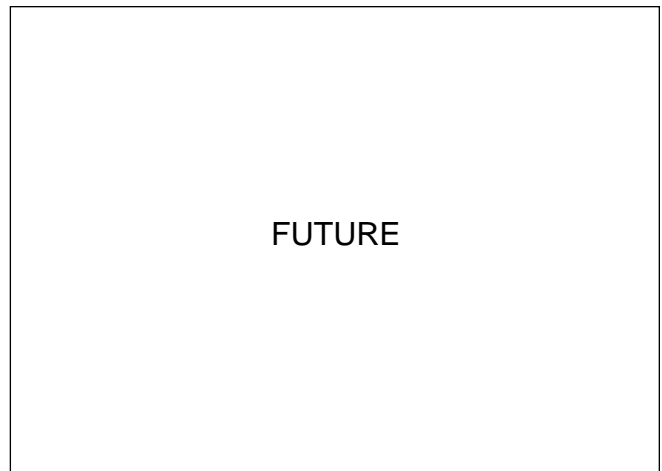

Isometric Plan

FUTURE





## Short Stay Unit (Infirmary) - Room Data Sheet

### 4.2 2-BED WARD

The 2-Bed Ward is used for medical and mental referral center for Short Stay patients requiring supervised overnight treatment. In the new HS model Short Stay Unit, universal respiratory isolation rooms will be developed as the standard room creating more flexibility in detainee care.

#### Following are functional uses of the 2-Bed Ward:

- ✓ Utilized by short stay unit patients as housing area for bath, eat, sleep etc
- ✓ Screening for physical examinations
- ✓ Recording vital signs, weight, and visual acuity
- ✓ Sick call triage
- ✓ Medication administration, patient and staff education
- ✓ Pill line
- ✓ Medication and OTC cart storage
- ✓ Handwashing, toilet and bathroom facilities

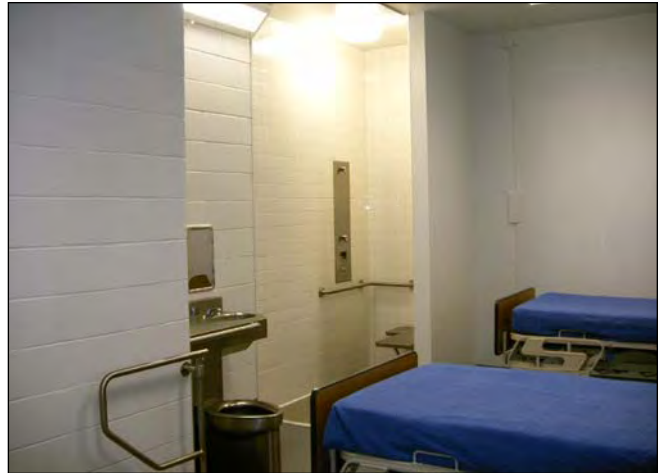

Photo

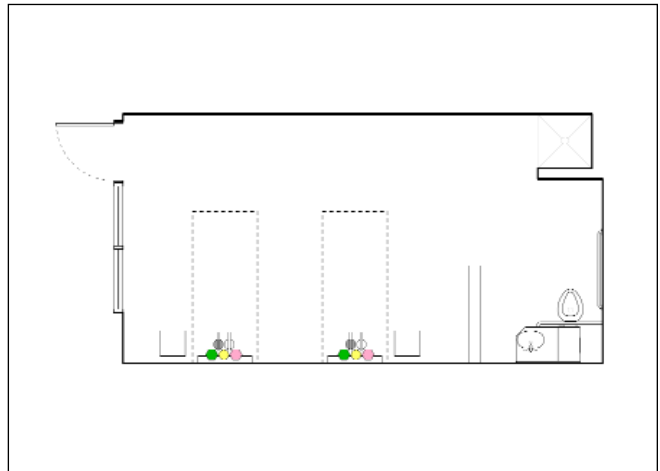

Floor Plan (180 nsf)

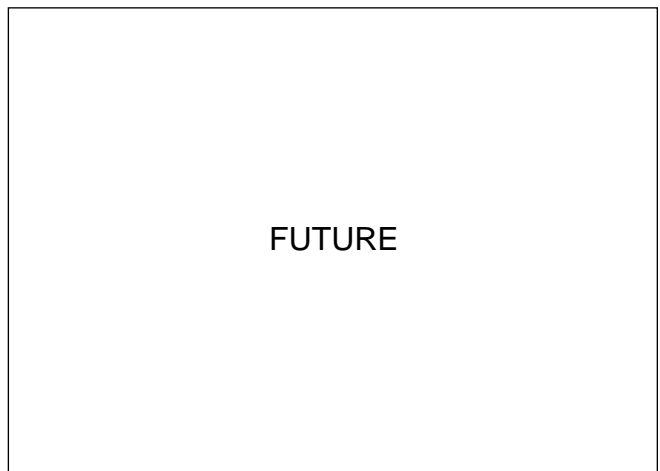

Isometric Plan





## Short Stay Unit (Infirmary) - Room Data Sheet

### 4.3 SINGLE BED ROOM

The Single Bed Room is used for medical and mental referral centers patients for single patient supervised overnight medical treatment. In the new HS model Short Stay Unit, universal respiratory isolation rooms will be developed as the standard room creating more flexibility in detainee care.

The Single Bed Room includes the following functions:

- ✓ Screening for physical examinations
- ✓ Recording vital signs, weight, and visual acuity
- ✓ Sick call and sick call triage
- ✓ Medication administration, patient and staff education
- ✓ Pill line
- ✓ Medication and OTC cart storage.
- ✓ Handwashing, toilet and bathroom facilities



Photo

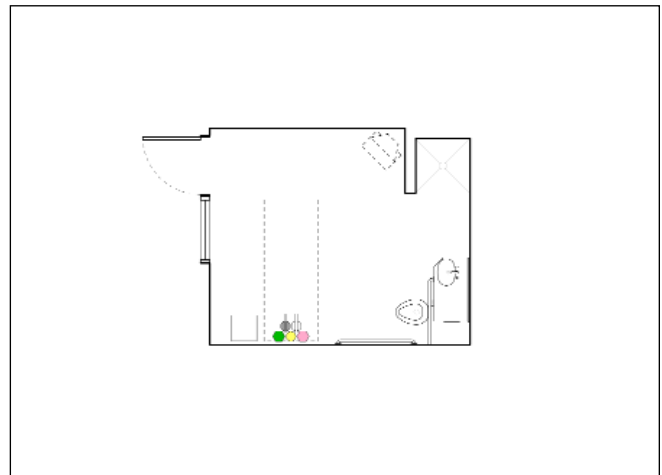

Floor Plan (80 nsf)

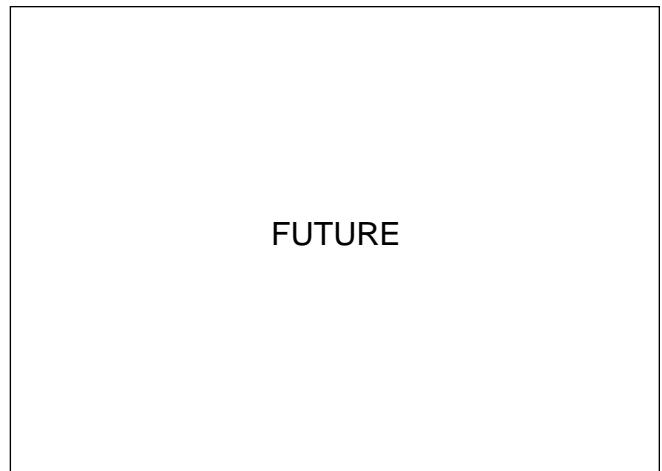

Isometric Plan







## Short Stay Unit (Infirmary) - Room Data Sheet

### 4.4 MENTAL HEALTH WARD

The Mental Health Ward is a set of treatment rooms in the Short Stay Unit that is used for Mental Health services.

#### Following are the functional uses of the Mental Health Ward:

- ✓ Performs mental health exam and on-going therapy.
- ✓ See mental health appointments.
- ✓ Performs mental health evaluations of patients-private and confidential interviews.
- ✓ Follow-up sessions with patient-private and confidential psychotherapy and psycho-educational sessions.
- ✓ Performance Improvement coordinator duties gathering, processing and storage of PI documents, various required documents.
- ✓ Conducts staff training development.
- ✓ Storage of mental health training materials, patient education material, psychology reference books and materials.



Photo

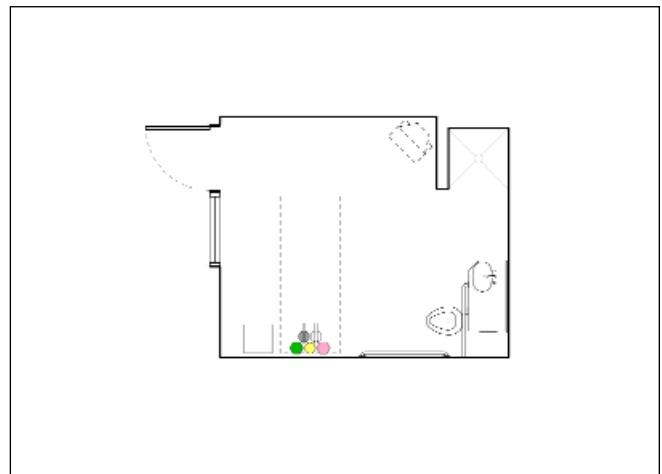

Floor Plan (100 nsf)

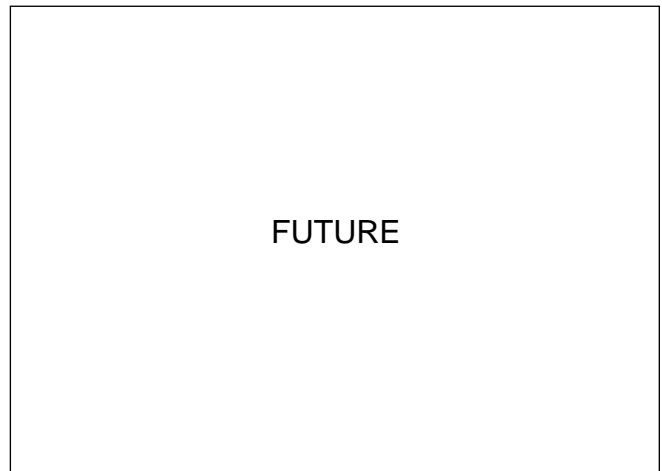

Isometric





## Short Stay Unit (Infirmery) - Room Data Sheet

### 4.5 SUICIDE OBSERVATION ROOM

The Suicide Observation Room is part of the Mental Health Ward. It contains windows for observation by Mental Health practitioners. The Observation Room provides safe, suicide proof environment without protrusions of any kind. This room may double as a Time-Out Room.



Photo

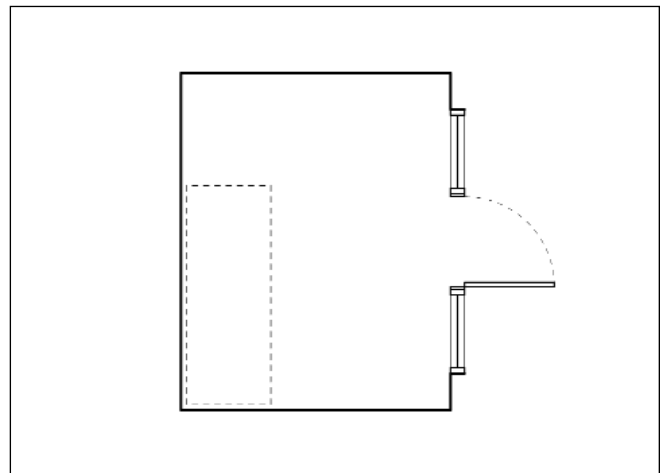

Floor Plan (80 nsf)

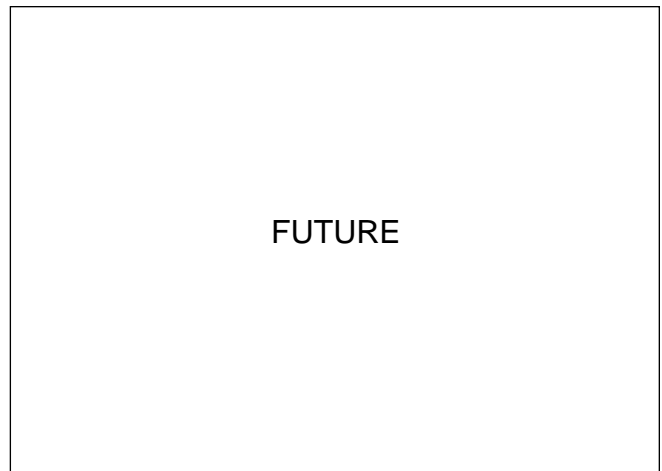

Isometric





## Short Stay Unit (Infirmery) - Room Data Sheet

### 4.6 SAFETY CELL

The Safety Cell is for detainees that require isolation for safety and observation or who exhibit behavior that may be harmful to themselves or others. This Room may also be used as treatment area for mentally ill detainees. This room requires special finishes that can be washed down and must be constructed without protrusions of any kind.

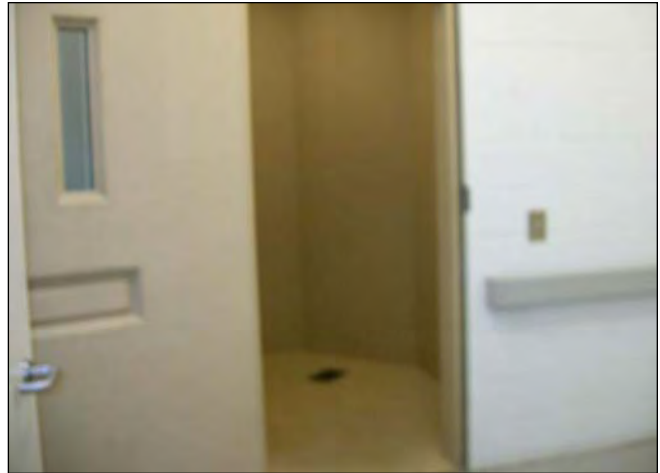

Photo

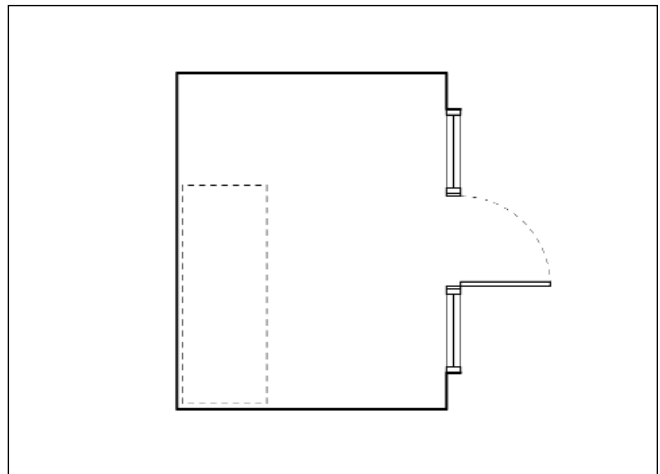

Floor Plan (64 nsf)

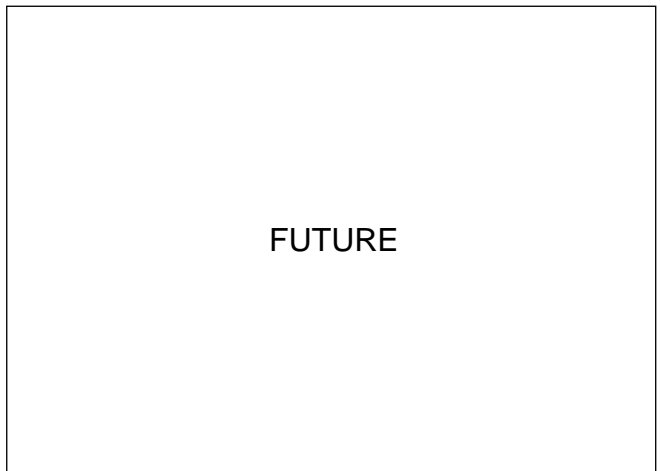

Isometric





## Short Stay Unit (Infirmary) - Room Data Sheet

### 4.7 RESPIRATORY ISOLATION ROOM w/VESTIBULE

The Respiratory Isolation Rooms are single occupant rooms with shared vestibule to physically isolate detainees with communicable respiratory illnesses. In the new Short Stay Unit model, these rooms will become the standard universal patient room (replacing 4, 2 and standard single-bed ward rooms) providing HS with a high degree in flexibility of detainee care.

#### Following are the functional characteristics of Respiratory Isolation Rooms:

- ✓ Provides a respiratory isolation environment for patients suspected to have active TB
- ✓ Contains toilet, sink and paper towel dispenser
- ✓ Contains a vestibule with sink and paper towel dispenser
- ✓ Floor bolted beds
- ✓ Safe environment



Photo

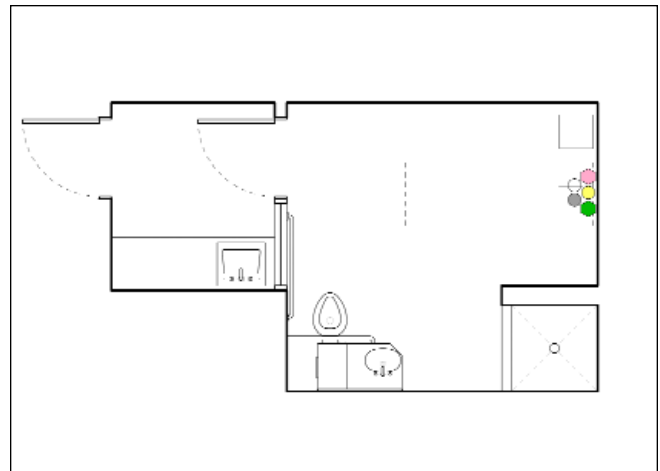

Floor Plan (180 nsf)

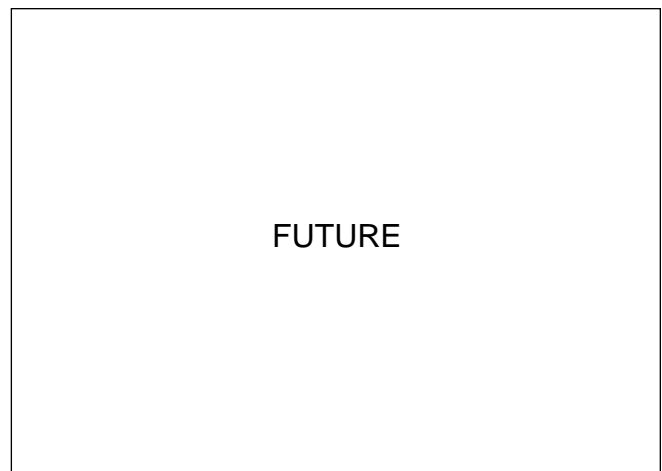

Isometric







## Short Stay Unit (Infirmary) - Room Data Sheet

### 4.8 NURSE MANAGER'S OFFICE

The Nurse Manager's Office is located adjacent to the nurse station in the Short Stay Unit. It functions as the administrative center for the nursing staff assigned to both Ambulatory Care, Medical Intake and Processing and Short Stay Units.

#### Following are the functional uses and characteristics of the Nurse Manager's Office:

- ✓ Used for completion of additional duties (HSO, IC, Education Coordinator, Project Coordinator, Medical Escort, JCAHO)
- ✓ Used for staff counseling, interviewing, training.
- ✓ Maintenance of completed logs and documentation (shift reports, sharps counts, lab log, tool control, urgent care log, nursing staff meeting minutes).
- ✓ For orientation of New Nursing Staff.



Photo

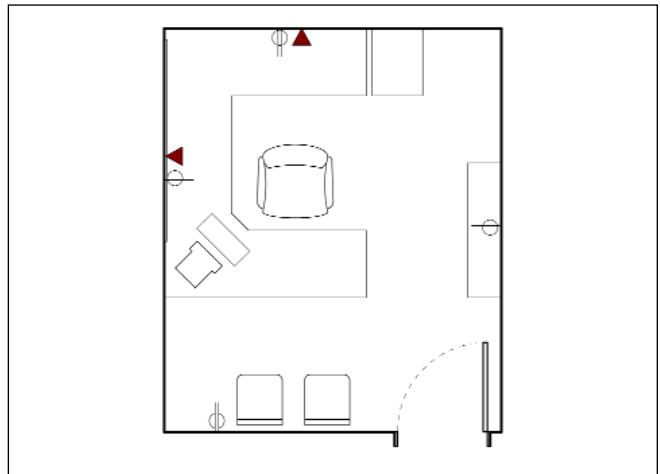

Floor Plan (80 nsf)

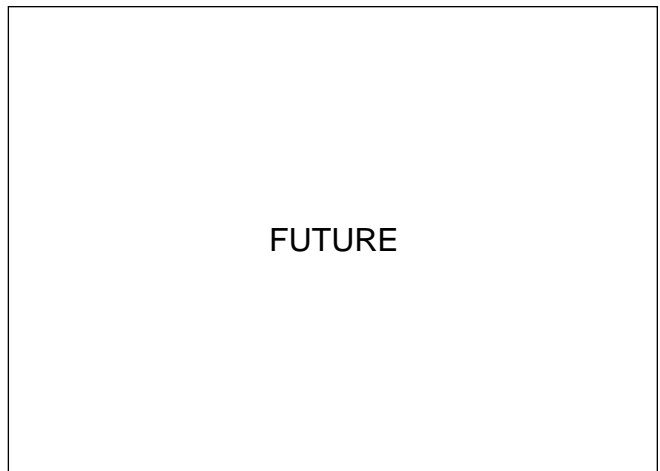

Isometric





## Short Stay Unit (Infirmery) - Room Data Sheet

### 4.9 NURSES STATION (w/SECURITY OFFICER)

The Nurses Station in Short Stay Unit is centrally located to provide visual access to all patient rooms from the station.

#### Following are the functions and characteristics of the Nurse Station:

- ✓ Conducts sick call triage
- ✓ Medication and OTC cart storage
- ✓ Patient and staff education
- ✓ Pill Line and narcotics count
- ✓ Storage of files and patient charts
- ✓ Houses necessary logs, reference materials, post orders and patient charts
- ✓ Provides a central place for nurses to chart and organize patient care
- ✓ Nurses conduct collateral duties



Photo

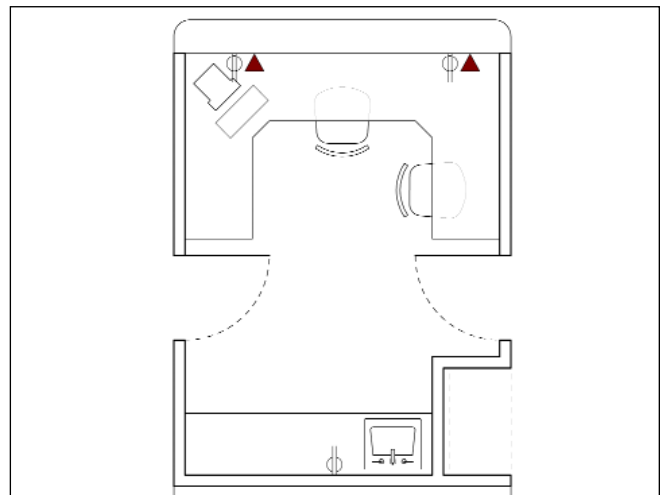

Floor Plan (128-192 nsf)

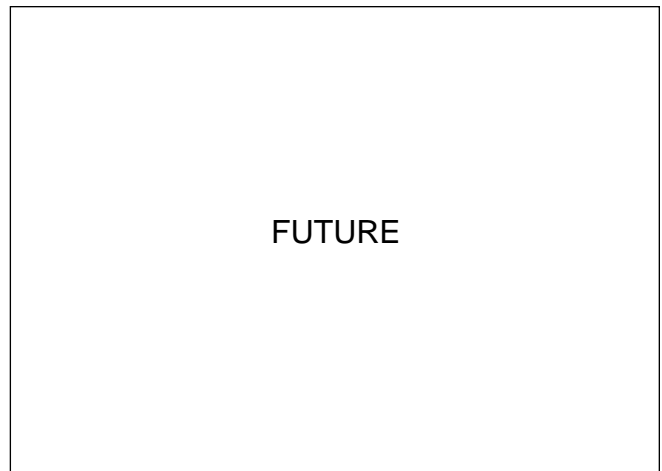

Isometric

FUTURE





## Short Stay Unit (Infirmery) - Room Data Sheet

### 4.10 DETAINEE SHOWER/TUB ROOM

Near Short Stay Wards and near the nurses station, the Shower/Tub Room is for supervised detainee bathing and shaving. Each room contains a shower for use by the patient. The Shower/Tub Room is for supervised use by patients needing assistance due to mental or physical disability.



Photo

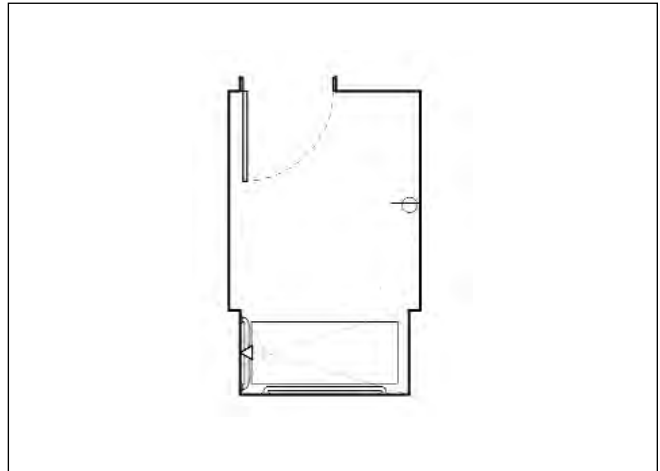

Floor Plan (50 nsf)

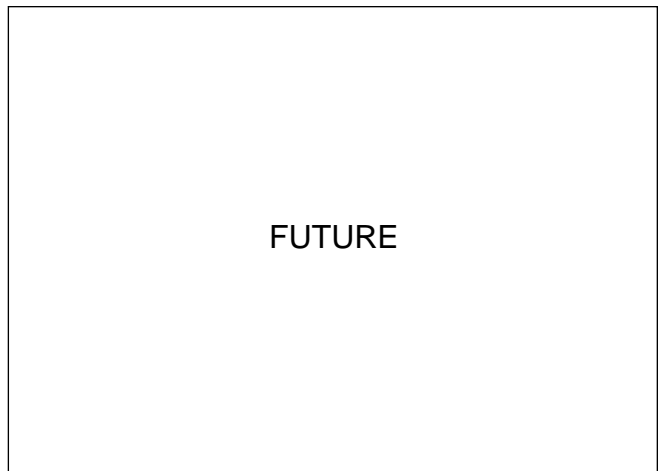

Isometric





## Short Stay Unit (Infirmary) - Room Data Sheet

### 4.11 MEDICATION PREPARATION ROOM

The Medication Preparation Room is a secure room located for easy access to Short Stay Unit nursing staff. It is used for the preparation of medications to be administered/dispensed to patients in the Short Stay Unit. Dispersion is accomplished with the use of a cart that is wheeled to the patient room where medication is administered.

**Following is the functional use and characteristics of the Medication Preparation Room:**

- ✓ Preparation of medication to give to detainees
- ✓ Storage of medicine carts
- ✓ Storage of appropriate medicine supplies
- ✓ Sink and paper towel dispenser



Photo

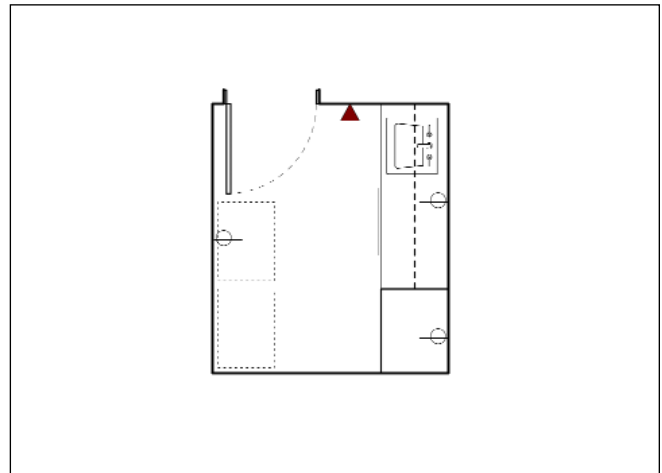

Floor Plan (25 nsf)

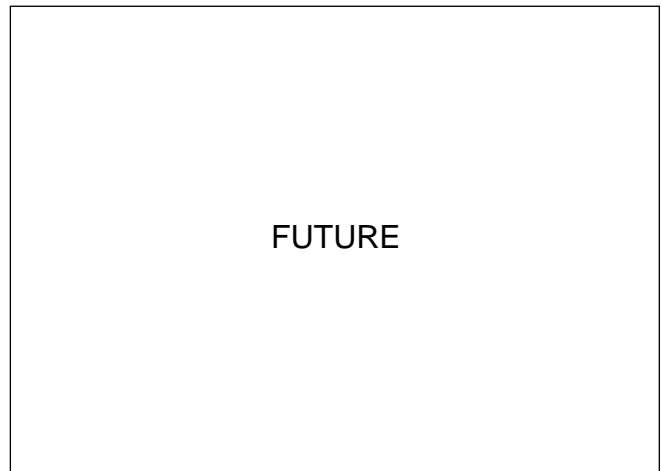

Isometric







## Short Stay Unit (Infirmary) - Room Data Sheet

### 4.12 KITCHENETTE

Within the Short Stay Unit, the Kitchenette is for staff use only. The kitchenette is used for staff lunch and snack storage and preparation.

Following are characteristics of the Kitchenette:

- ✓ Sink, paper towel dispenser, refrigerator and microwave oven
- ✓ Storage of snacks
- ✓ Used for staff lunches and breaks

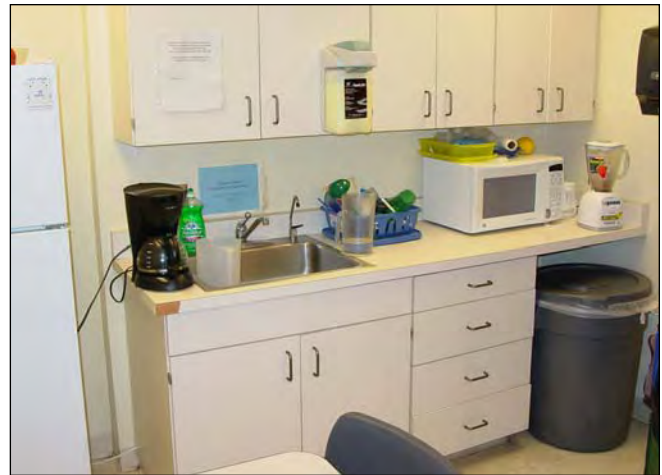

Photo

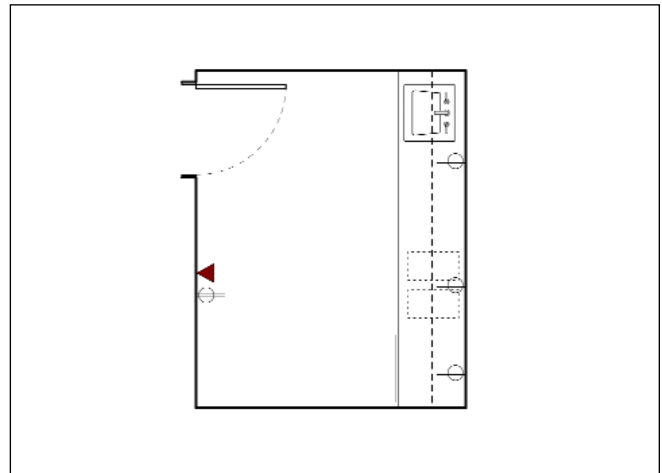

Floor Plan (125 nsf)

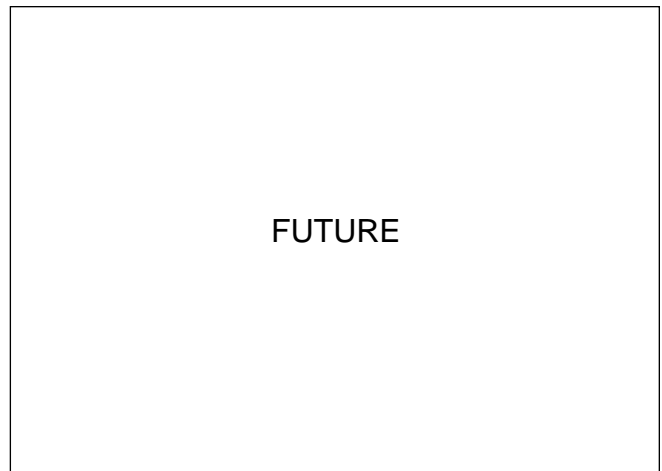

Isometric





## Short Stay Unit (Infirmery) - Room Data Sheet

### 4.14 INFIRMARY SUPPLY ROOM

The Infirmery Supply Room is for the storage of medical supplies necessary for treating patients in the Short Stay Unit. This room should be located central to the nursing operation.



Photo

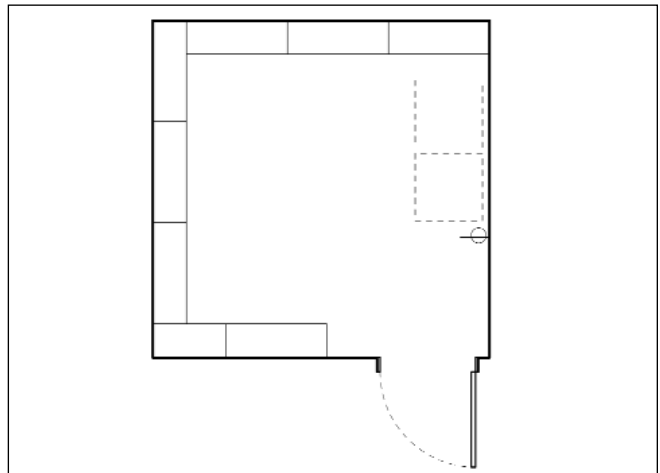

Floor Plan (100 nsf)

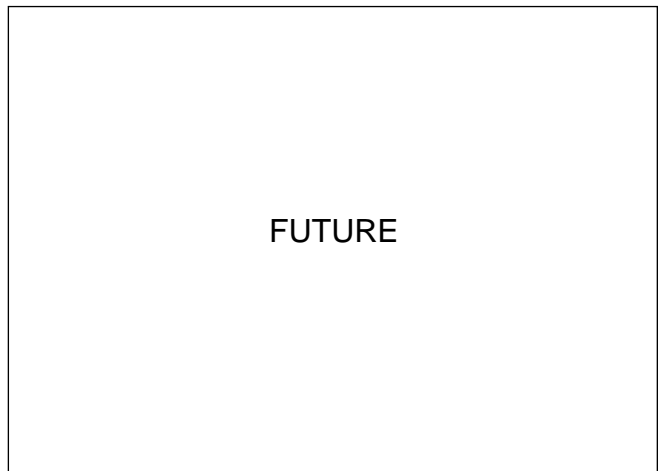

Isometric





## Short Stay Unit (Infirmary) - Room Data Sheet

### 4.15 SOILED (UTILITY) LINEN ROOM

The Soiled Utility Room is used for the storage of soiled waste and soiled linen. It should be centrally located in the Short Stay Unit and should contain sink, paper towel dispenser and floor drain. This room should have an adequately sized independent exhaust system.

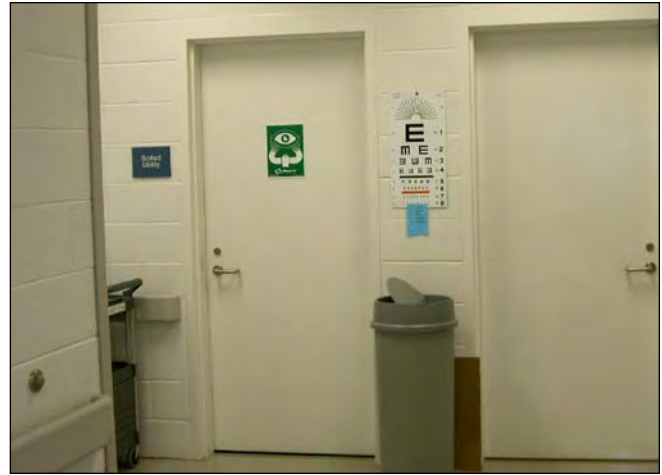

Photo

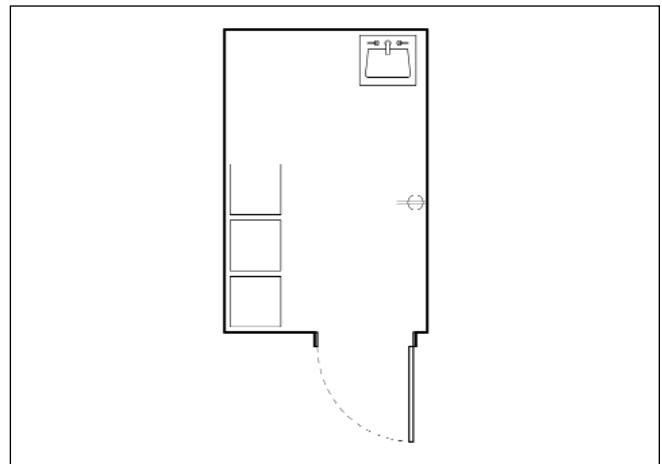

Floor Plan (40 - 50 nsf)

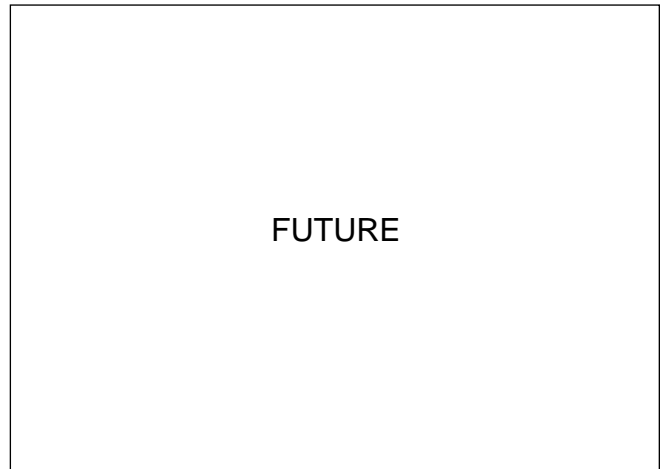

Isometric





## Short Stay Unit (Infirmery) - Room Data Sheet

### 4.16 CLEAN (UTILITY) LINEN ROOM

The Clean Utility Room is used for storage of clean linen. It should be in a central location within the Short Stay Unit. In some facilities it is also used for Ambulatory Medical Supply storage (for crutches, canes and wheelchairs).

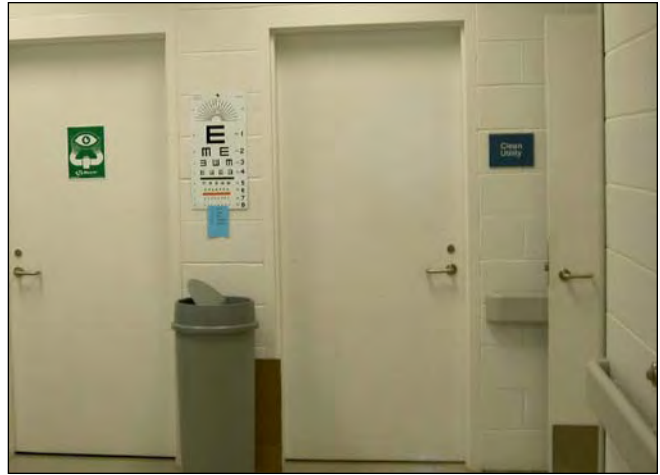

Photo

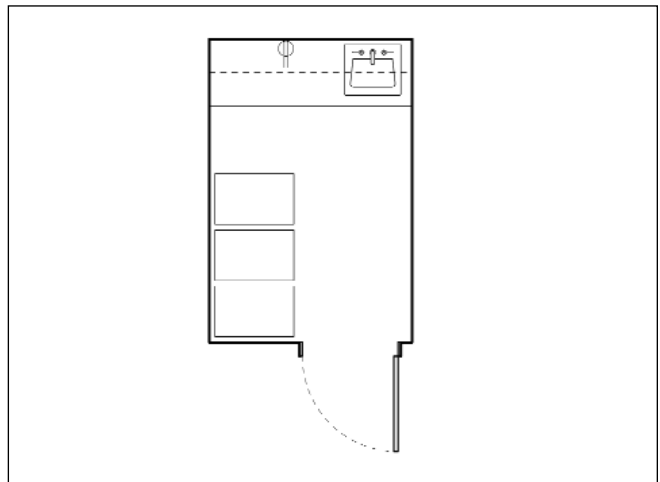

Floor Plan (40 - 50 nsf)

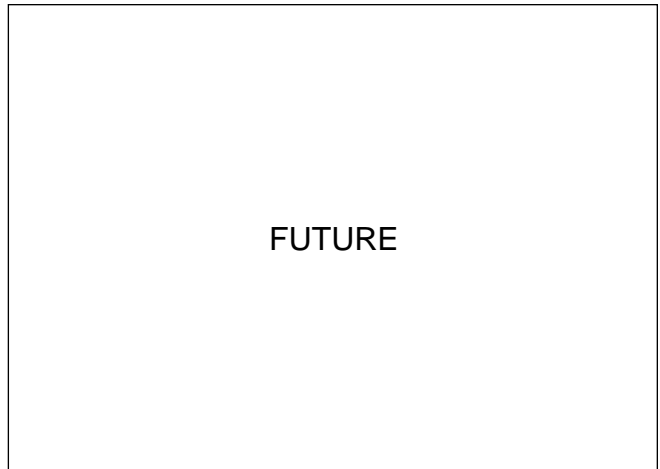

Isometric







## Short Stay Unit (Infirmery) - Room Data Sheet

### 4.17 JANITOR'S CLOSET

The Janitor's Closet should be adequately sized for a mop sink and potentially a hot water heater. Space should also be provided for storage of soap, detergents and other cleaning products. Included in the Janitor's Closet will be mop hangers, floor sink, germicidal soap and paper towel dispenser. It is important that there be a Janitor Closet located in Short Stay for easy access to the patient rooms.

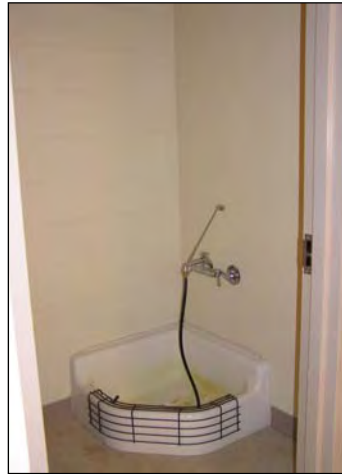

Photo

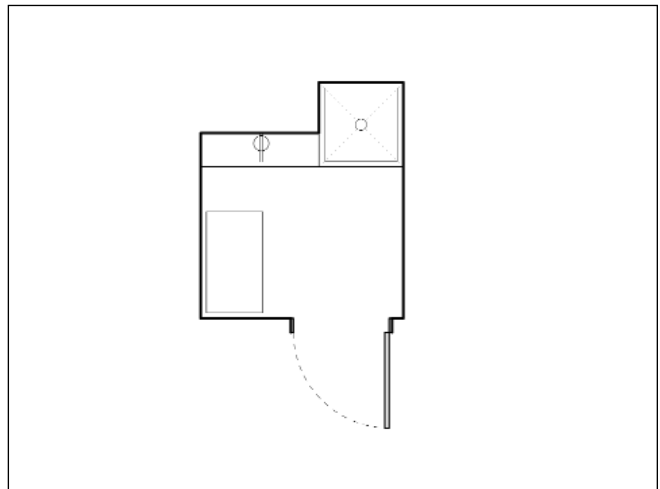

Floor Plan (35 nsf)

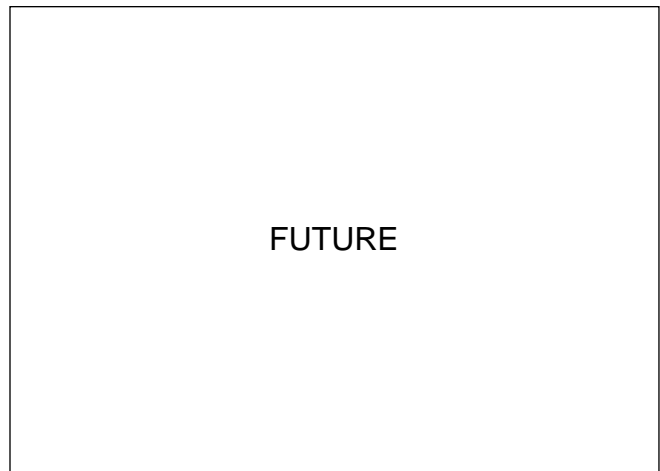

Isometric





## Administrative and Common Support Unit - Room Data Sheet

### 4.18 STAFF TOILET

The Staff Toilets should be provided for both male and female employees within the Short Stay Unit. The size and number of fixtures is dependent on current applicable plumbing codes. In most cases a single use restroom is sufficient. A separate toilet for staff is necessary to eliminate the need for staff to enter the Administrative and Common Support Unit to access restroom spaces.



Photo

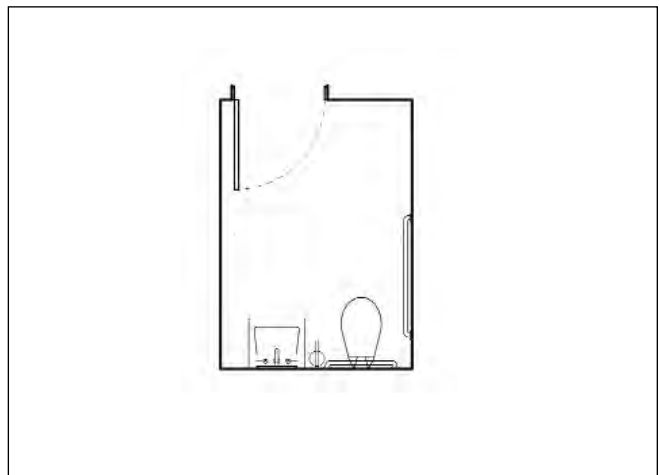

Floor Plan (49 nsf)

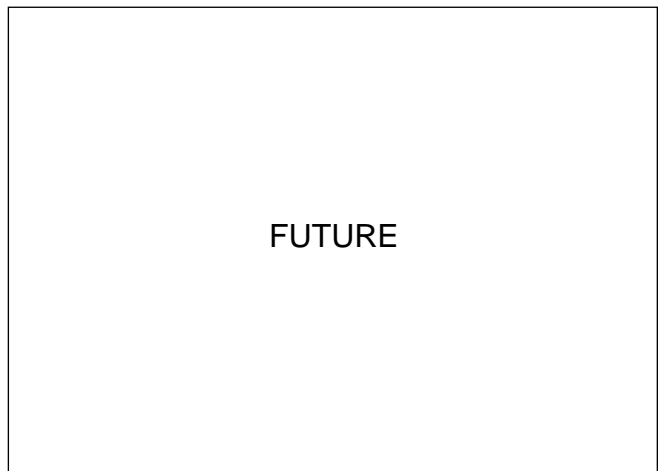

Isometric





## Short Stay Unit (Infirmery) - Room Data Sheet

### 4.18 DAY ROOM

The Day Room is used as an activity area within the Short Stay Unit for ward patients. It is a common area that allows unobstructed visual observation from the Nurse Station. The Day Room contains fixed tables and chairs and direct exterior access. A secure fenced exterior recreation yard should be located directly adjacent to the Day Room for patient use.

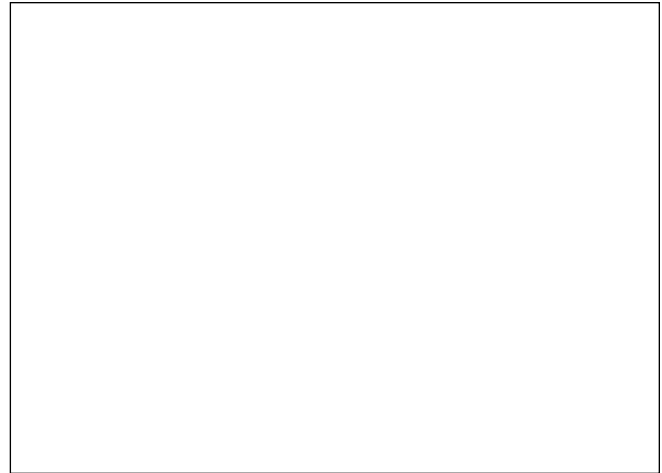

Photo

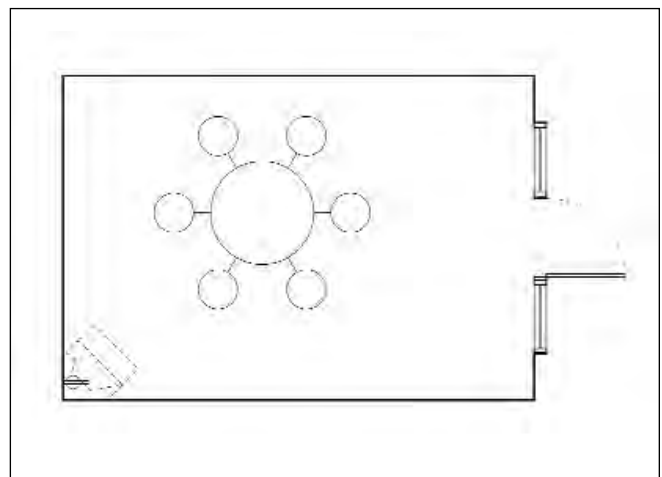

Floor Plan (180 nsf - capacity 6-8)

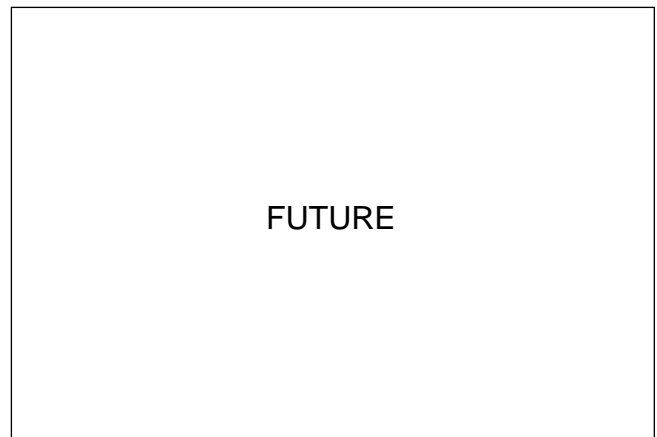

Isometric





## 6. APPENDIX

Reference Publications

Acronyms and Abbreviations

Health Services (HS)  
- *Case Studies*





## Reference Publications

### REFERENCE DOCUMENTS

The Offeror (Contractor) will conform their facility design to the following standards, at a minimum, plus any additional applicable standards that may be pertinent to the location where the facility is intended to be built. The Offeror will be solely responsible for complying with these standards and code requirements. Failure of ICE to identify particular construction code standards that are pertinent to a particular site will not relieve the Offeror of the responsibility of meeting those criteria.

American Correctional Association (ACA)

Standards for Adult Local Detention Facilities  
3rd Addition

American Correctional Association (2002  
Standards Supplement)

International Building Code, 2003

National Fire Protection Association

Life Safety Code 101, current edition

U.S. Department of Justice  
Immigration and Naturalization Service (Legacy)  
Service Processing Center Design Guide

Joint Commission on Accreditation of Healthcare  
Organizations (JCAHO)

National Commission on Correctional Healthcare  
(NCCHC)

Occupation, Safety and Health Association  
(OSHA)

ICE Detention Standards

### RELATED DOCUMENTS

Uniform Federal Accessibility Standards, 1988

Americans with Disabilities Act (ADA), Title III

American Society for Testing and Materials,  
current standards

Underwriters Laboratories, Inc.

American National Standards Institute, Inc.

National Association of Architectural Metal  
Manufacturers

Hollow Metal Manufacturers Association,  
Standard 863-96

H.P. White Laboratory, Inc. HPW-TP-0500.02

WMFL Physical Attack Test

**ACRONYMS AND ABBREVIATIONS**

ACA	American Correctional Association	manuf.	manufacturer
ADA	Americans with Disabilities Act	ME	medical Equipment
AHSA	Assistant Health Services Administrator	MRT	Medical Records Technician
BOP	Bureau of Prisons	NCCHC	National Commission on Correctional Health Care
BP	blood pressure	NFPA	National Fire Protection Association
BI	built-in	NP/PA	Nurse Practitioner/Physicians Assistant
CCTV	closed circuit television	NSF	Net Square Feet
CD	Clinical Director	OSHA	Occupation, Safety and Health Association
CDF	Contract Detention Facility	OTC	over-the-counter medications
IBC	International Building Code	P	primary
CBP	Customs and Border Protection	PA	public address system
DHS	U.S. Department of Homeland Security	PDT	Project Development Team
DRO	Detention and Removal Office	PI	performance improvement
EOIR	Executive Office of Immigration Review	pk	package
F	furniture	S	secondary
Fab.	Fabricators	SHU	Secured Housing Unit
FDA	U.S. Food and Drug Administration	SPC	Service Processing Center
Flr.	floor	SSU	Short Stay Unit
GFI	ground fault interupter	TB	tuberculosis
GSF	Gross Square Feet	RHIA	Registered Health Information Administrator
HCP	Health Carre Program	RN	Registered Nurse
H.M.	hollow metal	TBD	to be determined
HS	Health Services	USF	Usable Square Feet
HSA	Health Services Administrator	USPHS	United States Public Health Service
Ht.	height	VCT	vinyl composition tile
HVAC	heating, ventilating and air conditioning	w/	with
ICE	Bureau of Immigration and Customs Enforcement	Wt.	weight
IGSA	Inter-governmental service agreements		
INS	(Legacy) Bureau of Immigration and Naturalization Services		
DIHS	Division of Immigration Health Services		
DHHS	U.S. Department of Health and Human Services		
HRSA	Health Resources Services Administration		
JCAHO	Joint Commission on Accreditation of Healthcare Orgainzations		
LAN	local area network		
Lav.	lavatory		
LVN	Licensed Vocational Nurse		
qt.	quart		



# HS Floor Plan, Port Isabel SPC - Los Fresnos, TX

(b)(2)High

## FACILITY FACTS

**Facility:** Port Isabel SPC, Los Fresnos, TX  
**Number of SPC Beds:** 900  
**Total H.S. GSF:**

(b)(2)High

**H.S. Staff:**

## FACILITY ANALYSIS

### Pros

- ✓ Core support functions (Pharmacy, Medical Records) are located central to Ambulatory Care and Short Stay Units.
- ✓ General circulation pattern is around core functions, good use of space.
- ✓ Plumbing maintenance closets are accessible from outside building.

### Cons

- ✓ Administrative Unit is not separated from Ambulatory Care.
- ✓ Treatment Rooms 192, 203 and 204 should be closer to triage workstation
- ✓ Teleradiology should have large leaded window to allow observation into the room from the corridor
- ✓ Floor plan does not show x-ray machine (IM90) to proper scale (Unit is bigger than indicated)
- ✓ Guard Station lacks visual access to some of the exam rooms
- ✓ Ward rooms lack showers
- ✓ Doors in outpatient area should swing out
- ✓ Need handwashing sinks for staff



## Health Services Case Studies

### PEARSALL CDF - PEARSALL, TX

Following is the floor plan for Health Services at the Pearsall, Texas Contract Detention Facility. This facility plan is provided to give designers insight into the functional relationship between the spaces within a representative Health Services facility. It is not intended for this plan to dictate the layout of future facilities, but merely illustrates how one CDF developed their facility. The Pros and Cons describe the strengths and weaknesses of the layout and the affect the facility has on Health Services operations at Pearsall, Texas.



## **Health Services Case Studies**

### **PORT ISABEL SPC - LOS FRESNOS, TX**

Following is the floor plan for Health Services at the Port Isabel Service Processing Center in Los Fresnos, Texas. It is one of the newer facilities developed for Immigration and Customs Enforcement. This facility plan is provided to give designers insight into the functional relationship between the spaces within a representative Health Services facility. It is not intended for this plan to dictate the layout of future facilities but merely illustrates how one SPC developed their facility. The Pros and Cons describe the strengths and weaknesses of the layout and the affect the facility has on Health Services operations at Los Fresnos, Texas.



# HS Floor Plan, Pearsall CDF - Pearsall, TX

(b)(2)High

## FACILITY FACTS

Facility: Pearsall CDF, Pearsall, TX

Number of CDF Beds:

Total H.S. GSF:

(b)(2)High

H.S. Staff:

## FACILITY ANALYSIS

### Pros

- ✓ Administrative Unit is separated from general detainee treatment areas and flow
- ✓ Common support functions are located central to Ambulatory Care and Short Stay Unit
- ✓ General circulation pattern is efficient
- ✓ Showers in patient rooms

### Cons

- ✓ In Pharmacy the sink should be smaller and located on back wall
- ✓ Pharmacy door should open outward
- ✓ Holding/waiting rooms
  - Too small for facility and should have short partial privacy wall in front of the toilets
  - Too close to Administrative Offices
- ✓ All doors need to swing out
- ✓ Teleradiology room lacks large leaded glass window so that detention officer can see what goes on inside the room while they stand outside
- ✓ Need a Biohazardous Waste Storage Room





# U.S. Department of Homeland Security

U.S. Immigration and Customs Enforcement  
Office of Detention and Removal Operations

## CONTRACT DETENTION FACILITY

---

# DESIGN STANDARDS

for IMMIGRATION AND CUSTOMS ENFORCEMENT

May 14, 2007





**U.S. DEPARTMENT OF HOMELAND SECURITY**  
U.S. Immigration and Customs Enforcement  
Office of Detention and Removal Operations

**CDF Design Standards** for  

---

**Immigration and Customs Enforcement**  

---

*Immigration and Customs Enforcement (ICE) is a component of the U.S. Department of Homeland Security (DHS). ICE brings a unified and coordinated focus to the enforcement of federal immigration laws, customs laws, and air security laws. ICE brings to bear all of the considerable resources and authorities invested in it to fulfill its primary mission: to detect vulnerabilities and prevent violations that threaten national security.*

*As an Operational Division of ICE, the Office of Detention and Removal Operations (DRO) is responsible for public safety and national security by ensuring the departure from the United States of all removable aliens and by enforcing the Nation's immigration laws.*

*Because of increasing demands on Service resources, ICE/DRO personnel must be able to share information rapidly and efficiently in order to succeed in fulfilling the Service mission.*

*In addition to this document, which establishes the ICE components within a Contract Detention Facility (CDF) Design Standards, other documents are being developed that provide additional related information for planning and design of Contract Detention Facilities (CDF). Other documents already complete include Design Standards for Health Services and Executive Office for Immigration Review (EOIR) Courts.*

---

*The U.S. Department of Homeland Security gratefully acknowledges the participation and input of the following individuals:*

---

**U.S. Immigration and Customs Enforcement - Detention Management Office**

Dalton D. Lilly, *Chief of Facility Management Unit*  
Keeyoung Lee, *Facilities Administrator, Facilities Management Unit*  
John Jenkins, *Project Manager, Facilities Management Unit*  
Alan Riker, *Project Manager (Bearingpoint)*

**U.S. Immigration and Customs Enforcement**

Marc J. Moore, *Field Office Director - San Antonio*  
Marcos M. Reyna, *Assistant Field Office Director for Management, San Antonio*  
Jay A. Sparks, *Officer in Charge - Pearsall SPC*  
Diana Perez Estrada, *Officer in Charge - Port Isabel SPC*  
Ed Valls, *Telecommunications Project Manager*  
Tara Filicichia, *ICE Cable Group*

**Office of the Principal Legal Advisor**

Debbie Dusenberry, *Deputy Chief Mission Support - Dallas*  
Rick Moody, *Mission Support Specialist*  
Bob Feagin, *OPLA Supervisory Specialist*  
Kimberly Shepard, *DCC - Phoenix*

**Performa, Inc.**

David A. Robillard, *President - Governmental/Justice Program*  
Doug Page, *NCARB, AIA, Facility Planner*  
Scott Wotr, *Facility Planner*





# Table of Contents

	Page
<b>1. INTRODUCTION</b> .....	1.1
Project Statement .....	1.2
Design Standards Purpose .....	1.4
Design Standards Organization .....	1.6
<b>2. ORGANIZATIONAL REQUIREMENTS</b> .....	2.1
ICE Background .....	2.2
ICE Function .....	2.4
ICE Organization .....	2.6
<b>3. OPERATIONAL REQUIREMENTS</b> .....	3.1
CDF Facility Organization .....	3.2
ICE Staff Positions/Forecasts .....	3.4
ICE Staff Position Descriptions .....	3.6
<b>4. FUNCTIONAL REQUIREMENTS</b> .....	4.1
ICE Space Requirements .....	4.2
1.0 Office Zone .....	4.5
2.0 Court Interface Zone .....	4.197
3.0 Detainee Living Zone .....	4.207
4.0 Service Zone .....	4.247
5.0 Facility Support Zone .....	4.297
Technical Requirements .....	4.323
<b>5. APPENDIX</b> .....	5.1
Reference Publications .....	5.2
Acronyms and Abbreviations .....	5.3
ICE Structured Cable Plant Standard v5.1 .....	5.4





## 1. INTRODUCTION

Project Statement  
Design Standards Purpose  
Design Standards Organization



## Project Statement

### PROJECT INTENT

The U.S. Department of Homeland Security (DHS), Immigration and Customs Enforcement (ICE) are responsible for detaining those who have entered the United States illegally or violated their immigration status. Facilities used by DHS/ICE for detention are called Service Processing Centers (SPC's) or Contract Detention Facilities (CDF's). The purpose of these facilities is to provide a place of detention for aliens who are taken into custody pending completion of their deportation case, released on their own recognizance, or pending release.

### IMMIGRATION AND CUSTOMS ENFORCEMENT

Immigration and Customs Enforcement (ICE) is an agency of the U.S. Department of Homeland Security (DHS). ICE brings a unified and coordinated focus to the enforcement of federal immigration laws, customs laws, and air security laws. ICE brings to bear the considerable size of its invested resources and authorities to fulfill its primary mission: *to detect vulnerabilities and prevent violations that threaten national security.*

The diagrams on page 1.3 provide an example of a Contract Detention Facility. The Pearsall CDF was built in 2005 and has a current bed capacity of 1900 beds with approximately 251,950 gross square feet. The site plan illustrates the facility's organization while the floor plan illustrates ICE, Contractor, and other Government Agency operated spaces.

It is the intent of this project to develop planning and design standards from which Contract Detention Facilities can be designed and built. The operational components within a CDF are derived from categorizing the personnel groups and service activities of a CDF. The level of security required determines how the components are organized. The side bar to the right lists the main operational components and functional areas within a CDF. This document establishes the planning and design guidelines within ICE's operational authority for the spaces highlighted to the right in orange. Spaces operated by Contract Operations or other Government Agencies (Health Services and Executive Office for Immigration Review) are highlighted in yellow or blue.

### CDF Operational Components

#### 1.0 Office Components

Normal office setting for administrative and public functions of the CDF. (They are located outside the secure perimeter.)

- Public Entrance/Lobby
- ICE Administration
- CDF Administration
- Office of the Principal Legal Advisor (OPLA)
- Removal
- Staff Services & Training

#### 2.0 Court and Public/Detainee/Interface Components

This component includes the EOIR Court work area and courtroom space.

- Executive Office for Immigration Review (EOIR)
- Public/Detainee Visitation

#### 3.0 Detainee Living Components

Located inside the secure perimeter they are used by the detainees during their normal daily routine.

- Detention Administration
- Security Command
- Detainee Housing (w/dining)
- Detainee Services
- Recreation
- Library

#### 4.0 Service Components

Service functions for the CDF detainee population. They are typically placed in a secure area because detainees require frequent access to them or are given work details in these components.

- Processing
- Health Services
- Laundry
- Food Preparation

#### 5.0 Facility Support Components

These elements support the facility but do not provide direct services to the detainees and may be located outside the secure perimeter.

- Warehouse/Supply
- Maintenance/Fleet Operations
- Central Utility Plant

**EXAMPLE: Pearsall Contract Detention Facility, Pearsall, TX**



(b)(2)High





## Design Standards Purpose

### PURPOSE OF THE DESIGN STANDARDS

The ICE Design Standards (hereafter referred to as the Standards) contains criteria and concepts for the planning and design of the ICE operated spaces within a CDF. The standards contain the *organizational*, *operational*, and *functional* requirements for only the ICE Components.

The purpose of the Standards, is to establish operational directions and architectural relationships for ICE spaces. The decisions made and policies adopted during the development of the Standards are intended to provide direction and guidance during the planning and design of existing and future Contract Detention Facilities, bringing standardization to CDF's as well as reducing the amount of effort and time required to plan, design, construct and activate a CDF.

### USERS OF THE DESIGN STANDARDS

This document is intended for all individuals involved in the planning, design and construction of a CDF, including architects, engineers, contractors, DHS/ICE staff located at Headquarters, Regional, and District offices assigned to Detention and Removal and any other DHS agencies involved. This document is intended to communicate ICE requirements to service providers providing design, construction, and facility management services.

### APPLICATION OF THE DESIGN STANDARDS

The architectural information contained in the ICE Design Standards should be viewed as ICE policy applicable to the design of all CDF facilities. It is intended to provide to the user clear guidance on project requirements, conceptual solutions, and specific technical details. The information is intended to focus the user on meeting ICE needs, to educate regarding design of ICE operated CDF's, and to establish design performance conditions as well as to provide design solutions.

The requirements in the Standards are generic in nature. Specific applications such as the mission of the proposed facility, site conditions, ability to receive service support from local communities and other

institutions, and climactic differences must be considered.

The ICE Design Standards provide instructions that must be met, alternative acceptable solutions, and design issues the user should consider. For instructions that must be met, the user shall comply and provide final designs that meet these instructions. Alternative acceptable solutions provide the user with flexible choices to react to variations unique to the specific project. Issues being considered help the user understand the context of the problem and the needs of ICE.

The Design Standards are meant to be used as a guideline for the layout of the ICE Components. Design decisions must be coordinated through the ICE/DRO Facilities Management Unit. A review process will be established at the inception of each project, generally at the 30/60/90 percent design phases. ICE/DRO FMU will provide approvals after each stage.

Any deviations from the design standards must be approved by ICE/DRO FMU.





## Design Standards Organization

### ORGANIZATION OF THE ICE DESIGN STANDARDS

The ICE Design Standards are organized to provide conceptual and technical information in a structured manner.

The Design Standards document is organized for ease of use. The Standards are organized into five sections. Each section is designed to stand alone so it may be extracted for use in the planning and design process.

The side bar to the right briefly outlines the contents of each section of this document.

### DESIGN STANDARDS DEVELOPMENT PROCESS

The design standards documented herein have been developed by selected representatives from ICE/DRO FMU.

The Standards Development Team reviewed and evaluated existing ICE standards documents and assessed existing Service Processing Centers and Contract Detention Facilities noting advantages and disadvantages of each ICE layout and their post occupancy evaluation.

The goal of the design standards is to enhance the organizational, operational, and functional efficiencies of ICE components and their functional areas.

### Design Standards Contents

#### **Section 1. Introduction**

The Introduction identifies the overall function of a CDF and discusses the purpose and organization of the Design Standards.

#### **Section 2. Organizational Requirements**

This section of the Standards discusses the history of ICE and how it is organized within the Department of Homeland Security (DHS) as well as within a CDF.

#### **Section 3. Operational Requirements**

This section of the Standards discusses the physical relationships of ICE within a CDF. Staff positions are identified and quantity corresponds to the number of beds within the CDF.

#### **Section 4. Functional Requirements**

This section of the Standards discusses the spaces needed for each ICE Component and corresponding technical requirements (i.e. functional description, room or area photograph, space plan, material, and equipment list).

#### **Section 5. Appendix**

This section of the Standards contains a listing of reference publications and acronyms/abbreviations.

### Design Standards Report Contents



Project Statement  
Design Standards Purpose  
Design Standards Organization

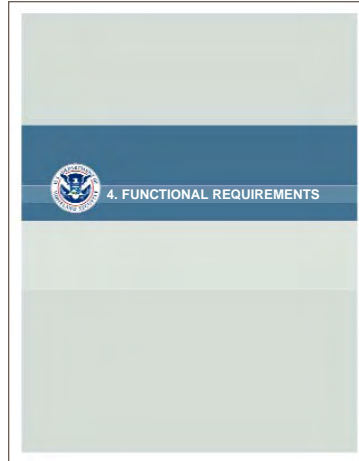

ICE Space Requirements  
1.0 Office Zone  
2.0 Court Interface Zone  
3.0 Detainee Living Zone  
4.0 Service Zone  
5.0 Facility Support Zone



ICE Background  
ICE Function  
ICE Organization



Reference Publications  
Acronyms and Abbreviations

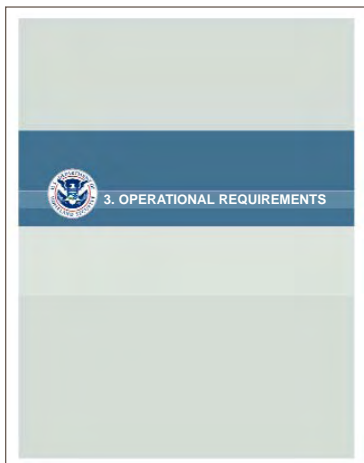

CDF Organization  
ICE Staff Positions/Organization  
ICE Staff Position Descriptions



## 2. ORGANIZATIONAL REQUIREMENTS

ICE Background  
ICE Function  
ICE Organization



## ICE Background

### U.S. DEPARTMENT OF HOMELAND SECURITY

Homeland Security leverages resources within federal, state, and local governments, coordinating the transition of multiple agencies and programs into a single, integrated agency focused on protecting the American people and their homeland. More than 87,000 different governmental jurisdictions at the federal, state, and local level have homeland security responsibilities. The comprehensive national strategy seeks to develop a complementary systems connecting all levels of government without duplicating effort. Homeland Security is truly a “national mission.”

The organizational chart on the following page contains the major components that currently make up the Department of Homeland Security.

### HISTORY OF ICE

ICE was formed pursuant to the Homeland Security Act of 2002 following the events of September 11, 2001. With the establishment of the Department of Homeland Security the functions and jurisdictions of several border and revenue enforcement agencies were combined and reconstituted into Immigration and Customs Enforcement. Consequently, ICE is the largest investigative arm of DHS, and the second largest contributor to the nation’s Joint Terrorism Task Force.

The agencies that were either moved entirely or merged in part, based upon their law enforcement functions, included the investigative and intelligence resources of the United States Customs Service, the law enforcement resources of the Immigration and Naturalization Service, and the United States Federal Protective Service. Consequently, ICE is also charged with the protection of federal buildings within the United States.



**U.S. Department Homeland Security (DHS)  
Organizational Chart**

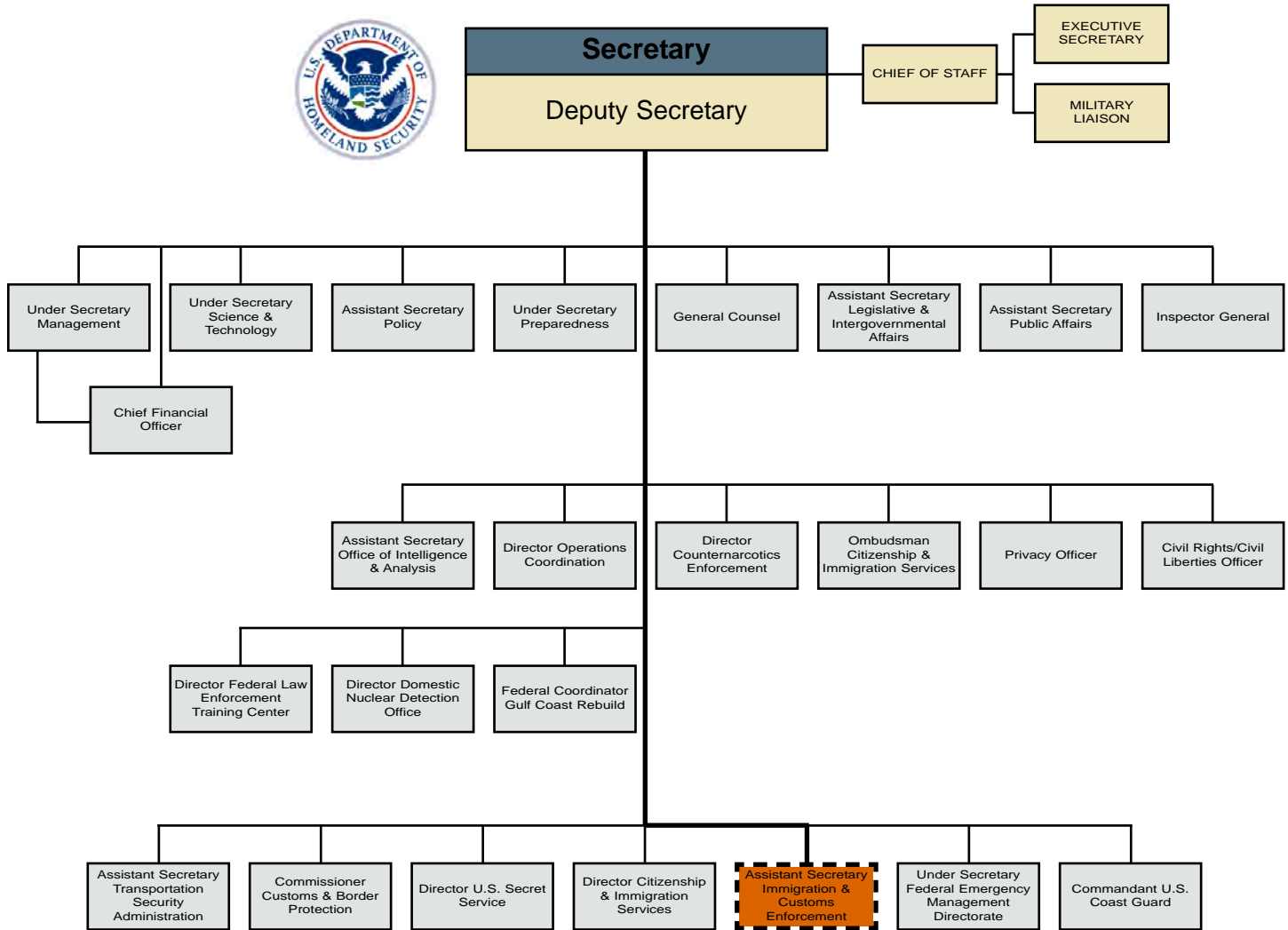

7/06



## ICE Function

### U.S. IMMIGRATION AND CUSTOMS ENFORCEMENT

The United States Immigration and Customs Enforcement (ICE) is the largest investigative arm of the United States Department of Homeland Security (DHS) and is responsible for identifying and dismantling vulnerabilities regarding the nation's border, economic, transportation and infrastructure security. Employing approximately 15,000 people, ICE is charged with the enforcement of over 400 federal statutes within the United States and maintains attaches at major U.S. embassies overseas. As such, ICE Special Agents arguably possess the broadest investigative authority within the United States Government. The mission of ICE is to protect America and uphold public safety by targeting the people, money and materials that support terrorist and criminal activities. ICE is led by an Assistant Secretary who is appointed by the President of the United States and confirmed by the U. S. Senate. The Assistant Secretary reports directly to the Secretary of Homeland Security.

The organizational chart on the following page contains the major components that make-up the Immigration and Customs Enforcement.





**U.S. Immigration and Customs Enforcement (ICE)  
Organizational Chart**

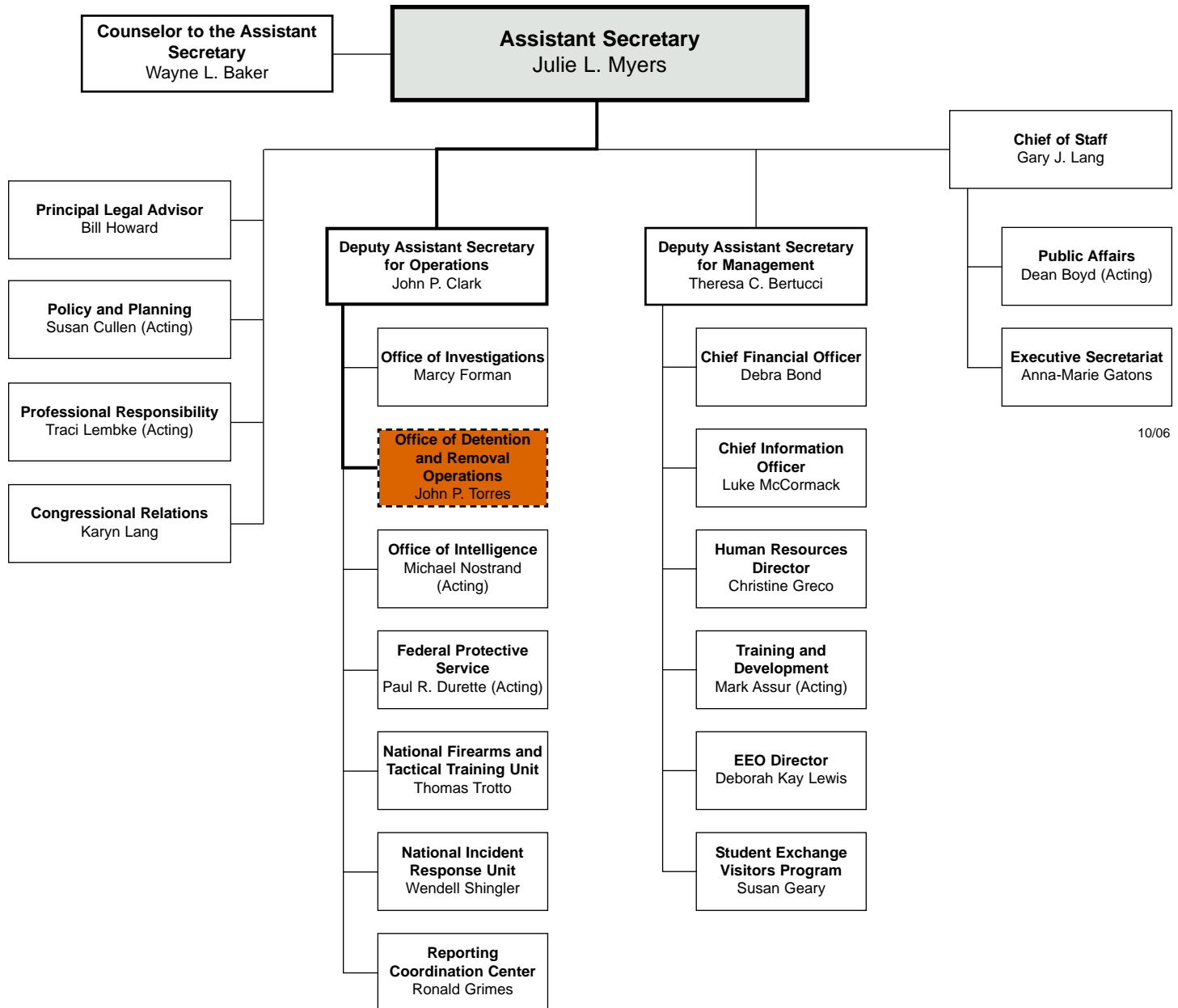

10/06



## ICE Organization

U.S. Immigration and Customs Enforcement is responsible for eliminating border, economic, transportation, and infrastructure security vulnerabilities. As such, the ICE organization is composed of four law enforcement divisions and several support divisions. These divisions of ICE combine to form a new investigative approach with new resources to provide unparalleled investigation, interdiction, and security services to the public and other law enforcement partners in the federal and local sectors.

The organizational chart on the following page contains the major components that make up a Contract Detention Facility. They include:

### **1. OFFICE OF DETENTION AND REMOVAL OPERATIONS (DRO)**

DRO is responsible for public safety and national security by enforcing the nation's immigration laws and ensuring the departure from the United States of all removable aliens. DRO has Immigration Enforcement Agents (IEAs) that are the uniformed presence of immigration enforcement within the interior of the United States, whereas the U.S. Border Patrol is the uniformed presence of immigration at the border. DRO also have Deportation Officers who identify, apprehend, and remove aliens that are deportable from the United States. DRO has the Criminal Alien Program (CAP) that apprehends and removes criminal aliens in jails and prisons. DRO has also been mandated by Congress to reduce the number of fugitive aliens through its Fugitive Operations Program (FUGOPS), aliens that are still in the United States with an outstanding Warrant of Deportation. As such, ICE is partnered with the U.S. Marshals Service in operating JPATS, the Justice Prisoner and Alien Transportation System, otherwise known as Con-Air to remove criminal aliens from the United States. DRO also is in charge of detention of aliens who are in deportation proceedings and managing ICE and contract detention facilities.

### **2. OFFICE OF THE PRINCIPAL LEGAL ADVISOR (OPLA)**

The Office of the Principal Legal Advisor (OPLA) within the Bureau of Immigration and Customs Enforcement (ICE) provides the full range of legal support, including core responsibilities for representing ICE before the Immigration Courts and the Board of Immigration Appeals.

### **3. EXECUTIVE OFFICE FOR IMMIGRATION REVIEW (EOIR)**

The Executive Office for Immigration Review (EOIR) is an administrative tribunal that presides over all trial and appellate cases involving charges of immigration violations. On behalf of the Attorney General, EOIR exercises authority to interpret and administer Federal immigration laws and regulations through Immigration court proceedings, appellate reviews, and administrative hearings in certain types of immigration-related cases.

### **4. HEALTH SERVICES (HS)**

The SPC/CDF is responsible for the health and welfare of individuals in its custody. This responsibility mandates the provision of medical staff to provide care to detainees at the SPC/CDF in accordance with the Legacy Immigration and Naturalization Service Health Care Program Policy Manual and in compliance with accreditation standards.

### Contract Detention Facility (CDF) Organizational Chart

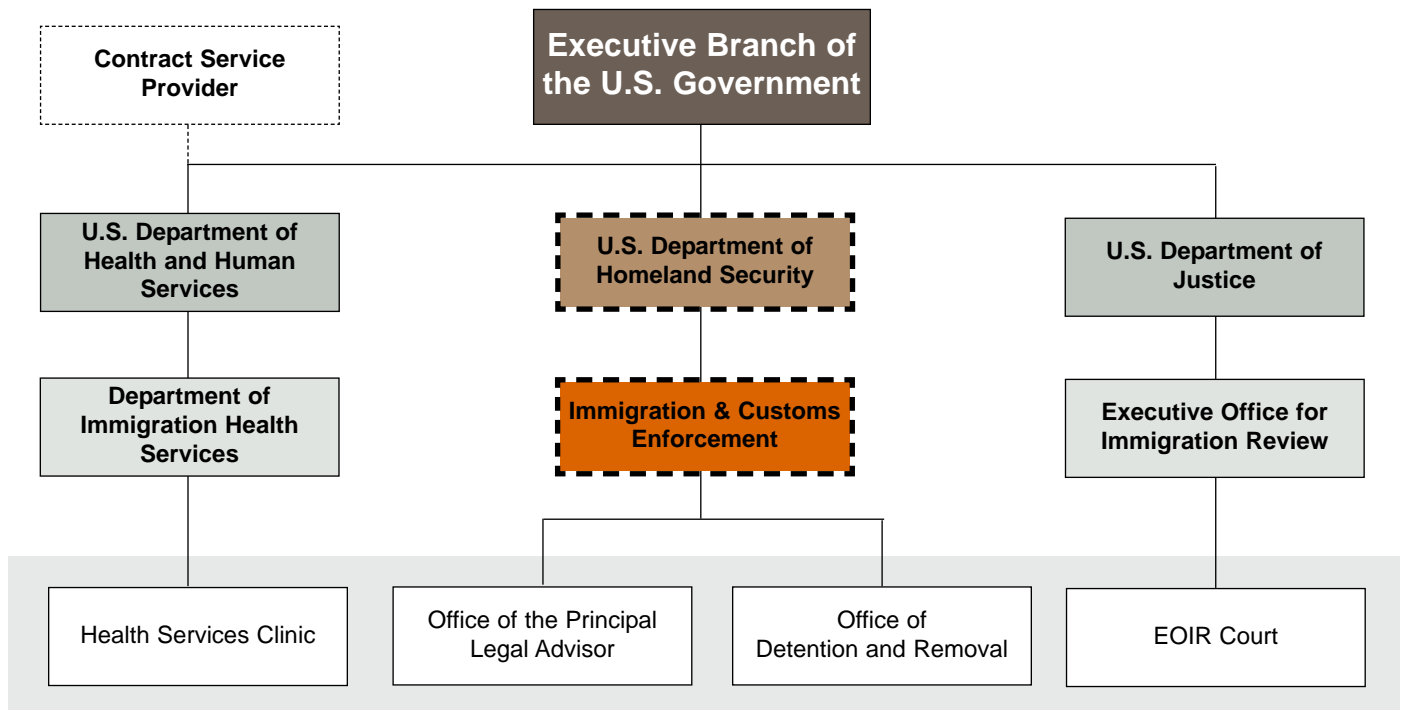

Four agencies are present within the CDF: Detention and Removal Operations (DRO), Office of the Principal Legal Advisor (OPLA), Executive Office for Immigration Review (EOIR) and Health Services (HS). These groups' respective areas of responsibility are:

1. Office of Detention and Removal Operations (DRO) is part of the Department of Homeland Security and is responsible for managing the detainees, presenting cases for deportation and executing deportations.
2. Office of the Principal Legal Advisor (OPLA) is part of the Department of Homeland Security and is responsible for prosecuting cases against detainees in the EOIR Court.
3. Executive Office for Immigration Review (EOIR) is part of the Department of Justice and is responsible for conducting the court hearings.
4. Health Services (HS) is part of the Department of Health and Human Services and is responsible for providing health services.

*NOTE: In some instances Health Services are provided through the Contract Detention Service Provider.*



### 3. OPERATIONAL REQUIREMENTS

CDF Organization  
ICE Staff Positions/Forecasts  
ICE Staff Position Descriptions



## CDF Organization

A Contract Detention Facility (CDF) is a detention facility where the DHS/ICE detains those who have entered the United States illegally or violated their immigration status. The purpose of this facility is to provide a place of detention for aliens who are taken into custody pending completion of their deportation case, released on their recognizance, or pending release.

The diagram on the following page illustrates the organizational requirements for a CDF. The diagram illustrates the various components and respective security zones. The secure zones of the facility correspond to the degree of detainee and public access required in the components. The facility has five major operational zones, they include:

- 1.0 Office Zone
- 2.0 Court Interface Zone
- 3.0 Detainee Living Zone
- 4.0 Service Zone
- 5.0 Facility Support Zone

### MANAGING AUTHORITY

CDF facilities are operated by private companies under contract to the DHS. These facilities must be organized and managed according to DHS/ICE-DRO standards.

<b>CDF Operational Zones</b>	
<b>1.0 Office Zone</b>	The Office Zone provides a normal office setting for administrative and public functions of the CDF. Office components do not have direct contact with, or are used by the detainees performing functions outside of the primary secure perimeter. The Office Zone is a non-secure area located outside the secure perimeter but requiring screening and control of the public entering the area. Security provisions should be appropriate for any government office area with confidential information. Access needs to be controlled and the building envelope should be monitored to detect unauthorized entry, though it does not need special hardened construction. Direct emergency egress may be provided. Points of public or service access must be readily identifiable with proper signage. (Flagpoles are popular devices used to identify public entrances.) Access points (both public and service) require means of audible and visual communication with the controlling point, usually the Central Control.
<b>2.0 Court Interface Zone</b>	The Court Interface Zone includes the EOIR work area and courtroom space, and is an interface area between the court personnel, the Removal Unit, the public, and detainees under restraint. It is a secure interface zone. The area should be in its own secondary perimeter, contiguous with but separate from the main facility primary secure perimeter. Access will be by hardened commercial grade doorways, with special controls for general and emergency egress. The perimeter barriers, electronic controls, and procedures should be at the same level as the other secondary secure perimeters. (See EOIR Design Standards under separate cover.)
<b>3.0 Detainee Living Zone</b>	The Detainee Living Zone contains functions that are used by detainees during their normal daily routine. It is a secure zone with normal routine detainee movement within the primary secure perimeter. Components within this zone should be separated from each other by secondary secure perimeters. Detainee movement between each component will be monitored by housing security staff.
<b>4.0 Service Zone</b>	The Service Zone provides services necessary for supporting detainees while they live in the CDF. It is a zone that is located inside the primary secure perimeter with restricted detainee movement. Components should be separated from each other by secondary secure perimeters. Detainee movement to any component will be by direct escort or continuously monitored/controlled movement with staff control of each individual detainee passing into or out of a component.
<b>5.0 Facility Support Zone</b>	The Facility Support Zone provides support to the facility, though not directly to the detainees, and generally are not accessed or occupied by detainees. It is a zone that is a restricted area limited to staff and service vendors who provide vital services to maintain functions of the facility.

### CDF Organizational Diagram

(b)(2)High



## ICE Staff Positions/Forecasts

ICE staff is assigned to specific components of the Office and Detainee Living Zones within a Contract Detention Facility (CDF). Contractor and other Government Agencies staff the remaining components.

For planning purposes, staff position forecasts have been developed for the zones and components for which ICE has responsibility/authority. The staff forecasts have been developed for the following detainee bed scenarios:

1. <200 beds
2. 200 - 450 beds
3. 450 - 900 beds
4. 900 - 1,200 beds
5. 1,200 - 1,500 beds
6. 1,500 - 1,800 beds
7. 1,800 - 2,000 beds
8. 2,000 - 3,000 beds

The Staff Forecasts Summary matrix illustrated on the following page, identifies the number of people, number of offices and number of workstations needed for each planning scenario. The staff forecast numbers represent a general rule and may vary based on the CDF's operational structure and geographic location. In all cases the staffing counts must be verified and approved by DHS/ICE-DRO.

The sidebar to the right identifies the five (5) zones within a CDF and for those containing ICE personnel provides general "rules of thumb" for calculating staff forecasts.

<b>ICE Staff Forecast Calculations</b>	
<b>1.0 Office Zone</b>	<p><u>Office of the Principal Legal Advisor (OPLA)</u></p> <p><b>Assistant Chief Counsel (ACC)</b> <i>2.3 Assistant Chief Counsel's per one courtroom</i></p> <p><b>Legal Technician</b> <i>1 Legal Technician per 3 ACC's</i></p>
<b>2.0 Court Interface Zone</b>	<p><b>Contractor Staffed</b></p>
<b>3.0 Detainee Living Zone</b>	<p><u>Detention Administration</u></p> <p><b>Detention Operations Supervisor (DOS)</b> <i>at 3,000 2 FT DOS and 1 on second shift</i></p>
<b>4.0 Service Zone</b>	<p><b>Contractor Staffed</b></p>
<b>5.0 Facility Support Zone</b>	<p><b>Contractor Staffed</b></p>

# ICE Staffing Requirements Summary

	< 200 Beds			200 - 450 Beds			450 - 900 Beds			900 - 1,200 Beds			1,200 - 1,500 Beds			1,500 - 1,800 Beds			1,800 - 2,000 Beds			3,000 Beds			Comments
	# of	# of	# of	# of	# of	# of	# of	# of	# of	# of	# of	# of	# of	# of	# of	# of	# of	# of	# of	# of	# of	# of	# of		
<b>1.0 OFFICE ZONE</b>																									
1.1 Public Entrance/Lobby																									
Contract Staff																									
1.2 ICE Administration																									
Officer in Charge (OIC)																									
Assistant Officer in Charge (AOIC)																									
Intelligence Officer																									
Supervisory Mission Support Specialists (SMSS)																									
Chief Immigration Enforcement Agent (CIEA)																									
Mission Support Specialists (MSS)																									
Contracting Officer's Technical Representative (COTR)																									
ICE IT Specialist (space only)																									
Mission Support Assistant (MSA)																									
Receptionist																									
Intelligence Research Specialist (IRS)																									
OIC Secretary																									
1.3 CDF Administration																									
Contract Staff																									
1.4 OPLA																									
Deputy Chief Counsel																									
Assistant Chief Counsel (ACC) (2,3/courtroom)																									
Legal Technicians (1 per 3 ACCs)																									
Mail/File Clerk																									
1.5 Removal																									
Supervisory Detention & Deportation Officer (SDDO)																									
Deportation Officer (DO)																									
Deportation Removal Assistant (DRA)																									
1.6 Staff Services & Training																									
Training Officer																									
<b>2.0 COURT INTERFACE ZONE</b>																									
2.1 EOIR Court																									
EOIR Staff																									
2.2 Public/Detainee Visitation																									
Contract Staff																									
<b>3.0 DETAINEE LIVING ZONE</b>																									
3.1 Detention Administration																									
Detention Operations Supervisor (DOS)																									
Supervisory Immigration Enforcement Agent (SIEA)																									
Immigration Enforcement Agent (IEA)																									
3.2 Detainee Housing w/ Dining																									
Contract Staff																									
3.3 Detainee Services																									
Contract Staff																									
3.4 Recreation																									
Contract Staff																									
3.5 Library																									
Contract Staff																									
<b>4.0 SERVICE ZONE</b>																									
4.1 Processing																									
Contract Staff																									
4.2 Health Services																									
Health Services Staff																									
4.3 Laundry																									
Contract Staff																									
4.4 Food Preparation																									
Contract Staff																									
<b>5.0 FACILITY SUPPORT ZONE</b>																									
5.1 Common Support																									
Contract Staff																									
5.2 Warehouse																									
Contract Staff																									
5.3 Maintenance																									
Contract Staff																									
5.4 Central Utility Plant																									
Contract Staff																									

(b)(2)-High

ed indicates shift work (use same office)

t 3,000 2 FT DOS and 1 on second shift ed indicates shift work (use same office) 5% positions = workstation on shift work oing both ways between Processing





### 3. OPERATIONAL REQUIREMENTS



## ICE Staff Position Descriptions

### STAFF DESCRIPTIONS

The following provides a listing of the ICE staff positions required to operate a CDF. The information is organized by facility zone, providing the position title and description.

It should be noted that generally a CDF is staffed by the following agencies:

- ICE
- Contractor/Facility Operator
- Other Government Agencies
  - Executive Office for Immigration Review (EOIR)
  - Health Services (HS)

<b>ICE Staff Positions</b>
<b>1.0 Office Zone</b>
<b>1.2 ICE Administration</b>
<p><b>Officer In Charge (OIC)</b> The Officer In Charge is the highest ranking officer at the CDF and has ultimate authority and responsibility at the site. The OIC oversees all CDF activities including those of contract personnel.</p> <p><b>Assistant Officer In Charge (AOIC)</b> The Assistant Officer In Charge is the second ranking officer at the CDF. They have responsibility for administrative and operations activities as directed by the OIC.</p> <p><b>Supervisory Mission Support Specialists (SMSS)</b> The SMSS position is responsible for supervising administrative positions who provide services in direct support of operational programs. The work provides complex administration services and supports and significantly affects the program's operations and objectives. Specific responsibilities include:</p> <ul style="list-style-type: none"> <li>- Assigns and explains work to subordinate staff.</li> <li>- Coordinates with other unit supervisors and peers to establish unit objectives, goals, priorities, and deadlines.</li> <li>- Adjusts work to meet new priorities or changing program requirements within available resources.</li> <li>- Establishes production standards and prepares performance work plans and appraisals.</li> <li>- Resolves complaints and grievances</li> </ul> <p><b>Intelligence Officer</b></p> <p><b>Chief Immigration Enforcement Agent (CIEA)</b></p> <p><b>Mission Support Specialists (MSS)</b> The MSS provides expert level advice in administrative specialty areas; and serves as a trouble-shooter, providing authoritative guidance on problems not susceptible to treatment by accepted methods. Specific duties include:</p> <ul style="list-style-type: none"> <li>- Provides advice, assistance and guidance to supervisors, managers, and employees on complex and sensitive issues.</li> <li>- Conducts studies on new requirements in program operations, legislation, or agency regulations.</li> <li>- Responds to changes in judicial and/or administrative law and policy as well as to conflicting goals and objectives.</li> <li>- Evaluates pertinent legislation and new policies or directives from DHS or other agencies.</li> <li>- Conducts studies concerning organization-wide and/or government-wide management issues; develops program policies and procedures as required.</li> </ul> <p><b>Mission Support Assistant (MSA)</b> The MSA position is to provide clerical support to the Mission Support Team. The MSA is a member of a cross-functional team to utilize resources and develop expertise in several mission support areas, and may work in one or more of the following areas:</p>

ICE Staff Positions
<b>1.0 Office Zone</b>
<b>1.2 ICE Administration cont.</b>
<ul style="list-style-type: none"> <li>- Public Affairs - gathers information for use in press releases; assembles, formats and reproduces documents.</li> <li>- LAN Administration - tasks related to maintaining and operating the local area network and other office automation.</li> <li>- Financial and Budget - gathers and compiles data, and prepares various budget documents for budget requests, reprogramming and fund transfers. Prepares budget and accounting reports, maintains financial records.</li> <li>- Logistics and Procurement - maintains a variety of log's and records related to the organization's property management and space utilization.</li> <li>- Human Resources - prepares requests, as directed, for a variety of personnel actions utilizing the appropriate automated systems.</li> <li>- General Management Support - establishes and maintains a variety of records and files.</li> </ul> <p><b>Contracting Officer's Technical Representative (COTR)</b></p> <p><b>ICE Information Technology Specialist (Space Only)</b> The IT Specialist serves as a senior management advisor regarding IT systems and information; leads major agency-wide IT policy development efforts; coordinated policy dissemination, manages policy maintenance, and develops mechanisms to measure policy effectiveness and compliance. Specific responsibilities include the following:</p> <ul style="list-style-type: none"> <li>- Develops policies, guidelines, and standards for the planning, development, integration and implementation of IT systems and subsystems.</li> <li>- Analyzes statutory requirements against existing directives to assess degree of change necessary to comply with new requirements.</li> <li>- Manages special projects that have impact on the delivery of customer support services.</li> <li>- Leads quick response teams in responding to customer service problems resulting from catastrophic events.</li> <li>- Explores ways to upgrade or enhance the level of service provided.</li> <li>- Acquires IT hardware and software, services and maintenance of IT contracts.</li> <li>- Conducts IT strategic planning and project management.</li> </ul> <p><b>Receptionist</b></p> <p><b>Intelligence Research Specialist (IRS)</b> The IRS serves as an expert and engages in developing sources of information for intelligence collection for projecting data and/or estimates of future situations, developing trends, patterns, profiles, estimates, studies and tactical data. Specific duties include the following:</p> <ul style="list-style-type: none"> <li>- Developing intelligence collection plans which support specific programs and activities.</li> </ul>

ICE Staff Positions
<b>1.0 Office Zone</b>
<b>1.2 ICE Administration cont.</b>
<ul style="list-style-type: none"> <li>- Conducting studies and preparing staff reports, delivering briefings to managers to encourage understanding and acceptance of findings and recommendations.</li> <li>- Reviews, processes and evaluates intelligence information from a variety of sources.</li> <li>- Participates in and/or develops intelligence collection plans</li> </ul> <p><b>OIC Secretary</b> The OIC Secretary is the senior administrative assistant and has the primary function of assisting the OIC in all administrative matters. The OIC Secretary may also serve the AOIC, schedule meetings and executive conference room use, and arrange for travel for the OIC.</p>
<b>1.4 Office of the Principal Legal Advisor (OPLA)</b>
<p><b>Deputy Chief Counsel</b> The Deputy Chief Counsel is responsible for assisting the Chief Counsel in the management of the Office of the Chief Counsel (OCC), and its offices within the detention facilities. Specific responsibilities include the following:</p> <ul style="list-style-type: none"> <li>- Serves as first line supervisor to the attorney staff</li> <li>- Serves as first line supervisor to the support staff</li> <li>- Manages and assigns duties</li> <li>- Provides and oversees the provision of legal advice to the Office of Detention and Removal (DRO) and other DHS components</li> <li>- Provides and oversees the provision of litigation support, legal assistance, and legal advice to the U.S. Attorney's Office in the litigation of petitions for review before the circuit courts</li> <li>- Researches and oversees the research of legal and policy issues</li> <li>- Writes and oversees the writing of memoranda, briefs, legal opinions, letters, reports and other documents</li> </ul> <p><b>Assistant Chief Counsel (ACC)</b> The Assistant Chief Counsels (ACCs) are principally responsible for representing the Department in removal proceedings before immigration courts and the Board of Immigration Appeals. Specific responsibilities include the following:</p> <ul style="list-style-type: none"> <li>- Reviews, prepares and presents cases for trial and on appeal</li> <li>- Represents the Department in meetings, conferences and other forums</li> <li>- Provides legal advice to the Office of Detention and Removal (DRO) and other DHS components</li> <li>- Provides litigation support, legal assistance, and legal advice to the U.S. Attorney's Office in the litigation of civil and criminal cases</li> <li>- Researches legal and policy issues</li> </ul>



## ICE Staff Positions

ICE Staff Positions
<b>1.0 Office Zone</b>
<b>1.4 Office of the Principal Legal Advisor (OPLA) cont.</b>
<ul style="list-style-type: none"> <li>- Drafts memoranda, briefs, legal opinions, letters, reports and other documents</li> </ul> <p><b>Legal Technician</b> The Legal Technicians provide direct support to the Deputy Chief Counsel and Assistant Chief Counsels. Specific responsibilities include the following:</p> <ul style="list-style-type: none"> <li>- Receives, screens, sorts, distributes and sends out mail</li> <li>- Types legal documents</li> <li>- Prepares and files motions, briefs, exhibits and other documents</li> <li>- Receives phone calls</li> <li>- Retrieves and distributes A-files for immigration court hearings, and related matters</li> <li>- Uses computers for data entry, tracking and ordering A-files and typing legal documents</li> <li>- With attorney supervision, drafts simple motions, responses, letters and other documents</li> </ul> <p><b>Mail/File Clerk</b> The Mail/File Clerk is responsible for receiving, sorting and distributing correspondence and files received through incoming mail, pulling and sorting files based on calendars received from the Immigration Court and General Attorneys and reviewing and dispatching all outgoing mail. The Mail/File Clerk is in the Legal Proceedings unit under direct supervision of the District Counsel or Senior Legal Technician. Specific responsibilities include the following:</p> <ul style="list-style-type: none"> <li>- Reads incoming correspondence and notes all references to previous correspondence.</li> <li>- Screens mail for priority items such as bond papers</li> <li>- Charges files into and out of Legal Proceedings Unit using AFACS local file tracking software system.</li> <li>- Files case files and secures related material or files from other sections of the District Office and other Service offices.</li> <li>- Pulls and sorts files for each case calendared for hearing based on Immigration Court and General Attorney provided calendars</li> <li>- As appropriate, receives and screens telephone calls requesting files and information from files.</li> <li>- Receives all materials for mailing out of unit</li> <li>- Types information into computer relating to files and documents in an effort to retrieve files</li> <li>- As appropriate, keeps and compiles statistical data for monthly unit reports</li> <li>- Performs other duties as assigned</li> </ul>
<b>1.5 Removal Unit</b>
<p><b>Supervisory Detention &amp; Deportation Officer (SDDO)</b> The SDDO provides administrative and technical supervision to DO's, IEA's and clerical personnel. Specific responsibilities include the following:</p>

ICE Staff Positions
<b>1.0 Office Zone</b>
<b>1.5 Removal Unit cont.</b>
<ul style="list-style-type: none"> <li>- Serves as principal advisor on all administrative management matters associated with programs and operations for a significant organizational segment of the agency.</li> <li>- Interprets and recommends administrative procedures and policies.</li> <li>- Advises on the administrative feasibility of operating plans, suggestions, and proposals.</li> <li>- Sets the overall objectives and resources available (in-house or contract)</li> <li>- This position requires the carrying of a firearm.</li> </ul> <p><b>Deportation Officer (DO)</b> The DO position performs law enforcement functions related to both criminal and non-criminal aliens in the United States who are at various stages of their deportation/exclusion proceedings. DO's work closely with ICE law enforcement officers and attorneys as well as with US Attorney Offices in identifying, locating, apprehending, and/or prosecuting aliens, developing and coordinating intelligence, and defending deportation of exclusion proceedings. Specific duties of the Deportation Officer are as follows:</p> <ul style="list-style-type: none"> <li>- Performs case management of alien custody until deportation.</li> <li>- Fugitive Operations and Investigations - establishes an investigative plan to identify, locate and/or apprehend aliens in the US; conducts undercover assignments; plans and directs surveillance work.</li> <li>- Intelligence Information Processing - analyzes intelligence reports, collects and analyzes multiple intelligence sources.</li> <li>- Detention and deportation hearing participation.</li> </ul> <p><b>Deportation Removal Assistant (DRA)</b> The primary function of the DRA is to provide clerical and administrative support to the Detention and Removal Program. The duties require the position to have access to classified files, materials that consist of enforcement of laws and regulations, pertaining to the detention and removal of detainees.</p> <ul style="list-style-type: none"> <li>- Under the guidance of a supervisor, the DRA performs routine and recurring processing functions related to the admission and release of detainees.</li> <li>- Participates in routine and basic counseling process under the supervision of higher grade personnel.</li> <li>- Provides routine information on questions and issues regarding detention and deportation policies, practices, and procedures.</li> <li>- Performs file searches and assembles documentation in accordance with specific instructions.</li> </ul>
<b>1.6 Staff Services/Training</b>
<p><b>Training Officer</b></p>

**ICE Staff Positions****3.0 Detainee Living Zone****3.1 Detention Administration****Detention Operations Supervisor (DOS)****Supervisory Immigration Enforcement Agent (SIEA)**

The SIEA is a first-line supervisor for conducting day-to-day operations, as well as, short and medium range planning and evaluation of a variety of enforcement functions associated with investigations, identification, apprehension, prosecution, detention, and deportation of aliens and criminal aliens, and apprehension of absconders from removal proceedings. Specific duties include:

- Directly supervises a work unit with a small to medium sized staff and performs a full range of supervisory functions.
- Plans and schedules work on a daily, weekly, and monthly basis.
- Monitors and evaluated employees work.
- Monitors and evaluates the delivery of service to customers and the methods and techniques to provide them.
- Forecasting, requesting and managing the unit's annual budget.
- Performs the law enforcement duties prescribed for the IEA position.

**Immigration Enforcement Agent (IEA)**

The IEA is responsible for a variety of enforcement functions related to investigations, identification, apprehension, prosecution, detention, and deportation of aliens and criminal aliens, and apprehension of absconders from removal proceedings. IEA's regularly enter hostile situations and may be required to make decisions affecting life, well being, and/or civil liberties of aliens, the public and other law enforcement officers. Specific duties include:

- Processing and deporting or escorting aliens, under final order of removal, to their country of citizenship.
- Detention functions associated with ensuring detainee care, intake and outtake processing, counseling, and supervision and transportation of aliens.
- Prosecution activities including initiating criminal proceedings.
- Determining alienage and fugitive operations; locates and arrests aliens who may or may not have a criminal background.
- Operational support processes for aliens who have been apprehended by others.



## 4. FUNCTIONAL REQUIREMENTS

- ICE Space Requirements
  - 1.0 Office Zone
  - 2.0 Court Interface Zone
  - 3.0 Detainee Living Zone
  - 4.0 Service Zone
  - 5.0 Facility Support Zone
- Technical Requirements



# ICE Space Requirements

## FUNCTIONAL REQUIREMENTS

The functional requirements defined in this document contain the ICE space requirements, adjacencies, and critical work-flow patterns of the Office, Detainee Living, and Facility Service zones of the CDF. The Court Interface and Facility Support zones do not have any ICE space requirements and can be found under separate cover.

The matrix on the following page summarizes the Net and Gross square footages for each of the components within the four ICE operated zones. Sub-sections that follow provide a breakdown of specific details for each of the components.

The CDF Facility Model diagram to the right represents the zones and components of a CDF. The zones and components operated by ICE are highlighted with color.

CDF FACILITY MODEL

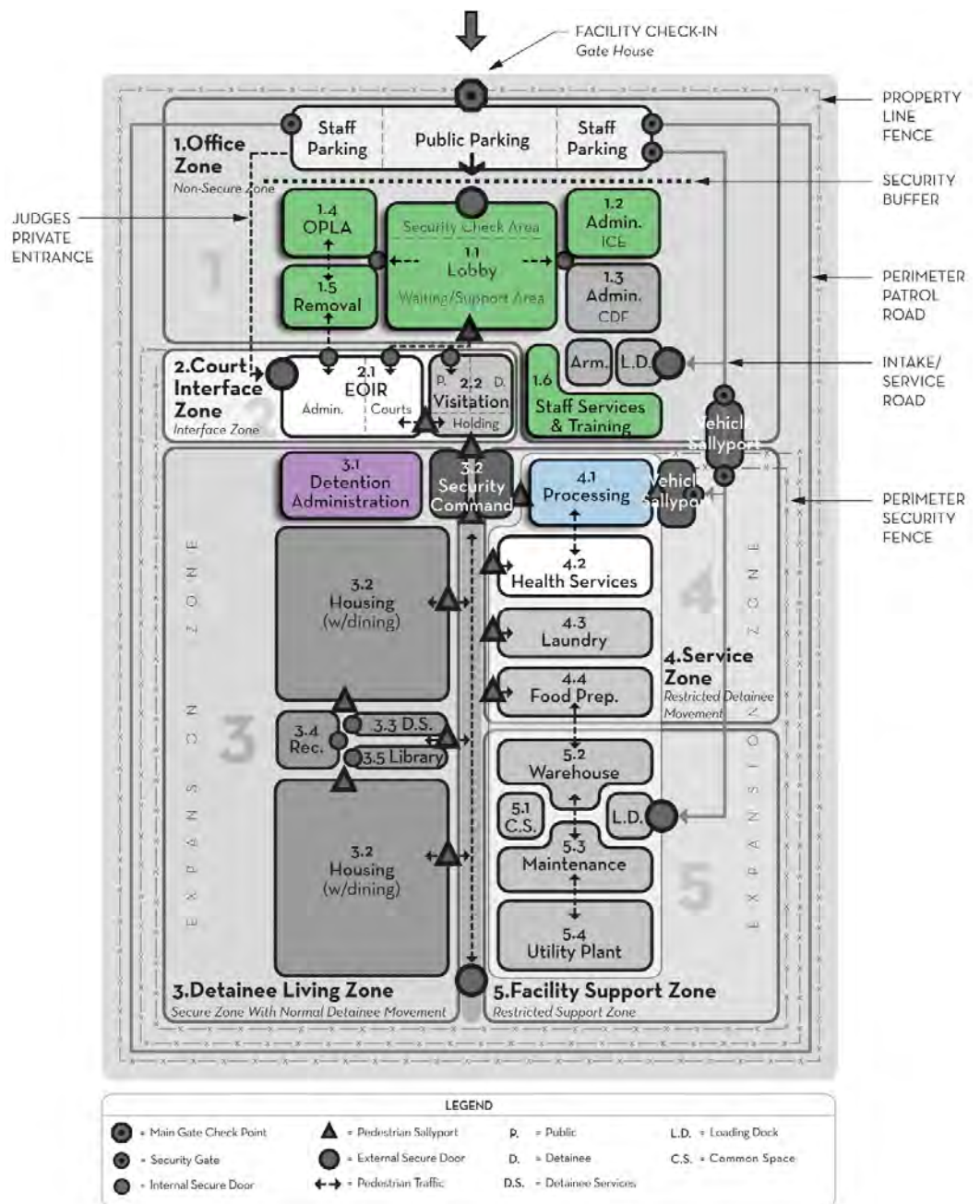

# ICE Space Requirements Summary

## Bed Forecast Scenarios

CDF User Groups	< 200 Beds		200-450 Beds		450-900 Beds		900-1,200 Beds		1,200-1,500 Beds		1,500-1,800 Beds		1,800-2,000 Beds		3,000 Beds	
	Total	Total	Total	Total	Total	Total	Total	Total	Total	Total	Total	Total	Total	Total	Total	
	NSF	GSF	NSF	GSF	NSF	GSF	NSF	GSF	NSF	GSF	NSF	GSF	NSF	GSF	NSF	GSF
<b>1.0 Office Zone</b>																
1.1	Public Entrance/Lobby															
1.2	ICE Administration															
1.3	CDF Administration															
1.4	OPLA															
1.5	Removal Unit															
1.6	Staff Services/Training															
<b>2.0 Court Interface Zone</b>																
2.1	EOIR Court															
2.2	Public/Detainee Visitation															
<b>3.0 Detainee Living Zone</b>																
3.1	Detention Administration															
3.2	Detainee Housing (w/Dining)															
3.3	Detainee Services															
3.4	Recreation															
3.5	Library															
<b>4.0 Service Zone</b>																
4.1	Processing															
4.2	Health Services															
4.3	Laundry															
4.4	Food Preparation															
<b>5.0 Facility Support Zone</b>																
5.1	Common Support															
5.2	Warehouse/Supply															
5.3	Maintenance/Fleet Operations															
5.4	Central Utility Plant															
<b>Total</b>																

(b)(2)High

- Color = ICE Operated
- White = Other Agency Operated
- Gray = Contractor Operated





## 4. FUNCTIONAL REQUIREMENTS





## 1.0 Office Zone

- 1.1 Public Entrance/Lobby (ICE Responsibility)
- 1.2 ICE Administration (ICE Responsibility)
- 1.3 CDF Administration (Contractor Responsibility)
- 1.4 Office of the Principal Legal Advisor (OPLA) (ICE Responsibility)
- 1.5 Removal Unit (ICE Responsibility)
- 1.6 Staff Services and Training (ICE Responsibility)



## 1.0 Office Zone

The Office Zone provides a normal office setting for administrative and public functions of the CDF. Office components do not have direct contact with, or are used by the detainees performing functions outside of the primary secure perimeter. The Office Zone is a non-secure area located outside the secure perimeter but requiring screening and control of the public entering the area. Security provisions should be appropriate for any government office area with confidential information. Access needs to be controlled and the building envelope should be monitored to detect unauthorized entry, though it does not need special hardened construction. Direct emergency egress may be provided. Points of public or service access must be readily identifiable with proper signage. (Flagpoles are popular devices used to identify public entrances.) Access points (both public and service) require means of audible and visual communication with the controlling point, usually the Central Control.

The Office Zone does not have direct contact with, and is not used by, the detainees. Office Zone functions are performed outside of the primary security perimeter.

The diagram on the following page illustrates the Office Zone components and the critical adjacency requirements for a productive work environment. It is highly recommended that the functional adjacencies be followed as close as possible when designing the space.

The following information has been provided for each of the components:

### **Function**

Describes the overall purpose of the component within the CDF.

### **Critical Workflow Patterns**

Identifies the most critical workflow patterns necessary for efficient staff productivity.

### **Room Data Sheets**

Provides detailed information on all spaces within the components (i.e., function statements, photograph, floor plan, systems, furniture, and equipment)

The components within the Office Zone are listed below:

### **1.1 Public Entrance/Lobby (ICE Operated)**

Spaces designated for receiving and supporting public visitors within the CDF.

### **1.2 ICE Administration (ICE Operated)**

Headed by the Facility Administrator directing and managing the CDF, including the staff and spaces required for this function.

### **1.3 CDF Administration (Contractor Operated)**

Contractor retained by DHS/ICE to operate the CDF.

### **1.4 Office of the Principal Legal Advisor (OPLA) (ICE Operated)**

Attorneys that prosecute the cases.

### **1.5 Removal Unit (ICE Operated)**

Staff, activities, and spaces of the Removal section of Detention and Removal Operations (DROP) within the CDF.

### **1.6 Staff Services/Training (ICE Operated)**

Spaces to be used for training and those areas used exclusively by the employees.

### 1.0 Office Zone : Organizational Diagram

(b)(2)High



## 1.0 Office Zone - Space Requirements

### SPACE FORECAST MATRIX

The Space Requirements Summary Matrix on the following page, identifies the spaces needed for each of the functional units within the Office Zone. The matrix is also designed to forecast these needs for the following planning scenarios:

1. <200 beds
2. 200 - 450 beds
3. 450 - 900 beds
4. 900 - 1,200 beds
5. 1,200 - 1,500 beds
6. 1,500 - 1,800 beds
7. 1,800 - 2,000 beds
8. 2,000 - 3,000 beds

The bed ranges were determined to best represent the capacity range for existing and planned detainee populations.

For each planning scenario, the following information is provided:

- # of Users is the number of persons (staff or detainees) in a given space.
- # of Spaces is the quantity of a given space.
- Space Size NSF is the net square feet or size of a given space.
- Total Size NSF is the number of spaces or quantity of a space times the NSF or size.

The sidebar to the right highlights some of the Space Planning Formulas that are used for calculating areas.

### SPACE CALCULATIONS/DEFINITIONS

The total Net Square Footage is the sum of all net areas of the spaces listed. This number is multiplied by a Net-Gross Factor (an industry factor based on space type) to determine Gross Square Footage (GSF). This factor is intended to account for space such as circulation space, mechanical space, wall thicknesses, etc., that are not programmed space.

- **Net Square Footage (NSF)**  
Total clear floor area within a given room, excluding walls, corridors, mechanical equipment rooms, shafts, stairs, and chases.
- **Gross Square Footage (GSF)**  
Total building area measured from outside face of exterior walls.

Space Planning Formulas	
<b>1.1 Public Entrance/Lobby</b>	<ul style="list-style-type: none"> <li>• Number of weapons lockers = total gun carrying staff + 20 visitors</li> </ul>
<b>1.2 ICE Administration</b>	<ul style="list-style-type: none"> <li>• None</li> </ul>
<b>1.3 CDF Administration</b>	<ul style="list-style-type: none"> <li>• None</li> </ul>
<b>1.4 Office of the Principal Legal Advisor (OPLA)</b>	<ul style="list-style-type: none"> <li>• Immigration Judges = 1 per each 200 detainees</li> <li>• Assistant Chief Counsel Offices = 2.3 per each courtroom</li> <li>• Legal Technicians = 1 per each 3 Assistant Chief Counsels positions</li> </ul>
<b>1.5 Removal Unit</b>	<ul style="list-style-type: none"> <li>• 1 file cabinet for each 60 detainees</li> </ul>
<b>1.6 Staff Services/Training</b>	<ul style="list-style-type: none"> <li>• Number of lockers:               <ul style="list-style-type: none"> <li>- 1 for each uniformed person + 1 for each 4 non-uniformed staff</li> <li>- Male/Female split = 85/15</li> </ul> </li> <li>• Number of showers = 1 for each 15 lockers</li> </ul>



1.0 Office Zone

## **1.1 Public Entrance/Lobby**

(ICE Operated)

### **Space Requirements**

- 1.1.1 Vestibule
- 1.1.2 Visitor Check-In/Prescreening Area
- 1.1.3 Weapons Drop Room
- 1.1.4 Visitor Property Lockers
- 1.1.5 Visitor Security Check-In Area
- 1.1.6 Reception/Security Post
- 1.1.7 Visitor Search Room
- 1.1.8 Visitor Waiting Area
- 1.1.9 Visitor Vending Area
- 1.1.10 Visitor Telephone Area
- 1.1.11 Visitor Toilets - Male
- 1.1.12 Visitor Toilets - Female





## 1.1 Public Entrance/Lobby - Function

### FUNCTION STATEMENT

The primary function of the Public Entrance/Lobby is to provide a place where the public can enter the facility, be greeted, be screened, wait and be directed to their destination. The Public Entrance/Lobby serves the public seeking access to detainee Visitation, EOIR Court, Removal Unit, and ICE/Contractor Administration.

All public access to the facility must be gained through the Public Entrance/Lobby. A security post/reception desk is located in the Public Entrance/Lobby to screen and search visitors and their possessions, and to provide directory assistance. Free access to the Public Entrance/Lobby is available during normal business hours and weekend visiting hours.

The Public Entrance/Lobby should be organized into "Four Zones". **Zone 1: Prescreening** where visitors can remove devices not allowed within the facility, **Zone 2: Security Check** where visitors are met by an officer, sign-in and pass through metal detector, **Zone 3: Waiting** is space for visitors to wait for their business, and **Zone 4: Transition** is a zone that permits visitors to gain access to areas beyond the Public Entrance/Lobby.

The Public Entrance/Lobby should permit the assigned security officer to have unobstructed sight lines to the facility's main entry door, waiting area, and all doors leading from the Public Entrance/Lobby to other areas.

The Public Entrance/Lobby is located outside the secure perimeter in the non-secure zone.

### Design Criteria

#### Critical Issues

- ✓ No more than one primary public entrance to the facility
- ✓ Clear and identifiable access from public parking
- ✓ Controlled access after passing through the vestibule
- ✓ Visitors are always escorted to their destination
- ✓ All visitors are subject to identification and security screening
- ✓ The main entrance must have direct visual monitoring
- ✓ Storage must be available for items that are restricted from being carried into the facility.

#### Special Requirements

- ✓ Video surveillance of lobby is required
- ✓ Security post is staffed by one or more officers
- ✓ Ballistic resistant material incorporated into modesty panel of reception counter
- ✓ Metal detector and baggage scanner are required

#### Space Requirements

##### 1.1 PUBLIC ENTRANCE/LOBBY

- 1.1.1 Vestibule
- 1.1.2 Visitor Check-In/Prescreening Area
- 1.1.3 Weapons Drop Room
- 1.1.4 Visitor Property Lockers
- 1.1.5 Visitor Security Check-In Area
- 1.1.6 Reception/Security Post
- 1.1.7 Visitor Search Room
- 1.1.8 Visitor Waiting Area
- 1.1.9 Visitor Vending Area
- 1.1.10 Visitor Telephone Area
- 1.1.11 Visitor Toilets - Male
- 1.1.12 Visitor Toilets - Female

### 1.1 Public Entrance/Lobby : Organizational Diagram

(b)(2)High



## **1.1 Public Entrance/Lobby - Critical Workflow Patterns**

### **INTRODUCTION**

The diagrams on the following page illustrate some of the most critical workflow issues and patterns for the Public Entrance/Lobby.

### 1.1 Public Entrance/Lobby : Critical Workflow Patterns

#### 1. "FOUR ZONES"

The Public Entrance/Lobby should be organized into "Four Zones". **Zone 1: Prescreening** where visitors can remove devices not allowed within the facility, **Zone 2: Security Check** where visitors are met by an officer, sign-in and pass through metal detector, **Zone 3: Waiting** is space for visitors to wait for their business, and **Zone 4: Transition** is a zone that permits visitors to gain access to areas beyond the Public Entrance/Lobby.



#### 2. "UNOBSTRUCTED SIGHT LINES"

The Public Entrance/Lobby should permit the assigned security officer to have unobstructed sight lines to the facility's main entry door, waiting area, and all doors leading from the Public Entrance/Lobby to other areas.

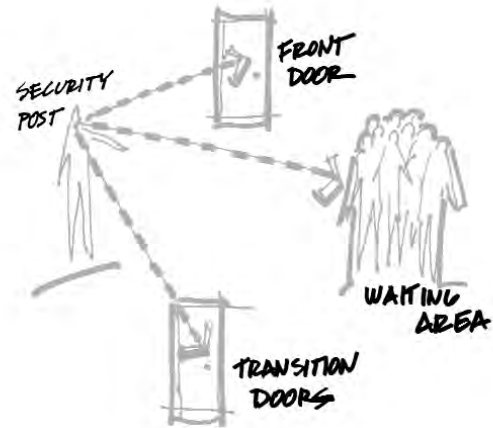



## 1.1 Public Entrance/Lobby - Room Data Sheet

### 1.1.1 VESTIBULE

#### Function

The Vestibule is used to provide a thermal break between the exterior and interior of the building. It also serves as a secure point when the interior doors are in the locked position.



Photograph

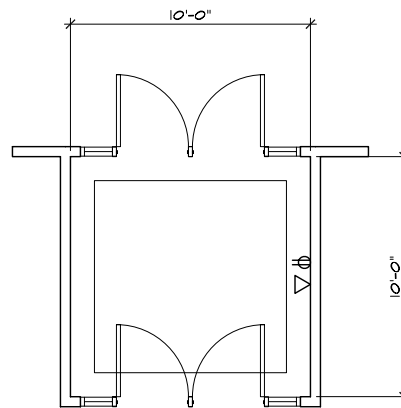

Floor Plan (100 nsf)

**SYMBOL LEGEND:**



Voice Outlet



Data Outlet



Voice/Data Outlet



Duplex Outlet



ISDN Outlet



Duress Alarm Outlet





## 1.1 Public Entrance/Lobby - Room Data Sheet

### 1.1.2 VISITOR CHECK-IN/PRESCREENING AREA

#### Function

The Visitor Check-In/Prescreening Area is space between the vestibule and the visitor security check-in area. The space is used to contain visitors as they arrive and are waiting to be processed/checked into the facility.

The Visitor Check-In/Prescreening Area should be located in Zone 1 of the Public Entrance/Lobby and directly adjacent to the Weapons Drop Room and the Visitor Property Storage Lockers.



Photograph

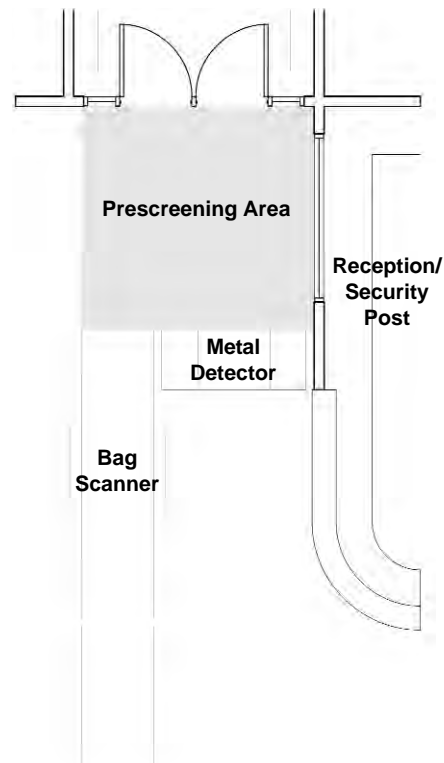

Floor Plan

**SYMBOL LEGEND:**

- Voice Outlet
- Data Outlet
- Voice/Data Outlet
- Duplex Outlet
- ISDN Outlet
- Duress Alarm Outlet







## 1.1 Public Entrance/Lobby - Room Data Sheet

### 1.1.3 WEAPONS DROP ROOM

#### Function

The Weapons Drop Room provides a secure space for Law Enforcement Agents to store their weapon while inside the facility. The space must be accessible from the Visitor Check-In/Prescreening Area and/or ahead of the metal detector as one enters the facility.

The Weapons Drop Room should be located in Zone 1 of the Public Entrance/Lobby.



Photograph

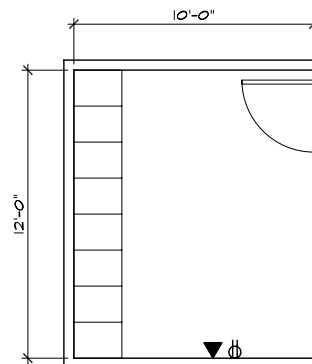

Floor Plan (120 nsf)

**SYMBOL LEGEND:**







## 1.1 Public Entrance/Lobby - Room Data Sheet

### 1.1.4 VISITOR PROPERTY LOCKERS

**Function**

The Visitor Property Lockers are located directly at or ahead of the check-in point. These lockers provide visitors a secure place to store items that are restricted from the facility.

The Visitor Property Lockers should be located in Zone 1 of the Public Entrance/Lobby.



Photograph

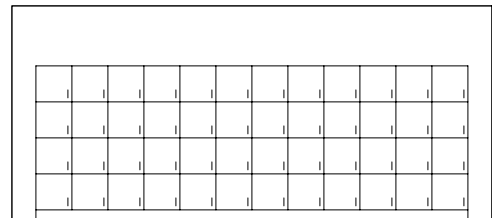
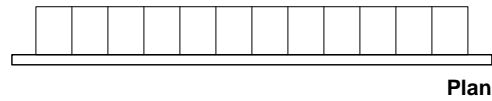

Floor Plan

**SYMBOL LEGEND:**



Voice Outlet



Data Outlet



Voice/Data Outlet



Duplex Outlet



ISDN Outlet



Duress Alarm Outlet





## 1.1 Public Entrance/Lobby - Room Data Sheet

### 1.1.5 VISITOR SECURITY CHECK-IN AREA

#### Function

The Visitor Security Check-In Area is located directly adjacent to the Visitor Check-In/Prescreening area and houses the metal detection and bag screening equipment. All entrants to the facility must pass through this point.

The Visitor Security Check-In Area should be located in Zone 2 of the Public Entrance/Lobby, directly adjacent to the Reception/Security Post.



Photograph

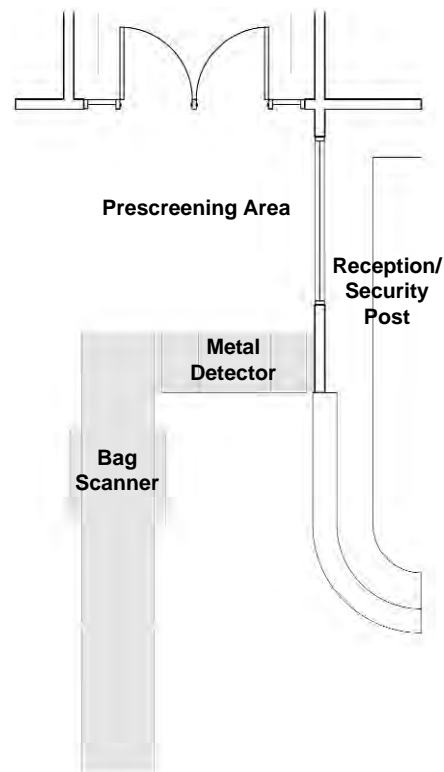

Floor Plan

**SYMBOL LEGEND:**

- Voice Outlet
- Data Outlet
- Voice/Data Outlet
- Duplex Outlet
- ISDN Outlet
- Duress Alarm Outlet





## 1.1 Public Entrance/Lobby - Room Data Sheet

### 1.1.6 RECEPTION/SECURITY POST

#### Function

The Reception/Security Post is the primary processing position for all visitors to the facility. This post also provides surveillance of the facility's main entrance "front door", the visitor's waiting area and Removal Unit public counter.

The post is staffed during normal business hours and during weekend visiting hours.

Staff positioned at this post will check and validate visitor identification, keep the visitor log and control access to and from the lobby.

The Reception/Security Post should be located in Zone 2 of the Public Entrance/Lobby and directly adjacent to the Visitor Search Room.



Photograph

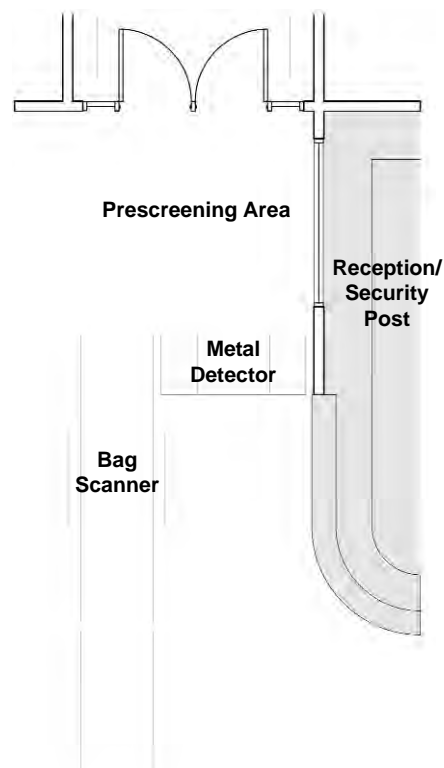

Floor Plan

#### SYMBOL LEGEND:



Voice Outlet



Data Outlet



Voice/Data Outlet



Duplex Outlet



ISDN Outlet



Duress Alarm Outlet







## 1.1 Public Entrance/Lobby - Room Data Sheet

### 1.1.7 VISITOR SEARCH ROOM

#### Function

The Visitor Search Room functions as a private place for Law Enforcement officers to search visitors that have not passed the Visitor Security Check-In process.

The Visitor Search Room should be located in Zone 2 of the Public Entrance/Lobby and directly adjacent to the Reception/Security Post.



Photograph

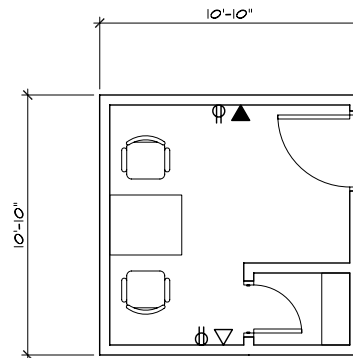

Floor Plan

**SYMBOL LEGEND:**



Voice Outlet



Data Outlet



Voice/Data Outlet



Duplex Outlet



ISDN Outlet



Duress Alarm Outlet





## 1.1 Public Entrance/Lobby - Room Data Sheet

### 1.1.8 VISITOR WAITING AREA

#### Function

The Visitor Waiting Area is an open area with fixed seating for visitors awaiting EOIR Court or visitation. The Visitor Waiting Area should be located in Zone 3 of the Public Entrance/Lobby and have access to toilets, drinking fountain, vending machines, and pay telephones.

Officer's station within the Public Entrance/Lobby should have a clear line of sight to the Visitor Waiting Area. Any movement outside of the Public Entrance/Lobby area will require an escort.



Photograph

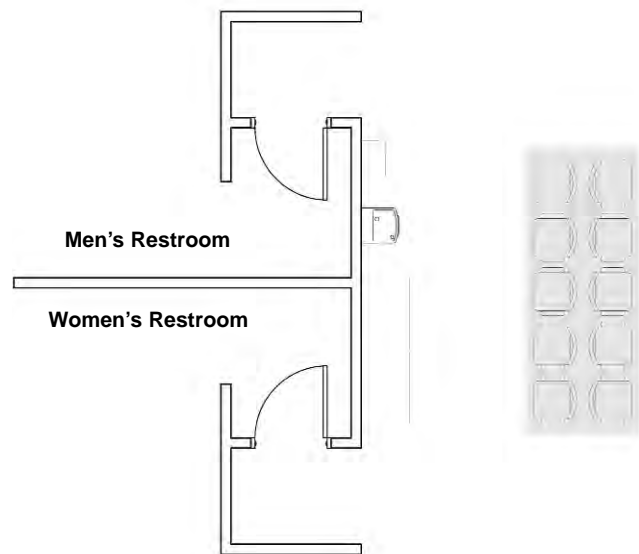

Floor Plan





## 1.1 Public Entrance/Lobby - Room Data Sheet

### 1.1.9 VISITOR VENDING AREA

#### Function

The Visitor Vending Area supports the needs of the public visitors while waiting for their business transaction. The Visitor Vending Area should be located in Zone 3 of the Public Entrance/Lobby, in clear sight of the Security Officer post.



Photograph

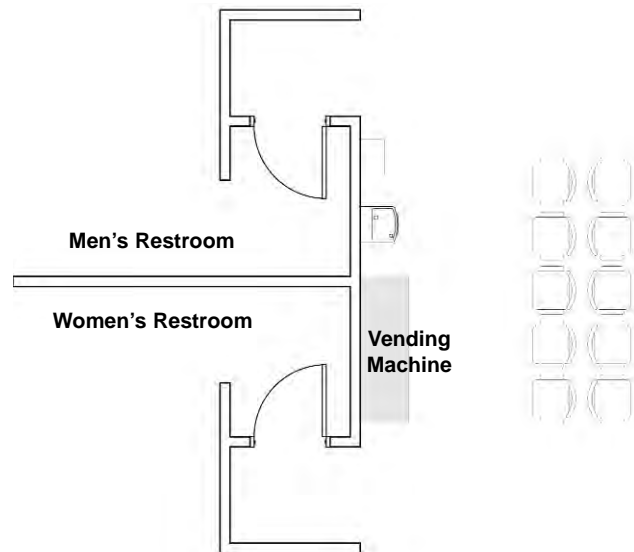

Floor Plan

**SYMBOL LEGEND:**



Voice Outlet



Data Outlet



Voice/Data Outlet



Duplex Outlet



ISDN Outlet



Duress Alarm Outlet





## 1.1 Public Entrance/Lobby - Room Data Sheet

### 1.1.10 VISITOR TELEPHONE AREA

#### Function

The Visitor Telephone Area utilized by visitors awaiting their business transaction. The Visitor Telephone Area should be located in Zone 3 of the Public Entrance/Lobby and have clear line of sight from the Security Officer's post.



Photograph

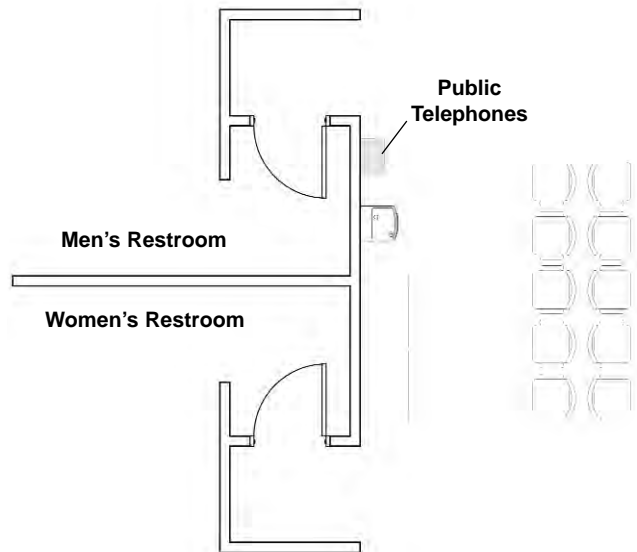

Floor Plan

**SYMBOL LEGEND:**

-  Voice Outlet    Data Outlet    Voice/Data Outlet    Duplex Outlet    ISDN Outlet    Duress Alarm Outlet







## 1.1 Public Entrance/Lobby - Room Data Sheet

### 1.1.11 PUBLIC TOILET - MALE

#### Function

The Male Public Toilet is a single use room located directly adjacent to the waiting area, in Zone 3 of the Public Entrance/Lobby.



Photograph

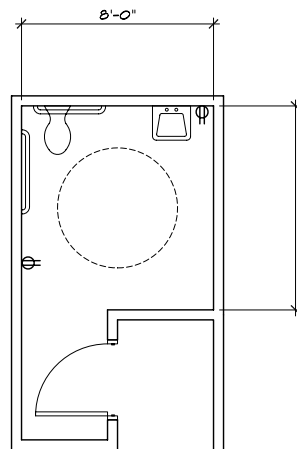

Floor Plan

SYMBOL LEGEND:



Voice Outlet



Data Outlet



Voice/Data Outlet



Duplex Outlet



ISDN Outlet



Duress Alarm Outlet





## 1.1 Public Entrance/Lobby - Room Data Sheet

### 1.1.12 PUBLIC TOILET - FEMALE

#### Function

The Female Public Toilet is a single use room located directly adjacent to the waiting area.



Photograph

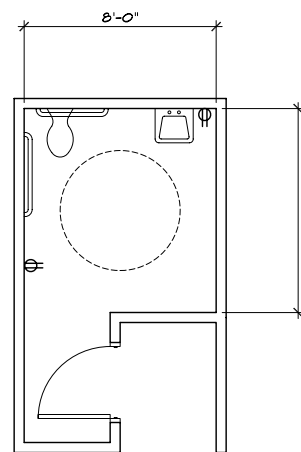

Floor Plan

**SYMBOL LEGEND:**

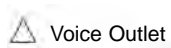

Voice Outlet

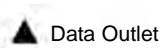

Data Outlet



Voice/Data Outlet



Duplex Outlet



ISDN Outlet



Duress Alarm Outlet





1.0 Office Zone

## 1.2 ICE Administration

(ICE Operated)

### Space Requirements

- 1.2.1 Officer in Charge (OIC) Office
- 1.2.2 Assistant Officer in Charge (AOIC) Office
- 1.2.3 Intelligence Officer Office
- 1.2.4 Supervisory Mission Support Specialist (SMSS) Office
- 1.2.5 Chief Immigration Enforcement Agent (CIEA) Office
- 1.2.6 Mission Support Specialist (MSS) Office
- 1.2.7 Contracting Officer's Technical Representative (COTR) Office
- 1.2.8 OIC Secretary Workstation
- 1.2.9 Receptionist Workstation w/Transaction Window
- 1.2.10 ICE IT Specialist (Space Only) Workstation
- 1.2.11 Mission Support Assistant (MSA) Workstations
- 1.2.12 Intelligence Research Specialist (IRS) Workstation
- 1.2.13 Executive Conference Room
- 1.2.14 Records/Files Room
- 1.2.15 Copier/Fax/Shredder Room
- 1.2.16 Printer Area
- 1.2.17 File Area
- 1.2.18 Officer Toilet - Male
- 1.2.19 Officer Toilet - Female



## 1.2 ICE Administration - Function

### FUNCTION STATEMENT

ICE Administration is responsible for administration and management of all services and activities performed by ICE. It directs the policies for ICE and delegates responsibility to the subordinate components. ICE Administration, through its direct staff or the ICE District Office, provides fiscal and personal services to the ICE operations and staff.

ICE Administration may receive public visitors, including detainee family members and acquaintances; or official visitors including lawyers, government officials, and individuals conducting business.

ICE Administration is located in the non-secure zone, though restricted only to staff and visitors accompanied by staff. Visitors will be under supervision of their host.

### Design Criteria

#### Critical Issues

- ✓ The OIC must be able to leave the facility without being seen by detainees.
- ✓ Entrance to ICE Administration should be under continuous visual observation by security or clerk.

#### Special Requirements

- ✓ Controlled access to ICE Administration space.
- ✓ File space for accreditation records.
- ✓ ICE Administration must be located directly adjacent to the CDF Public Entrance/Lobby. ICE Administration should be located in close proximity to the Removal Unit to access detainee records, and adjacent to Staff Services and Training which allows Administration easy access to participate in briefings.

#### Space Requirements

##### 1.2 ICE Administration

- 1.2.1 Officer in Charge (OIC) Office
- 1.2.2 Assistant Officer in Charge (AOIC) Office
- 1.2.3 Intelligence Officer Office
- 1.2.4 Supervisory Mission Support Specialist (SMSS) Office
- 1.2.5 Chief Immigration Enforcement Agent (CIEA) Office
- 1.2.6 Mission Support Specialist (MSS) Office
- 1.2.7 Contracting Officer's Technical Representative (COTR) Office
- 1.2.8 OIC Secretary Workstation
- 1.2.9 Receptionist Workstation w/Transaction Window
- 1.2.10 ICE IT Specialist (Space Only) Workstation
- 1.2.11 Mission Support Assistant (MSA) Workstations
- 1.2.12 Intelligence Research Specialist (IRS) Workstation
- 1.2.13 Executive Conference Room
- 1.2.14 Records/Files Room
- 1.2.15 Copier/Fax/Shredder Room
- 1.2.16 Printer Area
- 1.2.17 File Area
- 1.2.18 Officer Toilet - Male
- 1.2.19 Officer Toilet - Female

## 1.2 ICE Administration : Organizational Diagram

(b)(2)High





## **1.2 ICE Administration - Critical Workflow Patterns**

### **INTRODUCTION**

The diagrams on the following page illustrate some of the most critical workflow issues and patterns of the ICE Administration.

1.2 ICE Administration : Critical Workflow Patterns

1. "CLOSE PROXIMITY"

The ICE Administration area requires close proximity to the Public Entrance/Lobby, Removal Unit, and Staff Services and Training.



2. "CONTROLLED ACCESS"

Admission into the ICE Administration area is controlled by the Security Post located in the Public Entrance/Lobby area.

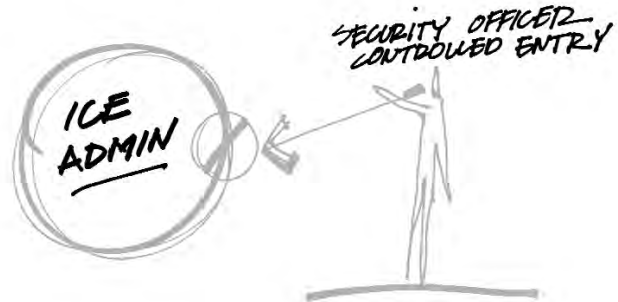



## 1.2 ICE Administration - Room Data Sheet

### 1.2.1 OFFICER IN CHARGE (OIC) OFFICE

#### Function

The Officer In Charge is the highest ranking officer at the CDF and has ultimate authority and responsibility at the site.

The OIC oversees all CDF activities including those of contract personnel. The OIC Office is located in a private office away from open office and high traffic areas and on an exterior wall.



Photograph

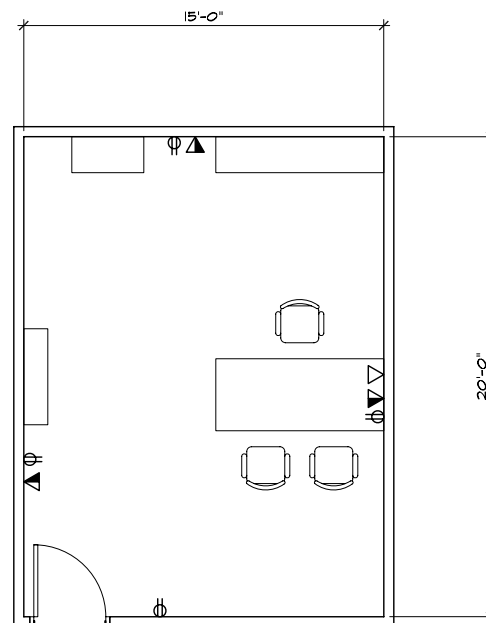

Floor Plan

**SYMBOL LEGEND:**

- Voice Outlet
- Data Outlet
- Voice/Data Outlet
- Duplex Outlet
- ISDN Outlet
- Duress Alarm Outlet





## 1.2 ICE Administration - Room Data Sheet

### 1.2.2 ASSISTANT OFFICER IN CHARGE (AOIC) OFFICE

#### Function

The Assistant Officer In Charge is the second ranking officer at the CDF. They have responsibility for administrative and operations activities as directed by the OIC.

The AOIC is located in the private office zone adjacent to the Executive Conference Room and OIC office, and on an external wall.



Photograph

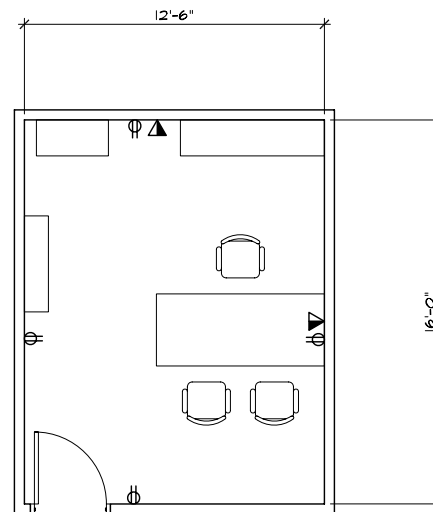

Floor Plan

SYMBOL LEGEND:

- Voice Outlet   Data Outlet   Voice/Data Outlet   Duplex Outlet   ISDN Outlet   Duress Alarm Outlet





## 1.2 ICE Administration - Room Data Sheet

### 1.2.3 INTELLIGENCE OFFICER OFFICE

#### Function

The Intelligence Officer is responsible for producing all-source tactical and strategic intelligence on issues related to the security of the U.S. Homeland to support the Department's senior leadership, state, local, tribal, territorial partners, and the private sector.

National responsibilities include: fusing and analyzing intelligence from DHS operating components, state and local partners, and other IC agencies into Homeland security assessments; ensuring analytic intelligence support to DHS elements that addresses the Secretary's top priorities, serving as the primary interface between IC and customers at state, local, tribal, territorial levels and in the private sector on Homeland security issues; and coordinating intelligence analytic operations between I&A and DHS operating components as an integrated DHS intelligence enterprise.



Photograph

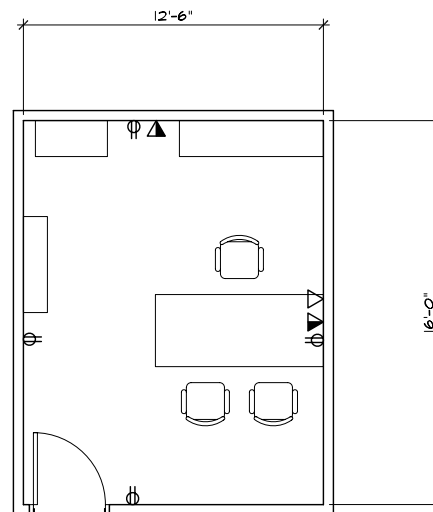

Floor Plan

**SYMBOL LEGEND:**

- Voice Outlet
- Data Outlet
- Voice/Data Outlet
- Duplex Outlet
- ISDN Outlet
- Duress Alarm Outlet







## 1.2 ICE Administration - Room Data Sheet

### 1.2.4 SUPERVISORY MISSION SUPPORT SPECIALIST (SMSS) OFFICE

#### Function

The Supervisory Mission Support Specialist supervises a group of Mission Support Specialists who are responsible for providing services in direct support of operational programs. The work of the SMSS provides complex administrative and support and significantly affects the program's operation and objectives. SMSS contacts are generally within the CDF's personnel to coordinate and plan the work.

The SMSS is located in a private office within the ICE Administration area, preferably on an exterior wall.



Photograph

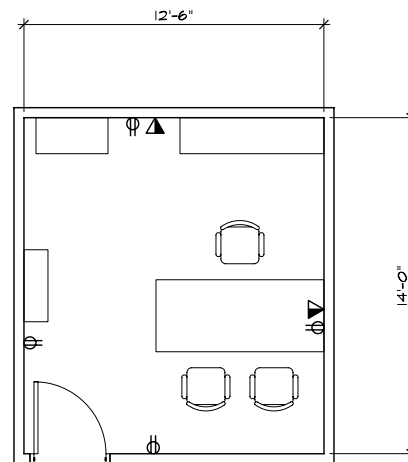

Floor Plan

**SYMBOL LEGEND:**



Voice Outlet



Data Outlet



Voice/Data Outlet



Duplex Outlet



ISDN Outlet



Duress Alarm Outlet





## 1.2 ICE Administration - Room Data Sheet

### 1.2.5 CHIEF IMMIGRATION ENFORCEMENT AGENT (CIEA) OFFICE

Function  
The....



Photograph

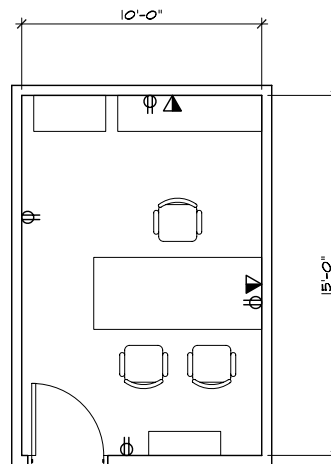

Floor Plan

SYMBOL LEGEND:

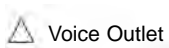

Voice Outlet

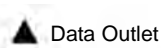

Data Outlet



Voice/Data Outlet



Duplex Outlet



ISDN Outlet



Duress Alarm Outlet





## 1.2 ICE Administration - Room Data Sheet

### 1.2.6 MISSION SUPPORT SPECIALIST (MSS) OFFICE

#### Function

The Mission Support Specialist has functional duties associated with budget, management analysis, human resource management, training, logistics/procurement, safety and security. The MSS performs management advisory services for specific requests related to immediate problems of limited scope for the SMSS.

The MSS Office is located in a private office within the ICE Administration area, preferably on an exterior wall.



Photograph

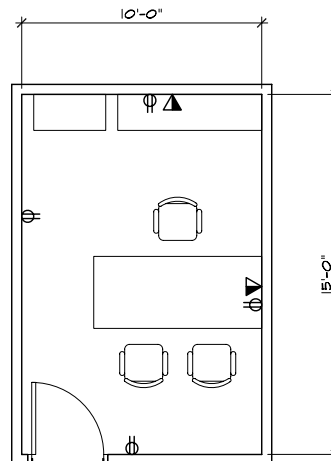

Floor Plan

SYMBOL LEGEND:



Voice Outlet



Data Outlet



Voice/Data Outlet



Duplex Outlet



ISDN Outlet



Duress Alarm Outlet





## 1.2 ICE Administration - Room Data Sheet

### 1.2.7 CONTRACTING OFFICER'S TECHNICAL REPRESENTATIVE (COTR) OFFICE

#### Function

The Contracting Officer is responsible for all aspects of the contracting transactions from initiation of a requirement to recommendation of contract award to procure supplies or services with specialized requirements such as the procurement of complex equipment, services, and/or constructions. The Contracting Officer also prepares solicitations documents, and incorporates provisions; prepares and conducts pre-proposal conferences and pre-solicitation site visits; prepares contracting work through use of negotiation techniques; coordinates a variety of contracts requiring the development of new or modified evaluation criteria, reporting requirements and contractual arrangements.



Photograph

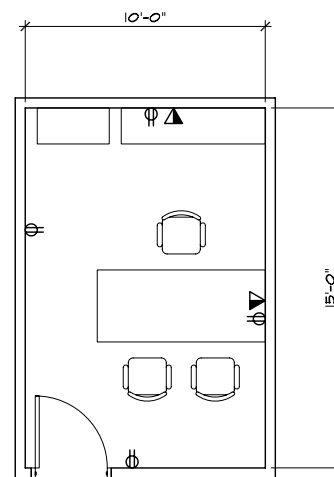

Floor Plan

SYMBOL LEGEND:

- Voice Outlet
- Data Outlet
- Voice/Data Outlet
- Duplex Outlet
- ISDN Outlet
- Duress Alarm Outlet







## 1.2 ICE Administration - Room Data Sheet

### 1.2.8 OIC SECRETARY WORKSTATION

#### Function

The OIC Secretary is the senior administrative assistant and has the primary function of assisting the OIC in all administrative matters. The OIC Secretary may also serve the AOIC, schedule meetings and executive conference room use, and arrange for travel for the OIC.

The OIC Secretary Workstation is located directly adjacent to the OIC office and should be positioned to screen all people seeking access to the OIC officer.



Photograph

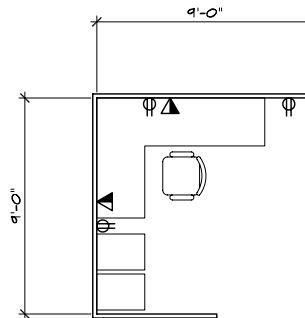

Floor Plan

**SYMBOL LEGEND:**

- Voice Outlet   Data Outlet   Voice/Data Outlet   Duplex Outlet   ISDN Outlet   Duress Alarm Outlet





## 1.2 ICE Administration - Room Data Sheet

### 1.2.9 RECEPTIONIST WORKSTATION W/TRANSACTION COUNTER

#### Function

The ICE Administration Receptionist supports ICE Administration staff and also acts as the point of contact for visitors, guests, etc., entering into the ICE Administrative department.



Photograph

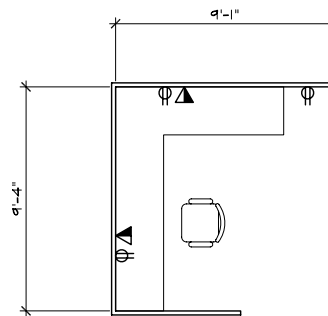

Floor Plan

SYMBOL LEGEND:



Voice Outlet



Data Outlet



Voice/Data Outlet



Duplex Outlet



ISDN Outlet



Duress Alarm Outlet





## 1.2 ICE Administration - Room Data Sheet

### 1.2.10 ICE IT SPECIALIST WORKSTATION

#### Function

The ICE IT Specialist develops policies, guidelines and standards for the planning, development, integration, implementation, and evaluation of information technology systems and subsystems that meet overall information needs of multiple organizational units.

The ICE IT Specialist also provides expert analysis and advice on complex program related information technology issues and problems. The IT Specialist implements technological changes in response to changing customer requirements.



Photograph

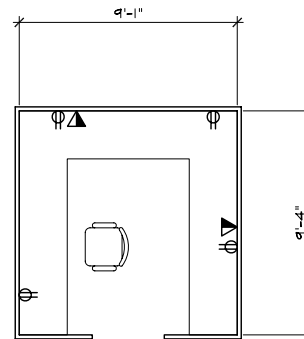

Floor Plan

**SYMBOL LEGEND:**

- Voice Outlet   Data Outlet   Voice/Data Outlet   Duplex Outlet   ISDN Outlet   Duress Alarm Outlet





## 1.2 ICE Administration - Room Data Sheet

### 1.2.11 MISSION SUPPORT ASSISTANT (MSA) WORKSTATION

#### Function

The Mission Support Assistant provides support to the MSS in the areas of public affairs, budget, logistics/procurement, human resource management, and records/file management.

The MSA Workstation is located in an open workstation within the ICE Administration area.



Photograph

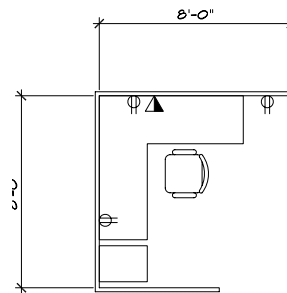

Floor Plan

**SYMBOL LEGEND:**

-  Voice Outlet    Data Outlet    Voice/Data Outlet    Duplex Outlet    ISDN Outlet    Duress Alarm Outlet







## 1.2 ICE Administration - Room Data Sheet

### 1.2.12 INTELLIGENCE RESEARCH SPECIALISTS (IRS) WORKSTATION

#### Function

The Intelligence Research Specialist serves as an expert and engages in developing sources of information for intelligence collection for protecting data and/or estimates of future situations, developing trends, patterns, profiles, studies and tactical data.

The work requires conducting studies and preparing staff reports, delivering briefings, and developing and recommending methods of solving analytical problems.



Photograph

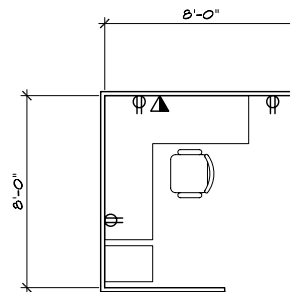

Floor Plan

**SYMBOL LEGEND:**

- Voice Outlet   Data Outlet   Voice/Data Outlet   Duplex Outlet   ISDN Outlet   Duress Alarm Outlet





## 1.2 ICE Administration - Room Data Sheet

### 1.2.13 EXECUTIVE CONFERENCE ROOM

#### Function

The Executive Conference Room is used for meetings of the facility leadership and visiting dignitaries. Its use is managed by the OIC Secretary.



Photograph

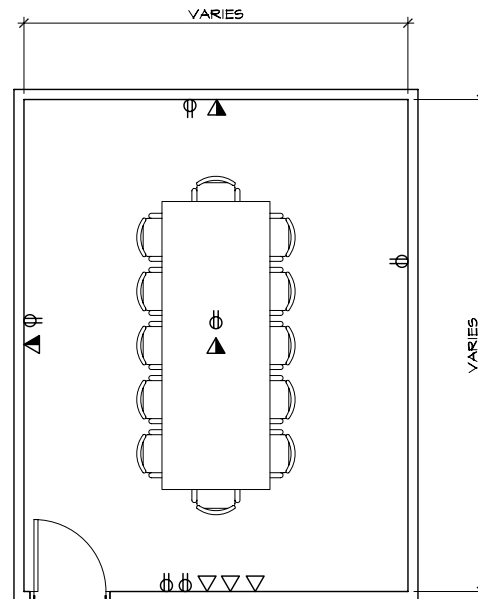

Floor Plan

SYMBOL LEGEND:



Voice Outlet



Data Outlet



Voice/Data Outlet



Duplex Outlet



ISDN Outlet



Duress Alarm Outlet





## 1.2 ICE Administration - Room Data Sheet

### 1.2.14 RECORDS/FILES ROOM

#### Function

The Records/File Room is used to secure files maintained by the ICE Administration.



Photograph

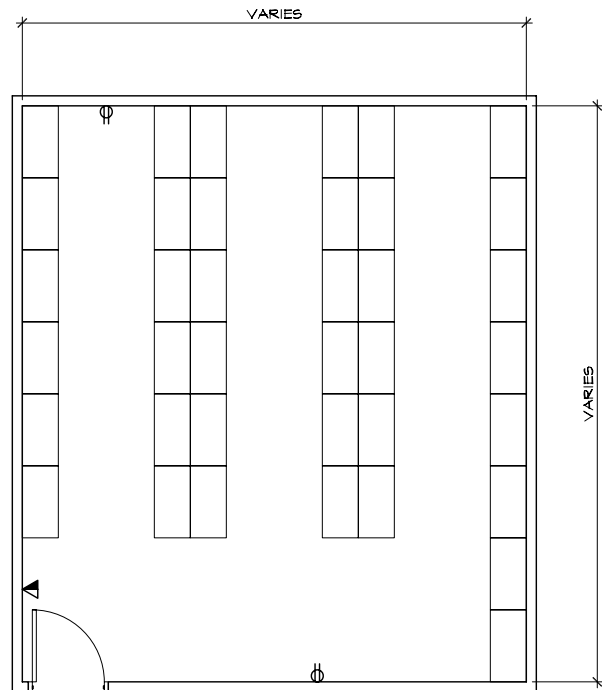

Floor Plan

SYMBOL LEGEND:

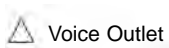

Voice Outlet



Data Outlet



Voice/Data Outlet



Duplex Outlet



ISDN Outlet



Duress Alarm Outlet





## 1.2 ICE Administration - Room Data Sheet

### 1.2.15 COPIER/SHREDDER/FAX ROOM

#### Function

The Copier/Fax/Shredder Room is used for mass copying, faxing documents, and shredding secure or sensitive documents.



Photograph

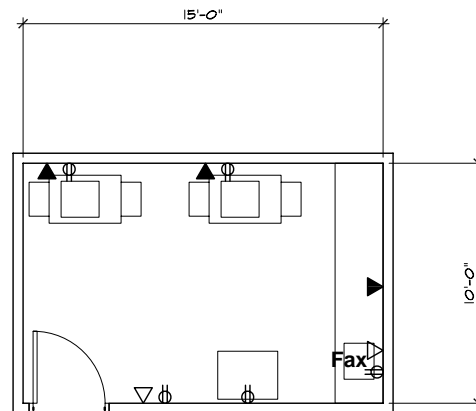

Floor Plan

**SYMBOL LEGEND:**



Voice Outlet



Data Outlet



Voice/Data Outlet



Duplex Outlet



ISDN Outlet



Duress Alarm Outlet







## 1.2 ICE Administration - Room Data Sheet

### 1.2.16 PRINTER AREA

#### Function

The Printer Area is an allocation of space within the open office environment for printers.



Photograph

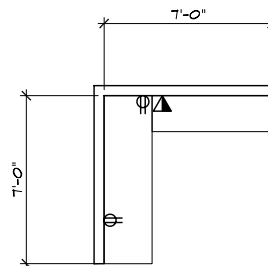

Floor Plan

**SYMBOL LEGEND:**

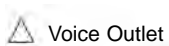

Voice Outlet



Data Outlet



Voice/Data Outlet



Duplex Outlet



ISDN Outlet



Duress Alarm Outlet





## 1.2 ICE Administration - Room Data Sheet

### 1.2.17 FILE AREA

#### Function

The File Area is an allocation of space within the open office environment for file cabinets.



Photograph

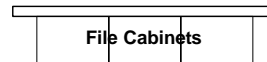

Floor Plan





## 1.2 ICE Administration - Room Data Sheet

### 1.2.18 OFFICER TOILET - MALE

#### Function

The Male Officer Toilet is a single use room located within ICE Administration.



Photograph

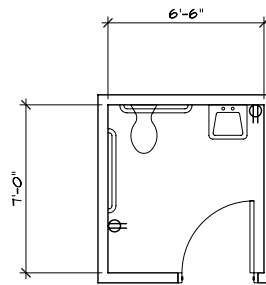

Floor Plan

SYMBOL LEGEND:

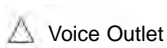

Voice Outlet



Data Outlet



Voice/Data Outlet



Duplex Outlet



ISDN Outlet



Duress Alarm Outlet





## 1.2 ICE Administration - Room Data Sheet

### 1.2.19 OFFICER TOILET - FEMALE

#### Function

The Female Officer Toilet is a single use room located within ICE Administration



Photograph

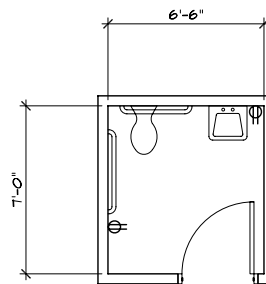

Floor Plan

**SYMBOL LEGEND:**

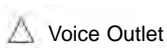

Voice Outlet

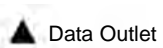

Data Outlet



Voice/Data Outlet



Duplex Outlet



ISDN Outlet



Duress Alarm Outlet







1.0 Office Zone

**1.3 CDF Administration**

(Contractor Operated)

**NOTE: Space Requirements Provided Per Contractor**



**Space Requirements**

- 1.4.1 Deputy Chief Counsel Office
- 1.4.2 Assistant Chief Counsel Office
- 1.4.3 Legal Technician Workstation
- 1.4.4 Mail/File Clerk Office
- 1.4.5 Support Workstation w/Scanner, Printer, Fax
- 1.4.6 Law Library/Conference Room
- 1.4.7 Copier/Storage Room
- 1.4.8 Supply Room
- 1.4.9 Break Room
- 1.4.10 Classified File Room



## 1.4 OPLA - Function

### FUNCTION STATEMENT

The main function of the Office of the Principal Legal Advisor (OPLA) is prosecuting cases against detainees in the EOIR Court.

The main activity in the OPLA Unit is preparing cases prior to the hearings. Attorneys use Removal Unit case files in preparing cases. Detainee cases are first administered in the Removal Unit and then move from the Docket Team to the OPLA attorneys.

The ratio of Assistant Chief Counsels is 2.3 ACC's for each courtroom; The ratio of Legal Technicians is 1 Legal Technician for each three Assistant Chief Counsel.

### MISSION STATEMENT

The mission of the Office of the Principal Legal Advisor (OPLA) is to protect the security of the United States by focusing its resources on immigration and customs law violators on behalf of the Department of Homeland Security; by providing legal advice, training, and service to support the ICE mission; and by defending the interests of the United States in the administrative and federal courts.

### Design Criteria

#### Critical Issues

- ✓ To provide a secure environment for the court attorneys while in the courtroom with detainees
- ✓ To ensure the privacy of records and information, they should be kept in locked attorneys' offices or in locked filing cabinets
- ✓ Attorney records are privileged information and should not be generally accessible to the ICE staff
- ✓ The attorney's back shall not face the door

#### Special Requirements

- ✓ OPLA is located outside the secure perimeter but restricted to staff only
- ✓ Visitors to the attorneys are under the guardianship of the attorneys
- ✓ No video and audio monitoring is permitted in the OPLA space located on the public side of the secure perimeter (in the secure Administration area)
- ✓ OPLA should be located adjacent to the Removal Unit (DRO) (to access case files) and to the EOIR Court
- ✓ Offices shall be equipped with doors and locks

#### Space Requirements

#### 1.4 OPLA

- 1.4.1 Deputy Chief Counsel Office
- 1.4.2 Assistant Chief Counsel Office
- 1.4.3 Legal Technician Workstation
- 1.4.4 Mail/File Clerk Office
- 1.4.5 Support Workstation w/Scanner, Printer, Fax
- 1.4.6 Law Library/Conference Room
- 1.4.7 Copier/Storage Room
- 1.4.8 Supply Room
- 1.4.9 Break Room
- 1.4.10 Classified File Room

### 1.4 OPLA : Organizational Diagram

(b)(2)High



## **1.4 OPLA - Critical Workflow Patterns**

### **INTRODUCTION**

The diagrams on the following page illustrate some of the most critical workflow issues and patterns of OPLA.

1.4 OPLA : Critical Workflow Patterns

1. "CLOSE PROXIMITIES"

Close Proximities and efficient workflows are necessary with EOIR Court, Removal Unit and the Public Entrance/Lobby. The OPLA Unit should be secure from the Public Lobby.

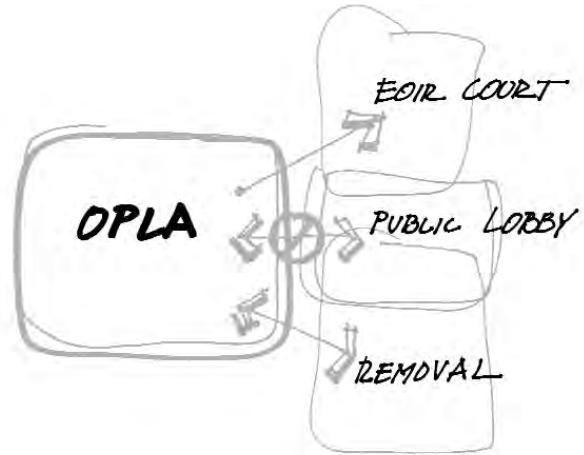

2. "CENTRALIZED INTERNAL SUPPORT"

The Legal Technician workstations and general file storage should be located in a centralized location for easy Attorney access/communication.

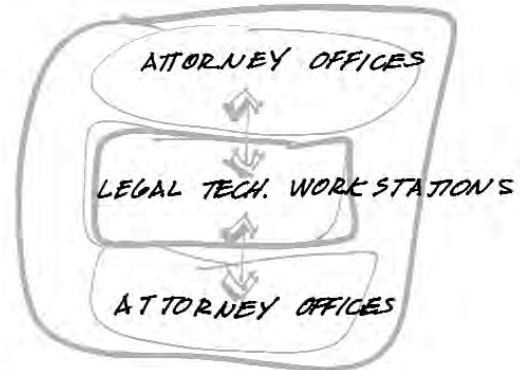





## 1.4 OPLA - Room Data Sheet

### 1.4.1 DEPUTY CHIEF COUNSEL OFFICE

#### Function

The Deputy Chief Counsel is responsible for assisting the Chief Counsel in the management of OPLA and its offices within the detention facilities. Specific responsibilities include the following:

- Serves as first line supervisor to the attorney staff
- Serves as first line supervisor to the support staff
- Manages and assigns duties
- Provides and oversees the provision of legal advice to the Office of Detention and Removal (DROP) and other DHS components
- Provides and oversees the provision of litigation support, legal assistance, and legal advice to the U.S. Attorney's Office in the litigation of petitions for review before the circuit courts
- Researches and oversees the research of legal and policy issues
- Writes and oversees the writing of memoranda, briefs, legal opinions, letters, reports and other documents

Normal occupancy is daily, 8-10 hours.



Photograph

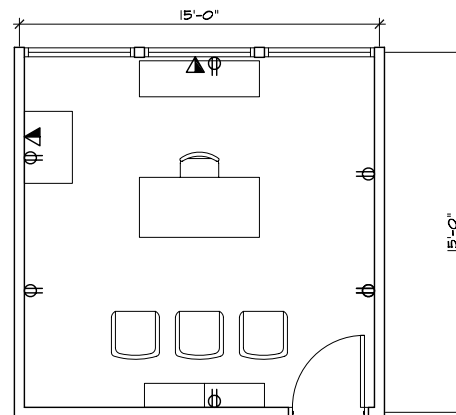

Floor Plan - Option 1 (225 nsf)

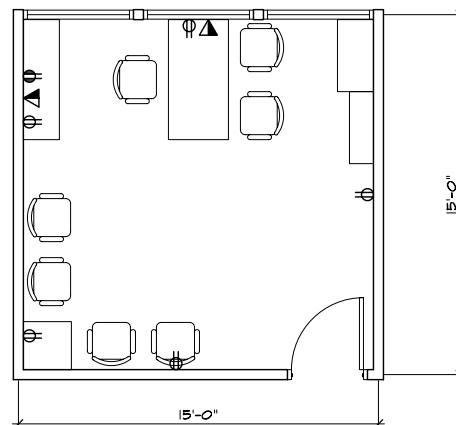

Floor Plan - Option 2 (225 nsf)

SYMBOL LEGEND: Voice Outlet Data Outlet Voice/Data Outlet Duplex Outlet ISDN Outlet Duress Alarm Outlet





## 1.4 OPLA - Room Data Sheet

### 1.4.2 ASSISTANT CHIEF COUNSEL OFFICE

#### Function

The Assistant Chief Counsels (ACCs) are principally responsible for representing the Department in removal proceedings before immigration courts and the Board of Immigration Appeals. Specific responsibilities include the following:

- Reviews, prepares and presents cases for trial and on appeal
- Represents the Department in meetings, conferences and other forums
- Provides legal advice to the Office of Detention and Removal (DRO) and other DHS components
- Provides litigation support, legal assistance, and legal advice to the U.S. Attorney's Office in the litigation of civil and criminal cases
- Researches legal and policy issues
- Drafts memoranda, briefs, legal opinions, letters, reports and other documents

Normal occupancy is daily, 8-10 hours.



Photograph

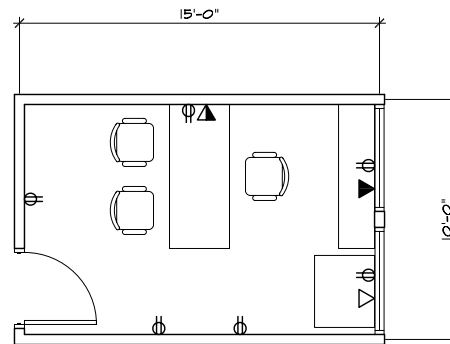

Floor Plan - Option 1 (150 nsf)

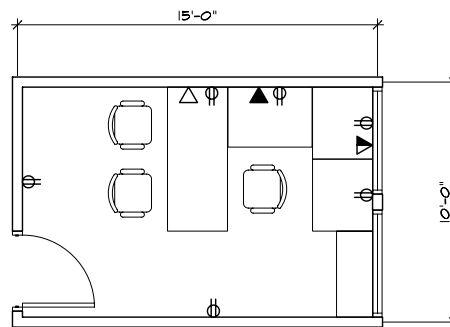

Floor Plan - Option 2 (150 nsf)

SYMBOL LEGEND:

- Voice Outlet  
 Data Outlet  
 Voice/Data Outlet  
 Duplex Outlet  
 ISDN Outlet  
 Duress Alarm Outlet





## 1.4 OPLA - Room Data Sheet

### 1.4.3 LEGAL TECHNICIAN WORKSTATION

#### Function

The Legal Technicians provide direct support to the Deputy Chief Counsel and Assistant Chief Counsels. Specific responsibilities include the following:

- Receives, screens, sorts, distributes and sends out mail
- Types legal documents
- Prepares and files motions, briefs, exhibits and other documents
- Receives phone calls
- Retrieves and distributes A-files for immigration court hearings, and related matters
- Uses computers for data entry, tracking and ordering A-files and typing legal documents
- With attorney supervision, drafts simple motions, responses, letters and other documents
- Conducts factual research for immigration court hearings, and related matters

Normal occupancy is daily, 8-10 hours.



Photograph

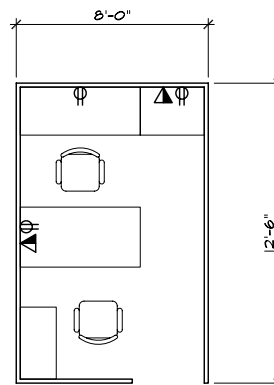

Floor Plan - Option 1 (100 nsf)

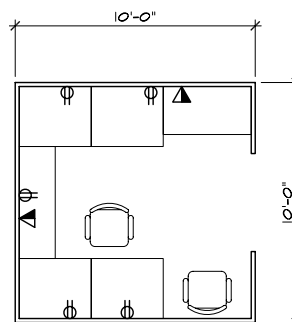

Floor Plan - Option 2 (100 nsf)

SYMBOL LEGEND:

- Voice Outlet
 Data Outlet
 Voice/Data Outlet
 Duplex Outlet
 ISDN Outlet
 Duress Alarm Outlet





## 1.4 OPLA - Room Data Sheet

### 1.4.4 MAIL/FILE CLERK OFFICE

#### Function

The Mail Room is used for the receipt, screening, sorting, and distribution of all mail received by OPLA. This space can be either an enclosed office or an open workstation.



Photograph

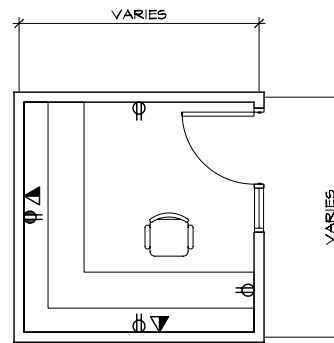

Floor Plan (square footage varies)

**SYMBOL LEGEND:**



Voice Outlet



Data Outlet



Voice/Data Outlet



Duplex Outlet



ISDN Outlet



Duress Alarm Outlet







## 1.4 OPLA - Room Data Sheet

### 1.4.5 SUPPORT WORKSTATION W/SCANNER, PRINTER, FAX

#### Function

The Support Workstation will serve to support the OPLA staff and will house the fax machine, a large multi-page scanner with attached computer, and a typewriter.



Photograph

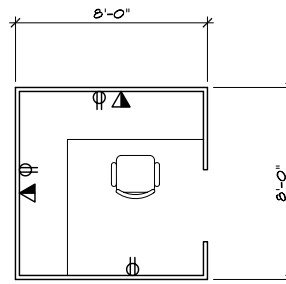

Floor Plan

**SYMBOL LEGEND:**



Voice Outlet

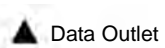

Data Outlet



Voice/Data Outlet



Duplex Outlet



ISDN Outlet



Duress Alarm Outlet





## 1.4 OPLA - Room Data Sheet

### 1.4.6 LAW LIBRARY/CONFERENCE ROOM

#### Function

The Law Library/Conference Room is used for legal research, and is also used by the OPLA attorneys for meetings with clients, OCC staff, EOIR, the private bar, and visitors. It is also used for training purposes.

Normal occupancy is daily, 8-10 hours.

The size of this space will vary based on the number of detainees and the total number of OPLA employees. The minimum size shall be 200 square feet and increase in size at 22 sf/occupant based on the occupant load prescribed in the space spreadsheet.



Photograph

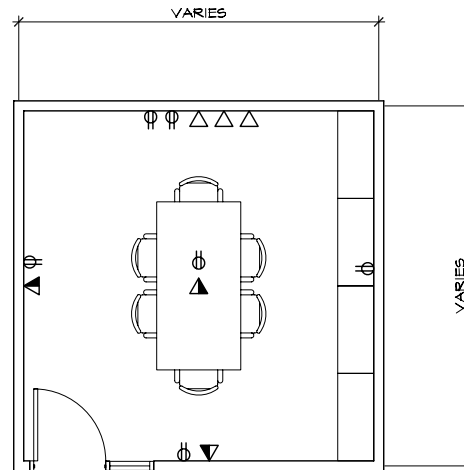

Floor Plan (square footage varies)

The number of bookcases shall be determined by actual room dimensions; fill full length of long wall.

The 3 voice outlets grouped on end wall represent six (6) RJ 11/RJ 45 receptacles for video conferencing.

SYMBOL LEGEND:



Voice Outlet



Data Outlet



Voice/Data Outlet



Duplex Outlet



ISDN Outlet



Duress Alarm Outlet

# 4. FUNCTIONAL REQUIREMENTS

## 1.4.6 SYSTEMS MATRIX

<b>Walls</b>	<b>Floors</b>	<b>Ceiling</b>	<b>Doors</b>	<b>Hardware</b>	<b>Glazing</b>
• PNT	• Floor capable of supporting live load of 150 lb. per sq. ft. • 35 oz 100% cut pile nylon carpet • Base - RB	• ACT-8' high min.	• Solid core wood	• See below	• None
<b>Plumbing</b>	<b>HVAC</b>	<b>Lighting</b>	<b>Power</b>	<b>Security</b>	<b>Communications</b>
• None	• Typical	• Recessed Fluorescent	• 110V duplex on each wall • 110V duplex in floor/table	• PIR Sensor	• Voice & data on 2 walls • A & B ports shall be active

## 1.4.6 FURNITURE - EQUIPMENT - HARDWARE SCHEDULE

ID	Item	Vendor*	Style	Model #	Qty.
<b>FURNITURE</b>					
	Bookcase	Unicor	Symphony	S352013MH	3
	Conference Table	Unicor	Symphony	S723602MH	1
	Chair	Unicor	Soprano	WVC6120MH7578	6
	Waste Receptacle				1
	NOTE: the size of the conference room table and the quantity of chairs and bookcases will vary based on room size and occupancy.				
<b>EQUIPMENT</b>					
	None				
<b>HARDWARE</b>					
	Lockset				

\* Vendor names are listed as a point of reference for equipment specs. Equal products by other manufactures can be used.  
 \*\* Lockset to be determined based on CDF facility requirements. Where an existing facility is being modified, new hardware shall be compatible with existing preference is for electronic keyless entry - via card readers or cipher locks. Each system must provide for key override.



## 1.4 OPLA - Room Data Sheet

### 1.4.7 COPIER/STORAGE ROOM

#### Function

The copier/storage room is used to house one or more large multi-function copier(s) (one copier for each 6 attorneys) and space to store miscellaneous items.



Photograph

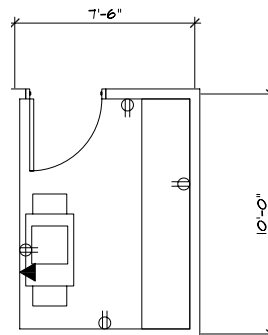

Floor Plan

**SYMBOL LEGEND:**



Voice Outlet



Data Outlet



Voice/Data Outlet



Duplex Outlet



ISDN Outlet



Duress Alarm Outlet





## 1.4 OPLA - Room Data Sheet

### 1.4.8 SUPPLY ROOM

#### Function

The Office Supply Storage Room is used to store paper, toner, notebooks, pens, and other office supplies necessary for the successful operation of a law office. It is also used to house one or more large multi-function copiers (one copier per six attorneys) and space to store miscellaneous items.

The size of this space will vary based on the number of detainees and the total number of OPLA employees. The minimum size shall be 50 square feet and increase in size at 2 sf/OPLA employee over 25, based on the staffing and space spreadsheets.



Photograph

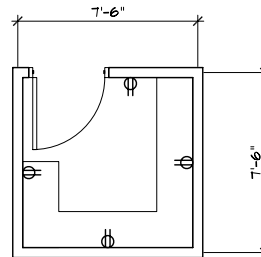

Floor Plan (square footage varies; 2 sq. ft. per employee)

*Shelving shall fill three walls adjacent to and opposite the wall with door.*

**SYMBOL LEGEND:**

-  Voice Outlet
-  Data Outlet
-  Voice/Data Outlet
-  Duplex Outlet
-  ISDN Outlet
-  Duress Alarm Outlet







## 1.4 OPLA - Room Data Sheet

### 1.4.9 BREAKROOM

#### Function

The breakroom is used to provide OPLA personnel with space to eat lunch and take breaks.

The size of this space will vary based on the total number of OPLA employees. The size shall be determined using 25 square feet per occupant based on the staffing and space spreadsheets



Photograph

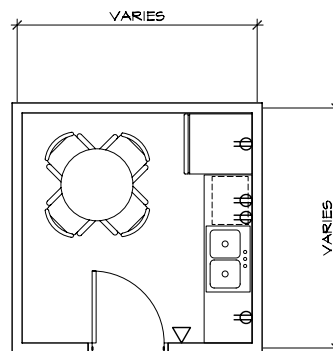

Floor Plan

SYMBOL LEGEND:



Voice Outlet



Data Outlet



Voice/Data Outlet



Duplex Outlet



ISDN Outlet



Duress Alarm Outlet





## 1.4 OPLA - Room Data Sheet

### 1.4.10 CLASSIFIED FILE ROOM

#### Function

The classified file room is used for securing and safeguarding classified files and other sensitive documents.

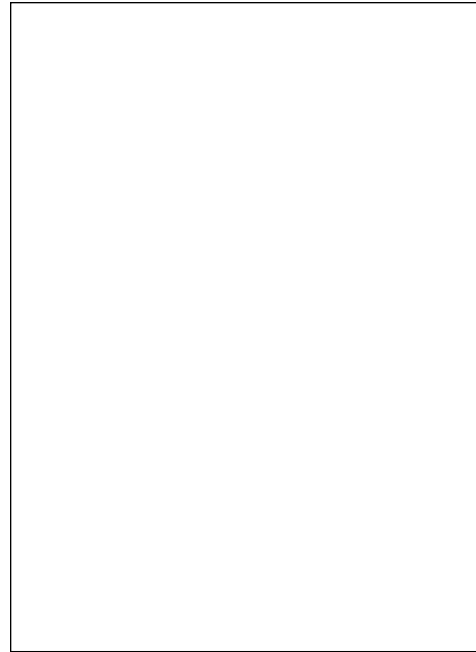

Photograph

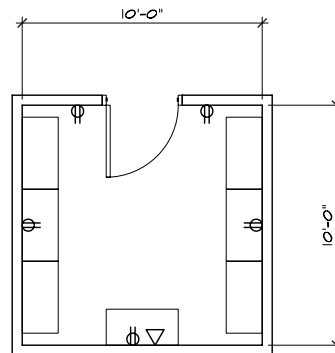

Floor Plan

**SYMBOL LEGEND:**



Voice Outlet

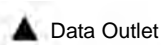

Data Outlet



Voice/Data Outlet



Duplex Outlet



ISDN Outlet



Duress Alarm Outlet





1.0 Office Zone

**1.5 Removal Unit**

(ICE Operated)

**Space Requirements**

- 1.5.1 Supervisory Detention & Deportation Officer (SDDO) Office
- 1.5.2 Deportation Officer (DO) Office
- 1.5.3 Deportation Removal Assistant (DRA) Workstation
- 1.5.4 Shared Computer Workstation
- 1.5.5 Conference Room
- 1.5.6 Records/Files Room
- 1.5.7 Supply/Storage Room
- 1.5.8 Copier/Fax/Shredder Room
- 1.5.9 Printer Area
- 1.5.10 Officer Toilet - Male
- 1.5.11 Officer Toilet - Female



## 1.5 Removal Unit- Function

### FUNCTION STATEMENT

The primary function of Removal Unit is managing and administering cases brought to the EOIR Court and arranging for the removal (deportation) of individuals to foreign countries.

The Removal Unit operates in docket teams. Multiple docket teams exist at larger facilities. They also maintain records on all individuals who have cases pending in the EOIR Court and those detained at the CDF.

Other activities include arranging for the travel documents and transportation for removal. Inquiries on the progress of cases are answered by the Removal Unit, and they may also issue Employment Authorization Documents for aliens who wish to work in the U.S.

The Removal Unit is located outside the secure perimeter and restricted to staff with controlled access to the public.

### Design Criteria

#### Critical Issues

- ✓ Share equipment and files with OPLA
- ✓ Large centralized filing
- ✓ Adjacent/convenient to EOIR Court
- ✓ Cash transactions take place at the counter

#### Special Requirements

- ✓ Transaction counter to separate the office area from the public; accessed by public through transaction window
- ✓ Identification camera
- ✓ Secured/controlled access from public spaces
- ✓ Ticket machine with secure lock/location

#### Space Requirements

#### 1.5 REMOVAL UNIT

- 1.5.1 Supervisory Detention & Deportation Officer (SDDO) Office
- 1.5.2 Deportation Officer (DO) Office
- 1.5.3 Deportation Removal Assistant (DRA) Workstation
- 1.5.4 Shared Computer Workstation
- 1.5.5 Conference Room
- 1.5.6 Records/Files Room
- 1.5.7 Supply/Storage Room
- 1.5.8 Copier/Fax/Shredder Room
- 1.5.9 Printer Area
- 1.5.10 Officer Toilet - Male
- 1.5.11 Officer Toilet - Female

### 1.5 Removal Unit : Organizational Diagram

(b)(2)High





## **1.5 Removal Unit - Critical Workflow Patterns**

### **INTRODUCTION**

The diagrams on the following page illustrate some of the most critical workflow issues and patterns of Removal Unit.

1.5 Removal Unit : Critical Workflow Patterns

1. "PUBLIC TRANSACTION COUNTER"

Removal Unit should have public transaction counter stations for employment authorization documents and travel clerk workstation. The counter should be accessible from the Public Entrance/Lobby and be controlled by the security officer stationed in the lobby.

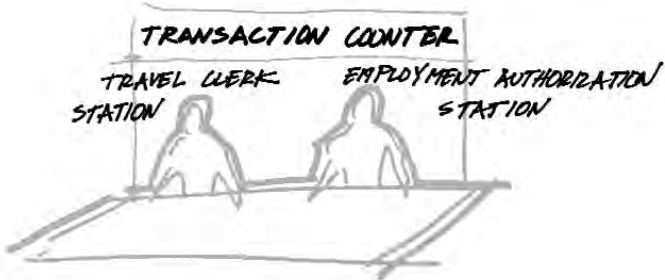

2. "CLOSE PROXIMITIES"

Removal Unit needs to be directly adjacent to the Public Entrance/Lobby and EOIR Court.

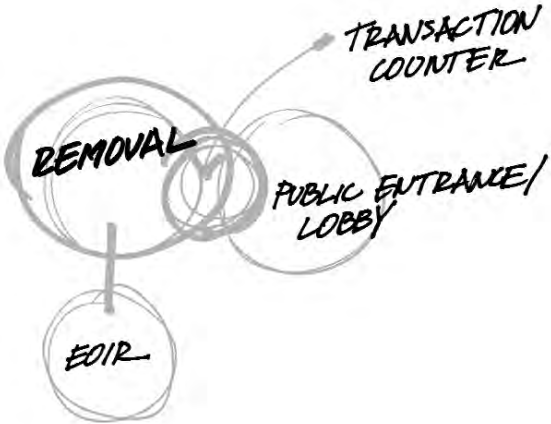



## 1.5 Removal Unit - Room Data Sheet

### 1.5.1 SUPERVISORY DETENTION & DEPORTATION OFFICER (SDDO) OFFICE

#### Function

The Supervisory Detention and Deportation Officer Office functions as an administrative and technical supervisor for DO's, IEA's and critical personnel. The SDDO serves as the principal advisor on all administrative management matters associated with programs and operations.



Photograph

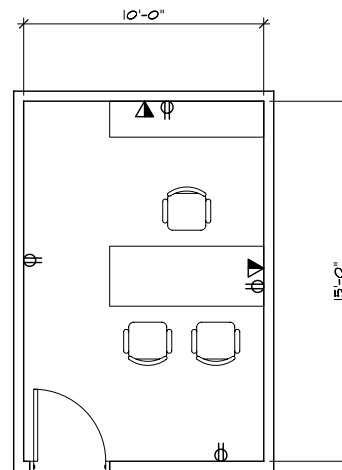

Floor Plan

**SYMBOL LEGEND:**



Voice Outlet



Data Outlet



Voice/Data Outlet



Duplex Outlet



ISDN Outlet



Duress Alarm Outlet





## 1.5 Removal Unit - Room Data Sheet

### 1.5.2 DEPORTATION OFFICER (DO) OFFICE

#### Function

The Deportation Officer's function is to manage removal cases, conduct fugitive operations and investigations, process intelligence information and participate in detention and removal hearings.

The DO works closely with ICE LED's and OPLA attorneys as well as US Attorney's Offices in identifying, locating, apprehending and prosecuting aliens, developing and coordinating intelligence, and defending removal or exclusion proceedings.



Photograph

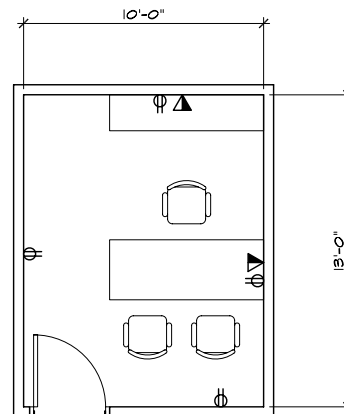

Floor Plan

**SYMBOL LEGEND:**

- Voice Outlet   Data Outlet   Voice/Data Outlet   Duplex Outlet   ISDN Outlet   Duress Alarm Outlet





## 1.5 Removal Unit - Room Data Sheet

### 1.5.3 DEPORTATION REMOVAL ASSISTANT (DRA) WORKSTATION

#### Function

The Deportation Removal Assistant's function is to provide clerical and administrative support to the detention and removal program. The DRA will have access to classified files and materials that consist of enforcement of laws and regulations pertaining to the detention and removal of aliens.

The DRA reviews removal and exclusion case files to determine the status of proceedings and takes appropriate action so that the case may be closed or moved onward; performs a variety of technical and clerical duties necessary in completing arrangements for physical removal.



Photograph

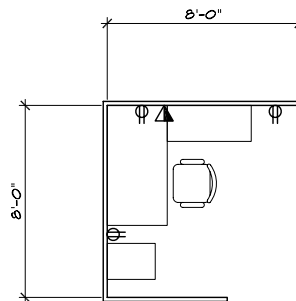

Floor Plan

**SYMBOL LEGEND:**



Voice Outlet



Data Outlet



Voice/Data Outlet



Duplex Outlet



ISDN Outlet



Duress Alarm Outlet







## 1.5 Removal Unit - Room Data Sheet

### 1.5.4 SHARED COMPUTER WORKSTATION

#### Function

The Shared Computer Workstation is an unassigned workspace used for computer access by staff not permanently assigned to this facility. Use is generally short term.



Photograph

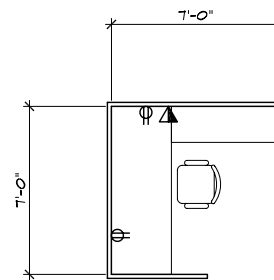

Floor Plan

**SYMBOL LEGEND:**



Voice Outlet



Data Outlet



Voice/Data Outlet



Duplex Outlet



ISDN Outlet



Duress Alarm Outlet





## 1.5 Removal Unit - Room Data Sheet

### 1.5.5 CONFERENCE ROOM

#### Function

The Conference Room is used for meetings and other intermittent training of Removal Unit staff. The size will increase based on the staff size and detainee population.



Photograph

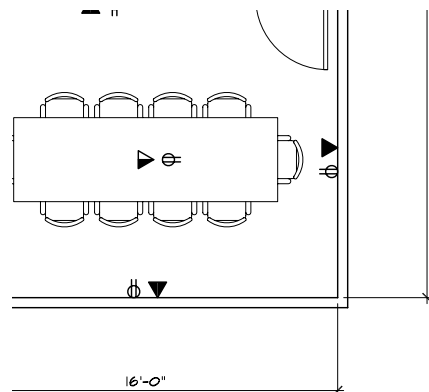

#### Floor Plan

The 3 voice outlets grouped on end wall represent six (6) RJ 11/RJ 45 receptacles for video teleconferencing.

#### SYMBOL LEGEND:

- Voice Outlet
- Data Outlet
- Voice/Data Outlet
- Duplex Outlet
- ISDN Outlet
- Duress Alarm Outlet





## 1.5 Removal Unit - Room Data Sheet

### 1.5.6 RECORDS/FILES ROOM

#### Function

The Records/File Room is used to secure detainee case files. The size of the Records/Files Room will vary based on the planned detainee population. This room shall be convenient to staff from OPLA and ICE Administration.



Photograph

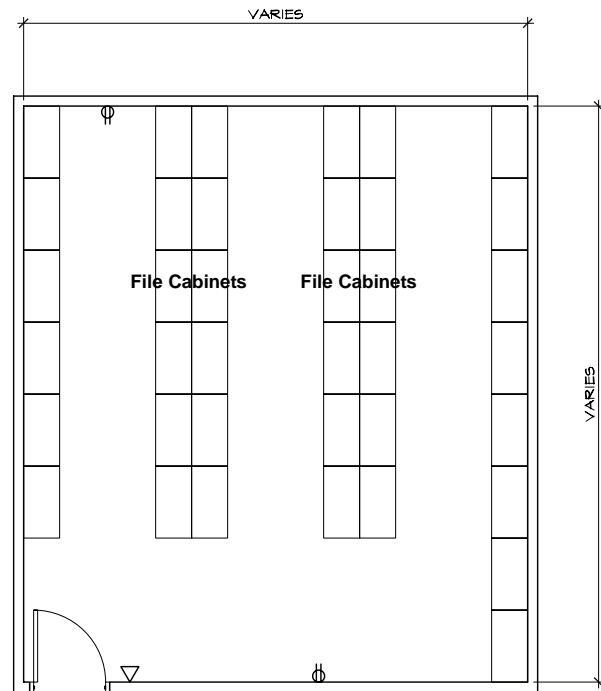

Floor Plan

SYMBOL LEGEND:



Voice Outlet



Data Outlet



Voice/Data Outlet



Duplex Outlet



ISDN Outlet



Duress Alarm Outlet





## 1.5 Removal Unit - Room Data Sheet

### 1.5.7 SUPPLY/STORAGE ROOM

#### Function

The Supply/Storage Room is used to stock boxes of copier paper, office supplies, standard forms and the like.

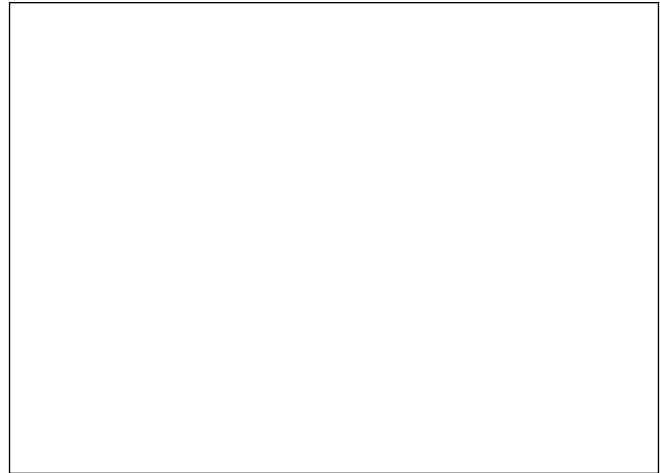

Photograph

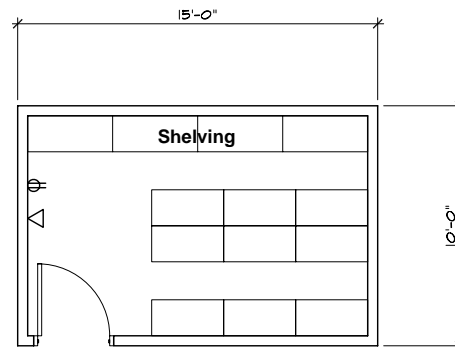

Floor Plan

**SYMBOL LEGEND:**

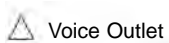

Voice Outlet



Data Outlet



Voice/Data Outlet



Duplex Outlet



ISDN Outlet



Duress Alarm Outlet







## 1.5 Removal Unit - Room Data Sheet

### 1.5.8 COPIER/FAX/SHREDDER ROOM

#### Function

The Copier/Fax/Shredder Room is used for mass copying, faxing documents, and shredding secure or sensitive documents.



Photograph

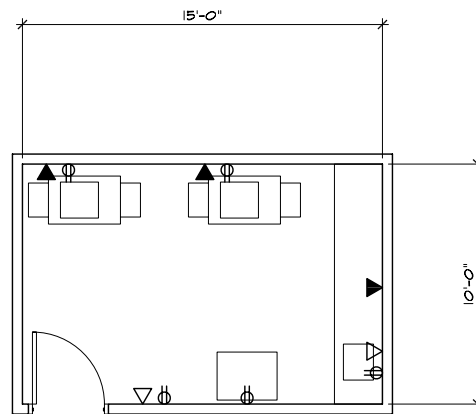

Floor Plan

**SYMBOL LEGEND:**



Voice Outlet



Data Outlet



Voice/Data Outlet



Duplex Outlet



ISDN Outlet



Duress Alarm Outlet





## 1.5 Removal Unit - Room Data Sheet

### 1.5.9 PRINTER AREA

#### Function

The Printer Area is an allocation of space within the open office environment for printers.



Photograph

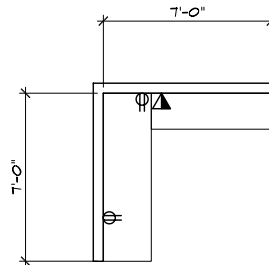

Floor Plan

**SYMBOL LEGEND:**

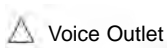

Voice Outlet

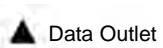

Data Outlet



Voice/Data Outlet



Duplex Outlet



ISDN Outlet



Duress Alarm Outlet





## 1.5 Removal Unit - Room Data Sheet

### 1.5.10 OFFICER TOILET - MALE

#### Function

The Male Officer Toilet is a single use room located within the Removal Unit.



Photograph

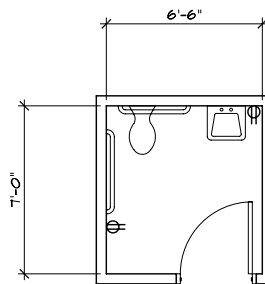

Floor Plan

SYMBOL LEGEND:

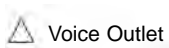

Voice Outlet



Data Outlet



Voice/Data Outlet



Duplex Outlet



ISDN Outlet



Duress Alarm Outlet





## 1.5 Removal Unit - Room Data Sheet

### 1.5.11 OFFICER TOILET - FEMALE

#### Function

The Female Officer Toilet is a single use room located within the Removal Unit.



Photograph

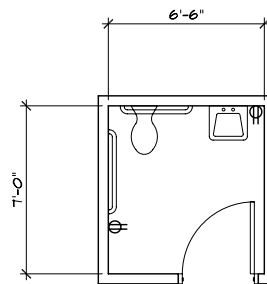

Floor Plan

**SYMBOL LEGEND:**

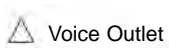

Voice Outlet



Data Outlet



Voice/Data Outlet



Duplex Outlet



ISDN Outlet



Duress Alarm Outlet







**Space Requirements**

- 1.6.1 Staff Entrance Vestibule
- 1.6.2 Weapons Drop Area
- 1.6.3 Training Officer Office
- 1.6.4 Visiting Trainer Officer Office
- 1.6.5 Muster Room
- 1.6.6 Exercise Room
- 1.6.7 Physical Training Room
- 1.6.8 Classroom/Computer Training Room
- 1.6.9 FATS Training Room
- 1.6.10 ICE Armory
- 1.6.11 ICE Ready Room
- 1.6.12 Training File Area
- 1.6.13 Workroom
- 1.6.14 Resource Library
- 1.6.15 Staff Breakroom
- 1.6.16 Vending Area
- 1.6.17 Male Staff Lockers
- 1.6.18 Male Staff Toilet
- 1.6.19 Male Staff Shower
- 1.6.20 Male Shower Dressing Area
- 1.6.21 Female Staff Lockers
- 1.6.22 Female Staff Toilet
- 1.6.23 Female Staff Shower
- 1.6.24 Female Shower Dressing Area
- 1.6.25 Bulk Storage Room (Disposed Property)
- 1.6.26 Loading Dock & Staging



## 1.6 Staff Services and Training - Function

### FUNCTION STATEMENT

The function of Staff Services and Training is to provide the level of instruction necessary for employees and the meeting, locker, and break facilities to serve the staff.

All staff requires training, including contract security guards, ICE detention officers, and clerical personnel. The training should accommodate all security and non-security personnel as recommended by the American Correctional Association (ACA). Training may occur on-site or off-site, and can be provided by trained officers, outside contract instructors, or in conjunction with other agencies.

Training may be divided into two broad categories: Staff Training and Special Training. Staff Training is site-specific training, some classroom training, plus some physical training. Special Training is provided on-site or at locations designated for the type of training, Special Training includes: Firearms Training, Bus Training, Commercial Driver's License (CDL) Training, Emergency Response Team (ERT), Special Weapons and Tactics (SWAT), and Fire Arms Training Scenarios (FATS).

Staff Services are the areas that allow the staff to change and prepare prior to coming on duty, store their personal items outside of the secure perimeter at the facility, plus perform tasks, such as report writing, away from their posts and to relax during breaks or exercise.

The CDF has a staff muster for each shift with all the security staff assembled for a daily briefing before they go on duty.

Design Criteria	
<b>Critical Issues</b>	
✓	Training located outside secure perimeter
<b>Special Requirements</b>	
✓	Audio visual equipment
✓	Physical fitness and training equipment
<b>Space Requirements</b>	
<b>1.6</b>	<b>STAFF SERVICES AND TRAINING</b>
1.6.1	Staff Entrance Vestibule
1.6.2	Weapons Drop Area
1.6.3	Training Officer Office
1.6.4	Visiting Trainer Officer Office
1.6.5	Muster Room
1.6.6	Exercise Room
1.6.7	Physical Training Room
1.6.8	Classroom/Computer Training Room
1.6.9	FATS Training Room
1.6.10	ICE Armory
1.6.11	ICE Ready Room
1.6.12	Training File Area
1.6.13	Workroom
1.6.14	Resource Library
1.6.15	Staff Breakroom
1.6.16	Vending Area
1.6.17	Male Staff Lockers
1.6.18	Male Staff Toilet
1.6.19	Male Staff Shower
1.6.20	Male Shower Dressing Area
1.6.21	Female Staff Lockers
1.6.22	Female Staff Toilet
1.6.23	Female Staff Shower
1.6.24	Female Shower Dressing Area
1.6.25	Bulk Storage Room (Disposed Property)
1.6.26	Loading Dock & Staging

### 1.6 Staff Services and Training : Organizational Diagram

(b)(2)High



## **1.6 Staff Services and Training - Critical Workflow Patterns**

### **INTRODUCTION**

The diagrams on the following page illustrate some of the most critical workflow issues and patterns of the Staff Services and Training.

1.6 Staff Services and Training : Critical Workflow Patterns

1. "CRITICAL ADJACENCIES - SERVICES"

Staff Services are the areas that allow the staff to change and prepare prior to coming on duty, store their personal items outside of the secure perimeter, perform tasks such as report writing away from their posts, and to relax during breaks.

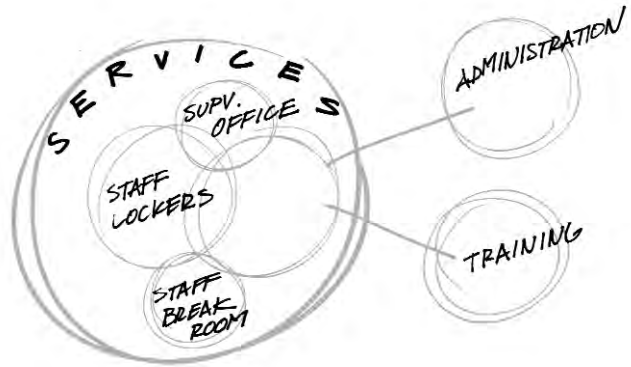

2. "CRITICAL ADJACENCIES - TRAINING"

Training should be located outside the main secure perimeter in a zone restricted only to staff.





## 1.6 Staff Services and Training - Room Data Sheet

### 1.6.1 STAFF ENTRANCE VESTIBULE

#### Function

The Staff Entrance Vestibule is used to provide a thermal break between the exterior and interior of the building. It also serves as a secure point when the interior doors are in the locked position. This entrance is used by staff and contract personnel only.



Photograph

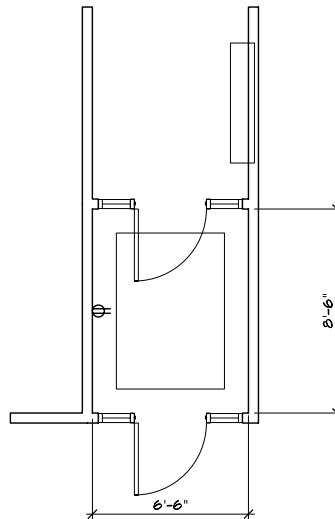

Floor Plan

SYMBOL LEGEND:



Voice Outlet



Data Outlet



Voice/Data Outlet



Duplex Outlet



ISDN Outlet



Duress Alarm Outlet







## 1.6 Staff Services and Training - Room Data Sheet

### 1.6.2 WEAPONS DROP AREA

#### Function

The Weapons Drop Area is a space located directly inside the Staff Entrance Vestibule for securing weapons prior to entering the facility.



Photograph

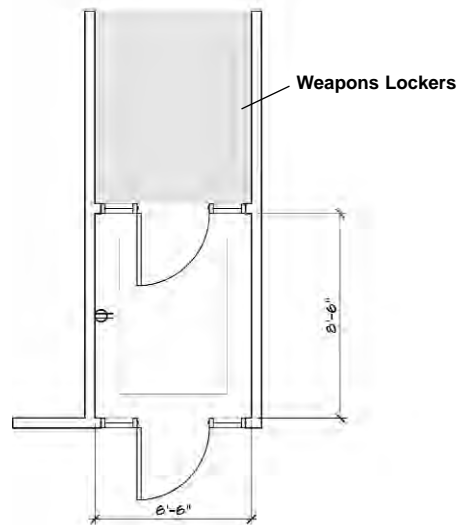

Floor Plan

SYMBOL LEGEND:



Voice Outlet



Data Outlet



Voice/Data Outlet



Duplex Outlet



ISDN Outlet



Duress Alarm Outlet





## 1.6 Staff Services and Training - Room Data Sheet

### 1.6.3 TRAINING OFFICER OFFICE

#### Function

The Training Officer plans, develops, monitors and evaluates courses and training activities for comprehensive emergency management programs. The Training Officer also monitors assigned training activities and assists in the completion of needs assessment, development and delivery actions, evaluation activities, and preparation of materials for assigned courses and activities. Responsible for development of assigned training activities, courses, and other adult learning events, to meet requirements.



Photograph

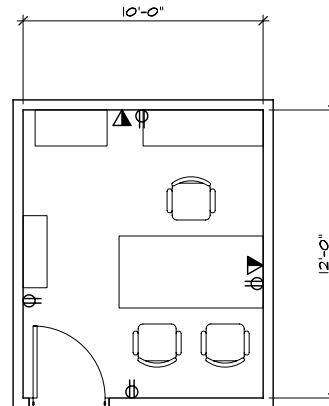

Floor Plan

**SYMBOL LEGEND:**



Voice Outlet



Data Outlet



Voice/Data Outlet



Duplex Outlet



ISDN Outlet



Duress Alarm Outlet





## 1.6 Staff Services and Training - Room Data Sheet

### 1.6.4 VISITING TRAINING OFFICER OFFICE

**Function**

The Visiting Training Officer supports the facility's Training Officer with their daily duties.



Photograph

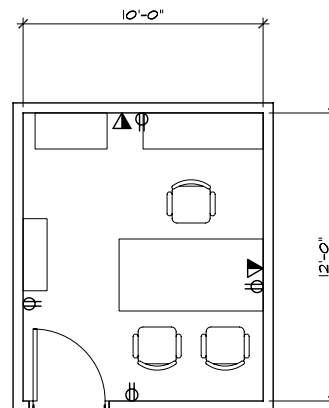

Floor Plan

**SYMBOL LEGEND:**

-  Voice Outlet
-  Data Outlet
-  Voice/Data Outlet
-  Duplex Outlet
-  ISDN Outlet
-  Duress Alarm Outlet





## 1.6 Staff Services and Training - Room Data Sheet

### 1.6.5 MUSTER ROOM

#### Function

The Muster Room is a large, flexible meeting space where officers meet before their shift to receive assignments, briefings and to discuss operational matters. The room could be set in a U-shape, classroom or theater set and may also double-function as a conference room or training room.



Photograph

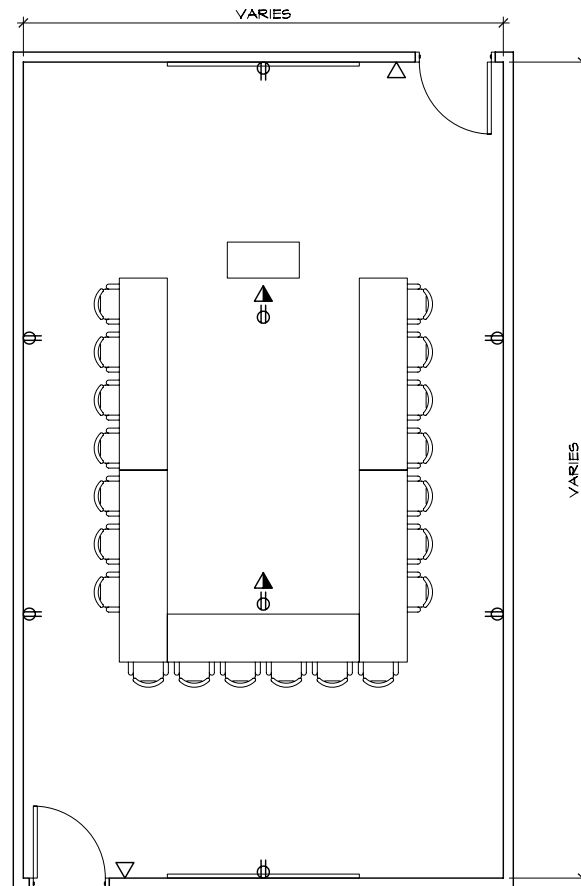

Floor Plan

SYMBOL LEGEND:

- Voice Outlet   Data Outlet   Voice/Data Outlet   Duplex Outlet   ISDN Outlet   Duress Alarm Outlet







## 1.6 Staff Services and Training - Room Data Sheet

### 1.6.6 EXERCISE ROOM

#### Function

The Exercise Room provides all ICE staff with the opportunity to exercise within the facility. Depending on the size of the facility, the Exercise Room may contain cardiovascular (ellipticals, treadmills, stationary bikes) and resistance (free weights, machines) equipment.



Photograph

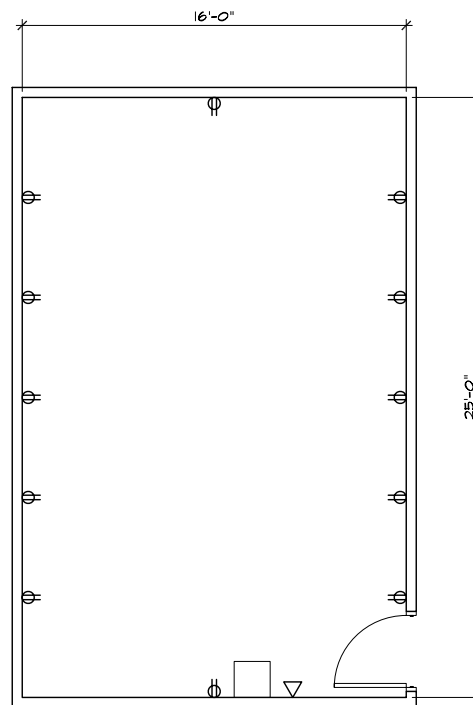

Floor Plan

**SYMBOL LEGEND:**

- Voice Outlet   Data Outlet   Voice/Data Outlet   Duplex Outlet   ISDN Outlet   Duress Alarm Outlet





## 1.6 Staff Services and Training - Room Data Sheet

### 1.6.7 PHYSICAL TRAINING ROOM

#### Function

The Physical Training Room is a training space for non-lethal weapons training, hand-to-hand training, and other physical training techniques.



Photograph

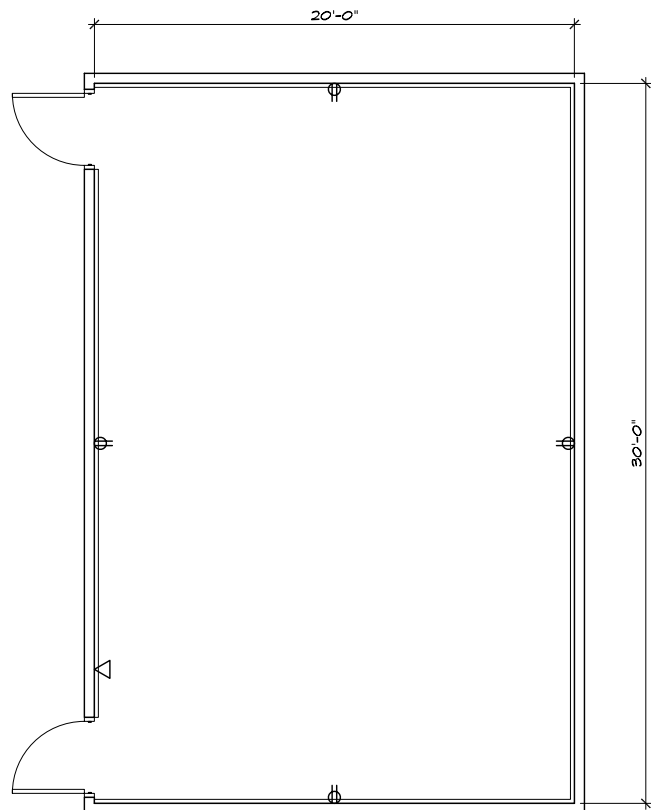

Floor Plan

SYMBOL LEGEND:



Voice Outlet



Data Outlet



Voice/Data Outlet



Duplex Outlet



ISDN Outlet



Duress Alarm Outlet





## 1.6 Staff Services and Training - Room Data Sheet

### 1.6.8 CLASSROOM/COMPUTER TRAINING ROOM

#### Function

The Classroom/Computer Training Room serves as the primary space within the facility for staff training. It is a multi-functional room with A/V and computer infrastructure as well as the flexibility to conduct basic classroom functions.



Photograph

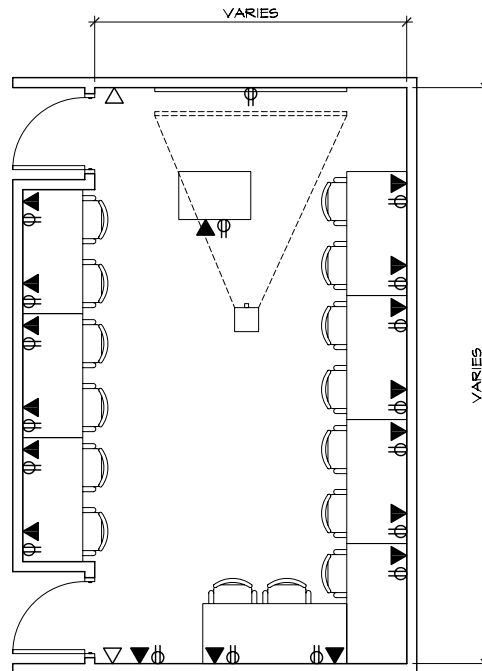

Floor Plan

**SYMBOL LEGEND:**

-  Voice Outlet
-  Data Outlet
-  Voice/Data Outlet
-  Duplex Outlet
-  ISDN Outlet
-  Duress Alarm Outlet





## 1.6 Staff Services and Training - Room Data Sheet

### 1.6.9 FATS TRAINING ROOM

Function  
The...



Photograph



Floor Plan

**SYMBOL LEGEND:**

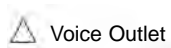

Voice Outlet



Data Outlet



Voice/Data Outlet



Duplex Outlet



ISDN Outlet

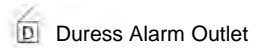

Duress Alarm Outlet







## 1.6 Staff Services and Training - Room Data Sheet

### 1.6.10 ICE ARMORY

#### Function

The armory should be located outside the secure perimeter but near Central Control in order to provide visual monitoring. Entrance to this area should be controlled with a key and alarm system. Entrances to the armory should be video monitored and recorded. The armory should be equipped with two (2) doors: a main door and a day door. The day door provides daytime access for security staff to the armory for practice, cleaning, and maintenance.

The armory should be at least a minimum of 18.5 square meters (200 square feet) and must be able to accommodate a workbench for cleaning and repairing weapons. Gas, weapons, ammunition, shotguns, riot guns, and specialized equipment are stored in the armory. Some disturbance equipment (shields, vests, batons, etc.) may also be stored in this space. Guns are double-locked or kept in a gun chamber within the armory.

The armory must be equipped with a fire suppression system and should be climate controlled. Venting to the outdoors is necessary because of solvents and waste storage.



Photograph

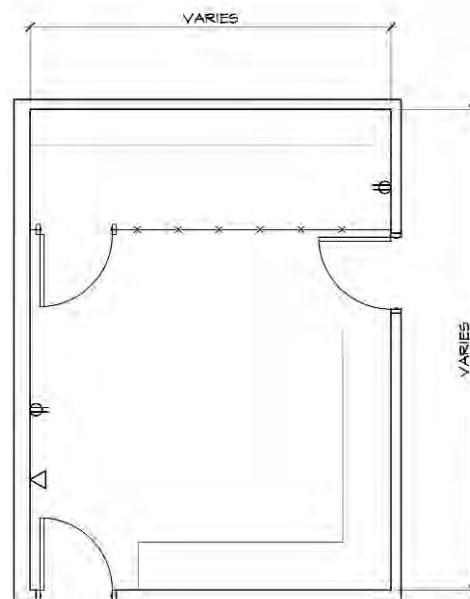

Floor Plan

SYMBOL LEGEND:



Voice Outlet



Data Outlet



Voice/Data Outlet



Duplex Outlet



ISDN Outlet



Duress Alarm Outlet





## 1.6 Staff Services and Training - Room Data Sheet

### 1.6.11 ICE READY ROOM

#### Function

A Ready Room is required adjacent to the armory. The ready room serves as an area for equipping security staff when an incident occurs. In some CDF facilities, the muster room may serve as the ready room. Ready rooms should be equipped with eyewash/shower stations.

Special Weapons and Tactics (SWAT) team equipment closets should be located at two or three decentralized locations in the CDF. Decentralized SWAT team equipment allows for quicker team response to incidents within the facility. These closets should hold disturbance equipment such as shields, vests, batons, etc.



Photograph

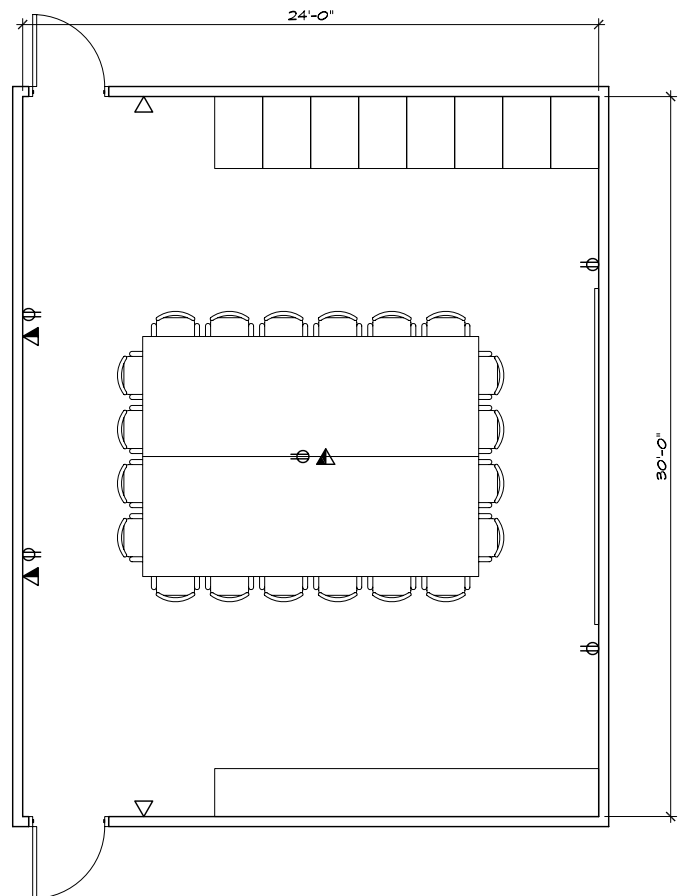

Floor Plan

**SYMBOL LEGEND:** Voice Outlet Data Outlet Voice/Data Outlet Duplex Outlet ISDN Outlet Duress Alarm Outlet





## 1.6 Staff Services and Training - Room Data Sheet

### 1.6.12 TRAINING FILE AREA

#### Function

The Training File Area is an allocation of space in the Staff Services and Training area for Training Files.



Photograph

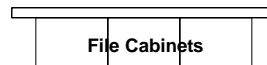

Floor Plan

**SYMBOL LEGEND:**

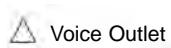

Voice Outlet



Data Outlet



Voice/Data Outlet



Duplex Outlet



ISDN Outlet



Duress Alarm Outlet





## 1.6 Staff Services and Training - Room Data Sheet

### 1.6.13 WORKROOM

#### Function

The Workroom is a space for copying, faxing, and scanning documents as well as duplicating, collating and assembling training materials.



Photograph

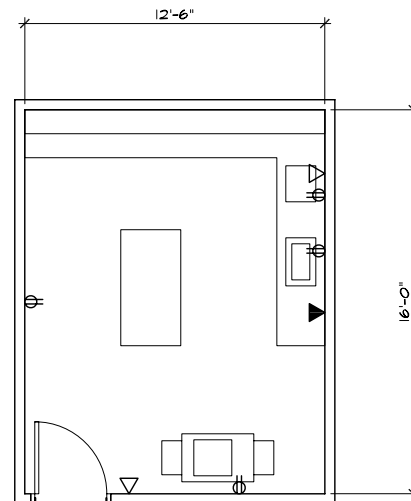

Floor Plan

**SYMBOL LEGEND:**



Voice Outlet



Data Outlet



Voice/Data Outlet



Duplex Outlet



ISDN Outlet



Duress Alarm Outlet







## 1.6 Staff Services and Training - Room Data Sheet

### 1.6.14 RESOURCE LIBRARY

#### Function

The function of the Resource Library is to serve as a secure space for storing training materials and aides.



Photograph

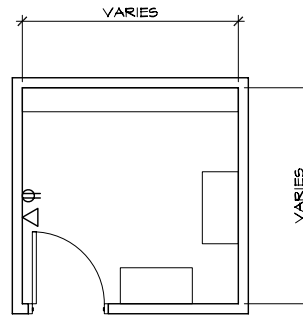

Floor Plan

**SYMBOL LEGEND:**



Voice Outlet



Data Outlet



Voice/Data Outlet



Duplex Outlet



ISDN Outlet



Duress Alarm Outlet





## 1.6 Staff Services and Training - Room Data Sheet

### 1.6.15 STAFF BREAKROOM

#### Function

The Staff Breakroom is used for food storage and minor food preparation (microwave) as well as staff lunch and coffee breaks.



Photograph

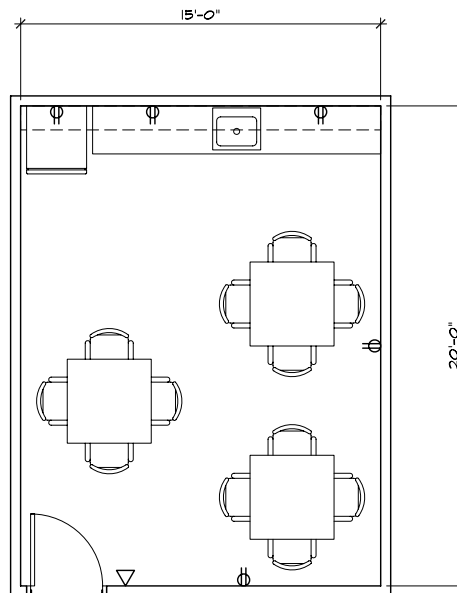

Floor Plan

SYMBOL LEGEND:

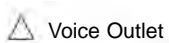

Voice Outlet



Data Outlet



Voice/Data Outlet



Duplex Outlet



ISDN Outlet



Duress Alarm Outlet





## 1.6 Staff Services and Training - Room Data Sheet

### 1.6.16 VENDING AREA

#### Function

The Vending Area is a space allocation for vending machines that provide the staff with food and refreshments.



Photograph

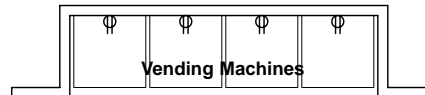

Floor Plan

**SYMBOL LEGEND:**

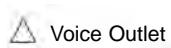

Voice Outlet



Data Outlet



Voice/Data Outlet



Duplex Outlet



ISDN Outlet



Duress Alarm Outlet





## 1.6 Staff Services and Training - Room Data Sheet

### 1.6.17 MALE STAFF LOCKERS

#### Function

The Male Staff Lockers provide all uniformed agents and selected staff members a place to secure and store clothing and personal belongings. Agents may choose to arrive to work in civilian clothing and then change into their uniform at the CDF. The Staff Locker area is intended to be the space where this occurs.



Photograph

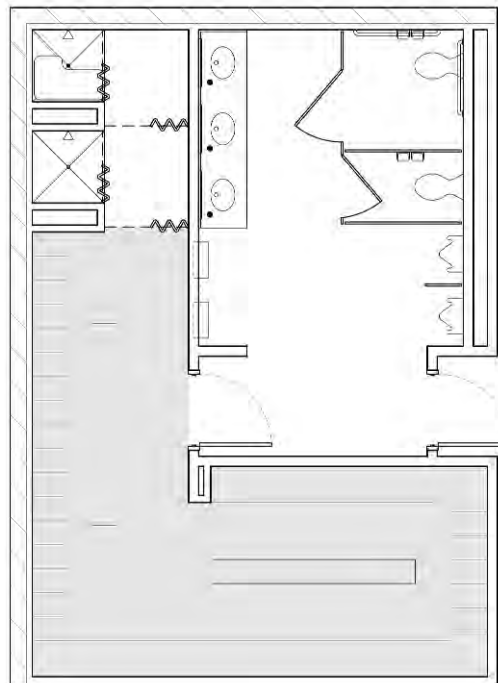

Floor Plan

**SYMBOL LEGEND:**

-  Voice Outlet    Data Outlet    Voice/Data Outlet    Duplex Outlet    ISDN Outlet    Duress Alarm Outlet







## 1.6 Staff Services and Training - Room Data Sheet

### 1.6.18 MALE STAFF TOILET

#### Function

The Male Staff Toilet is a multi-use toilet room directly adjacent to the Male Staff Lockers.



Photograph

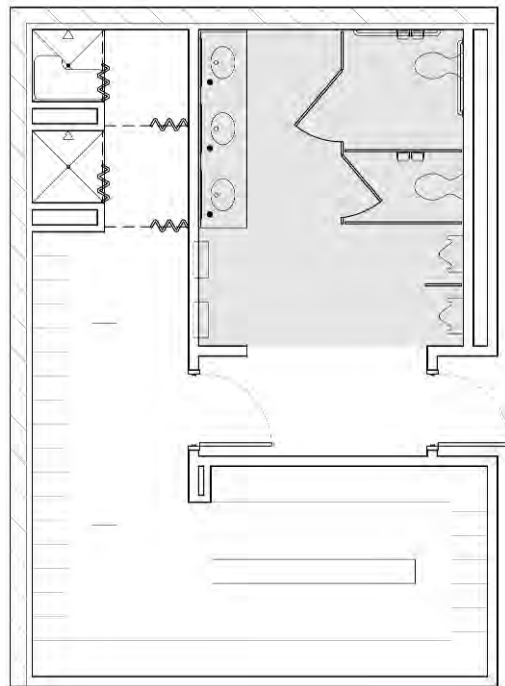

Floor Plan

**SYMBOL LEGEND:**

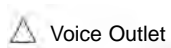

Voice Outlet

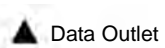

Data Outlet



Voice/Data Outlet



Duplex Outlet



ISDN Outlet



Duress Alarm Outlet





## 1.6 Staff Services and Training - Room Data Sheet

### 1.6.19 MALE STAFF SHOWER

#### Function

The Male Staff Shower is a place for agents or staff to shower after their shift or after exercising. It is directly adjacent to the Male Staff Lockers and Male Staff Toilets.



Photograph

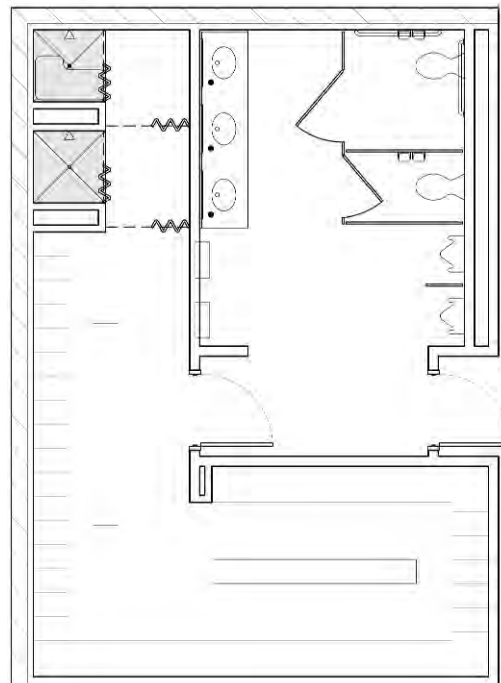

Floor Plan

**SYMBOL LEGEND:**

-  Voice Outlet    Data Outlet    Voice/Data Outlet    Duplex Outlet    ISDN Outlet    Duress Alarm Outlet





## 1.6 Staff Services and Training - Room Data Sheet

### 1.6.20 MALE SHOWER DRESSING AREA

#### Function

The Male Shower Dressing Area is a private space for agents/staff to towel off and get dressed after showering. It is located directly adjacent to the Male Staff Showers.



Photograph

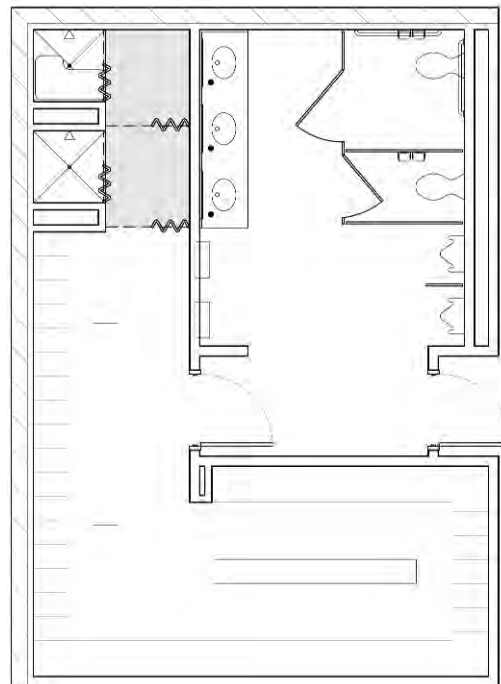

Floor Plan





## 1.6 Staff Services and Training - Room Data Sheet

### 1.6.21 FEMALE STAFF LOCKERS

#### Function

The Female Staff Lockers provide all uniformed agents and selected staff members a place to secure and store clothing and personal belongings. Agents may choose to arrive to work in civilian clothing and then change into their uniform at the CDF. The Staff Locker area is intended to be the space where this occurs.



Photograph

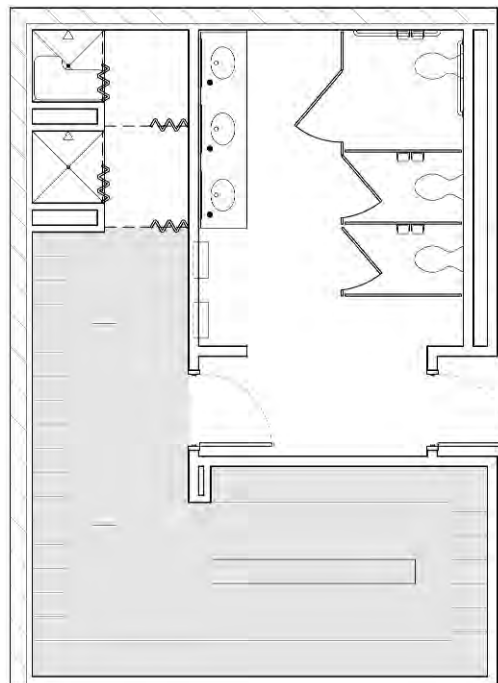

Floor Plan

**SYMBOL LEGEND:**

- Voice Outlet
- Data Outlet
- Voice/Data Outlet
- Duplex Outlet
- ISDN Outlet
- Duress Alarm Outlet







## 1.6 Staff Services and Training - Room Data Sheet

### 1.6.22 FEMALE STAFF TOILET

#### Function

The Female Staff Toilet is a multi-use toilet room directly adjacent to the Male Staff Lockers.



Photograph

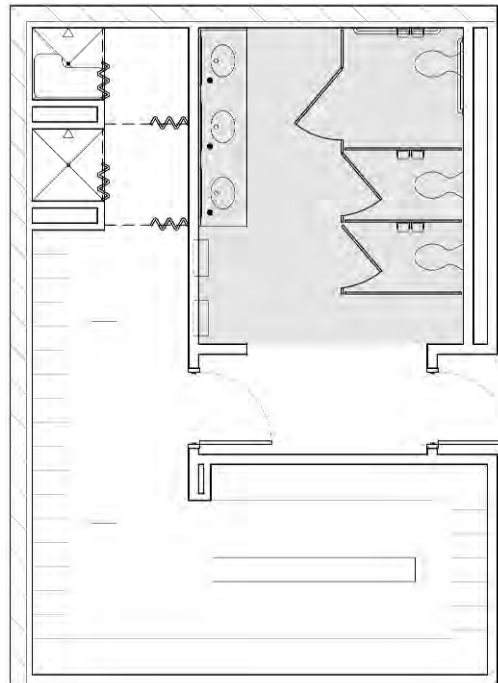

Floor Plan





## 1.6 Staff Services and Training - Room Data Sheet

### 1.6.23 FEMALE STAFF SHOWER

#### Function

The Female Staff Shower is a place for agents or staff to shower after their shift or after exercising. It is directly adjacent to the Male Staff Lockers and Male Staff Toilets.



Photograph

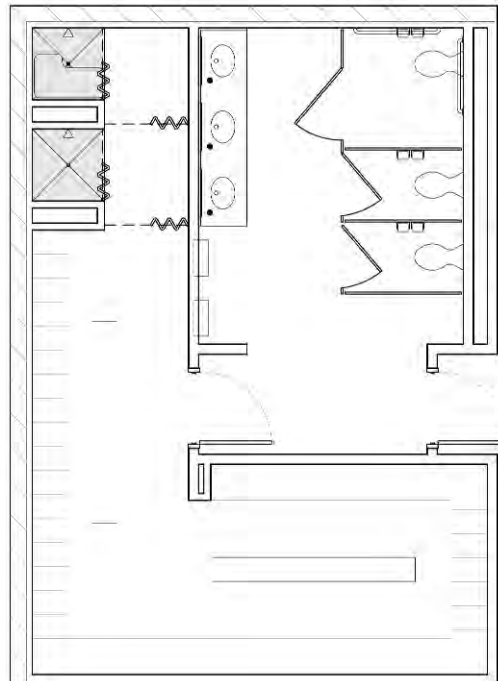

Floor Plan

**SYMBOL LEGEND:**

-  Voice Outlet    Data Outlet    Voice/Data Outlet    Duplex Outlet    ISDN Outlet    Duress Alarm Outlet





## 1.6 Staff Services and Training - Room Data Sheet

### 1.6.24 FEMALE SHOWER DRESSING AREA

#### Function

The Female Shower Dressing Area is a private space for agents/staff to towel off and get dressed after showering. It is located directly adjacent to the Male Staff Showers.



Photograph

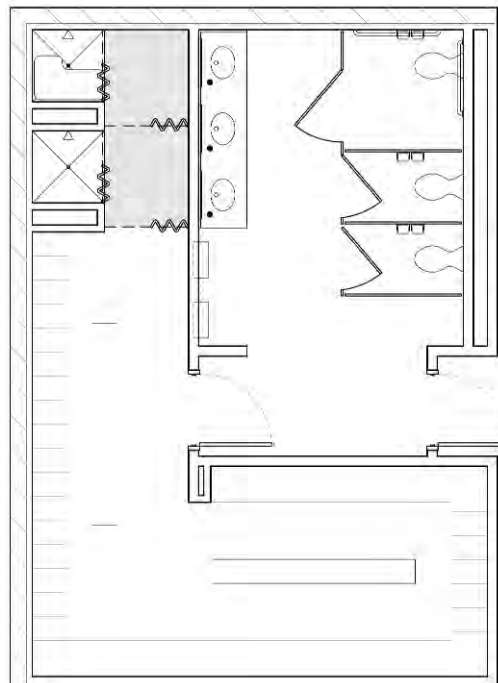

Floor Plan

**SYMBOL LEGEND:**



Voice Outlet



Data Outlet



Voice/Data Outlet



Duplex Outlet



ISDN Outlet



Duress Alarm Outlet





## 1.6 Staff Services and Training - Room Data Sheet

### 1.6.25 BULK STORAGE ROOM

#### Function

The Bulk Storage Room is a secured space for housing disposed property.



Photograph

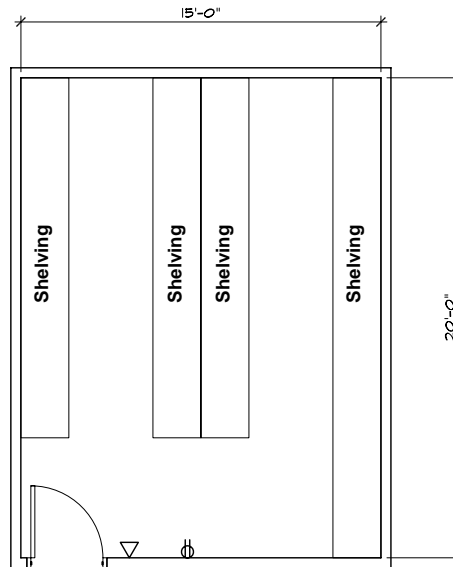

Floor Plan

**SYMBOL LEGEND:**

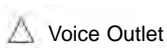

Voice Outlet

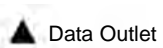

Data Outlet



Voice/Data Outlet



Duplex Outlet



ISDN Outlet



Duress Alarm Outlet







## 1.6 Staff Services and Training - Room Data Sheet

### 1.6.26 LOADING DOCK & STAGING

#### Function

The Loading Dock is the primary delivery point for all ICE related goods such as office supplies, furniture, training supplies and equipment, computers, and ammunition.



Photograph

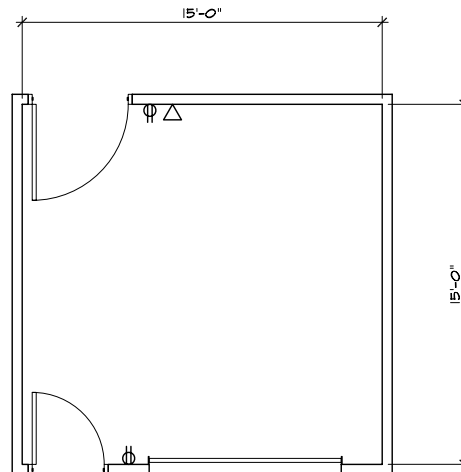

Floor Plan

**SYMBOL LEGEND:**



Voice Outlet



Data Outlet



Voice/Data Outlet



Duplex Outlet



ISDN Outlet



Duress Alarm Outlet







## 2.0 Court Interface Zone

- 2.1 EOIR Court (DOJ Responsibility)
- 2.2 Public/Detainee Visitation (Contractor Responsibility)



## **2.0 Court Interface Zone**

The Court Interface Zone includes the EOIR work area and courtroom space, and is an interface area between the court personnel, the Removal Unit, the public, and detainees under restraint. It is a secure interface zone. The area should be in its own secondary perimeter, contiguous with but separate from the main facility primary secure perimeter. Access will be by hardened commercial grade doorways, with special controls for general and emergency egress. The perimeter barriers, electronic controls, and procedures should be at the same level as the other secondary secure perimeters. (See EOIR Design Standards under separate cover.)

The Court Interface components within a CDF are operated by the Executive Office for Immigration Review (EOIR) and the selected contractor, and are not included in this document.

The components within the Court Interface Zone are listed below.

- 2.1 EOIR Court
- 2.2 Public/Detainee Visitation

## 2.0 Court Interface Zone : Organizational Diagram

(b)(2)High



## 2.0 Court Interface Zone - Space Requirements Summary

2.0 COURT INTERFACE ZONE		ICE CDF	< 200 BEDS	200-450 BEDS	450-900 BEDS	900-1200 BEDS	1200-1500 BEDS	1500-1800 BEDS	1800-2000 BEDS	3000 BEDS	Comments
ID#	SPACE NAME										
2.1	EOIR Court <a href="#">Contractor Space</a>										
2.2	Public/Detainee Visitation <a href="#">Contractor Space</a>										

(b)(2) High



2.0 Court Interface Zone

**2.1 EOIR Court**

(DOJ Operated)

**NOTE: See EOIR Court Design Standards Publication**



2.0 Court Interface Zone

**2.2 Public/Detainee Visitation**

(Contractor Operated)



## 2.2 Public/Detainee Visitation

### ORGANIZATIONAL REQUIREMENTS

The CDF must allow detainees to confer with their attorneys in person and, under normal conditions, to receive visits from family and acquaintances. The DHS encourages visiting by family and friends to maintain the morale of the detainee and to develop closer relationships between the detainee and family members. Visitation may be restricted to ensure the security and good order of the facility.

Types of visitation at a CDF include: general visitation (including visitation by minors), legal visitation, consultation visitation for expedited removal, and special family visits. For more information on detainee visiting, consult the DHS Detention Standard for Detainee Visitation.

(b)(2)High

### OPERATIONAL REQUIREMENTS

Visiting rooms should be comfortable and as pleasant as practical with appropriate furnishings. Supervision of visiting rooms should be adapted to the level of security required by the facility. Visiting is located centrally, minimizing the movement of the public throughout the facility. The number of staff supervising in the visitation area depends on the number of visiting areas and the design of the visiting space.

Visiting should be located adjacent to the Public Lobby. The primary secure perimeter separates the visiting public side from the detainee side.

Visiting should be located adjacent to Central Control or another fixed staff position to allow the staff to monitor security within the area. If direct visual surveillance of circulation systems is not possible from a fixed position, detainees are escorted to visiting by the housing area security staff.

Visitors must check in at the Public Lobby reception desk. The staff at the desk checks visitor I.D. and informs visitors of institutional visiting rules. The visitor is required to pass through a metal detector in the public lobby.







## **3.0 Detainee Living Zone**

- 3.1 Detention Administration (ICE Responsibility)
- 3.2 Detainee Housing (w/Dining) (Contractor Responsibility)
- 3.3 Detainee Services (Contractor Responsibility)
- 3.4 Recreation (Contractor Responsibility)
- 3.5 Library (Contractor Responsibility)



## 3.0 Detainee Living Zone

The Detainee Living Zone contains functions that are used by detainees during their normal daily routine. It is a secure zone with normal routine detainee movement within the primary secure perimeter. Components within this zone should be separated from each other by secondary secure perimeters. Detainee movement between each component will be monitored by housing security staff.

This document covers the ICE Detention Administration within component 3.1 Detention Administration. The other components within the Detainee Living Zone are typically defined and controlled by the Contract Detention Service Provider, and are not covered in this document.

The diagram on the following page illustrates the Detainee Living Zone components and the critical adjacency requirements needed for a productive work environment.

The following information has been provided for each of the components:

### **Function**

Describes the overall purpose of the component within the CDF.

### **Critical Workflow Patterns**

Identifies the most critical workflow patterns necessary for efficient staff productivity.

### **Room Data Sheets**

Provides detailed information on all spaces within the components (i.e., function statements, photograph, floor plan, systems, furniture, and equipment)

The components within the Detainee Living Zone are listed below:

- 3.1 Detention Administration (ICE Operated)**
- 3.2 Detainee Housing (w/Dining) (Contractor Operated)
- 3.3 Detainee Services (Contractor Operated)
- 3.4 Recreation (Contractor Operated)
- 3.5 Library (Contractor Operated)



### 3.0 Detainee Living Zone : Organizational Diagram

(b)(2)High



## 3.0 Detainee Living Zone - Space Summary

### SPACE FORECAST MATRIX

The Space Requirements Summary Matrix on the following page, identifies the spaces needed for each of the functional units within the Detainee Living Zone. The matrix listed below is also designed to forecast these needs for the planning scenarios.

1. <200 beds
2. 200 - 450 beds
3. 450 - 900 beds
4. 900 - 1,200 beds
5. 1,200 - 1,500 beds
6. 1,500 - 1,800 beds
7. 1,800 - 2,000 beds
8. 2,000 - 3,000 beds

The bed ranges were determined to best represent the capacity range for existing and planned detainee populations.

For each planning scenario, the following information is provided:

- # of Users is the number of persons (staff or detainees) in a given space.
- # of Spaces is the quantity of a given space.
- Space Size NSF is the net square feet or size of a given space.
- Total Size NSF is the number of spaces or quantity of a space times it's NSF or size.

The sidebar to the right highlights some of the Space Planning Formulas that are used for calculating areas.

### SPACE CALCULATIONS/DEFINITIONS

The total Net Square Footage is the sum of all net areas of the spaces listed. This number is multiplied by a Net-Gross Factor (an industry factor based on space) to determine Gross Square Footage (GSF).

- **Net Square Footage (NSF)**  
Total clear floor area within a given room, excluding walls, corridors, mechanical equipment rooms, shafts, stairs, and chases.
- **Gross Square Footage (GSF)**  
Total building area measured from outside face of exterior walls.

### Space Planning Formulas

#### 3.1 Detention Administration

- Maximum shift size = 75% of total IEA's
- Ready room capacity = 24 agents @ 25 sf per agent + 8 lockers at 15 sf per locker

#### 3.2 Detainee Housing (w/Dining)

*Contractor Operated.*

#### 3.3 Detainee Services

*Contractor Operated.*

#### 3.4 Recreation

*Contractor Operated.*

#### 3.5 Library

*Contractor Operated.*

### 3.0 Detainee Living Zone - Space Requirements Summary

3.0	DETAINEE LIVING ZONE	ICE CDF STANDARD	< 200 BEDS	200-450 BEDS	450-900 BEDS	900-1200 BEDS	1200-1500 BEDS	1500-1800 BEDS	1800-2000 BEDS	3000 BEDS	Comments
ID#	SPACE NAME										
3.1	<b>Detention Administration</b>										
3.1.1	Detention Operations Supervisor (DOS) Office										
3.1.2	Supervisory Immigration Enforcement Agent (SIEA) Office										
3.1.3	Immigration Enforcement Agent (IEA) Workstation										
3.1.4	ICE Armory										
3.1.5	ICE Ready Room										
3.1.6	ICE Toilet Male										team of 24 @ 25 sft ea; 8 lockers @ 15 sft ea.
3.1.7	ICE Toilet Female										
3.2	<b>Detainee Housing (w/Dining)</b>										
	Contractor Space										
3.3	<b>Detainee Services</b>										
	Contractor Space										
3.4	<b>Recreation</b>										
	Contractor Space										
3.5	<b>Library</b>										
	Contractor Space										

(b)(2)High

3.0 Detainee Living Zone

### **3.1 Detention Administration**

(ICE Operated)

#### **Space Requirements**

- 3.1.1 Detention Operations Supervisor (DOS) Office
- 3.1.2 Supervisory Immigration Enforcement Agent (SIEA) Office
- 3.1.3 Immigration Enforcement Agent (IEA) Workstation
- 3.1.4 ICE Armory
- 3.1.5 ICE Ready Room
- 3.1.6 ICE Toilet Male
- 3.1.7 ICE Toilet Female



## 3.1 Detention Administration - Function

### FUNCTION STATEMENT

ICE Detention Administration at a CDF is limited to the office functions carried out by ICE staff, the Armory and the ICE Ready Room.

ICE Detention Administration staff perform functions specifically related to the transportation of detainees. These staff positions, while performing duties in the Processing area and throughout the facility, require administrative space near ICE Administration.

Staff provided by the Contract Detention Service Provider have the primary responsibility for Central Control and the safety and security of the facility.

### Design Criteria

#### **Critical Issues**

- ✓ Adjacent to Staff Service and Training
- ✓ Adjacent to Loading Dock
- ✓ Armory must be located outside the secure perimeter
- ✓ ICE Ready Room must be located outside the secure perimeter

#### **Special Requirements**

- ✓ Controlled access to Armory
- ✓ Maximum security construction of Armory

#### **Space Requirements**

### **3.1 DETENTION ADMINISTRATION**

- 3.1.1 Detention Operations Supervisor (DOS) Office
- 3.1.2 Supervisory Immigration Enforcement Agent (SIEA) Office
- 3.1.3 Immigration Enforcement Agent (IEA) Workstation
- 3.1.4 ICE Armory
- 3.1.5 ICE Ready Room
- 3.1.6 ICE Toilet Male
- 3.1.7 ICE Toilet Female

### 3.1 Detention Administration : Organizational Diagram

(b)(2)High



## **3.1 Detention Administration - Critical Workflow Patterns**

### **INTRODUCTION**

The diagrams on the following page illustrate some of the most critical workflow issues and patterns of the Detention Administration.

3.1 Detention Administration : Critical Workflow Patterns

1. "CRITICAL ADJACENCIES"

Detention Administration must be located inside the primary secure perimeter in order to provide the security staff with direct supervision.



2. "TWO-HOUR SECURITY GLASS"

All glass in the Detention Administration and Central Control should meet the two-hour standard for attack resistance and must be shatter proof.

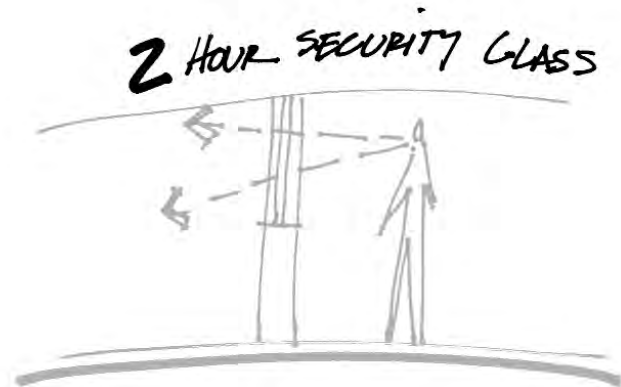

3. "CENTRAL CONTROL/ARMORY-VISUAL CONNECTION"

The armory should be located outside the secure perimeter but near central control for visual monitoring.

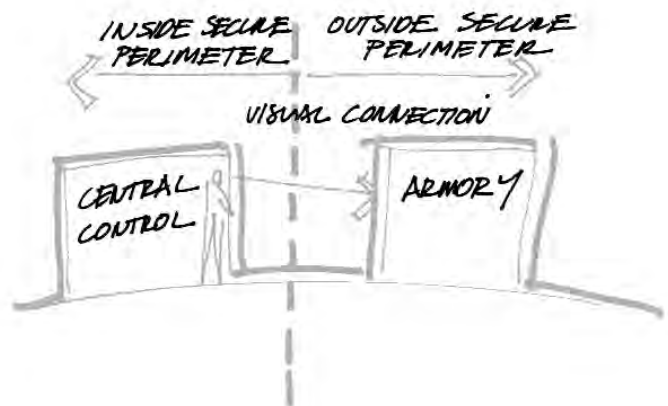





### 3.1 Detention Administration - Room Data Sheet

#### 3.1.1 DETENTION OPERATIONS SUPERVISOR (DOS) OFFICE

Function  
The....



Photograph

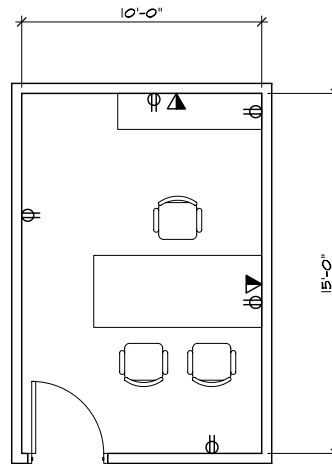

Floor Plan

SYMBOL LEGEND:

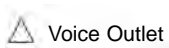

Voice Outlet

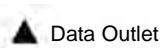

Data Outlet



Voice/Data Outlet



Duplex Outlet



ISDN Outlet



Duress Alarm Outlet





## 3.1 Detention Administration - Room Data Sheet

### 3.1.2 SUPERVISORY IMMIGRATION ENFORCEMENT AGENT (SIEA) OFFICE

#### Function

The Supervisory Immigration Enforcement Agent's function is as a first-line supervisor for conducting day-to-day immigration enforcement operations, as well as short and medium range planning and evaluation of a variety of enforcement functions associated with the identification, investigation, apprehension, prosecution, and removal of aliens and criminal aliens, and the apprehension of absconders from removal proceedings.

The SIEA plans and schedules work on a daily and weekly basis, and assigns work to subordinate IEA's.



Photograph

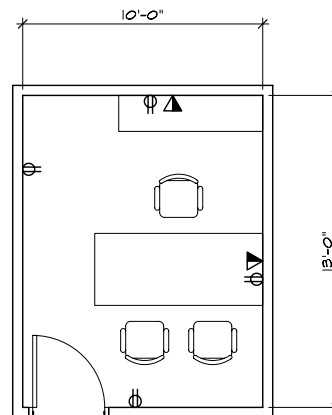

Floor Plan

**SYMBOL LEGEND:**



Voice Outlet



Data Outlet



Voice/Data Outlet



Duplex Outlet



ISDN Outlet



Duress Alarm Outlet





## 3.1 Detention Administration - Room Data Sheet

### 3.1.3 IMMIGRATION ENFORCEMENT AGENT OFFICE

#### Function

The Immigration Enforcement Agent's function is to perform a variety of enforcement functions related to the investigation, identification, apprehension, prosecution, detention and removal of aliens and criminal aliens, and apprehension of absconders from removal proceedings.

The IEA routinely enters hostile situations and may be required to make decisions affecting the life, well being, and/or civil liberties of aliens, the public, and other law enforcement officers as well as impacting regulations between the U.S. and other governments.

All IEA's perform two major duties:

- Removal, transport, and escort
- Detention

And one or more of the following duties:

- Jail check
- Prosecutions
- Determining Alienage and Fugitive Operations
- Operational Support/Law Enforcement Liaison
- Alien Criminal Apprehension Program, Law Enforcement Agency Support, Multi-Agency Task Force, Quick Response Teams, Duty Officer



Photograph

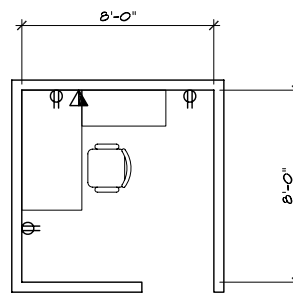

Floor Plan

#### SYMBOL LEGEND:

- Voice Outlet   Data Outlet   Voice/Data Outlet   Duplex Outlet   ISDN Outlet   Duress Alarm Outlet





## 3.1 Detention Administration - Room Data Sheet

### 3.1.4 ICE ARMORY

#### Function

The Armory functions as a highly secure room for storing weapons and ammunition as well as gas and other specialized equipment. Cleaning of weapons may also take place in the Armory.

Guns are double locked in a gun rack within the Armory. Ammunition is also stored within lockable shelves/cabinets.

The entrance to the Armory is controlled electronically and is kept under video surveillance.



Photograph

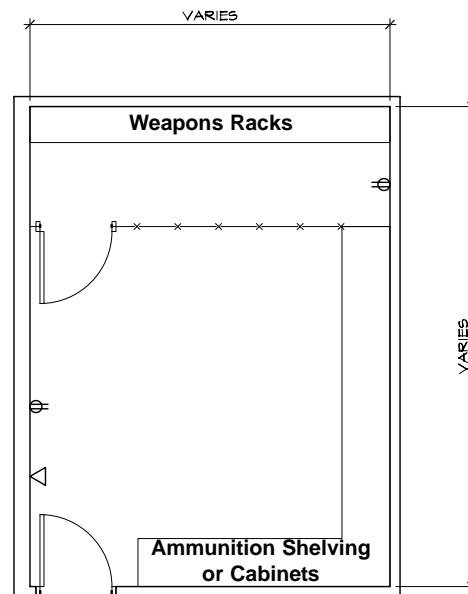

Floor Plan







## 3.1 Detention Administration - Room Data Sheet

### 3.1.5 ICE READY ROOM

#### Function

The Ready Room should be located adjacent to the Armory and serves as an area for equipping ICE staff when an incident occurs.

SWAT teams consist of 24 agents, most of which will not be located at the facility. The Ready Room also serves as a place to store equipment such as shields, vests, batons, etc. and conduct briefings.



Photograph

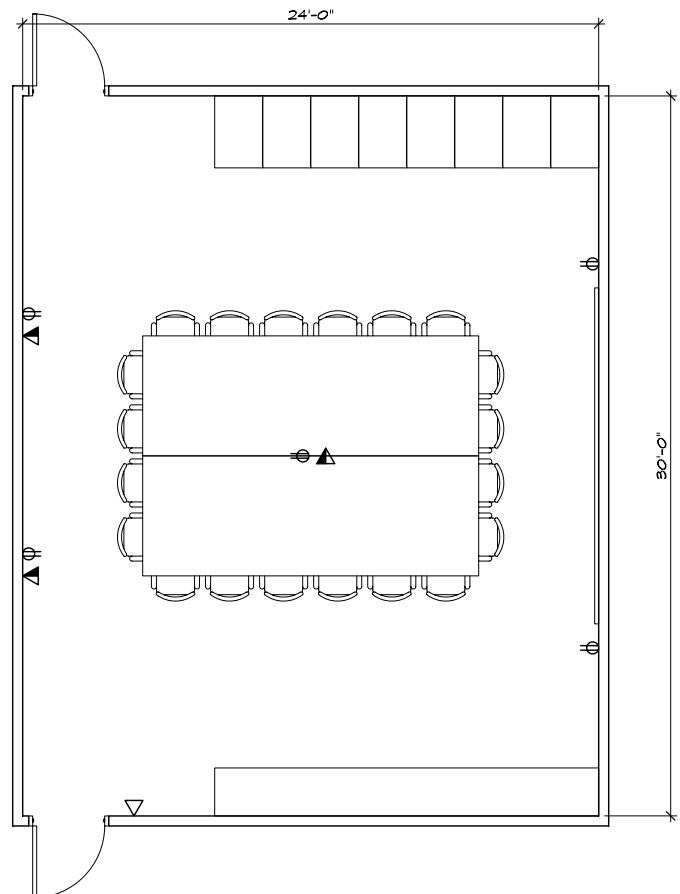

Floor Plan

**SYMBOL LEGEND:**

- Voice Outlet
- Data Outlet
- Voice/Data Outlet
- Duplex Outlet
- ISDN Outlet
- Duress Alarm Outlet





## 3.1 Detention Administration - Room Data Sheet

### 3.1.6 ICE TOILET - MALE

#### Function

The Male Officer Toilet is a single use room located within Detention Administration.



Photograph

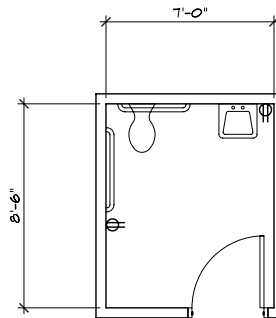

Floor Plan

SYMBOL LEGEND:

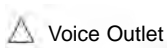

Voice Outlet

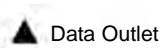

Data Outlet



Voice/Data Outlet



Duplex Outlet



ISDN Outlet



Duress Alarm Outlet





## 3.1 Detention Administration - Room Data Sheet

### 3.1.7 ICE TOILET - FEMALE

#### Function

The Female Officer Toilet is a single use room located within Detention Administration.



Photograph

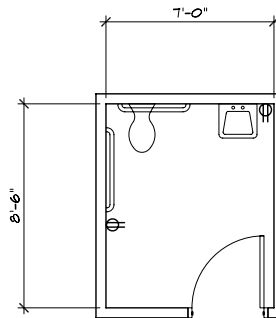

Floor Plan

**SYMBOL LEGEND:**

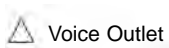

Voice Outlet



Data Outlet



Voice/Data Outlet



Duplex Outlet



ISDN Outlet



Duress Alarm Outlet





3.0 Detainee Living Zone

**3.2 Detainee Housing**

(Contractor Operated)





## 3.2 Detainee Housing

(b)(2)High





3.0 Detainee Living Zone

**3.3 Detainee Services**

(Contractor Operated)



## 3.3 Detainee Services

### **ORGANIZATIONAL REQUIREMENTS**

The CDF offers detainees the opportunity to purchase food items through the commissary. Commissary is a privilege, and can be denied for disciplinary purposes.

There are four ways in which commissary items can be distributed:

- A central commissary store with walk-up business window;
- Automatic coin-operated vending machines;
- An order and deliver system; or
- A circulating stocked cart

Programs are provided to give detainees the opportunity to exercise their religious rights, assist in adjusting to CDF life, and to offer constructive use of their time. The mission of the CDF is not to rehabilitate, punish, or reform the detainee. The offering of education programs and substance abuse rehabilitation programs is limited to the extent that there are requests for these services and the resources are available to offer them.

(b)(2)High

### **OPERATIONAL REQUIREMENTS**

The detainee services should be located within the secure zone, with normal detainee movement. Critical adjacencies for detainee services include detainee housing, library and recreation.





3.0 Detainee Living Zone

**3.4 Recreation**

(Contractor Operated)





## 3.4 Recreation

### ORGANIZATIONAL REQUIREMENTS

To comply with standards, all detainees are provided the opportunity for outside recreation at least once each day, five (5) days per week. For at least one hour per day, detainees must have the opportunity for outdoor exercise or an indoor equivalent during inclement weather. Providing recreation privileges beyond minimum requirements is an important management tool to promote a safe and cooperative detainee population.

Recreational activities are based on the size and location of each facility. Recreational activities are restricted to limited-contact sport activities such as soccer, basketball, volleyball, table games, and sporting competitions between units when approved by the Facility Administrator. All programs and activities are subject to security and operational guidelines for each facility and may be limited at the discretion of the Facility Administrator. Constant staff supervision is required for recreational activities. In outdoor situations supervising personnel require radios to maintain contact with the control center.

(b)(2)High

Outdoor recreation can be provided in two types of settings. The first is a large centralized recreation field, large enough for soccer and softball games, which allows detainees to leave their housing area to recreate. The second is a small recreation yard located directly adjacent to the housing area. This setting reduces the amount of detainee movement and associated escort supervision. This type of yard would allow small court games such as half-court basketball or volleyball.

### OPERATIONAL REQUIREMENTS

Recreation fields must be located within the primary secure perimeter. Centralized outdoor recreation should be located so detainees can exit directly from within the building security perimeter into the recreation field. For campus facilities, locating housing areas around a recreation yard provides easily accessible and supervised outdoor areas while maintaining the security perimeter. For facilities located in urban areas, views from off-site should be shielded. When adequate buffer zones cannot be maintained between recreation yards and public access areas, the yards must have a screened roof to prevent outsiders from lobbing contraband into the yards.

Recreation yards located directly adjacent to housing areas should be visible from a security post to allow supervision by the housing security staff.

The detainee's security risk determines the amount of recreational access. High security-risk detainees, administrative segregation, and disciplinary segregation should always be provided outdoor recreation yards directly adjacent to their housing area. General medium and low risk population detainees may utilize a centralized larger outdoor recreation area.





3.0 Detainee Living Zone

**3.5 Library**

(Contractor Operated)



## 3.5 Library

### **ORGANIZATIONAL REQUIREMENTS**

The facility holding DHS/ICE detainees shall permit detainees access to a Law Library, and provide legal materials, facilities, equipment and document copying privileges, and the opportunity to prepare legal documents. Detainees housed in Administrative Segregation and Disciplinary Segregation must be afforded the same legal access as the general population, unless security concerns require limitations.

The facility shall also offer recreational reading material as a privilege and a way to occupy detainee time.

(b)(2)High

Each detainee shall be permitted to use the law library for a minimum of five (5) hours per week.

### **OPERATIONAL REQUIREMENTS**

The law library should be located within the primary secure perimeter adjacent to a staff position such as Central Control or a fixed housing control post. The level of supervision required for the law library depends on the physical layout, category of detainees, available officer manpower and facility operating procedures. Each facility must have a designated officer with responsibility for updating the legal materials.

Due to the cost of legal reference material, the library is maintained in a central location. This library should be visually supervised from a staff position.







## **4.0 Service Zone**

- 4.1 Processing (ICE & Contractor Responsibility)
- 4.2 Health Services (H & HS Responsibility)
- 4.3 Laundry (Contractor Responsibility)
- 4.4 Food Preparation (Contractor Responsibility)





## 4.0 Service Zone

The Service Zone provides services necessary for supporting detainees while they live in the CDF. It is a zone that is located inside the primary secure perimeter with restricted detainee movement. Components should be separated from each other by secondary secure perimeters. Detainee movement to any component will be by direct escort or continuously monitored/controlled movement with staff control of each individual detainee passing into or out of a component.

This document covers the ICE Service areas within component 4.1 Processing. The other components are typically defined and controlled by Contract Detention Service provider and are not included in this document.

The diagram on the following page illustrates the Service Zone components and the critical adjacency requirements needed for a productive work environment.

The following information has been provided for the processing components:

### **Function**

Describes the overall purpose of the component within the CDF.

### **Critical Workflow Patterns**

Identifies the most critical workflow patterns necessary for efficient staff productivity.

### **Room Data Sheets**

Provides detailed information on all spaces within the components (i.e., function statements, photograph, floor plan, systems, furniture, and equipment)

The components within the Service Zone include:

- 4.1 Processing (ICE Operated)**
- 4.2 Health Services (Health Services Operated)
- 4.3 Laundry (Contractor Operated)
- 4.4 Food Preparation (Contractor Operated)

**Service Zone : Organizational Diagram**

(b)(2)High



## 4.0 Service Zone - Space Requirements

### SPACE FORECAST MATRIX

The Space Requirements Summary Matrix on the following page, identifies the spaces needed for each of the functional units within the Service Zone. The matrix listed below is also designed to forecast these needs for the planning scenarios.

1. <200 beds
2. 200 - 450 beds
3. 450 - 900 beds
4. 900 - 1,200 beds
5. 1,200 - 1,500 beds
6. 1,500 - 1,800 beds
7. 1,800 - 2,000 beds
8. 2,000 - 3,000 beds

The bed ranges were determined to best represent the capacity range for existing and planned detainee populations.

For each planning scenario, the following information is provided:

- # of Users is the number of persons (staff or detainees) in a given space.
- # of Spaces is the quantity of a given space.
- Space Size NSF is the net square feet or size of a given space.
- Total Size NSF is the number of spaces or quantity of a space times the NSF or size.

The sidebar to the right highlights some of the Space Planning Formulas that are used for calculating areas.

### SPACE CALCULATIONS/DEFINITIONS

The total Net Square Footage is the sum of all net areas of the spaces listed. This number is multiplied by a Net-Gross Factor (an industry factor based on space type) to determine Gross Square Footage (GSF). This factor is intended to account for space such as circulation space, mechanical space, wall thicknesses, etc., that are not programmed space.

- **Net Square Footage (NSF)**  
Total clear floor area within a given room, excluding walls, corridors, mechanical equipment rooms, shafts, stairs, and chases.
- **Gross Square Footage (GSF)**  
Total building area measured from outside face of exterior walls.

### Space Planning Formulas

#### 4.1 Processing

- Number of Processing Positions:
  - 1 for each 100 detainees
  - Male/female split = 60/40
- Number of interview rooms = 6 per 1,000 detainees

#### 4.2 Health Services

*Operated by the Department of Health and Human Services*

#### 4.3 Laundry

*Contractor Operated.*

#### 1.4 Food Preparation

*Contractor Operated.*



**Space Requirements**

- 4.1.1 Vehicular Sallyport
- 4.1.2 Pedestrian Sallyport & Search Room
- 4.1.3 Processing Counter - Male
- 4.1.4 Processing Counter - Female
- 4.1.5 ICE Transportation Work Area
- 4.1.6 ICE Interview Room
- 4.1.7 Large Holding - Male
- 4.1.8 Small Holding - Male
- 4.1.9 Segregation Holding - Male
- 4.1.10 Large Holding - Female
- 4.1.11 Small Holding - Female
- 4.1.12 Segregation Holding - Female
- 4.1.13 Special Case Holding - Male
- 4.1.14 Special Case Holding - Female
- 4.1.15 Staff Toilet



## 4.1 Processing - Function

### FUNCTION STATEMENT

Processing provides a space where detainees enter, wait, are held, and processed before being assigned to detention, transferred to other facilities or released from detention. Processing must complete specific activities upon detainee admittance, transfer, and release, including accurate identification and property exchange. Detention, transfer, and release activities are conducted in the same area to conserve staff and space.

The basic and support activities in the Processing Area include:

- Transportation and staging of arriving and departing detainees
- Holding detainees while waiting processing or transfer
- Orientation of incoming detainees
- Processing detainess
- Search, interview, and medical screening of incoming detainees
- Showering for incoming detainees
- Storage of detainee valuables and property
- Clothing and linen issue/exchange
- Providing snacks and sack lunches

Processing is located within the primary secure perimeter. It should be located directly adjacent to the vehicle sallyport. Processing should be located near Health Services and Security Command for immediate health screenings and direct visual supervision of the Processing Area and sallyport.

### Design Criteria

#### Critical Issues

- ✓ Highly secure detention environment
- ✓ Separation of male, female and juvenile detainees
- ✓ Separation of unprocessed & processed detainees
- ✓ Hardened environment
- ✓ Unobstructed sight lines
- ✓ Efficient process and flow

#### Special Requirements

- ✓ Detention-grade hardware & furnishings
- ✓ Detention-grade fixtures & equipment
- ✓ Security, control, and surveillance
- ✓ Hard, washable surfaces

#### Space Requirements

##### 4.1 PROCESSING

- 4.1.1 Vehicular Sallyport
- 4.1.2 Pedestrian Sallyport & Search Room
- 4.1.3 Processing Counter - Male
- 4.1.4 Processing Counter - Female
- 4.1.5 ICE Transportation Work Area
- 4.1.6 ICE Interview Room
- 4.1.7 Large Holding - Male
- 4.1.8 Small Holding - Male
- 4.1.9 Segregation Holding - Male
- 4.1.10 Large Holding - Female
- 4.1.11 Small Holding - Female
- 4.1.12 Segregation Holding - Female
- 4.1.13 Special Case Holding - Male
- 4.1.14 Special Case Holding - Female
- 4.1.15 Staff Toilet

### 4.1 Processing : Organizational Diagram

(b)(2)High



## **4.1 Processing - Critical Workflow Patterns**

### **INTRODUCTION**

The diagrams on the following page illustrate some of the most critical workflow issues and patterns of Processing.



4.1 Processing : Critical Workflow Patterns

1. "CRITICAL ADJACENCIES"

Processing is located within the primary secure perimeter, adjacent to the vehicle sallyport, Health Services, and administrative areas.

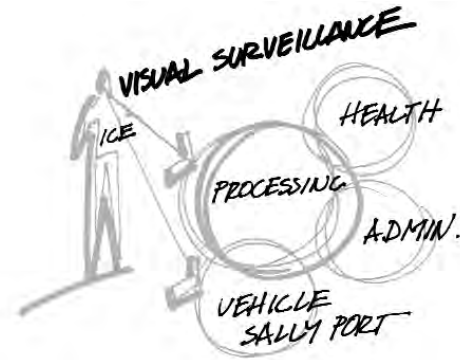

2. "INTAKE FLOW"

Processing activities are done sequentially to assure that each activity is thoroughly performed.

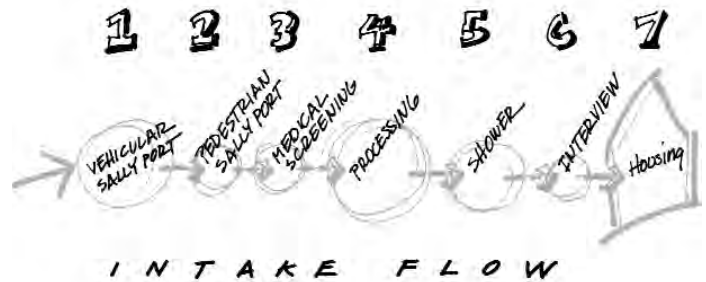

3. "PHYSICAL SEPARATION"

Detainees who have not been processed should be separated from those that have. Failure to do so provides unprocessed detainees with the opportunity to pass contraband.

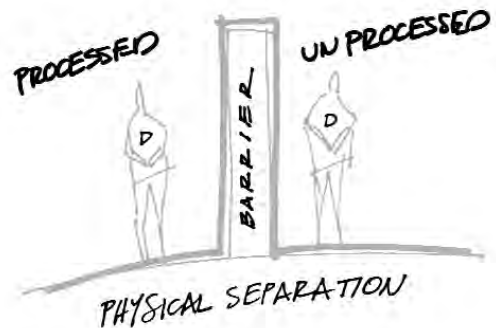

4. "ORIENTATION"

Orientation is provided to inform detainees of their rights and the institutional rules. Providing orientation in the holding cells provides greater assurance that the detainee will receive a proper orientation.





## 4.1 Processing - Room Data Sheet

### 4.1.1 VEHICULAR SALLYPORT

#### Function

The Vehicular Sallyport is a secure trap for one or more busses or vans. All transportation of all detainees (inbound and outbound) takes place through the Vehicular Sallyport.



Photograph

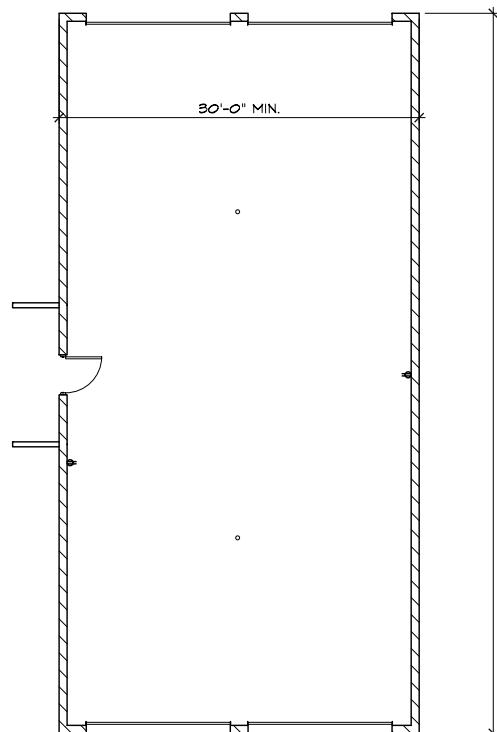

Floor Plan

SYMBOL LEGEND:



Voice Outlet



Data Outlet



Voice/Data Outlet



Duplex Outlet



ISDN Outlet



Duress Alarm Outlet





## 4.1 Processing - Room Data Sheet

### 4.1.2 PEDESTRIAN SALLYPORT & SEARCH ROOM

#### Function

This space serves a dual function - a pedestrian trap for temporarily confining detainees and as a secure place for pat-downs, search and physical inspection of detainees prior to moving them to a holding cell. Searches may take place on an individual basis or in small groups. The Pedestrian Sallyport and Search Room should be directly adjacent to the Vehicular Sallyport.



Photograph

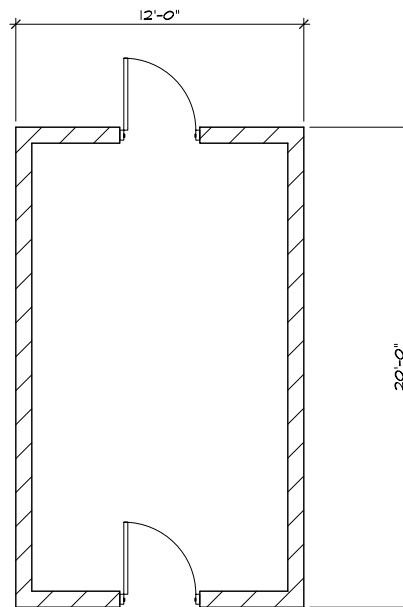

Floor Plan

SYMBOL LEGEND:



Voice Outlet



Data Outlet



Voice/Data Outlet



Duplex Outlet



ISDN Outlet



Duress Alarm Outlet





## 4.1 Processing - Room Data Sheet

### 4.1.3 PROCESSING COUNTER - MALE

#### Function

The Processing Counter-Male is the centerpiece to the Processing area. It is fixed and houses the identification and processing computers. All illegal immigrants are processed at this counter. It is a standing height counter made of very durable material.



Photograph

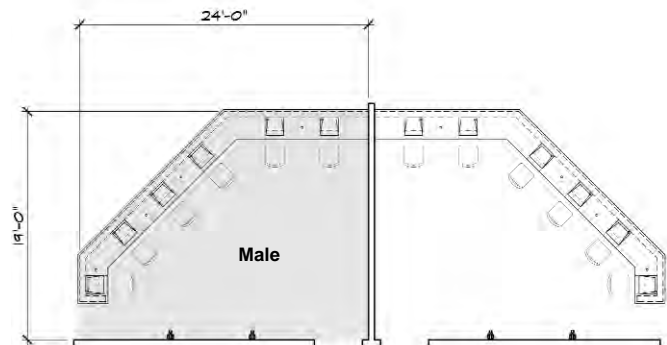

Floor Plan

*Note: duplex power outlet, voice and data outlet under counter at each processing position.*

*Provide grommets in worksurface for voice, data and power cables at all processing positions.*

**SYMBOL LEGEND:**



Voice Outlet



Data Outlet



Voice/Data Outlet



Duplex Outlet



ISDN Outlet



Duress Alarm Outlet





## 4.1 Processing - Room Data Sheet

### 4.1.4 PROCESSING COUNTER - FEMALE

#### Function

The Processing Counter-Female is the centerpiece to the Processing area. It is fixed and houses the identification and processing computers. All illegal immigrants are processed at this counter. It is a standing height counter made of very durable material.



Photograph

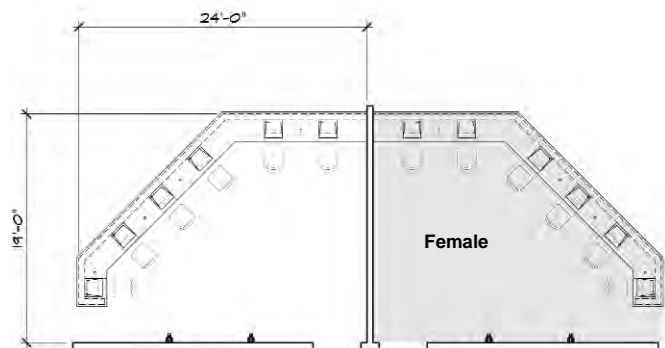

Floor Plan

*Note: duplex power outlet, voice and data outlet under counter at each processing position.*

**SYMBOL LEGEND:**

-  Voice Outlet    Data Outlet    Voice/Data Outlet    Duplex Outlet    ISDN Outlet    Duress Alarm Outlet







## 4.1 Processing - Room Data Sheet

### 4.1.5 ICE TRANSPORTATION WORK AREA

#### Function

ICE Transportation work area is a space used by staff to arrange for the transportation of detainees. Work functions include, paperwork, computer use and telephone.



Photograph

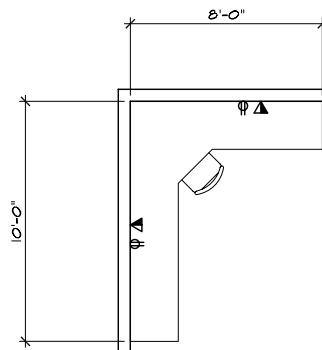

Floor Plan

**SYMBOL LEGEND:**



Voice Outlet



Data Outlet



Voice/Data Outlet



Duplex Outlet



ISDN Outlet



Duress Alarm Outlet





## 4.1 Processing - Room Data Sheet

### 4.1.6 ICE INTERVIEW ROOM

#### Function

The ICE Interview Room is an enclosed space where ICE Staff meet in a private setting with detainees on a one-to-one basis.



Photograph

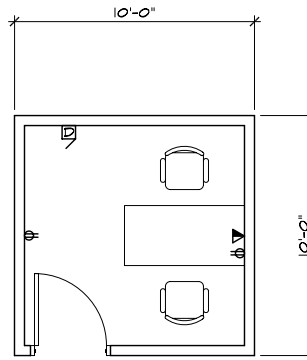

Floor Plan

**SYMBOL LEGEND:**



Voice Outlet



Data Outlet



Voice/Data Outlet



Duplex Outlet



ISDN Outlet



Duress Alarm Outlet





## 4.1 Processing - Room Data Sheet

### 4.1.7 LARGE HOLDING - MALE

#### Function

Detainees being transferred to housing or being released from the CDF are held in a Holding Room. Holding Rooms are temporary, secure confinement areas where detainees are generally held for 10 hours or less. Detainees may also be held in these rooms prior to court hearings or medical appointments for groups of twelve or greater.



Photograph

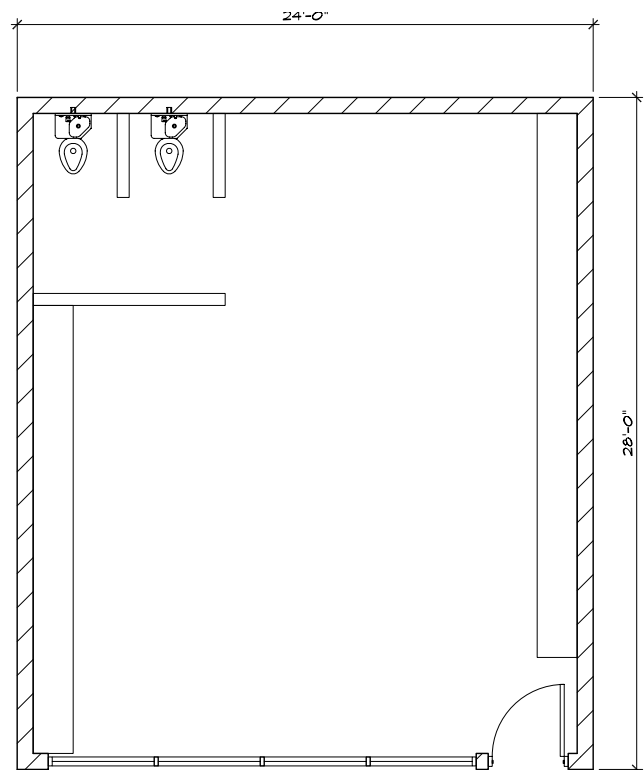

Floor Plan

SYMBOL LEGEND:

- Voice Outlet
- Data Outlet
- Voice/Data Outlet
- Duplex Outlet
- ISDN Outlet
- Duress Alarm Outlet





## 4.1 Processing - Room Data Sheet

### 4.1.8 SMALL HOLDING - MALE

#### Function

Detainees being transferred to housing or being released from the CDF are held in a Holding Room. Holding Rooms are temporary, secure confinement areas where detainees are generally held for 10 hours or less. Detainees may also be held in these rooms prior to court hearings or medical appointments for groups of four to twelve or greater.



Photograph

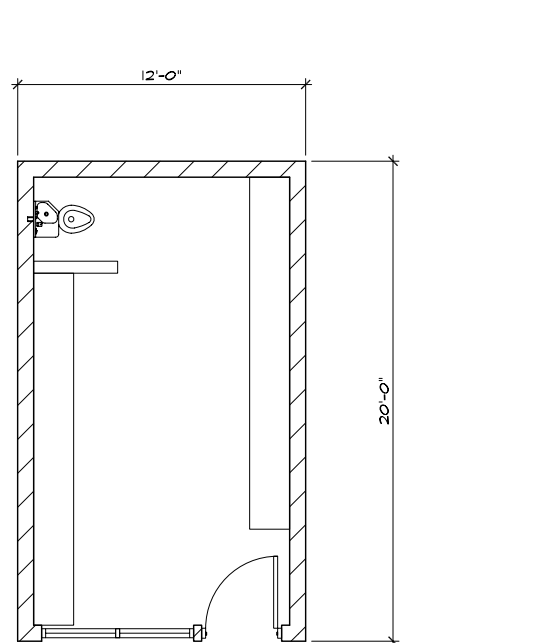

Floor Plan

SYMBOL LEGEND:



Voice Outlet



Data Outlet



Voice/Data Outlet



Duplex Outlet



ISDN Outlet



Duress Alarm Outlet







## 4.1 Processing - Room Data Sheet

### 4.1.9 SEGREGATION HOLDING - MALE

#### Function

Detainees being transferred to housing or being released from the CDF are held in a Holding Room. Holding Rooms are temporary, secure confinement areas where detainees are generally held for 10 hours or less. Segregation Holding cells are single occupant rooms generally used for separating detainees for disciplinary or medical reasons.



Photograph

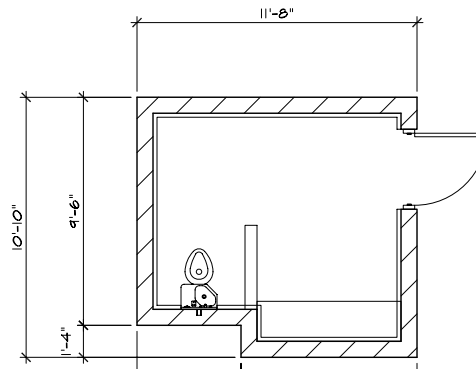

Floor Plan

SYMBOL LEGEND:



Voice Outlet



Data Outlet



Voice/Data Outlet



Duplex Outlet



ISDN Outlet



Duress Alarm Outlet





## 4.1 Processing - Room Data Sheet

### 4.1.10 LARGE HOLDING - FEMALE

#### Function

Detainees being transferred to housing or being released from the CDF are held in a Holding Room. Holding Rooms are temporary, secure confinement areas where detainees are generally held for 10 hours or less. Detainees may also be held in these rooms prior to court hearings or medical appointments for groups of twelve or greater.



Photograph

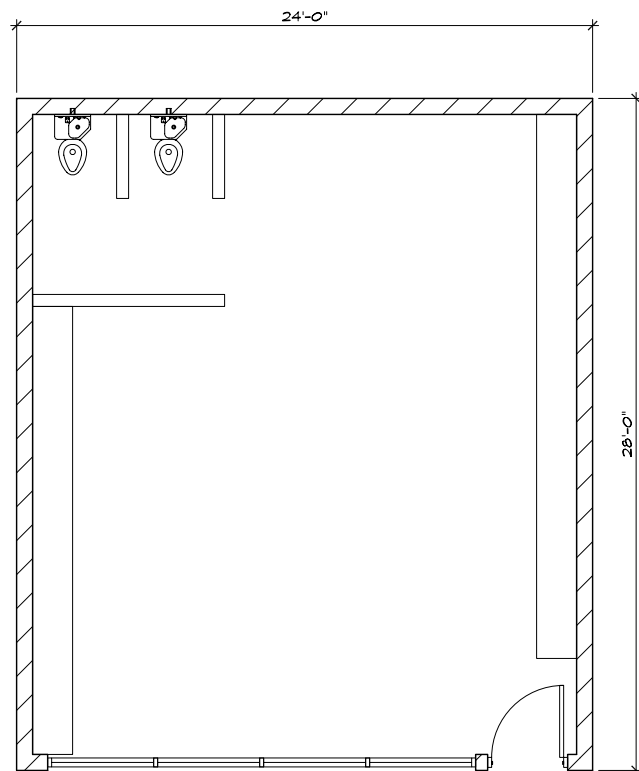

Floor Plan

SYMBOL LEGEND:

- △ Voice Outlet   ▲ Data Outlet   ▲ Voice/Data Outlet   ⊖ Duplex Outlet   △ ISDN Outlet   □ Duress Alarm Outlet





## 4.1 Processing - Room Data Sheet

### 4.1.11 SMALL HOLDING - FEMALE

#### Function

Detainees being transferred to housing or being released from the CDF are held in a Holding Room. Holding Rooms are temporary, secure confinement areas where detainees are generally held for 10 hours or less. Detainees may also be held in these rooms prior to court hearings or medical appointments for groups of four to twelve or greater.



Photograph

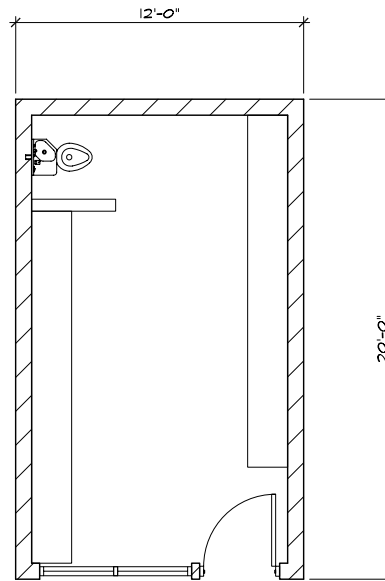

Floor Plan

**SYMBOL LEGEND:**



Voice Outlet



Data Outlet



Voice/Data Outlet



Duplex Outlet



ISDN Outlet



Duress Alarm Outlet





## 4.1 Processing - Room Data Sheet

### 4.1.12 SEGREGATION HOLDING - FEMALE

#### Function

Detainees being transferred to housing or being released from the CDF are held in a Holding Room. Holding Rooms are temporary, secure confinement areas where detainees are generally held for 10 hours or less. Segregation Holding cells are single occupant rooms generally used for separating detainees for disciplinary or medical reasons.



Photograph

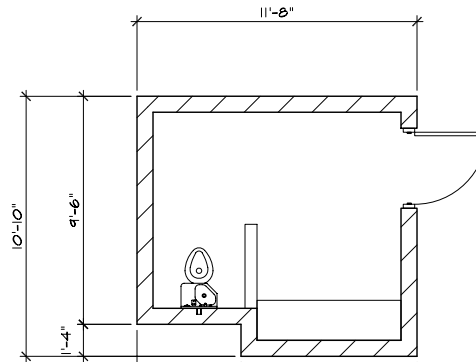

Floor Plan

SYMBOL LEGEND:



Voice Outlet



Data Outlet



Voice/Data Outlet



Duplex Outlet



ISDN Outlet



Duress Alarm Outlet







## 4.1 Processing - Room Data Sheet

### 4.1.13 SPECIAL CASE HOLDING - MALE

#### Function

The Special Case Holding room is used to detain and hold a single detainee that requires special care or protection. These spaces are sometimes referred to as rubber rooms or padded cells.



Photograph

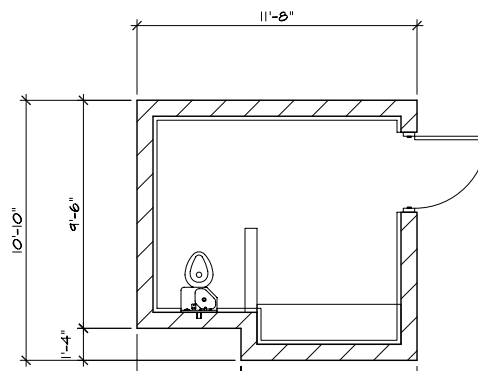

Floor Plan

SYMBOL LEGEND:



Voice Outlet



Data Outlet



Voice/Data Outlet



Duplex Outlet



ISDN Outlet



Duress Alarm Outlet





## 4.1 Processing - Room Data Sheet

### 4.1.14 SPECIAL CASE HOLDING - FEMALE

#### Function

The Special Case Holding room is used to detain and hold a single detainee that requires special care or protection. These spaces are sometimes referred to as rubber rooms or padded cells.



Photograph

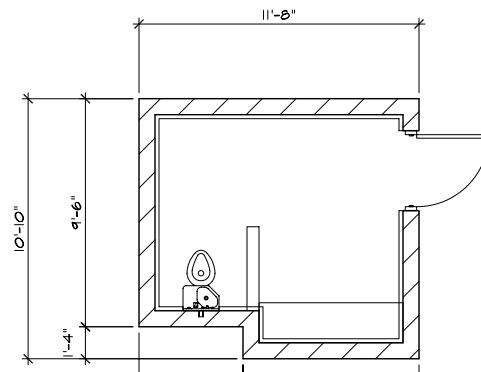

Floor Plan

SYMBOL LEGEND:



Voice Outlet



Data Outlet



Voice/Data Outlet



Duplex Outlet



ISDN Outlet



Duress Alarm Outlet





## 4.1 Processing - Room Data Sheet

### 4.1.15 STAFF TOILET

#### Function

The Staff Toilet is a unisex, single use room located in the Processing area.



Photograph

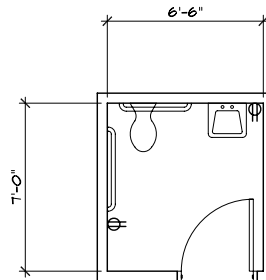

Floor Plan

**SYMBOL LEGEND:**

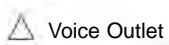

Voice Outlet



Data Outlet



Voice/Data Outlet



Duplex Outlet



ISDN Outlet



Duress Alarm Outlet







4.0 Service Zone

**4.2 Health Service**

(H&HS Operated)

**NOTE: See Health & Human Services Design Standards Publication**



4.0 Service Zone

**4.3 Laundry**

(Contractor Operated)



## 4.3 Laundry

### ORGANIZATIONAL REQUIREMENTS

Detainees must have clothing, bedding and towels that are clean, serviceable and presentable to maintain a hygienic and clean living environment.

Contract laundry services should be investigated for all CDF facilities. The institution launders institutional clothing and linen for the detainees. No dry cleaning services are provided to detainees or staff. Staff is not provided with laundry service. Laundry items are exchanged according to the following schedule:

- Institutional clothing is exchanged twice per week.
- Bed linen is exchanged once per week.
- Towels are exchanged twice per week.

(b)(2)High

Detainee laundry exchange occurs at the housing area. Soiled laundry is collected from the housing areas in carts and brought to a central area for laundering. Clean items are returned to the housing areas when the exchange stock is in need of replenishing. Separate personal laundry facilities may be considered at the housing areas for female housing areas. It is desirable to let female detainees launder their own personal garments.

Soiled laundry must be processed separately from clean laundry, requiring separate areas for each. Laundry is processed by detainees and supervised by security staff. Soiled laundry is brought into one area for sorting and staging, transferred to the washers and dryers, then moved to the clean laundry area to be sorted, mended, and folded. The transportation carts must be cleaned and sorted for return routing.

Mattresses are sanitized in place on the beds. Spare mattresses should be stored at the warehouse. Detainees leave mattresses in housing at the end of their stay.

### OPERATIONAL REQUIREMENTS

The central laundry should be located within the primary secure perimeter in an area restricted from general detainee access. It should be adjacent to the warehouse/receiving dock.





4.0 Service Zone

**4.4 Food Preparation**

(Contractor Operated)



## 4.4 Food Preparation

### ORGANIZATIONAL REQUIREMENTS

The CDF must provide each detainee with three nutritious meals per day, of which at least two must be hot. The meals must be palatable and served at reasonable times.

Food service can be provided to the detainees in one of three (3) ways depending on the facility setting, size, and security risk:

- At a centralized dining location, with detainees moving from their housing area to the dining hall for every meal;
- At the detainees' housing area, with food delivered in carts or in bulk and served in the dayroom; or
- In the cell, with food pre-trayed either at the kitchen or at a sub-kitchen at the housing area.

(b)(2)High

### OPERATIONAL REQUIREMENTS

Food service is located within the primary secure perimeter. The food preparation area must be in the secure zone, restricted from general detainee access. It should be located adjacent to the warehouse/receiving dock to receive food supplies. The unloading dock for the kitchen should be within the secure perimeter and separate from other docks. An inspection area should be included on the dock.

The food storage area must be secure to prevent theft of food products. A glass-enclosed knife workroom with a secure perimeter is required in the kitchen area for detainees using cutting utensils. All knives and sharp utensils must be kept in a locked cabinet. A shadow board is recommended to allow for visual accounting of missing utensils. Separate enclosed rooms are required in the food services area for meat cutting and vegetable preparation.

Separate dining facilities are provided for the staff. The area should be located within the primary secure perimeter adjacent to the food preparation area for ease of service.









## **5.0 Facility Support Zone**

- 5.1 Common Support (ICE Responsibility)
- 5.2 Warehouse/Supply (Contractor Responsibility)
- 5.3 Maintenance/Fleet Operations (Contractor Responsibility)
- 5.4 Central Utility Plant (Contractor Responsibility)



## 5.0 Facility Support Zone

The Facility Support Zone provides support to the facility, though not directly to the detainees, and generally are not accessed or occupied by detainees. It is a zone that is a restricted area limited to staff and service vendors who provide vital services to maintain functions of the facility.

This document covers the ICE Common Support areas within Component 5.1 Common Support. The other components within this zone are typically defined and controlled by the Contract Detention Service Provider and are not covered in this document.

The diagram on the following page illustrates the Facility Support Zone components and the critical adjacency requirements needed for a productive work environment.

The following information has been provided for each of the components:

### **Function**

Describes the overall purpose of the component within the CDF.

### **Critical Workflow Patterns**

Identifies the most critical workflow patterns necessary for efficient staff productivity.

### **Room Data Sheets**

Provides detailed information on all spaces within the components (i.e., function statements, photograph, floor plan, systems, furniture, and equipment)

The components within the Facility Support Zone are listed below:

#### **5.1 Common Support (ICE Operated)**

5.2 Warehouse/Supply (Contractor Operated)

5.3 Maintenance/Fleet Operations (Contractor Operated)

5.4 Central Utility Plan (Contractor Operated)

## 5.0 Facility Support Zone : Organizational Diagram

(b)(2)High



## 5.0 Facility Support Zone - Space Requirements

### SPACE FORECAST MATRIX

The Space Requirements Summary Matrix on the following page, identifies the spaces needed for each of the functional units within the Facility Support Zone. The matrix listed below is also designed to forecast these needs for the planning scenarios.

1. <200 beds
2. 200 - 450 beds
3. 450 - 900 beds
4. 900 - 1,200 beds
5. 1,200 - 1,500 beds
6. 1,500 - 1,800 beds
7. 1,800 - 2,000 beds
8. 2,000 - 3,000 beds

The bed ranges were determined to best represent the capacity range for existing and planned detainee populations.

For each planning scenario, the following information is provided:

- # of Users is the number of persons (staff or detainees) in a given space.
- # of Spaces is the quantity of a given space.
- Space Size NSF is the net square feet or size of a given space.
- Total Size NSF is the number of spaces or quantity of a space times the NSF or size.

The sidebar to the right highlights some of the Space Planning Formulas that are used for calculating areas.

### SPACE CALCULATIONS/DEFINITIONS

The total Net Square Footage is the sum of all net areas of the spaces listed. This number is multiplied by a Net-Gross Factor (an industry factor based on space type) to determine Gross Square Footage (GSF). This factor is intended to account for space such as circulation space, mechanical space, wall thicknesses, etc., that are not programmed space.

- **Net Square Footage (NSF)**  
Total clear floor area within a given room, excluding walls, corridors, mechanical equipment rooms, shafts, stairs, and chases.
- **Gross Square Footage (GSF)**  
Total building area measured from outside face of exterior walls.

### Space Phasing Formulas

#### 5.1 Common Support

- None

#### 5.2 Warehouse//Supply

*Contractor Operated.*

#### 5.3 Maintenance/Fleet Operations

*Contractor Operated.*

#### 5.4 Central Utility Plant

*Contractor Operated.*

## 5.0 Facility Support Zone - Space Requirements Summary

5.0 FACILITY SUPPORT ZONE		ICE CDF STANDARD				< 200 BEDS				200-450 BEDS				450-900 BEDS				900-1200 BEDS				1200-1500 BEDS				1500-1800 BEDS				1800-2000 BEDS				3000 BEDS				Comments
ID#	SPACE NAME	# of	# of	Space Size	Total	# of	# of	Space Size	Total	# of	# of	Space Size	Total	# of	# of	Space Size	Total	# of	# of	Space Size	Total	# of	# of	Space Size	Total	# of	# of	Space Size	Total									
5.1	<b>Common Support</b>																																					
5.1.1	ICE Common Use Mailroom																																					
5.1.2	ICE LAN/Phone MDF Room																																					
5.1.3	ICE LAN/Phone IDF Room																																					
5.2	<b>Warehouse/Supply</b>																																					
	Contractor Space																																					
5.3	<b>Maintenance/Fleet Operations</b>																																					
	Contractor Space																																					
5.4	<b>Central Utility Plant</b>																																					
	Contractor Space																																					

(b) (2) High

5.0 Facility Support Zone

**5.1 Common Support**

(ICE Operated)

Space Requirements

5.1.1 ICE Common Use Mailroom

5.1.2 ICE MDF Room

5.1.3 ICE IDF Room





## 5.1 Common Support - Function

### FUNCTION STATEMENT

The primary function of Common Support is to provide the overall facility with the space and amenities necessary to operate the facility and serve the administrative and detention operations. Support spaces are strategically located to minimize the space requirements and maximize the efficiency of staff and infrastructure systems.

### Design Criteria

#### *Critical Issues*

- ✓ Central location
- ✓ Involvement and guidance from the ICE IT staff

#### *Special Requirements*

- ✓ ICE Cabling Standards

#### *Space Requirements*

#### **5.1 COMMON SUPPORT**

- 5.1.1 ICE Common Use Mailroom
- 5.1.2 ICE MDF Room
- 5.1.3 ICE IDF Room

5.1 Common Support : Organizational Diagram

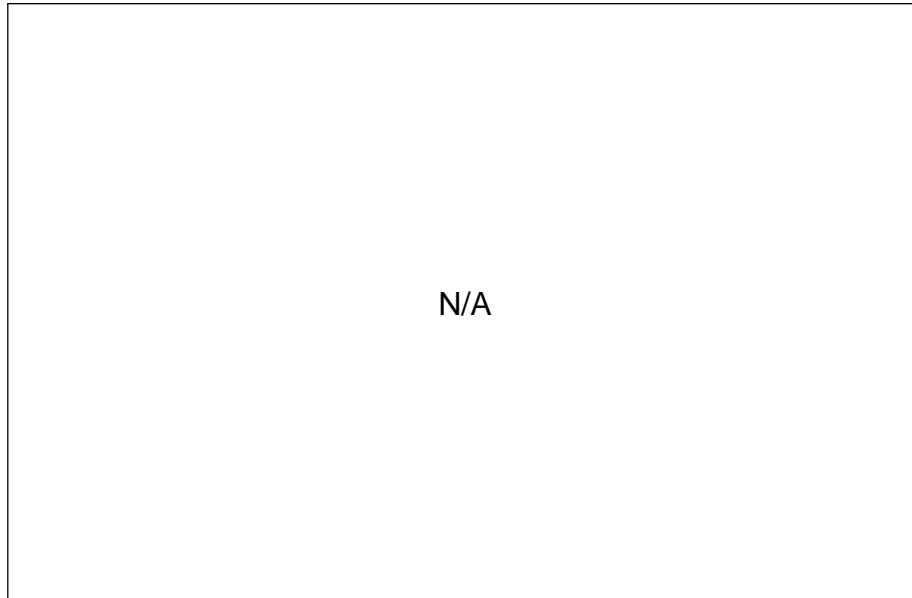

(b)(2)High



## 5.1 Common Support - Room Data Sheet

### 5.1.1 ICE COMMON USE MAILROOM

#### Function

The ICE Common Use Mailroom serves all ICE staff and agents. All mail is sent, received, and distributed from this room

The ICE Common Use Mailroom shall be centrally located and adjacent/close to the ICE Administration.

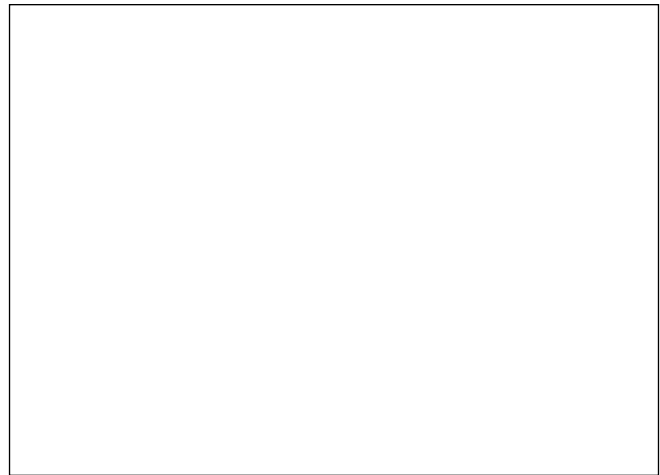

Photograph

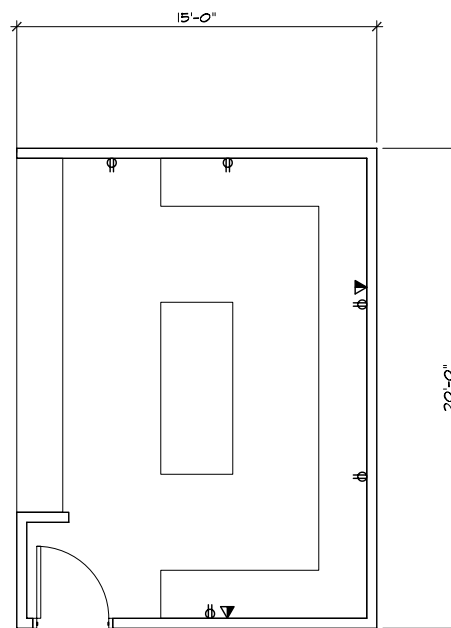

Floor Plan

**SYMBOL LEGEND:**



Voice Outlet



Data Outlet



Voice/Data Outlet



Duplex Outlet



ISDN Outlet



Duress Alarm Outlet





## 5.1 Common Support - Room Data Sheet

### 5.1.2 ICE LAN/PHONE MDF ROOM

#### Function

The ICE Main Distribution Frame Room co-locates ICE LAN and phone services to the facility. This room will house one LAN server for ICE and OPLA and a second server for Public Health Services. These facilities (CDF's) must be designated as multi-tenant facilities when planning and designing this space. Contractor LAN/phone requirements must not be accommodated in this room. If contractor requires LAN/phone space, it must be in a separate room.

The LAN/Phone MDF room shall be centrally located within the ICE Administration area. The LAN/Phone MDF room shall not be horizontally or vertically adjacent to building mechanical rooms, electrical rooms or toilet/shower areas. Fire suppression systems serving this space shall be separately zoned, pre-action systems and shall have audible and visual alarms for smoke and heat.

#### Specific Electrical Requirements

Five isolated, dedicated 120 volt, 20 Amp circuits with NEMA 5-20 quad receptacles shall be installed; two in the vicinity of the data rack and two in the vicinity of the telephone switch. If the compound has a generator, these four outlets should be connected to the generator. Each wall should have a standard duplex receptacle outlet. The duplex receptacle outlets are not required to be isolated, dedicated, or connected to a generator. One 120 volt, 20 Amp circuit with NEMA L5-20 locking receptacle is required in the vicinity of the server cabinet.

Certified electrical ground and bus required in each closet and connected to a dedicated building ground that is compliant with; the ANSI/TIA/EIA 607, the Motorola R56 Standards and Guidelines, and the Nortel Meridian 1 PBX Option 11C Environmental and Power Requirements document. If any of these documents are in conflict, then, as a general principle, the more stringent requirement shall apply. This ground is for communications equipment only.

#### ICE IT Specific Performance Requirements

- ✓ Must have capability to monitor detainee phone calls
- ✓ All station cable (data & voice) shall be 4 pair (see cable standard)
- ✓ Facility shall be designated as a multi-tenant facility when permit is sought
- ✓ Below slab conduit between MDF & EIOR as well as MDF & IDF's
- ✓ (2) 4" conduits + pull strings from pedestal to each EOIR, PHS & ICE MDS (demarcation points)



Photograph

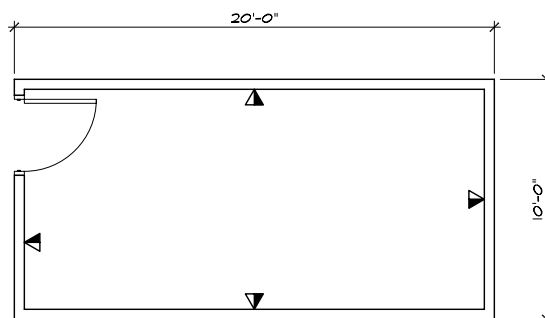

Floor Plan

Increase width of room to 15' for facilities of 1,500 detainees or more.

- ✓ All receptacles shall be isolated ground and shall be on the emergency generator
- ✓ 3-sided cable tray required; provide for 50% access capacity or space for stacked tray for future growth. All V/D cable tray must cross electrical at 90° or be at least 12" away
- ✓ UPS for data provided by ICE within equipment
- ✓ UPS for voice - 100% for two hours
- ✓ Every voice/data outlet shall have four cables (4 four pair cables)
- ✓ Every office shall have two voice/data outlets; every cubicle shall have one voice/data outlet
- ✓ Every voice/data outlet requires an adjacent power outlet
- ✓ All conduit shall include an additional pull string
- ✓ Home run conduit not preferred unless code required
- ✓ Outlet face plates for ICE shall be different color than those of the facility operator
- ✓ Cable runs & routing shall consider safety & security
- ✓ V/D required at ICE VTC locations
- ✓ Furniture (desks, credenzas) must have access to wall outlets through privacy screen

SYMBOL LEGEND:

- Voice Outlet
- Data Outlet
- Voice/Data Outlet
- Duplex Outlet
- ISDN Outlet
- Duress Alarm Outlet





## 5.1 Common Support - Room Data Sheet

### 5.1.3 ICE LAN/PHONE IDF ROOM

#### Function

The Intermediate Distribution Frame Room co-locates LAN and phone. ICE IDF Rooms are required if the data station cable exceeds 250 feet from MDF outlet to IDF outlet.

The ICE IDF Room shall be centrally located and not horizontally or vertically adjacent to building mechanical rooms, electrical rooms or toilet/shower areas.

Fire suppression systems serving this space shall be separately zoned, pre-action systems and shall have audible and visual alarms for smoke and heat.

#### Specific Electrical Requirements

Five isolated, dedicated 120 volt, 20 Amp circuits with NEMA 5-20 quad receptacles shall be installed; two in the vicinity of the data rack and two in the vicinity of the telephone switch. If the compound has a generator, these four outlets should be connected to the generator. Each wall should have a standard duplex receptacle outlet. The duplex receptacle outlets are not required to be isolated, dedicated, or connected to a generator. One 120 volt, 20 Amp circuit with NEMA L5-20 locking receptacle is required in the vicinity of the server cabinet.

Certified electrical ground and bus required in each closet and connected to a dedicated building ground that is compliant with; the ANSI/TIA/EIA 607, the Motorola R56 Standards and Guidelines, and the Nortel Meridian 1 PBX Option 11C Environmental and Power Requirements document. If any of these documents are in conflict, then, as a general principle, the more stringent requirement shall apply. This ground is for communications equipment only.

#### ICE IT Specific Performance Requirements

- ✓ Must have capability to monitor detainee phone calls
- ✓ All station cable (data & voice) shall be 4 pair (see cable standard)
- ✓ Facility shall be designated as a multi-tenant facility when permit is sought
- ✓ Below slab conduit between MDF & EIOR as well as MDF & IDF's
- ✓ (2) 4" conduits + pull strings from pedestal to each EOIR, PHS & ICE MDS (demarcation points)
- ✓ 3-sided cable tray required; provide for 50% access capacity or space for stacked tray for future growth. All V/D cable tray must cross electrical at 90° or be at least 12" away
- ✓ UPS for data provided by ICE within equipment



Photograph

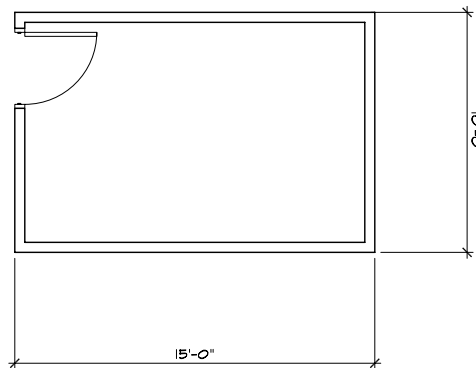

Floor Plan

- ✓ All receptacles shall be isolated ground and shall be on the emergency generator
- ✓ UPS for voice - 100% for two hours
- ✓ Every voice/data outlet shall have four cables (4 four pair cables)
- ✓ Every office shall have two voice/data outlets; every cubicle shall have one voice/data outlet
- ✓ Every voice/data outlet requires an adjacent power outlet
- ✓ All conduit shall include an additional pull string
- ✓ Home run conduit not preferred unless code required
- ✓ Outlet face plates for ICE shall be different color than those of the facility operator
- ✓ Cable runs & routing shall consider safety & security
- ✓ V/D required at ICE VTC locations
- ✓ Furniture (desks, credenzas) must have access to wall outlets through privacy screen

**SYMBOL LEGEND:**

- Voice Outlet
- Data Outlet
- Voice/Data Outlet
- Duplex Outlet
- ISDN Outlet
- Duress Alarm Outlet







5.0 Facility Support Zone

**5.2 Warehouse/Supply**

(Contractor Operated)



## 5.2 Warehouse/Supply

### ORGANIZATIONAL REQUIREMENTS

The warehouse is used for storage of office supplies, paper goods, cleaning/janitorial supplies, laundry and linen supplies, personal hygiene supplies, office furniture, extra food supplies and emergency supplies. This component is responsible for maintaining an inventory of supplies and ordering replacement stock as required.

### OPERATIONAL REQUIREMENTS

Warehouse/Supply may be placed in one of the following zones:

- **Secure zone restricted from general detainee access.** This allows frequent movement of materials to their destination with minimal crossing of the secure perimeter. Warehouses located in the secure zone should have an inspection area located near the loading dock.
- **The non-secure zone by the vehicular entrances.** This location allows the warehouse/supply to serve other institutions located nearby. This location does not allow the use of detainee labor and consequently does not require a secure service yard.

(b)(2)High

Warehouse/Supply should be located adjacent to laundry and maintenance for receipt and distribution of supplies.





5.0 Facility Support Zone

**5.3 Maintenance/Fleet Operations** (Contractor Operated)



## 5.3 Maintenance/Fleet Operations

### **ORGANIZATIONAL REQUIREMENTS**

The CDF provides its own facility maintenance. Generally speaking, for security reasons, maintenance of the facility is not contracted to outside parties, except for HVAC work and other specialized trades. Staffing should provide sufficient shop capability for upkeep, including electrical and electronics, plumbing, carpentry, and paint.

The staff level for maintenance depends on the age of the facility as well as the size, and the amount of work contracted to service vendors. As a general guideline, the facility should have one mechanic for every 80 detainees or 2,800 square meters (30,000 square feet). This number may be increased if the maintenance staff has engaged capital improvement projects in addition to preventative maintenance.

(b)(2)High

### **OPERATIONAL REQUIREMENTS**

The maintenance component may be located inside or outside the secure perimeter. If located outside, there is less control required inside the shop, though mechanics will be required to make frequent trips through the sallyport for service orders. It should be adjacent to the vehicle service area and sallyport for receipt and storage of bulk maintenance goods.

Maintenance located outside the secure perimeter can more easily serve other institutions at the site.







5.0 Facility Support Zone

**5.4 Central Utility Plant**

(Contractor Operated)



## 5.4 Central Utility Plant

### ORGANIZATIONAL REQUIREMENTS

The spaces and equipment required for heating, air conditioning, power, emergency power, communications, water service and fire suppression must be given special planning consideration to assure security and continuity of operation, even during emergency or equipment failure. Adequate consideration must also be given to the possible impact of facility expansion and overcrowding on the physical plant and infrastructure.

The Central Plant and facility infrastructure will include the following elements:

- Central Plant, including central mechanical equipment for building heating and cooling, water service, water heating and conditioning, and fire suppression entrance and pumps.
- Electric power service, emergency generators and fuel storage.
- Distribution closets for electrical and communications systems, local fan rooms for delivery of building heating and cooling; and in larger campus type institutions, water heating may also be decentralized.
- Accessible plumbing service chases throughout the facilities.

(b)(2)High

The user should refer to the Facility Standards of the Public Buildings Service for general recommendations among central energy equipment alternatives.

### OPERATIONAL REQUIREMENTS

The central physical plant area should be on an external wall with overhead rolling doors and/or removable panels for accessibility for long-term maintenance of central energy equipment. Regular access should be by means of eight-foot high double doors. The central plant should be equipped with a rack and pulley system for moving equipment. As a rule of thumb, provide central plant space at a ratio of 5 percent of the total building area.

The primary electric power service will enter the facility at the Central Plant. A separate space will be required for the main switchgear, transformation equipment, and the distribution panelboards. The stand-by generator for emergency power may be

located in the electrical section of the Central Plant or a unit with integral weather enclosure will be located just outside. Primary fuel storage should be outside.

The telecommunications systems should have centralized equipment room for PBX, computing equipment, video switches, door control systems, electronic monitoring systems, and radio communication systems. As a rule of thumb, provide equipment room area equal to one percent of the total building area.





## Technical Requirements



## Technical Requirements

### HANDICAPPED ACCESSIBILITY

Accommodations for the handicapped shall be provided in accordance with the Uniform Federal Accessibility Standards (UFAS), which identifies standards for complying with accessibility provisions contained in the Architectural Barriers Act, 42 U.S.C. 4251-4157, and/or applicable local codes, regulations and laws.

### FIRE PROTECTION AND LIFE SAFETY

Fire Protection and Life Safety requirements shall be in accordance with local statutes. Notwithstanding this provision, the requirements shall comply with National Fire and Protection Association, National Fire Codes, Occupational Safety and Health Administration standards, and applicable local and/or national codes.

### ELECTRICAL

The installation of two isolated ground duplex outlets with a limit of four isolated ground outlets per circuit shall be provided per 125 square feet of space. For each position, there shall be one quadruplex outlet (or equivalent). All power wiring shall be in floor, wall, or ceilings. No power poles are allowed. Panelboards shall have spare circuit spaces, which shall be defined by EOIR with each space request.

One electrical closet per 10,000 square feet shall be provided with sufficient ventilation. Notwithstanding this provision, a minimum number and location of outlets required by local and/or national codes shall be adhered to.

### MECHANICAL

Mechanical requirements shall be provided in accordance with the American Society of Heating, Refrigeration and Air-Conditioning Engineers (ASHRAE) Handbook and Standards.

### PHYSICAL SECURITY

Physical security guidelines have been established for EOIR to afford an adequate level of uniform protection. Each guideline is designed to achieve a separate security objective. All guidelines are mutually inclusive and the absence of any component, will result in a security vulnerability. These guidelines include the following:

#### Public Access Control

Agency requires contiguous space. Space will be

accessible to the public while providing adequate security measures, due to the highly sensitive and critical filing and archiving system and for increased personnel security. Unique building siting and/or security issues and concerns may also preclude building occupancy.

Visitors are required to pass through a public access control (PAC) point or screening area comprised of a guard(s), a magnetometer, and/or X-ray equipment. Emergency exits shall be accessible to the public.

**Employee Entrances:** Consideration shall be given to establishing one or more separate employee entrances.

#### Perimeter Security

Perimeter Security is the outer security boundary which surrounds the secured area, and provides the first level of control and protection. The perimeter security guidelines will contain the following minimum components:

**Site Perimeter:** The perimeter of the CDF property shall be delineated by a minimum 6 feet (1800 mm) high non-secure chain link fence with single barbed wire outrigger, or in an urban setting, a 6' (1800 mm) high concrete masonry fence to block views. This fencing is intended to clearly identify the limitations of the property to the general public. Appropriate fence-mounted signage shall identify US Government Property and specify the penalties for crossing the fence without authorization. A buffer zone of 200 feet (61 meters) shall be provided between the perimeter fence and the primary facility perimeter in order to diminish visual contact between the public and secure sides. In urban areas, where the buffer zone or a separate site perimeter is not attainable, other measures for the security and protection of the facility must be considered. At the site perimeter, maintain openings in the chain link fence for vehicular site access.

**Pedestrian Sallyport:** Where separate pedestrian access through the primary facility perimeter is provided, gates shall be interlocked and under CCTV surveillance from the central control room. The interlocked gates shall be operated from the central control room.

**Walls:** Slab to slab walls; either concrete block with drywall or plaster finish, or metal stud with drywall and fiberglass insulation.

The wall surrounding the Ballistic Transaction Window (BTW) will be reinforced with 9-11 gauge steel mesh lathe. Ballistic-rated walls may be considered where appropriate.

**Wall Construction:**

**“High” security walls** shall be constructed using one of the following methods:

Concrete masonry unit walls shall be a minimum nominal 8” (200 mm) wide units reinforced with #4 (No. 13 metric) vertical reinforcing bar at 8” (200 mm) on center. All cells of concrete masonry units shall be fully grouted with 3,000 psi (21 Mpa) grout.

Precast concrete panel walls shall be a minimum nominal 4” (100 mm) wide, minimum strength of 5,000 psi (35 Mpa) and reinforced with minimum W4 (MW26) welded wire fabric at 4” (100 mm) on center in both directions, conforming to ASTM A185. Cast-in-place concrete walls shall be a minimum 6” (150 mm) wide, minimum strength of 3,000 psi (21 Mpa) reinforced with #4 (No. 13 metric) reinforcing bars at 8” (200 mm) on center in one direction. Cast-in-place concrete walls that are less than 6” (150 mm) wide, but no less than 4” (100 mm) wide shall have a minimum strength of 5,000 psi (35 Mpa) reinforced with W4 (MW26) welded wire fabric at 4” (100 mm) on center in both directions.

Steel wall panels shall be 0.093 in. (12 gage) minimum thickness A-60 galvanized steel conforming to ASTM A 653-CS requirements. All structural or stiffening members shall be 0.058 in. (16 gage) minimum thickness A-60 galvanized steel conforming to ASTM A 653-LFQ requirements. All structural tubing shall be 0.115 in. (11 gage) minimum thickness steel conforming to ASTM A 653-CS and ASTM A-525, G-90 galvanized requirements.

**“Medium” security walls** shall be constructed using one of the following methods:

Concrete masonry unit walls shall be a minimum nominal 8” (200 mm) wide units reinforced with #4 (No. 13 metric) vertical reinforcing bar at 16” (400 mm) on center. All cells of concrete masonry units shall be fully grouted with 3,000 psi (21 Mpa) grout.

Precast concrete panel walls shall be a minimum nominal 4” (100 mm) wide, minimum strength of 5,000 psi (35 Mpa) and reinforced with minimum W4 (MW26) welded wire fabric at 4” (100 mm) on center in both directions, conforming to ASTM A185.

Cast-in-place concrete walls shall be a minimum 6” (150 mm) wide, minimum strength of 3,000 psi (21 Mpa) reinforced with #4 (No. 13 metric) reinforcing bars at 8” (200 mm) on center in one direction. Cast-in-place concrete walls that are less than 6” (150 mm) wide, but no less than 4” (100 mm) wide shall have a minimum strength of 5,000 psi (35 Mpa) reinforced with W4 (MW26) welded wire fabric at 4” (100 mm) on center in both directions.

Steel wall panels shall be 0.093 in. (12 gage) minimum thickness A-60 galvanized steel conforming to ASTM A 653-CS requirements. All structural or stiffening members shall be 0.058 in. (16 gage) minimum thickness A-60 galvanized steel conforming to ASTM A 653-LFQ requirements. All structural tubing shall be 0.115 in. (11 gage) minimum thickness steel conforming to ASTM A 653-CS and ASTM A-525, G-90 galvanized requirements.

**“Low” security walls** shall be constructed using one of the following methods:

Concrete masonry unit walls shall be a minimum nominal 6” (150 mm) wide units. All cells of concrete masonry units shall be fully grouted with 3,000 psi (21 Mpa) grout.

Gypsum wallboard walls (partitions) shall be a minimum 5/8” (16 mm) thick gypsum wall board on galvanized steel mesh panels 0.048” (1.2 mm) thick, 41 lbs/sf (200 kg/m) on each side of minimum 20 gauge metal studs at 16” (400 mm) on center. “High”, “medium”, and “low” security walls must be constructed continuously from a security floor to a secure ceiling. The secure ceiling may be either a secure roof deck or a cap of secure construction built below the roof deck in high bay areas. The continuity of the secure wall construction must be maintained by tying the wall reinforcing into the secure floor and ceiling construction. When this cannot be accomplished, a continuous #4 (No. 13) reinforcing bar shall be cast no more than 1 1/2” (38 mm) from the edge of the concrete unit where it meets other concrete or masonry members.

**Roofing / Ceiling Construction:**

**“High” security roof/ceiling** construction shall be constructed of the following:

Cast-in-place concrete slabs shall be a minimum of 6” (150 mm) thick, 3,000 psi (21 Mpa) concrete with #4 (No. 13 metric) reinforcing bars at 8” (200 mm) on center in one direction. Cast-in-place concrete



slabs that are less than 6" (150 mm) thick, but no less than 4" (100 mm) thick shall have a minimum strength of 5,000 psi (35 Mpa) reinforced with W4 (MW26) welded wire fabric at 4" (100 mm) on center in both directions.

Composite metal deck shall be a minimum of 4" (100 mm) total depth, 3,000 psi (21 Mpa) concrete, #4 (No. 13 metric) bars 8" (200 mm) on center in one direction. Prestressed concrete tees or hollow core slabs shall have a concrete topping to give adequate cover for #4 (No. 13 metric) bars 8" (200 mm) on center in one direction.

Solid concrete planks shall have #4 (No. 13 metric) reinforcing bars at 8" (200 mm) on center in one direction. No concrete topping is required.

Metal acoustical ceiling panel shall be maximum security double skin metal 0.125" (3.2 mm) thick with perforations.

Metal roof decks shall be a minimum of 12 gauge. No additional reinforcing is required, however the deck must be securely tied to the "high" security walls.

**"Medium" security roof/ceiling** construction shall be constructed of the following:

Cast-in-place concrete slabs shall be a minimum of 6" (150 mm) thick, 3,000 psi (21 Mpa) concrete with #4 (No. 13 metric) reinforcing bars at 16" (400 mm) on center in one direction. Cast-in-place concrete slabs that are less than 6" (150 mm) thick, but no less than 4" (100 mm) thick shall have a minimum strength of 5,000 psi (35 Mpa) reinforced with W4 (MW26) welded wire fabric at 4" (100 mm) on center in both directions.

Composite metal deck shall be a minimum of 4" (100 mm) total depth, 3,000 psi (21 Mpa) concrete, #4 (No. 13 metric) bars 16" (400 mm) on center in one direction.

Prestressed concrete tees or hollow core slabs shall have a concrete topping to give adequate cover for #4 (No. 13 metric) bars 16" (400 mm) on center in one direction.

Solid concrete planks shall have #4 (No. 13 metric) reinforcing bars at 16" (400 mm) on center in one direction. No concrete topping is required.

Metal acoustical ceiling panel shall be maximum security double skin metal 0.125" (3.2 mm) thick with perforations.

Metal roof decks shall be a minimum of 12 gauge. No additional reinforcing is required, however the deck must be securely tied to the "medium" security walls.

**"Low" security roof/ceiling** construction shall be constructed of the same level of security as "Medium" security described above.

## Reception Areas

**Ballistic Transaction Windows:** A ballistic transaction window (BTW), with a Level 3 ballistic rating (.44 Magnum) and incorporating a Natural Voice Channel and/or the indicated Level 3-rated center speech device, shall be installed.

**The Wall** surrounding the BTW will be reinforced with 9-11 gauge steel mesh lathe. Ballistic-rated walls may be considered where appropriate.

**The Door** leading from the reception area and/or waiting room into the staff area (generally, adjacent to the BTW) will be of solid wood construction and incorporate a keyed lockset. The door will also incorporate hardware which will enable the receptionist to remotely unlock the door by pressing a button at or near the reception desk. It shall also include a door closer and a peephole

## Other Office Areas

**Conference Rooms:** For conference rooms with power, voice, and data located at the center of the room (in the floor), boxes shall be recessed flush with the finished floor surface material.

All conference rooms shall have video teleconference capability. Each room will require six (6) RJ 11/RJ 45 receptacles. These may be combined in two duplex boxes. However, these must be adjacent to one another and they must be adjacent to one quad electrical outlet. ICE will determine final location during design.

**ADP Rooms:** The doors of ADP rooms will be secured with a push button (Trilogy) lock.

**File Rooms:** To control access, the room shall have full height walls and the door will be secured with a lock or access control device.

**Furniture:** Furniture shall be provided and installed as indicated herein. All desks and credenzas shall be equipped with privacy screens/panels with knock-out grommets for cabling.



**Restrooms:** Restrooms shall be incorporated within court staff areas, one male and one female minimum. Doors to restrooms located outside court space shall be secured by locking hardware as specified by the EOIR Security Office, and incorporate a key bypass for building management access.

**Evacuation Routes:** Floor plans and/or maps of evacuation routes for bomb threats, fires and other emergencies shall be strategically posted within office areas.

## **Safety Systems**

Safety systems shall be designed to meet the minimum requirements specified by the Occupational Safety and Health Administration (OSHA), for safe emergency egress. These requirements shall be coordinated with CDF facility security and safety requirements. This system includes the following.

1. Panic release bars installed on all main entrance doors and stairwell doors that sound audible alarm when opened, as per Security Specifications.
2. Electronic door strikes that are used on fire egress doors are designed to fail-safe (unlock) in the event of a power failure or emergency.
3. Fail-safe capability on selected door locks are to work in conjunction with smoke and fire alarms in those instances where emergency egress is restricted without such a configuration.
4. The use of fire certified or safety approved products.



## 5. APPENDIX

Reference Publications

Acronyms and Abbreviations

ICE Structured Cable Plant Standard, Version 5.1



## Reference Publications

### REFERENCE DOCUMENTS

The Offeror (Contractor) will conform their facility design to the following standards, at a minimum, plus any additional applicable standards that may be pertinent to the location where the facility is intended to be built. The Offeror will be solely responsible for complying with these standards and code requirements. Failure of ICE to identify particular construction code standards that are pertinent to a particular site will not relieve the Offeror of the responsibility of meeting those criteria.

American Correctional Association (ACA)

Standards for Adult Local Detention Facilities  
3rd Addition

American Correctional Association (2002 Standards  
Supplement)

International Building Code, 2003

National Fire Protection Association

Life Safety Code 101, current edition

U.S. Department of Justice  
Immigration and Naturalization Service (Legacy)  
Service Processing Center Design Guide

Joint Commission on Accreditation of Healthcare  
Organizations (JCAHO)

National Commission on Correctional Healthcare  
(NCCHC)

Occupation, Safety and Health Association (OSHA)

ICE Detention Standards

USICE Structured Cable Plant Standard

ANSI/TIA/EIA - 526-14, Optical Power Loss  
Measurement of Installed Multimode Fiber Cable Plant  
- OFSTP-14

ANSI/TIA/EIA - 568-B.1, Commercial Building  
Telecommunications Cabling Standard Part 1: General  
Requirements

ANSI/TIA/EIA - 568-B.2, Commercial Building  
Telecommunications Cabling Standard Part 2: Balanced  
Twisted-Pair Cabling Components

ANSI/TIA/EIA - 568-B.3, Commercial  
Telecommunications Cabling Standard Part 3: Optical  
Fiber Cabling Components

ANSI/TIA/EIA - 568-A, Commercial Building Standard  
for Telecommunications Pathways and Space

ANSI/TIA/EIA - 598, Optical Fiber Cable Color Coding

ANSI/TIA/EIA - 606-A, Administration Standard for  
Telecommunications Infrastructure of Commercial  
Building

ANSI/TIA/EIA - 607, Commercial Building Grounding  
and Bonding Requirements for Telecommunications

ANSI/TIA/EIA - 758, Customer-Owned Outside Plant  
Telecommunications Cabling Standard

### RELATED DOCUMENTS

Uniform Federal Accessibility Standards, 1988

Americans with Disabilities Act (ADA), Title III

American Society for Testing and Materials,  
current standards

Underwriters Laboratories, Inc.

American National Standards Institute, Inc.

National Association of Architectural Metal  
Manufacturers

Hollow Metal Manufacturers Association,  
Standard 863-96

H.P. White Laboratory, Inc. HPW-TP-0500.02

WMFL Physical Attack Test

**ACRONYMS AND ABBREVIATIONS**

ACA	American Correctional Association	manuf.	manufacturer
ADA	Americans with Disabilities Act	ME	medical Equipment
AHSA	Assistant Health Services Administrator	MRT	Medical Records Technician
BOP	Bureau of Prisons	NCCHC	National Commission on Correctional Health Care
BP	blood pressure	NFPA	National Fire Protection Association
BI	built-in	NP/PA	Nurse Practitioner/Physicians Assistant
CCTV	closed circuit television	NSF	Net Square Feet
CD	Clinical Director	OSHA	Occupation, Safety and Health Association
CDF	Contract Detention Facility	OTC	over-the-counter medications
IBC	International Building Code	P	primary
CBP	Customs and Border Protection	PA	public address system
DHS	U.S. Department of Homeland Security	PDT	Project Development Team
DRO	Detention and Removal Office	PI	performance improvement
EOIR	Executive Office of Immigration Review	pk	package
F	furniture	S	secondary
Fab.	Fabricators	SHU	Secured Housing Unit
FDA	U.S. Food and Drug Administration	SPC	Service Processing Center
Flr.	floor	SSU	Short Stay Unit
GFI	ground fault interrupter	TB	tuberculosis
GSF	Gross Square Feet	RHIA	Registered Health Information Administrator
HCP	Health Carre Program	RN	Registered Nurse
H.M.	hollow metal	TBD	to be determined
HS	Health Services	USF	Usable Square Feet
HSA	Health Services Administrator	USPHS	United States Public Health Service
Ht.	height	VCT	vinyl composition tile
HVAC	heating, ventilating and air conditioning	w/	with
ICE	Bureau of Immigration and Customs Enforcement	Wt.	weight
IGSA	Inter-governmental service agreements		
INS	(Legacy) Bureau of Immigration and Naturalization Services		
DIHS	Division of Immigration Health Services		
DHHS	U.S. Department of Health and Human Services		
HRSA	Health Resources Services Administration		
JCAHO	Joint Commission on Accreditation of Healthcare Organizations		
LAN	local area network		
Lav.	lavatory		
LVN	Licensed Vocational Nurse		
qt.	quart		



## **ICE Structured Cable Plant Standard**



# U.S. Immigration and Customs Enforcement

## Structured Cable Plant Standard

Version 5.1

Office of Chief Information Officer  
IT Service Delivery  
Deployment Services Branch

---

# CONTENTS

<b>1.0</b>	<b>INTRODUCTION.....</b>	<b>1</b>
1.1	Purpose.....	1
1.2	Background.....	1
1.3	Scope.....	1
1.3.1	System.....	1
1.3.2	Documentation.....	2
<b>2.0</b>	<b>NETWORK CABLE PLANT OBJECTIVES .....</b>	<b>2</b>
<b>3.0</b>	<b>STRUCTURED CABLE PLANT DESIGN .....</b>	<b>2</b>
3.1	Structured Cable Plant Approach.....	3
3.2	Horizontal Workstation Cabling.....	3
3.3	Workstation Outlets .....	6
3.4	Backbone Cabling.....	8
<b>4.0</b>	<b>SPECIFICATIONS.....</b>	<b>10</b>
4.1	Horizontal Cables.....	10
4.2	Information Management Outlets .....	10
4.3	Backbone Cabling.....	11
4.3.1	Intra-Building Fiber Optics.....	11
4.3.2	Inter-Building Fiber Optics.....	12
4.4	Patch Cables (Workstation and Patch Panel).....	12
4.5	Patch Panels .....	12
4.6	Equipment Racks .....	13
4.7	Cabinets and Swing Gates .....	13
<b>5.0</b>	<b>COPPER CABLE INSTALLATION SPECIFICATIONS.....</b>	<b>14</b>
5.1	Horizontal Cables.....	14
5.2	Patch Cables (Workstation) .....	15
5.3	Patch Cables (Panel) .....	15
5.4	Copper Cable Termination.....	16
<b>6.0</b>	<b>INSTALLATION OF OPTICAL FIBER CABLES AND CONNECTORS .....</b>	<b>17</b>
6.1	Fiber Horizontal Workstation Cable.....	17
6.2	Backbone Fiber Cable.....	17
6.3	Optical Fiber Cable Jacket.....	17
6.4	Optical Fiber Connector.....	17
6.5	Optical Fiber Cable Termination .....	18
<b>7.0</b>	<b>FACEPLATE CONFIGURATION .....</b>	<b>18</b>
<b>8.0</b>	<b>PATCH PANELS.....</b>	<b>18</b>
8.1	Copper Patch Panels .....	18
8.2	Fiber Optic Patch Panels.....	19
<b>9.0</b>	<b>EQUIPMENT RACK.....</b>	<b>19</b>
<b>10.0</b>	<b>GROUNDING .....</b>	<b>23</b>



<b>11.0</b>	<b>CABLE LADDERS AND FASTENERS .....</b>	<b>24</b>
<b>12.0</b>	<b>ADMINISTRATION AND LABELING CONVENTIONS.....</b>	<b>24</b>
12.1	Building Designation .....	24
12.1.1	Floor.....	24
12.1.2	Wiring Closets .....	24
12.1.3	Cable Numbers.....	25
12.2	Information Management Outlet.....	25
12.3	Intra and Inter-Building Backbone Cables .....	25
12.4	Patch Panel Patch Cables .....	26
<b>13.0</b>	<b>TEST AND DOCUMENTATION PROCEDURES .....</b>	<b>26</b>
13.1	Testing of Installed Copper Cable .....	26
13.2	Testing of Optical Fiber Cables .....	27
<b>14.0</b>	<b>BUILDING PATHWAYS, CONDUIT, AND CLOSETS .....</b>	<b>28</b>
14.1	Closet Specifications (MDF and RWC) .....	28
14.1.1	General Requirements.....	28
14.1.2	Environmental.....	28
14.1.3	Construction.....	29
14.2	Conduits .....	30
<b>15.0</b>	<b>DOCUMENTATION.....</b>	<b>30</b>
15.1	Letter of Certification .....	31
15.2	Implementation Report .....	31
15.3	Detailed Materials List.....	31
15.4	Cable Plant Test Certification Letter .....	32
15.5	Copper Cable Test Results.....	32
15.6	Fiber-optic backbone Cable Test Results .....	32
15.7	As-Built Site Drawings .....	32

**ATTACHMENT A—GLOSSARY**

**ATTACHMENT B—SAMPLE LETTER OF CERTIFICATION**

**ATTACHMENT C—SAMPLE CONTRACTOR INFORMATION FORM**

**ATTACHMENT D—SAMPLE IMPLEMENTATION REPORT**

**ATTACHMENT E—SAMPLE DETAILED MATERIALS LIST**

**ATTACHMENT F—SAMPLE CABLE TEST CERTIFICATION LETTER**

## EXHIBITS

Exhibit 1: Typical Office Cable Planning.....	4
Exhibit 2: Workstation (IMO) Faceplates without Optical Fiber Cables, Single Gang .....	6
Exhibit 3: Workstation (IMO) Faceplates without Optical Fiber Cables, Double Gang.....	7
Exhibit 4: Workstation Faceplate with Optical Fiber Cables .....	7
Exhibit 5: Backbone Fiber Distribution.....	9
Exhibit 6: 5e Cable Specifications.....	10
Exhibit 7: Typical Rack/Cabinet Enclosures .....	14
Exhibit 8: T568A Pair/Pin Assignments.....	16
Exhibit 9: Consolidated Closet, Voice and Data .....	20
Exhibit 10: Single Rack, Data Only (Voice and Data Not Consolidated).....	21
Exhibit 11: Consolidated Closet, Voice and Data; Share Single Rack (less than 72 locations)..	22
Exhibit 12: Multimode Fiber Cable Specifications .....	27
Exhibit 13: Single Mode Fiber Cable Specifications.....	27

## 1.0 INTRODUCTION

### 1.1 Purpose

This document has been prepared for the Immigration and Customs Enforcement (ICE) with the specific purpose of setting standards for structured cable plants in support of Local Area Network (LAN) and voice connectivity that will function as follows:

- Accommodate the functional requirements of present and future information services.
- Support a multi-product and multi-vendor environment.
- Facilitate the planning and installation of cabling systems that will support the diverse communication needs of building occupants.
- Ensure uniformity of structured wiring and hardware infrastructure installations in all ICE facilities.

The primary focus of this document is to define the standards for material, infrastructure, design, installation, and certification with respect to structured cabling systems for ICE facilities. This document shall replace, modify, or otherwise supersede previous releases of these standards. For questions or comments regarding this document, contact the ICE Deployment Services Branch (DSB) Installation Manager at (202) 307-5723.

An electronic version of this document resides in the ICE Intranet Enterprise Library, available on the Office of Chief Information Officer (OCIO) Web site.

### 1.2 Background

Immigration and Customs Enforcement (ICE) is a component of the U.S. Department of Homeland Security (DHS). ICE brings a unified and coordinated focus to the enforcement of federal immigration laws, customs laws, and air security laws. ICE brings to bear all of the considerable resources and authorities invested in it to fulfill its primary mission: to detect vulnerabilities and prevent violations that threaten national security.

Because of increasing demands on Service resources, ICE personnel must be able to share information rapidly and efficiently in order to succeed in fulfilling the Service mission.

In addition to this document, which establishes the cabling standards for ICE, other documents are being developed that provide additional related information such as:

- ICE LAN standards.
- ICE Wide Area Network (WAN) standards.
- Voice Communications standards.

### 1.3 Scope

#### 1.3.1 System

Typical structured cabling systems include the following elements:

- b2High

- 
- 
- 
- 
- 
- 
- 
- 
- 
- 
- 
- 
- 

b2High

### 1.3.2 Documentation

This document is intended to address the following specifications and installation practices related to structured cable plant installation:

- Recognized media.
- Closet requirements, environmental and design.
- Distribution cabling.
- Cabling specifications and limits.
- Installation practices.
- Performance testing.
- Supporting documentation.

## 2.0 NETWORK CABLE PLANT OBJECTIVES

The objective of this network approach is to provide ICE with a standardized, cost-effective cable plant infrastructure that will accommodate present and future voice, video, and data requirements. Workstation cabling infrastructure shall support bandwidth demands from 10 Megabits per second (Mbps) to Gigabit speeds. Backbone cable infrastructure shall support bandwidth demands from Gigabit speeds and beyond. The installation of the cable plant infrastructure shall comply with local codes, as well as, industry and Federal standards.

## 3.0 STRUCTURED CABLE PLANT DESIGN

The network cable plant shall utilize the following cable distribution methods to support connectivity throughout the building:

- 

b2High

- 

- 

b2High

- 

### **3.1 Structured Cable Plant Approach**

This section will describe the approach to structured cabling, identify and describe the various cable types, and provide detailed cable specifications for cable plant installation. These are minimum specifications for new cable plant installations or major renovations. These specifications follow the American National Standards Institute (ANSI)/Telecommunications Industries Association (TIA)/Electronic Industries Association (EIA) recommendations, and in addition, provide specific guidelines unique to ICE. Detailed cable plant material specifications and overall minimum characteristics are provided in Section 4.

### **3.2 Horizontal Workstation Cabling**

b2High

**Exhibit 1: Typical Office Cable Planning**

b2H1gn

b2High

b2High

### 3.3 Workstation Outlets

b2High



### **Exhibit 3: Workstation (IMO) Faceplates without Optical Fiber Cables, Double Gang**

b2High

## 3.4 Backbone Cabling

b2High

b2High

## **4.0 SPECIFICATIONS**

This section provides detailed component characteristics and specifications with respect to the materials used to install the structured cable plant.

### **4.1 Horizontal Cables**

b2High

### **4.2 Information Management Outlets**

- 
- 

b2High

- 
- 
- 
- 
- 
- 
- 
- 
- 
- 
- 
- 
- 
- 
- 
- 

b2High

### 4.3 Backbone Cabling

b2High

#### 4.3.1 Intra-Building Fiber Optics

Specifications for fiber backbone cabling that will interconnect closets within a single building or high-rise environment are defined in this section.

##### 4.3.1.1 Multi-Mode Fiber Optics

- 
- 
- 
- 

b2High

- b2High

## 4.3

- 
- 
- b2High
- 
- 

### 4.3.2 Inter-Building Fiber Optics

Specifications for fiber cable that will interconnect remote buildings in a campus environment.

#### 4.3.2.1 Multi-Mode Fiber Optics

- 
- 
- b2High
- 
- 

#### 4.3.2.2 Single-Mode Fiber Optics

- 
- 
- b2High
- 
- 

### 4.4 Patch Cables (Workstation and Patch Panel)

- 
- 
- 
- b2High
- 
- 
- 

### 4.5 Patch Panels

- 
- b2High

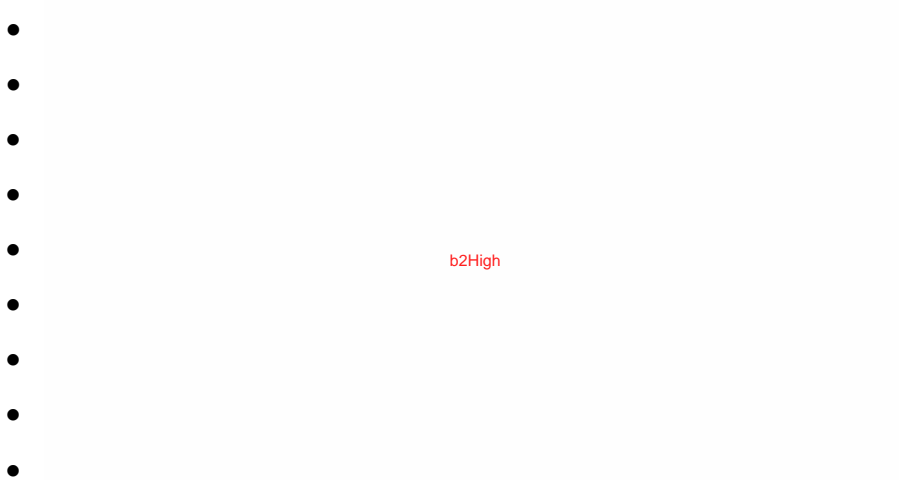

#### 4.6 Equipment Racks



See Exhibit 7 for a typical rack and cabinet structure.

#### 4.7 Cabinets and Swing Gates

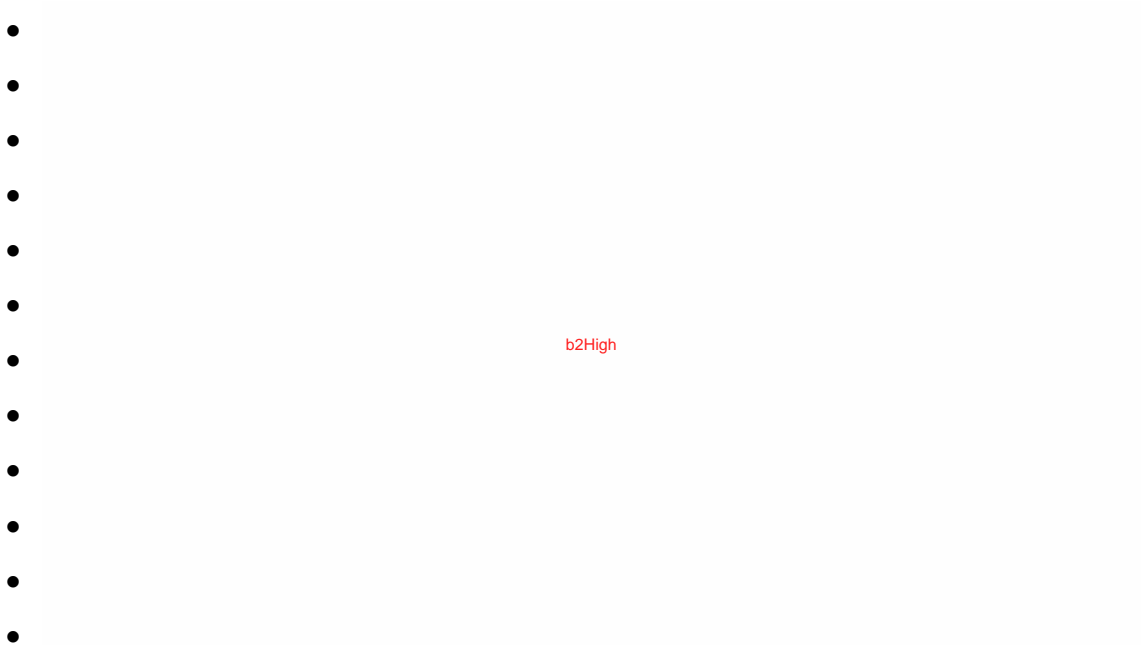

b2High

## Exhibit 7: Typical Rack/Cabinet Enclosures



b2High

### 5.0 COPPER CABLE INSTALLATION SPECIFICATIONS

b2High

#### 5.1 Horizontal Cables

b2High



b2High

## 5.2 Patch Cables (Workstation)

b2High

b2High

- 

- 

- 

b2High

- 

-

•

•

•

b2High

•

•

•

### 5.4 Copper Cable Termination

C

b2High

S

•

•

•

b2High

•

•

### Exhibit 8: T568A Pair/Pin Assignments

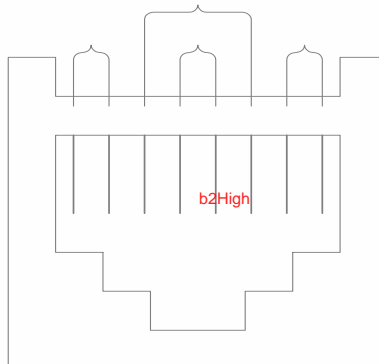

## **6.0 INSTALLATION OF OPTICAL FIBER CABLES AND CONNECTORS**

This section provides the specifications to be used when installing all optical fiber cabling.

### **6.1 Fiber Horizontal Workstation Cable**

b2High

### **6.2 Backbone Fiber Cable**

b2High

### **6.3 Optical Fiber Cable Jacket**

b2High

### **6.4 Optical Fiber Connector**

b2High

## 6.5 Optical Fiber Cable Termination

b2High

## 7.0 FACEPLATE CONFIGURATION

b2High

## 8.0 PATCH PANELS

b2High

## 8.1 Copper Patch Panels

b2High

b2High

## **8.2 Fiber Optic Patch Panels**

b2High

## **9.0 EQUIPMENT RACK**

b2High

## Exhibit 9: Consolidated Closet, Voice and Data

b2High

**Exhibit 10: Single Rack, Data Only (Voice and Data Not Consolidated)**

b2High

b2High



b2High

## 10.0 GROUNDING

b2High

- 
- 
- 
- 
- 
- 

b2High

b2High

b2High

## **11.0 CABLE LADDERS AND FASTENERS**

b2High

## **12.0 ADMINISTRATION AND LABELING CONVENTIONS**

b2High

### **12.1 Building Designation**

b2High

#### **12.1.1 Floor**

b2High

#### **12.1.2 Wiring Closets**

b2High

### 12.1.3 Cable Numbers

b2High

## 12.2 Information Management Outlet

b2High

- 
- 
- 
- 

b2High

b2High

## 12.3 Intra and Inter-Building Backbone Cables

b2High

- 
- 
- 
- 

b2High

b2High



## 13.2 Testing of Optical Fiber Cables

b2High

### Exhibit 12: Multimode Fiber Cable Specifications

b2High

### Exhibit 13: Single Mode Fiber Cable Specifications

b2High

- 
- 
- 
- 
- 
- 
- 
- 
- 

b2High

- b2High

b2High

## 14.0 BUILDING PATHWAYS, CONDUIT, AND CLOSETS

### 14.1 Closet Specifications (MDF and RWC)

b2High

#### 14.1.1 General Requirements

- 
- 
- b2High
- 

#### 14.1.2 Environmental

- 
- 
- 
- 
- b2High
- 
-

- b2High

### 14.1.3 Construction

- 
- 
- 
- 
- 
- b2High
- 
- 
- 
-

## 14.2 Conduits

b2High

- 

- 

- 

- 

- 

- 

b2High

- 

- 

- 

- 

## 15.0 DOCUMENTATION

b2High

- 

- 

b2High

-



- 
- 
- 
- 
- 
- 

b2High

b2High

b2High

### 15.1 Letter of Certification

b2High

### 15.2 Implementation Report

b2High

- 
- 
- 
- 
- 

b2High

b2High

### 15.3 Detailed Materials List

b2High

b2High

## 15.4 Cable Plant Test Certification Letter

b2High

## 15.5 Copper Cable Test Results

b2High

## 15.6 Fiber-optic backbone Cable Test Results

b2High

## 15.7 As-Built Site Drawings

b2High

- 
- 
- 
- 
- 
- 

b2High

- 
- 

b2High

b2High

*Attachment A*  
*Glossary*

b2High

b2High

b2High

b2High



b2High

***Attachment B***  
***Sample Letter of Certification***

[Use Corporate letterhead]

[Title]

**Date:** [Current date]

**To:** [Full name of individual to whom the letter is being sent]

**Address** [of individual to whom letter is addressed]

**Re:** Cable Plant Installation

**Task Order No.:** [XXX-xxx]

Dear [Mr., Ms., or Dr. and last name]:

I hereby certify that the cabling installation completed for the above referenced ICE site was completed by our firm, according to the ICE Structured Cabling Standards, on [date of installation in Month Day, Year].

Our firm has tested each unshielded twisted pair copper cable wire (not just cable pairs) we installed, as well as any previously installed Category 5 or 5e cable, if applicable, which will be re-used as part of this Task Order. I hereby certify that every wire and cable was tested and meets or exceeds the CAT 5e ANSI/TIA/EIA-568-B.2 transmission test requirements.

Our firm also tested each fiber-optic cable and strand we installed, as well as previously installed fiber-optic cable that will be used as part of this Task Order. I hereby certify that each strand of every cable meets or exceeds the required standards for fiber-optic cable.

[Mr., Ms., or Dr. and full name]

[Title]

*Attachment C*  
*Sample Contractor Information Form*

**CONTRACTOR INFORMATION**

JOB NAME: LOCATION:

**DATE:**      **PROJECT:** Cable Plant Installation

FIBER CONTRACTOR

NAME:      PHONE:

ADDRESS:

CITY, STATE, ZIP:

CONTACT NAME:

COMPLETION DATE:

**SCOPE OF WARRANTY RESPONSIBILITY:**

In accordance with Existing Contract

**SUPPLIED MATERIALS:**

In accordance with Task Order XXX-xxx

COPPER CONTRACTOR

NAME: PHONE:

ADDRESS:

CITY, STATE, ZIP:

CONTACT NAME:

COMPLETION DATE:

**SCOPE OF WARRANTY RESPONSIBILITY:**

In accordance with Existing Contract

**SUPPLIED MATERIALS:**

In accordance with Task Order XXX-xxx

*Attachment D*  
*Sample Implementation Report*

**PROJECT IMPLEMENTATION REPORT  
SITE C**

b2High

*Attachment E*  
*Sample Detailed Materials List*



b2High

***Attachment F***  
***Sample Cable Test Certification Letter***

*[Use Corporate letterhead]*

**Date:** [Current date]

**To:** [Full name of individual to whom the letter is being sent]

**Address:** *[of individual to whom letter is addressed]*

**Re:** ICE Cable Plant Installation at Site C

**Task Order No.:** [XXX-xxx]

Dear *[Mr., Ms., or Dr. and last name]*:

This letter is to certify that all cable test results included for the above mentioned project has been completed by Company A personnel who have been trained, and are competent in the use of, the required cable testing equipment.

Please accept this letter as certification of the accuracy of the test results furnished in lieu of individual signatures on each cable test result.

*[Mr., Ms., or Dr. and name]*

*[Title]*



**Immigration and Naturalization Service,  
U.S. Department of Justice**

# **INS Armory Design Standards**

**Construction Requirements for Space and Equipment for  
Storage of Weapons, Ammunition and Chemical Agents**

**Draft Edition  
February 4, 2000**

## Table of Contents

<a href="#">INS Armory Design Guide for Storage of Weapons, Ammunition and Chemical Agents</a> .....	3
<a href="#">Introduction</a> .....	3
<a href="#">Purpose of the Armory Design Standard</a> .....	3
<a href="#">Users of the Armory Design Standard</a> .....	4
<a href="#">Application of the Armory Design Standard</a> .....	4
<a href="#">Revisions to the Armory Design Standard</a> .....	4
<a href="#">Other References and Standards</a> .....	5
<a href="#">INS entities requiring Armory Facilities</a> .....	6
<a href="#">Facilities for Storage of Weapons, Ammunition and Chemical Agents</a> .....	7
<a href="#">Facilities Containing Armories</a> .....	8
<a href="#">Armory Storage Items</a> .....	8
<a href="#">Mission and Objectives</a> .....	10
<a href="#">Hazardous Safety Requirements for Ammunition and Explosives</a> .....	11
<a href="#">Physical Security Planning</a> .....	11
<a href="#">Stand-Alone Hand Gun Lockers</a> .....	12
<a href="#">Stand-Alone Gun Safe</a> .....	13
<a href="#">Armory Rooms</a> .....	14
<a href="#">Construction</a> .....	15
<a href="#">Mechanical Equipment</a> .....	25
<a href="#">Equipment</a> .....	26
<a href="#">Ready Rooms</a> .....	28
<a href="#">Independent Armory Magazine Structures</a> .....	30

## Table of Tables

<a href="#">Table 1: Weapons and Ammunition</a> .....	9
---	---

## Table of Figures

<a href="#">Figure 1: Gun Lockers</a> .....	12
<a href="#">Figure 2: Gun Safes</a> .....	13
<a href="#">Figure 3: Armory Layout</a> .....	15
<a href="#">Figure 4: Vault Partitions</a> .....	17
<a href="#">Figure 5: Alternative Secure Ceiling Construction</a> .....	18
<a href="#">Figure 6: Vault Door Jamb/Head Detail</a> .....	19
<a href="#">Figure 7: Opening Barrier Grille</a> .....	20
<a href="#">Figure 8: Overhead Counter Shutter</a> .....	21
<a href="#">Figure 9: Gun Rack</a> .....	27

# **INS Armory Design Guide for Storage of Weapons, Ammunition and Chemical Agents**

## **Introduction**

*This chapter establishes the purpose, the intended users, and the application of the Armory Design Standard. It describes what other reference documents, what programs require armory facilities, what facilities armories are typically located in, and what types of items are stored in armories.*

The Immigration and Naturalization Service is a law enforcement agency within the United States Department of Justice with the mission to enforce the Immigration and Nationality Act (8 USC 1103). The INS Law Enforcement units include the Border Patrol, Inspections, Intelligence, Investigations, Detention and Deportation. Each of these units plays an essential role in fulfilling INS's enforcement responsibilities. Law enforcement officers within these units include Border Patrol Agents, Inspectors, Investigators, Intelligence Officers, and Detention and Deportation Officers. The INS may also contract for services related to Detention and Deportation. INS officers carry a firearms in performance of their law enforcement responsibilities, and must undergo training and certification to have a permit to use firearms. To support these officers, the INS requires armories and gun storage vaults in a number of its facilities for storage of ammunition, weapons and chemical agents that are issued to the officers for training and performance of their duties.

## **Purpose of the Armory Design Standard**

*This section establishes why the INS has developed this document.*

The *Armory Design Standard* (hereinafter referred to as the Armory Standard or the Standard) contains planning and design criteria and standards for weapons, ammunition and chemical agent storage facilities. This Standard is intended to supplement the U.S. Border Patrol Facilities Design Guide, the SPC Design Guide, and the District Office Space Allocations. The criteria within this Standard shall be used for new construction, and to assess the adequacy of existing construction. The Standard in itself shall not be the cause of renovating existing facilities.

## Users of the Armory Design Standard

*This section identifies who should use this document.*

This document is intended for all individuals involved in the planning and design of armory facilities. These individuals include architects and engineers; INS staff located at INS Headquarters, Regional and Administrative Centers, and Sector Headquarters; and other federal agencies involved in providing space and facilities to the INS (such as the GSA and Corps of Engineers). The Standard also provides INS staff with a reference on the hazardous material storage, security and ballistic safety features that must be provided on an armory facility.

## Application of the Armory Design Standard

*This section establishes how the information contained in this document should be applied to armory facility design projects.*

The operational and architectural information contained in this Standard should be viewed as INS policy, applicable to the design of all new armory facilities and the evaluation of existing facilities. It also contains some specific criteria for hazardous material classification, code compliance, safety and ballistic protection issues that pertain to all facilities. However, Differences between existing conditions and this Standard shall not be the sole justification for retrofit projects, except for hazardous material storage issues.

The Standard provides a discussion of issues and three types of instruction to the user:

- Mandatory requirements that **must** or **shall** be met
- Recommendations for acceptable solutions that **should** be followed
- Features that are allowed, which **can** or **may** be provided

The verbs **must**, **shall**, **can**, or **may** are used to denote the level of instruction. The imperative verb **provide** is also used to denote mandatory instructions.

## Revisions to the Armory Design Standard

Armory standards will be overseen by the NFU Firing Range Design Standards steering committee. Any issues pertaining to this Standard will be referred to that committee for resolution. That committee is responsible for making the Standard a living document and for adding, modifying, or correcting the document. The steering committee consists of a full range of INS representatives including Operations, Border Patrol, Detention, Inspections, Security, Exams, National Firearms Unit, Labor Relations, and Engineering.



## Other References and Standards

Armories must be designed in compliance with the following codes, standards and regulations.

- One of the model Building Codes, either the International Building Code (IBC), Uniform Building Code (UBC), Standard Building Code (SBC) or Building Office Code Association Code (BOCA).
- National Fire Protection Association Standard 101
- Department of Defense DOD Contractor's Safety Manual for Ammunition and Explosives DOD 4145.26-M See <http://web7.whs.osd.mil/html/414526m.htm>
- Army Regulation 190-11 Physical Security of Arms, Ammunition and Explosives
- Underwriters Laboratory Standard UL 608 Burglary Resistant Vault Doors and Modular Panels
- Underwriters Laboratory Standard UL 687 Burglary-Resistant Safes
- Underwriters Laboratory Standard UL 680 Emergency Vault Ventilators and Vault-Ventilating Ports
- Underwriters Laboratory Standard UL 752 Standard for Bullet Resisting Equipment
- Underwriters Laboratory Standard UL 768 Combination Locks
- Underwriters Laboratory Standard UL 786 Key-Locked Safes (Class KL)
- Underwriters Laboratory Standard UL 1034 Burglary-Resistant Electric Locking Mechanisms
- Underwriters Laboratory Standard UL 1037 Anti-theft Alarms and Devices
- ASTM F1029 Standard Guide for Selection of Physical Security Measures for a Facility
- ASTM F 1233 Standard Test Method for Security Glazing Materials and System
- ASTM F 1247 Standard Specifications for Intrusion Resistant Generic Vault Structures
- ASTM E119-88 Fire Testing Building Construction and Materials

## **INS entities requiring Armory Facilities**

*This section describes those entities within the INS that require armory facilities.*

Entities of the INS that require armories for storage of weapons, ammunition and chemical agents include the following:

**Border Patrol.** The Border Patrol, as the mobile uniformed branch of the Immigration and Naturalization Service, has as its mission the detection and prevention of smuggling and illegal entry of into the United States, with primary responsibility between the Ports-of-Entry.

Patrol Agents perform their duties along, and in the vicinity of, the 8,000 miles of United States boundaries. Agents patrol by means of automobile, boat, aircraft, horseback, snowmobile, motorcycle, bicycle and afoot.

**Inspections.** Inspections is the uniformed branch tasked with the function of enforcing and administering the Immigration and Nationality laws by inspecting all persons seeking admission to or transiting through the United States at air, land and sea ports-of-entry. The Inspectors determine if the applicants qualify for admission and if so under what status. Inspectors look for fraudulent documents, previous overstays, question applicants under oath, and search without a warrant of the applicant and effects. The Inspectors are charged with intercepting terrorists, alien and narcotic smugglers, imposters, false claims to U.S. citizenship, criminals and undocumented aliens seeking admission.

The Inspection program also pre-inspects passengers overseas in five countries who are destined to the United States. Additionally, INS Officers work with foreign governments and carriers to assist them in identifying undocumented and/or unauthorized passengers before they board an aircraft to the United States. Inspectors provide fraudulent document training, both domestically and internationally, to airline personnel and foreign government officials.

**Investigations.** The Investigations Division is the interior enforcement arm of the service charged with investigating violations of the criminal and administrative provisions of the Immigration and Nationality Act (INA) and other related provisions of the United States Code. The Investigation's enforcement mission has five broad objectives: identify and remove criminal aliens; counter alien smuggling; counter immigration fraud; enforce employer provisions of the INA; and respond to community complaints regarding illegal criminal alien activity.

**Intelligence.** As the principle source of immigration-related intelligence, the INS Intelligence Program provides timely, accurate analyses to INS staff at all levels to aid in making day-to-day, mid-term, and long-term operational decisions; acquiring and allocating resources; and determining policy.

**Detention and Deportation.** The branch responsible for safely and humanely detaining, transporting, processing and supervising illegal aliens whom are awaiting removal or other disposition of their case.

## **Facilities for Storage of Weapons, Ammunition and Chemical Agents**

Depending on the types of items stored, amount of items requiring storage, the duration of the storage, and the access privileges provided, INS facilities may have one or more of the following storage facilities:

- **Gun locker.** Gun lockers are small secure compartments that may be assigned out to individual officers for the temporary storage of their weapons. They are normally located at the entrance to facilities where carrying weapons are prohibited. Gun lockers may be used for storage of non-INS officers who are visiting INS law enforcement facilities.
- **Gun Safe.** A gun safe may be used for storage of small amounts of weapons and ammunition. They can be used in very small ports of entry, checkpoints and very small stations and sub-stations where the compliment of staff is minimal, requiring only a small inventor for issuing
- **Armory.** Most INS law enforcement facilities will require an armory room for the storage of inventory issued to the officers.
- **Ready Room.** Some facilities may require a space for storage of emergency response inventory. Riot control, fire fighting, special surveillance and communication equipment and medical response supplies may be stored in ready rooms. Firearms and firearm ammunition will not be stored in ready rooms.
- **Magazine.** Firing ranges or Sector Headquarters may require separate buildings or structures for the storage of inventory used in the training and certification of large number of personnel.

## **Facilities Containing Armories**

Armories or gun storage lockers may typically be found in the following facility types owned or occupied by the INS.

- Land Port of Entry
- Airport
- District Office
- District Sub-Office
- Service Processing Center
- Firing Range
- Border Patrol Sector Headquarters
- Border Patrol Station
- Border Patrol Sub-Station
- Border Patrol Air Operations
- Border Patrol Checkpoint
- ASU Office

## **Armory Storage Items**

This section contains a list of weapons, ammunition and chemical agents that may be stored in armories. The armory criteria contained in this guide are appropriate for items that are classified as Hazard Class Division 1.4 – Moderate Fire, No Blast. Most prepackaged small arms cartridge ammunition, and are classified as compatibility group “S – Ammunition presenting no significant hazard” per the Joint Hazard Classification System. Gas canisters may be classified as compatibility group “C – Bulk Propellants”. Requirements for storage of items not contained on this list must be verified on an individual basis.

Unless otherwise noted, weapons storage shall be designed to accommodate all ammunition required by the INS. Only ammunition designated as authorized by the INS Firearms Policy is authorized in a facility.

Authorized Firearms weapons and ammunition includes:

**Table 1: Weapons and Ammunition**

<b>Ammunition</b>	<b>Description</b>	<b>Cm<sup>3</sup> (ft<sup>3</sup>)/1000 Rounds/</b>	<b>Kg (lbs)/1000 Rounds</b>
-------------------	--------------------	---	---------------------------------

---

(b)(2)High

No other ammunition shall be stored without special permission.

Other items that may be stored in the armory include the following.

**Riot Gear.** Riot gear refers to the protective shield and equipment or to items used to disperse rioters rather than inflict serious injury or death. Some of these include the following:

- Helmets
- Shields
- Riot sticks
- Tear gas equipment which is either thrown manually as grenades or canisters, or launched with fire arms
- Walkie-talkies, when there is no other storage in the facility

## **Mission and Objectives**

The armory facilities must be designed to accomplish the following.

- The secure storage of weapons to prevent unauthorized individuals from access weapons, ammunition or weapons paraphernalia and to secure the weapons, ammunition, and related items against theft from any source.
- A safe place for the handling and care of weapons, where accidental discharge will not cause other harm. Provide reasonable safety to the armories, the building as a whole, and the occupants or visitors.
- Provide appropriate climate conditions for the long-term storage of firearms and ammunition so as to prevent damage from moisture, heat and cold.
- Provide appropriate workspace for activities directly related to a firearms program, i.e., cleaning of firearms, issuance of firearms and ammunition, inventorying of ammunition, etc. Without compromising the conditions provided under objectives 1, 2, or 3 above, such space must be adequately ventilated to the outside air to provide for removal of fumes and odors associated with solvents used in the cleaning of firearms.

Specific objectives governing the design of armories include the following:

- Incorporate technology, equipment and construction to allow for cost effective protection, accountability and inventory control.
- Provide adequate storage security at individual sites based on the occupancy and conditions of the site. At unusual or unique facilities, local conditions must be evaluated and security must be tailored based on practicality and cost.
- Minimize the cost of physical security and control. Storage should be consolidated to the maximum extent possible consistent with operational, safety and training requirements.
- Storage of items that do not require restricted access should be separated into other storage areas from items designated for secure armory storage.
- Maintain continuous positive control for all inventories. No inventory will be left unattended or unsecured
- Allow for a system of inventory monitoring and control in the armory. The facility must allow for the controlled issuance and return of inventory.
- Staff must be capable of instantly sounding alarms when thefts are attempted or detected.
- Provide emergency response to protect inventory.
- Provide access to inventory for only specific individuals accountable for inventory security. Locking and keying systems will allow specific designation and auditing of access levels at all time periods.

## **Hazardous Safety Requirements for Ammunition and Explosives**

Please refer to DoD Contractor's Safety Manual for Ammunition and Explosives, Department of Defense document DoD 4145.26-M Section C6.7 and Table C6.T12. Note 2 of C6.T12 states that limited quantities of Hazard Division 1.4 items may be stored in facilities such as hangars and manufacturing or operating buildings without regard to Quantity/Distance separation. Examples include small arms ammunition, riot control munitions, and pyrotechnics. Also, small magazines used for similar purposes may be separated by applicable fire protection distances.

Table C6.T12 prescribes a minimum separation of 15 meters (50 feet) for storage of large quantities of Hazard Division 1.4 inventory in non-combustible structures, and a distance of 30 meters (100 feet) between combustible structures.

Table C5.T1 Storage Compatibility Mixing Chart allows storage of Compatibility Group "S" inventory with most other types of ammunition except bulk initiating devices (Group A), ammunition containing both explosives and toxic chemical agents (Group K), and (Group L) ammunition not in other groups having characteristics that do not permit storage with other types of ammunition.

## **Physical Security Planning**

This section is intended to guide the user in establishing the appropriate level of security construction based on the threat level and importance of the inventory. It will help in identifying the typical protective measures and instrumentation applicable for protection against various threat levels. This section is based on information contained in ASTM F 1029 Standards for Selection of Physical Security Measures for a Facility.

Weapons, ammunition and chemical agents represent a high-risk industrial asset that must be protected from falling into possession of unauthorized individuals.

Weapons, ammunition and chemical agents must be protected from external and internal threats. External threats will typically be individuals attempting to gain inventory for their own illegal use or sale. INS does not anticipate needing to protect inventory against highly trained espionage or terrorist activity, though the inventory does need to be protected from individuals who would be able to circumvent unsophisticated or improperly installed intrusion detection systems. These individuals may be capable of compromising medium security locking systems and avoid detection by unsophisticated interior detection systems. They may be capable of compromising monitoring of low security line supervision monitoring techniques.

Internal threats can come from individuals who have access to detection system and alarm systems and may have substantial knowledge of installation vulnerabilities. They can be motivated by misguided or emotional issues. Internal threats should be regarded as higher-level threat because of their knowledge, accessibility, motivation and likelihood of success.

## Stand-Alone Hand Gun Lockers

The INS requires handgun lockers for temporary storage of any weapons not permitted in INS facilities that may be carried on individuals authorized to possess weapons. Gun lockers are normally at the entrance of restricted facilities including Service Processing Centers visitor entrances and processing sallyport entrances, the entrance to EOIR Court facilities, the Border Patrol Station processing sallyport entrance and the District Office staging facility sallyport entrance.

**Figure 1: Gun Lockers**

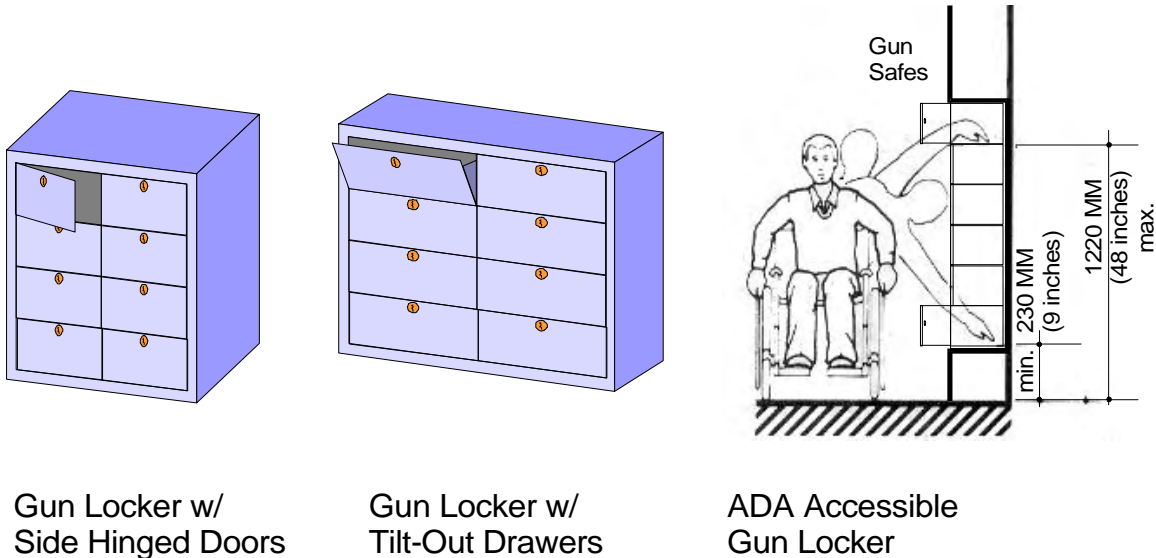

Handgun lockers and safes should comply with the requirements of UL 1037 Anti-theft Alarms and Devices Residential Secure Containers. Handgun safes should be double walled minimum 20 gauge steel construction with a minimum 14 gage steel door. Tilt-out drawers may be used for spaces where the depth of the lockers is a consideration. All gun lockers should have individual keyed deadbolt locks with one master key for all locks.

Handgun safes may be securely mounted on the wall surface or recessed into the wall. At least one safe compartment must be accessible for individuals with disabilities, mounted between 225 mm (9 inches) and 1200 mm (48 inches) above the floor, with a grip aid on the keys.

For guns that must be secured in a desk or other location, a minimum 16 gauge metal handgun safe with combination deadbolt lock or key lock must be provided.



## Stand-Alone Gun Safe

Gun safes may be required in facilities where there is insufficient inventory to warrant an armory or retrofitting an existing facility for an armory would be too difficult or expensive. Facilities that may have gun safes include the small older port of entry facilities along the US/Canada border, small Border Patrol Sub-Station facilities, small Border Patrol Checkpoint facilities, and small INS District Offices. Gun safes should be located in a space that is under direct supervision of the Officer in Charge. This is often inside their office. Gun Safes should not be located where they are visible to the general public or in common use spaces accessible to the general staff. Gun safes should be securely attached to the building structure.

**Figure 2: Gun Safes**

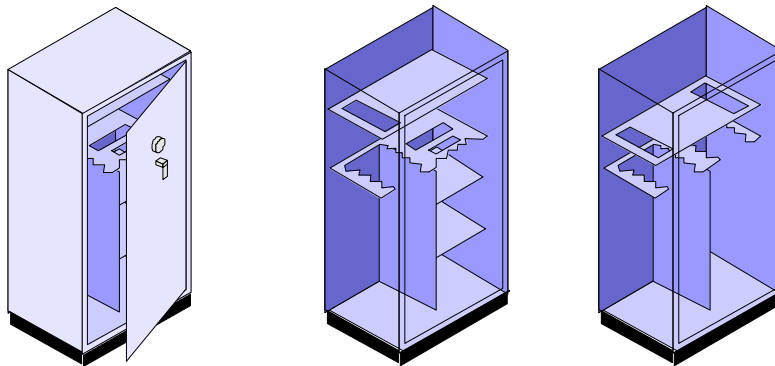

Gun Safe

Shelf/Rack Arrangement  
Option

The size and configuration of gun safes is dependant on the amount and type of inventory to be stored. Gun safes should comply with requirements for secure containers Underwriters Laboratory UL Standard 1037 Anti-Theft Alarms and Devices Residential Secure Container. The safe should not have manufacture information and should not be color keyed by the manufacture indicating the type and quality of safe.

The safe should weigh no less than 180 kilograms (400 pounds) as originally manufactured. Door metal face plate thickness should be a minimum 6 mm (.25 inch). Body metal face panel construction should be a minimum 3 mm (.12 inch). The top, bottom, sides and back body panels should be seamless construction, with double welds where panels meet. The doorframe should be reinforced by folding the body metal.

Locks should be internal either UL 768 Group 1R Combination Lock or Group 2M 3-Wheel Mechanical Locks. The lock should be protected by 5 mm (3/16 inch) hardplate. The lock should be mounted inside the door, centered so that the hinge side of the door cannot be detected. Lock handles should consist of single lever handle, with a clutch to prevent excessive force from being applied to the lock. The lock should activate four or more spaced deadbolts, with bolts located on the hinge side as well as the leaf side of the door.

Hinges should not be surfaced mounted. The hinge side should be concealed from detection from the outside of the safe. Security deadbolts and hinges must be protected from attack by drill deflector or 5 mm (3/16 inch) hard-plate.

Shelving surfaces inside the safe should have textile covering to protect inventory from damage.

The interior of the safe can have custom configurations, including butt rest and barrel supports for long arms, handgun racks, and shelves for ammunition and equipment.

## **Armory Rooms**

**General Definition.** Armories provide space within INS law enforcement and detention facilities for the storage, issuance and upkeep of weaponry, ammunition and chemical agents. Armory spaces can include the issuing area, weapons maintenance area, leather storage area, ammunition storage area, and high-powered weapons and ammunition storage area.

Armories may be constructed as part of new construction or installed in existing facilities. Armory construction will include the structural floor deck, partitions, ceiling, door, door frame and locking mechanism, issuance window shutter system, ventilation openings, lighting, fire detection and suppression, security monitoring intrusion detection systems, storage shelving and racks, counter work surfaces, pneumatic system and hazardous material storage containers.

**Placement within Facility.** Armories should be located within the secure perimeter of a building. The public should not have access to the exterior face of any portion of the armory exterior. The armory should not be placed contiguous to spaces where individuals can make attempts to compromise the armory without detection such as equipment rooms, physical plant space, infrequently accessed storage rooms, or shell space.

Armories should be located where the entrance is under the direct visual control of a manned post. The entrance should not be visible to the public. If the armory is located in a facility with secure detention areas, the armory should be accessible through a secure vestibule or sallyport; to prevent either detained individuals or individuals from the outside from accessing the armory.

**Armory Layout.** The armory should be divided into separate areas with a secure area or safes for high-powered and fully automatic weapons. The armory may have a separate space for chemical storage with its own 100% exhaust ventilation. The armory should also have a separate area for issuing and servicing weapons. This area should be located outside the primary vault perimeter in a vestibule located at the front of the armory. Access to the armory should be through this vestibule. Only individuals authorized to access the armory should be allowed in the issue vestibule.

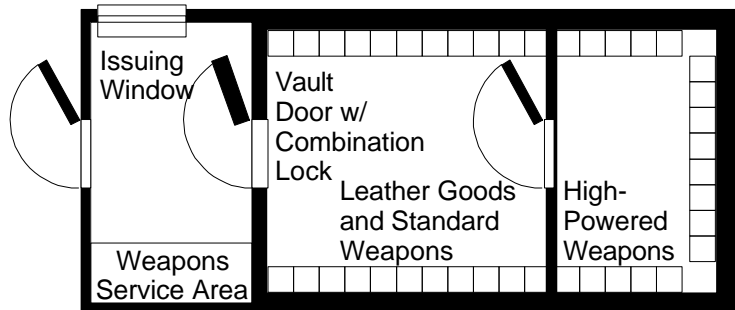
**Figure 3: Armory Layout**

Provide a counter area for cleaning and servicing weapons. Weapons can generate hazardous residue through the lead contaminates from firing. The areas provided for the cleaning and care of weapons should allow for the proper cleanup and disposal of any materials that become contaminated with lead. Safe storage should also be provided for the safe storage of solvents and equipment used for cleaning. A clearing barrel should be provided at the staff entrance to the facilities to assure the weapons are void of bullets after it is worn on duty.

While items in armories are classified for transport on commercial vehicles, to error on the side of caution, mechanical rooms and emergency generators should not be located directly contiguous with armory rooms to avoid any sparks ignition of inventory.

**Floor Loading.** Armories may receive inventory at one time for full year or portions of the year. This can add up to a substantial amount of weight. The inventory stored in the armory, combined with the armory construction and furnishings can exceed the structural floor load of existing buildings or the load required by code for business occupancies. The dead and live load must be calculated for each armory installation to assure that the structure is adequate to support the inventory. Weights for different ammunition types are given in the preceding section on armory storage items.

For existing structures that have floor load limitations, careful consideration of armory construction must be taken to reduce to the extent possible the dead loads created by partitions. To control live loads under these conditions, shelving heights must be limited to that supportable by the structure, and signs must be posted limiting the height that material may be stacked. If possible, the floor and structural frame should be reinforced to increase the load capacity.

### Construction

Suppliers of vault equipment can be found at <http://business.buildfind.com/telex/db/search/?arg=safes>

**Floors.** Armory floors must be designed to resist entry to the same level as partitions, ceilings, doors and other elements of the armory. For armories installed on existing floors, if the floor is less than 150 mm (6 inch) thick reinforced concrete, than an additional layer

of 6 mm (0.25 inch) metal plate should be secured over the floor. All seams and joints should be continuously welded.

Floors should be finished with anti-static material. Floor finish must be resistant to oil and solvents that may spill during gun cleaning. Flooring must be resistant to impacts from dropped items or heavy pallets.

Approved floor finish includes:

- Steel troweled concrete slab
- Resilient vinyl tile
- Sheet vinyl

(b)(2)High

(b)(2)High

(b)(2)High

(b)(2)High

(b)(2)High



(b)(2)High

(b)(2)High

(b)(2)High

Security equipment suppliers can be found at  
<http://business.buildfind.com/teXis/db/bix/+4wrrmwBeirAw/community.html>.

## **Mechanical Equipment**

**Environmental Requirements.** Weapons and ammunition shall be kept in a cool, dry environment. Room dehumidifiers shall be installed in the armory. In the gun vaults, install small heating elements.

**Ventilation.** Armories must have 15-minute Class M emergency vault ventilators and ventilator ports per UL 680 Emergency Vault Ventilators and Ports. Emergency vault ventilators provide fresh air to persons locked in the armory by accident or during robberies. The vault ventilating port is intended to be connected to an outside ventilating system that provides circulating air while the vault is open. The port shall not be able to be rendered inoperable from outside the armory. The port shall be equipped with a visual indicator showing that the location of the port to a person in the vault, and if the port is in the open or closed position. The ventilator port shall allow for voice communication to someone outside the vault, and shall allow the passage of small tools and food items to a person inside the vault. The ventilator ports shall allow for the supply of 0.28 cubic meters (10 cubic feet) of fresh air per minute per 9 square meters (100 square feet). The ventilator port shall provide a minimum of 1250 square mm (2 square inches) of openings in case of power failure. The port shall be protected by a minimum woven steel rod of 10 mm (3/8 inch) or larger steel bars at 150 mm or less on center or a 6 gauge steel mesh in 50 mm (2 inch) diamond pattern grille. The ventilator ports should be placed so that cabinets or equipment cannot be placed to obstruct the opening, both inside and outside the armory.

In the issue vestibule, provide adequate ventilation air exchange of 1.4 cubic meters (50 cubic feet) per minute of outside air in order to ensure the removal of fumes and odors associated with solvents that are used in the cleaning of firearms.

Chemical storage rooms should have 100% exhaust ventilation. Exhaust vents should be located away from air intake vents or equipment generating sparks.

**Duct Work.** Where heating, ventilating, and air conditioning ducts are located in a ceiling, provide reinforcement bars to act as a barrier between the ceilings of adjacent rooms and that of the armory. That will apply when the duct size permits a person through, approximately eight inches or larger. Reinforcing steel rods shall be size No. 5 with spacing not to exceed 150 mm (6 inches).

When ceilings are to be avoided, ducts can be run on the floor below or in the walls, within pipe chases.

Ductwork for chemical storage room exhausts should be of stainless steel construction. Supply ducting shall be wrapped or lined to conserve energy, to eliminate condensation, and to reduce noise.

**Air Inlets.** Grilles, registers, and diffusers shall be designed and fabricated for usage in penal/detention facilities. The face shall be cold-rolled steel 3/16-inch thick. Each unit shall be of welded construction and shall meet the requirements of the American Society for Testing of Materials. Supply units shall be 1-, 2-, 3-, or 4-way directional throw, as required, to provide a uniform air supply, free of drafts, throughout the area.

**Electrical.** Provide standard fluorescent light fixtures, switched inside the armory. Place switches immediately inside the armory door. Provide occupancy sensors to turn off lights when the armory is not occupied for extended time periods. Provide an emergency light.

Provide continuous light at the exterior of the vault door, and any emergency exit doors from the armory.

Provide two duplex receptacles inside each area of the armory. Provide a duplex electrical outlet at 900 mm (3 feet) on center at 1100 mm above the floor at weapon maintenance counters. Provide a dedicated electrical circuit for the pneumatic air cleaning system.

**Plumbing.** The equipment service area should have access to a hand wash sink available for use by staff. The sink should have hot and cold running water, with lever fixtures. It also should have a soap dispenser, mirror, paper towel dispenser and waste receptacle.

If chemical storage is required, then the area will be provided with an emergency eye wash station.

### **Equipment.**

The armory will be equipped with housing cabinets for the leather goods, weapons, ammunition and chemical agents. The type of housing for weapons varies in size, shape, level of security, and material used. Generically, they take the following forms, depending on the type of weapons being used:

- Cabinet
- Lockers
- Drawers
- Racks
- Lock boxes

For each type of housing, the materials, workmanship and fabrication are to be identified. Each component of the housing unit must comply with Federal specifications. At a minimum, specifications and drawings for individual projects should identify the following information:

- Body Construction, including metal gauge, welding, finish, and mounting or leveling system.
- Door construction, including frame, hinges, locks, and pulls.
- Keys, whether single, dual (like those for safe deposit boxes), combination, or master key
- Shelf type and adjustments
- The lining of drawers (inside material)
- Other hardware, including hooks, handles, reinforcements, slides or rollers.

**Cabinets.** Provide a 14 gauge welded double wall metal shell or body, with two-coat epoxy finish, vents with flash arrestors, and a leak-proof sill. Provide a 14 gauge doors, with continuous piano type hinges, integral key deadbolt lock or hasp for padlock. Locks should be recessed into door, with 3 mm (1/8 inch) protective plate. Provide combination or key operation. If key operation is used, key should be keyed to armory master key, and key control must be the same as for access into the armory. Provide metal or wood shelves, adjustable on 12 mm (0.5 inch) on center. Provide leveling legs. Provide wall anchor to secure cabinet to the partition, to prevent cabinet from tipping over or being removed by unauthorized individuals. Provide security and safety warning labels as required. If chemical agents are to be housed, provide anti-static grounding system.

Cabinets may be equipped with pull out drawers. Drawers should be constructed with slides designed to support a minimum of 56 kilogram (150 pound). Each drawer should have a combination deadbolt lock. Provide drawer inserts to accommodate specific weapon and gear inventory.

Cabinet suppliers may be found at <http://business.buildfind.com/tegis/db/search/?arg=Storage+Cabinets>.

**Lockers.** Provide a 14 gauge welded double wall metal shell or body, with two-coat epoxy finish and sloped roof. Provide a 14 gauge doors, with continuous piano type hinges, integral deadbolt lock or hasp for padlock. Provide combination or key operation. If key operation is used, key should be keyed to armory master key, and key control must be the same as for access into the armory. Provide one to two metal shelves and hooks for hanging items. Provide leveling legs. Provide wall anchor to secure locker to the partition, to prevent locker from tipping over or being removed by unauthorized individuals. Provide locker numbers and security and safety warning labels as required by inventory to be stored.

Locker suppliers may be located at <http://business.buildfind.com/tegis/db/bix/+RwwrmwpeqVAw/community.html>

**Gun Rack.** Open gun racks must be designed to accommodate rifles, shotguns and automatic weapons. They should allow for height adjustment up to a minimum of 950 mm (38 inches). Gun racks should be constructed of 14 gauge welded steel construction. They should have felt cushioned butt support and barrel rests. Gun racks should be securely mounted to the partition. The rack should either have a bar that locks the weapons in place, or a cable that can be threaded through the weapons to secure them in place.

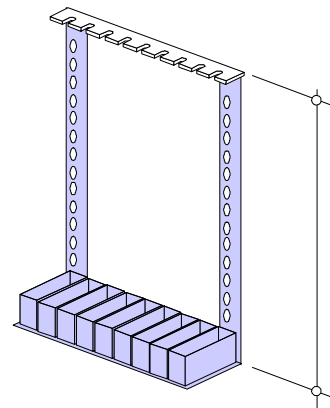

**Figure 9: Gun Rack**

Ammunition may be stored on open shelf systems within the armory. Shelf units may be constructed of either wood or metal. Shelf units should be secured to armory partitions to keep the shelf units from falling over.

**Lock Boxes.** Cabinets configured with lock boxes may be used to store restricted inventory in the armory. Lock boxes should be constructed to comply with the requirements of UL 1037 Anti-theft Alarms and Devices Residential Secure Containers. Lock boxes should be double walled minimum 14 gauge steel construction with a minimum 14 gage steel door. The boxes should be secured to the partition or floor. They should have individual keyed deadbolt locks, and have a key for all locks.

**Other Storage Devices.** The armory should have coat hooks and pegs for storage of gear and leather goods. These should be in the open air or in vented cabinets for ventilation to allow moisture to escape after the equipment has been used. Armory wall surfaces should have peg-board finishes to allow for hanging inventory.

**Gun Service Equipment.** Guns produce lead dust during use. When cleaned, the lead dust can contaminate solvents, rags and other items used while cleaning the gun. Therefore, gun service areas must be designed to control lead contaminates.

Areas for servicing weapons and equipment should have counters at 1050 mm (42 inches) above the floor. The counters may be plastic laminate or stainless steel. They should be American Woodworking Institute Custom Grade. The counters should have knee space, and may be equipped with equipment drawers, pedestals and upper cabinets for storage of equipment and cleaning supplies and solvents. Storage space must be provided for safety devices, such as goggles and gloves.

A hazardous material storage container should be provided in the gun service area for disposal of contaminated rags. Signage must be placed on the container indicating the presence of lead contaminates. Signage should also be located at each work counter position notifying the user that all contaminated materials must be disposed of properly.

The gun service area may also contain power tools and other equipment such as grinders, lathes, milling machines, drill presses and refinishing equipment.

## **Ready Rooms**

Space may be required for the storage of protective gear, clothing articles, fire and medical emergency response gear, communication gear, and other gear used by officers to respond to special situations. Ready rooms are not for the storage of weapons, ammunition or chemical agents. Ready rooms do not need to be designed to the same level of security as armory rooms.

**Location.** Ready rooms may be placed on public or staff corridor areas where officers can immediately access equipment.

**Partitions.** Either core filled concrete masonry unit partitions, or expanded steel mesh reinforced gypsum wallboard and metal stud partitions may be used. Concrete masonry partitions may be constructed of standard concrete masonry units with the cores and kerfs filled with concrete grout. No steel reinforcing is need for security purposes. Steel mesh gypsum wall board partitions should be constructed of one layer of gypsum wall board each face over 14 gauge expanded metal mesh under the outside face, on 92 mm (3 5/8 inch) metal studs. The partitions should extend from structural floor to structural deck above.



**Ceilings.** Ready rooms may have standard suspended acoustical tile ceiling or exposed ceilings. When existing conditions prevent extension of partitions to the structural deck above, provide a secure ceiling of 37 mm (1.5 inch) plaster on metal lath or 14 gauge perforated metal pan screwed on metal runners.

**Doors.** Provide 14 gauge hollow metal doors or 42 mm (1.75 inch) solid core wood doors. Provide 14-gauge hollow metal frame. Provide non-removable pin hinges. Provide keypad or cipher lock so officers can access the ready room without having to obtain keys during an emergency. The lockset should allow emergency egress from inside the ready room.

**Windows and Openings.** Ready rooms in new construction should not have windows. Existing windows should be protected with tempered glass fixed glazing panels or with wire mesh barrier grille. Enclosed chase spaces do not require barrier grilles. Exposed openings should have 14 gauge steel barrier grille.

**Security.** Ready rooms should have magnetic door position and lock keeper switches connected to a central monitoring station and to audio alarms at the ready room.

**Fire Detection and Suppression.** Ready rooms should have fire and smoke detection sensors. The system should be connected to a central monitoring station and audio alarms at the ready room. Ready rooms should be provided sprinklers based on requirements of the occupancy of the building.

**Mechanical system and ventilation.** The ready room should have standard mechanical service with a minimum supply of 0.56 cubic meters (20 cubic feet) of fresh air per minute per 9 square meters (100 square feet).

**Electrical and Lighting.** The ready room should have standard fluorescent light fixtures. The light should be switched inside the ready room. Provide occupancy sensors that turn the light off after extended periods when the room is unoccupied. A duplex electrical outlet should be provided on each wall of the ready room. Place the electrical outlets where they are not obstructed by cabinets or stored items.

**Equipment.** The ready rooms should be equipped with shelving units, cabinets, cabinet drawers, lockers, hooks and peg boards for storage of equipment.

Equipment should be minimum 20 gauge steel construction. Individual units do not require key or combination locks. Units should be provided with floor leveling devices, and should be secured to partitions to prevent tipping over of loaded units.

## **Independent Armory Magazine Structures**

If the armory is located in a separate structure more than 150 meters (500 feet) from other occupied facilities, or is larger than 300 square feet, than the armory building must be equipped with male and female toilet facilities. These facilities must be accessible for individuals with disabilities.

If the armory is located in a separate structure and will contain large quantities of ammunition on pallets, than the armory should be equipped with a receiving dock. The receiving dock should have an elevated platform 1200 mm (4 feet) above the vehicle parking surface. The vehicle parking surface should extend 36 meters (120 feet) beyond the dock edge to accommodate tractor-trailer delivery vehicles. The dock should have a 15-meter (50 foot) by 3600 mm (12 foot) area for unloading of delivery vehicle contents.

The armory located in a separate structure may require an office space for range master duties. This should be located with views to the issue window and receiving dock.

Armories in separate structure will require mechanical, electrical, telephone and janitor closet space. Physical plant equipment spaces should not open directly into armory storage areas. Exhaust and air supply vents should be located remote from any direct exhaust from storage areas.

Armories located in separate structures should be surrounded by security fences. The fences should be located a minimum of 6 meters (20 feet) from the structure, providing a buffer zone for security monitoring. The fence should be a minimum of 2.4 meters (10 feet) high, and have a sloped top or be topped with concertina wire.

This page left blank.

**Stevens, Richard P**

---

**From:** Wyatt-Powell, Wendie M  
**Sent:** Monday, March 31, 2008 2:39 PM  
**To:** Neveleff, Jerald; Erickson, Susan D  
**Cc:** Washington, John W; Jenkins, John E  
**Subject:** Dedicated IGSA SOW 3\_25\_08(Has Tele Lang not Sec Lang) (3).doc  
**Attachments:** Dedicated IGSA SOW 3\_25\_08(Has Tele Lang not Sec Lang) (3).doc

Jerald and Susan

Attached is your IGSA SOW with the corrected address for Farmville. Upon clarification the service provider will be the Town of Farmville which is now reflected in the address line.

Wendie

X (b)(2)Low

**DEPARTMENT OF HOMELAND SECURITY (DHS)  
IMMIGRATION AND CUSTOMS ENFORCEMENT (ICE)  
OFFICE OF DETENTION AND REMOVAL (DRO)**

**REQUEST FOR PROPOSAL--ICE Detainee Services**

**STATEMENT OF WORK**

**Date: 3/24/2008**

**FACILITY LOCATION**

**Town of Farmville**  
116 North Main Street  
Farmville, Virginia 23901

**I. Performance:**

The **PROVIDER** is required, in units housing U.S. Immigration and Customs Enforcement (ICE) detainees, to perform in accordance with the most current editions of the ICE National Detention Standards, American Correctional Association (ACA) Standards for Adult Local Detention Facilities (ALDF), and Standards Supplement, Standards for Health Services in Jails, latest edition, National Commission on Correctional Health Care (NCCHC). Some ACA standards are augmented by ICE policy and/or procedure. In cases where other standards conflict with ICE Policy or Standards, ICE Policy and Standards prevail. ICE Inspectors will conduct periodic inspections of the facility to assure compliance of the aforementioned standards.

**II. Anticipated Start Of Performance: TBD**

**III. Exclusivity:**

The **CONTRACTOR** or **PROVIDER** agrees that the facility is to be for the exclusive use of ICE and its detainee population. No other agency will be allowed to use the facility to house its detainees, prisoners, or inmates without prior approval *of the Contracting Officer with input from the Contracting Officer's Technical Representative*. If given approval, a separate bed day rate shall be negotiated with the other agency and ICE shall not be responsible for payment related to beds used by another agency. The other agency will be separately invoiced for the beds it uses. The duration of the use of beds will be determined on a case by case basis.

**IV. Transportation Service:**

- A. Transportation service shall include the following:
  - 1. The **PROVIDER** shall provide all such ground transportation services as may be required to transport detainees securely, in a timely manner, to locations as directed by the COTR or designated ICE Official. When **PROVIDER** employees are not providing transportation services, the

**PROVIDER** shall assign the employees to supplement security duties within the Facility to assist ICE as directed by the COTR or designated ICE official. However, the primary function of these Service Provider employees is transportation. Duties as directed by the COTR utilizing these employees shall not incur any additional expense to ICE.

2. The **PROVIDER** shall assign, at a minimum, two person teams of transportation officers on a daily basis distributed throughout a twenty-four (24) hour period seven (7) days a week including weekends and holidays. The COTR shall approve the number of teams assigned to any shift or period of time in order to meet the needs of ICE transportation requirements.
3. The **PROVIDER** shall furnish suitable vehicles in good condition, approved by the Government, to safely provide the required transportation services per facility as listed below. The **PROVIDER** shall comply with all federal and state laws with regard to inspections, licensing, and registration for all vehicles used for transportation.
4. Nothing in this agreement shall restrict the **PROVIDER** from acquiring additional vehicles as deemed necessary by the **PROVIDER** at no cost to the Government. The **PROVIDER** shall not allow employees to use their privately owned vehicles to transport detainees. The **PROVIDER** shall furnish vehicles equipped with interior security features (such as, but not limited to: door lock controls, window locks, a wire cage with acrylic panel between the driver seat and the rear passenger seats) and be in accordance with ICE National Detention Standards including physical separation of detainees from guards. The **PROVIDER** shall provide the interior security specification of the vehicles to ICE for review and approval prior to installation.
5. In the event of transportation services involving distances that exceed a standard eight (8) hour workday to complete, the **PROVIDER** shall be reimbursed for related costs of lodging and meals commiserate with the U.S. General Services Administration rates for such within the geographical area of occurrence. Any incurred overtime pay for such services will be reimbursed at the applicable Department of Labor overtime rate for the transportation officer position incorporated within this agreement. The **PROVIDER** shall comply with ICE transportation standards related to the number of hours the **PROVIDER** employee may operate a vehicle. Overnight lodging resulting from transportation services shall be approved in advance by the COTR or designated ICE official.
6. All transportation shall be accomplished in the most economical manner.

7. The **PROVIDER** shall, upon order of the COTR, or upon his own decision in an urgent medical situation with notification to the COTR immediately thereafter, transport a detainee to a hospital location. An officer(s) shall keep the detainee under supervision 24 hours per day until the detainee is ordered released from the hospital, or at the order of the COTR. The **PROVIDER** shall then return the detainee to the Facility.
8. The **PROVIDER** personnel provided for the above services shall be of the same qualifications, receive the same training, complete the same security clearances, and wear the same uniforms as those **PROVIDER** personnel provided in the other areas of this agreement. Transportation officers shall have the required state licenses for commercial drivers with the proper endorsement limited to vehicles with Automatic Transmission and the state DMV Medical Certification.
9. During all transportation activities, at least one transportation officer shall be the same sex as the detainee(s). Questions concerning guard assignments shall be directed to the COTR for final determination.
10. All transportation Detention Officers shall be armed in the performance of these duties.
11. The COTR may direct the **PROVIDER** to transport detainees to miscellaneous locations.
12. When the COTR provides documents to the **PROVIDER** concerning the detainee(s) to be transported and/or escorted, the **PROVIDER** shall deliver these documents only to the named authorized recipients. The **PROVIDER** shall ensure the material is kept confidential and not viewed by any person other than the authorized recipient.
13. The **PROVIDER** shall establish a fully operational communication system compatible with ICE communication equipment that has direct and immediate contact with all transportation vehicles and post assignments. Upon demand, the COTR shall be provided with current status of all vehicles and post assignment employees.
14. Failure of the **PROVIDER** to comply fully with the detainee(s) departure as pre-scheduled shall result in the **PROVIDER** having deductions made for non-performance.

B. ANTICIPATED TRANSPORTATION ROUTES

The following transportation routes/destinations are anticipated requirements for this agreement. The following requirements are **one way routes**; these routes (mile approximations) are not all inclusive and should not be limited to the following:

<i>Legend</i>	<i>Daily = 2 times plus per week; Weekly = 2 or less per week; Periodic = as required Mileage = One Way</i>		
<b>Mileage From Farmville, VA</b>	<b>Locations</b>	<b>City</b>	<b>Frequency</b>
	<b>Field Offices</b>		
164	Detention and Removal Office	Fairfax	Daily
121	Detention and Removal Office	Harrisonburg	Weekly
153	Detention and Removal Office	Norfolk	Daily
65	Detention and Removal Office	Richmond	Daily
100	Detention and Removal Office	Roanoke	Weekly
	<b>JPATS/DOCC Destinations</b>		
173	Dulles International Airport	Washington, DC	Periodic
289	Harrisburg International Airport	Harrisburg, PA	Weekly
69	Richmond International Airport	Richmond	Proposed weekly
143	Piedmont Triad International Airport	Greensboro, NC	Proposed weekly
455	Stewart Detention Center	Stewart, GA	Periodic
266	York Detention Center	York, PA	Weekly
	<b>Jails</b>		
162	Alexandria City Jail	Alexandria	Daily
166	Arlington County Jail	Arlington	Daily
120	Augusta Correctional Center	Craigsville	Daily
180	Bland Correctional Center	Bland	Daily
59	Brunswick Correctional Center	Lawrenceville	Daily
22	Buckingham Correctional Center	Dillwyn	Daily
85	Central Virginia Regional Jail	Orange	Daily
145	Chesapeake City Jail	Chesapeake	Daily
96	Coffeewood Correctional Center	Coffeewood	Daily
170	DC Jail (Central Detention, Central Treatment)	Washington, DC	Daily
47	Deep Meadow Correctional Center	State Farm	Daily
22	Dillwyn Correctional Center	Dillwyn	Daily
48	Dinwiddie Correctional Unit	Church Road	Daily
160	Fairfax County Jail	Fairfax	Daily
67	FCI Petersburg - Camp - Virginia	Petersburg	Daily
67	FCI Petersburg - Low - Virginia	Petersburg	Daily
67	FCI Petersburg - Medium - Virginia	Petersburg	Daily



<b>Mileage From Farmville, VA</b>	<b>Locations</b>	<b>City</b>	<b>Frequency</b>
92	Green Rock Corr Center (New 06/2007)	Chatham	Daily
74	Greensville Correctional Center	Jarratt	Daily
138	Hampton City Jail	Hampton	Daily
136	Hampton Roads Regional Jail	Portsmouth	Daily
124	Haynesville Correctional Center	Haynesville	Daily
64	Henrico County Jail	Richmond	Daily
48	James River Correctional Center	State Farm	Daily
59	Lawrenceville Correctional Center	Lawrenceville	Daily
169	Loudoun County Jail	Leesburg	Daily
53	Mecklenburg Correctional Center	Boydton	Daily
116	Middle Peninsula Regional Jail	Saluda	Daily
141	Newport News City Jail	Newport News	Daily
141	Norfolk City Jail	Norfolk	Daily
194	Northampton County Jail	Eastville	Daily
115	Northern Neck Regional Jail	Warsaw	Daily
190	Northwestern Regional ADC	Winchester	Daily
19	Nottoway Correctional Center	Burkeville	Daily
79	Pamunkey Regional Jail	Hanover	Daily
67	Petersburg City Jail	Petersburg	Daily
0	Piedmont Regional Jail	Farmville	Daily
140	Portsmouth City Jail	Portsmouth	Daily
48	Powhatan Correctional Center	State Farm	Daily
156	Prince William/Manassas Regional Jail	Manassas	Daily
126	Rappahannock Regional Jail	Stafford	Daily
296	Red Onion State Prison	Pound	Daily
67	Richmond City Jail	Richmond	Daily
73	Riverside Regional Jail	Hopewell	Daily
122	Rockingham/Harrisonburg Regional Jail	Harrisonburg	Daily
155	St. Brides Correctional Center	Chesapeake	Daily
77	Sussex County Jail	Sussex	Daily
155	Virginia Beach City Jail	Virginia Beach	Daily
46	Virginia Correctional Center for Woman	Goochland	Daily
121	Western Tidewater Regional Jail	Suffolk	Daily
29	Appomattox County Jail	Appomattox	Daily to Weekly
52	Chesterfield County Jail	Chesterfield	Daily to Weekly
111	Culpeper County Jail	Culpepper	Daily to Weekly
135	Fauquier County Jail	Warrenton	Daily to Weekly
100	Roanoke City Jail	Roanoke	Daily to Weekly
158	Shenandoah County Jail	Woodstock	Daily to Weekly
119	Virginia Peninsula Regional Jail	Williamsburg	Daily to Weekly
89	Danville City Jail	Danville	Weekly
108	Franklin County Jail	Rocky Mount	Weekly
120	Gloucester County Jail	Gloucester	Weekly

<b>Mileage From Farmville, VA</b>	<b>Jails</b>	<b>City</b>	<b>Frequency</b>
119	Henry County Jail	Martinsville	Weekly
155	Indian Creek Correctional Center	Chesapeake	Weekly
30	Lunenburg Correctional Center	Victoria	Weekly
100	Middle River Regional Jail	Staunton	Weekly
153	New River Valley Regional Jail	Dublin	Weekly
103	Peumansend Creek Regional Jail	Bowling Green	Weekly
111	Roanoke County Jail	Salem	Weekly
94	Southampton Correctional Center	Capron	Weekly
204	Marion Treatment Center	Marion	Weekly to Periodic
310	USP Lee - Virginia	Jonesville	Weekly to Periodic
225	Accomack County Jail	Accomac	Periodic
59	Albemarle/Charlottesville Regional Jail	Charlottesville	Periodic
135	Alleghany County Regional Jail	Covington	Periodic
60	Amherst County Jail	Amherst	Periodic
72	B.R.R.J. - Bedford County ADC	Bedford	Periodic
47	B.R.R.J. - Campbell County ADC	Rustburg	Periodic
50	B.R.R.J. - Lynchburg City Jail	Lynchburg	Periodic
58	B.R.R.J.A. - Halifax County ADC	Halifax	Periodic
53	Baskerville Correctional Center	Baskerville	Periodic
103	Botetourt Correctional Center	Troutville	Periodic
108	Botetourt County Jail	Fincastle	Periodic
247	Bristol City Jail	Bristol	Periodic
60	Brunswick County Jail	Lawrenceville	Periodic
59	Brunswick Work Center for Women	Lawrenceville	Periodic
90	Caroline Correctional Unit #2	Hanover	Periodic
52	Central Virginia Correctional Unit #13	Chesterfield	Periodic
26	Charlotte County Jail	Charlotte Court House	Periodic
87	Cold Springs Correctional Unit #10	Greenville	Periodic
87	Cold Springs Work Center	Greenville	Periodic
88	Danville City Jail Farm	Danville	Periodic
992	Deerfield Correctional Center	Capron	Periodic
60	Dinwiddie County Jail	Dinwiddie	Periodic
65	Fluvanna Correctional Center for Women	Troy	Periodic
74	Greensville Work Center	Jarratt	Periodic
58	Halifax Correctional Unit #23	Halifax	Periodic
124	Haynesville Correctional Unit #17	Haynesville	Periodic
48	James River Work Center	State Farm	Periodic
265	Keen Mountain Correctional Center	Oakwood	Periodic
141	Lancaster County Jail	Lancaster	Periodic
123	Martinsville City Jail	Martinsville	Periodic
51	Mecklenburg County Jail	Boydton	Periodic
66	Medical College of Virginia	Richmond	Periodic

Mileage From Farmville, VA	Jails	City	Frequency
136	Montgomery County Jail	Christiansburg	Periodic
131	Newport News City Jail Farm	Newport News	Periodic
19	Nottoway Work Center	Burkeville	Periodic
132	Page County Jail	Luray	Periodic
150	Patrick County Jail	Stuart	Periodic
130	Patrick Henry Correctional Unit #28	Ridgeway	Periodic
92	Pittsylvania County Jail	Chatham	Periodic
152	Pulaski Correctional Center	Dublin	Periodic
123	Rappahannock County Jail	Washington	Periodic
93	Rockbridge Regional Jail	Lexington	Periodic
47	Rustburg Correctional Unit #9	Rustburg	Periodic
109	Southampton County Jail	Courtland	Periodic
94	Southampton Pre-Release and Work Center for Women	Capron	Periodic
94	Southampton Work Center for Men	Capron	Periodic
79	Southside Regional Jail	Emporia	Periodic
288	Southwest Virginia Regional Jail	Hayso	Periodic
236	Southwest Virginia Regional Jail Authority - Abingdon	Abingdon	Periodic
291	Southwest Virginia Regional Jail Authority - Duffield	Duffield	Periodic
219	Southwest Virginia Regional Jail Authority - Tazewell	Tazewell	Periodic
91	Sussex I State Prison	Waverly	Periodic
91	Sussex II State Prison	Waverly	Periodic
219	Tazewell Correctional Unit #31	Tazewell	Periodic
310	USP Lee - Camp -Virginia	Jonesville	Periodic
294	Wallens Ridge State Prison	Big Stine Gap	Periodic
139	Warren County Jail	Front Royal	Periodic
275	Wise Correctional Unit	Coeburn	Periodic

**V. Guard Services:**

- A. The **PROVIDER** agrees to provide stationary guard services on demand by the COTR and shall include, but not limited to, escorting and guarding detainees to medical or doctor's appointments, hearings, ICE interviews, and any other remote location requested by the COTR. Qualified detention officer personnel employed by the **PROVIDER** under its policies, procedures, and practices will perform such services. The **PROVIDER** agrees to augment such practices as may be requested by ICE to enhance specific requirements for security, detainee monitoring, visitation, and contraband control. Public contact is prohibited unless authorized in advance by the COTR.
  
- B. The **PROVIDER** shall be authorized one officer for each such remote location, unless at the direction of the COTR or designated Agency official as additional officers are required.

- C. The itemized monthly invoice for such stationary guard services shall state the number of hours being billed, the duration of the billing (times and dates) and the names of the detainees that were guarded. Such services shall be denoted as a separate item on submitted invoices. ICE agrees to reimburse the **PROVIDER** for actual stationary guard services provided at a negotiated rate.

## **VI. Medical Services:**

- A. The **PROVIDER** shall be responsible for the provision of health care services for ICE detainees at the facility.
- B. In the event of an emergency, the **PROVIDER** shall proceed immediately with necessary medical treatment. In such event, the **PROVIDER** shall notify ICE immediately regarding the nature of the transferred detainee's illness or injury and type of treatment provided.
- C. The **PROVIDER** shall ensure that all health care service providers utilized for ICE detainees hold current licenses, certifications, and/or registrations with the State and/or City where they are practicing. The **PROVIDER** shall retain a registered nurse to provide health care and sick call coverage unless expressly stated otherwise in this Agreement. In the absence of a health care professional, non-health care personnel may refer detainees to health care resources based upon protocols developed by the United States Public Health Service (USPHS) Division of Immigration Health Services (DIHS). Healthcare or health trained personnel may perform screenings.
- D. The **PROVIDER** shall ensure that onsite medical and health care coverage as defined below is available for all ICE detainees at the facility for at least eight (8) hours per day, seven (7) days per week. The **PROVIDER** shall ensure that its employees solicit each detainee for health complaints and deliver complaints in writing to the medical and health care staff.
- E. The **PROVIDER** shall furnish onsite health care under this Agreement. The **PROVIDER** shall not charge any ICE detainee an additional fee or co-payment for medical services or treatment provided at the **PROVIDER'S** facility. The **PROVIDER** shall ensure that ICE detainees receive no lower level of onsite medical care and services than those it provides to local inmates. Onsite health care services shall include arrival screening within twenty-four (24) hours of arrival to the facility, sick call coverage, provision of over-the-counter medications, treatment of minor injuries (e.g. lacerations, sprains, and contusions), treatment of special needs and mental health assessments. Detainees with chronic conditions shall receive prescribed treatment and follow-up care. Arrival screening shall include at a minimum TB symptom screening, planting of the Tuberculin; skin Test (PPD), and recording the history of past and present illnesses (mental and physical).

- F. If the **PROVIDER** determines that an ICE detainee has a medical condition which renders that person unacceptable for detention under this Agreement, (for example, contagious disease, condition needing life support, uncontrollable violence), the **PROVIDER** shall notify ICE. Upon such notification, the **PROVIDER** shall allow ICE reasonable time to make the proper arrangements for further disposition of that detainee.
- G. The DIHS acts as the agent and final health authority for ICE on all off-site detainee medical and health related matters. The relationship of the DIHS to the detainee equals that of physician to patient. The **PROVIDER** shall release any and all medical information for ICE detainees to the DIHS representatives upon request, except where prohibited by federal or state law or regulation. The **PROVIDER** shall solicit DIHS approval before proceeding with non-emergency, off-site medical care (e.g. off site lab testing, eyeglasses, cosmetic dental prosthetics, and dental care for cosmetic purposes). The **PROVIDER** shall submit supporting documentation for non-routine, off-site medical/health services to DIHS. For medical care provided outside the facility, the DIHS may determine that an alternative medical provider or institution is more cost-effective or more aptly meets the needs of ICE and the detainee. ICE may refuse to reimburse the **PROVIDER** for non-emergency medical costs incurred that were not pre-approved by the DIHS. The **PROVIDER** shall send requests for pre-approval for non-emergency off-site care to:

United States Public Health Service  
Division of Immigration Health Services  
1220 L Street, NW, PMB 468  
Washington, DC 20005-4018  
Phon  
Fax: (b)(2)Low

- H. The **PROVIDER** is to notify all medical providers approved to furnish off-site health care of detainees to submit their bills in accordance with instructions provided to:

BCE Emergis  
DIHS Claims  
P.O. Box 10250  
Gaithersburg, MD 20898-0250  
Phone  
Fax: (b)(2)Low

- I. The **PROVIDER** shall furnish twenty-four (24) hour emergency medical care and emergency evacuation procedures. In an emergency, the **PROVIDER** shall obtain the medical treatment required to preserve the detainee's health. The **PROVIDER** shall have access to an off site emergency medical provider at all times. The Health Authority of the **PROVIDER** shall notify the DIHS Managed Care Coordinators, ICE Health Services, 1220 L Street, NW, PMB 468, Washington, DC, 20005-4018, phone (888) 718-8947, fax (202) 318-0080, as

soon as possible, and in no case more than seventy-two (72) hours after detainee receipt of such care. The Health Authority will obtain pre-authorization from the DIHS Managed Care Coordinator for service(s) beyond the initial emergency situation.

- J. The **PROVIDER** shall allow DIHS Managed Care Coordinators reasonable access to its facility for the purpose of liaison activities with the Health Authority and associated Service Provider departments.
- K. The **PROVIDER** and all medical providers approved to furnish off-site health care of detainees shall submit their bills to:

BCE Emergis  
DIHS Claims  
P.O. Box 10250  
Gaithersburg, MD 20898-0250  
Phone: (b)(2)Low  
Fax:

- L. The ICE and PHS may refuse to reimburse the **PROVIDER** for non-emergency medical costs incurred that were not pre-approved by the DIHS.
- M. The **PROVIDER** agrees to accept and provide for the secure custody, care, and safekeeping of detainees in accordance with the State, and local laws, standards, policies, procedures, or court orders applicable to the operations of the facility.
- N. The **PROVIDER** agrees to provide ICE detainees with the same level of medical care and services as provided to non-ICE detainees as part of the per diem rate. This rate includes:
- On-site sick call (when provided by on-site staff);
  - Medication (over the counter/non-legend and routine drugs and medical supplies);
  - Escort/security services for transport to/from emergency or non-emergency health care services as either an in-patient or out-patient.

## VII. ICE Physical Plant Requirements

### A. ICE Office Space

The **PROVIDER** shall refer to ICE Design Standards for specific office and workstation sizes and specific furnishing requirements for a 1000 bed facility. The Standards include but are not limited to the following:

1. A total of 34 offices and 46 workstations as outlined below:
  - a. 1 Office - Assistant Field Office Director GS-1801-14

- b. 1 Office - Officer in Charge GS-1801-14
- c. 1 Office - Assistant Officer in Charge GS-1801-14
- d. 1 Office - Intelligence Officer GS-1801-14
- e. 1 Office - Chief Immigration Enforcement Agent GS-1801-13
- f. 4 Offices - Supervisory Detention & Deportation Officers GS-1801-13
- g. 16 Offices - Deportation Officers GS-1801-12
- h. 2 Offices - Supervisory Immigration Enforcement Agents GS-1801-11
- i. 26 Workstations - Immigration Enforcement Agents GS-1801-5/7/9
- j. 2 Offices - Supervisory Deportation Assistant, GS-1802-09
- k. 16 Workstations - Detention & Removal Assistants GS-1802-07
- l. 1 Office - Mission Support Specialist GS-0301-9/11/12
- m. 2 Offices - Contracting Officer's Technical Representative, GS-1102-09
- n. 1 Office - Intelligence Research Specialist GS-1801-09
- o. 1 Office - Training Officer GS-1801-11
- p. 2 Workstations - Mission Support Assistant GS-0301-5/7
- q. 1 Workstation – Receptionist
- r. 1 Workstation - OIC Secretary
- s. 1 Workstation - Records Tech
- t. 1 Workstation - Mail/File Clerk
- u. File rooms (see Standards for size and quantity)
- v. Conference rooms adjacent to or within ICE area (see Standards for size and quantity)
- w. Employee break rooms (see Standards for size and quantity)
- x. IT computer support rooms must be provided through out ICE space per the specifications. Including specialized requirements for climate control of IT equipment rooms for PHS, EOIR and ICE office area.
- y. Actual location, layout, configuration, and size of rooms will be determined during the final design phase.

## B. OPLA Space

The **PROVIDER** shall refer to ICE Design Standards for specific office and workstation sizes and specific furnishing requirements for a 1000 bed facility. All furniture and case goods shall be furnished by the service provider in accordance with ICE Design Standards. The Standards include but are not limited to the following:

- 1. 1 Office – Deputy Chief Counsel (see Standards for size)
- 2. 12 Offices – Assistant Chief Counsel (see Standards for size)
- 3. 4 Workstations - Legal Technicians (see Standards for size)
- 4. 1 Workstation - Mail/File Clerk
- 5. Office support space must be provided per the ICE/OPLA Design Standards.
- 6. OPLA Space

### C. EOIR Space

The **PROVIDER** shall refer to ICE/EOIR Design Standards for specific office and workstation sizes and specific furnishing requirements for a 1000 bed facility. All furniture and case goods shall be furnished by the service provider in accordance with ICE Design Standards. The Standards include but are not limited to the following:

1. 5 - Courtrooms and accompanying office and support space as per the EOIR Design Standards for a 1000 bed facility. The office space is per the EOIR Design Standards. Each courtroom should have the capability to hold live court as well as hold video tele-conferencing court. All furniture and case goods shall be furnished by the service provider in accordance with ICE Design Guide and specifications.
2. 15 - Hard walled offices (see Standards for size)
3. 15 - Workstations (see Standards for size)
4. Visitation space must be provided to meet the ACA and NDS standards.
5. Separate entrance for judges required with complete security system and access to parking lot. Must be ADA compliant.
6. EOIR Support Space must be provided per the EOIR Design Standards.

### D. Health Services

Healthcare services will be provided by the **PROVIDER**.

### E. Facility Requirements for Infectious Disease Screening

The Service Provider will ensure that there is adequate space and equipment to provide medical intake screening including a TB screening chest x-ray within the intake processing area. In order to prevent the spread of airborne infectious disease or cross contamination of zones within the facility, the HVAC system in the Intake Screening Area will be constructed to exhaust to the exterior and prevent air exchange between the intake screening area and any other area within the facility.

### F. Infectious Disease Screening

In order to prevent the transmission of Tuberculosis (TB) to the resident population of a detention facility, the Service Provider will perform TB screening as part of the a routine infectious disease screening within 12 hours of detainee admission and obtain documented clearance of transmissible disease before the detainee is assigned to a housing unit or is transferred from the intake processing area. A screening chest x-ray will be performed by a trained and qualified health care provider and interpreted by a credentialed radiologist. Detainees will remain isolated from the rest of the facility population (remain in the intake screening area) until the chest x-ray report is obtained and the interpretation verifies that the detainee is free of infectious TB (turnaround time for chest x-ray interpretation



should be 4 hours or less). Detainees who are found to be infected or where there is a possibility that they are infected will be assigned to a respiratory isolation unit until treatment or further testing is done and the detainee is no longer infectious.

#### G. Teleradiology Service Provider

1. The Detention Service Provider shall use the services of the ICE Teleradiology Service Provider (ITSP). The cost of the equipment; maintenance of the equipment; training of staff; arrangements for interpretation of the x-rays by credentialed radiologists; and transmission of data to and from the Detention Facility are provided by the ITSP and charged directly to ICE. The Service Provider shall coordinate with the ITSP to ensure adequate space is provided for the equipment, connectivity and electrical services are installed, immediate 24/7 access to equipment for service and maintenance by ITSP technicians is granted, a teleradiology coordinator is appointed and available for training by the ITSP, and medical staff is available to perform the screening exams and receive reports. The teleradiology coordinator may be a nurse or nurse practitioner and collateral duty of the appointed staff (it is not necessary to appoint a full time coordinator if the volume of work does not support a full time employee).
2. Teleradiology equipment requires high voltage power to accommodate x-ray equipment, specifications will be provided by ICE.

#### H. Processing Area

1. Expansion required in this area includes the need to accommodate processing varying numbers of detainees for intake and out-processing, i.e., large buses transport of up to 100 detainees.
2. Processing area must be designed to process male and/or female detainees as required in high frequency rates and varying numbers, i.e., a busload up to 100 detainees at one time.

#### I. Furniture

All furniture and case goods shall be furnished by the service provider in accordance with ICE Design Guide and specifications, which include ICE support space and all operational components which include EOIR, OPLA and DIHS space as required in accordance with the ICE Design Standards.

#### J. ICE IT Equipment

ICE will provide and install IT equipment in office spaces for ICE personnel only, to include computer workstations and screens, printers and fax machines. All infrastructure, cabling, and interfacing equipment shall be provided by the Service Provider at time of construction.

**NOTE:** ICE IT system must be a complete, independent and physically separate system from the Service Provider's IT system. The system shall serve all operational components: ICE, OPLA, and DIHS. EOIR shall have a separate system within EOIR IT space as per the EOIR Design Standards.

#### K. Communication Equipment

The service provider shall purchase, install and maintain a complete and operating communication system, which includes but is not limited to: cabling, fiber optics, patch panels, landing blocks, circuits, PBX and voice mail, phone sets and other supporting infrastructure and supporting system in compliance with ICE specifications. Separate billing to ICE must be established on all reoccurring service fees for communications and IT. Systems shall be installed specifically for ICE use.

**NOTE:** ICE communication system must be a complete, independent and physically separate system from the Service Provider communication system, and billed separately. The system shall serve all operational components: ICE, OPLA, and DIHS. EOIR shall have a separate system within EOIR IT space as per the EOIR Design Standards.

Service Provider see attached SOW for phone system details.

#### VIII. Detainee Work Program:

1. Detainee labor shall be used in accordance with the detainee work plan developed by the **PROVIDER**, and will adhere to the ICE National Detention Standard on Detainee Voluntary Work Program. The detainee work plan must be voluntary, and may include work or program assignments for industrial, maintenance, custodial, service, or other jobs. The detainee work program shall not conflict with any other requirements of the contract and must comply with all applicable laws and regulations.
2. Detainees shall not be used to perform the responsibilities or duties of an employee of the **PROVIDER**. Detainees shall not be used to perform work in areas where sensitive documents are maintained (designated ICE workspace). Custodial/janitorial services to be performed in designated ICE work space will be the responsibility of the **PROVIDER**.
3. Appropriate safety/protective clothing and equipment shall be provided to detainee workers as appropriate. Detainees shall not be assigned work that is considered hazardous or dangerous. This includes, but is not limited to, areas or assignments requiring great heights, extreme temperatures, use of toxic substances, and unusual physical demands.

4. The **PROVIDER** shall supply sufficient Detention Officers to monitor and control detainee work details. Unless approved by the COTR, these work details must be within the security perimeter.
5. It will be the sole responsibility of ICE to determine whether a detainee will be allowed to perform on voluntary work details and at what classification level. All detainees shall be searched when they are returned from work details.

**IX. Law Library:**

The **PROVIDER** shall provide secure space within the secure perimeter, either a dedicated room or a multipurpose room for books and materials to provide a reading area "Law Library" - in accordance with the ICE National Detention Standards on the Access to Legal Materials.

**X. Training:**

Employees shall not perform duties under this agreement until they have successfully completed all initial training and the COTR receives written certification from the **PROVIDER**.

**A. General Training Requirements**

1. All employees must have the training described in the ACA Standards and in this section. Any remuneration (pay) due PROVIDER employees in accordance with Department of Labor regulations for any training time is the responsibility of the PROVIDER. The PROVIDER shall provide the required refresher courses or have an institution acceptable to the COTR to provide the training. Failure of any employee to complete training successfully is sufficient reason to disqualify him or her from duty.
2. All new Detention Officers will receive 54 hours of basic training, not to include firearms and 40 hours of on-the-job training prior to entering on duty. The **PROVIDER'S** Training Officer will be responsible for administering an on-the-job training program for new employees. A senior Detention Officer, at all times during this latter 40-hour period, must accompany the Detention Officers. The **PROVIDER'S** Training Officer shall send a copy of the documentation to the COTR upon successful completion of the employee's on-the-job training.
3. In addition, after completion of the first 94 hours of training, the **PROVIDER** has 60 days to complete an additional 40 hours of training. During the remainder of the first year on duty, the officer will have an additional 40 hours of training for a total of 174 hours within the first year of employment. The training program must directly relate to the employee's assigned position and afford application of necessary job skills. Training site shall be provided by the **PROVIDER** at no cost to the Government.

a. Basic Training Subjects:

1. Employees must complete the following list of basic training subjects. The course title is followed by the estimated hours of training for that subject.

- a. In-service Orientation/Social Diversity 2 HRS
- b. Counseling Techniques/Suicide Prevention 2 HRS
- c. Conduct/Duties/Ethics and Courtroom Demeanor 2 HRS
- d. Bomb Defense and Threats 1 HR
- e. Telephone Communications/Radio Procedures 1 HR
- f. Fire and other Emergency Procedures 2 HRS
- g. Treatment and Supervision of Detainees 2 HRS
- h. ICE Use of Force Policy 2 HRS
- i. Security Methods/Key Control/Count 1 HR
- j. Procedures/Observational Techniques 4 HRS
- k. EEO/Sexual Harassment 2 HRS
- l. Detainee Escort Techniques 1 HR
- m. ICE Paperwork/Report Writing 2 HRS
- n. Detainee Searches/Detainee Personal Property 4 HRS
- o. Property/Contraband 2 HRS
- p. Detainee Rules and Regulations 2 HRS
- q. First Aid\* 4 HRS
- r. Cardiopulmonary resuscitation (CPR)\* 4 HRS
- s. Blood-borne Pathogens\* 2 HRS
- t. Self Defense 8 HRS
- u. Use of Restraints 6 HRS
- v. Firearm Training \*\*
- w. Sexual Abuse/Assault Prevention & Intervention\* 2 HRS
- x. National Detention Standards 2 HRS

*\* Critical Training Subjects*

*\*\* Firearm Training for Required Armed Detention Services in accordance with state licensing requirements. PROVIDER shall certify proficiency every quarter.*

b. Refresher Training

- 1. Every year the **PROVIDER** shall conduct 40 hours of Refresher Training for all Detention Officers including Supervisory Detention Officers. Refresher

training shall consist of these critical subjects listed above and a review of basic training subjects and others as approved by ICE.

2. The **PROVIDER** shall coordinate recertification in CPR and First Aid with the ICE training staff. This training shall be provided at no cost to the Government. Annually, upon completion, the **PROVIDER** shall provide documentation of refresher training to the COTR.
3. In addition to the refresher training requirements for all Detention Officers, supervisors must receive refresher training relating to supervisory duties.

c. On-the-Job Training

1. After completion of the minimum of 54 hours basic training, all Detention Officers will receive an additional 40 hours of on-the-job training at specific post positions. This training includes:
  - a. Authority of supervisors and organizational code of conduct.
  - b. General information and special orders.
  - c. Security systems operational procedures.
  - d. Facility self-protection plan or emergency operational procedures.
  - e. Disturbance Control Team training.

d. Training During Initial 60 Day Period

The **PROVIDER** shall provide an additional 40 hours of training for Detention Officers within 60 days after completion of first 94 hours of training. The **PROVIDER** shall provide the training format and subjects, for approval by the COTR and CO, prior to the commencement of training.

e. Basic First Aid and CPR Training

1. All members of the **PROVIDER'S** security staff shall be trained in basic first aid and CPR. They must be able to:
  - a. Respond to emergency situations within four minutes.
  - b. Perform cardiopulmonary resuscitation (CPR).
  - c. Recognize warning signs of impending medical emergencies.
  - d. Know how to obtain medical assistance.
  - e. Recognize signs and symptoms of mental illness.
  - f. Able to administer medication;
  - g. Know the universal precautions for protection against blood-borne

diseases.

## B. Supervisory Training

1. All new Supervisory Detention Officers assigned to perform work under this agreement must successfully complete a minimum of 40 hours of formal supervisory training provided by the **PROVIDER** prior to assuming duties. This training is in addition to mandatory training requirements for Detention Officers. Supervisory training shall include the following management areas:

- |   |       |
|---|-------|
| a. Techniques for issuing written and verbal orders | 2 HRS |
| b. Uniform clothing and grooming standards          | 1 HR  |
| c. Security Post Inspection procedures              | 2 HRS |
| d. Employee motivation                              | 1 HR  |
| e. Scheduling and overtime controls                 | 2 HRS |
| f. Managerial public relations                      | 4 HRS |
| g. Supervision of detainees                         | 4 HRS |
| h. Other company policies                           | 4 HRS |

Additional classes are at the discretion of the PROVIDER with the approval of the COTR.

The PROVIDER shall submit documentation to the COTR, to confirm that each supervisor has received basic training as specified in the basic training curriculum.

## C. Proficiency Testing

The PROVIDER shall give each Detention Officer a written examination consisting of at least 25 questions after each classroom-training course is completed. The PROVIDER may give practical exercises when appropriate. The COTR shall approve the questions before the PROVIDER can administer the examination. To pass any examination, each officer must achieve a score of 80% or better. The PROVIDER must provide the COTR with the eligible Detention Officer's completed exam before the Detention Officer may be assigned to duties under the agreement. Should an employee fail the written test on the initial attempt, he or she shall be given additional training by the PROVIDER and be given one additional opportunity to retake the test. If the employee fails to complete and pass the test the second time, the PROVIDER shall remove the employee from duties on this agreement.

## D. Certified Instructors

Certified instructors shall conduct all instruction and testing. A state or nationally recognized institution shall certify instructors unless otherwise approved in

writing by the COTR. Certifications of instructors may be established by documentation of past experience in teaching positions or by successful completion of a course of training for qualifying personnel as instructors. The COTR must approve the instructor prior to the training course.

E. Training Documentation

1. The **PROVIDER** shall submit a training forecast and lesson plans to the COTR or ICE designee, on a monthly basis, for the following 60-day period. The training forecast shall provide date, time, and location of scheduled training and afford the COTR observation/evaluation opportunity.
2. The **PROVIDER** shall certify and submit the training hours, type of training, date and location of training, and name of the instructor monthly for each employee to the COTR or ICE designee.

XI. Notification and Public Disclosures:

There shall be no public disclosures regarding this agreement made by the **PROVIDER** (or any subcontractors) without review and approval of such disclosure by ICE Public Affairs and express permission granted by the ICE Contracting Officer. The Government considers such information privileged or confidential until award of the agreement.

**XII. Establish and Maintain Program for Prevention of Sexual Abuse/Assault:**

The **PROVIDER** shall develop and implement a comprehensive sexual abuse/assault prevention and intervention program. This program shall include training that is given separately to both staff and detainees, in accordance with the Prison Rape Elimination Act (PREA).

**XIII. Business Permits and Licenses:**

The **PROVIDER** must obtain all required permits and licenses by the date of agreement award. The **PROVIDER** must (depending on the state's requirements) be licensed as a qualified security service company in accordance with the requirements of the district, municipality, county, and state in which ICE work site(s) is/are located. Throughout the term of this agreement, the **PROVIDER** shall maintain current permits/business licenses and make copies available for Government Inspection. The **PROVIDER** shall comply with all applicable federal, state, and local laws and all applicable Occupational Safety and Health Administration (OSHA) standards.

## **XIV. Firearms / Body Armor:**

### **A. Firearms Requirements**

1. The **PROVIDER** shall provide new firearms and maintain sufficient licensed firearms and ammunition to equip each armed Detention Officer and armed supervisor(s) with a licensed weapon while on duty. Firearms may be re-issued to new replacement employees throughout the life of the agreement as long as the firearm is in serviceable condition.
2. Personal firearms shall not be used. A licensed gunsmith, in writing, shall certify all firearms safe and accurate.
3. Firearms shall be standard police service-type, semi-automatic capable of firing hollow-point ammunition that meets the recommendations of the firearms manufacturer. Ammunition will be factory load only – no reloads. Ammunition will be replaced every year.
4. The **PROVIDER** shall provide sufficient ammunition for each armed Detention Officer, including uniformed contract supervisor(s); they shall be issued three full magazines.
5. The **PROVIDER** shall account for all firearms and ammunition daily.
6. If any weapons or ammunition are missing from the inventory, the COTR shall be notified immediately.
7. All firearms shall be licensed by the State.
8. Firearms will be inspected. This shall be documented by the Warden/Facility Director.
9. Loading, unloading, and cleaning of the firearms shall only take place in designated areas.
10. The firearms shall be cleaned and oiled as appropriate to ensure optimum operating conditions.
11. Firearms shall be carried with the safety on, if applicable, with a round in the chamber.
12. The **PROVIDER** shall maintain appropriate and ample supplies of firearms' upkeep and maintenance equipment (cleaning solvents, lubricating oil, rods, brushes, patches, and other normal maintenance tools).
13. The **PROVIDER** shall provide a complete listing of licensed firearms by serial numbers and by each safe location to the COTR prior to beginning performance under this agreement.
14. These lists shall be kept current through the terms of the agreement and posted within each firearms safe.
15. The **PROVIDER** shall obtain and maintain on file appropriate State and municipality permits and weapons permits for each officer.



16. A copy of this permit shall be provided to the COTR at least three working days prior to the anticipated assignment date of any individual.
17. The **PROVIDER** shall ensure that his/her employees have all permits and licenses in their possession at all times while in performance of this agreement.
18. The **PROVIDER** shall provide safes/vaults for storage of firearms and ammunition, for each location where firearms are issued or exchanged, which meet agency requirements and are approved for the storage of firearms and ammunition.
19. The COTR is responsible for approving the proposed safes/vaults prior to usage. **PROVIDER** supervisors and guards shall make accurate receipt and return entries on a Firearms and Equipment Control Register.
20. Except when issuing or returning ammunition or firearms, each safe/vault shall remain locked at all times.
21. The **PROVIDER** shall be responsible for having the combination of each safe/vault changed at least once every six months, or more often if circumstances warrant.
22. The **PROVIDER** certifies firearms training to the COTR.
23. The **PROVIDER** shall certify proficiency every quarter.
24. The **PROVIDER** shall provide an ICE approved intermediate weapon(s).

#### B. Body Armor Requirements

1. The **PROVIDER** shall provide body armor to all armed Detention Officers and armed supervisor(s).
2. Body armor shall be worn while on armed duty.
3. The body armor shall meet all requirements as set forth in the ICE Firearms Policy.
4. The **PROVIDER** shall procure replacement body armor if the body armor becomes unserviceable, ill-fitting, worn/damaged, or at the expiration of service life.
5. All armed Detention Officers and armed supervisors need to be made aware of the health risks associated with the wearing of body armor in high heat/high humidity conditions and/or during strenuous exertion. When Detention Officers and supervisors are required to wear body armor, they shall be provided opportunities to rehydrate and remove the body armor as necessary.
6. The use of personally owned body armor is not authorized.

## Stevens, Richard P

---

**From:** Neveleff, Jerald  
**Sent:** Thursday, May 01, 2008 11:20 AM  
**To:** Wyatt-Powell, Wendie M  
**Cc:** Jenkins, John E  
**Subject:** Re: Meeting

The field directed them to us first. So this meeting as far as I know its about the IGSA package. Any questions that the field needs to answer, we can forward them Jerry Sent using BlackBerry

----- Original Message -----

**From:** Wyatt-Powell, Wendie M  
**To:** Neveleff, Jerald  
**Cc:** Jenkins, John E  
**Sent:** Thu May 01 11:17:03 2008  
**Subject:** RE: Meeting

Jerry, we have no space over hear. Now that the meeting will be held in your space, to create space for our visitors, John Jenkins and I would like to call into your office. Who is going to be representing the field and will they be calling in as well?

Wendie Wyatt-Powell  
Detention Acquistion Support Unit  
Detention Management Division  
Office of Detention and Removal  
U.S. Immigration and Customs Enforcement US Department of Homeland Security  
202-732- (b)(2)Low  
202-732-

Warning: This document is UNCLASSIFIED//FOR OFFICIAL USE ONLY (U//FOUO). It contains information that may be exempt from public release under the Freedom of Information Act (5 U.S.C. 552). It is to be controlled, stored, handled, transmitted, distributed, and disposed of in accordance with DHS policy relating to FOUO information and is not to be released to the public or other personnel who do not have a valid "need-to-know" without prior approval of an authorized DHS official. No portion of this report should be furnished to the media, either in written or verbal form.

-----Original Message-----

**From:** Neveleff, Jerald  
**Sent:** Thursday, May 01, 2008 11:13 AM  
**To:** Wyatt-Powell, Wendie M  
**Subject:** Meeting

Wendie,  
I'm in a meeting. Email me if you've found a place to meet. They will be here at 1300. However, I will wait until noon before calling and changing location.  
Jerry  
Jerry  
Sent using BlackBerry

## Stevens, Richard P

---

**From:** Neveleff, Jerald  
**Sent:** Friday, May 02, 2008 7:04 AM  
**To:** Achim, Deborah; Evans, Mary Y; Dellar, William L; Quiroz, Jose; Davis, Dianna L; Jenkins, John E; Washington, John W; Raine, Craig K  
**Cc:** Weinberg, Bill; Wyatt-Powell, Wendie M; Casterline, Arnold P; 'rharper@ica-farmville.com'; gspates@farmvilleva.com; Lisa Hricko  
**Subject:** FARMVILLE

Good afternoon,

A meeting was held today with representative from ICA – Farmville, LLC, the owner and operator of the facility being built in Farmville, VA.

Questions ranged from what's in the agreement, how do they price the effort, standards to be performed to, length of the agreement, and how can they (ICA) receive detainees prior to the completion of the construction project. Some of the questions and recommendations presented by ICA were not able to be answered by John Jenkins and I as many of them addressed operational concerns.

It was suggested that as a minimum; representatives from the Field Office, Facilities Management Unit, Detention Acquisition Support Unit, Office of Acquisition Management, and Farmville (or duly authorized representative) gather to discuss a way ahead to get the facility on line as soon and efficiently as possible.

It was suggested that the meeting be held at the Field Office on the 8<sup>th</sup> of May around 1000.

Thoughts?

Jerry

Thank you,  
Jerry Neveleff  
Supervisory Contracting Officer/  
IGSA Team Lead  
Office of Acq. Management (OAQ)  
Detention Management Division  
202/616 (b)(2)Low

Help us support you better -

TELL US HOW WE ARE DOING!

Go to <<http://www.acqsolinc.com/ICE/OAQ/feedback.cfm>> <<<http://www.acqsolinc.com/ICE/OAQ/feedback.cfm>>>

## Stevens, Richard P

---

**From:** Neveleff, Jerald  
**Sent:** Friday, May 02, 2008 7:34 AM  
**To:** Dellar, William L  
**Subject:** RE: FARMVILLE

Not really. It will need open discussion as the questions addressed many what ifs and can we do this now and that later to start filling beds. It would be easier to have the key people in the room and throw ideas out there.

At least now we (OAQ) are getting invited to these meeting so we know what's going on and we can actual plan how to get there.

Thank you,  
Jerry Neveleff  
Supervisory Contracting Officer/  
IGSA Team Lead  
Office of Acq. Management (OAQ)  
Detention Management Division  
202/616- (b)(2)Low

Help us support you better -  
TELL US HOW WE ARE DOING!

Go to <<http://www.acqsolinc.com/ICE/OAQ/feedback.cfm>> <<<http://www.acqsolinc.com/ICE/OAQ/feedback.cfm>>>

---

**From:** Dellar, William L  
**Sent:** Friday, May 02, 2008 7:29 AM  
**To:** Neveleff, Jerald  
**Subject:** RE: FARMVILLE

Good Morning Jerry. Are these the types of questions and answers that are best reduced to writing?

---

**From:** Neveleff, Jerald  
**Sent:** Friday, May 02, 2008 7:04 AM  
**To:** Achim, Deborah; Evans, Mary Y; Dellar, William L; Quiroz, Jose; Davis, Dianna L; Jenkins, John E; Washington, John W; Raine, Craig K  
**Cc:** Weinberg, Bill; Wyatt-Powell, Wendie M; Casterline, Arnold P; 'rharper@ica-farmville.com'; gspates@farmvilleva.com; Lisa Hricko  
**Subject:** FARMVILLE

Good afternoon,  
A meeting was held today with representative from ICA – Farmville, LLC, the owner and operator of the facility being built in Farmville, VA.  
Questions ranged from what's in the agreement, how do they price the effort, standards to be performed to, length of the agreement, and how can they (ICA) receive detainees prior to the completion of the construction project. Some of the questions and recommendations presented by ICA were not able to be answered by John Jenkins and I as many of them addressed operational concerns.

It was suggested that as a minimum; representatives from the Field Office, Facilities Management Unit, Detention Acquisition Support Unit, Office of Acquisition Management, and Farmville (or duly authorized representative) gather to discuss a way ahead to get the facility on line as soon and efficiently as possible.

It was suggested that the meeting be held at the Field Office on the 8<sup>th</sup> of May around 1000.

Thoughts?

Jerry

Thank you,  
Jerry Neveleff  
Supervisory Contracting Officer/  
IGSA Team Lead  
Office of Acq. Management (OAQ)  
Detention Management Division  
202/616- (b)(2)Low

Help us support you better -  
TELL US HOW WE ARE DOING!

Go to <http://www.acqsolinc.com/ICE/OAQ/feedback.cfm> <<<http://www.acqsolinc.com/ICE/OAQ/feedback.cfm>>>

## Stevens, Richard P

---

**From:** Raine, Craig K  
**Sent:** Friday, May 02, 2008 10:44 AM  
**To:** Neveleff, Jerald  
**Cc:** Weinberg, Bill; Wyatt-Powell, Wendie M; Casterline, Arnold P; 'rharper@ica-farmville.com'; 'gspates@farmvilleva.com'; 'Lisa Hricko'; Archibeque, Vincent E; Achim, Deborah; 'Evans, Mary Y'; Dellar, William L; Quiroz, Jose; Davis, Dianna L; Jenkins, John E; Washington, John W  
**Subject:** RE: FARMVILLE  
**Importance:** High

Hello Jerry,

We will host the meeting and are interested in addressing the operational questions. If we could get the questions in writing in advance, we can do whatever research is needed and come away from the meeting with everything answered and keep the project on track. Please advise in advance who will attend so we can coordinate entrance through security.

Thx

Craig

(202) 439- (b)(2)Low

Washington Field Office  
2675 Prosperity Avenue, Ste 300  
Fairfax, VA 22031

---

**From:** Neveleff, Jerald  
**Sent:** Friday, May 02, 2008 7:04 AM  
**To:** Achim, Deborah; Evans, Mary Y; Dellar, William L; Quiroz, Jose; Davis, Dianna L; Jenkins, John E; Washington, John W; Raine, Craig K  
**Cc:** Weinberg, Bill; Wyatt-Powell, Wendie M; Casterline, Arnold P; 'rharper@ica-farmville.com'; gspates@farmvilleva.com; Lisa Hricko  
**Subject:** FARMVILLE

Good afternoon,  
A meeting was held today with representative from ICA – Farmville, LLC, the owner and operator of the facility being built in Farmville, VA.  
Questions ranged from what's in the agreement, how do they price the effort, standards to be performed to, length of the agreement, and how can they (ICA) receive detainees prior to the completion of the construction project. Some of the questions and recommendations presented by ICA were not able to be answered by John Jenkins and I as many of them addressed operational concerns.

It was suggested that as a minimum; representatives from the Field Office, Facilities Management Unit, Detention Acquisition Support Unit, Office of Acquisition Management, and Farmville (or duly authorized representative) gather to discuss a way ahead to get the facility on line as soon and efficiently as possible.

It was suggested that the meeting be held at the Field Office on the 8<sup>th</sup> of May around 1000.

Thoughts?  
Jerry

Thank you,  
Jerry Neveleff  
Supervisory Contracting Officer/  
IGSA Team Lead

Office of Acq. Management (OAQ)

Detention Management Division

202/616 (b)(2)Low

Help us support you better -

TELL US HOW WE ARE DOING!

Go to <http://www.acqsolinc.com/ICE/OAQ/feedback.cfm> <<<http://www.acqsolinc.com/ICE/OAQ/feedback.cfm>>>

## Stevens, Richard P

---

**From:** Neveleff, Jerald  
**Sent:** Friday, May 02, 2008 10:53 AM  
**To:** 'rharper@ica-farmville.com'  
**Cc:** 'gspates@farmvilleva.com'; Lisa Hricko; 'etoney@ica-farmville.com'; 'knewsome@ica-farmville.com'; 'wcoleman@ica-farmville.com'; Raine, Craig K  
**Subject:** FARMVILLE  
**Importance:** High

Mr. Harper,

It has been requested that a list of advance questions be submitted to me by Monday 5/5/08, 1200. This will enable the ICE team to research and coordinate responses to all your questions/concerns at the meeting and facilitate an effective meeting and keep the project on track.

I will also need a list of names of those that will be attending so access can be arranged at the location.

Jerry

Thank you,  
Jerry Neveleff  
Supervisory Contracting Officer/  
IGSA Team Lead  
Office of Acq. Management (OAQ)  
Detention Management Division  
202/616 (b)(2)Low

Help us support you better -  
TELL US HOW WE ARE DOING!

Go to <<http://www.acqsolinc.com/ICE/OAQ/feedback.cfm>> <<<http://www.acqsolinc.com/ICE/OAQ/feedback.cfm>>>



**Stevens, Richard P**

---

**From:** Russell Harper [rharper@hdcva.com]  
**Sent:** Friday, May 02, 2008 10:53 AM  
**To:** Raine, Craig K; Neveleff, Jerald  
**Cc:** Weinberg, Bill; Wyatt-Powell, Wendie M; Casterline, Arnold P; gspates@farmvilleva.com; lhricko@farmvilleva.com; Archibeque, Vincent E; Achim, Deborah; Evans, Mary Y; Dellar, William L; Quiroz, Jose; Davis, Dianna L; Jenkins, John E; Washington, John W; Warren Coleman; knewsome@amfbakery.com  
**Subject:** Re: FARMVILLE

We will have the questions to all by at 1000 AM Monday. Thank you,

Russell Harper

-----  
 Sent from Russell B. Harper

-----Original Message-----

**From:** Raine, Craig K <(b)(6)>  
**To:** Neveleff, Jerald <(b)(6)>  
**CC:** Weinberg, Bill <(b)(6)>; Wyatt-Powell, Wendie M <(b)(6)>; Casterline, Arnold P <(b)(6)>; Russell Harper <rharper@hdcva.com>; gspates@farmvilleva.com <gspates@farmvilleva.com>; Lisa Hricko <lhricko@farmvilleva.com>; Achim, Deborah <(b)(6)>; Evans, Marv Y <(b)(6)>; Dellar, William L <(b)(6)>; Quiroz, Jose <(b)(6)>; Davis, Dianna L <(b)(6)>; Jenkins, John E <(b)(6)>; Washington, John W <(b)(6)>

**Sent:** Fri May 02 10:44:17 2008  
**Subject:** RE: FARMVILLE

Hello Jerry,

We will host the meeting and are interested in addressing the operational questions. If we could get the questions in writing in advance, we can do whatever research is needed and come away from the meeting with everything answered and keep the project on track. Please advise in advance who will attend so we can coordinate entrance through security.

Thx

Craig

(202) 439- (b)(2)Low

Washington Field Office

2675 Prosperity Avenue, Ste 300

Fairfax, VA 22031

---

**From:** Neveleff, Jerald  
**Sent:** Friday, May 02, 2008 7:04 AM  
**To:** Achim, Deborah; Evans, Mary Y; Dellar, William L; Quiroz, Jose; Davis, Dianna L; Jenkins, John E; Washington, John W; Raine, Craig K  
**Cc:** Weinberg, Bill; Wyatt-Powell, Wendie M; Casterline, Arnold P; rharper@ica-farmville.com; gspates@farmvilleva.com; Lisa Hricko  
**Subject:** FARMVILLE

Good afternoon,

A meeting was held today with representative from ICA – Farmville, LLC, the owner and operator of the facility being built in Farmville, VA.

12/21/2008

Questions ranged from what's in the agreement, how do they price the effort, standards to be performed to, length of the agreement, and how can they (ICA) receive detainees prior to the completion of the construction project. Some of the questions and recommendations presented by ICA were not able to be answered by John Jenkins and I as many of them addressed operational concerns.

It was suggested that as a minimum; representatives from the Field Office, Facilities Management Unit, Detention Acquisition Support Unit, Office of Acquisition Management, and Farmville (or duly authorized representative) gather to discuss a way ahead to get the facility on line as soon and efficiently as possible.

It was suggested that the meeting be held at the Field Office on the 8th of May around 1000.

Thoughts?

Jerry

Thank you,

Jerry Neveleff

Supervisory Contracting Officer/

IGSA Team Lead

Office of Acq. Management (OAQ)

Detention Management Division

202/616. (b)(2)Low

Help us support you better -

TELL US HOW WE ARE DOING!

Go to <<http://www.acqsolinc.com/ICE/OAQ/feedback.cfm>> <<<http://www.acqsolinc.com/ICE/OAQ/feedback.cfm>>>

**Stevens, Richard P**

---

**From:** Russell Harper [rharper@hdcva.com]  
**Sent:** Friday, May 02, 2008 10:56 AM  
**To:** Neveleff, Jerald  
**Cc:** gspates@farmvilleva.com; lhricko@farmvilleva.com; etoney@ica-farmville.com; Ken Newsome; Warren Coleman; Raine, Craig K  
**Subject:** Re: FARMVILLE

Will do. Russell

-----  
Sent from Russell B. Harper

-----Original Message-----

From: Neveleff, Jerald <(b)(6)>  
To: Russell Harper <rharper@hdcva.com>  
CC: gspates@farmvilleva.com <gspates@farmvilleva.com>; Lisa Hricko <lhricko@farmvilleva.com>; etoney@ica-farmville.com <etoney@ica-farmville.com>; Ken Newsome <knewsome@hdcva.com>; Warren Coleman <wcoleman@hdcva.com>; Raine, Craig K <(b)(6)>  
Sent: Fri May 02 10:53:20 2008  
Subject: FARMVILLE

Mr. Harper,

It has been requested that a list of advance questions be submitted to me by Monday 5/5/08, 1200. This will enable the ICE team to research and coordinate responses to all your questions/concerns at the meeting and facilitate an effective meeting and keep the project on track.

I will also need a list of names of those that will be attending so access can be arranged at the location.

Jerry

Thank you,

Jerry Neveleff

Supervisory Contracting Officer/

IGSA Team Lead

Office of Acq. Management (OAQ)

Detention Management Division

202/616- (b)(2)Low

Help us support you better -

TELL US HOW WE ARE DOING!

Go to <<http://www.acqsolinc.com/ICE/OAQ/feedback.cfm> > <<<http://www.acqsolinc.com/ICE/OAQ/feedback.cfm> > >>

## Stevens, Richard P

---

**From:** Davis, Dianna L  
**Sent:** Friday, May 02, 2008 4:35 PM  
**To:** Raine, Craig K; Neveleff, Jerald  
**Subject:** RE: FARMVILLE

Are we having a meeting on this and if so, have we confirmed the date to be May 8th.

---

**From:** Raine, Craig K  
**Sent:** Friday, May 02, 2008 10:44 AM  
**To:** Neveleff, Jerald  
**Cc:** Weinberg, Bill; Wyatt-Powell, Wendie M; Casterline, Arnold P; 'rharper@ica-farmville.com'; 'gspates@farmvilleva.com'; 'Lisa Hricko'; Archibeque, Vincent E; Achim, Deborah; 'Evans, Mary Y'; Dellar, William L; Quiroz, Jose; Davis, Dianna L; Jenkins, John E; Washington, John W  
**Subject:** RE: FARMVILLE  
**Importance:** High

Hello Jerry,

We will host the meeting and are interested in addressing the operational questions. If we could get the questions in writing in advance, we can do whatever research is needed and come away from the meeting with everything answered and keep the project on track. Please advise in advance who will attend so we can coordinate entrance through security.

Thx

Craig

(202) 439- (b)(2)Low

Washington Field Office  
2675 Prosperity Avenue, Ste 300  
Fairfax, VA 22031

---

**From:** Neveleff, Jerald  
**Sent:** Friday, May 02, 2008 7:04 AM  
**To:** Achim, Deborah; Evans, Mary Y; Dellar, William L; Quiroz, Jose; Davis, Dianna L; Jenkins, John E; Washington, John W; Raine, Craig K  
**Cc:** Weinberg, Bill; Wyatt-Powell, Wendie M; Casterline, Arnold P; 'rharper@ica-farmville.com'; gspates@farmvilleva.com; Lisa Hricko  
**Subject:** FARMVILLE

Good afternoon,

A meeting was held today with representative from ICA – Farmville, LLC, the owner and operator of the facility being built in Farmville, VA.

Questions ranged from what's in the agreement, how do they price the effort, standards to be performed to, length of the agreement, and how can they (ICA) receive detainees prior to the completion of the construction project. Some of the questions and recommendations presented by ICA were not able to be answered by John Jenkins and I as many of them addressed operational concerns.

It was suggested that as a minimum; representatives from the Field Office, Facilities Management Unit, Detention Acquisition Support Unit, Office of Acquisition Management, and Farmville (or duly authorized representative) gather to discuss a way ahead to get the facility on line as soon and efficiently as possible.

It was suggested that the meeting be held at the Field Office on the 8<sup>th</sup> of May around 1000.

Thoughts?  
Jerry

Thank you,  
Jerry Neveleff  
Supervisory Contracting Officer/  
IGSA Team Lead  
Office of Acq. Management (OAQ)  
Detention Management Division  
202/616 (b)(2)Low

Help us support you better -  
TELL US HOW WE ARE DOING!

Go to <<http://www.acqsolinc.com/ICE/OAQ/feedback.cfm>> <<<http://www.acqsolinc.com/ICE/OAQ/feedback.cfm>>>

## Stevens, Richard P

---

**From:** Raine, Craig K  
**Sent:** Friday, May 02, 2008 4:37 PM  
**To:** Neveleff, Jerald; Davis, Dianna L  
**Subject:** RE: FARMVILLE

We are good with the date and time.

-----Original Message-----

**From:** Neveleff, Jerald  
**Sent:** Friday, May 02, 2008 4:36 PM  
**To:** Davis, Dianna L; Raine, Craig K  
**Subject:** Re: FARMVILLE

We are shooting for the 8th and the field office can support. I will be sending out an invite Monday morning.

Jerry  
Sent using BlackBerry

----- Original Message -----

**From:** Davis, Dianna L  
**To:** Raine, Craig K; Neveleff, Jerald  
**Sent:** Fri May 02 16:34:35 2008  
**Subject:** RE: FARMVILLE

Are we having a meeting on this and if so, have we confirmed the date to be May 8th.

---

**From:** Raine, Craig K  
**Sent:** Friday, May 02, 2008 10:44 AM  
**To:** Neveleff, Jerald  
**Cc:** Weinberg, Bill; Wyatt-Powell, Wendie M; Casterline, Arnold P; 'rharper@ica-farmville.com'; 'gspates@farmvilleva.com'; 'Lisa Hricko'; Archibeque, Vincent E; Achim, Deborah; 'Evans, Mary Y'; Dellar, William L; Quiroz, Jose; Davis, Dianna L; Jenkins, John E; Washington, John W  
**Subject:** RE: FARMVILLE  
**Importance:** High

Hello Jerry,

We will host the meeting and are interested in addressing the operational questions. If we could get the questions in writing in advance, we can do whatever research is needed and come away from the meeting with everything answered and keep the project on track. Please advise in advance who will attend so we can coordinate entrance through security.

Thx

Craig

(202) 439- (b)(2)Low

Washington Field Office  
2675 Prosperity Avenue, Ste 300  
Fairfax, VA 22031

---

**From:** Neveleff, Jerald  
**Sent:** Friday, May 02, 2008 7:04 AM  
**To:** Achim, Deborah; Evans, Mary Y; Dellar, William L; Quiroz, Jose; Davis, Dianna L; Jenkins, John E; Washington, John W; Raine, Craig K

Cc: Weinberg, Bill; Wyatt-Powell, Wendie M; Casterline, Arnold P; 'rharper@ica-farmville.com'; gspates@farmvilleva.com; Lisa Hricko  
Subject: FARMVILLE

Good afternoon,

A meeting was held today with representative from ICA - Farmville, LLC, the owner and operator of the facility being built in Farmville, VA. Questions ranged from what's in the agreement, how do they price the effort, standards to be performed to, length of the agreement, and how can they (ICA) receive detainees prior to the completion of the construction project. Some of the questions and recommendations presented by ICA were not able to be answered by John Jenkins and I as many of them addressed operational concerns.

It was suggested that as a minimum; representatives from the Field Office, Facilities Management Unit, Detention Acquisition Support Unit, Office of Acquisition Management, and Farmville (or duly authorized representative) gather to discuss a way ahead to get the facility on line as soon and efficiently as possible.

It was suggested that the meeting be held at the Field Office on the 8th of May around 1000.

Thoughts?  
Jerry

Thank you,  
Jerry Neveleff  
Supervisory Contracting Officer/  
IGSA Team Lead  
Office of Acq. Management (OAQ)  
Detention Management Division  
202/616 (b)(2)Low

Help us support you better -  
TELL US HOW WE ARE DOING!  
Go to <<http://www.acqsolinc.com/ICE/OAQ/feedback.cfm>>  
<<<http://www.acqsolinc.com/ICE/OAQ/feedback.cfm>>>

**Stevens, Richard P**

---

**From:** Raine, Craig K  
**Sent:** Friday, May 02, 2008 4:39 PM  
**To:** Neveleff, Jerald  
**Subject:** RE: FARMVILLE

1-2 hours max, but I really need to see the questions .

-----Original Message-----

From: Neveleff, Jerald  
Sent: Friday, May 02, 2008 4:38 PM  
To: Raine, Craig K  
Subject: Re: FARMVILLE

Craig,  
About how long do you think it will take?  
Jerry  
Jerry  
Sent using BlackBerry

----- Original Message -----

From: Raine, Craig K  
To: Neveleff, Jerald; Davis, Dianna L  
Sent: Fri May 02 16:36:58 2008  
Subject: RE: FARMVILLE

We are good with the date and time.

-----Original Message-----

From: Neveleff, Jerald  
Sent: Friday, May 02, 2008 4:36 PM  
To: Davis, Dianna L; Raine, Craig K  
Subject: Re: FARMVILLE

We are shooting for the 8th and the field office can support. I will be sending out an invite Monday morning.

Jerry  
Sent using BlackBerry

----- Original Message -----

From: Davis, Dianna L  
To: Raine, Craig K; Neveleff, Jerald  
Sent: Fri May 02 16:34:35 2008  
Subject: RE: FARMVILLE

Are we having a meeting on this and if so, have we confirmed the date to be May 8th.

---

From: Raine, Craig K  
Sent: Friday, May 02, 2008 10:44 AM  
To: Neveleff, Jerald  
Cc: Weinberg, Bill; Wyatt-Powell, Wendie M; Casterline, Arnold P; 'rharper@ica-farmville.com'; 'gspates@farmvilleva.com'; 'Lisa Hricko'; Archibeque, Vincent E; Achim, Deborah; 'Evans, Mary Y'; Dellar, William L; Quiroz, Jose; Davis, Dianna L; Jenkins, John E; Washington, John W  
Subject: RE: FARMVILLE  
Importance: High

Hello Jerry,



We will host the meeting and are interested in addressing the operational questions. If we could get the questions in writing in advance, we can do whatever research is needed and come away from the meeting with everything answered and keep the project on track. Please advise in advance who will attend so we can coordinate entrance through security.

Thx

Craig

(202) 439- (b)(2)Low

Washington Field Office  
2675 Prosperity Avenue, Ste 300  
Fairfax, VA 22031

---

From: Neveleff, Jerald  
Sent: Friday, May 02, 2008 7:04 AM  
To: Achim, Deborah; Evans, Mary Y; Dellar, William L; Quiroz, Jose; Davis, Dianna L; Jenkins, John E; Washington, John W; Raine, Craig K  
Cc: Weinberg, Bill; Wyatt-Powell, Wendie M; Casterline, Arnold P; 'rharper@ica-farmville.com'; gspates@farmvilleva.com; Lisa Hricko  
Subject: FARMVILLE

Good afternoon,

A meeting was held today with representative from ICA - Farmville, LLC, the owner and operator of the facility being built in Farmville, VA. Questions ranged from what's in the agreement, how do they price the effort, standards to be performed to, length of the agreement, and how can they (ICA) receive detainees prior to the completion of the construction project. Some of the questions and recommendations presented by ICA were not able to be answered by John Jenkins and I as many of them addressed operational concerns.

It was suggested that as a minimum; representatives from the Field Office, Facilities Management Unit, Detention Acquisition Support Unit, Office of Acquisition Management, and Farmville (or duly authorized representative) gather to discuss a way ahead to get the facility on line as soon and efficiently as possible.

It was suggested that the meeting be held at the Field Office on the 8th of May around 1000.

Thoughts?  
Jerry

Thank you,  
Jerry Neveleff  
Supervisory Contracting Officer/  
IGSA Team Lead  
Office of Acq. Management (OAQ)  
Detention Management Division  
202/616- (b)(2)Low

Help us support you better -  
TELL US HOW WE ARE DOING!  
Go to <<http://www.acqsolinc.com/ICE/OAQ/feedback.cfm>>  
<<<http://www.acqsolinc.com/ICE/OAQ/feedback.cfm>>>

## Stevens, Richard P

---

**Subject:** FARMVILLE DISCUSSIONS  
**Location:** 2675 Prosperity Ave, Fairfax, VA 22031 (Washington Field Office)

**Start:** Thu 5/8/2008 10:00 AM  
**End:** Thu 5/8/2008 12:00 PM  
**Show Time As:** Tentative

**Recurrence:** (none)

**Meeting Status:** Not yet responded

**Required Attendees:** Achim, Deborah; Evans, Mary Y; Dellar, William L; Quiroz, Jose; Davis, Dianna L; Jenkins, John E; Washington, John W; Weinberg, Bill; Wyatt-Powell, Wendie M; Casterline, Arnold P; rharper@ica-farmville.com; gspates@farmvilleva.com; Lisa Hricko; Raine, Craig K

Good morning,

Discussions regarding the Farmville facility is scheduled for Thursday, 08 May 2008 at 1000. Please let Mr. Craig Raine know if your will be attending so arrangements to gain access to the meeting can be made. His number is (202) 439- (b)(2)Low 1).

I understand the meeting space is limited to 20 people.

Jerry  
202/616 (b)(2)Low

**Stevens, Richard P**

---

**From:** Casterline, Arnold P  
**Sent:** Monday, May 05, 2008 7:22 AM  
**To:** Neveleff, Jerald  
**Subject:** Accepted: FARMVILLE DISCUSSIONs

**Stevens, Richard P**

---

**From:** Raine, Craig K  
**Sent:** Monday, May 05, 2008 7:24 AM  
**To:** Neveleff, Jerald  
**Subject:** Accepted: FARMVILLE DISCUSSIONs

Email confirmation is best.

**Stevens, Richard P**

---

**From:** Washington, John W  
**Sent:** Monday, May 05, 2008 7:30 AM  
**To:** Neveleff, Jerald  
**Subject:** Accepted: FARMVILLE DISCUSSIONS

**Stevens, Richard P**

---

**From:** Weinberg, Bill  
**Sent:** Monday, May 05, 2008 7:42 AM  
**To:** Neveleff, Jerald  
**Subject:** Tentative: FARMVILLE DISCUSSIONs

**Stevens, Richard P**

---

**From:** Washington, John W  
**Sent:** Monday, May 05, 2008 8:02 AM  
**To:** Neveeff, Jerald  
**Subject:** Accepted: FARMVILLE DISCUSSIONs

**Stevens, Richard P**

---

**From:** Dellar, William L  
**Sent:** Monday, May 05, 2008 8:02 AM  
**To:** Neveleff, Jerald  
**Subject:** Accepted: FARMVILLE DISCUSSIONs



**Stevens, Richard P**

---

**From:** Dellar, William L  
**Sent:** Monday, May 05, 2008 8:06 AM  
**To:** Raine, Craig K  
**Cc:** Evans, Mary Y; Neveleff, Jerald; Washington, John W  
**Subject:** FARMVILLE MEETING @ WFO Thursday, 08 May 2008 at 1000

Craig, I will be attending the subject meeting. Thanks, Bill

**Stevens, Richard P**

---

**From:** Neveleff, Jerald  
**Sent:** Monday, May 05, 2008 8:13 AM  
**To:** Raine, Craig K  
**Cc:** Casterline, Arnold P  
**Subject:** Meeting on 5/8/08

Good morning Craig,  
Mr. Arnold Casterline and I will be attending. I am the responsible Contracting Office for this requirement and Mr. Casterline is the assigned Contract Specialist.

Jerry

Thank you,  
Jerry Neveleff  
Supervisory Contracting Officer/  
IGSA Team Lead  
Office of Acq. Management (OAQ)  
Detention Management Division  
202/616 (b)(2)Low

Help us support you better -  
TELL US HOW WE ARE DOING!  
Go to <<http://www.acqsolinc.com/ICE/OAQ/feedback.cfm>> <<<http://www.acqsolinc.com/ICE/OAQ/feedback.cfm>>>

**Stevens, Richard P**

---

**From:** Neveleff, Jerald  
**Sent:** Monday, May 05, 2008 10:08 AM  
**To:** 'Russell Harper'  
**Cc:** gspates@farmvilleva.com; Lisa Hricko; Washington, John W; Raine, Craig K  
**Subject:** RE: Farmville Letter

Russell,  
Based on our discussions last week, it is my understanding that ICA is a new company (formed from a mix of business and detention experienced personnel). And that ICA does not have any other existing facilities that provide ICE detention services. Does ICA have any other Federal contracts?

(b)(5)

Jerry

Thank you,  
Jerry Neveleff  
Supervisory Contracting Officer/  
IGSA Team Lead  
Office of Acq. Management (OAQ)

12/21/2008

Detention Management Division

202/616 (b)(2)Low

Help us support you better -  
TELL US HOW WE ARE DOING!

Go to <<http://www.acqsolinc.com/ICE/OAQ/feedback.cfm>> <<<http://www.acqsolinc.com/ICE/OAQ/feedback.cfm>>>

---

**From:** Russell Harper [mailto:[rharper@hdcva.com](mailto:rharper@hdcva.com)]

**Sent:** Wednesday, April 30, 2008 3:39 PM

**To:** Neveleff, Jerald

**Cc:** [gspates@farmvilleva.com](mailto:gspates@farmvilleva.com); Lisa Hricko

**Subject:** Farmville Letter

Mr. Neveleff,

Attached is the letter you requested. I will see you at 1:00 tomorrow. Our objective is to review our contract questions. Our complete submittal will be in your hands the first of next week.

Thanks

Russell Harper

---

**Stevens, Richard P**

---

**From:** Neveleff, Jerald  
**Sent:** Monday, May 05, 2008 10:08 AM  
**To:** Casterline, Arnold P  
**Subject:** FW: Farmville Letter

Thank you,  
Jerry Neveleff  
Supervisory Contracting Officer/  
IGSA Team Lead  
Office of Acq. Management (OAQ)  
Detention Management Division  
202/616 (b)(2)Low

Help us support you better -  
TELL US HOW WE ARE DOING!  
Go to <<http://www.acqsolinc.com/ICE/OAQ/feedback.cfm>> <<<http://www.acqsolinc.com/ICE/OAQ/feedback.cfm>>>

---

**From:** Neveleff, Jerald  
**Sent:** Monday, May 05, 2008 10:08 AM  
**To:** 'Russell Harper'  
**Cc:** gspates@farmvilleva.com; Lisa Hricko; Washington, John W; Raine, Craig K  
**Subject:** RE: Farmville Letter

Russell,  
Based on our discussions last week, it is my understanding that ICA is a new company (formed from a mix of business and detention experienced personnel). And that ICA does not have any other existing facilities that provide ICE detention services. Does ICA have any other Federal contracts?

(b)(5)

(b)(5)

Jerry

Thank you,  
Jerry Neveleff  
Supervisory Contracting Officer/  
IGSA Team Lead  
Office of Acq. Management (OAQ)  
Detention Management Division  
202/616 (b)(2)Low

Help us support you better -  
TELL US HOW WE ARE DOING!

Go to <<http://www.acqsolinc.com/ICE/OAQ/feedback.cfm>> <<<http://www.acqsolinc.com/ICE/OAQ/feedback.cfm>>>

---

**From:** Russell Harper [mailto:rharper@hdcva.com]  
**Sent:** Wednesday, April 30, 2008 3:39 PM  
**To:** Neveleff, Jerald  
**Cc:** gspates@farmvilleva.com; Lisa Hricko  
**Subject:** Farmville Letter

Mr. Neveleff,

Attached is the letter you requested. I will see you at 1:00 tomorrow. Our objective is to review our contract questions. Our complete submittal will be in your hands the first of next week.

Thanks

Russell Harper

---

**Stevens, Richard P**

---

**From:** Jenkins, John E  
**Sent:** Monday, May 05, 2008 11:00 AM  
**To:** Neveleff, Jerald  
**Subject:** Accepted: FARMVILLE DISCUSSIONs

**Stevens, Richard P**

---

**From:** Russell Harper [rharper@hdcva.com]  
**Sent:** Monday, May 05, 2008 10:27 AM  
**To:** Neveleff, Jerald  
**Cc:** gspates@farmvilleva.com; Lisa Hricko; Washington, John W; Raine, Craig K  
**Subject:** RE: Farmville Letter

Jerry, I with our folks and get back to you this morning. Russell

---

**From:** Neveleff, Jerald [mailto: ] (b)(6)  
**Sent:** Monday, May 05, 2008 10:08 AM  
**To:** Russell Harper  
**Cc:** gspates@farmvilleva.com; Lisa Hricko; Washington, John W; Raine, Craig K  
**Subject:** RE: Farmville Letter

Russell,  
Based on our discussions last week, it is my understanding that ICA is a new company (formed from a mix of business and detention experienced personnel). And that ICA does not have any other existing facilities that provide ICE detention services. Does ICA have any other Federal contracts?

(b)(5)



Jerry

Thank you,  
Jerry Neveleff  
Supervisory Contracting Officer/  
IGSA Team Lead  
Office of Acq. Management (OAQ)  
Detention Management Division  
202/616 (b)(2)Low

Help us support you better -  
TELL US HOW WE ARE DOING!

Go to <http://www.acqsolinc.com/ICE/OAQ/feedback.cfm> <<<http://www.acqsolinc.com/ICE/OAQ/feedback.cfm>>>

---

**From:** Russell Harper [mailto:rharp@hdcva.com]  
**Sent:** Wednesday, April 30, 2008 3:39 PM  
**To:** Neveleff, Jerald  
**Cc:** gspates@farmvilleva.com; Lisa Hricko  
**Subject:** Farmville Letter

Mr. Neveleff,

Attached is the letter you requested. I will see you at 1:00 tomorrow. Our objective is to review our contract questions. Our complete submittal will be in your hands the first of next week.

Thanks

Russell Harper

---

**Stevens, Richard P**

---

**From:** Russell Harper [redacted] (b)(6)  
**Sent:** Monday, May 05, 2008 1:33 PM  
**To:** Neveleff, Jerald  
**Subject:** Response to ICE email on accountability  
**Attachments:** ICA\_proposal\_key\_personnel042008.doc; Harper\_Associates\_Summary2008.doc; Ken Newsome Resume.doc; WColeman\_resume\_ICA2008.doc

Mr. Neveleff,

We are proud our team and will be glad to provide details on their background so you can be assured that our team has the ability to operate the Town of Farmville – ICE Facility. I have attached a list of the key personnel, a resume for Warren Coleman – COO of this operation, a resume for Ken Newsome and a summary of my experience as a builder and businessman. I hope you will agree that this group is well equipped to build and operate this facility based on our experience in building and operating businesses and that the key personnel on our team who each have over a decade of experience working with various government branches responsible for detainees can operate a quality environment for all. Details on the work experience of our key personnel are being provided as part of the proposal but I will be glad to provide it in advance if needed.

Once you have reviewed this information, please contact us to discuss any additional information that is required for you to make an affirmative determination of responsibility.

Thanks in advance for your time and we look forward to talking on Thursday May, 8.

Russell Harper

[redacted] (b)(6)



**Town of Farmville – ICE Facility: DROISA-08-0021  
May 9, 2008**

**KEY PERSONNEL**

**Governmental Staff**

**Gerald Spates, Town Manager – Town of Farmville**

Office: (b)(6)  
116 N. Main Street  
PO Drawer 368  
Farmville, Va. 23901

**Immigration Centers of America – Farmville LLC**

**Partners:**

**Russell B. Harper – President of Harper Associates LLC**

**Kenneth R. Newsome- President of AMF Automation**

**Warren K. Coleman – CFO- Harper Associates LLC**

**OPERATIONS- Key Personnel**

**Chief Operations Officer**

**Warren K. Coleman CPA (resume attached)**

(b)(6)

Richmond, Va. 23229

(b)(6)

**General Manager / Department Head of Administration**

**Ernest L. Toney Sr. (resume attached)**

(b)(6)

**Department Head of Security**

**Charles L. Marshall (resume attached)**

(b)(6)

**Department Head of Medical Support**  
**Robert A. Pugh Sr. (resume attached)**

(b)(6)

**Department Head of Support Services**  
**Confidential-Due to Employment**

(b)(6)

**Director of Real Estate**

**Russell B. Harper**

President of Harper Associates

**Director of Community Relations**

**Kenneth R. Newsome**

President of AMF Automation

## **Harper Associates LLC**

410 North Ridge Road  
Richmond, Va. 23229

Russell B. Harper is the Managing Member of Harper Associates, L.L.C. Russell is a 1984 graduate of James Madison University with a degree in Political Science. Harper Associates L.L.C. is a Real Estate Development Company whose clients include Wal-Mart and Lowes. The following list is a sample of the development projects completed to date and a brief overview of properties still owned by Harper Associates.

### **Harper Associates LLC**

Administrative Company established in 1998 which provides oversight on all projects and provides administrative support to each entity.

### **Involvement on the following projects has ranged from ownership of land, fee development to building and selling to major clients**

Wal-Mart and Lowes – Short Pump, Va.  
Lowes and Sam's - Pemberton and Broad Street, Richmond, Va.  
Wal-Mart and Ukrops – Mechanicsville, Va.  
Lowes – Winterpock and Rt. 30, Va.  
Wal-Mart – Route 10, Chesterfield, Va,  
Wal-Mart and Lowes – Parham and Route 1, Richmond, Va.  
Lowes – Route 1 and Route 10, Chester, Va.  
Wal-Mart - Colonial Heights, Va.  
Wal-Mart - Petersburg, Va.  
Wal-Mart - Stafford, Va.  
Wal-Mart – Gloucester, Va.  
Wal-Mart – Tappahannock, Va.  
Lowes- Lombardy Street, Richmond, Va.  
Lowes, Wal-Mart, Sam's – Winchester, Va.  
Wal-Mart – Wise County, Va.  
Wal-Mart – Christiansburg, Va.  
Borders Books – Broad and Stilman Parkway, Richmond, Va.  
Hunton Park – 500 acre multi-use development, Rt.33 and 295, Richmond, Va.  
Shops at Hull and Court House Road, Richmond, Va.  
Shops at Three Chopt and Cox  
Graham Station Subdivision - Gayton and Broad Street, Richmond, Va.  
River Court – River Road- west of Gaskins Road, Richmond, Va.

### **Second Baptist Church**

Chairman of Building Committee on the recent \$ 10 million expansion of Second Baptist Church.

### **Properties Developed and still under Ownership**

1. CN 2, LLC: Shops at Stratford Hills – 029 Forest Hill Ave. Richmond, Va. 23225
  - a. Ownership: 80%
  - b. Start Date: 2002
  - c. Square Footage: 17,211
  - d. Anchor Stores: Target and Ukrops
  - e. Main Tenants: Mexico Restaurant, Starbucks, Ritz Camera, Vinny's Restaurant
2. Chip North 9 LLC: 7001 Forest Hill Ave. Richmond, Va. 23225
  - a. Ownership: 80%
  - b. Start Date: 2002
  - c. Square Footage: 58,260
  - d. Anchor Stores: Target and Ukrops
  - e. Main Tenants: Office Depot, Five Below, Sprint, Jason's Deli, Moe's Southwest
3. Chippenham Forest Square LLC – 2400-2518 Sheila Lane, Richmond, Va. 23225
  - a. Ownership: 100%
  - b. Start Date: 2002
  - c. Square Footage : 41,200
  - d. Anchor Stores: Wal-Mart and Lowes
  - e. Main Tenants: Cingular, CATO, Dollar Tree, A&N
4. New River, LLC: 1500 West Broad Street and 7339 Forest Hill Avenue
  - a. Ownership: 95%
  - b. Start Date:
  - c. Square Footage: 14,750 does not include Ground Rent being paid by Kroger, Wendy's or Chubby's
  - d. Anchor Stores: Kroger
  - e. Main Tenants: Starbucks, Gamestop, Levtran
5. Madison Heights Square LLC – 4817 S. Amherst Hwy, Madison Heights, VA.
  - a. Ownership: 100%
  - b. Start Date: 1997
  - c. Square Footage: 19,900
  - d. Anchor Stores: Wal-Mart
  - e. Main Tenants: CATO, Dollar Tree, Shoe Show, 5 Guys
6. Washington Square LLC – 91 Washington Square Plaza, Fredericksburg, VA.
  - a. Ownership: 100%
  - b. Start Date: 1998
  - c. Square Footage: 27,100
  - d. Anchor Stores: Wal-Mart
  - e. Main Tenants: Dollar Tree, CATO, Haas Hallmark, Radio Shack
7. Woodstock Square LLC: 467-495 W. Reservoir Road, Woodstock Va.
  - a. Ownership: 100%
  - b. Start Date: 1997
  - c. Square Footage: 27,660
  - d. Anchor Stores: Wal-Mart
  - e. Main Tenants: Dollar Tree, CATO, Adventure Entertainment

8. Pearisburg Square LLC: 120-140 Kinter Way, Pearisburg, Va.
  - a. Ownership: 100%
  - b. Start Date: 1998
  - c. Square Footage: 17,940
  - d. Anchor Stores: Wal-Mart
  - e. Main Tenants: Dollar Tree, Queen's Pizza, Adventure Entertainment
9. Pearisburg Five LLC: 100 Woodland Drive, Pearisburg, Va.
  - a. Ownership: 100%
  - b. Start Date: 1999
  - c. Square Footage:
  - d. Anchor Stores:
  - e. Main Tenants: Convenience Store
10. Ashland Square LLC: 95-139 Ill Carter Parkway, Ashland, Va.
  - a. Ownership: 100%
  - b. Start Date: 2002
  - c. Square Footage: 30,560
  - d. Anchor Stores: Wal-Mart
  - e. Main Tenants: Dollar Tree, CATO, Movie Gallery, Shoe Show
11. Blackstone Square LLC: 1421-1449 S Main Street, Blackstone, Va.
  - a. Ownership: 100%
  - b. Start Date: 1998
  - c. Square Footage: 20,880
  - d. Anchor Stores: Wal-Mart
  - e. Main Tenants: CATO, Movie Gallery, Shoe Show
12. Farm Ventures LLC: 1800-1828 Peery Drive, Farmville, Va.
  - a. Ownership: 50%
  - b. Start Date: 1996
  - c. Square Footage: 29,300
  - d. Anchor Stores: Wal-Mart
  - e. Main Tenants: CATO, Movie Gallery, Shoe Show, Kelly Rentals
13. Farmland Ventures LLC: 1800 Peery Drive, Farmville, Va.
  - a. Ownership: 50%
  - b. Start Date: 1997
  - c. Square Footage: 8,000
  - d. Anchor Stores: Wal-Mart
  - e. Main Tenants: Dollar Tree and Ground lease to Amerilube
14. Blackstone Investments LLC: 1400-1419 S Main Street, Blackstone, Va.
  - a. Ownership: 100%
  - b. Start Date: 1997
  - c. Square Footage: Ground Lease
  - d. Anchor Stores:
  - e. Main Tenants: Wendy's, Amerilube
15. Farmville 460/15 LLC: 2003 South Main Street, Farmville, Va.
  - a. Ownership: 100%
  - b. Start Date: 1995
  - c. Square Footage: Convenience Store and Taco Bell
  - d. Anchor Stores:
  - e. Main Tenants: Convenience Store and Taco Bell

16. Kilmarnock Six LLC: 608 North Main Street, Kilmarnock, Va.
  - a. Ownership: 28%
  - b. Start Date: 1999
  - c. Square Footage: 4,370
  - d. Anchor Stores:
  - e. Main Tenants: Convenience Store and Arby's
17. Powhatan 522/60: 4201 Anderson Highway, Powhatan, Va.
  - a. Ownership: 50%
  - b. Start Date: 1996
  - c. Square Footage: Convenience Store 4,370
  - d. Anchor Stores:
  - e. Main Tenants: Convenience Store
18. Bethlehem Storage LLC, Richmond, Va.
  - a. Ownership: 50%
  - b. Start Date: 2003
  - c. Square Footage: 104,253
  - d. Anchor Stores:
  - e. Main Tenants: Office, Warehouse and Self Storage
19. City Central LLC, 1400 Ingram Ave. Richmond, Va.
  - a. Ownership: 50%
  - b. Start Date: xxxxx
  - c. Square Footage: 1,000,000 plus 20 acres
  - d. Anchor Stores:
  - e. Main Tenants: Warehouses
20. Woody Real Estate: Richmond, Va.
  - a. Ownership: 90%
  - b. Start Date: 1996
  - c. Square Footage: 5 acres
  - d. Anchor Stores:
  - e. Main Tenants: Ground Rent – Chick Fil A, Wachovia, O'Charleys
21. Mulberry Condominiums: Richmond, Va.
  - a. Ownership: 25%
  - b. Start Date: 1996
  - c. Square Footage: luxury condominiums
  - d. Anchor Stores:
  - e. Main Tenants: remaining 2 condo on the market
22. IB Ventures: Chesterfield, Va.
  - a. Ownership: 50%
  - b. Start Date: 1996
  - c. Square Footage: 5 acres
  - d. Anchor Stores:
  - e. Main Tenants: Convenience Store
23. Farmville Investment Group - Farmville, Va.
  - a. Ownership: 100%
  - b. Start Date: xxxx
  - c. Square Footage: Single Family Homes
  - d. Anchor Stores:
  - e. Main Tenants: 90 lot Subdivision



24. Tempsford 3 Condominiums, Richmond, Va.
  - a. Ownership: 27%
  - b. Start Date: 2003
  - c. Square Footage: 10 unit Apartment Building
  - d. Anchor Stores:
  - e. Main Tenants: To be converted to condos or sold
25. Blue Sky LLC: Kilmarnock, Va.
  - a. Ownership: 33%
  - b. Start Date: 2006
  - c. Square Footage: 28,000
  - d. Anchor Stores: Wal-Mart
  - e. Main Tenants: Under Construction

**Other investments:**

Atlantic Constructors, Inc.

1401 Battery Brooke, Parkway

Richmond

Region's leading mechanical and industrial contractors with over 600 skilled employees with sales in excess of \$ 140 million

[www.atlanticconstructors.com](http://www.atlanticconstructors.com)

Ownership: 45%

Richmond Freight LLC

Warehouse and local Freight Company

Ownership: 40%

Urban Exchange

Market Street

Harrisonburg, Va.

Housing (194 units) and Retail (12,000 sq. ft) coming on line in Sept of 2009

[www.ueharrisonburg.com](http://www.ueharrisonburg.com)

30% ownership

**Banking Relationships**

Suntrust 804-782-7877

(b)(6)

Bank of Goochland 804-784-4000

(b)(6)

**KENNETH R. NEWSOME**

(b)(6)

Richmond, Virginia 23229

(b)(6)

b6

**Kenneth R. Newsome**

b6

## Warren Kyle Coleman

b6



**Stevens, Richard P**

---

**From:** Neveleff, Jerald  
**Sent:** Monday, May 05, 2008 2:38 PM  
**To:** 'Russell Harper'  
**Cc:** Washington, John W  
**Subject:** RE: Response to ICE email on accountability

Sir,

Thank you very much and I am not questioning the make up of the team. I am sure each and everyone is capable. However, that's not the only thing that goes into the area of determining responsibility and qualifications. Some of the things I will need are:

ICA has adequate financial resources to perform the contract, or the ability to obtain them:

- Please provide me a complete list of the company`s tangible assets
- Complete list of loans that have been applied for and received to build, staff, and maintain the Farmville facility.
- Lines of credit

Other needed Information:

- A complete list of corporate references,
- A detailed description of the accounting system and how it meets the requirements to perform financial accounting under federally funded contracts/agreements,

Depending on the information required and my ability as the Contracting Officer, I may have to have a "pre-award" survey performed to close up any open items that will be necessary to determine responsibility and whether ICA has the overall ability to meet the needs of the Government.

Jerry

Thank you,  
Jerry Neveleff  
Supervisory Contracting Officer/  
IGSA Team Lead  
Office of Acq. Management (OAQ)  
Detention Management Division  
202. (b)(6)

Help us support you better -  
TELL US HOW WE ARE DOING!

Go to <http://www.acqsolinc.com/ICE/OAQ/feedback.cfm> <<<http://www.acqsolinc.com/ICE/OAQ/feedback.cfm>>>

---

**From:** Russell Harper (b)(6)  
**Sent:** Monday, May 05, 2008 1:33 PM  
**To:** Neveleff, Jerald  
**Subject:** Response to ICE email on accountability

Mr. Neveleff,

We are proud our team and will be glad to provide details on their background so you can be assured that our team has the ability

12/21/2008

to operate the Town of Farmville – ICE Facility. I have attached a list of the key personnel, a resume for Warren Coleman – COO of this operation, a resume for Ken Newsome and a summary of my experience as a builder and businessman. I hope you will agree that this group is well equipped to build and operate this facility based on our experience in building and operating businesses and that the key personnel on our team who each have over a decade of experience working with various government branches responsible for detainees can operate a quality environment for all. Details on the work experience of our key personnel are being provided as part of the proposal but I will be glad to provide it in advance if needed.

Once you have reviewed this information, please contact us to discuss any additional information that is required for you to make an affirmative determination of responsibility.

Thanks in advance for your time and we look forward to talking on Thursday May, 8.

Russell Harper

(b)(6)

**Stevens, Richard P**

---

**From:** Russell Harper (b)(6)  
**Sent:** Monday, May 05, 2008 2:54 PM  
**To:** Neveleff, Jerald  
**Cc:** Washington, John W  
**Subject:** RE: Response to ICE email on accountability

Jerry,

ICA is a single purpose entity established to provide the best services available in order to address the needs of the United States in the Town of Farmville.

The project is being funded by the owners through equity and has applied for no loans. Once an IGSA is in place it may secure debt through SunTrust, BB+T or Nations Bank.

A list of references will be provided this week.

Please let me know if you have additional questions.

Russell B. Harper

---

**From:** Neveleff, Jerald [mailto: (b)(6)  
**Sent:** Monday, May 05, 2008 2:38 PM  
**To:** Russell Harper  
**Cc:** Washington, John W  
**Subject:** RE: Response to ICE email on accountability

Sir,

Thank you very much and I am not questioning the make up of the team. I am sure each and everyone is capable. However, that's not the only thing that goes into the area of determining responsibility and qualifications. Some of the things I will need are:

ICA has adequate financial resources to perform the contract, or the ability to obtain them:

Please provide me a complete list of the company's tangible assets

Complete list of loans that have been applied for and received to build, staff, and maintain the Farmville facility.

Lines of credit

Other needed Information:

A complete list of corporate references,

A detailed description of the accounting system and how it meets the requirements to perform financial accounting under federally funded contracts/agreements,

Depending on the information required and my ability as the Contracting Officer, I may have to have a "pre-award" survey performed to close up any open items that will be necessary to determine responsibility and whether ICA has the overall ability to meet the needs of the Government.

Jerry

Thank you,  
Jerry Neveleff  
Supervisory Contracting Officer/

12/21/2008



IGSA Team Lead  
Office of Acq. Management (OAQ)  
Detention Management Division  
202/ (b)(6)

Help us support you better -  
TELL US HOW WE ARE DOING!

Go to <<http://www.acqsolinc.com/ICE/OAQ/feedback.cfm>> <<<http://www.acqsolinc.com/ICE/OAQ/feedback.cfm>>>

---

**From:** Russell Harper (b)(6)  
**Sent:** Monday, May 05, 2008 1:33 PM  
**To:** Neveleff, Jerald  
**Subject:** Response to ICE email on accountability

Mr. Neveleff,

We are proud our team and will be glad to provide details on their background so you can be assured that our team has the ability to operate the Town of Farmville – ICE Facility. I have attached a list of the key personnel, a resume for Warren Coleman – COO of this operation, a resume for Ken Newsome and a summary of my experience as a builder and businessman. I hope you will agree that this group is well equipped to build and operate this facility based on our experience in building and operating businesses and that the key personnel on our team who each have over a decade of experience working with various government branches responsible for detainees can operate a quality environment for all. Details on the work experience of our key personnel are being provided as part of the proposal but I will be glad to provide it in advance if needed.

Once you have reviewed this information, please contact us to discuss any additional information that is required for you to make an affirmative determination of responsibility.

Thanks in advance for your time and we look forward to talking on Thursday May, 8.

Russell Harper  
(b)(6)

**Stevens, Richard P**

---

**From:** Russell Harper (b)(6)  
**Sent:** Monday, May 05, 2008 3:05 PM  
**To:** Neveleff, Jerald  
**Cc:** Warren Coleman  
**Subject:** Farmville Questions  
**Attachments:** HDCDHSContractQuestionsclean.doc

Jerry, attached are questions we would like to discuss Thursday. Thanks for your help. Russell

---



## **Town of Farmville – ICE Facility: DROISA-08-0021**

Questions for ICE  
Meeting with ICA-Farmville  
Thursday, May 8, 2008

### General

1. Is all funding in place and have all approvals been received?
2. What is the best way to expedite the contract? We are performing site work and spending money on architects so we need to move quickly.
3. We are complying with the request to provide capacity for 1,000 detainees. This requires a significant and reasonably fixed cost structure. We assume we will be paid for 1,000 detainee capacity even if the amount is below for a short time.
  - a. What is the best way to reflect this in the contract?
4. We are required to be at full staff for nearly one month prior to opening.
  - a. What is the means to pay for our start up costs?
5. Basis of price adjustment (Article XI)
  - a. What are the indexes used to update the per diem rate?
6. Who is the designated DTS provider? If unknown, can we provide?
7. How many ICE employees are expected to relocate to Farmville for jobs in the Administration Building? Are any of the positions expected to be filled by local residents?
8. What are the registrations and permits need by the Town of Farmville to do business with ICE?
9. Development of subcontractor clause
10. Development of termination for convenience clause
  - a. How will costs incurred prior to termination be addressed?
  - b. Will scope of recovery of termination costs follow general procedures in FAR Parts 31 and 49?

### Buildings

11. Detention Facility
  - a. Final design— Who is our contact to finalize the design?
  - b. we want someone with approval authority to look at the current architect designs to make sure we are on the same page
12. Administration Facility--final design on admin building
  - a. This is a new requirement—want to focus on detention first
  - b. Who is our contact to finalize the design of the administration building?

- c. Furniture and Case Goods specifications? Communication equipment specification and cost? Can ICE simply furnish the building to their specifications
- 13. Admin Building may lag behind in construction for up to 6 months as we concentrate on the detainee center.
  - a. Should we change our construction plans to adjust this time table?

#### Transportation

- 14. Has COTR estimated transportation needs (number of teams) per section IV
- 15. Can we begin transportation services immediately?
- 16. Are cell phones acceptable for ICE communications to transportation vehicles?

#### Staffing

- 17. LPN vs. RN

**Stevens, Richard P**

---

**From:** Neveleff, Jerald  
**Sent:** Monday, May 05, 2008 3:48 PM  
**To:** 'Russell Harper'  
**Cc:** Washington, John W  
**Subject:** RE: Response to ICE email on accountability

Russell,

I understand the purpose of the entity and why it has been created but that does not relieve me of my responsibility as a Contracting Officer and the determination of responsibility.

Before any agreement can be put into place for this effort, I will need to make a determination of responsibility. Based on what you've stated and provided to date, I do not have sufficient information for me to make that call at this time. I therefore, upon receipt of the proposal, I am going to have to obtain the services of a review/audit team to perform a Pre-Award Survey to obtain the necessary information along with appropriate recommendations that I will need to make that decision

Until such time that a Determination of Responsibility can be made and an agreement is put into place signed by an ICE warranted Contracting Office, any and all commitments and expenditures made by the Town of Farmville and its subcontractors, is done so at their own risk.

Jerry

Thank you,  
 Jerry Neveleff  
 Supervisory Contracting Officer/  
 IGSA Team Lead  
 Office of Acq. Management (OAQ)  
 Detention Management Division  
 202/ (b)(6)

Help us support you better -  
 TELL US HOW WE ARE DOING!

Go to <<http://www.acqsolinc.com/ICE/OAQ/feedback.cfm>> <<<http://www.acqsolinc.com/ICE/OAQ/feedback.cfm>>>

---

**From:** Russell Harper (b)(6)  
**Sent:** Monday, May 05, 2008 2:54 PM  
**To:** Neveleff, Jerald  
**Cc:** Washington, John W  
**Subject:** RE: Response to ICE email on accountability

Jerry,

ICA is a single purpose entity established to provide the best services available in order to address the needs of the United States in the Town of Farmville.

The project is being funded by the owners through equity and has applied for no loans. Once an IGSA is in place it may secure debt through SunTrust, BB+T or Nations Bank.

A list of references will be provided this week.

Please let me know if you have additional questions.

12/21/2008

Russell B. Harper

---

**From:** Neveleff, Jerald [mailto: (b)(6)]  
**Sent:** Monday, May 05, 2008 2:38 PM  
**To:** Russell Harper  
**Cc:** Washington, John W  
**Subject:** RE: Response to ICE email on accountability

Sir,

Thank you very much and I am not questioning the make up of the team. I am sure each and everyone is capable. However, that's not the only thing that goes into the area of determining responsibility and qualifications. Some of the things I will need are:

ICA has adequate financial resources to perform the contract, or the ability to obtain them:

- Please provide me a complete list of the company's tangible assets
- Complete list of loans that have been applied for and received to build, staff, and maintain the Farmville facility.
- Lines of credit

Other needed Information:

- A complete list of corporate references.
- A detailed description of the accounting system and how it meets the requirements to perform financial accounting under federally funded contracts/agreements,

Depending on the information required and my ability as the Contracting Officer, I may have to have a "pre-award" survey performed to close up any open items that will be necessary to determine responsibility and whether ICA has the overall ability to meet the needs of the Government.

Jerry

Thank you,  
 Jerry Neveleff  
 Supervisory Contracting Officer/  
 IGSA Team Lead  
 Office of Acq. Management (OAQ)  
 Detention Management Division  
 202 (b)(6)

Help us support you better -  
 TELL US HOW WE ARE DOING!

Go to <<http://www.acqsolinc.com/ICE/OAQ/feedback.cfm>> <<<http://www.acqsolinc.com/ICE/OAQ/feedback.cfm>>>

---

**From:** Russell Harper [mailto: (b)(6)]  
**Sent:** Monday, May 05, 2008 1:33 PM  
**To:** Neveleff, Jerald  
**Subject:** Response to ICE email on accountability

Mr. Neveleff,

We are proud our team and will be glad to provide details on their background so you can be assured that our team has the ability to operate the Town of Farmville – ICE Facility. I have attached a list of the key personnel, a resume for Warren Coleman – COO

12/21/2008

of this operation, a resume for Ken Newsome and a summary of my experience as a builder and businessman. I hope you will agree that this group is well equipped to build and operate this facility based on our experience in building and operating businesses and that the key personnel on our team who each have over a decade of experience working with various government branches responsible for detainees can operate a quality environment for all. Details on the work experience of our key personnel are being provided as part of the proposal but I will be glad to provide it in advance if needed.

Once you have reviewed this information, please contact us to discuss any additional information that is required for you to make an affirmative determination of responsibility.

Thanks in advance for your time and we look forward to talking on Thursday May, 8.

Russell Harper

(b)(6)

**Stevens, Richard P**

---

**From:** Neveleff, Jerald  
**Sent:** Monday, May 05, 2008 4:08 PM  
**To:** Achim, Deborah; Raine, Craig K; Evans, Mary Y; Davis, Dianna L; Jenkins, John E; Washington, John W; Dellar, William L; Weinberg, Bill; Quiroz, Jose  
**Cc:** Wyatt-Powell, Wendie M; Casterline, Arnold P  
**Subject:** FW: Farmville Questions  
**Attachments:** HDCDHSContractQuestionsclean.doc

Good afternoon,  
Attached is a list of questions submitted by Farmville.

Upon recent discussions, it's been determined that Farmville's subcontractor ICA has not performed previously as a company under any federally funded contracts/agreements and has not had a "Determination Of Responsibility made by any Contracting Officer. Therefore, before any IGSA can be put in place, that is one of the hurdles that must be overcome. However, at this time, I do not see that as a reason to cancel the meeting.

But it must be conveyed to the Provider that it MUST be done prior to any agreement and commitments on behalf of ICE can be made.

Jerry

Thank you,  
Jerry Neveleff  
Supervisory Contracting Officer/  
IGSA Team Lead  
Office of Acq. Management (OAQ)  
Detention Management Division  
202/ (b)(6)

Help us support you better -  
TELL US HOW WE ARE DOING!

Go to <<http://www.acqsolinc.com/ICE/OAQ/feedback.cfm>> <<<http://www.acqsolinc.com/ICE/OAQ/feedback.cfm>>>

---

**From:** Russell Harper [mailto: (b)(6)]  
**Sent:** Monday, May 05, 2008 3:05 PM  
**To:** Neveleff, Jerald  
**Cc:** Warren Coleman  
**Subject:** Farmville Questions

Jerry, attached are questions we would like to discuss Thursday. Thanks for your help. Russell

---





## **Town of Farmville – ICE Facility: DROISA-08-0021**

Questions for ICE  
Meeting with ICA-Farmville  
Thursday, May 8, 2008

### General

1. Is all funding in place and have all approvals been received?
2. What is the best way to expedite the contract? We are performing site work and spending money on architects so we need to move quickly.
3. We are complying with the request to provide capacity for 1,000 detainees. This requires a significant and reasonably fixed cost structure. We assume we will be paid for 1,000 detainee capacity even if the amount is below for a short time.
  - a. What is the best way to reflect this in the contract?
4. We are required to be at full staff for nearly one month prior to opening.
  - a. What is the means to pay for our start up costs?
5. Basis of price adjustment (Article XI)
  - a. What are the indexes used to update the per diem rate?
6. Who is the designated DTS provider? If unknown, can we provide?
7. How many ICE employees are expected to relocate to Farmville for jobs in the Administration Building? Are any of the positions expected to be filled by local residents?
8. What are the registrations and permits need by the Town of Farmville to do business with ICE?
9. Development of subcontractor clause
10. Development of termination for convenience clause
  - a. How will costs incurred prior to termination be addressed?
  - b. Will scope of recovery of termination costs follow general procedures in FAR Parts 31 and 49?

### Buildings

11. Detention Facility
  - a. Final design— Who is our contact to finalize the design?
  - b. we want someone with approval authority to look at the current architect designs to make sure we are on the same page
12. Administration Facility--final design on admin building
  - a. This is a new requirement—want to focus on detention first
  - b. Who is our contact to finalize the design of the administration building?

- c. Furniture and Case Goods specifications? Communication equipment specification and cost? Can ICE simply furnish the building to their specifications
- 13. Admin Building may lag behind in construction for up to 6 months as we concentrate on the detainee center.
  - a. Should we change our construction plans to adjust this time table?

#### Transportation

- 14. Has COTR estimated transportation needs (number of teams) per section IV
- 15. Can we begin transportation services immediately?
- 16. Are cell phones acceptable for ICE communications to transportation vehicles?

#### Staffing

- 17. LPN vs. RN

**Stevens, Richard P**

---

**From:** Neveleff, Jerald  
**Sent:** Monday, May 05, 2008 4:09 PM  
**To:** 'Russell Harper'  
**Cc:** Warren Coleman  
**Subject:** RE: Farmville Questions

Russell,  
I suggest that a representative from the City of Farmville be there. As the provider, they need to understand their roles and responsibilities in the agreement process.  
Jerry

Thank you,  
Jerry Neveleff  
Supervisory Contracting Officer/  
IGSA Team Lead  
Office of Acq. Management (OAQ)  
Detention Management Division  
202/(b)(6)

Help us support you better -  
TELL US HOW WE ARE DOING!  
Go to <<http://www.acqsolinc.com/ICE/OAQ/feedback.cfm>> <<<http://www.acqsolinc.com/ICE/OAQ/feedback.cfm>>>

---

**From:** Russell Harper [mailto:(b)(6)]  
**Sent:** Monday, May 05, 2008 3:05 PM  
**To:** Neveleff, Jerald  
**Cc:** Warren Coleman  
**Subject:** Farmville Questions

Jerry, attached are questions we would like to discuss Thursday. Thanks for your help. Russell

---

**Stevens, Richard P**

---

**From:** Russell Harper (b)(6)  
**Sent:** Tuesday, May 06, 2008 2:38 PM  
**To:** Neveleff, Jerald  
**Cc:** Warren Coleman; (b)(6)  
**Subject:** IGSA Form

Jerry,

We need the ISGA in word format vs. PDF so we can change the name from Otero to Farmville and redline additional comments. Can you provide this in word?

Thank you.

Russell

**Stevens, Richard P**

---

**From:** Neveleff, Jerald  
**Sent:** Tuesday, May 06, 2008 2:53 PM  
**To:** 'Russell Harper'  
**Cc:** Warren Coleman; (b)(6) Casterline, Arnold P  
**Subject:** RE: IGSA Form

Please point out the discrepancies and we will fix the errors prior to submission to Farmville for signature.

Thank you,  
Jerry Neveleff  
Supervisory Contracting Officer/  
IGSA Team Lead  
Office of Acq. Management (OAQ)  
Detention Management Division  
202/(b)(6)

Help us support you better -  
TELL US HOW WE ARE DOING!  
Go to <<http://www.acqsolinc.com/ICE/OAQ/feedback.cfm>> <<<http://www.acqsolinc.com/ICE/OAQ/feedback.cfm>>>

---

**From:** Russell Harper [mailto:(b)(6)]  
**Sent:** Tuesday, May 06, 2008 2:38 PM  
**To:** Neveleff, Jerald  
**Cc:** Warren Coleman; (b)(6)  
**Subject:** IGSA Form

Jerry,

We need the ISGA in word format vs. PDF so we can change the name from Otero to Farmville and redline additional comments. Can you provide this in word?

Thank you.

Russell

## Stevens, Richard P

---

**From:** Neveleff, Jerald  
**Sent:** Tuesday, May 06, 2008 3:22 PM  
**To:**  
**Cc:** (b)(6) Lisa Hricko  
**Subject:** Additional Information

Russell,

I am trying my best to not have to do a pre-award survey. The questions/requests for information below are being asked of ICA since the Town of Farmville has provided a letter authorizing this communication. Please provide me the following information:

1. How are the current construction costs being funded?
2. I need a copy of the Farmville and ICA agreement showing the terms and conditions of the Provider and subcontractor relationship along with financial terms and conditions.
3. Please provide a copy of your business plan for the running of the facility.
4. Does ICA have any open lines of credit and will there be any once performance begins?
5. How much will be in financial reserves and how long is that expected to last?

I also want to convey the need to ensure that since the IGSA will be with the Town of Farmville, they be invited to any and all meeting held. It will be their decision to attend or not.

Thank you,  
Jerry Neveleff  
Supervisory Contracting Officer/  
IGSA Team Lead  
Office of Acq. Management (OAQ)  
Detention Management Division  
202/ (b)(6)

Help us support you better -  
TELL US HOW WE ARE DOING!

Go to <<http://www.acqsolinc.com/ICE/OAQ/feedback.cfm>> <<<http://www.acqsolinc.com/ICE/OAQ/feedback.cfm>>>

**Stevens, Richard P**

---

**From:** Russell Harper (b)(6)  
**Sent:** Tuesday, May 06, 2008 2:59 PM  
**To:** Neveleff, Jerald  
**Cc:** Warren Coleman; (b)(6) Casterline, Arnold P  
**Subject:** RE: IGSA Form

Will do.

---

**From:** Neveleff, Jerald [mailto:(b)(6)]  
**Sent:** Tuesday, May 06, 2008 2:53 PM  
**To:** Russell Harper  
**Cc:** Warren Coleman; (b)(6) Casterline, Arnold P  
**Subject:** RE: IGSA Form

Please point out the discrepancies and we will fix the errors prior to submission to Farmville for signature.

Thank you,  
Jerry Neveleff  
Supervisory Contracting Officer/  
IGSA Team Lead  
Office of Acq. Management (OAQ)  
Detention Management Division  
202/616 (b)(2)Low

Help us support you better -  
TELL US HOW WE ARE DOING!  
Go to <<http://www.acqsolinc.com/ICE/OAQ/feedback.cfm>> <<<http://www.acqsolinc.com/ICE/OAQ/feedback.cfm>>>

---

**From:** Russell Harper [mailto:(b)(6)]  
**Sent:** Tuesday, May 06, 2008 2:38 PM  
**To:** Neveleff, Jerald  
**Cc:** Warren Coleman; gspates@farmvilleva.com  
**Subject:** IGSA Form

Jerry,

We need the ISGA in word format vs. PDF so we can change the name from Otero to Farmville and redline additional comments. Can you provide this in word?

Thank you.

Russell

12/21/2008

## Stevens, Richard P

---

**From:** Neveleff, Jerald  
**Sent:** Wednesday, May 07, 2008 8:17 AM  
**To:** Davis, Dianna L  
**Cc:** Raine, Craig K  
**Subject:** RE: Farmville

**Sensitivity:** Private

Good morning,  
I talked to Jennifer about this last week. We (her and I) didn't really see a need for her to attend. If any legal questions that arise, she'll be available by phone/blackberry or we can defer the answer until we're back in the office.  
Jerry

Thank you,  
Jerry Neveleff  
Supervisory Contracting Officer/  
IGSA Team Lead  
Office of Acq. Management (OAQ)  
Detention Management Division  
202/ (b)(6)

Help us support you better -  
TELL US HOW WE ARE DOING!  
Go to <<http://www.acqsolinc.com/ICE/OAQ/feedback.cfm>>  
<<<http://www.acqsolinc.com/ICE/OAQ/feedback.cfm>>>

-----Original Message-----  
From: Davis, Dianna L  
Sent: Wednesday, May 07, 2008 8:08 AM  
To: Raine, Craig K; Neveleff, Jerald  
Subject: Farmville  
Sensitivity: Private

Have we invited anyone from OPLA to attend this meeting? It might not be a bad idea to ask Jennifer Longmeyer-Wood if she can have someone attend.

dld  
Dianna Davis  
DAD, Mission Support  
Detention & Removal Operations  
Immigration & Customs Enforcement  
e-mail: (b)(6)  
Phone: 202  
Cell: 202 (b)(6)



**Stevens, Richard P**

---

**From:** Russell Harper (b)(6)  
**Sent:** Tuesday, May 06, 2008 3:11 PM  
**To:** Neveleff, Jerald  
**Cc:** Warren Coleman; (b)(6) Casterline, Arnold P  
**Subject:** RE: IGSA Form

We will mark up the document we have and hand it to you Thursday with our submittal.

---

**From:** Neveleff, Jerald [mailto: (b)(6)]  
**Sent:** Tuesday, May 06, 2008 3:02 PM  
**To:** Russell Harper; Neveleff, Jerald  
**Cc:** Warren Coleman; (b)(6) Casterline, Arnold P  
**Subject:** RE: IGSA Form

Its all about document control.

Thank you,  
Jerry Neveleff  
Supervisory Contracting Officer/  
IGSA Team Lead  
Office of Acq. Management (OAQ)  
Detention Management Division  
202/ (b)(2)Low

Help us support you better -  
TELL US HOW WE ARE DOING!  
Go to <<http://www.acqsolinc.com/ICE/OAQ/feedback.cfm>> <<<http://www.acqsolinc.com/ICE/OAQ/feedback.cfm>>>

---

**From:** Russell Harper [mailto:rharper@hdcva.com]  
**Sent:** Tuesday, May 06, 2008 2:59 PM  
**To:** Neveleff, Jerald  
**Cc:** Warren Coleman; gspates@farmvilleva.com; Casterline, Arnold P  
**Subject:** RE: IGSA Form

Will do.

---

**From:** Neveleff, Jerald [mailto: (b)(6)]  
**Sent:** Tuesday, May 06, 2008 2:53 PM  
**To:** Russell Harper  
**Cc:** Warren Coleman; (b)(6) Casterline, Arnold P  
**Subject:** RE: IGSA Form

Please point out the discrepancies and we will fix the errors prior to submission to Farmville for signature.

Thank you,

12/21/2008

Jerry Neveleff  
Supervisory Contracting Officer/  
IGSA Team Lead  
Office of Acq. Management (OAQ)  
Detention Management Division  
202 (b)(2)Low

Help us support you better -  
TELL US HOW WE ARE DOING!

Go to <http://www.acqsolinc.com/ICE/OAQ/feedback.cfm> <<<http://www.acqsolinc.com/ICE/OAQ/feedback.cfm>>>

---

**From:** Russell Harper [mailto:(b)(6)]  
**Sent:** Tuesday, May 06, 2008 2:38 PM  
**To:** Neveleff, Jerald  
**Cc:** Warren Coleman; (b)(6)  
**Subject:** IGSA Form

Jerry,

We need the ISGA in word format vs. PDF so we can change the name from Otero to Farmville and redline additional comments. Can you provide this in word?

Thank you.

Russell

## Stevens, Richard P

---

**From:** Dellar, William L  
**Sent:** Friday, May 09, 2008 9:08 AM  
**To:** Neveleff, Jerald  
**Cc:** Washington, John W  
**Subject:** FW: Health Care question

**Importance:** High

Jerry, I reached out to our health care folks and if a specific job duty calls for an RN then an LPN can not complete that task. Bill

-----Original Message-----

**From:** Jarres, Philip [mailto: (b)(6)]  
**Sent:** Friday, May 09, 2008 9:04 AM  
**To:** Dellar, William L; Flanagan, Lamont  
**Cc:** Anthony, Yvonne; Hrynyshen-Trimmer, Christa; Evans, Mary Y  
**Subject:** RE: Health Care question  
**Importance:** High

Depending on the scope of the healthcare services provided LPN's are not interchangeable with RN's. If a specific job duty calls for an RN then an LPN can not complete that task.

-----Original Message-----

**From:** Dellar, William L [mailto: (b)(6)]  
**Sent:** Friday, May 09, 2008 7:32 AM  
**To:** Jarres, Philip; Flanagan, Lamont  
**Cc:** Anthony, Yvonne CAPT; Hrynyshen-Trimmer, Christa; Evans, Mary Y  
**Subject:** RE: Health Care question

Can I take that as a yes provided the NCCH standards for health services in jails are met and the health authority approves the staffing plan?

-----Original Message-----

**From:** Jarres, Philip [mailto: (b)(6)]  
**Sent:** Thursday, May 08, 2008 4:34 PM  
**To:** Dellar, William L; Flanagan, Lamont  
**Cc:** Anthony, Yvonne; Hrynyshen-Trimmer, Christa  
**Subject:** FW: Health Care question

Mr Dellar,  
Please find our response below. We could provide information as to how we would staff a facility based on facility size.

According to NCCHC standards for health services in jails the responsible health authority approves the staffing plan. The number and types of qualified health care professionals required at a facility depend upon the size of the facility, the types (e.g., medical, nursing, dental, mental health) and scope (e.g., outpatient, specialty care, inpatient care) of health services delivered, the needs of the inmate population, and the organizational structure (e.g., hours of service, use of assistants, scheduling). Consideration is given to labor-intensive activities when developing a staffing plan. Such activities include medication distribution, sick call, or cell checks in segregated housing. These and other factors are to be reflected in the facility's staffing plan.

The general expectation is that the staffing plan includes, at a minimum, one physician on site 3.5 hours per week for each 100 inmates housed in the facility.

Thanks,

CAPT Yvonne Anthony, APRN-BC, MSN, M.Ed  
Associate Director- Compliance and Health Policy  
Division of Immigration Health Services  
202 (b)(6) (office)

-----Original Message-----

From: Jarres, Philip [mailto: (b)(6)]  
Sent: Thursday, May 08, 2008 3:33 PM  
To: Anthony, Yvonne; Flanagan, Lamont W; Hrynyshen-Trimmer, Christa  
Subject: Fw: Health Care question  
Importance: High

Yvonne. Please provide an answer based on NDS Standards for a response to this question. Thanks.

----- Original Message -----

From: Dellar, William L (b)(6)  
To: Flanagan, Lamont  
Cc: Jarres, Philip; Washington, John W  
Sent: Thu May 08 14:15:50 2008  
Subject: Health Care question

We are currently considering the possibility of entering into an IGSA with Farmville and have received a number of questions from them in response to our Request for Proposal.

One of the questions impacts health care. Specifically, can they use a LPN vs. RN?

Thanks, Bill

**Stevens, Richard P**

---

**From:** Neveleff, Jerald  
**Sent:** Monday, May 12, 2008 8:53 AM  
**To:** (b)(6)  
**Cc:** Dellar, William L; Washington, John W; Achim, Deborah; Raine, Craig K;  
(b)(6) Casterline, Arnold P; Wyatt-Powell, Wendie M  
**Subject:** RESPONSE TO LPN vs. RN

Russell,

With regards to the last question that was deferred until Public Health Services could be consulted. The answer is:

“LPN's are not interchangeable with RN's. If a specific job duty calls for an RN then an LPN can not complete that task.”

If you need additional staffing information, please let me know.

According to my notes, the above response should complete open questions. If this is not correct, please let me know.

Jerry

Thank you,  
Jerry Neveleff  
Supervisory Contracting Officer/  
IGSA Team Lead  
Office of Acq. Management (OAQ)  
Detention Management Division  
202/ (b)(6)

Help us support you better -  
TELL US HOW WE ARE DOING!  
Go to <<http://www.acqsolinc.com/ICE/OAQ/feedback.cfm>> <<<http://www.acqsolinc.com/ICE/OAQ/feedback.cfm>>>

**Stevens, Richard P**

---

**From:** Neveleff, Jerald  
**Sent:** Monday, May 12, 2008 2:27 PM  
**To:** (b)(6)  
**Cc:** Casterline, Arnold P; (b)(6)  
**Subject:** COST PROPOSAL

Good afternoon Russell,  
I received the UPS package with your copies of volumes 1 and 2. I have reviewed the package and cannot find the letter of submission from the Town of Farmville.  
Although the Town has authorized ICA to negotiate on its behalf, the proposal still needs to come from the one that ICE is entering into an agreement with.  
Please provide me the letter from the Town as soon as possible for my files.  
Thanks.  
Jerry

Thank you,  
Jerry Neveleff  
Supervisory Contracting Officer/  
IGSA Team Lead  
Office of Acq. Management (OAQ)  
Detention Management Division  
202 (b)(6)

Help us support you better -  
TELL US HOW WE ARE DOING!  
Go to <<http://www.acqsolinc.com/ICE/OAQ/feedback.cfm>> <<<http://www.acqsolinc.com/ICE/OAQ/feedback.cfm>>>

**Stevens, Richard P**

---

**From:** Neveleff, Jerald  
**Sent:** Monday, May 12, 2008 2:31 PM  
**To:** (b)(6)  
**Cc:** Achim, Deborah; Raine, Craig K; Washington, John W; Wyatt-Powell, Wendie M; Casterline, Arnold P; (b)(6)  
**Subject:** COST VOLUME

Russell,

A letter accompanying volumes 1 and 2 of the proposal mentioned that the provider wishes to take up the offer of delaying the submission of the cost volume. The letter did not mention how long the delay in submitting volume 3 would be. Could you give me a date when it will be provided?

Thanks

Jerry

Thank you,

Jerry Neveleff

Supervisory Contracting Officer/

IGSA Team Lead

Office of Acq. Management (OAQ)

Detention Management Division

202/ (b)(6)

Help us support you better -

TELL US HOW WE ARE DOING!

Go to <<http://www.acqsolinc.com/ICE/OAQ/feedback.cfm>> <<<http://www.acqsolinc.com/ICE/OAQ/feedback.cfm>>>

**Stevens, Richard P**

---

**From:** Russell Harper (b)(6)  
**Sent:** Monday, May 12, 2008 2:31 PM  
**To:** Neveleff, Jerald  
**Cc:** Casterline, Arnold P; (b)(6)  
**Subject:** RE: COST PROPOSAL

Will do. Thanks

---

**From:** Neveleff, Jerald [mailto: (b)(6)  
**Sent:** Monday, May 12, 2008 2:27 PM  
**To:** Russell Harper  
**Cc:** Casterline, Arnold P; (b)(6)  
**Subject:** COST PROPOSAL

Good afternoon Russell,

I received the UPS package with your copies of volumes I and 2. I have reviewed the package and cannot find the letter of submission from the Town of Farmville.

Although the Town has authorized ICA to negotiate on its behalf, the proposal still needs to come from the one that ICE is entering into an agreement with.

Please provide me the letter from the Town as soon as possible for my files.

Thanks.

Jerry

Thank you,

Jerry Neveleff

Supervisory Contracting Officer/

IGSA Team Lead

Office of Acq. Management (OAQ)

Detention Management Division

202 (b)(6)

Help us support you better -

TELL US HOW WE ARE DOING!

Go to <http://www.acqsolinc.com/ICE/OAQ/feedback.cfm> <<<http://www.acqsolinc.com/ICE/OAQ/feedback.cfm>>>

12/21/2008



## Stevens, Richard P

---

**From:** Neveleff, Jerald  
**Sent:** Thursday, May 22, 2008 12:37 PM  
**To:** Wyatt-Powell, Wendie M  
**Subject:** FARMVILLE

Good afternoon,

We've received the Farmville cost proposal. I will be over there sometime tomorrow morning. I plan to bring you a copy to support the technical review to ensure that the staffing proposed and those in the cost volume match.

Jerry

Thank you,  
Jerry Neveleff  
Supervisory Contracting Officer/  
IGSA Team Lead  
Office of Acq. Management (OAQ)  
Detention Management Division  
202/ (b)(6)

Help us support you better -  
TELL US HOW WE ARE DOING!

Go to <http://www.acqsolinc.com/ICE/OAQ/feedback.cfm> <<<http://www.acqsolinc.com/ICE/OAQ/feedback.cfm>>>

**Stevens, Richard P**

---

**From:** Neveleff, Jerald  
**Sent:** Thursday, May 22, 2008 12:43 PM  
**To:** Casterline, Arnold P  
**Cc:** Wyatt-Powell, Wendie M  
**Subject:** Farmville Transportation and Stationary Guards

Arnie,  
Looks like Farmville proposed the transportation and stationary guards from the same pool of labor providing services in the detention center. It also looks like they are proposing fringe benefits also.

I believe the requirement was that transportation guards are to be in addition to the housing guards. Based on the transportation needs, I can foresee a shortfall of housing guards if they proposing using the same labor force for both.

We need to point this out so we don't have an issue like we are with Eloy.  
Jerry

Thank you,  
Jerry Neveleff  
Supervisory Contracting Officer/  
IGSA Team Lead  
Office of Acq. Management (OAQ)  
Detention Management Division  
202/ (b)(6)

Help us support you better -  
TELL US HOW WE ARE DOING!  
Go to <<http://www.acqsolinc.com/ICE/OAQ/feedback.cfm>> <<<http://www.acqsolinc.com/ICE/OAQ/feedback.cfm>>>

**Stevens, Richard P**

---

**From:** Warren Coleman (b)(6)  
**Sent:** Tuesday, May 27, 2008 11:23 AM  
**To:** Neveleff, Jerald  
**Subject:** Farmville ICE proposal - status

Jerry

I hope you enjoyed the long weekend and the great weather. Now that we are back at work and only dreaming of the holiday, I want to be sure you have everything you need and to again offer our assistance.

Just keep us posted at your convenience regarding the progress unless you have information requests that we can provide as you know we are very anxious to move forward at a rapid pace with the project.

Thanks.

Warren Coleman

804- (b)(6)  
804-

**Stevens, Richard P**

---

**From:** Neveleff, Jerald  
**Sent:** Wednesday, May 28, 2008 9:50 AM  
**To:** Jenkins, John E

**Attachments:** Farmville INS-A1.0 floor plans.pdf; Farmville\_map.pdf; ICE farmville Facility-Phase I-051608.pdf; ICE farmville Facility-Phase II-051608.pdf; Location\_final1.doc; Phsyical\_Plant\_final.doc



Farmville INS-A1.0  
floor plans...



Farmville\_map.pdf  
(466 KB)



ICE farmville  
Facility-Phase I...



ICE farmville  
Facility-Phase I...



Location\_final1.doc  
(114 KB)



Phsyical\_Plant\_final  
.doc (110 ...)

Thank you,  
Jerry Neveleff  
Supervisory Contracting Officer/  
IGSA Team Lead  
Office of Acq. Management (OAQ)  
Detention Management Division  
202/ (b)(6)

Help us support you better -  
TELL US HOW WE ARE DOING!

Go to <http://www.acqsolinc.com/ICE/OAQ/feedback.cfm> <<<http://www.acqsolinc.com/ICE/OAQ/feedback.cfm>>>

(b)(2)High

**DETAINEE HOUSING FACILITY**

SCALE: 1" = 30'-0"

**SUBSILARIA** - 14,000 sq. ft.  
**COMM. UNITS** - 100 units - 100,000 sq. ft.  
**CELL UNITS** - 100 units - 100,000 sq. ft.

||  
||  
||



(b)(2)High

**DETAINEE HOUSING FACILITY - PHASE 1**  
SCALE: 1" = 20'-0"

**REVISIONS**  
NO. DATE BY  
1 01/15/10 J. KELLEY  
2 01/20/10 J. KELLEY  
3 01/20/10 J. KELLEY  
4 01/20/10 J. KELLEY  
5 01/20/10 J. KELLEY  
6 01/20/10 J. KELLEY  
7 01/20/10 J. KELLEY  
8 01/20/10 J. KELLEY  
9 01/20/10 J. KELLEY  
10 01/20/10 J. KELLEY

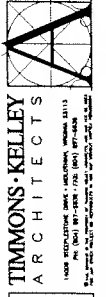

**TIMMONS • KELLEY**  
ARCHITECTS  
1000 INDUSTRIAL PARK - WASHINGTON, VIRGINIA 22113  
PH: (703) 891-8200 • FAX: (703) 891-8200  
WWW.TIMMONSKELLEYARCHITECTS.COM



FLOOR PLANS  
**ICE FARMVILLE FACILITY**  
DETAINEE HOUSING FACILITY  
FARMVILLE, VIRGINIA

NO.	DATE	BY	DESCRIPTION
1	01/15/10	J. KELLEY	ISSUED FOR PERMIT
2	01/20/10	J. KELLEY	REVISIONS
3	01/20/10	J. KELLEY	REVISIONS
4	01/20/10	J. KELLEY	REVISIONS
5	01/20/10	J. KELLEY	REVISIONS
6	01/20/10	J. KELLEY	REVISIONS
7	01/20/10	J. KELLEY	REVISIONS
8	01/20/10	J. KELLEY	REVISIONS
9	01/20/10	J. KELLEY	REVISIONS
10	01/20/10	J. KELLEY	REVISIONS

PROJECT NO. 08-1102  
DRAWING NO. 0804  
ARCHITECT: T. KELLEY  
DATE: 01/15/10  
**A1.0**



**TIMMONS • KELLEY**  
**ARCHITECTS**  
 1000 INTERNATIONAL DRIVE • SUITE 1000 • WASHINGTON, VIRGINIA 22113  
 PH: (703) 891-1000 • FAX: (703) 891-1000  
 WWW.TKARCHITECTS.COM



**FLOOR PLANS**  
**ICE FARMVILLE FACILITY**  
**DETAINEE HOUSING FACILITY**  
 FARMVILLE, VIRGINIA

NO.	DATE	DESCRIPTION

PROJECT NO. 08-102  
 SHEET NO. 100  
 ARCHITECT: T. KELLEY  
 SCALE: **A1.0**

(b)(2)High

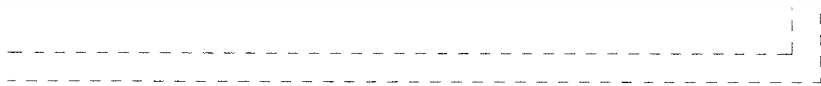

**DETAINEE HOUSING FACILITY - PHASE 2**  
 SCALE: 1" = 30'-0"

**GENERAL NOTES**  
 1. REFER TO ALL OTHER SHEETS FOR COMPLETE INFORMATION.  
 2. SEE ARCHITECT'S RECORD DRAWINGS FOR EXISTING CONDITIONS.  
 3. ALL CONSTRUCTION SHALL BE IN ACCORDANCE WITH THE LATEST EDITIONS OF THE INTERNATIONAL BUILDING CODE (IBC) AND THE VIRGINIA BUILDING CODE (VBC).  
 4. ALL MATERIALS AND WORKMANSHIP SHALL BE SUBJECT TO INSPECTION AND APPROVAL BY THE LOCAL BUILDING DEPARTMENT.  
 5. THE CONTRACTOR SHALL BE RESPONSIBLE FOR OBTAINING ALL NECESSARY PERMITS AND APPROVALS FROM THE LOCAL BUILDING DEPARTMENT.  
 6. THE CONTRACTOR SHALL MAINTAIN ACCESS TO ALL ADJACENT PROPERTIES AND UTILITIES AT ALL TIMES.  
 7. THE CONTRACTOR SHALL PROTECT ALL EXISTING UTILITIES AND STRUCTURES TO REMAIN.  
 8. THE CONTRACTOR SHALL MAINTAIN A SAFE WORKING ENVIRONMENT AT ALL TIMES.  
 9. THE CONTRACTOR SHALL BE RESPONSIBLE FOR THE PROTECTION OF ALL ADJACENT PROPERTIES AND UTILITIES.  
 10. THE CONTRACTOR SHALL MAINTAIN A SAFE WORKING ENVIRONMENT AT ALL TIMES.





**Town of Farmville – ICE Facility: DROISA-08-0021  
May 9, 2008**

**Location of Town of Farmville—ICE Facility**

The Town of Farmville-ICE facility will be located at 508 Waterworks Road, Farmville, Va. 23901.

- ❖ Farmville is located in central Virginia, approximately 65 miles from Richmond, Virginia and 165 miles from Washington D.C.
- ❖ The Town of Farmville—ICE Facility will be located on a 20+ acre site, which will allow for multiple buildings and expansion of the main detainee site, if/when needed.
- ❖ The Town of Farmville—ICE Facility will be within 3 miles of the local hospital and the Piedmont Regional Jail.
  - If the a need arises where a detainee will require medical care (other than that which will be provided at the Facility), or if a detainee’s behavior indicates that a jail environment would be more appropriate, the Facility will be able to easily utilize the services of the local hospital and the Piedmont Regional Jail.
- ❖ The local airport is within 3 miles of the Town of Farmville—ICE Facility, and the Facility is only 69 miles away from the Richmond International Airport.



## **Town of Farmville – ICE Facility: DROISA-08-0021**

May 9, 2008

### **Physical Plant**

The Town of Farmville-ICE detainee facility and proposed Administration building are being built according to the Statement of Work and Government guidelines as provided by the RFP. Our management team and our architects are working closely with the ICE division with oversight on building design and construction to ensure all unique physical plant requirements are met. We will continue this discussion during construction to ensure all parties are satisfied with the physical plant component of this facility.

**Stevens, Richard P**

---

**From:** Neveleff, Jerald  
**Sent:** Wednesday, May 28, 2008 9:51 AM  
**To:** Jenkins, John E  
**Subject:** 0718\_001.pdf - Adobe Reader  
**Attachments:** 0718\_001

(b)(2)High

**DETAINEE HOUSING FACILITY - PHASE 1**

ARCHITECT: TIMMONS • KELLEY ARCHITECTS  
DATE: 11/17/03  
SCALE: 1/8" = 1'-0"  
PROJECT NO.: 03-001  
SHEET NO.: 110

NO.	DATE	DESCRIPTION
1	11/17/03	ISSUED FOR PERMITS
2		
3		
4		
5		
6		
7		
8		
9		
10		

FLOOR PLANS

**ICE FARMVILLE FACILITY**  
**DETAINEE HOUSING FACILITY**  
 FARMVILLE, VIRGINIA

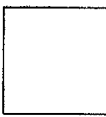

**TIMMONS • KELLEY**  
**ARCHITECTS**

1400 S. WINTERSTONE DRIVE • ARLINGTON, VIRGINIA 22113  
 TEL: (804) 897-5638 • FAX: (804) 897-3623



DATE: 11/17/03  
 SHEET NO.: 110

# Town of Farmville - ICE Facility

## Organization Chart

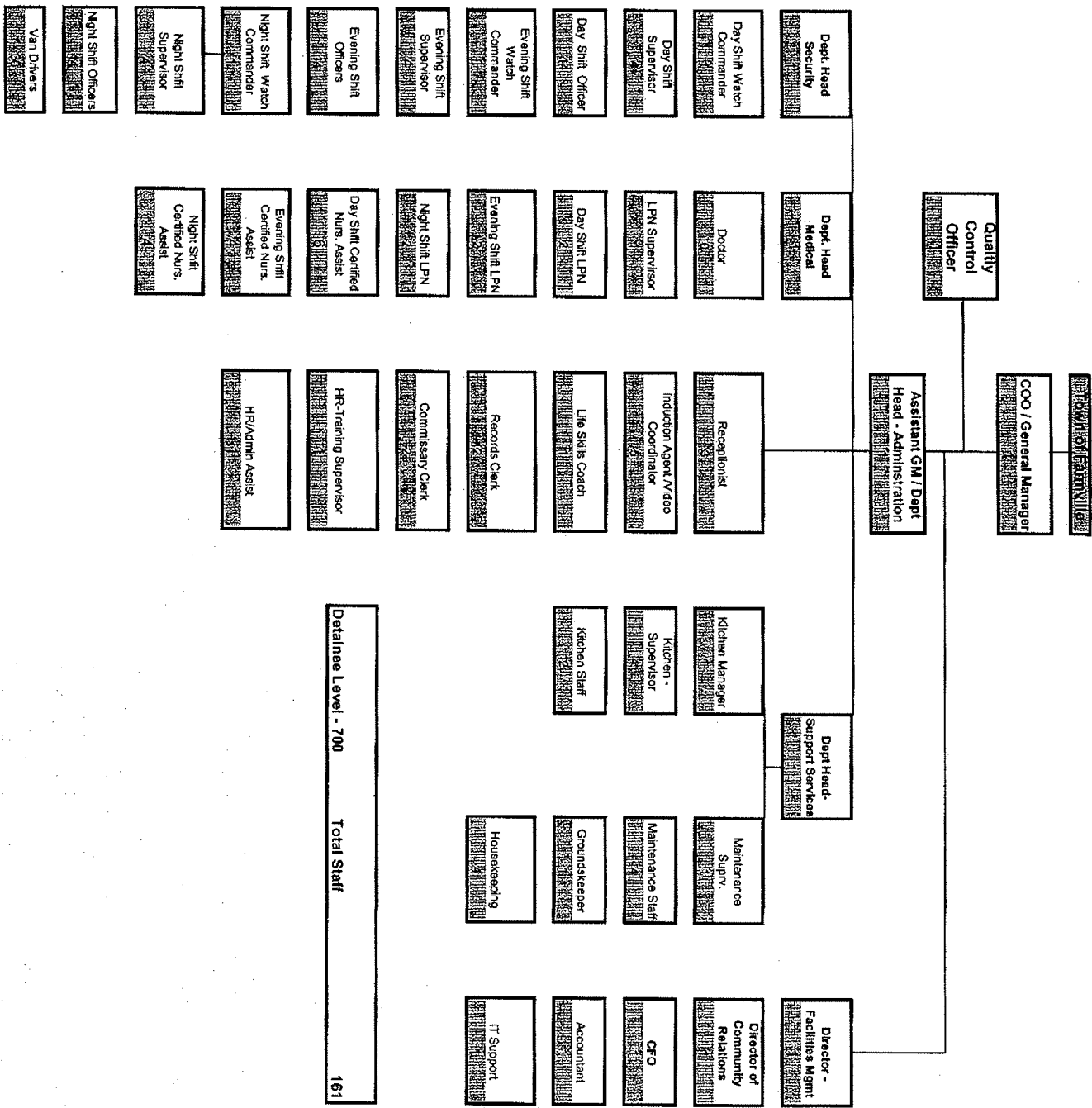

(b)(2)High

DETAINEE HOUSING FACILITY - PHASE 2

SCALE: 1/8" = 1'-0"

DATE: 11/17/04  
DRAWN BY: M. KELLEY  
CHECKED BY: M. KELLEY  
PROJECT NO. 04-0113  
SHEET NO. A10

FLOOR PLANS

ICE FARMVILLE FACILITY  
DETAINEE HOUSING FACILITY  
FARMVILLE, VIRGINIA

TIMMONS • KELLEY  
ARCHITECTS

14205 SLEEPSTONE DRIVE • HOLLISTON, VIRGINIA 23112  
PH: (804) 897-5438 • FAX: (804) 897-5435  
© 2004 TIMMONS & KELLEY ARCHITECTS. ALL RIGHTS RESERVED. THIS DRAWING IS THE PROPERTY OF TIMMONS & KELLEY ARCHITECTS. NO PART OF THIS DRAWING IS TO BE REPRODUCED OR TRANSMITTED IN ANY FORM OR BY ANY MEANS, ELECTRONIC OR MECHANICAL, INCLUDING PHOTOCOPYING, RECORDING, OR BY ANY INFORMATION STORAGE AND RETRIEVAL SYSTEM.



DATE:	11/17/04
DRAWN BY:	M. KELLEY
CHECKED BY:	M. KELLEY
PROJECT NO.:	04-0113
SHEET NO.:	A10

# Town of Farmville- ICE Facility

## Organization Chart

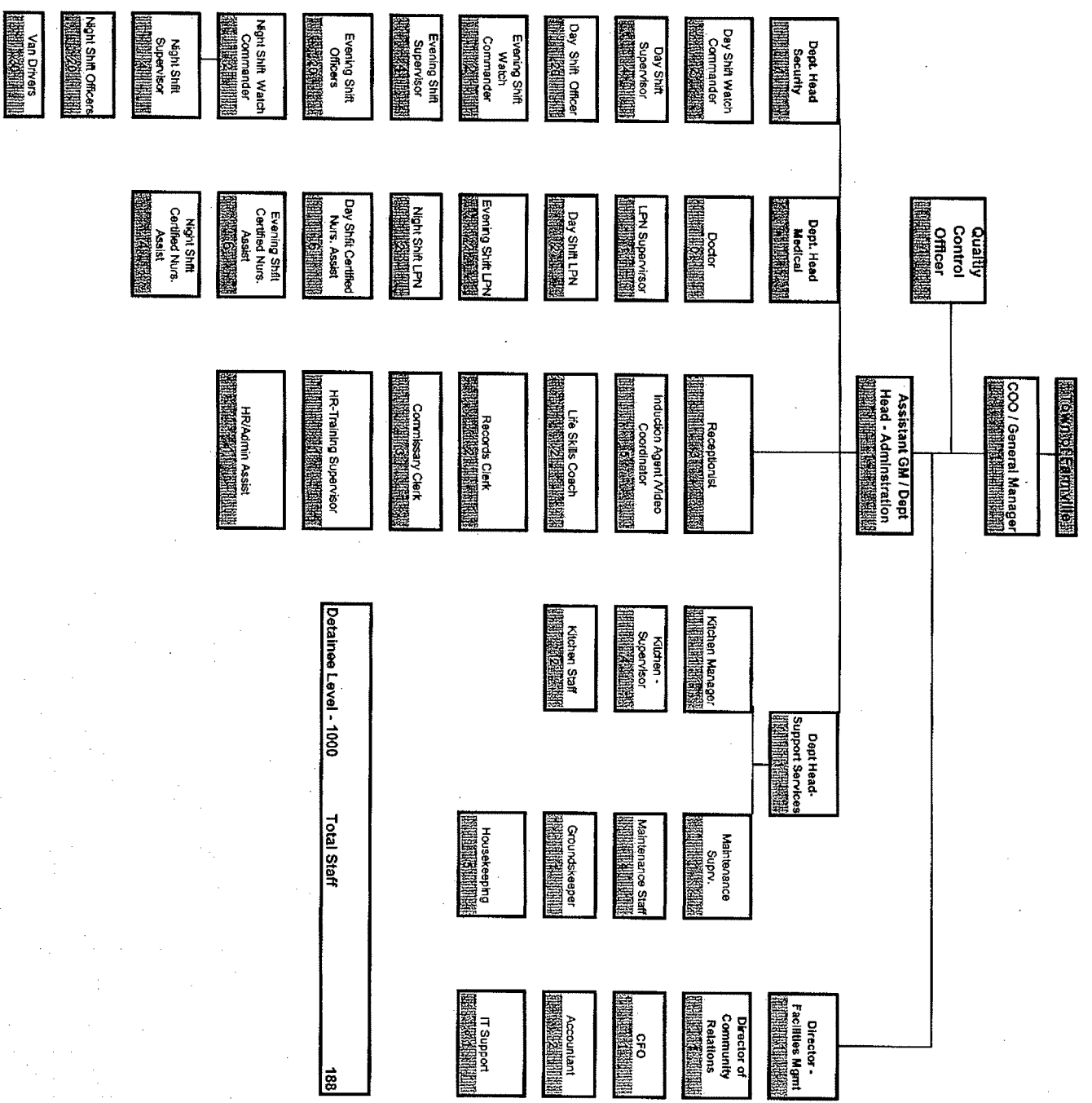

**Stevens, Richard P**

---

**From:** Neveleff, Jerald  
**Sent:** Thursday, June 05, 2008 8:10 AM  
**To:** 'Warren Coleman'  
**Cc:** Russell Harper  
**Subject:** RE: Status update- No calls from Facilities

Sir,

I have made a call this morning to find out the status of the comments to the drawings and plans that were submitted. As soon as I find out anything, I will let you know.

Thank you,  
Jerry Neveleff  
Supervisory Contracting Officer/  
IGSA Team Lead  
Office of Acq. Management (OAQ)  
Detention Management Division  
202/ (b)(6)

Help us support you better -  
TELL US HOW WE ARE DOING!

Go to <<http://www.acqsolinc.com/ICE/OAQ/feedback.cfm>> <<<http://www.acqsolinc.com/ICE/OAQ/feedback.cfm>>>

---

**From:** Warren Coleman [mailto: (b)(6)]  
**Sent:** Thursday, June 05, 2008 7:44 AM  
**To:** Neveleff, Jerald  
**Cc:** Russell Harper  
**Subject:** Status update- No calls from Facilities

Jerry,

Russell has not been contacted by anyone at ICE since we last spoke. As we are aggressively working with architects and engineers, we were looking forward to the call so we can be sure no unnecessary work/ cost is being incurred. If you think it is appropriate for us to call and follow up on your information about a call, please provide the person or persons you think we should contact.

As for the other parts of the review process, is everything moving along at your expected pace? How far along are we in the process at this time? I know you will let us know if you need additional data as you promised the last time we spoke but any update on the progress would be greatly appreciated as we are moving ahead and want to be sure we are on the right path.

Thanks in advance for your advice on whether we should contact anyone and your opinion of the stage that has been reached with the review process.

Warren Coleman  
840- (b)(6)

12/21/2008



**Stevens, Richard P**

---

**From:** Jenkins, John E  
**Sent:** Friday, June 13, 2008 10:10 AM  
**To:** Neveleff, Jerald  
**Subject:** FW: Farmville -revision 6.13.08  
**Importance:** High  
**Attachments:** Town of Farmville Volume I (2).doc; Town of Farmville Volume II.doc; MEMO from J.Jenkins to J.Washington (2).doc; Florence Service Processing Center TIFF TRAILER.pdf; Detainee Housing Changes.pdf

Jerry,

Here is what I am sending Bill Dellar in regards to Farmville. You will need to wait to hear from them officially.

I found my wallet.

Thanks

*John E. Jenkins*

Acting Unit Chief  
Facilities Management Unit  
Detention and Removal Operations  
Immigration and Customs Enforcement  
202- (b)(6) office  
202- (b)(6) mobile  
(b)(6)

**Warning: This document is UNCLASSIFIED//FOR OFFICIAL USE ONLY (U//FOUO).** It contains information that may be exempt from public release under the Freedom of Information Act (5 U.S.C. 552). It is to be controlled, stored, handled, transmitted, distributed, and disposed of in accordance with DHS policy relating to FOUO information and is not to be released to the public or other personnel who do not have a valid "need-to-know" without prior approval of an authorized DHS official. **No portion of this report should be furnished to the media, either in written or verbal form.**

---

**From:** Dane, Courtney L  
**Sent:** Friday, June 13, 2008 9:36 AM  
**To:** Jenkins, John E; Thompson, Arthur D  
**Subject:** Farmville -revision 6.13.08  
**Importance:** High

John and Dean,

I have made the changes to the memo, see attached. Please let me know if there are any other edits.

Thanks,

Courtney

Courtney Dane, Project Manager  
Facilities & Administrative Space Management

12/21/2008

Logistics & Fleet Management Unit  
Office of Detention & Removal  
Immigration & Customs Enforcement  
801 I St., NW  
Washington DC, 20536  
Phone (202) (b)(6)  
Fax (202) (b)(6)

---

**From:** Jenkins, John E  
**Sent:** Friday, June 13, 2008 9:06 AM  
**To:** Dane, Courtney L  
**Subject:** FW: Farmville  
**Importance:** High

*John E. Jenkins*  
Acting Unit Chief  
Facilities Management Unit  
Detention and Removal Operations  
Immigration and Customs Enforcement  
202- (b)(6) office  
202- (b)(6) mobile  
(b)(6)

**Warning:** This document is UNCLASSIFIED//FOR OFFICIAL USE ONLY (U//FOUO). It contains information that may be exempt from public release under the Freedom of Information Act (5 U.S.C. 552). It is to be controlled, stored, handled, transmitted, distributed, and disposed of in accordance with DHS policy relating to FOUO information and is not to be released to the public or other personnel who do not have a valid "need-to-know" without prior approval of an authorized DHS official. **No portion of this report should be furnished to the media, either in written or verbal form.**

---

**From:** Raine, Craig K  
**Sent:** Monday, June 09, 2008 9:40 AM  
**To:** Jenkins, John E; Dane, Courtney L  
**Subject:** FW: Farmville  
**Importance:** High

John,

Please see Paul's Comments.

---

**From:** Picone, Paul D  
**Sent:** Thursday, June 05, 2008 2:54 PM  
**To:** Archibeque, Vincent E; Henkel, Douglas ; Raine, Craig K; Achim, Deborah  
**Subject:** FW: Farmville

Re: Jenkins memo, Changes to Phase 1

1. Notation for Dorm #1 bathrooms needs to include two separate sets of bathrooms with equal number of showers and toilets.

12/21/2008

2. Notation for Dorm #1 needs to annotate moving control post over bathrooms in center of dorm straddling the new wall.
3. Inclusion in Processing room notation for holding cells with a max capacity of 50 and negative airflow.

Re: Detainee Housing Changes

Needs to show changes annotated above.

Paul D. Picone  
Assistant Field Office Director  
Washington Field Office  
ICE/DRO

**Warning: This document is UNCLASSIFIED//FOR OFFICIAL USE ONLY (U//FOUO).** It contains information that may be exempt from public release under the Freedom of Information Act (5 U.S.C. 552). It is to be controlled, stored, handled, transmitted, distributed, and disposed of in accordance with DHS policy relating to FOUO information and is not to be released to the public or other personnel who do not have a valid "need-to-know" without prior approval of an authorized DHS official. **No portion of this report should be furnished to the media, either in written or verbal form.**

---

**From:** Thompson, Arthur D  
**Sent:** Thursday, June 05, 2008 2:41 PM  
**To:** Raine, Craig K; Picone, Paul D  
**Cc:** Jenkins, John E; Wilson, Dietra N; Dane, Courtney L; Smyly, Elena L  
**Subject:** Farmville

.Please review the attached memo from John Jenkins John Washington, provide comments as needed. Review all other attachments as well.

We will be sending the Memo along with the other attachment as a package to contracting.

Please have comments back by 12:00 P.M. Friday June 6, 2008.

Respectfully,  
**Dean Thompson**  
**Project Manager**  
**Facilities Management unit**  
**HQDRO**  
**801 I Street N.W., Suite 800**  
**Washington D.C. 20536**  
**202- (b)(6)**  
  
(b)(6)

**Warning: This document is UNCLASSIFIED//FOR OFFICIAL USE ONLY (U//FOUO).** It contains information that may be exempt from public release under the Freedom of Information Act (5 U.S.C. 552). It is to be controlled, stored, handled, transmitted, distributed, and disposed of in accordance with DHS policy relating to FOUO information and is not to be released to the public or other personnel who do not have a valid "need-to-know" without prior approval of an authorized DHS official. **No portion of this report should be furnished to the media, either in written or verbal form.**

**Town of Farmville – ICE Facility  
IGSA  
DROIGSA-08-0021  
May 9, 2008**

**Volume I**

(b)(5)

**Town of Farmville – ICE Facility  
IGSA  
DROIGSA-08-0021  
May 9, 2008**

**Volume II**

(b)(5)

(b)(5)

(b)(5)



U.S. Immigration  
and Customs  
Enforcement

June 13, 2008

MEMORANDUM FOR: Bill Dellar  
Chief, Detention Planning and Acquisition Unit  
Detention Management Division

FROM: John Jenkins  
Acting Chief, Facilities Management Unit

SUBJECT: Proposal Review Comments of the Farmville Detention Facility

The purpose of this memorandum is to provide you with technical and design review comments on the Farmville Detention facility, located in the Town of Farmville, at 116 North Main Street, Farmville, and V.A. 23901. The design documents were provided on May 9, 2008 by the Town of Farmville, the facility service provider.

Project Background

The Town of Farmville proposes to design and construct a 1000 bed facility, with an addition of 2.5% or 25 segregation unit beds, by September 1, 2008. NTP is anticipated to be given on July 1, 2008.

Phase I shall consist of, however not limited to: level 3- 500 bed housing unit, commissary, dining facility, multi purpose room consisting of library/classes, health care, detainee shower/bathrooms, laundry, visitation, processing, 2 outside recreation areas and 25 bed segregation unit. A temporary administration facility will be provided to the ICE staff at the Farmville location via trailers or other suitable means. Staff parking will be provided as well.

**Note:** See attached drawing A1.0 Detainee Housing Facility – Phase 1 provided by the town of Farmville for floor plan details.

Phase II shall consist of, however not limit to ICE administrative staff support space, Executive Office of Immigration Review (EOIR) courts, Office of the Political Legal Advisor (OPLA), additional 500 bed expansion with 3 outside recreation areas.

**Note:** A detail floor plan has not been provided showing the ICE, EOIR, OPLA operational space or its location. See attached drawing A1.0 Detainee Housing Facility – Phase 2 provided by the town of Farmville for floor plan details.



Review Comments

(b)(5)

Changes to Phase I:

Below are the recommended changes to the facility:

(b)(5)

(b)(5)

**Note:** Please see location of changes on attached drawing, titled ICE Changes

We have also provided comments from the Washington Field Office on the proposal submitted, titled Volume II.

*Attachments:*

- (1) ICE Changes, "Detainee Housing Facility – Phase 2"*
- (2) Town of Farmville – ICE Facility / Volume I*
- (3) Town of Farmville – ICE Facility / Volume II*
- (4) Florence Detention Facility – TIFF Trailer*

(b)(2)High

TIF Modular Unit Layout  
Roughly 1,488 sq. feet.

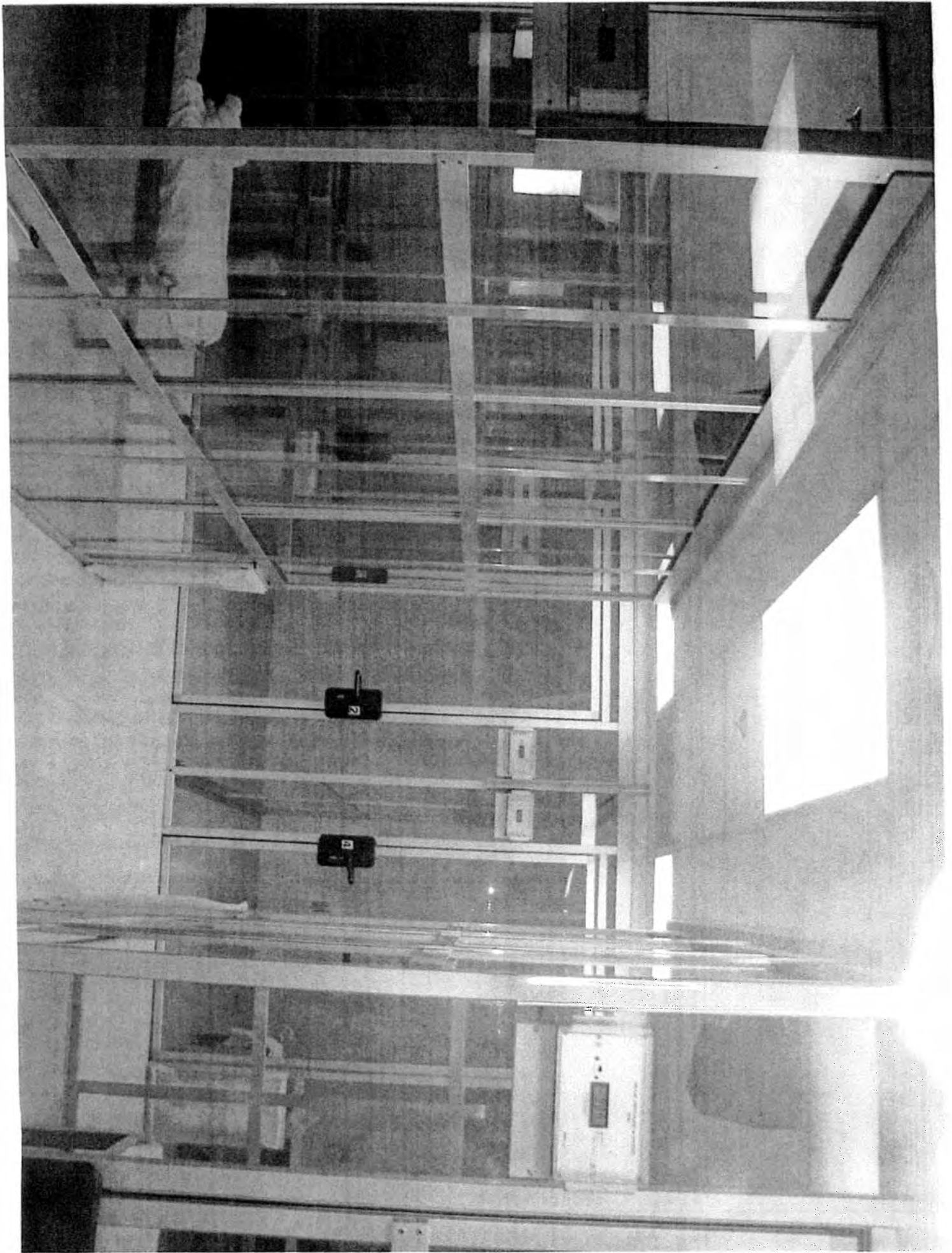

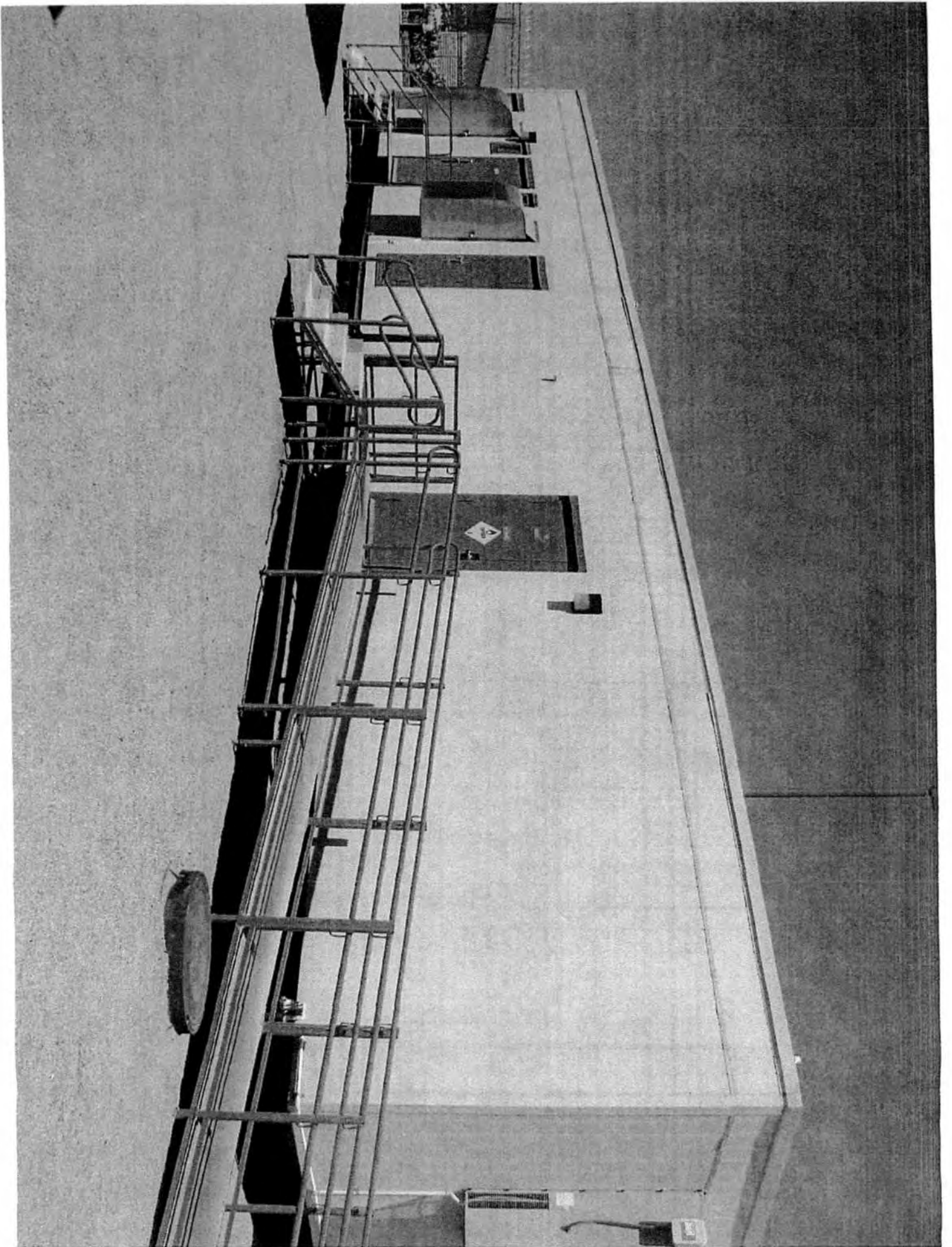

**US IMMIGRATION &  
NATURALIZATION SERVICE  
FLORENCE SERVICE  
CENTER**

**SYSTEMS MANUAL**

**HEPA Filtration Unit  
For Model #  
TRIMLINE 400 / 500 SERIES WALL  
MOUNTED HEPA FILTRATION UNITS**

Air Management Systems, Inc.  
3840 Villa Rica Lane  
Powder Springs, GA 30127-1511  
Phone: 770-943-9256  
800-368-5633  
Fax: 770-943-8361

*E-mail: AIRMANAGEMENT@COMCAST.NET*

# Table Of Contents

## ◆ Air Management Solutions Systems Specifications

	Page No.
◆ Filter Panel Specifications .....	3
◆ HEPA Filtration Unit Product Specifications .....	4
◆ System Enclosure Specifications .....	5
◆ Warranty .....	6
◆ HEPA Unit Filter Change Out Instructions .....	7
◆ Pre-Filter Change Out Instructions.....	8
◆ Recommended Prefilter Change Intervals.....	9
◆ Filter Reorder Form .....	10
◆ Prefilter Change Out Log	

# Filter Specifications

---

The filter shall be Air Management Systems, Inc.'s HEPA, individually factory tested for efficiency and pressure drop using a laser aerosol spectrometer. Minimum efficiency shall be 99.97% for particle 0.3-micron size. Each filter shall also be scanned for leaks for IES recommended practice cc-001-86.

The filtration medium shall be constructed by pleating a continuous sheet of Borosilicate Fiber media into a 70 panel (deep) "Mini-Pleat" media pak with non-metallic separators. String separators shall not only accurately space the pleats but also give additional strength and rigidity to the media pak.

The filtration media pak shall be permanently bonded with polyurethane to a (frame height) anodized aluminum frame using "Klip-Lok™" corners, for added structural integrity, allowing no exposed sealant or raw edges.

## MATERIAL SAFETY DATA SHEET:

- Frame:** Fiberboard or Aluminum Housed
- Media:** Borosilicate micro-glass, Acrylic resin, water repellent
- Sealant:** 2 part polyurethane elastomer (unfilled, self-extinguishing)
- Gasket:** 1/4" (H) x 3/4"(W) SCE-43 neoprene dove tail joints. PVC/Silicone available upon request
- Size:** 12" X 12" X 11.5



# Product Specification Trimline 400/500 Series HEPA Filtration Unit

---

The Trimline Series Units offers clean HEPA-filtered air.

With its HEPA grade level of efficiency (99.97% @ .3 $\mu$ ) and very low pressure drop this unit can be installed on a direct replacement basis. No additional costs are incurred for motors/blowers change-outs usually associated with higher filter capacity.

Standard sizes are 12 x 12 11.5 with boxboard frame.

## FEATURES:

**Efficiency:** 99.97% @ .3 $\mu$  (microns) particulate HEPA  
99.9995@ 0.12 $\mu$  ULPA filter

**Pressure Drop:** @ 90-100 FPM  $\approx$  20%

**String Separators:** Non-metallic HEPA-string separators are non-corrosive  
Reinforces the entire media pak  
No sagging, units can be aligned either vertically or horizontally

**Frames:** Wood board frames

**Testing:** Scanned for leaks per IES RP-CC-001-86  
Testing protocol is available for review

Page 4

## ISO-LOCK™ CLASS 2 SECURITY ENCLOSURE SYSTEM SPECIFICATIONS

---

Air Management Solutions, Inc. • 3840 Villa Rica Ln • Powder Springs, GA 30127

Ph: 800-368-5633 • 770-943-9256 • Fax: 770-943-8361

The ISO-LOCK™ class 2 Security Modular Enclosure System, is a totally integrated wall and ceiling frame system, std. Internal fasteners.

- Wall Frames are constructed using 40mm x 40mm square, primary smooth face profile, clear anodized finish, std. (internal ) fasteners. A special number of relief air vents shall be installed in wall panels to balance airflow in the room.
- Panel Inserts are installed using Lip Seal # 8 Gasket with the exception of 3/8" thick Lexan.
- Material: Lexan / Std. Clear 3/8" Polycarbonate.
- Corner Post is also made of 40mm x 40mm square, primary smooth face profile square, clear anodized finish.
- Ceiling support Beam: none
- Doors 42" x 7 Clamp profile, E version, Hinged left / right accordingly, with matching locks and keys.
- Floor mounting is 40 mm x 40mm angle anodized finish.
- 1 x 2 L channel aluminum.

# WARRANTY

All Air Management Solutions, Inc HEPA filtration units are warranted by the manufacturer, and are certified to the original user, against defects in material and workmanship for a period of one year after the date of purchase. AMS only obligation shall be, at AMS option, either to repair or replace the defective components, or make suitable adjustment for such defect(s) upon timely notification, provided the unit has been used, maintained with certified filter configuration, purchased through Air Management Solutions and handled in accordance with these instructions. THIS WARRANTY IS MADE TO THE COMMERCIAL USER IN LIEU OF WARRANTIES OF MERCHANTABILITY, FITNESS FOR PARTICULAR PURPOSE, AND ALL OTHER WARRANTIES EXPRESSED OR IMPLIED.

NOTE: ALL FILTERS ARE SPECIFIED TO AMS STANDARDS AND USE OF OTHER FILTERS WILL VOID THE WARRANTY.

## LIMITATION OF LIABILITY

Except as provided above, Air Management Solutions, INC., shall not be liable or responsible for any loss or damage, whether direct, indirect, incidental, special, or consequential, arising out of the sale, use or misuse of or the user's inability to use such products. The remedies set forth herein are exclusive.

Page 6

## HEPA Filter Removal and Replacement

---

Air Management Solutions, Inc. • 3840 Villa Rica Ln • Powder Springs, GA 30127

Ph: 800-368-5633 • 770-943-9256 • Fax: 770-943-8361

High efficiency ASHRAE rated prefilters are provided and recommended for use with this system.

**REMOVAL AND INSTALLATION OF HEPA FILTER  
SHOULD BE PERFORMED BY QUALIFIED PERSONEL  
ONLY.**

**NOTE: IT IS RECOMMENDED THE UNITS BE TESTED ANNUALLY. REMOVAL, RELOCATION OF HEPA UNITS OR ITS COMPONENTS SHOULD BE PERFORMED BY QUALIFIED PERSONEL ONLY.**

Page 7

# Pre- Filter Removal and Replacement

## FILTERS - GENERAL INFORMATION

The filter furnished in Air Management Solutions, Inc HEPA units are selected to provide the highest efficiency and airflow capability. Use of any other types of pre-filters will void the warranty and reduce performance efficiency.

AMS and its agents sell Air Management Solutions, Inc filters without any expressed or implied warranty that the pre-filters will prevent or cure any injury or health damage to the user.

## INSTRUCTIONS FOR REMOVAL

As per established procedure, the person responsible for the removal and disposal of used pre-filters, and the installation of new pre-filters should follow good housekeeping procedures or internal protocols set forth by the Safety Director of the Department.

## PRE-FILTER REPLACEMENT

Listed below are only recommendations, not to override existing or departmental procedures:

- ❶ The person responsible for the removal, disposal of used filters, and the installation of new filters, should utilize a facemask with eye shield.
- ❷ Put on latex gloves and any additional protective wear recommended by existing protocols.
- ❸ Slowly vacuum the outer face of the security grill with a HEPA Vac. Then spray the face of the pre-filter and the pre-filter door (closed) with a hospital grade disinfectant, spray while the unit is running. (Do not use a chlorine base spray.)
- ❹ Allow the unit to run 1-2 minutes before removing old pre-filters.
- ❺ Permit the unit to run the entire time when changing pre-filters.
- ❻ Remove the old pre-filter by dropping down the access door. Dispose of the old filter in accordance with the existing departmental procedure.
- ❼ Before replacing the new pre-filters, vacuum the outer perimeter and the inside of the grill door with the HEPA Vac. Place the new pre-filters (white side facing down) on access door, close and secure. Wipe down grill with clean cloth.

**NOTE: IT IS RECOMMENDED THE UNITS BE TESTED ANNUALLY. REMOVAL, RELOCATION OF HEPA UNITS OR ITS COMPONENTS SHOULD BE PREFORMED BY QUALIFIED PERSONEL ONLY.**

# RECOMMENDED PREFILTER CHANGE INTERVALS

On an average basis, the Pre-Filters should be changed each month, or more often if deemed necessary by departmental procedures or protocols.

At startup the Prefilters should be changed at the rate of one per week for the first two weeks. Once the unit is running for a period of time, the ambient dust, and particulate will be “scrubbed” from the environment, and the need for replacement of the Prefilters will decrease to one per month.

Antimicrobial Prefilters provide an antibacterial ingredient on the surface of the filter and may be used in place of a Prefilter. Charcoal filters are used for odor abatement and may be used alone or with a Prefilter. Using a Prefilter in conjunction with a Charcoal filter will decrease the CFM airflow of the units. In the first one to two weeks, these filters should be changed at least once per week. After that initial period, filters can be changed once per month.

This replacement schedule assumes a “typical” application in a confined patient's room or emergency room. Further, this assumes that the primary application is used in TB nuclei abatement. If the HEPA unit is used during construction or in conjunction with charcoal filters for volatile organic compound abatement, the Prefilters must be replaced on a more frequent basis. **By maintaining a regular Prefilter change out schedule, the HEPA Core Filter should last a minimum of 1 year.**

---

## Filter Order Form

---

**Ceiling-Mounted HEPA Air Filtration Units**

<b>HEPA MODEL</b>	<b>Filter Model</b>	<b>Price per each filter ordered in case lots*</b>	<b>Qty</b>	<b>Total Price</b>
<b>Trimline 400/500</b>	CIF-13 HEPA Prefilter (13x13x1)	\$6.40	X _____	= _____
	HEPA Core Filter (12x12x11.5)	\$399.00	X _____	= _____
<b>HUFP0650/350</b>	CIF-01 HEPA Prefilters (Two 20"x20"x1" Prefilters required)	\$6.40	X _____	= _____
	HUFP0650H HEPA Core Filters (Two Core Filters required)	\$499.00	X _____	= _____

**Isolation Chambers, Antechambers, Sputum Induction Booths and Hoods**

<b>ISOLATION CHAMBER/SPUTUM BOOTH/ ANTECHAMBER INLET FILTERS</b>	CIF01 (20"x20"x1") for Ceiling Mounted 2'x2' Diffuser	\$6.40	X _____	= _____
<b>INLET FILTERS</b>	CIF02 (12"x24"x1")	\$6.40	X _____	= _____
	CIF03 (8"x30"x2")	\$6.40	X _____	= _____
<b>SPUTUM INDUCTION HOOD</b>	Sputum Induction Hood Prefilters (15"x20"x1")	\$6.40	X _____	= _____

**Vehicle HEPA Units**

<b>VEHICLE HEPA UNIT - 350 CFM</b>	HUFO251H HEPA Core Filter for Roof Mounted Vehicle HEPA Unit (12"x18"x12")	\$299.00	X _____	= _____
------------------------------------	--	----------	---------	---------

**HEPA Filter Change Out Kits for all HEPA Air Filtration Units**

<b>HEPA Unit Filter Change Out Kit</b>	HUFC-01 Filter Change-Out Kit	\$6.95/ea. 12 kits/case	X _____	= _____
	HUFC01 Filter Change-Out Kit	\$9.95/ea. Individual kit	X _____	= _____

\*Prefilter Minimum Order: Case lot orders only (12 per case). HEPA Core Filters can be sold individually.

# **Air Management Solutions Isolock Isolation Detention Cells**

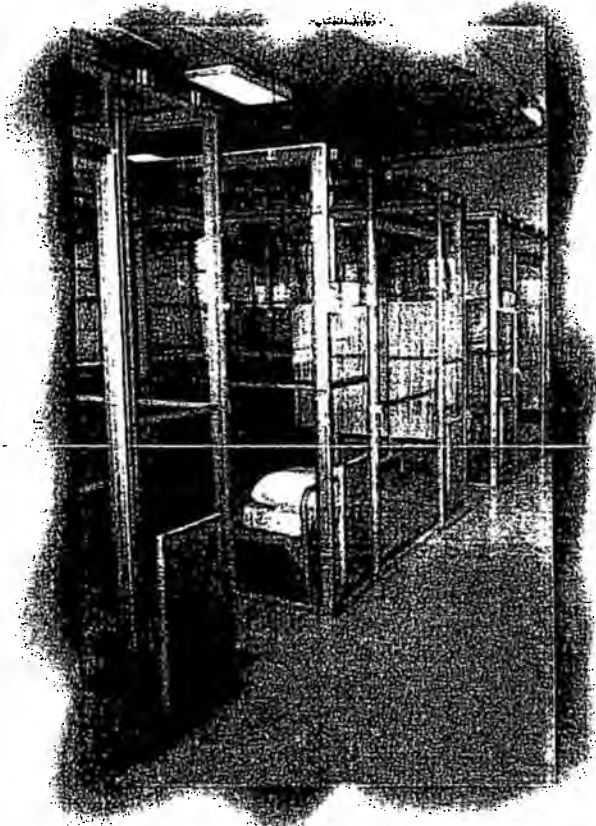

The Isolock Isolation Detention Cell is a versatile modular walled holding cell engineered for the containment and management of airborne particles using either positive or negative HEPA filtration, and at the same time providing a secure enclosure. The durable and flexible structure is constructed with superior quality materials at the lowest possible cost.

The frame is anodized aluminum utilizing a clamp profile. The modular walls are manufactured using a quarter inch Lexan, a clear totally visual product providing the highest level of containment and security. The Isolock Detention Cell may be custom designed, and reconfigured to meet every changing demand.

Heavy-duty hinges and deadbolt security locks are standard on all cells. A fully integrated electronic switch lock is optional.

## ***Air Management Solutions, Inc.***



Local: 770-943-9256   ■   Toll Free: 800-368-5633   ■   FAX: 770-943-8361  
3840 Villa Rica Lane Suite B   Powder Springs, Georgia 30127   [www.hepaair.com](http://www.hepaair.com)



# Isolock Enclosure Systems

The Isolock Enclosure System is a clear improvement in air management containment technology. The Isolock Enclosure walls assemble quickly, easily, and cost effectively with minimal use of tools. The latch-together system provides strong, clear, positive walls, corners and ceilings for virtually every connection.

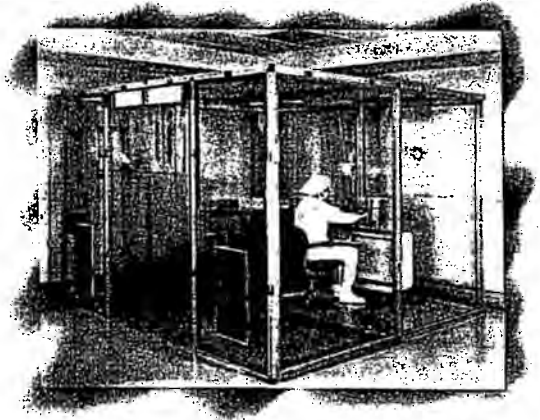

Isolock Enclosure System is effective in both permanent and temporary applications. The enclosures can easily expand or be reconfigured to meet every changing demand. The Isolock Enclosure System meets all of the California Fire Marshall and NFPA 701 standards and requirements.

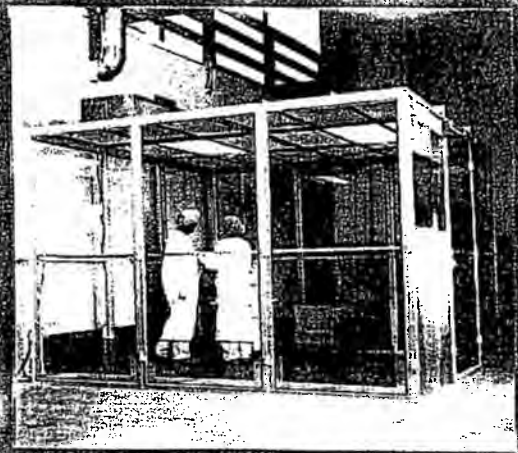

## Basic Construction Features

- Neoprene closed-cell foam gaskets seal frame-to-frame connections.
- Vinyl inserts lock into frame with an airtight seal. Cleaning is quick and easy.
- Frame construction with knock together corners allows for replacement of individual parts.
- Universal corner posts allow all walls to be interchanged for future expansion.
- Ceiling frames latch into position in the same manner as the walls, and can be designed to accommodate various types of filtration and lighting units.
- Lightweight aluminum frames are available in anodized clearcoat or epoxy powdercoat white.

Whether you need a brand new installation or expansion of an existing area, we will service you promptly. Call us to select a custom design system that suits your needs.

## ***Air Management Solutions, Inc.***



Local: 770-943-9256 ■ Toll Free: 800-368-5633 ■ FAX: 770-943-8361  
3840 Villa Rica Lane Suite B Powder Springs, Georgia 30127 www.hepaair.com

# **Air Management Solutions Isolock Isolation Detention Cells**

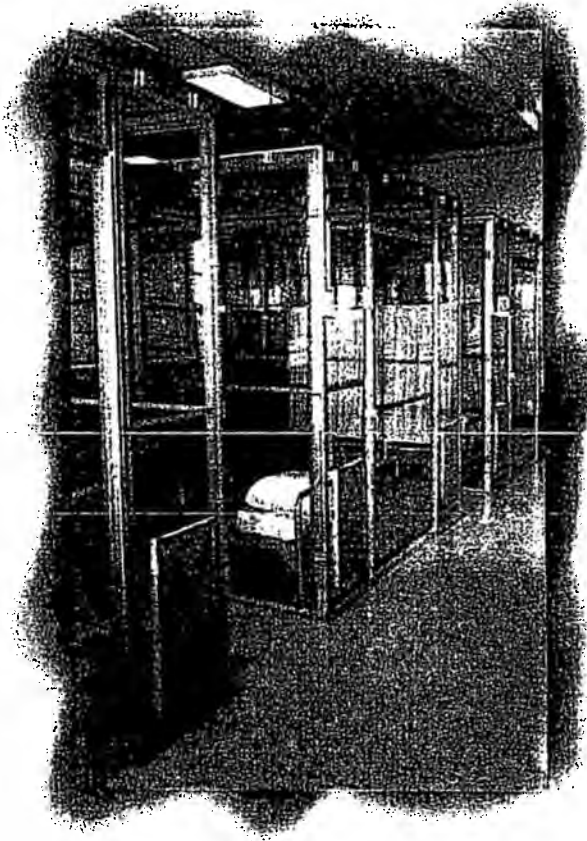

The Isolock Isolation Detention Cell is a versatile modular walled holding cell engineered for the containment and management of airborne particles using either positive or negative HEPA filtration, and at the same time providing a secure enclosure. The durable and flexible structure is constructed with superior quality materials at the lowest possible cost.

The frame is anodized aluminum utilizing a clamp profile. The modular walls are manufactured using a quarter inch Lexan, a clear totally visual product providing the highest level of containment and security. The Isolock Detention Cell may be custom designed, and reconfigured to meet every changing demand.

Heavy-duty hinges and deadbolt security locks are standard on all cells. A fully integrated electronic switch lock is optional.

## ***Air Management Solutions, Inc.***



Local: 770-943-9256 ■ Toll Free: 800-368-5633 ■ FAX: 770-943-8361  
3840 Villa Rica Lane Suite B Powder Springs, Georgia 30127 [www.hepaair.com](http://www.hepaair.com)

FACILITY	FLORENCE SERVICE CENTER			
WEEK	DATE	TIME	INITIALS	COMMENTS
<b>JANUARY</b>				
WEEK 1				
WEEK 2				
WEEK 3				
WEEK 4				
<b>FEBRUARY</b>				
WEEK 1				
WEEK 2				
WEEK 3				
WEEK 4				
<b>MARCH</b>				
WEEK 1				
WEEK 2				
WEEK 3				
WEEK 4				
<b>APRIL</b>				
WEEK 1				
WEEK 2				
WEEK 3				
WEEK 4				
<b>MAY</b>				
WEEK 1				
WEEK 2				
WEEK 3				
WEEK 4				
<b>JUNE</b>				
WEEK 1				
WEEK 2				
WEEK 3				
WEEK 4				
<b>JULY</b>				
WEEK 1				
WEEK 2				
WEEK 3				
WEEK 4				





**Stevens, Richard P**

---

**From:** Dellar, William L  
**Sent:** Friday, June 13, 2008 11:13 AM  
**To:** Smyly, Elena L; Casterline, Arnold P; Neveleff, Jerald  
**Subject:** FW: Farmville -revision 6.13.08  
**Importance:** High  
**Attachments:** Town of Farmville Volume I (2).doc; Town of Farmville Volume II.doc; MEMO from J.Jenkins to J.Washington (2).doc; Florence Service Processing Center TIFF TRAILER.pdf; Detainee Housing Changes.pdf

Farmville facility review comments attached.

---

**From:** Jenkins, John E  
**Sent:** Friday, June 13, 2008 10:11 AM  
**To:** Dellar, William L  
**Subject:** FW: Farmville -revision 6.13.08  
**Importance:** High

*John E. Jenkins*

Acting Unit Chief  
Facilities Management Unit  
Detention and Removal Operations  
Immigration and Customs Enforcement  
202 (b)(6) office  
202 (b)(6) mobile  
(b)(6)

**Warning:** This document is UNCLASSIFIED//FOR OFFICIAL USE ONLY (U//FOUO). It contains information that may be exempt from public release under the Freedom of Information Act (5 U.S.C. 552). It is to be controlled, stored, handled, transmitted, distributed, and disposed of in accordance with DHS policy relating to FOUO information and is not to be released to the public or other personnel who do not have a valid "need-to-know" without prior approval of an authorized DHS official. **No portion of this report should be furnished to the media, either in written or verbal form.**

---

**From:** Dane, Courtney L  
**Sent:** Friday, June 13, 2008 9:36 AM  
**To:** Jenkins, John E; Thompson, Arthur D  
**Subject:** Farmville -revision 6.13.08  
**Importance:** High

John and Dean,

I have made the changes to the memo, see attached. Please let me know if there are any other edits.

Thanks,

Courtney

12/21/2008

Courtney Dane, Project Manager  
Facilities & Administrative Space Management  
Logistics & Fleet Management Unit  
Office of Detention & Removal  
Immigration & Customs Enforcement  
801 I St., NW  
Washington DC, 20536  
Phone (202) (b)(6)  
Fax (202) (b)(6)

---

**From:** Jenkins, John E  
**Sent:** Friday, June 13, 2008 9:06 AM  
**To:** Dane, Courtney L  
**Subject:** FW: Farmville  
**Importance:** High

*John E. Jenkins*  
Acting Unit Chief  
Facilities Management Unit  
Detention and Removal Operations  
Immigration and Customs Enforcement  
202- (b)(6) office  
202- (b)(6) mobile  
(b)(6)

**Warning:** This document is UNCLASSIFIED//FOR OFFICIAL USE ONLY (U//FOUO). It contains information that may be exempt from public release under the Freedom of Information Act (5 U.S.C. 552). It is to be controlled, stored, handled, transmitted, distributed, and disposed of in accordance with DHS policy relating to FOUO information and is not to be released to the public or other personnel who do not have a valid "need-to-know" without prior approval of an authorized DHS official. **No portion of this report should be furnished to the media, either in written or verbal form.**

---

**From:** Raine, Craig K  
**Sent:** Monday, June 09, 2008 9:40 AM  
**To:** Jenkins, John E; Dane, Courtney L  
**Subject:** FW: Farmville  
**Importance:** High

John,

Please see Paul's Comments.

---

**From:** Picone, Paul D  
**Sent:** Thursday, June 05, 2008 2:54 PM  
**To:** Archibeque, Vincent E; Henkel, Douglas ; Raine, Craig K; Achim, Deborah  
**Subject:** FW: Farmville

Re: Jenkins memo, Changes to Phase 1

12/21/2008

1. Notation for Dorm #1 bathrooms needs to include two separate sets of bathrooms with equal number of showers and toilets.
2. Notation for Dorm #1 needs to annotate moving control post over bathrooms in center of dorm straddling the new wall.
3. Inclusion in Processing room notation for holding cells with a max capacity of 50 and negative airflow.

Re: Detainee Housing Changes

Needs to show changes annotated above.

Paul D. Picone  
Assistant Field Office Director  
Washington Field Office  
ICE/DRO

**Warning: This document is UNCLASSIFIED//FOR OFFICIAL USE ONLY (U//FOUO).** It contains information that may be exempt from public release under the Freedom of Information Act (5 U.S.C. 552). It is to be controlled, stored, handled, transmitted, distributed, and disposed of in accordance with DHS policy relating to FOUO information and is not to be released to the public or other personnel who do not have a valid "need-to-know" without prior approval of an authorized DHS official. **No portion of this report should be furnished to the media, either in written or verbal form.**

---

**From:** Thompson, Arthur D  
**Sent:** Thursday, June 05, 2008 2:41 PM  
**To:** Raine, Craig K; Picone, Paul D  
**Cc:** Jenkins, John E; Wilson, Dietra N; Dane, Courtney L; Smyly, Elena L  
**Subject:** Farmville

.Please review the attached memo from John Jenkins John Washington, provide comments as needed. Review all other attachments as well.

We will be sending the Memo along with the other attachment as a package to contracting.

Please have comments back by 12:00 P.M. Friday June 6, 2008.

Respectfully,  
**Dean Thompson**  
**Project Manager**  
**Facilities Management unit**  
**HQDRO**  
**801 I Street N.W., Suite 800**  
**Washington D.C. 20536**  
**202-** (b)(6)  
(b)(6)

**Warning: This document is UNCLASSIFIED//FOR OFFICIAL USE ONLY (U//FOUO).** It contains information that may be exempt from public release under the Freedom of Information Act (5 U.S.C. 552). It is to be controlled, stored, handled, transmitted, distributed, and disposed of in accordance with DHS policy relating to FOUO information and is not to be released to the public or other personnel who do not have a valid "need-to-know" without prior approval of an authorized DHS official. **No portion of this report should be furnished to the media, either in written or verbal form.**





**Town of Farmville – ICE Facility  
IGSA  
DROIGSA-08-0021  
May 9, 2008**

**Volume I**

(b)(5)

**Town of Farmville – ICE Facility**

**IGSA**

**DROIGSA-08-0021**

**May 9, 2008**

**Volume II**

(b)(5)

(b)(5)

(b)(5)

U.S. Department of Homeland Security  
801 I Street, NW  
Washington, DC 20536



U.S. Immigration  
and Customs  
Enforcement

June 13, 2008

MEMORANDUM FOR: Bill Dellar  
Chief, Detention Planning and Acquisition Unit  
Detention Management Division

FROM: John Jenkins  
Acting Chief, Facilities Management Unit

SUBJECT: Proposal Review Comments of the Farmville Detention Facility

The purpose of this memorandum is to provide you with technical and design review comments on the Farmville Detention facility, located in the Town of Farmville, at 116 North Main Street, Farmville, and V.A. 23901. The design documents were provided on May 9, 2008 by the Town of Farmville, the facility service provider.

Project Background

The Town of Farmville proposes to design and construct a 1000 bed facility, with an addition of 2.5% or 25 segregation unit beds, by September 1, 2008. NTP is anticipated to be given on July 1, 2008.

Phase I shall consist of, however not limited to: level 3- 500 bed housing unit, commissary, dining facility, multi purpose room consisting of library/classes, health care, detainee shower/bathrooms, laundry, visitation, processing, 2 outside recreation areas and 25 bed segregation unit. A temporary administration facility will be provided to the ICE staff at the Farmville location via trailers or other suitable means. Staff parking will be provided as well.

**Note:** See attached drawing A1.0 Detainee Housing Facility – Phase 1 provided by the town of Farmville for floor plan details.

Phase II shall consist of, however not limit to ICE administrative staff support space, Executive Office of Immigration Review (EOIR) courts, Office of the Political Legal Advisor (OPLA), additional 500 bed expansion with 3 outside recreation areas.

**Note:** A detail floor plan has not been provided showing the ICE, EOIR, OPLA operational space or its location. See attached drawing A1.0 Detainee Housing Facility – Phase 2 provided by the town of Farmville for floor plan details.

Review Comments

(b)(5)

Changes to Phase I:

Below are the recommended changes to the facility:

(b)(5)

(b)(5)

**Note:** Please see location of changes on attached drawing, titled ICE Changes

We have also provided comments from the Washington Field Office on the proposal submitted, titled Volume II.

*Attachments:*

- (1) ICE Changes, "Detainee Housing Facility – Phase 2"*
- (2) Town of Farmville – ICE Facility / Volume I*
- (3) Town of Farmville – ICE Facility / Volume II*
- (4) Florence Detention Facility – TIFF Trailer*



(b)(2)High

TIF Modular Unit Layout  
Roughly 1,488 sq. feet.



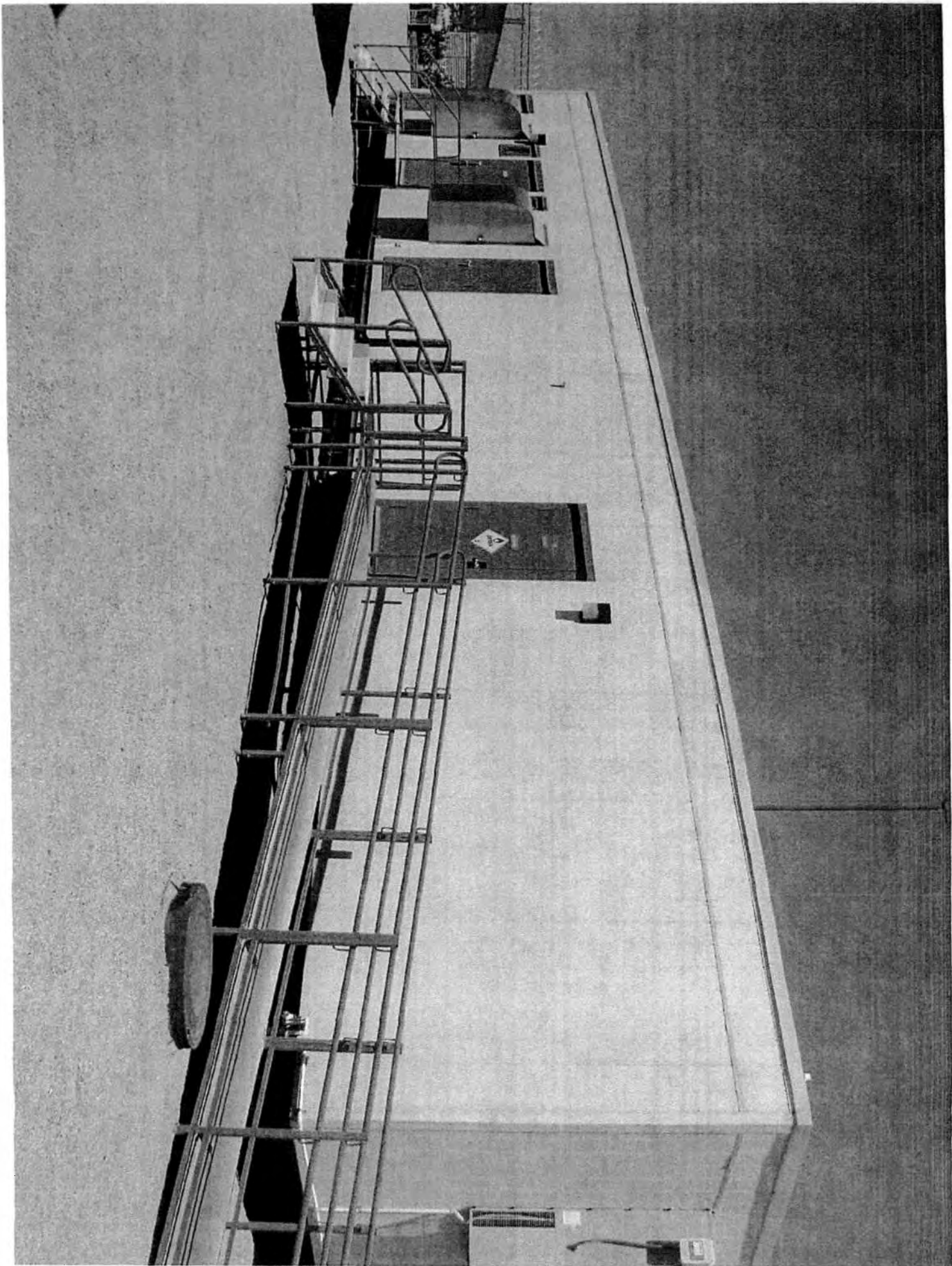

**US IMMIGRATION &  
NATURALIZATION SERVICE  
FLORENCE SERVICE  
CENTER**

**SYSTEMS MANUAL**

**HEPA Filtration Unit  
For Model #  
TRIMLINE 400 / 500 SERIES WALL  
MOUNTED HEPA FILTRATION UNITS**

Air Management Systems, Inc.  
3840 Villa Rica Lane  
Powder Springs, GA 30127-1511  
Phone: 770-943-9256  
800-368-5633  
Fax: 770-943-8361

*E-mail: AIRMANAGEMENT@COMCAST.NET*

# Table Of Contents

## ◆ Air Management Solutions Systems Specifications

Page No.

◆ Filter Panel Specifications .....	3
◆ HEPA Filtration Unit Product Specifications .....	4
◆ System Enclosure Specifications .....	5
◆ Warranty .....	6
◆ HEPA Unit Filter Change Out Instructions .....	7
◆ Pre-Filter Change Out Instructions.....	8
◆ Recommended Prefilter Change Intervals.....	9
◆ Filter Reorder Form .....	10
◆ Prefilter Change Out Log	

Page 2

# Filter Specifications

---

The filter shall be Air Management Systems, Inc.'s HEPA, individually factory tested for efficiency and pressure drop using a laser aerosol spectrometer. Minimum efficiency shall be 99.97% for particle 0.3-micron size. Each filter shall also be scanned for leaks for IES recommended practice cc-001-86.

The filtration medium shall be constructed by pleating a continuous sheet of Borosilicate Fiber media into a 70 panel (deep) "Mini-Pleat" media pak with non-metallic separators. String separators shall not only accurately space the pleats but also give additional strength and rigidity to the media pak.

The filtration media pak shall be permanently bonded with polyurethane to a (frame height) anodized aluminum frame using "Klip-Lok™" corners, for added structural integrity, allowing no exposed sealant or raw edges.

## MATERIAL SAFETY DATA SHEET:

- Frame:** Fiberboard or Aluminum Housed
- Media:** Borosilicate micro-glass, Acrylic resin, water repellent
- Sealant:** 2 part polyurethane elastomer (unfilled, self-extinguishing)
- Gasket:** 1/4" (H) x 3/4"(W) SCE-43 neoprene dove tail joints. PVC/Silicone available upon request
- Size:** 12" X 12" X 11.5

# Product Specification Trimline 400/500 Series HEPA Filtration Unit

---

The Trimline Series Units offers clean HEPA-filtered air.

With its HEPA grade level of efficiency (99.97% @ .3 $\mu$ ) and very low pressure drop this unit can be installed on a direct replacement basis. No additional costs are incurred for motors/blowers change-outs usually associated with higher filter capacity.

Standard sizes are 12 x 12 11.5 with boxboard frame.

## FEATURES:

**Efficiency:** 99.97% @ .3 $\mu$  (microns) particulate HEPA  
99.9995@0.12 $\mu$  ULPA filter

**Pressure Drop:** @ 90-100 FPM =/- 20%

**String Separators:** Non-metallic HEPA-string separators are non-corrosive  
Reinforces the entire media pak  
No sagging, units can be aligned either vertically or horizontally

**Frames:** Wood board frames

**Testing:** Scanned for leaks per IES RP-CC-001-86  
Testing protocol is available for review

Page 4

## ISO-LOCK™ CLASS 2 SECURITY ENCLOSURE SYSTEM SPECIFICATIONS

---

Air Management Solutions, Inc. • 3840 Villa Rica Ln • Powder Springs, GA 30127

Ph: 800-368-5633 • 770-943-9256 • Fax: 770-943-8361

The ISO-LOCK™ class 2 Security Modular Enclosure System, is a totally integrated wall and ceiling frame system, std. Internal fasteners.

- Wall Frames are constructed using 40mm x 40mm square, primary smooth face profile, clear anodized finish, std. (internal ) fasteners. A special number of relief air vents shall be installed in wall panels to balance airflow in the room.
- Panel Inserts are installed using Lip Seal # 8 Gasket with the exception of 3/8" thick Lexan.
- Material: Lexan / Std. Clear 3/8" Polycarbonate.
- Corner Post is also made of 40mm x 40mm square, primary smooth face profile square, clear anodized finish.
- Ceiling support Beam: none
- Doors 42" x 7 Clamp profile, E version, Hinged left / right accordingly, with matching locks and keys.
- Floor mounting is 40 mm x 40mm angle anodized finish.
- 1 x 2 L channel aluminum.



# WARRANTY

All Air Management Solutions, Inc HEPA filtration units are warranted by the manufacturer, and are certified to the original user, against defects in material and workmanship for a period of one year after the date of purchase. AMS only obligation shall be, at AMS option, either to repair or replace the defective components, or make suitable adjustment for such defect(s) upon timely notification, provided the unit has been used, maintained with certified filter configuration, purchased through Air Management Solutions and handled in accordance with these instructions. THIS WARRANTY IS MADE TO THE COMMERCIAL USER IN LIEU OF WARRANTIES OF MERCHANTABILITY, FITNESS FOR PARTICULAR PURPOSE, AND ALL OTHER WARRANTIES EXPRESSED OR IMPLIED.

NOTE: ALL FILTERS ARE SPECIFIED TO AMS STANDARDS AND USE OF OTHER FILTERS WILL VOID THE WARRANTY.

## LIMITATION OF LIABILITY

Except as provided above, Air Management Solutions, INC., shall not be liable or responsible for any loss or damage, whether direct, indirect, incidental, special, or consequential, arising out of the sale, use or misuse of or the user's inability to use such products. The remedies set forth herein are exclusive.

Page 6

## HEPA Filter Removal and Replacement

---

Air Management Solutions, Inc. • 3840 Villa Rica Ln • Powder Springs, GA 30127

Ph: 800-368-5633 • 770-943-9256 • Fax: 770-943-8361

High efficiency ASHRAE rated prefilters are provided and recommended for use with this system.

**REMOVAL AND INSTALLATION OF HEPA FILTER  
SHOULD BE PERFORMED BY QUALIFIED PERSONEL  
ONLY.**

**NOTE: IT IS RECOMMENDED THE UNITS BE TESTED ANNUALLY. REMOVAL, RELOCATION OF HEPA UNITS OR ITS COMPONENTS SHOULD BE PERFORMED BY QUALIFIED PERSONEL ONLY.**

Page 7

# Pre- Filter Removal and Replacement

## FILTERS - GENERAL INFORMATION

The filter furnished in Air Management Solutions, Inc HEPA units are selected to provide the highest efficiency and airflow capability. Use of any other types of pre-filters will void the warranty and reduce performance efficiency.

AMS and its agents sell Air Management Solutions, Inc filters without any expressed or implied warranty that the pre-filters will prevent or cure any injury or health damage to the user.

## INSTRUCTIONS FOR REMOVAL

As per established procedure, the person responsible for the removal and disposal of used pre-filters, and the installation of new pre-filters should follow good housekeeping procedures or internal protocols set forth by the Safety Director of the Department.

## PRE-FILTER REPLACEMENT

Listed below are only recommendations, not to override existing or departmental procedures:

- ① The person responsible for the removal, disposal of used filters, and the installation of new filters, should utilize a facemask with eye shield.
- ② Put on latex gloves and any additional protective wear recommended by existing protocols.
- ③ Slowly vacuum the outer face of the security grill with a HEPA Vac. Then spray the face of the pre-filter and the pre-filter door (closed) with a hospital grade disinfectant, spray while the unit is running. (Do not use a chlorine base spray.)
- ④ Allow the unit to run 1-2 minutes before removing old pre-filters.
- ⑤ Permit the unit to run the entire time when changing pre-filters.
- ⑥ Remove the old pre-filter by dropping down the access door. Dispose of the old filter in accordance with the existing departmental procedure.
- ⑦ Before replacing the new pre-filters, vacuum the outer perimeter and the inside of the grill door with the HEPA Vac. Place the new pre-filters (white side facing down) on access door, close and secure. Wipe down grill with clean cloth.

**NOTE: IT IS RECOMMENDED THE UNITS BE TESTED ANNUALLY. REMOVAL, RELOCATION OF HEPA UNITS OR ITS COMPONENTS SHOULD BE PREFORMED BY QUALIFIED PERSONEL ONLY.**

# RECOMMENDED PREFILTER CHANGE INTERVALS

On an average basis, the Pre-Filters should be changed each month, or more often if deemed necessary by departmental procedures or protocols.

At startup the Prefilters should be changed at the rate of one per week for the first two weeks. Once the unit is running for a period of time, the ambient dust, and particulate will be "scrubbed" from the environment, and the need for replacement of the Prefilters will decrease to one per month.

Antimicrobial Prefilters provide an antibacterial ingredient on the surface of the filter and may be used in place of a Prefilter. Charcoal filters are used for odor abatement and may be used alone or with a Prefilter. Using a Prefilter in conjunction with a Charcoal filter will decrease the CFM airflow of the units. In the first one to two weeks, these filters should be changed at least once per week. After that initial period, filters can be changed once per month.

This replacement schedule assumes a "typical" application in a confined patient's room or emergency room. Further, this assumes that the primary application is used in TB nuclei abatement. If the HEPA unit is used during construction or in conjunction with charcoal filters for volatile organic compound abatement, the Prefilters must be replaced on a more frequent basis. **By maintaining a regular Prefilter change out schedule, the HEPA Core Filter should last a minimum of 1 year.**

---

## Filter Order Form

---

**Ceiling-Mounted HEPA Air Filtration Units**

<b>HEPA MODEL</b>	<b>Filter Model</b>	<b>Price per each filter ordered in case lots*</b>	<b>Qty</b>	<b>Total Price</b>
<b>Trimline 400/500</b>	CIF-13 HEPA Prefilter (13x13x1)	\$6.40	X _____	= _____
	HEPA Core Filter (12x12x11.5)	\$399.00	X _____	= _____
<b>HUFP0650/350</b>	CIF-01 HEPA Prefilters (Two 20"x20"x1" Prefilters required)	\$6.40	X _____	= _____
	HUFP0650H HEPA Core Filters (Two Core Filters required)	\$499.00	X _____	= _____

**Isolation Chambers, Antechambers, Sputum Induction Booths and Hoods**

<b>ISOLATION CHAMBER/SPUTUM BOOTH/ ANTECHAMBER INLET FILTERS</b>	CIF01 (20"x20"x1") for Ceiling Mounted 2'x2' Diffuser	\$6.40	X _____	= _____
<b>INLET FILTERS</b>	CIF02 (12"x24"x1")	\$6.40	X _____	= _____
	CIF03 (8"x30"x2")	\$6.40	X _____	= _____
<b>SPUTUM INDUCTION HOOD</b>	Sputum Induction Hood Prefilters (15"x20"x1")	\$6.40	X _____	= _____

**Vehicle HEPA Units**

<b>VEHICLE HEPA UNIT - 350 CFM</b>	HUFO251H HEPA Core Filter for Roof Mounted Vehicle HEPA Unit (12"x18"x12")	\$299.00	X _____	= _____
------------------------------------	---	----------	---------	---------

**HEPA Filter Change Out Kits for all HEPA Air Filtration Units**

<b>HEPA Unit Filter Change Out Kit</b>	HUFC-01 Filter Change-Out Kit	\$6.95/ea. 12 kits/case	X _____	= _____
	HUFC01 Filter Change-Out Kit	\$9.95/ea. Individual kit	X _____	= _____

\*Prefilter Minimum Order: Case lot orders only (12 per case). HEPA Core Filters can be sold individually.

# **Air Management Solutions**

## **Isolock Isolation Detention Cells**

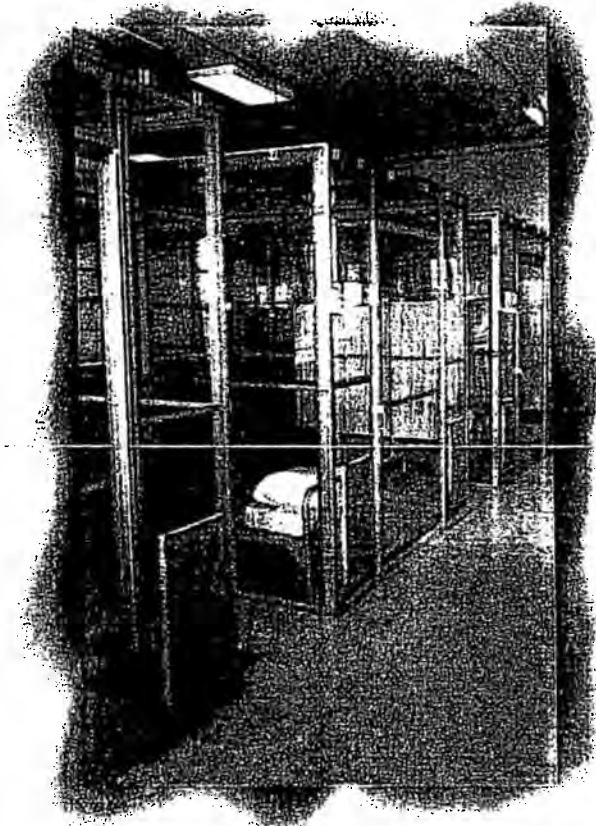

The Isolock Isolation Detention Cell is a versatile modular walled holding cell engineered for the containment and management of airborne particles using either positive or negative HEPA filtration, and at the same time providing a secure enclosure. The durable and flexible structure is constructed with superior quality materials at the lowest possible cost.

The frame is anodized aluminum utilizing a clamp profile. The modular walls are manufactured using a quarter inch Lexan, a clear totally visual product providing the highest level of containment and security. The Isolock Detention Cell may be custom designed, and reconfigured to meet every changing demand.

Heavy-duty hinges and deadbolt security locks are standard on all cells. A fully integrated electronic switch lock is optional.

## ***Air Management Solutions, Inc.***



Local: 770-943-9256 ■ Toll Free: 800-368-5633 ■ FAX: 770-943-8361  
3840 Villa Rica Lane Suite B Powder Springs, Georgia 30127 [www.hepaair.com](http://www.hepaair.com)

# Isolock Enclosure Systems

The Isolock Enclosure System is a clear improvement in air management containment technology. The Isolock Enclosure walls assemble quickly, easily, and cost effectively with minimal use of tools. The latch-together system provides strong, clear, positive walls, corners and ceilings for virtually every connection.

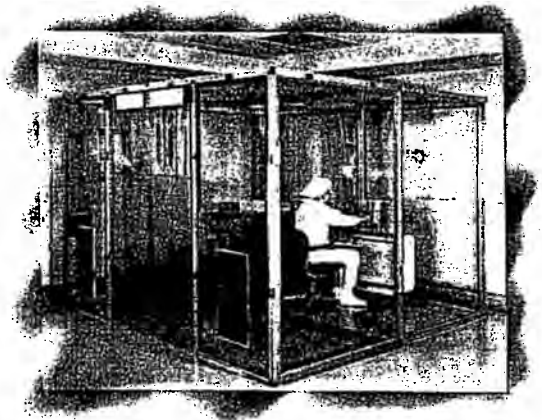

Isolock Enclosure System is effective in both permanent and temporary applications. The enclosures can easily expand or be reconfigured to meet every changing demand. The Isolock Enclosure System meets all of the California Fire Marshall and NFPA 701 standards and requirements.

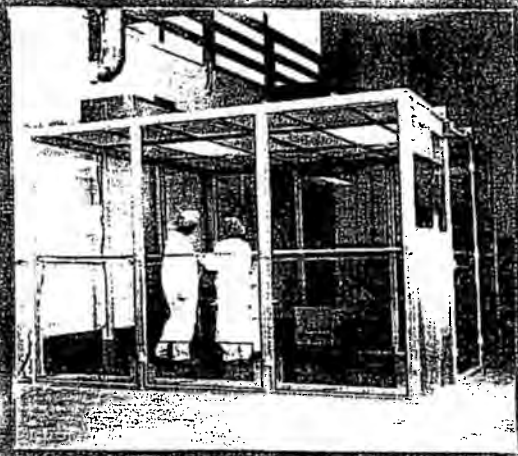

## Basic Construction Features

- Neoprene closed-cell foam gaskets seal frame-to-frame connections.
- Vinyl inserts lock into frame with an airtight seal. Cleaning is quick and easy.
- Frame construction with knock together corners allows for replacement of individual parts.
- Universal corner posts allow all walls to be interchanged for future expansion.
- Ceiling frames latch into position in the same manner as the walls, and can be designed to accommodate various types of filtration and lighting units.
- Lightweight aluminum frames are available in anodized clearcoat or epoxy powdercoat white.

Whether you need a brand new installation or expansion of an existing area, we will service you promptly. Call us to select a custom design system that suits your needs.

## ***Air Management Solutions, Inc.***



Local: 770-943-9256    ■    Toll Free: 800-368-5633    ■    FAX: 770-943-8361  
3840 Villa Rica Lane Suite B    Powder Springs, Georgia 30127    www.hepaair.com

# **Air Management Solutions Isolock Isolation Detention Cells**

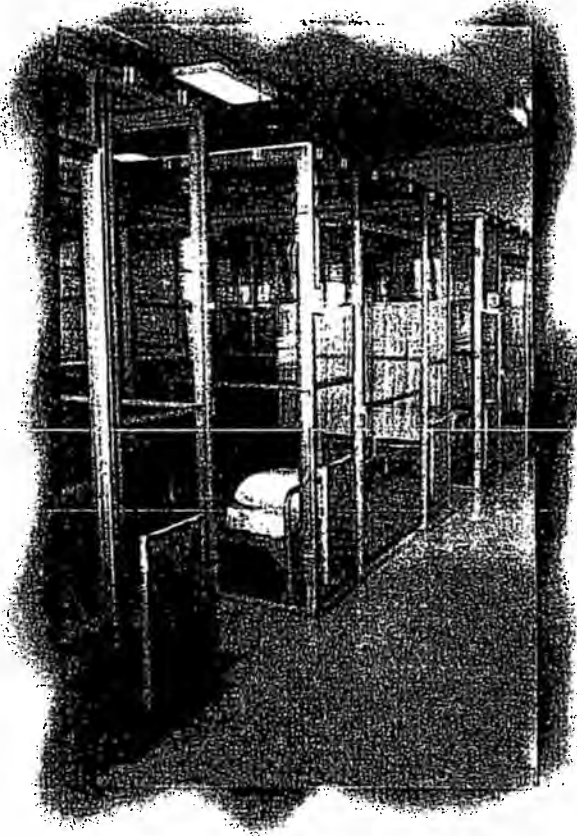

The Isolock Isolation Detention Cell is a versatile modular walled holding cell engineered for the containment and management of airborne particles using either positive or negative HEPA filtration, and at the same time providing a secure enclosure. The durable and flexible structure is constructed with superior quality materials at the lowest possible cost.

The frame is anodized aluminum utilizing a clamp profile. The modular walls are manufactured using a quarter inch Lexan, a clear totally visual product providing the highest level of containment and security. The Isolock Detention Cell may be custom designed, and reconfigured to meet every changing demand.

Heavy-duty hinges and deadbolt security locks are standard on all cells. A fully integrated electronic switch lock is optional.

## ***Air Management Solutions, Inc.***



Local: 770-943-9256 ■ Toll Free: 800-368-5633 ■ FAX: 770-943-8361  
3840 Villa Rica Lane Suite B Powder Springs, Georgia 30127 [www.hepaair.com](http://www.hepaair.com)



FACILITY	FLORENCE SERVICE CENTER			
WEEK	DATE	TIME	INITIALS	COMMENTS
<b>JANUARY</b>				
WEEK 1				
WEEK 2				
WEEK 3				
WEEK 4				
<b>FEBRUARY</b>				
WEEK 1				
WEEK 2				
WEEK 3				
WEEK 4				
<b>MARCH</b>				
WEEK 1				
WEEK 2				
WEEK 3				
WEEK 4				
<b>APRIL</b>				
WEEK 1				
WEEK 2				
WEEK 3				
WEEK 4				
<b>MAY</b>				
WEEK 1				
WEEK 2				
WEEK 3				
WEEK 4				
<b>JUNE</b>				
WEEK 1				
WEEK 2				
WEEK 3				
WEEK 4				
<b>JULY</b>				
WEEK 1				
WEEK 2				
WEEK 3				
WEEK 4				

WEEK	DATE	TIME	INITIALS	COMMENTS
<b>AUGUST</b>				
WEEK 1				
WEEK 2				
WEEK 3				
WEEK 4				
<b>SEPTEMBER</b>				
WEEK 1				
WEEK 2				
WEEK 3				
WEEK 4				
<b>OCTOBER</b>				
WEEK 1				
WEEK 2				
WEEK 3				
WEEK 4				
<b>NOVEMBER</b>				
WEEK 1				
WEEK 2				
WEEK 3				
WEEK 4				
<b>DECEMBER</b>				
WEEK 1				
WEEK 2				
WEEK 3				
WEEK 4				

*For safe and efficient change outs, contact:*  
**AIR MANAGEMENT SOLUTIONS, INC.**  
 3840 VILLA RICA LANE, STE B  
 POWDER SPRINGS, GA 30127  
 Phone: 800-368-5633  
 Fax: 770-943-8361



**Stevens, Richard P**

---

**From:** (b)(6)  
**Sent:** Monday, June 23, 2008 10:38 AM  
**To:** Jerald  
**Subject:** Attached Image  
**Attachments:** 1114\_001.pdf



**U.S. Immigration  
and Customs  
Enforcement**

June 23, 2008

Subject: Technical Review of Farmville Proposal

Attachments: (1) Mark-up Phase I Drawing  
(2) TIFF Trailer

Immigration and Customs Enforcement (ICE), Detention and Removal Operations (DRO) and Office of Acquisition Management (OAQ) have reviewed the proposal submitted by the Immigration Corporation of America (ICA). This document provides the ICE comments/areas of concern/suggested revisions to the proposal as follows:

(b)(5)

Changes to Phase I:

Below are the recommended changes to the facility:

(b)(5)

**General Technical Proposal Comments:**

(b)(5)

**Volume I Comments:**

(b)(5)

**Volume II Comments:**

(b)(5)

f

(b)(5)

If

(b)(5)



(b)(5)

**Stevens, Richard P**

---

**From:** Neveleff, Jerald  
**Sent:** Monday, June 23, 2008 10:57 AM  
**To:** Smyly, Elena L  
**Subject:** Farmville Technical Review

**Attachments:** Technical Comments to prop..pdf; Detainee Housing Changes.pdf; Florence Service Processing Center TIFF TRAILER.pdf

Good morning,  
The attached files are what I am planning to send to ICA today. Please review the response to the company to ensure that the comments/concerns/feedback is in accordance with the technical review of the proposal.

Upon your concurrence, I will forward for action by the Provider and subcontractor.

Detainee Housing Changes is Attachment (1).  
Florence Processing Center TIFF is Attachment (2)

Jerry

Thank you,  
Jerry Neveleff  
Supervisory Contracting Officer/  
IGSA Team Lead  
Office of Acq. Management (OAQ)  
Detention Management Division  
202/ (b)(6)

Help us support you better -  
TELL US HOW WE ARE DOING!  
Go to <<http://www.acqsolinc.com/ICE/OAQ/feedback.cfm>> <<<http://www.acqsolinc.com/ICE/OAQ/feedback.cfm>>>



Technical  
mments to prop..pd



Detainee Housing  
Changes.pdf (...)



Florence Service  
Processing Ce...



**U.S. Immigration  
and Customs  
Enforcement**

June 23, 2008

Subject: Technical Review of Farmville Proposal

Attachments: (1) Mark-up Phase I Drawing  
(2) TIFF Trailer

Immigration and Customs Enforcement (ICE), Detention and Removal Operations (DRO) and Office of Acquisition Management (OAQ) have reviewed the proposal submitted by the Immigration Corporation of America (ICA). This document provides the ICE comments/areas of concern/suggested revisions to the proposal as follows:

(b)(5)

Changes to Phase I:

Below are the recommended changes to the facility:

(b)(5)

**General Technical Proposal Comments:**

(b)(5)

**Volume I Comments:**

(b)(5)

**Volume II Comments:**

(b)(5)

(b)(5)

(b)(5)

(b)(5)

**DETAINEE HOUSING FACILITY - PHASE 2**

DRAWING NO. 2011-01  
 DATE 01/11/11  
 SCALE 1" = 30'-0"  
 PROJECT NO. 2011-01  
 SHEET NO. 110  
 110

(b)(2)High, (b)(5)

PROJECT NO. 2011-01  
 SHEET NO. 110  
 110

NO.	REVISION	DATE

FLOOR PLANS  
**ICE FARMVILLE FACILITY**  
 DETAINEE HOUSING FACILITY  
 FARMVILLE, VIRGINIA



**TIMMONS • KELLEY**  
 ARCHITECTS  
 11005 STEEPLERSONE DRIVE • WELLSFORD, VIRGINIA 22113  
 TEL: (804) 867-5636 • FAX: (804) 867-5635





(b)(2)High

TIF Modular Unit Layout  
Roughly 1,488 sq. feet.

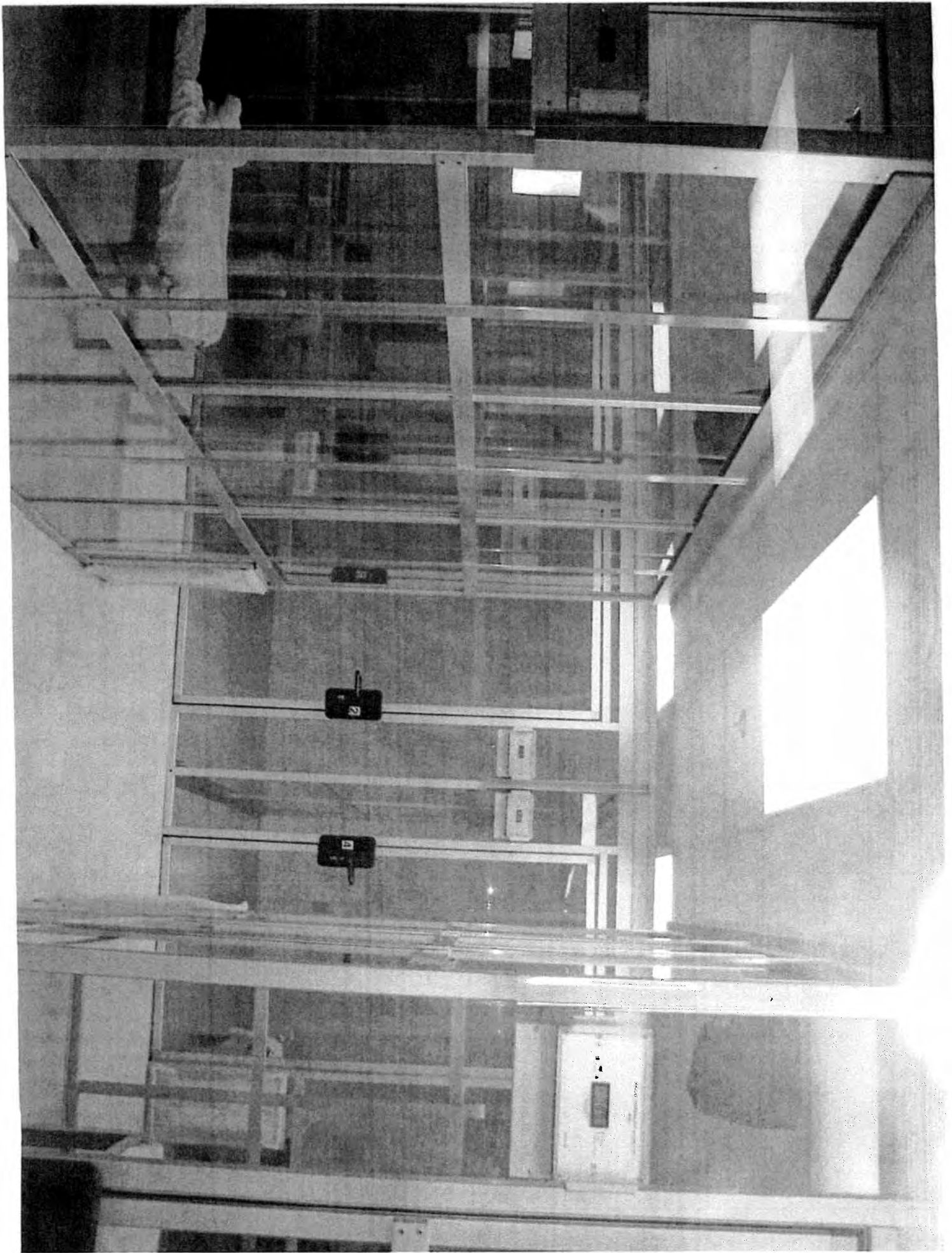

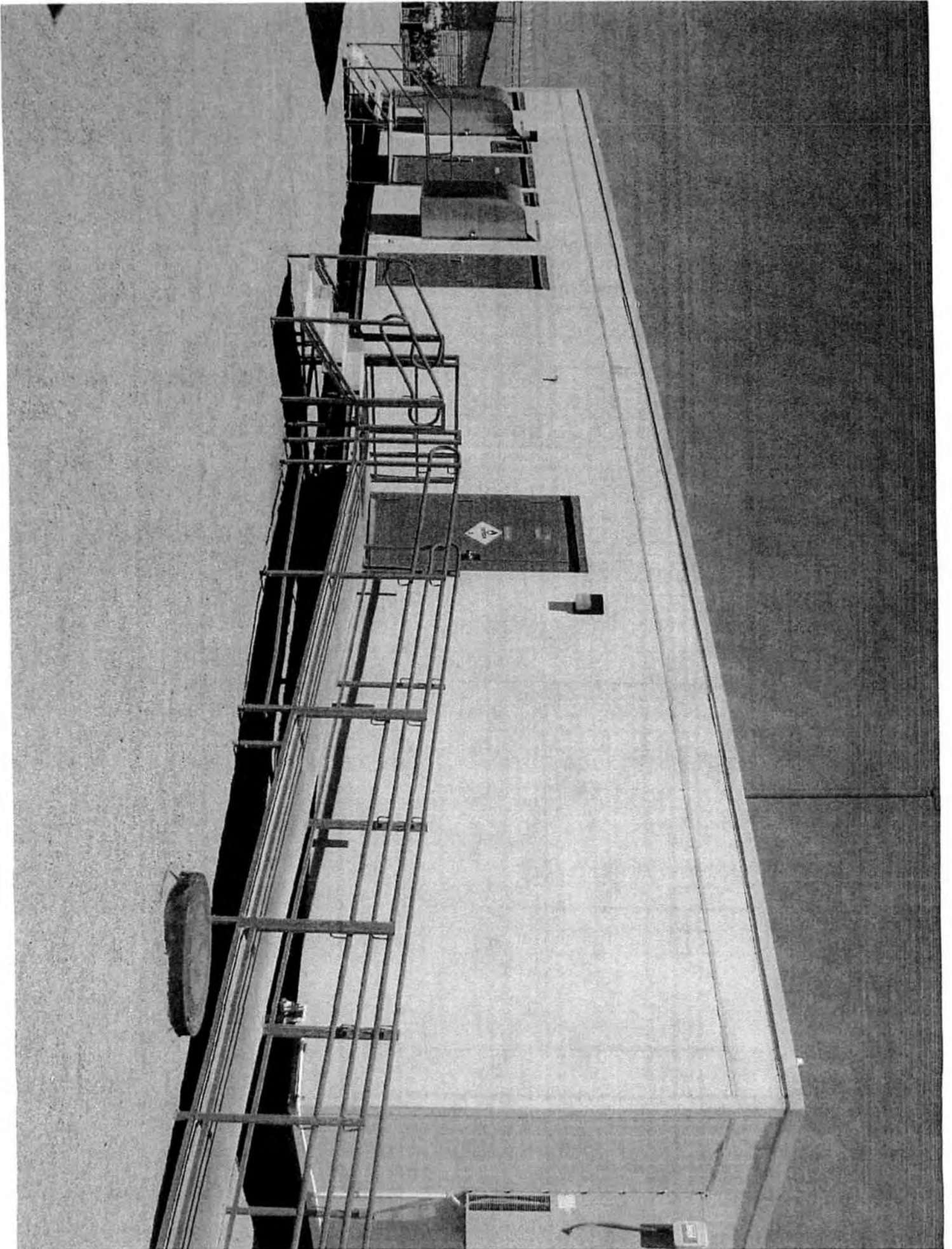

**US IMMIGRATION &  
NATURALIZATION SERVICE  
FLORENCE SERVICE  
CENTER**

**SYSTEMS MANUAL**

**HEPA Filtration Unit  
For Model #  
TRIMLINE 400 / 500 SERIES WALL  
MOUNTED HEPA FILTRATION UNITS**

Air Management Systems, Inc.  
3840 Villa Rica Lane  
Powder Springs, GA 30127-1511  
Phone: 770-943-9256  
800-368-5633  
Fax: 770-943-8361

*E-mail: AIRMANAGEMENT@COMCAST.NET*

# Table Of Contents

## ◆ Air Management Solutions Systems Specifications

Page No.

- ◆ Filter Panel Specifications ..... 3
- ◆ HEPA Filtration Unit Product Specifications ..... 4
- ◆ System Enclosure Specifications .....5
- ◆ Warranty ..... 6
- ◆ HEPA Unit Filter Change Out Instructions ..... 7
- ◆ Pre-Filter Change Out Instructions..... 8
- ◆ Recommended Prefilter Change Intervals..... 9
- ◆ Filter Reorder Form ..... 10
- ◆ Prefilter Change Out Log

# Filter Specifications

---

The filter shall be Air Management Systems, Inc.'s HEPA, individually factory tested for efficiency and pressure drop using a laser aerosol spectrometer. Minimum efficiency shall be 99.97% for particle 0.3-micron size. Each filter shall also be scanned for leaks for IES recommended practice cc-001-86.

The filtration medium shall be constructed by pleating a continuous sheet of Borosilicate Fiber media into a 70 panel (deep) "Mini-Pleat" media pak with non-metallic separators. String separators shall not only accurately space the pleats but also give additional strength and rigidity to the media pak.

The filtration media pak shall be permanently bonded with polyurethane to a (frame height) anodized aluminum frame using "Klip-Lok™" corners, for added structural integrity, allowing no exposed sealant or raw edges.

## MATERIAL SAFETY DATA SHEET:

- Frame:** Fiberboard or Aluminum Housed
- Media:** Borosilicate micro-glass, Acrylic resin, water repellent
- Sealant:** 2 part polyurethane elastomer (unfilled, self-extinguishing)
- Gasket:** 1/4" (H) x 3/4"(W) SCE-43 neoprene dove tail joints. PVC/Silicone available upon request
- Size:** 12" X 12" X 11.5

# Product Specification

## Trimline 400/500 Series

### HEPA Filtration Unit

---

The Trimline Series Units offers clean HEPA-filtered air.

With its HEPA grade level of efficiency (99.97% @ .3 $\mu$ ) and very low pressure drop this unit can be installed on a direct replacement basis. No additional costs are incurred for motors/blowers change-outs usually associated with higher filter capacity.

Standard sizes are 12 x 12 11.5 with boxboard frame.

#### FEATURES:

**Efficiency:** 99.97% @ .3 $\mu$  (microns) particulate HEPA  
99.9995@ 0.12 $\mu$  ULPA filter

#### Pressure

**Drop:** @ 90-100 FPM +/- 20%

#### String

#### Separators:

Non-metallic HEPA-string separators are non-corrosive  
Reinforces the entire media pak  
No sagging, units can be aligned either vertically or horizontally

**Frames:** Wood board frames

**Testing:** Scanned for leaks per IES RP-CC-001-86  
Testing protocol is available for review

Page 4

## ISO-LOCK™ CLASS 2 SECURITY ENCLOSURE SYSTEM SPECIFICATIONS

---

Air Management Solutions, Inc. • 3840 Villa Rica Ln • Powder Springs, GA 30127

Ph: 800-368-5633 • 770-943-9256 • Fax: 770-943-8361

The ISO-LOCK™ class 2 Security Modular Enclosure System, is a totally integrated wall and ceiling frame system, std. Internal fasteners.

- Wall Frames are constructed using 40mm x 40mm square, primary smooth face profile, clear anodized finish, std. (internal ) fasteners. A special number of relief air vents shall be installed in wall panels to balance airflow in the room.
- Panel Inserts are installed using Lip Seal # 8 Gasket with the exception of 3/8" thick Lexan.
- Material: Lexan / Std. Clear 3/8" Polycarbonate.
- Corner Post is also made of 40mm x 40mm square, primary smooth face profile square, clear anodized finish.
- Ceiling support Beam: none
- Doors 42" x 7" Clamp profile, E version, Hinged left / right accordingly, with matching locks and keys.
- Floor mounting is 40 mm x 40mm angle anodized finish.
- 1 x 2 L channel aluminum.



# WARRANTY

All Air Management Solutions, Inc HEPA filtration units are warranted by the manufacturer, and are certified to the original user, against defects in material and workmanship for a period of one year after the date of purchase. AMS only obligation shall be, at AMS option, either to repair or replace the defective components, or make suitable adjustment for such defect(s) upon timely notification, provided the unit has been used, maintained with certified filter configuration, purchased through Air Management Solutions and handled in accordance with these instructions. THIS WARRANTY IS MADE TO THE COMMERCIAL USER IN LIEU OF WARRANTIES OF MERCHANTABILITY, FITNESS FOR PARTICULAR PURPOSE, AND ALL OTHER WARRANTIES EXPRESSED OR IMPLIED.

NOTE: ALL FILTERS ARE SPECIFIED TO AMS STANDARDS AND USE OF OTHER FILTERS WILL VOID THE WARRANTY.

## LIMITATION OF LIABILITY

Except as provided above, Air Management Solutions, INC., shall not be liable or responsible for any loss or damage, whether direct, indirect, incidental, special, or consequential, arising out of the sale, use or misuse of or the user's inability to use such products. The remedies set forth herein are exclusive.

Page 6

## HEPA Filter Removal and Replacement

---

Air Management Solutions, Inc. • 3840 Villa Rica Ln • Powder Springs, GA 30127

Ph: 800-368-5633 • 770-943-9256 • Fax: 770-943-8361

High efficiency ASHRAE rated prefilters are provided and recommended for use with this system.

**REMOVAL AND INSTALLATION OF HEPA FILTER  
SHOULD BE PERFORMED BY QUALIFIED PERSONEL  
ONLY.**

**NOTE: IT IS RECOMMENDED THE UNITS BE TESTED ANNUALLY. REMOVAL, RELOCATION OF HEPA UNITS OR ITS COMPONENTS SHOULD BE PERFORMED BY QUALIFIED PERSONEL ONLY.**

Page 7

# Pre- Filter Removal and Replacement

## FILTERS - GENERAL INFORMATION

The filter furnished in Air Management Solutions, Inc HEPA units are selected to provide the highest efficiency and airflow capability. Use of any other types of pre-filters will void the warranty and reduce performance efficiency.

AMS and its agents sell Air Management Solutions, Inc filters without any expressed or implied warranty that the pre-filters will prevent or cure any injury or health damage to the user.

## INSTRUCTIONS FOR REMOVAL

As per established procedure, the person responsible for the removal and disposal of used pre-filters, and the installation of new pre-filters should follow good housekeeping procedures or internal protocols set forth by the Safety Director of the Department.

## PRE-FILTER REPLACEMENT

Listed below are only recommendations, not to override existing or departmental procedures:

- ❶ The person responsible for the removal, disposal of used filters, and the installation of new filters, should utilize a facemask with eye shield.
- ❷ Put on latex gloves and any additional protective wear recommended by existing protocols.
- ❸ Slowly vacuum the outer face of the security grill with a HEPA Vac. Then spray the face of the pre-filter and the pre-filter door (closed) with a hospital grade disinfectant, spray while the unit is running. (Do not use a chlorine base spray.)
- ❹ Allow the unit to run 1-2 minutes before removing old pre-filters.
- ❺ Permit the unit to run the entire time when changing pre-filters.
- ❻ Remove the old pre-filter by dropping down the access door. Dispose of the old filter in accordance with the existing departmental procedure.
- ❼ Before replacing the new pre-filters, vacuum the outer perimeter and the inside of the grill door with the HEPA Vac. Place the new pre-filters (white side facing down) on access door, close and secure. Wipe down grill with clean cloth.

**NOTE: IT IS RECOMMENDED THE UNITS BE TESTED ANNUALLY. REMOVAL, RELOCATION OF HEPA UNITS OR ITS COMPONENTS SHOULD BE PREFORMED BY QUALIFIED PERSONEL ONLY.**

# RECOMMENDED PREFILTER CHANGE INTERVALS

On an average basis, the Pre-Filters should be changed each month, or more often if deemed necessary by departmental procedures or protocols.

At startup the Prefilters should be changed at the rate of one per week for the first two weeks. Once the unit is running for a period of time, the ambient dust, and particulate will be “scrubbed” from the environment, and the need for replacement of the Prefilters will decrease to one per month.

Antimicrobial Prefilters provide an antibacterial ingredient on the surface of the filter and may be used in place of a Prefilter. Charcoal filters are used for odor abatement and may be used alone or with a Prefilter. Using a Prefilter in conjunction with a Charcoal filter will decrease the CFM airflow of the units. In the first one to two weeks, these filters should be changed at least once per week. After that initial period, filters can be changed once per month.

This replacement schedule assumes a “typical” application in a confined patient's room or emergency room. Further, this assumes that the primary application is used in TB nuclei abatement. If the HEPA unit is used during construction or in conjunction with charcoal filters for volatile organic compound abatement, the Prefilters must be replaced on a more frequent basis. **By maintaining a regular Prefilter change out schedule, the HEPA Core Filter should last a minimum of 1 year.**

---

## Filter Order Form

---

**Ceiling-Mounted HEPA Air Filtration Units**

<b>HEPA MODEL</b>	<b>Filter Model</b>	<b>Price per each filter ordered in case lots*</b>	<b>Qty</b>	<b>Total Price</b>
<b>Trimline 400/500</b>	CIF-13 HEPA Prefilter (13x13x1)	\$6.40	X _____	= _____
	HEPA Core Filter (12x12x11.5)	\$399.00	X _____	= _____
<b>HUFP0650/350</b>	CIF-01 HEPA Prefilters (Two 20"x20"x1" Prefilters required)	\$6.40	X _____	= _____
	HUFP0650H HEPA Core Filters (Two Core Filters required)	\$499.00	X _____	= _____

**Isolation Chambers, Antechambers, Sputum Induction Booths and Hoods**

<b>ISOLATION CHAMBER/SPUTUM BOOTH/ ANTECHAMBER INLET FILTERS</b>	CIF01 (20"x20"x1") for Ceiling Mounted 2'x2'			
	Diffuser	\$6.40	X _____	= _____
	CIF02 (12"x24"x1")	\$6.40	X _____	= _____
	CIF03 (8"x30"x2")	\$6.40	X _____	= _____
<b>SPUTUM INDUCTION HOOD</b>	Sputum Induction Hood Prefilters (15"x20"x1")	\$6.40	X _____	= _____

**Vehicle HEPA Units**

<b>VEHICLE HEPA UNIT - 350 CFM</b>	HUFO251H HEPA Core Filter for Roof Mounted Vehicle HEPA Unit (12"x18"x12")	\$299.00	X _____	= _____
------------------------------------	--	----------	---------	---------

**HEPA Filter Change Out Kits for all HEPA Air Filtration Units**

<b>HEPA Unit Filter Change Out Kit</b>	HUFC-01 Filter Change-Out Kit	\$6.95/ea. 12 kits/case	X _____	= _____
	HUFC01 Filter Change-Out Kit	\$9.95/ea. Individual kit	X _____	= _____

\*Prefilter Minimum Order: Case lot orders only (12 per case). HEPA Core Filters can be sold individually.

# **Air Management Solutions**

## **Isolock Isolation Detention Cells**

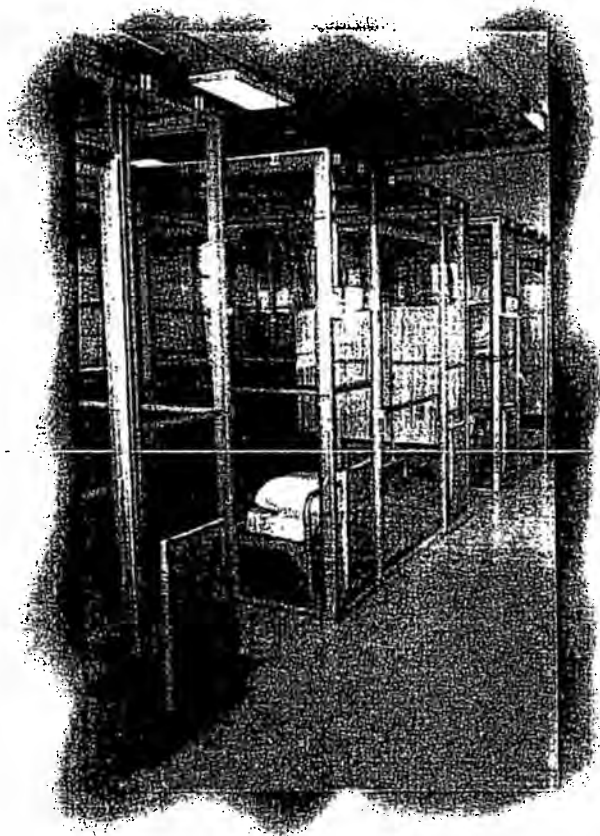

The Isolock Isolation Detention Cell is a versatile modular walled holding cell engineered for the containment and management of airborne particles using either positive or negative HEPA filtration, and at the same time providing a secure enclosure. The durable and flexible structure is constructed with superior quality materials at the lowest possible cost.

The frame is anodized aluminum utilizing a clamp profile. The modular walls are manufactured using a quarter inch Lexan, a clear totally visual product providing the highest level of containment and security. The Isolock Detention Cell may be custom designed, and reconfigured to meet every changing demand.

Heavy-duty hinges and deadbolt security locks are standard on all cells. A fully integrated electronic switch lock is optional.

## **Air Management Solutions, Inc.**



Local: 770-943-9256 ■ Toll Free: 800-368-5633 ■ FAX: 770-943-8361  
3840 Villa Rica Lane Suite B Powder Springs, Georgia 30127 [www.hepaair.com](http://www.hepaair.com)

# Isolock Enclosure Systems

The Isolock Enclosure System is a clear improvement in air management containment technology. The Isolock Enclosure walls assemble quickly, easily, and cost effectively with minimal use of tools. The latch-together system provides strong, clear, positive walls, corners and ceilings for virtually every connection.

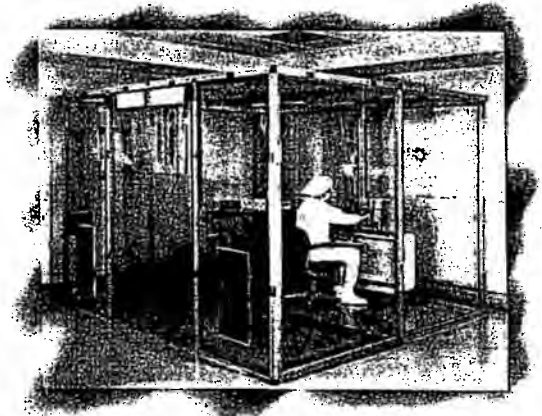

Isolock Enclosure System is effective in both permanent and temporary applications. The enclosures can easily expand or be reconfigured to meet every changing demand. The Isolock Enclosure System meets all of the California Fire Marshall and NFPA 701 standards and requirements.

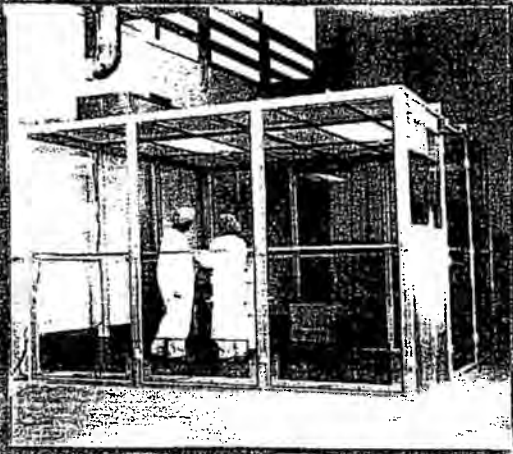

## Basic Construction Features

- Neoprene closed-cell foam gaskets seal frame-to-frame connections.
- Vinyl inserts lock into frame with an airtight seal. Cleaning is quick and easy.
- Frame construction with knock together corners allows for replacement of individual parts.
- Universal corner posts allow all walls to be interchanged for future expansion.
- Ceiling frames latch into position in the same manner as the walls, and can be designed to accommodate various types of filtration and lighting units.
- Lightweight aluminum frames are available in anodized clearcoat or epoxy powdercoat white.

Whether you need a brand new installation or expansion of an existing area, we will service you promptly. Call us to select a custom design system that suits your needs.

## ***Air Management Solutions, Inc.***



Local: 770-943-9256 ■ Toll Free: 800-368-5633 ■ FAX: 770-943-8361  
3840 Villa Rica Lane Suite B Powder Springs, Georgia 30127 www.hepaair.com

# **Air Management Solutions**

## **Isolock Isolation Detention Cells**

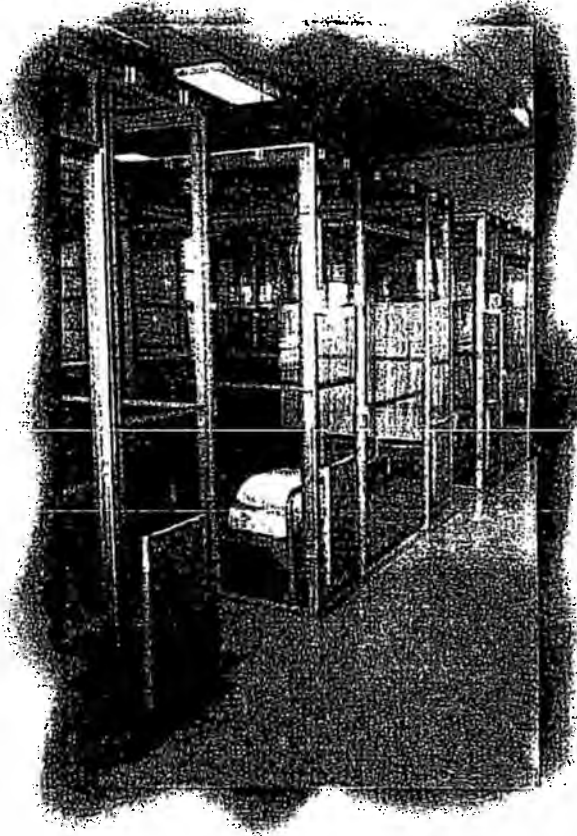

The Isolock Isolation Detention Cell is a versatile modular walled holding cell engineered for the containment and management of airborne particles using either positive or negative HEPA filtration, and at the same time providing a secure enclosure. The durable and flexible structure is constructed with superior quality materials at the lowest possible cost.

The frame is anodized aluminum utilizing a clamp profile. The modular walls are manufactured using a quarter inch Lexan, a clear totally visual product providing the highest level of containment and security. The Isolock Detention Cell may be custom designed, and reconfigured to meet every changing demand.

Heavy-duty hinges and deadbolt security locks are standard on all cells. A fully integrated electronic switch lock is optional.

## ***Air Management Solutions, Inc.***



Local: 770-943-9256    Toll Free: 800-368-5633    FAX: 770-943-8361  
3840 Villa Rica Lane Suite B    Powder Springs, Georgia 30127    [www.hepaair.com](http://www.hepaair.com)



FACILITY	FLORENCE SERVICE CENTER			
WEEK	DATE	TIME	INITIALS	COMMENTS
<b>JANUARY</b>				
WEEK 1				
WEEK 2				
WEEK 3				
WEEK 4				
<b>FEBRUARY</b>				
WEEK 1				
WEEK 2				
WEEK 3				
WEEK 4				
<b>MARCH</b>				
WEEK 1				
WEEK 2				
WEEK 3				
WEEK 4				
<b>APRIL</b>				
WEEK 1				
WEEK 2				
WEEK 3				
WEEK 4				
<b>MAY</b>				
WEEK 1				
WEEK 2				
WEEK 3				
WEEK 4				
<b>JUNE</b>				
WEEK 1				
WEEK 2				
WEEK 3				
WEEK 4				
<b>JULY</b>				
WEEK 1				
WEEK 2				
WEEK 3				
WEEK 4				



**Stevens, Richard P**

---

**From:** Smyly, Elena L  
**Sent:** Monday, June 23, 2008 12:53 PM  
**To:** Neveleff, Jerald  
**Subject:** RE: Farmville Technical Review

**Importance:** High

Hello Jerry,

(b)(5)

Other than that, I concur with the attached letter and attachments.

When is the requested response date?

Thank you,

*Elena Smyly, PMP  
Management and Program Analyst - Large IGSA  
DHS, U.S. Immigration and Customs Enforcement  
Office of Detention and Removal  
Detention Management Division  
(202, (b)(6)*

---

**From:** Neveleff, Jerald  
**Sent:** Monday, June 23, 2008 10:57 AM  
**To:** Smyly, Elena L  
**Subject:** Farmville Technical Review

Good morning,  
The attached files are what I am planning to send to ICA today. Please review the response to the company to ensure that the comments/concerns/feedback is in accordance with the technical review of the proposal.

Upon your concurrence, I will forward for action by the Provider and subcontractor.

Detainee Housing Changes is Attachment (1).  
Florence Processing Center TIFF is Attachment (2)

Jerry

Thank you,  
Jerry Neveleff  
Supervisory Contracting Officer/  
IGSA Team Lead  
Office of Acq. Management (OAQ)  
Detention Management Division  
202 (b)(6)

Help us support you better -  
TELL US HOW WE ARE DOING!  
Go to <http://www.acqsolinc.com/ICE/OAQ/feedback.cfm> <<<http://www.acqsolinc.com/ICE/OAQ/feedback.cfm>>>

<< File: Technical Comments to prop..pdf >> << File: Detainee Housing Changes.pdf >> << File: Florence Service Processing Center TIFF TRAILER.pdf >>

**Stevens, Richard P**

---

**From:** (b)(6)  
**Sent:** Monday, June 23, 2008 1:08 PM  
**To:** Jerald  
**Subject:** Attached Image  
**Attachments:** 1121\_001.pdf



**U.S. Immigration  
and Customs  
Enforcement**

June 23, 2008

Subject: Technical Review of Farmville Proposal

Attachments: (1) Mark-up Phase I Drawing  
(2) TIFF Trailer

Immigration and Customs Enforcement (ICE), Detention and Removal Operations (DRO) and Office of Acquisition Management (OAQ) have reviewed the proposal submitted by the Immigration Corporation of America (ICA). This document provides the ICE comments/areas of concern/suggested revisions to the proposal as follows:

(b)(5)

Changes to Phase I:

Below are the recommended changes to the facility:

(b)(5)

**General Technical Proposal Comments:**

(b)(5)

**Volume I Comments:**

(b)(5)

**Volume II Comments:**

(b)(5)

(b)(5)

(b)(5)



(b)(5)

**Stevens, Richard P**

---

**From:** Neveleff, Jerald  
**Sent:** Monday, June 23, 2008 1:41 PM  
**To:** (b)(6)  
**Cc:** Smyly, Elena L; Casterline, Arnold P; Jenkins, John E; Casterline, Arnold P  
**Subject:** FEEDBACK TO FARMVILLE PROPOSAL

**Attachments:** Technical Comments to prop..pdf; Detainee Housing Changes.pdf; Florence Service Processing Center TIFF TRAILER.pdf

Mr. Coleman,  
Attached are files providing DRO's feedback on the proposal submitted for the Farmville Detention Facility.

Please review the files and provide me an estimated date when Farmville/ICA can provide comments/adjustments to your proposal.

Technical Comments  
Detainee Housing Charges – Attachment (1) to the Technical Comments  
Florence SPC TIFF Trailer – Attachment (2) to the Technical Comments



Technical  
Comments to prop..pd



Detainee Housing  
Changes.pdf (...)



Florence Service  
Processing Ce...

Thank you,  
Jerry Neveleff  
Supervisory Contracting Officer/  
IGSA Team Lead  
Office of Acq. Management (OAQ)  
Detention Management Division  
202/ (b)(6)

Help us support you better -  
TELL US HOW WE ARE DOING!  
Go to <<http://www.acqsolinc.com/ICE/OAQ/feedback.cfm>> <<<http://www.acqsolinc.com/ICE/OAQ/feedback.cfm>>>



**U.S. Immigration  
and Customs  
Enforcement**

June 23, 2008

**Subject:** Technical Review of Farmville Proposal

**Attachments:** (1) Mark-up Phase I Drawing  
(2) TIFF Trailer

Immigration and Customs Enforcement (ICE), Detention and Removal Operations (DRO) and Office of Acquisition Management (OAQ) have reviewed the proposal submitted by the Immigration Corporation of America (ICA). This document provides the ICE comments/areas of concern/suggested revisions to the proposal as follows:

(b)(5)

Changes to Phase I:

Below are the recommended changes to the facility:

(b)(5)

**General Technical Proposal Comments:**

(b)(5)

**Volume I Comments:**

(b)(5)

**Volume II Comments:**

(b)(5)

(b)(5)

(b)(5)

(b)(5)



**U.S. Immigration  
and Customs  
Enforcement**

June 23, 2008

Subject: Technical Review of Farmville Proposal

Attachments: (1) Mark-up Phase I Drawing  
(2) TIFF Trailer

Immigration and Customs Enforcement (ICE), Detention and Removal Operations (DRO) and Office of Acquisition Management (OAQ) have reviewed the proposal submitted by the Immigration Corporation of America (ICA). This document provides the ICE comments/areas of concern/suggested revisions to the proposal as follows:

(b)(5)

Changes to Phase I:

Below are the recommended changes to the facility:

(b)(5)



**General Technical Proposal Comments:**

(b)(5)

**Volume I Comments:**

(b)(5)

**Volume II Comments:**

(b)(5)

(b)(5)

(b)(5)

(b)(5)

(b)(2)High

TIF Modular Unit Layout  
Roughly 1,488 sq. feet.



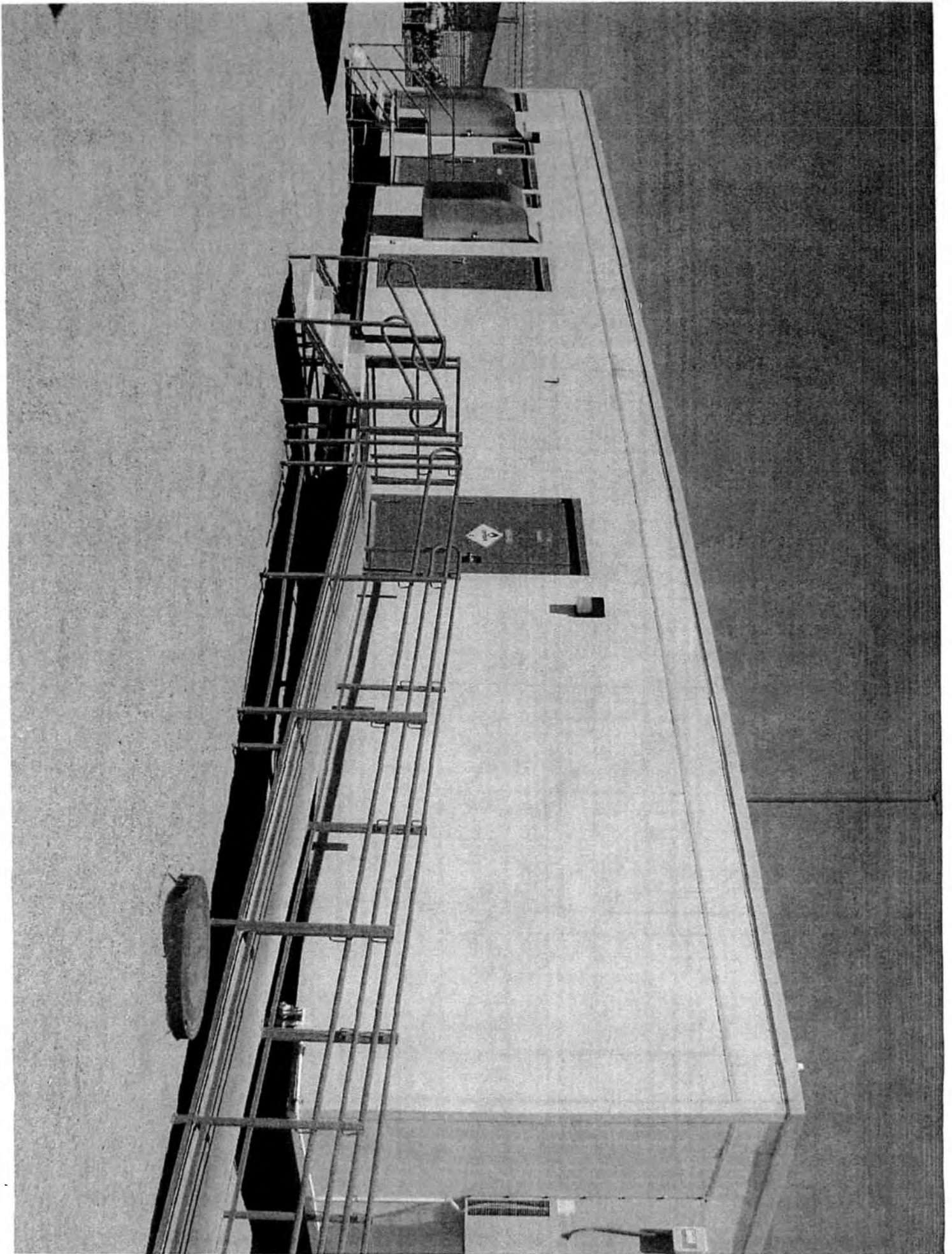

**US IMMIGRATION &  
NATURALIZATION SERVICE  
FLORENCE SERVICE  
CENTER**

**SYSTEMS MANUAL**

**HEPA Filtration Unit  
For Model #  
TRIMLINE 400 / 500 SERIES WALL  
MOUNTED HEPA FILTRATION UNITS**

Air Management Systems, Inc.  
3840 Villa Rica Lane  
Powder Springs, GA 30127-1511  
Phone: 770-943-9256  
800-368-5633  
Fax: 770-943-8361

*E-mail: AIRMANAGEMENT@COMCAST.NET*



# Table Of Contents

## ◆ Air Management Solutions Systems Specifications

	Page No.
◆ Filter Panel Specifications .....	3
◆ HEPA Filtration Unit Product Specifications .....	4
◆ System Enclosure Specifications .....	5
◆ Warranty .....	6
◆ HEPA Unit Filter Change Out Instructions .....	7
◆ Pre-Filter Change Out Instructions.....	8
◆ Recommended Prefilter Change Intervals.....	9
◆ Filter Reorder Form .....	10
◆ Prefilter Change Out Log	

# Filter Specifications

---

The filter shall be Air Management Systems, Inc.'s HEPA, individually factory tested for efficiency and pressure drop using a laser aerosol spectrometer. Minimum efficiency shall be 99.97% for particle 0.3-micron size. Each filter shall also be scanned for leaks for IES recommended practice cc-001-86.

The filtration medium shall be constructed by pleating a continuous sheet of Borosilicate Fiber media into a 70 panel (deep) "Mini-Pleat" media pak with non-metallic separators. String separators shall not only accurately space the pleats but also give additional strength and rigidity to the media pak.

The filtration media pak shall be permanently bonded with polyurethane to a (frame height) anodized aluminum frame using "Klip-Lok™" corners, for added structural integrity, allowing no exposed sealant or raw edges.

## MATERIAL SAFETY DATA SHEET:

- Frame:** Fiberboard or Aluminum Housed
- Media:** Borosilicate micro-glass, Acrylic resin, water repellent
- Sealant:** 2 part polyurethane elastomer (unfilled, self-extinguishing)
- Gasket:** 1/4" (H) x 3/4"(W) SCE-43 neoprene dove tail joints. PVC/Silicone available upon request
- Size:** 12" X 12" X 11.5

# Product Specification Trimline 400/500 Series HEPA Filtration Unit

---

The Trimline Series Units offers clean HEPA-filtered air.

With its HEPA grade level of efficiency (99.97% @ .3 $\mu$ ) and very low pressure drop this unit can be installed on a direct replacement basis. No additional costs are incurred for motors/blowers change-outs usually associated with higher filter capacity.

Standard sizes are 12 x 12 11.5 with boxboard frame.

## FEATURES:

**Efficiency:** 99.97% @ .3 $\mu$  (microns) particulate HEPA  
99.9995@ 0.12 $\mu$  ULPA filter.

**Pressure Drop:** @ 90-100 FPM +/- 20%

**String Separators:** Non-metallic HEPA-string separators are non-corrosive  
Reinforces the entire media pak  
No sagging, units can be aligned either vertically or horizontally

**Frames:** Wood board frames

**Testing:** Scanned for leaks per IES RP-CC-001-86  
Testing protocol is available for review

Page 4

## ISO-LOCK™ CLASS 2 SECURITY ENCLOSURE SYSTEM SPECIFICATIONS

---

Air Management Solutions, Inc. • 3840 Villa Rica Ln • Powder Springs, GA 30127

Ph: 800-368-5633 • 770-943-9256 • Fax: 770-943-8361

The ISO-LOCK™ class 2 Security Modular Enclosure System, is a totally integrated wall and ceiling frame system, std. Internal fasteners.

- Wall Frames are constructed using 40mm x 40mm square, primary smooth face profile, clear anodized finish, std. (internal ) fasteners. A special number of relief air vents shall be installed in wall panels to balance airflow in the room.
- Panel Inserts are installed using Lip Seal # 8 Gasket with the exception of 3/8" thick Lexan.
- Material: Lexan / Std. Clear 3/8" Polycarbonate.
- Corner Post is also made of 40mm x 40mm square, primary smooth face profile square, clear anodized finish.
- Ceiling support Beam: none
- Doors 42" x 7 Clamp profile, E version, Hinged left / right accordingly, with matching locks and keys.
- Floor mounting is 40 mm x 40mm angle anodized finish.
- 1 x 2 L channel aluminum.

# WARRANTY

All Air Management Solutions, Inc HEPA filtration units are warranted by the manufacturer, and are certified to the original user, against defects in material and workmanship for a period of one year after the date of purchase. AMS only obligation shall be, at AMS option, either to repair or replace the defective components, or make suitable adjustment for such defect(s) upon timely notification, provided the unit has been used, maintained with certified filter configuration, purchased through Air Management Solutions and handled in accordance with these instructions. THIS WARRANTY IS MADE TO THE COMMERCIAL USER IN LIEU OF WARRANTIES OF MERCHANTABILITY, FITNESS FOR PARTICULAR PURPOSE, AND ALL OTHER WARRANTIES EXPRESSED OR IMPLIED.

NOTE: ALL FILTERS ARE SPECIFIED TO AMS STANDARDS AND USE OF OTHER FILTERS WILL VOID THE WARRANTY.

## LIMITATION OF LIABILITY

Except as provided above, Air Management Solutions, INC., shall not be liable or responsible for any loss or damage, whether direct, indirect, incidental, special, or consequential, arising out of the sale, use or misuse of or the user's inability to use such products. The remedies set forth herein are exclusive.

Page 6

## HEPA Filter Removal and Replacement

---

Air Management Solutions, Inc. • 3840 Villa Rica Ln • Powder Springs, GA 30127

Ph: 800-368-5633 • 770-943-9256 • Fax: 770-943-8361

High efficiency ASHRAE rated prefilters are provided and recommended for use with this system.

**REMOVAL AND INSTALLATION OF HEPA FILTER  
SHOULD BE PERFORMED BY QUALIFIED PERSONEL  
ONLY.**

**NOTE: IT IS RECOMMENDED THE UNITS BE TESTED ANNUALLY. REMOVAL, RELOCATION OF HEPA UNITS OR ITS COMPONENTS SHOULD BE PERFORMED BY QUALIFIED PERSONEL ONLY.**

Page 7

# Pre- Filter Removal and Replacement

## FILTERS - GENERAL INFORMATION

The filter furnished in Air Management Solutions, Inc HEPA units are selected to provide the highest efficiency and airflow capability. Use of any other types of pre-filters will void the warranty and reduce performance efficiency.

AMS and its agents sell Air Management Solutions, Inc filters without any expressed or implied warranty that the pre-filters will prevent or cure any injury or health damage to the user.

## INSTRUCTIONS FOR REMOVAL

As per established procedure, the person responsible for the removal and disposal of used pre-filters, and the installation of new pre-filters should follow good housekeeping procedures or internal protocols set forth by the Safety Director of the Department.

## PRE-FILTER REPLACEMENT

Listed below are only recommendations, not to override existing or departmental procedures:

- ① The person responsible for the removal, disposal of used filters, and the installation of new filters, should utilize a facemask with eye shield.
- ② Put on latex gloves and any additional protective wear recommended by existing protocols.
- ③ Slowly vacuum the outer face of the security grill with a HEPA Vac. Then spray the face of the pre-filter and the pre-filter door (closed) with a hospital grade disinfectant, spray while the unit is running. (Do not use a chlorine base spray.)
- ④ Allow the unit to run 1-2 minutes before removing old pre-filters.
- ⑤ Permit the unit to run the entire time when changing pre-filters.
- ⑥ Remove the old pre-filter by dropping down the access door. Dispose of the old filter in accordance with the existing departmental procedure.
- ⑦ Before replacing the new pre-filters, vacuum the outer perimeter and the inside of the grill door with the HEPA Vac. Place the new pre-filters (white side facing down) on access door, close and secure. Wipe down grill with clean cloth.

**NOTE: IT IS RECOMMENDED THE UNITS BE TESTED ANNUALLY. REMOVAL, RELOCATION OF HEPA UNITS OR ITS COMPONENTS SHOULD BE PREFORMED BY QUALIFIED PERSONEL ONLY.**

# RECOMMENDED PREFILTER CHANGE INTERVALS

On an average basis, the Pre-Filters should be changed each month, or more often if deemed necessary by departmental procedures or protocols.

At startup the Prefilters should be changed at the rate of one per week for the first two weeks. Once the unit is running for a period of time, the ambient dust, and particulate will be "scrubbed" from the environment, and the need for replacement of the Prefilters will decrease to one per month.

Antimicrobial Prefilters provide an antibacterial ingredient on the surface of the filter and may be used in place of a Prefilter. Charcoal filters are used for odor abatement and may be used alone or with a Prefilter. Using a Prefilter in conjunction with a Charcoal filter will decrease the CFM airflow of the units. In the first one to two weeks, these filters should be changed at least once per week. After that initial period, filters can be changed once per month.

This replacement schedule assumes a "typical" application in a confined patient's room or emergency room. Further, this assumes that the primary application is used in TB nuclei abatement. If the HEPA unit is used during construction or in conjunction with charcoal filters for volatile organic compound abatement, the Prefilters must be replaced on a more frequent basis. **By maintaining a regular Prefilter change out schedule, the HEPA Core Filter should last a minimum of 1 year.**

---

## Filter Order Form

---



### Ceiling-Mounted HEPA Air Filtration Units

HEPA MODEL	Filter Model	Price per each filter ordered in case lots*	Qty	Total Price
Trimline 400/500	CIF-13 HEPA Prefilter (13x13x1)	\$6.40	X _____	= _____
	HEPA Core Filter (12x12x11.5)	\$399.00	X _____	= _____
HUFPO650/350	CIF-01 HEPA Prefilters (Two 20"x20"x1" Prefilters required)	\$6.40	X _____	= _____
	HUFPO650H HEPA Core Filters (Two Core Filters required)	\$499.00	X _____	= _____

### Isolation Chambers, Antechambers, Sputum Induction Booths and Hoods

ISOLATION CHAMBER/SPUTUM BOOTH/ ANTECHAMBER INLET FILTERS	CIF01 (20"x20"x1") for Ceiling Mounted 2'x2' Diffuser	\$6.40	X _____	= _____
	CIF02 (12"x24"x1")	\$6.40	X _____	= _____
	CIF03 (8"x30"x2")	\$6.40	X _____	= _____
SPUTUM INDUCTION HOOD	Sputum Induction Hood Prefilters (15"x20"x1")	\$6.40	X _____	= _____

### Vehicle HEPA Units

VEHICLE HEPA UNIT - 350 CFM	HUFO251H HEPA Core Filter for Roof Mounted Vehicle HEPA Unit (12"x18"x12")	\$299.00	X _____	= _____
-----------------------------	--	----------	---------	---------

### HEPA Filter Change Out Kits for all HEPA Air Filtration Units

HEPA Unit Filter Change Out Kit	HUFC-01 Filter Change-Out Kit	\$6.95/ea. 12 kits/case	X _____	= _____
	HUFC01 Filter Change-Out Kit	\$9.95/ea. Individual kit	X _____	= _____

\*Prefilter Minimum Order: Case lot orders only (12 per case). HEPA Core Filters can be sold individually.

# **Air Management Solutions**

## **Isolock Isolation Detention Cells**

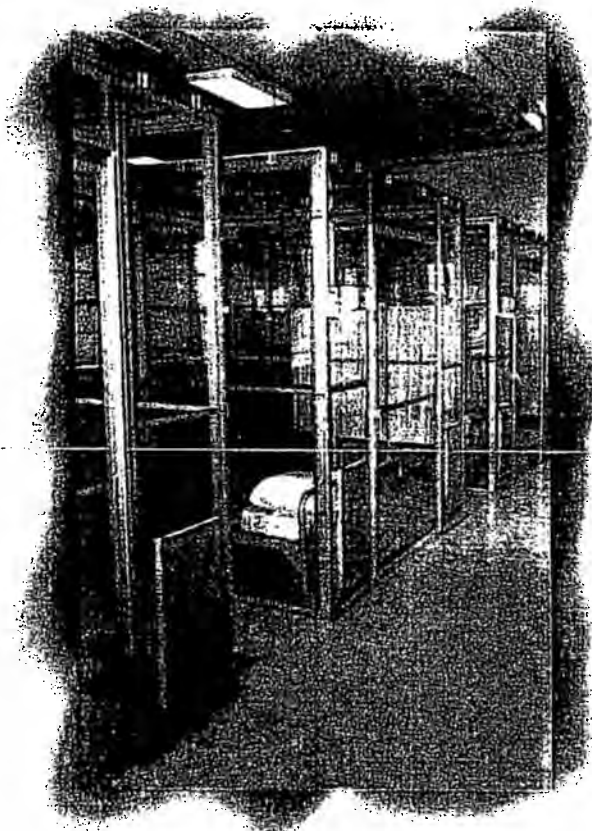

The Isolock Isolation Detention Cell is a versatile modular walled holding cell engineered for the containment and management of airborne particles using either positive or negative HEPA filtration, and at the same time providing a secure enclosure. The durable and flexible structure is constructed with superior quality materials at the lowest possible cost.

The frame is anodized aluminum utilizing a clamp profile. The modular walls are manufactured using a quarter inch Lexan, a clear totally visual product providing the highest level of containment and security. The Isolock Detention Cell may be custom designed, and reconfigured to meet every changing demand.

Heavy-duty hinges and deadbolt security locks are standard on all cells. A fully integrated electronic switch lock is optional.

## **Air Management Solutions, Inc.**



Local: 770-943-9256    Toll Free: 800-368-5633    FAX: 770-943-8361  
3840 Villa Rica Lane Suite B    Powder Springs, Georgia 30127    [www.hepaair.com](http://www.hepaair.com)

# Isolock Enclosure Systems

The Isolock Enclosure System is a clear improvement in air management containment technology. The Isolock Enclosure walls assemble quickly, easily, and cost effectively with minimal use of tools. The latch-together system provides strong, clear, positive walls, corners and ceilings for virtually every connection.

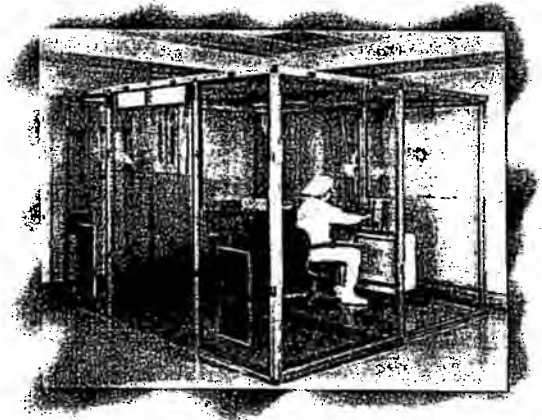

Isolock Enclosure System is effective in both permanent and temporary applications. The enclosures can easily expand or be reconfigured to meet every changing demand. The Isolock Enclosure System meets all of the California Fire Marshall and NFPA 701 standards and requirements.

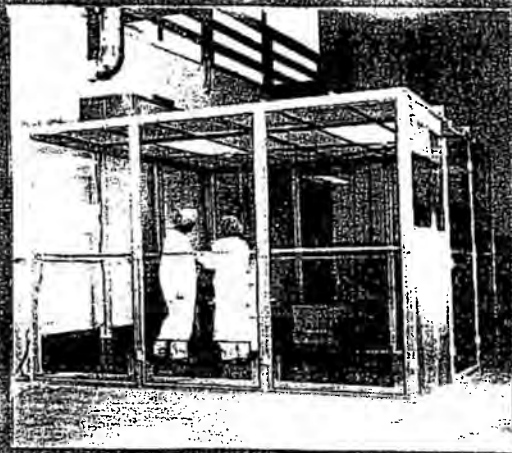

## Basic Construction Features

- Neoprene closed-cell foam gaskets seal frame-to-frame connections.
- Vinyl inserts lock into frame with an airtight seal. Cleaning is quick and easy.
- Frame construction with knock together corners allows for replacement of individual parts.
- Universal corner posts allow all walls to be interchanged for future expansion.
- Ceiling frames latch into position in the same manner as the walls, and can be designed to accommodate various types of filtration and lighting units.
- Lightweight aluminum frames are available in anodized clearcoat or epoxy powdercoat white.

Whether you need a brand new installation or expansion of an existing area, we will service you promptly. Call us to select a custom design system that suits your needs.

## ***Air Management Solutions, Inc.***



Local: 770-943-9256 ■ Toll Free: 800-368-5633 ■ FAX: 770-943-8361  
3840 Villa Rica Lane Suite B Powder Springs, Georgia 30127 [www.hepaair.com](http://www.hepaair.com)

# **Air Management Solutions**

## **Isolock Isolation Detention Cells**

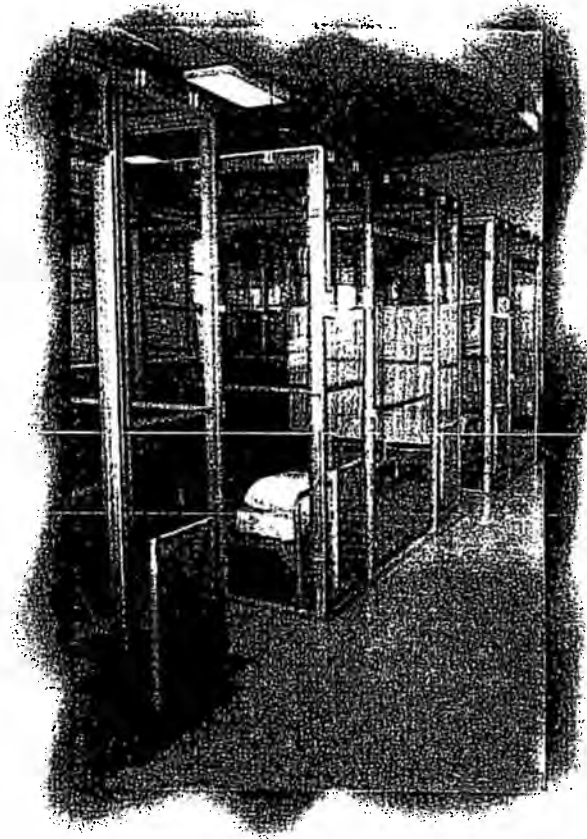

The Isolock Isolation Detention Cell is a versatile modular walled holding cell engineered for the containment and management of airborne particles using either positive or negative HEPA filtration, and at the same time providing a secure enclosure. The durable and flexible structure is constructed with superior quality materials at the lowest possible cost.

The frame is anodized aluminum utilizing a clamp profile. The modular walls are manufactured using a quarter inch Lexan, a clear totally visual product providing the highest level of containment and security. The Isolock Detention Cell may be custom designed, and reconfigured to meet every changing demand.

Heavy-duty hinges and deadbolt security locks are standard on all cells. A fully integrated electronic switch lock is optional.

## ***Air Management Solutions, Inc.***



Local: 770-943-9256 ■ Toll Free: 800-368-5633 ■ FAX: 770-943-8361  
3840 Villa Rica Lane Suite B Powder Springs, Georgia 30127 [www.hepaair.com](http://www.hepaair.com)

FACILITY	FLORENCE SERVICE CENTER			
WEEK	DATE	TIME	INITIALS	COMMENTS
<b>JANUARY</b>				
WEEK 1				
WEEK 2				
WEEK 3				
WEEK 4				
<b>FEBRUARY</b>				
WEEK 1				
WEEK 2				
WEEK 3				
WEEK 4				
<b>MARCH</b>				
WEEK 1				
WEEK 2				
WEEK 3				
WEEK 4				
<b>APRIL</b>				
WEEK 1				
WEEK 2				
WEEK 3				
WEEK 4				
<b>MAY</b>				
WEEK 1				
WEEK 2				
WEEK 3				
WEEK 4				
<b>JUNE</b>				
WEEK 1				
WEEK 2				
WEEK 3				
WEEK 4				
<b>JULY</b>				
WEEK 1				
WEEK 2				
WEEK 3				
WEEK 4				



**Stevens, Richard P**

---

**From:** Neveleff, Jerald  
**Sent:** Tuesday, June 24, 2008 1:25 PM  
**To:** (b)(6)  
**Cc:** Smyly, Elena L; Casterline, Arnold P; Jenkins, John E; Casterline, Arnold P  
**Subject:** RE: FEEDBACK TO FARMVILLE PROPOSAL

Mr. Coleman,  
Wondering if you have been able to assess what was sent and determined a date that Farmville and ICA can provide responses.

Thank you,  
Jerry Neveleff  
Supervisory Contracting Officer/  
IGSA Team Lead  
Office of Acq. Management (OAQ)  
Detention Management Division  
202 (b)(6)

Help us support you better -  
TELL US HOW WE ARE DOING!  
Go to <<http://www.acqsolinc.com/ICE/OAQ/feedback.cfm>> <<<http://www.acqsolinc.com/ICE/OAQ/feedback.cfm>>>

---

**From:** Neveleff, Jerald  
**Sent:** Monday, June 23, 2008 1:41 PM  
**To:** 'wcoleman@hdcva.com'  
**Cc:** Smyly, Elena L; Casterline, Arnold P; Jenkins, John E; Casterline, Arnold P  
**Subject:** FEEDBACK TO FARMVILLE PROPOSAL

Mr. Coleman,  
Attached are files providing DRO's feedback on the proposal submitted for the Farmville Detention Facility.

Please review the files and provide me an estimated date when Farmville/ICA can provide comments/adjustments to your proposal.

Technical Comments  
Detainee Housing Charges – Attachment (1) to the Technical Comments  
Florence SPC TIFF Trailer – Attachment (2) to the Technical Comments

<< File: Technical Comments to prop..pdf >> << File: Detainee Housing Changes.pdf >> << File: Florence Service Processing Center TIFF TRAILER.pdf >>

Thank you,  
Jerry Neveleff  
Supervisory Contracting Officer/  
IGSA Team Lead  
Office of Acq. Management (OAQ)  
Detention Management Division  
202/(b)(6)

Help us support you better -  
TELL US HOW WE ARE DOING!  
Go to <<http://www.acqsolinc.com/ICE/OAQ/feedback.cfm>> <<<http://www.acqsolinc.com/ICE/OAQ/feedback.cfm>>>

**Tracking:**

**Recipient**

(b)(6)

Smyly, Elena L

Casterline, Arnold P

Jenkins, John E

Casterline, Arnold P

**Delivery**

Delivered: 6/24/2008 1:25 PM

Delivered: 6/24/2008 1:25 PM

Delivered: 6/24/2008 1:25 PM

**Read**

Read: 6/24/2008 1:28 PM

Read: 6/24/2008 2:35 PM



**Stevens, Richard P**

---

**From:** System Administrator  
**To:** Smyly, Elena L  
**Sent:** Tuesday, June 24, 2008 1:25 PM  
**Subject:** Delivered: RE: FEEDBACK TO FARMVILLE PROPOSAL

Your message

**To:** (b)(6)  
**Cc:** Smyly, Elena L; Casterline, Arnold P; Jenkins, John E; Casterline, Arnold P  
**Subject:** RE: FEEDBACK TO FARMVILLE PROPOSAL  
**Sent:** 6/24/2008 1:25 PM

was delivered to the following recipient(s):

Smyly, Elena L on 6/24/2008 1:25 PM

## Stevens, Richard P

---

**From:** System Administrator  
**To:** Casterline, Arnold P  
**Sent:** Tuesday, June 24, 2008 1:25 PM  
**Subject:** Delivered: RE: FEEDBACK TO FARMVILLE PROPOSAL

Your message

**To:** (b)(6)  
**Cc:** Smyly, Elena L; Casterline, Arnold P; Jenkins, John E; Casterline, Arnold P  
**Subject:** RE: FEEDBACK TO FARMVILLE PROPOSAL  
**Sent:** 6/24/2008 1:25 PM

was delivered to the following recipient(s):

Casterline, Arnold P on 6/24/2008 1:25 PM

## Stevens, Richard P

---

**From:** System Administrator  
**To:** Jenkins, John E  
**Sent:** Tuesday, June 24, 2008 1:25 PM  
**Subject:** Delivered: RE: FEEDBACK TO FARMVILLE PROPOSAL

Your message

**To:** (b)(6)  
**Cc:** Smyly, Elena L; Casterline, Arnold P; Jenkins, John E; Casterline, Arnold P  
**Subject:** RE: FEEDBACK TO FARMVILLE PROPOSAL  
**Sent:** 6/24/2008 1:25 PM

was delivered to the following recipient(s):

Jenkins, John E on 6/24/2008 1:25 PM

**Stevens, Richard P**

---

**From:** Mail Delivery System [MAILER-DAEMON@dhsmail1.dhs.gov]  
**Sent:** Tuesday, June 24, 2008 1:26 PM  
**To:** Neveleff, Jerald  
**Subject:** Successful Mail Delivery Report

**Attachments:** Delivery report; Message Headers



Delivery report.txt  
(808 B)

Message  
Headers.txt (2 KB)

This is the mail system at host dhsmail1.dhs.gov.

Your message was successfully delivered to the destination(s) listed below. If the message was delivered to mailbox you will receive no further notifications. Otherwise you may still receive notifications of mail delivery errors from other systems.

The mail system

(b)(6) : delivery via 127.0.0.1[127.0.0.1]:10025: 250 OK, sent  
48612E3D\_23025\_159\_1 CB00D2B06

**Stevens, Richard P**

---

**From:** Smyly, Elena L  
**To:** Neveleff, Jerald  
**Sent:** Tuesday, June 24, 2008 1:28 PM  
**Subject:** Read: FEEDBACK TO FARMVILLE PROPOSAL

Your message

**To:** (b)(6)  
**Cc:** Smyly, Elena L; Casterline, Arnold P; Jenkins, John E; Casterline, Arnold P  
**Subject:** RE: FEEDBACK TO FARMVILLE PROPOSAL  
**Sent:** 6/24/2008 1:25 PM

was read on 6/24/2008 1:28 PM.

## Stevens, Richard P

---

**From:** Smyly, Elena L  
**Sent:** Tuesday, June 24, 2008 1:28 PM  
**To:** Neveleff, Jerald  
**Subject:** RE: FEEDBACK TO FARMVILLE PROPOSAL

Jerry,  
Thank you for staying on top of this!

*Elena Smyly, PMP  
Management and Program Analyst - Large IGSA  
DHS, U.S. Immigration and Customs Enforcement  
Office of Detention and Removal  
Detention Management Division  
(202) 732- (b)(2)Low*

---

**From:** Neveleff, Jerald  
**Sent:** Tuesday, June 24, 2008 1:25 PM  
**To:** (b)(6)  
**Cc:** Smyly, Elena L; Casterline, Arnold P; Jenkins, John E; Casterline, Arnold P  
**Subject:** RE: FEEDBACK TO FARMVILLE PROPOSAL

Mr. Coleman,  
Wondering if you have been able to assess what was sent and determined a date that Farmville and ICA can provide responses.

Thank you,  
Jerry Neveleff  
Supervisory Contracting Officer/  
IGSA Team Lead  
Office of Acq. Management (OAQ)  
Detention Management Division  
202/ (b)(6)

Help us support you better -  
TELL US HOW WE ARE DOING!  
Go to <<http://www.acqsolinc.com/ICE/OAQ/feedback.cfm>> <<<http://www.acqsolinc.com/ICE/OAQ/feedback.cfm>>>

---

**From:** Neveleff, Jerald  
**Sent:** Monday, June 23, 2008 1:41 PM  
**To:** (b)(6)  
**Cc:** Smyly, Elena L; Casterline, Arnold P; Jenkins, John E; Casterline, Arnold P  
**Subject:** FEEDBACK TO FARMVILLE PROPOSAL

Mr. Coleman,  
Attached are files providing DRO's feedback on the proposal submitted for the Farmville Detention Facility.

Please review the files and provide me an estimated date when Farmville/ICA can provide comments/adjustments to your proposal.

Technical Comments  
Detainee Housing Charges – Attachment (1) to the Technical Comments  
Florence SPC TIFF Trailer – Attachment (2) to the Technical Comments

<< File: Technical Comments to prop..pdf >> << File: Detainee Housing Changes.pdf >> << File: Florence Service Processing Center TIFF TRAILER.pdf >>

Thank you,  
Jerry Neveleff  
Supervisory Contracting Officer/  
IGSA Team Lead  
Office of Acq. Management (OAQ)  
Detention Management Division  
202 (b)(6)

Help us support you better -  
TELL US HOW WE ARE DOING!

Go to <<http://www.acqsolinc.com/ICE/OAQ/feedback.cfm>> <<<http://www.acqsolinc.com/ICE/OAQ/feedback.cfm>>>

**Stevens, Richard P**

---

**From:** Warren Coleman (b)(6)  
**Sent:** Tuesday, June 24, 2008 2:27 PM  
**To:** Neveleff, Jerald; Russell Harper  
**Subject:** Re: FEEDBACK TO FARMVILLE PROPOSAL

Jerry

I am out of the office this week and had problems with emails yesterday. I hope to review your document today. Russell is returning to the office today and I will be able to have a better estimate of time when I speak with him later this afternoon. One of us will be in touch with you tomorrow.

Warren Coleman  
Warren Colemen

-----Original Message-----

**From:** Neveleff, Jerald (b)(6)  
**To:** Warren Coleman (b)(6)  
**CC:** Smyly, Elena L (b)(6); Casterline, Arnold P (b)(6); Jenkins, John E (b)(6), b7c; Casterline, Arnold P (b)(6)  
**Sent:** Tue Jun 24 13:25:15 2008  
**Subject:** RE: FEEDBACK TO FARMVILLE PROPOSAL

Mr. Coleman,

Wondering if you have been able to assess what was sent and determined a date that Farmville and ICA can provide responses.

Thank you,

Jerry Neveleff

Supervisory Contracting Officer/

IGSA Team Lead

Office of Acq. Management (OAQ)

Detention Management Division

202/ (b)(2)Low

Help us support you better -

TELL US HOW WE ARE DOING!

Go to <<http://www.acqsolinc.com/ICE/OAQ/feedback.cfm>> <<<http://www.acqsolinc.com/ICE/OAQ/feedback.cfm>>>

---

**From:** Neveleff, Jerald  
**Sent:** Monday, June 23, 2008 1:41 PM  
**To:** (b)(6)  
**Cc:** Smyly, Elena L; Casterline, Arnold P; Jenkins, John E; Casterline, Arnold P  
**Subject:** FEEDBACK TO FARMVILLE PROPOSAL

Mr. Coleman,

Attached are files providing DRO's feedback on the proposal submitted for the Farmville Detention Facility.



Please review the files and provide me an estimated date when Farmville/ICA can provide comments/adjustments to your proposal.

Technical Comments

Detainee Housing Charges – Attachment (1) to the Technical Comments

Florence SPC TIFF Trailer – Attachment (2) to the Technical Comments

<< File: Technical Comments to prop..pdf >> << File: Detainee Housing Changes.pdf >> << File: Florence Service Processing Center TIFF TRAILER.pdf >>

Thank you,

Jerry Neveleff

Supervisory Contracting Officer/

IGSA Team Lead

Office of Acq. Management (OAQ)

Detention Management Division

202, (b)(6)

Help us support you better -

TELL US HOW WE ARE DOING!

Go to <<http://www.acqsolinc.com/ICE/OAQ/feedback.cfm>> <<<http://www.acqsolinc.com/ICE/OAQ/feedback.cfm>>>

**Stevens, Richard P**

---

**From:** Warren Coleman (b)(6)  
**To:** Neveleff, Jerald  
**Sent:** Tuesday, June 24, 2008 2:27 PM  
**Subject:** Read: RE: FEEDBACK TO FARMVILLE PROPOSAL

Your message

To: (b)(6)  
Subject:

was read on 6/24/2008 2:27 PM.

**Stevens, Richard P**

---

**From:** Casterline, Arnold P  
**To:** Neveleff, Jerald  
**Sent:** Tuesday, June 24, 2008 2:35 PM  
**Subject:** Read: RE: FEEDBACK TO FARMVILLE PROPOSAL

Your message

**To:** (b)(6)  
**Cc:** Smyly, Elena L; Casterline, Arnold P; Jenkins, John E; Casterline, Arnold P  
**Subject:** RE: FEEDBACK TO FARMVILLE PROPOSAL  
**Sent:** 6/24/2008 1:25 PM

was read on 6/24/2008 2:35 PM.

**Stevens, Richard P**

---

**From:** Neveleff, Jerald  
**Sent:** Tuesday, June 24, 2008 3:05 PM  
**To:** 'Warren Coleman'; Russell Harper  
**Subject:** RE: FEEDBACK TO FARMVILLE PROPOSAL

Thanks

Thank you,  
Jerry Neveleff  
Supervisory Contracting Officer/  
IGSA Team Lead  
Office of Acq. Management (OAQ)  
Detention Management Division  
202/(b)(6)

Help us support you better -  
TELL US HOW WE ARE DOING!  
Go to <<http://www.acqsolinc.com/ICE/OAQ/feedback.cfm>> <<<http://www.acqsolinc.com/ICE/OAQ/feedback.cfm>>>

---

**From:** Warren Coleman [mailto:(b)(6)]  
**Sent:** Tuesday, June 24, 2008 2:27 PM  
**To:** Neveleff, Jerald; Russell Harper  
**Subject:** Re: FEEDBACK TO FARMVILLE PROPOSAL

Jerry  
I am out of the office this week and had problems with emails yesterday. I hope to review your document today. Russell is returning to the office today and I will be able to have a better estimate of time when I speak with him later this afternoon. One of us will be in touch with you tomorrow.  
Warren Coleman  
Warren Coleman

-----Original Message-----  
From: Neveleff, Jerald (b)(6)  
To: Warren Coleman <wcoleman@hdcva.com>  
CC: Smyly, Elena L <(b)(6)>; Casterline, Arnold P <(b)(6)>; Jenkins, John E <(b)(6), b7c>; Casterline, Arnold P <(b)(6)>  
Sent: Tue Jun 24 13:25:15 2008  
Subject: RE: FEEDBACK TO FARMVILLE PROPOSAL

Mr. Coleman,

Wondering if you have been able to assess what was sent and determined a date that Farmville and ICA can provide responses.

Thank you,

Jerry Neveleff

Supervisory Contracting Officer/

12/21/2008

IGSA Team Lead

Office of Acq. Management (OAQ)

Detention Management Division

202 (b)(6)

Help us support you better -

TELL US HOW WE ARE DOING!

Go to <<http://www.acqsolinc.com/ICE/OAQ/feedback.cfm>> <<<http://www.acqsolinc.com/ICE/OAQ/feedback.cfm>>>

---

From: Neveleff, Jerald

Sent: Monday, June 23, 2008 1:41 PM

To: (b)(6)

Cc: Smyly, Elena L; Casterline, Arnold P; Jenkins, John E; Casterline, Arnold P

Subject: FEEDBACK TO FARMVILLE PROPOSAL

Mr. Coleman,

Attached are files providing DRO's feedback on the proposal submitted for the Farmville Detention Facility.

Please review the files and provide me an estimated date when Farmville/ICA can provide comments/adjustments to your proposal.

Technical Comments

Detainee Housing Charges – Attachment (1) to the Technical Comments

Florence SPC TIFF Trailer – Attachment (2) to the Technical Comments

<< File: Technical Comments to prop..pdf >> << File: Detainee Housing Changes.pdf >> << File: Florence Service Processing Center TIFF TRAILER.pdf >>

Thank you,

Jerry Neveleff

Supervisory Contracting Officer/

IGSA Team Lead

Office of Acq. Management (OAQ)

Detention Management Division

202/ (b)(6)

Help us support you better -

TELL US HOW WE ARE DOING!

Go to <<http://www.acqsolinc.com/ICE/OAQ/feedback.cfm>> <<<http://www.acqsolinc.com/ICE/OAQ/feedback.cfm>>>

**Stevens, Richard P**

---

**From:** Russell Harper (b)(6)  
**Sent:** Wednesday, June 25, 2008 10:06 AM  
**To:** Neveleff, Jerald  
**Cc:** Smyly, Elena L; Warren Coleman  
**Subject:** RE: FEEDBACK TO FARMVILLE PROPOSAL

Jerry,

Please help me understand the process. May I assume these are the only questions outstanding and once addressed and acceptable to your team you can execute the IGSA? The reason I ask is that we need the executed IGSA in order to alert our contractor, suppliers and lenders in order to meet the project lead time requirements. We would like to shoot to execute all documents by July 18<sup>th</sup>. Is this a realistic timeframe?

Thanks

Russell

---

**From:** Neveleff, Jerald [mailto: (b)(6)]  
**Sent:** Wednesday, June 25, 2008 9:40 AM  
**To:** Warren Coleman; Russell Harper  
**Cc:** Smyly, Elena L  
**Subject:** RE: FEEDBACK TO FARMVILLE PROPOSAL

Thanks.

Thank you,  
Jerry Neveleff  
Supervisory Contracting Officer/  
IGSA Team Lead  
Office of Acq. Management (OAQ)  
Detention Management Division  
202/ (b)(6)

Help us support you better -  
TELL US HOW WE ARE DOING!

Go to <<http://www.acqsolinc.com/ICE/OAQ/feedback.cfm>> <<<http://www.acqsolinc.com/ICE/OAQ/feedback.cfm>>>

---

**From:** Warren Coleman [mailto: (b)(6)]  
**Sent:** Wednesday, June 25, 2008 9:38 AM  
**To:** Neveleff, Jerald; Russell Harper  
**Subject:** Re: FEEDBACK TO FARMVILLE PROPOSAL

Jerry

Russell has a meeting tomorrow with our construction team and we have started addressing the Vol 1 and 11 issues. I will call on Monday with an update but expect to have our responses to you no later than July 3.

Warren Coleman

Warren Coleman

-----Original Message-----

From: Neveleff, Jerald <(b)(6)>  
To: Warren Coleman <(b)(6)>, Russell Harper <(b)(6)>  
Sent: Tue Jun 24 15:05:27 2008  
Subject: RE: FEEDBACK TO FARMVILLE PROPOSAL

Thanks

Thank you,  
Jerry Neveleff  
Supervisory Contracting Officer/  
IGSA Team Lead  
Office of Acq. Management (OAQ)  
Detention Management Division  
202. (b)(6)

Help us support you better -  
TELL US HOW WE ARE DOING!  
Go to <<http://www.acqsolinc.com/ICE/OAQ/feedback.cfm>> <<<http://www.acqsolinc.com/ICE/OAQ/feedback.cfm>>>

---

From: Warren Coleman [mailto:(b)(6)]  
Sent: Tuesday, June 24, 2008 2:27 PM  
To: Neveleff, Jerald; Russell Harper  
Subject: Re: FEEDBACK TO FARMVILLE PROPOSAL

Jerry  
I am out of the office this week and had problems with emails yesterday. I hope to review your document today. Russell is returning to the office today and I will be able to have a better estimate of time when I speak with him later this afternoon. One of us will be in touch with you tomorrow.  
Warren Coleman  
Warren Coleman

-----Original Message-----

From: Neveleff, Jerald <(b)(6)>  
To: Warren Coleman <(b)(6)>  
CC: Smyly, Elena L <(b)(6)>; Casterline, Arnold P <(b)(6)>; Jenkins, John E <(b)(6), b7c>  
Casterline, Arnold P <(b)(6)>  
Sent: Tue Jun 24 13:25:15 2008  
Subject: RE: FEEDBACK TO FARMVILLE PROPOSAL

Mr. Coleman,

Wondering if you have been able to assess what was sent and determined a date that Farmville and ICA can provide responses.

Thank you,

Jerry Neveleff  
Supervisory Contracting Officer/  
IGSA Team Lead

Office of Acq. Management (OAQ)

Detention Management Division

202, (b)(6)

Help us support you better -

TELL US HOW WE ARE DOING!

Go to <<http://www.acqsolinc.com/ICE/OAQ/feedback.cfm>> <<<http://www.acqsolinc.com/ICE/OAQ/feedback.cfm>>>

---

From: Neveleff, Jerald

Sent: Monday, June 23, 2008 1:41 PM

To: (b)(6)

Cc: Smyly, Elena L; Casterline, Arnold P; Jenkins, John E; Casterline, Arnold P

Subject: FEEDBACK TO FARMVILLE PROPOSAL

Mr. Coleman,

Attached are files providing DRO's feedback on the proposal submitted for the Farmville Detention Facility.

Please review the files and provide me an estimated date when Farmville/ICA can provide comments/adjustments to your proposal.

Technical Comments

Detainee Housing Charges – Attachment (1) to the Technical Comments

Florence SPC TIFF Trailer – Attachment (2) to the Technical Comments

<< File: Technical Comments to prop..pdf >> << File: Detainee Housing Changes.pdf >> << File: Florence Service Processing Center TIFF TRAILER.pdf >>

Thank you,

Jerry Neveleff

Supervisory Contracting Officer/

IGSA Team Lead

Office of Acq. Management (OAQ)

Detention Management Division

202, (b)(6)

Help us support you better -

TELL US HOW WE ARE DOING!

Go to <<http://www.acqsolinc.com/ICE/OAQ/feedback.cfm>> <<<http://www.acqsolinc.com/ICE/OAQ/feedback.cfm>>>



**Stevens, Richard P**

---

**From:** Smyly, Elena L (b)(6)  
**Sent:** Wednesday, June 25, 2008 10:12 AM  
**To:** Neveleff, Jerald  
**Subject:** RE: FEEDBACK TO FARMVILLE PROPOSAL

Jerry,  
From us and facilities, these are the only questions at this point. Not to say that their answers would not raise any more questions or concerns.  
Thanks,

*Elena Smyly, PMP  
Management and Program Analyst - Large IGSA  
DHS, U.S. Immigration and Customs Enforcement  
Office of Detention and Removal  
Detention Management Division  
(202) (b)(6)*

---

**From:** Russell Harper [mailto: (b)(6)]  
**Sent:** Wednesday, June 25, 2008 10:06 AM  
**To:** Neveleff, Jerald  
**Cc:** Smyly, Elena L; Warren Coleman  
**Subject:** RE: FEEDBACK TO FARMVILLE PROPOSAL

Jerry,  
Please help me understand the process. May I assume these are the only questions outstanding and once addressed and acceptable to your team you can execute the IGSA? The reason I ask is that we need the executed IGSA in order to alert our contractor, suppliers and lenders in order to meet the project lead time requirements. We would like to shoot to execute all documents by July 18<sup>th</sup>. Is this a realistic timeframe?

Thanks

Russell

---

**From:** Neveleff, Jerald [mailto: (b)(6)]  
**Sent:** Wednesday, June 25, 2008 9:40 AM  
**To:** Warren Coleman; Russell Harper  
**Cc:** Smyly, Elena L  
**Subject:** RE: FEEDBACK TO FARMVILLE PROPOSAL

Thanks.

Thank you,  
Jerry Neveleff  
Supervisory Contracting Officer/  
IGSA Team Lead  
Office of Acq. Management (OAQ)  
Detention Management Division  
202/ (b)(6)

Help us support you better -

TELL US HOW WE ARE DOING!

Go to <<http://www.acqsolinc.com/ICE/OAQ/feedback.cfm>> <<<http://www.acqsolinc.com/ICE/OAQ/feedback.cfm>>>

---

**From:** Warren Coleman [mailto:(b)(6)]  
**Sent:** Wednesday, June 25, 2008 9:38 AM  
**To:** Neveleff, Jerald; Russell Harper  
**Subject:** Re: FEEDBACK TO FARMVILLE PROPOSAL

Jerry  
Russell has a meeting tomorrow with our construction team and we have started addressing the Vol 1 and 11 issues. I will call on Monday with an update but expect to have our responses to you no later than July 3.  
Warren Coleman  
Warren Coleman

-----Original Message-----  
From: Neveleff, Jerald <(b)(6)>  
To: Warren Coleman <(b)(6)> ; Russell Harper <(b)(6)>  
Sent: Tue Jun 24 15:05:27 2008  
Subject: RE: FEEDBACK TO FARMVILLE PROPOSAL

Thanks

Thank you,  
Jerry Neveleff  
Supervisory Contracting Officer/  
IGSA Team Lead  
Office of Acq. Management (OAQ)  
Detention Management Division  
202/ (b)(6)

Help us support you better -  
TELL US HOW WE ARE DOING!  
Go to <<http://www.acqsolinc.com/ICE/OAQ/feedback.cfm>> <<<http://www.acqsolinc.com/ICE/OAQ/feedback.cfm>>>

---

**From:** Warren Coleman [mailto:(b)(6)]  
**Sent:** Tuesday, June 24, 2008 2:27 PM  
**To:** Neveleff, Jerald; Russell Harper  
**Subject:** Re: FEEDBACK TO FARMVILLE PROPOSAL

Jerry  
I am out of the office this week and had problems with emails yesterday. I hope to review your document today. Russell is returning to the office today and I will be able to have a better estimate of time when I speak with him later this afternoon. One of us will be in touch with you tomorrow.  
Warren Coleman  
Warren Coleman

-----Original Message-----  
From: Neveleff, Jerald <(b)(6)>  
To: Warren Coleman <(b)(6)>  
CC: Smyly, Elena L <(b)(6)> ; Casterline, Arnold P <(b)(6)> ; Jenkins, John E

< (b)(6), b7c . Casterline, Arnold P < (b)(6) >  
Sent: Tue Jun 24 13:25:15 2008  
Subject: RE: FEEDBACK TO FARMVILLE PROPOSAL

Mr. Coleman,

Wondering if you have been able to assess what was sent and determined a date that Farmville and ICA can provide responses.

Thank you,

Jerry Neveleff

Supervisory Contracting Officer/

IGSA Team Lead

Office of Acq. Management (OAQ)

Detention Management Division

202/ b6

Help us support you better -

TELL US HOW WE ARE DOING!

Go to <<http://www.acqsolinc.com/ICE/OAQ/feedback.cfm>> <<<http://www.acqsolinc.com/ICE/OAQ/feedback.cfm>>>

---

From: Neveleff, Jerald  
Sent: Monday, June 23, 2008 1:41 PM  
To: (b)(6)  
Cc: Smyly, Elena L; Casterline, Arnold P; Jenkins, John E; Casterline, Arnold P  
Subject: FEEDBACK TO FARMVILLE PROPOSAL

Mr. Coleman,

Attached are files providing DRO's feedback on the proposal submitted for the Farmville Detention Facility.

Please review the files and provide me an estimated date when Farmville/ICA can provide comments/adjustments to your proposal.

Technical Comments

Detainee Housing Charges – Attachment (1) to the Technical Comments

Florence SPC TIFF Trailer – Attachment (2) to the Technical Comments

<< File: Technical Comments to prop..pdf >> << File: Detainee Housing Changes.pdf >> << File: Florence Service Processing Center TIFF TRAILER.pdf >>

Thank you,

Jerry Neveleff

Supervisory Contracting Officer/

IGSA Team Lead

Office of Acq. Management (OAQ)

12/21/2008

Detention Management Division

202. b6

Help us support you better -

TELL US HOW WE ARE DOING!

Go to <<http://www.acqsolinc.com/ICE/OAQ/feedback.cfm>> <<<http://www.acqsolinc.com/ICE/OAQ/feedback.cfm>>>

**Stevens, Richard P**

---

**From:** Neveleff, Jerald  
**Sent:** Wednesday, June 25, 2008 11:15 AM  
**To:** 'Russell Harper'  
**Cc:** Smyly, Elena L; Warren Coleman; Casterline, Arnold P  
**Subject:** RE: FEEDBACK TO FARMVILLE PROPOSAL

Russell,  
The questions/comments/concerns sent are not necessarily the only outstanding issues. Based on the answers, additional questions may arise. Also, questions regarding cost are still being developed. Plus we still will need to negotiate the bed day rates along with associated transportation and guard rates.

As for the 18<sup>th</sup> of July, that will depend on what is received in response to the questions and how things go in negotiations. We are certainly trying to get things done as soon as possible.

Thank you,  
Jerry Neveleff  
Supervisory Contracting Officer/  
IGSA Team Lead  
Office of Acq. Management (OAQ)  
Detention Management Division  
202/ b6

Help us support you better -  
TELL US HOW WE ARE DOING!  
Go to <<http://www.acqsolinc.com/ICE/OAQ/feedback.cfm>> <<<http://www.acqsolinc.com/ICE/OAQ/feedback.cfm>>>

---

**From:** Russell Harper [mailto:(b)(6)]  
**Sent:** Wednesday, June 25, 2008 10:06 AM  
**To:** Neveleff, Jerald  
**Cc:** Smyly, Elena L; Warren Coleman  
**Subject:** RE: FEEDBACK TO FARMVILLE PROPOSAL

Jerry,

Please help me understand the process. May I assume these are the only questions outstanding and once addressed and acceptable to your team you can execute the IGSA? The reason I ask is that we need the executed IGSA in order to alert our contractor, suppliers and lenders in order to meet the project lead time requirements. We would like to shoot to execute all documents by July 18<sup>th</sup>. Is this a realistic timeframe?

Thanks

Russell

---

**From:** Neveleff, Jerald [mailto:(b)(6)]  
**Sent:** Wednesday, June 25, 2008 9:40 AM  
**To:** Warren Coleman; Russell Harper  
**Cc:** Smyly, Elena L  
**Subject:** RE: FEEDBACK TO FARMVILLE PROPOSAL

12/21/2008

Thanks.

Thank you,  
Jerry Neveleff  
Supervisory Contracting Officer/  
IGSA Team Lead  
Office of Acq. Management (OAQ)  
Detention Management Division  
202 b6

Help us support you better -  
TELL US HOW WE ARE DOING!  
Go to <<http://www.acqsolinc.com/ICE/OAQ/feedback.cfm>> <<<http://www.acqsolinc.com/ICE/OAQ/feedback.cfm>>>

---

**From:** Warren Coleman [mailto: (b)(6)]  
**Sent:** Wednesday, June 25, 2008 9:38 AM  
**To:** Neveleff, Jerald; Russell Harper  
**Subject:** Re; FEEDBACK TO FARMVILLE PROPOSAL

Jerry  
Russell has a meeting tomorrow with our construction team and we have started addressing the Vol 1 and 11 issues. I will call on Monday with an update but expect to have our responses to you no later than July 3.  
Warren Coleman  
Warren Coleman

-----Original Message-----  
From: Neveleff, Jerald (b)(6)  
To: Warren Coleman < b6 >; Russell Harper < b6 >  
Sent: Tue Jun 24 15:05:27 2008  
Subject: RE: FEEDBACK TO FARMVILLE PROPOSAL

Thanks

Thank you,  
Jerry Neveleff  
Supervisory Contracting Officer/  
IGSA Team Lead  
Office of Acq. Management (OAQ)  
Detention Management Division  
202/ b6

Help us support you better -  
TELL US HOW WE ARE DOING!  
Go to <<http://www.acqsolinc.com/ICE/OAQ/feedback.cfm>> <<<http://www.acqsolinc.com/ICE/OAQ/feedback.cfm>>>

---

From: Warren Coleman [mailto: (b)(6)]  
Sent: Tuesday, June 24, 2008 2:27 PM  
To: Neveleff, Jerald; Russell Harper  
Subject: Re: FEEDBACK TO FARMVILLE PROPOSAL

Jerry

I am out of the office this week and had problems with emails yesterday. I hope to review your document today. Russell is returning to the office today and I will be able to have a better estimate of time when I speak with him later this afternoon. One of us will be in touch with you tomorrow.

Warren Coleman  
Warren Coleman

-----Original Message-----

From: Neveleff, Jerald <(b)(6)>  
To: Warren Coleman <(b)(6)>  
CC: Smylv. Elena L <(b)(6)>; Casterline, Arnold P <(b)(6)>; Jenkins, John E <(b)(6)>  
<b6,b7c>; Casterline, Arnold P <(b)(6)>  
Sent: Tue Jun 24 13:25:15 2008  
Subject: RE: FEEDBACK TO FARMVILLE PROPOSAL

Mr. Coleman,

Wondering if you have been able to assess what was sent and determined a date that Farmville and ICA can provide responses.

Thank you,

Jerry Neveleff

Supervisory Contracting Officer/

IGSA Team Lead

Office of Acq. Management (OAQ)

Detention Management Division

202/ b6

Help us support you better -

TELL US HOW WE ARE DOING!

Go to <<http://www.acqsolinc.com/ICE/OAQ/feedback.cfm>> <<<http://www.acqsolinc.com/ICE/OAQ/feedback.cfm>>>

---

From: Neveleff, Jerald  
Sent: Monday, June 23, 2008 1:41 PM  
To: (b)(6)  
Cc: Smyly, Elena L; Casterline, Arnold P; Jenkins, John E; Casterline, Arnold P  
Subject: FEEDBACK TO FARMVILLE PROPOSAL

Mr. Coleman,

Attached are files providing DRO's feedback on the proposal submitted for the Farmville Detention Facility.

Please review the files and provide me an estimated date when Farmville/ICA can provide comments/adjustments to your proposal.

Technical Comments

Detainee Housing Charges -- Attachment (1) to the Technical Comments

Florence SPC TIFF Trailer -- Attachment (2) to the Technical Comments

12/21/2008

<< File: Technical Comments to prop..pdf >> << File: Detainee Housing Changes.pdf >> << File: Florence Service Processing Center TIFF TRAILER.pdf >>

Thank you,

Jerry Neveleff

Supervisory Contracting Officer/

IGSA Team Lead

Office of Acq. Management (OAQ)

Detention Management Division

202     b6

Help us support you better -

TELL US HOW WE ARE DOING!

Go to <<http://www.acqsolinc.com/ICE/OAQ/feedback.cfm>> <<<http://www.acqsolinc.com/ICE/OAQ/feedback.cfm>>>



**Stevens, Richard P**

---

**From:** Russell Harper (b)(6)  
**Sent:** Wednesday, June 25, 2008 2:34 PM  
**To:** Neveleff, Jerald  
**Cc:** Smyly, Elena L; Warren Coleman; Casterline, Arnold P  
**Subject:** RE: FEEDBACK TO FARMVILLE PROPOSAL

Jerry,

Thank you. We will respond as quickly as possible in hopes of meeting the 18<sup>th</sup>.

Russell

---

**From:** Neveleff, Jerald [mailto:] (b)(6)  
**Sent:** Wednesday, June 25, 2008 11:15 AM  
**To:** Russell Harper  
**Cc:** Smyly, Elena L; Warren Coleman; Casterline, Arnold P  
**Subject:** RE: FEEDBACK TO FARMVILLE PROPOSAL

Russell,  
The questions/comments/concerns sent are not necessarily the only outstanding issues. Based on the answers, additional questions may arise. Also, questions regarding cost are still being developed. Plus we still will need to negotiate the bed day rates along with associated transportation and guard rates.

As for the 18<sup>th</sup> of July, that will depend on what is received in response to the questions and how things go in negotiations. We are certainly trying to get things done as soon as possible.

Thank you,  
Jerry Neveleff  
Supervisory Contracting Officer/  
IGSA Team Lead  
Office of Acq. Management (OAQ)  
Detention Management Division  
202/ (b)6

Help us support you better -  
TELL US HOW WE ARE DOING!  
Go to <<http://www.acqsolinc.com/ICE/OAQ/feedback.cfm>> <<<http://www.acqsolinc.com/ICE/OAQ/feedback.cfm>>>

---

**From:** Russell Harper [mailto:] (b)(6)  
**Sent:** Wednesday, June 25, 2008 10:06 AM  
**To:** Neveleff, Jerald  
**Cc:** Smyly, Elena L; Warren Coleman  
**Subject:** RE: FEEDBACK TO FARMVILLE PROPOSAL

Jerry,

Please help me understand the process. May I assume these are the only questions outstanding and once addressed and acceptable to your team you can execute the IGSA? The reason I ask is that we need the executed IGSA in order to alert our contractor, suppliers and lenders in order to meet the project lead time requirements. We would like to shoot to execute all

documents by July 18<sup>th</sup>. Is this a realistic timeframe?

Thanks

Russell

---

**From:** Neveleff, Jerald [mailto:(b)(6)]  
**Sent:** Wednesday, June 25, 2008 9:40 AM  
**To:** Warren Coleman; Russell Harper  
**Cc:** Smyly, Elena L  
**Subject:** RE: FEEDBACK TO FARMVILLE PROPOSAL

Thanks.

Thank you,  
Jerry Neveleff  
Supervisory Contracting Officer/  
IGSA Team Lead  
Office of Acq. Management (OAQ)  
Detention Management Division  
202/ b6

Help us support you better -  
TELL US HOW WE ARE DOING!  
Go to <<http://www.acqsolinc.com/ICE/OAQ/feedback.cfm>> <<<http://www.acqsolinc.com/ICE/OAQ/feedback.cfm>>>

---

**From:** Warren Coleman [mailto:wcoleman@hdcva.com]  
**Sent:** Wednesday, June 25, 2008 9:38 AM  
**To:** Neveleff, Jerald; Russell Harper  
**Subject:** Re: FEEDBACK TO FARMVILLE PROPOSAL

Jerry  
Russell has a meeting tomorrow with our construction team and we have started addressing the Vol 1 and 11 issues. I will call on Monday with an update but expect to have our responses to you no later than July 3.  
Warren Coleman  
Warren Coleman

-----Original Message-----  
From: Neveleff, Jerald (b)(6)  
To: Warren Coleman <(b)(6)> Russell Harper <(b)(6)>  
Sent: Tue Jun 24 15:05:27 2008  
Subject: RE: FEEDBACK TO FARMVILLE PROPOSAL

Thanks

Thank you,  
Jerry Neveleff  
Supervisory Contracting Officer/  
IGSA Team Lead

Office of Acq. Management (OAQ)  
Detention Management Division  
202/ b6

Help us support you better -  
TELL US HOW WE ARE DOING!

Go to <<http://www.acqsolinc.com/ICE/OAQ/feedback.cfm>> <<<http://www.acqsolinc.com/ICE/OAQ/feedback.cfm>>>

---

From: Warren Coleman [mailto: (b)(6)]  
Sent: Tuesday, June 24, 2008 2:27 PM  
To: Neveleff, Jerald; Russell Harper  
Subject: Re: FEEDBACK TO FARMVILLE PROPOSAL

Jerry  
I am out of the office this week and had problems with emails yesterday. I hope to review your document today. Russell is returning to the office today and I will be able to have a better estimate of time when I speak with him later this afternoon. One of us will be in touch with you tomorrow.  
Warren Coleman  
Warren Coleman

-----Original Message-----

From: Neveleff, Jerald < (b)(6)>  
To: Warren Coleman (b)(6)  
CC: Smyly, Elena L < (b)(6)>; Casterline, Arnold P (b)(6) b6,b7c  
< (b)(6), b7c Casterline, Arnold P (b)(6)>  
Sent: Tue Jun 24 13:25:15 2008  
Subject: RE: FEEDBACK TO FARMVILLE PROPOSAL

Mr. Coleman,

Wondering if you have been able to assess what was sent and determined a date that Farmville and ICA can provide responses.

Thank you,

Jerry Neveleff

Supervisory Contracting Officer/

IGSA Team Lead

Office of Acq. Management (OAQ)

Detention Management Division

202/616. b6

Help us support you better -

TELL US HOW WE ARE DOING!

Go to <<http://www.acqsolinc.com/ICE/OAQ/feedback.cfm>> <<<http://www.acqsolinc.com/ICE/OAQ/feedback.cfm>>>

---

From: Neveleff, Jerald  
Sent: Monday, June 23, 2008 1:41 PM  
To: ' (b)(6)

Cc: Smyly, Elena L; Casterline, Arnold P; Jenkins, John E; Casterline, Arnold P  
Subject: FEEDBACK TO FARMVILLE PROPOSAL

Mr. Coleman,

Attached are files providing DRO's feedback on the proposal submitted for the Farmville Detention Facility.

Please review the files and provide me an estimated date when Farmville/ICA can provide comments/adjustments to your proposal.

Technical Comments

Detainee Housing Charges – Attachment (1) to the Technical Comments

Florence SPC TIFF Trailer – Attachment (2) to the Technical Comments

<< File: Technical Comments to prop..pdf >> << File: Detainee Housing Changes.pdf >> << File: Florence Service Processing Center TIFF TRAILER.pdf >>

Thank you,

Jerry Neveleff

Supervisory Contracting Officer/

IGSA Team Lead

Office of Acq. Management (OAQ)

Detention Management Division

202. b6

Help us support you better -

TELL US HOW WE ARE DOING!

Go to <<http://www.acqsolinc.com/ICE/OAQ/feedback.cfm>> <<<http://www.acqsolinc.com/ICE/OAQ/feedback.cfm>>>

**Stevens, Richard P**

---

**From:** Casterline, Arnold P

**Sent:** Thursday, June 26, 2008 1:46 PM

**To:** Neveleff, Jerald

Mr. Harper,

I need some clarification on the some of the costs;

Schedule B

What is the Incentive Program for Senior Management \$480,000.00

Schedule C

General breakout of all Services listed. If there is a service contract proposed, please provide a copy.

Medical: RN/LPNs are associated in your Personnel Costs, Who is all other staff?

Legal and Dental: if these are consultant contracts, please provide a copy of them.

Auditing and Payroll: There are two Accountants listed on the personnel costs and you have have associated 10.5% on Schedule E for Town of Farmville Treasury, How many people need to evaluate your books? Will ICA Farmville become publicly traded? May need a copy of the Corporate Charter.

Information Tech Software and Technical Support: Computer Support/ Network listed in Personnel costs.

Management Advisory Counsel and BOD: Dept. Heads are listed in personnel costs, are these the same people? If not who are they?(Names)

Schedule D

What are you basing these costs on? Please give rational and break outs if possible.

Food and Supplies

Utilities

Office Supplies and Postage

Rent (Who to?)

Schedule E

Town of Farmville: Managers Office 10%; What will their involvement be? Is ICA Farmville running the facility .

Schedule G

What is the estimated depreciation cost?

*Arnold P. Casterline Jr.*

Contract Specialist

Immigration and Customs Enforcement

Office of Acquisition Management

Department of Homeland Security

425 I Street NW, 5<sup>th</sup> Floor Room 5009

Washington, DC 20536

e-mail: (b)(6)

phone: 202

Main: 202- b6

**Help us support you better –  
TELL US HOW WE ARE DOING!**

**Go to** <http://www.acqsolinc.com/ICE/OAQ/feedback.cfm>



**Stevens, Richard P**

---

**From:** Casterline, Arnold P  
**Sent:** Thursday, June 26, 2008 1:18 PM  
**To:** Neveleff, Jerald  
**Subject:** fARMVILLE Jail cost statement

Mr. Harper,

I need some clarification on the some of the costs;

Schedule B

What is the Incentive Program for Senior Management \$480,000.00

Schedule C

General breakout of all Services listed. If there is a service contract proposed, please provide a copy.

Schedule D

What are you basing these costs on? Please give rational and break outs if possible.

Food and Supplies

Utilities

Office Supplies and Postage

Rent (Who to?)

Schedule G

What is the estimated depreciation cost?

*Arnold P. Casterline Jr.*

Contract Specialist

Immigration and Customs Enforcement

Office of Acquisition Management

Department of Homeland Security

425 I Street NW, 5<sup>th</sup> Floor Room 5009

Washington, DC 20536

e-mail: (b)(6)

phone: 202

Main: 202- b6

**Help us support you better –**

**TELL US HOW WE ARE DOING!**

**Go to** <http://www.acqsolinc.com/ICE/OAQ/feedback.cfm>

**Stevens, Richard P**

---

**From:** Casterline, Arnold P  
**Sent:** Monday, June 30, 2008 10:10 AM  
**To:** Neveleff, Jerald  
**Subject:** FW: Farmville Jail Cost Statement

**Attachments:** ICE\_questions62608word.doc



ICE\_questions62608word.doc (35...

Arnold P. Casterline Jr.  
Contract Specialist  
Immigration and Customs Enforcement  
Office of Acquisition Management  
Department of Homeland Security  
425 I Street NW, 5th Floor Room 5009  
Washington, DC 20536  
e-mail: (b)(6)  
phone: 202 (b)(6)  
Main: 202- b6

Help us support you better -  
TELL US HOW WE ARE DOING!  
Go to <http://www.acqsolinc.com/ICE/OAQ/feedback.cfm>

-----Original Message-----  
From: Warren Coleman [mailto: (b)(6)]  
Sent: Monday, June 30, 2008 9:55 AM  
To: Casterline, Arnold P  
Cc: Russell Harper  
Subject: FW: Farmville Jail Cost Statement

Arnie  
Please let us know if you need additional explanations on these questions or have other questions.

Thanks  
Warren

-----Original Message-----  
From: Warren Coleman  
Sent: Thursday, June 26, 2008 4:25 PM  
To: Russell Harper  
Subject: Re: Farmville Jail Cost Statement

Russell  
I will send responses tomorrow. Will copy you first  
Warren  
Warren Coleman

-----Original Message-----  
From: Russell Harper (b)(6)  
To: Casterline, Arnold P (b)(6)  
CC: Warren Coleman < (b)(6) Newsome, Ken



(b)(6)

Sent: Thu Jun 26 16:20:13 2008  
Subject: RE: Farmville Jail Cost Statement

Arnold Thanks for your questions. We will get back to you ASAP. Russell

---

From: Casterline, Arnold P [mailto: (b)(6)]  
Sent: Thursday, June 26, 2008 2:04 PM  
To: Russell Harper; Wyatt-Powell, Wendie M; Smyly, Elena L  
Subject: Farmville Jail Cost Statement

Mr. Harper,

I need some clarification on some of the costs;

Schedule B

Senior Management      What is the purpose of the Incentive Program for  
\$480,000.00

Schedule C

General breakout of all Services listed. If there is a service contract proposed, please provide a copy.

Medical: RN/LPNs are associated in your Personnel Costs, Who are all other staff?

Legal and Dental: if these are consultant contracts, please provide a copy of them.

Auditing and Payroll: There are two Accountants listed on the personnel costs and you have

associated 10.5% on Schedule E for Town of Farmville Treasury, have

are there so many people evaluating your books? Why

Information Tech Software and Technical Support: Computer Support/Network listed in

Personnel costs, what's the difference between the two

Management Advisory Counsel and BOD: Dept. Heads are listed in personnel costs, are these

the same people? If not who are they?(Names)

Schedule D

What are you basing the costs for the elements below? Please give rational and break outs if possible.

Food and Supplies

Utilities

Office Supplies and Postage

Rent (for what and to who?) Doesn't ICA  
own the facility and land?

Schedule E

Town of Farmville: Managers Office 10%;  
what will their involvement be?

Schedule G

What is the estimated depreciation cost?

If you can get me this information, we should be able to start  
negotiations shortly. Thank you and have a great day.

Arnie Casterline

Arnold P. Casterline Jr.

Contract Specialist

Immigration and Customs Enforcement

Office of Acquisition Management

Department of Homeland Security

425 I Street NW, 5th Floor Room 5009

Washington, DC 20536

e-mail: (b)(6)

phone: 202

Main: 202- b6

Help us support you better -

TELL US HOW WE ARE DOING!

Go to <http://www.acqsolinc.com/ICE/OAQ/feedback.cfm>  
<<http://www.acqsolinc.com/ICE/OAQ/feedback.cfm>>

ICA-Farmville: Response to Questions dated June 26, 2008

**Schedule B**

b2High

**Schedule C**

b2High

b2High

**Schedule E**

b2High

**Stevens, Richard P**

---

**From:** Casterline, Arnold P  
**Sent:** Tuesday, July 01, 2008 3:15 PM  
**To:** Neveleff, Jerald  
**Subject:** FW: Farmville Jail Cost Statement

**Attachments:** 070108\_ICA-Farmville\_Response ICE\_questions62608word.doc



070108\_ICA-Farmville\_Response ...

Arnold P. Casterline Jr.  
Contract Specialist  
Immigration and Customs Enforcement  
Office of Acquisition Management  
Department of Homeland Security  
425 I Street NW, 5th Floor Room 5009  
Washington, DC 20536  
e-mail: (b)(6)  
phone: 202 b6  
Main: 202-

Help us support you better -  
TELL US HOW WE ARE DOING!  
Go to <http://www.acqsolinc.com/ICE/OAQ/feedback.cfm>

-----Original Message-----  
From: Warren Coleman [mailto:(b)(6)]  
Sent: Tuesday, July 01, 2008 2:59 PM  
To: Casterline, Arnold P  
Subject: RE: Farmville Jail Cost Statement

Arnie  
Hope this is helpful.

Warren

-----Original Message-----  
From: Casterline, Arnold P [mailto:(b)(6)]  
Sent: Monday, June 30, 2008 12:57 PM  
To: Warren Coleman  
Subject: RE: Farmville Jail Cost Statement

I need a little more clarification on a few things. If you have any questions please give me a call or send me an email. Thank you and have a great day.

Arnie Casterline  
Arnold P. Casterline Jr.  
Contract Specialist  
Immigration and Customs Enforcement  
Office of Acquisition Management  
Department of Homeland Security  
425 I Street NW, 5th Floor Room 5009  
Washington, DC 20536  
e-mail: (b)(6)  
phone: 202- b6  
Main: 202-5

Help us support you better -  
TELL US HOW WE ARE DOING!  
Go to <http://www.acqsolinc.com/ICE/OAQ/feedback.cfm>

-----Original Message-----  
From: Warren Coleman [mailto: (b)(6)]  
Sent: Monday, June 30, 2008 9:55 AM  
To: Casterline, Arnold P  
Cc: Russell Harper  
Subject: FW: Farmville Jail Cost Statement

Arnie  
Please let us know if you need additional explanations on these questions or have other questions.

Thanks  
Warren

-----Original Message-----  
From: Warren Coleman  
Sent: Thursday, June 26, 2008 4:25 PM  
To: Russell Harper  
Subject: Re: Farmville Jail Cost Statement

Russell  
I will send responses tomorrow. Will copy you first  
Warren  
Warren Coleman

-----Original Message-----  
From: Russell Harper < (b)(6)>  
To: Casterline, Arnold P < (b)(6)>  
CC: Warren Coleman < (b)(6)>, Newsome, Ken  
Sent: Thu Jun 26 16:20:13 2008  
Subject: RE: Farmville Jail Cost Statement

Arnold Thanks for your questions. We will get back to you ASAP. Russell

---

From: Casterline, Arnold P [mailto: (b)(6)]  
Sent: Thursday, June 26, 2008 2:04 PM  
To: Russell Harper; Wyatt-Powell, Wendie M; Smyly, Elena L  
Subject: Farmville Jail Cost Statement

Mr. Harper,

I need some clarification on some of the costs;

Schedule B

Senior Management      What is the purpose of the Incentive Program for  
\$480,000.00

Schedule C

General breakout of all Services listed. If

there is a service contract proposed, please provide a copy.

Medical: RN/LPNs are associated in your Personnel Costs, Who are all other staff?

Legal and Dental: if these are consultant contracts, please provide a copy of them.

Auditing and Payroll: There are two Accountants listed on the personnel costs and you have

associated 10.5% on Schedule E for Town of Farmville Treasury, have

are there so many people evaluating your books? Why

Information Tech Software and Technical Support: Computer Support/ Network listed in

Personnel costs, what's the difference between the two

Management Advisory Counsel and BOD: Dept. Heads are listed in personnel costs, are these

the same people? If not who are they?(Names)

#### Schedule D

What are you basing the costs for the elements below? Please give rational and break outs if possible.

Food and Supplies

Utilities

Office Supplies and Postage

Rent (for what and to who?) Doesn't ICA own the facility and land?

#### Schedule E

Town of Farmville: Managers Office 10%; what will their involvement be?

#### Schedule G

What is the estimated depreciation cost?

If you can get me this information, we should be able to start negotiations shortly. Thank you and have a great day.

Arnie Casterline

Arnold P. Casterline Jr.

Contract Specialist

Immigration and Customs Enforcement

Office of Acquisition Management  
Department of Homeland Security  
425 I Street NW, 5th Floor Room 5009  
Washington, DC 20536

e-mail: (b)(6)

phone: 202

Main: 202 b6

Help us support you better -

TELL US HOW WE ARE DOING!

Go to <http://www.acqsolinc.com/ICE/OAQ/feedback.cfm>  
<<http://www.acqsolinc.com/ICE/OAQ/feedback.cfm>>



ICA-Farmville: Response to Questions dated June 26, 2008

**Schedule B**

b2High

**Schedule C**

b2High

b2High

**Schedule D**

4  
1

b2High

b2High

**Schedule E**

b2High

b2High

**Schedule G**

b2High

**Stevens, Richard P**

---

**From:** Warren Coleman (b)(6)  
**Sent:** Thursday, July 03, 2008 2:36 PM  
**To:** Neveleff, Jerald  
**Cc:** Russell Harper; (b)(6)  
**Subject:** Responses to Technical Letter 6/23/08  
**Attachments:** Note\_JerryN\_070308.doc; QualityControlPlan.final070208.doc; TrainingandStaffDevelopment\_final070208.doc; TransportationOfDetainees\_final070308.doc; background\_final070208.doc; Contraband\_final070308.doc; Detainee records\_reports070308.doc; DetaineeCounts\_final070308.doc; DetaineeOrientationForDetaineeManua\_final070308.doc; EmergencyResponse\_final070308.doc; EmploymentofQualifiedStaff\_final070308.doc; FoodServiceOperations\_FINAL070308.doc; ICECoordination\_final070308.doc

Jerry

I have attached our response to the Technical Letter and new reports for the package. I am hoping to send you the architect's comments in a separate email later today but if not, then I will send it on Monday at the latest.

I will call on Monday to make sure you received everything you need and to determine how we can assist you in the review process.

Have a great holiday.

Warren Coleman



7/3/04

Jerry Neveleff  
Supervisory Contracting Officer/  
IGSA Team Lead  
Office of Acq. Management (OAQ)  
Detention Management Division  
US Department of Homeland Security  
425 I St. NW, Suite 5009  
Washington, DC 20536

Jerry,

In response to your Technical Review letter dated 6/23/08, we are working with our architects, construction team and future management team to address all questions. In the following comments, I have addressed each point in your letter and I have attached updated policies for the ones changed in response to the Technical Review letter dated 6/23/08. As stated in my responses, we will be sending the architect's report on the building issues in a separate correspondence later today.

We will be glad to continue to respond to questions by email or phone and will make ourselves available for a visit to your office at any time over the next two weeks. We would very much like to hit the July 18 target date that Russell discussed with you so please let us posted on outstanding issues.

Sincerely

Warren Coleman

CC: Russell Harper

## **Responses to Technical Review Letter Dated 6/23/08**

### **Changes to Phase I**

In regards to the bullet points under “Changes to Phase 1”, our architects and construction team are finalizing their comments and we will send those comments in a separate letter.

### **General Technical Proposal Comments**

In regards to the bullet points under “Changes to Phase 1”, our architects and construction team are finalizing their comments and we will send those comments in a separate letter.

### **Volume I**

b2High

### **Volume II**

#### **Quality Control Plan**

b2High

### **Organizational Chart**

b2High

b2High

**Qualified Staff**

b2High

**Training and Staff development:**  
Business

b2High

**Policy**

b2High

**Training Resources:**

b2High

**Professional Development**

1

b2High



**Management Responsibilities**

b2High

**New Officer Training**

b2High

**Specialized Training**

b2High

**Detainee Counts**

b2High

**Daily Records and Reports**  
**Procedure:**

b2High

**Contraband:**

b2High

**Emergency:**

**Apprehension of Escanee (s):**

**1**

b2High

**Hunger Strike:**

**1**

b2High

**Mass Detention:**

**1**

b2High

**Suicide:**

b2High

**Death of a Detainee:**

b2High

**Detainee Orientation Manual**

b2High

**Food Service**

b2High

W

**ICE Coordination  
Contact Information**

b2High





**Town of Farmville – ICE Facility: DROISA-08-0021**

**May 9, 2008**

**Quality Control Plan**

**PURPOSE**

To develop and implement a Quality Control Plan which will ensure compliance with all required Town of Farmville—ICE Facility quality standards and the ICE standards to be monitored under the Government’s Quality Assurance Surveillance Plan.

**POLICY**

It is the policy of the Town of Farmville—ICE Facility to ensure all applicable standards, polices and procedures are adhered to.

- A. The Town of Farmville—ICE Facility will adopt, adapt and/or establish procedures that will meet or exceed the objective represented by each of the 38 Detention Standards outlined in the QUASP Attachment 3—Performance Monitoring Tool. It is our goal to achieve ACA accreditation or to meet and exceed ACA standards.

**PROCEDURES**

b2High

Staff Actions

b2High

Confidentiality

b2High

Plan Details

b2High



## **Town of Farmville – ICE Facility: DROISA-08-0021**

**May 9, 2008**

### **Training and Staff Development**

#### **PURPOSE**

To outline the general training and orientation that will apply to the Town of Farmville—ICE Facility personnel. To establish guidelines governing training and orientation for part-time employees, volunteers and contract personnel entering or employed at the Town of Farmville—ICE Facility. A detail training schedule will be developed once the contract is awarded.

#### **POLICY**

It is the policy of the Town of Farmville—ICE Facility to provide training and orientation to each full time and part time employee, contract civilian personnel, volunteers who help with religious services and visitors, to ensure compliance with policies, procedures, job performance and professional development.

#### **References: A.C.A. 1D-01/02/03/04/05/06/07/08/09/10/11/12**

- A. Written policy, procedure, and practice provide that the Town of Farmville—ICE Facility's employee staff development and training programs are planned, coordinated, and supervised by a qualified employee.
  1. The training plan is reviewed annually.
- B. The Town of Farmville—ICE Facility's training plan provides for ongoing formal evaluation of all pre-service, in-service, and specialized training programs.
  1. A written report is prepared annually.
- C. Library and reference services are available to complement the training and staff development program.
- D. Written policy, procedure, and practice provide that the training and staff development program uses outside resources when appropriate.
- E. Written policy, procedure, and practice provide for collaboration with colleges and universities in areas of mutual interest, when such resources are available.
- F. The training plan is developed, evaluated, and updated based on an annual assessment that identifies current job-related training needs.
- G. The Town of Farmville Facility's training plan is developed by an advisory training committee composed of the Facility's Training Coordinator and representatives from other facility departments.
  1. The committee meets at least quarterly to review progress and resolve problems.

2. A written record of these meetings is forwarded to the Town of Farmville—ICE Facility Manager.
- H. The necessary space and equipment required for the training and staff development program(s) will be available when needed.
  - I. The Town of Farmville—ICE Facility budget includes funds to reimburse staff for additional time spent in training, or for replacement personnel required, when regular personnel are off duty for training purposes.
  - J. The Town of Farmville—ICE Facility administration encourages employees to continue their education and provides reimbursement to employees attending approved professional meetings, seminars, and similar work-related activities.
  - K. Written policy, procedure, and practice provide that all new clerical/support employees who have minimal detainee contact receive 16 hours of orientation and training during their first year of employment.
    1. All persons in this category are given an additional 16 hours of training each subsequent year of employment.
  - L. Written policy, procedure, and practice provide that all new Officers receive:
    1. 40 hours of training prior to entry on duty.
    2. An additional 120 hours of training during their first year of employment.
    3. An additional 40 hours of training each subsequent year of employment.
    4. At a minimum, this training covers the following areas:
      - a. All Detention Standards
      - b. Security procedures.
      - c. Supervision of detainees.
      - d. Signs of suicide.
      - e. Suicide precautions.
      - f. Use of Force.
      - g. Report writing.
      - h. Detainee rules and regulations.
      - i. Rights and responsibilities.
      - j. Fire and emergency procedures.
      - k. Firearms training.
        - l. Key control.
      - m. Interpersonal relations.
      - n. Social/cultural lifestyle of detainee population.
      - o. Communication skills.
      - p. First aid.
      - q. Cardiopulmonary resuscitation (CPR).
  - M. Written policy, procedure, and practice provide that all administrative and managerial staff receive:
    1. Training in regards to all Detention Standards
    2. 40 hours of training in addition to orientation training during the first year of employment.
    3. 40 hours of training each year thereafter.
    4. This training covers at a minimum the following areas:
      - a. General management.
      - b. Labor law.
      - c. Employee-management relations.
      - d. The criminal justice system.

- e. Relationship with other service agencies.
- N. Written policy, procedure, and practice provide that all support employees who have regular or daily contact with detainees receive:
  - 1. Training in regards to all Detention Standards
  - 2. 40 hours of training, in addition to orientation training, during the first year of employment.
  - 3. 40 hours of training each year thereafter.
- O. All part-time staff and contract personnel receive formal orientation appropriate to their assignments and additional training as needed as well as training in regards to all Detention Standards.
- P. Written policy, procedure, and practice provides that officers assigned to an emergency unit have:
  - 1. At least one year of experience as an Officer.
  - 2. 40 hours of specialized training, which may be part of the Officer's first year training program.
  - 3. 40 hours of training annually, at least 16 hours of which are specifically related to his/her emergency unit assignment.

## **PROCEDURES**

b2High

### Training Requirements

b2High

### Types of Training

b2High



b2High

Training Program

b2High

Outside Resources

b2High

Training Resources

b2High

b2High

Training Aids

b2High

Professional Development

b2High

Management Responsibilities

b2High

b2High

Space and Equipment

b2High

Training Records

b2High

New Officers Training

b2High

b2High

Specialized Training

b2High



## **Town of Farmville – ICE Facility: DROISA-08-0021**

**May 9, 2008**

### **Transportation of Detainees**

#### **PURPOSE**

To provide policy and procedures to be used when transporting detainees outside of the Town of Farmville—ICE Facility.

#### **POLICY**

It is the policy of the Town of Farmville—ICE Facility to transport detainees in a safe and humane manner and in accordance with ICE Detention Standards

#### **References: A.C.A. 3A-15/15/23/ 4E-30/31**

- A. Written policy, procedure and practice, provides that staff regulate detainee movement.
- B. Written policy, procedure and practice, governs the transportation of detainees outside of the Town of Farmville—ICE Facility.
- C. Written policy, procedure and practice, governs the use and security of the Town of Farmville—ICE Facility vehicles.
- D. Written policy, procedure and practice, requires that patients who need health care beyond the resources available in the Town of Farmville—ICE Facility, as determined by the responsible physician, are transferred under appropriate security to a facility where such care is available.
- E. Written policy, procedure and practice, provides that prior to transfer to another facility or other substantial travel, either the detainee and/or his/her records are evaluated by health care personnel to assess suitability for travel.
- F. Written policy, procedure and practice, requires that when travel is approved, pertinent data (including medication, behavior management procedures and other treatment or special requirements for observation and care during travel) are documented in a manner readily accessible to, and easily understood by those transporting detainees, as well as those at the receiving facility.

## **PROCEDURES**

The Transportation Supervisor will be responsible for the overall transportation operations. All detainees in legal custody of the Town of Farmville—ICE Facility will be transported with security, safety of the detainees, as well as safety for the general public and others as a focal point at all times and in accordance with ICE Detention Standards.

### **Transportation of Detainees Outside of the Town of Farmville—ICE Facility**

(b)(2)High

(b)(2) High

(b)(2) High

Transporting in an Un-caged / Caged Town of Farmville—ICE Vehicle

(b)(2) High

Transporting Opposite Sex Detainees

(b)(2) High



(b)(2) High

Transporting Juveniles

(b)(2) High

Returning to the Town of Farmville—ICE Facility

(b)(2) High

(b)(2) High

Transportation of Detainees to Funerals

(b)(2) High

Medical Transports

(b)(2) High

(b)(2) High

## Emergency Transports

(b)(2) High

## Emergency Situations

(b)(2) High

(b)(2) High

High Risk Transports

(b)(2) High

Movement of Detainees *Inside* of the Town of Farmville—ICE Facility

(b)(2) High

(b)(2) High

Transportation Vehicles

(b)(2) High

Transportation Log

(b)(2) High



**Town of Farmville – ICE Facility: DROISA-08-0021**

**May 9, 2008**

**Background Investigation**

**PURPOSE**

To establish guidelines to ensure comprehensive and complete background investigations on all persons hired by the Town of Farmville—ICE Facility.

**POLICY**

It is the policy of the Town of Farmville—ICE Facility to conduct complete comprehensive background investigations on all applicants applying for employment with the Town of Farmville—ICE Facility. Final list of all perspective employees will be sent to ICE for a final security clearance.

**PROCEDURES**

The following procedures will be followed when conducting background investigations on all perspective hires of the Town of Farmville—ICE Facility.

(b)(2) High

(b)(2) High



## **Town of Farmville – ICE Facility: DROISA-08-0021**

**May 9, 2008**

### **Contraband**

#### **PURPOSE**

To provide guidelines per the ICE Detention Standards for the control and prevention of contraband within the Town of Farmville—ICE Facility.

#### **POLICY**

It is the policy of the Town of Farmville—ICE Facility to detect and prevent the introduction of contraband into the Facility.

#### **References: A.C.A. 3A-18**

- A. Written policy per the ICE Detention Standards, procedure and practice, provide for searches of the Town of Farmville—ICE Facility and detainees to control contraband and provide for its disposition.
  1. These policies are made available to staff and detainees annually.
  2. These policies are updated and kept current.
- B. Contraband
  1. Anything in the possession on the person or in the room of a detainee not purchased from the Town of Farmville—ICE Facility Commissary or authorized by the Facility Manager.
  2. Any permissible item converted into something other than the item's original intended use and/or purpose.
    - a. This includes unauthorized and excessive amounts of allowable and issued items.
- C. Dangerous Contraband
  1. Any item mentioned under item B (Contraband--*above*) which can threaten the security of the Town of Farmville—ICE Facility or its occupants including:
    - a. Potentially dangerous instruments.
    - b. Illegal and/or prescription drugs.
    - c. Intoxication substances.
    - d. Anything designated as contraband by the Town of Farmville—ICE Facility Manager or designee.



# PROCEDURES

## Staff Training

(b)(2) High

## Visitors

(b)(2) High

## Detainees

(b)(2) High

## Contraband Inside the Facility

(b)(2) High

(b)(2) High

Contraband From Outside the Facility

(b)(2) High

Reporting Contraband

(b)(2) High

Disposition of Contraband

(b)(2) High

(b)(2) High



**Town of Farmville – ICE Facility: DROISA-08-0021  
May 9, 2008**

**DAILY RECORDS AND REPORTS**

**PURPOSE:**

To establish written policy and procedure for the production of daily records and reports by the staff of the Town of Farmville- ICE Facility.

**POLICY**

It is the policy of the Town of Farmville – ICE Facility to collect and maintain the appropriate information on each detainee who is processed/received into the facility.

- A. Written policy and procedure provide for a detainee population accounting system that includes records on admission, processing, and release of detainees
- B. The facility maintains a system that identifies all detainees in the detention facility and their physical location
- C. The facility administration maintains a written record of the following:
  1. personnel on duty
  2. detainee population count
  3. admissions and releases of detainees
  4. shift activities
  5. entry and exit of physicians, attorneys, and other visitors
  6. unusual occurrences.
- D. The facility shall maintain a daily log (s) which records the following information:
  1. Detainee count and location
  2. Intake and release of detainees
  3. Entries and exits of physicians, attorneys, ministers, and other
  4. non-facility personnel;
  5. Any unusual incidents such as those that result in physical harm to or threaten the safety of any person, or the security of the facility.

**PROCEDURES:**

- A. The collecting of detainee records shall begin at admission and continue on an on-going basis until release.
- B. Detainee permanent records shall be maintained in the records section under the directives supervision of the records supervisor. Medical Records shall be maintained in the Medical Section and under the direct supervision of the Medical Supervisor.

- C. If a detainee is unwilling or unable to provide the required information, staff shall record as much information as can be obtained. Staff shall document the fact that they were unable to obtain the information and at a later time, make an effort to obtain this information.
- D. All detainees records shall meet ICE Detention Standards and contain at a minimum the following information:
  - 1. Detainee records
  - 2. Intake and Admissions Documentation
  - 3. Transportation Order
  - 4. Form 213
  - 5. Major/ Minor Rule Violation Reports
  - 6. Work/ Program Involvement
  - 7. Property Receipt/ Release
  - 8. Photograph
  - 9. Computer Print Outs
  - 10. Detainee Comment Forms
  - 11. Other Relative Information
- E. All detainee files shall be maintained in a consistent manner, the Records Clerk shall establish an order for all files. Information shall be posted daily and in order. The Town of Farmville-ICE Facility will incorporate ICE Detention Standards regarding detention files to include; creation of a detainee detention file, required contents of file, additions to file, location of file, active/ archive file, and access to file.
- F. All information obtained at Booking shall adhere to ICE Detention Standards and shall be reviewed by the shift supervisor prior to submission to the records section.
- G. Records shall maintain in the Records Section, the active records and the previous years records. All additional records shall be boxed and maintained.
- H. Records may be destroyed in accordance with the Va. State Library and Archives Record Division and their General Schedule No. 8, Records Retention and Disposition Scheme.
- I. The booking officer will ensure that all admissions, booking, transfer and release information is accurately recorded on the Detainee Management System ( computer ) and/or the booking log.
- J. The watch commander/supervisor will review all booking documentation to ensure that all information is accurate.
- K. Daily Activity Reports
  - 1. Watch Commander will submit a daily activity report ( DR ) ( daily ).
  - 2. The daily activity report will contain the following information to be forwarded to the Department Head of Security:
    - a. Personnel on duty
    - b. Detainee count sheet
    - c. Number of admissions, processes, transfers and release of detainees
    - d. Shift activities
    - e. Incident / supplement reports
    - f. Unusual occurrences
    - g. Meal count sheet
- L. The Records Supervisor is responsible for maintaining accurate documentation on all new incarcerations. The Records Supervisor will review the booking and facility management system daily.

M. All logs will be closed at 2400 hrs. by the watch commander supervisor on duty and the new day will be initiated at 0001 hrs. daily.



## **Town of Farmville – ICE Facility: DROISA-08-0021**

**May 9, 2008**

### **Detainee Counts**

#### **PURPOSE**

To provide instructions for conducting detainee counts.

#### **POLICY**

It is the policy of the Town of Farmville—ICE Facility to maintain an accurate accounting of detainee locations and population, by conducting detainee counts at a minimum of one (1) time per shift.

- A. The Town of Farmville—ICE Facility has a system for physically counting detainees.
  1. There is a strict accountability for detainees on site as well as those temporarily off site due to court visits, hospital visits etc..
  2. The facility shall maintain a daily log(s) which record(s):
    - a. Detainee count and location.
    - b. Intake and release of detainees.
    - c. Entries and exits of physicians, attorneys, ministers and other non-facility personnel.
    - d. Any unusual incidents, such as those that result in physical harm to or threaten the safety of any person, or the security of the Town of Farmville—ICE Facility.

#### **PROCEDURES**

##### **Formal Counts**

(b)(2) High

(b)(2) High

### Emergency Counts

(b)(2) High

### Booking Responsibilities

(b)(2) High



**Stevens, Richard P**

---

**From:** Warren Coleman b6  
**Sent:** Monday, July 07, 2008 10:10 AM  
**To:** Neveleff, Jerald  
**Cc:** Russell Harper  
**Subject:** FW:

**Attachments:** image001.jpg; image002.jpg; Letter-ICE Response 7-3-08.doc; Farmville ICE-II-A1.2 partial floor plans-A1.5.pdf; Farmville ICE-II-A1.1 floor plans-A1.1.pdf; Farmville ICE-II-A1.2 partial floor plans-A1.2.pdf; Farmville ICE-II-A1.2 partial floor plans-A1.3.pdf; Farmville ICE-II-A1.2 partial floor plans-A1.4.pdf

Jerry,

Attached are revised drawings and responses to your construction questions from our architect. I have added responses for Questions 13, 14, 15, 17, 18 below. Please let us know if additional comments/explanations are needed for the drawings or for the comments sent on Thursday July 3. We look forward to working this week to finalize any outstanding issues in hopes that we can have a signed document by July 18.

Warren Coleman

13. How does ICA plan to construct Phase II, the ICE administration spaces?

Response: ICA's plans can not be finalized until we received the final requirements for the ICE Administration space. Once plans are finalized, we will provide detail construction plans.

14. How does the Provider plan to secure the facility during construction during Phase II while Phase I of the facility is being activated/occupied?

Response: A plan to secure the occupied space will be developed once it is determined where the ICE Administration space will be located on the site. Regardless of the location on the site, security of the occupied space will not be compromised.

15. Provide the construction schedule.

Response: Construction schedule will be finalized once we receive ICE's approval of the construction plans. It is anticipated that this will be 8 months after the approval date.

17 Provide site plan detailing the lay-out of the facility. At a minimum the plan should show secure perimeter fencing and sally- port, position of building or buildings and adjacent public roads.

Response: The site plan will be provided later this week as the final plan could not be determined until the revised architectural drawings were completed.

18 If it is decided to waive the ICE Design Space Requirements for OPLA and EOIR, the service provider will need to incorporate in their design, expansion capability if the need for full compliment of courts is needed in the future.

Response: We will be glad to expand or redesign the facility in the future to meet the needs and requirements of ICE.

---

**From:** Bill Mason [I] (b)(6)  
**Sent:** Thursday, July 03, 2008 4:45 PM  
**To:** Warren Coleman  
**Cc:** Russell Harper  
**Subject:**

Warren,

I have attached the current floor plans regarding the ICE Response letter per Mac Kelley. If you have any comments or questions, please contact Mac.

12/21/2008

Thanks,  
Bill Mason

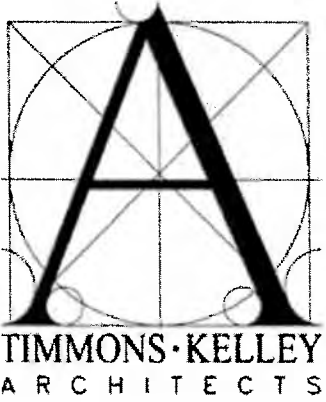

William D. Mason  
Timmons/Kelley Architects  
14005 Steeplestone Drive  
Midlothian, Va. 23113

Phone: (b)(6)

Fax: 804-897-5635

(b)(6)

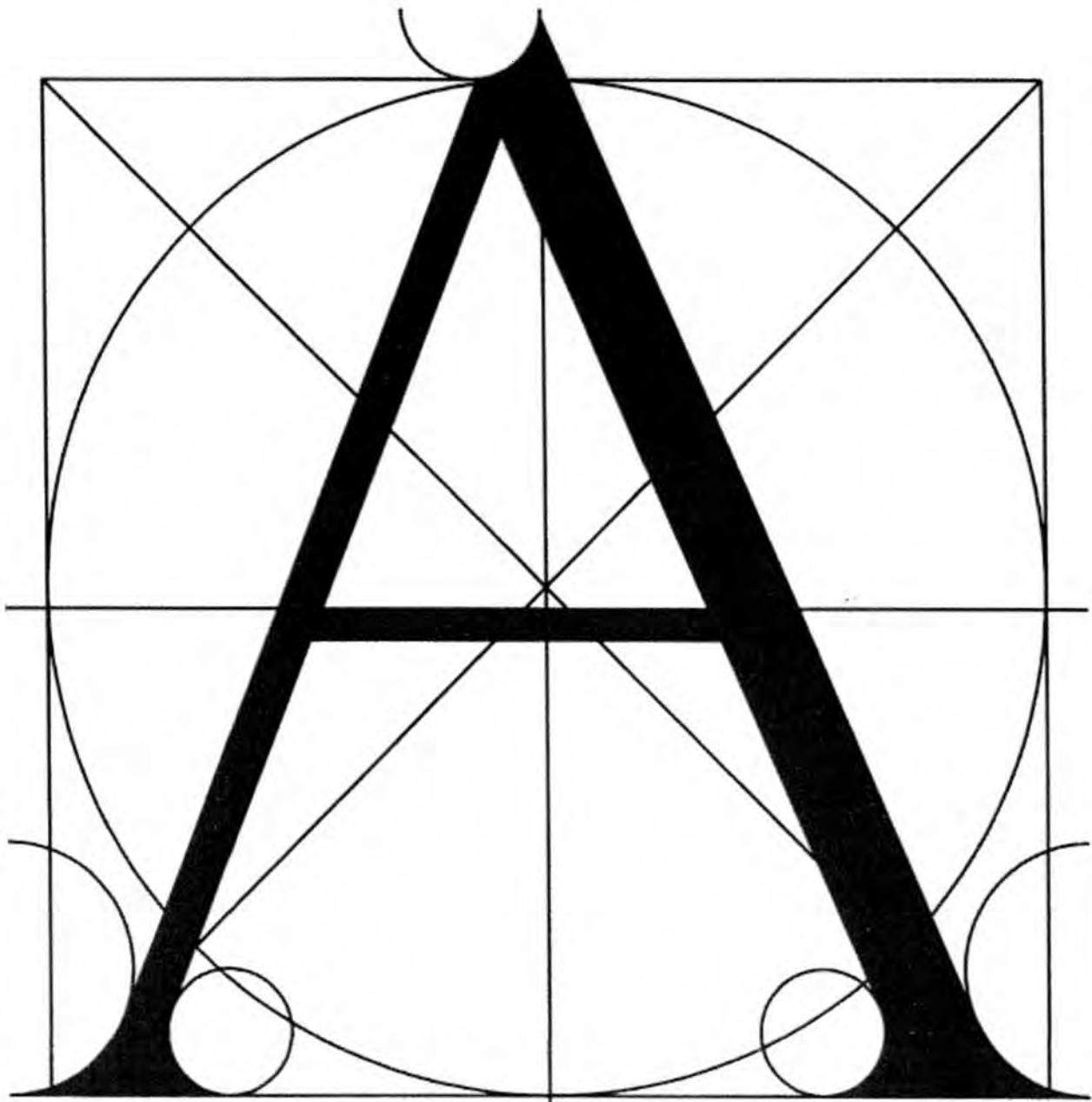

TIMMONS • KELLEY  
A R C H I T E C T S

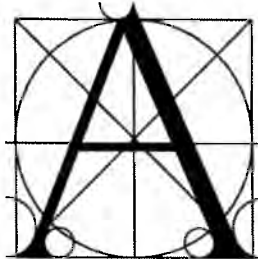

TIMMONS • KELLEY  
ARCHITECTS

December 21, 2008

To: U.S. Immigration and Customs Enforcement  
Office of Acquisition Management  
U.S. Department of Homeland Security  
425 I Street, NW  
Washington, DC 20536

RE: Technical Review of Farmville Proposal  
Letter dated June 23, 2008

Dear Sir,

Following is response to the Review Comments in the letter referenced above.

Changes to Phase I:

b2High

b2High

b2High

Volume I Comments: Response to be provided by other than the Architect.

Volume II Comments:

b2High

b2High

If you wish further discuss any aspect of this submittal please contact me at telephone number \_\_\_\_\_ or by mail at 14005 Steeplestone Drive, Midlothian, Virginia 23113, or by email a \_\_\_\_\_ b6

With Regards,

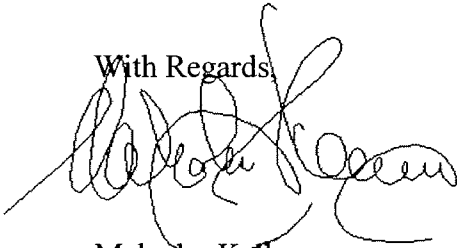
A handwritten signature in black ink, appearing to read "Malcolm Kelley", written in a cursive style.

Malcolm Kelley  
Architect



**TIMMONS • KELLEY**  
ARCHITECTS  
1000 WEST BROADWAY, SUITE 1000, WASHINGTON, DC 20004  
PH: (202) 637-1000 FAX: (202) 637-1000  
WWW.TKARCH.COM



AREA "D"  
**FACILITY**  
**3 BUILDING**  
IRGINIA

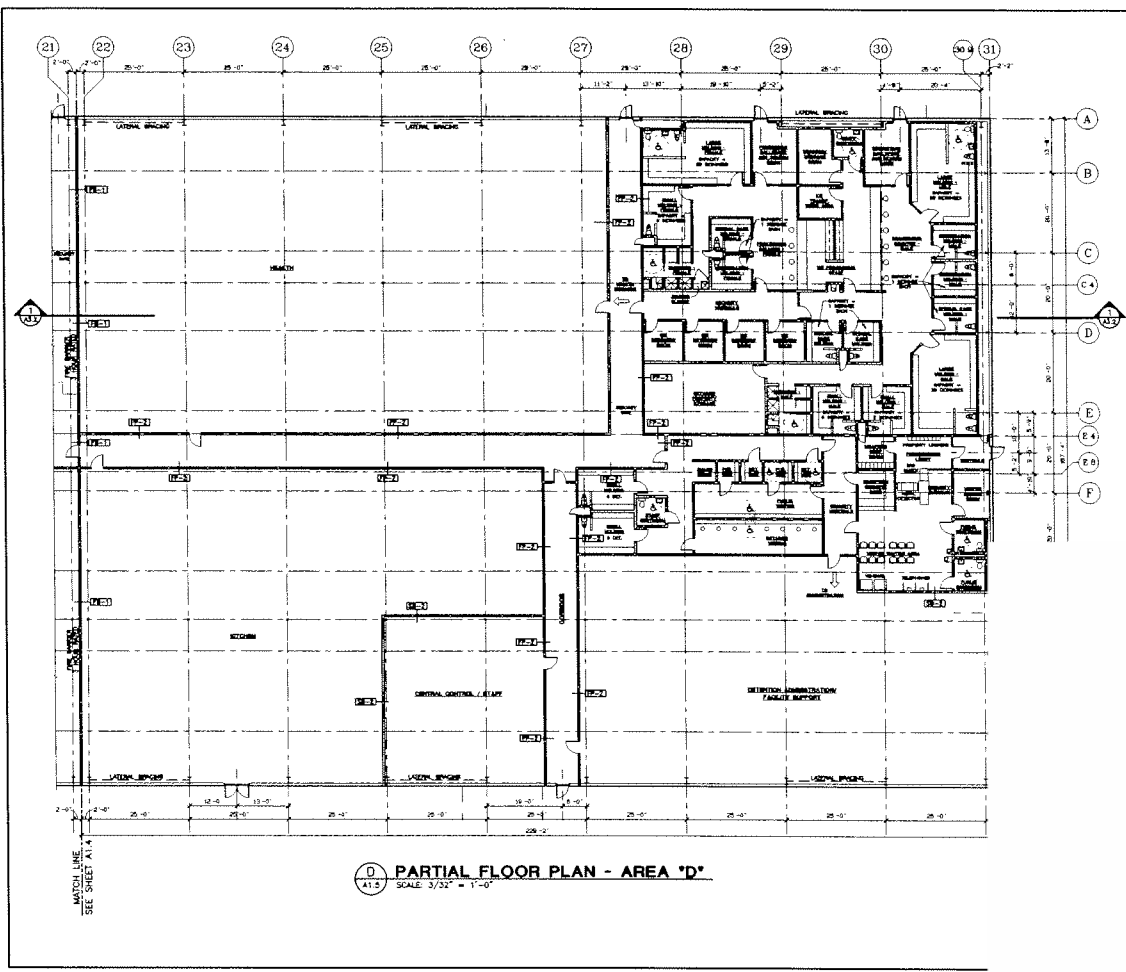

b2High



b2High

DATE	REVISION
4/29/98	ISSUED FOR PERMIT
7/7/98	REV. PERMITTING

PROJECT NO. 88-02  
NAME OF WORK  
ARCHITECT  
LIMMUNS • NELLEY  
A1.1

BUILDING FLOOR PLAN  
**ICE FARMVILLE FACILITY**  
DETAINEE HOUSING BUILDING  
FARMVILLE, VIRGINIA

**LIMMUNS • NELLEY**  
ARCHITECTS  
1408 WESTLARK ROAD - ROCKY HILL, VIRGINIA 22152  
PH: (801) 897-8839 FAX: (801) 897-8834  
WWW.LIMMUNS-NELELEY.COM



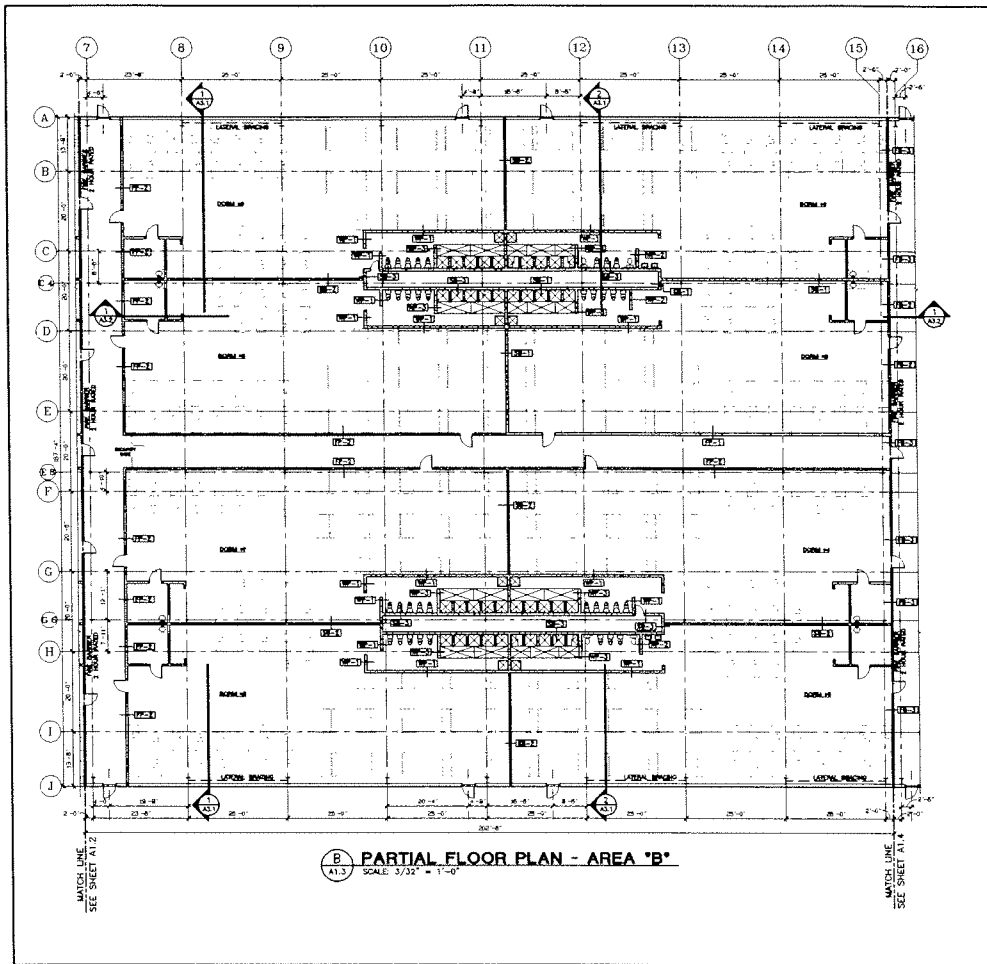

**B** PARTIAL FLOOR PLAN - AREA "B"  
 SCALE: 3/32" = 1'-0"

**TIMMONS · KELLEY**  
 ARCHITECTS

14008 BENTLEY AVENUE, SUITE 100, BOSTON, MASSACHUSETTS 02115  
 TEL: (617) 552-1100 FAX: (617) 552-1101  
 WWW.TKARCH.COM

**A "B"**  
 CITY BUILDING  
 SINIA

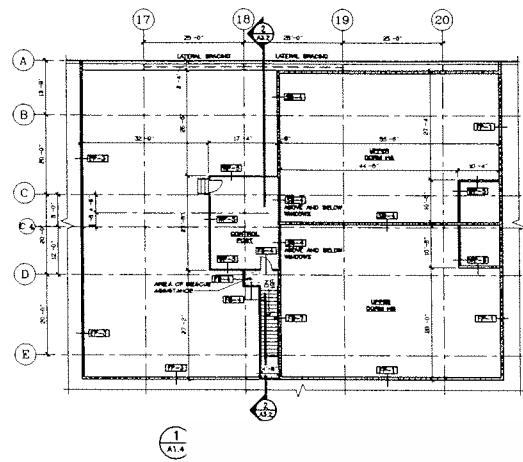
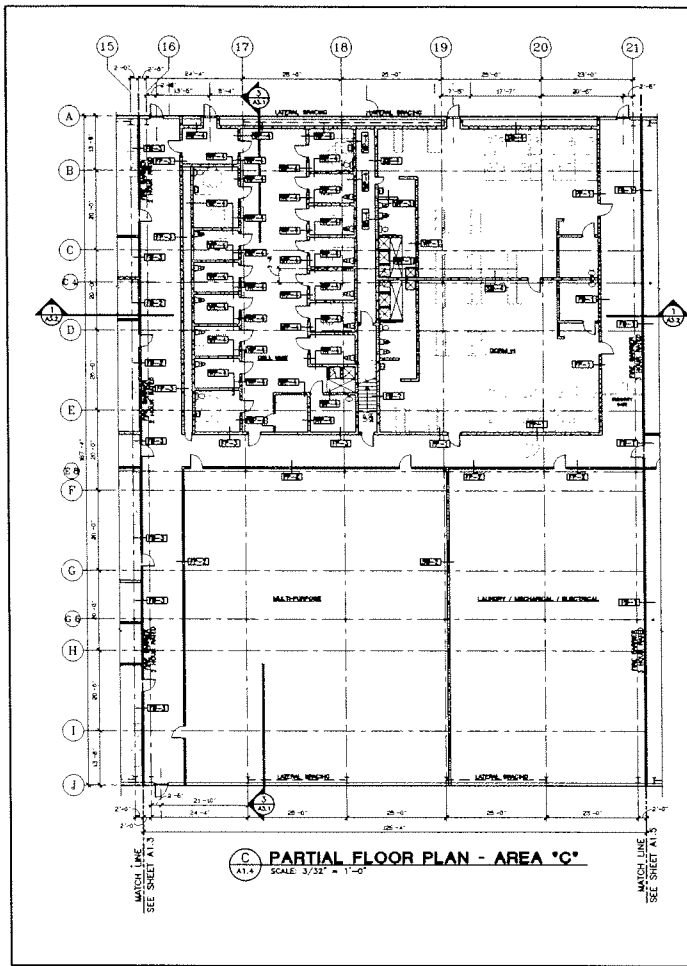

**TIMMONS • KELLEY**  
 ARCHITECTS

1400 BRIDGEMAN DRIVE • ROCKFORD, ILLINOIS 61112  
 TEL: (815) 997-8888 FAX: (815) 997-8888  
 WWW.TKARCHITECTS.COM

**ILITY**  
 LDING  
 N I A

b2High

**Stevens, Richard P**

---

**From:** Neveleff, Jerald  
**Sent:** Monday, July 07, 2008 10:29 AM  
**To:** 'Jenkins, John E'; Wyatt-Powell, Wendie M.  
**Cc:** Casterline, Arnold P  
**Subject:** FW:  
**Attachments:** image001.jpg; image002.jpg; Letter-ICE Response 7-3-08.doc; Farmville ICE-II-A1.2 partial floor plans-A1.5.pdf; Farmville ICE-II-A1.1 floor plans-A1.1.pdf; Farmville ICE-II-A1.2 partial floor plans-A1.2.pdf; Farmville ICE-II-A1.2 partial floor plans-A1.3.pdf; Farmville ICE-II-A1.2 partial floor plans-A1.4.pdf; image002.jpg

All,  
 Farmville responses to facility questions

Thank you,  
 Jerry Neveleff  
 Supervisory Contracting Officer/  
 IGSA Team Lead  
 Office of Acq. Management (OAQ)  
 Detention Management Division  
 202      b6

Help us support you better -  
 TELL US HOW WE ARE DOING!  
 Go to <<http://www.acqsolinc.com/ICE/OAQ/feedback.cfm>> <<<http://www.acqsolinc.com/ICE/OAQ/feedback.cfm>>>

---

**From:** Warren Coleman [ (b)(6) ]  
**Sent:** Monday, July 07, 2008 10:10 AM  
**To:** Neveleff, Jerald  
**Cc:** Russell Harper  
**Subject:** FW:

Jerry,

Attached are revised drawings and responses to your construction questions from our architect. I have added responses for Questions 13, 14, 15, 17, 18 below. Please let us know if additional comments/explanations are needed for the drawings or for the comments sent on Thursday July 3. We look forward to working this week to finalize any outstanding issues in hopes that we can have a signed document by July 18.

Warren Coleman

13. How does ICA plan to construct Phase II, the ICE administration spaces?  
 Response: ICA's plans can not be finalized until we received the final requirements for the ICE Administration space. Once plans are finalized, we will provide detail construction plans.
14. How does the Provider plan to secure the facility during construction during Phase II while Phase I of the facility is being activated/occupied?  
 Response: A plan to secure the occupied space will be developed once it is determined where the ICE Administration space will be located on the site. Regardless of the location on the site, security of the occupied space will not be compromised.
15. Provide the construction schedule.

Response: Construction schedule will be finalized once we receive ICE's approval of the construction plans. It is anticipated that this will be 8 months after the approval date.

- 17 Provide site plan detailing the lay-out of the facility. At a minimum the plan should show secure perimeter fencing and sally- port, position of building or buildings and adjacent public roads.

Response: The site plan will be provided later this week as the final plan could not be determined until the revised architectural drawings were completed.

- 18 If it is decided to waive the ICE Design Space Requirements for OPLA and EOIR, the service provider will need to incorporate in their design, expansion capability if the need for full compliment of courts is needed in the future.

Response: We will be glad to expand or redesign the facility in the future to meet the needs and requirements of ICE.

---

**From:** Bill Mason [mailto: (b)6]  
**Sent:** Thursday, July 03, 2008 4:45 PM  
**To:** Warren Coleman  
**Cc:** Russell Harper  
**Subject:**

Warren,

I have attached the current floor plans regarding the ICE Response letter per Mac Kelley. If you have any comments or questions, please contact Mac.

Thanks,  
Bill Mason

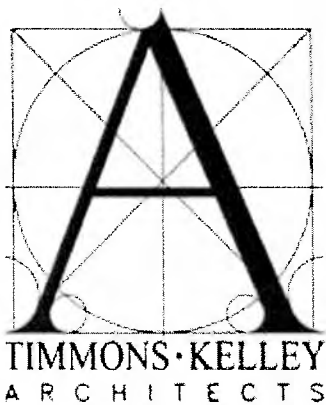

William D. Mason  
Timmons/Kelley Architects  
14005 Steeplestone Drive  
Midlothian, Va. 23113

Phone: (b)6  
Fax: 804-897-5635

(b)6

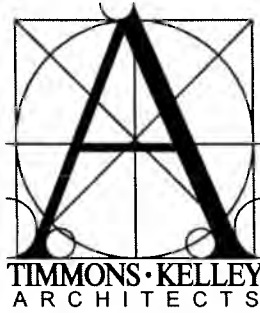

December 21, 2008

To: U.S. Immigration and Customs Enforcement  
Office of Acquisition Management  
U.S. Department of Homeland Security  
425 I Street, NW  
Washington, DC 20536

RE: Technical Review of Farmville Proposal  
Letter dated June 23, 2008

Dear Sir,

Following is response to the Review Comments in the letter referenced above.

Changes to Phase I:

b2High

b2High

b2High



b2High

If you wish further discuss any aspect of this submittal please contact me at telephone number **b6** or by mail at 14005 Steeplestone Drive, Midlothian, Virginia 23113, or by email at **b6**

With Regards,

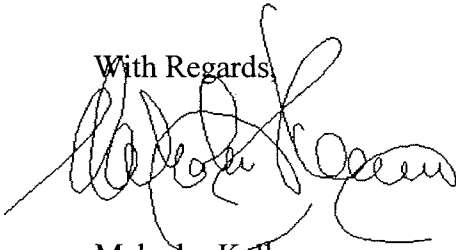
A handwritten signature in black ink, appearing to read 'Malcolm Kelley', written over the typed name below.

Malcolm Kelley  
Architect



TIMMONS-KELLEY  
ARCHITECTS  
1400 BUCKLEUP DRIVE - ALEXANDRIA, VIRGINIA 22304  
TEL: (800) 897-4288 / FAX: (703) 897-4288  
WWW.TKARCHITECTS.COM



EA "D"  
ACILITY  
BUILDING  
GINNIA

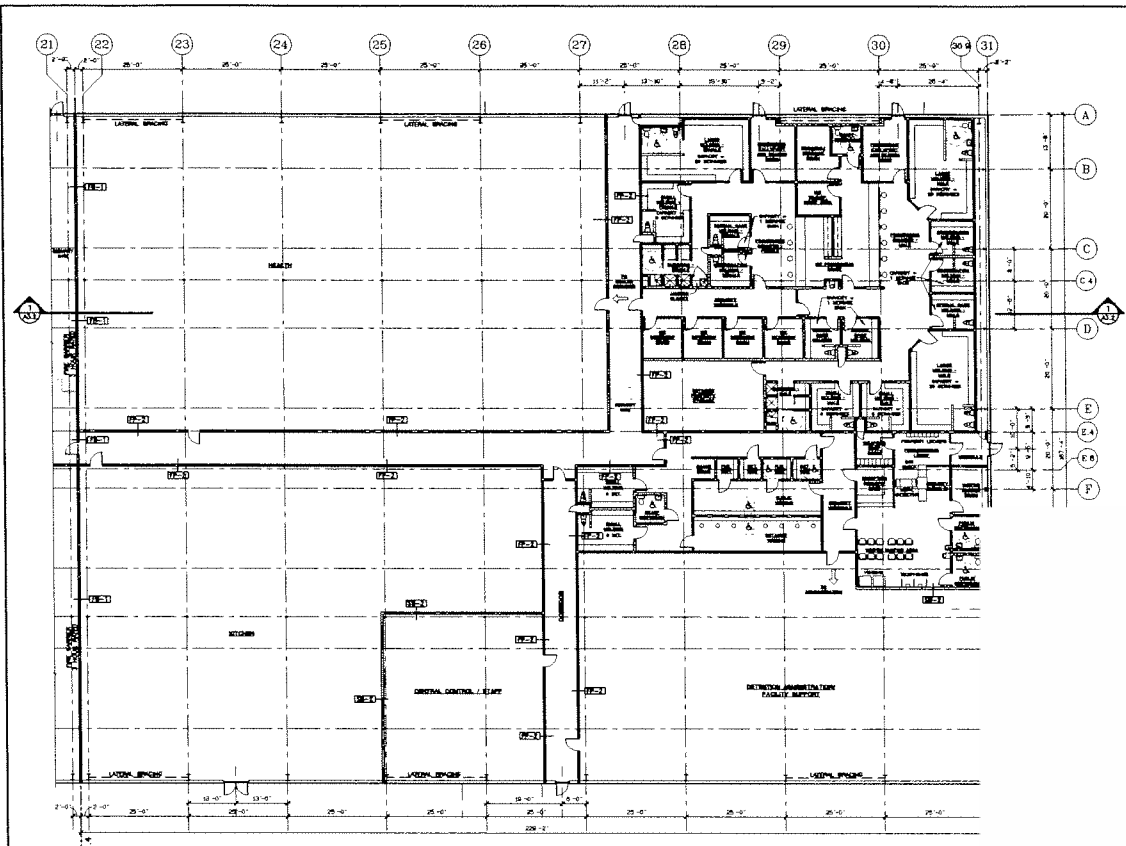

**D** PARTIAL FLOOR PLAN - AREA "D"  
SCALE: 3/32" = 1'-0"

MATCH LINE  
SEE SHEET A1.4

b2High

b2High



**JIMMUNS \* KELLEY**  
ARCHITECTS  
1400 BROADWAY, SUITE 1000, WASHINGTON, DC 20004  
PH: (202) 871-1000 FAX: (202) 871-1000  
WWW.JIMMUNS-KELLEY.COM



BUILDING FLOOR PLAN  
**ICE FARMVILLE FACILITY**  
DETAINEE HOUSING BUILDING  
FARMVILLE, VIRGINIA

DATE	ISSUED	REVISION
1/21/08	1/21/08	1/21/08
1/21/08	1/21/08	1/21/08

PROJECT no. 08-182  
DRAWN BY: JMK  
CHECKED BY: JMK  
SHEET no. **A1.1**



**TIMMONS-KELLEY**  
ARCHITECTS

**"A"**  
CITY  
BUILDING  
INDIA

14000 STATE ST. SUITE 1000, INDIANAPOLIS, IN 46204  
TEL: (317) 634-1000 FAX: (317) 634-1001  
WWW.TKARCH.COM

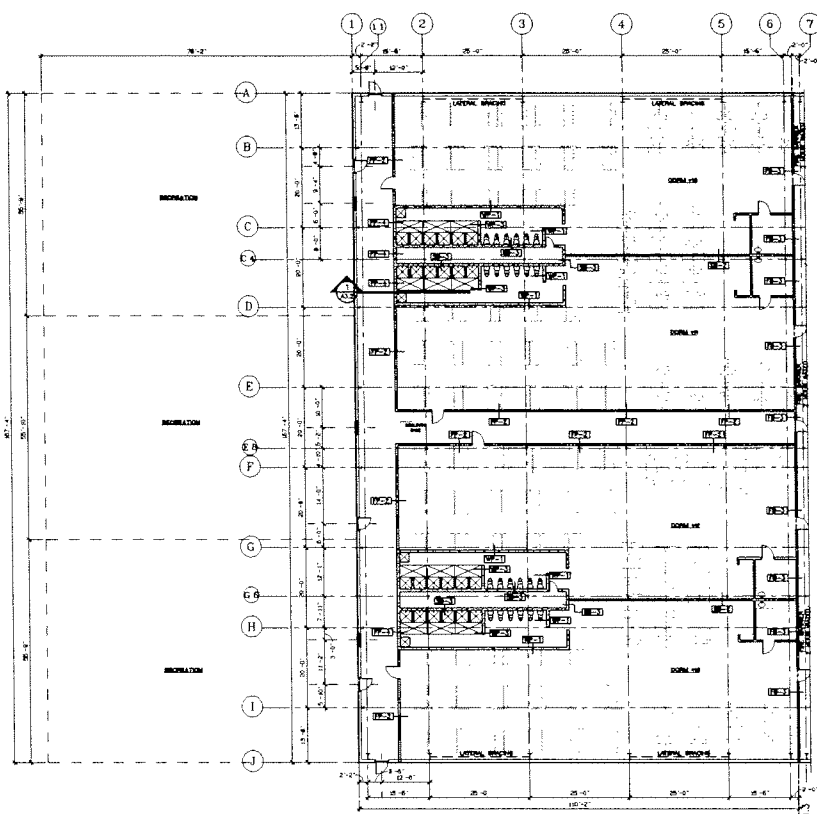

**A**  
PARTIAL FLOOR PLAN - AREA "A"  
SCALE: 3/32" = 1'-0"

WALLS, LINE  
SEE SHEET "A1.2"

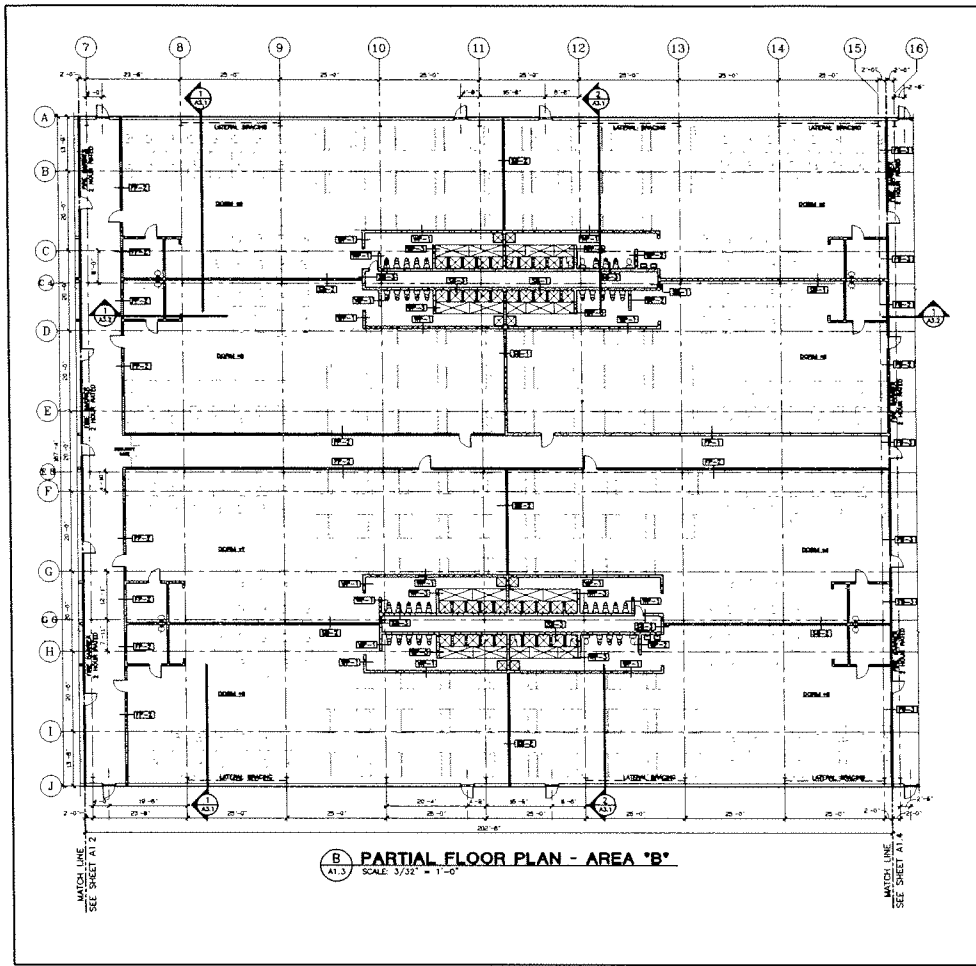



**B** PARTIAL FLOOR PLAN - AREA "B"  
 SCALE: 3/32" = 1'-0"

**TIMMONS-KELLEY**  
 ARCHITECTS

11008 E. BROADWAY, SUITE 100, DENVER, COLORADO 80231  
 TEL: (303) 897-4888 / FAX: (303) 897-4848  
 WWW.TKARCHITECTS.COM

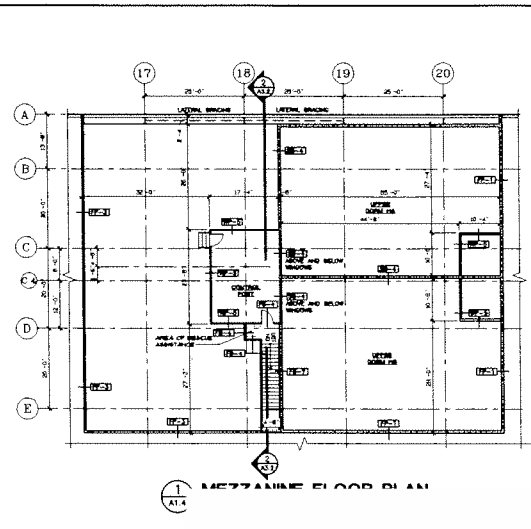
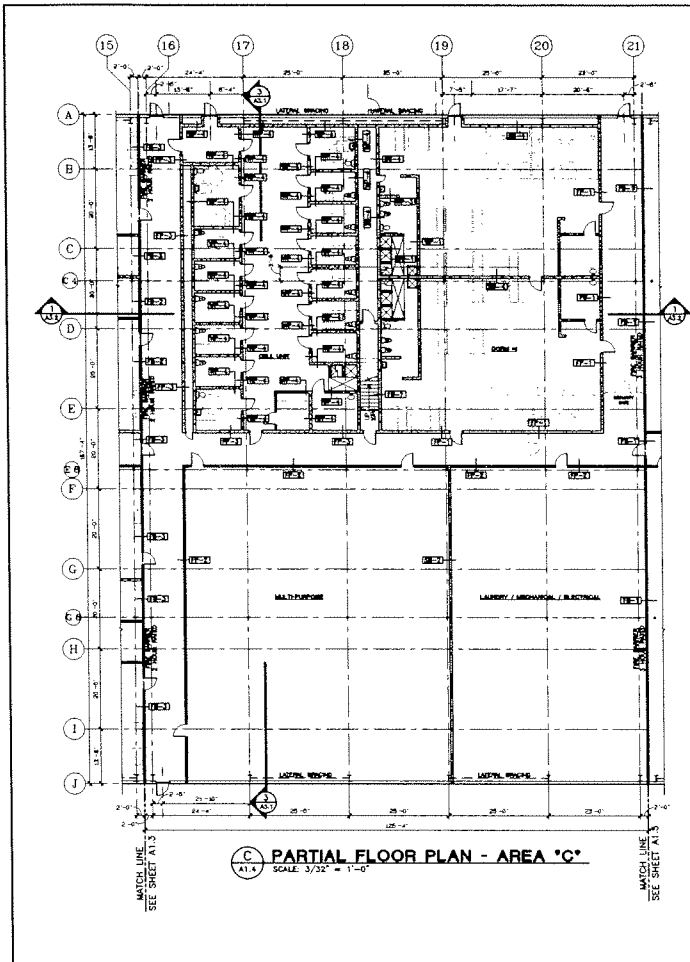
**"B"**  
 CITY BUILDING  
 I N I A



  
**TIMMONS-KELLEY**  
 ARCHITECTS  
 1400 BROADWAY, SUITE 1400, NEW YORK, NY 10013  
 TEL: (212) 697-4000 FAX: (212) 697-4001  
 WWW: WWW.TIMMONS-KELLEY.COM

---

**CITY**  
 BUILDING  
 INDIA

**Stevens, Richard P**

---

**From:** Neveleff, Jerald  
**Sent:** Monday, July 07, 2008 10:48 AM  
**To:** Smyly, Elena L  
**Subject:** FW:  
**Attachments:** image001.jpg; image002.jpg; Letter-ICE Response 7-3-08.doc; Farmville ICE-II-A1.2 partial floor plans-A1.5.pdf; Farmville ICE-II-A1.1 floor plans-A1.1.pdf; Farmville ICE-II-A1.2 partial floor plans-A1.2.pdf; Farmville ICE-II-A1.2 partial floor plans-A1.3.pdf; Farmville ICE-II-A1.2 partial floor plans-A1.4.pdf; image003.jpg; image002.jpg

Sorry,  
I sent this to Wendie this morning. I still haven't gotten the separation of the large IGSA's memorized yet.

Thank you,  
Jerry Neveleff  
Supervisory Contracting Officer/  
IGSA Team Lead  
Office of Acq. Management (OAQ)  
Detention Management Division  
202/ b6

Help us support you better -  
TELL US HOW WE ARE DOING!  
Go to <<http://www.acqsolinc.com/ICE/OAQ/feedback.cfm>> <<<http://www.acqsolinc.com/ICE/OAQ/feedback.cfm>>>

---

**From:** Neveleff, Jerald  
**Sent:** Monday, July 07, 2008 10:29 AM  
**To:** 'Jenkins, John E'; Wyatt-Powell, Wendie M  
**Cc:** Casterline, Arnold P  
**Subject:** FW:

All,  
Farmville responses to facility questions

Thank you,  
Jerry Neveleff  
Supervisory Contracting Officer/  
IGSA Team Lead  
Office of Acq. Management (OAQ)  
Detention Management Division  
202/ b6

Help us support you better -  
TELL US HOW WE ARE DOING!  
Go to <<http://www.acqsolinc.com/ICE/OAQ/feedback.cfm>> <<<http://www.acqsolinc.com/ICE/OAQ/feedback.cfm>>>

---

**From:** Warren Coleman [mailto:[\(b\)\(6\)](#)]  
**Sent:** Monday, July 07, 2008 10:10 AM  
**To:** Neveleff, Jerald  
**Cc:** Russell Harper  
**Subject:** FW:

Jerry,

Attached are revised drawings and responses to your construction questions from our architect. I have added responses for Questions 13, 14, 15, 17, 18 below. Please let us know if additional comments/explanations are needed for the drawings or for the comments sent on Thursday July 3. We look forward to working this week to finalize any outstanding issues in hopes that we can have a signed document by July 18.

Warren Coleman

13. How does ICA plan to construct Phase II, the ICE administration spaces?

Response: ICA's plans can not be finalized until we received the final requirements for the ICE Administration space. Once plans are finalized, we will provide detail construction plans.

14. How does the Provider plan to secure the facility during construction during Phase II while Phase I of the facility is being activated/occupied?

Response: A plan to secure the occupied space will be developed once it is determined where the ICE Administration space will be located on the site. Regardless of the location on the site, security of the occupied space will not be compromised.

15. Provide the construction schedule.

Response: Construction schedule will be finalized once we receive ICE's approval of the construction plans. It is anticipated that this will be 8 months after the approval date.

17 Provide site plan detailing the lay-out of the facility. At a minimum the plan should show secure perimeter fencing and sally- port, position of building or buildings and adjacent public roads.

Response: The site plan will be provided later this week as the final plan could not be determined until the revised architectural drawings were completed.

18 If it is decided to waive the ICE Design Space Requirements for OPLA and EOIR, the service provider will need to incorporate in their design, expansion capability if the need for full compliment of courts is needed in the future.

Response: We will be glad to expand or redesign the facility in the future to meet the needs and requirements of ICE.

---

**From:** Bill Mason [mailto:[\(b\)\(6\)](#)]  
**Sent:** Thursday, July 03, 2008 4:45 PM  
**To:** Warren Coleman  
**Cc:** Russell Harper  
**Subject:**

Warren,

I have attached the current floor plans regarding the ICE Response letter per Mac Kelley. If you have any comments or questions, please contact Mac.

Thanks,  
 Bill Mason







William D. Mason  
Timmons/Kelley Architects  
14005 Steeplestone Drive  
Midlothian, Va. 23113

Phone: (b)(6)

Fax: 804-897-5635

(b)(6)

**Stevens, Richard P**

---

**From:** Warren Coleman (b)(6)  
**Sent:** Monday, July 07, 2008 5:02 PM  
**To:** Neveleff, Jerald  
**Subject:** ICA-Farmville - site layout  
**Attachments:** image003.jpg; 07081opt12 Model (1).PDF

Jerry

I have attached the site lay plan in response to Question # 17. I will follow up tomorrow to make sure you have everything you need.

As always, call if you have questions.

Thanks  
Warren Coleman  
(b)(6)

---

**From:** John M. Duggan [mailto: (b)(6)]  
**Sent:** Monday, July 07, 2008 2:13 PM  
**To:** Warren Coleman  
**Subject:** Re: FW:

Sincerely,

John M. Duggan LS

**WATSON & DUGGAN PLC**  
1001 East Third Street  
Farmville Virginia 23901  
PH (b)(6) Fx 434.391.3501  
(b)(6)

[www.watsonandduggan.com](http://www.watsonandduggan.com)

**Confidentiality Note:** This e-mail and any attachments are confidential and may be protected by legal privilege. If you are not the intended recipient, be aware that any disclosure, copying, distribution or use of this e-mail or any attachment is prohibited. If you have received this e-mail in error, please notify us immediately by returning it to the sender and delete this copy from your system. Thank you for your cooperation.

----- Original Message -----

**From:** Warren Coleman  
**To:** (b)(6)  
**Cc:** Russell Harper  
**Sent:** Monday, July 07, 2008 10:14 AM  
**Subject:** FW:

John

We received the following question from ICE and need your help responding to it. I told them that the answer would be provided later this week so let me know when you think it would be possible to have this request prepared.

Thanks  
Warren

b2High

b2High

---

**From:** Bill Mason [mailto: (b)(6)]  
**Sent:** Thursday, July 03, 2008 4:45 PM  
**To:** Warren Coleman  
**Cc:** Russell Harper  
**Subject:**

Warren,

I have attached the current floor plans regarding the ICE Response letter per Mac Kelley. If you have any comments or questions, please contact Mac.

Thanks,  
Bill Mason

x

William D. Mason  
Timmons/Kelley Architects  
14005 Steeplestone Drive  
Midlothian, Va. 23113

Phone: (b)(6)

Fax: 804-897-5635

(b)(6)

b2High

OF 2 SHEETS 1	SHEET NO. 1	DATE 4-1-08	PROJECT NO. 070911121	SITE PLAN		NO.	DATE	REVISIONS
				FARMVILLE ICE DETENTION FACILITY				
WATSON & DUGGAN P.L.C. 1001 East Third Street Farmville Virginia 23901								

**Stevens, Richard P**

---

**From:** Neveleff, Jerald  
**Sent:** Tuesday, July 08, 2008 7:03 AM  
**To:** 'Jenkins, John E'; Smyly, Elena L  
**Subject:** FW: ICA-Farmville - site layout  
**Attachments:** image003.jpg; 07081opt12 Model (1).PDF

Received yesterday.

Thank you,  
Jerry Neveleff  
Supervisory Contracting Officer/  
IGSA Team Lead  
Office of Acq. Management (OAQ)  
Detention Management Division  
202. b6

Help us support you better -  
TELL US HOW WE ARE DOING!  
Go to <http://www.acqsolinc.com/ICE/OAQ/feedback.cfm> <<<http://www.acqsolinc.com/ICE/OAQ/feedback.cfm>>>

---

**From:** Warren Coleman [mailto:(b)(6)]  
**Sent:** Monday, July 07, 2008 5:02 PM  
**To:** Neveleff, Jerald  
**Subject:** ICA-Farmville - site layout

Jerry  
I have attached the site lay plan in response to Question # 17. I will follow up tomorrow to make sure you have everything you need.

As always, call if you have questions.

Thanks  
Warren Coleman  
(b)(6)

---

**From:** John M. Duggan [mailto:(b)(6)]  
**Sent:** Monday, July 07, 2008 2:13 PM  
**To:** Warren Coleman  
**Subject:** Re: FW:

Sincerely,  
  
John M. Duggan LS

**WATSON & DUGGAN PLC**  
1001 East Third Street  
Farmville Virginia 23901  
PH (b)(6) Fx 434.391.3501

(b)(6)

[www.watsonandduggan.com](http://www.watsonandduggan.com)

Confidentiality Note: This e-mail and any attachments are confidential and may be protected by legal privilege. If you are not the intended recipient, be aware that any disclosure, copying, distribution or use of this e-mail or any attachment is prohibited. If you have received this e-mail in error, please notify us immediately by returning it to the sender and delete this copy from your system. Thank you for your cooperation.

----- Original Message -----

**From:** [Warren Coleman](#)

**To:** (b)(6)

**Cc:** [Russell Harper](#)

**Sent:** Monday, July 07, 2008 10:14 AM

**Subject:** FW:

John

We received the following question from ICE and need your help responding to it. I told them that the answer would be provided later this week so let me know when you think it would be possible to have this request prepared.

Thanks  
Warren

b2High

---

**From:** Bill Mason [mailto:(b)(6)]

**Sent:** Thursday, July 03, 2008 4:45 PM

**To:** Warren Coleman

**Cc:** Russell Harper

**Subject:**

Warren,

I have attached the current floor plans regarding the ICE Response letter per Mac Kelley. If you have any comments or questions, please contact Mac.

Thanks,  
Bill Mason

✘

William D. Mason  
Timmons/Kelley Architects  
14005 Steeplestone Drive  
Midlothian, Va. 23113

Phone: (b)(6)

Fax: 804-897-5635

(b)(6)

**Stevens, Richard P**

---

**From:** Neveleff, Jerald  
**Sent:** Tuesday, July 08, 2008 7:03 AM  
**To:** Casterline, Arnold P  
**Subject:** FW: ICA-Farmville - site layout  
**Attachments:** image003.jpg; 07081opt12 Model (1).PDF

fyi

Thank you,  
Jerry Neveleff  
Supervisory Contracting Officer/  
IGSA Team Lead  
Office of Acq. Management (OAQ)  
Detention Management Division  
202 b6

Help us support you better -  
TELL US HOW WE ARE DOING!  
Go to <<http://www.acqsolinc.com/ICE/OAQ/feedback.cfm>> <<<http://www.acqsolinc.com/ICE/OAQ/feedback.cfm>>>

---

**From:** Neveleff, Jerald  
**Sent:** Tuesday, July 08, 2008 7:03 AM  
**To:** 'Jenkins, John E'; Smyly, Elena L  
**Subject:** FW: ICA-Farmville - site layout

Received yesterday.

Thank you,  
Jerry Neveleff  
Supervisory Contracting Officer/  
IGSA Team Lead  
Office of Acq. Management (OAQ)  
Detention Management Division  
202 b6

Help us support you better -  
TELL US HOW WE ARE DOING!  
Go to <<http://www.acqsolinc.com/ICE/OAQ/feedback.cfm>> <<<http://www.acqsolinc.com/ICE/OAQ/feedback.cfm>>>

---

**From:** Warren Coleman [mailto:] (b)(6)  
**Sent:** Monday, July 07, 2008 5:02 PM  
**To:** Neveleff, Jerald  
**Subject:** ICA-Farmville - site layout

Jerry  
I have attached the site lay plan in response to Question # 17. I will follow up tomorrow to make sure you have everything you

12/21/2008



need.

As always, call if you have questions.

Thanks  
Warren Coleman

(b)(6)

---

**From:** John M. Duggan [mailto:  
**Sent:** Monday, July 07, 2008 2:13 PM  
**To:** Warren Coleman  
**Subject:** Re: FW: ]

Sincerely,

John M. Duggan LS

**WATSON & DUGGAN PLC**  
1001 East Third Street  
Farmville Virginia 23901  
PH (b)(6) Fx 434.391.3501

(b)(6)

[www.watsonandduggan.com](http://www.watsonandduggan.com)

**Confidentiality Note:** This e-mail and any attachments are confidential and may be protected by legal privilege. If you are not the intended recipient, be aware that any disclosure, copying, distribution or use of this e-mail or any attachment is prohibited. If you have received this e-mail in error, please notify us immediately by returning it to the sender and delete this copy from your system. Thank you for your cooperation.

----- Original Message -----

**From:** Warren Coleman  
**To:** (b)(6)  
**Cc:** Russell Harper  
**Sent:** Monday, July 07, 2008 10:14 AM  
**Subject:** FW:

John

We received the following question from ICE and need your help responding to it. I told them that the answer would be provided later this week so let me know when you think it would be possible to have this request prepared.

Thanks  
Warren

b2High

---

**From:** Bill Mason [mailto:  
**Sent:** Thursday, July 03, 2008 4:45 PM  
**To:** Warren Coleman  
**Cc:** Russell Harper  
**Subject:**

Warren,

I have attached the current floor plans regarding the ICE Response letter per Mac Kelley. If you have any comments or questions, please contact Mac.

Thanks,  
Bill Mason

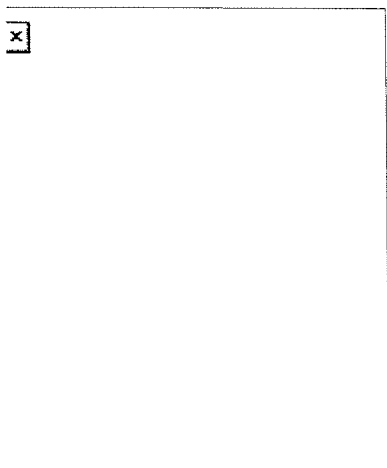

William D. Mason  
Timmons/Kelley Architects  
14005 Steeplestone Drive  
Midlothian, Va. 23113

Phone (b)(6)

Fax: 804-897-5635

(b)(6)

**Stevens, Richard P**

---

**From:** Warren Coleman (b)(6)  
**Sent:** Tuesday, July 08, 2008 11:54 AM  
**To:** Neveleff, Jerald  
**Subject:** FW:  
**Attachments:** image002.jpg; image001.jpg; image002.jpg; Letter-ICE Response 7-3-08.doc; Farmville ICE-II-A1.2 partial floor plans-A1.5.pdf; Farmville ICE-II-A1.1 floor plans-A1.1.pdf; Farmville ICE-II-A1.2 partial floor plans-A1.2.pdf; Farmville ICE-II-A1.2 partial floor plans-A1.3.pdf; Farmville ICE-II-A1.2 partial floor plans-A1.4.pdf

Jerry  
We sent responses on Thursday 7/3 and this document on 7/7. I will send the document from 7/3 just in case it was not received.

Thanks. We would appreciate a progress report when you have time.

Warren Coleman

---

**From:** Warren Coleman  
**Sent:** Monday, July 07, 2008 10:10 AM  
**To:** 'Neveleff, Jerald'  
**Cc:** Russell Harper  
**Subject:** FW:

Jerry,

Attached are revised drawings and responses to your construction questions from our architect. I have added responses for Questions 13, 14, 15, 17, 18 below. Please let us know if additional comments/explanations are needed for the drawings or for the comments sent on Thursday July 3. We look forward to working this week to finalize any outstanding issues in hopes that we can have a signed document by July 18.

Warren Coleman

b2High

b2High

---

**From:** Bill Mason [mailto:[\(b\)\(6\)](#)]  
**Sent:** Thursday, July 03, 2008 4:45 PM  
**To:** Warren Coleman  
**Cc:** Russell Harper  
**Subject:**

Warren,

I have attached the current floor plans regarding the ICE Response letter per Mac Kelley. If you have any comments or questions, please contact Mac.

Thanks,  
Bill Mason

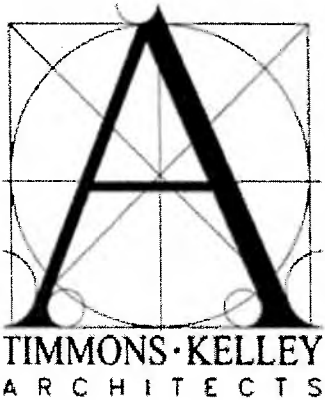

William D. Mason  
Timmons/Kelley Architects  
14005 Steeplestone Drive  
Midlothian, Va. 23113

Phone: [\(b\)\(6\)](#)  
Fax: 804-897-5635  
[\(b\)\(6\)](#)

**Stevens, Richard P**

---

**From:** Warren Coleman (b)(6)  
**Sent:** Tuesday, July 08, 2008 11:55 AM  
**To:** Neveleff, Jerald  
**Subject:** FW: Responses to Technical Letter 6/23/08  
**Attachments:** Note\_JerryN\_070308.doc; QualityControlPlan.final070208.doc; TrainingandStaffDevelopment\_final070208.doc; TransportationOfDetainees\_final070308.doc; background\_final070208.doc; Contraband\_final070308.doc; Detainee records\_reports070308.doc; DetaineeCounts\_final070308.doc; DetaineeOrientationForDetaineeManua\_final070308.doc; EmergencyResponse\_final070308.doc; EmploymentofQualifiedStaff\_final070308.doc; FoodServiceOperations\_FINAL070308.doc; ICECoordination\_final070308.doc

Jerry  
Responses sent on 7/3  
Warren Coleman

---

**From:** Warren Coleman  
**Sent:** Thursday, July 03, 2008 2:36 PM  
**To:** 'Neveleff, Jerald'  
**Cc:** Russell Harper; ' b6  
**Subject:** Responses to Technical Letter 6/23/08

Jerry  
I have attached our response to the Technical Letter and new reports for the package. I am hoping to send you the architect's comments in a separate email later today but if not, then I will send it on Monday at the latest. I will call on Monday to make sure you received everything you need and to determine how we can assist you in the review process.

Have a great holiday.

Warren Coleman



7/3/04

Jerry Neveleff  
Supervisory Contracting Officer/  
IGSA Team Lead  
Office of Acq. Management (OAQ)  
Detention Management Division  
US Department of Homeland Security  
425 I St. NW, Suite 5009  
Washington, DC 20536

Jerry,

In response to your Technical Review letter dated 6/23/08, we are working with our architects, construction team and future management team to address all questions. In the following comments, I have addressed each point in your letter and I have attached updated policies for the ones changed in response to the Technical Review letter dated 6/23/08. As stated in my responses, we will be sending the architect's report on the building issues in a separate correspondence later today.

We will be glad to continue to respond to questions by email or phone and will make ourselves available for a visit to your office at any time over the next two weeks. We would very much like to hit the July 18 target date that Russell discussed with you so please let us posted on outstanding issues.

Sincerely

Warren Coleman

CC: Russell Harper

## **Responses to Technical Review Letter Dated 6/23/08**

### **Changes to Phase I**

In regards to the bullet points under “Changes to Phase 1”, our architects and construction team are finalizing their comments and we will send those comments in a separate letter.

### **General Technical Proposal Comments**

In regards to the bullet points under “Changes to Phase 1”, our architects and construction team are finalizing their comments and we will send those comments in a separate letter.

### **Volume I**

b2High

### **Volume II**

#### **Quality Control Plan**

b2High

#### **Organizational Chart**

b2High

b2High

**Qualified Staff**

b2High

**Training and Staff development:  
Purpose**

b2High

**Policy**

b2High

**Training Resources:**

b2High

**Professional Development**

b2High



**Management Responsibilities**

b2High

**New Officer Training**

b2High

**Specialized Training**

b2High

**Detainee Counts**

b2High

**Daily Records and Reports  
Procedure:**

b2High

**Contraband:**

b2High

**Emergency:  
Apprehension of Escapee (s):**

b2High

**Hunger Strike:**

b2High

**Mass Detention:**

b2High

**Suicide:**

b2High

**Death of a Detainee:**

b2High

**Detainee Orientation Manual**

b2High

**Food Service**

b2High

DW

:

:

**ICE Coordination**  
**Contact Information**

b2High





## **Town of Farmville – ICE Facility: DROISA-08-0021**

**May 9, 2008**

### **Quality Control Plan**

#### **PURPOSE**

To develop and implement a Quality Control Plan which will ensure compliance with all required Town of Farmville—ICE Facility quality standards and the ICE standards to be monitored under the Government's Quality Assurance Surveillance Plan.

#### **POLICY**

It is the policy of the Town of Farmville—ICE Facility to ensure all applicable standards, policies and procedures are adhered to.

- A. The Town of Farmville—ICE Facility will adopt, adapt and/or establish procedures that will meet or exceed the objective represented by each of the 38 Detention Standards outlined in the QUASP Attachment 3—Performance Monitoring Tool. It is our goal to achieve ACA accreditation or to meet and exceed ACA standards.

#### **PROCEDURES**

b2High

Quality Control Plan

b2High

b2High

### Staff Actions

b2High

### Confidentiality

b2High

### Plan Details

b2High



## **Town of Farmville – ICE Facility: DROISA-08-0021**

**May 9, 2008**

### **Training and Staff Development**

#### **PURPOSE**

To outline the general training and orientation that will apply to the Town of Farmville—ICE Facility personnel. To establish guidelines governing training and orientation for part-time employees, volunteers and contract personnel entering or employed at the Town of Farmville—ICE Facility. A detail training schedule will be developed once the contract is awarded.

#### **POLICY**

It is the policy of the Town of Farmville—ICE Facility to provide training and orientation to each full time and part time employee, contract civilian personnel, volunteers who help with religious services and visitors, to ensure compliance with policies, procedures, job performance and professional development.

#### **References: A.C.A. 1D-01/02/03/04/05/06/07/08/09/10/11/12**

- A. Written policy, procedure, and practice provide that the Town of Farmville—ICE Facility's employee staff development and training programs are planned, coordinated, and supervised by a qualified employee.
  1. The training plan is reviewed annually.
- B. The Town of Farmville—ICE Facility's training plan provides for ongoing formal evaluation of all pre-service, in-service, and specialized training programs.
  1. A written report is prepared annually.
- C. Library and reference services are available to complement the training and staff development program.
- D. Written policy, procedure, and practice provide that the training and staff development program uses outside resources when appropriate.
- E. Written policy, procedure, and practice provide for collaboration with colleges and universities in areas of mutual interest, when such resources are available.
- F. The training plan is developed, evaluated, and updated based on an annual assessment that identifies current job-related training needs.
- G. The Town of Farmville Facility's training plan is developed by an advisory training committee composed of the Facility's Training Coordinator and representatives from other facility departments.
  1. The committee meets at least quarterly to review progress and resolve problems.

2. A written record of these meetings is forwarded to the Town of Farmville—ICE Facility Manager.
- H. The necessary space and equipment required for the training and staff development program(s) will be available when needed.
- I. The Town of Farmville—ICE Facility budget includes funds to reimburse staff for additional time spent in training, or for replacement personnel required, when regular personnel are off duty for training purposes.
- J. The Town of Farmville—ICE Facility administration encourages employees to continue their education and provides reimbursement to employees attending approved professional meetings, seminars, and similar work-related activities.
- K. Written policy, procedure, and practice provide that all new clerical/support employees who have minimal detainee contact receive 16 hours of orientation and training during their first year of employment.
1. All persons in this category are given an additional 16 hours of training each subsequent year of employment.
- L. Written policy, procedure, and practice provide that all new Officers receive:
1. 40 hours of training prior to entry on duty.
  2. An additional 120 hours of training during their first year of employment.
  3. An additional 40 hours of training each subsequent year of employment.
  4. At a minimum, this training covers the following areas:
    - a. All Detention Standards
    - b. Security procedures.
    - c. Supervision of detainees.
    - d. Signs of suicide.
    - e. Suicide precautions.
    - f. Use of Force.
    - g. Report writing.
    - h. Detainee rules and regulations.
    - i. Rights and responsibilities.
    - j. Fire and emergency procedures.
    - k. Firearms training.
    - l. Key control.
    - m. Interpersonal relations.
    - n. Social/cultural lifestyle of detainee population.
    - o. Communication skills.
    - p. First aid.
    - q. Cardiopulmonary resuscitation (CPR).
- M. Written policy, procedure, and practice provide that all administrative and managerial staff receive:
1. Training in regards to all Detention Standards
  2. 40 hours of training in addition to orientation training during the first year of employment.
  3. 40 hours of training each year thereafter.
  4. This training covers at a minimum the following areas:
    - a. General management.
    - b. Labor law.
    - c. Employee-management relations.
    - d. The criminal justice system.

- e. Relationship with other service agencies.
- N. Written policy, procedure, and practice provide that all support employees who have regular or daily contact with detainees receive:
  - 1. Training in regards to all Detention Standards
  - 2. 40 hours of training, in addition to orientation training, during the first year of employment.
  - 3. 40 hours of training each year thereafter.
- O. All part-time staff and contract personnel receive formal orientation appropriate to their assignments and additional training as needed as well as training in regards to all Detention Standards.
- P. Written policy, procedure, and practice provides that officers assigned to an emergency unit have:
  - 1. At least one year of experience as an Officer.
  - 2. 40 hours of specialized training, which may be part of the Officer's first year training program.
  - 3. 40 hours of training annually, at least 16 hours of which are specifically related to his/her emergency unit assignment.

## **PROCEDURES**



b2High

Training Program

b2High

Outside Resources

b2High

Training Resources

b2High

b2High

Training Aids

Professional Development

b2High

Management Responsibilities

b2High

b2High

Space and Equipment

b2High

Training Records

b2High

New Officers Training

b2High

b2High

Specialized Training

b2High



## **Town of Farmville – ICE Facility: DROISA-08-0021**

**May 9, 2008**

### **Transportation of Detainees**

#### **PURPOSE**

To provide policy and procedures to be used when transporting detainees outside of the Town of Farmville—ICE Facility.

#### **POLICY**

It is the policy of the Town of Farmville—ICE Facility to transport detainees in a safe and humane manner and in accordance with ICE Detention Standards

#### **References: A.C.A. 3A-15/15/23/ 4E-30/31**

- A. Written policy, procedure and practice, provides that staff regulate detainee movement.
- B. Written policy, procedure and practice, governs the transportation of detainees outside of the Town of Farmville—ICE Facility.
- C. Written policy, procedure and practice, governs the use and security of the Town of Farmville—ICE Facility vehicles.
- D. Written policy, procedure and practice, requires that patients who need health care beyond the resources available in the Town of Farmville—ICE Facility, as determined by the responsible physician, are transferred under appropriate security to a facility where such care is available.
- E. Written policy, procedure and practice, provides that prior to transfer to another facility or other substantial travel, either the detainee and/or his/her records are evaluated by health care personnel to assess suitability for travel.
- F. Written policy, procedure and practice, requires that when travel is approved, pertinent data (including medication, behavior management procedures and other treatment or special requirements for observation and care during travel) are documented in a manner readily accessible to, and easily understood by those transporting detainees, as well as those at the receiving facility.

**PROCEDURES**

Non-Responsive

**Transportation of Detainees Outside of the Town of Farmville—ICE Facility**

b2High

b2High

b2High

Transporting in an Un-caged / Caged Town of Farmville—ICE Vehicle

b2High

Transporting Opposite Sex Detainees

b2High



b2High

Transporting Juveniles

b2High

Returning to the Town of Farmville—ICE Facility

b2High

b2High

Transportation of Detainees to Funerals

b2High

Medical Transports

b2High

b2High

Emergency Transports

b2High

Emergency Situations

b2High

b2High

High Risk Transports

b2High

Movement of Detainees *Inside* of the Town of Farmville—ICE Facility

b2High

b2High

Transportation Vehicles

b2High

Transportation Log

b2High



**Town of Farmville – ICE Facility: DROISA-08-0021**

**May 9, 2008**

**Background Investigation**

**PURPOSE**

To establish guidelines to ensure comprehensive and complete background investigations on all persons hired by the Town of Farmville—ICE Facility.

**POLICY**

It is the policy of the Town of Farmville—ICE Facility to conduct complete comprehensive background investigations on all applicants applying for employment with the Town of Farmville—ICE Facility. Final list of all perspective employees will be sent to ICE for a final security clearance.

**PROCEDURES**

b2High

b2High



## **Town of Farmville – ICE Facility: DROISA-08-0021**

**May 9, 2008**

### **Contraband**

#### **PURPOSE**

To provide guidelines per the ICE Detention Standards for the control and prevention of contraband within the Town of Farmville—ICE Facility.

#### **POLICY**

It is the policy of the Town of Farmville—ICE Facility to detect and prevent the introduction of contraband into the Facility.

#### **References: A.C.A. 3A-18**

- A. Written policy per the ICE Detention Standards, procedure and practice, provide for searches of the Town of Farmville—ICE Facility and detainees to control contraband and provide for its disposition.
  1. These policies are made available to staff and detainees annually.
  2. These policies are updated and kept current.
- B. Contraband
  1. Anything in the possession on the person or in the room of a detainee not purchased from the Town of Farmville—ICE Facility Commissary or authorized by the Facility Manager.
  2. Any permissible item converted into something other than the item's original intended use and/or purpose.
    - a. This includes unauthorized and excessive amounts of allowable and issued items.
- C. Dangerous Contraband
  1. Any item mentioned under item B (Contraband--*above*) which can threaten the security of the Town of Farmville—ICE Facility or its occupants including:
    - a. Potentially dangerous instruments.
    - b. Illegal and/or prescription drugs.
    - c. Intoxication substances.
    - d. Anything designated as contraband by the Town of Farmville—ICE Facility Manager or designee.



**PROCEDURES**

Staff Training

b2High

Visitors

b2High

Detainees

b2High

Contraband Inside the Facility

b2High

b2High

Contraband From Outside the Facility

b2High

Reporting Contraband

b2High

Disposition of Contraband

b2High

b2High



**Town of Farmville – ICE Facility: DROISA-08-0021  
May 9, 2008**

**DAILY RECORDS AND REPORTS**

**PURPOSE:**

To establish written policy and procedure for the production of daily records and reports by the staff of the Town of Farmville- ICE Facility.

**POLICY**

It is the policy of the Town of Farmville – ICE Facility to collect and maintain the appropriate information on each detainee who is processed/received into the facility.

- A. Written policy and procedure provide for a detainee population accounting system that includes records on admission, processing, and release of detainees
- B. The facility maintains a system that identifies all detainees in the detention facility and their physical location
- C. The facility administration maintains a written record of the following:
  1. personnel on duty
  2. detainee population count
  3. admissions and releases of detainees
  4. shift activities
  5. entry and exit of physicians, attorneys, and other visitors
  6. unusual occurrences.
- D. The facility shall maintain a daily log (s) which records the following information:
  1. Detainee count and location
  2. Intake and release of detainees
  3. Entries and exits of physicians, attorneys, ministers, and other
  4. non-facility personnel;
  5. Any unusual incidents such as those that result in physical harm to or threaten the safety of any person, or the security of the facility.

**PROCEDURES:**

- A. The collecting of detainee records shall begin at admission and continue on an on-going basis until release.
- B. Detainee permanent records shall be maintained in the records section under the directives supervision of the records supervisor. Medical Records shall be maintained in the Medical Section and under the direct supervision of the Medical Supervisor.

- C. If a detainee is unwilling or unable to provide the required information, staff shall record as much information as can be obtained. Staff shall document the fact that they were unable to obtain the information and at a later time, make an effort to obtain this information.
- D. All detainees records shall meet ICE Detention Standards and contain at a minimum the following information:
  - 1. Detainee records
  - 2. Intake and Admissions Documentation
  - 3. Transportation Order
  - 4. Form 213
  - 5. Major/ Minor Rule Violation Reports
  - 6. Work/ Program Involvement
  - 7. Property Receipt/ Release
  - 8. Photograph
  - 9. Computer Print Outs
  - 10. Detainee Comment Forms
  - 11. Other Relative Information
- E. All detainee files shall be maintained in a consistent manner, the Records Clerk shall establish an order for all files. Information shall be posted daily and in order. The Town of Farmville-ICE Facility will incorporate ICE Detention Standards regarding detention files to include; creation of a detainee detention file, required contents of file, additions to file, location of file, active/ archive file, and access to file.
- F. All information obtained at Booking shall adhere to ICE Detention Standards and shall be reviewed by the shift supervisor prior to submission to the records section.
- G. Records shall maintain in the Records Section, the active records and the previous years records. All additional records shall be boxed and maintained.
- H. Records may be destroyed in accordance with the Va. State Library and Archives Record Division and their General Schedule No. 8, Records Retention and Disposition Scheme.
- I. The booking officer will ensure that all admissions, booking, transfer and release information is accurately recorded on the Detainee Management System ( computer ) and/or the booking log.
- J. The watch commander/supervisor will review all booking documentation to ensure that all information is accurate.
- K. Daily Activity Reports
  - 1. Watch Commander will submit a daily activity report ( DR ) ( daily ).
  - 2. The daily activity report will contain the following information to be forwarded to the Department Head of Security:
    - a. Personnel on duty
    - b. Detainee count sheet
    - c. Number of admissions, processes, transfers and release of detainees
    - d. Shift activities
    - e. Incident / supplement reports
    - f. Unusual occurrences
    - g. Meal count sheet
- L. The Records Supervisor is responsible for maintaining accurate documentation on all new incarcerations. The Records Supervisor will review the booking and facility management system daily.

M. All logs will be closed at 2400 hrs. by the watch commander supervisor on duty and the new day will be initiated at 0001 hrs. daily.



## **Town of Farmville – ICE Facility: DROISA-08-0021**

**May 9, 2008**

### **Detainee Counts**

#### **PURPOSE**

To provide instructions for conducting detainee counts.

#### **POLICY**

It is the policy of the Town of Farmville—ICE Facility to maintain an accurate accounting of detainee locations and population, by conducting detainee counts at a minimum of one (1) time per shift.

- A. The Town of Farmville—ICE Facility has a system for physically counting detainees.
  1. There is a strict accountability for detainees on site as well as those temporarily off site due to court visits, hospital visits etc..
  2. The facility shall maintain a daily log(s) which record(s):
    - a. Detainee count and location.
    - b. Intake and release of detainees.
    - c. Entries and exits of physicians, attorneys, ministers and other non-facility personnel.
    - d. Any unusual incidents, such as those that result in physical harm to or threaten the safety of any person, or the security of the Town of Farmville—ICE Facility.

#### **PROCEDURES**

##### **Formal Counts**

b2High

Emergency Counts

b2High

Booking Responsibilities

b2High





**Town of Farmville – ICE Facility: DROISA-08-0021  
May 9, 2008**

**DETAINEE ORIENTATION MANUAL**

**INTRODUCTION**

The U.S. Department of Homeland Security (DHS), U.S. Immigration and Customs Enforcement (ICE), and the Office of Detention and Removal Operations (DRO) are currently detaining you pending the outcome of your immigration removal case. It is our responsibility to ensure that you are housed in an environment that is safe and clean, and that your daily needs are met while you are in ICE custody at the Town of Farmville—ICE Facility.

The purpose of this information is to provide you with an overview of the general rules, regulations, policies and procedures, that we require you to follow while you are in ICE custody. This information will also provide an overview of the programs and services available while you are residing in this ICE-approved Facility.

In addition to this handbook, the Town of Farmville—ICE Facility, where you are being detained, will provide a local Detainee Handbook (referred to as a Local Supplement), which should address all of your day-to-day concerns. We request that you become familiar with the contents of both Handbooks, as you will be expected to comply with these rules while you are detained in this Facility.

If you lose your copy of the Detainee Handbook, you may request a replacement copy from the Facility Staff.

**RESPONSIBILITIES of The Town of Farmville—ICE Facility**

It is the Town of Farmville—ICE Facility's policy to follow all ICE Detention Standards as we treat detainees with dignity and respect, while maintaining a safe, secure, and sanitary detention Facility. To assist us with maintaining a safe, secure, and sanitary facility, please cooperate with our staff in the following respects:

- A. Familiarize yourself with all rules, policies, and procedures of the Town of Farmville—ICE Facility where you are detained, as we will expect you to comply accordingly.

- B. Comply with directions given by Staff Members.
- C. Be respectful towards Staff and other detainees.
- D. Be respectful of the Facility property, and the property of other detainees.
- E. Maintain yourself, your clothing, and your living area, in a clean and sanitary condition.
- F. When addressing our Staff, please refer to the Staff Members by their title and last name ( i.e. Doctor Jones, Officer Smith, Nurse Clark) or refer to staff by Mr., Mrs., or Ms., followed by their last name.

### **RIGHTS and RESPONSIBILITIES of Detainee**

- A. You have the right to be informed of the rules, procedures, and schedules concerning the operation of the Town of Farmville—ICE Facility.

*You have the responsibility to know them and abide by them.*

- B. You have the right to freedom of religious affiliation, and to voluntary religious worship that does not detrimentally affect others or the good order and security of the Facility.

*You have the responsibility to recognize and respect the rights of other religious groups or beliefs.*

- C. You have the right to reasonable care and to be held in acceptable conditions of detention, which includes nutritious meals, proper bedding and clothing, a laundry schedule for cleanliness of bedding and clothing, an opportunity to shower regularly, proper ventilation for warmth and fresh air, a regular exercise period, toilet articles, and medical treatment.

*It is your responsibility not to waste food, to follow the laundry and shower schedule, to maintain neat and clean living quarters, and to seek medical care as needed.*

- D. You have the right to have family members and friends visit with you, according to the Town of Farmville—ICE Facility's rules and schedules.

*It is your responsibility to conduct yourself properly during visits, and to not accept or pass contraband.*

- E. You have the right to unrestricted and confidential access to your attorney and the courts, by correspondence.

*Presentation of your case is your responsibility, in consultation with your attorney.*

- F. You have the right to legal counsel from an attorney of your choice by means of interviews and correspondence, at no cost to the United States Government.

*It is your responsibility to obtain the services of an attorney.*

- G. You have the right to use law library reference materials to assist you in resolving legal problems. You also have the right to receive help when it is available through a legal assistance program.

*It is your responsibility to use those resources according to the prescribed procedures and schedule, and to respect the rights of other detainees to the use of the material.*

- H. You have the right to a wide range of reading material for educational purposes and for your own enjoyment.

- I. You may have the right to participate in a work program, depending on those programs available near the Town of Farmville—ICE Facility.

*You have the responsibility to take advantage of activities, which may help you live successfully within the Facility and the community. You are expected to abide by the regulations governing the use of such activities.*

- J. You have the right to an administrative hearing before an Immigration Judge, depending on the particular facts and circumstances of your case. Alternative removal proceedings (as authorized by statute) may be utilized to determine your status in the United States. Should you have any questions in these areas, you should discuss them with your Deportation Officer.

*Presentation of your case is your responsibility, in consultation with your attorney.*

- K. You may be authorized for release on bond until your scheduled Administrative Hearing.

*It is responsibility to seek methods of payment for your bond.*

- L. You have the right to apply for political asylum if you believe that you could be persecuted in your native country because of your race, religion, nationality, membership in a particular social group, or political opinion.

*It is your responsibility to prepare and submit the proper forms.*

- M. You have the right to request voluntary departure, if statutorily eligible, prior to a hearing. If voluntary departure is granted, you waive your right to have your case presented at a hearing. Free legal phone calls are available, should you need to make them.

*It is your responsibility to inform an ICE/DRO Officer that you request voluntary departure.*

- N. The Town of Farmville—ICE Facility will provide you with a list of rules regarding the operation, where you are detained. The Facility must also provide you with reasonable information regarding all of the subjects covered in this Handbook relating to non-security related operations of the facility.

*It is your responsibility to act responsibly and follow the rules of the Facility and lawful instructions of the Staff. Failure to follow these rules and instructions may result in disciplinary action being taken against you, as necessary, to ensure the good order and security of the Facility. ICE officers will visit all housing units weekly. You should discuss any issues of concern with the ICE Staff, and you should have a reasonable expectation that they will respond appropriately to your request for information or assistance.*

\_\_\_\_\_  
Detainee Signature

\_\_\_\_\_  
Date

\_\_\_\_\_  
Receiving/Booking Officer Signature

\_\_\_\_\_  
Date



**Town of Farmville – ICE Facility: DROISA-08-0021  
May 9, 2008**

**Emergency Response**

**PURPOSE**

To establish emergency procedures that provide contingency information in situations such as disturbances, riots, hostage situations, bomb threats, and work stoppage.

**POLICY**

It is the policy of the Town of Farmville—ICE Facility to establish emergency contingency procedures that will enable staff to respond effectively to emergency situations.

**REFERENCES: A.C.A. 1A 18 / 3B01 / 3B-02 / 3B-03 / 3B-06 / 3B-09 / 3B-10 / 3B-11/  
3B-12 / 3B-13 / 3B-14 / 3B-15/ 2E-08 / 2E-09/ 2G-05**

- A. Written policy, procedure and practice, ensures that the Town of Farmville—ICE Facility reports its activities, at least quarterly, to its parent agency.
  - 1. These reports are in writing and include major developments in each department or administrative unit; major incidents, population data, assessment of staff and inmate morale, as well as major problems and plans for solving them.
- B. Written policy, procedure and practice, specify that the Town of Farmville—ICE Facility's fire prevention regulations and practices ensure the safety of staff, detainees, and visitors. These regulations and practices include, but are not limited to:
  - 1. Provision for adequate fire protection service.
  - 2. A system of fire inspection and testing of equipment, at least quarterly.
  - 3. An annual inspection by local or state fire officials or other qualified person(s).
  - 4. Availability of fire hoses or extinguishers at appropriate locations throughout the facility.
- C. Written policy, procedure and practice, provide for a comprehensive and thorough monthly inspection of the facility by a qualified fire and safety officer for compliance with safety and fire prevention standards. This policy and procedure is reviewed annually and updated as needed.

1. There is a weekly fire and safety inspection of the Town of Farmville—ICE Facility by a qualified departmental staff member.
  2. There are written specifications for the selection and purchase of the Town of Farmville—ICE Facility’s furnishings indicating the fire safety performance requirements of the materials selected.
- D. The Town of Farmville—ICE Facility has the equipment necessary to maintain essential lights, power, and communications, in an emergency.
1. Power generators are tested at least every two weeks.
  2. Other emergency equipment and systems are tested at least quarterly for effectiveness and are repaired or replaced, if necessary.
- E. All Town of Farmville—ICE Facility personnel are trained in the implementation of written Emergency Plans.
1. There is a written Evacuation Plan to be used in the event of fire or major emergency.
    - a. The Evacuation Plan is certified by an independent, outside Inspector, trained in the application of National Fire Safety Codes.
    - b. The Evacuation Plan is reviewed annually and updated if necessary, and is then reissued to the local fire jurisdictions.
    - c. The Evacuation Plan includes:
      1. Location of building/room floor plans.
      2. Use of exit and directional arrows for traffic flow.
      3. Location of publicly posted plan.
      4. At least quarterly drills in all facility locations, including administrative areas.
      5. Staff drills when evacuation of extremely dangerous detainees may not be included.
- F. Written policy, procedure and practice, specifies the means for the immediate release of detainees from the locked areas in case of emergency and provides a backup system.
- G. There is a written plan regarding continuing operations in the event of a work stoppage or other job action.
1. Copies of the plan are available to the appropriate Supervisory Personnel.
- H. There are written plans that specify the procedures to be followed in situations that threaten facility security. Such situations include but are not limited to:
1. Loss of Power.
  2. Bomb Threats.
  3. Hostage Situations.
  4. Riots.
  5. Natural Disasters.
  6. Fire.
  7. Evacuations.
  8. Escapes.
  9. Hunger strikes.
    - a. These written plans are made available to all applicable personnel, are reviewed at least annually, and updated, as needed.

- I. Toilet and wash basin facilities are available to food service personnel and detainees in the vicinity of the food preparation area.
- J. Adequate space is provided for janitorial closets accessible to the living and activity areas.
  - 1. The closets are equipped with a sink and cleaning implements.
- K. The facility has exits that are properly positioned, clear, and distinctly and permanently marked, to ensure the timely evacuation of detainees and staff in the event of fire or other emergency.
  - 1. All housing areas and places of assembly for 50 or more persons have two exits.

## **PROCEDURES**

b2High

D. Bomb or *Suspected Bomb* is found

b2High

E. Housing Block Evacuation

b2High

Actual Bombing

b2High

Hostage Situation

b2High



b2High

E. Hostage Negotiation

b2High

F. Ranking Officer or Hostage Negotiator

b2High

Riot/Disturbance

b2High

B. Riot in progress

b2High

b2High

C. Riot Aftermath

b2High

Natural Disaster

b2High

b2High

## Fire

b2High

## Fire Prevention

b2High

### C. Fire Extinguishers

b2High

b2High

Evacuation

b2High

b2High

Evacuation of Living Areas

b2High

Evacuation Outside of the Perimeter

b2High

Escape / Attempted Escape

b2High

b2High

Apprehension of Escapee(s)

b2High

b2High

Hunger Strike

b2High

Action Taken

b2High

Review and Updates

b2High

Mechanical Emergency Procedures

b2High

Mass Detention

b2High



Suicide

b2High

Death of Detainee

b2High



## **Town of Farmville – ICE Facility: DROISA-08-0021**

**May 9, 2008**

### **Employment of Qualified Staff**

#### **PURPOSE**

To describe procedures to be followed by the Town of Farmville—ICE Facility staff for recruitment and selection of employees to work in the drug-free work environment of the ICE Facility.

#### **POLICY**

It is the policy of the Town of Farmville—ICE Facility to ensure that its recruitment complies with Equal Employment Opportunity guidelines, federal and state laws, ICE Security clearance standards as well as the guidelines of the Town of Farmville—ICE Facility.

#### **References: A.C.A. 1C-04/08/12/13**

- A. Written policy, procedure and practice provide for the transfer, assignment, and selection of employees, on the basis of Town of Farmville—ICE Facility's need and the ability of employees to perform the job.
  - 1. These procedures will include but not be limited to random drug tests and security clearance reviews.
- B. Written policy, procedure and practice provide for the selection, retention, and promotion of all personnel on the basis of merit and specified qualifications.
- C. Written policy, procedure and practice provides for a criminal records check to be conducted on all new employees, in accordance with state and federal statutes.
  - 1. The purpose of a criminal records check is to detect any criminal convictions that relate specifically to job performance.
  - 2. The purpose of the criminal records check is also to ensure all employees meet ICE Security Clearance for employment and renewal of this clearance
- D. Written policy, procedure and practice provide that employees who have direct contact with detainees receive physical examinations prior to job assignment.
  - 1. All other employees receive a medical screening prior to job assignment.
  - 2. Employees receive re-examination according to a defined need or schedule.

#### **PROCEDURES**

b2High

Merit

b2High

Posting of Open Position(s)

b2High

Interviews

b2High



## **Town of Farmville – ICE Facility: DROISA-08-0021**

**May 9, 2008**

### **Food Services**

#### **PURPOSE**

To establish policy and procedures for the Food Service Operations to include budgetary requirements, health and safety inspections, supervision of Staff, detainee meals and culinary items.

#### **POLICY**

It is the policy of the Town of Farmville—ICE Facility to manage the Facility's food services in accordance with ICE Detention Standards, Federal, State and Local health and safety requirements.

- A. Food Service Operations are supervised by a full-time Staff Member who is experienced in food service management.
- B. Written policy, procedures and practice, specify the food service budgeting, purchasing, and accounting practices, including but not limited to:
  1. Food expenditure cost accounting designed to determine cost per meal, per detainee.
  2. Estimation of food service requirements.
  3. Purchase of supplies at wholesale and other favored prices and conditions, when possible.
  4. Refrigeration of food, with specific storage periods.
- C. Written policy, procedure and practice, require that accurate records are maintained of all meals served.
- D. Written policy, procedure and practice, precludes the use of food as a disciplinary measure.
- E. Written policy, procedure and practice require weekly inspections of all food service areas, including dining and food preparation area and equipment, by Administrative, Medical or Dietary Personnel.
  1. Inspections may be performed by the person supervising food service operations or his/her designee.
  2. Refrigeration and water temperatures are checked daily by Administrative Medical, or Dietary Personnel.
  3. There is documentation by an independent, outside source, that the Town of Farmville—ICE Facility's food service facilities and equipment meet established governmental health and safety.
- F. Written policy, procedure and practice provide that meals are served under conditions that minimize regimentation and with supervision by Staff Members.

**PROCEDURES**

**Food Service System**

b2High

b2High

Requirements

b2High

b2High

Utensils / Sanitation

b2High

Food (Disciplinary)

b2High

Culinary Equipment

b2High

Food Cart Storage and Usage

b2High

Cart Inspection

b2High

Cleaning Schedule / Equipment

b2High

Internal Agriculture Products

b2High





## **Town of Farmville – ICE Facility: DROISA-08-0021**

**May 9, 2008**

### **ICE Coordination**

#### **PURPOSE**

To provide guidelines for communication with ICE during the initial activation of the Town of Farmville—ICE Facility and on-going communication, during the daily operation of the Facility.

#### **POLICY**

It is the policy of the Town of Farmville—ICE Facility to maintain on-going communication with ICE to ensure that proper departments and individuals can be contacted immediately in the event of a situation which would require immediate decisions or assistance from ICE.

#### **PROCEDURES**

b2High

### **CONTACT INFORMATION—Town Farmville- ICE Facility**

b2High

b2High

**Stevens, Richard P**

---

**From:** Neveleff, Jerald  
**Sent:** Tuesday, July 08, 2008 12:02 PM  
**To:** Smyly, Elena L; 'Jenkins, John E'  
**Cc:** Casterline, Arnold P  
**Subject:** FW: Responses to Technical Letter 6/23/08  
**Attachments:** Note\_JerryN\_070308.doc; QualityControlPlan.final070208.doc; TrainingandStaffDevelopment\_final070208.doc; TransportationOfDetainees\_final070308.doc; background\_final070208.doc; Contraband\_final070308.doc; Detainee records\_reports070308.doc; DetaineeCounts\_final070308.doc; DetaineeOrientationForDetaineeManua\_final070308.doc; EmergencyResponse\_final070308.doc; EmploymentofQualifiedStaff\_final070308.doc; FoodServiceOperations\_FINAL070308.doc; ICECoordination\_final070308.doc

FYI

Thank you,  
 Jerry Neveleff  
 Supervisory Contracting Officer/  
 IGSA Team Lead  
 Office of Acq. Management (OAQ)  
 Detention Management Division  
 202. b6

Help us support you better -  
 TELL US HOW WE ARE DOING!

Go to <http://www.acqsolinc.com/ICE/OAQ/feedback.cfm> <<<http://www.acqsolinc.com/ICE/OAQ/feedback.cfm>>>

---

**From:** Warren Coleman [mailto:(b)(6)]  
**Sent:** Tuesday, July 08, 2008 11:55 AM  
**To:** Neveleff, Jerald  
**Subject:** FW: Responses to Technical Letter 6/23/08

Jerry  
 Responses sent on 7/3  
 Warren Coleman

---

**From:** Warren Coleman  
**Sent:** Thursday, July 03, 2008 2:36 PM  
**To:** 'Neveleff, Jerald'  
**Cc:** Russell Harper; b6  
**Subject:** Responses to Technical Letter 6/23/08

Jerry  
 I have attached our response to the Technical Letter and new reports for the package. I am hoping to send you the architect's comments in a separate email later today but if not, then I will send it on Monday at the latest.  
 I will call on Monday to make sure you received everything you need and to determine how we can assist you in the review process.

Have a great holiday.

12/21/2008

Warren Coleman

**Stevens, Richard P**

---

**From:** Casterline, Arnold P  
**Sent:** Tuesday, July 15, 2008 7:16 AM  
**To:** Neveleff, Jerald  
**Subject:** FW: Cost reconciliation 85%  
**Attachments:** cost\_proposal\_JerryN\_051608.doc

*Arnold P. Casterline Jr.*

Contract Specialist  
Immigration and Customs Enforcement  
Office of Acquisition Management  
Department of Homeland Security  
425 I Street NW, 5<sup>th</sup> Floor Room 5009  
Washington, DC 20536  
e-mail: (b)(6)  
phone: 202 (b)(6)  
Main: 202 (b)(6)

*Help us support you better –  
TELL US HOW WE ARE DOING!*

**Go to** <http://www.acqsolinc.com/ICE/OAQ/feedback.cfm>

---

**From:** Warren Coleman [mailto: (b)(6)]  
**Sent:** Monday, July 14, 2008 4:04 PM  
**To:** Casterline, Arnold P  
**Cc:** Russell Harper  
**Subject:** Cost reconciliation 85%

Arnold

b5

b5

Thanks for your help with the project.

Warren Coleman



**May 16, 2008**

Jerry Neveleff  
Supervisory Contracting Officer/  
IGSA Team Lead  
Office of Acq. Management (OAQ)  
Detention Management Division  
US Department of Homeland Security  
425 I St. NW, Suite 5009  
Washington, DC 20536

Jerry,

During the last week, we have worked with our architect to develop a phased approach to the construction which will allow us to open a facility capable of housing 700 initially and then easily expandable to 1,000. Based on this phasing approach, I have prepared a cost sheet for 700 and for 1,000 detainees. As suggested, we have developed a phased pricing structure as well. The phased pricing structure consists of the following three break points: 1) First 500, 2) 501 to 700 and 3) 701 to 1,000. The average of these break points equates to the pricing per detainee at the 1,000 capacity level but with an occupancy rate of 85%. We will be glad to discuss the reasoning for the 85% occupancy rate and will be glad to adjust it upward if we can be provided a better assumption by ICE for a particular rate. As stated in the meeting, we will not be guaranteed a minimum number of detainees so we made this assumption. We know at times we may be higher than this level but we have a greater risk on the downside. We will be glad to add additional details to any of the topics in the proposal so please let us know your needs and we will respond as quickly as possible.

I have also included a page to support the suggested hourly rate for Transportation and the Stationary Guards.

I am enclosing an electronic copy of Volume I and Volume II and Volume III plus Organization charts for both levels and building layouts for both levels.

Mr. Spates will be glad to sign the IGSA once the proposed rates have been incorporated into the document and the Town of Farmville inserted versus Otero County. Mr. Spates also provided the cost allocation information.

We look forward to working through the details to finalize the rates and move forward with the project.

Sincerely,

Warren Coleman

**Proposed Daily Rates per Detainee**

Our rates are based on a phased construction approach and a phased pricing structure based on the number of detainees assigned to the facility. Phase 1 of the construction will provide housing for up to 700 detainees. The second phase of construction will increase capacity to 1,000. As we have a great exposure at the low levels of detainee, our cost for the first 500 is projected to be higher. As the assigned population grows, we will reduce the daily rate.

The stated rates are based on an 85% occupancy rate. With better projects on the expected level of detainees assigned to the facility, we will be glad to revise the proposed daily rates.

First 500 Detainees

501-700

b5

701-1,000

**Proposed Daily Rates for Stationary Guards**

Rates are based on the average cost of personnel that may be assigned to this task at any time based on their availability.

Hourly Rate:

b5

**Proposed Daily Rates for Transportation Guards**

Rates are based on the average cost of personnel that may be assigned to this task at any time based on their availability.

Hourly Rate:

b5



## Stevens, Richard P

---

**From:** Neveleff, Jerald  
**Sent:** Tuesday, July 15, 2008 9:52 AM  
**To:** 'Warren Coleman'  
**Cc:** Raine, Craig K; Smyly, Elena L; Casterline, Arnold P; Picone, Paul D; Jenkins, John E  
**Subject:** FARMVILLE

Good morning Warren,  
ICE has been reviewing the most current drawings/plans submitted for the Farmville project and have determined that there is a need for some major changes. There is a meeting scheduled at the Fairfax Office on Thursday at 0900 to go over them. In the spirit to speed up the process, ICA will be invited to attend to understand first hand, the concerns that have been raised.

Please keep in mind that this NOT negotiations but rather a real time sharing of information.

Mr. Raine will be contacting you directly to provide any additional information for the meeting. I am providing your number (804) 282- (b)(2)Low If there is another means to contact you, please email that to him.

Thank you,  
Jerry Neveleff  
Supervisory Contracting Officer/  
IGSA Team Lead  
Office of Acq. Management (OAQ)  
Detention Management Division  
202/ b6

Help us support you better -  
TELL US HOW WE ARE DOING!  
Go to <<http://www.acqsolinc.com/ICE/OAQ/feedback.cfm>> <<<http://www.acqsolinc.com/ICE/OAQ/feedback.cfm>>>

**Stevens, Richard P**

---

**From:** Raine, Craig K  
**Sent:** Tuesday, July 15, 2008 8:11 AM  
**To:** Neveleff, Jerald; (b)(6), b7c  
**Cc:** (b)(6) Picone, Paul D; Casterline, Arnold P  
**Subject:** Re: FARMVILLE

That will be fine.

-----  
Sent from my BlackBerry Wireless Handheld

---

**From:** Neveleff, Jerald  
**To:** Raine, Craig K; (b)(6)  
**Cc:** (b)(6) Picone, Paul D; Casterline, Arnold P  
**Sent:** Tue Jul 15 07:46:23 2008  
**Subject:** RE: FARMVILLE

Craig,  
In the spirit of time, do you think you can invite ICA to the review? I don't see any issues with them being present and this way you wouldn't have to have two meetings to accomplish the effort.

Jerry

Thank you,  
Jerry Neveleff  
Supervisory Contracting Officer/  
IGSA Team Lead  
Office of Acq. Management (OAQ)  
Detention Management Division  
202 b6

Help us support you better -  
TELL US HOW WE ARE DOING!  
Go to <<http://www.acqsolinc.com/ICE/OAQ/feedback.cfm>> <<<http://www.acqsolinc.com/ICE/OAQ/feedback.cfm>>>

---

**From:** Raine, Craig K  
**Sent:** Tuesday, July 15, 2008 7:28 AM  
**To:** Neveleff, Jerald; (b)(6)  
**Cc:** (b)(6) Picone, Paul D  
**Subject:** Re: FARMVILLE

John,

Can you forward this to Deane Thompson please, I cannot get him to come up in the BB. The tech review data he sent was cleared by Paul Picone and I. However the drawings/plans need some major changes.

We can discuss on Thursday at 0900 at our office with whomever comes over.

12/21/2008

Thx

Craig

-----  
Sent from my BlackBerry Wireless Handheld

---

**From:** Neveleff, Jerald  
**To:** 'Jenkins, John E'  
**Cc:** Smyly, Elena L ; Raine, Craig K  
**Sent:** Mon Jul 14 13:03:53 2008  
**Subject:** FARMVILLE

John,

Do you have everything you need for the Farmville Project?

Thank you,

Jerry Neveleff

Supervisory Contracting Officer/

IGSA Team Lead

Office of Acq. Management (OAQ)

Detention Management Division

202/ b6

Help us support you better -

TELL US HOW WE ARE DOING!

Go to <http://www.acqsolinc.com/ICE/OAQ/feedback.cfm> <<<http://www.acqsolinc.com/ICE/OAQ/feedback.cfm>>>

**Stevens, Richard P**

---

**From:** Raine, Craig K  
**Sent:** Tuesday, July 15, 2008 10:02 AM  
**To:** Neveleff, Jerald; (b)(6)  
**Cc:** Smyly, Elena L; Casterline, Arnold P; Picone, Paul D; Jenkins, John E; Achim, Deborah; Henkel, Douglas ; Young, Erika Y  
**Subject:** Re: FARMVILLE

Warren,

Per our conversation we will meet you and whomever you bring this coming Thursday at our office in Fairfax at 0900. This should help clarify some issues and speed the process along.

Thx

Craig

-----  
Sent from my BlackBerry Wireless Handheld

---

**From:** Neveleff, Jerald  
**To:** 'Warren Coleman'  
**Cc:** Raine, Craig K; Smyly, Elena L; Casterline, Arnold P; Picone, Paul D; Jenkins, John E  
**Sent:** Tue Jul 15 09:52:21 2008  
**Subject:** FARMVILLE

Good morning Warren,

ICE has been reviewing the most current drawings/plans submitted for the Farmville project and have determined that there is a need for some major changes. There is a meeting scheduled at the Fairfax Office on Thursday at 0900 to go over them. In the spirit to speed up the process, ICA will be invited to attend to understand first hand, the concerns that have been raised.

Please keep in mind that this NOT negotiations but rather a real time sharing of information.

Mr. Raine will be contacting you directly to provide any additional information for the meeting. I am providing your number (804) (b)(2)Low If there is another means to contact you, please email that to him.

Thank you,

Jerry Neveleff

Supervisory Contracting Officer/

IGSA Team Lead

Office of Acq. Management (OAQ)

Detention Management Division

202 b6

12/21/2008

Help us support you better -

TELL US HOW WE ARE DOING!

Go to <http://www.acqsolinc.com/ICE/OAQ/feedback.cfm> <<<http://www.acqsolinc.com/ICE/OAQ/feedback.cfm>>>

**Stevens, Richard P**

---

**From:** Warren Coleman (b)(6)  
**Sent:** Tuesday, July 15, 2008 10:01 AM  
**To:** Neveleff, Jerald  
**Cc:** Russell Harper  
**Subject:** RE: FARMVILLE

Jerry

Thanks for the invitation. I just spoke with Craig and told him that Russell and I will attend and that we will probably bring our architect. I will leave Craig a note with the number of attendees to expect from our side.

See you on Thursday.

Warren

---

**From:** Neveleff, Jerald [mailto: (b)(6)  
**Sent:** Tuesday, July 15, 2008 9:52 AM  
**To:** Warren Coleman  
**Cc:** Raine, Craig K; Smyly, Elena L; Casterline, Arnold P; Picone, Paul D; Jenkins, John E  
**Subject:** FARMVILLE

Good morning Warren,

(b)(5)

Mr. Raine will be contacting you directly to provide any additional information for the meeting. I am providing your number (804) 282- (b)(2)Low If there is another means to contact you, please email that to him.

Thank you,

Jerry Neveleff

Supervisory Contracting Officer/

IGSA Team Lead

Office of Acq. Management (OAQ)

Detention Management Division

202. b6

12/21/2008

Help us support you better -

TELL US HOW WE ARE DOING!

Go to <http://www.acqsolinc.com/ICE/OAQ/feedback.cfm> <<<http://www.acqsolinc.com/ICE/OAQ/feedback.cfm>>>

**Stevens, Richard P**

---

**From:** Warren Coleman (b)(6)  
**Sent:** Tuesday, July 15, 2008 4:05 PM  
**To:** Neveleff, Jerald  
**Cc:** Russell Harper  
**Subject:** FW:  
**Attachments:** Farmville ICE-A1.5 building area 4.pdf; Farmville ICE-A1.1 overall floor plan.pdf; Farmville ICE-A1.2 building area 1.pdf; Farmville ICE-A1.3 building area 2.pdf; Farmville ICE-A1.4 building area 3.pdf

Jerry  
Please share these latest drawings with the appropriate individuals so they will have them prior to our meeting on Thursday.

Thanks  
Warren

---

**From:** Mark Evans [mailto: (b)(6)]  
**Sent:** Monday, July 14, 2008 5:57 PM  
**To:** Russell Harper  
**Cc:** Doug Sauer; John Duggan; John Dunlap; Spriggs, Dave; Larry Huber; Warren Coleman  
**Subject:**

Russell,  
  
Attached are pdf files showing the current overall building plan and the partial plans of each building area. Please review the areas at Health Services, Processing, Entrance, and Visitation.  
  
If the layout meets your approval, please forward on to ICE for their review.  
  
We will continue design for wall partitions and ceiling types in these areas.  
  
Please call Mac Kelly with any questions.  
  
Thank you,

**Mark Evans**

(b)(6)



**TIMMONS · KELLEY**  
ARCHITECTS









(b)(2)High

DATE	REVISION

PROJECT NO. 99-102  
DESIGN BY JMK/WHK  
DRAWN BY M. KELLEY  
SHEET NO. **A1.3**

FLOOR PLAN - BUILDING AREA No. 2  
**ICE FARMVILLE PROJECT**  
DETAINEE HOUSING FACILITY  
FARMVILLE, VIRGINIA



**TIMMONS • KELLEY**  
ARCHITECTS  
1000 LITTLEPIPER ROAD • ROCKY HILL, VIRGINIA 22153  
PH: (804) 887-8833 • FAX: (804) 887-8838  
WWW.TIMMONSKELLEYARCHITECTS.COM



(b)(2)High



**TIMMONS • KELLEY**  
ARCHITECTS  
1400 W. STATE STREET, SUITE 100, FARMVILLE, VIRGINIA 23113  
PH: (804) 897-3434 FAX: (804) 897-4444  
WWW.TKARCHITECTS.COM

FLOOR PLAN - BUILDING AREA No. 3  
**ICE FARMVILLE PROJECT**  
DETAINEE HOUSING FACILITY  
FARMVILLE, VIRGINIA

DATE	REVISION
1/2/04	SCHEMATIC DEVELOPMENT
1/15/04	SCHEMATIC DEVELOPMENT
1/15/04	SCHEMATIC DEVELOPMENT

PROJECT NO: 04-192  
DESIGN BY: TKC/WJK  
ARCHITECT: K. KELLEY  
SHEET NO: **A14**

**Stevens, Richard P**

---

**From:** Neveleff, Jerald  
**Sent:** Tuesday, July 15, 2008 4:14 PM  
**To:** Jenkins, John E; 'Thompson, Arthur D'  
**Cc:** Raine, Craig K; Picone, Paul D; Henkel, Douglas ; Casterline, Arnold P; Smyly, Elena L  
**Subject:** FW:  
**Attachments:** Farmville ICE-A1.5 building area 4.pdf; Farmville ICE-A1.1 overall floor plan.pdf; Farmville ICE-A1.2 building area 1.pdf; Farmville ICE-A1.3 building area 2.pdf; Farmville ICE-A1.4 building area 3.pdf

From Farmville.

Thank you,  
Jerry Neveleff  
Supervisory Contracting Officer/  
IGSA Team Lead  
Office of Acq. Management (OAQ)  
Detention Management Division  
202      b6

Help us support you better -  
TELL US HOW WE ARE DOING!  
Go to <<http://www.acqsolinc.com/ICE/OAQ/feedback.cfm>> <<<http://www.acqsolinc.com/ICE/OAQ/feedback.cfm>>>

---

**From:** Warren Coleman [mailto:      (b)(6)]  
**Sent:** Tuesday, July 15, 2008 4:05 PM  
**To:** Neveleff, Jerald  
**Cc:** Russell Harper  
**Subject:** FW:

Jerry  
Please share these latest drawings with the appropriate individuals so they will have them prior to our meeting on Thursday.

Thanks  
Warren

---

**From:** Mark Evans [mailto:      (b)(6)]  
**Sent:** Monday, July 14, 2008 5:57 PM  
**To:** Russell Harper  
**Cc:** Doug Sauer; John Duggan; John Dunlap; Spriggs, Dave; Larry Huber; Warren Coleman  
**Subject:**

Russell,

Attached are pdf files showing the current overall building plan and the partial plans of each building area. Please review the areas at Health Services, Processing, Entrance, and Visitation.

If the layout meets your approval, please forward on to ICE for their review.

We will continue design for wall partitions and ceiling types in these areas.

Please call Mac Kelly with any questions.

Thank you,

**Mark Evans**

(b)(6)

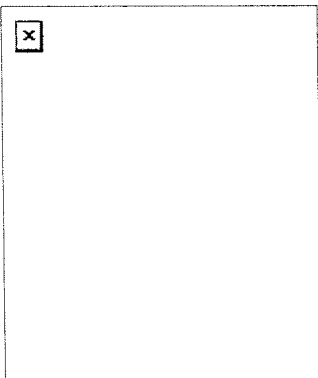

**Stevens, Richard P**

---

**From:** Neveleff, Jerald  
**Sent:** Thursday, July 17, 2008 4:36 PM  
**To:** 'Warren Coleman'  
**Cc:** Raine, Craig K; Casterline, Arnold P  
**Subject:** Farmville

Mr. Coleman,

I met with the DC Field Office today it appears that the drawings presented today did not represent what was presented previously. As far as I can understand, they were very much surprised at what they saw.

As such, I understand that there remains a lot of work to do to make the necessary revision.

Until such time that the drawing are revise, submitted and approved, I see no further benefit for Mr Casterline to continue his review of the cost data as it does not appear to reflect the costs of the plans at time of submission.

When the plans are approved by ICE, I will at that time request you submit an updated proposal that reflects what is being built. At which time we will restart the cost evaluation.

Jerry



## Stevens, Richard P

---

**From:** Warren Coleman (b)(6)  
**Sent:** Thursday, July 17, 2008 9:19 PM  
**To:** Neveleff, Jerald  
**Cc:** Raine, Craig K; Casterline, Arnold P; Russell Harper  
**Subject:** RE: Farmville

Jerry  
ICE did have some changes but I don't think we left the meeting thinking they were "very much surprised". They agreed to help us revise the plan within the next two weeks so we do not want to stop the cost review.

The meeting today was extremely helpful and we only wish it could have taken place a couple of weeks ago because we now have clear directions from ICE on their construction needs. As Craig said in his email regarding the meeting... we can probably save two weeks by meeting vs. trading emails.

We feel the same could be true of the cost sheet. Yes, the revised plan may have a few changes in some line items but if we could meet and clear up any questions to date then we could quickly respond after the design and get this process under way in the next month.

I am out of the office tomorrow but will call to discuss our desire to meet next week to review any outstanding questions and get us closer to completing the IGSA.

Warren Coleman

-----Original Message-----

**From:** Neveleff, Jerald [mailto: (b)(6)  
**Sent:** Thursday, July 17, 2008 4:36 PM  
**To:** Warren Coleman  
**Cc:** Raine, Craig K; Casterline, Arnold P  
**Subject:** Farmville

Mr. Coleman,  
I met with the DC Field Office today it appears that the drawings presented today did not represent what was presented previously. As far as I can understand, they were very much surprised at what they saw. As such, I understand that there remains a lot of work to do to make the necessary revision.

Until such time that the drawing are revise, submitted and approved, I see no further benefit for Mr Casterline to continue his review of the cost data as it does not appear to reflect the costs of the plans at time of submission.

When the plans are approved by ICE, I will at that time request you submit an updated proposal that reflects what is being built. At which time we will restart the cost evaluation.

Jerry

## Stevens, Richard P

---

**From:** Neveleff, Jerald  
**Sent:** Thursday, July 17, 2008 9:26 PM  
**To:** (b)(6)  
**Cc:** (b)(6) rharper@hdcva.com'  
**Subject:** RE: Farmville

Warren,  
Triple v double bunk? One floor verses two? Uncovered Sally Port, double bunks in isolation cells? 6500 square feet v second floor ice space, and I'm sure there are a few other changes that I forgot that were not conveyed.  
Until the design is finalized, and approved by ice, I am not authorizing and negotiations until I am confident that the numbers proposed reflect what's being built.

Jerry

-----Original Message-----

**From:** Warren Coleman  
**To:** Work  
**Cc:** Raine, Craig K  
**Cc:** Casterline, Arnold P  
**Cc:** Russell Harper  
**Sent:** Jul 17, 2008 21:19  
**Subject:** RE: Farmville

Jerry

ICE did have some changes but I don't think we left the meeting thinking they were "very much surprised". They agreed to help us revise the plan within the next two weeks so we do not want to stop the cost review.

The meeting today was extremely helpful and we only wish it could have taken place a couple of weeks ago because we now have clear directions from ICE on their construction needs. As Craig said in his email regarding the meeting... we can probably save two weeks by meeting vs. trading emails.

We feel the same could be true of the cost sheet. Yes, the revised plan may have a few changes in some line items but if we could meet and clear up any questions to date then we could quickly respond after the design and get this process under way in the next month.

I am out of the office tomorrow but will call to discuss our desire to meet next week to review any outstanding questions and get us closer to completing the IGSA.

Warren Coleman

-----Original Message-----

**From:** Neveleff, Jerald [mailto:(b)(6)]  
**Sent:** Thursday, July 17, 2008 4:36 PM  
**To:** Warren Coleman  
**Cc:** Raine, Craig K; Casterline, Arnold P  
**Subject:** Farmville

Mr. Coleman,

I met with the DC Field Office today it appears that the drawings presented today did not represent what was presented previously. As far as I can understand, they were very much surprised at what they saw. As such, I understand that there remains a lot of work to do to make the

-----Original Message Truncated-----

Jerry

Sent using BlackBerry



**Stevens, Richard P**

---

**From:** Warren Coleman (b)(6)  
**Sent:** Friday, July 18, 2008 5:55 AM  
**To:** Neveleff, Jerald  
**Cc:** Raine, Craig K; Casterline, Arnold P; Russell Harper  
**Subject:** Re: Farmville

Jerry,

I understand the negotiation will not take place but we were just hoping a meeting would ensure we have all your questions answered in regards to how the numbers were developed so we would not delay your evaluation.

We are available to answer questions if you have any outstanding ones while the design is completed.

Thanks.

Warren  
Warren Coleman

-----Original Message-----

**From:** Neveleff, Jerald (b)(6)  
**To:** Warren Coleman (b)(6)  
**CC:** Raine, Craig K <(b)(6)> ; Casterline, Arnold P <(b)(6)> ; Russell Harper <rharper@hdcva.com>  
**Sent:** Thu Jul 17 21:26:21 2008  
**Subject:** Re: Farmville

Warren,  
Triple v double bunk? One floor verses two? Uncovered Sally Port, double bunks in isolation cells? 6500 square feet v second floor ice space, and I'm sure there are a few other changes that I forgot that were not conveyed.  
Until the design is finalized, and approved by ice, I am not authorizing and negotiations until I am confident that the numbers proposed reflect what's being built.

Jerry  
-----Original Message-----

**From:** Warren Coleman  
**To:** Work  
**Cc:** Raine, Craig K  
**Cc:** Casterline, Arnold P  
**Cc:** Russell Harper  
**Sent:** Jul 17, 2008 21:19  
**Subject:** RE: Farmville

Jerry  
ICE did have some changes but I don't think we left the meeting thinking they were "very much surprised". They agreed to help us revise the plan within the next two weeks so we do not want to stop the cost review.

The meeting today was extremely helpful and we only wish it could have taken place a couple of weeks ago because we now have clear directions from ICE on their construction needs. As Craig said in his email regarding the meeting... we can probably save two weeks by meeting vs. trading emails.

We feel the same could be true of the cost sheet. Yes, the revised plan may have a few changes in some line items but if we could meet and clear up any questions to date then we could quickly respond after the design

and get this process under way in the next month.

I am out of the office tomorrow but will call to discuss our desire to meet next week to review any outstanding questions and get us closer to completing the IGSA.

Warren Coleman

-----Original Message-----

From: Neveleff, Jerald [<mailto:>] (b)(6)

Sent: Thursday, July 17, 2008 4:36 PM

To: Warren Coleman

Cc: Raine, Craig K; Casterline, Arnold P

Subject: Farmville

Mr. Coleman,

I met with the DC Field Office today it appears that the drawings presented today did not represent what was presented previously. As far as I can understand, they were very much surprised at what they saw.

As such, I understand that there remains a lot of work to do to make the

-----Original Message Truncated-----

Jerry

Sent using BlackBerry

**Stevens, Richard P**

---

**From:** Russell Harper (b)(6), (b)(7)c  
**Sent:** Friday, July 18, 2008 7:42 AM  
**To:** Warren Coleman; Neveleff, Jerald  
**Subject:** Re: Farmville

Gentleman, I did not realize the review today created any surprises. The comments generated at the meeting are typical of a construction review. The plans comply with the published standards with a few changes and the ICE revisions should not impact our budget greatly.

I would appreciate Arnolds continued uninterrupted attention to the review process. If the construction cost and day rate needs to be adjusted in a few weeks when ICE provides its suggested changes then we can address it at that time.

Thank you.

Russell Harper  
-----Original Message-----  
From: Warren Coleman  
To: Russell Harper  
Subject: FW: Farmville  
Sent: Jul 17, 2008 4:50 PM

Russell  
How would you like me to respond?

Warren

-----Original Message-----  
From: Neveleff, Jerald [mailto: ] (b)(6)  
Sent: Thursday, July 17, 2008 4:50 PM  
To: Warren Coleman  
Cc: Raine, Craig K; Casterline, Arnold P  
Subject: Farmville

Mr. Coleman,  
I met with the DC Field Office today it appears that the drawings presented today did not represent what was presented previously. As far as I can understand, they were very much surprised at what they saw. As such, I understand that there remains a lot of work to do to make the necessary revision.

Until such time that the drawing are revise, submitted and approved, I see no further benefit for Mr Casterline to continue his review of the cost data as it does not appear to reflect the costs of the plans at time of submission.

When the plans are approved by ICE, I will at that time request you submit an updated proposal that reflects what is being built. At which time we will restart the cost evaluation.  
Jerry

-----  
Sent from Russell B. Harper

**Stevens, Richard P**

---

**From:** Warren Coleman (b)(6)  
**Sent:** Thursday, July 24, 2008 9:33 AM  
**To:** Neveleff, Jerald; Raine, Craig K; Picone, Paul D  
**Cc:** Russell Harper; Mac Kelley  
**Subject:** FW: Farmville ICE  
**Attachments:** Farmville ICE-II-A1.1 overall floor plan.pdf; Farmville ICE-II-A1.2 building area plans.PDF; Farmville ICE-II-A1.3 building area plans.pdf; Farmville ICE-II-A1.4 building area plans.pdf; Farmville ICE-II-A1.5 building area plans.pdf

Gentlemen,  
These drawings reflect changes discussed in our meeting on 7/17. Once we receive the conceptual drawings from Paul regarding the processing area and the ICE Administration space, we will turn around the documents for final approval.

To allow our architects to plan their schedule, do you have an estimated date on which we should expect to receive the conceptual drawings for the processing area and the ICE administration space?

Warren Coleman

---

**From:** Mark Evans [mailto: (b)(6)]  
**Sent:** Tuesday, July 22, 2008 4:57 PM  
**To:** Russell Harper; Warren Coleman  
**Subject:** Farmville ICE

Russell and Warren,

Attached are the current plans for the ICE facility.

Please call Mac with any comments or questions.

Thanks,

**Mark Evans**

(b)(6)



**TIMMONS · KELLEY**  
ARCHITECTS

(b)(2)High

REV.	DESCRIPTION	DATE
1	ISSUED FOR PERMIT	1/14/08
2	REVISIONS	1/14/08
3	REVISIONS	1/14/08
4	REVISIONS	1/14/08
5	REVISIONS	1/14/08
6	REVISIONS	1/14/08
7	REVISIONS	1/14/08
8	REVISIONS	1/14/08
9	REVISIONS	1/14/08
10	REVISIONS	1/14/08

PROJECT NO. 08-182  
DRAWN BY: JME/MDM  
CHECKED BY: M. KELLEY  
DATE: 1/14/08  
**A1.1**

OVERALL FLOOR PLAN & ROOF PLAN  
**ICE FARMVILLE PROJECT**  
DETAINEE HOUSING FACILITY  
FARMVILLE, VIRGINIA



**TIMMONS • KELLEY**  
ARCHITECTS  
1008 BRIDGEWAY DRIVE - 2ND FLOOR, SUITE 201  
FARMVILLE, VA 22431  
TEL: (804) 897-1434 FAX: (804) 897-1434  
WWW.TKARCHITECTS.COM





(b)(2)High

NO.	REVISION
1	ISSUED FOR PERMIT
2	REVISED
3	REVISED
4	REVISED
5	REVISED
6	REVISED
7	REVISED
8	REVISED
9	REVISED
10	REVISED
11	REVISED
12	REVISED
13	REVISED
14	REVISED
15	REVISED
16	REVISED
17	REVISED
18	REVISED
19	REVISED
20	REVISED
21	REVISED
22	REVISED
23	REVISED
24	REVISED
25	REVISED
26	REVISED
27	REVISED
28	REVISED
29	REVISED
30	REVISED
31	REVISED
32	REVISED
33	REVISED
34	REVISED
35	REVISED
36	REVISED
37	REVISED
38	REVISED
39	REVISED
40	REVISED
41	REVISED
42	REVISED
43	REVISED
44	REVISED
45	REVISED
46	REVISED
47	REVISED
48	REVISED
49	REVISED
50	REVISED
51	REVISED
52	REVISED
53	REVISED
54	REVISED
55	REVISED
56	REVISED
57	REVISED
58	REVISED
59	REVISED
60	REVISED
61	REVISED
62	REVISED
63	REVISED
64	REVISED
65	REVISED
66	REVISED
67	REVISED
68	REVISED
69	REVISED
70	REVISED
71	REVISED
72	REVISED
73	REVISED
74	REVISED
75	REVISED
76	REVISED
77	REVISED
78	REVISED
79	REVISED
80	REVISED
81	REVISED
82	REVISED
83	REVISED
84	REVISED
85	REVISED
86	REVISED
87	REVISED
88	REVISED
89	REVISED
90	REVISED
91	REVISED
92	REVISED
93	REVISED
94	REVISED
95	REVISED
96	REVISED
97	REVISED
98	REVISED
99	REVISED
100	REVISED

FLOOR PLAN - BUILDING AREA NO. 1  
**ICE FARMVILLE PROJECT**  
DETAINEE HOUSING FACILITY  
FARMVILLE, VIRGINIA

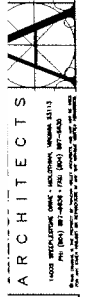

(b)(2)High



**JIMMUNS • BELLEI**  
**ARCHITECTS**  
14000 100th Avenue East - Redmond, WA 98073  
PH: (509) 881-4444 FAX: (509) 881-4444  
www.jim-muns.com



FLOOR PLAN - BUILDING AREA No. 2  
**ICE FARMVILLE PROJECT**  
DETAINEE HOUSING FACILITY  
FARMVILLE, VIRGINIA

DATE	DESCRIPTION
1/22/08	ISSUED FOR PERMIT
1/22/08	ISSUED FOR PERMIT
1/22/08	ISSUED FOR PERMIT
1/22/08	ISSUED FOR PERMIT
1/22/08	ISSUED FOR PERMIT
1/22/08	ISSUED FOR PERMIT
1/22/08	ISSUED FOR PERMIT
1/22/08	ISSUED FOR PERMIT
1/22/08	ISSUED FOR PERMIT
1/22/08	ISSUED FOR PERMIT

PROJECT NO. CR-102  
DRAWN BY: HBE/WHM  
CHECKED BY: M. KELLEY  
**A1.3**

(b)(2)High

DATE	NO.	REVISED
1957	1	BY: H. KELLEY
A1.4		

**ICE FARMVILLE PROJECT**  
**DETAINEE HOUSING FACILITY**  
FARMVILLE, VIRGINIA

ARCHITECTS

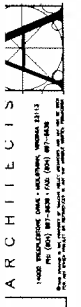

1400 INDUSTRIAL DRIVE - SUITE 100, WASHINGTON, D.C. 20004  
PH: (202) 331-1000 FAX: (202) 331-1001  
WWW.A14ARCHITECTS.COM

(b)(2)High

DATE	DESCRIPTION
1/28/94	ISSUED FOR PERMIT
1/27/94	REVISED PER PERMITTING AGENCY
1/27/94	REVISED PER PERMITTING AGENCY
1/27/94	REVISED PER PERMITTING AGENCY

PROJECT NO. 98-102  
DRAWN BY: RSK/TKS  
ARCHITECT: R. KELLEY  
SHEET NO. **A1.5**

FLOOR PLAN - BUILDING AREA No. 4  
**ICE FARMVILLE PROJECT**  
DETAINEE HOUSING FACILITY  
FARMVILLE, VIRGINIA



**TIMMONS • KELLEY**  
ARCHITECTS  
1000 INTERNATIONAL DRIVE • SUITE 1000 • WASHINGTON, D.C. 20004  
TEL: (202) 331-1111  
FAX: (202) 331-1112



**Stevens, Richard P**

---

**From:** Warren Coleman (b)(6)  
**Sent:** Monday, July 28, 2008 4:19 PM  
**To:** Neveleff, Jerald  
**Cc:** Russell Harper; Raine, Craig K; Thompson, Arthur D; Raine, Craig K  
**Subject:** FW: Farmville ICE: Processing Area  
**Attachments:** Farmville ICE-processing.pdf; Farmville ICE-overall floor plan.pdf

Jerry,

The attached drawings have been revised based on comments received during the 7/17 meeting. The building space has increased due to the change in bunk levels and at this point, the only area that has not been designed in detail is the ICE administration area. The other component that was not finalized during the meeting was a "ramp up" plan that would meet ICE's ability to staff the site and their comfort level for increasing this facility to a 1,000 bed facility. Several members of the ICE team indicated that they would be having internal discussion to formalize their desired plan so we are awaiting this update. The ramp up rate will impact our staffing and cost as well so please keep us informed regarding any decisions.

We will revise our cost based on this version regarding the building cost and await the decision on the "ramp up" so we can respond quickly with a day rate and continue the negotiation process when you return to the office.

Warren Coleman

---

**From:** Mark Evans [mailto: (b)(6)]  
**Sent:** Friday, July 25, 2008 4:46 PM  
**To:** Russell Harper; Warren Coleman  
**Subject:** Farmville ICE: Processing Area

Russell & Warren,

These drawings are based on what was received from Doug Henkel of ICE. We have sent this to him for his review and approval.

Call Mac with any questions or comments.

Thank you,

**Mark Evans**

(b)(6)



**TIMMONS · KELLEY**  
ARCHITECTS



(b)(2)High

REV	DESCRIPTION
1/2/06	ISSUED FOR PERMITS
2/2/06	REVISED PERMITS
3/2/06	REVISED PERMITS
4/2/06	REVISED PERMITS
5/2/06	REVISED PERMITS
6/2/06	REVISED PERMITS
7/2/06	REVISED PERMITS
8/2/06	REVISED PERMITS
9/2/06	REVISED PERMITS
10/2/06	REVISED PERMITS
11/2/06	REVISED PERMITS
12/2/06	REVISED PERMITS

PROJECT NO. 05-152  
DRAWN BY: JMK/MSH  
CHECKED BY: M. KELLEY  
DATE: **A11**

OVERALL FLOOR PLAN  
**ICE FARMVILLE PROJECT**  
DETAINEE HOUSING FACILITY  
FARMVILLE, VIRGINIA



**TIMMONS • KELLEY**  
ARCHITECTS  
1400 WESTLARK ROAD - SUITE 100  
FARMVILLE, VIRGINIA 22434  
PH: (804) 897-8888 FAX: (804) 897-8888  
WWW.TKARCHITECTS.COM



## Stevens, Richard P

---

**From:** Neveleff, Jerald  
**Sent:** Monday, August 04, 2008 10:29 AM  
**To:** 'Warren Coleman'  
**Cc:** Casterline, Arnold P; Henkel, Douglas ; Raine, Craig K; Ross, Natalie C; Russell Harper  
**Subject:** Transportation Plan

Warren,

As you are reviewing the costs to determine what revisions need to be made as a result of the construction changes, I would like to have Farmville (ICA) and Arnie focus on trying to develop an IGSA for transportation.

I believe that once the construction is all worked out and a bed day rate negotiated, The transportation IGSA could be modified or replaced at that time.

Unfortunately, Arnie's father passed last week and he is expected to be out at least through the rest of this week.

If there is any problems, please let me know.

Jerry

Thank you,  
Jerry Neveleff  
Supervisory Contracting Officer/  
IGSA Team Lead  
Office of Acq. Management (OAQ)  
Detention Management Division  
202      b6

Help us support you better -  
TELL US HOW WE ARE DOING!

Go to <http://www.acqsolinc.com/ICE/OAQ/feedback.cfm> <<<http://www.acqsolinc.com/ICE/OAQ/feedback.cfm>>>



**Stevens, Richard P**

---

**From:** Neveleff, Jerald  
**Sent:** Tuesday, August 05, 2008 8:11 AM  
**To:** Smyly, Elena L  
**Subject:** Re: Farmville IGSA

I understand they were revised and submitted to the field office. However, I am not sure if they have been approved.

-----Original Message-----

From: Smyly, Elena L  
To: Neveleff, Jerald  
Sent: Aug 5, 2008 08:07  
Subject: Farmville IGSA

Good Morning Jerry,

Did the architect (or the county) provide you with the revised blueprints?

Elena

Elena Smyly, PMP

Management and Program Analyst - Large IGSA

DHS, U.S. Immigration and Customs Enforcement

Office of Detention and Removal

Detention Management Division

(202) b6

Jerry  
Sent using BlackBerry

**Stevens, Richard P**

---

**From:** Warren Coleman (b)(6)  
**Sent:** Wednesday, August 13, 2008 8:05 AM  
**To:** Neveleff, Jerald  
**Cc:** Russell Harper  
**Subject:** IGSA for Transportation and Housing

Jerry,

You indicated on Monday that Arnold should be caught up on his duties and would call on Wednesday to start the IGSA process for Transportation. Are there any particular items or facts that I should have for the call and should I contact him directly this morning or continue to communicate directly with you.

We are looking forward to getting these talks on the fast track and thank you for your assistance.

Warren Coleman  
804- b6

**Stevens, Richard P**

---

**From:** Warren Coleman (b)(6)  
**Sent:** Wednesday, August 13, 2008 8:13 AM  
**To:** Neveleff, Jerald  
**Cc:** Russell Harper; Casterline, Arnold P  
**Subject:** RE: IGSA for Transportation and Housing

Thanks. Just let us know if we can be working on anything at this end to help the process.

Warren Coleman

---

**From:** Neveleff, Jerald [mailto: (b)(6)  
**Sent:** Wednesday, August 13, 2008 8:10 AM  
**To:** Warren Coleman  
**Cc:** Russell Harper; Casterline, Arnold P  
**Subject:** RE: IGSA for Transportation and Housing

Warren,  
Arnold is aware of what he has to do and get accomplished. He will be contacting you once he is ready.

---

**From:** Warren Coleman [mailto: (b)(6)  
**Sent:** Wednesday, August 13, 2008 8:05 AM  
**To:** Neveleff, Jerald  
**Cc:** Russell Harper  
**Subject:** IGSA for Transportation and Housing

Jerry,

You indicated on Monday that Arnold should be caught up on his duties and would call on Wednesday to start the IGSA process for Transportation. Are there any particular items or facts that I should have for the call and should I contact him directly this morning or continue to communicate directly with you.

We are looking forward to getting these talks on the fast track and thank you for your assistance.

Warren Coleman  
(b)(6)

## Stevens, Richard P

---

**From:** Neveleff, Jerald  
**Sent:** Wednesday, August 13, 2008 8:34 AM  
**To:** Casterline, Arnold P  
**Subject:** Fw: IGSA for Transportation and Housing

**Importance:** High

Is this enough for you to revise the plan in what was sent to farmville? If u believe so, review the email, tailor as you seem necessary and send to coleman for them to generate some numbers.

-----Original Message-----

From: Craig Raine  
To: Neveleff, Jerald  
To: Arnie  
To: Watson, Joe  
To: Picone, Paul D  
Sent: Aug 13, 2008 08:29  
Subject: RE: IGSA for Transportation and Housing

Jerry,

This is what we have so far. Please let us know what else we need to add.

The Transportation Company should be able to pickup and transport detainees to this office between the hours of 0400 hours and 0600 hours. The form I-203, Order to Detain or Release of Alien will be an order instructing what is requested of the Transportation Company. The Form I-203, Order to Detain or Release of Alien and the Record of Deportable /Inadmissibility Alien, form I-213, will be submitted when service is requested from the Transportation Company. Also the form I-203, will direct the Transportation Company of what detainee(s) need to be transported and the time they need to be at the ICE office.

Piedmont Regional Jail is 164 miles from the ICE Office in Fairfax, Virginia, and this trip should take approximately 3.5 hour one way. This office daily operation for jail releases are from the following facility: Hampton Roads (136 miles-2.5 hours), Northwestern Regional ADC, (190 miles-4.5 hours) , Pamunkey Regional Jail (79 miles-1.5 hours), Rappahannock Regional Jail (126-2.5 hours), Richmond City Jail (67 miles-1.25), Riverside Regional Jail (73 miles-1.5 hours) Rockingham/Harrisonburg Regional Jail (122miles-2.5 hours) Virginia Beach City Jail, (155 miles-3.25 hours), Roanoke City Jail (100 miles-2 hours), Shenandoah County Jail (158 miles-3.5 hours), Virginia Peninsula Regional Jail (119 miles 2.5 miles), Danville (89 miles-1.75 hours), Albemarle/

-----Original Message Truncated-----

Jerry  
Sent using BlackBerry

**Stevens, Richard P**

---

**From:** Raine, Craig K  
**Sent:** Wednesday, August 13, 2008 8:30 AM  
**To:** Neveleff, Jerald; Casterline, Arnold P; Watson, Joe; Picone, Paul D  
**Subject:** RE: IGSA for Transportation and Housing  
**Importance:** High

Jerry,

This is what we have so far. Please let us know what else we need to add.

The Transportation Company should be able to pickup and transport detainees to this office between the hours of 0400 hours and 0600 hours. The form I-203, Order to Detain or Release of Alien will be an order instructing what is requested of the Transportation Company. The Form I-203, Order to Detain or Release of Alien and the Record of Deportable /Inadmissibility Alien, form I-213, will be submitted when service is requested from the Transportation Company. Also the form I-203, will direct the Transportation Company of what detainee(s) need to be transported and the time they need to be at the ICE office.

Piedmont Regional Jail is 164 miles from the ICE Office in Fairfax, Virginia, and this trip should take approximately 3.5 hour one way. This office daily operation for jail releases are from the following facility: Hampton Roads (**136 miles-2.5 hours**), Northwestern Regional ADC, (**190 miles-4.5 hours**), Pamunkey Regional Jail (**79 miles-1.5 hours**), Rappahannock Regional Jail (**126-2.5 hours**), Richmond City Jail (**67 miles-1.25**), Riverside Regional Jail (**73 miles-1.5 hours**) Rockingham/Harrisonburg Regional Jail (**122miles-2.5 hours**) Virginia Beach City Jail, (**155 miles-3.25 hours**), Roanoke City Jail (**100 miles-2 hours**), Shenandoah County Jail (**158 miles-3.5 hours**), Virginia Peninsula Regional Jail (**119 miles 2.5 miles**), Danville (**89 miles-1.75 hours**), **Albemarle/ Charlottesville Regional Jail (59 miles- 1.25 hours)**. The information in parenthesis provides the distance and the approximate time it will take from the facilities locations to Piedmont Regional Jail. Consideration needs to be taken of the time allotted to obtain detainee from the facility.

There is a need for an evening pickup at the ICE office in Fairfax, Virginia. The Transportation Company should be about to pickup in the evening between hours of 1600 hours and 1700 hours. This will provide enough time for the ICE Officers to process the detainee(s) and the Transportation Company should not have to wait around for departure. The Form I-203, Order to Detain or Release of Alien will be the order directing what is requested of the Transportation Company movement unless otherwise directed by an ICE official.

There will be at times not on a daily basic that the Transportation Company will need to pickup up from the Correctional Facilities within the State of Virginia. This is something that will need to be addressed maybe not at this time but at a later date.

---

**From:** Neveleff, Jerald  
**Sent:** Wednesday, August 13, 2008 8:15 AM  
**To:** Raine, Craig K  
**Cc:** Casterline, Arnold P  
**Subject:** FW: IGSA for Transportation and Housing

Craig,  
Do you have the revised transportation plan for Farmville you can send Arnie?  
Jerry

---

12/21/2008

**From:** Warren Coleman [mailto:[\(b\)\(6\)](#)]  
**Sent:** Wednesday, August 13, 2008 8:13 AM  
**To:** Neveleff, Jerald  
**Cc:** Russell Harper; Casterline, Arnold P  
**Subject:** RE: IGSA for Transportation and Housing

Thanks. Just let us know if we can be working on anything at this end to help the process.

Warren Coleman

---

**From:** Neveleff, Jerald [mailto:[\(b\)\(6\)](#)]  
**Sent:** Wednesday, August 13, 2008 8:10 AM  
**To:** Warren Coleman  
**Cc:** Russell Harper; Casterline, Arnold P  
**Subject:** RE: IGSA for Transportation and Housing

Warren,  
Arnold is aware of what he has to do and get accomplished. He will be contacting you once he is ready.

---

**From:** Warren Coleman [mailto:[wc](#)] [mailto:[\(b\)\(6\)](#)]  
**Sent:** Wednesday, August 13, 2008 8:05 AM  
**To:** Neveleff, Jerald  
**Cc:** Russell Harper  
**Subject:** IGSA for Transportation and Housing

Jerry,

You indicated on Monday that Arnold should be caught up on his duties and would call on Wednesday to start the IGSA process for Transportation. Are there any particular items or facts that I should have for the call and should I contact him directly this morning or continue to communicate directly with you.

We are looking forward to getting these talks on the fast track and thank you for your assistance.

Warren Coleman  
[\(b\)\(6\)](#)

**Stevens, Richard P**

---

**From:** Casterline, Arnold P  
**Sent:** Wednesday, August 13, 2008 10:13 AM  
**To:** Neveleff, Jerald  
**Subject:** RE: IGSA for Transportation and Housing

Revise the SOW right? Do you want it in a chart form?

Arnold P. Casterline Jr.  
Contract Specialist  
Immigration and Customs Enforcement  
Office of Acquisition Management  
Department of Homeland Security  
425 I Street NW, 5th Floor Room 5009  
Washington, DC 20536  
e-mail: (b)(6)  
phone: 202  
Main: 202- b6

Help us support you better -  
TELL US HOW WE ARE DOING!  
Go to <http://www.acqsolinc.com/ICE/OAQ/feedback.cfm>

-----Original Message-----

**From:** Neveleff, Jerald  
**Sent:** Wednesday, August 13, 2008 8:34 AM  
**To:** Casterline, Arnold P  
**Subject:** Fw: IGSA for Transportation and Housing  
**Importance:** High

Is this enough for you to revise the plan in what was sent to farmville? If u believe so, review the email, tailor as you seem necessary and send to coleman for them to generate some numbers.

-----Original Message-----

**From:** Craig Raine  
**To:** Neveleff, Jerald  
**To:** Arnie  
**To:** Watson, Joe  
**To:** Picone, Paul D  
**Sent:** Aug 13, 2008 08:29  
**Subject:** RE: IGSA for Transportation and Housing

Jerry,

This is what we have so far. Please let us know what else we need to add.

The Transportation Company should be able to pickup and transport detainees to this office between the hours of 0400 hours and 0600 hours. The form I-203, Order to Detain or Release of Alien will be an order instructing what is requested of the Transportation Company. The Form I-203, Order to Detain or Release of Alien and the Record of Deportable

/Inadmissibility Alien, form I-213, will be submitted when service is requested from the Transportation Company. Also the form I-203, will direct the Transportation Company of what detainee(s) need to be transported and the time they need to be at the ICE office.

Piedmont Regional Jail is 164 miles from the ICE Office in Fairfax, Virginia, and this trip should take approximately 3.5 hour one way. This office daily operation for jail releases are from the following facility: Hampton Roads (136 miles-2.5 hours), Northwestern Regional ADC, (190 miles-4.5 hours) , Pamunkey Regional Jail (79 miles-1.5 hours), Rappahannock Regional Jail (126-2.5 hours), Richmond City Jail (67 miles-1.25), Riverside Regional Jail (73 miles-1.5 hours) Rockingham/Harrisonburg Regional Jail (122miles-2.5 hours) Virginia Beach City Jail, (155 miles-3.25 hours), Roanoke City Jail (100 miles-2 hours), Shenandoah County Jail (158 miles-3.5 hours), Virginia Peninsula Regional Jail (119 miles 2.5 miles), Danville (89 miles-1.75 hours), Albemarle/

-----Original Message Truncated-----

Jerry  
Sent using BlackBerry



## Stevens, Richard P

---

**From:** Neveleff, Jerald  
**Sent:** Wednesday, August 13, 2008 10:15 AM  
**To:** Casterline, Arnold P  
**Subject:** Re: IGSA for Transportation and Housing

I think we're talking the same. Take the current a(tached plan and modify it with what craig sent. Table might be best. Don't be surprised to see labor for a dispatcher. They planned to use the facility (when built) for that -----Original Message-----

From: Arnie  
To: Neveleff, Jerald  
Sent: Aug 13, 2008 10:12  
Subject: RE: IGSA for Transportation and Housing

Revise the SOW right? Do you want it in a chart form?

Arnold P. Casterline Jr.  
Contract Specialist  
Immigration and Customs Enforcement  
Office of Acquisition Management  
Department of Homeland Security  
425 I Street NW, 5th Floor Room 5009  
Washington, DC 20536  
e-mail: (b)(6)  
phone: 202  
Main: 202- b6

Help us support you better -  
TELL US HOW WE ARE DOING!  
Go to <http://www.acqsolinc.com/ICE/OAQ/feedback.cfm>

-----Original Message-----  
From: Neveleff, Jerald  
Sent: Wednesday, August 13, 2008 8:34 AM  
To: Casterline, Arnold P  
Subject: Fw: IGSA for Transportation and Housing  
Importance: High

Is this enough for you to revise the plan in what was sent to farmville? If u believe so, review the email, tailor as you seem necessary and send to coleman for them to generate some numbers.

-----Original Message-----  
From: Craig Raine  
To: Neveleff, Jerald  
To: Arnie  
To: Watson, Joe  
To: Picone, Paul D  
Sent: Aug 13, 2008 08:29  
Subject: RE: IGSA for Transportation and Housing

Jerry,

This is what we have so far. Please let us know what else we need to add.

The Transportation Company should be able to pickup and transport detainees to this office between the hours of 0400 hours and 0600 hours. The form I-203, Order to Detain or Release of Alien will be an order instructing what is requested of the Transportation Company. The Form I-203, Order to Detain or Release of Alien and the Record

-----Original Message Truncated-----

Jerry  
Sent using BlackBerry

**Stevens, Richard P**

---

**From:** Casterline, Arnold P  
**Sent:** Wednesday, August 13, 2008 10:16 AM  
**To:** Neveleff, Jerald  
**Subject:** RE: IGSA for Transportation and Housing

Ok

Arnold P. Casterline Jr.  
Contract Specialist  
Immigration and Customs Enforcement  
Office of Acquisition Management  
Department of Homeland Security  
425 I Street NW, 5th Floor Room 5009  
Washington, DC 20536  
e-mail: (b)(6)  
phone: 202  
Main: 202- b6

Help us support you better -  
TELL US HOW WE ARE DOING!  
Go to <http://www.acqsolinc.com/ICE/OAQ/feedback.cfm>

-----Original Message-----  
From: Neveleff, Jerald  
Sent: Wednesday, August 13, 2008 10:15 AM  
To: Casterline, Arnold P  
Subject: Re: IGSA for Transportation and Housing

I think we're talking the same. Take the current a(tached plan and modify it with what craig sent. Table might be best. Don't be surprised to see labor for a dispatcher. They planned to use the facility (when built) for that -----Original Message-----

From: Arnie  
To: Neveleff, Jerald  
Sent: Aug 13, 2008 10:12  
Subject: RE: IGSA for Transportation and Housing

Revise the SOW right? Do you want it in a chart form?

Arnold P. Casterline Jr.  
Contract Specialist  
Immigration and Customs Enforcement  
Office of Acquisition Management  
Department of Homeland Security  
425 I Street NW, 5th Floor Room 5009  
Washington, DC 20536  
e-mail: (b)(6)  
phone: 202  
Main: 202- b6

Help us support you better -  
TELL US HOW WE ARE DOING!  
Go to <http://www.acqsolinc.com/ICE/OAQ/feedback.cfm>

-----Original Message-----  
From: Neveleff, Jerald  
Sent: Wednesday, August 13, 2008 8:34 AM  
To: Casterline, Arnold P

Subject: Fw: IGSA for Transportation and Housing  
Importance: High

Is this enough for you to revise the plan in what was sent to farmville? If u believe so, review the email, tailor as you seem necessary and send to coleman for them to generate some numbers.

-----Original Message-----

From: Craig Raine  
To: Neveleff, Jerald  
To: Arnie  
To: Watson, Joe  
To: Picone, Paul D  
Sent: Aug 13, 2008 08:29  
Subject: RE: IGSA for Transportation and Housing

Jerry,

This is what we have so far. Please let us know what else we need to add.

The Transportation Company should be able to pickup and transport detainees to this office between the hours of 0400 hours and 0600 hours. The form I-203, Order to Detain or Release of Alien will be an order instructing what is requested of the Transportation Company. The Form I-203, Order to Detain or Release of Alien and the Record

-----Original Message Truncated-----

Jerry  
Sent using BlackBerry

**Stevens, Richard P**

---

**From:** Casterline, Arnold P  
**Sent:** Wednesday, August 13, 2008 11:07 AM  
**To:** Neveleff, Jerald  
**Attachments:** Farmville trans adj..doc

How's this? I can cut and paste this into the SOW and replace the chart that is there now. It seems as though this is all the transportation that the field office wants right now, this is the impression I get from the email.

*Arnold P. Casterline Jr.*

Contract Specialist  
Immigration and Customs Enforcement  
Office of Acquisition Management  
Detention Management  
Department of Homeland Security  
425 I Street NW, 5<sup>th</sup> Floor Room 5009  
Washington, DC 20536  
e-mail: (b)(6)  
phone: 202-  
Main: 202- b6

**Help us support you better –  
TELL US HOW WE ARE DOING!**

**Go to** <http://www.acqsolinc.com/ICE/OAQ/feedback.cfm>

The Transportation Company should be able to pickup and transport detainees to this office between the hours of 0400 hours and 0600 hours. The form I-203, Order to Detain or Release of Alien will be an order instructing what is requested of the Transportation Company. The Form I-203, Order to Detain or Release of Alien and the Record of Deportable /Inadmissibility Alien, form I-213, will be submitted when service is requested from the Transportation Company. Also the form I-203, will direct the Transportation Company of what detainee(s) need to be transported and the time they need to be at the ICE office.

Piedmont Regional Jail is 164 miles from the ICE Office in Fairfax, Virginia, and this trip should take approximately 3.5 hour one way.

This office daily operation for jail releases are from the following facility:

Hampton Roads (**136 miles-2.5 hours**),  
Northwestern Regional ADC (**190 miles-4.5 hours**)  
Pamunkey Regional Jail (**79 miles-1.5 hours**)  
Rappahannock Regional Jail (**126-2.5 hours**)  
Richmond City Jail (**67 miles-1.25**)  
Riverside Regional Jail (**73 miles-1.5 hours**)  
Rockingham/Harrisonburg Regional Jail (**122miles-2.5 hours**)  
Virginia Beach City Jail, (**155 miles-3.25 hours**)  
Roanoke City Jail (**100 miles-2 hours**)  
Shenandoah County Jail (**158 miles-3.5 hours**)  
Virginia Peninsula Regional Jail (**119 miles 2.5 miles**)  
Danville (**89 miles-1.75 hours**)  
Albemarle/ Charlottesville Regional Jail (**59 miles- 1.25 hours**)

The information in parenthesis provides the distance and the approximate time it will take from the facilities locations to Piedmont Regional Jail. Consideration needs to be taken of the time allotted to obtain detainee from the facility.

There is a need for an evening pickup at the ICE office in Fairfax, Virginia. The Transportation Company should be about to pickup in the evening between hours of 1600 hours and 1700 hours.

This will provide enough time for the ICE Officers to process the detainee(s) and the Transportation Company should not have to wait around for departure. The Form I-203, Order to Detain or Release of Alien will be the order directing what is requested of the Transportation Company movement unless otherwise directed by an ICE official.

There will be at times not on a daily basic that the Transportation Company will need to pickup up from the Correctional Facilities within the State of Virginia. This is something that will need to be addressed maybe not at this time but at a later date.

**Stevens, Richard P**

---

**From:** Warren Coleman [wcoleman@hdcva.com]  
**Sent:** Friday, August 15, 2008 10:07 AM  
**To:** Achim, Deborah; Henkel, Douglas ; Raine, Craig K; Neveleff, Jerald; Picone, Paul D; Jenkins, John E; Thompson, Arthur D  
**Cc:** Russell Harper; b6 Gerry  
**Subject:** ICE- Farmville project.

Management Team of ICE

I am writing to update you on the action steps taken by the ICA-Farmville team since our last meeting and request a meeting to finalize the IGSA so we can move forward to construction. Since the last meeting, our architect has redesigned the receiving area, medical area and isolation areas to reflect comments from the July 17 meeting and those plans have been resubmitted to Jerry and Craig for review. At this time, we are still waiting on comments regarding the administrative area but this seems to be the only area that is holding up the process.

The Town of Farmville as well as the management team of Immigration Centers of America-Farmville is very eager to start construction so we can assist ICE with their immediate housing needs and bring this business venture and jobs to the people of the town and surrounding area. The Town has secured several time sensitive grants for the project and many of the key personnel are already in place to operate the facility. We do not want to lose this momentum so we are requesting that we finalize the IGSA without the final plans for the administration space. We will ensure there is adequate space either in the building or on the building site to house all of the administrative needs once they are determined. We can treat the administration needs as either a change order or a possibly a new IGSA.

We would like to request a meeting any day during the week of 8/18 to wrap up any loose ends and to negotiate and sign the IGSA agreement. Once the IGSA is signed, we will start construction the next day and move as quickly as possible to provide the needed housing.

Please email or call Russell Harper b6 or myself b6 to set up a meeting time and place. As always we appreciate this opportunity to work with ICE and look forward to a long and healthy business relationship.

Warren Coleman

**Stevens, Richard P**

---

**From:** Warren Coleman [wcoleman@hdcva.com]  
**Sent:** Friday, August 15, 2008 11:21 AM  
**To:** Neveleff, Jerald; Achim, Deborah; Henkel, Douglas; Raine, Craig K; Picone, Paul D; Jenkins, John E; Thompson, Arthur D  
**Cc:** Russell Harper; b6 Casterline, Arnold P  
**Subject:** RE: ICE- Farmville project.

Jerry,

Since next week is not an option to negotiate and finalize the IGSA due to your travel plans, please suggest the earliest time that we can meet. In your absence, if others can meet as we did in July to resolve any outstanding issues and leave the negotiation of the day rate for your return, we would like to request such a meeting so we can move ahead and be ready to complete the IGSA when you return to the office. Please suggest who we should contact to set up a meeting to resolve any remaining operational and construction issues.

We look forward to meeting on your suggested date and do hope we can meet next week to resolve any outstanding issues from the Field Office.

Warren Coleman

---

**From:** Neveleff, Jerald [mailto: (b)(6)]  
**Sent:** Friday, August 15, 2008 10:16 AM  
**To:** Warren Coleman; Achim, Deborah; Henkel, Douglas; Raine, Craig K; Neveleff, Jerald; Picone, Paul D; Jenkins, John E; Thompson, Arthur D  
**Cc:** Russell Harper; b6 Casterline, Arnold P  
**Subject:** Re: ICE- Farmville project.

The week of 18 Aug is not possible. I am on travel that week and will not be back until the 25th. I also need to get with the field office to ensure they have everything they need and all plans are acceptable to them.

Jerry  
-----Original Message-----  
From: Warren Coleman  
To: Achim, Deborah  
To: Henkel, Douglas  
To: Raine, Craig K  
To: Work  
To: Picone, Paul D  
To: Jenkins, John E  
To: Thompson, Arthur D  
Cc: Russell Harper  
Cc: b6 Gerry  
Sent: Aug 15, 2008 10:06  
Subject: ICE- Farmville project.

Management Team of ICE

I am writing to update you on the action steps taken by the ICA-Farmville team since our last meeting and request a meeting to finalize the IGSA so we can move forward to construction. Since the last meeting, our architect has redesigned the receiving area, medical area and

12/21/2008



isolation areas to reflect comments from the July 17 meeting and those plans have been resubmitted to Jerry and Craig for review. At this time, we are still waiting on comments regarding the administrative area but this seems to be the only area that is holding up the process.

The Town of Farmville as well as the management team of Immigration Centers of America-Farmville is very eager to start construction so we can assist ICE with their immediate housing needs and bring this business venture and jobs to the people of the town and surrounding area. The Town has secured several time sensitive grants for the project and many of the key personnel are already in place to operate the facility. We do not want to lose this momentum so we are requesting that we finalize the IGSA without the final plans for the administration space. We will ensure there is adequate space either in the building or on the building site to house all of the administrative needs once they are determined. We can treat the administration needs as either a change order or a possibly a new IGSA.

We would like to request a meeting any day during the week of 8/18 to wrap up any loose ends and to negotiate and sign the IGSA agreement. Once the IGSA is signed, we will start construction the next day and move as quickly as possible to provide the needed housing.

Please email or call Russell Harper b6 or myself b6 to set up a meeting time and place. As always we appreciate this opportunity to work with ICE and look forward to a long and healthy business relationship.

Warren Coleman

Jerry  
Sent using BlackBerry

**Stevens, Richard P**

---

**From:** Casterline, Arnold P  
**Sent:** Friday, August 15, 2008 1:46 PM  
**To:** Neveleff, Jerald  
**Subject:** RE:

Yes, I thought they were going to submit a new one being they were having to alter their building plans.

Arnold P. Casterline Jr.  
Contract Specialist  
Immigration and Customs Enforcement  
Office of Acquisition Management  
Detention Management  
Department of Homeland Security  
425 I Street NW, 5th Floor Room 5009  
Washington, DC 20536  
e-mail: (b)(6)  
phone: 202  
Main: 202- b6

Help us support you better -  
TELL US HOW WE ARE DOING!  
Go to <http://www.acqsolinc.com/ICE/OAQ/feedback.cfm>

-----Original Message-----

From: Neveleff, Jerald  
Sent: Friday, August 15, 2008 1:42 PM  
To: Casterline, Arnold P  
Subject: Re:

Have they given u everything u have asked for in the original proposal?

-----Original Message-----

From: Arnie  
To: Neveleff, Jerald  
Sent: Aug 15, 2008 13:41  
Subject: RE:

I don't have any new cost data. I have the old one, if that is all they are going to use then I guess I have it.

Arnold P. Casterline Jr.  
Contract Specialist  
Immigration and Customs Enforcement  
Office of Acquisition Management  
Detention Management  
Department of Homeland Security  
425 I Street NW, 5th Floor Room 5009  
Washington, DC 20536  
e-mail: (b)(6)  
phone: 202  
Main: 202- b6

Help us support you better -  
TELL US HOW WE ARE DOING!  
Go to <http://www.acqsolinc.com/ICE/OAQ/feedback.cfm>

-----Original Message-----

From: Neveleff, Jerald

Sent: Friday, August 15, 2008 1:40 PM  
To: Casterline, Arnold P  
Subject: Re:

According to farmville drawings were submitted to FOD -----Original Message-----  
From: Arnie  
To: Neveleff, Jerald  
Sent: Aug 15, 2008 13:38  
Subject:

Montgomery is done and in obligations right now

Eloy have no idea about

Farmville : what cost data? They can't get the drawings straight.

Arnold P. Casterline Jr.

Contract Specialist

Immigration and Customs Enforcement

Office of Acquisition Management

Detention Management

Department of Homeland Security

425 I Street NW, 5th Floor Room 5009

Washington, DC 20536

e-mail: (b)(6)

phone: 202

b6

Main: 202-

Help us support you better -

TELL US HOW WE ARE DOING!

Go to <http://www.acqsolinc.com/ICE/OAQ/feedback.cfm>  
<<http://www.acqsolinc.com/ICE/OAQ/feedback.cfm>>

Jerry  
Sent using BlackBerry

Jerry  
Sent using BlackBerry

**Stevens, Richard P**

---

**From:** Casterline, Arnold P  
**Sent:** Friday, August 15, 2008 2:48 PM  
**To:** Neveleff, Jerald  
**Subject:** FW: New Building diagram

*Arnold P. Casterline Jr.*  
Contract Specialist  
Immigration and Customs Enforcement  
Office of Acquisition Management  
Detention Management  
Department of Homeland Security  
425 I Street NW, 5<sup>th</sup> Floor Room 5009  
Washington, DC 20536  
e-mail: (b)(6)  
phone: 202- (b)(6)  
Main: 202- (b)(6)

**Help us support you better –  
TELL US HOW WE ARE DOING!**  
**Go to** <http://www.acqsolinc.com/ICE/OAQ/feedback.cfm>

---

**From:** Warren Coleman [mailto: ] (b)(6)  
**Sent:** Friday, August 15, 2008 2:40 PM  
**To:** Casterline, Arnold P  
**Subject:** RE: New Building diagram

Arnold,

Yes we have prepared an updated cost proposal for the new space. If everyone is in agreement that the cost of the administrative area which is yet to be designed can be added later I believe we have all other cost ready for your review. One of the main questions that is still outstanding is the "ramp up" scenario that ICE expects to use at the Farmville site since it will impact how the day rate should be calculated. At one point in the meeting, Debbie mentioned that they would send 250 and then make sure everything was working and then send more. As you know, we will have many fixed cost that will not vary by the initial ramp up so we just need to reach an agreement and then determine the rate.

Please call or email if you have questions. We are eager to start so just let us know how we can best serve your efforts.

Glad to hear you are back in the office. Our sincere sympathy is extended to your family during this adjustment to the loss of your father.

Warren

**From:** Casterline, Arnold P [mailto: (b)(6)]  
**Sent:** Friday, August 15, 2008 2:02 PM  
**To:** Warren Coleman  
**Subject:** New Building diagram

Does ICA Farmville need to submit an updated cost proposal to reflect any new costs associated with the new configuration of the building?

*Arnold P. Casterline Jr.*  
Contract Specialist  
Immigration and Customs Enforcement  
Office of Acquisition Management  
Detention Management  
Department of Homeland Security  
425 I Street NW, 5<sup>th</sup> Floor Room 5009  
Washington, DC 20536  
e-mail: (b)(6)  
phone: 20  
Main: 202 b6

***Help us support you better –  
TELL US HOW WE ARE DOING!***

**Go to** <http://www.acqsolinc.com/ICE/OAQ/feedback.cfm>

**Stevens, Richard P**

---

**From:** Warren Coleman b6  
**Sent:** Tuesday, August 19, 2008 10:13 AM  
**To:** Casterline, Arnold P  
**Cc:** Russell Harper; Neveleff, Jerald  
**Subject:** Farmville- Cost Sheet for 1040  
**Attachments:** ICE- org chart\_1040\_081908.xls; JailServicesCostStatement\_1040\_081808.doc

Arnold,

As promised yesterday, I have attached a copy of the revised Jail Cost Sheet and organization chart. If you need other documents related to the package sent in May, please let me know and I will forward those to your attention. The cost sheet outlines our budget for the operations based on housing 1,040 detainees without detail plans for the ICE administrative area. As we mentioned in the email to Jerry, we would like to consider the admin area a "change order" or even new IGSA since this plan does not include any build out of this space, furniture for the space or computers. (Some of these items may be furnished by ICE and not cost to ICA-Farmville but I just want to be sure everyone is aware that they are not part of this cost sheet)

Please review and pass along your questions so we can respond to them and be prepared for a meeting when Jerry returns. I hope our answers to your first set of questions on 6/30/08 were satisfactory but if you still have any outstanding issues related to those questions, please let us know so they can be resolved as well. As we also discussed yesterday, we will need to discuss the "ramp up" of the facility and the occupancy rate for the facility but I know it is critical at this point to be comfortable with the cost for 1,040 and then we can negotiate the other items.

As we mentioned earlier to Jerry, Farmville has some time sensitive grants for this project that we do not want to miss so keep us informed of your needs and anything we can do to help your review move along smoothly. I am out of the office tomorrow but can be reached on my cell b6 so please don't hesitate to call. I will be back in the office on Thursday. We would really like to address the transportation IGSA and this negotiation before we move into September because the fall is a great time to get construction started so we can be inside the building by winter.

Thanks in advance for your attention to this project.

Warren Coleman

# Town of Farmville- ICE Facility

## Organization Chart

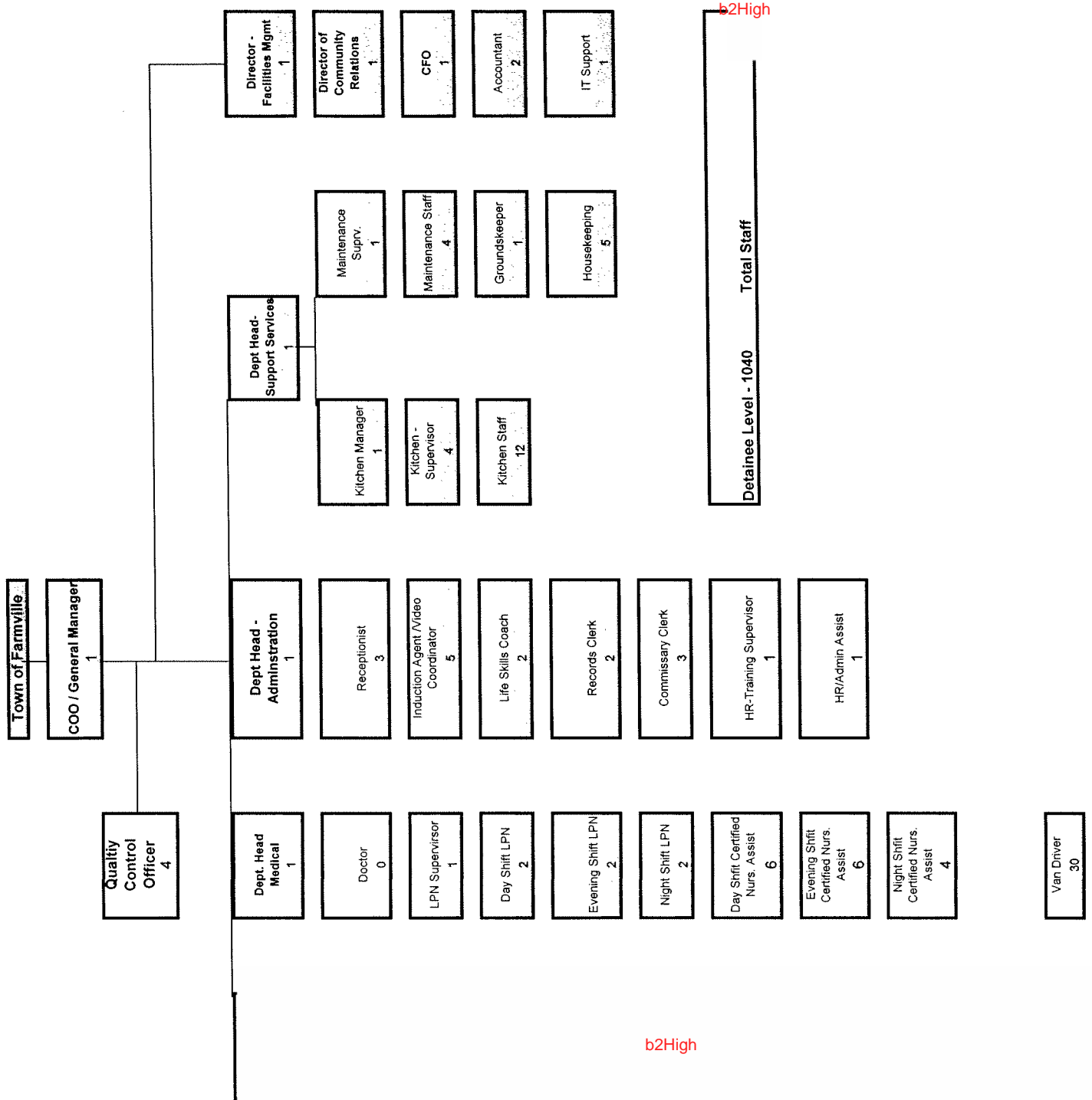

b2High

b2High

## Jail Services Cost Statement Cost Sheet for Detention Services

### SCHEDULE A

**Instructions:** This cost statement should be completed by the local government and submitted to the appropriate Immigration Customs Enforcement (ICE) Detention and Removal Office (DRO) representative for the acquisition of detention services for ICE detainees. Upon request, additional supporting data in addition to that included as part of this cost sheet may be requested. The individual designated in Section V will be contacted by an ICE DRO representative to negotiate a detainee per diem rate and its effective date. Upon completion of negotiations, an Intergovernmental Service Agreement (IGSA) will be issued by ICE DRO and forwarded to the local government for review and signature.

OMB Circular No. A-87, as amended 8/29/97, sets forth the principles and standards for determining allowable costs for Federal agreements with state and local governments. A copy of OMB Circular A-87 can be obtained online at: <http://www.whitehouse.gov/omb/circulars/a087/a087-all.html>.

**Please note that the per diem rate will include detention services and guard transportation services.**

If additional guidance is required, please contact the ICE DRO representative at (202) 732-7405.

#### SECTION I – GENERAL INFORMATION

**NAME OF JAIL:** Immigration Centers of America- Farmville LLC

**PHYSICAL ADDRESS OF JAIL**  
**STREET:** 508 Waterworks Road

**CITY:** Farmville

**STATE:** Virginia

**ZIP:** 23901

**PHONE NUMBER:**

#### SECTION II – FINANCIAL DATA SUMMARY

**TOTAL OPERATING COST FOR JAIL:**

A. Time Frame (Fiscal Year) Proposed Budget	FROM: (Month/Year) 9/08	TO: (Month/Year) 08/09
	<b>ANNUAL COST</b>	
<b>B. Total Personnel Costs (Schedule B – Part I)</b>	<b>\$ 6,547,790.00</b>	
<b>C. Total Personnel Benefits (Schedule B – Part II)</b>	<b>\$ 1,826,779.00</b>	
<b>D. Total Consultants and Contract Service (Schedule C)</b>	<b>\$ 618,308.00</b>	
<b>E. Other Direct Operating Costs (Schedule D)</b>	<b>\$ 10,139,223.00</b>	
<b>F. Indirect Costs (Schedule E)*</b> <i>* A certified cost allocation plan must be submitted if reimbursement for indirect costs is requested.</i>	<b>\$ 368,465.00</b>	
<b>G. Equipment Depreciation Costs (Schedule F)</b>	<b>\$ 265,376.00</b>	
<b>H. Building Depreciation Costs (Schedule G)</b>	<b>\$</b>	
<b>I. Total Operating Costs (Sum of Schedules B-G)</b>	<b>\$ 19,765,941.00</b>	
<b>J. Profit</b>	<b>\$ 3,952,227.00</b>	
<b>TOTAL Budgeted OPERATING COST</b>	<b>\$ 23,718,168.00</b>	
<b>PROPOSED DETAINEE PER DIEM RATE</b> ( <i>"Total actual operating cost for prior fiscal year" divided by 365, divided by the total average daily jail population</i> )	<b>\$</b>	

Copy 1 – ICE DRO HQ

Copy 2 – Field Office District

Copy 3 – IGSA File



U.S. Department of Homeland Security  
U.S. Immigration Customs Enforcement  
*Detention and Removal Office*

Copy 1 – ICE DRO HQ  
Copy 2 – Field Office District  
Copy 3 – IGSA File

<b>SECTION III – DETAINEE POPULATION INFORMATION</b>				
<b>Time Frame of Detainee Information (Must correspond with time frame Section II/A)</b>		<b>FROM: (Month/Year)</b> 9/08	<b>TO: (Month/Year)</b> 8/09	
Proposed Budget				
<b>Detainee Capacity of Facility</b>				
	Male	Female	Juvenile	TOTAL
	1,040			1,040
<b>Average Daily Population</b>				
Type of Detainee	Male	Female	Juvenile	TOTAL
Federal (assume 85%)	884			884
Local				
State				
<b>SECTION IV – PER DIEM</b>				
<b>Proposed Per Diem Rate for Detainee:</b>		\$		
<b>Detainee Per Diem Rate (If Applicable):</b>		\$		
<b>SECTION V – LOCAL GOVERNMENT CONTACT</b>				
Please provide the name of the individual authorized to represent and to act for the local government in the jail day rate negotiations.				
<b>NAME: Gerald Spates, Town Manager Warren Coleman, Partner: ICA-Farmville LLC</b>		<b>DEPARTMENT/OFFICE:</b>		
<b>TITLE:</b>		<b>STREET: 508 Waterworks Road</b>		
<b>PHONE: Spates: (434) 392-5686 Coleman (804) 282-6550 ext 14</b>		<b>CITY: Farmville</b>		
<b>FAX: 804-282-6544</b>		<b>STATE: Virginia</b>	<b>ZIP:23901</b>	
<b>SECTION VI – CERTIFICATION STATEMENT</b>				
This is to certify that, to the best of my knowledge and belief, the data furnished in Schedules B through G are accurate, complete and current, and do not include any unallowable costs prohibited by OMB Circular No. A-87 (Cost Principles for State and Local Governments) or any cost not related to the jail facility as discussed on the Cost Sheet for Detention Services). The records of this agency are available for review and audit by the authorized representative of the U.S. Government to verify any jail per diem rate negotiated.				
<b>SIGNATURE:</b>			<b>DATE:</b>	
<b>NAME: Russell Harper</b>			<b>TITLE: Managing Partner, ICA-Farmville LLC</b>	

**SCHEDULE B**  
**PART I – PERSONNEL COSTS**  
(Direct Costs – Personnel Supporting Detention Facility)

**Instructions:** List only those positions directly involved in jail operations and benefiting federal inmates.

Type of Position	(A) Annual Salary Cost \$	(B) Full Time or Part Time	(C) Number of Positions	(D) Total Salary Cost (A) x (C) = (D) \$
Asst GM, Dept Head- Admin	80,000	FT	1	80,000.00
Dept. Head- Security	75,000	FT	1	75,000.00
Dept. Head - Medical	75,000	FT	1	75,000.00
Dept. Head – Support Services	75,000	FT	1	75,000.00
Quality Control Officer	60,000	FT	4	180,000.00
Officers	32,000	FT	68	2,176,000.00
Supervisors	37,000	FT	12	444,000.00
Commander	45,000	FT	6	270,000.00
Induction Agent / Admin Assistant	35,670	FT	5	178,350.00
Life Skills/Recreation Leader	45,391	FT	2	90,782.00
Receptionist	29,499	FT	3	88,497.00
Record Clerk	35,670	FT	2	71,340.00
Commissary Clerk	35,670	FT	3	107,010.00
RN	56,516	FT	1	56,516.00
LPN	39,086	FT	6	234,516.00
Certified Nursing Assistants	26,014	FT	16	416,224.00
Maintenance Supervisor	54,705	FT	1	54,705.00
Maintenance Workers	35,387	FT	4	141,548.00
Housekeeping	21,166	FT	5	105,830.00
Groundskeeper	29,170	FT	1	29,170.00
Kitchen Manager	48,193	FT	1	48,193.00

U.S. Department of Homeland Security  
 U.S. Immigration Customs Enforcement  
 Detention and Removal Office

Kitchen Supervisor	34,234	FT	4	136,936.00
Kitchen Staff	21,164	FT	12	253,968.00
Van Drivers/ Hourly Stationary Guard	Listed in Hourly Guard Section	FT		
Accountant II	53,913	FT	2	107,826.00
Computer Support / Network	66,837	FT	1	66,837.00
HR-Training Supervisor	55,611	FT	1	55,611.00
Human Resource Generalist	48,621	FT	1	48,621.00
Chief Operations Officer	175,000	FT	1	175,000.00
Chief Financial Officer / Controller	90,000	FT	1	90,000.00
Director - Communications	75,000	PT	1	75,000.00
Director - Facilities Management	75,000	PT	1	75,000.00
<b>Total Salary Cost</b>			<b>\$ 6,082,480.50</b>	
<b>FICA Benefits</b>		<b>7.65 %</b>	<b>\$ 465,309.76</b>	
<b>Total Salary Cost plus FICA</b>			<b>\$ 6,547,790.26</b>	

*(Use continuation sheet if needed.)*

<b>SCHEDULE B</b>				
<b>PART II – PERSONNEL BENEFITS</b>				
(Direct Costs – Personnel Supporting Detention Facility)				
<b>Instructions:</b> Provide name of retirement plans (i.e. N.Y.S. employees retirement system), insurance plans (i.e. Blue Cross/Blue Shield), or unemployment insurance contribution plans for positions listed in Schedule B – Part I).				
	Number of Employees Participating	Total Salary Base	Employer Contribution	Annual Cost
<b>1. Retirement Program(s)</b>				
a. 401K	Full-time:	\$ 5,932,480.50	5%	\$ 303,374.03
b.	Part-time:	\$ 150,000.00	5%	\$ 7,500.00
Incentive Program for Senior Management	Full –time	\$ 480,000.00	100%	\$ 240,000.00
<b>2. Insurance Program(s)</b>				
a. Name: Health, Dental and Vision		\$ 6,082,480.50	100%	\$ 1,014,000.00
b. Name: Long Term Disability		\$ 6,082,480.50	100%	\$ 48,659.84
c. Name: Life Insurance		\$ 6,082,480.50	100%	\$ 40,560.00
<b>3. Other Employee Contribution Plans (i.e. unemployment, worker's compensation)</b>				
a. FUI	Full-time:	\$ 5,932,480.50	100%	\$ 9,352.00
	Part-time:	\$ 150,000.00	100%	\$ 112.00
b. SUI	Full-time:	\$ 5,932,480.50	100%	\$ 21,876.00
	Part-time:	\$ 150,000.00	100%	\$ 262.00
c. Worker's Compensation Ins.	Full-time:	\$ 5,932,480.50	100%	\$ 140,756.58
	Part-time:	\$ 150,000.00	100%	\$ 327.00

**SCHEDULE C  
 CONSULTANTS AND CONTRACT SERVICES**

**Instructions:** List only those services directly involved in jail operations and benefiting federal inmates. Provide a detailed "description of service".

Type of Service	Description of Service	No. of Contract Employees	Annual Cost
1. Medical	Physician. All others on staff,		\$ 179,975.00
2. Dental	Routine check ups and emergency services to Hygienist		\$ 110,833.00
3. Other:	Legal service		\$ 125,000.00
4. Other:	Auditing and Payroll Services		\$ 52,500.00
5. Other:	Information Tech software and technical support		\$ 50,000.00
6. Other:	Management Advisory Counsel and Board of Directors		\$ 100,000.00
<b>Total Consultants and Contract Services</b>			<b>\$ 618,308.00</b>

**SCHEDULE D  
 OTHER DIRECT JAIL OPERATING COSTS**

**Instructions:** List only those costs associated with the operation of the jail that directly benefit federal inmates. Costs associated with local court and law enforcement activities are not allowable costs for the purpose of determining facility operating costs.

Type of Service	Description	Annual Cost
<b>Food and Kitchen Supplies</b>	Food and Supplies for Kitchen staff	\$ 2,467,400.00
<b>Clothing (Detainee)</b>	2 outfits per detainee based on expected turnover	\$ 130,000.00
<b>Medical Care Supplies</b>	Per person rate	\$ 156,000.00
<b>Bedding &amp; Linen</b>	Multiple sets of sheets, blankets, towels etc	\$ 234,000.00
<b>Toiletries</b>	Various personal care supplies based on each new detainee	\$ 130,000.00
<b>Recreation and Education</b>	Supplies: exercise equipment listed below with equipment under \$ 5,000	\$ 5,000.00
<b>Utilities</b>	HVAC, water, sewer, etc. for facility	\$ 987,520.00
<b>Uniforms (Officer's)</b>	Uniforms and supplies	\$ 39,400.00
<b>Facility Maintenance and repairs</b>	Based on square footage of building (includes supplies for Grounds	\$ 617,200.00
<b>Body Armor/ Weapons</b>	Body Armor and weapons for staff	\$ 50,000.00
<b>Office Supplies and Postage</b>	Administration, Supervisors and Staff	\$ 90,000.00
<b>Telephone and Communications</b>	Local phone lines, video conferencing and internet	\$ 50,000.00
<b>Training/ Certification</b>	Training and Certification for staff	\$ 102,000.00
<b>Equipment under \$5,000 (Please use Schedule F for equipment over \$5,000.)</b>	Desk, storage units for detainees, beds, tables and chairs, staff equipment, exercise equipment, computer equipment	\$ 1,250,672.00
<b>Credits (e.g., telephone credits, insurance rebates, recoveries or indemnities on losses commissary income)</b>		\$

U.S. Department of Homeland Security  
 U.S. Immigration Customs Enforcement  
 Detention and Removal Office

<b>Property Taxes and Business Licenses</b>	Property taxes / Business license	\$ 215,563.00
<b>Rent</b>	Rent on facility	\$ 2,957,837.00
<b>Insurance: Property &amp; Casualty</b>	Insurance premiums	\$ 46,630.00
<b>Insurance: Liability Umbrella</b>	Insurance premiums	\$ 500,000.00
<b>Other Insurance: O&amp;D</b>	Insurance premiums	\$ 50,000.00
<b>Transportation Cost</b>	Gas reimbursement and travel cost for staff	\$ 60,000.00
<b>Total Other Direct Costs</b>		<b>\$ 10,139,223.00</b>



**SCHEDULE E  
 COST ALLOCATION PLANS/INDIRECT COST PROPOSALS**

**Instructions:** If you intend to claim central service costs you must provide a cost allocation plan. See OMB Circular A-87, Attachment C. Similarly, if you intend to claim indirect costs you must provide an indirect cost proposal. An indirect cost is any cost not directly identified with a single, final cost objective and is not subject to treatment as a direct cost. See OMB Circular A-87, Attachment E.

(A) Type of Service Provided	(B) Organization Providing Service	(C) No. of Employees Involved	(D) Total Cost of Salaries and Benefits	(E) % of Time Spent in Support of Jail Operations	(F) Allowable Indirect Cost (D) x (E) = (F)
Town of Farmville- Police			\$2,352,000	11.0%	\$258,720.00
Town of Farmville- Treasury Dept.			\$489,000	10.5%	\$ 51,345.00
Town of Farmville- Town Manager's office			\$584,000	10.0%	\$ 58,400.00
			\$	%	\$
			\$	%	\$
			\$	%	\$
			\$	%	\$
			\$	%	\$
			\$	%	\$
			\$	%	\$
			\$	%	\$
			\$	%	\$
<b>Total</b>			\$	%	\$ 368,465.00

## CERTIFICATE OF COST ALLOCATION PLAN

This is to certify that I have reviewed the cost allocation plan submitted herewith and to the best of my knowledge and belief:

- 1) All costs included in this proposal (identify date) to establish cost allocations or billings for (identify period covered by plan) are allowable in accordance with the requirements of OMB Circular A-87, "Cost Principles for State and Local Governments," and the Federal Award(s) to which they apply. Unallowable costs have been adjusted for in allocation costs as indicated in the cost allocation plan.
- 2) All cost included in this proposal are properly allocable to Federal awards on the basis of a beneficial or casual relationship between the expenses incurred and the awards to which they are allocated in accordance with applicable requirements. Further, the same costs that have been treated as indirect costs have not been claimed as direct costs. Similar types of costs have been accounted for consistency.

I declare that the foregoing is true and correct:

<b>Governmental Unit:</b>	
<b>Signature:</b>	
<b>Name of Official:</b>	
<b>Title:</b>	
<b>Date of Execution:</b>	

## SCHEDULE F EQUIPMENT COSTS

**Instructions:** A listing of equipment that is in the current approved jail operating budget for this contract period may be provided and/or attached to this worksheet for full purchase value consideration. If equipment is depreciated, show total acquisition amount and method used by state, country or city in calculating depreciation. A use allowance not to exceed 6-2/3% of acquisition cost of usable equipment may be substituted in lieu of depreciation. Equipment must be used directly for jail operations. Treatment of these costs must be consistent with local government's method.

### A. New Equipment Approved in Current Operating Budget (Use Continuation Sheet if Necessary)

(1) Item Description	(2) Proposed Utilization	(3) No. of Units	(4) Cost per Unit	(5) Enter % of use by the jail (i.e., if equipment is used by several depts.)	(6) Equipment Cost Allowance (4) x (5) x (6)
Security System		1	\$ 706,000.00	100%	\$706,000.00
Medical Facilities		1	\$ 50,000.00	100%	\$50,000.00
Kitchen and Laundry		1	759,331.00	100%	\$759,331.00
Transportation Vans`		15	\$ 20,000	100%	\$300,000.00
			<b>Total Current Equipment Costs</b>		\$ 1,815,331.00
			<b>Equipment Allowance (6-2/3% of above)</b>		\$ 265,376

### B. Show Method of Calculating Depreciation of Equipment if 6-2/3% depreciation is not used.

Vans depreciated over maximum amount for weight: \$ 3,260 per year  
 All other assets depreciated over 7 years

**SCHEDULE G  
 BUILDING DEPRECIATION**

**Instructions:** Provide an explanation of method used by state, county or city to depreciate buildings. Show date of construction; cost of construction (cost of land/site is not allowable); numbers of years in depreciation cycle. Note that federal assistance revenues used for building construction are considered offsetting revenues and are to be subtracted from cost of construction. In lieu of building depreciation an annual use allowance of 2% of acquisition cost may be substituted. Treatment of these costs must be consistent with local government's method. If claiming debt service arising from construction or renovation of a facility, please specify in "other" below.

**Part I – Depreciation Computation**

Facility	Year of Construction	Original Construction Cost	Annual Depreciation Claimed*
Main Building		\$	\$
Additions(s)		\$	\$
Annex		\$	\$
Other (Please specify)		\$	\$
Other (Please specify)		\$	\$
<b>Subtotal</b>		\$	\$
<b>Less Federal Assistance Revenues or Grants including Awards under Cooperative Agreement Program</b>			\$
<b>Total</b>			\$
* Generally 2% of original construction cost.			\$

**Part II – Method of calculating depreciation used by state, county or city (i.e., specify depreciation method if 2% depreciation allowance is not utilized by the state, county, or city.)**

## SCHEDULE H HOURLY STATIONARY GUARD SERVICES RATE

**Instructions:** List only those positions that will perform the stationary guard services. Qualified law enforcement or correctional officer personnel employed by the jail facility under their policies, procedure and practices should only perform these services. Provide annual cost of benefits to include retirement plans (i.e. N.Y.S. employees retirement system), insurance plans (i.e. Blue Cross/Blue Shield), or unemployment insurance contribution plans for positions listed.

The stationary guard services are not to be included in the total operating costs. These services are required for detainees attending off site court proceedings or who are committed to a medical facility.

Title of Position	(A) Annual Salary Cost	(B) Full Time or Part Time	(C) Number of Positio ns	(D) Total Salary Base  (A) x (C) = (D)  \$	(E) Annual Cost of Benefits	(F) Total Salary Cost  (D) + (E) = (F)	(G) Hourly Rate  (F)/2080 = (G)  \$
<b>Officer</b>	32,000	FT	68	2,176,000	791,941	2,967,941	20.98
<b>Supervisors</b>	37,000	FT	12	444,000	149,540	593,540	23.78
<b>Commanders</b>	45,000	FT	6	270,000	82,599	352,599	28.25
<b>Department Heads</b>							
<b>Average Rate based on personnel</b>							21.88
<b>Overhead 5%</b>							1.09
<b>Profit 20%</b>							4.60
<b>SUM</b>							27.57
<b>Requested Rate</b>							<b>27.50</b>

**Stevens, Richard P**

---

**From:** Thompson, Arthur D (CTR)  
**Sent:** Wednesday, August 20, 2008 10:38 AM  
**To:** b6  
**Cc:** Jenkins, John E; Neveleff, Jerald; Picone, Paul D; Raine, Craig K; b6  
**Subject:** FW: Farmville plans as of 8/11/08  
**Attachments:** Typical Compact Plus Right.pdf

This is the reply from Dr. Johnson at Dian associates regarding the space for telerad.

Thank You,

Dean Thompson

---

**From:** Geralyn Johnson [mailto: b6  
**Sent:** Wednesday, August 20, 2008 9:11 AM  
**To:** Thompson, Arthur D (CTR)  
**Subject:** RE: Farmville plans as of 8/11/08

The design does not meet the minimum requirements set out in the medical facility design guide in the telerad and other areas.

The most critical issue is that the telerad room is too small.

Minimum is 14' x 17' with a 4' door and 10' ceiling.

It appears to me that this room is about 9' x 20'

It may have the required square footage – but that isn't enough. The room has to be configured correctly in order to get the equipment in.

There are several other requirements but it is impossible to tell if they have been included.

I have cut and pasted the requirements below

Remember that there are different models of telerad machines:

1. Modulair
2. Compact Plus R
3. Compact Plus L
4. Compact R
5. Compact L

The requirements below are for a Compact Plus R

I have also attached generic plans for the Compact Plus R ( you will find the requirements in the document)

Note that they say that they can use a 36" door, but that is only if there is a very wide hall so they can turn the machine.

We select the type of machine that is used based on the amount of throughput expected and availability of machines (you have to get on a waiting list for these machines)

Hope this helps.

**REQUIREMENTS**

**DOORS & PASSAGEWAYS:**

MINIMUM EQUIPMENT ENTRY DOOR WIDTH: 36" RECOMMENDED: 48"  
MINIMUM EQUIPMENT ENTRY DOOR HEIGHT: 80"  
MINIMUM EQUIPMENT CORRIDOR WIDTH: 60"

**EQUIPMENT ROUTING ELEVATORS:**

MINIMUM EQUIPMENT ENTRY DOOR WIDTH: 36" RECOMMENDED: 48"  
MINIMUM EQUIPMENT ENTRY DOOR HEIGHT: 80"  
MINIMUM ELEVATOR LENGTH: 98"

**CEILING, WALLS & FLOOR:**

MINIMUM EXAM ROOM CEILING HEIGHT: 9'-6" A.F.F. RECOMMENDED: 10'-0" A.F.F.  
MINIMUM CONTROL AREA WALL HEIGHT: 7'-0" A.F.F. (IF APPLICABLE)  
EXAM ROOM FLOOR MUST BE LEVEL/FLAT FOR OPTIMIZED PERFORMANCE OF EQUIPMENT.

**POWER:**

3 PHASE, 480 VAC, 100 AMP, 60 HZ (5% UNDER LOAD CONDITIONS)  
1 PHASE, 208-230 VAC, 20 AMP, 60 HZ (5% UNDER LOAD CONDITIONS)  
THE BUILDING GROUND CONDUCTOR MUST BE 100 OHMS OR LESS TO EARTH GROUND.

**SUGGESTED ENVIRONMENTAL ROOM CONDITIONS:**

70° - 75° FAHRENHEIT, 10% - 80% RELATIVE HUMIDITY.  
THE TEMPERATURE IN THE EXAM ROOM SHOULD BE MAINTAINED IF THE DDR SYSTEM REMAINS POWERED ON.  
FAILURE TO COMPLY MAY CAUSE EXTENDED DOWN TIME IN ORDER TO RESTABILIZE THE DDR SYSTEM.

***DIAN Associates, Incorporated***

Geralyn Johnson, DDS, MPH  
513 Benfield Road  
Severna Park, Maryland 21146 USA  
[www.dianassociates.com](http://www.dianassociates.com)  
CELL: b6

---

**From:** Thompson, Arthur D (CTR) [mailto: (b)(6) |  
**Sent:** Wednesday, August 20, 2008 6:56 AM  
**To:** Geralyn Johnson  
**Subject:** FW: Farmville plans as of 8/11/08

Gerry

Take a look at the area for Telerad and let me know if this will work.

What size of door is needed for the equipment?

Talk to you later,

Dean

---

**From:** Warren Coleman [mailto: b6  
**Sent:** Tuesday, August 19, 2008 2:28 PM  
**To:** Thompson, Arthur D  
**Subject:** FW: Farmville plans as of 8/11/08

Arthur  
Our architect Mac Kelly still has some outstanding questions that I am hoping you can help clear up. If you have time, please contact him directly at b6

Thanks

Warren

---

**From:** Warren Coleman  
**Sent:** Tuesday, August 12, 2008 3:38 PM  
**To:** (b)(6)  
**Subject:** Farmville plans as of 8/11/08

Dean  
I spoke with Mac Kelly today and he suggested I send the attached plans to be sure you so you would have the latest ones based on our discussions at the meeting you attended. We look forward to starting on this project and appreciate any help you can offer to help improve our design and to speed up the process.

Please call if you have any questions or time to talk about things we can do to move the decision process along.

Thanks

Warren Coleman  
b6





# TYPICAL ROOM PLANS

SYSTEM: COMPACT PLUS - RIGHT

### DRAWING LEGEND

SHEET	DESCRIPTION
1.0	COVER
2.0	PREFACE
3.0	EQUIPMENT NOTES
3.1	EQUIPMENT LAYOUT
4.0	STRUCTURAL LAYOUT
5.0	ELECTRICAL NOTES
6.0	CHECKLIST

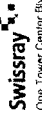

One Tower Center Blvd  
East Windsor, NJ 08816  
7629 303-5543

THESE DOCUMENTS CONTAIN PROPRIETARY DATA OF SWISSRAY INTERNATIONAL AND ITS CUSTOMER. THESE DRAWINGS ARE NOT TO BE USED FOR CONSTRUCTION PURPOSES AND ARE FOR REFERRING PURPOSES ONLY.

TYPICAL ROOM PLANS

DRAWN BY: SR

SCALE: NTS

DATE: 2/7/08

PROJECT NO: SR0000-P

SHEET NO: 1.0

PREFACE

THESE DRAWINGS HAVE BEEN PREPARED BY SWISSRAY INTERNATIONAL INC. AND THEIR PURPOSE IS TO PROVIDE THE SITING, ELECTRICAL, MECHANICAL AND ENVIRONMENTAL SPECIFICATIONS REQUIRED TO ACCOMMODATE THE INSTALLATION AND OPERATION OF THE DIAGNOSTIC IMAGING EQUIPMENT AND SUB-COMPONENTS ILLUSTRATED.

THE LAYOUT(S) PROVIDED FOR ALL COMPONENTS PURCHASED FROM AND/OR PROVIDED BY SWISSRAY INTERNATIONAL INC. SHALL SERVE AS A GUIDE FOR INSTALLATION BY THE LOCAL SWISSRAY INTERNATIONAL INC. SERVICE/INSTALLATION REPRESENTATIVES.

INFORMATION IN THIS PACKAGE RELATING TO BUILDING/FACILITY SPECIFICATIONS THAT WILL SUPPORT SWISSRAY INTERNATIONAL INC. COMPONENTS SUCH AS ELECTRICAL, STRUCTURAL, MECHANICAL AND ENVIRONMENTAL REQUIREMENTS SHALL BE UTILIZED AS A GUIDE BY THE CUSTOMER'S ARCHITECT AND/OR CONTRACTOR. FACILITY CONDITIONS MAY DICTATE ACTUAL CONSTRUCTION METHODS AND MATERIALS APPLIED. HOWEVER, ALL METHODS AND MATERIALS MUST COMPLY WITH SWISSRAY INTERNATIONAL INC. SPECIFICATIONS, AS WELL AS LOCAL AND/OR NATIONAL BUILDING CODES.

THE QUALITY OF CONSTRUCTION METHODS, MATERIALS AND CONFORMANCE TO SWISSRAY INTERNATIONAL INC. SPECIFICATIONS AND TOLERANCES, WILL AFFECT SWISSRAY INTERNATIONAL INC. EQUIPMENT PERFORMANCE.

DISCLAIMER

THESE DRAWINGS ARE REFERENCE DRAWINGS ILLUSTRATING GENERAL EQUIPMENT LAYOUT AND FACILITY-RELATED EQUIPMENT REQUIREMENTS. THE INFORMATION CONTAINED IN THESE DRAWINGS ARE PROVIDED FOR THE USE OF CUSTOMERS AND/OR THEIR DESIGNATED ARCHITECTS, ENGINEERS OR OTHER DESIGN/CONSTRUCTION PROFESSIONALS IN THE PREPARATION OF OFFICIAL CONSTRUCTION DOCUMENTS. SWISSRAY INTERNATIONAL INC. MAKES NO WARRANTY OR REPRESENTATION, EITHER EXPRESS OR IMPLIED, WITH RESPECT TO THE ATTACHED DRAWINGS, AND IN NO EVENT WILL SWISSRAY INTERNATIONAL INC. OR THEIR AGENTS BE LIABLE FOR ANY DIRECT, INDIRECT, SPECIAL, INCIDENTAL OR CONSEQUENTIAL DAMAGES RESULTING IN ANY MANNER FROM USE OF THE ATTACHED DRAWINGS. THESE DRAWINGS ARE PROVIDED WITH THE UNDERSTANDING THAT PROVIDING SUCH DRAWINGS DOES NOT ALTER ANY OF THE TERMS AND CONDITIONS OF SALE BETWEEN SWISSRAY INTERNATIONAL INC. AND THEIR CUSTOMER.

THESE DRAWINGS ARE NOT TO BE USED AS CONSTRUCTION DOCUMENTS. IT IS THE RESPONSIBILITY OF THE CUSTOMER OR THEIR DESIGNATE TO ENSURE THE CORRECT SITING AND PLACEMENT OF ALL PURCHASED DIAGNOSTIC EQUIPMENT, BASED ON THESE SWISSRAY INTERNATIONAL INC. REFERENCE DRAWINGS. THE CUSTOMER OR THEIR DESIGNATE SHALL BE RESPONSIBLE FOR THE COMPLETE AND ACCURATE INCORPORATION OF ALL PREPARATION OF THE SITE.

THE ATTACHED DRAWINGS ARE SUBJECT TO CHANGE WITHOUT NOTICE. NO SWISSRAY INTERNATIONAL INC. PERSONNEL ARE AUTHORIZED TO MODIFY THIS DISCLAIMER. SWISSRAY INTERNATIONAL INC. RESERVES THE RIGHT TO MAKE CHANGES TO SPECIFICATIONS REGARDING THESE PLANS WITHOUT PRIOR NOTIFICATION.

NOTICE: THESE DRAWINGS ARE THE SOLE PROPERTY OF SWISSRAY INTERNATIONAL INC.

IT'S USE IS AUTHORIZED ONLY FOR THE CUSTOMER/CONTRACTOR TO DESIGN AND INCORPORATE OUR CONCEPT DRAWING INTO A FINAL SET OF ARCHITECTURAL DRAWINGS. THESE DRAWINGS SHALL NOT BE USED FOR ANY OTHER PURPOSE OTHER THAN THE AGREED UPON DESIGN BETWEEN SWISSRAY INTERNATIONAL INC. AND THEIR CUSTOMER.

THE CUSTOMER IS RESPONSIBLE FOR ALL ROOM PREPARATION COSTS, FEES, PERMITS AND INSPECTIONS UNLESS OTHERWISE SPECIFIED IN THE GENERAL ORDER FOR THE EQUIPMENT PURCHASE.

RADIATION SHIELDING IS NOT SHOWN ON THESE PLANS. HOWEVER, THE CUSTOMER SHALL, AT THEIR OWN EXPENSE, HAVE SHIELDING CALCULATIONS FOR THE ROOM PREPARED BY A LICENSED RADIATION PHYSICIST.

EQUIPMENT DELIVERY RESPONSIBILITIES

- BY SWISSRAY:
1. DETERMINE POSSIBLE DELIVERY ROUTE(S) FOR EQUIPMENT.
  2. WITH THE AID OF THE CUSTOMER IDENTIFY A STORAGE AREA OR A PLAN TO ENSURE THE PROTECTION OF THE EQUIPMENT IN THE EVENT THE INSTALLATION IS NOT IMMEDIATE.
  3. DIRECT FINAL PLACEMENT OF THE EQUIPMENT.
  4. COORDINATE SYSTEM DELIVERY DETAILS WITH THE CUSTOMER, SHIPPING COMPANY AND RIGGING CREW.

- BY CUSTOMER:
1. WITH THE AID OF A SWISSRAY SERVICE REPRESENTATIVE VERIFY EQUIPMENT DELIVERY ROUTE(S) TO THE ROOM PRIOR TO DELIVERY.
  2. WITH THE AID OF A SWISSRAY SERVICE REPRESENTATIVE VERIFY SIZE/INTEGRITY OF ANY ELEVATOR(S) USED FOR ROUTING OF EQUIPMENT PRIOR TO DELIVERY.
  3. IF RAMPS ARE BEING USED, VERIFY ANGLE AND DEGREE OF SLOPE SO EQUIPMENT MAY BE TRANSPORTED WITHOUT DIFFICULTIES.
  4. ENSURE THAT THE AREA REQUESTED BY THE CUSTOMER IS OPEN AND FREE OF ALL OBSTRUCTIONS.
  5. REMOVE ANY OBSTRUCTIONS ALONG THE DELIVERY ROUTE.
  6. HAVE A FACILITIES REPRESENTATIVE AVAILABLE AT THE TIME OF DELIVERY.

PLEASE NOTE THAT THESE ARE FIRST VERSION PLANS SO SOME INFORMATION SPECIFIED MAY CHANGE.



THESE DOCUMENTS CONTAIN PROPRIETARY DATA OF SWISSRAY INTERNATIONAL INC. AND SHALL NOT BE USED FOR PURPOSES OTHER THAN THOSE AGREED UPON BETWEEN SWISSRAY INTERNATIONAL AND ITS CUSTOMER. THESE DRAWINGS ARE NOT TO BE USED FOR CONSTRUCTION PURPOSES AND ARE FOR REVIEWING PURPOSES ONLY.

TYPICAL ROOM PLANS

DRAWN BY	SR
SCALE	NTS
DATE	2/7/08
PROJECT NO.	SR0000-P
SHEET NO.	2.0

**REQUIREMENTS**

**DOORS & PASSAGEWAYS:**  
 MINIMUM EQUIPMENT ENTRY DOOR WIDTH: 36" RECOMMENDED: 48"  
 MINIMUM EQUIPMENT ENTRY DOOR HEIGHT: 80"  
 MINIMUM EQUIPMENT CORRIDOR WIDTH: 60"

**EQUIPMENT ROUTING ELEVATORS:**  
 MINIMUM EQUIPMENT ENTRY DOOR WIDTH: 36" RECOMMENDED: 48"  
 MINIMUM EQUIPMENT ENTRY DOOR HEIGHT: 80"  
 MINIMUM ELEVATOR LENGTH: 98"

**CEILING, WALLS & FLOOR:**  
 MINIMUM EXAM ROOM CEILING HEIGHT: 9'-6" A.F.F. RECOMMENDED: 10'-0" A.F.F.  
 MINIMUM CONTROL AREA WALL HEIGHT: 7'-0" A.F.F. (IF APPLICABLE)  
 EXAM ROOM FLOOR MUST BE LEVEL/FLAT FOR OPTIMIZED PERFORMANCE OF EQUIPMENT.

**POWER:**  
 3 PHASE, 480 VAC, 100 AMP, 60 HZ (5% UNDER LOAD CONDITIONS)  
 1 PHASE, 208-230 VAC, 20 AMP, 60 HZ (5% UNDER LOAD CONDITIONS)  
 THE BUILDING GROUND CONDUCTOR MUST BE 100 OHMS OR LESS TO EARTH GROUND.

**SUGGESTED ENVIRONMENTAL ROOM CONDITIONS:**  
 70° - 75° FAHRENHEIT, 10% - 80% RELATIVE HUMIDITY.  
 THE TEMPERATURE IN THE EXAM ROOM SHOULD BE MAINTAINED IF THE DDR SYSTEM REMAINS POWERED ON.  
 FAILURE TO COMPLY MAY CAUSE EXTENDED DOWN TIME IN ORDER TO RESTABLIZE THE DDR SYSTEM.

**EQUIPMENT INSTALL RESPONSIBILITIES**

**BY SWISSRAY:**  
 1. TO PROVIDE ALL INTERCONNECT WIRES AND CABLING FOR THE SWISSRAY SYSTEM COMPONENTS.  
 2. ALL CABLES PROVIDED WILL BE SELF-SHIELDING AND NO SPLICES WILL BE MADE.

**BY CUSTOMER/CONTRACTOR:**  
 1. CONTACT PHYSICIST TO DETERMINE AREA SHIELDING REQUIREMENTS.  
 2. TO PROVIDE, INSTALL AND DETERMINE LOCATION/SIZE OF LEAD LINED WINDOWS/WALLS PER LOCAL CODE/OTHERS.  
 3. TO PROVIDE AND INSTALL 5'W X 2'D (MINIMUM) WORK SURFACE IN CONTROL AREA ALONG WITH ANY CABINETRY, COUNTERS AND SINKS THROUGHOUT THE SUITE PER CUSTOMER NEEDS.  
 4. TO PROVIDE AND INSTALL DATA OUTLET CAT 5 WITH COLOR CODED RJ45 JACKS IN CONTROL AREA.  
 5. TO PROVIDE AND INSTALL ALL A.C. PANELS, CONDUITS, JUNCTION BOXES AND WIRE WAYS FROM THE MAIN SERVICE EQUIPMENT, (OR THE SEPARATELY DIVIDED POWER SOURCES), TO THE SWISSRAY SYSTEMS.  
 6. ALL CONDUITS AND WIRE WAYS IN THE EXAM ROOM/CONTROL AREA MUST BE INSTALLED PRIOR TO COMMENCEMENT OF EQUIPMENT INSTALLATION.

**DESIGN & LAYOUT CONSIDERATIONS**

**GENERAL:**  
 1. PROVIDE SUFFICIENT ACCESS TO THE BUILDING EXTERIOR FOR EASE OF SYSTEM DELIVERY.  
 2. SUFFICIENT AREA FOR SERVICE ACCESS TO ALL EQUIPMENT.  
 3. CONVENIENT OUTLETS LOCATED THROUGHOUT THE SUITE.  
 4. NO CARPET IN EXAM ROOM OR CONTROL AREA.

**OPERATIONS:**  
 1. STRONG VISUAL CONTACT BETWEEN OPERATOR AND PATIENT.  
 2. CONVENIENT WORK SURFACE SPACE WITH SUFFICIENT STORAGE SPACE.  
 3. INSTALL KEYBOARD TRAY UNDER WORK SURFACE IN CONTROL AREA FOR THE EXPERT AND DELL SWISSVISION KEYBOARD TO FREE UP WORK SURFACE SPACE.  
 4. INSTALL WALL MOUNT BRACKET ON WALL IN CONTROL AREA FOR THE DELL SWISSVISION MONITOR TO FREE UP WORK SURFACE SPACE.  
 5. INSTALL CPU HOLDER/DOLLY IN CONTROL AREA UNDER THE DELL SWISSVISION TOWER FOR EASY MOBILITY.

**EQUIPMENT CASES, WEIGHTS & SIZES**

TRANSPORT CASE NO.	DESCRIPTION	SIZE OF SHIPPING CRATE	CRATED WEIGHT
1	STAND & INSTALLATION HARDWARE	95" X 41" X 54"	1587 LBS.
2	OPTIC, PC, EXPERT, MONITOR & MANUALS	95" X 41" X 43"	782 LBS.
3	IGS 500 OR 1000 TABLE & COVERS	95" X 34" X 45"	630 LBS.
4	GEN-X 4000 X-RAY GENERATOR	32" X 32" X 60"	254 LBS.
5	IGS 1000H TABLE	94" X 34" X 36"	623 LBS.

**EQUIPMENT LEGEND**

CODE	ITEM	W"	D"	H"	WT. LBS.	WATTS
001	SWISSVISION COMPUTER	9	20	20	45	90
002	SWISSVISION KEYBOARD	18	7	2	3	N/A
003	SWISSVISION MONITOR	20	9	20	19	N/A
004	GEN-X 4000 X-RAY GENERATOR	19	18	49	235	400
005	DDR COMPACT SYSTEM	111	68	89	1711	1800
006	IGS 500 PATIENT TABLE	85	26	28	131	N/A
007	IGS 1000 PATIENT TABLE	89	30	32	304	N/A
008	IGS 1000H PATIENT TABLE	89	30	24-32	326	N/A
009	WEIGHT BEARING STAND	60	24	62	145	N/A
010	LONG LEG STAND	30	26	80	158	N/A

SYSTEM CODE: CPTP-R

**Swissray**  
 One Tower Center Blvd.  
 East Brunswick, NJ 08816  
 1-800-803-5543

THESE DOCUMENTS CONTAIN PROPRIETARY DATA OF SWISSRAY. ANY REPRODUCTION OR DISSEMINATION OF THESE DRAWINGS OTHER THAN THOSE AGREED UPON BETWEEN SWISSRAY INTERNATIONAL AND ITS CUSTOMER, THESE DRAWINGS ARE NOT TO BE USED FOR CONSTRUCTION PURPOSES AND ARE FOR REVIEWING PURPOSES ONLY.

**TYPICAL ROOM PLANS**

DRAWN BY:	SR
SCALE:	NTS
DATE:	2/7/08
PROJECT NO:	SR00000-P
SHEET NO:	3.0

# EQUIPMENT LAYOUT



b2High

SEE EQUIPMENT LEGEND FOR CODE DESCRIPTION

RECOMMENDED CEILING HEIGHT 10'-0" A.F.F.  
MINIMUM CEILING HEIGHT 9'-6" A.F.F.  
ACTUAL CEILING HEIGHT 9'-6" A.F.F.

**Swissray**

One Tower Center Blvd  
Lynnwood, WA 98016  
Tel: 425.833.6543

THESE DOCUMENTS CONTAIN PROPRIETARY DATA OF SWISSRAY INTERNATIONAL AND ITS CUSTOMER. THESE DRAWINGS ARE NOT TO BE USED FOR CONSTRUCTION PURPOSES AND ARE FOR REVIEWING PURPOSES ONLY.

TYPICAL ROOM PLANS

DRAWN BY: SR

SCALE: NTS

DATE: 2/7/08

PROJECT NO: SR0000-P

SHEET NO: 3.1

# STRUCTURAL LAYOUT



b2High

SWISSRAY COMPACT STAND, INSTALLED BY SWISSRAY SERVICE ENG. THE STAND IS ANCHORED TO THE FLOOR BY MEANS OF 4 BOLTS. USE HILTI HSL 3M12/25 BOLTS ON COMPOUND PLASTER FLOOR CONCRETE CLASS \*)Bn OR ACCORDING TO OTHER NATIONAL REQUIREMENTS. MAY NEED TO THRU BOLT STAND TO THE FLOOR IF CONCRETE DOES NOT MEET REQUIREMENTS. IN CASE OF COMPUTER/SILTED FLOORS AN APPROPRIATE UNDER STRUCTURE OR STAY BOLTS HAVE TO BE USED. A 1:1 DRILL TEMPLATE IS INCLUDED WITH SYSTEM DELIVERY.

\*)Bn = CONCRETE HIGH QUALITY 30 N/mm<sup>2</sup>

BEARING CAPACITY OF FLOOR:  
FLOOR LOAD OF SYSTEM STAND INCLUDING ADDON BUCKY = 1711 LBS  
FLOOR LOAD OF X-RAY GENERATOR = 235 LBS

**Swissray**

One Tower Center Blvd.  
East Brunswick, NJ 08816  
1-800-903-5543

THESE DOCUMENTS CONTAIN PROPRIETARY DATA OF SWISSRAY. ANY REPRODUCTION OR USE FOR PURPOSES OTHER THAN THOSE AGREED UPON BETWEEN SWISSRAY INTERNATIONAL AND ITS CUSTOMER THESE DRAWINGS ARE NOT TO BE USED FOR CONSTRUCTION PURPOSES AND ARE FOR REVIEWING PURPOSES ONLY.

TYPICAL ROOM PLANS

DRAWN BY  
SR

SCALE  
NTS

DATE  
2/7/08

PROJECT NO.  
SR0000-P

SHEET NO.  
4.0

# ELECTRICAL NOTES

b2High



One Tower Center Blvd  
East Brunswick, NJ 08816  
1-800-903-8893

THESE DOCUMENTS CONTAIN PROPRIETARY DATA OF SWISSRAY INTERNATIONAL AND ITS CUSTOMER. THESE DRAWINGS ARE NOT TO BE USED FOR CONSTRUCTION PURPOSES AND ARE FOR REVIEWING PURPOSES ONLY.

TYPICAL ROOM PLANS

DRAWN BY	SR
SCALE	NTS
DATE	2/7/08
PROJECT NO	SR0000-P
SHEET NO	5.0

# CHECKLIST

BEFORE SWISSRAY CAN PRODUCE FINAL PLANS THE CUSTOMER MUST ANSWER THE FOLLOWING QUESTIONS ALONG WITH PROVIDING SIGNATURE. THE CUSTOMER CAN FAX THE COMPLETED CHECKLIST DIRECTLY TO SWISSRAY'S SITE PLANNER AT (908)845-0426. THANK YOU IN ADVANCE.

## EQUIPMENT:

WHICH DDR SYSTEM WILL BE ORDERED? \_\_\_\_\_  
IS IT A RIGHT OR LEFT HANDED SYSTEM? \_\_\_\_\_

## DOORS & PASSAGEWAYS:

IS THE EQUIPMENT ENTRY DOOR WIDTH AT LEAST 36"? \_\_\_\_\_  
IS THE EQUIPMENT ENTRY DOOR HEIGHT AT LEAST 80"? \_\_\_\_\_  
IS THE EQUIPMENT CORRIDOR WIDTH AT LEAST 60"? \_\_\_\_\_

## CEILING, WALLS & FLOOR:

IS THE EXAM ROOM CEILING HEIGHT AT LEAST 9'-6" A.F.F.? \_\_\_\_\_  
IS THE CONTROL AREA WALL HEIGHT AT LEAST 7'-0" A.F.F. (IF APPLICABLE)? \_\_\_\_\_  
IS THE EXAM ROOM FLOOR LEVEL/FLAT? \_\_\_\_\_  
IS THE EXAM ROOM FLOOR CAPABLE OF BEING ANCHOR BOLTED? \_\_\_\_\_

## POWER:

IS THERE 3 PHASE, 480 VAC POWER? \_\_\_\_\_  
IS THERE 1 PHASE, 208-230 VAC POWER? \_\_\_\_\_

\_\_\_\_\_  
CUSTOMER SIGNATURE

\_\_\_\_\_  
PRINT NAME

\_\_\_\_\_  
DATE

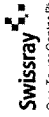

One Tower Center Blvd.  
East Brunswick, NJ 08816  
1-800-903-5543

THESE DOCUMENTS CONTAIN PROPRIETARY DATA OF SWISSRAY INTERNATIONAL AND SHALL NOT BE USED FOR ANY OTHER PROJECTS WITHOUT THE WRITTEN PERMISSION OF SWISSRAY INTERNATIONAL AND ITS CUSTOMER. THESE DRAWINGS ARE NOT TO BE USED FOR CONSTRUCTION PURPOSES AND ARE FOR REVIEWING PURPOSES ONLY.

TYPICAL ROOM PLANS

DRAWN BY	SR
SCALE	NTS
DATE	2/7/08
PROJECT NO.	SR0000-P
SHEET NO.	6.0

**Stevens, Richard P**

---

**From:** Jenkins, John E  
**Sent:** Wednesday, August 20, 2008 11:03 AM  
**To:** Neveleff, Jerald  
**Cc:** Thompson, Arthur D (CTR); Dane, Courtney L (CTR)  
**Subject:** RE: farmville  
**Attachments:** EOIR Farmville.doc

Jerry,

I apologize for not getting back to you yesterday. As far as I know the Field Offices is good with the plan, however with that being said EOIR and OPLA have issues with the facility. The EOIR space that is set aside is not adequate for their space requirements, OPLA requirement have not even been considered. DIHS stated that the layout does not meet their requirements as well. I think that there have been a lot of discussions going on, but not with the proper people. I think it would be wise to regroup and go over the requirement again. We have already missed the original activation date, so let's take the time and get it right.

I would like to have a meeting as soon as possible here in Head Quarters. Let me know when you have time so I can reserve the conference room at 801 I Street.

I have attached a copy of an e-mail below soliciting Bill Weinberg and Bill Dellar help on locating an Interagency Agreement with EOIR. So far no one has been able to locate it. Bill W, suggest that I may need to go to legal to request the information, can you recommend the person that I should talk to on this issue. I don't want to ask EOIR for a copy of the agreement. Please read e-mail below.

I have also attached above EOIR concerns on the Farmville project. OPLA will be sending me letter stating their concern today as well.

Give me a call so we can talk and make arrangements for the meeting.

Thanks

John

*John E. Jenkins*

Acting Unit Chief

Facilities Management Unit

Detention and Removal Operations

Immigration and Customs Enforcement

202- office

202- b6 mobile

(b)(6)

**Warning: This document is UNCLASSIFIED//FOR OFFICIAL USE ONLY (U//FOUO).** It contains information that may be exempt from public release under the Freedom of Information Act (5 U.S.C. 552). It is to be controlled, stored, handled, transmitted, distributed, and disposed of in accordance with DHS policy relating to FOUO information and is not to be released to the public or other personnel who do not have a valid "need-to-know" without prior approval of an authorized DHS official. **No portion of this report should be furnished to the media, either in written or verbal form.**

Good morning Bill and Bill,

I am hoping you can help me locate an Interagency Agreement that we may have with the U.S. Department of Justice, Executive Office for Immigration Review (EOIR).

In accordance with the Intergovernmental Service Agreement (IGSA) and Contract Detention Facilities (CDF) we provide space for EOIR such as Court Rooms, Judges Chambers, Administration Space, Parking and so forth. We have also provided office

12/21/2008



court room furniture as well as electronic equipment, Video Teleconference equipment (V-Tel) basically a full turn key operation at our agency expense. I am finding that the facilities are built pursuant to the agreements with no commitment of placing a judge at the facility. Examples include the Jena and Stewart County projects.

I am trying to locate the agreement to verify the requirements and to determine if (lacking an agreement) we should be getting a commitment letter stating EOIR will be placing a Judge at the facility once activated before we enter into an IGSA and incur unnecessary additional costs. The costs associated with their build-out have a direct cost impact on the day rate at these facilities, as well as other operational requirement such as OPLA.

Please provide me with the agreement. Any advice on how we should proceed in the future is also welcome and appreciated.

Regards

John

*John E. Jenkins*

Acting Unit Chief

Facilities Management Unit

Detention and Removal Operations

Immigration and Customs Enforcement

202- office

202- b6 mobile

(b)(6)

---

**From:** Neveleff, Jerald  
**Sent:** Wednesday, August 20, 2008 8:58 AM  
**To:** Jenkins, John E  
**Subject:** FW: farmville

John,  
Have you had a change to review the latest and greatest from Farmville (separate admin building to be built after the housing unit, just like we discussed back in May)? They are now showing a population of 1040. Please let Arnie know so he can move on with the process.  
Thanks.

By the way, how the heck are you?

Jerry

---

**From:** Casterline, Arnold P  
**Sent:** Wednesday, August 20, 2008 8:17 AM  
**To:** Neveleff, Jerald  
**Subject:** RE: farmville

I have not seen the drawings and the Fairfax office said they were fine, sent an email to John Jenkins to see if he approved them. I have not heard back from him.

*Arnold P. Casterline Jr.*  
Contract Specialist

12/21/2008

Immigration and Customs Enforcement  
Office of Acquisition Management  
Detention Management  
Department of Homeland Security  
425 I Street NW, 5<sup>th</sup> Floor Room 5009  
Washington, DC 20536

e-mail: (b)(6)

phone: 202

Main: 202 b6

*Help us support you better –  
TELL US HOW WE ARE DOING!*

**Go to** <http://www.acqsolinc.com/ICE/OAQ/feedback.cfm>

---

**From:** Neveleff, Jerald  
**Sent:** Wednesday, August 20, 2008 8:14 AM  
**To:** Casterline, Arnold P  
**Subject:** farmville

Have you gotten a response from the DC Field Office regarding the drawings and whether they are satisfied with the detention facility plans?

Refer to EOIR

**Stevens, Richard P**

---

**From:** Thompson, Arthur D (CTR)  
**Sent:** Thursday, August 21, 2008 3:05 PM  
**To:** Neveleff, Jerald  
**Subject:** FW: ICE Farmville Facility  
**Attachments:** image001.jpg; image002.jpg; adfs-01-ocr.doc; adfs-02.doc; ADFS-02-073008.pdf; ADFS-01-073008.pdf

Jerry,

Susan said to forward you a copy of the questions from Farmville that I received today.

Dean

---

**From:** Warren Coleman [mailto:[warren@icefarmville.com](mailto:warren@icefarmville.com)] b6  
**Sent:** Thursday, August 21, 2008 10:07 AM  
**To:** Thompson, Arthur D  
**Subject:** FW: ICE Farmville Facility

Dean

I am sorry for the delay in responding to your call but I was out of the office yesterday. I have attached questions from Mac so please call either one of us if you have questions. At this point, we have submitted a cost sheet to Jerry and Arnold that left the facilities as drawn without any changes. IF you need copies of the latest drawings, please let me know and I will forward them.

Warren

-----Original Message-----

**From:** Russell Harper  
**Sent:** Thursday, August 21, 2008 9:49 AM  
**To:** Warren Coleman  
**Subject:** Fw: ICE Farmville Facility

-----  
Sent from Russell B. Harper

-----Original Message-----

**From:** Bill Mason <[billmason@icefarmville.com](mailto:billmason@icefarmville.com)>  
**To:** Russell Harper b6  
**CC:** b6  
**Sent:** Thu Aug 21 09:50:29 2008  
**Subject:** RE: ICE Farmville Facility

Russell,

I have attached the original documents that were sent to you on 7/30/08 along with questions below.

Attached are our responses/questions to the received standards.

12/21/2008

Questions to you:

1. By these standards, toilets/lavatories/showers have differing requirements than those required by building codes.

We will need to increase the number of fixtures and/or reduce the number of detainee occupants in each dorm to meet these new standards.

Do you want to define what dorm rooms are for Men and for Women, they have differing requirements for plumbing fixtures.

The alternate would be to meet the most restrictive requirements (for Women's dorms) for all dorms regardless of gender.

2. Please review with the local staff, how many detainees they feel is a maximum in the recreation yards (low security use, medium security use, high security use.

3. See "hold room design guide" standard no. 8. The construction of walls in hold room areas can be reinforced masonry or impact resistant steel frame walls. The impact resis <<image002.jpg>> tant steel frame walls are likely to be less expensive, but if hosing down a holding area is the means of cleaning, these area may have special requirements such as epoxy coated walls or portions of walls which can be expensive. Consideration will need to be given to this soon.

Please review this email and attachments, provide your questions and comments, we will revise this response and send it on to Dean Thompson for answers.

Thanks,

Bill Mason

William D. Mason

Timmons/Kelley Architects

14005 Steeplestone Drive

Midlothian, Va. 23113

12/21/2008

Pho b6

Fax: 804-897-5635

b6

Adult local detention facility standards 4th edition

**General Questions:**

b2High

b2High



b2High

The following hold-room specifications are based on the forthcoming INS Hold Room design Guide. These standards emerged from the Hold Room Design standards Workshop held in 1999 in Fort Worth, Texas. Effective immediately, hold rooms shall be designed and constructed to comply with the following criteria:

**General Questions:**

b2High

b2High

b2High

*The following hold-room specifications are based on the forthcoming INS Hold Room Design Guide. These standards emerged from the Hold Room Design Standards Workshop held in 1999 in Fort Worth, Texas. Effective immediately, hold rooms shall be designed and constructed to comply with the following criteria:*

- 1. Hold rooms will be situated in a location within the secure perimeter.*
- 2. Single-occupant hold rooms shall contain a minimum of 37 square feet (seven unencumbered square feet for the detainee, five square feet for a combination lavatory/toilet fixture, and 25 square feet for wheelchair turnaround). Multipleoccupant hold rooms shall provide an additional seven square feet of unencumbered space for each additional detainee.*

*Note: unencumbered space does not include space taken up by benches and tables.*

- 3. Hold rooms shall be well ventilated and well lit. All activating switches/controls shall be located outside the room, in places accessible to staff only.*
- 4. Hold rooms will contain sufficient seating for the maximum room-capacity. The hold room will contain no moveable furniture. Benches may be bolted to the floor or attached to the wall if the wall is of suitable construction. The benches shall provide 18" of seat space per detainee.*
- 5. Bunks/cots/beds and other makeshift sleeping apparatus are not permitted inside holdrooms.*
- 6. All hold rooms shall be equipped with stainless steel, combination lavatory/toilet fixtures with modesty panels, in compliance with the Americans with Disabilities Act of 1990. Consistent with the International Plumbing Code, small hold rooms (up to 14 detainees) will have one combi-unit; large hold rooms (15 to 49 detainees), at least two. (The Hold Room Design Standards A-E, HDR Architecture, recommends a third combi-unit for hold rooms with 30 or more detainees, or one combi-unit for every 15 detainees).*
- 7. Each hold room shall be provided with floor drain(s).*
- 8. Hold-room walls shall be escape- and tamperproof, e.g., 8-inch, reinforced concrete masonry unit wall. Impact-resistant, steel-studded surfaces will also meet this standard, especially in existing buildings that cannot support reinforced concrete. The walls shall extend and be tied into the floor/room structure above. Ceilings shall also be escape- and tamperproof, preferably 10-16' high but no less than nine feet, except in currently existing facilities with lower floor-to-floor heights.*
- 9. Each hold room shall have two-inch thick, detention-grade, 14-gauge steel doors that swing outward. The 14-gauge steel doorframes of shall also be grouted into the surrounding wall. Requirements include tamper-resistant bolt locks, door-mounted with paracentric keys; jamb-mounted, with mogul keys.*
- 10. The solid doors shall be equipped with security-glass or barred windows, 12"x12",*

*Mailroom, telephones,*

**Adult local detention facility standards 4<sup>th</sup> edition:**

Single-occupancy cells: single cells provide at least 35 SF of unencumbered space. At least 70 SF of total floor space is provided when the occupant is confined for more than 10 hours per day.

Multiple-occupancy rooms/cells: multiple-occupancy rooms/cells house between 2 and 64 occupants and provide 25 SF of unencumbered space per occupant. When confinement exceeds 10 hrs per day, at least 35 SF of unencumbered space is provided for each occupant.

Dayrooms provide a min of 35 SF of space per inmate (exclusive of lavatories, showers, and toilets). No dayroom encompasses less than 100 SF of space, exclusive of lavatories, showers, toilets.

Light levels in inmate cells/rooms are at least 20 foot-candles in personal grooming areas and at the writing surface.

All inmate rooms/cells provide the occupants with access to natural light

Each dayroom provides a min of 12 SF of transparent glazing with a view to the outside, plus 2 additional SF of glazing per inmate whose room/cell does not contain an opening or window with a view to the outside.

A ventilation system supplies at least 15 cubic feet per minute of circulated air per occupant with a min of 5 cubic feet per minute of outside air. Toilet rooms and cells with toilets have no less than 4 air changes per hour unless state or local codes require a different number of air changes.

Space is provided for a 24-hr secure control center for monitoring and coordinating the facility's security, life-safety, and communications systems. There are multiple communication systems between the control center and inmate-occupied areas.

Toilets are provided at a min ratio of one for every 12 inmates in male facilities and one for every 8 female inmates and one washbasin for every 12 inmates.

Showers at a minimum ratio of one for every 12 inmates.

Outdoor Exercise areas where 100 or more inmates utilize one recreation area: 15 SF per inmate for the max number of inmates expected to use the space at one time, but not less than 1500 SF of unencumbered space. For less than 100 inmates, 15 SF per inmate and min 750 SF of unencumbered space.

Seg units have both outdoor and covered/enclosed exercise areas. Group yard modules – 15 SF per inmate, min 500 SF. Individual yard modules – 180 SF.

**Stevens, Richard P**

---

**From:** Neveleff, Jerald  
**Sent:** Monday, August 25, 2008 3:26 PM  
**To:** 'Russell Harper'  
**Cc:** Casterline, Arnold P  
**Subject:** RE: Farmville IGSA

Please keep in mind that we are now in our 4<sup>th</sup> restart of the process. Like I said, the goal is as soon as possible with a target of mid September.

Thank you,  
Jerry Neveleff  
Supervisory Contracting Officer/  
IGSA Team Lead  
Office of Acq. Management (OAQ)  
Detention Management Division  
202 b6

Help us support you better -  
TELL US HOW WE ARE DOING!  
Go to <<http://www.acqsolinc.com/ICE/OAQ/feedback.cfm>> <<<http://www.acqsolinc.com/ICE/OAQ/feedback.cfm>>>

---

**From:** Russell Harper [mailto: b6  
**Sent:** Monday, August 25, 2008 3:22 PM  
**To:** Neveleff, Jerald  
**Subject:** Farmville IGSA

Mr. Neveleff,

Thanks for taking the time to review the transportation and housing programs with us this morning. I know you are extremely busy and our team stands ready to address any questions you all may have as quickly as we can in order to execute the contracts by mid September.

Russell B. Harper

b6

## Stevens, Richard P

---

**From:** Neveleff, Jerald  
**Sent:** Tuesday, August 26, 2008 1:38 PM  
**To:** Dellar, William L  
**Subject:** Re: Farmville

Bill  
We r in regular contact with them. I believe we have everything from them except the drawing approval.

Jerry  
-----Original Message-----

From: William Dellar  
To: Neveleff, Jerald  
Sent: Aug 26, 2008 14:25  
Subject: Farmville

Jerry, I plan on calling Craig Raine this afternoon. What specific information do we need from the FO beyond review and approval of the last set of plans and the transportation requirements? Thanks, Bill

Jerry  
Sent using BlackBerry



**Stevens, Richard P**

---

**From:** Raine, Craig K  
**Sent:** Tuesday, August 26, 2008 1:30 PM  
**To:** Achim, Deborah  
**Cc:** Picone, Paul D; Thompson, Arthur D (CTR); Neveleff, Jerald; Jenkins, John E  
**Subject:** RE: Farmville IGSA

Debbie,

Paul and I are fine with the plans. DIHS asked that the door to the Teleradiology area be made larger to accommodate the machine (Farmville agreed) and we ensured that no triple bunking was in place. We had cleared the plans two weeks ago, but DIHS was looking at them as well. Per the meeting on Monday, adding Jerry, Dean and John.

Craig

---

**From:** Achim, Deborah  
**Sent:** Tuesday, August 26, 2008 1:01 PM  
**To:** Raine, Craig K; Picone, Paul D  
**Subject:** FW: Farmville IGSA  
**Importance:** High

Where are we on the latest plans?

---

**From:** Smyly, Elena L  
**Sent:** Tuesday, August 26, 2008 10:32 AM  
**To:** Smyly, Elena L; Achim, Deborah  
**Cc:** Neveleff, Jerald  
**Subject:** RE: Farmville IGSA  
**Importance:** High

Good Morning Deborah,  
Could you please let me know if the blueprints / redesign plans for the Farmville facility were satisfactory? Do we need to have another meeting with the architects and/or county at this point?  
Thank you,

*Elena Smyly, PMP  
Management and Program Analyst - Large IGSA  
DHS, U.S. Immigration and Customs Enforcement  
Office of Detention and Removal  
Detention Management Division  
(202. b6*

---

**From:** Smyly, Elena L  
**Sent:** Tuesday, August 05, 2008 8:06 AM  
**To:** Achim, Deborah  
**Subject:** Farmville IGSA  
**Importance:** High

Hello Deborah,  
We met at the July 17 blueprints discussion meeting in Fairfax.  
Did the architect provide revised blueprints to you?

12/21/2008

Please let me know,  
Thank you,

*Elena Smyly, PMP  
Management and Program Analyst - Large IGSA  
DHS, U.S. Immigration and Customs Enforcement  
Office of Detention and Removal  
Detention Management Division  
(202) b6*

**Stevens, Richard P**

---

**From:** Neveleff, Jerald  
**Sent:** Tuesday, August 26, 2008 1:42 PM  
**To:** Smyly, Elena L  
**Subject:** Re: Farmville

We have all the parts already and are doing the transportation while waiting for the housing to be finalized. I think medical is the last part. I heard the space is ok but layout is wrong -----Original Message-----

From: Smyly, Elena L  
To: Neveleff, Jerald  
Sent: Aug 26, 2008 14:38  
Subject: Farmville

Hi Jerry,

I just spoke with Dean Thompson and he said that he spoke with Craig Raine. According to Dean, field office is OK with the revised design and no changes will be needed. Craig will send us a formal email regarding that.

Once I touch base with Lemont re: medical, I will communicate back to you.

Do you want to wrap transportation part into the IGSA or do you want to separate it out?

Thanks,

Elena Smyly, PMP

Management and Program Analyst - Large IGSA

DHS, U.S. Immigration and Customs Enforcement

Office of Detention and Removal

Detention Management Division

(202) b6

Jerry  
Sent using BlackBerry

**Stevens, Richard P**

---

**From:** Smyly, Elena L  
**Sent:** Tuesday, August 26, 2008 1:38 PM  
**To:** Neveleff, Jerald  
**Subject:** Farmville  
**Importance:** High

Hi Jerry,  
I just spoke with Dean Thompson and he said that he spoke with Craig Raine. According to Dean, field office is OK with the revised design and no changes will be needed. Craig will send us a formal email regarding that. Once I touch base with Lemont re: medical, I will communicate back to you.  
Do you want to wrap transportation part into the IGSA or do you want to separate it out?  
Thanks,

*Elena Smyly, PMP  
Management and Program Analyst - Large IGSA  
DHS, U.S. Immigration and Customs Enforcement  
Office of Detention and Removal  
Detention Management Division  
(202 b6*

## Stevens, Richard P

---

**From:** Neveleff, Jerald  
**Sent:** Thursday, August 28, 2008 8:00 AM  
**To:** 'Warren Coleman'  
**Cc:** 'Russell Harper'; Dellar, William L; Smyly, Elena L; Casterline, Arnold P; Raine, Craig K  
**Subject:** FARMVILLE PROPOSAL

Warren,  
Arnie has been reviewing the latest set of numbers we have to ensure we have everything based on the latest plans to move ahead.

As he was working the transportation efforts, he wanted to make sure all needs are covered somewhere (as we are doing this piece-meal). One thing he noticed was that your numbers had 15 transportation vans in your proposal. Based on the transportation conversations Monday, how are the number and type of vehicles in your proposal affected?

As these vehicles and associated depreciation will be addressed in the bed day rate, it should not slow down the transportation discussions. However, it will need to be discussed before being able to develop an offer for the bed day rates.

Another thing; it appears that the guards you are using for transportation are also housing guards. How does your approach of using guards from the facility to do the transportation affect staffing levels? The concern is that this is being seen at other facilities and in some instances, ICE has been required to perform facility duties at a cost to ICE.

Please be reminded that the SOW (attachment 1) in the RFP states:

“The **PROVIDER** shall provide all such ground transportation services as may be required to transport detainees securely, in a timely manner, to locations as directed by the COTR or designated ICE official. When officers are not providing transportation services, the **PROVIDER** shall assign the employees to supplement security duties within the facility to assist ICE as directed by the COTR or designated ICE official. However, the primary function of these officers is transportation. Duties as directed by the COTR utilizing these officers should not incur any additional expenses to the Government.”

Jerry

Thank you,  
Jerry Neveleff  
Supervisory Contracting Officer/  
IGSA Team Lead  
Office of Acq. Management (OAQ)  
Detention Management Division  
202     b6

Help us support you better -  
TELL US HOW WE ARE DOING!

Go to <http://www.acqsolinc.com/ICE/OAQ/feedback.cfm> <<<http://www.acqsolinc.com/ICE/OAQ/feedback.cfm>>>

**Stevens, Richard P**

---

**From:** Warren Coleman [wcoleman@hdcva.com]  
**Sent:** Thursday, August 28, 2008 8:40 AM  
**To:** Neveleff, Jerald  
**Cc:** Russell Harper; Dellar, William L; Smyly, Elena L; Casterline, Arnold P; Raine, Craig K  
**Subject:** RE: FARMVILLE PROPOSAL

Jerry,

We would like to consider transportation as a stand alone IGSA and completely separate the cost between transportation and housing. The Town of Farmville is in agreement with this approach as it will allow us to separate the liability that is associated with over the road transportation of the detainees from the liability of housing the detainees. We have prepared a cost sheet with this approach in mind that will be sent to you and Arnie within the half hour.

If we take this approach, we should remove the depreciation of the vans from the bed day rate and thus eliminate your concern regarding double coverage for cost.

In our housing proposal, we listed transportation guards on the organization chart to highlight the total organization but we did not have them included in the day rate calculation. We only included the personnel assigned to the housing units in the day rate. We are using the same compensation package for the transportation guards as we have for the housing guards as we see these positions as being interchangeable.

It is our intention to not impose on any ICE resources at the housing facility as we know your staff has a full set of duties to accomplish. We discussed the assignment of the guards as well as the coverage provided by video surveillance in the control room at the July meeting in DC and the people attending the meeting agreed that it was acceptable. If anyone has outstanding questions about the staffing plan, please let us know immediately so we can pass along any impact of their comments to Arnie.

Please call if you have questions regarding our responses or the cost sheet for transportation.

Thanks  
Warren Coleman

---

**From:** Neveleff, Jerald [mailto:] (b)(6)  
**Sent:** Thursday, August 28, 2008 8:00 AM  
**To:** Warren Coleman  
**Cc:** Russell Harper; Dellar, William L; Smyly, Elena L; Casterline, Arnold P; Raine, Craig K  
**Subject:** FARMVILLE PROPOSAL

Warren,

Arnie has been reviewing the latest set of numbers we have to ensure we have everything based on the latest plans to move ahead.

As he was working the transportation efforts, he wanted to make sure all needs are covered somewhere (as we are doing this piece-meal). One thing he noticed was that your numbers had 15 transportation vans in your proposal. Based on the transportation conversations Monday, how are the number and type of vehicles in your proposal affected?

As these vehicles and associated depreciation will be addressed in the bed day rate, it should not slow down the transportation discussions. However, it will need to be discussed before being able to develop an offer for the bed day rates.

Another thing; it appears that the guards you are using for transportation are also housing guards. How does your approach of

12/21/2008

using guards from the facility to do the transportation affect staffing levels? The concern is that this is being seen at other facilities and in some instances, ICE has been required to perform facility duties at a cost to ICE.

Please be reminded that the SOW (attachment 1) in the RFP states:

“The **PROVIDER** shall provide all such ground transportation services as may be required to transport detainees securely, in a timely manner, to locations as directed by the COTR or designated ICE official. When officers are not providing transportation services, the **PROVIDER** shall assign the employees to supplement security duties within the facility to assist ICE as directed by the COTR or designated ICE official. However, the primary function of these officers is transportation. Duties as directed by the COTR utilizing these officers should not incur any additional expenses to the Government.”

Jerry

Thank you,

Jerry Neveleff

Supervisory Contracting Officer/

IGSA Team Lead

Office of Acq. Management (OAQ)

Detention Management Division

202 b6

Help us support you better -

TELL US HOW WE ARE DOING!

Go to <http://www.acqsolinc.com/ICE/OAQ/feedback.cfm> <<<http://www.acqsolinc.com/ICE/OAQ/feedback.cfm>>>

**Stevens, Richard P**

---

**From:** Warren Coleman | b6  
**Sent:** Thursday, August 28, 2008 8:52 AM  
**To:** Neveleff, Jerald; Casterline, Arnold P  
**Cc:** Russell Harper  
**Subject:** Transportation Company Cost Sheet  
**Attachments:** Transportation\_cost\_sheet\_082808.xls

Jerry

As mentioned in my response to your email regarding the transportation project, we would like to treat this company as a stand alone IGSA. The Town of Farmville will be your provider and ICA Transportation LLC (same principals just a separate LLC) will be the sub contractor for this service.

We have developed the cost sheet based on our interpretation of the services needed by ICE and the associated cost to provide quality transportation for all the needs of ICE. We have started with 10 vans but will be glad to increase or decrease that number based on ICE's commitment for services.

Please call if you have any questions.

Warren Coleman



b4

**Stevens, Richard P**

---

**From:** Neveleff, Jerald  
**Sent:** Thursday, August 28, 2008 11:38 AM  
**To:** 'Warren Coleman'  
**Cc:** Russell Harper; Smyly, Elena L; Casterline, Arnold P; Raine, Craig K  
**Subject:** RE: FARMVILLE PROPOSAL

Warren,  
Thank you for answering the concerns.  
As for separating the transportation into its own IGSA, the plan has been and will continue to have ALL Farmville services provided services under ONE IGSA, whichever way we phase it in.

Thank you,  
Jerry Neveleff  
Supervisory Contracting Officer/  
IGSA Team Lead  
Office of Acq. Management (OAQ)  
Detention Management Division  
202 b6

Help us support you better -  
TELL US HOW WE ARE DOING!  
Go to <http://www.acqsolinc.com/ICE/OAQ/feedback.cfm> <<<http://www.acqsolinc.com/ICE/OAQ/feedback.cfm>>>

---

**From:** Warren Coleman [mailto:b6]  
**Sent:** Thursday, August 28, 2008 8:40 AM  
**To:** Neveleff, Jerald  
**Cc:** Russell Harper; Dellar, William L; Smyly, Elena L; Casterline, Arnold P; Raine, Craig K  
**Subject:** RE: FARMVILLE PROPOSAL

Jerry,

We would like to consider transportation as a stand alone IGSA and completely separate the cost between transportation and housing. The Town of Farmville is in agreement with this approach as it will allow us to separate the liability that is associated with over the road transportation of the detainees from the liability of housing the detainees. We have prepared a cost sheet with this approach in mind that will be sent to you and Arnie within the half hour.

If we take this approach, we should remove the depreciation of the vans from the bed day rate and thus eliminate your concern regarding double coverage for cost.

In our housing proposal, we listed transportation guards on the organization chart to highlight the total organization but we did not have them included in the day rate calculation. We only included the personnel assigned to the housing units in the day rate. We are using the same compensation package for the transportation guards as we have for the housing guards as we see these positions as being interchangeable.

It is our intention to not impose on any ICE resources at the housing facility as we know your staff has a full set of duties to accomplish. We discussed the assignment of the guards as well as the coverage provided by video surveillance in the control room at the July meeting in DC and the people attending the meeting agreed that it was acceptable. If anyone has outstanding questions about the staffing plan, please let us know immediately so we can pass along any impact of their comments to Arnie.

Please call if you have questions regarding our responses or the cost sheet for transportation.

Thanks  
Warren Coleman

---

**From:** Neveleff, Jerald [mailto: (b)(6)]  
**Sent:** Thursday, August 28, 2008 8:00 AM  
**To:** Warren Coleman  
**Cc:** Russell Harper; Dellar, William L; Smyly, Elena L; Casterline, Arnold P; Raine, Craig K  
**Subject:** FARMVILLE PROPOSAL

Warren,

Arnie has been reviewing the latest set of numbers we have to ensure we have everything based on the latest plans to move ahead.

As he was working the transportation efforts, he wanted to make sure all needs are covered somewhere (as we are doing this piece-meal). One thing he noticed was that your numbers had 15 transportation vans in your proposal. Based on the transportation conversations Monday, how are the number and type of vehicles in your proposal affected?

As these vehicles and associated depreciation will be addressed in the bed day rate, it should not slow down the transportation discussions. However, it will need to be discussed before being able to develop an offer for the bed day rates.

Another thing; it appears that the guards you are using for transportation are also housing guards. How does your approach of using guards from the facility to do the transportation affect staffing levels? The concern is that this is being seen at other facilities and in some instances, ICE has been required to perform facility duties at a cost to ICE.

Please be reminded that the SOW (attachment 1) in the RFP states:

“The **PROVIDER** shall provide all such ground transportation services as may be required to transport detainees securely, in a timely manner, to locations as directed by the COTR or designated ICE official. When officers are not providing transportation services, the **PROVIDER** shall assign the employees to supplement security duties within the facility to assist ICE as directed by the COTR or designated ICE official. However, the primary function of these officers is transportation. Duties as directed by the COTR utilizing these officers should not incur any additional expenses to the Government.”

Jerry

Thank you,

Jerry Neveleff

Supervisory Contracting Officer/

IGSA Team Lead

Office of Acq. Management (OAQ)

Detention Management Division

20 b6

12/21/2008

Help us support you better -

TELL US HOW WE ARE DOING!

Go to <http://www.acqsolinc.com/ICE/OAQ/feedback.cfm> <<<http://www.acqsolinc.com/ICE/OAQ/feedback.cfm>>>

**Stevens, Richard P**

---

**From:** Warren Coleman [wcoleman@hdcva.com]  
**Sent:** Thursday, August 28, 2008 1:56 PM  
**To:** Neveleff, Jerald  
**Cc:** Russell Harper; Smyly, Elena L; Casterline, Arnold P; Raine, Craig K  
**Subject:** RE: FARMVILLE PROPOSAL

Jerry

I spoke with Russell and understand the need for one IGSA. We were only hoping to simply the process and definitely not complicate or slow it down.

Thanks for working to move this forward to completion.

Warren

---

**From:** Neveleff, Jerald [mailto: (b)(6)]  
**Sent:** Thursday, August 28, 2008 11:38 AM  
**To:** Warren Coleman  
**Cc:** Russell Harper; Smyly, Elena L; Casterline, Arnold P; Raine, Craig K  
**Subject:** RE: FARMVILLE PROPOSAL

Warren,  
Thank you for answering the concerns.  
As for separating the transportation into its own IGSA, the plan has been and will continue to have ALL Farmville services provided services under ONE IGSA, whichever way we phase it in.

Thank you,  
Jerry Neveleff  
Supervisory Contracting Officer/  
IGSA Team Lead  
Office of Acq. Management (OAQ)  
Detention Management Division  
202 b6

Help us support you better -  
TELL US HOW WE ARE DOING!

Go to <<http://www.acqsolinc.com/ICE/OAQ/feedback.cfm>> <<<http://www.acqsolinc.com/ICE/OAQ/feedback.cfm>>>

---

**From:** Warren Coleman [mailto:wcoleman@hdcva.com]  
**Sent:** Thursday, August 28, 2008 8:40 AM  
**To:** Neveleff, Jerald  
**Cc:** Russell Harper; Dellar, William L; Smyly, Elena L; Casterline, Arnold P; Raine, Craig K  
**Subject:** RE: FARMVILLE PROPOSAL

Jerry,

We would like to consider transportation as a stand alone IGSA and completely separate the cost between transportation and housing. The Town of Farmville is in agreement with this approach as it will allow us to separate the liability that is associated with over the road transportation of the detainees from the liability of housing the detainees. We have prepared a cost sheet with this approach in mind that will be sent to you and Arnie within the half hour.

12/21/2008

If we take this approach, we should remove the depreciation of the vans from the bed day rate and thus eliminate your concern regarding double coverage for cost.

In our housing proposal, we listed transportation guards on the organization chart to highlight the total organization but we did not have them included in the day rate calculation. We only included the personnel assigned to the housing units in the day rate. We are using the same compensation package for the transportation guards as we have for the housing guards as we see these positions as being interchangeable.

It is our intention to not impose on any ICE resources at the housing facility as we know your staff has a full set of duties to accomplish. We discussed the assignment of the guards as well as the coverage provided by video surveillance in the control room at the July meeting in DC and the people attending the meeting agreed that it was acceptable. If anyone has outstanding questions about the staffing plan, please let us know immediately so we can pass along any impact of their comments to Arnie.

Please call if you have questions regarding our responses or the cost sheet for transportation.

Thanks  
Warren Coleman

---

**From:** Neveleff, Jerald [mailto: (b)(6)]  
**Sent:** Thursday, August 28, 2008 8:00 AM  
**To:** Warren Coleman  
**Cc:** Russell Harper; Dellar, William L; Smyly, Elena L; Casterline, Arnold P; Raine, Craig K  
**Subject:** FARMVILLE PROPOSAL

Warren,

Arnie has been reviewing the latest set of numbers we have to ensure we have everything based on the latest plans to move ahead.

As he was working the transportation efforts, he wanted to make sure all needs are covered somewhere (as we are doing this piece-meal). One thing he noticed was that your numbers had 15 transportation vans in your proposal. Based on the transportation conversations Monday, how are the number and type of vehicles in your proposal affected?

As these vehicles and associated depreciation will be addressed in the bed day rate, it should not slow down the transportation discussions. However, it will need to be discussed before being able to develop an offer for the bed day rates.

Another thing; it appears that the guards you are using for transportation are also housing guards. How does your approach of using guards from the facility to do the transportation affect staffing levels? The concern is that this is being seen at other facilities and in some instances, ICE has been required to perform facility duties at a cost to ICE.

Please be reminded that the SOW (attachment 1) in the RFP states:

“The **PROVIDER** shall provide all such ground transportation services as may be required to transport detainees securely, in a timely manner, to locations as directed by the COTR or designated ICE official. When officers are not providing transportation services, the **PROVIDER** shall assign the employees to supplement security duties within the facility to assist ICE as directed by the COTR or designated ICE official. However, the primary function of these officers is transportation. Duties as directed by the COTR utilizing these officers should not incur any additional expenses to the Government.”

Jerry

Thank you,

12/21/2008

Jerry Neveleff

Supervisory Contracting Officer/

IGSA Team Lead

Office of Acq. Management (OAQ)

Detention Management Division

20: b6

Help us support you better -

TELL US HOW WE ARE DOING!

Go to <http://www.acqsolinc.com/ICE/OAQ/feedback.cfm> <<<http://www.acqsolinc.com/ICE/OAQ/feedback.cfm>>>

**Stevens, Richard P**

---

**From:** Russell Harper (b6)  
**Sent:** Friday, August 29, 2008 9:40 AM  
**To:** Neveleff, Jerald; Warren Coleman  
**Cc:** Smyly, Elena L; Casterline, Arnold P; Raine, Craig K  
**Subject:** RE: FARMVILLE PROPOSAL

Jerry,

Can you let me know what date you see this starting? You mentioned two weeks. We need to coordinate delivery of vans, personnel and logistics.

Thank you,

Russell Harper

---

**From:** Neveleff, Jerald [mailto: (b)(6)]  
**Sent:** Thursday, August 28, 2008 11:38 AM  
**To:** Warren Coleman  
**Cc:** Russell Harper; Smyly, Elena L; Casterline, Arnold P; Raine, Craig K  
**Subject:** RE: FARMVILLE PROPOSAL

Warren,  
Thank you for answering the concerns.  
As for separating the transportation into its own IGSA, the plan has been and will continue to have ALL Farmville services provided services under ONE IGSA, whichever way we phase it in.

Thank you,  
Jerry Neveleff  
Supervisory Contracting Officer/  
IGSA Team Lead  
Office of Acq. Management (OAQ)  
Detention Management Division  
202, (b6)

Help us support you better -  
TELL US HOW WE ARE DOING!  
Go to <<http://www.acqsolinc.com/ICE/OAQ/feedback.cfm>> <<<http://www.acqsolinc.com/ICE/OAQ/feedback.cfm>>>

---

**From:** Warren Coleman [mailto: (b6)]  
**Sent:** Thursday, August 28, 2008 8:40 AM  
**To:** Neveleff, Jerald  
**Cc:** Russell Harper; Dellar, William L; Smyly, Elena L; Casterline, Arnold P; Raine, Craig K  
**Subject:** RE: FARMVILLE PROPOSAL

Jerry,

We would like to consider transportation as a stand alone IGSA and completely separate the cost between transportation and



housing. The Town of Farmville is in agreement with this approach as it will allow us to separate the liability that is associated with over the road transportation of the detainees from the liability of housing the detainees. We have prepared a cost sheet with this approach in mind that will be sent to you and Arnie within the half hour.

If we take this approach, we should remove the depreciation of the vans from the bed day rate and thus eliminate your concern regarding double coverage for cost.

In our housing proposal, we listed transportation guards on the organization chart to highlight the total organization but we did not have them included in the day rate calculation. We only included the personnel assigned to the housing units in the day rate. We are using the same compensation package for the transportation guards as we have for the housing guards as we see these positions as being interchangeable.

It is our intention to not impose on any ICE resources at the housing facility as we know your staff has a full set of duties to accomplish. We discussed the assignment of the guards as well as the coverage provided by video surveillance in the control room at the July meeting in DC and the people attending the meeting agreed that it was acceptable. If anyone has outstanding questions about the staffing plan, please let us know immediately so we can pass along any impact of their comments to Arnie.

Please call if you have questions regarding our responses or the cost sheet for transportation.

Thanks  
Warren Coleman

---

**From:** Neveleff, Jerald [mailto: ] (b)(6)  
**Sent:** Thursday, August 28, 2008 8:00 AM  
**To:** Warren Coleman  
**Cc:** Russell Harper; Dellar, William L; Smyly, Elena L; Casterline, Arnold P; Raine, Craig K  
**Subject:** FARMVILLE PROPOSAL

Warren,

Arnie has been reviewing the latest set of numbers we have to ensure we have everything based on the latest plans to move ahead.

As he was working the transportation efforts, he wanted to make sure all needs are covered somewhere (as we are doing this piece-meal). One thing he noticed was that your numbers had 15 transportation vans in your proposal. Based on the transportation conversations Monday, how are the number and type of vehicles in your proposal affected?

As these vehicles and associated depreciation will be addressed in the bed day rate, it should not slow down the transportation discussions. However, it will need to be discussed before being able to develop an offer for the bed day rates.

Another thing; it appears that the guards you are using for transportation are also housing guards. How does your approach of using guards from the facility to do the transportation affect staffing levels? The concern is that this is being seen at other facilities and in some instances, ICE has been required to perform facility duties at a cost to ICE.

Please be reminded that the SOW (attachment 1) in the RFP states:

“The **PROVIDER** shall provide all such ground transportation services as may be required to transport detainees securely, in a timely manner, to locations as directed by the COTR or designated ICE official. When officers are not providing transportation services, the **PROVIDER** shall assign the employees to supplement security duties within the facility to assist ICE as directed by the COTR or designated ICE official. However, the primary function of these officers is transportation. Duties as directed by the COTR utilizing these officers should not incur any additional expenses to the Government.”

Jerry

Thank you,

Jerry Neveleff

Supervisory Contracting Officer/

IGSA Team Lead

Office of Acq. Management (OAQ)

Detention Management Division

20: b6

Help us support you better -

TELL US HOW WE ARE DOING!

Go to <http://www.acqsolinc.com/ICE/OAQ/feedback.cfm> <<<http://www.acqsolinc.com/ICE/OAQ/feedback.cfm>>>

**Stevens, Richard P**

---

**From:** Russell Harper (b6)  
**Sent:** Friday, August 29, 2008 9:51 AM  
**To:** Neveleff, Jerald  
**Cc:** Smyly, Elena L; Casterline, Arnold P; Raine, Craig K; Warren Coleman  
**Subject:** RE: FARMVILLE PROPOSAL

Thanks. We have internally scheduled to start September 11<sup>th</sup>. If we need to start prior to that we will be available.

---

**From:** Neveleff, Jerald [mailto: (b)(6)]  
**Sent:** Friday, August 29, 2008 9:46 AM  
**To:** Russell Harper; Neveleff, Jerald; Warren Coleman  
**Cc:** Smyly, Elena L; Casterline, Arnold P; Raine, Craig K  
**Subject:** Re: FARMVILLE PROPOSAL

I'll know more tuesday

-----Original Message-----

**From:** Russell Harper  
**To:** Work  
**To:** Warren Coleman  
**Cc:** Smyly, Elena L  
**Cc:** Casterline, Arnold P  
**Cc:** Raine, Craig K  
**Sent:** Aug 29, 2008 09:40  
**Subject:** RE: FARMVILLE PROPOSAL

Jerry,

Can you let me know what date you see this starting? You mentioned two weeks. We need to coordinate delivery of vans, personnel and logistics.

Thank you,

Russell Harper

---

**From:** Neveleff, Jerald [mailto: (b)(6)]  
**Sent:** Thursday, August 28, 2008 11:38 AM  
**To:** Warren Coleman  
**Cc:** Russell Harper; Smyly, Elena L; Casterline, Arnold P; Raine, Craig K

Subject: RE: FARMVILLE PROPOSAL

Warren,

Thank you for answering the concerns.

As for separating the transportation into its own IGSA, the plan has been and will continue to have ALL Farmville services provided services under ONE IGSA, whichever way we phase it in.

Thank you,  
Jerry Neveleff  
Supervisory Contracting Officer/  
IGSA Team Lead  
Office of Acq. Management (OAQ)  
Detention Management Division  
20. b6

Help us support you better -  
TELL US HOW WE ARE DOING!  
Go to <<http://www.acqsolinc.com/ICE/OAQ/feedback.cfm>> <<<http://www.acqsolinc.com/ICE/OAQ/feedback.cfm>>>

---

From: Warren Coleman [<mailto:wcoleman@hdcva.com>]  
Sent: Thursday, August 28, 2008 8:40 AM  
To: Neveleff, Jerald  
Cc: Russell Harper; Dellar, William L; Smyly, Elena L; Casterline, Arnold P; Raine, Craig K  
Subject: RE: FARMVILLE PROPOSAL

Jerry,

We would like to consider transportation as a stand alone IGSA and completely separate the cost between transportation and

-----Original Message Truncated-----

Jerry  
Sent using BlackBerry

**Stevens, Richard P**

---

**From:** Warren Coleman b6  
**Sent:** Friday, August 29, 2008 4:35 PM  
**To:** Neveleff, Jerald  
**Cc:** Casterline, Arnold P; Russell Harper  
**Subject:** FW: Farmville ICE

**Attachments:** Farmville ICE-A1.1 overall floor plan.pdf; Farmville ICE-A1.4A floor plan-building area A.pdf; Farmville ICE-A1.4B floor plan-building area B.pdf; Farmville ICE-A1.4C floor plan-building areaC.pdf; Farmville ICE-A1.4D floor plan-building areaD.pdf

Jerry

Please pass along these drawings which reflect the requested changes to the appropriate individuals in ICE. Our architect has added more details to hopefully answer any outstanding questions but please call if anyone has questions. We will follow up on Tuesday to ensure you have what you need.

Have a good weekend.

Warren

---

**Mark Evans**

**Office:** b6

**Cell:** b6

b6

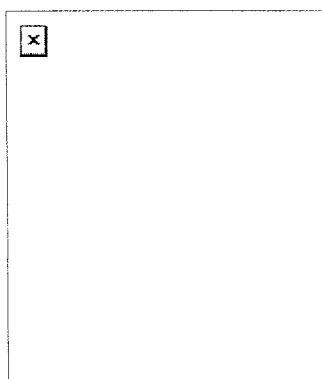

**Stevens, Richard P**

---

**From:** Jenkins, John E  
**Sent:** Friday, August 29, 2008 9:55 AM  
**To:** Neveleff, Jerald  
**Cc:** Flanagan, Lamont; Vazquez, Edwin; Thompson, Arthur D (CTR); Dane, Courtney L (CTR)  
**Subject:** Farmville (DIHS) review concerns

Jerry,

The Washington Field Office has approved the most recent floor plan for the Farmville Facility which I support. With that being said DIHS will be supporting the mission and are in the process of reviewing the layout, their comments are due September 2<sup>nd</sup>. It has come to my attention, they may have some concerns. Please wait for their comment before proceeding any further.

Please feel free to contact me if you would like to discuss this with me.

Thanks

*John E. Jenkins*  
Acting Unit Chief  
Facilities Management Unit  
Detention and Removal Operations  
Immigration and Customs Enforcement  
202- office  
202- b6 mobile  
(b)(6)

**Warning: This document is UNCLASSIFIED//FOR OFFICIAL USE ONLY (U//FOUO).** It contains information that may be exempt from public release under the Freedom of Information Act (5 U.S.C. 552). It is to be controlled, stored, handled, transmitted, distributed, and disposed of in accordance with DHS policy relating to FOUO information and is not to be released to the public or other personnel who do not have a valid "need-to-know" without prior approval of an authorized DHS official. **No portion of this report should be furnished to the media, either in written or verbal form.**

b2High



TIMMONS-KELLEY  
ARCHITECTS  
1008 BRIDLE PATH, SUITE 1000, FARMVILLE, VIRGINIA 22431  
TEL: (800) 881-8888 FAX: (800) 881-8888  
WWW.TKARCHITECTS.COM



OVERALL FLOOR PLAN  
**ICE FARMVILLE PROJECT**  
DETAINEE HOUSING FACILITY  
FARMVILLE, VIRGINIA

REV.	DATE	DESCRIPTION
1.0	08-11-12	ISSUED FOR PERMIT
2.0	08-11-12	ISSUED FOR PERMIT
3.0	08-11-12	ISSUED FOR PERMIT
4.0	08-11-12	ISSUED FOR PERMIT
5.0	08-11-12	ISSUED FOR PERMIT
6.0	08-11-12	ISSUED FOR PERMIT
7.0	08-11-12	ISSUED FOR PERMIT
8.0	08-11-12	ISSUED FOR PERMIT
9.0	08-11-12	ISSUED FOR PERMIT
10.0	08-11-12	ISSUED FOR PERMIT

PROJECT NO. 08-112  
DRAWN BY: MKJ/TKA  
ARCHITECT: K. KELLEY  
SHEET NO. **A1.1**

b2High



TIMMONS-KELLEY  
ARCHITECTS  
11000 WOODBRIDGE ROAD, SUITE 100, WASHINGTON, VIRGINIA 22102  
PH: (703) 897-8800 / FAX: (703) 897-8804  
WWW.TKARCHITECTS.COM



MAIN FLOOR PLAN - BUILDING AREA A  
**ICE FARMVILLE PROJECT**  
DETAINEE HOUSING FACILITY  
FARMVILLE, VIRGINIA

DATE	ISSUED FOR
6/29/08	CONTRACT
7/16/08	FOR PERMIT
8/14/08	FOR CONSTRUCTION

PROJECT NO: 08-1182  
DESIGNER: TK ARCHITECTS  
ARCHITECT: M. KELLEY  
SHEET NO: **A1.4A**



b2High



TIMMONS-KELLEY  
ARCHITECTS  
1000 EASTPARK DRIVE, SUITE 1000  
FARMVILLE, VIRGINIA 22431  
TEL: 804-426-1000 FAX: 804-426-1001



MAIN FLOOR PLAN - BUILDING AREA B  
**ICE FARMVILLE PROJECT**  
DETAINEE HOUSING FACILITY  
FARMVILLE, VIRGINIA

DATE	DESCRIPTION
12/10/08	ISSUED FOR PERMIT
12/10/08	ISSUED FOR PERMIT
12/10/08	ISSUED FOR PERMIT
12/10/08	ISSUED FOR PERMIT
12/10/08	ISSUED FOR PERMIT
12/10/08	ISSUED FOR PERMIT
12/10/08	ISSUED FOR PERMIT
12/10/08	ISSUED FOR PERMIT
12/10/08	ISSUED FOR PERMIT
12/10/08	ISSUED FOR PERMIT

PROJECT NO. 08-192  
DRAWN BY: M. KELLEY  
ARCHITECT: M. KELLEY  
SHEET NO. **A1.4B**

b2High



**TIMMONS-KELLEY**  
ARCHITECTS  
1000  
EMPLOYERS' STATE ASSOCIATION, 2011  
1000



MAIN FLR. & MEZZ FLR. PLANS - BLDG. AREA C  
**ICE FARMVILLE PROJECT**  
DETAINEE HOUSING FACILITY  
FARMVILLE, VIRGINIA

REV.	DESCRIPTION
1/2/18	ISSUED FOR PERMIT
2/2/18	ISSUED FOR PERMIT
3/2/18	ISSUED FOR PERMIT
4/2/18	ISSUED FOR PERMIT
5/2/18	ISSUED FOR PERMIT
6/2/18	ISSUED FOR PERMIT
7/2/18	ISSUED FOR PERMIT
8/2/18	ISSUED FOR PERMIT
9/2/18	ISSUED FOR PERMIT
10/2/18	ISSUED FOR PERMIT
11/2/18	ISSUED FOR PERMIT
12/2/18	ISSUED FOR PERMIT

PROJECT NO. DR-102  
DATE: 10/2/18  
DRAWN BY: H. KELLEY  
CHECKED BY: H. KELLEY  
DATE: 10/2/18  
PROJECT NO. **A1.4C**

b2High



**TIMMONS-KELLEY**  
ARCHITECTS  
11000 WASHINGTON AVE. - SUITE 2000, WASHINGTON, DC 20037  
TEL: (202) 877-3434 • FAX: (202) 877-3434  
WWW.TIMMONSKELLEYARCHITECTS.COM



MAIN FLOOR PLAN - BUILDING AREA D  
**ICE FARMVILLE PROJECT**  
DETAINEE HOUSING FACILITY  
FARMVILLE, VIRGINIA

DATE	ISSUED FOR

PROJECT NO. 00-102  
DESIGNER: TIMMONS-KELLEY ARCHITECTS  
ARCHITECT: M. KELLEY  
DATE: 01/14/04

**Stevens, Richard P**

---

**From:** Neveleff, Jerald  
**Sent:** Tuesday, September 02, 2008 10:11 AM  
**To:** Casterline, Arnold P  
**Subject:** FW: ICE Farmville Facility  
**Attachments:** image001.jpg; image002.jpg; adfs-01-ocr.doc; adfs-02.doc; ADFS-02-073008.pdf; ADFS-01-073008.pdf

Thank you,  
Jerry Neveleff  
Supervisory Contracting Officer/  
IGSA Team Lead  
Office of Acq. Management (OAQ)  
Detention Management Division  
202 b6

Help us support you better -  
TELL US HOW WE ARE DOING!  
Go to <http://www.acqsolinc.com/ICE/OAQ/feedback.cfm> <<<http://www.acqsolinc.com/ICE/OAQ/feedback.cfm>>>

---

**From:** Thompson, Arthur D (CTR)  
**Sent:** Thursday, August 21, 2008 3:05 PM  
**To:** Neveleff, Jerald  
**Subject:** FW: ICE Farmville Facility

Jerry,  
  
Susan said to forward you a copy of the questions from Farmville that I received today.  
  
Dean

---

**From:** Warren Coleman [mailto: b6]  
**Sent:** Thursday, August 21, 2008 10:07 AM  
**To:** Thompson, Arthur D  
**Subject:** FW: ICE Farmville Facility

Dean  
I am sorry for the delay in responding to your call but I was out of the office yesterday. I have attached questions from Mac so please call either one of us if you have questions. At this point, we have submitted a cost sheet to Jerry and Arnold that left the facilities as drawn without any changes. IF you need <<adfs-01-ocr.doc>> copies of the latest <<adfs-02.doc>> drawings, please <<ADFS-02-073008.pdf>> let me know and I will forward them.

Warren  
  
-----Original Message-----  
From: Russell Harper  
Sent: Thursday, August 21, 2008 9:49 AM  
To: Warren Coleman

Subject: Fw: ICE Farmville Facility

-----  
Sent from Russell B. Harper

-----Original Message-----

From: Bill Mason ·  
To: Russell Harper b6  
CC:  
Sent: Thu Aug 21 09:50:29 2008 b6  
Subject: RE: ICE Farmville Facility

Russell,

I have attached the original documents that were sent to you on 7/30/08 along with questions below.

Attached are our responses/questions to the received standards.

Questions to you:

1. By these standards, toilets/lavatories/showers have differing requirements than those required by building codes.

We will need to increase the number of fixtures and/or reduce the number of detainee occupants in each dorm to meet these new standards.

Do you want to define what dorm rooms are for Men and for Women, they have differing requirements for plumbing fixtures.

The alternate would be to meet the most restrictive requirements (for Women's dorms) for all dorms regardless of gender.

2. Please review with the local staff, how many detainees they feel is a maximum in the recreation yards (low security use, medium security use, high security use.

3. See "hold room design guide" standard no. 8. The construction of walls in hold room areas can be reinforced masonry or impact resistant steel frame walls. The impact resis <<image002.jpg>> tant steel frame walls are likely to be less expensive, but if hosing down a holding area is the means of cleaning, these area may have special requirements such as epoxy coated walls or portions of walls which can be expensive. Consideration will need to be given to this soon.

Please review this email and attachments, provide your questions and comments, we will revise this response and send it on to Dean Thompson for answers.

Thanks,

Bill Mason

William D. Mason

Timmons/Kelley Architects

14005 Steeplestone Drive

Midlothian, Va. 23113

Phone: b6

Fax: 804-897-5635

b6

Adult local detention facility standards 4th edition

**General Questions:**

b2High

b2High



b2High

The following hold-room specifications are based on the forthcoming INS Hold Room design Guide. These standards emerged from the Hold Room Design standards Workshop held in 1999 in Fort Worth, Texas. Effective immediately, hold rooms shall be designed and constructed to comply with the following criteria:

**General Questions:**

b2High

b2High

b2High

*The following hold-room specifications are based on the forthcoming INS Hold Room Design Guide. These standards emerged from the Hold Room Design Standards Workshop held in 1999 in Fort Worth, Texas. Effective immediately, hold rooms shall be designed and constructed to comply with the following criteria:*

- 1. Hold rooms will be situated in a location within the secure perimeter.*
- 2. Single-occupant hold rooms shall contain a minimum of 37 square feet (seven unencumbered square feet for the detainee, five square feet for a combination lavatory/toilet fixture, and 25 square feet for wheelchair turnaround). Multipleoccupant hold rooms shall provide an additional seven square feet of unencumbered space for each additional detainee.*

*Note: unencumbered space does not include space taken up by benches and tables.*

- 3. Hold rooms shall be well ventilated and well lit. All activating switches/controls shall be located outside the room, in places accessible to staff only.*
- 4. Hold rooms will contain sufficient seating for the maximum room-capacity. The hold room will contain no moveable furniture. Benches may be bolted to the floor or attached to the wall if the wall is of suitable construction. The benches shall provide 18" of seat space per detainee.*
- 5. Bunks/cots/beds and other makeshift sleeping apparatus are not permitted inside holdrooms.*
- 6. All hold rooms shall be equipped with stainless steel, combination lavatory/toilet fixtures with modesty panels, in compliance with the Americans with Disabilities Act of 1990. Consistent with the International Plumbing Code, small hold rooms (up to 14 detainees) will have one combi-unit; large hold rooms (15 to 49 detainees), at least two. (The Hold Room Design Standards A-E, HDR Architecture, recommends a third combi-unit for hold rooms with 30 or more detainees, or one combi-unit for every 15 detainees).*
- 7. Each hold room shall be provided with floor drain(s).*
- 8. Hold-room walls shall be escape- and tamperproof, e.g., 8-inch, reinforced concrete masonry unit wall. Impact-resistant, steel-studded surfaces will also meet this standard, especially in existing buildings that cannot support reinforced concrete. The walls shall extend and be tied into the floor/room structure above. Ceilings shall also be escape- and tamperproof, preferably 10-16' high but no less than nine feet, except in currently existing facilities with lower floor-to-floor heights.*
- 9. Each hold room shall have two-inch thick, detention-grade, 14-gauge steel doors that swing outward. The 14-gauge steel doorframes of shall also be grouted into the surrounding wall. Requirements include tamper-resistant bolt locks, door-mounted with paracentric keys; jamb-mounted, with mogul keys.*
- 10. The solid doors shall be equipped with security-glass or barred windows, 12"x12",*

*Mailroom, telephones,*

**Adult local detention facility standards 4<sup>th</sup> edition:**

Single-occupancy cells: single cells provide at least 35 SF of unencumbered space. At least 70 SF of total floor space is provided when the occupant is confined for more than 10 hours per day.

Multiple-occupancy rooms/cells: multiple-occupancy rooms/cells house between 2 and 64 occupants and provide 25 SF of unencumbered space per occupant. When confinement exceeds 10 hrs per day, at least 35 SF of unencumbered space is provided for each occupant.

Dayrooms provide a min of 35 SF of space per inmate (exclusive of lavatories, showers, and toilets). No dayroom encompasses less than 100 SF of space, exclusive of lavatories, showers, toilets.

Light levels in inmate cells/rooms are at least 20 foot-candles in personal grooming areas and at the writing surface.

All inmate rooms/cells provide the occupants with access to natural light

Each dayroom provides a min of 12 SF of transparent glazing with a view to the outside, plus 2 additional SF of glazing per inmate whose room/cell does not contain an opening or window with a view to the outside.

A ventilation system supplies at least 15 cubic feet per minute of circulated air per occupant with a min of 5 cubic feet per minute of outside air. Toilet rooms and cells with toilets have no less than 4 air changes per hour unless state or local codes require a different number of air changes.

Space is provided for a 24-hr secure control center for monitoring and coordinating the facility's security, life-safety, and communications systems. There are multiple communication systems between the control center and inmate-occupied areas.

Toilets are provided at a min ratio of one for every 12 inmates in male facilities and one for every 8 female inmates and one washbasin for every 12 inmates.

Showers at a minimum ratio of one for every 12 inmates.

Outdoor Exercise areas where 100 or more inmates utilize one recreation area: 15 SF per inmate for the max number of inmates expected to use the space at one time, but not less than 1500 SF of unencumbered space. For less than 100 inmates, 15 SF per inmate and min 750 SF of unencumbered space.

Seg units have both outdoor and covered/enclosed exercise areas. Group yard modules – 15 SF per inmate, min 500 SF. Individual yard modules – 180 SF.

**Stevens, Richard P**

---

**From:** Casterline, Arnold P  
**Sent:** Tuesday, September 02, 2008 10:15 AM  
**To:** 'Warren Coleman'; Raine, Craig K; Neveleff, Jerald  
**Subject:** Transportation

Mr. Coleman,

After evaluating your transportation costs, we have come up with the following hourly rates.



The three positions will be paid individually. They will be funded as three separate line items on the task order. If you have any questions please feel free to give me a call at [redacted] or send me an email to [redacted]

[redacted] Thank you and have a great day.

b6

b6

*Arnold P. Casterline Jr.*

Contract Specialist  
Immigration and Customs Enforcement  
Office of Acquisition Management  
Detention Management  
Department of Homeland Security  
425 I Street NW, 5<sup>th</sup> Floor Room 5009  
Washington, DC 20536  
e-mail: [redacted] (b)(6)  
phone: 202- [redacted]  
Main: 202- [redacted] b6

**Help us support you better –  
TELL US HOW WE ARE DOING!**

**Go to** <http://www.acqsolinc.com/ICE/OAQ/feedback.cfm>

**Stevens, Richard P**

---

**From:** Warren Coleman [mailto: [REDACTED] b6]  
**Sent:** Tuesday, September 02, 2008 10:58 AM  
**To:** Casterline, Arnold P; Raine, Craig K; Neveleff, Jerald  
**Cc:** Russell Harper  
**Subject:** RE: Transportation

Arnie  
 Thanks for your email. I will call shortly to discuss the following questions

1. Per earlier conversations, it was stated that the compensation for drivers would be based on hours worked to eliminate the need to estimate layover time at each site. For example if they left the home base at 7 am and returned at 7pm, then we would be compensated for 12 hours. Of these twelve hours, 8 would be at regular time and 4 at overtime rates (1.5 times). Is this a correct interpretation of the earlier conversation?
2. For the dispatcher and Director of Transportation, assuming they work a 40 hour week, am I correct to assume we would be compensated at 40 hours times their individual rates?
3. Can you provide details on how benefit dollars were determined? What benefits are included in this number and the % or rate used for each? I need to know so I can compare our benefit plan to the one included in your calculation to determine the differences and what adjustments might be needed if we accept this rate.
4. How was the profit % determined?
5. On our cost sheet, we listed other cost to get this business up and running like vehicles, insurance on vehicles, body armor, uniforms, weapons, training etc. How would these expenses be covered? At one point, I know it was mentioned that depreciation on the vehicles would be part of the day rate but how do we deal with these expenses until the facility is up and running? As stated earlier, transportation guards and thus their cost (weapons, training, uniforms etc.) are not included in the day rate since they have to be separate people performing separate duties.

I understand your position that we can not have two separate IGSA but somehow we need to price it and set an hourly rate that will allow us to cover these other cost. In my transportation cost sheet, I spread these cost over the transportation guard hours to include them in the rate.

I look forward to working through these questions towards a successfully conclusion for all parties. Do you have an estimated date when you would like us to start providing this service?

Warren

---

**From:** Casterline, Arnold P [mailto: [REDACTED] (b)(6)]  
**Sent:** Tuesday, September 02, 2008 10:15 AM  
**To:** Warren Coleman; Raine, Craig K; Neveleff, Jerald  
**Subject:** Transportation

Mr. Coleman,

After evaluating your transportation costs, we have come up with the following hourly rates.

[REDACTED]

b4



b4

The three positions will be paid individually. They will be funded as three separate line Items on the task order. If you have any questions please feel free to give me a call at [REDACTED] or send me an email to [REDACTED]

b6

Thank you and have a great day.

*Arnold P. Casterline Jr.*

Contract Specialist

Immigration and Customs Enforcement

Office of Acquisition Management

Detention Management

Department of Homeland Security

425 I Street NW, 5<sup>th</sup> Floor Room 5009

Washington, DC 20536

e-mail: [REDACTED] (b)(6)

phone: 202- [REDACTED]

Main: 202- [REDACTED] b6

***Help us support you better –***

***TELL US HOW WE ARE DOING!***

**Go to** <http://www.acqsolinc.com/ICE/OAQ/feedback.cfm>

## Stevens, Richard P

---

**From:** Neveleff, Jerald  
**Sent:** Tuesday, September 02, 2008 3:25 PM  
**To:** Henkel, Douglas ; Raine, Craig K  
**Cc:** Casterline, Arnold P  
**Subject:** Farmville Transportation

Doug/Craig,  
Arnie has entered into negotiations for the transportation. He has held a phoncon and it seems there is a disconnect from the plans.

The plan I was aware of was from May 08. As PODs are ready, we were going to fill them provided a suitable plan to isolate detainees from construction was submitted. As of today, ICA tells me that the whole facility will be built before detainees will be able to arrive. Therefore it will take 6 months from the time they get the go ahead before detainee one will be able to go into the facility.

We are trying to find a middle of the road approach to start the transportation services 9/15/08 including a lot of costs that should be in the bed day rate that we now have to consider up front.

Thank you,  
Jerry Neveleff  
Supervisory Contracting Officer/  
IGSA Team Lead  
Office of Acq. Management (OAQ)  
Detention Management Division  
202 [REDACTED] b6

Help us support you better -  
TELL US HOW WE ARE DOING!  
Go to <<http://www.acqsolinc.com/ICE/OAQ/feedback.cfm>> <<<http://www.acqsolinc.com/ICE/OAQ/feedback.cfm>>>

**Stevens, Richard P**

---

**From:** Casterline, Arnold P  
**Sent:** Tuesday, September 02, 2008 3:27 PM  
**To:** Neveleff, Jerald  
**Subject:** FW: Transportation

*Arnold P. Casterline Jr.*

Contract Specialist  
Immigration and Customs Enforcement  
Office of Acquisition Management  
Detention Management  
Department of Homeland Security  
425 I Street NW, 5<sup>th</sup> Floor Room 5009  
Washington, DC 20536  
e-mail: (b)(6)  
phone: 202-514- (b)(6)  
Main: 202-514- (b)(6)

**Help us support you better –  
TELL US HOW WE ARE DOING!**

**Go to** <http://www.acqsolinc.com/ICE/OAQ/feedback.cfm>

---

**From:** Warren Coleman [mailto:(b)(6)]  
**Sent:** Tuesday, September 02, 2008 2:52 PM  
**To:** Casterline, Arnold P  
**Cc:** Russell Harper  
**Subject:** FW: Transportation

Arnold

If we use the cost sheet I proposed and I can prove that no cost associated with transportation is included in the calculation for the bed day rate we can reach the same goal. The day rate will cover the cost of housing detainees and the hourly transportation rate will cover the cost of transporting detainees and can more easily be adjusted if the needs of ICE change.

Thanks in advance for considering this option.

Warren

---

**From:** Warren Coleman  
**Sent:** Tuesday, September 02, 2008 10:58 AM  
**To:** 'Casterline, Arnold P'; Raine, Craig K; Neveleff, Jerald  
**Cc:** Russell Harper  
**Subject:** RE: Transportation

Arnie

Thanks for your email. I will call shortly to discuss the following questions

1. Per earlier conversations, it was stated that the compensation for drivers would be based on hours worked to eliminate the

need to estimate layover time at each site. For example if they left the home base at 7 am and returned at 7pm, then we would be compensated for 12 hours. Of these twelve hours, 8 would be at regular time and 4 at overtime rates (1.5 times). Is this a correct interpretation of the earlier conversation?

2. For the dispatcher and Director of Transportation, assuming they work a 40 hour week, am I correct to assume we would be compensated at 40 hours times their individual rates?
3. Can you provide details on how benefit dollars were determined? What benefits are included in this number and the % or rate used for each? I need to know so I can compare our benefit plan to the one included in your calculation to determine the differences and what adjustments might be needed if we accept this rate.
4. How was the profit % determined?
5. On our cost sheet, we listed other cost to get this business up and running like vehicles, insurance on vehicles, body armor, uniforms, weapons, training etc. How would these expenses be covered? At one point, I know it was mentioned that depreciation on the vehicles would be part of the day rate but how do we deal with these expenses until the facility is up and running? As stated earlier, transportation guards and thus their cost (weapons, training, uniforms etc.) are not included in the day rate since they have to be separate people performing separate duties.

I understand your position that we can not have two separate IGSA but somehow we need to price it and set an hourly rate that will allow us to cover these other cost. In my transportation cost sheet, I spread these cost over the transportation guard hours to include them in the rate.

I look forward to working through these questions towards a successfully conclusion for all parties. Do you have an estimated date when you would like us to start providing this service?

Warren

---

**From:** Casterline, Arnold P [mailto: (b)(6)]  
**Sent:** Tuesday, September 02, 2008 10:15 AM  
**To:** Warren Coleman; Raine, Craig K; Neveleff, Jerald  
**Subject:** Transportation

Mr. Coleman.



b4, b6

*Arnold P. Casterline Jr.*

Contract Specialist

Immigration and Customs Enforcement

Office of Acquisition Management

Detention Management

Department of Homeland Security

425 I Street NW, 5<sup>th</sup> Floor Room 5009

Washington, DC 20536

e-mail: [REDACTED] (b)(6)

phone: 202-514- [REDACTED] b6

Main: 202-514- [REDACTED]

***Help us support you better –***

***TELL US HOW WE ARE DOING!***

**Go to** <http://www.acqsolinc.com/ICE/OAQ/feedback.cfm>

**Stevens, Richard P**

---

**From:** Smyly, Elena L  
**Sent:** Wednesday, September 03, 2008 10:49 AM  
**To:** Flanagan, Lamont  
**Cc:** Neveleff, Jerald; Jenkins, John E  
**Subject:** Farmville review  
**Importance:** High

Hello Lamont,

It looks like Jerry Neveleff is or about to start negotiation of Farmville. In the past, you mentioned you had some problems with the layout. Would you please let us know the issues that you have with the plans?

Thank you,

*Elena Smyly, PMP  
Management and Program Analyst - Large IGSA  
DHS, U.S. Immigration and Customs Enforcement  
Office of Detention and Removal  
Detention Management Division  
(202) 732-[REDACTED]*

**Stevens, Richard P**

---

**From:** Casterline, Arnold P  
**Sent:** Wednesday, September 03, 2008 11:58 AM  
**To:** 'Warren Coleman'; Raine, Craig K  
**Cc:** Neveleff, Jerald; Russell Harper  
**Subject:** Trans Costs

We have developed a rate on the overhead costs that we feel can be included now. After the facility is up and running we will put these costs back into the Jail Costs Statement and include them in the bed day rate were they belong. The overhead costs that we feel should be included are uniforms, annual training, body armor, weapons, Insurance (Auto), phones, office supplies, equipment, and van depreciation. This all totals \$126,700 which we amortized over 5 years and came up with a rate of \$2,112.00 per month. If you have any questions please feel free to contact me at 202- [REDACTED] b6 or send me an email to [REDACTED] b6. Thank you and have a great day.

*Arnold P. Casterline Jr.*

Contract Specialist  
Immigration and Customs Enforcement  
Office of Acquisition Management  
Detention Management  
Department of Homeland Security  
425 I Street NW, 5<sup>th</sup> Floor Room 5009  
Washington, DC 20536  
e-mail: [REDACTED] (b)(6)  
phone: 202-51 [REDACTED] b6  
Main: 202-514 [REDACTED]

**Help us support you better –  
TELL US HOW WE ARE DOING!**

**Go to** <http://www.acqsolinc.com/ICE/OAQ/feedback.cfm>

**Stevens, Richard P**

---

**From:** Smyly, Elena L [redacted (b)(6)]  
**Sent:** Wednesday, September 03, 2008 1:29 PM  
**To:** Neveleff, Jerald  
**Subject:** FW: Farmville Detainee Housing Facility Comments  
**Importance:** High  
**Attachments:** Comments for Farmville Detainee Housing Facility.doc

Jerry,  
These are the comments from the DIHS. I will call you to discuss.

Thank you,  
Elena Smyly, PMP  
Management and Program Analyst - Large IGSA  
DHS, U.S. Immigration and Customs Enforcement  
Office of Detention and Removal  
Detention Management Division  
(202) 732- [redacted b6]

---

**From:** Flanagan, Lamont  
**Sent:** Wednesday, September 03, 2008 12:36 PM  
**To:** Smyly, Elena L  
**Subject:** FW: Farmville Detainee Housing Facility Comments  
**Importance:** High

Kindly Review .

---

**From:** Adams, Shauntece [mailto:[redacted (b)(6)]] **On Behalf Of** Flanagan, Lamont  
**Sent:** Tuesday, September 02, 2008 4:44 PM  
**To:** Flanagan, Lamont  
**Subject:** FW: Farmville Detainee Housing Facility Comments

*FYI*

*Shauntece Adams  
Executive Assistant  
Office of the Chief  
Division of Immigration Health Services  
1220 L Street, N.W.  
Suite 500  
Washington, DC 20005  
Phone (202) 732- [redacted b6]  
Fax (202) 732- [redacted b6]  
Email [redacted (b)(6)]*

---

**From:** Ritz, Paul  
**Sent:** Tuesday, September 02, 2008 4:43 PM  
**To:** Flanagan, Lamont



**Cc:** Vazquez, Edwin CDR

**Subject:** Farmville Detainee Housing Facility Comments

Enclosed are the comments for the Farmville project. There maybe more in the future.

If there are any questions, please ask.

Thank you,

#### Information Technology Comments:

I have not had time to put together PHS cabling and computer requirements for Farmville, but I wanted to give you some preliminary comments:

1. The clinic is over 500 ft from the farthest housing unit with 3 traps in between. It may be difficult to meet the required response time from the clinic to that housing unit per NCCHC regulations.
2. The TIF unit appears to be a separate building outside. The doors to the unit are pointing away from the clinic, requiring that medical walk around the unit to access it. Also, we have no details on the layout of this unit. There are strict specifications for reverse airflow, oxygen, and access. We need design details to ensure the building will meet requirements.
3. The PHS Server should be co-located with the ICE equipment. Therefore, the PHS area should be cabled back to the ICE Server room. The PHS Server room may be used as a wiring closet if needed, or remove the wall between it and the supply room to make the supply room larger. The switch, if needed, could be in the supply room – no need to waste a room for one small switch the size of a pizza box.
4. Quick count yields 40 computers, 6 printers, 1 fax and a copier.

#### Pharmacy Comments:

1. The sink needs to be moved down the wall to be by the sink on the staff toilet.
2. Additional comments will be provided to evaluate the functionality of the pharmacy once we get the details of the casework

#### Teleradiology Comments:

1. Please note the minimum electrical requirements for Teleradiology to include: a 480 volt, 3 phase, 100 amp circuit.
2. The ceiling height in the room should be at least 10 feet high.
3. The HVAC plan has to be designed to deal with the room humidity and the heat.
4. The interior partition should be lead lined.
5. What is the (leaded glass) window configuration on the interior partition?
6. Casework is needed behind the partition to hold the computer, monitor, printer, phone, etc.

**Stevens, Richard P**

---

**From:** Russell Harper [redacted] b6  
**Sent:** Wednesday, September 03, 2008 2:31 PM  
**To:** Casterline, Arnold P  
**Cc:** Neveleff, Jerald; Warren Coleman; Raine, Craig K  
**Subject:** RE: Trans Costs

Arnold,

I will call you shortly.

Our annual recurring operational costs are as follows;

[Large redacted area]

b4

Thanks

Russell

---

**From:** Casterline, Arnold P [mailto:[redacted]] (b)(6)  
**Sent:** Wednesday, September 03, 2008 11:58 AM  
**To:** Warren Coleman; Raine, Craig K  
**Cc:** Neveleff, Jerald; Russell Harper  
**Subject:** Trans Costs

We have developed a rate on the overhead costs that we feel can be included now. After the facility is up and running we will put these costs back into the Jail Costs Statement and include them in the bed day rate were they belong. The

overhead costs that we feel should be included are uniforms, annual training, body armor, weapons, Insurance (Auto), phones, office supplies, equipment, and van depreciation. This all totals \$126,700 which we amortized over 5 years and came up with a rate of \$2,112.00 per month. If you have any questions please feel free to contact me at 202 [REDACTED] b6 or send me an email to [REDACTED] b6 Thank you and have a great day.

*Arnold P. Casterline Jr.*

Contract Specialist

Immigration and Customs Enforcement

Office of Acquisition Management

Detention Management

Department of Homeland Security

425 I Street NW, 5<sup>th</sup> Floor Room 5009

Washington, DC 20536

e-mail [REDACTED] (b)(6)

phone: 202-514- [REDACTED]

Main: 202-514- [REDACTED] b6

**Help us support you better –  
TELL US HOW WE ARE DOING!**

**Go to** <http://www.acqsolinc.com/ICE/OAQ/feedback.cfm>

**Stevens, Richard P**

---

**From:** Casterline, Arnold P  
**Sent:** Wednesday, September 03, 2008 3:07 PM  
**To:** Neveleff, Jerald  
**Subject:** FW: Depreciation

*Arnold P. Casterline Jr.*  
Contract Specialist  
Immigration and Customs Enforcement  
Office of Acquisition Management  
Detention Management  
Department of Homeland Security  
425 I Street NW, 5<sup>th</sup> Floor Room 5009  
Washington, DC 20536  
e-mail: [REDACTED] (b)(6)  
phone: 202-514-[REDACTED]  
Main: 202-514-[REDACTED] b6

*Help us support you better –  
TELL US HOW WE ARE DOING!*  
**Go to** <http://www.acqsolinc.com/ICE/OAQ/feedback.cfm>

---

**From:** Warren Coleman [mailto:[REDACTED] b6]  
**Sent:** Wednesday, September 03, 2008 3:04 PM  
**To:** Casterline, Arnold P  
**Cc:** Russell Harper  
**Subject:** Depreciation

Arnold  
Just wanted to make sure you noted my error in depreciation on the worksheet. The cost of the vans is estimated at \$ 320,000 and with a 5 year life, depreciation would be \$64,000. We are concerned that the vans will not last 5 years due to the high mileage requirement but I wanted to be sure that you have the correct number if 5 years is the mandatory depreciation period.

Warren

**Stevens, Richard P**

---

**From:** Neveleff, Jerald  
**Sent:** Thursday, September 04, 2008 3:42 PM  
**To:** [REDACTED] b6  
**Cc:** Dougherty, Deane b6  
**Subject:** June 2008 Invoice # FS-30-Jun-2008

Mark,  
I understand what you did but cannot accept the invoice as presented.  
The invoice for the family shelter is line item 0001 of the task order, the invoices against meeting the standards is against a different line item and need to be invoiced separately.

Please resubmit the invoices for June 08 family and the costs to implement the items necessary to meet the residential standards separately.

Also, please ensure you include the Task order on your invoices. For FY08 its HSCEDM-08-F-IG001.

Deane,  
When you receive the corrected invoices, please sign and forward to me so I can process and get them sent to Dallas for payment.

Jerry

Thank you,  
Jerry Neveleff  
Supervisory Contracting Officer/  
IGSA Team Lead  
Office of Acq. Management (OAQ)  
Detention Management Division  
202/616 [REDACTED] b6

Help us support you better -  
TELL US HOW WE ARE DOING!  
Go to <<http://www.acqsolinc.com/ICE/OAQ/feedback.cfm>> <<<http://www.acqsolinc.com/ICE/OAQ/feedback.cfm>>>

**Stevens, Richard P**

---

**From:** Russell Harper [mailto: [REDACTED] b6]  
**Sent:** Wednesday, September 03, 2008 3:23 PM  
**To:** Neveleff, Jerald; Warren Coleman  
**Cc:** Smyly, Elena L  
**Subject:** RE: Farmville Detainee Housing Facility Comments

Jerry, thanks for the comments. I agree with your approach. Russell

---

**From:** Neveleff, Jerald [mailto: [REDACTED] (b)(6)]  
**Sent:** Wednesday, September 03, 2008 3:20 PM  
**To:** Russell Harper; Warren Coleman  
**Cc:** Smyly, Elena L  
**Subject:** FW: Farmville Detainee Housing Facility Comments  
**Importance:** High

Russell/Warren,  
Here are the initial comments on the medical spaces from DIHS.  
As I said, it doesn't look to be too big of an issue. Just need to ensure we have accurate numbers to work to.

If we keep detailed notes during the process and changes happen that have a cost impact, we should be able to adjust during the process.

I do not want to linger this too much but we rely on the information provided as our starting place.

Thank you,  
Jerry Neveleff  
Supervisory Contracting Officer/  
IGSA Team Lead  
Office of Acq. Management (OAQ)  
Detention Management Division  
202/616 [REDACTED] b6

Help us support you better -  
TELL US HOW WE ARE DOING!  
Go to <<http://www.acqsolinc.com/ICE/OAQ/feedback.cfm>> <<<http://www.acqsolinc.com/ICE/OAQ/feedback.cfm>>>

---

**From:** Smyly, Elena L [mailto: [REDACTED] (b)(6)]  
**Sent:** Wednesday, September 03, 2008 1:29 PM  
**To:** Neveleff, Jerald  
**Subject:** FW: Farmville Detainee Housing Facility Comments  
**Importance:** High

Jerry,  
These are the comments from the DIHS. I will call you to discuss.

Thank you,  
Elena Smyly, PMP  
Management and Program Analyst - Large IGSA  
DHS, U.S. Immigration and Customs Enforcement  
Office of Detention and Removal

Detention Management Division  
(202) 732- [REDACTED] b6

---

**From:** Flanagan, Lamont  
**Sent:** Wednesday, September 03, 2008 12:36 PM  
**To:** Smyly, Elena L  
**Subject:** FW: Farmville Detainee Housing Facility Comments  
**Importance:** High

Kindly Review .

---

**From:** Adams, Shauntece [mailto:[REDACTED] (b)(6)] **On Behalf Of** Flanagan, Lamont  
**Sent:** Tuesday, September 02, 2008 4:44 PM  
**To:** Flanagan, Lamont  
**Subject:** FW: Farmville Detainee Housing Facility Comments

*FYI*

*Shauntece Adams  
Executive Assistant  
Office of the Chief  
Division of Immigration Health Services  
1220 L Street, N.W.  
Suite 500  
Washington, DC 20005  
Phone (202) 732- [REDACTED] b6  
Fax (202) 732- [REDACTED]  
Email [REDACTED] (b)(6)*

---

**From:** Ritz, Paul  
**Sent:** Tuesday, September 02, 2008 4:43 PM  
**To:** Flanagan, Lamont  
**Cc:** Vazquez, Edwin CDR  
**Subject:** Farmville Detainee Housing Facility Comments

Enclosed are the comments for the Farmville project. There maybe more in the future.

If there are any questions, please ask.

Thank you,



**Stevens, Richard P**

---

**From:** Neveleff, Jerald  
**Sent:** Friday, September 05, 2008 10:08 AM  
**To:** Russell Harper  
**Cc:** Casterline, Arnold P; Raine, Craig K  
**Subject:** START OF TRANSPORTATION

Russell,

As the legal binding Official for the Government as it relates to the Farmville effort, we are doing everything we can to start the effort on 9/15/08.

Until I have all paperwork signed and funds obligated, I am unable to say with 100% assurance that the 15<sup>th</sup> is will be the; be all end all date.

Everything we have is using that date for start of performance. All paperwork reflects as such.

Thank you,  
Jerry Neveleff  
Supervisory Contracting Officer/  
IGSA Team Lead  
Office of Acq. Management (OAQ)  
Detention Management Division  
202/616-[REDACTED] b6

Help us support you better -

TELL US HOW WE ARE DOING!

Go to <http://www.acqsolinc.com/ICE/OAQ/feedback.cfm> <<<http://www.acqsolinc.com/ICE/OAQ/feedback.cfm>>>

**Stevens, Richard P**

---

**From:** Neveleff, Jerald  
**Sent:** Friday, September 05, 2008 8:52 AM  
**To:** Casterline, Arnold P; 'Raine, Craig K'  
**Subject:** RE: IGSA for transportation needs

I would like the 15<sup>th</sup> but that will depend on when we get the signed IGSA back, Policy and OPLA reviews. He needs to get things done.

The official answer is we are shooting for the 15<sup>th</sup> provided we get the signed IGSA back this morning and we can get it through policy and OPLA.

Thank you,  
Jerry Neveleff  
Supervisory Contracting Officer/  
IGSA Team Lead  
Office of Acq. Management (OAQ)  
Detention Management Division  
202/616- [REDACTED] b6

Help us support you better -  
TELL US HOW WE ARE DOING!  
Go to <http://www.acqsolinc.com/ICE/OAQ/feedback.cfm> <<<http://www.acqsolinc.com/ICE/OAQ/feedback.cfm>>>

---

**From:** Casterline, Arnold P  
**Sent:** Friday, September 05, 2008 8:48 AM  
**To:** Neveleff, Jerald; Raine, Craig K  
**Subject:** FW: IGSA for transportation needs

I have told Russell Harper that the start date for the Farmville transportation is September 15, 2008. He has asked me to confirm this date.

*Arnold P. Casterline Jr.*  
Contract Specialist  
Immigration and Customs Enforcement  
Office of Acquisition Management  
Detention Management  
Department of Homeland Security  
425 I Street NW, 5<sup>th</sup> Floor Room 5009  
Washington, DC 20536  
e-mail: [REDACTED] (b)(6)  
phone: 202-514- [REDACTED]  
Main: 202-514- [REDACTED] b6

**Help us support you better –**  
**TELL US HOW WE ARE DOING!**  
**Go to** <http://www.acqsolinc.com/ICE/OAQ/feedback.cfm>

---

**From:** Russell Harper [mailto: [REDACTED] b6]  
**Sent:** Friday, September 05, 2008 8:44 AM  
**To:** Casterline, Arnold P  
**Cc:** Warren Coleman; Raine, Craig K; Henkel, Douglas ; [REDACTED] b6  
**Subject:** RE: IGSA for transportation needs

Arnold,

We should be sending the executed IGSA back to you today.

Can you please confirm a start date of September 15<sup>th</sup> for the transportation?

Thank you,

Russell Harper

---

**From:** Casterline, Arnold P [mailto: [REDACTED] (b)(6)]  
**Sent:** Thursday, September 04, 2008 1:23 PM  
**To:** Henkel, Douglas [REDACTED] b6  
**Cc:** Russell Harper; Warren Coleman; Raine, Craig K  
**Subject:** IGSA for transportation needs

Dear Mr. Spates,

Attached is the IGSA for the Town of Farmville. This is only partially completed due to the fact that we have not negotiated a bed day rate yet however we need to get this signed and returned to us in an email form if possible with a mailed copy to follow. I need a response back by email no later than Tuesday September 9, 2008. We are attempting to obtain transportation services prior to finalizing a bed day rate. The end of the fiscal year is approaching and we need to get this action on the road to completion before FY08 ends. If you have any questions concerning this please give me a call at [REDACTED] b6 or send me an email to [REDACTED] b6 Thank you and have a great day.

Arnie Casterline  
*Arnold P. Casterline Jr.*  
Contract Specialist  
Immigration and Customs Enforcement  
Office of Acquisition Management  
Detention Management  
Department of Homeland Security  
425 I Street NW, 5<sup>th</sup> Floor Room 5009  
Washington, DC 20536  
e-mail [REDACTED] (b)(6)  
phone: 202-514- [REDACTED]  
Main: 202-514- [REDACTED] b6

**Help us support you better –  
TELL US HOW WE ARE DOING!**  
**Go to** <http://www.acqsolinc.com/ICE/OAQ/feedback.cfm>

**Stevens, Richard P**

---

**From:** Picone, Paul D  
**Sent:** Friday, September 05, 2008 10:18 AM  
**To:** Raine, Craig K; Neveleff, Jerald  
**Subject:** Re: START OF TRANSPORTATION

Has anyone approached the contractor regarding the need and number of restraints, i.e.: handcuffs, leg irons and belly chains?

---

**From:** Raine, Craig K  
**To:** Achim, Deborah; Henkel, Douglas ; Picone, Paul D  
**Sent:** Fri Sep 05 07:15:15 2008  
**Subject:** Fw: START OF TRANSPORTATION

Fyi

-----  
Sent from my BlackBerry Wireless Handheld

---

**From:** Neveleff, Jerald  
**To:** Russell Harper  
**Cc:** Casterline, Arnold P; Raine, Craig K  
**Sent:** Fri Sep 05 10:08:15 2008  
**Subject:** START OF TRANSPORTATION

Russell,

As the legal binding Official for the Government as it relates to the Farmville effort, we are doing everything we can to start the effort on 9/15/08.

Until I have all paperwork signed and funds obligated, I am unable to say with 100% assurance that the 15<sup>th</sup> is will be the; be all end all date.

Everything we have is using that date for start of performance. All paperwork reflects as such.

Thank you,

Jerry Neveleff

Supervisory Contracting Officer/

IGSA Team Lead

Office of Acq. Management (OAQ)

Detention Management Division

202/616 [REDACTED] b6

Help us support you better -

12/21/2008

TELL US HOW WE ARE DOING!

Go to <http://www.acqsolinc.com/ICE/OAQ/feedback.cfm> <<<http://www.acqsolinc.com/ICE/OAQ/feedback.cfm>>>

**Stevens, Richard P**

---

**From:** Picone, Paul D  
**Sent:** Friday, September 05, 2008 10:24 AM  
**To:** Neveleff, Jerald; Raine, Craig K  
**Subject:** Re: START OF TRANSPORTATION

The question needs to be asked.

Please check on this.

---

**From:** Neveleff, Jerald  
**To:** Picone, Paul D; Raine, Craig K  
**Sent:** Fri Sep 05 07:19:36 2008  
**Subject:** RE: START OF TRANSPORTATION

Paul,  
I thought they knew that. We did not see those costs unless they we "supplies for the vans".  
Jerry

Thank you,  
Jerry Neveleff  
Supervisory Contracting Officer/  
IGSA Team Lead  
Office of Acq. Management (OAQ)  
Detention Management Division  
202/616 [REDACTED] b6

Help us support you better -  
TELL US HOW WE ARE DOING!  
Go to <<http://www.acqsolinc.com/ICE/OAQ/feedback.cfm>> <<<http://www.acqsolinc.com/ICE/OAQ/feedback.cfm>>>

---

**From:** Picone, Paul D  
**Sent:** Friday, September 05, 2008 10:18 AM  
**To:** Raine, Craig K; Neveleff, Jerald  
**Subject:** Re: START OF TRANSPORTATION

Has anyone approached the contractor regarding the need and number of restraints, i.e.: handcuffs, leg irons and belly chains?

---

**From:** Raine, Craig K  
**To:** Achim, Deborah; Henkel, Douglas ; Picone, Paul D  
**Sent:** Fri Sep 05 07:15:15 2008  
**Subject:** Fw: START OF TRANSPORTATION

Fyi

-----  
Sent from my BlackBerry Wireless Handheld

12/21/2008

---

**From:** Neveleff, Jerald  
**To:** Russell Harper  
**Cc:** Casterline, Arnold P; Raine, Craig K  
**Sent:** Fri Sep 05 10:08:15 2008  
**Subject:** START OF TRANSPORTATION

Russell,

As the legal binding Official for the Government as it relates to the Farmville effort, we are doing everything we can to start the effort on 9/15/08.

Until I have all paperwork signed and funds obligated, I am unable to say with 100% assurance that the 15<sup>th</sup> is will be the; be all end all date.

Everything we have is using that date for start of performance. All paperwork reflects as such.

Thank you,

Jerry Neveleff

Supervisory Contracting Officer/

IGSA Team Lead

Office of Acq. Management (OAQ)

Detention Management Division

202/616 [REDACTED] b6

Help us support you better -

TELL US HOW WE ARE DOING!

Go to <http://www.acqsolinc.com/ICE/OAQ/feedback.cfm> <<<http://www.acqsolinc.com/ICE/OAQ/feedback.cfm>>>

**Stevens, Richard P**

---

**From:** Raine, Craig K  
**Sent:** Friday, September 05, 2008 10:35 AM  
**To:** Neveleff, Jerald [REDACTED] Picone, Paul D; Watson, Joe  
**Cc:** Casterline, Arnold P  
**Subject:** Re: START OF TRANSPORTATION

Russ,

Although not discussed at length, we need to confirm that each vehicle will be equipped with an appropriate amount of restraints, hand cuffs, leg irons and belly chains.

Please have your staff get with Paul Picone or Joe Watson to answer any questions.

Thx

Craig

-----  
Sent from my BlackBerry Wireless Handheld

---

**From:** Neveleff, Jerald  
**To:** Russell Harper  
**Cc:** Casterline, Arnold P; Raine, Craig K  
**Sent:** Fri Sep 05 10:08:15 2008  
**Subject:** START OF TRANSPORTATION

Russell,

As the legal binding Official for the Government as it relates to the Farmville effort, we are doing everything we can to start the effort on 9/15/08.

Until I have all paperwork signed and funds obligated, I am unable to say with 100% assurance that the 15<sup>th</sup> is will be the; be all end all date.

Everything we have is using that date for start of performance. All paperwork reflects as such.

Thank you,

Jerry Neveleff

Supervisory Contracting Officer/

IGSA Team Lead

Office of Acq. Management (OAQ)

Detention Management Division

202/616 [REDACTED]

12/21/2008



Help us support you better -

TELL US HOW WE ARE DOING!

Go to <http://www.acqsolinc.com/ICE/OAQ/feedback.cfm> <<<http://www.acqsolinc.com/ICE/OAQ/feedback.cfm>>>

**Stevens, Richard P**

---

**From:** Raine, Craig K  
**Sent:** Friday, September 05, 2008 1:56 PM  
**To:** Picone, Paul D; Neveleff, Jerald  
**Subject:** Re: START OF TRANSPORTATION

I spoke to Russ this morning, and they had already factored in the restraints and were aware of the requirements.

Who will be their POC for operational issues once they get started?

-----  
Sent from my BlackBerry Wireless Handheld

---

**From:** Picone, Paul D  
**To:** Neveleff, Jerald; Raine, Craig K  
**Sent:** Fri Sep 05 10:24:13 2008  
**Subject:** Re: START OF TRANSPORTATION

The question needs to be asked.

Please check on this.

---

**From:** Neveleff, Jerald  
**To:** Picone, Paul D; Raine, Craig K  
**Sent:** Fri Sep 05 07:19:36 2008  
**Subject:** RE: START OF TRANSPORTATION

Paul,  
I thought they knew that. We did not see those costs unless they we "supplies for the vans".  
Jerry

Thank you,  
Jerry Neveleff  
Supervisory Contracting Officer/  
IGSA Team Lead  
Office of Acq. Management (OAQ)  
Detention Management Division  
202/616 [REDACTED] b6

Help us support you better -  
TELL US HOW WE ARE DOING!  
Go to <<http://www.acqsolinc.com/ICE/OAQ/feedback.cfm>> <<<http://www.acqsolinc.com/ICE/OAQ/feedback.cfm>>>

---

**From:** Picone, Paul D  
**Sent:** Friday, September 05, 2008 10:18 AM  
**To:** Raine, Craig K; Neveleff, Jerald  
**Subject:** Re: START OF TRANSPORTATION

Has anyone approached the contractor regarding the need and number of restraints, i.e.: handcuffs, leg irons and belly chains?

---

**From:** Raine, Craig K  
**To:** Achim, Deborah; Henkel, Douglas ; Picone, Paul D  
**Sent:** Fri Sep 05 07:15:15 2008  
**Subject:** Fw: START OF TRANSPORTATION

Fyi

-----  
Sent from my BlackBerry Wireless Handheld

---

**From:** Neveleff, Jerald  
**To:** Russell Harper  
**Cc:** Casterline, Arnold P; Raine, Craig K  
**Sent:** Fri Sep 05 10:08:15 2008  
**Subject:** START OF TRANSPORTATION

Russell,

As the legal binding Official for the Government as it relates to the Farmville effort, we are doing everything we can to start the effort on 9/15/08.

Until I have all paperwork signed and funds obligated, I am unable to say with 100% assurance that the 15<sup>th</sup> is will be the; be all end all date.

Everything we have is using that date for start of performance. All paperwork reflects as such.

Thank you,

Jerry Neveleff

Supervisory Contracting Officer/

IGSA Team Lead

Office of Acq. Management (OAQ)

Detention Management Division

202/616 [REDACTED] b6

Help us support you better -

TELL US HOW WE ARE DOING!

Go to <http://www.acqsolinc.com/ICE/OAQ/feedback.cfm> <<<http://www.acqsolinc.com/ICE/OAQ/feedback.cfm>>>

**Stevens, Richard P**

---

**From:** Neveleff, Jerald  
**Sent:** Monday, September 08, 2008 11:09 AM  
**To:** [REDACTED]  
**Cc:** [REDACTED] (b)(6)  
**Subject:** RE: Jail Costs Statements for Review

Thx

-----Original Message-----

**From:** Mark Boyer  
**To:** Work  
**Cc:** [REDACTED] b6  
**Cc:** Ken Borkey  
**Sent:** Sep 8, 2008 11:05  
**Subject:** RE: Jail Costs Statements for Review

Hello Mr. Neveleff,

The workbook that was originally sent on August 22, 2008, titled "2008 Jail Service cost Statement" is actual cost including the medical expense from April 2007 to March 2008. The workbook that was sent titled "2008 Jail Service Cost Statement (comp) 6.18.08 has other costs built. Those costs are the removal of the medical expense and nursing wages and the addition of the pastor care and voluntary work program.

In reviewing the Jail Costs Statement that has the removal of the nursing wages, I believe that I did not lower the cost of the fringe benefits, in accordance with the lower wags. I will look into this and respond with an answer soon.

Please do not hesitate to contact me if further information is needed.

Thank you for your patience,

Mark

Mark Boyer  
Fiscal Manager  
Berks County Youth Center  
Ph# [REDACTED] b6  
Fax# 610-376-7136  
www.co.berks.pa.us

"Neveleff, Jerald" <[REDACTED] (b)(6)>

09/08/2008 10:40 AM

To: [REDACTED] b6  
cc: [REDACTED] b6 <[REDACTED] b6> Subject: RE: Jail Costs Statements for Review

Mark,  
Hopefully this will be my last question.

ARE THE COSTS PROPOSED BASED ON ACTUALS FROM YOUR FY 2007-2008 WITHOUT ANY FACTORS ADDED BY BERKS?

If any factors were added to the actuals, please tell me where and what the factors were.  
Jerry

Thank you,  
Jerry Neveleff  
Supervisory Contracting Officer/  
IGSA

-----Original Message Truncated-----

Jerry  
Sent using BlackBerry

**Stevens, Richard P**

---

**From:** Thompson, Arthur D (CTR)  
**Sent:** Tuesday, September 09, 2008 9:48 AM  
**To:** Raine, Craig K; Picone, Paul D  
**Cc:** Jenkins, John E; Neveleff, Jerald; Dane, Courtney L (CTR); Smyly, Elena L; Flanagan, Lamont; Brady, Kathie  
**Subject:** FW: Farmville Comments  
**Attachments:** Pharmacy Changes.pdf; Intake and Dental Changes.pdf

Craig,

I received the comments from Kathy Brady, Project Manager for DIHS with concerns regarding the Farmville project. The changes requested are not structural and can be changed with little effort to make the health area flow more efficient and safe for the staff.

Dean

---

**From:** Brady, Kathie [mailto: (b)(6)]  
**Sent:** Monday, September 08, 2008 4:25 PM  
**To:** Thompson, Arthur D (CTR)  
**Cc:** Ritz, Paul CDR; Anderson, Michael CAPT  
**Subject:** Farmville Comments

Dean,

1. ALL doors on ALL rooms where detainees are seen by medical staff must open outward. The issue is that you don't want a detainee to block a door with a nurse inside and the guards not be able to get in. If the door opens outward, it can always be opened from the outside. Many of the doors in this clinic open inward. So a detainee could shut the door and shove the exam table in front of it, blocking it closed.
2. The double doors between Processing and Intake screening is a bad design. That means to move a patient to medical for the intake requires going through 2 controlled doors. That will really slow down the process. Also, there is another door before medical, which means there needs to be a separate guard in this area during intakes. I've attached a recommended redesign of this area.
3. We don't want to be going through the Dental Lab to get to the Dental Office and vice versa. The Dental Lab is where we sterilize equipment. See the recommended redesign on this.
4. The security gate before pharmacy and lab is a problem. The pharmacy has a pass-through window to give meds to the detainees. The lab is here where we perform lab tests. Having to open the security gate for labs and medication distribution is not good. We do want a gate to separate the administrative area from medical area, but it needs to be to the left (north) of the pharmacy and lab. Best if it is left of the Biohazard waste. With the current design, a second guard is needed when a patient is back there.
5. The TIF unit appears to be in a separate building outside. The TIF unit will have to be monitored by nursing. The current design means there has to be a separate guard and nurse for this unit. At a minimum, the doors to access the unit should be on the opposite wall for easier access versus walking around the building to the doors. Also, we will need to see a detailed design of this at some point.
6. Does ICE have a presence here? We are supposed to co-locate our servers with ICE in the ICE server room. I don't see an ICE server room anywhere. If there is an ICE server room, then we don't need the LAN room unless they need it as a wiring closet with a jumper between medical and the ICE server room. If you take away the LAN room, make the supply room larger.
7. There are 7 doors and 500 feet between medical and Dorms 11-14. Getting to those last dorms during an emergency will be a challenge. I don't see a way to make that any better, just something to be aware of.

Let me know if you have any questions.

Thank You,

12/21/2008

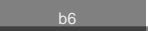
*Kathie Brady, PMP*  
IT Project Manager  
Division of Immigration Health Services  
1220 L ST NW, Suite 500  
Washington, DC 20005  
202-732- b6

 (b)(6)

*This email message is for the sole use of the intended recipient(s) and may contain confidential and privileged information. Any unauthorized review, use, disclosure or distribution is prohibited. If you are not the intended recipient, please contact the sender by reply email and destroy all copies of the original message.*

(b)(2)High



(b)(2)High

**Stevens, Richard P**

---

**From:** Brady, Kathie [REDACTED] (b)(6)  
**Sent:** Tuesday, September 09, 2008 11:22 AM  
**To:** Picone, Paul D; Thompson, Arthur D (CTR); Raine, Craig K  
**Cc:** Jenkins, John E; Neveleff, Jerald; Dane, Courtney L (CTR); Smyly, Elena L; Flanagan, Lamont; Brady, Kathie; Henkel, Douglas ; Achim, Deborah  
**Subject:** RE: Farmville Comments

#2 There will need to be a second guard in the Medical Intake Screening area during intake.

#4 Detainees will need to go into the lab.

-----Original Message-----

**From:** Picone, Paul D [REDACTED] b6  
**Sent:** Tuesday, September 09, 2008 11:05 AM  
**To:** Thompson, Arthur D (CTR); Raine, Craig K  
**Cc:** Jenkins, John E; Neveleff, Jerald; Dane, Courtney L (CTR); Smyly, Elena L; Flanagan, Lamont; Brady, Kathie; Henkel, Douglas ; Achim, Deborah  
**Subject:** RE: Farmville Comments  
**Importance:** High

Re #2: The double doors between Processing and Intake are necessary for security and control purposes. The interlocking mechanism can be overridden by Control in the event of an emergency.

Re #4: DRO would prefer if detainees only had access to the area near the pass-through window and not any of the other areas annotated.

Re #5: A similar unit is utilized at the Florence SPC. That unit is maintained by a security guard only. A nurse comes over on regular intervals but is not there all the time.

Re #7: Established protocols for emergent circumstances will be prepared prior to the opening of the facility. The protocols will include medical emergencies. These protocols will be incorporated into post orders as well. The contractor will produce the protocols and post orders and DRO will review. At the time of the review DRO will invite DIHS for their input as well.

Paul D. Picone  
Assistant Field Office Director  
Washington Field Office  
ICE/DRO

**Warning: This document is UNCLASSIFIED//FOR OFFICIAL USE ONLY (U//FOUO).** It contains information that may be exempt from public release under the Freedom of Information Act (5 U.S.C. 552). It is to be controlled, stored, handled, transmitted, distributed, and disposed of in accordance with DHS policy relating to FOUO information and is not to be released to the public or other personnel who do not have a valid "need-to-know" without prior approval of an authorized DHS official. **No portion of this report should be furnished to the media, either in written or verbal form.**

---

**From:** Thompson, Arthur D (CTR)  
**Sent:** Tuesday, September 09, 2008 9:48 AM  
**To:** Raine, Craig K; Picone, Paul D

**Cc:** Jenkins, John E; Neveleff, Jerald; Dane, Courtney L (CTR); Smyly, Elena L; Flanagan, Lamont; Brady, Kathie  
**Subject:** FW: Farmville Comments

Craig,

I received the comments from Kathy Brady, Project Manager for DIHS with concerns regarding the Farmville project. The changes requested are not structural and can be changed with little effort to make the health area flow more efficient and safe for the staff.

Dean

---

**From:** Brady, Kathie [mailto: (b)(6)]  
**Sent:** Monday, September 08, 2008 4:25 PM  
**To:** Thompson, Arthur D (CTR)  
**Cc:** Ritz, Paul CDR; Anderson, Michael CAPT  
**Subject:** Farmville Comments

Dean,

1. ALL doors on ALL rooms where detainees are seen by medical staff must open outward. The issue is that you don't want a detainee to block a door with a nurse inside and the guards not be able to get in. If the door opens outward, it can always be opened from the outside. Many of the doors in this clinic open inward. So a detainee could shut the door and shove the exam table in front of it, blocking it closed.
2. The double doors between Processing and Intake screening is a bad design. That means to move a patient to medical for the intake requires going through 2 controlled doors. That will really slow down the process. Also, there is another door before medical, which means there needs to be a separate guard in this area during intakes. I've attached a recommended redesign of this area.
3. We don't want to be going through the Dental Lab to get to the Dental Office and vice versa. The Dental Lab is where we sterilize equipment. See the recommended redesign on this.
4. The security gate before pharmacy and lab is a problem. The pharmacy has a pass-through window to give meds to the detainees. The lab is here where we perform lab tests. Having to open the security gate for labs and medication distribution is not good. We do want a gate to separate the administrative area from medical area, but it needs to be to the left (north) of the pharmacy and lab. Best if it is left of the Biohazard waste. With the current design, a second guard is needed when a patient is back there.
5. The TIF unit appears to be in a separate building outside. The TIF unit will have to be monitored by nursing. The current design means there has to be a separate guard and nurse for this unit. At a minimum, the doors to access the unit should be on the opposite wall for easier access versus walking around the building to the doors. Also, we will need to see a detailed design of this at some point.
6. Does ICE have a presence here? We are supposed to co-locate our servers with ICE in the ICE server room. I don't see an ICE server room anywhere. If there is an ICE server room, then we don't need the LAN room unless they need it as a wiring closet with a jumper between medical and the ICE server room. If you take away the LAN room, make the supply room larger.
7. There are 7 doors and 500 feet between medical and Dorms 11-14. Getting to those last dorms during an emergency will be a challenge. I don't see a way to make that any better, just something to be aware of.

Let me know if you have any questions.

Thank You,

*Kathie Brady, PMP*

IT Project Manager

Division of Immigration Health Services

1220 L ST NW, Suite 500

Washington, DC 20005

202-732- (b)(6)

kat (b)(6)

*This email message is for the sole use of the intended recipient(s) and may contain confidential and privileged*

*information. Any unauthorized review, use, disclosure of distribution is prohibited. If you are not the intended recipient, please contact the sender by reply email and destroy all copies of the original message.*

**Stevens, Richard P**

---

**From:** Neveleff, Jerald  
**Sent:** Tuesday, September 09, 2008 11:50 AM  
**To:** Picone, Paul D; Brady, Kathie P; Thompson, Arthur D (CTR); Raine, Craig K  
**Cc:** Jenkins, John E; Dane, Courtney L (CTR); Smyly, Elena L; Flanagan, Lamont; Brady, Kathie; Henkel, Douglas ; Achim, Deborah  
**Subject:** RE: Farmville Comments

When the medical space review is completed and all recommended changes agreed to, please send me an email with the recommendations so I can let Farmville know and they can inform their architect.  
Jerry

Thank you,  
Jerry Neveleff  
Supervisory Contracting Officer/  
IGSA Team Lead  
Office of Acq. Management (OAQ)  
Detention Management Division  
202/616 [REDACTED] b6

Help us support you better -  
TELL US HOW WE ARE DOING!  
Go to <<http://www.acqsolinc.com/ICE/OAQ/feedback.cfm>> <<<http://www.acqsolinc.com/ICE/OAQ/feedback.cfm>>>

---

**From:** Picone, Paul D [mailto:p[REDACTED] (b)(6)]  
**Sent:** Tuesday, September 09, 2008 11:31 AM  
**To:** Brady, Kathie P; Thompson, Arthur D (CTR); Raine, Craig K  
**Cc:** Jenkins, John E; Neveleff, Jerald; Dane, Courtney L (CTR); Smyly, Elena L; Flanagan, Lamont; Brady, Kathie; Henkel, Douglas ; Achim, Deborah  
**Subject:** RE: Farmville Comments

Re #4: Detainees going to the lab would not be an issue. They will need to be escorted. In general, however, DRO would prefer that the area is not within their readily accessible reach.

Paul D. Picone  
Assistant Field Office Director  
Washington Field Office  
ICE/DRO

**Warning: This document is UNCLASSIFIED//FOR OFFICIAL USE ONLY (U//FOUO).** It contains information that may be exempt from public release under the Freedom of Information Act (5 U.S.C. 552). It is to be controlled, stored, handled, transmitted, distributed, and disposed of in accordance with DHS policy relating to FOUO information and is not to be released to the public or other personnel who do not have a valid "need-to-know" without prior approval of an authorized DHS official. **No portion of this report should be furnished to the media, either in written or verbal form.**

---

**From:** Brady, Kathie [mailto:Ka[REDACTED] (b)(6)]

**Sent:** Tuesday, September 09, 2008 11:22 AM

**To:** Picone, Paul D; Thompson, Arthur D (CTR); Raine, Craig K

**Cc:** Jenkins, John E; Neveleff, Jerald; Dane, Courtney L (CTR); Smyly, Elena L; Flanagan, Lamont; Brady, Kathie; Henkel, Douglas ; Achim, Deborah

**Subject:** RE: Farmville Comments

#2 There will need to be a second guard in the Medical Intake Screening area during intake.

#4 Detainees will need to go into the lab.

-----Original Message-----

**From:** Picone, Paul D [mailto: (b)(6)]

**Sent:** Tuesday, September 09, 2008 11:05 AM

**To:** Thompson, Arthur D (CTR); Raine, Craig K

**Cc:** Jenkins, John E; Neveleff, Jerald; Dane, Courtney L (CTR); Smyly, Elena L; Flanagan, Lamont; Brady, Kathie; Henkel, Douglas ; Achim, Deborah

**Subject:** RE: Farmville Comments

**Importance:** High

Re #2: The double doors between Processing and Intake are necessary for security and control purposes. The interlocking mechanism can be overridden by Control in the event of an emergency.

Re #4: DRO would prefer if detainees only had access to the area near the pass-through window and not any of the other areas annotated.

Re #5: A similar unit is utilized at the Florence SPC. That unit is maintained by a security guard only. A nurse comes over on regular intervals but is not there all the time.

Re #7: Established protocols for emergent circumstances will be prepared prior to the opening of the facility. The protocols will include medical emergencies. These protocols will be incorporated into post orders as well. The contractor will produce the protocols and post orders and DRO will review. At the time of the review DRO will invite DIHS for their input as well.

Paul D. Picone  
Assistant Field Office Director  
Washington Field Office  
ICE/DRO

**Warning: This document is UNCLASSIFIED//FOR OFFICIAL USE ONLY (U//FOUO).** It contains information that may be exempt from public release under the Freedom of Information Act (5 U.S.C. 552). It is to be controlled, stored, handled, transmitted, distributed, and disposed of in accordance with DHS policy relating to FOUO information and is not to be released to the public or other personnel who do not have a valid "need-to-know" without prior approval of an authorized DHS official. **No portion of this report should be furnished to the media, either in written or verbal form.**

---

**From:** Thompson, Arthur D (CTR)

**Sent:** Tuesday, September 09, 2008 9:48 AM

**To:** Raine, Craig K; Picone, Paul D

**Cc:** Jenkins, John E; Neveleff, Jerald; Dane, Courtney L (CTR); Smyly, Elena L; Flanagan, Lamont; Brady, Kathie

**Subject:** FW: Farmville Comments

Craig,

I received the comments from Kathy Brady, Project Manager for DIHS with concerns regarding the Farmville project. The

changes requested are not structural and can be changed with little effort to make the health area flow more efficient and safe for the staff.

Dean

---

**From:** Brady, Kathie [mailto: (b)(6)]  
**Sent:** Monday, September 08, 2008 4:25 PM  
**To:** Thompson, Arthur D (CTR)  
**Cc:** Ritz, Paul CDR; Anderson, Michael CAPT  
**Subject:** Farmville Comments

Dean,

1. ALL doors on ALL rooms where detainees are seen by medical staff must open outward. The issue is that you don't want a detainee to block a door with a nurse inside and the guards not be able to get in. If the door opens outward, it can always be opened from the outside. Many of the doors in this clinic open inward. So a detainee could shut the door and shove the exam table in front of it, blocking it closed.
2. The double doors between Processing and Intake screening is a bad design. That means to move a patient to medical for the intake requires going through 2 controlled doors. That will really slow down the process. Also, there is another door before medical, which means there needs to be a separate guard in this area during intakes. I've attached a recommended redesign of this area.
3. We don't want to be going through the Dental Lab to get to the Dental Office and vice versa. The Dental Lab is where we sterilize equipment. See the recommended redesign on this.
4. The security gate before pharmacy and lab is a problem. The pharmacy has a pass-through window to give meds to the detainees. The lab is here where we perform lab tests. Having to open the security gate for labs and medication distribution is not good. We do want a gate to separate the administrative area from medical area, but it needs to be to the left (north) of the pharmacy and lab. Best if it is left of the Biohazard waste. With the current design, a second guard is needed when a patient is back there.
5. The TIF unit appears to be in a separate building outside. The TIF unit will have to be monitored by nursing. The current design means there has to be a separate guard and nurse for this unit. At a minimum, the doors to access the unit should be on the opposite wall for easier access versus walking around the building to the doors. Also, we will need to see a detailed design of this at some point.
6. Does ICE have a presence here? We are supposed to co-locate our servers with ICE in the ICE server room. I don't see an ICE server room anywhere. If there is an ICE server room, then we don't need the LAN room unless they need it as a wiring closet with a jumper between medical and the ICE server room. If you take away the LAN room, make the supply room larger.
7. There are 7 doors and 500 feet between medical and Dorms 11-14. Getting to those last dorms during an emergency will be a challenge. I don't see a way to make that any better, just something to be aware of.

Let me know if you have any questions.

Thank You,

*Kathie Brady, PMP*

IT Project Manager

Division of Immigration Health Services

1220 L ST NW, Suite 500

Washington, DC 20005

202-732- (b)(6)

(b)(6)

*This email message is for the sole use of the intended recipient(s) and may contain confidential and privileged information. Any unauthorized review, use, disclosure or distribution is prohibited. If you are not the intended recipient, please contact the sender by reply email and destroy all copies of the original message.*

**Stevens, Richard P**

---

**From:** Neveleff, Jerald  
**Sent:** Tuesday, September 09, 2008 11:50 AM  
**To:** Casterline, Arnold P  
**Subject:** FW: Farmville Comments

Culmination of a lot of emails

Thank you,  
Jerry Neveleff  
Supervisory Contracting Officer/  
IGSA Team Lead  
Office of Acq. Management (OAQ)  
Detention Management Division  
202/616 [REDACTED] b6

Help us support you better -  
TELL US HOW WE ARE DOING!  
Go to <<http://www.acqsolinc.com/ICE/OAQ/feedback.cfm>> <<<http://www.acqsolinc.com/ICE/OAQ/feedback.cfm>>>

---

**From:** Picone, Paul D [mailto:p [REDACTED] (b)(6)]  
**Sent:** Tuesday, September 09, 2008 11:31 AM  
**To:** Brady, Kathie P; Thompson, Arthur D (CTR); Raine, Craig K  
**Cc:** Jenkins, John E; Neveleff, Jerald; Dane, Courtney L (CTR); Smyly, Elena L; Flanagan, Lamont; Brady, Kathie; Henkel, Douglas ; Achim, Deborah  
**Subject:** RE: Farmville Comments

Re #4: Detainees going to the lab would not be an issue. They will need to be escorted. In general, however, DRO would prefer that the area is not within their readily accessible reach.

Paul D. Picone  
Assistant Field Office Director  
Washington Field Office  
ICE/DRO

**Warning: This document is UNCLASSIFIED//FOR OFFICIAL USE ONLY (U//FOUO).** It contains information that may be exempt from public release under the Freedom of Information Act (5 U.S.C. 552). It is to be controlled, stored, handled, transmitted, distributed, and disposed of in accordance with DHS policy relating to FOUO information and is not to be released to the public or other personnel who do not have a valid "need-to-know" without prior approval of an authorized DHS official. **No portion of this report should be furnished to the media, either in written or verbal form.**

---

**From:** Brady, Kathie [mailto:Ka [REDACTED] (b)(6)]  
**Sent:** Tuesday, September 09, 2008 11:22 AM  
**To:** Picone, Paul D; Thompson, Arthur D (CTR); Raine, Craig K  
**Cc:** Jenkins, John E; Neveleff, Jerald; Dane, Courtney L (CTR); Smyly, Elena L; Flanagan, Lamont; Brady, Kathie; Henkel, Douglas ; Achim, Deborah



**Subject:** RE: Farmville Comments

#2 There will need to be a second guard in the Medical Intake Screening area during intake.

#4 Detainees will need to go into the lab.

-----Original Message-----

**From:** Picone, Paul D [mailto: (b)(6)]

**Sent:** Tuesday, September 09, 2008 11:05 AM

**To:** Thompson, Arthur D (CTR); Raine, Craig K

**Cc:** Jenkins, John E; Neveleff, Jerald; Dane, Courtney L (CTR); Smyly, Elena L; Flanagan, Lamont; Brady, Kathie; Henkel, Douglas ; Achim, Deborah

**Subject:** RE: Farmville Comments

**Importance:** High

Re #2: The double doors between Processing and Intake are necessary for security and control purposes. The interlocking mechanism can be overridden by Control in the event of an emergency.

Re #4: DRO would prefer if detainees only had access to the area near the pass-through window and not any of the other areas annotated.

Re #5: A similar unit is utilized at the Florence SPC. That unit is maintained by a security guard only. A nurse comes over on regular intervals but is not there all the time.

Re #7: Established protocols for emergent circumstances will be prepared prior to the opening of the facility. The protocols will include medical emergencies. These protocols will be incorporated into post orders as well. The contractor will produce the protocols and post orders and DRO will review. At the time of the review DRO will invite DIHS for their input as well.

Paul D. Picone  
Assistant Field Office Director  
Washington Field Office  
ICE/DRO

**Warning: This document is UNCLASSIFIED//FOR OFFICIAL USE ONLY (U//FOUO).** It contains information that may be exempt from public release under the Freedom of Information Act (5 U.S.C. 552). It is to be controlled, stored, handled, transmitted, distributed, and disposed of in accordance with DHS policy relating to FOUO information and is not to be released to the public or other personnel who do not have a valid "need-to-know" without prior approval of an authorized DHS official. **No portion of this report should be furnished to the media, either in written or verbal form.**

---

**From:** Thompson, Arthur D (CTR)

**Sent:** Tuesday, September 09, 2008 9:48 AM

**To:** Raine, Craig K; Picone, Paul D

**Cc:** Jenkins, John E; Neveleff, Jerald; Dane, Courtney L (CTR); Smyly, Elena L; Flanagan, Lamont; Brady, Kathie

**Subject:** FW: Farmville Comments

Craig,

I received the comments from Kathy Brady, Project Manager for DIHS with concerns regarding the Farmville project. The changes requested are not structural and can be changed with little effort to make the health area flow more efficient and safe for the staff.

Dean

---

**From:** Brady, Kathie [mailto: (b)(6)]  
**Sent:** Monday, September 08, 2008 4:25 PM  
**To:** Thompson, Arthur D (CTR)  
**Cc:** Ritz, Paul CDR; Anderson, Michael CAPT  
**Subject:** Farmville Comments

Dean,

1. ALL doors on ALL rooms where detainees are seen by medical staff must open outward. The issue is that you don't want a detainee to block a door with a nurse inside and the guards not be able to get in. If the door opens outward, it can always be opened from the outside. Many of the doors in this clinic open inward. So a detainee could shut the door and shove the exam table in front of it, blocking it closed.
2. The double doors between Processing and Intake screening is a bad design. That means to move a patient to medical for the intake requires going through 2 controlled doors. That will really slow down the process. Also, there is another door before medical, which means there needs to be a separate guard in this area during intakes. I've attached a recommended redesign of this area.
3. We don't want to be going through the Dental Lab to get to the Dental Office and vice versa. The Dental Lab is where we sterilize equipment. See the recommended redesign on this.
4. The security gate before pharmacy and lab is a problem. The pharmacy has a pass-through window to give meds to the detainees. The lab is here where we perform lab tests. Having to open the security gate for labs and medication distribution is not good. We do want a gate to separate the administrative area from medical area, but it needs to be to the left (north) of the pharmacy and lab. Best if it is left of the Biohazard waste. With the current design, a second guard is needed when a patient is back there.
5. The TIF unit appears to be in a separate building outside. The TIF unit will have to be monitored by nursing. The current design means there has to be a separate guard and nurse for this unit. At a minimum, the doors to access the unit should be on the opposite wall for easier access versus walking around the building to the doors. Also, we will need to see a detailed design of this at some point.
6. Does ICE have a presence here? We are supposed to co-locate our servers with ICE in the ICE server room. I don't see an ICE server room anywhere. If there is an ICE server room, then we don't need the LAN room unless they need it as a wiring closet with a jumper between medical and the ICE server room. If you take away the LAN room, make the supply room larger.
7. There are 7 doors and 500 feet between medical and Dorms 11-14. Getting to those last dorms during an emergency will be a challenge. I don't see a way to make that any better, just something to be aware of.

Let me know if you have any questions.

Thank You,

*Kathie Brady, PMP*

IT Project Manager

Division of Immigration Health Services

1220 L ST NW, Suite 500

Washington, DC 20005

202-732- (b)(6)

(b)(6)

*This email message is for the sole use of the intended recipient(s) and may contain confidential and privileged information. Any unauthorized review, use, disclosure or distribution is prohibited. If you are not the intended recipient, please contact the sender by reply email and destroy all copies of the original message.*

**Stevens, Richard P**

**From:** Brady, Kathie (b)(6)  
**Sent:** Tuesday, September 09, 2008 12:04 PM  
**To:** Neveleff, Jerald; Picone, Paul D; Brady, Kathie P; Thompson, Arthur D (CTR); Raine, Craig K  
**Cc:** Jenkins, John E; Dane, Courtney L (CTR); Smyly, Elena L; Flanagan, Lamont; Brady, Kathie; Henkel, Douglas ; Achim, Deborah  
**Subject:** FW: Farmville Comments  
**Importance:** High

Please see comments below regarding Item #4.

-----Original Message-----

**From:** Anderson, Michael CAPT [mailto:M (b)(6), b7c]  
**Sent:** Tuesday, September 09, 2008 11:58 AM  
**To:** Brady, Kathie  
**Subject:** RE: Farmville Comments  
**Importance:** High

Since construction has not begun, this needs to be fixed. Detainees do not need to move through the admin area for any reason.

Thank you.

CAPT Michael B. Anderson  
Associate Director for Operations  
1220 Street NW, Suite #500  
Washington, DC 20005  
202-732- (b)(6)  
202-641- (b)(6)  
e-mail: M (b)(6)

-----Original Message-----

**From:** Brady, Kathie [mailto:k (b)(6)]  
**Sent:** Tuesday, September 09, 2008 11:46 AM  
**To:** Anderson, Michael CAPT  
**Subject:** FW: Farmville Comments

CAPT Anderson,

Please see comment stream below. The most concerning is that the detainees must be allowed into the admin area to get to the lab. This means an extra guard and less controlled access to the admin area.

Do you want to weigh in on this?

Kathie

-----Original Message-----

**From:** Picone, Paul D [mailto:PD (b)(6)]  
**Sent:** Tuesday, September 09, 2008 11:31 AM  
**To:** Brady, Kathie; Thompson, Arthur D (CTR); Raine, Craig K  
**Cc:** Jenkins, John E; Neveleff, Jerald; Dane, Courtney L (CTR); Smyly, Elena L; Flanagan, Lamont; Brady, Kathie; Henkel, Douglas ; Achim, Deborah  
**Subject:** RE: Farmville Comments

Re #4: Detainees going to the lab would not be an issue. They will need to be escorted. In general, however, DRO would prefer that the area is not within their readily accessible reach.

Paul D. Picone  
Assistant Field Office Director  
Washington Field Office  
ICE/DRO

**Warning: This document is UNCLASSIFIED//FOR OFFICIAL USE ONLY (U//FOUO).** It contains information that may be exempt from public release under the Freedom of Information Act (5 U.S.C. 552). It is to be controlled, stored, handled, transmitted, distributed, and disposed of in accordance with DHS policy relating to FOUO information and is not to be released to the public or other personnel who do not have a valid "need-to-know" without prior approval of an authorized DHS official. **No portion of this report should be furnished to the media, either in written or verbal form.**

---

**From:** Brady, Kathie [mailto: (b)(6)]  
**Sent:** Tuesday, September 09, 2008 11:22 AM  
**To:** Picone, Paul D; Thompson, Arthur D (CTR); Raine, Craig K  
**Cc:** Jenkins, John E; Neveleff, Jerald; Dane, Courtney L (CTR); Smyly, Elena L; Flanagan, Lamont; Brady, Kathie; Henkel, Douglas ; Achim, Deborah  
**Subject:** RE: Farmville Comments

#2 There will need to be a second guard in the Medical Intake Screening area during intake.

#4 Detainees will need to go into the lab.

-----Original Message-----

**From:** Picone, Paul D [mailto: (b)(6)]  
**Sent:** Tuesday, September 09, 2008 11:05 AM  
**To:** Thompson, Arthur D (CTR); Raine, Craig K  
**Cc:** Jenkins, John E; Neveleff, Jerald; Dane, Courtney L (CTR); Smyly, Elena L; Flanagan, Lamont; Brady, Kathie; Henkel, Douglas ; Achim, Deborah  
**Subject:** RE: Farmville Comments  
**Importance:** High

Re #2: The double doors between Processing and Intake are necessary for security and control purposes. The interlocking mechanism can be overridden by Control in the event of an emergency.

Re #4: DRO would prefer if detainees only had access to the area near the pass-through window and not any of the other areas annotated.

Re #5: A similar unit is utilized at the Florence SPC. That unit is maintained by a security guard only. A nurse comes over on regular intervals but is not there all the time.

Re #7: Established protocols for emergent circumstances will be prepared prior to the opening of the facility. The protocols will include medical emergencies. These protocols will be incorporated into post orders as well. The contractor will produce the protocols and post orders and DRO will review. At the time of the review DRO will invite DIHS for their input as well.

Paul D. Picone  
Assistant Field Office Director  
Washington Field Office  
ICE/DRO

**Warning: This document is UNCLASSIFIED//FOR OFFICIAL USE ONLY (U//FOUO).** It contains information that may be exempt from public release under the Freedom of Information Act (5 U.S.C. 552). It is to be controlled, stored, handled, transmitted, distributed, and disposed of in accordance with DHS policy relating to FOUO information and is not to be released to the public or other personnel who do not have a valid "need-to-know" without prior approval of an authorized DHS official. **No portion of this report should be furnished to the media, either in written or verbal form.**

---

**From:** Thompson, Arthur D (CTR)  
**Sent:** Tuesday, September 09, 2008 9:48 AM  
**To:** Raine, Craig K; Picone, Paul D  
**Cc:** Jenkins, John E; Neveleff, Jerald; Dane, Courtney L (CTR); Smyly, Elena L; Flanagan, Lamont; Brady, Kathie  
**Subject:** FW: Farmville Comments

Craig,

I received the comments from Kathy Brady, Project Manager for DIHS with concerns regarding the Farmville project. The changes requested are not structural and can be changed with little effort to make the health area flow more efficient and safe for the staff.

Dean

---

**From:** Brady, Kathie [mailto:Kathie.Brady@dhs.gov] (b)(6)  
**Sent:** Monday, September 08, 2008 4:25 PM  
**To:** Thompson, Arthur D (CTR)  
**Cc:** Ritz, Paul CDR; Anderson, Michael CAPT  
**Subject:** Farmville Comments

Dean,

1. ALL doors on ALL rooms where detainees are seen by medical staff must open outward. The issue is that you don't want a detainee to block a door with a nurse inside and the guards not be able to get in. If the door opens outward, it can always be opened from the outside. Many of the doors in this clinic open inward. So a detainee could shut the door and shove the exam table in front of it, blocking it closed.
2. The double doors between Processing and Intake screening is a bad design. That means to move a patient to medical for the intake requires going through 2 controlled doors. That will really slow down the process. Also, there is another door before medical, which means there needs to be a separate guard in this area during intakes. I've attached a recommended redesign of this area.
3. We don't want to be going through the Dental Lab to get to the Dental Office and vice versa. The Dental Lab is where we sterilize equipment. See the recommended redesign on this.
4. The security gate before pharmacy and lab is a problem. The pharmacy has a pass-through window to give meds to the detainees. The lab is here where we perform lab tests. Having to open the security gate for labs and medication distribution is not good. We do want a gate to separate the administrative area from medical area, but it needs to be to the left (north) of the pharmacy and lab. Best if it is left of the Biohazard waste. With the current design, a second guard is needed when a patient is back there.
5. The TIF unit appears to be in a separate building outside. The TIF unit will have to be monitored by nursing. The current design means there has to be a separate guard and nurse for this unit. At a minimum, the doors to access the unit should be on the opposite wall for easier access versus walking around the building to the doors. Also, we will need to see a detailed design of this at some point.
6. Does ICE have a presence here? We are supposed to co-locate our servers with ICE in the ICE server room. I don't see an ICE server room anywhere. If there is an ICE server room, then we don't need the LAN room unless they need it as a wiring closet with a jumper between medical and the ICE server room. If you take away the LAN room, make the supply room larger.
7. There are 7 doors and 500 feet between medical and Dorms 11-14. Getting to those last dorms during an emergency will be a challenge. I don't see a way to make that any better, just something to be aware of.

Let me know if you have any questions.

Thank You,

*Kathie Brady, PMP*

IT Project Manager

Division of Immigration Health Services

1220 L ST NW, Suite 500

Washington, DC 20005

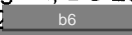
202-732-

b6

  
(b)(6)

*This email message is for the sole use of the intended recipient(s) and may contain confidential and privileged information. Any unauthorized review, use, disclosure of distribution is prohibited. If you are not the intended recipient, please contact the sender by reply email and destroy all copies of the original message.*

**Stevens, Richard P**

---

**From:** Thompson, Arthur D (CTR)  
**Sent:** Wednesday, September 10, 2008 7:25 AM  
**To:** (b)(6)  
**Cc:** Jenkins, John E; Flanagan, Lamont; Brady, Kathie; Neveleff, Jerald; Raine, Craig K; Picone, Paul D; Dane, Courtney L (CTR)  
**Subject:** Farmville Facility DIHS

Mrs. Achim,

Facilities, DIHS, and Contracting would like to confirm your wishes by having DIHS staff the Farmville IGSA facility upon completion.

If DIHS will be staffing the facility we would like to have meeting to discuss some changes in the health area that DIHS would be occupying.

The changes would be non structural but would require resolution for the Architectural lay out.

Contraction would like a definite answer in writing of your recommendation for moving forward with the Health Services staffing plan. Will it be more feasible for Farmville to

Provide Health Services or is it preferred DIHS provide these services.

Your immediate response would be greatly appreciated in helping us plan accordingly.

Thank You,

**Dean Thompson**  
**Project Manager**

**STG International Inc. (Contractor)**  
**DRO/Support Operations for Facilities Management Unit**

202-732 (b)(6)  
202-732 (b)(6)

**Warning: This document is UNCLASSIFIED//FOR OFFICIAL USE ONLY (U//FOUO).** It contains information that may be exempt from public release under the Freedom of Information Act (5 U.S.C. 552). It is to be controlled, stored, handled, transmitted, distributed, and disposed of in accordance with DHS policy relating to FOUO information and is not to be released to the public or other personnel who do not have a valid "need-to-know" without prior approval of an authorized DHS official. **No portion of this report should be furnished to the media, either in written or verbal form.**

12/21/2008

**Stevens, Richard P**

---

**From:** Achim, Deborah (b)(6)  
**Sent:** Wednesday, September 10, 2008 8:17 AM  
**To:** Thompson, Arthur D; Achim, Deborah  
**Cc:** Jenkins, John E; Flanagan, Lamont W; Brady, Kathie P; Neveleff, Jerald; Raine, Craig K; Picone, Paul D; Dane, Courtney L  
**Subject:** Re: Farmville Facility DIHS

Yes, we want DIHS there. Please send us your needs so we can get started asap. We will set up a call as soon as possible.

---

**From:** Thompson, Arthur D (CTR)  
**To:** Achim, Deborah  
**Cc:** Jenkins, John E ; Flanagan, Lamont ; Brady, Kathie ; Neveleff, Jerald ; Raine, Craig K ; Picone, Paul D; Dane, Courtney L (CTR)  
**Sent:** Wed Sep 10 07:25:26 2008  
**Subject:** Farmville Facility DIHS

Mrs. Achim,

Facilities, DIHS, and Contracting would like to confirm your wishes by having DIHS staff the Farmville IGSA facility upon completion.

If DIHS will be staffing the facility we would like to have meeting to discuss some changes in the health area that DIHS would be occupying.

The changes would be non structural but would require resolution for the Architectural lay out.

Contraction would like a definite answer in writing of your recommendation for moving forward with the Health Services staffing plan. Will it be more feasible for Farmville to

Provide Health Services or is it preferred DIHS provide these services.

Your immediate response would be greatly appreciated in helping us plan accordingly.

Thank You,

**Dean Thompson**  
**Project Manager**

**STG International Inc. (Contractor)**  
**DRO/Support Operations for Facilities Management Unit**

202-732-  
202-732- (b6)

**Warning: This document is UNCLASSIFIED//FOR OFFICIAL USE ONLY (U//FOUO).** It contains information that may be exempt from public release under the Freedom of Information Act (5 U.S.C. 552). It is to be controlled, stored, handled, transmitted, distributed, and disposed of in accordance with DHS policy relating to FOUO information and is not to be released to the public or other personnel who do not have a valid "need-to-know" without prior approval of an authorized DHS official. **No portion of this report should be furnished to the media, either in written or verbal form.**

12/21/2008





**Stevens, Richard P**

---

**From:** Achim, Deborah (b)(6)  
**Sent:** Wednesday, September 10, 2008 9:04 AM  
**To:** Thompson, Arthur D; Achim, Deborah  
**Cc:** Jenkins, John E; Flanagan, Lamont W; Neveleff, Jerald  
**Subject:** Re: Farmville Facility DIHS

We would like a breakdown of your concerns this week. We are on a tight timeline. Today would be best.

---

**From:** Thompson, Arthur D (CTR)  
**To:** Achim, Deborah  
**Cc:** Jenkins, John E ; Flanagan, Lamont ; Neveleff, Jerald  
**Sent:** Wed Sep 10 08:40:32 2008  
**Subject:** RE: Farmville Facility DIHS

Thank you for the rapid reply. We will be looking for the call date.

Dean

---

**From:** Achim, Deborah [mailto:(b)(6)]  
**Sent:** Wednesday, September 10, 2008 8:17 AM  
**To:** Thompson, Arthur D; Achim, Deborah  
**Cc:** Jenkins, John E; Flanagan, Lamont W; Brady, Kathie P; Neveleff, Jerald; Raine, Craig K; Picone, Paul D; Dane, Courtney L  
**Subject:** Re: Farmville Facility DIHS

Yes, we want DIHS there. Please send us your needs so we can get started asap. We will set up a call as soon as possible.

---

**From:** Thompson, Arthur D (CTR)  
**To:** Achim, Deborah  
**Cc:** Jenkins, John E ; Flanagan, Lamont ; Brady, Kathie ; Neveleff, Jerald ; Raine, Craig K ; Picone, Paul D; Dane, Courtney L (CTR)  
**Sent:** Wed Sep 10 07:25:26 2008  
**Subject:** Farmville Facility DIHS  
Mrs. Achim,

Facilities, DIHS, and Contracting would like to confirm your wishes by having DIHS staff the Farmville IGSA facility upon completion.

If DIHS will be staffing the facility we would like to have meeting to discuss some changes in the health area that DIHS would be occupying.

The changes would be non structural but would require resolution for the Architectural lay out.

Contraction would like a definite answer in writing of your recommendation for moving forward with the Health Services staffing plan. Will it be more feasible for Farmville to

Provide Health Services or is it preferred DIHS provide these services.

Your immediate response would be greatly appreciated in helping us plan accordingly.

12/21/2008

Thank You,

**Dean Thompson**  
**Project Manager**

**STG International Inc. (Contractor)**  
**DRO/Support Operations for Facilities Management Unit**

202-732- [REDACTED]  
202-732- [REDACTED] b6

**Warning: This document is UNCLASSIFIED//FOR OFFICIAL USE ONLY (U//FOUO).** It contains information that may be exempt from public release under the Freedom of Information Act (5 U.S.C. 552). It is to be controlled, stored, handled, transmitted, distributed, and disposed of in accordance with DHS policy relating to FOUO information and is not to be released to the public or other personnel who do not have a valid "need-to-know" without prior approval of an authorized DHS official. **No portion of this report should be furnished to the media, either in written or verbal form.**

**Stevens, Richard P**

---

**From:** Thompson, Arthur D (CTR)  
**Sent:** Wednesday, September 10, 2008 8:41 AM  
**To:** Achim, Deborah  
**Cc:** Jenkins, John E; Flanagan, Lamont; Neveleff, Jerald  
**Subject:** RE: Farmville Facility DIHS

Thank you for the rapid reply. We will be looking for the call date.

Dean

---

**From:** Achim, Deborah [mailto:deborah.achim@dnr.gov] (b)(6)  
**Sent:** Wednesday, September 10, 2008 8:17 AM  
**To:** Thompson, Arthur D; Achim, Deborah  
**Cc:** Jenkins, John E; Flanagan, Lamont W; Brady, Kathie P; Neveleff, Jerald; Raine, Craig K; Picone, Paul D; Dane, Courtney L  
**Subject:** Re: Farmville Facility DIHS

Yes, we want DIHS there. Please send us your needs so we can get started asap. We will set up a call as soon as possible.

---

**From:** Thompson, Arthur D (CTR)  
**To:** Achim, Deborah  
**Cc:** Jenkins, John E ; Flanagan, Lamont ; Brady, Kathie ; Neveleff, Jerald ; Raine, Craig K ; Picone, Paul D; Dane, Courtney L (CTR)  
**Sent:** Wed Sep 10 07:25:26 2008  
**Subject:** Farmville Facility DIHS  
Mrs. Achim,

Facilities, DIHS, and Contracting would like to confirm your wishes by having DIHS staff the Farmville IGSA facility upon completion.

If DIHS will be staffing the facility we would like to have meeting to discuss some changes in the health area that DIHS would be occupying.

The changes would be non structural but would require resolution for the Architectural lay out.

Contraction would like a definite answer in writing of your recommendation for moving forward with the Health Services staffing plan. Will it be more feasible for Farmville to

Provide Health Services or is it preferred DIHS provide these services.

Your immediate response would be greatly appreciated in helping us plan accordingly.

Thank You,

**Dean Thompson**  
**Project Manager**

**STG International Inc. (Contractor)**  
**DRO/Support Operations for Facilities Management Unit**

12/21/2008

202-732  
202-732

b6

**Warning: This document is UNCLASSIFIED//FOR OFFICIAL USE ONLY (U//FOUO).** It contains information that may be exempt from public release under the Freedom of Information Act (5 U.S.C. 552). It is to be controlled, stored, handled, transmitted, distributed, and disposed of in accordance with DHS policy relating to FOUO information and is not to be released to the public or other personnel who do not have a valid "need-to-know" without prior approval of an authorized DHS official. **No portion of this report should be furnished to the media, either in written or verbal form.**

**Stevens, Richard P**

---

**From:** Neveleff, Jerald  
**Sent:** Wednesday, September 10, 2008 10:34 AM  
**To:** 'Achim, Deborah'; Thompson, Arthur D  
**Cc:** Jenkins, John E; Flanagan, Lamont W; Casterline, Arnold P  
**Subject:** RE: Farmville Facility DIHS

I believe the DIHS staffing question for OAQ is:

Will DIHS be providing the medical staffing when the facility opens (approximately April 09)? Or will it be sometime further down the road and Farmville will need to staff the positions in the mean time? Either way, Farmville will construct the medical space any way ICE makes the call.

For OAQ and the negotiations, that is the question we need answered now as we are trying to establish a bed day rate. If it's when the facility opens, then OAQ will remove the Farmville medical staffing from the calculations. If sometime after the facility opens, then OAQ will leave in the proposed staffing but highlight it for removal at a time DIHS will provide the medical staffing.

Jerry

Thank you,  
Jerry Neveleff  
Supervisory Contracting Officer/  
IGSA Team Lead  
Office of Acq. Management (OAQ)  
Detention Management Division  
202/616 [REDACTED] b6

Help us support you better -  
TELL US HOW WE ARE DOING!  
Go to <<http://www.acqsolinc.com/ICE/OAQ/feedback.cfm>> <<<http://www.acqsolinc.com/ICE/OAQ/feedback.cfm>>>

---

**From:** Achim, Deborah [mailto:d [REDACTED] (b)(6), b7c]  
**Sent:** Wednesday, September 10, 2008 9:04 AM  
**To:** Thompson, Arthur D; Achim, Deborah  
**Cc:** Jenkins, John E; Flanagan, Lamont W; Neveleff, Jerald  
**Subject:** Re: Farmville Facility DIHS

We would like a breakdown of your concerns this week. We are on a tight timeline. Today would be best.

---

**From:** Thompson, Arthur D (CTR)  
**To:** Achim, Deborah  
**Cc:** Jenkins, John E ; Flanagan, Lamont ; Neveleff, Jerald  
**Sent:** Wed Sep 10 08:40:32 2008  
**Subject:** RE: Farmville Facility DIHS  
Thank you for the rapid reply. We will be looking for the call date.

Dean

12/21/2008

---

**From:** Achim, Deborah [mailto: (b)(6)]  
**Sent:** Wednesday, September 10, 2008 8:17 AM  
**To:** Thompson, Arthur D; Achim, Deborah  
**Cc:** Jenkins, John E; Flanagan, Lamont W; Brady, Kathie P; Neveleff, Jerald; Raine, Craig K; Picone, Paul D; Dane, Courtney L  
**Subject:** Re: Farmville Facility DIHS

Yes, we want DIHS there. Please send us your needs so we can get started asap. We will set up a call as soon as possible.

---

**From:** Thompson, Arthur D (CTR)  
**To:** Achim, Deborah  
**Cc:** Jenkins, John E ; Flanagan, Lamont ; Brady, Kathie ; Neveleff, Jerald ; Raine, Craig K ; Picone, Paul D; Dane, Courtney L (CTR)  
**Sent:** Wed Sep 10 07:25:26 2008  
**Subject:** Farmville Facility DIHS  
Mrs. Achim,

Facilities, DIHS, and Contracting would like to confirm your wishes by having DIHS staff the Farmville IGSA facility upon completion.

If DIHS will be staffing the facility we would like to have meeting to discuss some changes in the health area that DIHS would be occupying.

The changes would be non structural but would require resolution for the Architectural lay out.

Contraction would like a definite answer in writing of your recommendation for moving forward with the Health Services staffing plan. Will it be more feasible for Farmville to

Provide Health Services or is it preferred DIHS provide these services.

Your immediate response would be greatly appreciated in helping us plan accordingly.

Thank You,

**Dean Thompson**  
**Project Manager**

**STG International Inc. (Contractor)**  
**DRO/Support Operations for Facilities Management Unit**

202-732- (b6)  
202-732-

**Warning:** This document is UNCLASSIFIED//FOR OFFICIAL USE ONLY (U//FOUO). It contains information that may be exempt from public release under the Freedom of Information Act (5 U.S.C. 552). It is to be controlled, stored, handled, transmitted, distributed, and disposed of in accordance with DHS policy relating to FOUO information and is not to be released to the public or other personnel who do not have a valid "need-to-know" without prior approval of an authorized DHS official. **No portion of this report should be furnished to the media, either in written or verbal form.**

**Stevens, Richard P**

---

**From:** Daragan, Joseph J (CTR)  
**Sent:** Thursday, September 11, 2008 9:11 AM  
**To:** Casterline, Arnold P  
**Cc:** Neveleff, Jerald; Thompson, Samuel L

What is the status of the Farmville Detention Facility? How many beds will be available on September 15? Why are we negotiating with Farmville rather than with Prince Edward County?

Joseph Daragan  
Senior Contract Specialist  
BAE IT  
Supporting DHS/ICE/Office of Acquisition Management (OAQ)

Main: 202-5 [REDACTED] b6  
Desk: 202-6 [REDACTED]

Email: [REDACTED] (b)(6)

**Help us support you better –  
TELL US HOW WE ARE DOING!**

**Go to** <<http://www.acqsolinc.com/ICE/OAQ/feedback.cfm>>



**Stevens, Richard P**

---

**From:** Neveleff, Jerald  
**Sent:** Thursday, September 11, 2008 9:13 AM  
**To:** Daragan, Joseph J (CTR); Casterline, Arnold P  
**Cc:** Thompson, Samuel L  
**Subject:** RE:

The building is in the construction phase. Beds won't be ready until March/April 2009. City of Farmville is the Governmental entity we will be placing an IGSA with.

Thank you,  
Jerry Neveleff  
Supervisory Contracting Officer/  
IGSA Team Lead  
Office of Acq. Management (OAQ)  
Detention Management Division  
202/6 [REDACTED] b6

Help us support you better -  
TELL US HOW WE ARE DOING!  
Go to <http://www.acqsolinc.com/ICE/OAQ/feedback.cfm> <<<http://www.acqsolinc.com/ICE/OAQ/feedback.cfm>>>

---

**From:** Daragan, Joseph J (CTR)  
**Sent:** Thursday, September 11, 2008 9:11 AM  
**To:** Casterline, Arnold P  
**Cc:** Neveleff, Jerald; Thompson, Samuel L  
**Subject:**

What is the status of the Farmville Detention Facility? How many beds will be available on September 15? Why are we negotiating with Farmville rather than with Prince Edward County?

Joseph Daragan  
Senior Contract Specialist  
BAE IT  
Supporting DHS/ICE/Office of Acquisition Management (OAQ)  
Main: 202-5 [REDACTED] b6  
Desk: 202-6 [REDACTED]  
Email: jo. [REDACTED] (b)(6)

**Help us support you better –**  
**TELL US HOW WE ARE DOING!**  
Go to <http://www.acqsolinc.com/ICE/OAQ/feedback.cfm>

**Stevens, Richard P**

**From:** Daragan, Joseph J (CTR)  
**Sent:** Thursday, September 11, 2008 9:16 AM  
**To:** Neveleff, Jerald; Casterline, Arnold P  
**Cc:** Thompson, Samuel L  
**Subject:** RE:

So why are entering into an agreement for transportation only? This IGSA doesn't seem ripe for review or approval.

Joseph Daragan  
Senior Contract Specialist  
BAE IT  
Supporting DHS/ICE/Office of Acquisition Management (OAQ)  
Main: 202-514 [redacted]  
Desk: 202-616 [redacted] b6

Email [redacted] (b)(6)

**Help us support you better –  
TELL US HOW WE ARE DOING!**

Go to <<http://www.acqsolinc.com/ICE/OAQ/feedback.cfm>>

---

**From:** Neveleff, Jerald  
**Sent:** Thursday, September 11, 2008 9:13 AM  
**To:** Daragan, Joseph J (CTR); Casterline, Arnold P  
**Cc:** Thompson, Samuel L  
**Subject:** RE:

The building is in the construction phase. Beds won't be ready until March/April 2009. City of Farmville is the Governmental entity we will be placing an IGSA with.

Thank you,  
Jerry Neveleff  
Supervisory Contracting Officer/  
IGSA Team Lead  
Office of Acq. Management (OAQ)  
Detention Management Division  
202/616 [redacted] b6

Help us support you better -  
**TELL US HOW WE ARE DOING!**  
Go to <<http://www.acqsolinc.com/ICE/OAQ/feedback.cfm>> <<<http://www.acqsolinc.com/ICE/OAQ/feedback.cfm>>>

---

**From:** Daragan, Joseph J (CTR)  
**Sent:** Thursday, September 11, 2008 9:11 AM  
**To:** Casterline, Arnold P  
**Cc:** Neveleff, Jerald; Thompson, Samuel L  
**Subject:**

What is the status of the Farmville Detention Facility? How many beds will be available on September 15? Why are we negotiating with Farmville rather than with Prince Edward County?

Joseph Daragan  
Senior Contract Specialist  
BAE IT  
Supporting DHS/ICE/Office of Acquisition Management (OAQ)

Main: 202-514 [REDACTED]

Desk: 202-616 [REDACTED] b6

Email [REDACTED] (b)(6)

**Help us support you better –  
TELL US HOW WE ARE DOING!**

**Go to** <<http://www.acqsolinc.com/ICE/OAQ/feedback.cfm>>

**Stevens, Richard P**

---

**From:** Neveleff, Jerald  
**Sent:** Thursday, September 11, 2008 9:20 AM  
**To:** Daragan, Joseph J (CTR); Casterline, Arnold P  
**Cc:** Thompson, Samuel L  
**Subject:** RE:

As the cover letter says, we need the Transportation now. The ICE Officers on detail will be departing this month and there will be ZERO assets available to perform the function.

The only thing left to do is negotiate the Housing rate. No exceptions to terms and conditions of the IGSA was taken. The housing rate will be implemented as a Bi-Lateral modification to the agreement when finalized.

Thank you,  
Jerry Neveleff  
Supervisory Contracting Officer/  
IGSA Team Lead  
Office of Acq. Management (OAQ)  
Detention Management Division  
202/616- [REDACTED] b6

Help us support you better -  
TELL US HOW WE ARE DOING!  
Go to <<http://www.acqsolinc.com/ICE/OAQ/feedback.cfm>> <<<http://www.acqsolinc.com/ICE/OAQ/feedback.cfm>>>

---

**From:** Daragan, Joseph J (CTR)  
**Sent:** Thursday, September 11, 2008 9:16 AM  
**To:** Neveleff, Jerald; Casterline, Arnold P  
**Cc:** Thompson, Samuel L  
**Subject:** RE:

So why are entering into an agreement for transportation only? This IGSA doesn't seem ripe for review or approval.

Joseph Daragan  
Senior Contract Specialist  
BAE IT  
Supporting DHS/ICE/Office of Acquisition Management (OAQ)  
Main: 202-514- [REDACTED] b6  
Desk: 202-616- [REDACTED]  
Email: [REDACTED] (b)(6)  
**Help us support you better –**  
**TELL US HOW WE ARE DOING!**  
Go to <<http://www.acqsolinc.com/ICE/OAQ/feedback.cfm>>

---

**From:** Neveleff, Jerald  
**Sent:** Thursday, September 11, 2008 9:13 AM  
**To:** Daragan, Joseph J (CTR); Casterline, Arnold P

**Cc:** Thompson, Samuel L  
**Subject:** RE:

The building is in the construction phase. Beds won't be ready until March/April 2009. City of Farmville is the Governmental entity we will be placing an IGSA with.

Thank you,  
Jerry Neveleff  
Supervisory Contracting Officer/  
IGSA Team Lead  
Office of Acq. Management (OAQ)  
Detention Management Division  
202/616 [redacted] b6

Help us support you better -  
TELL US HOW WE ARE DOING!  
Go to <<http://www.acqsolinc.com/ICE/OAQ/feedback.cfm>> <<<http://www.acqsolinc.com/ICE/OAQ/feedback.cfm>>>

---

**From:** Daragan, Joseph J (CTR)  
**Sent:** Thursday, September 11, 2008 9:11 AM  
**To:** Casterline, Arnold P  
**Cc:** Neveleff, Jerald; Thompson, Samuel L  
**Subject:**

What is the status of the Farmville Detention Facility? How many beds will be available on September 15? Why are we negotiating with Farmville rather than with Prince Edward County?

Joseph Daragan  
Senior Contract Specialist  
BAE IT  
Supporting DHS/ICE/Office of Acquisition Management (OAQ)  
Main: 202-5 [redacted] b6  
Desk: 202-6 [redacted] b6  
Email: [redacted] (b)(6)

**Help us support you better -**  
**TELL US HOW WE ARE DOING!**  
Go to <<http://www.acqsolinc.com/ICE/OAQ/feedback.cfm>>

**Stevens, Richard P**

---

**From:** Picone, Paul D  
**Sent:** Thursday, September 11, 2008 1:09 PM  
**To:** Neveleff, Jerald  
**Cc:** Raine, Craig K; Henkel, Douglas ; Achim, Deborah; Casterline, Arnold P  
**Subject:** Re: Transportation contract

The sooner the better. We have several initiatives planned that require the manpower that this contract affords us to have available. Additionally, we have planned for the contractor to be utilized for a large operation planned with our partner, OI, on the 22nd. Ideally, things would go smoother if they were already onboard.

----- Original Message -----

**From:** Neveleff, Jerald  
**To:** Picone, Paul D  
**Cc:** Raine, Craig K; Henkel, Douglas ; Achim, Deborah; Casterline, Arnold P  
**Sent:** Thu Sep 11 09:43:36 2008  
**Subject:** Re: Transportation contract

The award package JUST got to OPLA. Its marked urgent. Do we have to start the transportation the 15th or can we do so on the 16th, the 22nd? If you need it on the 15th because you have nothing else, I can make it effective then but only if there is nothing negative in the review. I won't know that until tomorrow.

Jerry

-----Original Message-----

**From:** Picone, Paul D  
**To:** Neveleff, Jerald  
**Cc:** Craig Raine  
**Cc:** Henkel, Douglas  
**Cc:** Achim, Deborah  
**Sent:** Sep 11, 2008 09:57  
**Subject:** Transportation contract

Jerry:

Please advise as to the status of the transportation contract. The last we heard there was a tentative date of 9/15. Is this still a tentative date, has the date been pushed back or are we a go?

Please advise.

Jerry  
Sent using BlackBerry

**Stevens, Richard P**

---

**From:** Raine, Craig K  
**Sent:** Friday, September 12, 2008 10:08 AM  
**To:** Neveleff, Jerald  
**Subject:** Re: Transportation contract

Full funding is in place and ready.

Thx

-----  
Sent from my BlackBerry Wireless Handheld

----- Original Message -----  
From: Neveleff, Jerald  
To: Raine, Craig K  
Sent: Thu Sep 11 15:16:36 2008  
Subject: RE: Transportation contract

I am trying to set up the transportation piece for 6 months. Its about \$161,333.34/month.

Is there an issue with the money?

Thank you,  
Jerry Neveleff  
Supervisory Contracting Officer/  
IGSA Team Lead  
Office of Acq. Management (OAQ)  
Detention Management Division  
202/6 [REDACTED] b6

Help us support you better -  
TELL US HOW WE ARE DOING!  
Go to <<http://www.acqsolinc.com/ICE/OAQ/feedback.cfm>>  
<<<http://www.acqsolinc.com/ICE/OAQ/feedback.cfm>>>

-----Original Message-----  
From: Raine, Craig K  
Sent: Thursday, September 11, 2008 3:00 PM  
To: Neveleff, Jerald  
Subject: Re: Transportation contract

Jerry,

How much are we estimating to spend the last 2 weeks of the year?

Thx

-----  
Sent from my BlackBerry Wireless Handheld

----- Original Message -----  
From: Neveleff, Jerald  
To: Picone, Paul D  
Cc: Raine, Craig K; Henkel, Douglas ; Achim, Deborah; Casterline, Arnold P  
Sent: Thu Sep 11 13:49:23 2008  
Subject: RE: Transportation contract

Hopefully no bumps, just developments.  
Arnie has all the award documents drafted. Just waiting for OPLA to say okay.

Thank you,

Jerry Neveleff  
Supervisory Contracting Officer/  
IGSA Team Lead  
Office of Acq. Management (OAQ)  
Detention Management Division  
202/616- [REDACTED] b6

Help us support you better -  
TELL US HOW WE ARE DOING!  
Go to <<http://www.acqsolinc.com/ICE/OAQ/feedback.cfm>>  
<<<http://www.acqsolinc.com/ICE/OAQ/feedback.cfm>>>

-----Original Message-----

From: Picone, Paul D  
Sent: Thursday, September 11, 2008 1:18 PM  
To: Neveleff, Jerald  
Cc: Raine, Craig K; Henkel, Douglas ; Achim, Deborah; Casterline, Arnold P  
Subject: Re: Transportation contract

Thanks Jerry.

Please keep us posted on any developments or bumps in the road.

----- Original Message -----

From: Neveleff, Jerald  
To: Picone, Paul D  
Cc: Raine, Craig K; Henkel, Douglas ; Achim, Deborah; Casterline, Arnold P  
Sent: Thu Sep 11 10:16:11 2008  
Subject: RE: Transportation contract

Okay. Again, if there are no negative comments that prevent me from moving forward, we can plan to start using them next week. It may not be the 15th, but before the 19th. This way they are already on board and have the assets necessary to perform.

Unfortunately we lost two days in the signature process.

Please have someone verify that \$968,000 is still available on the G-514 (FDG08FARM).

Jerry

Thank you,  
Jerry Neveleff  
Supervisory Contracting Officer/  
IGSA Team Lead  
Office of Acq. Management (OAQ)  
Detention Management Division  
202/616- [REDACTED] b6

Help us support you better -  
TELL US HOW WE ARE DOING!  
Go to <<http://www.acqsolinc.com/ICE/OAQ/feedback.cfm>>  
<<<http://www.acqsolinc.com/ICE/OAQ/feedback.cfm>>>

-----Original Message-----

From: Picone, Paul D  
Sent: Thursday, September 11, 2008 1:09 PM  
To: Neveleff, Jerald  
Cc: Raine, Craig K; Henkel, Douglas ; Achim, Deborah; Casterline, Arnold P  
Subject: Re: Transportation contract

The sooner the better. We have several initiatives planned that require the manpower that this contract affords us to have available. Additionally, we have planned for the contractor to be utilized for a large operation planned with our partner, OI, on the 22nd. Ideally, things would go smoother if they were already onboard.



----- Original Message -----

From: Neveleff, Jerald

To: Picone, Paul D

Cc: Raine, Craig K; Henkel, Douglas ; Achim, Deborah; Casterline, Arnold P

Sent: Thu Sep 11 09:43:36 2008

Subject: Re: Transportation contract

The award package JUST got to OPLA. Its marked urgent. Do we have to start the transportation the 15th or can we do so on the 16th, the 22nd? If you need it on the 15th because you have nothing else, I can make it effective then but only if there is nothing negative in the review. I won't know that until tomorrow.

Jerry

-----Original Message-----

From: Picone, Paul D

To: Neveleff, Jerald

Cc: Craig Raine

Cc: Henkel, Douglas

Cc: Achim, Deborah

Sent: Sep 11, 2008 09:57

Subject: Transportation contract

Jerry:

Please advise as to the status of the transportation contract. The last we heard there was a tentative date of 9/15. Is this still a tentative date, has the date been pushed back or are we a go?

Please advise.

Jerry

Sent using BlackBerry

**Stevens, Richard P**

---

**From:** Neveleff, Jerald  
**Sent:** Friday, September 12, 2008 10:09 AM  
**To:** Raine, Craig K  
**Subject:** Re: Transportation contract

Thx. Waiting for opla

-----Original Message-----

**From:** Craig Raine  
**To:** Neveleff, Jerald  
**Sent:** Sep 12, 2008 10:07  
**Subject:** Re: Transportation contract

Full funding is in place and ready.

Thx

-----  
Sent from my BlackBerry Wireless Handheld

----- Original Message -----

**From:** Neveleff, Jerald  
**To:** Raine, Craig K  
**Sent:** Thu Sep 11 15:16:36 2008  
**Subject:** RE: Transportation contract

I am trying to set up the transportation piece for 6 months. Its about \$161,333.34/month.

Is there an issue with the money?

Thank you,  
Jerry Neveleff  
Supervisory Contracting Officer/  
IGSA Team Lead  
Office of Acq. Management (OAQ)  
Detention Management Division  
202/616-2000 b6

Help us support you better -  
TELL US HOW WE ARE DOING!  
Go to <<http://www.acqsolinc.com/ICE/OAQ/feedback.cfm>>  
<<<http://www.acqsolinc.com/ICE/OAQ/feedback.cfm>>>

-----Original Message-----

**From:** Raine, Craig K  
**Sent:** Thursday, September 11, 2008 3:00 PM  
**To:** Neveleff, Jerald  
**Subject:** Re: Transportation contract

Jerry,

How much are we estimating to spend the last 2 weeks of the year?

Thx

-----  
Sent from my BlackBerry Wireless Handheld

----- Original Message -----

**From:** Neveleff, Jerald  
**To:** Picone, Paul D  
**Cc:** Raine, Craig K; Henkel, Douglas ; Achim, Deborah; Casterline, Arnold P

Sent: Thu Sep 11 13:49:23 2008  
Subject: RE: Transportation contract

Hopefully no bumps, just developments.  
Arnie has all the award documents drafted. Just waiting for OPLA to say okay.

Thank you,  
Jerry Neveleff  
Supervisory Contracting Officer/  
IGSA Team Lead  
Office of Acq. Management (OAQ)  
Detention

-----Original Message Truncated-----

Jerry  
Sent using BlackBerry

**Stevens, Richard P**

---

**From:** Russell Harper <[REDACTED] b6>  
**Sent:** Friday, September 12, 2008 11:59 AM  
**To:** Neveleff, Jerald  
**Cc:** Raine, Craig K; Casterline, Arnold P  
**Subject:** Re: FARMVILLE TRANSPORTATION

We will be ready. Thanks

-----  
Sent from Russell B. Harper

-----Original Message-----

**From:** Neveleff, Jerald <[REDACTED] (b)(6)>  
**To:** Russell Harper <[REDACTED] b6>  
**CC:** Raine, Craig K <[REDACTED] (b)(6)>; Casterline, Arnold P <[REDACTED] (b)(6)> <arnold.casterline@dns.gov>  
**Sent:** Fri Sep 12 11:54:33 2008  
**Subject:** FARMVILLE TRANSPORTATION

Russell,

I am waiting to hear from the legal review of the award document. I am hoping to have that very soon. Provided all is acceptable to the reviewer, and I hope to get that today. If I do, were looking to start Monday or Tuesday depending on when I get the word today. If after 5pm, then I'd say we'd start Tuesday so Monday can be a coordination day.

I am not in the office today but am reviewing emails.

Jerry

**Stevens, Richard P**

---

**From:** Longmeyer-Wood, Jennifer L  
**Sent:** Friday, September 12, 2008 1:04 PM  
**To:** Neveleff, Jerald  
**Subject:** Farmville

Just approved and giving back to our mission support to send back to you guys.

Jennifer L. Longmeyer-Wood  
Associate Legal Advisor  
ICE Office of the Principal Legal Advisor  
425 I Street, NW, Room 6100  
Washington, DC 20536  
(p) 202.616 [REDACTED]  
(f) 202.514. [REDACTED] b6

\*\*\* Warning \*\*\* Attorney/Client Privilege \*\*\* Attorney Work Product \*\*\*

This document contains confidential and/or sensitive attorney/client privileged information or attorney work product and is not for release, review, retransmission, dissemination or use by anyone other than the intended recipient. Please notify the sender if this email has been misdirected and immediately destroy all originals and copies. Any disclosure of this document must be approved by the Office of the Principal Legal Advisor, U.S. Immigration & Customs Enforcement. This document is for INTERNAL GOVERNMENT USE ONLY. FOIA exempt under 5 USC 552(b)(5).

**Stevens, Richard P**

---

**From:** Longmeyer-Wood, Jennifer L  
**Sent:** Friday, September 12, 2008 1:07 PM  
**To:** Neveleff, Jerald  
**Subject:** RE: Farmville

No. although I don't agree with policy that we should have done transportation separately. As you and I discussed, usually all this would be done in one fell swoop, no need to double our work.

Oh, one small thing - Farmington folks did not sign all the pages of the cost statement.

Jennifer L. Longmeyer-Wood  
Associate Legal Advisor  
ICE Office of the Principal Legal Advisor  
(p) 202.616 [REDACTED] b6

\*\*\* Warning \*\*\* Attorney/Client Privilege \*\*\* Attorney Work Product \*\*\*

This document contains confidential and/or sensitive attorney/client privileged information or attorney work product and is not for release, review, retransmission, dissemination or use by anyone other than the intended recipient. Please notify the sender if this email has been misdirected and immediately destroy all originals and copies. Any disclosure of this document must be approved by the Office of the Principal Legal Advisor, U.S. Immigration & Customs Enforcement. This document is for INTERNAL GOVERNMENT USE ONLY. FOIA exempt under 5 USC 552(b)(5).

-----Original Message-----

From: Neveleff, Jerald  
Sent: Friday, September 12, 2008 1:04 PM  
To: Longmeyer-Wood, Jennifer L  
Subject: Re: Farmville

No issues?

-----Original Message-----

From: Longmeyer-Wood, Jennifer L  
To: Neveleff, Jerald  
Sent: Sep 12, 2008 13:03  
Subject: Farmville

Just approved and giving back to our mission support to send back to you guys.

Jennifer L. Longmeyer-Wood

Associate Legal Advisor

ICE Office of the Principal Legal Advisor

425 I Street, NW, Room 6100

Washington, DC 20536

(p) 202.61 [REDACTED]

b6

(f) 202.51 [REDACTED]

\*\*\* Warning \*\*\* Attorney/Client Privilege \*\*\* Attorney Work Product \*\*\*

This document contains confidential and/or sensitive attorney/client privileged

information or attorney work product and is not for release, review, retransmission, dissemination or use by anyone other than the intended recipient. Please notify the sender if this email has been misdirected and immediately destroy all originals and copies. Any disclosure of this document must be approved by the Office of the Principal Legal Advisor, U.S. Immigration & Customs Enforcement. This document is for INTERNAL GOVERNMENT USE ONLY. FOIA exempt under 5 USC 552(b)(5).

Jerry  
Sent using BlackBerry

**Stevens, Richard P**

**From:** Picone, Paul D [redacted (b)(6)]  
**Sent:** Friday, September 12, 2008 4:11 PM  
**To:** Neveleff, Jerald  
**Cc:** Achim, Deborah; Henkel, Douglas ; Raine, Craig K  
**Subject:** FW: Notifications to Jails  
**Importance:** High

Jerry:

Did the company not supply a list of employees for background investigations?

Why would he be stalling?

His delay reduces our ability to adequately notify the jails so his employees can gain access.

Paul D. Picone  
Assistant Field Office Director  
Washington Field Office  
ICE/DRO

**Warning: This document is UNCLASSIFIED//FOR OFFICIAL USE ONLY (U//FOUO).** It contains information that may be exempt from public release under the Freedom of Information Act (5 U.S.C. 552). It is to be controlled, stored, handled, transmitted, distributed, and disposed of in accordance with DHS policy relating to FOUO information and is not to be released to the public or other personnel who do not have a valid "need-to-know" without prior approval of an authorized DHS official. **No portion of this report should be furnished to the media, either in written or verbal form.**

**From:** Warren Coleman [mailto:wcolem@nau.edu] [redacted b6]  
**Sent:** Friday, September 12, 2008 2:34 PM  
**To:** Witte, Diane L  
**Cc:** McManus, Judd R; Watson, Joe; Picone, Paul D  
**Subject:** Re: Notifications to Jails

Diane  
We will provide the name on Monday as I understand that our start date is Tuesday.  
We look forward to working with you.  
Warren  
Warren Coleman

-----Original Message-----

**From:** Witte, Diane L <dianewitte@dhs.gov> [redacted (b)(6)]  
**To:** Warren Coleman <wcolem@nau.edu> [redacted b6]  
**CC:** McManus, Judd R <juddmcmanus@dhs.gov> [redacted (b)(6)], watson, Joe <joe.watson@dhs.gov> [redacted (b)(6)], Picone, Paul D <paul.picone@dhs.gov> [redacted (b)(6)]  
**Sent:** Fri Sep 12 11:28:09 2008  
**Subject:** Notifications to Jails

Mr. Coleman,

12/21/2008



I am the supervisor of the Population Control Unit. We will be working very closely with you and your staff as you begin to take over the transportation of our detainees for us. In order to assure a smooth transition the Deportation Officer in charge of detention standards, Judd McManus, would like to provide all of our jails with a notification letter that explains the changes that are occurring regarding transportation. If you could please provide me with a list of employees that will be transporting (and contact numbers if possible), supervisor contact information, and a list of vehicle make/model and license plate numbers so that I can disseminate this information to the jails.

Thank you for your cooperation,

Diane Witte

ASIEA

202-345 [REDACTED] b6

**Stevens, Richard P**

---

**From:** Russell Harper [redacted] b6  
**Sent:** Friday, September 12, 2008 4:43 PM  
**To:** Raine, Craig K; Warren Coleman  
**Cc:** Picone, Paul D; Neveleff, Jerald  
**Subject:** Re: FARMVILLE TRANSPORTATION

Drivers  
[redacted] b6

Sent from Russell B. Harper

-----Original Message-----

From: Raine, Craig K <[redacted] (b)(6)>  
To: Russell Harper <[redacted] b6>; Warren Coleman <[redacted] b6>  
CC: Picone, Paul D <[redacted] (b)(6)>  
Sent: Fri Sep 12 14:08:18 2008  
Subject: RE: FARMVILLE TRANSPORTATION

Guys,

Tuesday is the start day. Legal has approved the contract, funds are in place, and Jerry will obligate the funds on Monday.

Thx

Craig

---

From: Russell Harper [mailto:rha@redacted] b6  
Sent: Friday, September 12, 2008 11:59 AM  
To: Neveleff, Jerald  
Cc: Raine, Craig K; Casterline, Arnold P  
Subject: Re: FARMVILLE TRANSPORTATION

12/21/2008

We will be ready. Thanks

-----  
Sent from Russell B. Harper

-----Original Message-----

From: Neveleff, Jerald <(b)(6)>  
To: Russell Harper <b6>  
CC: Raine, Craig K <(b)(6)>; Casterline, Arnold P <(b)(6)>  
Sent: Fri Sep 12 11:54:33 2008  
Subject: FARMVILLE TRANSPORTATION

Russell,

I am waiting to hear from the legal review of the award document. I am hoping to have that very soon. Provided all is acceptable to the reviewer, and I hope to get that today. If I do, were looking to start Monday or Tuesday depending on when I get the word today. If after 5pm, then I'd say we'd start Tuesday so Monday can be a coordination day.

I am not in the office today but am reviewing emails.

Jerry

**Stevens, Richard P**

---

**From:** Casterline, Arnold P  
**Sent:** Monday, September 15, 2008 7:01 AM  
**To:** Neveleff, Jerald  
**Subject:** FW: Farmville

*Arnold P. Casterline Jr.*

Contract Specialist  
Immigration and Customs Enforcement  
Office of Acquisition Management  
Detention Management  
Department of Homeland Security  
425 I Street NW, 5<sup>th</sup> Floor Room 5009  
Washington, DC 20536  
e-mail: (b)(6)  
phone: 202-511-1234  
Main: 202-511-1234

*Help us support you better –  
TELL US HOW WE ARE DOING!*

**Go to** <http://www.acqsolinc.com/ICE/OAQ/feedback.cfm>

---

**From:** Russell Harper [mailto:(b)(6)]  
**Sent:** Friday, September 12, 2008 7:41 AM  
**To:** Casterline, Arnold P  
**Subject:** Farmville

Arnold,

I am pleased to let you know that we can bring aboard the former Transportation Director at Piedmont Regional with 12+ years of ICE experience, Charles Marshall, for \$60,000 and an Assistant Director of Transportation /Dispatcher with over 10 years of ICE experience, Robert Pugh, for \$50,000. Please let me know if this is acceptable. They need to give two weeks notice to their current employer.

Russell Harper

**Stevens, Richard P**

---

**From:** Casterline, Arnold P  
**Sent:** Monday, September 15, 2008 1:18 PM  
**To:** 'Russell Harper'; Smyly, Elena L; Raine, Craig K  
**Cc:** Neveleff, Jerald; 'Warren Coleman'; [REDACTED] b6  
**Subject:** Signed IGSA and task order  
**Attachments:** HSCEDM08FIG064.pdf; TRANSIGSASIGNED\_001.pdf

Mr. Harper and Mr. Spates,

Attached are the signed IGSA for transportation and the task order for the transportation. If you have any questions please feel free to call me at 202-51 [REDACTED] b6 or send me an email to [REDACTED] (b)(6). Thank you and have a great day.

Arnie Casterline

*Arnold P. Casterline Jr.*

Contract Specialist

Immigration and Customs Enforcement

Office of Acquisition Management

Detention Management

Department of Homeland Security

425 I Street NW, 5<sup>th</sup> Floor Room 5009

Washington, DC 20536

e-mail: [REDACTED] (b)(6)

phone: 202-51 [REDACTED]

Main: 202-514 [REDACTED] b6

**Help us support you better –  
TELL US HOW WE ARE DOING!**

**Go to** <http://www.acqsolinc.com/ICE/OAQ/feedback.cfm>

**ORDER FOR SUPPLIES OR SERVICES**

PAGE OF PAGES

1                      3

**IMPORTANT: Mark all packages and papers with contract and/or order numbers.**

1. DATE OF ORDER 09/15/2008		2. CONTRACT NO. (If any) DROIGSA-08-0021		6. SHIP TO:	
3. ORDER NO. HSCEM-08-F-IG064		4. REQUISITION/REFERENCE NO. FDG08FARM		a. NAME OF CONSIGNEE ICE Detention & Removal	
5. ISSUING OFFICE (Address correspondence to) ICE/Detention Mngt/Detention IGSA's Immigration and Customs Enforcement Office of Acquisition Management 425 I Street NW, Suite 2208 Washington DC 20536				b. STREET ADDRESS Immigration and Customs Enforcement 801 I Street, NW Suite 900	
				c. CITY Washington	e. ZIP CODE 20536
7. TO:				d. STATE DC	
a. NAME OF CONTRACTOR FARMVILLE TOWN OF				f. SHIP VIA	
b. COMPANY NAME				8. TYPE OF ORDER	
c. STREET ADDRESS P O BOX 368				<input type="checkbox"/> a. PURCHASE <input checked="" type="checkbox"/> b. DELIVERY	
d. CITY FARMVILLE				REFERENCE YOUR:  Please furnish the following on the terms and conditions specified on both sides of this order and on the attached sheet, if any, including delivery as indicated.	
e. STATE VA				Except for billing instructions on the reverse, this delivery order is subject to instructions contained on this side only of this form and is issued subject to the terms and conditions of the above-numbered contract.	
f. ZIP CODE 239010368					
9. ACCOUNTING AND APPROPRIATION DATA See Schedule				10. REQUISITIONING OFFICE ICE Detention & Removal	
11. BUSINESS CLASSIFICATION (Check appropriate box(es))					
<input type="checkbox"/> a. SMALL <input type="checkbox"/> b. OTHER THAN SMALL <input type="checkbox"/> c. DISADVANTAGED <input type="checkbox"/> g. SERVICE-DISABLED VETERAN-OWNED <input type="checkbox"/> d. WOMEN-OWNED <input type="checkbox"/> e. HUBZone <input type="checkbox"/> f. EMERGING SMALL BUSINESS					
12. F.O.B. POINT Destination					
13. PLACE OF		14. GOVERNMENT B/L NO.		15. DELIVER TO F.O.B. POINT ON OR BEFORE (Date) Multiple	
a. INSPECTION Destination	b. ACCEPTANCE Destination			16. DISCOUNT TERMS  (b)(2)Low	

17. SCHEDULE (See reverse for Rejections)

ITEM NO. (a)	SUPPLIES OR SERVICES (b)	QUANTITY ORDERED (c)	UNIT (d)	UNIT PRICE (e)	AMOUNT (f)	QUANTITY ACCEPTED (g)
	DUNS Number: 040156218 Field office POC: Phllis Chapman 703-285- Craig Raine 703-285- Program POC: Elena Smyly 202-732- Continued ...					

18. SHIPPING POINT		19. GROSS SHIPPING WEIGHT		20. INVOICE NO.		17(h) TOTAL (Cont. pages)
21. MAIL INVOICE TO:						
a. NAME Department of Homeland Security				\$968,000.00		17(i) GRAND TOTAL
b. STREET ADDRESS (or P.O. Box) Citizenship & Immigration Services 2675 Prosperity Avenue Suite 300						
c. CITY Fairfax		d. STATE VA	e. ZIP CODE 22031-4906		\$968,000.00	

22. UNITED STATES OF AMERICA BY (Signature)		23. NAME (Typed) Jerald H. Neveleff TITLE: CONTRACTING/ORDERING OFFICER	
--	--	---	--

AUTHORIZED FOR LOCAL REPRODUCTION  
PREVIOUS EDITION NOT USABLE

**ORDER FOR SUPPLIES OR SERVICES  
SCHEDULE - CONTINUATION**

PAGE OF PAGES

2 3

**IMPORTANT:** Mark all packages and papers with contract and/or order numbers.

DATE OF ORDER 09/15/2008 CONTRACT NO. DROIGSA-08-0021

ORDER NO. HSCEDM-08-F-IG064

ITEM NO. (A)	SUPPLIES/SERVICES (B)	QUANTITY ORDERED (C)	UNIT (D)	UNIT PRICE (E)	AMOUNT (F)	QUANTITY ACCEPTED (G)
	M.J. Bates 202-732- [REDACTED] b6  OAO POC: Jerald Neveleff, Contracting Officer, 202-616- [REDACTED] b6 Arnold Casterline, Contract Specialist, 202-514- [REDACTED] b6  This is a Task Order for the Farmville transportation in support of the Washington field office. Accounting Info: [REDACTED] (b)(2)Low  Period of Performance: 09/15/2008 to 03/14/2009					
0001	Adult Alien Detainees Bed day rate (TBD)  Delivery: 30 Days After Award		EA	0.00	0.00	
0002	Transportation Guard hourly rate Product/Service Code: S206 Product/Service Description: GUARD SERVICES  Delivery: 09/15/2008	18615.9967	HR	24.28	451,996.40	
0003	Dispatcher for Transportation Product/Service Code: S206 Product/Service Description: GUARD SERVICES  Delivery: 09/15/2008	1040	HR	25.00	26,000.00	
0004	Director of Transportation Product/Service Code: S206 Product/Service Description: GUARD SERVICES  Delivery: 09/15/2008	1040	HR	40.12	41,724.80	
0005	Transportation Initiation Charges  Delivery: 09/15/2008		6 MO	2,112.00	12,672.00	
0006	Estimated mileage for six months of Continued ...	744627	EA	0.585	435,606.80	

TOTAL CARRIED FORWARD TO 1ST PAGE (ITEM 17(H))

**ORDER FOR SUPPLIES OR SERVICES  
SCHEDULE - CONTINUATION**

PAGE OF PAGES

3 3

**IMPORTANT:** Mark all packages and papers with contract and/or order numbers.

DATE OF ORDER 09/15/2008 CONTRACT NO. DROIGSA-08-0021

ORDER NO. HSCEDM-08-F-IG064

ITEM NO. (A)	SUPPLIES/SERVICES (B)	QUANTITY ORDERED (C)	UNIT (D)	UNIT PRICE (E)	AMOUNT (F)	QUANTITY ACCEPTED (G)
	transportation. Approximately 744,627 miles @ .585 per mile is \$435,606.80  Delivery: 09/15/2008  The total amount of award: \$968,000.00. The obligation for this award is shown in box 17(i).					

TOTAL CARRIED FORWARD TO 1ST PAGE (ITEM 17(H))



DROIGSA-08-0021  
INTERGOVERNMENTAL SERVICE AGREEMENT  
BETWEEN THE  
UNITED STATES DEPARTMENT OF HOMELAND SECURITY  
U.S. IMMIGRATION AND CUSTOMS ENFORCEMENT  
AND  
Town of Farmville

This Intergovernmental Service Agreement ("Agreement") is entered into between United States Department of Homeland Security Immigration and Customs Enforcement ("ICE"), and the Town of Farmville ("Service Provider") for the detention and care of aliens ("detainees"). The term "Parties" is used in this Agreement to refer jointly to ICE and the Service Provider.

**FACILITY LOCATION:**

The Service Provider shall provide detention services for detainees at the following institution(s):

Town of Farmville  
116 North Main Street  
Farmville, Virginia 23901

The following constitute the complete agreement:

- INTERGOVERNMENTAL SERVICE AGREEMENT (IGSA)
- PROPOSAL, DATED \_\_\_\_\_ (Incorporated by reference)
- ATTACHMENT 1—STATEMENT OF WORK
- ATTACHMENT 2—QUALITY CONTROL PLAN
- ATTACHMENT 3—QUALITY ASSURANCE SURVEILLANCE PLAN (w/ PRS, CDR and PMT)
- ATTACHMENT 4—STAFFING PLAN
- ATTACHMENT 5—LABOR STANDARDS
- ATTACHMENT 6—WAGE DETERMINATION Number \_\_\_\_\_ Dated \_\_\_\_\_

**IN WITNESS WHEREOF**, the undersigned, duly authorized officers, have subscribed their names on behalf of the Town of Farmville and Department of Homeland Security, U.S. Immigration and Customs Enforcement.

**ACCEPTED:**

U.S. Immigration and Customs Enforcement

Jerald Neveleff  
Contracting Officer

Print Name: Jerald Neveleff  
Date: 15 Sept 08

**ACCEPTED:**

Town of Farmville

Gerald J. Spates  
Town Manager

Print Name: GERALD J. SPATES  
Date: 9/9/08

## Article I. Purpose

- A. **Purpose:** The purpose of this Intergovernmental Service Agreement (IGSA) is to establish an Agreement between ICE and the Service Provider for the detention and care of persons detained under the authority of Immigration and Nationality Act, as amended. All persons in the custody of the ICE are "Administrative Detainees". This term recognizes that ICE detainees are not charged with criminal violations and are only held in custody to assure their presence throughout the administrative hearing process and to assure their presence for removal from the United States pursuant to a lawful final order by the Immigration Court, the Board of Immigration Appeals or other Federal judicial body.
- B. **Responsibilities:** This Agreement sets forth the responsibilities of ICE and the Service Provider. The Agreement states the services the Service Provider shall perform satisfactorily to receive payment from ICE at the rate prescribed in Article I, C.
- C. **Guidance:** This is a fixed rate agreement, not a cost reimbursable agreement, with respect to the detainee day rate. The detainee daily rate is \$TBD. ICE shall be responsible for reviewing and approving the costs associated with this Agreement and subsequent modifications utilizing all applicable federal procurement laws, regulations and standards in arriving at the detainee day rate.

## Article II. General

- A. **Funding:** The obligation of ICE to make payments to the Service Provider is contingent upon the availability of Federal funds. ICE will neither present detainees to the Service Provider nor direct performance of any other services until ICE has the appropriate funding. Orders will be placed under this Agreement when specific requirements have been identified and funding obtained. Performance under this Agreement is not authorized until the Contracting Officer issues an order, in writing. The effective date of the Agreement will be negotiated and specified in an order to this Agreement by the Contracting Officer. This Agreement is neither binding nor effective unless signed by the Contracting Officer. Payments at the approved rate will be paid upon the return of the signed Agreement by the authorized Local Government official to ICE.
- B. **Subcontractors:** The Service Provider shall notify and obtain approval from the Contracting Officer if it intends to house detainees in a facility other than the Facility named in this Agreement. If either that facility or any future facility is operated by an entity other than the Service Provider, ICE shall treat the entity as a subcontractor to the Service Provider. The Service Provider shall obtain the Contracting Officer's approval before subcontracting the detention and care of detainees to another entity. The Contracting Officer has the right to deny, withhold, or withdraw approval of the proposed subcontractor. Upon approval by the Contracting Officer, the Service Provider shall ensure that any subcontract includes all provisions of this Agreement, and shall provide ICE with copies of all subcontracts. All payments will be made to the Service Provider. ICE will not accept invoices from, or make payments to a subcontractor.
- C. **Consistent with Law:** This is a firm fixed rate agreement, not cost reimbursable agreement. This Agreement is permitted under applicable statutes, regulation, policies or

judicial mandates. Any provision of this Agreement contrary to applicable statutes, regulation, policies or judicial mandates is null and void and shall not necessarily affect the balance of the Agreement.

- D. Use of Service Provider's Policies and Procedures: The Contracting Officer shall approve Service Provider's policies and procedures for use under this Agreement. Upon approval, the Service Provider can use its policies and procedures in conjunction with the detention standards mandated under this Agreement.
- E. Notification and Public Disclosure: No public disclosures (i.e. press releases, press conferences) regarding this IGSA shall be made by the Service Provider or any of its contractors or subcontractors without the review and approval of such disclosure by ICE Public Affairs and express permission granted by the ICE Contracting Officer.

### Article III. Covered Services

Below are the general requirements under this Agreement. Specific requirements for the services under this Agreement are stated in the attached Statement of Work. See Attachment 1.

- A. Bedspace: The Service Provider shall provide male/female beds on a space available basis. The Service Provider shall house all detainees as determined within the Service Provider's classification system.
- B. Basic Needs: The Service Provider shall provide detainees with safekeeping, housing, subsistence, medical and other services in accordance with this Agreement. In providing these services, the Service Provider shall ensure compliance with all applicable laws, regulations, fire and safety codes, policies and procedures. If the Service Provider determines that ICE has delivered a person for custody who is under the age of eighteen (18), the Service Provider shall not house that person with adult detainees and shall immediately notify the Contracting Officer's Technical Representative (COTR).
- C. Interpretive Services: The Service Provider shall make special provisions for non-English speaking, handicapped or illiterate detainees. ICE will reimburse the Service Provider for the actual costs associated with providing commercial written or telephone language interpretive services. Upon request, ICE will assist the Service Provider in obtaining translation services. The Service Provider shall provide all instructions verbally either in English or the detainees' language, as appropriate, to detainees who cannot read. The Service Provider shall include the actual costs that the Service Provider paid for such services on its monthly invoice. Except in emergency situations, the Service Provider shall not use detainees for translation services. If the Service Provider uses a detainee for translation service, it shall notify ICE within 24 hours of the translation service.
- D. Escort and Transportation Services: The Service Provider will provide, upon request and as scheduled by the Contracting Officer's Technical Representative (COTR) or Contracting Officer (CO), necessary escort and transportation services for detainees to and from designated locations. Escort services will be required for escorting detainees to court hearings; escorting witnesses to the courtroom and any escort services as requested by an ICE judge during proceedings. Escort and transportation services shall also include

providing all such air and/or ground transportation services as may be required to transport detainees securely and in a timely manner. Transportation and/or escort services may be required to transport detainees from the Facility to and from a medical facility for outpatient care. During all transportation activities, at least one (1) transportation officer shall be of the same sex as the detainees being transported. The Service Provider shall use a communications system that has direct and immediate contact with all transportation vehicles. Transportation and escort services shall be provided in the most economical and efficient manner. The Service Provider personnel provided for these services shall be of the same qualifications, receive training, complete the same security clearances, and wear the same uniforms as those personnel provided for in other areas of this Agreement. The Statement of Work shall provide specific escort and transportation services unique for this Agreement.

E. Guard Services: The Service Provider agrees to provide stationary guard services on demand by the COTR or Contracting Officer and shall include, but are not limited to, escorting and guarding detainees to medical or doctor's appointments, hearings, ICE interviews, and any other location requested by the COTR. Qualified personnel employed by the Service Provider will perform such services. The Service Provider agrees to augment such practices as may be requested by ICE to enhance specific requirements for security, detainee monitoring, visitation, and contraband control. Public contact is prohibited unless authorized in advance by the COTR or Contracting Officer. The Service Provider shall be authorized to provide at least two (2) officers for each remote post, as directed by the COTR or Contracting Officer.

F. Medical Services: The Statement of Work shall provide specific medical service requirements unique to this Agreement. Regardless of the unique requirements for this contract, the Service Provider shall provide the following services regarding medical care of detainees:

- 1) The Service Provider shall provide for medical screening of every detainee upon arrival at the Facility performed by health care personnel or health trained personnel.
- 2) Medical coverage at the Facility shall be no less than twenty-four (24) hours per day, seven (7) days per week.
- 3) The Service Provider shall provide the detainees written instructions for gaining access to health care services. Procedures shall be explained to all detainees in the detainees' native language, and orally to detainees' who are unable to read. The detainee shall similarly be provided instructions and assistance in personal hygiene, dental hygiene, grooming and health care. It shall be made routinely available.
- 4) The Service Provider shall provide to all detainees a written policy and defined procedure to require that detainee's written health complaints are solicited and delivered to the medical facility for appropriate follow-up. Written policy and defined procedure shall require that health care complaints are responded to and that sick call, conducted by health care personnel or health trained personnel is available to detainees daily. If a detainee's custody status precludes attendance at sick call, arrangements shall be made to provide sick call services in the place of the detainee's detention. A minimum of one sick call shall be conducted daily.

USPHS reserves the right to conduct triage and sick call in the place of the detainee's detention.

- 5) The Service Provider shall provide and maintain basic first aid kits throughout the Facility. First aid kits shall be available at all times to allow quick access.
- 6) The Service Provider shall provide security with a minimum of a staff of one at all times. When detainees are housed in the infirmary, a security guard shall be posted to the unit 24 hours a day, seven days a week. The Service Provider shall coordinate and escort detainees to the medical clinic for sick call, appointments and pill line.
- 7) When communicable or debilitating physical problems are suspected, the detainee shall be separated from the detainee population, and immediately notify USPHS staff. Behavioral problems (detainee who is not diagnosed as psychotic) and suicide observation will be the responsibility of the Service Provider.

#### **Article IV. Receiving and Discharging Detainees**

- A. **Required Activity:** The Service Provider shall receive and discharge detainees only to and from properly identified ICE personnel or other properly identified Federal law enforcement officials with prior authorization from DHS/ICE. Presentation of U.S. Government identification shall constitute "proper identification." The Service Provider shall furnish receiving and discharging services twenty-four (24) hours per day, seven (7) days per week. ICE shall furnish the Service Provider with reasonable notice of receiving and discharging detainees. The Service Provider shall ensure positive identification and recording of detainees and ICE officers. The Service Provider shall not permit medical or emergency discharges except through coordination with on-duty ICE officers.
- B. **Restricted Release of Detainees:** The Service Provider shall not release detainees from its physical custody to any persons other than those described in Paragraph A of Article IV for any reason, except for either medical, other emergency situations, or in response to a federal writ of habeas corpus. If a detainee is sought for federal, state, or local proceedings, only ICE may authorize release of the detainee for such purposes. The Service Provider shall contact the COTR immediately regarding any such requests.
- C. **Service Provider Right of Refusal:** The Service Provider retains the right to refuse acceptance or request removal of any detainee exhibiting violent or disruptive behavior, or of any detainee found to have a medical condition that requires medical care beyond the scope of the Service Provider's health care provider. In the case of a detainee already in custody, the Service Provider shall notify ICE and request removal of the detainee from the Facility. The Service Provider shall allow ICE reasonable time to make alternative arrangements for the detainee.
- D. **Emergency Evacuation:** In the event of an emergency requiring evacuation of the Facility, the Service Provider shall evacuate detainees in the same manner, and with the same safeguards, as it employs for persons detained under the Service Provider's authority. The Service Provider shall notify the Contracting Officer and COTR within two (2) hours of evacuation.

#### **Article V. ICE National Detention Standards**

- A. The Service Provider is required to house detainees and perform related detention services in accordance with the most current edition of the ICE National Detention Standards found within the ICE Detention Operations Manual. This manual can be found at <http://www.ice.gov/partners/dro/opsmanual/index>. ICE Inspectors will conduct periodic inspections of the facility to assure compliance with the ICE National Detention Standards.
- B. The Service Provider shall certify to the Contracting Officer and COTR that its personnel have completed all training as required by the ICE Detention Operations Manual, the Service Provider's own manual (if it is approved for use by the Contracting Officer), and any additional training as required in any manuals or detention standards referenced in this Agreement.

#### **Article VI. No Employment of Unauthorized Aliens**

Subject to existing laws, regulations, Executive Orders, and addenda to this Agreement, the Service Provider shall not employ aliens unauthorized to work in the United States. Except for maintaining personal living areas, detainees shall not be required to perform manual labor.

#### **Article VII. Period of Performance**

This Agreement shall become effective upon the date of final signature by the ICE Contracting Officer and the authorized signatory of the Service Provider and will remain in effect for a period not to exceed sixty (60) months, unless terminated in writing, by either party. Either party must provide written notice of intentions to terminate the agreement, 60 days in advance of the effective date of formal termination, or the Parties may agree to a shorter period under the procedures prescribed in Article X.

#### **Article VIII. Inspections**

The Facility and Provider's services shall be inspected in accordance with the following procedures:

- A. Definitions. "Services," as used in this clause, includes services performed, workmanship, and material furnished or utilized in the performance of services.
- B. The Provider shall provide and maintain an inspection system acceptable to the Government covering the services under this agreement. Complete records of all inspection work performed by the Provider shall be maintained and made available to the Government during contract performance and for as long afterwards as the agreement requires.
- C. The Government has the right to inspect and test all services called for by the agreement, to the extent practicable at all times and places during the term of the agreement. The Government shall perform inspections and tests in a manner that will not unduly delay the work.

- D. If the Government performs inspections or tests on the premises of the Provider or a subcontractor, the Provider shall furnish, and shall require subcontractors to furnish, at no increase in agreement price, all reasonable facilities and assistance for the safe and convenient performance of these duties.
- E. If any of the services do not conform to agreement requirements, the Government may require the Provider to perform the services again in conformity with agreement requirements, at no increase in agreement amount. When the defects in services cannot be corrected by re-performance, the Government may (1) require the Provider to take necessary action to ensure that future performance conforms to agreement requirements and (2) reduce the agreement price to reflect the reduced value of the services performed.
- F. If the Provider fails to promptly perform the services again or to take the necessary action to ensure future performance in conformity with agreement requirements, the Government may (1) by contract or otherwise, perform the services and charge to the Provider any cost incurred by the Government that is directly related to the performance of such service or (2) terminate the agreement for default.

#### **Article IX. Inspection Reports**

- A. **Inspection Report:** The Inspection Report stipulates minimum requirements for fire/safety code compliance, supervision, segregation, sleeping utensils, meals, medical care, confidential communication, telephone access, legal counsel, legal library, visitation, and recreation. The Service Provider shall allow ICE to conduct inspections of the facility, as required, to ensure an acceptable level of services and acceptable conditions of confinement as determined by ICE. No notice to the Service Provider is required prior to an inspection. ICE will conduct such inspections in accordance with the Inspection Report. ICE will share findings of the inspection with the Service Provider's facility administrator. The Inspection Report will state any improvements to facility operation, conditions of confinement, and level of service that will be required by the Service Provider.
- B. **Possible Termination:** If the Service Provider fails to remedy deficient service ICE identifies through inspection, ICE may terminate this Agreement without regard to the provisions of Articles VII and X.
- C. **Share Findings:** The Service Provider shall provide ICE copies of facility inspections, reviews, examinations, and surveys performed by accreditation sources.
- D. **Access to Detainee Records:** The Service Provider shall, upon request, grant ICE access to any record in its possession, regardless of whether the Service Provider created the record, concerning any detainee held pursuant to this Agreement. This right of access shall include, but is not limited to, incident reports, records relating to suicide attempts, and behavioral assessments and other records relating to the detainee's behavior while in the Service Provider's custody. Furthermore, the Service Provider shall retain all records where this right of access applies for a period of two (2) years from the date of the detainee's discharge from the Service Provider's custody.

## **Article X. Modifications and Disputes**

- A. **Modifications:** Actions other than those designated in this Agreement will not bind or incur liability on behalf of either Party. Either Party may request a modification to this Agreement by submitting a written request to the other Party. A modification will become a part of this Agreement only after the ICE Contracting Officer and the authorized signatory of the Service Provider have approved the modification in writing.
- B. **Disputes:** The ICE Contracting Officer and the authorized signatory of the Service Provider will settle disputes, questions and concerns arising from this Agreement. Settlement of disputes shall be memorialized in a written modification between the ICE Contracting Officer and authorized signatory of the Service Provider. In the event a dispute is not able to be resolved between the Service Provider and the ICE Contracting Officer, the ICE Contracting Officer will make the final decision. If the Service Provider does not agree with the final decision, the matter may be appealed to the ICE Head of the Contracting Activity (HCA) for resolution. The ICE HCA may employ all methods available to resolve the dispute including alternative dispute resolution techniques. The Service Provider shall proceed diligently with performance of this Agreement pending final resolution of any dispute.

## **Article XI. DETAINEE DAY RATE and ADJUSTMENT to the DAY RATE**

- A. **Detainee Day Rate:** In consideration for the Service Provider's performance under this Agreement, ICE shall make payment to the Service Provider for each detainee accepted and housed by the Service Provider. This "detainee day rate" is a per diem rate for the support of one Detainee per day and shall include the day of arrival but not the day of departure.
- B. The detainee day rate is TBD.
- C. The Service Provider, by execution of this Agreement, certifies that the pricing established under this agreement is in compliance with OMB Circular A-87 and includes only allowable costs of performance under this agreement.
- D. **Basis for Price Adjustment:** A firm fixed price with economic adjustment provides for upward and downward revision of the stated Per Diem based upon cost indexes of labor and operating expenses, or based upon the Service Provider's actual cost experience in providing the service.
- E. ICE shall reimburse the Service Provider at the fixed detainee day rate shown on the cover page of the document, Article I (C). The Parties may adjust the rate twelve (12) months after the effective date of the agreement and no sooner than every twelve (12) months. The Parties shall base the cost portion of the rate adjustment on the principles of allowability and allocability as set forth in OMB Circular A-87, federal procurement laws, regulations, and standards in arriving at the detainee day rate. The request for adjustment shall be submitted on an ICE Jail Services Cost Statement. If ICE does not receive an official request for a detainee day rate adjustment that is supported by an ICE Jail Services Cost Statement, the detainee day rate as stated in this Agreement will control.



- F. ICE reserves the right to audit the actual and/or prospective costs upon which the rate adjustment is based. All rate adjustments are prospective. As this is a fixed rate agreement, there are no retroactive adjustment(s).
- G. Guard and transportation services shall be denoted as separate items on submitted invoices. ICE agrees to reimburse the Service Provider for actual stationary guard services provided at a negotiated rate of \$24.28. Transportation mileage reimbursable rates will be commensurate with current applicable federal travel allowance rates. Any additional operational costs will be reimbursed at the negotiated rate identified in the task order (HSCEDM-08-F-IG064). The additional items shall also be billed as separate line items until modified in the task order.

**Article XII. Enrollment, Invoicing, and Payment**

- A. Enrollment in Electronic Funds Transfer: The Service Provider shall provide ICE with the information needed to make payments by electronic funds transfer (EFT). Since January 1, 1999, ICE makes all payments only by EFT. The Service Provider shall identify their financial institution and related information on Standard Form 3881, Automated Clearing House (ACH) Vendor Miscellaneous Payment Enrollment Form. The Service Provider shall submit a completed SF 3881 to ICE payment office prior to submitting its initial request for payment under this Agreement. If the EFT data changes, the Service Provider shall be responsible for providing updated information to the ICE payment office.
- B. Invoicing: The Service Provider shall submit an original itemized invoice containing the following information: the name and address of the facility; the name of each ICE detainee; detainee's A-number; specific dates of detention for each detainee; the total number of detainee days; the daily rate; the total detainee days multiplied by the daily rate; an itemized listing of all other charges; and the name, title, address, and phone number of the local official responsible for invoice preparation. For stationary guard services, the itemized monthly invoice shall state the number of hours being billed, the duration of the billing (times and dates) and the name of the detainee(s) that was guarded. The Service Provider shall submit monthly invoices within the first ten (10) working days of the month following the calendar month when it provided the services, to:

Department of Homeland Security  
ATTN: Immigration and Customs Enforcement  
Contracting Officer's Technical Representative (COTR)  
2675 Property Avenue  
Fairfax, Va. 22031  
Phone: 703-285-6200  
Fax: 703-285-6236

- C. Payment: ICE will transfer funds electronically through either an Automated Clearing House subject to the banking laws of the United States, or the Federal Reserve Wire Transfer System. The Prompt Payment Act applies to this Agreement. The Prompt Payment Act requires ICE to make payments under this Agreement the thirtieth (30<sup>th</sup>) calendar day after the ICE Deportation office receives a complete invoice. Either the date

on the Government's check, or the date it executes an electronic transfer of funds, shall constitute the payment date. The Prompt Payment Act requires ICE to pay interest on overdue payments to the Service Provider. ICE will determine any interest due in accordance with the Prompt Payment Act.

#### **Article XIII. Government Furnished Property**

- A. **Federal Property Furnished to the Service Provider:** ICE may furnish Federal Government property and equipment to the Service Provider. Accountable property remains titled to ICE and shall be returned to the custody of ICE upon termination of the Agreement. The suspension of use of bed space made available to ICE is agreed to be grounds for the recall and return of any or all government furnished property.
- B. **Service Provider Responsibility:** The Service Provider shall not remove ICE property from the facility without the prior written approval of ICE. The Service Provider shall report any loss or destruction of any Federal Government property immediately to ICE.

#### **Article XIV. Hold Harmless and Indemnification Provisions**

- A. **Service Provider Held Harmless:** ICE shall, subject to the availability of funds, save and hold the Service Provider harmless and indemnify the Service Provider against any and all liability claims and costs of whatever kind and nature, for injury to or death of any person(s), or loss or damage to any property, which occurs in connection with or is incident to performance of work under the terms of this Agreement, and which results from negligent acts or omissions of ICE officers or employees, to the extent that ICE would be liable for such negligent acts or omissions under the Federal Tort Claims Act, 28 USC 2691 *et seq.*
- B. **Federal Government Held Harmless:** The Service Provider shall save and hold harmless and indemnify federal government agencies to the extent allowed by law against any and all liability claims, and costs of whatsoever kind and nature for injury to or death of any person or persons and for loss or damage to any property occurring in connection with, or in any way incident to or arising out of the occupancy, use, service, operation or performance of work under the tenets of this Agreement, resulting from the negligent acts or omissions of the Service Provider, or any employee, or agent of the Service Provider. In so agreeing, the Service Provider does not waive any defenses, immunities or limits of liability available to it under state or federal law. The Service Provider agrees to hold harmless and indemnify DHS/ICE and its officials in their official and individual capacities from any liability, including third-party liability or worker's compensation, arising from the conduct of the Service Provider and its employees during the course of transporting detainees on behalf of ICE.
- C. **Defense of Suit:** In the event a detainee files suit against the Service Provider contesting the legality of the detainee's incarceration and/or immigration/citizenship status, ICE shall request that the U.S. Attorney's Office, as appropriate, move either to have the Service Provider dismissed from such suit, to have ICE substituted as the proper party defendant; or to have the case removed to a court of proper jurisdiction. Regardless of the decision on any such motion, ICE shall request that the U.S. Attorney's Office be responsible for the defense of any suit on these grounds.

- D. **ICE Recovery Right:** The Service Provider shall do nothing to prejudice ICE's right to recover against third parties for any loss, destruction of, or damage to U.S. Government property. Upon request of the Contracting Officer, the Service Provider shall, at ICE's expense, furnish to ICE all reasonable assistance and cooperation, including assistance in the prosecution of suit and execution of the instruments of assignment in favor of ICE in obtaining recovery.

**Article XV. IGSA/Financial Records**

- A. **Retention of Records:** All IGSA and financial records including, but not limited to, supporting documents, statistical records, and other records, pertinent contracts, or subordinate agreements under this Agreement shall be retained by the Service Provider for three (3) years after the expiration of the Agreement for purposes of federal examinations and audit. If any litigation, claim, negotiation, audit, or other action involving the records has been started before the expiration of the three (3) year period, the records must be retained until completion of the action and resolution of all issues which arise from it or until the end of the regular three (3) year period, whichever is later.
- B. **Access to Records:** ICE and the Comptroller General of the United States, or any of their authorized representatives, shall have the right of access to any pertinent books, documents, papers or other records of the Service Provider or its sub-contractors, which are pertinent to the award, in order to make audits, examinations, excerpts, and transcripts. The rights of access must not be limited to the required retention period, but shall last as long as the records are retained.
- C. **Delinquent Debt Collection:** ICE will hold the Service Provider accountable for any overpayment, or any breach of this Agreement that results in a debt owed to the Federal Government. ICE shall apply interest, penalties, and administrative costs to a delinquent debt owed to the Federal Government by the Service Provider pursuant to the Debt Collection Improvement Act of 1982, as amended.

**Article XVI. Detainee Telephone Services (DTS)**

- A. The PROVIDER shall provide detainees with reasonable and equitable access to telephones as specified in ICE National Detention Standards on Telephone Access. Telephones shall be located in an area that provides for a reasonable degree of privacy and a minimal amount of environmental noise during phone calls.
- B. If authorized to do so under applicable law, the PROVIDER shall monitor and record detainee conversations. If detainee telephone conversations can be monitored under applicable law, the PROVIDER shall provide notice to detainees of the potential for monitoring. However, the PROVIDER shall also provide procedures at the facility for detainees to be able to place unmonitored telephone calls to their attorneys.
- C. Telephone rates shall not exceed the dominant carrier tariff rate and shall conform to all applicable federal, state, and local telephone regulations.

- D. The ICE designated DTS Contractor will be the exclusive provider of detainee telephones for this facility. The DTS Contractor shall be allowed to install vending debit machines and shall receive 100 percent of all revenues collected by sale of prepaid debit services. The DTS Contractor shall be responsible for furnishing all inventory and supply of prepaid debit cards to the PROVIDER. The DTS Contractor shall be responsible for the costs incurred for installation of the equipment, any monthly telephone charges incurred from the operation of DTS, and the maintenance and operation of the system. The PROVIDER will not be entitled to any commissions, fees, or revenues generated by the use of the DTS or the detainee telephones.
- E. The PROVIDER shall inspect telephones for serviceability, in accordance with ICE policies and procedures. The PROVIDER will notify the COTR or ICE designees of any inoperable telephones.

#### Article XVII. Maintain Institutional Emergency Readiness

- A. The Service Provider shall submit an institutional emergency plan that will be operational prior to start of the Agreement. The plan shall receive the concurrence of the Contracting Officer prior to implementation and shall not be modified without the further written concurrence of the Contracting Officer.
- B. The Service Provider shall have written agreements with appropriate state and local authorities that will allow the Service Provider to make requests for assistance in the event of any emergency incident that would adversely affect the community.
- C. Likewise, the Service Provider shall have in place, an internal corporate nation-wide staff contingency plan consisting of employees who possess the same expertise and skills required of staff working directly on this agreement. At the discretion of ICE, these employees would be required to respond to an institutional emergency at the Facility, when necessary.
- D. The emergency plans shall include provisions for two or more disturbance control teams. Protective clothing and equipment for each team member and 30 percent of all additional facility staff members shall be provided by the Service Provider, and maintained in a secure location outside the secure perimeter of the facility.
- E. Any decision by ICE or other federal agencies to provide and/or direct emergency assistance will be at the discretion of the Government. The Service Provider shall reimburse the Government for any and all expenses incurred in providing such assistance.
- F. The Contracting Officer and COTR shall be notified immediately in the event of all serious incidents. Serious incidents include, but are not limited to the following: activation of disturbance control team(s); disturbances (including gang activities, group demonstrations, food boycotts, work strikes, work-place violence, civil disturbances/protests); staff use of force including use of lethal and less-lethal force (includes inmates in restraints more than eight hours); assaults on staff/inmates resulting in injuries requiring medical attention (does not include routine medical evaluation after the incident); fights resulting in injuries requiring medical attention; fires; full or partial lock down of the facility; escape; weapons discharge; suicide attempts; deaths; declared

or non-declared hunger strikes; adverse incidents that attract unusual interest or significant publicity; adverse weather (e.g., hurricanes, floods, ice/snow storms, heat waves, tornadoes); fence damage; power outages; bomb threats; central inmate monitoring cases admitted to a community hospital; witness security cases taken outside the facility; significant environmental problems that impact the facility operations; transportation accidents (i.e. airlift, bus) resulting in injuries, death or property damage; and sexual assaults.

- G. Attempts to apprehend the escapee(s) shall be in accordance with the Emergency Plan, which should comply with ICE Detention Operations Manual regarding Emergency Plans.
- H. The Service Provider shall submit to the COTR a proposed inventory of intervention equipment (weapons, munitions, chemical agents, electronics/stun technology, etc.) intended for use during performance of this Agreement. Prior to the start of this Agreement, the Contracting Officer shall approve the intervention equipment. The approved intervention equipment inventory shall not be modified without prior written concurrence of the Contracting Officer.
- I. The Service Provider shall obtain the appropriate authority from state or local law enforcement agencies to use force as necessary to maintain the security of the institution. The use of force by the Provider shall at all times be consistent with all applicable policies of ICE Detention Operations Manual regarding Use of Force.

## **XVIII. Security Requirements**

### **A. GENERAL**

The Department of Homeland Security (DHS), U.S. Immigration and Customs Enforcement (ICE), Office of Professional Responsibility, Personnel Security Unit (DHS-ICE-OPR-PSU, hereinafter OPR-PSU) has determined that performance of the tasks as described in IGSA (Contract) \_\_\_\_\_ requires that the Service Provider (Contractor, subcontractor(s), vendor(s), etc. (herein known as Service Provider) have access to ICE detainees, and that the Service Provider will adhere to the following and shall expressly incorporate this provision into any and all Subcontracts or subordinate agreements issued in support of this Agreement .

### **B. SUITABILITY DETERMINATION**

ICE-OPR-PSU shall have and exercise full control over granting, denying, withholding or terminating unescorted government facility and/or access to ICE detainees, as well as, when applicable, sensitive Government information access for Service Provider employees, based upon the results of a background investigation.

ICE-OPR-PSU may, as it deems appropriate, authorize and make a favorable entry on duty (EOD) decision based on preliminary security checks. The favorable EOD decision would allow the Service Provider employees to commence work temporarily prior to the completion

of the full investigation. The granting of a favorable EOD decision shall not be considered as assurance that a full employment suitability authorization will follow as a result thereof.

The granting of a favorable EOD decision or a full employment suitability determination shall in no way prevent, preclude, or bar the withdrawal or termination of any such access by ICE-OPR-PSU, at any time during the term of the IGSA. No employee of the Service Provider shall be allowed to EOD and/or access facilities or ICE detainees without a favorable EOD decision or suitability determination by OPR-PSU. No employee of the Service Provider shall be allowed unescorted access to a Government facility without a favorable EOD decision or suitability determination by OPR-PSU. Service Provider employees assigned to the IGSA not needing access to ICE detainees or recurring access to DHS-ICE facilities will not be subject to security suitability screening.

Suitability criteria as detailed in ICE Policy Directives that will exclude applicants from consideration to perform under this agreement include, but not limited to:

- Felony convictions, or a conviction for any crime that involves violence
- Conviction of a sex crime
- Offense/s involving a child victim
- Pattern of arrests, without convictions, that brings into question a person's judgment and reliability to promote the efficiency and integrity of the ICE mission.
- Intentional falsification and/or omission of pertinent personal information
- Drug and/or Alcohol Abuse
- Personal conduct to include failure to pay just debts

The process for suitability determination includes, but is not limited to, criminal, employment, citizenship, residential and financial records checks and reviews.

### C. BACKGROUND INVESTIGATIONS

IGSA Service Provider employees (to include applicants, temporaries, part-time and replacement employees) under the contract, needing access to ICE detainees, shall undergo a position sensitivity analysis based on the duties each individual will perform on the contract. The results of the position sensitivity analysis shall identify the appropriate background investigation to be conducted. Background investigations will be processed, managed and conducted under direction of OPR-PSU.

In those cases where prospective IGSA Service Provider employees already have a security clearance issued by the Defense Industrial Security Clearance Office (DISCO), that was granted using an appropriate background investigation, reciprocity may apply in that those prospective employees may not be required to submit complete security packages, as the clearance issued by DISCO may be accepted.

Prospective Service Provider employees without adequate security clearances issued by DISCO shall submit the following completed forms to the Personnel Security Unit through the COTR, no less than 45 days before the starting date of the IGSA (contract), or 45 days prior to the expected entry on duty of any employees, whether a replacement, addition, subcontractor employee, or vendor:

Standard Form 85P, "Questionnaire for Public Trust Positions"  
Form will be submitted via e-QIP (electronic Questionnaires for  
Investigation Processing)  
FD Form 258, "Fingerprint Card" (2 copies)  
Foreign National Relatives or Associates Statement  
DHS 11000-9, "Disclosure and Authorization Pertaining to Consumer Reports Pursuant  
to the Fair Credit Reporting Act"  
Drug Questionnaire  
Alcohol Questionnaire

Details regarding the required forms will be provided by ICE-OPR. Only complete packages will be accepted by OPR-PSU. Specific instructions on submission of packages will be provided by OPR-PSU.

**PLEASE NOTE:** Unless an applicant has resided in the US for three of the past five years, with few exceptions such as military or other federal service overseas, the Government may not be able to complete a satisfactory background investigation. In such cases, OPR-PSU retains the right to deem an applicant as ineligible due to insufficient background information.

#### D. SUITABILITY -- RETROACTIVE EFFECT

Employees of the Service Provider(s) who have not been previously investigated as described under the Background Investigations section, above, must be scheduled not later than six months after implementation of this IGSA. Employees of the Service Provider(s) may continue to work while the investigation is in progress.

#### E. CONTINUED ELIGIBILITY

If a prospective Service Provider employee is found to be ineligible for access to Government facilities or information, the COTR will advise the Service Provider that the employee shall not continue to work or to be assigned to work under the contract.

The OPR-PSU may require drug screening for probable cause at any time and/ or when the contractor independently identifies, circumstances where probable cause exists.

The OPR-PSU may require reinvestigations when derogatory information is received and/ or every 10 years.

ICE-OPR reserves the right and prerogative to deny and/ or restrict the facility and information access of any Service Provider employee whose actions are in conflict with the standards of conduct as detailed in 5 CFR 2635 and 5 CFR 3801, or whom ICE-OPR-PSU determines to present a risk of compromising ICE standards and conduct, including sensitive Government information, to which he or she would have access under this contract.

The Service Provider will report any adverse information coming to their attention concerning contract employees under the IGSA to OPR-PSU through the COTR. Reports based on rumor or innuendo should not be made. The subsequent termination of employment of an employee does not obviate the requirement to submit this report. The

report shall include the employees' name and social security number, along with the adverse information being reported.

OPR-PSU must be notified of all terminations/ resignations within five days of occurrences.

If applicable, the Service Provider will return any expired ICE-DRO owned employee identification cards and/or building passes, or those of employees terminated and/or removed from the IGSA to the COTR within five (5) workdays. If an identification card or building pass is not available to be returned, a report must be submitted to the COTR, referencing the pass or card number, name of individual to whom issued, the last known location and disposition of the pass or card. The COTR will return the identification cards and building passes to the responsible ID Unit.

#### F. EMPLOYMENT ELIGIBILITY

The Service Provider must agree that each employee working on this IGSA will have a Social Security Card issued and approved by the Social Security Administration.

The Service Provider shall be responsible to the Government for acts and omissions of his own employees and for any Subcontractor(s) and their employees.

ICE-DRO has determined that employment on this IGSA (Contract) shall be limited to U.S. Citizens, Lawful Permanent Residents and Conditional Permanent Residents.

Subject to existing law, regulations and/ or other provisions of this IGSA, illegal or undocumented aliens will not be employed by the Service Provider, or with this IGSA. Service Provider will ensure that this provision is expressly incorporated into any and all Subcontracts or subordinate agreements issued in support of this IGSA.

#### G. SECURITY MANAGEMENT

The Service Provider shall appoint a senior official to act as the Corporate Security Officer. The individual will interface with the OPR-PSU through the COTR on all personnel security matters and if applicable, information security matters.

The COTR and OPR-PSU shall have the right to inspect the procedures, methods, and facilities utilized by the Service Provider in complying with the security requirements under this contract. Should the COTR determine that the Service Provider is not complying with the security requirements of this contract, the Service Provider will be informed in writing by the Contracting Officer of the proper action to be taken in order to effect compliance with such requirements. Copies of these communications by both the

Contracting Officer and the Service Provider shall be provided to OPR-PSU.

#### H. INFORMATION TECHNOLOGY SECURITY

Should the scope of the work change to require IGSA Service Provider personnel to access DHS-ICE IT systems, DHS IT Management Directives preclude routine access to any DHS



ICE IT systems, to include those utilized by ICE-DRO, by Non-U.S. citizens, including Lawful Permanent Residents (LPRs).

The following computer security requirements apply to both Department of Homeland Security (DHS) operations and to the former Immigration and Naturalization Service operations (FINS). These entities are hereafter referred to as the Department.

#### **I. INFORMATION TECHNOLOGY SECURITY CLEARANCE**

When sensitive government information is processed on Department telecommunications and automated information systems, the Contractor agrees to provide for the administrative control of sensitive data being processed and to adhere to the procedures governing such data as outlined in *DHS IT Security Program Publication DHS MD 4300.Pub. or its replacement*. Contractor personnel must have favorably adjudicated background investigations commensurate with the defined sensitivity level.

Contractors who fail to comply with Department security policy are subject to having their access to Department IT systems and facilities terminated, whether or not the failure results in criminal prosecution. Any person who improperly discloses sensitive information is subject to criminal and civil penalties and sanctions under a variety of laws (e.g., Privacy Act).

#### **XIX. Accreditation**

The Service Provider will have eighteen (18) months from commencement of this Agreement to become ACA accredited. The Service Provider shall, within nine (9) months from the date this facility becomes operational, formally apply for accreditation to the American Correctional Association. The Service Provider shall provide the Contracting Officer with written proof of such application to ICE within five (5) days of the application. The Service Provider shall provide the Contracting Officer with written proof of its accreditation within five (5) days of notification of its accreditation.

#### **XX. Quality Control**

- A. The Service Provider shall establish and maintain a complete Quality Control Program (QCP) acceptable to the Contracting Officer ("CO"), in consultation with the Contracting Officer's Technical Representative ("COTR") to assure the requirements of this Agreement are provided as specified in the Performance Requirement Summary (PRS)—Attachment 3.

The QCP shall:

1. Be implemented prior to the start of performance.
2. Provide quality control services that cover the scope of the IGSA and implement proactive actions to prevent non-performance issues.

B. A complete QCP addressing all areas of agreement performance shall be submitted to the COTR no later than 30 days after the Agreement effective date. All proposed changes to the QCP must be approved by the Contracting Officer. The Service Provider shall submit a resume of the proposed individual(s) responsible for the QCP to the CO for approval. The Service Provider shall not change the individual(s) responsible for the QCP without prior approval of the Contracting Officer.

C. The QCP shall include, at a minimum:

1. Specific areas to be inspected on either a scheduled or unscheduled basis and the method of inspection.
2. Procedures for written and verbal communication with the Government regarding the performance of the Agreement.
3. Specific surveillance techniques for each service identified in the Agreement and each functional area identified in the PRS.
4. The QCP shall contain procedures for investigation of complaints by the Service Provider and Government staff and feedback to the Government on the actions taken to resolve such complaints.

D. A file of all inspections, inspection results, and any corrective action required, shall be maintained by the Service Provider during the term of this Agreement. The Service Provider shall provide copies of all inspections, inspection results, and any corrective action taken to the COTR and Contracting Officer.

E. Failure by the Service Provider to maintain adequate quality control can result in monetary deductions based upon the schedule of deductions incorporated herein.

#### **XXI. Contracting Officer's Technical Representative**

The Contracting Officer's Technical Representative (COTR) shall be designated by the Contracting Officer. When and if the COTR duties are reassigned, an administrative modification will be issued to reflect the changes. This designation does not include authority to sign contractual documents or to otherwise commit to, or issue changes, which could affect the price, quantity, or performance of this Agreement.

#### **XXII. Labor Standards and Wage Determination**

A. The Service Contract Act, 41 U.S.C. 351 et seq., Title 29, Part 4 Labor Standards for Federal Service Contracts, is hereby incorporated into this Agreement at Attachment 5. These standards and provisions are included in every contract over \$2,500, or in an indefinite amount, that is entered into by the United States, the principal purpose of which is to furnish services through the use of service employees.

**B. Wage Determination:** Each service employee employed in the performance of this Agreement shall be paid not less than the minimum monetary wages and shall be furnished fringe benefits in accordance with the wages and fringe benefits determined by the Secretary of Labor or authorized representative, as specified in any wage determination attached to this Agreement at Attachment 6.

\*\*\*\*\*  
END OF DOCUMENT  
\*\*\*\*\*

**Stevens, Richard P**

---

**From:** Casterline, Arnold P  
**Sent:** Wednesday, September 17, 2008 12:38 PM  
**To:** Neveleff, Jerald  
**Subject:** FW: Jail costs  
**Attachments:** QualityControlPlan.final070208.doc; ICA\_proposal\_key\_personnel042008.doc

*Arnold P. Casterline Jr.*

Contract Specialist  
Immigration and Customs Enforcement  
Office of Acquisition Management  
Detention Management  
Department of Homeland Security  
425 I Street NW, 5<sup>th</sup> Floor Room 5009  
Washington, DC 20536  
e-mail: (b)(6)  
phone: 202-514- (b)(6)  
Main: 202-514- (b)(6)

**Help us support you better –  
TELL US HOW WE ARE DOING!**

**Go to** <http://www.acqsolinc.com/ICE/OAQ/feedback.cfm>

---

**From:** Warren Coleman [mailto:wcoleman@hdcva.com]  
**Sent:** Wednesday, September 17, 2008 11:30 AM  
**To:** Casterline, Arnold P  
**Cc:** Russell Harper  
**Subject:** FW: Jail costs

Arnie  
Please see answers below in blue to your questions. Please call if you have additional questions or need clarification on the answers below.

Warren

---

**From:** Casterline, Arnold P [mailto:(b)(6)]  
**Sent:** Tuesday, September 16, 2008 1:50 PM  
**To:** Russell Harper; Warren Coleman  
**Subject:** Jail costs

Russell,

I need some clarification on a few things listed in the jail cost statement.

- Schedule C: How many Physicians will be under contract? **Current plans are to have one doctor under contract. We will have others on call if needed during an emergency**  
How many Dentists will be under contract? **Current plans are to have one dentist under contract on a part time basis and one dental hygienist on a part time basis. We will have other dentists**

12/21/2008

on call if needed during an emergency.

Who is the Management Advisory Counsel/ Board of Directors?

**I apologize for the confusion but these are the same groups. These individuals are yet to be named but will serve as a Board of Directors over this operation. With the size of this entity and the importance of its role to the government and detainees, it is a necessity to have a Board of Directors /Advisory to ensure the company is following the mission and serving the government and detainees at the highest level possible while continuing to operation a financially sound business. The individuals have not been named at this time but the membership will mirror the boards in for profit businesses will individuals from the community, management team, experts in the field of Detention as well as the investment community.**

Names of the people on the board and reasoning for these two groups.

- Schedule D: Food and Kitchen Supplies; does this include kitchen equipment?

**This amount does not include the major kitchen equipment like refrigerators, walk in coolers, stoves etc but does include pots, pans, utensils etc need in the kitchen.**

Facility Maintenance and repairs, What costs are associated with this?

**These are the cost associated with keeping a 125,000 square foot building in excellent condition for our staff and the detainees housed at the facility.**

How is the Rent on the Facility calculated? **Our landlord is basing the rent for this speculative single use facility on the cost of construction, risk involved in a single use buildings and the length of the ICE contract with the expectation of a 14% rent on the cost of construction.**

- Personnel:

Can I get a job description on

**Quality control Officer: Per ACA accreditation standards, we will be required to have 1 Quality Control Officer per 250 detainees to ensure the Quality Control Plan of the facility is being followed. I have attached our draft of the Quality Control Plan which we will enhance and complete one month prior to operations. The Officer will be auditing and tracking the 38 Detention Standards outlined in the QUASP Attachment 3—Performance Monitoring Tool. These individuals will have a direct reporting relationship with the COO as well as their day to day supervisors to ensure no standards are compromised and full disclosure is the standard operating procedure.**

**Director of Facilities Management: Our facility will be state of the art and we want to ensure with have an expert available to ensure we maintain the facility to the highest standards possible. We will also be planning to work with ICE on their future expansion projects on the site (administration building, more dorms etc) so we feel it is critical to have an expert on our team in a part time role to ensure we provide the best service and facility for our staff and detainees.**

**Human Resource Generalist, With a staff of 200 employees, the individual will be responsible for coordination of our benefit plans (sign up, changes, responding to questions) for our employees. This individual will also be responsible for the selections of benefit providers to ensure our staff has the best possible coverage and a competitive benefit package as we view retention of staff as being just as important as the hiring process.**

**HR- Training Supervisor. This individual will be responsible for all training needs of the staff. This will involve the coordination of outside training to ensure our staff has the proper certifications and training to meet ACA accreditation. In addition to the coordination of outside training for a staff of 200, this person will also coordinate / conduct training for our staff in the areas of teamwork, conflict resolution among co workers and many other personal developmental skills needs by the staff. In**

**addition to training, this individual will be responsible for development and the evaluation process for our staff. It is our plan to provide constant feedback to our staff with written evaluations as least annually.**

**This person will also provide supervisor for the HR Generalist and all HR complaints from the staff which can not be handled by the HR Generalist will be presented to this supervisor for resolution or to the COO.**

According to your proposal, you are to be the COO and Mr. Coleman is To be the CFO, are you both cutting ties with Harper and Associates?

**Per our May 9 proposal, Mr. Coleman will be the COO and the CFO is yet to be named. We will not be “cutting our ties” with Harper Associates as Mr. Harper is the founder and principal. With that being said, we view this project as our #1 priority and will devoted all our attention to this project to ensure it is a success for the government, employees and investors.**

Director of Communications and Director-Facilities Management are Part time positions?

**Yes, we view these positions as part time as we do not expect these individuals to be on site 100% of the time but we do view their roles as critical and thus expect to hire experts in the specific field to fill the positions. The role of the Director of Communication is to be the liaison between our facility and the local municipality as well as state and federal governmental units. Even though we have full support from the Town Council regarding the value of this venture and the positive impact on this locality, we are sure that we will encounter the need to communicate with the citizens of the area to ensure we have all their questions answered as well our responses to various governmental units from time to time. As stated above the Director of Facilities Management will be the expert on maintaining and improving our current facility as well as providing guidance on additions to the site for ICE administrative needs and future expansion.**

The sooner we get a response the sooner we can get this done. Thank you for your help.

Arnie Casterline

*Arnold P. Casterline Jr.*

Contract Specialist

Immigration and Customs Enforcement

Office of Acquisition Management

Detention Management

Department of Homeland Security

425 I Street NW, 5<sup>th</sup> Floor Room 5009

Washington, DC 20536

e-mail: (b)(6)

phone: 202-514- (b)(6)

Main: 202-514- (b)(6)

**Help us support you better –  
TELL US HOW WE ARE DOING!**

**Go to** <http://www.acqsolinc.com/ICE/OAQ/feedback.cfm>



**Town of Farmville – ICE Facility: DROISA-08-0021**

**May 9, 2008**

**Quality Control Plan**

**PURPOSE**

To develop and implement a Quality Control Plan which will ensure compliance with all required Town of Farmville—ICE Facility quality standards and the ICE standards to be monitored under the Government’s Quality Assurance Surveillance Plan.

**POLICY**

It is the policy of the Town of Farmville—ICE Facility to ensure all applicable standards, polices and procedures are adhered to.

- A. The Town of Farmville—ICE Facility will adopt, adapt and/or establish procedures that will meet or exceed the objective represented by each of the 38 Detention Standards outlined in the QUASP Attachment 3—Performance Monitoring Tool. It is our goal to achieve ACA accreditation or to meet and exceed ACA standards.

**PROCEDURES**

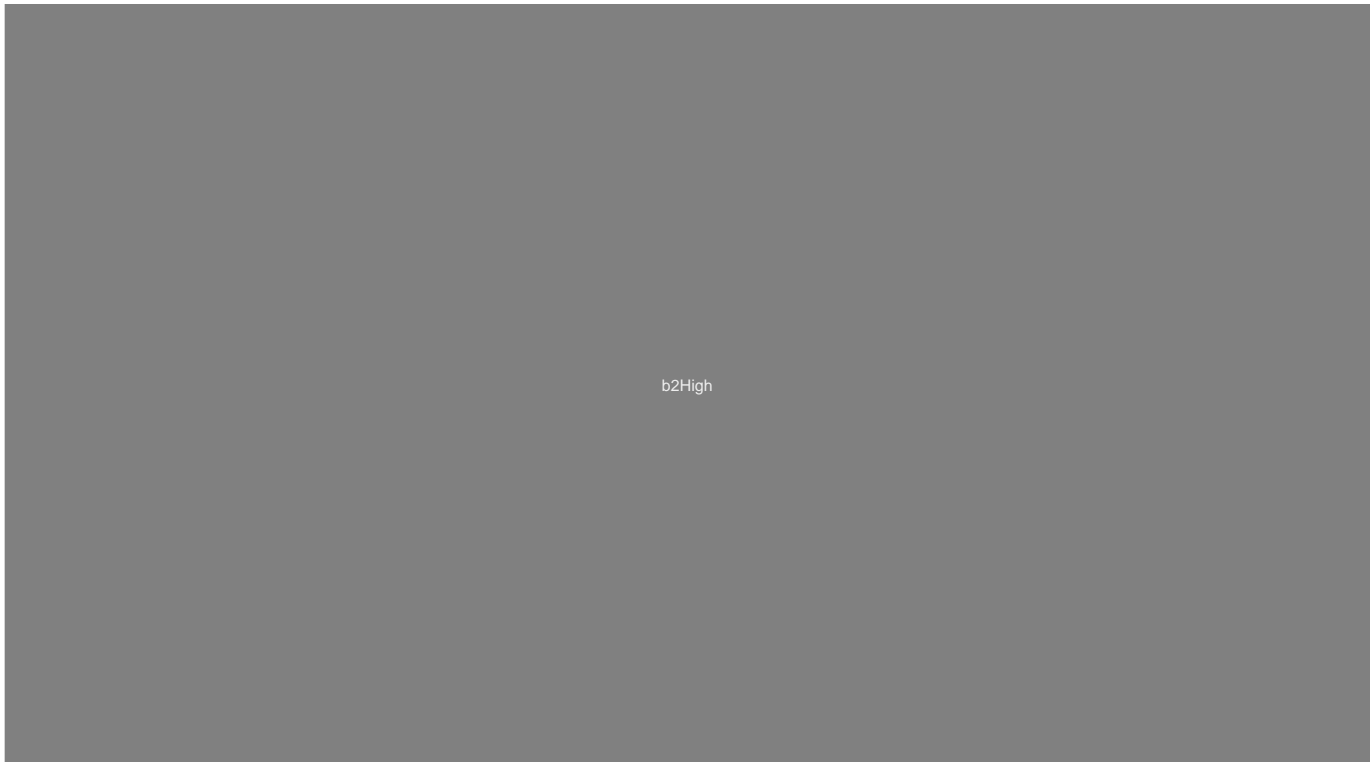

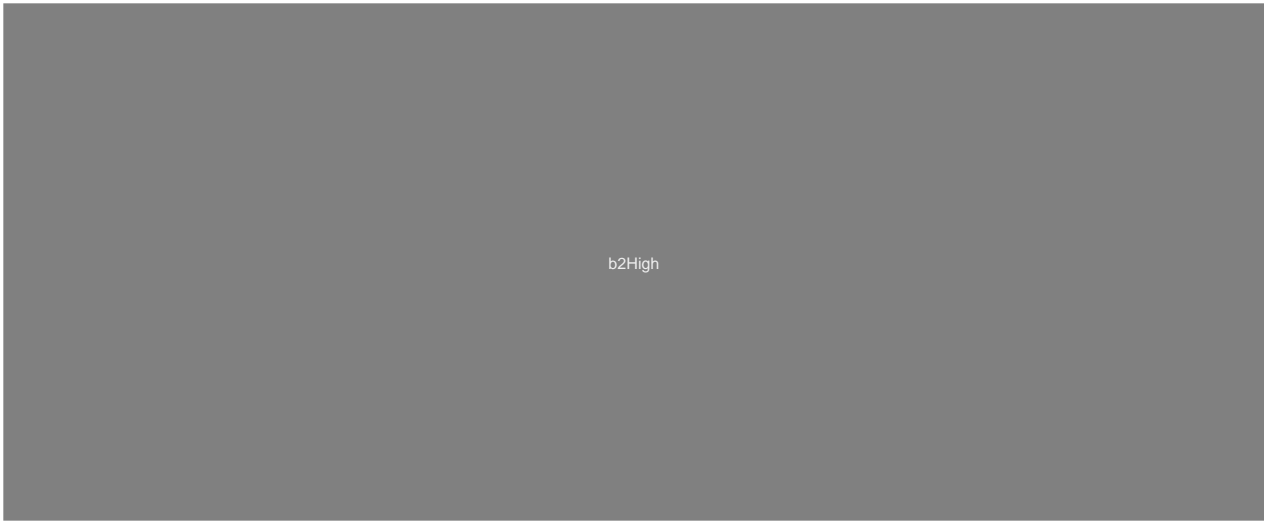

b2High

Staff Actions

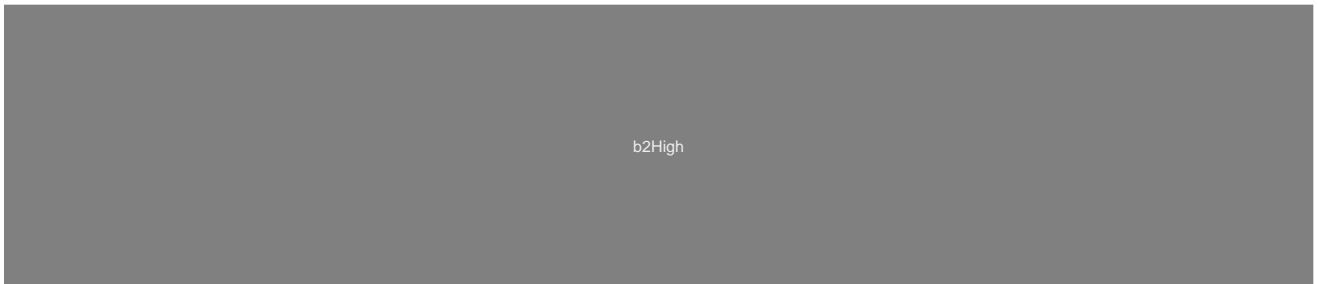

b2High

Confidentiality



b2High

Plan Details

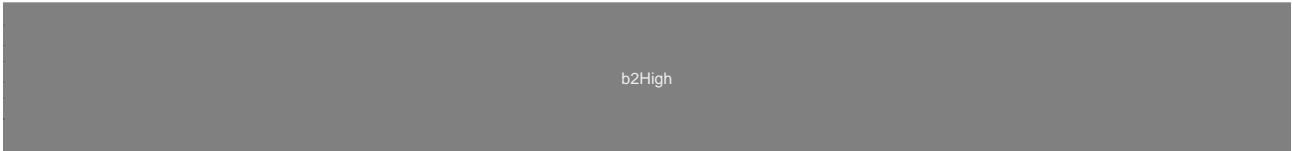

b2High





**Town of Farmville – ICE Facility: DROISA-08-0021  
May 9, 2008**

**KEY PERSONNEL**

**Governmental Staff**

**Gerald Snates, Town Manager – Town of Farmville**

Office: [REDACTED] b6

116 N. Main Street

PO Drawer 368

Farmville, Va. 23901

**Immigration Centers of America – Farmville LLC**

**Partners:**

**Russell B. Harper – President of Harper Associates LLC**

**Kenneth R. Newsome- President of AMF Automation**

**Warren K. Coleman – CFO- Harper Associates LLC**

**OPERATIONS- Key Personnel**

**Chief Operations Officer**

**Warren K. Coleman CPA (resume attached)**

[REDACTED] b6

Richmond, Va 23229

[REDACTED] b6

**General Manager / Department Head of Administration**

**Ernest L. Toney Sr. (resume attached)**

[REDACTED] b6

**Department Head of Security**

**Charles L. Marshall (resume attached)**

[REDACTED] b6

**Department Head of Medical Support**  
**Robert A. Pugh Sr. (resume attached)**

b6

**Department Head of Support Services**  
**Confidential-Due to Employment**

b6

**Director of Real Estate**  
**Russell B. Harper**  
President of Harper Associates

**Director of Community Relations**  
**Kenneth R. Newsome**  
President of AMF Automation

**Stevens, Richard P**

---

**From:** Neveleff, Jerald  
**Sent:** Thursday, September 18, 2008 10:28 AM  
**To:** Smyly, Elena L  
**Subject:** RE: IGSA Weekly Update

Here's the story. The facility will not start being built until the bed day rate is established. The it will take 6 months according to Russell Harper.

Thank you,  
Jerry Neveleff  
Supervisory Contracting Officer/  
IGSA Team Lead  
Office of Acq. Management (OAQ)  
Detention Management Division  
202/610-[REDACTED] b6

Help us support you better -  
TELL US HOW WE ARE DOING!  
Go to <http://www.acqsolinc.com/ICE/OAQ/feedback.cfm> <<<http://www.acqsolinc.com/ICE/OAQ/feedback.cfm>>>

---

**From:** Smyly, Elena L  
**Sent:** Thursday, September 18, 2008 10:22 AM  
**To:** Neveleff, Jerald  
**Subject:** RE: IGSA Weekly Update

With Dean and JJ out, do you know when Farmville is scheduled to start accepting detainees? I did not see the schedule.  
Thanks

*Elena Smyly, PMP  
Management and Program Analyst - Large IGSA  
DHS, U.S. Immigration and Customs Enforcement  
Office of Detention and Removal  
Detention Management Division  
(202) 732-[REDACTED] b6*

---

**From:** Neveleff, Jerald  
**Sent:** Thursday, September 18, 2008 10:14 AM  
**To:** Smyly, Elena L  
**Subject:** RE: IGSA Weekly Update

We awarded the whole IGSA (except bed day rate). Transportation what been funded and started on 9/16/08.

Thank you,  
Jerry Neveleff  
Supervisory Contracting Officer/  
IGSA Team Lead  
Office of Acq. Management (OAQ)  
Detention Management Division

12/21/2008

202/616 [b6]

Help us support you better -  
TELL US HOW WE ARE DOING!

Go to <<http://www.acqsolinc.com/ICE/OAQ/feedback.cfm>> <<<http://www.acqsolinc.com/ICE/OAQ/feedback.cfm>>>

---

**From:** Smyly, Elena L  
**Sent:** Thursday, September 18, 2008 10:12 AM  
**To:** Neveleff, Jerald  
**Subject:** RE: IGSA Weekly Update  
**Importance:** High

Jerry,  
Did you award the Farmville IGSA or the Transportations IGSA?

*Elena Smyly, PMP  
Management and Program Analyst - Large IGSA  
DHS, U.S. Immigration and Customs Enforcement  
Office of Detention and Removal  
Detention Management Division  
(202) 732 [b6]*

---

**From:** Neveleff, Jerald  
**Sent:** Thursday, September 18, 2008 9:10 AM  
**To:** Hofer, Ann-Marie P (CTR)  
**Cc:** Smyly, Elena L; Taylor, Vickie M; 'Ross, Natalie C'; Dellar, William L  
**Subject:** FW: IGSA Weekly Update

My mark-ups in red.

Thank you,  
Jerry Neveleff  
Supervisory Contracting Officer/  
IGSA Team Lead  
Office of Acq. Management (OAQ)  
Detention Management Division  
202/616 [b6]

Help us support you better -  
TELL US HOW WE ARE DOING!

Go to <<http://www.acqsolinc.com/ICE/OAQ/feedback.cfm>> <<<http://www.acqsolinc.com/ICE/OAQ/feedback.cfm>>>

---

**From:** Hofer, Ann-Marie P (CTR)  
**Sent:** Thursday, September 18, 2008 8:42 AM  
**To:** Smyly, Elena L; Taylor, Vickie M; Ross, Natalie C  
**Cc:** Dellar, William L; Ford, Daniel J (CTR); Neveleff, Jerald  
**Subject:** IGSA Weekly Update

Hi Everyone,

Attached are the IGSA reports broken out by POC. Please update your list of facilities by noon tomorrow. Thank you!

Kind Regards,

12/21/2008

Ann-Marie

---

**Ann-Marie Hofer**  
Detention Management Division  
DHS / ICE / DRO  
Office: 202.732. [REDACTED] b6  
Cell: 443.570 [REDACTED] b6

[REDACTED] (b)(6)

**Stevens, Richard P**

---

**From:** Smyly, Elena L  
**Sent:** Thursday, September 18, 2008 3:00 PM  
**To:** Neveleff, Jerald  
**Subject:** FW: Staffing level  
**Importance:** High  
**Attachments:** Farmville JSCS.xls

*Elena Smyly, PMP  
Management and Program Analyst - Large IGSA  
DHS, U.S. Immigration and Customs Enforcement  
Office of Detention and Removal  
Detention Management Division  
(202) 731-b6*

---

**From:** Raine, Craig K  
**Sent:** Thursday, September 18, 2008 2:35 PM  
**To:** Smyly, Elena L; Casterline, Arnold P  
**Cc:** Picone, Paul D  
**Subject:** FW: Staffing level  
**Importance:** High

Sorry, I was out of town when it was sent. We have reviewed the attachment and feel that it will adequately meet our needs.

---

**From:** Smyly, Elena L  
**Sent:** Thursday, September 18, 2008 2:28 PM  
**To:** Raine, Craig K  
**Subject:** FW: Staffing level  
**Importance:** High

Craig,  
Could you please follow up on the Farmville Staffing? OAQ needs it.  
Thank you,

*Elena Smyly, PMP  
Management and Program Analyst - Large IGSA  
DHS, U.S. Immigration and Customs Enforcement  
Office of Detention and Removal  
Detention Management Division  
(202) 731-b6*

---

**From:** Casterline, Arnold P  
**Sent:** Tuesday, September 09, 2008 1:01 PM  
**To:** Raine, Craig K; Wyatt-Powell, Wendie M (CTR)  
**Subject:** Staffing level

Craig,

Attached is the revised JSCS for Farmville, Virginia. I am looking for feedback on their staffing levels. Wendie, if possible a technical review of their JSCS would be appreciated. Thank you and have a great day.

12/21/2008

Arnie Casterline  
*Arnold P. Casterline Jr.*  
Contract Specialist  
Immigration and Customs Enforcement  
Office of Acquisition Management  
Detention Management  
Department of Homeland Security  
425 I Street NW, 5<sup>th</sup> Floor Room 5009  
Washington, DC 20536

e-mail: [REDACTED] (b)(6)

phone: 202-514-[REDACTED] b6

Main: 202-514-[REDACTED] b6

**Help us support you better –  
TELL US HOW WE ARE DOING!**  
**Go to** <http://www.acqsolinc.com/ICE/OAQ/feedback.cfm>





**SECTION III DETAINEE POPULATION INFORMATION**

<b>Time Frame of Detainee Information (Must correspond with time frame Section II/A)</b>	<b>FROM: (Month/Year)</b> July 2006	<b>To: (Month/Year)</b> June 2007
--	--	--------------------------------------

**Detainee Capacity of Facility**

	<b>Male</b>	<b>Female</b>	<b>Juvenile</b>	<b>TOTAL</b>
	1000	0	0	1000
	0			0.00
<b>Adjusted Total</b>				1000

**Average Daily Population**

<b>Type of Detainee</b>	<b>Male</b>	<b>Female</b>	<b>Juvenile</b>	<b>TOTAL</b>
<b>Federal</b>	850	0	0	850
<b>Local</b>	0	0	0	0
<b>State</b>	0	0	0	0
<b>Total</b>	850	0	0	850

**SECTION IV - PER DIEM**

**Proposed Per Diem Rate for Detainee:**

**Detainee Per Diem Rate (If Applicable):**

**SECTION V - LOCAL GOVERNMENT CONTACT**

Please provide the name of the individual authorized to represent and act for the local government in he jail day rate negotiations.

<b>Name:</b> Gerald Spates, Town Manager Warren Coleman. Partner: ICA Farmville LLC.	<b>DEPARTMENT/OFFICE:</b>
<b>TITLE:</b>	<b>STREET:</b> 508 Waterworks Road.
<b>PHONE:</b> Spates 434-392-5686 804-282-6550 ext.14 Coleman	<b>CITY:</b> Farmville
<b>FAX:</b> 282-6544	<b>STATE:</b> VA <b>ZIP:</b> 23901

**SECTION VI - CERTIFICATION STATEMENT**

This is to certify that, to the best of my knowledge and belief, the data furnished in Schedules B through G are accurate, complete and current, and do not include any unallowable costs prohibited by OMB Circular No. A-87 (Cost Principles for State and Local Governments) or any cost not related to the jail facility as discussed on the Cost Sheet for Detention Services). The records of this agency are available for review and audit by the authorized representative of the U.S. Government to verify any jail per diem rate negotiated.

<b>Signature:</b>	<b>Date:</b>
<b>Name:</b>	<b>Title:</b>

1080  
0.856115

**SCHEDULE B**  
**PART 1 - PERSONNEL COSTS**  
(Direct Costs - Personnel Supporting Detention Facility)

**Instructions: List only those positions directly involved in jail operations and benefiting federal inmates.**

Type of Position	(A) Annual Salary Cost \$	(B) Full Time or Part Time	(C.) Number of Position	(D) Total Salary Cost (A) x (C.) = (D) \$
Asst. Gm. Dept. Head Admini	\$ 80,000.00	Full Time	1	\$ 80,000.00
Head Security	\$ 75,000.00	Full Time	1	\$ 75,000.00
Head Medical	\$ 75,000.00	Full Time	1	\$ 75,000.00
Head Support Services	\$ 75,000.00	Full Time	1	\$ 75,000.00
Quality control Officer	\$ 60,000.00	Full Time	4	\$ 240,000.00
Officers	\$ 32,000.00	Full Time	68	\$ 2,176,000.00
Supervisors	\$ 37,000.00	Full Time	12	\$ 444,000.00
Commander	\$ 45,000.00	Full Time	6	\$ 270,000.00
Induction Agent/ Admin Assist.	\$ 35,670.00	Full Time	5	\$ 178,350.00
Life Skills/ Recreation Leader	\$ 45,391.00	Full Time	2	\$ 90,782.00
Receptionist	\$ 29,499.00	Full Time	3	\$ 88,497.00
Record Clerk	\$ 35,670.00	Full Time	2	\$ 71,340.00
Commissary Clerk	\$ 35,670.00	Full Time	3	\$ 107,010.00
RN	\$ 56,516.00	Full Time	1	\$ 56,516.00
LPN	\$ 39,086.00	Full Time	6	\$ 234,516.00
Cert Nursing Assist	\$ 26,014.00	Full Time	16	\$ 416,224.00
Maintenance Supervisor	\$ 54,705.00	Full Time	1	\$ 54,705.00
Maintenance Workers	\$ 35,387.00	Full Time	4	\$ 141,548.00
Housekeeping	\$ 21,166.00	Full Time	5	\$ 105,830.00
Groundskeeper	\$ 29,170.00	Full Time	1	\$ 29,170.00
Kitchen Manager	\$ 48,193.00	Full Time	1	\$ 48,193.00
Kitchen Supervisor	\$ 34,234.00	Full Time	4	\$ 136,936.00
Kitchen Staff	\$ 21,164.00	Full Time	12	\$ 253,968.00
Accountant II	\$ 53,913.00	Full Time	2	\$ 107,826.00
Computer Support/ Network	\$ 66,837.00	Full Time	1	\$ 66,837.00
HR- Training Supervisor	\$ 55,611.00	Full Time	1	\$ 55,611.00
Human Resources Generalist	\$ 48,621.00	Full Time	1	\$ 48,621.00
Chief Operations Officer	\$ 175,000.00	Full Time	1	\$ 175,000.00
CFO/ Controller	\$ 90,000.00	Full Time	1	\$ 90,000.00
Director- Communications	\$ 75,000.00	Part Time	1	\$ 75,000.00
Director- Facilities Management	\$ 75,000.00	Part Time	1	\$ 75,000.00
			169	\$ -
				\$ -
				\$ -
<b>Total Salary Cost:</b>				\$ 6,142,480.00
<b>FICA Benefits</b>		<b>7.65%</b>		\$ 469,899.72
<b>Total Salary Cost plus FICA</b>				\$ 6,612,379.72

# Tot salaries

**SCHEDULE B  
PART II - PERSONNEL COSTS**

(Direct Costs - Personnel Supporting Detention Facility)

**Instructions: Provide name of retirement plans (i.e. N.Y.S. employees retirement system), insurance plans (i.e. Blue Cross/Blue Shield), or unemployment insurance contribution plans for positions listed in Schedule B - Part 1).**

	Number of Employees Participating	Total Salary Base	Employer Contribution	Annual Cost.
<b>1. Retirement Program(s)</b>				
a. Defined Benefit Plan 401K	Full-time:	\$ 5,992,480.00	5.114%	\$ 306,442.27
b.	Part Time	\$ 150,000.00	5%	\$ 7,500.00
c. Incentive Program for Senior Management	Full-time:	\$ 480,000.00	50%	\$ 240,000.00
<b>2. Insurance program(s)</b>				
a. Health, Dental, Vision	Full-time:	\$ 5,992,480.00	16.671%	\$ 998,996.17
Long Term Disability		\$ 5,992,480.00	0.800%	\$ 47,939.84
Life Insurance		\$ 5,992,480.00	0.667%	\$ 39,959.85
<b>3. Other Employee Contribution Plan(s) (i.e. unemployment, worker's compensation)</b>				
a. Worker's Comp	Full-time:	\$ 5,992,480.00	2.373%	\$ 142,180.15
	Part Time	\$ 150,000.00	0.218%	\$ 327.00
b. FUI	Full-time:	\$ 5,992,480.00	0.158%	\$ 9,446.58
	Part Time	\$ 150,000.00	0.075%	\$ 112.00
c. SUI	Full-time:	\$ 5,992,480.00	0.369%	\$ 22,097.25
	Part Time	\$ 150,000.00	0.175%	\$ 262.00
				\$ -
				\$ -
<b>Total Benefits Cost:</b>			\$	1,815,263.11

**SCHEDULE C**

**CONSULTANTS AND CONTRACT SERVICES**

*Instructions:* List only those services directly involved in jail operations and benefiting federal inmates. Provide a detailed "description of service".

Type of Service	Description of Service	No. of Contract Employees	Annual Cost
1. Medical	Physicians. All others on staff		\$ 179,975.00
2. Dental	Routine check ups and emergency services to Hygienist		\$ 110,832.00
3. Other:	Legal Service		\$ 125,000.00
4. Other:	Auditing and payroll services		\$ 52,500.00
5. Other	Information Tech software and technical support		\$ 50,000.00
6. Other:	Management Advisory Counsel and Board of Directors		\$ 100,000.00
<b>Total Consultants and Contract Services</b>			<b>\$ 618,307.00</b>

## SCHEDULE D

### OTHER DIRECT JAIL OPERATING COSTS

**Instructions:** List only those costs associated with the operation of the jail that directly benefit federal inmates. Costs associated with local court and law enforcement activities are not allowable costs for the purpose of determining facility operating costs.

Type of Service	Description	Annual Cost
Food and Kitchen Supplies		\$ 2,467,400.00
Clothing (Detainee)	Includes Clothing	\$ 130,000.00
Medical Care Supplies		\$ 156,000.00
Bedding & Linen		\$ 234,000.00
Toiletries		\$ 130,000.00
Recreation and Education		\$ 5,000.00
Utilities		\$ 987,520.00
Uniforms (Jail Staff Only)		\$ 39,400.00
Facility Maintenance and repairs		\$ 617,200.00
Body Armor/ Weapons		\$ 50,000.00
Office Supplies and Postage		\$ 90,000.00
Training/ Certificates		\$ 102,000.00
Telephone and Communications		\$ 50,000.00
Property Taxes and Bus. License		\$ 215,563.00
Rent		\$ 2,957,837.00
Equipment under \$5,000 (Please use Schedule F for equipment over \$5,000.)		\$ 1,250,672.00
Credits (e.g., telephone credits, insurance rebates, recoveries or indemnities on losses commissary income)		\$ -
Insurance: Property & Casualty		\$ 46,630.00
Insurance: Liability Umbrella		\$ 500,000.00

Other Insurance: O&D		\$	50,000.00
Other: transportation Costs	Gas reimbursement and travel cost staff	\$	60,000.00
Other		\$	-
Other		\$	-
<b>Total Other Direct Costs</b>		<b>\$</b>	<b>10,139,222.00</b>



## CERTIFICATE OF COST ALLOCATION PLAN

This is to certify that I have reviewed the cost allocation plan submitted herewith and to the best of my knowledge and belief:

1) All costs included in this proposal (identify date) to establish cost allocations or billings for (identify period covered by plan) are allowable in accordance with the requirements of OMB Circular A-87, "Cost Principles for State and Local Governments," and the Federal Award(s) to which they apply. Unallowable costs have been adjusted for in allocation costs as indicated in the cost allocation plan.

2) All cost included in this proposal are properly allocable to Federal awards on the basis of a beneficial or casual relationship between the expenses incurred and the awards to which they are allocated in accordance with applicable requirements. Further, the same costs that have been treated as indirect costs have not been claimed as direct costs. Similar types of costs have been accounted for consistency.

I declare that the foregoing is true and correct:

<b>Governmental Unit:</b>	
<b>Signature:</b>	
<b>Name of Official:</b>	
<b>Title:</b>	
<b>Date of Execution:</b>	



## SCHEDULE F EQUIPMENT COSTS

**Instructions:** A listing of equipment that is in the current approved jail operating budget for this contract period may be provided and/or attached to this worksheet for full purchase value consideration. If equipment is depreciated, show total acquisition amount and method used by state, country or city in calculating depreciation. A use allowance not to exceed 6-2/3% of acquisition cost of usable equipment may be substituted in lieu of depreciation. Equipment must be used directly for jail operations. Treatment of these costs must be consistent with local government's method.

### A. New Equipment Approved in Current Operating Budget (Use Continuation Sheet if Necessary)

-1 Item Description	-2 Proposed Utilization	-3 No. of Units	-4 Cost per Unit	-5 Enter % of use by the jail (i.e., If equipment is used by several depts.)	-6 Equipment Cost Allowance (4) x (5) x (6)
Security System		1	\$ 706,000.00	100.00%	\$ 706,000.00
Medical Facilities		1	\$ 50,000.00	100.00%	\$ 50,000.00
Vehicle		15	\$ 20,000.00	100.00%	\$ 300,000.00
Kitchen and Laundry			\$ 759,331.00	100.00%	\$ 759,331.00
			\$ -		\$ -
			\$ -		\$ -
			\$ -		\$ -
			\$ -		\$ -
			<b>Total Current Equipment Costs</b>		\$ 1,815,331.00
			<b>Equipment Allowance (6-2/3% of above)</b>		\$ \$ 265,376.00

### B. Show Method of Calculating Depreciation of Equipment if 6-2/3% depreciation is not used.

## SCHEDULE G BUILDING DEPRECIATION

**Instructions:** Provide an explanation of method used by state, county or city to depreciate buildings. Show date of construction; cost of construction (cost of land/site is not allowable); numbers of years in depreciation cycle. Note that federal assistance revenues used for building construction are considered offsetting revenues and are to be subtracted from cost of construction. In lieu of building depreciation an annual use allowance of 2% of acquisition cost may be substituted. Treatment of these costs must be consistent with local government's method. If claiming debt service arising from construction or renovation of a facility, please specify in "other" below.

### Part I – Depreciation Computation

Facility	Year of Construction	Original Construction Cost	Annual Depreciation Claimed*
Main Building	1986	\$ -	\$ -
Additions(s)	2007	\$ -	\$ -
Annex	2004	\$ -	\$ -
Other (Please specify): Finance Interest Expense		\$ -	\$ -
Other (Please specify)		\$ -	\$ -
Subtotal		\$ -	\$ -
Less Federal Assistance Revenues or Grants including Awards under Cooperative Agreement Program			\$ -
Total			\$ -
* Generally 2% of original construction cost.			

**Part II – Method of calculating depreciation used by state, county or city (i.e., specify depreciation method if 2% depreciation allowance is not utilized by the state, county, or city.)**

## SCHEDULE H HOURLY STATIONARY GUARD SERVICES RATE

**Instructions:** List only those positions that will perform the stationary guard services. Qualified law enforcement or correctional officer personnel employed by the jail facility under their policies, procedure and practices should only perform these services. Provide annual cost of benefits to include retirement plans (i.e. N.Y.S. employees retirement system), insurance plans (i.e. Blue Cross/Blue Shield), or unemployment insurance contribution plans for positions listed.

The stationary guard services are not to be included in the total operating costs. These services are required for detainees attending off site court proceedings or who are committed to a medical facility.

Title of Position	(A) Annual Salary Cost  \$	(B) Full Time or Part Time	(C) Number of Positions	(D) Total Salary Base  (A) x (C) = (D)  \$	(E) Annual Cost of Benefits  \$	(F) Total Salary Cost  (D) + (E) = (F)  \$	(G) Hourly Rate  (F)/2080 = (G)  \$
Officer	\$ 32,000.00		68	\$ 2,176,000.00	\$ 791,941.00	\$ 2,967,941.00	\$ 20.98
Supervisors	\$ 37,000.00	0	12	\$ 444,000.00	\$ 149,540.00	\$ 593,540.00	\$ 23.78
Commanders	\$ 45,000.00		6	\$ 270,000.00	\$ 82,599.00	\$ 352,599.00	\$ 28.25
5% overhead							\$ 1.09
						\$ 3,914,080.00	\$ 21.88
						<i>Overtime</i>	\$ 32.82
						<i>Profit 20%</i>	\$ 26.26
						<i>Profit OT 20%</i>	\$ 39.39







**Stevens, Richard P**

---

**From:** Raine, Craig K  
**Sent:** Thursday, September 18, 2008 6:43 PM  
**To:** Neveleff, Jerald; Smyly, Elena L  
**Cc:** 'Henkel, Douglas '; Casterline, Arnold P; Dellar, William L; Picone, Paul D  
**Subject:** RE: FARMVILLE STAFFING

**Importance:** High

To All,

Paul and I looked at the staffing charts and determined that the position of Chief Operating Officer could be considered the same as a Warden in that it is usually a management/administrator/ business function. Many of the subordinate management positions identified in the staffing chart have more of a day to day involvement in the LEO activities which is consistent with other facilities we have encountered.

Thx Again for all the work on this project!

Craig

---

**From:** Neveleff, Jerald  
**Sent:** Thursday, September 18, 2008 11:41 AM  
**To:** Raine, Craig K; Smyly, Elena L  
**Cc:** Henkel, Douglas ; Casterline, Arnold P; Dellar, William L  
**Subject:** FARMVILLE STAFFING

Craig/Elena,

We are still waiting for the technical review of the staffing. Arnie and I went through the offer he has prepared but I am a bit concerned.

The Farmville staffing has Russell Harper listed as the Chief Operating Officer. We're taken this as the Warden because we do not see that position anywhere else. If you are okay with that, please let me know.  
Jerry

Thank you,  
Jerry Neveleff  
Supervisory Contracting Officer/  
IGSA Team Lead  
Office of Acq. Management (OAQ)  
Detention Management Division  
202/61 [REDACTED] b6

Help us support you better -  
TELL US HOW WE ARE DOING!

Go to <<http://www.acqsolinc.com/ICE/OAQ/feedback.cfm>> <<<http://www.acqsolinc.com/ICE/OAQ/feedback.cfm>>>

**Stevens, Richard P**

---

**From:** Neveleff, Jerald  
**Sent:** Wednesday, September 24, 2008 4:04 PM  
**To:** Evans, Mary Y  
**Cc:** Dellar, William L; Smyly, Elena L; Casterline, Arnold P; Weinberg, Bill  
**Subject:** Farmville

Yvonne,

The bed day rate for Farmville was agreed upon 9/22/08. We are waiting for the Town of Farmville to sign their side of the modification so we can complete the process.

The bed day rate of \$62.83 was based on the drawings agreed to by the field office knowing that a wall here and there may need to be changed, doors repositioned, and the teleradiology being in a trailer.

We understood that DIHS and the Field Office disagreed on some of the facility design but we did not see changing a wall or door or repositioning the radiology trailer any impact to cost.

We do have details on the cost that when DIHS provides the medical, we can adjust the bed day rate accordingly.

If you need more info, let me know.  
Jerry

Thank you,  
Jerry Neveleff  
Supervisory Contracting Officer/  
IGSA Team Lead  
Office of Acq. Management (OAQ)  
Detention Management Division  
202/616-b6

Help us support you better -  
TELL US HOW WE ARE DOING!

Go to <http://www.acqsolinc.com/ICE/OAQ/feedback.cfm> <<<http://www.acqsolinc.com/ICE/OAQ/feedback.cfm>>>



**Stevens, Richard P**

---

**From:** Neveleff, Jerald  
**Sent:** Wednesday, September 24, 2008 8:08 AM  
**To:** Casterline, Arnold P  
**Subject:** RE: Invoice for Transportation

First, monthly invoicing is the most efficient frequency for ICE. So the answer is no, there is no allowance for invoicing more often. Craig Raine I believe will be the COTR, please contact him and lets get the process going to have him named (is he certified?) I'm guessing the fixed costs are those already in the task order and established monthly amounts.

I am not aware of the dispatcher and manager having overtime. We based the hourly rate based on salary and broke it down to 1040 hours (1/2 year).

Thank you,  
Jerry Neveleff  
Supervisory Contracting Officer/  
IGSA Team Lead  
Office of Acq. Management (OAQ)  
Detention Management Division  
202/616-[REDACTED] b6

Help us support you better -  
TELL US HOW WE ARE DOING!

Go to <http://www.acqsolinc.com/ICE/OAQ/feedback.cfm> <<<http://www.acqsolinc.com/ICE/OAQ/feedback.cfm>>>

---

**From:** Casterline, Arnold P  
**Sent:** Wednesday, September 24, 2008 7:59 AM  
**To:** Neveleff, Jerald  
**Subject:** FW: Invoice for Transportation

What did he miss?

*Arnold P. Casterline Jr.*  
Contract Specialist  
Immigration and Customs Enforcement  
Office of Acquisition Management  
Detention Management  
Department of Homeland Security  
425 I Street NW, 5<sup>th</sup> Floor Room 5009  
Washington, DC 20536  
e-mail: [REDACTED] (b)(6)  
phone: 202-514-[REDACTED]  
Main: 202-514-[REDACTED] b6

*Help us support you better -  
TELL US HOW WE ARE DOING!*

**Go to** <http://www.acqsolinc.com/ICE/OAQ/feedback.cfm>

12/21/2008

---

**From:** Warren Coleman [mailto: [REDACTED] b6]  
**Sent:** Wednesday, September 24, 2008 7:55 AM  
**To:** Casterline, Arnold P  
**Subject:** RE: Invoice for Transportation

Arnold  
Any options for billing more frequently than monthly?

Since we are only providing transportation at this time, we have developed a worksheet that list the work order, time on run, number of detainees and miles. I have attached a worksheet with two tabs. Tab one will list hours on the run plus miles and the other tab will list time for the dispatcher and Dept Head as we are promised an hourly rate plus overtime for their work as well as the transportation officer and mileage. I will also add the monthly fixed cost to the invoice so it will have the three components of our compensation for this service.

I would like to review this with the COTR before the first invoice is submitted to eliminate any confusion. Please provide the contact information for the COTR.

Thanks in advance for your help.

Warren

---

**From:** Casterline, Arnold P [mailto: [REDACTED] (b)(6)]  
**Sent:** Wednesday, September 24, 2008 7:40 AM  
**To:** Warren Coleman  
**Subject:** RE: Invoice for Transportation

- B. Invoicing: The Service Provider shall submit an original itemized invoice containing the following information: the name and address of the facility; the name of each ICE detainee; detainee's A-number; specific dates of detention for each detainee; the total number of detainee days; the daily rate; the total detainee days multiplied by the daily rate; an itemized listing of all other charges; and the name, title, address, and phone number of the local official responsible for invoice preparation. For stationary guard services, the itemized monthly invoice shall state the number of hours being billed, the duration of the billing (times and dates) and the name of the detainee(s) that was guarded. The Service Provider shall submit monthly invoices within the first ten (10) working days of the month following the calendar month when it provided the services, to:

Department of Homeland Security  
ATTN: Immigration and Customs Enforcement  
Contracting Officer's Technical Representative (COTR)  
2675 Property Avenue  
Fairfax, Va. 22031  
Phone: 703-285-6200  
Fax: 703-285-6236

These are the terms of the agreement.

*Arnold P. Casterline Jr.*  
Contract Specialist  
Immigration and Customs Enforcement  
Office of Acquisition Management

12/21/2008

Detention Management  
Department of Homeland Security  
425 I Street NW, 5<sup>th</sup> Floor Room 5009  
Washington, DC 20536  
e-mail: [REDACTED] (b)(6)  
phone: 202-514-[REDACTED]  
Main: 202-514-[REDACTED] b6

*Help us support you better –  
TELL US HOW WE ARE DOING!*

**Go to** <http://www.acqsolinc.com/ICE/OAQ/feedback.cfm>

---

**From:** Warren Coleman [mailto:wcolem@ndevr.com] b6  
**Sent:** Tuesday, September 23, 2008 5:20 PM  
**To:** Casterline, Arnold P  
**Subject:** Invoice for Transportation

Arnie

Who do I need to contact/send our invoice for transportation? We are racking up the miles and cost so I would like to send over invoices weekly so they get into the payment cycle.

Thanks for you help.  
Warren Coleman

**Stevens, Richard P**

---

**From:** Smyly, Elena L  
**Sent:** Wednesday, September 24, 2008 4:08 PM  
**To:** Dellar, William L; Neveleff, Jerald; Evans, Mary Y  
**Cc:** Casterline, Arnold P; Weinberg, Bill  
**Subject:** RE: Farmville

According to the Facilities, 6 months after the start of construction. And they should start construction once the bed rate is agreed upon.

*Elena Smyly, PMP  
Management and Program Analyst - Large IGSA  
DHS, U.S. Immigration and Customs Enforcement  
Office of Detention and Removal  
Detention Management Division  
(202) 732-[REDACTED] b6*

---

**From:** Dellar, William L  
**Sent:** Wednesday, September 24, 2008 4:07 PM  
**To:** Neveleff, Jerald; Evans, Mary Y  
**Cc:** Smyly, Elena L; Casterline, Arnold P; Weinberg, Bill  
**Subject:** Re: Farmville

When will the facility be ready to receive detainees?

---

**From:** Neveleff, Jerald  
**To:** Evans, Mary Y  
**Cc:** Dellar, William L; Smyly, Elena L; Casterline, Arnold P; Weinberg, Bill  
**Sent:** Wed Sep 24 16:04:01 2008  
**Subject:** Farmville

Yvonne,

The bed day rate for Farmville was agreed upon 9/22/08. We are waiting for the Town of Farmville to sign their side of the modification so we can complete the process.

The bed day rate of \$62.83 was based on the drawings agreed to by the field office knowing that a wall here and there may need to be changed, doors repositioned, and the teleradiology being in a trailer.

We understood that DIHS and the Field Office disagreed on some of the facility design but we did not see changing a wall or door or repositioning the radiology trailer any impact to cost.

We do have details on the cost that when DIHS provides the medical, we can adjust the bed day rate accordingly.

If you need more info, let me know.

Jerry

Thank you,

12/21/2008

Jerry Neveleff

Supervisory Contracting Officer/

IGSA Team Lead

Office of Acq. Management (OAQ)

Detention Management Division

202/616 [REDACTED] b6

Help us support you better -

TELL US HOW WE ARE DOING!

Go to <http://www.acqsolinc.com/ICE/OAQ/feedback.cfm> <<<http://www.acqsolinc.com/ICE/OAQ/feedback.cfm>>>

**Stevens, Richard P**

---

**From:** Neveleff, Jerald  
**Sent:** Wednesday, September 24, 2008 4:20 PM  
**To:** Evans, Mary Y  
**Subject:** FW: Farmville IGSA  
**Attachments:** DROIGSA080021TRANS\_001.pdf; SOW9908\_001.pdf; LSFARM001.pdf; QASP9908001.pdf; QASP2\_026.pdf; HSCEDM08FIG064.pdf

Quality Assurance plan still to be submitted to ICE for reviewed and approval  
Staffing plan from proposal to be inserted next modification

DROIGSA080021TRANS - Basic IGSA with bed day as TBD  
SOW9908\_001 is the attached SOW  
LSFARM001 is the Labor Standards  
QASP - 2 parts  
HSCEDM08FIG064 is the task order to fund the transportation portion.

Thank you,  
Jerry Neveleff  
Supervisory Contracting Officer/  
IGSA Team Lead  
Office of Acq. Management (OAQ)  
Detention Management Division  
202/616 [REDACTED] b6

Help us support you better -  
TELL US HOW WE ARE DOING!  
Go to <<http://www.acqsolinc.com/ICE/OAQ/feedback.cfm>> <<<http://www.acqsolinc.com/ICE/OAQ/feedback.cfm>>>

---

**From:** Evans, Mary Y  
**Sent:** Wednesday, September 24, 2008 4:15 PM  
**To:** Neveleff, Jerald  
**Cc:** Casterline, Arnold P; Weinberg, Bill; Smyly, Elena L; Dellar, William L  
**Subject:** RE: Farmville

Do you have a copy of the agreement ? Marc would like to review it... thanks!

---

**From:** Neveleff, Jerald  
**Sent:** Wednesday, September 24, 2008 4:11 PM  
**To:** Smyly, Elena L; Dellar, William L; Evans, Mary Y  
**Cc:** Casterline, Arnold P; Weinberg, Bill  
**Subject:** RE: Farmville

We were told that Farmville signed the modification, they are looking for it now to send to us.

Thank you,  
Jerry Neveleff  
Supervisory Contracting Officer/  
IGSA Team Lead

12/21/2008

Office of Acq. Management (OAQ)  
Detention Management Division  
202/616- [REDACTED] b6

Help us support you better -  
TELL US HOW WE ARE DOING!

Go to <<http://www.acqsolinc.com/ICE/OAQ/feedback.cfm>> <<<http://www.acqsolinc.com/ICE/OAQ/feedback.cfm>>>

---

**From:** Smyly, Elena L  
**Sent:** Wednesday, September 24, 2008 4:08 PM  
**To:** Dellar, William L; Neveleff, Jerald; Evans, Mary Y  
**Cc:** Casterline, Arnold P; Weinberg, Bill  
**Subject:** RE: Farmville

According to the Facilities, 6 months after the start of construction. And they should start construction once the bed rate is agreed upon.

*Elena Smyly, PMP  
Management and Program Analyst - Large IGSA  
DHS, U.S. Immigration and Customs Enforcement  
Office of Detention and Removal  
Detention Management Division  
(202) 732- [REDACTED] b6*

---

**From:** Dellar, William L  
**Sent:** Wednesday, September 24, 2008 4:07 PM  
**To:** Neveleff, Jerald; Evans, Mary Y  
**Cc:** Smyly, Elena L; Casterline, Arnold P; Weinberg, Bill  
**Subject:** Re: Farmville

When will the facility be ready to receive detainees?

---

**From:** Neveleff, Jerald  
**To:** Evans, Mary Y  
**Cc:** Dellar, William L; Smyly, Elena L; Casterline, Arnold P; Weinberg, Bill  
**Sent:** Wed Sep 24 16:04:01 2008  
**Subject:** Farmville

Yvonne,

The bed day rate for Farmville was agreed upon 9/22/08. We are waiting for the Town of Farmville to sign their side of the modification so we can complete the process.

The bed day rate of \$62.83 was based on the drawings agreed to by the field office knowing that a wall here and there may need to be changed, doors repositioned, and the teleradiology being in a trailer.

We understood that DIHS and the Field Office disagreed on some of the facility design but we did not see changing a wall or door or repositioning the radiology trailer any impact to cost.

We do have details on the cost that when DIHS provides the medical, we can adjust the bed day rate accordingly.

If you need more info, let me know.

12/21/2008

Jerry

Thank you,

Jerry Neveleff

Supervisory Contracting Officer/

IGSA Team Lead

Office of Acq. Management (OAQ)

Detention Management Division

202/616 [REDACTED] b6

Help us support you better -

TELL US HOW WE ARE DOING!

Go to <http://www.acqsolinc.com/ICE/OAQ/feedback.cfm> <<<http://www.acqsolinc.com/ICE/OAQ/feedback.cfm>>>



DROIGSA-08-0021  
INTERGOVERNMENTAL SERVICE AGREEMENT  
BETWEEN THE  
UNITED STATES DEPARTMENT OF HOMELAND SECURITY  
U.S. IMMIGRATION AND CUSTOMS ENFORCEMENT  
AND  
Town of Farmville

This Intergovernmental Service Agreement ("Agreement") is entered into between United States Department of Homeland Security Immigration and Customs Enforcement ("ICE"), and the Town of Farmville ("Service Provider") for the detention and care of aliens ("detainees"). The term "Parties" is used in this Agreement to refer jointly to ICE and the Service Provider.

**FACILITY LOCATION:**

The Service Provider shall provide detention services for detainees at the following institution(s):

Town of Farmville  
116 North Main Street  
Farmville, Virginia 23901

The following constitute the complete agreement:

- INTERGOVERNMENTAL SERVICE AGREEMENT (IGSA)
- PROPOSAL, DATED \_\_\_\_\_ (Incorporated by reference)
- ATTACHMENT 1--STATEMENT OF WORK
- ATTACHMENT 2--QUALITY CONTROL PLAN
- ATTACHMENT 3--QUALITY ASSURANCE SURVEILLANCE PLAN (w/ PRS, CDR and PMT)
- ATTACHMENT 4--STAFFING PLAN
- ATTACHMENT 5--LABOR STANDARDS
- ATTACHMENT 6--WAGE DETERMINATION Number \_\_\_\_\_ Dated \_\_\_\_\_

**IN WITNESS WHEREOF**, the undersigned, duly authorized officers, have subscribed their names on behalf of the Town of Farmville and Department of Homeland Security, U.S. Immigration and Customs Enforcement.

**ACCEPTED:**

U.S. Immigration and Customs Enforcement

Jerald Neveleff  
Contracting Officer

Sign  
Print Name: Jerald Neveleff  
Date: 15 Sept 08

**ACCEPTED:**

Town of Farmville

Gerald J. Spates  
Town Manager

Print Name: GERALD J. SPATES  
Date: 9/9/08

## Article I. Purpose

- A. **Purpose:** The purpose of this Intergovernmental Service Agreement (IGSA) is to establish an Agreement between ICE and the Service Provider for the detention and care of persons detained under the authority of Immigration and Nationality Act, as amended. All persons in the custody of the ICE are "Administrative Detainees". This term recognizes that ICE detainees are not charged with criminal violations and are only held in custody to assure their presence throughout the administrative hearing process and to assure their presence for removal from the United States pursuant to a lawful final order by the Immigration Court, the Board of Immigration Appeals or other Federal judicial body.
- B. **Responsibilities:** This Agreement sets forth the responsibilities of ICE and the Service Provider. The Agreement states the services the Service Provider shall perform satisfactorily to receive payment from ICE at the rate prescribed in Article I, C.
- C. **Guidance:** This is a fixed rate agreement, not a cost reimbursable agreement, with respect to the detainee day rate. The detainee daily rate is \$TBD. ICE shall be responsible for reviewing and approving the costs associated with this Agreement and subsequent modifications utilizing all applicable federal procurement laws, regulations and standards in arriving at the detainee day rate.

## Article II. General

- A. **Funding:** The obligation of ICE to make payments to the Service Provider is contingent upon the availability of Federal funds. ICE will neither present detainees to the Service Provider nor direct performance of any other services until ICE has the appropriate funding. Orders will be placed under this Agreement when specific requirements have been identified and funding obtained. Performance under this Agreement is not authorized until the Contracting Officer issues an order, in writing. The effective date of the Agreement will be negotiated and specified in an order to this Agreement by the Contracting Officer. This Agreement is neither binding nor effective unless signed by the Contracting Officer. Payments at the approved rate will be paid upon the return of the signed Agreement by the authorized Local Government official to ICE.
- B. **Subcontractors:** The Service Provider shall notify and obtain approval from the Contracting Officer if it intends to house detainees in a facility other than the Facility named in this Agreement. If either that facility or any future facility is operated by an entity other than the Service Provider, ICE shall treat the entity as a subcontractor to the Service Provider. The Service Provider shall obtain the Contracting Officer's approval before subcontracting the detention and care of detainees to another entity. The Contracting Officer has the right to deny, withhold, or withdraw approval of the proposed subcontractor. Upon approval by the Contracting Officer, the Service Provider shall ensure that any subcontract includes all provisions of this Agreement, and shall provide ICE with copies of all subcontracts. All payments will be made to the Service Provider. ICE will not accept invoices from, or make payments to a subcontractor.
- C. **Consistent with Law:** This is a firm fixed rate agreement, not cost reimbursable agreement. This Agreement is permitted under applicable statutes, regulation, policies or

judicial mandates. Any provision of this Agreement contrary to applicable statutes, regulation, policies or judicial mandates is null and void and shall not necessarily affect the balance of the Agreement.

- D. Use of Service Provider's Policies and Procedures: The Contracting Officer shall approve Service Provider's policies and procedures for use under this Agreement. Upon approval, the Service Provider can use its policies and procedures in conjunction with the detention standards mandated under this Agreement.
- E. Notification and Public Disclosure: No public disclosures (i.e. press releases, press conferences) regarding this IGSA shall be made by the Service Provider or any of its contractors or subcontractors without the review and approval of such disclosure by ICE Public Affairs and express permission granted by the ICE Contracting Officer.

### Article III. Covered Services

Below are the general requirements under this Agreement. Specific requirements for the services under this Agreement are stated in the attached Statement of Work. See Attachment 1.

- A. Bedspace: The Service Provider shall provide male/female beds on a space available basis. The Service Provider shall house all detainees as determined within the Service Provider's classification system.
- B. Basic Needs: The Service Provider shall provide detainees with safekeeping, housing, subsistence, medical and other services in accordance with this Agreement. In providing these services, the Service Provider shall ensure compliance with all applicable laws, regulations, fire and safety codes, policies and procedures. If the Service Provider determines that ICE has delivered a person for custody who is under the age of eighteen (18), the Service Provider shall not house that person with adult detainees and shall immediately notify the Contracting Officer's Technical Representative (COTR).
- C. Interpretive Services: The Service Provider shall make special provisions for non-English speaking, handicapped or illiterate detainees. ICE will reimburse the Service Provider for the actual costs associated with providing commercial written or telephone language interpretive services. Upon request, ICE will assist the Service Provider in obtaining translation services. The Service Provider shall provide all instructions verbally either in English or the detainees' language, as appropriate, to detainees who cannot read. The Service Provider shall include the actual costs that the Service Provider paid for such services on its monthly invoice. Except in emergency situations, the Service Provider shall not use detainees for translation services. If the Service Provider uses a detainee for translation service, it shall notify ICE within 24 hours of the translation service.
- D. Escort and Transportation Services: The Service Provider will provide, upon request and as scheduled by the Contracting Officer's Technical Representative (COTR) or Contracting Officer (CO), necessary escort and transportation services for detainees to and from designated locations. Escort services will be required for escorting detainees to court hearings; escorting witnesses to the courtroom and any escort services as requested by an ICE judge during proceedings. Escort and transportation services shall also include

providing all such air and/or ground transportation services as may be required to transport detainees securely and in a timely manner. Transportation and/or escort services may be required to transport detainees from the Facility to and from a medical facility for outpatient care. During all transportation activities, at least one (1) transportation officer shall be of the same sex as the detainees being transported. The Service Provider shall use a communications system that has direct and immediate contact with all transportation vehicles. Transportation and escort services shall be provided in the most economical and efficient manner. The Service Provider personnel provided for these services shall be of the same qualifications, receive training, complete the same security clearances, and wear the same uniforms as those personnel provided for in other areas of this Agreement. The Statement of Work shall provide specific escort and transportation services unique for this Agreement.

**E. Guard Services:** The Service Provider agrees to provide stationary guard services on demand by the COTR or Contracting Officer and shall include, but are not limited to, escorting and guarding detainees to medical or doctor's appointments, hearings, ICE interviews, and any other location requested by the COTR. Qualified personnel employed by the Service Provider will perform such services. The Service Provider agrees to augment such practices as may be requested by ICE to enhance specific requirements for security, detainee monitoring, visitation, and contraband control. Public contact is prohibited unless authorized in advance by the COTR or Contracting Officer. The Service Provider shall be authorized to provide at least two (2) officers for each remote post, as directed by the COTR or Contracting Officer.

**F. Medical Services:** The Statement of Work shall provide specific medical service requirements unique to this Agreement. Regardless of the unique requirements for this contract, the Service Provider shall provide the following services regarding medical care of detainees:

- 1) The Service Provider shall provide for medical screening of every detainee upon arrival at the Facility performed by health care personnel or health trained personnel.
- 2) Medical coverage at the Facility shall be no less than twenty-four (24) hours per day, seven (7) days per week.
- 3) The Service Provider shall provide the detainees written instructions for gaining access to health care services. Procedures shall be explained to all detainees in the detainees' native language, and orally to detainees' who are unable to read. The detainee shall similarly be provided instructions and assistance in personal hygiene, dental hygiene, grooming and health care. It shall be made routinely available.
- 4) The Service Provider shall provide to all detainees a written policy and defined procedure to require that detainee's written health complaints are solicited and delivered to the medical facility for appropriate follow-up. Written policy and defined procedure shall require that health care complaints are responded to and that sick call, conducted by health care personnel or health trained personnel is available to detainees daily. If a detainee's custody status precludes attendance at sick call, arrangements shall be made to provide sick call services in the place of the detainee's detention. A minimum of one sick call shall be conducted daily.

USPHS reserves the right to conduct triage and sick call in the place of the detainee's detention.

- 5) The Service Provider shall provide and maintain basic first aid kits throughout the Facility. First aid kits shall be available at all times to allow quick access.
- 6) The Service Provider shall provide security with a minimum of a staff of one at all times. When detainees are housed in the infirmary, a security guard shall be posted to the unit 24 hours a day, seven days a week. The Service Provider shall coordinate and escort detainees to the medical clinic for sick call, appointments and pill line.
- 7) When communicable or debilitating physical problems are suspected, the detainee shall be separated from the detainee population, and immediately notify USPHS staff. Behavioral problems (detainee who is not diagnosed as psychotic) and suicide observation will be the responsibility of the Service Provider.

#### **Article IV. Receiving and Discharging Detainees**

- A. **Required Activity:** The Service Provider shall receive and discharge detainees only to and from properly identified ICE personnel or other properly identified Federal law enforcement officials with prior authorization from DHS/ICE. Presentation of U.S. Government identification shall constitute "proper identification." The Service Provider shall furnish receiving and discharging services twenty-four (24) hours per day, seven (7) days per week. ICE shall furnish the Service Provider with reasonable notice of receiving and discharging detainees. The Service Provider shall ensure positive identification and recording of detainees and ICE officers. The Service Provider shall not permit medical or emergency discharges except through coordination with on-duty ICE officers.
- B. **Restricted Release of Detainees:** The Service Provider shall not release detainees from its physical custody to any persons other than those described in Paragraph A of Article IV for any reason, except for either medical, other emergency situations, or in response to a federal writ of habeas corpus. If a detainee is sought for federal, state, or local proceedings, only ICE may authorize release of the detainee for such purposes. The Service Provider shall contact the COTR immediately regarding any such requests.
- C. **Service Provider Right of Refusal:** The Service Provider retains the right to refuse acceptance or request removal of any detainee exhibiting violent or disruptive behavior, or of any detainee found to have a medical condition that requires medical care beyond the scope of the Service Provider's health care provider. In the case of a detainee already in custody, the Service Provider shall notify ICE and request removal of the detainee from the Facility. The Service Provider shall allow ICE reasonable time to make alternative arrangements for the detainee.
- D. **Emergency Evacuation:** In the event of an emergency requiring evacuation of the Facility, the Service Provider shall evacuate detainees in the same manner, and with the same safeguards, as it employs for persons detained under the Service Provider's authority. The Service Provider shall notify the Contracting Officer and COTR within two (2) hours of evacuation.

#### **Article V. ICE National Detention Standards**

- A. The Service Provider is required to house detainees and perform related detention services in accordance with the most current edition of the ICE National Detention Standards found within the ICE Detention Operations Manual. This manual can be found at <http://www.ice.gov/partners/dro/opsmanual/index>. ICE Inspectors will conduct periodic inspections of the facility to assure compliance with the ICE National Detention Standards.
- B. The Service Provider shall certify to the Contracting Officer and COTR that its personnel have completed all training as required by the ICE Detention Operations Manual, the Service Provider's own manual (if it is approved for use by the Contracting Officer), and any additional training as required in any manuals or detention standards referenced in this Agreement.

#### **Article VI. No Employment of Unauthorized Aliens**

Subject to existing laws, regulations, Executive Orders, and addenda to this Agreement, the Service Provider shall not employ aliens unauthorized to work in the United States. Except for maintaining personal living areas, detainees shall not be required to perform manual labor.

#### **Article VII. Period of Performance**

This Agreement shall become effective upon the date of final signature by the ICE Contracting Officer and the authorized signatory of the Service Provider and will remain in effect for a period not to exceed sixty (60) months, unless terminated in writing, by either party. Either party must provide written notice of intentions to terminate the agreement, 60 days in advance of the effective date of formal termination, or the Parties may agree to a shorter period under the procedures prescribed in Article X.

#### **Article VIII. Inspections**

The Facility and Provider's services shall be inspected in accordance with the following procedures:

- A. Definitions. "Services," as used in this clause, includes services performed, workmanship, and material furnished or utilized in the performance of services.
- B. The Provider shall provide and maintain an inspection system acceptable to the Government covering the services under this agreement. Complete records of all inspection work performed by the Provider shall be maintained and made available to the Government during contract performance and for as long afterwards as the agreement requires.
- C. The Government has the right to inspect and test all services called for by the agreement, to the extent practicable at all times and places during the term of the agreement. The Government shall perform inspections and tests in a manner that will not unduly delay the work.

- D. If the Government performs inspections or tests on the premises of the Provider or a subcontractor, the Provider shall furnish, and shall require subcontractors to furnish, at no increase in agreement price, all reasonable facilities and assistance for the safe and convenient performance of these duties.
- E. If any of the services do not conform to agreement requirements, the Government may require the Provider to perform the services again in conformity with agreement requirements, at no increase in agreement amount. When the defects in services cannot be corrected by re-performance, the Government may (1) require the Provider to take necessary action to ensure that future performance conforms to agreement requirements and (2) reduce the agreement price to reflect the reduced value of the services performed.
- F. If the Provider fails to promptly perform the services again or to take the necessary action to ensure future performance in conformity with agreement requirements, the Government may (1) by contract or otherwise, perform the services and charge to the Provider any cost incurred by the Government that is directly related to the performance of such service or (2) terminate the agreement for default.

#### Article IX. Inspection Reports

- A. Inspection Report: The Inspection Report stipulates minimum requirements for fire/safety code compliance, supervision, segregation, sleeping utensils, meals, medical care, confidential communication, telephone access, legal counsel, legal library, visitation, and recreation. The Service Provider shall allow ICE to conduct inspections of the facility, as required, to ensure an acceptable level of services and acceptable conditions of confinement as determined by ICE. No notice to the Service Provider is required prior to an inspection. ICE will conduct such inspections in accordance with the Inspection Report. ICE will share findings of the inspection with the Service Provider's facility administrator. The Inspection Report will state any improvements to facility operation, conditions of confinement, and level of service that will be required by the Service Provider.
- B. Possible Termination: If the Service Provider fails to remedy deficient service ICE identifies through inspection, ICE may terminate this Agreement without regard to the provisions of Articles VII and X.
- C. Share Findings: The Service Provider shall provide ICE copies of facility inspections, reviews, examinations, and surveys performed by accreditation sources.
- D. Access to Detainee Records: The Service Provider shall, upon request, grant ICE access to any record in its possession, regardless of whether the Service Provider created the record, concerning any detainee held pursuant to this Agreement. This right of access shall include, but is not limited to, incident reports, records relating to suicide attempts, and behavioral assessments and other records relating to the detainee's behavior while in the Service Provider's custody. Furthermore, the Service Provider shall retain all records where this right of access applies for a period of two (2) years from the date of the detainee's discharge from the Service Provider's custody.

#### **Article X. Modifications and Disputes**

- A. **Modifications:** Actions other than those designated in this Agreement will not bind or incur liability on behalf of either Party. Either Party may request a modification to this Agreement by submitting a written request to the other Party. A modification will become a part of this Agreement only after the ICE Contracting Officer and the authorized signatory of the Service Provider have approved the modification in writing.
- B. **Disputes:** The ICE Contracting Officer and the authorized signatory of the Service Provider will settle disputes, questions and concerns arising from this Agreement. Settlement of disputes shall be memorialized in a written modification between the ICE Contracting Officer and authorized signatory of the Service Provider. In the event a dispute is not able to be resolved between the Service Provider and the ICE Contracting Officer, the ICE Contracting Officer will make the final decision. If the Service Provider does not agree with the final decision, the matter may be appealed to the ICE Head of the Contracting Activity (HCA) for resolution. The ICE HCA may employ all methods available to resolve the dispute including alternative dispute resolution techniques. The Service Provider shall proceed diligently with performance of this Agreement pending final resolution of any dispute.

#### **Article XI. DETAINEE DAY RATE and ADJUSTMENT to the DAY RATE**

- A. **Detainee Day Rate:** In consideration for the Service Provider's performance under this Agreement, ICE shall make payment to the Service Provider for each detainee accepted and housed by the Service Provider. This "detainee day rate" is a per diem rate for the support of one Detainee per day and shall include the day of arrival but not the day of departure.
- B. The detainee day rate is TBD.
- C. The Service Provider, by execution of this Agreement, certifies that the pricing established under this agreement is in compliance with OMB Circular A-87 and includes only allowable costs of performance under this agreement.
- D. **Basis for Price Adjustment:** A firm fixed price with economic adjustment provides for upward and downward revision of the stated Per Diem based upon cost indexes of labor and operating expenses, or based upon the Service Provider's actual cost experience in providing the service.
- E. ICE shall reimburse the Service Provider at the fixed detainee day rate shown on the cover page of the document, Article I. (C). The Parties may adjust the rate twelve (12) months after the effective date of the agreement and no sooner than every twelve (12) months. The Parties shall base the cost portion of the rate adjustment on the principles of allowability and allocability as set forth in OMB Circular A-87, federal procurement laws, regulations, and standards in arriving at the detainee day rate. The request for adjustment shall be submitted on an ICE Jail Services Cost Statement. If ICE does not receive an official request for a detainee day rate adjustment that is supported by an ICE Jail Services Cost Statement, the detainee day rate as stated in this Agreement will control.



- F. ICE reserves the right to audit the actual and/or prospective costs upon which the rate adjustment is based. All rate adjustments are prospective. As this is a fixed rate agreement, there are no retroactive adjustment(s).
- G. Guard and transportation services shall be denoted as separate items on submitted invoices. ICE agrees to reimburse the Service Provider for actual stationary guard services provided at a negotiated rate of \$24.28. Transportation mileage reimbursable rates will be commensurate with current applicable federal travel allowance rates. Any additional operational costs will be reimbursed at the negotiated rate identified in the task order (HSCEDM-08-F-IG064). The additional items shall also be billed as separate line items until modified in the task order.

**Article XII. Enrollment, Invoicing, and Payment**

- A. Enrollment in Electronic Funds Transfer: The Service Provider shall provide ICE with the information needed to make payments by electronic funds transfer (EFT). Since January 1, 1999, ICE makes all payments only by EFT. The Service Provider shall identify their financial institution and related information on Standard Form 3881, Automated Clearing House (ACH) Vendor Miscellaneous Payment Enrollment Form. The Service Provider shall submit a completed SF 3881 to ICE payment office prior to submitting its initial request for payment under this Agreement. If the EFT data changes, the Service Provider shall be responsible for providing updated information to the ICE payment office.
- B. Invoicing: The Service Provider shall submit an original itemized invoice containing the following information: the name and address of the facility; the name of each ICE detainee; detainee's A-number; specific dates of detention for each detainee; the total number of detainee days; the daily rate; the total detainee days multiplied by the daily rate; an itemized listing of all other charges; and the name, title, address, and phone number of the local official responsible for invoice preparation. For stationary guard services, the itemized monthly invoice shall state the number of hours being billed, the duration of the billing (times and dates) and the name of the detainee(s) that was guarded. The Service Provider shall submit monthly invoices within the first ten (10) working days of the month following the calendar month when it provided the services, to:

Department of Homeland Security  
ATTN: Immigration and Customs Enforcement  
Contracting Officer's Technical Representative (COTR)  
2675 Property Avenue  
Fairfax, Va. 22031  
Phone: 703-285-6200  
Fax: 703-285-6236

- C. Payment: ICE will transfer funds electronically through either an Automated Clearing House subject to the banking laws of the United States, or the Federal Reserve Wire Transfer System. The Prompt Payment Act applies to this Agreement. The Prompt Payment Act requires ICE to make payments under this Agreement the thirtieth (30<sup>th</sup>) calendar day after the ICE Deportation office receives a complete invoice. Either the date

on the Government's check, or the date it executes an electronic transfer of funds, shall constitute the payment date. The Prompt Payment Act requires ICE to pay interest on overdue payments to the Service Provider. ICE will determine any interest due in accordance with the Prompt Payment Act.

#### **Article XIII. Government Furnished Property**

- A. Federal Property Furnished to the Service Provider: ICE may furnish Federal Government property and equipment to the Service Provider. Accountable property remains titled to ICE and shall be returned to the custody of ICE upon termination of the Agreement. The suspension of use of bed space made available to ICE is agreed to be grounds for the recall and return of any or all government furnished property.
- B. Service Provider Responsibility: The Service Provider shall not remove ICE property from the facility without the prior written approval of ICE. The Service Provider shall report any loss or destruction of any Federal Government property immediately to ICE.

#### **Article XIV. Hold Harmless and Indemnification Provisions**

- A. Service Provider Held Harmless: ICE shall, subject to the availability of funds, save and hold the Service Provider harmless and indemnify the Service Provider against any and all liability claims and costs of whatever kind and nature, for injury to or death of any person(s), or loss or damage to any property, which occurs in connection with or is incident to performance of work under the terms of this Agreement, and which results from negligent acts or omissions of ICE officers or employees, to the extent that ICE would be liable for such negligent acts or omissions under the Federal Tort Claims Act, 28 USC 2691 *et seq.*
- B. Federal Government Held Harmless: The Service Provider shall save and hold harmless and indemnify federal government agencies to the extent allowed by law against any and all liability claims, and costs of whatsoever kind and nature for injury to or death of any person or persons and for loss or damage to any property occurring in connection with, or in any way incident to or arising out of the occupancy, use, service, operation or performance of work under the tenets of this Agreement, resulting from the negligent acts or omissions of the Service Provider, or any employee, or agent of the Service Provider. In so agreeing, the Service Provider does not waive any defenses, immunities or limits of liability available to it under state or federal law. The Service Provider agrees to hold harmless and indemnify DHS/ICE and its officials in their official and individual capacities from any liability, including third-party liability or worker's compensation, arising from the conduct of the Service Provider and its employees during the course of transporting detainees on behalf of ICE.
- C. Defense of Suit: In the event a detainee files suit against the Service Provider contesting the legality of the detainee's incarceration and/or immigration/citizenship status, ICE shall request that the U.S. Attorney's Office, as appropriate, move either to have the Service Provider dismissed from such suit, to have ICE substituted as the proper party defendant; or to have the case removed to a court of proper jurisdiction. Regardless of the decision on any such motion, ICE shall request that the U.S. Attorney's Office be responsible for the defense of any suit on these grounds.

- D. **ICE Recovery Right:** The Service Provider shall do nothing to prejudice ICE's right to recover against third parties for any loss, destruction of, or damage to U.S. Government property. Upon request of the Contracting Officer, the Service Provider shall, at ICE's expense, furnish to ICE all reasonable assistance and cooperation, including assistance in the prosecution of suit and execution of the instruments of assignment in favor of ICE in obtaining recovery.

#### **Article XV. IGSA/Financial Records**

- A. **Retention of Records:** All IGSA and financial records including, but not limited to, supporting documents, statistical records, and other records, pertinent contracts, or subordinate agreements under this Agreement shall be retained by the Service Provider for three (3) years after the expiration of the Agreement for purposes of federal examinations and audit. If any litigation, claim, negotiation, audit, or other action involving the records has been started before the expiration of the three (3) year period, the records must be retained until completion of the action and resolution of all issues which arise from it or until the end of the regular three (3) year period, whichever is later.
- B. **Access to Records:** ICE and the Comptroller General of the United States, or any of their authorized representatives, shall have the right of access to any pertinent books, documents, papers or other records of the Service Provider or its sub-contractors, which are pertinent to the award, in order to make audits, examinations, excerpts, and transcripts. The rights of access must not be limited to the required retention period, but shall last as long as the records are retained.
- C. **Delinquent Debt Collection:** ICE will hold the Service Provider accountable for any overpayment, or any breach of this Agreement that results in a debt owed to the Federal Government. ICE shall apply interest, penalties, and administrative costs to a delinquent debt owed to the Federal Government by the Service Provider pursuant to the Debt Collection Improvement Act of 1982, as amended.

#### **Article XVI. Detainee Telephone Services (DTS)**

- A. The PROVIDER shall provide detainees with reasonable and equitable access to telephones as specified in ICE National Detention Standards on Telephone Access. Telephones shall be located in an area that provides for a reasonable degree of privacy and a minimal amount of environmental noise during phone calls.
- B. If authorized to do so under applicable law, the PROVIDER shall monitor and record detainee conversations. If detainee telephone conversations can be monitored under applicable law, the PROVIDER shall provide notice to detainees of the potential for monitoring. However, the PROVIDER shall also provide procedures at the facility for detainees to be able to place unmonitored telephone calls to their attorneys.
- C. Telephone rates shall not exceed the dominant carrier tariff rate and shall conform to all applicable federal, state, and local telephone regulations.

- D. The ICE designated DTS Contractor will be the exclusive provider of detainee telephones for this facility. The DTS Contractor shall be allowed to install vending debit machines and shall receive 100 percent of all revenues collected by sale of prepaid debit services. The DTS Contractor shall be responsible for furnishing all inventory and supply of prepaid debit cards to the PROVIDER. The DTS Contractor shall be responsible for the costs incurred for installation of the equipment, any monthly telephone charges incurred from the operation of DTS, and the maintenance and operation of the system. The PROVIDER will not be entitled to any commissions, fees, or revenues generated by the use of the DTS or the detainee telephones.
- E. The PROVIDER shall inspect telephones for serviceability, in accordance with ICE policies and procedures. The PROVIDER will notify the COTR or ICE designees of any inoperable telephones.

#### Article XVII. Maintain Institutional Emergency Readiness

- A. The Service Provider shall submit an institutional emergency plan that will be operational prior to start of the Agreement. The plan shall receive the concurrence of the Contracting Officer prior to implementation and shall not be modified without the further written concurrence of the Contracting Officer.
- B. The Service Provider shall have written agreements with appropriate state and local authorities that will allow the Service Provider to make requests for assistance in the event of any emergency incident that would adversely affect the community.
- C. Likewise, the Service Provider shall have in place, an internal corporate nation-wide staff contingency plan consisting of employees who possess the same expertise and skills required of staff working directly on this agreement. At the discretion of ICE, these employees would be required to respond to an institutional emergency at the Facility, when necessary.
- D. The emergency plans shall include provisions for two or more disturbance control teams. Protective clothing and equipment for each team member and 30 percent of all additional facility staff members shall be provided by the Service Provider, and maintained in a secure location outside the secure perimeter of the facility.
- E. Any decision by ICE or other federal agencies to provide and/or direct emergency assistance will be at the discretion of the Government. The Service Provider shall reimburse the Government for any and all expenses incurred in providing such assistance.
- F. The Contracting Officer and COTR shall be notified immediately in the event of all serious incidents. Serious incidents include, but are not limited to the following: activation of disturbance control team(s); disturbances (including gang activities, group demonstrations, food boycotts, work strikes, work-place violence, civil disturbances/protests); staff use of force including use of lethal and less-lethal force (includes inmates in restraints more than eight hours); assaults on staff/inmates resulting in injuries requiring medical attention (does not include routine medical evaluation after the incident); fights resulting in injuries requiring medical attention; fires; full or partial lock down of the facility; escape; weapons discharge; suicide attempts; deaths; declared
- Dedicated IGSA Template  
RFP Attachment 2  
Page 12 of 19

or non-declared hunger strikes; adverse incidents that attract unusual interest or significant publicity; adverse weather (e.g., hurricanes, floods, ice/snow storms, heat waves, tornadoes); fence damage; power outages; bomb threats; central inmate monitoring cases admitted to a community hospital; witness security cases taken outside the facility; significant environmental problems that impact the facility operations; transportation accidents (i.e. airlift, bus) resulting in injuries, death or property damage; and sexual assaults.

- G. Attempts to apprehend the escapee(s) shall be in accordance with the Emergency Plan, which should comply with ICE Detention Operations Manual regarding Emergency Plans.
- H. The Service Provider shall submit to the COTR a proposed inventory of intervention equipment (weapons, munitions, chemical agents, electronics/stun technology, etc.) intended for use during performance of this Agreement. Prior to the start of this Agreement, the Contracting Officer shall approve the intervention equipment. The approved intervention equipment inventory shall not be modified without prior written concurrence of the Contracting Officer.
- I. The Service Provider shall obtain the appropriate authority from state or local law enforcement agencies to use force as necessary to maintain the security of the institution. The use of force by the Provider shall at all times be consistent with all applicable policies of ICE Detention Operations Manual regarding Use of Force.

#### **XVIII. Security Requirements**

##### **A. GENERAL**

The Department of Homeland Security (DHS), U.S. Immigration and Customs Enforcement (ICE), Office of Professional Responsibility, Personnel Security Unit (DHS-ICE-OPR-PSU, hereinafter OPR-PSU) has determined that performance of the tasks as described in IGSA (Contract) \_\_\_\_\_ requires that the Service Provider (Contractor, subcontractor(s), vendor(s), etc. (herein known as Service Provider) have access to ICE detainees, and that the Service Provider will adhere to the following and shall expressly incorporate this provision into any and all Subcontracts or subordinate agreements issued in support of this Agreement .

##### **B. SUITABILITY DETERMINATION**

ICE-OPR-PSU shall have and exercise full control over granting, denying, withholding or terminating unescorted government facility and/or access to ICE detainees, as well as, when applicable, sensitive Government information access for Service Provider employees, based upon the results of a background investigation.

ICE-OPR-PSU may, as it deems appropriate, authorize and make a favorable entry on duty (EOD) decision based on preliminary security checks. The favorable EOD decision would allow the Service Provider employees to commence work temporarily prior to the completion

of the full investigation. The granting of a favorable EOD decision shall not be considered as assurance that a full employment suitability authorization will follow as a result thereof.

The granting of a favorable EOD decision or a full employment suitability determination shall in no way prevent, preclude, or bar the withdrawal or termination of any such access by ICE-OPR-PSU, at any time during the term of the IGSA. No employee of the Service Provider shall be allowed to EOD and/or access facilities or ICE detainees without a favorable EOD decision or suitability determination by OPR-PSU. No employee of the Service Provider shall be allowed unescorted access to a Government facility without a favorable EOD decision or suitability determination by OPR-PSU. Service Provider employees assigned to the IGSA not needing access to ICE detainees or recurring access to DHS-ICE facilities will not be subject to security suitability screening.

Suitability criteria as detailed in ICE Policy Directives that will exclude applicants from consideration to perform under this agreement include, but not limited to:

- Felony convictions, or a conviction for any crime that involves violence
- Conviction of a sex crime
- Offense/s involving a child victim
- Pattern of arrests, without convictions, that brings into question a person's judgment and reliability to promote the efficiency and integrity of the ICE mission.
- Intentional falsification and/or omission of pertinent personal information
- Drug and/or Alcohol Abuse
- Personal conduct to include failure to pay just debts

The process for suitability determination includes, but is not limited to, criminal, employment, citizenship, residential and financial records checks and reviews.

### C. BACKGROUND INVESTIGATIONS

IGSA Service Provider employees (to include applicants, temporaries, part-time and replacement employees) under the contract, needing access to ICE detainees, shall undergo a position sensitivity analysis based on the duties each individual will perform on the contract. The results of the position sensitivity analysis shall identify the appropriate background investigation to be conducted. Background investigations will be processed, managed and conducted under direction of OPR-PSU.

In those cases where prospective IGSA Service Provider employees already have a security clearance issued by the Defense Industrial Security Clearance Office (DISCO), that was granted using an appropriate background investigation, reciprocity may apply in that those prospective employees may not be required to submit complete security packages, as the clearance issued by DISCO may be accepted.

Prospective Service Provider employees without adequate security clearances issued by DISCO shall submit the following completed forms to the Personnel Security Unit through the COTR, no less than 45 days before the starting date of the IGSA (contract), or 45 days prior to the expected entry on duty of any employees, whether a replacement, addition, subcontractor employee, or vendor:

Standard Form 85P, "Questionnaire for Public Trust Positions"  
Form will be submitted via e-QIP (electronic Questionnaires for  
Investigation Processing)  
FD Form 258, "Fingerprint Card" (2 copies)  
Foreign National Relatives or Associates Statement  
DHS 11000-9, "Disclosure and Authorization Pertaining to Consumer Reports Pursuant  
to the Fair Credit Reporting Act"  
Drug Questionnaire  
Alcohol Questionnaire

Details regarding the required forms will be provided by ICE-OPR. Only complete packages will be accepted by OPR-PSU. Specific instructions on submission of packages will be provided by OPR-PSU.

**PLEASE NOTE:** Unless an applicant has resided in the US for three of the past five years, with few exceptions such as military or other federal service overseas, the Government may not be able to complete a satisfactory background investigation. In such cases, OPR-PSU retains the right to deem an applicant as ineligible due to insufficient background information.

#### D. SUITABILITY – RETROACTIVE EFFECT

Employees of the Service Provider(s) who have not been previously investigated as described under the Background Investigations section, above, must be scheduled not later than six months after implementation of this IGSA. Employees of the Service Provider(s) may continue to work while the investigation is in progress.

#### E. CONTINUED ELIGIBILITY

If a prospective Service Provider employee is found to be ineligible for access to Government facilities or information, the COTR will advise the Service Provider that the employee shall not continue to work or to be assigned to work under the contract.

The OPR-PSU may require drug screening for probable cause at any time and/ or when the contractor independently identifies, circumstances where probable cause exists.

The OPR-PSU may require reinvestigations when derogatory information is received and/or every 10 years.

ICE-OPR reserves the right and prerogative to deny and/ or restrict the facility and information access of any Service Provider employee whose actions are in conflict with the standards of conduct as detailed in 5 CFR 2635 and 5 CFR 3801, or whom ICE-OPR-PSU determines to present a risk of compromising ICE standards and conduct, including sensitive Government information, to which he or she would have access under this contract.

The Service Provider will report any adverse information coming to their attention concerning contract employees under the IGSA to OPR-PSU through the COTR. Reports based on rumor or innuendo should not be made. The subsequent termination of employment of an employee does not obviate the requirement to submit this report. The  
Dedicated IGSA Template RFP Attachment 2 Page 15 of 19

report shall include the employees' name and social security number, along with the adverse information being reported.

OPR-PSU must be notified of all terminations/ resignations within five days of occurrence.

If applicable, the Service Provider will return any expired ICE-DRO owned employee identification cards and/or building passes, or those of employees terminated and/or removed from the IGSA to the COTR within five (5) workdays. If an identification card or building pass is not available to be returned, a report must be submitted to the COTR, referencing the pass or card number, name of individual to whom issued, the last known location and disposition of the pass or card. The COTR will return the identification cards and building passes to the responsible ID Unit.

#### F. EMPLOYMENT ELIGIBILITY

The Service Provider must agree that each employee working on this IGSA will have a Social Security Card issued and approved by the Social Security Administration.

The Service Provider shall be responsible to the Government for acts and omissions of his own employees and for any Subcontractor(s) and their employees.

ICE-DRO has determined that employment on this IGSA (Contract) shall be limited to U.S. Citizens, Lawful Permanent Residents and Conditional Permanent Residents.

Subject to existing law, regulations and/ or other provisions of this IGSA, illegal or undocumented aliens will not be employed by the Service Provider, or with this IGSA. Service Provider will ensure that this provision is expressly incorporated into any and all Subcontracts or subordinate agreements issued in support of this IGSA.

#### G. SECURITY MANAGEMENT

The Service Provider shall appoint a senior official to act as the Corporate Security Officer. The individual will interface with the OPR-PSU through the COTR on all personnel security matters and if applicable, information security matters.

The COTR and OPR-PSU shall have the right to inspect the procedures, methods, and facilities utilized by the Service Provider in complying with the security requirements under this contract. Should the COTR determine that the Service Provider is not complying with the security requirements of this contract, the Service Provider will be informed in writing by the Contracting Officer of the proper action to be taken in order to effect compliance with such requirements. Copies of these communications by both the

Contracting Officer and the Service Provider shall be provided to OPR-PSU.

#### H. INFORMATION TECHNOLOGY SECURITY

Should the scope of the work change to require IGSA Service Provider personnel to access DHS-ICE IT systems, DHS IT Management Directives preclude routine access to any DHS



ICE IT systems, to include those utilized by ICE-DRO, by Non-U.S. citizens, including Lawful Permanent Residents (LPRs).

The following computer security requirements apply to both Department of Homeland Security (DHS) operations and to the former Immigration and Naturalization Service operations (FINS). These entities are hereafter referred to as the Department.

#### I. INFORMATION TECHNOLOGY SECURITY CLEARANCE

When sensitive government information is processed on Department telecommunications and automated information systems, the Contractor agrees to provide for the administrative control of sensitive data being processed and to adhere to the procedures governing such data as outlined in *DHS IT Security Program Publication DHS MD 4300.Pub. or its replacement*. Contractor personnel must have favorably adjudicated background investigations commensurate with the defined sensitivity level.

Contractors who fail to comply with Department security policy are subject to having their access to Department IT systems and facilities terminated, whether or not the failure results in criminal prosecution. Any person who improperly discloses sensitive information is subject to criminal and civil penalties and sanctions under a variety of laws (e.g., Privacy Act).

#### XIX. Accreditation

The Service Provider will have eighteen (18) months from commencement of this Agreement to become ACA accredited. The Service Provider shall, within nine (9) months from the date this facility becomes operational, formally apply for accreditation to the American Correctional Association. The Service Provider shall provide the Contracting Officer with written proof of such application to ICE within five (5) days of the application. The Service Provider shall provide the Contracting Officer with written proof of its accreditation within five (5) days of notification of its accreditation.

#### XX. Quality Control

- A. The Service Provider shall establish and maintain a complete Quality Control Program (QCP) acceptable to the Contracting Officer ("CO"), in consultation with the Contracting Officer's Technical Representative ("COTR") to assure the requirements of this Agreement are provided as specified in the Performance Requirement Summary (PRS)—Attachment 3.

The QCP shall:

1. Be implemented prior to the start of performance.
2. Provide quality control services that cover the scope of the IGSA and implement proactive actions to prevent non-performance issues.

- B. A complete QCP addressing all areas of agreement performance shall be submitted to the COTR no later than 30 days after the Agreement effective date. All proposed changes to the QCP must be approved by the Contracting Officer. The Service Provider shall submit a resume of the proposed individual(s) responsible for the QCP to the CO for approval. The Service Provider shall not change the individual(s) responsible for the QCP without prior approval of the Contracting Officer.
- C. The QCP shall include, at a minimum:
1. Specific areas to be inspected on either a scheduled or unscheduled basis and the method of inspection.
  2. Procedures for written and verbal communication with the Government regarding the performance of the Agreement.
  3. Specific surveillance techniques for each service identified in the Agreement and each functional area identified in the PRS.
  4. The QCP shall contain procedures for investigation of complaints by the Service Provider and Government staff and feedback to the Government on the actions taken to resolve such complaints.
- D. A file of all inspections, inspection results, and any corrective action required, shall be maintained by the Service Provider during the term of this Agreement. The Service Provider shall provide copies of all inspections, inspection results, and any corrective action taken to the COTR and Contracting Officer.
- E. Failure by the Service Provider to maintain adequate quality control can result in monetary deductions based upon the schedule of deductions incorporated herein.

**XXI. Contracting Officer's Technical Representative**

The Contracting Officer's Technical Representative (COTR) shall be designated by the Contracting Officer. When and if the COTR duties are reassigned, an administrative modification will be issued to reflect the changes. This designation does not include authority to sign contractual documents or to otherwise commit to, or issue changes, which could affect the price, quantity, or performance of this Agreement.

**XXII. Labor Standards and Wage Determination**

- A. The Service Contract Act, 41 U.S.C. 351 et seq., Title 29, Part 4 Labor Standards for Federal Service Contracts, is here by incorporated into this Agreement at Attachment 5. These standards and provisions are included in every contract over \$2,500, or in an indefinite amount, that is entered into by the United States, the principal purpose of which is to furnish services through the use of service employees.

**B. Wage Determination:** Each service employee employed in the performance of this Agreement shall be paid not less than the minimum monetary wages and shall be furnished fringe benefits in accordance with the wages and fringe benefits determined by the Secretary of Labor or authorized representative, as specified in any wage determination attached to this Agreement at Attachment 6.

\*\*\*\*\*  
**END OF DOCUMENT**  
\*\*\*\*\*

DEPARTMENT OF HOMELAND SECURITY (DHS)  
IMMIGRATION AND CUSTOMS ENFORCEMENT (ICE)  
OFFICE OF DETENTION AND REMOVAL (DRO)

REQUEST FOR PROPOSAL—ICE Detainee Services

STATEMENT OF WORK

Date: 4/02/2008

FACILITY LOCATION

Town of Farmville  
116 North Main Street  
Farmville, Virginia 23901

**I. Performance:**

The **PROVIDER** is required, in units housing U.S. Immigration and Customs Enforcement (ICE) detainees, to perform in accordance with the most current editions of the ICE National Detention Standards, American Correctional Association (ACA) Standards for Adult Local Detention Facilities (ALDF), and Standards Supplement, Standards for Health Services in Jails, latest edition, National Commission on Correctional Health Care (NCCHC). Some ACA standards are augmented by ICE policy and/or procedure. In cases where other standards conflict with ICE Policy or Standards, ICE Policy and Standards prevail. ICE Inspectors will conduct periodic inspections of the facility to assure compliance of the aforementioned standards.

**II. Anticipated Start Of Performance: TBD**

**III. Exclusivity:**

The **CONTRACTOR** or **PROVIDER** agrees that the facility is to be for the exclusive use of ICE and its detainee population. No other agency will be allowed to use the facility to house its detainees, prisoners, or inmates without prior approval of the Contracting Officer with input from the Contracting Officer's Technical Representative. If given approval, a separate bed day rate shall be negotiated with the other agency and ICE shall not be responsible for payment related to beds used by another agency. The other agency will be separately invoiced for the beds it uses. The duration of the use of beds will be determined on a case by case basis.

**IV. Armed Transportation Service:**

A. Transportation service shall include the following:

1. The **PROVIDER** shall provide all such ground transportation services as may be required to transport detainees securely, in a timely manner, to locations as directed by the COTR or designated ICE Official. When **PROVIDER** employees are not providing transportation services, the

**PROVIDER** shall assign the employees to supplement security duties within the Facility to assist ICE as directed by the COTR or designated ICE official. However, the primary function of these Service Provider employees is transportation. Duties as directed by the COTR utilizing these employees shall not incur any additional expense to ICE.

2. The **PROVIDER** shall assign, at a minimum, two person teams of transportation officers on a daily basis distributed throughout a twenty-four (24) hour period seven (7) days a week including weekends and holidays. The COTR shall approve the number of teams assigned to any shift or period of time in order to meet the needs of ICE transportation requirements.
3. The **PROVIDER** shall furnish suitable vehicles in good condition, approved by the Government, to safely provide the required transportation services per facility as listed below. The **PROVIDER** shall comply with all federal and state laws with regard to inspections, licensing, and registration for all vehicles used for transportation.
4. Nothing in this agreement shall restrict the **PROVIDER** from acquiring additional vehicles as deemed necessary by the **PROVIDER** at no cost to the Government. The **PROVIDER** shall not allow employees to use their privately owned vehicles to transport detainees. The **PROVIDER** shall furnish vehicles equipped with interior security features (such as, but not limited to: door lock controls, window locks, a wire cage with acrylic panel between the driver seat and the rear passenger seats) and be in accordance with ICE National Detention Standards including physical separation of detainees from guards. The **PROVIDER** shall provide the interior security specification of the vehicles to ICE for review and approval prior to installation.
5. In the event of transportation services involving distances that exceed a standard eight (8) hour workday to complete, the **PROVIDER** shall be reimbursed for related costs of lodging and meals commiserate with the U.S. General Services Administration rates for such within the geographical area of occurrence. Any incurred overtime pay for such services will be reimbursed at the applicable Department of Labor overtime rate for the transportation officer position incorporated within this agreement. The **PROVIDER** shall comply with ICE transportation standards related to the number of hours the **PROVIDER** employee may operate a vehicle. Overnight lodging resulting from transportation services shall be approved in advance by the COTR or designated ICE official.
6. All transportation shall be accomplished in the most economical manner.

7. The **PROVIDER** shall, upon order of the COTR, or upon his own decision in an urgent medical situation with notification to the COTR immediately thereafter, transport a detainee to a hospital location. An officer(s) shall keep the detainee under supervision 24 hours per day until the detainee is ordered released from the hospital, or at the order of the COTR. The **PROVIDER** shall then return the detainee to the Facility.
8. The **PROVIDER** personnel provided for the above services shall be of the same qualifications, receive the same training, complete the same security clearances, and wear the same uniforms as those **PROVIDER** personnel provided in the other areas of this agreement. Transportation officers shall have the required state licenses for commercial drivers with the proper endorsement limited to vehicles with Automatic Transmission and the state DMV Medical Certification.
9. During all transportation activities, at least one transportation officer shall be the same sex as the detainee(s). Questions concerning guard assignments shall be directed to the COTR for final determination.
10. All transportation Detention Officers shall be armed in the performance of these duties.
11. The COTR may direct the **PROVIDER** to transport detainees to miscellaneous locations.
12. When the COTR provides documents to the **PROVIDER** concerning the detainee(s) to be transported and/or escorted, the **PROVIDER** shall deliver these documents only to the named authorized recipients. The **PROVIDER** shall ensure the material is kept confidential and not viewed by any person other than the authorized recipient.
13. The **PROVIDER** shall establish a fully operational communication system compatible with ICE communication equipment that has direct and immediate contact with all transportation vehicles and post assignments. Upon demand, the COTR shall be provided with current status of all vehicles and post assignment employees.
14. Failure of the **PROVIDER** to comply fully with the detainee(s) departure as pre-scheduled shall result in the **PROVIDER** having deductions made for non-performance.

B. ANTICIPATED TRANSPORTATION ROUTES

The following transportation routes/destinations are anticipated requirements for this agreement. The following requirements are **one way routes**; these routes (mile approximations) are not all inclusive and should not be limited to the following:

<i>Legend</i>	<i>Daily = 2 times plus per week; Weekly = 2 or less per week; Periodic = as required Mileage = One Way</i>		
<b>Mileage From Farmville, VA</b>	<b>Locations</b>	<b>City</b>	<b>Frequency</b>
	<b>Field Offices</b>		
164	Detention and Removal Office	Fairfax	Daily
121	Detention and Removal Office	Harrisonburg	Weekly
153	Detention and Removal Office	Norfolk	Daily
65	Detention and Removal Office	Richmond	Daily
100	Detention and Removal Office	Roanoke	Weekly
	<b>JPATS/DOCC Destinations</b>		
173	Dulles International Airport	Washington, DC	Periodic
289	Harrisburg International Airport	Harrisburg, PA	Weekly
69	Richmond International Airport	Richmond	Proposed weekly
143	Piedmont Triad International Airport	Greensboro, NC	Proposed weekly
455	Stewart Detention Center	Stewart, GA	Periodic
266	York Detention Center	York, PA	Weekly
	<b>Jails</b>		
162	Alexandria City Jail	Alexandria	Daily
166	Arlington County Jail	Arlington	Daily
120	Augusta Correctional Center	Craigsville	Daily
180	Bland Correctional Center	Bland	Daily
59	Brunswick Correctional Center	Lawrenceville	Daily
22	Buckingham Correctional Center	Dillwyn	Daily
85	Central Virginia Regional Jail	Orange	Daily
145	Chesapeake City Jail	Chesapeake	Daily
96	Coffeewood Correctional Center	Coffeewood	Daily
170	DC Jail (Central Detention, Central Treatment)	Washington, DC	Daily
47	Deep Meadow Correctional Center	State Farm	Daily
22	Dillwyn Correctional Center	Dillwyn	Daily
48	Dinwiddie Correctional Unit	Church Road	Daily
160	Fairfax County Jail	Fairfax	Daily
67	FCI Petersburg - Camp - Virginia	Petersburg	Daily
67	FCI Petersburg - Low - Virginia	Petersburg	Daily
67	FCI Petersburg - Medium - Virginia	Petersburg	Daily

Mileage From Farmville, VA	Locations	City	Frequency
92	Green Rock Corr Center (New 06/2007)	Chatham	Daily
74	Greensville Correctional Center	Jarratt	Daily
138	Hampton City Jail	Hampton	Daily
136	Hampton Roads Regional Jail	Portsmouth	Daily
124	Haynesville Correctional Center	Haynesville	Daily
64	Henrico County Jail	Richmond	Daily
48	James River Correctional Center	State Farm	Daily
59	Lawrenceville Correctional Center	Lawrenceville	Daily
169	Loudoun County Jail	Leesburg	Daily
53	Mecklenburg Correctional Center	Boydton	Daily
116	Middle Peninsula Regional Jail	Saluda	Daily
141	Newport News City Jail	Newport News	Daily
141	Norfolk City Jail	Norfolk	Daily
194	Northampton County Jail	Eastville	Daily
115	Northern Neck Regional Jail	Warsaw	Daily
190	Northwestern Regional ADC	Winchester	Daily
19	Nottoway Correctional Center	Burkeville	Daily
79	Pamunkey Regional Jail	Hanover	Daily
67	Petersburg City Jail	Petersburg	Daily
0	Piedmont Regional Jail	Farmville	Daily
140	Portsmouth City Jail	Portsmouth	Daily
48	Powhatan Correctional Center	State Farm	Daily
156	Prince William/Manassas Regional Jail	Manassas	Daily
126	Rappahannock Regional Jail	Stafford	Daily
296	Red Onion State Prison	Pound	Daily
67	Richmond City Jail	Richmond	Daily
73	Riverside Regional Jail	Hopewell	Daily
122	Rockingham/Harrisonburg Regional Jail	Harrisonburg	Daily
155	St. Brides Correctional Center	Chesapeake	Daily
77	Sussex County Jail	Sussex	Daily
155	Virginia Beach City Jail	Virginia Beach	Daily
46	Virginia Correctional Center for Woman	Goochland	Daily
121	Western Tidewater Regional Jail	Suffolk	Daily
29	Appomattox County Jail	Appomattox	Daily to Weekly
52	Chesterfield County Jail	Chesterfield	Daily to Weekly
111	Culpeper County Jail	Culpepper	Daily to Weekly
135	Fauquier County Jail	Warrenton	Daily to Weekly
100	Roanoke City Jail	Roanoke	Daily to Weekly
158	Shenandoah County Jail	Woodstock	Daily to Weekly
119	Virginia Peninsula Regional Jail	Williamsburg	Daily to Weekly
89	Danville City Jail	Danville	Weekly
108	Franklin County Jail	Rocky Mount	Weekly
120	Gloucester County Jail	Gloucester	Weekly



Mileage From Farmville, VA	Jails	City	Frequency
119	Henry County Jail	Martinsville	Weekly
155	Indian Creek Correctional Center	Chesapeake	Weekly
30	Lunenburg Correctional Center	Victoria	Weekly
100	Middle River Regional Jail	Staunton	Weekly
153	New River Valley Regional Jail	Dublin	Weekly
103	Peumansend Creek Regional Jail	Bowling Green	Weekly
111	Roanoke County Jail	Salem	Weekly
94	Southampton Correctional Center	Capron	Weekly
204	Marion Treatment Center	Marion	Weekly to Periodic
310	USP Lee - Virginia	Jonesville	Weekly to Periodic
225	Accomack County Jail	Accomac	Periodic
59	Albemarle/Charlottesville Regional Jail	Charlottesville	Periodic
135	Alleghany County Regional Jail	Covington	Periodic
60	Amherst County Jail	Amherst	Periodic
72	B.R.R.J. - Bedford County ADC	Bedford	Periodic
47	B.R.R.J. - Campbell County ADC	Rustburg	Periodic
50	B.R.R.J. - Lynchburg City Jail	Lynchburg	Periodic
58	B.R.R.J.A. - Halifax County ADC	Halifax	Periodic
53	Baskerville Correctional Center	Baskerville	Periodic
103	Botetourt Correctional Center	Troutville	Periodic
108	Botetourt County Jail	Fincastle	Periodic
247	Bristol City Jail	Bristol	Periodic
60	Brunswick County Jail	Lawrenceville	Periodic
59	Brunswick Work Center for Women	Lawrenceville	Periodic
90	Caroline Correctional Unit #2	Hanover	Periodic
52	Central Virginia Correctional Unit #13	Chesterfield	Periodic
	Charlotte County Jail	Charlotte Court House	Periodic
26			
87	Cold Springs Correctional Unit #10	Greenville	Periodic
87	Cold Springs Work Center	Greenville	Periodic
88	Danville City Jail Farm	Danville	Periodic
992	Deerfield Correctional Center	Capron	Periodic
60	Dinwiddie County Jail	Dinwiddie	Periodic
	Fluvanna Correctional Center for Women	Troy	Periodic
65			
74	Greensville Work Center	Jarratt	Periodic
58	Halifax Correctional Unit #23	Halifax	Periodic
124	Haynesville Correctional Unit #17	Haynesville	Periodic
48	James River Work Center	State Farm	Periodic
265	Keen Mountain Correctional Center	Oakwood	Periodic
141	Lancaster County Jail	Lancaster	Periodic
123	Martinsville City Jail	Martinsville	Periodic
51	Mecklenburg County Jail	Boydton	Periodic
66	Medical College of Virginia	Richmond	Periodic

Mileage From Farmville, VA	Jails	City	Frequency
136	Montgomery County Jail	Christiansburg	Periodic
131	Newport News City Jail Farm	Newport News	Periodic
19	Nottoway Work Center	Burkeville	Periodic
132	Page County Jail	Luray	Periodic
150	Patrick County Jail	Stuart	Periodic
130	Patrick Henry Correctional Unit #28	Ridgeway	Periodic
92	Pittsylvania County Jail	Chatham	Periodic
152	Pulaski Correctional Center	Dublin	Periodic
123	Rappahannock County Jail	Washington	Periodic
93	Rockbridge Regional Jail	Lexington	Periodic
47	Rustburg Correctional Unit #9	Rustburg	Periodic
109	Southampton County Jail	Courtland	Periodic
94	Southampton Pre-Release and Work Center for Women	Capron	Periodic
94	Southampton Work Center for Men	Capron	Periodic
79	Southside Regional Jail	Emporia	Periodic
288	Southwest Virginia Regional Jail	Hayso	Periodic
236	Southwest Virginia Regional Jail Authority - Abingdon	Abingdon	Periodic
291	Southwest Virginia Regional Jail Authority - Duffield	Duffield	Periodic
219	Southwest Virginia Regional Jail Authority - Tazewell	Tazewell	Periodic
91	Sussex I State Prison	Waverly	Periodic
91	Sussex II State Prison	Waverly	Periodic
219	Tazewell Correctional Unit #31	Tazewell	Periodic
310	USP Lee - Camp - Virginia	Jonesville	Periodic
294	Wallens Ridge State Prison	Big Stine Gap	Periodic
139	Warren County Jail	Front Royal	Periodic
275	Wise Correctional Unit	Coeburn	Periodic

**V. Guard Services:**

- A. The **PROVIDER** agrees to provide stationary guard services on demand by the COTR and shall include, but not limited to, escorting and guarding detainees to medical or doctor's appointments, hearings, ICE interviews, and any other remote location requested by the COTR. Qualified detention officer personnel employed by the **PROVIDER** under its policies, procedures, and practices will perform such services. The **PROVIDER** agrees to augment such practices as may be requested by ICE to enhance specific requirements for security, detainee monitoring, visitation, and contraband control. Public contact is prohibited unless authorized in advance by the COTR.
- B. The **PROVIDER** shall be authorized two (2) officers for each such remote location, unless at the direction of the COTR or designated Agency official as additional officers are required.

- C. The itemized monthly invoice for such stationary guard services shall state the number of hours being billed, the duration of the billing (times and dates) and the names of the detainees that were guarded. Such services shall be denoted as a separate item on submitted invoices. ICE agrees to reimburse the **PROVIDER** for actual stationary guard services provided at a negotiated rate.

**VI. Medical Services:**

- A. The **PROVIDER** shall be responsible for the provision of health care services for ICE detainees at the facility.
- B. In the event of an emergency, the **PROVIDER** shall proceed immediately with necessary medical treatment. In such event, the **PROVIDER** shall notify ICE immediately regarding the nature of the transferred detainee's illness or injury and type of treatment provided.
- C. The **PROVIDER** shall ensure that all health care service providers utilized for ICE detainees hold current licenses, certifications, and/or registrations with the State and/or City where they are practicing. The **PROVIDER** shall retain a registered nurse to provide health care and sick call coverage unless expressly stated otherwise in this Agreement. In the absence of a health care professional, non-health care personnel may refer detainees to health care resources based upon protocols developed by the United States Public Health Service (USPHS) Division of Immigration Health Services (DIHS). Healthcare or health trained personnel may perform screenings.
- D. The **PROVIDER** shall ensure that onsite medical and health care coverage as defined below is available for all ICE detainees at the facility for twenty-four (24) hours per day, seven (7) days per week. The **PROVIDER** shall ensure that its employees solicit each detainee for health complaints and deliver complaints in writing to the medical and health care staff.
- E. The **PROVIDER** shall furnish onsite health care under this Agreement. The **PROVIDER** shall not charge any ICE detainee an additional fee or co-payment for medical services or treatment provided at the **PROVIDER'S** facility. The **PROVIDER** shall ensure that ICE detainees receive no lower level of onsite medical care and services than those it provides to local inmates. Onsite health care services shall perform initial medical screening (inclusive of the skin test/PPD) within the first twenty-four (24) hours of arrival to the facility, sick call coverage, provision of over-the-counter medications, treatment of minor injuries (e.g. lacerations, sprains, and contusions), treatment of special needs and mental health assessments. A full medical screening must be done within the first 14 days of detainee arrival. Detainees with chronic conditions shall receive prescribed treatment and follow-up care. Arrival screening shall include at a minimum TB symptom screening, planting of the Tuberculin; skin Test (PPD), and recording the history of past and present illnesses (mental and physical).

F. If the **PROVIDER** determines that an ICE detainee has a medical condition which renders that person unacceptable for detention under this Agreement, (for example, contagious disease, condition needing life support, uncontrollable violence), the **PROVIDER** shall notify ICE. Upon such notification, the **PROVIDER** shall allow ICE reasonable time to make the proper arrangements for further disposition of that detainee.

G. The DIHS acts as the agent and final health authority for ICE on all off-site detainee medical and health related matters. The relationship of the DIHS to the detainee equals that of physician to patient. The **PROVIDER** shall release any and all medical information for ICE detainees to the DIHS representatives upon request, except where prohibited by federal or state law or regulation. The **PROVIDER** shall solicit DIHS approval before proceeding with non-emergency, off-site medical care (e.g. off site lab testing, eyeglasses, cosmetic dental prosthetics, and dental care for cosmetic purposes). The **PROVIDER** shall submit supporting documentation for non-routine, off-site medical/health services to DIHS. For medical care provided outside the facility, the DIHS may determine that an alternative medical provider or institution is more cost-effective or more aptly meets the needs of ICE and the detainee. ICE may refuse to reimburse the **PROVIDER** for non-emergency medical costs incurred that were not pre-approved by the DIHS. The **PROVIDER** shall send requests for pre-approval for non-emergency off-site care to:

United States Public Health Service  
Division of Immigration Health Services  
1220 L Street, NW, PMB 468  
Washington, DC 20005-4018  
Phone: (703) 541-2155  
Fax: (202) 318-0080

H. The **PROVIDER** is to notify all medical providers approved to furnish off-site health care of detainees to submit their bills in accordance with instructions provided to:

BCE Emergis  
DIHS Claims  
P.O. Box 10250  
Gaithersburg, MD 20898-0250  
Phone: (888) 383-3922  
Fax: (888) 383-3957

I. The **PROVIDER** shall furnish twenty-four (24) hour emergency medical care and emergency evacuation procedures. In an emergency, the **PROVIDER** shall obtain the medical treatment required to preserve the detainee's health. The **PROVIDER** shall have access to an off site emergency medical provider at all times. The Health Authority of the **PROVIDER** shall notify the DIHS Managed Care Coordinators, ICE Health Services, 1220 L Street, NW, PMB 468,

Washington, DC, 20005-4018, phone (888) 718-8947, fax (202) 318-0080, as soon as possible, and in no case more than seventy-two (72) hours after detainee receipt of such care. The Health Authority will obtain pre-authorization from the DIHS Managed Care Coordinator for service(s) beyond the initial emergency situation.

- J. The **PROVIDER** shall allow DIHS Managed Care Coordinators reasonable access to its facility for the purpose of liaison activities with the Health Authority and associated Service Provider departments.
- K. The **PROVIDER** and all medical providers approved to furnish off-site health care of detainees shall submit their bills to:

BCE Emergis  
DIHS Claims  
P.O. Box 10250  
Gaithersburg, MD 20898-0250  
Phone: (888) 383-3922  
Fax: (888) 383-3957

- L. The ICE and PHS may refuse to reimburse the **PROVIDER** for non-emergency medical costs incurred that were not pre-approved by the DIHS.
- M. The **PROVIDER** agrees to accept and provide for the secure custody, care, and safekeeping of detainees in accordance with the State, and local laws, standards, policies, procedures, or court orders applicable to the operations of the facility.
- N. The **PROVIDER** agrees to provide ICE detainees with the same level of medical care and services as provided to non-ICE detainees as part of the per diem rate. This rate includes:
- On-site sick call (when provided by on-site staff);
  - Medication (over the counter/non-legend and routine drugs and medical supplies);
  - Escort/security services for transport to/from emergency or non-emergency health care services as either an in-patient or out-patient.

## VII. ICE Physical Plant Requirements

### A. ICE Office Space

The **PROVIDER** shall refer to ICE Design Standards for specific office and workstation sizes and specific furnishing requirements for a 1000 bed facility. The Standards include but are not limited to the following:

1. A total of 34 offices and 46 workstations as outlined below:

- a. 1 Office - Assistant Field Office Director GS-1801-14
- b. 1 Office - Officer in Charge GS-1801-14
- c. 1 Office - Assistant Officer in Charge GS-1801-14
- d. 1 Office - Intelligence Officer GS-1801-14
- e. 1 Office - Chief Immigration Enforcement Agent GS-1801-13
- f. 4 Offices - Supervisory Detention & Deportation Officers GS-1801-13
- g. 16 Offices - Deportation Officers GS-1801-12
- h. 2 Offices - Supervisory Immigration Enforcement Agents GS-1801-11
- i. 26 Workstations - Immigration Enforcement Agents GS-1801-5/7/9
- j. 2 Offices - Supervisory Deportation Assistant, GS-1802-09
- k. 16 Workstations - Detention & Removal Assistants GS-1802-07
- l. 1 Office - Mission Support Specialist GS-0301-9/11/12
- m. 2 Offices - Contracting Officer's Technical Representative, GS-1102-09
- n. 1 Office - Intelligence Research Specialist GS-1801-09
- o. 1 Office - Training Officer GS-1801-11
- p. 2 Workstations - Mission Support Assistant GS-0301-5/7
- q. 1 Workstation - Receptionist
- r. 1 Workstation - OIC Secretary
- s. 1 Workstation - Records Tech
- t. 1 Workstation - Mail/File Clerk
- u. File rooms (see Standards for size and quantity)
- v. Conference rooms adjacent to or within ICE area (see Standards for size and quantity)
- w. Employee break rooms (see Standards for size and quantity)
- x. IT computer support rooms must be provided through out ICE space per the specifications. Including specialized requirements for climate control of IT equipment rooms for PHS, EOIR and ICE office area.
- y. Actual location, layout, configuration, and size of rooms will be determined during the final design phase.

#### B. OPLA Space

The **PROVIDER** shall refer to ICE Design Standards for specific office and workstation sizes and specific furnishing requirements for a 1000 bed facility. All furniture and case goods shall be furnished by the service provider in accordance with ICE Design Standards. The Standards include but are not limited to the following:

- 1. 1 Office - Deputy Chief Counsel (see Standards for size)
- 2. 12 Offices - Assistant Chief Counsel (see Standards for size)
- 3. 4 Workstations - Legal Technicians (see Standards for size)
- 4. 1 Workstation - Mail/File Clerk

5. Office support space must be provided per the ICE/OPLA Design Standards.
6. OPLA Space

#### C. EOIR Space

The **PROVIDER** shall refer to ICE/EOIR Design Standards for specific office and workstation sizes and specific furnishing requirements for a 1000 bed facility. All furniture and case goods shall be furnished by the service provider in accordance with ICE Design Standards. The Standards include but are not limited to the following:

1. 5 - Courtrooms and accompanying office and support space as per the EOIR Design Standards for a 1000 bed facility. The office space is per the EOIR Design Standards. Each courtroom should have the capability to hold live court as well as hold video tele-conferencing court. All furniture and case goods shall be furnished by the service provider in accordance with ICE Design Guide and specifications.
2. 15 - Hard walled offices (see Standards for size)
3. 15 - Workstations (see Standards for size)
4. Visitation space must be provided to meet the ACA and NDS standards.
5. Separate entrance for judges required with complete security system and access to parking lot. Must be ADA compliant.
6. EOIR Support Space must be provided per the EOIR Design Standards.

#### D. Health Services

Healthcare services will be provided by the **PROVIDER**.

#### E. Facility Requirements for Infectious Disease Screening

The Service Provider will ensure that there is adequate space and equipment to provide medical intake screening including a TB screening chest x-ray within the intake processing area. In order to prevent the spread of airborne infectious disease or cross contamination of zones within the facility, the HVAC system in the Intake Screening Area will be constructed to exhaust to the exterior and prevent air exchange between the intake screening area and any other area within the facility.

#### F. Infectious Disease Screening

In order to prevent the transmission of Tuberculosis (TB) to the resident population of a detention facility, the Service Provider will perform TB screening as part of the a routine infectious disease screening within 12 hours of detainee admission and obtain documented clearance of transmissible disease before the detainee is assigned to a housing unit or is transferred from the intake processing area. A screening chest x-ray will be performed by a trained and qualified health care provider and interpreted by a credentialed radiologist. Detainees will remain isolated from the rest of the facility population (remain in the intake screening

area) until the chest x-ray report is obtained and the interpretation verifies that the detainee is free of infectious TB (turnaround time for chest x-ray interpretation should be 4 hours or less). Detainees who are found to be infected or where there is a possibility that they are infected will be assigned to a respiratory isolation unit until treatment or further testing is done and the detainee is no longer infectious.

#### G. Teleradiology Service Provider

1. The Detention Service Provider shall use the services of the ICE Teleradiology Service Provider (ITSP). The cost of the equipment; maintenance of the equipment; training of staff; arrangements for interpretation of the x-rays by credentialed radiologists; and transmission of data to and from the Detention Facility are provided by the ITSP and charged directly to ICE. The Service Provider shall coordinate with the ITSP to ensure adequate space is provided for the equipment, connectivity and electrical services are installed, immediate 24/7 access to equipment for service and maintenance by ITSP technicians is granted, a teleradiology coordinator is appointed and available for training by the ITSP, and medical staff is available to perform the screening exams and receive reports. The teleradiology coordinator may be a nurse or nurse practitioner and collateral duty of the appointed staff (it is not necessary to appoint a full time coordinator if the volume of work does not support a full time employee).
2. Teleradiology equipment requires high voltage power to accommodate x-ray equipment, specifications will be provided by ICE.

#### H. Processing Area

1. Expansion required in this area includes the need to accommodate processing varying numbers of detainees for intake and out-processing, i.e., large buses transport of up to 100 detainees.
2. Processing area must be designed to process male and/or female detainees as required in high frequency rates and varying numbers, i.e., a busload up to 100 detainees at one time.

#### I. Furniture

All furniture and case goods shall be furnished by the service provider in accordance with ICE Design Guide and specifications, which include ICE support space and all operational components which include EOIR, OPLA and DIHS space as required in accordance with the ICE Design Standards.

#### J. ICE IT Equipment

ICE will provide and install IT equipment in office spaces for ICE personnel only, to include computer workstations and screens, printers and fax machines. All



infrastructure, cabling, and interfacing equipment shall be provided by the Service Provider at time of construction.

**NOTE:** ICE IT system must be a complete, independent and physically separate system from the Service Provider's IT system. The system shall serve all operational components: ICE, OPLA, and DIHS. EOIR shall have a separate system within EOIR IT space as per the EOIR Design Standards.

#### K. Communication Equipment

The service provider shall purchase, install and maintain a complete and operating communication system, which includes but is not limited to: cabling, fiber optics, patch panels, landing blocks, circuits, PBX and voice mail, phone sets and other supporting infrastructure and supporting system in compliance with ICE specifications. Separate billing to ICE must be established on all reoccurring service fees for communications and IT. Systems shall be installed specifically for ICE use.

**NOTE:** ICE communication system must be a complete, independent and physically separate system from the Service Provider communication system, and billed separately. The system shall serve all operational components: ICE, OPLA, and DIHS. EOIR shall have a separate system within EOIR IT space as per the EOIR Design Standards.

Service Provider see attached SOW for phone system details.

#### VIII. Detainee Work Program:

1. Detainee labor shall be used in accordance with the detainee work plan developed by the **PROVIDER**, and will adhere to the ICE National Detention Standard on Detainee Voluntary Work Program. The detainee work plan must be voluntary, and may include work or program assignments for industrial, maintenance, custodial, service, or other jobs. The detainee work program shall not conflict with any other requirements of the contract and must comply with all applicable laws and regulations.
2. Detainees shall not be used to perform the responsibilities or duties of an employee of the **PROVIDER**. Detainees shall not be used to perform work in areas where sensitive documents are maintained (designated ICE workspace). Custodial/janitorial services to be performed in designated ICE work space will be the responsibility of the **PROVIDER**.
3. Appropriate safety/protective clothing and equipment shall be provided to detainee workers as appropriate. Detainees shall not be assigned work that is considered hazardous or dangerous. This includes, but is not limited to, areas or

assignments requiring great heights, extreme temperatures, use of toxic substances, and unusual physical demands.

4. The **PROVIDER** shall supply sufficient Detention Officers to monitor and control detainee work details. Unless approved by the COTR, these work details must be within the security perimeter.
5. It will be the sole responsibility of ICE to determine whether a detainee will be allowed to perform on voluntary work details and at what classification level. All detainees shall be searched when they are returned from work details.

**IX. Law Library:**

The **PROVIDER** shall provide secure space within the secure perimeter, either a dedicated room or a multipurpose room for books and materials to provide a reading area "Law Library" - in accordance with the ICE National Detention Standards on the Access to Legal Materials.

**X. Training:**

Employees shall not perform duties under this agreement until they have successfully completed all initial training and the COTR receives written certification from the **PROVIDER**.

**A. General Training Requirements**

1. All employees must have the training described in the ACA Standards and in this section. Any remuneration (pay) due **PROVIDER** employees in accordance with Department of Labor regulations for any training time is the responsibility of the **PROVIDER**. The **PROVIDER** shall provide the required refresher courses or have an institution acceptable to the COTR to provide the training. Failure of any employee to complete training successfully is sufficient reason to disqualify him or her from duty.
2. All new Detention Officers will receive 54 hours of basic training, not to include firearms and 40 hours of on-the-job training prior to entering on duty. The **PROVIDER'S** Training Officer will be responsible for administering an on-the-job training program for new employees. A senior Detention Officer, at all times during this latter 40-hour period, must accompany the Detention Officers. The **PROVIDER'S** Training Officer shall send a copy of the documentation to the COTR upon successful completion of the employee's on-the-job training.
3. In addition, after completion of the first 94 hours of training, the **PROVIDER** has 60 days to complete an additional 40 hours of training. During the remainder of the first year on duty, the officer will have an additional 40 hours of training for a total of 174 hours within the first year of employment. The training program must directly relate to the employee's assigned position and

afford application of necessary job skills. Training site shall be provided by the **PROVIDER** at no cost to the Government.

a. Basic Training Subjects:

1. Employees must complete the following list of basic training subjects. The course title is followed by the estimated hours of training for that subject.

a. In-service Orientation/Social Diversity	2 HRS
b. Counseling Techniques/Suicide Prevention	2 HRS
c. Conduct/Duties/Ethics and Courtroom Demeanor	2 HRS
d. Bomb Defense and Threats	1 HR
e. Telephone Communications/Radio Procedures	1 HR
f. Fire and other Emergency Procedures	2 HRS
g. Treatment and Supervision of Detainees	2 HRS
h. ICE Use of Force Policy	2 HRS
i. Security Methods/Key Control/Count	1 HR
j. Procedures/Observational Techniques	4 HRS
k. EEO/Sexual Harassment	2 HRS
l. Detainee Escort Techniques	1 HR
m. ICE Paperwork/Report Writing	2 HRS
n. Detainee Searches/Detainee Personal Property	4 HRS
o. Property/Contraband	2 HRS
p. Detainee Rules and Regulations	2 HRS
q. First Aid*	4 HRS
r. Cardiopulmonary resuscitation (CPR)*	4 HRS
s. Blood-borne Pathogens*	2 HRS
t. Self Defense	8 HRS
u. Use of Restraints	6 HRS
v. Firearm Training	**
w. Sexual Abuse/Assault Prevention & Intervention*	2 HRS
x. National Detention Standards	2 HRS

\* Critical Training Subjects

\*\* Firearm Training for Required Armed Detention Services in accordance with state licensing requirements. **PROVIDER** shall certify proficiency every quarter.

b. Refresher Training

1. Every year the **PROVIDER** shall conduct 40 hours of Refresher Training for all Detention Officers including Supervisory Detention Officers. Refresher training shall consist of these critical subjects listed above and a review of basic training subjects and others as approved by ICE.
2. The **PROVIDER** shall coordinate recertification in CPR and First Aid with the ICE training staff. This training shall be provided at no cost to the Government. Annually, upon completion, the **PROVIDER** shall provide documentation of refresher training to the COTR.
3. In addition to the refresher training requirements for all Detention Officers, supervisors must receive refresher training relating to supervisory duties.

c. On-the-Job Training

1. After completion of the minimum of 54 hours basic training, all Detention Officers will receive an additional 40 hours of on-the-job training at specific post positions. This training includes:
  - a. Authority of supervisors and organizational code of conduct.
  - b. General information and special orders.
  - c. Security systems operational procedures.
  - d. Facility self-protection plan or emergency operational procedures.
  - e. Disturbance Control Team training.

d. Training During Initial 60 Day Period

The **PROVIDER** shall provide an additional 40 hours of training for Detention Officers within 60 days after completion of first 94 hours of training. The **PROVIDER** shall provide the training format and subjects, for approval by the COTR and CO, prior to the commencement of training.

e. Basic First Aid and CPR Training

1. All members of the **PROVIDER'S** security staff shall be trained in basic first aid and CPR. They must be able to:
  - a. Respond to emergency situations within four minutes.
  - b. Perform cardiopulmonary resuscitation (CPR).
  - c. Recognize warning signs of impending medical emergencies.
  - d. Know how to obtain medical assistance.
  - e. Recognize signs and symptoms of mental illness.

- f. Able to administer medication;
- g. Know the universal precautions for protection against blood-borne diseases.

**B. Supervisory Training**

1. All new Supervisory Detention Officers assigned to perform work under this agreement must successfully complete a minimum of 40 hours of formal supervisory training provided by the **PROVIDER** prior to assuming duties. This training is in addition to mandatory training requirements for Detention Officers. Supervisory training shall include the following management areas:

- |   |       |
|---|-------|
| a. Techniques for issuing written and verbal orders | 2 HRS |
| b. Uniform clothing and grooming standards          | 1 HR  |
| c. Security Post Inspection procedures              | 2 HRS |
| d. Employee motivation                              | 1 HR  |
| e. Scheduling and overtime controls                 | 2 HRS |
| f. Managerial public relations                      | 4 HRS |
| g. Supervision of detainees                         | 4 HRS |
| h. Other company policies                           | 4 HRS |

Additional classes are at the discretion of the **PROVIDER** with the approval of the **COTR**.

The **PROVIDER** shall submit documentation to the **COTR**, to confirm that each supervisor has received basic training as specified in the basic training curriculum.

**C. Proficiency Testing**

The **PROVIDER** shall give each Detention Officer a written examination consisting of at least 25 questions after each classroom-training course is completed. The **PROVIDER** may give practical exercises when appropriate. The **COTR** shall approve the questions before the **PROVIDER** can administer the examination. To pass any examination, each officer must achieve a score of 80% or better. The **PROVIDER** must provide the **COTR** with the eligible Detention Officer's completed exam before the Detention Officer may be assigned to duties under the agreement. Should an employee fail the written test on the initial attempt, he or she shall be given additional training by the **PROVIDER** and be given one additional opportunity to retake the test. If the employee fails to complete and pass the test the second time, the **PROVIDER** shall remove the employee from duties on this agreement.

**D. Certified Instructors**

Certified instructors shall conduct all instruction and testing. A state or nationally recognized institution shall certify instructors unless otherwise approved in writing by the COTR. Certifications of instructors may be established by documentation of past experience in teaching positions or by successful completion of a course of training for qualifying personnel as instructors. The COTR must approve the instructor prior to the training course.

**E. Training Documentation**

1. The **PROVIDER** shall submit a training forecast and lesson plans to the COTR or ICE designee, on a monthly basis, for the following 60-day period. The training forecast shall provide date, time, and location of scheduled training and afford the COTR observation/evaluation opportunity.
2. The **PROVIDER** shall certify and submit the training hours, type of training, date and location of training, and name of the instructor monthly for each employee to the COTR or ICE designee.

**XI. Notification and Public Disclosures:**

There shall be no public disclosures regarding this agreement made by the **PROVIDER** (or any subcontractors) without review and approval of such disclosure by ICE Public Affairs and express permission granted by the ICE Contracting Officer. The Government considers such information privileged or confidential until award of the agreement.

**XII. Establish and Maintain Program for Prevention of Sexual Abuse/Assault:**

The **PROVIDER** shall develop and implement a comprehensive sexual abuse/assault prevention and intervention program. This program shall include training that is given separately to both staff and detainees, in accordance with the Prison Rape Elimination Act (PREA).

**XIII. Business Permits and Licenses:**

The **PROVIDER** must obtain all required permits and licenses by the date of agreement award. The **PROVIDER** must (depending on the state's requirements) be licensed as a qualified security service company in accordance with the requirements of the district, municipality, county, and state in which ICE work site(s) is/are located. Throughout the term of this agreement, the **PROVIDER** shall maintain current permits/business licenses and make copies available for Government Inspection. The **PROVIDER** shall comply with all applicable federal, state, and local laws and all applicable Occupational Safety and Health Administration (OSHA) standards.

#### XIV. Firearms / Body Armor:

##### A. Firearms Requirements

1. The **PROVIDER** shall provide new firearms and maintain sufficient licensed firearms and ammunition to equip each armed Detention Officer and armed supervisor(s) with a licensed weapon while on duty. Firearms may be re-issued to new replacement employees throughout the life of the agreement as long as the firearm is in serviceable condition.
2. Personal firearms shall not be used. A licensed gunsmith, in writing, shall certify all firearms safe and accurate.
3. Firearms shall be standard police service-type, semi-automatic capable of firing hollow-point ammunition that meets the recommendations of the firearms manufacturer. Ammunition will be factory load only – no reloads. Ammunition will be replaced every year.
4. The **PROVIDER** shall provide sufficient ammunition for each armed Detention Officer, including uniformed contract supervisor(s); they shall be issued three full magazines.
5. The **PROVIDER** shall account for all firearms and ammunition daily.
6. If any weapons or ammunition are missing from the inventory, the COTR shall be notified immediately.
7. All firearms shall be licensed by the State.
8. Firearms will be inspected. This shall be documented by the Warden/Facility Director.
9. Loading, unloading, and cleaning of the firearms shall only take place in designated areas.
10. The firearms shall be cleaned and oiled as appropriate to ensure optimum operating conditions.
11. Firearms shall be carried with the safety on, if applicable, with a round in the chamber.
12. The **PROVIDER** shall maintain appropriate and ample supplies of firearms' upkeep and maintenance equipment (cleaning solvents, lubricating oil, rods, brushes, patches, and other normal maintenance tools).
13. The **PROVIDER** shall provide a complete listing of licensed firearms by serial numbers and by each safe location to the COTR prior to beginning performance under this agreement.
14. These lists shall be kept current through the terms of the agreement and posted within each firearms safe.
15. The **PROVIDER** shall obtain and maintain on file appropriate State and municipality permits and weapons permits for each officer.

16. A copy of this permit shall be provided to the COTR at least three working days prior to the anticipated assignment date of any individual.
17. The **PROVIDER** shall ensure that his/her employees have all permits and licenses in their possession at all times while in performance of this agreement.
18. The **PROVIDER** shall provide safes/vaults for storage of firearms and ammunition, for each location where firearms are issued or exchanged, which meet agency requirements and are approved for the storage of firearms and ammunition.
19. The COTR is responsible for approving the proposed safes/vaults prior to usage. **PROVIDER** supervisors and guards shall make accurate receipt and return entries on a Firearms and Equipment Control Register.
20. Except when issuing or returning ammunition or firearms, each safe/vault shall remain locked at all times.
21. The **PROVIDER** shall be responsible for having the combination of each safe/vault changed at least once every six months, or more often if circumstances warrant.
22. The **PROVIDER** certifies firearms training to the COTR.
23. The **PROVIDER** shall certify proficiency every quarter.
24. The **PROVIDER** shall provide an ICE approved intermediate weapon(s).

#### B. Body Armor Requirements

1. The **PROVIDER** shall provide body armor to all armed Detention Officers and armed supervisor(s).
2. Body armor shall be worn while on armed duty.
3. The body armor shall meet all requirements as set forth in the ICE Firearms Policy.
4. The **PROVIDER** shall procure replacement body armor if the body armor becomes unserviceable, ill-fitting, worn/damaged, or at the expiration of service life.
5. All armed Detention Officers and armed supervisors need to be made aware of the health risks associated with the wearing of body armor in high heat/high humidity conditions and/or during strenuous exertion. When Detention Officers and supervisors are required to wear body armor, they shall be provided opportunities to rehydrate and remove the body armor as necessary.
6. The use of personally owned body armor is not authorized.



**XVI. FEDERAL GOVERNMENT QUALITY ASSURANCE**

A. The Government's Quality Assurance Program (QASP) is based on the premise that the provider, and not the Government, is responsible for management and quality control actions to meet the terms of the agreement. The QASP procedures recognize that the provider is not a perfect manager and that unforeseen and uncontrollable problems do occur. Good management and use of an adequate Quality Control Plan will allow the facility to operate within acceptable quality levels.

B. Each phase of the services rendered under this agreement is subject to inspection both during the Provider's operations and after completion of the tasks.

C. When the Provider is advised of any unsatisfactory condition(s), the contractor shall submit a written report to the Contracting Officer addressing corrective/preventive actions taken. The QASP is not a substitute for quality control by the Provider.

D. The COTR may check the Provider's performance and document any noncompliance, however, only the Contracting Officer may take formal action against for unsatisfactory performance.

E. The Government may reduce the invoice or otherwise withhold payment for any individual item of nonconformance observed. The Government may apply various inspection and extrapolation techniques (i.e., 100 % surveillance, random sampling, planned sampling, unscheduled inspections, etc.) to determine the quality of services and the total payment due.

F. FAILURE TO PERFORM REQUIRED SERVICES. The rights of the Government and remedies described in this section are in addition to all other rights and remedies set forth in this agreement. Any reductions in the invoice shall reflect the agreement's reduced value resulting from the failure to perform required services.

\*\*\*\*\*  
END OF DOCUMENT  
\*\*\*\*\*

**TITLE 29--LABOR****PART 4 LABOR STANDARDS FOR FEDERAL SERVICE CONTRACTS--Table of Contents**

Subpart A Service Contract Labor Standards Provisions and Procedures

Sec. 4.6 Labor standards clauses for Federal service contracts exceeding \$2,500.

The clauses set forth in the following paragraphs shall be included in full by the contracting agency in every contract/Inter-Governmental Service Agreement (IGSA) entered into by the United States or the District of Columbia, in excess of \$2,500, or in an indefinite amount, the principal purpose of which is to furnish services through the use of service employees:

(a) Service Contract Act of 1965, as amended: This contract/IGSA is subject to the Service Contract Act of 1965 as amended (41 U.S.C. 351 et seq.) and is subject to the following provisions and to all other applicable provisions of the Act and regulations of the Secretary of Labor issued there under (29 CFR part 4).

(b) (1) Each service employee employed in the performance of this Contract/IGSA by the contractor or any subcontractor shall be paid not less than the minimum monetary wages and shall be furnished fringe benefits in accordance with the wages and fringe benefits determined by the Secretary of Labor or authorized representative, as specified in any wage determination attached to this contract.

(2) (i) If there is such a wage determination attached to this Contract/IGSA, the contracting officer shall require that any class of service employee which is not listed therein and which is to be employed under the Contract/IGSA (i.e., the work to be performed is not performed by any classification listed in the wage determination), be classified by the contractor so as to provide a reasonable relationship (i.e., appropriate level of skill comparison) between such unlisted classifications and the classifications listed in the wage determination. Such conformed class of employees shall be paid the monetary wages and furnished the fringe benefits as are determined pursuant to the procedures in this section.

(ii) Such conforming procedure shall be initiated by the contractor prior to the performance of contract/IGSA work by such unlisted class of employee. A written report of the proposed conforming action, including information regarding the agreement or disagreement of the authorized representative of the employees involved or, where there is no authorized representative, the employees themselves, shall be submitted by the contractor to the contracting officer no later than 30 days after such unlisted class of employees performs any Contract/IGSA work. The contracting officer shall review the proposed action and promptly submit a report of the action, together with the agency's recommendation and all pertinent information including the position of the contractor and the employees, to the Wage and Hour Division, Employment Standards Administration, U.S. Department of Labor, for review. The Wage and Hour Division will approve, modify, or disapprove the action or render a final determination in the event of disagreement.

within 30 days of receipt or will notify the contracting officer within 30 days of receipt that additional time is necessary.

(iii) The final determination of the conformance action by the Wage and Hour Division shall be transmitted to the contracting officer who shall promptly notify the contractor of the action taken. Each affected employee shall be furnished by the contractor with a written copy of such determination or it shall be posted as a part of the wage determination.

(iv) (A) The process of establishing wage and fringe benefit rates that bears a reasonable relationship to those listed in a wage determination cannot be [[Page 41]] reduced to any single formula. The approach used may vary from wage determination to wage determination depending on the circumstances. Standard wage and salary administration practices, which rank various job classifications by pay grade pursuant to point schemes or other job factors may, for example, be relied upon. Guidance may also be obtained from the way different jobs are rated under Federal pay systems (Federal Wage Board Pay System and the General Schedule) or from other wage determinations issued in the same locality. Basic to the establishment of any conformable wage rate(s) is the concept that a pay relationship should be maintained between job classifications based on the skill required and the duties performed.

(B) In the case of a Contract/IGSA modification, an exercise of an option or extension of an existing contract, or in any other case where a contractor succeeds a Contract/IGSA under which the classification in question was previously conformed pursuant to this section, a new conformed wage rate and fringe benefits may be assigned to such conformed classification by indexing (i.e., adjusting) the previous conformed rate and fringe benefits by an amount equal to the average (mean) percentage increase (or decrease, where appropriate) between the wages and fringe benefits specified for all classifications to be used on the Contract/IGSA which are listed in the current wage determination, and those specified for the corresponding classifications in the previously applicable wage determination. Where conforming actions are accomplished in accordance with this paragraph prior to the performance of Contract/IGSA work by the unlisted class of employees, the contractor shall advise the contracting officer of the action taken but the other procedures in paragraph (b) (2) (ii) of this section need not be followed.

(C) No employee engaged in performing work on this Contract/IGSA shall in any event be paid less than the currently applicable minimum wage specified under section 6(a) (1) of the Fair Labor Standards Act of 1938, as amended. (v) The wage rate and fringe benefits finally determined pursuant to paragraphs (b) (2) (i) and (ii) of this section shall be paid to all employees performing in the classification from the first day on which Contract/IGSA work is performed by them in the classification. Failure to pay such unlisted employees the compensation agreed upon by the interested parties and/or finally determined by the Wage and Hour Division retroactive to the date such class of employees commenced Contract/IGSA work shall be a violation of the Act and this contract. (vi) Upon discovery of failure to comply with paragraphs (b) (2) (i) through (v) of this section, the Wage and Hour Division shall make a final determination of conformed classification, wage rate,

and/or fringe benefits which shall be retroactive to the date such class of employees commenced Contract/IGSA work.

(3) If, as authorized pursuant to section 4(d) of the Service Contract Act of 1965 as amended, the term of this Contract/IGSA is more than 1 year, the minimum monetary wages and fringe benefits required to be paid or furnished there under to service employees shall be subject to adjustment after 1 year and not less often than once every 2 years, pursuant to wage determinations to be issued by the Wage and Hour Division, Employment Standards Administration of the Department of Labor as provided in such Act.

(c) The contractor or subcontractor may discharge the obligation to furnish fringe benefits specified in the attachment or determined conformably thereto by furnishing any equivalent combinations of bona fide fringe benefits, or by making equivalent or differential payments in cash in accordance with the applicable rules set forth in subpart D of 29 CFR part 4, and not otherwise.

(d) (1) In the absence of a minimum wage attachment for this contract, neither the contractor nor any subcontractor under this Contract/IGSA shall pay any person performing work under the Contract/IGSA (regardless of whether they are service employees) less than the minimum wage specified by section 6(a)(1) of the Fair Labor Standards Act of 1938. Nothing in this provision shall relieve the contractor or any subcontractor of any other obligation under [[Page 42]] law or Contract/IGSA for the payment of a higher wage to any employee.

(2) If this Contract/IGSA succeeds a contract, subject to the Service Contract Act of 1965 as amended, under which substantially the same services were furnished in the same locality and service employees were paid wages and fringe benefits provided for in a collective bargaining agreement, in the absence of the minimum wage attachment for this Contract/IGSA setting forth such collectively bargained wage rates and fringe benefits, neither the contractor nor any subcontractor under this Contract/IGSA shall pay any service employee performing any of the Contract/IGSA work (regardless of whether or not such employee was employed under the predecessor contract), less than the wages and fringe benefits provided for in such collective bargaining agreements, to which such employee would have been entitled if employed under the predecessor contract, including accrued wages and fringe benefits and any prospective increases in wages and fringe benefits provided for under such agreement. No contractor or subcontractor under this Contract/IGSA may be relieved of the foregoing obligation unless the limitations of Sec. 4.1b(b) of 29 CFR part 4 apply or unless the Secretary of Labor or his authorized representative finds, after a hearing as provided in Sec. 4.10 of 29 CFR part 4 that the wages and/or fringe benefits provided for in such agreement are substantially at variance with those which prevail for services of a character similar in the locality, or determines, as provided in Sec. 4.11 of 29 CFR part 4, that the collective bargaining agreement applicable to service employees employed under the predecessor Contract/IGSA was not entered into as a result of arm's-length negotiations. Where it is found in accordance with the review procedures provided in 29 CFR 4.10 and/or 4.11 and parts 6 and 8 that some or all of the wages and/or fringe benefits contained in a predecessor contractor's collective bargaining agreement are substantially at variance with those which prevail for

services of a character similar in the locality, and/or that the collective bargaining agreement applicable to service employees employed under the predecessor Contract/IGSA was not entered into as a result of arm's-length negotiations, the Department will issue a new or revised wage determination setting forth the applicable wage rates and fringe benefits. Such determination shall be made part of the Contract/IGSA or subcontract, in accordance with the decision of the Administrator, the Administrative Law Judge, or the Administrative Review Board, as the case may be, irrespective of whether such issuance occurs prior to or after the award of a Contract/IGSA or subcontract. 53 Comp. Gen. 401 (1973). In the case of a wage determination issued solely as a result of a finding of substantial variance, such determination shall be effective as of the date of the final administrative decision.

(e) The contractor and any subcontractor under this Contract/IGSA shall notify each service employee commencing work on this Contract/IGSA of the minimum monetary wage and any fringe benefits required to be paid pursuant to this contract, or shall post the wage determination attached to this contract. The poster provided by the Department of Labor (Publication WH 1313) shall be posted in a prominent and accessible place at the worksite. Failure to comply with this requirement is a violation of section 2(a) (4) of the Act and of this contract.

(f) The contractor or subcontractor shall not permit any part of the services called for by this Contract/IGSA to be performed in buildings or surroundings or under working conditions provided by or under the control or supervision of the contractor or subcontractor which are unsanitary or hazardous or dangerous to the health or safety of service employees engaged to furnish these services, and the contractor or subcontractor shall comply with the safety and health standards applied under 29 CFR part 1925.

(g) (1) The contractor and each subcontractor performing work subject to the Act shall make and maintain for 3 years from the completion of the work records containing the information specified in paragraphs (g) (1) (i) through (vi) of this section for each employee subject to the Act and shall make them available for inspection [[Page 43]] and transcription by authorized representatives of the Wage and Hour Division, Employment Standards Administration of the U.S. Department of Labor:

- (i) Name and address and social security number of each employee.
- (ii) The correct work classification or classifications, rate or rates of monetary wages paid and fringe benefits provided, rate or rates of fringe benefit payments in lieu thereof, and total daily and weekly compensation of each employee.
- (iii) The number of daily and weekly hours so worked by each employee.
- (iv) Any deductions, rebates, or refunds from the total daily or weekly compensation of each employee.
- (v) A list of monetary wages and fringe benefits for those classes of service employees not included in the wage

determination attached to this Contract/IGSA but for which such wage rates or fringe benefits have been determined by the interested parties or by the Administrator or authorized representative pursuant to the labor standards clause in paragraph (b) of this section. A copy of the report required by the clause in Paragraph (b) (2) (ii) of this section shall be deemed to be such a list.

(vi) Any list of the predecessor contractor's employees which had been furnished to the contractor pursuant to Sec. 4.6(1)(2).

(2) The contractor shall also make available a copy of this Contract/IGSA for inspection or transcription by authorized representatives of the Wage and Hour Division.

(3) Failure to make and maintain or to make available such records for inspection and transcription shall be a violation of the regulations and this contract, and in the case of failure to produce such records, the contracting officer, upon direction of the Department of Labor and notification of the contractor, shall take action to cause suspension of any further payment or advance of funds until such violation ceases.

(4) The contractor shall permit authorized representatives of the Wage and Hour Division to conduct interviews with employees at the worksite during normal working hours.

(h) The contractor shall unconditionally pay to each employee subject to the Act all wages due free and clear and without subsequent deduction (except as otherwise provided by law or Regulations, 29 CFR part 4), rebate, or kickback on any account. Such payments shall be made no later than one pay period following the end of the regular pay period in which such wages were earned or accrued. A pay period under this Act may not be of any duration longer than semi-monthly.

(i) The contracting officer shall withhold or cause to be withheld from the Government prime contractor under this or any other Government Contract/IGSA with the prime contractor such sums as an appropriate official of the Department of Labor requests or such sums as the contracting officer decides may be necessary to pay underpaid employees employed by the contractor or subcontractor. In the event of failure to pay any employees subject to the Act all or part of the wages or fringe benefits due under the Act, the agency may, after authorization or by direction of the Department of Labor and written notification to the contractor, take action to cause suspension of any further payment or advance of funds until such violations have ceased. Additionally, any failure to comply with the requirements of these clauses relating to the Service Contract Act of 1965, may be grounds for termination of the right to proceed with the Contract/IGSA work. In such event, the Government may enter into other contracts or arrangements for completion of the work, charging the contractor in default with any additional cost.

(j) The contractor agrees to insert these clauses in this section relating to the Service Contract Act of 1965 in all Subcontracts subject to the Act. The term contractor as used in these clauses in any subcontract shall be deemed to refer to the subcontractor, except in the term Government prime contractor.

(k)(1) As used in these clauses, the term service employee means any person engaged in the performance of this Contract/IGSA other than any person employed in a bona fide executive, administrative, or professional capacity, as those terms are defined in part 541 of title 29, Code of Federal Regulations, as of July [(Page44)) 30, 1976, and any subsequent revision of those regulations. The term service employee includes all such persons regardless of any contractual relationship that may be alleged to exist between a contractor or subcontractor and such persons.

(2) The following statement is included in contracts pursuant to section 2(a) (5) of the Act and is for informational purposes only:

The following classes of service employees expected to be employed under the Contract/IGSA with the Government would be subject, if employed by the contracting agency, to the provisions of 5 U.S.C. 5341 or 5 U.S.C. 5332 and would, if so employed, be paid not less than the following rates of wages and fringe benefits:

Employee class	wage-fringe benefit
GS-05	\$13.83 (As of Dec 07)
GS-07	\$17.83 (As of Dec 07)

Search current rates at <http://www.opm.gov/oca/08tables/>

(1)(1) If wages to be paid or fringe benefits to be furnished any service employees employed by the Government prime contractor or any subcontractor under the Contract/IGSA are provided for in a collective bargaining agreement which is or will be effective during any period in which the Contract/IGSA is being performed, the Government prime contractor shall report such fact to the contracting officer, together with full information as to the application and accrual of such wages and fringe benefits, including any prospective increases, to service employees engaged in work on the contract, and a copy of the collective bargaining agreement. Such report shall be made upon commencing performance of the contract, in the case of collective bargaining agreements effective at such time, and in the case of such agreements or provisions or amendments thereof effective at a later time during the period of Contract/IGSA performance, such agreements shall be reported promptly after negotiation thereof.

(2) Not less than 10 days prior to completion of any Contract/IGSA being performed at a Federal facility where service employees may be retained in the performance of the succeeding Contract/IGSA and subject to a wage determination which contains vacation or other benefit provisions based upon length of service with a contractor (predecessor) or successor (Sec. 4.173 of Regulations, 29 CFR part 4), the incumbent prime contractor shall furnish to the contracting officer a certified list of the names of all service employees on the contractor's or subcontractor's payroll during the last month of Contract/IGSA performance. Such list shall also contain anniversary dates of employment on the Contract/IGSA either with the current or predecessor contractors of each such service employee. The contracting officer shall turn over such list to the successor contractor at the commencement of the succeeding contract.

(m) Rulings and interpretations of the Service Contract Act of 1965, as amended, are contained in Regulations, 29 CFR part 4.

(n)(1) By entering into this contract, the contractor (and officials thereof) certifies that neither it (nor he or she) nor any person or firm who has a substantial interest in the contractor's firm is a person or firm ineligible to be awarded Government contracts by virtue of the sanctions imposed pursuant to section 5 of the Act.

(2) No part of this Contract/IGSA shall be subcontracted to any person or firm ineligible for award of a Government Contract/IGSA pursuant to section 5 of the Act.

(3) The penalty for making false statements is prescribed in the U.S. Criminal Code, 18 U.S.C. 1001.

(o) Notwithstanding any of the clauses in paragraphs (b) through (m) of this section relating to the Service Contract Act of 1965, the following employees may be employed in accordance with the following variations, tolerances, and exemptions, which the Secretary of Labor, pursuant to section 4(b) of the Act prior to its amendment by Public Law 92-473, found to be necessary and proper in the public interest or to avoid serious impairment of the conduct of Government business:

(1) Apprentices, student-learners, and workers whose earning capacity is impaired by age, physical, or mental deficiency or injury may be employed at wages lower than the minimum wages otherwise required by section 2(a) (1) or [[Page 45]]

(2)(b)(1) of the Service Contract Act without diminishing any fringe benefits or cash payments in lieu thereof required under section 2(a)

(2) of that Act, in accordance with the conditions and procedures prescribed for the employment of apprentices, student-learners, handicapped persons, and handicapped clients of sheltered workshops under section 14 of the Fair Labor Standards Act of 1938, in the regulations issued by the Administrator (29 CFR parts 520, 521, 524, and 525).

(3) The Administrator will issue certificates under the Service Contract Act for the employment of apprentices, student-learners, handicapped persons, or handicapped clients of sheltered workshops not subject to the Fair Labor Standards Act of 1938, or subject to different minimum rates of pay under the two acts, authorizing appropriate rates of minimum wages (but without changing requirements concerning fringe benefits or supplementary cash payments in lieu thereof), applying procedures prescribed by the applicable regulations issued under the Fair Labor Standards Act of 1938 (29 CFR parts 520, 521, 524, and 525).

(4) The Administrator will also withdraw, annul, or cancel such certificates in accordance with the regulations in parts 525 and 528 of title 29 of the Code of Federal Regulations.

(p) Apprentices will be permitted to work at less than the predetermined rate for the work they perform when they are employed and individually registered in a bona fide apprenticeship program



registered with a State Apprenticeship Agency which is recognized by the U.S. Department of Labor, or if no such recognized agency exists in a State, under a program registered with the Bureau of Apprenticeship and Training, Employment and Training Administration, U.S. Department of Labor. Any employee who is not registered as an apprentice in an approved program shall be paid the wage rate and fringe benefits contained in the applicable wage determination for the journeyman classification of work actually performed. The wage rates paid apprentices shall not be less than the wage rate for their level of progress set forth in the registered program, expressed as the appropriate percentage of the journeyman's rate contained in the applicable wage determination. The allowable ratio of apprentices to journeymen employed on the Contract/IGSA work in any craft classification shall not be greater than the ratio permitted to the contractor as to his entire work force under the registered program.

(q) Where an employee engaged in an occupation in which he or she customarily and regularly receives more than \$30 a month in tips, the amount of tips received by the employee may be credited by the employer against the minimum wage required by Section 2(a)(1) or 2(b)(1) of the Act to the extent permitted by section 3(m) of the Fair Labor Standards Act and Regulations, 29 CFR Part 531. To utilize this provision:

(1) The employer must inform tipped employees about this tip credit allowance before the credit is utilized;

(2) The employees must be allowed to retain all tips (individually or through a pooling arrangement and regardless of whether the employer elects to take a credit for tips received);

(3) The employer must be able to show by records that the employee receives at least the applicable Service Contract Act minimum wage through the combination of direct wages and tip credit;

(4) The use of such tip credit must have been permitted under any predecessor collective bargaining agreement applicable by virtue of section 4(c) of the Act.

(r) Disputes concerning labor standards. Disputes arising out of the labor standards provisions of this Contract/IGSA shall not be subject to the general disputes clause of this contract. Such disputes shall be resolved in accordance with the procedures of the Department of Labor set forth in 29 CFR parts 4, 6, and 8. Disputes within the meaning of this clause include disputes between the contractor (or any of its subcontractors) and the contracting agency, the U.S. Department of Labor, or the employees or their representatives. (The information, collection, recordkeeping, and reporting requirements contained in this section have been approved by the Office of Management and Budget under the following numbers:

[[Page 46]]

Paragraph	OMB control number
(b) (2) (i) -- (iv)	1215-0150
(e)	1215-0150
(g) (1) (i) -- (iv)	1215-0017
(g) (1) (v), (vi)	1215-0150

(l) (1), (2)..... 1215-0150  
(q) (3)..... 1215-0017

---

[48 FR 49762, Oct. 27, 1983; 48 FR 50529, Nov. 2, 1983, as amended at  
61 FR 68663, Dec. 30, 1996]

**DHS/ICE/DRO—DEDICATED IGSA  
QUALITY ASSURANCE SURVEILLANCE PLAN (QASP)  
for IGSA NUMBER DROIGSA-08-0021**

## **1. INTRODUCTION**

The Government's Quality Assurance Surveillance Plan (QASP) is based on the premise that the service provider, and not the Government, is responsible for the day-to-day operation of the facility and all the management and quality control actions required to meet the terms of the contract. The role of the Government in quality assurance is to ensure performance standards are achieved and maintained. The service provider is required to develop a comprehensive program of inspections and monitoring actions and to document its approach in a Quality Control Plan (QCP). The service provider's QCP, upon approval by the Government, will be made a part of the resultant agreement.

This QASP is designed to provide an effective surveillance method to monitor the service provider's performance relative to the requirements listed in the agreement. The QASP illustrates the systematic method the Government (or its designated representative) will use to evaluate the services the service provider is required to furnish.

This QASP is based on the premise the Government must validate that the service provider is complying with DRO-mandated quality standards in operating, maintaining, and repairing detention facilities. Performance standards address all facets of detainee handling, including safety, health, legal rights, facility and records management, etc. Good management by the service provider and use of an approved QCP will ensure that the facility is operating within acceptable quality levels.

## **2. DEFINITIONS**

**Performance Requirements Summary (Attachment 1):** The Performance Requirements Summary (PRS) communicates what the Government intends to qualitatively inspect. The PRS is based on the American Correctional Association (ACA) Standards for Adult Local Detention Facilities (ALDF) and Immigration And Customs Enforcement (ICE) National Detention Standards (NDS). The PRS identifies performance standards grouped into nine functional areas, and quality levels essential for successful performance of each requirement. The PRS is used by the Government (or its designated representative) when conducting quality assurance surveillance to guide them through the inspection and review processes.

**Functional Area:** A logical grouping of performance standards.

**Contracting Officer's Technical Representative (COTR):** The COTR interacts with the service provider to inspect and accept services/work performed in accordance with the technical standards prescribed in the agreement. The Contracting Officer issues a written memorandum that appoints the COTR. Other individuals may be designated to assist in the inspection and quality assurance surveillance activities.

**Performance Standards:** The performance standards are established in the ICE Office Of Detention And Removal (DRO) NDS and contained in the Detention Operations Manual, at <http://www.ice.gov/partners/dro/opsmanual/index.htm>, as well as the ACA standards for ALDF. Other standards may also be defined in the agreement.

**Measures:** The method for evaluating compliance with the standards.

**Acceptable Quality Level:** The minimum level of quality that will be accepted by the Government in order to meet the performance standard.

**Withholding:** Amount of monthly invoice payment withheld pending correction of a deficiency. See Attachment 1 for information on percentage of invoice amount that may be withheld for each functional area. Funds withheld from payment are recoverable (See Sections 6 and 7) if the COTR and Contracting Officer confirm resolution/correction, and should be included in the next month's invoice.

**Deduction:** Funds may be deducted from a monthly invoice for an egregious act or event, or if the same deficiency continues to occur. The service provider will be notified immediately if such a situation arises. The Contracting Officer in consultation with the Program Office will determine the amount of the deduction. Amounts deducted are not recoverable.

### **3. QUALITY CONTROL PLAN:**

As a part of its agreement with the Government, the service provider is required to develop, implement, and maintain a Quality Control Plan (QCP) that illustrates the methods it will use to review its performance to ensure it conforms to the performance requirements. (See Attachment 1 for a summary list of performance requirements.) Such reviews are performed by the service provider in order to validate its operations, and assure the Government that the services meet the performance standards.

The service provider's QCP should include monitoring methods that ensure and demonstrate its compliance with the performance standards. This includes inspection methods and schedules that are consistent with the regular reviews conducted by DRO. The reports and other results generated by the service provider's QCP activities should be provided to the COTR as requested.

The frequency and type of the service provider's reviews should be consistent with what is necessary in order to ensure compliance with the performance standards, but no less frequent than what is described in the Government's monitoring instrument/worksheets (See Attachment 3).

The service provider is encouraged not to limit its inspection to only the processes outlined in the Government's standard; however, certain key documents must be produced by the provider to assure the Government that the services meet the performance standards. Some of the documentation that must be generated and made available to the COTR for inspection is listed below. The list is intended as illustrative and is not all-inclusive. The service provider must develop and implement a program that addresses the specific requirement of each standard and the means it will use to document compliance.

- Written policies and procedures to implement and assess operational requirements of the standard
- Documentation and record keeping to ensure ongoing operational compliance with the standards (e.g.; inventories, logbooks, register of receipts, reports, etc.)
- Staff training records
- Contract discrepancy reports (CDRs)
- Investigative reports
- Medical records
- Records of investigative actions taken
- Equipment inspections
- System tests and evaluation

#### **4. METHODS OF SURVEILLANCE**

The Government will inspect the service provider's facility and operations using worksheets it developed for this purpose. All facilities will be subject to an annual full facility review using the procedures outlined in the Detention Management Control Program (DMCP) as well as the ACA Standards for Adult Local Detention Facilities (ALDF). The Government's annual full facility reviews will use the monitoring instruments embedded in the standards.

Facilities with 500 beds or more have an on-site COTR and/or designees who will perform regular and more frequent inspections using the worksheet in Attachment 3. This worksheet, which distills some 600 review areas included in the standards, will help the COTR or designee assess overall performance, by reviewing specific items within the 9 functional areas on a daily, weekly, monthly, and/or quarterly basis. Both annual and routine inspections will include a review of the service provider's QCP activities including the reports and results generated by them.

The COTR or designee will evaluate the service provider's performance by (a) conducting site visits to assess the facility and detainee conditions, (b) reviewing documentation, and (c) interviewing the service provider's personnel and/or detainees. NOTE: For day-to-day activities, the Government will conduct its surveillance using the worksheets created for this purpose, along with the Contract Deficiency Reports (CDRs; See Attachment 2) and the "Contract Performance Monitoring Tool" set forth in Attachment 3. Where ICE/DRO standards are referenced for annual review purposes, the "Monitoring Instruments" and "Verification Sources" identified in the DRO standard will be used.

**4.1 Site Visits:** Site visits are used to observe actual performance and to conduct interviews to determine the extent of compliance with performance standards, and to ensure any noted defects are effectively addressed and corrected as quickly as possible. Sites with 500+ beds will have an on-site COTR designee. Routine reviews may involve direct observation of the service provider personnel performing tasks, interacting with detainees and other staff members, and/or reviewing documentation that demonstrates compliance with the DRO standards. On-site inspections may be performed by the ICE COTR or by other parties designated as representatives of ICE.

Inspections may be planned (e.g., annual inspections and the regular inspections identified in Attachment 3) or ad-hoc.

**4.2 Ad-Hoc:** These inspections are unscheduled and will be conducted as a result of special interests arising from routine monitoring of the service provider's QCP, an unusual occurrence pertaining to the agreement or other ICE concerns. These inspections may also be used as a follow-up to a previous inspection. Inspection findings will be provided to the service provider as appropriate.

When visiting a site, either the COTR or a designated third party may conduct their own inspections of service provider performance activities, or accompany the service provider's designated Quality Control Inspector (QCI) on scheduled inspections. The COTR may also immediately inspect the same area as soon as the QCI has completed the quality control inspection to determine if any surveillance areas were overlooked. The COTR may also inspect an area prior to the QCI and compare results. The COTR will record all findings; certain deficiencies noted will be provided in writing and must be corrected within a reasonable amount of time (See Attachment 2).

**4.3 Review of Documentation:** The service provider must develop and maintain all documentation as prescribed in the performance standards (e.g., post logs, policies, and records of corrective actions). In addition to the documentation prescribed by the standards, the service provider must also develop and maintain documentation that demonstrates the results of its own inspections as prescribed in its QCP. The COTR will review both forms of documentation to affirm that the facility conditions, policies/procedures, and handling of detainees all conform to the performance standards stated herein. When reviewing the service provider's documentation, the Government may review 100% of the documents, or a representative sample. Documentation may be reviewed during a site visit, or at periodic points throughout the period of performance.

**4.4 Interviews and Other Feedback:** The COTR will interview key members of the service provider's staff, detainees and other Government personnel to ascertain current practices and the extent of compliance with the performance standards.

## **5. FUNCTIONAL PERFORMANCE AREAS AND STANDARDS**

To facilitate the performance review process, the required performance standards are organized into nine functional areas. Each functional area represents a proportionate share (i.e., weight) of the monthly invoice amount payable to the service provider based on meeting the performance standards. Payment withholdings will be based on these percentages and weights applied to the overall monthly invoice.

ICE may, consistent with the scope the agreement, unilaterally change the functional areas and associated standards affiliated with a specific functional area. The Contracting Officer will notify the service provider at least 30 calendar days in advance of implementation of the new standard(s). If the service provider is not provided with the notification, adjustment to the new standard must be made within 30 calendar days after notification. If any change affects pricing,

the service provider may submit a request for equitable price adjustment in accordance with the "Changes" clause. ICE reserves the right to develop and implement new inspection techniques and instructions at any time during performance without notice to the service provider, so long as the standards are not more stringent than those being replaced.

## 6. FAILURE TO MEET PERFORMANCE STANDARDS

Performance of services in conformance with the PRS standards is essential for the service provider to receive full payment as identified in the agreement. The Contracting Officer may take deductions against the monthly invoices for unsatisfactory performance documented through surveillance of the service provider's activities gained through site inspections, reviews of documentation (including monthly QCP reports), interviews and other feedback. As a result of its surveillance, the service provider will be assigned the following rating relative to each performance standard:

Rating	Description
Acceptable	Based on the measures, the performance standard is demonstrated.
Deficient	Based on the measures, compliance with most of the attributes of the performance standard is demonstrated/observed with some area(s) needing improvement. There are no critical areas of unacceptable performance
At-Risk	Based on the performance measures, the majority of a performance standard's attributes are not met.

Using the above standards as a guide, the Contracting Officer will implement adjustments to the service provider's monthly invoice as prescribed in Attachment 1.

Rather than withholding funds until a deficiency is corrected, there may be times when an event or a deficiency is so egregious that the Government *deducts* (vs. "withholds") amounts from the service provider's monthly invoice. This may happen when an event occurs, such as sexual abuse, when a particular deficiency is noted 3 or more times without correction, or when the service provider has failed to take timely action on a deficiency about which he was properly and timely notified. The amount deducted will be consistent with the relative weight of the functional performance area where the deficiency was noted. The deduction may be a one-time event, or may continue until the service provider has either corrected the deficiency, or made substantial progress in the correction.

Further, a deficiency found in one functional area may tie into another. If a detainee escaped, for example, a deficiency would be noted in "Security and Control," but may also relate to a deficiency in the area of "Administration and Management."

## 7. NOTIFICATIONS

- (a) Based on the inspection of the service provider's performance, the COTR will document instances of deficient or at-risk performance (e.g., noncompliance with the standard) using the CDR located at Attachment 2. To the extent practicable, issues should be resolved

informally, with the COTR and service provider working together. When documentation of an issue or deficiency is required, the procedures set forth in this section will be followed.

- (b) When a CDR is required to document performance issues, it will be submitted to the service provider with a date when a response is due. Upon receipt of a CDR, the service provider must immediately assess the situation and either correct the deficiency as quickly as possible or prepare a corrective action plan. In either event, the service provider must return the CDR with the action planned or taken noted. After the COTR reviews the service provider's response to the CDR including its plan/remedy, the COTR will either accept plan or correction or reject the correction/plan for revision and provide an explanation. This process should take no more than one week. The CDR should not be used as a substitute for quality control by the service provider.
- (c) The COTR and CO, in addition to any other designated ICE official, shall be notified immediately in the event of all emergencies. Emergencies include, but are not limited to the following: activation of disturbance control team(s); disturbances (including gang activities, group demonstrations, food boycotts, work strikes, work-place violence, civil disturbances/protests); staff use of force including use of lethal and less-lethal force (includes inmates in restraints more than eight hours); assaults on staff/inmates resulting in injuries requiring medical attention (does not include routine medical evaluation after the incident); fights resulting in injuries requiring medical attention; fires; full or partial lock down of the facility; escape; weapons discharge; suicide attempts; deaths; declared or non-declared hunger strikes; adverse incidents that attract unusual interest or significant publicity; adverse weather (e.g., hurricanes, floods, ice/snow storms, heat waves, tornadoes); fence damage; power outages; bomb threats; central inmate monitoring cases admitted to a community hospital; witness security cases taken outside the facility; significant environmental problems that impact the facility operations; transportation accidents (airlift, bus, etc.) resulting in injuries, death or property damage; and sexual assaults. Note that in an emergency situation, a CDR may not be issued until an investigation has been completed.
- (d) If the COTR concludes that the deficient or at-risk performance warrants a withholding or deduction, the COTR must include the CDR in its monthly report to DRO Headquarters, with a copy to the Contracting Officer. The CDR must be accompanied by the COTR's investigation report and written recommendation for any withholding. If contractual action including a withholding or deduction is appropriate, DRO headquarters will forward the CDR and supporting information to the Contracting Officer for action. The Contracting Officer will consider the COTR's recommendation and forward the CDR along with any relevant supporting information to the service provider in order to confirm or further discuss the prospective cure, including the Government's proposed course of action. As described in section 7 above, portions of the monthly invoice amount may be withheld until such time as the corrective action is completed, *or* a deduction may be taken
- (e) Following receipt of the service provider's notification that the correction has been made, the COTR may re-inspect the facility. Based upon the COTR's findings, he will recommend that the Contracting Officer continue to withhold a proportionate share of the payment until the



correction is made, or accept the correction as final and release the full amount withheld for that issue.

- (f) If funds have been withheld and either the Government or the service provider terminates the agreement, those funds will not be released. The service provider may only receive withheld payments upon successful correction of an instance of non-compliance. Further, the service provider is not relieved of full performance of the required services hereunder; the agreement may be terminated upon adequate notice from the Government based upon any once instance, or failure to remedy deficient performance, even if a deduction was previously taken for any inadequate performance.
- (g) The COTR will maintain a record of all open and resolved CDRs.

#### **8. DETAINEE/MEMBER OF PUBLIC COMPLAINTS:**

The detainee and the public are the ultimate recipients of the services identified in this agreement. Any complaints made known to the COTR will be logged and forwarded to the service provider for remedy. Upon notification, the service provider will be given a pre-specified number of hours after verbal notification from the COTR to address the issue. The service provider will submit documentation to the COTR regarding the actions taken to remedy the situation. If the complaint is found to be invalid, the service provider will document its findings and notify the COTR.

#### **9. ATTACHMENTS**

- 1 Performance Requirements Summary
- 2 Contract Discrepancy Report
- 3 Performance Monitoring Tool

**QUASP Attachment 1  
Performance Requirements Summary**

FUNCTIONAL AREA/ WEIGHT	PERFORMANCE STANDARD	PERFORMANCE MEASURE	METHOD OF SURVEILLANCE	ACCEPTABLE QUALITY LEVEL	WITHHOLDING CRITERIA	
<b>Administration and Management (10%)</b>  (Addresses facility policy development, internal inspection and reviews, detainee records, administration and orientation, personal property and monies, release and accommodations for the disabled)	Accommodations for the Disabled, 4-ALDF-6B-04, 4-ALDF-6B-07	Performance measures are reflected in the monitoring instrument that accompanies each standard or in the supplemental performance monitoring tool issued by the COIR	<ul style="list-style-type: none"> <li>Annual review of facility using Detention Management Control Program (DCMP) procedures and based upon the performance standard</li> <li>Periodic reviews in accordance with the contract performance monitoring tool (see attached)</li> <li>Monthly review of corrective action plan results.</li> <li>Ad-hoc reviews as needed</li> <li>Review of service provider's quality control program monitoring reports</li> <li>CDRs</li> </ul>	Performance fully complies with all elements of standard at a level no less than acceptable (see Section 7 of the QASP)	A rating of Deficient on any three of the standards will result in a 10% withholding in the monthly invoiced per-diem rate until compliance with the standard is established.	
	Contractor Quality Control/ Assurance Program (Contract) 4-ALDF-7D-02					
	Admission and Release/Orientation (ICE Standard) ( <a href="http://www.ice.gov/doclib/partners/dro/opsmanual/admiss.pdf">http://www.ice.gov/doclib/partners/dro/opsmanual/admiss.pdf</a> )					
	Detainee Records/ Detention Files (ICE Standard) ( <a href="http://www.ice.gov/doclib/partners/dro/opsmanual/DetentFiles.pdf">http://www.ice.gov/doclib/partners/dro/opsmanual/DetentFiles.pdf</a> )					
	Detainee Handbook (ICE Standard) ( <a href="http://www.ice.gov/doclib/partners/dro/opsmanual/handbk.pdf">http://www.ice.gov/doclib/partners/dro/opsmanual/handbk.pdf</a> )					
	Internal Inspections and/or Reviews/ Detention Management & Control Program (ICE Standard)					
	Funds & Personal Property (ICE Standard) ( <a href="http://www.ice.gov/doclib/partners/dro/opsmanual/fundprop.pdf">http://www.ice.gov/doclib/partners/dro/opsmanual/fundprop.pdf</a> )					
	Policy Development and Monitoring 4-ALDF-7D-06					

FUNCTIONAL AREA/ WEIGHT	PERFORMANCE STANDARD	PERFORMANCE MEASURE	METHOD OF SURVEILLANCE	ACCEPTABLE QUALITY LEVEL	WITHHOLDING CRITERIA
<p><b>Health Care (15%)</b> (Addresses overall access to routine, chronic health care, mental health, emergency health and dental services provided by the institution)</p>	<p>Communicable Disease 4-ALDF-4C-14</p> <p><u>Detainee Hunger Strikes (ICE Standard)</u> (<a href="http://www.ice.gov/doclib/partners/dro/opsmanual/hunger.pdf">http://www.ice.gov/doclib/partners/dro/opsmanual/hunger.pdf</a>)</p> <p>4-ALDF-4D-18</p> <p><u>Experimental Research</u></p>	<p>Performance measures are reflected in the monitoring instrument that accompanies each standard or in the supplemental performance monitoring tool issued by the COIR</p>	<ul style="list-style-type: none"> <li>Annual review of facility using Detention Management Control Program (DCMP) procedures and based upon the performance standard</li> <li>Periodic reviews in accordance with the attached performance monitoring tool</li> <li>Monthly review of corrective action plan results.</li> <li>Ad-hoc reviews as needed</li> <li>CDRs</li> </ul>	<p>Performance fully complies with all elements of standard at a level no less than acceptable (see Section 7 of the QASP)</p>	<p>A rating of Deficient on any two of the standards will result in a 15% withholding in the monthly invoiced per-diem day rate until compliance with the standard is established.</p> <p>A rating of At-Risk on any of the standards will result in a 15% withholding in the monthly invoiced per-diem day rate until compliance with the standard is established.</p>
	<p><u>Medical, Dental, and Appraisals/Medical Care (ICE Standard)</u> (<a href="http://www.ice.gov/doclib/partners/dro/opsmanual/medical.pdf">http://www.ice.gov/doclib/partners/dro/opsmanual/medical.pdf</a>)</p> <p><u>Suicide Prevention (ICE Standard)</u> (<a href="http://www.ice.gov/doclib/partners/dro/opsmanual/suicprev.pdf">http://www.ice.gov/doclib/partners/dro/opsmanual/suicprev.pdf</a>)</p> <p><u>Terminal Illness, Advanced Directives and Death (ICE Standard)</u> (<a href="http://www.ice.gov/doclib/partners/dro/opsmanual/terminal.pdf">http://www.ice.gov/doclib/partners/dro/opsmanual/terminal.pdf</a>)</p>				

FUNCTIONAL AREA/ WEIGHT	PERFORMANCE STANDARD	PERFORMANCE MEASURE	METHOD OF SURVEILLANCE	ACCEPTABLE QUALITY LEVEL	WITHHOLDING CRITERIA
<p align="center"><b>Security and Control (25%)</b></p> <p>(Addresses post orders, permanent logs, security features, security inspections, control of contraband, detainee searches, detainee accountability, use of force, non-routine use of restraints, tool and equipment control, detainee discipline, supervision for special housing, contingency and emergency plans.)</p>	Detainee Searches 4-ALDF-2C-01-06 Detainee Accountability & Supervision/ Population Counts (ICE Standard) <a href="http://www.ice.gov/docli/b/partners/dro/opsmanual/popula.pdf">http://www.ice.gov/docli/b/partners/dro/opsmanual/popula.pdf</a>	Performance measures are reflected in the monitoring instrument that accompanies each standard or in the supplemental performance monitoring tool issued by the COTR	<ul style="list-style-type: none"> <li>Monthly review of corrective action plan results.</li> <li>Ad-hoc reviews as needed</li> <li>CDRs</li> <li>Review of service provider's quality control program monitoring reports and output data</li> </ul>	Performance fully complies with all elements of standard at a level no less than acceptable (see Section 7 of the QASP)	A rating of Deficient on any two of the standards will result in a 15% withholding in the monthly invoiced per-diem day rate until compliance with the standard is established.
	Use of Force (ICE Standard) <a href="http://www.ice.gov/docli/b/partners/dro/opsmanual/useoffor.pdf">http://www.ice.gov/docli/b/partners/dro/opsmanual/useoffor.pdf</a>	<ul style="list-style-type: none"> <li>Annual review of facility using Detention Management Control Program (DCMP) procedures and based upon the performance standard</li> <li>Periodic reviews in accordance with the contract performance monitoring tool (see attached)</li> </ul>	A rating of Deficient on any three of the standards will result in a 25% withholding in the monthly invoiced per-diem day rate until compliance with the standard is established.	A rating of At-Risk on any of the standards will result in a 25% withholding in the monthly invoiced per-diem day rate until compliance with the standard is established.	
	Detainee Transfers (ICE Standard) <a href="http://www.ice.gov/docli/b/partners/dro/opsmanual/detTransStdfinal.pdf">http://www.ice.gov/docli/b/partners/dro/opsmanual/detTransStdfinal.pdf</a>				
	Tool and Equipment Control (ICE Standard) <a href="http://www.ice.gov/docli/b/partners/dro/opsmanual/toolent.pdf">http://www.ice.gov/docli/b/partners/dro/opsmanual/toolent.pdf</a>				
	Weapon Control 4-ALDF-2B-04, 4-ALDF-2B-08, 4-ALDF-7B-14				
	Detainee Discipline (ICE Standard) <a href="http://www.ice.gov/docli/b/partners/dro/opsmanual/discip.pdf">http://www.ice.gov/docli/b/partners/dro/opsmanual/discip.pdf</a>				
	Special Management Unit- Administrative Segregation (ICE Standard) <a href="http://www.ice.gov/docli/b/partners/dro/opsmanual/smu_admin.pdf">http://www.ice.gov/docli/b/partners/dro/opsmanual/smu_admin.pdf</a>				

FUNCTIONAL AREA/ WEIGHT	PERFORMANCE STANDARD	PERFORMANCE MEASURE	METHOD OF SURVEILLANCE	ACCEPTABLE QUALITY LEVEL	WITHHOLDING CRITERIA
	<p>Special Management Unit-Disciplinary Segregation (ICE Standard) (<a href="http://www.ice.gov/doclib/partners/dro/opsmanual/smu_dis.pdf">http://www.ice.gov/doclib/partners/dro/opsmanual/smu_dis.pdf</a>) Contingency/Emergency Plan (ICE Standard) (<a href="http://www.ice.gov/doclib/partners/dro/opsmanual/emerge.pdf">http://www.ice.gov/doclib/partners/dro/opsmanual/emerge.pdf</a>) Hold Rooms in Detention Facilities (ICE Standard) (<a href="http://www.ice.gov/doclib/partners/dro/opsmanual/holdrm.pdf">http://www.ice.gov/doclib/partners/dro/opsmanual/holdrm.pdf</a>) Control of Contraband (ICE Standard) (<a href="http://www.ice.gov/doclib/partners/dro/opsmanual/contr.pdf">http://www.ice.gov/doclib/partners/dro/opsmanual/contr.pdf</a>) Post Orders (ICE Standard)(<a href="http://www.ice.gov/doclib/partners/dro/opsmanual/postord.pdf">http://www.ice.gov/doclib/partners/dro/opsmanual/postord.pdf</a>) Permanent Logs 4- ALDF-2A-11 Security Features (ICE Standard) (<a href="http://www.ice.gov/doclib/partners/dro/opsmanual/keylock.pdf">http://www.ice.gov/doclib/partners/dro/opsmanual/keylock.pdf</a>) Security Inspections and/or Reviews (ICE Standard) (<a href="http://www.ice.gov/doclib/partners/dro/opsmanual/secutisp.pdf">http://www.ice.gov/doclib/partners/dro/opsmanual/secutisp.pdf</a>) Sexual Assault 4-ALDF- 4D-22-8</p>				

FUNCTIONAL AREA/ WEIGHT	PERFORMANCE STANDARD	PERFORMANCE MEASURE	METHOD OF SURVEILLANCE	ACCEPTABLE QUALITY LEVEL	WITHHOLDING CRITERIA
<b>Food Service (10%)</b> (Addresses basic sanitation and adequacy of varied meals and special diets provided to detainees)	Transportation (Land Transportation) (ICE Standard) <a href="http://www.ice.gov/doclib/partners/dro/opsmanual/transp.pdf">http://www.ice.gov/doclib/partners/dro/opsmanual/transp.pdf</a> Weapons Control 4-ALDF-2B-04, 4-ALDF-2B-08, 4-ALDF-7B-14	Performance measures are reflected in the monitoring instrument that accompanies each standard or in the supplemental performance monitoring tool issued by the COTR	<ul style="list-style-type: none"> <li>Annual review of facility using Detention Management Control Program (DCMP) procedures and based upon the performance standard               <ul style="list-style-type: none"> <li>Periodic review in accordance with the attached performance monitoring tool</li> <li>Monthly review of corrective action plan results.</li> <li>Ad-hoc reviews as needed</li> <li>CDRs</li> </ul> </li> </ul>	Performance fully complies with all elements of standard at a level no less than acceptable (see Section 7 of the QASP)	A rating of Deficient on any the standards will result in a 10% withholding in the monthly invoiced per-diem day rate until compliance with the standard is established.
	Environmental Health & Safety (ICE Standard) <a href="http://www.ice.gov/doclib/partners/dro/opsmanual/enviroh.pdf">http://www.ice.gov/doclib/partners/dro/opsmanual/enviroh.pdf</a> Food Service Standards (ICE Standard) <a href="http://www.ice.gov/doclib/partners/dro/opsmanual/FoodService.pdf">http://www.ice.gov/doclib/partners/dro/opsmanual/FoodService.pdf</a>	Performance measures are reflected in the monitoring instrument that accompanies each standard or in the supplemental performance monitoring tool issued by the COTR	<ul style="list-style-type: none"> <li>Annual review of facility using Detention Management Control Program (DCMP) procedures and based upon the performance standard               <ul style="list-style-type: none"> <li>Periodic review in accordance with the attached performance monitoring tool</li> <li>Monthly review of corrective action plan results.</li> <li>Ad-hoc reviews as needed</li> <li>CDRs</li> </ul> </li> </ul>	Performance fully complies with all elements of standard at a level no less than acceptable (see Section 7 of the QASP)	A rating of At-Risk on any of the standards will result in a 10% withholding in the monthly invoiced per-diem day rate until compliance with the standard is established.

FUNCTIONAL AREA/ WEIGHT	PERFORMANCE STANDARD	PERFORMANCE MEASURE	METHOD OF SURVEILLANCE	ACCEPTABLE QUALITY LEVEL	WITHHOLDING CRITERIA
<p><b>Staff and Detainee Communication (2.5%)</b> (Addresses methods of communicating with detainees, detention/correctional staff training in diversity, and the detainee grievance process)</p>	<p>Detainee Grievances (ICE Standard) (<a href="http://www.ice.gov/doclib/partners/dro/opsmanual/griev.pdf">http://www.ice.gov/doclib/partners/dro/opsmanual/griev.pdf</a>)</p>	<p>Performance measures are reflected in the monitoring instrument that accompanies each standard or in the supplemental performance monitoring tool issued by the COTR</p>	<ul style="list-style-type: none"> <li>Annual review of facility using Detention Management Control Program (DCMP) procedures and based upon the performance standard</li> <li>Periodic reviews in accordance with the attached performance monitoring tool</li> <li>Monthly review of corrective action plan results.</li> <li>Ad-hoc reviews as needed</li> <li>CDRs</li> </ul>	<p>Performance fully complies with all elements of standard at a level no less than acceptable (see Section 7 of the QASP)</p>	<p>A rating of Deficient on any two of the standards will result in a 2.5% withholding in the monthly invoiced per-diem day rate until compliance with the standard is established.</p>
	<p>Diversity Training 4-ALDF-6A-08, 4-ALDF-7B-10</p>				<p>A rating of At-Risk on any of the standards will result in a 2.5% withholding in the monthly invoiced per-diem day rate until compliance with the standard is established.</p>
	<p>Staff Detainee Communication (ICE Standard) (<a href="http://www.ice.gov/doclib/partners/dro/opsmanual/Staff-Detainee-Communication.pdf">http://www.ice.gov/doclib/partners/dro/opsmanual/Staff-Detainee-Communication.pdf</a>)</p>				
<p><b>Safety and Sanitation (10%)</b> (Addresses the adequacy of fire safety programs, the control of dangerous materials, the general facility environment (including air quality, noise levels, and sanitation and hygiene programs), the adequacy of clothing and bedding, and from infectious diseases)</p>	<p>Environmental Health &amp; Safety (ICE Standard) (<a href="http://www.ice.gov/doclib/partners/dro/opsmanual/enviro.pdf">http://www.ice.gov/doclib/partners/dro/opsmanual/enviro.pdf</a>)</p>	<p>Performance measures are reflected in the monitoring instrument that accompanies each standard or in the supplemental performance monitoring tool issued by the COTR</p>	<ul style="list-style-type: none"> <li>Annual review of facility using Detention Management Control Program (DCMP) procedures and based upon the performance standard</li> <li>Periodic reviews in accordance with the attached performance monitoring tool</li> <li>Monthly review of corrective action plan results.</li> <li>Ad-hoc reviews as needed</li> <li>CDRs</li> </ul>	<p>Performance fully complies with all elements of standard at a level no less than acceptable (see Section 7 of the QASP)</p>	<p>A rating of Deficient on any two of the standards will result in a 10% withholding in the monthly invoiced per-diem day rate until compliance with the standard is established.</p>
	<p>Clothing and Bedding (ICE Standard) (<a href="http://www.ice.gov/doclib/partners/dro/opsmanual/cloth.pdf">http://www.ice.gov/doclib/partners/dro/opsmanual/cloth.pdf</a>)</p>				<p>A rating of At-Risk on any of the standards will result in a 10% withholding in the monthly invoiced per-diem day rate until compliance with the standard is established.</p>

FUNCTIONAL AREA/ WEIGHT	PERFORMANCE STANDARD	PERFORMANCE MEASURE	METHOD OF SURVEILLANCE	ACCEPTABLE QUALITY LEVEL	WITHHOLDING CRITERIA
<p align="center"><b>Services and Programs (10%)</b></p> <p>(Addresses detainee security classification, religious practices, work assignments, availability of exercise programs, access to legal materials, access to legal representation, access to a telephone, the handling of detainee mail and other correspondence, and visitation privileges)</p>	<p>Access to Legal Material (ICE Standard) (<a href="http://www.ice.gov/doclib/partners/dro/opsmanual/legal.pdf">http://www.ice.gov/doclib/partners/dro/opsmanual/legal.pdf</a>)</p> <p>Classification, Review, and Housing (ICE Standard) (<a href="http://www.ice.gov/doclib/partners/dro/opsmanual/classif.pdf">http://www.ice.gov/doclib/partners/dro/opsmanual/classif.pdf</a>)</p> <p>Detainee Mail &amp; Correspondence (ICE Standard) (<a href="http://www.ice.gov/doclib/partners/dro/opsmanual/corresp.pdf">http://www.ice.gov/doclib/partners/dro/opsmanual/corresp.pdf</a>)</p> <p>Group Legal Representation (ICE Standard) (<a href="http://www.ice.gov/doclib/partners/dro/opsmanual/grplegal.pdf">http://www.ice.gov/doclib/partners/dro/opsmanual/grplegal.pdf</a>)</p> <p>Marriage Requests (ICE Standard) (<a href="http://www.ice.gov/doclib/partners/dro/opsmanual/marreq.pdf">http://www.ice.gov/doclib/partners/dro/opsmanual/marreq.pdf</a>)</p> <p>Non-Medical Emergency Escorted Trips (ICE Standard) (<a href="http://www.ice.gov/doclib/partners/dro/opsmanual/escoort.pdf">http://www.ice.gov/doclib/partners/dro/opsmanual/escoort.pdf</a>)</p> <p>Recreation (ICE Standard) (<a href="http://www.ice.gov/doclib/partners/dro/opsmanual/recreat.pdf">http://www.ice.gov/doclib/partners/dro/opsmanual/recreat.pdf</a>)</p>	<p>Performance measures are reflected in the monitoring instrument that accompanies each standard or in the supplemental performance monitoring tool issued by the COIR</p>	<ul style="list-style-type: none"> <li>Annual review of facility using Detention Management Control Program (DCMP) procedures and based upon the performance standard</li> <li>Periodic reviews in accordance with the attached performance monitoring tool</li> <li>Monthly review of corrective action plan results.</li> <li>Ad-hoc reviews as needed</li> <li>CDRs</li> </ul>	<p>Performance fully complies with all elements of standard at a level no less than acceptable (See section 7 of the QASP)</p>	<p>A rating of Deficient on any two of the standards will result in a 10% withholding in the monthly invoiced per-diem day rate until compliance with the standard is established.</p> <p>A rating of At-Risk on any of the standards will result in a 10% withholding in the monthly invoiced per-diem day rate until compliance with the standard is established.</p>



FUNCTIONAL AREA/ WEIGHT	PERFORMANCE STANDARD	PERFORMANCE MEASURE	METHOD OF SURVEILLANCE	ACCEPTABLE QUALITY LEVEL	WITHHOLDING CRITERIA
<b>Workforce Integrity (15%)</b> (Addresses the adequacy of the detention/correctional officer hiring process, staff training and licensing/certification and adequacy of systems to report and address staff misconduct)	Religious Practices (ICE Standard) <a href="http://www.ice.gov/doclib/partners/dro/opsmanual/cloth.pdf">http://www.ice.gov/doclib/partners/dro/opsmanual/cloth.pdf</a> Telephone Access (ICE Standard) <a href="http://www.ice.gov/doclib/partners/dro/opsmanual/telecc.pdf">http://www.ice.gov/doclib/partners/dro/opsmanual/telecc.pdf</a> Voluntary Work Program (ICE Standard) <a href="http://www.ice.gov/doclib/partners/dro/opsmanual/work.pdf">http://www.ice.gov/doclib/partners/dro/opsmanual/work.pdf</a> Visitation Privileges (ICE Standard) <a href="http://www.ice.gov/doclib/partners/dro/opsmanual/visit.pdf">http://www.ice.gov/doclib/partners/dro/opsmanual/visit.pdf</a>	Performance measures are reflected in the monitoring instrument that accompanies each standard or in the supplemental performance monitoring tool issued by the COTR	<ul style="list-style-type: none"> <li>Annual review of facility using Detention Management Control Program (DCMP) procedures and based upon the performance standard               <ul style="list-style-type: none"> <li>Periodic reviews in accordance with the attached contract performance monitoring tool</li> <li>Monthly review of corrective action plan results.</li> <li>Ad-hoc reviews as needed</li> <li>CDRs</li> </ul> </li> </ul>	Performance fully complies with all elements of standard at a level no less than acceptable (See section 7 of the QASP)	A rating of Deficient on any three of the standards will result in a 15% withholding in the monthly invoiced per-diem day rate until compliance with the standard is established.  A rating of At-Risk on any of the standards will result in a 15% withholding in the monthly invoiced per-diem day rate until compliance with the standard is established.
	Staff Background and Reference Checks (Contract) 4-ALDF-7B-03 Staff Misconduct 4-ALDF-7B-01 Staffing Pattern Compliance within 10% of required (Contract) 4-ALDF-2A-14 Staff Training, Licensing, and Credentialing (Contract) 4-ALDF-4D-05, 4-ALDF-7B-05, 4-ALDF-7B-08	Performance measures are reflected in the monitoring instrument that accompanies each standard or in the supplemental performance monitoring tool issued by the COTR	<ul style="list-style-type: none"> <li>Annual review of facility using Detention Management Control Program (DCMP) procedures and based upon the performance standard               <ul style="list-style-type: none"> <li>Periodic reviews in accordance with the attached contract performance monitoring tool</li> <li>Monthly review of corrective action plan results.</li> <li>Ad-hoc reviews as needed</li> <li>CDRs</li> </ul> </li> </ul>	Performance fully complies with all elements of standard at a level no less than acceptable (See section 7 of the QASP)	A rating of Deficient on any three of the standards will result in a 15% withholding in the monthly invoiced per-diem day rate until compliance with the standard is established.  A rating of At-Risk on any of the standards will result in a 15% withholding in the monthly invoiced per-diem day rate until compliance with the standard is established.

FUNCTIONAL AREA/ WEIGHT	PERFORMANCE STANDARD	PERFORMANCE MEASURE	METHOD OF SURVEILLANCE	ACCEPTABLE QUALITY LEVEL	WITHHOLDING CRITERIA
<p><b>Detainee Discrimination (2.5%)</b> (Addresses the adequacy of policies and procedures to prevent discrimination against detainees based on their gender, race, religion, national origin, or disability)</p>	<p>Discrimination Prevention 4-ALDF-6B-02-03</p>	<p>Performance measures are reflected in the monitoring instrument that accompanies each standard or in the supplemental performance monitoring tool issued by the COTR</p>	<ul style="list-style-type: none"> <li>• Annual review of facility using Detention Management Control Program (DCMP) procedures and based upon the performance standard</li> <li>• Periodic reviews in accordance with the attached performance monitoring tool (see attached)</li> <li>• Monthly review of corrective action plan results.</li> <li>• Ad-hoc reviews as needed</li> <li>• CDRs</li> </ul>	<p>Performance fully complies with all elements of standard at a level no less than acceptable (see Section 7 of the QASP)</p>	<p>A rating of Deficient on the standards will result in a 2.5% withholding in the monthly invoiced per-diem day rate until compliance with the standard is established.</p> <p>A rating of At-Risk on any of the standards will result in a 2.5% withholding in the monthly invoiced per-diem day rate until compliance with the standard is established.</p>

## QUASP Attachment 2 - Contract Discrepancy Report

CONTRACT DISCREPANCY REPORT			1. CONTRACT NUMBER
<b>Report Number:</b>		<b>Date:</b>	
2. TO: (Contractor and Manager Name)		3. FROM: (Name of COTR)	
<b>DATES</b>			
CONTRACTOR NOTIFICATION	CONTRACTOR RESPONSE DUE BY	RETURNED BY CONTRACTOR	ACTION COMPLETE
4. DISCREPANCY OR PROBLEM <i>(Describe in Detail: Include reference in PWS / Directive: Attach continuation sheet if necessary.)</i>			
5. SIGNATURE OF CONTRACTING OFFICER'S TECHNICAL REPRESENTATIVE (COTR)			
6. TO: (COTR)		7. FROM: (Contractor)	
8. CONTRACTOR RESPONSE AS TO CAUSE, CORRECTIVE ACTION AND ACTIONS TO PREVENT RECURRENCE. ATTACH CONTINUATION SHEET IF NECESSARY. <i>(Cite applicable Q.A. program procedures or new A.W. procedures.)</i>			
9. SIGNATURE OF CONTRACTOR REPRESENTATIVE			10. DATE
11. GOVERNMENT EVALUATION OF CONTRACTOR RESPONSE/RESOLUTION PLAN: <i>(Acceptable response/plan, partial acceptance of response/plan, rejection: attach continuation sheet if necessary)</i>			
12. GOVERNMENT ACTIONS <i>(Payment withholding, cure notice, show cause, other.)</i>			
<b>CLOSE OUT</b>			
CONTRACTOR NOTIFIED COTR	NAME AND TITLE	SIGNATURE	DATE
CONTRACTING OFFICER			

**Dedicated IGSA**

# QUASP Attachment 3 – Performance Monitoring Tool

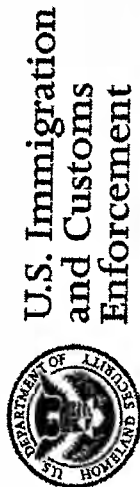

U.S. Immigration and Customs Enforcement

Detention and Removal Operations  
 Performance Monitoring Tool  
 Facility Name: \_\_\_\_\_ Month/Year: \_\_\_\_\_

Frequency	Rating	Corrective Action Required/Comments	Due Date
D	A/D/R		
		<b>1. Admission and Release</b>	
		A. ICE information is available for initial classification	
		B. Medical screening taking place within timeframes	
		C. Inventory detainee personal effects	
		D. Detainee funds accountability in place for admin/release	
		E. All visual searches documented and are not routine in procedure	
		F. Appropriate clothing and bedding issued	
		G. Orientation material in English, Spanish or most prevalent second language	
		<b>2. Detainee Classification System</b>	
		A. All detainees classified appropriately upon arrival	
		B. Reassessment and reclassification process in place	
		C. Housing assignments are based upon classification	
		D. Work assignments are based upon classification system	
		E. Detainees are assigned color coded uniforms/wrist bands to reflect classification level	
		<b>3. Contraband</b>	
		A. Policy in place for handling contraband	
		B. Contraband disposed of properly and documented	
		C. Facility staff make a concerted effort to control	

D	M	contraband	DETECTION STANDARD	Rating A/D/R	Corrective Action Required/ Comments	Due Date
			<b>4. Correspondence and Other Mail</b>			
			A. Incoming mail screened and delivered daily			
			B. Outgoing mail screened for contraband			
			C. Legal mail opened in front of detainee			
			D. Incoming funds processed properly			
			E. Rules for correspondence and other mail posted in housing unit or common areas, and detainee handbook			
			F. Facility has a system for detainees to purchase stamps			
			G. SMU has same correspondence privileges as general population			
			<b>5. Detainee Handbook</b>			
			A. Staff aware of handbook contents and follow procedures			
			B. Available in both English and Spanish and/or second most prevalent language			
			C. Handbook is updated as necessary			
			D. Orientation material available to illiterate detainees			
			<b>6. Detention Files</b>			
			A. Detention file created for each new arrival			
			B. Detention files contain documents generated during custody			
			C. Detention files maintained in a secure area			
			<b>7. Disciplinary Policy</b>			
			A. Rules of conduct/sanctions provided in writing			
			B. Incident reports investigated within 24 hours			
			C. Disciplinary panel adjudicate infractions			
			D. Disciplinary sanctions are in accordance with standards			

D	W	M	E. Staff representation available	DEFINITION STANDARD	Rating A/D/R	Corrective Action Required/Comments	Due Date
				<b>8. Emergency Plans</b>			
				A. Staff trained			
				B. Written plans			
				C. Evacuation routes primary and secondary			
				D. A complete set of emergency plans is available			
				E. Staff work stoppage plan is available			
				<b>9. Environmental Health and Safety</b>			
				A. System for storing/issuing/maintaining hazardous materials			
				B. Complete inventories of hazardous materials maintained			
				C. A complete list of MSDS readily accessible to staff and detainees			
				D. Fire prevention/control/evacuation plan			
				E. Conduct fire/evacuation drills according to schedule/standard			
				F. Staff trained to prevent contact with blood and bodily fluids			
				G. Emergency generators are tested bi-weekly			
				H. Every employee and detainee using flammable, toxic, or caustic materials receives advance training in their use, storage, and disposal			
				I. Safety Office (or officer) maintains files of inspection reports; Including corrective actions taken			
				J. Facility appears clean and well maintained			
				K. All flammable and combustible materials (liquid and aerosol) are stored and used according to label recommendations			

D	W	M	T	F	S	S	DEFINITION STANDARDS	Rating M/D/R	Corrective Action Required/ Comments	Due Date
							<b>10. Non-Medical Emergency Escorted Trips</b> The Field Office Director considers and approves, on a case-by-case basis, trips to visit an immediate family member in accordance with standards			
							<b>A.</b>			
							<b>11. Security Inspections</b>			
							<b>A.</b> Staff are required to conduct security check of assigned areas			
							<b>B.</b> All visitors officially recorded in a visitor log book			
							<b>C.</b> Front entrance staff inspect ID of everyone entering/exiting			
							<b>D.</b> Maintain a log of all incoming and departing vehicles			
							<b>E.</b> Housing unit searches occur at irregular times			
							<b>F.</b> Area searches documented in log book			
							<b>G.</b> Daily/Monthly fence checks completed and logged			
							Facility administrator or designee and department heads visit housing units and activity areas weekly			
							<b>H.</b> Officers monitor all vehicular traffic entering and leaving the facility			
							<b>I.</b> The facility has a written policy and procedures to prevent the introduction of contraband into the facility or any of its components			
							<b>J.</b> Security officer posts located in or immediately adjacent to detainee living areas to permit officers to see or hear and respond promptly to emergency situations. Personal contact and interaction between staff and detainees is required and facilitated			
							<b>K.</b> Daily procedures include: perimeter alarm system tests; physical checks of the perimeter fence; documenting the results			
							<b>L.</b>			

D	W	M	T	TH	F	S	SUN	DEFINITION STANDARDS	Rating A/D/R	Corrective Action Required/ Comments	Due Date
								M. Tools being taken into the secure area of the facility are inspected and inventoried			
								12. Food Service			
								A. Appropriate security measures for sharps are in place			
								B. Appropriate food temperatures are maintained for both hot and cold food			
								C. Food Service department maintained at a high level of sanitation			
								D. Detainees receive safety and appropriate equipment training prior to beginning work in department			
								E. A minimum of two hot meals served daily			
								F. Facility has a standard 35 day cycle menu			
								G. A registered dietician conducts nutritional analysis			
								H. All menu changes documented			
								I. Common fare menu for authorized detainees			
								J. Weekly inspections conducted and documented			
								13. Funds and Personal Property			
								A. Inventory personal property/funds is maintained			
								B. Funds/valuables documented on receipt			
								C. Detainees property searched for contraband			
								D. Staff forward arriving detainees medication to medical staff			
								E. Detainee funds are deposited into the cash box			
								F. Staff secure every container used to store property with a tamper-proof numbered strap			
								G. Quarterly audits of detainee baggage & luggage are conducted, verified, and logged			
D	W	M	T <td>TH</td> <td>F</td> <td>S</td> <td>SUN</td> <th>DEFINITION STANDARDS</th> <th>Rating A/D/R</th> <th>Corrective Action Required/ Comments</th> <th>Due Date</th>	TH	F	S	SUN	DEFINITION STANDARDS	Rating A/D/R	Corrective Action Required/ Comments	Due Date



14. Detainee Grievance Procedures	
A.	Grievance procedures in place
B.	Staff awareness of procedures for emergency grievances
C.	Grievance log is utilized
D.	Staff forward any grievances alleging staff misconduct to ICE
E.	Informal resolution to a detainee grievance documented in detention file
15. Hold Rooms in Detention Facilities	
A.	Detainees are not held in hold rooms longer than 12 hours
B.	All detainees pat searched prior to placement in hold room
C.	Maintain detention log for each detainee in hold room
D.	Written evacuation plan posted for each hold room
E.	Hold rooms contain sufficient seating for the number of detainees held
F.	No bunks/cots/beds or other related make shift sleeping apparatuses are permitted inside hold rooms
G.	Male and females are segregated from each other at all times
H.	Detainees are provided with basic personal hygiene items such as water, soap, toilet paper, cups for water, feminine hygiene items, diapers and wipes
I.	Officers closely supervise the detention hold rooms. Hold rooms are irregularly monitored every 15 minutes
16. Hunger Strikes	
A.	Procedures for referring detainee to medical if

D	W	M	verbal refusal or observed refusing to eat beyond 72 hours	Katana	Corrective Action Required / Comments	Due Date
<b>DEFINITION STANDARDS</b>						
			B. Staff receive training in identification of hunger strike			
			C. Process for determining reason for hunger strike			
<b>17. Key and Lock Control</b>						
			A. Maintain inventories of all keys/locks/locking devices			
			Emergency keys are available for all areas of the facility			
			C. Chit system used to issue security equip./keys/radios			
			D. Policy regarding restricted keys present and followed by staff			
			E. Facility has a key accountability policy and procedures to ensure key accountability. The keys are physically counted daily			
			F. Locks and locking devices are continually inspected, maintained, and inventoried			
<b>18. Access to Legal Material</b>						
			A. Adequate equipment is available for detainees			
			B. Legal materials/law library current and available for detainees			
			C. Detainee access provided to include SMU			
			D. Denials documented			
			E. Schedule for use implemented 5 hours weekly per detainee			
			F. Access to legal material within 24 hours of written request			
			G. Indigent detainees provided free stamps/envelopes for legal matters			
<b>19. Group Presentations on Legal Rights</b>						







	SMU daily									
I.	A health care provider visits every detainee in a SMU at least 3x week, and detainees are provided any medications prescribed for them									
D	W	M	T	F	S	S	S	S	S	
DETENTION STANDARDS										
								Rating A/D/R	Concave Admin Required/ Comments	Due Date
J.	Detainees in the SMU are offered at least one hour of recreation per day, scheduled at a reasonable time, at least five days per week. Where cover is not provided to mitigate inclement weather, detainees are provided weather-appropriate equipment and attire									
J.	When a detainee has been held in Admin Segregation for more than 30 days, the facility administrator notifies the Field Office Director, who notifies the ICE/DRO Deputy Assistant Director, Detention Management Division									
K.										
28. Special Management Unit (Disciplinary Segregation)										
A.	Written order accompany detainee placed in SMU									
B.	SMU reviews are conducted in a timely manner (3,7,14,30,60)									
C.	Admin SMU detainees enjoy same privileges as gen pop									
D.	Detainees in SMU have access to legal materials									
E.	Detainees in SMU retain visiting privileges									
F.	Maintain a permanent log regarding detainee related activities									
G.	Written order accompany detainee placed in disciplinary SMU									
H.	Detainees in disciplinary SMU have access to legal materials									
I.	Detainees in disciplinary SMU retain visiting privileges									
J.	Disciplinary SMU phone access limited to legal/consular calls									















**Town of Farmville – ICE Facility**  
**TRANSPORTATION WORK ASSIGNMENT**

NAMES: \_\_\_\_\_

DATE: \_\_\_\_\_

HOURS: \_\_\_\_\_

MILEAGE: \_\_\_\_\_

DESCRIPTION: \_\_\_\_\_  
\_\_\_\_\_  
\_\_\_\_\_  
\_\_\_\_\_

I \_\_\_\_\_ CERTIFY THAT THE  
HOURS ON THIS SHEET ARE ACCURATE AND CORRECT.

TIME OF DEPARTURE \_\_\_\_\_ TIME OF RETURN \_\_\_\_\_

SIGNATURE: \_\_\_\_\_

SUPERVISOR'S SIGNATURE: \_\_\_\_\_

DATE: \_\_\_\_\_

**ORDER FOR SUPPLIES OR SERVICES**

PAGE OF PAGES

1 3

**IMPORTANT: Mark all packages and papers with contract and/or order numbers.**

1. DATE OF ORDER 09/15/2008		2. CONTRACT NO. (if any) DROIGSA-08-0021		6. SHIP TO:	
3. ORDER NO. HSCEDM-08-F-IG064		4. REQUISITION/REFERENCE NO. FDG08FARM		a. NAME OF CONSIGNEE ICE Detention & Removal	
5. ISSUING OFFICE (Address correspondence to) ICE/Detention Mngt/Detention IGSA Immigration and Customs Enforcement Office of Acquisition Management 425 I Street NW, Suite 2208 Washington DC 20536				b. STREET ADDRESS Immigration and Customs Enforcement 801 I Street, NW Suite 900	
7. TO:		c. CITY Washington		d. STATE DC	e. ZIP CODE 20536
a. NAME OF CONTRACTOR FARMVILLE TOWN OF		f. SHIP VIA		8. TYPE OF ORDER	
b. COMPANY NAME		<input type="checkbox"/> a. PURCHASE		<input checked="" type="checkbox"/> b. DELIVERY	
c. STREET ADDRESS P O BOX 368		REFERENCE YOUR:		Except for billing instructions on the reverse, this delivery order is subject to instructions contained on this side only of this form and is issued subject to the terms and conditions of the above-numbered contract.	
d. CITY FARMVILLE		e. STATE VA	f. ZIP CODE 239010368		
9. ACCOUNTING AND APPROPRIATION DATA See Schedule				10. REQUISITIONING OFFICE ICE Detention & Removal	
11. BUSINESS CLASSIFICATION (Check appropriate box(es))				12. F.O.B. POINT Destination	
<input type="checkbox"/> a. SMALL <input type="checkbox"/> b. OTHER THAN SMALL <input type="checkbox"/> c. DISADVANTAGED <input type="checkbox"/> g. SERVICE-DISABLED VETERAN-OWNED <input type="checkbox"/> d. WOMEN-OWNED <input type="checkbox"/> e. HUBZone <input type="checkbox"/> f. EMERGING SMALL BUSINESS					
13. PLACE OF		14. GOVERNMENT B/L NO.		15. DELIVER TO F.O.B. POINT ON OR BEFORE (Date) Multiple	
a. INSPECTION Destination	b. ACCEPTANCE Destination			16. DISCOUNT TERMS  (b)(2)Low	

17. SCHEDULE (See reverse for Rejections)

ITEM NO. (a)	SUPPLIES OR SERVICES (b)	QUANTITY ORDERED (c)	UNIT (d)	UNIT PRICE (e)	AMOUNT (f)	QUANTITY ACCEPTED (g)
	DUNS Number: 040156218 Field office POC: Phllis Chapman 703-285- [b6] Craig Raine 703-285- [b6] Program POC: Elena Smyly 202-732- [b6] Continued ...					

18. SHIPPING POINT		19. GROSS SHIPPING WEIGHT		20. INVOICE NO.		17(h) TOTAL (Cont. pages)
21. MAIL INVOICE TO:						
SEE BILLING INSTRUCTIONS ON REVERSE	a. NAME Department of Homeland Security				\$968,000.00	17(i) GRAND TOTAL
	b. STREET ADDRESS (or P.O. Box) Citizenship & Immigration Services 2675 Prosperity Avenue Suite 300					
	c. CITY Fairfax	d. STATE VA	e. ZIP CODE 22031-4906		\$968,000.00	
22. UNITED STATES OF AMERICA BY (Signature)				23. NAME (Typed) Jerald H. Neveleff		
				TITLE: CONTRACTING/ORDERING OFFICER		

AUTHORIZED FOR LOCAL REPRODUCTION  
PREVIOUS EDITION NOT USABLE

**ORDER FOR SUPPLIES OR SERVICES  
SCHEDULE - CONTINUATION**

PAGE OF PAGES

2

3

**IMPORTANT:** Mark all packages and papers with contract and/or order numbers.

DATE OF ORDER 09/15/2008	CONTRACT NO. DROIGSA-08-0021	ORDER NO. HSCEDM-08-F-IG064
-----------------------------	---------------------------------	--------------------------------

ITEM NO. (A)	SUPPLIES/SERVICES (B)	QUANTITY ORDERED (C)	UNIT (D)	UNIT PRICE (E)	AMOUNT (F)	QUANTITY ACCEPTED (G)
	M.J. Bates 202-732- [b6]					
	OAQ POC: Jerald Neveleff, Contracting Officer, 202-616- [b6] Arnold Casterline, Contract Specialist, 202-514- [b6]					
	This is a Task Order for the Farmville transportation in support of the Washington field office. Accounting Info: [b(2)Low]					
	Period of Performance: 09/15/2008 to 03/14/2009					
0001	Adult Alien Detainess Bed day rate (TBD) Delivery: 30 Days After Award		EA	0.00	0.00	
0002	Transportation Guard hourly rate Product/Service Code: S206 Product/Service Description: GUARD SERVICES Delivery: 09/15/2008	18615.9967	HR	24.28	451,996.40	
0003	Dispatcher for Transportation Product/Service Code: S206 Product/Service Description: GUARD SERVICES Delivery: 09/15/2008	1040	HR	25.00	26,000.00	
0004	Director of Transportation Product/Service Code: S206 Product/Service Description: GUARD SERVICES Delivery: 09/15/2008	1040	HR	40.12	41,724.80	
0005	Transportation Initiation Charges Delivery: 09/15/2008	6	MO	2,112.00	12,672.00	
0006	Estimated mileage for six months of Continued ...	744627	EA	0.585	435,606.80	
TOTAL CARRIED FORWARD TO 1ST PAGE (ITEM 17(H))						

**ORDER FOR SUPPLIES OR SERVICES  
SCHEDULE - CONTINUATION**

PAGE OF PAGES

3

3

**IMPORTANT:** Mark all packages and papers with contract and/or order numbers.

DATE OF ORDER

CONTRACT NO.

09/15/2008

DROIGSA-08-0021

ORDER NO.

HSCEDM-08-F-IG064

ITEM NO. (A)	SUPPLIES/SERVICES (B)	QUANTITY ORDERED (C)	UNIT (D)	UNIT PRICE (E)	AMOUNT (F)	QUANTITY ACCEPTED (G)
	transportation. Approximately 744,627 miles @ .585 per mile is \$435,606.80  Delivery: 09/15/2008  The total amount of award: \$968,000.00. The obligation for this award is shown in box 17(i).					

TOTAL CARRIED FORWARD TO 1ST PAGE (ITEM 17(H))

**Stevens, Richard P**

---

**From:** Russell Harper [REDACTED] b6  
**Sent:** Wednesday, September 24, 2008 4:21 PM  
**To:** Neveleff, Jerald  
**Cc:** Casterline, Arnold P  
**Subject:** Fw: ICA\_092408(a).pdf  
**Attachments:** ICA\_092408(a).pdf

-----  
Sent from Russell B. Harper

-----Original Message-----

**From:** Lisa Hricko <[REDACTED] b6>  
**To:** Russell Harper [REDACTED] b6  
**Sent:** Wed Sep 24 16:17:04 2008  
**Subject:** ICA\_092408(a).pdf

<<ICA\_092408(a).pdf>>



<b>AMENDMENT OF SOLICITATION/MODIFICATION OF CONTRACT</b>		1. CONTRACT ID CODE		PAGE OF PAGES 1 2	
2. AMENDMENT/MODIFICATION NO. P00001		3. EFFECTIVE DATE 09/22/2008		4. REQUISITION/PURCHASE REG. NO.	
5. PROJECT NO. (If applicable)		6. ISSUED BY ICE/DM/DC-DC		7. ADMINISTERED BY (If other than Item 6) ICE/DM/DC-DC	
ICE/Detent Mngt/Detent Contracts-DC Immigration and Customs Enforcement Office of Acquisition Management 425 I Street NW, Suite 2208 Washington DC 20536		ICE/Detent Mngt/Detent Contracts-DC Immigration and Customs Enforcement Office of Acquisition Management 425 I Street NW, Suite 2208 Washington DC 20536			
8. NAME AND ADDRESS OF CONTRACTOR (No., street, county, State and ZIP Code) FARMVILLE TOWN OF P O BOX 368 FARMVILLE VA 239010368		9A. AMENDMENT OF SOLICITATION NO.		9B. DATED (SEE ITEM 11)	
CODE 0401562180000 FACILITY CODE		10A. MODIFICATION OF CONTRACT/ORDER NO. DROIGSA-08-0021/		10B. DATED (SEE ITEM 11) 09/22/2008	

11. THIS ITEM ONLY APPLIES TO AMENDMENTS OF SOLICITATIONS

The above numbered solicitation is amended as set forth in Item 14. The hour and date specified for receipt of Offers  is extended,  is not extended.  
 Offers must acknowledge receipt of this amendment prior to the hour and date specified in the solicitation or as amended, by one of the following methods: (a) By completing Items 8 and 10, and returning \_\_\_\_\_ copies of the amendment; (b) By acknowledging receipt of this amendment on each copy of the offer submitted; or (c) By separate letter or telegram which includes a reference to the solicitation and amendment numbers. FAILURE OF YOUR ACKNOWLEDGEMENT TO BE RECEIVED AT THE PLACE DESIGNATED FOR THE RECEIPT OF OFFERS PRIOR TO THE HOUR AND DATE SPECIFIED MAY RESULT IN REJECTION OF YOUR OFFER. If by virtue of this amendment you desire to change an offer already submitted, such change may be made by telegram or letter, provided each telegram or letter makes reference to the solicitation and this amendment, and is received prior to the opening hour and date specified.

12. ACCOUNTING AND APPROPRIATION DATA (If required)  
See Schedule

13. THIS ITEM ONLY APPLIES TO MODIFICATION OF CONTRACT/ORDERS. IT MODIFIES THE CONTRACT/ORDER NO. AS DESCRIBED IN ITEM 14.

CHECK ONE	A. THIS CHANGE ORDER IS ISSUED PURSUANT TO: (Specify authority) THE CHANGES SET FORTH IN ITEM 14 ARE MADE IN THE CONTRACT ORDER NO. IN ITEM 10A.
X	B. THE ABOVE NUMBERED CONTRACT/ORDER IS MODIFIED TO REFLECT THE ADMINISTRATIVE CHANGES (such as changes in paying office, appropriation data, etc.) SET FORTH IN ITEM 14, PURSUANT TO THE AUTHORITY OF FAR 43.103(d).
	C. THIS SUPPLEMENTAL AGREEMENT IS ENTERED INTO PURSUANT TO AUTHORITY OF:
	D. OTHER (Specify type of modification and authority)

E. IMPORTANT: Contractor  is not,  is required to sign this document and return 1 copies to the issuing office.

14. DESCRIPTION OF AMENDMENT/MODIFICATION (Organized by UCF section headings, including solicitation/contract subject matter where feasible.)  
 DUNS Number: 040156218  
 FIELD POC: Craig Raine 703-285- [b6]  
 Paul Picone 703-285- [b6]  
 Program POC: Elena Smyly 202-732- [b6]  
 M.J.Bates 202-732- [b6]  
 OAQ POC: Jerald Neveleff, Contracting Officer, 202-616- [b6]  
 Arnold Casterline, Contract Specialist, 202-514- [b6]

The purpose of this modification is to change ARTICLE I: Section C: The detainee daily rate is TBD. To: The detainee daily rate is \$62.83. This will also modify ARTICLE XI:  
 Continued ...

Except as provided herein, all terms and conditions of the document referenced in Item 9A or 10A, as heretofore changed, remains unchanged and in full force and effect.

15A. NAME AND TITLE OF SIGNER (Type or print) GERALD H. NEVELEFF TOWN MGR		16A. NAME AND TITLE OF CONTRACTING OFFICER (Type or print) Jerald H. Neveleff	
15B. CONTRACT OFFEROR 		16B. UNITED STATES OF AMERICA	
15C. DATE SIGNED 9/24/08		16C. DATE SIGNED	

**CONTINUATION SHEET**

REFERENCE NO. OF DOCUMENT BEING CONTINUED  
DROIGSA-08-0021//P00001

PAGE 2 OF 2

NAME OF OFFEROR OR CONTRACTOR  
FARMVILLE TOWN OF

ITEM NO. (A)	SUPPLIES/SERVICES (B)	QUANTITY (C)	UNIT (D)	UNIT PRICE (E)	AMOUNT (F)
	Section B: The detainee day rate is TBD. To: The detainee day rate is \$62.83. After completion and approval of the facility, another Task Order will be issued with funding for the bed days. Period of Performance: 09/22/2008 to 09/30/2009				

**Stevens, Richard P**

---

**From:** Casterline, Arnold P  
**Sent:** Thursday, September 25, 2008 8:27 AM  
**To:** 'Russell Harper'; [REDACTED] b6  
**Cc:** Raine, Craig K; Smyly, Elena L; Neveleff, Jerald  
**Subject:** Modification to IGSA  
**Attachments:** DROIGSA080021 P00001\_001 (2).pdf

Mr. Spates,

Attached is the executed modification to establish the bed day rate for ICA Farmville. If you have any questions concerning this please feel free to contact me at 202-514- [REDACTED] b6 or send me an email at [REDACTED] (b)(6). Thank you and have a great day.

Arnie Casterline  
*Arnold P. Casterline Jr.*  
Contract Specialist  
Immigration and Customs Enforcement  
Office of Acquisition Management  
Detention Management  
Department of Homeland Security  
425 I Street NW, 5<sup>th</sup> Floor Room 5009  
Washington, DC 20536  
e-mail: [REDACTED] (b)(6)  
phone: 202-514- [REDACTED]  
Main: 202-514- [REDACTED] b6

**Help us support you better –  
TELL US HOW WE ARE DOING!**  
**Go to** <http://www.acqsolinc.com/ICE/OAQ/feedback.cfm>

AMENDMENT OF SOLICITATION/MODIFICATION OF CONTRACT		1. CONTRACT ID CODE		PAGE OF PAGES 1 2	
2. AMENDMENT/MODIFICATION NO. P00001		3. EFFECTIVE DATE 09/22/2008		4. REQUISITION/PURCHASE REG. NO.	
6. ISSUED BY ICE/Detent Mngt/Detent Contracts-DC Immigration and Customs Enforcement Office of Acquisition Management 425 I Street NW, Suite 2208 Washington DC 20536		CODE ICE/DM/DC-DC		5. PROJECT NO. (if applicable)	
8. NAME AND ADDRESS OF CONTRACTOR (no, street, county, State and ZIP Code) FARMVILLE TOWN OF P O BOX 368 FARMVILLE VA 239010368		7. ADMINISTERED BY (if other than Item 6) ICE/Detent Mngt/Detent Contracts-DC Immigration and Customs Enforcement Office of Acquisition Management 425 I Street NW, Suite 2208 Washington DC 20536		CODE ICE/DM/DC-DC	
CODE 0401562180000		FACILITY CODE		9A. AMENDMENT OF SOLICITATION NO.	
				9B. DATED (SEE ITEM 11)	
				10A. MODIFICATION OF CONTRACT/ORDER NO. DROIGSA-08-0021/	
				10B. DATED (SEE ITEM 11) 09/22/2008	

11. THIS ITEM ONLY APPLIES TO AMENDMENTS OF SOLICITATIONS

The above numbered solicitation is amended as set forth in Item 14. The hour and date specified for receipt of Offers  is extended,  is not extended. Offers must acknowledge receipt of the amendment prior to the hour and date specified in the solicitation or as amended, by one of the following methods: (a) By completing Items 6 and 15, and returning \_\_\_\_\_ copies of the amendment; (b) By acknowledging receipt of the amendment on each copy of the offer submitted; or (c) By separate letter or telegram which includes a reference to the solicitation and amendment numbers. FAILURE OF YOUR ACKNOWLEDGMENT TO BE RECEIVED AT THE PLACE DESIGNATED FOR THE RECEIPT OF OFFERS PRIOR TO THE HOUR AND DATE SPECIFIED MAY RESULT IN REJECTION OF YOUR OFFER. If by virtue of this amendment you desire to change an offer already submitted, such change may be made by telegram or letter, provided each telegram or letter makes reference to the solicitation and this amendment, and is received prior to the opening hour and date specified.

12. ACCOUNTING AND APPROPRIATION DATA (if required)  
See Schedule

13. THIS ITEM ONLY APPLIES TO MODIFICATION OF CONTRACT/ORDERS. IT MODIFIES THE CONTRACT/ORDER NO. AS DESCRIBED IN ITEM 14.

CHECK ONE	A. THIS CHANGE ORDER IS ISSUED PURSUANT TO: (Specify authority) THE CHANGES SET FORTH IN ITEM 14 ARE MADE IN THE CONTRACT ORDER NO. IN ITEM 10A.
X	B. THE ABOVE NUMBERED CONTRACT/ORDER IS MODIFIED TO REFLECT THE ADMINISTRATIVE CHANGES (such as changes in paying office, appropriation data, etc.) SET FORTH IN ITEM 14, PURSUANT TO THE AUTHORITY OF FAR 43.103(b).
	C. THIS SUPPLEMENTAL AGREEMENT IS ENTERED INTO PURSUANT TO AUTHORITY OF:
	D. OTHER (Specify type of modification and authority)

E. IMPORTANT: Contractor  is not,  is required to sign this document and return \_\_\_\_\_ 1 \_\_\_\_\_ copies to the issuing office.

14. DESCRIPTION OF AMENDMENT/MODIFICATION (Organized by UCF section headings, including solicitation/contract subject matter where feasible.)  
 DUNS Number: 040156218  
 FIELD POC: Craig Raine 703-285-  
 Paul Picone 703-285-  
 Program POC: Elena Smyly 202-73-  
 M.J. Bates 202-732-  
 OAQ POC: Jerald Neveleff, Contracting Officer, 202-6-  
 Arnold Casterline, Contract Specialist, 202-514-

The purpose of this modification is to change ARTICLE I: Section C: The detainee daily rate is TBD. To: The detainee daily rate is \$62.83. This will also modify ARTICLE XI:  
Continued ...

Except as provided herein, all terms and conditions of the document referenced in Item 9A or 10A, as heretofore changed, remains unchanged and in full force and effect.

15A. NAME AND TITLE OF SIGNER (Type or print) GERALD J. SPATERS Town Mgr.		16A. NAME AND TITLE OF CONTRACTING OFFICER (Type or print) Jerald H. Neveleff	
15B. CONTRACTING OFFICER 		16B. UNITED STATES OF AMERICA 	
15C. DATE SIGNED 9/24/08		16C. DATE SIGNED 25 Sept 08	

**CONTINUATION SHEET**

REFERENCE NO. OF DOCUMENT BEING CONTINUED  
DROIGSA-08-0021//P00001

PAGE OF  
2 2

NAME OF OFFEROR OR CONTRACTOR  
FARMVILLE TOWN OF

ITEM NO. (A)	SUPPLIES/SERVICES (B)	QUANTITY (C)	UNIT (D)	UNIT PRICE (E)	AMOUNT (F)
	<p>Section B: The detainee day rate is TBD. To: The detainee day rate is \$62.83.</p> <p>After completion and approval of the facility, another Task Order will be issued with funding for the bed days.</p> <p>Period of Performance: 09/22/2008 to 09/30/2009</p>				

**Stevens, Richard P**

---

**From:** Russell Harper [b6]  
**Sent:** Thursday, September 25, 2008 8:30 AM  
**To:** Casterline, Arnold P; [b6]  
**Cc:** Raine, Craig K; Smyly, Elena L; Neveleff, Jerald  
**Subject:** RE: Modification to IGSA

Thanks Arnold. We will push ahead.

Russell

---

**From:** Casterline, Arnold P [mailto:[b6]]  
**Sent:** Thursday, September 25, 2008 8:27 AM  
**To:** Russell Harper; [b6]  
**Cc:** Raine, Craig K; Smyly, Elena L; Neveleff, Jerald  
**Subject:** Modification to IGSA

Mr. Spates,

Attached is the executed modification to establish the bed day rate for ICA Farmville. If you have any questions concerning this please feel free to contact me at [b6] or send me an email at [b6]. Thank you and have a great day.

Arnie Casterline  
*Arnold P. Casterline Jr.*  
Contract Specialist  
Immigration and Customs Enforcement  
Office of Acquisition Management  
Detention Management  
Department of Homeland Security  
425 I Street NW, 5<sup>th</sup> Floor Room 5009  
Washington, DC 20536  
e-mail: [b6] (b)(6)  
phone: 202-51 [b6]  
Main: 202-514 [b6]

**Help us support you better –  
TELL US HOW WE ARE DOING!**  
**Go to** <http://www.acqsolinc.com/ICE/OAQ/feedback.cfm>

**Stevens, Richard P**

---

**From:** Neveleff, Jerald  
**Sent:** Thursday, September 25, 2008 1:19 PM  
**To:** Archibeque, Vincent E  
**Subject:** Accepted: Piedmont Regional Jail / Farmville project

**Stevens, Richard P**

---

**From:** Neveleff, Jerald  
**Sent:** Thursday, September 25, 2008 1:53 PM  
**To:** Quiroz, Jose  
**Subject:** Re: Farmville

Field office does and I believe elena may have a copy. I also sent a copy to Yvonne.

-----Original Message-----

**From:** Quiroz, Jose  
**To:** Neveleff, Jerald  
**Sent:** Sep 25, 2008 13:35  
**Subject:** Farmville

Who has a copy of the agreement.

Jose Quiroz, Special Assistant  
Detention Management Division  
Detention and Removal Operations

U.S. Immigration and Customs Enforcement Department of Homeland Security  
801 "I" STREET, NW WASHINGTON, DC 20536 | 202.498-[REDACTED] | 202.732-[REDACTED] b6

Warning: This document is UNCLASSIFIED//FOR OFFICIAL USE ONLY (U//FOUO). It contains information that may be exempt from public release under the Freedom of Information Act (5 U.S.C. 552). It is to be controlled, stored, handled, transmitted, distributed, and disposed of in accordance with DHS policy relating to FOUO information and is not to be released to the public or other personnel who do not have a valid "need-to-know" without prior approval of an authorized DHS official. No portion of this report should be furnished to the media, either in written or verbal form.

Jerry  
Sent using BlackBerry



**Stevens, Richard P**

---

**From:** Lewis, Ashley J  
**Sent:** Thursday, September 25, 2008 7:00 PM  
**To:** Neveleff, Jerald  
**Cc:** Rocha, Richard A; Weinberg, Bill; Loiselle, Mary F  
**Subject:** FW: FYI Farmville  
**Importance:** High

Jerry,

Here is the inquiry from Public Affairs. Please reach out to Farmville and remind them that under the terms of the IGSA, all press releases or any other public disclosures of information (page 3, Article 2, paragraph E. of the IGSA) must first be coordinated with the Contracting Officer and ICE Public Affairs. Also, work with Public Affairs and Mary Loiselle to see what, if any, damage control we need to do on our end.

Thanks for taking time away from bowling! It is much appreciated.

***Ashley J. Lewis***

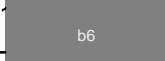
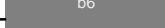
Head of Contracting Activity  
 Immigration and Customs Enforcement  
 Department of Homeland Security  
 Phone: 202-511-  
 Cell: 202-441- b6

***Help us support you better –***

***TELL US HOW WE ARE DOING!***

**Go to** <http://www.acqsolinc.com/ICE/OAQ/feedback.cfm>

---

**From:** Loiselle, Mary F  
**Sent:** Thursday, September 25, 2008 6:41 PM  
**To:** Lewis, Ashley J; Weinberg, Bill  
**Subject:** FYI Farmville

PAO has inquired as to whether or not DRO has signed an agreement with Farmville. The following information comes from a news article published by local media:

A 1,040-bed holding facility for illegal aliens will be built in Farmville.

Construction on the \$21 million 125,000-square-foot facility is expected to begin in mid-October and be completed by June 30, with its occupation beginning within days.

Ken Newsome, a spokesman for ICA-Farmville and one of the investors, said the contract to operate the facility is between Immigration and Customs Enforcement and the town. ICA-Farmville is a subcontractor that will run the facility.

In addition, ICE is expected to relocate some of its northern Virginia operation and up to 200 employees to an administrative building to be constructed on the grounds in 2010, said Newsome, a spokesman for ICA-Farmville and one of the investors.

12/21/2008

*Mary F. Loisel*  
*Assistant Director, Management*  
*Detention and Removal Operations*  
*Immigration and Customs Enforcement*  
*Department of Homeland Security*  
*801 I Street, NW*  
*Washington, DC 20536*  
*(202) 732-[REDACTED]*

b6

**Stevens, Richard P**

---

**From:** Neveleff, Jerald  
**Sent:** Thursday, September 25, 2008 9:18 PM  
**To:** [REDACTED] b6  
**Cc:** [REDACTED] b6 Weinberg, Bill  
**Subject:** PUBLIC RELEASE OF INFORMATION

Mr. Spates,

It has been brought to my attention that Farmville, specifically, ICA-Farmville (Mr. Newsome) has made a public release of information. The following was :

“A 1,040-bed holding facility for illegal aliens will be built in Farmville.

Construction on the \$21 million 125,000-square-foot facility is expected to begin in mid-October and be completed by June 30, with its occupation beginning within days.

Ken Newsome, a spokesman for ICA-Farmville and one of the investors, said the contract to operate the facility is between Immigration and Customs Enforcement and the town. ICA-Farmville is a subcontractor that will run the facility.

In addition, ICE is expected to relocate some of its northern Virginia operation and up to 200 employees to an administrative building to be constructed on the grounds in 2010, said Newsome, a spokesman for ICA-Farmville and one of the investors.

This release is in direct violation of the agreement that was just recently awarded. Article II, Subsection E of the Agreement specifically states,

- E. Notification and Public Disclosure: No public disclosures (i.e. press releases, press conferences) regarding this IGSA shall be made by the Service Provider or any of its contractors or subcontractors without the review and approval of such disclosure by ICE Public Affairs and express permission granted by the ICE Contracting Officer.

As a result of the unauthorized release, please direct your subcontractor to retract the press release.

Jerry Neveleff  
Supervisory Contracting Officer  
Immigration and Customs Enforcement  
IGSA Team Lead

**Stevens, Richard P**

---

**From:** Neveleff, Jerald  
**Sent:** Friday, September 26, 2008 6:38 AM  
**To:** [REDACTED] b6  
**Subject:** Re: Farmville

Council meetings are public. Therefore the statements made including ICE operations.

-----Original Message-----

From: Russell Harper  
To: Work  
Sent: Sep 26, 2008 05:17  
Subject: Farmville

We had a meeting with City Council to share the status of the project.  
We had NO press release.

-----  
Sent from Russell B. Harper

-----Original Message-----

From: Neveleff, Jerald [REDACTED] (b)(6)  
To: Russell Harper <rharper@hdcva.com>  
Sent: Thu Sep 25 18:59:07 2008  
Subject:

Call me please. 202 271 [REDACTED] b6  
Jerry  
Sent using BlackBerry

Jerry  
Sent using BlackBerry

**Stevens, Richard P**

---

**From:** Loiselle, Mary F  
**Sent:** Friday, September 26, 2008 7:16 AM  
**To:** Evans, Mary Y  
**Cc:** Quiroz, Jose; Carter, Albert E; Neveleff, Jerald; Moore, Marc J; Rocha, Richard A  
**Subject:** RE: Know anything an IGSA signed for Farmville?

IF we provide anything for public distribution, it must be carefully coordinated with OAQ and PAO. ICA Farmville has already violated the terms of the IGSA by speaking publicly and not clearing it with the contracting officer, Jerry. The statement that DMD provided yesterday is incomplete. There is NO funding associated with this IGSA for beds. It was put into place for the transportation aspect only, less than \$1M for 6 months. NO positions have been allocated to WAS field office for this yet. Jerry has already directed them to retract the statement. Depending upon whether or not they do, we may need to present the complete and accurate picture.

---

**From:** Evans, Mary Y  
**Sent:** Thursday, September 25, 2008 6:26 PM  
**To:** Loiselle, Mary F  
**Subject:** Re: Know anything an IGSA signed for Farmville?

Yes - according to Jerry, they signed the IGSA last week - and agreed to do transportation now. The per diem rate was finally agreed upon towards the end of the week, but as of yesterday, the county had not returned the signed copy to set the rate. We were told it would take six months after the IGSA to have the building.

Marc asked for a briefing today. OAQ and I sent him all the docs he asked for yesterday.

-----  
 Sent from my BlackBerry Wireless Handheld

---

**From:** Loiselle, Mary F  
**To:** Evans, Mary Y  
**Sent:** Thu Sep 25 17:58:19 2008  
**Subject:** Know anything an IGSA signed for Farmville?

Reporters from the Washington Post and Virginia Times Dispatch called to confirm that ICE had signed an agreement for a 1,040 bed detention facility in Farmville, Va. The company, ICA Farmville, apparently put out a news release about the agreement. Working with DRO to confirm and get details. (R. Rocha) COB Report

*Mary F. Loiselle*  
*Assistant Director, Management*  
*Detention and Removal Operations*  
*Immigration and Customs Enforcement*  
*Department of Homeland Security*  
*801 I Street, NW*  
*Washington, DC 20536*  
 (202) 732-[REDACTED] b6

**Stevens, Richard P**

---

**From:** Neveleff, Jerald  
**Sent:** Friday, September 26, 2008 7:49 AM  
**To:** Loiselle, Mary F; Evans, Mary Y  
**Subject:** Piedmont IGSA

Good morning,  
The Piedmont agreement is through the Marshall's Service.  
I am trying to get a copy of the latest and greatest version. The 1997 agreement was modified in February 2003 adding "INS" as a rider on the agreement.

Jerry

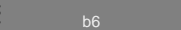
Thank you,  
Jerry Neveleff  
Supervisory Contracting Officer/  
IGSA Team Lead  
Office of Acq. Management (OAQ)  
Detention Management Division  
202/616- b6

Help us support you better -  
TELL US HOW WE ARE DOING!  
Go to <<http://www.acqsolinc.com/ICE/OAQ/feedback.cfm>> <<<http://www.acqsolinc.com/ICE/OAQ/feedback.cfm>>>

**Stevens, Richard P**

---

**From:** Russell Harper [b6]  
**Sent:** Friday, September 26, 2008 7:24 AM  
**To:** Neveleff, Jerald  
**Subject:** FARMVILLE

Jerry,

Apparently Congressman Virgil Goode had questions about the facility and its impact on Piedmont in Farmville. On Tuesday evening at 8:00 PM the Farmville Town Manager spoke Mr. Goode and updated him on the project. I understand he was comfortable after the conversation and supports the jobs and economic impact for Farmville and the region.

For months the Farmville Town Council members have requested a formal briefing to be brought up to speed on the particulars of the facility. We had put them off stating we had nothing to show but now the plans are complete and we have filed for building permits (All plans are public information) we could no longer put them off. On Wednesday September 24<sup>th</sup> at 12:00 noon we met Council in the council chambers and shared our site and building plan and the jobs.

All meetings are open to the public and about 15 folks attended; Mayor, Council members, Police Chief, Fire Chief, Building Official, a representative from the Virginia Employment Agency, reporters from the local paper, Richmond Times and Washington Post.

All were pleased and the VAE representative wanted to start advertising for jobs.

After the meeting two reporters from the Post started asking questions. I told them we were not at liberty to discuss anything with them and left.

We fully understand we are not to speak to the press but we do have to keep Farmville officials informed.

From now on there will be no need to present anything in a public forum.

Thanks

Russell

**Stevens, Richard P**

---

**From:** Neveleff, Jerald  
**Sent:** Friday, September 26, 2008 7:56 AM  
**To:** Evans, Mary Y; Quiroz, Jose  
**Cc:** Quiroz, Jose; Carter, Albert E; Rocha, Richard A  
**Subject:** RE: Know anything an IGSA signed for Farmville?

Yvonne,  
 I understand the statements were made at a Council meeting where reporters were in attendance.  
 Jerry

Thank you,  
 Jerry Neveleff  
 Supervisory Contracting Officer/  
 IGSA Team Lead  
 Office of Acq. Management (OAQ)  
 Detention Management Division  
 202/616 [REDACTED] b6

Help us support you better -  
 TELL US HOW WE ARE DOING!  
 Go to <<http://www.acqsolinc.com/ICE/OAQ/feedback.cfm>> <<<http://www.acqsolinc.com/ICE/OAQ/feedback.cfm>>>

---

**From:** Evans, Mary Y  
**Sent:** Friday, September 26, 2008 7:48 AM  
**To:** Quiroz, Jose  
**Cc:** Quiroz, Jose; Carter, Albert E; Neveleff, Jerald; Rocha, Richard A  
**Subject:** Re: Know anything an IGSA signed for Farmville?

Jose - Please send me the statement Mary referred to. Thanks

-----  
 Sent from my BlackBerry Wireless Handheld

---

**From:** Loiselle, Mary F  
**To:** Evans, Mary Y  
**Cc:** Quiroz, Jose; Carter, Albert E; Neveleff, Jerald; Moore, Marc J; Rocha, Richard A  
**Sent:** Fri Sep 26 07:15:58 2008  
**Subject:** RE: Know anything an IGSA signed for Farmville?

IF we provide anything for public distribution, it must be carefully coordinated with OAQ and PAO. ICA Farmville has already violated the terms of the IGSA by speaking publicly and not clearing it with the contracting officer, Jerry. The statement that DMD provided yesterday is incomplete. There is NO funding associated with this IGSA for beds. It was put into place for the transportation aspect only, less than \$1M for 6 months. NO positions have been allocated to WAS field office for this yet. Jerry has already directed them to retract the statement. Depending upon whether or not they do, we may need to present the complete and accurate picture.

---

**From:** Evans, Mary Y  
**Sent:** Thursday, September 25, 2008 6:26 PM

12/21/2008



**To:** Loïselle, Mary F  
**Subject:** Re: Know anything an IGSA signed for Farmville?

Yes - according to Jerry, they signed the IGSA last week - and agreed to do transportation now. The per diem rate was finally agreed upon towards the end of the week, but as of yesterday, the county had not returned the signed copy to set the rate. We were told it would take six months after the IGSA to have the building.

Marc asked for a briefing today. OAQ and I sent him all the docs he asked for yesterday.

-----  
Sent from my BlackBerry Wireless Handheld

---

**From:** Loïselle, Mary F  
**To:** Evans, Mary Y  
**Sent:** Thu Sep 25 17:58:19 2008  
**Subject:** Know anything an IGSA signed for Farmville?

· Reporters from the Washington Post and Virginia Times Dispatch called to confirm that ICE had signed an agreement for a 1,040 bed detention facility in Farmville, Va. The company, ICA Farmville, apparently put out a news release about the agreement. Working with DRO to confirm and get details. (R. Rocha) COB Report

*Mary F. Loïselle*  
*Assistant Director, Management*  
*Detention and Removal Operations*  
*Immigration and Customs Enforcement*  
*Department of Homeland Security*  
*801 I Street, NW*  
*Washington, DC 20536*  
*(202) 732-[REDACTED]*

b6

**Stevens, Richard P**

---

**From:** Neveleff, Jerald  
**Sent:** Friday, September 26, 2008 8:01 AM  
**To:** 'Lewis, Ashley J'  
**Cc:** Weinberg, Bill  
**Subject:** FW: Know anything an IGSA signed for Farmville?

Based on the call last night, and evidenced by May's email below, DRO has a better understanding of the details surrounding Farmville.

No funds have been provided for Beds. The only funding provided is in support of the transportation plan.

I understand the modification implementing the bed day rate could have been written better. I apologize.  
 Jerry

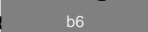
Thank you,  
 Jerry Neveleff  
 Supervisory Contracting Officer/  
 IGSA Team Lead  
 Office of Acq. Management (OAQ)  
 Detention Management Division  
 202/610- b6

Help us support you better -  
 TELL US HOW WE ARE DOING!

Go to <<http://www.acqsolinc.com/ICE/OAQ/feedback.cfm>> <<<http://www.acqsolinc.com/ICE/OAQ/feedback.cfm>>>

---

**From:** Loiselle, Mary F  
**Sent:** Friday, September 26, 2008 7:16 AM  
**To:** Evans, Mary Y  
**Cc:** Quiroz, Jose; Carter, Albert E; Neveleff, Jerald; Moore, Marc J; Rocha, Richard A  
**Subject:** RE: Know anything an IGSA signed for Farmville?

IF we provide anything for public distribution, it must be carefully coordinated with OAQ and PAO. ICA Farmville has already violated the terms of the IGSA by speaking publicly and not clearing it with the contracting officer, Jerry. The statement that DMD provided yesterday is incomplete. There is NO funding associated with this IGSA for beds. It was put into place for the transportation aspect only, less than \$1M for 6 months. NO positions have been allocated to WAS field office for this yet. Jerry has already directed them to retract the statement. Depending upon whether or not they do, we may need to present the complete and accurate picture.

---

**From:** Evans, Mary Y  
**Sent:** Thursday, September 25, 2008 6:26 PM  
**To:** Loiselle, Mary F  
**Subject:** Re: Know anything an IGSA signed for Farmville?

Yes - according to Jerry, they signed the IGSA last week - and agreed to do transportation now. The per diem rate was finally agreed upon towards the end of the week, but as of yesterday, the county had not returned the signed copy to set the rate. We were told it would take six months after the IGSA to have the building.

Marc asked for a briefing today. OAQ and I sent him all the docs he asked for yesterday.

-----

12/21/2008

Sent from my BlackBerry Wireless Handheld

---

**From:** Loisel, Mary F

**To:** Evans, Mary Y

**Sent:** Thu Sep 25 17:58:19 2008

**Subject:** Know anything an IGSA signed for Farmville?

Reporters from the Washington Post and Virginia Times Dispatch called to confirm that ICE had signed an agreement for a 1,040 bed detention facility in Farmville, Va. The company, ICA Farmville, apparently put out a news release about the agreement. Working with DRO to confirm and get details. (R. Rocha) COB Report

*Mary F. Loisel*  
*Assistant Director, Management*  
*Detention and Removal Operations*  
*Immigration and Customs Enforcement*  
*Department of Homeland Security*  
*801 I Street, NW*  
*Washington, DC 20536*  
(202) 73. b6

12/21/2008

**Stevens, Richard P**

---

**From:** Neveleff, Jerald  
**Sent:** Friday, September 26, 2008 8:16 AM  
**To:** Loiselle, Mary F; Evans, Mary Y; 'Lewis, Ashley J'  
**Cc:** Nantel, Kelly A  
**Subject:** FW: PUBLIC RELEASE OF INFORMATION

This is the email I sent last night.

Thank you,  
 Jerry Neveleff  
 Supervisory Contracting Officer/  
 IGSA Team Lead  
 Office of Acq. Management (OAQ)  
 Detention Management Division  
 202/616- [REDACTED] b6

Help us support you better -  
 TELL US HOW WE ARE DOING!  
 Go to <<http://www.acqsolinc.com/ICE/OAQ/feedback.cfm>> <<<http://www.acqsolinc.com/ICE/OAQ/feedback.cfm>>>

---

**From:** Neveleff, Jerald  
**Sent:** Thursday, September 25, 2008 9:18 PM  
**To:** [REDACTED] b6  
**Cc:** [REDACTED] b6 /einberg, Bill  
**Subject:** PUBLIC RELEASE OF INFORMATION

Mr. Spates,  
 It has been brought to my attention that Farmville, specifically, ICA-Farmville (Mr. Newsome) has made a public release of information. The following was :

"A 1,040-bed holding facility for illegal aliens will be built in Farmville.

Construction on the \$21 million 125,000-square-foot facility is expected to begin in mid-October and be completed by June 30, with its occupation beginning within days.

Ken Newsome, a spokesman for ICA-Farmville and one of the investors, said the contract to operate the facility is between Immigration and Customs Enforcement and the town. ICA-Farmville is a subcontractor that will run the facility.

In addition, ICE is expected to relocate some of its northern Virginia operation and up to 200 employees to an administrative building to be constructed on the grounds in 2010, said Newsome, a spokesman for ICA-Farmville and one of the investors.

This release is in direct violation of the agreement that was just recently awarded. Article II, Subsection E of the Agreement specifically states,

- E. Notification and Public Disclosure: No public disclosures (i.e. press releases, press conferences) regarding this IGSA shall be made by the Service Provider or any of its contractors or subcontractors without the review and approval of such disclosure by ICE Public Affairs and express permission granted by the ICE Contracting

12/21/2008

Officer.

As a result of the unauthorized release, please direct your subcontractor to retract the press release.

Jerry Neveleff  
Supervisory Contracting Officer  
Immigration and Customs Enforcement  
IGSA Team Lead

**Stevens, Richard P**

---

**From:** Nantel, Kelly A  
**Sent:** Friday, September 26, 2008 8:30 AM  
**To:** Neveleff, Jerald; 'Loiselle, Mary F'; Evans, Mary Y; 'Lewis, Ashley J'  
**Cc:** Burrell, Wendy G  
**Subject:** RE: PUBLIC RELEASE OF INFORMATION

While it is necessary to get them to retract the release – it doesn't address the damaged that has already been done. We still have to answer the media questions from yesterday and need details. In addition, we need to figure out a way forward so that OPA isn't left flat footed when we enter into these agreements in the future. Like OCR, we need advance notice as well. Thanks.

---

**From:** Neveleff, Jerald  
**Sent:** Friday, September 26, 2008 8:16 AM  
**To:** Loiselle, Mary F; Evans, Mary Y; 'Lewis, Ashley J'  
**Cc:** Nantel, Kelly A  
**Subject:** FW: PUBLIC RELEASE OF INFORMATION

This is the email I sent last night.

Thank you,  
Jerry Neveleff  
Supervisory Contracting Officer/  
IGSA Team Lead  
Office of Acq. Management (OAQ)  
Detention Management Division  
202/616- [b6]

Help us support you better -  
TELL US HOW WE ARE DOING!  
Go to <<http://www.acqsolinc.com/ICE/OAQ/feedback.cfm>> <<<http://www.acqsolinc.com/ICE/OAQ/feedback.cfm>>>

---

**From:** Neveleff, Jerald  
**Sent:** Thursday, September 25, 2008 9:18 PM  
**To:** [b6]  
**Cc:** [b6] /einberg, Bill  
**Subject:** PUBLIC RELEASE OF INFORMATION

Mr. Spates,  
It has been brought to my attention that Farmville, specifically, ICA-Farmville (Mr. Newsome) has made a public release of information. The following was :

"A 1,040-bed holding facility for illegal aliens will be built in Farmville.

Construction on the \$21 million 125,000-square-foot facility is expected to begin in mid-October and be completed by June 30, with its occupation beginning within days.

Ken Newsome, a spokesman for ICA-Farmville and one of the investors, said the contract to operate the facility is between Immigration and Customs Enforcement and the town. ICA-Farmville is a subcontractor that will run the facility.

In addition, ICE is expected to relocate some of its northern Virginia operation and up to 200 employees to an administrative building to be constructed on the grounds in 2010, said Newsome, a spokesman for ICA-Farmville and one of the investors.

This release is in direct violation of the agreement that was just recently awarded. Article II, Subsection E of the Agreement specifically states,

- E. Notification and Public Disclosure: No public disclosures (i.e. press releases, press conferences) regarding this IGSA shall be made by the Service Provider or any of its contractors or subcontractors without the review and approval of such disclosure by ICE Public Affairs and express permission granted by the ICE Contracting Officer.

As a result of the unauthorized release, please direct your subcontractor to retract the press release.

Jerry Neveleff  
Supervisory Contracting Officer  
Immigration and Customs Enforcement  
IGSA Team Lead

**Stevens, Richard P**

---

**From:** Lewis, Ashley J [REDACTED] (b)(6)  
**Sent:** Friday, September 26, 2008 8:32 AM  
**To:** Neveleff, Jerald  
**Subject:** Re: PUBLIC RELEASE OF INFORMATION

Great!

-----  
Sent using BlackBerry. Please pardon any typos!

---

**From:** Neveleff, Jerald  
**To:** Loiselle, Mary F ; Evans, Mary Y ; Lewis, Ashley J  
**Cc:** Nantel, Kelly A  
**Sent:** Fri Sep 26 08:16:11 2008  
**Subject:** FW: PUBLIC RELEASE OF INFORMATION

This is the email I sent last night.

Thank you,  
Jerry Neveleff  
Supervisory Contracting Officer/  
IGSA Team Lead  
Office of Acq. Management (OAO)  
Detention Management Division  
202/616 [REDACTED] b6

Help us support you better -  
TELL US HOW WE ARE DOING!  
Go to <<http://www.acqsolinc.com/ICE/OAQ/feedback.cfm>> <<<http://www.acqsolinc.com/ICE/OAQ/feedback.cfm>>>

---

**From:** Neveleff, Jerald  
**Sent:** Thursday, September 25, 2008 9:18 PM  
**To:** [REDACTED] b6  
**Cc:** [REDACTED] b6 Weinberg, Bill  
**Subject:** PUBLIC RELEASE OF INFORMATION

Mr. Spates,  
It has been brought to my attention that Farmville, specifically, ICA-Farmville (Mr. Newsome) has made a public release of information. The following was :

"A 1,040-bed holding facility for illegal aliens will be built in Farmville.

Construction on the \$21 million 125,000-square-foot facility is expected to begin in mid-October and be completed by June 30, with its occupation beginning within days.

Ken Newsome, a spokesman for ICA-Farmville and one of the investors, said the contract to operate the facility is between Immigration and Customs Enforcement and the town. ICA-Farmville is a subcontractor that will run the facility.

12/21/2008



In addition, ICE is expected to relocate some of its northern Virginia operation and up to 200 employees to an administrative building to be constructed on the grounds in 2010, said Newsome, a spokesman for ICA-Farmville and one of the investors.

This release is in direct violation of the agreement that was just recently awarded. Article II, Subsection E of the Agreement specifically states,

- E. Notification and Public Disclosure: No public disclosures (i.e. press releases, press conferences) regarding this IGSA shall be made by the Service Provider or any of its contractors or subcontractors without the review and approval of such disclosure by ICE Public Affairs and express permission granted by the ICE Contracting Officer.

As a result of the unauthorized release, please direct your subcontractor to retract the press release.

Jerry Neveleff  
Supervisory Contracting Officer  
Immigration and Customs Enforcement  
IGSA Team Lead

**Stevens, Richard P**

---

**From:** Lewis, Ashley J (b)(6)  
**Sent:** Friday, September 26, 2008 8:33 AM  
**To:** Nantel, Kelly A; Neveleff, Jerald; Loiselle, Mary F; Evans, Mary Y; Lewis, Ashley J  
**Cc:** Burrell, Wendy G  
**Subject:** Re: PUBLIC RELEASE OF INFORMATION

Kelly-call my cell 20244 (b)(6)

Sent using BlackBerry. Please pardon any typos!

---

**From:** Nantel, Kelly A  
**To:** Neveleff, Jerald ; Loiselle, Mary F ; Evans, Mary Y ; Lewis, Ashley J  
**Cc:** Burrell, Wendy G  
**Sent:** Fri Sep 26 08:29:44 2008  
**Subject:** RE: PUBLIC RELEASE OF INFORMATION

While it is necessary to get them to retract the release – it doesn't address the damaged that has already been done. We still have to answer the media questions from yesterday and need details. In addition, we need to figure out a way forward so that OPA isn't left flat footed when we enter into these agreements in the future. Like OCR, we need advance notice as well. Thanks.

---

**From:** Neveleff, Jerald  
**Sent:** Friday, September 26, 2008 8:16 AM  
**To:** Loiselle, Mary F; Evans, Mary Y; 'Lewis, Ashley J'  
**Cc:** Nantel, Kelly A  
**Subject:** FW: PUBLIC RELEASE OF INFORMATION

This is the email I sent last night.

Thank you,  
Jerry Neveleff  
Supervisory Contracting Officer/  
IGSA Team Lead  
Office of Acq. Management (OAQ)  
Detention Management Division  
202/616 (b)(6)

Help us support you better -  
TELL US HOW WE ARE DOING!  
Go to <<http://www.acqsolinc.com/ICE/OAQ/feedback.cfm>> <<<http://www.acqsolinc.com/ICE/OAQ/feedback.cfm>>>

---

**From:** Neveleff, Jerald  
**Sent:** Thursday, September 25, 2008 9:18 PM  
**To:** 'gspates@farmvilleva.com'  
**Cc:** 'rharper@hdcva.com'; Weinberg, Bill  
**Subject:** PUBLIC RELEASE OF INFORMATION

Mr. Spates,

It has been brought to my attention that Farmville, specifically, ICA-Farmville (Mr. Newsome) has made a public release of information. The following was :

"A 1,040-bed holding facility for illegal aliens will be built in Farmville.

Construction on the \$21 million 125,000-square-foot facility is expected to begin in mid-October and be completed by June 30, with its occupation beginning within days.

Ken Newsome, a spokesman for ICA-Farmville and one of the investors, said the contract to operate the facility is between Immigration and Customs Enforcement and the town. ICA-Farmville is a subcontractor that will run the facility.

In addition, ICE is expected to relocate some of its northern Virginia operation and up to 200 employees to an administrative building to be constructed on the grounds in 2010, said Newsome, a spokesman for ICA-Farmville and one of the investors.

This release is in direct violation of the agreement that was just recently awarded. Article II, Subsection E of the Agreement specifically states,

- E. Notification and Public Disclosure: No public disclosures (i.e. press releases, press conferences) regarding this IGSA shall be made by the Service Provider or any of its contractors or subcontractors without the review and approval of such disclosure by ICE Public Affairs and express permission granted by the ICE Contracting Officer.

As a result of the unauthorized release, please direct your subcontractor to retract the press release.

Jerry Neveleff  
Supervisory Contracting Officer  
Immigration and Customs Enforcement  
IGSA Team Lead

**Stevens, Richard P**

---

**From:** Nantel, Kelly A [REDACTED] (b)(6)  
**Sent:** Friday, September 26, 2008 8:40 AM  
**To:** Lewis, Ashley J; Nantel, Kelly A; Neveleff, Jerald; Loiselle, Mary F; Evans, Mary Y  
**Cc:** Burrell, Wendy G  
**Subject:** RE: PUBLIC RELEASE OF INFORMATION

Folks – as I re-read my email, I realized that it could read as a bit testy – my apologies for that – it wasn't my intention. What I was trying to get across is that between OPA and DRO, we need to figure out a way to ensure that changes like this are communicated to us before they occur so we aren't faced with a situation where a member of the press knows more than we do. Again, sorry if the email sounded testy – I know folks are working hard to get the release rescinded. Thanks.

---

**From:** Nantel, Kelly A  
**To:** Neveleff, Jerald ; Loiselle, Mary F ; Evans, Mary Y ; Lewis, Ashley J  
**Cc:** Burrell, Wendy G  
**Sent:** Fri Sep 26 08:29:44 2008  
**Subject:** RE: PUBLIC RELEASE OF INFORMATION

While it is necessary to get them to retract the release – it doesn't address the damaged that has already been done. We still have to answer the media questions from yesterday and need details. In addition, we need to figure out a way forward so that OPA isn't left flat footed when we enter into these agreements in the future. Like OCR, we need advance notice as well. Thanks.

---

**From:** Neveleff, Jerald  
**Sent:** Friday, September 26, 2008 8:16 AM  
**To:** Loiselle, Mary F; Evans, Mary Y; 'Lewis, Ashley J'  
**Cc:** Nantel, Kelly A  
**Subject:** FW: PUBLIC RELEASE OF INFORMATION

This is the email I sent last night.

Thank you,  
 Jerry Neveleff  
 Supervisory Contracting Officer/  
 IGSA Team Lead  
 Office of Acq. Management (OAQ)  
 Detention Management Division  
 202/616 [REDACTED] b6

Help us support you better -  
 TELL US HOW WE ARE DOING!  
 Go to <http://www.acqsolinc.com/ICE/OAQ/feedback.cfm> <<<http://www.acqsolinc.com/ICE/OAQ/feedback.cfm>>>

---

**From:** Neveleff, Jerald  
**Sent:** Thursday, September 25, 2008 9:18 PM  
**To:** [REDACTED] b6  
**Cc:** [REDACTED] b6 Weinberg, Bill  
**Subject:** PUBLIC RELEASE OF INFORMATION

12/21/2008

Mr. Spates,

It has been brought to my attention that Farmville, specifically, ICA-Farmville (Mr. Newsome) has made a public release of information. The following was :

"A 1,040-bed holding facility for illegal aliens will be built in Farmville.

Construction on the \$21 million 125,000-square-foot facility is expected to begin in mid-October and be completed by June 30, with its occupation beginning within days.

Ken Newsome, a spokesman for ICA-Farmville and one of the investors, said the contract to operate the facility is between Immigration and Customs Enforcement and the town. ICA-Farmville is a subcontractor that will run the facility.

In addition, ICE is expected to relocate some of its northern Virginia operation and up to 200 employees to an administrative building to be constructed on the grounds in 2010, said Newsome, a spokesman for ICA-Farmville and one of the investors.

This release is in direct violation of the agreement that was just recently awarded. Article II, Subsection E of the Agreement specifically states,

- E. Notification and Public Disclosure: No public disclosures (i.e. press releases, press conferences) regarding this IGSA shall be made by the Service Provider or any of its contractors or subcontractors without the review and approval of such disclosure by ICE Public Affairs and express permission granted by the ICE Contracting Officer.

As a result of the unauthorized release, please direct your subcontractor to retract the press release.

Jerry Neveleff  
Supervisory Contracting Officer  
Immigration and Customs Enforcement  
IGSA Team Lead

**Stevens, Richard P**

---

**From:** Weinberg, Bill  
**Sent:** Friday, September 26, 2008 9:28 AM  
**To:** Neveleff, Jerald  
**Subject:** FW: DRAFT EMAIL

*J. William Weinberg*  
**Assistant Director (AD),  
Office of Acquisition Management (OAQ)  
Detention Management Division (DMD)  
Immigration & Customs Enforcement (ICE)  
Department of Homeland Security (DHS)**

Main: 202-514

Desk: 202-307

Cell: 202-271

Fax: 202-305

b6

eMail:

(b)(6)

*Help us support you better -  
TELL US HOW WE ARE DOING!*

Go To <http://www.acqsolinc.com/ICE/OAQ/feedback.cfm>

---

**From:** Neveleff, Jerald  
**Sent:** Friday, September 26, 2008 9:20 AM  
**To:** Weinberg, Bill  
**Subject:** RE: DRAFT EMAIL

Still a draft;

(b)(5)

(b)(5)

Thank you,  
Jerry Neveleff  
Supervisory Contracting Officer/  
IGSA Team Lead  
Office of Acq. Management (OAQ)  
Detention Management Division  
202/616-b6

Help us support you better -  
TELL US HOW WE ARE DOING!

Go to <http://www.acqsolinc.com/ICE/OAQ/feedback.cfm> <<<http://www.acqsolinc.com/ICE/OAQ/feedback.cfm>>>

**Stevens, Richard P**

---

**From:** Lewis, Ashley J (b)(6)  
**Sent:** Friday, September 26, 2008 11:13 AM  
**To:** Neveleff, Jerald; Longmeyer-Wood, Jennifer L  
**Cc:** Loiselle, Mary F; Evans, Mary Y; Dellar, William L; Lewis, Ashley J; Nantel, Kelly A  
**Subject:** RE: DRAFT EMAIL  
**Importance:** High

Jerry,

See changes and ensure you clean-up formatting before release.

***Ashley J. Lewis***

Head of Contracting Activity  
Immigration and Customs Enforcement  
Department of Homeland Security  
Phone: 202-511- (b)(6)  
Cell: 202-441- (b)(6)

***Help us support you better –***

***TELL US HOW WE ARE DOING!***

**Go to** <http://www.acqsolinc.com/ICE/OAQ/feedback.cfm>

---

**From:** Neveleff, Jerald [mailto:(b)(6)]  
**Sent:** Friday, September 26, 2008 10:56 AM  
**To:** Longmeyer-Wood, Jennifer L  
**Cc:** Loiselle, Mary F; Evans, Mary Y; Dellar, William L; Lewis, Ashley J; Nantel, Kelly A  
**Subject:** FW: DRAFT EMAIL

This reformats what was sent earlier but addresses in appropriate release of info.

(b)(5)



(b)(5)

Thank you,

Jerry Neveleff

Supervisory Contracting Officer/

IGSA Team Lead

Office of Acq. Management (OAQ)

Detention Management Division

202/616-b6

Help us support you better -

TELL US HOW WE ARE DOING!

Go to <http://www.acqsolinc.com/ICE/OAQ/feedback.cfm> <<<http://www.acqsolinc.com/ICE/OAQ/feedback.cfm>>>

12/21/2008

**Stevens, Richard P**

---

**From:** Lewis, Ashley J [redacted] (b)(6)  
**Sent:** Friday, September 26, 2008 11:19 AM  
**To:** Loiselle, Mary F  
**Cc:** Evans, Mary Y; Dellar, William L; Nantel, Kelly A; Neveleff, Jerald; Longmeyer-Wood, Jennifer L  
**Subject:** RE: DRAFT EMAIL

Not being a public relations expert (in fact some would say I fall a little short in this area), I will defer to PAO to make the call as to what should be done.

***Ashley J. Lewis***

Head of Contracting Activity  
Immigration and Customs Enforcement  
Department of Homeland Security  
Phone: 202-5 [redacted]  
Cell: 202-441 [redacted] b6

***Help us support you better –***

***TELL US HOW WE ARE DOING!***

**Go to** <http://www.acqsolinc.com/ICE/OAQ/feedback.cfm>

---

**From:** Loiselle, Mary F [mailto:[redacted]] (b)(6)  
**Sent:** Friday, September 26, 2008 11:17 AM  
**To:** Lewis, Ashley J; Neveleff, Jerald; Longmeyer-Wood, Jennifer L  
**Cc:** Loiselle, Mary F; Evans, Mary Y; Dellar, William L; Nantel, Kelly A  
**Subject:** Re: DRAFT EMAIL

It covers the points that I consider necessary. Thanks.

Kelly makes a point about whether or not they retract yesterday's info, it's already out there. What do we want PAO to tell the reporter today?

---

**From:** Lewis, Ashley J  
**To:** Neveleff, Jerald ; Longmeyer-Wood, Jennifer L  
**Cc:** Loiselle, Mary F ; Evans, Mary Y ; Dellar, William L ; Lewis, Ashley J ; Nantel, Kelly A  
**Sent:** Fri Sep 26 11:13:13 2008  
**Subject:** RE: DRAFT EMAIL

Jerry,

See changes and ensure you clean-up formatting before release.

***Ashley J. Lewis***

12/21/2008

Head of Contracting Activity  
Immigration and Customs Enforcement  
Department of Homeland Security  
Phone: 202-51-  
Cell: 202-441-

b6

*Help us support you better –  
TELL US HOW WE ARE DOING!*

Go to <http://www.acqsolinc.com/ICE/OAQ/feedback.cfm>

---

**From:** Neveleff, Jerald [mailto:  
**Sent:** Friday, September 26, 2008 10:56 AM  
**To:** Longmeyer-Wood, Jennifer L  
**Cc:** Loiselle, Mary F; Evans, Mary Y; Dellar, William L; Lewis, Ashley J; Nantel, Kelly A  
**Subject:** FW: DRAFT EMAIL

This reformats what was sent earlier but addresses in appropriate release of info.

(b)(5)

(b)(5)

Thank you,

Jerry Neveleff

Supervisory Contracting Officer/

IGSA Team Lead

Office of Acq. Management (OAQ)

Detention Management Division

202/616-b6

Help us support you better -

TELL US HOW WE ARE DOING!

Go to <http://www.acqsolinc.com/ICE/OAQ/feedback.cfm> <<<http://www.acqsolinc.com/ICE/OAQ/feedback.cfm>>>

## Stevens, Richard P

---

**From:** Neveleff, Jerald  
**Sent:** Friday, September 26, 2008 12:59 PM  
**To:** [REDACTED] b6  
**Cc:** 'Loiselle, Mary F'; Evans, Mary Y; Dellar, William L; Longmeyer-Wood, Jennifer L; 'Lewis, Ashley J'; Weinberg, Bill  
**Subject:** PUBLIC DISCLOSURE OF INFORMATION

Mr. Spates,

It has come to our attention that at a recent Council meeting, a person affiliated with the Subcontractor ICA-Farmville, released information about the recently awarded Inter-Governmental Service Agreement (IGSA). The information released was misleading to those not familiar with an IGSA. Specifically, ICE has grave concerns with the following actions and/or statements that were released.

First - You are reminded that in accordance with the terms of the IGSA the disclosure of any information pertaining to the agreement must first be approved by ICE and authorized by the Contracting Officer. Additionally, any information regarding staffing and operations for this facility can only be released by ICE. Article II Section E of the IGSA states:

Notification and Public Disclosure: No public disclosures (i.e. press releases, press conferences) regarding this IGSA shall be made by the Service Provider or any of its contractors or subcontractors without the review and approval of such disclosure by ICE Public Affairs and express permission granted by the ICE Contracting Officer.

Second - At this time, ICE has provided funding in the amount of \$968,000 solely for transportation services. Accordingly, the information released yesterday is not accurate. ICE has not provided any funding for the housing of detainees and will not do so until all of the following conditions are satisfied:

- an operational need is identified;
- funding becomes available; and,
- the facility is complete and meets all ICE detention requirements

To ensure there is no misunderstanding with respect to our obligations to the County, I am restating Article II, Section A of the IGSA:

Funding: *The obligation of ICE to make payments to the Service Provider is contingent upon the availability of Federal funds. ICE will neither present detainees to the Service Provider nor direct performance of any other services until ICE has the appropriate funding. Orders will be placed under this Agreement when specific requirements have been identified and funding obtained. Performance under this Agreement is not authorized until the Contracting Officer issues an order, in writing.* The effective date of the Agreement will be negotiated and specified in an order to this Agreement by the Contracting Officer. This Agreement is neither binding nor effective unless signed by the Contracting Officer. Payments at the approved rate will be paid upon the return of the signed Agreement by the authorized Local Government official to ICE.

We look forward to a mutually beneficial relationship with your County, however to prevent further incidents of this nature please review the IGSA in its entirety. If you have questions or would like to discuss any term or condition of the IGSA, please do not hesitate to reach out to me.

Thank you,  
Jerry Neveleff  
Supervisory Contracting Officer/  
IGSA Team Lead  
Office of Acq. Management (OAQ)  
Detention Management Division  
202/616-b6

Help us support you better -  
TELL US HOW WE ARE DOING!

Go to <http://www.acqsolinc.com/ICE/OAQ/feedback.cfm> <<<http://www.acqsolinc.com/ICE/OAQ/feedback.cfm>>>

**Stevens, Richard P**

---

**From:** Rocha, Richard A  
**Sent:** Friday, September 26, 2008 12:16 PM  
**To:** Dellar, William L; Neveleff, Jerald  
**Cc:** Evans, Mary Y  
**Subject:** RE: DRAFT EMAIL

- Bill and Jerry, please let me know when you think i might be able to meet with you two in the next couple of hours. i was at a training but i'm back in the building now ... anytime except for 230- 3pm works for me .. i'm hoping we can do it before then if possible. Thanks, Richard Rocha ICE Public Affairs.

202-616 [REDACTED] b6

---

**From:** Evans, Mary Y  
**Sent:** Friday, September 26, 2008 12:02 PM  
**To:** Rocha, Richard A  
**Cc:** Dellar, William L  
**Subject:** Re: DRAFT EMAIL

Bill - Jerry has been working this all morning too.

-----  
Sent from my BlackBerry Wireless Handheld

---

**From:** Loiselle, Mary F  
**To:** Rocha, Richard A  
**Cc:** Evans, Mary Y; Dellar, William L  
**Sent:** Fri Sep 26 12:00:27 2008  
**Subject:** Fw: DRAFT EMAIL

Richard-  
Here's the most recent exchange with OAQ, DRO and Kelly. Not sure of Kelly's response but I think the points below are what we need to emphasize. I disagree that Shanahan is the POC. Please coordinate with Bill Dellar. Thanks.  
Mary

---

**From:** Lewis, Ashley J  
**To:** Loiselle, Mary F  
**Cc:** Evans, Mary Y ; Dellar, William L ; Nantel, Kelly A ; Neveleff, Jerald ; Longmeyer-Wood, Jennifer L  
**Sent:** Fri Sep 26 11:19:06 2008  
**Subject:** RE: DRAFT EMAIL

Not being a public relations expert (in fact some would say I fall a little short in this area), I will defer to PAO to make the call as to what should be done.

*Ashley J. Lewis*  
Head of Contracting Activity  
Immigration and Customs Enforcement

12/21/2008

Department of Homeland Security  
Phone: 202-5 [REDACTED]  
Cell: 202-441 [REDACTED]

b6

**Help us support you better –  
TELL US HOW WE ARE DOING!**

Go to <http://www.acqsolinc.com/ICE/OAQ/feedback.cfm>

---

**From:** Loisel, Mary F [mailto:[REDACTED]]  
**Sent:** Friday, September 26, 2008 11:17 AM  
**To:** Lewis, Ashley J; Neveleff, Jerald; Longmeyer-Wood, Jennifer L  
**Cc:** Loisel, Mary F; Evans, Mary Y; Dellar, William L; Nantel, Kelly A  
**Subject:** Re: DRAFT EMAIL

It covers the points that I consider necessary. Thanks.  
Kelly makes a point about whether or not they retract yesterday's info, it's already out there. What do we want PAO to tell the reporter today?

---

**From:** Lewis, Ashley J  
**To:** Neveleff, Jerald ; Longmeyer-Wood, Jennifer L  
**Cc:** Loisel, Mary F ; Evans, Mary Y ; Dellar, William L ; Lewis, Ashley J ; Nantel, Kelly A  
**Sent:** Fri Sep 26 11:13:13 2008  
**Subject:** RE: DRAFT EMAIL

Jerry,

See changes and ensure you clean-up formatting before release.

**Ashley J. Lewis**  
Head of Contracting Activity  
Immigration and Customs Enforcement  
Department of Homeland Security  
Phone: 202-5 [REDACTED]  
Cell: 202-441 [REDACTED]

b6

**Help us support you better –  
TELL US HOW WE ARE DOING!**

Go to <http://www.acqsolinc.com/ICE/OAQ/feedback.cfm>

---

**From:** Neveleff, Jerald [mailto:[REDACTED]]  
**Sent:** Friday, September 26, 2008 10:56 AM  
**To:** Longmeyer-Wood, Jennifer L



**Cc:** Loiselle, Mary F; Evans, Mary Y; Dellar, William L; Lewis, Ashley J; Nantel, Kelly A  
**Subject:** FW: DRAFT EMAIL

This reformats what was sent earlier but addresses in appropriate release of info.



(b)(5)

Thank you,

Jerry Neveleff

Supervisory Contracting Officer/

IGSA Team Lead

12/21/2008

Office of Acq. Management (OAQ)

Detention Management Division

202/616 [REDACTED] b6

Help us support you better -

TELL US HOW WE ARE DOING!

Go to <http://www.acqsolinc.com/ICE/OAQ/feedback.cfm> <<<http://www.acqsolinc.com/ICE/OAQ/feedback.cfm>>>

**Stevens, Richard P**

---

**From:** Lewis, Ashley J (b)(6)  
**Sent:** Friday, September 26, 2008 12:17 PM  
**To:** Neveleff, Jerald; Lewis, Ashley J  
**Cc:** Longmeyer-Wood, Jennifer L  
**Subject:** Re: Farmville Email

Terrific. Let her rip and copy all involved.

-----  
Sent using BlackBerry. Please pardon any typos!

---

**From:** Neveleff, Jerald  
**To:** Lewis, Ashley J  
**Cc:** Longmeyer-Wood, Jennifer L  
**Sent:** Fri Sep 26 12:14:15 2008  
**Subject:** Farmville Email

Here's the email as reviewed with Jennifer. Please let me know if you are okay with the version.

Jerry



(b)(5)

(b)(5)

Thank you,

Jerry Neveleff

Supervisory Contracting Officer/

IGSA Team Lead

Office of Acq. Management (OAQ)

Detention Management Division

202/616-b6

Help us support you better -

TELL US HOW WE ARE DOING!

Go to <http://www.acqsolinc.com/ICE/OAQ/feedback.cfm> <<<http://www.acqsolinc.com/ICE/OAQ/feedback.cfm>>>

**Stevens, Richard P**

---

**From:** Neveleff, Jerald  
**Sent:** Friday, September 26, 2008 1:04 PM  
**To:** Rocha, Richard A  
**Subject:** FW: PUBLIC DISCLOSURE OF INFORMATION

Richard,  
Here's the email I sent to Farmville and the POCs

Mr. Gerald Spates, Town Manager, Town of Farmville, 434 [b6] (Provider)  
Mr. Russell Harper, Immigration Centers of America (ICA) – Farmville LLC, 804 [b6] (Subcontractor)

Jerry

Thank you,  
Jerry Neveleff  
Supervisory Contracting Officer/  
IGSA Team Lead  
Office of Acq. Management (OAQ)  
Detention Management Division  
202/616 [b6]

Help us support you better -  
TELL US HOW WE ARE DOING!  
Go to <<http://www.acqsolinc.com/ICE/OAQ/feedback.cfm>> <<<http://www.acqsolinc.com/ICE/OAQ/feedback.cfm>>>

---

**From:** Neveleff, Jerald  
**Sent:** Friday, September 26, 2008 12:59 PM  
**To:** [b6]  
**Cc:** 'Loiselle, Mary F'; Evans, Mary Y; Dellar, William L; Longmeyer-Wood, Jennifer L; 'Lewis, Ashley J'; Weinberg, Bill  
**Subject:** PUBLIC DISCLOSURE OF INFORMATION

Mr. Spates,

It has come to our attention that at a recent Council meeting, a person affiliated with the Subcontractor ICA-Farmville, released information about the recently awarded Inter-Governmental Service Agreement (IGSA). The information released was misleading to those not familiar with an IGSA. Specifically, ICE has grave concerns with the following actions and/or statements that were released.

First - You are reminded that in accordance with the terms of the IGSA the disclosure of any information pertaining to the agreement must first be approved by ICE and authorized by the Contracting Officer. Additionally, any information regarding staffing and operations for this facility can only be released by ICE. Article II Section E of the IGSA states:

Notification and Public Disclosure: No public disclosures (i.e. press releases, press conferences) regarding this IGSA shall be made by the Service Provider or any of its contractors or subcontractors without the review and approval of such disclosure by ICE Public Affairs and express permission granted by the ICE Contracting Officer.

Second - At this time, ICE has provided funding in the amount of \$968,000 solely for transportation services. Accordingly, the information released yesterday is not accurate. ICE has not provided any funding for the housing of detainees and will not do so until all of the following conditions are satisfied:

- an operational need is identified;
- funding becomes available; and,
- the facility is complete and meets all ICE detention requirements

To ensure there is no misunderstanding with respect to our obligations to the County, I am restating Article II, Section A of the IGSA:

**Funding: The obligation of ICE to make payments to the Service Provider is contingent upon the availability of Federal funds. ICE will neither present detainees to the Service Provider nor direct performance of any other services until ICE has the appropriate funding. Orders will be placed under this Agreement when specific requirements have been identified and funding obtained. Performance under this Agreement is not authorized until the Contracting Officer issues an order, in writing.** The effective date of the Agreement will be negotiated and specified in an order to this Agreement by the Contracting Officer. This Agreement is neither binding nor effective unless signed by the Contracting Officer. Payments at the approved rate will be paid upon the return of the signed Agreement by the authorized Local Government official to ICE.

We look forward to a mutually beneficial relationship with your County, however to prevent further incidents of this nature please review the IGSA in its entirety. If you have questions or would like to discuss any term or condition of the IGSA, please do not hesitate to reach out to me.

Thank you,  
Jerry Neveleff  
Supervisory Contracting Officer/  
IGSA Team Lead  
Office of Acq. Management (OAQ)  
Detention Management Division  
202/616-b6

Help us support you better -  
TELL US HOW WE ARE DOING!  
Go to <http://www.acqsolinc.com/ICE/OAQ/feedback.cfm> <<<http://www.acqsolinc.com/ICE/OAQ/feedback.cfm>>>

**Stevens, Richard P**

---

**From:** Lewis, Ashley J [REDACTED] (b)(6)  
**Sent:** Friday, September 26, 2008 1:06 PM  
**To:** Neveleff, Jerald  
**Cc:** Weinberg, Bill  
**Subject:** Re: PUBLIC DISCLOSURE OF INFORMATION

Good job, Jerry.

-----  
Sent using BlackBerry. Please pardon any typos!

---

**From:** Neveleff, Jerald  
**To:** [REDACTED] b6  
**Cc:** Loiselle, Mary F ; Evans, Mary Y ; Dellar, William L ; Longmeyer-Wood, Jennifer L ; Lewis, Ashley J ; Weinberg, Bill  
**Sent:** Fri Sep 26 12:59:27 2008  
**Subject:** PUBLIC DISCLOSURE OF INFORMATION

Mr. Spates,

It has come to our attention that at a recent Council meeting, a person affiliated with the Subcontractor ICA-Farmville, released information about the recently awarded Inter-Governmental Service Agreement (IGSA). The information released was misleading to those not familiar with an IGSA. Specifically, ICE has grave concerns with the following actions and/or statements that were released.

First - You are reminded that in accordance with the terms of the IGSA the disclosure of any information pertaining to the agreement must first be approved by ICE and authorized by the Contracting Officer. Additionally, any information regarding staffing and operations for this facility can only be released by ICE. Article II Section E of the IGSA states:

Notification and Public Disclosure: No public disclosures (i.e. press releases, press conferences) regarding this IGSA shall be made by the Service Provider or any of its contractors or subcontractors without the review and approval of such disclosure by ICE Public Affairs and express permission granted by the ICE Contracting Officer.

Second - At this time, ICE has provided funding in the amount of \$968,000 solely for transportation services. Accordingly, the information released yesterday is not accurate. ICE has not provided any funding for the housing of detainees and will not do so until all of the following conditions are satisfied:

- an operational need is identified;
- funding becomes available; and,
- the facility is complete and meets all ICE detention requirements

To ensure there is no misunderstanding with respect to our obligations to the County, I am restating Article II, Section A of the IGSA:

Funding: *The obligation of ICE to make payments to the Service Provider is contingent*

12/21/2008

**upon the availability of Federal funds. ICE will neither present detainees to the Service Provider nor direct performance of any other services until ICE has the appropriate funding. Orders will be placed under this Agreement when specific requirements have been identified and funding obtained. Performance under this Agreement is not authorized until the Contracting Officer issues an order, in writing.** The effective date of the Agreement will be negotiated and specified in an order to this Agreement by the Contracting Officer. This Agreement is neither binding nor effective unless signed by the Contracting Officer. Payments at the approved rate will be paid upon the return of the signed Agreement by the authorized Local Government official to ICE.

We look forward to a mutually beneficial relationship with your County, however to prevent further incidents of this nature please review the IGSA in its entirety. If you have questions or would like to discuss any term or condition of the IGSA, please do not hesitate to reach out to me.

Thank you,

Jerry Neveleff

Supervisory Contracting Officer/

IGSA Team Lead

Office of Acq. Management (OAQ)

Detention Management Division

202/616 [REDACTED] b6

Help us support you better -

TELL US HOW WE ARE DOING!

Go to <http://www.acqsolinc.com/ICE/OAQ/feedback.cfm> <<<http://www.acqsolinc.com/ICE/OAQ/feedback.cfm>>>



**Stevens, Richard P**

---

**From:** Russell Harper [b6]  
**Sent:** Friday, September 26, 2008 1:11 PM  
**To:** Neveleff, Jerald  
**Subject:** Farmville

I am sorry information was provided to the Town during the update meeting. Our intent was to share how the building could or would utilized. It will not happen again.

Russell

-----  
Sent from Russell B. Harper

**Stevens, Richard P**

---

**From:** Nantel, Kelly A (b)(6)  
**Sent:** Friday, September 26, 2008 1:15 PM  
**To:** Lewis, Ashley J; Loiselle, Mary F  
**Cc:** Evans, Mary Y; Dellar, William L; Neveleff, Jerald; Longmeyer-Wood, Jennifer L; Rocha, Richard A; Burrell, Wendy G  
**Subject:** RE: DRAFT EMAIL

Folks - below is the very simple message points I want Richard to be able to share with the reporter who inquired about Farmville. I want to keep this clean and simple. Please let me know ASAP if okay to move forward. Thank you.

**Talking Points**

(b)(5)

---

**From:** Lewis, Ashley J [mailto:(b)(6)]  
**Sent:** Friday, September 26, 2008 11:19 AM  
**To:** Loiselle, Mary F  
**Cc:** Evans, Mary Y; Dellar, William L; Nantel, Kelly A; Neveleff, Jerald; Longmeyer-Wood, Jennifer L  
**Subject:** RE: DRAFT EMAIL

Not being a public relations expert (in fact some would say I fall a little short in this area), I will defer to PAO to make the call as to what should be done.

***Ashley J. Lewis***

Head of Contracting Activity  
Immigration and Customs Enforcement  
Department of Homeland Security  
Phone: 202-5 (b)(6)  
Cell: 202-441- (b)(6)

***Help us support you better –***

***TELL US HOW WE ARE DOING!***

**Go to** <http://www.acqsolinc.com/ICE/OAQ/feedback.cfm>

---

**From:** Loiselle, Mary F [mailto:(b)(6)]

12/21/2008

**Sent:** Friday, September 26, 2008 11:17 AM  
**To:** Lewis, Ashley J; Neveleff, Jerald; Longmeyer-Wood, Jennifer L  
**Cc:** Loiselle, Mary F; Evans, Mary Y; Dellar, William L; Nantel, Kelly A  
**Subject:** Re: DRAFT EMAIL

It covers the points that I consider necessary. Thanks.

Kelly makes a point about whether or not they retract yesterday's info, it's already out there. What do we want PAO to tell the reporter today?

---

**From:** Lewis, Ashley J  
**To:** Neveleff, Jerald ; Longmeyer-Wood, Jennifer L  
**Cc:** Loiselle, Mary F ; Evans, Mary Y ; Dellar, William L ; Lewis, Ashley J ; Nantel, Kelly A  
**Sent:** Fri Sep 26 11:13:13 2008  
**Subject:** RE: DRAFT EMAIL

Jerry,

See changes and ensure you clean-up formatting before release.

***Ashley J. Lewis***

Head of Contracting Activity  
Immigration and Customs Enforcement  
Department of Homeland Security  
Phone: 202-441-1111  
Cell: 202-441-1111

b6

***Help us support you better –***

***TELL US HOW WE ARE DOING!***

**Go to** <http://www.acqsolinc.com/ICE/OAQ/feedback.cfm>

---

**From:** Neveleff, Jerald [mailto:neveleff.jerald@ice.dhs.gov] (b)(6)  
**Sent:** Friday, September 26, 2008 10:56 AM  
**To:** Longmeyer-Wood, Jennifer L  
**Cc:** Loiselle, Mary F; Evans, Mary Y; Dellar, William L; Lewis, Ashley J; Nantel, Kelly A  
**Subject:** FW: DRAFT EMAIL

This reformats what was sent earlier but addresses in appropriate release of info.

(b)(5)

(b)(5)

Thank you,

Jerry Neveleff

Supervisory Contracting Officer/

IGSA Team Lead

Office of Acq. Management (OAQ)

Detention Management Division

202/616-b6

Help us support you better -

TELL US HOW WE ARE DOING!

Go to <http://www.acqsolinc.com/ICE/OAQ/feedback.cfm> <<<http://www.acqsolinc.com/ICE/OAQ/feedback.cfm>>>

12/21/2008

**Stevens, Richard P**

---

**From:** Neveleff, Jerald  
**Sent:** Friday, September 26, 2008 1:21 PM  
**To:** 'Russell Harper'  
**Subject:** RE: Farmville

I understand.

FYI, as a result of the comments made at the Council meeting, ICE now has to prepare a response to a media inquiry.  
Jerry

Thank you,  
Jerry Neveleff  
Supervisory Contracting Officer/  
IGSA Team Lead  
Office of Acq. Management (OAQ)  
Detention Management Division  
202/616 [REDACTED] b6

Help us support you better -  
TELL US HOW WE ARE DOING!  
Go to <<http://www.acqsolinc.com/ICE/OAQ/feedback.cfm>> <<<http://www.acqsolinc.com/ICE/OAQ/feedback.cfm>>>

---

**From:** Russell Harper [mailto:[REDACTED] b6]  
**Sent:** Friday, September 26, 2008 1:11 PM  
**To:** Neveleff, Jerald  
**Subject:** Farmville

I am sorry information was provided to the Town during the update meeting. Our intent was to share how the building could or would be utilized. It will not happen again.

Russell  
-----  
Sent from Russell B. Harper

**Stevens, Richard P**

---

**From:** Lewis, Ashley J [mailto: (b)(6)]  
**Sent:** Friday, September 26, 2008 1:19 PM  
**To:** Nantel, Kelly A; Loiselle, Mary F  
**Cc:** Evans, Mary Y; Dellar, William L; Neveleff, Jerald; Longmeyer-Wood, Jennifer L; Rocha, Richard A; Burrell, Wendy G  
**Subject:** RE: DRAFT EMAIL

See change to second bullet. Jerry, verify pricing info please.

**Ashley J. Lewis**

Head of Contracting Activity  
Immigration and Customs Enforcement  
Department of Homeland Security  
Phone: 202-5 (b)(6)  
Cell: 202-441- (b)(6)

**Help us support you better –**

**TELL US HOW WE ARE DOING!**

Go to <http://www.acqsolinc.com/ICE/OAQ/feedback.cfm>

---

**From:** Nantel, Kelly A [mailto: (b)(6)]  
**Sent:** Friday, September 26, 2008 1:15 PM  
**To:** Lewis, Ashley J; Loiselle, Mary F  
**Cc:** Evans, Mary Y; Dellar, William L; Neveleff, Jerald; Longmeyer-Wood, Jennifer L; Rocha, Richard A; Burrell, Wendy G  
**Subject:** RE: DRAFT EMAIL

Folks - below is the very simple message points I want Richard to be able to share with the reporter who inquired about Farmville. I want to keep this clean and simple. Please let me know ASAP if okay to move forward. Thank you.

**Talking Points**

(b)(5)

---

**From:** Lewis, Ashley J [mailto: (b)(6)]  
**Sent:** Friday, September 26, 2008 11:19 AM  
**To:** Loiselle, Mary F

12/21/2008

**Cc:** Evans, Mary Y; Dellar, William L; Nantel, Kelly A; Neveleff, Jerald; Longmeyer-Wood, Jennifer L  
**Subject:** RE: DRAFT EMAIL

Not being a public relations expert (in fact some would say I fall a little short in this area), I will defer to PAO to make the call as to what should be done.

***Ashley J. Lewis***

Head of Contracting Activity  
Immigration and Customs Enforcement  
Department of Homeland Security  
Phone: 202-5 [REDACTED]  
Cell: 202-441 [REDACTED] b6

***Help us support you better –***

***TELL US HOW WE ARE DOING!***

**Go to** <http://www.acqsolinc.com/ICE/OAQ/feedback.cfm>

---

**From:** Loiselle, Mary F [mailto:[REDACTED] (b)(6)]  
**Sent:** Friday, September 26, 2008 11:17 AM  
**To:** Lewis, Ashley J; Neveleff, Jerald; Longmeyer-Wood, Jennifer L  
**Cc:** Loiselle, Mary F; Evans, Mary Y; Dellar, William L; Nantel, Kelly A  
**Subject:** Re: DRAFT EMAIL

It covers the points that I consider necessary. Thanks.  
Kelly makes a point about whether or not they retract yesterday's info, it's already out there. What do we want PAO to tell the reporter today?

---

**From:** Lewis, Ashley J  
**To:** Neveleff, Jerald ; Longmeyer-Wood, Jennifer L  
**Cc:** Loiselle, Mary F ; Evans, Mary Y ; Dellar, William L ; Lewis, Ashley J ; Nantel, Kelly A  
**Sent:** Fri Sep 26 11:13:13 2008  
**Subject:** RE: DRAFT EMAIL  
Jerry,

See changes and ensure you clean-up formatting before release.

***Ashley J. Lewis***

Head of Contracting Activity  
Immigration and Customs Enforcement  
Department of Homeland Security  
Phone: 202-5 [REDACTED]  
Cell: 202-441 [REDACTED] b6

**Help us support you better –  
TELL US HOW WE ARE DOING!**

Go to <http://www.acqsolinc.com/ICE/OAQ/feedback.cfm>

---

**From:** Neveleff, Jerald [mailto:(b)(6)]  
**Sent:** Friday, September 26, 2008 10:56 AM  
**To:** Longmeyer-Wood, Jennifer L  
**Cc:** Loiselle, Mary F; Evans, Mary Y; Dellar, William L; Lewis, Ashley J; Nantel, Kelly A  
**Subject:** FW: DRAFT EMAIL

This reformats what was sent earlier but addresses in appropriate release of info.

(b)(5)



Thank you,

Jerry Neveleff

Supervisory Contracting Officer/

IGSA Team Lead

Office of Acq. Management (OAQ)

Detention Management Division

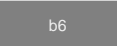
202/6  b6

Help us support you better -

TELL US HOW WE ARE DOING!

Go to <http://www.acqsolinc.com/ICE/OAQ/feedback.cfm> <<<http://www.acqsolinc.com/ICE/OAQ/feedback.cfm>>>

**Stevens, Richard P**

---

**From:** Neveleff, Jerald  
**Sent:** Friday, September 26, 2008 1:25 PM  
**To:** 'Lewis, Ashley J'; Nantel, Kelly A; Loiselle, Mary F  
**Cc:** Evans, Mary Y; Dellar, William L; Longmeyer-Wood, Jennifer L; Rocha, Richard A; Burrell, Wendy G  
**Subject:** RE: DRAFT EMAIL

The actual rate is \$62.83.

Also, please replace the word City with Town.

Thank you,  
Jerry Neveleff  
Supervisory Contracting Officer/  
IGSA Team Lead  
Office of Acq. Management (OAQ)  
Detention Management Division  
202/616- [REDACTED] b6

Help us support you better -  
**TELL US HOW WE ARE DOING!**  
Go to <http://www.acqsolinc.com/ICE/OAQ/feedback.cfm> <<<http://www.acqsolinc.com/ICE/OAQ/feedback.cfm>>>

---

**From:** Lewis, Ashley J [mailto:[REDACTED] (b)(6)]  
**Sent:** Friday, September 26, 2008 1:19 PM  
**To:** Nantel, Kelly A; Loiselle, Mary F  
**Cc:** Evans, Mary Y; Dellar, William L; Neveleff, Jerald; Longmeyer-Wood, Jennifer L; Rocha, Richard A; Burrell, Wendy G  
**Subject:** RE: DRAFT EMAIL

See change to second bullet. Jerry, verify pricing info please.

*Ashley J. Lewis*  
Head of Contracting Activity  
Immigration and Customs Enforcement  
Department of Homeland Security  
Phone: 202-5- [REDACTED]  
Cell: 202-441- [REDACTED] b6

**Help us support you better –**  
**TELL US HOW WE ARE DOING!**  
Go to <http://www.acqsolinc.com/ICE/OAQ/feedback.cfm>

---

**From:** Nantel, Kelly A [mailto: (b)(6)]  
**Sent:** Friday, September 26, 2008 1:15 PM  
**To:** Lewis, Ashley J; Loiselle, Mary F  
**Cc:** Evans, Mary Y; Dellar, William L; Neveleff, Jerald; Longmeyer-Wood, Jennifer L; Rocha, Richard A; Burrell, Wendy G  
**Subject:** RE: DRAFT EMAIL

Folks - below is the very simple message points I want Richard to be able to share with the reporter who inquired about Farmville. I want to keep this clean and simple. Please let me know ASAP if okay to move forward. Thank you.

Talking Points

(b)(5)

---

**From:** Lewis, Ashley J [mailto: (b)(6)]  
**Sent:** Friday, September 26, 2008 11:19 AM  
**To:** Loiselle, Mary F  
**Cc:** Evans, Mary Y; Dellar, William L; Nantel, Kelly A; Neveleff, Jerald; Longmeyer-Wood, Jennifer L  
**Subject:** RE: DRAFT EMAIL

Not being a public relations expert (in fact some would say I fall a little short in this area), I will defer to PAO to make the call as to what should be done.

*Ashley J. Lewis*

Head of Contracting Activity  
Immigration and Customs Enforcement  
Department of Homeland Security  
Phone: 202-5 (b)(6)  
Cell: 202-441 (b)(6)

*Help us support you better –*

**TELL US HOW WE ARE DOING!**

Go to <http://www.acqsolinc.com/ICE/OAQ/feedback.cfm>

---

**From:** Loiselle, Mary F [mailto: (b)(6)]  
**Sent:** Friday, September 26, 2008 11:17 AM  
**To:** Lewis, Ashley J; Neveleff, Jerald; Longmeyer-Wood, Jennifer L  
**Cc:** Loiselle, Mary F; Evans, Mary Y; Dellar, William L; Nantel, Kelly A

**Subject:** Re: DRAFT EMAIL

It covers the points that I consider necessary. Thanks.

Kelly makes a point about whether or not they retract yesterday's info, it's already out there. What do we want PAO to tell the reporter today?

---

**From:** Lewis, Ashley J  
**To:** Neveleff, Jerald ; Longmeyer-Wood, Jennifer L  
**Cc:** Loiselle, Mary F ; Evans, Mary Y ; Dellar, William L ; Lewis, Ashley J ; Nantel, Kelly A  
**Sent:** Fri Sep 26 11:13:13 2008  
**Subject:** RE: DRAFT EMAIL  
Jerry,

See changes and ensure you clean-up formatting before release.

*Ashley J. Lewis*  
Head of Contracting Activity  
Immigration and Customs Enforcement  
Department of Homeland Security  
Phone: 202-5 [REDACTED]  
Cell: 202-441 [REDACTED] b6

**Help us support you better –**  
**TELL US HOW WE ARE DOING!**  
**Go to** <http://www.acqsolinc.com/ICE/OAQ/feedback.cfm>

---

**From:** Neveleff, Jerald [mailto:[REDACTED] (b)(6)]  
**Sent:** Friday, September 26, 2008 10:56 AM  
**To:** Longmeyer-Wood, Jennifer L  
**Cc:** Loiselle, Mary F; Evans, Mary Y; Dellar, William L; Lewis, Ashley J; Nantel, Kelly A  
**Subject:** FW: DRAFT EMAIL

This reformats what was sent earlier but addresses in appropriate release of info.

(b)(5)

(b)(5)

Thank you,

Jerry Neveleff

Supervisory Contracting Officer/

IGSA Team Lead

Office of Acq. Management (OAQ)

Detention Management Division

202/616-b6

Help us support you better -

TELL US HOW WE ARE DOING!

Go to <http://www.acqsolinc.com/ICE/OAQ/feedback.cfm> <<<http://www.acqsolinc.com/ICE/OAQ/feedback.cfm>>>

12/21/2008

**Stevens, Richard P**

---

**From:** Russell Harper [redacted] b6  
**Sent:** Friday, September 26, 2008 1:27 PM  
**To:** Neveleff, Jerald  
**Subject:** Re: Farmville

Other than being QUIET can we help?

-----  
Sent from Russell B. Harper

-----Original Message-----

**From:** Neveleff, Jerald [redacted] (b)(6)  
**To:** Russell Harper [redacted] b6  
**Sent:** Fri Sep 26 13:20:55 2008  
**Subject:** RE: Farmville

I understand.

FYI, as a result of the comments made at the Council meeting, ICE now has to prepare a response to a media inquiry.

Jerry

Thank you,  
Jerry Neveleff  
Supervisory Contracting Officer/  
IGSA Team Lead  
Office of Acq. Management (OAQ)  
Detention Management Division  
202/616-[redacted] b6

Help us support you better -  
TELL US HOW WE ARE DOING!  
Go to <<http://www.acqsolinc.com/ICE/OAQ/feedback.cfm>> <<<http://www.acqsolinc.com/ICE/OAQ/feedback.cfm>>>

---

**From:** Russell Harper [mailto:[redacted] b6]  
**Sent:** Friday, September 26, 2008 1:11 PM  
**To:** Neveleff, Jerald  
**Subject:** Farmville

I am sorry information was provided to the Town during the update meeting. Our intent was to share how the building could or would be utilized. It will not happen again.

Russell

-----  
Sent from Russell B. Harper

12/21/2008

**Stevens, Richard P**

---

**From:** Neveleff, Jerald  
**Sent:** Friday, September 26, 2008 1:40 PM  
**To:** [REDACTED] b6  
**Cc:** Russell Harper; Dellar, William L; Smyly, Elena L

Mr. Spates,  
Now that negotiation for the bed day rate and transportation for Farmville has completed, future meetings surrounding the facility needs to have the Town of Farmville in attendance especially now that the construction and schedules will be the newest focus. Please remember that the Inter-Governmental Service Agreement (IGSA) is with the Town of Farmville, not ICA.  
Jerry

Thank you,  
Jerry Neveleff  
Supervisory Contracting Officer/  
IGSA Team Lead  
Office of Acq. Management (OAQ)  
Detention Management Division  
202/616 [REDACTED] b6

Help us support you better -  
TELL US HOW WE ARE DOING!  
Go to <<http://www.acqsolinc.com/ICE/OAQ/feedback.cfm>> <<<http://www.acqsolinc.com/ICE/OAQ/feedback.cfm>>>

**Stevens, Richard P**

---

**From:** Nantel, Kelly A (b)(6)  
**Sent:** Friday, September 26, 2008 1:28 PM  
**To:** Lewis, Ashley J; Loiselle, Mary F  
**Cc:** Evans, Mary Y; Dellar, William L; Neveleff, Jerald; Longmeyer-Wood, Jennifer L; Rocha, Richard A; Burrell, Wendy G  
**Subject:** Re: DRAFT EMAIL

Richard - can you make the changes and also note that it is town not city. Thanks.

-----  
Kelly A. Nantel, Press Secretary  
US Immigration and Customs Enforcement  
Sent using BlackBerry

---

**From:** Lewis, Ashley J  
**To:** Nantel, Kelly A ; Loiselle, Mary F  
**Cc:** Evans, Mary Y ; Dellar, William L ; Neveleff, Jerald ; Longmeyer-Wood, Jennifer L ; Rocha, Richard A ; Burrell, Wendy G  
**Sent:** Fri Sep 26 13:19:02 2008  
**Subject:** RE: DRAFT EMAIL

See change to second bullet. Jerry, verify pricing info please.

*Ashley J. Lewis*  
Head of Contracting Activity  
Immigration and Customs Enforcement  
Department of Homeland Security  
Phone: 202-5 (b)(6)  
Cell: 202-441- (b)(6)

**Help us support you better –  
TELL US HOW WE ARE DOING!**  
Go to <http://www.acqsolinc.com/ICE/OAQ/feedback.cfm>

---

**From:** Nantel, Kelly A [mailto: (b)(6)]  
**Sent:** Friday, September 26, 2008 1:15 PM  
**To:** Lewis, Ashley J; Loiselle, Mary F  
**Cc:** Evans, Mary Y; Dellar, William L; Neveleff, Jerald; Longmeyer-Wood, Jennifer L; Rocha, Richard A; Burrell, Wendy G  
**Subject:** RE: DRAFT EMAIL

Folks – below is the very simple message points I want Richard to be able to share with the reporter who inquired about Farmville. I want to keep this clean and simple. Please let me know ASAP if okay to move forward. Thank you.

**Talking Points**

12/21/2008



(b)(5)

---

**From:** Lewis, Ashley J [mailto: (b)(6)]  
**Sent:** Friday, September 26, 2008 11:19 AM  
**To:** Loiselle, Mary F  
**Cc:** Evans, Mary Y; Dellar, William L; Nantel, Kelly A; Neveleff, Jerald; Longmeyer-Wood, Jennifer L  
**Subject:** RE: DRAFT EMAIL

Not being a public relations expert (in fact some would say I fall a little short in this area), I will defer to PAO to make the call as to what should be done.

*Ashley J. Lewis*  
Head of Contracting Activity  
Immigration and Customs Enforcement  
Department of Homeland Security  
Phone: 202-5 (b)(6)  
Cell: 202-441 (b)(6)

*Help us support you better –  
TELL US HOW WE ARE DOING!*  
Go to <http://www.acqsolinc.com/ICE/OAQ/feedback.cfm>

---

**From:** Loiselle, Mary F [mailto: (b)(6)]  
**Sent:** Friday, September 26, 2008 11:17 AM  
**To:** Lewis, Ashley J; Neveleff, Jerald; Longmeyer-Wood, Jennifer L  
**Cc:** Loiselle, Mary F; Evans, Mary Y; Dellar, William L; Nantel, Kelly A  
**Subject:** Re: DRAFT EMAIL

It covers the points that I consider necessary. Thanks.  
Kelly makes a point about whether or not they retract yesterday's info, it's already out there. What do we want PAO to tell the reporter today?

---

**From:** Lewis, Ashley J  
**To:** Neveleff, Jerald ; Longmeyer-Wood, Jennifer L  
**Cc:** Loiselle, Mary F ; Evans, Mary Y ; Dellar, William L ; Lewis, Ashley J ; Nantel, Kelly A  
**Sent:** Fri Sep 26 11:13:13 2008  
**Subject:** RE: DRAFT EMAIL  
Jerry,

12/21/2008

See changes and ensure you clean-up formatting before release.

***Ashley J. Lewis***

Head of Contracting Activity  
Immigration and Customs Enforcement  
Department of Homeland Security  
Phone: 202-5 [REDACTED] b6  
Cell: 202-441 [REDACTED]

***Help us support you better –***

***TELL US HOW WE ARE DOING!***

**Go to** <http://www.acqsolinc.com/ICE/OAQ/feedback.cfm>

---

**From:** Neveleff, Jerald [mailto:[REDACTED] (b)(6)]  
**Sent:** Friday, September 26, 2008 10:56 AM  
**To:** Longmeyer-Wood, Jennifer L  
**Cc:** Loiselle, Mary F; Evans, Mary Y; Dellar, William L; Lewis, Ashley J; Nantel, Kelly A  
**Subject:** FW: DRAFT EMAIL

This reformats what was sent earlier but addresses in appropriate release of info.

(b)(5)

(b)(5)

Thank you,

Jerry Neveleff

Supervisory Contracting Officer/

IGSA Team Lead

Office of Acq. Management (OAQ)

Detention Management Division

202/616-b6

Help us support you better -

TELL US HOW WE ARE DOING!

Go to <http://www.acqsolinc.com/ICE/OAQ/feedback.cfm> <<<http://www.acqsolinc.com/ICE/OAQ/feedback.cfm>>>

**Stevens, Richard P**

---

**From:** Neveleff, Jerald  
**Sent:** Friday, September 26, 2008 1:31 PM  
**To:** 'Russell Harper'  
**Subject:** RE: Farmville

At this time, ICE Public Affairs has assumed the lead. It's been elevated above my pay grade. I am strictly informational at this point.

Thank you,  
Jerry Neveleff  
Supervisory Contracting Officer/  
IGSA Team Lead  
Office of Acq. Management (OAQ)  
Detention Management Division  
202/616 [REDACTED] b6

Help us support you better -  
TELL US HOW WE ARE DOING!

Go to <<http://www.acqsolinc.com/ICE/OAQ/feedback.cfm>> <<<http://www.acqsolinc.com/ICE/OAQ/feedback.cfm>>>

---

**From:** Russell Harper [mailto:[REDACTED] b6]  
**Sent:** Friday, September 26, 2008 1:27 PM  
**To:** Neveleff, Jerald  
**Subject:** Re: Farmville

Other than being QUIET can we help?

-----  
Sent from Russell B. Harper

-----Original Message-----

From: Neveleff, Jerald <[REDACTED] (b)(6)>  
To: Russell Harper <[REDACTED] b6>  
Sent: Fri Sep 26 13:20:55 2008  
Subject: RE: Farmville

I understand.

FYI, as a result of the comments made at the Council meeting, ICE now has to prepare a response to a media inquiry.

Jerry

Thank you,  
Jerry Neveleff

12/21/2008

Supervisory Contracting Officer/  
IGSA Team Lead  
Office of Acq. Management (OAQ)  
Detention Management Division  
202/616 [REDACTED] b6

Help us support you better -  
TELL US HOW WE ARE DOING!

Go to <<http://www.acqsolinc.com/ICE/OAQ/feedback.cfm>> <<<http://www.acqsolinc.com/ICE/OAQ/feedback.cfm>>>

---

From: Russell Harper [mailto:[REDACTED] b6]  
Sent: Friday, September 26, 2008 1:11 PM  
To: Neveleff, Jerald  
Subject: Farmville

I am sorry information was provided to the Town during the update meeting. Our intent was to share how the building could or would be utilized. It will not happen again.

Russell

-----  
Sent from Russell B. Harper

**Stevens, Richard P**

---

**From:** Russell Harper [redacted] b6  
**Sent:** Friday, September 26, 2008 3:45 PM  
**To:** Neveleff, Jerald  
**Subject:** Re: Farmville

Jerry,  
Are you aware of something being said that was incorrect?  
Thanks

Russell  
-----  
Sent from Russell B. Harper

-----Original Message-----  
From: Neveleff, Jerald [redacted] (b)(6)  
To: Russell Harper <[redacted] b6>  
Sent: Fri Sep 26 13:20:55 2008  
Subject: RE: Farmville

I understand.

FYI, as a result of the comments made at the Council meeting, ICE now has to prepare a response to a media inquiry.

Jerry

Thank you,  
Jerry Neveleff  
Supervisory Contracting Officer/  
IGSA Team Lead  
Office of Acq. Management (OAQ)  
Detention Management Division  
202/616 [redacted] b6

Help us support you better -  
TELL US HOW WE ARE DOING!  
Go to <<http://www.acqsolinc.com/ICE/OAQ/feedback.cfm>> <<<http://www.acqsolinc.com/ICE/OAQ/feedback.cfm>>>

---

From: Russell Harper [mailto:[redacted] b6]  
Sent: Friday, September 26, 2008 1:11 PM  
To: Neveleff, Jerald  
Subject: Farmville

I am sorry information was provided to the Town during the update meeting. Our intent was to share how the building could or would utilized. It will not happen again.

Russell

-----  
Sent from Russell B. Harper

**Stevens, Richard P**

---

**From:** Gerry [REDACTED] b6  
**Sent:** Friday, September 26, 2008 4:45 PM  
**To:** 'Neveleff, Jerald'  
**Cc:** Lisa Hricko  
**Subject:** appointment

Mr. Neveleff,

Let me begin by apologizing for the recent incident that has caused so much confusion. I would like to schedule a date and time meet with you and those you feel necessary to discuss any issues you may feel uncomfortable with. I assure you the Town of Farmville and the subcontractor support this project. I would be glad to come up there at your convenience.

Thank you for your time.

Gerry

Gerald J. Spates  
Town Manager  
Town of Farmville  
PO Drawer 368  
Farmville, VA 23901  
(434) [REDACTED] b6  
[REDACTED] b6

**From:** Neveleff, Jerald [mailto:[REDACTED] (b)(6)]  
**Sent:** Friday, September 26, 2008 1:40 PM  
**To:** [REDACTED] b6  
**Cc:** Russell Harper; Dellar, William L; Smyly, Elena L  
**Subject:**

Mr. Spates,

Now that negotiation for the bed day rate and transportation for Farmville has completed, future meetings surrounding the facility needs to have the Town of Farmville in attendance especially now that the construction and schedules will be the newest focus. Please remember that the Inter-Governmental Service Agreement (IGSA) is with the Town of Farmville, not ICA.

Jerry

Thank you,

Jerry Neveleff

Supervisory Contracting Officer/

12/21/2008



IGSA Team Lead

Office of Acq. Management (OAQ)

Detention Management Division

202/616 b6

Help us support you better -

TELL US HOW WE ARE DOING!

Go to <http://www.acqsolinc.com/ICE/OAQ/feedback.cfm> <<<http://www.acqsolinc.com/ICE/OAQ/feedback.cfm>>>

**Stevens, Richard P**

---

**From:** Neveleff, Jerald  
**Sent:** Friday, September 26, 2008 6:24 PM  
**To:** [REDACTED] b6 [REDACTED] (b)(6)  
**Cc:** [REDACTED] b6  
**Subject:** Re: Farmville [REDACTED]@cambridge.com, webleman@ndcva.com

Russell,  
I understand what people may have said but that's not what was conveyed to me nor was it what was requested by the media.  
Also just mentioning what was "heard" is enough to have the media start digging.

Either way, we had the inquiry and we had to respond. Doesn't matter what was said, how it was said or what was meant by it.

-----Original Message-----  
From: Russell Harper  
To: Work  
Cc: g [REDACTED] b6  
Cc: k [REDACTED]  
Cc: Warren Coleman  
Sent: Sep 26, 2008 18:12  
Subject: Farmville

Jerry,

I have spoken to Mr Spates and Newsome.

At no time during the council presentation did we state 200 ICE employees were being transferred to Farmville.

When asked about the number of ICE employees we stated that the plans were not complete and we had no idea. We stated we have heard 100 to 200 but had no information on that. We were asked if they were new jobs or relocations and we said we did not know. After the meeting the Post reporter approached us for questions and we told him we could not speak to the press.

I will forward a copy of the article that appeared in the Farmville paper that confirms the content of our presentation.

Thanks

Russell

-----  
Sent from Russell B. Harper

-----Original Message-----  
From: Neveleff, Jerald <[REDACTED]@ms.gov> (b)(6)  
To: Russell Harper <[REDACTED]> b6  
Sent: Fri Sep 26 13:31:14 2008  
Subject: RE: Farmville

At this time, ICE Public Affairs has assumed the lead. It's been elevated above my pay grade. I am strictly informational at this point.

Thank you,

Jerry Neveleff  
Supervisory Contracting Officer/  
IGSA Team Lead  
Office of Acq. Management (OAQ)  
Detention Management Division  
202/616 [REDACTED]

Help us support you better -  
TELL US HOW WE ARE DOING!  
Go to <<http://www.acqsolinc.com/ICE/OAQ/feedback.cfm>>  
<<<http://www.acqsolinc.com/ICE/OAQ/feedback.cfm>>>

---

From: Russell Harper [mailto:[REDACTED]]  
Sent: Friday, September [REDACTED]

-----Original Message Truncated-----

Jerry  
Sent using BlackBerry

**Stevens, Richard P**

---

**From:** Russell Harper [redacted] b6  
**Sent:** Friday, September 26, 2008 6:12 PM  
**To:** Neveleff, Jerald  
**Cc:** [redacted] b6 Warren Coleman  
**Subject:** Farmville

Jerry,

I have spoken to Mr Spates and Newsome.

At no time during the council presentation did we state 200 ICE employees were being transferred to Farmville.

When asked about the number of ICE employees we stated that the plans were not complete and we had no idea. We stated we have heard 100 to 200 but had no information on that. We were asked if they were new jobs or relocations and we said we did not know. After the meeting the Post reporter approached us for questions and we told him we could not speak to the press.

I will forward a copy of the article that appeared in the Farmville paper that confirms the content of our presentation.

Thanks

Russell

-----  
Sent from Russell B. Harper

-----Original Message-----

**From:** Neveleff, Jerald [redacted] (b)(6)  
**To:** Russell Harper <[redacted] b6>  
**Sent:** Fri Sep 26 13:31:14 2008  
**Subject:** RE: Farmville

At this time, ICE Public Affairs has assumed the lead. It's been elevated above my pay grade. I am strictly informational at this point.

Thank you,  
Jerry Neveleff  
Supervisory Contracting Officer/  
IGSA Team Lead  
Office of Acq. Management (OAQ)  
Detention Management Division  
202/616 [redacted] b6

Help us support you better -  
TELL US HOW WE ARE DOING!  
Go to <<http://www.acqsolinc.com/ICE/OAQ/feedback.cfm>> <<<http://www.acqsolinc.com/ICE/OAQ/feedback.cfm>>>

---

**From:** Russell Harper [mailto:[redacted] b6]  
**Sent:** Friday, September 26, 2008 1:27 PM  
**To:** Neveleff, Jerald  
**Subject:** Re: Farmville

12/21/2008

Other than being QUIET can we help?

-----  
Sent from Russell B. Harper

-----Original Message-----

From: Neveleff, Jerald <(b)(6)>  
To: Russell Harper <b6>  
Sent: Fri Sep 26 13:20:55 2008  
Subject: RE: Farmville

I understand.

FYI, as a result of the comments made at the Council meeting, ICE now has to prepare a response to a media inquiry.

Jerry

Thank you,  
Jerry Neveleff  
Supervisory Contracting Officer/  
IGSA Team Lead  
Office of Acq. Management (OAQ)  
Detention Management Division  
202/616 b6

Help us support you better -  
TELL US HOW WE ARE DOING!  
Go to <<http://www.acqsolinc.com/ICE/OAQ/feedback.cfm>> <<<http://www.acqsolinc.com/ICE/OAQ/feedback.cfm>>>

---

From: Russell Harper [mailto:b6]  
Sent: Friday, September 26, 2008 1:11 PM  
To: Neveleff, Jerald  
Subject: Farmville

I am sorry information was provided to the Town during the update meeting. Our intent was to share how the building could or would utilized. It will not happen again.

Russell

-----  
Sent from Russell B. Harper

**Stevens, Richard P**

---

**From:** Russell Harper [REDACTED] b6  
**Sent:** Saturday, September 27, 2008 9:10 AM  
**To:** Achim, Deborah  
**Cc:** [REDACTED] b6 Raine, Craig K; Picone, Paul D; Loiselle, Mary F; Neveleff, Jerald; Watson, Joe  
**Subject:** Farmville Council Briefing September 24th 2008

Debbie,

It has come to our attention that ICE has been told we represented 200 ICE jobs were being relocated to Farmville. This is not accurate. We stated we did not know details as the plans were not complete. When pushed for a number we said we have heard 100 to 200 but had no idea. We were asked if they were new jobs or relocations we said we had no idea. We apologize for allowing the topic to be discussed and will make sure all inquiries from the media are directed to ICE.

There is much enthusiasm about the facility in Farmville and the region. We have already hired 20 folks for Transportation and will be bringing on another 179 once we reach capacity. This facility is needed in our area. Not one day goes by that someone calls looking for an employment opportunity, a civic group or church offering support. Our House of Delegate members Hogan and Abbott and Congressman Goode have been updated and support the facility. We have been awarded a State of Virginia Tobacco Commission grant for over \$600,000.

This facility is needed in our community. Mr. Spates, Farmville Town Manager, and myself are available meet with you to address questions or concerns as we go through this process.

Thank you,

Russell Harper

**Stevens, Richard P**

---

**From:** Neveleff, Jerald  
**Sent:** Saturday, September 27, 2008 9:41 AM  
**To:** Snow, Melissa  
**Subject:** Re: Ratifications

Thanks

-----Original Message-----

From: Snow, Melissa  
To: Neveleff, Jerald  
Sent: Sep 27, 2008 09:38  
Subject: RE: Ratifications

I'll just set it up as a new obligation and put both requests on the same obligation.

Thank-You,  
Sunshine Snow  
Financial Analyst  
DHS/CFO/OFM/BFC  
Phone (802) 288- [REDACTED] b6

-----Original Message-----

From: Neveleff, Jerald  
Sent: Friday, September 26, 2008 4:38 PM  
To: Snow, Melissa  
Subject: Re: Ratifications

Not sure. How do I tell?

-----Original Message-----

From: Snow, Melissa  
To: Neveleff, Jerald  
Sent: Sep 26, 2008 16:29  
Subject: RE: Ratifications

Jerry,

I had a few questions. You provided DHS Doc# 0783920082. Has this number ever been obligated in FFMS? I cannot locate.

Also you have the same DHS Doc# for both requests. Do you want them both on one obligation? On the same Item/MDL? They both have the same ACCS.

Please advise. We will be in the office tomorrow and Sunday.

Thank-You,

Sunshine Snow

Financial Analyst

DHS/CFO/OFM/BFC

Phone (802) 288- [REDACTED] b6

---

From: Neveleff, Jerald  
Sent: Friday, September 26, 2008 2:20 PM

To: Snow, Melissa  
Cc: Payne, Deanna; Cummings, Christopher W  
Subject: RE: Ratifications

Sorry,

Here are the two request for prior year funds. Its all in one email but each request is 3 pages (Signed form, Invoice, invoice backup).

Jerry

Thank you,  
Jerry Neveleff  
Supervisory Contracting Officer/  
IGSA Team Lead  
Office of Acq. Management (OAQ)  
Detention Management Division  
202/616-b6

Help us support you better -

-----Original Message Truncated-----

Jerry  
Sent using BlackBerry



**Stevens, Richard P**

---

**From:** Neveleff, Jerald  
**Sent:** Saturday, September 27, 2008 10:43 AM  
**To:** 'Russell Harper'  
**Subject:** RE: Farmville Council Briefing September 24th 2008

Russell,  
Remember when you said besides being quiet, what can you do? Its now time to drop this.

Your email below states that, "When pushed for a number we said we have heard 100 to 200 but had no idea." That's all it takes when it comes to ICE and detention.

Now that you've apologized, its time to move on. Use this as a lesson in immigration and the media.

Jerry

Thank you,  
Jerry Neveleff  
Supervisory Contracting Officer/  
IGSA Team Lead  
Office of Acq. Management (OAQ)  
Detention Management Division  
202/616 [REDACTED] b6

Help us support you better -  
TELL US HOW WE ARE DOING!

Go to <<http://www.acqsolinc.com/ICE/OAQ/feedback.cfm>> <<<http://www.acqsolinc.com/ICE/OAQ/feedback.cfm>>>

---

**From:** Russell Harper [mailto:r [REDACTED] b6]  
**Sent:** Saturday, September 27, 2008 9:10 AM  
**To:** Achim, Deborah  
**Cc:** g [REDACTED] b6; aine, Craig K; Picone, Paul D; Loiselle, Mary F; Neveleff, Jerald; Watson, Joe  
**Subject:** Farmville Council Briefing September 24th 2008

Debbie,

It has come to our attention that ICE has been told we represented 200 ICE jobs were being relocated to Farmville. This is not accurate. We stated we did not know details as the plans were not complete. When pushed for a number we said we have heard 100 to 200 but had no idea. We were asked if they were new jobs or relocations we said we had no idea. We apologize for allowing the topic to be discussed and will make sure all inquiries from the media are directed to ICE.

There is much enthusiasm about the facility in Farmville and the region. We have already hired 20 folks for Transportation and will be bringing on another 179 once we reach capacity. This facility is needed in our area. Not one day goes by that someone calls looking for an employment opportunity, a civic group or church offering support. Our House of Delegate members Hogan and Abbott and Congressman Goode have been updated and support the facility. We have been awarded a State of Virginia Tobacco Commission grant for over \$600,000.

This facility is needed in our community. Mr. Spates, Farmville Town Manager, and myself are available meet with

12/21/2008

you to address questions or concerns as we go through this process.

Thank you,

Russell Harper

**Stevens, Richard P**

---

**From:** Russell Harper [redacted] b6  
**Sent:** Saturday, September 27, 2008 10:47 AM  
**To:** Neveleff, Jerald  
**Subject:** Re: Farmville Council Briefing September 24th 2008

Thanks sir.

-----  
Sent from Russell B. Harper

-----Original Message-----  
**From:** Neveleff, Jerald [redacted] (b)(6)  
**To:** Russell Harper <r[redacted] b6>  
**Sent:** Sat Sep 27 10:43:24 2008  
**Subject:** RE: Farmville Council Briefing September 24th 2008

Russell,

Remember when you said besides being quiet, what can you do? Its now time to drop this.

Your email below states that, "When pushed for a number we said we have heard 100 to 200 but had no idea." That's all it takes when it comes to ICE and detention.

Now that you've apologized, its time to move on. Use this as a lesson in immigration and the media.

Jerry

Thank you,  
Jerry Neveleff  
Supervisory Contracting Officer/  
IGSA Team Lead  
Office of Acq. Management (OAQ)  
Detention Management Division  
202/616 [redacted] b6

Help us support you better -  
TELL US HOW WE ARE DOING!  
Go to <<http://www.acqsolinc.com/ICE/OAQ/feedback.cfm>> <<<http://www.acqsolinc.com/ICE/OAQ/feedback.cfm>>>

---

**From:** Russell Harper [mailto:rhar[redacted] b6]  
**Sent:** Saturday, September 27, 2008 9:10 AM  
**To:** Achim, Deborah  
**Cc:** gsp[redacted] b6, ne, Craig K; Picone, Paul D; Loiselle, Mary F; Neveleff, Jerald; Watson, Joe  
**Subject:** Farmville Council Briefing September 24th 2008

Debbie,

12/21/2008

It has come to our attention that ICE has been told we represented 200 ICE jobs were being relocated to Farmville. This is not accurate. We stated we did not know details as the plans were not complete. When pushed for a number we said we have heard 100 to 200 but had no idea. We were asked if they were new jobs or relocations we said we had no idea. We apologize for allowing the topic to be discussed and will make sure all inquiries from the media are directed to ICE.

There is much enthusiasm about the facility in Farmville and the region. We have already hired 20 folks for Transportation and will be bringing on another 179 once we reach capacity.

This facility is needed in our area. Not one day goes by that someone calls looking for an employment opportunity, a civic group or church offering support. Our House of Delegate members Hogan and Abbott and Congressman Goode have been updated and support the facility. We have been awarded a State of Virginia Tobacco Commission grant for over \$600,000.

This facility is needed in our community. Mr. Spates, Farmville Town Manager, and myself are available meet with you to address questions or concerns as we go through this process.

Thank you,

Russell Harper

**Stevens, Richard P**

---

**From:** Jenkins, John E  
**Sent:** Monday, September 29, 2008 3:12 PM  
**To:** Evans, Mary Y; Flanagan, Lamont  
**Cc:** Neveleff, Jerald  
**Subject:** Farmville DIHS requirements

Ms. Evans and Mr. Flanagan,

Per a conversation that I had with Jerry Neveleff in regards to the DIHS requirements. The service provider will meet all of DIHS requirements. The service provider did not believe the changes required by DIHS had a significant cost impact on their proposal to the government.

Regards

John

*John E. Jenkins*

Acting Unit Chief

Facilities Management Unit

Detention and Removal Operations

Immigration and Customs Enforcement

202-732-

b6

202-345-

e

(b)(6)

**Warning: This document is UNCLASSIFIED//FOR OFFICIAL USE ONLY (U//FOUO).** It contains information that may be exempt from public release under the Freedom of Information Act (5 U.S.C. 552). It is to be controlled, stored, handled, transmitted, distributed, and disposed of in accordance with DHS policy relating to FOUO information and is not to be released to the public or other personnel who do not have a valid "need-to-know" without prior approval of an authorized DHS official. **No portion of this report should be furnished to the media, either in written or verbal form.**

12/21/2008

**Stevens, Richard P**

**From:** [redacted] b6  
**Sent:** Thursday, October 02, 2008 11:36 AM  
**To:** Neveleff, Jerald  
**Cc:** Dougherty, Deane; [redacted] b6, Patricia Pepe; Decker, Thomas  
**Subject:** RE: BERKS

Jerry,

Please see Mark's response below in blue. I do not understand your question, "I need to allow for the officers that support the family and juvenile. How is the square footage calculated?" The space is was measured by the room dimensions which will be occupied by ICE/PHS personnel. Please clarify your question.

From January 2008 to July 2008, we are averaging 77. There has been a decline in bed usage and I'm not comfortable with the 78 number.  
Thank you...

Ken...

Hello Ken,

[redacted] b5

Please do not hesitate to contact me if further information is needed.

Thanks,

Mark

Ken Borkey, Jr.  
Executive Director  
Berks County Youth Center  
610-39 [redacted] b6  
kb [redacted] b6

"Neveleff, Jerald" <je [redacted] (b)(6)@ang.gov>

10/02/2008 10:57 AM

To <KBorkey@countyofber [redacted] b6>  
cc "Dougherty, Deane" <d [redacted] (b)(6)>, MBoyer@cou [redacted] b6  
"Decker, Thomas" <thomas.decker@dhs.gov>, "Patricia Pepe" <patricia.pepe@dhs.gov>  
Subject RE: BERKS

12/21/2008

Thank you,  
Jerry Neveleff  
Deputy Assistant Director/IGSA  
Office of Acq. Management (OAQ)  
Detention Management Division  
202/616 (b)(2)Low

Help us support you better -  
TELL US HOW WE ARE DOING!  
Go to <<http://www.acqsolinc.com/ICE/OAQ/feedback.cfm>> <<<http://www.acqsolinc.com/ICE/OAQ/feedback.cfm>>>

---

**From:** (b6) [mailto:(b6)]  
**Sent:** Thursday, October 02, 2008 10:18 AM  
**To:** Neveleff, Jerald  
**Cc:** Dougherty, Deane; (b6) Decker, Thomas; Patricia Pepe  
**Subject:** Re: BERKS

Jerry,

I beleive we need to address a few areas of concern with the JSCS.

(b)(5)

Jerry

12/21/2008

Thank you for your attention to this matter. Please contact myself or Mark Boyer for additional information concerning these items.

Ken.....

Ken Borkey, Jr.  
Executive Director  
Berks County Youth Center

610-  
b6  
b6

"Neveleff, Jerald"

(b)(6)

10/02/2008 07:57 AM

To <k  
b6  
(b)(6)  
cc <M  
(b)(6) "Decker, Thomas" <thomas.decker@dhs.gov>, "Dougherty, Deane"  
(b)(6)  
<.....@dhs.gov>

Subject BERKS

Good morning Ken,



(b)(5)

Thank you,

Jerry Neveleff

Supervisory Contracting Officer/

12/21/2008



IGSA Team Lead

Office of Acq. Management (OAQ)

Detention Management Division

202/616- (b)(2)Low

Help us support you better -

TELL US HOW WE ARE DOING!

Go to <http://www.acqsolinc.com/ICE/OAQ/feedback.cfm> <<<http://www.acqsolinc.com/ICE/OAQ/feedback.cfm>>>

## Stevens, Richard P

---

**From:** Loiselle, Mary F  
**Sent:** Sunday, October 05, 2008 8:06 AM  
**To:** Evans, Mary Y; Neveleff, Jerald; Weinberg, Bill; Dellar, William L  
**Cc:** Carter, Albert E  
**Subject:** Wash Post stories today

Front page - WAS field office  
P.C8 - Farmville facility

**Stevens, Richard P**

---

**From:** Raine, Craig K  
**Sent:** Thursday, October 02, 2008 12:25 PM  
**To:** Neveleff, Jerald  
**Subject:** FW:

fyi

---

**From:** Russell Harper [mailto: [REDACTED] b6]  
**Sent:** Thursday, October 02, 2008 7:17 AM  
**To:** Raine, Craig K; Picone, Paul D; Achim, Deborah  
**Subject:**

A reporter named Nick Miroff called from the Post and wanted to confirm a few points. He was told to contact ICE and without any discussion the conversation ended.

**Stevens, Richard P**

---

**From:** Weinberg, Bill  
**Sent:** Sunday, October 05, 2008 11:25 AM  
**To:** Loiselle, Mary F; Evans, Mary Y; Neveleff, Jerald; Dellar, William L  
**Cc:** Carter, Albert E  
**Subject:** Re: Wash Post stories today

The impression that the investment group would be making "millions" in easy profits is a little troubling, but at least they properly noted that no commitment for any beds had been made.

Bill Weinberg  
Assistant Director,  
ICE Office of Acquisition,  
Detention Management  
Sent from my Blackberry

----- Original Message -----

**From:** Loiselle, Mary F  
**To:** Evans, Mary Y; Neveleff, Jerald; Weinberg, Bill; Dellar, William L  
**Cc:** Carter, Albert E  
**Sent:** Sun Oct 05 08:05:52 2008  
**Subject:** Wash Post stories today

Front page - WAS field office  
P.C8 - Farmville facility

**Stevens, Richard P**

---

**From:** Casterline, Arnold P  
**Sent:** Monday, October 06, 2008 7:28 AM  
**To:** Neveleff, Jerald  
**Subject:** farmville  
**Attachments:** Farmville2 JSCS.xls; Farmville JSCS.xls

*Arnold P. Casterline Jr.*

Contract Specialist  
Immigration and Customs Enforcement  
Office of Acquisition Management  
Detention Management  
Department of Homeland Security  
425 I Street NW, 5<sup>th</sup> Floor Room 5009  
Washington, DC 20536  
e-mail: [REDACTED] (b)(6)  
phone: 202-51 [REDACTED] b6  
Main: 202-514 [REDACTED] b6

**Help us support you better –  
TELL US HOW WE ARE DOING!**  
**Go to** <http://www.acqsolinc.com/ICE/OAQ/feedback.cfm>

**SECTION I - GENERAL INFORMATION**

Name of Jail: Town of Farmville  
 Physical Address of Jail Street: 508 Waterworks Road  
 City: Farmville State: Va. Zip: 23901  
 Phone Number: 804-356-4444

**SECTION II - FINANCIAL DATA SUMMARY**

**TOTAL OPERATING COST FOR JAIL:**

A. Time Frame (Fiscal Year) 2006-2007	From: (Month/Year): September-08	To: (Month/Year): August-09	ANNUAL COST	
<b>B. Total Personnel Costs (Schedule B - Part I)</b>	\$	6,406,714.83	\$ 6,406,714.83	\$ 6,406,714.83
<b>C. Total Personnel Benefits (Schedule B - Part II)</b>	\$	1,783,917.56	\$ 1,783,917.56	
<b>D. Total Consultants and Contract Service (Schedule C)</b>	\$	618,307.00	\$ 618,307.00	
<b>E. Other Direct Operating Costs (Schedule D)</b>	\$	7,733,610.00	\$ 6,695,445.85	
<b>F. Indirect Costs (Schedule E)*</b> <i>*A certified cost allocation plan must be submitted if reimbursement for indirect costs are requested.</i>	\$	368,465.00	\$ 368,465.00	
<b>G. Equipment Depreciation Costs (Schedule F)</b>	\$	448,206.75	\$ 448,206.75	
<b>H. Building Depreciation Costs (Schedule G)</b>	\$	-		1040
<b>I. Total Operating Costs (Sum of Schedules B-G)</b>	\$	17,359,221.14	\$ 16,321,056.99	\$ 45.73
<b>J. Profit</b>	\$	3,952,227.00	\$ 3,952,227.00	
<b>TOTAL ACTUAL OPERATING COST FOR PRIOR FISCAL YEAR</b>	\$	21,311,448.14	\$ 20,273,283.99	\$ 56.14
<b>PROPOSED DETAINEE PER DIEM RATE (*Total actual operating cost for prior fiscal year" divided by 365, divided by the total average daily jail population)</b>	\$	66.05	\$ 62.83	

Profit	Per detainee	days	avg pop	Per Diem	
23%	\$ 12.25	365	884	\$ 66.05	0
	\$ 10.41	365	1040	\$ 56.14	
					0

**\$ 66.05**

**SECTION III DETAINEE POPULATION INFORMATION**

<b>Time Frame of Detainee Information (Must correspond with time frame Section II/A)</b>	<b>FROM: (Month/Year)</b> July 2006	<b>To: (Month/Year)</b> June 2007
--	--	--------------------------------------

**Detainee Capacity of Facility**

	<b>Male</b>	<b>Female</b>	<b>Juvenile</b>	<b>TOTAL</b>
	1000	0	0	1000
	0			0.00
<b>Adjusted Total</b>				1000

**Average Daily Population**

<b>Type of Detainee</b>	<b>Male</b>	<b>Female</b>	<b>Juvenile</b>	<b>TOTAL</b>
<b>Federal</b>	850	0	0	850
<b>Local</b>	0	0	0	0
<b>State</b>	0	0	0	0
<b>Total</b>	850	0	0	850

**SECTION IV - PER DIEM**

**Proposed Per Diem Rate for Detainee:**

**Detainee Per Diem Rate (If Applicable):**

**SECTION V - LOCAL GOVERNMENT CONTACT**

Please provide the name of the individual authorized to represent and act for the local government in he jail day rate negotiations.

<b>Name:</b> Gerald Spates, Town Manager Warren Coleman. Partner: ICA Farmville LLC.	<b>DEPARTMENT/OFFICE:</b>
<b>TITLE:</b>	<b>STREET:</b> 508 Waterworks Road.
<b>PHONE:</b> Spates 434-392-5686 804-282-6550 ext.14	<b>CITY:</b> Farmville
<b>FAX:</b> 282-6544	<b>STATE:</b> VA <b>ZIP:</b> 23901

**SECTION VI - CERTIFICATION STATEMENT**

This is to certify that, to the best of my knowledge and belief, the data furnished in Schedules B through G are accurate, complete and current, and do not include any unallowable costs prohibited by OMB Circular No. A-87 (Cost Principles for State and Local Governments) or any cost not related to the jail facility as discussed on the Cost Sheet for Detention Services). The records of this agency are available for review and audit by the authorized representative of the U.S. Government to verify any jail per diem rate negotiated.

<b>Signature:</b>	<b>Date:</b>
<b>Name:</b>	<b>Title:</b>

1080  
0.856115

**SCHEDULE B**  
**PART 1 - PERSONNEL COSTS**  
(Direct Costs - Personnel Supporting Detention Facility)

**Instructions: List only those positions directly involved in jail operations and benefiting federal inmates.**

Type of Position	(A) Annual Salary Cost \$	(B) Full Time or Part Time	(C.) Number of Position	(D) Total Salary Cost (A) x (C.) = (D) \$
Assst. Gm. Dept. Head Admini	\$ 80,000.00	Full Time	1	\$ 80,000.00
Head Security	\$ 60,000.00	Full Time	1	\$ 60,000.00
Head Medical	\$ 60,000.00	Full Time	1	\$ 60,000.00
Head Support Services	\$ 60,000.00	Full Time	1	\$ 60,000.00
Quality control Officer	\$ 60,000.00	Full Time	4	\$ 240,000.00
Officers	\$ 32,572.80	Full Time	68	\$ 2,214,950.40
Supervisors	\$ 37,000.00	Full Time	12	\$ 444,000.00
Commander	\$ 45,000.00	Full Time	6	\$ 270,000.00
Induction Agent/ Admin Assist.	\$ 35,670.00	Full Time	5	\$ 178,350.00
Life Skills/ Recreation Leader	\$ 45,391.00	Full Time	2	\$ 90,782.00
Receptionist	\$ 29,499.00	Full Time	3	\$ 88,497.00
Record Clerk	\$ 35,670.00	Full Time	2	\$ 71,340.00
Commissary Clerk	\$ 35,670.00	Full Time	3	\$ 107,010.00
RN	\$ 56,516.00	Full Time	1	\$ 56,516.00
LPN	\$ 39,086.00	Full Time	6	\$ 234,516.00
Cert Nursing Assist	\$ 26,014.00	Full Time	16	\$ 416,224.00
Maintenance Supervisor	\$ 54,705.00	Full Time	1	\$ 54,705.00
Maintenance Workers	\$ 35,387.00	Full Time	4	\$ 141,548.00
Housekeeping	\$ 21,166.00	Full Time	5	\$ 105,830.00
Groundskeeper	\$ 29,170.00	Full Time	1	\$ 29,170.00
Kitchen Manager	\$ 48,193.00	Full Time	1	\$ 48,193.00
Kitchen Supervisor	\$ 34,234.00	Full Time	4	\$ 136,936.00
Kitchen Staff	\$ 21,164.00	Full Time	12	\$ 253,968.00
Accountant II	\$ 53,913.00	Full Time	2	\$ 107,826.00
Computer Support/ Network	\$ 66,837.00	Full Time	1	\$ 66,837.00
HR- Training Supervisor	\$ 55,611.00	Full Time	1	\$ 55,611.00
Human Resources Generalist	\$ 48,621.00	Full Time	1	\$ 48,621.00
Chief Operations Officer	\$ 95,000.00	Full Time	1	\$ 95,000.00
CFO/ Controller	\$ 75,000.00	Full Time	1	\$ 75,000.00
Director- Communications	\$ 30,000.00	Part Time	1	\$ 30,000.00
Director- Facilities Management	\$ 30,000.00	Part Time	1	\$ 30,000.00
			169	\$ -
				\$ -
				\$ -
<b>Total Salary Cost:</b>				\$ 5,951,430.40
<b>FICA Benefits</b>		<b>7.65%</b>		\$ 455,284.43
<b>Total Salary Cost plus FICA</b>				\$ 6,406,714.83

# Tot salaries



**SCHEDULE B**  
**PART II - PERSONNEL COSTS**  
(Direct Costs - Personnel Supporting Detention Facility)

**Instructions: Provide name of retirement plans (i.e. N.Y.S. employees retirement system), insurance plans (i.e. Blue Cross/Blue Shield), or unemployment insurance contribution plans for positions listed in Schedule B - Part 1).**

	Number of Employees Participating	Total Salary Base	Employer Contribution	Annual Cost.
<b>1. Retirement Program(s)</b>				
a. Defined Benefit Plan 401K	Full-time:	\$ 5,891,430.40	5.114%	\$ 301,274.82
b.	Part Time	\$ 60,000.00	5%	\$ 3,000.00
c. Incentive Program for Senior Management	Full-time:	\$ 480,000.00	50%	\$ 240,000.00
<b>2. Insurance program(s)</b>				
a. Health, Dental, Vision	Full-time:	\$ 5,891,430.40	16.671%	\$ 982,150.36
Long Term Disability		\$ 5,891,430.40	0.800%	\$ 47,131.44
Life Insurance		\$ 5,891,430.40	0.667%	\$ 39,286.01
<b>3. Other Employee Contribution Plan(s) (i.e. unemployment, worker's compensation)</b>				
a. Worker's Comp	Full-time:	\$ 5,891,430.40	2.373%	\$ 139,782.61
	Part Time	\$ 60,000.00	0.218%	\$ 130.80
b. FUI	Full-time:	\$ 5,891,430.40	0.158%	\$ 9,287.29
	Part Time	\$ 60,000.00	0.075%	\$ 44.80
c. SUI	Full-time:	\$ 5,891,430.40	0.369%	\$ 21,724.63
	Part Time	\$ 60,000.00	0.175%	\$ 104.80
				\$ -
				\$ -
<b>Total Benefits Cost:</b>		\$		1,783,917.56

**SCHEDULE C****CONSULTANTS AND CONTRACT SERVICES**

**Instructions:** List only those services directly involved in jail operations and benefiting federal inmates. Provide a detailed "description of service".

Type of Service	Description of Service	No. of Contract Employees	Annual Cost
1. Medical	Physicians. All others on staff		\$ 179,975.00
2. Dental	Routine check ups and emergency services to Hygienist		\$ 110,832.00
3. Other:	Legal Service		\$ 125,000.00
4. Other:	Auditing and payroll services		\$ 52,500.00
5. Other	Information Tech software and technical support		\$ 50,000.00
6. Other:	Management Advisory Counsel and Board of Directors	Allowable?	\$ 100,000.00
<b>Total Consultants and Contract Services</b>			<b>\$ 618,307.00</b>

**SCHEDULE D**

**OTHER DIRECT JAIL OPERATING COSTS**

*Instructions:* List only those costs associated with the operation of the jail that directly benefit federal inmates. Costs associated with local court and law enforcement activities are not allowable costs for the purpose of determining facility operating costs.

Type of Service	Description	Annual Cost
Food and Kitchen Supplies		\$ 2,467,400.00
Clothing (Detainee)	Includes Clothing	\$ 130,000.00
Medical Care Supplies		\$ 156,000.00
Bedding & Linen		\$ 234,000.00
Toiletries		\$ 130,000.00
Recreation and Education		\$ 5,000.00
Utilities	Seems High	\$ 987,520.00
Uniforms (Jail Staff Only)		\$ 39,400.00
Facility Maintenance and repairs	Brand new building.	\$ 617,200.00
Body Armor/ Weapons		\$ 50,000.00
Office Supplies and Postage		\$ 90,000.00
Training/ Certificates		\$ 102,000.00
Telephone and Communications		\$ 50,000.00
Property Taxes and Bus. License		\$ 215,563.00
Rent	Why does rent increase with the # of inmates	\$ 2,957,837.00
Equipment under \$5,000		\$ 1,250,672.00

(Please use Schedule F for equipment over \$5,000.)

Credits (e.g., telephone credits, insurance rebates, recoveries or insurance: Property & Casualty		\$	-
Insurance: Liability Umbrella	allowable?	\$	46,630.00
Other Insurance: O&D		\$	500,000.00
Other: transportation Costs	Gas reimbursement and travel cost staff	\$	50,000.00
Other		\$	60,000.00
Other		\$	-
<b>Total Other Direct Costs</b>		<b>\$</b>	<b>10,139,222.00</b>

## SCHEDULE E

### COST ALLOCATION PLANS/INDIRECT COST PROPOSALS

**Instructions:** If you intend to claim central service costs you must provide a cost allocation plan. See OMB Circular A-87, Attachment C. Similarly, if you intend to claim indirect costs you must provide an indirect cost proposal. An indirect cost is any cost not directly identified with a single, final cost objective and is not subject to treatment as a direct cost. See OMB Circular A-87, Attachment E.

(A) Type of Service Provided	(B) Organization Providing Service	(C) No. of Employees Involved	(D) Total Cost of Salaries and Benefits	(E) % of Time Spent in Support of Jail Operations	(F) Allowable Indirect Cost (D) x (E) = (F)
Town of Farmville			\$ 2,352,000.00	11.00%	\$ 258,720.00
TOF/ Treasury Dept.			\$ 489,000.00	10.50%	\$ 51,345.00
TOF/ Manager's Office			\$ 584,000.00	10.00%	\$ 58,400.00
			\$ -		\$ -
			\$ -		\$ -
			\$ -		\$ -
			\$ -		\$ -
			\$ -		\$ -
			\$ -		\$ -
			\$ -		\$ -
			\$ -		\$ -
			\$ -		\$ -
			\$ -		\$ -
			\$ -		\$ -
<b>Total</b>					<b>\$ 368,465.00</b>

## CERTIFICATE OF COST ALLOCATION PLAN

This is to certify that I have reviewed the cost allocation plan submitted herewith and to the best of my knowledge and belief:

- 1) All costs included in this proposal (identify date) to establish cost allocations or billings for (identify period covered by plan) are allowable in accordance with the requirements of OMB Circular A-87, "Cost Principles for State and Local Governments," and the Federal Award(s) to which they apply. Unallowable costs have been adjusted for in allocation costs as indicated in the cost allocation plan.
  
- 2) All cost included in this proposal are properly allocable to Federal awards on the basis of a beneficial or casual relationship between the expenses incurred and the awards to which they are allocated in accordance with applicable requirements. Further, the same costs that have been treated as indirect costs have not been claimed as direct costs. Similar types of costs have been accounted for consistency.

I declare that the foregoing is true and correct:

<b>Governmental Unit:</b>	
<b>Signature:</b>	
<b>Name of Official:</b>	
<b>Title:</b>	
<b>Date of Execution:</b>	

## SCHEDULE F EQUIPMENT COSTS

**Instructions:** A listing of equipment that is in the current approved jail operating budget for this contract period may be provided and/or attached to this worksheet for full purchase value consideration. If equipment is depreciated, show total acquisition amount and method used by state, country or city in calculating depreciation. A use allowance not to exceed 6-2/3% of acquisition cost of usable equipment may be substituted in lieu of depreciation. Equipment must be used directly for jail operations. Treatment of these costs must be consistent with local government's method.

### A. New Equipment Approved in Current Operating Budget (Use Continuation Sheet if Necessary)

-1 Item Description	-2 Proposed Utilization	-3 No. of Units	-4 Cost per Unit	-5 Enter % of use by the jail (i.e., if equipment is used by several depts.)	-6 Equipment Cost Allowance (4) x (5) x (6)
Security System		1	\$ 706,000.00	100.00%	\$ 706,000.00
Medical Facilities		1	\$ 50,000.00	100.00%	\$ 50,000.00
Vehicle		15	\$ 20,000.00	100.00%	\$ 300,000.00
Kitchen and Laundry			\$ 759,331.00	100.00%	\$ 759,331.00
Equipment			\$ 1,250,672.00	100.00%	\$ 1,250,672.00
			\$ -		\$ -
			\$ -		\$ -
			\$ -		\$ -
				<b>Total Current Equipment Costs</b>	<b>\$ 3,066,003.00</b>
				<b>Equipment Allowance (6-2/3% of above)</b>	<b>\$ \$ 448,206.75</b>

### B. Show Method of Calculating Depreciation of Equipment if 6-2/3% depreciation is not used.

**SCHEDULE G  
BUILDING DEPRECIATION**

**Instructions:** Provide an explanation of method used by state, county or city to depreciate buildings. Show date of construction; cost of construction (cost of land/site is not allowable); numbers of years in depreciation cycle. Note that federal assistance revenues used for building construction are considered offsetting revenues and are to be subtracted from cost of construction. In lieu of building depreciation an annual use allowance of 2% of acquisition cost may be substituted. Treatment of these costs must be consistent with local government's method. If claiming debt service arising from construction or renovation of a facility, please specify in "other" below.

**Part I – Depreciation Computation**

Facility	Year of Construction	Original Construction Cost	Annual Depreciation Claimed*
Main Building	1986	\$ -	\$ -
Additions(s)	2007	\$ -	\$ -
Annex	2004	\$ -	\$ -
Other (Please specify): Finance Interest Expense		\$	\$ -
Other (Please specify)		\$	\$
Subtotal		\$	\$ -
Less Federal Assistance Revenues or Grants including Awards under Cooperative Agreement Program			\$ -
<b>Total</b>			\$ -
* Generally 2% of original construction cost.			

**Part II – Method of calculating depreciation used by state, county or city (i.e., specify depreciation method if 2% depreciation allowance is not utilized by the state, county, or city.)**



## SCHEDULE H HOURLY STATIONARY GUARD SERVICES RATE

**Instructions:** List only those positions that will perform the stationary guard services. Qualified law enforcement or correctional officer personnel employed by the jail facility under their policies, procedure and practices should only perform these services. Provide annual cost of benefits to include retirement plans (i.e. N.Y.S. employees retirement system), insurance plans (i.e. Blue Cross/Blue Shield), or unemployment insurance contribution plans for positions listed.

The stationary guard services are not to be included in the total operating costs. These services are required for detainees attending off site court proceedings or who are committed to a medical facility.

Title of Position	(A) Annual Salary Cost  \$	(B) Full Time or Part Time	(C) Number of Positions	(D) Total Salary Base  (A) x (C) = (D)  \$	(E) Annual Cost of Benefits  \$	(F) Total Salary Cost  (D) + (E) = (F)  \$	(G) Hourly Rate  (F)/2080 = (G)  \$
Officer	\$ 32,000.00		68	\$ 2,176,000.00	\$ 791,941.00	\$ 2,967,941.00	\$ 20.98
Supervisors	\$ 37,000.00	0	12	\$ 444,000.00	\$ 149,540.00	\$ 593,540.00	\$ 23.78
Commanders	\$ 45,000.00		6	\$ 270,000.00	\$ 82,599.00	\$ 352,599.00	\$ 28.25
5% overhead							\$ 1.09
						\$ 3,914,080.00	\$ 21.88
						<i>Overtime</i>	\$ 32.82
						<i>Profit 20%</i>	\$ 26.26
						<i>Profit OT 20%</i>	\$ 39.39







**Stevens, Richard P**

---

**From:** Smyly, Elena L  
**Sent:** Tuesday, October 07, 2008 10:24 AM  
**To:** Neveleff, Jerald; Jenkins, John E  
**Cc:** Dellar, William L  
**Subject:** Farmville agenda

Hello Jerry and John,

Can you please help me with the agenda for Farmville – what topics do you want to cover? Please send them in any format to me by the 14<sup>th</sup>.

Thanks,

*Elena Smyly, PMP  
Management and Program Analyst - Large IGSA  
DHS, U.S. Immigration and Customs Enforcement  
Office of Detention and Removal  
Detention Management Division  
(202) 732- [REDACTED] b6*

12/21/2008

**Stevens, Richard P**

---

**From:** Nantel, Kelly A [redacted (b)(6)]  
**Sent:** Tuesday, October 07, 2008 11:03 AM  
**To:** Weinberg, Bill; Lewis, Ashley J; Neveleff, Jerald  
**Cc:** Loisel, Mary F  
**Subject:** RE: Article on Farmville

Folks - just an FYI, the issue came up when Mr. Moore was being interviewed on an unrelated topic.

---

**From:** Weinberg, Bill [mailto:weinberg@ice.dhs.gov] [redacted (b)(6)]  
**Sent:** Tuesday, October 07, 2008 10:32 AM  
**To:** Lewis, Ashley J; Neveleff, Jerald  
**Cc:** Nantel, Kelly A; Loisel, Mary F  
**Subject:** Re: Article on Farmville

OK

Bill Weinberg  
Assistant Director,  
ICE Office of Acquisition,  
Detention Management  
Sent from my Blackberry

---

**From:** Lewis, Ashley J  
**To:** Weinberg, Bill; Neveleff, Jerald  
**Cc:** [redacted (b)(6)]; [redacted (b)(6)]  
**Sent:** Tue Oct 07 10:29:29 2008  
**Subject:** RE: Article on Farmville  
Please ensure that you are both there.

*Ashley J. Lewis*  
Head of Contracting Activity  
Immigration and Customs Enforcement  
Department of Homeland Security  
Phone: 202-5 [redacted (b)(6)]  
Cell: 202-441 [redacted (b)(6)]

**Help us support you better –**  
**TELL US HOW WE ARE DOING!**  
Go to <http://www.acqsolinc.com/ICE/OAQ/feedback.cfm>

**From:** Weinberg, Bill  
**Sent:** Tuesday, October 07, 2008 10:29 AM  
**To:** Neveleff, Jerald; Lewis, Ashley J (b)(6)  
**Cc:** (b)(6)  
**Subject:** Re: Article on Farmville

I should be able to be there also.

Bill Weinberg  
Assistant Director,  
ICE Office of Acquisition,  
Detention Management  
Sent from my Blackberry

---

**From:** Neveleff, Jerald  
**To:** Lewis, Ashley J; 'Loiselle, Mary F'  
**Cc:** Weinberg, Bill; 'Nantel, Kelly A'  
**Sent:** Tue Oct 07 10:27:49 2008  
**Subject:** RE: Article on Farmville  
I'll be there.

Thank you,  
Jerry Neveleff  
Deputy Assistant Director/IGSA  
Office of Acq. Management (OAQ)  
Detention Management Division  
202/616 (b)6

Help us support you better -  
TELL US HOW WE ARE DOING!  
Go to <<http://www.acqsolinc.com/ICE/OAQ/feedback.cfm>> <<<http://www.acqsolinc.com/ICE/OAQ/feedback.cfm>>>

---

**From:** Lewis, Ashley J  
**Sent:** Tuesday, October 07, 2008 10:26 AM  
**To:** Loiselle, Mary F  
**Cc:** Neveleff, Jerald; Weinberg, Bill; Nantel, Kelly A  
**Subject:** FW: Article on Farmville  
**Importance:** High

Mary,

Please see info below from Jerry. The capacity issue is a concern, so we may want to loop-in PAO.

Bill/Jerry-I need you to attend the meeting tomorrow with Mary. I also want to pass info along to you prior to the meeting.

*Ashley J. Lewis*  
Head of Contracting Activity  
Immigration and Customs Enforcement  
Department of Homeland Security  
Phone: 202-5 (b)6  
Cell: 202-441 (b)6

12/21/2008

**Help us support you better –**

**TELL US HOW WE ARE DOING!**

Go to <http://www.acqsolinc.com/ICE/OAQ/feedback.cfm>

---

**From:** Neveleff, Jerald

**Sent:** Tuesday, October 07, 2008 10:07 AM

**To:** Lewis, Ashley J

**Cc:** Weinberg, Bill

**Subject:** RE: Article on Farmville

Ashley,

I saw the article Mary mentioned. It looks like the article is the culmination of information that's been out there for the past week or so. It included info that was "slipped" on the 25<sup>th</sup> of Sept and the information provided to Kelly the next day. The information from Mr. Moore seems to be what was in our response also.

The only thing I'm concerned about was the 85% capacity. I never mentioned that to anyone. We based the initial bed day rate on an average daily population of 85%.

I however did receive an email that the Washington Post contacted the subcontractor (ICA) on Oct 2<sup>nd</sup>. The below was their response.

"A reporter named Nick Miroff called from the Post and wanted to confirm a few points. He was told to contact ICE and without any discussion the conversation ended."

Jerry

Thank you,

Jerry Neveleff

Deputy Assistant Director/IGSA

Office of Acq. Management (OAQ)

Detention Management Division

202/616 [REDACTED] b6

Help us support you better -

TELL US HOW WE ARE DOING!

Go to <http://www.acqsolinc.com/ICE/OAQ/feedback.cfm> <<<http://www.acqsolinc.com/ICE/OAQ/feedback.cfm>>>

---

**From:** Lewis, Ashley J

**Sent:** Tuesday, October 07, 2008 9:56 AM

**To:** Loiselle, Mary F; Neveleff, Jerald

**Cc:** Weinberg, Bill

**Subject:** RE: Article on Farmville

Mary: Please do not meet with them without me. I am in interviews at FPS Wednesday at 3:00. If the meeting can't be moved, I'd like Bill and Jerry to attend. Let me know how you want to proceed.

Jerry: Please see below email and lets discuss.

12/21/2008



*Ashley J. Lewis*

Head of Contracting Activity  
Immigration and Customs Enforcement  
Department of Homeland Security  
Phone: 202-5 [REDACTED]  
Cell: 202-441 [REDACTED]

**Help us support you better –**

**TELL US HOW WE ARE DOING!**

Go to <http://www.acqsolinc.com/ICE/OAQ/feedback.cfm>

---

**From:** Loisel, Mary F  
**Sent:** Monday, October 06, 2008 6:02 PM  
**To:** Lewis, Ashley J  
**Subject:** Article on Farmville

Ashley-  
Did you see the article in the Washington Post yesterday about the detention facility being built in Farmville? I'm not sure Jerry cleared this per the IGSA but Marc Moore is quoted so DRO/PAO must have known about it and I assume ran it by Jerry. Anyway, the article mentions that they are breaking ground on the facility on October 15 and I have directed the DRO staff here that they will not be within 100 miles of that location on that date to ensure that ICE is not represented in any way, shape or form. I'm going to follow up with the field office staff but I wanted to know if you agreed that neither Jerry nor any other OAQ rep should be there either. Let me know if you want a copy, I'll have it scanned and sent to you.  
Thanks.

Mary  
PS CCA has asked to meet with me on Hall County IGSA, when they are in DC on other business. I have defended your letter and request for additional information so I'm not sure what they want to offer but do you want to join me? It's 3:00 this Wednesday, on the 9<sup>th</sup> floor here. I have asked them to bring the documents that we need to review.

*Mary F. Loisel*  
*Assistant Director, Management*  
*Detention and Removal Operations*  
*Immigration and Customs Enforcement*  
*Department of Homeland Security*  
*801 I Street, NW*  
*Washington, DC 20536*  
*(202) 73 [REDACTED]*

**Stevens, Richard P**

---

**From:** Bassett, Cori W  
**Sent:** Wednesday, October 15, 2008 12:58 PM  
**To:** Neveleff, Jerald; Loiselle, Mary F; Achim, Deborah  
**Subject:** Public Disclosure Guidelines

All,

After my discussion with Jeff and a read of the IGSA with Farmville, I drafted some guidelines to help clarify public disclosures.

Please review the guidelines below and make suggestions or edits to this by 11 am 10/16 so we can ensure the appropriate information is communicated at the meeting tomorrow.

IGSA agreement guidelines

No public disclosures about the IGSA by the service provider or any contractors or subcontractors without ICE consent for the lifetime of the agreement.

**According to this agreement Farmville CAN talk about**

Its contractors and subcontractors – history, previous contracts, etc., the contractors previous experience  
What it intends to do with the facility  
Updates on the building process

**According to this agreement Farmville and its contractors and subcontractors CANNOT talk about**

Any part of the agreement or its terms  
What ICE will or will not do related to this facility  
Speak about ICE's intentions related to the facility

Thanks.

Cori

Cori W. Bassett, Public Affairs Officer  
U.S. Immigration and Customs Enforcement  
425 I Street, NW  
Washington, DC 20536  
202- [REDACTED] ffice  
202- [REDACTED] ell

(b)(6)

12/21/2008

**Stevens, Richard P**

---

**From:** Neveleff, Jerald  
**Sent:** Thursday, October 23, 2008 10:05 AM  
**To:** [REDACTED] b6  
**Cc:** [REDACTED], Smyly, Elena L; Raine, Craig K; Barr, Jose G; Mullin, Edward F; HORYN, IWONA B; Dellar, William L  
**Subject:** Farmville

Jerry,

[REDACTED]

(b)(5), b6,b7c

PLEASE NOTE EFFECTIVE 1600 23 OCT 2008, ICE OAQ WILL BE RELOCATING TO 801 I STREET NW, SUITE 900, WASHINGTON, DC 20536. STARTING 10/27/08, MY NEW NUMBER WILL BE 202-752-2301. [REDACTED] b6

Thank you,  
Jerry Neveleff  
Deputy Assistant Director/IGSA  
Office of Acquisition Management (OAQ)  
Immigration & Customs Enforcement (ICE)  
Department of Homeland Security (DHS)  
801 I Street, NW Washington DC 20536  
Phone: 202-752-2301 [REDACTED] b6  
Fax: 202-xxx [REDACTED]  
E-mail: j[REDACTED] (b)(6)

**Please note new office address & phone/fax numbers!**

Help us support you better -  
TELL US HOW WE ARE DOING!

Go to <http://www.acqsolinc.com/ICE/OAQ/feedback.cfm> <<<http://www.acqsolinc.com/ICE/OAQ/feedback.cfm>>>

**Stevens, Richard P**

---

**From:** Thompson, Arthur D (CTR)  
**Sent:** Tuesday, October 21, 2008 12:54 PM  
**To:** Smyly, Elena L  
**Cc:** Neveleff, Jerald  
**Subject:** FW: Farmville Facility

Elena

This is the email I received from Mr. Kelly, the architect for the Farmville project.

Dean

---

**From:** Mac Kelley [mailto:[REDACTED] b6]  
**Sent:** Thursday, October 16, 2008 5:21 PM  
**To:** Dean Thompson  
**Subject:** ICE: Farmville Facility

Good afternoon Dean,

I'm looking for information about the TIF Modular Unit. It is included in our project at Paul's suggestion. So far I can't find any information about it beyond the floor plan we received. If possible would you please look into this and let me know the name of the manufacturer. Perhaps any other info you find.

Thanks,

Mac Kelley, Architect

**Stevens, Richard P**

---

**From:** Casterline, Arnold P  
**Sent:** Wednesday, October 29, 2008 12:55 PM  
**To:** Neveleff, Jerald  
**Subject:** FW:  
**Attachments:** DROIGSA080021 P00001\_001 (2).pdf; DROIGSA080021TRANS\_001.pdf; LSFARM001.pdf; QASP2\_026.pdf; QASP9908001.pdf; SOW9908\_001.pdf; Quality Control Plan\_001.pdf; Staffing Plan\_001.pdf; HSCEDM08FIG064.pdf; Wage Determination 2008-0334, 1.htm

*Arnold P. Casterline Jr.*

Contract Specialist  
Immigration and Customs Enforcement  
Office of Acquisition Management  
Detention Management  
Department of Homeland Security  
801 I. St. NW, 9th Floor, Room 910  
Washington, D.C. 20536

e-mail: [REDACTED] (b)(6)

**Please note new address and desk phone number!**

Phone: 202-7 [REDACTED]  
Main: 202-732 [REDACTED] b6  
Fax: 202-732 [REDACTED]

**Help us support you better –  
TELL US HOW WE ARE DOING!**

**Go to** <http://www.acqsolinc.com/ICE/OAQ/feedback.cfm>

---

**From:** Casterline, Arnold P  
**Sent:** Thursday, October 16, 2008 3:17 PM  
**To:** Barr, Jose G; Watson, Joe  
**Subject:**

Mr. Barr and Mr. Watson,

Attached are the IGSA and the Task order for Farmville. If there are any questions or if you need something further, please feel free to get in touch with me and I will get it to you. Thank you and have a great day.

Arnie Casterline  
*Arnold P. Casterline Jr.*  
Contract Specialist  
Immigration and Customs Enforcement  
Office of Acquisition Management  
Detention Management

Department of Homeland Security  
425 I Street NW, 5<sup>th</sup> Floor Room 5009  
Washington, DC 20536  
e-mail: [REDACTED] (b)(6)  
phone: 202-5 [REDACTED]  
Main: 202-51 [REDACTED] b6

**Help us support you better –  
TELL US HOW WE ARE DOING!**  
**Go to** <http://www.acqsolinc.com/ICE/OAQ/feedback.cfm>

AMENDMENT OF SOLICITATION/MODIFICATION OF CONTRACT		1. CONTRACT ID CODE		PAGE OF PAGES	
2. AMENDMENT/MODIFICATION NO.		3. EFFECTIVE DATE		1 2	
P00001		09/22/2008		5. PROJECT NO. (if applicable)	
6. ISSUED BY		7. ADMINISTERED BY (if other than Item 6)		CODE	
ICE/DM/DC-DC		ICE/DM/DC-DC		ICE/DM/DC-DC	
ICE/Detent Mngt/Detent Contracts-DC Immigration and Customs Enforcement Office of Acquisition Management 425 I Street NW, Suite 2208 Washington DC 20536			ICE/Detent Mngt/Detent Contracts-DC Immigration and Customs Enforcement Office of Acquisition Management 425 I Street NW, Suite 2208 Washington DC 20536		
8. NAME AND ADDRESS OF CONTRACTOR (No. street, county, State and ZIP Code)			9A. AMENDMENT OF SOLICITATION NO.		
FARMVILLE TOWN OF P O BOX 368 FARMVILLE VA 239010368			(X)		
9B. DATED (SEE ITEM 11)			9C. AMENDMENT OF SOLICITATION NO.		
9D. DATED (SEE ITEM 11)			10A. MODIFICATION OF CONTRACT ORDER NO.		
			DROIGGA-08-0021		
10B. DATED (SEE ITEM 11)			10C. MODIFICATION OF CONTRACT ORDER NO.		
09/22/2008					
CODE 0401562180000		FACILITY CODE			

11. THIS ITEM ONLY APPLIES TO AMENDMENTS OF SOLICITATIONS

The above numbered solicitation is amended as set forth in Item 14. The hour and date specified for receipt of Offers  is extended,  is not extended. Offers must acknowledge receipt of this amendment prior to the hour and date specified in the solicitation or as amended, by one of the following methods: (a) By completing Items 6 and 15, and returning \_\_\_\_\_ copies of the amendment; (b) By acknowledging receipt of this amendment on each copy of the offer submitted; or (c) By separate letter or telegram which includes a reference to the solicitation and amendment numbers. FAILURE OF YOUR ACKNOWLEDGEMENT TO BE RECEIVED AT THE PLACE DESIGNATED FOR THE RECEIPT OF OFFERS PRIOR TO THE HOUR AND DATE SPECIFIED MAY RESULT IN REJECTION OF YOUR OFFER. If by virtue of this amendment you desire to change an offer already submitted, such change may be made by telegram or letter, provided each telegram or letter makes reference to the solicitation and this amendment, and is received prior to the opening hour and date specified.

12. ACCOUNTING AND APPROPRIATION DATA (if required)  
See Schedule

13. THIS ITEM ONLY APPLIES TO MODIFICATION OF CONTRACT ORDERS. IT MODIFIES THE CONTRACT ORDER NO. AS DESCRIBED IN ITEM 14.

CHECK ONE	A. THIS CHANGE ORDER IS ISSUED PURSUANT TO: (Specify authority) THE CHANGES SET FORTH IN ITEM 14 ARE MADE IN THE CONTRACT ORDER NO. IN ITEM 10A.
X	B. THE ABOVE NUMBERED CONTRACT ORDER IS MODIFIED TO REFLECT THE ADMINISTRATIVE CHANGES (such as changes in paying office, appropriation date, etc.) SET FORTH IN ITEM 14, PURSUANT TO THE AUTHORITY OF FAR 43.103(D).
	C. THIS SUPPLEMENTAL AGREEMENT IS ENTERED INTO PURSUANT TO AUTHORITY OF:
	D. OTHER (Specify type of modification and authority)

14. IMPORTANT: Contractor  is not,  is required to sign this document and return \_\_\_\_\_ 1 \_\_\_\_\_ copies to the issuing office.

14. DESCRIPTION OF AMENDMENT/MODIFICATION (Organized by UCF section headings, including solicitation/contract subject matter where feasible.)

DUNS Number: 040156218

FIELD POC: Craig Raine 703-285- [b6]

Paul Picone 703-285- [b6]

Program POC: Elena Smyly 202-732- [b6]

M.J. Bates 202-732- [b6]

OAQ POC: Jerald Neveleff, Contracting Officer, 202-616- [b6]

Arnold Casterline, Contract Specialist, 202-514- [b6]

The purpose of this modification is to change ARTICLE I: Section C: The detainee daily rate is TBD. To: The detainee daily rate is \$62.83. This will also modify ARTICLE XI:  
Continued ...

Except as provided herein, all terms and conditions of the document referenced in Item 9A or 10A, as heretofore changed, remains unchanged and in full force and effect.

15A. NAME AND TITLE OF SIGNER (Type or print)		16A. NAME AND TITLE OF CONTRACTING OFFICER (Type or print)	
GERALD J. SPATERS TOWN MGR.		Jerald H. Neveleff	
15B. CONTRACTING OFFEROR		16B. UNITED STATES OF AMERICA	
(Signature of person authorized to sign)		(Signature of Contracting Officer)	
15C. DATE SIGNED		15C. DATE SIGNED	
9/24/08		25 Sept 08	

**CONTINUATION SHEET**

REFERENCE NO. OF DOCUMENT BEING CONTINUED  
DROIGSA-08-0021//P00001

PAGE OF  
2 2

NAME OF OFFEROR OR CONTRACTOR  
FARMVILLE TOWN OF

ITEM NO. (A)	SUPPLIES/SERVICES (B)	QUANTITY (C)	UNIT (D)	UNIT PRICE (E)	AMOUNT (F)
	Section B: The detainee day rate is TBD. To: The detainee day rate is \$62.83.				
	After completion and approval of the facility, another Task Order will be issued with funding for the bed days.				
	Period of Performance: 09/22/2008 to 09/30/2009				



DROIGSA-08-0021  
INTERGOVERNMENTAL SERVICE AGREEMENT  
BETWEEN THE  
UNITED STATES DEPARTMENT OF HOMELAND SECURITY  
U.S. IMMIGRATION AND CUSTOMS ENFORCEMENT  
AND  
Town of Farmville

This Intergovernmental Service Agreement ("Agreement") is entered into between United States Department of Homeland Security Immigration and Customs Enforcement ("ICE"), and the Town of Farmville ("Service Provider") for the detention and care of aliens ("detainees"). The term "Parties" is used in this Agreement to refer jointly to ICE and the Service Provider.

**FACILITY LOCATION:**

The Service Provider shall provide detention services for detainees at the following institution(s):

Town of Farmville  
116 North Main Street  
Farmville, Virginia 23901

The following constitute the complete agreement:

- INTERGOVERNMENTAL SERVICE AGREEMENT (IGSA)
- PROPOSAL, DATED \_\_\_\_\_ (Incorporated by reference)
- ATTACHMENT 1--STATEMENT OF WORK
- ATTACHMENT 2--QUALITY CONTROL PLAN
- ATTACHMENT 3--QUALITY ASSURANCE SURVEILLANCE PLAN (w/ PRS, CDR and PMT)
- ATTACHMENT 4--STAFFING PLAN
- ATTACHMENT 5--LABOR STANDARDS
- ATTACHMENT 6--WAGE DETERMINATION Number \_\_\_\_\_ Dated \_\_\_\_\_

**IN WITNESS WHEREOF**, the undersigned, duly authorized officers, have subscribed their names on behalf of the Town of Farmville and Department of Homeland Security, U.S. Immigration and Customs Enforcement.

**ACCEPTED:**

U.S. Immigration and Customs Enforcement

Jerald Neveleff  
Contracting Officer

Print Name: Jerald Neveleff  
Date: 15 Sept 08

**ACCEPTED:**

Town of Farmville

Gerald J. Spates  
Town Manager

Print Name: GERALD J. SPATES  
Date: 9/9/08

## Article I. Purpose

- A. **Purpose:** The purpose of this Intergovernmental Service Agreement (IGSA) is to establish an Agreement between ICE and the Service Provider for the detention and care of persons detained under the authority of Immigration and Nationality Act, as amended. All persons in the custody of the ICE are "Administrative Detainees". This term recognizes that ICE detainees are not charged with criminal violations and are only held in custody to assure their presence throughout the administrative hearing process and to assure their presence for removal from the United States pursuant to a lawful final order by the Immigration Court, the Board of Immigration Appeals or other Federal judicial body.
- B. **Responsibilities:** This Agreement sets forth the responsibilities of ICE and the Service Provider. The Agreement states the services the Service Provider shall perform satisfactorily to receive payment from ICE at the rate prescribed in Article I, C.
- C. **Guidance:** This is a fixed rate agreement, not a cost reimbursable agreement, with respect to the detainee day rate. The detainee daily rate is \$TBD. ICE shall be responsible for reviewing and approving the costs associated with this Agreement and subsequent modifications utilizing all applicable federal procurement laws, regulations and standards in arriving at the detainee day rate.

## Article II. General

- A. **Funding:** The obligation of ICE to make payments to the Service Provider is contingent upon the availability of Federal funds. ICE will neither present detainees to the Service Provider nor direct performance of any other services until ICE has the appropriate funding. Orders will be placed under this Agreement when specific requirements have been identified and funding obtained. Performance under this Agreement is not authorized until the Contracting Officer issues an order, in writing. The effective date of the Agreement will be negotiated and specified in an order to this Agreement by the Contracting Officer. This Agreement is neither binding nor effective unless signed by the Contracting Officer. Payments at the approved rate will be paid upon the return of the signed Agreement by the authorized Local Government official to ICE.
- B. **Subcontractors:** The Service Provider shall notify and obtain approval from the Contracting Officer if it intends to house detainees in a facility other than the Facility named in this Agreement. If either that facility or any future facility is operated by an entity other than the Service Provider, ICE shall treat the entity as a subcontractor to the Service Provider. The Service Provider shall obtain the Contracting Officer's approval before subcontracting the detention and care of detainees to another entity. The Contracting Officer has the right to deny, withhold, or withdraw approval of the proposed subcontractor. Upon approval by the Contracting Officer, the Service Provider shall ensure that any subcontract includes all provisions of this Agreement, and shall provide ICE with copies of all subcontracts. All payments will be made to the Service Provider. ICE will not accept invoices from, or make payments to a subcontractor.
- C. **Consistent with Law:** This is a firm fixed rate agreement, not cost reimbursable agreement. This Agreement is permitted under applicable statutes, regulation, policies or

judicial mandates. Any provision of this Agreement contrary to applicable statutes, regulation, policies or judicial mandates is null and void and shall not necessarily affect the balance of the Agreement.

- D. Use of Service Provider's Policies and Procedures: The Contracting Officer shall approve Service Provider's policies and procedures for use under this Agreement. Upon approval, the Service Provider can use its policies and procedures in conjunction with the detention standards mandated under this Agreement.
- E. Notification and Public Disclosure: No public disclosures (i.e. press releases, press conferences) regarding this IGSA shall be made by the Service Provider or any of its contractors or subcontractors without the review and approval of such disclosure by ICE Public Affairs and express permission granted by the ICE Contracting Officer.

### Article III. Covered Services

Below are the general requirements under this Agreement. Specific requirements for the services under this Agreement are stated in the attached Statement of Work. See Attachment 1.

- A. Bedspace: The Service Provider shall provide male/female beds on a space available basis. The Service Provider shall house all detainees as determined within the Service Provider's classification system.
- B. Basic Needs: The Service Provider shall provide detainees with safekeeping, housing, subsistence, medical and other services in accordance with this Agreement. In providing these services, the Service Provider shall ensure compliance with all applicable laws, regulations, fire and safety codes, policies and procedures. If the Service Provider determines that ICE has delivered a person for custody who is under the age of eighteen (18), the Service Provider shall not house that person with adult detainees and shall immediately notify the Contracting Officer's Technical Representative (COTR).
- C. Interpretive Services: The Service Provider shall make special provisions for non-English speaking, handicapped or illiterate detainees. ICE will reimburse the Service Provider for the actual costs associated with providing commercial written or telephone language interpretive services. Upon request, ICE will assist the Service Provider in obtaining translation services. The Service Provider shall provide all instructions verbally either in English or the detainees' language, as appropriate, to detainees who cannot read. The Service Provider shall include the actual costs that the Service Provider paid for such services on its monthly invoice. Except in emergency situations, the Service Provider shall not use detainees for translation services. If the Service Provider uses a detainee for translation service, it shall notify ICE within 24 hours of the translation service.
- D. Escort and Transportation Services: The Service Provider will provide, upon request and as scheduled by the Contracting Officer's Technical Representative (COTR) or Contracting Officer (CO), necessary escort and transportation services for detainees to and from designated locations. Escort services will be required for escorting detainees to court hearings; escorting witnesses to the courtroom and any escort services as requested by an ICE judge during proceedings. Escort and transportation services shall also include

providing all such air and/or ground transportation services as may be required to transport detainees securely and in a timely manner. Transportation and/or escort services may be required to transport detainees from the Facility to and from a medical facility for outpatient care. During all transportation activities, at least one (1) transportation officer shall be of the same sex as the detainees being transported. The Service Provider shall use a communications system that has direct and immediate contact with all transportation vehicles. Transportation and escort services shall be provided in the most economical and efficient manner. The Service Provider personnel provided for these services shall be of the same qualifications, receive training, complete the same security clearances, and wear the same uniforms as those personnel provided for in other areas of this Agreement. The Statement of Work shall provide specific escort and transportation services unique for this Agreement.

E. **Guard Services:** The Service Provider agrees to provide stationary guard services on demand by the COTR or Contracting Officer and shall include, but are not limited to, escorting and guarding detainees to medical or doctor's appointments, hearings, ICE interviews, and any other location requested by the COTR. Qualified personnel employed by the Service Provider will perform such services. The Service Provider agrees to augment such practices as may be requested by ICE to enhance specific requirements for security, detainee monitoring, visitation, and contraband control. Public contact is prohibited unless authorized in advance by the COTR or Contracting Officer. The Service Provider shall be authorized to provide at least two (2) officers for each remote post, as directed by the COTR or Contracting Officer.

F. **Medical Services:** The Statement of Work shall provide specific medical service requirements unique to this Agreement. Regardless of the unique requirements for this contract, the Service Provider shall provide the following services regarding medical care of detainees:

- 1) The Service Provider shall provide for medical screening of every detainee upon arrival at the Facility performed by health care personnel or health trained personnel.
- 2) Medical coverage at the Facility shall be no less than twenty-four (24) hours per day, seven (7) days per week.
- 3) The Service Provider shall provide the detainees written instructions for gaining access to health care services. Procedures shall be explained to all detainees in the detainees' native language, and orally to detainees' who are unable to read. The detainee shall similarly be provided instructions and assistance in personal hygiene, dental hygiene, grooming and health care. It shall be made routinely available.
- 4) The Service Provider shall provide to all detainees a written policy and defined procedure to require that detainee's written health complaints are solicited and delivered to the medical facility for appropriate follow-up. Written policy and defined procedure shall require that health care complaints are responded to and that sick call, conducted by health care personnel or health trained personnel is available to detainees daily. If a detainee's custody status precludes attendance at sick call, arrangements shall be made to provide sick call services in the place of the detainee's detention. A minimum of one sick call shall be conducted daily.

USPHS reserves the right to conduct triage and sick call in the place of the detainee's detention.

- 5) The Service Provider shall provide and maintain basic first aid kits throughout the Facility. First aid kits shall be available at all times to allow quick access.
- 6) The Service Provider shall provide security with a minimum of a staff of one at all times. When detainees are housed in the infirmary, a security guard shall be posted to the unit 24 hours a day, seven days a week. The Service Provider shall coordinate and escort detainees to the medical clinic for sick call, appointments and pill line.
- 7) When communicable or debilitating physical problems are suspected, the detainee shall be separated from the detainee population, and immediately notify USPHS staff. Behavioral problems (detainee who is not diagnosed as psychotic) and suicide observation will be the responsibility of the Service Provider.

#### Article IV. Receiving and Discharging Detainees

- A. Required Activity: The Service Provider shall receive and discharge detainees only to and from properly identified ICE personnel or other properly identified Federal law enforcement officials with prior authorization from DHS/ICE. Presentation of U.S. Government identification shall constitute "proper identification." The Service Provider shall furnish receiving and discharging services twenty-four (24) hours per day, seven (7) days per week. ICE shall furnish the Service Provider with reasonable notice of receiving and discharging detainees. The Service Provider shall ensure positive identification and recording of detainees and ICE officers. The Service Provider shall not permit medical or emergency discharges except through coordination with on-duty ICE officers.
- B. Restricted Release of Detainees: The Service Provider shall not release detainees from its physical custody to any persons other than those described in Paragraph A of Article IV for any reason, except for either medical, other emergency situations, or in response to a federal writ of habeas corpus. If a detainee is sought for federal, state, or local proceedings, only ICE may authorize release of the detainee for such purposes. The Service Provider shall contact the COTR immediately regarding any such requests.
- C. Service Provider Right of Refusal: The Service Provider retains the right to refuse acceptance or request removal of any detainee exhibiting violent or disruptive behavior, or of any detainee found to have a medical condition that requires medical care beyond the scope of the Service Provider's health care provider. In the case of a detainee already in custody, the Service Provider shall notify ICE and request removal of the detainee from the Facility. The Service Provider shall allow ICE reasonable time to make alternative arrangements for the detainee.
- D. Emergency Evacuation: In the event of an emergency requiring evacuation of the Facility, the Service Provider shall evacuate detainees in the same manner, and with the same safeguards, as it employs for persons detained under the Service Provider's authority. The Service Provider shall notify the Contracting Officer and COTR within two (2) hours of evacuation.

#### **Article V. ICE National Detention Standards**

- A. The Service Provider is required to house detainees and perform related detention services in accordance with the most current edition of the ICE National Detention Standards found within the ICE Detention Operations Manual. This manual can be found at <http://www.ice.gov/partners/dro/opsmanual/index>. ICE Inspectors will conduct periodic inspections of the facility to assure compliance with the ICE National Detention Standards.
- B. The Service Provider shall certify to the Contracting Officer and COTR that its personnel have completed all training as required by the ICE Detention Operations Manual, the Service Provider's own manual (if it is approved for use by the Contracting Officer), and any additional training as required in any manuals or detention standards referenced in this Agreement.

#### **Article VI. No Employment of Unauthorized Aliens**

Subject to existing laws, regulations, Executive Orders, and addenda to this Agreement, the Service Provider shall not employ aliens unauthorized to work in the United States. Except for maintaining personal living areas, detainees shall not be required to perform manual labor.

#### **Article VII. Period of Performance**

This Agreement shall become effective upon the date of final signature by the ICE Contracting Officer and the authorized signatory of the Service Provider and will remain in effect for a period not to exceed sixty (60) months, unless terminated in writing, by either party. Either party must provide written notice of intentions to terminate the agreement, 60 days in advance of the effective date of formal termination, or the Parties may agree to a shorter period under the procedures prescribed in Article X.

#### **Article VIII. Inspections**

The Facility and Provider's services shall be inspected in accordance with the following procedures:

- A. Definitions. "Services," as used in this clause, includes services performed, workmanship, and material furnished or utilized in the performance of services.
- B. The Provider shall provide and maintain an inspection system acceptable to the Government covering the services under this agreement. Complete records of all inspection work performed by the Provider shall be maintained and made available to the Government during contract performance and for as long afterwards as the agreement requires.
- C. The Government has the right to inspect and test all services called for by the agreement, to the extent practicable at all times and places during the term of the agreement. The Government shall perform inspections and tests in a manner that will not unduly delay the work.

- D. If the Government performs inspections or tests on the premises of the Provider or a subcontractor, the Provider shall furnish, and shall require subcontractors to furnish, at no increase in agreement price, all reasonable facilities and assistance for the safe and convenient performance of these duties.
- E. If any of the services do not conform to agreement requirements, the Government may require the Provider to perform the services again in conformity with agreement requirements, at no increase in agreement amount. When the defects in services cannot be corrected by re-performance, the Government may (1) require the Provider to take necessary action to ensure that future performance conforms to agreement requirements and (2) reduce the agreement price to reflect the reduced value of the services performed.
- F. If the Provider fails to promptly perform the services again or to take the necessary action to ensure future performance in conformity with agreement requirements, the Government may (1) by contract or otherwise, perform the services and charge to the Provider any cost incurred by the Government that is directly related to the performance of such service or (2) terminate the agreement for default.

#### Article IX. Inspection Reports

- A. Inspection Report: The Inspection Report stipulates minimum requirements for fire/safety code compliance, supervision, segregation, sleeping utensils, meals, medical care, confidential communication, telephone access, legal counsel, legal library, visitation, and recreation. The Service Provider shall allow ICE to conduct inspections of the facility, as required, to ensure an acceptable level of services and acceptable conditions of confinement as determined by ICE. No notice to the Service Provider is required prior to an inspection. ICE will conduct such inspections in accordance with the Inspection Report. ICE will share findings of the inspection with the Service Provider's facility administrator. The Inspection Report will state any improvements to facility operation, conditions of confinement, and level of service that will be required by the Service Provider.
- B. Possible Termination: If the Service Provider fails to remedy deficient service ICE identifies through inspection, ICE may terminate this Agreement without regard to the provisions of Articles VII and X.
- C. Share Findings: The Service Provider shall provide ICE copies of facility inspections, reviews, examinations, and surveys performed by accreditation sources.
- D. Access to Detainee Records: The Service Provider shall, upon request, grant ICE access to any record in its possession, regardless of whether the Service Provider created the record, concerning any detainee held pursuant to this Agreement. This right of access shall include, but is not limited to, incident reports, records relating to suicide attempts, and behavioral assessments and other records relating to the detainee's behavior while in the Service Provider's custody. Furthermore, the Service Provider shall retain all records where this right of access applies for a period of two (2) years from the date of the detainee's discharge from the Service Provider's custody.

## **Article X. Modifications and Disputes**

- A. **Modifications:** Actions other than those designated in this Agreement will not bind or incur liability on behalf of either Party. Either Party may request a modification to this Agreement by submitting a written request to the other Party. A modification will become a part of this Agreement only after the ICE Contracting Officer and the authorized signatory of the Service Provider have approved the modification in writing.
- B. **Disputes:** The ICE Contracting Officer and the authorized signatory of the Service Provider will settle disputes, questions and concerns arising from this Agreement. Settlement of disputes shall be memorialized in a written modification between the ICE Contracting Officer and authorized signatory of the Service Provider. In the event a dispute is not able to be resolved between the Service Provider and the ICE Contracting Officer, the ICE Contracting Officer will make the final decision. If the Service Provider does not agree with the final decision, the matter may be appealed to the ICE Head of the Contracting Activity (HCA) for resolution. The ICE HCA may employ all methods available to resolve the dispute including alternative dispute resolution techniques. The Service Provider shall proceed diligently with performance of this Agreement pending final resolution of any dispute.

## **Article XI. DETAINEE DAY RATE and ADJUSTMENT to the DAY RATE**

- A. **Detainee Day Rate:** In consideration for the Service Provider's performance under this Agreement, ICE shall make payment to the Service Provider for each detainee accepted and housed by the Service Provider. This "detainee day rate" is a per diem rate for the support of one Detainee per day and shall include the day of arrival but not the day of departure.
- B. The detainee day rate is TBD.
- C. The Service Provider, by execution of this Agreement, certifies that the pricing established under this agreement is in compliance with OMB Circular A-87 and includes only allowable costs of performance under this agreement.
- D. **Basis for Price Adjustment:** A firm fixed price with economic adjustment provides for upward and downward revision of the stated Per Diem based upon cost indexes of labor and operating expenses, or based upon the Service Provider's actual cost experience in providing the service.
- E. ICE shall reimburse the Service Provider at the fixed detainee day rate shown on the cover page of the document, Article I. (C). The Parties may adjust the rate twelve (12) months after the effective date of the agreement and no sooner than every twelve (12) months. The Parties shall base the cost portion of the rate adjustment on the principles of allowability and allocability as set forth in OMB Circular A-87, federal procurement laws, regulations, and standards in arriving at the detainee day rate. The request for adjustment shall be submitted on an ICE Jail Services Cost Statement. If ICE does not receive an official request for a detainee day rate adjustment that is supported by an ICE Jail Services Cost Statement, the detainee day rate as stated in this Agreement will control.



- F. ICE reserves the right to audit the actual and/or prospective costs upon which the rate adjustment is based. All rate adjustments are prospective. As this is a fixed rate agreement, there are no retroactive adjustment(s).
- G. Guard and transportation services shall be denoted as separate items on submitted invoices. ICE agrees to reimburse the Service Provider for actual stationary guard services provided at a negotiated rate of \$24.28. Transportation mileage reimbursable rates will be commensurate with current applicable federal travel allowance rates. Any additional operational costs will be reimbursed at the negotiated rate identified in the task order (HSCEDM-08-F-IG064). The additional items shall also be billed as separate line items until modified in the task order.

**Article XII. Enrollment, Invoicing, and Payment**

- A. Enrollment in Electronic Funds Transfer: The Service Provider shall provide ICE with the information needed to make payments by electronic funds transfer (EFT). Since January 1, 1999, ICE makes all payments only by EFT. The Service Provider shall identify their financial institution and related information on Standard Form 3881, Automated Clearing House (ACH) Vendor Miscellaneous Payment Enrollment Form. The Service Provider shall submit a completed SF 3881 to ICE payment office prior to submitting its initial request for payment under this Agreement. If the EFT data changes, the Service Provider shall be responsible for providing updated information to the ICE payment office.
- B. Invoicing: The Service Provider shall submit an original itemized invoice containing the following information: the name and address of the facility; the name of each ICE detainee; detainee's A-number; specific dates of detention for each detainee; the total number of detainee days; the daily rate; the total detainee days multiplied by the daily rate; an itemized listing of all other charges; and the name, title, address, and phone number of the local official responsible for invoice preparation. For stationary guard services, the itemized monthly invoice shall state the number of hours being billed, the duration of the billing (times and dates) and the name of the detainee(s) that was guarded. The Service Provider shall submit monthly invoices within the first ten (10) working days of the month following the calendar month when it provided the services, to:

Department of Homeland Security  
ATTN: Immigration and Customs Enforcement  
Contracting Officer's Technical Representative (COTR)  
2675 Property Avenue  
Fairfax, Va. 22031  
Phone: 703-285-6200  
Fax: 703-285-6236

- C. Payment: ICE will transfer funds electronically through either an Automated Clearing House subject to the banking laws of the United States, or the Federal Reserve Wire Transfer System. The Prompt Payment Act applies to this Agreement. The Prompt Payment Act requires ICE to make payments under this Agreement the thirtieth (30<sup>th</sup>) calendar day after the ICE Deportation office receives a complete invoice. Either the date

on the Government's check, or the date it executes an electronic transfer of funds, shall constitute the payment date. The Prompt Payment Act requires ICE to pay interest on overdue payments to the Service Provider. ICE will determine any interest due in accordance with the Prompt Payment Act.

#### **Article XIII. Government Furnished Property**

- A. **Federal Property Furnished to the Service Provider:** ICE may furnish Federal Government property and equipment to the Service Provider. Accountable property remains titled to ICE and shall be returned to the custody of ICE upon termination of the Agreement. The suspension of use of bed space made available to ICE is agreed to be grounds for the recall and return of any or all government furnished property.
- B. **Service Provider Responsibility:** The Service Provider shall not remove ICE property from the facility without the prior written approval of ICE. The Service Provider shall report any loss or destruction of any Federal Government property immediately to ICE.

#### **Article XIV. Hold Harmless and Indemnification Provisions**

- A. **Service Provider Held Harmless:** ICE shall, subject to the availability of funds, save and hold the Service Provider harmless and indemnify the Service Provider against any and all liability claims and costs of whatever kind and nature, for injury to or death of any person(s), or loss or damage to any property, which occurs in connection with or is incident to performance of work under the terms of this Agreement, and which results from negligent acts or omissions of ICE officers or employees, to the extent that ICE would be liable for such negligent acts or omissions under the Federal Tort Claims Act, 28 USC 2691 *et seq.*
- B. **Federal Government Held Harmless:** The Service Provider shall save and hold harmless and indemnify federal government agencies to the extent allowed by law against any and all liability claims, and costs of whatsoever kind and nature for injury to or death of any person or persons and for loss or damage to any property occurring in connection with, or in any way incident to or arising out of the occupancy, use, service, operation or performance of work under the tenets of this Agreement, resulting from the negligent acts or omissions of the Service Provider, or any employee, or agent of the Service Provider. In so agreeing, the Service Provider does not waive any defenses, immunities or limits of liability available to it under state or federal law. The Service Provider agrees to hold harmless and indemnify DHS/ICE and its officials in their official and individual capacities from any liability, including third-party liability or worker's compensation, arising from the conduct of the Service Provider and its employees during the course of transporting detainees on behalf of ICE.
- C. **Defense of Suit:** In the event a detainee files suit against the Service Provider contesting the legality of the detainee's incarceration and/or immigration/citizenship status, ICE shall request that the U.S. Attorney's Office, as appropriate, move either to have the Service Provider dismissed from such suit, to have ICE substituted as the proper party defendant; or to have the case removed to a court of proper jurisdiction. Regardless of the decision on any such motion, ICE shall request that the U.S. Attorney's Office be responsible for the defense of any suit on these grounds.

- D. **ICE Recovery Right:** The Service Provider shall do nothing to prejudice ICE's right to recover against third parties for any loss, destruction of, or damage to U.S. Government property. Upon request of the Contracting Officer, the Service Provider shall, at ICE's expense, furnish to ICE all reasonable assistance and cooperation, including assistance in the prosecution of suit and execution of the instruments of assignment in favor of ICE in obtaining recovery.

**Article XV. IGSA/Financial Records**

- A. **Retention of Records:** All IGSA and financial records including, but not limited to, supporting documents, statistical records, and other records, pertinent contracts, or subordinate agreements under this Agreement shall be retained by the Service Provider for three (3) years after the expiration of the Agreement for purposes of federal examinations and audit. If any litigation, claim, negotiation, audit, or other action involving the records has been started before the expiration of the three (3) year period, the records must be retained until completion of the action and resolution of all issues which arise from it or until the end of the regular three (3) year period, whichever is later.
- B. **Access to Records:** ICE and the Comptroller General of the United States, or any of their authorized representatives, shall have the right of access to any pertinent books, documents, papers or other records of the Service Provider or its sub-contractors, which are pertinent to the award, in order to make audits, examinations, excerpts, and transcripts. The rights of access must not be limited to the required retention period, but shall last as long as the records are retained.
- C. **Delinquent Debt Collection:** ICE will hold the Service Provider accountable for any overpayment, or any breach of this Agreement that results in a debt owed to the Federal Government. ICE shall apply interest, penalties, and administrative costs to a delinquent debt owed to the Federal Government by the Service Provider pursuant to the Debt Collection Improvement Act of 1982, as amended.

**Article XVI. Detainee Telephone Services (DTS)**

- A. The PROVIDER shall provide detainees with reasonable and equitable access to telephones as specified in ICE National Detention Standards on Telephone Access. Telephones shall be located in an area that provides for a reasonable degree of privacy and a minimal amount of environmental noise during phone calls.
- B. If authorized to do so under applicable law, the PROVIDER shall monitor and record detainee conversations. If detainee telephone conversations can be monitored under applicable law, the PROVIDER shall provide notice to detainees of the potential for monitoring. However, the PROVIDER shall also provide procedures at the facility for detainees to be able to place unmonitored telephone calls to their attorneys.
- C. Telephone rates shall not exceed the dominant carrier tariff rate and shall conform to all applicable federal, state, and local telephone regulations.

- D. The ICE designated DTS Contractor will be the exclusive provider of detainee telephones for this facility. The DTS Contractor shall be allowed to install vending debit machines and shall receive 100 percent of all revenues collected by sale of prepaid debit services. The DTS Contractor shall be responsible for furnishing all inventory and supply of prepaid debit cards to the PROVIDER. The DTS Contractor shall be responsible for the costs incurred for installation of the equipment, any monthly telephone charges incurred from the operation of DTS, and the maintenance and operation of the system. The PROVIDER will not be entitled to any commissions, fees, or revenues generated by the use of the DTS or the detainee telephones.
- E. The PROVIDER shall inspect telephones for serviceability, in accordance with ICE policies and procedures. The PROVIDER will notify the COTR or ICE designees of any inoperable telephones.

#### **Article XVII. Maintain Institutional Emergency Readiness**

- A. The Service Provider shall submit an institutional emergency plan that will be operational prior to start of the Agreement. The plan shall receive the concurrence of the Contracting Officer prior to implementation and shall not be modified without the further written concurrence of the Contracting Officer.
- B. The Service Provider shall have written agreements with appropriate state and local authorities that will allow the Service Provider to make requests for assistance in the event of any emergency incident that would adversely affect the community.
- C. Likewise, the Service Provider shall have in place, an internal corporate nation-wide staff contingency plan consisting of employees who possess the same expertise and skills required of staff working directly on this agreement. At the discretion of ICE, these employees would be required to respond to an institutional emergency at the Facility, when necessary.
- D. The emergency plans shall include provisions for two or more disturbance control teams. Protective clothing and equipment for each team member and 30 percent of all additional facility staff members shall be provided by the Service Provider, and maintained in a secure location outside the secure perimeter of the facility.
- E. Any decision by ICE or other federal agencies to provide and/or direct emergency assistance will be at the discretion of the Government. The Service Provider shall reimburse the Government for any and all expenses incurred in providing such assistance.
- F. The Contracting Officer and COTR shall be notified immediately in the event of all serious incidents. Serious incidents include, but are not limited to the following: activation of disturbance control team(s); disturbances (including gang activities, group demonstrations, food boycotts, work strikes, work-place violence, civil disturbances/protests); staff use of force including use of lethal and less-lethal force (includes inmates in restraints more than eight hours); assaults on staff/inmates resulting in injuries requiring medical attention (does not include routine medical evaluation after the incident); fights resulting in injuries requiring medical attention; fires; full or partial lock down of the facility; escape; weapons discharge; suicide attempts; deaths; declared

or non-declared hunger strikes; adverse incidents that attract unusual interest or significant publicity; adverse weather (e.g., hurricanes, floods, ice/snow storms, heat waves, tornadoes); fence damage; power outages; bomb threats; central inmate monitoring cases admitted to a community hospital; witness security cases taken outside the facility; significant environmental problems that impact the facility operations; transportation accidents (i.e. airlift, bus) resulting in injuries, death or property damage; and sexual assaults.

- G. Attempts to apprehend the escapee(s) shall be in accordance with the Emergency Plan, which should comply with ICE Detention Operations Manual regarding Emergency Plans.
- H. The Service Provider shall submit to the COTR a proposed inventory of intervention equipment (weapons, munitions, chemical agents, electronics/stun technology, etc.) intended for use during performance of this Agreement. Prior to the start of this Agreement, the Contracting Officer shall approve the intervention equipment. The approved intervention equipment inventory shall not be modified without prior written concurrence of the Contracting Officer.
- I. The Service Provider shall obtain the appropriate authority from state or local law enforcement agencies to use force as necessary to maintain the security of the institution. The use of force by the Provider shall at all times be consistent with all applicable policies of ICE Detention Operations Manual regarding Use of Force.

#### **XVIII. Security Requirements**

##### **A. GENERAL**

The Department of Homeland Security (DHS), U.S. Immigration and Customs Enforcement (ICE), Office of Professional Responsibility, Personnel Security Unit (DHS-ICE-OPR-PSU, hereinafter OPR-PSU) has determined that performance of the tasks as described in IGSA (Contract) \_\_\_\_\_ requires that the Service Provider (Contractor, subcontractor(s), vendor(s), etc. (herein known as Service Provider) have access to ICE detainees, and that the Service Provider will adhere to the following and shall expressly incorporate this provision into any and all Subcontracts or subordinate agreements issued in support of this Agreement .

##### **B. SUITABILITY DETERMINATION**

ICE-OPR-PSU shall have and exercise full control over granting, denying, withholding or terminating unescorted government facility and/or access to ICE detainees, as well as, when applicable, sensitive Government information access for Service Provider employees, based upon the results of a background investigation.

ICE-OPR-PSU may, as it deems appropriate, authorize and make a favorable entry on duty (EOD) decision based on preliminary security checks. The favorable EOD decision would allow the Service Provider employees to commence work temporarily prior to the completion

of the full investigation. The granting of a favorable EOD decision shall not be considered as assurance that a full employment suitability authorization will follow as a result thereof.

The granting of a favorable EOD decision or a full employment suitability determination shall in no way prevent, preclude, or bar the withdrawal or termination of any such access by ICE-OPR-PSU, at any time during the term of the IGSA. No employee of the Service Provider shall be allowed to EOD and/or access facilities or ICE detainees without a favorable EOD decision or suitability determination by OPR-PSU. No employee of the Service Provider shall be allowed unescorted access to a Government facility without a favorable EOD decision or suitability determination by OPR-PSU. Service Provider employees assigned to the IGSA not needing access to ICE detainees or recurring access to DHS-ICE facilities will not be subject to security suitability screening.

Suitability criteria as detailed in ICE Policy Directives that will exclude applicants from consideration to perform under this agreement include, but not limited to:

- Felony convictions, or a conviction for any crime that involves violence
- Conviction of a sex crime
- Offense/s involving a child victim
- Pattern of arrests, without convictions, that brings into question a person's judgment and reliability to promote the efficiency and integrity of the ICE mission.
- Intentional falsification and/or omission of pertinent personal information
- Drug and/or Alcohol Abuse
- Personal conduct to include failure to pay just debts

The process for suitability determination includes, but is not limited to, criminal, employment, citizenship, residential and financial records checks and reviews.

### C. BACKGROUND INVESTIGATIONS

IGSA Service Provider employees (to include applicants, temporaries, part-time and replacement employees) under the contract, needing access to ICE detainees, shall undergo a position sensitivity analysis based on the duties each individual will perform on the contract. The results of the position sensitivity analysis shall identify the appropriate background investigation to be conducted. Background investigations will be processed, managed and conducted under direction of OPR-PSU.

In those cases where prospective IGSA Service Provider employees already have a security clearance issued by the Defense Industrial Security Clearance Office (DISCO), that was granted using an appropriate background investigation, reciprocity may apply in that those prospective employees may not be required to submit complete security packages, as the clearance issued by DISCO may be accepted.

Prospective Service Provider employees without adequate security clearances issued by DISCO shall submit the following completed forms to the Personnel Security Unit through the COTR, no less than 45 days before the starting date of the IGSA (contract), or 45 days prior to the expected entry on duty of any employees, whether a replacement, addition, subcontractor employee, or vendor:

Standard Form 85P, "Questionnaire for Public Trust Positions"  
Form will be submitted via e-QIP (electronic Questionnaires for  
Investigation Processing)  
FD Form 258, "Fingerprint Card" (2 copies)  
Foreign National Relatives or Associates Statement  
DHS 11000-9, "Disclosure and Authorization Pertaining to Consumer Reports Pursuant  
to the Fair Credit Reporting Act"  
Drug Questionnaire  
Alcohol Questionnaire

Details regarding the required forms will be provided by ICE-OPR. Only complete packages will be accepted by OPR-PSU. Specific instructions on submission of packages will be provided by OPR-PSU.

**PLEASE NOTE:** Unless an applicant has resided in the US for three of the past five years, with few exceptions such as military or other federal service overseas, the Government may not be able to complete a satisfactory background investigation. In such cases, OPR-PSU retains the right to deem an applicant as ineligible due to insufficient background information.

#### D. SUITABILITY - RETROACTIVE EFFECT

Employees of the Service Provider(s) who have not been previously investigated as described under the Background Investigations section, above, must be scheduled not later than six months after implementation of this IGSA. Employees of the Service Provider(s) may continue to work while the investigation is in progress.

#### E. CONTINUED ELIGIBILITY

If a prospective Service Provider employee is found to be ineligible for access to Government facilities or information, the COTR will advise the Service Provider that the employee shall not continue to work or to be assigned to work under the contract.

The OPR-PSU may require drug screening for probable cause at any time and/ or when the contractor independently identifies, circumstances where probable cause exists.

The OPR-PSU may require reinvestigations when derogatory information is received and/or every 10 years.

ICE-OPR reserves the right and prerogative to deny and/ or restrict the facility and information access of any Service Provider employee whose actions are in conflict with the standards of conduct as detailed in 5 CFR 2635 and 5 CFR 3801, or whom ICE-OPR-PSU determines to present a risk of compromising ICE standards and conduct, including sensitive Government information, to which he or she would have access under this contract.

The Service Provider will report any adverse information coming to their attention concerning contract employees under the IGSA to OPR-PSU through the COTR. Reports based on rumor or innuendo should not be made. The subsequent termination of employment of an employee does not obviate the requirement to submit this report. The

report shall include the employees' name and social security number, along with the adverse information being reported.

OPR-PSU must be notified of all terminations/ resignations within five days of occurrence.

If applicable, the Service Provider will return any expired ICE-DRO owned employee identification cards and/or building passes, or those of employees terminated and/or removed from the IGSA to the COTR within five (5) workdays. If an identification card or building pass is not available to be returned, a report must be submitted to the COTR, referencing the pass or card number, name of individual to whom issued, the last known location and disposition of the pass or card. The COTR will return the identification cards and building passes to the responsible ID Unit.

#### F. EMPLOYMENT ELIGIBILITY

The Service Provider must agree that each employee working on this IGSA will have a Social Security Card issued and approved by the Social Security Administration.

The Service Provider shall be responsible to the Government for acts and omissions of his own employees and for any Subcontractor(s) and their employees.

ICE-DRO has determined that employment on this IGSA (Contract) shall be limited to U.S. Citizens, Lawful Permanent Residents and Conditional Permanent Residents.

Subject to existing law, regulations and/ or other provisions of this IGSA, illegal or undocumented aliens will not be employed by the Service Provider, or with this IGSA. Service Provider will ensure that this provision is expressly incorporated into any and all Subcontracts or subordinate agreements issued in support of this IGSA.

#### G. SECURITY MANAGEMENT

The Service Provider shall appoint a senior official to act as the Corporate Security Officer. The individual will interface with the OPR-PSU through the COTR on all personnel security matters and if applicable, information security matters.

The COTR and OPR-PSU shall have the right to inspect the procedures, methods, and facilities utilized by the Service Provider in complying with the security requirements under this contract. Should the COTR determine that the Service Provider is not complying with the security requirements of this contract, the Service Provider will be informed in writing by the Contracting Officer of the proper action to be taken in order to effect compliance with such requirements. Copies of these communications by both the

Contracting Officer and the Service Provider shall be provided to OPR-PSU.

#### H. INFORMATION TECHNOLOGY SECURITY

Should the scope of the work change to require IGSA Service Provider personnel to access DHS-ICE IT systems, DHS IT Management Directives preclude routine access to any DHS



ICE IT systems, to include those utilized by ICE-DRO, by Non-U.S. citizens, including Lawful Permanent Residents (LPRs).

The following computer security requirements apply to both Department of Homeland Security (DHS) operations and to the former Immigration and Naturalization Service operations (FINS). These entities are hereafter referred to as the Department.

#### **I. INFORMATION TECHNOLOGY SECURITY CLEARANCE**

When sensitive government information is processed on Department telecommunications and automated information systems, the Contractor agrees to provide for the administrative control of sensitive data being processed and to adhere to the procedures governing such data as outlined in *DHS IT Security Program Publication DHS MD 4300.Pub. or its replacement*. Contractor personnel must have favorably adjudicated background investigations commensurate with the defined sensitivity level.

Contractors who fail to comply with Department security policy are subject to having their access to Department IT systems and facilities terminated, whether or not the failure results in criminal prosecution. Any person who improperly discloses sensitive information is subject to criminal and civil penalties and sanctions under a variety of laws (e.g., Privacy Act).

#### **XIX. Accreditation**

The Service Provider will have eighteen (18) months from commencement of this Agreement to become ACA accredited. The Service Provider shall, within nine (9) months from the date this facility becomes operational, formally apply for accreditation to the American Correctional Association. The Service Provider shall provide the Contracting Officer with written proof of such application to ICE within five (5) days of the application. The Service Provider shall provide the Contracting Officer with written proof of its accreditation within five (5) days of notification of its accreditation.

#### **XX. Quality Control**

- A. The Service Provider shall establish and maintain a complete Quality Control Program (QCP) acceptable to the Contracting Officer ("CO"), in consultation with the Contracting Officer's Technical Representative ("COTR") to assure the requirements of this Agreement are provided as specified in the Performance Requirement Summary (PRS)—Attachment 3.

The QCP shall:

1. Be implemented prior to the start of performance.
2. Provide quality control services that cover the scope of the IGSA and implement proactive actions to prevent non-performance issues.

B. A complete QCP addressing all areas of agreement performance shall be submitted to the COTR no later than 30 days after the Agreement effective date. All proposed changes to the QCP must be approved by the Contracting Officer. The Service Provider shall submit a resume of the proposed individual(s) responsible for the QCP to the CO for approval. The Service Provider shall not change the individual(s) responsible for the QCP without prior approval of the Contracting Officer.

C. The QCP shall include, at a minimum:

1. Specific areas to be inspected on either a scheduled or unscheduled basis and the method of inspection.
2. Procedures for written and verbal communication with the Government regarding the performance of the Agreement.
3. Specific surveillance techniques for each service identified in the Agreement and each functional area identified in the PRS.
4. The QCP shall contain procedures for investigation of complaints by the Service Provider and Government staff and feedback to the Government on the actions taken to resolve such complaints.

D. A file of all inspections, inspection results, and any corrective action required, shall be maintained by the Service Provider during the term of this Agreement. The Service Provider shall provide copies of all inspections, inspection results, and any corrective action taken to the COTR and Contracting Officer.

E. Failure by the Service Provider to maintain adequate quality control can result in monetary deductions based upon the schedule of deductions incorporated herein.

#### **XXI. Contracting Officer's Technical Representative**

The Contracting Officer's Technical Representative (COTR) shall be designated by the Contracting Officer. When and if the COTR duties are reassigned, an administrative modification will be issued to reflect the changes. This designation does not include authority to sign contractual documents or to otherwise commit to, or issue changes, which could affect the price, quantity, or performance of this Agreement.

#### **XXII. Labor Standards and Wage Determination**

A. The Service Contract Act, 41 U.S.C. 351 et seq., Title 29, Part 4 Labor Standards for Federal Service Contracts, is here by incorporated into this Agreement at Attachment 5. These standards and provisions are included in every contract over \$2,500, or in an indefinite amount, that is entered into by the United States, the principal purpose of which is to furnish services through the use of service employees.

**B. Wage Determination:** Each service employee employed in the performance of this Agreement shall be paid not less than the minimum monetary wages and shall be furnished fringe benefits in accordance with the wages and fringe benefits determined by the Secretary of Labor or authorized representative, as specified in any wage determination attached to this Agreement at Attachment 6.

\*\*\*\*\*  
**END OF DOCUMENT**  
\*\*\*\*\*

**TITLE 29--LABOR****PART 4 LABOR STANDARDS FOR FEDERAL SERVICE CONTRACTS--Table of Contents**

Subpart A Service Contract Labor Standards Provisions and Procedures

Sec. 4.6 Labor standards clauses for Federal service contracts exceeding \$2,500.

The clauses set forth in the following paragraphs shall be included in full by the contracting agency in every contract/Inter-Governmental Service Agreement (IGSA) entered into by the United States or the District of Columbia, in excess of \$2,500, or in an indefinite amount, the principal purpose of which is to furnish services through the use of service employees:

(a) Service Contract Act of 1965, as amended: This contract/IGSA is subject to the Service Contract Act of 1965 as amended (41 U.S.C. 351 et seq.) and is subject to the following provisions and to all other applicable provisions of the Act and regulations of the Secretary of Labor issued there under (29 CFR part 4).

(b) (1) Each service employee employed in the performance of this Contract/IGSA by the contractor or any subcontractor shall be paid not less than the minimum monetary wages and shall be furnished fringe benefits in accordance with the wages and fringe benefits determined by the Secretary of Labor or authorized representative, as specified in any wage determination attached to this contract.

(2) (i) If there is such a wage determination attached to this Contract/IGSA, the contracting officer shall require that any class of service employee which is not listed therein and which is to be employed under the Contract/IGSA (i.e., the work to be performed is not performed by any classification listed in the wage determination), be classified by the contractor so as to provide a reasonable relationship (i.e., appropriate level of skill comparison) between such unlisted classifications and the classifications listed in the wage determination. Such conformed class of employees shall be paid the monetary wages and furnished the fringe benefits as are determined pursuant to the procedures in this section.

(ii) Such conforming procedure shall be initiated by the contractor prior to the performance of contract/IGSA work by such unlisted class of employee. A written report of the proposed conforming action, including information regarding the agreement or disagreement of the authorized representative of the employees involved or, where there is no authorized representative, the employees themselves, shall be submitted by the contractor to the contracting officer no later than 30 days after such unlisted class of employees performs any Contract/IGSA work. The contracting officer shall review the proposed action and promptly submit a report of the action, together with the agency's recommendation and all pertinent information including the position of the contractor and the employees, to the Wage and Hour Division, Employment Standards Administration, U.S. Department of Labor, for review. The Wage and Hour Division will approve, modify, or disapprove the action or render a final determination in the event of disagreement.

within 30 days of receipt or will notify the contracting officer within 30 days of receipt that additional time is necessary.

(iii) The final determination of the conformance action by the Wage and Hour Division shall be transmitted to the contracting officer who shall promptly notify the contractor of the action taken. Each affected employee shall be furnished by the contractor with a written copy of such determination or it shall be posted as a part of the wage determination.

(iv) (A) The process of establishing wage and fringe benefit rates that bears a reasonable relationship to those listed in a wage determination cannot be [[Page 41]] reduced to any single formula. The approach used may vary from wage determination to wage determination depending on the circumstances. Standard wage and salary administration practices, which rank various job classifications by pay grade pursuant to point schemes or other job factors may, for example, be relied upon. Guidance may also be obtained from the way different jobs are rated under Federal pay systems (Federal Wage Board Pay System and the General Schedule) or from other wage determinations issued in the same locality. Basic to the establishment of any conformable wage rate(s) is the concept that a pay relationship should be maintained between job classifications based on the skill required and the duties performed.

(B) In the case of a Contract/IGSA modification, an exercise of an option or extension of an existing contract, or in any other case where a contractor succeeds a Contract/IGSA under which the classification in question was previously conformed pursuant to this section, a new conformed wage rate and fringe benefits may be assigned to such conformed classification by indexing (i.e., adjusting) the previous conformed rate and fringe benefits by an amount equal to the average (mean) percentage increase (or decrease, where appropriate) between the wages and fringe benefits specified for all classifications to be used on the Contract/IGSA which are listed in the current wage determination, and those specified for the corresponding classifications in the previously applicable wage determination. Where conforming actions are accomplished in accordance with this paragraph prior to the performance of Contract/IGSA work by the unlisted class of employees, the contractor shall advise the contracting officer of the action taken but the other procedures in paragraph (b) (2) (ii) of this section need not be followed.

(C) No employee engaged in performing work on this Contract/IGSA shall in any event be paid less than the currently applicable minimum wage specified under section 6(a) (1) of the Fair Labor Standards Act of 1938, as amended. (v) The wage rate and fringe benefits finally determined pursuant to paragraphs (b) (2) (i) and (ii) of this section shall be paid to all employees performing in the classification from the first day on which Contract/IGSA work is performed by them in the classification. Failure to pay such unlisted employees the compensation agreed upon by the interested parties and/or finally determined by the Wage and Hour Division retroactive to the date such class of employees commenced Contract/IGSA work shall be a violation of the Act and this contract. (vi) Upon discovery of failure to comply with paragraphs (b) (2) (i) through (v) of this section, the Wage and Hour Division shall make a final determination of conformed classification, wage rate,

and/or fringe benefits which shall be retroactive to the date such class of employees commenced Contract/IGSA work.

(3) If, as authorized pursuant to section 4(d) of the Service Contract Act of 1965 as amended, the term of this Contract/IGSA is more than 1 year, the minimum monetary wages and fringe benefits required to be paid or furnished there under to service employees shall be subject to adjustment after 1 year and not less often than once every 2 years, pursuant to wage determinations to be issued by the Wage and Hour Division, Employment Standards Administration of the Department of Labor as provided in such Act.

(c) The contractor or subcontractor may discharge the obligation to furnish fringe benefits specified in the attachment or determined conformably thereto by furnishing any equivalent combinations of bona fide fringe benefits, or by making equivalent or differential payments in cash in accordance with the applicable rules set forth in subpart D of 29 CFR part 4, and not otherwise.

(d) (1) In the absence of a minimum wage attachment for this contract, neither the contractor nor any subcontractor under this Contract/IGSA shall pay any person performing work under the Contract/IGSA (regardless of whether they are service employees) less than the minimum wage specified by section 6(a)(1) of the Fair Labor Standards Act of 1938. Nothing in this provision shall relieve the contractor or any subcontractor of any other obligation under [[Page 42]] law or Contract/IGSA for the payment of a higher wage to any employee.

(2) If this Contract/IGSA succeeds a contract, subject to the Service Contract Act of 1965 as amended, under which substantially the same services were furnished in the same locality and service employees were paid wages and fringe benefits provided for in a collective bargaining agreement, in the absence of the minimum wage attachment for this Contract/IGSA setting forth such collectively bargained wage rates and fringe benefits, neither the contractor nor any subcontractor under this Contract/IGSA shall pay any service employee performing any of the Contract/IGSA work (regardless of whether or not such employee was employed under the predecessor contract), less than the wages and fringe benefits provided for in such collective bargaining agreements, to which such employee would have been entitled if employed under the predecessor contract, including accrued wages and fringe benefits and any prospective increases in wages and fringe benefits provided for under such agreement. No contractor or subcontractor under this Contract/IGSA may be relieved of the foregoing obligation unless the limitations of Sec. 4.1b(b) of 29 CFR part 4 apply or unless the Secretary of Labor or his authorized representative finds, after a hearing as provided in Sec. 4.10 of 29 CFR part 4 that the wages and/or fringe benefits provided for in such agreement are substantially at variance with those which prevail for services of a character similar in the locality, or determines, as provided in Sec. 4.11 of 29 CFR part 4, that the collective bargaining agreement applicable to service employees employed under the predecessor Contract/IGSA was not entered into as a result of arm's-length negotiations. Where it is found in accordance with the review procedures provided in 29 CFR 4.10 and/or 4.11 and parts 6 and 8 that some or all of the wages and/or fringe benefits contained in a predecessor contractor's collective bargaining agreement are substantially at variance with those which prevail for

services of a character similar in the locality, and/or that the collective bargaining agreement applicable to service employees employed under the predecessor Contract/IGSA was not entered into as a result of arm's-length negotiations, the Department will issue a new or revised wage determination setting forth the applicable wage rates and fringe benefits. Such determination shall be made part of the Contract/IGSA or subcontract, in accordance with the decision of the Administrator, the Administrative Law Judge, or the Administrative Review Board, as the case may be, irrespective of whether such issuance occurs prior to or after the award of a Contract/IGSA or subcontract. 53 Comp. Gen. 401 (1973). In the case of a wage determination issued solely as a result of a finding of substantial variance, such determination shall be effective as of the date of the final administrative decision.

(e) The contractor and any subcontractor under this Contract/IGSA shall notify each service employee commencing work on this Contract/IGSA of the minimum monetary wage and any fringe benefits required to be paid pursuant to this contract, or shall post the wage determination attached to this contract. The poster provided by the Department of Labor (Publication WH 1313) shall be posted in a prominent and accessible place at the worksite. Failure to comply with this requirement is a violation of section 2(a) (4) of the Act and of this contract.

(f) The contractor or subcontractor shall not permit any part of the services called for by this Contract/IGSA to be performed in buildings or surroundings or under working conditions provided by or under the control or supervision of the contractor or subcontractor which are unsanitary or hazardous or dangerous to the health or safety of service employees engaged to furnish these services, and the contractor or subcontractor shall comply with the safety and health standards applied under 29 CFR part 1925.

(g)(1) The contractor and each subcontractor performing work subject to the Act shall make and maintain for 3 years from the completion of the work records containing the information specified in paragraphs (g)(1) (i) through (vi) of this section for each employee subject to the Act and shall make them available for inspection [[Page 43]] and transcription by authorized representatives of the Wage and Hour Division, Employment Standards Administration of the U.S. Department of Labor:

(i) Name and address and social security number of each employee.

(ii) The correct work classification or classifications, rate or rates of monetary wages paid and fringe benefits provided, rate or rates of fringe benefit payments in lieu thereof, and total daily and weekly compensation of each employee.

(iii) The number of daily and weekly hours so worked by each employee.

(iv) Any deductions, rebates, or refunds from the total daily or weekly compensation of each employee.

(v) A list of monetary wages and fringe benefits for those classes of service employees not included in the wage

determination attached to this Contract/IGSA but for which such wage rates or fringe benefits have been determined by the interested parties or by the Administrator or authorized representative pursuant to the labor standards clause in paragraph (b) of this section. A copy of the report required by the clause in Paragraph (b) (2) (ii) of this section shall be deemed to be such a list.

(vi) Any list of the predecessor contractor's employees which had been furnished to the contractor pursuant to Sec. 4.6(1)(2).

(2) The contractor shall also make available a copy of this Contract/IGSA for inspection or transcription by authorized representatives of the Wage and Hour Division.

(3) Failure to make and maintain or to make available such records for inspection and transcription shall be a violation of the regulations and this contract, and in the case of failure to produce such records, the contracting officer, upon direction of the Department of Labor and notification of the contractor, shall take action to cause suspension of any further payment or advance of funds until such violation ceases.

(4) The contractor shall permit authorized representatives of the Wage and Hour Division to conduct interviews with employees at the worksite during normal working hours.

(h) The contractor shall unconditionally pay to each employee subject to the Act all wages due free and clear and without subsequent deduction (except as otherwise provided by law or Regulations, 29 CFR part 4), rebate, or kickback on any account. Such payments shall be made no later than one pay period following the end of the regular pay period in which such wages were earned or accrued. A pay period under this Act may not be of any duration longer than semi-monthly.

(i) The contracting officer shall withhold or cause to be withheld from the Government prime contractor under this or any other Government Contract/IGSA with the prime contractor such sums as an appropriate official of the Department of Labor requests or such sums as the contracting officer decides may be necessary to pay underpaid employees employed by the contractor or subcontractor. In the event of failure to pay any employees subject to the Act all or part of the wages or fringe benefits due under the Act, the agency may, after authorization or by direction of the Department of Labor and written notification to the contractor, take action to cause suspension of any further payment or advance of funds until such violations have ceased. Additionally, any failure to comply with the requirements of these clauses relating to the Service Contract Act of 1965, may be grounds for termination of the right to proceed with the Contract/IGSA work. In such event, the Government may enter into other contracts or arrangements for completion of the work, charging the contractor in default with any additional cost.

(j) The contractor agrees to insert these clauses in this section relating to the Service Contract Act of 1965 in all Subcontracts subject to the Act. The term contractor as used in these clauses in any subcontract shall be deemed to refer to the subcontractor, except in the term Government prime contractor.



(k) (1) As used in these clauses, the term service employee means any person engaged in the performance of this Contract/IGSA other than any person employed in a bona fide executive, administrative, or professional capacity, as those terms are defined in part 541 of title 29, Code of Federal Regulations, as of July [(Page44)) 30, 1976, and any subsequent revision of those regulations. The term service employee includes all such persons regardless of any contractual relationship that may be alleged to exist between a contractor or subcontractor and such persons.

(2) The following statement is included in contracts pursuant to section 2(a) (5) of the Act and is for informational purposes only:

The following classes of service employees expected to be employed under the Contract/IGSA with the Government would be subject, if employed by the contracting agency, to the provisions of 5 U.S.C. 5341 or 5 U.S.C. 5332 and would, if so employed, be paid not less than the following rates of wages and fringe benefits:

Employee class	wage-fringe benefit
GS-05	\$13.83 (As of Dec 07)
GS-07	\$17.83 (As of Dec 07)

Search current rates at <http://www.opm.gov/oca/08tables/>

(1) (1) If wages to be paid or fringe benefits to be furnished any service employees employed by the Government prime contractor or any subcontractor under the Contract/IGSA are provided for in a collective bargaining agreement which is or will be effective during any period in which the Contract/IGSA is being performed, the Government prime contractor shall report such fact to the contracting officer, together with full information as to the application and accrual of such wages and fringe benefits, including any prospective increases, to service employees engaged in work on the contract, and a copy of the collective bargaining agreement. Such report shall be made upon commencing performance of the contract, in the case of collective bargaining agreements effective at such time, and in the case of such agreements or provisions or amendments thereof effective at a later time during the period of Contract/IGSA performance, such agreements shall be reported promptly after negotiation thereof.

(2) Not less than 10 days prior to completion of any Contract/IGSA being performed at a Federal facility where service employees may be retained in the performance of the succeeding Contract/IGSA and subject to a wage determination which contains vacation or other benefit provisions based upon length of service with a contractor (predecessor) or successor (Sec. 4.173 of Regulations, 29 CFR part 4), the incumbent prime contractor shall furnish to the contracting officer a certified list of the names of all service employees on the contractor's or subcontractor's payroll during the last month of Contract/IGSA performance. Such list shall also contain anniversary dates of employment on the Contract/IGSA either with the current or predecessor contractors of each such service employee. The contracting officer shall turn over such list to the successor contractor at the commencement of the succeeding contract.

(m) Rulings and interpretations of the Service Contract Act of 1965, as amended, are contained in Regulations, 29 CFR part 4.

(n) (1) By entering into this contract, the contractor (and officials thereof) certifies that neither it (nor he or she) nor any person or firm who has a substantial interest in the contractor's firm is a person or firm ineligible to be awarded Government contracts by virtue of the sanctions imposed pursuant to section 5 of the Act.

(2) No part of this Contract/IGSA shall be subcontracted to any person or firm ineligible for award of a Government Contract/IGSA pursuant to section 5 of the Act.

(3) The penalty for making false statements is prescribed in the U.S. Criminal Code, 18 U.S.C. 1001.

(o) Notwithstanding any of the clauses in paragraphs (b) through (m) of this section relating to the Service Contract Act of 1965, the following employees may be employed in accordance with the following variations, tolerances, and exemptions, which the Secretary of Labor, pursuant to section 4(b) of the Act prior to its amendment by Public Law 92-473, found to be necessary and proper in the public interest or to avoid serious impairment of the conduct of Government business:

(1) Apprentices, student-learners, and workers whose earning capacity is impaired by age, physical, or mental deficiency or injury may be employed at wages lower than the minimum wages otherwise required by section 2(a) (1) or [[Page 45]]

(2) (b) (1) of the Service Contract Act without diminishing any fringe benefits or cash payments in lieu thereof required under section 2(a) (2) of that Act, in accordance with the conditions and procedures prescribed for the employment of apprentices, student-learners, handicapped persons, and handicapped clients of sheltered workshops under section 14 of the Fair Labor Standards Act of 1938, in the regulations issued by the Administrator (29 CFR parts 520, 521, 524, and 525).

(3) The Administrator will issue certificates under the Service Contract Act for the employment of apprentices, student-learners, handicapped persons, or handicapped clients of sheltered workshops not subject to the Fair Labor Standards Act of 1938, or subject to different minimum rates of pay under the two acts, authorizing appropriate rates of minimum wages (but without changing requirements concerning fringe benefits or supplementary cash payments in lieu thereof), applying procedures prescribed by the applicable regulations issued under the Fair Labor Standards Act of 1938 (29 CFR parts 520, 521, 524, and 525).

(4) The Administrator will also withdraw, annul, or cancel such certificates in accordance with the regulations in parts 525 and 528 of title 29 of the Code of Federal Regulations.

(p) Apprentices will be permitted to work at less than the predetermined rate for the work they perform when they are employed and individually registered in a bona fide apprenticeship program

registered with a State Apprenticeship Agency which is recognized by the U.S. Department of Labor, or if no such recognized agency exists in a State, under a program registered with the Bureau of Apprenticeship and Training, Employment and Training Administration, U.S. Department of Labor. Any employee who is not registered as an apprentice in an approved program shall be paid the wage rate and fringe benefits contained in the applicable wage determination for the journeyman classification of work actually performed. The wage rates paid apprentices shall not be less than the wage rate for their level of progress set forth in the registered program, expressed as the appropriate percentage of the journeyman's rate contained in the applicable wage determination. The allowable ratio of apprentices to journeymen employed on the Contract/IGSA work in any craft classification shall not be greater than the ratio permitted to the contractor as to his entire work force under the registered program.

(q) Where an employee engaged in an occupation in which he or she customarily and regularly receives more than \$30 a month in tips, the amount of tips received by the employee may be credited by the employer against the minimum wage required by Section 2(a)(1) or 2(b)(1) of the Act to the extent permitted by section 3(m) of the Fair Labor Standards Act and Regulations, 29 CFR Part 531. To utilize this provision:

(1) The employer must inform tipped employees about this tip credit allowance before the credit is utilized;

(2) The employees must be allowed to retain all tips (individually or through a pooling arrangement and regardless of whether the employer elects to take a credit for tips received);

(3) The employer must be able to show by records that the employee receives at least the applicable Service Contract Act minimum wage through the combination of direct wages and tip credit;

(4) The use of such tip credit must have been permitted under any predecessor collective bargaining agreement applicable by virtue of section 4(c) of the Act.

(r) Disputes concerning labor standards. Disputes arising out of the labor standards provisions of this Contract/IGSA shall not be subject to the general disputes clause of this contract. Such disputes shall be resolved in accordance with the procedures of the Department of Labor set forth in 29 CFR parts 4, 6, and 8. Disputes within the meaning of this clause include disputes between the contractor (or any of its subcontractors) and the contracting agency, the U.S. Department of Labor, or the employees or their representatives. (The information, collection, recordkeeping, and reporting requirements contained in this section have been approved by the Office of Management and Budget under the following numbers:

[[Page 46]]

- Paragraph	OMB control number
(b)(2) (i) -- (iv) .....	1215-0150
(e) .....	1215-0150
(g)(1) (i) -- (iv) .....	1215-0017
(g)(1) (v), (vi) .....	1215-0150

(1) (1), (2)..... 1215-0150  
(q) (3)..... 1215-0017

---

[48 FR 49762, Oct. 27, 1983; 48 FR 50529, Nov. 2, 1983, as amended at  
61 FR 68663, Dec. 30, 1996]

of sanitation									
D	W	M	T	F	S	S	Rating Y/D/R	Corrective Action Required/ Comments	Due Date
22. Issuance and Exchange of Clothing, Bedding, and Towels									
A. Clothing provided upon intake and exchanged weekly									
<b>DEFINITION STANDARDS</b>									
B. Sheets and towels exchanged weekly									
C. Climate appropriate clothing issued and maintained in good repair									
D. Facility provides and replenishes personal hygiene items as needed, at no cost to detainee									
E. Showers operate between 100 degrees and 120 degrees									
F. Showers meet ADA standards and requirements									
G. Food Service detainee volunteers exchange garments daily									
23. Population Counts									
A. Staff conduct formal count at least once per 8 hour shift/ 3x per day									
B. At least two officers participate in count for each area									
C. Recount conducted when incorrect count is reported									
D. Face to photo count conducted as necessary									
E. Each detainee positively identified during count									
24. Post Orders									
A. Every post has a post order, current & signed by the facility administrator									
B. Housing unit officers record all detainee activity in a log									
C. Supervisor visits each housing area once per shift									
D. Staff sign post orders, regardless of whether the assignment is temporary, permanent, or due to an									

		emergency							
		E.	Anyone assigned to an armed post qualifies with the post weapons before assuming post duty						
D	W	M	T	F	S	S	S	S	S
DEFENTION STANDARDS									
25. Recreation									
		A.	Outdoor/indoor recreation is provided						
		B.	Access to recreation activities 1 hour x 5 days						
		C.	Staff conduct daily searches of recreation areas						
		D.	In unit sedentary activities are available						
26. Religious Practices									
		A.	Detainees are allowed to engage in religious services						
		B.	Authorized religious items are allowed in detainee possession						
27. Special Management Unit (Administrative Segregation)									
		A.	Written order accompany detainee placed in SMU						
		B.	SMU reviews are conducted in a timely manner (3,7,14,30,60)						
		C.	Detainees in SMU have access to legal materials						
		D.	Detainees in SMU retain visiting privileges						
		E.	Maintain a permanent log regarding detainee related activities						
		F.	SMU phone access same as general pop unless exception is made						
		G.	Detainees in SMUs may shave and shower three times weekly and receive other basic services (laundry, hair care, barbering, clothing, bedding, linen) on the same basis as the general population						
		H.	The facility administrator (or designee) visits each						
			Rating A/D/R	Corrective Action Required/Comments	Due Date				









		33. Tool Control	Rating A/D/R	Corrective Action Required/ Comments	Due Date
	A.	Tool inventories conducted as specified			
	B.	Tools marked and readily identifiable			
	C.	Procedures for issuance of tools to staff and detainees			
	D.	Inventory made of all tools by contractors prior to enter and exit			
D	W	<b>DEFENTION STANDARDS</b>			
	E.	There is an individual who is responsible for developing a tool control procedure and an inspection system to ensure accountability			
	F.	A metal or plastic chit is taken in exchange for all tools issued, and when a tool is issued from a shadow board the receipt chit shall be visible on the shadow board			
	G.	Broken or worn out tools are surveyed and disposed of in an appropriate and secure manner			
	H.	Department heads are responsible for implementing proper tool control procedures as described in the standard			
		<b>34. Detainee Transfer</b>			
	A.	Detainee provided with detainee transfer notification form			
	B.	Health records/transfer summary accompany detainee			
	C.	Funds and personal property accompany detainee			
	D.	A-File/work folder accompany detainee			
		<b>35. Transportation (Land Transportation)</b>			
	A.	Documentation indicating safety repairs are completed immediately and vehicles are not used until they have been repaired and inspected, is available for review			
	B.	Officers use a checklist during every vehicle inspection			







**Town of Farmville – ICE Facility**  
**TRANSPORTATION WORK ASSIGNMENT**

NAMES: \_\_\_\_\_

DATE: \_\_\_\_\_

HOURS: \_\_\_\_\_

MILEAGE: \_\_\_\_\_

DESCRIPTION: \_\_\_\_\_  
\_\_\_\_\_  
\_\_\_\_\_  
\_\_\_\_\_

I \_\_\_\_\_ CERTIFY THAT THE  
HOURS ON THIS SHEET ARE ACCURATE AND CORRECT.

TIME OF DEPARTURE \_\_\_\_\_ TIME OF RETURN \_\_\_\_\_

SIGNATURE: \_\_\_\_\_

SUPERVISOR'S SIGNATURE: \_\_\_\_\_

DATE: \_\_\_\_\_

**DHS/ICE/DRO—DEDICATED IGSA  
QUALITY ASSURANCE SURVEILLANCE PLAN (QASP)  
for IGSA NUMBER DROIGSA-08-0021**

## **1. INTRODUCTION**

The Government's Quality Assurance Surveillance Plan (QASP) is based on the premise that the service provider, and not the Government, is responsible for the day-to-day operation of the facility and all the management and quality control actions required to meet the terms of the contract. The role of the Government in quality assurance is to ensure performance standards are achieved and maintained. The service provider is required to develop a comprehensive program of inspections and monitoring actions and to document its approach in a Quality Control Plan (QCP). The service provider's QCP, upon approval by the Government, will be made a part of the resultant agreement.

This QASP is designed to provide an effective surveillance method to monitor the service provider's performance relative to the requirements listed in the agreement. The QASP illustrates the systematic method the Government (or its designated representative) will use to evaluate the services the service provider is required to furnish.

This QASP is based on the premise the Government must validate that the service provider is complying with DRO-mandated quality standards in operating, maintaining, and repairing detention facilities. Performance standards address all facets of detainee handling, including safety, health, legal rights, facility and records management, etc. Good management by the service provider and use of an approved QCP will ensure that the facility is operating within acceptable quality levels.

## **2. DEFINITIONS**

**Performance Requirements Summary (Attachment 1):** The Performance Requirements Summary (PRS) communicates what the Government intends to qualitatively inspect. The PRS is based on the American Correctional Association (ACA) Standards for Adult Local Detention Facilities (ALDF) and Immigration And Customs Enforcement (ICE) National Detention Standards (NDS). The PRS identifies performance standards grouped into nine functional areas, and quality levels essential for successful performance of each requirement. The PRS is used by the Government (or its designated representative) when conducting quality assurance surveillance to guide them through the inspection and review processes.

**Functional Area:** A logical grouping of performance standards.

**Contracting Officer's Technical Representative (COTR):** The COTR interacts with the service provider to inspect and accept services/work performed in accordance with the technical standards prescribed in the agreement. The Contracting Officer issues a written memorandum that appoints the COTR. Other individuals may be designated to assist in the inspection and quality assurance surveillance activities.

**Performance Standards:** The performance standards are established in the ICE Office Of Detention And Removal (DRO) NDS and contained in the Detention Operations Manual, at <http://www.ice.gov/partners/dro/opsmanual/index.htm>, as well as the ACA standards for ALDF. Other standards may also be defined in the agreement.

**Measures:** The method for evaluating compliance with the standards.

**Acceptable Quality Level:** The minimum level of quality that will be accepted by the Government in order to meet the performance standard.

**Withholding:** Amount of monthly invoice payment withheld pending correction of a deficiency. See Attachment 1 for information on percentage of invoice amount that may be withheld for each functional area. Funds withheld from payment are recoverable (See Sections 6 and 7) if the COTR and Contracting Officer confirm resolution/correction, and should be included in the next month's invoice.

**Deduction:** Funds may be deducted from a monthly invoice for an egregious act or event, or if the same deficiency continues to occur. The service provider will be notified immediately if such a situation arises. The Contracting Officer in consultation with the Program Office will determine the amount of the deduction. Amounts deducted are not recoverable.

### 3. QUALITY CONTROL PLAN:

As a part of its agreement with the Government, the service provider is required to develop, implement, and maintain a Quality Control Plan (QCP) that illustrates the methods it will use to review its performance to ensure it conforms to the performance requirements. (See Attachment 1 for a summary list of performance requirements.) Such reviews are performed by the service provider in order to validate its operations, and assure the Government that the services meet the performance standards.

The service provider's QCP should include monitoring methods that ensure and demonstrate its compliance with the performance standards. This includes inspection methods and schedules that are consistent with the regular reviews conducted by DRO. The reports and other results generated by the service provider's QCP activities should be provided to the COTR as requested.

The frequency and type of the service provider's reviews should be consistent with what is necessary in order to ensure compliance with the performance standards, but no less frequent than what is described in the Government's monitoring instrument/worksheets (See Attachment 3).

The service provider is encouraged not to limit its inspection to only the processes outlined in the Government's standard; however, certain key documents must be produced by the provider to assure the Government that the services meet the performance standards. Some of the documentation that must be generated and made available to the COTR for inspection is listed below. The list is intended as illustrative and is not all-inclusive. The service provider must develop and implement a program that addresses the specific requirement of each standard and the means it will use to document compliance.

- Written policies and procedures to implement and assess operational requirements of the standard
- Documentation and record keeping to ensure ongoing operational compliance with the standards (e.g.; inventories, logbooks, register of receipts, reports, etc.)
- Staff training records
- Contract discrepancy reports (CDRs)
- Investigative reports
- Medical records
- Records of investigative actions taken
- Equipment inspections
- System tests and evaluation

#### 4. METHODS OF SURVEILLANCE

The Government will inspect the service provider's facility and operations using worksheets it developed for this purpose. All facilities will be subject to an annual full facility review using the procedures outlined in the Detention Management Control Program (DMCP) as well as the ACA Standards for Adult Local Detention Facilities (ALDF). The Government's annual full facility reviews will use the monitoring instruments embedded in the standards.

Facilities with 500 beds or more have an on-site COTR and/or designees who will perform regular and more frequent inspections using the worksheet in Attachment 3. This worksheet, which distills some 600 review areas included in the standards, will help the COTR or designee assess overall performance, by reviewing specific items within the 9 functional areas on a daily, weekly, monthly, and/or quarterly basis. Both annual and routine inspections will include a review of the service provider's QCP activities including the reports and results generated by them.

The COTR or designee will evaluate the service provider's performance by (a) conducting site visits to assess the facility and detainee conditions, (b) reviewing documentation, and (c) interviewing the service provider's personnel and/or detainees. NOTE: For day-to-day activities, the Government will conduct its surveillance using the worksheets created for this purpose, along with the Contract Deficiency Reports (CDRs; See Attachment 2) and the "Contract Performance Monitoring Tool" set forth in Attachment 3. Where ICE/DRO standards are referenced for annual review purposes, the "Monitoring Instruments" and "Verification Sources" identified in the DRO standard will be used.

**4.1 Site Visits:** Site visits are used to observe actual performance and to conduct interviews to determine the extent of compliance with performance standards, and to ensure any noted defects are effectively addressed and corrected as quickly as possible. Sites with 500+ beds will have an on-site COTR designee. Routine reviews may involve direct observation of the service provider personnel performing tasks, interacting with detainees and other staff members, and/or reviewing documentation that demonstrates compliance with the DRO standards. On-site inspections may be performed by the ICE COTR or by other parties designated as representatives of ICE.



Inspections may be planned (e.g., annual inspections and the regular inspections identified in Attachment 3) or ad-hoc.

**4.2 Ad-Hoc:** These inspections are unscheduled and will be conducted as a result of special interests arising from routine monitoring of the service provider's QCP, an unusual occurrence pertaining to the agreement or other ICE concerns. These inspections may also be used as a follow-up to a previous inspection. Inspection findings will be provided to the service provider as appropriate.

When visiting a site, either the COTR or a designated third party may conduct their own inspections of service provider performance activities, or accompany the service provider's designated Quality Control Inspector (QCI) on scheduled inspections. The COTR may also immediately inspect the same area as soon as the QCI has completed the quality control inspection to determine if any surveillance areas were overlooked. The COTR may also inspect an area prior to the QCI and compare results. The COTR will record all findings; certain deficiencies noted will be provided in writing and must be corrected within a reasonable amount of time (See Attachment 2).

**4.3 Review of Documentation:** The service provider must develop and maintain all documentation as prescribed in the performance standards (e.g., post logs, policies, and records of corrective actions). In addition to the documentation prescribed by the standards, the service provider must also develop and maintain documentation that demonstrates the results of its own inspections as prescribed in its QCP. The COTR will review both forms of documentation to affirm that the facility conditions, policies/procedures, and handling of detainees all conform to the performance standards stated herein. When reviewing the service provider's documentation, the Government may review 100% of the documents, or a representative sample. Documentation may be reviewed during a site visit, or at periodic points throughout the period of performance.

**4.4 Interviews and Other Feedback:** The COTR will interview key members of the service provider's staff, detainees and other Government personnel to ascertain current practices and the extent of compliance with the performance standards.

## **5. FUNCTIONAL PERFORMANCE AREAS AND STANDARDS**

To facilitate the performance review process, the required performance standards are organized into nine functional areas. Each functional area represents a proportionate share (i.e., weight) of the monthly invoice amount payable to the service provider based on meeting the performance standards. Payment withholdings will be based on these percentages and weights applied to the overall monthly invoice.

ICE may, consistent with the scope the agreement, unilaterally change the functional areas and associated standards affiliated with a specific functional area. The Contracting Officer will notify the service provider at least 30 calendar days in advance of implementation of the new standard(s). If the service provider is not provided with the notification, adjustment to the new standard must be made within 30 calendar days after notification. If any change affects pricing,

the service provider may submit a request for equitable price adjustment in accordance with the "Changes" clause. ICE reserves the right to develop and implement new inspection techniques and instructions at any time during performance without notice to the service provider, so long as the standards are not more stringent than those being replaced.

## 6. FAILURE TO MEET PERFORMANCE STANDARDS

Performance of services in conformance with the PRS standards is essential for the service provider to receive full payment as identified in the agreement. The Contracting Officer may take deductions against the monthly invoices for unsatisfactory performance documented through surveillance of the service provider's activities gained through site inspections, reviews of documentation (including monthly QCP reports), interviews and other feedback. As a result of its surveillance, the service provider will be assigned the following rating relative to each performance standard:

Rating	Description
Acceptable	Based on the measures, the performance standard is demonstrated.
Deficient	Based on the measures, compliance with most of the attributes of the performance standard is demonstrated/observed with some area(s) needing improvement. There are no critical areas of unacceptable performance
At-Risk	Based on the performance measures, the majority of a performance standard's attributes are not met.

Using the above standards as a guide, the Contracting Officer will implement adjustments to the service provider's monthly invoice as prescribed in Attachment 1.

Rather than withholding funds until a deficiency is corrected, there may be times when an event or a deficiency is so egregious that the Government *deducts* (vs. "withholds") amounts from the service provider's monthly invoice. This may happen when an event occurs, such as sexual abuse, when a particular deficiency is noted 3 or more times without correction, or when the service provider has failed to take timely action on a deficiency about which he was properly and timely notified. The amount deducted will be consistent with the relative weight of the functional performance area where the deficiency was noted. The deduction may be a one-time event, or may continue until the service provider has either corrected the deficiency, or made substantial progress in the correction.

Further, a deficiency found in one functional area may tie into another. If a detainee escaped, for example, a deficiency would be noted in "Security and Control," but may also relate to a deficiency in the area of "Administration and Management."

## 7. NOTIFICATIONS

- (a) Based on the inspection of the service provider's performance, the COTR will document instances of deficient or at-risk performance (e.g., noncompliance with the standard) using the CDR located at Attachment 2. To the extent practicable, issues should be resolved

informally, with the COTR and service provider working together. When documentation of an issue or deficiency is required, the procedures set forth in this section will be followed.

- (b) When a CDR is required to document performance issues, it will be submitted to the service provider with a date when a response is due. Upon receipt of a CDR, the service provider must immediately assess the situation and either correct the deficiency as quickly as possible or prepare a corrective action plan. In either event, the service provider must return the CDR with the action planned or taken noted. After the COTR reviews the service provider's response to the CDR including its plan/remedy, the COTR will either accept plan or correction or reject the correction/plan for revision and provide an explanation. This process should take no more than one week. The CDR should not be used as a substitute for quality control by the service provider.
- (c) The COTR and CO, in addition to any other designated ICE official, shall be notified immediately in the event of all emergencies. Emergencies include, but are not limited to the following: activation of disturbance control team(s); disturbances (including gang activities, group demonstrations, food boycotts, work strikes, work-place violence, civil disturbances/protests); staff use of force including use of lethal and less-lethal force (includes inmates in restraints more than eight hours); assaults on staff/inmates resulting in injuries requiring medical attention (does not include routine medical evaluation after the incident); fights resulting in injuries requiring medical attention; fires; full or partial lock down of the facility; escape; weapons discharge; suicide attempts; deaths; declared or non-declared hunger strikes; adverse incidents that attract unusual interest or significant publicity; adverse weather (e.g., hurricanes, floods, ice/snow storms, heat waves, tornadoes); fence damage; power outages; bomb threats; central inmate monitoring cases admitted to a community hospital; witness security cases taken outside the facility; significant environmental problems that impact the facility operations; transportation accidents (airlift, bus, etc.) resulting in injuries, death or property damage; and sexual assaults. Note that in an emergency situation, a CDR may not be issued until an investigation has been completed.
- (d) If the COTR concludes that the deficient or at-risk performance warrants a withholding or deduction, the COTR must include the CDR in its monthly report to DRO Headquarters, with a copy to the Contracting Officer. The CDR must be accompanied by the COTR's investigation report and written recommendation for any withholding. If contractual action including a withholding or deduction is appropriate, DRO headquarters will forward the CDR and supporting information to the Contracting Officer for action. The Contracting Officer will consider the COTR's recommendation and forward the CDR along with any relevant supporting information to the service provider in order to confirm or further discuss the prospective cure, including the Government's proposed course of action. As described in section 7 above, portions of the monthly invoice amount may be withheld until such time as the corrective action is completed, *or* a deduction may be taken
- (e) Following receipt of the service provider's notification that the correction has been made, the COTR may re-inspect the facility. Based upon the COTR's findings, he will recommend that the Contracting Officer continue to withhold a proportionate share of the payment until the

correction is made, or accept the correction as final and release the full amount withheld for that issue.

- (f) If funds have been withheld and either the Government or the service provider terminates the agreement, those funds will not be released. The service provider may only receive withheld payments upon successful correction of an instance of non-compliance. Further, the service provider is not relieved of full performance of the required services hereunder; the agreement may be terminated upon adequate notice from the Government based upon any once instance, or failure to remedy deficient performance, even if a deduction was previously taken for any inadequate performance.
- (g) The COTR will maintain a record of all open and resolved CDRs.

#### **8. DETAINEE/MEMBER OF PUBLIC COMPLAINTS:**

The detainee and the public are the ultimate recipients of the services identified in this agreement. Any complaints made known to the COTR will be logged and forwarded to the service provider for remedy. Upon notification, the service provider will be given a pre-specified number of hours after verbal notification from the COTR to address the issue. The service provider will submit documentation to the COTR regarding the actions taken to remedy the situation. If the complaint is found to be invalid, the service provider will document its findings and notify the COTR.

#### **9. ATTACHMENTS**

- 1 Performance Requirements Summary
- 2 Contract Discrepancy Report
- 3 Performance Monitoring Tool

**QUASP Attachment 1  
Performance Requirements Summary**

FUNCTIONAL AREA/ WEIGHT	PERFORMANCE STANDARD	PERFORMANCE MEASURE	METHOD OF SURVEILLANCE	ACCEPTABLE QUALITY LEVEL	WITHHOLDING CRITERIA	
<b>Administration and Management (10%)</b>  (Addresses facility policy development, internal inspection and reviews, detainee records, administration and orientation, personal property and monies, release and accommodations for the disabled)	Accommodations for the Disabled, 4-ALDF-6B-04, 4-ALDF-6B-07	Performance measures are reflected in the monitoring instrument that accompanies each standard or in the supplemental performance monitoring tool issued by the COTR	<ul style="list-style-type: none"> <li>Annual review of facility using Detention Management Control Program (DCMP) procedures and based upon the performance standard</li> <li>Periodic reviews in accordance with the contract performance monitoring tool (see attached)</li> <li>Monthly review of corrective action plan results.</li> <li>Ad-hoc reviews as needed</li> <li>Review of service provider's quality control program monitoring reports</li> <li>CDRs</li> </ul>	Performance fully complies with all elements of standard at a level no less than acceptable (see Section 7 of the QASP)	A rating of Deficient on any three of the standards will result in a 10% withholding in the monthly invoiced per-diem day rate until compliance with the standard is established.  A rating of At-Risk on any of the standards will result in a 10% withholding in the monthly invoiced per-diem day rate until compliance with the standard is established.	
	Contractor Quality Control/ Assurance Program (Contract) 4-ALDF-7D-02					
	Admission and Release/Orientation (ICE Standard) ( <a href="http://www.ice.gov/doclib/partners/dro/opsmanual/admiss.pdf">http://www.ice.gov/doclib/partners/dro/opsmanual/admiss.pdf</a> )					
	Detainee Records/ Detention Files (ICE Standard) ( <a href="http://www.ice.gov/doclib/partners/dro/opsmanual/DetentFiles.pdf">http://www.ice.gov/doclib/partners/dro/opsmanual/DetentFiles.pdf</a> )					
	Detainee Handbook (ICE Standard) ( <a href="http://www.ice.gov/doclib/partners/dro/opsmanual/handbk.pdf">http://www.ice.gov/doclib/partners/dro/opsmanual/handbk.pdf</a> )					
	Internal Inspections and/or Reviews/ Detention Management & Control Program (ICE Standard)					
	Funds & Personal Property (ICE Standard) ( <a href="http://www.ice.gov/doclib/partners/dro/opsmanual/fundprop.pdf">http://www.ice.gov/doclib/partners/dro/opsmanual/fundprop.pdf</a> )					
	Policy Development and Monitoring 4-ALDF-7D-06					

FUNCTIONAL AREA/ WEIGHT	PERFORMANCE STANDARD	PERFORMANCE MEASURE	METHOD OF SURVEILLANCE	ACCEPTABLE QUALITY LEVEL	WITHHOLDING CRITERIA
<p><b>Health Care (15%)</b> (Addresses overall access to routine, chronic health care, mental health, emergency health and dental services provided by the institution)</p>	<p>Communicable Disease 4-ALDF-4C-14</p> <p>Detainee Hunger Strikes (ICE Standard) (<a href="http://www.ice.gov/doclib/partners/dro/opsmanual/hunger.pdf">http://www.ice.gov/doclib/partners/dro/opsmanual/hunger.pdf</a>)</p> <p>Experimental Research 4-ALDF-4D-18</p> <p>Medical, Dental, and Appraisals/Medical Care (ICE Standard) (<a href="http://www.ice.gov/doclib/partners/dro/opsmanual/medical.pdf">http://www.ice.gov/doclib/partners/dro/opsmanual/medical.pdf</a>)</p> <p>Suicide Prevention (ICE Standard) (<a href="http://www.ice.gov/doclib/partners/dro/opsmanual/sucprev.pdf">http://www.ice.gov/doclib/partners/dro/opsmanual/sucprev.pdf</a>)</p> <p>Terminal Illness, Advanced Directives and Death (ICE Standard) (<a href="http://www.ice.gov/doclib/partners/dro/opsmanual/terminal.pdf">http://www.ice.gov/doclib/partners/dro/opsmanual/terminal.pdf</a>)</p>	<p>Performance measures are reflected in the monitoring instrument that accompanies each standard or in the supplemental performance monitoring tool issued by the COTR</p>	<ul style="list-style-type: none"> <li>Annual review of facility using Detention Management Control Program (DCMP) procedures and based upon the performance standard</li> <li>Periodic reviews in accordance with the attached performance monitoring tool</li> <li>Monthly review of corrective action plan results.</li> <li>Ad-hoc reviews as needed</li> <li>CDRs</li> </ul>	<p>Performance fully complies with all elements of standard at a level no less than acceptable (see Section 7 of the QASP)</p>	<p>A rating of Deficient on any two of the standards will result in a 15% withholding in the monthly invoiced per-diem day rate until compliance with the standard is established.</p> <p>A rating of At-Risk on any of the standards will result in a 15% withholding in the monthly invoiced per-diem day rate until compliance with the standard is established.</p>

FUNCTIONAL AREA/ WEIGHT	PERFORMANCE STANDARD	PERFORMANCE MEASURE	METHOD OF SURVEILLANCE	ACCEPTABLE QUALITY LEVEL	WITHHOLDING CRITERIA
<p align="center"><b>Security and Control (25%)</b></p> <p>(Addresses post orders, permanent logs, security features, security inspections, control of contraband, detainee searches, detainee accountability, use of force, non-routine use of restraints, tool and equipment control, detainee discipline, supervision for special housing, contingency and emergency plans.)</p>	Detainee Searches 4-ALDF-2C-01-06	Performance measures are reflected in the monitoring instrument that accompanies each standard or in the supplemental performance monitoring tool issued by the COTR	<ul style="list-style-type: none"> <li>Monthly review of corrective action plan results.</li> <li>Ad-hoc reviews as needed</li> <li>CDRs</li> <li>Review of service provider's quality control program monitoring reports and output data</li> </ul>	Performance fully complies with all elements of standard at a level no less than acceptable (see Section 7 of the QASP)	A rating of Deficient on any two of the standards will result in a 15% withholding in the monthly invoiced per-diem day rate until compliance with the standard is established.
	Detainees Accountability & Supervision/ Population Counts (ICE Standard) ( <a href="http://www.ice.gov/doclib/partners/dro/opsmanual/popula.pdf">http://www.ice.gov/doclib/partners/dro/opsmanual/popula.pdf</a> )	Annual review of facility using Detention Management Control Program (DCMP) procedures and based upon the performance standard		A rating of Deficient on any three of the standards will result in a 25% withholding in the monthly invoiced per-diem day rate until compliance with the standard is established.	
	Use of Force (ICE Standard) ( <a href="http://www.ice.gov/doclib/partners/dro/opsmanual/usooffor.pdf">http://www.ice.gov/doclib/partners/dro/opsmanual/usooffor.pdf</a> )	Periodic reviews in accordance with the contract performance monitoring tool (see attached)			
	Detainee Transfers (ICE Standard) ( <a href="http://www.ice.gov/doclib/partners/dro/opsmanual/detTransStdfinal.pdf">http://www.ice.gov/doclib/partners/dro/opsmanual/detTransStdfinal.pdf</a> )				
	Tool and Equipment Control (ICE Standard) ( <a href="http://www.ice.gov/doclib/partners/dro/opsmanual/toolent.pdf">http://www.ice.gov/doclib/partners/dro/opsmanual/toolent.pdf</a> )				
	Weapon Control 4-ALDF-2B-04, 4-ALDF-2B-08, 4-ALDF-7B-14				
	Detainee Discipline (ICE Standard) ( <a href="http://www.ice.gov/doclib/partners/dro/opsmanual/discip.pdf">http://www.ice.gov/doclib/partners/dro/opsmanual/discip.pdf</a> )				
	Special Management Unit- Administrative Segregation (ICE Standard) ( <a href="http://www.ice.gov/doclib/partners/dro/opsmanual/smu_actm.pdf">http://www.ice.gov/doclib/partners/dro/opsmanual/smu_actm.pdf</a> )				

FUNCTIONAL AREA/ WEIGHT	PERFORMANCE STANDARD	PERFORMANCE MEASURE	METHOD OF SURVEILLANCE	ACCEPTABLE QUALITY LEVEL	WITHHOLDING CRITERIA
	Special Management Unit-Disciplinary Segregation (ICE Standard) ( <a href="http://www.ice.gov/doclib/partners/dro/opsmanual/smu_dis.pdf">http://www.ice.gov/doclib/partners/dro/opsmanual/smu_dis.pdf</a> )				
	Contingency/Emergency Plan (ICE Standard) ( <a href="http://www.ice.gov/doclib/partners/dro/opsmanual/emeece.pdf">http://www.ice.gov/doclib/partners/dro/opsmanual/emeece.pdf</a> )				
	Hold Rooms in Detention Facilities (ICE Standard) ( <a href="http://www.ice.gov/doclib/partners/dro/opsmanual/holdrm.pdf">http://www.ice.gov/doclib/partners/dro/opsmanual/holdrm.pdf</a> )				
	Control of Contraband (ICE Standard) ( <a href="http://www.ice.gov/doclib/partners/dro/opsmanual/contra.pdf">http://www.ice.gov/doclib/partners/dro/opsmanual/contra.pdf</a> )				
	Post Orders (ICE Standard)( <a href="http://www.ice.gov/doclib/partners/dro/opsmanual/postord.pdf">http://www.ice.gov/doclib/partners/dro/opsmanual/postord.pdf</a> )				
	Permanent Logs 4- ALDF-2A-11				
	Security Features (ICE Standard) ( <a href="http://www.ice.gov/doclib/partners/dro/opsmanual/keylock.pdf">http://www.ice.gov/doclib/partners/dro/opsmanual/keylock.pdf</a> )				
	Security Inspections and/or Reviews (ICE Standard) ( <a href="http://www.ice.gov/doclib/partners/dro/opsmanual/sectitp.pdf">http://www.ice.gov/doclib/partners/dro/opsmanual/sectitp.pdf</a> )				
	Sexual Assault 4-ALDF- 4D-22-8				



FUNCTIONAL AREA/ WEIGHT	PERFORMANCE STANDARD	PERFORMANCE MEASURE	METHOD OF SURVEILLANCE	ACCEPTABLE QUALITY LEVEL	WITHHOLDING CRITERIA
<b>Food Service (10%)</b> (Addresses basic sanitation and adequacy of varied meals and special diets provided to detainees)	Transportation (Land Transportation) (ICE Standard) <a href="http://www.ice.gov/doclib/partners/dro/opsmanual/transport.pdf">http://www.ice.gov/doclib/partners/dro/opsmanual/transport.pdf</a> Weapons Control 4-ALDF-2B-04, 4-ALDF-2B-08, 4-ALDF-7B-14	Performance measures are reflected in the monitoring instrument that accompanies each standard or in the supplemental performance monitoring tool issued by the COTR	<ul style="list-style-type: none"> <li>Annual review of facility using Detention Management Control Program (DCMP) procedures and based upon the performance standard</li> <li>Periodic review in accordance with the attached performance monitoring tool</li> <li>Monthly review of corrective action plan results.</li> <li>Ad-hoc reviews as needed</li> <li>CDRs</li> </ul>	Performance fully complies with all elements of standard at a level no less than acceptable (see Section 7 of the QASP)	A rating of Deficient on any the standards will result in a 10% withholding in the monthly invoiced per-diem day rate until compliance with the standard is established.  A rating of At-Risk on any of the standards will result in a 10% withholding in the monthly invoiced per-diem day rate until compliance with the standard is established.
	Environmental Health & Safety (ICE Standard) <a href="http://www.ice.gov/doclib/partners/dro/opsmanual/envirom.pdf">http://www.ice.gov/doclib/partners/dro/opsmanual/envirom.pdf</a> Food Service Standards (ICE Standard) <a href="http://www.ice.gov/doclib/partners/dro/opsmanual/FoodService.pdf">http://www.ice.gov/doclib/partners/dro/opsmanual/FoodService.pdf</a>				

FUNCTIONAL AREA/ WEIGHT	PERFORMANCE STANDARD	PERFORMANCE MEASURE	METHOD OF SURVEILLANCE	ACCEPTABLE QUALITY LEVEL	WITHHOLDING CRITERIA
<p><b>Staff and Detainee Communication (2.5%)</b> (Addresses methods of communicating with detainees, detention/correctional staff training in diversity, and the detainee grievance process)</p>	<p>Detainee Grievances (ICE Standard) (<a href="http://www.ice.gov/doclib/partners/dro/opsmanual/griev.pdf">http://www.ice.gov/doclib/partners/dro/opsmanual/griev.pdf</a>)</p> <p>Diversity Training 4-ALDF-6A-08, 4-ALDF-7B-10</p> <p>Staff Detainee Communication (ICE Standard) (<a href="http://www.ice.gov/doclib/partners/dro/opsmanual/StaffDetaineeCommunication.pdf">http://www.ice.gov/doclib/partners/dro/opsmanual/StaffDetaineeCommunication.pdf</a>)</p>	<p>Performance measures are reflected in the monitoring instrument that accompanies each standard or in the supplemental performance monitoring tool issued by the COTR</p>	<ul style="list-style-type: none"> <li>Annual review of facility using Detention Management Control Program (DCMP) procedures and based upon the performance standard</li> <li>Periodic reviews in accordance with the attached performance monitoring tool</li> <li>Monthly review of corrective action plan results.</li> <li>Ad-hoc reviews as needed</li> <li>CDRs</li> </ul>	<p>Performance fully complies with all elements of standard at a level no less than acceptable (see Section 7 of the QASP)</p>	<p>A rating of Deficient on any two of the standards will result in a 2.5% withholding in the monthly invoiced per-diem day rate until compliance with the standard is established.</p> <p>A rating of At-Risk on any of the standards will result in a 2.5% withholding in the monthly invoiced per-diem day rate until compliance with the standard is established.</p>
<p><b>Safety and Sanitation (10%)</b> (Addresses the adequacy of fire safety programs, the control of dangerous materials, the general facility environment (including air quality, noise levels, and sanitation and hygiene programs), the adequacy of clothing and bedding, and from infectious diseases)</p>	<p>Environmental Health &amp; Safety (ICE Standard) (<a href="http://www.ice.gov/doclib/partners/dro/opsmanual/Environment.pdf">http://www.ice.gov/doclib/partners/dro/opsmanual/Environment.pdf</a>)</p> <p>Clothing and Bedding (ICE Standard) (<a href="http://www.ice.gov/doclib/partners/dro/opsmanual/cloth.pdf">http://www.ice.gov/doclib/partners/dro/opsmanual/cloth.pdf</a>)</p>	<p>Performance measures are reflected in the monitoring instrument that accompanies each standard or in the supplemental performance monitoring tool issued by the COTR</p>	<ul style="list-style-type: none"> <li>Annual review of facility using Detention Management Control Program (DCMP) procedures and based upon the performance standard</li> <li>Periodic reviews in accordance with the attached performance monitoring tool</li> <li>Monthly review of corrective action plan results.</li> <li>Ad-hoc reviews as needed</li> <li>CDRs</li> </ul>	<p>Performance fully complies with all elements of standard at a level no less than acceptable (see Section 7 of the QASP)</p>	<p>A rating of Deficient on any two of the standards will result in a 10% withholding in the monthly invoiced per-diem day rate until compliance with the standard is established.</p> <p>A rating of At-Risk on any of the standards will result in a 10% withholding in the monthly invoiced per-diem day rate until compliance with the standard is established.</p>

FUNCTIONAL AREA/ WEIGHT	PERFORMANCE STANDARD	PERFORMANCE MEASURE	METHOD OF SURVEILLANCE	ACCEPTABLE QUALITY LEVEL	WITHHOLDING CRITERIA
<p align="center"><b>Services and Programs (10%)</b>            (Addresses detainee security classification, religious practices, work assignments, availability of exercise programs, access to legal materials, access to legal representation, access to a telephone, the handling of detainee mail and other correspondence, and visitation privileges)</p>	Access to Legal Material (ICE Standard) ( <a href="http://www.ice.gov/doclib/partners/dro/opsmanual/legal.pdf">http://www.ice.gov/doclib/partners/dro/opsmanual/legal.pdf</a> )	Performance measures are reflected in the monitoring instrument that accompanies each standard or in the supplemental performance monitoring tool issued by the COTR	<ul style="list-style-type: none"> <li>Annual review of facility using Detention Management Control Program (DCMP) procedures and based upon the performance standard</li> <li>Periodic reviews in accordance with the attached performance monitoring tool</li> <li>Monthly review of corrective action plan results.</li> <li>Ad-hoc reviews as needed</li> <li>CDRs</li> </ul>	Performance fully complies with all elements of standard at a level no less than acceptable (See section 7 of the QASP)	A rating of Deficient on any two of the standards will result in a 10% withholding in the monthly invoiced per-diem day rate until compliance with the standard is established.
	Classification, Review, and Housing (ICE Standard) ( <a href="http://www.ice.gov/doclib/partners/dro/opsmanual/classif.pdf">http://www.ice.gov/doclib/partners/dro/opsmanual/classif.pdf</a> )				
	Correspondence (ICE Standard) ( <a href="http://www.ice.gov/doclib/partners/dro/opsmanual/corresp.pdf">http://www.ice.gov/doclib/partners/dro/opsmanual/corresp.pdf</a> )				
	Group Legal Representation (ICE Standard) ( <a href="http://www.ice.gov/doclib/partners/dro/opsmanual/grplegal.pdf">http://www.ice.gov/doclib/partners/dro/opsmanual/grplegal.pdf</a> )				
	Marriage Requests (ICE Standard) ( <a href="http://www.ice.gov/doclib/partners/dro/opsmanual/marreq.pdf">http://www.ice.gov/doclib/partners/dro/opsmanual/marreq.pdf</a> )				
	Non-Medical Emergency Escorted Trips (ICE Standard) ( <a href="http://www.ice.gov/doclib/partners/dro/opsmanual/essort.pdf">http://www.ice.gov/doclib/partners/dro/opsmanual/essort.pdf</a> )				
	Recreation (ICE Standard) ( <a href="http://www.ice.gov/doclib/partners/dro/opsmanual/recreat.pdf">http://www.ice.gov/doclib/partners/dro/opsmanual/recreat.pdf</a> )				

FUNCTIONAL AREA/ WEIGHT	PERFORMANCE STANDARD	PERFORMANCE MEASURE	METHOD OF SURVEILLANCE	ACCEPTABLE QUALITY LEVEL	WITHHOLDING CRITERIA
<b>Workforce Integrity (15%)</b> (Addresses the adequacy of the detention/correctional officer hiring process, staff training and licensing/certification and adequacy of systems to report and address staff misconduct)	Religious Practices (ICE Standard) <a href="http://www.ice.gov/doclib/partners/dro/opsman/ual/cloth.pdf">http://www.ice.gov/doclib/partners/dro/opsman/ual/cloth.pdf</a> Telephone Access (ICE Standard) <a href="http://www.ice.gov/doclib/partners/dro/opsman/ual/telephone.pdf">http://www.ice.gov/doclib/partners/dro/opsman/ual/telephone.pdf</a> Voluntary Work Program (ICE Standard) <a href="http://www.ice.gov/doclib/partners/dro/opsman/ual/work.pdf">http://www.ice.gov/doclib/partners/dro/opsman/ual/work.pdf</a>				
	Visitation Privileges (ICE Standard) <a href="http://www.ice.gov/doclib/partners/dro/opsman/ual/visit.pdf">http://www.ice.gov/doclib/partners/dro/opsman/ual/visit.pdf</a>	Performance measures are reflected in the monitoring instrument that accompanies each standard or in the supplemental performance monitoring tool issued by the COTR	<ul style="list-style-type: none"> <li>Annual review of facility using Detention Management Control Program (DCMP) procedures and based upon the performance standard               <ul style="list-style-type: none"> <li>Periodic reviews in accordance with the attached contract performance monitoring tool</li> <li>Monthly review of corrective action plan results.</li> <li>Ad-hoc reviews as needed</li> <li>CDRs</li> </ul> </li> </ul>	Performance fully complies with all elements of standard at a level no less than acceptable (See section 7 of the QASP)	A rating of Deficient on any three of the standards will result in a 15% withholding in the monthly invoiced per-diem day rate until compliance with the standard is established.  A rating of At-Risk on any of the standards will result in a 15% withholding in the monthly invoiced per-diem day rate until compliance with the standard is established.
	Staff Background and Reference Checks (Contract) 4-ALDF-7B-03  Staff Misconduct 4-ALDF-7B-01  Staffing Pattern Compliance within 10% of required (Contract) 4-ALDF-2A-14  Staff Training, Licensing, and Credentialing (Contract) 4-ALDF-4D-06, 4-ALDF-7B-05, 4-ALDF-7B-08	Performance measures are reflected in the monitoring instrument that accompanies each standard or in the supplemental performance monitoring tool issued by the COTR	<ul style="list-style-type: none"> <li>Annual review of facility using Detention Management Control Program (DCMP) procedures and based upon the performance standard               <ul style="list-style-type: none"> <li>Periodic reviews in accordance with the attached contract performance monitoring tool</li> <li>Monthly review of corrective action plan results.</li> <li>Ad-hoc reviews as needed</li> <li>CDRs</li> </ul> </li> </ul>	Performance fully complies with all elements of standard at a level no less than acceptable (See section 7 of the QASP)	A rating of Deficient on any three of the standards will result in a 15% withholding in the monthly invoiced per-diem day rate until compliance with the standard is established.  A rating of At-Risk on any of the standards will result in a 15% withholding in the monthly invoiced per-diem day rate until compliance with the standard is established.

FUNCTIONAL AREA/ WEIGHT	PERFORMANCE STANDARD	PERFORMANCE MEASURE	METHOD OF SURVEILLANCE	ACCEPTABLE QUALITY LEVEL	WITHHOLDING CRITERIA
<p align="center"><b>Detainee Discrimination (2.5%)</b> (Addresses the adequacy of policies and procedures to prevent discrimination against detainees based on their gender, race, religion, national origin, or disability)</p>	<p>Discrimination Prevention 4-ALDF-6B-02-03</p>	<p>Performance measures are reflected in the monitoring instrument that accompanies each standard or in the supplemental performance monitoring tool issued by the COTR</p>	<ul style="list-style-type: none"> <li>• Annual review of facility using Detention Management Control Program (DCMP) procedures and based upon the performance standard</li> <li>• Periodic reviews in accordance with the attached performance monitoring tool (see attached)</li> <li>• Monthly review of corrective action plan results.</li> <li>• Ad-hoc reviews as needed</li> <li>• CDRs</li> </ul>	<p>Performance fully complies with all elements of standard at a level no less than acceptable (see Section 7 of the QASP)</p>	<p>A rating of Deficient on the standards will result in a 2.5% withholding in the monthly invoiced per-diem day rate until compliance with the standard is established.</p> <p>A rating of At-Risk on any of the standards will result in a 2.5% withholding in the monthly invoiced per-diem day rate until compliance with the standard is established.</p>

## QUASP Attachment 2 - Contract Discrepancy Report

CONTRACT DISCREPANCY REPORT			1. CONTRACT NUMBER
<b>Report Number:</b>		<b>Date:</b>	
2. TO: (Contractor and Manager Name)		3. FROM: (Name of COTR)	
DATES			
CONTRACTOR NOTIFICATION	CONTRACTOR RESPONSE DUE BY	RETURNED BY CONTRACTOR	ACTION COMPLETE
4. DISCREPANCY OR PROBLEM <i>(Describe in Detail: Include reference in PWS / Directive: Attach continuation sheet if necessary.)</i>			
5. SIGNATURE OF CONTRACTING OFFICER'S TECHNICAL REPRESENTATIVE (COTR)			
6. TO: (COTR)		7. FROM: (Contractor)	
8. CONTRACTOR RESPONSE AS TO CAUSE, CORRECTIVE ACTION AND ACTIONS TO PREVENT RECURRENCE. ATTACH CONTINUATION SHEET IF NECESSARY. <i>(Cite applicable Q.A. program procedures or new A.W. procedures.)</i>			
9. SIGNATURE OF CONTRACTOR REPRESENTATIVE			10. DATE
11. GOVERNMENT EVALUATION OF CONTRACTOR RESPONSE/RESOLUTION PLAN: <i>(Acceptable response/plan, partial acceptance of response/plan, rejection: attach continuation sheet if necessary)</i>			
12. GOVERNMENT ACTIONS <i>(Payment withholding, cure notice, show cause, other.)</i>			
CLOSE OUT			
CONTRACTOR NOTIFIED COTR	NAME AND TITLE	SIGNATURE	DATE
CONTRACTING OFFICER			

**Dedicated IGSA**

# QUASP Attachment 3 – Performance Monitoring Tool



U.S. Immigration  
and Customs  
Enforcement

Detention and Removal Operations  
Performance Monitoring Tool  
Month/Year: \_\_\_\_\_

Frequency		DEFINITION STANDARD	Rating A/D/R	Corrective Action Required / Comments	Due Date
D	W				
		<b>1. Admission and Release</b>			
		A. ICE information is available for initial classification			
		B. Medical screening taking place within timeframes			
		C. Inventory detainee personal effects			
		D. Detainee funds accountability in place for admin/release			
		E. All visual searches documented and are not routine in procedure			
		F. Appropriate clothing and bedding issued			
		G. Orientation material in English, Spanish or most prevalent second language			
		<b>2. Detainee Classification System</b>			
		A. All detainees classified appropriately upon arrival			
		B. Reassessment and reclassification process in place			
		C. Housing assignments are based upon classification			
		D. Work assignments are based upon classification system			
		E. Detainees are assigned color coded uniforms/wrist bands to reflect classification level			
		<b>3. Contraband</b>			
		A. Policy in place for handling contraband			
		B. Contraband disposed of properly and documented			
		C. Facility staff make a concerted effort to control			

D	M	contraband	DETERMINATION STANDARD	Rating A/D/R	Corrective Action Required/ Comments	Due Date
			<b>4. Correspondence and Other Mail</b>			
			A. Incoming mail screened and delivered daily			
			B. Outgoing mail screened for contraband			
			C. Legal mail opened in front of detainee			
			D. Incoming funds processed properly			
			E. Rules for correspondence and other mail posted in housing unit or common areas, and detainee handbook			
			F. Facility has a system for detainees to purchase stamps			
			G. SMU has same correspondence privileges as general population			
			<b>5. Detainee Handbook</b>			
			A. Staff aware of handbook contents and follow procedures			
			B. Available in both English and Spanish and/or second most prevalent language			
			C. Handbook is updated as necessary			
			D. Orientation material available to illiterate detainees			
			<b>6. Detention Files</b>			
			A. Detention file created for each new arrival			
			B. Detention files contain documents generated during custody			
			C. Detention files maintained in a secure area			
			<b>7. Disciplinary Policy</b>			
			A. Rules of conduct/sanctions provided in writing			
			B. Incident reports investigated within 24 hours			
			C. Disciplinary panel adjudicate infractions			
			D. Disciplinary sanctions are in accordance with standards			



D	W	M	E. Staff representation available	DEFINITION STANDARD	Rating A/D/R	Corrective Action Required/ Comments	Due Date
				<b>8. Emergency Plans</b>			
			A. Staff trained				
			B. Written plans				
			C. Evacuation routes primary and secondary				
			D. A complete set of emergency plans is available				
			E. Staff work stoppage plan is available				
				<b>9. Environmental Health and Safety</b>			
			A. System for storing/issuing/maintaining hazardous materials				
			B. Complete inventories of hazardous materials maintained				
			C. A complete list of MSDS readily accessible to staff and detainees				
			D. Fire prevention/control/evacuation plan				
			E. Conduct fire/evacuation drills according to schedule/standard				
			F. Staff trained to prevent contact with blood and bodily fluids				
			G. Emergency generators are tested bi-weekly				
			H. Every employee and detainee using flammable, toxic, or caustic materials receives advance training in their use, storage, and disposal				
			I. Safety Office (or officer) maintains files of inspection reports; Including corrective actions taken				
			J. Facility appears clean and well maintained				
			K. All flammable and combustible materials (liquid and aerosol) are stored and used according to label recommendations				

D	W	M	C	DEFENSE STANDARDS	Rating A/D/R	Corrective Action Required/Comments	Due Date
				10. Non-Medical Emergency Escorted Trips			
			A.	The Field Office Director considers and approves, on a case-by-case basis, trips to visit an immediate family member in accordance with standards			
				11. Security Inspections			
			A.	Staff are required to conduct security check of assigned areas			
			B.	All visitors officially recorded in a visitor log book			
			C.	Front entrance staff inspect ID of everyone entering/exiting			
			D.	Maintain a log of all incoming and departing vehicles			
			E.	Housing unit searches occur at irregular times			
			F.	Area searches documented in log book			
			G.	Daily/Monthly fence checks completed and logged			
			H.	Facility administrator or designee and department heads visit housing units and activity areas weekly			
			I.	Officers monitor all vehicular traffic entering and leaving the facility			
			J.	The facility has a written policy and procedures to prevent the introduction of contraband into the facility or any of its components			
			K.	Security officer posts located in or immediately adjacent to detainee living areas to permit officers to see or hear and respond promptly to emergency situations. Personal contact and interaction between staff and detainees is required and facilitated			
			L.	Daily procedures include: perimeter alarm system tests; physical checks of the perimeter fence; documenting the results			

D	W	M	O	DEFINITION STANDARDS	Rating A/D/R	Corrective Action Required/ Comments	Due Date
				M. Tools being taken into the secure area of the facility are inspected and inventoried			
				<b>12. Food Service</b>			
				A. Appropriate security measures for sharps are in place			
				B. Appropriate food temperatures are maintained for both hot and cold food			
				C. Food Service department maintained at a high level of sanitation			
				D. Detainees receive safety and appropriate equipment training prior to beginning work in department			
				E. A minimum of two hot meals served daily			
				F. Facility has a standard 35 day cycle menu			
				G. A registered dietician conducts nutritional analysis			
				H. All menu changes documented			
				I. Common fare menu for authorized detainees			
				J. Weekly inspections conducted and documented			
				<b>13. Funds and Personal Property</b>			
				A. Inventory personal property/funds is maintained			
				B. Funds/valuables documented on receipt			
				C. Detainees property searched for contraband			
				D. Staff forward arriving detainees medication to medical staff			
				E. Detainee funds are deposited into the cash box			
				F. Staff secure every container used to store property with a tamper-proof numbered strap			
				G. Quarterly audits of detainee baggage & luggage are conducted, verified, and logged			
D	W	M	O	DEFINITION STANDARDS	RATING A/D/R	Corrective Action Required/ Comments	Due Date

14. Detainee Grievance Procedures	
A.	Grievance procedures in place
B.	Staff awareness of procedures for emergency grievances
C.	Grievance log is utilized
D.	Staff forward any grievances alleging staff misconduct to ICE
E.	Informal resolution to a detainee grievance documented in detention file
15. Hold Rooms in Detention Facilities	
A.	Detainees are not held in hold rooms longer than 12 hours
B.	All detainees pat searched prior to placement in hold room
C.	Maintain detention log for each detainee in hold room
D.	Written evacuation plan posted for each hold room
E.	Hold rooms contain sufficient seating for the number of detainees held
F.	No bunks/cots/beds or other related make shift sleeping apparatuses are permitted inside hold rooms
G.	Male and females are segregated from each other at all times
H.	Detainees are provided with basic personal hygiene items such as water, soap, toilet paper, cups for water, feminine hygiene items, diapers and wipes
I.	Officers closely supervise the detention hold rooms. Hold rooms are irregularly monitored every 15 minutes
16. Hunger Strikes	
A.	Procedures for referring detainee to medical if

D	W	M							
				verbally refused or observed refusing to eat beyond 72 hours					
<b>DEFINITION STANDARDS</b>									
				B. Staff receive training in identification of hunger strike					
				C. Process for determining reason for hunger strike					
<b>17. Key and Lock Control</b>									
				A. Maintain inventories of all keys/locks/locking devices					
				Emergency keys are available for all areas of the facility					
				B. Chit system used to issue security equip./keys/radios					
				C. Policy regarding restricted keys present and followed by staff					
				D. Facility has a key accountability policy and procedures to ensure key accountability. The keys are physically counted daily					
				E. Locks and locking devices are continually inspected, maintained, and inventoried					
				F.					
<b>18. Access to Legal Material</b>									
				A. Adequate equipment is available for detainees					
				B. Legal materials/law library current and available for detainees					
				C. Detainee access provided to include SMU					
				D. Denials documented					
				E. Schedule for use implemented 5 hours weekly per detainee					
				F. Access to legal material within 24 hours of written request					
				G. Indigent detainees provided free stamps/envelopes for legal matters					
<b>19. Group Presentations on Legal Rights</b>									

Rabbinic /  
 A/D/R  
 Corrective Action Required /  
 Comments  
 Due Date



DEPARTMENT OF HOMELAND SECURITY (DHS)  
IMMIGRATION AND CUSTOMS ENFORCEMENT (ICE)  
OFFICE OF DETENTION AND REMOVAL (DRO)

REQUEST FOR PROPOSAL--ICE Detainee Services

STATEMENT OF WORK

Date: 4/02/2008

FACILITY LOCATION

Town of Farmville  
116 North Main Street  
Farmville, Virginia 23901

**I. Performance:**

The **PROVIDER** is required, in units housing U.S. Immigration and Customs Enforcement (ICE) detainees, to perform in accordance with the most current editions of the ICE National Detention Standards, American Correctional Association (ACA) Standards for Adult Local Detention Facilities (ALDF), and Standards Supplement, Standards for Health Services in Jails, latest edition, National Commission on Correctional Health Care (NCCHC). Some ACA standards are augmented by ICE policy and/or procedure. In cases where other standards conflict with ICE Policy or Standards, ICE Policy and Standards prevail. ICE Inspectors will conduct periodic inspections of the facility to assure compliance of the aforementioned standards.

**II. Anticipated Start Of Performance: TBD**

**III. Exclusivity:**

The **CONTRACTOR** or **PROVIDER** agrees that the facility is to be for the exclusive use of ICE and its detainee population. No other agency will be allowed to use the facility to house its detainees, prisoners, or inmates without prior approval of the Contracting Officer with input from the Contracting Officer's Technical Representative. If given approval, a separate bed day rate shall be negotiated with the other agency and ICE shall not be responsible for payment related to beds used by another agency. The other agency will be separately invoiced for the beds it uses. The duration of the use of beds will be determined on a case by case basis.

**IV. Armed Transportation Service:**

A. Transportation service shall include the following:

1. The **PROVIDER** shall provide all such ground transportation services as may be required to transport detainees securely, in a timely manner, to locations as directed by the COTR or designated ICE Official. When **PROVIDER** employees are not providing transportation services, the

**PROVIDER** shall assign the employees to supplement security duties within the Facility to assist ICE as directed by the COTR or designated ICE official. However, the primary function of these Service Provider employees is transportation. Duties as directed by the COTR utilizing these employees shall not incur any additional expense to ICE.

2. The **PROVIDER** shall assign, at a minimum, two person teams of transportation officers on a daily basis distributed throughout a twenty-four (24) hour period seven (7) days a week including weekends and holidays. The COTR shall approve the number of teams assigned to any shift or period of time in order to meet the needs of ICE transportation requirements.
3. The **PROVIDER** shall furnish suitable vehicles in good condition, approved by the Government, to safely provide the required transportation services per facility as listed below. The **PROVIDER** shall comply with all federal and state laws with regard to inspections, licensing, and registration for all vehicles used for transportation.
4. Nothing in this agreement shall restrict the **PROVIDER** from acquiring additional vehicles as deemed necessary by the **PROVIDER** at no cost to the Government. The **PROVIDER** shall not allow employees to use their privately owned vehicles to transport detainees. The **PROVIDER** shall furnish vehicles equipped with interior security features (such as, but not limited to: door lock controls, window locks, a wire cage with acrylic panel between the driver seat and the rear passenger seats) and be in accordance with ICE National Detention Standards including physical separation of detainees from guards. The **PROVIDER** shall provide the interior security specification of the vehicles to ICE for review and approval prior to installation.
5. In the event of transportation services involving distances that exceed a standard eight (8) hour workday to complete, the **PROVIDER** shall be reimbursed for related costs of lodging and meals commiserate with the U.S. General Services Administration rates for such within the geographical area of occurrence. Any incurred overtime pay for such services will be reimbursed at the applicable Department of Labor overtime rate for the transportation officer position incorporated within this agreement. The **PROVIDER** shall comply with ICE transportation standards related to the number of hours the **PROVIDER** employee may operate a vehicle. Overnight lodging resulting from transportation services shall be approved in advance by the COTR or designated ICE official.
6. All transportation shall be accomplished in the most economical manner.



7. The **PROVIDER** shall, upon order of the COTR, or upon his own decision in an urgent medical situation with notification to the COTR immediately thereafter, transport a detainee to a hospital location. An officer(s) shall keep the detainee under supervision 24 hours per day until the detainee is ordered released from the hospital, or at the order of the COTR. The **PROVIDER** shall then return the detainee to the Facility.
8. The **PROVIDER** personnel provided for the above services shall be of the same qualifications, receive the same training, complete the same security clearances, and wear the same uniforms as those **PROVIDER** personnel provided in the other areas of this agreement. Transportation officers shall have the required state licenses for commercial drivers with the proper endorsement limited to vehicles with Automatic Transmission and the state DMV Medical Certification.
9. During all transportation activities, at least one transportation officer shall be the same sex as the detainee(s). Questions concerning guard assignments shall be directed to the COTR for final determination.
10. All transportation Detention Officers shall be armed in the performance of these duties.
11. The COTR may direct the **PROVIDER** to transport detainees to miscellaneous locations.
12. When the COTR provides documents to the **PROVIDER** concerning the detainee(s) to be transported and/or escorted, the **PROVIDER** shall deliver these documents only to the named authorized recipients. The **PROVIDER** shall ensure the material is kept confidential and not viewed by any person other than the authorized recipient.
13. The **PROVIDER** shall establish a fully operational communication system compatible with ICE communication equipment that has direct and immediate contact with all transportation vehicles and post assignments. Upon demand, the COTR shall be provided with current status of all vehicles and post assignment employees.
14. Failure of the **PROVIDER** to comply fully with the detainee(s) departure as pre-scheduled shall result in the **PROVIDER** having deductions made for non-performance.

## B. ANTICIPATED TRANSPORTATION ROUTES

The following transportation routes/destinations are anticipated requirements for this agreement. The following requirements are **one way routes**; these routes (mile approximations) are not all inclusive and should not be limited to the following:

<i>Legend</i>	<i>Daily = 2 times plus per week; Weekly = 2 or less per week; Periodic = as required Mileage = One Way</i>		
<b>Mileage From Farmville, VA</b>	<b>Locations</b>	<b>City</b>	<b>Frequency</b>
	<b>Field Offices</b>		
164	Detention and Removal Office	Fairfax	Daily
121	Detention and Removal Office	Harrisonburg	Weekly
153	Detention and Removal Office	Norfolk	Daily
65	Detention and Removal Office	Richmond	Daily
100	Detention and Removal Office	Roanoke	Weekly
	<b>JPATS/DOCC Destinations</b>		
173	Dulles International Airport	Washington, DC	Periodic
289	Harrisburg International Airport	Harrisburg, PA	Weekly
69	Richmond International Airport	Richmond	Proposed weekly
143	Piedmont Triad International Airport	Greensboro, NC	Proposed weekly
455	Stewart Detention Center	Stewart, GA	Periodic
266	York Detention Center	York, PA	Weekly
	<b>Jails</b>		
162	Alexandria City Jail	Alexandria	Daily
166	Arlington County Jail	Arlington	Daily
120	Augusta Correctional Center	Craigsville	Daily
180	Bland Correctional Center	Bland	Daily
59	Brunswick Correctional Center	Lawrenceville	Daily
22	Buckingham Correctional Center	Dillwyn	Daily
85	Central Virginia Regional Jail	Orange	Daily
145	Chesapeake City Jail	Chesapeake	Daily
96	Coffeewood Correctional Center	Coffeewood	Daily
170	DC Jail (Central Detention, Central Treatment)	Washington, DC	Daily
47	Deep Meadow Correctional Center	State Farm	Daily
22	Dillwyn Correctional Center	Dillwyn	Daily
48	Dinwiddie Correctional Unit	Church Road	Daily
160	Fairfax County Jail	Fairfax	Daily
67	FCI Petersburg - Camp - Virginia	Petersburg	Daily
67	FCI Petersburg - Low - Virginia	Petersburg	Daily
67	FCI Petersburg - Medium - Virginia	Petersburg	Daily

Mileage From Farmville, VA	Locations	City	Frequency
92	Green Rock Corr Center (New 06/2007)	Chatham	Daily
74	Greensville Correctional Center	Jarratt	Daily
138	Hampton City Jail	Hampton	Daily
136	Hampton Roads Regional Jail	Portsmouth	Daily
124	Haynesville Correctional Center	Haynesville	Daily
64	Henrico County Jail	Richmond	Daily
48	James River Correctional Center	State Farm	Daily
59	Lawrenceville Correctional Center	Lawrenceville	Daily
169	Loudoun County Jail	Leesburg	Daily
53	Mecklenburg Correctional Center	Boydton	Daily
116	Middle Peninsula Regional Jail	Saluda	Daily
141	Newport News City Jail	Newport News	Daily
141	Norfolk City Jail	Norfolk	Daily
194	Northampton County Jail	Eastville	Daily
115	Northern Neck Regional Jail	Warsaw	Daily
190	Northwestern Regional ADC	Winchester	Daily
19	Nottoway Correctional Center	Burkeville	Daily
79	Pamunkey Regional Jail	Hanover	Daily
67	Petersburg City Jail	Petersburg	Daily
0	Piedmont Regional Jail	Farmville	Daily
140	Portsmouth City Jail	Portsmouth	Daily
48	Powhatan Correctional Center	State Farm	Daily
156	Prince William/Manassas Regional Jail	Manassas	Daily
126	Rappahannock Regional Jail	Stafford	Daily
296	Red Onion State Prison	Pound	Daily
67	Richmond City Jail	Richmond	Daily
73	Riverside Regional Jail	Hopewell	Daily
122	Rockingham/Harrisonburg Regional Jail	Harrisonburg	Daily
155	St. Brides Correctional Center	Chesapeake	Daily
77	Sussex County Jail	Sussex	Daily
155	Virginia Beach City Jail	Virginia Beach	Daily
46	Virginia Correctional Center for Woman	Goochland	Daily
121	Western Tidewater Regional Jail	Suffolk	Daily
29	Appomattox County Jail	Appomattox	Daily to Weekly
52	Chesterfield County Jail	Chesterfield	Daily to Weekly
111	Culpeper County Jail	Culpepper	Daily to Weekly
135	Fauquier County Jail	Warrenton	Daily to Weekly
100	Roanoke City Jail	Roanoke	Daily to Weekly
158	Shenandoah County Jail	Woodstock	Daily to Weekly
119	Virginia Peninsula Regional Jail	Williamsburg	Daily to Weekly
89	Danville City Jail	Danville	Weekly
108	Franklin County Jail	Rocky Mount	Weekly
120	Gloucester County Jail	Gloucester	Weekly

Mileage From Farmville, VA	Jails	City	Frequency
119	Henry County Jail	Martinsville	Weekly
155	Indian Creek Correctional Center	Chesapeake	Weekly
30	Lunenburg Correctional Center	Victoria	Weekly
100	Middle River Regional Jail	Staunton	Weekly
153	New River Valley Regional Jail	Dublin	Weekly
103	Peumansend Creek Regional Jail	Bowling Green	Weekly
111	Roanoke County Jail	Salem	Weekly
94	Southampton Correctional Center	Capron	Weekly
204	Marion Treatment Center	Marion	Weekly to Periodic
310	USP Lee - Virginia	Jonesville	Weekly to Periodic
225	Accomack County Jail	Accomac	Periodic
59	Albemarle/Charlottesville Regional Jail	Charlottesville	Periodic
135	Alleghany County Regional Jail	Covington	Periodic
60	Amherst County Jail	Amherst	Periodic
72	B.R.R.J. - Bedford County ADC	Bedford	Periodic
47	B.R.R.J. - Campbell County ADC	Rustburg	Periodic
50	B.R.R.J. - Lynchburg City Jail	Lynchburg	Periodic
58	B.R.R.J.A. - Halifax County ADC	Halifax	Periodic
53	Baskerville Correctional Center	Baskerville	Periodic
103	Botetourt Correctional Center	Troutville	Periodic
108	Botetourt County Jail	Fincastle	Periodic
247	Bristol City Jail	Bristol	Periodic
60	Brunswick County Jail	Lawrenceville	Periodic
59	Brunswick Work Center for Women	Lawrenceville	Periodic
90	Caroline Correctional Unit #2	Hanover	Periodic
52	Central Virginia Correctional Unit #13	Chesterfield	Periodic
26	Charlotte County Jail	Charlotte Court House	Periodic
87	Cold Springs Correctional Unit #10	Greenville	Periodic
87	Cold Springs Work Center	Greenville	Periodic
88	Danville City Jail Farm	Danville	Periodic
992	Deerfield Correctional Center	Capron	Periodic
60	Dinwiddie County Jail	Dinwiddie	Periodic
65	Fluvanna Correctional Center for Women	Troy	Periodic
74	Greenville Work Center	Jarratt	Periodic
58	Halifax Correctional Unit #23	Halifax	Periodic
124	Haynesville Correctional Unit #17	Haynesville	Periodic
48	James River Work Center	State Farm	Periodic
265	Keen Mountain Correctional Center	Oakwood	Periodic
141	Lancaster County Jail	Lancaster	Periodic
123	Martinsville City Jail	Martinsville	Periodic
51	Mecklenburg County Jail	Boydton	Periodic
66	Medical College of Virginia	Richmond	Periodic

Mileage From Farmville, VA	Jails	City	Frequency
136	Montgomery County Jail	Christiansburg	Periodic
131	Newport News City Jail Farm	Newport News	Periodic
19	Nottoway Work Center	Burkeville	Periodic
132	Page County Jail	Luray	Periodic
150	Patrick County Jail	Stuart	Periodic
130	Patrick Henry Correctional Unit #28	Ridgeway	Periodic
92	Pittsylvania County Jail	Chatham	Periodic
152	Pulaski Correctional Center	Dublin	Periodic
123	Rappahannock County Jail	Washington	Periodic
93	Rockbridge Regional Jail	Lexington	Periodic
47	Rustburg Correctional Unit #9	Rustburg	Periodic
109	Southampton County Jail	Courtland	Periodic
94	Southampton Pre-Release and Work Center for Women	Capron	Periodic
94	Southampton Work Center for Men	Capron	Periodic
79	Southside Regional Jail	Emporia	Periodic
288	Southwest Virginia Regional Jail	Hayso	Periodic
236	Southwest Virginia Regional Jail Authority - Abingdon	Abingdon	Periodic
291	Southwest Virginia Regional Jail Authority - Duffield	Duffield	Periodic
219	Southwest Virginia Regional Jail Authority - Tazewell	Tazewell	Periodic
91	Sussex I State Prison	Waverly	Periodic
91	Sussex II State Prison	Waverly	Periodic
219	Tazewell Correctional Unit #31	Tazewell	Periodic
310	USP Lee - Camp - Virginia	Jonesville	Periodic
294	Wallens Ridge State Prison	Big Stine Gap	Periodic
139	Warren County Jail	Front Royal	Periodic
275	Wise Correctional Unit	Coeburn	Periodic

**V. Guard Services:**

- A. The **PROVIDER** agrees to provide stationary guard services on demand by the COTR and shall include, but not limited to, escorting and guarding detainees to medical or doctor's appointments, hearings, ICE interviews, and any other remote location requested by the COTR. Qualified detention officer personnel employed by the **PROVIDER** under its policies, procedures, and practices will perform such services. The **PROVIDER** agrees to augment such practices as may be requested by ICE to enhance specific requirements for security, detainee monitoring, visitation, and contraband control. Public contact is prohibited unless authorized in advance by the COTR.
- B. The **PROVIDER** shall be authorized two (2) officers for each such remote location, unless at the direction of the COTR or designated Agency official as additional officers are required.

- C. The itemized monthly invoice for such stationary guard services shall state the number of hours being billed, the duration of the billing (times and dates) and the names of the detainees that were guarded. Such services shall be denoted as a separate item on submitted invoices. ICE agrees to reimburse the **PROVIDER** for actual stationary guard services provided at a negotiated rate.

**VI. Medical Services:**

- A. The **PROVIDER** shall be responsible for the provision of health care services for ICE detainees at the facility.
- B. In the event of an emergency, the **PROVIDER** shall proceed immediately with necessary medical treatment. In such event, the **PROVIDER** shall notify ICE immediately regarding the nature of the transferred detainee's illness or injury and type of treatment provided.
- C. The **PROVIDER** shall ensure that all health care service providers utilized for ICE detainees hold current licenses, certifications, and/or registrations with the State and/or City where they are practicing. The **PROVIDER** shall retain a registered nurse to provide health care and sick call coverage unless expressly stated otherwise in this Agreement. In the absence of a health care professional, non-health care personnel may refer detainees to health care resources based upon protocols developed by the United States Public Health Service (USPHS) Division of Immigration Health Services (DIHS). Healthcare or health trained personnel may perform screenings.
- D. The **PROVIDER** shall ensure that onsite medical and health care coverage as defined below is available for all ICE detainees at the facility for twenty-four (24) hours per day, seven (7) days per week. The **PROVIDER** shall ensure that its employees solicit each detainee for health complaints and deliver complaints in writing to the medical and health care staff.
- E. The **PROVIDER** shall furnish onsite health care under this Agreement. The **PROVIDER** shall not charge any ICE detainee an additional fee or co-payment for medical services or treatment provided at the **PROVIDER'S** facility. The **PROVIDER** shall ensure that ICE detainees receive no lower level of onsite medical care and services than those it provides to local inmates. Onsite health care services shall perform initial medical screening (inclusive of the skin test/PPD) within the first twenty-four (24) hours of arrival to the facility, sick call coverage, provision of over-the-counter medications, treatment of minor injuries (e.g. lacerations, sprains, and contusions), treatment of special needs and mental health assessments. A full medical screening must be done within the first 14 days of detainee arrival. Detainees with chronic conditions shall receive prescribed treatment and follow-up care. Arrival screening shall include at a minimum TB symptom screening, planting of the Tuberculin; skin Test (PPD), and recording the history of past and present illnesses (mental and physical).

- F. If the **PROVIDER** determines that an ICE detainee has a medical condition which renders that person unacceptable for detention under this Agreement, (for example, contagious disease, condition needing life support, uncontrollable violence), the **PROVIDER** shall notify ICE. Upon such notification, the **PROVIDER** shall allow ICE reasonable time to make the proper arrangements for further disposition of that detainee.
- G. The DIHS acts as the agent and final health authority for ICE on all off-site detainee medical and health related matters. The relationship of the DIHS to the detainee equals that of physician to patient. The **PROVIDER** shall release any and all medical information for ICE detainees to the DIHS representatives upon request, except where prohibited by federal or state law or regulation. The **PROVIDER** shall solicit DIHS approval before proceeding with non-emergency, off-site medical care (e.g. off site lab testing, eyeglasses, cosmetic dental prosthetics, and dental care for cosmetic purposes). The **PROVIDER** shall submit supporting documentation for non-routine, off-site medical/health services to DIHS. For medical care provided outside the facility, the DIHS may determine that an alternative medical provider or institution is more cost-effective or more aptly meets the needs of ICE and the detainee. ICE may refuse to reimburse the **PROVIDER** for non-emergency medical costs incurred that were not pre-approved by the DIHS. The **PROVIDER** shall send requests for pre-approval for non-emergency off-site care to:

United States Public Health Service  
Division of Immigration Health Services  
1220 L Street, NW, PMB 468  
Washington, DC 20005-4018  
Phone: (703) 541-2155  
Fax: (202) 318-0080

- H. The **PROVIDER** is to notify all medical providers approved to furnish off-site health care of detainees to submit their bills in accordance with instructions provided to:

BCE Emergis  
DIHS Claims  
P.O. Box 10250  
Gaithersburg, MD 20898-0250  
Phone: (888) 383-3922  
Fax: (888) 383-3957

- I. The **PROVIDER** shall furnish twenty-four (24) hour emergency medical care and emergency evacuation procedures. In an emergency, the **PROVIDER** shall obtain the medical treatment required to preserve the detainee's health. The **PROVIDER** shall have access to an off site emergency medical provider at all times. The Health Authority of the **PROVIDER** shall notify the DIHS Managed Care Coordinators, ICE Health Services, 1220 L Street, NW, PMB 468,

Washington, DC, 20005-4018, phone (888) 718-8947, fax (202) 318-0080, as soon as possible, and in no case more than seventy-two (72) hours after detainee receipt of such care. The Health Authority will obtain pre-authorization from the DIHS Managed Care Coordinator for service(s) beyond the initial emergency situation.

- J. The **PROVIDER** shall allow DIHS Managed Care Coordinators reasonable access to its facility for the purpose of liaison activities with the Health Authority and associated Service Provider departments.
- K. The **PROVIDER** and all medical providers approved to furnish off-site health care of detainees shall submit their bills to:

BCE Emergis  
DIHS Claims  
P.O. Box 10250  
Gaithersburg, MD 20898-0250  
Phone: (888) 383-3922  
Fax: (888) 383-3957

- L. The ICE and PHS may refuse to reimburse the **PROVIDER** for non-emergency medical costs incurred that were not pre-approved by the DIHS.
- M. The **PROVIDER** agrees to accept and provide for the secure custody, care, and safekeeping of detainees in accordance with the State, and local laws, standards, policies, procedures, or court orders applicable to the operations of the facility.
- N. The **PROVIDER** agrees to provide ICE detainees with the same level of medical care and services as provided to non-ICE detainees as part of the per diem rate. This rate includes:
- On-site sick call (when provided by on-site staff);
  - Medication (over the counter/non-legend and routine drugs and medical supplies);
  - Escort/security services for transport to/from emergency or non-emergency health care services as either an in-patient or out-patient.

## VII. ICE Physical Plant Requirements

### A. ICE Office Space

The **PROVIDER** shall refer to ICE Design Standards for specific office and workstation sizes and specific furnishing requirements for a 1000 bed facility. The Standards include but are not limited to the following:

1. A total of 34 offices and 46 workstations as outlined below:



- a. 1 Office - Assistant Field Office Director GS-1801-14
- b. 1 Office - Officer in Charge GS-1801-14
- c. 1 Office - Assistant Officer in Charge GS-1801-14
- d. 1 Office - Intelligence Officer GS-1801-14
- e. 1 Office - Chief Immigration Enforcement Agent GS-1801-13
- f. 4 Offices - Supervisory Detention & Deportation Officers GS-1801-13
- g. 16 Offices - Deportation Officers GS-1801-12
- h. 2 Offices - Supervisory Immigration Enforcement Agents GS-1801-11
- i. 26 Workstations - Immigration Enforcement Agents GS-1801-5/7/9
- j. 2 Offices - Supervisory Deportation Assistant, GS-1802-09
- k. 16 Workstations - Detention & Removal Assistants GS-1802-07
- l. 1 Office - Mission Support Specialist GS-0301-9/11/12
- m. 2 Offices - Contracting Officer's Technical Representative, GS-1102-09
- n. 1 Office - Intelligence Research Specialist GS-1801-09
- o. 1 Office - Training Officer GS-1801-11
- p. 2 Workstations - Mission Support Assistant GS-0301-5/7
- q. 1 Workstation - Receptionist
- r. 1 Workstation - OIC Secretary
- s. 1 Workstation - Records Tech
- t. 1 Workstation - Mail/File Clerk
- u. File rooms (see Standards for size and quantity)
- v. Conference rooms adjacent to or within ICE area (see Standards for size and quantity)
- w. Employee break rooms (see Standards for size and quantity)
- x. IT computer support rooms must be provided through out ICE space per the specifications. Including specialized requirements for climate control of IT equipment rooms for PHS, EOIR and ICE office area.
- y. Actual location, layout, configuration, and size of rooms will be determined during the final design phase.

B. OPLA Space

The **PROVIDER** shall refer to ICE Design Standards for specific office and workstation sizes and specific furnishing requirements for a 1000 bed facility. All furniture and case goods shall be furnished by the service provider in accordance with ICE Design Standards. The Standards include but are not limited to the following:

- 1. 1 Office - Deputy Chief Counsel (see Standards for size)
- 2. 12 Offices - Assistant Chief Counsel (see Standards for size)
- 3. 4 Workstations - Legal Technicians (see Standards for size)
- 4. 1 Workstation - Mail/File Clerk

5. Office support space must be provided per the ICE/OPLA Design Standards.
6. OPLA Space

#### C. EOIR Space

The **PROVIDER** shall refer to ICE/EOIR Design Standards for specific office and workstation sizes and specific furnishing requirements for a 1000 bed facility. All furniture and case goods shall be furnished by the service provider in accordance with ICE Design Standards. The Standards include but are not limited to the following:

1. 5 - Courtrooms and accompanying office and support space as per the EOIR Design Standards for a 1000 bed facility. The office space is per the EOIR Design Standards. Each courtroom should have the capability to hold live court as well as hold video tele-conferencing court. All furniture and case goods shall be furnished by the service provider in accordance with ICE Design Guide and specifications.
2. 15 - Hard walled offices (see Standards for size)
3. 15 - Workstations (see Standards for size)
4. Visitation space must be provided to meet the ACA and NDS standards.
5. Separate entrance for judges required with complete security system and access to parking lot. Must be ADA compliant.
6. EOIR Support Space must be provided per the EOIR Design Standards.

#### D. Health Services

Healthcare services will be provided by the **PROVIDER**.

#### E. Facility Requirements for Infectious Disease Screening

The Service Provider will ensure that there is adequate space and equipment to provide medical intake screening including a TB screening chest x-ray within the intake processing area. In order to prevent the spread of airborne infectious disease or cross contamination of zones within the facility, the HVAC system in the Intake Screening Area will be constructed to exhaust to the exterior and prevent air exchange between the intake screening area and any other area within the facility.

#### F. Infectious Disease Screening

In order to prevent the transmission of Tuberculosis (TB) to the resident population of a detention facility, the Service Provider will perform TB screening as part of the a routine infectious disease screening within 12 hours of detainee admission and obtain documented clearance of transmissible disease before the detainee is assigned to a housing unit or is transferred from the intake processing area. A screening chest x-ray will be performed by a trained and qualified health care provider and interpreted by a credentialed radiologist. Detainees will remain isolated from the rest of the facility population (remain in the intake screening

area) until the chest x-ray report is obtained and the interpretation verifies that the detainee is free of infectious TB (turnaround time for chest x-ray interpretation should be 4 hours or less). Detainees who are found to be infected or where there is a possibility that they are infected will be assigned to a respiratory isolation unit until treatment or further testing is done and the detainee is no longer infectious.

#### G. Teleradiology Service Provider

1. The Detention Service Provider shall use the services of the ICE Teleradiology Service Provider (ITSP). The cost of the equipment; maintenance of the equipment; training of staff; arrangements for interpretation of the x-rays by credentialed radiologists; and transmission of data to and from the Detention Facility are provided by the ITSP and charged directly to ICE. The Service Provider shall coordinate with the ITSP to ensure adequate space is provided for the equipment, connectivity and electrical services are installed, immediate 24/7 access to equipment for service and maintenance by ITSP technicians is granted, a teleradiology coordinator is appointed and available for training by the ITSP, and medical staff is available to perform the screening exams and receive reports. The teleradiology coordinator may be a nurse or nurse practitioner and collateral duty of the appointed staff (it is not necessary to appoint a full time coordinator if the volume of work does not support a full time employee).
2. Teleradiology equipment requires high voltage power to accommodate x-ray equipment, specifications will be provided by ICE.

#### H. Processing Area

1. Expansion required in this area includes the need to accommodate processing varying numbers of detainees for intake and out-processing, i.e., large buses transport of up to 100 detainees.
2. Processing area must be designed to process male and/or female detainees as required in high frequency rates and varying numbers, i.e., a busload up to 100 detainees at one time.

#### I. Furniture

All furniture and case goods shall be furnished by the service provider in accordance with ICE Design Guide and specifications, which include ICE support space and all operational components which include EOIR, OPLA and DIHS space as required in accordance with the ICE Design Standards.

#### J. ICE IT Equipment

ICE will provide and install IT equipment in office spaces for ICE personnel only, to include computer workstations and screens, printers and fax machines. All

infrastructure, cabling, and interfacing equipment shall be provided by the Service Provider at time of construction.

**NOTE:** ICE IT system must be a complete, independent and physically separate system from the Service Provider's IT system. The system shall serve all operational components: ICE, OPLA, and DIHS. EOIR shall have a separate system within EOIR IT space as per the EOIR Design Standards.

#### K. Communication Equipment

The service provider shall purchase, install and maintain a complete and operating communication system, which includes but is not limited to: cabling, fiber optics, patch panels, landing blocks, circuits, PBX and voice mail, phone sets and other supporting infrastructure and supporting system in compliance with ICE specifications. Separate billing to ICE must be established on all reoccurring service fees for communications and IT. Systems shall be installed specifically for ICE use.

**NOTE:** ICE communication system must be a complete, independent and physically separate system from the Service Provider communication system, and billed separately. The system shall serve all operational components: ICE, OPLA, and DIHS. EOIR shall have a separate system within EOIR IT space as per the EOIR Design Standards.

Service Provider see attached SOW for phone system details.

#### VIII. Detainee Work Program:

1. Detainee labor shall be used in accordance with the detainee work plan developed by the **PROVIDER**, and will adhere to the ICE National Detention Standard on Detainee Voluntary Work Program. The detainee work plan must be voluntary, and may include work or program assignments for industrial, maintenance, custodial, service, or other jobs. The detainee work program shall not conflict with any other requirements of the contract and must comply with all applicable laws and regulations.
2. Detainees shall not be used to perform the responsibilities or duties of an employee of the **PROVIDER**. Detainees shall not be used to perform work in areas where sensitive documents are maintained (designated ICE workspace). Custodial/janitorial services to be performed in designated ICE work space will be the responsibility of the **PROVIDER**.
3. Appropriate safety/protective clothing and equipment shall be provided to detainee workers as appropriate. Detainees shall not be assigned work that is considered hazardous or dangerous. This includes, but is not limited to, areas or

assignments requiring great heights, extreme temperatures, use of toxic substances, and unusual physical demands.

4. The **PROVIDER** shall supply sufficient Detention Officers to monitor and control detainee work details. Unless approved by the COTR, these work details must be within the security perimeter.
5. It will be the sole responsibility of ICE to determine whether a detainee will be allowed to perform on voluntary work details and at what classification level. All detainees shall be searched when they are returned from work details.

**IX. Law Library:**

The **PROVIDER** shall provide secure space within the secure perimeter, either a dedicated room or a multipurpose room for books and materials to provide a reading area "Law Library" - in accordance with the ICE National Detention Standards on the Access to Legal Materials.

**X. Training:**

Employees shall not perform duties under this agreement until they have successfully completed all initial training and the COTR receives written certification from the **PROVIDER**.

**A. General Training Requirements**

1. All employees must have the training described in the ACA Standards and in this section. Any remuneration (pay) due **PROVIDER** employees in accordance with Department of Labor regulations for any training time is the responsibility of the **PROVIDER**. The **PROVIDER** shall provide the required refresher courses or have an institution acceptable to the COTR to provide the training. Failure of any employee to complete training successfully is sufficient reason to disqualify him or her from duty.
2. All new Detention Officers will receive 54 hours of basic training, not to include firearms and 40 hours of on-the-job training prior to entering on duty. The **PROVIDER'S** Training Officer will be responsible for administering an on-the-job training program for new employees. A senior Detention Officer, at all times during this latter 40-hour period, must accompany the Detention Officers. The **PROVIDER'S** Training Officer shall send a copy of the documentation to the COTR upon successful completion of the employee's on-the-job training.
3. In addition, after completion of the first 94 hours of training, the **PROVIDER** has 60 days to complete an additional 40 hours of training. During the remainder of the first year on duty, the officer will have an additional 40 hours of training for a total of 174 hours within the first year of employment. The training program must directly relate to the employee's assigned position and

afford application of necessary job skills. Training site shall be provided by the **PROVIDER** at no cost to the Government.

a. Basic Training Subjects:

1. Employees must complete the following list of basic training subjects. The course title is followed by the estimated hours of training for that subject.

a. In-service Orientation/Social Diversity	2 HRS
b. Counseling Techniques/Suicide Prevention	2 HRS
c. Conduct/Duties/Ethics and Courtroom Demeanor	2 HRS
d. Bomb Defense and Threats	1 HR
e. Telephone Communications/Radio Procedures	1 HR
f. Fire and other Emergency Procedures	2 HRS
g. Treatment and Supervision of Detainees	2 HRS
h. ICE Use of Force Policy	2 HRS
i. Security Methods/Key Control/Count	1 HR
j. Procedures/Observational Techniques	4 HRS
k. EEO/Sexual Harassment	2 HRS
l. Detainee Escort Techniques	1 HR
m. ICE Paperwork/Report Writing	2 HRS
n. Detainee Searches/Detainee Personal Property	4 HRS
o. Property/Contraband	2 HRS
p. Detainee Rules and Regulations	2 HRS
q. First Aid*	4 HRS
r. Cardiopulmonary resuscitation (CPR)*	4 HRS
s. Blood-borne Pathogens*	2 HRS
t. Self Defense	8 HRS
u. Use of Restraints	6 HRS
v. Firearm Training	**
w. Sexual Abuse/Assault Prevention & Intervention*	2 HRS
x. National Detention Standards	2 HRS

\* Critical Training Subjects

\*\* Firearm Training for Required Armed Detention Services in accordance with state licensing requirements. **PROVIDER** shall certify proficiency every quarter.

b. Refresher Training

1. Every year the **PROVIDER** shall conduct 40 hours of Refresher Training for all Detention Officers including Supervisory Detention Officers. Refresher training shall consist of these critical subjects listed above and a review of basic training subjects and others as approved by ICE.
2. The **PROVIDER** shall coordinate recertification in CPR and First Aid with the ICE training staff. This training shall be provided at no cost to the Government. Annually, upon completion, the **PROVIDER** shall provide documentation of refresher training to the COTR.
3. In addition to the refresher training requirements for all Detention Officers, supervisors must receive refresher training relating to supervisory duties.

c. On-the-Job Training

1. After completion of the minimum of 54 hours basic training, all Detention Officers will receive an additional 40 hours of on-the-job training at specific post positions. This training includes:
  - a. Authority of supervisors and organizational code of conduct.
  - b. General information and special orders.
  - c. Security systems operational procedures.
  - d. Facility self-protection plan or emergency operational procedures.
  - e. Disturbance Control Team training.

d. Training During Initial 60 Day Period

The **PROVIDER** shall provide an additional 40 hours of training for Detention Officers within 60 days after completion of first 94 hours of training. The **PROVIDER** shall provide the training format and subjects, for approval by the COTR and CO, prior to the commencement of training.

e. Basic First Aid and CPR Training

1. All members of the **PROVIDER'S** security staff shall be trained in basic first aid and CPR. They must be able to:
  - a. Respond to emergency situations within four minutes.
  - b. Perform cardiopulmonary resuscitation (CPR).
  - c. Recognize warning signs of impending medical emergencies.
  - d. Know how to obtain medical assistance.
  - e. Recognize signs and symptoms of mental illness.

- f. Able to administer medication;
- g. Know the universal precautions for protection against blood-borne diseases.

**B. Supervisory Training**

1. All new Supervisory Detention Officers assigned to perform work under this agreement must successfully complete a minimum of 40 hours of formal supervisory training provided by the **PROVIDER** prior to assuming duties. This training is in addition to mandatory training requirements for Detention Officers. Supervisory training shall include the following management areas:

a. Techniques for issuing written and verbal orders	2 HRS
b. Uniform clothing and grooming standards	1 HR
c. Security Post Inspection procedures	2 HRS
d. Employee motivation	1 HR
e. Scheduling and overtime controls	2 HRS
f. Managerial public relations	4 HRS
g. Supervision of detainees	4 HRS
h. Other company policies	4 HRS

Additional classes are at the discretion of the **PROVIDER** with the approval of the COTR.

The **PROVIDER** shall submit documentation to the COTR, to confirm that each supervisor has received basic training as specified in the basic training curriculum.

**C. Proficiency Testing**

The **PROVIDER** shall give each Detention Officer a written examination consisting of at least 25 questions after each classroom-training course is completed. The **PROVIDER** may give practical exercises when appropriate. The COTR shall approve the questions before the **PROVIDER** can administer the examination. To pass any examination, each officer must achieve a score of 80% or better. The **PROVIDER** must provide the COTR with the eligible Detention Officer's completed exam before the Detention Officer may be assigned to duties under the agreement. Should an employee fail the written test on the initial attempt, he or she shall be given additional training by the **PROVIDER** and be given one additional opportunity to retake the test. If the employee fails to complete and pass the test the second time, the **PROVIDER** shall remove the employee from duties on this agreement.

**D. Certified Instructors**



Certified instructors shall conduct all instruction and testing. A state or nationally recognized institution shall certify instructors unless otherwise approved in writing by the COTR. Certifications of instructors may be established by documentation of past experience in teaching positions or by successful completion of a course of training for qualifying personnel as instructors. The COTR must approve the instructor prior to the training course.

E. Training Documentation

1. The **PROVIDER** shall submit a training forecast and lesson plans to the COTR or ICE designee, on a monthly basis, for the following 60-day period. The training forecast shall provide date, time, and location of scheduled training and afford the COTR observation/evaluation opportunity.
2. The **PROVIDER** shall certify and submit the training hours, type of training, date and location of training, and name of the instructor monthly for each employee to the COTR or ICE designee.

XI. Notification and Public Disclosures:

There shall be no public disclosures regarding this agreement made by the **PROVIDER** (or any subcontractors) without review and approval of such disclosure by ICE Public Affairs and express permission granted by the ICE Contracting Officer. The Government considers such information privileged or confidential until award of the agreement.

XII. Establish and Maintain Program for Prevention of Sexual Abuse/Assault:

The **PROVIDER** shall develop and implement a comprehensive sexual abuse/assault prevention and intervention program. This program shall include training that is given separately to both staff and detainees, in accordance with the Prison Rape Elimination Act (PREA).

XIII. Business Permits and Licenses:

The **PROVIDER** must obtain all required permits and licenses by the date of agreement award. The **PROVIDER** must (depending on the state's requirements) be licensed as a qualified security service company in accordance with the requirements of the district, municipality, county, and state in which ICE work site(s) is/are located. Throughout the term of this agreement, the **PROVIDER** shall maintain current permits/business licenses and make copies available for Government Inspection. The **PROVIDER** shall comply with all applicable federal, state, and local laws and all applicable Occupational Safety and Health Administration (OSHA) standards.

#### **XIV. Firearms / Body Armor:**

##### **A. Firearms Requirements**

1. The **PROVIDER** shall provide new firearms and maintain sufficient licensed firearms and ammunition to equip each armed Detention Officer and armed supervisor(s) with a licensed weapon while on duty. Firearms may be re-issued to new replacement employees throughout the life of the agreement as long as the firearm is in serviceable condition.
2. Personal firearms shall not be used. A licensed gunsmith, in writing, shall certify all firearms safe and accurate.
3. Firearms shall be standard police service-type, semi-automatic capable of firing hollow-point ammunition that meets the recommendations of the firearms manufacturer. Ammunition will be factory load only – no reloads. Ammunition will be replaced every year.
4. The **PROVIDER** shall provide sufficient ammunition for each armed Detention Officer, including uniformed contract supervisor(s); they shall be issued three full magazines.
5. The **PROVIDER** shall account for all firearms and ammunition daily.
6. If any weapons or ammunition are missing from the inventory, the COTR shall be notified immediately.
7. All firearms shall be licensed by the State.
8. Firearms will be inspected. This shall be documented by the Warden/Facility Director.
9. Loading, unloading, and cleaning of the firearms shall only take place in designated areas.
10. The firearms shall be cleaned and oiled as appropriate to ensure optimum operating conditions.
11. Firearms shall be carried with the safety on, if applicable, with a round in the chamber.
12. The **PROVIDER** shall maintain appropriate and ample supplies of firearms' upkeep and maintenance equipment (cleaning solvents, lubricating oil, rods, brushes, patches, and other normal maintenance tools).
13. The **PROVIDER** shall provide a complete listing of licensed firearms by serial numbers and by each safe location to the COTR prior to beginning performance under this agreement.
14. These lists shall be kept current through the terms of the agreement and posted within each firearms safe.
15. The **PROVIDER** shall obtain and maintain on file appropriate State and municipality permits and weapons permits for each officer.

16. A copy of this permit shall be provided to the COTR at least three working days prior to the anticipated assignment date of any individual.
17. The **PROVIDER** shall ensure that his/her employees have all permits and licenses in their possession at all times while in performance of this agreement.
18. The **PROVIDER** shall provide safes/vaults for storage of firearms and ammunition, for each location where firearms are issued or exchanged, which meet agency requirements and are approved for the storage of firearms and ammunition.
19. The COTR is responsible for approving the proposed safes/vaults prior to usage. **PROVIDER** supervisors and guards shall make accurate receipt and return entries on a Firearms and Equipment Control Register.
20. Except when issuing or returning ammunition or firearms, each safe/vault shall remain locked at all times.
21. The **PROVIDER** shall be responsible for having the combination of each safe/vault changed at least once every six months, or more often if circumstances warrant.
22. The **PROVIDER** certifies firearms training to the COTR.
23. The **PROVIDER** shall certify proficiency every quarter.
24. The **PROVIDER** shall provide an ICE approved intermediate weapon(s).

#### B. Body Armor Requirements

1. The **PROVIDER** shall provide body armor to all armed Detention Officers and armed supervisor(s).
2. Body armor shall be worn while on armed duty.
3. The body armor shall meet all requirements as set forth in the ICE Firearms Policy.
4. The **PROVIDER** shall procure replacement body armor if the body armor becomes unserviceable, ill-fitting, worn/damaged, or at the expiration of service life.
5. All armed Detention Officers and armed supervisors need to be made aware of the health risks associated with the wearing of body armor in high heat/high humidity conditions and/or during strenuous exertion. When Detention Officers and supervisors are required to wear body armor, they shall be provided opportunities to rehydrate and remove the body armor as necessary.
6. The use of personally owned body armor is not authorized.

**XVI. FEDERAL GOVERNMENT QUALITY ASSURANCE**

- A. The Government's Quality Assurance Program (QASP) is based on the premise that the provider, and not the Government, is responsible for management and quality control actions to meet the terms of the agreement. The QASP procedures recognize that the provider is not a perfect manager and that unforeseen and uncontrollable problems do occur. Good management and use of an adequate Quality Control Plan will allow the facility to operate within acceptable quality levels.
- B. Each phase of the services rendered under this agreement is subject to inspection both during the Provider's operations and after completion of the tasks.
- C. When the Provider is advised of any unsatisfactory condition(s), the contractor shall submit a written report to the Contracting Officer addressing corrective/preventive actions taken. The QASP is not a substitute for quality control by the Provider.
- D. The COTR may check the Provider's performance and document any noncompliance, however, only the Contracting Officer may take formal action against for unsatisfactory performance.
- E. The Government may reduce the invoice or otherwise withhold payment for any individual item of nonconformance observed. The Government may apply various inspection and extrapolation techniques (i.e., 100 % surveillance, random sampling, planned sampling, unscheduled inspections, etc.) to determine the quality of services and the total payment due.
- F. **FAILURE TO PERFORM REQUIRED SERVICES.** The rights of the Government and remedies described in this section are in addition to all other rights and remedies set forth in this agreement. Any reductions in the invoice shall reflect the agreement's reduced value resulting from the failure to perform required services.

\*\*\*\*\*  
END OF DOCUMENT  
\*\*\*\*\*



## Town of Farmville – ICE Facility: DROISA-08-0021

May 9, 2008

### Quality Control Plan

#### PURPOSE

To develop and implement a Quality Control Plan which will ensure compliance with all required Town of Farmville—ICE Facility quality standards and the ICE standards to be monitored under the Government's Quality Assurance Surveillance Plan.

#### POLICY

It is the policy of the Town of Farmville—ICE Facility to ensure all applicable standards, policies and procedures are adhered to.

- A. The Town of Farmville—ICE Facility will adopt, adapt and/or establish procedures that will meet or exceed the objective represented by each of the 38 Detention Standards outlined in the QUASP Attachment 3—Performance Monitoring Tool.

#### PROCEDURES

The Town of Farmville—ICE Facility will establish policies and procedures that will govern the facility.

- A. These policies and procedures will meet or exceed the minimum standards required by the Department of Homeland Security and the Department of Immigration and Customs Enforcement.
- B. A designated employee(s) will be responsible for the compliance of such policies and procedures.
  1. The enforcement of these practices will be considered the Quality Control Plan.

#### Quality Control Plan

- A. All policies and procedures will be reviewed on an annual basis by the Quality Control Officer and other designated staff.
- B. The COO (Senior Member of Management) at the Town of Farmville—ICE Facility will meet quarterly with the Quality Control Officer to ensure that all policies and procedures are enforced.
  1. All policies and procedure plans will comply with the Town of Farmville—ICE Facility standards of confidentiality, accountability, review and revision.

- C. The Quality Control Officer will maintain a cooperative relationship with ICE and will share information with his/her ICE "counterpart" and coordinate planning to interact with him/her accordingly.
- D. The QCO will train and brief the staff in the implementation and enforcement of the policies and procedures.
- E. The QCO will tap into the expertise of all Department Heads during the review process.
  - 1. This inclusive process will ensure that all departments have input into the plan.
  - 2. It will also ensure the compliance of all standards and improve the quality of service to the detainee residents and the DHS—ICE.
- F. The QCO will update the policy and procedure plans, as often as is necessary, to keep them current.
  - 1. All revisions recommended by the QCO will be forwarded to the Town of Farmville—ICE Facility's COO (Senior Member of Management) for approval.

#### Staff Actions

The enforcement of the Quality Control Plan will allow staff members to improve the quality of the detainee's care and improve the chance of deflecting detainee unrest, if the staff:

- A. Discusses the set Quality Control Plan, as well as policies, procedures and programs, at all staff meetings and during on-going interaction during work hours.
- B. Always acts in a manner that treats detainees fairly and impartially.
- C. Consistently follows and enforces the established policies and procedures.

#### Confidentiality

Every Quality Control Plan will include a statement prohibiting unauthorized Plan disclosure. This applies equally to the development stages to the finished Quality Control Plan.

- A. The staff will not discuss any aspects of a Quality Control Plan anywhere within hearing distance of a detainee and visitor.

#### Plan Details

Detail plans for each of the 38 Detention Standards (outlined in the QUASP Attachment 3—Performance Monitoring Tool) will be complete once the contract is awarded and forwarded to ICE for review within two weeks of the contract being signed.



**Town of Farmville—ICE Facility: DROISA-08-0021**  
**May 9, 2008**

**Staffing Post Plan**

**PURPOSE**

To establish guidelines for staffing needs within the Town of Farmville—ICE Facility, by department, to ensure adequate coverage is provided to operate the Facility at maximum efficiency. To provide coverage for time off to allow staff job training, personal time off, and unexpected absenteeism.

**POLICY**

It is the policy of the Town of Farmville—ICE Facility to ensure that the facility is being managed and supported by a well trained staff at all times. The planned staffing levels will ensure all requirements for the safety and security of the detainees is met on a daily basis and will allow for training and planned as well as unplanned absenteeism.

**PROCEDURES**

The Town of Farmville-ICE Facility will utilize the following work schedule to operate the facility.

**Administration**

- A. Split Shifts are worked by the Receptionist and the Induction Assistant.
  1. For these positions, one employee works Sunday to Thursday, and the other employee works Tuesday to Saturday.
  2. The overlap during the middle of the week allows for training, personal time off, and administrative coverage in other areas of the facility if needed.
- B. Work Week
  1. The Administration's routine work week will be Monday to Friday for the Department Head, HR Training Supervisor, HR Administrative Assistant and Life Skills Coach.

- a. These individuals may switch a day during the week for a Saturday or Sunday, if work with the detainee is required during the weekend.
- b. The Department Head is always on call.
2. See the attached "Shift Staffing Report" for more details on the Administration's work week.

#### Security

- A. Split Shifts are worked by the Watch Commander, Security Supervisors, Officers and Stationary Guards.
- B. Work Week
  1. A routine Monday to Friday work week is the norm for the Department Head, but this individual is always on call.
  2. See the attached "Shift Staffing Report" for more details on the Security's work week.

#### Medical

- A. Split Shifts are worked by the Shift LPNs and the Shift Certified Nursing Assistants.
- B. Work Week
  1. A routine Monday to Friday work week is the norm for the Department Head, Doctor and LPN supervisor.
    - a. The Department Head and the Doctor are always on call.
  2. See the attached "Shift Staffing Report" for more details on the Medical's work week.

#### Support

- A. Maintenance Staff works a regular weekly schedule as well as Split Shifts.
  1. Maintenance Staff on the 'Day Shift' typically Monday to Friday but may switch days if weekend work provides a better opportunity for repairs.
  2. The Evening shift staff works a 'split week' to provide coverage during the weekend.
- B. A routine Monday to Friday work week is the norm for the Department Head, Maintenance Supervisor and Grounds Keepers.
  1. These individuals may work on weekends, if needed.
    - a. The Department Head is always on call.
- C. The Kitchen Staff works a split shift, as does the Kitchen Supervisor.
- D. Work Week
  1. The attached "Shift Staffing Report" will provide details on the Support Staff's work week.



Accounting and IT Support

- A. A routine Monday to Friday work week is the norm for the CFO and Accounting Staff and IT Staff, but these individuals may work weekends when needed.
  - a. The Accountants provide back up to each other and provide coverage while the each other is out of the office.
  - b. The IT staff provides back up for each other and provides coverage while the each other is out of the office.

Director of Facilities Management

- A. A routine Monday to Friday work week is the norm for the Director of Facilities Management, but this individual may work weekends, when needed.

Director of Communications

- A. A routine Monday to Friday work week is the norm for the Director of Communications, but this individual may work weekends, when needed.

# The Town of Farmville- ICE Facility

## Organization Structure

### Job Titles and Description of Duties

Department	Position	Duties
Administration	Chief Operations Officer	Ultimate responsibility for Compliance to ICE Guidelines, Operations and Financial Issues related to operating the facility
	Quality Control Officer	Chief compliance officer responsible for developing and monitoring quality control for all areas of facility
	Dept. Head - Administration	Responsible for daily administrative and operations duties and serves as immediate supervisor for Dept Heads
	Receptionist	Responsible for welcoming guest, residents and assist with other administrative task
	Induction Agent/Video Coordinator	Responsible for induction paperwork for detainees and coordination/operation of video conferencing when needed
	Records Clerk	Responsible for tracking all individual records for the detainees including funds they bring to site as well as time as a detainee
	Commissary Clerk	Responsible for commissary sales and inventory tracking of supplies for the commissary
	Life Skills Coach	Plan and supervise recreational activities for residents. Work with Local groups to provide life skill programs
	HR- Training Supervisor	Responsible for development and implementation of training programs as well as required certification
	HR- Admin Assistant	Responsible for daily guidance on HR issues and assist other administrative positions
Security	Dept. Head- Security	Responsible for oversight of security staff and stationary guards
	Shift Watch Commander	Supervise Supervisors and fill in for Supervisors as needed.
	Shift Supervisor	Supervise Officers and fill in for Officers as needed
	Shift Officers	Immediate supervision of detainees
	Stationary Guards	Immediate supervision of detainees during transportation or other offsite trips
Medical	Dept. Head	Responsible for all phases of medical support for facility
	Doctor	Provide medical treatment to residents
	LPN Supervisor	Provide supervision to Shift LPN and fill in for any nursing position if necessary
	Shift LPN	Provide leadership and support to Certified Nursing Assistants as they provide health care to residents
	Shift Certified Nursing Assistant	Provide medical treatment to residents as directed by Physician and LPNs
Support Services	Dept. Head - Support Services	Responsible for Food Services and maintenance of the facility and grounds
	Kitchen Manager	Plan menus, order food and supervise kitchen staff
	Kitchen Supervisor	Supervise kitchen staff in absence of Kitchen Manager
	Kitchen Staff	Prepare and serve meals to residents, 3 meals per day.
	Maintenance Supervisor	Supervise maintenance workers and ensure physical plant is operating at top efficiency
	Maintenance Workers	Repair items as needed
	Grounds Keeper	Maintain grounds and assist Maintenance as needed
Housekeeping	General cleaning of building's interior	
Accounting and IT	CFO	Responsible for all accounting duties and financial reporting needs of the government
	Accountant	Responsible for daily accounting duties related to AR, AP and monthly/annual financial reporting
Facilities Management	IT System and Desk Top support	Provide network and desk top support
	Director	Responsible for facilities maintenance, upgrades and expansion
Community Relations	Director	Responsible for all external communication and government relations
	Director	

The Town of Farmville- ICE Facility  
 Organization Structure  
 Staffing Post Plan

Salaries based on www.Salary.com for Farmville, Va.

See Detail work schedule in Volume I, Attachment VI - Staffing

Department	Position	Total Compliment	Work Days/wk	Split Shifts Yes	Weekends On Call Yes	Annual Salary	Hourly Rate if applicable	Labor Standards	Labor Std. Classification
Administration	Chief Operations Officer	1	5	Yes	Yes	150,000.00			
	Quality Control Officer	1	5	Yes	Yes	75,000.00			
Administration	Dept. Head - Administration	1	5		Yes	80,000.00			
	Receptionist	3	5			29,499.00	14.18	13.94	Receptionist
	Induction Agent/Video Coordinator	5	5	Yes		35,670.00	17.15	17.12	General Clerk III
	Records Clerk	2	5			35,670.00	17.15	17.12	General Clerk III
	Commissary Clerk	3	5			35,670.00	17.15	17.12	General Clerk III
	Life Skills Coach	2	5		Yes	45,391.00	21.82		
	HR- Training Supervisor	1	5		Yes	55,611.00	26.74		
	HR- Admin Assistant	1	5		Yes	48,621.00	23.38	18.46	
Security	Dept. Head- Security	1	5		Yes	75,000.00			
	Shift Watch Commander	6	5	Yes		45,000.00	21.63	15.66	Corrections Officer
	Shift Supervisor	12	5	Yes		37,000.00	17.79	15.66	Corrections Officer
	Shift Officers	60	5	Yes		32,000.00	15.38	12.79	Guard II
	Stationary Guards	30	5	Yes		32,000.00	15.38	12.79	Guard II
Medical	Dept. Head	1	5		Yes	75,000.00			
	Doctor	1	5	Yes		179,975.00			
	LPN Supervisor	1	5	Yes		39,086.00	18.79	17.37	LPN II
	Shift LPN	6	5	Yes		39,086.00	18.79	15.48	LPN II
	Shift Certified Nursing Assistant	16	5	Yes		26,014.00	12.51	10.61	Nursing Assistant III
Support Services	Dept. Head - Support Services	1	5		Yes	75,000.00			
	Kitchen Manager	1	5	Yes		48,193.00	23.17		
	Kitchen Supervisor	4	5	Yes		34,234.00			
	Kitchen Staff	12	5	Yes		21,164.00	10.18	9.72	Food Service Worker
	Maintenance Supervisor	1	5	Yes		54,705.50	26.30		
	Maintenance Workers	5	5	Yes		35,387.00	17.01	17.34	General Maintenance Worker
	Grounds Keeper	2	5	Yes		29,170.00	14.02	10.63	Laborer - Grounds Maintenance
	Housekeeping	8	5	Yes		21,166.00	10.18	10.06	Janitor
	Accounting and IT								
	CFO	1	5	Yes		90,000.00			
Accountant	2	5	Yes		53,913.00	25.92	16.33	Accounting Clerk III	
IT System and Desk Top support	2	5	Yes		66,837.00	32.13	27.62	Computer Analyst II	
Facilities Management	Director	1	PT			50,000.00			
	Community Relations								
Director	1	PT			25,000.00				
<b>TOTAL</b>		<b>195</b>							

# Town of Farmville - ICE Facility

Staffing Post Plan- per Shift

## ADMINISTRATION

Day Shift            8AM -4PM  
 Evening Shift      4PM-12AM  
 Night Shift         12AM-8AM

### DAY SHIFT

#### Team A

Position	Sunday	Monday	Tuesday	Wednesday	Thursday	Friday	Saturday
Receptionist	X		1	1	1	1	X
Receptionist	X	X		1	1	1	
Receptionist							1
Induction Agent	X		1	1	1		X
Induction Agent		1	1	1	1	X	X
Records Clerk	X		1	1	1		X
Records Clerk	X		1	1	1	1	X
Commissary Clerk	X		1	1	1	1	X
Commissary Clerk	X		1	1	1	1	X
Commissary Clerk	X		1	1	1	1	X
<b>Total Team A</b>	<b>1</b>	<b>8</b>	<b>9</b>	<b>9</b>	<b>9</b>	<b>8</b>	<b>1</b>

#### Team B

Position	Sunday	Monday	Tuesday	Wednesday	Thursday	Friday	Saturday
Receptionist	1	1	1	1	1	X	X
Induction Agent							
Induction Agent	X	X		1	1		1
Records Clerk			1	1	1	1	1
Commissary Clerk							
<b>Total Team A</b>	<b>1</b>	<b>1</b>	<b>2</b>	<b>2</b>	<b>2</b>	<b>1</b>	<b>1</b>
<b>Total Shift</b>	<b>2</b>	<b>9</b>	<b>11</b>	<b>11</b>	<b>11</b>	<b>9</b>	<b>2</b>

### EVENING SHIFT

#### Team A

Position	Sunday	Monday	Tuesday	Wednesday	Thursday	Friday	Saturday
Receptionist							
Induction Agent	1	1	1	1	1	X	X
Induction Agent							
Records Clerk							
Commissary Clerk							
<b>Total Team A</b>	<b>1</b>	<b>1</b>	<b>1</b>	<b>1</b>	<b>1</b>	<b>0</b>	<b>0</b>

**Team B**Position

	Sunday	Monday	Tuesday	Wednesday	Thursday	Friday	Saturday
Receptionist							
Induction Agent	X	X	1	1	1	1	1
Induction Agent							
Records Clerk							
Commissary Clerk							

Total Team A	0	0	1	1	1	1	1
--------------	---	---	---	---	---	---	---

Total Shift	1	1	2	2	2	1	1
-------------	---	---	---	---	---	---	---

**NIGHT SHIFT****Team A**Position

	Sunday	Monday	Tuesday	Wednesday	Thursday	Friday	Saturday
Receptionist							
Induction Agent							
Induction Agent							
Records Clerk							
Commissary Clerk							

Total Team A	0	0	0	0	0	0	0
--------------	---	---	---	---	---	---	---

**Team B**Position

	Sunday	Monday	Tuesday	Wednesday	Thursday	Friday	Saturday
Receptionist							
Induction Agent							
Induction Agent							
Records Clerk							
Commissary Clerk							

Total Team A	0	0	0	0	0	0	0
--------------	---	---	---	---	---	---	---

Total Shift	0	0	0	0	0	0	0
-------------	---	---	---	---	---	---	---

TOTAL STAFF	3	10	13	13	13	10	3
-------------	---	----	----	----	----	----	---

**Town of Farmville - ICE Facility**

Staffing Post Plan- per Shift

**SECURITY DEPARTMENT**

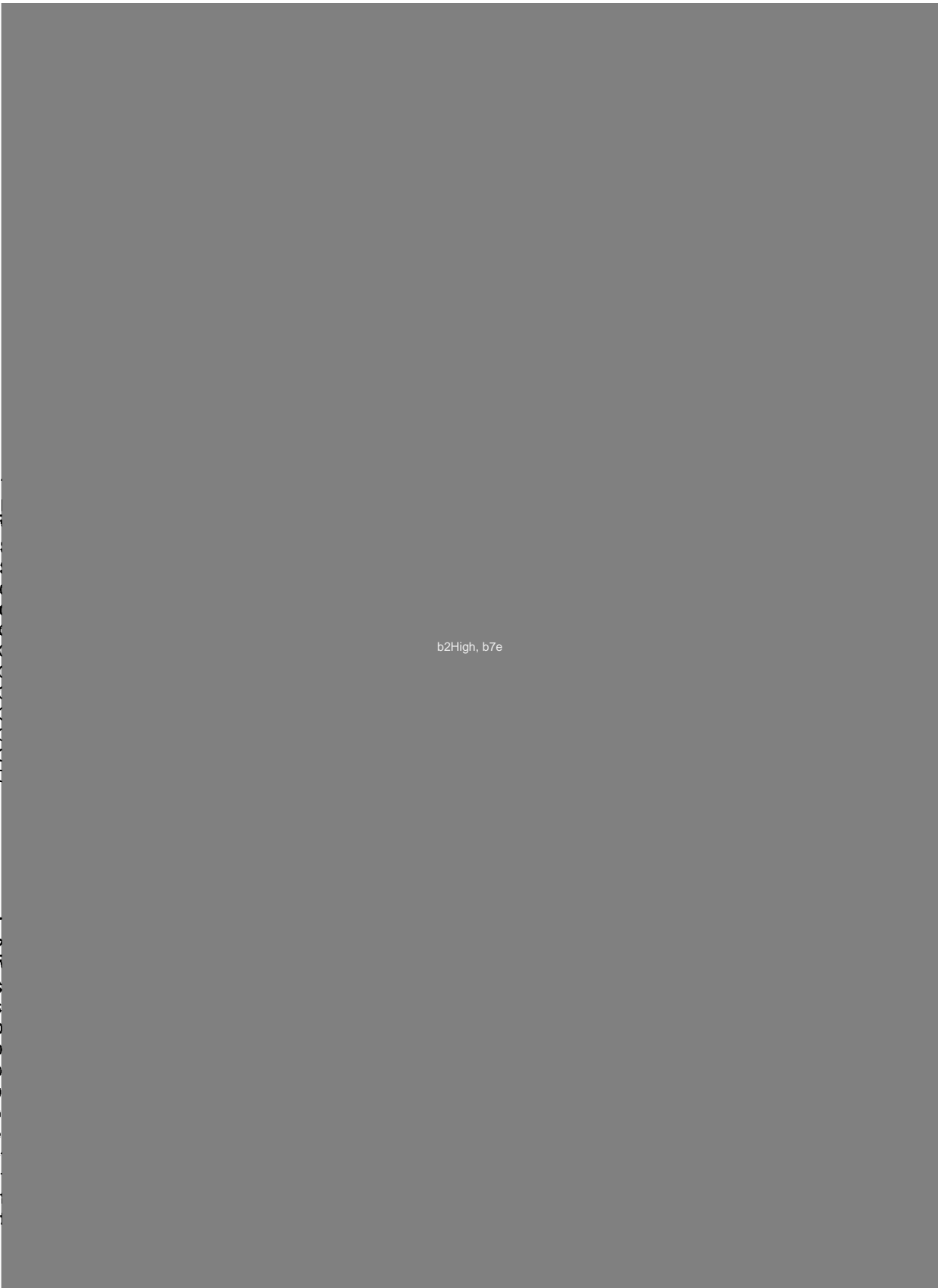

b2High, b7e

T  
S  
S  
O  
O  
O  
O  
O  
O  
O  
O  
O  
O

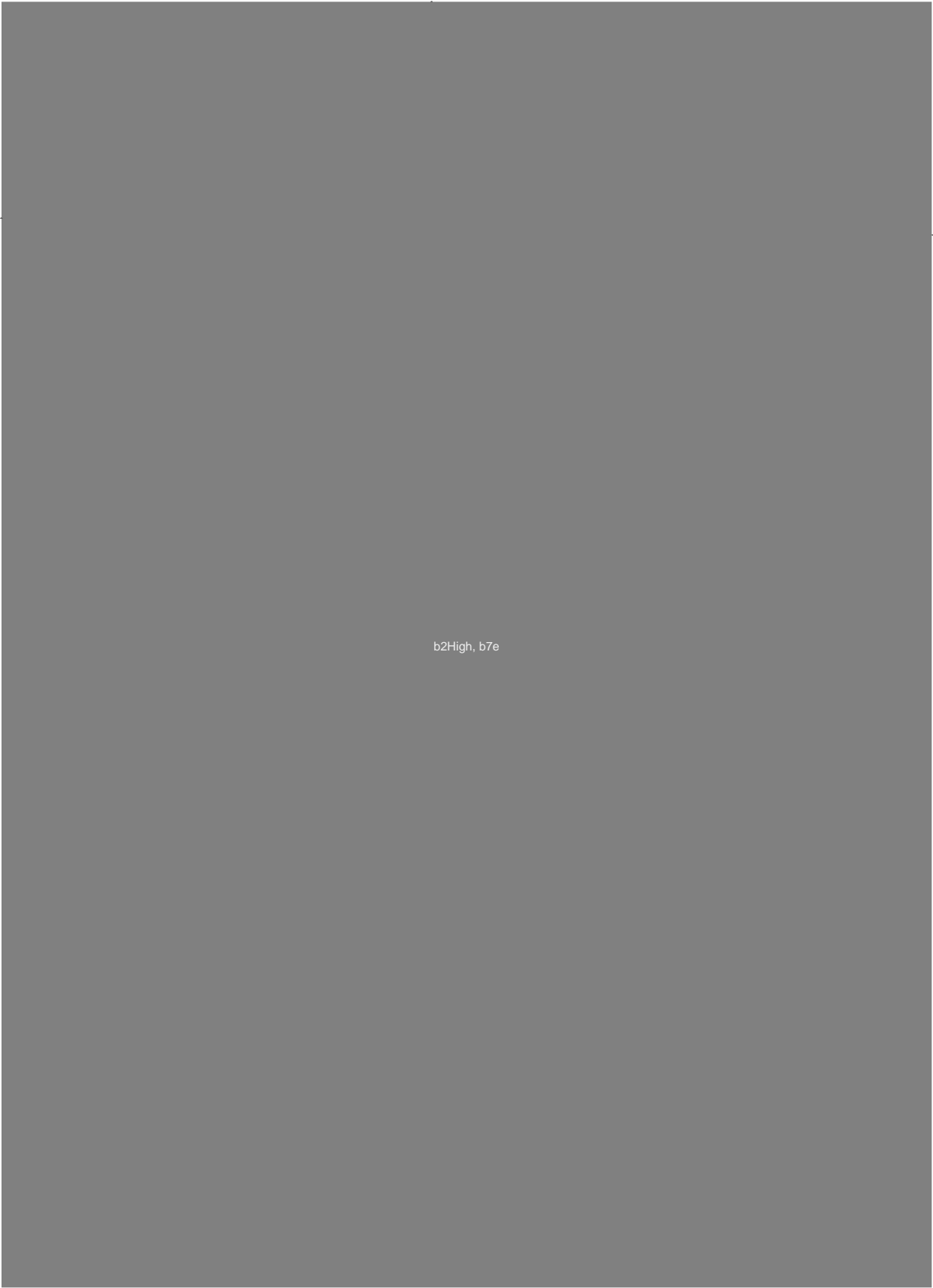

b2High, b7e



# Town of Farmville - ICE Facility

Staffing Post Plan- per Shift

## MEDICAL DEPARTMENT

Day Shift            8AM -4PM  
 Evening Shift       4PM-12AM  
 Night Shift          12AM-8AM

### DAY SHIFT

#### Team A

Position	Sunday	Monday	Tuesday	Wednesday	Thursday	Friday	Saturday
Doctor	X	1	1	1	1	1	X
LPN Supervisor	X	1	1	1	1	1	X
LPN	1	1	1	1	1	X	X
LPN							
Certified Nursing Assistant	1	1	1	1	1	X	X
Certified Nursing Assistant	1	1	1	1	1	X	X
Certified Nursing Assistant	1	1	1	1	1	X	X
Certified Nursing Assistant							
<b>Total Team A</b>	<b>4</b>	<b>6</b>	<b>6</b>	<b>6</b>	<b>6</b>	<b>2</b>	<b>0</b>

#### Team B

Position	Sunday	Monday	Tuesday	Wednesday	Thursday	Friday	Saturday
Doctor							
LPN Supervisor							
LPN	X	X	1	1	1	1	1
LPN							
Certified Nursing Assistant	X	X	1	1	1	1	1
Certified Nursing Assistant	X	X	1	1	1	1	1
Certified Nursing Assistant	X	X	1	1	1	1	1
Certified Nursing Assistant							
<b>Total Team B</b>	<b>0</b>	<b>0</b>	<b>4</b>	<b>4</b>	<b>4</b>	<b>4</b>	<b>4</b>
<b>Total Shift</b>	<b>4</b>	<b>6</b>	<b>10</b>	<b>10</b>	<b>10</b>	<b>6</b>	<b>4</b>

### EVENING SHIFT

#### Team A

Position	Sunday	Monday	Tuesday	Wednesday	Thursday	Friday	Saturday
Doctor							
LPN Supervisor							
LPN	1	1	1	1	1	X	X
LPN							
Certified Nursing Assistant	1	1	1	1	1	X	X
Certified Nursing Assistant	1	1	1	1	1	X	X
Certified Nursing Assistant	1	1	1	1	1	X	X
Certified Nursing Assistant							
<b>Total Team A</b>	<b>4</b>	<b>4</b>	<b>4</b>	<b>4</b>	<b>4</b>	<b>0</b>	<b>0</b>



**Team B**Position

Doctor

LPN Supervisor

LPN

LPN

Certified Nursing Assistant

Certified Nursing Assistant

Certified Nursing Assistant

Certified Nursing Assistant

Total Team B

Total Shift

	Sunday	Monday	Tuesday	Wednesday	Thursday	Friday	Saturday
Doctor							
LPN Supervisor							
LPN	X	X	1	1	1	1	1
LPN							
Certified Nursing Assistant	X	X	1	1	1	1	1
Certified Nursing Assistant	X	X	1	1	1	1	1
Certified Nursing Assistant	X	X	1	1	1	1	1
Certified Nursing Assistant							
Total Team B	0	0	4	4	4	4	4
Total Shift	4	4	8	8	8	4	4

**NIGHT SHIFT****Team A**Position

Doctor

LPN Supervisor

LPN

LPN

Certified Nursing Assistant

Certified Nursing Assistant

Certified Nursing Assistant

Total Team A

	Sunday	Monday	Tuesday	Wednesday	Thursday	Friday	Saturday
Doctor							
LPN Supervisor							
LPN	1	1	1	1	1	X	X
LPN							
Certified Nursing Assistant	1	1	1	1	1	X	X
Certified Nursing Assistant	1	1	1	1	1	X	X
Certified Nursing Assistant							
Total Team A	3	3	3	3	3	0	0

**Team B**Position

Doctor

LPN Supervisor

LPN

LPN

Certified Nursing Assistant

Certified Nursing Assistant

Certified Nursing Assistant

Total Team B

Total Shift

TOTAL STAFF

	Sunday	Monday	Tuesday	Wednesday	Thursday	Friday	Saturday
Doctor							
LPN Supervisor							
LPN	X	X	1	1	1	1	1
LPN							
Certified Nursing Assistant	X	X	1	1	1	1	1
Certified Nursing Assistant	X	X	1	1	1	1	1
Certified Nursing Assistant							
Total Team B	0	0	3	3	3	3	3
Total Shift	3	3	6	6	6	3	3
TOTAL STAFF	11	13	24	24	24	13	11

# Town of Farmville - ICE Facility

Staffing Post Plan- per Shift

## SUPPORT SERVICES-MAINTENANCE

Day Shift            8AM -4PM  
 Evening Shift       4PM-12AM  
 Night Shift          12AM-8AM

### DAY SHIFT

#### Team A

Position	Sunday	Monday	Tuesday	Wednesday	Thursday	Friday	Saturday
Maintenance Supervisor	X	1	1	1	1	1	X
Maintenance Worker	X	1	1	1	1	1	X
Maintenance Worker	X	1	1	1	1	1	X
Maintenance Worker -Admin	X	1	1	1	1	1	X
Grounds Keeper	X	1	1	1	1	1	X
Grounds Keeper	X	1	1	1	1	1	X
Housekeeping	X	1	1	1	1	1	X
Housekeeping		1	1	1	1	X	X
Housekeeping- Admin	X	1	1	1	1	1	X
<b>Total Team A</b>	<b>1</b>	<b>9</b>	<b>9</b>	<b>9</b>	<b>9</b>	<b>8</b>	<b>0</b>

#### Team B

Position	Sunday	Monday	Tuesday	Wednesday	Thursday	Friday	Saturday
Maintenance Supervisor							
Maintenance Worker							
Maintenance Worker							
Grounds Keeper							
Grounds Keeper							
Housekeeping							
Housekeeping	X	X	1	1	1	1	1
<b>Total Team B</b>	<b>0</b>	<b>0</b>	<b>1</b>	<b>1</b>	<b>1</b>	<b>1</b>	<b>1</b>
<b>Total Shift</b>	<b>1</b>	<b>9</b>	<b>10</b>	<b>10</b>	<b>10</b>	<b>9</b>	<b>1</b>

### EVENING SHIFT

#### Team A

Position	Sunday	Monday	Tuesday	Wednesday	Thursday	Friday	Saturday
Maintenance Supervisor							
Maintenance Worker							
Maintenance Worker		1	1	1	1	X	X
Grounds Keeper							
Grounds Keeper							
Housekeeping		1	1	1	1	X	X
Housekeeping							
Housekeeping- Admin	X	1	1	1	1	1	X
Housekeeping- Admin	X	1	1	1	1	1	X
<b>Total Team A</b>	<b>2</b>	<b>4</b>	<b>4</b>	<b>4</b>	<b>4</b>	<b>2</b>	<b>0</b>

**Team B**

<u>Position</u>	<u>Sunday</u>	<u>Monday</u>	<u>Tuesday</u>	<u>Wednesday</u>	<u>Thursday</u>	<u>Friday</u>	<u>Saturday</u>
Maintenance Supervisor							
Maintenance Worker							
Maintenance Worker	X	X	1	1	1	1	1
Grounds Keeper							
Grounds Keeper							
Housekeeping							
Housekeeping	X	X	1	1	1	1	1
<b>Total Team B</b>	<b>0</b>	<b>0</b>	<b>2</b>	<b>2</b>	<b>2</b>	<b>2</b>	<b>2</b>
<b>Total Shift</b>	<b>2</b>	<b>4</b>	<b>6</b>	<b>6</b>	<b>6</b>	<b>4</b>	<b>2</b>

**NIGHT SHIFT**

**Team A**

<u>Position</u>	<u>Sunday</u>	<u>Monday</u>	<u>Tuesday</u>	<u>Wednesday</u>	<u>Thursday</u>	<u>Friday</u>	<u>Saturday</u>
Maintenance Supervisor							
Maintenance Worker							
Maintenance Worker							
Grounds Keeper							
Grounds Keeper							
Housekeeping							
Housekeeping							
<b>Total Team A</b>	<b>0</b>	<b>0</b>	<b>0</b>	<b>0</b>	<b>0</b>	<b>0</b>	<b>0</b>

**Team B**

<u>Position</u>	<u>Sunday</u>	<u>Monday</u>	<u>Tuesday</u>	<u>Wednesday</u>	<u>Thursday</u>	<u>Friday</u>	<u>Saturday</u>
Maintenance Supervisor							
Maintenance Worker							
Maintenance Worker							
Grounds Keeper							
Grounds Keeper							
Housekeeping							
Housekeeping							
<b>Total Team B</b>	<b>0</b>	<b>0</b>	<b>0</b>	<b>0</b>	<b>0</b>	<b>0</b>	<b>0</b>
<b>Total Shift</b>	<b>0</b>	<b>0</b>	<b>0</b>	<b>0</b>	<b>0</b>	<b>0</b>	<b>0</b>
<b>TOTAL STAFF</b>	<b>3</b>	<b>13</b>	<b>16</b>	<b>16</b>	<b>16</b>	<b>13</b>	<b>3</b>

# Town of Farmville - ICE Facility

Staffing Post Plan- per Shift

## SUPPORT SERVICES-KITCHEN

**3:00 AM to 11:00 AM**

Team A Position	Sunday	Monday	Tuesday	Wednesday	Thursday	Friday	Saturday
Kitchen Manager							
Kitchen Manager							
Kitchen Staff Supervisor	1	1	1	1	1	X	X
Kitchen Staff	1	1	1	1	1	X	X
Kitchen Staff	1	1	1	1	1	X	X
Kitchen Staff							
<b>Total Team A</b>	<b>3</b>	<b>3</b>	<b>3</b>	<b>3</b>	<b>3</b>	<b>0</b>	<b>0</b>

**Team B**

Position	Sunday	Monday	Tuesday	Wednesday	Thursday	Friday	Saturday
Kitchen Manager							
Kitchen Manager							
Kitchen Staff Supervisor	X	X	1	1	1	1	1
Kitchen Staff	X	X	1	1	1	1	1
Kitchen Staff	X	X	1	1	1	1	1
Kitchen Staff							
<b>Total Team B</b>	<b>0</b>	<b>0</b>	<b>3</b>	<b>3</b>	<b>3</b>	<b>3</b>	<b>3</b>
<b>Total Shift</b>	<b>3</b>	<b>3</b>	<b>6</b>	<b>6</b>	<b>6</b>	<b>3</b>	<b>3</b>

**5:00 AM to 1:00 AM**

Team A Position	Sunday	Monday	Tuesday	Wednesday	Thursday	Friday	Saturday
Kitchen Manager							
Kitchen Manager							
Kitchen Staff Supervisor							
Kitchen Staff							
Kitchen Staff	1	1	1	1	1	X	X
Kitchen Staff	1	1	1	1	1	X	X
<b>Total Team A</b>	<b>2</b>	<b>2</b>	<b>2</b>	<b>2</b>	<b>2</b>	<b>0</b>	<b>0</b>

**Team B**

Position	Sunday	Monday	Tuesday	Wednesday	Thursday	Friday	Saturday
Kitchen Manager							
Kitchen Manager							
Kitchen Staff Supervisor							
Kitchen Staff	X	X	1	1	1	1	1
Kitchen Staff	X	X	1	1	1	1	1
Kitchen Staff							
<b>Total Team B</b>	<b>0</b>	<b>0</b>	<b>2</b>	<b>2</b>	<b>2</b>	<b>2</b>	<b>2</b>
<b>Total Shift</b>	<b>2</b>	<b>2</b>	<b>4</b>	<b>4</b>	<b>4</b>	<b>2</b>	<b>2</b>

**Team A**

7:00 AM to 3:00 AM

Position
 Kitchen Manager  
 Kitchen Manager  
 Kitchen Staff Supervisor  
 Kitchen Staff

	Sunday	Monday	Tuesday	Wednesday	Thursday	Friday	Saturday
Kitchen Manager	X	1	1	1	1	1	X
Kitchen Manager							
Kitchen Staff Supervisor							
Kitchen Staff							
<b>Total Team A</b>	0	1	1	1	1	1	0

**Team B**Position
 Kitchen Manager  
 Kitchen Manager  
 Kitchen Staff Supervisor  
 Kitchen Staff

	Sunday	Monday	Tuesday	Wednesday	Thursday	Friday	Saturday
Kitchen Manager							
Kitchen Manager							
Kitchen Staff Supervisor							
Kitchen Staff							
<b>Total Team B</b>	0	0	0	0	0	0	0
<b>Total Shift</b>	0	1	1	1	1	1	0

**Team A**

11:00 AM to 7:00 AM

Position
 Kitchen Manager  
 Kitchen Manager  
 Kitchen Staff Supervisor  
 Kitchen Staff  
 Kitchen Staff  
 Kitchen Staff

	Sunday	Monday	Tuesday	Wednesday	Thursday	Friday	Saturday
Kitchen Manager							
Kitchen Manager							
Kitchen Staff Supervisor	1	1	1	1	1	X	X
Kitchen Staff	1	1	1	1	1	X	X
Kitchen Staff	1	1	1	1	1	X	X
Kitchen Staff							
<b>Total Team A</b>	3	3	3	3	3	0	0

**Team B**Position
 Kitchen Manager  
 Kitchen Manager  
 Kitchen Staff Supervisor  
 Kitchen Staff  
 Kitchen Staff  
 Kitchen Staff

	Sunday	Monday	Tuesday	Wednesday	Thursday	Friday	Saturday
Kitchen Manager							
Kitchen Manager							
Kitchen Staff Supervisor	X	X	1	1	1	1	1
Kitchen Staff	X	X	1	1	1	1	1
Kitchen Staff	X	X	1	1	1	1	1
Kitchen Staff							
<b>Total Team B</b>	0	0	3	3	3	3	3
<b>Total Shift</b>	3	3	6	6	6	3	3
<b>TOTAL STAFF</b>	8	9	17	17	17	9	8

**ORDER FOR SUPPLIES OR SERVICES**

PAGE OF PAGES

1 3

**IMPORTANT: Mark all packages and papers with contract and/or order numbers.**

1. DATE OF ORDER 09/15/2008	2. CONTRACT NO. (If any) DROIGSA-08-0021	6. SHIP TO:	
3. ORDER NO. HSCEDM-08-F-IG064	4. REQUISITION/REFERENCE NO. FDG08FARM	a. NAME OF CONSIGNEE ICE Detention & Removal	
5. ISSUING OFFICE (Address correspondence to) ICE/Detention Mngt/Detention IGSA's Immigration and Customs Enforcement Office of Acquisition Management 425 I Street NW, Suite 2208 Washington DC 20536		b. STREET ADDRESS Immigration and Customs Enforcement 801 I Street, NW Suite 900	c. CITY Washington
7. TO:		d. STATE DC	e. ZIP CODE 20536

a. NAME OF CONTRACTOR FARMVILLE TOWN OF	8. TYPE OF ORDER <input type="checkbox"/> a. PURCHASE <input checked="" type="checkbox"/> b. DELIVERY	
b. COMPANY NAME	REFERENCE YOUR:  Please furnish the following on the terms and conditions specified on both sides of this order and on the attached sheet, if any, including delivery as indicated.	
c. STREET ADDRESS P O BOX 368	Except for billing instructions on the reverse, this delivery order is subject to instructions contained on this side only of this form and is issued subject to the terms and conditions of the above-numbered contract.	
d. CITY FARMVILLE	e. STATE VA	f. ZIP CODE 239010368

9. ACCOUNTING AND APPROPRIATION DATA See Schedule	10. REQUISITIONING OFFICE ICE Detention & Removal
11. BUSINESS CLASSIFICATION (Check appropriate box(es))	
<input type="checkbox"/> a. SMALL <input type="checkbox"/> b. OTHER THAN SMALL <input type="checkbox"/> c. DISADVANTAGED <input type="checkbox"/> g. SERVICE-DISABLED VETERAN-OWNED <input type="checkbox"/> d. WOMEN-OWNED <input type="checkbox"/> e. HUBZone <input type="checkbox"/> f. EMERGING SMALL BUSINESS	
12. F.O.B. POINT Destination	13. PLACE OF

a. INSPECTION Destination	b. ACCEPTANCE Destination	14. GOVERNMENT B/L NO.	15. DELIVER TO F.O.B. POINT ON OR BEFORE (Date) Multiple	16. DISCOUNT TERM Net 30
------------------------------	------------------------------	------------------------	--	-----------------------------

17. SCHEDULE (See reverse for Rejections)

ITEM NO. (a)	SUPPLIES OR SERVICES (b)	QUANTITY ORDERED (c)	UNIT (d)	UNIT PRICE (e)	AMOUNT (f)	QUANTITY ACCEPTED (g)
	DUNS Number: 040156218 Field of [redacted] Phillis Chapman 703-285-[redacted] b6 Craig Raine 703-285-[redacted] b6 Program POC: Elena Smyly 202-732-[redacted] b6 Continued ...					

18. SHIPPING POINT	19. GROSS SHIPPING WEIGHT	20. INVOICE NO.	17(h) TOTAL (Cont. pages)
21. MAIL INVOICE TO:			
a. NAME Department of Homeland Security			\$968,000.00
b. STREET ADDRESS (or P.O. Box) Citizenship & Immigration Services 2675 Prosperity Avenue Suite 300			
c. CITY Fairfax	d. STATE VA	e. ZIP CODE 22031-4906	\$968,000.00

22. UNITED STATES OF AMERICA BY (Signature) 	23. NAME (Typed) Gerald H. Neveleff TITLE: CONTRACTING/ORDERING OFFICER
--	---

AUTHORIZED FOR LOCAL REPRODUCTION  
PREVIOUS EDITION NOT USABLE

**ORDER FOR SUPPLIES OR SERVICES  
SCHEDULE - CONTINUATION**

PAGE OF PAGES

2 | 3

**IMPORTANT:** Mark all packages and papers with contract and/or order numbers.

DATE OF ORDER: 09/15/2008  
CONTRACT NO.: DROIGSA-08-0021

ORDER NO.: HSCEDM-08-F-IG064

ITEM NO. (A)	SUPPLIES/SERVICES (B)	QUANTITY ORDERED (C)	UNIT (D)	UNIT PRICE (E)	AMOUNT (F)	QUANTITY ACCEPTED (G)
	M.J. Bates 202-732-7410 <span style="background-color: black; color: black;">b6</span>					
	OAQ POC: Jerald <span style="background-color: black; color: black;">b6</span> Contracting Officer, 202-616- <span style="background-color: black; color: black;">b6</span> Arnold Casterline Contract Specialist, 202-514- <span style="background-color: black; color: black;">b6</span>  This is a Task Order for the Farmville transportation in support of the Washington field office. Accounting Info: <span style="background-color: black; color: black;">(b)(2)Low</span> LE 01-0000-05-00-00-00 GE-25-72-00-000000 Period of Performance: 09/15/2008 to 03/14/2009					
0001	Adult Alien Detainees Bed day rate (TBD)  Delivery: 30 Days After Award		EA	0.00	0.00	
0002	Transportation Guard hourly rate Product/Service Code: S206 Product/Service Description: GUARD SERVICES  Delivery: 09/15/2008	18615.9967	HR	24.28	451,996.40	
0003	Dispatcher for Transportation Product/Service Code: S206 Product/Service Description: GUARD SERVICES  Delivery: 09/15/2008	1040	HR	25.00	26,000.00	
0004	Director of Transportation Product/Service Code: S206 Product/Service Description: GUARD SERVICES  Delivery: 09/15/2008	1040	HR	40.12	41,724.80	
0005	Transportation Initiation Charges  Delivery: 09/15/2008	6	MO	2,112.00	12,672.00	
0006	Estimated mileage for six months of Continued ...	744627	EA	0.585	435,606.80	

TOTAL CARRIED FORWARD TO 1ST PAGE (ITEM 17(H))

**ORDER FOR SUPPLIES OR SERVICES  
SCHEDULE - CONTINUATION**

PAGE OF PAGES

3 3

**IMPORTANT:** Mark all packages and papers with contract and/or order numbers.

DATE OF ORDER  
09/15/2008

CONTRACT NO.

DROIGSA-08-0021

ORDER NO.

HSCEDM-08-F-IG064

ITEM NO. (A)	SUPPLIES/SERVICES (B)	QUANTITY ORDERED (C)	UNIT (D)	UNIT PRICE (E)	AMOUNT (F)	QUANTITY ACCEPTED (G)
	transportation. Approximately 744,627 miles @ .585 per mile is \$435,606.80  Delivery: 09/15/2008  The total amount of award: \$968,000.00. The obligation for this award is shown in box 17(i).					
TOTAL CARRIED FORWARD TO 1ST PAGE (ITEM 17(H))						





**Stevens, Richard P**

---

**From:** Neveleff, Jerald  
**Sent:** Thursday, October 30, 2008 12:00 PM  
**To:** Smyly, Elena L; Thompson, Arthur D (CTR)  
**Subject:** Here is the word version of the physical requirements for ICE

**Attachments:** Doc2.doc



Doc2.doc (43 KB)

## VII. ICE Physical Plant Requirements

### A. ICE Office Space

The **PROVIDER** shall refer to ICE Design Standards for specific office and workstation sizes and specific furnishing requirements for a 1000 bed facility. The Standards include but are not limited to the following:

1. A total of 34 offices and 46 workstations as outlined below:
  - a. [REDACTED] Assistant Field Office Director GS-1801-14
  - b. [REDACTED] Officer in Charge GS-1801-14
  - c. [REDACTED] Assistant Officer in Charge GS-1801-14
  - d. [REDACTED] Intelligence Officer GS-1801-14
  - e. [REDACTED] Chief Immigration Enforcement Agent GS-1801-13
  - f. [REDACTED] Supervisory Detention & Deportation Officers GS-1801-13
  - g. [REDACTED] Deportation Officers GS-1801-12
  - h. [REDACTED] Supervisory Immigration Enforcement Agents GS-1801-11
  - i. 2 [REDACTED] Immigration Enforcement Agents GS-1801-5/7/9
  - j. 2 [REDACTED] Supervisory Deportation Assistant, GS-1802-09
  - k. 1 [REDACTED] Detention & Removal Assistants GS-1802-07
  - l. 1 [REDACTED] Mission Support Specialist GS-0301-9/11/12
  - m. 2 [REDACTED] Contracting Officer's Technical Representative, GS-1102-09
  - n. 1 [REDACTED] Intelligence Research Specialist GS-1801-09
  - o. 1 [REDACTED] Training Officer GS-1801-11
  - p. 2 [REDACTED] Mission Support Assistant GS-0301-5/7
  - q. 1 [REDACTED] Receptionist
  - r. 1 [REDACTED] C Secretary
  - s. 1 [REDACTED] Records Tech
  - t. 1 Workstation - Mail/File Clerk
  - u. File rooms (see Standards for size and quantity)
  - v. Conference rooms adjacent to or within ICE area (see Standards for size and quantity)
  - w. Employee break rooms (see Standards for size and quantity)
  - x. IT computer support rooms must be provided through out ICE space per the specifications. Including specialized requirements for climate control of IT equipment rooms for PHS, EOIR and ICE office area.
  - y. Actual location, layout, configuration, and size of rooms will be determined during the final design phase.

### B. OPLA Space

The **PROVIDER** shall refer to ICE Design Standards for specific office and workstation sizes and specific furnishing requirements for a 1000 bed facility. All furniture and case goods shall be furnished by the service provider in accordance with ICE Design Standards. The Standards include but are not limited to the following:

1. 1 Office – Deputy Chief Counsel (see Standards for size)
2. 12 Offices – Assistant Chief Counsel (see Standards for size)
3. 4 Workstations - Legal Technicians (see Standards for size)
4. 1 Workstation - Mail/File Clerk
5. Office support space must be provided per the ICE/OPLA Design Standards.
6. OPLA Space

#### C. EOIR Space

The **PROVIDER** shall refer to ICE/EOIR Design Standards for specific office and workstation sizes and specific furnishing requirements for a 1000 bed facility. All furniture and case goods shall be furnished by the service provider in accordance with ICE Design Standards. The Standards include but are not limited to the following:

1. 5 - Courtrooms and accompanying office and support space as per the EOIR Design Standards for a 1000 bed facility. The office space is per the EOIR Design Standards. Each courtroom should have the capability to hold live court as well as hold video tele-conferencing court. All furniture and case goods shall be furnished by the service provider in accordance with ICE Design Guide and specifications.
2. 15 - Hard walled offices (see Standards for size)
3. 15 - Workstations (see Standards for size)
4. Visitation space must be provided to meet the ACA and NDS standards.
5. Separate entrance for judges required with complete security system and access to parking lot. Must be ADA compliant.
6. EOIR Support Space must be provided per the EOIR Design Standards.

#### D. Health Services

Healthcare services will be provided by the **PROVIDER**.

#### E. Facility Requirements for Infectious Disease Screening

The Service Provider will ensure that there is adequate space and equipment to provide medical intake screening including a TB screening chest x-ray within the intake processing area. In order to prevent the spread of airborne infectious disease or cross contamination of zones within the facility, the HVAC system in the Intake Screening Area will be constructed to exhaust to the exterior and

prevent air exchange between the intake screening area and any other area within the facility.

#### F. Infectious Disease Screening

In order to prevent the transmission of Tuberculosis (TB) to the resident population of a detention facility, the Service Provider will perform TB screening as part of the a routine infectious disease screening within 12 hours of detainee admission and obtain documented clearance of transmissible disease before the detainee is assigned to a housing unit or is transferred from the intake processing area. A screening chest x-ray will be performed by a trained and qualified health care provider and interpreted by a credentialed radiologist. Detainees will remain isolated from the rest of the facility population (remain in the intake screening area) until the chest x-ray report is obtained and the interpretation verifies that the detainee is free of infectious TB (turnaround time for chest x-ray interpretation should be 4 hours or less). Detainees who are found to be infected or where there is a possibility that they are infected will be assigned to a respiratory isolation unit until treatment or further testing is done and the detainee is no longer infectious.

#### G. Teleradiology Service Provider

1. The Detention Service Provider shall use the services of the ICE Teleradiology Service Provider (ITSP). The cost of the equipment; maintenance of the equipment; training of staff; arrangements for interpretation of the x-rays by credentialed radiologists; and transmission of data to and from the Detention Facility are provided by the ITSP and charged directly to ICE. The Service Provider shall coordinate with the ITSP to ensure adequate space is provided for the equipment, connectivity and electrical services are installed, immediate 24/7 access to equipment for service and maintenance by ITSP technicians is granted, a teleradiology coordinator is appointed and available for training by the ITSP, and medical staff is available to perform the screening exams and receive reports. The teleradiology coordinator may be a nurse or nurse practitioner and collateral duty of the appointed staff (it is not necessary to appoint a full time coordinator if the volume of work does not support a full time employee).
2. Teleradiology equipment requires high voltage power to accommodate x-ray equipment, specifications will be provided by ICE.

#### H. Processing Area

1. Expansion required in this area includes the need to accommodate processing varying numbers of detainees for intake and out-processing, i.e., large buses transport of up to 100 detainees.

2. Processing area must be designed to process male and/or female detainees as required in high frequency rates and varying numbers, i.e., a busload up to 100 detainees at one time.

I. Furniture

All furniture and case goods shall be furnished by the service provider in accordance with ICE Design Guide and specifications, which include ICE support space and all operational components which include EOIR, OPLA and DIHS space as required in accordance with the ICE Design Standards.

J. ICE IT Equipment

ICE will provide and install IT equipment in office spaces for ICE personnel only, to include computer workstations and screens, printers and fax machines. All infrastructure, cabling, and interfacing equipment shall be provided by the Service Provider at time of construction.

**NOTE:** ICE IT system must be a complete, independent and physically separate system from the Service Provider's IT system. The system shall serve all operational components: ICE, OPLA, and DIHS. EOIR shall have a separate system within EOIR IT space as per the EOIR Design Standards.

K. Communication Equipment

The service provider shall purchase, install and maintain a complete and operating communication system, which includes but is not limited to: cabling, fiber optics, patch panels, landing blocks, circuits, PBX and voice mail, phone sets and other supporting infrastructure and supporting system in compliance with ICE specifications. Separate billing to ICE must be established on all reoccurring service fees for communications and IT. Systems shall be installed specifically for ICE use.

**NOTE:** ICE communication system must be a complete, independent and physically separate system from the Service Provider communication system, and billed separately. The system shall serve all operational components: ICE, OPLA, and DIHS. EOIR shall have a separate system within EOIR IT space as per the EOIR Design Standards.

Service Provider see attached SOW for phone system details.

Non-Responsive

**Stevens, Richard P**

**From:** Neveleff, Jerald  
**Sent:** Tuesday, November 04, 2008 6:26 AM  
**To:** Smyly, Elena L  
**Cc:** Thompson, Arthur D (CTR)  
**Subject:** RE: Farmville capacity question

Elena,  
The situation for the 2000 beds was for planning purposes only when it comes to the admin spaces. Since there will be a need for a separate building for EOIR, OPLA and Courtrooms, do we want to "plan" ahead and develop two sets of requirements and see what is most cost effective.

The first set of requirements would be the 1040 population.  
The second set would be for 2000.

We can get proposals for both and if it is cost effective, plan ahead. Its less expensive at this point in the construction phase then it would be in the future if we need to expand.

Jerry

PLEASE NOTE EFFECTIVE 1600 23 OCT 2008, MY NEW LOCATION IS:  
801 I STREET NW, SUITE 900, WASHINGTON, DC 20536. MY NEW NUMBER WILL BE 202-732-2384.

b6

Thank you,  
Jerry Neveleff  
Deputy Assistant Director/IGSA  
Office of Acquisition Management (OAQ)  
Immigration & Customs Enforcement (ICE)  
Department of Homeland Security (DHS)  
801 I Street, NW Washington DC 20536  
Phone: 202- [b6]  
Fax: 202-73 [b6]  
E-mail: jerry.neveleff@ice.dhs.gov (b)(6)

**Please note new office address & phone/fax numbers!**

Help us support you better -  
TELL US HOW WE ARE DOING!  
Go to <<http://www.acqsolinc.com/ICE/OAQ/feedback.cfm>> <<<http://www.acqsolinc.com/ICE/OAQ/feedback.cfm>>>

---

**From:** Smyly, Elena L  
**Sent:** Monday, November 03, 2008 4:17 PM  
**To:** Thompson, Arthur D (CTR); Neveleff, Jerald  
**Subject:** FW: Farmville capacity question

Gentlemen,  
So now we need to validate requirements for 1040 beds.  
Thanks,

Elena Smyly, PMP

12/21/2008



Management and Program Analyst - Large IGSA  
DHS, U.S. Immigration and Customs Enforcement  
Office of Detention and Removal  
Detention Management Division  
(202) 732- [redacted] b6

---

**From:** Raine, Craig K  
**Sent:** Monday, November 03, 2008 4:04 PM  
**To:** Smyly, Elena L  
**Subject:** RE: Farmville capacity question

Yes, 1040. The 2,000 was discussed for future, but we do not have staffing for 2,000.

Thx

---

**From:** Smyly, Elena L  
**Sent:** Monday, November 03, 2008 3:58 PM  
**To:** Raine, Craig K  
**Subject:** RE: Farmville capacity question

Just to make sure, 1040, not 2000?

Elena Smyly, PMP  
Management and Program Analyst - Large IGSA  
DHS, U.S. Immigration and Customs Enforcement  
Office of Detention and Removal  
Detention Management Division  
(202) 732- [redacted] b6

---

**From:** Raine, Craig K  
**Sent:** Monday, November 03, 2008 3:38 PM  
**To:** Smyly, Elena L  
**Subject:** RE: Farmville capacity question

Yes, we need all of those beds. 1040

Thx

---

**From:** Smyly, Elena L  
**Sent:** Monday, November 03, 2008 1:11 PM  
**To:** Raine, Craig K  
**Subject:** Farmville capacity question  
**Importance:** High

Hi Craig,

I have a capacity question for Farmville.

The facility, as designed now, will be 1040 beds. Any additional beds later will require more money. At a meeting, a question was raised to see if our requirements (roughly 1040 beds) changed. Previously, we discussed 2,000 beds at Farmville. Since capacity is determined by the Field Office, would you be able to tell me if your bed needs change? What are ICE bed needs for Farmville? This is a rather urgent question as we are validating our physical requirements which are driven by the number of beds.

Thank you,

Elena Smyly, PMP  
Management and Program Analyst - Large IGSA  
DHS, U.S. Immigration and Customs Enforcement  
Office of Detention and Removal  
Detention Management Division  
(202) 732- [redacted] b6

12/21/2008

**Stevens, Richard P**

---

**From:** Thompson, Arthur D (CTR)  
**Sent:** Tuesday, November 04, 2008 7:48 AM  
**To:** Neveleff, Jerald  
**Cc:** Jenkins, John E; Raine, Craig K; Jovanovic, Zlatko (EOIR); Smyly, Elena L; Hardy, Stewart  
**Subject:** RE: Farmville capacity question

Jerry,

I agree with the proposals for both the 1040 and 2000 bed. Your suggestion for the larger 2000 bed at this point is will taken; the extra space can always be used for storage until needed.

Dean

---

**From:** Neveleff, Jerald  
**Sent:** Tuesday, November 04, 2008 6:26 AM  
**To:** Smyly, Elena L  
**Cc:** Thompson, Arthur D (CTR)  
**Subject:** RE: Farmville capacity question

Elena,

The situation for the 2000 beds was for planning purposes only when it comes to the admin spaces. Since there will be a need for a separate building for EOIR, OPLA and Courtrooms, do we want to "plan" ahead and develop two sets or requirements and see what is most cost effective.

The first set of requirements would be the 1040 population.  
The second set would be for 2000.

We can get proposals for both and if it is cost effective, plan ahead. Its less expensive at this point in the construction phase then it would be in the future if we need to expand.

Jerry

PLEASE NOTE EFFECTIVE 1600 23 OCT 2008, MY NEW LOCATION IS:  
801 I STREET NW, SUITE 900, WASHINGTON, DC 20536. MY NEW NUMBER WILL BE 202-732-2384.

b6

Thank you,  
Jerry Neveleff  
Deputy Assistant Director/IGSA  
Office of Acquisition Management (OAQ)  
Immigration & Customs Enforcement (ICE)  
Department of Homeland Security (DHS)  
801 I Street, NW, Washington DC 20536  
Phone: 202-732-  
Fax: 202-732-  
E-mail: jera

b6

(b)(6)

**Please note new office address & phone/fax numbers!**

Help us support you better -  
TELL US HOW WE ARE DOING!

Go to <<http://www.acqsolinc.com/ICE/OAQ/feedback.cfm>> <<<http://www.acqsolinc.com/ICE/OAQ/feedback.cfm>>>

---

**From:** Smyly, Elena L  
**Sent:** Monday, November 03, 2008 4:17 PM  
**To:** Thompson, Arthur D (CTR); Neveleff, Jerald  
**Subject:** FW: Farmville capacity question

Gentlemen,  
So now we need to validate requirements for 1040 beds.  
Thanks,

*Elena Smyly, PMP  
Management and Program Analyst - Large IGSA  
DHS, U.S. Immigration and Customs Enforcement  
Office of Detention and Removal  
Detention Management Division  
(202) 732- [REDACTED] b6*

---

**From:** Raine, Craig K  
**Sent:** Monday, November 03, 2008 4:04 PM  
**To:** Smyly, Elena L  
**Subject:** RE: Farmville capacity question

Yes, 1040. The 2,000 was discussed for future, but we do not have staffing for 2,000.

Thx

---

**From:** Smyly, Elena L  
**Sent:** Monday, November 03, 2008 3:58 PM  
**To:** Raine, Craig K  
**Subject:** RE: Farmville capacity question

Just to make sure, 1040, not 2000?

*Elena Smyly, PMP  
Management and Program Analyst - Large IGSA  
DHS, U.S. Immigration and Customs Enforcement  
Office of Detention and Removal  
Detention Management Division  
(202) 732- [REDACTED] b6*

---

**From:** Raine, Craig K  
**Sent:** Monday, November 03, 2008 3:38 PM  
**To:** Smyly, Elena L  
**Subject:** RE: Farmville capacity question

Yes, we need all of those beds. 1040

Thx

---

**From:** Smyly, Elena L  
**Sent:** Monday, November 03, 2008 1:11 PM  
**To:** Raine, Craig K  
**Subject:** Farmville capacity question  
**Importance:** High

12/21/2008

Hi Craig,  
I have a capacity question for Farmville.  
The facility, as designed now, will be 1040 beds. Any additional beds later will require more money. At a meeting, a question was raised to see if our requirements (roughly 1040 beds) changed. Previously, we discussed 2,000 beds at Farmville. Since capacity is determined by the Field Office, would you be able to tell me if your bed needs change? What are ICE bed needs for Farmville? This is a rather urgent question as we are validating our physical requirements which are driven by the number of beds.

Thank you,

Elena Smyly, PMP  
Management and Program Analyst - Large IGSA  
DHS, U.S. Immigration and Customs Enforcement  
Office of Detention and Removal  
Detention Management Division  
(202) 732-b6

**Stevens, Richard P**

---

**From:** Raine, Craig K  
**Sent:** Tuesday, November 04, 2008 8:14 AM  
**To:** Thompson, Arthur D (CTR); Neveleff, Jerald  
**Cc:** 'Jenkins, John E'; 'Jovanovic, Zlatko (EOIR)'; Smyly, Elena L; Hardy, Stewart  
**Subject:** RE: Farmville capacity question

Understanding the reasoning behind the question, I concur with below on the possible cost savings potential.

---

**From:** Thompson, Arthur D (CTR)  
**Sent:** Tuesday, November 04, 2008 7:48 AM  
**To:** Neveleff, Jerald  
**Cc:** Jenkins, John E; Raine, Craig K; Jovanovic, Zlatko (EOIR); Smyly, Elena L; Hardy, Stewart  
**Subject:** RE: Farmville capacity question

Jerry,

I agree with the proposals for both the 1040 and 2000 bed. Your suggestion for the larger 2000 bed at this point is will taken; the extra space can always be used for storage until needed.

Dean

---

**From:** Neveleff, Jerald  
**Sent:** Tuesday, November 04, 2008 6:26 AM  
**To:** Smyly, Elena L  
**Cc:** Thompson, Arthur D (CTR)  
**Subject:** RE: Farmville capacity question

Elena,  
The situation for the 2000 beds was for planning purposes only when it comes to the admin spaces. Since there will be a need for a separate building for EOIR, OPLA and Courtrooms, do we want to "plan" ahead and develop two sets or requirements and see what is most cost effective.

The first set of requirements would be the 1040 population.  
The second set would be for 2000.

We can get proposals for both and if it is cost effective, plan ahead. Its less expensive at this point in the construction phase then it would be in the future if we need to expand.

Jerry

PLEASE NOTE EFFECTIVE 1600 23 OCT 2008, MY NEW LOCATION IS:  
801 I STREET NW, SUITE 900, WASHINGTON, DC 20536. MY NEW NUMBER WILL BE 202-732-2384.

b6

Thank you,  
Jerry Neveleff  
Deputy Assistant Director/IGSA  
Office of Acquisition Management (OAQ)  
Immigration & Customs Enforcement (ICE)  
Department of Homeland Security (DHS)

12/21/2008

801 I Street, NW, Washington DC 20536

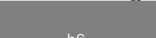
Phone: 202-732-

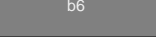
Fax: 202-732-

E-mail:  (b)(6)

**Please note new office address & phone/fax numbers!**

Help us support you better -  
TELL US HOW WE ARE DOING!

Go to <http://www.acqsolinc.com/ICE/OAQ/feedback.cfm> <<<http://www.acqsolinc.com/ICE/OAQ/feedback.cfm>>>

---

**From:** Smyly, Elena L  
**Sent:** Monday, November 03, 2008 4:17 PM  
**To:** Thompson, Arthur D (CTR); Neveleff, Jerald  
**Subject:** FW: Farmville capacity question

Gentlemen,  
So now we need to validate requirements for 1040 beds.  
Thanks,

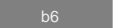
*Elena Smyly, PMP  
Management and Program Analyst - Large IGSA  
DHS, U.S. Immigration and Customs Enforcement  
Office of Detention and Removal  
Detention Management Division  
(202) 732-*

---

**From:** Raine, Craig K  
**Sent:** Monday, November 03, 2008 4:04 PM  
**To:** Smyly, Elena L  
**Subject:** RE: Farmville capacity question

Yes, 1040. The 2,000 was discussed for future, but we do not have staffing for 2,000.

Thx

---

**From:** Smyly, Elena L  
**Sent:** Monday, November 03, 2008 3:58 PM  
**To:** Raine, Craig K  
**Subject:** RE: Farmville capacity question

Just to make sure, 1040, not 2000?

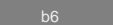
*Elena Smyly, PMP  
Management and Program Analyst - Large IGSA  
DHS, U.S. Immigration and Customs Enforcement  
Office of Detention and Removal  
Detention Management Division  
(202) 732-*

---

**From:** Raine, Craig K  
**Sent:** Monday, November 03, 2008 3:38 PM  
**To:** Smyly, Elena L  
**Subject:** RE: Farmville capacity question

Yes, we need all of those beds. 1040

12/21/2008

Thx

---

**From:** Smyly, Elena L  
**Sent:** Monday, November 03, 2008 1:11 PM  
**To:** Raine, Craig K  
**Subject:** Farmville capacity question  
**Importance:** High

Hi Craig,  
I have a capacity question for Farmville.  
The facility, as designed now, will be 1040 beds. Any additional beds later will require more money. At a meeting, a question was raised to see if our requirements (roughly 1040 beds) changed. Previously, we discussed 2,000 beds at Farmville. Since capacity is determined by the Field Office, would you be able to tell me if your bed needs change? What are ICE bed needs for Farmville? This is a rather urgent question as we are validating our physical requirements which are driven by the number of beds.

Thank you,  
Elena Smyly, PMP  
Management and Program Analyst - Large IGSA  
DHS, U.S. Immigration and Customs Enforcement  
Office of Detention and Removal  
Detention Management Division  
(202) 732-b6

**Stevens, Richard P**

---

**From:** Jovanovic, Zlatko (EOIR) [Zlatko.Jovanovic@usdoj.gov]  
**Sent:** Wednesday, November 05, 2008 4:02 PM  
**To:** Thompson, Arthur D (CTR); Raine, Craig K; Neveleff, Jerald; Jovanovic, Zlatko (EOIR)  
**Cc:** Jenkins, John E; Smyly, Elena L; Hardy, Stewart  
**Subject:** RE: Farmville capacity question

Dean...

I've requested input from EOIR's Office of the Chief Immigration Judge regarding number of courtrooms needed if a 2000 facility was constructed, or expanded to from 1040. I should have an answer confirmed within couple of days.

**ZJ, Deputy Chief, Space and Facilities**

---

**From:** Raine, Craig K [mailto: [REDACTED]@usdoj.gov] b6  
**Sent:** Tuesday, November 04, 2008 8:14 AM  
**To:** Thompson, Arthur D (CTR); Neveleff, Jerald  
**Cc:** Jenkins, John E; Jovanovic, Zlatko (EOIR); Smyly, Elena L; Hardy, Stewart  
**Subject:** RE: Farmville capacity question

Understanding the reasoning behind the question, I concur with below on the possible cost savings potential.

---

**From:** Thompson, Arthur D (CTR)  
**Sent:** Tuesday, November 04, 2008 7:48 AM  
**To:** Neveleff, Jerald  
**Cc:** Jenkins, John E; Raine, Craig K; Jovanovic, Zlatko (EOIR); Smyly, Elena L; Hardy, Stewart  
**Subject:** RE: Farmville capacity question

Jerry,

I agree with the proposals for both the 1040 and 2000 bed. Your suggestion for the larger 2000 bed at this point is will taken; the extra space can always be used for storage until needed.

Dean

---

**From:** Neveleff, Jerald  
**Sent:** Tuesday, November 04, 2008 6:26 AM  
**To:** Smyly, Elena L  
**Cc:** Thompson, Arthur D (CTR)  
**Subject:** RE: Farmville capacity question

Elena,

The situation for the 2000 beds was for planning purposes only when it comes to the admin spaces. Since there will be a need for a separate building for EOIR, OPLA and Courtrooms, do we want to "plan" ahead and develop two sets or requirements and see what is most cost effective.

The first set of requirements would be the 1040 population.  
The second set would be for 2000.

We can get proposals for both and if it is cost effective, plan ahead. Its less expensive at this point in the construction phase then it would be in the future if we need to expand.

12/21/2008



Jerry

PLEASE NOTE EFFECTIVE 1600 23 OCT 2008, MY NEW LOCATION IS:  
801 I STREET NW, SUITE 900, WASHINGTON, DC 20536. MY NEW NUMBER WILL BE 202-732-2384.

b6

Thank you,  
Jerry Neveleff  
Deputy Assistant Director/IGSA  
Office of Acquisition Management (OAQ)  
Immigration & Customs Enforcement (ICE)  
Department of Homeland Security (DHS)  
801 I Street, NW, Washington DC 20536  
Phone: 202-732-  
Fax: 202-732-  
E-mail:

b6

(b)(6)

**Please note new office address & phone/fax numbers!**

Help us support you better -  
TELL US HOW WE ARE DOING!

Go to <<http://www.acqsolinc.com/ICE/OAQ/feedback.cfm>> <<<http://www.acqsolinc.com/ICE/OAQ/feedback.cfm>>>

---

**From:** Smyly, Elena L  
**Sent:** Monday, November 03, 2008 4:17 PM  
**To:** Thompson, Arthur D (CTR); Neveleff, Jerald  
**Subject:** FW: Farmville capacity question

Gentlemen,  
So now we need to validate requirements for 1040 beds.  
Thanks,

*Elena Smyly, PMP  
Management and Program Analyst - Large IGSA  
DHS, U.S. Immigration and Customs Enforcement  
Office of Detention and Removal  
Detention Management Division  
(202) 732-*

b6

---

**From:** Raine, Craig K  
**Sent:** Monday, November 03, 2008 4:04 PM  
**To:** Smyly, Elena L  
**Subject:** RE: Farmville capacity question

Yes, 1040. The 2,000 was discussed for future, but we do not have staffing for 2,000.

Thx

---

**From:** Smyly, Elena L  
**Sent:** Monday, November 03, 2008 3:58 PM  
**To:** Raine, Craig K  
**Subject:** RE: Farmville capacity question

Just to make sure, 1040, not 2000?

12/21/2008

Elena Smyly, PMP  
Management and Program Analyst - Large IGSA  
DHS, U.S. Immigration and Customs Enforcement  
Office of Detention and Removal  
Detention Management Division  
(202) 732- [REDACTED] b6

---

**From:** Raine, Craig K  
**Sent:** Monday, November 03, 2008 3:38 PM  
**To:** Smyly, Elena L  
**Subject:** RE: Farmville capacity question

Yes, we need all of those beds. 1040

Thx

---

**From:** Smyly, Elena L  
**Sent:** Monday, November 03, 2008 1:11 PM  
**To:** Raine, Craig K  
**Subject:** Farmville capacity question  
**Importance:** High

Hi Craig,  
I have a capacity question for Farmville.  
The facility, as designed now, will be 1040 beds. Any additional beds later will require more money. At a meeting, a question was raised to see if our requirements (roughly 1040 beds) changed. Previously, we discussed 2,000 beds at Farmville. Since capacity is determined by the Field Office, would you be able to tell me if your bed needs change? What are ICE bed needs for Farmville? This is a rather urgent question as we are validating our physical requirements which are driven by the number of beds.

Thank you,  
Elena Smyly, PMP  
Management and Program Analyst - Large IGSA  
DHS, U.S. Immigration and Customs Enforcement  
Office of Detention and Removal  
Detention Management Division  
(202) 732- [REDACTED] b6

**Stevens, Richard P**

---

**From:** Neveleff, Jerald  
**Sent:** Thursday, November 06, 2008 8:08 AM  
**To:** Jenkins, John E; Thompson, Arthur D (CTR)  
**Subject:** FW: Farmville

Can someone answer #1? The answer to #2 is that they are still being finalized. I have #3.

1. Do you have a specification on the perimeter fencing?
2. Do you have the requirement for your Administrative space.
3. Can we have the contact information for your DTS contractor if you have chosen one.

PLEASE NOTE EFFECTIVE 1600 23 OCT 2008, MY NEW LOCATION IS:  
801 I STREET NW, SUITE 900, WASHINGTON, DC 20536. MY NEW NUMBER WILL BE 202-732-2384.

b6

Thank you,  
Jerry Neveleff  
Deputy Assistant Director/IGSA  
Office of Acquisition Management (OAQ)  
Immigration & Customs Enforcement (ICE)  
Department of Homeland Security (DHS)  
801 I Street, NW, Washington DC 20536  
Phone: 202-  
Fax: 202-73  
E-mail: je

b6

(b)(6)

**Please note new office address & phone/fax numbers!**

Help us support you better -

TELL US HOW WE ARE DOING!

Go to <http://www.acqsolinc.com/ICE/OAQ/feedback.cfm> <<<http://www.acqsolinc.com/ICE/OAQ/feedback.cfm>>>

---

**From:** Casterline, Arnold P  
**Sent:** Wednesday, November 05, 2008 1:58 PM  
**To:** Neveleff, Jerald  
**Subject:** FW: Farmville

*Arnold P. Casterline Jr.*

Contract Specialist  
Immigration and Customs Enforcement  
Office of Acquisition Management  
Detention Management  
Department of Homeland Security  
801 I. St. NW, 9th Floor, Room 910

12/21/2008

Washington, D.C. 20536

e-mail [redacted] (b)(6)

**Please note new address and desk phone number!**

Phone: 202-[redacted]  
Main: 202-732-[redacted] b6  
Fax: 202-732-[redacted]

**Help us support you better –  
TELL US HOW WE ARE DOING!**

**Go to** <http://www.acqsolinc.com/ICE/OAQ/feedback.cfm>

---

**From:** Russell Harper [mailto:[redacted] b6]  
**Sent:** Wednesday, November 05, 2008 1:55 PM  
**To:** Casterline, Arnold P  
**Cc:** [redacted] b6  
**Subject:** Farmville

I hope your doing well.

We have a few questions.

1. Do you have a specification on the perimeter fencing?
2. Do you have the requirement for your Administrative space.
3. Can we have the contact information for your DTS contractor if you have chosen one.

Thanks

Russell

-----  
Sent from Russell B. Harper

**Stevens, Richard P**

---

**From:** Neveleff, Jerald  
**Sent:** Thursday, November 06, 2008 8:17 AM  
**To:** [REDACTED] b6  
**Cc:** Casterline, Arnold P; Jenkins, John E; Thompson, Arthur D (CTR); Barr, Jose G  
**Subject:** FW: Farmville

Russell,  
Here's what we have so far:

1. Do you have a specification on the perimeter fencing? I am waiting a response.
2. Do you have the requirement for your Administrative space. Still trying to finalize. Should be about 2-3 weeks.
3. Can we have the contact information for your DTS contractor if you have chosen one. POCs at PCS are:

Doyle Schaefers – 310/954-[REDACTED] b6

Saam Dowlatshahi – 310/954-3[REDACTED] b6

Jerry

PLEASE NOTE EFFECTIVE 1600 23 OCT 2008, MY NEW LOCATION IS:  
801 I STREET NW, SUITE 900, WASHINGTON, DC 20536. MY NEW NUMBER WILL BE 202-732-2384. [REDACTED] b6

Thank you,  
Jerry Neveleff

Deputy Assistant Director/IGSA  
Office of Acquisition Management (OAQ)  
Immigration & Customs Enforcement (ICE)  
Department of Homeland Security (DHS)  
801 I Street, NW, Washington DC 20536  
Phone: 202-[REDACTED] b6  
Fax: 202-73[REDACTED]  
E-mail: je[REDACTED] (b)(6)

**Please note new office address & phone/fax numbers!**

Help us support you better -

TELL US HOW WE ARE DOING!

Go to <<http://www.acqsolinc.com/ICE/OAQ/feedback.cfm>> <<<http://www.acqsolinc.com/ICE/OAQ/feedback.cfm>>>

---

**From:** Casterline, Arnold P  
**Sent:** Wednesday, November 05, 2008 1:58 PM  
**To:** Neveleff, Jerald  
**Subject:** FW: Farmville

12/21/2008

*Arnold P. Casterline Jr.*

Contract Specialist  
Immigration and Customs Enforcement  
Office of Acquisition Management  
Detention Management  
Department of Homeland Security  
801 I. St. NW, 9th Floor, Room 910  
Washington, D.C. 20536

e-mail: [REDACTED] (b)(6)

**Please note new address and desk phone number!**

Phone: 202-7 [REDACTED]  
Main: 202-73 [REDACTED] b6  
Fax: 202-732 [REDACTED]

**Help us support you better –  
TELL US HOW WE ARE DOING!**

**Go to** <http://www.acqsolinc.com/ICE/OAQ/feedback.cfm>

---

**From:** Russell Harper [mailto: [REDACTED] b6]  
**Sent:** Wednesday, November 05, 2008 1:55 PM  
**To:** Casterline, Arnold P  
**Cc:** g [REDACTED] b6  
**Subject:** Farmville

I hope your doing well.

We have a few questions.

1. Do you have a specification on the perimeter fencing?
2. Do you have the requirement for your Administrative space.
3. Can we have the contact information for your DTS contractor if you have chosen one.

Thanks

Russell

-----  
Sent from Russell B. Harper

**Stevens, Richard P**

---

**From:** Russell Harper [redacted] b6  
**Sent:** Thursday, November 06, 2008 8:51 AM  
**To:** Neveleff, Jerald  
**Cc:** Casterline, Arnold P; Jenkins, John E; Thompson, Arthur D (CTR); Barr, Jose G; gspates@farmvilleva.com b6  
**Subject:** RE: Farmville

Thank you.

---

**From:** Neveleff, Jerald [mailto:[redacted]] (b)(6)  
**Sent:** Thursday, November 06, 2008 8:17 AM  
**To:** Russell Harper  
**Cc:** Casterline, Arnold P; Jenkins, John E; Thompson, Arthur D (CTR); Barr, Jose G  
**Subject:** FW: Farmville

Russell,  
Here's what we have so far:

1. Do you have a specification on the perimeter fencing? I am waiting a response.
2. Do you have the requirement for your Administrative space. Still trying to finalize. Should be about 2-3 weeks.
3. Can we have the contact information for your DTS contractor if you have chosen one. POC's at PCS are:

Doyle Schaefers – 310/954-3027 [redacted] b6  
doyle.schaefers@teampcs.com

Saam Dowlatshahi – 310/954-3027 [redacted] b6

Jerry

PLEASE NOTE EFFECTIVE 1600 23 OCT 2008, MY NEW LOCATION IS:  
801 I STREET NW, SUITE 900, WASHINGTON, DC 20536. MY NEW NUMBER WILL BE 202-732-2384. [redacted] b6

Thank you,  
 Jerry Neveleff  
 Deputy Assistant Director/IGSA  
 Office of Acquisition Management (OAQ)  
 Immigration & Customs Enforcement (ICE)  
 Department of Homeland Security (DHS)  
 801 I Street, NW, Washington DC 20536  
 Phone: 202-732- [redacted] b6  
 Fax: 202-732- [redacted]  
 E-mail: jerald [redacted] (b)(6)

**Please note new office address & phone/fax numbers!**

Help us support you better -  
 TELL US HOW WE ARE DOING!  
 Go to <<http://www.acqsolinc.com/ICE/OAQ/feedback.cfm>> <<<http://www.acqsolinc.com/ICE/OAQ/feedback.cfm>>>

---

**From:** Casterline, Arnold P  
**Sent:** Wednesday, November 05, 2008 1:58 PM  
**To:** Neveleff, Jerald  
**Subject:** FW: Farmville

*Arnold P. Casterline Jr.*  
Contract Specialist  
Immigration and Customs Enforcement  
Office of Acquisition Management  
Detention Management  
Department of Homeland Security  
801 I. St. NW, 9th Floor, Room 910  
Washington, D.C. 20536

e-mail: a [redacted] (b)(6)

**Please note new address and desk phone number!**

Phone: 202-7 [redacted]  
Main: 202-732 [redacted] b6  
Fax: 202-732 [redacted]

**Help us support you better –  
TELL US HOW WE ARE DOING!**  
**Go to** <http://www.acqsolinc.com/ICE/OAQ/feedback.cfm>

---

**From:** Russell Harper [mailto:r [redacted] b6]  
**Sent:** Wednesday, November 05, 2008 1:55 PM  
**To:** Casterline, Arnold P  
**Cc:** g [redacted] b6  
**Subject:** Farmville

I hope your doing well.  
We have a few questions.  
1. Do you have a specification on the perimeter fencing?  
2. Do you have the requirement for your Administrative space.  
3. Can we have the contact information for your DTS contractor if you have chosen one.

Thanks  
Russell

-----  
Sent from Russell B. Harper