

# **Millstone River Basin, New Jersey**

## **Flood Risk Management Feasibility Study**

### **Final Feasibility Report**



**U.S. Army Corps of Engineers  
New York District  
26 Federal Plaza  
New York, New York 10278**

November 2016



**US Army Corps  
of Engineers**  
New York District



**New Jersey Department of  
Environmental Protection**

## ***Executive Summary***

The focus of this study is the Millstone River Basin, New Jersey, also referred to as the study area. The 238-square mile basin is located in north-central New Jersey. The Millstone River Basin is bounded by the Raritan River to the north, the Millstone River to the east and Royce Brook to the south. The basin includes the Millstone River and its major tributaries located in the New Jersey counties of Mercer, Middlesex, Monmouth, Hunterdon, and Somerset. From its headwaters near Millstone Township in Monmouth County, the Millstone River flows northward through Somerset County to its confluence with the Raritan River in the Borough of Manville (“Manville”).

The water resources problem identified as the focus of this study is fluvial flooding in the Millstone River Basin. Fluvial flooding occurs as a result of storm events within the basin. For most of the Millstone River Basin communities flood-prone structures are widely distributed. Upon examination the most significant flooding problems in the Millstone River Basin are in Manville. Officials from Manville report that the recurrent flooding problems are prevalent throughout the municipality in areas with proximity to the Raritan River and the Millstone River. With Manville as the highest impact municipality, plan formulation focused on flooding problems and opportunities in this area.

Various measures (e.g. levees, channelization, elevation of individual structures, etc.) were considered, screened for applicability, and developed into alternative plans to provide flood risk management within Manville. Alternative plans are a set of one or more flood risk management measures functioning together.

Economic analysis has demonstrated that all formulated alternative plans have Benefit-Cost Ratios (BCRs) less than one and thus no alternative plan has been identified that favorably contributes to National Economic Development (NED). Therefore this report recommends that no Federal flood risk management alternative plan be further developed and implemented. This analysis and finding is presented in more detail in Sections 13.0, 14.0 and 15.0 of this report. National Environmental Policy Act (NEPA) documentation and a Real Estate Plan were not prepared for this report due to lack of identification of an economically justified plan and the related recommendation of no further Federal action.

The non-Federal sponsor, the New Jersey Department of Environmental Protection (NJDEP), concurs with the finding of no further Federal action for flood risk management within the Millstone River Basin, as documented within this report and appendices. Coordination with the NJDEP, and local stakeholders such as the Raritan Millstone River Flood Control Commission (RMRFCC) and Manville have been ongoing throughout this study.



**MILLSTONE RIVER BASIN, NEW JERSEY  
FLOOD RISK MANAGEMENT STUDY  
FEASIBILITY REPORT**

**TABLE OF CONTENTS**

<b>TABLE OF CONTENTS</b> .....	ii
1.0 Introduction.....	1
2.0 Timeline .....	1
3.0 Study Authority.....	2
4.0 Non-Federal Sponsor .....	2
5.0 Prior Reports and Existing Water Projects .....	2
6.0 Purpose and Need .....	4
6.1 Federal Participation .....	4
7.0 Study Scope .....	5
7.1 Study Area .....	5
7.2 Study Area Screening .....	10
7.3 Project Area .....	12
8.0 Problems/Opportunities .....	13
8.1 Problems .....	13
8.2 Opportunities.....	13
9.0 Planning Goals/Objectives.....	13
9.1 Planning Constraints .....	14
10.0 Existing Conditions.....	15
10.1 Physical Conditions .....	15
10.2 Environmental Conditions .....	19
10.3 Economic and Social Setting .....	28
10.5 Without Project Future Conditions .....	32
11.0 Key Uncertainties.....	34
12.0 Formulating Alternative Plans .....	34
12.1 Management Measures .....	36
12.2 Screening of Measures.....	39
12.3 Final Array of Alternative Plans .....	43
13.0 Evaluation and Comparison of Array of Alternative Plans .....	56
14.0 Identifying a Tentatively Selected Plan .....	62
15.0 Recommendation .....	64
16.0 References.....	65



**LIST OF FIGURES**

Figure 1. Millstone River Basin with 1% Annual Chance Exceedance Floodplain ..... 7  
Figure 2: Millstone River Basin with 1% Annual Chance Exceedance Floodplain ..... 8  
Figure 3: Millstone River Basin with 1% Annual Chance Exceedance Floodplain ..... 9  
Figure 4: Project Area ..... 12  
Figure 5. Borough of Manville with 10% and 2% Annual Chance Exceedance Floodplain ..... 17  
Figure 6: Wetlands Mapped by New Jersey Department of Environmental Protection... 20  
Figure 7: Alternative 1 – Levees and Floodwalls ..... 47  
Figure 8: Alternative 2 – Channel Modifications ..... 49  
Figure 9: Zarephath and Lost Valley areas ..... 50

**LIST OF TABLES**

Table 1. Feasibility Study Milestone Schedule..... 2  
Table 2. Millstone River Basin Structure Count by Municipality ..... 10  
Table 3. State and National Register Eligible and Listed Historic Sites ..... 24  
Table 4. Archaeological Sites ..... 26  
Table 5. Population Data for the State, Counties, and Affected Municipalities ..... 29  
Table 6. Income Comparison for the State, Counties, and Affected Municipalities ..... 30  
Table 7. Employment Status for the State, Counties, and Affected Municipalities ..... 31  
Table 8. Occupational Status for the State, Counties, and Affected Municipalities..... 32  
Table 9. Screening of Measures..... 40  
Table 10. Millstone River Nonstructural Plan for the 1% (100-yr), 2% (50-yr) and 10% (10-yr) Annual Chance Exceedance Events ..... 54  
Table 11. Alternative #3B, #3C and #3D Millstone River Nonstructural Plan Comparison for the 2% (50-yr) Annual Chance Exceedance Event..... 55  
Table 12. Alternative #4B, #4C and #4D Millstone River Nonstructural Plan Comparison for the 10% (10-yr) Annual Chance Exceedance Event..... 55  
Table 13. Physical Characteristics Surveyed for in Structure Inventory ..... 57  
Table 14. Summary of Damages, Costs, Benefits and BCRs ..... 61

**LIST OF APPENDICES**

- Appendix A – Hydrology & Hydraulics  
(Nonstructural Appendix Addended)
- Appendix B – Economics
- Appendix C – Cost Engineering
- Appendix D - Structural
- Appendix E – Geotechnical





## ***1.0 Introduction***

The Millstone River Basin, New Jersey, Flood Risk Management Feasibility Study, which is in the second phase of the U.S. Army Corps of Engineers (USACE) planning process, follows a favorable Reconnaissance Report and execution of a Feasibility Cost Sharing Agreement (FCSA) between USACE and the non-Federal sponsor, the New Jersey Department of Environmental Protection (NJDEP). The scope of this Feasibility Study includes the planning, engineering, design, real estate, economic and environmental analysis and documentation required to support a decision on Federal participation for implementation of a flood risk management project in the Millstone River Basin based on the study authority of August 1999. A Feasibility Report is a complete decision document that provides the basis for recommending construction authorization of a project to the U.S. Congress, if warranted. This Feasibility Report is a final response to the study authority to examine flood risk management within the Millstone River Basin.

Due to the flow of federal funding, there were delays in obtaining sufficient funding until recently in order to complete the alternatives analysis and to develop this report.

The scope of this study is to fully evaluate all reasonable solutions to the flooding problems identified and to determine whether there is justification for Federal participation in providing flood risk management measures for the Millstone River Basin, New Jersey. The feasibility of flood risk management measures in the basin will be examined by:

- Defining the problems and opportunities for flood risk management associated with periodic flooding from storms within the Millstone River Basin, New Jersey;
- Evaluating the technical, economic, environmental, and institutional feasibility for Federal participation in addressing flooding issues;
- Identifying and evaluating potential solutions to flooding issues, including a possible recommendation for a project; and
- Determining if there is local support for implementation of the recommended plan.

The analysis and conclusions these tasks entail are documented within this Feasibility Report and Appendices.

## ***2.0 Timeline***

A Reconnaissance Report was approved in September 2000 and a Feasibility Cost Sharing Agreement (FCSA) was executed with the NJDEP in March 2002 to cost share the Feasibility Phase. The public release of the Draft Feasibility Report occurred in July 2016.



Table 1 provides a list of the major study milestones and their anticipated schedule date. These dates are subject to the availability of Federal and non-Federal sponsor funding.

**Table 1. Feasibility Study Milestone Schedule**

<b>Feasibility Study Milestone</b>	<b>Date</b>
Reconnaissance Report	September 2000
Execute Feasibility Cost Sharing Agreement (FCSA)	March 2002
Public Release of Draft Feasibility Report	July 2016
Final Report Milestone	November 2016

### **3.0 Study Authority**

The Millstone River Basin, New Jersey, Flood Risk Management Study is being conducted under the USACE General Investigations Program. The study was authorized by the U.S. House of Representatives Resolution dated 05 August 1999. This authority states:

*“Resolved by the Committee on Transportation and Infrastructure of the United States House of Representatives, That the Secretary of the Army is requested to review the report of the Chief of Engineers titled Basinwide Water Resources Development Report on the Raritan River Basin, New Jersey, published as House Document 53, 7 F1 Congress, 2nd Session, Section 729 of the Water Resources Development Act 1986 and other pertinent reports, to determine whether modifications of the recommendations contained therein are advisable at the present time in the interest of water resources development, including flood control, environmental restoration and protection and other allied purposes on the Millstone River, New Jersey.”*

### **4.0 Non-Federal Sponsor**

The New Jersey Department of Environmental Protection (NJDEP) is the non-Federal sponsor for this study. The Millstone River Basin, New Jersey, Reconnaissance Report was approved in September 2000 and a FCSA was executed with NJDEP in March 2002, initiating this Feasibility Phase.

Although ecosystem restoration is an authorized study purpose and the approved Reconnaissance Report indicates the existence of opportunities in both flood risk management and ecosystem restoration, the NJDEP indicated their intent that this study examine only flood risk management at this time.

### **5.0 Prior Reports and Existing Water Projects**

A number of prior reports and studies by USACE as well as other agencies and municipalities were reviewed as part of this investigation. The following is a list of



documents reviewed and utilized in this report as they relate to the Millstone River Basin. Information from the following documents was deemed the most significant to the problem identification and plan formulation.

Studies by USACE include:

- U.S. Army Corps of Engineers, The Floods of August and September 1971 (Hurricane Doria) (1975)
- U.S. Army Corps of Engineers, Survey Report for Flood Control, Raritan River Basin, New Jersey (August 1982)
- U.S. Army Corps of Engineers, Survey Report for Flood Control Raritan River Basin, New Jersey (March 1985)
- U.S. Army Corps of Engineers, Final Tropical Storm Floyd September 16, 1999 Post Flood Report, New Jersey (July 2000)
- U.S. Army Corps of Engineers, Reconnaissance Study, Section 905(b) (WRDA 86) Preliminary Analysis, Millstone River Basin, New Jersey, Flood Control and Ecosystem Restoration Study (September 2000)

The purpose of the Section 905(b) preliminary analysis was to study flood risk management and ecosystem restoration opportunities along the Millstone River and evaluate the feasibility of further study and implementation of a project within the Millstone River Basin in New Jersey. Specific objectives of the Reconnaissance Phase were to: (1) determine if the water resources problem(s) warrant Federal participation in feasibility studies; (2) define the criteria for Federal involvement in a project; (3) complete an Section 905(b) preliminary analysis; (4) prepare a Project Management Plan (PMP); (5) assess the level of interest and support from non-Federal entities; and (6) negotiate and execute a Feasibility Cost Sharing Agreement (FCSA).

The 905(b) report concluded that potential existed for Federal involvement in flood risk management in the Millstone River Basin. It was also concluded that significant local support for flood risk management existed and that it was expected that a non-Federal project sponsor would be willing and able to cost-share feasibility studies and project implementation. Furthermore, the preliminary ecosystem evaluation of the Basin resulted in the identification of numerous opportunities for ecosystem restoration and/or enhancement. It was recommended that the 905(b) report be approved as the basis for completing a project management plan for a cost-shared feasibility phase.

Studies by others include:

- U.S. Department of Agriculture Soil and Water Conservation Plan for Stony Brook Watershed (July 1951)
- U.S. Department of Agriculture Soil and Water Conservation Plan for Stony Brook Watershed (July 1956)
- State of New Jersey Department of Environmental Protection Delineation of Flood Hazard Areas, Raritan Basin Millstone River, Rock Brook (February



- 1973)
- New Jersey Water Supply Authority, Water Budget in the Raritan River Basin, A technical Report for the Raritan Basin Watershed Management Project (March 2000)
  - New Jersey Water Supply Authority, Setting of the Raritan River Basin, A Technical Report for the Raritan Basin Watershed Management Project (July 2000)
  - U.S. Department of Agriculture, Natural Resources Conservation Service, Millstone River Watershed, Flood Damage and Mitigation Analysis Report (December 2004)

Of particular importance is the last report. This report documented that USACE and the Natural Resources Conservation Service (NRCS) agreed that USACE would conduct a flood risk management Feasibility Study for Manville while the NRCS would conduct a study of flooding and potential solutions in the upstream municipalities (the upstream municipalities are located to the south of Manville, which is located in the northern portion of the basin).

The NRCS analyzed flood water storage at various sites throughout the watershed and levees at locations in the Millstone River area. These locations are in Hillsborough Township, Millstone Borough and Franklin Township. Both the flood water storage and levee measures were found not to meet the benefit cost criteria required of all USACE-assisted flood risk management projects. Other nonstructural flood risk management measures were evaluated in Millstone Borough where the greatest density of potentially benefiting structures exist (aside from Manville). The study found that these measures were not cost effective in terms of reduced flood damages to residential and commercial structures. Federal agencies are required to show that benefits exceed costs in order to recommend implementation of a flood risk management project. As a result, the NRCS discontinued the investigation of potential flood risk management measures in the Millstone River Basin.

## ***6.0 Purpose and Need***

Based on the occurrence of damages and risk to life safety caused by storm events in the Millstone River Basin, a clear purpose and need to investigate fluvial flooding within the basin exists. Section 8.0 describes the problems, opportunities and storm events associated with flooding in the Millstone River Basin in detail.

### ***6.1 Federal Participation***

Flood risk management is an approved authority for USACE. Any potential project must be feasible from an engineering and environmental aspect and must display economic feasibility by satisfying benefit-cost criteria. In order for Federal participation in a flood risk management project a plan with a Benefit-Cost Ratio (BCR) of one or greater must



be identified. If all formulated alternatives fail to meet these criteria a recommendation of no further Federal action is made.

## **7.0 Study Scope**

The scope of this study is to fully evaluate all reasonable solutions to the flooding problems identified and determine whether feasibility exists for Federal participation in providing flood risk management measures for the Millstone River Basin, New Jersey. The feasibility of flood risk management measures in the basin will be examined by:

- Defining the problems and opportunities for flood risk management associated with periodic flooding from storms within the Millstone River Basin, New Jersey;
- Evaluating the technical, economic, environmental, and institutional feasibility for Federal participation in addressing flooding issues;
- Identifying and evaluating potential solutions to flooding issues, including a possible recommendation for a project; and
- Determining if there is local support for implementation of the recommended plan.

The analysis and conclusions these tasks entail are documented within this Feasibility Report and Appendices.

## **7.1 Study Area**

The study area is the Millstone River Basin. The 238-square mile basin is located in north-central New Jersey, halfway between Philadelphia and New York City. The study area is bounded by the Raritan River to the north, the Millstone River to the east and Royce Brook to the south. The basin includes the Millstone River and its major tributaries located in the New Jersey counties of Mercer, Middlesex, Monmouth, Hunterdon, and Somerset. From its headwaters near Millstone Township in Monmouth County, the Millstone River flows northward through Somerset County to its confluence with the Raritan River in Manville.

The Millstone River, a tributary of the Raritan River, enters the Raritan River in Manville, about 22 miles upstream of Raritan Bay. The Raritan River flows eastward into Raritan Bay, the Millstone River flows northward into the Raritan River, and Royce Brook flows eastward into the Millstone River.

Tributaries to the Millstone within the currently delineated study area include Royce Brook and Stony Brook. Royce Brook, a tributary of the Millstone River, enters the Millstone River in Manville about 1.5 miles upstream of the Millstone River's mouth. Royce Brook originates east of Manville in Hillsborough Township and has a drainage area of 16.5 square miles. Royce Brook runs for approximately 9 miles before discharging into the Millstone River in the southern east portion of Manville. Stony Brook, which is the

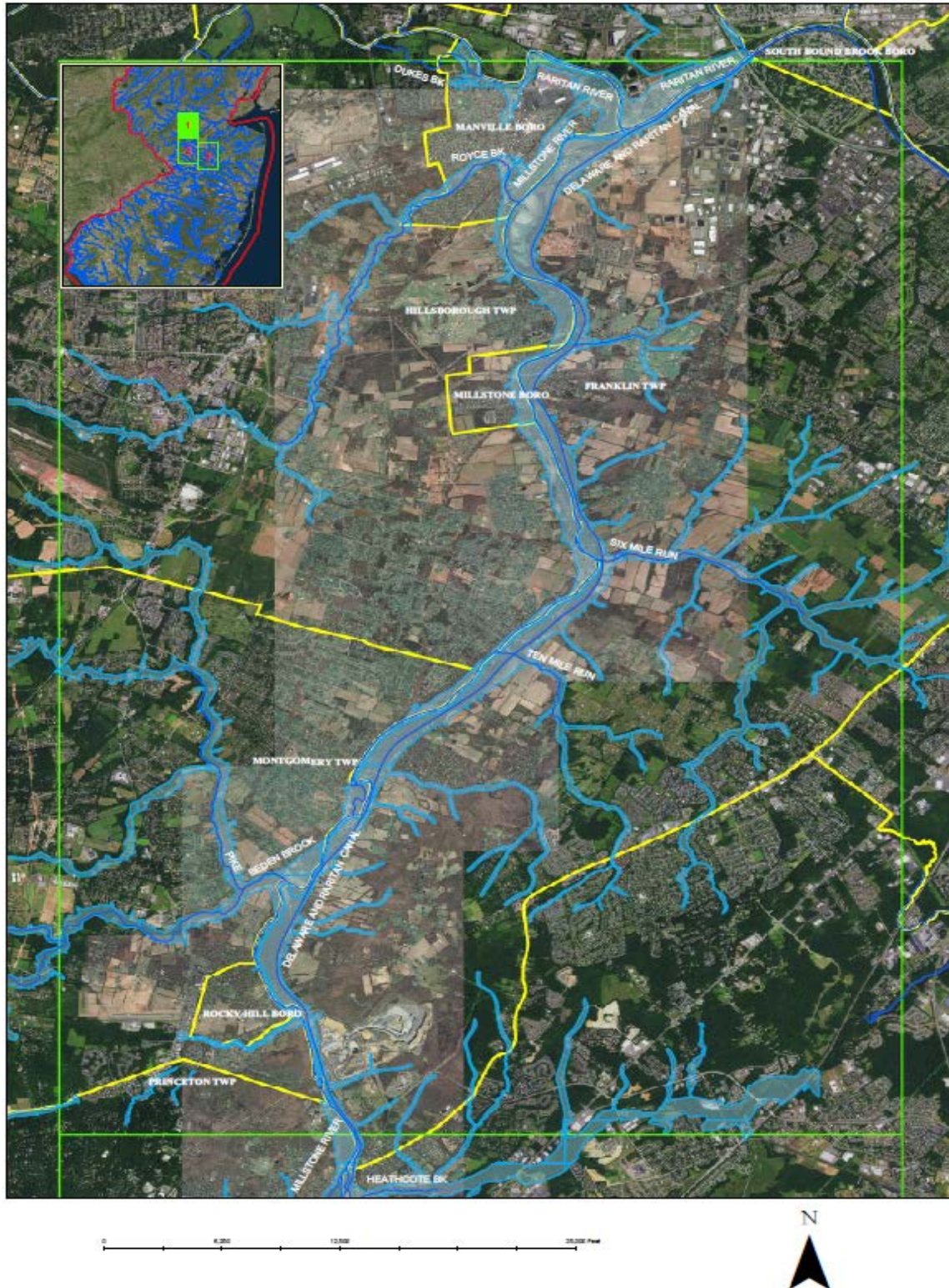


largest tributary to the Millstone River, is located near Princeton Township, New Jersey. This sub-basin has a drainage area of 56 square miles.

The study area is a relatively flat floodplain. The basin receives about 47 inches of precipitation annually, which is fairly evenly distributed throughout the year. The Millstone River is a source of drinking water to portions of central New Jersey with a pumping station located near where the Millstone River meets the Raritan. Figures 1, 2 and 3 depict the Millstone River Basin and its location within New Jersey. The 1% annual chance exceedance floodplain for the Millstone River and its tributaries are overlaid on these figures. The term 1% annual chance exceedance is a term used to define storm and floodplain frequency and is synonymous to the 1% flood or floodplain. The 1% annual chance exceedance storm or floodplain frequency is the storm or floodplain that has a 1% chance of occurring per year. The term annual chance exceedance will be used throughout this report in conjunction with either a storm event or a floodplain. The study area is located in New Jersey's 7<sup>th</sup> and 9<sup>th</sup> Congressional Districts.



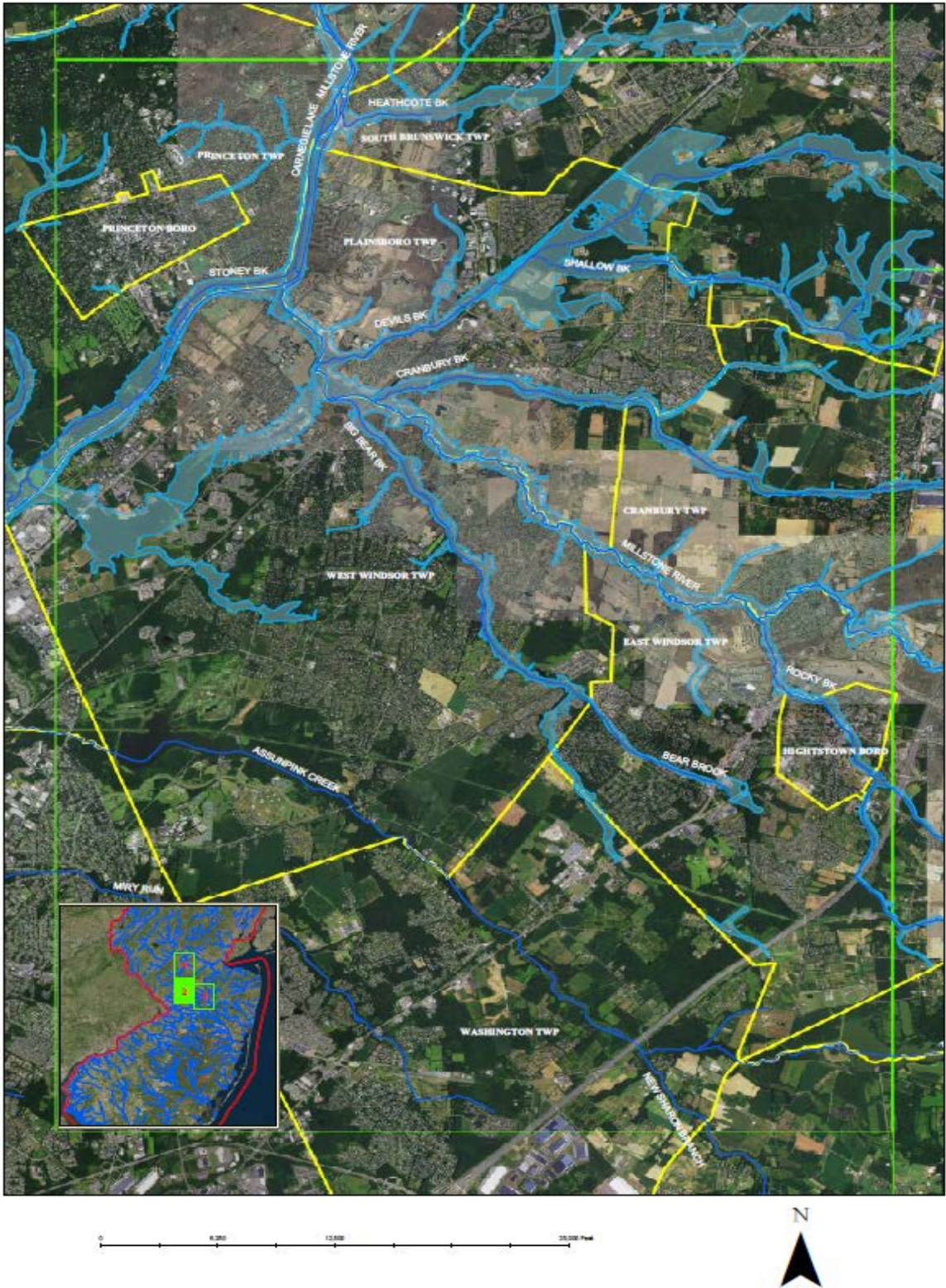




*Figure 1. Millstone River Basin with 1% Annual Chance Exceedance Floodplain*



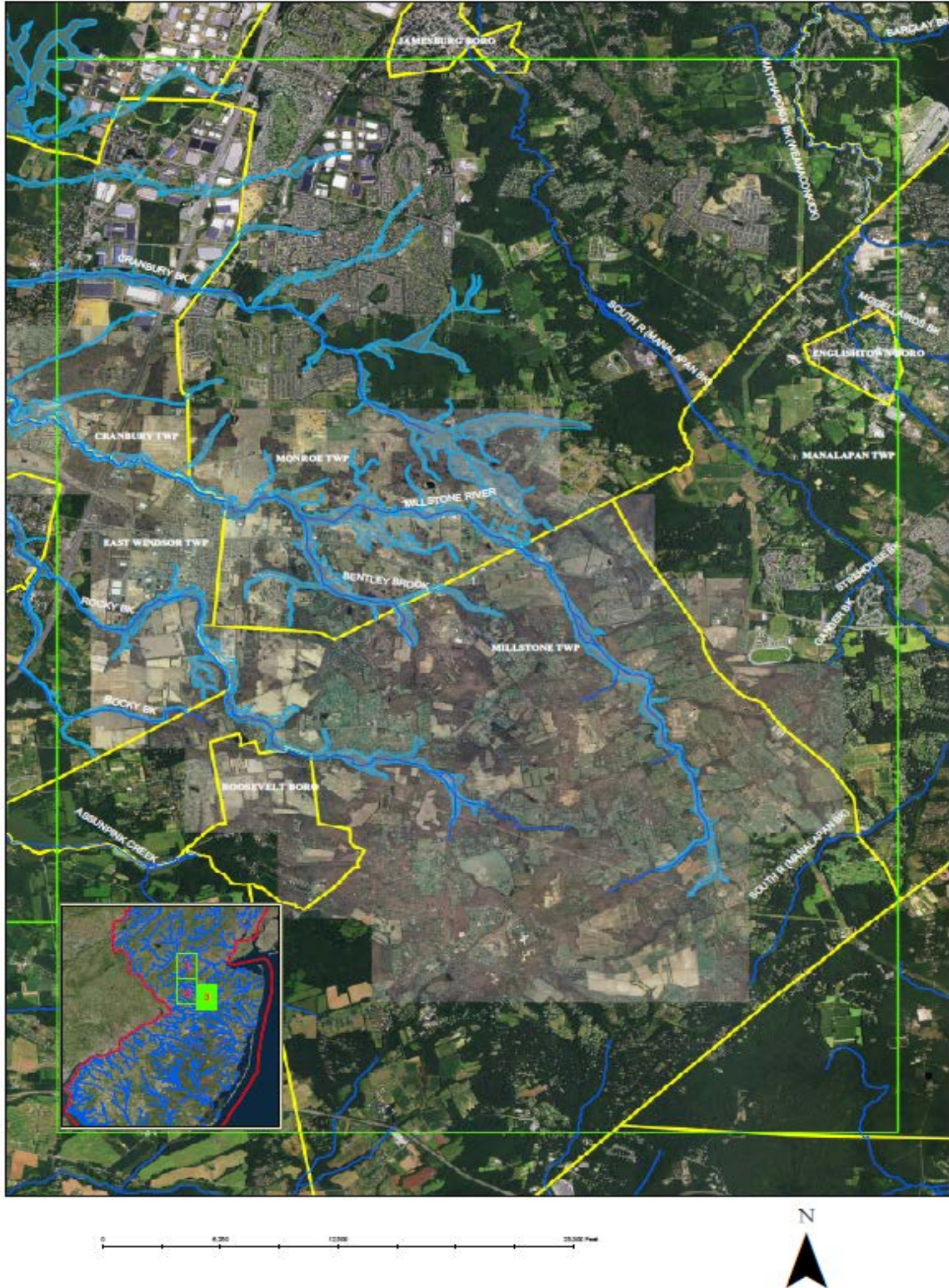




*Figure 2: Millstone River Basin with 1% Annual Chance Exceedance Floodplain*







*Figure 3: Millstone River Basin with 1% Annual Chance Exceedance Floodplain*



## 7.2 Study Area Screening

As part of this study, USACE has coordinated with interested Federal, State, and local stakeholders to identify problems and opportunities for flood risk management in the Millstone River Basin. Municipalities in the study area were contacted during this investigation to determine the severity of their flooding problems associated with the Millstone River and its tributaries. Municipal engineers, public works officials, and construction superintendents were interviewed. In addition, a literature search and review was conducted to identify available information regarding water resources issues in the basin.

Based on the above it was determined that the most significant flooding problems in the Millstone River Basin are in Manville. The structure count for the 1% annual chance exceedance floodplain in the Millstone River Basin is illustrated in Table 2 directly below. Included are Federal Emergency Management Agency (FEMA) National Flood Insurance Program (NFIP) Damage Claims from 01 January 1978 – 31 March 2016 for municipalities in the basin in FY16 Price Levels (P.L.).

**Table 2. Millstone River Basin Structure Count by Municipality**

<b>Municipality Name</b>	<b>Number of Structures</b>	<b>Figure #</b>	<b>Flood Damage Claims*</b>
Cranbury Twp	15-20	2, 3	\$654,757
East Windsor Twp	40-55	2, 3	\$129,517
Franklin Twp	90-130	1	\$3,517,463
Hillsborough Twp.	20-30	1	\$6,469,476
Manville Boro	490	1	\$48,971,590
Millstone Boro	20-30	1	\$3,335,616
Millstone Twp	4-8	3	\$46,633
Monroe Twp	4-8	3	\$2,678,160
Montgomery Twp	8-12	1	\$ 2,040,712
Plainsboro Twp	25-35	2	\$72,382
Princeton Boro	20-30	1, 2	\$1,958,301
Rocky Hill Boro	4-8	1	\$398,098
South Brunswick Twp	5-10	1, 2	\$406,718
West Windsor Twp	50-65	2	\$3,632,584
<b>Total</b>	<b>795-931</b>	<b>1, 2, 3</b>	<b>\$74,312,007</b>

\*Federal Emergency Management Agency (FEMA) National Flood Insurance Program (NFIP) Damage Claims from 01 January 1978 – 31 March 2016 in FY16 P.L.

Manville was selected within this investigation for detailed consideration of Federal participation in a flood risk management project as it is the highest impact municipality in



the Millstone River Basin. This is due to a relatively greater number and density of structures within the 1% annual chance exceedance floodplain in the Manville area and consequently an estimated greater possibility of producing an economically viable project. There are approximately 490 structures within the 1% annual chance exceedance floodplain in Manville, the majority of which are residential with some commercial and industrial facilities. The Lost Valley area of Manville contains approximately 250 residential structures within the 1% annual chance exceedance floodplain. Economic analysis of the 0.2% annual chance exceedance floodplain in Manville indicates an annualized damage pool of approximately \$2,850,000. This figure is equivalent to without project flood damages and is reflected in Table 14.

Examination of Table 2 in conjunction with the study area maps (Figures 1-3) illustrates the relatively greater number and density of structures within Manville as compared to the other municipalities within the study area. The floodplain tends to be narrow and relatively less urbanized in many of the municipalities other than Manville. Flood-prone structures tend to be few and widely distributed for communities other than Manville. It is thus assumed that if an economically viable alternative to address flooding problems in the Manville area cannot be identified, it is unlikely that an economically viable alternative would be found elsewhere within the basin. In this case a recommendation of no further Federal action would be made.

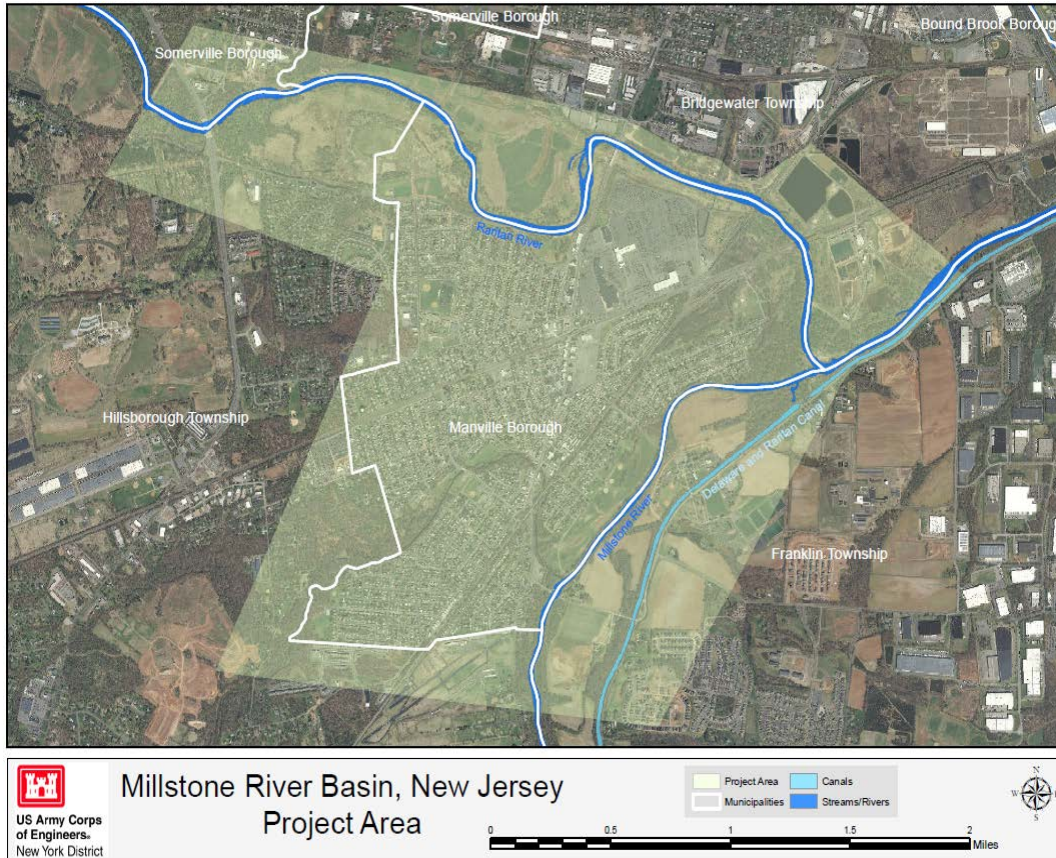
This reasoning is supported by the much larger NFIP flood claims for Manville in relation to other basin municipalities as listed in Table 2. Manville had almost \$50 million in NFIP claims from 1978 to 2016 with the next largest amount being the Township of Hillsborough with over \$6 million in NFIP claims. This difference in the number of flooding claims and the associated damages for other municipalities in the basin is due to the aforementioned significantly lower density and number of structures in the floodplain for those municipalities. In addition, the December 2004 report by the USDA NRCS concluded that flood risk management measures in select higher flood risk municipalities within the upstream portion of the basin were not cost effective. The USDA NRCS report is summarized in Section 5.0 of this report.





### 7.3 Project Area

The project area includes portions of the Millstone River and Raritan River in Manville. Manville is bounded by the Raritan River on the north, the Millstone River on the east, Royce Brook to the south and Hillsborough Township on the west. Manville has a population of approximately 10,000 people. Transportation infrastructure includes local streets and interstate highways. Figure 4 depicts the location of the project area within Manville. Officials from Manville report that recurrent flooding problems are prevalent throughout Manville in areas proximate to the Raritan River and the Millstone River.



**Figure 4: Project Area**

The area from the Borough of Millstone to the confluence of the Millstone River with Royce Brook is characterized by a rather flat floodplain and is mostly undeveloped on the right bank with residential development on the left bank. The Royce Brook area, extending from Sunnymead Road to the confluence of Royce Brook with the Millstone River, is urban in character with steep banks and nearly all of the floodplain developed. This reach contains a major damage area called Lost Valley, located on the left bank of the Millstone



River within Manville. The community of Zarephath area and the Delaware-Raritan Canal are within this portion of the project area.

The Raritan River, extending from the abandoned West Railroad Bridge just upstream of Route 206 to its confluence with the Millstone River, is characterized by a broad flat floodplain with some undeveloped portions and some industrial and residential development. The Raritan River, extending downstream from the its confluence with the Millstone River, is characterized by a broad flat floodplain mostly undeveloped with some industrial development on the left bank.

## ***8.0 Problems/Opportunities***

### ***8.1 Problems***

The water resources problem to be solved is fluvial flooding in the study area. Fluvial flooding in the Millstone River Basin occurs as a result of storm events within the basin. Development in the watershed has increased runoff potential and flood hazards. Many areas that previously were not subject to flooding are now reporting damages during severe events, such as Hurricane Floyd in 1999.

Upon examination the most significant flooding problems in the Millstone River Basin are in Manville. As a result, plan formulation focused on flooding problems and opportunities in this area. Flood-prone structures tend to be few and widely distributed for the other Millstone River Basin communities. Section 7.2 explains the study area screening in more detail and Section 10.1 describes storms and flooding problems in greater detail.

### ***8.2 Opportunities***

There exists an opportunity to reduce the frequency and severity with which fluvial flooding occurs in the study area through implementation of one or more flood risk management measures. The greatest opportunities for flood risk management lies within Manville as discussed in Section 7.0 and its subsections.

## ***9.0 Planning Goals/Objectives***

### ***Goals***

Study goals, objectives, and constraints were developed to comply with the study authority and to respond to study area problems. The goal of the Millstone River Basin Feasibility Study is to reduce the damages to life and property caused by fluvial flooding within the Millstone River Basin.

### ***Objectives***

Planning objectives were identified based on the problems, needs and opportunities as well as existing physical and environmental conditions present in the study area. The



main Federal objective is to contribute to National Economic Development (NED) consistent with the nation's environment, pursuant to national environmental statutes, applicable executive orders and other Federal planning requirements. Recommended plans should avoid, minimize, and then mitigate, if necessary, adverse project impacts to the environment.

In pursuit of the goal to reduce flooding damages in the study area, the following objectives for flood risk management in the Millstone River Basin were established:

- Reduce the damages to life and property caused by fluvial flooding within the Millstone River Basin over the lifespan of the potential project, including reduction of backwater flooding from the Raritan River. This study focuses on the location of the Manville for flood risk management investigations. Manville has been identified as the area of greatest flood impact within the basin for reasons stated in Section 7.2.
- Avoid and minimize adverse environmental impacts.

### *9.1 Planning Constraints*

Unlike planning objectives that represent desired positive changes, planning constraints represent restrictions that should not be violated. Further, plan formulation must provide safe conditions in the interest of public safety and be socially acceptable to the community. Planning constraints that were considered are as follows:

#### *Universal Constraints*

- **Flood Heights:** The industry standard is not to induce any additional flood damages to any areas within or beyond the limits of the fluvial flood risk management project.
- **Environmental and Cultural Resources:** Alternatives should be designed to avoid or minimize negative impacts to these resources, to the maximum extent practical.

#### *Study Specific Constraints*

- **Detention & Diversion:** The infeasibility of implementing detention basins or diversions to provide flood risk management was identified as a constraint during the study. No area exists that has the potential to detain enough water temporarily to sufficiently reduce water surface elevations and flood damages downstream. A hydraulically suitable location has not been identified for a diversion culvert. Detention and diversion of flood waters were precluded for further study during screening as they would not meet the planning objective of reducing flood impacts in the basin.



## *Considerations*

- **Formulation:** Alternatives should take into consideration local laws, policies and preferences while avoiding adverse social impacts to the fullest extent possible.

## *10.0 Existing Conditions*

### *10.1 Physical Conditions*

#### ***Water Resources***

The study area is bounded by the Raritan River to the north, the Millstone River to the east and Royce Brook to the south. All three water bodies are designated as FW2-NT or freshwater river not supporting trout spawning or maintenance (N.J.A.C. 7:9B 2008). Additionally, all three water bodies experience some impairment as a result of the urbanized nature of their settings, with phosphorus loading as the largest contributing factor to the degraded water quality within the study area.

The main branch of the Raritan River forms west of Somerville where the North Branch converges with the South Branch. The width of the Raritan within the study area ranges from 140 to 185 feet and its depth is about 1 to 2 feet. The substrate is comprised of cobbles, gravel and mud.

The Millstone River, the largest tributary to the Raritan River, originates in Millstone Township, Monmouth County, and has a drainage area of approximately 238 square miles. The Millstone River flows northward through southern Somerset County and meets the Raritan River at Manville. The Millstone River is a source of drinking water to portions of central New Jersey with a pumping station located near where the Millstone River meets the Raritan. Tributaries to the Millstone River within the currently delineated study area include Royce Brook and Stony Brook. The width of the river in the study area ranges from 100 to 150 feet and substrate is comprised of gravel and sand.

Royce Brook originates east of Manville in Hillsborough Township and has a drainage area of 16.5 square miles. Royce Brook runs for approximately 9 miles before discharging into the Millstone River in the southern east portion of Manville. The substrate of the Brook within the study area is predominantly gravel/sand with cobble, mud and silt. Royce Brook ranges from 58 feet wide and 1 to 1.5 feet deep.

#### ***Storms and Flooding***

The storms which occur over the northeastern states have their origins in or near the Pacific and the North Atlantic oceans and may be classified as: rain events, nor'easters, extra tropical storms, tropical storms and hurricanes. These storms can deposit large amounts of precipitation in the watershed, producing significant flooding of the low-lying



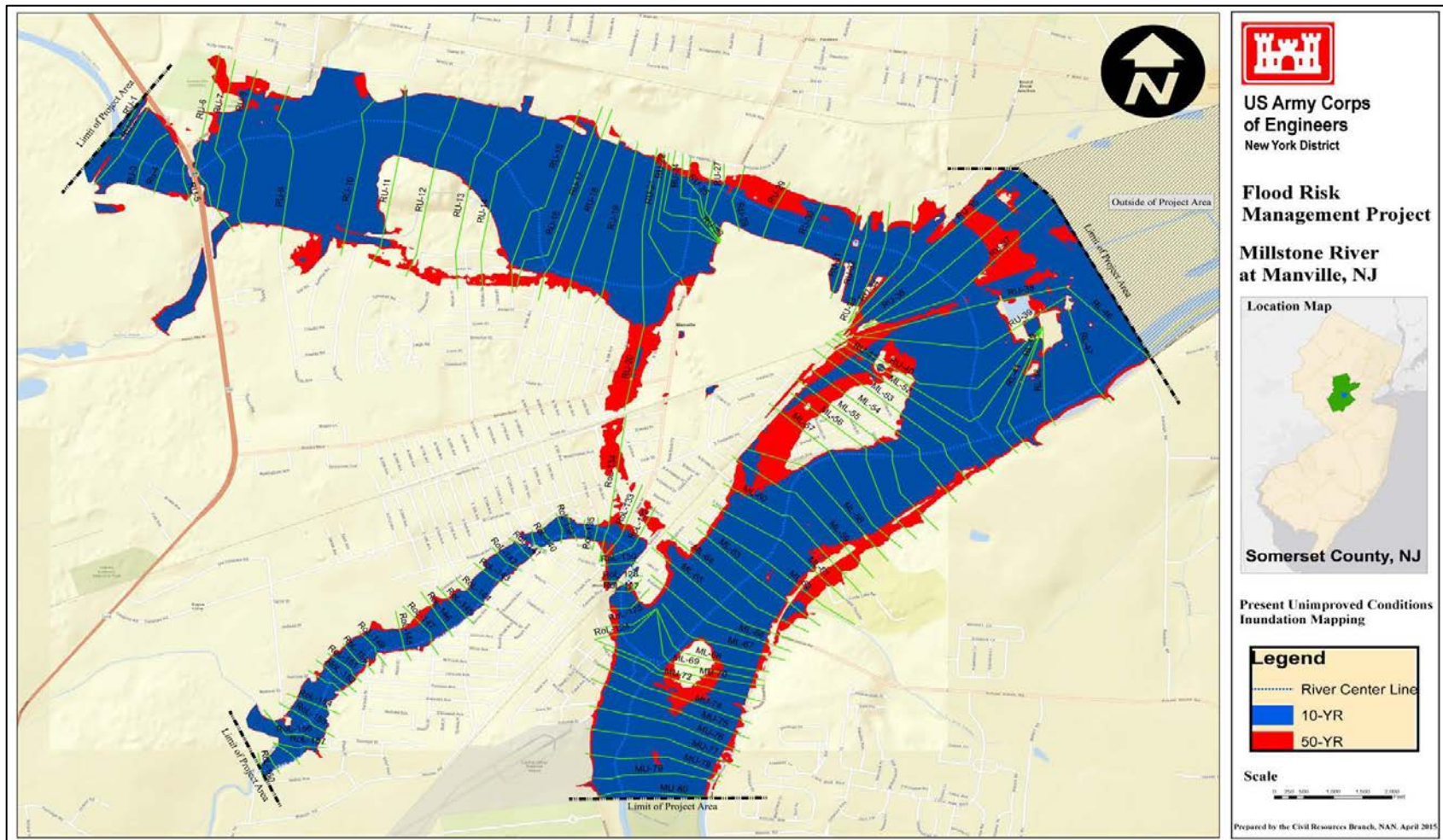
and relatively flat floodplain. Fluvial flooding from the Raritan and Millstone Rivers in the Millstone River Basin occurs as the result of intense thunderstorms, northeasters, and hurricanes. Development in the watershed has increased runoff potential and flood hazards. Many areas that previously were not subject to flooding are now reporting damages during severe events, such as Hurricane Floyd.

Upon examination the most significant flooding problems in the Millstone River Basin are in Manville. Flood-prone structures tend to be few and widely distributed for other Millstone River Basin communities within narrow floodplains and as a result flood damages tend to be much less severe in other portions of the basin (Section 7.2 above explains the study area screening in more detail). Economic analysis of the 0.2% annual chance exceedance floodplain in Manville indicates an annualized damage pool of approximately \$2.85 million. This figure is equivalent to without project flood damages and is reflected in Table 14.

During large riverine floods, Manville is surrounded by the flood waters of the Raritan and Millstone Rivers. They thereby isolate Manville as an island, with limited to no access by road. Fluvial flooding in Manville is associated with the Millstone River in conjunction with coincident and backwater flooding from the Raritan River during storm events. Officials from Manville report that the recurrent flooding problems are prevalent throughout the municipality in areas proximate to the Raritan River and the Millstone River. As a result, plan formulation focused on flooding problems and opportunities in this area. Almost all areas of Manville adjacent to streams and rivers have flooding problems. There are approximately 490 structures within the 1% annual chance exceedance floodplain in Manville, the majority of which are residential with some commercial and industrial facilities. The Lost Valley section is one of the most densely populated portions of the floodplain within Manville and has traditionally experienced a large proportion of the damages within Manville. The Lost Valley area of Manville contains approximately 250 residential structures within the 1% annual chance exceedance floodplain. Figure 5 illustrates Manville with the 10% and 2% annual chance exceedance floodplains.







*Figure 5. Borough of Manville with 10% and 2% Annual Chance Exceedance Floodplain*



Some of the major flood-producing storms that have occurred over the Millstone and Raritan River Basins are the following: July 1938; September 1938; June 1946; December 1948; March 1967; August 1971 (Tropical Storm Doria); August 1973 (thunderstorm over the Watchung Mountains); September 1989 (Tropical Storm Hugo); January 1996 (rainfall on snowmelt); October 1996 (nor'easter); September 1999 (Tropical Storm Floyd); April 2005 (northeaster); October 2005 (Tropical Storm Tammi); April 2007 (northeaster); and August 2011 (Tropical Storm Irene).

Manville, located at the confluence of the Millstone and the Raritan Rivers, experiences the most significant flooding problems within the study area. Significant historic floods at Manville are those of September 1938 and August 1955 (both tropical storms); August 1942 (thunderstorm); August 1971 (Tropical Storm Doria); October 1996; April 2007; and August 2011 (Tropical Storm Irene). The Lost Valley area of Manville is usually one of the areas hardest hit by floods.

Tropical Storms Doria in 1971 and Floyd in 1999 caused significant damages. More than 1,200 homes were affected by flooding during Tropical Storm Floyd, a storm estimated to have a magnitude equal to approximately the 0.2% annual chance exceedance storm event. Local officials estimated that 75 homes suffered major structural damage. The Lost Valley District was one of the hardest hit areas with over 500 homes damaged. Total damages in Manville from Tropical Storm Floyd were estimated to be more than \$15.9 million. A severe storm in April 2007 caused damages in the Lost Valley section. Tropical Storm Irene caused severe damages in Manville in August 2011 with one out every three homes damaged. Irene particularly damaged the Lost Valley section, leaving many homes abandoned. Further information on flooding and storms can be located in the Hydrology and Hydraulics associated with this report.

### ***Soils***

Dominant soils in the study area are comprised of Birdsboro silt loam, Dunellen Sandy loam, Penn silt loam and Rowland silt loam. The Birdsboro series consists of very deep, well drained, and moderately well drained soils. Birdsboro series are formed in old alluvial deposits derived from red sandstone, shale, and siltstone and are typically located on terraces and alluvial fans with convex slopes of 0 to 15 percent. The Dunellen series consists of very deep, well drained soils formed in stratified materials. Dunellen soils are on outwash plains and stream terrace with slopes ranging from 0 to 35 percent. The Penn series consists of moderately deep, well drained soils formed in residuum weathered from noncalcareous reddish shale, siltstone, and fine-grained sandstone normally of Triassic age. Slopes range from 0 to 60 percent.

The Rowland series is located along the Millstone and Raritan Rivers and consists of very deep, moderately well and somewhat poorly drained soils formed in alluvial sediments weathered from red and brown shale, sandstone, and conglomerate. Slopes range from 0



to 3 percent. The Rowland soils are flooded by streams during wet periods when the water table can fluctuate between 2 and 6 feet.

## **10.2 Environmental Conditions**

### **Vegetation**

Vegetation within the study area is predominantly limited to landscaped lawns with a few forested sections along the Royce Brook, Millstone River and Raritan River corridors. The largest tract of undeveloped land is located on the northeastern side of the study area and is a combination of field and forest. Dominant overstory trees within the region include silver maple (*Acer saccharinum*), green ash (*Fraxinus pennsylvanica*), balsam poplar (*Populus balsamifera*), and pin oak (*Quercus palustris*), with fewer numbers of black cherry (*Prunus serotina*), American elm (*Ulmus americana*), boxelder (*Acer negundo*), eastern sycamore (*Platanus occidentalis*), and shagbark hickory (*Carya ovata*) (USACE 2008).

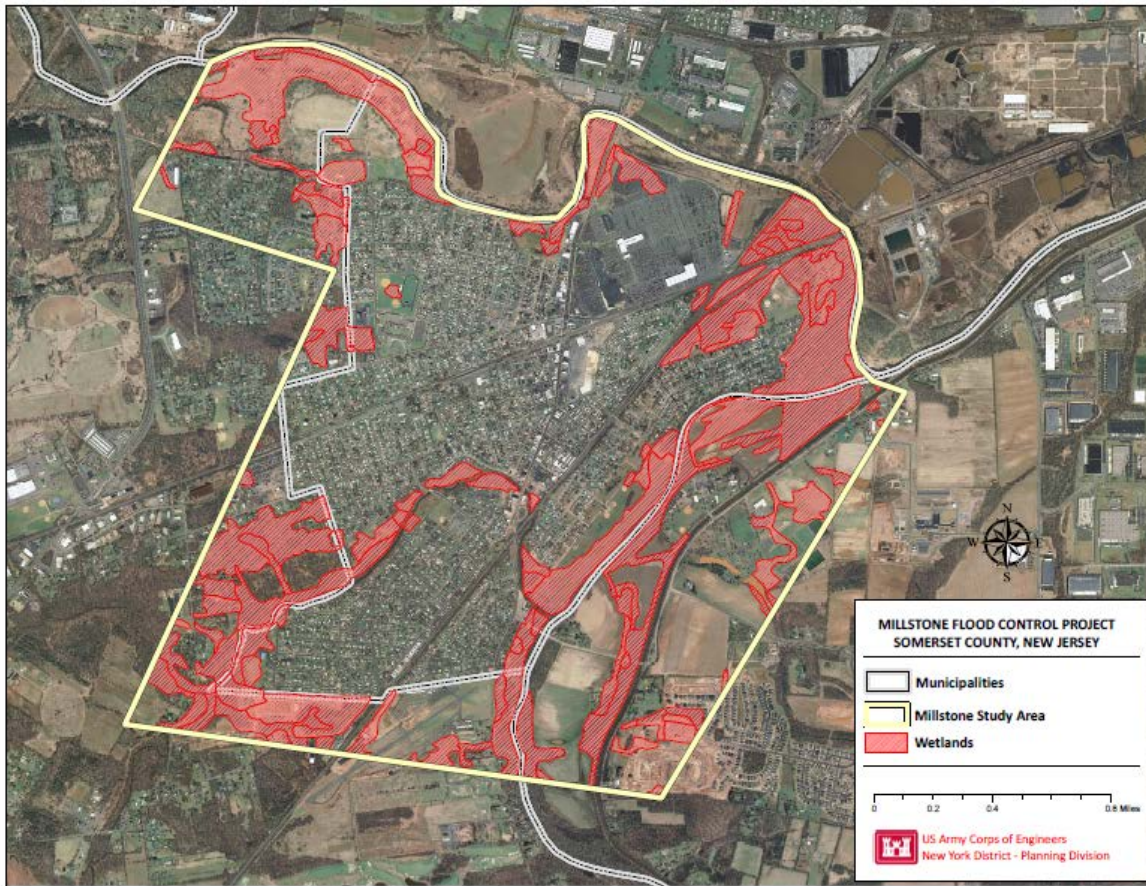
### **Wetlands**

Federal (33 CFR 328.3(b); EO 11990) and State (N.J.A.C. 7:7A1.4) definitions of wetlands are similar, identifying wetlands as “those areas that are inundated or saturated by surface or groundwater at a frequency and duration sufficient to support, and that under normal circumstances do support, a prevalence of vegetation typically adapted for life in saturated soil conditions.” As defined above, wetlands generally include swamps, marshes, bogs, and similar areas.

A review of the NJ Geo-web and the U.S. Fish and Wildlife Service National Wetland Inventory Maps (USFWS NWI maps) indicated herbaceous and deciduous wetlands within the study area (Figure 6). The eastern portion of the study area has approximately 110 combined acres of deciduous and herbaceous wetlands. Smaller wetland complexes are scattered throughout the remainder of study area in discreet, undeveloped portions of properties.







**Figure 6: Wetlands Mapped by New Jersey Department of Environmental Protection**

Lincoln Avenue Park was originally investigated as a potential mitigation site for the Green Brook Flood Damage Reduction Project. As part of the investigation, a wetland delineation was performed and identified approximately 4.10 acres as mix of emergent and forested wetland.

### ***Fish and Wildlife***

Fish sampling conducted by NJDEP in 2005 in Royce Brook, approximately a quarter mile from its confluence with the Millstone River, found tessellated darter (*Etheostoma olmstedi*), green sunfish (*Lepomis cyanellus*), American eel (*Anguilla rostrata*), white sucker (*Catostomus commersoni*), spottail shiner (*Notropis hudsonius*), redbreast sunfish (*Lepomis auritus*), fallfish (*Semotilus corporalis*), Pumpkinseed (*Lepomis gibbosus*), yellow bullhead (*Ameiurus natalis*), bluegill (*Lepomis macrochirus*), swallowtail shiner (*Notropis procerne*), rock bass (*Ambloplites rupestris*), golden shiner (*Notemigonus crysoleucas*), creek chub (*Semotilus atromaculatus*), banded killifish (*Fundulus diaphanus*), smallmouth bass (*Micropterus dolomieu*), largemouth bass (*Micropterus salmoides*), and redbfin pickerel (*Esox americanus americanus*) (NJDEP 2005).



The Raritan River contains fish species such as common carp (*Cyprinus carpio*), white perch (*Morone Americana*), channel catfish (*Ictalurus punctatus*), eastern silvery minnow (*Hybognathus regius*) and other warm water fisheries species and anadromous fish (USACE 2008). Limited existing information is available on the fish species that inhabit the portion of the Millstone River within the study area although it is presumable that it would contain similar fish species as the Raritan River and Royce Brook.

Mammal species that inhabit the study area include raccoon (*Procyon lotor*), chipmunk (*Tamias*), Red fox (*Vulpes vulpes*), woodchuck (*Marmota monax*), and muskrat (*Ondatra zibethicus*). White tailed deer (*Odocoileus virginianus*) have been observed in the Funderne Mitigation area which is located in Bridgewater directly north of Manville so it is reasonable to expect that they occur within the study area as well.

Common bird species of the study area include mourning dove (*Zenaida macroura*), American robin (*Turdus migratorius*), northern mockingbird (*Mimus polyglottos*), grey catbird (*Dumetella carolinensis*), American goldfinch (*Carduelis tristis*), house finch (*Carpodacus mexicanus*), red-tailed hawk (*Buteo jamaicensis*), sharp-shinned hawk (*Accipiter striatus*), blue jay (*Cyanocitta cristata*), American crow (*Corvus brachyrhynchos*), northern cardinal (*Cardinalis cardinalis*), European starling (*Sturnus vulgaris*), barn swallow (*Hirundo rustica*), mallard duck (*Anas platyrhynchos*), Canada goose (*Branta Canadensis*), downy woodpecker (*Picoides pubescens*), tufted titmouse (*Baeolophus bicolor*), black capped chickadee (*Poecile atricapillus*), and house wren (*Troglodytes aedon*) (USACE 2008).

### ***Threatened and Endangered Species***

A review of the U.S. Fish and Wildlife Service's (USFWS) Information, Planning and Conservation System indicated the potential presence of the federally endangered Indiana bat (*Myotis sodalis*), and the federally threatened northern long-eared bat (*Myotis septentrionalis*) within the project area (USFWS, 2015a).

In addition, the USFWS is currently evaluating the little brown bat (*Myotis lucifugus*), tri-colored bat (*Perimyotis subflavus*) and American eel to determine if listing under the Endangered Species Act (ESA) is warranted. A decision on whether to list the American eel is anticipated to be made by 30 September 2015 (USFWS, 2015b).

### ***Hazardous, Toxic, and Radioactive Waste (HTRW)***

As required by ER 1165-2-132 (Hazardous, Toxic and Radioactive Waste Guidance for Civil Works, 26 June 1992), an assessment of hazardous, toxic, and radioactive waste (HTRW) was conducted in the study area. Assessment of the study area was focused on the primary damage center of Manville and surrounding areas and consisted of Regulatory Agency File Reviews.



Despite the area's background as formerly agricultural, a review of data bases for the presence of environmental impacts showed more than what would be expected for such an area. Reviewing the US-EPA, Region II database for Superfund sites revealed five listed sites;

- Rocky Hill Municipal Wells, Rocky Hill Borough.
- Montgomery Township Housing Development.
- Higgins Farm, Franklin Township.
- Higgins Disposal Services, Franklin Township
- Federal Creosote, Manville.

These were listed on the Superfund list as early as the mid 1980's. By 2005, the first four sites were in the final phases of clean-up and controlled. Federal Creosote was the last to achieve complete removal of all impacted soils and sediments in 2008. All sites are now classified as in operation and maintenance mode with quarterly groundwater monitoring conducted. All five sites are located several hundred yards away and further, from the potential line of construction for any proposed flood control structures.

A review of the New Jersey Department of Environmental Protection (NJDEP) data bases showed much more activity. The NJDEP Known Contaminated Sites List, updated on 24 March 2009, showed the following;

Active:

- Franklin Township: Two sites on Canal Road and one site on Weston Canal Road.
- Hillsborough Township: Two sites, the Kupper Airport and a private residence, on Millstone River Road.
- Manville: The database identified 15 active sites distributed throughout the town. They include a mix of active gasoline stations, private residences, machine shops and other facilities.
- Millstone: No active sites were listed.
- Montgomery Township: This included the housing development on Robin Place and Sycamore Drive identified previously as a Superfund site. This site is now in Operation and Maintenance mode.
- Rocky Hill Borough: No active sites were listed.

Closed Sites;

- Franklin Township: There is a closed site on Canal Road and one on Weston Canal Road. They should not be an issue.
- Hillsborough Township: There are three closed sites, all on Millstone River Road.



- Manville: There are thirty-three closed sites distributed throughout the town and included home heating oil tanks located in private residences as well as several former gasoline stations and repair shops
- Millstone: The Department of Public Works site on Millstone River Road is listed as closed.
- Montgomery Township: One site, a private residence on Millstone River Road, is listed as closed.
- Rocky Hill Borough: No closed sites were listed.

Pending Sites:

- Franklin Township: Two pending sites were listed: 108 Route 518, Weston Canal Road near the north end of the project area.
- Hillsborough Township: One pending site is identified on Millstone River Road.
- Manville: Two potential pending sites are located on North Main Street.
- Millstone: No pending sites were listed.
- Montgomery Township: No pending sites were listed.
- Rocky Hill Borough: No pending sites were listed.

Based on the results of the database reports, several “Active” HTRW sites of concern were identified. Sites classified as “Active” HTRW concern mean that the NJDEP is monitoring cleanup of the site or the site will have to be addressed accordance with NJDEP requirements. A “Closed” site designation means the remediation effort was sufficient to NJDEP standards for that certification. A “Pending” site designation indicates the NJDEP is reviewing this case and is in discussions with the property owner(s) on what is needed to meet state guidelines. Property owners currently in compliance with HTRW regulations do not warrant investigation.

The number of impacted sites along the river is few. Many of the potential sites consist of leaking underground storage tanks that have been removed but residual soil contamination may persist. Limited pockets of such contamination can be identified by pre-construction testing and avoided or removed through engineering and site management controls. Those sites listed as “Active” if along the propose line of construction would have to be addressed according NJDEP requirements, meaning possible excavation of impacted soils. Sites listed as “Closed” are exactly that, remedial actions on that location were deemed adequate to meet state clean-up requirements and should not be an issue. Sites listed as “Pending” would have to be considered on a case-by-case basis.

There may be potential impacts to ground water resulting from the presence of underground storage tanks and other former sources, particularly in areas adjacent to the Rocky Hill Borough and Montgomery Housing Development Superfund Sites. The levels of contaminants presently in the groundwater at these locations are currently stabilized or are decreasing.



***Cultural Resources***

In accordance with Section 106 of the National Historic Preservation Act of 1966, as amended, and its implementing regulations, 36 CFR 800, the District has conducted preliminary investigations to identify potentially significant cultural resources within the study area of the Millstone River Basin. A review of background information including local histories and maps was undertaken at the Millstone Library, the Somerset County Library and the New Jersey State Library. Research on previous surveys and documented archaeological sites was undertaken at the New Jersey State Historic Preservation Office (NJSHPO) and the New Jersey State Museum (NJSM).

Since the 1970’s the study area has been subject to a number of archaeological and architectural surveys. There are two National Register of Historic Places (NRHP) listed properties and ten eligible properties within the study area. There were six NRHP listed and seven eligible properties within a mile of the study area. Table 3 lists these properties and their distance from the study area. A search of the site files at the New Jersey State Bureau of Archaeology at the New Jersey State Museum identified nineteen archaeological sites within or just outside the study area. These are listed in Table 4.

***Table 3. State and National Register Eligible and Listed Historic Sites***

<b>Property Name</b>	<b>SR/NR Status</b>	<b>Description</b>	<b>Proximity to Study Area</b>
Delaware and Raritan Canal	SR/NR		Within study area
Van Nest Farmstead	NR Eligible	Extension of D&R III	Within study area
Bridge Street Bridge over Conrail	NR Eligible	1918 thru truss steel bridge	Within study area
Manville Municipal Building (demolished)	NR Eligible		Within study area
Central RR of New Jersey Mainline Linear Historic District	NR Eligible		Within study area
Finderne Avenue Bridge (replaced)	NR Eligible		Within study area
Van Veghten House	SR/NR	Eighteenth and Nineteenth Century brick mansion.	Within study area
Van Veghten House Boundary Increase	NR Eligible		Within study area
Lehigh Valley RR Historic District	NR Eligible		Within study area
Duke Estate	NR Eligible		Within study area
Rt. U.S. 206 Bridge over	NR Eligible		Within study area





the Raritan River			
Somerville Historic District	NR Eligible		Partially within study area
Somerville Motor Vehicle Inspection Station	NR Eligible	One lane rectangular concrete masonry building with brick exterior.	100 feet
Reading RR Bridge c. 1875-1895	NR Eligible	Through-truss, Parker-type.	150 feet
Somerville RR Station	NR Eligible	Contributing element to the Somerville HD.	700 feet
Water Tower Stone Foundation	NR Eligible		1000 feet
Lehigh Valley RR Bridge	NR Eligible	Double span, through-truss, Pratt-type.	1000 feet
Reading RR Bridge c. 1900 (eastern)	NR Eligible	Double span, through-truss, Pratt-type.	1000 feet
Percey Smith Farm	NR Eligible	Early 19 <sup>th</sup> Century Georgian style clapboard house	1000 feet
Wallace House	SR/NR	Contributing element to the Somerville HD. General Washington's headquarters in 1778. Pre-1778 with 1778 addition.	1200 feet
Old Dutch Parsonage	SR/NR	Contributing element to the Somerville HD. 1751 Flemish bond brick pattern with Victorian modifications.	1500 feet
Somerset Court House Green	SR/NR	Contributing element to the Somerville HD. Consisting of a beaux-arts classicist Courthouse, a Neo-classical revival fountain and a high-victorian gothic cathedral.	1700 feet
West End Hose Company No. 3	SR/NR	Contributing element to the Somerville HD. Late Victorian/Romanesque brick structure dating to	.4 mi.



		1888.	
St. John's Church Complex	SR/NR	Contributing element to the Somerville HD. Three buildings dating to the 19 <sup>th</sup> and early 20 <sup>th</sup> centuries displaying late gothic revival character.	.5 mi.
J. Harper Smith Mansion	SR/NR	Contributing element to the Somerville HD. Consisting of residential structure, carriage house, and garden all in late Victorian style.	.75 mi.

**Table 4. Archaeological Sites**

<b>Archaeological Site</b>	<b>Description</b>	<b>Source</b>	<b>Proximity to Study Area</b>
Lincoln Avenue Prehistoric Site 28-So-109	Woodland Period, poss. Camp, low density	Hunter Research 1989	Within study area
Bridge Street Prehistoric Site 28-So-108	Woodland Period, poss. Camp, low density	Hunter Research 1989	Within study area
Weston House Prehistoric Site 28-So-111	Early Archaic, lithic scatter, surface find	Hunter Research 1990	Within study area
Van Veghten Prehistoric Site 28-So-124	Late Woodland, poss. Village or seasonal camp	Berger 1998	Within study area
Zarephath 1 28-So-138	Undetermined period, camp, surface collection	Grubb 2003	Within study area
Zarephath 2 28-So-139	Early Woodland, camp	Grubb 2003	Within study area
Zarephath 3 28-So-140	Late Archaic to Early Woodland, large camp	Grubb 2003	Within study area
Zarephath 4 28-So-141	Undetermined period, camp, surface collection, surface collection	Grubb 2003	Within study area
Dorris Duke 28-So-37	Archaic to Late Woodland, disturbed surface scatter	Kraft 1980	Within study area



Dumont Farmstead 28-So-61		Berger 1983	Within study area
Peter A. Dumont Farmstead 28-So-72		Berger 1983	Within study area
Josiah J. Schenk Farm 28-So-81	Early to Late 19 <sup>th</sup> Century farmstead c. 1848, prehistoric artifacts in the plow zone.	Kraft 1978	Approx. 1000 feet outside study area
I. Stryker farmstead 28-So-83	18 <sup>th</sup> to 19 <sup>th</sup> Century Farmstead	Berger 1985	Approx. 0.3 miles outside study area
Zaccheus Bergen Farmstead 28-So-52	Historic 19 <sup>th</sup> Century house site	Berger 1960	Approx. 0.5 miles outside study area
Bergen/Wilson Farmstead 28-So-53	Historic 19 <sup>th</sup> Century House Site	Berger 1960	Approx. 0.5 miles outside study area
Wilson Woodland House 28-So-54	Historic 19 <sup>th</sup> Century House site	Berger 1960	Approx. 0.5 miles outside study area
Stryker House 28-So-55	Historic 19 <sup>th</sup> Century House Site	Berger 1960	Approx. 0.5 miles outside study area
Voorhees/Paradise House 28-So-56	Historic 19 <sup>th</sup> Century House Site	Berger 1960	Approx. 0.5 miles outside study area
Henry Staats Farmstead 28-So-79	Late 18 <sup>th</sup> and 19 <sup>th</sup> Century Farmstead (on Selody property), disturbed	Berger 1985	Approx. 0.5 miles outside study area

Due to the location of the study area amidst the confluences of three rivers and the existing record of nine prehistoric sites within the study area from archaeological investigations, the study area is believed to have a high potential to contain significant prehistoric sites. There are two properties listed on the State and National Registers of Historic Places (SRHP and NRHP), the Delaware and Raritan Canal Historic District and the Van Veghten House, and nine properties that are eligible for listing on the NRHP that are located within the study area. Historic sites of this significance, such as those that are associated with the D&R Canal, early agricultural enterprises, or the development of Millstone or other surrounding towns are likely to be encountered during construction activities. Sites will be less likely to be found in areas that have been disturbed in the past.

***Recreation***

The Study Area includes multiple small and medium sized parks and land held as open space that provide both active recreation opportunities such as baseball or swimming and



passive recreation opportunities. Many of the parks are situated along the floodplains of the Raritan and Millstone Rivers and Royce Brook.

### ***Delaware and Raritan Canal***

The Delaware and Raritan Canal Park (Park) system is located just outside the southeastern border of Manville. However, as per the New Jersey State enacted the Delaware and Raritan Canal State Park Law (Law) of 1974, N.J.S.A 13:13A-1, the Study Area lies within the 400 square mile drainage area to the canal system and is subject to this Law and the associated Regulations for the Review Zone of the Delaware and Raritan Canal State Park established to prevent adverse impacts to the water quality, aesthetics and the cultural significance of the Delaware and Raritan Canal Park system.

The Delaware and Raritan Canal Regulatory Program consists of two Review Zones; Zone A which consists of the area on both sides of the canal within one thousand feet of the centerline of the canal, and Zone B which accounts for the remaining drainage area. The southern half of Manville is located with Review Zone B and a small portion of Manville in the vicinity of Lincoln Ave Park and a small section of forested area at the confluence of the Millstone River with the Raritan is located in Review Zone A.

Based on coordination with Delaware and Raritan Canal staff, flood risk management alternatives described in Section 14 of this report would be subject to the Rules.

### ***Green Acres Program***

The Green Acres Program, created in 1961 and administered by the NJDEP provides funds for the State or local municipalities through financial assistance by the State, to acquire and maintain lands for the purposes of recreation. Cooper Street Park and Lincoln Avenue Park are both Green Acres sites located along the west bank of the Millstone River.

## ***10.3 Economic and Social Setting***

### ***Economic and Social Setting – Population***

U.S. Census data indicates that the population for the state of New Jersey has increased by 4.5% between 2000 and 2010, while populations of the counties in the study area have increased between 2.5% and 8.7%. Population change in the study area municipalities ranges 0.0% to 39.8% (Table 5).



**Table 5. Population Data for the State, Counties, and Affected Municipalities  
(Courtesy of the U.S. Census Bureau, 2000 and 2010 U.S. Census)**

<b>Population Data</b>			
<b>Area Name</b>	<b>2000</b>	<b>2010</b>	<b>% Change</b>
Cranbury Twp	3,227	3,857	19.5
East Windsor Twp	24,919	27,190	9.1
Franklin Twp	50,903	62,300	22.4
Hillsborough Twp	36,634	38,303	4.6
Manville Boro	10,343	10,344	0.0
Millstone Boro	410	418	2.0
Millstone Twp	8,970	10,566	17.8
Monroe Twp	27,999	39,132	39.8
Montgomery Twp	17,481	22,254	27.3
Plainsboro Twp	20,215	22,999	13.8
Princeton Boro	N/A	28,572	N/A
Rocky Hill Boro	662	682	3.0
South Brunswick Twp	37,734	43,417	15.1
West Windsor Twp	21,907	27,165	24.0
Hunterdon County	121,989	128,349	5.2
Mercer County	350,761	366,513	4.5
Middlesex County	750,162	809,858	8.0
Monmouth County	615,301	630,380	2.5
Somerset County	297,490	323,444	8.7
New Jersey State	8,414,350	8,791,894	4.5

The project area, Manville, has had no effective change. The 2010 U.S. Census data indicates that there are 10,344 people living in the Manville as opposed to 10,343 people in 2000 (Table 3).

***Economic and Social Setting – Income***

Table 6 illustrates per capita income, median household income and the percentages of individuals below the poverty level for New Jersey and the counties and municipalities within the study area. West Windsor Township has the highest per capita income and median household income at \$63,928 and \$155,067, respectively. Cranbury Township has the lowest proportion of individuals below the poverty level at 1.4%. Manville has the lowest per capita income and median household income at \$29,298 and \$62,583, respectively. Mercer County has the highest proportion of individuals below the poverty level at 11.2%.



**Table 6. Income Comparison for the State, Counties, and Affected Municipalities**  
 (Courtesy of the U.S. Census Bureau, 2009-2013 5-Year American Community Survey)

Comparison of Income			
Area Name	Per Capita Income	Median Household Income	Individual Below Poverty Level (%)
Cranbury Twp	63,600	149,450	1.4
East Windsor Twp	37,183	84,656	8.1
Franklin Twp	40,332	88,726	5.8
Hillsborough Twp.	46,097	113,156	3.9
Manville Boro	29,298	62,583	7.0
Millstone Boro	38,190	81,250	2.3
Millstone Twp	54,103	135,556	3.6
Monroe Twp	44,470	70,384	4.2
Montgomery Twp	61,397	152,195	3.1
Plainsboro Twp	48,832	93,284	3.5
Princeton Boro	60,469	109,865	6.1
Rocky Hill Boro	57,618	90,972	3.7
South Brunswick Twp	43,643	108,315	2.9
West Windsor Twp	63,928	155,067	4.7
Hunterdon County	50,349	106,143	4.0
Mercer County	37,465	73,480	11.2
Middlesex County	34,345	79,596	8.5
Monmouth County	42,749	84,526	7.0
Somerset County	47,803	99,020	5.0
New Jersey State	36,027	71,629	10.4

**Labor Force:** Rocky Hill Borough has the lowest unemployment rate at 3.0% while the Manville has the highest at 14.0% (Table 7). Management, business, science and arts occupations tend to employ the highest percentages of individuals within the study area while production, transportation and material moving occupations tend to employ the lowest percentage of individuals (Table 8).

Within the study area (Table 8) sales and office occupations form the largest segment of the working population for Manville (26.5%). Production, transportation and material moving occupations employ the lowest percentage of individuals for Manville (14.0%).



**Table 7. Employment Status for the State, Counties, and Affected Municipalities  
(Courtesy of the U.S. Census Bureau, 2009-2013 5-Year American Community Survey)**

<b>Employment Status of Civilian Labor Force</b>					
<b>Area Name</b>	<b>Population 16 years and over</b>	<b>In Labor Force</b>	<b>Employed</b>	<b>Unemployed</b>	<b>% Unemployment</b>
Cranbury Twp	2,766	1,866	1,733	133	7.1
East Windsor Twp	21,896	15,842	14,342	1,500	9.5
Franklin Twp	50,984	34,617	31,908	2,671	7.7
Hillsborough Twp.	30,166	22,179	20,803	1,376	6.2
Manville Boro	8,706	6,107	5,255	852	14.0
Millstone Boro	328	226	217	9	4.0
Millstone Twp	8,398	5,870	5,489	363	6.2
Monroe Twp	33,751	15,933	14,548	1,385	8.7
Montgomery Twp	16,292	10,610	9,976	634	6.0
Plainsboro Twp	18,056	13,197	12,349	848	6.4
Princeton Boro	24,467	14,996	13,819	1,139	7.6
Rocky Hill Boro	441	296	287	9	3.0
South Brunswick Twp	33,866	23,754	22,222	1,476	6.2
West Windsor Twp	20,697	14,213	13,180	1,012	7.1
Hunterdon County	102,022	70,204	64,648	5,523	7.9
Mercer County	295,849	197,953	176,840	20,969	10.6
Middlesex County	654,049	433,807	394,477	39,087	9.0
Monmouth County	501,783	335,790	305,222	30,144	9.0
Somerset County	256,051	178,036	165,266	12,732	7.2
New Jersey State	7,028,795	4,677,666	4,197,483	472,094	6.7



**Table 8. Occupational Status for the State, Counties, and Affected Municipalities  
(Courtesy of the U.S. Census Bureau, 2009-2013 5-Year American Community Survey)**

<b>Occupation Status of Employed Civilian Population 16 Years and Over (%)</b>					
<b>Area Name</b>	<b>Management, business, science and arts occupations</b>	<b>Service occupations</b>	<b>Sales and office occupations</b>	<b>Natural resources, construction, and maintenance occupations</b>	<b>Production, transportation, and material moving occupations</b>
Cranbury Twp	58.7	11.9	22.7	3.3	3.3
East Windsor Twp	43.7	12.4	25.7	5.2	13
Franklin Twp	50.7	13.5	22.4	5.1	8.3
Hillsborough Twp.	55	9.9	24.4	6.5	4.3
Manville Boro	22.3	21.2	26.5	15.9	14.0
Millstone Boro	49.8	18.4	10.6	11.5	9.7
Millstone Twp	52.3	12.1	22.6	7.1	5.9
Monroe Twp	47.8	10	29.6	6.2	6.4
Montgomery Twp	76	6.4	13.7	1.6	2.2
Plainsboro Twp	69.2	5.9	18.5	2.8	3.6
Princeton Boro	68.8	12.9	15.6	0.9	1.9
Rocky Hill Borough	66.2	7.3	14.3	3.5	8.7
South Brunswick Twp	57.1	10.1	22.5	4.2	6.0
West Windsor Twp	72.2	5.3	18.4	1.6	2.4
Hunterdon County	49.7	12.8	24.8	6.9	5.9
Mercer County	42.7	17.9	24.2	5.8	9.4
Middlesex County	43.9	13.8	25	6.2	11.1
Monmouth County	42.8	15.8	26.4	7.5	7.5
Somerset County	51.1	12.4	23	6.1	7.4
New Jersey State	40	16.7	25	7	10.3

### **10.5 Without Project Future Conditions**

The without-project condition was determined by projecting conditions in the project area over a 50-year period of analysis (2018 - 2067). In the absence of Federal action, flooding problems associated with rainfall events in the study area are expected to continue. These problems may be exacerbated by increased damage potential in the floodplains of communities within the Millstone River Basin based upon increases in population and the values of structures and contents. Climate change could cause changes to storm impacts. The most likely scenario for the future without project condition would





be the continuation of existing social and environmental conditions and trends as well as economic growth within the study area.

Generally, the absence of Federal action would result in no reduction of the frequency of repetitive flood damage in the community of Manville. This reflects the continuation of existing social and environmental conditions and trends as well as economic growth within the affected area. Implicit in taking no action would be the continuation of Federally-subsidized flood insurance coverage for property owners that is currently available through the National Flood Insurance Program and the enforcement of local floodplain zoning ordinances. Significant flooding can result in the overtopping of sewage treatment works, contamination of drinking water supplies, dispersion of HTRW and large quantities of solid waste. Experience has shown that vast quantities of debris (e.g., homes, vehicles, mobile homes, etc.) and sediment must be removed from the floodplain after a flooding event. The physical removal of the debris from the floodplain typically involves large, heavy equipment and requires the removal of trees and vegetation to provide points of ingress and egress for the cleanup equipment. Hauling the collected debris to the local municipal landfill requires significant transportation resources, and involves huge quantities of solid waste that fill available landfill space.

In summary, the most likely scenario for the future without project condition would be the continuation of existing social and environmental conditions and trends as well as economic growth within the study area. The Millstone River watershed is currently heavily urbanized and developed in Manville. Under without project future conditions, the damage center in Manville will continue to be subject to flooding. However, the counties and other local municipalities could implement stormwater management techniques, such as requiring new development to retain 100% of stormwater and retrofitting of existing impervious structures, including creating green roofs and using planting pavers in parking lots. Although stormwater management is not in the USACE authority, a reduction in stormwater input into the river may reduce flood impacts during some storm events. There would be no reduction of the frequency of repetitive flood damage in Manville. Residential and commercial buildings in the study area would continue to flood from both the Millstone and the Raritan Rivers.

### ***Blue Acres***

The Blue Acres Program is part of the NJDEP Green Acres Program that purchases properties that are at risk for flooding. Through this program, New Jersey is spending federal disaster recovery funds to give homeowners the option to sell flood damaged homes at pre-storm value in areas at risk for flooding.

New Jersey is buying clusters of homes or whole neighborhoods that were flooded in Hurricane Sandy and previous storms through the Blue Acres Program. Homes bought out through the program are/will be demolished with the land permanently preserved as open space and accessible to the public for recreation or conservation. The preserved land



will serve as natural buffers against future storms and floods. The goal of the Blue Acres Program is to reduce the risk of future flood damage, and to assist families in moving out of areas where flood safety is an issue. This buyout program was launched in May 2013.

Approximately 104 structures in the Lost Valley section are currently being bought out for demolition through the Blue Acres Program. These structures were not scheduled for inclusion in a Blue Acres program buyout at the time existing conditions for this study were being developed and were thus inventoried and included in the damage pool as part of the analysis for this study. These structures were noted as buyouts and addressed as part of the recommendation provided. Any additional future buyouts would reduce flood damages even further.

### **11.0 Key Uncertainties**

The following tasks and their respective potential impacts, uncertainties and decisions to address those impacts and uncertainties are stated below.

1. *Task:* The alternative plans that employed structural measures were formulated and compared to reduce risk against a 2% annual chance exceedance storm event in terms of cost-benefit analysis.

*Potential Impacts:* It would take more effort and funding to compare each alternative plan at various levels of performance.

*Uncertainties:* Plans may have varying net benefits at different levels of performance due to varying benefits and costs.

*Planning Decisions:* Due to finite amounts of time and funding, alternative plans that included structural measures were all designed at a similar level of performance (2% annual chance exceedance), after which the plan that maximizes net benefits will be optimized.

2. *Task:* Alternative plans are designed to a low level of detail reducing the precision of cost estimates for those alternatives.

*Potential Impacts:* Project contingency for costs would rise, increasing the current project cost estimate.

*Uncertainties:* The study level of detail in the alternative plan designs increases uncertainty with respect to the cost estimates of the alternative plans.

*Planning Decisions:* Due to finite amounts of time and funding, alternative plans were designed at a feasibility level of detail.

### **12.0 Formulating Alternative Plans**

Plan formulation is the process of building alternative plans that meet planning objectives and avoid planning constraints. Alternative plans are a set of one or more flood risk management measures functioning together to address one or more planning objectives.



A management measure is a feature or activity that can be implemented at a specific geographic site to address one or more planning objectives.

The guidance for conducting Civil Works planning studies (ER 1105-2-100) requires the systematic formulation of alternative plans that contribute to the Federal objective. In order to ensure that sound decisions are made with respect to development of alternatives and ultimately plan selection, the plan formulation process requires a systematic and repeatable approach. The Economic and Environmental Principles and Guidelines for Water and Related Land Implementation Studies (Principles and Guidelines) describe the USACE study process and requirements.

Alternatives for the proposed action were formulated in consideration of study area problems and opportunities, as well as study goals, objectives and constraints with consideration of four criteria: completeness, effectiveness, efficiency, and acceptability.

- Completeness is the extent to which a given alternative plan provides and accounts for all necessary investments or other actions to ensure the realization of the planned effects.
- Effectiveness is the extent to which an alternative plan alleviates the specified problems and achieves the specified opportunities.
- Efficiency is the extent to which an alternative plan is the most cost-effective means of alleviating the specified problems and realizing the specified opportunities, consistent with protecting the Nation's environment.
- Acceptability is the workability and viability of the alternative plan with respect to acceptance by state and local entities and the public and compatibility with existing laws, regulations, and public policies.

### ***USACE Planning Process***

The first step of the planning process defines study area problems and opportunities, as well as study constraints, goals, and objectives. Because this is a flood risk management study, problems and opportunities are developed to address the Federal objective of National Economic Development (NED). Goals, objectives, and constraints are developed to provide potential solutions to reduce flood risk and achieve the opportunities within the confines of legislative authority, policies, and other restrictions.

The second planning step consists of the inventory and forecast of resources within the study area. This evaluation, or inventory step, accounts for the level or amount of a particular resource that currently exists within the study area, i.e., identification of existing conditions. This step also involves forecasting to predict what changes will occur to resources throughout the 50-year period of analysis, assuming no actions are taken to



address the problems in the study area. Comparison of the existing and forecast conditions of the study area measures the problems resulting from the change in resources over time. Study area problems are quantified based on this predicted change in resources. This second step also results in the delineation of opportunities that fully or partially address the problems in the study area. An opportunity is a resource, action, or policy that, if acted upon, may alter the conditions related to an identified problem.

The third step in the planning process is to generate alternative solutions. Alternative plans are formulated across a range of potential scales to demonstrate the relative effectiveness of various approaches at varying scales.

In the fourth step, alternative plans are evaluated for their potential results in addressing the specific problems, needs, and objectives of the study. The measure of output is expressed by the difference in amount or effect of a resource between the “No-Action Alternative” conditions and those predicted to occur with each “Action Alternative” in place. This difference is referred to as the benefits of the alternative. The evaluation focuses on flood risk management benefits, which are measured in damages avoided.

The planning process continues with the fifth step, comparison of alternative plans to each other utilizing the benefit outputs and costs of the alternatives.

The sixth and final step in the process is the selection of the plan that best meets the study objectives and the four criteria in the Principles and Guidelines: completeness, effectiveness, efficiency, and acceptability. Using the six-step planning process, a Tentatively Selected Plan is identified.

### ***12.1 Management Measures***

A management measure is a feature or activity that can be implemented at a specific geographic site to address one or more planning objectives. Measures must also not induce damages upstream or downstream of the measure. Structural and nonstructural measures were evaluated to alleviate flooding at this location.

#### ***No-Action***

The No-Action Alternative reflects the continuation of existing economic, social, and environmental conditions and trends within the affected area. Failure to provide the Millstone River Basin study area with flood risk management measures could continue to contribute to the potential loss of life and physical, as well as environmental damage to study area communities in the occurrence of significant flooding. Significant flooding can result in municipal infrastructure damage, loss of jobs, and closure of businesses in addition to damages to residential, commercial and industrial structures.



### ***Nonstructural Measures***

Nonstructural measures typically provide flood risk management to individual structures and may include property buy-outs, elevating structures, floodproofing, ringwalls, rebuilding, flood warning systems and zoning. Nonstructural measures include:

#### ***Property Buy-Outs***

Buyout or acquisition results in the permanent removal or evacuation of the structure from the floodplain and is typically applied when other nonstructural measures are too costly. Buy-outs involve the acquisition of a property and its structures, either by purchase or by exercising the powers of eminent domain. Following acquisition, the structure and associated property development is either demolished or relocated. Acquired lands are typically restored to a natural condition and used for recreation or other purposes that would not be jeopardized by the flood hazard. This type of program frequently causes emotional hardship, involves expensive relocation costs, and results in the loss of a community/local tax base.

#### ***Elevating Structures***

Elevation is the process of raising a structure so that the main living area will be above design flood elevation. In most cases, the process involves separating a structure from its foundation, raising it on hydraulic jacks, and holding it in place with temporary supports while a new or extended foundation is constructed below. The result is the living area is raised and only the foundation remains exposed to flooding. The new or extended foundation may consist of continuous walls or separate piers, posts, columns or pilings.

#### ***Floodproofing***

Floodproofing is the process of making adjustments to individual buildings or properties in order to reduce flood damages. There are two categories of floodproofing: wet floodproofing and dry floodproofing.

Wet floodproofing refers to the reduction in risk to a building in a manner that allows floodwaters to enter and exit freely, in such a way that internal and external hydrostatic pressures are equalized. This equalization of pressures reduces the loads imposed on a structure and reduces the probability of structural damage or failure. Basement utilities subjected to flooding may be relocated to an above-grade utility room, where space permits, otherwise, the basement utilities may be surrounded by a watertight barrier.

Dry floodproofing is the process of protecting a building by sealing its exterior walls and by providing removable flood shields at structure openings to prevent the entry of floodwaters. Dry floodproofing is practical only for buildings with structurally sound walls and only where flood depths are low.



### ***Ringwalls***

For structures that are too large to elevate or for a small group of closely spaced structures, a concrete wall or levee (ringwall) may be considered around the structure's property, where space and aesthetics permit.

### ***Rebuilding***

If the estimated cost of any other nonstructural alternative exceeds the estimated cost to demolish a structure and rebuild an equivalent structure, rebuilding the structure above the design flood elevation may be an economically viable nonstructural alternative.

### ***Flood Warning Systems***

Flood warning systems may be utilized to warn property owners of impending floods, and therefore allow time to evacuate and relocate property subject to flood damage. With the use of a flood warning system, property, such as motor vehicles, can be relocated to higher ground in time to prevent damage from rising waters. In addition, moveable items can be taken to higher floors within structures, where they will not be impacted. Finally, residents will have time to leave the area, if necessary, for their own safety. Elaborate flood warning systems can be designed and implemented for a particular location.

### ***Zoning***

Through proper land use regulation, floodplains can be managed to insure that their use is compatible with the severity of a flood hazard. Several means of regulation are available, including zoning ordinances, subdivision regulations, and building and housing codes. Their purpose is to reduce losses by controlling the future use of floodplain lands.

### ***Structural Measures***

Structural alternatives typically consist of constructed barriers that protect areas of development, and may include levees, floodwalls, channel modifications, diversions, detention basins and road raisings. Structural measures also typically require that runoff from behind any constructed barrier be temporarily stored or conveyed through the barrier. In addition, any barrier must not increase flooding from interior runoff that becomes trapped behind it. To address these requirements, any structural plan that includes a barrier may also require interior drainage facilities that may include pump stations, ponding areas, or pipe diversions. Structural measures include:

### ***Levees***

Levees are intended to provide flood risk management to homes, commercial buildings, municipal buildings, roadways, and bridges by prohibiting floodwaters from reaching these structures. Levees are typically low, wide earthen embankments built to retain floodwater inside a channel. While levees can provide a cost-effective means to prevent flooding of low-lying areas, interior drainage facilities are often required to collect, control and disperse water trapped behind the barriers. Otherwise, floodwaters would pond behind the barrier.





### ***Floodwalls***

Floodwalls are intended to provide flood risk management to homes, commercial buildings, municipal buildings, roadways, and bridges by prohibiting floodwaters from reaching these structures. Floodwalls are structures composed of steel, concrete and other manufactured materials and are sometimes used when residential properties directly abut a channel or the shoreline and there is not enough space to construct a levee. Interior drainage facilities, located on the landward side of the floodwall, are often necessary to collect, control, and disperse water trapped behind the barriers. Otherwise, floodwaters would pond behind the barrier.

### ***Channel Modifications***

Channel modifications may be used to provide flood risk management to homes, commercial buildings, municipal buildings, roadways, and bridges. Channel modifications can include deepening and widening, dam modifications, and elevating or widening bridges. Channel modifications can be an effective means to reduce flooding. Environmental impacts due to channelization may be significant.

### ***Diversions***

An underground culvert may be used to divert river flow from a developed area. Flood flows contained within the culvert would bypass the developed area and would re-enter the river downstream or flow into another river. Under normal conditions, base flow would continue to flow within the river channel. An intake structure would allow flood flows to be diverted into the culvert. This type of alternative can also minimize environmental impacts to the stream by avoiding alterations within the river channel.

### ***Detention Basins***

Detention basins may be used to reduce the peak flood flows by temporarily storing (detaining) floodwater, then releasing it at a substantially reduced flow to reduce peak flood flows. This reduces peak water surface elevations and helps to minimize flood damages downstream.

### ***Road Raising***

Roads that currently experience flooding during storms would be elevated to heights that would minimize or eliminate the impacts of such events. This may give people the ability to leave an inundated area. Roads may also be raised as part of another structural measure such as levees or floodwalls to maintain height for certain segments of the levee or floodwall.

## ***12.2 Screening of Measures***

The screening of flood risk management measures includes an assessment of the potential engineering, economic, environmental, public, financial, and institutional feasibility of implementing each measure. Those measures that are not entirely screened out are carried forward for more detailed analysis as alternative plan components. Based on the



physical layout of the study area, the flood hydrology, and the profiles of structures at risk, the following flood risk management measures were considered for application to flooding problems in the study area: These measures and the results of the initial screening are described in Table 9.

**Table 9. Screening of Measures**

<b>Opportunity</b>	<b>Objective</b>	<b>Constraint</b>	<b>Retained for Further Study?</b>
No Action	<ul style="list-style-type: none"> <li>Existing economic, social, and environmental conditions and trends within the affected area continue with no recommended USACE project.</li> </ul>	<ul style="list-style-type: none"> <li>Continued potential for loss of life and physical, as well as environmental, damage to study area communities in the occurrence of significant flooding.</li> <li>Significant flooding can result in municipal infrastructure damage, loss of jobs, and closure of businesses.</li> </ul>	<ul style="list-style-type: none"> <li>Yes, as per NEPA and ER 1105-2-100, the No Action alternative is the baseline for analysis and comparison of alternative plans. Failure to identify an economically justified plan with further analysis could result in the recommendation of no Federal action.</li> </ul>
Levee / Floodwall	<ul style="list-style-type: none"> <li>Help reduce fluvial flood damages and life safety risks throughout the basin by protecting areas traditionally sustaining flood damages from overbank flooding.</li> </ul>	<ul style="list-style-type: none"> <li>Destruction of wetlands and impacts to jurisdictional waters. Full environmental assessment and impact analysis is required. This could result in high environmental mitigation costs.</li> <li>Costs for acquisition of real estate interests may be high.</li> <li>Additional exploration for potential cultural and historic resources needs to be completed. Significant cultural resource mitigation may be required.</li> </ul>	<ul style="list-style-type: none"> <li>Yes, this measure will meet the planning objectives to reduce fluvial flood damages and life safety risks in the basin.</li> </ul>
Channel Modifications	<ul style="list-style-type: none"> <li>Help reduce fluvial flood damages and life safety risks throughout the basin by lowering water surface levels/increasing conveyance capacity of stream.</li> <li>Reduce channel blockages resulting from high sediment loads and bank material transported</li> </ul>	<ul style="list-style-type: none"> <li>Destruction of wetlands and impacts to jurisdictional waters. Full environmental assessment and impact analysis is required. This could result in high environmental mitigation costs.</li> <li>Costs for acquisition of real estate interests may be high.</li> <li>Additional exploration for potential cultural and historic resources needs to be completed. Significant cultural resource mitigation costs may</li> </ul>	<ul style="list-style-type: none"> <li>Yes, this measure will meet the planning objectives to reduce fluvial flood damages and life safety risks in the basin.</li> </ul>



	during flood events.	be required.	
Diversion Culvert	<ul style="list-style-type: none"> <li>• Help reduce fluvial flood damages and life safety risks throughout the basin by lowering water surface levels/increasing conveyance capacity of stream.</li> </ul>	<ul style="list-style-type: none"> <li>• A hydraulically suitable location is required between the Millstone and Raritan Rivers.</li> <li>• Costs for acquisition of real estate interests may be high.</li> <li>• Additional exploration for potential cultural and historic resources needs to be completed. Significant cultural resource mitigation costs may be required.</li> </ul>	<ul style="list-style-type: none"> <li>• Not considered for further study as this measure would not meet the planning objectives of reducing fluvial flood damages and life safety risks within the basin. A hydraulically suitable location has not been identified.</li> </ul>
Detention Basins	<ul style="list-style-type: none"> <li>• Help reduce fluvial flood damages and life safety risks by temporarily detaining waters upstream of areas traditionally sustaining flood damages.</li> </ul>	<ul style="list-style-type: none"> <li>• No area exists that has the potential to store enough water temporarily to sufficiently reduce water surface elevations and flood damages downstream.</li> </ul>	<ul style="list-style-type: none"> <li>• Not considered for further study as this measure would not meet the planning objectives of reducing fluvial flood damages and life safety risks within the basin.</li> </ul>
Road Raising	<ul style="list-style-type: none"> <li>• Help reduce fluvial flood damages and life safety risks throughout the basin by protecting areas traditionally sustaining flood damages from overbank flooding.</li> </ul>	<ul style="list-style-type: none"> <li>• Often used in conjunction with other flood risk measures.</li> </ul>	<ul style="list-style-type: none"> <li>• Yes, this measure will meet the planning objectives to reduce fluvial flood damages and life safety risks in the basin.</li> </ul>
Clearing and Snagging	<ul style="list-style-type: none"> <li>• Help reduce fluvial flood damages and life safety risks throughout the basin by reducing water surface elevations.</li> <li>• Minimize environmental impacts and allow stream channel to maintain carrying capacity.</li> </ul>	<ul style="list-style-type: none"> <li>• Minor snagging and clearing would not have a measurable impact on flood stages and resulting damages.</li> </ul>	<ul style="list-style-type: none"> <li>• Not considered for further study as this measure would not meet the planning objectives of reducing fluvial flood damages and life safety risks within the basin.</li> </ul>
Permanent evacuation of residences and businesses (buyouts)	<ul style="list-style-type: none"> <li>• Help reduce fluvial flood damages and life safety risks throughout the basin by reducing flooding impacts to</li> </ul>	<ul style="list-style-type: none"> <li>• Acquisition and relocation of a significant portion of floodplain properties would be prohibitively expensive.</li> <li>• Public acceptability of a mandatory plan is unlikely.</li> </ul>	<ul style="list-style-type: none"> <li>• Retained for further study. As per ER 1105-2-100, a nonstructural flood risk management plan must be examined to compare against</li> </ul>



	<p>properties.</p> <ul style="list-style-type: none"> <li>• Minimize environmental impacts and possibly create additional open space and floodplain area.</li> </ul>		<p>structural flood risk management plans.</p>
Elevating Structures	<ul style="list-style-type: none"> <li>• Help reduce fluvial flood damages and life safety risks throughout the basin by reducing flooding impacts to properties.</li> <li>• Minimize environmental impacts.</li> </ul>	<ul style="list-style-type: none"> <li>• Elevating a significant portion of floodplain structures would be prohibitively expensive.</li> <li>• Public acceptability of a mandatory large-scale plan is typically difficult.</li> </ul>	<ul style="list-style-type: none"> <li>• Retained for further study. As per ER 1105-2-100, a nonstructural flood risk management plan must be examined to compare against structural flood risk management plans.</li> </ul>
Floodproofing of flood prone residences, businesses and public facilities subject to frequent flooding	<ul style="list-style-type: none"> <li>• Help reduce fluvial flood damages and life safety risks throughout the basin by reducing flooding impacts to properties.</li> <li>• Minimize environmental impacts.</li> </ul>	<ul style="list-style-type: none"> <li>• Floodproofing a significant portion of floodplain properties would be prohibitively expensive.</li> <li>• Public acceptability of a mandatory large-scale plan is typically difficult.</li> </ul>	<ul style="list-style-type: none"> <li>• Retained for further study. As per ER 1105-2-100, a nonstructural flood risk management plan must be examined to compare against structural flood risk management plans.</li> </ul>
Ringwalls	<ul style="list-style-type: none"> <li>• Help reduce fluvial flood damages and life safety risks throughout the basin by reducing flooding impacts to properties.</li> <li>• Minimize environmental impacts.</li> </ul>	<ul style="list-style-type: none"> <li>• Constructing ringwalls around a significant portion of floodplain properties could be prohibitively expensive.</li> <li>• Typically used to protect apartment buildings, complexes, clusters of structures, etc.</li> </ul>	<ul style="list-style-type: none"> <li>• Retained for further study. As per ER 1105-2-100, a nonstructural flood risk management plan must be examined to compare against structural flood risk management plans.</li> </ul>
Rebuilding	<ul style="list-style-type: none"> <li>• Help reduce fluvial flood damages and life safety risks throughout the basin by reducing flooding impacts to properties.</li> <li>• Minimize environmental impacts and possibly create additional open space and</li> </ul>	<ul style="list-style-type: none"> <li>• Rebuilding of a significant portion of floodplain properties would be prohibitively expensive.</li> <li>• Public acceptability of a mandatory plan is unlikely.</li> </ul>	<ul style="list-style-type: none"> <li>• Retained for further study. As per ER 1105-2-100, a nonstructural flood risk management plan must be examined to compare against structural flood risk management plans.</li> </ul>



	floodplain area.		
Floodwarning System	<ul style="list-style-type: none"> <li>• Help reduce fluvial flood damages and life safety risks throughout the basin by reducing flooding impacts to properties.</li> <li>• Minimize environmental impacts.</li> </ul>	<ul style="list-style-type: none"> <li>• Would have no effect on residential and commercial buildings or non-movable property.</li> </ul>	<ul style="list-style-type: none"> <li>• Retained for further study. As per ER 1105-2-100, a nonstructural flood risk management plan must be examined to compare against structural flood risk management plans.</li> </ul>
Zoning	<ul style="list-style-type: none"> <li>• Help reduce fluvial flood damages and life safety risks throughout the basin by reducing flooding impacts to properties.</li> <li>• Minimize environmental impacts and possibly create additional open space and floodplain area.</li> </ul>	<ul style="list-style-type: none"> <li>• Study area is highly developed and zoning may have limited effect due to the little land left to develop.</li> </ul>	<ul style="list-style-type: none"> <li>• Retained for further study. As per ER 1105-2-100, a nonstructural flood risk management plan must be examined to compare against structural flood risk management plans.</li> </ul>

Opportunities with potential for addressing flood risk management that met USACE policy were developed into alternatives and are discussed in the following section.

### ***12.3 Final Array of Alternative Plans***

Alternative plans are combinations of management measures that collectively meet study goals and objectives within the defined study constraints. A variety of structural and nonstructural alternative plans were evaluated to satisfy the study objectives and constraints. Formulation and evaluation of the alternative plans were conducted consistent with Federal water resources policies and practices. As required by ER 1105-2-100, alternative plans were evaluated by comparing conditions expected under with and without-project scenarios.

Alternative plans and their component management measures were assessed relative to the objective of National Economic Development (NED). Alternative plans are assembled and compared against one another using performance outputs and costs.

Preliminary costs, benefits, and impacts of each potential alternative were developed to determine which flood risk management plans would be considered for more detailed design and economic analysis.



Structural alternative plans 1 and 2 were formulated at a level meant to provide flood risk management up to the 2% annual chance exceedance storm event while nonstructural alternative plans 3 through 10 were formulated at levels meant to provide flood risk management up to the 2% and 10% annual chance exceedance storm events. Structural and nonstructural alternative plans were evaluated. The following alternative plans have been carried forward for detailed analysis of benefits, costs and impacts.

1. Levees and Floodwalls in Manville, NJ
2. Channel Modifications (Raritan River)
  - 3A. Nonstructural Plan - 2% annual chance exceedance floodplain
  - 3B. Nonstructural Plan - 2% annual chance exceedance floodplain (not including Blue Acres Program structures)
  - 3C. Nonstructural Plan - 2% annual chance exceedance floodplain (not including Blue Acres Program & Zarephath structures)
  - 3D. Nonstructural Plan - 2% annual chance exceedance floodplain (not including Blue Acres Program & Lost Valley structures)
  - 4A. Nonstructural Plan - 10% annual chance exceedance floodplain
  - 4B. Nonstructural Plan - 10% annual chance exceedance floodplain (not including Blue Acres Program structures)
  - 4C. Nonstructural Plan - 10% annual chance exceedance floodplain (not including Blue Acres Program & Zarephath structures)
  - 4D. Nonstructural Plan - 10% annual chance exceedance floodplain (not including Blue Acres Program & Lost Valley structures)

Descriptions of these alternative plans follow below. Additional information and technical details can be found in the appendices.

### ***Alternative 1 – Levees and Floodwalls***

This alternative consists of three independent flood risk management zones – the north, central and south – that consist of flood risk management structures throughout the Raritan and Millstone River watersheds in Manville and in the subcommunity of Zerephath. It is anticipated that the components of this alternative would manage flood risk against the 2% chance of annual exceedance flood in these locations. The flood risk management zones are described in Figure 7.

Flood Risk Management Zone - North: The flood risk management system within this zone is located in Manville and consists of approximately 2,075 feet of levees, approximately 2,000 feet of floodwalls, associated interior drainage structures and a road-raising. The levee and floodwall system runs north of Dukes Parkway East at a distance of approximately 40 feet from the edge-of-pavement, extending from near the intersection of N 13<sup>th</sup> Street to the intersection of N 6<sup>th</sup> Street. From this location the system begins to run parallel to the Raritan River through Duke Island Park at an average distance of approximately 20 feet from the top of the riverbank until it reaches North





Main Street, which would be raised. The entire levee and floodwall system ranges in height from approximately 2 feet at the upstream end of the system near N 13<sup>th</sup> Street, to approximately 14.5 feet at the downstream end of the system near North Main Street (heights in reference to grade). North Main Street would be raised to an elevation approximately 3 to 5 feet higher than its existing elevation. Approximately 810 feet of North Main Street would be altered as a result of the road raising.

Flood Risk Management Zone - Central: The flood risk management system within this zone is located in Manville and consists of approximately 2,325 feet of levees and associated interior drainage structures, 4,400 linear feet of floodwalls, a gate closure structure and a road-raising.

A small levee, approximately 75 feet long and 3.5 feet high from grade, extends from behind a residential structure on East Camplain Road near the intersection with Valerie Drive. This levee runs perpendicular to the CSX Railroad and ties into a gate closure structure, approximately 4 feet high from grade, which would span the width of the railroad right-of-way (ROW) (heights in reference to ground). A second levee ties into the gate closure structure from the south side of the railroad ROW and extends toward Manville Avenue. The levee turns northeast and runs parallel to Manville Avenue at a distance of approximately 80 feet from the edge of the pavement and for a distance of approximately 840 feet. From this point, the levee turns eastward and runs just adjacent to Manville Ave. for a distance of approximately 460 feet. The levee turns south at the eastern-most end of Manville Ave. for approximately 130 feet and runs directly behind the last few residential properties at the eastern-most end of Huff Ave. There would be a short road-raising at the intersection of Huff Ave. and Lincoln Ave. This intersection would be raised approximately 2.5 feet for a distance of approximately 100 feet.

An approximately 1,815 foot floodwall begins at the southeastern-most end of S. Arlington Ave. and runs adjacent to the left bank of the Millstone River. The exposed elevation of this section of floodwall ranges from 3 to 14 feet with respect to grade. The wall ties into a short 385-foot levee along the south side of Lincoln Avenue between Pulaski Street and Kosciusko Street, and is approximately 3 feet high from grade. A final section of floodwall ties into the previous levee and continues along the Millstone River for about 1,255 feet, at which point it turns toward the north behind residential properties along the east side of Cooper St. The wall continues northeast along the steep bank that parallels the east side of Lincoln Ave. The floodwall terminates at the proposed road-raising at the intersection of Huff Ave and Cooper Ave. The exposed elevations of this floodwall range from approximately 3 to 5.5 feet as it runs adjacent to the Millstone River, down to approximately 2.5 feet as it runs parallel to the Upper Raritan River and approaches its tie-in to the road-raising at the intersection of Huff Ave. and Lincoln Ave (heights from grade).



Flood Risk Management Zone - South: This system is located in Manville and consists of approximately 6,120 feet of levees, 1,655 feet of floodwalls, associated interior drainage structures, a gate closure structure, a bridge/road-raising and the elevation of a portion of the Delaware & Raritan Canal tow path.

The upstream end of the system begins with a floodwall located on the left bank (north side) of the Royce Brook, tying into high ground near the intersection of Roosevelt Avenue and S 6<sup>th</sup> Avenue. This section of the floodwall has an exposed elevation of approximately 3 feet from grade. It runs adjacent to Royce Brook until it intersects with South Main Street at a point approximately 130 feet south of Roosevelt Avenue. At this location, the floodwall ties into a gate closure structure, approximately 50 feet long and 3 feet high, that spans the width of South Main Street. A second section of floodwall, with an exposed elevation of approximately 3 to 4 feet from grade, ties into the gate closure structure from the east side of Roosevelt Avenue and continues along Royce Brook for approximately 450 feet. At this point, the floodwall ties into high ground north of the CSX Railroad ROW.

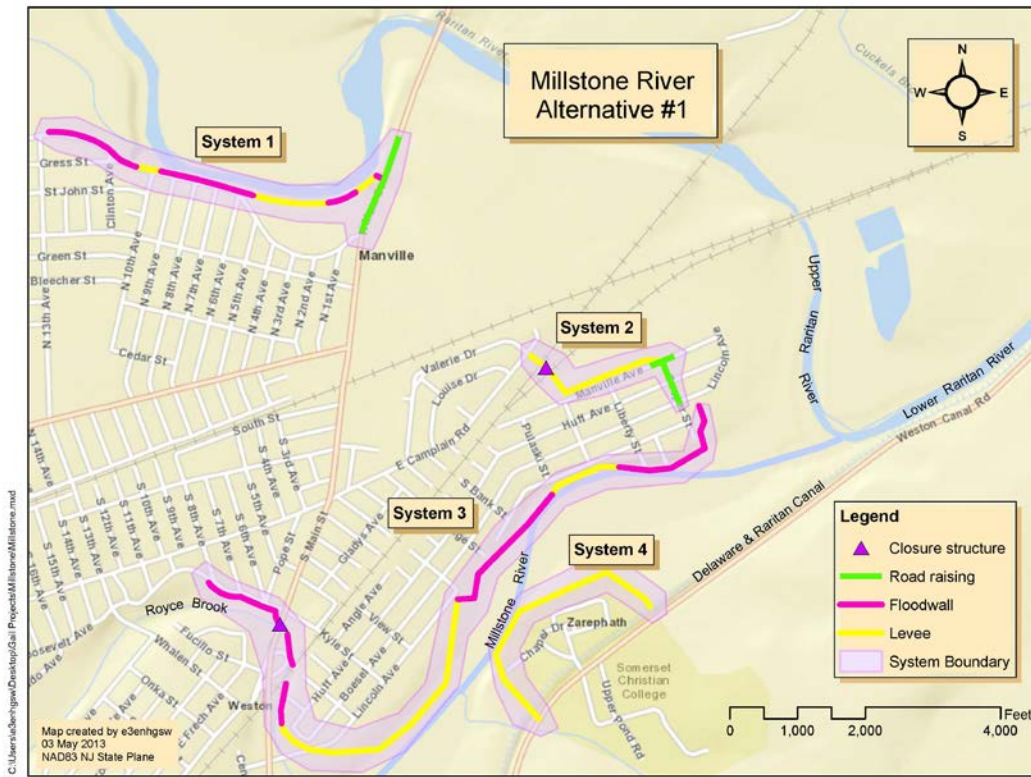
A third floodwall ties into high ground adjacent to Royce Brook on the south side of the CSX Railroad ROW at a location approximately 150 feet southwest of Benjamin Street. This section of wall, which has an exposed elevation of approximately 6 feet from grade and an approximate length of 330 feet, ties into a levee that begins adjacent to Royce Brook at a location south of Woodrow Street. The levee continues southeast for approximately 800 feet toward Lincoln Avenue before it turns northeast through the Lincoln Avenue Park. It ends near the intersection of Lincoln Avenue and South Arlington Street, tying into a proposed floodwall within the central flood risk management zone. This levee ranges in height from 10 to 14 feet in reference to grade.

A separate levee system within this southern flood risk management zone consists of elevating the existing “ring” levee that surrounds and reduces risk to the Zarephath sub-community of Somerset Township. The ring levee ties into the elevated Delaware & Raritan (D&R) Canal tow path/walking trail and is approximately 2,910 feet long. The length of the D&R Canal tow path encompassed by the elevated existing ring levee, approximately 150 feet, would be raised by approximately 1.5 feet. The existing bridge over the D&R Canal, which connects Chapel Dr. and Lindy Lake Dr., would be raised by approximately 1.5 feet to accommodate the raising of the tow path.

The total first cost of the levee and floodwall alternative is \$66,380,000 with a total investment cost of \$66,833,000, including construction, planning, engineering and design, construction management and interest during construction (IDC). The levee and floodwall alternative provides \$1,566,000 in annual benefits. The equivalent annual costs for the levee and floodwall alternative are \$4,004,000. The Benefit Cost Ratio (BCR) of the levee and floodwall alternative is 0.39. Lands and Damages and environmental



mitigation costs were not calculated since there are insufficient benefits to support this plan without the inclusion of those additional costs.



**Figure 7: Alternative 1 – Levees and Floodwalls**

**Alternative 2 – Channel Modifications**

This alternative consists of channel modifications along the Upper Raritan and Lower Raritan River reaches. It is anticipated that the components of this alternative would manage flood risk against the 2% chance of annual exceedance flood along the Millstone River and the Upper and Lower Raritan River reaches (Figure 8).

Channel modifications would be implemented along the Raritan River. The Raritan River would be divided into two river systems (“Upper Raritan” and “Lower Raritan”) at the Island Farm Weir and the Lower Raritan would be divided into two reaches. The greatest deepening of the channel would occur in the vicinity of the confluence of the Millstone and Raritan Rivers and consists of removing sediment approximately 8 feet below the existing channel bottom elevation. Approximately 795,000 cubic yards of material would be excavated from the channel beds as a result of this modification.

Channel Modification for Upper Raritan River (Reach 1): Approximately 0.31 miles of channel would be modified on the Upper Raritan reach, from the CSX Railroad crossing



to approximately 90 feet upstream of the Island Farm Weir. Since the Island Farm Weir would remain unchanged, the channel bottom would be sloped from the new channel elevation at the upstream end of the Raritan River (approx. +12.59 feet North American Vertical Datum of 1988 (NAVD88)) to the existing channel bottom near the weir (approx. +19.4 feet NAVD88). The channel bottom would be 290 feet wide for approximately 0.31 miles from the beginning of the channel modification. Then for the rest of this reach, the channel bottom width would be decreased from 290 feet to 210 feet. The side slopes of the channel modification would remain 1 foot vertical on 3 feet horizontal (1V:3H).

Channel Modification for Lower Raritan River (Reach 2): Approximately 1.09 miles of channel would be modified for this reach, from the Island Farm Weir to the Raritan River at Calco Dam gage (USGS 01403060). Since the Island Farm Weir would remain unchanged, the channel bottom would be sloped from a new channel elevation (approx. +12.57 feet NAVD88) and the channel bottom width (100 feet to 290 feet.) would increase for approximately 0.13 miles, then the channel bottom would be a constant 290 feet wide for the rest of the reach. The side slopes of the channel modification would remain 1 foot vertical on 3 feet horizontal (1V:3H). Downstream of the Island Farm Weir, riprap (approx. 12 inch stone) would be placed for a total length of 200 feet to decrease the amount of erosion that could occur with the flow velocities coming from the Island Farm Weir.

Channel Modification for Lower Raritan River (Reach 3): Approximately 0.66 miles of channel would be modified for this reach, from the Raritan River at Calco Dam gage (USGS 01403060) to the downstream end of Middle Brook/Raritan River confluence (approx. 1,600 feet downstream). From the Calco Dam gage, the channel bottom width would decrease from 290 feet to 100 feet at the upstream face of the I-287 bridge, then increase at the downstream face of I-287 bridge from 100 feet to 170 feet wide near the Middle Brook/Raritan river confluence, then decrease from 170 feet width to the end of the channel modification, where it would go back to existing channel bottom. The channel slope would be approximately 0.241 feet/mile from the Calco gage. Since channel modification would impact the I-287 bridge piers, a decision was made to reduce the channel bottom width under the bridge to 100 feet. This would only impact one pier and this adjustment would not impact the water level for the improved conditions. Riprap (12 inch stone) would be placed for a total length of 145 feet to reduce the erosion that could occur near the bridge piers. The side slopes of the channel modifications would remain 1 foot vertical on 3 feet horizontal (1V:3H).

The total first cost of the channel modification alternative is \$125,588,000 with a total investment cost of \$130,347,000, including construction, planning, engineering and design, construction management and IDC. The channel modification alternative provides \$1,317,000 in annual benefits. The equivalent annual costs for the channel alternative are \$6,510,000. The BCR of the channel alternative is 0.2. Lands and



Damages and environmental mitigation costs were not calculated since there are insufficient benefits to support this plan without the inclusion of those additional costs.



**Figure 8: Alternative 2 – Channel Modifications**

**Nonstructural Alternatives**

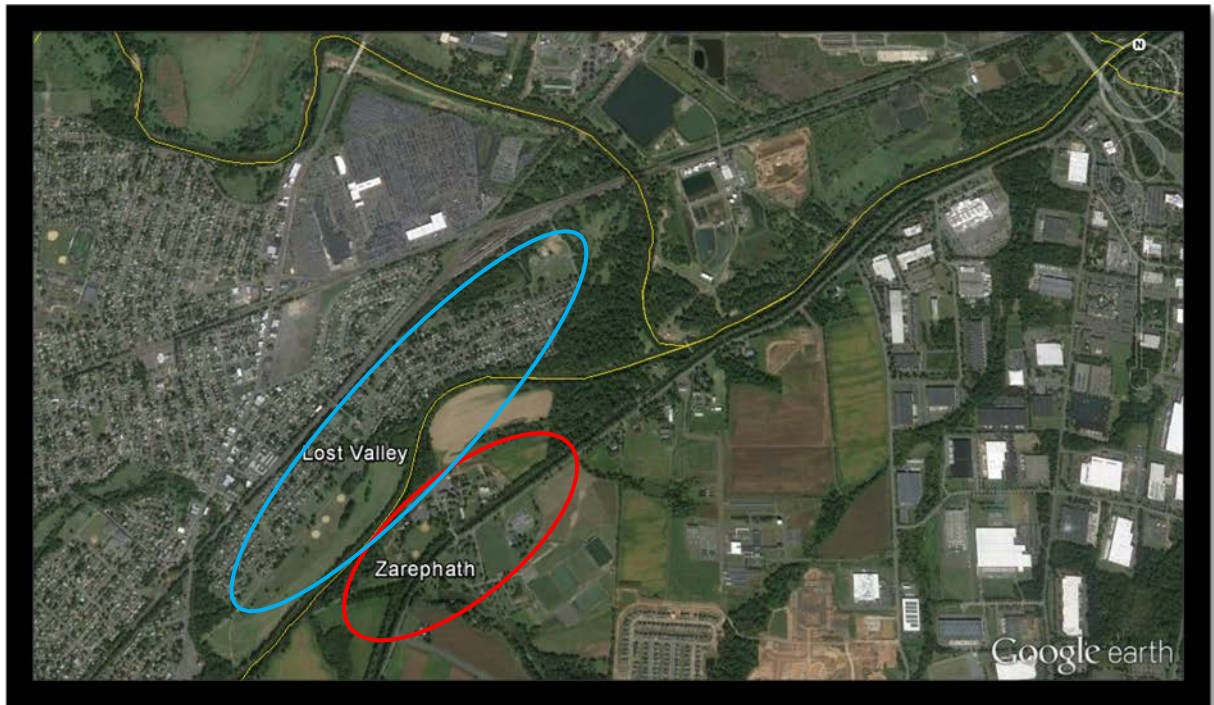
Nonstructural measures were identified and evaluated for structures in Manville near Royce Brook and the Millstone and Raritan Rivers. Measures evaluated included elevating buildings (elevation), wet (reduction of risk to utilities) and dry (sealants and closures) flood proofing, barriers (ring walls/ring levees) and buyouts (acquisition). The main objective for the nonstructural measures is to reduce flood damages through modifications of the existing structures without impacting the residential, commercial and industrial areas.

Nonstructural measures were formulated into specific alternative plans for evaluation. These were selected based on the 10%, 2% and 1% annual chance exceedance floodplains. Through the request of local stakeholders the NJDEP specifically requested analysis of six extra combinations (3B, 3C, 3D, 4B, 4C and 4D) within the 10% and 2% annual chance exceedance floodplains in addition to what was originally formulated (3A





and 4A). Within these combinations USACE was asked to exclude from our current analyses structures that applied for buyouts under the Blue Acres Program. The Blue Acres Program is a federally budgeted program run by the NJDEP that is currently buying out 104 structures in the area. Other combinations excluded structures within the Zarephath and Lost Valley vicinities (Figure 9) as well as those under the Blue Acres Program.



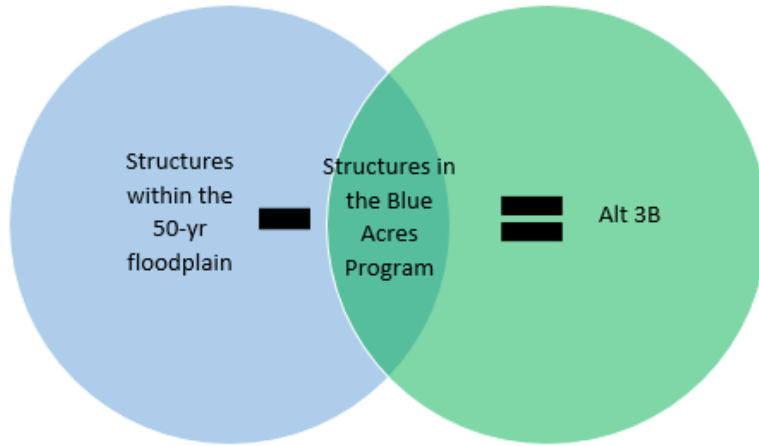
*Figure 9: Zarephath and Lost Valley areas*

Nonstructural alternatives considered by this Study are as follows:

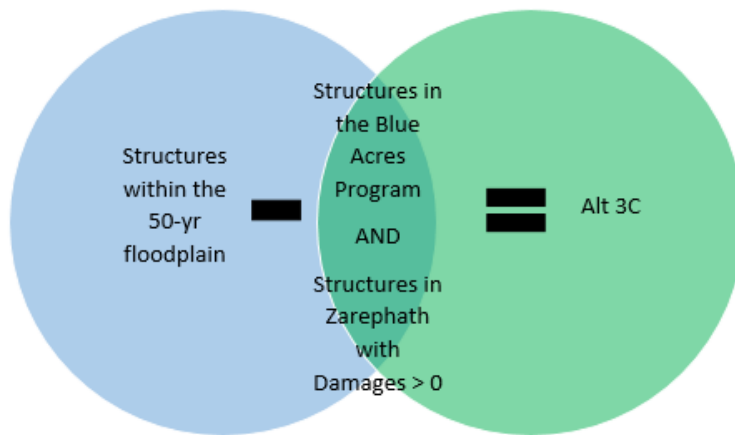
- Alternative 3A: All structures within the 2% (50-yr) annual exceedance floodplain.
- Alternative 3B: Structures within the 2% (50-yr) annual exceedance floodplain, excluding structures under the Blue Acres Program (104 structures max).





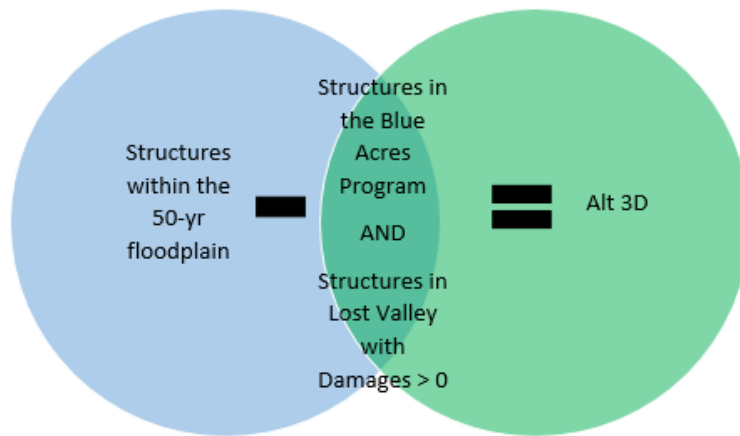


- Alternative 3C: Structures within the 2% (50-yr) annual exceedance floodplain, excluding structures under the Blue Acres Program and structures within the Zarephath area.

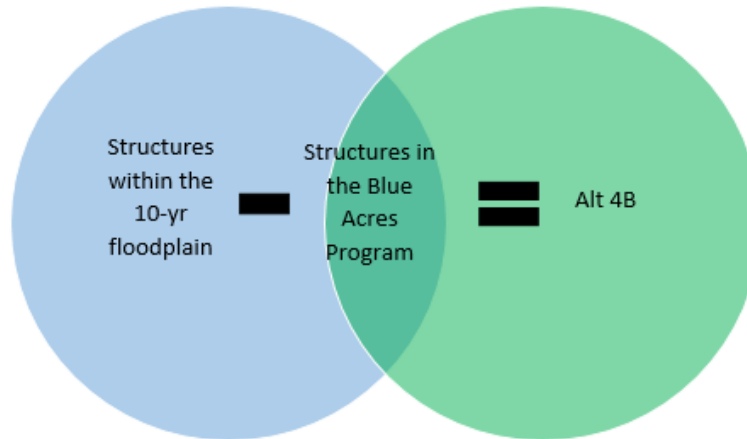


- Alternative 3D: Structures within the 2% (50-yr) annual exceedance floodplain, excluding structures under the Blue Acres Program and structures within the Lost Valley area.



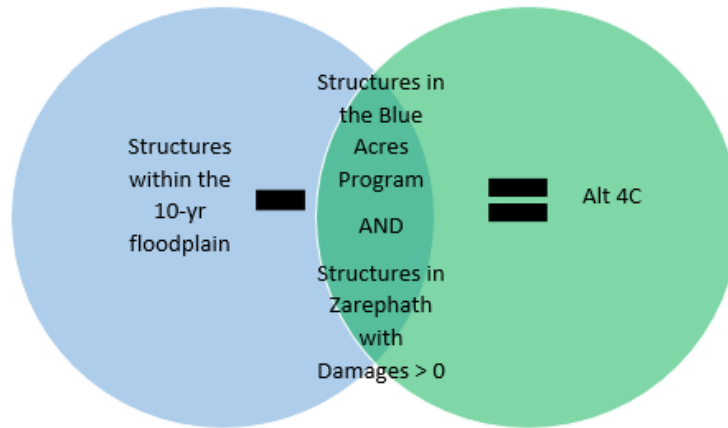


- Alternative 4A: All structures within the 10% (10-yr) annual exceedance floodplain.
- Alternative 4B: Structures within the 10% (10-yr) annual exceedance floodplain, excluding structures under the Blue Acres Program.

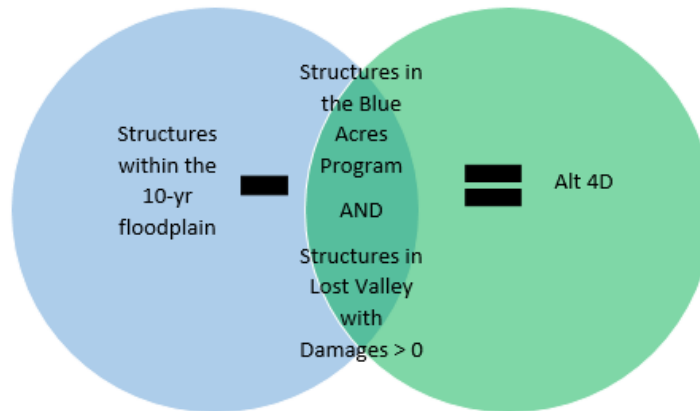


- Alternative 4C: Structures within the 10% (10-yr) annual exceedance floodplain, excluding structures under the Blue Acres Program and structures within the Zarephath area.





- Alternative 4D: Structures within the 10% (10-yr) annual exceedance floodplain, excluding structures under the Blue Acres Program and structures within the Lost Valley area.



- An alternative for all structures within the 1% (100-yr) annual exceedance floodplain was also considered but later removed from further analysis as it was considered to be likely to be cost prohibitive.

***Level of Performance***

All of the nonstructural plans were designed to withstand inundation for up to and including a 1% annual chance exceedance storm event plus one foot. These alternatives would reduce risk to most of the residential and nonresidential structures on both banks of the Royce Brook, Millstone and Raritan Rivers from a 1% annual chance exceedance flood at Manville.

***Existing Structures Characteristics***

The types of structures located in the 1% annual chance exceedance floodplain of the Millstone River study area are mostly residential and commercial. The predominant land



use within the study area is primarily residential with a combination of residential and commercial structures.

**Screening Level Results**

Results of the screening levels analysis using the algorithms by structure type are presented in Table 10 for all three floodplains (1%, 2% and 10% annual chance exceedance). Table 10 identifies the number of residential and non-residential structures targeted for treatment in the 1%, 2% and the 10% annual chance exceedance nonstructural plans, as well as the number of structures identified for each of the different types of nonstructural treatments. All nonstructural measures would provide flood risk management to the 1% chance of exceedance event plus an additional foot regardless of the size of the nonstructural plan. Therefore, while the number of structures treated under each plan changes, the design water level of treatment for each structure does not vary by plan. Based on preliminary assessment of cost and benefit for the 1%, 2% and 10% annual chance exceedance nonstructural plans, a deeper exploration was requested by our non-Federal sponsor in order to find a more suitable plan. Therefore, three sub-alternatives were developed for the 2% and 10% annual chance exceedance events, respectively (see Tables 11 and 12).

**Table 10. Millstone River Nonstructural Plan for the 1% (100-yr), 2% (50-yr) and 10% (10-yr) Annual Chance Exceedance Events**

Nonstructural Flood Proofing Measure	1% (100-yr) Annual Chance Exceedance*			2% (50-yr) Annual Chance Exceedance or Alt #3A			10% (10-yr) Annual Chance Exceedance or Alt #4A		
	Residential	Non-Residential	Sub Total	Residential	Non-Residential	Sub Total	Residential	Non-Residential	Sub Total
Dry	11	17	28	9	15	24	2	4	6
Wet	217	6	223	172	4	176	17	1	18
Barriers	4	68	72	3	63	66	1	34	35
Raise	279	2	281	273	2	275	77	2	79
Buyout	82	29	111	76	29	105	32	27	59
<b>Total number of Structures</b>	593	122	<b>715</b>	533	113	<b>646</b>	129	68	<b>197</b>



**Table 11. Alternative #3B, #3C and #3D Millstone River Nonstructural Plan  
Comparison for the 2% (50-yr) Annual Chance Exceedance Event**

Nonstructural Flood Proofing Measure	Alt #3B: Nonstructural Plan Not including Blue Acres Program Structures			Alt #3C: Nonstructural Plan Not including Blue Acres Program & Zarephath Structures			Alt #3D: Nonstructural Plan Not including Blue Acres Program & Lost Valley Structures		
	Residential	Non-Residential	Sub Total	Residential	Non-Residential	Sub Total	Residential	Non-Residential	Sub Total
Dry	9	15	24	9	15	24	9	15	24
Wet	166	4	170	166	4	170	172	4	176
Barriers	3	63	66	3	57	60	3	66	69
Raise	187	2	189	187	2	189	203	2	205
Buyout	64	29	93	57	21	78	67	29	96
<b>Total of Structures</b>	<b>429</b>	<b>113</b>	<b>542</b>	<b>422</b>	<b>99</b>	<b>521</b>	<b>454</b>	<b>113</b>	<b>567</b>

**Table 12. Alternative #4B, #4C and #4D Millstone River Nonstructural Plan  
Comparison for the 10% (10-yr) Annual Chance Exceedance Event**

Nonstructural Flood Proofing Measure	Alt #4B: Nonstructural Plan Not including Blue Acres Program Structures			Alt #4C: Nonstructural Plan Not including Blue Acres Program & Zarephath Structures			Alt #4D: Nonstructural Plan Not including Blue Acres Program & Lost Valley Structures		
	Residential	Non-Residential	Sub Total	Residential	Non-Residential	Sub Total	Residential	Non-Residential	Sub Total
Dry	2	4	6	2	4	6	2	4	6
Wet	15	1	16	15	1	16	16	1	17
Barriers	1	34	35	1	29	30	1	34	35
Raise	41	2	43	41	2	43	51	2	53
Buyout	22	27	49	16	19	35	25	27	52
<b>Total of Structures</b>	<b>81</b>	<b>68</b>	<b>149</b>	<b>75</b>	<b>55</b>	<b>130</b>	<b>95</b>	<b>68</b>	<b>163</b>



### ***13.0 Evaluation and Comparison of Array of Alternative Plans***

The following describes the procedures used to economically evaluate the alternative plans.

#### ***General***

The following basic steps were used to analyze flood damage:

- Assign evaluation reaches
- Inventory structures within the 0.2% annual chance exceedance floodplain
- Estimate depreciated replacement cost
- Assign generalized stage vs. damage functions to each structure
- Calculate aggregated stage vs. damage relationships
- Calculate average equivalent annual damages

The first four steps provide inputs to the estimation of flood damages. The calculation of damages was then completed using the Hydrologic Engineering Center's (HEC) Flood Damage Analysis (FDA) application.

#### ***Reach Selection***

In order to conduct economic benefit analyses for the without-project condition, with-project alternative plans, and to simplify the stage vs. damage analyses, the FDA analysis area was divided into 22 economic reaches; seven along the Millstone River, nine along the Raritan river, and six along Royce Brook.

- Reaches and riverfront areas: Reach selection was based on the structural inventory and the alternatives designed to mitigate flood risk.
- Potential project alignment limits: Certain assets within the community could potentially lie outside some of the flood risk management measures presented. For example, any docks or other structures adjacent to the river may lie beyond the levees and floodwalls, and would not receive any of the risk mitigation benefits of the structures.
- Interior drainage areas: Minor residual internal drainage issues related to levee and floodwall structures were not considered to be sufficient to warrant reach assignments and damage calculations.

#### ***Inventory Methodology***

The structural database, or inventory, was generated via a "windshield survey" of the area, using topographic mapping with contour intervals. The structure inventory survey focused on Manville and the adjacent community of Zarephath. To account for potential flooding effects to nearby areas, the inventory also includes some adjacent structures that lie within Somerville Borough, Bridgewater Township, Franklin Township, and Hillsborough Township. The limit of the inventory survey area has been taken to be the



assumed extent of the 0.2% annual chance exceedance floodplain, which has been based on consultation with USACE and NFIP Flood Insurance Rate Mapping.

Structure elevations are expressed in feet and tenths of a foot, and refer to the North American Vertical Datum of 1988 (NAVD 88). The structure inventory was originally developed in 2004 to assist in predicting flood damages. The depreciated replacement value of each building in the floodplain was calculated using standard building cost procedures from the RSMeans square foot cost replacement manual and Marshall & Swift Valuation Service. This analysis combines the physical characteristics obtained in the inventory with standard unit prices per square foot. Depreciation was then calculated based on the observed quality and condition of each structure. The inventory was reviewed, and depreciated structure replacement values were re-calculated with fiscal year 2014 (October 2013) price levels. Table 13 outlines the data obtained for the structure inventory.

<b>Table 13. Physical Characteristics Surveyed for in Structure Inventory</b>	
1) Structure ID	2) Damage Reach
3) Station	4) Structure Type/Damage Category
5) Usage Code Lookup	6) Size (Sq. Ft.)
7) Stories	8) Basement
9) Garages	10) Exterior
11) Build Quality	12) Condition
13) Reference Elevation	14) First Floor Height
15) Low Opening	16) Depreciated Replacement Structure Value

The data collected was used to categorize the structure population into groups with common physical features. Data pertaining to structure usage, condition, size and number of stories assisted in the structure value analysis. For each building, data was also gathered pertaining to its damage potential including ground and main floor elevations, lowest opening, construction material, condition, and the presence of basements and garages. 1,539 structures were identified in the original survey, of which 1,476 structures were included as structures susceptible to flood damage for the 2013 inventory update and analysis.

***Description of Damage Functions & Source of Stage-Frequency Curves***

Depth-percent damage functions for structure, content, and other damages were applied to each of the structures in the updated inventory to calculate floodwater damage. Floodwater damage for the Millstone River Basin was calculated using generic depth-





damage functions originally developed in 1982 by USACE for the Passaic River Basin, New Jersey, Flood Risk Management Feasibility Study. These Passaic River Basin (PRB) damage functions were developed for specific residential and non-residential (commercial, industrial, municipal, and utility) structure types and were later updated in 1995. Damage functions were included for structures, contents, and other-to-structure damages. Other-to-structure damages may include damage estimates to landscaping, out buildings, emergency response, commercial disruption, and cleanup costs. The following areas of uncertainty were incorporated into the HEC-FDA application:

- discharge frequency & stage frequency (using equivalent record length)
- first floor elevation
- depreciated structure value
- content-to-structure value ratio
- other-to-structure value ratio

PRB structure values are assumed to have a coefficient of variation of 10%. A coefficient of variation of 25% was applied to the content-to-structure value ratio, and the other-to-structure value ratio has a coefficient of variation of 10%. First floor elevation estimates contain a coefficient of variation of 0.6 feet. The damage functions and input variability estimates were formulated after extensive analysis of impacts from flood events within the Passaic River Basin. These PRB damage functions are appropriate for the Millstone River Basin due to the proximity and similarity of structures, contents, and other-to-structure values within the basins.

Water surface profiles containing stage and frequency functions were generated through the HEC River Analysis System. This process is explained in detail in the Hydrology & Hydraulics appendix.

#### ***Flood Damage Analysis & Cost Estimates***

Modeling of the benefits was conducted using the HEC-FDA software application. This application applies Monte Carlo Simulations to calculate expected damage values while explicitly accounting for uncertainty in the input data. Average annual expected damages were calculated within HEC-FDA using the damage-frequency curves, derived from relating damage values from various inundation levels with estimated probabilities of occurrence. Damage estimates aggregate the simulated damages from structures, contents and other-to-structure values.

Applying the fiscal year 2014 discount rate of 3.5%, models were used to determine both current and future year damages for with and without-project scenarios. Benefits are considered to be the damages reduced from the without-project condition estimate to the with-project condition estimate.



Cost estimates were generated based on construction estimates for the flood risk management measures.

### ***Screening of Alternatives***

The structural flood risk management alternative plans were evaluated to provide flood risk management for a 2% annual chance exceedance storm event as a basis for comparison. Nonstructural alternative plans were evaluated at the 2% and 10% annual chance exceedance storm events. The following alternative plans carried forth for the economic analysis are as follows.

1. Levees and Floodwalls in Manville
2. Channel Modifications (Raritan River)
  - 3A. Nonstructural Plan - 2% annual chance exceedance floodplain
  - 3B. Nonstructural Plan - 2% annual chance exceedance floodplain (not including Blue Acres Program structures)
  - 3C. Nonstructural Plan - 2% annual chance exceedance floodplain (not including Blue Acres Program & Zarephath structures)
  - 3D. Nonstructural Plan - 2% annual chance exceedance floodplain (not including Blue Acres Program & Lost Valley structures)
  - 4A. Nonstructural Plan - 10% annual chance exceedance floodplain
  - 4B. Nonstructural Plan - 10% annual chance exceedance floodplain (not including Blue Acres Program structures)
  - 4C. Nonstructural Plan - 10% annual chance exceedance floodplain (not including Blue Acres Program & Zarephath structures)
  - 4D. Nonstructural Plan - 10% annual chance exceedance floodplain (not including Blue Acres Program & Lost Valley structures)

The evaluation of effects, or comparison of the with-project and without-project conditions for each alternative, is a requirement of NEPA and ER-1105-2-100. The evaluation was conducted by assessing or measuring the differences between each with- and without-project condition and by appraising or weighting those differences. Evaluation consisted of four general tasks described below:

- Forecast the most likely with-project condition expected under each alternative plan,
- Compare each with-project condition to the without-project condition and document the differences between the two,
- Characterize the beneficial and adverse effects by magnitude, location, timing and duration, and
- Identify the plans that will be further considered in the planning process, based on a comparison of the adverse and beneficial effects and the evaluation criteria.



Plans were evaluated based on the following criteria: all relevant resources, outputs and plan effects; contributions to the Federal objective (NED), the study goals and objectives, compliance with environmental protection requirements, the four evaluation criteria (completeness, effectiveness, efficiency and acceptability) described in ER 1105-2-100, and other criteria deemed significant by participating stakeholders. Any alternative plans that did not meet the four evaluation criteria would not be carried forward for further evaluation.

Table 14, summarizes the cost and benefits for each alternative.



**Table 14. Summary of Damages, Costs, Benefits and BCRs**

Summary of Damages, Costs, Benefits, and BCRs (Note 7)								
Alternative	Flood Damages	Flood Damages	Annual Benefits (Note 2)	Total First Cost	Total Investment Cost (Note 3)	Total Annual Cost (Note 4)	Net Excess Benefits (Note 5)	BCR (Note 6)
	Without Project	With Project (Note 1)						
1. Levees and Floodwalls in Manville, N.J.	\$ 2,850,000	\$ 1,284,000	\$ 1,566,000	\$ 66,380,000	\$ 66,833,000	\$ 4,004,000	\$ (2,438,000)	0.39
2. Channel Modifications (Raritan River)	\$ 2,850,000	\$ 1,533,000	\$ 1,317,000	\$ 125,588,000	\$ 130,347,000	\$ 6,510,000	\$ (5,193,000)	0.20
3A. Nonstructural Plan - 50-year flood plain	\$ 2,850,000	\$ 479,000	\$ 2,371,000	\$ 211,435,000	\$ 218,565,000	\$ 9,318,000	\$ (6,947,000)	0.25
3B. Nonstructural Plan - 50-year flood plain (not including Blue Acres Program structures)	\$ 2,850,000	\$ 455,000	\$ 2,396,000	\$ 198,344,000	\$ 205,033,000	\$ 8,741,000	\$ (6,346,000)	0.27
3C. Nonstructural Plan - 50-year flood plain (not including Blue Acres Program & Zarephath structures)	\$ 2,850,000	\$ 450,000	\$ 2,400,000	\$ 180,993,000	\$ 187,096,000	\$ 7,977,000	\$ (5,576,000)	0.30
3D. Nonstructural Plan - 50-year flood plain (not including Blue Acres Program & Lost Valley structures)	\$ 2,850,000	\$ 467,000	\$ 2,383,000	\$ 203,911,000	\$ 210,787,000	\$ 8,987,000	\$ (6,604,000)	0.27
4A. Nonstructural Plan - 10-year flood plain	\$ 2,850,000	\$ 1,224,000	\$ 1,626,000	\$ 98,689,000	\$ 102,017,000	\$ 4,349,000	\$ (2,724,000)	0.37
4B. Nonstructural Plan - 10-year flood plain (not including Blue Acres Program structures)	\$ 2,850,000	\$ 1,212,000	\$ 1,638,000	\$ 91,352,000	\$ 94,432,000	\$ 4,026,000	\$ (2,388,000)	0.41
4C. Nonstructural Plan - 10-year flood plain (not including Blue Acres Program & Zarephath structures)	\$ 2,850,000	\$ 1,208,000	\$ 1,643,000	\$ 75,662,000	\$ 78,214,000	\$ 3,335,000	\$ (1,692,000)	0.49
4D. Nonstructural Plan - 10-year flood plain (not including Blue Acres Program & Lost Valley structures)	\$ 2,850,000	\$ 1,219,000	\$ 1,631,000	\$ 95,577,000	\$ 98,800,000	\$ 4,212,000	\$ (2,581,000)	0.39

Notes

1. Damages incurred with the project in place due to storms that exceed the design criteria.
2. Without Project Annual Damages minus With Project Annual Damages.
3. Total Investment Costs include Interest During Construction: Alt-1: 46 months construction duration; Alt-2: 37 months construction duration.
4. Total Annual Cost based on 50 year period of analysis includes annualized O&M costs.
5. Net Excess Benefits = Annual Benefits minus Annual Costs.
6. Benefit-Cost Ratio (BCR) = Annual Benefits divided by Annual Cost.
7. All costs and benefits are at October 2013 price levels with a FY2014 discount rate of 3.5%.



#### ***14.0 Identifying a Tentatively Selected Plan***

Economic analysis has demonstrated that all formulated alternative plans have Benefit-Cost Ratios (BCRs) less than unity and thus no alternative plan has been identified that favorably contributes to National Economic Development (NED). Although Manville and other municipalities have experienced recurrent serious flooding as documented in Sections 8.0 and 10.0 the study was unable to identify an economically justified solution due to a relatively small potential for benefits. Economic analysis of the 0.2% annual chance exceedance floodplain in Manville indicates an annualized damage pool of approximately \$2,850,000 million. A plan with a BCR of one or greater is a necessary criteria for project recommendation, as stated in Section 6.1.

As illustrated in Table 14, the benefits (damages avoided) do not equal or exceed the cost of any alternative. This is true for both structural alternatives:

1. Levees and Floodwalls in Manville with a BCR of 0.39; and
2. Channel Modifications (Raritan River) with a BCR of 0.20.

Both structural alternatives did not exclude structures associated with the Blue Acres Program buyouts or any of the structures in the Zarephath area from the damage pool.

All of the following nonstructural alternatives had BCRs below unity:

- 3A. Nonstructural Plan - 2% annual chance exceedance floodplain
- 3B. Nonstructural Plan - 2% annual chance exceedance floodplain (not including Blue Acres Program structures)
- 3C. Nonstructural Plan - 2% annual chance exceedance floodplain (not including Blue Acres Program & Zarephath structures)
- 3D. Nonstructural Plan - 2% annual chance exceedance floodplain (not including Blue Acres Program & Lost Valley structures)
- 4A. Nonstructural Plan - 10% annual chance exceedance floodplain
- 4B. Nonstructural Plan - 10% annual chance exceedance floodplain (not including Blue Acres Program structures)
- 4C. Nonstructural Plan - 10% annual chance exceedance floodplain (not including Blue Acres Program & Zarephath structures)
- 4D. Nonstructural Plan - 10% annual chance exceedance floodplain (not including Blue Acres Program & Lost Valley structures)

The nonstructural alternatives examined various combinations of structures as previously within the 2% and 10% annual chance exceedance floodplains. These included the inclusion or exclusion of structures within the Lost Valley or Zarephath areas or associated with the Blue Acres Program buyouts. Alternative 4C had the highest BCR of 0.49 for the nonstructural alternatives.



Despite the range of measures and alternatives considered and analyzed, no economically viable alternative was identified to address flooding problems in the Manville area. Structure buyouts through the Blue Acres Program reduces the potential benefits and thus the likelihood of economic justification of a plan to address flooding problems within the basin. However, Manville still has the highest number and density of structures within the Millstone River Basin and is still the appropriate area to use as a test for comparative screening of the basin. Based on the study area screening described in Section 7.2 it is thus concluded that an economically viable alternative would not be found elsewhere within the basin (reference study area screening in Section 7.2).

This report therefore identifies no flood risk management alternative plan as a Tentatively Selected Plan (TSP) to be further developed and recommended for implementation. The non-Federal sponsor, the NJDEP, concurs with the finding of no further Federal action for flood risk management for the Millstone River Basin, New Jersey, as documented within this report and appendices. Coordination with the non-Federal sponsor, the NJDEP, and local stakeholders such as the Raritan Millstone River Flood Control Commission (RMRFCC) and the Borough of Manville have been ongoing throughout the study.

#### ***Non-Federal Sponsor and Stakeholder Coordination***

Public involvement and citizen participation are an integral part of this feasibility study. Coordination by USACE and the NJDEP with the local stakeholders, municipalities within the study and project areas, other agencies, and interested parties has occurred on a regular basis since the beginning of the study.

Meetings with members of the RMRFCC, officials and residents of Manville and other interested parties were conducted in groups and on an individual basis. The purpose of carrying out coordination with officials, citizens and other interested parties is to ensure that the study addresses all pertinent questions from the public, is of the highest quality, and ultimately meets the needs of the people it will serve. Numerous meetings and coordination activities were conducted to gather data, conduct field studies, and notify property owners in the study area of the work being conducted. Coordination with elected representatives at the Federal, State, and local level has also been integral to the process.

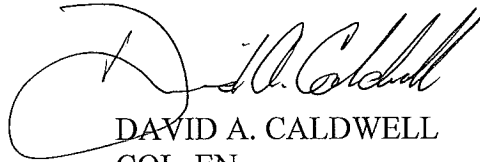
During the public review of the draft feasibility report the public, agencies, and all interested parties were asked to comment on the report. Responses have been incorporated where appropriate.



### ***15.0 Recommendation***

In making the following recommendations, I have given consideration to all significant aspects in the overall public interest, including environmental, social and economic effects, engineering feasibility and compatibility of the project with the policies, desires and capabilities of the non-Federal sponsor, the NJDEP, and other non-Federal interests. In light of the conclusions described in Sections 13.0 and 14.0, I do not recommend that the measures considered and analyzed for flood risk management within the Millstone River Basin, located in New Jersey, as detailed in this Feasibility Report and Appendices, be authorized for construction as a Federal project for flood risk management.

This recommendation is made because the contributions of this project, taken as a whole, do not add significantly to national economic development as a flood risk management project. The recommendations contained herein reflect the information available at this time and current Departmental policies governing formulation of individual projects. They do not reflect program and budgeting priorities inherent in the formulation of a national Civil Works construction program nor the perspective of higher review levels within the Executive Branch.



DAVID A. CALDWELL  
COL, EN  
Commanding





## **16.0 References**

New Jersey Department of Environmental Protection, Division of Fish and Wildlife (NJDEP). 2005. Summary of Results for Royce Brook Fish Sampling. Found at: <http://www.state.nj.us/dep/wms/bfbm/ibiyear2005.html>

N.J.A.C. 7:9B Surface Water Quality Standards. June 16, 2008 (40 N.J.R. 3630(b))

New Jersey Department of Environmental Protection  
Known Contaminated Sites List. March 2009

United States Army Corps of Engineers, New York District. *Environmental Assessment, Segment R2 Levee and Floodwall Construction, Green Brook Flood Damage Reduction Project Bound Brook, Somerset County, NJ*. October 2008.

United States Department of Agriculture, Natural Resources Conservation District (NRCS). February 2007. New Jersey Hydric Soil List. <http://soils.usda.gov/use/hydric/>

United States Environmental Protection Agency (US-EPA) Region Two  
Database for Superfund Sites in New Jersey

United States Fish and Wildlife Service (USFWS). 2015a. Information, Planning and Conservation (IPAC) website. Accessed September 10, 2015.

\_\_\_\_\_. 2015 b. 20 February 2015. Planning Aid Letter for the Rahway River Basin Flood Risk Management Feasibility Study, Essex, Middlesex and Union Counties, New York.



# **Millstone River Basin, New Jersey**

## **Flood Risk Management Feasibility Study**

### **Appendix A – Hydrology & Hydraulics**

**U.S. Army Corps of Engineers  
New York District  
26 Federal Plaza  
New York, New York 10278**

**November 2016**



**US Army Corps  
of Engineers**  
New York District



**New Jersey Department of  
Environmental Protection**

# Table of Contents

<b>1.0</b>	<b>PURPOSE OF STUDY .....</b>	<b>1</b>
1.1	BASIN DESCRIPTION.....	1
1.2	PROJECT AREA.....	1
1.3	PROBLEM IDENTIFICATION.....	2
<b>2.0</b>	<b>EXISTING CONDITIONS .....</b>	<b>2</b>
2.1	CLIMATE .....	2
2.2	PEAK & AVERAGE DISCHARGE RECORDS .....	3
2.3	STORM TYPES.....	3
2.3.1	<i>October 19-20 1996 storm and flood:</i> .....	4
2.3.2	<i>September 15-16 1999 (Tropical Storm Floyd) storm and flood:</i> .....	4
2.3.3	<i>April 15-16 2007 storm and flood:</i> .....	5
2.4	HYDROLOGY .....	6
2.4.1	<i>Hydrologic Modeling Procedures:</i> .....	6
2.4.2	<i>Calibration of Historic Floods:</i> .....	8
2.4.3	<i>Flood Frequency Analysis:</i> .....	9
2.4.4	<i>Hypothetical Flood Hydrograph Computations:</i> .....	11
2.5	HYDRAULICS.....	13
2.5.1	<i>Existing Channels:</i> .....	13
2.5.1.1	<i>Millstone River Upper:</i> .....	13
2.5.1.2	<i>Royce Brook:</i> .....	13
2.5.1.3	<i>Millstone River Lower:</i> .....	13
2.5.1.4	<i>Raritan River Upper:</i> .....	13
2.5.1.5	<i>Raritan River Lower:</i> .....	14
2.5.2	<i>Modeling Description:</i> .....	14
2.5.2.1	<i>Channel Cross-Sections:</i> .....	14
2.5.2.3	<i>Channel Roughness Factor &amp; Contraction/Expansion coefficients:</i> .....	15
2.5.3	<i>Flow Line Computations:</i> .....	15
2.5.3.1	<i>Peak and Coincidental Flows:</i> .....	15
2.5.4	<i>Calibration of Historic Events:</i> .....	16
2.5.5	<i>Hydraulic Profiles &amp; Inundation Mapping:</i> .....	16
<b>3.0</b>	<b>FUTURE UNIMPROVED CONDITIONS .....</b>	<b>17</b>
3.1	HYDROLOGY .....	17
3.2	HYDRAULICS.....	19
3.3	CLIMATE CHANGE.....	19
3.4	RISK AND UNCERTAINTY.....	19
3.4.1	<i>Hydrology:</i> .....	19
3.4.1	<i>Hydraulics:</i> .....	20
<b>4.0</b>	<b>IMPROVED CONDITIONS .....</b>	<b>20</b>
4.1	HYDROLOGY .....	20
4.1.1	<i>Channel Modification (Deepening) Plan:</i> .....	20
4.1.2	<i>Levee &amp; Floodwall Plan:</i> .....	21
4.2	HYDRAULICS.....	22
4.2.1	<i>Screened Alternatives:</i> .....	22
4.2.1.1	<i>No Action Alternative:</i> .....	22
4.2.1.2	<i>Non-Structural Alternative:</i> .....	22
4.2.1.3	<i>Channel Deepening Alternative:</i> .....	23
4.2.1.4	<i>Levee &amp; Floodwall Alternative:</i> .....	24
<b>5.0</b>	<b>CONCLUSION.....</b>	<b>27</b>



# LIST OF TABLES

TABLE 1: OCTOBER 19 – 20, 1996 STORM RECORDS AND FLOOD DATA .....	29
TABLE 2: SEPTEMBER 15 – 16, 1996 (TS FLOYD) STORM RECORDS AND FLOOD DATA.....	29
TABLE 3: APRIL 15 – 16, 2007 STORM RECORDS AND FLOOD DATA.....	29
TABLE 4: HEC-1 MODEL SUB-BASIN INPUT PARAMETERS UNDER EXISTING CONDITIONS .....	29
TABLE 5: MUSKINGUM VALUES FOR REACHES IN HEC-1 MODEL .....	31
TABLE 5: MUSKINGUM VALUES FOR REACHES IN HEC-1 MODEL (CONT.).....	32
TABLE 6: INITIAL LOSS PARAMETERS AT SELECTED NODES WITHIN THE RARITAN RIVER HEC-1 MODEL .....	33
TABLE 6: INITIAL LOSS PARAMETERS AT SELECTED NODES WITHIN THE RARITAN RIVER HEC-1 MODEL (CONT.) .....	34
TABLE 7: STATISTICAL PARAMETES FOR USGS GAGES WITHIN STUDY AREA .....	35
TABLE 8: POINT RAINFALL DEPTHS FOR HYPOTHETICAL STORMS .....	35
TABLE 9A: 48-HR, 785 SQUARE MILE TEMPORAL DISTRIBUTION OF RAINFALL FOR 100-YR STORM IN 15-MINUTE INCREMENTS* .....	35
TABLE 9B: TOTAL 48-HR, 785 SQ. MI. STORM RAINFALL – HYPOTHETICAL STORMS .....	36
TABLE 10: EXISTING CONDITIONS – PEAK DISCHARGE IN CFS.....	37
TABLE 11: HEC-RAS MODEL GEOMETRY SUMMARY .....	38
TABLE 12: WEIR DATA WITHIN HEC-RAS MODEL .....	38
TABLE 13: BRIDGE DATA WITHIN HEC-RAS MODEL .....	39
TABLE 14: BOUNDARY CONDITION RATING CURVE.....	39
TABLE 15: FLOOD MARKS FROM HISTORICAL EVENTS .....	40
TABLE 16: STEADY FLOWS FOR HISTORICAL EVENTS .....	41
TABLE 17: EXISTING CONDITIONS FOR FIRST RUN – LOWER RARITAN RIVER PEAKING.....	42
TABLE 18: EXISTING CONDITIONS FOR SECOND RUN – UPPER RARITAN RIVER PEAKING .....	43
TABLE 19: EXISTING CONDITIONS FOR THIRD RUN – LOWER MILLSTONE PEAKING AT RARITAN & MILLS TONE CONFLUENCE.....	44
TABLE 20: EXISTING CONDITIONS FOR FOURTH RUN – LOWER MILLSTONE PEAKING AT MILLS TONE R. & ROYCE BK. CONFL. ....	45
TABLE 21: EXISTING CONDITIONS FOR FIFTH RUN – UPPER MILLS TONE PEAKING.....	46
TABLE 22: EXISTING CONDITIONS FOR SIXTH RUN – ROYCE BROOK PEAKING .....	47
TABLE 23: HEC-1 MODEL SUB-BASIN INPUT PARAMETERS - FUTURE UNIMP. CONDITIONS .....	48
TABLE 24: FUTURE UNIMPROVED CONDITIONS – PEAK DISCHARGE IN CFS .....	49
TABLE 25: FUTURE UNIMPROVED CONDITIONS FOR FIRST RUN – LOWER RARITAN RIVER PEAKING .....	50
TABLE 26: FUTURE UNIMPROVED CONDITIONS FOR SECOND RUN – UPPER RARITAN RIVER PEAKING .....	51
TABLE 27: FUTURE UNIMPROVED CONDITIONS FOR THIRD RUN – LOWER MILLSTONE PEAKING AT RARITAN & MILLS TONE CONFL. ....	52



**TABLE 28: FUTURE UNIMPROVED CONDITIONS FOR FOURTH RUN – LOWER MILLSTONE PEAKING AT MILLS TONE R. & ROYCE BK. CONFL.....53**

**TABLE 29: FUTURE UNIMPROVED CONDITIONS FOR FIFTH RUN – UPPER MILLSTONE PEAKING .....54**

**TABLE 30: FUTURE UNIMPROVED CONDITIONS FOR SIXTH RUN – ROYCE BROOK PEAKING ...55**

**TABLE 31: COMPARISONS OF EXISTING AND IMPROVED CONDITIONS: ROYCE BROOK AT MOUTH – PEAK DISCHARGE IN CFS .....56**



# LIST OF FIGURES

FIGURE 1: RARITAN RIVER BASIN MAP WITH STUDY AREA .....	57
FIGURE 2: PROJECT AREA WITH THE RARITAN RIVER BASIN.....	58
FIGURE 3: HEC-1 SCHEMATIC DRAWING OF THE RARITAN RIVER BASIN TO CALCO DAM GAGE.....	59
FIGURE 4 (B): MODIFIED PULS ROUTING RELATIONS .....	61
FIGURE 4 (C): MODIFIED PULS ROUTING RELATIONS .....	62
FIGURE 4 (D): MODIFIED PULS ROUTING RELATIONS .....	63
FIGURE 5: OCTOBER 19 – 20 1996 NOR'EASTER FLOOD MODEL REPRODUCTION AT THE CALCO DAM GAGE. ....	64
FIGURE 6: SEPTEMBER 15 – 16 1999 (TS FLOYD) FLOOD MODEL REPRODUCTION AT THE CALCO DAM GAGE. ....	65
FIGURE 8: PEAK DISCHARGE VS. FREQUENCY CURVE FOR RARITAN RIVER AT MANVILLE, NJ (D.A. = 490 M <sup>2</sup> ) .....	67
FIGURE 9: PEAK DISCHARGE VS. FREQUENCY CURVE FOR MILLSTONE RIVER AT BLACKWELLS MILLS, NJ (D.A. = 258 M <sup>2</sup> ) .....	68
FIGURE 10: PEAK DISCHARGE VS. FREQUENCY CURVE FOR RARITAN RIVER AT CALCO DAM (UPSTREAM OF BOUND BROOK) (D.A. = 785 M <sup>2</sup> ) .....	69
FIGURE 11: PEAK DISCHARGE VS. FREQUENCY CURVE FOR BEDEN BROOK NEAR ROCKY HILL, NJ (D.A. = 27.6 M <sup>2</sup> ) .....	70
FIGURE 12: INTERPOLATION OF PEAK DISCHARGE VS. FREQUENCY FOR ROYCE BROOK AT MO UTH .....	71
FIGURE 13: 10-YEAR STORM AND 10-YR FLOOD FREQUENCY HYDROGRAPH .....	72
FIGURE 14: 100-YEAR STORM AND 100-YR FLOOD FREQUENCY HYDROGRAPH.....	73
FIGURE 15: PEAK DISCHARGE VS. FREQUENCY CURVE AT NODES ALONG ROYCE BROOK.....	74
FIGURE 16: PEAK DISCHARGE VS. FREQUENCY CURVE AT NODES ALONG RARITAN AND MILLSTONE RIVERS .....	75
FIGURE 17: EXISTING CONDITIONS SPECIFIC-FREQUENCY AREA-AVERAGE CURVES .....	76
FIGURE 18: WATER SURFACE PROFILE FOR HISTORICAL - OCT1996 & SEPT 1999 (MILLSTONE RIVER UPPER) .....	78
FIGURE 19: WATER SURFACE PROFILE FOR HISTORICAL - OCT1996 & SEPT 1999 (MILLSTONE RIVER UPPER) .....	79
FIGURE 20: WATER SURFACE PROFILE FOR HISTORICAL - OCT1996 & SEPT 1999 (ROYCE BROOK).....	80
FIGURE 21: WATER SURFACE PROFILE FOR HISTORICAL - OCT1996 & SEPT 1999 (ROYCE BROOK).....	81
FIGURE 22: WATER SURFACE PROFILE FOR HISTORICAL - OCT1996 & SEPT 1999 (MILLSTONE RIVER LOWER).....	82
FIGURE 23: WATER SURFACE PROFILE FOR HISTORICAL - OCT1996 & SEPT 1999 (RARITAN RIVER UPPER) .....	83
FIGURE 24: WATER SURFACE PROFILE FOR HISTORICAL - OCT1996 & SEPT 1999 (RARITAN RIVER UPPER) .....	84



FIGURE 25: WATER SURFACE PROFILE FOR HISTORICAL - OCT1996 & SEPT 1999 (RARITAN RIVER UPPER) .....	85
FIGURE 26: WATER SURFACE PROFILE FOR HISTORICAL - OCT1996 & SEPT 1999 (RARITAN RIVER LOWER).....	86
FIGURE 27: WATER SURFACE PROFILE FOR PRESENT CONDITIONS (MILLSTONE RIVER UPPER) .....	87
FIGURE 28: WATER SURFACE PROFILE FOR PRESENT CONDITIONS (MILLSTONE RIVER UPPER) .....	88
FIGURE 29: WATER SURFACE PROFILE FOR PRESENT CONDITIONS (ROYCE BROOK).....	89
FIGURE 30: WATER SURFACE PROFILE FOR PRESENT CONDITIONS (ROYCE BROOK).....	90
FIGURE 31: WATER SURFACE PROFILE FOR PRESENT CONDITIONS (MILLSTONE RIVER LOWER) .....	91
FIGURE 32: WATER SURFACE PROFILE FOR PRESENT CONDITIONS (RARITAN RIVER UPPER).....	92
FIGURE 33: WATER SURFACE PROFILE FOR PRESENT CONDITIONS (RARITAN RIVER UPPER).....	93
FIGURE 34: WATER SURFACE PROFILE FOR PRESENT CONDITIONS (RARITAN RIVER UPPER).....	94
FIGURE 35: WATER SURFACE PROFILE FOR PRESENT CONDITIONS (RARITAN RIVER LOWER) .....	95
FIGURE 36: WATER SURFACE PROFILE FOR PRESENT CONDITIONS (RARITAN RIVER LOWER) .....	96
FIGURE 37: INUNDATION MAPPING OF PROJECT AREA .....	97
FIGURE 38: MAXIMUM WATER SURFACE PROFILE FOR FUTURE UNIMPROVED CONDITIONS (MILLSTONE RIVER UPPER) .....	98
FIGURE 39: MAXIMUM WATER SURFACE PROFILE FOR FUTURE UNIMPROVED CONDITIONS (MILLSTONE RIVER UPPER) .....	99
FIGURE 40: MAXIMUM WATER SURFACE PROFILE FOR FUTURE UNIMPROVED CONDITIONS (ROYCE BROOK) .....	100
FIGURE 41: MAXIMUM WATER SURFACE PROFILE FOR FUTURE UNIMPROVED CONDITIONS (ROYCE BROOK) .....	101
FIGURE 42: MAXIMUM WATER SURFACE PROFILE FOR FUTURE UNIMPROVED CONDITIONS (MILLSTONE RIVER LOWER) .....	102
FIGURE 43: MAXIMUM WATER SURFACE PROFILE FOR FUTURE UNIMPROVED CONDITIONS (RARITAN RIVER UPPER).....	103
FIGURE 44: MAXIMUM WATER SURFACE PROFILE FOR FUTURE UNIMPROVED CONDITIONS (RARITAN RIVER UPPER).....	104
FIGURE 45: MAXIMUM WATER SURFACE PROFILE FOR FUTURE UNIMPROVED CONDITIONS (RARITAN RIVER UPPER).....	105
FIGURE 46: MAXIMUM WATER SURFACE PROFILE FOR FUTURE UNIMPROVED CONDITIONS (RARITAN RIVER LOWER) .....	106
FIGURE 47: MAXIMUM WATER SURFACE PROFILE FOR FUTURE UNIMPROVED CONDITIONS (RARITAN RIVER LOWER) .....	107
FIGURE 48: CHANNEL PLAN LAYOUT.....	108
FIGURE 49: CHANNEL PLAN (SHEET #1) .....	109
FIGURE 50: CHANNEL PLAN (SHEET #2) .....	110





**FIGURE 51: MAXIMUM WATER SURFACE PROFILE FOR CHANNEL PLAN - FUTURE IMPROVED CONDITIONS (MILLS TONE RIVER LOWER) ..... 111**

**FIGURE 52: MAXIMUM WATER SURFACE PROFILE FOR CHANNEL PLAN - FUTURE IMPROVED CONDITIONS (RARITAN RIVER UPPER)..... 112**

**FIGURE 53: MAXIMUM WATER SURFACE PROFILE FOR CHANNEL PLAN - FUTURE IMPROVED CONDITIONS (RARITAN RIVER UPPER)..... 113**

**FIGURE 54: MAXIMUM WATER SURFACE PROFILE FOR CHANNEL PLAN - FUTURE IMPROVED CONDITIONS (RARITAN RIVER UPPER)..... 114**

**FIGURE 55: MAXIMUM WATER SURFACE PROFILE FOR CHANNEL PLAN - FUTURE IMPROVED CONDITIONS (RARITAN RIVER LOWER)..... 115**

**FIGURE 56: MAXIMUM WATER SURFACE PROFILE FOR CHANNEL PLAN - FUTURE IMPROVED CONDITIONS (RARITAN RIVER LOWER)..... 116**

**FIGURE 57: LEVEE & FLOODWALL PLAN LAYOUT..... 117**

**FIGURE 58: LEVEE & FLOODWALL PLAN LAYOUT (SHEET 2 OF 4)..... 118**

**FIGURE 59: LEVEE & FLOODWALL PLAN LAYOUT (SHEET 3 OF 4)..... 119**

**FIGURE 60: LEVEE & FLOODWALL PLAN LAYOUT (SHEET 4 OF 4)..... 120**

**FIGURE 61: MAXIMUM WATER SURFACE PROFILE FOR LEVEE & FLOODWALL PLAN - FUTURE IMPROVED CONDITIONS (ROYCE BROOK) ..... 121**

**FIGURE 62: MAXIMUM WATER SURFACE PROFILE FOR LEVEE & FLOODWALL PLAN - FUTURE IMPROVED CONDITIONS (MILLS TONE RIVER LOWER)..... 122**

**FIGURE 63: MAXIMUM WATER SURFACE PROFILE FOR LEVEE & FLOODWALL PLAN - FUTURE IMPROVED CONDITIONS (RARITAN RIVER UPPER) ..... 123**

**FIGURE 64: MAXIMUM WATER SURFACE PROFILE FOR LEVEE & FLOODWALL PLAN - FUTURE IMPROVED CONDITIONS (RARITAN RIVER UPPER) ..... 124**

**FIGURE 65: MAXIMUM WATER SURFACE PROFILE FOR LEVEE & FLOODWALL PLAN - FUTURE IMPROVED CONDITIONS (RARITAN RIVER LOWER)..... 125**

**FIGURE 66: MAXIMUM WATER SURFACE PROFILE FOR LEVEE & FLOODWALL PLAN - FUTURE IMPROVED CONDITIONS (RARITAN RIVER LOWER)..... 126**

**Non Structural Appendix.....127**



# **MILLSTONE RIVER BASIN SOMERSET COUNTY, NEW JERSEY FLOOD RISK MANAGEMENT STUDY**

## **1.0 PURPOSE OF STUDY**

This appendix documents the existing and improved conditions hydrology & hydraulic analyses, that were done for the flood risk management study of the Millstone River Basin in Somerset County, New Jersey. The only area in the basin that had potential to justify a flood risk management project was the Borough of Manville, NJ. An in-depth feasibility analysis was performed to determine if flood risk reduction features would be cost justified.

## **1.1 Basin Description**

The Raritan River drains an area of 1105 square miles in northeastern New Jersey. It is the largest drainage basin entirely within the state of New Jersey. It discharges into Raritan Bay at the southern border between New York City and the State of New Jersey. The Raritan River Basin is roughly trapezoidal in shape, with a maximum length of about 40 miles and a maximum width of almost 30 miles. Its major tributaries are its North and South Branches and the Millstone and South Rivers. Royce Brook a tributary of the Millstone River, is an important feature of this study. Figure 1 shows the entire Raritan River basin including the study area at the confluence of the Raritan and Millstone Rivers.

## **1.2 Project Area**

The study area, located within the Raritan River Basin, includes the Lower Millstone River and Lower Royce Brook. The Millstone River, a tributary of the Raritan River, enters the Raritan River in Manville, about 22 miles upstream of Raritan Bay. Royce Brook, a tributary of the Millstone River, enters the Millstone River in Manville about 1.5 miles upstream of the Millstone River's mouth. The Raritan River flows eastward into Raritan Bay, the Millstone River flows northward into the Raritan River, and Royce Brook flows eastward into the Millstone River. (See Figure 2) The project area is located in Manville NJ, and is bounded by all three of these streams. The Raritan River portion of the project extends from the Route 206 Bridge downstream to the Raritan River and Green Brook confluence. Its total length is 41,290 feet (7.82 miles). The



Millstone River portion of the project extends from the Amwell Road Bridge to its mouth in the Raritan River. Its total length is 24,600 feet (4.66 miles). The Royce Brook portion of the project extends from Whalen Street to the mouth of Royce Brook in the Millstone River. Its total length is 4,800 feet (0.91 miles). The USGS stream gages relevant to the project area are the following: Raritan River at Manville NJ (Gage no. 01400500), Millstone River at Blackwells Mills, NJ (Gage no. 01402000), and Raritan River below Calco Dam at Bound Brook NJ (Gage no. 01403060). Data from these gages was used in the hydrologic and hydraulic analyses. During large riverine floods, the Borough of Manville is surrounded by the flood waters of the Raritan and Millstone Rivers. They thereby isolate Manville as an island, with limited to no access by road. The project area is shown on Figure 2.

### **1.3 Problem Identification**

Early in the feasibility phase, meetings and site visits were held with NJDEP, Somerset County, local governments, and area residents, to determine the extent of flooding in Manville, NJ. Flooding in the Raritan and Millstone River Basins occurs as the result of intense thunderstorms, northeasters, and hurricanes. The Borough of Manville, located at the confluence of the Millstone and the Raritan Rivers, experiences the most significant flooding problems within the study area. Two of the most recent of the seven greatest floods in Manville have occurred as the direct result of tropical storms (Doria in 1971 and Floyd in 1999). The other five greatest historic floods of the Raritan River at Manville are those of September 1938, August 1955 (both tropical storms) August 1942 (thunderstorm) October 1996 and April 2007 (both nor'easters). The Lost Valley area of Manville is usually one of the areas hardest hit by floods. There are approximately 1,311 structures in the 500-year floodplain in Manville.

## **2.0 EXISTING CONDITIONS**

### **2.1 Climate**

The climate of the Raritan River Basin is characteristic of the entire Middle Atlantic seaboard. Marked changes of weather are frequent, particularly during the spring and fall. The winters are moderate, with moderate snowfall, and the summers are moderate, with hot, sultry weather midway, and frequent thunderstorms. Precipitation is also moderate, averaging about 44 inches annually, and well-distributed throughout the year. Summer totals of precipitation are slightly



higher than winter totals. The relative humidity is high. Average annual temperature ranges from 49 to 53 degrees F, with extremes ranging from -24°F at Long Valley, NJ to 109°F at Somerville NJ. The growing season averages 174 days, and the mean annual relative humidity varies from 67 to 71 percent. Prevailing winds are from the northwest, with an average annual velocity of about 12 miles per hour. The number of days per year with rainfall of 0.01 inch or greater averages from about 111 to 123.

## **2.2 Peak & Average Discharge Records**

The three continuously recording USGS stream gages, used in this study, are : Raritan River at Manville, Millstone River at Blackwells Mills, and Raritan River below Calco Dam at Bound Brook NJ. The records of these USGS gaging stations are available on-line at the USGS NJ website.

A fourth continuous recording USGS stream gage, Beden Brook near Rocky Hill (Gage no. 01401600), was used to develop a peak discharge vs. frequency curve at itself. It was then translated to the Royce Brook at its mouth, because it has similar watershed parameters, and was used as a calibration point for specific frequency hypothetical floods. See Section 2.4.3 for more detail.

The average annual discharge of the three gages is as follows: Raritan River at Manville. N.J. stream gage for water years 1904 through 2007 is 784.7 cfs, or 1.601 csm (cfs per square mile); Millstone River at Blackwells Mills N.J. stream gage for water years (WY) 1922 through 2008 is 386.5 cfs, or 1.498 csm (cfs per square mile); and the Raritan River below Calco Dam at Bound Brook, N.J. stream gage for water years 1903 through 2008 is 1204.0 cfs, or 1.534 csm (cfs per square mile).

## **2.3 Storm Types**

The storms which occur over the northeastern states have their origins in or near the Pacific and the North Atlantic oceans and may be classified as: extra tropical storms; which include thunderstorms, cyclonic (transcontinental) storms; tropical storms, which include the West Indies hurricanes, and nor'easter storms.



Some of the major flood-producing storms that have occurred over the Raritan River Basin, through WY 2009 are the following: July 1938, September 1938, June 1946, December 1948, March 1967, August 1971 (Tropical Storm Doria), August 2 1973 thunderstorm over the Watchung Mountains, September 1989 (Tropical Storm Hugo), January 19-20 1996, (rainfall on snowmelt) October 1996 (nor'easter), September 1999 (Tropical Storm Floyd), April 2005 (Nor'easter), October 2005, (Tropical Storm Tammi) and April 2007 (Nor'easter). Three major storms, and the floods they produced in the Raritan River Basin, were selected from WY 1989 through 2009, for analysis and reproduction, in this study. They are described in more detail below.

### **2.3.1 October 19-20 1996 storm and flood:**

Three to 8.6 inches of rain fell across parts of New Jersey in about 18 hours from about 4 a.m. to about 10 p.m. Saturday October 19 1996. It brought rivers above their banks and caused serious flooding in New Jersey. The maximum storm total for New Jersey of 8.6 inches was recorded at Passaic Township. Four deaths were reported for this flood. Somerset County declared a state of emergency. Over 30 people in neighboring Manville were unable to return home. More than 20 homes were damaged in the Lost Valley section of Manville, where flooding reached a depth of 8 feet.

Table 1 gives data for the October 19-20 1996 storm and flood for the three major gaged basins in this study.

### **2.3.2 September 15-16 1999 (Tropical Storm Floyd) storm and flood:**

Rainfall totals from Floyd were as high as 12 to 16 inches over portions of New Jersey, 4 to 8 inches over southeastern New York, and up to 11 inches over portions of New England.

Floyd resulted in new flood peaks of record at a minimum of sixty stream gages within the portions of New Jersey and New York within New York District's civil works boundaries. This included the three long-term USGS gages of this study: Manville, Blackwells Mills, and Bound Brook, New Jersey. The flood resulting from Floyd in the Raritan River basin was estimated by the Trenton NJ office of the United States Geological Survey to be the largest since at least the year 1700. More than 1,200 homes were affected by flooding resulting from Tropical Storm Floyd. About 75 homes suffered major structural damage. The Lost Valley District of Manville was one of the hardest hit areas with over 500 homes damaged. Table 2 gives data for the Tropical Storm Floyd and resulting flood for the three major gaged basins in this study.



### **2.3.3 April 15-16 2007 storm and flood:**

The April 15-16 2007 nor-easter storm dropped about three to ten inches of rain on the watersheds within the New York District's civil works boundaries between the early morning of Sunday April 15<sup>th</sup> 2007 and the early afternoon of Monday April 16<sup>th</sup>, 2007. It resulted in new flood peaks of record at ten USGS gages in New Jersey. This storm caused the worst flooding in the Raritan and Passaic River basins, and the worst flooding in the Raritan basin, since Tropical Storm Floyd, in September 1999. Bound Brook and Manville were once again hit hard, as were communities on the other side of the Raritan River in Middlesex County.

The approximate time distribution of the total rainfall of the April 15-16 2007 nor-easter over the watersheds of the New York District was an average of 7 to 7 ½ inches between about 2 a.m. on Sunday April 15<sup>th</sup> to 2 p.m. on Monday April 16<sup>th</sup> 2007, with most within the 24 hours beginning at 2 a.m. on Sunday the 15<sup>th</sup>. Greatest hourly amounts were from 0.6 to 0.8 inches at about 2 p.m. on Sunday April 15<sup>th</sup> 2007. Tropical Storm Floyd broke the summer 1999 drought and fell on dry ground. By contrast, the April 2007 nor'easter caused as much flooding as it did because it was preceded by the smaller March 1-2 and April 12-13 2007 storms. As such, and for other reasons of antecedent soil moisture conditions, it fell on saturated ground. Table 3 gives data for the April 15-16 2007 storm and flood for the three major gaged basins in this study.



## 2.4 Hydrology

### 2.4.1 Hydrologic Modeling Procedures:

The Generalized Stream Network Option of the HEC-1 Flood Hydrograph Package (U.S. Army Corps of Engineers) was used to hydrologically model the Raritan River watershed to the USGS gage # 01403060 Raritan River below Calco Dam at Bound Brook, the downstream boundary condition and calibration point of the hydrology analysis. The hydraulics of the study continues further downstream to the confluence of Green Brook and the Raritan River.

The Calco Dam itself has been removed. However, it is still part of the name of the USGS gaging station 01403060, Raritan River Below Calco Dam at Bound Brook New Jersey. The gage will continue to be so named in this report until USGS revises it. To do otherwise would cause confusion and a waste of effort.

HEC-1 was used rather than the newer program HEC-HMS, because at the time of this study, HEC-HMS lacked the capability of varying specific frequency hypothetical rainfall from sub-basin to sub-basin. HEC-1 has this capability and was therefore used for this study.

The watershed to the Bound Brook gage was divided into twenty-eight (28) sub-basins, with eighteen (18) routing reaches and twenty-six (26) combining points defined for the purpose of hydrologic analysis and calibration. The most important HEC-1 model nodes, with their descriptions and contributing drainage areas, starting at the upstream-most point, and working downstream to the USGS gage below Calco Dam at Bound Brook, are shown in Table 4 and Figure 3.

The Middle Brook and Green Brook sub-watersheds portion of the HEC-1 model used in this study consist of 88 sub-basins total (20 sub-basins for Middle Brook and 68 sub-basins for Green Brook). These two additional sub-watersheds were added to the hydrology analysis because of additional river reaches that needed to be incorporated for the channel modification (deepening) alternative. However, this detail is not relevant to the project area.

Clark unit hydrograph parameters  $T_c$  and  $R$  were determined for the USGS-gaged basins, Raritan River at Manville (490 sq. mi.) and Millstone River at Blackwells Mills (258 sq. mi.), the two largest HEC-1 model sub-basins in this study, by HEC-1 unit hydrograph optimizations of a full range of large recent storms and floods, beginning with the May 29 1968 flood, and including, most recently, the October 19-20 1996 nor'easter storm and flood, Tropical Storm Floyd





(September 15-16 1999) and the April 15-16 2007 nor'easter storm. Optimized unit hydrograph  $T_c$  and  $R$  for Raritan River at Manville were transposed to the upstream-most ungaged location in the HEC-1 model, Raritan River downstream of the confluence of North and South Branches (466 square miles) with a drainage area ratio to the 0.25 power factor. Adjustments were made for the main channel lengths and slopes of the two watersheds. These adjustments were made due to differences between the main channel lengths and slopes of the Raritan River downstream of the confluence of North and South Branches and the Raritan River at Manville USGS gage.

Clark unit hydrograph parameters  $T_c$  and  $R$  were determined for the other, smaller, mostly ungaged 26 HEC-1 model sub-basins from their physical parameters longest length  $L$ , main channel slope,  $S$ , and percent impervious area (RTIMP) using regression equations computed from a comprehensive gaged basin unit hydrograph data base. It consisted of the data base from the May 1997 Green Brook GRR Hydrology, Support Document F. It was augmented with data from gaged sub-basins of the upper Raritan River basin, taken from Philadelphia District COE's 1982 Raritan River basin study, and modified for the Green Brook Watershed Analysis (NYD and HEC, Corps of Engineers, May 1985).

Sub-basin length and slope were scaled from the USGS quad sheet topographic map ensemble for the study. Sub-basin percent impervious area (HEC-1 input variable RTIMP) was determined from land use types shown on the quad sheet ensemble, and augmented with recent (3 years old at most) Google Earth aerial photography of the study area sub-basins. The sub-basin names, along with their drainage areas, percent impervious areas, and resulting Clark unit hydrograph parameters  $T_c$  and  $R$ , are given in Table 4. Sub-basin names are also given in Figure 3.

The Muskingum routing parameter, reach travel time  $K$ , was estimated for 5 of the 18 routing reaches using their lengths and slopes. Muskingum weighting factor  $X$  was set to zero for the five Muskingum reaches to make them computationally equivalent to the other thirteen Modified Puls routing reaches. Note that the number of routing steps was set within the proper limits for each reach using the equation in the HEC-1 User's Manual. Muskingum routing input parameters for the five basic Muskingum routing reaches in the HEC-1 model are given in Table 5.

Modified Puls routing storage-outflow data from the output of calibrated HEC-RAS water surface profile computer program runs of the Raritan and Millstone Rivers, and Royce Brook, were





available for eleven (11) of the eighteen (18) routing reaches of the HEC-1 model of the current study. These reaches are shown on Figures 4(A) to 4(D).

Four of the Modified Puls routing reaches (RARRT3, MILLR1, MILLR2, and MILLR3) were augmented with four supplemental Muskingum routing reaches (RART3A, MILR1A, MILR2A, and MILR3A) respectively, to provide needed additional flood peak attenuation for calibration to the Bound Brook gage, given perfect calibration upstream at the Manville and Blackwells Mills gages, for the 10 through 500 year hypothetical floods, and the October 19-20 1996 nor'easter, Tropical Storm Floyd and April 15-16 2007 nor'easter historic floods, as described in subsequent sections. Part of the physical reason for this is the probable tendency of the Raritan River to back up into the Millstone River during these largest floods, when the flood resulting on the Raritan River from any given historic storm over the Raritan River basin is appreciably larger than the flood on the Millstone River resulting from that same storm. Recent examples are the October 1996 nor'easter flood and the flood that resulted from Tropical Storm Floyd. The opposite was true of the April 15-19 2007 nor'easter flood, which was more severe in the Millstone River Basin than in the Raritan River Basin upstream of the Millstone River.

The travel times of these supplemental Muskingum routing reaches were adjusted as a calibration parameter for these floods to match both USGS gage observed hydrograph data and statistically computed specific-frequency hypothetical peak flow data (1 to 500 year flood peaks) at the USGS gage, Raritan River below Calco Dam at Bound Brook NJ.

Another physical reason for these supplemental Muskingum routing reaches was that the storage-outflow relations for the routing reaches are nearly linear over the full (1 year to Floyd) range of flows, and do not account for reach travel time increasing due to increasing overbank storage, once flood flows overtop the banks of the Raritan and Millstone Rivers. The travel times of the four supplemental Muskingum routing reaches are a means of accounting for, and incorporating, this additional overbank storage in the analysis. They are an easy way to include it in the HEC-1 models, without having to increase and input many storage values in the HEC-1 models' Modified Puls routing reaches.

#### **2.4.2 Calibration of Historic Floods:**



The HEC-1 models of the three historic floods that occurred in the Raritan River Basin were calibrated to the flood hydrographs recorded at the three major USGS stream gages listed in Section 2.2. For more information on the HEC-RAS modeling approach, which used floodmarks for calibration, see the hydraulics section of this appendix.

Hourly and total storm rainfall data were gathered for the Raritan River Basin for the October 19-20 1996 nor-easter storm, Tropical Storm Floyd, and the April 15-16 2007 nor-easter storm. This data was applied to the HEC-1 model of the Raritan River Basin to the Bound Brook gage, as both direct input (both time series and total storm rainfall data), and as HEC-1 model sub-basin rainfall gage weightings. as the gage weightings were determined by Thiessen networks drawn for the Raritan River watershed for these three recent historic storms. The emphasis of the current study is on the damage reaches between the Raritan River at Manville, Millstone River at Blackwells Mills, and Raritan River below Calco Dam at Bound Brook USGS gages.

Model input parameters were adjusted in a trial and error process until the three historical flood hydrographs, computed by the HEC-1 models, closely matched the three observed and recorded hydrographs in terms of peak discharge, time of peak, shape, and volume. Part of this trial and error process is to update the Modified Puls values within the HEC-1 model with storage vs discharge information from HEC-RAS for the same historical event, which includes floodmarks of the event. This was only done for the October 19 1996 and September 1999 (TS Floyd) historic floods.

Adopted calibration values of the infiltration loss and routing parameters (Basic & Supplemental) are given in Tables 5 and 6. The observed hydrograph reproductions at the Bound Brook gage appear on Figures 5 to 7. The October 19-20 1996 nor-easter flood and Tropical Storm Floyd flood existing conditions flows thus computed by the calibrated HEC-1 model enabled matching of the available high water marks for these two large recent historic floods, using the hydraulic (HEC-RAS) water surface profile model of the Raritan and Millstone Rivers, and Royce Brook. Table 10 gives the historical flood peaks at the USGS gages and other locations within the HEC-1 model.

### **2.4.3 Flood Frequency Analysis:**

The peak discharge vs. frequency curves of the three long-term USGS-stream gaged locations in the Raritan River Basin, that form the boundary conditions of the study area, Raritan River at



Manville, Millstone River at Blackwells Mills, and Raritan River below Calco Dam at Bound Brook, were revised and updated to include the twenty-four years of flood peak history that had accumulated since the completion of the hydrology for the Green Brook GRR: water years 1986 through 2009.

Annual series peak discharge vs. frequency relations were determined in accordance with Guidelines for Determining Flood Flow Frequency, Bulletin 17B, U.S. Water Resources Council, Washington D.C., revised September 1981. A generalized skew of 0.3, and a mean-square error of this generalized skew of 0.207, were used for all three Raritan and Millstone River basin gages. These values were taken from the Generalized Skew Study for the State of New Jersey, Special Projects Memo 480, Hydrologic Engineering Center, December 1977. Statistical parameters computed for the three large long-term Raritan and Millstone River basin gaged watersheds are shown in Table 7. Confidence limits for 5 and 95 percent levels of significance are provided as a measure of the uncertainty of estimated exceedence probability. The annual series peak discharge versus frequency curves appear on Figures 8 to 10.

The partial duration portions of the existing conditions peak discharge vs. frequency curves computed as described above for the three long-term Raritan and Millstone River Basin gages were determined by partial duration analyses of all hydrologically and economically independent peak discharges above base recorded at these three gages. This is done when the size of the watershed is relatively small, which includes most of the watersheds within the New York District civil works boundaries. In addition, the partial duration peak discharges give more accurate values on the lower portion of the curve (between the 1-year to 10-year return periods). This precision assists the economist in developing benefits from flood damage within the project area, for their economic analysis.

As stated in section 2.2, the Royce Brook watershed near its mouth is mostly ungaged. Therefore, a flood frequency analysis of a gaged watershed of similar size, Beden Brook near Rocky Hill NJ, was performed to estimate as accurately as possible the peak discharge vs. frequency for Royce Brook at its mouth. This was interpolated logarithmically on a peak discharge per square mile basis between peak discharge vs. frequency for Beden Brook near Rocky Hill and Millstone River at Blackwells Mills using the factor :  $(\text{Slope})^{**} 0.5 / \text{Length}$  as an index of peakedness. The peak discharge vs. frequency curve that was used for Beden Brook near Rocky Hill is shown in Figure



11. The graph that was used to translate peak discharge from Beden Brook near Rock Hill to Royce Brook at mouth is shown in Figure 12.

#### **2.4.4 Hypothetical Flood Hydrograph Computations:**

##### *Hypothetical Rainfall*

Point precipitation frequency estimates (in inches) were obtained for the Raritan River Basin at the USGS Bound Brook gage, from NOAA Atlas 14, for return periods (1- to 500-yr) and durations (5 minutes to 48 hours). The maximum duration value of 48 hours was used to accommodate the greatest basin time of concentration within the HEC-1 model, which is estimated between 24 to 48 hours, at the mouth of the Millstone River. The point rainfall values are given in Table 8. The point rainfall data values were modified to finite area rainfall values, for the respective drainage areas at the three gages, using procedures contained in Technical Paper No. 40, Rainfall Frequency Atlas of the United States, U.S. Department of Commerce, Washington, D.C., 1961, and in program HEC-1. These are the drainage areas, respectively, of the USGS gages, Raritan River at Manville NJ, Millstone River at Blackwells Mills, NJ and the USGS gage Raritan River below Calco Dam at Bound Brook, NJ. Tables 9 (a) and (b) give the 48-hour, 785 square mile temporal distribution of rainfall for the 100-year storm.

785 square miles is the drainage area of the USGS gage, Raritan River below Calco Dam at Bound Brook NJ. This gage is the downstream boundary condition and calibration point for the hydrology and hydraulics of this study.

A computation interval of 15 minutes and a time base of 120 hours were used in the HEC-1 models of the hypothetical floods. The former was used because of the small drainage areas and times of concentration of the smallest HEC-1 model sub-basins. The latter was used to allow 72 hours after the end of the 48-hour hypothetical storms. This would adequately compute the falling limbs of the slowest-reacting watersheds in the model, those of the Millstone River at its mouth, and at the downstream terminus of the models, the Raritan River at the USGS gage below Calco Dam at Bound Brook N.J.

##### *Calibration of HEC-1 models of Hypothetical Floods*

Infiltration loss and routing input parameters of the HEC-1 models were adjusted in a trial and error process until the peak discharges of the statistically computed peak discharge vs. frequency



curves of Raritan River at Manville, Royce Brook at mouth, Millstone River at Blackwells Mills, and Raritan River below Calco Dam at Bound Brook NJ were matched to the nearest 10 cfs.

Once the quality of the HEC-1 models of the Raritan River Basin had been verified by the three observed flood hydrograph reproductions (October 1996, September 1999 (TS Floyd) and April 2007), the specific frequency hypothetical storm and flood HEC-1 models of the Raritan River Basin were then created.

They were then calibrated to the existing conditions peak discharge vs. frequency relations. These HEC-1 models used, as their driving input, appropriate hypothetical point precipitation values from on-line NOAA Atlas 14.

The resulting existing conditions specific frequency hypothetical peak discharges are given in Table 10. Hydrographs of the 10-year and 100-year flood at selected gaged locations are shown in Figures 13 and 14. The resulting existing conditions peak discharge vs. frequency relations throughout the Raritan River Basin for both USGS-gaged and ungaged locations are shown on Figures 15 and 16.

Existing conditions specific-frequency area-averaged hypothetical storm hydrographs and flood hydrographs for the Raritan River below Calco Dam at Bound Brook NJ USGS gage appear on Figure 17.

Tables 17 through 29 give peak and coincidental flows for both existing and future unimproved conditions, and for all peak and coincidental flow scenarios analyzed. In these tables, the Royce Brook coincidental flows do not necessarily progressively increase as one moves from the smallest hypothetical flood (1 year) to the largest hypothetical flood (500 year). The reason for this is the difference in the times to peak of the location, or HEC-1 node that is stated to be peaking, in any given table. This difference is a result of the specific frequency hypothetical floods calibration process described above. This process involved varying the travel times of the supplemental Muskingum routing reaches from one flood frequency to the next.

The lack of progressive increase of Royce Brook coincidental flows from the 1 year to the 500 year frequency is not an error, and need not be of concern, for the following two reasons : 1) The change in Royce Brook coincidental flow from frequency to frequency is very small 2) The



controlling, or highest, water surface elevation of the Royce Brook proposed improvement reach is set by the peak flows of the Millstone River downstream of Royce Brook, not by the very small (by comparison) coincident flows of Royce Brook. The coincident flows of Royce Brook in Tables 17 through 29 are also small compared to the peak flows of Royce Brook.

## **2.5 Hydraulics**

### **2.5.1 Existing Channels:**

For the hydraulic analysis within the project area, the Raritan River, Millstone River and Royce Brook were divided into 5 reaches. A brief summary of each reach is given below and the reaches are shown in Figure 18A.

#### **2.5.1.1 Millstone River Upper:**

This reach extends from about 0.5 mile upstream of the Amwell Road in Millstone, NJ to the confluence with Royce Brook, a distance of approximately 3.24 miles. This reach is characterized by a rather flat floodplain, which is mostly undeveloped on the right bank and with residential development on the left bank.

#### **2.5.1.2 Royce Brook:**

This reach extends from Sunnymeade Road (excluding this bridge) to the confluence with the Millstone River, a distance of approximately 2.05 miles. The entire reach is urban in character with steep banks and nearly all of the floodplain is developed.

#### **2.5.1.3 Millstone River Lower:**

This reach extends from the confluence with Royce Brook to the confluence with the Raritan River, a distance of approximately 1.40 mile. This reach is characterized by a broad flat floodplain, which is mostly undeveloped on the right bank and with residential development on the left bank. This reach contains a major damage area called Lost Valley, which is part of Manville and is located in the left overbank. On the right overbank, there is an existing levee that protects a community called Zarephath (Christian Seminary) and the Delaware-Raritan Canal.

#### **2.5.1.4 Raritan River Upper:**

This reach extends from the abandon West Railroad Bridge about 0.3 miles upstream of Route 206 to the confluence with Millstone River, a distance of approximately 3.88 miles. This reach is



characterized by a broad flat floodplain with some parts undeveloped, some industrial and some residential development. Most of the residential development is in the town of Manville, NJ.

#### **2.5.1.5 Raritan River Lower:**

This reach extends from the confluence with Millstone River downstream approximately 1.38 miles. This reach is characterized by a broad flat floodplain mostly undeveloped with some industrial development on the left overbank. For this reach only, additional cross-sections were added to the analysis because the impacts from the channel deepening alternative went further than the USGS Gage at Calco Dam. It was necessary to extend the downstream boundary condition beyond the Calco Dam so that the improved water surface elevation would match the existing water surface elevation. The impacts of the channel deepening went to the confluence of the Raritan River and Middle Brook. This will be explained in more detail in section 4.2.1.

#### **2.5.2 Modeling Description:**

The HEC-RAS program was used to hydraulically model the project area. As stated in section 2.5.1, the rivers within the project area were divided into five reaches and their geometry elements are summarized in Tables 11 to 13. The following sections describe the physical parameters that were input into HEC-RAS.

##### **2.5.2.1 Channel Cross-Sections:**

Channel cross-sections were developed from the topographic mapping and surveyed channel cross-sectional data. The average distance between surveyed cross-sections is approximately 400 feet for Upper Millstone, approximately 450 feet for Lower Millstone River, approximately 300 feet for Royce Brook, approximately 400 feet for Upper Raritan River and approximately 600 feet along Lower Raritan River. Overbank cross-section data was obtained from the 2003 topographic mapping. Cross-sections were drawn perpendicular to the flow of the river and then distance and elevation data was extract at each contour line.

Bridge cross-sections were surveyed immediate downstream and upstream of the bridge waterway openings and include piers, structural low steel, and tops of roadways. Weir cross-sections were surveyed at the crest and immediate downstream of the weir. These hydraulic features was used as input for the existing conditions HEC-RAS model. Locations of the bridges & weirs, with their representative cross-sections, are shown in Tables 12 and 13.





### **2.5.2.3 Channel Roughness Factor & Contraction/Expansion coefficients:**

A composite channel bottom and banks, the channel n value of 0.035 was used for all of the reaches except the Lower Raritan River, which was set between 0.035 to 0.08. Overbank n values for Millstone River Upper were set at 0.1, Millstone River Lower at 0.035 - 0.1, Raritan River Upper at 0.1, Raritan River Lower between 0.035 to 1000, and Royce Brook values were set at 0.06. (The high “n” value of 1000 came from an older section of the model and was used in an area of highly ineffective and blocked flow.)

The contraction and expansion coefficients for all open channel sections were set at 0.1 and 0.3 and for bridges at Raritan and Millstone Rivers at 0.3 and 0.5, respectively. Contraction and expansion coefficients for bridges at Royce Brook were set at 0.4 and 0.6, respectively.

### **2.5.3 Flow Line Computations:**

Flow line computations were generated in accordance with EM 1110-2-1409, “Backwater Curves in River Channels,” using HEC-RAS version 3.1.3 and were used to develop the hydraulic gradients for Royce Brook and the Millstone and Raritan Rivers under existing and improved conditions. The water surface elevations serve as the basis for establishing the extent of protection required.

#### **2.5.3.1 Peak and Coincidental Flows:**

Stages on the Millstone River are influenced by the backwater from the Raritan River. Stages on Royce Brook are influenced by the backwater from the Millstone River. Hydrographs of the Raritan River, Millstone River and Royce Brook, indicate that timing of the peaks of each river are significantly different, with the Millstone River peaking much earlier than the Raritan River, and Royce Brook peaking much earlier than the Millstone River. In order to accurately evaluate flood stages along these river bodies, six scenarios were analyzed: (1) Lower Raritan River peak flows with coincidental flows on all other reaches (2) Upper Raritan River peak flows with coincidental flows on all other reaches (3) Lower Millstone River peak flows with coincidental flows on all other reaches, (4) Lower Millstone River peak flows with coincidental flows on all other reaches (5) Upper Millstone River peak flows with coincidental flows on all other reaches and (6) Royce Brook peak flows with coincidental flows on all other reaches. For example, when the 100 year peak flow occurs on the Lower Millstone River, a coincident flow occurs on Lower





Raritan River, Upper Raritan River, Upper Millstone River and Royce Brook. These coincident flows on the other four river segments are usually less than the peak flow on the selected river segment. Section 2.5.5 shows the peak and coincidental flow used in this analysis.

The downstream boundary conditions for the HEC-RAS analysis of Lower Raritan River are the water surface elevations that were taken from the HEC-2 model within the 1997 Green Brook GRR. It was necessary to extend the downstream boundary condition to a point downstream of the Calco Dam and upstream of the Interstate 287 overpass, where the existing conditions water surface elevation matched the improved condition water surface elevation. Starting WSELs for existing conditions are shown in Table 14.

#### **2.5.4 Calibration of Historic Events:**

The HEC-RAS model was calibrated to recent storm events. Manning's  $n$  values and other loss coefficients were adjusted within reasonable limits until the computed water surface elevations were within about 0.5 foot of the observed floodmarks and the two gage readings on Raritan River (Manville gage and Calco Dam gage). Floodmarks were obtained for northeaster of October 19, 1996 and tropical storm of September 16, 1999 (Floyd). October 1996 storm has been generally regarded as a 25-year event and Floyd has been regarded as a 500-year event for the study area based upon observed peak discharge data up to WY2009. Floodmarks were obtained for these events as part of the 2003 Scope of Work. The floodmarks and computed water surface elevations at selected cross-sections are shown in Table 15. The October 1996 and September 1999 calibration profile are shown in Figures 18 to 26 and the corresponding peak flows are shown in Table 16.

#### **2.5.5 Hydraulic Profiles & Inundation Mapping:**

HEC-RAS models of the Raritan River, Millstone River, and Royce Brook were developed and run for a variety of hypothetical conditions. They included peak discharges run for 6 different plan scenarios: Raritan River Lower peaking, Raritan Upper peaking, Millstone at Royce Brook peaking, Millstone at Raritan River peaking, Millstone Upper peaking, and Royce Brook peaking. Tables 17 to 22 give the peak and coincidental flow for all six runs under existing conditions. The hypothetical (present) condition flow lines for Royce Brook, Millstone River and Raritan River are shown in Figures 27 to 35 for only the maximum water surface elevation. For clarity sake,



only the 10, 50, and 100-year flow lines are plotted and they are the final design water surface profiles.

As previously described, the six scenarios of peak-coincident flows were used to calculate profiles on the Raritan River, Millstone River and Royce Brook. For each of the six scenarios HEC-RAS water surface elevations (WSEL's) were computed for all five reaches. All the WSEL's were imported into an excel spreadsheet for all six runs. For each cross-section, the maximum WSEL's was identified from the results of the six runs. The maximum water surface elevation was then used to develop the final design water surface profiles. The maximum WSEL's for each frequency were also input into the HEC-FDA model for Economic and Plan Formulation purposes. The existing condition inundation maps for the 10-, and 50-year are shown in Figure 36.

### **3.0 FUTURE UNIMPROVED CONDITIONS**

#### **3.1 Hydrology**

Hypothetical flows for future unimproved conditions were developed by estimating the amount of urbanization or development likely to occur in the basin from base year 2016 to a future conditions year of 2067. In the HEC-1 model sub-basin variables RTIMP (percent impervious area) and Clark unit hydrograph parameters  $T_c$  and R were modified. The percentage of impervious area was updated to 2067 conditions using USGS quad sheet and Google Earth aerial photographs. Year 2067 values of Clark unit hydrograph  $T_c$  and R for sub-basins in which future development is anticipated were computed using year 2067 values of RTIMP and other sub-basin physical parameters using regression equations developed as described above.

Zero future increase in peak flows, from base year 2016 to future year 2067, was assumed for the Raritan at the confluence of its North and South Branches, and for the USGS gaged watershed Millstone River at Blackwells Mills, NJ for the following reasons: a) There were no noticeable increases (observed upward trends) in mean daily flows at the USGS gage station on the Raritan River below Calco Dam in Bound Brook, NJ between 1980 and 2009 from careful visual inspection of the graph at this gage. In addition, the same USGS data showed the same results for annual peak flows for the same period. b) No upward trend of annual peak discharges was observed for the aforesaid three gaged locations in the post-WW II period of greatest urban



development, 1945-1970. Therefore, as in the Green Brook GRR (US Army Corps of Engineers, N.Y. District, May 1997) none was anticipated for them, for any possible future (2016-2067) development.

Based upon the data shown from the USGS gages within the study area, future development was estimated, within reason, in the HEC-1 model. Percent impervious values, and the values of the Clark unit hydrograph  $T_c$  and  $R$  (computed from the percent impervious values), via the regression equation, are shown in Table 23. Note that an increase in sub-basin peak flow due to future development is a conservative assumption, given the on-site detention of increased runoff volume due to new urbanization development, mandated by the Clean Water Act of 1992, and implemented in the state of New Jersey since only a few years afterwards.

The only study stream significantly affected by these increases in runoff due to future development is Royce Brook. The increases in the peak discharge of Royce Brook at its mouth due to future development anticipated within a 50-year period (2016-2067) are reasonable, and range between 7.9 % for the 1 year flood to 7.1 % for the 500 year flood.

The average percent impervious area in the Royce Brook basin at its mouth for existing conditions (year 2016) is 14.89 %, and is projected to be 20.95 % for future (year 2067) conditions. The difference, 6.06 % impervious area, is a 40.7 % increase from the present value of 14.89 % and is considered to be the largest increase in percent impervious area reasonably possible in the next fifty years for the Royce Brook watershed.

The sub-basins that are contributing lateral inflows to the mainstem Raritan and Millstone Rivers, within the project area, are expected to experience future development. However, the difference in timing between the peak flows of these small (about 1 square mile) sub-basins and that of the mainstream Raritan and Millstone Rivers is so large that future development of these small sub-basins only changes peak flows of the Raritan and Millstone Rivers by 10 cfs or less, which is an insignificant change of 0.1 % or less.

Future unimproved conditions hypothetical peak discharges computed by the HEC-1 models as described above are provided in Table 24.



## 3.2 Hydraulics

Calibrated HEC-RAS models of the Millstone River, Raritan River and Royce Brook were used to determine future unimproved WSE for the 1, 2, 5, 10, 25, 50, 100, 250, and 500-year frequency events. Future hypothetical peak flows from the HEC-1 model can be observed in Tables 25 to 30. The future unimproved model was created using the future hypothetical peak discharges and the calibrated existing conditions HEC-RAS model. The future unimproved flow line profiles for all five river reaches are shown in Figures 37 to 46.

## 3.3 Climate Change

In accordance with Corps of Engineers ECB 2014-10 “Guidance for Incorporating Climate Change Impacts to Inland Hydrology in Civil Works Studies, Designs and Projects”, no action is needed because there is not a cost-effective plan to proceed with for this project. In addition since climate change is not relevant to the study results or project design, no action is needed. Finally, future conditions flows were developed and used so any additional change in future flows associated with climate change is likely to be too small to have an impact on any future plan formulation process.

## 3.4 Risk and Uncertainty

### 3.4.1 Hydrology:

Risk and uncertainty input appropriate to the project area was prepared. It was based upon the following: 1) years of systematic record of annual peak discharges at the three USGS stream gages used in this analysis and 2) Relative size of the recent flood peaks (October 1996 and Floyd (September 1999)) as compared to the historic flood peaks of September 1882 and February 1896. The information generated from the gages below is in accordance with guidance contained in EM 1110-2-1619, Risk-Based Analysis for Flood Damage Reduction Studies,

The peak discharge vs. frequency curves at the three USGS gages, all through WY 2009, are the following: Raritan River below Calco Dam at Bound Brook NJ is based on 78 recorded flood peaks, Raritan River at Manville, NJ is based upon 98 recorded flood peaks, and the Millstone River at Blackwells Mills, NJ is based upon 88 recorded flood peaks. For input into the HEC-FDA model for economic analysis, it was determined that the equivalent record length for all the river reaches within the project area is between 75 to 80 years. This range was used in the HEC-FDA model.



### **3.4.1 Hydraulics:**

For input into the HEC-FDA model for economic analysis, it was determined that the hydraulic input should be as a stage vs. frequency curve at each cross-section. A stage frequency curve (not a stage vs. discharge curve) was chosen because the maximum water surface elevation was selected from a series of six different flow scenarios. The six flow scenarios were done as an approach in constructing an unsteady hydraulic condition with a steady-state model. The stage vs., frequency curves at each cross-section were derived from the same curve mentioned in Section 2.5.5. Since a rating curve (stage vs discharge) was not used the FDA model could not specifically address the uncertainty in stage. The equivalent record length, discussed above, was used to represent the uncertainty for both flow and stage.

## **4.0 IMPROVED CONDITIONS**

### **4.1 Hydrology**

Selection of alternatives was based on the hydraulic improvements that could manage flood risk at a 2 % chance annual exceedence (50 year) flood level within the project area. The two structural plans of improvement that were studied in more detail are Levees and Floodwalls and Channel Modification (Deepening). These two plans were analyzed further to determine the extent to which they could manage the 2 % chance annual exceedence or 50 year flood within the study area. Both plans were investigated to see if they would increase peak discharges and water surface elevations downstream of the project area.

For the channel modification plan, the geometry within the HEC-RAS model needed to be extended downstream to the confluence of Raritan River and Green Brook. This requires flow data of the Raritan River downstream of Middle Brook and Green Brook. This extension was necessary to be able to determine where the impacts from the channel plan end.

#### **4.1.1 Channel Modification (Deepening) Plan:**

The following four HEC-1 model reaches contain the channel modification plan: a) RARRT3 (Raritan River from USGS gage at Manville (Main St Bridge) to confluence with Millstone River); b) RARRT4 (Raritan River from Millstone confluence to USGS gage 01403060 Raritan River below Calco Dam at Bound Brook NJ); c) RART0 (Raritan River from Raritan River below Calco



Dam USGS gage to Middle Brook confluence); and d) RART1 (Raritan River from Middle Brook confluence to Green Brook confluence). Improved channel storage outflow functions were determined for the four reaches from appropriate HEC-RAS storage-discharge output.

Out of the four reaches, only reach RART0 was found to have an appreciably shorter travel time with the improved channel than with the existing channel. HEC-1 runs were then made for the hypothetical floods to examine the impacts of this shorter reach travel time on peak flows at the downstream end of this reach and determine if there is significant increase in peak discharges. The resulting increases in peak discharges were found to be so small (order of a tenth of a percent (0.1%) or less) show that the channel improvement scheme proposed for the Raritan River would have no significant effect on peak discharges and water surface elevations, both within, and downstream of, the project area (i.e. Bound Brook Levee System along the Raritan River). Based upon this analysis, there are considered to be no differences in peak discharges from existing to improved conditions. The channel modification plan is explained in more detail in section 4.2.1.3.

#### **4.1.2 Levee & Floodwall Plan:**

The following four HEC-1 routing reaches contain the levee and floodwall plan: a) RARRT2 (Raritan River from confluence with Dukes and Peters Brooks to USGS gage at Manville NJ (Main Street Bridge); b) RARRT3 (Raritan River from USGS gage at Manville to confluence with Millstone River); c) ROYR6 (Royce Brook from confluence with un-named left bank tributary to mouth); and d) MILLR3 (Millstone River, from confluence with Royce Brook to mouth, confluence with Raritan River).

Improved conditions storage-discharge functions for the levee & floodwall plan were determined for the above four reaches from appropriate HEC-RAS output. They were then incorporated in the HEC-1 models of existing and future unimproved conditions to generate present and future improved conditions flows. The peak flows from these HEC-1 runs were then tabulated and plotted. The present and future improved conditions peak discharges for Royce Brook at its mouth are given in Table 31.

From the HEC-1 results for present and future improved conditions, it was noted that the only significant increase in peak discharges from unimproved to improved conditions was for Royce



Brook at its mouth (HEC-1 node ROYMO). Peak discharge increases at other locations on the Raritan and Millstone Rivers were found to be so small as to be insignificant.

For the Royce Brook portion of the levee & floodwall plan, the controlling (highest) water surface profile was found to be the Millstone River backwater. Based upon this result, it was concluded that the levee & floodwall plan for the Raritan and Millstone Rivers, and Royce Brook, would have no significant impact on peak flows and water surface elevations downstream of the project area. The levee & floodwall plan is explained in more detail in section 4.2.1.4.

## **4.2 Hydraulics**

### **4.2.1 Screened Alternatives:**

Most the alternatives were targeted to help manage the risk of flooding from a 2% chance of annual exceedence flood (50-yr). Two structural plans of improvement identified for a detail analysis were: the Levee and Floodwall Plan and the Channel Modification Plan. Both plans were examined to determine if either plan would increase peak discharges and water surface elevations downstream of the project area.

It was necessary to extend the downstream boundary condition to a point below the Calco Dam so the improved water surface elevation would match the existing water surface elevation. The point at which these two water surface elevations matched occurred upstream of the Interstate 287 bridge. The model shows that only the channel plan would not cause impacts downstream of the project area (i.e. Bound Brook, NJ).

#### **4.2.1.1 No Action Alternative:**

This plan involves no additional Federal action to provide flood risk reduction. The no action alternative would avoid environmental and other impacts associated with implementation of additional plans for flood risk reduction. However, this plan fails to meet any of the study objectives. The result would be the continuation and potential exacerbation of flooding problems in the study area. This alternative represents the default condition if a Federal project is not recommended and provides a reference for evaluation of without project future conditions.

#### **4.2.1.2 Non-Structural Alternative:**





Non-structural measures were identified and evaluated for structures in the Manville area along the Royce Brook, Millstone River and Raritan River. Non-structural plans for the 100-, 50-, and 10-year floodplains were evaluated as well as other sub-sets of these alternatives. Variations of this alternative consisted of extracting some defined group of structures (Blue Acres Structure Program, Blue Acres Structures Program & Zarephath Structures, and Blue Acres Structures Program and Lost Valley Structures) from the 50-yr and 10-yr floodplains as requested by the Non-Federal Sponsor.

#### **4.2.1.3 Channel Deepening Alternative:**

This alternative consists of channel modifications along the Upper Raritan and Lower Raritan River reaches. It is anticipated that the components of this alternative will manage flood risk against the 2% chance of annual exceedance flood (50yr event) along the Millstone River and the Upper and Lower Raritan River reaches. (See Figures 48 through 56.)

Channel modifications are proposed along the Raritan River. The modifications are proposed for both the “Upper Raritan” and the “Lower Raritan”. The channel modifications along the Lower Raritan can be divided into areas. The greatest deepening of the channel will occur just upstream of the Island Farm Weir located at the confluence of the Millstone and Raritan Rivers and will consist of removing approximately 8 feet sediment from the existing channel bottom. Approximately 795,000 cubic feet of material will be excavated from the channel beds as a result of this modification. The channel deepening layout is shown in Figures 47 to 49. The flow lines for the channel deepening alternative are shown in Figures 50 to 54. A description of each reach is given in the following paragraphs.

Channel Modification for Upper Raritan River Reach 1: Approximately 0.31 miles of channel will be modified on the Upper Raritan, from the CSX Railroad crossing to approximately 90 feet upstream of the Island Farm Weir. Since the Island Farm Weir will remain unchanged, the channel bottom will be sloped from the new channel elevation at the upstream end of the Raritan River (approx. 12.59 ft. NAVD88) to the existing channel bottom near the weir (approx. 19.4 ft. NAVD88). The channel bottom width will be at 290 ft. wide for approximately 0.55 miles from the beginning of the channel modification. Then for the rest of this reach, the channel bottom





width will be decreased to 210 ft. The side slopes of the channel modification will remain 1 foot vertical on 3 feet horizontal (1V:3H).

Channel Modification for Lower Raritan River (Reach 2): Approximately 1.09 miles of channel will be modified for this reach, from the Island Farm Weir downstream to Calco Dam gage (USGS 01403060). The Island Farm Weir will remain unchanged and the channel bottom width will taper from 100 feet at the weir to 290 feet wide at a point be sloped from a new channel elevation (approx. 12.57 ft. NAVD88) and the channel bottom width (100 ft. to 290 ft.) will increase for approximately 0.13 miles downstream. The channel bottom will be a constant 290 feet for the rest of the reach. The side slopes of the channel modification will remain 1 foot vertical on 3 feet horizontal (1V:3H). Downstream of the Island Farm Weir, a 12 inch layer of riprap will be placed for a total length of 200 feet to decrease the amount of erosion that could occur downstream of the Island Farm Weir.

Channel Modification for Lower Raritan River (Reach 3): Approximately 0.66 miles of channel will be modified for the Raritan River in the area of the Calco Dam gage (USGS 01403060), the Rt 287 Bridge and of the confluence with Middle Brook. These channel modification are continuous with the other areas, but due to Calco Dam and the Bridge piers in this area the channel bottom width varies considerably. See the Figure 50 Plan View and the Figure 56 Profile for details of this area. A 12 inch layer of riprap will be placed for a total length of 145 feet around the Rt 287 Bridge piers to reduce the potential for erosion. The side slopes of the channel modifications will remain 1 foot vertical on 3 feet horizontal (1V:3H).

#### **4.2.1.4 Levee & Floodwall Alternative:**

This alternative was broken into four flood risk management zones – the north, central, south and Zarephath zones all in the Borough of Manville, NJ. This alternative was designed to help manage the flood risk of the 2% chance of annual exceedance flood (50yr event). The four zones are shown on Figure 57. Details of the levee & floodwall layout for each zone are shown in Figures 58 to 60. The flow lines for the levee & floodwall alternative are shown in Figures 61 to 66. A description of each reach is given in the following paragraphs.

Flood Risk Management Zone - North: The flood risk management system within this zone is located in Manville and consists of approximately 2,075 feet of levees, approximately 2,000 feet



of floodwalls, associated interior drainage structures and a road-raising. The levee and floodwall system runs north of Dukes Parkway East at a distance of approximately 40 feet from the edge-of-pavement, extending from near the intersection of N 13<sup>th</sup> Street to the intersection of N 6<sup>th</sup> Street. From this location the system begins to run parallel to the Raritan River through Duke Island Park at an average distance of approximately 20 feet from the top of the riverbank until it reaches North Main Street, which will be raised. The entire levee/floodwall system ranges in height from approximately 2 feet at the upstream end of the system near N 13<sup>th</sup> Street, to approximately 14.5 feet at the downstream end of the system near North Main Street (heights in reference to grade). North Main Street will be raised to an elevation approximately 3 to 5 feet higher than its existing elevation. Approximately 810 feet of North Main Street will be altered as a result of the road raising.

Flood Risk Management Zone - Central: The flood risk management system within this zone is also located in Manville and consists of approximately 2,325 feet of levees and associated interior drainage structures, 4,400 linear feet of floodwalls, a gate closure structure and a road-raising.

A small levee, approximately 75 feet long and 3.5 feet high from grade, will extend from behind a residential structure on East Camplain Road near the intersection with Valerie Drive. This levee will run perpendicular to the CSX Railroad and will tie into a gate closure structure, approximately 4 feet high, which will span the width of the railroad right-of-way (ROW). A second levee will tie into the gate closure structure from the south side of the railroad ROW and will extend toward Manville Avenue. The levee will turn northeast and run parallel to Manville Avenue at a distance of approximately 80 feet from the edge of the pavement and for a distance of approximately 840 feet. From this point, the levee will turn eastward and run just adjacent to Manville Ave. for a distance of approximately 460 ft. The levee will turn south at the eastern-most end of Manville Ave. for approximately 130 ft and will run directly behind the last few residential properties at the eastern-most end of Huff Ave. There will be a short road-raising at the intersection of Huff Ave. and Lincoln Ave. This intersection will be raised approximately 2.5 ft from grade for a distance of approximately 100 ft.

An approximately 1,815 foot floodwall begins at the southeastern-most end of S. Arlington Ave. and runs adjacent to the left bank of the Millstone River. The exposed elevation of this section of floodwall ranges from 3 to 14 feet (heights in reference to grade). The wall ties into a short 385-foot levee along the south side of Lincoln Avenue between Pulaski Street and Kosciusko Street, and is approximately 3 feet high from grade.



A final section of floodwall ties into the previous levee and continues along the Millstone River for about 1,255 feet, at which point it turns toward the north behind residential properties along the east side of Cooper St. The wall continues northeast along the steep bank that parallels the east side of Lincoln Ave. The floodwall will terminate at the proposed road-raising at the intersection of Huff Ave and Cooper Ave. The exposed elevations of this floodwall range from approximately 3 to 5.5 ft as it runs adjacent to the Millstone River, down to approximately 2.5 ft as it runs parallel to the Upper Raritan River and approaches its tie-in to the road-raising near the intersection of Huff Ave. and Lincoln Ave (heights in reference to grade).

Flood Risk Management Zone - South: This system is also located in Manville and consists of approximately 6,120 feet of levees, 1655 feet of floodwalls, associated interior drainage structures, a gate closure structure, a bridge/road-raising and the elevation of a portion of the Delaware & Raritan Canal tow path.

The upstream end of the system begins with a floodwall located on the left bank (north side) of the Royce Brook, tying into high ground near the intersection of Roosevelt Avenue and S 6<sup>th</sup> Avenue. This section of the floodwall has an exposed elevation of approximately 3 feet from grade. It runs adjacent to Royce Brook until it intersects with South Main Street at a point approximately 130 feet south of Roosevelt Avenue. At this location, the floodwall ties into a gate closure structure, approximately 50 feet long and 3 feet high from grade, that spans the width of South Main Street. A second section of floodwall, with an exposed elevation of approximately 3 to 4 feet from grade, ties into the gate closure structure from the east side of Roosevelt Avenue and continues along Royce Brook for approximately 450 feet. At this point, the floodwall ties into high ground north of the CSX Railroad ROW.

A third floodwall ties into high ground adjacent to Royce Brook on the south side of the CSX Railroad ROW at a location approximately 150 feet southwest of Benjamin Street. This section of wall, which has an exposed elevation of approximately 6 feet from grade and an approximate length of 330 feet, ties into a levee that begins adjacent to Royce Brook at a location south of Woodrow Street. The levee continues southeast for approximately 800 feet toward Lincoln Avenue before it turns northeast through the Lincoln Avenue Park. It ends near the intersection of Lincoln Avenue and South Arlington Street, tying into a proposed floodwall within the central flood risk management zone. This levee ranges from 10 to 14 feet high from grade.



Flood Risk Management Zone – Zarephath: A separate levee system adjacent to the southern flood risk management zone consists of elevating the existing “ring” levee that surrounds and provides protection to the Zarephath sub-community of Somerset Township. The ring levee ties into the elevated Delaware & Raritan (D&R) Canal tow path/walking trail and is approximately 2,910 feet long. The length of the D&R Canal tow path encompassed by the elevated existing ring levee, approximately 150 feet, will be raised by approximately 1.5 feet. The existing bridge over the D&R Canal, which connects Chapel Dr. and Lindy Lake Dr., will be raised by approximately 1.5 feet to accommodate the raising of the tow path.

## **5.0 CONCLUSION**

Three plans of improvements were analyzed to help manage the risk of flooding at the primary damage centers along Royce Brook, the Millstone and Raritan Rivers. These plans are: a channel deepening plan, a levee & floodwall plan, and several combinations of non-structural plans. The majority of the plans were designed to help manage the flood risk against the 2% chance of annual exceedence flood (50-yr event. However, all of the plans evaluated were determined to have a BCR considerably less than 1. Since none of the structural or non-structural plans are cost-justified, there appears to be no federal interest in flood risk management for this area.



MILLSTONE RIVER BASIN  
SOMERSET COUNTY, NEW JERSEY  
FLOOD RISK MANAGEMENT STUDY

**APPENDIX – TABLES & FIGURES**

HYDROLOGY & HYDRAULICS



**TABLE 1: OCTOBER 19 – 20, 1996 STORM RECORDS AND FLOOD DATA**

Parameters	Selected HEC-1 Nodes			
	Raritan River at Manville, NJ	Millstone River at Blackwells Mills, NJ	Raritan River Below Calco Dam at Bound Brook, NJ	Royce Brook AT Mouth
Drainage Area (Mi <sup>2</sup> )	490	258	785	17.19
Peak Flow (cfs)	32,000	13,400	40,100	2,760
Frequency of Event (Years)	30	15.4	28.6	8.7
Area-Average Total Rainfall (inches)	6.23	4.64	5.69	5.68

**TABLE 2: SEPTEMBER 15 – 16, 1999 (TS FLOYD) STORM RECORDS AND FLOOD DATA**

Parameters	Selected HEC-1 Nodes			
	Raritan River at Manville, NJ	Millstone River at Blackwells Mills, NJ	Raritan River Below Calco Dam at Bound Brook, NJ	Royce Brook AT Mouth
Drainage Area (Mi <sup>2</sup> )	490	258	785	17.19
Peak Flow (cfs)	54,000	26,200	67,000	4,470
Frequency of Event (Years)	770	170	670	90.9
Area-Average Total Rainfall (inches)	9.08	9.15	9.04	8.68

**TABLE 3: APRIL 15 – 16, 2007 STORM RECORDS AND FLOOD DATA**

Parameters	Selected HEC-1 Nodes			
	Raritan River at Manville, NJ	Millstone River at Blackwells Mills, NJ	Raritan River Below Calco Dam at Bound Brook, NJ	Royce Brook AT Mouth
Drainage Area (Mi <sup>2</sup> )	490	258	785	17.19
Peak Flow (cfs)	30,400	21,600	50,500	2,500
Frequency of Event (Years)	22	77	120	6.1
Area-Average Total Rainfall (inches)	5.68	6.42	5.92	6.46

**TABLE 4: HEC-1 MODEL SUB-BASIN INPUT PARAMETERS UNDER EXISTING CONDITIONS**

Sub-Watershed Name	HEC-1 Model Sub-basin name	Drainage Area (mi <sup>2</sup> )	Percent Impervious Area	Clark Unit Hydrographs	
				T <sub>c</sub> (hours)	R (hours)
Raritan River	RARCNS	466.00	4.40	15.48	11.96
Raritan River	RARS1	7.12	15.33	0.70	1.06
	DUKEMO	4.37	2.36	7.60	7.79
	RARS3	0.19	28.85	0.44	0.59
Raritan River	400360	7.37	30.87	1.85	2.07
	PETES2	2.56	27.58	1.09	1.43
Raritan River	RARS4	2.39	22.92	1.12	1.29
	RARS5	1.19	19.70	0.57	0.61
Millstone River	402000	258.00	4.90	19.55	22.83
Millstone River	MILLS1	5.29	9.13	1.16	1.68
	MILLS2	4.88	9.41	1.53	1.91
Royce Brook	402600	1.20	19.45	1.45	1.60
Royce Brook	ROYS1	2.96	15.00	2.27	2.60
	ROYS2	0.18	15.62	0.75	0.91
	ROYS3	0.73	28.53	0.35	0.52
	ROYS4	2.19	10.32	2.04	2.26
	ROYS5	0.24	3.40	0.42	0.78
	ROYS6	0.9 1	6.05	1.61	2.05
	ROYS7	0.85	16.69	0.58	0.83
	BROYMO	2.38	15.00	1.42	1.52
	ROYS9	1.51	10.00	1.19	1.46
	ROYS10	2.86	16.99	2.82	2.67
	ROYS11	1.18	18.71	0.35	0.57
Millstone River	MILLS3	1.74	10.75	6.40	3.72
Raritan River	RARS6	0.48	18.47	0.18	0.34
	CUCKMO	3.13	27.53	2.20	2.29
	RARS7	0.03	34.73	0.08	0.15
	RANDMO	1.10	34.57	0.70	0.92



**TABLE 5: MUSKINGUM VALUES FOR REACHES IN HEC-1 MODEL**

Flood :	Muskingum Values	Basic reaches :					Supplemental reaches :				Sum of supplemental reach travel times :
		PETER1	ROYR1	ROYR2	ROYR3	ROYR4	RART3A	MILR1A	MILR2A	MILR3A	
Oct-96	X	N/A	1	6	5	9	N/A	1	1	1	5.40
	K		0.24	1.29	1.05	1.72		2.20	2.68	0.52	
Floyd (Sept 1999)	X	N/A	1	1	1	1	1	1	1	1	5.06
	K		0.24	1.29	1.05	1.72	0.65	1.57	1.82	1.02	
Apr-07	X	N/A	1	1	1	1	N/A	N/A	N/A	N/A	0.00
	K		0.24	1.29	1.05	1.72					
1 year	X	3	1	10	8	13	N/A	N/A	N/A	N/A	1.00
	K	3.66	0.24	1.29	1.05	1.72					
2 year	X	3	1	10	8	13	N/A	N/A	N/A	N/A	2.00
	K	3.66	0.24	1.29	1.05	1.72					
5 year	X	3	1	10	8	13	N/A	N/A	N/A	N/A	3.00
	K	3.66	0.24	1.29	1.05	1.72					
10 year	X	3	1	7	5	9	1	1	1	1	3.75
	K	3.66	0.24	1.29	1.05	1.72	0.45	0.94	1.20	1.16	
25 year	X	3	1	6	5	9	1	1	1	1	5.88
	K	3.66	0.24	1.29	1.05	1.72	0.82	1.76	2.14	1.16	
50 year	X	3	1	6	5	9	1	1	1	1	6.87
	K	3.66	0.24	1.29	1.05	1.72	0.88	2.09	2.53	1.37	
100 year	X	3	1	2	2	2	1	1	1	1	7.85
	K	3.66	0.24	1.29	1.05	1.72	0.98	2.39	2.87	1.61	
150 year	X	3	1	1	1	1	1	1	1	1	7.48
	K	3.66	0.24	1.29	1.05	1.72	0.90	2.17	2.32	1.27	





**TABLE 5: MUSKINGUM VALUES FOR REACHES IN HEC-1 MODEL (CONT.)**

Flood :	Muskingum Values	Basic reaches :					Supplemental reaches :				Sum of supplemental reach travel times :
		PETER1	ROYR1	ROYR2	ROYR3	ROYR4	RART3A	MILR1A	MILR2A	MILR3A	
250 year	X	3	1	1	1	1	1	1	1	1	9.17
	K	3.66	0.24	1.29	1.05	1.72	1.10	2.66	2.84	1.56	
500 year	X	3	1	1	1	1	1	1	1	1	12.90
	K	3.66	0.24	1.29	1.05	1.72	1.67	3.91	4.72	2.60	



**TABLE 6: INITIAL LOSS AND CONSTANT LOSS RATE PARAMETERS AT SELECTED NODES WITHIN THE RARITAN RIVER HEC-1 MODEL**

HEC-1 Node		RRCUSM	MILLC2	402600	ROYMO	MILLMO	403060
Location Description		Raritan River upstream of Millstone River	Millstone River upstream of Royce Brook	USGS gage Royce Brook Tributary at Belle Mead, N.J.	Royce Brook at mouth	Millstone River at mouth	USGS gage Raritan River below Calco Dam at Bound Brook, N.J.
Drainage Area (mi <sup>2</sup> )		491.19	268.17	1.20	17.19	287.10	785.00
Percent Impervious Area		6.30	5.07	19.45	14.89	5.56	6.20
Flood Events: Historical	Initial Loss (inches) and Constant Loss Rate (inches per hour) Variables						
October 1996	Initial Loss	1.85	0.10	1.46	1.46	1.46	1.46
	Constant Loss Rate	0.20	0.07	0.20	0.20	0.20	0.20
September 1999 (Floyd)	Initial Loss	2.72	1.37	2.28	2.28	1.37	2.28
	Constant Loss Rate	0.33	0.19	0.32	0.32	0.19	0.32
April 2007	Initial Loss	0.19	0.40	0.07	0.07	0.40	0.07
	Constant Loss Rate	0.06	0.03	0.06	0.06	0.03	0.06
Flood Events: Hypothetical							
1-year	Initial Loss	1.00	1.00	1.00	1.00	1.00	1.00
	Constant Loss Rate	0.08	0.07	0.08	0.08	0.07	0.08
2-year	Initial Loss	1.00	1.00	1.00	1.00	1.00	1.00
	Constant Loss Rate	0.15	0.11	0.13	0.13	0.11	0.13
5-year	Initial Loss	1.00	1.00	1.00	1.00	1.00	1.00
	Constant Loss Rate	0.17	0.12	0.15	0.15	0.12	0.15
10-year	Initial Loss	1.00	1.00	1.00	1.00	1.00	1.00
	Constant Loss Rate	0.20	0.13	0.17	0.17	0.13	0.17
25-year	Initial Loss	1.00	1.00	1.00	1.00	1.00	1.00



	Constant Loss Rate	0.24	0.13	0.20	0.20	0.13	0.20
--	--------------------	------	------	------	------	------	------

**TABLE 6: INITIAL LOSS AND CONSTANT LOSS RATE PARAMETERS AT SELECTED NODES WITHIN THE RARITAN RIVER HEC-1 MODEL (CONT.)**

HEC-1 Node		RRCUSM	MILLC2	402600	ROYMO	MILLMO	403060
Location Description		Raritan River upstream of Millstone River	Millstone River upstream of Royce Brook	USGS gage Royce Brook Tributary at Belle Mead, N.J.	Royce Brook at mouth	Millstone River at mouth	USGS gage Raritan River below Calco Dam at Bound Brook, N.J.
Drainage Area (mi <sup>2</sup> )		491.19	268.17	1.20	17.19	287.10	785.00
Percent Impervious		6.30	5.07	19.45	14.89	5.56	6.20
Flood Events: Hypothetical	Initial Loss (inches) and Constant Loss Rate (inches per hour) Variables						
50-year	Initial Loss	1.00	1.00	1.00	1.00	1.00	1.00
	Constant Loss Rate	0.28	0.15	0.24	0.24	0.15	0.24
100-year	Initial Loss	1.00	1.00	1.00	1.00	1.00	1.00
	Constant Loss Rate	0.33	0.16	0.27	0.27	0.16	0.27
150-year	Initial Loss	1.00	1.00	1.00	1.00	1.00	1.00
	Constant Loss Rate	0.34	0.16	0.28	0.28	0.16	0.28
250-year	Initial Loss	1.00	1.00	1.00	1.00	1.00	1.00
	Constant Loss Rate	0.36	0.17	0.30	0.30	0.17	0.30
500-year	Constant Loss Rate	2.00	1.00	1.65	1.65	1.00	1.65
	Initial Loss	0.40	0.20	0.33	0.33	0.20	0.33



**TABLE 7: STATISTICAL PARAMETERS FOR USGS GAGES WITHIN STUDY AREA**

Parameters	USGS Gages		
	Raritan River at Manville, NJ	Millstone River at Blackwells Mills, NJ	Raritan River Below Calco Dam at Bound Brook, NJ
USGS gage ID	01400500	01402000	01403060
DA (mi.2)	490	258	785
System Record	1904-1906, 1909-1915, 1922-2009	1921-2009	1882,1896,1904-1909, 1936-1942,1945-2009
Historical Period (Floyd Flood Peak of Record (cfs))	1705-2009 (54,000)	1921-2009 (26,200)	1705-2005 (67,000)
Mean Log	4.2021	3.7772	4.3095
Std. Deviation	0.1553	0.2235	0.1548
Computed Skew	0.2580	0.3717	0.1860
Generalized Skew	0.3000	0.3000	0.3000
Adopted Skew	0.3000	0.4000	0.2000

**TABLE 8: POINT RAINFALL DEPTHS FOR HYPOTHETICAL STORMS**

Duration	Precipitation in inches								
	5 min	15 min	1 hour	2 hours	3 hours	6 hours	12 hours	24 hours	48 hours
<b>1-year</b>	0.33	0.65	1.19	1.48	1.63	1.95	2.30	2.70	3.11
<b>2-year</b>	0.40	0.80	1.39	1.70	1.92	2.43	2.98	3.50	3.98
<b>5-year</b>	0.47	0.96	1.74	2.17	2.46	3.06	3.78	4.41	5.05
<b>10-year</b>	0.53	1.07	2.01	2.50	2.87	3.58	4.46	5.21	5.93
<b>25-year</b>	0.60	1.20	2.36	2.99	3.45	4.32	5.47	6.36	7.20
<b>50-year</b>	0.65	1.29	2.64	3.39	3.89	4.94	6.33	7.36	8.26
<b>100-year</b>	0.70	1.39	2.93	3.79	4.39	5.62	7.29	8.45	9.43
<b>150-year</b>	0.72	1.42	3.10	4.00	4.65	6.00	7.75	9.10	10.15
<b>250-year</b>	0.74	1.48	3.25	4.27	5.00	6.47	8.35	9.80	11.00
<b>500-year</b>	0.78	1.53	3.48	4.66	5.47	7.16	9.31	10.93	12.05

**TABLE 9A: 48-HR, 785 SQUARE MILE TEMPORAL DISTRIBUTION OF RAINFALL FOR 100-YR STORM IN 15-MINUTE INCREMENTS\***



6 hrs	12 hrs	18 hrs	24 hrs	30 hrs	36 hrs	42 hrs	48 hrs
0.01	0.01	0.02	0.06	0.72	0.04	0.02	0.01
0.01	0.01	0.02	0.06	0.41	0.03	0.02	0.01
0.01	0.01	0.02	0.06	0.25	0.03	0.01	0.01
0.01	0.01	0.02	0.07	0.21	0.03	0.01	0.01
0.01	0.01	0.02	0.07	0.17	0.03	0.01	0.01
0.01	0.01	0.02	0.07	0.15	0.03	0.01	0.01
0.01	0.01	0.02	0.07	0.12	0.03	0.01	0.01
0.01	0.01	0.02	0.07	0.11	0.03	0.01	0.01
0.01	0.01	0.02	0.08	0.11	0.03	0.01	0.01
0.01	0.01	0.03	0.08	0.10	0.03	0.01	0.01
0.01	0.01	0.03	0.08	0.09	0.03	0.01	0.01
0.01	0.01	0.03	0.09	0.09	0.03	0.01	0.01
0.01	0.01	0.03	0.09	0.09	0.03	0.01	0.01
0.01	0.01	0.03	0.09	0.08	0.03	0.01	0.01
0.01	0.01	0.03	0.10	0.08	0.03	0.01	0.01
0.01	0.01	0.03	0.10	0.08	0.02	0.01	0.01
0.01	0.01	0.03	0.11	0.07	0.02	0.01	0.01
0.01	0.01	0.03	0.12	0.07	0.02	0.01	0.01
0.01	0.01	0.03	0.14	0.07	0.02	0.01	0.01
0.01	0.01	0.03	0.16	0.07	0.02	0.01	0.01
0.01	0.01	0.03	0.20	0.07	0.02	0.01	0.01
0.01	0.01	0.03	0.23	0.06	0.02	0.01	0.01
0.01	0.02	0.03	0.38	0.06	0.02	0.01	0.01
0.01	0.02	0.03	0.39	0.06	0.02	0.01	0.01
Total for each six hour period							
<b>0.24</b>	<b>0.26</b>	<b>0.64</b>	<b>2.97</b>	<b>3.54</b>	<b>0.64</b>	<b>0.26</b>	<b>0.24</b>

\* - 6-hr period ending at hour counted from the beginning of 48-hr hypothetical storm

**TABLE 9B: TOTAL 48-HR, 785 SQ. ML STORM RAINFALL – HYPOTHETICAL STORMS**

Return Period	1-yr	2-yr	5-yr	10-yr	25-yr	50-yr	100-yr	150-yr	250-yr	500-yr
Rainfall Total (inches)	2.90	3.71	4.71	5.53	6.71	7.70	8.79	9.45	10.20	11.23



**TABLE 10: EXISTING CONDITIONS – PEAK DISCHARGE IN CFS**

HEC-1 Node	D.A. (mi. <sup>2</sup> )	Hypothetical										Historical		
		1-year	2-year	5-year	10-year	25-year	50-year	100-year	150-year	250-year	500-year	Oct. 1996	Sept. 1999	April 2007
RARCNS	466.00	14,910	17,750	23,480	27,530	33,290	37,480	41,470	44,240	48,260	53,280	34,620	58,600	32,940
RARC1	473.12	14,180	17,250	22,230	25,970	31,240	35,250	39,270	41,710	45,300	49,790	32,510	54,760	30,920
RARC2A	477.68	14,270	17,350	22,360	26,120	31,430	35,460	39,510	41,960	45,580	50,090	32,710	55,090	31,110
RARC3	487.61	14,360	17,470	22,520	26,300	31,640	35,700	39,780	42,260	45,910	50,420	32,930	55,450	31,320
400500	490.00	14,000	17,200	21,900	25,600	30,700	34,800	38,900	41,300	44,800	49,100	32,000	54,000	30,400
RRCUSM	491.19	14,000	17,190	21,820	25,390	30,290	34,220	38,090	40,490	43,740	47,840	31,610	52,460	30,120
402000	258.00	4,900	6,700	9,550	11,900	15,700	18,400	21,800	24,000	26,900	31,100	13,400	26,200	21,600
MILLC1	263.29	4,910	6,720	9,410	11,500	15,000	17,570	20,800	22,850	25,340	29,040	13,130	25,710	21,490
MILLC2	268.17	4,920	6,740	9,230	10,950	14,230	16,720	19,760	21,650	23,830	27,150	12,640	25,000	21,400
ROYC9	13.15	1,390	1,640	2,090	2,450	3,000	3,430	3,800	4,060	4,480	5,020	2,370	3,630	1,960
ROYC10	16.01	1,890	2,210	2,880	3,400	4,140	4,730	5,260	5,630	6,190	6,840	3,130	5,460	2,390
ROYMO	17.19	1,510	1,790	2,380	2,840	3,500	4,030	4,560	4,930	5,510	6,190	2,760	4,470	2,500
MILLC3	285.38	5,060	6,900	9,350	11,090	14,380	16,890	19,940	21,850	24,040	27,270	12,640	25,020	21,870
MILLMO	287.10	5,040	6,850	9,280	10,910	14,120	16,570	19,500	21,320	23,400	26,510	12,530	24,570	21,840
RARDSM	778.29	18,960	24,000	29,450	33,650	39,430	44,530	49,750	53,440	57,530	62,960	40,320	67,210	51,080
403000	779.00	18,780	23,780	29,370	33,480	39,170	44,270	49,460	52,960	56,960	62,260	40,140	66,160	51,050
403060	785.00	18,800	23,800	29,400	33,500	39,200	44,300	49,500	53,000	57,000	62,300	40,140	66,160	51,120
RARC2	802.63	18,840	23,850	29,460	33,570	39,290	44,410	49,620	53,140	57,160	62,840	40,300	66,320	51,320
RARC3	803.27	18,860	23,870	29,490	33,600	39,320	44,440	49,640	53,170	57,190	62,870	40,330	66,350	51,350

D.A. – Drainage Area (Sub-basin)



**TABLE 11: HEC-RAS MODEL GEOMETRY SUMMARY**

Reach Name	Number of Cross-Sections	Reach Length (miles)	Number of Bridges	Number of Weirs
Millstone River (Upper)	42	3.29	2	1
Royce Brook	36	2.24	3	0
Millstone River (Lower)	20	1.52	0	1
Raritan River (Upper)	41	3.93	6	0
Raritan River (Lower)*	16 (29)*	3.84	2*	2
<b>Total</b>	<b>168</b>	<b>14.82</b>	<b>13</b>	<b>4</b>

\* - This includes cross-sectional data from the 1997 Greenbrook GRR (13 cross-sections and two bridges)

**TABLE 12: WEIR DATA WITHIN HEC-RAS MODEL**

Reach Name	Weir Number	River Station	Invert Elevation (ft., NAVD88)	Weir Length	Crest Elevation (ft., NAVD88)
Millstone River (Upper)	#2	196	19.4	202	24.6
Millstone River (Lower)	#3	4	17.6	148	20.1
Raritan River (Lower)	#4	7508	19.4	202	21.9
Raritan River (Lower)	#5	1486	15.7	205	17.2



**TABLE 13: BRIDGE DATA WITHIN HEC-RAS MODEL**

Reach Name	Bridge Name	River Station	Invert Elevation (ft., NAVD88)	Bridge Length (ft.)	Low Chord Elevation (ft., NAVD88)	Area Normal to Flow (ft <sup>2</sup> )	Number of Piers
Millstone River (Upper)	Amwell Road	13886	21.7	810	40.7	3968.2	27
	Manville Causeway	278	17.8	217	36.7	2780.2	3
Royce Brook	Whalen Street	3664	25.6	61	42.3	426.4	0
	S. Main Street	1839	22.2	68	34.1	564.7	1
	Reading Railroad	1316	20.6	60	41.3	590.8	0
Raritan River (Upper)	Route 206	18877	24.2	392	48.1	3432.5	2
	Finderne Avenue /N. Main Street	6302	21.3	550	38.7	5562.3	8
	East Railroad #1	3910	16.0	597	44.7	4680.1	5
	East Railroad #2	2912	16.3	580	36.9	4276.7	9
	North Lehigh Valley	1750	13.2	504	36.6	4456.1	7
	South Lehigh Valley	1659	11.6	567	35.1	4771.8	9
Raritan River (Lower)	Interstate 287	1092*	12.68	2240	53.08	5357.8	18
	Elizabeth Avenue /Main Street	1036*	11.68	574	29.58	3492.9	2

\* - This includes cross-sectional data from the 1997 Greenbrook GRR

**TABLE 14: BOUNDARY CONDITION RATING CURVE**

Stage (ft., NAVD88)	8.68	10	14.5	18.75	19.75	24.5	28.32	31.16	32.43	34.83	36.04
Flows (cfs)	0	2,000	10,000	18,000	20,000	30,000	38,430	53,010	60,310	75,390	84,060





**TABLE 15: FLOOD MARKS FROM HISTORICAL EVENTS**

Reach Name	River Station (Cross Section No.)	October 1996		September 1999 (TS Floyd)	
		Flood Mark Elevation (ft., NAVD88)	Computed Water Surface Elevation (ft., NAVD88)	Flood Mark Elevation (ft., NAVD88)	Computed Water Surface Elevation (ft., NAVD88)
Millstone River (Upper)	17104 (110)			46.9	46.9
	15427(106)			45.9	46.7
	14018(104)			45.9	46.6
	3753(82)			44.4	45.2
	278(216)	38.7	38.8	44.0	44.8
Royce Brook	1952 (133)			43.9	45.0
	1807 (226)			44.0	45.1
	0 (124)			44.8	44.9
Millstone River (Lower)	7404 (69)			44.8	44.8
	7143 (68)			44.2	44.8
	5639 (64)			44.5	44.7
	4901 (62)			45.9	44.6
	4437 (61)			44.1	44.6
	3960 (60)			43.9	44.5
	3505 (59)			45.0	44.5
	2987 (58)			44.5	44.5
1897 (56)			44.1	44.5	
Raritan River (Upper)	11150 (16)			49.7	49.0
	10475 (18)			49.4	48.9
	9901 (19)			47.1	48.9
	9249 (20)			49.4	48.9
	6644 (26)	41.9	42.5	46.6	48.1
	6424 (27)			47.5	47.8
Raritan River (Lower)	0	34.5	34.5	41.0	41.2



**TABLE 16: STEADY FLOWS FOR HISTORICAL EVENTS**

Reach Name	River Station (Cross Section No.)	October 1996 Flows (cfs)	September 1999 Flows (cfs)
Millstone River (Upper)	17105 (110)	13130	25710
	5716 (86)	12640	25000
Royce Brook	10805 (160)	2370	3630
	9634 (156)	3130	5460
	4529 (143)	2760	4470
Millstone River (Lower)	7404 (69)	12640	25020
	2987 (58)	12530	24570
Raritan River (Upper)	20462 (1)	34620	58600
	19781 (3)	32510	54760
	15711 (10)	32930	55450
	6648 (26)	32000	54000
	3074 (34)	31610	52460
Raritan River (Lower)*	8243 (41)	40320	67210
	3370 (46)	40140	66160
	0*	40140	66160

\* - For the historical runs, the cross-sectional data in the HEC-RAS geometry did not continue past the Calco Dam USGS gage.



**TABLE 17: EXISTING CONDITIONS FOR FIRST RUN – LOWER RARITAN RIVER PEAKING**

Reach Name	River Station	Hypothetical Events								
		1-year	2-year	5-year	10-year	25-year	50-year	100-year	250-year	500-year
Millstone River (Upper)	17105	4910	6710	9410	11470	14960	17500	20690	25310	29030
	5716	4920	6730	8780	9980	12020	14050	16460	19860	22530
Millstone River (Lower)	7404	5060	6880	8940	10160	12220	14280	16720	20130	22750
	2987	4960	6810	8150	8930	9880	11360	13100	15370	17010
Raritan River (Upper)	20462	11720	13530	15840	18200	20730	23350	25830	27050	27840
	19781	13240	15880	18750	21710	25240	28330	31050	27840	29470
	15711	13360	16030	18910	21890	25430	28540	31280	34000	36330
	6648	13850	16980	20460	23750	27910	31010	33970	37660	41050
	3047	13990	17190	21140	24720	29550	33170	36650	42150	45950
Raritan River (Lower)	8243	18960	24000	29450	33650	39430	44530	49750	57530	62960
	3770	18530	23080	29060	33270	38500	43540	47800	55910	61080
	1100	18550	23100	29090	33300	38540	43580	48740	55960	61120
	1092.36*	18540	23780	29370	33460	39160	44240	49430	56860	62180
	1073.58*	18580	23830	29440	33530	39300	44370	49590	57070	62450
	1041.48*	18560	23820	29440	33530	39290	44360	49530	57030	62200
	1030.13*	19820	25380	31510	36460	43510	50530	56770	71640	80610
Royce Brook	10805	80	90	100	110	130	140	160	180	120
	9634	90	100	110	120	140	160	180	200	150
	4529	140	150	160	180	200	230	260	270	210

\* - These cross-sections were imported from the 1997 Green Brook GRR



**TABLE 18: EXISTING CONDITIONS FOR SECOND RUN – UPPER RARITAN RIVER PEAKING**

Reach Name	River Station	Hypothetical Events								
		1-year	2-year	5-year	10-year	25-year	50-year	100-year	250-year	500-year
Millstone River (Upper)	17105	4910	6720	9120	11100	14430	16730	19540	24280	27800
	5716	4920	6740	7800	8980	10500	11930	13580	16560	18420
Millstone River (Lower)	7404	5060	6900	8020	9220	10750	12240	13950	16940	18770
	2987	4940	6790	6580	7580	8380	9470	10510	12300	13360
Raritan River (Upper)	20462	11950	13800	18570	20930	23850	27400	30930	33320	36020
	19781	13400	16100	20930	23990	28000	31790	35390	39560	43140
	15711	13530	16250	21130	24210	28240	32060	35700	39900	43480
	6648	13910	17070	21750	25230	29840	33740	37530	42670	46690
	3047	14000	17190	21820	25390	30290	34220	38090	43740	47840
Raritan River (Lower)	8243	18940	23980	28380	32970	38670	43690	48600	56040	61190
	3770	18440	22880	27120	31940	36550	40940	45240	52330	56710
	1100	18460	22900	27150	31970	36590	40980	45280	52370	56750
	1092.36*	18310	23560	28970	33250	39160	44180	49250	56940	62220
	1073.58*	18350	23610	29050	33330	39300	44310	49420	57140	62480
	1041.48*	18260	23560	28980	33280	39290	44280	49300	57180	62490
	1030.13*	19610	25190	31370	36510	43510	50540	57000	71240	79890
Royce Brook	10805	80	90	120	130	150	170	200	220	170
	9634	90	100	130	150	160	190	230	240	200
	4529	140	160	220	240	250	310	370	380	350

\* - These cross-sections were imported from the 1997 Green Brook GRR



**TABLE 19: EXISTING CONDITIONS FOR THIRD RUN – LOWER MILLSTONE PEAKING AT RARITAN & MILLSTONE CONFLUENCE**

Reach Name	River Station	Hypothetical Events								
		1-year	2-year	5-year	10-year	25-year	50-year	100-year	250-year	500-year
Millstone River (Upper)	17105	4780	6610	8550	9850	12260	14320	16760	19550	22060
	5716	4790	6630	9090	10720	13800	16140	19020	22700	25800
Millstone River (Lower)	7404	4900	6760	9210	10840	13950	16130	19200	22900	25920
	2987	5040	6850	9280	10910	14120	16570	19500	23400	26510
Raritan River (Upper)	20462	10200	12500	11300	10630	10510	11590	12300	12260	12400
	19781	11970	14950	13860	13130	13040	14430	15360	15320	15540
	15711	12070	15080	13960	13220	13130	14530	15470	15440	15660
	6648	13040	16450	15930	15300	15300	16920	18020	18010	18290
	3047	13520	16930	16950	16770	17460	19450	20900	21410	22120
Raritan River (Lower)	8243	18560	23780	26530	27680	31570	36020	40400	44810	48630
	3770	18780	23680	27650	28850	33680	38540	43150	45410	52240
	1100	18780	23680	27650	28850	33680	38540	43150	48030	52240
	1092.36*	18540	23800	25520	25620	26710	29840	32560	34140	35650
	1073.58*	18570	23840	25570	25660	26800	29910	32640	34240	35770
	1041.48*	18600	23850	25800	25900	27040	30180	32940	34560	36150
	1030.13*	19820	25380	27240	27180	28380	32150	35440	38620	40880
Royce Brook	10805	60	80	80	90	110	120	140	160	90
	9634	70	90	90	110	120	140	160	180	100
	4529	100	130	110	120	140	160	180	190	120

\* - These cross-sections were imported from the 1997 Green Brook GRR



**TABLE 20: EXISTING CONDITIONS FOR FOURTH RUN – LOWER MILLSTONE PEAKING AT MILLSTONE R. & ROYCE BK. CONFL.**

Reach Name	River Station	Hypothetical Events								
		1-year	2-year	5-year	10-year	25-year	50-year	100-year	250-year	500-year
Millstone River (Upper)	17105	4910	6710	9060	10740	13670	16090	18840	22600	25740
	5716	4920	6730	9230	10950	14230	16720	19780	23830	27150
Millstone River (Lower)	7404	5060	6900	9350	11090	14380	16890	19940	24040	27270
	2987	4940	6710	9110	10640	13540	15840	18680	22100	24880
Raritan River (Upper)	20462	11950	14360	12980	12970	13360	15030	15970	16900	17470
	19781	13400	16490	15790	15970	16600	18760	20010	21260	22100
	15711	13530	16650	15910	16090	16720	18900	20150	21410	22240
	6648	13910	17180	17880	18370	19320	21870	23350	24850	25830
	3047	14000	17140	18890	19970	21930	25020	26850	29060	30590
Raritan River (Lower)	8243	18940	23850	28260	30620	35460	40860	45530	51160	55560
	3770	18440	22450	28930	31560	37200	42610	47310	53510	58500
	1100	18460	22470	28960	31580	37220	42640	47340	53550	58520
	1092.36*	18310	23360	27610	28760	30710	34730	37900	41200	43570
	1073.58*	18350	23410	27670	28820	30810	34810	38000	41330	43730
	1041.48*	18260	23340	27890	29070	31090	35130	38370	41740	44180
	1030.13*	19610	25040	29460	30960	32890	37870	41930	47600	51150
Royce Brook	10805	80	100	80	90	110	120	140	160	90
	9634	90	110	100	110	130	140	160	180	110
	4529	140	180	120	130	150	170	190	210	130

\* - These cross-sections were imported from the 1997 Green Brook GRR



**TABLE 21: EXISTING CONDITIONS FOR FIFTH RUN – UPPER MILLSTONE PEAKING**

Reach Name	River Station	Hypothetical Events								
		1-year	2-year	5-year	10-year	25-year	50-year	100-year	250-year	500-year
Millstone River (Upper)	17105	4910	6720	9000	10740	13670	15960	18840	22600	25740
	5716	4920	6740	9230	10950	14230	16720	19760	23830	27150
Millstone River (Lower)	7404	5060	6900	9350	11090	14380	16880	19940	24040	27270
	2987	4960	6790	9160	10640	13540	15950	18680	22100	24880
Raritan River (Upper)	20462	11720	13800	12730	12970	13360	14730	15970	16900	17470
	19781	13240	16100	15500	15970	16600	18390	20010	21260	22100
	15711	13360	16250	15620	16090	16720	18520	20150	21410	22240
	6648	13850	17070	17600	18370	19320	21450	23350	24850	25830
	3047	13990	17130	18620	19970	21930	24560	26850	29060	30690
Raritan River (Lower)	8243	18950	23980	28050	30620	35460	40510	45330	51160	55560
	3770	18530	22880	28810	31560	37200	42380	47310	53510	58500
	1100	18550	22900	28830	31580	37220	42410	47340	53550	58520
	1092.36*	18380	23560	27320	28760	30710	34330	37900	41200	43570
	1073.58*	18420	23610	27370	28820	30810	34410	38000	41330	43730
	1041.48*	18340	23560	27600	29070	31090	34720	38370	41740	44180
	1030.13*	19670	25190	29150	30690	32890	37370	41930	47600	51150
Royce Brook	10805	80	90	80	90	110	120	140	160	90
	9634	90	100	90	110	130	140	160	180	110
	4529	140	160	120	130	150	170	190	210	130

\* - These cross-sections were imported from the 1997 Green Brook GRR



**TABLE 22: EXISTING CONDITIONS FOR SIXTH RUN – ROYCE BROOK PEAKING**

Reach Name	River Station	Hypothetical Events								
		1-year	2-year	5-year	10-year	25-year	50-year	100-year	250-year	500-year
Millstone River (Upper)	17105	1350	1880	1460	1740	1990	2340	2770	3210	3720
	5716	1640	2260	1840	2070	2340	2690	3100	3500	3810
Millstone River (Lower)	7404	3150	4060	4220	4920	5840	6720	7650	9010	10010
	2987	3120	3430	3600	3980	4270	4870	5540	6320	7310
Raritan River (Upper)	20462	4880	6150	8750	10250	12390	13950	15440	18090	21240
	19781	2790	3260	5110	5790	7220	8200	9020	10630	12750
	15711	3780	4580	6850	8020	9690	11000	12150	14210	16550
	6648	3130	3630	5370	6280	7580	8620	9520	11170	12830
	3047	2850	3420	4800	5440	6260	7010	7700	8670	9570
Raritan River (Lower)	8243	5980	6840	8260	9420	10530	11880	13240	14990	16880
	3770	5000	5680	7260	8200	8260	9160	10010	10490	11540
	1100	5330	6070	7730	8760	8960	9970	10930	11630	12750
	1092.36*	3910	4900	6480	7370	8260	9730	10820	12430	14570
	1073.58*	4480	5670	7650	8670	10700	12010	14320	17800	20830
	1041.48*	4270	5390	7320	8280	10390	11650	14210	17710	20740
	1030.13*	5720	7290	9150	11270	14360	17300	21870	29330	38200
Royce Brook	10805	1200	1430	1880	2250	2770	3190	3620	4390	4920
	9634	1530	1810	2360	2810	3460	4000	4540	5530	6110
	4529	1510	1790	2380	2840	3500	4030	4560	5510	6190

\* - These cross-sections were imported from the 1997 Green Brook GRR





**TABLE 23: HEC-1 MODEL SUB-BASIN INPUT PARAMETERS - FUTURE UNIMP. CONDITIONS**

Sub-Watershed Name	HEC-1 Model Sub-basin name	Drainage Area (mi <sup>2</sup> )	Percent Impervious Area	Clark Unit Hydrographs	
				Tc (hours)	R (hours)
Raritan River	RARCNS	466.00	4.40	15.48	11.96
Raritan River	RARS1	7.12	20.00	0.64	0.95
	DUKEMO	4.37	2.36	7.60	7.79
	RARS3	0.19	28.85	0.44	0.59
Raritan River	400360	7.37	30.87	1.85	2.07
	PETES2	2.56	27.58	1.09	1.43
Raritan River	RARS4	2.39	30.00	1.02	1.16
	RARS5	1.19	30.00	0.49	0.51
Millstone River	402000	258.00	4.90	19.55	22.83
Millstone River	MILLS1	5.29	15.00	0.97	1.37
	MILLS2	4.88	15.00	1.30	1.58
Royce Brook	402600	1.20	19.45	1.45	1.60
Royce Brook	ROYS1	2.96	20.00	2.05	2.32
	ROYS2	0.18	15.62	0.75	0.91
	ROYS3	0.73	35.00	0.33	0.48
	ROYS4	2.19	20.00	1.61	1.73
	ROYS5	0.24	27.50	0.20	0.34
	ROYS6	0.91	20.00	1.05	1.26
	ROYS7	0.85	25.00	0.50	0.07
	BROYMO	2.38	20.00	1.28	1.35
	ROYS9	1.51	15.00	1.03	1.24
	ROYS10	2.86	20.00	2.66	2.50
	ROYS11	1.18	27.00	0.31	0.49
Millstone River	MILLS3	1.74	15.00	5.68	3.25
Raritan River	RARS6	0.48	25.00	0.16	0.30
	CUCKMO	3.13	27.53	2.20	2.29
	RARS7	0.03	34.73	0.08	0.15
	RANDMO	1.10	34.57	0.70	0.92



**TABLE 24: FUTURE UNIMPROVED CONDITIONS – PEAK DISCHARGE IN CFS**

HEC-1 Node	D.A. (mi. <sup>2</sup> )	Hypothetical									
		1-year	2-year	5-year	10-year	25-year	50-year	100-year	150-year	250-year	500-year
RARCNS	466.00	14,910	17,750	23,480	27,530	33,290	37,480	41,470	44,240	48,260	53,280
RARC1	473.12	14,180	17,260	22,230	25,970	31,250	35,260	39,270	41,720	45,320	49,790
RARC2A	477.68	14,270	17,360	22,370	26,120	31,430	35,460	39,510	41,960	45,590	50,090
RARC3	487.61	14,360	17,480	22,520	26,310	31,640	35,700	39,790	42,260	45,920	50,430
400500	490.00	14,000	17,210	21,910	25,610	30,710	34,810	38,910	41,310	44,810	49,110
RRCUSM	491.19	14,000	17,200	21,830	25,390	30,300	34,240	38,110	40,500	43,760	47,850
402000	258.00	4,900	6,700	9,550	11,900	15,700	18,400	21,800	24,000	26,900	31,100
MILLC1	263.29	4,910	6,720	9,410	11,500	15,010	17,580	20,800	22,860	25,350	29,050
MILLC2	268.17	4,930	6,740	9,240	10,960	14,240	16,730	19,770	21,660	23,840	27,160
ROYC9	13.15	1,560	1,790	2,290	2,710	3,290	3,730	4,110	4,390	4,820	5,420
ROYC10	16.01	2,060	2,400	3,120	3,700	4,500	5,050	5,640	6,050	6,640	7,370
ROYMO	17.19	1,630	1,940	2,560	3,060	3,760	4,310	4,880	5,270	5,890	6,630
MILLC3	285.38	5,070	6,910	9,370	11,110	14,410	16,910	19,970	21,880	24,070	27,310
MILLMO	287.10	5,040	6,860	9,300	10,930	14,140	16,600	19,530	21,350	23,430	26,540
RARDSM	778.29	18,960	24,010	29,460	33,660	39,440	44,530	49,750	53,430	57,520	62,950
403000	779.00	18,780	23,790	29,380	33,480	39,170	44,270	49,460	52,960	56,950	62,260
403060	785.00	18,800	23,810	29,410	33,510	39,200	44,300	49,500	53,000	56,990	62,290
RARC2	802.63	18,840	23,860	29,470	33,580	39,290	44,410	49,620	53,140	57,150	62,830
RARC3	803.27	18,860	23,880	29,500	33,610	39,320	44,440	49,640	53,170	57,180	62,860

D.A. – Drainage Area (Sub-basin)



**TABLE 25: FUTURE UNIMPROVED CONDITIONS FOR FIRST RUN – LOWER RARITAN RIVER PEAKING**

Reach Name	River Station	Hypothetical Events								
		1-year	2-year	5-year	10-year	25-year	50-year	100-year	250-year	500-year
Millstone River (Upper)	17105	4910	6720	9410	11480	14960	17510	20700	25320	29030
	5716	4930	6740	8790	9990	12030	14060	16470	19870	22540
Millstone River (Lower)	7404	5060	6890	8950	10170	12230	14300	16740	20150	22780
	2987	4960	6810	8160	8930	9870	11350	13090	15360	16990
Raritan River (Upper)	20462	11720	13530	15840	18200	20730	23350	25830	27840	29470
	19781	13240	15890	18750	21720	25250	28330	31050	33750	36070
	15711	13360	16030	18910	21890	25440	28550	31290	34010	36330
	6648	13850	16990	20460	23760	27920	31020	33980	37670	41060
	3047	13990	17190	21140	24730	29560	33180	36660	42160	45960
Raritan River (Lower)	8243	18960	24010	29460	33660	39440	44530	49750	57520	62950
	3770	18530	23080	29060	33270	38490	43530	48680	55890	61050
	1100	18540	23100	29090	33290	38520	43560	48720	55930	61110
	1092.36*	18540	23780	29370	33460	39160	44240	49430	56860	62180
	1073.58*	18580	23830	29440	33530	39300	44370	49590	57070	62450
	1041.48*	18560	23820	29440	33530	39290	44360	49530	57030	62200
	1030.13*	19820	25380	31510	36460	43510	50530	56770	71640	80610
Royce Brook	10805	80	90	100	120	140	160	180	190	150
	9634	90	100	120	130	160	180	200	220	170
	4529	140	150	160	190	210	240	270	290	240

\* - These cross-sections were imported from the 1997 Green Brook GRR



**TABLE 26: FUTURE UNIMPROVED CONDITIONS FOR SECOND RUN – UPPER RARITAN RIVER PEAKING**

Reach Name	River Station	Hypothetical Events								
		1-year	2-year	5-year	10-year	25-year	50-year	100-year	250-year	500-year
Millstone River (Upper)	17105	4910	6720	9120	11100	14440	16730	19550	24290	27810
	5716	4920	6740	7810	8990	10500	11940	13590	16570	18430
Millstone River (Lower)	7404	5060	6900	8030	9220	10760	12240	13950	16940	18780
	2987	4940	6780	6560	7570	8360	9440	10470	12250	13310
Raritan River (Upper)	20462	11950	13800	18570	20930	23850	2740	30930	33320	36020
	19781	13400	16100	20930	24000	28000	31790	35400	39570	43140
	15711	13530	16250	21130	24200	28240	32060	35710	39900	43480
	6648	13910	17070	21760	25230	29850	33750	37540	42680	46690
	3047	14000	17200	21830	25390	30300	34240	38110	43760	47850
Raritan River (Lower)	8243	18940	23980	28380	32960	38660	43680	48570	56010	61160
	3770	18440	22880	27110	31920	36530	40920	45200	52280	56660
	1100	18460	22900	27140	31960	36560	40960	45250	52330	56710
	1092.36*	18310	23560	28970	33250	39160	44180	49250	56940	62220
	1073.58*	18350	23610	29050	33330	39300	44310	49420	57140	62480
	1041.48*	18260	23560	28980	33280	39290	44280	49300	57180	62490
	1030.13*	19610	25190	31370	36510	43510	50540	57000	71240	79890
Royce Brook	10805	80	90	130	140	160	180	210	220	190
	9634	90	110	140	150	170	200	230	250	220
	4529	140	160	220	240	260	310	370	380	350

\* - These cross-sections were imported from the 1997 Green Brook GRR



**TABLE 27: FUTURE UNIMPROVED CONDITIONS FOR THIRD RUN – LOWER MILLSTONE PEAKING AT RARITAN & MILLSTONE CONFL.**

Reach Name	River Station	Hypothetical Events								
		1-year	2-year	5-year	10-year	25-year	50-year	100-year	250-year	500-year
Millstone River (Upper)	17105	4780	6620	8850	9850	12270	14320	16770	19550	22070
	5716	4800	6640	9100	10730	13810	16150	19030	22710	25820
Millstone River (Lower)	7404	4910	6670	9220	10870	13970	16330	19230	22940	25950
	2987	5040	6860	9300	10930	14140	16600	19530	23430	26540
Raritan River (Upper)	20462	10200	12500	11300	10630	10510	11590	12300	12260	12400
	19781	11970	14950	13860	13130	13040	14440	15370	15330	15550
	15711	12080	15080	13960	13230	13130	14540	15470	15440	15660
	6648	13040	16450	15930	15300	15300	16920	18030	18010	18300
	3047	13520	16930	16960	16770	17460	19460	20910	21200	21420
Raritan River (Lower)	8243	18560	23790	26550	27700	31600	36050	40440	44850	48670
	3770	18780	23680	27670	28870	33710	38570	43190	48070	52280
	1100	18800	23700	27700	28890	33740	38600	43220	48110	52300
	1092.36*	18540	23800	25520	25620	26710	29840	32560	34140	35650
	1073.58*	18570	23840	25570	25660	26800	29910	32640	34240	35770
	1041.48*	18600	23850	25800	25900	27040	30180	32940	34560	36150
	1030.13*	19820	25380	27240	27180	28380	32150	35440	38620	40880
Royce Brook	10805	70	80	90	110	120	140	150	180	100
	9634	80	90	100	120	140	160	180	200	110
	4529	110	130	130	140	160	180	200	230	130

\* - These cross-sections were imported from the 1997 Green Brook GRR



**TABLE 28: FUTURE UNIMPROVED CONDITIONS FOR FOURTH RUN – LOWER MILLSTONE PEAKING AT MILLSTONE R. & ROYCE BK. CONFL.**

Reach Name	River Station	Hypothetical Events								
		1-year	2-year	5-year	10-year	25-year	50-year	100-year	250-year	500-year
Millstone River (Upper)	17105	4910	6720	9070	10750	13680	16090	18840	22610	25750
	5716	4920	6730	9230	10960	14240	16730	19770	23840	27160
Millstone River (Lower)	7404	5070	6910	9370	11110	14410	16910	19970	24070	27310
	2987	4940	6700	9120	10660	13560	15860	18700	22130	24910
Raritan River (Upper)	20462	11950	14360	12980	12970	13360	15030	15970	16900	17470
	19781	13400	16490	15790	15970	16600	18770	20010	21270	22100
	15711	13530	16650	15920	16090	16720	18900	20150	21420	22250
	6648	13910	17180	17880	18370	19320	21880	23350	24860	25830
	3047	14000	17150	18900	19980	21930	25030	26860	29070	30690
Raritan River (Lower)	8243	18940	23850	28280	30640	35490	40890	45560	51190	55600
	3770	18440	22450	28950	31580	37220	42640	47330	53540	58530
	1100	18460	22470	28970	31600	37250	42670	47370	53580	58560
	1092.36*	18310	23360	27610	28760	30710	34730	37900	41200	43570
	1073.58*	18350	23410	27670	28820	30810	34810	38000	41330	43730
	1041.48*	18260	23340	27890	29070	31090	35130	38370	41740	44180
	1030.13*	19610	25040	29460	30960	32890	37870	41930	47600	51150
Royce Brook	10805	80	100	90	110	130	140	160	180	110
	9634	90	110	110	120	140	160	180	200	120
	4529	140	170	130	150	170	190	210	240	150

\* - These cross-sections were imported from the 1997 Green Brook GRR



**TABLE 29: FUTURE UNIMPROVED CONDITIONS FOR FIFTH RUN – UPPER MILLSTONE PEAKING**

Reach Name	River Station	Hypothetical Events								
		1-year	2-year	5-year	10-year	25-year	50-year	100-year	250-year	500-year
Millstone River (Upper)	17105	4910	6720	9000	10750	13680	16730	18840	22610	25750
	5716	4930	6740	9240	10960	14240	16370	19770	23840	27160
Millstone River (Lower)	7404	5060	6900	9370	11110	14410	16910	19970	24070	27310
	2987	4960	6780	9170	10660	13560	15980	18700	22130	24910
Raritan River (Upper)	20462	11720	13800	12730	12970	13360	14730	15970	16900	17470
	19781	13240	16100	15510	15970	16600	18400	20010	21270	22100
	15711	13360	16250	15630	16090	16720	18530	20150	21420	22250
	6648	13850	17070	17600	18370	19320	21460	23350	24860	25830
	3047	13990	17200	18630	19980	21930	24570	26860	29070	30690
Raritan River (Lower)	8243	18960	23980	28070	30640	35490	40540	45560	51190	55600
	3770	18530	22880	28820	31580	37220	42200	47330	53540	58530
	1100	18540	22900	28840	31600	37250	42430	47370	53580	58560
	1092.36*	18380	23560	27320	28760	30710	34330	37900	41200	43570
	1073.58*	18420	23610	27370	28820	30810	34410	38000	41330	43730
	1041.48*	18340	23560	27600	29070	31090	34720	38370	41740	44180
	1030.13*	19670	25190	29150	30690	32890	37370	41930	47600	51150
Royce Brook	10805	80	90	90	110	130	140	160	180	110
	9634	90	110	110	120	140	160	180	200	120
	4529	140	160	130	140	170	190	210	230	150

\* - These cross-sections were imported from the 1997 Green Brook GRR



**TABLE 30: FUTURE UNIMPROVED CONDITIONS FOR SIXTH RUN – ROYCE BROOK PEAKING**

Reach Name	River Station	Hypothetical Events								
		1-year	2-year	5-year	10-year	25-year	50-year	100-year	250-year	500-year
Millstone River (Upper)	17105	1300	1760	1340	1600	1840	2170	2570	3000	3470
	5716	1550	2140	1860	2080	2360	2710	3120	3530	3830
Millstone River (Lower)	7404	3180	4070	4420	5150	6120	7020	8000	9410	10460
	2987	3350	3590	3840	4240	4550	5220	5930	6800	7830
Raritan River (Upper)	20462	4880	5730	8180	9580	11570	13030	14420	16900	19910
	19781	2770	2990	4720	5520	6670	7530	8340	9840	11650
	15711	3850	4280	6440	7530	9110	10290	11430	13370	15590
	6648	3110	3510	5130	5990	7230	8180	9090	10670	12220
	3047	2840	3410	4670	5310	6130	6880	7570	8510	9350
Raritan River (Lower)	8243	6200	6990	8400	9550	10690	12100	13500	15300	17190
	3770	5360	5820	7440	8370	8400	9370	10200	10690	11780
	1100	5690	6240	7950	8980	9160	10250	11210	11910	13080
	1092.36*	3910	4900	6480	7370	8260	9730	10820	12430	14570
	1073.58*	4480	5670	7650	8670	10700	12010	14320	17800	20830
	1041.48*	4270	5390	7320	8280	10390	11650	14210	17710	20740
	1030.13*	5720	7290	9150	11270	14360	17300	21870	29330	38200
Royce Brook	10805	1280	1540	2020	2400	2960	3410	3870	4700	5240
	9634	1600	1960	2520	3010	3700	4270	4850	5890	6490
	4529	1630	1940	2560	3060	3760	4310	4880	5890	6630

\* - These cross-sections were imported from the 1997 Green Brook GRR



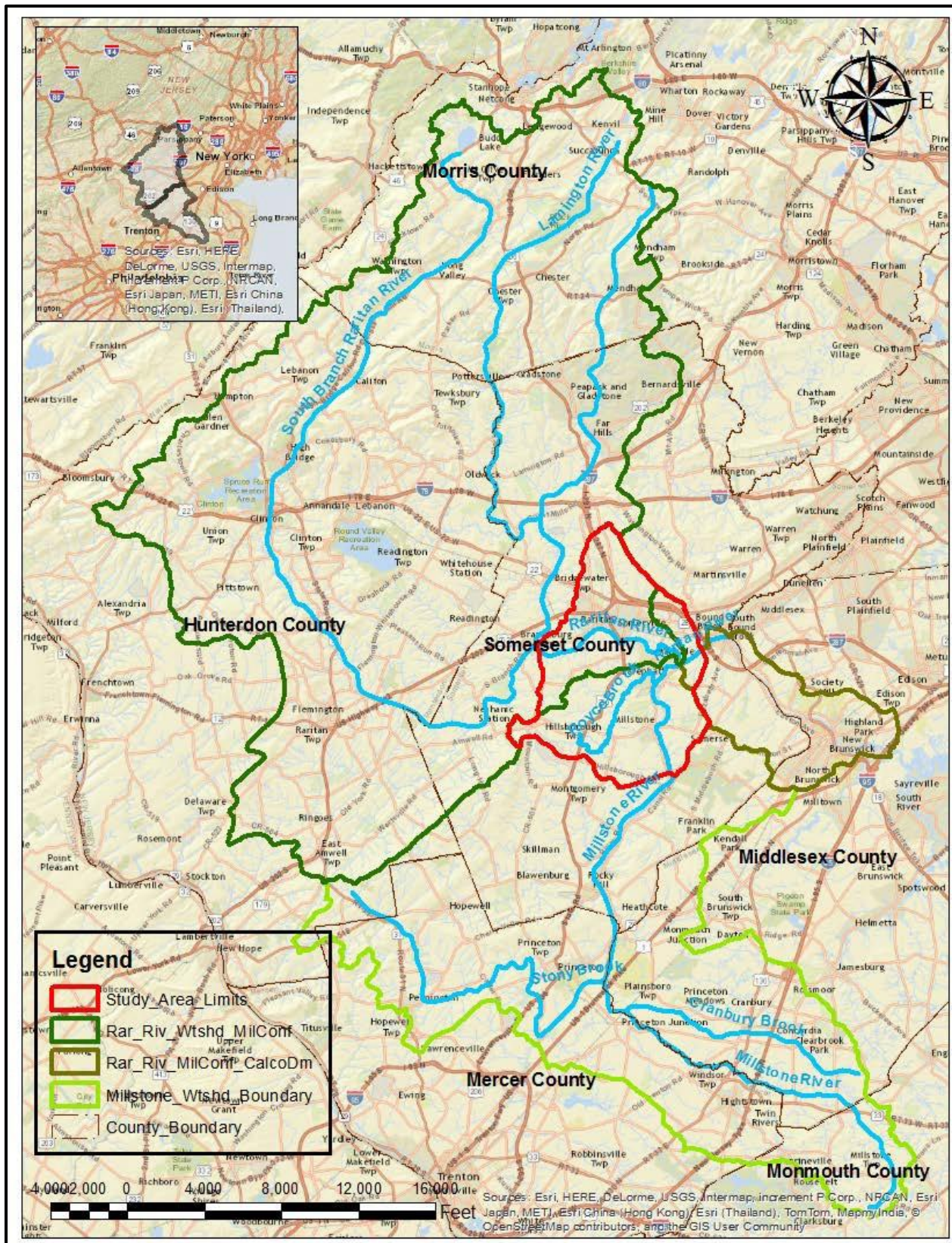


**TABLE 31: COMPARISONS OF EXISTING AND IMPROVED CONDITIONS: ROYCE BROOK AT MOUTH – PEAK DISCHARGE IN CFS**

Condition	D.A. (mi. <sup>2</sup> )	Hypothetical									
		1-year	2-year	5-year	10-year	25-year	50-year	100-year	150-year	250-year	500-year
Existing	17.19	1,510	1,790	2,380	2,840	3,500	4,030	4,560	4,930	5,510	6,190
Future Unimproved		1,580	1,870	2,480	2,970	3,650	4,190	4,730	5,110	5,700	6,390
Present Improved		1,630	1,940	2,560	3,060	3,760	4,310	4,880	5,270	5,890	6,630
Future Improved		1,710	2,030	2,670	3,200	3,920	4,480	5,060	5,460	6,090	6,840

D.A. – Drainage Area (Sub-basin)





**FIGURE 1: RARITAN RIVER BASIN MAP WITH STUDY AREA**





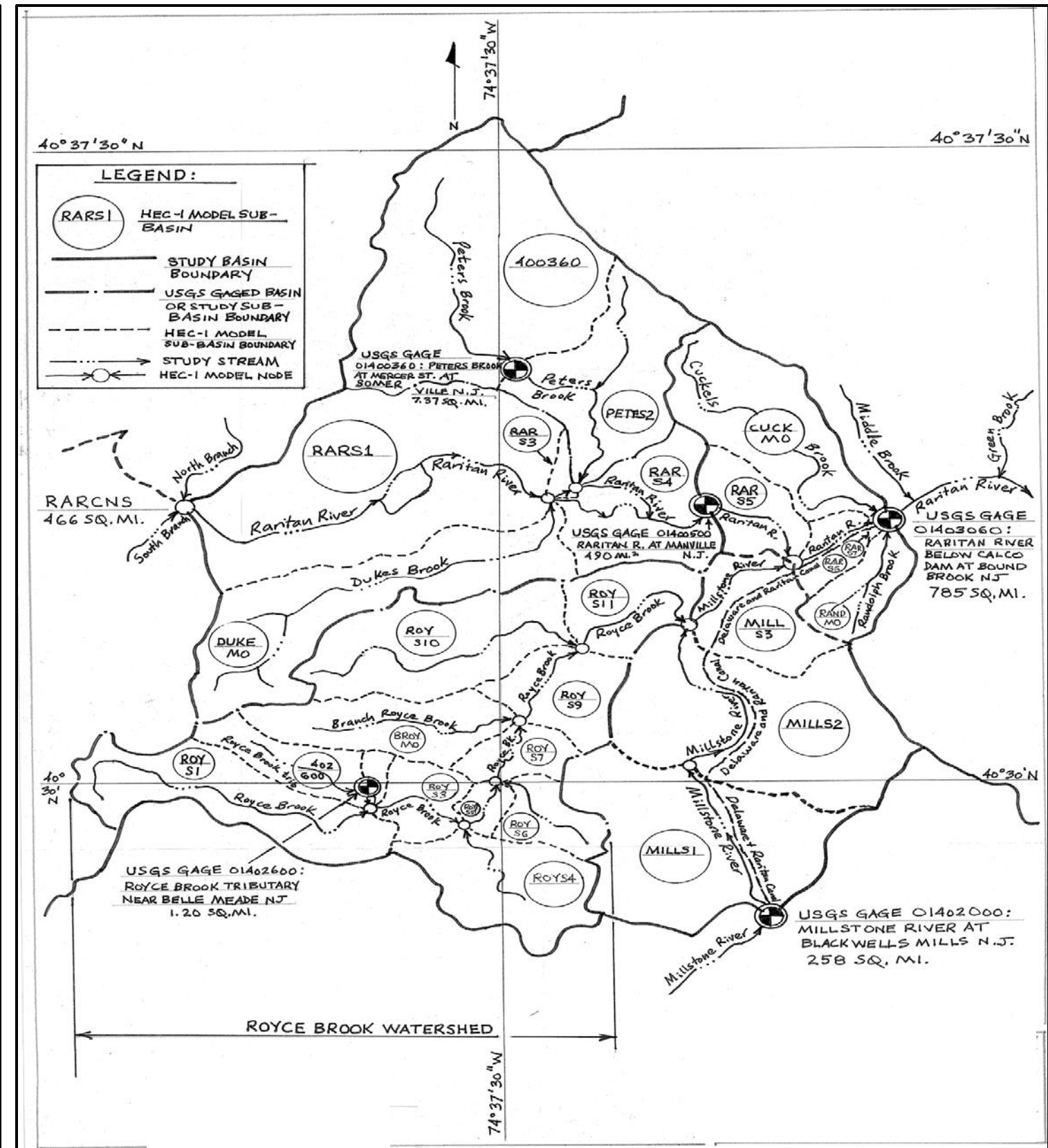
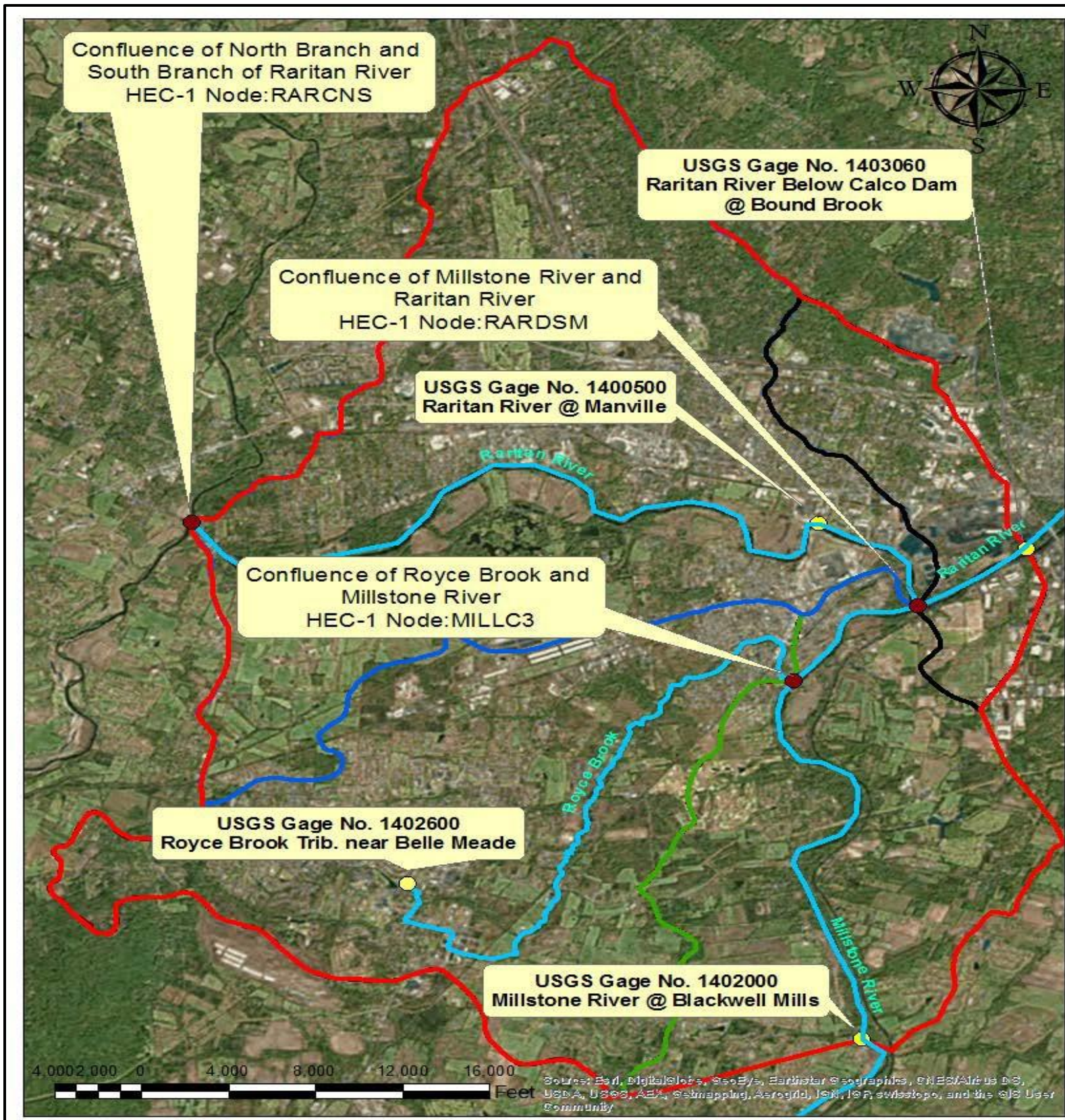
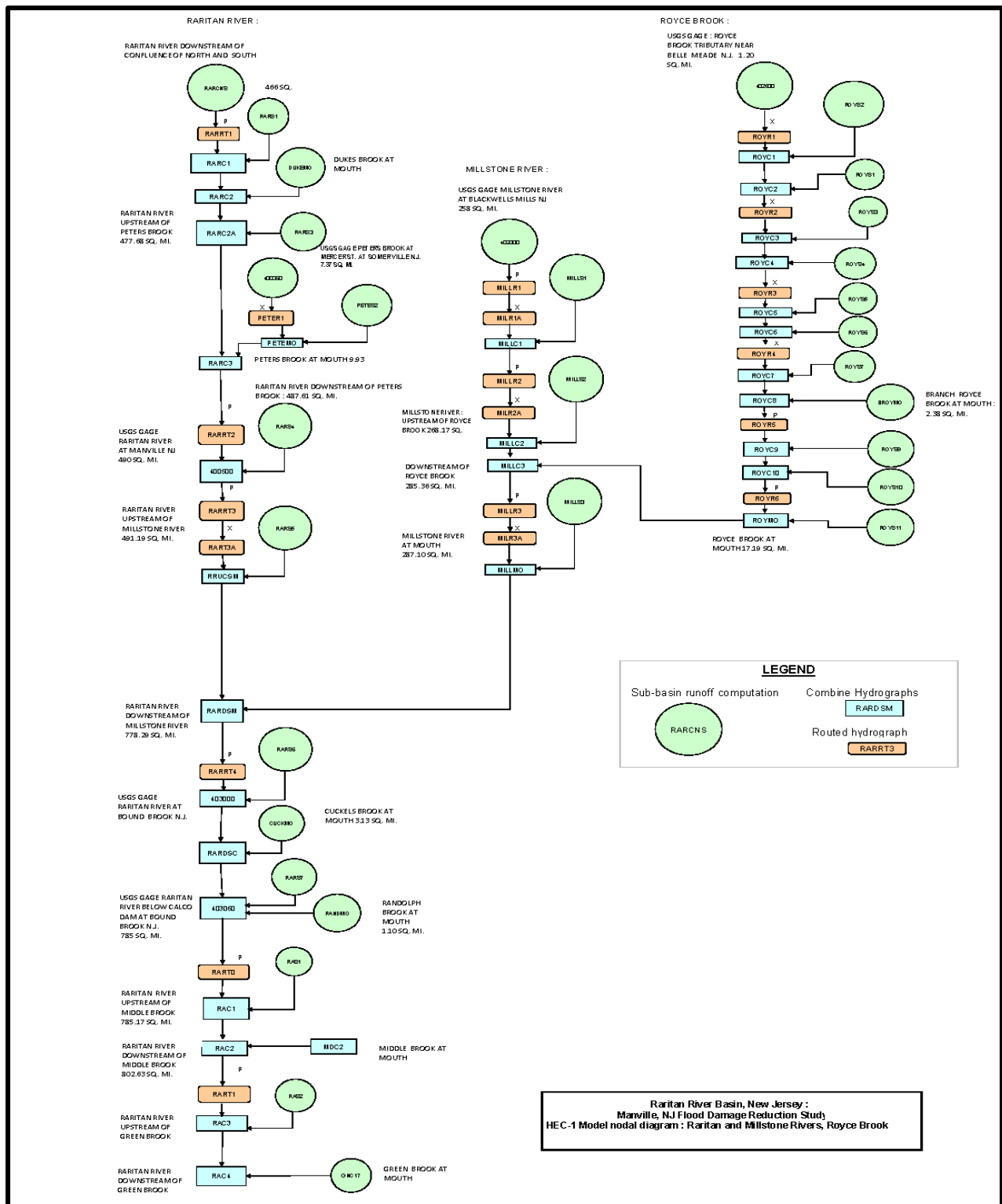


FIGURE 2: PROJECT AREA WITHIN THE RARITAN RIVER BASIN

LINE DRAWING







**FIGURE 3: HEC-1 SCHEMATIC DRAWING OF THE RARITAN RIVER BASIN TO DOWNSTREAM OF GREEN BROOK**



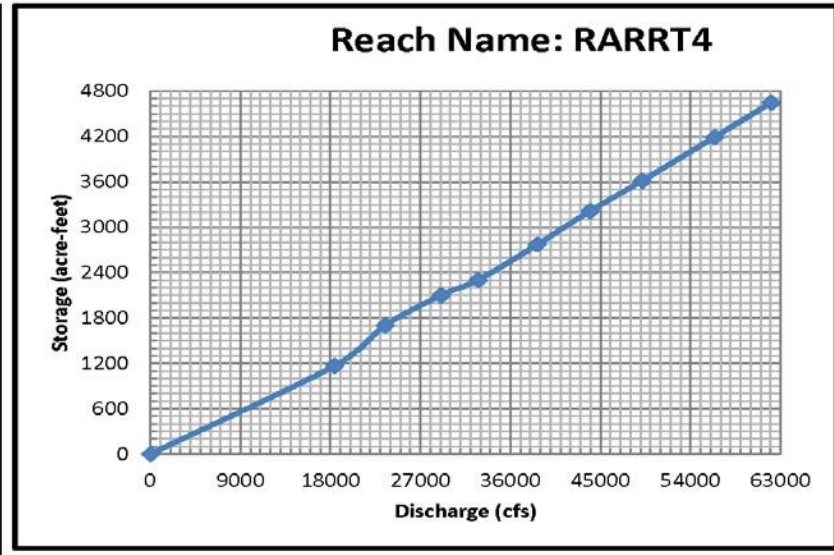
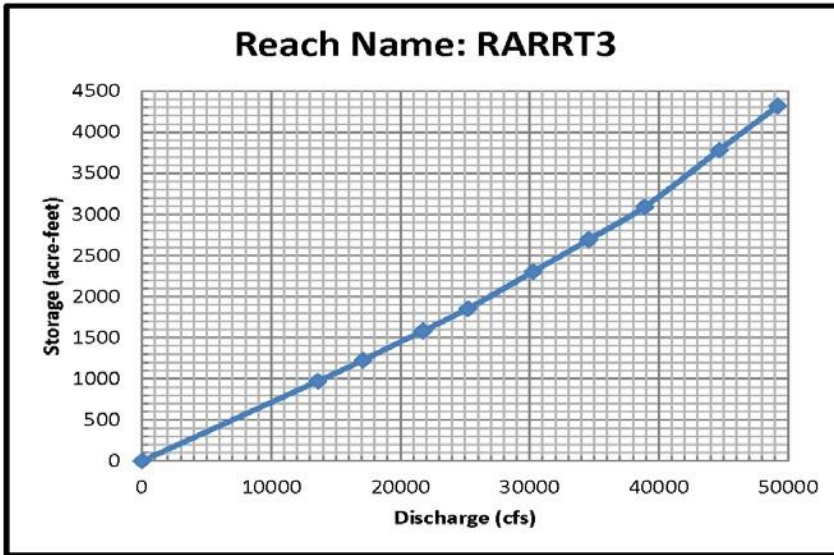
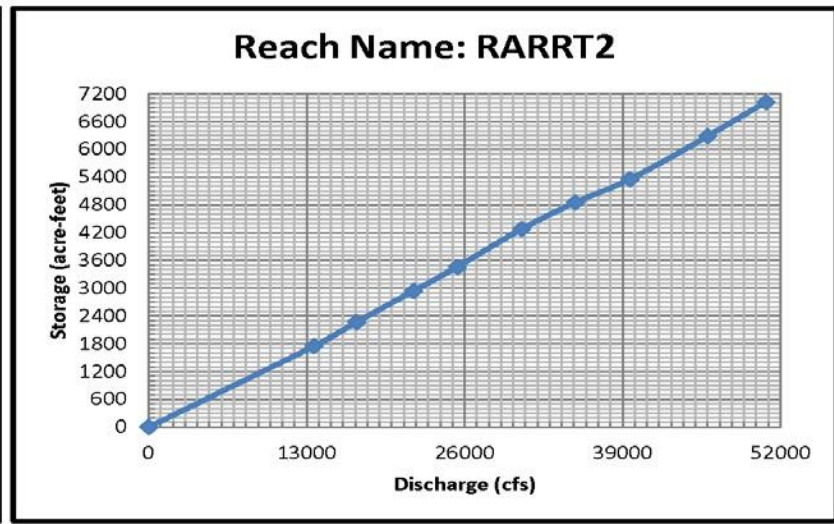
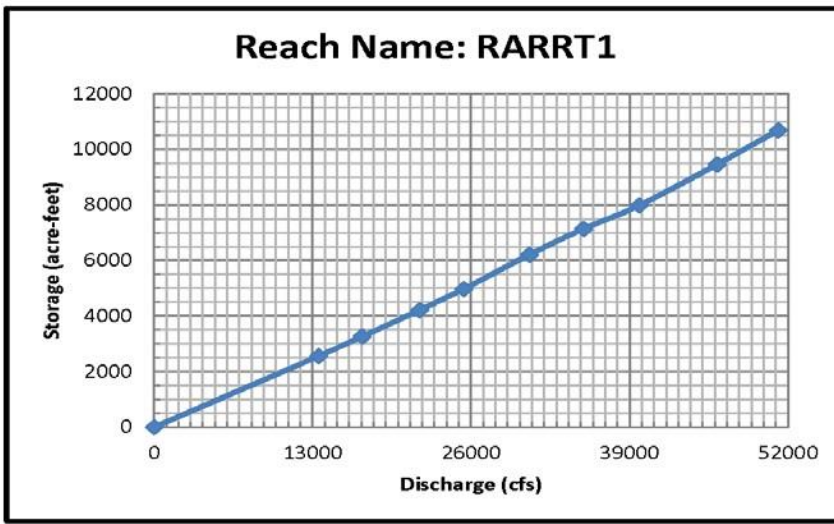
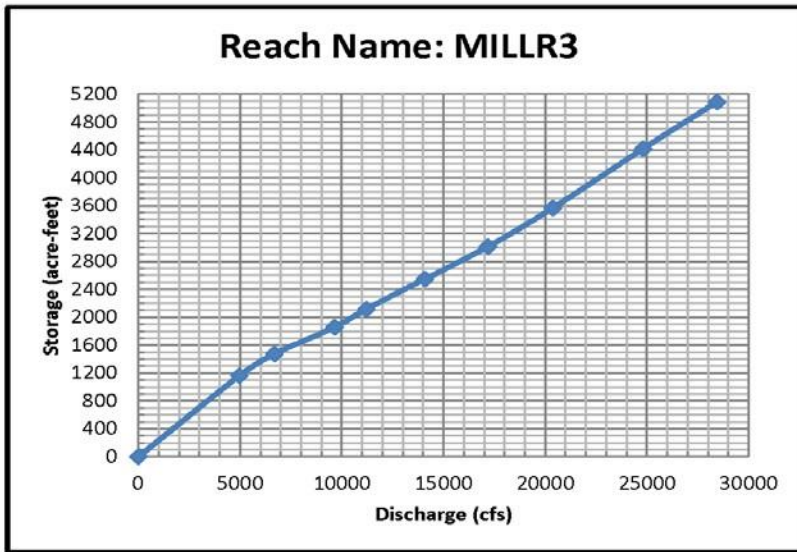
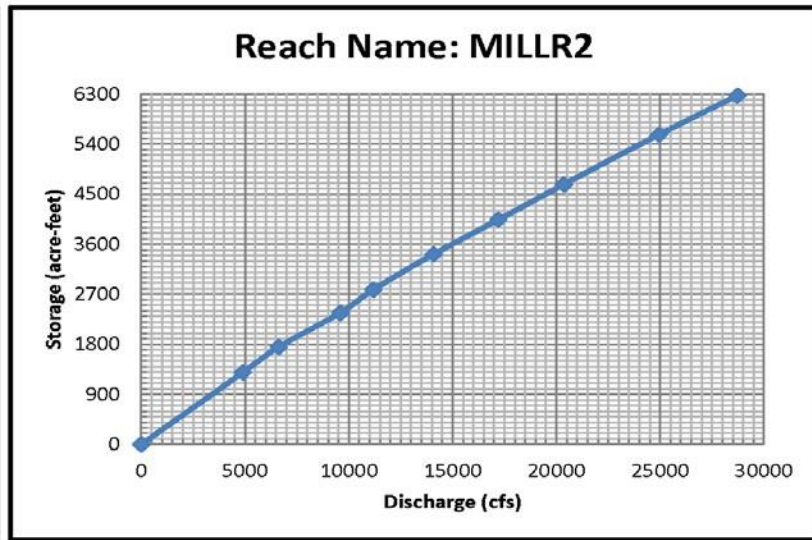
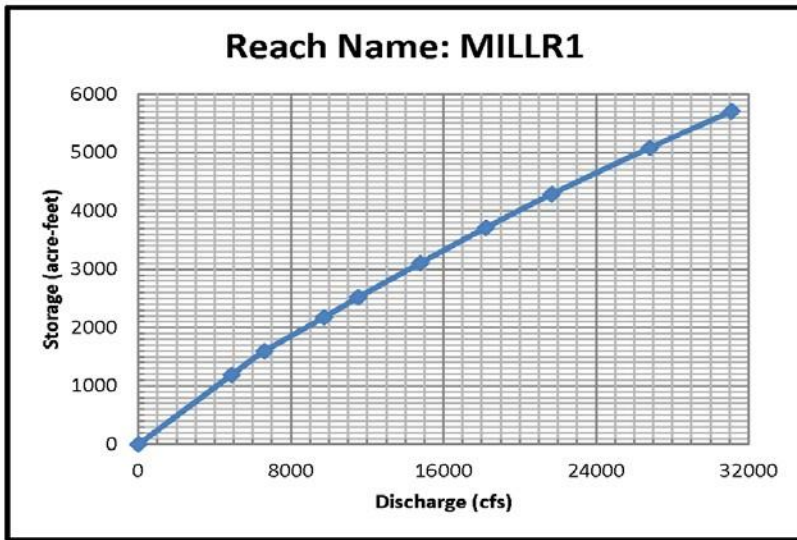


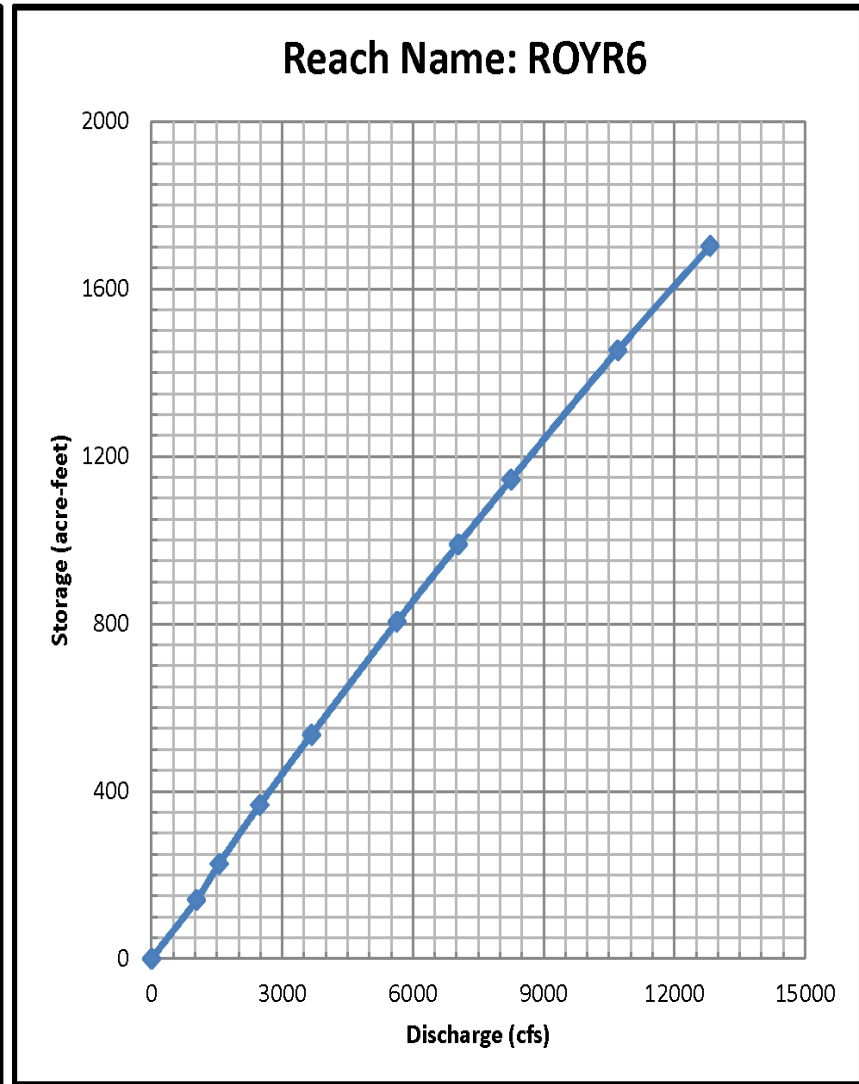
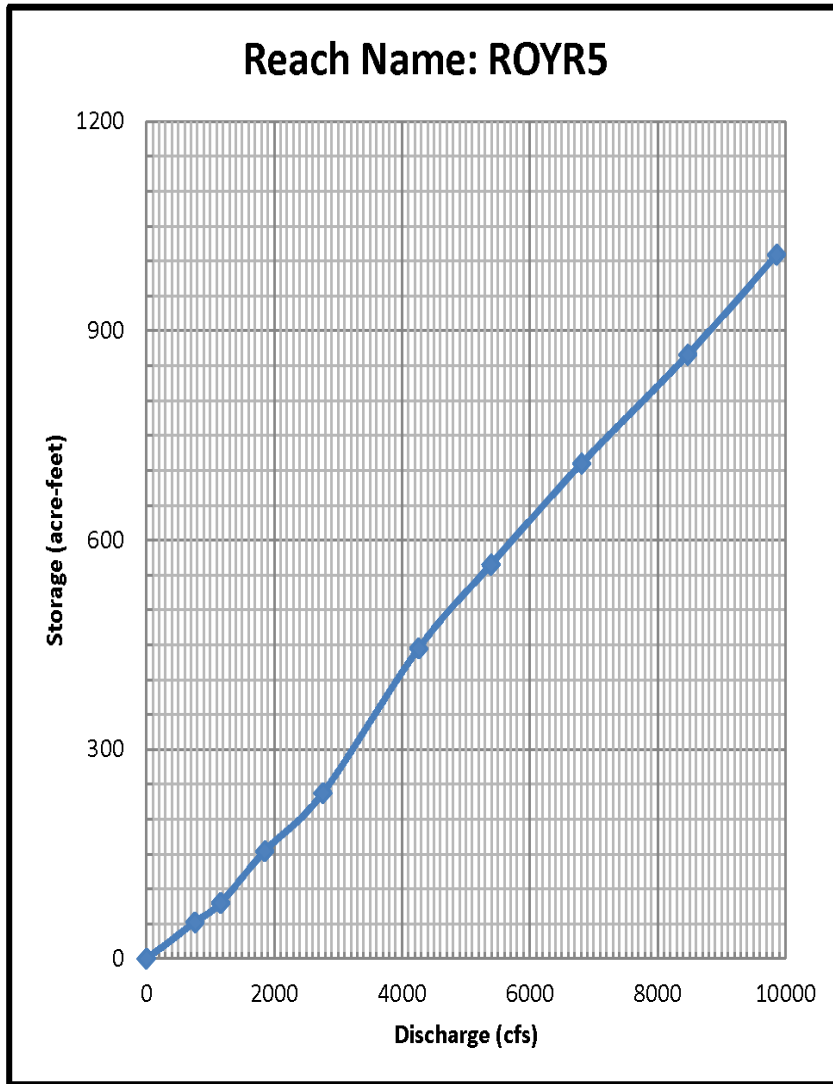
Figure 4 (A): Modified Puls Routing Relations





**FIGURE 4 (B): MODIFIED PULS ROUTING RELATIONS**





**FIGURE 4 (C): MODIFIED PULS ROUTING RELATIONS**



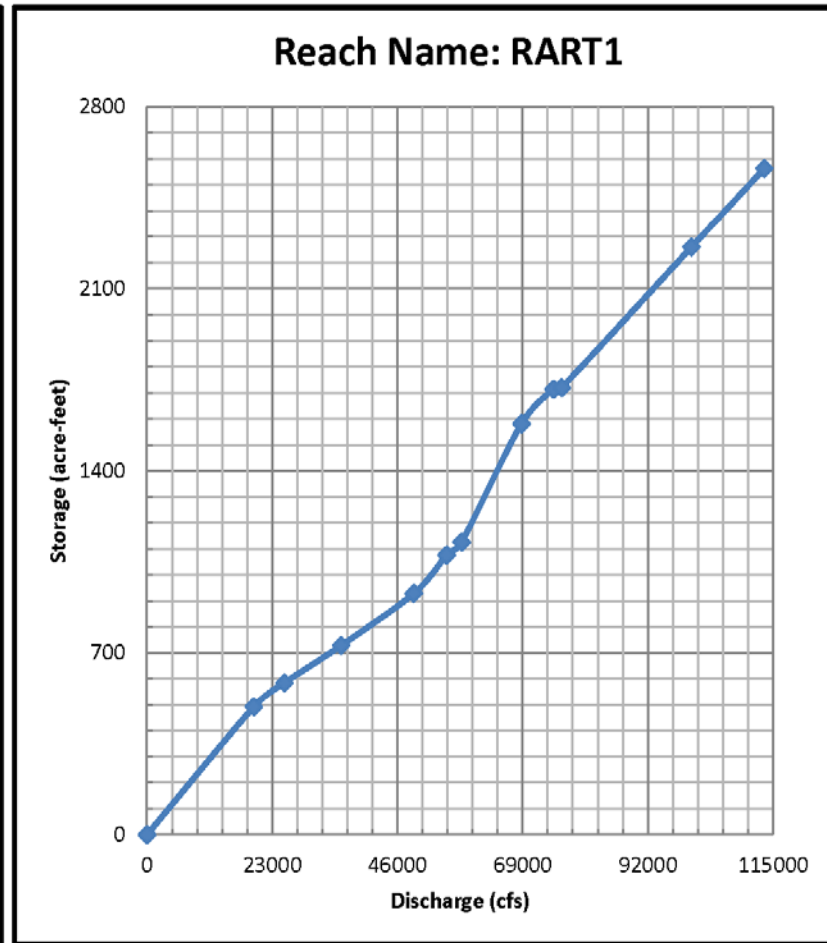
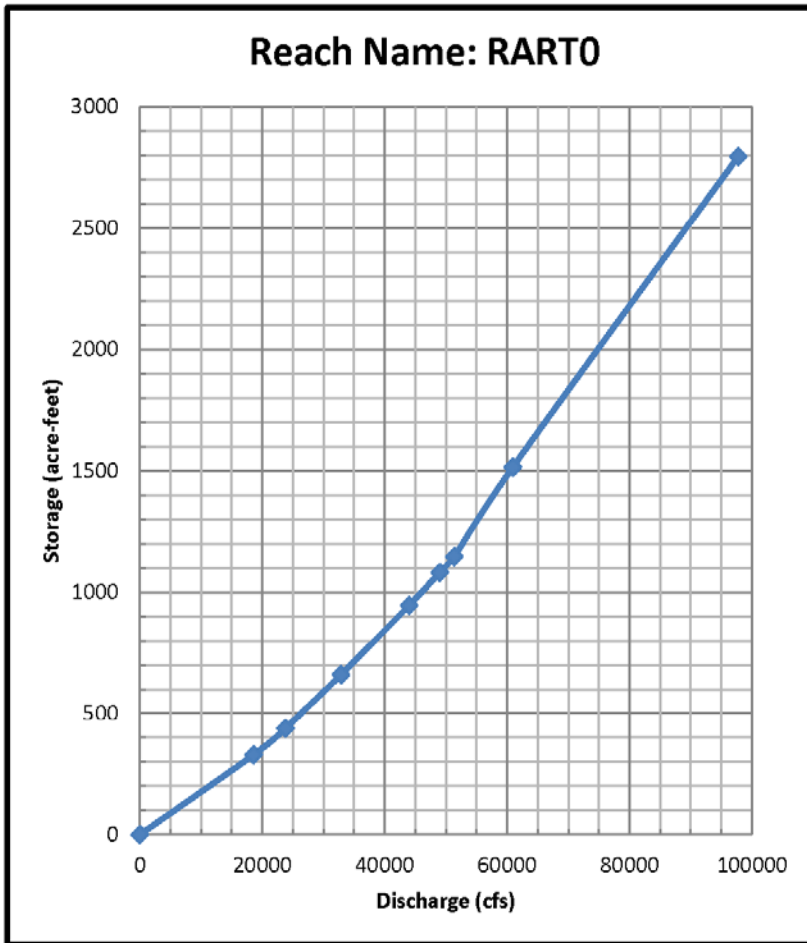


FIGURE 4 (D): MODIFIED PULS ROUTING RELATIONS





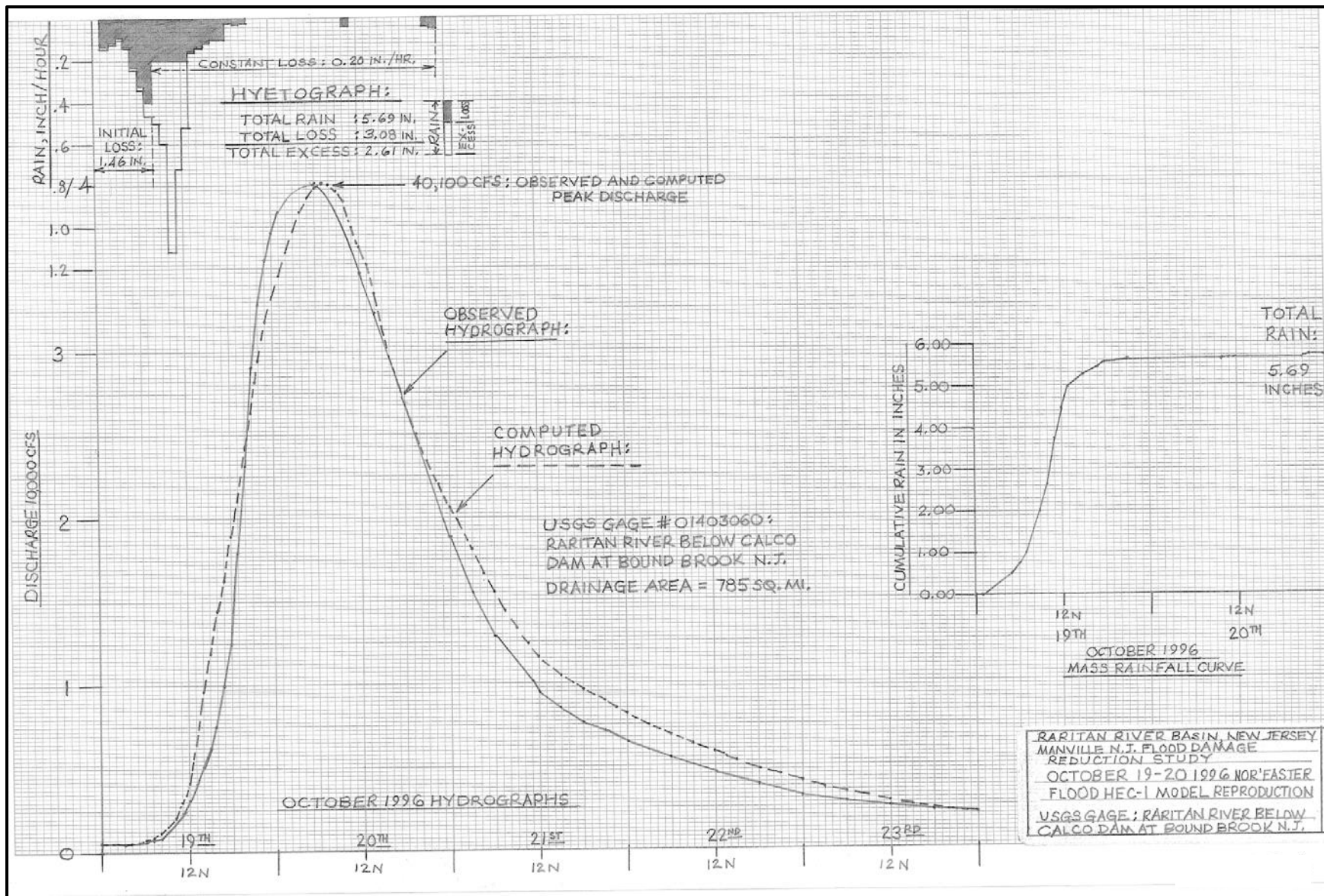


FIGURE 5: OCTOBER 19 – 20 1996 NOR'EASTER FLOOD MODEL REPRODUCTION AT THE CALCO DAM GAGE.





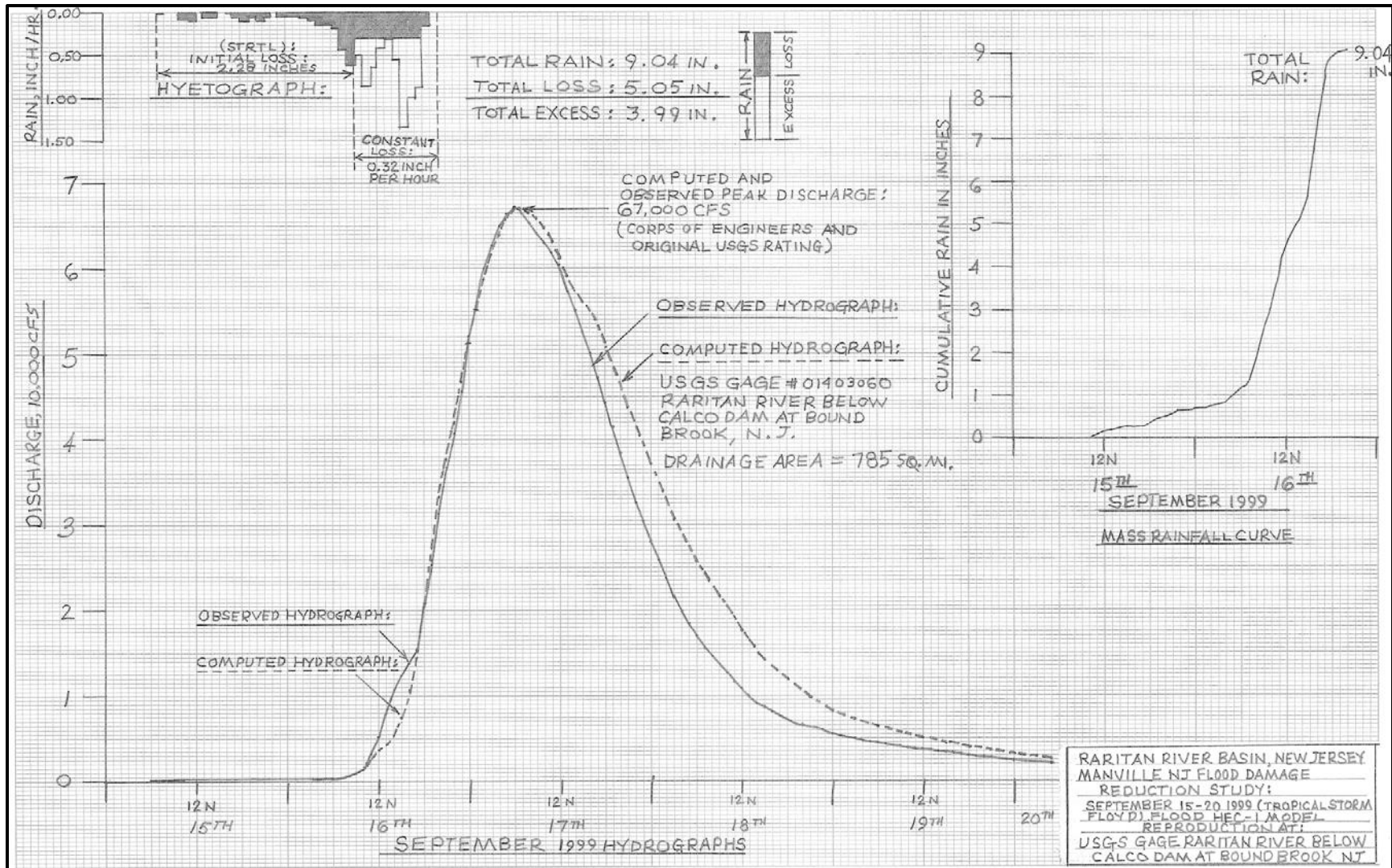


FIGURE 6: SEPTEMBER 15 – 16 1999 (TS FLOYD) FLOOD MODEL REPRODUCTION AT THE CALCO DAM GAGE.





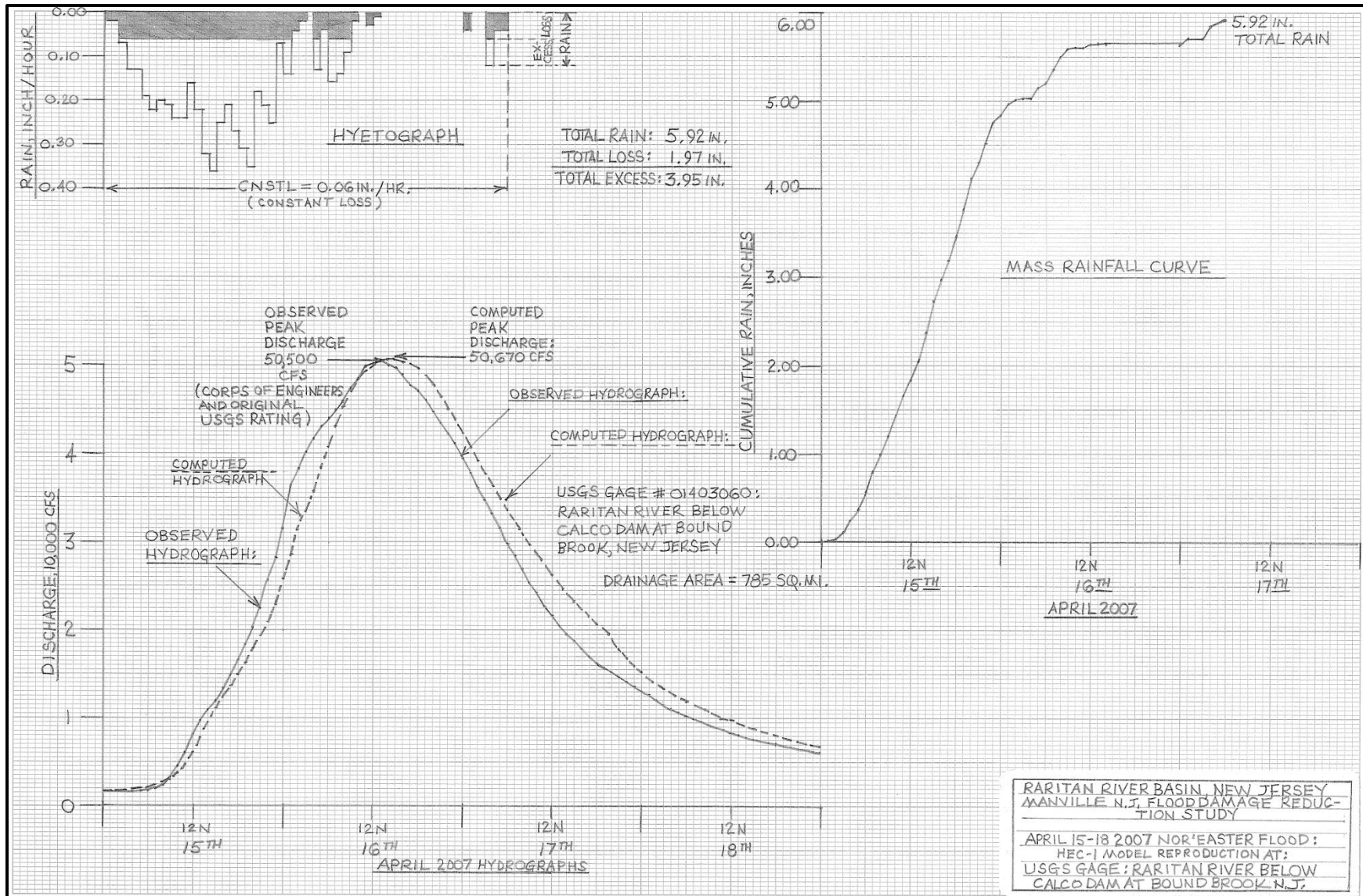
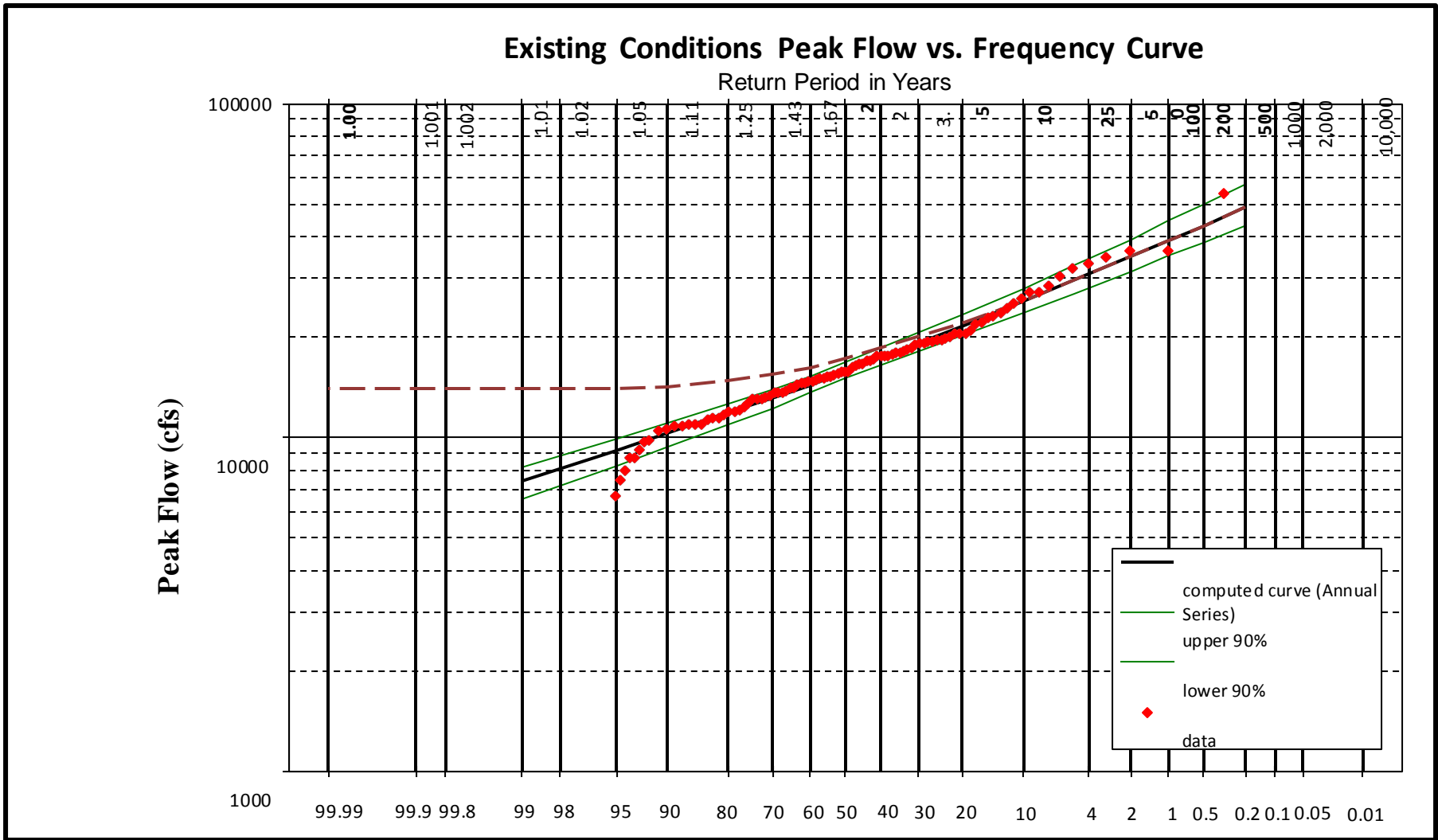


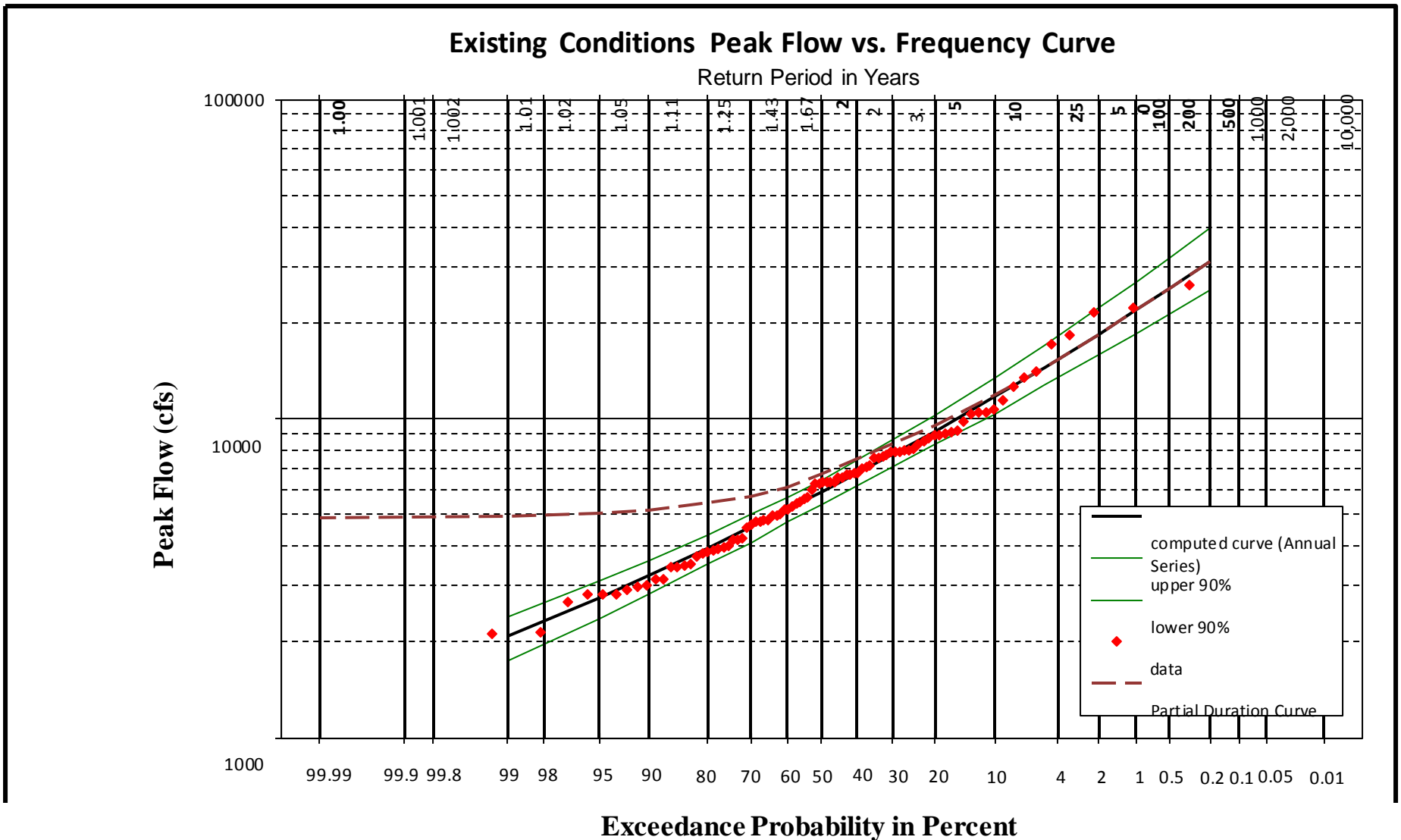
FIGURE 7: APRIL 15 – 16 2007 NOR'EASTER FLOOD MODEL REPRODUCTION AT THE CALCO DAM GAGE.





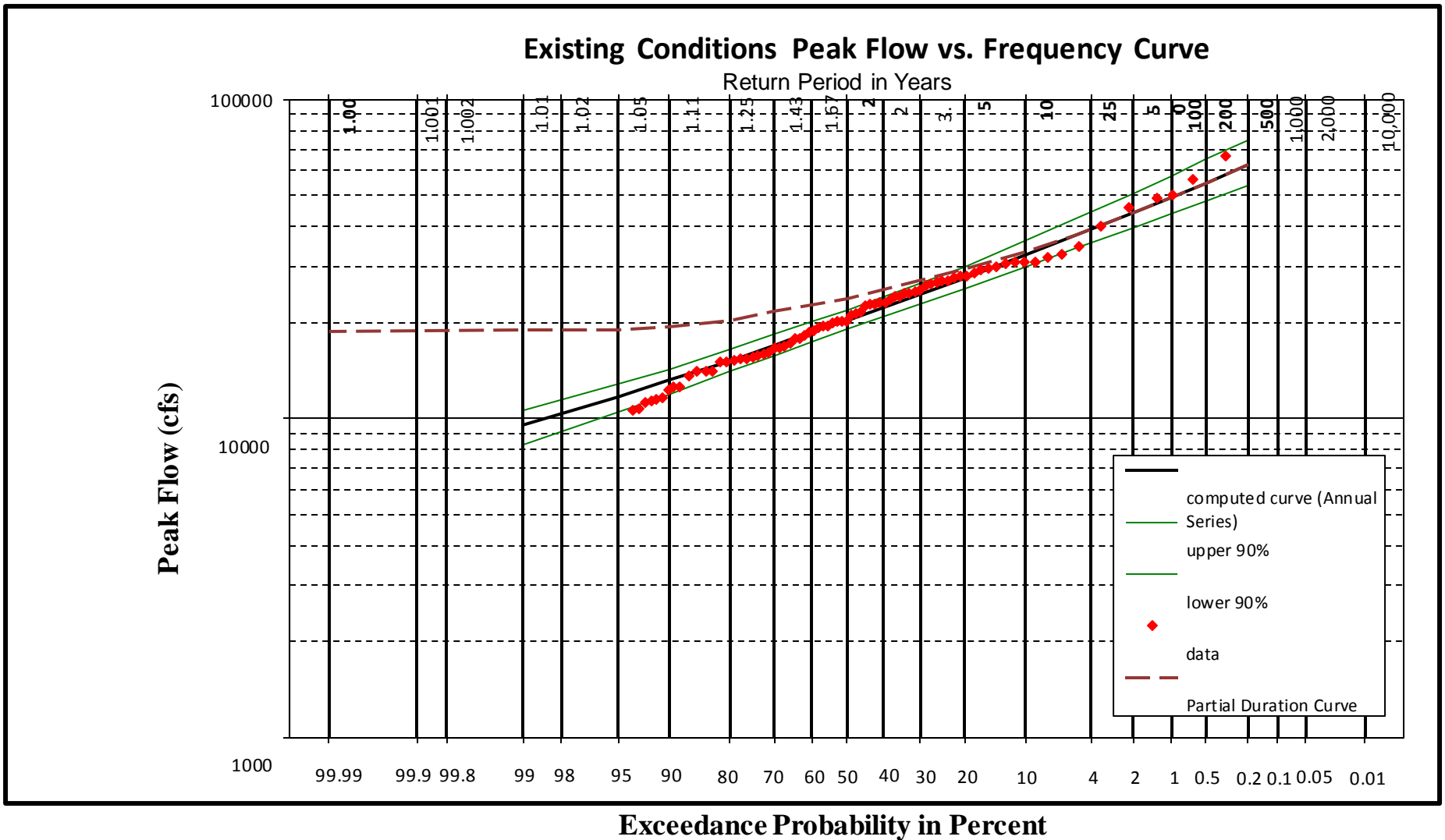
**FIGURE 8: PEAK DISCHARGE VS. FREQUENCY CURVE FOR RARITAN RIVER AT MANVILLE, NJ (D.A. = 490 MI<sup>2</sup>)**





**FIGURE 9: PEAK DISCHARGE VS. FREQUENCY CURVE FOR MILLSTONE RIVER AT BLACKWELLS MILLS, NJ (D.A. = 258 m<sup>2</sup>)**





**FIGURE 10: PEAK DISCHARGE VS. FREQUENCY CURVE FOR RARITAN RIVER AT CALCO DAM (UPSTREAM OF BOUND BROOK) (D.A. = 785 mi<sup>2</sup>)**



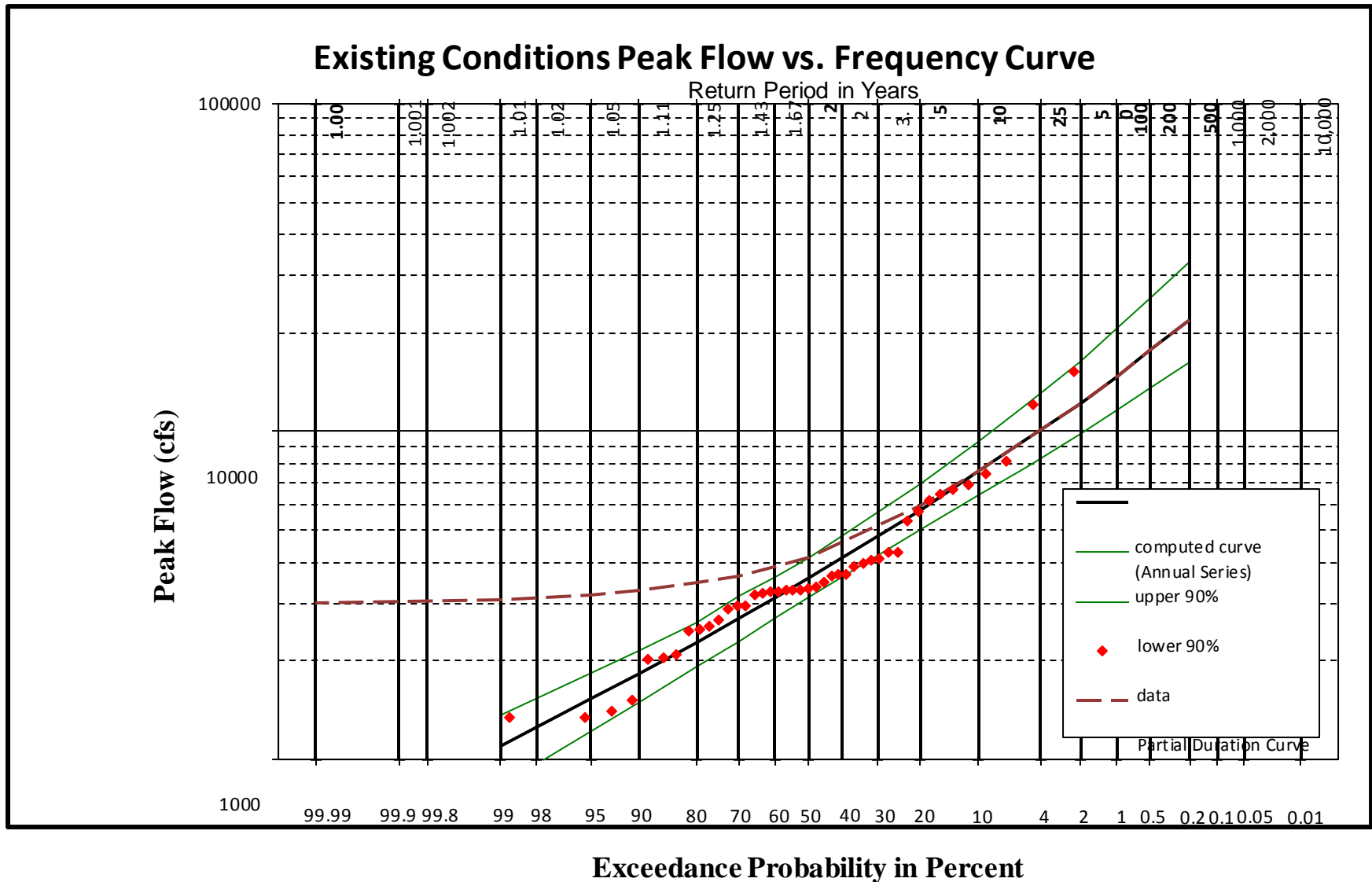


FIGURE 11: PEAK DISCHARGE VS. FREQUENCY CURVE FOR BEDEN BROOK NEAR ROCKY HILL, NJ (D.A. = 27.6 MI<sup>2</sup>)





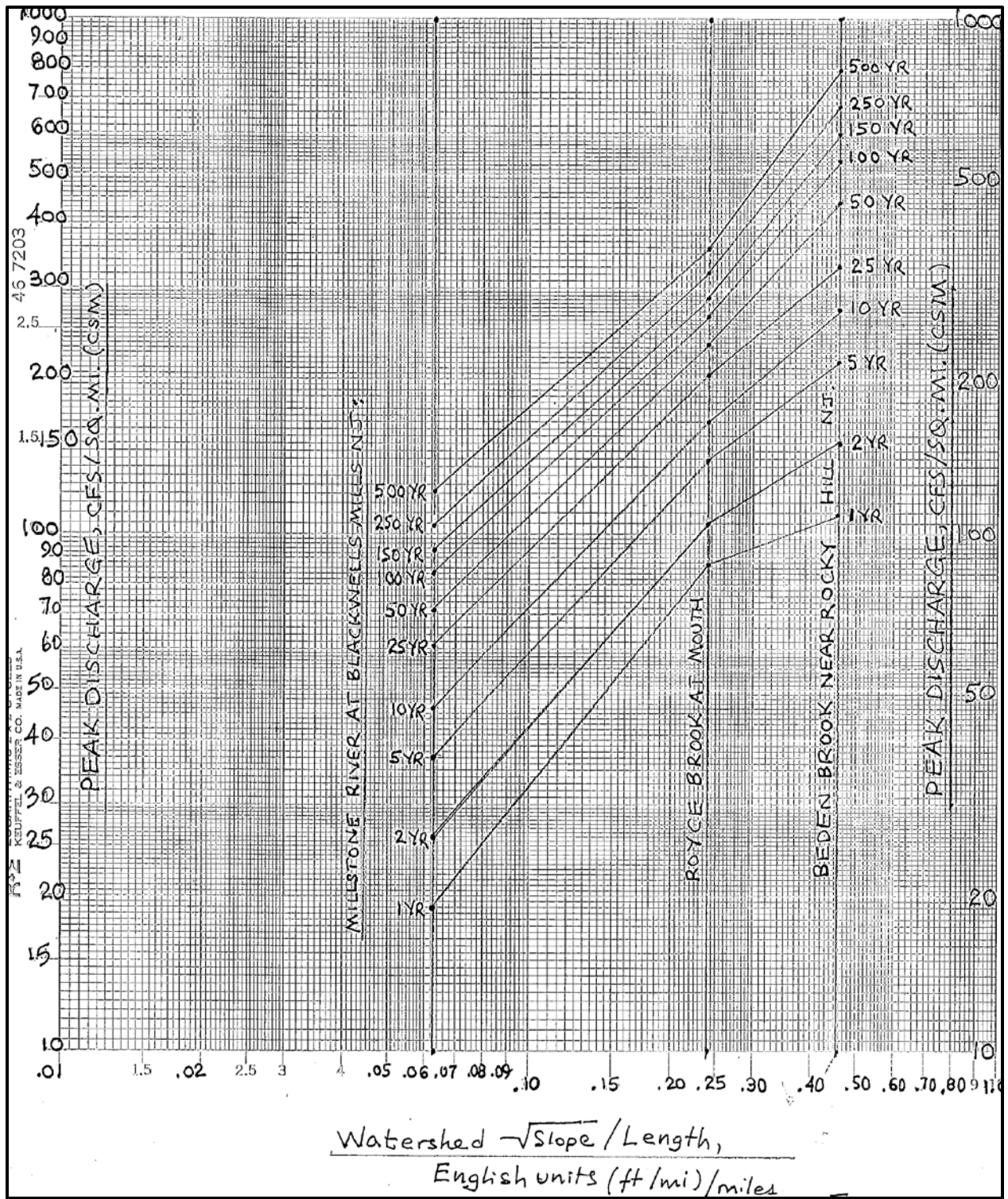
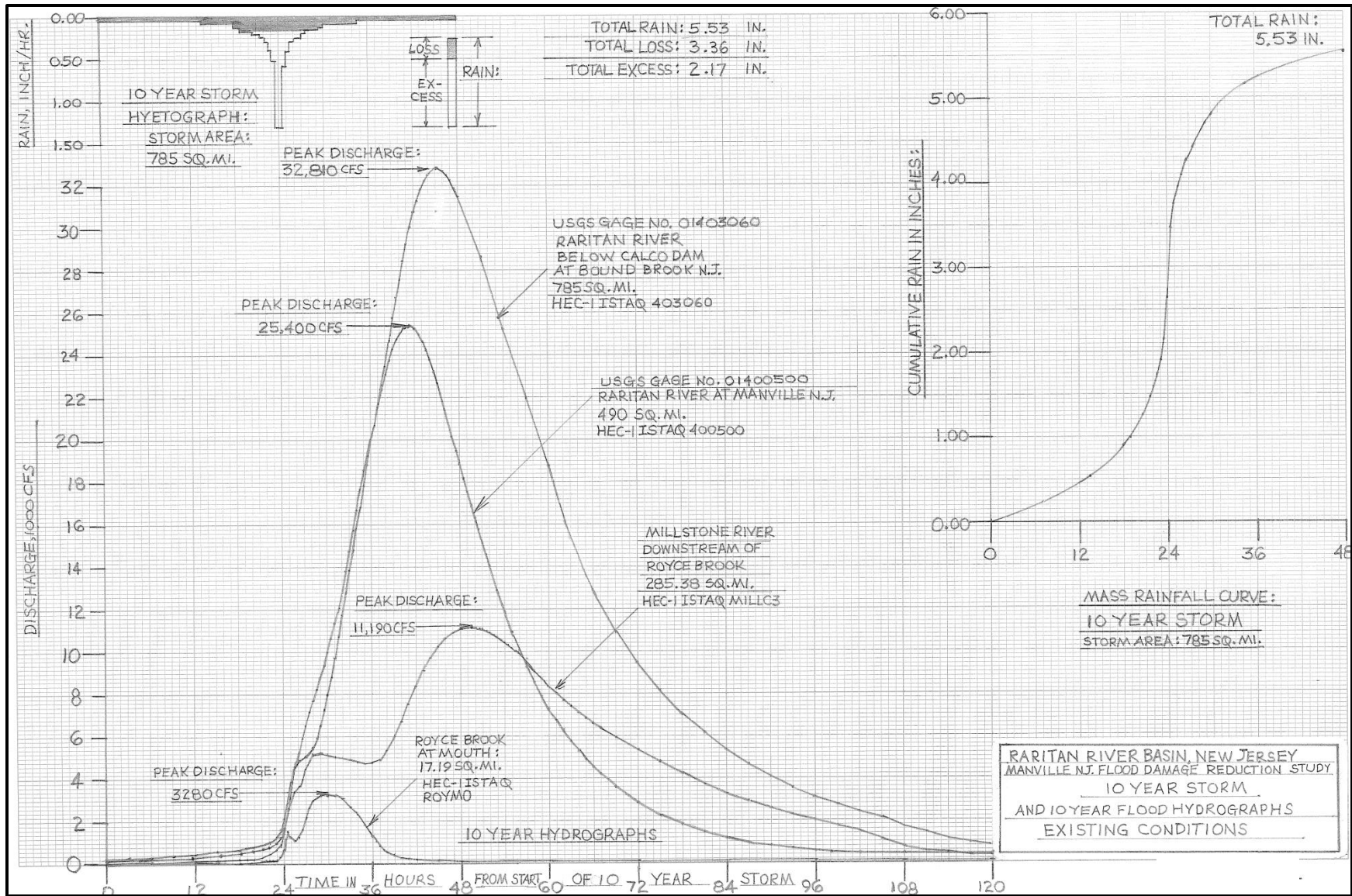


FIGURE 12: INTERPOLATION OF PEAK DISCHARGE VS. FREQUENCY FOR ROYCE BROOK AT MOUTH







**FIGURE 13: 10-YEAR STORM AND 10-YR FLOOD FREQUENCY HYDROGRAPH**





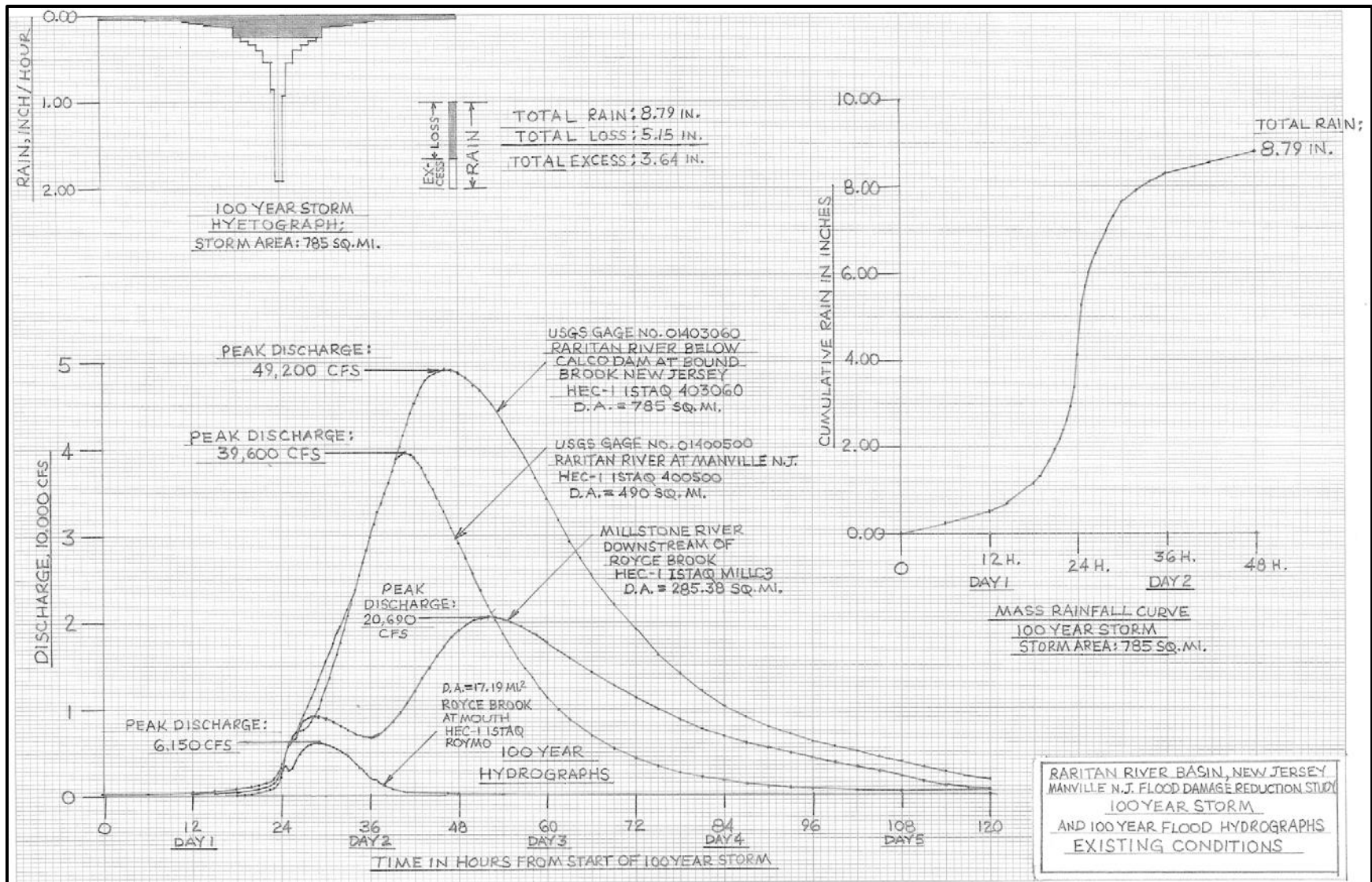


FIGURE 14: 100-YEAR STORM AND 100-YR FLOOD FREQUENCY HYDROGRAPH







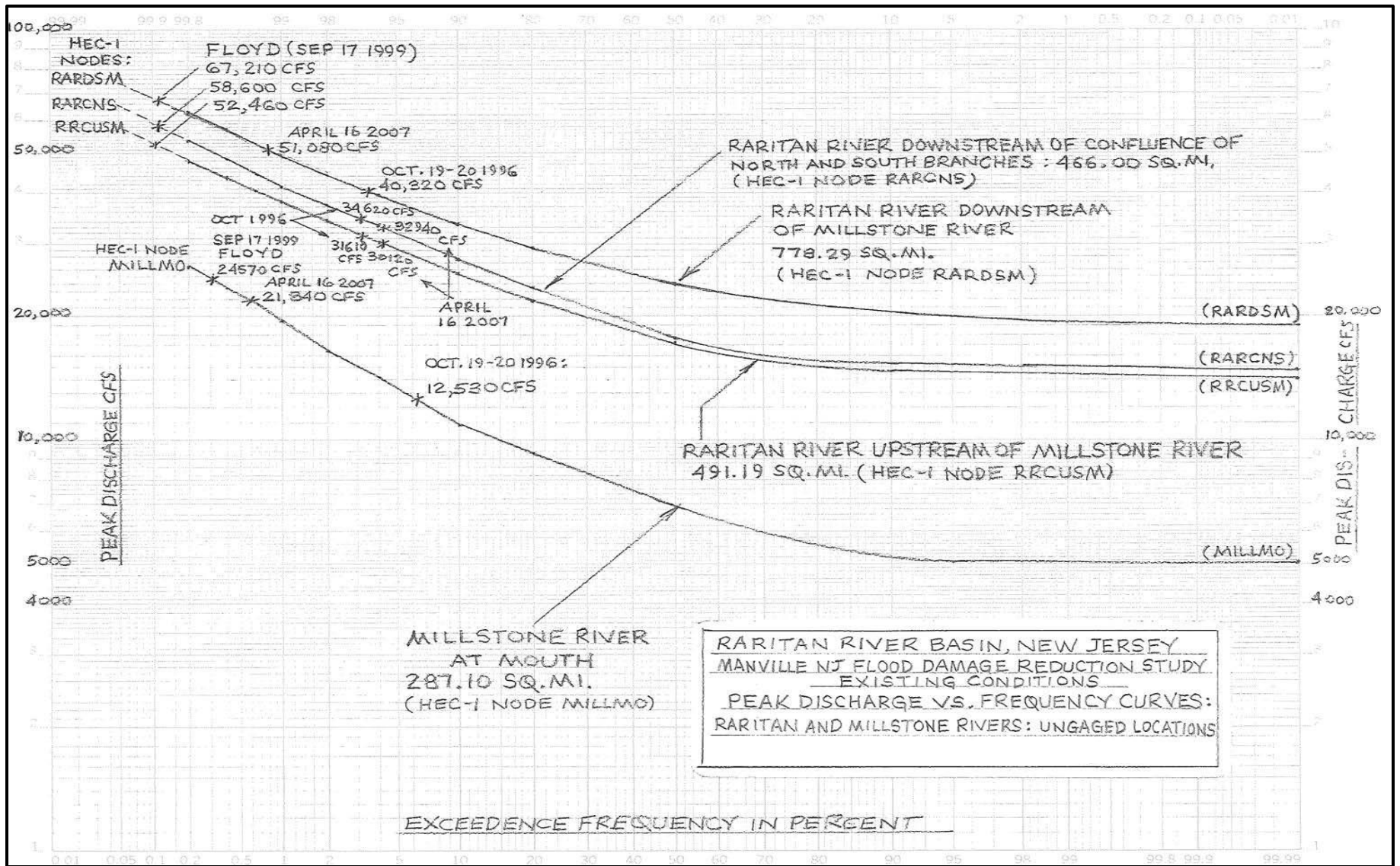


FIGURE 16: PEAK DISCHARGE VS. FREQUENCY CURVE AT NODES ALONG RARITAN AND MILLSTONE RIVERS



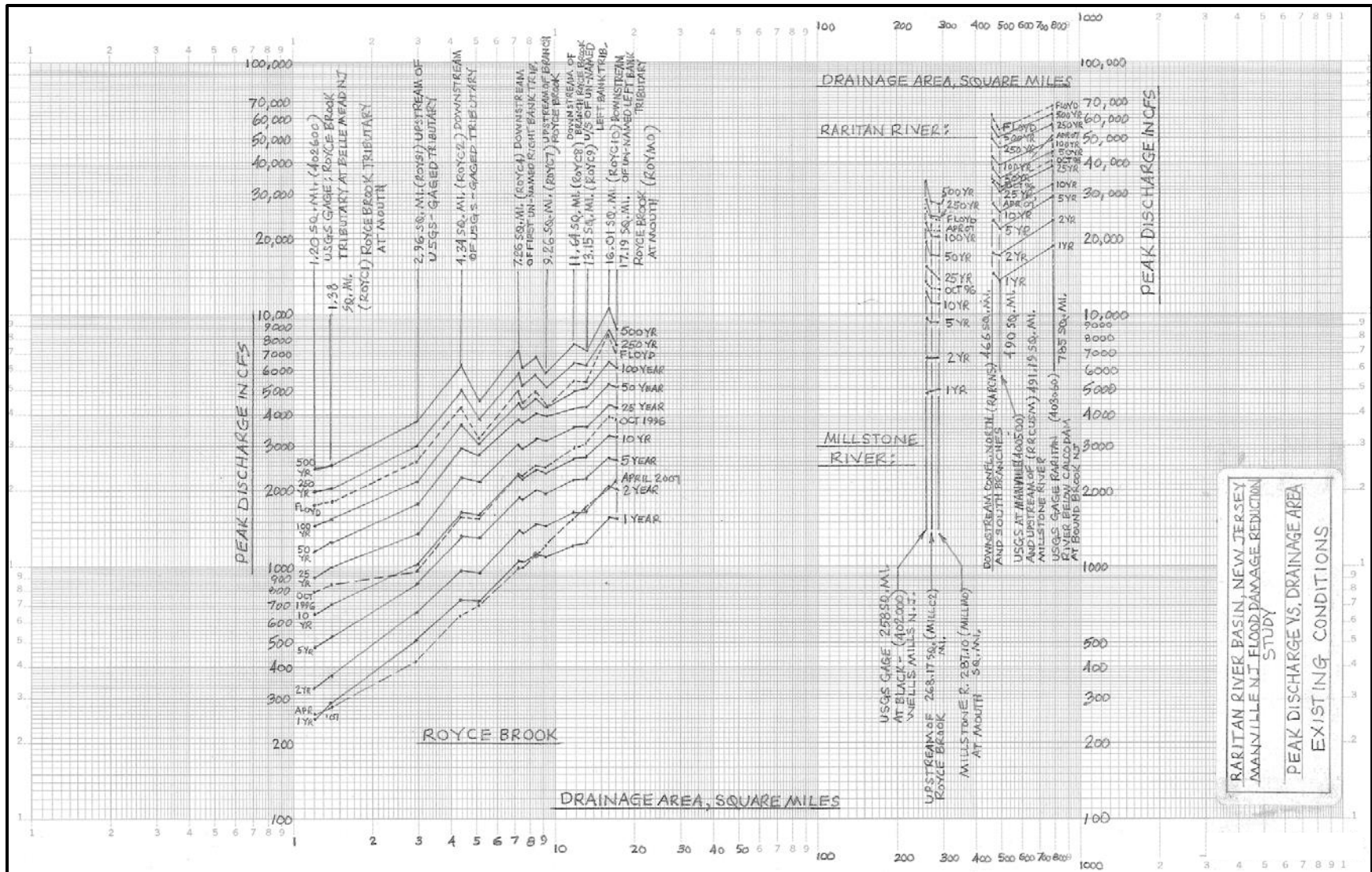
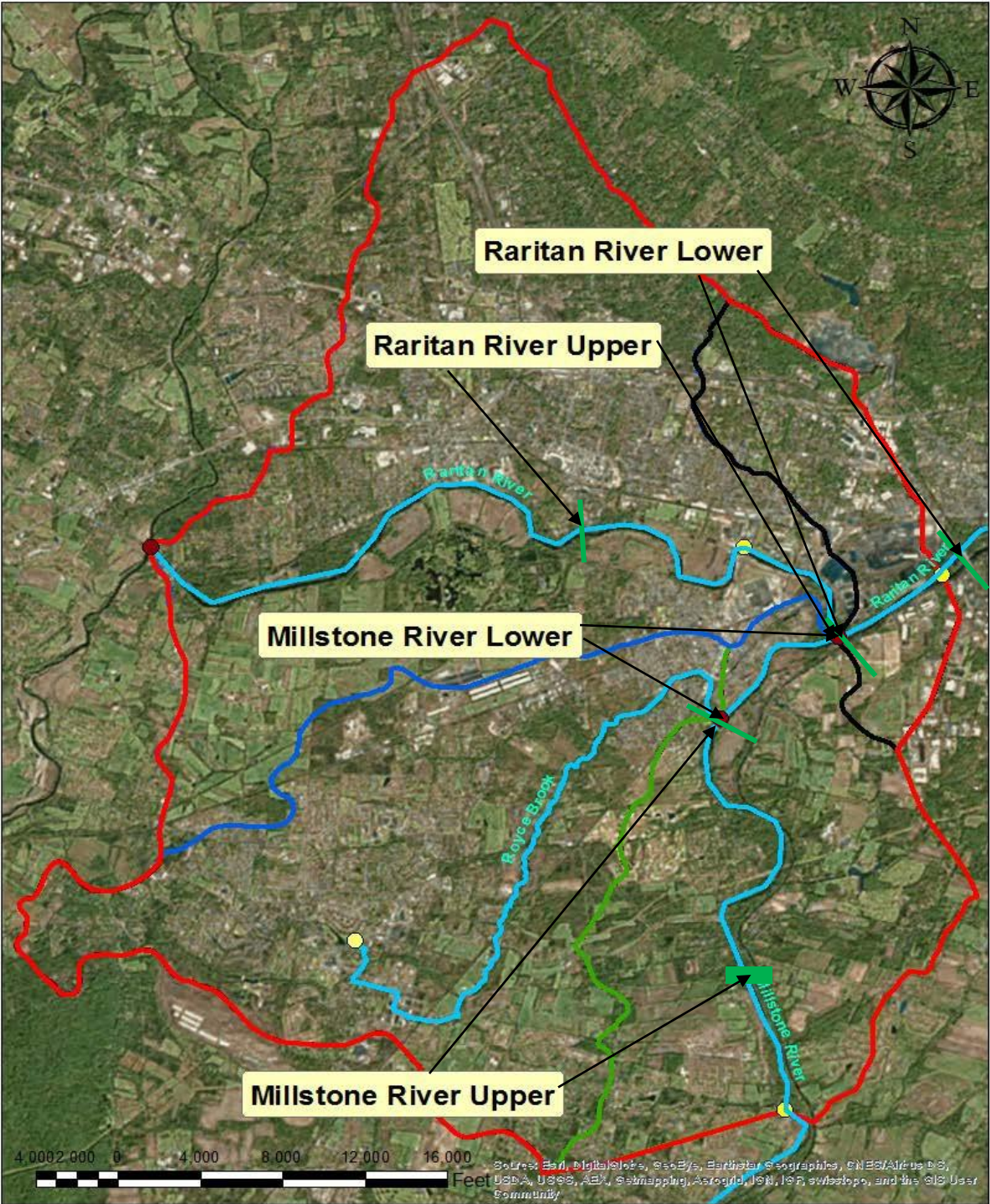


FIGURE 17: EXISTING CONDITIONS SPECIFIC-FREQUENCY AREA-AVERAGE CURVES







**Figure 18A: Raritan and Millstone River Reaches 1**





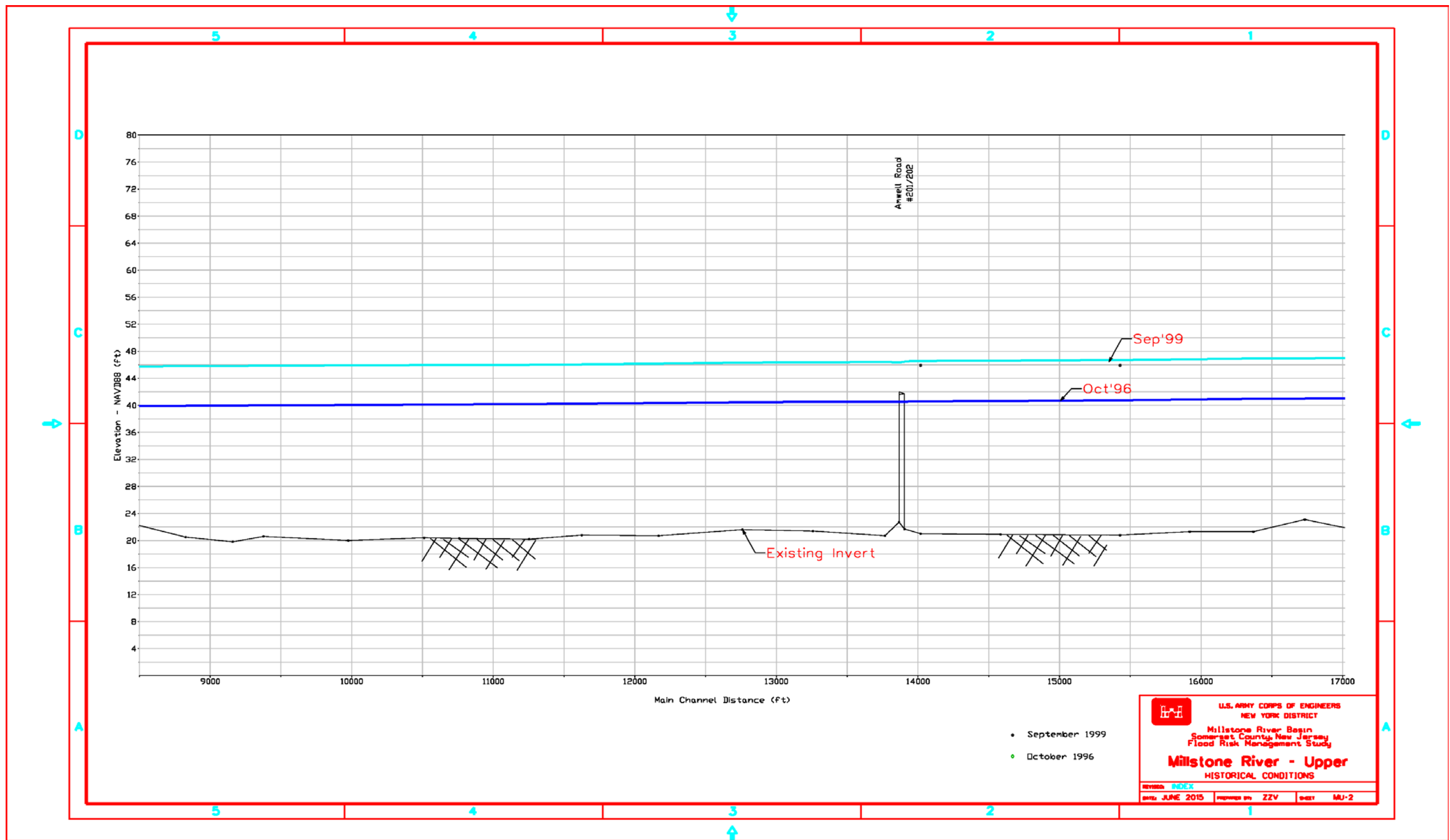


FIGURE 18: WATER SURFACE PROFILE FOR HISTORICAL - OCT1996 & SEPT 1999 (MILLSTONE RIVER UPPER)



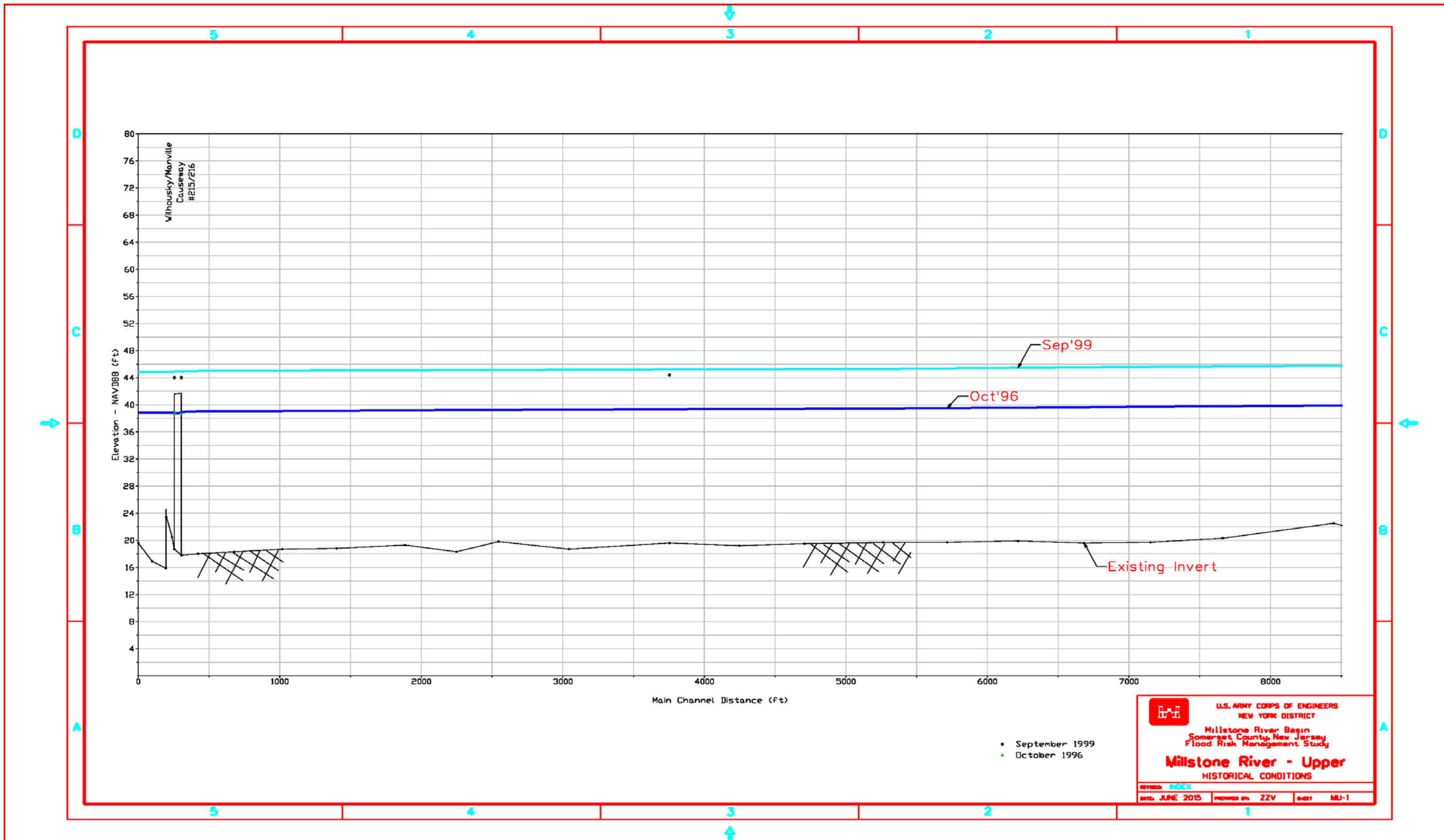
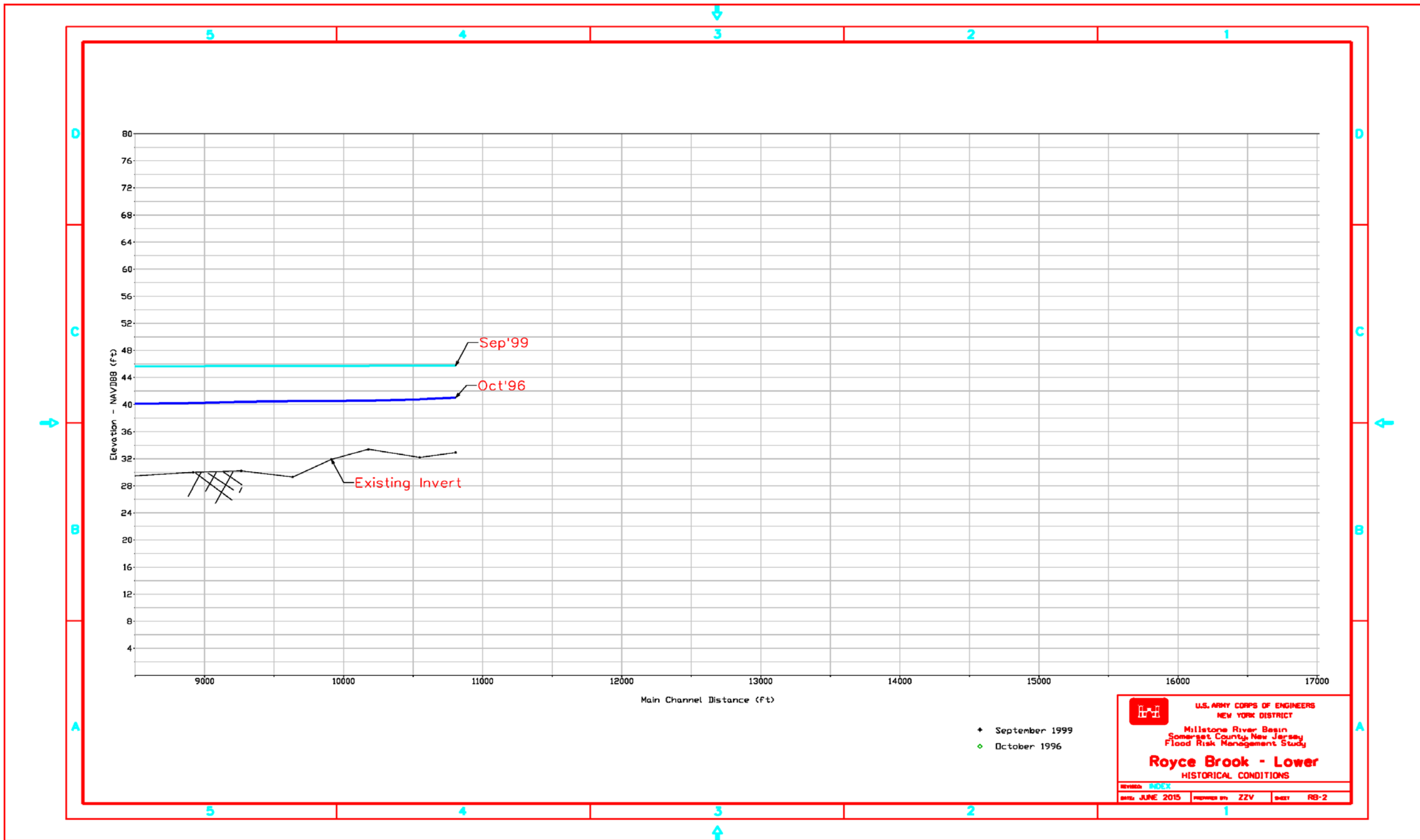
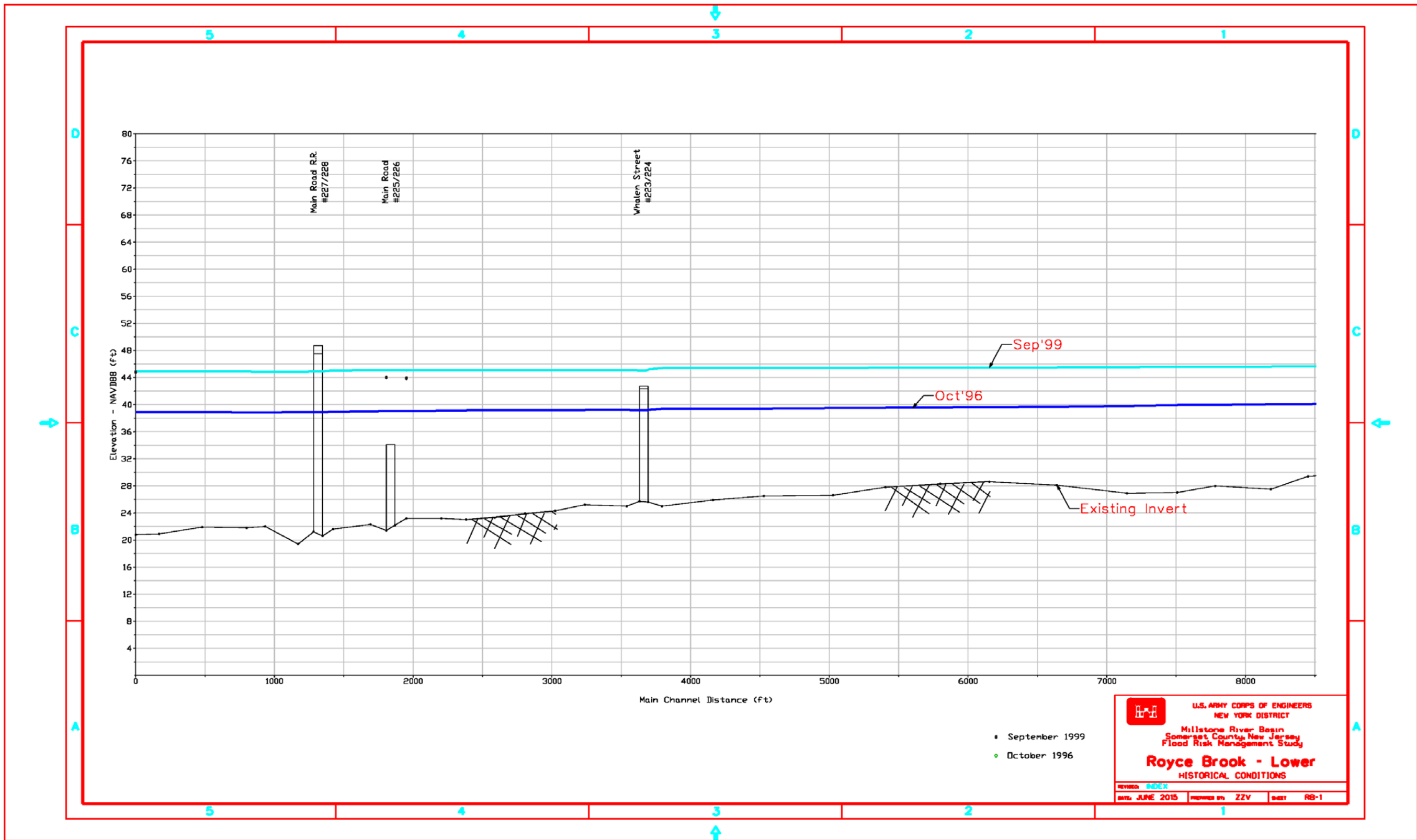


FIGURE 19: WATER SURFACE PROFILE FOR HISTORICAL - OCT1996 & SEPT 1999 (MILLSTONE RIVER UPPER)





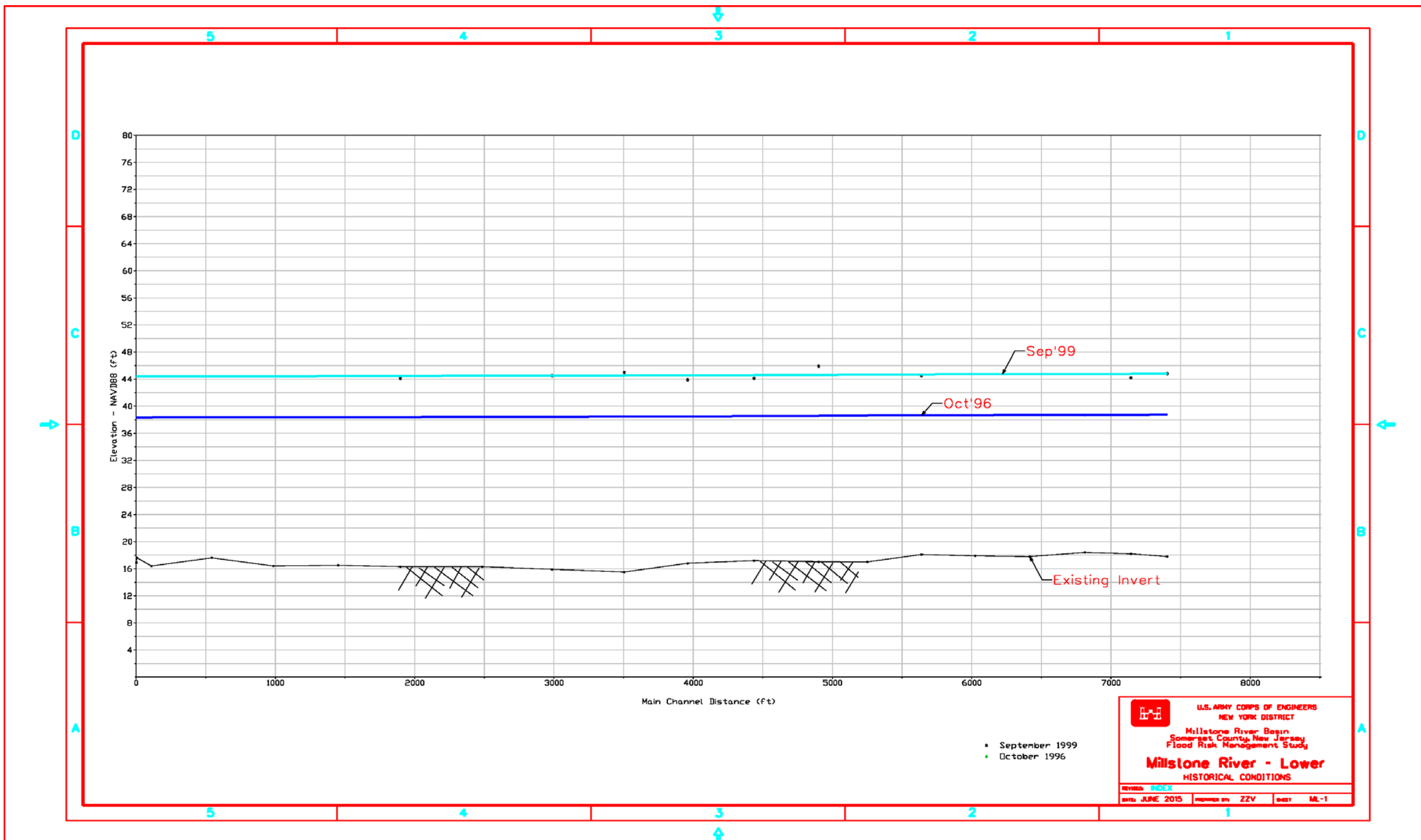


FIGURE 22: WATER SURFACE PROFILE FOR HISTORICAL - OCT1996 & SEPT 1999 (MILLSTONE RIVER LOWER)



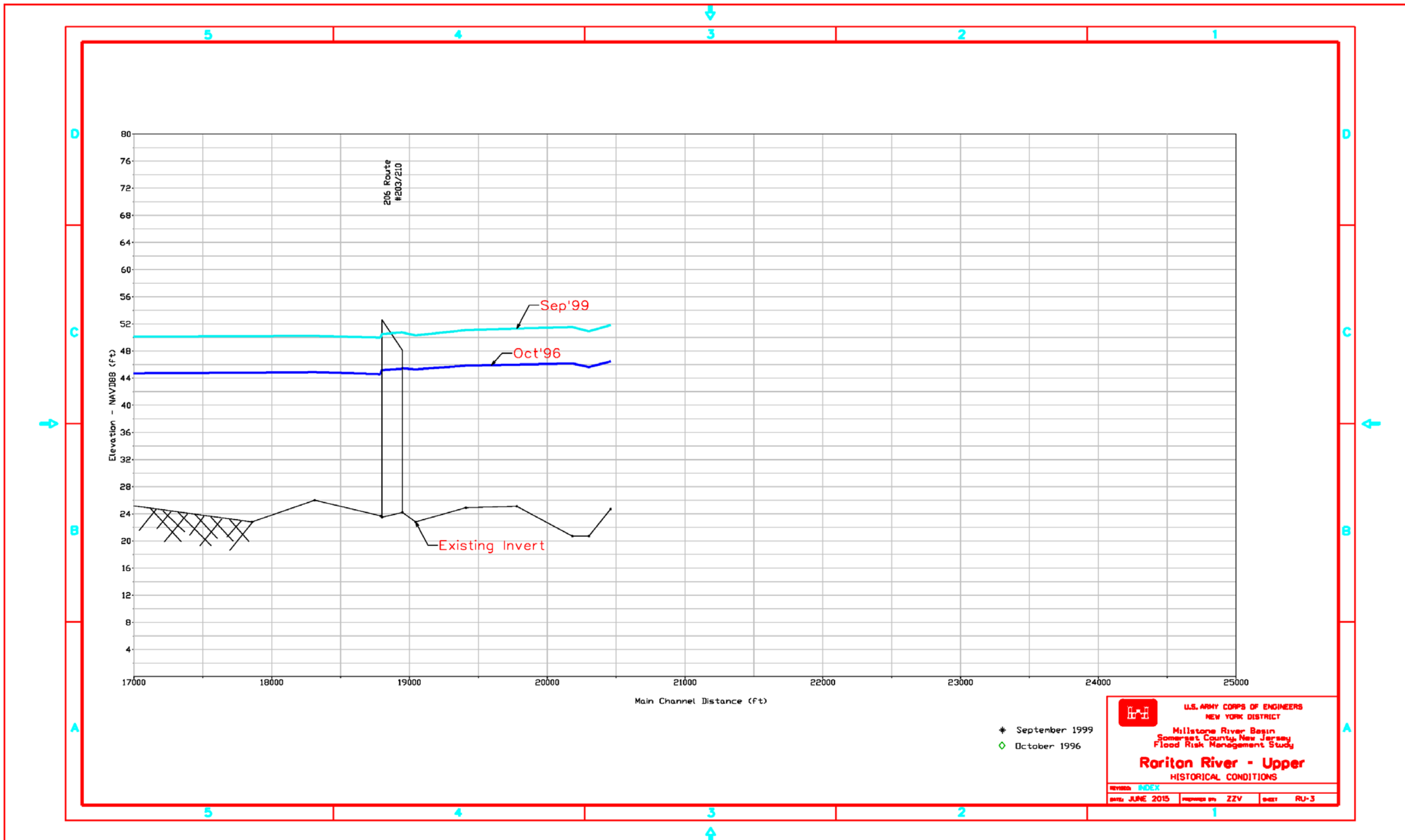


FIGURE 23: WATER SURFACE PROFILE FOR HISTORICAL - OCT1996 & SEPT 1999 (RARITAN RIVER UPPER)





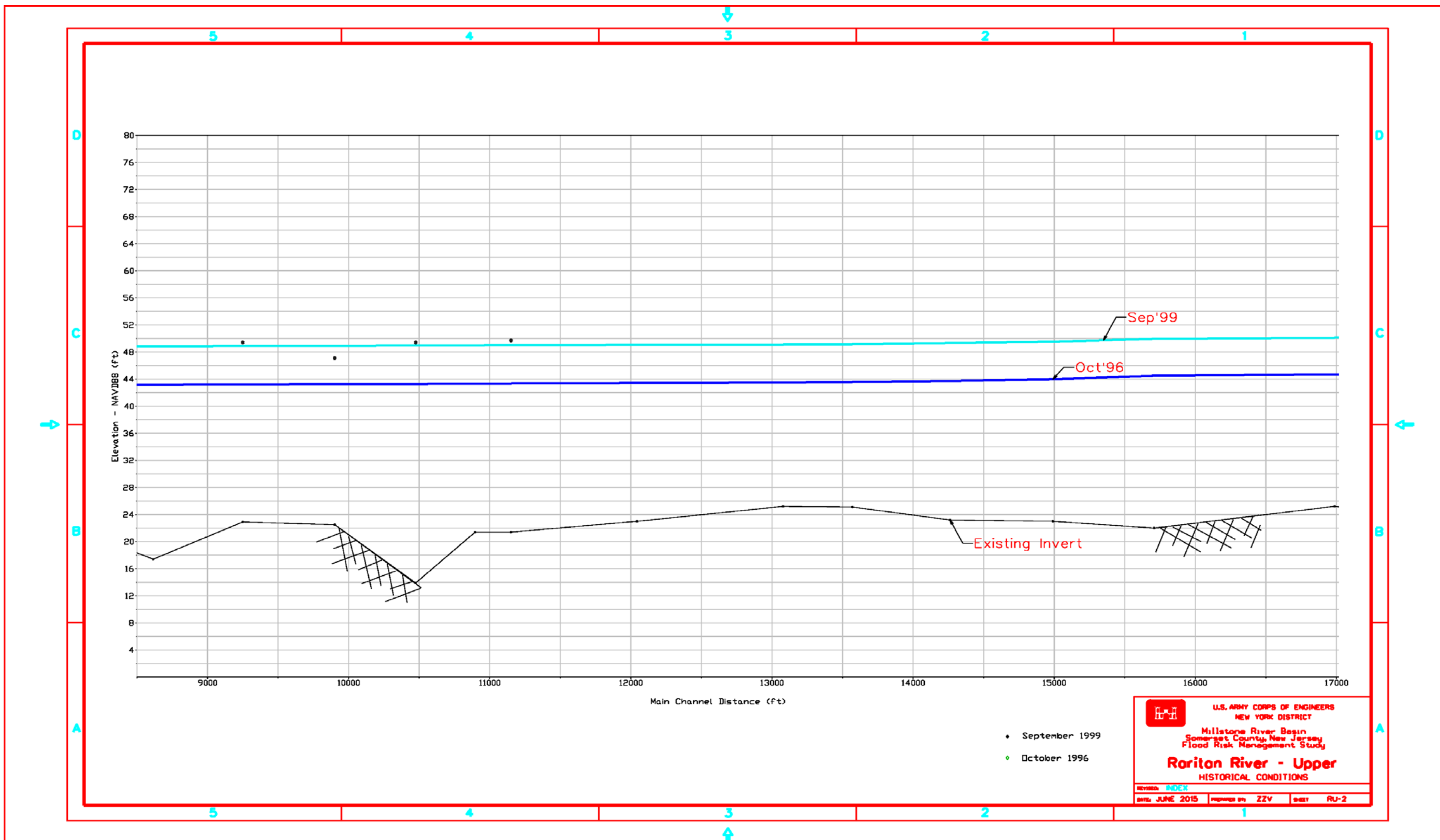


FIGURE 24: WATER SURFACE PROFILE FOR HISTORICAL - OCT1996 & SEPT 1999 (RARITAN RIVER UPPER)



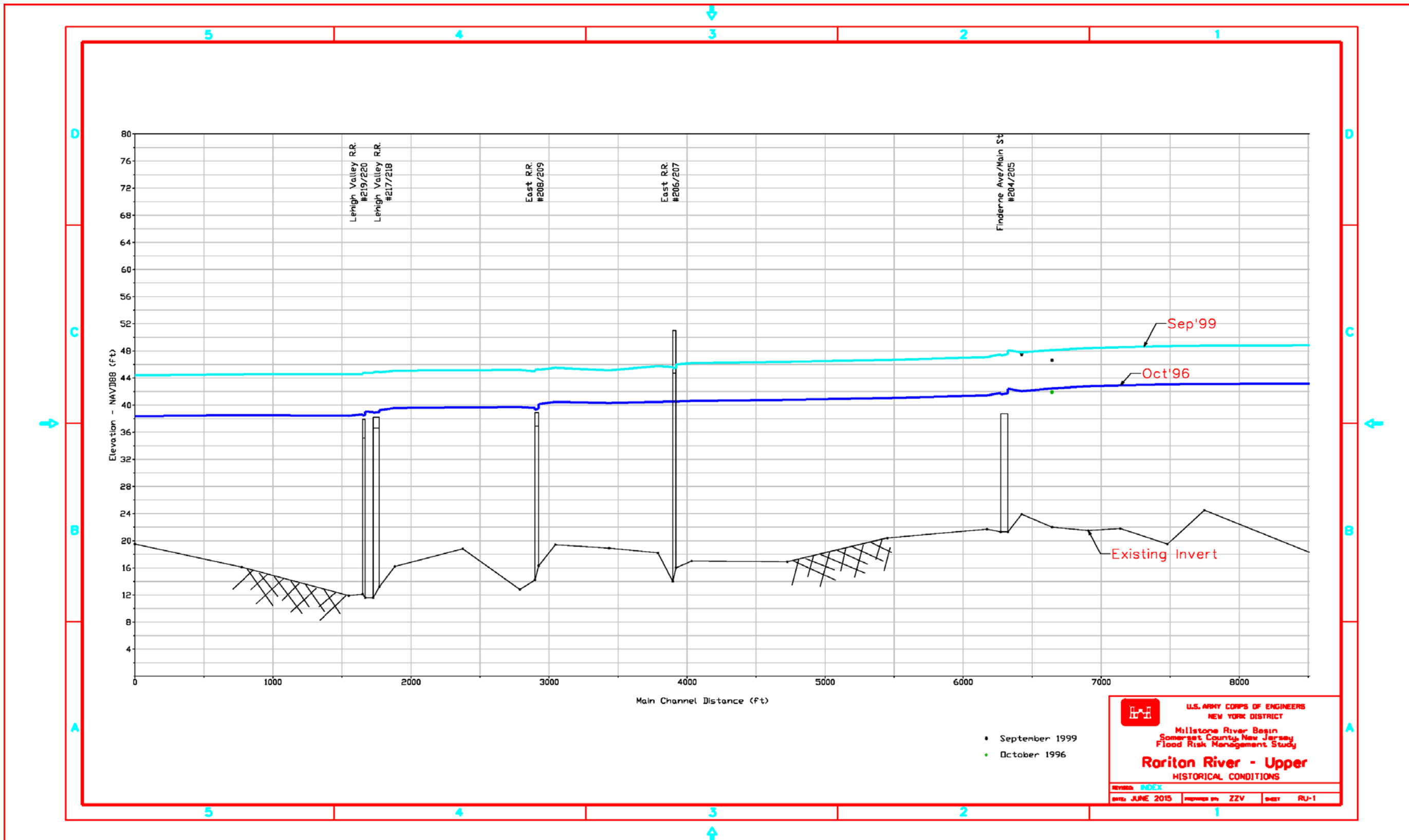


FIGURE 25: WATER SURFACE PROFILE FOR HISTORICAL - OCT1996 & SEPT 1999 (RARITAN RIVER UPPER)

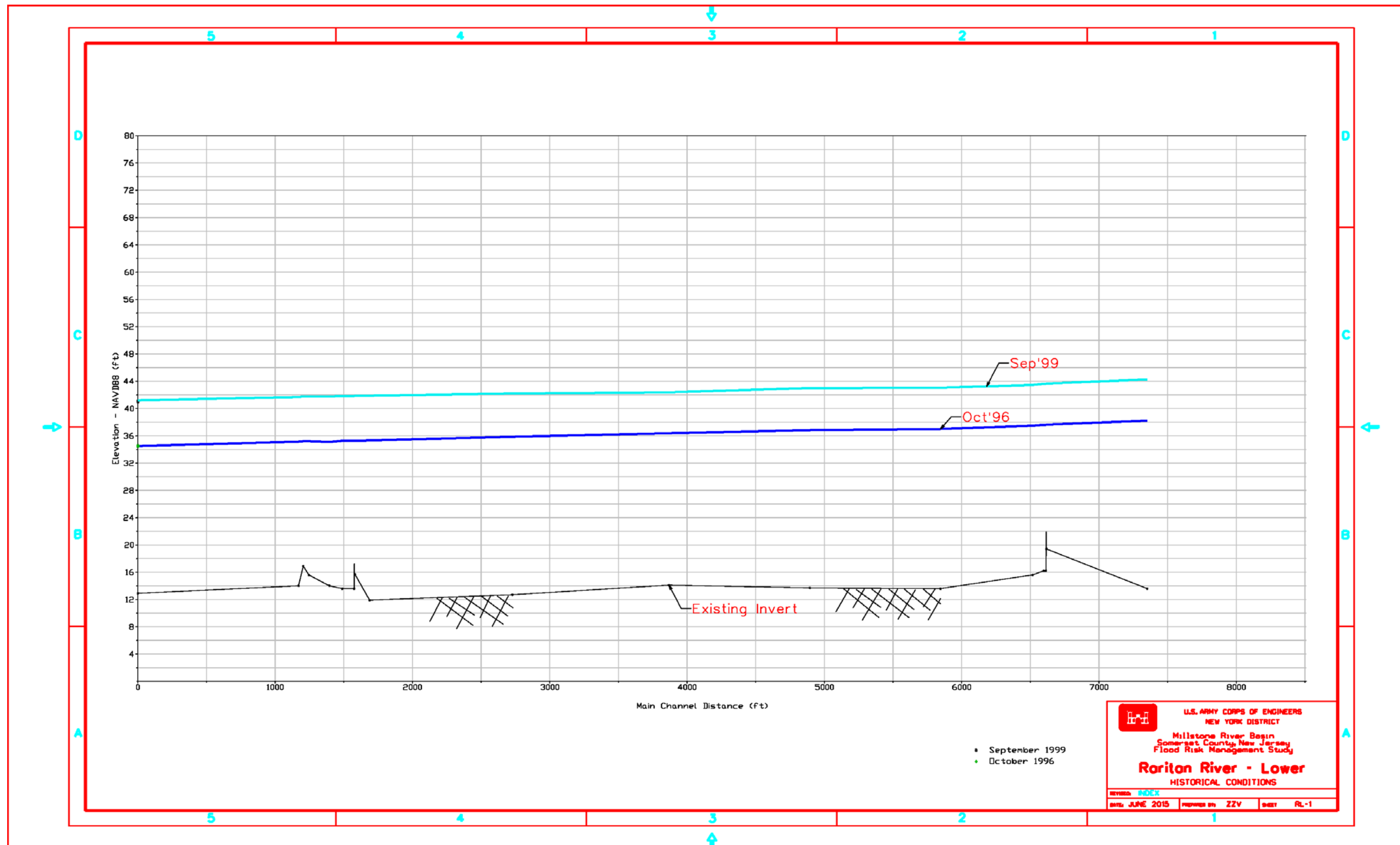


FIGURE 26: WATER SURFACE PROFILE FOR HISTORICAL - OCT1996 & SEPT 1999 (RARITAN RIVER LOWER)



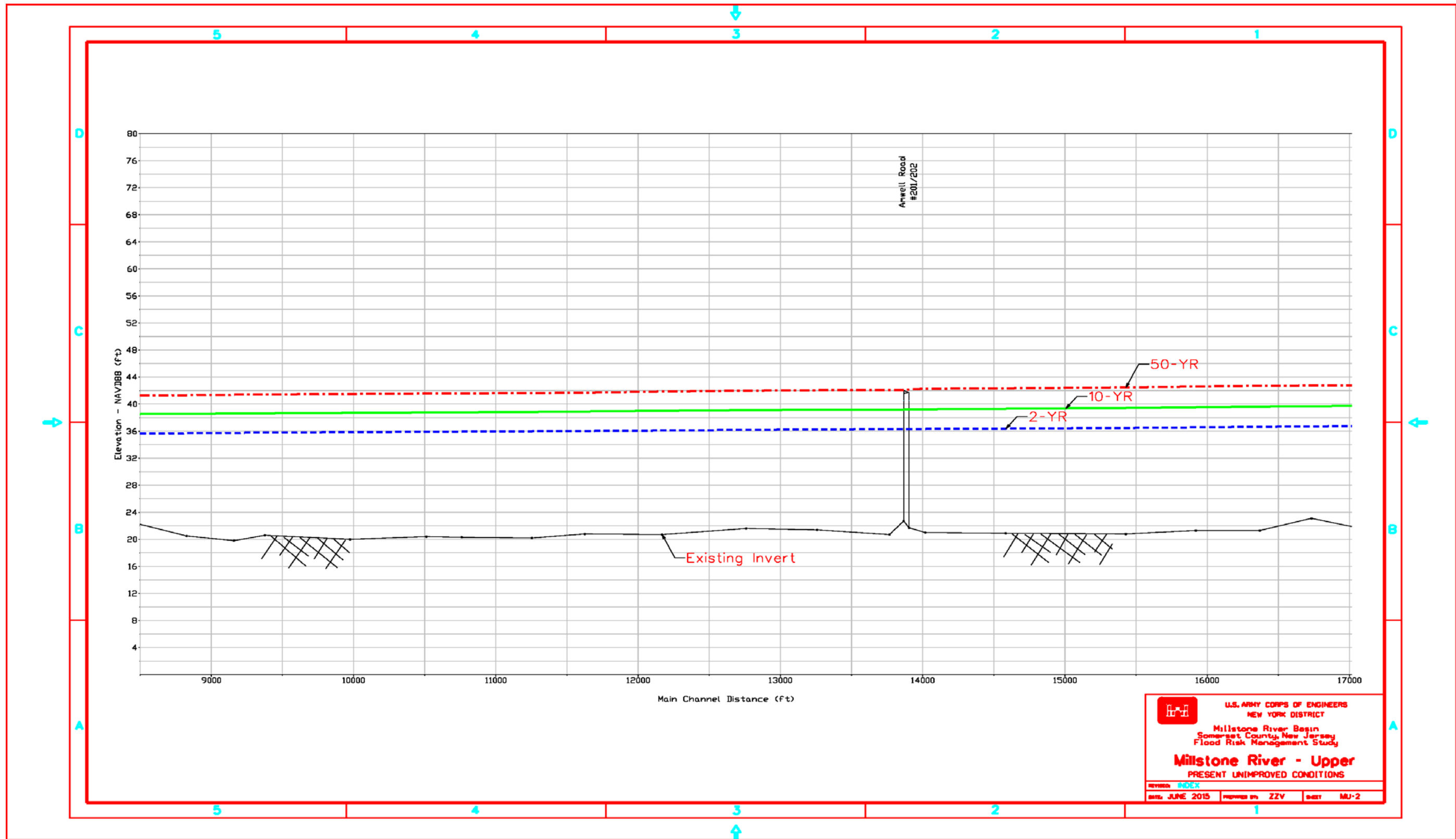


FIGURE 27: WATER SURFACE PROFILE FOR PRESENT CONDITIONS (MILLSTONE RIVER UPPER)



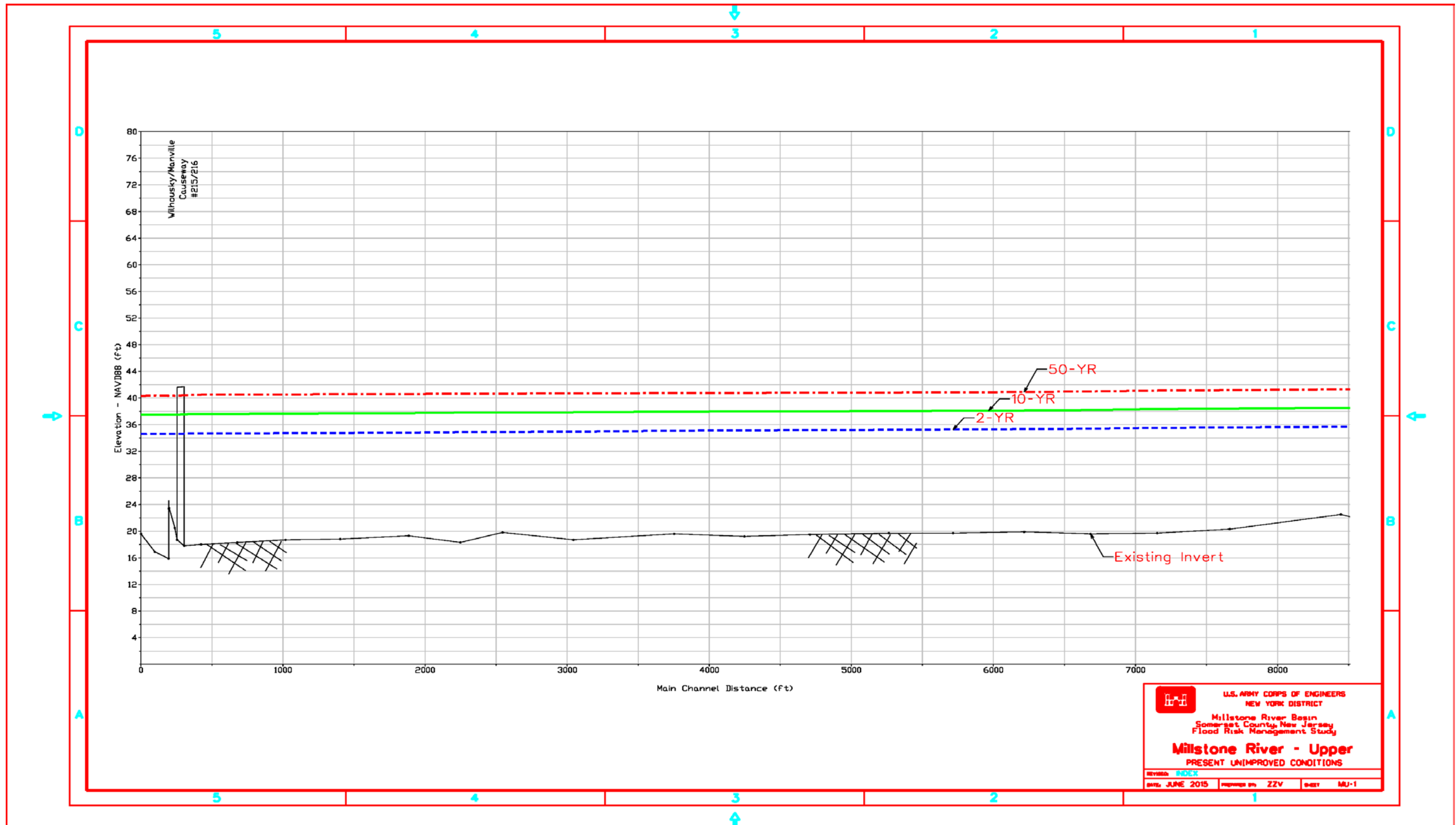


FIGURE 28: WATER SURFACE PROFILE FOR PRESENT CONDITIONS (MILLSTONE RIVER UPPER)



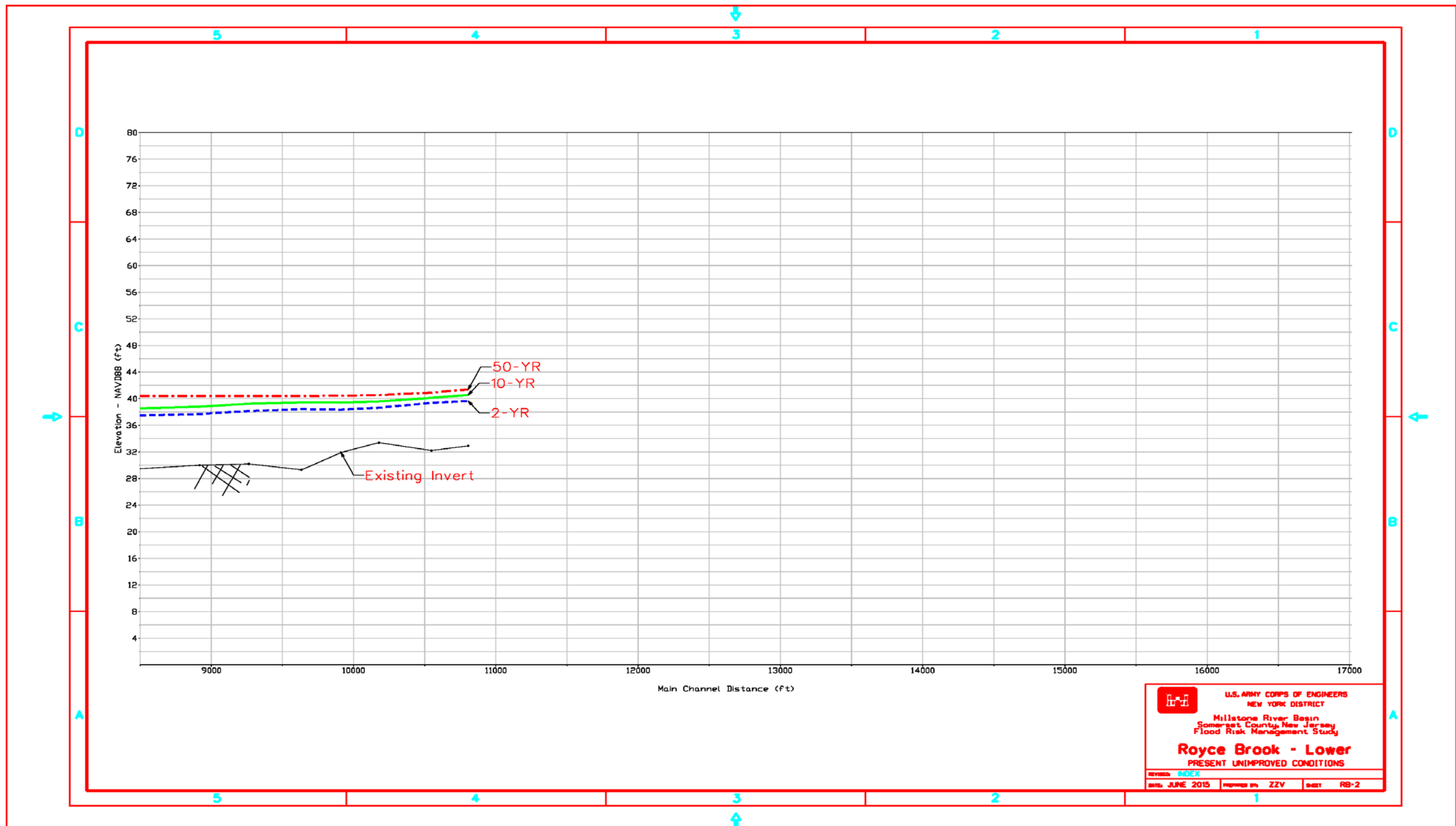


FIGURE 29: WATER SURFACE PROFILE FOR PRESENT CONDITIONS (ROYCE BROOK)





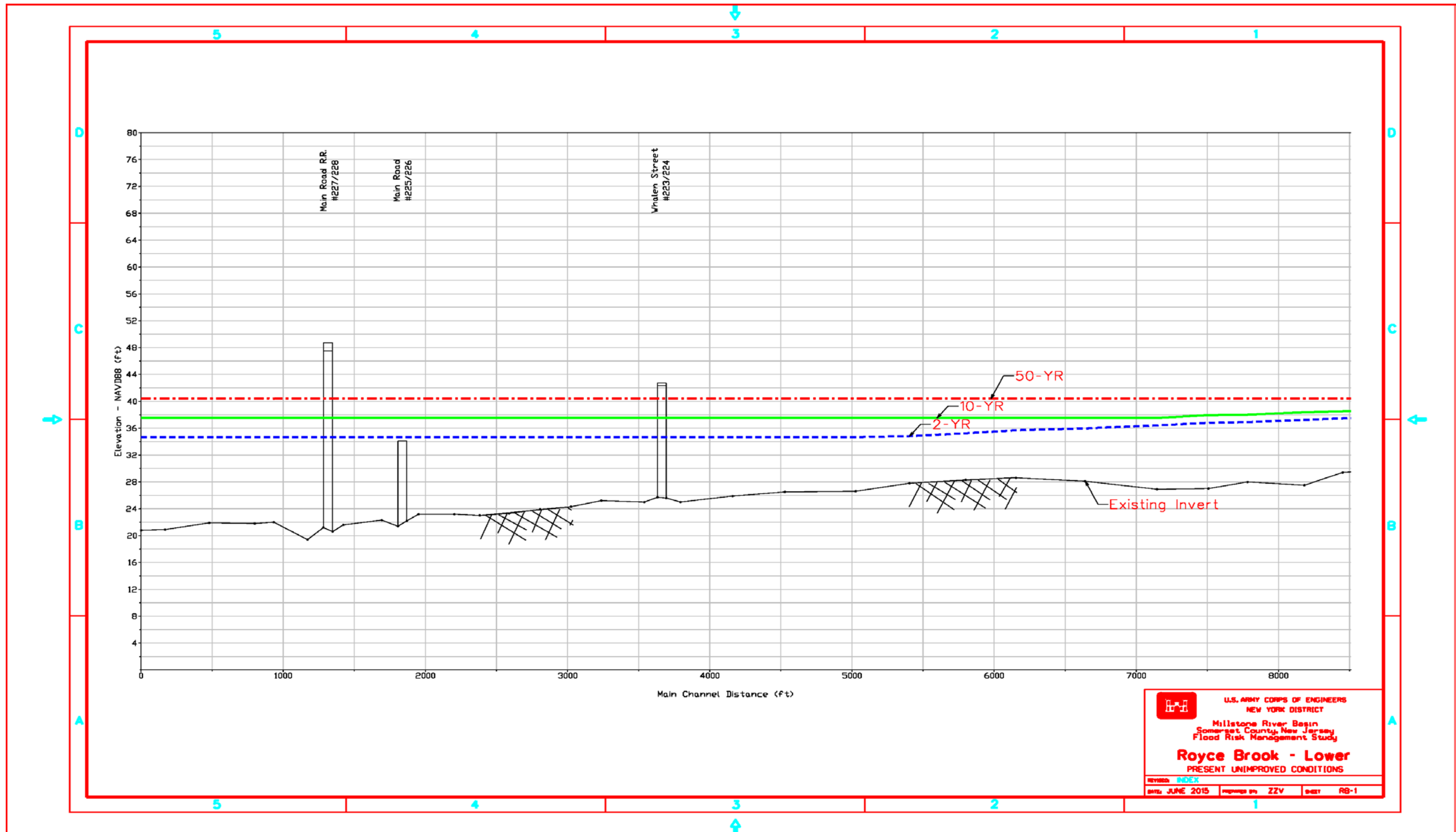


FIGURE 30: WATER SURFACE PROFILE FOR PRESENT CONDITIONS (ROYCE BROOK)



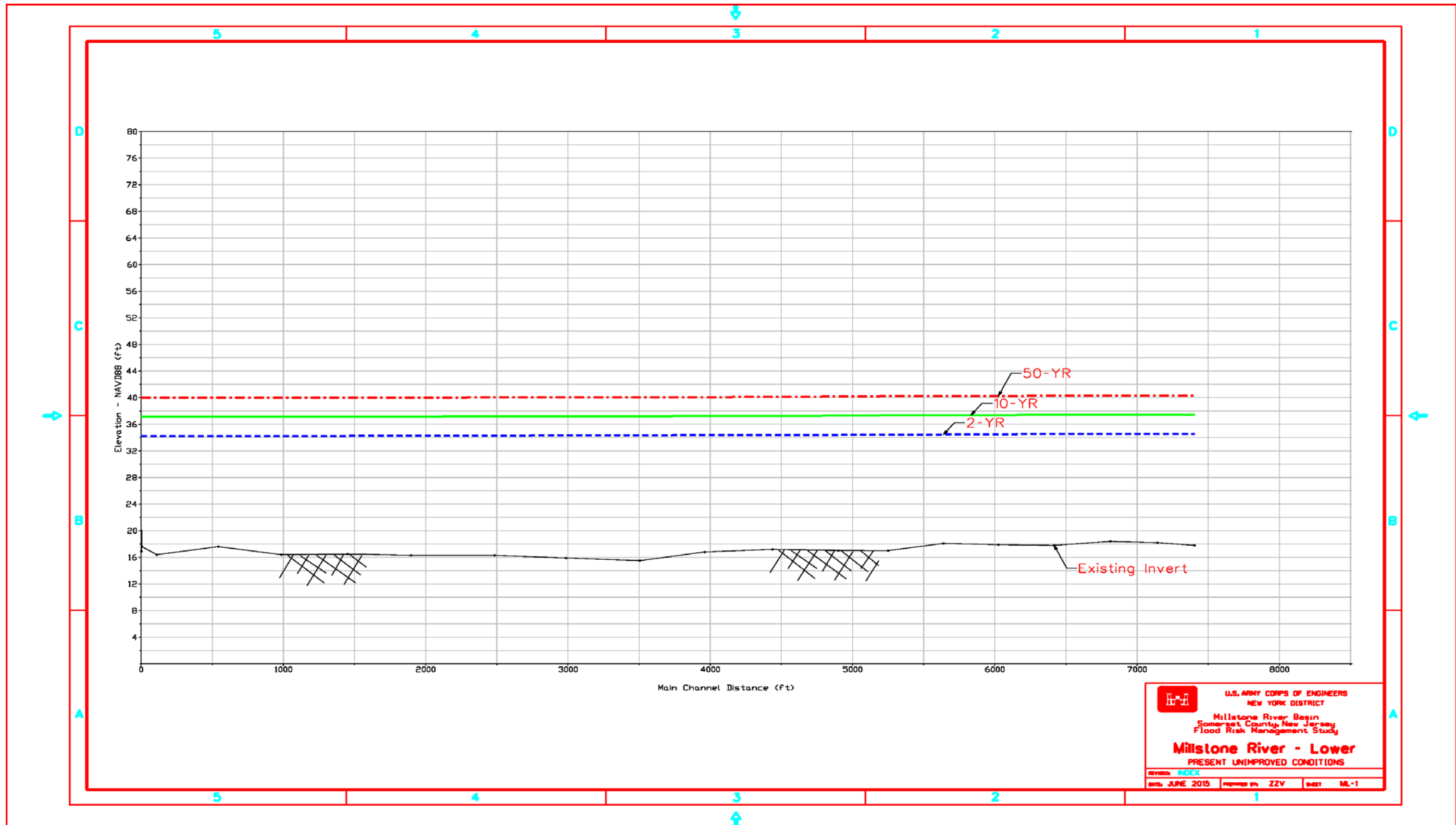


FIGURE 31: WATER SURFACE PROFILE FOR PRESENT CONDITIONS (MILLSTONE RIVER LOWER)



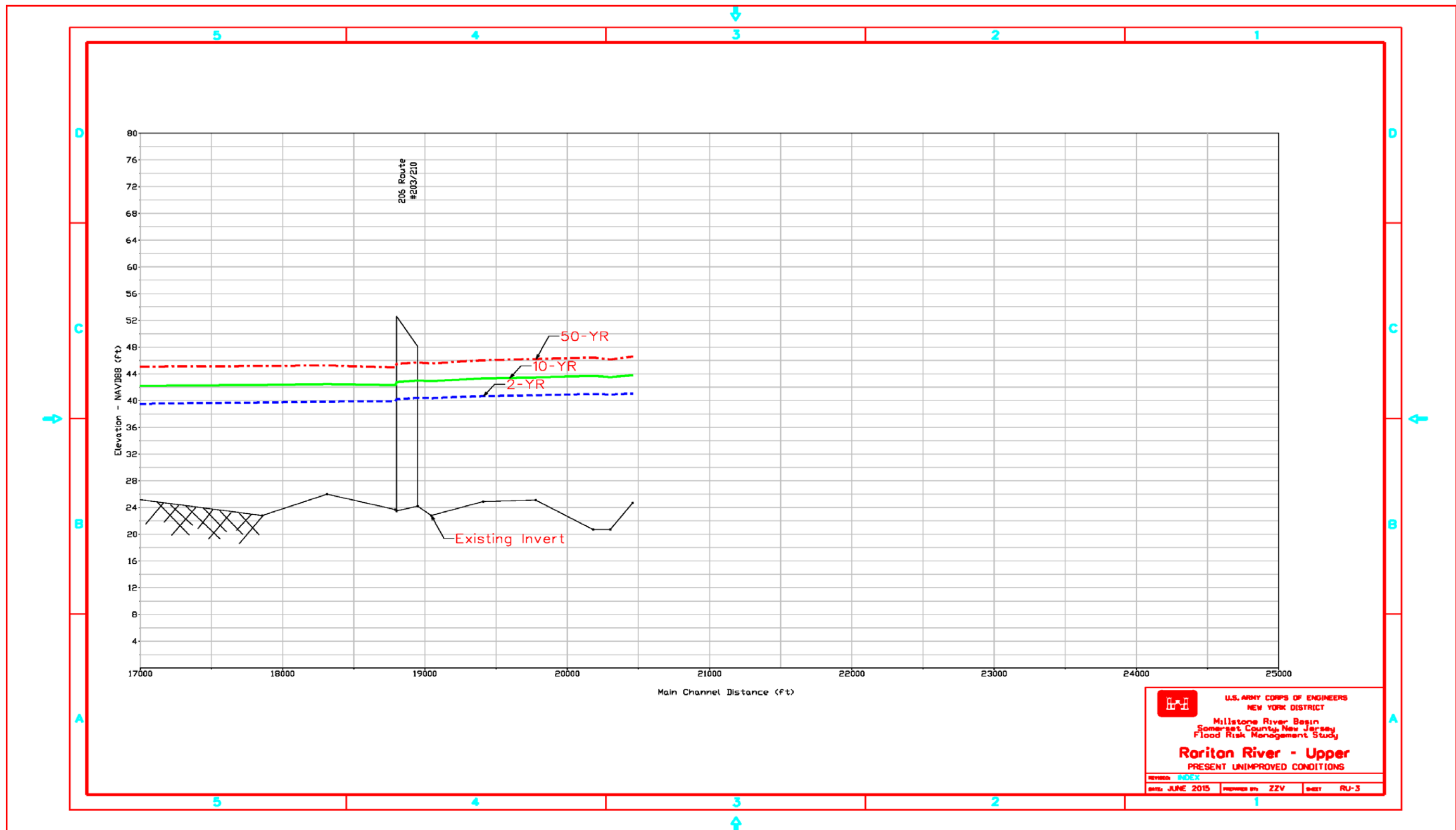


FIGURE 32: WATER SURFACE PROFILE FOR PRESENT CONDITIONS (RARITAN RIVER UPPER)



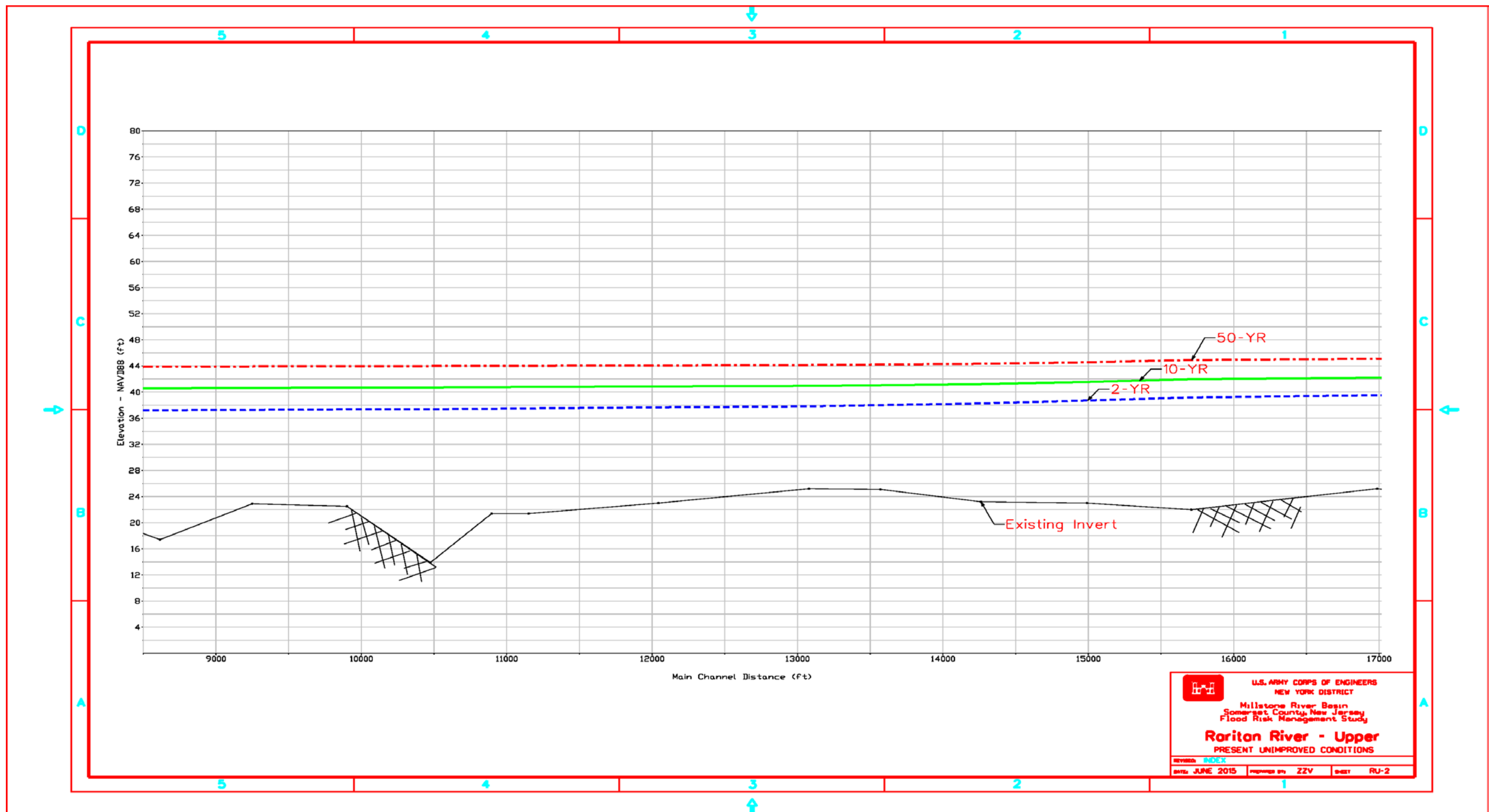


FIGURE 33: WATER SURFACE PROFILE FOR PRESENT CONDITIONS (RARITAN RIVER UPPER)



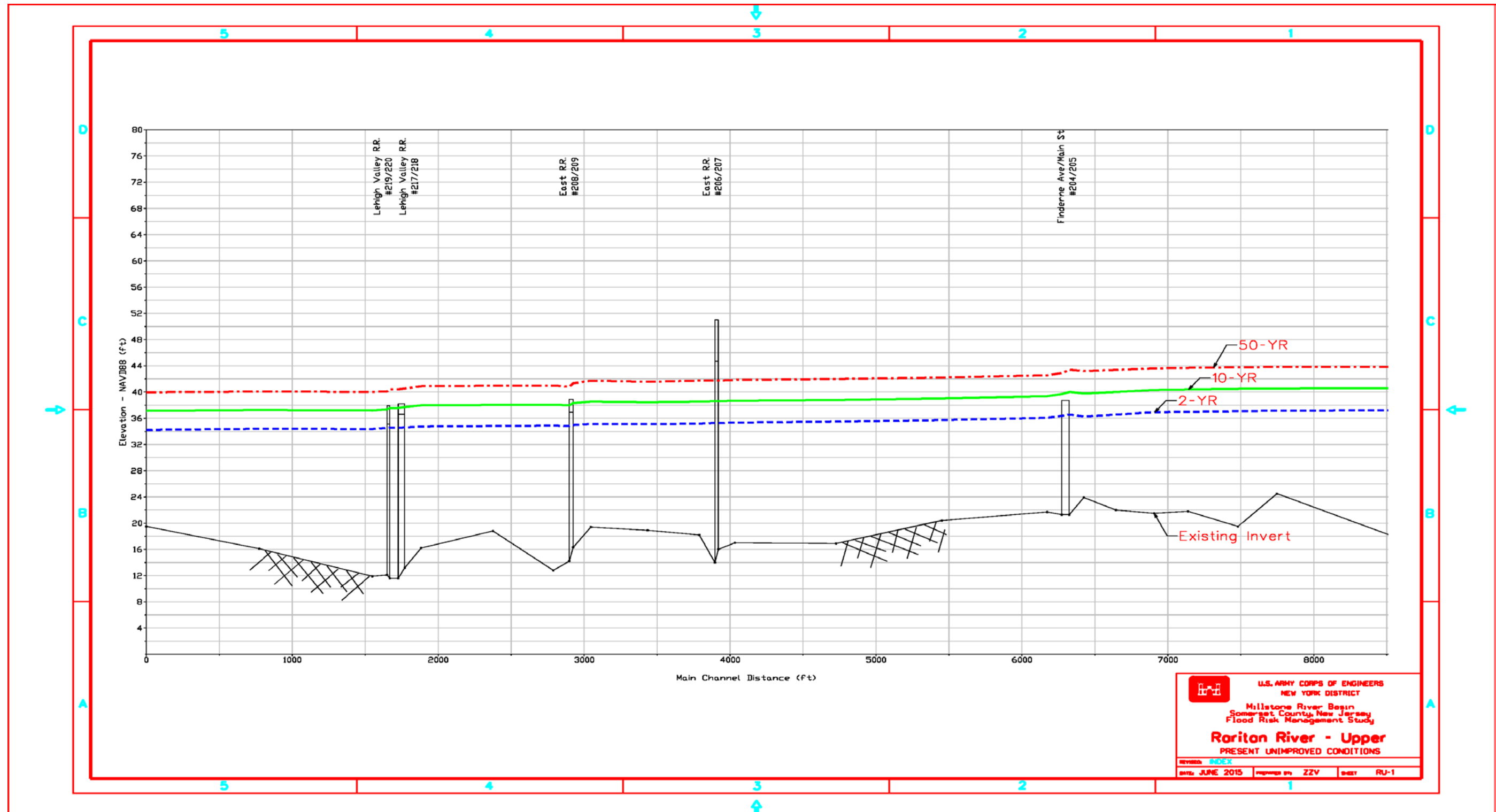
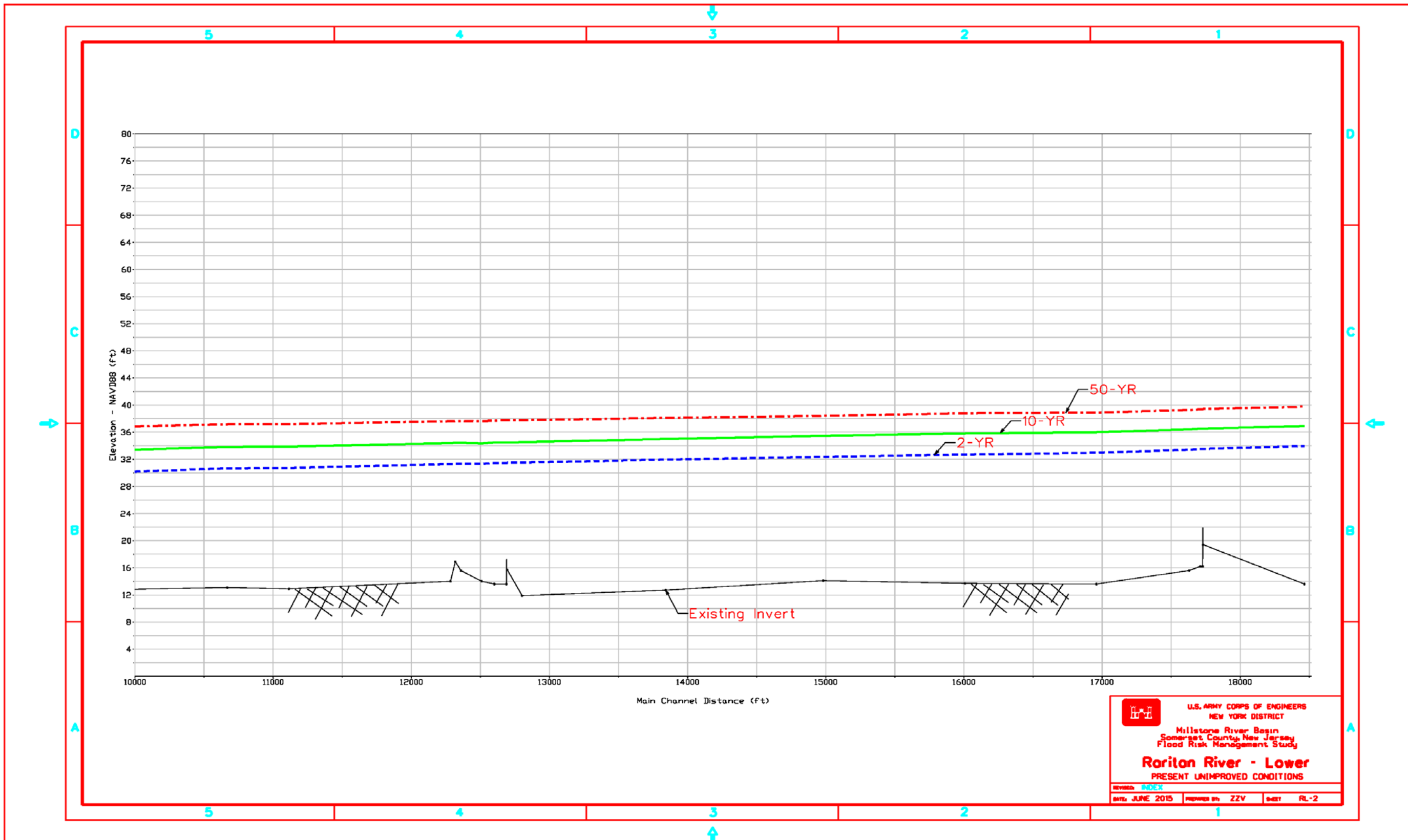
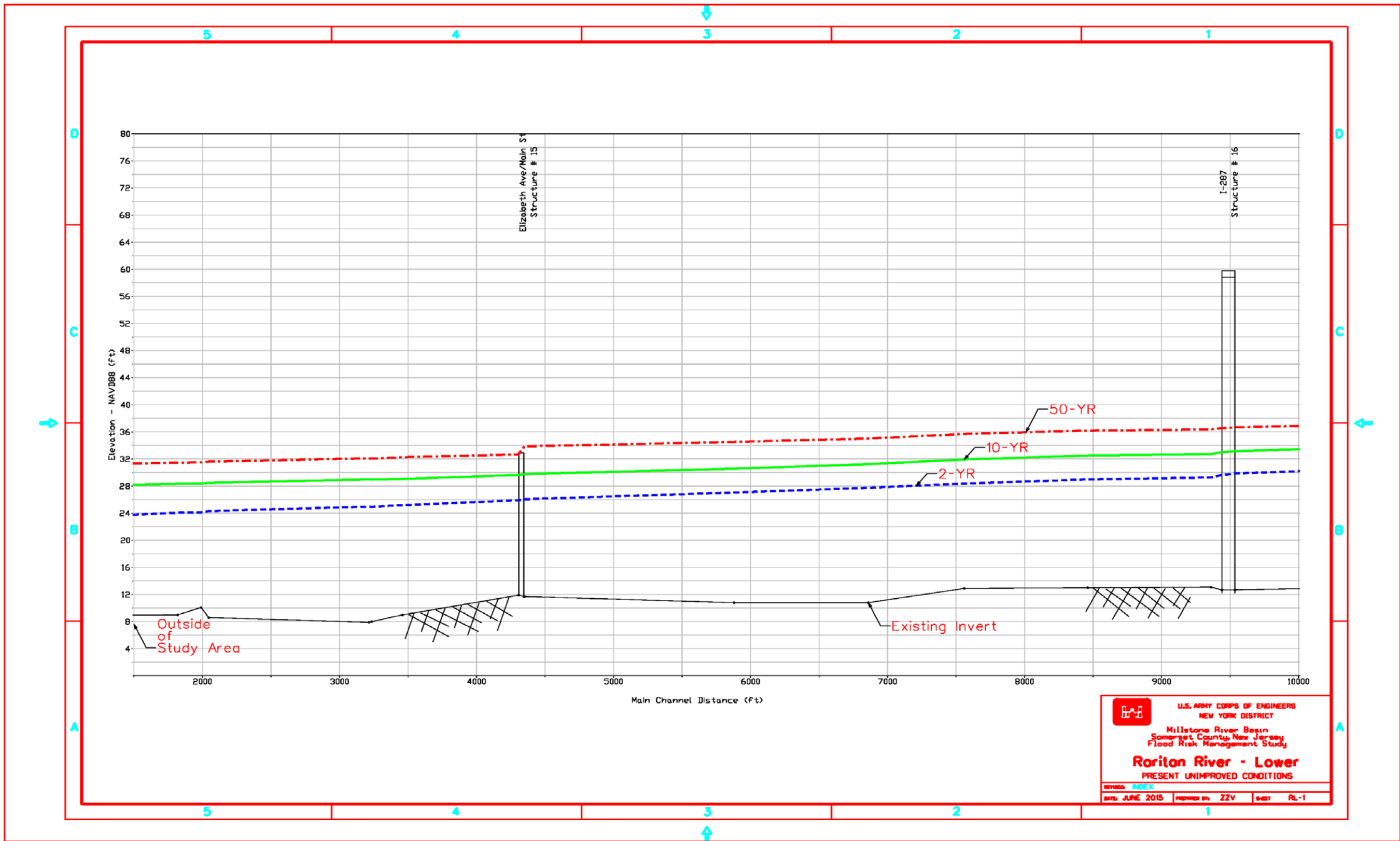


FIGURE 34: WATER SURFACE PROFILE FOR PRESENT CONDITIONS (RARITAN RIVER UPPER)











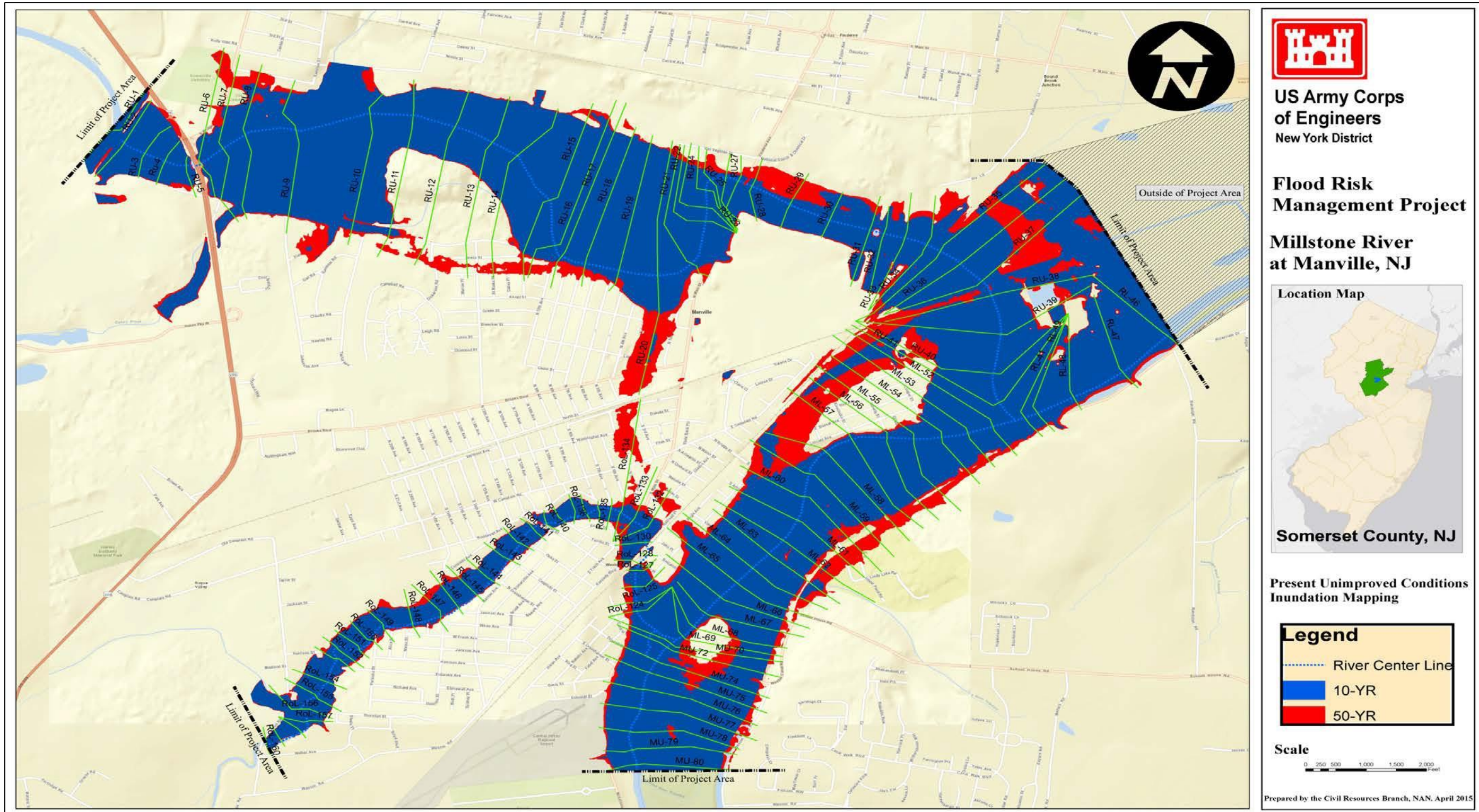


FIGURE 37: INUNDATION MAPPING OF PROJECT AREA





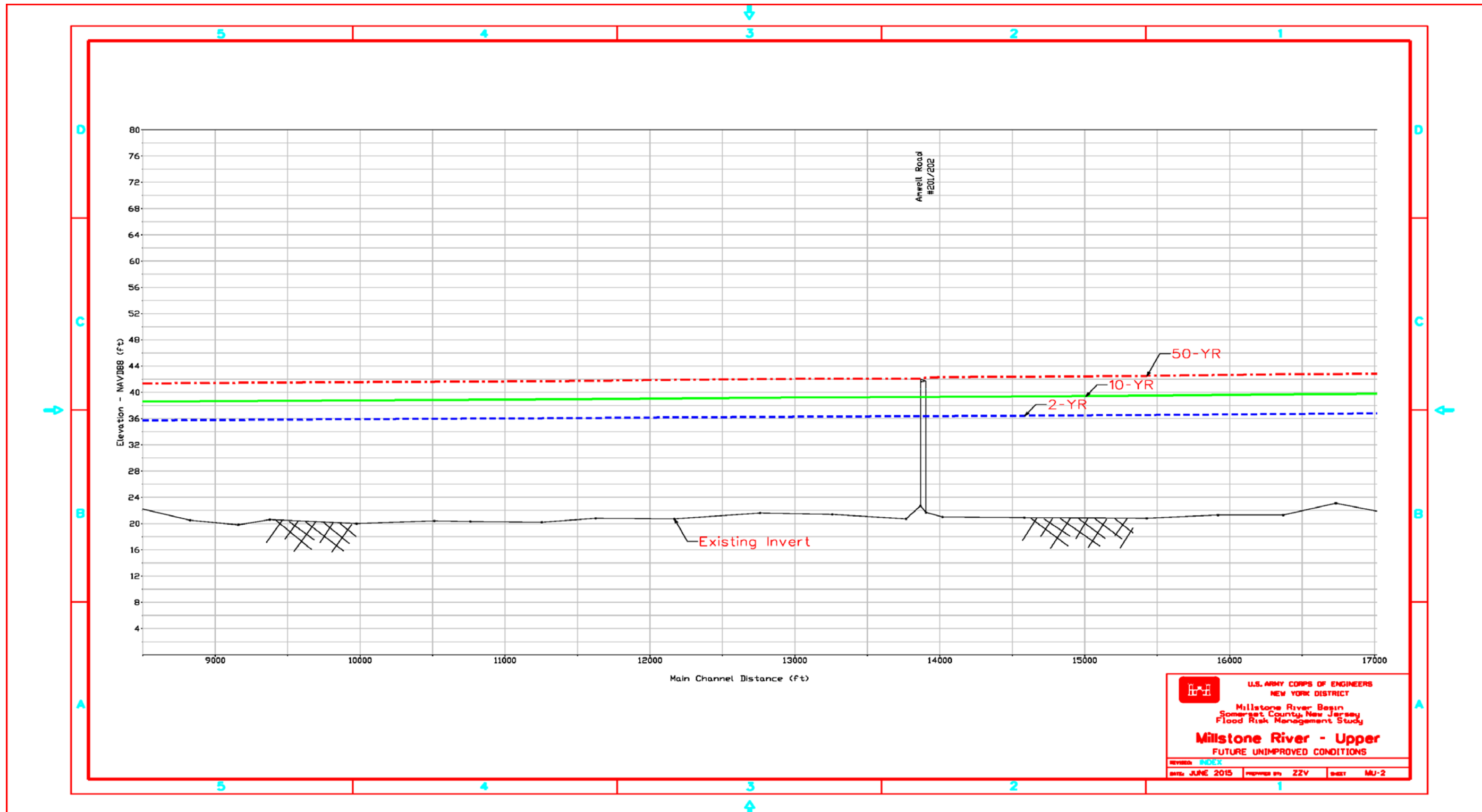


FIGURE 38: MAXIMUM WATER SURFACE PROFILE FOR FUTURE UNIMPROVED CONDITIONS (MILLSTONE RIVER UPPER)



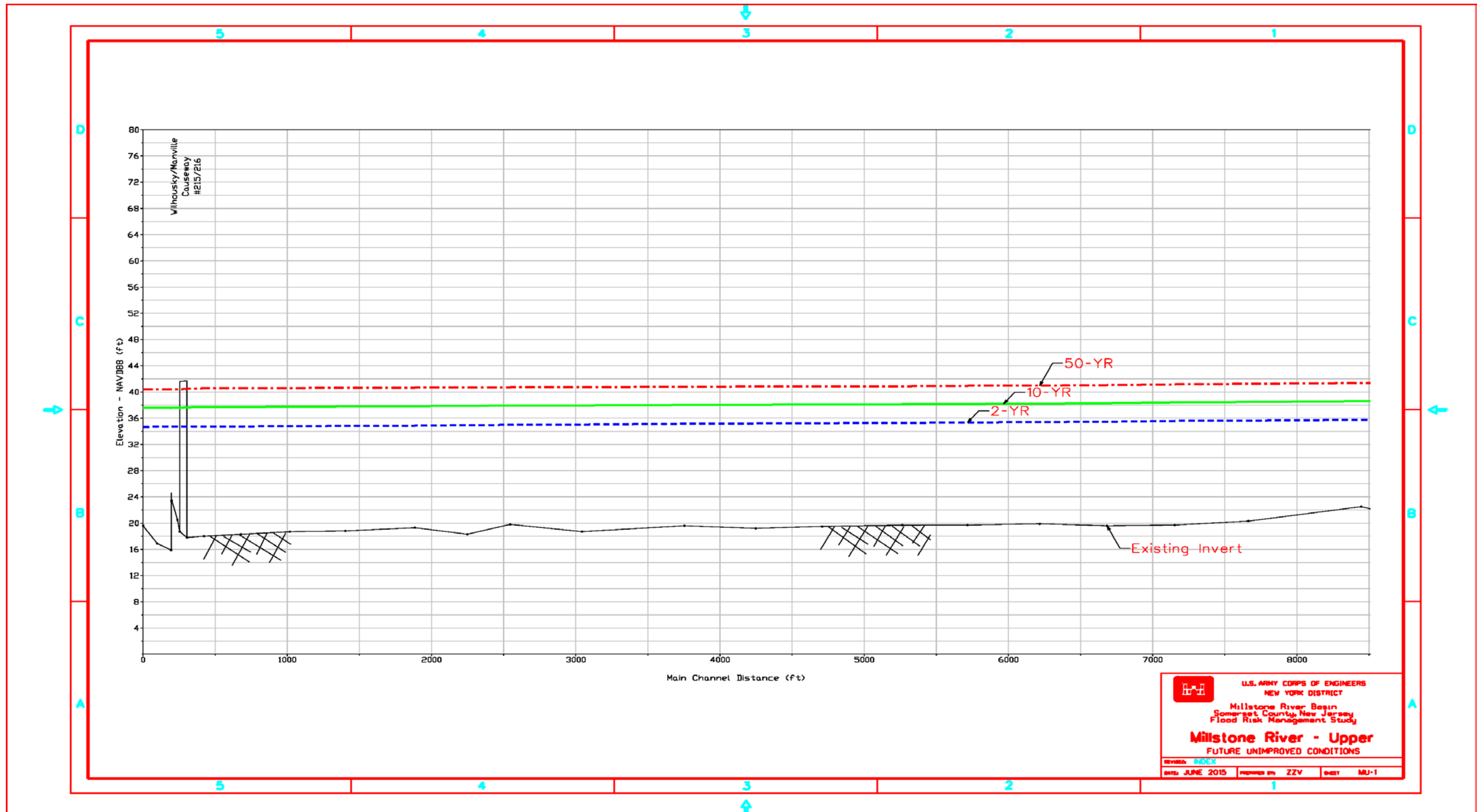


FIGURE 39: MAXIMUM WATER SURFACE PROFILE FOR FUTURE UNIMPROVED CONDITIONS (MILLSTONE RIVER UPPER)



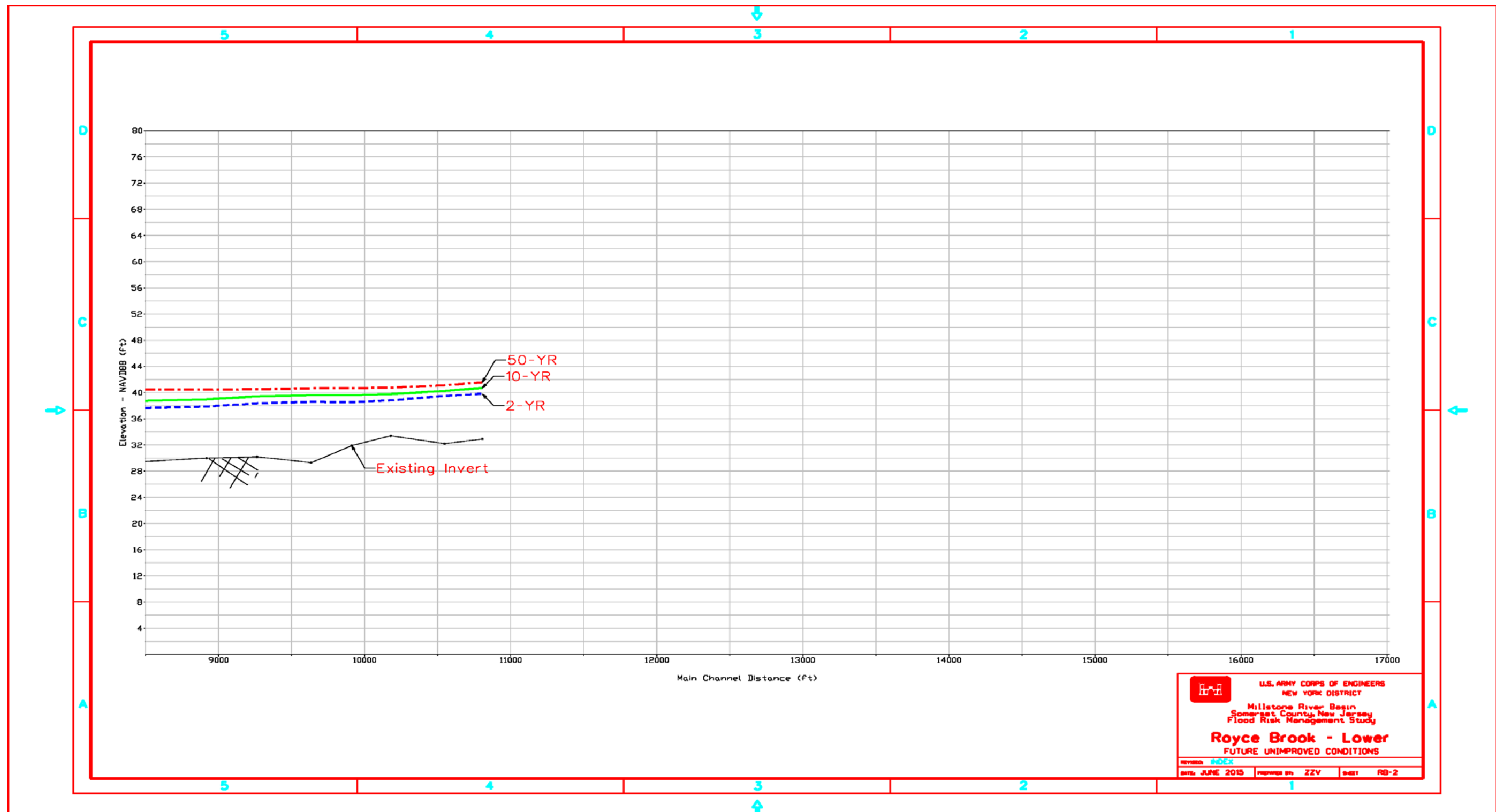


FIGURE 40: MAXIMUM WATER SURFACE PROFILE FOR FUTURE UNIMPROVED CONDITIONS (ROYCE BROOK)



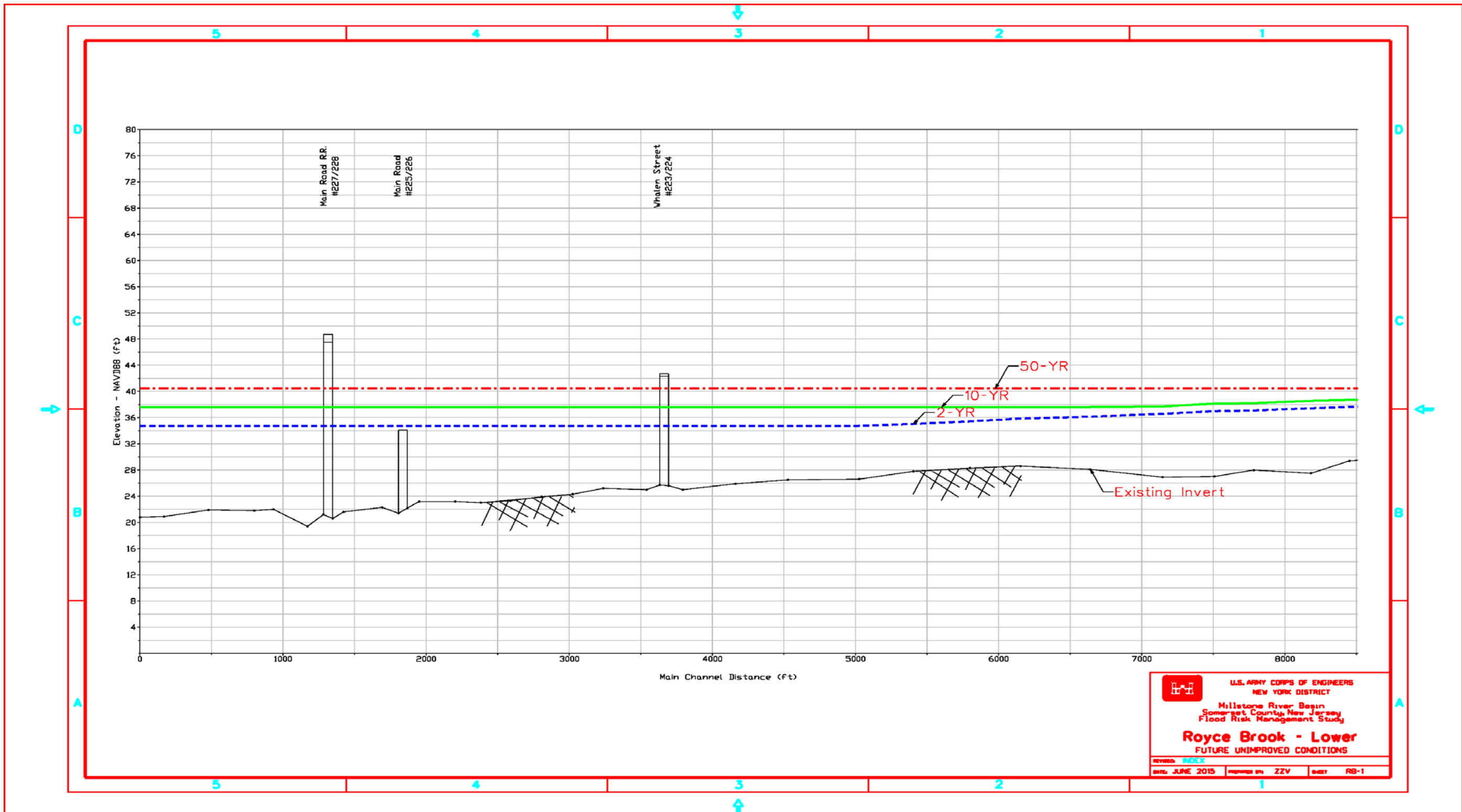


FIGURE 41: MAXIMUM WATER SURFACE PROFILE FOR FUTURE UNIMPROVED CONDITIONS (ROYCE BROOK)



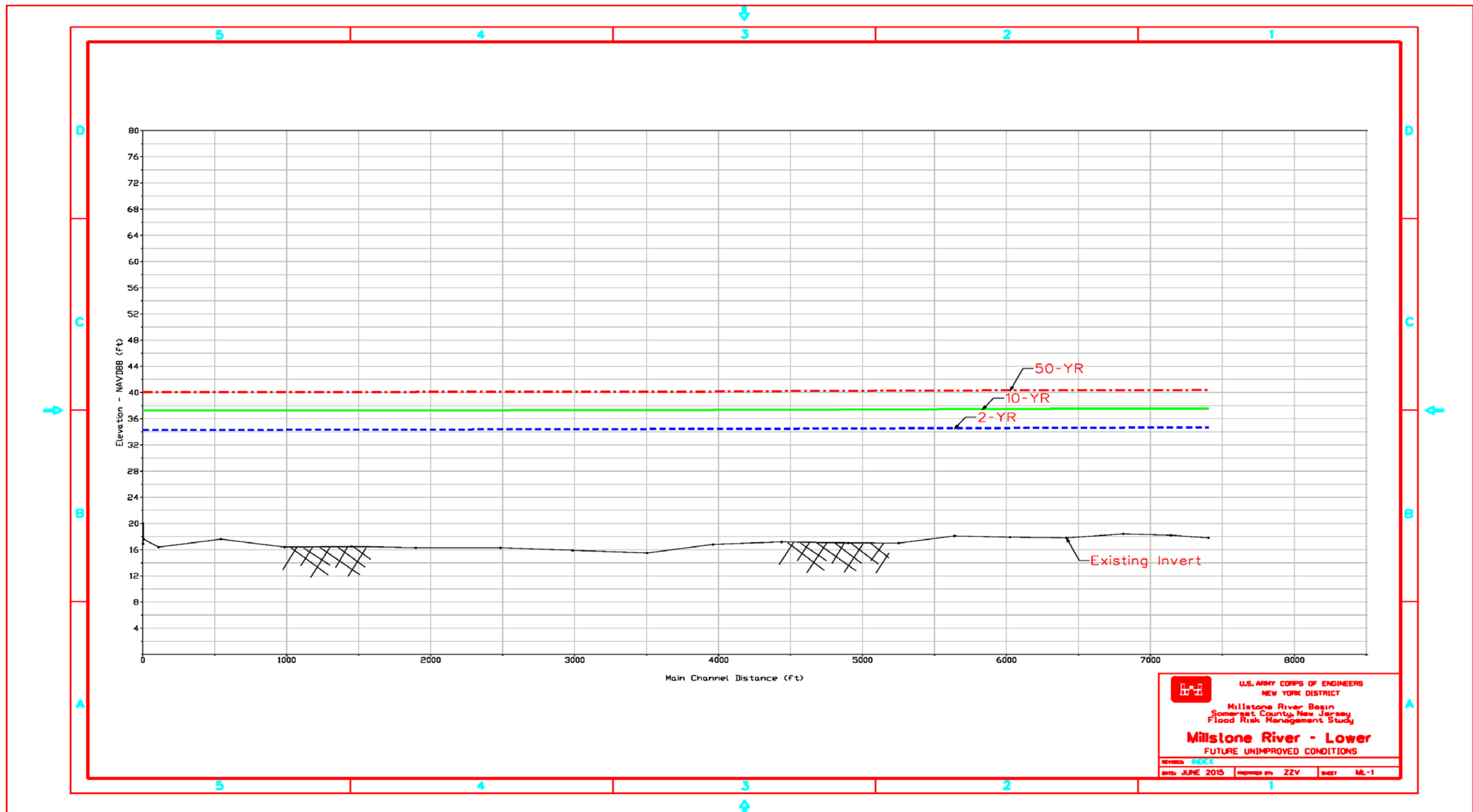


FIGURE 42: MAXIMUM WATER SURFACE PROFILE FOR FUTURE UNIMPROVED CONDITIONS (MILLSTONE RIVER LOWER)



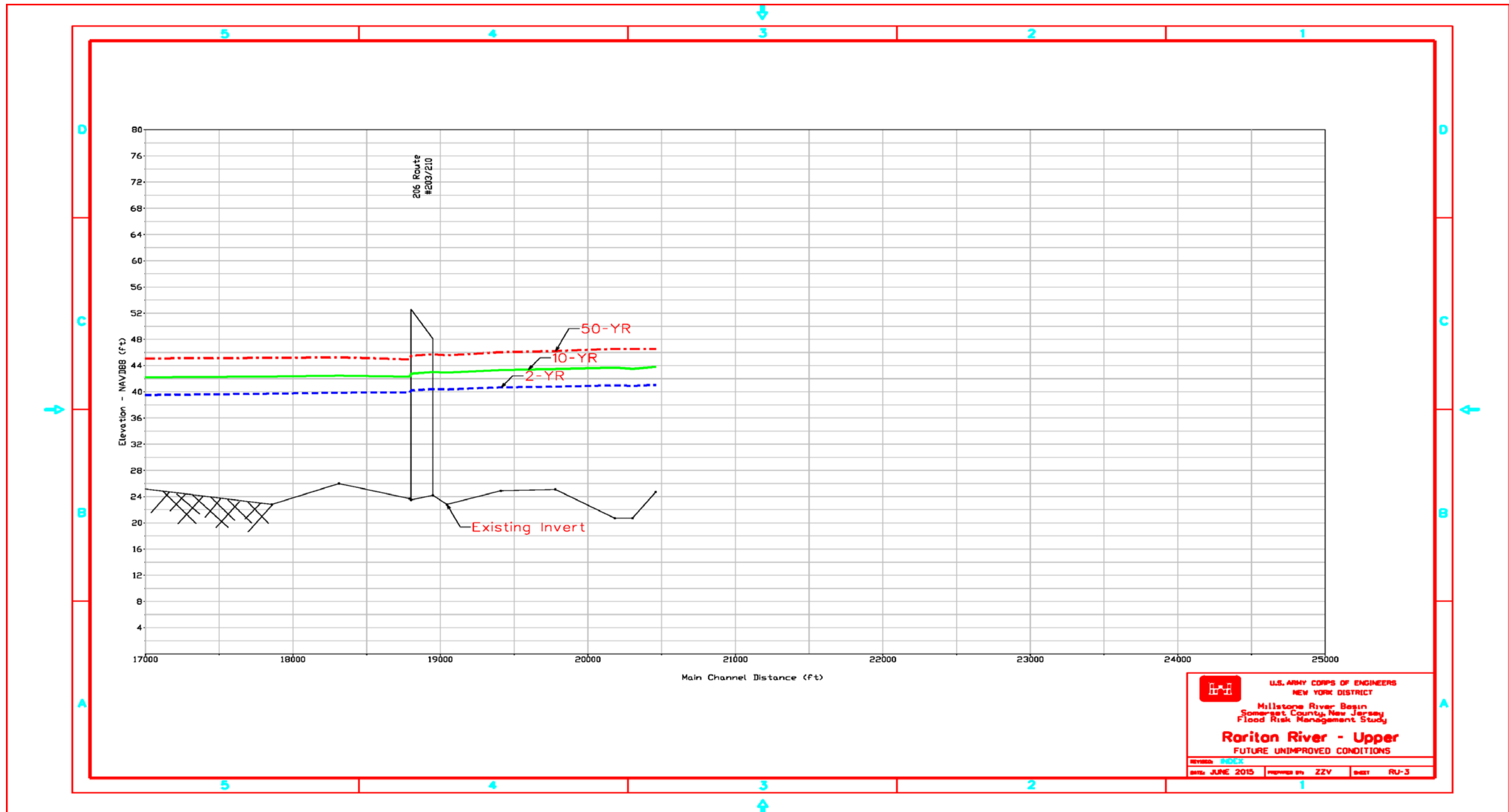


FIGURE 43: MAXIMUM WATER SURFACE PROFILE FOR FUTURE UNIMPROVED CONDITIONS (RARITAN RIVER UPPER)



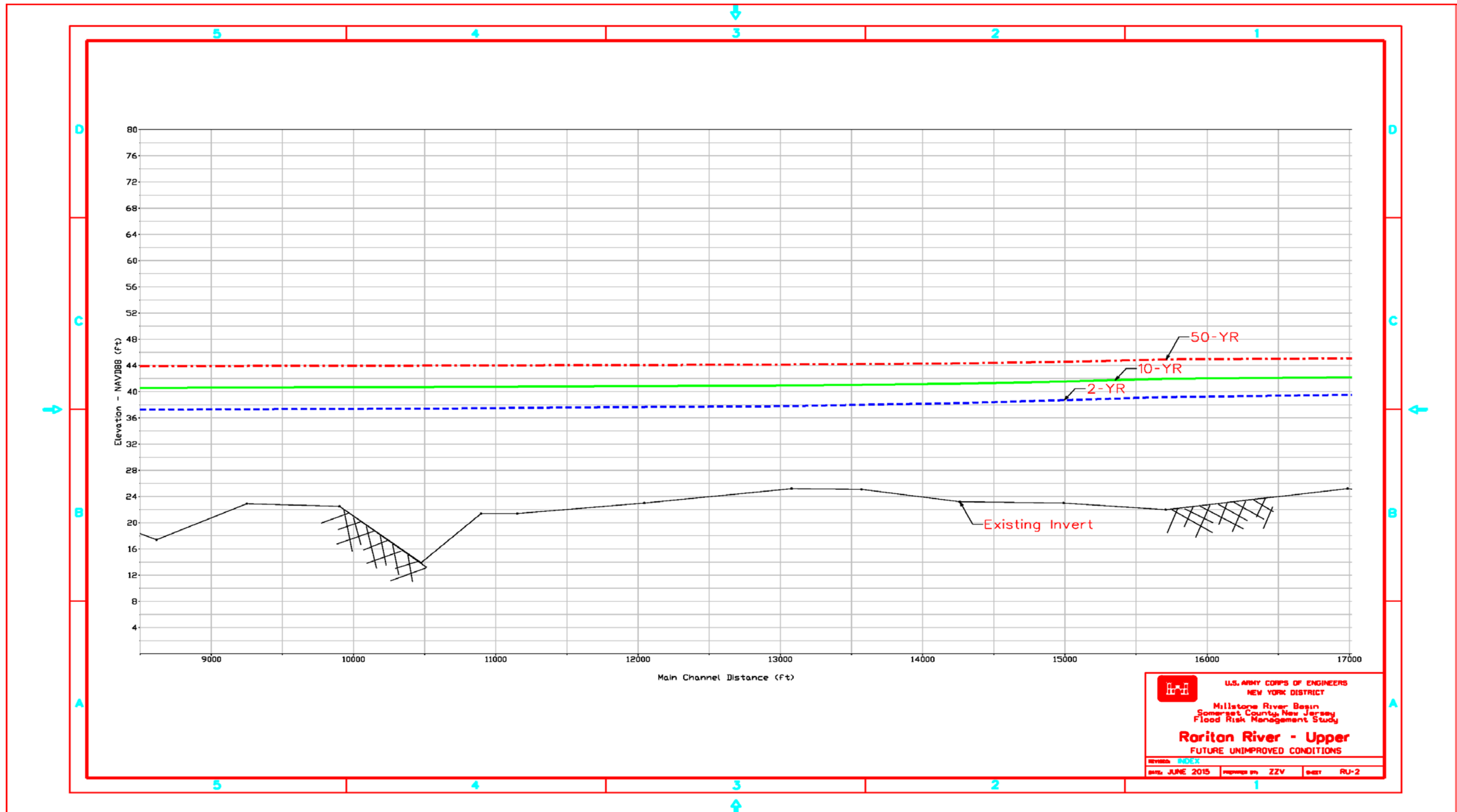


FIGURE 44: MAXIMUM WATER SURFACE PROFILE FOR FUTURE UNIMPROVED CONDITIONS (RARITAN RIVER UPPER)



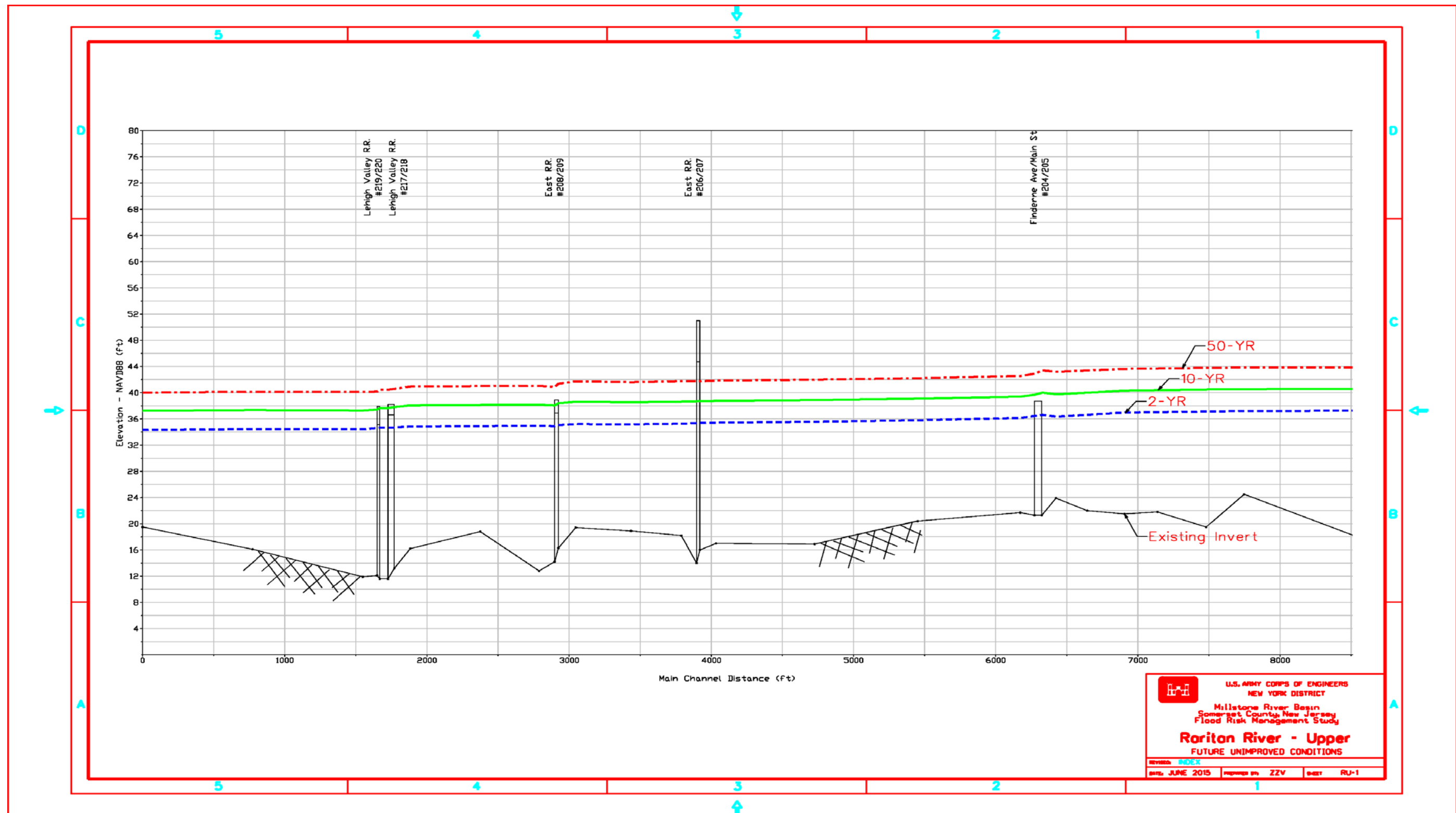


FIGURE 45: MAXIMUM WATER SURFACE PROFILE FOR FUTURE UNIMPROVED CONDITIONS (RARITAN RIVER UPPER)



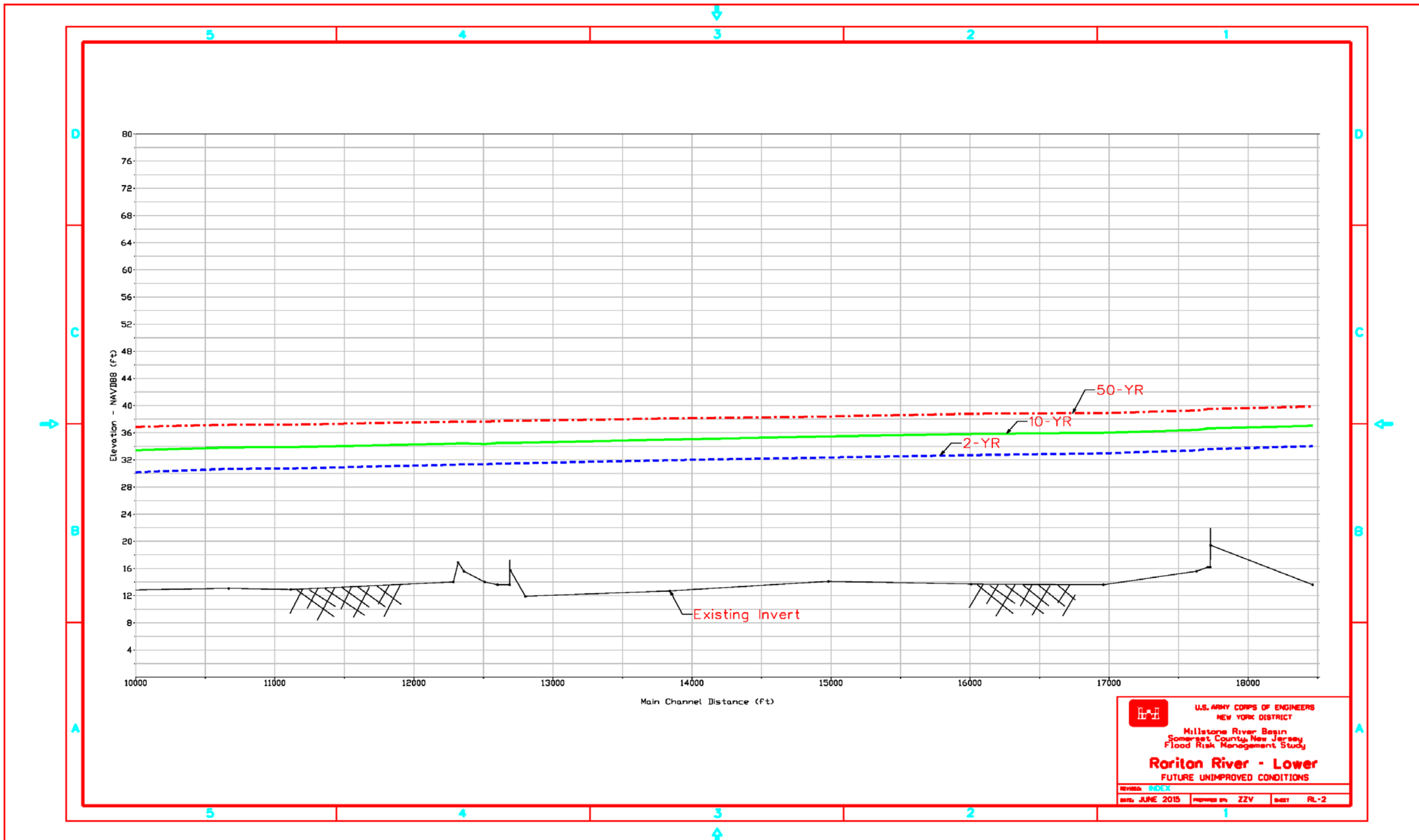


FIGURE 46: MAXIMUM WATER SURFACE PROFILE FOR FUTURE UNIMPROVED CONDITIONS (RARITAN RIVER LOWER)

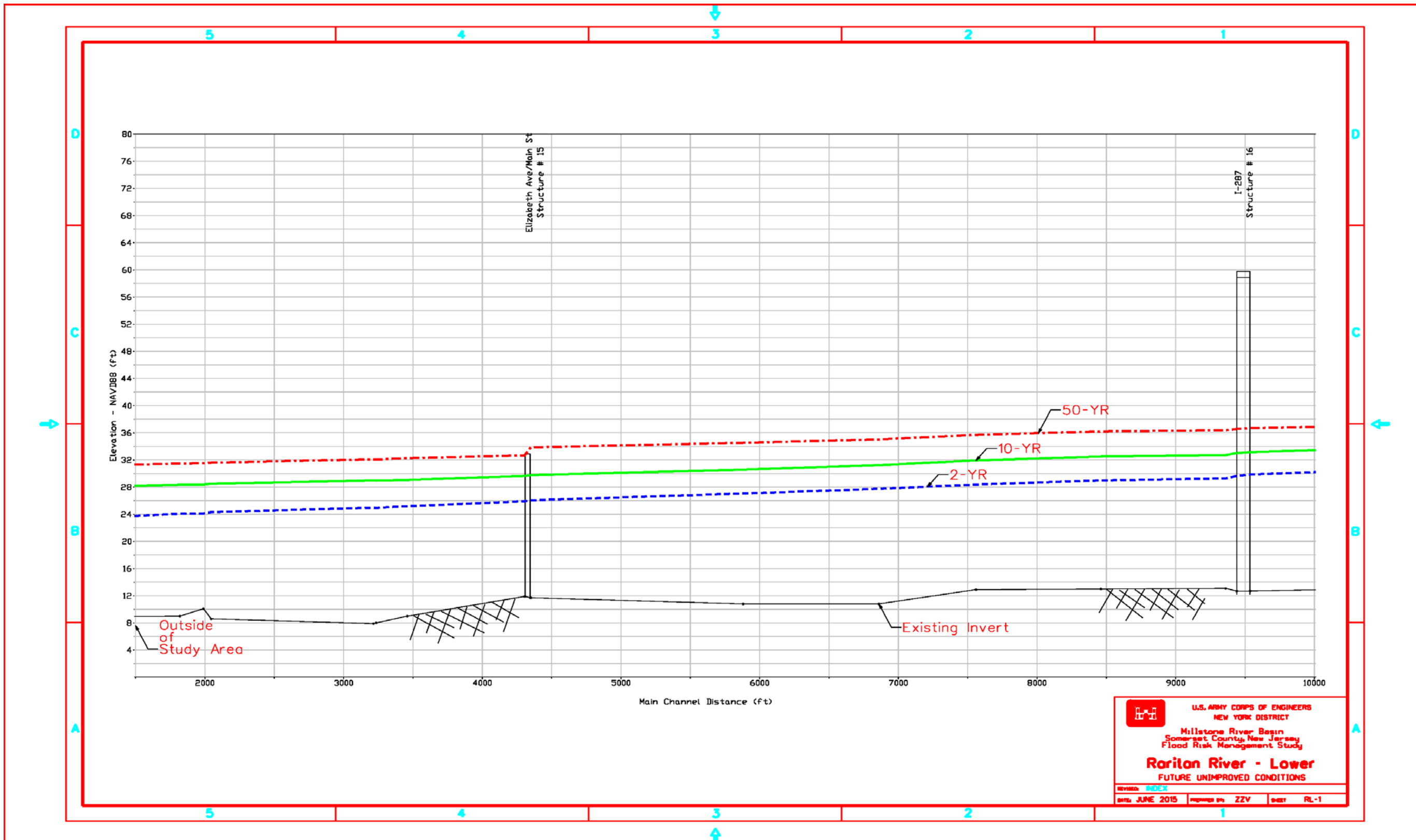


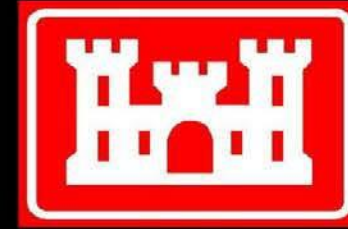
FIGURE 47: MAXIMUM WATER SURFACE PROFILE FOR FUTURE UNIMPROVED CONDITIONS (RARITAN RIVER LOWER)





# Millstone River Flood Risk Management Project

US Army Corps of Engineers New York District



Disclaimer - While the United States Army Corps of Engineers, (hereinafter referred to as USACE) has made every reasonable effort to insure the accuracy of the maps and associated data, it should be explicitly noted that USACE makes no warranty, representation or guarantee, either expressed or implied, as to the content, sequence, accuracy, timeliness or completeness of any of the data provided herein. The USACE, its officers, agents, employees, or servants, shall assume no liability of any nature for any errors, omissions, or inaccuracies in the information provided regardless of the cause. The USACE, its officers, agents, employees, or servants shall assume no liability for any decisions made or actions taken or not taken by the user of the maps and associated data in reliance upon any information or data furnished here.

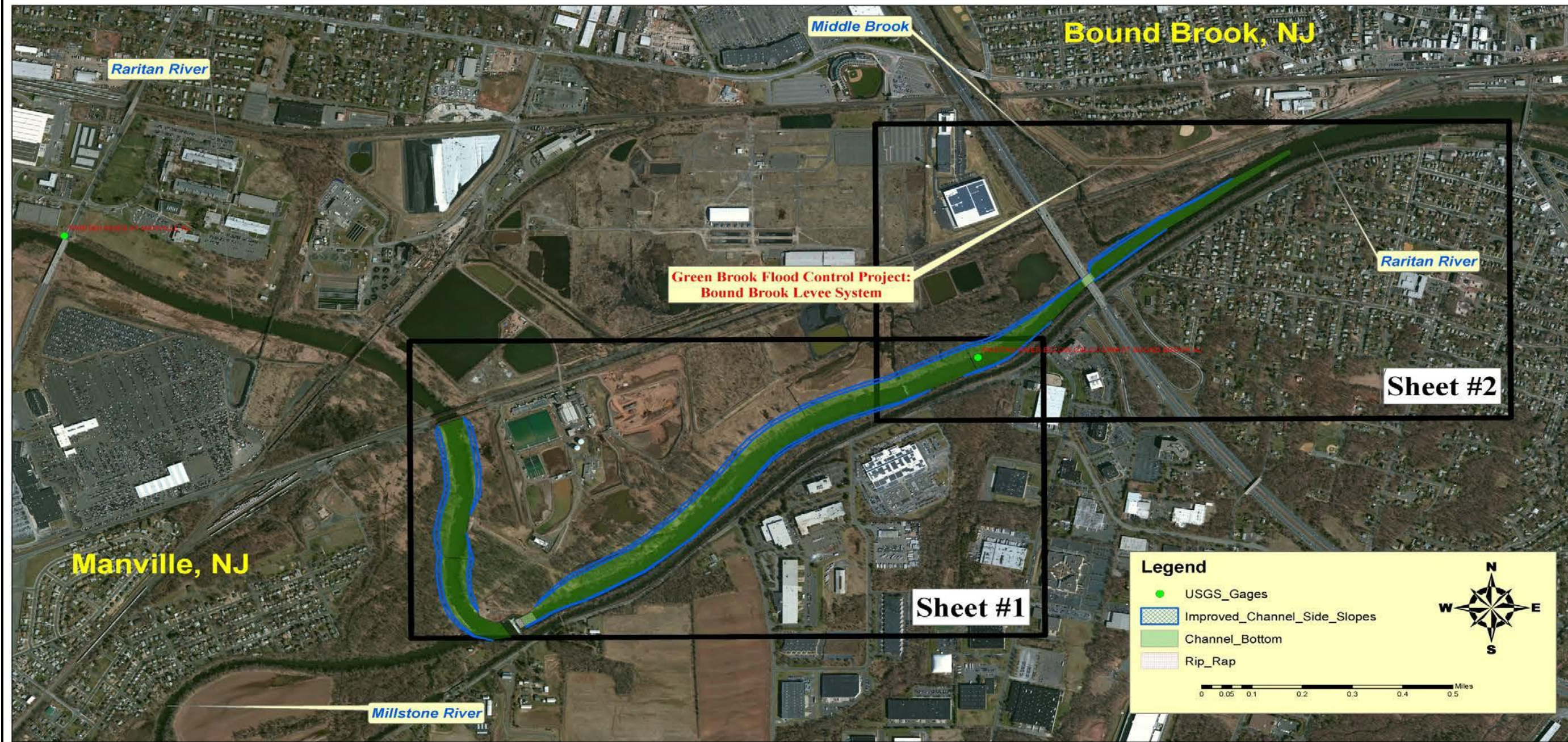


FIGURE 48: CHANNEL PLAN LAYOUT





# Millstone River Flood Risk Management Project

## US Army Corps of Engineers New York District



Disclaimer - While the United States Army Corps of Engineers, (hereinafter referred to as USACE) has made every reasonable effort to insure the accuracy of the maps and associated data, it should be explicitly noted that USACE makes no warranty, representation or guarantee, either expressed or implied, as to the content, sequence, accuracy, timeliness or completeness of any of the data provided herein. The USACE, its officers, agents, employees, or servants, shall assume no liability of any nature for any errors, omissions, or inaccuracies in the information provided regardless of the cause. The USACE, its officers, agents, employees, or servants shall assume no liability for any decisions made or actions taken or not taken by the user of the maps and associated data in reliance upon any information or data furnished here.

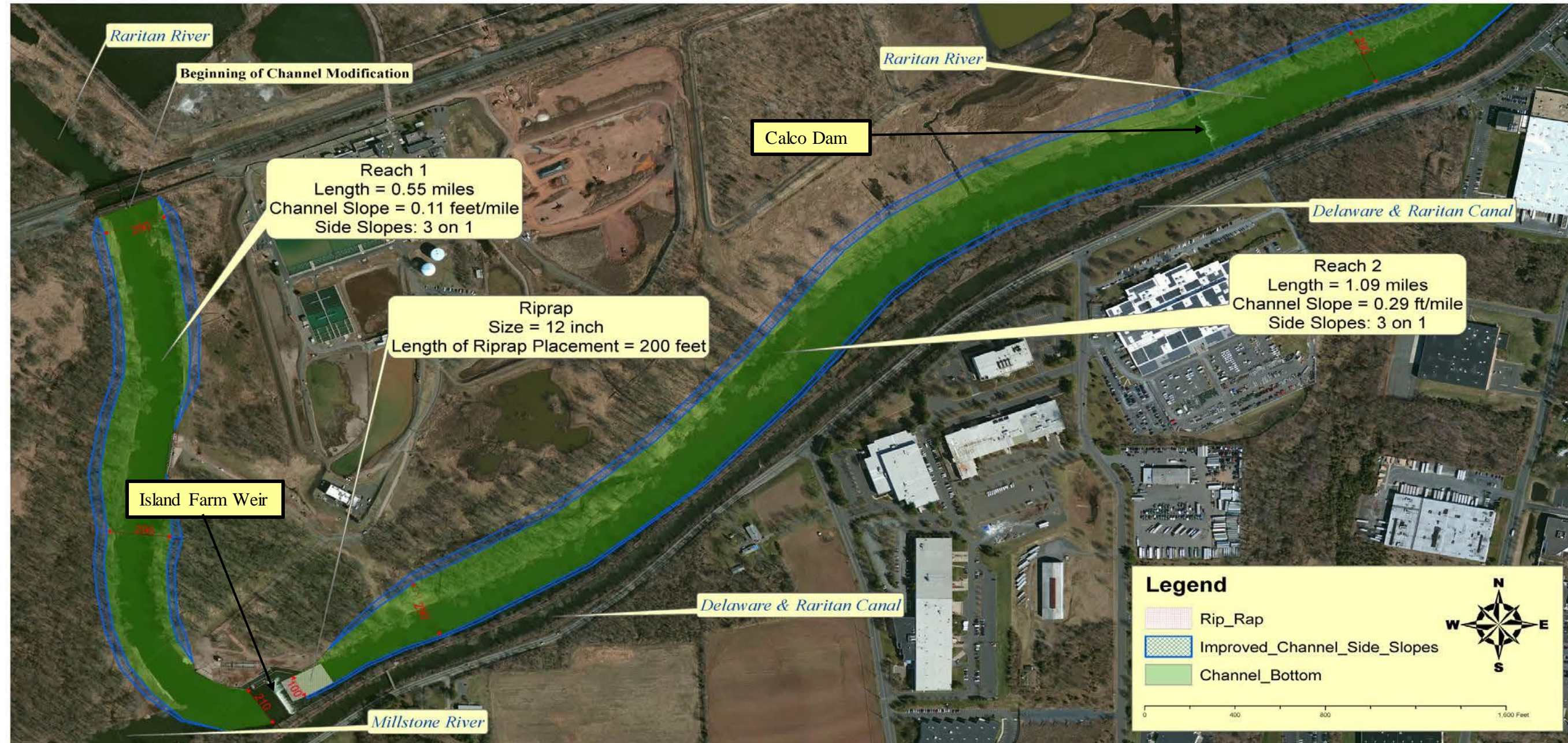


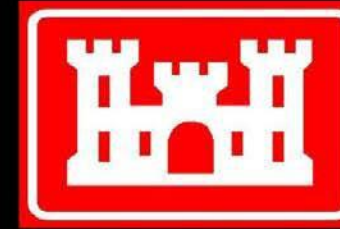
FIGURE 49: CHANNEL PLAN (SHEET #1)





# Millstone River Flood Risk Management Project

## US Army Corps of Engineers New York District



Disclaimer - While the United States Army Corps of Engineers, (hereinafter referred to USACE) has made every reasonable effort to insure the accuracy of the maps and associated data, it should be explicitly noted that USACE makes no warranty, representation or guarantee, either expressed or implied, as to the content, sequence, accuracy, timeliness or completeness of any of the data provided herein. The USACE, its officers, agents, employees, or servants, shall assume no liability of any nature for any errors, omissions, or inaccuracies in the information provided regardless of the cause. The USACE, its officers, agents, employees, or servants shall assume no liability for any decisions made or actions taken or not taken by the user of the maps and associated data in reliance upon any information or data furnished here.



FIGURE 50: CHANNEL PLAN (SHEET #2)





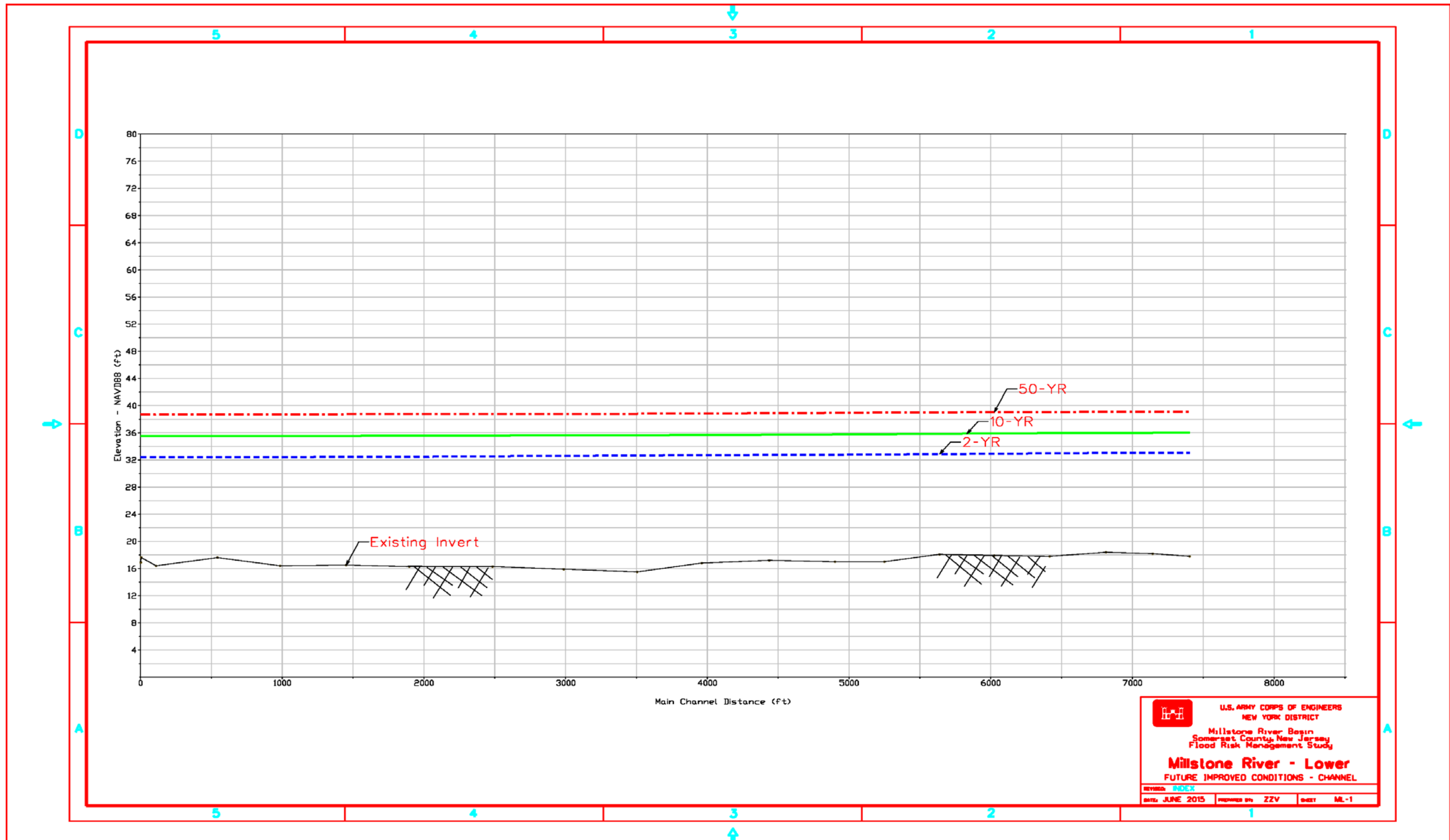


FIGURE 51: MAXIMUM WATER SURFACE PROFILE FOR CHANNEL PLAN - FUTURE IMPROVED CONDITIONS (MILLSTONE RIVER LOWER)



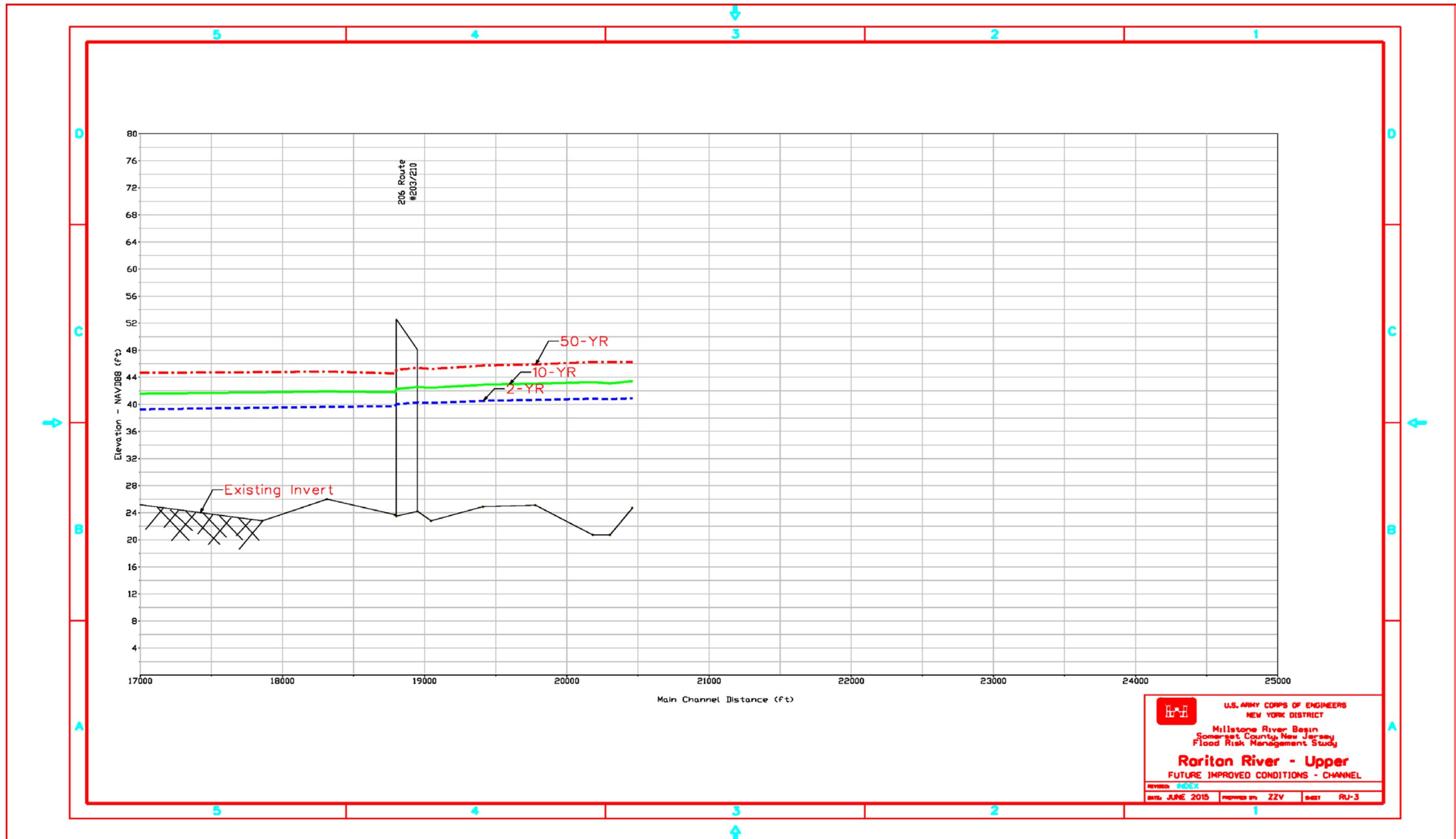


FIGURE 52: MAXIMUM WATER SURFACE PROFILE FOR CHANNEL PLAN - FUTURE IMPROVED CONDITIONS (RARITAN RIVER UPPER)



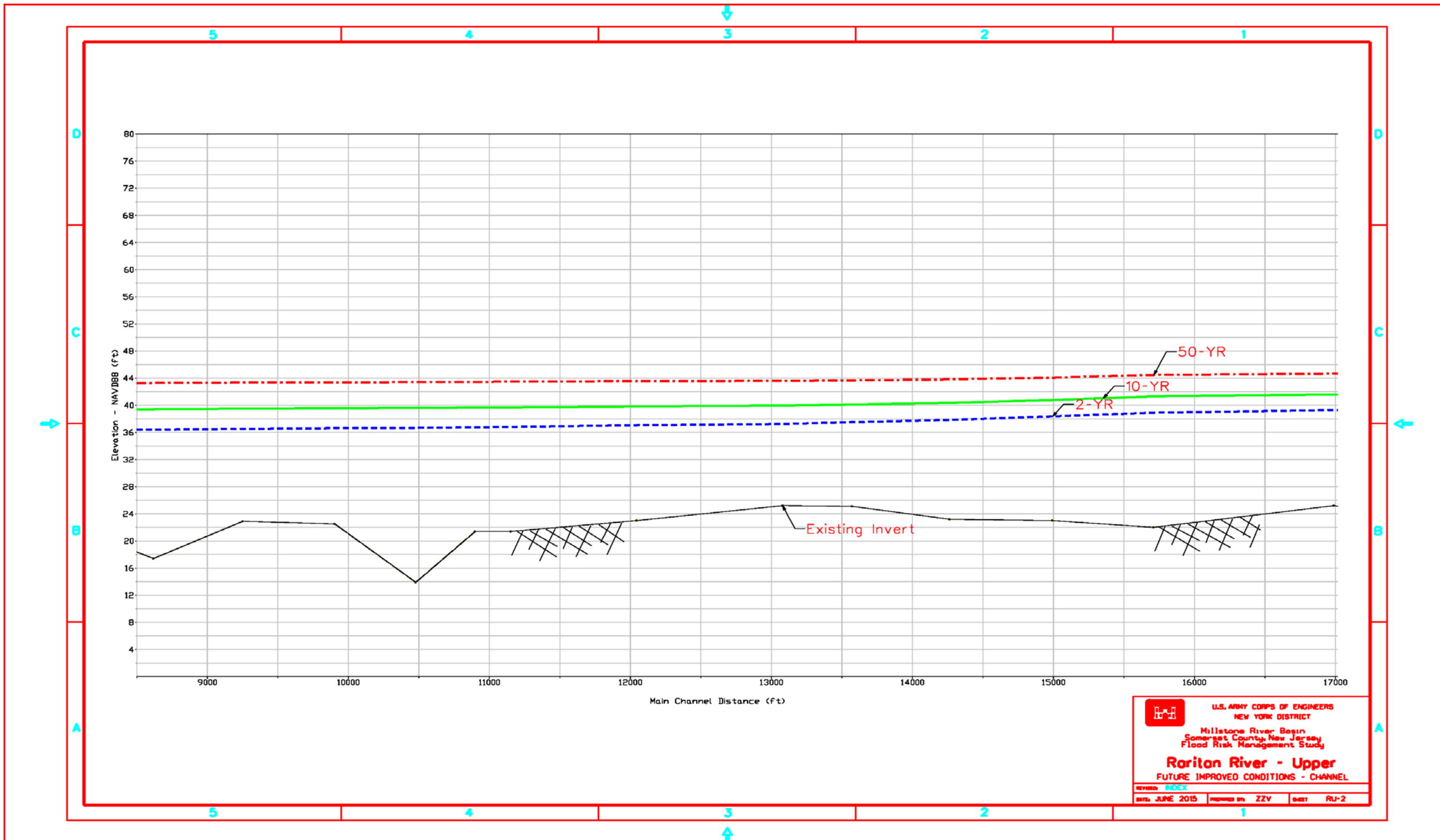


FIGURE 53: MAXIMUM WATER SURFACE PROFILE FOR CHANNEL PLAN - FUTURE IMPROVED CONDITIONS (RARITAN RIVER UPPER)



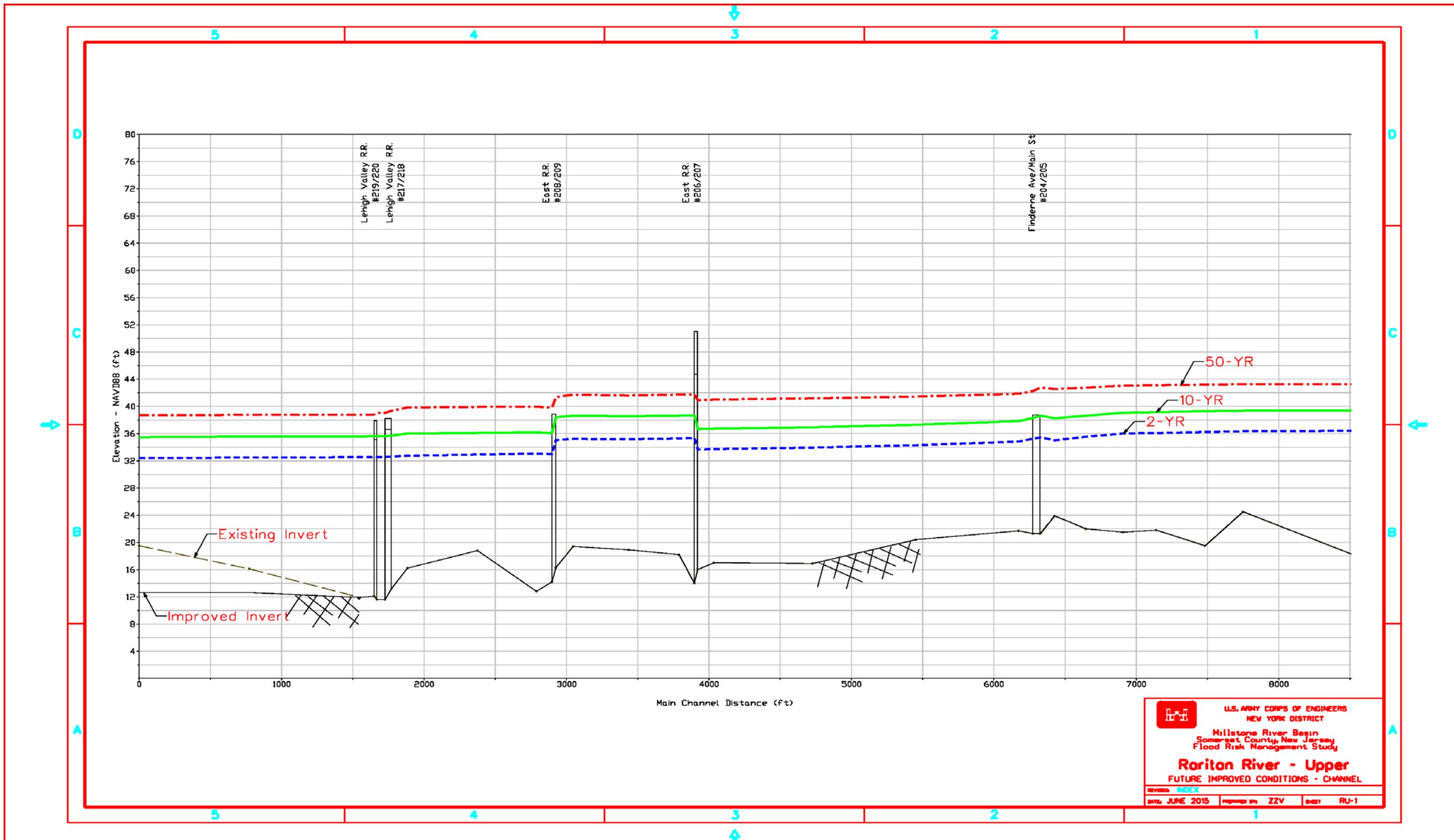
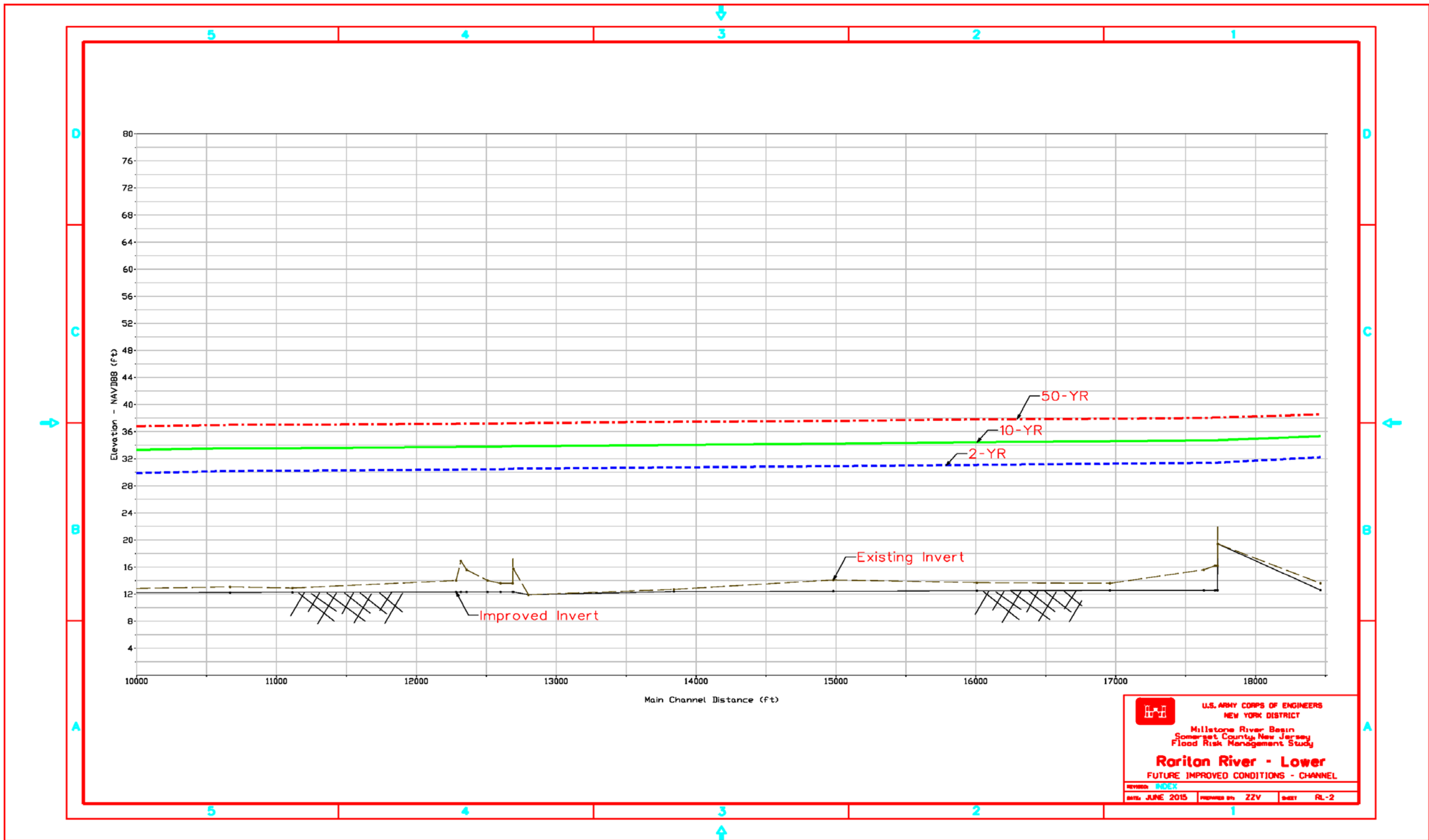
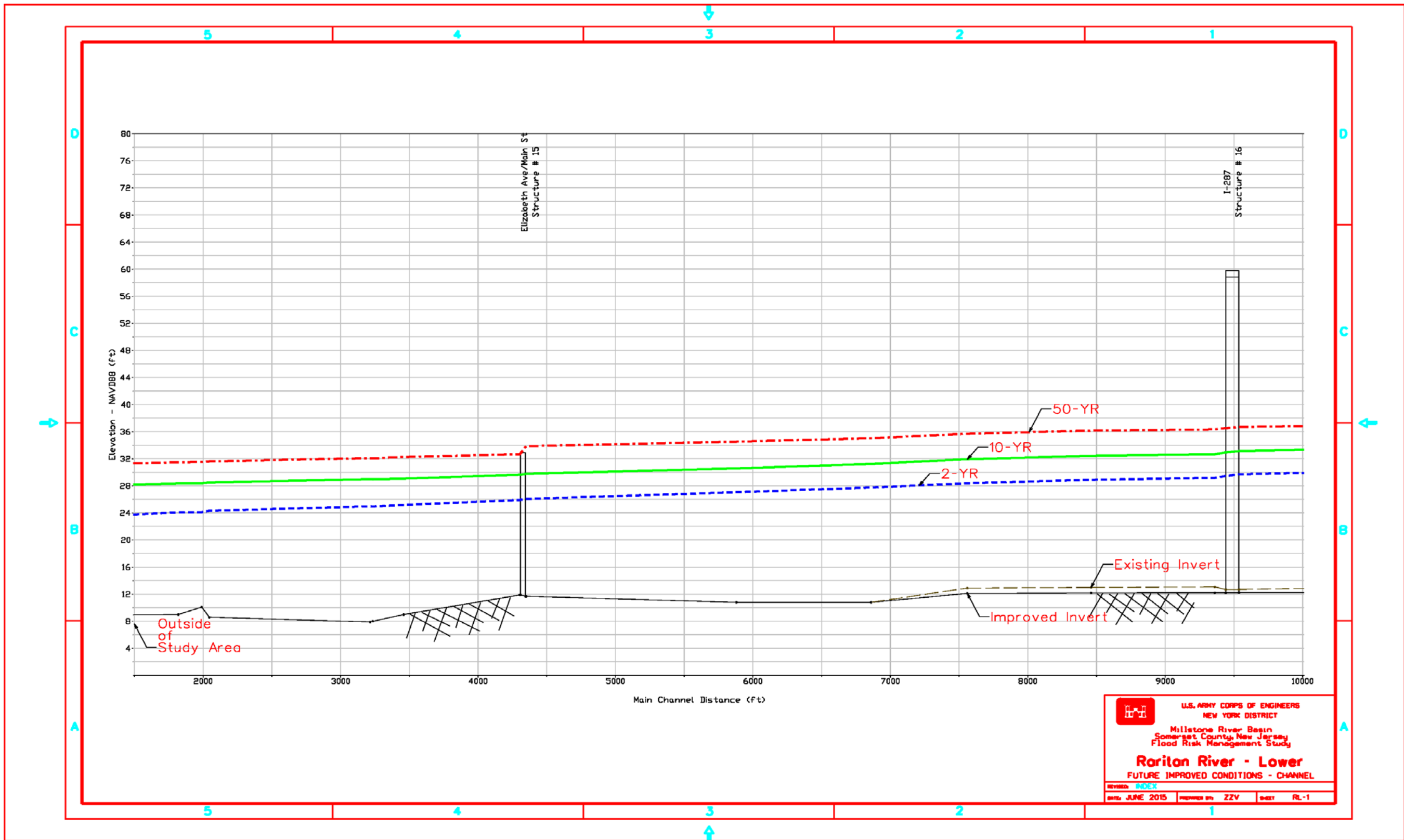


FIGURE 54: MAXIMUM WATER SURFACE PROFILE FOR CHANNEL PLAN - FUTURE IMPROVED CONDITIONS (RARITAN RIVER UPPER)





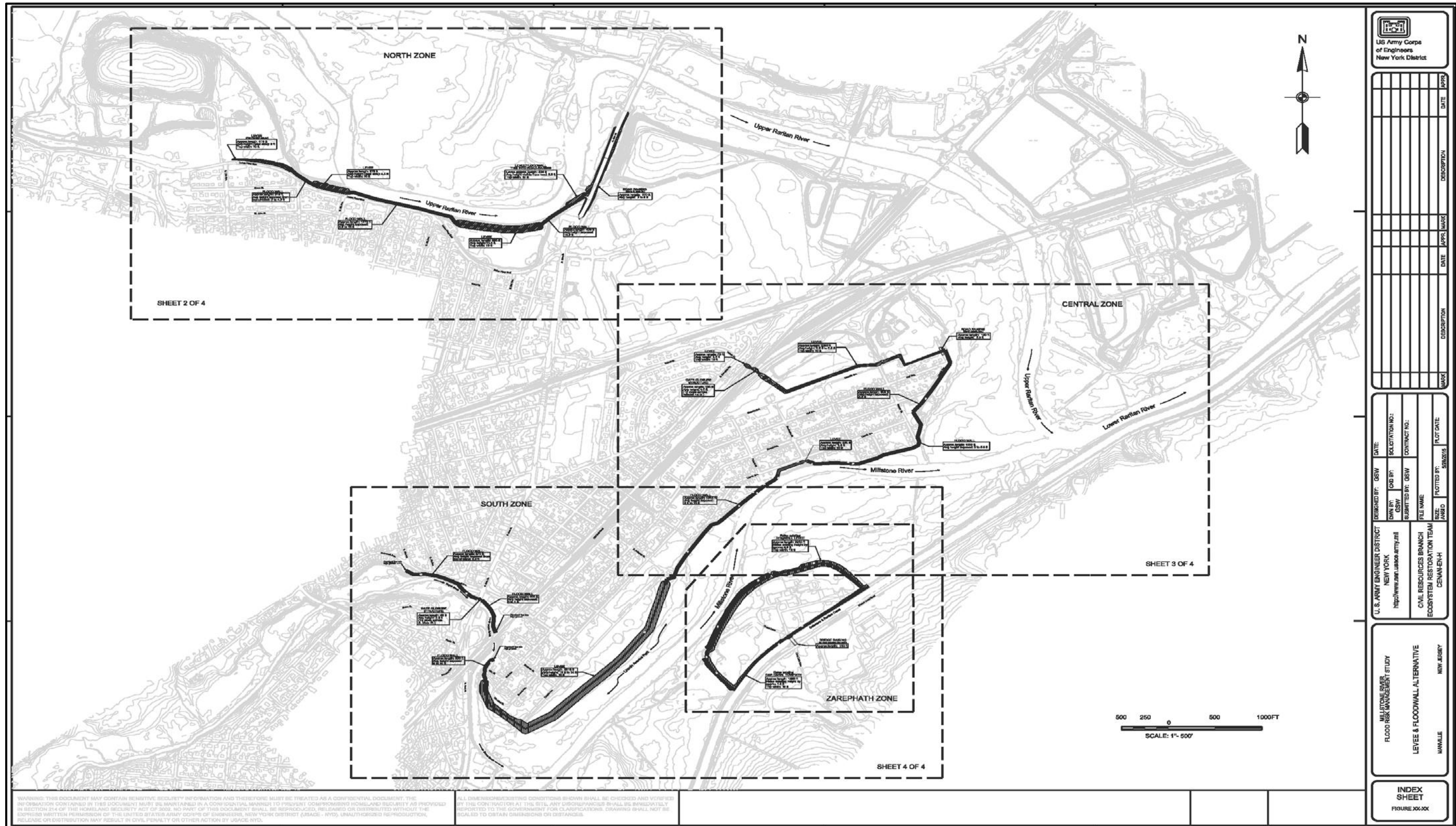


FIGURE 57: LEVEE & FLOODWALL PLAN LAYOUT





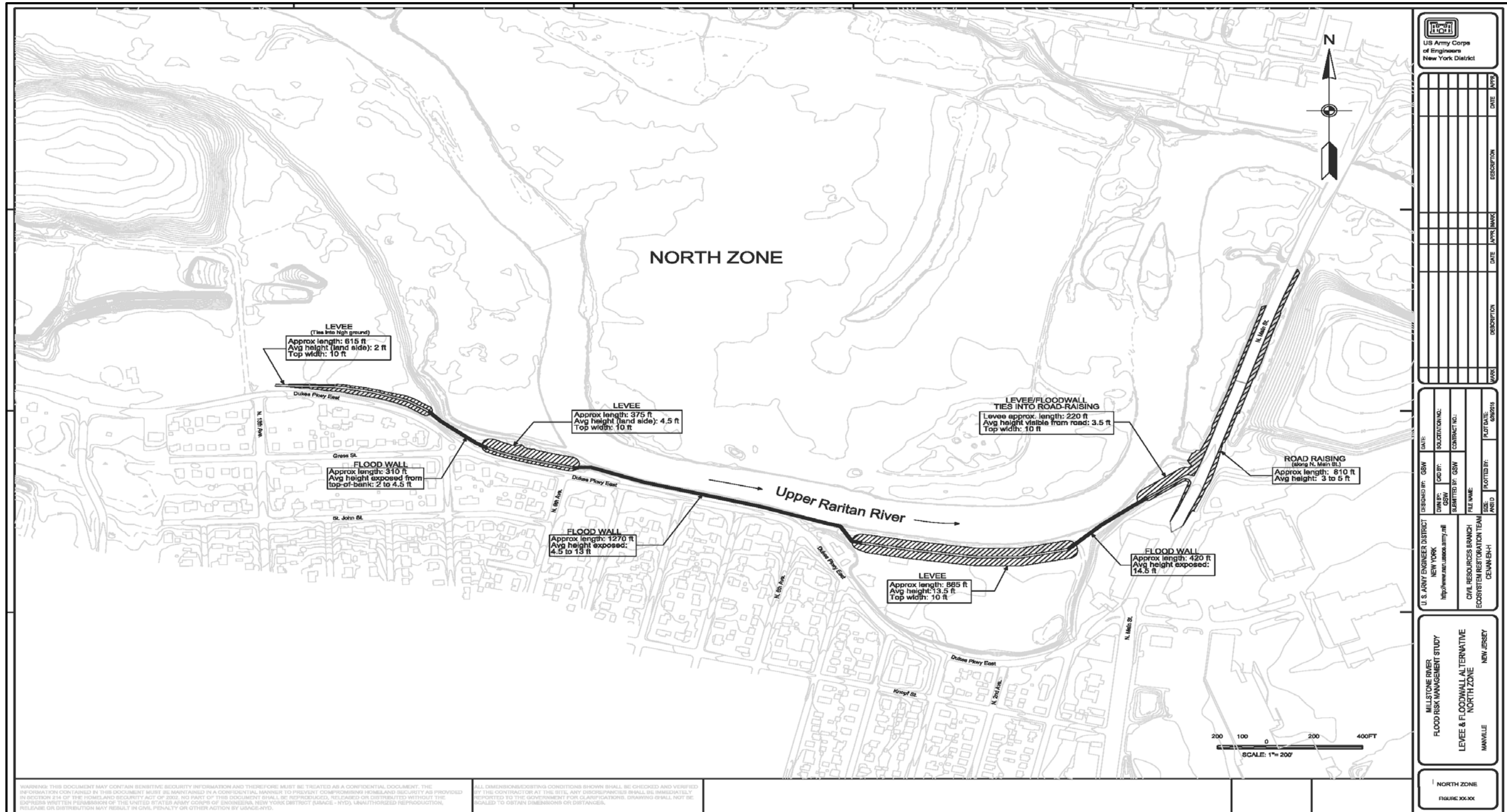


FIGURE 58:LEVEE & FLOODWALL PLAN LAYOUT (SHEET 2 OF 4)







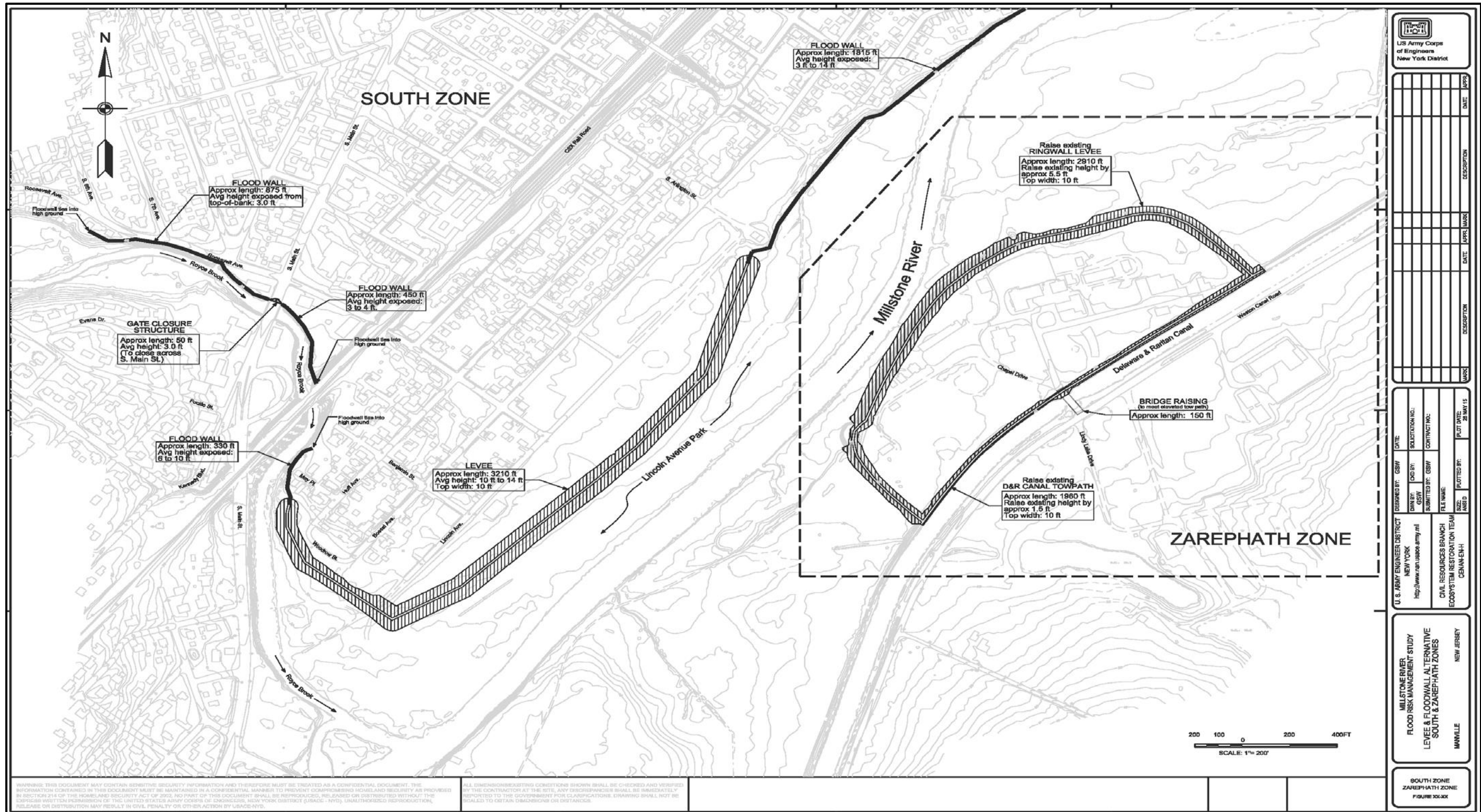


FIGURE 60:LEVEE & FLOODWALL PLAN LAYOUT (SHEET 4 OF 4)



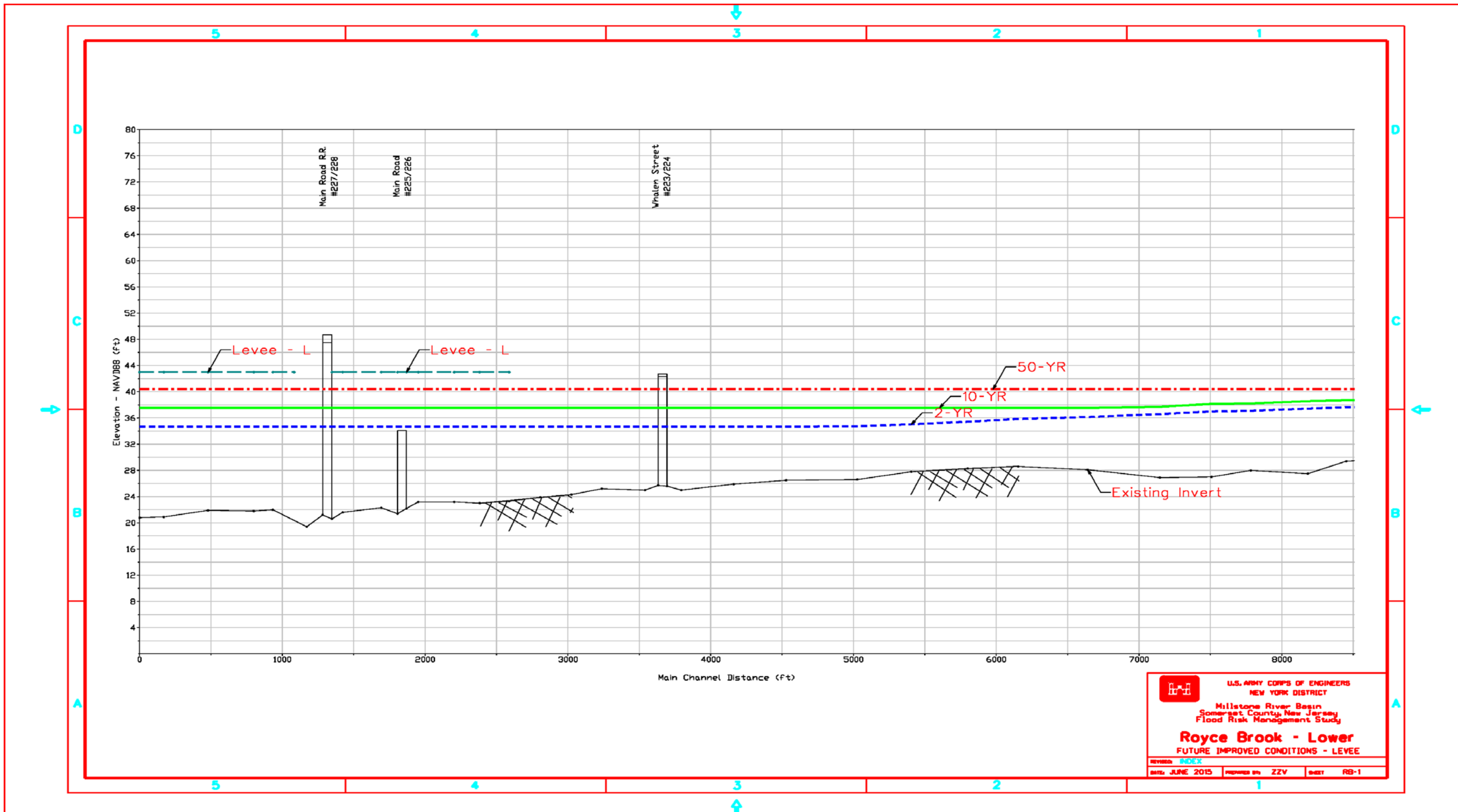


FIGURE 61: MAXIMUM WATER SURFACE PROFILE FOR LEVEE & FLOODWALL PLAN - FUTURE IMPROVED CONDITIONS (ROYCE BROOK)





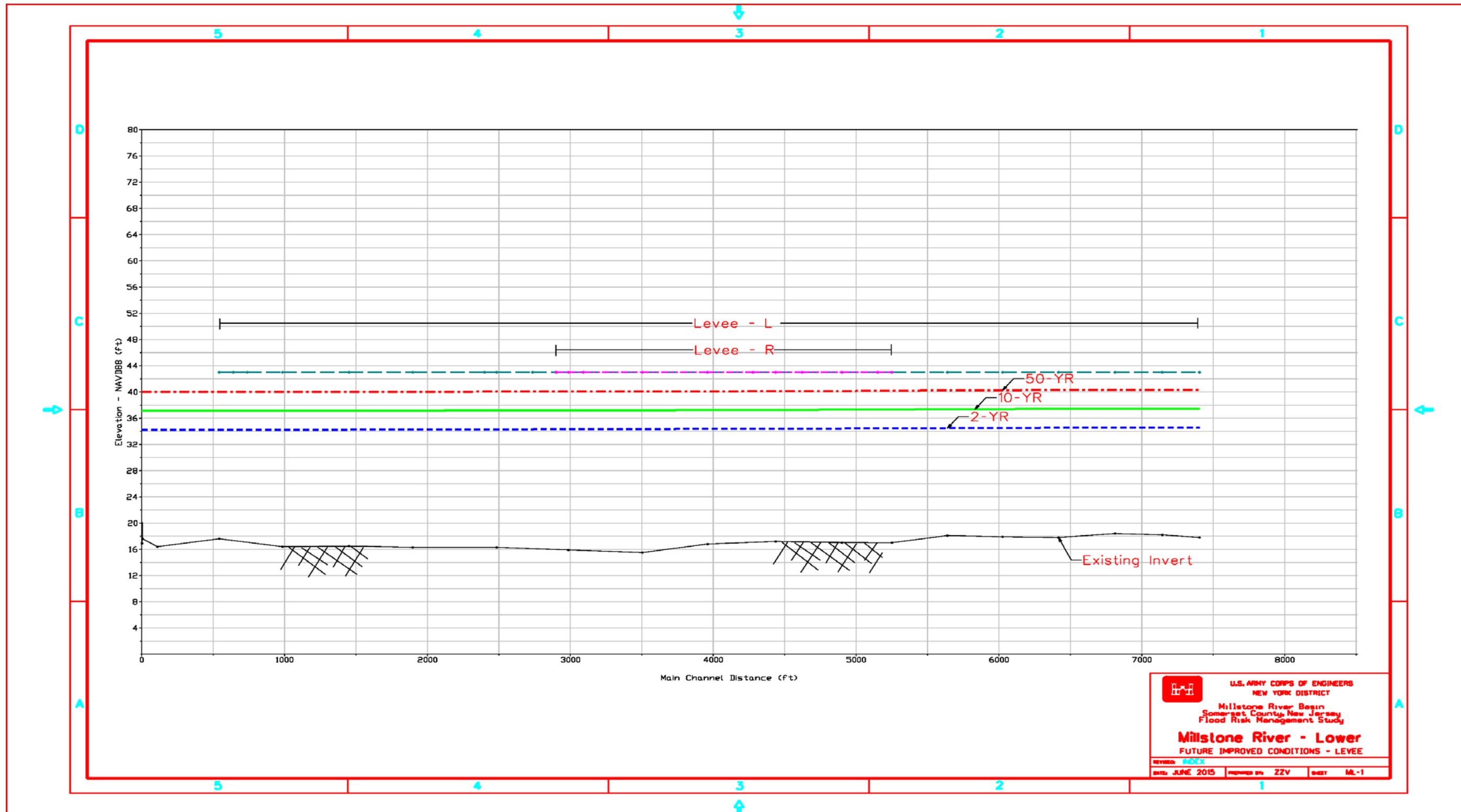


FIGURE 62: MAXIMUM WATER SURFACE PROFILE FOR LEVEE & FLOODWALL PLAN - FUTURE IMPROVED CONDITIONS (MILLSTONE RIVER LOWER)



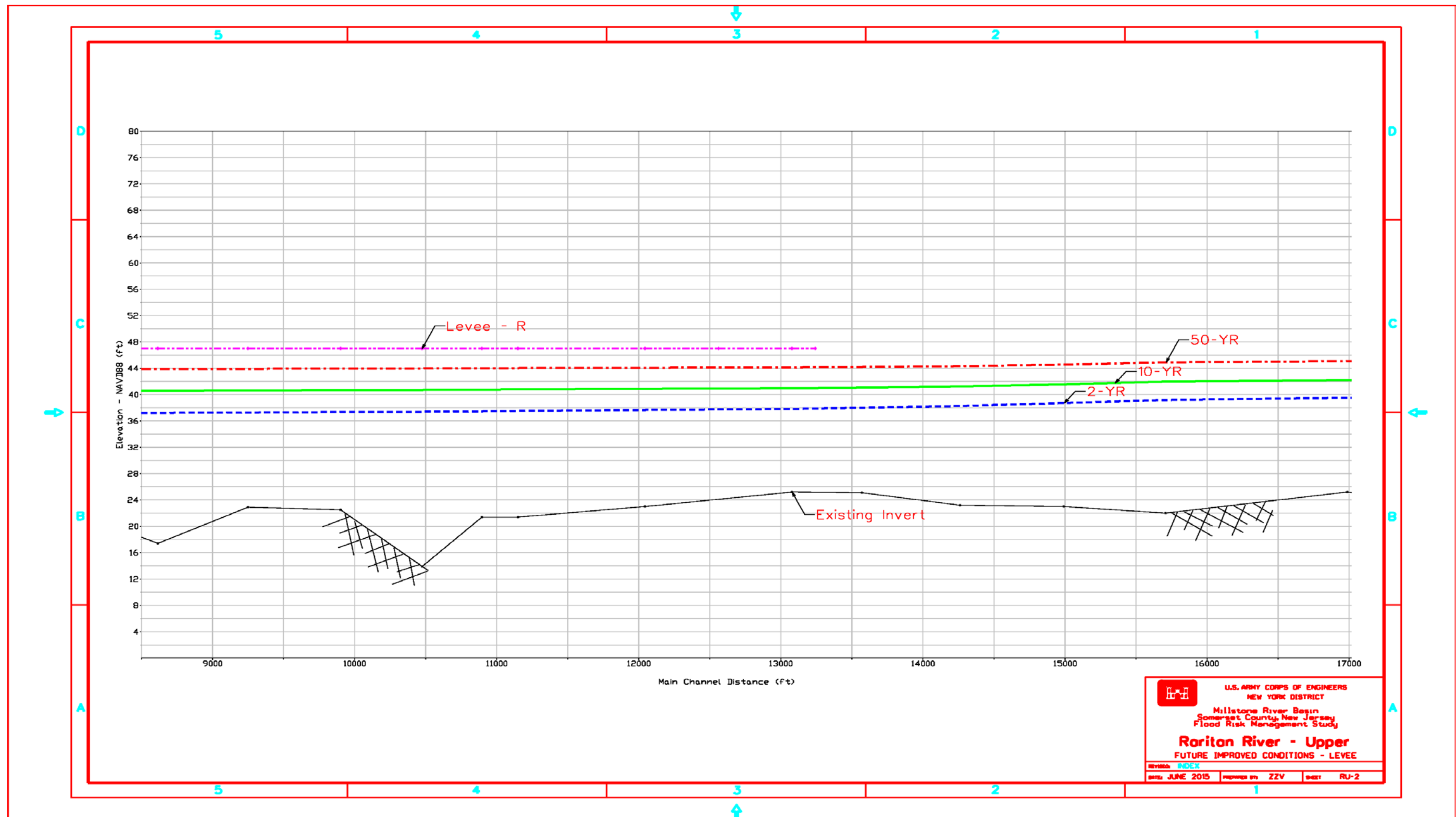


FIGURE 63: MAXIMUM WATER SURFACE PROFILE FOR LEVEE & FLOODWALL PLAN - FUTURE IMPROVED CONDITIONS (RARITAN RIVER UPPER)



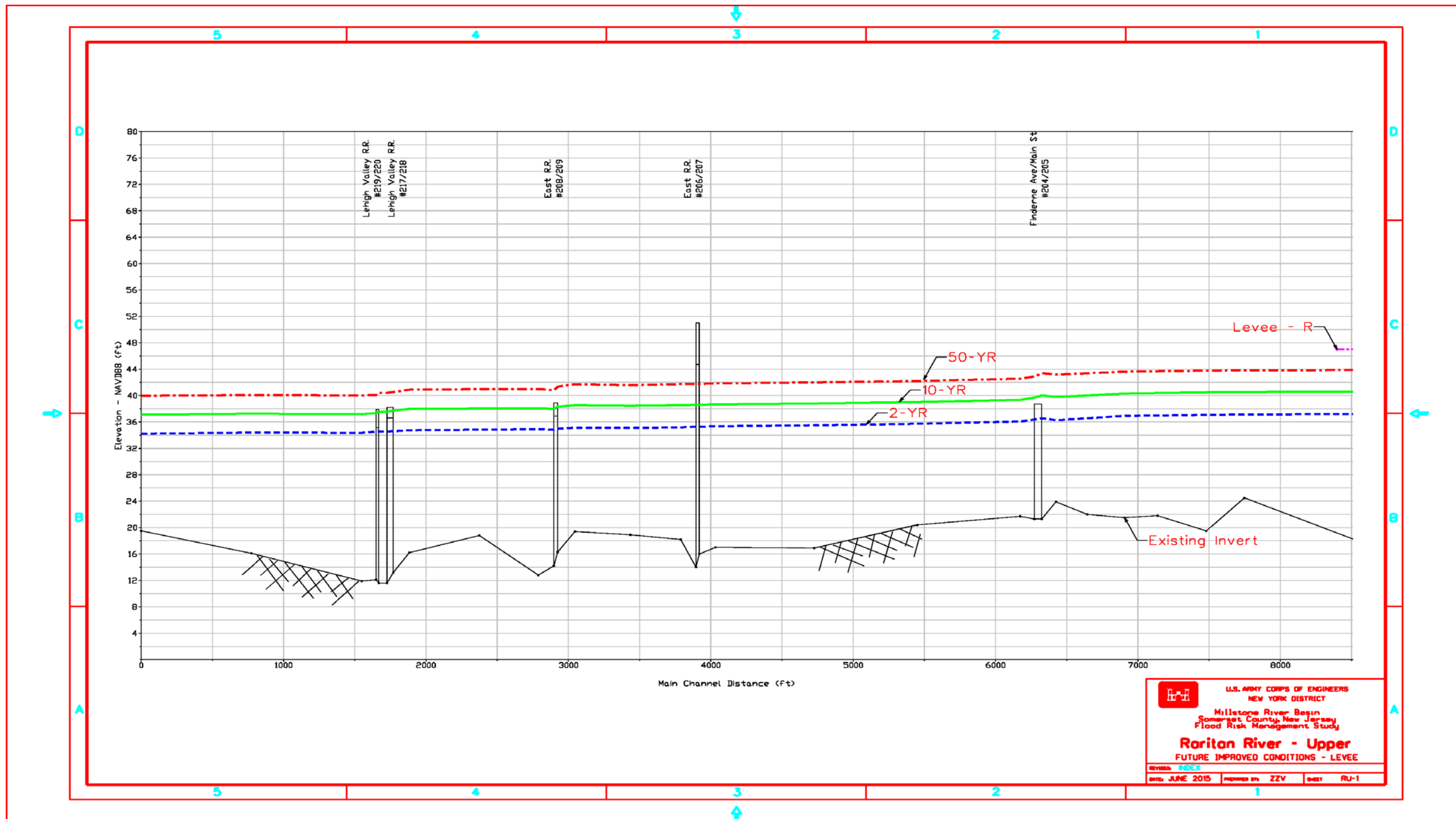


FIGURE 64: MAXIMUM WATER SURFACE PROFILE FOR LEVEE & FLOODWALL PLAN - FUTURE IMPROVED CONDITIONS (RARITAN RIVER UPPER)





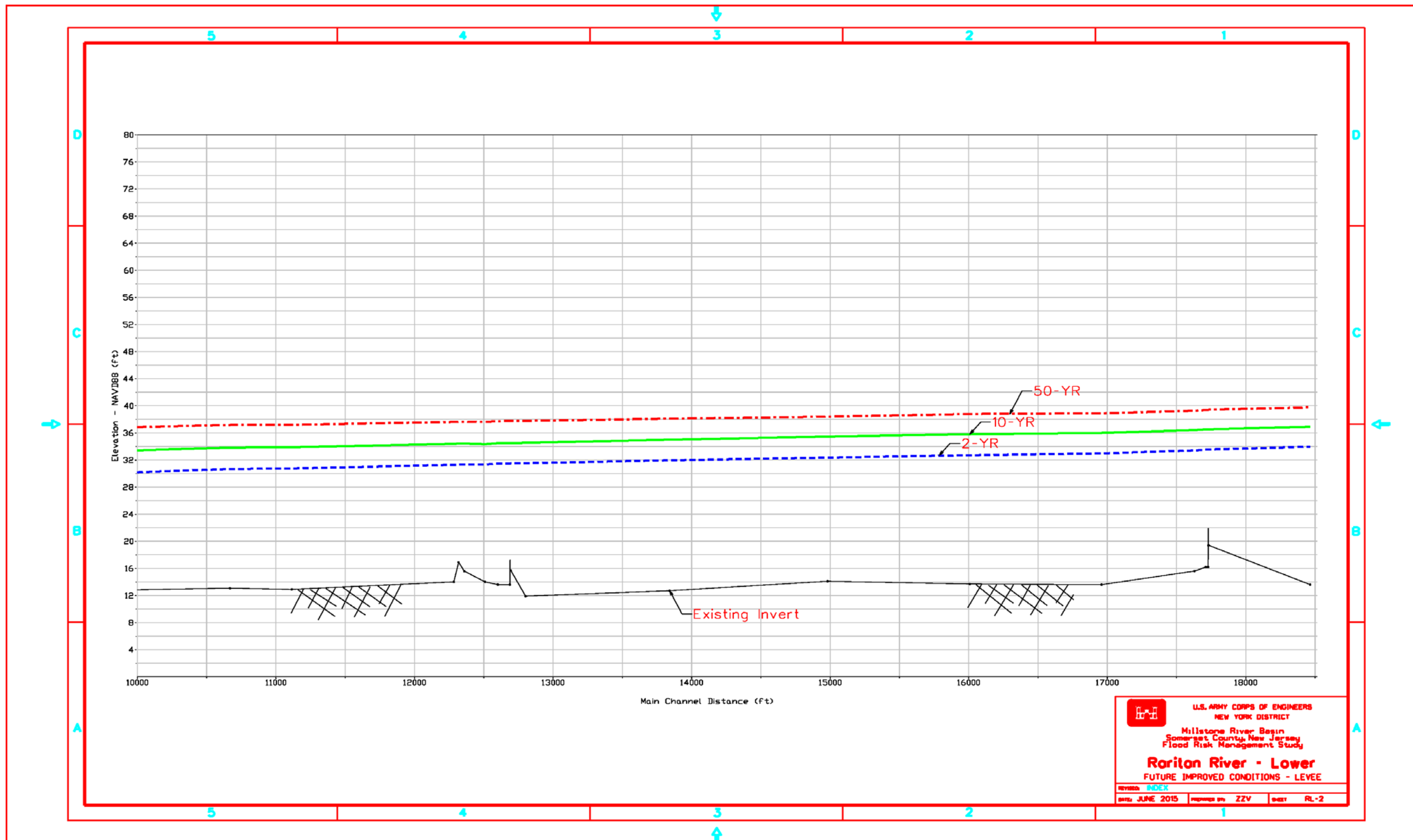


FIGURE 65: MAXIMUM WATER SURFACE PROFILE FOR LEVEE & FLOODWALL PLAN - FUTURE IMPROVED CONDITIONS (RARITAN RIVER LOWER)



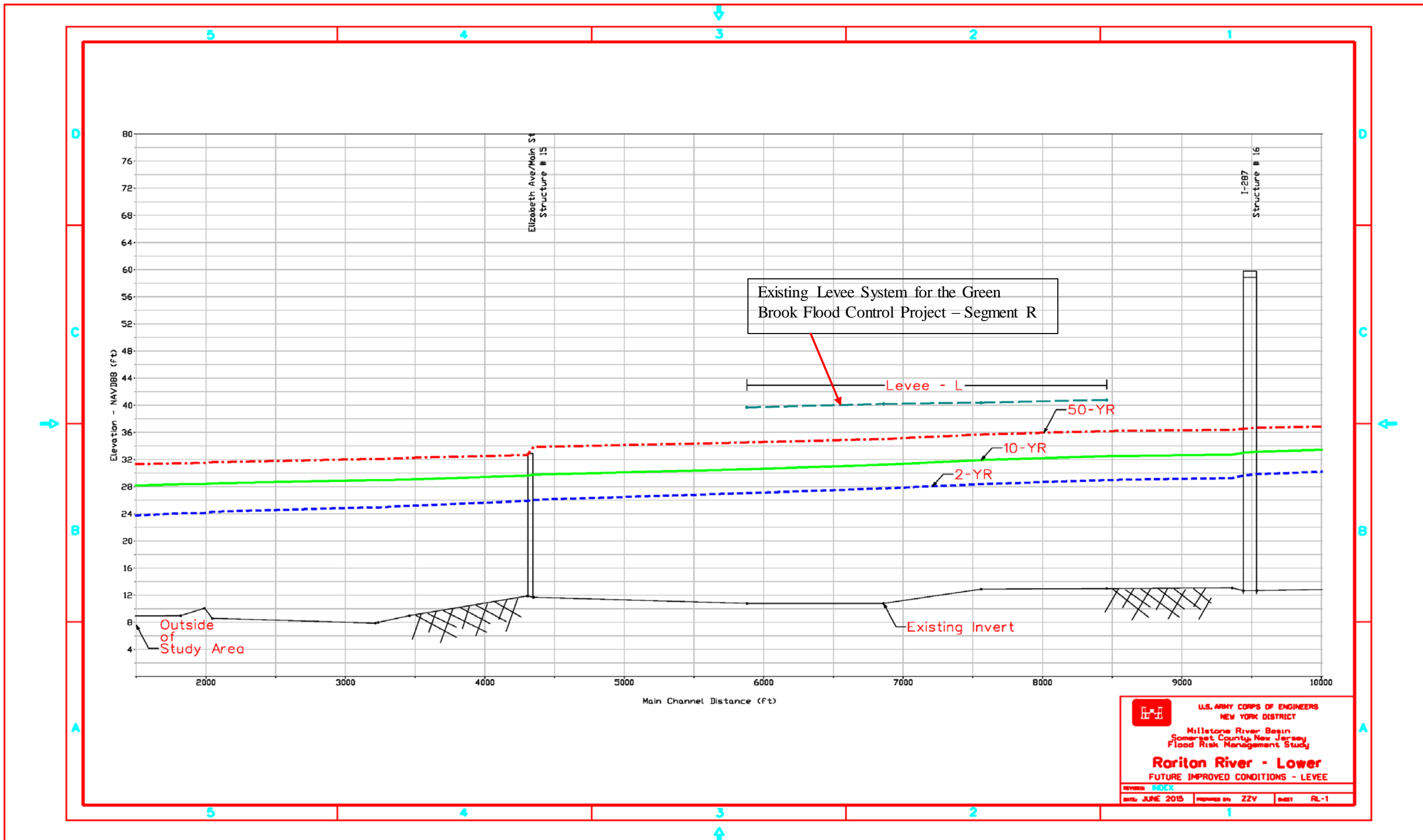


FIGURE 66: MAXIMUM WATER SURFACE PROFILE FOR LEVEE & FLOODWALL PLAN - FUTURE IMPROVED CONDITIONS (RARITAN RIVER LOWER)

MILLSTONE RIVER BASIN  
NEW JERSEY  
FLOOD RISK MANAGEMENT STUDY

**SUB-APPENDIX: Non-Structural Analysis**



# TABLE OF CONTENTS

1	NON-STRUCTURAL ALTERNATIVES .....	131
1.1	NON-STRUCTURAL ALTERNATIVES .....	131
1.2	LEVEL OF PROTECTION .....	135
1.3	EXISTING STRUCTURES CHARACTERISTICS .....	135
1.3.1	RESIDENTIAL .....	135
1.3.1.1	SLAB-ON-GRADE FOUNDATION TYPE.....	136
1.3.1.2	RAISED (CRAWLSPACE) FOUNDATION TYPE.....	136
1.3.1.3	SUBGRADE BASEMENT .....	136
1.3.1.4	BI-LEVELS AND RAISED RANCHES (SLAB-ON-GRADE ONLY) .....	137
1.3.1.5	RAISED RANCH STRUCTURE TYPE.....	138
1.3.1.6	SPLIT LEVELS (SLAB-ON-GRADE ONLY).....	138
1.3.1.7	LARGER RESIDENTIAL .....	139
1.3.2	NON-RESIDENTIAL.....	139
1.3.2.1	NONSTRUCTURAL FLOOD PROOFING .....	140
1.3.2.1.1	DRY FLOOD PROOFING.....	140
1.3.2.1.2	WET FLOOD PROOFING .....	141
1.3.2.1.3	ELEVATION (AKA. RAISE).....	142
1.3.2.1.4	BARRIERS (AKA. RINGWALL) .....	143
1.3.2.1.5	BUYOUT .....	143
1.3.2.2	NON-STRUCTURAL SCREENING LEVEL ANALYSIS DESIGN ASSUMPTIONS .....	144
1.3.2.2.1	SCREENING LEVELS ALGORITHMS .....	144
1.3.2.2.2	SCREENING LEVEL RESULTS .....	146
2	NON-STRUCTURAL ALTERNATIVE MAPS .....	149



## LIST OF FIGURES

FIGURE 1: ZAREPHATH AND LOST VALLEY AREAS .....	132
FIGURE 2: TYPICAL SLAB-ON-GRADE FOUNDATION TYPE .....	136
FIGURE 3: TYPICAL RAISED (CRAWLSPACE) FOUNDATION TYPE .....	136
FIGURE 4: TYPICAL SUBGRADE BASEMENT FOUNDATION TYPE .....	137
FIGURE 5: TYPICAL BI-LEVEL STRUCTURE TYPE .....	137
FIGURE 6: TYPICAL RAISED RANCH STRUCTURE TYPE .....	138
FIGURE 7: TYPICAL SPLIT LEVEL STRUCTURE TYPE .....	139
FIGURE 8: TYPICAL MULTI-FAMILY UNITS .....	139
FIGURE 9: TYPICAL NON-RESIDENTIAL UNIT .....	140
FIGURE 10: DRY FLOOD PROOFING DIAGRAM .....	141
FIGURE 11: WET FLOOD PROOFING DIAGRAM .....	141
FIGURE 12: WET FLOOD PROOFING UTILITIES PROTECTION .....	142
FIGURE 13: ELEVATION ON EXTENDED FOUNDATION WALLS .....	142
FIGURE 14: EXAMPLE OF A RINGWALL ARRANGEMENT BUILT AROUND A STRUCTURE .....	143
FIGURE 15: NON-STRUCTURAL ALTERNATIVE FOR THE 1% (100-YR) FLOODPLAIN.....	150
FIGURE 16: ALTERNATIVE 3A   NON-STRUCTURAL PLAN FOR THE 2% (50-YR) FLOODPLAIN.....	151
FIGURE 17: ALTERNATIVE 4A   NON-STRUCTURAL PLAN FOR THE 10% (10-YR) FLOODPLAIN....	152
FIGURE 18: ALTERNATIVE 4C   NON-STRUCTURAL PLAN FOR THE 10% (10-YR) FLOODPLAIN EXCLUDING BLUE ACRES PROGRAM AND ZAREPHATH STRUCTURES (A1). .....	153
FIGURE 19: ALTERNATIVE 4C   NON-STRUCTURAL PLAN FOR THE 10% (10-YR) FLOODPLAIN EXCLUDING BLUE ACRES PROGRAM AND ZAREPHATH STRUCTURES (A2). .....	154
FIGURE 20: ALTERNATIVE 4C   NON-STRUCTURAL PLAN FOR THE 10% (10-YR) FLOODPLAIN EXCLUDING BLUE ACRES PROGRAM AND ZAREPHATH STRUCTURES (B2). .....	155
FIGURE 21: ALTERNATIVE 4C   NON-STRUCTURAL PLAN FOR THE 10% (10-YR) FLOODPLAIN EXCLUDING BLUE ACRES PROGRAM AND ZAREPHATH STRUCTURES (C1). .....	156
FIGURE 22: ALTERNATIVE 4C   NON-STRUCTURAL PLAN FOR THE 10% (10-YR) FLOODPLAIN EXCLUDING BLUE ACRES PROGRAM AND ZAREPHATH STRUCTURES (C2). .....	157





## LIST OF TABLES

TABLE 1: ASSUMPTIONS INHERENT TO THE SCREENING OF NON-STRUCTURAL ALTERNATIVES FOR REPRESENTATIVE BUILDINGS .....	145
TABLE 2: MILLSTONE RIVER NONSTRUCTURAL PLAN FOR THE 1% (100-YR), 2% (50-YR) AND 10% (10-YR) ANNUAL CHANCE EXCEEDANCE EVENTS .....	146
TABLE 3: ALTERNATIVE #3B, #3C AND #3D MILLSTONE RIVER NONSTRUCTURAL PLAN COMPARISON FOR THE 2% (50-YR) ANNUAL CHANCE EXCEEDANCE EVENT .....	147
TABLE 4: ALTERNATIVE #4B, #4C AND #4D MILLSTONE RIVER NONSTRUCTURAL PLAN COMPARISON FOR THE 10% (10-YR) ANNUAL CHANCE EXCEEDANCE EVENT .....	148



**MILLSTONE RIVER BASIN  
SOMERSET COUNTY, NEW JERSEY  
FLOOD RISK MANAGEMENT STUDY**

## **1 NON-STRUCTURAL ALTERNATIVES**

Non-structural measures were identified and evaluated for structures in the Manville Borough near the Royce Brook and, Millstone and Raritan Rivers. Measures evaluated included raising buildings (elevation), wet (protect utilities) and dry (sealants and closures) flood proofing, barriers (ring walls/ring levees) and buyouts (acquisition). The main objective for the non-structural measures is to reduce flood damages through modifications of the existing structures without impacting the residential, commercial and industrial areas.

These non-structural measures are generally used for the reduction of damages in frequently flooded events (4% annual chance exceedance event or below). Due to the large number of structures inundated during large events (above 2% annual chance exceedance event), the use of non-structural measures to provide a sizable level of protection is not expected to be cost effective, nor supported by local government.

Floodplains corresponding to a flood frequency of 10%, 2% and 1% annual chance exceedance were evaluated without considering future sea level change.

### **1.1 Non-structural Alternatives**

A nonstructural component was formulated into specific alternative plans for evaluation. These were selected based on the 10%, 2% and 1% floodplains. The Manville Borough specifically requested to analyze six extra combinations within the 10% and 2% events in addition to what was originally formulated. Within these combinations, we excluded from our current analyses structures that applied for buyouts under the Blue Acres Program. The Blue Acres Program is a federal budgeted program that currently will be buying out 104 structures in the area.



Alternatives are listed below.

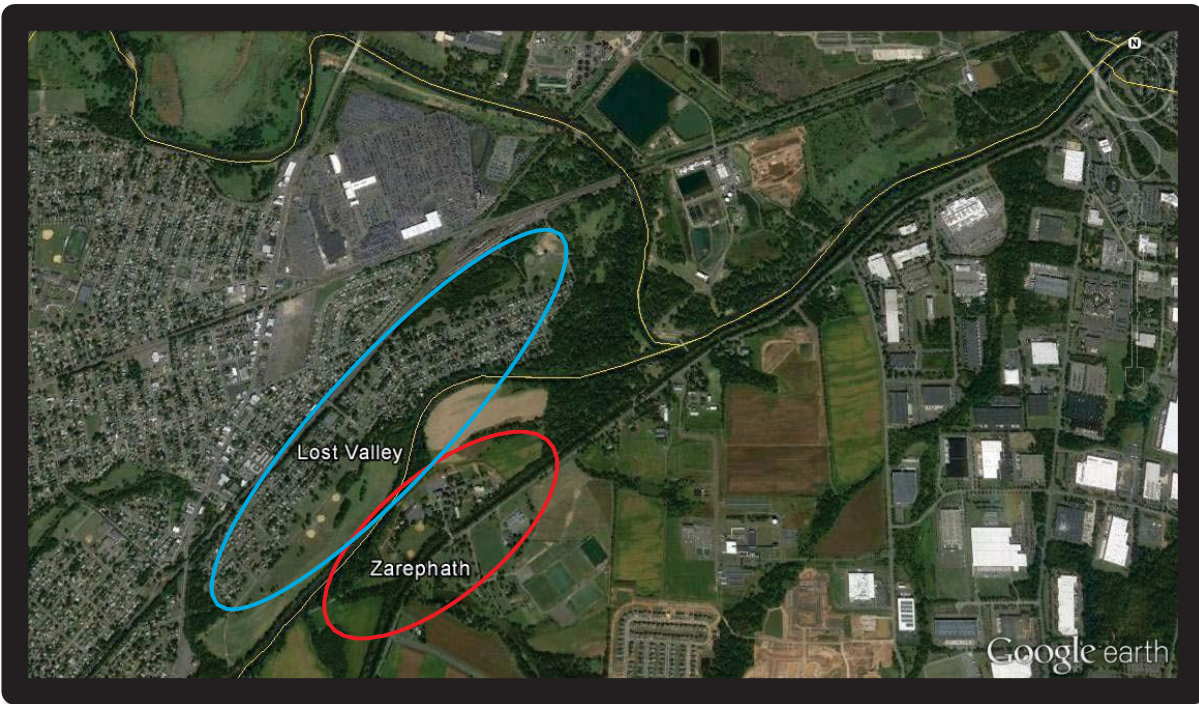
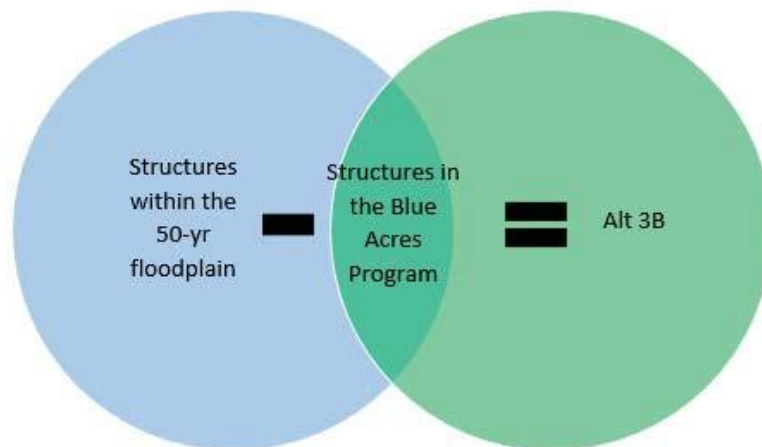
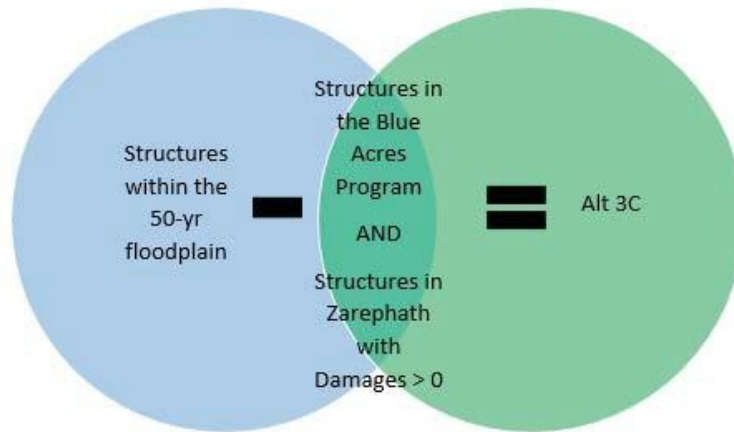


Figure 1: Zarephath and Lost Valley areas

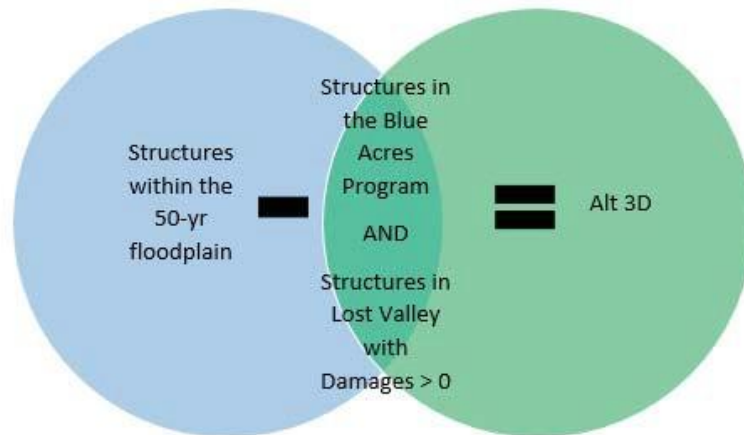
- f Alternative 3A: All structures within the 2% (50-yr) annual chance exceedance floodplain.
- f Alternative 3B: Structures within the 2% (50-yr) annual chance exceedance floodplain, excluding structures under the Blue Acres Program (104 structures max).



- f Alternative 3C: Structures within the 2% (50-yr) annual chance exceedance floodplain, excluding structures under the Blue Acres Program and structures within the Zarephath area (125 structures).

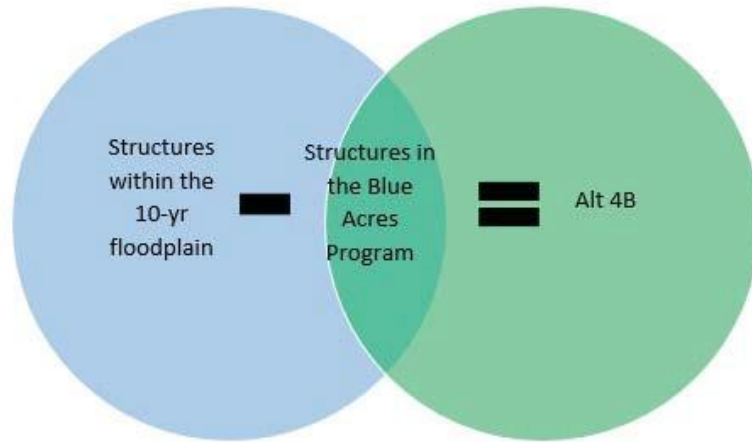


- f Alternative 3D: Structures within the 2% (50-yr) annual chance exceedance floodplain, excluding structures under the Blue Acres Program and structures within the Lost Valley area (79 structures).

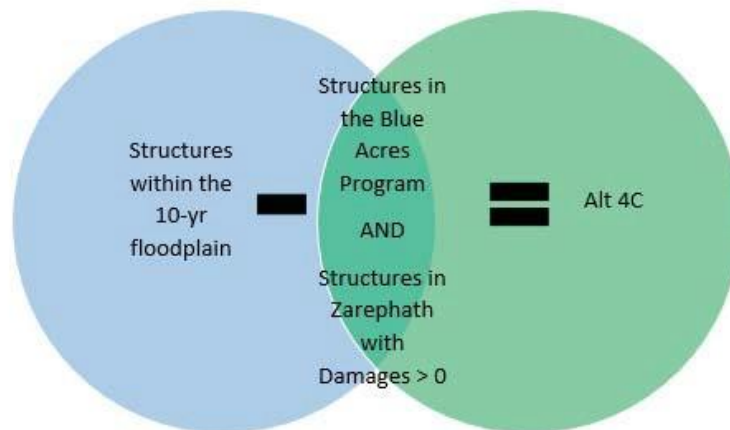


- f Alternative 4A: All structures within the 10% (10-yr) annual chance exceedance floodplain.
- f Alternative 4B: Structures within the 10% (10-yr) annual chance exceedance floodplain, excluding structures under the Blue Acres Program (48 structures).





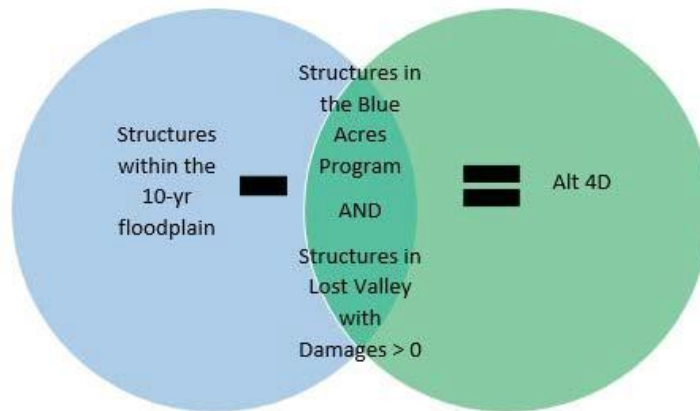
- f Alternative 4C: Structures within the 10% (10-yr) annual chance exceedance floodplain, excluding structures under the Blue Acres Program and structures within the Zarephath area (67 structures).



- f Alternative 4D: Structures within the 10% (10-yr) annual chance exceedance floodplain, excluding structures under the Blue Acres Program and structures within the Lost Valley area (34 structures).







- f An alternative for all structures within the 1% (100-yr) annual exceedance floodplain was also evaluated but later removed from further analysis do the fact that the level of protection was over target.

## 1.2 Level of Protection

All of the nonstructural plans were designed to withstand inundation for up to and including a 1% (100-yr) return period event plus one foot of “freeboard”. These alternatives would protect most of the residential and nonresidential structures on both banks of the Royce Brook, Millstone and Raritan Rivers from a 1% (100-year) flood at Manville.

## 1.3 Existing Structures Characteristics

The types of structures located in the 1% (100-year) floodplain of the Millstone river study at Manville area are mostly residential and commercial.

### 1.3.1 Residential

The predominant land use within the study area is primarily residential with a combination of residential and commercial structures. In the case where the land had both commercial and residential use, a residential use was assumed for the purpose of determining flood protection measures. Structure types were divided into the following categories:



### 1.3.1.1 Slab-on-Grade Foundation Type

This structure is constructed on a slab foundation at grade (Figure 2).



Figure 2: Typical Slab-on-Grade Foundation Type

### 1.3.1.2 Raised (Crawlspace) Foundation Type

This structure is on a raised foundation, typically concrete masonry, not high enough for a basement (Figure 3).



Figure 3: Typical Raised (Crawlspace) Foundation Type

### 1.3.1.3 Subgrade Basement

All basements were assumed to be subgrade full (not partial) basements. Typically, one floor equivalent of space is located under the main floor on a slab. The foundation walls may be



poured concrete or concrete masonry. The basement may be finished or unfinished. The subgrade basement slab is completely below grade on all four sides (Figure 4).



Figure 4: Typical Subgrade Basement Foundation Type

#### *1.3.1.4 Bi-Levels and Raised Ranches (Slab-on-Grade only)*

The bi-level structure consists of two stories. In most cases, the first story is partially below grade, consisting of living space or a garage or both. The main floor of the bi-level tends to be above the first story of the structure, with the main entrance located between the lower and main floor (Figure 5).



Figure 5: Typical Bi-Level Structure Type



### 1.3.1.5 *Raised Ranch Structure Type*

The Raised Ranch Structure Type is similar to a Bi-Level. The lower level is built slab-on-grade and the main entrance is usually at the main floor or second level (Figure 6).



Figure 6: Typical Raised Ranch Structure Type

Due to the similarities between the characteristics of bi-levels and raised ranches, these structure types were considered identical for flood proofing alternatives screening. Elevation methodology and costs are generally similar to structures with basements.

### 1.3.1.6 *Split Levels (Slab-on-Grade only)*

This structure consists of three levels: a stacked lower and upper level, with an adjacent main floor between the upper and lower floor levels. Each floor (lower, main, and upper) has a different elevation, and is connected by short stairways. The lower level is generally on a slab foundation and the main floor is usually raised. The lower level may be living space and/or a garage (Figure 7). The main entrance is at the main floor level. There was assumed to be no basement below the main level.





Figure 7: Typical Split Level Structure Type

### *1.3.1.7 Larger Residential*

This category included multi-family units (>2 families), garden apartments, and townhouses. Foundation types for this category included slab-on-grade, raised crawlspace, or subgrade basement (Figure 8).



Figure 8: Typical multi-family units

### *1.3.2 Non-Residential*

This category includes commercial, industrial, and municipal structures, where persons would not reasonably be expected to sleep (Figure 9).







Figure 9: Typical *Non-Residential unit*

### *1.3.2.1 Nonstructural Flood Proofing*

*Nonstructural Flood Proofing measures* considered in this project were dry and wet flood proofing, elevation (aka. raise), barriers (aka. ringwall) and buyouts.

#### *1.3.2.1.1 Dry Flood Proofing*

Dry flood proofing measures (Figure 10) allow flood waters to reach the structure but diminish the flood threat by preventing the water from getting inside the structure walls. Dry flood proofing measures considered in this screening make the portion of a building that is below the flood level watertight through attaching watertight membranes and installing closure structures in doorway and window openings.



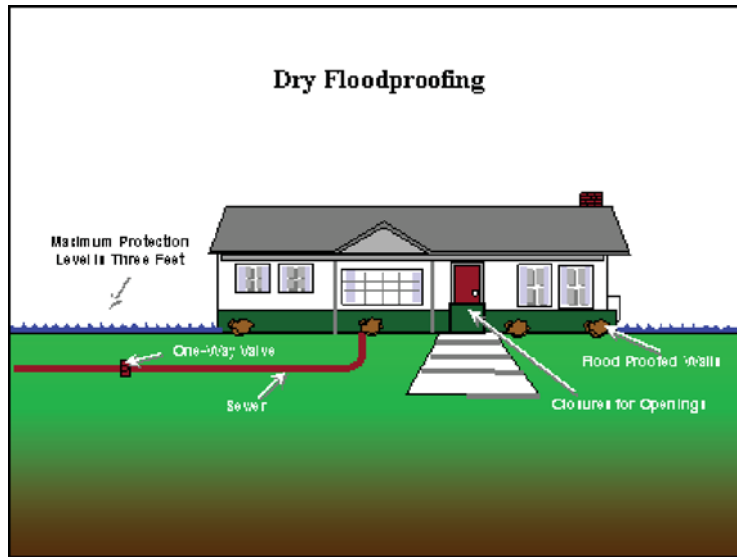


Figure 10: Dry Flood Proofing Diagram

#### 1.3.2.1.2 Wet Flood Proofing

Wet flood proofing measures (Figure 11) involves elevating and/or protecting vulnerable utilities (Figure 12) and other contents allowing flood water to get inside lower, non-living space areas of the structure via vents and openings in order to reduce interior damages and the effects of hydrostatic pressure and, in turn, reduce flood-related damages to the structure's foundation.

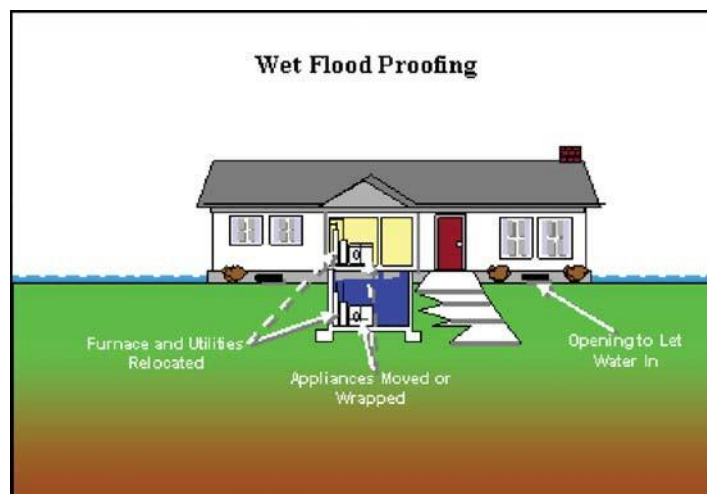


Figure 11: Wet Flood Proofing Diagram





Figure 12: Wet Flood Proofing Utilities Protection

#### 1.3.2.1.3 Elevation (aka. Raise)

Elevation involves raising the lowest finished floor of a building to a height that is above the flood level. In most cases, the structure is lifted in place and the foundation walls are extended up (Figure 13) to the new level of the lowest floor.

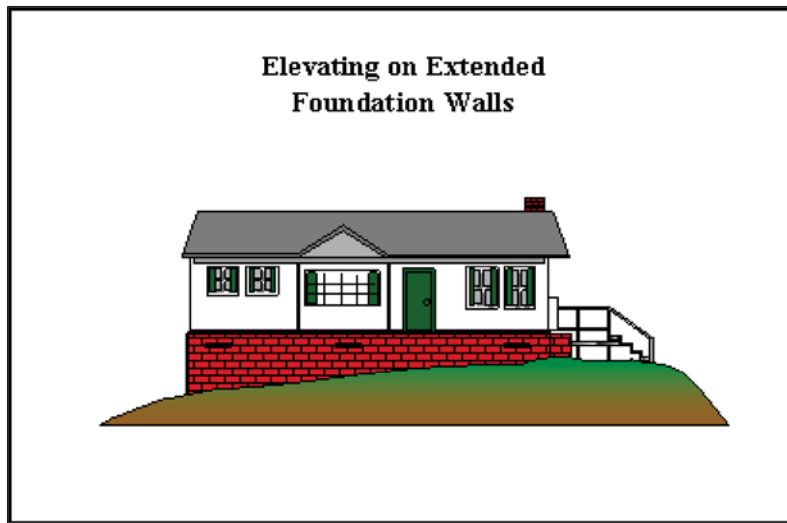


Figure 13: Elevation on Extended Foundation Walls



The elevation process differs for different foundation types: slab-on-grade, sub grade basement, walkout basement, raised (crawlspace) foundation, bi-levels/raised ranches, or split levels. In this study area, no structures were assumed to be elevated on piers, posts, or piles.

#### 1.3.2.1.4 Barriers (aka. Ringwall)

Usually barriers (Figure 14) surround the building but are not attached, such as in the case of ring walls, levees, or berms. They are used where the elevation isn't feasible. Due to the density of structures in the study area, only ring walls were considered.

#### 1.3.2.1.5 Buyout

Buyouts are the direct purchase and removal of structures from the floodplain, allowing owners to move to places away from flood risk. Structures are usually classified as a buyout when elevation or barriers are not feasible, the structure condition is poor or flood depth is greater than six feet.



Figure 14: Example of a ringwall arrangement built around a structure



### *1.3.2.2 Non-Structural Screening Level Analysis Design Assumptions*

Several assumptions were made for design and unit cost development because this was a screening level analysis as described below in Table 1.

#### *1.3.2.2.1 Screening Levels Algorithms*

The analysis applied generalized algorithms to a database of structures. The algorithms use flood levels along with information for each structure (i.e., ground elevation, main floor elevation, type of construction, etc.) to determine the appropriate method of flood proofing. It should be noted that this was a screening level analysis. Actual determination of which type of flood proofing is most appropriate for a specific building would need to be determined by examining individual structures and site specific conditions.





Table 1: Assumptions Inherent to the Screening of Non-Structural Alternatives for Representative Buildings

General Assumptions	<ul style="list-style-type: none"> <li>x Flood velocity is negligible.</li> <li>x Debris impacts will not be considered.</li> <li>x The area is considered non-coastal and thus not subject to wave and erosion impacts. No areas were designated as “V-zone” by FEMA, subject to 3-foot breaking waves.</li> <li>x Buildings elevated will be raised (finished floor elevation) to the 100-year water surface plus 1 foot of freeboard.</li> <li>x Flooding is gradual (no flash flooding).</li> </ul>
Foundation Walls	<ul style="list-style-type: none"> <li>x All basement foundation types are assumed to be unreinforced, 8” concrete masonry units (CMUs).</li> </ul>
Raised Structures (Crawlspace)	<ul style="list-style-type: none"> <li>x No utilities are located in the crawlspace.</li> <li>x Wet flood proofing of raised structures includes the elevation of utilities only.</li> </ul>
Slab-On-Grade Structures	<ul style="list-style-type: none"> <li>x Wet flood proofing is possible if the expected flood elevation is below the main floor (shallow flooding). This alternative includes the elevation of utilities only.</li> <li>x Consistent with Corps’ flood proofing guidance, structures will not be dry flood proofed for flooding depths greater than 2 feet with a maximum 3 feet of dry flood proofing protection.</li> </ul>
Structures With Basements	<ul style="list-style-type: none"> <li>x All basements are unfinished and contain major utilities.</li> </ul>
Bi-Levels	<ul style="list-style-type: none"> <li>x The lower portion of the first floor walls are masonry construction.</li> <li>x The foundation is slab-on-grade.</li> <li>x The main floor can be raised separately from the lower level by lifting off the sill of the masonry wall.</li> </ul>
Raised Ranches	<ul style="list-style-type: none"> <li>x The first floor (lower) walls are masonry.</li> <li>x The foundation is slab-on-grade.</li> <li>x The main floor can be raised separately from the lower level (similar to a structure with a basement).</li> </ul>
Split-Levels	<ul style="list-style-type: none"> <li>x The lower level is slab-on-grade.</li> <li>x The lower portions of the lower level walls are masonry construction.</li> <li>x The main floor level is raised over a crawl space.</li> <li>x The main floor and upper level can be separated from the lower level by rising at the sill.</li> </ul>



### 1.3.2.2.2 Screening Level Results

Results of the screening levels analysis using the algorithms by structure type are shown on Table 2 for all three floodplains (100-, 50-, and 10-year). Table 2 identifies the number of residential and non-residential structures targeted for treatment in the 1%, 2% and the 10% annual chance of exceedance non-structural plans, as well as the number of structures identified for each of the different types of non-structural treatments. All structures will be treated to the 100 year (1% annual chance of exceedance event) level plus an additional foot of freeboard regardless of the size of the non-structural plan. Therefore, while the number of structures treated under each plan changes, the design water level of treatment for each structure does not vary by plan. Finally, the identification of structures and types of treatment is only a computer screened identification at this point; if should a non-structural features be selected for implementation then a more detailed analysis of each structure and each treatment would have to be conducted. The home owners would also be consulted before final determination on any non-structural treatment before implementation.

Table 2: Millstone River Nonstructural Plan IRU the 1% (100-yr), 2% (50-yr) and 10% (10-yr) annual chance exceedance events

Nonstructural Flood Proofing Measure	1% (100-yr) Annual &KDQFH Exceedance*			2% (50-yr) Annual &KDQFH Exceedance or Alt #3A			10% (10-yr) Annual &KDQFH Exceedance or Alt #4A		
	Residential	Non- Residential	Sub Total	Residential	Non- Residential	Sub Total	Residential	Non- Residential	Sub Total
Dry	11	17	28	9	15	24	2	4	6
Wet	217	6	223	172	4	176	17	1	18
Barriers	4	68	72	3	63	66	1	34	35
Raise	279	2	281	273	2	275	77	2	79
Buyout	82	29	111	76	29	105	32	27	59
<b>Total of Structures</b>	593	122	<b>715</b>	533	113	<b>646</b>	129	68	<b>197</b>

\*Note: Alternative was later removed from further analysis. Level of protection was over the target.



Based on preliminary assessment of cost and benefit for the 1%, 2% and 10% annual exceedance events non-structural plans, a deeper exploration was requested by our non-federal sponsors in order to find a more suitable plan. Therefore, three sub-alternatives were developed for the 2% and 10% annual chance exceedance events, respectfully.

Table 3: Alternative #3B, #3C and #3D Millstone River Nonstructural Plan comparison for the 2% (50-yr) annual chance exceedance event

Nonstructural Flood Proofing Measure	Alt #3B: Non-structural Plan Not including Blue Acres Program Structures			Alt #3C: Non-structural Plan Not including Blue Acres Program & Zarephath Struc.			Alt #3D: Non-structural Plan Not including Blue Acres Program & Lost Valley Struc.		
	Residential	Non-Residential	Sub Total	Residential	Non-Residential	Sub Total	Residential	Non-Residential	Sub Total
Dry	9	15	24	9	15	24	9	15	24
Wet	166	4	170	166	4	170	172	4	176
Barriers	3	63	66	3	57	60	3	66	69
Raise	187	2	189	187	2	189	203	2	205
Buyout	64	29	93	57	21	78	67	29	96
<b>Total of Structures</b>	429	113	<b>542</b>	422	99	<b>521</b>	454	113	<b>567</b>



Table 4: Alternative #4B, #4C and #4D Millstone River Nonstructural Plan comparison for the 10% (10-yr) annual chance exceedance event

Nonstructural Flood Proofing Measure	Alt #4B: Non-structural Plan Not including Blue Acres Program Structures			Alt #4C: Non-structural Plan Not including Blue Acres Program & Zarephath Struc.			Alt #4D: Non-structural Plan Not including Blue Acres Program & Lost Valley Struc.		
	Residential	Non- Residential	Sub Total	Residential	Non- Residential	Sub Total	Residential	Non- Residential	Sub Total
Dry	2	4	6	2	4	6	2	4	6
Wet	15	1	16	15	1	16	16	1	17
Barriers	1	34	35	1	29	30	1	34	35
Raise	41	2	43	41	2	43	51	2	53
Buyout	22	27	49	16	19	35	25	27	52
<b>Total of Structures</b>	81	68	<b>149</b>	75	55	<b>130</b>	95	68	<b>163</b>



## 2 NON-STRUCTURAL ALTERNATIVE MAPS





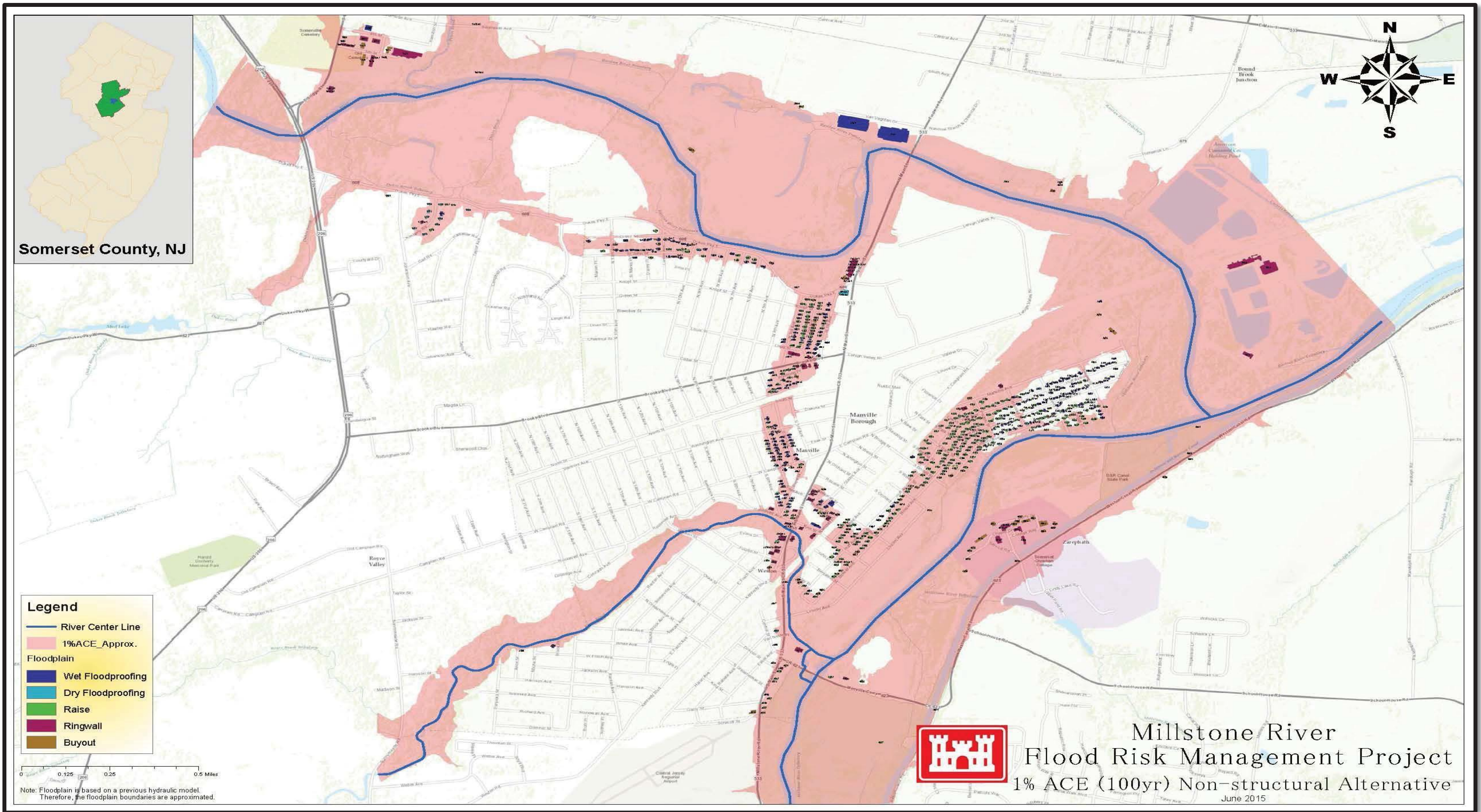


Figure 15: Non-structural alternative for the 1% (100-yr) floodplain.







# Millstone River Flood Risk Management Project Alternative 3A: Non-structural Plan | 2% ACE (50-yr) Floodplain

Disclaimer - While the United States Army Corps of Engineers, (hereinafter referred to USACE) has made every reasonable effort to insure the accuracy of the maps and associated data, it should be explicitly noted that USACE makes no warranty, representation or guarantee, either expressed or implied, as to the content, sequence, accuracy, timeliness or completeness of any of the data provided herein. The USACE, its officers, agents, employees, or servants, shall assume no liability of any nature for any errors, omissions, or inaccuracies in the information provided regardless of the cause. The USACE, its officers, agents, employees, or servants shall assume no liability for any decisions made or actions taken or not taken by the user of the maps and associated data in reliance upon any information or data furnished here.

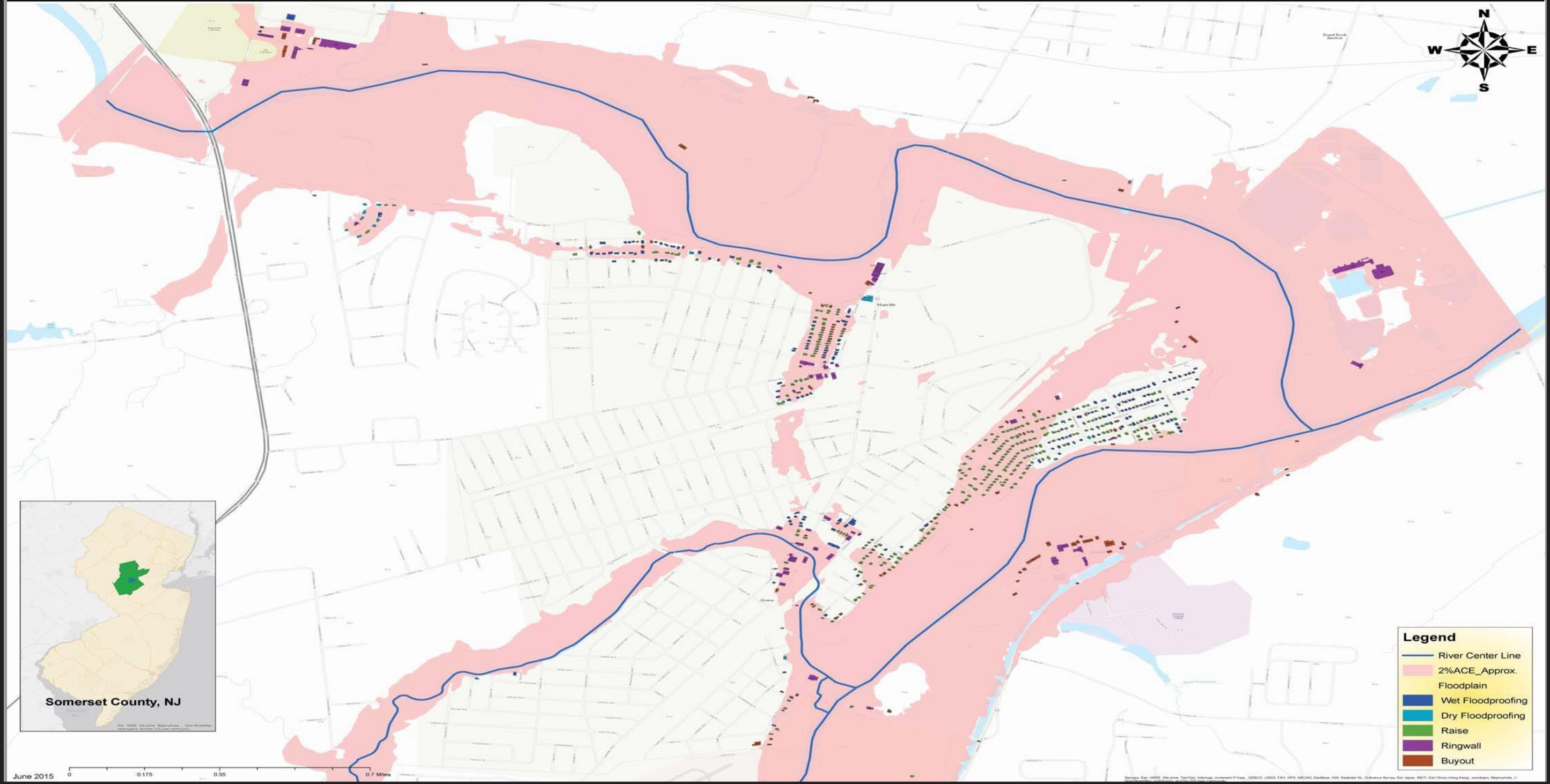


Figure 16: Alternative 3A | Non-structural plan for the 2% (50-yr) floodplain.







# Millstone River Flood Risk Management Project

## Alternative 4A: Non-structural Plan | 10% ACE (10-yr) Floodplain

Disclaimer - While the United States Army Corps of Engineers, (hereinafter referred to as USACE) has made every reasonable effort to insure the accuracy of the maps and associated data, it should be explicitly noted that USACE makes no warranty, representation or guarantee, either expressed or implied, as to the content, sequence, accuracy, timeliness or completeness of any of the data provided herein. The USACE, its officers, agents, employees, or servants, shall assume no liability of any nature for any errors, omissions, or inaccuracies in the information provided regardless of the cause. The USACE, its officers, agents, employees, or servants shall assume no liability for any decisions made or actions taken or not taken by the user of the maps and associated data in reliance upon any information or data furnished here.

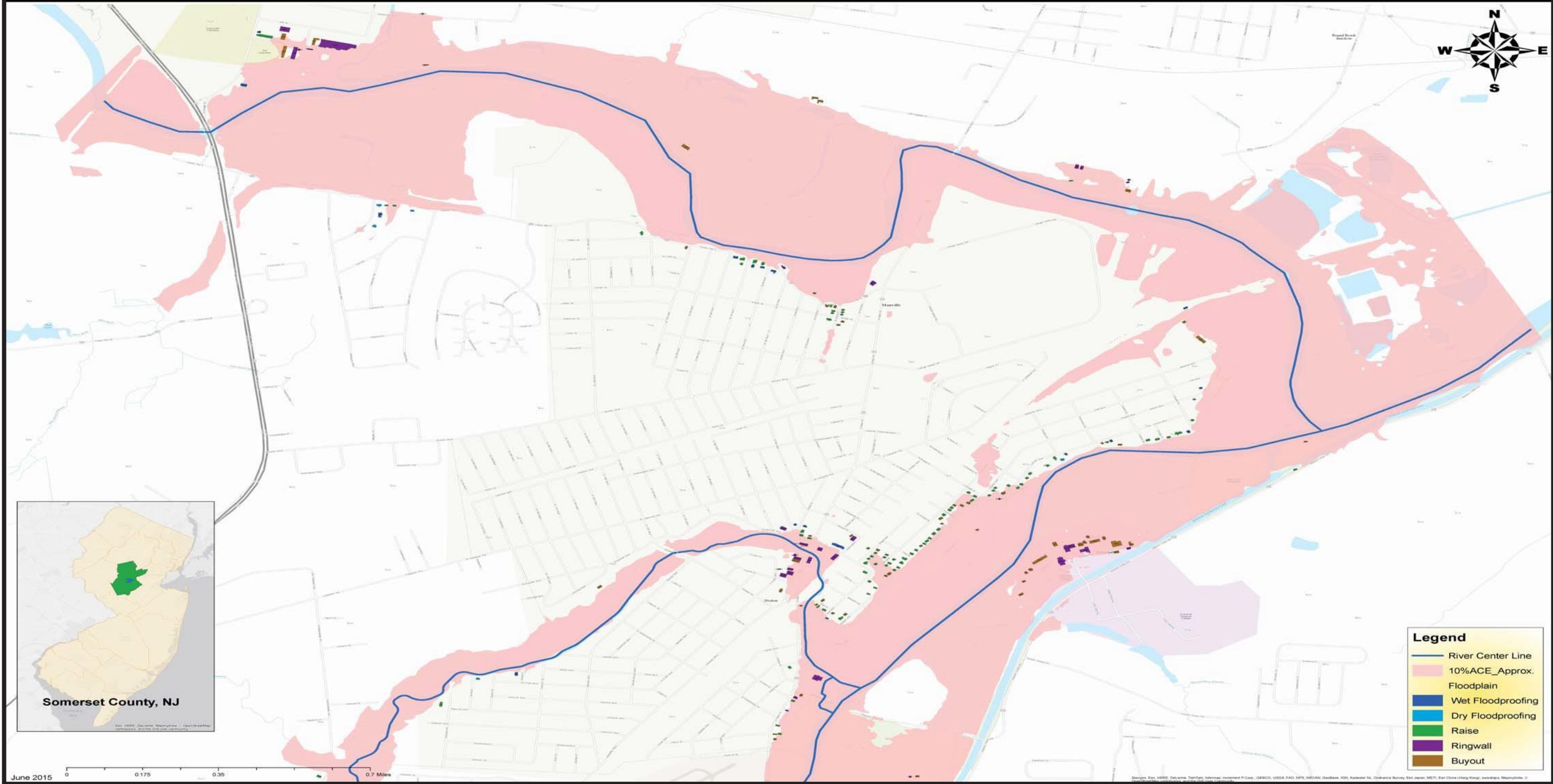


Figure 17: Alternative 4A | Non-structural plan for the 10% (10-yr) floodplain.



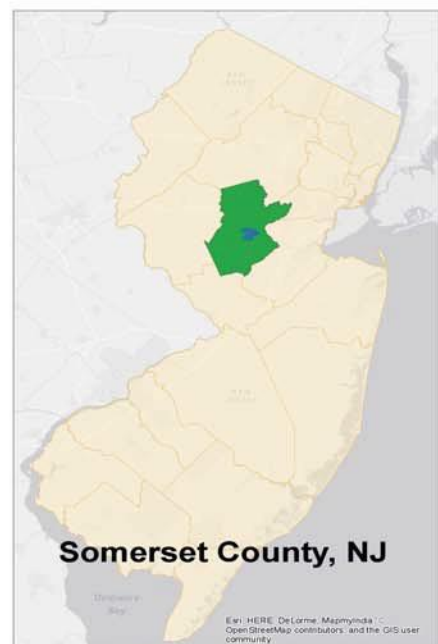




# Millstone River Flood Risk Management Project

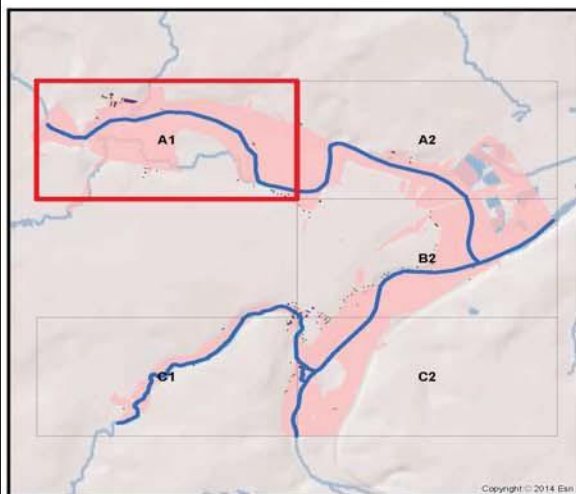
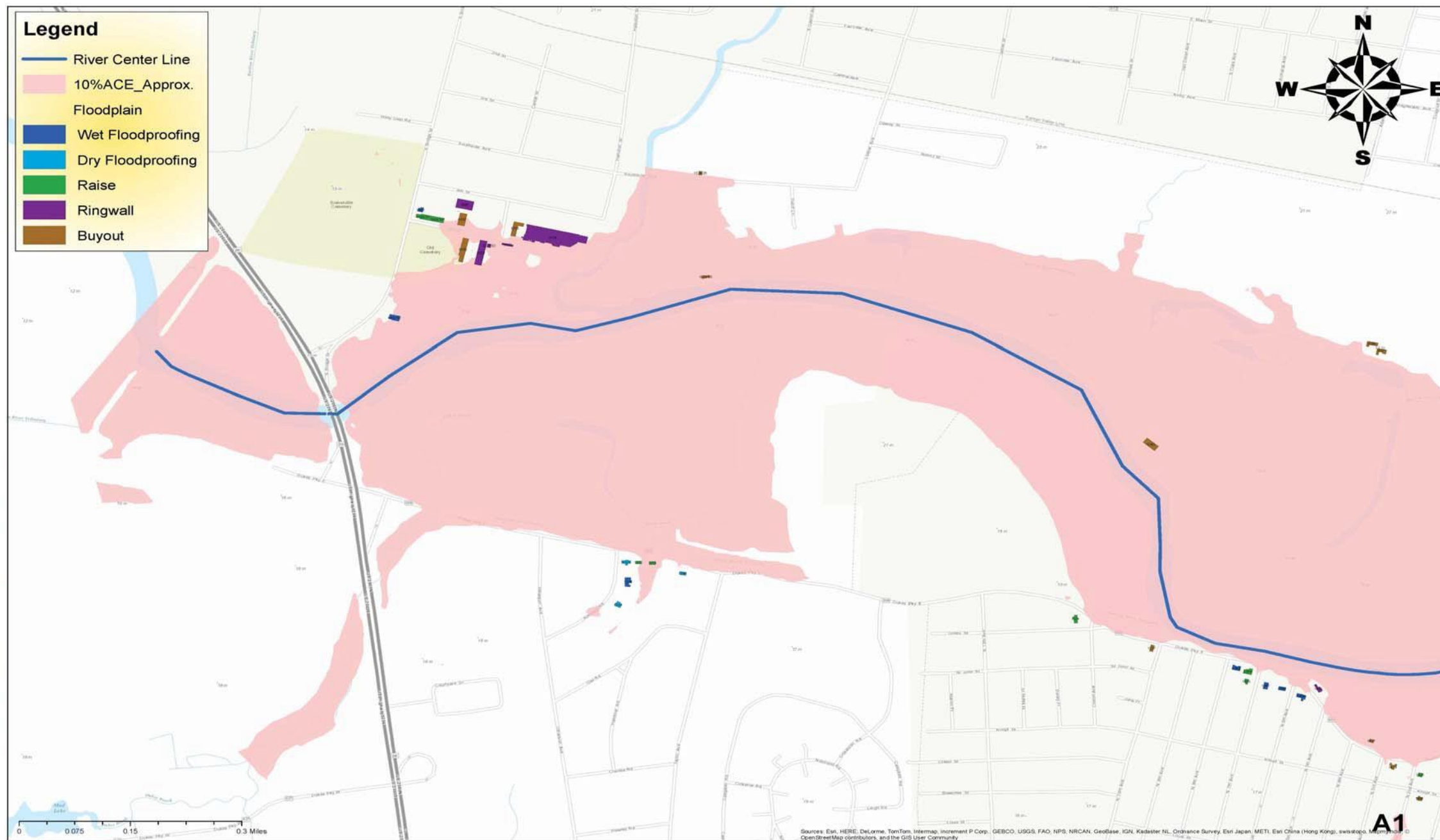
## Alternative 4C: Non-structural Plan | 10% ACE (10-yr) Floodplain Not Including Blue Acres Program and Zarephath Structures

Disclaimer - While the United States Army Corps of Engineers, (hereinafter referred to as USACE) has made every reasonable effort to insure the accuracy of the maps and associated data, it should be explicitly noted that USACE makes no warranty, representation or guarantee, either expressed or implied, as to the content, sequence, accuracy, timeliness or completeness of any of the data provided herein. The USACE, its officers, agents, employees, or servants, shall assume no liability of any nature for any errors, omissions, or inaccuracies in the information provided regardless of the cause. The USACE, its officers, agents, employees, or servants shall assume no liability for any decisions made or actions taken or not taken by the user of the maps and associated data in reliance upon any information or data furnished here.



Somerset County, NJ

- Legend**
- River Center Line
  - 10%ACE\_Approx. Floodplain
  - Wet Floodproofing
  - Dry Floodproofing
  - Raise
  - Ringwall
  - Buyout



June 2015

Figure 18: Alternative 4C | Non-structural plan for the 10% (10-yr) floodplain excluding Blue Acres Program and Zarephath structures (A1).







# Millstone River Flood Risk Management Project

## Alternative 4C: Non-structural Plan | 10% ACE (10-yr) Floodplain Not Including Blue Acres Program and Zarephath Structures

Disclaimer - While the United States Army Corps of Engineers, (hereinafter referred to USACE) has made every reasonable effort to insure the accuracy of the maps and associated data, it should be explicitly noted that USACE makes no warranty, representation or guarantee, either expressed or implied, as to the content, sequence, accuracy, timeliness or completeness of any of the data provided herein. The USACE, its officers, agents, employees, or servants, shall assume no liability of any nature for any errors, omissions, or inaccuracies in the information provided regardless of the cause. The USACE, its officers, agents, employees, or servants shall assume no liability for any decisions made or actions taken or not taken by the user of the maps and associated data in reliance upon any information or data furnished here.

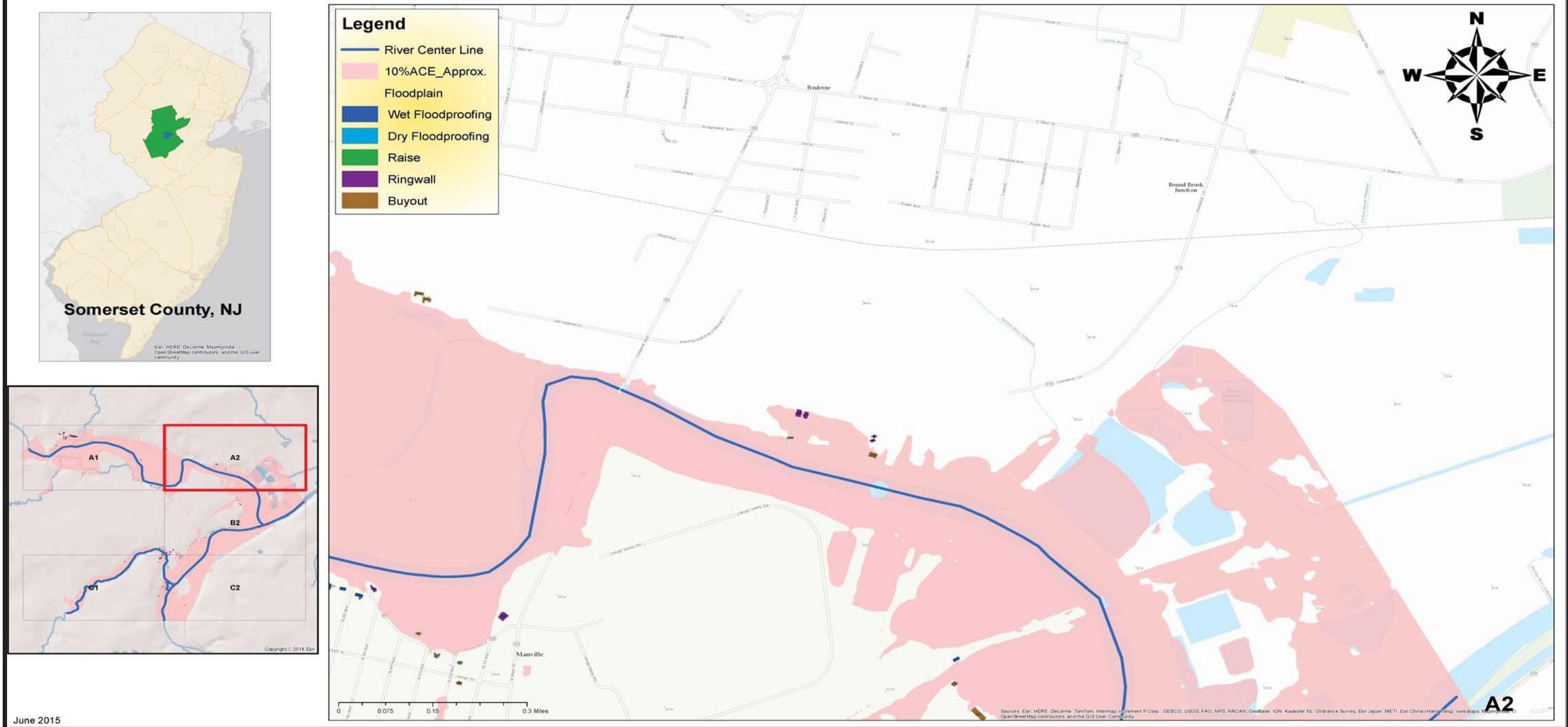


Figure 19: Alternative 4C | Non-structural plan for the 10% (10-yr) floodplain excluding Blue Acres Program and Zarephath structures (A2).







# Millstone River Flood Risk Management Project

## Alternative 4C: Non-structural Plan | 10% ACE (10-yr) Floodplain Not Including Blue Acres Program and Zarephath Structures

Disclaimer - While the United States Army Corps of Engineers, (hereinafter referred to USACE) has made every reasonable effort to insure the accuracy of the maps and associated data, it should be explicitly noted that USACE makes no warranty, representation or guarantee, either expressed or implied, as to the content, sequence, accuracy, timeliness or completeness of any of the data provided herein. The USACE, its officers, agents, employees, or servants, shall assume no liability of any nature for any errors, omissions, or inaccuracies in the information provided regardless of the cause. The USACE, its officers, agents, employees, or servants shall assume no liability for any decisions made or actions taken or not taken by the user of the maps and associated data in reliance upon any information or data furnished here.

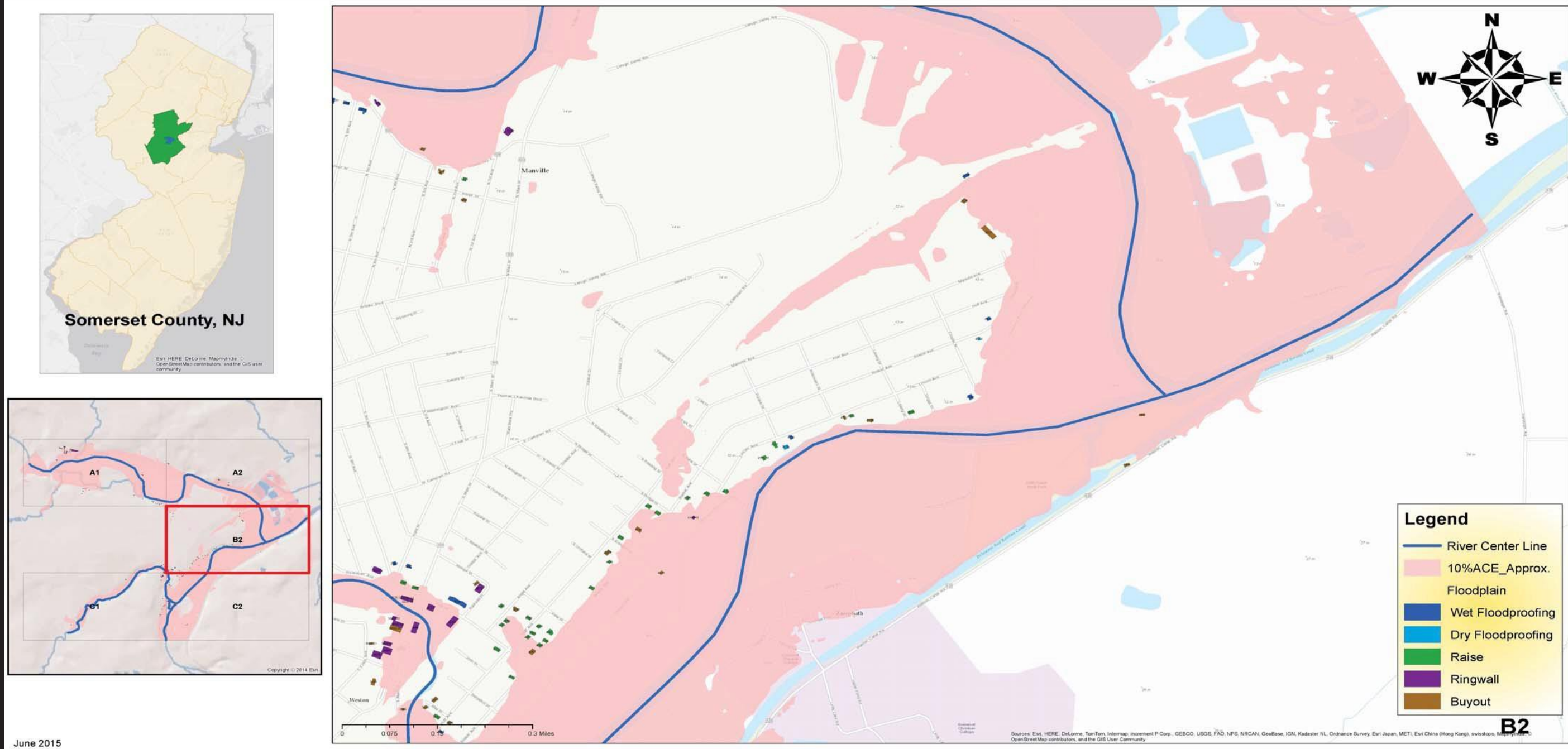


Figure 20: Alternative 4C | Non-structural plan for the 10% (10-yr) floodplain excluding Blue Acres Program and Zarephath structures (B2).







# Millstone River Flood Risk Management Project

## Alternative 4C: Non-structural Plan | 10% ACE (10-yr) Floodplain Not Including Blue Acres Program and Zarephath Structures

Disclaimer - While the United States Army Corps of Engineers, (hereinafter referred to as USACE) has made every reasonable effort to insure the accuracy of the maps and associated data, it should be explicitly noted that USACE makes no warranty, representation or guarantee, either expressed or implied, as to the content, sequence, accuracy, timeliness or completeness of any of the data provided herein. The USACE, its officers, agents, employees, or servants, shall assume no liability of any nature for any errors, omissions, or inaccuracies in the information provided regardless of the cause. The USACE, its officers, agents, employees, or servants shall assume no liability for any decisions made or actions taken or not taken by the user of the maps and associated data in reliance upon any information or data furnished here.

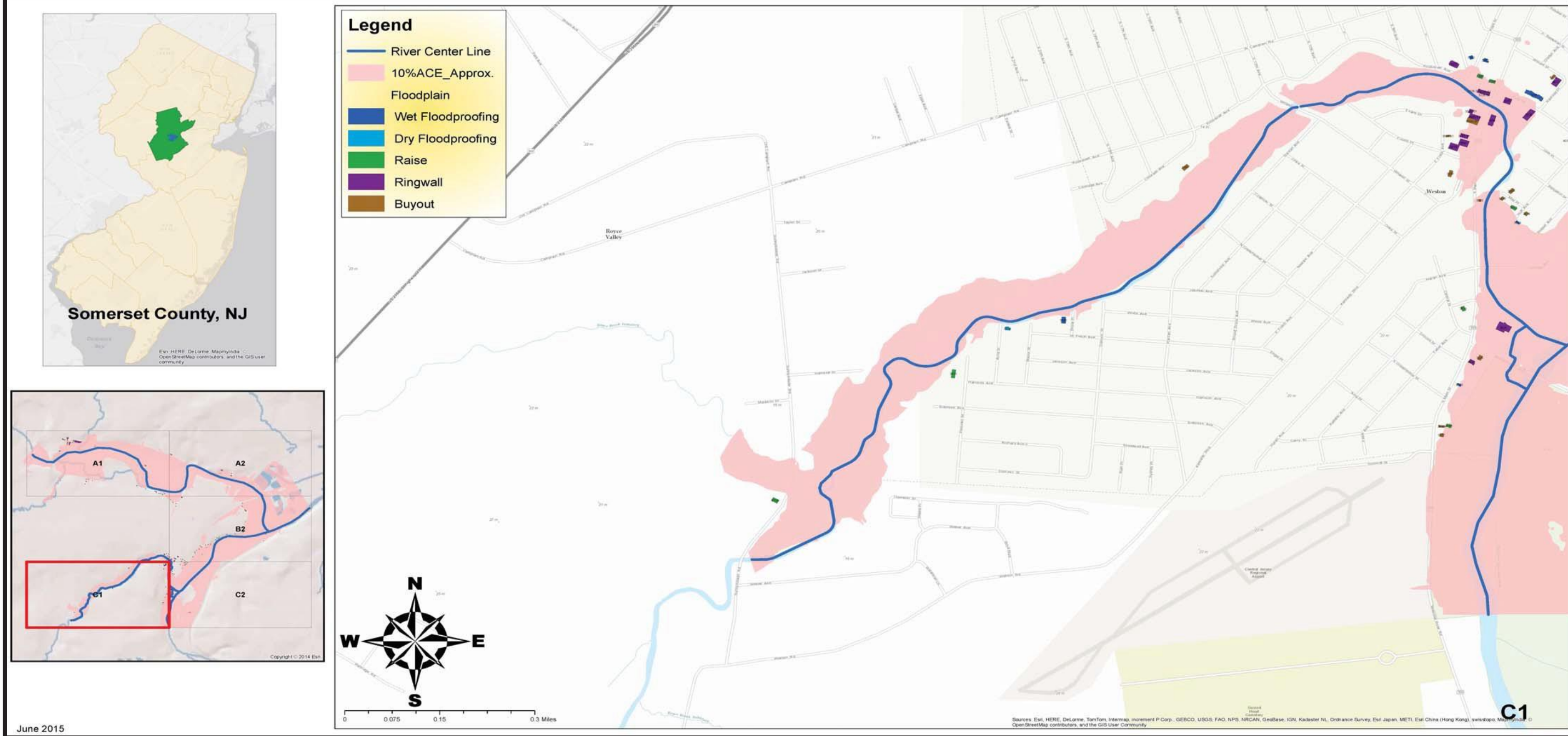


Figure 21: Alternative 4C | Non-structural plan for the 10% (10-yr) floodplain excluding Blue Acres Program and Zarephath structures (C1).







# Millstone River Flood Risk Management Project

## Alternative 4C: Non-structural Plan | 10% ACE (10-yr) Floodplain Not Including Blue Acres Program and Zarephath Structures

Disclaimer - While the United States Army Corps of Engineers, (hereinafter referred to USACE) has made every reasonable effort to insure the accuracy of the maps and associated data, it should be explicitly noted that USACE makes no warranty, representation or guarantee, either expressed or implied, as to the content, sequence, accuracy, timeliness or completeness of any of the data provided herein. The USACE, its officers, agents, employees, or servants, shall assume no liability of any nature for any errors, omissions, or inaccuracies in the information provided regardless of the cause. The USACE, its officers, agents, employees, or servants shall assume no liability for any decisions made or actions taken or not taken by the user of the maps and associated data in reliance upon any information or data furnished here.

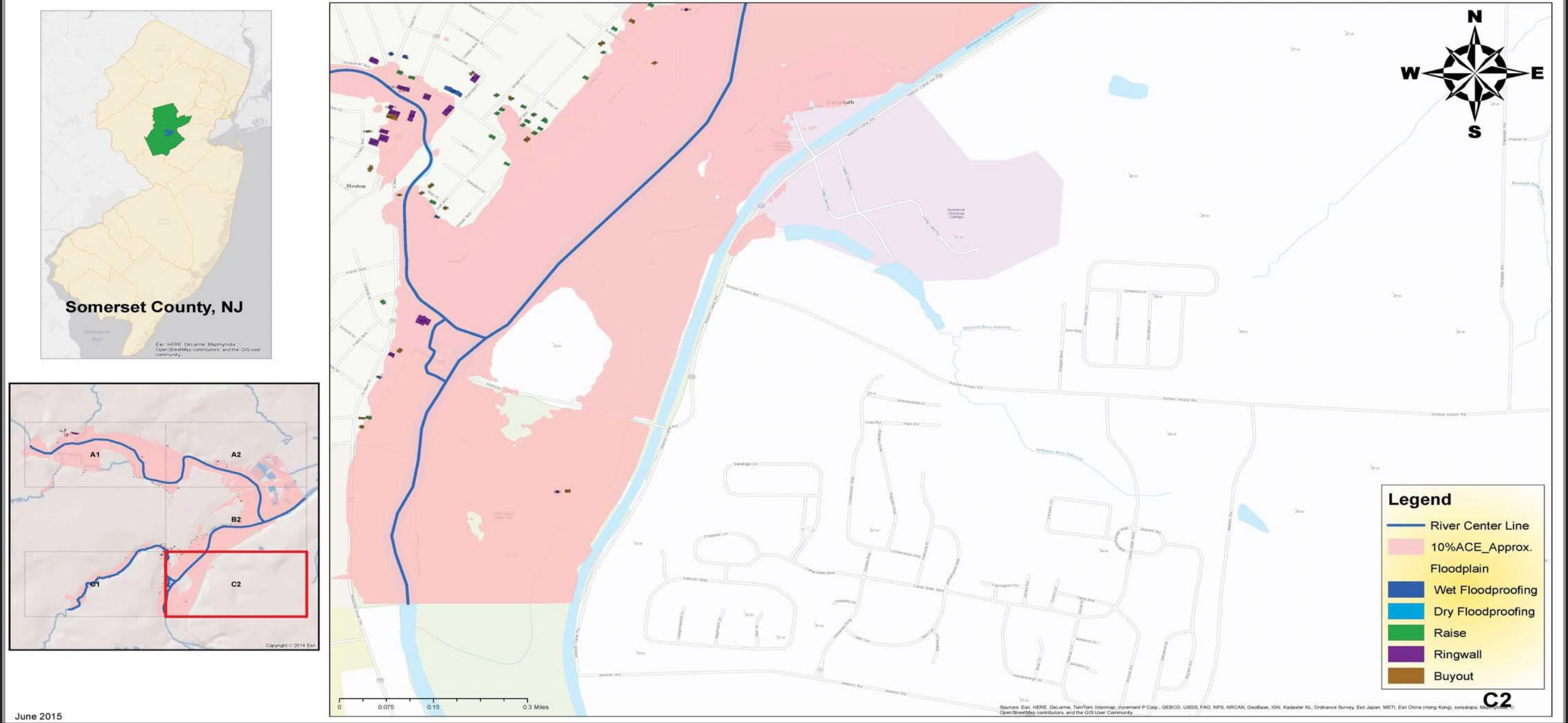


Figure 22: Alternative 4C | Non-structural plan for the 10% (10-yr) floodplain excluding Blue Acres Program and Zarephath structures (C2).



# **Millstone River Basin, New Jersey**

## **Flood Risk Management Feasibility Study**

### **Appendix B – Economics**

**U.S. Army Corps of Engineers  
New York District  
26 Federal Plaza  
New York, New York 10278**

**November 2016**



**US Army Corps  
of Engineers**  
New York District



**New Jersey Department of  
Environmental Protection**

## Table of Contents

<b>INTRODUCTION.....</b>	<b>2</b>
<b>PURPOSE.....</b>	<b>2</b>
<b>BENEFIT TYPES.....</b>	<b>3</b>
<b>CONDITIONS.....</b>	<b>3</b>
<b>DESCRIPTION OF THE STUDY AREA.....</b>	<b>4</b>
<b>LOCATION.....</b>	<b>4</b>
<b>ACCESSIBILITY.....</b>	<b>10</b>
<b>HISTORY AND DEVELOPMENT.....</b>	<b>11</b>
<b>POPULATION.....</b>	<b>12</b>
<b>INCOME AND ECONOMIC SETTING.....</b>	<b>14</b>
<b>LAND USE.....</b>	<b>17</b>
<b>RECREATION.....</b>	<b>18</b>
<b>PROBLEM IDENTIFICATION.....</b>	<b>19</b>
<b>WITHOUT-PROJECT FUTURE CONDITIONS.....</b>	<b>20</b>
<b>STORM DAMAGE.....</b>	<b>22</b>
<b>GENERAL.....</b>	<b>22</b>
<b>REACH SELECTION.....</b>	<b>22</b>
<b>INVENTORY METHODOLOGY.....</b>	<b>23</b>
<b>DESCRIPTION OF DAMAGE FUNCTIONS &amp; SOURCE OF STAGE-FREQUENCY CURVES.....</b>	<b>24</b>
<b>FLOOD DAMAGE ANALYSIS, COST ESTIMATES.....</b>	<b>25</b>
<b>WITHOUT-PROJECT ANNUAL DAMAGES.....</b>	<b>26</b>
<b>ALTERNATIVES EVALUATED.....</b>	<b>27</b>
<b>NONSTRUCTURAL ALTERNATIVES.....</b>	<b>28</b>
<i>Nonstructural Screening Level Results.....</i>	<i>30</i>
<i>Nonstructural Benefits and Costs.....</i>	<i>32</i>
<b>STRUCTURAL ALTERNATIVES.....</b>	<b>32</b>
<i>Alternative 1 – Levee/Floodwall.....</i>	<i>32</i>
<i>Alternative 2 – Channel Modifications.....</i>	<i>33</i>
<b>SUMMARY EVALUATION AND COMPARISON OF ALTERNATIVE PLANS.....</b>	<b>35</b>



## **INTRODUCTION**

### **Purpose**

This appendix documents economic analysis procedures used to evaluate alternative plans for their contribution to National Economic Development (NED). The report estimates potential flood damages and the effectiveness of flood risk management measures within the Millstone river basin study area. Descriptions are provided for the processes used to conduct the economic base study, compile a structure inventory and value survey, and develop structure damage functions used in the flood damage analysis. The flood damage analysis quantified without-project equivalent annual damages (EAD) and the with-project EAD over a 50-year period of analysis. Results of the analysis confirm that none of the studied alternatives meet the minimum federal requirements for economic justification.

The economic analysis includes a description of the study area in terms of its existing development, local economy, population, income, and employment. The structure survey includes an inventory of the structures within the 500-year floodplain to determine residential and non-residential structure characteristics and values. Estimates for content values and modified stage-damage curves were assigned according to building type. Estimates of flood damage reduction benefits were used to determine if there is federal financial interest in a storm risk management project.

Benefits were calculated as a reduction in flood damages from the without-project condition. The damage analysis considers inundation impacts to structures and contents located within the Millstone River Basin. Both structural and nonstructural flood risk mitigation alternatives have been considered. Each of the structural alternatives were designed to address inundation impacts expected from a 2% annual probability flood event, plus one foot. Nonstructural alternatives were designed to address inundation impacts expected from a 1% probability flood event.

It was determined early on that the most significant flooding problems in the Millstone River Basin are in the Borough of Manville. Many other areas contain flood-prone structures that are more widely distributed, making it less economically feasible to provide flood risk management measures. This screening and determination allowed this report to be more narrowly focused on the Borough of Manville for project analysis.



## **Benefit Types**

The potential range of benefits to be derived from proposed structural and/or nonstructural measures include:

- reduced inundation damage to buildings
- reduced damage to building contents
- reduced other-to-structure related damages including automobile, landscaping, and out building damages, and emergency and cleanup costs

## **Conditions**

The original inventory survey was conducted in 2004. The building structures and content values of the original inventory were then updated to current depreciated replacement values in October 2013, and the flood damage analysis was completed in November 2013 at the October 2013 price level. The study used a base year of 2018 for a 50-year period of analysis, and used the fiscal year 2014 discount rate of 3.5%.





## **DESCRIPTION OF THE STUDY AREA**

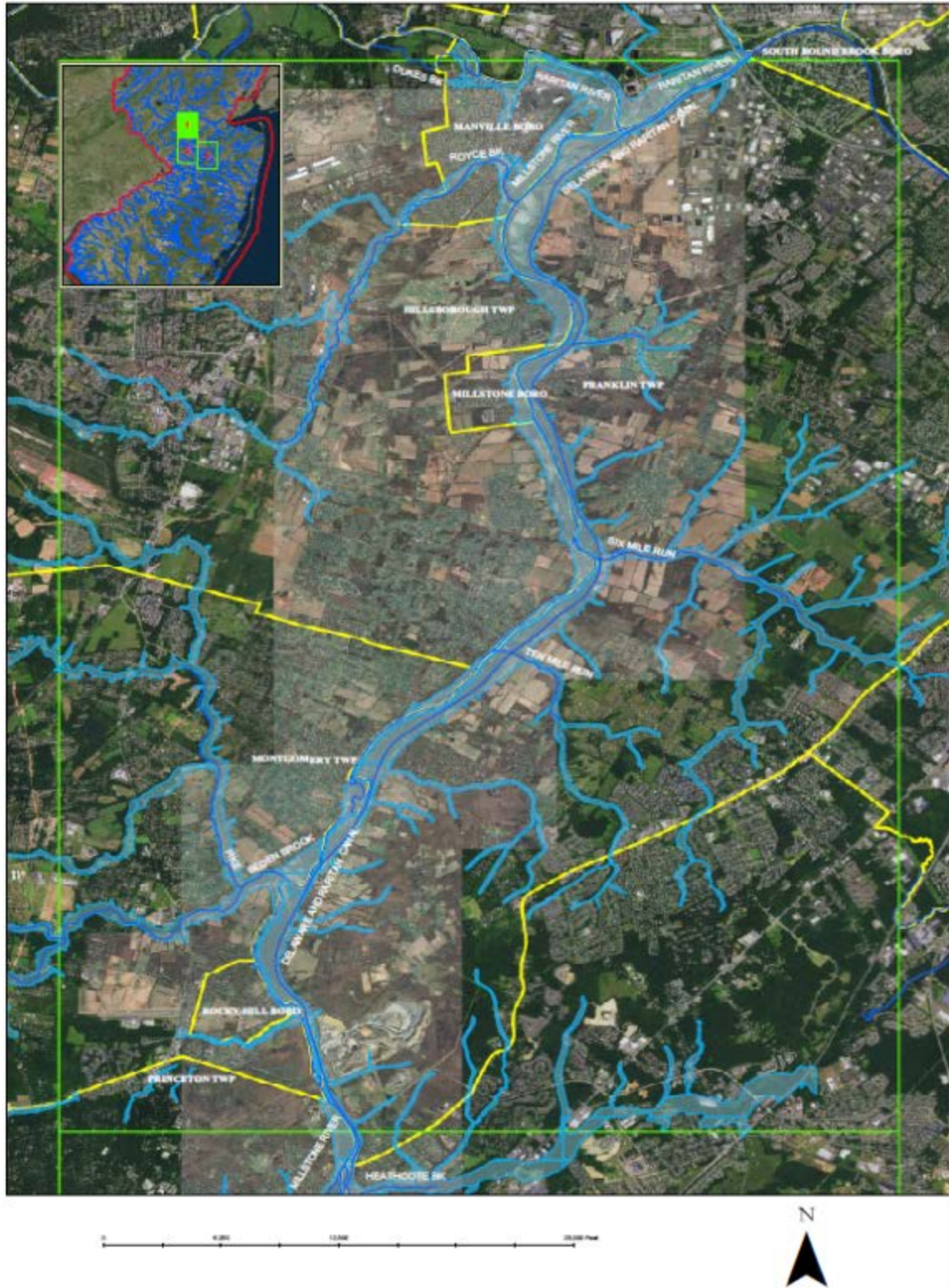
### **Location**

The study area is the Millstone River Basin (Map 1, 2 and 3). The 238-square mile basin is located in north-central New Jersey, halfway between Philadelphia and New York City. The study area is bounded by the Raritan River to the north, the Millstone River to the east and Royce Brook to the south. The basin includes the Millstone River and its major tributaries located in the New Jersey counties of Mercer, Middlesex, Monmouth, Hunterdon, and Somerset. From its headwaters near Millstone Township in Monmouth County, the Millstone River flows northward through Somerset County to its confluence with the Raritan River in the Borough of Manville.

Tributaries to the Millstone within the currently delineated study area include Royce Brook and Stony Brook. Stony Brook, which is the largest tributary to the Millstone River, is located near Princeton Township, New Jersey. This sub-basin has a drainage area of 56 square miles. Royce Brook originates east of Manville in Hillsborough Township and has a drainage area of 16.5 square miles. Royce Brook runs for approximately 9 miles before discharging into the Millstone River in the southern east portion of Manville.

A literature review and interviews were conducted to identify water resources issues in the basin. Federal, State, municipal and local stakeholders coordinated with each other to identify problems and opportunities for flood risk management within the basin. Delineation of the 0.2 percent (500-year) floodplain in the Millstone River Basin showed the greatest density of at-risk structures to be located in the Borough of Manville, Somerset County. After determining that the most significant flooding problems in the Millstone River Basin were in the Borough of Manville, Manville became the area of focus. For the remainder of the Millstone River communities, flood risk management is not economically feasible, since flood-prone structures are widely distributed. This screening and determination allowed the study area to be narrowed for project and benefit analysis. The refined project area and this report focuses on portions of the Millstone River, Raritan River and Royce Brook near the Borough of Manville (Map 4). Map 4 depicts the location of the project area.



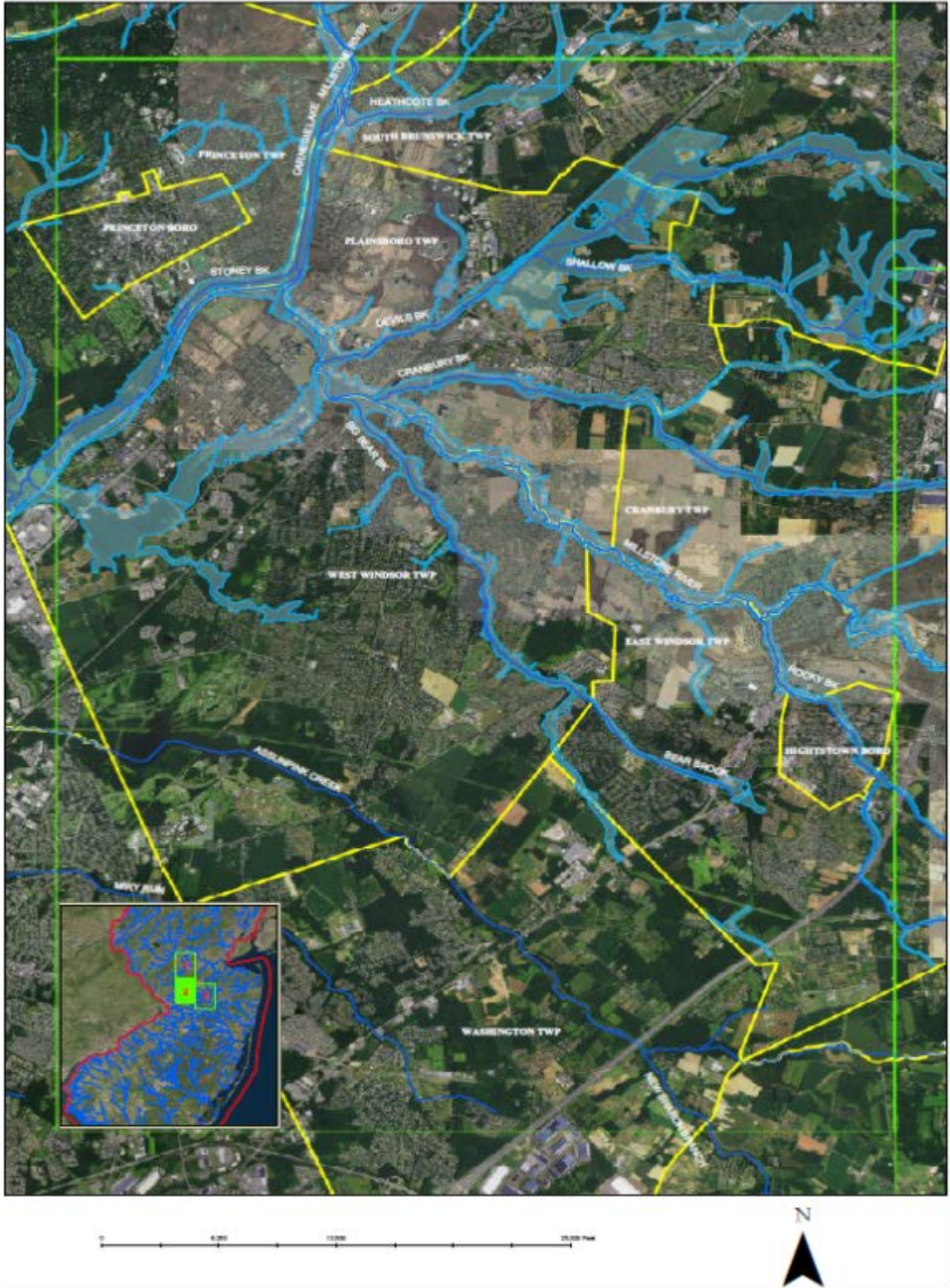


**MILLSTONE RIVER BASIN, NEW JERSEY  
FLOOD RISK MANAGEMENT FEASIBILITY STUDY**

*Map 1. Millstone River Basin with 1% annual chance exceedance floodplain*





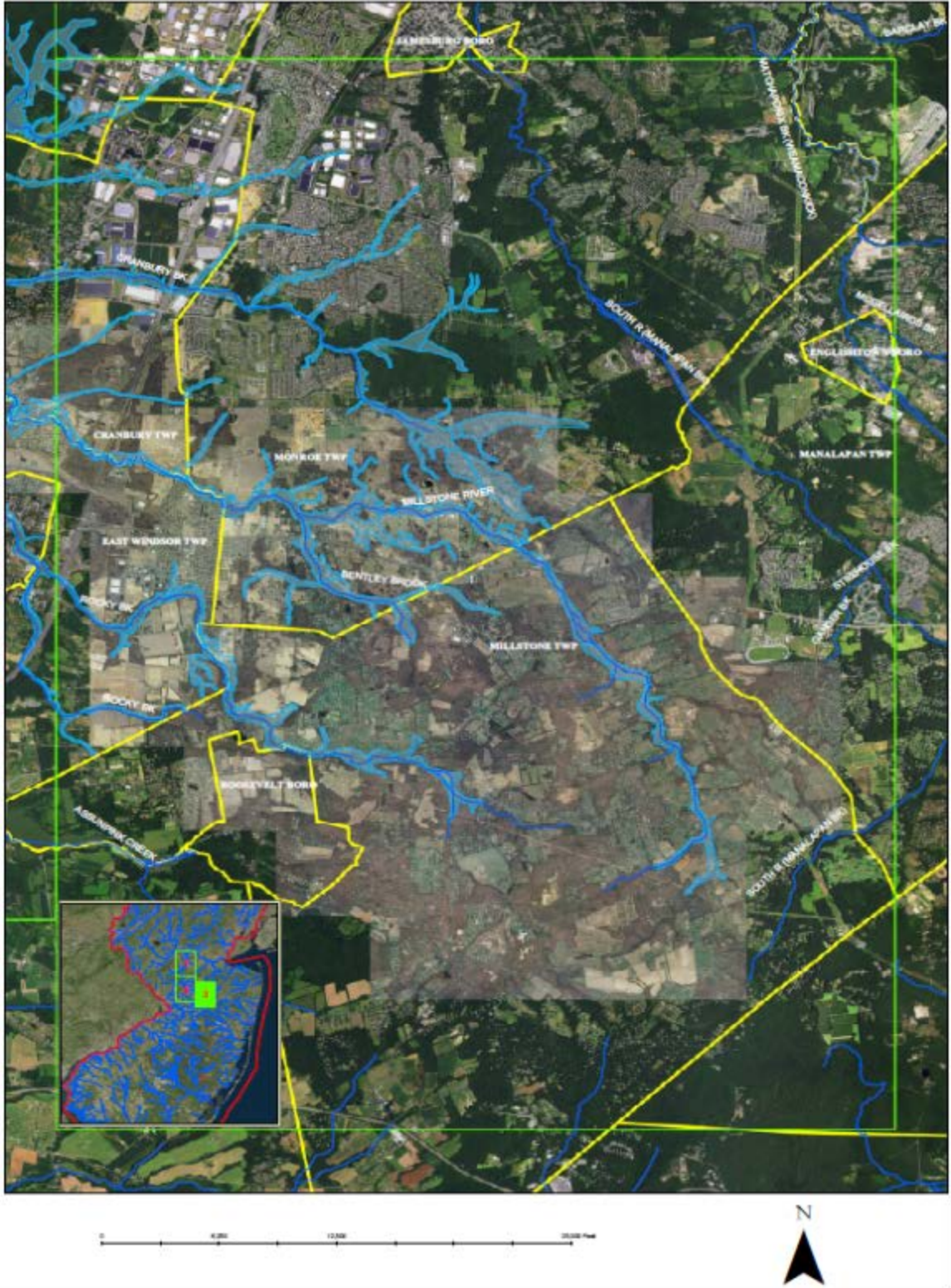


**MILLSTONE RIVER BASIN, NEW JERSEY  
FLOOD RISK MANAGEMENT FEASIBILITY STUDY**

***Map 2. Millstone River Basin with 1% annual chance exceedance floodplain***



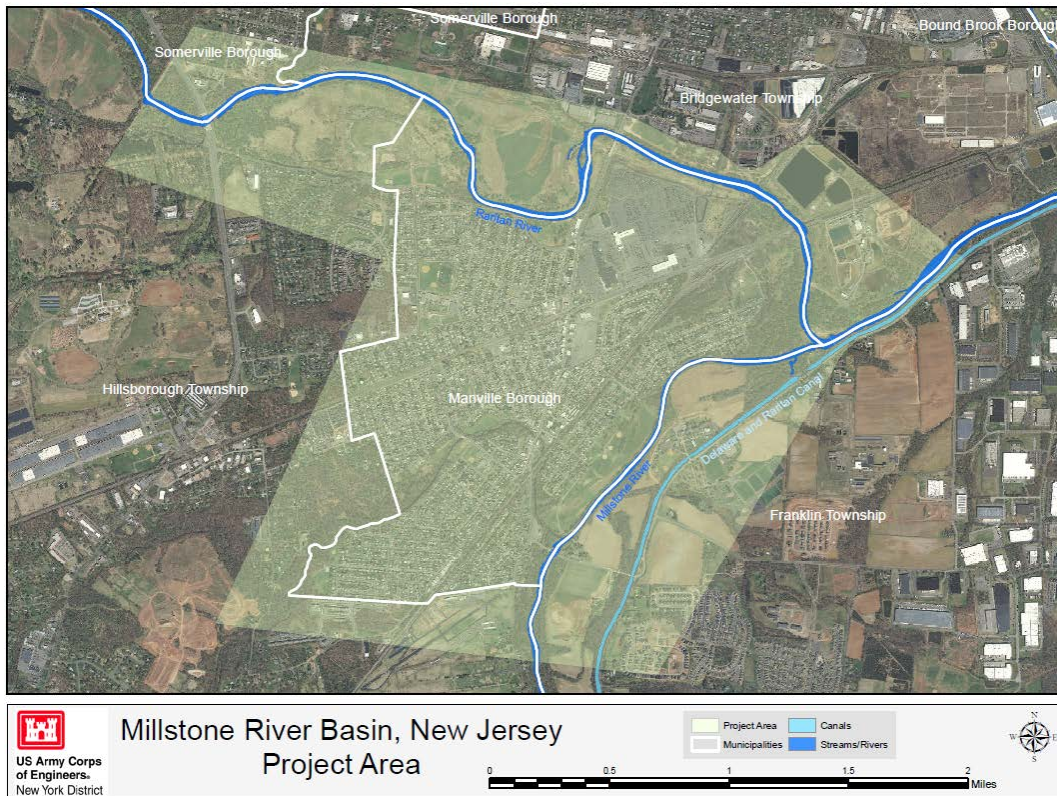




**MILLSTONE RIVER BASIN, NEW JERSEY  
FLOOD RISK MANAGEMENT FEASIBILITY STUDY**



**Map 3. Millstone River Basin with 1% annual chance exceedance floodplain**



**Map 4. Refined Project Area**

## Accessibility

Several key roads including major highways border the study area. Interstate Route 287 passes close to the northeast corner of the study area, Routes 28 and 22 pass through Somerville Borough immediately to the north, and Route 206 passes close to the western edge of the study area. Important local roads include Millstone River Road (CR 533), which enters from the south and passes through along the easterly portion of the community to become Main Street before continuing north to Somerville Borough, and Dukes Parkway, which runs parallel to the Raritan River and connects Route 206 with Main Street. Camplain Road also connects Main Street to Rt. 206, and Weston Canal Road (CR 623) connects the eastern part of the study area with I-287.



Several freight railroads pass through the Borough of Manville, and the nearest railroad stations with passenger services are located in Bridgewater and Bound Brook, between one and three miles from downtown Manville.

As the Reading RR passes across the Borough, it forms a barrier separating the south east section of Manville from the remainder of the town. Low lying and adjacent to the Millstone River, this area is particularly prone to flooding, and is known locally as “Lost Valley”. The principal vehicular access to and from the Lost Valley area is the bridge over the railroad at North Bridge Street. The only other point of entry to this area is at Kyle Street, where there is a single lane vehicular tunnel beneath the railroad. This access is too small to be passable by most emergency vehicles, and may not be suitable for use by evacuation traffic in the event of a serious flood.

Central Jersey Regional Airport (formerly Kupper Airport) borders the southern edge of the Borough of Manville, catering principally to private light aircraft.

## **History and Development**

Historically, Manville was an industrial town that developed around its primary employer, the Johns Manville Corporation, a manufacturer of asbestos products. In 1912, the Johns-Manville Company of New York selected a site in Manville (then part of Hillsborough Township) on which to relocate their growing business. The company would become the largest asbestos manufacturing concern in North America, and the Manville plant was the largest of the company’s operations, employing 2,000 men and women, 60 % of whom lived in Manville. In 1929, after years of tension between the village of Manville and Hillsborough Township, village officials successfully petitioned the state Legislature for separation from the township, making Manville a separate borough.

In 1982, Johns-Manville filed for bankruptcy protection, citing pending and anticipated health claims from asbestos workers and their survivors, and consequently the Johns-Manville plant closed in 1986. The plant was Manville’s largest property taxpayer and thereby provided the bulk of property taxes to the municipality. With high unemployment and reduced tax revenues, the Borough subsequently suffered a significant economic downturn.



In 1987, work crews took the first step in a \$40 million cleanup in which thousands of tons of hazardous waste and asbestos-containing materials were removed from the Johns-Manville site. The site has subsequently been redeveloped, including a 26 acre retail development adjacent to North Main Street known as Marketplace at Manville. This development features a Wal-Mart, various strip mall stores, and a 12-screen movie theater. The remainder of the site has been taken over by auto sales and auction company Adesa Corporation, with offices and extensive parking lots.

Despite the ongoing redevelopment, Manville still faces contamination issues. Creosote, a wood preservative that has been linked to cancer, was discovered in the Claremont development area of the Borough. Between 1910 and 1956 the Federal Creosote Company operated a plant treating railroad ties and telegraph poles on a site to the east of Manville's Main Street between the two railroads. These activities generated process waste, including creosote-contaminated sludge, sediments, process residuals, preservative drippings, and spent process liquids. Area soil was also contaminated.

After the plant ceased operations, the site was sold to a developer, and fill material was used to cover the canals and lagoons that had been used to transport and hold spent creosote during operations, although the original coal tar creosote and associated wastes were not removed. In the early 1960s, a parcel of approximately 15 acres of the site was developed as a shopping mall and commercial area. In the mid-1960s, 137 houses were built on another 35 acres of the site, and this development is known as the Claremont development. The federal Environmental Protection Agency (EPA) designated this area as a priority site for toxic cleanup and began remedial action to remove contaminated soil in 2001.

## **Population**

U.S. Census data indicates that the population for the state of New Jersey has increased by 1.7% between 2010 and 2014. Population change in the counties and municipalities near the study area has ranged between -1.1% and 9.4% (Table 1).



The project area, the Borough of Manville, has increased slightly. The 2014 U.S. Census data indicates that there are 10,388 people living in Manville as opposed to 10,344 people in 2010 (Table 1).

**Table 1: Population Data for the State, Counties, and Affected Municipalities**  
(Courtesy of the U.S. Census Bureau)

Population Data				
Area Name	2000	2010	2014	% Change 2010-14
Cranbury Twp	3,227	3,857	3,857	0
East Windsor Twp	24,919	27,190	27,536	1.3
Franklin Twp	50,903	62,300	65,938	5.8
Hillsborough Twp	36,634	38,303	39,544	3.2
Manville Boro	10,343	10,344	10,388	0.4
Millstone Twp	8,970	10,566	10,448	-1.1
Monroe Twp	27,999	39,132	42,810	9.4
Montgomery Twp	17,481	22,254	22,746	2.2
Plainsboro Twp	20,215	22,999	23,429	1.9
Princeton Twp	N/A	28,572	30,108	5.4
South Brunswick Twp	37,734	43,417	45,163	4.0
West Windsor Twp	21,907	27,165	28,465	4.8
Hunterdon County	121,989	128,349	126,067	-1.0
Mercer County	350,761	366,513	371,537	1.1
Middlesex County	750,162	809,858	836,297	3.3
Monmouth County	615,301	630,380	629,279	-0.2
Somerset County	297,490	323,444	332,568	2.8
New Jersey State	8,414,350	8,791,894	8,938,175	1.7





## Income and Economic Setting

Table 2 illustrates per capita income, median household income and the percentages of individuals below the poverty level for New Jersey and the counties and municipalities near the study area. West Windsor Township has the highest per capita income and median household income at \$63,928 and \$155,067, respectively. Cranbury Township has the lowest proportion of individuals below the poverty level at 1.4%. The Borough of Manville has the lowest per capita income and median household income at \$29,298 and \$62,583, respectively. Mercer County has the highest proportion of individuals below the poverty level at 11.2%.

**Table 2: Income Comparison for the State, Counties, and Affected Municipalities**

*(U.S. Census Bureau, 2009-2013 5-Year American Community Survey<sup>1</sup>)*

Comparison of Income			
Area Name	Per Capita Income	Median Household Income	Individual Below Poverty Level (%)
Cranbury Twp	63,600	149,450	1.4
East Windsor Twp	37,183	84,656	8.1
Franklin Twp	40,332	88,726	5.8
Hillsborough Twp.	46,097	113,156	3.9
Manville Boro	29,298	62,583	7.0
Millstone Twp	54,103	135,556	3.6
Monroe Twp	44,470	70,384	4.2
Montgomery Twp	61,397	152,195	3.1
Plainsboro Twp	48,832	93,284	3.5
South Brunswick Twp	43,643	108,315	2.9
West Windsor Twp	63,928	155,067	4.7
Hunterdon County	50,349	106,143	4.0
Mercer County	37,465	73,480	11.2
Middlesex County	34,345	79,596	8.5
Monmouth County	42,749	84,526	7.0
Somerset County	47,803	99,020	5.0
New Jersey State	36,027	71,629	10.4

<sup>1</sup> The American Community Survey is an ongoing U.S. Census survey that provides vital information on a yearly basis about the United States and its people.



Within the labor force, management, business, science and arts occupations tend to employ the highest percentages of individuals within the study area, while production, transportation, and material moving occupations tend to employ the lowest percentage of individuals (Table 4).

Within the project area of Manville, sales and office occupations form the largest segment of the working population (26.5%). Production, transportation and material moving occupations employ the lowest percentage of individuals for Manville (14.0%).

For more than 70 years the Johns-Manville Corporation employed thousands of people and was the primary payer of local property taxes. Following the closure of the plant and the resulting loss of property tax dollars, local homeowners were assessed with property tax increases. The Marketplace at Manville retail development has been constructed on the western portion of the former Johns-Manville site. It is assumed that the majority of the working population is employed at locations outside of Manville.



**Table 3: Employment Status for the State, Counties, and Affected Municipalities**

*(U.S. Census Bureau, 2009-2013 5-Year American Community Survey)*

<b>Employment Status of Civilian Labor Force</b>					
<b>Area Name</b>	<b>Population 16 years and over</b>	<b>In Labor Force</b>	<b>Employed</b>	<b>Unemployed</b>	<b>% Unemployment</b>
Cranbury Twp	2,766	1,866	1,733	133	7.1
East Windsor Twp	21,896	15,842	14,342	1,500	9.5
Franklin Twp	50,984	34,617	31,908	2,671	7.7
Hillsborough Twp.	30,166	22,179	20,803	1,376	6.2
Manville Boro	8,706	6,107	5,255	852	14.0
Millstone Twp	8,398	5,870	5,489	363	6.2
Monroe Twp	33,751	15,933	14,548	1,385	8.7
Montgomery Twp	16,292	10,610	9,976	634	6.0
Plainsboro Twp	18,056	13,197	12,349	848	6.4
South Brunswick Twp	33,866	23,754	22,222	1,476	6.2
West Windsor Twp	20,697	14,213	13,180	1,012	7.1
Hunterdon County	102,022	70,204	64,648	5,523	7.9
Mercer County	295,849	197,953	176,840	20,969	10.6
Middlesex County	654,049	433,807	394,477	39,087	9.0
Monmouth County	501,783	335,790	305,222	30,144	9.0
Somerset County	256,051	178,036	165,266	12,732	7.2
New Jersey State	7,028,795	4,677,666	4,197,483	472,094	6.7



**Table 4: Occupational Status for the State, Counties, and Affected Municipalities**

*(U.S. Census Bureau, 2009-2013 5-Year American Community Survey)*

<b>Occupation Status of Employed Civilian Population 16 Years and Over (%)</b>					
<b>Area Name</b>	<b>Management, business, science and arts occupations</b>	<b>Service occupations</b>	<b>Sales and office occupations</b>	<b>Natural resources, construction, and maintenance occupations</b>	<b>Production, transportation, and material moving occupations</b>
Cranbury Twp	58.7	11.9	22.7	3.3	3.3
East Windsor Twp	43.7	12.4	25.7	5.2	13
Franklin Twp	50.7	13.5	22.4	5.1	8.3
Hillsborough Twp.	55	9.9	24.4	6.5	4.3
Manville Boro	22.3	21.2	26.5	15.9	14.0
Millstone Twp	52.3	12.1	22.6	7.1	5.9
Monroe Twp	47.8	10	29.6	6.2	6.4
Montgomery Twp	76	6.4	13.7	1.6	2.2
Plainsboro Twp	69.2	5.9	18.5	2.8	3.6
South Brunswick Twp	57.1	10.1	22.5	4.2	6.0
West Windsor Twp	72.2	5.3	18.4	1.6	2.4
Hunterdon County	49.7	12.8	24.8	6.9	5.9
Mercer County	42.7	17.9	24.2	5.8	9.4
Middlesex County	43.9	13.8	25	6.2	11.1
Monmouth County	42.8	15.8	26.4	7.5	7.5
Somerset County	51.1	12.4	23	6.1	7.4
New Jersey State	40	16.7	25	7	10.3

### **Land Use**

The total land area of Manville is approximately 2.5 square miles (1,573 acres). Manville is predominantly residential and the once significant industrial component of its land use has largely been redeveloped for commercial use as the town emerges from its industrial past. Approximately 50-55% of the town has a residential land use, with 17-23% under commercial and service use, and only 2% is currently under industrial use, compared to more than 10% a couple of decades ago.



Transportation, communication and utilities also account for 2-6%, with 1-3% used for recreational purposes, and almost 3% remains in agricultural use as crop or pastureland. There remains a significant amount of undeveloped land in the borough (roughly 15% or 236 acres), of which almost half consists of deciduous wooded wetlands, with the remainder a mix of deciduous wood and shrub lands. Most of this land is low-lying and immediately adjacent to one of the three watercourses in the study area, and hence is likely to remain undeveloped.

Most of the housing stock was constructed prior to the implementation of the National Flood Insurance Program (NFIP) and adoption of associated floodplain management regulations. As a result, much of the development in the study area does not meet NFIP regulations. Newer developments are more likely to have implemented measures to mitigate flood risk and comply with NFIP regulations. However, there is remains a strong possibility of frequent flood damage.

Some properties within the study area have participated in the State of New Jersey Blue Acres Program. This federally budgeted program authorizes the New Jersey Department of Environmental Protection (NJDEP) to purchase properties at risk of flood damage from willing sellers, and then repurposes the properties for recreation and conservation land uses.

## **Recreation**

The Study Area includes multiple small and medium sized parks and land held as open space that provide both active recreation opportunities such as baseball or swimming and passive recreation opportunities. Many of the parks are situated along the floodplains of the Raritan and Millstone Rivers and Royce Brook. The Delaware and Raritan Canal passes through the periphery of the study area, parallel to the Millstone River just outside Manville Borough. The area immediately adjacent to the canal, which consists mainly of the towpath and some areas of the floodplain between the canal and the Millstone River, is designated as the Delaware and Raritan Canal State Park. None of the alternatives studied will significantly increase nor decrease the value of recreation resources. Thus, no recreation benefits have been included in the analysis.





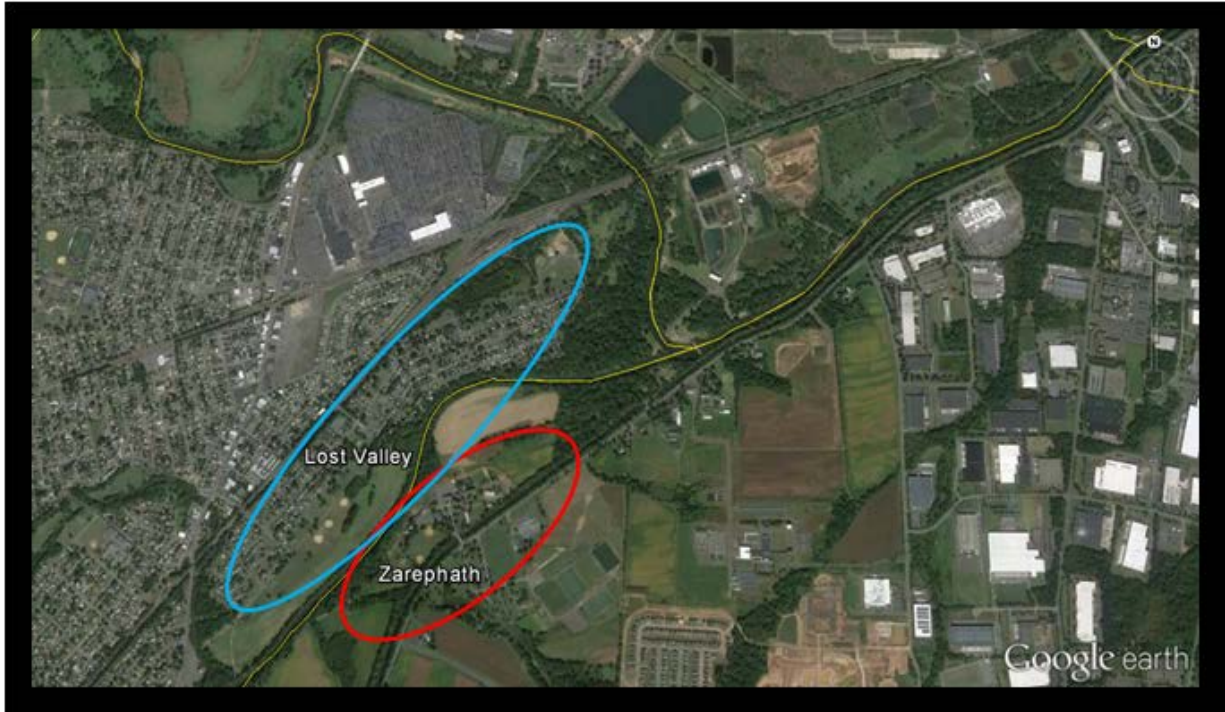
## **Problem Identification**

The study area is subject to fluvial flooding throughout low lying areas in the basin. Fluvial flooding in the Millstone river basin may occur as a result of high precipitation storm events, and the impacts can be exacerbated by melt water from thawing snow and ice accumulation. Development in the watershed has increased runoff potential and flood hazards. Many areas that previously were not known to be subject to flooding are now reporting damages during severe events, such as Hurricane Floyd.

Most of the study area's flood-prone structures are widely distributed. Upon examination the most significant flooding problems in the Millstone river basin are in the Borough of Manville. Officials from Manville report that the recurrent flooding problems are prevalent throughout the Borough in areas proximate to the Raritan River and the Millstone River. As a result, plan formulation focused on flooding problems and opportunities in this area. Almost all areas adjacent to streams and rivers have flood risks. The Lost Valley section is one of the most densely populated portions of the floodplain within Manville and has traditionally experienced a large proportion of the damages within Manville (Map 5). Some houses in the Lost Valley section have been elevated or bought out through the NJDEP Blue Acre Program.

Flooding problems in Manville are exacerbated by land use changes in the basin and consequent hydrologic modification of the Millstone River, increasing runoff and headwater flows. Coincident and backwater flooding also occurs in association with the Raritan River. The Borough of Manville located at the confluence of the Millstone and the Raritan Rivers is flooded by headwater and backwater events. Backwater flooding from the Raritan River may also increase with a reduction in channel capacity and the lowering of the hydraulic gradient of the river due to sedimentation.





**Map 5: Zarephath and Lost Valley areas**

### **Without-Project Future Conditions**

The without-project future conditions in the Borough of Manville are identified as: (1) flooding from future precipitation events and melt water, and (2) the possibility of an increase in erosion and sedimentation along riparian zones and riverbeds. Storm severity is expected to increase gradually in relation to climate change and additional development within the river basin.

In the absence of Federal action, flooding problems associated with rainfall events and/or melt water in the study area are expected to continue. These problems may be exacerbated by increased damage potential in the floodplains of communities within the Millstone river basin. Continued development in Manville and in portions of the Millstone river basin will increase the volume of runoff. Changes in the values of structures, contents, and population, combined with the potential for increased intensity and frequency of storm events, may generate an increase in future storm damages. The most likely scenario for the future without-project condition would be the continuation of existing social, environmental, and economic conditions and trends within the study area.



Implicit in taking no action would be the continuation of Federally-subsidized flood insurance coverage for property owners that is currently available through the National Flood Insurance Program and the enforcement of local floodplain zoning ordinances. Significant flooding can result in the overtopping of sewage treatment works, contamination of drinking water supplies, dispersion of HTRW and large quantities of solid waste. Experience has shown that vast quantities of debris (e.g., homes, vehicles, mobile homes, etc.) and sediment must be removed from the floodplain after a flooding event. The physical removal of the debris from the floodplain typically involves large, heavy equipment and requires the removal of trees and vegetation to provide points of access for the cleanup equipment. Hauling the collected debris to the local municipal landfill requires significant transportation resources, and involves huge quantities of solid waste that fill available landfill space.

Counties and other local municipalities could implement storm water management techniques, such as requiring new development to retain 100% of storm water and retrofitting of existing impervious structures, including creating green roofs and using planting pavers in parking lots. Although storm water management is not in the USACE authority, a reduction in storm water input into the river may reduce flood impacts during some storm events. There is likely to be no reduction in the frequency of repetitive flood events within Manville. Residential and commercial buildings in the study area floodplain are likely to continue to flood from both the Millstone and the Raritan Rivers.



## **STORM DAMAGE**

### **General**

The following basic steps were used to analyze flood damage:

- Assign evaluation reaches
- Inventory structures within the 0.2 percent annual probability floodplain
- Estimate depreciated replacement cost
- Assign generalized stage vs. damage functions to each structure
- Calculate aggregated stage vs. damage relationships
- Calculate average equivalent annual damages

The first four steps provide inputs to the estimation of flood damages. The calculation of damages was then completed using the Hydrologic Engineering Center's (HEC) Flood Damage Analysis (FDA) application.

### **Reach Selection**

In order to conduct economic benefit analyses for without-project and with-project alternative plans, and to simplify the stage vs. damage analyses, the FDA analysis area has been divided into 22 economic reaches; seven along the Millstone river, nine along the Raritan river, and six along Royce brook.

- Reaches and riverfront areas: Reach selection was based on location of structures, river bank gradient, and the location of alternative flood risk management designs.
- Potential risk management limits: Certain assets within the community may potentially lie outside some of the risk reduction measures presented. For example, any docks or structures adjacent to the river may lie beyond the levee and floodwall structures, and would not receive any of the risk management benefits of the structures.
- Interior drainage areas: Minor residual internal drainage issues related to levee and floodwall structures were not considered to be sufficient to warrant reach assignments and damage calculations.



## Inventory Methodology

The structure inventory was originally developed in 2004, with in-person visits to the study area to survey for structures at risk of flooding. The survey was accomplished using topographic mapping with contour intervals to assess structures that fell within the 500-year floodplain. The inventory survey focused on the Borough of Manville and the adjacent community of Zarephath. To account for potential flooding effects to nearby areas, the inventory also includes structures that lie within Somerville Borough, Bridgewater Township, Franklin Township, and Hillsborough Township. The limit of the inventory survey area is the assumed extent of the 500-year floodplain, which has been based on consultation with USACE and NFIP Flood Insurance Rate Mapping.

Structure elevations are expressed in feet and tenths of a foot, and refer to the North American Vertical Datum of 1988 (NAVD88). The depreciated replacement value of each building in the floodplain was calculated using standard building cost procedures from the RSMMeans square foot cost replacement manual and Marshall & Swift Valuation Service. The analysis combines the physical characteristics obtained in the inventory with standard unit prices per square foot. Depreciation is calculated based on the observed quality and condition of each structure. The inventory was reviewed and updated with depreciated structure replacement values, re-calculated with October 2013 price levels. The inventory update also accounted for structures participating in the Blue Acres property buyouts. Table 5 outlines data characteristics obtained for the inventory.

1)	Structure ID	2)	Damage Reach
3)	Station	4)	Structure Type/Damage Category
5)	Usage Code Lookup	6)	Size (Sq. Ft.)
7)	Stories	8)	Basement
9)	Garages	10)	Exterior
11)	Build Quality	12)	Condition
13)	Reference Elevation	14)	First Floor Height
15)	Low Opening	16)	Depreciated Replacement Structure Value





The data collected was used to categorize the structure population into groups with common physical features. Data pertaining to structure usage, condition, size and number of stories assisted in the structure value analysis. For each building, data was also gathered pertaining to its damage potential including ground and main floor elevations, lowest opening, construction material, condition, and the presence of basements and garages. 1,539 structures were identified in the original survey, of which 1,476 structures were included as structures susceptible to flood damage for the 2013 inventory update and analysis. The inventory may not reflect recent buyouts that could have taken place prior to publication of this report.

### **Description of Damage Functions & Source of Stage-Frequency Curves**

Depth-percent damage functions for structure, content, and other damages were applied to each of the structures in the updated inventory to calculate floodwater damage. Generic depth-damage functions for residential and non-residential structures were developed by the U.S. Army Corps of Engineers for the Passaic River Basin, NJ study. The Passaic River Basin (PRB) damage functions were originally developed in 1982 as part of the Passaic River Basin Feasibility Study. The Functions were later updated in 1995. PRB functions were developed for specific residential and non-residential (commercial, industrial, municipal, and utility) structure types. Damage functions are included for structures, contents, and other-to-structure damages. Other-to-structure damages may include damage estimates to landscaping, out buildings, emergency response, commercial disruption, and cleanup costs. The following areas of uncertainty were incorporated into the HEC-FDA application:

- discharge frequency & stage frequency (using equivalent record length)
- first floor elevation
- depreciated structure value
- content-to-structure value ratio
- other-to-structure value ratio

PRB structure values are assumed to have a coefficient of variation of 10%. A coefficient of variation of 25% was applied to the content-to-structure value ratio, and the other-to-structure value ratio has a coefficient of variation of 10%. First floor elevation estimates contain a coefficient of variation of 0.6 feet. The damage functions and input variability estimates were formulated after extensive analysis of impacts from flood events within the Passiac river basin. These PRB damage



functions are appropriate for the Millstone river basin due to the proximity and similarity of structures, contents, and other-to-structure values within the basins.

Water surface profiles containing stage and frequency functions were generated through the HEC River Analysis System. This process is explained in detail in the Hydrology & Hydraulics appendix.

### **Flood Damage Analysis, Cost Estimates**

Modeling of the benefits was conducted using the Hydrologic Engineering Center's Flood Damage Analysis software application. This application applies Monte Carlo Simulations to calculate expected damage values while explicitly accounting for uncertainty in the input data. Average annual expected damages were calculated within HEC-FDA using the damage-frequency curves, derived from relating damage values from various inundation levels with estimated probabilities of occurrence. Damage estimates aggregate the simulated damages from structures, contents and other-to-structure values.

Applying the fiscal year 2014 discount rate of 3.5% to October 2013 price levels, models were used to determine both current and future year damages for with and without-project scenarios. Benefits are considered to be the damages reduced from the without-project condition estimate to the with-project condition estimate.

Cost estimates were generated by the USACE cost engineering division, based on construction estimates for the management measures. As with the benefit estimate, cost estimates also applied the FY 2014 discount rate of 3.5%, with an October 2013 price level.

Updating benefit and cost estimates to current price levels and discount rates would not significantly alter the benefit cost ratios (BCR). Benefit and cost price levels have trended similarly, and the lower discount rate (FY2016 discount rate: 3.125%), while slightly improving the BCRs, would be insufficient to alter plan formulation results.



## Without-Project Annual Damages

HEC-FDA modeling was performed using the reaches as defined above, structure inventory with calculated structure values, corresponding water surface profiles, and the assigned depth-damage functions. The without-project condition was determined by projecting conditions in the project area over a 50-year period of analysis (base year 2018).

<b>Table 6: Equivalent Annual Damage (EAD), Without-Project</b>							
Price Level: October 2013. FY 2014 Discount Rate: 3.5%							
	<b>BUILDING CATEGORIES <sup>(1)</sup></b>						
<b>Stream</b>	<b>APT</b>	<b>COM</b>	<b>IND</b>	<b>MUN</b>	<b>RES</b>	<b>UTL</b>	<b>Total</b>
Millstone	\$ -	\$ 378,000	\$ 2,000	\$ 196,000	\$ 853,000	\$ 7,000	<b>\$ 1,436,000</b>
Raritan	\$ 4,000	\$ 122,000	\$ 149,000	\$ 43,000	\$ 366,000	\$128,000	<b>\$ 812,000</b>
Royce Brook	\$ 1,000	\$ 324,000	\$ 1,000	\$ 33,000	\$ 235,000	\$ 7,000	<b>\$ 602,000</b>
<b>Totals</b>	<b>\$ 5,000</b>	<b>\$ 824,000</b>	<b>\$ 153,000</b>	<b>\$ 273,000</b>	<b>\$ 1,453,000</b>	<b>\$ 142,000</b>	<b>\$ 2,850,000</b>

Building Categories: APT = Apartment, COM = Commercial, IND = Industrial, MUN = Municipal, RES = Residential, UTL = Utility



## **Alternatives Evaluated**

Alternatives and management measures were developed in coordination with the New Jersey Department of Environmental Protection (NJDEP), the non-Federal Sponsor, and in conjunction with input from local municipalities and other interested parties.

Nonstructural alternatives were designed to provide flood risk management to a 1% probability storm event, plus one foot. Nonstructural plans 3A through 3D were formulated at levels meant to provide flood risk management to structures in a floodplain area impacted a 2% or greater annual probability storm event. And nonstructural plans 4A through 4D were formulated at levels meant to provide flood risk management to structures in a smaller floodplain area, impacted a 10% or greater annual probability storm event.

Structural alternative plans 1 and 2 were formulated at a level meant to provide flood risk management to a 2% or greater annual probability storm event. If the preliminary analysis showed favorable results, the structural alternatives would later be optimized to provide management to a 1% or greater probability storm event.

Economic performance of the various alternatives was evaluated and compared using a 1 percent flood probability simulation. The following alternative plans have been carried forward for detailed analysis of benefits, costs and impacts.

- 3A. Non-structural Plan – 2 percent floodplain
- 3B. Non-structural Plan – 2 percent floodplain (not including Blue Acres Program structures)
- 3C. Non-structural Plan – 2 percent floodplain (not including Blue Acres Program & Zarephath structures)
- 3D. Non-structural Plan – 2 percent floodplain (not including Blue Acres Program & Lost Valley structures)
- 4A. Non-structural Plan – 10 percent floodplain
- 4B. Non-structural Plan – 10 percent floodplain (not including Blue Acres Program structures)



4C. Non-structural Plan – 10 percent floodplain (not including Blue Acres Program & Zarephath structures)

4D. Non-structural Plan – 10 percent floodplain (not including Blue Acres Program & Lost Valley structures)

Alternative 1. Levee/Floodwall system in Manville, NJ

Alternative 2. Channel Modifications/dredging (Raritan River)

## **Nonstructural Alternatives**

Nonstructural measures were identified and evaluated for structures in Manville near Royce Brook and the Millstone and Raritan Rivers. Measures evaluated included raising buildings (elevation), wet (protection of utilities) and dry (sealants and closures) flood proofing, barriers (ring walls/ring levees) and buyouts (acquisition). The main objective for the non-structural measures is to reduce flood damages through modifications of the existing structures without impacting the residential, commercial and industrial areas.

All of the nonstructural plans were designed to withstand inundation for up to and including a 1 percent storm event plus one foot, regardless of the size of the floodplain. These alternatives would reduce flood risk to residential and nonresidential structures on both banks of the Royce Brook, Millstone and Raritan Rivers from a 1% annual probability flood. While the number of structures treated under each plan changes, according to the size of floodplain targeted by the plan, the designed level of treatment for each structure does not vary by plan.

Nonstructural measures were formulated into specific alternative plans for evaluation. These were selected based on the 10 percent, 2 percent and 1 percent probability floodplains. At the request of local stakeholders, the NJDEP specifically requested analysis of six additional combinations (sub-alternatives 3B, 3C, 3D, 4B, 4C and 4D) within the 10 percent and 2 percent probability floodplains in addition to what was originally formulated (3A and 4A). Within these combinations the Corps of Engineers was asked to exclude from the current analyses approximately 104 structures that applied for buyouts under the Blue Acres Program. Other combinations excluded structures within the Zarephath and Lost Valley vicinities (Map 5) as well as those under the Blue Acres Program. These alternatives are further outlined in the following bullets.





- Alternative 3A: All structures within the 2 percent floodplain (50-yr).
- Alternative 3B: Structures within the 2 percent floodplain (50-yr), excluding structures under the Blue Acres Program (104 structures max).

$$\begin{aligned} &50\text{-yr floodplain structures} - \text{Blue Acres program structures} \\ &= \text{Alt 3B} \end{aligned}$$

- Alternative 3C: Structures within the 2 percent floodplain (50-yr), excluding structures under the Blue Acres Program and structures within the Zarephath area.

$$\begin{aligned} &50\text{-yr floodplain structures} - \text{Blue Acres program structures} - \text{Zarephath structures} \\ &= \text{Alt 3C} \end{aligned}$$

- Alternative 3D: Structures within the 2 percent floodplain (50-yr), excluding structures under the Blue Acres Program and structures within the Lost Valley area.

$$\begin{aligned} &50\text{-yr floodplain structures} - \text{Blue Acres program structures} - \text{Lost Valley structures} \\ &= \text{Alt 3D} \end{aligned}$$

- Alternative 4A: All structures within the 10 percent floodplain (10-yr).
- Alternative 4B: Structures within the 10 percent floodplain (10-yr), excluding structures under the Blue Acres Program.

$$\begin{aligned} &10\text{-yr floodplain structures} - \text{Blue Acres program structures} \\ &= \text{Alt 4B} \end{aligned}$$

- Alternative 4C: Structures within the 10 percent floodplain (10-yr), excluding structures under the Blue Acres Program and structures within the Zarephath area.

$$\begin{aligned} &10\text{-yr floodplain structures} - \text{Blue Acres program structures} - \text{Zarephath structures} \\ &= \text{Alt 4C} \end{aligned}$$

- Alternative 4D: Structures within the 10 percent floodplain (10-yr), excluding structures under the Blue Acres Program and structures within the Lost Valley area.

$$\begin{aligned} &10\text{-yr floodplain structures} - \text{Blue Acres program structures} - \text{Lost Valley structures} \\ &= \text{Alt 4D} \end{aligned}$$



- An alternative for all structures within the 1 percent floodplain (100-yr) was also evaluated but later removed from further analysis do the fact that the level of risk management was over target.

***Nonstructural Screening Level Results***

Results of the screening by structure type are shown in Table 7 for all three floodplains (1 percent, 2 percent and 10 percent probability floodplains). Table 7 also displays the number of structures identified for each of the different nonstructural treatments. The identification of structures and types of treatment presented in Table 7 is a computer screened identification; if a nonstructural plan were selected for implementation, then a more detailed analysis of each structure and each treatment would have to be conducted. The homeowners would also be consulted before final determination on any non-structural treatment. The preliminary screening results of the three sub-alternatives developed for each of the 2 percent and 10 percent floodplains are presented in Tables 8 and 9, respectively.

**Table 7: Millstone River Nonstructural Plan for the 1 Percent (100-yr), 2 Percent (50-yr) and 10 Percent (10-yr) Probability Flood Events**

Nonstructural Flood Management Measure	1 Percent Flood (100-yr) *			2 Percent Flood (50-yr) (Alt #3A)			10 Percent Flood(10-yr)(Alt #4A)		
	Residential	Non-Residential	Sub Total	Residential	Non-Residential	Sub Total	Residential	Non-Residential	Sub Total
Dry	11	17	28	9	15	24	2	4	6
Wet	217	6	223	172	4	176	17	1	18
Barriers	4	68	72	3	63	66	1	34	35
Raise	279	2	281	273	2	275	77	2	79
Buyout	82	29	111	76	29	105	32	27	59
<b>Total number of Structures</b>	593	122	<b>715</b>	533	113	<b>646</b>	129	68	<b>197</b>

\*Note: Alternative was later removed from further analysis. Level of flood risk management was over the target.



**Table 8: Alternative #3B, #3C and #3D Millstone River Nonstructural Plan Comparison for the 2 Percent Flood (50-yr) Event**

Nonstructural Flood Management Measure	Alt #3B: Nonstructural Plan Not including Blue Acres Program Structures			Alt #3C: Nonstructural Plan Not including Blue Acres Program & Zarephath Structures			Alt #3D: Nonstructural Plan Not including Blue Acres Program & Lost Valley Structures		
	Residential	Non-Residential	Sub Total	Residential	Non-Residential	Sub Total	Residential	Non-Residential	Sub Total
Dry	9	15	24	9	15	24	9	15	24
Wet	166	4	170	166	4	170	172	4	176
Barriers	3	63	66	3	57	60	3	66	69
Raise	187	2	189	187	2	189	203	2	205
Buyout	64	29	93	57	21	78	67	29	96
<b>Total number of Structures</b>	<b>429</b>	<b>113</b>	<b>542</b>	<b>422</b>	<b>99</b>	<b>521</b>	<b>454</b>	<b>113</b>	<b>567</b>

**Table 9: Alternative #4B, #4C and #4D Millstone River Nonstructural Plan Comparison for the 10 Percent Flood (10-yr) Event**

Nonstructural Flood Management Measure	Alt #4B: Nonstructural Plan Not including Blue Acres Program Structures			Alt #4C: Nonstructural Plan Not including Blue Acres Program & Zarephath Structures			Alt #4D: Nonstructural Plan Not including Blue Acres Program & Lost Valley Structures		
	Residential	Non-Residential	Sub Total	Residential	Non-Residential	Sub Total	Residential	Non-Residential	Sub Total
Dry	2	4	6	2	4	6	2	4	6
Wet	15	1	16	15	1	16	16	1	17
Barriers	1	34	35	1	29	30	1	34	35
Raise	41	2	43	41	2	43	51	2	53
Buyout	22	27	49	16	19	35	25	27	52
<b>Total number of Structures</b>	<b>81</b>	<b>68</b>	<b>149</b>	<b>75</b>	<b>55</b>	<b>130</b>	<b>95</b>	<b>68</b>	<b>163</b>



## ***Nonstructural Benefits and Costs***

Since all nonstructural alternatives provide flood risk management to the 1 percent flood event plus one foot, with-project damages for the different floodplain alternatives were determined by adjusting the lowest opening and/or first floor elevation upwards for the relevant structures receiving flood risk management measures within the HEC-FDA structural inventory. Also, structures that were elevated or enclosed with ring-walls were assigned modified depth-damage functions. These inventory and damage function adjustments allowed the HEC-FDA application to simulate with-project damage conditions for nonstructural plans. For all plans, benefits were calculated by subtracting with-project damages from without-project damages. The damages reduced in the with-project condition are regarded as the benefits.

The type of nonstructural flood management measure assigned to structures, as summarized in tables 7, 8, and 9, was used to calculate the cost estimate for implementing the various nonstructural alternatives. All nonstructural plans produced benefit cost ratios that were less than 1.0. The benefit and cost estimates can be viewed in Table 11.

## **Structural Alternatives**

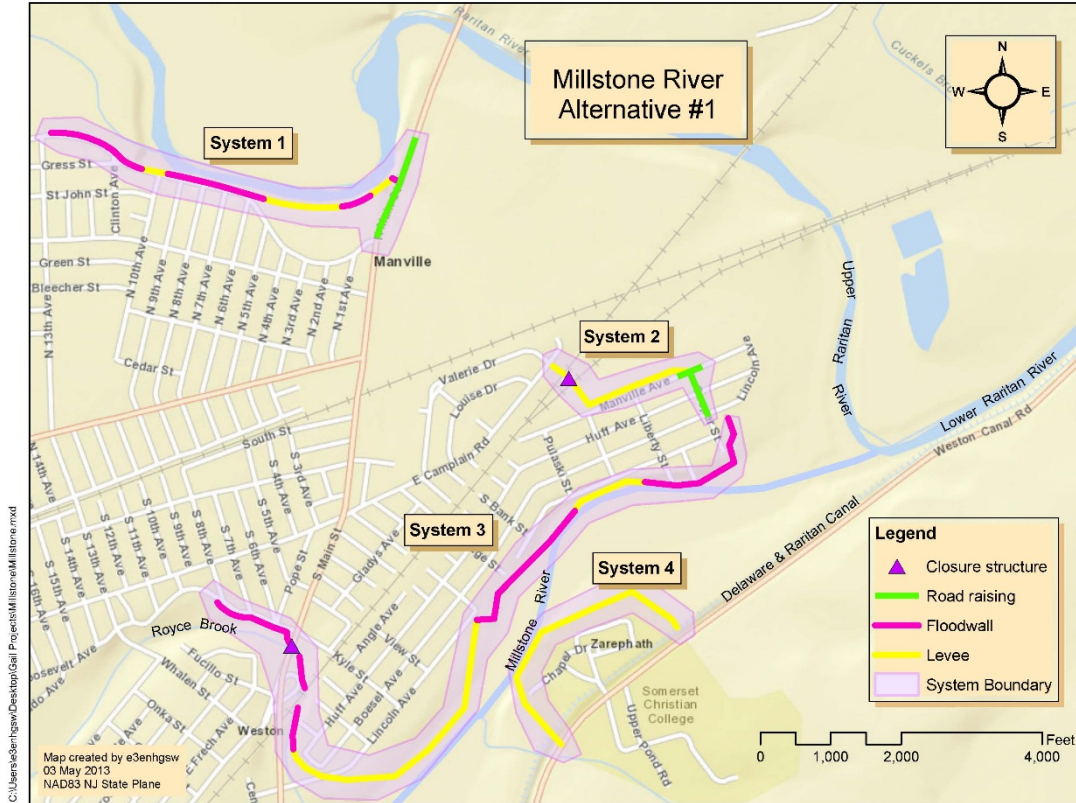
### ***Alternative 1 – Levee/Floodwall***

Alternative 1 consists of three independent flood risk management zones – the north, central and south (Figure 1). The flood risk management structures consist mainly of levees and floodwalls throughout the Raritan and Millstone River watersheds in Manville, and in the sub community of Zerephath, NJ. It is anticipated that the components of this levee/floodwall alternative will manage flood risk against the 2 percent probability flood in these locations.

The levee/flood wall alternative provides \$1,566,000 in equivalent annual benefits. The benefit estimate is defined as the expected flood damages reduced, and calculated by subtracting the with-project damages from the without-project damages. The total first cost of the levee/floodwall alternative is \$66,380,000 with a total investment cost of \$66,833,000, including construction, planning, engineering and design and construction management. The equivalent annual cost for the levee/flood wall alternative, which includes OMRR&R costs (operations, maintenance, repair, replacement and rehabilitation), is \$4,004,000. The BCR of the levee/flood wall alternative is 0.39.



Lands, damages, and environmental mitigation costs were not calculated, since there are insufficient benefits to support this plan even without the additional costs.



**Figure 1: Alternative 1 – Levee/Floodwall System**

**Alternative 2 – Channel Modifications**

Alternative 2 consists of channel modifications along the Upper Raritan and Lower Raritan River reaches. It is anticipated that the components of this alternative will manage flood risk against a 2 percent flood along the Millstone River and the Upper and Lower Raritan River reaches (Figure 2).

The Raritan River will be divided into two river systems (“Upper Raritan” and “Lower Raritan”) at the Island Farm Weir location, and the Lower Raritan will be divided into two reaches. The greatest deepening of the channel will occur in the vicinity of the confluence of the Millstone and





Raritan Rivers and will consist of removing sediment approximately 8 feet below the existing channel bottom elevation.

The channel modification alternative provides \$1,317,000 in equivalent annual benefits. The total first cost of the channel modification alternative is \$125,588,000 with a total investment cost of \$130,347,000, including construction, planning, engineering and design and construction management. The equivalent annual cost for the channel alternative, including annualized OMRR&R, is \$6,510,000. The BCR of the channel alternative is 0.2. Lands, damages and environmental mitigation costs were not calculated, since there are insufficient benefits to support this plan even without the inclusion of additional costs.



*Figure 2: Alternative 2 – Channel Modifications*



**Table 10: Equivalent Annual Damage (EAD), Structural Projects**

Price Level: October 2013. FY 2014 Discount Rate: 3.5%

Alternative	BUILDING CATEGORIES <sup>(1)</sup>						Total
	APT	COM	IND	MUN	RES	UTL	
Without-Project	\$ 5,000	\$ 824,000	\$ 153,000	\$ 273,000	\$ 1,453,000	\$ 142,000	\$ <b>2,850,000</b>
1. Levees and Floodwalls	\$ 5,000	\$ 322,000	\$ 130,000	\$ 65,000	\$ 629,000	\$ 134,000	\$ <b>1,284,000</b>
2. Channel Modifications	\$ 4,000	\$ 414,000	\$ 114,000	\$ 135,000	\$ 790,000	\$ 75,000	\$ <b>1,533,000</b>

Building Categories: APT = Apartment, COM = Commercial, IND = Industrial, MUN = Municipal, RES = Residential, UTL = Utility

## SUMMARY EVALUATION AND COMPARISON OF ALTERNATIVE PLANS

The alternative flood risk management plans were evaluated for economic performance. For a project to have federal interest, it is mandated that the calculated project benefits must be greater than the project costs. For this measurement, the benefit cost ratio must be greater than one. None of the alternatives studied meet this federal requirement. As a result, the analysis concludes that none of the studied alternatives contribute favorably to National Economic Development (NED). Unable to identify an alternative with a positive impact on NED, the economic analysis does not support any studied alternative to be further developed and recommended for implementation. Table 11 summarizes the benefits and costs of each alternative for the purpose of plan comparison.



**Table 11: Summary of Damages, Costs, Benefits and BCRs**

Summary of Damages, Costs, Benefits, and BCRs. Price Level October 2013 (Note 7), Fiscal Year 2014 discount rate 3.5%.								
Alternative	Flood Damages	Flood Damages	Annual Benefits (Note 2)	Total First Cost	Total Investment Cost (Note 3)	Total Annual Cost (Note 4)	Net Excess Benefits (Note 5)	BCR (Note 6)
	Without-Project	With-Project (Note 1)						
3A. Non-structural Plan - 50-year flood plain	\$ 2,850,000	\$ 479,000	\$ 2,371,000	\$ 211,435,000	\$ 218,565,000	\$ 9,318,000	\$ (6,947,000)	0.25
3B. Non-structural Plan - 50-year flood plain (not including Blue Acres Program structures)	\$ 2,850,000	\$ 455,000	\$ 2,396,000	\$ 198,344,000	\$ 205,033,000	\$ 8,741,000	\$ (6,346,000)	0.27
3C. Non-structural Plan - 50-year flood plain (not including Blue Acres Program & Zarephath structures)	\$ 2,850,000	\$ 450,000	\$ 2,400,000	\$ 180,993,000	\$ 187,096,000	\$ 7,977,000	\$ (5,576,000)	0.30
3D. Non-structural Plan - 50-year flood plain (not including Blue Acres Program & Lost Valley structures)	\$ 2,850,000	\$ 467,000	\$ 2,383,000	\$ 203,911,000	\$ 210,787,000	\$ 8,987,000	\$ (6,604,000)	0.27
4A. Non-structural Plan - 10-year flood plain	\$ 2,850,000	\$ 1,224,000	\$ 1,626,000	\$ 98,689,000	\$ 102,017,000	\$ 4,349,000	\$ (2,724,000)	0.37
4B. Non-structural Plan - 10-year flood plain (not including Blue Acres Program structures)	\$ 2,850,000	\$ 1,212,000	\$ 1,638,000	\$ 91,352,000	\$ 94,432,000	\$ 4,026,000	\$ (2,388,000)	0.41
4C. Non-structural Plan - 10-year flood plain (not including Blue Acres Program & Zarephath structures)	\$ 2,850,000	\$ 1,208,000	\$ 1,643,000	\$ 75,662,000	\$ 78,214,000	\$ 3,335,000	\$ (1,692,000)	0.49
4D. Non-structural Plan - 10-year flood plain (not including Blue Acres Program & Lost Valley structures)	\$ 2,850,000	\$ 1,219,000	\$ 1,631,000	\$ 95,577,000	\$ 98,800,000	\$ 4,212,000	\$ (2,581,000)	0.39
1. Levee/Floodwall in Manville, N.J.	\$ 2,850,000	\$ 1,284,000	\$ 1,566,000	\$ 66,380,000	\$ 66,833,000	\$ 4,004,000	\$ (2,438,000)	0.39
2. Channel Modifications (Raritan River)	\$ 2,850,000	\$ 1,533,000	\$ 1,317,000	\$ 125,588,000	\$ 130,347,000	\$ 6,510,000	\$ (5,193,000)	0.20



**MILLSTONE RIVER BASIN, NEW JERSEY  
FLOOD RISK MANAGEMENT FEASIBILITY STUDY**

Notes

1. Damages incurred with the project in place due to storms that exceed the design criteria.
2. Without-Project Annual Damages minus With-Project Annual Damages.
3. Total Investment Costs include Interest During Construction: Alt-1: 46 months construction duration; Alt-2: 37 months construction duration.
4. Total Annual Cost based on 50-year period of analysis, includes annualized OMRR&R costs. Only structural plans are considered to have OMRR&R costs, which accounts for the relatively higher Total Annual Costs to Total First Costs in structural plans.
5. Net Excess Benefits = Annual Benefits minus Annual Costs.
6. BCR = Annual Benefits divided by Annual Cost.
7. Dollar amounts rounded to the nearest \$1,000.



# **Millstone River Basin, New Jersey**

## **Flood Risk Management Feasibility Study**

### **Appendix D – Structural**

**U.S. Army Corps of Engineers  
New York District  
26 Federal Plaza  
New York, New York 10278**

**November 2016**



**US Army Corps  
of Engineers**  
New York District



**New Jersey Department of  
Environmental Protection**



## Table of Contents

1	INTRODUCTION .....	1
2	PROPOSED DESIGN .....	1
2.1	SITE LAYOUT .....	1
2.2	DESIGN DATA .....	4
2.2.1	REFERENCES .....	4
2.2.2	FLOODWALL DESIGN CRITERIA.....	5
2.2.3	CLOSURE GATE DESIGN CRITERIA .....	6
2.2.4	DESIGN LOADS AND SOIL PARAMETERS .....	6
2.3	FLOODWALL DESIGN ANALYSIS .....	7
2.4	CLOSURE GATE DESIGN ANALYSIS .....	8
3	CONCLUSION.....	9

## **1 INTRODUCTION**

The purpose of the report is to provide sufficient detail about the structural alternatives of the Millstone Project. The goal of the project is to reduce flood damages from flooding caused primarily by Millstone River as well as backwater flooding from the Raritan River within the Millstone River Basin. Ten alternatives have been developed to meet this goal, but only two of the alternatives have been labeled as structural alternatives, Alternatives #1 and #2. Alternative #1 is made up of three zones which contain approximately 10,520ft of levees, 8055ft of floodwall, interior drainage structures, two closure gates and bridge/road raisings. Alternative #2 consists of channel modifications along the Upper Raritan and Lower Raritan River. Both alternatives are designed for a 50yr flood event. The floodwall and closure gate design will be discussed in detail within this appendix. The interior drainage and bridge/road raising will not be discussed in detail within this appendix even though they are significant components in the alternative. This is because there are already insufficient benefits to support this alternative without adding those components. The channel modification, which consists of deepening the channel and changing the side slopes of the channels, will be discussed in the Hydrology & Hydraulic Appendix.

## **2 PROPOSED DESIGN**

### **2.1 SITE LAYOUT**

The Millstone Project is located in the Borough of Manville. The Borough of Manville is bounded by the Raritan River on the north, the Millstone River on the east, Royce Brook to the south and Hillsborough Township on the west. There are currently no floodwalls nor closure gates along the length of the Millstone Project. As mentioned before, the Alternative #1 is made up of three zones (north, central and south). These zones are visible in Figure 1.

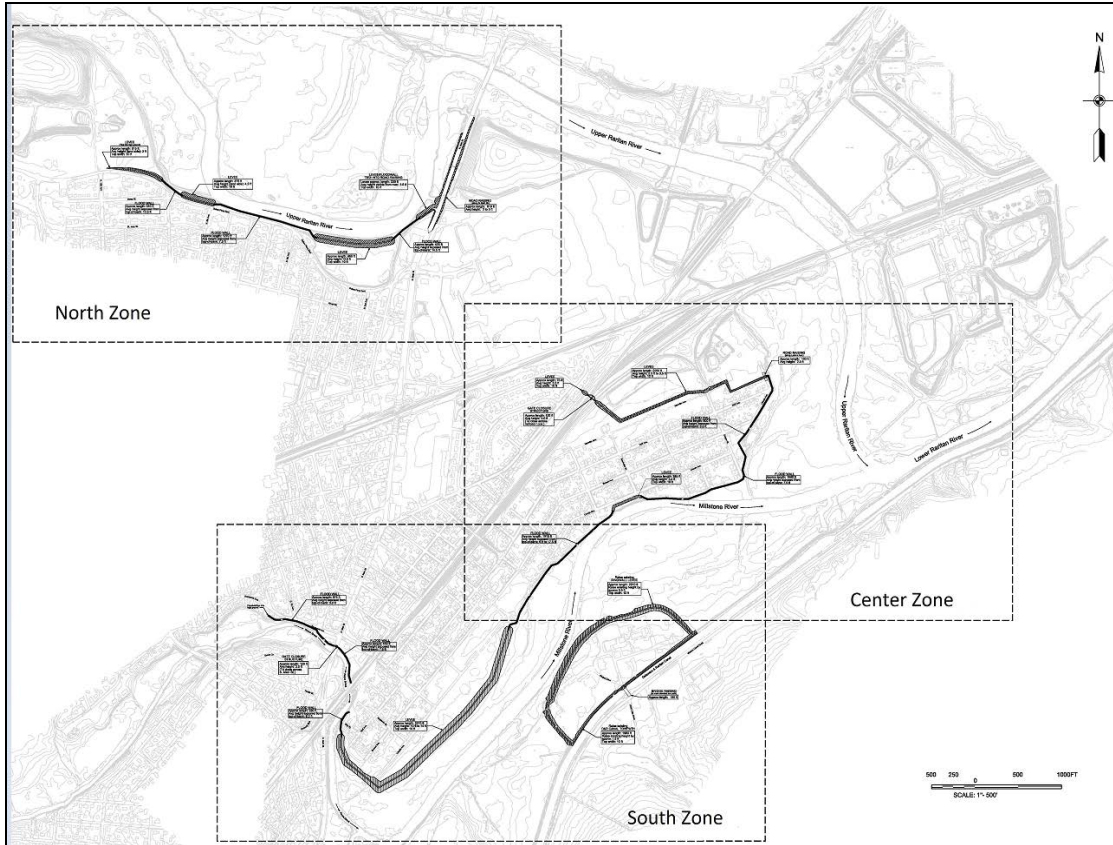


Figure 1: Site Layout of Alternative 1

The north zone consists of approximately 2,075 feet of levees, approximately 2,000 feet of floodwalls, associated interior drainage structures and a road-raising. The approximate 2,000 feet of floodwall is broken into three sections and are labeled as Floodwalls 1A, 1B, and 1C as shown in Figure 2.

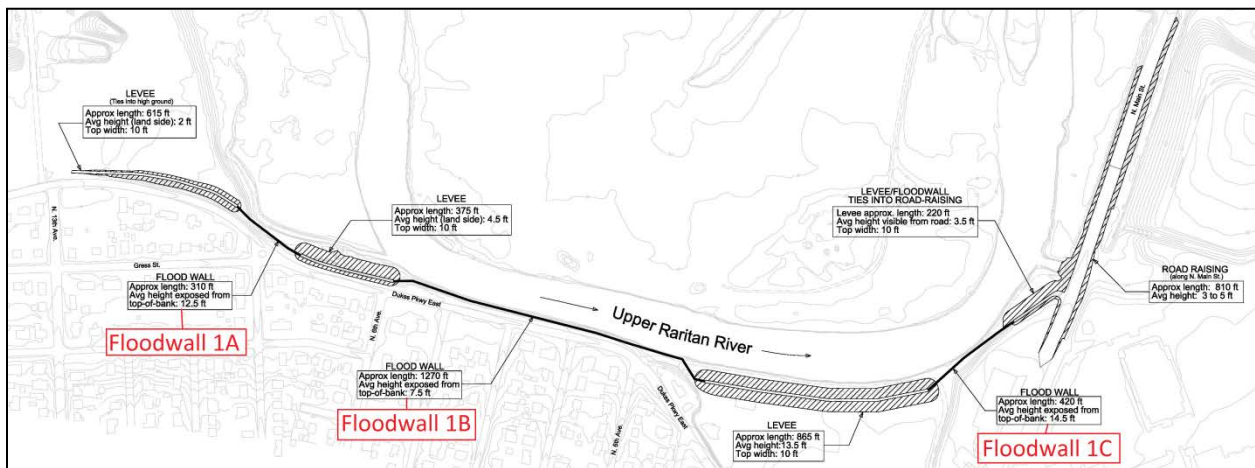


Figure 2: Site contents of the North Zone

The central zone consists of approximately 2,325 feet of levees and associated interior drainage structures, 4,400 linear feet of floodwalls, a gate closure structure and a road-raising. The approximate 4,400 feet of floodwall is broken into five sections and are labeled as Floodwalls 3D-1, 3D-2, 3D-3, 3D-4, and 3D-5 as shown in Figure 3.

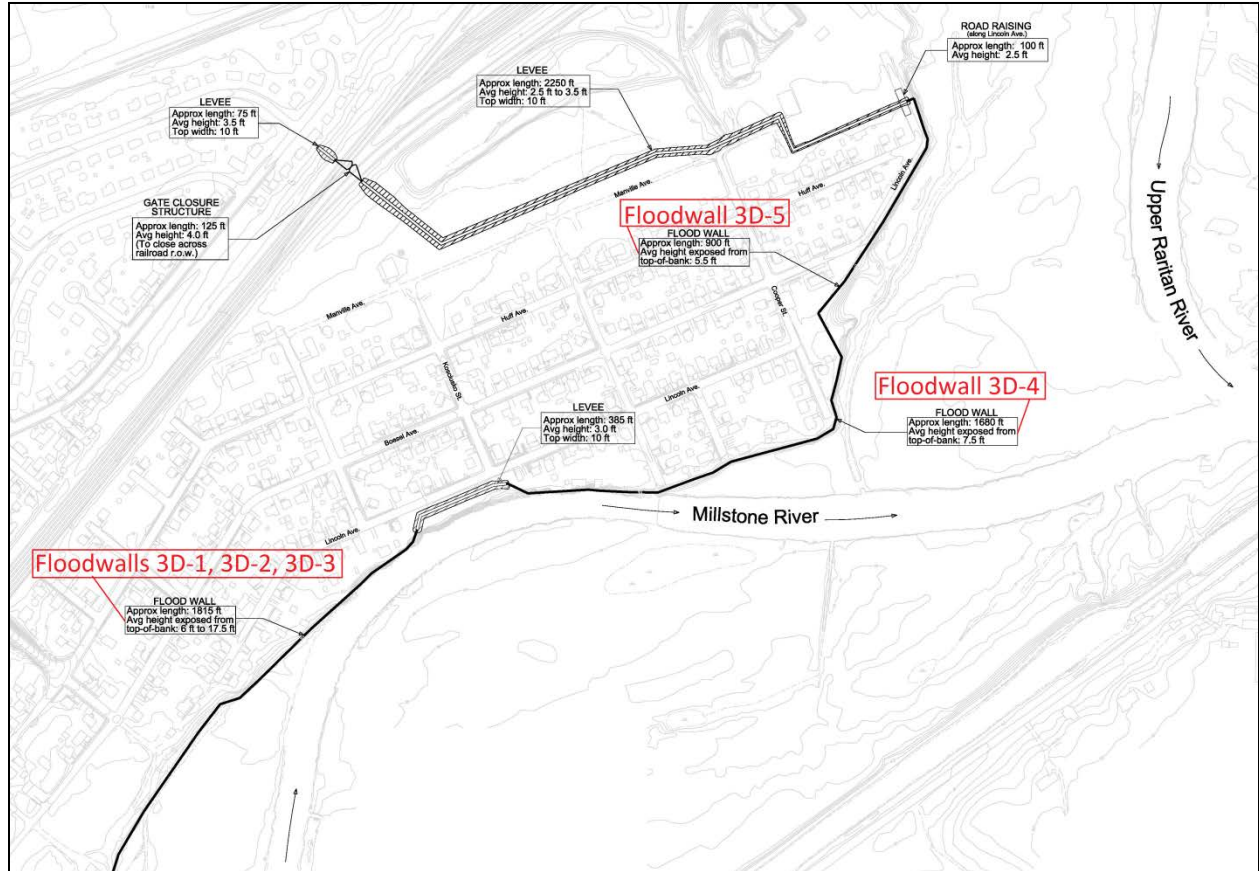


Figure 3: Site contents of the Center Zone

The south zone consists of approximately 6,120 feet of levees, 1,655 feet of floodwalls, associated interior drainage structures, a gate closure structure, a bridge/road-raising and the elevation of a portion of the Delaware & Raritan Canal tow path. The approximate 1,655 feet of floodwall is broken into three sections and are labeled as Floodwalls 3A, 3B, and 3C as shown in Figure 4.

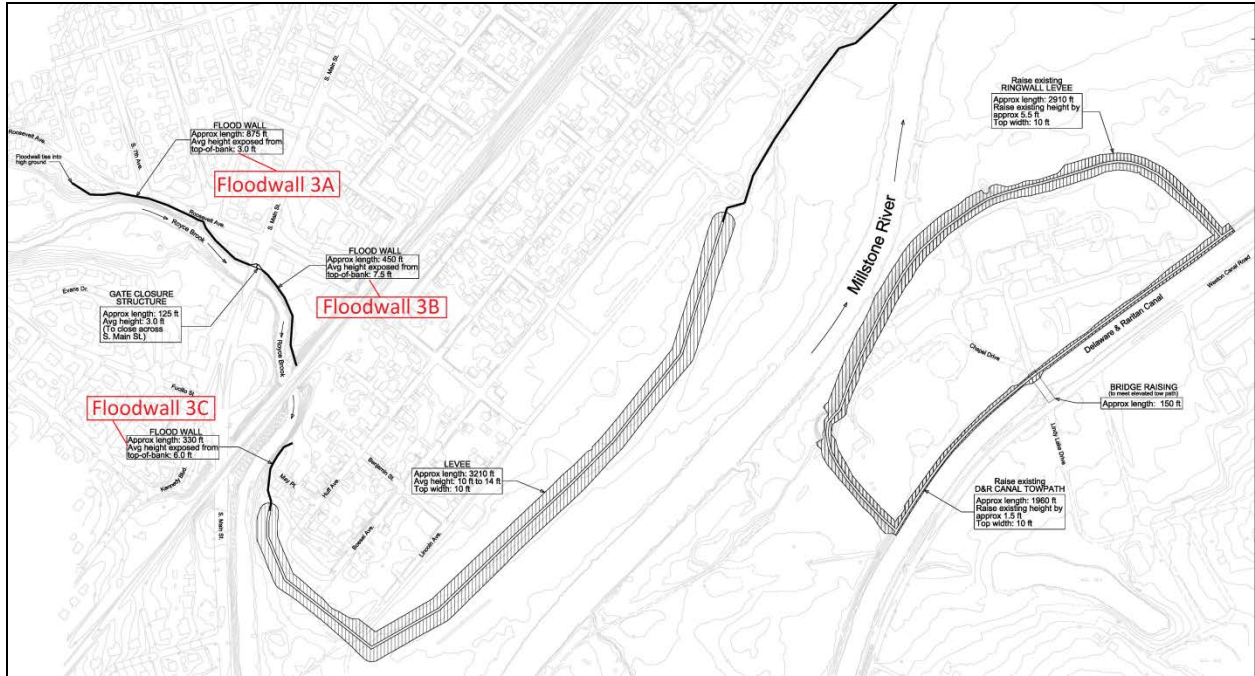


Figure 4: Site contents of the South Zone

## 2.2 DESIGN DATA

### 2.2.1 REFERENCES

The design of the floodwall will conform to the requirements of the following:

- Design of Sheet Pile Walls (USACE EM 1110-2-2504),
- Retaining and Floodwalls (USACE EM 1110-2-2502)
- Standard Practice for Concrete for Civil Works Structures (USACE EM 1110-2-2000)
- Strength Design for Reinforced-Concrete Hydraulic Structure (USACE EM 1110-2-2104)
- Building Code Requirements for Structural Concrete (ACI 318-11),
- AISC Steel Construction Manual 14<sup>th</sup> ed
- And other acceptable design specifications

The design of the closure gates will conform to the requirements of the following:

- Design of Hydraulic Steel Structures (USACE ETL 1110-2-584)
- AISC Steel Construction Manual, 14<sup>th</sup> ed.
- And other acceptable design specifications



## 2.2.2 FLOODWALL DESIGN CRITERIA

Based on the references, the sheet pile has to be designed using two different safety factors. The penetration depth of the sheet pile has to be sized utilizing the safety factors in Table 1 below.

**Table 1: Stability Analysis- Penetration Depth Safety Factors from EM 1110-2-2504**

Loading Case	Fine-Grain Soils Silt-Clay	Free-Draining Soils Sand-Gravel
Usual	2.00 Q –Case, 1.50 S-Case	1.50 S-Case
Unusual	1.75 Q –Case, 1.25 S-Case	1.25 S-Case
Extreme	1.50 Q –Case, 1.10 S-Case	1.10 S-Case

Note: Q Case=Unconsolidated undrained, S Case= Consolidated drained

The required strength of the sheet pile is determined using the safety factor of 1 for both active and passive soil pressures to avoid combining the factors of safety that were applied to the sheeting penetration depth. The following criteria have to be taken into consideration during the design:

- Sheet Piles and Steel Sheeting conform to ASTM A690 Grade 50
- Allowable Stress per EM 1110-2-2504 Section 6-1
  - Combined loading and axial loading ( $F_b$ )=  $0.5F_y$
  - Shear ( $F_v$ )=  $0.33F_y$
  - For unusual loadings the allowable stress maybe increased by 33%
  - For extreme loadings the allowable stress maybe increased by 75%

According to the EM 1110-2-2504 and EM 1110-2-2502, the following loading cases should be looked at

- Case 1: Usual Loading Case- Design Flood Condition
- Case 2: Unusual Loading Case 1- Construction Condition
- Case 3: Unusual Loading Case 2- Wind Condition
- Case 4: Extreme Loading Case 1- Earthquake Condition
- Case 5: Extreme Loading Case 2- Low Water Level on River Side and High Water Level on Land Side

The dominant loading cases for this project are cases 2 and 5. These cases will be used to determine the penetration depth of the typical sections shown in Section 3. The rest of the cases will not be discussed in this report. The anchors shall be designed from the anchor force obtained from the stability analysis used to determine the penetration depth of the sheeting.

### 2.2.3 CLOSURE GATE DESIGN CRITERIA

Based on the references, the closure gate has to be designed using the following design load cases:

- Case 1 - Strength I, Gate not operating  
***Design Load = 1.4 \* Hydrostatic Load***
- Case 2 - Strength I, Gate not operating, Gate subjected to the upper level Wind pressure of up to 50 psf  
***Design Load = 1.2 \* Dead Load + 1.3 \* Wind Load***
- Case 3 - Strength II, Gate operating, Hinged gate subjected to Dead and Wind (lower level of 15 psf), operating load is treated as a reaction  
***Design Load = 1.2 \* Dead Load + 1.3 \* Wind Load***
- Case 4: Strength II, Gate operating, Wheeled gate subjected to Dead and Operating load  
***Design Load = 1.3 \* Operating load***

The components of the gate shall be designed using the following guidelines:

- The skin plates shall be sized such that the maximum calculated stress is less than the yield limit state of  $\alpha\phi F_y$  where  $\alpha$  is performance factor,  $\phi$  is the resistance factor, and  $F_y$  is the yield strength of the material. Skin plates shall be designed for hydrostatic loading only.
- The intercostals shall be sized so the maximum calculated moment is less than the nominal bending strength of  $\alpha\phi M_n$  where  $M_n$  is nominal bending moment.
- The rolling gate girders shall be designed for flexure due to hydrostatic loading only.
- The vertical diaphragms for wheel gates shall be designed to resist flexure loads only, except for those diaphragms that are in line with wheels, which include axial and bending due to the forces from the wheels.

The foundation for the closure gate shall be designed to support the weight of the closure gate and the forces applied to it.

### 2.2.4 DESIGN LOADS AND SOIL PARAMETERS

The floodwalls will be designed with the following loads:

- Dead Load = 150 pcf for the concrete cap
- Construction Load = 250 pcf of live load surcharge
- Hydrostatic Pressure = 62.4 pcf (Applies to the closure gate design as well)

The water levels used for the floodwall design cases varies based on the elevation of the top of the streambank and the height of the floodwalls. The soil parameters that will be used to develop the typical floodwall sections in Section 3 are from a neighboring project in NJ since borings were not taken for this project. The neighboring project is Segment B1 of the Green Brook Flood Damage

Reduction Project. It is located in Middlesex, NJ. The soil parameters for that project are provided in Table 2 below. During the preliminary design of the Millstone project, borings will have to be taken to get soil parameters that are more reliable than the ones presented below.

**Table 2: Soil Parameters**

Unit Weight of the Homogeneous Soil (pcf)	Angle of Internal Soil Friction (deg)	Angle of Wall Friction (deg)	Cohesion Strength of the Soil
120	30	14	0

### 2.3 FLOODWALL DESIGN ANALYSIS

There are 11 floodwall sections within Alternative #1. Each section was analyzed to determine the penetration depth of the sheeting using the soil parameters given above. The penetration depth of the floodwall is subject to change after the soil from the area has been analyzed. The penetration depths have been determined using CWALSHT, the safety factors from Table 1, design cases 2 and 5, and the soil parameters in section 2.2.4. The results of this analysis are shown below in Table 3. The floodwalls with an exposure length greater than eight feet will be designed with a tie-back. This maximum exposure length was determined using engineering judgment and past experiences. The sections that will have the tiebacks are stated in the table below.

**Table 3: Floodwall Design Analysis Results**

Floodwall	Top of Wall Elevation	Top of Streambank Elevation	Estimated Exposure Length (ft)	Floodwall Type	Design Case 2 Penetration Elevation	Design Case 5 Penetration Elevation	Final Penetration Elevation
1A	47.5	36	11.5	Tie-Back	18.43	23.74	18.43
1B	47.5	40	7.5	Cantilever	27.74	17.22	17.22
1C	47.5	33	14.5	Tie-Back	11.48	16.73	11.48
3A	43.85	41	2.85	Cantilever	35.06	31	31
3B	43.85	36	7.85	Cantilever	23.27	12.26	12.26
3C	43.85	38	5.85	Cantilever	29.95	19.74	19.74
3D-1	43.1	27	16.1	Tie-Back	3.37	10.26	3.37
3D-2	43.53	26	17.53	Tie-Back	0.49	7.28	0.49
3D-3	43.53	29	14.53	Tie-Back	7.44	14.59	7.44
3D-4	43.5	26	17.5	Tie-Back	0.53	7.32	0.53
3D-5	43.5	39	4.5	Cantilever	24.45	30.78	24.45

The required strength of the sheet pile was determined using the safety factor of 1 for both active and passive soil pressures. The required strengths of the sheet piles obtained from CWALSHT are listed in Table 4. The lengths of the sections are also listed in the table.

**Table 4: Design Moment for the Sheet Pile**

	FLOODWALL SECTIONS										
	1A	1B	1C	3A	3B	3C	3D-1	3D-2	3D-3	3D-4	3D-5
Approx. Length (ft)	309	1,269	421	876	450	331	605	605	605	1,681	902
Moment (k-ft)	33.5	29.9	61.7	2.5	33.8	15.4	81.8	103	62.1	102.5	7.8

The biggest design moment from the table is 103kips-ft, so the required section modulus for the sheet pile is

$$S_{min} = \frac{M}{\sigma} = \frac{103kip - ft * \frac{12in}{ft}}{0.5 * 1.33 * 50ksi} = 37.2 in^3$$

PZ 35 has a section modulus of 57.17in<sup>3</sup>/ft, which is greater than S<sub>min</sub>. The deflection for the sheet pile is within acceptable range when taking into account the concrete cap will provide resistance to deflection. Therefore, PZ 35 shall be used. There is no corrosion concern for the sheet pile since the floodwall is located inland where there is fresh water.

The floodwalls with a tieback will have the tiebacks roughly 10 ft below the ground surface (to reduce the chances of hitting utilities) and set at an angle of 45 degrees. The design force for the tiebacks was obtained from the stability analysis used to determine the penetration depth of the sheeting. The maximum design horizontal tieback force is 16.8kips/ft, so the design tieback force is 23.8kips/ft. The spacing for the tiebacks when using PZ 35 sheet piles is 45.2 inches, so the tieback should have a capacity of 90 kips.

## 2.4 CLOSURE GATE DESIGN ANALYSIS

There are two closure gates within Alternative #1. One of the closure gates is located in the center zone along railroad right of way (ROW). The location of the gate determined the required height and width of the closure gate. The average gate height is 4 ft and the approximate width is 125 ft. The other closure gate is located in the south zone along South Main St between Roosevelt Avenue

and Royce Brook. The location of the gate determined the required height and width of the closure gate. The average gate height is 3 ft and the approximate width is 125 ft.

Comparison of different closure gate types led to the decision to pursue a roller gate. Summary of pros and cons of the different alternatives is listed below.

Advantages		
Miter Gate	Single-leaf Swing Gate	Roller Gate
The operation is simple and quick	The operation is simple and quick	The operation is simple and quick
It requires no heavy equipment	It requires no heavy equipment	----
The gate leafs are slightly lighter	----	----
Disadvantages		
Miter Gate	Single-leaf Swing Gate	Roller Gate
High winds could cause difficulty for operation	High winds could cause difficulty for operation	Requires maintenance of track (clearing of debris)
Complex fabrication required for hinges, quoin posts, and miter post	Moderately complex fabrication required for hinges	More force required to operate gate (winches and pulley system required)
More right of way required for operation (swing path)	More right of way required for operation (swing path)	----
Complex support piers required to limit deflections	----	----
Sensitive to differential settlements between piers	----	----
----	----	The wheels should be designed to accommodate the lateral bottom girder deflection or else jacks must be provided to lift the wheels when the gate is in the closed position.

The length of the gates is very long so support points along the path of the gate will be provided to reduce the deflection of the gate. The required strength of the components of the gate will be determined during the design phase of the project when the ground elevation of the south main street and the railroad right of way are determined.

### 3 CONCLUSION

For Alternative #1, the typical floodwall section that should be used for floodwall sections 1A, 1C, 3D-1, 3D-2, 3D-3, and 3D-4 is shown in Figure 5. The rest of the floodwall sections should use the typical floodwall section shown in Figure 6. The highest bottom of pile elevation for the sections is provided in Table 3. These typical sections are subject to change after the soil from the



area has been analyzed. The typical elevation for the two closure gates is shown in Figure 7. The support points along the path of the gate are not shown in the figure for clarity reasons. A typical foundation detail for the closure gates is shown in Figure 8. Typical details for the interior drainage and bridge/road raising have not been provided since there are already insufficient benefits to support this alternative without adding those components. For Alternative #2, the channel modification information can be found in the Hydrology & Hydraulic Appendix

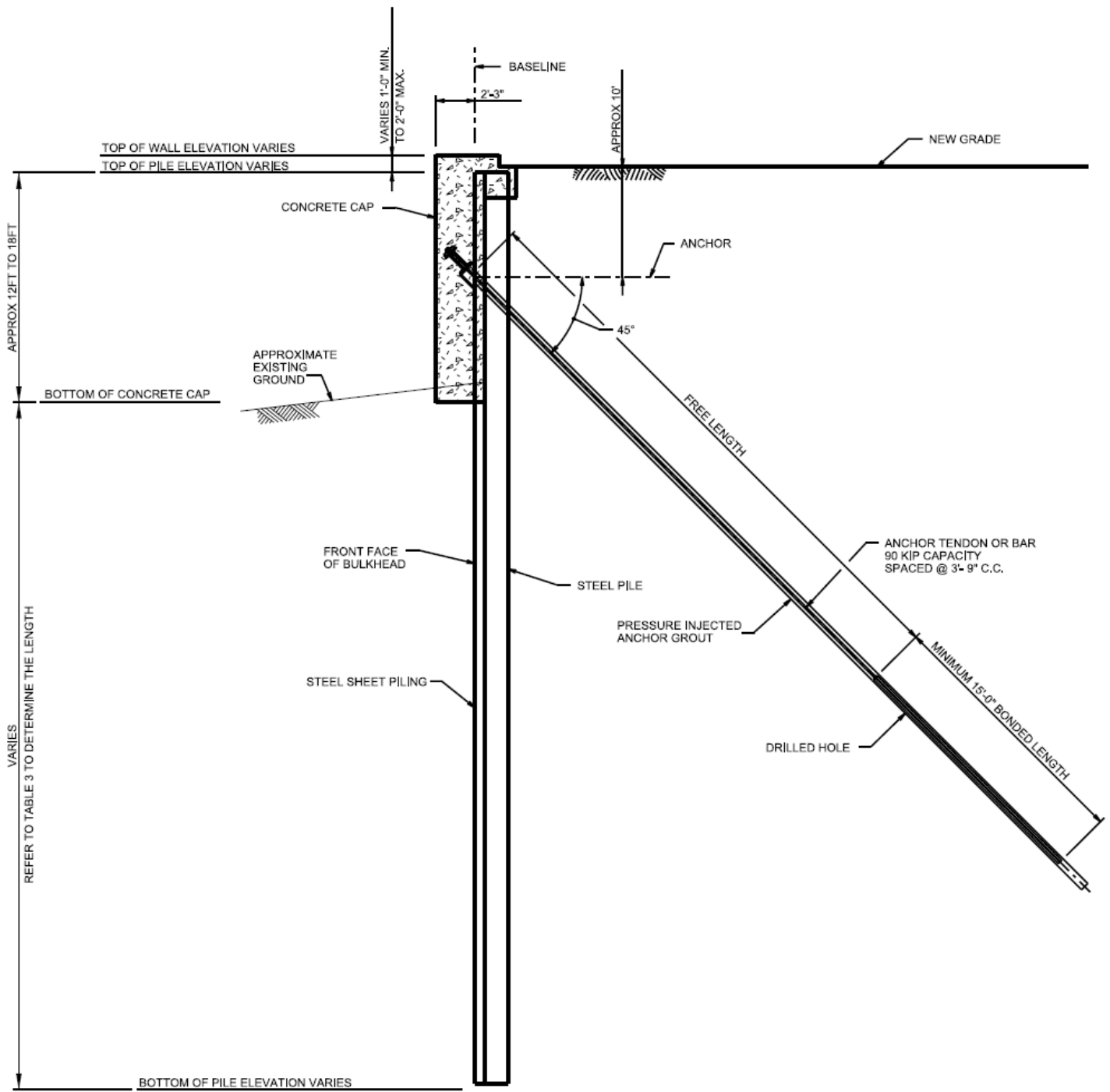


Figure 5: Typical Floodwall Section with Tieback

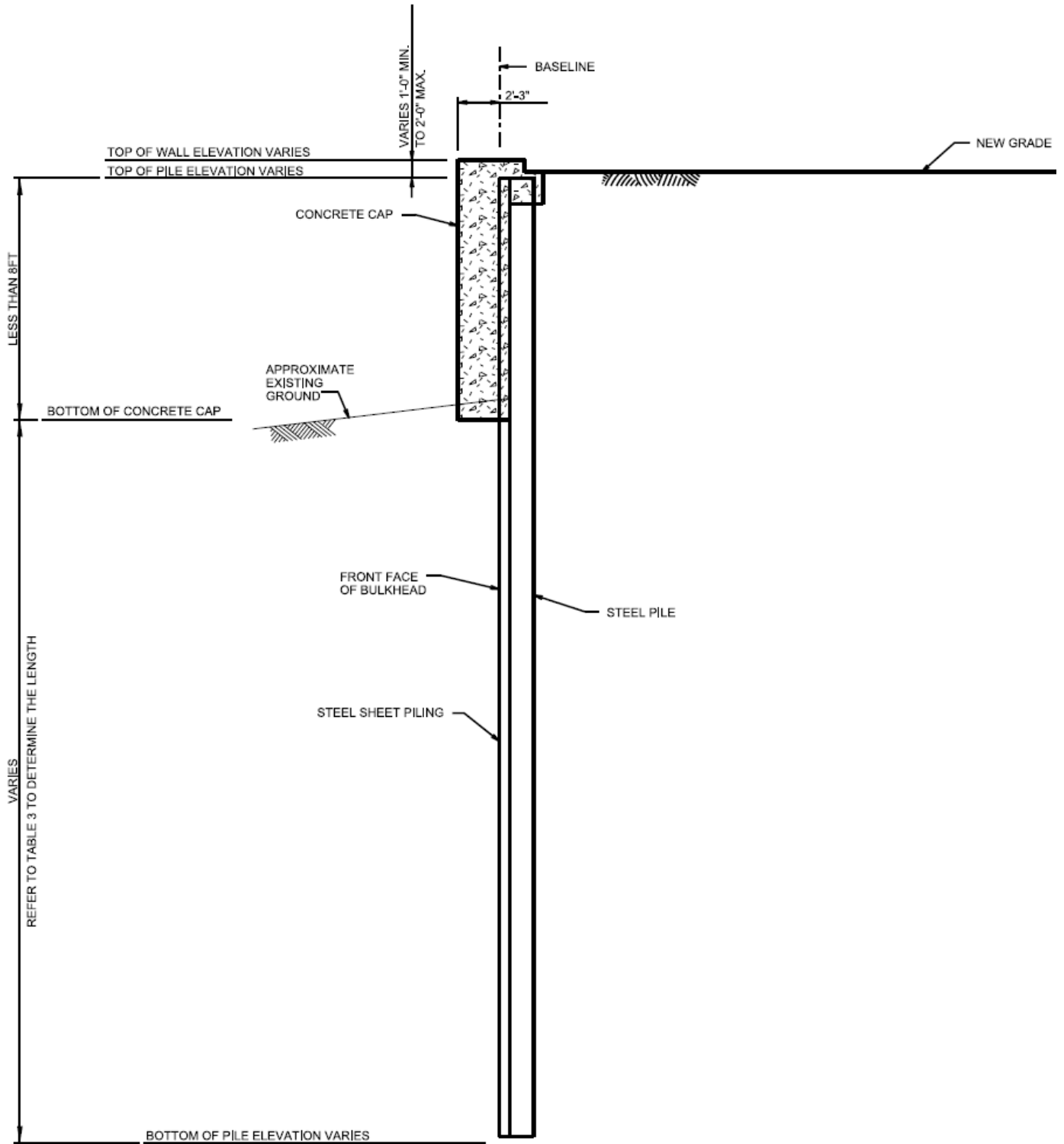


Figure 6: Typical Section without Tieback

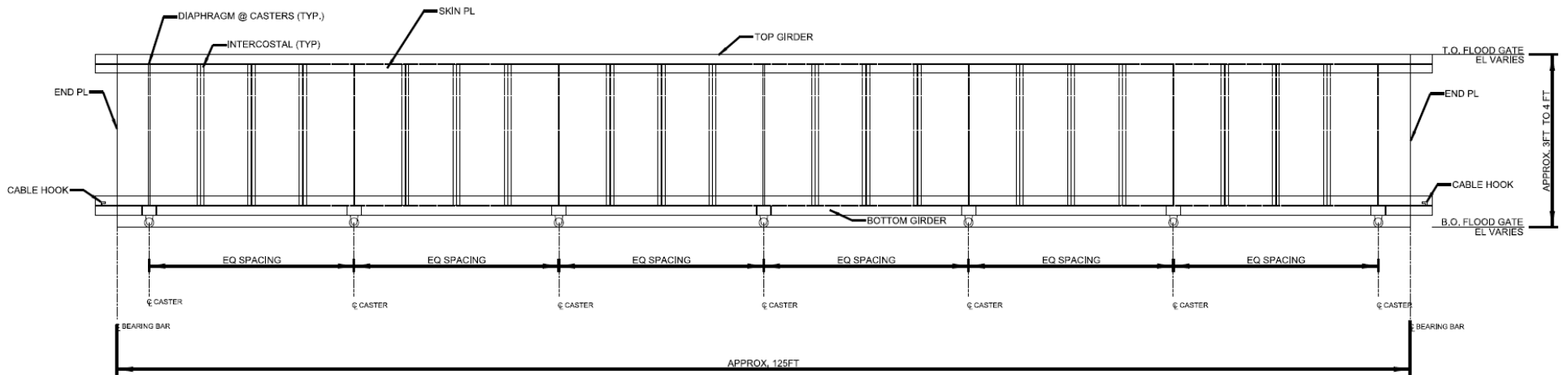


Figure 7: Typical Elevation of a Closure Gate

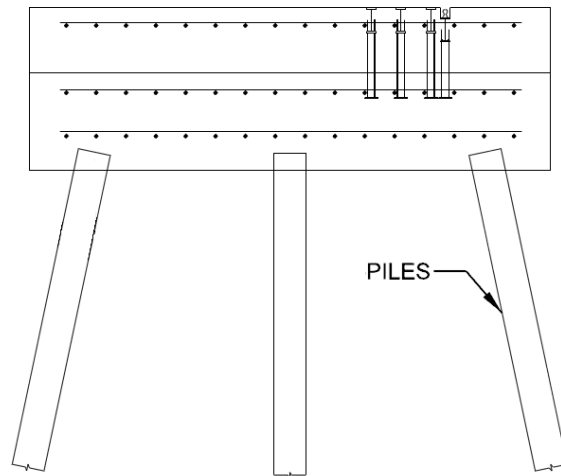


Figure 8: Typical Elevation of a Foundation for a Closure Gate

# **Millstone River Basin, New Jersey**

## **Flood Risk Management Feasibility Study**

### **Appendix C – Cost Engineering**

**U.S. Army Corps of Engineers  
New York District  
26 Federal Plaza  
New York, New York 10278**

**November 2016**



**US Army Corps  
of Engineers**  
New York District



**New Jersey Department of  
Environmental Protection**



# Cost Engineering Appendix

## TABLE OF CONTENTS

### Table of Contents

Introduction..... 3

Total Project Cost Summaries ..... 4

Abbreviated Risk Analysis (ARA) Results ..... 23

Schedules..... 25

## Introduction

This Appendix presents the cost estimate and pertinent information for the alternative plans in the main report. Alternative #1 is made up of three zones which contain approximately 10,520ft of levees, 8055ft of floodwall, interior drainage structures, two closure gates and bridge/road raisings. Alternative #2 consists of channel modifications along the Upper Raritan and Lower Raritan River reaches. Alternatives #3A-D and #4A-D consist of non-structural measures. Both alternatives #1 and #2 are designed to protect against a 50-yr flood event, while alternatives 3 & 4 deal with 50- and 10-yr levels of protection, respectively.

Alternative 1 consists of modifications to the existing levee and floodwall system. There are 5 areas, broken up into 9 different contracts per PM's direction. Contracts 1 and 2 are for the levees and floodwalls in Area 1, Contract 3 and 4 are for the levees in Area 2, Contracts 5 and 6 are for the levees and floodwalls in Area 3, Contract 7 is the levee in area 4, and Contracts 8 and 9 are the levees in Area 5. The levee work is assumed to consist of excavating/removing the existing levee, and re-building with common embankment material over a clay core. The floodwall design is 35-50 ft long steel sheet pile (PZ-35 assumed) with a 2' tall x 1' wide concrete cap. Quantities for the levee and floodwall work were provided by Gail Woolley and Sean O'Donnell/Jenae Pennie, respectively. Since there is little site information, each reach assumes that roughly 2 acres will need to be cleared so that 1/2 mile of access roads can be built to access the site. Access roads are assumed to be 30 ft wide crushed gravel roads to accommodate two-way dump truck traffic.

The estimate for alternative 2 contains work to perform channel deepening on a portion of the Raritan River, with no levee or floodwall work. The work consists of deepening the Raritan River by 1-4' over a ~2.5 mile stretch from Manville, NJ to the I-287 Bridge. The alternative has been broken up into two contracts - one for the Upper Raritan reach, and one for the Lower Raritan Reach. Due to the depth of the river averaging 5-7 ft deep, it is assumed that work will not be done by dredge, rather by an excavator mounted on pontoon tracks (marsh buggy). The marsh buggy is assumed to excavate the material and dump into a material into small tracked dump trucks (essentially tracked dozer frames with dump beds), which will ferry the material to the bank, where it will be dumped and loaded into highway haulers for removal off site. Per confirmation with the PDT and Andre Chauncey of H&H, it has been assumed that roughly 1/4 of the excavated material would have some small level of contaminant in it and would need to be disposed of at a certified landfill. The rest is assumed to become the property of the contractor, so costs have been included to haul the material off, but no costs have been added to the estimate for disposal fees.

Alternatives #3A-D and #4A-D area non-structural alternatives that were developed by, and whose quantities were provided by Civil Resources Branch, along with some costs that were based on previous MII estimates from feasibility studies. The scopes include the buyout/relocation of structures that cannot be adequately floodproofed, and the work required to floodproof varying structures in the floodplain, depending on the level of protection identified. Only one contract folder has been used for this alternative, since the discussion with Chris was that the current plan is to have individual contracts for each structure to be floodproofed, managed by each individual homeowner/business.

An abbreviated cost and schedule risk analysis was performed on a project level to assess contingencies by CWBS feature accounts. PED costs/percentages were discussed with the PM. S&A costs were developed based on the log formula used by NAN (has been used on all other Civil Works projects). First Cost Estimates (construction contract cost only) for all alternatives are included at the end of the Cost Appendix. The contract cost shown in those estimates translates to the TPCS sheet for each alternative, where contingency, E&D and S&A are added in.

**Total Project Cost Summaries**

# Total Project Cost Summary (cont.)

\*\*\*\* CONTRACT COST SUMMARY \*\*\*\*

PROJECT: Millstone River, NJ - Alt #1  
 LOCATION: Manville, NJ  
 This Estimate reflects the scope and schedule in report:

Negative Report

DISTRICT: NAN New York District  
 POC: CHIEF, COST ENGINEERING, Mukesh Kumar

PREPARED: 7/15/2015

Civil Works Work Breakdown Structure		ESTIMATED COST				PROJECT FIRST COST (Constant Dollar Basis)				TOTAL PROJECT COST (FULLY FUNDED)				
		Estimate Prepared:		1-Jul-15		Program Year (Budget EC):		2015						
		Effective Price Level:		1-Oct-14		Effective Price Level Date:		1 OCT 14						
		RISK BASED												
WBS NUMBER	Civil Works Feature & Sub-Feature Description	COST (\$K)	CNTG (\$K)	CNTG (%)	TOTAL (\$K)	ESC (%)	COST (\$K)	CNTG (\$K)	TOTAL (\$K)	Mid-Point Date	INFLATED (%)	COST (\$K)	CNTG (\$K)	FULL (\$K)
A	B	C	D	E	F	G	H	I	J	P	L	M	N	O
<b>Contract 1</b>														
08	ROADS, RAILROADS & BRIDGES	\$2,329	\$447	19.2%	\$2,776	0.0%	\$2,329	\$447	\$2,776	2016Q2	1.9%	\$2,374	\$456	\$2,830
11	LEVEES & FLOODWALLS	\$5,175	\$994	19.2%	\$6,168	0.0%	\$5,175	\$994	\$6,168	2016Q2	1.9%	\$5,275	\$1,013	\$6,287
<b>CONSTRUCTION ESTIMATE TOTALS:</b>		\$7,504	\$1,441	19.2%	\$8,945		\$7,504	\$1,441	\$8,945			\$7,649	\$1,469	\$9,117
01	LANDS AND DAMAGES	\$0	\$0	20.0%	\$0	0.0%	\$0	\$0	\$0	0	0.0%	\$0	\$0	\$0
30	PLANNING, ENGINEERING & DESIGN													
2.5%	Project Management	\$188	\$9	5.0%	\$197	0.0%	\$188	\$9	\$197	2015Q2	0.5%	\$189	\$9	\$198
2.0%	Planning & Environmental Compliance	\$150	\$8	5.0%	\$158	0.0%	\$150	\$8	\$158	2015Q2	0.5%	\$151	\$8	\$158
8.5%	Engineering & Design	\$638	\$32	5.0%	\$670	0.0%	\$638	\$32	\$670	2015Q2	0.5%	\$641	\$32	\$673
0.5%	Reviews, ATRs, IEPRs, VE	\$38	\$2	5.0%	\$40	0.0%	\$38	\$2	\$40	2015Q2	0.5%	\$38	\$2	\$40
0.5%	risks)	\$38	\$2	5.0%	\$40	0.0%	\$38	\$2	\$40	2015Q2	0.5%	\$38	\$2	\$40
2.0%	Contracting & Reprographics	\$150	\$8	5.0%	\$158	0.0%	\$150	\$8	\$158	2015Q2	0.5%	\$151	\$8	\$158
3.0%	Engineering During Construction	\$225	\$11	5.0%	\$236	0.0%	\$225	\$11	\$236	2016Q2	2.9%	\$232	\$12	\$243
2.0%	Planning During Construction	\$150	\$8	5.0%	\$158	0.0%	\$150	\$8	\$158	2016Q2	2.9%	\$154	\$8	\$162
2.0%	Project Operations	\$150	\$8	5.0%	\$158	0.0%	\$150	\$8	\$158	2015Q2	0.5%	\$151	\$8	\$158
31	CONSTRUCTION MANAGEMENT													
7.2%	Construction Management	\$544	\$27	5.0%	\$571	0.0%	\$544	\$27	\$571	2016Q2	2.9%	\$560	\$28	\$588
0.0%	Project Operation:	\$0	\$0	5.0%	\$0	0.0%	\$0	\$0	\$0	0	0.0%	\$0	\$0	\$0
0.0%	Project Management	\$0	\$0	5.0%	\$0	0.0%	\$0	\$0	\$0	0	0.0%	\$0	\$0	\$0
<b>CONTRACT COST TOTALS:</b>		\$9,775	\$1,554		\$11,329		\$9,775	\$1,554	\$11,329			\$9,953	\$1,584	\$11,537

# Total Project Cost Summary (cont.)

\*\*\*\* CONTRACT COST SUMMARY \*\*\*\*

PROJECT: Millstone River, NJ - Alt #1  
 LOCATION: Manville, NJ  
 This Estimate reflects the scope and schedule in report; Negative Report

DISTRICT: NAN New York District  
 POC: CHIEF, COST ENGINEERING, Mukesh Kumar  
 PREPARED: 7/15/2015

Civil Works Work Breakdown Structure		ESTIMATED COST				PROJECT FIRST COST (Constant Dollar Basis)				TOTAL PROJECT COST (FULLY FUNDED)				
WBS NUMBER A	Civil Works Feature & Sub-Feature Description B	Estimate Prepared: Effective Price Level:		1-Jul-15 1-Oct-14	ESC (%) G	COST (\$K) H	CNTG (\$K) I	TOTAL (\$K) J	Mid-Point Date P	INFLATED (%) L	COST (\$K) M	CNTG (\$K) N	FULL (\$K) O	
		COST (\$K) C	CNTG (\$K) D	CNTG (%) E										TOTAL (\$K) F
11	LEVEES & FLOODWALLS	\$3,299	\$633	19.2%	0.0%	\$3,299	\$633	\$3,933	2016Q3	2.3%	\$3,376	\$648	\$4,024	
<b>CONSTRUCTION ESTIMATE TOTALS:</b>		\$3,299	\$633	19.2%		\$3,299	\$633	\$3,933			\$3,376	\$648	\$4,024	
01	LANDS AND DAMAGES	\$0	\$0	25.0%	0.0%	\$0	\$0	\$0	0	0.0%	\$0	\$0	\$0	
30	PLANNING, ENGINEERING & DESIGN													
2.5%	Project Management	\$82	\$4	5.0%	0.0%	\$82	\$4	\$86	2015Q4	1.7%	\$83	\$4	\$88	
2.0%	Planning & Environmental Compliance	\$66	\$3	5.0%	0.0%	\$66	\$3	\$69	2015Q4	1.7%	\$67	\$3	\$70	
8.5%	Engineering & Design	\$280	\$14	5.0%	0.0%	\$280	\$14	\$294	2015Q4	1.7%	\$285	\$14	\$299	
0.5%	Reviews, ATRs, IEPRs, VE	\$16	\$1	5.0%	0.0%	\$16	\$1	\$17	2015Q4	1.7%	\$16	\$1	\$17	
0.5%	risks)	\$16	\$1	5.0%	0.0%	\$16	\$1	\$17	2015Q4	1.7%	\$16	\$1	\$17	
2.0%	Contracting & Reprographics	\$66	\$3	5.0%	0.0%	\$66	\$3	\$69	2015Q4	1.7%	\$67	\$3	\$70	
3.0%	Engineering During Construction	\$99	\$5	5.0%	0.0%	\$99	\$5	\$104	2016Q3	3.9%	\$103	\$5	\$108	
2.0%	Planning During Construction	\$66	\$3	5.0%	0.0%	\$66	\$3	\$69	2016Q3	3.9%	\$69	\$3	\$72	
2.0%	Project Operations	\$66	\$3	5.0%	0.0%	\$66	\$3	\$69	2015Q4	1.7%	\$67	\$3	\$70	
31	CONSTRUCTION MANAGEMENT													
7.2%	Construction Management	\$239	\$12	5.0%	0.0%	\$239	\$12	\$251	2016Q3	3.9%	\$248	\$12	\$261	
0.0%	Project Operation:	\$0	\$0	5.0%	0.0%	\$0	\$0	\$0	0	0.0%	\$0	\$0	\$0	
0.0%	Project Management	\$0	\$0	5.0%	0.0%	\$0	\$0	\$0	0	0.0%	\$0	\$0	\$0	
<b>CONTRACT COST TOTALS:</b>		\$4,295	\$683			\$4,295	\$683	\$4,978			\$4,398	\$699	\$5,098	



# Total Project Cost Summary (cont.)

\*\*\*\* CONTRACT COST SUMMARY \*\*\*\*

PROJECT: Millstone River, NJ - Alt #1  
 LOCATION: Manville, NJ  
 This Estimate reflects the scope and schedule in report:

Negative Report

DISTRICT: NAN New York District  
 POC: CHIEF, COST ENGINEERING, Mukesh Kumar

PREPARED: 7/15/2015

Civil Works Work Breakdown Structure		ESTIMATED COST				PROJECT FIRST COST (Constant Dollar Basis)				TOTAL PROJECT COST (FULLY FUNDED)				
WBS NUMBER A	Civil Works Feature & Sub-Feature Description B	Estimate Prepared: Effective Price Level:			1-Jul-15 1-Oct-14	Program Year (Budget EC): Effective Price Level Date:			2015 1 OCT 14	Mid-Point Date P	INFLATED (%) L	COST (\$K) M	CNTG (\$K) N	FULL (\$K) O
		COST (\$K) C	CNTG (\$K) D	CNTG (%) E	TOTAL (\$K) F	ESC (%) G	COST (\$K) H	CNTG (\$K) I	TOTAL (\$K) J					
11	LEVEES & FLOODWALLS	\$4,450	\$854	19.2%	\$5,304	0.0%	\$4,450	\$854	\$5,304	2016Q4	2.7%	\$4,572	\$878	\$5,450
<b>CONSTRUCTION ESTIMATE TOTALS:</b>		\$4,450	\$854	19.2%	\$5,304		\$4,450	\$854	\$5,304			\$4,572	\$878	\$5,450
01	LANDS AND DAMAGES	\$0	\$0	25.0%	\$0	0.0%	\$0	\$0	\$0	0	0.0%	\$0	\$0	\$0
30	PLANNING, ENGINEERING & DESIGN													
2.5%	Project Management	\$111	\$6	5.0%	\$117	0.0%	\$111	\$6	\$117	2016Q1	2.3%	\$114	\$6	\$119
2.0%	Planning & Environmental Compliance	\$89	\$4	5.0%	\$93	0.0%	\$89	\$4	\$93	2016Q1	2.3%	\$91	\$5	\$96
8.5%	Engineering & Design	\$378	\$19	5.0%	\$397	0.0%	\$378	\$19	\$397	2016Q1	2.3%	\$387	\$19	\$406
0.5%	Reviews, ATRs, IEPRs, VE	\$22	\$1	5.0%	\$23	0.0%	\$22	\$1	\$23	2016Q1	2.3%	\$23	\$1	\$24
0.5%	risks)	\$22	\$1	5.0%	\$23	0.0%	\$22	\$1	\$23	2016Q1	2.3%	\$23	\$1	\$24
2.0%	Contracting & Reprographics	\$89	\$4	5.0%	\$93	0.0%	\$89	\$4	\$93	2016Q1	2.3%	\$91	\$5	\$96
3.0%	Engineering During Construction	\$133	\$7	5.0%	\$140	0.0%	\$133	\$7	\$140	2016Q4	5.0%	\$140	\$7	\$147
2.0%	Planning During Construction	\$89	\$4	5.0%	\$93	0.0%	\$89	\$4	\$93	2016Q4	5.0%	\$93	\$5	\$98
2.0%	Project Operations	\$89	\$4	5.0%	\$93	0.0%	\$89	\$4	\$93	2016Q1	2.3%	\$91	\$5	\$96
31	CONSTRUCTION MANAGEMENT													
7.2%	Construction Management	\$323	\$16	5.0%	\$339	0.0%	\$323	\$16	\$339	2016Q4	5.0%	\$339	\$17	\$356
0.0%	Project Operation:	\$0	\$0	5.0%	\$0	0.0%	\$0	\$0	\$0	0	0.0%	\$0	\$0	\$0
0.0%	Project Management	\$0	\$0	5.0%	\$0	0.0%	\$0	\$0	\$0	0	0.0%	\$0	\$0	\$0
<b>CONTRACT COST TOTALS:</b>		\$5,795	\$922		\$6,716		\$5,795	\$922	\$6,716			\$5,963	\$947	\$6,910

# Total Project Cost Summary (cont.)

\*\*\*\* CONTRACT COST SUMMARY \*\*\*\*

PROJECT: Millstone River, NJ - Alt #1  
 LOCATION: Manville, NJ  
 This Estimate reflects the scope and schedule in report; Negative Report

DISTRICT: NAN New York District  
 POC: CHIEF, COST ENGINEERING, Mukesh Kumar

PREPARED: 7/15/2015

Civil Works Work Breakdown Structure		ESTIMATED COST				PROJECT FIRST COST (Constant Dollar Basis)				TOTAL PROJECT COST (FULLY FUNDED)				
WBS NUMBER A	Civil Works Feature & Sub-Feature Description B	Estimate Prepared: Effective Price Level:		1-Jul-15 1-Oct-14	TOTAL (\$K) F	Program Year (Budget EC): 2015 Effective Price Level Date: 1 OCT 14				FULLY FUNDED PROJECT ESTIMATE				
		COST (\$K) C	CNTG (\$K) D	CNTG (%) E		ESC (%) G	COST (\$K) H	CNTG (\$K) I	TOTAL (\$K) J	Mid-Point Date P	INFLATED (%) L	COST (\$K) M	CNTG (\$K) N	FULL (\$K) O
11	LEVEES & FLOODWALLS	\$1,174	\$225	19.2%	\$1,399	0.0%	\$1,174	\$225	\$1,399	2016Q4	2.7%	\$1,206	\$232	\$1,438
<b>CONSTRUCTION ESTIMATE TOTALS:</b>		\$1,174	\$225	19.2%	\$1,399		\$1,174	\$225	\$1,399			\$1,206	\$232	\$1,438
01	LANDS AND DAMAGES	\$0	\$0	25.0%	\$0	0.0%	\$0	\$0	\$0	0	0.0%	\$0	\$0	\$0
30	PLANNING, ENGINEERING & DESIGN													
2.5%	Project Management	\$29	\$1	5.0%	\$30	0.0%	\$29	\$1	\$30	2016Q1	2.3%	\$30	\$1	\$31
2.0%	Planning & Environmental Compliance	\$23	\$1	5.0%	\$24	0.0%	\$23	\$1	\$24	2016Q1	2.3%	\$24	\$1	\$25
8.5%	Engineering & Design	\$100	\$5	5.0%	\$105	0.0%	\$100	\$5	\$105	2016Q1	2.3%	\$102	\$5	\$107
0.5%	Reviews, ATRs, IEPRs, VE	\$6	\$0	5.0%	\$6	0.0%	\$6	\$0	\$6	2016Q1	2.3%	\$6	\$0	\$6
0.5%	risks)	\$6	\$0	5.0%	\$6	0.0%	\$6	\$0	\$6	2016Q1	2.3%	\$6	\$0	\$6
2.0%	Contracting & Reprographics	\$23	\$1	5.0%	\$24	0.0%	\$23	\$1	\$24	2016Q1	2.3%	\$24	\$1	\$25
3.0%	Engineering During Construction	\$35	\$2	5.0%	\$37	0.0%	\$35	\$2	\$37	2016Q4	5.0%	\$37	\$2	\$39
2.0%	Planning During Construction	\$23	\$1	5.0%	\$24	0.0%	\$23	\$1	\$24	2016Q4	5.0%	\$24	\$1	\$25
2.0%	Project Operations	\$23	\$1	5.0%	\$24	0.0%	\$23	\$1	\$24	2016Q1	2.3%	\$24	\$1	\$25
31	CONSTRUCTION MANAGEMENT													
7.2%	Construction Management	\$85	\$4	5.0%	\$89	0.0%	\$85	\$4	\$89	2016Q4	5.0%	\$89	\$4	\$94
0.0%	Project Operation:	\$0	\$0	5.0%	\$0	0.0%	\$0	\$0	\$0	0	0.0%	\$0	\$0	\$0
0.0%	Project Management	\$0	\$0	5.0%	\$0	0.0%	\$0	\$0	\$0	0	0.0%	\$0	\$0	\$0
<b>CONTRACT COST TOTALS:</b>		\$1,527	\$243		\$1,770		\$1,527	\$243	\$1,770			\$1,571	\$250	\$1,821

# Total Project Cost Summary (cont.)

\*\*\*\* CONTRACT COST SUMMARY \*\*\*\*

PROJECT: Millstone River, NJ - Alt #1  
 LOCATION: Manville, NJ  
 This Estimate reflects the scope and schedule in report; Negative Report

DISTRICT: NAN New York District  
 POC: CHIEF, COST ENGINEERING, Mukesh Kumar  
 PREPARED: 7/15/2015

Civil Works Work Breakdown Structure		ESTIMATED COST				PROJECT FIRST COST (Constant Dollar Basis)				TOTAL PROJECT COST (FULLY FUNDED)				
		Estimate Prepared: 1-Jul-15		Effective Price Level: 1-Oct-14		Program Year (Budget EC): 2015		Effective Price Level Date: 1 OCT 14		FULLY FUNDED PROJECT ESTIMATE				
WBS NUMBER	Civil Works Feature & Sub-Feature Description	COST (\$K)	CNTG (\$K)	CNTG (%)	TOTAL (\$K)	ESC (%)	COST (\$K)	CNTG (\$K)	TOTAL (\$K)	Mid-Point Date	INFLATED (%)	COST (\$K)	CNTG (\$K)	FULL (\$K)
A	B	C	D	E	F	G	H	I	J	P	L	M	N	O
11	Contract 5 LEVEES & FLOODWALLS	\$7,320	\$1,405	19.2%	\$8,726	0.0%	\$7,320	\$1,405	\$8,726	2017Q2	3.7%	\$7,593	\$1,458	\$9,050
<b>CONSTRUCTION ESTIMATE TOTALS:</b>		\$7,320	\$1,405	19.2%	\$8,726		\$7,320	\$1,405	\$8,726			\$7,593	\$1,458	\$9,050
01	LANDS AND DAMAGES	\$0	\$0	25.0%	\$0	0.0%	\$0	\$0	\$0	0	0.0%	\$0	\$0	\$0
30	PLANNING, ENGINEERING & DESIGN													
2.5%	Project Management	\$183	\$9	5.0%	\$192	0.0%	\$183	\$9	\$192	2016Q3	3.9%	\$190	\$10	\$200
2.0%	Planning & Environmental Compliance	\$146	\$7	5.0%	\$153	0.0%	\$146	\$7	\$153	2016Q3	3.9%	\$152	\$8	\$159
8.5%	Engineering & Design	\$622	\$31	5.0%	\$653	0.0%	\$622	\$31	\$653	2016Q3	3.9%	\$646	\$32	\$679
0.5%	Reviews, ATRs, IEPRs, VE	\$37	\$2	5.0%	\$39	0.0%	\$37	\$2	\$39	2016Q3	3.9%	\$38	\$2	\$40
0.5%	risks)	\$37	\$2	5.0%	\$39	0.0%	\$37	\$2	\$39	2016Q3	3.9%	\$38	\$2	\$40
2.0%	Contracting & Reprographics	\$146	\$7	5.0%	\$153	0.0%	\$146	\$7	\$153	2016Q3	3.9%	\$152	\$8	\$159
3.0%	Engineering During Construction	\$220	\$11	5.0%	\$231	0.0%	\$220	\$11	\$231	2017Q2	7.0%	\$235	\$12	\$247
2.0%	Planning During Construction	\$146	\$7	5.0%	\$153	0.0%	\$146	\$7	\$153	2017Q2	7.0%	\$156	\$8	\$164
2.0%	Project Operations	\$146	\$7	5.0%	\$153	0.0%	\$146	\$7	\$153	2016Q3	3.9%	\$152	\$8	\$159
31	CONSTRUCTION MANAGEMENT													
7.2%	Construction Management	\$531	\$27	5.0%	\$558	0.0%	\$531	\$27	\$558	2017Q2	7.0%	\$568	\$28	\$597
0.0%	Project Operation:	\$0	\$0	5.0%	\$0	0.0%	\$0	\$0	\$0	0	0.0%	\$0	\$0	\$0
0.0%	Project Management	\$0	\$0	5.0%	\$0	0.0%	\$0	\$0	\$0	0	0.0%	\$0	\$0	\$0
<b>CONTRACT COST TOTALS:</b>		\$9,534	\$1,516		\$11,050		\$9,534	\$1,516	\$11,050			\$9,921	\$1,574	\$11,496

# Total Project Cost Summary (cont.)

\*\*\*\* CONTRACT COST SUMMARY \*\*\*\*

PROJECT: Millstone River, NJ - Alt #1  
 LOCATION: Manville, NJ  
 This Estimate reflects the scope and schedule in report; Negative Report

DISTRICT: NAN New York District  
 POC: CHIEF, COST ENGINEERING, Mukesh Kumar  
 PREPARED: 7/15/2015

Civil Works Work Breakdown Structure		ESTIMATED COST				PROJECT FIRST COST (Constant Dollar Basis)				TOTAL PROJECT COST (FULLY FUNDED)				
WBS NUMBER A	Civil Works Feature & Sub-Feature Description B	Estimate Prepared: Effective Price Level:		1-Jul-15 1-Oct-14	Program Year (Budget EC): 2015 Effective Price Level Date: 1 OCT 14				FULLY FUNDED PROJECT ESTIMATE					
		COST (\$K) C	CNTG (\$K) D	CNTG (%) E	TOTAL (\$K) F	ESC (%) G	COST (\$K) H	CNTG (\$K) I	TOTAL (\$K) J	Mid-Point Date P	INFLATED (%) L	COST (\$K) M	CNTG (\$K) N	FULL (\$K) O
11	LEVEES & FLOODWALLS	\$13,536	\$2,599	19.2%	\$16,135	0.0%	\$13,536	\$2,599	\$16,135	2018Q1	5.2%	\$14,237	\$2,733	\$16,970
<b>CONSTRUCTION ESTIMATE TOTALS:</b>		\$13,536	\$2,599	19.2%	\$16,135		\$13,536	\$2,599	\$16,135			\$14,237	\$2,733	\$16,970
01	LANDS AND DAMAGES	\$0	\$0	25.0%	\$0	0.0%	\$0	\$0	\$0	0	0.0%	\$0	\$0	\$0
30	PLANNING, ENGINEERING & DESIGN													
2.5%	Project Management	\$338	\$17	5.0%	\$355	0.0%	\$338	\$17	\$355	2017Q1	6.0%	\$358	\$18	\$376
2.0%	Planning & Environmental Compliance	\$271	\$14	5.0%	\$285	0.0%	\$271	\$14	\$285	2017Q1	6.0%	\$287	\$14	\$302
8.5%	Engineering & Design	\$1,151	\$58	5.0%	\$1,209	0.0%	\$1,151	\$58	\$1,209	2017Q1	6.0%	\$1,220	\$61	\$1,281
0.5%	Reviews, ATRs, IEPRs, VE	\$68	\$3	5.0%	\$71	0.0%	\$68	\$3	\$71	2017Q1	6.0%	\$72	\$4	\$76
0.5%	risks)	\$68	\$3	5.0%	\$71	0.0%	\$68	\$3	\$71	2017Q1	6.0%	\$72	\$4	\$76
2.0%	Contracting & Reprographics	\$271	\$14	5.0%	\$285	0.0%	\$271	\$14	\$285	2017Q1	6.0%	\$287	\$14	\$302
3.0%	Engineering During Construction	\$406	\$20	5.0%	\$426	0.0%	\$406	\$20	\$426	2018Q1	10.2%	\$448	\$22	\$470
2.0%	Planning During Construction	\$271	\$14	5.0%	\$285	0.0%	\$271	\$14	\$285	2018Q1	10.2%	\$299	\$15	\$314
2.0%	Project Operations	\$271	\$14	5.0%	\$285	0.0%	\$271	\$14	\$285	2017Q1	6.0%	\$287	\$14	\$302
31	CONSTRUCTION MANAGEMENT													
7.2%	Construction Management	\$981	\$49	5.0%	\$1,030	0.0%	\$981	\$49	\$1,030	2018Q1	10.2%	\$1,081	\$54	\$1,135
0.0%	Project Operation:	\$0	\$0	5.0%	\$0	0.0%	\$0	\$0	\$0	0	0.0%	\$0	\$0	\$0
0.0%	Project Management	\$0	\$0	5.0%	\$0	0.0%	\$0	\$0	\$0	0	0.0%	\$0	\$0	\$0
<b>CONTRACT COST TOTALS:</b>		\$17,632	\$2,804		\$20,436		\$17,632	\$2,804	\$20,436			\$18,649	\$2,954	\$21,603

# Total Project Cost Summary (cont.)

\*\*\*\* CONTRACT COST SUMMARY \*\*\*\*

PROJECT: Millstone River, NJ - Alt #1  
 LOCATION: Manville, NJ  
 This Estimate reflects the scope and schedule in report; Negative Report

DISTRICT: NAN New York District  
 POC: CHIEF, COST ENGINEERING, Mukesh Kumar  
 PREPARED: 7/15/2015

Civil Works Work Breakdown Structure		ESTIMATED COST				PROJECT FIRST COST (Constant Dollar Basis)				TOTAL PROJECT COST (FULLY FUNDED)				
		Estimate Prepared: 1-Jul-15		Effective Price Level: 1-Oct-14		Program Year (Budget EC): 2015		Effective Price Level Date: 1 OCT 14		FULLY FUNDED PROJECT ESTIMATE				
WBS NUMBER	Civil Works Feature & Sub-Feature Description	COST (\$K)	CNTG (\$K)	CNTG (%)	TOTAL (\$K)	ESC (%)	COST (\$K)	CNTG (\$K)	TOTAL (\$K)	Mid-Point Date	INFLATED (%)	COST (\$K)	CNTG (\$K)	FULL (\$K)
A	B	C	D	E	F	G	H	I	J	P	L	M	N	O
11	Contract 7 LEVEES & FLOODWALLS	\$365	\$70	19.2%	\$435	0.0%	\$365	\$70	\$435	2017Q3	4.2%	\$380	\$73	\$454
<b>CONSTRUCTION ESTIMATE TOTALS:</b>		\$365	\$70	19.2%	\$435		\$365	\$70	\$435			\$380	\$73	\$454
01	LANDS AND DAMAGES	\$0	\$0	25.0%	\$0	0.0%	\$0	\$0	\$0	0	0.0%	\$0	\$0	\$0
30	PLANNING, ENGINEERING & DESIGN													
2.5%	Project Management	\$9	\$0	5.0%	\$9	0.0%	\$9	\$0	\$9	2016Q4	5.0%	\$9	\$0	\$10
2.0%	Planning & Environmental Compliance	\$7	\$0	5.0%	\$7	0.0%	\$7	\$0	\$7	2016Q4	5.0%	\$7	\$0	\$8
8.5%	Engineering & Design	\$31	\$2	5.0%	\$33	0.0%	\$31	\$2	\$33	2016Q4	5.0%	\$33	\$2	\$34
0.5%	Reviews, ATRs, IEPRs, VE	\$2	\$0	5.0%	\$2	0.0%	\$2	\$0	\$2	2016Q4	5.0%	\$2	\$0	\$2
0.5%	risks)	\$2	\$0	5.0%	\$2	0.0%	\$2	\$0	\$2	2016Q4	5.0%	\$2	\$0	\$2
2.0%	Contracting & Reprographics	\$7	\$0	5.0%	\$7	0.0%	\$7	\$0	\$7	2016Q4	5.0%	\$7	\$0	\$8
3.0%	Engineering During Construction	\$11	\$1	5.0%	\$12	0.0%	\$11	\$1	\$12	2017Q3	8.1%	\$12	\$1	\$12
2.0%	Planning During Construction	\$7	\$0	5.0%	\$7	0.0%	\$7	\$0	\$7	2017Q3	8.1%	\$8	\$0	\$8
2.0%	Project Operations	\$7	\$0	5.0%	\$7	0.0%	\$7	\$0	\$7	2016Q4	5.0%	\$7	\$0	\$8
31	CONSTRUCTION MANAGEMENT													
7.2%	Construction Management	\$26	\$1	5.0%	\$27	0.0%	\$26	\$1	\$27	2017Q3	8.1%	\$28	\$1	\$30
0.0%	Project Operation:	\$0	\$0	5.0%	\$0	0.0%	\$0	\$0	\$0	0	0.0%	\$0	\$0	\$0
0.0%	Project Management	\$0	\$0	5.0%	\$0	0.0%	\$0	\$0	\$0	0	0.0%	\$0	\$0	\$0
<b>CONTRACT COST TOTALS:</b>		\$474	\$76		\$550		\$474	\$76	\$550			\$496	\$79	\$575



# Total Project Cost Summary (cont.)

\*\*\*\* CONTRACT COST SUMMARY \*\*\*\*

PROJECT: Millstone River, NJ - Alt #1  
 LOCATION: Manville, NJ  
 This Estimate reflects the scope and schedule in report; Negative Report

DISTRICT: NAN New York District  
 POC: CHIEF, COST ENGINEERING, Mukesh Kumar  
 PREPARED: 7/15/2015

Civil Works Work Breakdown Structure		ESTIMATED COST				PROJECT FIRST COST (Constant Dollar Basis)				TOTAL PROJECT COST (FULLY FUNDED)				
		Estimate Prepared: 1-Jul-15		Effective Price Level: 1-Oct-14		Program Year (Budget EC): 2015		Effective Price Level Date: 1 OCT 14		FULLY FUNDED PROJECT ESTIMATE				
WBS NUMBER	Civil Works Feature & Sub-Feature Description	COST (\$K)	CNTG (\$K)	CNTG (%)	TOTAL (\$K)	ESC (%)	COST (\$K)	CNTG (\$K)	TOTAL (\$K)	Mid-Point Date	INFLATED (%)	COST (\$K)	CNTG (\$K)	FULL (\$K)
A	B	C	D	E	F	G	H	I	J	P	L	M	N	O
<b>11</b>	<b>Contract 8</b> LEVEES & FLOODWALLS	\$3,329	\$639	19.2%	\$ 3,968	0.0%	\$3,329	\$639	\$3,968	2018Q1	5.2%	\$3,501	\$672	\$4,173
<b>CONSTRUCTION ESTIMATE TOTALS:</b>		\$3,329	\$639	19.2%	\$3,968		\$3,329	\$639	\$3,968			\$3,501	\$672	\$4,173
<b>01</b>	LANDS AND DAMAGES	\$0	\$0	25.0%	\$ -	0.0%	\$0	\$0	\$0	0	0.0%	\$0	\$0	\$0
<b>30</b>	PLANNING, ENGINEERING & DESIGN													
2.5%	Project Management	\$83	\$4	5.0%	87	0.0%	\$83	\$4	\$87	2017Q2	7.0%	\$89	\$4	\$93
2.0%	Planning & Environmental Compliance	\$67	\$3	5.0%	70	0.0%	\$67	\$3	\$70	2017Q2	7.0%	\$72	\$4	\$75
8.5%	Engineering & Design	\$283	\$14	5.0%	297	0.0%	\$283	\$14	\$297	2017Q2	7.0%	\$303	\$15	\$318
0.5%	Reviews, ATRs, IEPRs, VE	\$17	\$1	5.0%	18	0.0%	\$17	\$1	\$18	2017Q2	7.0%	\$18	\$1	\$19
0.5%	risks)	\$17	\$1	5.0%	\$18	0.0%	\$17	\$1	\$18	2017Q2	7.0%	\$18	\$1	\$19
2.0%	Contracting & Reprographics	\$67	\$3	5.0%	70	0.0%	\$67	\$3	\$70	2017Q2	7.0%	\$72	\$4	\$75
3.0%	Engineering During Construction	\$100	\$5	5.0%	105	0.0%	\$100	\$5	\$105	2018Q1	10.2%	\$110	\$6	\$116
2.0%	Planning During Construction	\$67	\$3	5.0%	70	0.0%	\$67	\$3	\$70	2018Q1	10.2%	\$74	\$4	\$78
2.0%	Project Operations	\$67	\$3	5.0%	70	0.0%	\$67	\$3	\$70	2017Q2	7.0%	\$72	\$4	\$75
<b>31</b>	CONSTRUCTION MANAGEMENT													
7.2%	Construction Management	\$241	\$12	5.0%	253	0.0%	\$241	\$12	\$253	2018Q1	10.2%	\$266	\$13	\$279
0.0%	Project Operation:	\$0	\$0	5.0%	0	0.0%	\$0	\$0	\$0	0	0.0%	\$0	\$0	\$0
0.0%	Project Management	\$0	\$0	5.0%	0	0.0%	\$0	\$0	\$0	0	0.0%	\$0	\$0	\$0
<b>CONTRACT COST TOTALS:</b>		\$4,338	\$690		\$5,027		\$4,338	\$690	\$5,027			\$4,594	\$727	\$5,321

# Total Project Cost Summary (cont.)

\*\*\*\* CONTRACT COST SUMMARY \*\*\*\*

PROJECT: Millstone River, NJ - Alt #1  
 LOCATION: Manville, NJ  
 This Estimate reflects the scope and schedule in report; Negative Report

DISTRICT: NAN New York District  
 POC: CHIEF, COST ENGINEERING, Mukesh Kumar  
 PREPARED: 7/15/2015

Civil Works Work Breakdown Structure		ESTIMATED COST				PROJECT FIRST COST (Constant Dollar Basis)				TOTAL PROJECT COST (FULLY FUNDED)				
WBS NUMBER A	Civil Works Feature & Sub-Feature Description B	Estimate Prepared: Effective Price Level:		1-Jul-15 1-Oct-14	Program Year (Budget EC): 2015 Effective Price Level Date: 1 OCT 14				FULLY FUNDED PROJECT ESTIMATE					
		COST (\$K) C	CNTG (\$K) D	CNTG (%) E	TOTAL (\$K) F	ESC (%) G	COST (\$K) H	CNTG (\$K) I	TOTAL (\$K) J	Mid-Point Date P	INFLATED (%) L	COST (\$K) M	CNTG (\$K) N	FULL (\$K) O
11	LEVEES & FLOODWALLS	\$2,995	\$575	19.2%	\$3,570	0.0%	\$2,995	\$575	\$3,570	2019Q1	7.2%	\$3,212	\$617	\$3,829
<b>CONSTRUCTION ESTIMATE TOTALS:</b>		\$2,995	\$575	19.2%	\$3,570		\$2,995	\$575	\$3,570			\$3,212	\$617	\$3,829
01	LANDS AND DAMAGES	\$0	\$0	25.0%	\$0	0.0%	\$0	\$0	\$0	0	0.0%	\$0	\$0	\$0
30	PLANNING, ENGINEERING & DESIGN													
2.5%	Project Management	\$75	\$4	5.0%	\$79	0.0%	\$75	\$4	\$79	2018Q1	10.2%	\$83	\$4	\$87
2.0%	Planning & Environmental Compliance	\$60	\$3	5.0%	\$63	0.0%	\$60	\$3	\$63	2018Q1	10.2%	\$66	\$3	\$69
8.5%	Engineering & Design	\$255	\$13	5.0%	\$268	0.0%	\$255	\$13	\$268	2018Q1	10.2%	\$281	\$14	\$295
0.5%	Reviews, ATRs, IEPRs, VE	\$15	\$1	5.0%	\$16	0.0%	\$15	\$1	\$16	2018Q1	10.2%	\$17	\$1	\$17
0.5%	risks)	\$15	\$1	5.0%	\$16	0.0%	\$15	\$1	\$16	2018Q1	10.2%	\$17	\$1	\$17
2.0%	Contracting & Reprographics	\$60	\$3	5.0%	\$63	0.0%	\$60	\$3	\$63	2018Q1	10.2%	\$66	\$3	\$69
3.0%	Engineering During Construction	\$90	\$5	5.0%	\$95	0.0%	\$90	\$5	\$95	2019Q1	14.6%	\$103	\$5	\$108
2.0%	Planning During Construction	\$60	\$3	5.0%	\$63	0.0%	\$60	\$3	\$63	2019Q1	14.6%	\$69	\$3	\$72
2.0%	Project Operations	\$60	\$3	5.0%	\$63	0.0%	\$60	\$3	\$63	2018Q1	10.2%	\$66	\$3	\$69
31	CONSTRUCTION MANAGEMENT													
7.2%	Construction Management	\$217	\$11	5.0%	\$228	0.0%	\$217	\$11	\$228	2019Q1	14.6%	\$249	\$12	\$261
0.0%	Project Operation:	\$0	\$0	5.0%	\$0	0.0%	\$0	\$0	\$0	0	0.0%	\$0	\$0	\$0
0.0%	Project Management	\$0	\$0	5.0%	\$0	0.0%	\$0	\$0	\$0	0	0.0%	\$0	\$0	\$0
<b>CONTRACT COST TOTALS:</b>		\$3,902	\$620		\$4,523		\$3,902	\$620	\$4,523			\$4,228	\$668	\$4,896

# Total Project Cost Summary (cont.)

## Alternative 2 – Channel Deepening

PROJECT: Millstone River, NJ - Alt #2 - Channel Deepening      DISTRICT: NAN New York District      PREPARED: 7/15/2015  
 PROJECT NO: P2 109445      POC: CHIEF, COST ENGINEERING, Mukesh Kumar  
 LOCATION: Manville, NJ

This Estimate reflects the scope and schedule in report: Negative Report

Civil Works Work Breakdown Structure		ESTIMATED COST				PROJECT FIRST COST (Constant Dollar Basis)					TOTAL PROJECT COST (FULLY FUNDED)				
WBS NUMBER A	Civil Works Feature & Sub-Feature Description B	COST (\$K) C	CNTG (\$K) D	CNTG (%) E	TOTAL (\$K) F	ESC (%) G	COST (\$K) H	CNTG (\$K) I	TOTAL (\$K) J	Program Year (Budget EC): 2015 Effective Price Level Date: 1 OCT 14		INFLATED (%) L	COST (\$K) M	CNTG (\$K) N	FULL (\$K) O
										Spent Thru: 10/1/2013 (\$K)	TOTAL FIRST COST (\$K) K				
09	CHANNELS & CANALS	\$81,970	\$18,074	22.1%	\$100,044	0.0%	\$81,970	\$18,074	\$100,044	\$0	\$100,044	3.7%	\$84,984	\$18,739	\$103,723
<b>CONSTRUCTION ESTIMATE TOTALS:</b>		\$81,970	\$18,074		\$100,044	0.0%	\$81,970	\$18,074	\$100,044	\$0	\$100,044	3.7%	\$84,984	\$18,739	\$103,723
01	LANDS AND DAMAGES	\$0	\$0	-	\$0	-	\$0	\$0	\$0	\$0	\$0	-	\$0	\$0	\$0
30	PLANNING, ENGINEERING & DESIGN	\$18,851	\$943	5.0%	\$19,794	0.0%	\$18,851	\$943	\$19,794	\$0	\$19,794	3.4%	\$19,500	\$975	\$20,475
31	CONSTRUCTION MANAGEMENT	\$5,477	\$274	5.0%	\$5,751	0.0%	\$5,477	\$274	\$5,751	\$0	\$5,751	6.9%	\$5,857	\$293	\$6,150
<b>PROJECT COST TOTALS:</b>		\$106,298	\$19,291	18.1%	\$125,588		\$106,298	\$19,291	\$125,588	\$0	\$125,588	3.8%	\$110,341	\$20,007	\$130,347

\_\_\_\_\_  
**CHIEF, COST ENGINEERING, Mukesh Kumar**

\_\_\_\_\_  
**PROJECT MANAGER, Bob Greco**

\_\_\_\_\_  
**CHIEF, REAL ESTATE, Noreen Dresser**

\_\_\_\_\_  
**CHIEF, PLANNING, Frank Santomauro**

\_\_\_\_\_  
**CHIEF, ENGINEERING, Arthur Connolly**

\_\_\_\_\_  
**CHIEF, OPERATIONS, Tom Creamer**

\_\_\_\_\_  
**CHIEF, CONSTRUCTION, Gerald Byrne**

\_\_\_\_\_  
**CHIEF, CONTRACTING, Frank Cashman**

\_\_\_\_\_  
**CHIEF, PM-PB, Anthony Ciorra**

\_\_\_\_\_  
**CHIEF, DPM, Joseph Seebode**

ESTIMATED FEDERAL COST: **65%** \$84,726  
 ESTIMATED NON-FEDERAL COST: **35%** \$45,622  
**ESTIMATED TOTAL PROJECT COST: \$130,347**

g4edcjgn:  
**Required Signatures  
 by Regulations**

# Total Project Cost Summary (cont.)

\*\*\*\* CONTRACT COST SUMMARY \*\*\*\*

PROJECT: Millstone River, NJ - Alt #2 - Channel Deepening  
 LOCATION: Manville, NJ  
 This Estimate reflects the scope and schedule in report; Negative Report

DISTRICT: NAN New York District  
 POC: CHIEF, COST ENGINEERING, Mukesh Kumar  
 PREPARED: 7/15/2015

Civil Works Work Breakdown Structure		ESTIMATED COST				PROJECT FIRST COST (Constant Dollar Basis)				TOTAL PROJECT COST (FULLY FUNDED)				
		Estimate Prepared: 1-Jul-15				Program Year (Budget EC): 2015								
		Effective Price Level: 1-Oct-14				Effective Price Level Date: 1 OCT 14								
		RISK BASED												
WBS NUMBER	Civil Works Feature & Sub-Feature Description	COST (\$K)	CNTG (\$K)	CNTG (%)	TOTAL (\$K)	ESC (%)	COST (\$K)	CNTG (\$K)	TOTAL (\$K)	Mid-Point Date	INFLATED (%)	COST (\$K)	CNTG (\$K)	FULL (\$K)
A	B	C	D	E	F	G	H	I	J	P	L	M	N	O
09	Contract 1 CHANNELS & CANALS	\$22,647	\$4,994	22.05%	\$27,641	0.0%	\$22,647	\$4,994	\$27,641	2016Q3	2.3%	\$23,177	\$5,110	\$28,287
<b>CONSTRUCTION ESTIMATE TOTALS:</b>		\$22,647	\$4,994	22.1%	\$27,641		\$22,647	\$4,994	\$27,641			\$23,177	\$5,110	\$28,287
01	LANDS AND DAMAGES	\$0	\$0	20.0%	\$0	0.0%	\$0	\$0	\$0	0	0.0%	\$0	\$0	\$0
30	PLANNING, ENGINEERING & DESIGN													
2.5%	Project Management	\$566	\$28	5.0%	\$594	0.0%	\$566	\$28	\$594	2016Q2	2.9%	\$582	\$29	\$612
2.0%	Planning & Environmental Compliance	\$453	\$23	5.0%	\$476	0.0%	\$453	\$23	\$476	2016Q2	2.9%	\$466	\$23	\$489
8.5%	Engineering & Design	\$1,925	\$96	5.0%	\$2,021	0.0%	\$1,925	\$96	\$2,021	2016Q2	2.9%	\$1,981	\$99	\$2,080
0.5%	Reviews, ATRs, IEPRs, VE	\$113	\$6	5.0%	\$119	0.0%	\$113	\$6	\$119	2016Q2	2.9%	\$116	\$6	\$122
0.5%	risks)	\$113	\$6	5.0%	\$119	0.0%	\$113	\$6	\$119	2016Q2	2.9%	\$116	\$6	\$122
2.0%	Contracting & Reprographics	\$453	\$23	5.0%	\$476	0.0%	\$453	\$23	\$476	2016Q2	2.9%	\$466	\$23	\$489
3.0%	Engineering During Construction	\$679	\$34	5.0%	\$713	0.0%	\$679	\$34	\$713	2016Q3	3.9%	\$706	\$35	\$741
2.0%	Planning During Construction	\$453	\$23	5.0%	\$476	0.0%	\$453	\$23	\$476	2016Q3	3.9%	\$471	\$24	\$494
2.0%	Project Operations	\$453	\$23	5.0%	\$476	0.0%	\$453	\$23	\$476	2016Q2	2.9%	\$466	\$23	\$489
31	CONSTRUCTION MANAGEMENT													
6.7%	Construction Management	\$1,513	\$76	5.0%	\$1,589	0.0%	\$1,513	\$76	\$1,589	2016Q3	3.9%	\$1,573	\$79	\$1,651
0.0%	Project Operation:	\$0	\$0	5.0%	\$0	0.0%	\$0	\$0	\$0	0	0.0%	\$0	\$0	\$0
0.0%	Project Management	\$0	\$0	5.0%	\$0	0.0%	\$0	\$0	\$0	0	0.0%	\$0	\$0	\$0
<b>CONTRACT COST TOTALS:</b>		\$29,368	\$5,330		\$34,698		\$29,368	\$5,330	\$34,698			\$30,120	\$5,458	\$35,578

# Total Project Cost Summary (cont.)

\*\*\*\* CONTRACT COST SUMMARY \*\*\*\*

PROJECT: Millstone River, NJ - Alt #2 - Channel Deepening  
 LOCATION: Manville, NJ  
 This Estimate reflects the scope and schedule in report: Negative Report

DISTRICT: NAN New York District  
 POC: CHIEF, COST ENGINEERING, Mukesh Kumar  
 PREPARED: 7/15/2015

Civil Works Work Breakdown Structure		ESTIMATED COST				PROJECT FIRST COST (Constant Dollar Basis)				TOTAL PROJECT COST (FULLY FUNDED)				
WBS NUMBER A	Civil Works Feature & Sub-Feature Description B	Estimate Prepared: Effective Price Level:		1-Jul-15 1-Oct-14	Program Year (Budget EC): 2015 Effective Price Level Date: 1 OCT 14				Mid-Point Date P	INFLATED (%) L	COST (\$K) M	CNTG (\$K) N	FULL (\$K) O	
		COST (\$K) C	CNTG (\$K) D	CNTG (%) E	TOTAL (\$K) F	ESC (%) G	COST (\$K) H	CNTG (\$K) I						TOTAL (\$K) J
09	CHANNELS & CANALS	\$59,322	\$13,081	22.05%	\$72,403	0.0%	\$59,322	\$13,081	\$72,403	2017Q3	4.2%	\$61,807	\$13,628	\$75,435
<b>CONSTRUCTION ESTIMATE TOTALS:</b>		\$59,322	\$13,081	22.1%	\$72,403		\$59,322	\$13,081	\$72,403			\$61,807	\$13,628	\$75,435
01	LANDS AND DAMAGES	\$0	\$0	20.0%	\$0	0.0%	\$0	\$0	\$0	0	0.0%	\$0	\$0	\$0
30	PLANNING, ENGINEERING & DESIGN													
2.5%	Project Management	\$1,483	\$74	5.0%	\$1,557	0.0%	\$1,483	\$74	\$1,557	2016Q1	2.3%	\$1,517	\$76	\$1,593
2.0%	Planning & Environmental Compliance	\$1,186	\$59	5.0%	\$1,245	0.0%	\$1,186	\$59	\$1,245	2016Q1	2.3%	\$1,213	\$61	\$1,274
8.5%	Engineering & Design	\$5,042	\$252	5.0%	\$5,294	0.0%	\$5,042	\$252	\$5,294	2016Q1	2.3%	\$5,158	\$258	\$5,416
0.5%	Reviews, ATRs, IEPRs, VE	\$297	\$15	5.0%	\$312	0.0%	\$297	\$15	\$312	2016Q1	2.3%	\$304	\$15	\$319
0.5%	risks)	\$297	\$15	5.0%	\$312	0.0%	\$297	\$15	\$312	2016Q1	2.3%	\$304	\$15	\$319
2.0%	Contracting & Reprographics	\$1,186	\$59	5.0%	\$1,245	0.0%	\$1,186	\$59	\$1,245	2016Q1	2.3%	\$1,213	\$61	\$1,274
3.0%	Engineering During Construction	\$1,780	\$89	5.0%	\$1,869	0.0%	\$1,780	\$89	\$1,869	2017Q3	8.1%	\$1,924	\$96	\$2,020
2.0%	Planning During Construction	\$1,186	\$59	5.0%	\$1,245	0.0%	\$1,186	\$59	\$1,245	2017Q3	8.1%	\$1,282	\$64	\$1,346
2.0%	Project Operations	\$1,186	\$59	5.0%	\$1,245	0.0%	\$1,186	\$59	\$1,245	2016Q1	2.3%	\$1,213	\$61	\$1,274
31	CONSTRUCTION MANAGEMENT													
6.7%	Construction Management	\$3,964	\$198	5.0%	\$4,162	0.0%	\$3,964	\$198	\$4,162	2017Q3	8.1%	\$4,285	\$214	\$4,499
0.0%	Project Operation:	\$0	\$0	5.0%	\$0	0.0%	\$0	\$0	\$0	0	0.0%	\$0	\$0	\$0
0.0%	Project Management	\$0	\$0	5.0%	\$0	0.0%	\$0	\$0	\$0	0	0.0%	\$0	\$0	\$0
<b>CONTRACT COST TOTALS:</b>		\$76,929	\$13,961		\$90,890		\$76,929	\$13,961	\$90,890			\$80,220	\$14,549	\$94,769

# Total Project Cost Summary (cont.)

## Alternative 3 – Non-Structural

**PROJECT:** Millstone River, NJ - Alt #3 - 10-Yr Non-Structural  
**PROJECT NO:** P2 109445  
**LOCATION:** Manville, NJ  
**DISTRICT:** NAN New York District  
**POC:** CHIEF, COST ENGINEERING, Mukesh Kumar  
**PREPARED:** 7/15/2015  
 This Estimate reflects the scope and schedule in report: Negative Report

Civil Works Work Breakdown Structure		ESTIMATED COST				PROJECT FIRST COST (Constant Dollar Basis)					TOTAL PROJECT COST (FULLY FUNDED)					
WBS NUMBER A	Civil Works Feature & Sub-Feature Description B	COST (\$K) C	CNTG (\$K) D	CNTG (%) E	TOTAL (\$K) F	ESC (%) G	COST (\$K) H	CNTG (\$K) I	TOTAL (\$K) J	Program Year (Budget EC): Effective Price Level Date: 2015 1 OCT 14		TOTAL FIRST COST (\$K) K	INFLATED (%) L	COST (\$K) M	CNTG (\$K) N	FULL (\$K) O
										Spent Thru: 10/1/2013 (\$K)						
19	BUILDINGS, GROUNDS & UTILITIES	\$76,609	\$21,948	28.7%	\$98,557	0.0%	\$76,609	\$21,948	\$98,557		\$0	\$98,557	5.2%	\$80,573	\$23,084	\$103,658
<b>CONSTRUCTION ESTIMATE TOTALS:</b>		\$76,609	\$21,948		\$98,557	0.0%	\$76,609	\$21,948	\$98,557		\$0	\$98,557	5.2%	\$80,573	\$23,084	\$103,658
01	LANDS AND DAMAGES	\$0	\$0	-	\$0	-	\$0	\$0	\$0		\$0	\$0		\$0	\$0	\$0
30	PLANNING, ENGINEERING & DESIGN	\$17,619	\$881	5.0%	\$18,500	0.0%	\$17,619	\$881	\$18,500		\$0	\$18,500	4.5%	\$18,411	\$921	\$19,332
31	CONSTRUCTION MANAGEMENT	\$5,166	\$258	5.0%	\$5,424	0.0%	\$5,166	\$258	\$5,424		\$0	\$5,424	10.2%	\$5,695	\$285	\$5,979
<b>PROJECT COST TOTALS:</b>		\$99,394	\$23,088	23.2%	\$122,481		\$99,394	\$23,088	\$122,481		\$0	\$122,481	5.3%	\$104,679	\$24,290	\$128,969

\_\_\_\_\_ **CHIEF, COST ENGINEERING, Mukesh Kumar**  
 \_\_\_\_\_ **PROJECT MANAGER, Bob Greco**  
 \_\_\_\_\_ **CHIEF, REAL ESTATE, Noreen Dresser**  
 \_\_\_\_\_ **CHIEF, PLANNING, Frank Santomauro**  
 \_\_\_\_\_ **CHIEF, ENGINEERING, Arthur Connolly**  
 \_\_\_\_\_ **CHIEF, OPERATIONS, Tom Creamer**  
 \_\_\_\_\_ **CHIEF, CONSTRUCTION, Gerald Byrne**  
 \_\_\_\_\_ **CHIEF, CONTRACTING, Frank Cashman**  
 \_\_\_\_\_ **CHIEF, PM-PB, Anthony Ciorra**  
 \_\_\_\_\_ **CHIEF, DPM, Joseph Seebode**

ESTIMATED FEDERAL COST: **65%** \$83,830  
 ESTIMATED NON-FEDERAL COST: **35%** \$45,139  
**ESTIMATED TOTAL PROJECT COST: \$128,969**

g4edcjgn:  
**Required Signatures  
 by Regulations**



# Total Project Cost Summary (cont.)

\*\*\*\* CONTRACT COST SUMMARY \*\*\*\*

PROJECT: Millstone River, NJ - Alt #3 - 10-Yr Non-Structural  
 LOCATION: Manville, NJ  
 This Estimate reflects the scope and schedule in report: Negative Report

DISTRICT: NAN New York District  
 POC: CHIEF, COST ENGINEERING, Mukesh Kumar  
 PREPARED: 7/15/2015

Civil Works Work Breakdown Structure		ESTIMATED COST				PROJECT FIRST COST (Constant Dollar Basis)				TOTAL PROJECT COST (FULLY FUNDED)				
WBS NUMBER	Civil Works Feature & Sub-Feature Description	Estimate Prepared: 1-Jul-15 Effective Price Level: 1-Oct-14			TOTAL (\$K)	Program Year (Budget EC): 2015 Effective Price Level Date: 1 OCT 14			Mid-Point Date	INFLATED (%)	COST (\$K)	CNTG (\$K)	FULL (\$K)	
		COST (\$K)	CNTG (\$K)	CNTG (%)		ESC (%)	COST (\$K)	CNTG (\$K)						TOTAL (\$K)
A	B	C	D	E	F	G	H	I	J	P	L	M	N	O
19	BUILDINGS, GROUNDS & UTILITIES	\$76,609	\$21,948	28.7%	\$98,557	0.0%	\$76,609	\$21,948	\$98,557	2018Q1	5.2%	\$80,573	\$23,084	\$103,658
<b>CONSTRUCTION ESTIMATE TOTALS:</b>		\$76,609	\$21,948	28.7%	\$98,557		\$76,609	\$21,948	\$98,557			\$80,573	\$23,084	\$103,658
01	LANDS AND DAMAGES	\$0	\$0	25.0%	\$0	0.0%	\$0	\$0	\$0	0	0.0%	\$0	\$0	\$0
30	PLANNING, ENGINEERING & DESIGN													
2.5%	Project Management	\$1,915	\$96	5.0%	\$2,011	0.0%	\$1,915	\$96	\$2,011	2016Q2	2.9%	\$1,971	\$99	\$2,069
2.0%	Planning & Environmental Compliance	\$1,532	\$77	5.0%	\$1,609	0.0%	\$1,532	\$77	\$1,609	2016Q2	2.9%	\$1,576	\$79	\$1,655
8.5%	Engineering & Design	\$6,512	\$326	5.0%	\$6,838	0.0%	\$6,512	\$326	\$6,838	2016Q2	2.9%	\$6,701	\$335	\$7,036
0.5%	Reviews, ATRs, IEPRs, VE	\$383	\$19	5.0%	\$402	0.0%	\$383	\$19	\$402	2016Q2	2.9%	\$394	\$20	\$414
0.5%	risks)	\$383	\$19	5.0%	\$402	0.0%	\$383	\$19	\$402	2016Q2	2.9%	\$394	\$20	\$414
2.0%	Contracting & Reprographics	\$1,532	\$77	5.0%	\$1,609	0.0%	\$1,532	\$77	\$1,609	2016Q2	2.9%	\$1,576	\$79	\$1,655
3.0%	Engineering During Construction	\$2,298	\$115	5.0%	\$2,413	0.0%	\$2,298	\$115	\$2,413	2018Q1	10.2%	\$2,533	\$127	\$2,660
2.0%	Planning During Construction	\$1,532	\$77	5.0%	\$1,609	0.0%	\$1,532	\$77	\$1,609	2018Q1	10.2%	\$1,689	\$84	\$1,773
2.0%	Project Operations	\$1,532	\$77	5.0%	\$1,609	0.0%	\$1,532	\$77	\$1,609	2016Q2	2.9%	\$1,576	\$79	\$1,655
31	CONSTRUCTION MANAGEMENT													
6.7%	Construction Management	\$5,166	\$258	5.0%	\$5,424	0.0%	\$5,166	\$258	\$5,424	2018Q1	10.2%	\$5,695	\$285	\$5,979
0.0%	Project Operation:	\$0	\$0	5.0%	\$0	0.0%	\$0	\$0	\$0	0	0.0%	\$0	\$0	\$0
0.0%	Project Management	\$0	\$0	5.0%	\$0	0.0%	\$0	\$0	\$0	0	0.0%	\$0	\$0	\$0
<b>CONTRACT COST TOTALS:</b>		\$99,394	\$23,088		\$122,481		\$99,394	\$23,088	\$122,481			\$104,679	\$24,290	\$128,969

# Total Project Cost Summary (cont.)

PROJECT: Millstone River, NJ - Alt #3 - 50-Yr Non-Structural  
 PROJECT NO: P2 109445  
 LOCATION: Manville, NJ

DISTRICT: NAN New York District  
 POC: CHIEF, COST ENGINEERING, Mukesh Kumar

PREPARED: 7/15/2015

This Estimate reflects the scope and schedule in report: Negative Report

Civil Works Work Breakdown Structure		ESTIMATED COST				PROJECT FIRST COST (Constant Dollar Basis)				TOTAL PROJECT COST (FULLY FUNDED)					
WBS NUMBER A	Civil Works Feature & Sub-Feature Description B	COST (\$K) C	CNTG (\$K) D	CNTG (%) E	TOTAL (\$K) F	ESC (%) G	COST (\$K) H	CNTG (\$K) I	TOTAL (\$K) J	Program Year (Budget EC): Effective Price Level Date: 2015 1 OCT 14 Spent Thru: 10/1/2013 (\$K) K	TOTAL FIRST COST (\$K) K	INFLATED (%) L	COST (\$K) M	CNTG (\$K) N	FULL (\$K) O
19	BUILDINGS, GROUNDS & UTILITIES	\$147,938	\$42,384	28.7%	\$190,322	0.0%	\$147,938	\$42,384	\$190,322	\$0	\$190,322	5.2%	\$155,594	\$44,578	\$200,171
<b>CONSTRUCTION ESTIMATE TOTALS:</b>		\$147,938	\$42,384		\$190,322	0.0%	\$147,938	\$42,384	\$190,322	\$0	\$190,322	5.2%	\$155,594	\$44,578	\$200,171
01	LANDS AND DAMAGES	\$0	\$0	-	\$0	-	\$0	\$0	\$0	\$0	\$0	-	\$0	\$0	\$0
30	PLANNING, ENGINEERING & DESIGN	\$34,027	\$1,701	5.0%	\$35,728	0.0%	\$34,027	\$1,701	\$35,728	\$0	\$35,728	4.5%	\$35,557	\$1,778	\$37,335
31	CONSTRUCTION MANAGEMENT	\$9,088	\$454	5.0%	\$9,542	0.0%	\$9,088	\$454	\$9,542	\$0	\$9,542	10.2%	\$10,018	\$501	\$10,519
<b>PROJECT COST TOTALS:</b>		\$191,053	\$44,540	23.3%	\$235,593		\$191,053	\$44,540	\$235,593	\$0	\$235,593	5.3%	\$201,169	\$46,856	\$248,025

\_\_\_\_\_ CHIEF, COST ENGINEERING, Mukesh Kumar  
 \_\_\_\_\_ PROJECT MANAGER, Bob Greco  
 \_\_\_\_\_ CHIEF, REAL ESTATE, Noreen Dresser  
 \_\_\_\_\_ CHIEF, PLANNING, Frank Santomauro  
 \_\_\_\_\_ CHIEF, ENGINEERING, Arthur Connolly  
 \_\_\_\_\_ CHIEF, OPERATIONS, Tom Creamer  
 \_\_\_\_\_ CHIEF, CONSTRUCTION, Gerald Byrne  
 \_\_\_\_\_ CHIEF, CONTRACTING, Frank Cashman  
 \_\_\_\_\_ CHIEF, PM-PB, Anthony Ciorra  
 \_\_\_\_\_ CHIEF, DPM, Joseph Seebode

ESTIMATED FEDERAL COST: 65% \$161,216  
 ESTIMATED NON-FEDERAL COST: 35% \$86,809  
**ESTIMATED TOTAL PROJECT COST: \$248,025**

g4edc1gn:  
**Required Signatures  
by Regulations**

# Total Project Cost Summary (cont.)

**** CONTRACT COST SUMMARY ****														
PROJECT: Millstone River, NJ - Alt #3 - 50-Yr Non-Structural				DISTRICT: NAN New York District				PREPARED: 7/15/2015						
LOCATION: Manville, NJ				POC: CHIEF, COST ENGINEERING, Mukesh Kumar										
This Estimate reflects the scope and schedule in report: Negative Report														
Civil Works Work Breakdown Structure		ESTIMATED COST				PROJECT FIRST COST (Constant Dollar Basis)				TOTAL PROJECT COST (FULLY FUNDED)				
		Estimate Prepared: 1-Jul-15		Effective Price Level: 1-Oct-14		Program Year (Budget EC): 2015		Effective Price Level Date: 1 OCT 14						
		RISK BASED												
WBS NUMBER	Civil Works Feature & Sub-Feature Description	COST (\$K)	CNTG (\$K)	CNTG (%)	TOTAL (\$K)	ESC (%)	COST (\$K)	CNTG (\$K)	TOTAL (\$K)	Mid-Point Date	INFLATED (%)	COST (\$K)	CNTG (\$K)	FULL (\$K)
A	B	C	D	E	F	G	H	I	J	P	L	M	N	O
19	BUILDINGS, GROUNDS & UTILITIES	\$147,938	\$42,384	28.7%	\$190,322	0.0%	\$147,938	\$42,384	\$190,322	2018Q1	5.2%	\$155,594	\$44,578	\$200,171
<b>CONSTRUCTION ESTIMATE TOTALS:</b>		\$147,938	\$42,384	28.7%	\$190,322		\$147,938	\$42,384	\$190,322			\$155,594	\$44,578	\$200,171
01	LANDS AND DAMAGES	\$0	\$0	25.0%	\$0	0.0%	\$0	\$0	\$0	0	0.0%	\$0	\$0	\$0
30	PLANNING, ENGINEERING & DESIGN													
2.5%	Project Management	\$3,698	\$185	5.0%	\$3,883	0.0%	\$3,698	\$185	\$3,883	2016Q2	2.9%	\$3,805	\$190	\$3,996
2.0%	Planning & Environmental Compliance	\$2,959	\$148	5.0%	\$3,107	0.0%	\$2,959	\$148	\$3,107	2016Q2	2.9%	\$3,045	\$152	\$3,197
8.5%	Engineering & Design	\$12,575	\$629	5.0%	\$13,204	0.0%	\$12,575	\$629	\$13,204	2016Q2	2.9%	\$12,940	\$647	\$13,587
0.5%	Reviews, ATRs, IEPRs, VE	\$740	\$37	5.0%	\$777	0.0%	\$740	\$37	\$777	2016Q2	2.9%	\$761	\$38	\$800
0.5%	risks)	\$740	\$37	5.0%	\$777	0.0%	\$740	\$37	\$777	2016Q2	2.9%	\$761	\$38	\$800
2.0%	Contracting & Reprographics	\$2,959	\$148	5.0%	\$3,107	0.0%	\$2,959	\$148	\$3,107	2016Q2	2.9%	\$3,045	\$152	\$3,197
3.0%	Engineering During Construction	\$4,438	\$222	5.0%	\$4,660	0.0%	\$4,438	\$222	\$4,660	2018Q1	10.2%	\$4,892	\$245	\$5,137
2.0%	Planning During Construction	\$2,959	\$148	5.0%	\$3,107	0.0%	\$2,959	\$148	\$3,107	2018Q1	10.2%	\$3,262	\$163	\$3,425
2.0%	Project Operations	\$2,959	\$148	5.0%	\$3,107	0.0%	\$2,959	\$148	\$3,107	2016Q2	2.9%	\$3,045	\$152	\$3,197
31	CONSTRUCTION MANAGEMENT													
6.1%	Construction Management	\$9,088	\$454	5.0%	\$9,542	0.0%	\$9,088	\$454	\$9,542	2018Q1	10.2%	\$10,018	\$501	\$10,519
0.0%	Project Operation:	\$0	\$0	5.0%	\$0	0.0%	\$0	\$0	\$0	0	0.0%	\$0	\$0	\$0
0.0%	Project Management	\$0	\$0	5.0%	\$0	0.0%	\$0	\$0	\$0	0	0.0%	\$0	\$0	\$0
<b>CONTRACT COST TOTALS:</b>		\$191,053	\$44,540		\$235,593		\$191,053	\$44,540	\$235,593			\$201,169	\$46,856	\$248,025

# Total Project Cost Summary (cont.)

PROJECT: Millstone River, NJ - Alt #3 - 100-Yr Non-Structural  
 PROJECT NO: P2 109445  
 LOCATION: Manville, NJ

DISTRICT: NAN New York District  
 POC: CHIEF, COST ENGINEERING, Mukesh Kumar

PREPARED: 7/15/2015

This Estimate reflects the scope and schedule in report: Negative Report

Civil Works Work Breakdown Structure		ESTIMATED COST				PROJECT FIRST COST (Constant Dollar Basis)					TOTAL PROJECT COST (FULLY FUNDED)					
WBS NUMBER A	Civil Works Feature & Sub-Feature Description B	COST (\$K) C	CNTG (\$K) D	CNTG (%) E	TOTAL (\$K) F	ESC (%) G	COST (\$K) H	CNTG (\$K) I	TOTAL (\$K) J	Program Year (Budget EC): Effective Price Level Date: 2015 1 OCT 14		TOTAL FIRST COST (\$K) K	INFLATED (%) L	COST (\$K) M	CNTG (\$K) N	FULL (\$K) O
										Spent Thru: 10/1/2013 (\$K)						
19	BUILDINGS, GROUNDS & UTILITIES	\$153,023	\$43,841	28.7%	\$196,865	0.0%	\$153,023	\$43,841	\$196,865	\$0	\$196,865	5.2%	\$160,943	\$46,110	\$207,053	
<b>CONSTRUCTION ESTIMATE TOTALS:</b>		\$153,023	\$43,841		\$196,865	0.0%	\$153,023	\$43,841	\$196,865	\$0	\$196,865	5.2%	\$160,943	\$46,110	\$207,053	
01	LANDS AND DAMAGES	\$0	\$0		\$0	-	\$0	\$0	\$0	\$0	\$0		\$0	\$0	\$0	
30	PLANNING, ENGINEERING & DESIGN	\$35,194	\$1,760	5.0%	\$36,954	0.0%	\$35,194	\$1,760	\$36,954	\$0	\$36,954	4.5%	\$36,777	\$1,839	\$38,616	
31	CONSTRUCTION MANAGEMENT	\$9,353	\$468	5.0%	\$9,821	0.0%	\$9,353	\$468	\$9,821	\$0	\$9,821	10.2%	\$10,310	\$515	\$10,825	
<b>PROJECT COST TOTALS:</b>		\$197,570	\$46,069	23.3%	\$243,639		\$197,570	\$46,069	\$243,639	\$0	\$243,639	5.3%	\$208,029	\$48,464	\$256,494	

\_\_\_\_\_ CHIEF, COST ENGINEERING, Mukesh Kumar

\_\_\_\_\_ PROJECT MANAGER, Bob Greco

\_\_\_\_\_ CHIEF, REAL ESTATE, Noreen Dresser

\_\_\_\_\_ CHIEF, PLANNING, Frank Santomauro

\_\_\_\_\_ CHIEF, ENGINEERING, Arthur Connolly

\_\_\_\_\_ CHIEF, OPERATIONS, Tom Creamer

\_\_\_\_\_ CHIEF, CONSTRUCTION, Gerald Byrne

\_\_\_\_\_ CHIEF, CONTRACTING, Frank Cashman

\_\_\_\_\_ CHIEF, PM-PB, Anthony Ciorra

\_\_\_\_\_ CHIEF, DPM, Joseph Seebode

ESTIMATED FEDERAL COST: 65% \$166,721  
 ESTIMATED NON-FEDERAL COST: 35% \$89,773  
**ESTIMATED TOTAL PROJECT COST: \$256,494**

g4edcjgn:  
**Required Signatures  
 by Regulations**

# Total Project Cost Summary (cont.)

\*\*\*\* CONTRACT COST SUMMARY \*\*\*\*

PROJECT: Millstone River, NJ - Alt #3 - 100-Yr Non-Structural  
 LOCATION: Manville, NJ  
 This Estimate reflects the scope and schedule in report: Negative Report

DISTRICT: NAN New York District  
 POC: CHIEF, COST ENGINEERING, Mukesh Kumar  
 PREPARED: 7/15/2015

Civil Works Work Breakdown Structure		ESTIMATED COST				PROJECT FIRST COST (Constant Dollar Basis)				TOTAL PROJECT COST (FULLY FUNDED)				
WBS NUMBER A	Civil Works Feature & Sub-Feature Description B	RISK BASED			TOTAL (\$K) F	ESC (%) G	COST (\$K) H	CNTG (\$K) I	TOTAL (\$K) J	Mid-Point Date P	INFLATED (%) L	COST (\$K) M	CNTG (\$K) N	FULL (\$K) O
		COST (\$K) C	CNTG (\$K) D	CNTG (%) E										
		Estimate Prepared: 1-Jul-15 Effective Price Level: 1-Oct-14			Program Year (Budget EC): 2015 Effective Price Level Date: 1 OCT 14									
19	BUILDINGS, GROUNDS & UTILITIES	\$153,023	\$43,841	28.7%	\$196,865	0.0%	\$153,023	\$43,841	\$196,865	2018Q1	5.2%	\$160,943	\$46,110	\$207,053
<b>CONSTRUCTION ESTIMATE TOTALS:</b>		\$153,023	\$43,841	28.7%	\$196,865		\$153,023	\$43,841	\$196,865			\$160,943	\$46,110	\$207,053
01	LANDS AND DAMAGES	\$0	\$0	25.0%	\$0	0.0%	\$0	\$0	\$0	0	0.0%	\$0	\$0	\$0
30	PLANNING, ENGINEERING & DESIGN													
2.5%	Project Management	\$3,826	\$191	5.0%	\$4,017	0.0%	\$3,826	\$191	\$4,017	2016Q2	2.9%	\$3,937	\$197	\$4,134
2.0%	Planning & Environmental Compliance	\$3,060	\$153	5.0%	\$3,213	0.0%	\$3,060	\$153	\$3,213	2016Q2	2.9%	\$3,149	\$157	\$3,306
8.5%	Engineering & Design	\$13,007	\$650	5.0%	\$13,657	0.0%	\$13,007	\$650	\$13,657	2016Q2	2.9%	\$13,385	\$669	\$14,054
0.5%	Reviews, ATRs, IEPRs, VE	\$765	\$38	5.0%	\$803	0.0%	\$765	\$38	\$803	2016Q2	2.9%	\$787	\$39	\$827
0.5%	risks)	\$765	\$38	5.0%	\$803	0.0%	\$765	\$38	\$803	2016Q2	2.9%	\$787	\$39	\$827
2.0%	Contracting & Reprographics	\$3,060	\$153	5.0%	\$3,213	0.0%	\$3,060	\$153	\$3,213	2016Q2	2.9%	\$3,149	\$157	\$3,306
3.0%	Engineering During Construction	\$4,591	\$230	5.0%	\$4,821	0.0%	\$4,591	\$230	\$4,821	2018Q1	10.2%	\$5,061	\$253	\$5,314
2.0%	Planning During Construction	\$3,060	\$153	5.0%	\$3,213	0.0%	\$3,060	\$153	\$3,213	2018Q1	10.2%	\$3,373	\$169	\$3,542
2.0%	Project Operations	\$3,060	\$153	5.0%	\$3,213	0.0%	\$3,060	\$153	\$3,213	2016Q2	2.9%	\$3,149	\$157	\$3,306
31	CONSTRUCTION MANAGEMENT													
6.1%	Construction Management	\$9,353	\$468	5.0%	\$9,821	0.0%	\$9,353	\$468	\$9,821	2018Q1	10.2%	\$10,310	\$515	\$10,825
0.0%	Project Operation:	\$0	\$0	5.0%	\$0	0.0%	\$0	\$0	\$0	0	0.0%	\$0	\$0	\$0
0.0%	Project Management	\$0	\$0	5.0%	\$0	0.0%	\$0	\$0	\$0	0	0.0%	\$0	\$0	\$0
<b>CONTRACT COST TOTALS:</b>		\$197,570	\$46,069		\$243,639		\$197,570	\$46,069	\$243,639			\$208,029	\$48,464	\$256,494

# Abbreviated Risk Analysis (ARA) Results

## Alternative 1 – Levee/Floodwall

Abbreviated Risk Analysis						
Project (less than \$40M): <b>Millstone, NJ - Alt #1 Levee/Floodwall</b>						
Project Development Stage: <b>Feasibility (Recommended Plan)</b>						
Risk Category: <b>Moderate Risk: Typical Project or Possible Life Safety</b>						
Total Construction Contract Cost = \$ <b>43,972,528</b>						
CWWBS	Feature of Work	Contract Cost		% Contingency	\$ Contingency	Total
01 LANDS AND DAMAGES	Real Estate	\$ -		20.00%	\$ -	\$ -
1 08 01 ROADS	Demo Pavement	\$ 1,233,228		8.72%	\$ 107,589	\$ 1,340,817.42
2 11 01 LEVEES	Gate Closure Structure	\$ 6,942,964		21.11%	\$ 1,465,589	\$ 8,408,552.69
3 11 01 LEVEES	High-Strength Geotextile	\$ 1,967,763		8.99%	\$ 176,999	\$ 2,144,762.47
4 11 01 LEVEES	Levee Embankment, New Clay Fill	\$ 4,845,999		16.72%	\$ 810,105	\$ 5,656,104.55
5 11 01 LEVEES	Levee Embankment, Re-Use Existing Fill	\$ 1,065,308		15.22%	\$ 162,173	\$ 1,227,481.13
6 11 01 LEVEES	Traffic Control	\$ 1,953,433		15.22%	\$ 297,373	\$ 2,250,806.58
7 11 02 FLOODWALLS	Steel Sheet Piling	\$ 16,177,900		24.99%	\$ 4,042,524	\$ 20,220,424.20
8 11 02 FLOODWALLS	Concrete Cap	\$ 1,120,998		11.37%	\$ 127,417	\$ 1,248,414.63
9 11 02 FLOODWALLS	Tiebacks	\$ 1,764,410		11.37%	\$ 200,549	\$ 1,964,959.32
12	Remaining Construction Items	\$ 6,900,524	18.6%	15.22%	\$ 1,050,474	\$ 7,950,997.67
13 30 PLANNING, ENGINEERING, AND DESIGN	Planning, Engineering, & Design	\$ 10,113,681		5.00%	\$ 505,684	\$ 10,619,365.42
14 31 CONSTRUCTION MANAGEMENT	Construction Management	\$ 3,187,709		5.00%	\$ 159,385	\$ 3,347,094.24
<b>Totals</b>						
	Real Estate	\$ -		0.00%	\$ -	\$ -
	Total Construction Estimate	\$ 43,972,528		19.20%	\$ 8,440,793	\$ 52,413,321
	Total Planning, Engineering & Design	\$ 10,113,681		5.00%	\$ 505,684	\$ 10,619,365
	Total Construction Management	\$ 3,187,709		5.00%	\$ 159,385	\$ 3,347,094
	<b>Total</b>	<b>\$ 57,273,918</b>			<b>\$ 9,105,863</b>	<b>\$ 66,379,780</b>

## Alternative 2 – Channel Deepening

Abbreviated Risk Analysis						
Project (less than \$40M): <b>Millstone, NJ - Alt #2 - Channel Deepening</b>						
Project Development Stage: <b>Feasibility (Recommended Plan)</b>						
Risk Category: <b>Moderate Risk: Typical Project or Possible Life Safety</b>						
Total Construction Contract Cost = \$ <b>81,969,540</b>						
CWWBS	Feature of Work	Contract Cost		% Contingency	\$ Contingency	Total
01 LANDS AND DAMAGES	Real Estate	\$ -		20.00%	\$ -	\$ -
1 09 01 CHANNELS	Excavation	\$ 12,878,988		19.70%	\$ 2,537,722	\$ 15,416,709.72
2 09 01 CHANNELS	Hauling	\$ 65,704,538		22.96%	\$ 15,083,560	\$ 80,788,097.86
12	Remaining Construction Items	\$ 3,386,014	4.3%	13.40%	\$ 453,812	\$ 3,839,825.80
13 30 PLANNING, ENGINEERING, AND DESIGN	Planning, Engineering, & Design	\$ 18,852,994		5.00%	\$ 942,650	\$ 19,795,643.82
14 31 CONSTRUCTION MANAGEMENT	Construction Management	\$ 5,476,655		5.00%	\$ 273,833	\$ 5,750,488.01
<b>Totals</b>						
	Real Estate	\$ -		0.00%	\$ -	\$ -
	Total Construction Estimate	\$ 81,969,540		22.05%	\$ 18,075,094	\$ 100,044,633
	Total Planning, Engineering & Design	\$ 18,852,994		5.00%	\$ 942,650	\$ 19,795,644
	Total Construction Management	\$ 5,476,655		5.00%	\$ 273,833	\$ 5,750,488
	<b>Total</b>	<b>\$ 106,299,189</b>			<b>\$ 19,291,576</b>	<b>\$ 125,590,765</b>



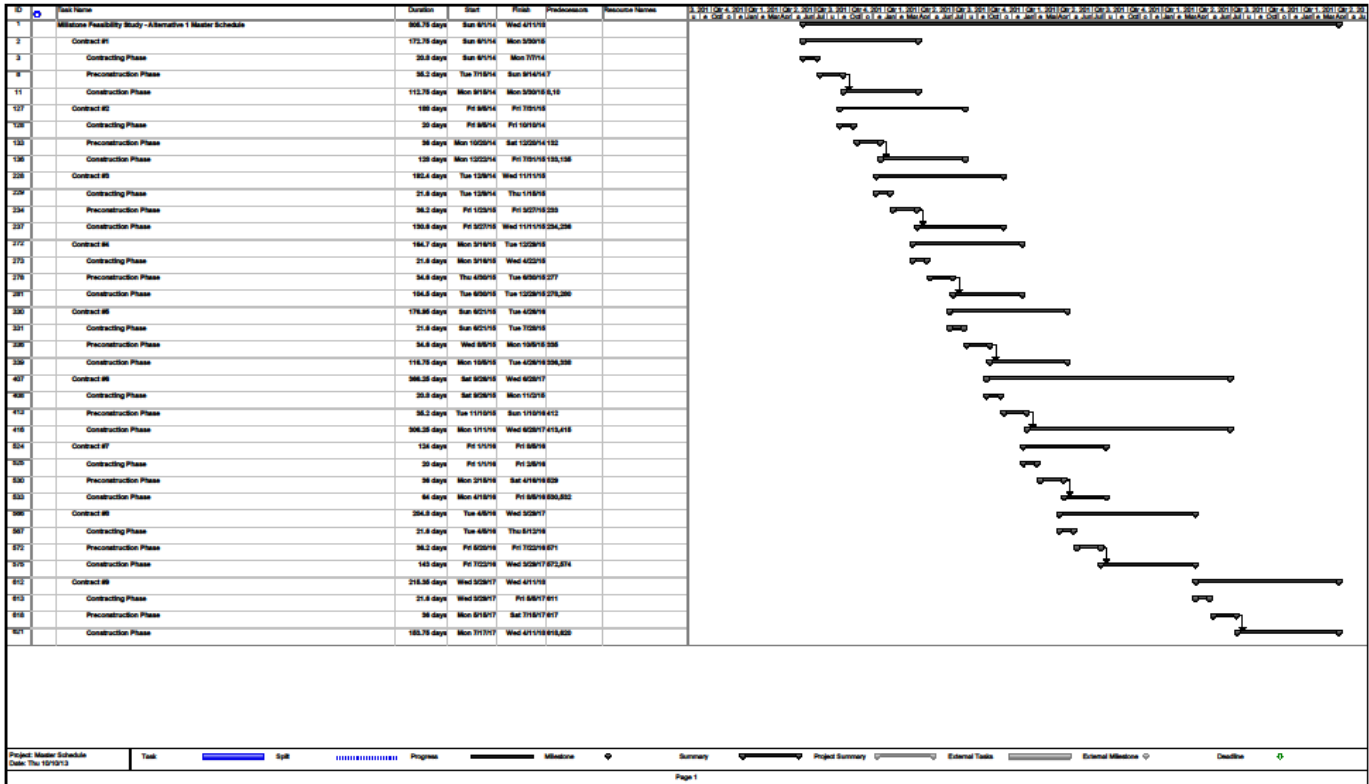
**Alternative 3 – Non-Structural (only 50-yr shown but same contingency used for all 3)**

<b>Abbreviated Risk Analysis</b>						
Project (less than \$40M): <b>Millstone, NJ - Alt 3 - Non-Structural (50-yr)</b>						
Project Development Stage: <b>Feasibility (Recommended Plan)</b>						
Risk Category: <b>Moderate Risk: Typical Project or Possible Life Safety</b>						
Total Construction Contract Cost = \$ <b>147,937,751</b>						
<u>CWWBS</u>	<u>Feature of Work</u>	<u>Contract Cost</u>	<u>% Contingency</u>	<u>\$ Contingency</u>	<u>Total</u>	
01 LANDS AND DAMAGES	Real Estate		20.00%	\$ -	\$ -	\$ -
1	19 BUILDINGS, GROUNDS, AND UTILITIES	Relocations/Buyouts of Structures	\$ 52,519,117	39.59%	\$ 20,792,909	\$ 73,312,025.93
2	19 BUILDINGS, GROUNDS, AND UTILITIES	Real Estate Agreement/Housing Costs	\$ 16,010,105	30.82%	\$ 4,934,802	\$ 20,944,906.69
3	19 BUILDINGS, GROUNDS, AND UTILITIES	Raise Basements	\$ 26,427,177	21.00%	\$ 5,549,872	\$ 31,977,048.54
4	19 BUILDINGS, GROUNDS, AND UTILITIES	Ringwall - 5 ft high	\$ 12,989,775	21.00%	\$ 2,727,934	\$ 15,717,708.94
5	19 BUILDINGS, GROUNDS, AND UTILITIES	Ringwall - 10 ft high	\$ 14,923,810	21.00%	\$ 3,134,093	\$ 18,057,902.96
6	19 BUILDINGS, GROUNDS, AND UTILITIES	Floodgates	\$ 4,848,366	28.71%	\$ 1,392,123	\$ 6,240,488.35
12		Remaining Construction Items	\$ 20,219,402	15.8%	\$ 3,846,998	\$ 24,066,400.36
13	30 PLANNING, ENGINEERING, AND DESIGN	Planning, Engineering, & Design	\$ 34,025,683	5.00%	\$ 1,701,284	\$ 35,726,966.96
14	31 CONSTRUCTION MANAGEMENT	Construction Management	\$ 9,087,571	5.00%	\$ 454,379	\$ 9,541,949.13
<b>Totals</b>						
		Real Estate	\$ -	0.00%	\$ -	\$ -
		Total Construction Estimate	\$ 147,937,751	28.65%	\$ 42,378,730	\$ 190,316,482
		Total Planning, Engineering & Design	\$ 34,025,683	5.00%	\$ 1,701,284	\$ 35,726,967
		Total Construction Management	\$ 9,087,571	5.00%	\$ 454,379	\$ 9,541,949
		<b>Total</b>	<b>\$ 191,051,005</b>		<b>\$ 44,534,393</b>	<b>\$ 235,585,398</b>

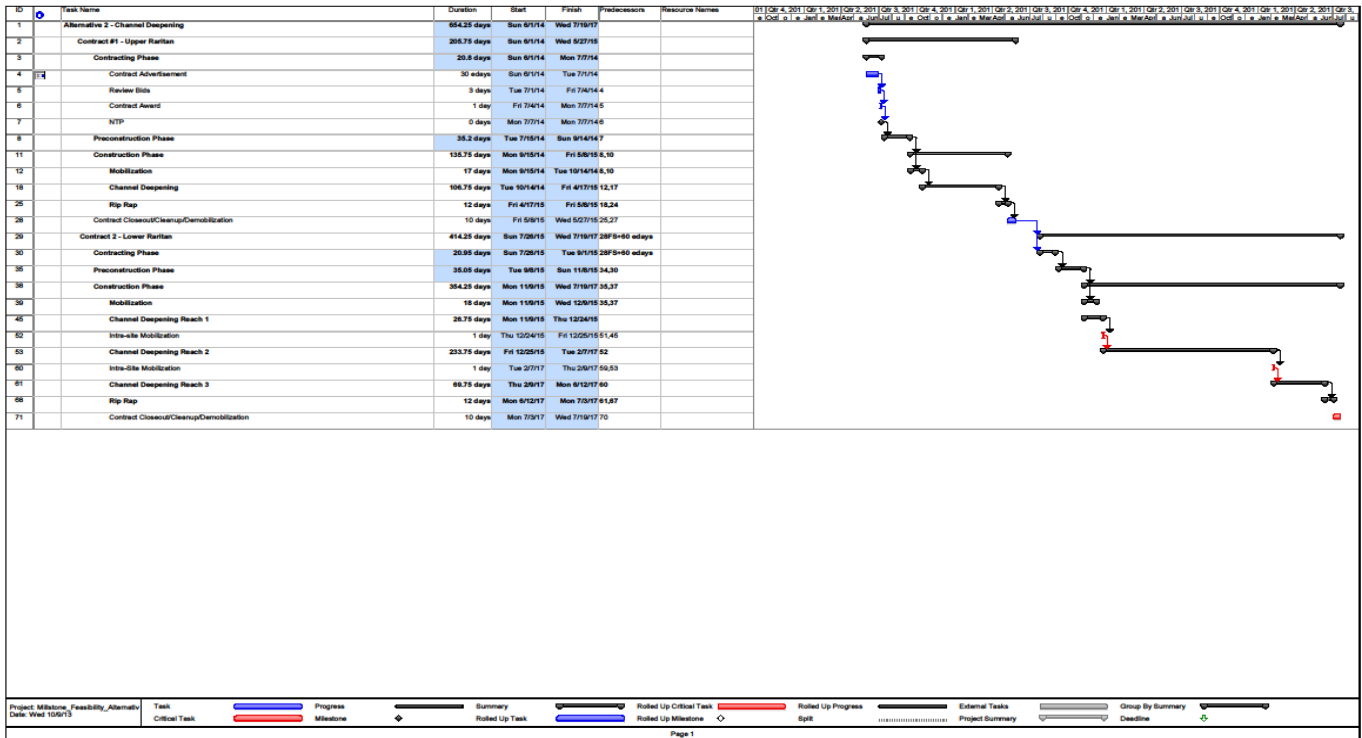
# Schedules

(double-click to open in Adobe)

## Alternative 1 – Levee/Floodwall



## Alternative 2 – Channel Deepening



# **Millstone River Basin, New Jersey**

## **Flood Risk Management Feasibility Study**

### **Appendix E – Geotechnical**

**U.S. Army Corps of Engineers  
New York District  
26 Federal Plaza  
New York, New York 10278**

**November 2016**



**US Army Corps  
of Engineers**  
New York District



**New Jersey Department of  
Environmental Protection**

# MILLSTONE RIVER BASIN, NEW JERSEY FLOOD RISK MANAGEMENT FEASIBILITY STUDY

## GEOTECHNICAL APPENDIX NOVEMBER 2016

### **PROJECT DESCRIPTION**

The U.S. Army Corps of Engineers, New York District, is evaluating potential flood damage reduction measures for the Millstone River and the Raritan River in Millstone, New Jersey. The potential flood risk management includes two alternatives.

One alternative includes floodwalls, levees and road raising for the upper portion of the project. The upper portion lies mainly along the Millstone River which empties into the Raritan River. There are a few levees, floodwalls, and road raising along the Upper Raritan River in Millstone.

The other alternative would be channel deepening of the lower portion of the project with the river banks to 1 on 3 slopes. The lower portion lies within the Lower Raritan River between the Central New Jersey Railroad Bridge and Route 287 Highway Bridge.

### **GEOLOGY**

The project area, especially the lower portion is near from the Green Brook Flood Control at Bound Brook, New Jersey. The Millstone area is located in a geological, structural, and topographic province known as the Piedmont Physiographic Province, which is underlain by rocks of the Newark Basin. The Newark Basin consists of slightly folded and faulted, red (colored, sedimentary sandstones, siltstones, and shales of Triassic and Jurassic ages (about 200 million years ago) and dark igneous basalts and diabase of Jurassic age. The general topography of the area is characterized by a broad, southeastward sloping and gently rolling lowland. The project area is at an elevation of about 30 to 40 ft and underlain by the Passaic Formation. The Passaic Formation is a Lower Jurassic and Upper Triassic unit of the Brunswick Group consisting of grayish red to reddish brown, evenly to irregularly bedded, thin to thick bedded shale, siltstone, very fine to coarse grained sandstone, and red matrix conglomerate. The maximum thickness of the formation is about 19,000 feet. The depth to the underlying Passaic Formation in the project area is about 30 feet. The overburden consists of fill, sand, and weathered rock. A detailed description of the overburden and rock units is provided below.

## **SUBSURFACE EXPLORATION PLAN**

As the project progresses subsurface exploration will need to be performed in the actual area of the proposed flood damage reduction project. The subsurface exploration data will be used to determine the soil properties that may affect excavation and costs. Sampling and testing should include undisturbed samples for consolidation in clays and permeability tests, constant head or falling head tests for Sands. The subsurface exploration plan would require at least 65 borings at 30 feet deep from the surface or a few maybe deeper to determine the depth of the any pervious layer. These borings would be required to define the geological stratum and obtain samples for laboratory testing. Test would include grain size analysis with hydrometer, moisture content, specific gravity, and unit weight. If cohesive soils are encountered, laboratory test would also include consolidation tests and triaxial tests. The borings and the laboratory testing would be able to determine the soil/rock strength properties for design of the levee, floodwalls, and road raising in the upper portion of the project. There would be permeability test in some of the borings using the falling head tests or the constant tests. This would be required for determining the permeability constants for seepage analysis of the levees and floodwalls.

## **GEOTECHNICAL ENGINEERING CONSIDERATIONS**

Design of the levees and floodwalls will require seepage, settlement, and stability analyses. The type soils encounter in the borings will determine the availability of material for the levees and backfill for the floodwalls. The levee heights range from 10 to 18 feet above the ground surface with an impervious core that go at least six feet below the ground surface depending upon the amount of underseepage. The underseepage would be determined in later phases of the project after the completion of the subsurface and laboratory testing. Riprap would line the slope of the levee on the riverside. This will require riprap gradation design and finding sources for the riprap and bedding stone. Road raising will require the new backfill under the new pavements and resurfacing of the roadways using pavement materials specified in the NJDOT Standard Specifications. Levee sections are shown in the main report for the upper portion of the project as one alternative. Sheet piling used for the floodwalls will be anchored along the upper portion of the project along the river banks. The borings will determine the depth of the Red Shale bedrock for the maximum depth of the sheet piling.

Preliminary analysis was performed for the floodwalls using soil parameters from the Green Brook Geotechnical Report. This report was based on the borings for Segment B1 and B2 which is about a mile north of the Millstone Project. As mentioned before, it is highly recommended to perform borings and laboratory testing for this project site. This would more accurately determine the soil/rock parameters for this site.

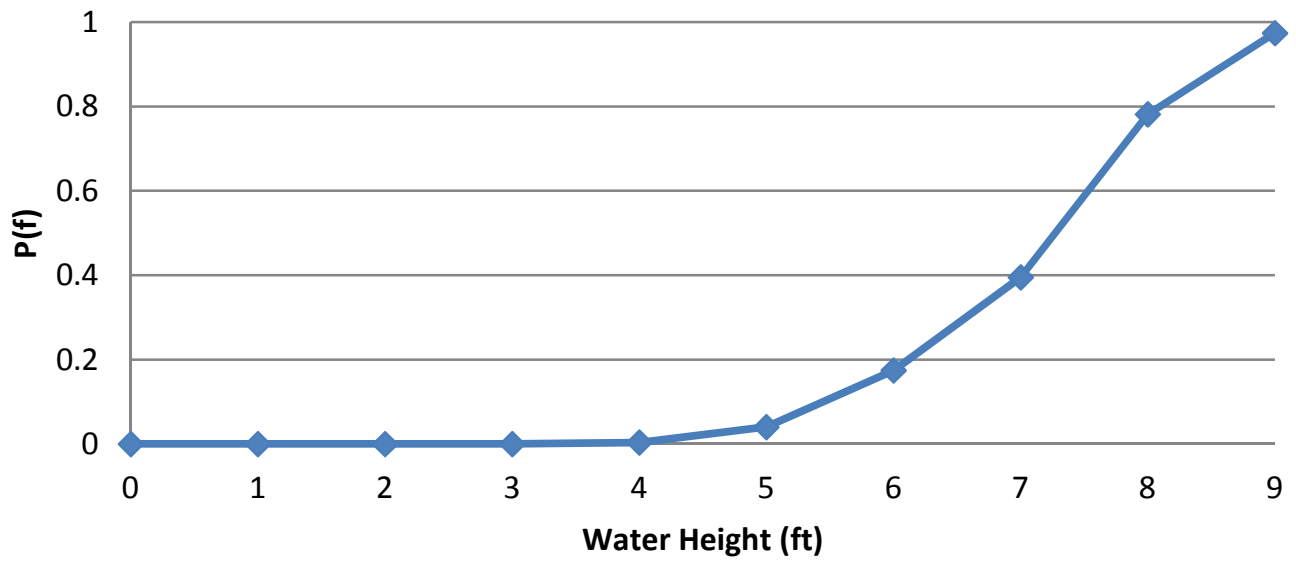
Channelization of the Millstone River will require slope stability analyses and for the slopes of 1 on 3. Slopes of this grade are relatively shallow but vary in height above the channel bottom. Many of the newly graded slopes are next to the Delaware Raritan Canal. The river bank slopes next to the Canal would be checked carefully for stability and to ensure stable river banks next to the canal. It is possible some retaining walls would be needed next to the Canal for the riverbank stability. Another concern is the depth of bedrock in relation to depth of the channelization of the river bottom. Excavation into the Red Shale bedrock would be more costly than excavating soil. Riprap would be placed underneath the 287 Highway Bridge to prevent scour and erosion. This would require gradation of the riprap and bedding stone.

### **FRAGILITY CURVES**

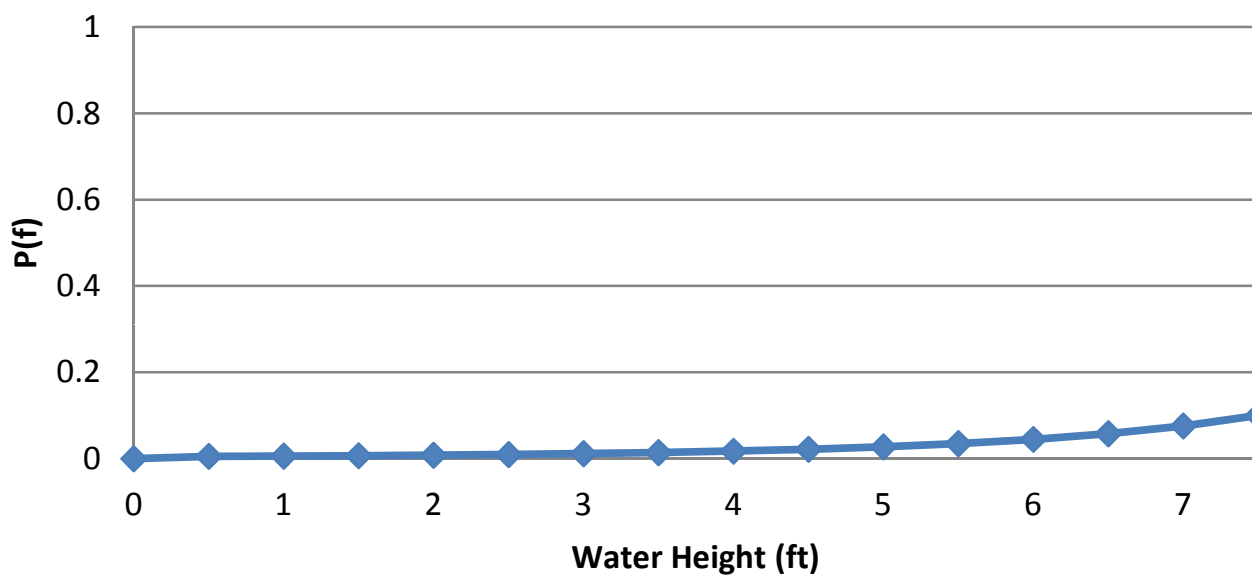
A number of fragility curves were plotted showing the height of the water and the probability of failure for certain water heights of the levees and floodwaters. Curves 1A, 1B, 1C, 1D, 2A, 2B, 3A/3B, 4, and 5 are shown along with the Existing Curve. The Existing Curve without any project has a probability of failure of .98 for a water height of 9 feet. Curves with the new levees and floodwalls would have a probability of failure at 0.2 for heights of 12 to 14 feet. Water height of 6 to 8 feet would have a probability of failure at .1. Clearly this indicates that the levees and floodwater would decrease the probability of failure although with increased costs of the project.



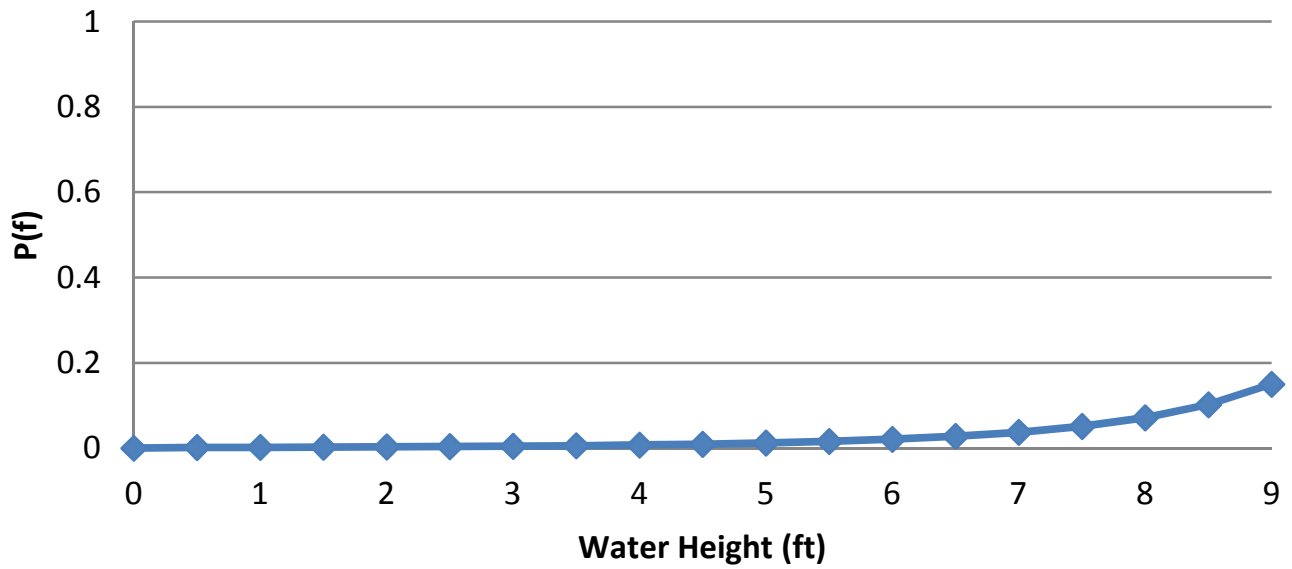
## Fragility Curve (Existing)



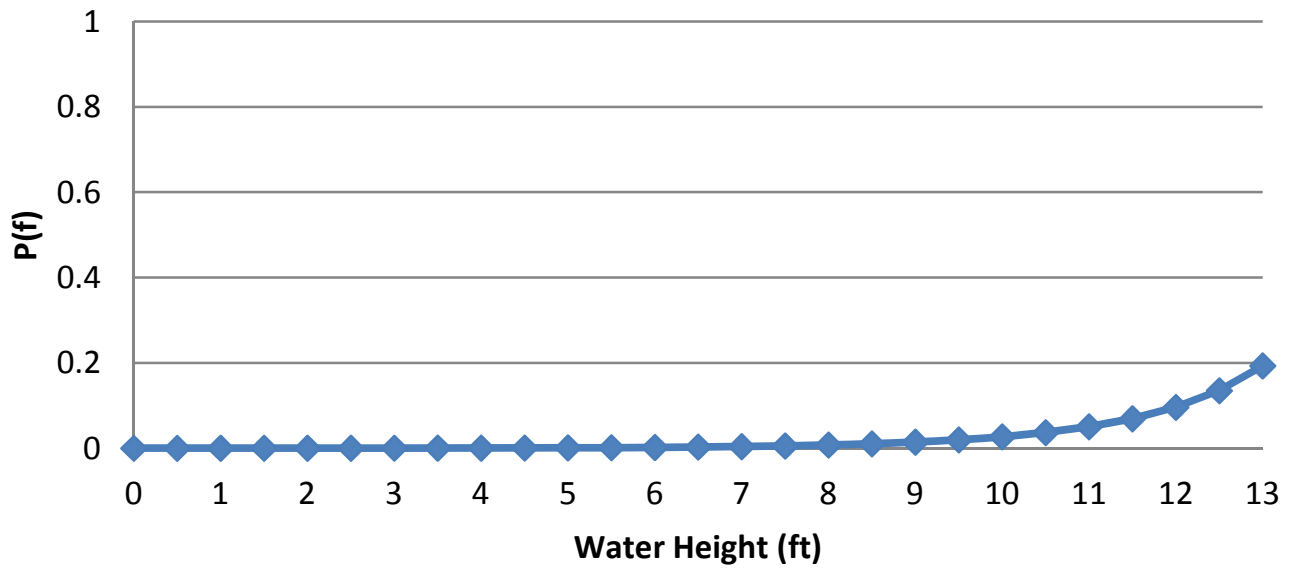
# Fragility Curve (1A)



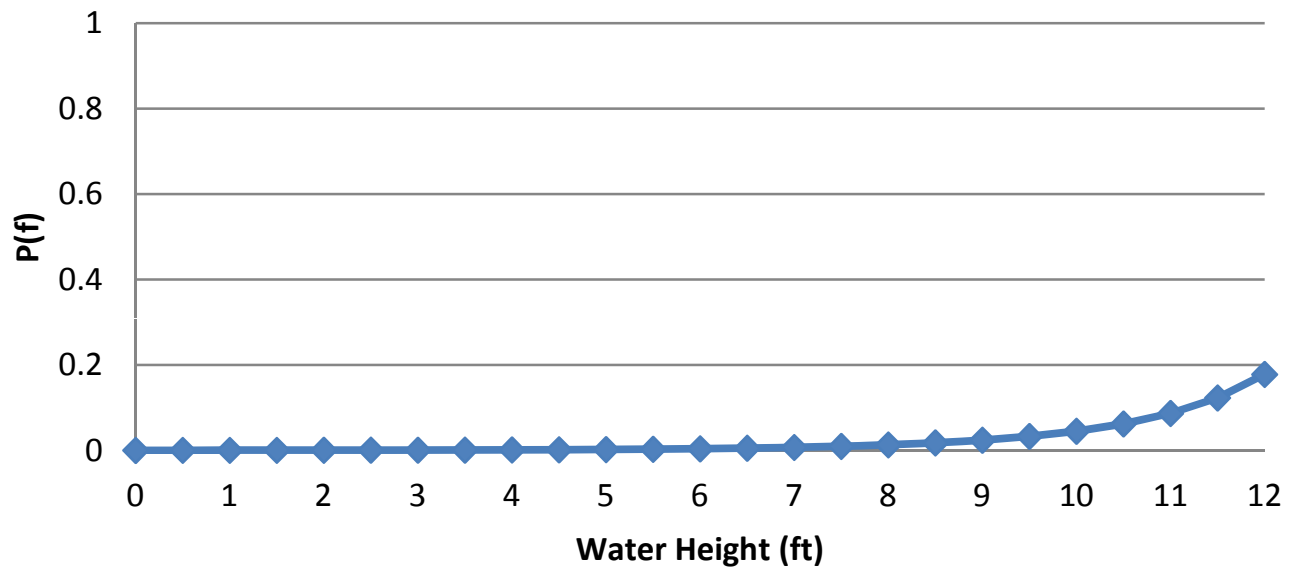
# Fragility Curve (1B)



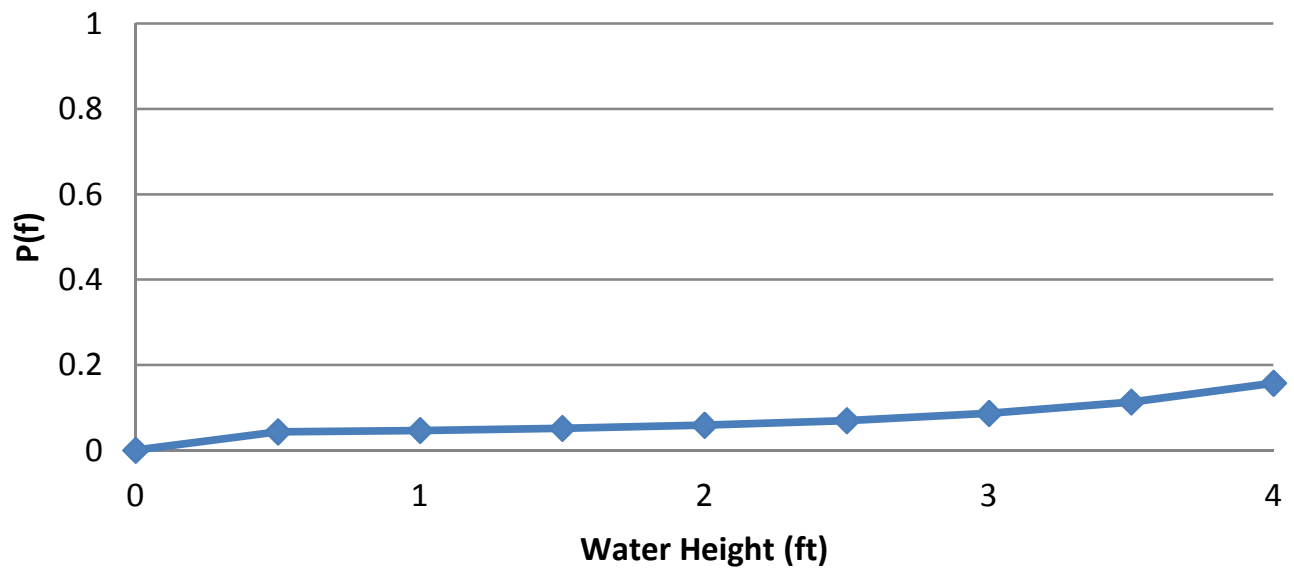
# Fragility Curve (1C)



## Fragility Curve (1D)

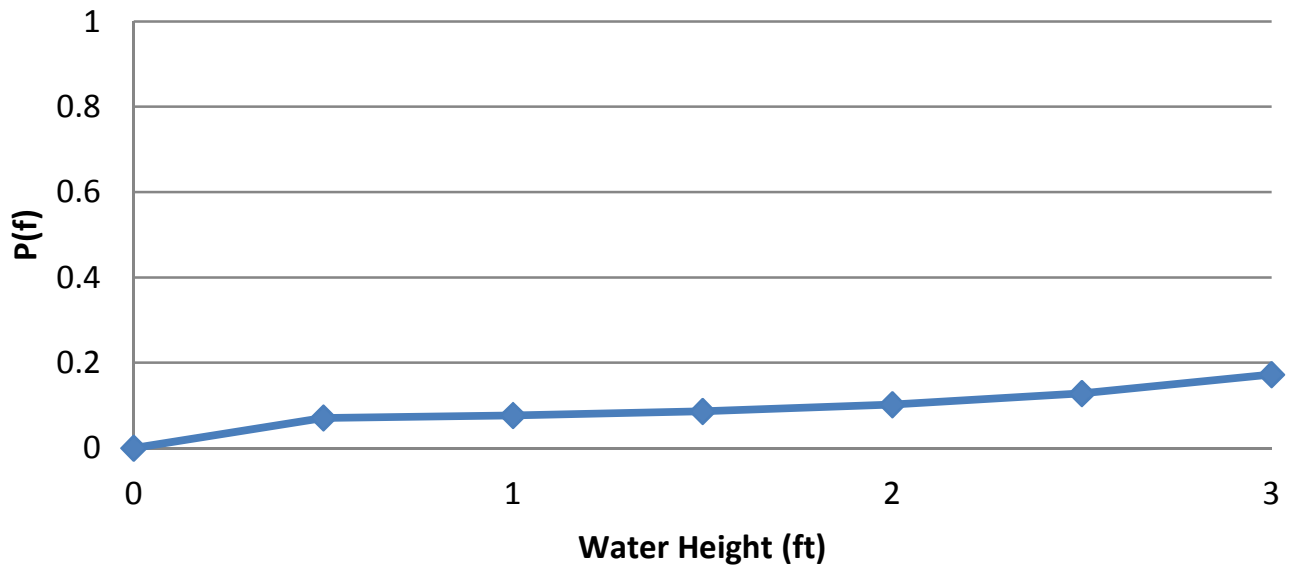


## Fragility Curve (2A)

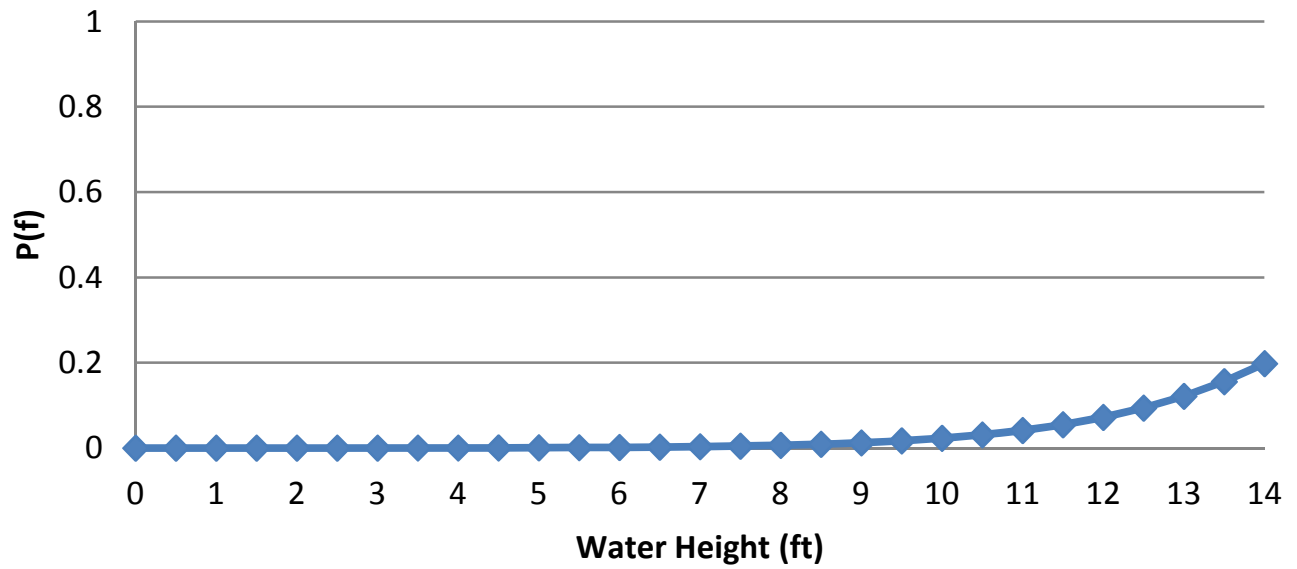




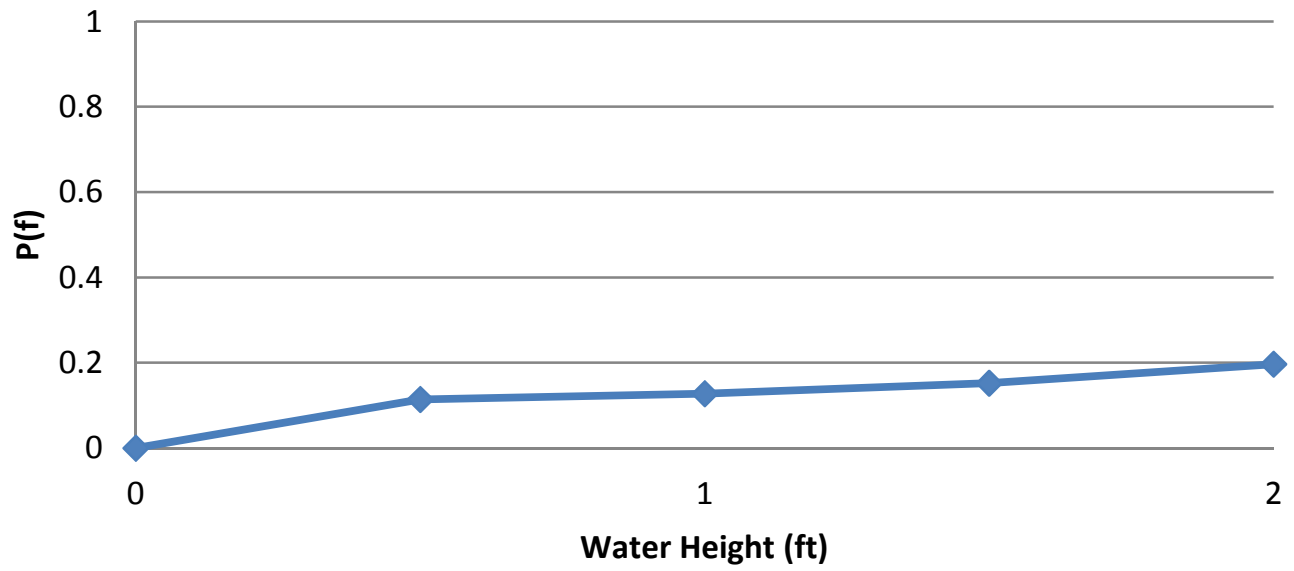
## Fragility Curve (2B)



## Fragility Curve (3A/3B)



## Fragility Curve (4)



## Fragility Curve (5)

