

**RENEWABLE ENERGY
AND ENERGY EFFICIENCY
SCIENCE PROJECTS**

SCIENCE PROJECTS IN RENEWABLE ENERGY AND ENERGY EFFICIENCY

A guide for Secondary School Teachers

Authors and Acknowledgements:

This second edition was produced at the National Renewable Energy Laboratory (NREL), through the laboratory's Office of Education Programs, under the leadership of the Manager, Dr. Cynthia Howell and guidance of the Program Coordinators, Matt Kuhn and Linda Lung. The contents are the result of contributions by a select group of teacher researchers that were invited to NREL as part of the Department of Energy's Teacher Research Programs. During the summers between 2003 and 2007, fifty four secondary pre-service and experienced teachers came to NREL to do real research in renewable energy sciences. As part of their research responsibilities, each teacher researcher was required to put together an educational module. Some teacher researchers updated a previous NREL publication with the title Science Projects in Renewable Energy and Energy Efficiency (Copyright 1991 American Solar Energy Society).

These contributing teacher researchers produced new and updated science project ideas with the unique perspective of being in education and in laboratory research. Participants that contributed to this publication include Nick Babcock, Jennifer Bakisae, Eric Benson, Lisa Boes, Matt Brown, Lindsey Buehler, Laura Butterfield, Ph.D., Don Cameron, Robert Depew, Alexis Durow, Chris Ederer, Brigid Esposito, Linda Esposito, Doug Gagnon, Brandon Gillette, Rebecca Hall, Brenna Haley, Brianna Harp, Karen Harrell, Bill Heldman, Tom Hersh, Chris Hilleary, Loren Lykins, Kiley Mack, Martin Nagy, Derek Nalley, Scott Pinegar, Jennifer Pratt, Ray Quintana, Steve Rapp, Kristen Record, Emily Reith, Leah Riley, Nancy Rose, Wilbur Sameshima, Matthew Schmitt, Melinda Schroeder, Tom Sherow, Daniel Steever, Andrea Vermeer, Brittany Walker, Dwight Warnke, Mark Wehrenberg and Rick Winters.

Finally, this book owes much to the original authors and advisors of the 1st Edition in 1991. They include Ann Brennan, Barbara Glenn, Suzanne Grudstrom, Joan Miller, Tom Milne, Dan Black, Hal Link, Bob Mconnel, Rick Schwerdtfeger, Patricia Bleil, Rosalie Craig, Steve Iona, Larry Jakel, Larry Lindauer, Bob McFadden, Beverly Meier, and Helen Wilson.



The National Renewable Energy Laboratory (NREL) is the nation's premier laboratory for renewable energy research and development and a leading laboratory for energy efficiency R&D. NREL is managed by Midwest Research Institute and Battelle.

Established in 1974, NREL began operating in 1977 as the Solar Energy Research Institute. It was designated a national laboratory of the U.S. Department of Energy (DOE) in September 1991 and its name changed to NREL.

NREL develops renewable energy and energy efficiency technologies and practices, advances related science and engineering, and transfers knowledge and innovations to address the nation's energy and environmental goals. NREL's renewable energy and energy efficiency research spans fundamental science to technology solutions. Major program areas are:

- [Advanced Vehicle Technologies & Fuels](#) (hybrid vehicles, fuels utilization)
- [Basic Energy Science](#)
- [Biomass](#) (biorefineries, biosciences)
- [Building Technologies](#) (building efficiency, zero energy buildings)
- [Electric Infrastructure Systems](#) (distribution & interconnection, thermal systems, superconductivity)
- [Energy Analysis](#)
- [Geothermal Energy](#)
- [Hydrogen & Fuel Cells](#) (production, storage, infrastructure & end use)
- [Solar](#) (photovoltaics, concentrating solar power and solar thermal)
- [Wind Energy](#)

Contents

Introduction	4
The Role of the Teacher	7
How to Do a Science Project.....	14
Project Ideas.....	18
What Does the Sun Give Us	19
Photovoltaics and Solar Energy	31
Material and Chemical Processing.....	56
Modeling the Process of Mining Silicon Through a Single-Displacement/Redox Reaction	60
Utilizing Photovoltaic Cells and Systems	73
Photosynthesis and Biomass Growth.....	85
Statistical Analysis of Corn Plants and Ethanol Production.....	98
Biofuel Production.....	103
Renewable Energy Plants in Your Gas Tank: From Photosynthesis to Ethanol	110
Cell Wall Recipe: A Lesson on Biofuels	129
Reaction Rates and Catalysts in Ethanol Production	140
A Pre-treatment Model for Ethanol Production Using a Colorimetric Analysis of Starch Solutions	151
The Bio-Fuel Project.....	158
Biofuel Utilization	193
Wind.....	198
Hydropower	207
Ocean Power	211
Alternative Fuels Used in Transportation	216
Computer Based Energy Projects.....	226
Environmental Aspects	231

Introduction

Renewable energy technologies are clean sources of energy that have a much lower environmental impact than conventional energy technologies. Importing energy is costly while most renewable energy investments are spent on local materials and workmanship to build and maintain the facilities. Renewable energy investments are usually spent within the United States, frequently in the same state, and often in the same town. This means your energy dollars stay home to create jobs and fuel local economies, rather than going overseas. After the oil supply disruptions of the early 1970s, our nation has increased its dependence on foreign oil supplies instead of decreasing it. This increased dependence impacts more than just our national energy policy.

We can be pretty certain that electricity use will grow worldwide. The International Energy Agency projects that the world's electrical generating capacity will increase to nearly 5.8 million megawatts by the year 2020, up from about 3.3 million in 2000. However, the world supplies of fossil fuels—our current main source of electricity—will start to run out from the years 2020 to 2060, according to the petroleum industry's best analysts.

Shell International predicts that renewable energy will supply 60% of the world's energy by 2060. The World Bank estimates that the global market for solar electricity will reach \$4 trillion in about 30 years. Other fuels such as Hydrogen and biomass fuels could help replace gasoline. It is estimated that the United States could produce 190 billion

gallons per year of ethanol using available biomass resources in the USA.

And unlike fossil fuels, renewable energy sources are sustainable. They will never run out. According to the World Commission on Environment and Development, sustainability is the concept of meeting "the needs of the present without compromising the ability of future generations to meet their own needs." That means our actions today to use renewable energy technologies will not only benefit us now, but will benefit many generations to come.

Important local and national decisions will be made during the coming years concerning our energy supply. It will be important to consider all aspects of a particular energy source—its availability; its benefits; and its monetary, environmental, and social costs. Our nation's citizens must be well informed so that they can make the appropriate decisions. This book is a tool to help teachers, parents, and mentors inform our young citizens about the various ways that renewable energy and efficiency can be used to contribute to our society.

Choices about energy supply are just one of the many scientific and technical issues our nation faces now and in the future. Evaluating all these issues will be easier if our citizens have a basic understanding of the scientific process and can consider scientific issues rationally. Through the ideas and methods presented here, we hope to help teachers foster in students a new sense of wonder and curiosity about science and energy.

The Value of Science Projects

Science projects are an especially effective way of teaching students about the world around them. Whether conducted in the classroom or for a science fair, science projects can help develop critical thinking and problem-solving skills. In the classroom setting, science projects offer a way for teachers to put “action” into the lessons. The students have fun while they’re learning important knowledge and skills. And the teacher often learns with the students, experiencing excitement with each new discovery.

Science projects are generally of two types: nonexperimental and experimental. The **nonexperimental** type usually reflects what the student has read or heard about an area of science. By creating displays or collections of scientific information or demonstrating certain natural phenomena, the student goes through a process similar to a library research report or meta-analysis in any other subject. Projects of this type may be appropriate for some students at a very early level, but they usually do not provide experiences that develop problem-solving skills related to the scientific process.

On the other hand, the **experimental** project poses a question, or hypothesis, which is then answered by doing an experiment or modeling a phenomenon. The question doesn’t have to be something never before answered by scientist—it’s not necessary to conduct original research. The process of picking a topic, designing an experiment, and recording and analyzing data is what’s important.

Consequently, this book focuses on the experimental project.

Teachers can use classroom projects several different ways. Sometimes it’s appropriate for the whole class to work together; other times students can work in groups or individually. The decision depends on the capabilities of the students, how the experimental results are to be used, and the imagination of the teacher. In any case, the project should follow the scientific method and the students should all maintain laboratory notebooks and prepare final written and/or oral reports for the class.

Many of the ideas contained in this book will also be suitable for individual projects at science fairs and conventions. In these situations, students are generally expected to work independently, with a written report and a display for the fair as the final products. There are a number of good references on the process of preparing projects for science fairs. References are listed in each chapter.

Safety and Ethical Considerations

Basic safety precautions should be taken when an experiment is in progress. All students should wear safety glasses at all times. In addition, some science projects involve flammable or toxic materials that are potentially hazardous, and extreme care should be taken. And when heat or electricity is used, make sure the students wear protective gloves and handle the equipment correctly. Teachers should check their school policies and state laws concerning the

use of hazardous chemicals or biological materials. (For example, mercury thermometers are rarely used at all in science classrooms today.) Also, students anticipating science fair competition should make sure they understand the rules governing science fair projects. (Details should be available from the director of your local, regional, or state fair.)

There are ethical and legal considerations related to using animals and human in science projects—even those that simply ask questions of people. The practice is generally discouraged, both in classrooms and in science fairs. However, if a vertebrate or human subject is to be used in a science project, the teacher should consult school policies and seek the advice of appropriate school administrators. As is the case for safety issues, students designing projects for science fairs should understand the regulations on animal and human experimentation **before** beginning the project.

About This Book...

Throughout the process of compiling this book, we've benefited tremendously from the all the teacher researchers and their NREL mentors that have contributed to the project ideas.

First, the book is written for teachers and other adults who educate children in grades K-12 *by* K-12 teachers. This allows us to include projects with a variety of levels of

difficulty, leaving it to the teacher to adapt them to the appropriate skill level.

Second, the book generally focuses on experimental projects that demonstrate the scientific method. We believe that learning the experimental process is most beneficial for students and prepares them for further endeavors in science and for life itself by developing skill in making decisions and solving problems. Although this may appear to limit the book's application to more advanced students and more experienced science teachers, we believe that some of the ideas can be applied to elementary school level children and teachers as well. In addition, we recognize that there are numerous sources of nonexperimental science activities in the field, and we hope this book will fill a gap in the available material.

Third, we've tried to address the difficulties many teachers face in helping their students get started on science projects. By explaining the processes and including extensive resource suggestions, we hope to make the science projects more approachable and enjoyable. We hope the book will provide direction for teachers who are new to experimental science.

And finally, in each section of ideas, we've tried to include a broad sampling of projects that cover most of the important concepts related to each technology.

We hope the book will be helpful and will fill a gap in published material on science projects in renewable energy and energy conservation. If so, every member of our society will benefit.

The Role of the Teacher

Science projects are an effective tool for helping students learn valuable skills they'll need later in their education and their careers because they are interdisciplinary activities involving math, language, arts, and other academic areas. Yet when students are asked to do a project for the first time—either alone or in a group—the process sometimes seems somewhat intimidating, and the student often has a hard time knowing where to start. That's why encouragement and direction from the teacher are vital. Keep in mind that involving each student in a science project can often do more to generate interest in science than a teacher can ever hope to achieve through lectures and demonstrations.

Doing science projects may also seem difficult for teachers who were not science majors or who are using science projects as instructional tools for the first time, but it really isn't. All you need to do is to coach students to break the project up into manageable parts and follow the **scientific method** as outlined in the next section. The references cited in the back of the book can also help you get started. And remember, you are not alone. In every community—no matter how remote or small there are resources that can help you and your students.

Help and information can be obtained from industries, hospitals, government agencies, education departments, colleges, and universities, animal hospitals, zoos, and museums.

Don't overlook resources in your own school district. Chances are good that someone has experience with science projects or even specific

research interests. These people are often quite willing to help either you or your students. A number of school districts even offer workshops that deal with science projects (often with graduate credit). You may find this a good way to get started. We also offer suggestions here that should be useful to teachers when using science projects as instructional tools.

Types of Science Projects

When introducing the concept of science projects, one of your first tasks will be to help students understand the difference between the basic types of science projects: nonexperimental and experimental.

Nonexperimental projects basically display or demonstrate information that is already known; they do not involve experiments designed by students to solve a problem. Projects of this type are more useful to students in learning how to search for information about a given topic on the web or in the library and to report the information gathered to the teacher or those interested. In general, these projects are not appropriate for competitive science fairs and do not teach the skills of critical thinking and problem solving.

Experimental projects involve the student in critical thinking and scientific processes, such as designing experiments to solve problems, developing models of scientific concepts or mathematical processes, collecting and recording data, analyzing and presenting data, and drawing conclusions that result in some new

understanding of a concept or idea. Projects of this type focus on discovery and investigation. Unfortunately, these projects do not generally predominate in either the classroom or at science fairs.

Tips for the Teacher

The teacher can help the student at each step along the way of an experimental project. We've tried to outline some tips below for each step.

1. Selecting a project topic

One of the most difficult parts of a science project for students is selecting a topic. Too often, students think they must do a project that involves truly groundbreaking research-like "curing cancer" or inventing something new. That's not at all the case. Instead, you should encourage student to choose an area of interest and use information written or presented by others to identify a project topic. **Above all, keep it simple!** This process must begin early in the year and can be accomplished in a variety of ways:

- Introduce students to possible topics with each lesson or concept presented and solicit ideas.
- Inform students early in the year that they will be doing a science fair project and that they should be thinking about a topic.
- Have students write down and assign priorities to areas of interest.

- Encourage students to ask questions.
- Provide lists of topic ideas for students to use. (Keep a list on file and add to it as students make suggestions and you read of new ideas.)
- Have students read articles in scientific periodicals and on trusted scientific websites. This can help students focus on project ideas.
- Encourage students to go to the library (or take them there yourself.)

During the process of identifying a topic, the student reviews articles written by other researchers and is, in essence, conducting a literature review. Regardless of the student's age, the teacher should encourage the student to record the sources of her information. We suggest using index cards because they're easy to organize. The student will need this information when it's time to write the final report.

2. Identifying a specific problem or question

This portion of a science project is very closely related to the selection of a specific topic because it simply involves asking questions about the topic chosen. The difficulty comes in deciding whether it is possible for the student to answer the question. Here are some suggestions:

- Have the student gather more information, only this time be very specific. If the topic is

beyond you or the references in the school library, look to community resources or the internet. Students will be less frustrated if they first learn some basic background knowledge before beginning.

- Have the student make the community contacts. It may be necessary for you to make the initial contact, but once this is done, you will be able to call on that person in the future.
- Encourage the student to think about
 - what she wants to find out
 - what materials and equipment are needed
 - how she'll try to answer the question.

3. Preparing the research proposal

Students of all ages should have a plan of action. The sophistication of this portion of the project depends on the ability of the student, your expectations, and whether the student intends to participate in a science fair. In all cases, the research proposal should contain background information, problem or purpose or hypothesis, experimental plan, and references. Here are some suggestions:

- Have each student prepare a project proposal.
- Remind the student to write the methods and materials section so that anyone could read it and do the experiments. Do **not** write this section in steps, e.g., Step 1, Step 2, and so on.

- Review the proposal and determine whether the project is
 - feasible for the student to do
 - safe
 - experimentally sound, e.g., experiments are controlled and only one variable at a time is tested, experiments are replicable (important if statistics will be applied).
- Do **not** allow students to begin their projects until they have your approval and have done their background research.
- Meet with each student and review the project proposal. Discuss problems that might be encountered and the kinds of data she expects to collect.
- Discuss how and where the data are to be recorded.

4. Conducting the experiment(s)

This part of the project has the tendency to generate excitement because of the anticipation that has built up in the planning stages. Students will approach this part at a high energy level and must be monitored carefully so that they operate safely. It is also the time when problems will crop up. To avoid some of these problems, we suggest:

- Make certain that students have a notebook for recording data and that they have made plans on how to do so, e.g., tables, charts, sketches, computers.
- Have the student prepare a schedule for conducting experiments and record it in her notebook.

- Make sure that proper safety procedures are followed.
- Encourage the student to approach the experiment in a conservative fashion and not put “all her eggs in one basket.” In other words, conduct some preliminary tests and refine the procedures as necessary. Record any revisions in the notebook.
- Monitor progress frequently at this stage.

5. Analyzing and interpreting the data

In this section, you will most likely need to spend extra time monitoring the student’s progress. Analysis and presentation of one’s data are extremely important because they can facilitate the interpretive process and the formulation of conclusions. If students have not had practice in preparing graphs and tables, or in doing simple mathematical calculations, then it may be prudent to present a lesson at this point. Here are some suggestions that may be helpful.

- Quantitative data usually are best presented in tables and graphs with the aid of graphing software such as Excel. Have some examples on hand such as those found in journals, textbooks, or even from the work of other students.
- Insist that advanced students apply simple statistics such as calculating the mean, standard deviation, standard error of the mean, t-tests, or Chi-square. Remember, experimental design

is important when it comes to the application of statistics.

- Coach the student to prepare a narrative in her notebook that presents the data and refers to graphs and tables. A results section that includes only a table or graph and no text is not complete.
- Emphasize that results are best presented in a straightforward manner, with **no** conclusions or value judgments. (This is hard for most students to do but is a skill one can develop.) Instead, significant data should be pointed out.
- Remind students that use of photographs, sounds, and even video, are excellent ways to report qualitative data and to show comparisons or relationships. However caution the student to keep the media focused more on the science than entertainment so that it does not distract from the project.

6. Interpreting and discussing the results

Now it’s time for the student to explain what she thinks the results mean. Again, this is a skill that many students have not fully mastered and is one that improves with practice. The tendency is for the student to make statements that are not supported by the data. If the data have been analyzed and presented in a satisfactory manner, inferences can be made more easily. If not, frustration tends to build in both the teacher and the student.

Be patient and consider these suggestions.

- Have the student prepare a list of conclusion statements and any possible patterns (interpretations of the data) and write them in her notebook.
- Meet with the student and go over the statements. If students are working in groups on a project, meet with all of them at the same time. Some teachers will have sessions where students present their data and conclusions to the class. This is times consuming, but it is very educational for the students and may give them some new ideas. Students could even create PowerPoint presentations.
- Once conclusion statements have been developed, have the student prepare a written discussion that includes descriptions of any patterns or relationships that she thinks are meaningful. In effect, she is preparing a defense of her project conclusions.

7. Preparing the final report

Whether students are working in groups or as individuals, it is important that you require a final written report. The format of this report is up to you, the teacher, but we suggest you follow the outline presented in the next chapter of this book. It would be unfair to assume that students could instantly write a final report by simply giving them a list of the components. But if the

student has followed the guidelines up to this point, most of the material is completed, either in the research proposal or her notebook. Here are some additional suggestions.

- Decide, before students begin their projects, what you want in the final report. (Students doing projects for science fairs will need to include all the suggested components in the section on **How To Do a Science Project**.) This is also a great opportunity to team up with a language arts teacher and integrate the curriculum with the language arts teachings in technical writing.
- Before students begin preparing their final reports, review the format and explain what you expect.

8. Preparing for the oral report

If you have used science projects as a class activity, then you should give each group or individual the opportunity to share with the class the results of the research. This is important in building communication skills and can serve as a source of information about science for other students. It is also the job of all scientists to communicate what they have learned from their research. Here are some suggestions:

- Limit the presentations to a maximum of 10 minutes followed by 5 minutes of questions from the class.

- Have students pattern the format after the written report: title, introduction, statement of the problem or hypothesis, methods (brief), discussion, and analysis & conclusions.
- Allow the group reports to be longer because every member of the group must be involved in some aspect of the oral presentation.
- Help prepare students competing in science fairs. They won't have timed presentations, but they will have to explain their projects to judges. Many teachers will have students who are preparing for science fairs present their project results to other students and undergo intense questioning of their conclusions. This is good practice and sharpens their presentations.

9. Preparing displays for science fairs

Preparing displays can be very time consuming and requires a lot of planning by the student before preparation. Most project displays are prepared by the student at home, but parts can be prepared at school, depending on the facility and the teacher. For example, the school can supply computers, printers, copy machines, and art supplies. Students will need access to this equipment, therefore involving the teacher. Some suggestions:

- Secure registration information, rules and regulations, and other requirements from the science

fair director well in advance of the science fair. Included in this information should be instructions and size limitations for science project displays.

- Have the student prepare a plan illustrating the layout of her display before actual construction begins. There are several references in this book that are useful and contain information that is directly related. Here is another opportunity to integrate curriculum with the art teacher.

A couple of other pointers can help you throughout the process. Our first suggestion is to establish a schedule at the outset, so that each student knows what's expected. Science projects take time to plan and complete; therefore, careful planning makes the work more enjoyable for the student and the teacher, especially if it prevents working past midnight the week before the due date. If you are using projects as classroom activities, you are easily looking at 1-3 weeks of class time from beginning to end. Students who are working on projects for science fairs should expect to spend 2-6 months. Don't let this discourage you from using science projects as a learning tool. Some of the best learning takes place when students are involved. Here are some suggestions for establishing a schedule.

- Break up the project into units that follow the steps outlined in this section.
- Allocate time to each unit depending on your objectives or when the science fair is to be held.

- Give a copy of the schedule to each student and post it on the bulletin board. Some teachers even prepare a large visual display on a bulletin board that depicts how much is done by a certain time.

Finally, don't overlook the positive contributions that your students' parents can make. They often serve as key actors science fair projects. You should capitalize on this resource and provide information to parents in the form of:

- Guidelines for selecting projects
- Guidelines for constructing projects
- Guidelines for parental involvement
- Grading or judging criteria
- Schedule for completing various aspects of the projects.

This information should be provided to parents in written form. Some teachers send the information through the postal service or present it a parent meeting early in the process. A little assistance to parents can establish their role and set them up as guides who can provide individualized instruction to their child. Not only will learning take place, but sharing between parent and child will be enhanced.

The ideas presented in this section are not intended to be answers to all problems facing teachers who use science projects as instructional tools. Instead, they represent useful techniques that teachers have used as a foundation for developing their own ideas and strategies in using science projects in or out of the classroom. Teachers play key roles in the education

of children, and they must continue to identify and develop strategies that result in the improvement of skills in creative thinking and problem solving. The use of science projects offers, in or out of the classroom, one strategy to develop these skills. We hope that you use the suggestions presented in this book and that its resources can help you develop your own strategies for teaching creative thinking skills.

How To Do a Science Project

The scientific method is a pattern of inquiry that forms a structure for advancing scientific understanding. By identifying a problem, forming a hypothesis, designing and conducting an experiment, taking data, and analyzing the results, scientists have answered questions ranging from the simplest to the most complex. Yet the process can be broken down into several distinct steps.

We've tried to be quite explicit in outlining the steps of the process. And we believe doing all the steps is appropriate for the student doing an individual project—either as a classroom project or for a competitive fair. On the other hand, teachers doing projects in the classroom might choose to skip some of the steps, depending on the level of the students and the time available.

1. Identify an area of interest

- Decide what area of science is of interest e.g. physics, biology, chemistry, or engineering.
- Narrow the area of interest so that it is more specific, e.g. solar energy, plants, or structures.

2. Gather information

Our knowledge of the world results from ideas and observations made by us and others. Many of these observations are recorded in such scientific literature as scientific journals, government documents, periodicals, websites, and books.

- Search for information in the area of interest in the library and on the internet.
- Begin in an organized manner by using reference material such as the *Reader's Guide* or the card catalog.
- Keep in mind that most scientific journals publish information pertaining to a single field of science. For example, the *American Journal of Physics* and the *American Journal of Botany* relate to specific topics. On the other hand, some periodicals, such as *Scientific American* and *Science*, cover a range of scientific issues.
- Make sure to record the author(s), titles of the article and the journal, the page numbers, website addresses, and pertinent publishing information for every reference used. (Recording this information on note cards is helpful.)

3. Select a specific problem within the area of interest

It is important to narrow the research area to a specific problem. One common error is to try to do too much. (This process would be repeated as more information is gathered.)

4. Gather more information

It may be necessary to return to the library and look for information that deals **directly** with the specific topic. Look for ideas that may help in the experimental design or for ideas that complement the topic.

5. Plan an investigation or an experiment

Keep these things in mind when designing the experiment:

- What are the variables?
- Are the variables appropriate?
- Are the variables independent?
- Are the variables measurable?
- What kind of controls will be included?
- What data will be collected?
- Is the experiment designed appropriately if the results are to be analyzed statistically?
- Are the materials and equipment available?
- Are there any special safety or environmental concerns?

If the project uses mathematical or computer modeling instead of experimentation, how will the results be validated? Is there a way to test the model?

When the approach to the experiment is clear, it's time to write a proposal. The proposal should describe the experiment in detail, including required materials and equipment, any safety concerns, and expected results. It will allow the teacher or the science fair review committee to

evaluate the appropriateness of the project.

Include the following in the proposal:

- Background information: A review of the literature summarizing information related to the project. Be sure to cite all references.
- Purpose and hypothesis: A brief description of the purpose of the project and a statement of the hypothesis.
- Experimental design: A detailed explanation of the research plan and the materials needed is included in this section. The methods and materials should be described in a way that anyone could duplicate the experiment(s).
- Literature cited and references: Include a list of all authors and websites cited and list of supplemental references.

6. Obtain approval of the proposal from the teacher or science fair review committee

7. Conduct the experiment(s) and collect data

- Record the data in a notebook. Record the data immediately, completely, and accurately. (It is better to record too much data than not enough.)
- Record other observations about the progress, take pictures, make sketches. Are some things not going according to plan? Are there

any surprises? These observations may be important later.

8. Organize and report the results

Most data involve numbers and can be quantified. Therefore, using statistics, graphs, tables, and charts is appropriate. Remember, this is the portion of the research on which conclusions are based. The better this portion is presented, the easier it is to formulate conclusions. Data should be presented:

- In written or word processed form with graphs, table and charts
- Without conclusions or value judgments.

9. Analyze and discuss the results

Think about the results. What do they mean? How should they be interpreted? By discussing various aspects of the experiment and observations, provide additional context for the results shown by the data. Look for patterns, relationships, and correlations.

10. Formulate conclusions

Was the hypothesis supported or disproved? This is an important step and must emphasize what has been learned from doing the project. Conclusion statements must be supported by data collected and related directly to the purpose and hypothesis.

11. Assess the project

Did the experiment go as planned? If so, were there other interesting aspects that deserve follow-up research? If the experiment did not go as planned, why not? Was the hypothesis too broad? Was the experimental design inappropriate? If the hypothesis was not confirmed, what was learned? Answers to all these questions can help form recommendations for further research.

12. Write the final report

The final report, whether it is to be presented orally or in written form, should include the following:

- Title
 - should be self-explanatory, i.e. the reader should be able to tell what the research is about without reading the paper. Avoid technical jargon in the title.
- Abstract
 - a brief condensation of the entire report, 150 to 250 words for advanced students; shorter for students in lower grade levels. This should be written last.
 - Includes the purpose, very brief explanation of methods, and conclusions.
- Introduction
 - contains background information with cited references and a statement of the problem or purpose.
- Methods and Materials

- contains an explanation of how the work was done (experimental design)
- describes materials – what? – how used?
- Is stated briefly and clearly so that others could repeat the experiments.
- Results
- includes written explanation of the data in a straightforward manner with no conclusions or judged statements
- uses tables, graphs, pictures, and other types of data where appropriate.
- Discussion
- explains what the results mean
- describes patterns, relationships, and correlations.
- Conclusions
- presents the important conclusions that the reader needs to know
- includes a discussion of problems encountered and recommendations for further research.
- Literature Cited
- lists alphabetically by author all published information referred to in the text of the paper. Other references can be used and referred to in a bibliography.
- Acknowledgements
- lists and gives credit to people who were helpful in providing materials and equipment or ideas.

13. Present the results orally

If this is a project for the classroom, make an oral presentation about the work to the class. If the project is for a science fair, prepare a display (see science fair officials for details) and prepare to discuss the project with the judges. In either case, be prepared by:

- becoming knowledgeable about the project
- practicing the presentation before others
- talking clearly
- acting interested
- dressing neatly

Project Ideas

On the following pages you'll find ideas contributed by a select group of teacher researchers from across the nation for science projects in all the renewable energy technologies. We've also included ideas in related areas, such as superconductivity and material and chemical processes—these are technologies that will increase the usefulness of renewable energy systems. In addition, we've included a project for geothermal energy, which, strictly speaking, is inexhaustible—not renewable. For each technology, we begin with a brief introduction and a list of sources of information relevant to that particular topic.

Most of the ideas for projects in energy efficiency relate to uses of energy familiar to students. They should help show the student the wide variety of actions that can be taken to save energy in our homes, schools, and businesses. Yet these topics don't begin to demonstrate the diverse research under way in government and industry laboratories that will save energy in our industries, our utilities, and our transportation system. Research in these areas is very industry-specific and is difficult to summarize with a few science projects. If you'd like to pursue these areas further, contact the U.S. Department of Energy

For each project idea, we've tried to give you enough information to get started without providing all the answers. We've given hints on how to set up and conduct the experiment and included schematics, where appropriate. Lists of special required equipment (other than standard laboratory equipment) are also included. In

addition, information on specific resources should help you find special equipment or in-depth information on the individual project. In this case, we've tried to keep references general to avoid naming specific companies or individual scientists. You can refer to the **Resources** section of each section for more detailed information. Finally, many projects include tips for expanding the idea for more advanced students.

And a special note about safety—each project idea lists unusual safety or environmental concerns. However, the lists are not exhaustive and do not list basic safety principles common to all laboratory procedures such as wearing protective eyewear and clothing. If you're unsure about a certain procedure, always err on the side of precaution. And if you're new to the business of conducting science projects, seek advice from an experienced teacher or the science coordinator in your school district.

At the end of each section we've added a list of simple statements or questions that could form the basis for additional projects. These should provide lots of ideas for you and your students.

We hope you'll use the "white spaces" and the blank pages designed into the book to record more ideas, lessons learned, and personal experiences gained from conducting the various projects. If you find errors in this book, please bring them to the attention of the NREL Education Programs at the National Renewable Energy Laboratory in Golden, CO at 303-275-3000.

What does the Sun give us?

For the Teacher

One of the fun parts of science is discovering things on your own. This is the focus of Standard A, Science as Inquiry, from the National Science Education Standards. Under the abilities to do scientific inquiry, this standard states, "Students should develop the ability to refine and refocus broad and ill-defined questions." For this reason, we recommend stating the objective, and then have the students try to figure out the best options for accomplishing that objective. We think this is a better approach than giving a step-by-step cookbook approach to making instruments that measure the sun's energy. Because of this, we suggest that you do not show students this book and instead have the students try to design and test their work as much as possible with a little coaching from you. After the students have designed and tried their experiments, get them to suggest improvements and if there is time, test their improvements. After these experiments are run, then teach the concepts about why they work.

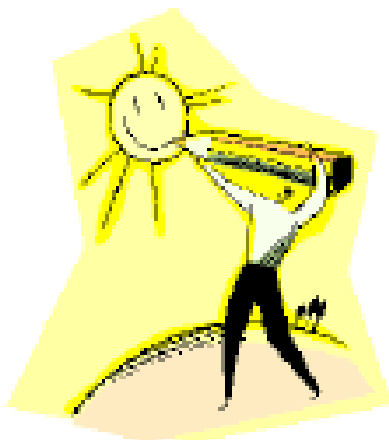

All projects have an element of inquiry (standard A) by posing questions and then having the student try to discover the answer through the data collection, interpretation, and communication. Because the projects involve the sun and its energy, all include physical science transfer of energy (standard B) and earth science through the relation of the sun and how it affects the earth (standard D). In addition to these standards, each of the projects has additional strengths. The science content standard letter shows in the second column as well as other strong areas. You know your students the best, but we've also included a suggested range of grades for each project.

Project	Key Standards	Grades
Pizza Box Oven	E-Design	6-8 (3-5 if given Web site first)
Solar Resource Simulator	E-Design, D-Earth, social studies	6-8
Measuring Solar Radiation	E-Design	6-12
Length of Day around the World	A-Communication (ePals), D-Earth, social studies, English	3-8
Capture Solar Energy!	A-Communication (ePals), math	8-12 (3-7 temp only)

Pizza Box Solar Heater: The first project is the pizza box solar heater. We are excited because it has so many possibilities to teach multiple standards and to motivate students. We suggest you do the following:

1. Give each group of students a pizza box.
2. Have available in a supply area for all students various materials such as glue, scissors, clear packing tape, new overhead transparencies, wax paper, aluminum foil, white, black, and other colors of construction paper).
3. Tell the students that their objective is to make the hottest "oven" possible using the sun.



4. You may want to stimulate prior knowledge by asking them why it gets hot in a car.
5. In the first period, have the students design their oven in a notebook.
6. During this period or the next, work with the class to design a rubric on what is meant by the "best" oven. Options could include hottest oven, quickest to heat, easiest design and instructions to read.
7. In the second class period, have the students construct their pizza box oven.

8. In the third period, ask the students what factors might affect the temperature in their oven (outside air temperature, wind, clouds). Ask them to measure these factors and the oven temperature over time. Make sure you have thermometers that can register up to 300°F or 150°C.
9. If you have time in a fourth period, have students graph the temperature over time.
10. Allow additional periods to have the students communicate about their oven and improve their design.
11. After the students build the "ultimate" ovens, ask the students why they think the best ovens worked the way they did. This could be a discussion or written.
12. Have students grade their ovens based on the rubric the class created.
13. Allow students to improve their grade by making changes to their oven, possibly as homework.
14. Only at this point would we introduce the students to the Web site <http://www.solarnow.org/pizzabx.htm>. You could have the students construct the oven on the site using their instructions and compare the performance.
15. When students start talking about the sun's angles, colors of the paper, ability of the sunlight to bounce and stick in the box, you can introduce the physical science (content standard B) concepts. These may include light, heat, and energy definitions including reflection, absorption, photons vs.

waves, motions of molecules, and so forth. The discussion could also lead to the sun's energy and how the tilt of the earth produces different seasons because the rays of the sun spread out more or less directly (Earth in the Solar System - content standard D).

16. If desired as a final assessment, have the students explain in diagrams and words, why the box heats up. This should include their ideas in step 11 but would also include the technical terms that the class discussed in step 15.
17. Another final assessment is to have the students design an even more efficient solar cooker or water heater using any materials they have. You could tell the students that the goal would be to speed up the time for the temperature to reach a certain point or increase the maximum temperature.
18. As a bonus, have the students cook s'mores, popcorn, cookies, hotdogs or something else fun in their pizza boxes.



Solar Resource Simulator: Project number 2 is also a versatile teaching tool: it can be adapted to teach Earth Systems (seasons) as well as Physical Science (properties of light). Further, the visual nature of the project can help

meet the needs of a variety of learners and address common misconceptions of Earth Systems.

Class Project ideas: The class could investigate the differences in voltage for a given geographic region as the year progresses. For example: in the summer, the North Pole may read 0.35v and 0.00v in the winter. Create a spreadsheet and graph the solar irradiance (in volts or amperage) for a given area over a given time frame. The class could also investigate the changes that occur when the Earth is tilted greater than or less than 23.5°.

Measuring Solar Radiation: We liked the pizza box solar cooker because it is so inexpensive to make and most of the materials you can easily get. The pyranometer is more expensive, but gives more immediate results. This instrument measures the sun's energy by displaying electrical current. It offers a great introduction or illustration of measuring energy and the concepts of electricity. The benefit of this experiment is that the results from the meter are immediate and you can change the environmental conditions and get the result right away. Both these experiments can lead to discussions of pollution and global warming.



Length of Day Around World: This experiment is the least expensive if you already have a computer and an Internet connection. The strength of this project is that your students get to communicate with other classes throughout the world and so in addition to the Physical and Earth Standards you're working on, you can include social studies (geography) standards as well. Because of the possibilities of communicating and analyzing other results with students across the world via the Internet this project meets the communication portion Science as Inquiry (content standard A) and Science and Technology (content standard E).

You will need to sign up a few weeks before you want to do this project. First, go to www.epals.com and sign up your class. Second, find classes that also want to work on this project.



Capture Solar Energy: Project 5 is another lesson that is very inexpensive and a good lesson in understanding energy conversion. As an extension, students could start with ice below 0°C and graph the temperature increase. Students should see the slope of the graph decrease at 0°C due to the latent heat of fusion (heat of fusion for water is 0.366 Joules/ gram).

Other ideas: Students can calculate the efficiency of the solar collector and challenge each other to build more efficient solar collectors.

Calculations: The following is an example of calculating the energy captured by a solar collector.

How much solar energy is captured if 100ml of water is raised 10 degrees over 10 minutes using a 10cm x 10cm solar collector?

Answer:

1. 100ml water x 1 g/ml = 100g
2. 100 g x 10°C = 1000 calories
3. 1000 cal x 4.186 Joules=4,186 J
4. 10 minutes x 60 seconds = 600 seconds
5. 4,186 J ÷ 600 s = ~ 6.97 Watts

Answer = ~ 6.97 Watts

To convert to W/M²:

1. 10cm x 10cm = 100cm² = 0.01M²
 2. 6.97 Watts ÷ 0.01M² = 697 W/M²
- Answer: 697 W/M²

*Note: Solar irradiance is ~ 1000 W/M² on a clear summer day.

For elementary and middle school students, you could modify this experiment to just have students measure temperature of this apparatus on various days. Have students record other possible environmental factors that might affect the temperature of the water. To reinforce the inquiry basis of this experiment, ask the students about which variables they think might affect the water temperature.

This is the second experiment that would work well through global collaboration with www.epals.com. Have classes throughout the world send you their data.



National Science Education Standards by the National Academy of Sciences

Science Content Standards: 5-8

Science As Inquiry

– Content Standard A:

“Abilities Necessary To Do Scientific Inquiry”

“Understandings About Scientific Inquiry”

Physical Science

- Content Standard B:

“Transfer of Energy”

Earth Science

- Content Standard D:

“Earth in the Solar System”

Science and Technology

- Content Standard E:

“Abilities of technological design”

“Understandings about science and technology”

Science Content Standards: 9-12

Science As Inquiry

– Content Standard A:

“Abilities Necessary To Do Scientific Inquiry”

“Understandings About Scientific Inquiry”

Physical Science

- Content Standard B:

“Conservation of energy and increase in disorder”

“Interactions of energy and matter”

Earth Science

- Content Standard D:

“Energy in the Earth System”

Science and Technology

- Content Standard E:

“Abilities of technological design”

“Understandings about science and technology”



Technology Description



Ah, the sun. Picture yourself outside right now, or even better go outside if the sun is shining. What do you think the sun is good for? How does it affect you? There is no right answer. Just think a minute before you continue reading.

One of the ideas that you may have thought is that the sun provides us heat. It feels so good when we are cold and we feel the warm sun on our skin. Of course, if we have too much sun, we get sunburned. Can you imagine if the Earth were closer to the sun? Yeah, we would get toasted. If we had too much sun, it would be too hot for us and other living things to live. The sun has an amazing amount of heat and we get just a very small amount since we are so far away, but that amount is just right for us.



Another idea you may have thought of is light. Without the sun, we couldn't see. You say, "what about the moon?" Aha, the moon doesn't have any light of its own. All of the light we see is really sunlight that is reflected or bounced off our moon.

You might argue again, well I would just turn on a light or use a flashlight. Then I would be able to see. Well, where did that energy to shine the light come from? In fact, where does the energy to build, light, and heat our houses and schools come from? The sun actually has created almost all of the energy we use today. Oil and gas is made up of compressed plants and dinosaurs and other living things from many millions years ago. The living things depended on plants to make energy from sunlight. That energy was stored and we get to use it now, at least until we run out or it gets too expensive.

If we want to find more energy, we can look back to the sun itself. All the light and heat we feel is energy that we might be able to use. How much energy could the sun give us? How much would this energy cost us? How can we capture the energy and use it for our needs? You will be doing some experiments that will begin to answer these questions.

The first experiment you can do is build a solar oven from a pizza box. The energy from the sun will increase the temperature. The more efficient you make your solar oven and the more energy available from the sun, the higher the temperature will go. You can measure the energy you have by using an oven thermometer.



For Advanced Students: The term for the amount of energy produced by the sun over a specific area is **solar irradiation** and is usually expressed in terms of watts per square meter (Watts/m^2). One of the ways you can measure this energy is through special instruments called **pyranometers** or **pyrheliometers**. A pyranometer measures the sun's radiation and any extra radiation that has been scattered by particles in the sky. A pyrheliometer measures the direct sun's radiation. In project 3 you make a pyranometer and pyrheliometer by using a solar cell (also called a **photovoltaic** or **PV cell**). You connect the cell to something that measures current such as a millimeter or voltmeter.

The first step in understanding solar irradiation is understanding the sun itself. The sun is a sphere of intensely hot gasses about 150 million kilometers from Earth. The temperature on the sun ranges from about 5,700 degrees Celsius at the surface to an estimated 14 million degrees Celsius in the center. The amount of energy that reaches earth is an extremely small fraction, only about one-billionth of the energy on the sun.

This energy that reaches the outside of the Earth's atmosphere only changes about $\pm 3\%$ over the course of the year. This energy is known as the **solar constant**. The number for this is generally accepted as 1367 Watts/m^2 . However, the dust, air molecules, and moisture in the atmosphere, combined with the exact location of the observer in relation to the sun, dictate the amount of energy that reaches Earth's surface. In project 2 you measure the difference in energy between different parts on a model of the Earth and in project 4 you measure the amount of light people see in different parts of the world.

Resources:

C. Freudenrich, "How the Sun Works," [Online document], Available: <http://science.howstuffworks.com>.

National Aeronautics and Space Administration (NASA), "The Sun. NASA Fact Sheet," [Online document], Available: www.nasa.gov.

National Aeronautics and Space Administration (NASA), "Watching the Sun: Measuring Variation in Solar Energy Output to Gauge its Effect on Long-term Climate Change" [Online document], Available: <http://earthobservatory.nasa.gov/> and <http://terra.nasa.gov/>. These sights also contain images and data about global conditions.

National Renewable Energy Laboratory (NREL), "Glossary of Solar Radiation Resource Terms," [Online document], Available: www.nrel.gov.

National Renewable Resources Laboratory (NREL), Science Projects in Renewable Energy and Energy Efficiency, 1991, American Solar Energy Society.



Project Ideas

1 Pizza Box Solar Oven

Learning Objective: To design and effective pizza box solar oven.

Questions: How can you trap the energy from the sun and turn it into something useful, like heat? What factors will affect how high the temperature will go?

Control and Variables: Day of year (season and tilt of earth will determine how direct the rays of the sun are), sky conditions (pollution, clouds), temperature of the air, design and dimensions of oven.

Materials and Equipment: Pizza box (eat out or ask for one at a pizza restaurant), black construction paper, aluminum foil, clear transparencies (office supply store), scissors, clear packing tape or glue, drinking straw or dowel to hold the box open, oven thermometer.

Safety and Environmental

Requirements: Never look directly at the sun. If the temperature in your oven gets too warm, you may need oven mitts or open the box and wait until the box cools down to touch anything inside the box.

Suggestions: Cover bottom of box with aluminum foil and then a layer of black paper. One inch from the edge of the box cut a hole in the top of the box leaving one edge on the same side as the box's hinge. Glue aluminum foil on inside part of the box lid. Tape clear plastic over this hole. When you glue the clear plastic to the pizza box, make sure you have a tight seal. Point the opening of the box directly at the sun and prop the lid open. Record the temperature inside the box on different days. Also, record any data you think might affect the temperature in the box (cloud cover, date and time, and temperature outside the box). After you check your temperature, line your box with plastic wrap and try cooking popcorn, cookies, or heating water to make tea or hot chocolate.

For your science project display the data you recorded above. Explain how the oven works. Make suggestions on how to create a better solar oven. For example, you might check out <http://www.solarnow.org/pizzabx.htm> and see how they did their box.

2 Solar Resource Simulator

Learning Objective: To design an earth-sun simulator in order to learn how solar energy is distributed around the Earth.

Control and Variables: Day of the year, time of day.

Costs: solar cell = \$5, multimeter = \$20, globe = varies, 100 Watt halogen lamp = \$10 (you can substitute with a projector if available)

Project:

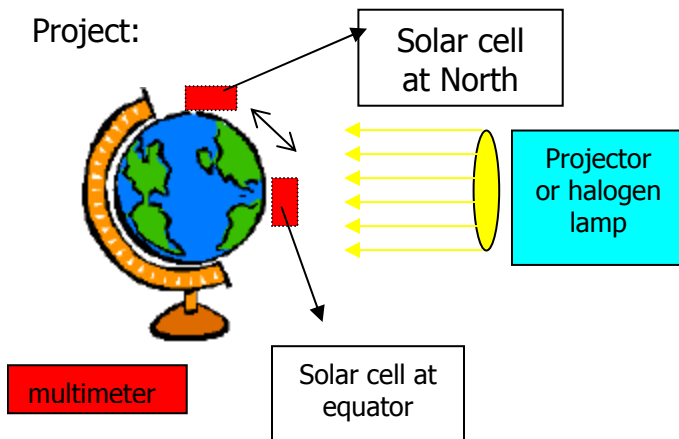

Materials and Equipment: World globe or Styrofoam sphere, solar cell and/or pyranometer, multimeter, Velcro tape, protractor/angle finder, projector and/or halogen lamp.

Solar cells, voltmeter, halogen lamp and projector can be found at major electronic stores. You can purchase the Styrofoam sphere at a hobby shop.

Safety and Environmental

Requirements: **CAUTION:** Don't look directly at the sun or projector. You can damage your eyesight permanently.

Suggestions: Cut the Velcro strip long enough to reach both North and South poles. Tape the "other side" of Velcro to the solar cell. Stick the solar cell where you want on the globe or Styrofoam sphere. Place the projector or light source about 20-30 inches from the globe and shine the light on the equator. Make sure the solar cell is parallel to the globe's surface. Measure the voltage/amperage for North Pole, 40° N latitude, the Tropic of Cancer, the equator, the Tropic of Capricorn, 40° S latitude, and the South Pole.

Further Inquiry:

1. Compare the length of time of illumination and angle of light rays with the energy collected from the solar cell. For example record the energy for direct rays for 5, 10, and 15 minutes. Then record the energy for indirect rays.
2. Investigate the effects of distance from light source to the solar cell. Compare this to the distance sunlight travels through the atmosphere from sunrise to noon and/or the equator to the Arctic Circle.
3. What conclusions can you make? What can you say about how hot the sun must be to receive the amount of energy at the Earth's surface?

3 Measuring Solar Radiation

Learning Objective: To measure the energy of the sun.

Questions: How much solar radiation is available each day? Week? Month?

Control and Variables: Day of year (hours of daylight), orientation of

equipment toward sun: Horizontal, tilt angle, azimuth, sky conditions.

Materials and Equipment: Solar cell. Paper towel tube or another tube that is 10 times longer than radius. Millammeter (0-50) or resistors and a voltmeter (0-10 volts).

Safety and Environmental Requirements: **CAUTION:** Do not look directly at the sun. It can damage your eyesight permanently.

Suggestions: Install a low-cost pyranometer (without tube) and pyrhellometer (with tube) system as shown in the figures. Compare the data you get with summaries of the 30-year means.

Further Inquiry:

1. Compare direct sun (with tube) with full sky radiation (without tube).
2. How does cloud cover and humidity affect measurements?
3. How do different colored filters affect measurements? Try colored transparencies or other transparent material.
4. How does air pollution affect your results? What could you use to simulate air pollution?

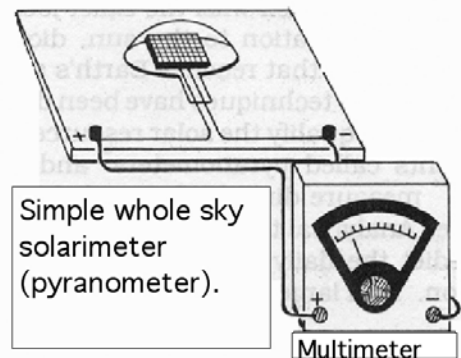
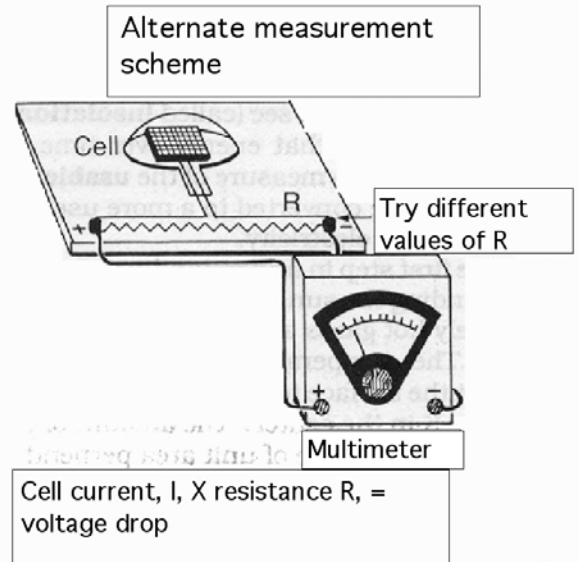
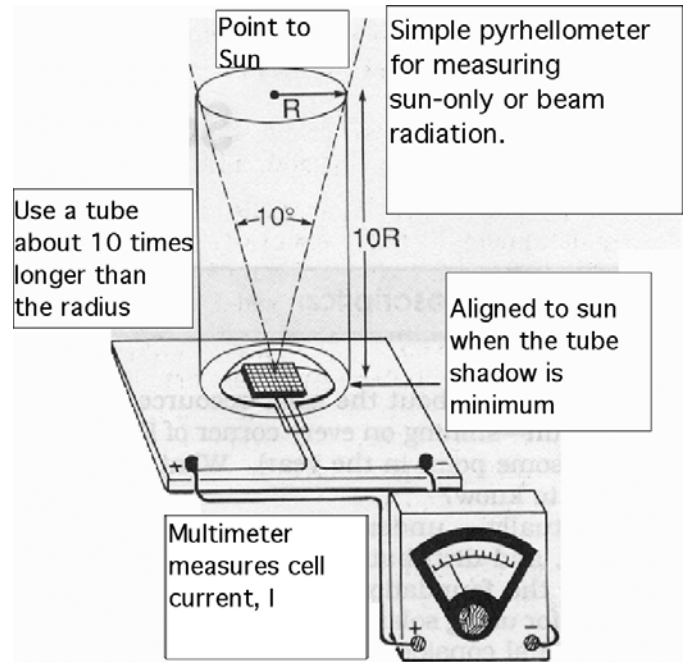

4 Length of Day around the World

Learning Objective: To measure how the length of day changes depending on where you are in the world.

Control and Variables: Day of year and geographic location.

Materials and Equipment: Internet access, local newspaper.

Suggestions: Epals.com is a Web site for students and teachers. This site allows you to communicate with over 4 million students around the world. The teacher needs to sign up the class first. You will need to record how long the day is and send this information to other students throughout the world and record and graph their answers.

5 Capture Solar Energy!

Objective: To measure solar energy with a homemade solar collector.

Variables: Time of day, time of year, location, atmospheric conditions.

Special Equipment: square plastic food storage container, black paint, heavy-duty clear plastic wrap, thermometer, graduated cylinder, clock / watch, and ruler.

Set up:

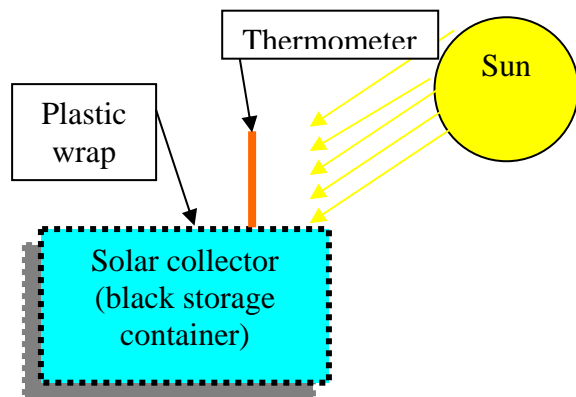

Hints: What was the volume of water before you started? What is the area of your solar collector? What was the temperature of the water vs. outside air before you began your investigation? What was the final temperature of the water? Did you use the metric system? How often did you record the temperature? What did the graph look like?

Useful Conversions:

1 calorie = 1 gram water raised 1°C

1 Watt = 1 Joule per second (1 J/s)

1 calorie = 4.186 Joules

Area = Length x Width

1 ml water = 1 gram water

Standard irradiance value (Sun's Power)
= Watts per Meter squared (Watts/ M²)

Further Inquiry:

1. Does the rate of temperature increase differ if you started with ice instead of water?
2. Can you use something other than water to collect the Sun's energy?
3. What factors can affect solar irradiance?
4. How does outside air temperatures affect your measurements?

More Project Ideas

What is the connection between weather variables, such as temperature, relative humidity, and cloudiness, and the changes in available solar energy.

How does the available solar energy change with altitude or elevation? (Hint: How does the density of the atmosphere change with altitude?)

How does the brightness of various indoor lamps compare to that of sunlight?

How would you determine the approximate solar radiation resource at your home if you had values for several cities nearby?

How does the pattern of solar radiation through the day (or year) match the need for air conditioning, heating, cooking, and hot water in your home?

Where are the warmest and coldest parts of your home in the summer? In the winter? Compare the locations with the position of the sun in the sky.

How much solar energy comes from scattered light rather than directly from the sun? What factors affect this?
What is the color of sunlight?

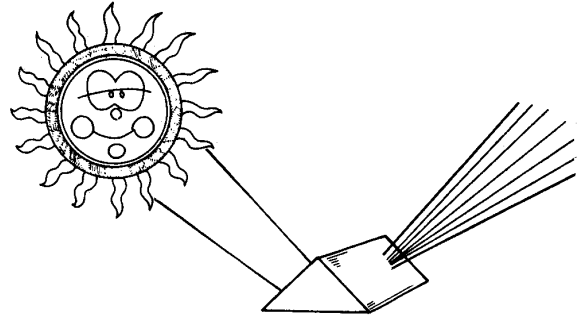

How rapidly does the focused light from a magnifying glass move at different times of a day?

How does a light source spread out with distance?

How can you determine solar noon and solar north at various longitudes and days of the year?

Why are sunrises and sunsets predominantly red?

Why does the sky turn blue?

Why are the oceans blue?

Investigate the terrestrial solar irradiance spectrum, why is the UV spectrum relatively low? Why are there "dips" periodically in the spectrum? (For irradiance data: www.nrel.gov/srrl)

Photovoltaics and Solar Energy

Derek Nalley and Scott Pinegar

National Science Standards:

Standard A: Science as Inquiry: Students have the ability to develop questions/ideas, formulate tests and experiments, analyze data and come to conclusions about their questions/ideas.

Specific standards met in this module:

- Abilities necessary to do scientific inquiry
- Understandings about scientific inquiry



Standard B: Physical Science: Students know and understand the nature of matter from the microscopic to the macroscopic levels and the interaction of energy and matter. Students understand mathematics as an interpretation of physical phenomena.

Specific standards met in this module:

- Conservation of energy and increase in disorder
- Interactions of energy and matter

Standard D: Earth and Space Science: Students understand the earth's processes, interaction of matter and energy, origin and evolution of the earth system and the universe.

Specific standards met in this module:

- Energy in the earth system

Standard E: Science and Technology: Students understand the interrelationship between science and technological design and advancement.

Specific standards met in this module:

- Abilities of technological design
- Understandings about science and technology

Standard F: Science in Personal and Social Perspectives: students understand health issues relating to their own health and the health of communities.

Students understand the human impact on natural resources and the environment and that they are part of a global environment.

Specific standards met in this module:

- Natural Resources
- Environmental quality
- Natural and human induced hazards
- Science and technology in local, national, and global challenges

Standard G: History and Nature of Science: Students understand that science is done by humans either individually or in teams and can be done on a small scale of field tests or on a large scale with many scientists working on one question. Science is also a unique way of knowing which depends on logic and observation of the natural world and also is ever changing based on new ideas and data.

Specific standards met in this module:

- Science as a human endeavor
- Nature of scientific knowledge

Teacher's Overview:

This module will address issues dealing with the energy from the sun, the energy needs of students in the classroom and ultimately energy needs as a nation. Students will use a Photovoltaic (PV) cell to measure the energy from the sun. Using a light bulb with a known wattage the students will illuminate the light bulb using the PV cell. This way the students will know the approximate energy coming from the PV cell. An alternative way for the students to calculate the energy coming from the PV cell is to measure the voltage and the current output from the PV cell across a resistor and use the equation $P = IV$ to calculate the power produced. This is the way that is planned out in the labs related to this unit. From here the students use the efficiency of the PV cell and the area of the cell to calculate the energy of the sun at that time of day. Also students will experiment with different color filters to determine the energy output of the solar panel at different wavelengths. This will allow them determine the spectrum of light in which the sun emits the most energy.

At home the students keep track of the energy they use in terms of kilowatt-hours by finding the energy usage of all of the appliances they use on a daily basis. After investigating their daily usage of energy the students can then calculate how much PV they would need in order to supply them with the energy they use on a daily basis. Next they compare the benefits of using PV rather than conventional means of electricity generation such as coal burning or nuclear power. Specifically the students calculate how much coal is required to create the electricity they use on a daily basis and then compare this cost to the cost of the PV system they would need. Environmental benefits and consequences are also addressed in this comparison.

Learning Objectives:

Students will learn about energy conservation and transformation, specifically from radiant energy to electrical energy. Students will understand scientific inquiry as it pertains to taking data and making conclusions about that data. Students will understand their personal connection to the energy they use and the cost of generating that energy. Students will explore further the energy associated with the Earth/Sun system and how the energy from the sun drives many of the processes on Earth. Finally the students will begin to understand the

connection between science and technology, the limitations of technology and what science and engineering is doing to overcome these limitations.

Time Allotted:

Pre-Test and Review:	45-50 min
Introduction and basic instruction:	2 hrs
Lab-Measuring the Sun’s energy(Weather Dependent):	2 hrs
HW-Student Energy Use worksheet:	30 min
Lab-Measuring the Sun’s Spectrum(Weather Dependent)	1 hr
Lab-Measuring the Sun’s Spectrum(Plant setup in advance)	1 hr
Review of nation wide energy use:	30 min
Research Traditional methods of electricity production:	1 hr
Design PV system that fits students energy needs:	30 min
Research cost of PV system:	30 min
Compare/Contrast PV electricity and Coal electricity	1 hr
Post-Test	1 hr

Vocabulary:

Photovoltaic	Photoelectric Effect	Efficiency
Watts	Current	Spectrum
Kilowatts	Voltage	Wavelength
Kilowatt Hours	Power	Filter

Resources/Materials:

Materials

- Photovoltaic Solar Cells with attached resistor (10 Ohm)
(www.siliconsolar.com prices range from \$6.00 to \$20.00)
- Color Filters (Clear, Red, Green, Blue, Black)
(www.pasco.com "Ray box color filter set")
- 5 Cardboard Boxes (shoe boxes work well, students can donate from home)
- 5 Plants (Any green house, Home Depot, Lowes etc...)
\$2 - \$3 per plant

Worksheets (see attached)

- Measuring Sun’s Energy Lab
- Measuring Sun’s Wavelength Lab
- Plant Info Sheet
- Student Energy Use worksheet
- Pre-Test
- Post-Test
- Electricity generation research on world wide web
- Price list of PV cells for home use

Resources

World Wide Web for research on electricity generation and PV price lists.

Prerequisite Knowledge:

Beginning the lesson the students must have a basic knowledge of the photoelectric effect. Generally, students would not come into class with this knowledge so the introduction must give a short explanation of the effect. This does not have to be in much depth, just enough to understand that light can be converted to electricity.

Main Activities:

Labs-Measuring the Sun's Energy and Spectrum

1. Students are given an introduction to the equipment they will be using and how to use the equipment properly/safely.
2. Students read the procedure as they follow along while the teacher demonstrates each step of the lab. This is presented in front of the entire class.
3. Give students time to set up the lab and begin testing their apparatus.
4. The next day students have the class period to set up their apparatus and take data for the lab.

HW Student Energy Use Profile

1. Hand out profile worksheet to each student.
2. Explain the procedure for the profile and explain any calculations that need to be done within the profile worksheet. This should be presented to the entire class.
3. Answer any individual question that may arise after the explanation.

Research Traditional Electricity Production

1. This will be done on the internet, suggested websites should be given so students may find the information.
2. Present assignment to the entire class explaining each question they must answer.
3. Give the rest of the class period for the students to do independent research on the internet.

Design a PV System

1. Students must have their energy use profile done and with them to do this activity.
2. Each student will use their energy profile and the data they collected in the "Measuring the Sun's Energy" lab to calculate the area of PV they would need to supply them with electricity.
3. Walk the students through a simple example calculation of the area of PV that they would need.

4. Give students websites/handouts that have price lists of PV systems that they can choose from. Students then decide on the cost of their personal PV system.

Compare/Contrast PV Electricity to Traditional Electricity

1. Demonstrate to the students the format of writing desired by the teacher. (ex: Two column list, paragraph form, essay form, etc...)
2. Each student should have their work from the previous activities before they attempt this activity. Students should use the information that they obtained through the unit to support their points in this activity.

Evaluation:

Pre-Test

The pre-test will evaluate the students knowledge of PV and solar energy at the beginning of the module.

Post-Test

The post-test will be given to the students after the module to formally examine their knowledge of the material covered. This test will cover the basic knowledge students should have gained about PV systems, the sun's spectrum, the environmental impact of traditional energy production, the cost analysis of the PV system, energy conservation and transformation, the earth/sun energy relationship, and the basic calculations that the students performed during the module.

Formative Assessments

The formative assessments such as the lab, the compare/contrast assignment and other activities will assess student knowledge of scientific inquiry, energy transfer and conservation, the connection between science and technology, and personal and social perspectives of the science.



Photovoltaic Pre-Test

Answer the following questions to the best of your ability.

- Electricity is generated when a photon of light reacts with what other type of substance?
 - metal
 - water
 - glass
 - plastic
- How much estimated energy reaches the surface of the earth?
 - 300 watts
 - 1500 watts/meter²
 - 1000 watts/meter³
 - 1000 watts/meter²
- A particular solar panel produces 500 watts of power. How many 150 watt light bulbs could the solar panel completely light up?
 - 4 light bulbs
 - 3 light bulbs
 - 7 light bulbs
 - 9 light bulbs
- How is most of the electricity generated in the United States?
 - Coal power plants
 - Hydroelectric power plants
 - Nuclear power plants
 - Wind farms
- In a solar panel we convert _____ energy to _____ energy.
 - chemical, electrical
 - electrical, radiant
 - kinetic, chemical
 - radiant, electrical
- (True/False) The energy from the sun is completely transformed into electrical energy by using a solar panel.
- (True/False) We will never run out of fossil fuel natural resources that create the majority of the electricity we use in the United States.
- Describe, in the space below, how you might measure the amount of energy is coming from the sun at any given time during the day.

**LAB:
Measuring the Power from the Sun**

In this lab you and your partner will measure the energy of the sun using a small solar panel, a meter stick and a calculator. You will see from just a few simple calculations and measurements the energy from the sun can be calculated.

Part I: Angle of the sun

1. Write down the time of day you are taking the measurements in the box to the right.
2. Measure the height of the post in the court yard in meters.
3. Measure the length of the shadow of the post in meters.
4. Draw a diagram of this situation and label the lengths on the diagram.
5. Calculate the angle of the sun from your measured height and length using the following equation:

$$\text{Tan}\theta = \text{Post height}/\text{shadow length}$$

6. This is the angle of the sun at this time of day.

Time: _____

Post height: _____

Shadow Length: _____

Diagram:

Angle: _____ (show work below)

Part II: Set up of the solar panel

Use the solar panel that you have been given and set it up so that its face is perpendicular (90 degrees) to a ray of sunlight that is coming from the sun. Measure the angle of the solar panel with respect to the ground and label this angle in a diagram you draw in the space provided below.

Solar Panel Diagram

Part III: The Data

Now you must perform the experiment and collect the data for this experiment.

1. Measure the area and find the efficiency of the solar panel. Draw a diagram of that area below and label the length of each side.
2. Measure the current and voltage coming from the solar panel when everything is set up correctly.

The Data:

1. Area of Solar Panel: _____
Efficiency: _____

2. Current: _____
Voltage: _____

Part IV: The calculations

Now that you have measured the current and the voltage from the solar panel you can calculate the power given by the solar panel using the equation $\text{Power} = \text{Current} \times \text{Voltage}$. Do this calculation and show your work below. (don't forget units)

Power: _____

The power calculated above is the power given by the solar panel, but the solar panel has a particular efficiency. This means that the solar panel only converts part of the energy of the sun to electricity. Use this efficiency to calculate the power coming from the Sun. (don't forget units)

Power of the Sun: _____

The power of the sun is a bit misleading because the power that the solar panel produces is a function of its area. Thus it is better to talk about the energy of the

sun per area. We call this quantity the **Irradiance** of the sun and use the units W/m^2 . Use the area measurement of the solar panel and determine the irradiance of the sun in W/m^2 . Use the space provided below to show your work.

Irradiance of the Sun: _____

Part V: Analysis Questions

1. A house that is run completely on solar power will have a maximum need of 10.5 kW of energy at any one time. If you use the solar panels that we used in this lab to supply the power, what would the total solar panel area need to be?
2. What would we have to do in order to decrease the area of the solar panels in question 1 above?
3. What are the advantages to using solar power to provide energy to a house over the traditional methods of providing energy?
4. What are the disadvantages of using solar power to provide energy to a house?

LAB:
Measuring the Sun's Spectrum

In this lab you and your partner will measure the energy of different light spectra using a small solar panel, a meter stick, color filters, plants, cardboard boxes, and a calculator. You can then decide which spectrum of light the sun is radiating more and then find out why certain things in nature are how they are.

Part I: Setting up the plant boxes

Start with 5 plants that are as close to identical as possible. Measure the individual plants' height and take note of how healthy the plant looks. Make notes of any dead or wilting leaves. Keep the plant info sheet with the plant so that its info isn't mixed with another plant.

Now take the five cardboard boxes and remove the top and one side for each box. Place a plant in each box and center it. Now tape the individual color filters onto each box so that they fully enclose the plant, but do not tape it so securely that it can't be removed easily. This is because you'll still need to water the plants daily. Tape the plant info sheet to the back of the box. You should now have 5 boxes, one with a clear filter, black filter, green filter, red filter, and blue filter enclosing the plant; each with plant info attached. Place the boxes in the window so that each is facing outward to get the most sunlight into the box.

Part II: Measuring the angle of the sun

1. Write down the time of day you are taking the measurements in the box to the right.
2. Measure the height of the post in the court yard in meters.
3. Measure the length of the shadow of the post in meters.
4. Draw a diagram of this situation and label the lengths on the diagram.
5. Calculate the angle of the sun from your measured height and length using the following equation:

$\text{Tan}\theta = \text{Post height}/\text{shadow length}$

6. This is the angle of the sun at this time of day.

Time: _____

Post height: _____

Shadow Length: _____

Diagram: _____

Angle: _____ (show work below)

Part III: Set up of the solar panel

Use the solar panel that you have been given and set it up so that its face is perpendicular (90 degrees) to a ray of sunlight that is coming from the sun. Measure the angle of the solar panel with respect to the ground and label this angle in a diagram you draw in the space provided below.

Solar Panel Diagram

Part IV: The Data

Now you must perform the experiment and collect the data for this experiment.

1. Measure the current and voltage across the resistor attached to the panel when everything is set up correctly. Only record numbers as positive when measuring voltage and current.
2. Now place the color filters over the solar panel and record the voltage and current for each filter in the data box.

The Data:

No Filter Current: _____
No Filter Voltage: _____
Clear Current: _____
Clear Voltage: _____
Red Current: _____
Red Voltage: _____
Green Current: _____
Green Voltage: _____
Blue Current: _____
Blue Voltage: _____
Black Current: _____
Black Voltage: _____

Part V: The calculations

Now that you have measured the current and the voltage from the solar panel you can calculate the power given by the solar panel using the equation $\text{Power} = \text{Current} \times \text{Voltage}$. Do this calculation and show your work below. (don't forget units)

No Filter Power: _____

Clear Filter Power: _____

Red Filter Power: _____

Green Filter Power: _____

Blue Filter Power: _____

Black Filter Power: _____

According to your Data above number the filters according to their power output 1 through 5 in the box below, 1 being the most power and 5 the least.

Clear Filter: _____

Red Filter: _____

Green Filter: _____

Blue Filter: _____

Black Filter: _____

Part VI: Analysis Questions

1. If you add the Red, Green, Blue, and Black filter powers and compare that to the Clear filter power is it larger or smaller than the Clear filter power? Why do you think this is?
2. According to your data which of the three color spectrums, Red, Blue, and Green, does the sun emit the most? Can you describe anything around you in nature that would benefit from this?
3. Describe the changes for each of the plants with the color filters on them.
Clear-

Red-

Green-

Blue-

Black-
4. Compare the plants to each other. Explain the differences and why you think they occur. (Example: Blue filter plant was nearly the same size as the Red filter plant, but much smaller than the Clear filter)



Plant Info Sheet

Starting Size (height): _____

Color of Filter: _____

Noticeable Features (wilting, coloring, etc):

Ending Size (height): _____

Ending Noticeable Features(wilting, coloring, etc):

PV Design

How Much PV Do You Need?

In the following calculations you will determine the area of the photovoltaic system you would need to supply your energy requirements. Given an efficiency of 10% how big in terms of the area does a photovoltaic system have to be in order to supply your energy needs at your house? Assume 750 W/m^2 is the average irradiance of the sun.

1. Assuming 10% efficiency how much energy would a 1m^2 solar panel supply in watts?
2. Add the power for each appliance in your house together to get the maximum power needed at any given time. (Use the energy use homework)
3. What is the area of the solar panel system that you will need to supply the power needs for you house?

Part II: Energy usage for one day

This part will require you to find your energy consumption meter. This meter has five dials and a wheel that spins underneath the dials. You will check the reading on the meter at a particular time during the day and then re-check the meter at the exact same time the following day. The difference in the readings will tell you the energy used in the house during that 24 hour period of time.

Time of day: _____ Meter Reading: _____ _____	Energy used (kW): _____ Total Elapsed Time (hrs): _____
Time of day: _____ Meter Reading: _____	Energy used in kWhrs: _____

Part IV: Energy Cost\$\$\$

Now we will determine the cost of the energy you use on your own and the cost of the energy used in your house. Obtain the most recent utility bill for your house and determine the price of energy per kilowatt hour. Then calculate the cost for the energy you use individually on a daily basis and the cost for the energy used by your house on a daily basis.

Individual Cost	Household Cost
Price per kWhr: _____	Price per kWhr: _____
Total kWhrs used: _____	Total kWhrs used: _____
Cost of energy for one day: _____	Cost of energy for one day: _____

Independent Research: Traditional Electricity vs. Photovoltaics

In the following assignment you will research three traditional methods of producing electricity in Part I. You will do your research on the internet and answer the following questions. In Part II you will use the information from your energy use homework to research the cost of photovoltaics for your energy needs.

Part I: Traditional power plants

1. Coal burning power plants

A. Describe the production of electricity using a coal burning power plant in the space below.

B. What percent of the United States electricity needs are produced by coal burning power plants? _____

C. What are the byproducts of coal burning power plants? (ex. Waste, Greenhouse Gas Emissions, Environmental Impacts, etc...)

D. What is the average cost per kilowatt hour for electricity produced by this method? _____

F. What other industries must be in production to supply electricity by these means? (ex. Mining, Construction, etc...)

2. Nuclear Power Plants

A. Describe the production of electricity using a nuclear power plant in the space below.

B. What percent of the United States electricity needs are produced by nuclear power plants? _____

C. What are the byproducts of nuclear power plants? (ex. Waste, Greenhouse Gas Emissions, Environmental Impacts, etc...)

D. What is the average cost per kilowatt hour for electricity produced by this method? _____

F. What other industries must be in production to supply electricity by these means? (ex. Mining, Construction, etc...)

3. Hydroelectric Power Plants

A. Describe the production of electricity using a hydroelectric power plant in the space below.

B. What percent of the United States electricity needs are produced by hydroelectric power plants? _____

C. What are the byproducts of hydroelectric power plants? (ex. Waste, Greenhouse Gas Emissions, Environmental Impacts, etc...)

D. What is the average cost per kilowatt hour for electricity produced by this method? _____

F. What other industries must be in production to supply electricity by these means? (ex. Mining, Construction, etc...)

Part II: Photovoltaics used for electricity production

Now we will compare photovoltaic electricity production with traditional methods and find how much it would cost to power your house using photovoltaics.

A. Describe the production of electricity using photovoltaics in the space below.

B. What percent of the United States electricity needs are produced by photovoltaics? _____

C. What are the byproducts of photovoltaics? (ex. Waste, Greenhouse Gas Emissions, Environmental Impacts, etc...)

D. What is the average cost per kilowatt hour for electricity produced by this method? _____

F. What other industries must be in production to supply electricity by these means? (ex. Mining, Construction, etc...)

Now you will do some research on the internet to find a photovoltaic system that will fit the needs of your household. Go to the following website to help in determining the system that you will need: www.mrsolar.com. One at the website click on the "Remote Home" under Pre-Packaged systems on the left side of the window. Using the Energy use homework that you received determine the following:

1. Daily electric power needs (for your house) in kilowatt hours:

2. Average power needs in Watts for one day. (divide answer above by 24hrs). _____

3. Determine the system you need for your home. (remember you need Alternating Current AC, not Direct Current DC) Give the name of the system you chose and why you chose that system below.

4. List the parts that come with the package that you have chosen and give the efficiency for the solar panels you get in that package.

5. What is the price of this system? _____

6. How long would you have to run this system for it to pay for itself? (How many years would it take paying for traditional electricity to equal the price of the photovoltaic system?) Show your work below.

7. Would the photovoltaic system be cost effective over the short run, how about the long run?

**Compare/Contrast:
Photovoltaics vs. Coal Produced Electricity**

In the space provided below compare and contrast the benefits and drawbacks in using coal and photovoltaics to produce electricity. Consider environmental impacts, economic impacts, practicality, and other points while writing your statement. You should not pick a side in this paper, you should give an unbiased comparison of the two technologies. Write in complete sentences and proper paragraph format. Use extra paper if needed.

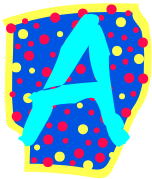

Photovoltaics Test

1. Electricity is formed when a photon of light reacts with what other type of substance?
a. metal b. water c. glass d. plastic
2. How much estimated energy reaches the surface of the earth?
a. 300 watts b. 1500 watts/meter²
c. 1000 watts/meter³ d. 1000 watts/meter²
3. A particular solar panel produces 500 watts of power. How many 150 watt light bulbs could the solar panel completely light up?
a. 4 light bulbs b. 3 light bulbs
c. 7 light bulbs d. 9 light bulbs
4. How is most of the electricity generated in the United States?
a. Coal power plants b. Hydroelectric power plants
c. Nuclear power plants d. Wind farms
5. In a solar panel we convert _____ energy to _____ energy.
a. chemical, electrical b. electrical, radiant
c. kinetic, chemical d. radiant, electrical
6. What is the approximate maximum efficiency reached by a solar panel up to this point?
a. 100% b. 54%
c. 10% c. 35%
7. Solar panels must be faced which direction in order to receive the most sunlight during any given day?
a. South b. North
c. West d. East
8. A house that supplies all of its own energy needs is called...
a. Energy Efficient b. Tree Hugging Home
c. Off the Grid d. Non-Existent
9. What is the main element used in most photovoltaic cells?
a. Silicon b. Copper
c. Aluminum d. Iron

10. Photovoltaics are mainly used for what purpose currently?
 - a. small applications such as street lights and small well pumps
 - b. large power grids feeding power to entire cities
 - c. supplying power to commercial vehicles such as a passenger car
 - d. supplying power to perform electrolysis to obtain hydrogen
11. (True/False) The energy from the sun is completely transformed into electrical energy by using a solar panel.
12. (True/False) We will never run out of fossil fuel natural resources that create the majority of the electricity we use in the United States.
13. (True/False) All of the energy needed in a house can be supplied by photovoltaics.
14. (True/False) Photovoltaics do not produce pollution to our atmosphere unlike coal power plants.
15. (True/False) Photovoltaics are very cost effective in the long run but not in the short run.
16. Describe, in the space below, how you might measure the amount of energy is coming from the sun at any given time during the day.
17. Calculate how much energy is produced by a photovoltaic cell that has an efficiency of 13.4% if the average sun irradiance is 745 W/m^2 ? The dimensions of the cell are 1.25m long and 3.2m wide.
18. How much energy will the photovoltaic cell from #17 produce in kilowatt hours if it is allowed to produce electricity for 4.6 hours?
19. A well has a power need of 1200W. How big does a photovoltaic cell need to be in order to supply this power if the cell has an efficiency of 35% and the solar irradiance is approximately 940 W/m^2 ?
20. Do you think that photovoltaic cells have the ability to meet the power needs of the United States if the country would commit to using solar energy? Describe why or why not and use evidence from the class to support your argument.

21. Label the following diagram of the simple solar cell and describe the process in which electricity is generated by sunlight passing through the layers of the solar cell.

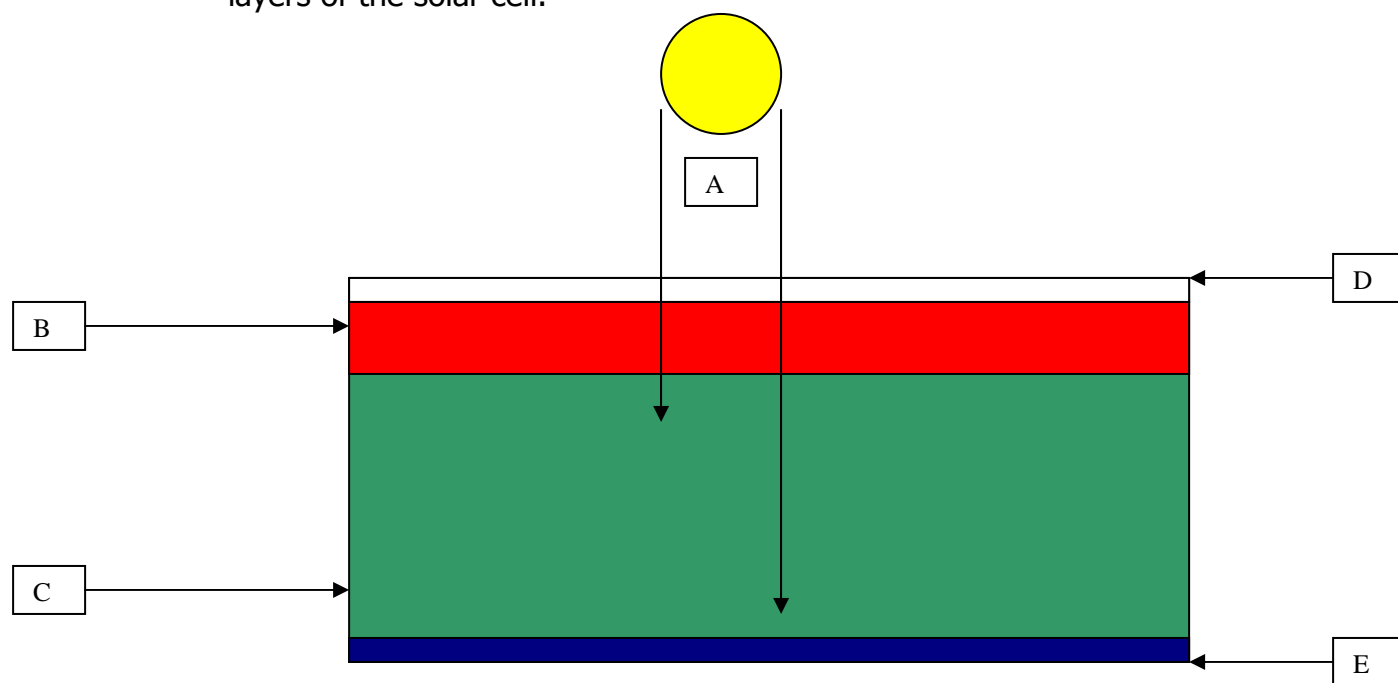

Material and Chemical Processing

For the Teacher

Concentrated sunlight is a versatile and high-quality form of energy with several potential applications besides process heat and electricity. Today scientist are developing systems that use concentrated sunlight to detoxify hazardous wastes, to drive chemical reactions, and to treat materials for increased hardness and resistance to corrosion.

National Science Education Standards by the National Academy of Sciences

Science Content Standards: 5-8 Science As Inquiry

– Content Standard A:

“Abilities necessary to do scientific inquiry”

“Understandings about scientific inquiry”

Physical Science

– Content Standard B:

“Properties and change of Properties in matter”

“Transfer of energy”

Earth and Space Science

– Content Standard D:

“Earth in the solar system”

Science and Technology

– Content Standard E:

“Abilities of technological design”



“Understandings about science and technology”

Science in Personal and Social Perspectives

– Content Standard F:

“Science and technology in society”

Technology Description

Solar detoxification shows exciting promise for helping us clean up contaminated water, soil, and industrial wastes. It's the distinctive properties of photons-the tiny packets of energy that make up light-that make solar detoxification possible. The low energy photons in the infrared and visible parts of the solar spectrum provide thermal energy to heat the waste.

The very energetic photons in the near-ultraviolet range add the quantum energy necessary to break the bonds between molecules in chemical compounds.

Most of the systems being designed use a catalyst to speed up the sunlight-driven

reaction. For example, in one case, scientists add a semiconductor powder to the contaminated liquid and expose the mixture to sunlight. The catalyst powder absorbs the sunlight and produces a reactive chemical that attacks the pollutant.

Research on other applications has used sunlight concentrated to 60,000 times! Solar radiation this intense can be used to power lasers or treat surface of metals. Scientists in Russia, Japan, Israel France Spain, and the United States are all studying ways of developing cost-effective systems that take advantage of the many possible uses of highly concentrated sunlight.

Resources:

United States Department of Energy
<http://www.doe.gov/>

National Renewable Energy Laboratory
<http://www.nrel.gov/>

MTU Institute of Materials Processing
<http://www.imp.mtu.edu/>

IEA Solar Paces
<http://www.solarpaces.org/>

SRI International
<http://www.sri.com/>

Institute of Energy Technology
<http://www.pre.ethz.ch/cgi-bin/main.pl?home>

Project Ideas

1 Can sunlight break down different kinds of plastics?

Learning Objective: Designing, construction, and evaluating sunlight affects on plastics.



Controls and Variables: Types and colors of plastics, time of exposure, sunlight intensity, direct exposure versus through glass, temperature

Materials and Equipment: Thermometer, watch, radiometer (can be a photographic light meter and patch of light-colored material), box to regulate temperature.

Safety and Environmental Requirements: *Wear eye protection when working with ultraviolet-emitting lamps. Dispose of experiment materials in a responsible manner.*

Suggestions: Expose samples of plastic to direct sunlight and to sunlight that pass through a pane of ordinary window glass. How long does it take for the plastic to lose its color or show signs of

degradation? What effect does the window glass have? What effects do temperature; presence of microorganisms, oxygen, and different chemicals have on degradation rate? Determine loss of strength quantitatively. Investigate glazing other than plain window glass. Determine degradation rates for exposure to different types of lamps (infrared, fluorescent, outdoor flood, black light, tanning).

2 Can hydrogen peroxide work with sunlight to break down dyes?

Learning Objective: Investigating the effects of sunlight on dyes, and the types of plastics and exposure time.

Controls and Variables: Intensity of light, different dilution of hydrogen peroxide, exposure time to sunlight and hydrogen peroxide.

Materials and Equipment:

Measuring cups or similar equipment, food coloring, or clothing dyes, tanning lamp or black light, hydrogen peroxide

Safety and Environmental Requirements: Wear safety goggles. Use caution when using high concentrations of hydrogen peroxide. Dispose of waste materials in a responsible manner.

Suggestions: Prepare equal amounts of water add food coloring to water. Expose your solutions to sunlight. Compare this to other solutions with hydrogen peroxide add. Conduct experiments on the hydrogen peroxide and the rate of the breakdown.

3 Can sunlight be used to clean up water?

Learning Objective: Students will investigate how water can be cleaned by the use of sunlight.

Controls and Variables: Sunlight, types of commercial dyes, different catalyst.

Materials and Equipment:

Titanium dioxide (TiO₂), small (3-6mm) glass balls, hot plate to bake the titanium into a coating on the glass balls, pan to hold the slurry. Equipment available from chemical supply houses or hobby stores.

Safety and Environmental Requirements: Safety glasses are needed. Do not ingest any of the materials.

Suggestions: Make the titanium into slurry in the pan. Immerse the glass balls in to the slurry, heat at 60 degrees centigrade until the water evaporates. Add the coated balls to the dye and water mixture place in sunlight. Note the time it takes to remove the color from the solution. Search for information on photocatalytic oxidation. Determine what other contaminants might be candidates for clean up using this method.

4 Make a solar dehydrator

Learning Objective: Investigating the effects of sunlight or heat on drying.

Controls and Variables: Intensity of light, exposure time, different types of dehydrator, and different types of food matter.

Materials and Equipment: Different types of food, materials need to construct the dehydrators.

Safety and Environmental Requirements: Keep hands clean when handling the food.

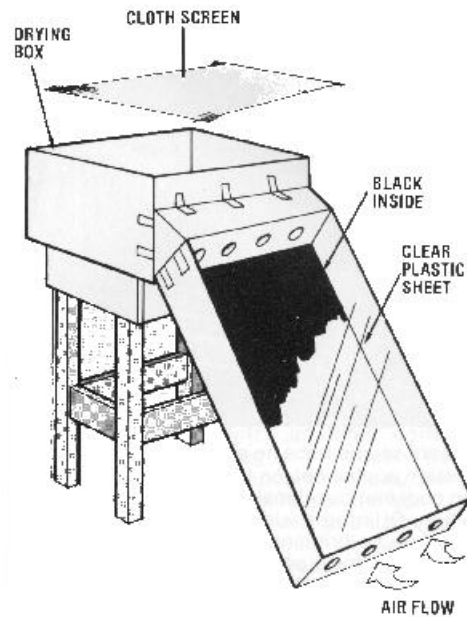

MCP #4

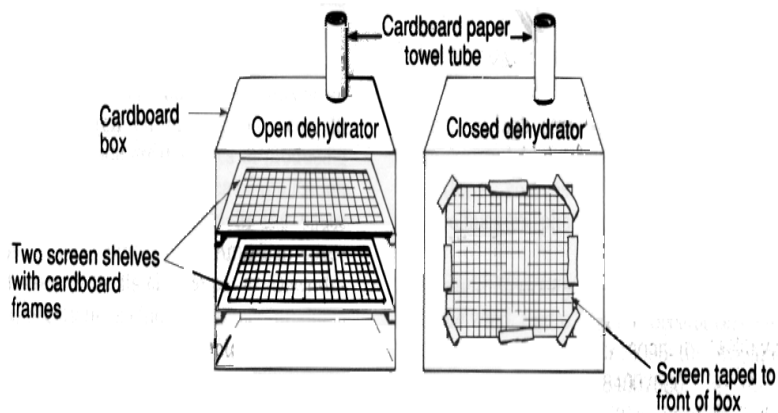

Suggestions: Compare the loss of water in the different types of food. Compare the drying time for different foodstuffs. What food can be dried in this manner and what food cannot be dried? Compare the cost of food prepared this way and purchasing them in a store.

Modeling the Process of Mining Silicon Through a Single-Displacement/Redox Reaction

Andrea Vermeer and Alexis Durow

Course/Grade Level: 10th-12th grade Environmental Science, Chemistry and/or Physics

NSES Standards:

Content Standard A – Science as Inquiry

- Abilities necessary to do scientific inquiry
- Understandings about scientific inquiry

Content Standard B- Physical science

- Structure of atoms
- Structure and properties of matter
- Chemical reactions
- Motions and forces
- Conservation of energy and increase in disorder
- Interactions of energy and matter

Content Standard E- Science and Technology

- Abilities of technological design
- Understandings about science and technology

Content Standard F- Science in Personal and Social Perspectives

- Personal and community health
- Population growth
- Natural resources
- Environmental quality
- Natural and human-induced hazards
- Science and technology in local, national, and global challenges

Content Standard G- History and Nature of Science

- Science as a human endeavor
- Nature of scientific knowledge
- Historical perspectives

Teacher overview:

As the popularity of photovoltaic (PV) cells and integrated circuits (IC) increases, the need for silicon also increases. Silicon is one of the most used materials in these two industries. It is an inexpensive and abundant semi conductor. However, the process of producing pure silicon adds cost and is unfamiliar to the public.

One of the first steps of producing silicon is through a process called carbonthermic reduction. Silicon dioxide (SiO_2) that is found in beach sand and quartz is melted down in a caldron at a temperature of 1450 degrees Celsius. Coke, and other forms of carbon, is then added to the mixture, because at this high temperature, the oxygen has more of an affinity to carbon instead of the silicon. A current is then run through the solution-(See figure 1). As the impurities float to the top of the mixture, carbon monoxide (CO) vaporizes out of the solution and the metallurgical grade silicon (MGS) is siphoned off the bottom. Although there are more steps needed to produce silicon for the IC and PV industries, this initial step may be modeled in a high school laboratory, through a single displacement, redox reaction.

Solar Cells made of silicon.



Figure 1. Carbothermic reduction model

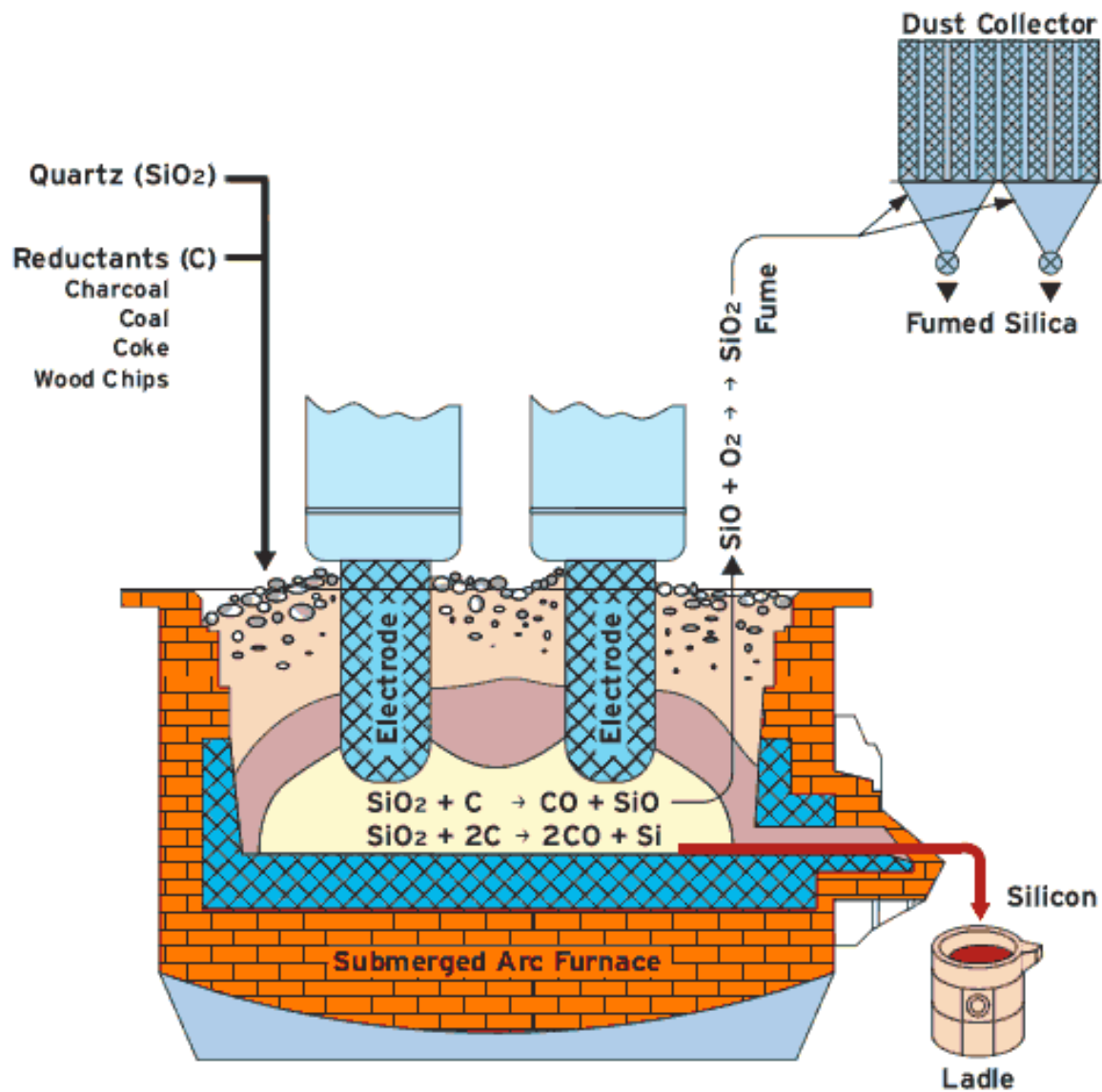

PLEASE NOTE:

This lesson includes ideas for a teacher to use in a variety of topics, including types of chemical reactions, modeling, nature of science and technology, renewable energy sources, semi-conductors and silicon use. However, there will be specific references for use in a *chemistry* class. Use this module as you see fit for your objective. You may introduce this lesson however you see fit, depending on what curricular topics you are covering.

Some suggestions to introducing this lesson:

1. Pass around some computer chips or a circuit board, PV /solar cell, LED's, laser pointers, silicon rubber, silicon wafers or anything else that is a silicon based product. Ask the students what they have in common. Lead them into saying that they all have silicon in them.
2. Ask them where silicon comes from. The students may not know.
3. Do an internet search and find pictures of mining production or any other images that would enhance the lesson. Share these with the students. A good website is <http://www.simcoa.com.au/process.htm>
4. Talk to them about the uses/importance of silicon in the solar energy and computer industry.
5. Discuss what a model is and explain how the lab will be a model of silicon production.
6. Review single displacement and/or redox chemical reactions. Perform a demonstration. An example is magnesium and hydrochloric acid. The reaction would be as follows: $\text{Mg} + \text{HCl} \rightarrow \text{MgCl}_2 + \text{H}_2 (\text{gas})$

This is a short lesson that can be incorporated into a variety of possible topics including:

- Renewable energy sources
- Separation of mixtures
- Modeling and simulation
- Types of reactions (this lesson involves a single displacement and a redox reaction)
- Stoichiometry
- Nature of science and technology

The following could be included if the lesson plan involves actually using a solar cell or a light emitting diode (LED):

- Electricity
- Efficiency of a device
- Conduction/semi conduction
- p-n junctions

Objectives: When finished with this module, students should be able to:

- Compare and contrast various renewable and non-renewable sources of energy, including abundance, cost structure, and environmental impact
- Describe the function of and uses for photovoltaic devices
- Describe the properties of silicon that make it important in the field of photovoltaic and integrated circuits
- Describe the process of mining for silicon
- Perform and describe laboratory that involves a single displacement reaction

Specific Chemistry Objectives:

- Determine the number of moles of copper produced in the reaction of aluminum and copper sulfate
- Determine the number of moles of aluminum used up in the reaction of aluminum and copper sulfate
- Determine the ratio of moles of aluminum to moles of copper
- Determine the number of atoms and formula units involved in the reaction

Time allotted: 1-2 class periods.

Vocabulary (depending on where this lesson fits into the curriculum)

photovoltaic

solar energy

ore

mine

crystal

semiconductor

redox reaction

single displacement reaction

Resource Materials:

Reagents:

copper sulfate (solid)

aluminum (foil or wire)

1.0 molar HCl (*if using the specific chemistry lesson*)

Apparatus:

250 ml-beaker

drying oven

graduated cylinder

wash bottle stirring rod

tongs

ring stand

goggles

lab apron

steel wool

balance

funnel

filter paper

Prerequisite knowledge (depending on where this lesson fits into the curriculum)

Renewable energy, especially solar energy

Semiconductors

Photovoltaic

Modeling

Types of reactions

Stoichiometry

Main activities

The main activity is to carry out a single displacement/redox reaction of copper sulfate (CuSO_4) with aluminum metal (Al) to form copper metal (Cu) and aluminum sulfate [$\text{Al}_2(\text{SO}_4)_3$]. This will model the single displacement/redox reaction of separating silicon (Si) from silicon dioxide (SiO_2). This reaction can also be done using an iron nail instead of aluminum or substituting 1.0 molar copper chloride for copper sulfate. You may also want to do two or all three of these reactions to enhance your lesson.

We suggest having samples of beach sand, quartz, coke (or any other form of carbon) and a piece of silicon and discuss what is being represented in the model (See figure 2).

Figure 2. Schematic of the model.

The following diagram represents this simulation:

(Model)

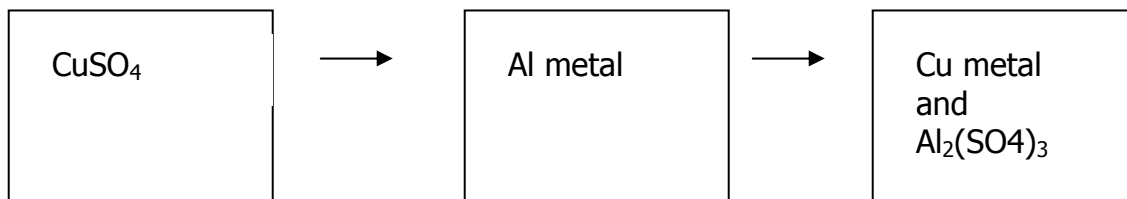

(Real production of silicon)

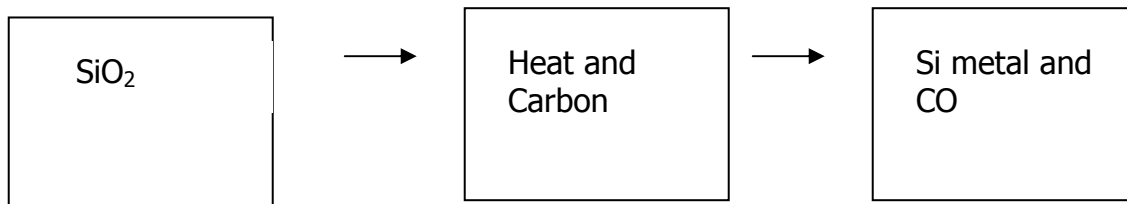

The actual activity that the students will perform is attached to the end of this module. It is written specifically for a chemistry class, so you may need to modify it to fit your lesson.

Evaluation

Specific to chemistry lesson:

1. Determine the number of moles of aluminum used and copper produced.
2. Determine the initial number of moles of copper sulfate
3. Determine the ratio of moles of aluminum used to moles of copper produced.
4. Write a balanced equation for this reaction.

Suggested questions:

You could also have students work in groups and prepare a presentation.

1. Describe and give a history of 'Silicon Valley'.
2. What is a PV (solar cell) and what are its uses? What is possible for the future of PV's?
3. What properties of silicon (or any semi-conductor) make it widely used the field of integrated circuits and solar energy?
4. Describe, illustrate and give an example of a semi-conductor, conductor and insulator.
5. Explain 'renewable energy'. What are other sources, besides the sun? Do you feel it is important for the government to spend money on renewable energy research? Why or why not?
6. Computers are constantly being updated and need to be replaced. What problems can this cause for landfills? What options do consumers and businesses have?
7. Why is knowing the crystal shape of a molecule important to understanding its properties? Describe and illustrate 3 crystal shapes.
8. What is a model? Give an example, other than the one in this lab. Why are models used? (especially in science!)
9. Explain how this lab modeled the production of silicon. Be sure to explain each step and what it is modeling.
10. Describe a single displacement reaction. Write and balance the reaction from this lab.
11. Describe a redox reaction. Explain what is being reduced and oxidized in this reaction.
12. Carbon monoxide is a greenhouse gas that is emitted during this process of producing silicon. Explain what a greenhouse gas is and the problems they can cause. Do you think society or the government should invest in developing more production of silicon to cut down on these emissions? Why or why not?
13. Many other industries use silicon. Name a few and what needs to be done to the MGS to make it useful for their industry.

Student Section:

1. Calculate the grams of CuSO_4 needed to make 50 ml of a 1 molar solution. Show your work here. You may not move on until your teacher has initialed this section.

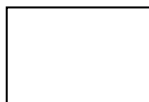

Teacher's initials

2. Read through the lab. Prepare a data table for all of the measurements and calculations you will be performing. You may not move on until your teacher has initialed this section.

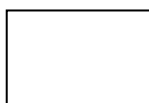

Teacher's initials

3. Place an empty 250 ml beaker on the balance. Tare the balance and add the amount of copper sulfate crystals you calculated in step 1 to the beaker. Record the exact amount.

4. Add 50 ml of deionized water to the beaker. Swirl the beaker around to dissolve all of the copper sulfate crystals.
5. Obtain two clean, dry pieces of aluminum wire. Find the mass of the aluminum and record the mass.
6. Place the nails into the solution and leave them undisturbed for about 20 minutes. During that time, you should see the formation of copper in the beaker. At the same time, some of the aluminum will be used up. Observe and record in your data table what you see.
7. After the reaction is complete, use the tongs to carefully pick up the aluminum, one at a time. Use deionized water in a wash bottle to rinse off any remaining copper from the aluminum before removing them completely from the beaker. If necessary, use a stirring rod to scrape any excess copper from the aluminum. Set the aluminum aside to dry on a paper towel.
8. After the aluminum is completely dry, find the mass of them and record.
9. *Decant* means to pour off only the liquid from a container that is holding both solid and liquid. Decant the liquid from the solid. Pour the liquid into another beaker so that you can still recover the solid if you over pour. (**NOTE:** you may want to use the remaining liquid solution to grow some crystals!)

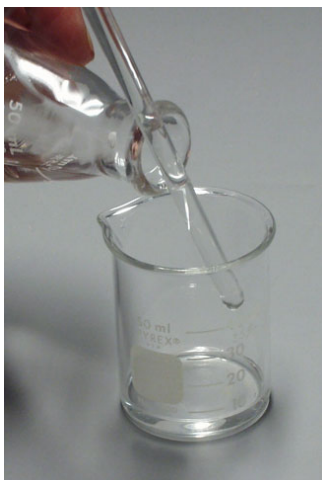

10. After decanting, rinse the solid again with about 25 ml of deionized water. Decant again three or four more times.
 11. Wash the solid with about 25 ml of 1.0 hydrochloric acid. Decant again, then clean the solid with 25 ml of deionized water.
 12. Obtain a piece of filter paper and write your name on it in pencil. Mass the filter paper and record.
 13. Filter the copper and water and allow the water to completely drain. Put the damp filter paper into the drying oven until it is completely dry.
 14. When it is dry, mass the filter paper and the copper and record
 15. Clean up as per your instructor's directions.
- (Optional)** Do a laboratory report.

Teacher's key:

1. Determine the number of moles of aluminum used and copper produced.
final mass of copper(g) x 1mole/63.5g =
final mass of aluminum (g) x 1mole/27.0g=
2. Determine the initial number of moles of copper sulfate.
8.1gx 1mole/162.5g = .05 moles
3. Determine the ratio of moles of aluminum used to moles of copper produced.
2 moles Al: 3 moles Cu
4. Write a balanced equation for this reaction.
 $3 \text{CuSO}_4 + 2 \text{Al} \rightarrow \text{Al}_2(\text{SO}_4)_3 + 3 \text{Cu}$

From the student section:

1. $50\text{ml} \times 1\text{L}/1000\text{ml} \times 1\text{mol}/1\text{L} \times 162.5 \text{ grams}/1\text{mol} = 8.1 \text{ grams}$
2. An example of a data table could look like this:

	Mass (g)	Observations
Initial copper sulfate		
Initial aluminum metal		
Final aluminum metal		
Δ aluminum metal		
Final copper metal		

Suggested questions:

1. Describe and give a history of 'Silicon Valley'.
(Answers may vary).
<http://www.siliconvalleyonline.org/history.html>.
2. What is a PV (solar cell) and what are its uses? What is possible for the future of PV's?
(Answers may vary).
A solar cell is a devise that is produced to take light energy from the sun and transfer it into electrical energy. It is used to generate electricity for the use in a home, small electrical devices and some cars (in conjunction with another form of energy). In the future, entire cities could be powered on solar cells, and many forms of transportation could be powered by solar cells.
3. What properties of silicon (or any semi-conductor) make it widely used the field of integrated circuits and solar energy?
Semi-conductors have a wide enough band gap that allows them to produce a sufficient amount of energy when a p-n junction is formed. They also can easily be doped, to improve their efficiency.

4. Describe, illustrate and give an example of a semi-conductor, conductor and insulator.

In an insulator, there is a large potential between the conduction and valence band (> 4 eV), in a semi-conductor potential is between 1 and 2 eV, and in a conductor the eV is << 1.

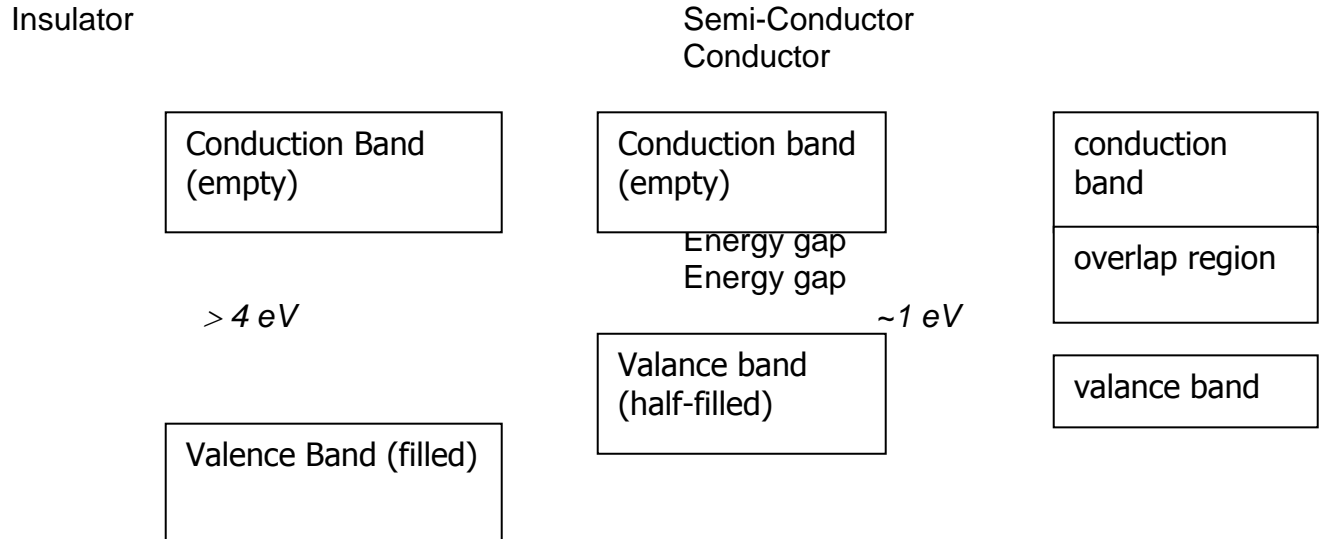

An example of an insulator is diamond, a semi-conductor is silicon and a conductor is copper.

5. Explain 'renewable energy'. What are other sources, besides the sun? Do you feel it is important for the government to spend money on renewable energy research? Why or why not?

Renewable energy is a form of energy that can be replaced at a faster rate than it is used. Other sources of renewable energy are wind, geothermal, biomass, tidal and hydrogen.

(Answers may vary).

6. Computers are constantly being updated and need to be replaced. What problems can this cause for landfills? What options do consumers and businesses have?

They are taking up a lot of space in the landfills, are made with materials, such as gold and copper, that could be recycled and they leak toxic metals such as cadmium, chromium, lead and mercury. Customers and businesses have the option to take their old computers to be recycled or donated.

7. Why is knowing the crystal shape of a molecule important to understanding its properties? Describe and illustrate 3 crystal shapes.

*The crystalline shape of a molecule determines its properties and characteristics. There are 6 main shapes are: **Isometric (or Cubic), Hexagonal, Rhombohedral, Tetragonal, Orthorhombic, Monoclinic, and Triclinic***

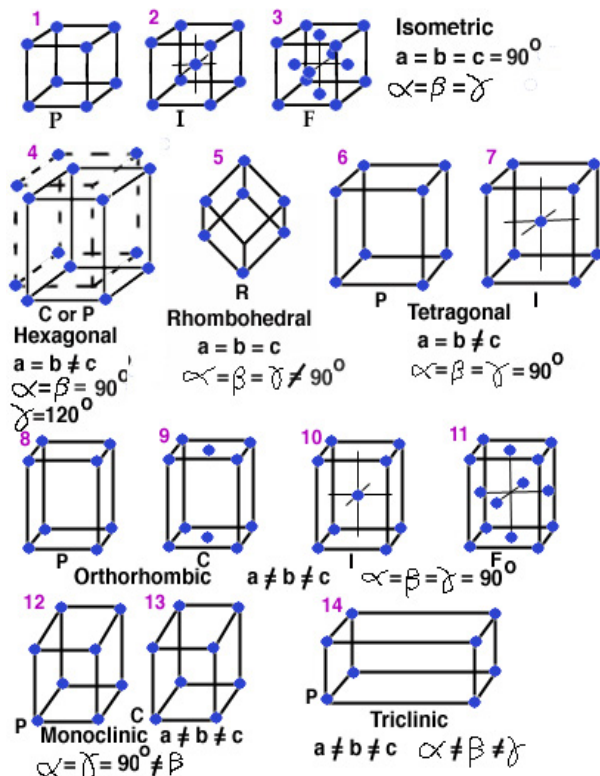

8. What is a model? Give an example, other than the one in this lab. Why are models used? (especially in science!)
 A model is a representation of a process or structure that is too small or too large to see with the human eye.
(Answers may vary). Another example of a model is a map. Many concepts, especially in science are too small or large to be studied with the human eye. Models are made so that these concepts can be studied and taught.
9. Explain how this lab modeled the production of silicon. Be sure to explain each step and what it is modeling.
Refer to Figure 2.
10. Describe a single displacement reaction. Write and balance the reaction from this lab.
(Answers may vary). $A + BC \rightarrow AC + B$
 $3 \text{CuSO}_4 + 2 \text{Al} \rightarrow \text{Al}_2(\text{SO}_4)_3 + 3 \text{Cu}$
11. Describe a redox reaction. Explain what is being reduced and oxidized in this reaction.
A redox reaction involves the reduction of one element and the oxidation of another. In this reaction, the copper is being reduced and the aluminum is being oxidized.
12. Carbon monoxide is a greenhouse gas that is emitted during this process of producing silicon. Explain what a greenhouse gas is and the problems they can cause. Do you think society or the government should invest in developing more production of silicon to cut down on these emissions? Why or why not?

A greenhouse gas is a gas in the atmosphere that traps thermal energy. If too many greenhouse gasses are in the atmosphere, global warming can occur.

(Answers may vary).

13. Many other industries use silicon. Name a few and what needs to be done to the MGS to make it useful for their industry.

(Answers may vary). Other industries that use silicon are steel, petroleum, rubber, caulking and medical. The MGS must be purified and grown into perfect crystals in order to be used.

Utilizing Photovoltaic Cells and Systems

For the Teacher

As teachers, we want students to learn about energy, how we use it, and where it comes from. It is important that students become aware of both renewable and nonrenewable forms of energy resources so that as they grow into adults, they can be informed citizens and can make good choices about the resources they use.

One renewable resource that many of us use today is solar energy. Solar energy is used in residential homes, industrial applications, central power stations, commercial buildings, etc. Students may know a little about solar energy as many of their homes may use solar panels for heating/cooling purposes. The following projects allow students to set up their own investigations and manipulate variables surrounding photovoltaic cells. These projects can be easily integrated into a normal science classroom curriculum, or can be completed by students individually for science fair projects.

All of the projects listed will fit easily into classroom lessons surrounding scientific inquiry and the scientific method. The projects will also help illustrate concepts in electricity, light and color, velocity and gravity, chemistry and polarity, and could even lead to social studies or social action projects.

At NREL today, scientists are researching ways to make solar energy easier and less expensive to use. The authors of this section are studying different transparent conducting oxides

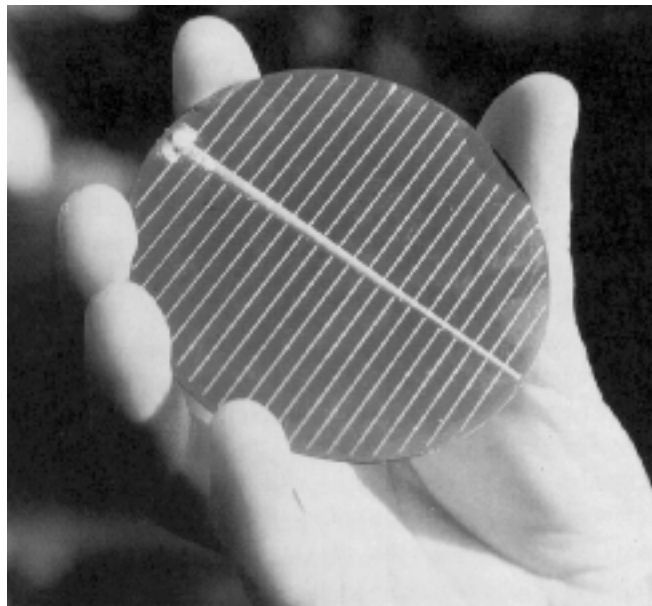

(the semiconductors on the surface of photovoltaic cells) to find the best possible materials for harnessing the sun's energy.

National Science Education Standards by the National Academy of Sciences

Science Content Standards: 5-8

Science As Inquiry

– Content Standard A:

“Abilities necessary to do scientific inquiry”

“Understandings about scientific inquiry”

Physical Science

– Content Standard B:

“Transfer of energy”

Earth and Space Science

– Content Standard D:

“Earth in the solar system”

Science and Technology

– Content Standard E:

“Abilities of technological design”

“Understandings about science and technology”

Science in Personal and Social Perspectives

– Content Standard F:

“Science and technology in society”

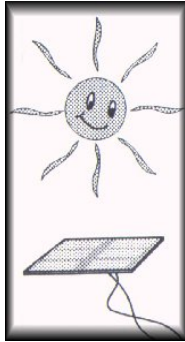

Technology Description

In 1839, at age nineteen, French scientist Edmund Becquerel was the first person to observe an extraordinary and very useful phenomenon called the photovoltaic effect. The photovoltaic effect is the process that occurs when photons, or particles of energy in a beam of sunlight, hit atoms in semiconductors knocking electrons loose, which makes electrical current possible.

Semiconductors are materials that allow electric currents to flow through them under certain conditions. Semiconductors are neither excellent conductors (like copper wiring) nor are they excellent insulators (like glass or plastic), but have properties somewhere in the middle. Semiconductors are used in photovoltaic cells (sometimes referred to as PV cells or solar cells), computers, windows, etc.

Although Becquerel discovered the photovoltaic effect in the 1800's, solar cells were not produced until the mid

1950's. In 1954, the first crystalline silicon cell was created in Bell Laboratories in the United States. This cell was 4.5% efficient meaning that it only turned 4.5% of the sun's energy into electricity.

Today's PV cells are made of several layers of semiconductor material. On the bottom of the cell is a layer of a conductive metal, and on the top is an additional conductive film. When sunlight strikes the upper semiconductor layer, photons excite electrons in the semiconductor, causing them to migrate to the next layer. As you probably know, electrons have a negative charge. When they move to the next layer, they leave a positively charged hole behind. When the excited electron reaches the surface of the cell, it moves through the external circuit and returns to the opposite layer to fill in the positively charged hole. This creates electricity.

You may have seen photovoltaic cells and modules on people's homes and businesses. These cells are capturing the sun's energy and changing it into electricity for us to use. Buildings are not the only place where photovoltaic cells are used. The sun powers illuminated warning signs on many highways and almost every American space satellite uses PV for its electric power!

You may be asking yourself why we would want to use the sun's light for electricity when we have so many other energy resources. The answer is that *every day* more solar energy falls to the Earth than the total amount of energy the planet's 6.1 billion inhabitants would consume in 27 years. In other words, there is plenty of sunlight to go around and we won't run out of it until the sun dies (which is not expected to happen for

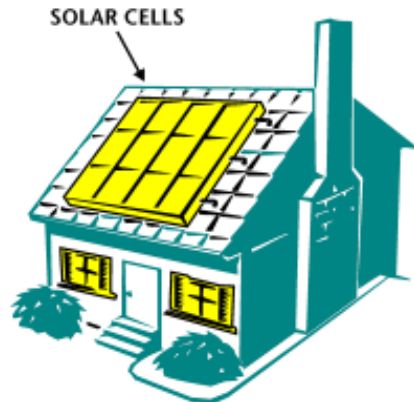

another 4.5 billion years). This makes the sun a renewable resource.

Today scientists continue the quest for an economical system for converting sunlight to electricity. Scientists want to make energy from the sun cheaper for us to use in our homes and businesses so that we can decrease our nonrenewable energy use.

Resources:

U.S. Department of Energy PV Home Page
<http://www1.eere.energy.gov/solar/photo voltaics.html>

How Stuff Works
www.howstuffworks.com/solar-cell.htm

Florida Solar Energy Center
www.fsec.ucf.edu/pvt/

Roofus' Solar Home
<http://www1.eere.energy.gov/kids/roofus/>

Solar Energy
<http://www.eia.doe.gov/kids/energyfacts/sources/renewable/solar.html>

SunWind
<http://sunwindsolar.com/>

Resources for the following projects: PV and Electrical Measuring Supplies

PV cells: (please note that when searching for PV cells on the internet, use key words "solar cells")

www.scientificsonline.com (click on solar energy tab, click on solar cells (contains low-cost solar cells to be assembled)

<http://www.solarnature.com/education1.html> (many choices at many prices)

radio shack stores or
www.radioshack.com

<http://www.solar-world.com/default.htm>
(many choices – prices range from \$8.00-\$16.00)

Resistors (1 ohm to 1 megaohm):

radio shack stores or
www.radioshack.com - be sure to get a low watt resistor for safety purposes (Cat#'s 271-1116 and 271-1108 are fine - they are \$0.99 each)

Voltmeters:

www.nebraskascientific.com (use the site search option and type voltmeter - \$15.95)

Multimeters:

www.nebraskascientific.com (use the site search option and type multimeter - \$33.50)

www.cs-sales.com (do a search on the site - options range from \$7.95-59.95)

Project Ideas

1 What is the output of a photovoltaic (PV) cell?

Learning Objective: You will be able to measure and find out for yourself just how much energy (voltage) a photovoltaic cell can create simply by placing it in front of a light source!

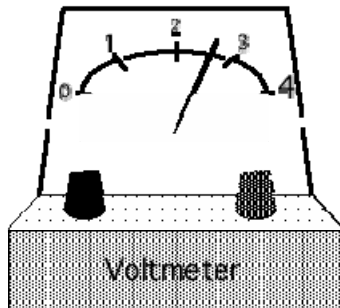

Controls and Variables: light intensity, distance from PV cell to light source, load (resistor or light bulb)

Materials and Equipment:

PV cells:

(see resource section)

Resistors (1 ohm to 1 megaohm):
(see resource section)

25W-100W Light bulbs:
grocery store (\$0.75-\$1.00 each)

Voltmeter:
(see resource section)

Multimeter:
(see resource section - this equipment is not absolutely necessary for this project, but it allows you to measure both voltage *and* current.)

Safety and Environmental

Requirements: *Even if you wear sunglasses, DO NOT look directly at the reflected image of the sun. Bulbs can get hot! The PV cell is most likely brittle; handle it with care. Also, be sure to follow all instructions on the voltmeter or multimeter carefully because you are dealing with electricity.*

Suggestions: Connect the resistor and voltmeter (or multimeter) to PV cell leads (leads may have to be soldered on with low-temperature solder.) Try 25W, 40W, etc., bulbs at a fixed distance from the PV cell to the light source and record voltages of each bulb. Then try one bulb at several distances. Also, try a fixed distance with one bulb, but hook up a load to be powered by the PV cell. Measure the voltage drop across the load and the current to the load. Calculate the power generated by: $\text{power} = \text{current} \times \text{voltage}$ (or $\text{power} = \frac{\text{voltage}^2}{\text{resistance}}$).

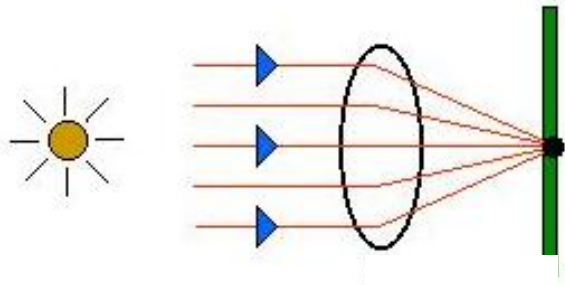

2 How does concentrating the sunlight affect the output from a solar cell?

Learning Objective: You will be able to determine for yourself whether concentrating light with mirrors and/or Fresnel lenses (special lenses used in car headlights, overhead projectors, and spotlights with a short focal length) affects output from a solar cell.

Controls and Variables: Intensity of light, size of concentrating mirrors, angle of mirrors

Materials and Equipment:

PV cell: (see resource section)

Mirrors or aluminum foil:

www.carolina.com (search for mirrors, go to page 3 of 4, prices range from about \$5.00 to \$18.00 for a set of mirrors)

Hardware store or grocery store (range of prices)

Voltmeter:

(see resource section)

Multimeter:

(see resource section - this is not absolutely necessary for this project,

but it allows you to measure voltage *and* current.)

Flashlight bulbs:

Hardware store (range of prices)

Fresnel Lens:

www.sciplus.com (do a search for Fresnel lenses – a variety exist between \$0.75 and \$1.25).

Hardware store (range of prices)

Safety and Environmental

Requirements: Concentrated sunlight can be extremely dangerous to the naked eye. *Even if you wear sunglasses, DO NOT* look directly at the reflected image of the sun. Also, light bulbs can get hot! The PV cell is most likely brittle-handle it with care. Also, be sure to follow all instructions on the voltmeter or multimeter carefully because you are dealing with electricity.

Suggestions: Measure the voltage (amount of potential energy in the electricity) between cell connections from a plain solar cell in the sun. Next, put mirrors around the cell to reflect more light back onto it. Try several positions and foil shapes. How is the voltage affected? Hook a flashlight bulb to the solar cell and see which combination of mirrors and foil you have created causes the bulb to shine the brightest. Try a Fresnel lens to concentrate the sunlight.

(For information about Fresnel lenses, go to www.howstuffworks.com and do a search for Fresnel lenses.)

3 Does a tracking PV system collect more energy than a stationary system?

Learning Objective: For this project, you will be able to see whether tracking, or following the sun with your PV system, increases or decreases its energy output.

Controls and Variables: Tracking speed, tracking angle

Materials and Equipment:

PV cells:
(see resource section)

Voltmeter:
(see resource section)

Multimeter:
(see resource section - this is not absolutely necessary for this project, but it allows you to measure voltage *and* current.)

Resistors (1 ohm to 1 megaohm):
(see resource section)

Tripod or other support system:
www.carolina.com (do a search on the catalog for tripods – prices range from \$10.50 and up)

Photo shops

Safety and Environmental

Requirements: *Even if you wear sunglasses, DO NOT look directly at the sun. To aim the PV cell at the sun, point the cell towards the sun and adjust the cell until its shadow is as small as possible. The PV cell is most likely brittle; handle it with care. Also, be sure to follow all instructions on the voltmeter or*

multimeter carefully because you are dealing with electricity.

Suggestions: Connect a resistor (1-10 ohms) to the two wires of the PV cell. Measure the voltage drop across the resistor with each position of the tracker. Adjust the tracker periodically (every 15, 30, or 60 minutes) and see which way gives the most power. Compare to a fixed PV cell. Remember, power(watts) = $\text{voltage}^2/\text{resistance}$. If you would like, try making an automatic tracking device.

4 How long does the sun spend behind clouds each day?

Learning Objective: Using a PV cell, you will be able to tell your friends about how much time the sun spends behind clouds each day!

Controls and Variables: Size of PV cell, type of clock

Materials and Equipment:

Several PV cells of different sizes:
(see resource section)

DC powered clock (any battery powered analog clock):

Grocery store (range of styles and prices)

Hardware store (range of styles and prices)

High Gauge Wire:

www.radioshack.com or radioshack store

Hardware store (range of styles and prices)

Safety and Environmental Requirements: *Even if you wear sunglasses, DO NOT look directly at the sun. To aim the PV cell at the sun, point the cell towards the sun and adjust the cell until its shadow is as small as possible.*

Suggestions: Be sure to get a clock that requires only the voltage available from the PV cell. If you need more voltage, hook several PV cells together in series. When the sun shines, the clock will run. If the clock runs when the sun is behind a cloud, try putting the PV cell(s) in the bottom of a tall tube or box and aiming it directly at sun. (See diagrams.) This will cut out indirect light. This sunshine time could be used in conjunction with some of the projects in the Process Heat and Electricity section of this book.

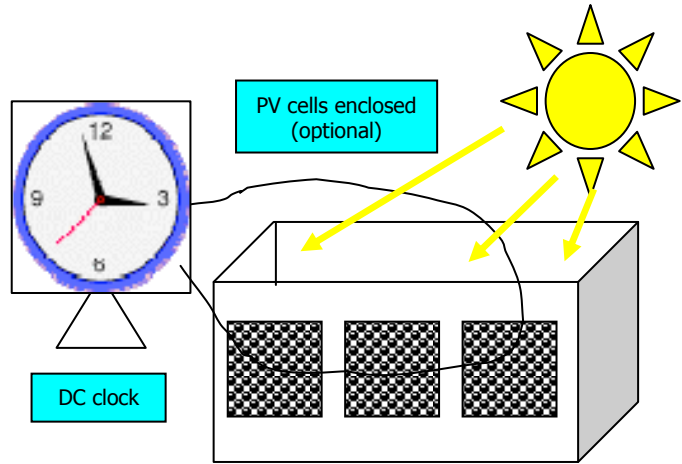

5 How fast can a solar powered car go?



Learning Objectives: You will be able to design and build a car powered only by the energy from the sun! Calculate the speed of your car. Compare it to a gravity-powered car.

Controls and Variables: Light intensity, weight of cars, size of the solar panel and motor.

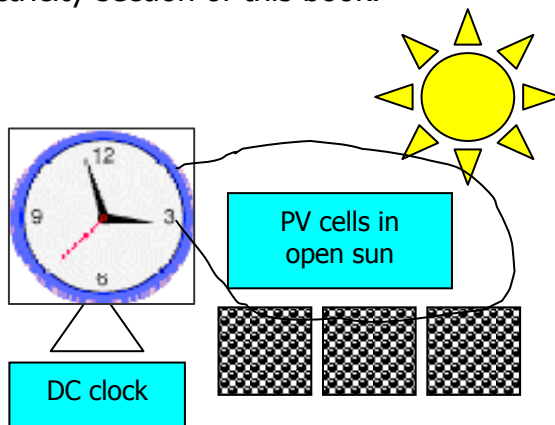

Materials and Equipment:

Gears, rods and electric motor:

Junior Solar Sprint suppliers (<http://www.solar-world.com/default.htm>) have kits with wheels, gears, rods, and motors for your car.

- Gears Wheels and rod kit = \$4.00
- Motor and accessories = \$3.25

Balsa Wood & Glue (for the car frames):

Any crafts or hobby store

PV cell:

Junior Solar Sprint suppliers (<http://www.solar-world.com/default.htm>) have PV cells especially built for make a solar car.

- PV cell = \$28.00
- PV cell and motor = \$30.00

Stopwatch:

Any sporting goods store = \$5.00 - \$10.00

Measuring tape:

Any hardware store

Safety and Environmental Requirements: None

Suggestions: Demonstrate the differences between a solar powered car and a gravity powered car by racing them from the top of a hill. Make sure the two cars weigh the same.

6 Is it practical to store the energy produced from a PV cell in a tank of water?

Learning Objectives: Design, build and test a water storage machine that uses the energy produced by a PV panel to indirectly power a light bulb or other electrical devices. (Wires from the PV panel cannot touch the electrical device).

Controls and Variables: Size and angle of the PV panel, height of water storage, and the resistance of the electrical device.

Materials and Equipment:

PV panel: Several PV cells connected in series to produce 50 W or greater. See resource section

Small Electric Water Pump:

<http://www.hobbylinc.com/> (do a search for "water pump"- \$10.00)

Small Electric Generator:

(*Electric motor hooked up backwards*) www.radioshack.com or radioshack store

Water Wheel that can attached to the Generator:

Two water storage tanks or buckets:

Any home improvement store

Plastic tubing:

Fish aquarium store

6 m of 14 gauge electrical wire:

www.radioshack.com or radioshack store

Electric load (light bulb, radio, etc.):
www.radioshack.com
or radioshack store

Safety and Environmental Requirements: *Even if you wear sunglasses, DO NOT look directly at the sun.* Be careful not to have any electrical wires touching the water. A short circuit will occur causing an electric shock. You can get hurt and your electrical devices could be damaged. Be careful of the sharp edges of the water wheel. Be careful not to over power any of the electrical devices (load). You can use a multimeter to check the voltage and current of the power supply. Compare the measurement to the load specification before connecting power supply to the load.

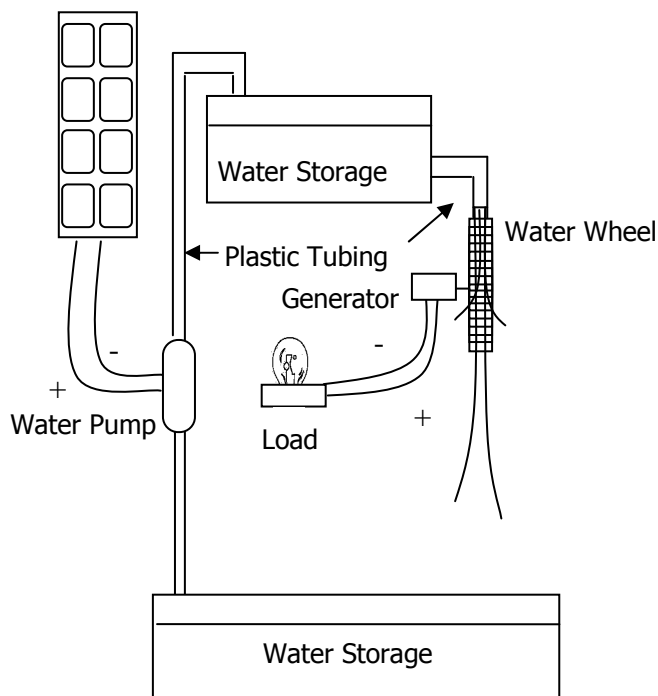

Suggestions: Try connecting load directly to the PV panel, then try connecting the load through the water wheel generator. Which way works the

best and why? Try varying the height of the top water storage and the generator. Does it make a difference?

7 How does a photovoltaic (PV) solar cell respond to different wavelengths (colors) of light?

Learning Objective:
You will learn the affects of different colored light on PV cell output.



Controls and Variables:
Wavelength (color of light), voltage, current, resistance

Materials and Equipment:
Several types of PV cells (crystalline silicon, amorphous silicon, copper indium diselenide, gallium arsenide if available - see resource section)

Color filters:
Grocery store – colored plastic wrap

Hobby store – colored cellophane or polypropylene

www.papermart.com - click on the "film" section, go to colored polypropylene section (prices range from \$4.85 - \$100.00 depending on how much you want)

Incandescent bulb:
Grocery store or Hardware store (\$0.25-\$1.00)

Fluorescent bulb:
Hardware store (\$6.00-\$8.00)

Voltmeter/ammeter/multimeter:
(see resource section)

Resistors (1 ohm to 1 megaohm):
(see resource section)

Safety and Environmental

Requirements: Bulbs will be hot! Also, *Even if you wear sunglasses, DO NOT* look directly at the sun!

Suggestions: Try different light sources and record current (how many electrons pass by a point in a certain amount of time) and voltage output. Try several filters and record current and voltage output. Try several resistors and record current and voltage output. Try different types of solar panels, if available, and repeat the above three actions.

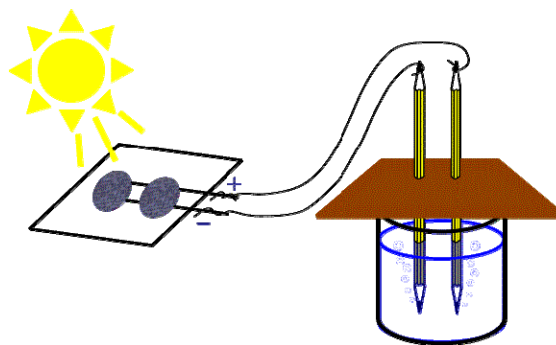
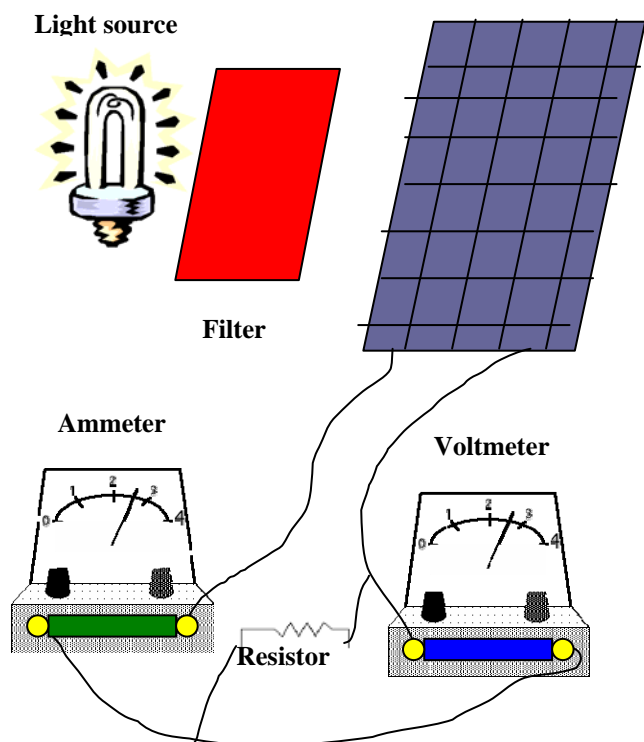

8 Can sunlight be used to split the water molecule, producing hydrogen?

Learning Objectives: Use the energy produced by a PV cell or panel to break up water molecules into oxygen and hydrogen. Test for and determine the ratio of oxygen to hydrogen produced.

Controls and Variables: Size and angle of the PV panel, and type of electrodes

Materials and Equipment:
PV cell or panel (A PV panel is just several PV cells connected in series to produce greater voltage):

Electrolysis kit:

(Kit must contain at least a set of electrodes and wires)

<https://www1.fishersci.com/index.jsp>

Pack of two \$19.95

Beaker (if not part of electrolysis kit):

<https://www1.fishersci.com/wps/portal/HOME> Pack of 12, 250 ml for \$44.75

Two Test tubes (if not part of electrolysis kit):

<https://www1.fishersci.com/wps/portal/HOME> Pack of 100 for \$28.00

Popsicle sticks: Any discount store

Safety and Environmental

Requirements: *Even if you wear sunglasses, DO NOT look directly at the sun!* Always wear some type of eye protection when testing for flammability.

Suggestions: Use the PV cell/panel as the power source for the electrolysis kit. Test flammability of the two gases formed with a lit/glowing Popsicle stick. Oxygen should make a glowing stick shine brighter. Hydrogen should ignite and make a popping sound with a lit stick.

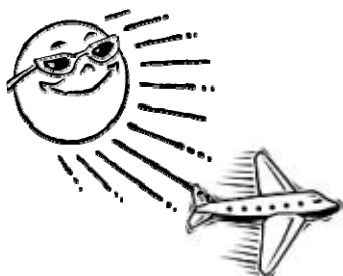

9 Can an airplane be powered only by the energy from the sun?

Learning Objectives: You will be able to design, build and fly an airplane powered only by the energy from the sun! Test how long it can fly.

Controls and Variables: Light intensity, weight and size of airplane, size of the solar panel and motor.

Materials and Equipment:

Flying airplane model kit:
www.guilow.com \$7.00-\$15.00

PV panel or cell:
(see resource section)

Electric motor:
www.radioshack.com or radioshack store

Stopwatch:
Any sporting goods store = \$5.00 - \$10.00

Safety and Environmental

Requirements: Be careful of the spinning propeller.

Suggestions: Build a flying airplane model. Use the electrical motor instead of the motor from the kit. Attach PV cell to the top of the wing and connect it to the electric motor. Try to keep the total weight of your airplane to minimum.

More Project Ideas

How does the angle of the sun affect the output of a solar cell?

How does the magnification of a light source affect the electrical output of a solar cell?

What is the effect of temperature on a PV cell?

Which delivers more power to a motor; two solar cells in series or two solar cells in parallel?

Can a model boat be powered with energy from the sun?

References:

Science Projects in Renewable Energy and Efficiency, 1990

www.nrel.gov

Photo References:

http://www.nmsea.org/Curriculum/7_12/electrolysis/electrolysis.htm

www.shodor.org/succeed/projects/hi/skath

<http://enrich.sdsc.edu/SE/opticsfresnel.html>

www.solazone.com.au/tracker.htm

www.physics.emich.edu/phy110/circuits.htm

www.fcpud.com/images/energy%20bulb.gif

Photosynthesis and Biomass Growth

For the Teacher

Today, corn plants are being used to create a renewable energy source called ethanol. Ethanol is used in our gas tanks to power our cars and is one of the leading alternatives to natural gas. We all know that Earth's fossil fuel supply is finite so fuels like ethanol provide an alternative to petroleum. Biomass research is the starting point for alternative fuel production. IREL's Biofuels Program, is uncovering ways to convert biomass into innovative materials, such as fuel, paper. In addition, biomass research is necessary for efficient food production and for understanding the numerous other products that plants provide.



Introduce your students to the power of plants! Photosynthesis is arguably the most important energy transformation and is a fundamental concept for students of all ages. Projects listed in this section should be used as an exciting starting point for both classroom and science fair projects. Most of the materials are easily obtainable at your local home or garden center. We encourage you to modify the experiments to fit your curriculum needs.

National Science Education Standards by the National Academy of Sciences

Science Content Standards: 5-8

Science As Inquiry

- Content Standard A:

"Abilities necessary to do scientific inquiry"

"Understandings about scientific inquiry"

Life Science

- Content Standard C:

"Regulation and behavior"

"Populations and ecosystems"

"Diversity and adaptations of organisms"

Science and Technology

- Content Standard E:

"Abilities of technological design"

"Understandings about science and technology"

Science in Personal and Social Perspectives

- Content Standard F:

"Personal health"

"Populations, resources, and environments"

"Natural hazards"

"Risks and benefits"

"Science and technology in society"

Science Content Standards: 9-12

Science As Inquiry

- Content Standard A:

"Abilities necessary to do scientific inquiry"

"Understandings about scientific inquiry"

Life Science

- Content Standard C:

- "Interdependence of organisms"
- "Matter, energy, and organization in living systems"

Science and Technology

- Content Standard E:

- "Abilities of technological design"
- "Understandings about science and technology"

Science in Personal and Social Perspectives

- Content Standard F:

- "Personal and community health"
- "Population growth"
- "Natural resources"
- "Environmental quality"
- "Natural and human-induced hazards"
- "Science and technology in local, national, and global challenges"

Technology Description

Why are plant leaves green? How do plants get energy to live? Do plants "breathe"? All of these questions can be answered with one idea, **photosynthesis**. Photosynthesis is a process where plants take the sun's light energy and change it into **glucose**, a kind of sugar. A green chemical in the in plant leaves, called **chlorophyll**, makes it all happen and gives plants their green color.

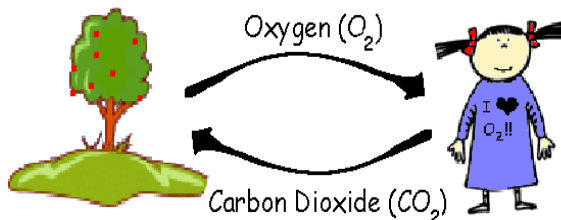

When you breathe, your body uses oxygen (O₂) and gives off carbon dioxide (CO₂). Since all animals breathe in oxygen, why don't we ever run out? During photosynthesis, plants use carbon dioxide and release oxygen, so animals and plants have a **symbiotic** relationship; we rely on each other to survive!

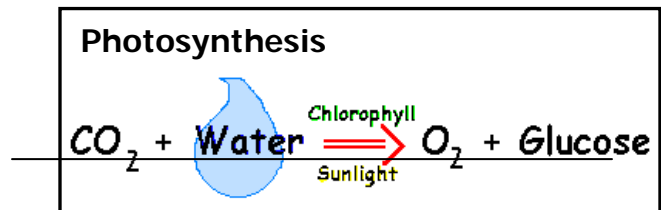

Plants, trees and aquatic algae all create energy (in the form of glucose) through photosynthesis. Since people can't make their own energy from the sun, we eat food instead. We can use the energy stored in plants in other ways too! Scientists are interested in **biomass** energy for things such as fuel for your car. Biomass can be found all over the world and there is an endless supply since it can keep growing! Such things as corn stalks that are leftover from harvesting and forest brush that may cause a fire hazard can be converted into fuels. These biomass fuels burn cleaner than gas or oil does, so it is also safer for the environment. The only problem is that right now, biomass fuels are not as economical (or cheap) as we would like. Scientists are trying to find ways to grow biomass in ways where they can get the most energy with the lowest cost. Can you discover some ways in which we should grow biomass? Use the

ideas below or come up with your own!

Resources:

Arizona State University photosynthesis research

<http://photoscience.la.asu.edu/photosyn/default.html>

Department of Energy biomass site

<http://www1.eere.energy.gov/biomass/>

Department of Agriculture biofuel site

http://ttic.nal.usda.gov/nal_display/index.php?info_center=6&tax_level=1&tax_subject=318

State of Florida Agricultural Science

<http://www.florida-agriculture.com/PlanetAg/>

Vocabulary

Biomass: Plant material, vegetation, or agricultural waste used as a fuel or energy source.

Chlorophyll: Green pigment in the Chloroplast that aids in creating sugar (glucose) from sunlight.

Chromatography: A process used to separate mixtures by differences in absorbency.

Control: A standard of comparison for checking or verifying the results of an experiment.

Ecosystem: Organisms and their environment functioning as a whole.

Glucose: Sugar created in photosynthesis and the main energy source for our bodies. ($C_6H_{12}O_6$)

Interdependence: Relying on each other.

Photosynthesis: "Putting together with light." This process uses sunlight to create chemical energy (sugar) in plants and some other organisms.

Pigment: Coloring or dye. Chlorophyll is a green pigment.

Pollutants: Waste material that contaminates air, soil or water.

Symbiotic: Organisms mutually needing or helping each other.

Variable: Something that is changed.

Wetland: A lowland area, such as a marsh or swamp that is saturated with moisture.

Project Ideas

1 How do modern farming techniques affect the growth of biomass?

Learning Objectives: The population of the Earth continues to grow about 7.4 million people a year, reaching 6.3 billion people in 2003 ([HTTP://WWW.CENSUS.GOV/](http://www.census.gov/)). That is a lot of mouths to feed! With new advances in science and technology,

we are able to create crops that are bigger and better through genetic alterations, pesticides, new fertilizers and synthetic (or fake) hormones. As the population of the world continues to increase and farming area decreases, there is a widespread need for farmers to produce "miracle crops." This project will help you discover and understand the benefits and problems that arise with crop modifications.

Control and Variables: In this project, you will be selecting one or more modern farming technique to look at more closely. You can choose to do several, however you must remember that you will need to have a control set-up so that you can compare your results to the control (the control would have no modifications). To start, you would want to set up one growth chamber (like an aquarium or large glass container) with several plants and a modern farming technique. Set up another growth chamber the same as the first, but do not add a modern farming technique. Then you can compare the two results.

You may also choose to do more than one modification, such as "how do pesticides and hormones affect plant growth." In this case, be sure to have a control with no modifications, a control with just pesticide treatment and another with just hormone treatment. This way you can see what changes occurred when they were separate and which ones only occur when they are used together.

Materials and Equipment:

Growth Chambers (2 minimum)

Plants (3-4 per growth chamber)

Scale

Choose one or more of the following:

Plant hormone (Gibberellin: Sigma \$25.00)

"Miracle Grow" (All purpose fertilizer: Home Depot \$4.00)

Pesticides (Ortho Insect and Disease Control: Home Depot \$14.00)

Safety and Environment

Requirements: When using materials such as insecticides and hormones, gloves and safety glasses should always be worn. Some plant hormones, such as Gibberellin, are poisonous, so should not be used on food plants that will be eaten. With all experiments, be sure to wash hands thoroughly after application and handling.

Suggestions: Since you will want to look for changes in growth, plants in the different growing chambers should be as similar as possible. You can use a scale to weigh biomass before and after the experiment. Regular observations will identify other changes as well, so a journal will help to keep track of changes such as colors, leaf conditions, general appearance and smell.

Other Ideas: After you have looked at the affects of a modern farming technique on your plant species, try a different species, such as a food plant or a flowering plant. Are the effects the same as what you saw before?

How do aquatic plants react to the same variable?

There are also other ways to avoid pests, such as biological controls. This is when a predator of the pest is brought into the area to get rid of the problem. What are the risks and advantages to this method? Would they be less risky? Would this method be as quick or cost efficient as a pesticide?

In addition, consider having a discussion about genetically engineered food crops, such as those that produce their own pesticides. Should they be used for food? What is the controversy between organic and non-organic products? How do your results make you feel about these issues?

Resources:

Carson, Rachel (1962) Silent Spring

Note: *This book may not be appropriate for all age levels*

EPA fact sheets and current pesticide information:

<http://www.epa.gov/pesticides/>

Current issues and problems facing the use of pesticides:

<http://www.beyondpesticides.org>

2 Is natural sunlight, imitation sunlight, fluorescent light or incandescent light best for plants?

Learning Objectives: In this activity, students observe how sunlight separates into a variety of colors when passed through a prism, and these visible colors correspond to different wavelengths in the electromagnetic spectrum. Plant

pigments reflect or absorb the wavelengths resulting in the wide variety of plant color. In this experiment, discover what happens when plants are grown under various types of light. Will different light sources generate a change in the size, color and rate of the growth responses?

Control and Variables:

Control- Plant type, temperature, amount of light, and planting medium should all be the same. Collect the data at the same time for all plants.

Variables- Different types of light. Water according to the plants needs.

Materials and Equipment:

Prism (www.boreal.com, \$6.00)

Light fixtures (Home Depot, \$10.00 each)

Grow light bulb (Home Depot, \$10.00 each)

Fluorescent bulb

Incandescent bulb

Rapid radish seeds (www.boreal.com, \$10.00/50)

16 mini peat plant pots

Potting Soil

Labels

Graph paper

Sample Data Table

DATE	HEIGHT	COLOR	NUMBER OF LEAVES

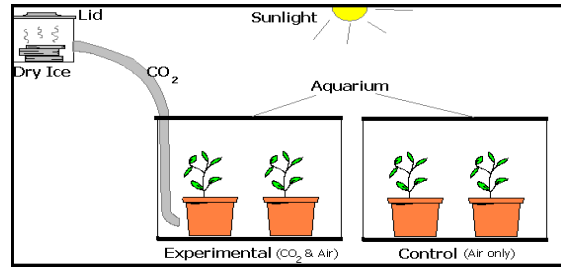

Safety and Environmental

Requirements: Electrical shocks and SERIOUS INJURY CAN OCCUR if the light fixtures are mishandled. Adult supervision is necessary!

Suggestions:

- Grow four radish seedlings under each light source. Collect data after germination for 3-6 weeks.
- You are encouraged to run this experiment with a variety of plant types, such as coleus, geraniums, or sunflowers.
- Does reflected light also impact plant growth? Design an experiment to see if tomatoes produce more fruit surrounded by red plastic mulch; cucumbers and cantaloupe surrounded by blue!

Good sources of information about plants and gardening products include:

Fun site that shows videos of seed germinations.

<http://sunflower.bio.indiana.edu/~rhanga rt/>

Colored mulch gardening supplies

<http://www.gardeners.com/>

Organic garden supplies

<http://www.seedsofchange.com/>

3 How does varying CO₂ levels affect the rate of growth in plants?

Learning Objectives: Understanding how carbon dioxide (CO₂) levels affect biomass growth is key to understanding environmental concerns such as global warming, rainforest destruction and much more. Since carbon dioxide is often released into the environment by factories, cars and natural processes, it is important to know how plants will react to changes in the air.

Control and Variables: When setting up your experiment, run a control as well. In this project, you would have one aquarium with plants in it and an outside carbon dioxide source. Another aquarium would be set up the same way, but without the carbon dioxide. Remember to keep the soil, temperature, moisture levels and time run the same for both aquaria. Try to keep the plants as close to the same as possible, with the species, size and number of leaves all similar.

Materials and Equipment:

2 Aquaria or other types of growth chambers (even 2 large glass jars will work!)

Thermometer

At least four plants with a minimum of 5-6 leaves per plant

CO₂ Source:

Dry ice can be purchased at places that sell ice, such as grocery or ice cream stores.

If your school has a CO₂ cylinder, that would also work well.

Safety and Environment

Requirements: Dry ice can cause severe burns, so be sure to always have adult supervision and insulated gloves. Dry ice is a solid form of CO₂, so it gives off CO₂ gases (which is what we want for this project). Be sure that the room you are working in is ventilated well and you have a fresh supply of air. Also, CO₂ compressed cylinders are under a lot of pressure and should be handled with great care.

Suggestions: Plants should have a minimum of 5-6 leaves and be of about equal size. Calculate total leaf area at beginning and end of the experiment for each plant (graph paper may be useful). If dry ice is used, consider that CO₂ is heavier than air. Like its name suggests, dry ice is very cold (-109.3 °F or -78.5 °C) so the gas from the ice may be too cold for your plants, depending on how you set up your experiment.

Other Ideas: Collect data in varying concentrations of CO₂ to find a pattern of biomass growth. Graph the results and see if you can find a fitting equation (if you have this math background). According to your results, how will global

warming affect the growth of plants in different regions of the world, such as high elevations, deserts, rainforests, and tundra?

Good sources of information about global warming include:

EPA Climate Change Website for Kids:
<http://epa.gov/climatechange/kids/index.html>

Rainforest Action Network for Kids:
http://www.ran.org/kids_action/

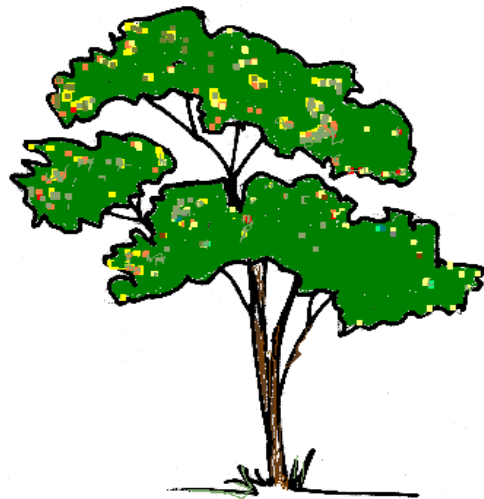

4 What are the true colors of leaves?

Learning Objective: This experiment uses chromatography techniques to separate the pigments found in leaves. Students come away with an understanding of extraction methods and information on the three main groups of plant pigments - chlorophyll (green), carotenoids

(yellow-orange) and anthocyanins (blue-red).

Control and Variables:

Control - Rubbing alcohol solvent

Variables - Variety of plant material



Materials and Equipment:

Coffee filters, cut 2-3 cm wide, approximately 10 cm long strips (depending on jar size).

Assortment of leaves and petals

Tape

Pencil

Small clear jar

Rubbing alcohol

Safety and Environmental

Requirements: Use caution when using alcohol! It is flammable and should not be splashed into eyes or on skin. Goggles, gloves and a protective lab coat are needed!

Suggestions:

- Place the leaf upside down. At a spot 2 cm from the bottom of the filter strip, rub gently on the leaf with the pencil point. Make the rubbing approximately the size of a penny. Re-adjust the leaf and continue rubbing until the spot on the filter paper is

dark. The transferred pigment should be placed above the solvent level, with about 1 cm of the strip in the solvent. Tape the strip to the top of the jar. Remove once the solvent reaches the top; dry for comparisons.

- Discuss the fact that the reds, yellows, and oranges that we see in fall are always present in leaves, but are obscured by the green of chlorophyll in spring and summer. Green bananas show chlorophyll too! As the chlorophyll breaks down the yellow pigments can be seen.
- Conduct this test with leaves grown in Project 2.
- Scientists at NREL use solvents such as water and alcohol to separate the chemicals in biomass. Can you design an experiment to capture a plant's fragrance? *Recommended plants:* lavender, rosemary, rose petals; *Recommended solvents:* try sunflower oil, olive oil or hot water.



- Here's a great demo! Tea is a solution that extracts plant compounds to flavor water. The sugar that we generally use to sweeten tea is sucrose. Amazingly, when you add the sucrose to hot tea, there is a chemical reaction changing sucrose to two other sugars: glucose and fructose. These two sugars make tea nearly 10% sweeter than tea that was sweetened when cold!

5 How do aquatic plants survive underwater? Do they still need light to make oxygen?

Learning Objectives: We know that plants need sunlight for photosynthesis.

What happens when the plants are underwater? In this activity, you will discover how aquatic plants react to

different intensities of light. Following this activity you will also be able to set up an aquarium with aquatic plants and organisms in order to demonstrate the interdependence of plants and animals.



Control and Variables: In order to understand what happens to aquatic plants when they are placed in the sunlight, you will be setting up a wide range of aquatic plant samples. In your containers, you should have the same volume of water and amount of plants so that you can compare the results between the control and variables. Also, make sure the water and plants are from the same supply. Try to keep the conditions for all the containers as close to the same as possible. Different temperatures and light sources will make plants act differently.

Materials and Equipment:

Aquatic plants: Elodea can be found in many ponds. It can also be purchased at pet stores for about \$1.75/ plant.

6 Jars or glass containers

Scale

Dissolved Oxygen (DO) Test Kit
(PETCO: \$12.00)

DO meter may be substituted

UV light source (must be available
24 hours/ day)

Pipette

Thermometer

Beta Fish or goldfish for the end of
the activity (optional)

Safety and Environment

Requirements: Always use safety glasses and gloves when working with chemicals and heat.

Suggestions: Set up 6 jars with equal volumes of water and biomass. Place two jars in 24 hours of UV light, two jars in 24 hours of darkness, and two in 12 hours of UV light and 12 hours in darkness. Measure the dissolved oxygen (DO) levels every 24 hours and record. Get DO levels before starting your experiment also so that you can see if it has changed over time. Where is the dissolved oxygen going or coming from? What does this mean in a freshwater environment? Do the DO levels increase, decrease or stay the same over time?

Other Ideas: After running your experiment, consider how aquatic and terrestrial (land) systems are similar/ different. Create an aquatic ecosystem using the oxygen/ carbon dioxide cycle that we have learned about. How would you create an ecosystem on land? Consider moving

life to Mars or to the International Space Station. What would you need to live in either of those places?

Resources:

Information about the International Space Station (including sighting information) can be found at:

<http://spaceflight.nasa.gov/station/>

Lots of information about water systems and biomes of the world:

<http://mbqnet.mobot.org/>

6 What happens when plants are crowded?

Learning Objective:

When we have plants in our house, we usually only have one or



two plants in each pot. However, in many eco-systems there are lots of plants and trees crowded together. This is one reason why the rainforest is so amazing to us! In this experiment, you will document ways in which plants change their growth strategies to compensate for lack of nutrients, light and root space. Can you think about ways that plants survive in crowded conditions?

Control and Variables:

Control - Plants grown without crowding
Variables – Similar plants grown in small, congested areas, 2” pots recommended with up to 4 plants

Materials and Equipment:

Up to 24 sets of plants (use vegetables grown from seeds or a variety of house plants)

6 - 2” pots

6 – 6” pots

Potting soil

Metric Ruler

Graph Paper

2 Root-View Farms *optional*
(www.Boreal.com, \$52.00)

Safety and Environmental

Requirements: No special requirements needed.

Suggestions:

Use the data generated from this experiment to compare and contrast growth patterns between crowded and uncrowded plants.

Plants are amazing in how they can survive under adverse conditions. In the rainforests, understory plants devised ways of using just one fleck of light to provide the energy for growth and reproduction. This system took millions of years to evolve. Identify the structural differences between plants that like shade and plants that need full sun.

- What short-term strategies did your plants exhibit? Did your vegetable plants produce seeds? Plants that are stressed often try to reproduce before their nutrients are lost. How is this triggered?
- Take one medium-sized plant and

remove one leave at a regulated rate to represent predation. How many leaves can be "eaten" before the plant changes?

- Bonsai trees first appeared over a thousand years ago! It is an ancient practice first started by the Chinese where plant roots are restricted from growing, so the plant does not have enough nutrients to develop naturally. You may want to research bonsai trees and start your own bonsai tree project!



Resources:

Rainforest Education
<http://www.rainforesteducation.com/>

American Bonsai Society
[HTTP://WWW.ABSBONSAI.ORG/](http://www.absbonsai.org/)

7 Can a cascade of wetlands be a pollution solution?

Learning Objectives:

Often overlooked in the past, **wetland** ecosystems are now recognized as playing a vital part in earth's water cycle. Through this exercise, children gain an understanding of the complexity of wetlands and measure the impact of pollution on common wetland species.

Control and Variables:

Control - Container of cattails without any **pollutants**.

Variables – Similar plants treated with pollutants.

Materials and Equipment:

4 – 6"containers of cattails or bulrushes (Approximately \$25.00 in local garden centers)

For every 2 liters of water add:

- ½ cup sunflower oil
- 1 cup sand and soil mix

Epson salt (optional)

Graph Paper

Metric Ruler

Saucers to collect runoff water



Bucket (optional)

Safety and Environmental Requirements

No special requirements needed.

Suggestions:

- First, measure and record the height and health of your plants.
- In this experiment, the first "wetland" should be watered with the polluted water. Runoff water from the first is then used to water the second, and so on. Document the characteristics and volume of each watering.
- Water the plants three to seven days with the polluted water, documenting changes in the plants. What happened to the sediments? Where is the oil deposited? Are all

the plants alive? Are the pollutants hurting them?

- Irrigated agricultural lands often leave salt residue in the soil. Will high salt concentrations harm plant growth? If time is available, use salt as a pollutant and check the impacts after a few months.



- Wetlands are not just cattails marshes; there are untold varieties of plant species in these ecosystems. Would a floating plant, such as duckweed or water hyacinths, help the cattails filter the pollutants? Explain why.
- What are the current laws regarding wetlands? Can a developer fill in to build a house? What about the birds and animals that live there?
- Search the Internet to find a city that uses wetlands in their water purification systems.

Resources:

Environmental Protection Agency wetland homepage

<http://www.epa.gov/OWOW/wetlands/index.html>

In depth information on midwestern wetlands.

<http://www.npwrc.usgs.gov/resource/1998/mnplant/mnplant.htm>

Florida State University wetland research center.

<http://aquat1.ifas.ufl.edu/welcome.html>

More Project Ideas

What growing medium produces more biomass: regular soil or a hydroponic solution?

What percentage of a plant's mass and nutrients are contained in its roots? Stems? Leaves?

Collect soils from across your state and run soil tests on each. Make a prediction on which agricultural crop would grow best in each soil.

How do plants climb? Do plants grow toward light? How does light direction effect plant growth?

Test inorganic vs. organic growing techniques.

How much can you dilute a pesticide while retaining its effectiveness?

How successful are natural pest deterrents?

What are the fastest growing grasses in your area? Trees?

What factors positively influence seed germination? Experiment with variables such as seed orientation, planting depth, or soil types, temperature.

What are the effects of magnetic or electrical fields on plant development?

Do different size seeds have different germination rates? How strong are germinating seeds? Does the size of the seed correspond to the final size of the plant?

Which edible seeds sprout in water? Will frozen seeds sprout?

Place uncut, hydroponically grown tomatoes near grow lights for a few weeks and see if you can make the seeds sprout inside the tomato!!

What are the effects of oil, salt or bleach on algal growth?

Which plants and vegetables make the best dye?

References

National Renewable Energy Laboratory, *Science Projects in Renewable Energy and Energy Efficiency*. Boulder, CO, 1991
American Solar Energy Society, pp. 41-45.

Unknown, "Experiment of the Week - Sweet Tea #220" in *The Teacher's Corner*, 2001
May 13, [Cited 2003 July 8],
Available:<http://www.theteacherscorner.net/science/experiments/tea.htm>.

Statistical Analysis of Corn Plants and Ethanol Production

Brianna Harp

Grade Level/Subject

Grades 9-12, Algebra II, statistics, interdisciplinary biology section

Curriculum Standard

This lesson plan meets these Colorado math standards.

- | | |
|-----------------|--|
| CO.MTH.9-12.3 | STD: Students use data collection and analysis, statistics, and probability in problem-solving situations and communicate the reasoning used in solving these problems |
| CO.MTH.9-12.3.8 | ... testing hypotheses using appropriate statistics |
| CO.MTH.K-12.3.1 | ... solve problems by systematically collecting, organizing, describing, and analyzing data using surveys, tables, charts, and graphs |

This lesson plan meets these NCTM standards.

The students will be able to . . .

- understand histograms, parallel box plots, and scatterplots and use them to display data;
- compute basic statistics and understand the distinction between a statistic and a parameter.
- for univariate measurement data, be able to display the distribution, describe its shape, and select and calculate summary statistics;

Overview

Five weeks before our statistics unit begins the students will plant corn seeds in either fertilized or unfertilized soil. A statistics pre test will begin the unit in order to evaluate the students' prior knowledge and introduce the topic. In class, the students will be taught about the mean, median, standard deviation and outliers of a data set. They will learn how to construct and read stem and leaf plots and histograms. The class will harvest the corn, measure its height, and dry and weigh it. All data will be recorded in student journals and on a class chart. Using their knowledge from the previous lesson, the students will perform a statistical analysis of their class crop. This will include using all of the previously mentioned statistics and graphs. Next, the students will read an article about ethanol production and research and calculate how much ethanol their class crop would produce. They will also research average fertilizer costs and perform an analysis on the use of fertilizer as a cost effective method for increasing ethanol production. Then, each student will write a research paper describing the experiment and their findings. Lastly, a test very similar to the pre-test will be given to assess student progress.

Learning Objectives

Subject matter knowledge-

- 1a. The learner will demonstrate his/her understanding of what the mean and median are by writing out an explanation of these terms.
- 2a. The learner will demonstrate his/her understanding of the standard deviation and outliers by writing out an explanation of these terms.
- 3a. The learner will demonstrate his/her understanding of stem and leaf plots and histograms by reading, interpreting, and answering questions about them.
- 4a. The learner will demonstrate his/her knowledge of biofuels by explaining how ethanol is formed.

Skills-

- 1b. The learner will demonstrate his/her ability to find the mean and median of a data set.
- 2b. The learner will demonstrate his/her ability to find the standard deviation of a data set.
- 3b. The learner will demonstrate his/her ability to construct a stem and leaf plot and a histogram of a data set.
- 4b. The learner will calculate how much ethanol can be made from corn grown with and without fertilizer.

Reasoning Ability-

- 1c. The learner will understand the relationship between the median and mean of a data set. They will explain why the mean is higher, lower, or the same as the median for any particular data set.
- 2c. The learner will explain what relation the standard deviation has to the rest of the data set.
- 3c. The learner will draw conclusions about a data set by reading and interpreting the stem and leaf plot and histogram.
- 4c. The learner will perform a cost analysis on ethanol made from corn grown with and without fertilizer, to determine which method is more efficient.

Time Allotted

7 class periods

Vocabulary

Mean	Stem and Leaf Plot
Median	Histogram
Outliers	Ethanol
Standard Deviation	Biofuels
Normal Curve	

Resources/Materials

Fertilizer resources at

http://southwestfarmpress.com/mag/farming_figuring_corn_fertilizer/index.html

Prerequisite Knowledge

Students should have previous knowledge in calculating the mean, median, and mode from Algebra one. However, these calculations will be reviewed briskly in the first class period of the unit.

Main Activities

Five weeks before beginning the unit, the class will use half of a period to plant corn seeds. Each student will receive a pot and a seed. Half of the class will use fertilized soil and half will use regular soil. The teacher will water each plant with an exact amount of water on a consistent basis for the month. One week before beginning the unit, the students will receive their project journal, measure and record their plant heights, and harvest the plants so that they may dry out.

On the first day of the unit, preferably a Friday, the students will take an un-graded statistics pre-test. This test will serve as an introduction to the unit, an assessment of the students' prior knowledge, and will be very similar to the unit post-test, so that the teacher may effectively evaluate how much progress the students made. Each test will contain work problems, write-in word definitions, and short answer questions. The work problems will include calculating the mean, median, and standard deviation of a given data set. Construction and analysis of a stem and leaf plot and a histogram will also be included. For the second part of the test, students will be asked to define in their own words certain math terms like mean, median, outliers, and standard deviation. The short answer questions will include an explanation of how ethanol is formed; why the mean could be higher, lower, or the same as the median; what relation the standard deviation has to the rest of the data set; and which corn growing method is most efficient and why. The class will then begin discussing what ethanol is and how it is used. The students will be given a handout about ethanol production to read for homework

Day two will include a review of how to calculate the mean and median of a group of numbers. Then, the class will discuss what the center of a data set is and what effect outliers can have on it. Also, the concepts of the normal curve and standard deviation will be introduced and related to one another. The students will then be taught how to calculate the standard deviation and given practice problems to work on for homework.

On the third day the student will weigh and record their plants mass. Then, each student will compile their data with the rest of the class' into the following tables. For each column, the students will calculate the mean, median, and standard deviation of the class plants. Another reading will be given as homework.

Student Name	Fertilized Plant Height	Fertilized Plant Mass
Mean	=	=

Median	=	=
Standard Deviation	=	=

Student Name	Unfertilized Plant Height	Unfertilized Plant Mass
Mean	=	=
Median	=	=
Standard Deviation	=	=

During the next day, the students will be taught how to construct and read a stem and leaf plot and a histogram. A few work problems and a homework assignment will be assigned for practice. Also, each student will construct a stem and leaf plot and histogram for each data set as part of their homework.

In class, on the fifth day, the students will research some statistics on how much ethanol can be produced from a certain mass of corn. Together, the class will determine how much ethanol could be produced from the unfertilized and fertilized plants separately. Lastly, the students will research average fertilizer costs so they can perform a cost analysis for the production of ethanol from plants grown in fertilized and unfertilized soil.

The culminating project of the unit will be to write a 2-3 page research paper describing the entire experiment. The students will write up everything they did to perform the experiment and all of the results they recorded in their project journal. Then, they will discuss if fertilizer is a cost effective approach to increasing ethanol production. Short answer questions similar to those on the pre- and post-tests will be provided as a guide. The students will be assigned this paper on the first day of the unit, so that they may be writing as they go along. They will be given one class period and a weekend to work on their paper. On the final day of the unit, preferably a Monday, the students will turn in their papers and take the statistics post-test.

Evaluation

Type of Assessments	Learning Objectives	Format of Assessment	Modifications (if needed)
1. Pre-Assessment	1a, 2a, 3a, 4a, 1b, 2b, 3b, 4b, 1c, 2c, 3c, 4c	Math test with work problems, write in word definitions, and short answer questions	Work problems, matching word definitions, and multiple choice questions.
2. Formative Assessment	1b, 2b, 3b, 4b	Project Journal with work problems and graphing.	none
3. Formative Assessment	1a, 2a, 3a, 4a, 1c, 2c, 3c, 4c	2-3 page research paper written about their experiment and the possible use of fertilizer to help increase ethanol	none

		production. Questions will be provided as a guide.	
4. Post-Assessment	1a, 2a, 3a, 4a, 1b, 2b, 3b, 4b, 1c, 2c, 3c, 4c	Math test with work problems, write in word definitions, and short answer questions	Work problems, matching word definitions, and multiple choice questions.

The use of multiple forms of assessment was chosen for a few reasons. First of all, by providing different forms of assessment, students should be able to find one assessment that best fits their learning style. Secondly, this is a great way to incorporate reading, writing, and science integration into the math classroom. Finally, all of the learning objectives are met at least two or three times using these multiple assessments. Each learning objective is met as follows: math skills by work problems and the project journal, subject matter knowledge by the definitions and the research paper, and reasoning skills by the short answer questions and research paper. Some of the graphing work problems require the students to analyze the data and answer questions. This tends to meet all three learning objectives at once.

The reliability and validity of the assessments are achieved in several ways. For instance, if a student is able to calculate the mean, but cannot define it, then there is a gap in their understanding between the definition and application of the mean. Thus, each skill is tested in multiple ways, so if a misconception occurs, it will be evident on one test or another. Also, the assessments accurately measure the learning objectives, because each part of the assignment is based upon an objective.

Another great aspect of these assessments is that they build on each other. The pre-test assesses previous knowledge, while simultaneously introducing the concepts and creating student interest. Progressing through the unit, the students will be able to use their pre-test as a guidebook and study guide for the post-test. If they have trouble with a certain concept they will have the opportunity to get help on it while they are working on the project journal or the research paper. Then, by the time they get to the final test, they will have used all of the skills necessary in a practical situation and written about it. The student should have a fairly good idea by this point where they are struggling and where they need to ask for help. These assessments are appropriate for evaluating the students' progress in understanding the mean, median, standard deviation, etc. by virtue of their dependence upon each other.

Biofuel Production

For the Teacher

The projects in this section are written in a manner that can be incorporated into a science class's curriculum in two ways. In the Project Ideas area, the questions are about general area and not specific scientific problems to be worked out. First, it can be done as long term semester project depending on how in depth and how much time the teacher would want to put into the project. Secondly the teacher writes them with the purpose of so that the project could be accomplished

With 60% of our petroleum supplies being imported into our country, there is a huge need to develop alternative fuel supplies for our future energy demands. The projects show ways of developing alternatives to petroleum fuels. The projects could also lead to more projects studying the impacts on the environment of using these types of fuels in the future. A great connection for more information on any of these projects would be the National Renewable Energy Labs in Golden, Colorado. The base web-site is www.nrel.gov. On the next two pages you will find the National Science Standards by the National Academy of Sciences that apply to this part of the book.

National Science Education Standards by the National Academy of Sciences

Science Content Standards: 5-8

Science of Inquiry

– Content Standard A

“Science of Inquiry”

“Abilities necessary to do scientific inquiry”

Physical Science

– Content Standard B

“Properties and Changes of Properties in Matter”

“Transfer of Energy”

Science and Technology

– Content Standard E

“Abilities of Technological Design”

“Understandings about Science and Technology”

Science in Personal and Social Perspective

– Content Standard F

“Populations, Resources, and Environments”

“Risks and Benefits”

“Science and Technology in Society”

History and Nature of Science

– Content Standard G

“Science as a Human Endeavor”

“Nature of Scientific Knowledge”

Science Content Standards: 9-12

Science of Inquiry

– Content Standard A

“Science of Inquiry”

“Abilities necessary to do scientific inquiry”

Physical Science

– Content Standard B

“Structure and Properties of Matter”

“Chemical Reactions”

“Conservation of Energy and Increase in Disorder”

“Interactions of Energy and Matter”

Life Science

– Content Standard C

“Matter, Energy, and Organization in Living Systems”

Earth and Space Science

– Content Standard D

“Energy in the Earth System”

Science and Technology

– Content Standard E

“Abilities of Technological Design”

“Understandings about Science and Technology”

Science in Personal and Social Perspective

– Content Standard F

“Personal and Community Health”

“Natural Resources”

“Environmental Quality”

“Natural and Human-induced Hazards”

“Science and Technology in Local, National, and Global Challenges”

History and Nature of Science

– Content Standard G

“Science as a Human Endeavor”

“Nature of Scientific Knowledge”

Technology Description

The traditional use of biomass is combustion in stoves or boilers for heat. Biomass is a term that refers to anything that is or was living at

sometime. This is a significant source of energy for U.S. industries and homes. Yet biomass can also be converted to “biofuels” – liquid and gaseous fuels such as ethanol, methanol, gasoline, diesel fuel and methane. Making ethanol from corn is a major U.S. industry, producing nearly 1 billion gallons each year. The processes for converting biomass to fuels include a broad range of thermal, chemical and biological processes.

Combustion processes heat the biomass in the presence of unlimited oxygen. The products of the reaction are additional heat, ash, and smoke.

Gasification heats the biomass to higher temperatures of 600^o – 1000^o C in an environment of limited oxygen. The biomass begins to char and gives off a gaseous product that is a mixture of carbon monoxide, hydrogen, and methane. The mixture of gases, known as “syngas,” can be burned directly in industrial processes, or it can be cleaned up and used as a substitute for natural gas. The syngas can also be converted to methanol, which can be used as a pure fuel or in blends with gasoline.

Pyrolysis heats the biomass to temperatures of 300^o – 500^o C. in the absence of air. The biomass “melts” and vaporizes, producing petroleum-like oil called “biocrude.” This biocrude can be converted to gasoline or other chemicals or materials.

Anaerobic digestion is a biological process that uses bacteria in the absence of oxygen to convert biomass to a mixture of methane and carbon dioxide called “biogas.” Liquid and solid wastes are particularly amendable to this process, which is already providing energy in many locations around the

world. Like syngas, biogas can be used directly or converted to other fuels.

Fermentation is another biological process that uses yeast to convert the sugars in biomass to ethanol. This is the same process that has been used for thousands of years to make wine and beer. Some forms of biomass are made up of simple sugars that can be used directly, for example, sugar cane and sugar beets. Others are made up of carbohydrates –chains of sugar molecules- that must first be broken down (hydrolysis) using enzymes. Starch crops such as corn and woody crops such as trees and grasses both fall into this category. Like methanol, ethanol can be used as a pure fuel or in gasoline blends.

Oil extraction can be used with a variety of plants that produce oils directly. Peanut, rapeseed, and some species of aquatic algae are examples of these plants. The oils can be chemically upgraded to diesel fuel and burned in engines. Some of these plants are already grown as crops in several regions of the country. And micro-algae could be grown in saline water in the Southwest, using large quantities of carbon dioxide as a nutrient.

Bio-diesel is being produced from various types and conditions of vegetable oil in Europe and in the States. Bio-diesel is being made in considerable quantities at home-sites for use in diesel engines as a substitute or an additive to mix with petroleum-diesel fuels. The main advantage in using bio-diesel is that it produces no by-products containing sulfur.

The technologies for producing biofuels are at various stages of commercial development. Most are

already providing limited amounts of energy today and greater amounts in times of tight supply such as the oil embargo of the 1970's or the World Wars. But the efficiencies and economics of all the processes stand to benefit from ongoing research. It was predicted in the 1980's that we would be producing large amounts of our liquid and gaseous fuels economically from biomass, but there is still a lot of work to done in the research fields to make biofuels economically feasible.

Good sources of information about biofuels in general are readily available via the Internet. Any good search engine will attain 1000's of possible websites to be looked at with a good healthy perspective. A few websites that might be a good start for further research could be as follows.

www.ethanolrfa.org/

<http://www1.eere.energy.gov/biomass/>

www.nal.usda.gov

This is just a partial listing of many and various websites that can again be obtained by using most search engines on the Internet.

Project Ideas

1 What can be controlled to increase the efficiency of ethanol production?

Variables: Sugar source (grain crops, fruits, cellulose), temperature, type of yeast

Specific Resources: Most life science, biology or chemistry textbooks and lab manuals give numerous setups on fermentation equipment.

Hints: Use the rate or total volume of CO₂ production as an indicator of the production of ethanol. A gas chromatography unit can determine exact quantities of ethanol.

Other Ideas: Advanced students could investigate the optimum temperature for fermentation, develop prototypes for efficient production of ethanol, investigate aerobic and anaerobic conditions, and investigate methods of quantifying ethanol production.

2 What kinds of biomass have the most heat energy in a given quantity?

Variables: Types of Biomass (i.e. plant species, grasses, wood, etc.), heat loss (depending of the efficiency of the calorimeter)

Special Equipment: Balance, calorimeter, thermometer, burner set-up.

Specific Resources: Many biology manuals will give instructions for making a calorimeter or a commercial unit may be purchased from Fisher Scientific for about \$250 (not necessary). www.fishersci.com

Special Safety and Environmental Concerns: Work in well-ventilated areas. Be extremely careful of burns because a lot of heat energy can be generated and released.

Hints: Conduct preliminary tests to determine the best amount of biomass to test. The amount of water used in the calorimeter is important to keep consistent.

Other Ideas: More advanced students could decrease the margin of error by using a bomb calorimeter. Check with a local university for access to this equipment. Extraction of hydrocarbons (oils) from various kinds of plants could be investigated, especially those containing latex, e.g., milkweeds. Their heat energy could be compared in a search for the best source. Determine usable heat energy that could be produced on an acre of land if certain crops, e.g., castor beans, sunflowers, corn, and milkweed. This would require one to know the caloric value (Energy/unit mass) and the amount of biomass produced per unit area.

3 What type of "Biomass" will produce the greatest quantity of "biogases" by heating?

Variables: Biomass sources, moisture content, heating source/temperature.

Special Equipment: Heating container, heat source, gas collection apparatus.

Special Safety and Environmental Concerns: Provide adequate ventilation. Be careful in the way that the biomass is heated. The major gas produced is methane, which is explosive when mixed with air. Take care to avoid burns.

Hints: The amount of gas produced can be quantified using a water displacement method. An alternate method is to burn the methane produced as it leaves the heating vessel via a small glass tube. The burn time gives an indication of amount of gas produced. Extra care should be taken if using this method.

Other Ideas: Advanced students could determine if this method is energy efficient since the biomass source has to be heated. Various sources such as corncobs, old tires and sludge straw could be tested. The material remaining is charcoal. Is there any energy value remaining? If so, what is the total amount of available energy in a given amount of biomass using the destructive distillation process?

4 What conditions provide the maximum yield of charcoal from biomass?

Variables: Types of biomass, temperature, heating rate, pressure, gaseous environment, catalysts.

Special Equipment: Heating device, containment vessel, thermocouples, sources of gases.

Special Safety and Environmental Concerns: Heated pressurized vessels require special precautions and supervision.

Hints: Begin simply by heating something like cellulose in a test tube sealed to permit the escape of gases.

Other Ideas: Advanced students could possibly design their own heating vessels and also could devise ways to heat in the presence of other gases and in the absence of most atmospheric gases.

5 What conditions will produce the most efficient breakdown of paper into sugars?

Variables: Time of reaction, temperature, enzymes, type of paper, the amount of paper, the amount of water.

Specific Equipment: Cellulase, available from Fisher Scientific for \$10-\$20 (www.fishersci.com), Benedict's solution for testing for glucose or some other method to test for glucose. Benedict's solution can also be obtained from Fisher Scientific for \$5.

Specific Resources: Biological and/or chemical laboratory manuals for sugar test procedures.

Special Safety and Environmental Concerns: Use of goggles while testing

for the presence of sugar and while handling the enzymes.

Hints: Make the pulp using a high-speed blender. Make varying concentrations by adding different amounts of the dried pulp to water. Cover the container containing the pulp and enzymes because the fermentation is anaerobic.

Other Ideas: Advanced students could design an experiment that would allow for the hydrolysis and fermentation to ethanol. Factors to consider are pH, sterilization of the media and paper, filter, the cellulose solutions. The mixtures of yeast and cellulose could be varied to identify the most efficient culture. A gas chromatograph could be used to quantify the amount of ethanol produced. (Local labs or colleges could provide a gas chromatograph)

6 What conditions and/or biomass are best for producing methane?

Variables: types of biomass (plants, animal dung, food waste), moisture content, time, aerobic or anaerobic conditions, temperature and air pressure.

Special Equipment: Biogas generator, heat source such as a hot plate, and a gas collection apparatus.

Special Safety and Environmental Concerns: Methane the main component of biogas is explosive when mixed with air. Extreme care should be taken when attempting to generate large quantities of biogas.

Hints: Fill the jar with biomass and make sure it is well squashed down to remove as much air as possible. The biomass must be moist (add water if needed). Use equal masses of the different types of biomass.

Other Ideas: Compare the efficiency of producing methane from crop wastes, e.g., corncobs and corn silage to predict what the best crop source would be.

7 What conditions would produce the most efficient conversion of algae to a useful fuel?

Variables: Type of algae, amount of light, type of light, salinity of water, concentration of nutrients (carbon dioxide, nitrogen, phosphorus)

Special Equipment: Laboratory glassware, microscope, algae cultures from Fisher Scientific for \$7.40 per algae culture, WWW.Fishersci.com

Specific Resources: *Fuels from Micro-algae*, 1989, SP-320-3396, Golden, Colorado: SERF

Special Safety and Environmental Concerns: None

Hints: Grow micro-algae in flasks exposed to a specific type of light. Examine samples of cells under microscope. Hydrocarbon oil, called lipids, will be visible as yellowish droplets.

Other Ideas: Advanced students could quantify the amount of lipids using a staining technique known as "Nile Red."

The procedure requires specialized equipment, probably available at local colleges or universities. The "nile red" is available through source like Fisher Scientific but is very expensive to purchase.

8 What is the most efficient way to produce biodiesel?

Variables: new vegetable oil, used vegetable oil, types of oils, stir times, rate of stirring, amounts of sodium hydroxide and ethanol, temperature of mixture during the mixing process.

Special Equipment: liquid volume measuring devices, thermometer, mixing container, mixing device, mass measuring devices, pH measuring device

Special Safety and Environmental Concerns: materials produced are flammable, Sodium hydroxide is corrosive and poisonous, Sodium methoxide is extremely corrosive and poisonous, ethanol is flammable and poisonous, electrical safety issues, disposal of waste products

Hints: Web-sites showing the directions for making biodiesel-
http://journeytoforever.org/biodiesel_make.html,
<http://www.nrel.gov/education/>, Stirring is a major key in bio-diesel production.

Renewable Energy Plants in Your Gas Tank: From Photosynthesis to Ethanol

AUTHORS:

Chris Ederer, Eric Benson, Loren Lykins

GRADE LEVEL/SUBJECT:

Secondary Life Science - 7 – 12 grades

Break-out activities to be used during the study of plants.

- Each designated with grade level but can be adapted to any secondary level*
- Each taking a variable amount of time (from 1 day to 1 month)*

NATIONAL SCIENCE EDUCATION STANDARDS:

CONTENT STANDARD A: Science as Inquiry

As a result of activities in grades 9-12, all students should develop

- Abilities necessary to do scientific inquiry
- Understandings about scientific inquiry

CONTENT STANDARD B: Physical Science

As a result of their activities in grades 9-12, all students should develop an understanding of

- Structure of atoms
- Structures and of properties in matter
- Chemical reactions

CONTENT STANDARD C: Life Science

understanding of the cell

CONTENT STANDARD E: Science and Technology

As a result of their activities in grades 9-12, all students should develop

- Abilities of technological design
- Understandings about science and technology

CONTENT STANDARD F: Science in Personal and Social Perspectives

As a result of activities in grades 9-12, all students should develop understanding of

- Natural resources

- Environmental quality
- Science and technology in local, national, and global challenges

CONTENT STANDARD G: **History and Nature of Science**

As a result of their activities in grades 9-12, all students should develop understanding of

- Science as a human endeavor
- Nature of scientific knowledge

TEACHER’S OVERVIEW AND BACKGROUND INFORMATION:

With ethanol becoming more prevalent in the media and in gas tanks, it is important for students to know from where it comes. This module uses a series of activities to show how energy and mass are converted from one form to another. It focuses on the conversion of light energy into chemical energy via photosynthesis. It then goes on to show how the chemical energy in plant sugars can be fermented to produce ethanol. Finally, the reasons for using ethanol as a fuel are discussed.

In the initial activity, students use paper chromatography to separate plant pigments from leaves. In this module’s second activity the students consider what the source of mass for plants is as they grow. They form hypotheses then design and perform experiments to test their hypotheses. Next the students design an experiment to determine which of three different sugars produces the most fermentation products. Once they figure this out, they then determine what concentration of their “best” sugar would maximize ethanol production and minimize cost. Finally, students discuss the production and use of ethanol as a fuel.

This module follows the path of energy from the sun and photosynthesis to ethanol production. Teachers can stress that in every step of the process energy is neither created nor destroyed. It just changes form. The same can be said of mass.

The module highlights a general method of chemical analysis (chromatography – activity one) that is used in more high tech forms to determine the types and concentrations of fermentable sugars produced from cellulosic biomass. Activity two investigates from where plants get their mass. Producing ethanol from cellulose is difficult but does not compete with food production. Activity three in this module will help show students why it is important to measure the types and concentrations of the sugars produced.

PURPOSE OF THE EDUCATION MODULE:

The purpose of this module is to help students understand an important aspect of environmental maintenance; the use of plants for the production of fuel resulting in 0-net Carbon Dioxide yield.

LEARNING OBJECTIVES:

Students will

- Discuss the role of plant pigments in photosynthesis.
- Know that photosynthesis produces sugars.
- Discover that as plants grow the mass required to do so comes from the air(carbon dioxide).
- Identify ethanol as a product of sugar fermentation and discover that not all sugars produce equal amounts of fermentation products.
- Relate photosynthesis and fermentation to the concept of conservation of energy and mass.
- Discuss the environmental and economic benefits of ethanol as a fuel additive
- Demonstrate appropriate safe laboratory behavior and techniques
- Document observations and data in an organized appropriate laboratory format
- Analyze and interpret the results of the experimental data and observations
- *Communicate their results and conclusions in written lab reports*

VOCABULARY: *The terminology listed below should be used throughout the unit*

Photosynthesis
Chromatography
Chlorophyll
Ethanol
Calorie
Fermentation
Energy
Glucose
Cellulose

MATERIALS*:

Eye protection

1, 2, and 3 liter bottles

Plant seeds (radish, spinach, bean, etc.)

Centigram balance

Dried soil

Pots

Water

Light source

*Included are the materials for a variety of projects. Depending on time and goals for students it is up to the educator to select necessary resources. Estimated cost and purchase suggestions are listed within the materials section of each activity.

PREPARATORY ACTIVITIES: *There is an abundance of information to help the instructor and students understand the concepts associated with this module. Look at the Web resources to get more information.*

WEB RESOURCES:

Ethanol

<http://www.gcsescience.com/rc16.htm>

Chromatography

For an excellent ready to use high school laboratory procedure with handouts and explanations of plant metabolic processes, chromatography, and spectroscopy try:

http://www.chem.purdue.edu/teacher/table_of_contents/UVVUS/UVVIS.Plant.Pigments.CH.pdf

The above lab requires the use of petroleum ether and other solvents, therefore it is recommended that this lab be performed outside or under a fume hood.

For information on performing a laboratory investigation suitable for middle school try:

<http://www.garden.org/articles/articles.php?q=show&id=1334>

This activity requires the use of acetone (nail polish remover.) Once again, consideration must be made for ventilation.

For a virtual lab with many amenities including a lab quiz try:

http://www.phschool.com/science/biology_place/labbench/lab4/concepts1.html

For a classroom investigation illustrating the principals of chromatography by separating ink samples in various solvents, in a relatively safe procedure for a middle school setting:

http://library.thinkquest.org/19037/paper_chromatography.html

Biomass

<http://www.eia.doe.gov/kids/energyfacts/sources/renewable/biomass.html>

Photosynthesis

<http://photoscience.la.asu.edu/photosyn/education/learn.html>

Fermentation

<http://www.umsl.edu/~microbes/pdf/blue.pdf>

http://www.pasco.com/experiments/biology/january_2002/home.html

<http://www.gcsescience.com/rc16.htm>

<http://spot.colorado.edu/~kompala/lab2.html>

HANDOUTS/Teacher Reference Sheets and Diagrams:

Rubric

KWL Chart

Lab Report Template

Article Summary Template

Before carrying out these activities students should know and understand:

How to follow safety procedures when performing science experiments

Should be comfortable with inquiry based learning

Should have a basic understanding of the life cycles of plants

Plant Pigment Chromatography

Activity #1 – 7-12 grades

(Time: one 45-60 min. class period)

Rationale and Overview:

Separating impure substances into pure substances is one of the basic skills of a chemist. One technique for doing this is chromatography. In 1903 Russian botanist, Mikhail Tswett documented how he isolated leaf pigments seen during the fall color change by grinding up leaves in a solvent and pouring the extract through a column of powdered chalk. He noted that various pigments produced concentrated colored bands at unique positions in the chalk column. He studied the individual pigments by carefully removing the chalk column from the containing tube, separating the bands, and extracting the pigments with a solvent.

Thus, chromatography works on two principles: solubility (mobile phase) and adsorption (solid phase). The substances in the mixture being analyzed or separated have similar or varying degrees of solubilities in various solvents. Each substance has varying or similar affinities for adsorptive physical/chemical properties of the paper (sorberent). The combination of the solubility and adsorptive properties enable the individual molecular components of a mixture to be separated.

Isolating plant pigments requires solvents which may be problematic in a safe middle school science laboratory classroom. The following is an adaptation of a procedure cited above in the Web Resources for Chromatography.

Objectives:

You will separate the colors out of the black ink mark from a marking pen line on a coffee filter. As water seeps up the filter paper, the molecules of color are carried with them. They can be separated because they are in a mixture rather than being chemically combined. They will attach themselves to the cellulose in the paper, but with differing affinities depending on their chemical nature. Some cling hard, others are only weakly held. Those that are weakly attached to the cellulose travel further up the paper than those with the stronger bond, and they will spread further. Components can be identified by how far they are carried in similar chemical tests, such as chromatography of plant pigments or gel electrophoresis of DNA segments.

Comparisons of the pigments of various materials are made by measuring the distance they are moved on the sorberent by the solvent. The ratio of this distance is termed "RF factor" and is calculated: $RF_{\text{pigment}} = \text{pigment front/solvent front}$.

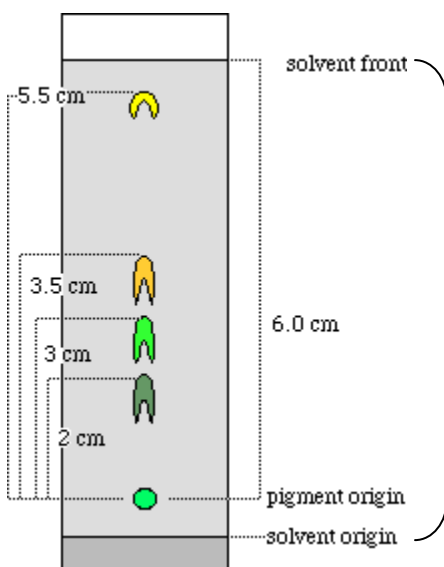

Materials:

*water and rubbing alcohol,
coffee filter (or filter paper),
marking pens (both water soluble and non-water soluble),
clear glasses or other containers*

Procedure:

1. *Cut the coffee filters into strips about 3cm wide.*
2. Fill one glass about 2cm full of water, the other about 2cm full of rubbing alcohol.
3. Draw a line across the strip of paper with a marking pen about 4cm from the end of a filter strip. (This may take several times to get a dense concentration of ink on the paper.) Label the end of each strip to identify the kind of marker used. Let them dry.
4. *Determine the independent.*
5. *Determine the dependant variables.*
6. *State the conditions that were controlled.*

Obtaining Results:

7. Make a table of measurements for each pigment on each strip.
8. Calculate the RF factor for each pigment.

Conclusion and Post-lab Discussion:

9. What did you see? What colors were actually in the each ink sample?
10. Which colors were carried furthest? (*the lighter colors*) Which remained lowest? (*the darker colors*)
11. Which pigment from which ink has the greatest rf? (*those lightest in color*) Which pigment from which ink has the least? (*the darker colors*)
12. What pattern was there to the differences in rf of various pigments?
13. What is happening when the colors move up the paper? (*the molecules of color are being dissolved by the water and carried with the water up the paper*)
14. What causes the colors to separate? (*the different colors have different affinities for clinging to the paper, and those that cling hardest to the cellulose in the paper will stop first, and those that cling the weakest will travel further up the filter paper before stopping*)

Extensions: Create your own controlled experiment. Predict what might happen with different sources of ink, or different solvents like vinegar or cooking oil. Record the results? *Set up experiments to test:*

Plant Mass

Activity #3: 7-12 grades

Time: 2 ½ - 50 minute class periods

Rationale and Overview:

Where do plants get their mass? We can begin to answer this thought provoking question if we look at the work of Lavoisier in the 18th century. Lavoisier did careful analytical work with chemical reactions and made this statement based upon his observations, "Nothing is created, either via artificial processes or those of nature, and we can state as a principle that, in every process, there is an equal amount of matter before and after the process; that the quality and the quantity of the elements remain unchanged and that there are only alterations or modifications." The simplification of this statement...matter is not created or destroyed in chemical reactions... is commonly found in science texts. So, where did the 4000 lbs of firewood from a large oak tree get its tremendous amount of mass? Some of the mass comes from water, but even when dried, the wood still contains a large amount of mass. At one time, scientists thought that trees got their mass entirely from the soil. This is still a common misconception with people that have not studied the chemical processes that take place in the leaves of plants. In reality, 96-97% of the dry mass of plants can be related directly to the amount of carbon dioxide processed during photosynthesis. Photosynthesis utilizes CO₂ and H₂O in the presence of sunlight to produce glucose (C₆H₁₂O₆) and oxygen gas (O₂). The glucose that is produced is the basis for food chains, and it forms structural polymers like cellulose which forms stems, leaves, and roots. Plants get the bulk of their dry mass from carbon dioxide that is removed from the air. The diagram shows this aspect of the carbon cycle as well as others.

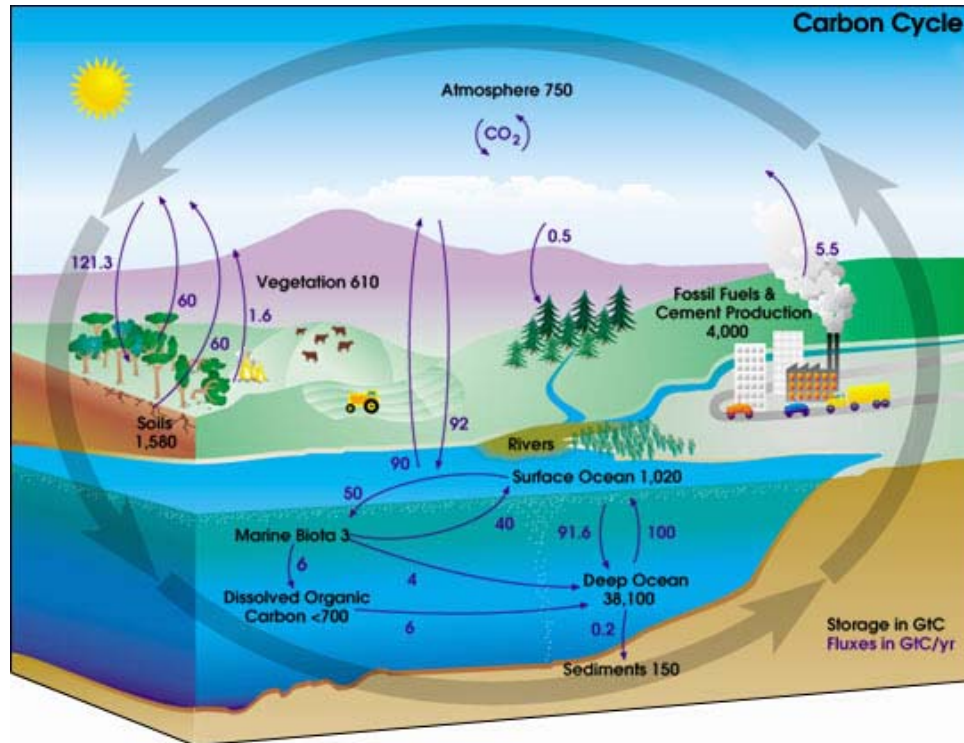

Illustration courtesy NASA Earth Science Enterprise

Objectives:

Students will

- *Learn about photosynthesis and its contribution not only to the food chain but the mass of plants and the organisms that consume plants*
- *Learn to generate a hypothesis and design an experiment to determine the amount of CO₂ removed from the air by growing plants*
- *Measure and record mass*
- *Graph data*
- *Write a report that will explain and summarize the results of the experiment*

Materials:

- Plant seeds (radish, spinach, bean, etc.)
- Centigram balance
- Dried soil
- Pots
- Water
- Light source

Procedure:

The purpose of this lab activity is to design an experiment that will show that plants do not get the bulk of their dry mass from the soil or water but from CO₂ in the air. Students working in groups of two should design their experiment for teacher approval.

A typical experimental design:

1. 5 pots will be obtained, labeled, and their masses recorded.
2. Each pot will be filled with dry soil. The mass of the dry soil for each pot will be determined.
3. Radish seeds will be weighed and their masses recorded.
4. The seeds will be planted, watered, and placed under the light source. (fluorescent grow lamp)
5. After 1 month of growth, the plants will be removed from the pots, and the soil from the roots and pots will be placed in individual drying trays for later weighing.
6. The wet mass of the plants will be recorded.
7. The plants and soil will be allowed to dry for two weeks (an oven may be used to speed up the process)
8. The dry mass of the soil samples, and plants will be recorded.
9. Was the mass of the soil considerably different?
10. Where did the plants get their mass?
11. How much CO₂ did the plants remove from the air?

Students should complete a lab report (see Lab write-up template)

Activity #2

Article summary:

Included is an article on biofuel that can be incorporated into the curriculum.

Stored Chemical Energy

Activity #4: 7-12 grades

Activity (Running time: 6 weeks)

Initial Setup Procedure (1 x 45 minute class period):

Rationale and Overview:

Ethanol is produced from the fermentation of sugars. In the United States the source of the sugars for ethanol used in fuels is corn. Currently only corn kernels are used in the fermentation process, but research continues on using

corn stover as the sugar source. Corn stover is what's left of the corn plant after the kernels have been removed. Corn stover does not include the roots.

*Yeast, *Saccharomyces cerevisiae*, is the microorganism used to ferment sugars into ethanol. Yeast easily ferments corn starch, but can't ferment the cellulose and hemicellulose found in stover unless the stover is pretreated. And even after pretreatment, yeast can't produce as much ethanol using stover because there's much less of the sugar that yeast "like" – glucose.*

This activity first demonstrates yeast fermentation of sucrose (yeast convert the sucrose into its component sugars, glucose and fructose). The activity then has students design their own yeast fermentation experiments. One possible experiment that students may come up with (or that the teacher may suggest), is testing fermentation rates of yeast in different sugar solutions. This will show students that not all sugars are equally fermentable. This is one of the challenges associated with fermentation of corn stover. Corn stover contains more xylose than it does glucose. Yeast, unless genetically modified, do not ferment xylose.

Objectives:

Students will:

- Record observations from the activity.
- Explain their observations including the terms fermentation, carbon dioxide, and ethanol.
- *Design an experiment to answer their own question about yeast fermentation.*
- *Generate a hypothesis.*
- *Perform their experiment to test their hypothesis.*
- *Write a report that will explain and summarize the results of the experiment.*

Materials (per group):

One half packet of "rapid rise" yeast

One plastic liter bottle

One balloon that fits over the mouth of the bottle

¼ cup table sugar (sucrose)

Warm water

Stirring rod

Procedure:

- 1. Fill the bottle roughly 2/3 full of warm water.*
- 2. Add sugar to the water in the bottle.*
- 3. Cover bottle and shake until the sugar is dissolved.*
- 4. Add yeast to the sugar solution in the bottle and stir.*
- 5. Put the balloon over the mouth of the bottle.*

6. Record observations after one minute, 5 minutes, 10 minutes, 30 minutes, and 24 hours

Student experiments:

*After the above activity is performed, students should be ready to design their own experiment. One possible experiment would be to test the ability of yeast to ferment different sugars (if no student group chooses to do this, it could be done as a teacher demonstration). Sugar solutions that could be tested might be table sugar (sucrose = glucose + fructose), corn syrup (fructose), honey (glucose and fructose but **not** combined to form sucrose), and glucose.*

Discussion – why use ethanol and why get it from corn stover?

Ethanol is a renewable energy source often added to gasoline. In this country some gasoline blends contain 10% - 12% ethanol. Other countries, like Brazil, have higher percentages of ethanol in their automotive fuels. The presence of ethanol in gasoline reduces the consumption of this nonrenewable resource. It also reduces pollution as ethanol combustion produces far fewer pollutants than the burning of gasoline. Another advantage of using ethanol for fuel is that it does not increase the level of carbon dioxide in the atmosphere (unlike gasoline). Ethanol comes from plants that absorbed CO₂ from the atmosphere for photosynthesis. The amount of CO₂ released during combustion of ethanol equals the amount used in photosynthesis, so there is not net atmospheric gain.

In the United States corn is used almost exclusively for the fermentation of sugar into ethanol. As the demand for ethanol as a fuel additive continues to rise, the amount of corn used for fuel will also rise. This raises an ethical issue pitting rich auto owners who want cheaper gas against poor people who need cheaper food. So a different, non-edible source of sugar is needed. One such source is corn stover though there are many other possible sources. The best source of cellulosic ethanol will be whatever non-edible biomass is in the area.

Attachments

RUBRIC

Lab write-up rubric

30 pts. Clear, concise writing at the appropriate age level

10 pts. Introduction properly written

10 pts. Safety concerns discussed

10 pts. Well written procedure

10 pts. Properly written data (descriptions or tables and graphs)

10 pts. Analysis showing math / calculations

20 pts. Properly stated conclusions

Article Summary rubric

30 pts. Clear, concise writing at appropriate age level

30 pts. Good summary of the article written in the first section

40 pts. Student response involving thought and insight

KWL Chart Group _____

<i>What I KNOW</i>	<i>What I Want to Know</i>	<i>What I Learned</i>

Lab Write-up Template (replace with appropriate title)

Introduction

This is where you state the problem, sub-problems, hypotheses (one for each sub-problem), and discuss relevant concepts. Try to avoid personal pronouns throughout the write-up (i.e. you, me, I, we, etc.) (replace this text with your introduction)

Safety

In this section, safety concerns are discussed with relevant personal protection measures (i.e. goggles, etc.) It is unlikely that you will use this section in a virtual science course, and most of the time you will place "not applicable" in this section. In a science class where you are actually manipulating chemicals or specimens, make sure that you describe potential dangers and protective measures. (replace this text with your safety)

Procedure

This part of a lab report needs to be written in such a way, that another scientist could follow your instructions and exactly replicate your experiment (detailed). (replace this text with your procedure)

Data

Data can be both qualitative and quantitative. Qualitative data must be described, while quantitative data can be listed in tables or graphed. Graphs produced in Microsoft excel can be pasted into this section, as well as pictures that show qualitative data. (replace this text with your data)

Analysis

Calculations performed on quantitative data are placed in this section. If no calculations are needed, place "not applicable" in this section. (replace this text with your analysis)

Conclusions

Discuss data, interpretation of the data, and its relevance to concepts discussed in the Introduction. If there are hypotheses, they should be addressed in this section. (i.e. the data supported hypothesis 1 in that...)

Stay clear of broad statements like (the hypothesis was proven to be true or false). Use words like "supported" or "not supported" (replace this text with your conclusions)

Name: John Smith
Date: 5/5/2003
Course: IPC

Article Summary Template (replace with appropriate title)

McCosh, Dan. (1986, July). No-springs, no-shocks suspension. Popular Science. Pp. 60-63. (replace with appropriate reference info)

Summary

The author believes active suspension will replace springs and shocks with a computer and high-speed hydraulics. The primary benefit of the system is to isolate one suspension characteristic from another. Essentially, MacPherson struts are replaced with hydraulic struts which can react within 3/1000 second, and can cycle up to 1500 times a minute. A computer responds to tiny changes in body and wheel movement by controlling double-acting struts. As well as sensing bumps, the system reads the forces acting on the car body preventing it from banking to the outside of a curve. The idea of active suspension is credited to Britain's great interest in its application. American auto manufacturers have characterized the system as expensive, noisy, and consuming power, however, it may appear on some "expensive" U.S. automobiles, by 1990. (replace with your summary of the article)

Reaction

This article has good appeal for automobile enthusiasts who want to keep abreast of the latest technology. The reporting of this innovative suspension system was very consistent and well documented by the use of interviews. Several pictures of the system components were shown as well as a pictorial schematic of the complete suspension system. Upon reading this article, anyone would have a good working knowledge of the computer controlled suspension. (replace with your reaction and thoughts related to the article)

Do not change margins or fonts. (one page maximum)

Brazil: the giant of South America is weaning itself from oil and bringing the Net to the poor. (World Changing Ideas) *Laura Somoggi.*

Full Text: COPYRIGHT 2005 Technology Review, Inc.

BRAZIL'S TWO TOP priorities are to reduce dependence on imported energy sources and to bring digital technologies to the vast majority of the country's 180 million people who cannot now afford them.

In energy, the center of the greatest activity is biodiesel, a fuel made from the oil of seeds such as soybeans, castor beans, and cottonseed. Biodiesel could become an attractive, domestically produced alternative to petroleum-based fuels. Brazil has enacted a law requiring diesel oil sold in the country to be 2 percent biodiesel by 2008 and 5 percent biodiesel by 2013. Because the country has huge amounts of land that is unsuited for food crops but that can easily grow oil seeds, "Brazil can become a global biodiesel power," says Maria das Gracas Foster, secretary of oil, gas, and renewable energy at the Ministry of Mines and Energy.

The consequences could be considerable. Brazil now imports 15 percent of the 37 billion liters of diesel it consumes annually. Large-scale use of biodiesel fuels would allow it to all but discontinue those imports and would create jobs in needy farming communities. There are also significant environmental benefits: substituting biodiesel for petroleum-based fuels reduces emissions of unburned hydrocarbons, carbon monoxide, sulfates, sulfur, and other pollutants.

Another alternative fuel that could help Brazil reduce its oil dependence is ethanol from sugarcane. A study conducted by Roberto Giannetti da Fonseca, a specialist in foreign trade, found that Brazil is the producer of fuel ethanol in the world, with an export potential of up to 10 billion liters per year for about \$2 billion in revenue. Because of its extensive use of ethanol fuel, Brazil has developed the flex-fuel car, which features a combustion engine that can burn ethanol, gasoline, or any combination of both. Volkswagen introduced the car in Brazil in March 2003. Last year, sales of new flex-fuel or ethanol vehicles amounted to 26 percent of overall car sales. According to Booz Allen estimates, that fraction could rise to 40 percent within the next two years, and Brazil could begin to export the flex-fuel technology. "Thanks to this technology, Brazil will be dependent on neither oil nor ethanol," says Fernando Reinach, executive director of Votorantim Novos Negocios, the venture capital subsidiary of the Votorantimi Group, a major

Brazilian industrial conglomerate.

While reducing energy dependence will help the Brazilian economy in the long run, another technological initiative is starting to have more-immediate consequences. Only about 12 percent of Brazilians own PCs. The last few years have seen a number of projects designed to make computer technology accessible to large numbers of Brazilians for whom it was previously unaffordable. The Committee for Democracy in Information Technology (CDI), for example, collects PCs in good working condition that businesses

have discarded as obsolete and ships them to information-technology training centers. More than 900 schools in Brazil and abroad have benefited from this program. In 2001 a new project was born. one to provide Brazilian who don't own PCs with a sort of virtual machine--as long as they have access to a publicly shared computer terminal. The project is called Computador de R\$1.00, or Computers for 1 Real--the equivalent of about 40 cents. That's the price of a recordable CD that stores personal data and settings that customize the appearance of a computer screen. The user simply inserts the disc into the CD drive of a computer at a school, a public library, or even a shopping mall. The system reads the disc and presents a personalized computing environment, complete with application software and access to additional content over the Internet. The system is already in place in pilot form in community centers and schools in cities such as Silo Paulo, Brasilia, and Campinas; hundreds of Brazilian schools will soon begin offering system discs to their students. Project collaborators include Siemens, T-Systems, Brasil Telecom, Brasilia University, publisher Editora Abril, and Brazilian infotech firm Samurai.

One application of information technology in which Brazil is taking a leading role is voting machines. In Brazil's 2000 local elections, for the first time, all 5,559 of its municipal districts offered voters the chance to cast their ballots electronically. Most polling places used a simple, portable electronic voting machine. To boost confidence in the system's reliability, Brazilian law guarantees that all political parties can examine the machine's software before the election, says Paulo Cesar Bhering Camarao, information technology secretary of the Supreme Electoral Court. A digital signature extracted from the software can then be used to verify that the used on election day is the same one examined previously.

Cell Wall Recipe: A Lesson on Biofuels

By Daniel Steever

Grade Level/Subject
Middle School Life Science

Relevant Curriculum Standards

CONTENT STANDARD A:

As a result of activities in grades 5-8, all students should develop

- Abilities necessary to do scientific inquiry
- Understandings about scientific inquiry

CONTENT STANDARD C:

As a result of their activities in grades 5-8, all students should develop understanding of

- Structure and function in living systems
- Reproduction and heredity
- Regulation and behavior
- Populations and ecosystems
- Diversity and adaptations of organisms

CONTENT STANDARD E:

As a result of activities in grades 5-8, all students should develop

- Abilities of technological design
- Understandings about science and technology

CONTENT STANDARD F:

As a result of activities in grades 5-8, all students should develop understanding of

- Personal health
- Populations, resources, and environments
- Natural hazards
- Risks and benefits
- Science and technology in society

CONTENT STANDARD G:

As a result of activities in grades 5-8, all students should develop understanding of

- Science as a human endeavor
- Nature of science
- History of science

Teacher Overview:

In this activity students will investigate how changes in the DNA sequence that codes for cell wall formation can have a favorable outcome in producing plants that have higher levels of cellulose than the parent plant. It is the yield of cellulose that is most important in the production of ethanol, the greater the amount of cellulose within in the cell wall the greater the amount of ethanol that can be produced. To engage students, the first part of this lesson has students participating in a discovery activity where they will extract DNA from wheat germ. This activity is simple and in my experience has worked great in the 7th grade science classroom. Following this (different day) students will be given 3 strips of paper at random with different symbols on them; these strips are the DNA strands. While each strip has four symbols, only three symbols represent a gene (codon to be specific) and students will read the strips from left to right. By having four symbols per strip, students will have a variety of possible combinations as they lay out their strips to be decoded. Students will look at the key provided and build their cell walls based on the genetic code they were given. Students can make adjustments in their code if they have a fatal mutation or they did not get a gene for cellulose, lignin, or hemicellulose. Once students have built their cell walls they will evaluate codes that would be most favorable in producing cell walls with a high percentage of cellulose and low percentages of lignin and hemicellulose. This module can be used as part of a whole Unit or an activity in understanding cell wall structure and function, DNA and genetics, evolution, technology, or science and society.

Relevance: This unit was inspired by the research conducted at NREL on cell wall mutations and the development of higher cellulose yielding feedstock for ethanol production.

Background:

Biomass refers to any organic substance and can range from vegetable or trees to solid wastes such as paper and food based trash. This biomass can be converted to fuel by two main processes: biological conversion or thermochemical conversion. Below is a diagram that highlights the major steps to fuel conversion.

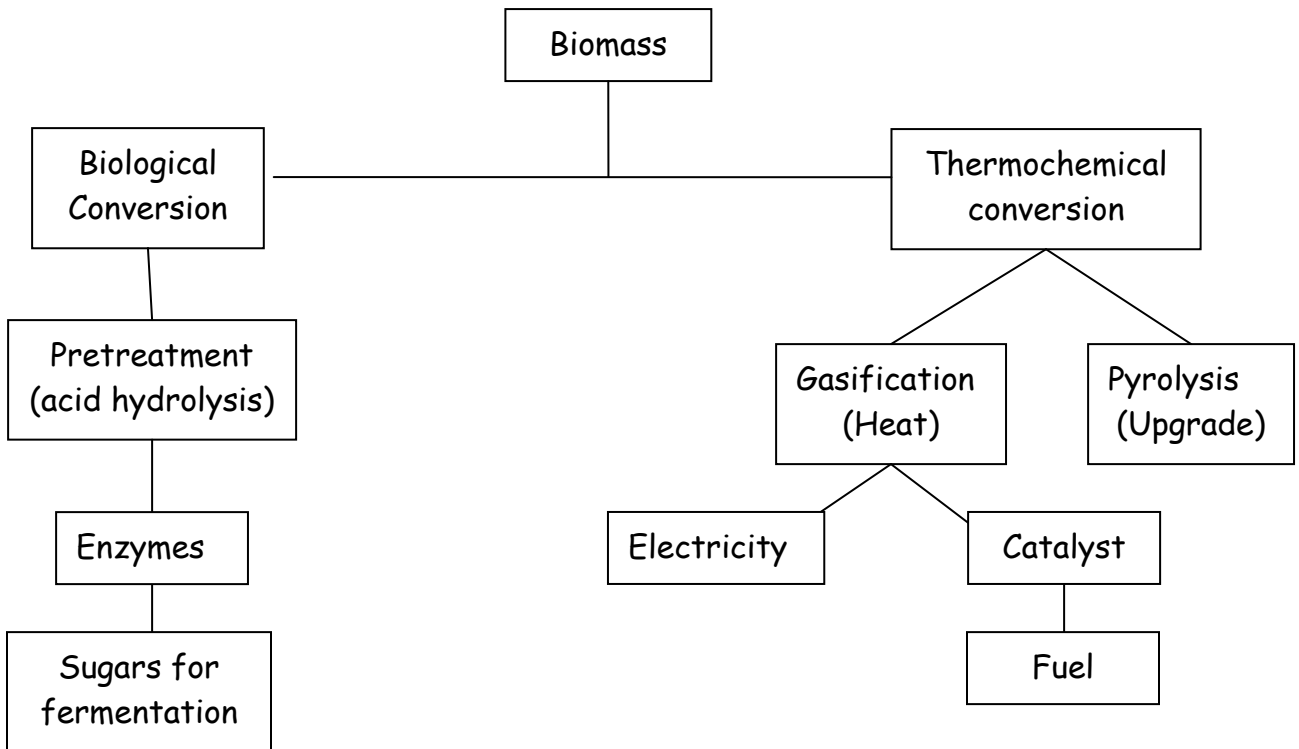

In biological conversion, the biomass is first treated using acid hydrolysis. The purpose of this step is to break up the lignin and hemicellulose within the cell walls which interfere with the enzymes ability to work on the cellulose. The enzymes break up the cellulose into sugars that can be used in fermentation. After fermentation, the ethanol produced is distilled and can now be used as fuel.

In thermochemical conversion, the biomass can be gasified or used in pyrolysis. Gasification creates heat that can be used to generate electricity or heating a home. Pyrolysis requires burning at high temperatures and pressure in the absence of oxygen. The product then needs to be upgraded to a more useful fuel.

Unfortunately the production of biofuels is not a cost competitive alternative to fossil fuels as of 2006. Improvements that must be made start with the biomass itself and follow through the various stages of biological conversion and

thermochemical conversion. This activity looks at ways scientists are trying to “improve” the biomass in organisms such as corn, switch grass, and other plants.

Scientists have mapped the genome of maize (corn plants) and are genetically modifying the maize such that the cell walls contain higher amounts of cellulose than they have in the past. The challenge scientists face is figuring out what genes are involved in producing a cellulose-rich cell wall and further, how they can create a healthy plant with this high cellulose cell wall with a reduction in lignin and hemicellulose.

Learning Objectives:

1. Students will be able to list the 4 nitrogenous bases associated with DNA.
2. Students will be able to “decode” a hypothetical strand of DNA.
3. Students will be able to list the 3 major building blocks of a cell wall.
4. Students will be able to articulate the structure of their cell walls.
5. Students will be able to create a flowchart illustrating ethanol production from planting through distillation in 5 steps.
6. Students will be able to improve their “cell wall” by making at least one genetic modification through collaboration with peers.
7. Students will be able to articulate 2 challenges facing scientists who are working on biofuels and 2 possible solutions.
8. Students will be able to articulate what a genetic modification is.

Time Allotted: Four 50 minute class periods.

Vocabulary:

Biofuel	Hemicellulose	Enzyme
Ethanol	DNA	Fermentation
Cell	Genetics	mutation
Cell Wall	Modification	
Lignin	Biomass	
Cellulose	Gene	

Wheat Germ DNA Extraction Lab

Background:

Remember that the four basic biological molecules that make up cells are nucleic acids, proteins, carbohydrates, and lipids. We can actually separate these molecules here in the 7th grade lab using regular household products. Our task for today is to extract DNA from the nucleus of wheat germ cells. Sounds tricky, but in fact if we follow the procedure carefully we can do this.

We will be using a combination of household products to accomplish this. We will be using hot water, to speed up reactions, and assist in breaking up the biological molecules. We will also be using a mild soap (Dawn or Ivory) to break-up membranes. Remember, that membranes are made of lipids, commonly called fat, and Dawn "cuts grease out of your way". Unfortunately we do not have a centrifuge in the classroom to "spin down" heavy molecules such as proteins and carbohydrates so we will use a 70% mixture of rubbing alcohol to separate the nucleic acids from the solution. The alcohol will create a precipitate with the DNA and after about 5 minutes the precipitate will float on top bringing the DNA to the surface. The DNA will appear white and stringy. So why would we want to do such a thing? Well DNA extraction is the first step to DNA "finger printing" or just about anything else involving DNA experimentation.

Materials:

Wheat germ	rubbing alcohol
Hotplate*	thermometer
50 ml conical test tubes*	mild dish soap
Straws (for stirring)*	paper clips

*These items can be substituted with anything available that can serve the same function.

Procedure:

1. Obtain a 50ml conical test tube.
2. Add 1 teaspoon of wheat germ to the test tube.
3. Mix 20ml of hot water (50-60 degrees C) and mix by stirring with a paper clip for 3-4 minutes.
4. GENTLY mix 1 ml (3 drops) of detergent for about 5 minutes. **Keep foaming to a minimum by not stirring vigorously!**
5. Remove any foam that arises with the pipette.
6. Hold the tube at an angle. Slowly pour 14ml of alcohol down the side of the test tube. It should form a layer on top of the mixture since it has a lower density. **DO NOT MIX!!!** Return the tube to an upright position.
7. After letting the tube sit for several minutes, DNA should appear where the water and alcohol layers touch. DNA is the stringy white material that is seen. After 15 minutes, the DNA should float on top of the alcohol.
8. Remove the DNA from solution with a "modified" paper clip and place the DNA in the test tube containing 70% alcohol at the front of the room.

Analysis Questions:

1. What did the DNA look like?
2. Where would you likely find DNA in an organism?
3. What do you think was the specific purpose of adding each of the following:
(a) detergent (b) alcohol
4. Why might it be important to be able to isolate DNA in the lab?

DNA Decoder

Cell Wall Composition

Possible "genes"

Low % cellulose:

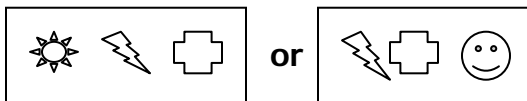

Medium % cellulose:

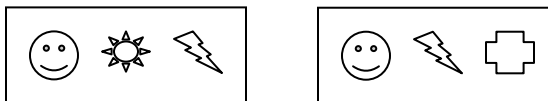

High % cellulose:

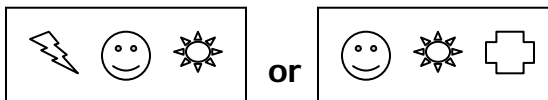

Low % Lignin:

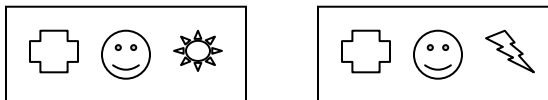

Medium % Lignin:

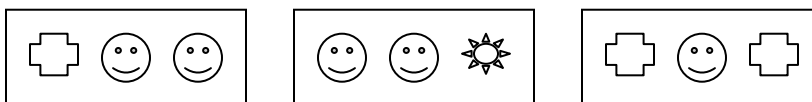

High % Lignin:

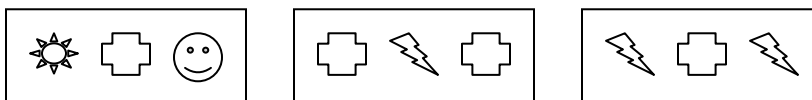

Low % Hemicellulose

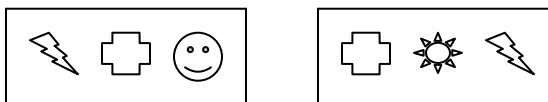

Medium % Hemicellulose

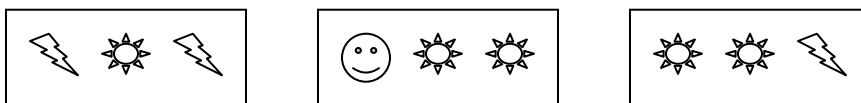

High % Hemicellulose

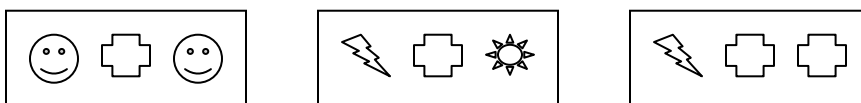

Fatal mutations:

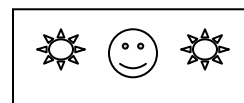
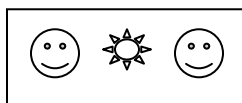
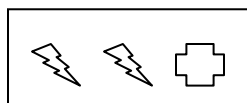
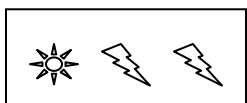
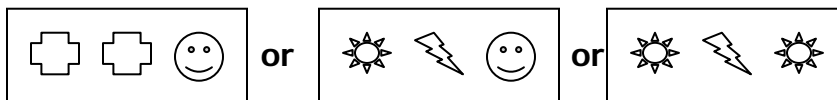

Resources and Materials:

Literature on biofuels can be found at NREL's website: www.nrel.gov.

Material List:

Strips of construction paper (3 different colors)	glue
DNA strips (included)	DNA decoder (included)
Scissors	poster board or butcher paper

Prerequisite knowledge:

Understanding of energy and energy conversion.

Understanding of what DNA is and what genes are.

Plant cell anatomy.

Main Activities:

1. Engage students on day 1 by doing the Wheat Germ DNA Extraction Lab.
2. Mini-lecture on biofuels and plant biology (plant biology should be a review)
3. Tell students that they are genetic engineers and that they will be constructing a cell wall based on a genetic code they have picked out with the DNA strips.
4. Distribute the DNA decoder sheet.
5. Have DNA strips cut out and placed in some sort of container and mix the strips up such that the strips will be picked by students randomly.
6. Have students choose 3 DNA strips from the container at random.
7. Students will now arrange the 3 strips to form a chain such that the 3 strips give 12 symbols in a row.
8. Tell students that every 3 symbols represents a gene and to use the decoder to figure out what their DNA strand codes for.
9. Remind students what a genetic mutation is and review dominant and recessive genes.

Example:

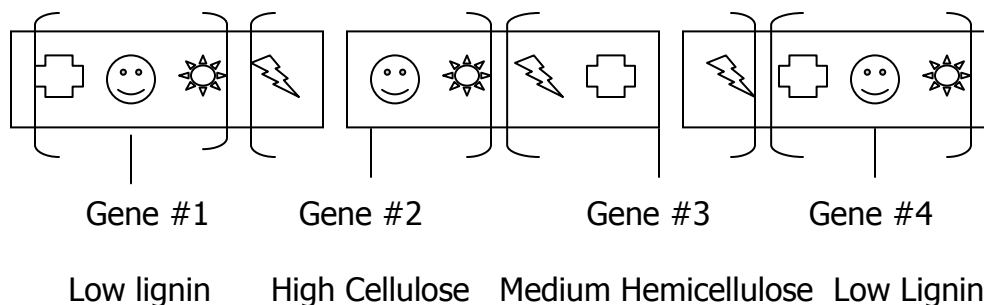

10. Students can arrange their strips in anyway they wish. The target is to get low lignin and hemicellulose and high cellulose. The first time through it is fine if the student does not get the desired combination but students should work on arranging their DNA in the best possible combination. You may allow students to switch out strips as many times as they wish to get the desired outcome however the desired outcome is statistically based and the student may spend a great deal of time trying to get the "correct" combination.

Issues:

If the student can't get three genes for the three components of a cell wall they must "throw out" one strip and replace it with something different from the DNA container and then find another combination.

If the student gets a fatal mutation they must rearrange their strips or replace it with another. (many mutations scientists create to improve cell walls are fatal.)

If the student gets 2 genes for the same component (lignin, hemicellulose, or cellulose) the student uses the gene that is most desirable.

11. Have students "build" their cell wall using strips of construction paper. Students should glue the strips down in a way that cellulose is glued first, hemicellulose second, and lignin third. Students should use a criss-cross pattern so that all three layers are visible. The number of strips for low, medium, and high, is determined by the teacher. Suggestions: 3 strips = low, 6 = medium, 9 = high.

12. Now have students "improve" their cell wall by changing the code. They can draw the new code or pick out the same strips as before and cut out individual symbols and glue them down as their new code. Repeat step 10 for the new code.
13. Students can display their work; do a write up, etc.

Assessment: Students will be asked to present their "cell walls" to the teacher one on one as a "show and tell".

Students will be asked to articulate the following:

1. What are the 3 principle components of plant cell walls?
2. How did you read your genetic code? Did you have to manipulate anything?
3. What was the ideal composition of the cell wall?
4. Why are high amounts of cellulose desirable?
5. What genetic modifications did you make to improve your cell wall?
6. Describe the process of converting biomass into ethanol in 5 steps.
7. What is a genetically modified organism?
8. How can biofuels help our society and environment?

DNA Strips:

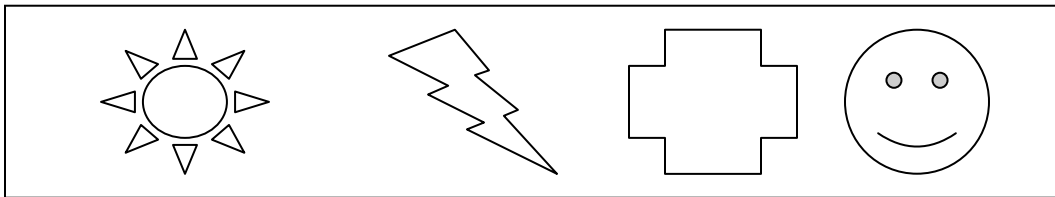
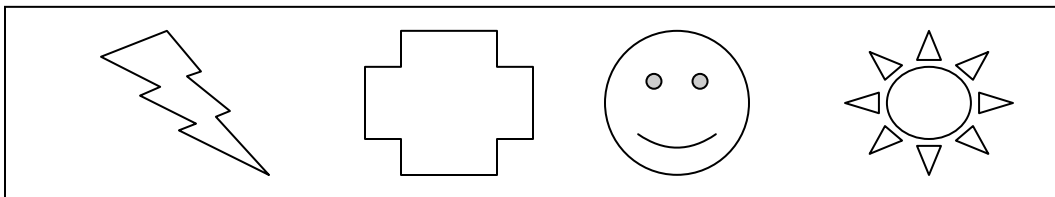
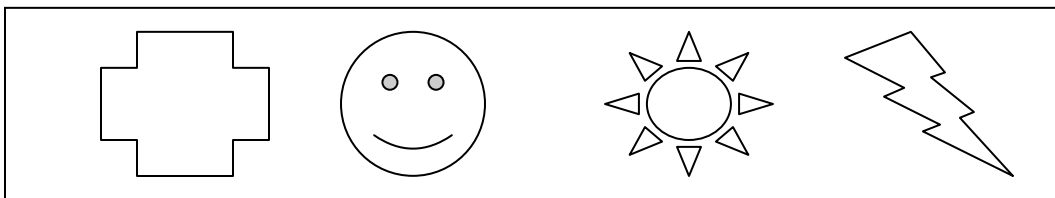
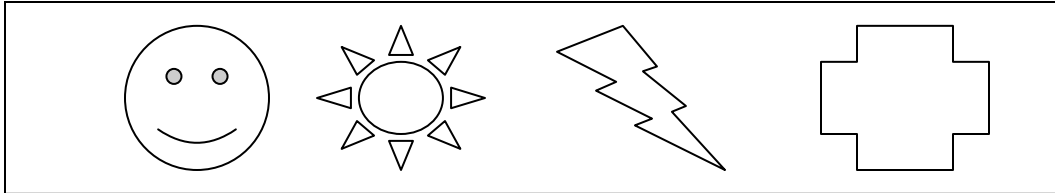

Reaction Rates and Catalysts in Ethanol Production

By
Emily Reith
Arvada High School

Grade Level/Subject

This lesson is intended for use in a high school chemistry class. The lesson could be adapted for a middle school physical science class or AP Chemistry as well.

Standards

Colorado Content Standards

Standard 1: Students understand the processes of scientific investigation and design, conduct, communicate about, and evaluate such investigations.

Standard 2.3: Students understand that interactions can produce changes in a system, although the total quantities of matter and energy remain unchanged.

Standard 5: Students know and understand interrelationships among science, technology, and human activity and how they can affect the world.

Standard 6: Students understand that science involves a particular way of knowing and understand common connections among scientific disciplines.

Overview

Ethanol is produced by fermenting sugar. The source of the sugar can be simple sugars and starched found in the kernels of corn, or it can be found in polymers of sugar molecules known more commonly as cellulose. In order to improve the efficiency and decrease the cost associated with ethanol production, cellulose can be used as a source of sugar for fermentation, if it can be broken down into its component sugar molecules. This process, called hydrolysis, is the subject of a major research effort today. The current methods of hydrolysis involve using either sulfuric acid and high temperatures or complex biological enzymes. Both methods have their drawbacks, so the search is on for an alternative catalyst which will be easier to use and produces the fast reaction rates required for large scale production.

Students will have the opportunity to investigate alternative catalysts for the degradation of hydrogen peroxide, which will be used as a model system for the breaking down of cellulose into sugar. After identifying other potential catalysts, students will develop their own research question relating to catalysts and conduct an additional experiment of

their own design to investigate their question. This lesson not only involves a system similar to one used in the production of ethanol, it also give students the opportunity to conduct research in a manner similar to that of research scientists. Use of the scientific method and presentation of research is emphasized.

This module can be used later in the school year as a lead in to equilibrium as it introduces the idea of reaction rates and activation energy. Parts of this module would also fit in with lessons on polymers or simply on qualitative/quantitative observations.

Learning Objectives

- Students will be introduced to the steps involved with the production of ethanol from cellulose.
- Students will be introduced to catalysts and gain an understanding of how they work.
- Students will understand the factors that affect reaction rate
- Students will be able to make qualitative and quantitative observations.
- Students will be able to use the scientific method to design an experiment and properly control variables.
- Students will be able to use computer software to display data and communicate results.
- Students will be able to interpret and draw reaction progress diagrams for catalyzed and uncatalyzed reactions.

Time Allotted

Five 45 minute periods are needed to complete the entire module. Any of the days can be combined to accommodate block scheduling.

The break down is:

Day 1: Introduction

Day 2: Lab, part 1

Day 3: Lab, part 2

Day 4: Data analysis and time in computer lab

Day 5: Class presentations

The time required for this unit can be reduced if an alternate report format is used (other than the PowerPoint presentation) or if only one part of the lab is done. Also note that days 4 and 5 can be separated from the others by a few days.

Vocabulary

catalyst
decomposition
cellulose
biomass
ethanol
sugar
polymer
enthalpy

endothermic
exothermic
renewable energy
non-renewable energy
Microsoft Excel
spreadsheet
Microsoft PowerPoint
anticatalyst

Resources/Materials

3% hydrogen peroxide
microwell plates
pipettes
manganese dioxide
a variety of other possible catalysts (suggest zinc oxide, copper oxide, sugar, salts, sand, other manganese compounds, etc.)
access to computers with Excel and PowerPoint or similar software
test tubes, hot plates, ice baths, and any other equipment needed for independent student experiments

Prerequisite Knowledge

Students should know how to make and record observations in a lab notebook

Students should have some experience with designing their own experiments, or time should be added to the module to allow for this to be taught.

Students should be familiar with the different types of reactions, especially decomposition reactions.

Students should have had some exposure to thermodynamics, with familiarity of endothermic and exothermic reactions.

Main Activities

Day One:

The following material can be presented as a teacher led discussion, as a PowerPoint presentation, or assigned to small groups to be researched using reference materials.

Part 1 -- Introduction to reaction rates and catalysts

- What is required for a reaction to take place?
 - the right molecules must collide with each other in the right orientation and with enough energy to overcome the activation energy barrier.
- What factors can increase the likelihood of a reaction taking place?
 - increasing the speed and therefore energy of the molecules by raising the temperature
 - increasing the concentration so odds of collision go up
 - somehow lowering the activation energy barrier
- How can the activation energy barrier be lowered?
 - use a catalyst (which creates an alternate pathway)
- Reaction Pathway diagram

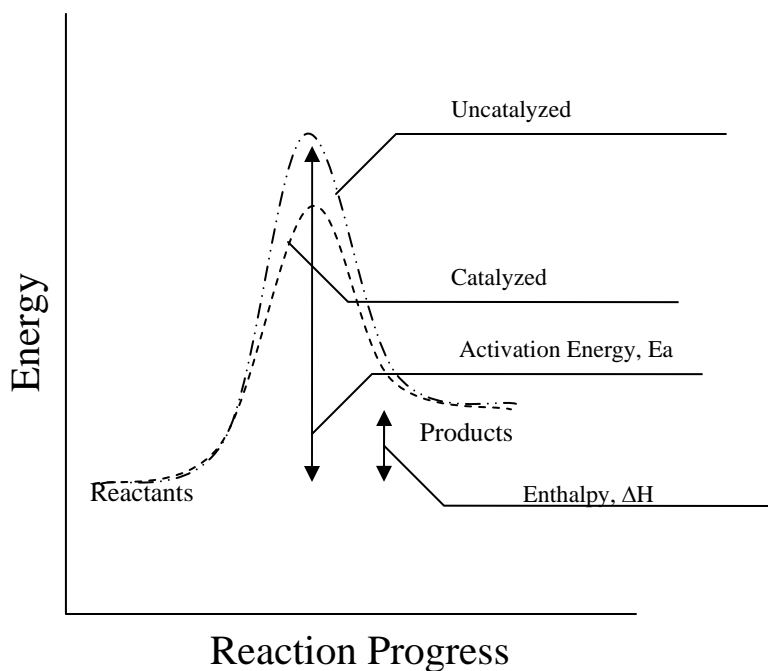

Part 2 -- Connection to renewable energy and ethanol production

- What are some sources of energy?
 - coal
 - sun
 - wind
 - gasoline
 - wood
 - biomass

- geothermal
 - nuclear
 - hydrogen
 - ethanol
- Which of those sources of energy are in limited supply?
 - coal
 - gasoline
 - What does it mean to be a renewable source of energy?
 - Ethanol is a liquid fuel which is considered renewable because it is made from corn, which is a fast growing crop.
 - Sugar from corn kernels is fermented to make ethanol
 - Most of the corn plant is made of cellulose, which is chains of sugar but that cannot be directly fermented into ethanol. Cellulose is a polymer of sugar.
 - A catalyst must be used to break the bonds holding the sugar molecules together in cellulose, such that the sugar can then be fermented into alcohol.
 - Using the cellulose to also make ethanol will make the production of ethanol much less costly in terms of money and energy.
 - The 2 current catalysts have drawbacks, so scientists are interested in finding different catalysts to break the cellulose down into sugar molecules.

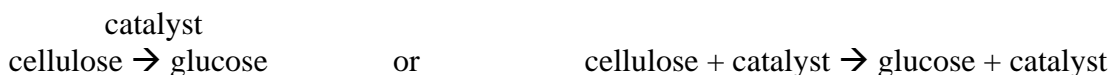

Day 2: Alternative catalysts for a model decomposition reaction

Guided Inquiry Lab:

Student Directions

You are going to be doing research on alternative catalysts for a model system. Instead of breaking cellulose into sugar molecules, you are going to be breaking hydrogen peroxide (H₂O₂) down into oxygen (O₂) and water (H₂O).

Write a balanced equation for this process



or



One known catalyst for our model system is MnO_2 , which works well and relatively quickly. But what if we needed the reaction to happen a little less quickly for some reason (say, to waste less hydrogen peroxide in our micro-mole rockets experiment)? One way might be to simply use less of the catalyst (we'd need to test that to see if it would work), but another would be to find an alternative catalyst that doesn't work quite as well and therefore would take longer to complete the breakdown of the hydrogen peroxide.

The research question is given for this part: "What compounds can be used to decompose hydrogen peroxide and how does their effectiveness compare to manganese dioxide?"

Your initial research will have two main parts:

- 1) Test a variety of compounds for their potential use as a catalyst. Use about 20 drops of H_2O_2 in a microwell and add a tiny sample of the test compound (about the size of a flea). Start by testing the manganese dioxide in this manner to see what a positive result looks like. Test as many or few substances as you like, but try and find at least 2 other compounds that have some ability to break down the hydrogen peroxide. Be sure to keep careful records of which compounds you tested and the results. Record your observations in an organized table. (These tests will be QUALITATIVE)
- 2) Taking the compounds which showed potential as a catalyst, perform additional tests to rank them from most effective (rank=1) to least effective. Support your rankings with data and a graph! (These tests will be QUANTITATIVE)
 - a. What is the independent variable in these experiments? What factors will stay constant?
 - b. What is the dependent variable? (What measurement will you make?)
 - c. How does the measurement relate to effectiveness?
 - d. How many trials will you conduct for each condition?

Day 3: Further investigation of catalysts and reaction rates

Student Directions

Choose 1 additional research question and design and conduct an additional experiment to answer the question. Your question and experiment design must be approved before you begin experimental work. For this investigation, you must choose only one independent variable.

Suggested Questions:

How does temperature affect the decomposition of hydrogen peroxide?

How does the amount of catalyst affect reaction rate?

How does total volume affect reaction rate?

How does agitation affect reaction rate?

What effect does combining catalysts have on reaction rate?

Write your own question...

Complete the following diagram to discuss your experiment with your teacher and classmates.

Title: The Effect of _____ on the _____				
Hypothesis: If _____ then _____ because _____.				
Independent Variable (IV)				
Levels of IV				
Number of Trials				
Dependent Variable				
Constants:				

Note: Students can present their experimental plans to the class prior to experimentation to help them refine their methods and plans.

Day 4: Data Analysis and Presentation Preparation

Students will need access to computers in order to graph their data and prepare their PowerPoint presentations.

Presentation Guidelines (see example)

Title Slide – Topic, presenter names, date

Presentation Outline – What will you be telling us about?

Research question – variables, controls

Experimental design – What did you do to test the question?

Results – What did you find out? Include graphs

Conclusions – What did you take away from this research? How is it useful? How does it relate to class? to life?

Day 5: Class Presentations

Students will present short (3-5 min) PowerPoint presentations to the class on their individual research questions. The audience should write 1-2 sentences summarizing the major findings of each research project.

Evaluation

- A short Pre and Post Test will be administered to students to measure their increase in content knowledge. Suggested questions are as follows.
1. What is required for a reaction to take place? (circle any/all that apply)
 - a. the right molecules must collide with each other
 - b. the temperature must be high
 - c. bonds must be broken
 - d. the reacting molecules must collide with enough energy to overcome the activation energy barrier
 - e. the products must have lower energy than the reactants
 - f. a catalyst must be present
 2. Which of the following chemical equations represent(s) a catalyzed reaction? (circle any/all that apply)
 - a. $\text{C}_2\text{H}_4 + \text{O}_2 \rightarrow \text{CO}_2 + \text{H}_2\text{O}$
 - b. $\text{CH}_3\text{CH}_2\text{OH}(\text{g}) + \text{HCl}(\text{g}) + \text{H}_2\text{SO}_4 \rightarrow \text{CH}_3\text{CH}_2\text{Cl} + \text{H}_2\text{O}(\text{l}) + \text{H}_2\text{SO}_4$
 - c. $\text{H}_2\text{C}=\text{CH}_2(\text{g}) + \text{H}_2(\text{g}) \rightarrow \text{H}_3\text{CH}-\text{CH}_3(\text{g})$
 - d. $\text{H}_2\text{C}=\text{CH}_2(\text{g}) + \text{H}_2(\text{g}) + \text{Pt}(\text{s}) \rightarrow \text{H}_3\text{CH}-\text{CH}_3(\text{g}) + \text{Pt}(\text{s})$
 3. Which of the following would NOT increase the rate of a reaction? (circle any/all that apply)
 - a. increasing the concentration of reactants
 - b. increasing the activation energy barrier
 - c. increasing the temperature
 - d. adding a catalyst

4. Which of the following is/are characteristics of catalysts? (circle any/all that apply)
- catalysts are consumed in the reaction
 - catalysts lower the activation energy barrier
 - catalysts can be homogenous or heterogeneous
 - catalysts increase the amount of product made
 - catalysts can be recovered at the end of the reaction
5. In the diagram below, label the two reaction pathways as either **catalyzed** or **uncatalyzed**. Also label the activation energy, E_a , and enthalpy, ΔH , on the diagram.

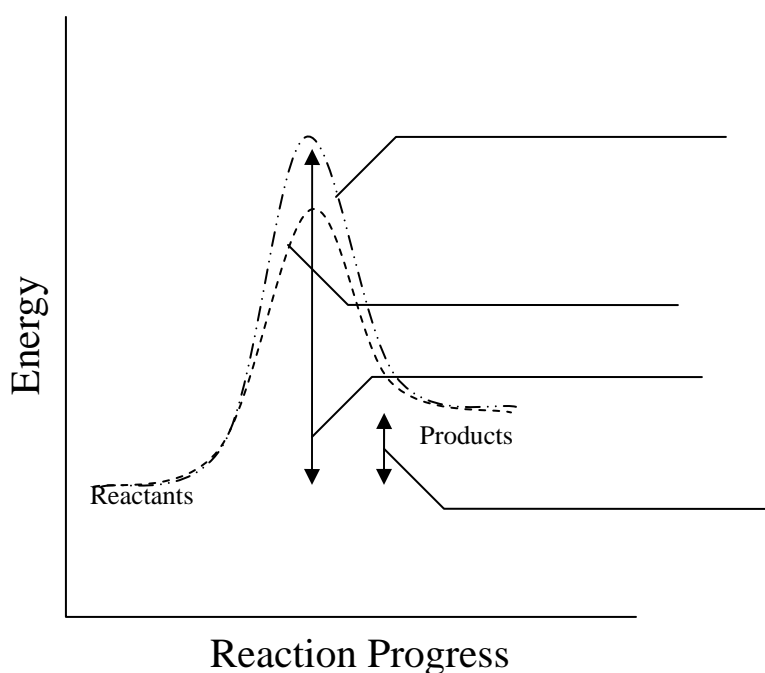

- To further evaluate and develop student understanding at the end of the unit, the following questions will be answered. These questions should be discussed before the Post Test is given.

A) Food preservatives are added to food to slow the spoiling process, which is a chemical change. Different preservatives work in different ways: some help remove water, others attack microbes which spoil food. Other preservatives work by displacing oxygen which is required for many food spoiling organisms to function. Dr. Ilona has just invented a new food preservative which she believes works as an “anticatalyst.”

- 1) What do you think she means by “anticatalyst”?

2) Write a technical definition for anticatalyst. Use the term activation energy in your definition. If you choose to look up the word first, use the first definition to guide your response. The dictionary definition does not use the term activation energy in the definition (sorry!).

3) Add a reaction pathway to the graph below for the “anticatalyzed” reaction of food spoiling.

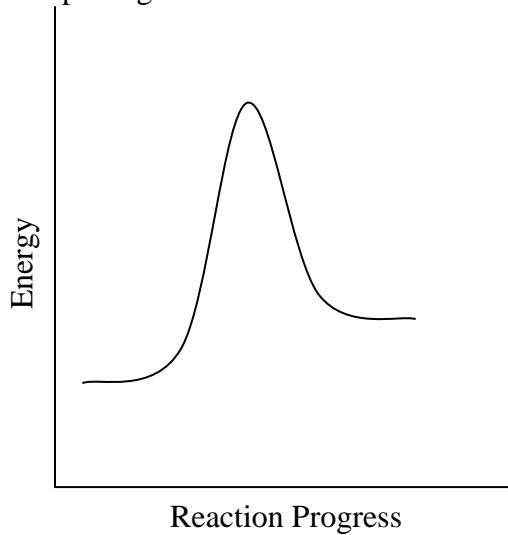

4) What are three questions you would like to ask Dr. Ilona about her new discovery?

B) “When Marco joined the company, he was a real catalyst for change.”

5) What do you think is meant by this statement?

6) Choose a book you have read in the last year. Describe how one of the characters was a catalyst (or anticatalyst) for an event in the book.

C) Below is a graph of data from an experiment to see how the surface area of a catalyst affected reaction rate.

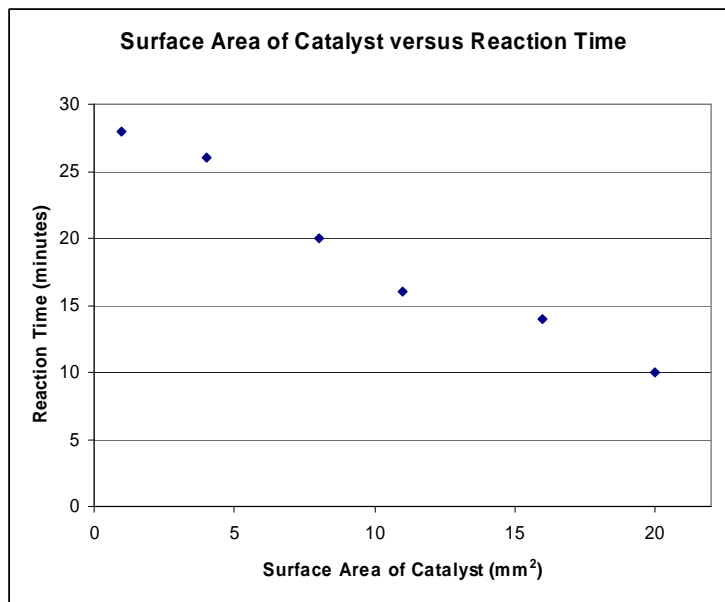

8) Write one sentence describing the results of the experiment. Make sure your sentence includes the terms catalyst, surface area, and reaction time.

9) Does this graph indicate an inverse or direct relationship between surface area of catalyst and reaction time?

- Lab notebooks will be evaluated using a standard rubric. Lab notebooks should include data and observations, graphs, procedures, etc.
- PowerPoint presentations will be evaluated using a rubric, provided to students at the start of the unit.

A Pre-treatment Model for Ethanol Production Using a Colorimetric Analysis of Starch Solutions

AUTHORS:

Eric Benson and Chris Ederer

E-mail Addresses:

eric.benson@theloganschool.org

chris.ederer@isd623.org

GRADE LEVEL/SUBJECT:

9-12th Grade

Environmental Science/Chemistry

Curriculum Standards (from National Science Education Standards)

Science Content Standards: 9-12

CONTENT STANDARD A: Science as Inquiry

As a result of activities in grades 9-12, all students should develop

- Abilities necessary to do scientific inquiry
- Understandings about scientific inquiry

CONTENT STANDARD B: Physical Science

As a result of their activities in grades 9-12, all students should develop an understanding of

- Structure of atoms
- Structures and of properties in matter
- Chemical reactions

CONTENT STANDARD C: Life Science

understanding of the cell

CONTENT STANDARD E: Science and Technology

As a result of their activities in grades 9-12, all students should develop

- Abilities of technological design
- Understandings about science and technology

CONTENT STANDARD F: Science in Personal and Social Perspectives

As a result of activities in grades 9-12, all students should develop understanding of

- Natural resources
- Environmental quality
- Science and technology in local, national, and global challenges

CONTENT STANDARD G: **History and Nature of Science**

As a result of their activities in grades 9-12, all students should develop understanding of

- Science as a human endeavor
- Nature of scientific knowledge

TEACHER'S OVERVIEW:

This module focuses on the production of sugar (glucose and maltose) from cornstarch. The first lesson from this module relates glucose production from cornstarch to ethanol fuel production from corn stover. Another lesson uses a calculator based colorimeter interface from the Vernier® Company to quantify the hydrolysis of starch to sugar by salivary amylase. In this lesson saliva is added to a starch solution containing a couple of drops of iodine. Light initially doesn't pass through this solution. If the absorption decreases after the addition of the saliva, this means more light is passing through and the starch is being hydrolyzed (broken down into maltose and glucose). The third lesson again uses colorimetry but this time to measure starch hydrolysis by dilute (1% volume to volume) sulfuric acid. Finally, we offer suggestions for using starch hydrolysis and colorimetry as a basis for student designed experiments.

Learning Objectives:

Students will

- Recognize the environmental and economic benefits of ethanol as a fuel additive
 - Identify ethanol as a product of sugar fermentation
 - Know that photosynthesis produces complex carbohydrates (polysaccharides)
 - Understand that hydrolysis is a technique used by chemists to break apart polysaccharides into saccharides that can be fermented
 - Demonstrate that starch can be hydrolyzed by salivary amylase
 - Demonstrate appropriate safe laboratory behavior and technique while mixing chemicals
 - Follow correct procedures for using a colorimeter
 - Document observations and data in an organized appropriate laboratory format
 - Analyze and interpret the results of the colorimetric data and observations
 - Communicate their results orally

TIME ALLOTTED:

Five 45minute class periods, one for each of the following topics

- Background information and discussion
- Sulfuric acid tests
- Spit test
- Self-directed investigation
- Discussion of results and conclusions
- Evaluation

VOCABULARY

Ethanol	Corn stover	Hydrolysis
Cellulose	Hemicellulose	Carbohydrate
Polysaccharide	Starch	Saccharide
Glucose	Enzyme	Salivary Amylase
Cellulase	Colorimeter	Cuvette
Blank sample	Test Sample	Concentration
Absorbance	Wavelength	Nanometer
Fermentation	Renewable resource	Non-renewable Resource

RESOURCES/MATERIALS:

Protective eye wear

Vinyl gloves

Lab apron

Graduated cylinder

250 mL beaker

Stirring rod

Distilled water

Four to eight 15mL test tubes and stoppers per group

Labels for glassware

Waterproof pen

Notebook

Mass balance

Weighing paper

Vernier LabPro and cords

Order Code: LABPRO

Price: \$220

Vernier Colorimeter and cuvettes

Order Code: COL-BTA

Price: \$110

<http://vernier.com/>

Kimwipes

Disposable pipettes Carolina Biological Supply

Product Code 73-6984

3.0 mL capacity

Price: \$4.10 Pack of 100

<http://carolina.com>

TI Graphing Calculator (preferably TI-83 Plus Silver Edition), or a computer

Corn Starch (grocery item)

Iodine Tincture (pharmaceutical item and there are hazards for Iodine Tincture, please know and follow all safety measures)

PREREQUISITE KNOWLEDGE:

Students should have used the scientific method in previous student-created experiments. In addition, they should know lab safety rules. Students need also be familiar with photosynthesis and using either the Vernier Labpro® or TI CBL equipment with either a computer or TI calculator.

MAIN ACTIVITIES:

Day one: Introduce students to concepts related to the significance and production of Ethanol as a renewable resource and fuel. (See teacher background information.)

Day two: Students hydrolyze a solution of corn starch and distilled water in saliva (salivary amylase) and make comparisons using the colorimeter.

Corn starch does not dissolve in water. Therefore, it will be necessary to frequently and vigorously mix it at strategic times during this inquiry, such as before decanting or placing in the colorimeter. It may be necessary to vigorously mix the cuvettes during their colorimetric analysis.

Also, salivary amylase hydrolyzes starch over time. Consequently, it may be valuable for students to prepare their mixtures with starch solution one day before collecting their colorimetric data.

Colorimetric analysis should be performed at a wavelength of 635 nm, at this wavelength the color change from the addition of iodine does not interfere with the effects of salivary amylase on the starch. (You may wish to have students check the absorption of just water with a couple of drops of iodine in it. At 635 nm the absorption should be zero. Ask the students why. *Answer: the iodine solution is reddish yellow. This means the solution absorbs other colors but reflects reddish yellow. The wavelengths of yellow to red range from about 570 nm to 700 nm. 635 nm falls right in the middle of that range.*)

- In a 100 mL graduated cylinder prepare a stock sample of 0.5g of corn starch in 100mL of water. (Individual student groups will need less than 10 mL of this sample.)
- Calibrate the colorimeter with 3 mL of distilled water in a cuvette
- Prepare and analyze a blank sample cuvette of 3 mL of distilled water and one drop of iodine
- One student, who hasn't eaten in a while, collects about 10 mL of saliva
- Prepare and analyze one test sample cuvette by pipetting 1.5 mL of stock solution and 1.5 mL of saliva and record colorimetric data
- Prepare and analyze a second test sample cuvette by pipetting 1.5 mL of stock solution and 1.5 mL of saliva and adding one drop of iodine and record colorimetric data. (The absorbance should decrease with time in this sample. This shows that the starch is changing, but it doesn't show that glucose is formed. A Benedict's solution test could be done as a demonstration at this point.)

Day three: Acid hydrolysis of corn starch and colorimetric analysis of the acid solution and saliva. Repeat the steps given for day one only substitute 1% sulfuric

acid for distilled water. Prepare a 1% sulfuric acid solution by adding 1 ml of concentrated sulfuric acid to 99 ml of distilled water.

- In a 100 mL graduated cylinder prepare a stock sample of 0.5g of corn starch in 100mL of water 1% sulfuric acid. (Individual student groups will need less than 10 mL of this sample.)
- Calibrate the colorimeter with 3 mL of 1% Sulfuric Acid in a cuvette
- Prepare and analyze a blank sample cuvette of 3 mL of 1% Sulfuric Acid and one drop of iodine
- One student, who hasn't eaten in a while, collects about 10 mL of saliva
- Prepare and analyze one test sample cuvette by pipetting 1.5 mL of stock solution of 1% sulfuric acid and 1.5 mL of saliva and record colorimetric data
- Prepare and analyze a second test sample cuvette by pipetting 1.5 mL of stock solution of 1% sulfuric acid and 1.5 mL of saliva and adding one drop of iodine and record colorimetric data.

Group Homework for Inquiry Lab: Students create an experiment involving starch hydrolysis and colorimetry. Students write the title, purpose, materials, and methods for their experiment.

Some possibilities for further inquiry include testing the affect of temperature on the amylase in saliva, seeing how temperature affects the rate of starch hydrolysis, testing individual differences in the amounts of amylase in each others' saliva, testing dog saliva (if a student has a "drooly" dog), or seeing if exercise affects the amylase concentration in saliva.

These are only suggestions. You may wish to encourage students to come up with their own questions.

Day four: Students perform experiments of their choosing or design. (See our list of possibilities in the Group Homework for Inquiry Lab section above.)

Day five: Discussion and Evaluation

EVALUATION POSSIBILITIES:

- Use a lab rubric to evaluate the experiment. Students could be assessed on participation, safe lab techniques and proper methodologies.
- A written lab report could be evaluated by the teacher or by student groups.
- Use a rubric or score student presentations on the results and conclusions from the experiments they created.
- Have students write an essay summarizing the environmental and economic impacts of ethanol blended gasoline.
- Have students summarize the basic ideas behind colorimetry and how the colorimeter showed the hydrolysis of starch.

TEACHER BACKGROUND

Ethanol is a renewable energy source often added to gasoline. In this country some gasoline blends contain 10% - 12% ethanol. Other countries, like Brazil, have higher percentages of ethanol in their automotive fuels. The presence of ethanol in gasoline reduces the consumption of this nonrenewable resource. It also reduces pollution as ethanol combustion produces far fewer pollutants than the burning of gasoline. Another advantage of using ethanol for fuel is that it does not increase the level of carbon dioxide in the atmosphere (unlike gasoline). Ethanol comes from plants that absorbed CO₂ from the atmosphere for photosynthesis. The amount of CO₂ released during combustion of ethanol equals the amount used in photosynthesis, so there is not net atmospheric gain.

Ethanol is produced from the fermentation of sugars by microorganisms, typically yeast. Plant starch is commonly used as a source of sugar (mainly glucose) for fermentation. In the United States corn is used almost exclusively for the fermentation of sugar into ethanol. As the demand for ethanol as a fuel additive continues to rise, the amount of corn used for fuel will also rise. This raises an ethical issue pitting rich auto owners who want cheaper gas against poor people who need cheaper food. So a different, non-edible source of sugar is needed. One such source is corn stover. Corn stover is everything that is left of the corn plant after the kernels have been removed; cobs, stem, leaves, etc. Corn stover is approximately 45% cellulose, 30% hemicellulose, and 15% lignin. The remaining 10% is comprised of a variety of other materials.



The sugars are found in the cellulose and hemicellulose. Unfortunately, it is much more difficult to get sugars from corn stover than from cornstarch (this is why we used cornstarch in this education module rather than corn stover). Both starch and cellulose are polymers of glucose. The difference is that starch is comprised of repeating monomers of α - glucose while cellulose is made from chains of β - glucose. Can you spot the difference below?

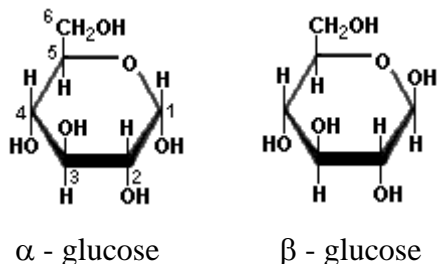

The β - glucose has a hydroxyl group on the first carbon on the same side as CH_2OH . This small difference accounts for the great differences between starch and cellulose (this could be a good tie-in to evolution). It is the reason why starch can be hydrolyzed (split apart by the addition of a water molecule) into glucose and maltose by amylase (found in saliva) but cellulose cannot. Cellulose requires cellulase to hydrolyze it into fermentable glucose.

The commercial production of ethanol from corn stover involves a dilute sulfuric acid and heat pretreatment. This hydrolyzes the hemicellulose into (among other things) fermentable pentoses (5-carbon sugars). Prior to pretreatment, the hemicellulose is a huge obstacle to enzymatic cellulose hydrolysis. After the hydrolysis of hemicellulose, cellulase is now able to break cellulose into fermentable glucose.

The trick is to get just the right acid concentrations and heat conditions. Too hot and/or too acidic and the sugars degrade and can't be fermented. But if it isn't hot or acidic enough, not all the hemicellulose is hydrolyzed and the cellulase can't do its thing.

In this education module, starch is good substitute for corn stover. It shows biological hydrolysis (amylase) with a quantifiable method. It also shows that amylase is much more effective in breaking down starch than is 1% sulfuric acid (a fact that might surprise students). Amylase actually comprises less than 1 % of the volume of saliva. It is usually over 99% water.

For more information visit www.nrel.gov.

For more information of the colorimetry portion of this module, refer to the literature accompanying your Vernier® colorimeter.

The Bio-Fuel Project

AUTHORS:

Matthew A. Brown and Raymond I. Quintana

GRADE LEVEL/SUBJECT:

10th, 11th, 12th Chemistry & Technology Education



Relevant Curriculum Standards:

From The National Science Education Content Standards

Science as Inquiry Standard A:

- Use appropriate tools and techniques to gather, analyze, and interpret data.
- Develop descriptions, explanations, predictions, and models using evidence
- Think critically and logically to make the relationships between evidence and explanations.

Physical Science Standard B:

- Structure and Properties of Matter - The physical properties of compounds reflect the nature of the interactions among its molecules. Carbon atoms can bond to one another...to form a variety of structures, including synthetic polymers, oils, and the large molecules essential to life.

- Chemical Reactions – Chemical reactions occur all around us, for example in health care, cooking, cosmetics, and automobiles. Chemical reactions may release or consume energy. Some reactions such as the burning of fossil fuels release large amounts of energy by losing heat and by emitting light. Catalysts, such as metal surfaces, accelerate chemical reactions.
- Transfer of energy – energy is a property of many substances and is associated with heat, light, and electricity. Energy is transferred in many ways.
- Conservation of Energy – Everything tends to become less orderly over time. Thus, in all energy transfers, the overall effect is that the energy is spread out uniformly. Examples are the transfer of energy from hotter to cooler objects by conduction, radiation, or convection and the warming of our surroundings when we burn fuels.

Science and Technology Standard E:

- Identify a problem.
- Propose designs and choose between alternative solutions.
- Implement a proposed solution.
- Evaluate the solution and its consequences.

From *The Standards for Technological Literacy*

Standard 5: Students will develop an understanding of the effects of technology on the Environment:

- L. Decisions regarding the implementation of technologies involve the weighing of trade-offs between predicted positive and negative effects on the environment.

Standard 10: Students will develop an understanding of the role of troubleshooting, research and development, invention and innovation, and experimentation in problem solving:

- L. Many technological problems require a multidisciplinary approach.

Standard 16. Students will develop an understanding of and be able to select and use energy and power technologies:

- N. Power systems must have a source of energy, a process, and loads.

Standard 17. Students will develop an understanding of and be able to select and use information and communication technologies:

- Q. Technological knowledge and processes are communicated using symbols, measurement, conventions, icons, graphic images, and languages that incorporate a variety of visual, auditory, and tactile stimuli.

Standard 18. Students will develop an understanding of and be able to select and use transportation technologies:

- K. Intermodalism is the use of different modes of transportation, such as highways, railways, and waterways as part of an interconnected system that can move people and goods easily from one mode to another.
- L. Transportation services and methods have led to a population that is regularly on the move.
- M. The design of intelligent and non-intelligent transportation systems depends on many processes and innovative techniques.

TEACHER'S OVERVIEW:

This exercise introduces students to the concept of alternative fuels, and gives them an opportunity to produce their own biodiesel fuel using an analytical approach. The text of the exercise gives students a brief background in the environmental benefits of using biodiesel as a diesel substitute. The lab portion of this exercise demonstrates the basic chemistry involved in making biodiesel from vegetable oils and waste oils.

Many students have heard of biodiesel without realizing that to produce the fuel from waste vegetable oil is a fairly simple process. Seeing the process firsthand, and better yet, going through the steps from oil to fuel, enables the student to grasp the fuel making process. Included in this exercise is some basic oil analysis that is necessary to differentiate between various oils that a biodiesel producer may encounter. This is an easy exercise to set up: it requires primarily basic equipment commonly found in a high school chemistry laboratory. Interest sparked by this exercise may inspire students to become more familiar with the various aspects of renewable energy technologies.

Safety practices for handling the materials involved in producing biodiesel fuel cannot be overemphasized, especially if students attempt to synthesize biodiesel outside of class.

LEARNING OBJECTIVES:

Students participating in this activity are expected to learn the following:

- The definition of a renewable fuel
- How the substitution of biodiesel fuel for petroleum diesel benefits the environment
- How biodiesel fuel is made from waste vegetable oil
- How this fuel-making process can be adjusted to utilize waste oils from different sources, and the chemical analyses necessary to determine oil quality
- How to assess the finished products from the biodiesel reaction
- How issues of waste stream management can be addressed in an environmentally responsible way

TIME ALLOTTED: Two weeks

VOCABULARY

Energy

Transesterification

Fuel

Biodiesel

Triglycerides

pH

Titration

Esters

Glycerol

RESOURCES AND MATERIALS:

Resources:

Bio-Fuel design brief handouts, computers for web research of Bio-Diesel processing.

Materials:

Chemical resistant gloves, goggles, and lab aprons

New vegetable oil (500 ml)

Two samples of waste vegetable oil (about 600 ml or more of each)

Sodium Hydroxide (lye)

Methanol

Isopropyl alcohol

0.1% sodium hydroxide stock solution for titrations

2 quart mason jars, or HDPE plastic bottles with tight fitting lids

Graduated cylinders: 1000 ml, 100 ml, and 10 ml.

Pipettes, or burets graduated to measure 0.1 ml, graduated eyedroppers, or graduated plastic syringes

Scale accurate to 0.1 grams

Hot plates with stirring rods or suitable substitute

1 L beakers for heating oil

Beaker tongs for transferring warmed oil to graduated cylinders

Celsius thermometers

PH strips accurate in the 8-9 range or phenol red indicator solution

A 250 ml beaker for each group for decanting stock NaOH solution.

Several small beakers for titration (3 or 4 per group).

Labeling tape and permanent markers

PREREQUISITE KNOWLEDGE:

- Students should be able to use computers to do Internet research.
- Students should be able to use common laboratory equipment to measure liquid volumes, to measure mass, and to prepare solutions.

Creating Bio-Diesel

Teaching and Prep time:

Gathering materials: 2 hours+. This exercise is most effective if there are a variety of waste vegetable oils to work with. These can be accessed from the school cafeteria, the teacher's own kitchen, or restaurants that fry foods in vegetable oil. It is advisable to consider the oil source a few weeks in advance.

Classroom setup: 30 minutes

Teaching time: The entire exercise can be completed in one 2-3 hr. lab session. An additional follow-up exercise is included.

Introducing the exercise: 20-30 minutes

Step I, making fuel from new vegetable oil: 40 minutes

Step II, chemical analysis of used vegetable oil: 30 minutes

Step III, making experimental fuel from used vegetable oils: 30 minutes

Optional 2nd week analyses: 1 hr+

Day 1: Review the history, background, materials, safety, and process for making biodiesel. Emphasis the importance of safely using KOH or NaOH and methanol.

- ❖ An inquiry based activity that could be added in lieu of the provided activity is to have the student groups come with their own history, background, material, safety, and process for making biodiesel and an additional experiment that they developed. Students should discuss whether they would use KOH or NaOH and why they made that decision. After students present their findings they can be given the brief.

Background information:

Biodiesel is a renewable fuel made from any biologically based oil, and can be used to power any diesel engine. Now accepted by the federal government as an environmentally friendly alternative to petroleum diesel, biodiesel is in use throughout the world. Biodiesel is made commercially from soybeans and other oilseeds in an industrial process, but it is also commonly made in home shops from waste fryer grease. The simple chemistry involved in small-scale production can be easily mastered by novices with patience and practice. In this exercise, students will learn the process of making biodiesel and practice some analytical techniques.

Dr. Rudolf Diesel first demonstrated his diesel engine to the world running on peanut oil in the early 1900's. The high compression of diesel engines creates heat in the combustion cylinder, and thus does not require a highly flammable fuel such as that used in gasoline engines. The diesel engine was originally promoted to farmers as one for which they could "grow their own fuel". Diesels, with their high torque, excellent fuel efficiency, and long engine life are now the engine of choice for large trucks, tractors, machinery, and some passenger vehicles. Diesel passenger vehicles are not presently common in the United States due to engine noise, smoky exhaust, and cold weather starting challenges. However, their use is quite normal in Europe and Latin America, and more diesels are starting to appear in the US market.

Over time, the practice of running the engines on vegetable oil became less common as petroleum diesel fuel became cheap and readily available. Today, people are rediscovering the environmental and economic benefits of making fuel from raw and used vegetable oils. Fuel made from waste fryer grease has the following benefits when compared to petroleum diesel:

- Using a waste product as an energy source
- Cleaner burning: lower in soot, particulate matter, carbon monoxide, and carcinogens
- Lower in sulfur compounds: does not contribute to acid rain

- Significant carbon dioxide reductions: less impact on global climate change
- Domestically available: over 30 million gallons of waste restaurant grease are produced annually in the US

In addition, use of well-made biodiesel fuel can actually help engines run better. Petroleum diesel fuels previously relied on sulfur compounds in the oil to keep engines lubricated. However, sulfur tailpipe emissions are a significant contributor to the formation of acid rain, so regulators have forced the reduction of sulfur in diesel fuel. Biodiesel made from vegetable oil has a better lubricating quality and can help solve engine wear problems without increasing acid rain. For this reason, use of biodiesel is already common in trucking fleets across the country.

Some other interesting facts:

- Biodiesel can be readily mixed with diesel fuel in any proportion. Mixtures of biodiesel and diesel fuel are commonly referred to by the percentage of biodiesel in the mix. For example B100 contains 100% biodiesel, B20 contains 20%.
- Biodiesel can be run in any unmodified diesel engine.
- Biodiesel is less flammable than diesel. It will gel at a higher temperature (typically around 20F) and thus should be mixed with petroleum fuel in cold weather.

Making Biodiesel Fuel

The reaction that converts vegetable oil into biodiesel is known as transesterification, which is similar to saponification, the process for making soap. Vegetable oil is comprised of triglycerides, which are glycerol-based esters of fatty acids. Glycerol is too thick to burn properly in a diesel engine at room temperatures, while esters make an excellent combustible material. The goal when making biodiesel is to convert the triglycerides from glycerol-based esters to methyl esters of fatty acids, thus *transesterification*. Sodium hydroxide (lye) is necessary to convert the methanol into methoxide ions, which will cleave the fatty acid from the glycerol by replacing the one glycerol with three methoxy groups per each triglyceride.

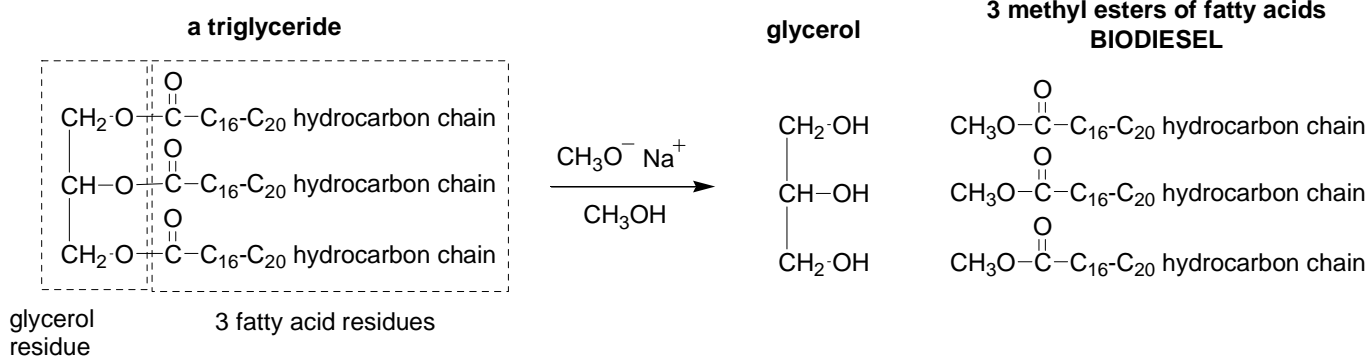

For every liter of vegetable oil, the reaction uses 220 milliliters (22% by volume) of methanol. New oil requires 4 grams of lye per liter of oil, whereas used oil will require somewhat more. The quantity of lye will vary depending upon the quality of our vegetable oil, and will need to be determined by chemical analysis. Students will first practice making fuel from new vegetable oil, which requires a known amount of lye for the reaction. In the second step, students will determine the quantity of lye needed for different used vegetable oils, then test our analyses by making fuel from those oils.

SAFETY NOTES!: Methanol and lye are dangerous substances and should be handled with caution! Methanol is poisonous to skin, and its fumes are highly flammable. Lye is a strong skin irritant and can cause blindness! Always wear gloves and goggles when working with these chemicals, and keep any sparks or flame away from methanol containers. Work under a chemical hood or other well ventilated space.

Other cautions: Biodiesel fuel made in a school lab is experimental in nature, and should be burned in diesel engines at the users own risk. While well made fuel will not harm a diesel engine, interested teachers & students are advised to read further on the subject before actually testing biodiesel in an engine. Students should not remove biodiesel fuel from the laboratory classroom without instructor permission.

Materials:

Chemical resistant gloves and goggles for each student

New vegetable oil (500 mL per group)

Two samples of waste vegetable oil (about 600 mL or more of each per group)

3 one-quart mason jars per group, or HDPE plastic bottles with tight fitting lids
Sodium Hydroxide (lye)
Methanol (400 mL per group)
Graduated cylinders: 1000 mL, 100 mL, and 10 mL.
Pipettes graduated to measure 0.1 mL, graduated eyedroppers, or graduated plastic syringes
Scale accurate to 0.1 grams
Hot plates with stirring rods or suitable substitute
Large beakers or pots for heating oil
Plastic scoops or ladles for transferring warmed oil to graduated cylinders
Celsius thermometers
Isopropyl alcohol (91% or 99%)
Packets of pH strips accurate in the 8-9 ranges. Phenol red indicator solution is an option if pH strips are not available. Phenylalanine is also effective.
A stock solution made from 1000.0 mL distilled water and 1.00 grams of sodium hydroxide (a 0.1% solution, 1 liter should accommodate the whole class, and stores well if uncontaminated.) The accuracy of this solution is important to the whole exercise.
A 100 mL beaker for each group for decanting stock NaOH solution.
Several small beakers for titration (about 4 per group).
Labeling tape and permanent markers

Procedure:

Day 2: Making fuel from new vegetable oil

Note to Instructor: The instructor may choose to give students a basic refresher in chemistry techniques, such as reading a meniscus in a graduated cylinder. If time permits it may help to demonstrate the reaction technique once prior to the students engaging in the activity, or to prepare a well-settled sample of biodiesel ahead of time.

1. Put on your gloves and goggles. Everyone must wear protective gear while handling chemicals!

Check point 1 - No group may progress beyond this point without this step being signed off by the instructor.

2. Measure out 500 mL or more of new vegetable oil and pour it into a large beaker.
3. Heat 500 mL of new vegetable oil to 50 °C on a hotplate using a stirrer. One person in your group should watch the temperature closely so the oil does not overheat.

Note to instructor*: If hotplates are in short supply, one large beaker can be used to heat oil for several groups. This beaker should be located near a sink for easy transfer by scooping to graduated cylinders.

Perform the following two steps under the chemical hood or other well ventilated space.

Check point 2 - No group may progress beyond this point without this step being signed off by the instructor.

4. Measure 110 mL of methanol in a graduated cylinder and pour into your mixing bottle. Cap the methanol bottle and your mixing bottle tightly.
5. Weigh out 2.0 grams of sodium hydroxide (lye) and add to the methanol in your mixing bottle. Cap the bottle and swirl gently for a few minutes until all of the lye dissolves. You now have sodium methoxide in your bottle, a strong base. Be careful!
6. When the lye is dissolved and the oil reaches 50 °C, add 500 mL of warm oil to the methoxide and cap the bottle tightly. Invert the bottle once over a sink to check for leaks. **Caution: Be certain that the oil is not over 60 °C, or the methanol may boil.**
7. Shake the bottle vigorously for a few seconds then, while holding the bottle upright, open the cap to release any pressure. Retighten the cap and shake for at least one minute venting any pressure occasionally. Set the bottle on the bench and allow the layers to separate.
8. Over the next 30-60 minutes, you should see a darker layer (glycerol) forming on the bottom of the bottle, with a lighter layer (biodiesel) floating on top. Complete separation of the reaction mixture will require several hours to overnight. Move on to the next step of the exercise while your biodiesel is separating.

Questions for your lab book:

- If the base rate for sodium hydroxide (lye) is 4.0 grams per liter of oil, why did you only use 2.0 grams for this batch? *Ans: This reaction used only 500 mL (0.5 liters) of oil.*

- How much lye would be used to convert 50 liters of new oil? *Ans: 50 L x 4.0 g/L = 200 g of lye.*
- For a given quantity of new oil, what variables could be changed to effect the reaction? *Ans: Mixing time, temperature, amount of lye, amount of methanol.*

Day 3: Testing waste oil by titration to determine the quantity of lye.

As vegetable oil is used for frying foods, the high heat, water, and food products in the fryer can degrade the oil into various byproducts. One byproduct is the development of free fatty acids in the oil. These acids will act to neutralize some of the lye used in the biodiesel reaction. Since the reaction requires four grams of catalyst for every liter of oil, we will need to add extra lye to make up for that neutralized by the free fatty acids. More heavily used oil will tend to contain more acid, and thus require larger quantities of lye than lightly used oil.

It is important when making biodiesel to use the proper amount of lye for a given oil. Too much lye can result in a solid soap forming in the reaction vessel, and too little lye will result in an incomplete reaction and poor quality fuel.

A process called titration determines the exact amount of extra lye required. To perform the titration, a known solution of lye is added to a sample of used oil in measured amounts, until a desired pH shift is seen. Because it is difficult to measure the pH of oil, the oil will first be dissolved in isopropyl alcohol to make testing easier.

For this exercise, you will determine the quantity of lye needed to make biodiesel from two different oils: one that is heavily used and one that is lightly used.

1. Obtain a sample of used vegetable oil from two different sources. Preferably one will be more heavily used than the other. Label the lightly used oil as sample A, and the heavily used oil as sample B.
2. Using a pipette, syringe, or graduated eyedropper, measure 1.0 mL of oil from one sample into a small mixing beaker. Make a note in your lab book of which oil you are using first: lightly used (A) or heavily used (B).
3. Measure 10 mL of isopropyl alcohol using a graduated cylinder, add this to the oil, and swirl to mix
4. Test the pH of the oil-alcohol solution using a pH strip
5. Using a different pipette, add lye-water (from a stock 1% solution of NaOH in distilled water) to the oil-alcohol solution in 0.5 mL increments. Add the lye-water carefully so that you are sure to only add 0.5 mL at a time.

6. After each 0.5 mL addition of lye-water, recheck the pH with a pH strip. Record the number of 0.5 mL additions you make on a tally sheet!
7. Continue adding lye-water until the pH of the solution reaches approximately 8.5. At this point, count the number of milliliters of lye-water that you added. (For example, if you added 0.5 mL of lye-water three times, you added a total of 1.5 mL of lye-water).
8. Calling the number of mL of lye-water that you added "X", put that number into the following equation:

$$X + 4.0 \text{ grams} = L$$

L = the total number of grams of lye needed to make biodiesel from 1 liter of this particular oil. Record this number in your lab book.
9. Repeat steps 1 through 7 using a second batch of oil of different quality, and record the value for L in your lab book. Be sure to keep track of which value for L refers to which oil sample. You may want to repeat the titration for each oil to be sure of your results.

If using phenol red instead of pH strips, follow these steps:

1. Add 5 drops of phenol red to the beaker containing 10 mL of isopropyl alcohol and 1 mL of oil to be tested.
2. The solution will appear yellow at an acid pH, and will turn pink when the pH is between 8 and 9. Add lye-water in 0.5 mL increments, counting as you go, until the oil alcohol solution turns pink or purple and stays that way for 30 seconds or more.
3. The number of milliliters of lye-water it took to turn the solution pink is "X". Refer to the equation above.

Questions:

- Why is it necessary to perform a titration on used vegetable oil?
- How much lye will be required to convert 1.0 liters of vegetable oil sample A to biodiesel? Sample B?
- How much lye will be required for 0.5 liters of each oil: A? B?
- When biodiesel brewers make large batches of fuel, they typically repeat the titration procedure several times per batch. Why do you think they would do this? *Ans: because the titration uses a very small sample of oil to determine the lye amount for a large volume*

of oil and thorough mixing is difficult for large batches (try having answers in different color, even just for viewing on the monitor)

- Which type of oil do you think requires more lye catalyst, lightly used or heavily used? Why? *Ans: Heavily used oil will require more catalyst. As the oil is used it breaks down and forms free fatty acids, which neutralize some of the lye.*
- Can you see any difference in color between the heavily used oil and lightly used oil? *Ans: Heavily used oil is usually darker in color than lightly used oil. This information can be helpful when trying to assess whether or not a titration figure is "in the ballpark".*

Day 4: Making biodiesel using waste vegetable oils

In part 3, you will use the value for L that you determined in step 2 to make fuel from waste oil. This is basically a repeat of the procedure from part 1, except that you will be varying the quantity of lye for each batch.

1. Put on your gloves and goggles. Everyone must wear protective gear while handling chemicals!
2. Measure out 500 mL or more of each waste vegetable oil, and pour it into a large beaker. Mark each beaker "A" or "B" depending on the oil you are using. Obtain two mixing bottles and label one "A" and the other "B"
3. Heat 500 mL of each vegetable oil to 50 °C on a hotplate using a stirrer. One person in your group should watch the temperature closely so the oil does not overheat.

Check point 3 - No group may progress beyond this point without this step being signed off by the instructor.

Perform this step and the next under the chemical hood.

4. Measure 110 mL of methanol in a graduated cylinder for each batch and pour into your mixing bottles. Cap the methanol and mixing bottles when you are finished.
5. Weigh out and add the correct amount of lye for each oil to your mixing bottles. Recap the bottles tightly. Gently agitate each bottle until the lye is dissolved.
6. When the oil samples are up to 50 °C, add 500 mL of the proper oil to the each mixing bottle and cap them tightly.

Be sure that the oil is not over 60 °C to avoid boiling the methanol!

7. Invert the mixing bottle once over a sink to check for any leaks.
8. Shake the bottle vigorously for a few seconds then, while holding the bottle upright, open the cap to release any pressure. Retighten the cap and shake for at least one minute venting any pressure occasionally. Set the bottle on the bench and allow the layers to separate.
9. Leave the bottles to separate until next week.
10. Clean up your lab space.

Day 5: Separating and washing your biodiesel

If your procedure worked correctly, there should be two distinct layers after settling. The darker layer at the bottom is a crude glycerine byproduct, and the lighter layer on top is biodiesel. If you pick up the settling bottle and rock it slightly from side to side, notice how the darker layer is thicker than the fuel floating on top. This higher viscosity of glycerine is one of the reasons that it isn't suitable for use in a diesel engine at room temperatures. By removing the heavier, more viscous part of the oil, the esters pass through the engine's injectors and combust that much easier.

It is common to see a whitish third layer floating between glycerine and the biodiesel. This soap like material is a result of adding too much lye, or having water in the oil. It should be discarded with the glycerine. Oil can be tested for water content by heating it to the boiling point of water (100 °C) and watching for bubbles.

After settling for a few days (or a week), biodiesel producers will decant the fuel off the top of the glycerine, pass it through a filter, and use it like diesel fuel in any diesel engine. Many fuel producers further refine the fuel by washing with water, which removes any residual glycerol, lye or methanol, before use.

Your bottle now contains biodiesel, glycerin, mono- and di-glycerides, soap, methanol, lye, and possibly a little leftover oil (triglycerides). The glycerides are all oil-soluble, so they'll reside predominantly in the upper, biodiesel layer. The thin layer of glycerin, which is water-soluble, will sink. Depending on the oil and catalyst you used, it might be either liquid or solid. Soap, methanol, and lye, which are also water-soluble, will be mixed throughout both layers – although some of the soap can sometimes form its own thin layer between the bio-diesel and glycerin.

If you see more than two layers, or only one, then something is wrong – possibly excessive soap or monoglyceride formation. These are both emulsifiers, and in sufficient quantities they will prevent separation. In this case, check your scales, measurements, and temperatures. You can reprocess the bio-diesel with more

methoxide, or try again with fresher oil (or new oil). If you can, shake the bottle even harder next time. In an engine, glycerin droplets in bio-diesel will clog fuel filters, soap can form ash that will damage injectors, and lye can also abrade fuel injectors. Meanwhile, methanol has toxic and combustible fumes that make bio-diesel dangerous to store. You don't want any of these contaminants in your bio-diesel. If you left your bio-diesel to settle undisturbed for several weeks, these water-soluble impurities would slowly fall out of the bio-diesel (except the methanol). Washing your bio-diesel with water removes the harmful impurities, including the methanol, much faster.

Days 6 & 7: Additional Testing

Cleanup: Biodiesel can be discarded with other non-halogenated organic chemical waste from the school chemistry lab.

Making Soap: Glycerine can be used to make soap, or discarded with other waste products. To make soap from glycerine, heat it to 80 °C for several hours to boil off the methanol. This process must be done under a chemical hood and away from open flame. When the methanol has been removed, the liquid glycerine will stop bubbling, and about 20% or more will reduce the total volume of the fluid. We prefer to wait until the heated glycerine has reached 100 degrees C to be certain the methanol is removed.

For every liter of warm glycerine, add 200 mL of distilled water combined with 30 grams of sodium lye. Add the lye water to the glycerine, stir well, and pour into a plastic mold to cool. The resulting soap should cure for several weeks before use. It is effective at cutting grease on hands. Methanol must be removed from the glycerine before making soap!

Yield Determination: Different factors affect the success of a biodiesel reaction, including temperature, mixing time, and the relative amount of each ingredients. A "complete" reaction will result in a glycerine layer approximately equal to the amount of methanol added (in the case of the 500 mL batches, about 110 mL of glycerine.) Reactions that come up short on glycerine have residual byproducts, including mono and di-glycerides in the fuel layer. These compounds result in a poorer quality fuel that is more difficult to refine.

To determine the glycerine yield, the contents of a mixing bottle can be poured into a graduated cylinder, and the relative volume of each layer measured. Comparisons can be made between the results from different batches of oil, or by changing variables between batches of the same oil.

Wash Test: Many of the impurities contained in settled biodiesel are soluble in water. A good way to assess your different batches of fuel is to pour a sample

into a mixing bottle with an equal amount of water, then shake this vigorously until the two are mixed together. After mixing, allow the fluids to settle and observe what happens. Fuel with a lot of soap in it (too much lye, or fuel made from oil high in free fatty acids) will form an emulsion (like mayonnaise) that is difficult to separate even with time. Well-made fuel will separate into a layer of milky wash water and amber biodiesel after about 10 or 20 minutes. Comparisons can be made between settling/ separation times for different batches of fuel, to assess the level of impurities in each batch.

It is common in large scale biodiesel processing to continue the wash process until the water no longer becomes cloudy. In water washing, water is very gently combined with the fuel to avoid emulsification (adding water via fine mist nozzles is one option, running air bubbles through the water layer beneath a column of fuel is another.)

After the initial wash, saturated water is drained off, and the process is repeated until water runs clear and is relatively neutral in pH. Washed biodiesel should be allowed to settle several days until it becomes completely clear before using. You will notice that washed fuel is typically clear enough to see through.

Specific Gravity: The specific gravity of biodiesel should be somewhere between 0 and 0.90. Although this is reported to be an unreliable indicator of fuel quality, it does present an interesting comparison between batches of fuel or between fuel and unprocessed vegetable oil.

Biodiesel resources:

Matt Steiman, Wilson College, Chambersburg PA

Websites:

Homebrew biodiesel:

www.kitchen-biodiesel.com

<http://www.biodieselcommunity.org/>

www.journeytoforever.org

www.biodieselamerica.com

Discussion board with great archives:

<http://biodiesel.infopop.cc/6/ubb.x?a=cfrm&s=447609751>

Industrial biodiesel: www.biodiesel.org

Books:

- "From the Fryer to the Fuel Tank" by Joshua Tickell. The original book on biodiesel, including basic information on how to make small batches, build

a biodiesel processor, and convert a vehicle to straight vegetable oil. Also contains nice informative sections on biodiesel history and environmental benefits. The website www.biodieselamerica.org sells the book, and lots of other useful information.

- "Biodiesel Homebrewer's Manual", by Maria "Mark" Alovert. This resource guide contains a step-by-step explanation of how to make fuel in small and large batches, as well as an affordable processor design. Answers most of the questions one will have after reading "From the Fryer" and making fuel for a while. Highly recommended! Ms. Alovert sells her book at www.localb100.com, another very useful website!

Other safety information

Methanol Safety:



Methanol is POISON! This powerful alcohol causes eye and skin irritation, and may be absorbed through intact skin. This substance has caused adverse reproductive and fetal effects in animals. Harmful if inhaled. May be **FATAL** or cause **BLINDNESS** if swallowed. May cause central nervous system depression. May cause digestive tract irritation with nausea, vomiting, and diarrhea.

Danger! Flammable liquid and vapor. Keep sparks and flame away. Methanol vapors sink in air

The MSDS for methanol is available from http://www.kitchen-biodiesel.com/Methanol_MSDS.htm

Sodium hydroxide (Iye)



POISON! DANGER! CORROSIVE. MAY BE FATAL IF SWALLOWED, AND HARMFUL IF INHALED. THIS COMPOUND CAUSES BURNS TO ANY AREA OF CONTACT. REACTS WITH WATER, ACIDS AND OTHER MATERIALS.

The MSDS for Sodium Hydroxide (Iye) is available from http://www.kitchen-biodiesel.com/NaOH_MSDS.htm

Materials Sources:

- Most materials and equipment for this procedure can be obtained through normal school lab supply companies.
- Sodium hydroxide (Iye) can be obtained from the school chemical supplier. Red Devil Lye may also be found in the cleaning section of

hardware and grocery stores. Sodium Hydroxide can also be ordered online.

- Methanol can also be ordered from the school chemical supplier. Race fuel shops also carry methanol, and the yellow bottle of Heet gas line deicer (from auto parts stores) is 99% methanol.
- Small plastic syringes for titration can be found affordably at many pharmacy stores
- Phenol red can be found at many swimming pool supply stores
- A cheap and effective indicator solution can be made from Turmeric (an Indian spice available in grocery stores) using the following recipe: Add 6 grams (1 Tbs) turmeric to 100 mL of isopropyl (rubbing) alcohol. Place turmeric and alcohol in a jar and shake, allow to settle overnight, then decant the liquid. 5 drops makes an effective indicator that changes to red at pH 8.5

Making Bio-Diesel



Technology Education

Statement of the Problem

To create a fuel to be used in a diesel engine from a renewable feedstock and use as many by-products of the process for other end use products

**IDEAS * DEVELOPING * BUILDING * TESTING
EVALUATING * REDESIGN/REBUILD/RETEST
to
SUCCESS**

NAME: _____

DATE STARTED: _____

DATE DUE: _____

OVERALL ACTIVITY GRADE: _____

Requirements

1. This activity will be completed in _____.
2. You will work in teams of two and create 1 quart of Biodiesel.
3. Your completed brief is due on _____
4. Answer the Research Questions on page 3 prior to beginning biodiesel process.
5. You must fully complete part five by recording all data.
6. Complete all the work asked for and answer all questions in this brief booklet.
7. Names of all group members must be on the front page and assessment rubric.
8. Review the Assessment Rubric to know all grade requirements were satisfied.
9. Present all findings in a 2 page report and PowerPoint presentation to the class.

Objectives

1. Definition of a renewable fuel.
2. How the substitution of biodiesel fuel for petroleum diesel benefits the environment.
3. How biodiesel fuel is made from waste vegetable oil.
4. How the process can be adjusted to utilize waste oils from different sources, and the chemical analyses necessary to determine oil quality.
5. How to assess the finished product.

Research Paper and PowerPoint Presentation

Requirements

Each group will prepare a 5 page paper outlining the following (all members **must** participate):

1. An abstract
2. Introduction
3. An overview of the entire process
4. Data, findings, and calculation.
5. Difficulties and solutions
6. Conclusion

Each group will prepare a ten minute PowerPoint presentation and present to the class.

1. This presentation should be a snapshot of your paper and design brief.
2. All students **must** participate in the presentation (changing slides doesn't count)
3. Students should be professionally dressed.

PART ONE : Research Questions

Describe the process used to produce diesel fuel. Be specific.

Besides the type of fuels used what is the major difference between gasoline and diesel engines? (how do they work)

List and describe 5 major advantages and 5 major disadvantages to fossil fuels

What is the process called that we will be using to produce fuel from vegetable oil? (describe)

List and describe 5 major advantages and 5 major disadvantages to renewable fuels?

What is the key difference between WVO and bio-diesel? (what does one have that the other doesn't?)

Part Two: Background Information:

Biodiesel is a renewable fuel made from any biologically based oil, and can be used to power any diesel engine. Now accepted by the federal government as an environmentally friendly alternative to petroleum diesel, biodiesel is in use throughout the world. Biodiesel is made commercially from soybeans and other oilseeds in an industrial process, but it is also commonly made in home shops from waste fryer grease. The simple chemistry involved in small-scale production can be easily mastered by novices with patience and practice. In this exercise, students will learn the process of making biodiesel and practice some analytical techniques.

Dr. Rudolf Diesel first demonstrated his diesel engine to the world running on peanut oil in the early 1900's. The high compression of diesel engines creates heat in the combustion cylinder, and thus does not require a highly flammable fuel such as that used in gasoline engines. The diesel engine was originally promoted to farmers as one for which they could "grow their own fuel". Diesels, with their high torque, excellent fuel efficiency, and long engine life are now the engine of choice for large trucks, tractors, machinery, and some passenger vehicles. Diesel passenger vehicles are not presently common in the United States due to engine noise, smoky exhaust, and cold weather starting challenges. However, their use is quite normal in Europe and Latin America, and more diesels are starting to appear in the US market.

Over time, the practice of running the engines on vegetable oil became less common as petroleum diesel fuel became cheap and readily available. Today, people are rediscovering the environmental and economic benefits of making fuel from raw and used vegetable oils. Fuel made from waste fryer grease has the following benefits when compared to petroleum diesel:

- Using a waste product as an energy source
 - Cleaner burning: lower in soot, particulate matter, carbon monoxide, and carcinogens
 - Lower in sulfur compounds: does not contribute to acid rain
 - Significant carbon dioxide reductions: less impact on global climate change
 - Domestically available: over 30 million gallons of waste restaurant grease are
- In addition, use of well-made biodiesel fuel can actually help engines run better.

Petroleum diesel fuels previously relied on sulfur compounds in the oil to keep engines lubricated. However, sulfur tailpipe emissions are a significant contributor to the formation of acid rain, so regulators have forced the reduction of sulfur in diesel fuel. Biodiesel made from vegetable oil has a better lubricating quality and can help solve engine wear problems without increasing acid rain. For this reason, use of Biodiesel is already common in trucking fleets across the country.

Some other interesting facts:

- Biodiesel can be readily mixed with diesel fuel in any proportion. Mixtures of biodiesel
- Biodiesel can be run in any unmodified diesel engine.
- Biodiesel is less flammable than diesel. It will gel at a higher temperature (typically

Part Two cont.: Materials List:

Chemical resistant gloves and goggles
Two samples of waste vegetable oil (about 600 ml or more of each)
Sodium Hydroxide (lye)
Graduated cylinders: 1000 ml, 100 ml, and 10 ml.
Pipettes graduated to measure 0.1 ml, graduated eyedroppers, or graduated plastic syringes
Hot plates with stirring rods or suitable substitute
Large beakers or pots for heating oil
Packets of pH strips accurate in the 8-9 range. Phenol red indicator solution is an option if pH strips are not available.
A stock solution of lye in distilled water (0.1%)
New vegetable oil (500 ml)
Labeling tape and permanent markers
A 100 ml beaker for each group for decanting stock NaOH solution
Several small beakers for titration (3 or 4 per group).
Isopropyl alcohol
Celsius thermometer
3 quart mason jars, or HDPE plastic bottles with tight fitting lids
Methanol
Scale accurate to 0.1 grams
Plastic scoops or ladles for transferring warmed oil to graduated cylinders



5

PART TWO cont'd: Making Biodiesel Fuel & Safety

The process of converting vegetable oil into biodiesel is known as transesterification, which is similar to saponification, the process for making soap. Vegetable oil molecules are triglycerides: they are made up of a heavy glycerol molecule, and three lighter fatty acid chains called esters. Glycerol is too thick to burn properly in a diesel engine at room temperatures, while esters make an excellent combustible material. Thus, the goal is to separate the esters from the glycerol. In this reaction, the vegetable oil molecules are cleaved apart with the catalyst Sodium Hydroxide (Lye), which is a strong base. Then the esters are combined with methanol to become methyl esters, otherwise known as biodiesel.

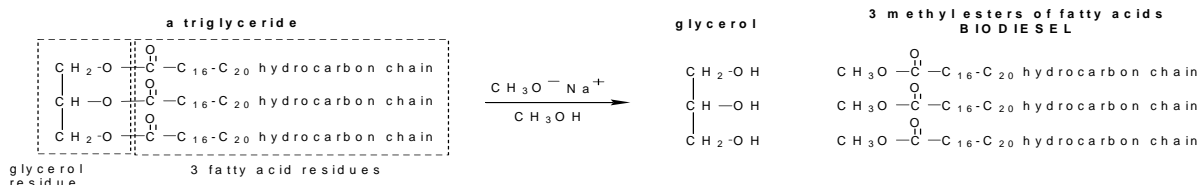

For every liter of vegetable oil, the reaction uses 220 milliliters (22% by volume) of methanol, a powerful alcohol. New oil requires 4 grams of lye per liter of oil, whereas used oil will require somewhat more. The quantity of lye will vary depending upon the quality of our vegetable oil, and will need to be determined by chemical analysis. Students will first practice making fuel from new vegetable oil, which requires a known amount of lye for the reaction. In the second step, students will determine the quantity of lye needed for different used vegetable oils, then test our analyses by making fuel from those oils.

SAFETY NOTES!: Methanol and lye are dangerous substances and should be handled with caution! Methanol is poisonous to skin, and its fumes are highly flammable. Lye is a strong skin irritant and can cause blindness! Always wear gloves and goggles when working with these chemicals, and keep any sparks or flame away from methanol containers. Work under a chemical hood or other well ventilated space.

Other cautions: Biodiesel fuel made in a school lab is experimental in nature, and should be burned in diesel engines at the users own risk. While well made fuel will not harm a diesel engine, interested students are advised to read further on the subject before actually testing biodiesel in an engine. Do not remove biodiesel fuel from the laboratory classroom.

PART THREE : Procedure Steps

Part 1: Making fuel from new vegetable oil

1. Put on your gloves and goggles. Everyone must wear protective gear while handling chemicals!
2. Measure out 500 ml or more of new vegetable oil and pour it into a large beaker.
3. Heat 500 ml of new vegetable oil to 50 C on a hotplate using a stirrer. One person in your group should watch the temperature closely so the oil does not overheat.

Perform the following 2 steps under a chemical hood or other well ventilated space.

4. Measure 110 ml of methanol in a graduated cylinder and pour into your mixing bottle. Cap the methanol bottle and your mixing bottle tightly.
5. Weigh out 2.0 grams of sodium hydroxide (lye) and add to the methanol in your mixing bottle. Cap the bottle and swirl gently for a few minutes until all of the lye dissolves. You now have sodium methoxide in your bottle, a strong base. Be careful!
6. When the lye is dissolved and the oil is up to 50C, add 500 ml of warm oil to the methoxide and cap the bottle tightly. Invert the bottle once over a sink to check for leaks. ***Caution: Be certain that the oil is not over 60 degrees C, or the methanol may boil.***
7. Shake the bottle vigorously for at least one minute, then allow your reaction to settle.
8. Over the next 30-60 minutes, you should see a darker layer (glycerol) forming on the bottom of the bottle, with a lighter layer (biodiesel) floating on top. Complete settling of the reaction will require several hours to overnight. Move on to the next step of the exercise while your biodiesel is settling.

Questions for your lab book:

- If the base rate for Sodium Hydroxide (lye) is 4.0 grams per liter of oil, why did you only use 2.0 grams for this batch?
- How much lye would be used to convert 50 liters of new oil?
- For a given quantity of new oil, what variables could be changed to effect the reaction?

Part 2: Testing waste oil by titration to determine the quantity of lye.

As vegetable oil is used for frying foods, the high heat, water, and food products in the fryer can degrade the oil into various byproducts. One byproduct is the development of free fatty acids in the oil. These acids will act to neutralize some of the lye used in the biodiesel reaction. Since the reaction requires 4 grams of catalyst for every liter of oil, we will need to add extra lye to make up for that neutralized by the free fatty acids. More heavily used oil will tend to be more acid, and thus require larger quantities of lye than lightly used oil. It is important when making biodiesel to use the proper amount of lye for a given oil. Too much lye can result in a solid soap forming in the reaction vessel, and too little lye will result in an incomplete reaction and poor quality fuel.

The exact amount of extra lye required is determined by a process called titration. To perform the titration, a known solution of lye is added to a sample of used oil in measured amounts, until a desired pH shift is seen. Because it is difficult to measure the pH of an oil, the oil will first be dissolved in isopropyl alcohol to make testing easier. For this exercise, you will determine the quantity of lye needed to make biodiesel from two different oils: one that is heavily used and one that is lightly used.

PART THREE con't : Procedure Steps

1. Obtain a sample of used vegetable oil from two different sources. Preferably one will be more heavily used than the other. Label the lightly used oil as sample A, and the heavily used oil as sample B.
2. Using a pipette, syringe, or graduated eyedropper, measure 1.0 ml of oil from one sample into a small mixing beaker. Make a note in your lab book of which oil you are using first: lightly used (A) or heavily used (B).
3. Measure 10 ml of isopropyl alcohol using a graduated cylinder, add this to the oil, and swirl to mix
4. Test the pH of the oil-alcohol solution using a pH strip
5. Using a different pipette, add lye-water (from a stock 1% solution of NaOH in distilled water) to the oil-alcohol solution in 0.5ml increments. Add the lye-water carefully so that you are sure to only add 0.5 ml at a time.
6. After each 0.5ml addition of lye-water, recheck the pH with a pH strip. Record the number of 0.5ml additions you make on a tally sheet!
7. Continue adding lye-water until the pH of the solution reaches approximately 8.5. At this point, count the number of ml of lye-water that you added. (For example, if you added ½ ml of lye-water three times, you added a total of 1.5 ml of lye-water).
8. Calling the number of ml of lye-water that you added "X", put that number into the following equation:

$$X + 4.0 \text{ grams} = L$$

L = the total number of grams of lye needed to make biodiesel from 1 liter of this particular oil. Record this number in your lab book.

9. Repeat steps 1 through 7 using a second batch of oil of different quality, and record the value for L in your lab book. Be sure to keep track of which value for L refers to which oil sample. You may want to repeat the titration for each oil to be sure of your results.

If using phenol red instead of pH strips, follow these steps:

1. Add 5 drops of phenol red to the beaker containing 10 ml of isopropyl alcohol and 1 ml of oil to be tested.
2. The solution will appear yellow at an acid pH, and will turn pink when the pH is between 8 and 9. Add lye-water in 0.5 ml increments, counting as you go, until the oil alcohol solution turns pink or purple and stays that way for 30 seconds or more.
3. The number of ml of lye-water it took to turn the solution pink is "X". Refer to the equation above.

Questions:

- Why is it necessary to perform a titration on used vegetable oil?
- How much lye will be required to convert 1.0 liters of vegetable oil sample A to biodiesel? Sample B?
- How much lye will be required for 0.5 liters of each oil: A? B?
- When biodiesel brewers make large batches of fuel, they typically repeat the titration procedure several times per batch. Why do you think they would do this?
- Which type of oil do you think requires more lye catalyst, lightly used or heavily used? Why?
- Can you see any difference in color between the heavily used oil and lightly used oil?

PART THREE con't : Procedure Steps

Part 3. Making biodiesel using waste vegetable oils

In part 3, you will use the value for L that you determined in step 2 to make fuel from waste oil. This is basically a repeat of the procedure from part 1, except that you will be varying the quantity of lye for each batch.

1. Put on your gloves and goggles. Everyone must wear protective gear while handling chemicals!

2. Measure out 500 ml or more of each waste vegetable oil, and pour it into a large beaker. Mark each beaker "A" or "B" depending on the oil you are using. Obtain two mixing bottles and label one "A" and the other "B"

3. Heat 500 ml of each vegetable oil to 50 C on a hotplate using a stirrer. One person in your group should watch the temperature closely so the oil does not overheat.

4. Measure 110 ml of methanol in a graduated cylinder for each batch and pour into your mixing bottles. **Perform this step and the next under the chemical hood.** Cap the methanol and mixing bottles when you are finished.

5. Weigh out and add the correct amount of lye for each oil to your mixing bottles. Recap the bottles tightly. Gently agitate each bottle until the lye is dissolved.

6. When the oil samples are up to 50 degrees C, add 500 ml of the proper oil to the each mixing bottle and cap them tightly.

Be sure that the oil is not over 60 degrees C to avoid boiling the methanol!

7. Invert the mixing bottle once over a sink to check for any leaks.

8. Shake the bottles vigorously for at least one minute, then allow your reactions to settle.

9. Leave the bottles to settle until next week.

10. Clean up your lab space.

Assessing your biodiesel (Week 2)

If your procedure worked correctly, there should be two distinct layers after settling. The darker layer at the bottom is a crude glycerine byproduct, and the lighter layer on top is biodiesel. If you pick up the settling bottle and rock it slightly from side to side, notice how the darker layer is thicker than the fuel floating on top. This higher viscosity of glycerine is one of the reasons that it isn't suitable for use in a diesel engine at room temperatures. By removing the heavier, more viscous part of the oil, the esters pass through the engine's injectors and combust that much easier.

It is common to see a whitish third layer floating between glycerine and the biodiesel. This soaplike material is a result of adding too much lye, or having water in the oil. It should be discarded with the glycerine. Oil can be tested for water content by heating it to the boiling point of water (100C) and watching for bubbles.

After settling for a few days (or a week), biodiesel producers will decant the fuel off the top of the glycerine, pass it through a filter, and use it like diesel fuel in any diesel engine. Many fuel producers further refine the fuel by washing with water before use.

Cleanup: Biodiesel can be discarded with other chemical wastes from the school chemistry lab.

PART THREE con't : Procedure Steps

Washing the Bio-Diesel

Your bottle now contains biodiesel, glycerin, mono- and di-glycerides, soap, methanol, lye, and possibly a little leftover oil (triglycerides). The glycerides are all oil-soluble, so they'll reside predominantly in the upper, biodiesel layer. The thin layer of glycerin, which is water-soluble, will sink. Depending on the oil and catalyst you used, it might be either liquid or solid. Soap, methanol, and lye, which are also water-soluble, will be mixed throughout both layers – although some of the soap can sometimes form its own thin layer between the bio-diesel and glycerin.

If you see more than two layers, or only one, then something is wrong – possibly excessive soap or monoglyceride formation. These are both emulsifiers, and in sufficient quantities they will prevent separation. In this case, check your scales, measurements, and temperatures. You can reprocess the bio-diesel with more methoxide, or try again with fresher oil (or new oil). If you can, shake the bottle even harder next time. In an engine, glycerin droplets in bio-diesel will clog fuel filters, soap can form ash that will damage injectors, and lye can also abrade fuel injectors. Meanwhile, methanol has toxic and combustible fumes that make bio-diesel dangerous to store. You don't want any of these contaminants in your bio-diesel. If you left your bio-diesel to settle undisturbed for several weeks, these water-soluble impurities would slowly fall out of the bio-diesel (except the methanol). Washing your bio-diesel with water removes the harmful impurities, including the methanol, much faster.

Unfortunately, washing will not remove the invisible, oil-soluble mono- and di-glycerides. These are a problem in rare instances when large amounts of certain types of monoglycerides crystallize. This can clog fuel filters and injectors, and cause hard starts, especially in cold weather. High quality commercial bio-diesel has very low levels of mono- and di-glycerides, which in the ideal fir bio-diesel homebrewing. You can roughly test for the presence of mono- and di-glycerides in your own batch by processing it a second time, as if it were vegetable oil. If more glycerin drops out, then your first reaction left some unfinished business behind.

Washing the Bio-Diesel

1. Once you have poured off any glycerin off you are ready to wash the remaining bio-diesel.
2. Gently add some warm distilled water to the bio-diesel.
3. Rotate the bottle end over end until the water starts to take on a little bit of soapiness, which may take a few minutes. Do not shake the bottle! You will want to bring the water and bio-diesel into contact without mixing it too vigorously. The bio-diesel contains soap and if you overdo the agitation the soap, bio-diesel, and water will make a stable emulsion that won't separate.
4. Turn the bottle upside-down crack the cap and drain away the soapy water. If you're using a soft drink bottle with a narrow neck, you can plug the opening with your thumb.
5. Add more warm water and keep repeating the sloshing and draining process. Each time there will be less soap and you can mix a little more vigorously. If you go too far and get a pale-colored emulsion layer between the bio-diesel and white, soapy water, don't drain it away; it's mostly bio-diesel. Just keep washing and diluting until the water becomes clear and separates out quickly. It takes a lot of water. But if the emulsification layer persists, try applying heat, adding salt, and adding vinegar, in that order.
6. After draining the last wash water away, let the bio-diesel sit to dry in open air until it's perfectly clear, which may take up to a couple of days. In general, the better your washing, the faster the fuel will clear. If you're in a hurry, you can dry the fuel faster by heating it at a low temperature. As with the evaporation method, the fuel is done when it clears. If you can read a newspaper through the bio-diesel, it's dry and ready to pour into a vehicle.

PART THREE con't : Procedure Steps

Optional Fuel Analyses:

Yield test: Different factors affect the success of a biodiesel reaction, including temperature, mixing time, and the relative amount of each ingredients. A "complete" reaction will result in a glycerine layer approximately equal to the amount of methanol added (in the case of the 500 ml batches, about 110 ml of glycerine.) Reactions that come up short on glycerine have residual byproducts, including mono and diglycerides in the fuel layer. These compounds result in a poorer quality fuel that is more difficult to refine.

To test for glycerine yield, the contents of a mixing bottle can be poured into a graduated cylinder, and the relative volume of each layer measured. Comparisons can be made between the results from different batches of oil, or by changing variables between batches of the same oil.

Wash Test: Many of the impurities contained in settled biodiesel are soluble in water. A good way to assess your different batches of fuel is to pour a sample into a mixing bottle with an equal amount of water, then shake this violently until the two are mixed together. After mixing, allow the fluids to settle and observe what happens. Fuel with a lot of soap in it (too much lye, or fuel made from oil high in free fatty acids) will form an emulsion (like mayonnaise) that is difficult to separate even with time. Well made fuel will separate into a layer of milky wash water and amber biodiesel after about 10 or 20 minutes. Comparisons can be made between settling/ separation times for different batches of fuel, to assess the level of impurities in each batch.

It is common in large scale biodiesel processing to continue the wash process until the water no longer becomes cloudy. In water washing, water is very gently combined with the fuel to avoid emulsification (adding water via fine mist nozzles is one option, running air bubbles through the water layer beneath a column of fuel is another.)

After the initial wash, saturated water is drained off, and the process is repeated until water runs clear and is relatively neutral in pH. Washed biodiesel should be allowed to settle several days until it becomes completely clear before using. You will notice that washed fuel is typically clear enough to see through.

Specific Gravity: The specific gravity of biodiesel should be somewhere between .88 and .90. Although this is reported to be an unreliable indicator of fuel quality, it does present an interesting comparison between batches of fuel or between fuel and unprocessed vegetable oil.

Minimizing the Waste

Glycerine can be used to make soap, or discarded with other waste products. To make soap from glycerine, heat it to 80 °C for several hours to boil off the methanol. This process must be done under a chemical hood and away from open flame. When the methanol has been removed, the liquid glycerine will stop bubbling, and the total volume of the fluid will be reduced by about 20% or more. We prefer to wait until the heated glycerine has reached 100 degrees C to be certain the methanol is removed.

For every liter of warm glycerine, add 200 mL of distilled water combined with 30 grams of sodium lye. Add the lye water to the glycerine, stir well, and pour into a plastic mold to cool. The resulting soap should cure for several weeks before use. It is effective at cutting grease on hands. Methanol must be removed from the glycerine before making soap!

PART FOUR : RESOURCE USAGE

*These are the **SEVEN RESOURCES** of **TECHNOLOGY**. How have you used these resources to complete your Biofuels Project?*

PEOPLE

<i>Name</i>	<i>Briefly describe how each helped you</i>

TOOLS & MACHINES

<i>Tools used</i>	<i>Briefly explain how each extended your abilities</i>

INFORMATION

Where did you find and/or how did you acquire information needed to reach your goals?

<i>Place/Event</i>	<i>Briefly describe the information you acquired</i>

PART FIVE : Design Data Collection Log

In the boxes below, describe the results for each batch of biodiesel. Be sure to record the amount of each chemical added, the results of titration, separation time, etc. Record each washing, the amount of time and the clarity of the bio-diesel on a scale of 1-5 (1=clearest) will lead you to your goal more quickly.

#1	Record All Measurements Here	Washing	Time	Clarity (1-5)
		Dry Time		

#2	Record All Measurements Here	Washing	Time	Clarity (1-5)
		Dry Time		

#3	Record All Measurements Here	Washing	Time	Clarity (1-5)
		Dry Time		

#4	Record All Measurements Here	Washing	Time	Clarity (1-5)
		Dry Time		

PART SIX : Activity & Student Assessment

Describe two problems/difficulties that you had to solve/overcome during this project.

Roughly, what was the ratio of bio-diesel to glycerin? List 3 products we can use the glycerin for?

Explain the purpose of titrating the WVO. What should pH of the finished bio-diesel be?

What is the purpose of shaking the bottle after you add the methoxide to the vegetable oil?

Why is it important to add water to your biodiesel after the glycerine has been drained off?

Discuss two things that you learned from the other group presentations.

PART SIX cont'd: Student Assessment

Did you understand what you had to do? Yes - No - With Help (Circle one). Explain how:

Which of these describes the research you did? Sufficient - Not Enough - Enough to Get By (Circle one) Explain your answer:

Did the design brief guide you to do a better job? Yes - No - To some degree (Circle one) Explain your answer:

Was the activity challenging? OK - Very Hard - Too Easy (Circle one) Explain in what way:

Was the activity interesting? Yes - No - Could be Better (Circle one) Explain why:

Was this activity relevant to the course? Yes - No - OK (Circle one) Explain why or why not:

Rate your effort on the following graphs

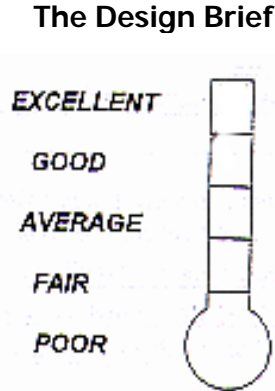

Describe something new that you learned from this activity beyond building of an insulated container. **The more information you can provide the better - be specific!**

What is the grade you expect to get for the work you did? _____ forever optimistic

Creating Bio-Diesel Assessment Rubric

Student: _____ **Period:** _____

Assessment Scale:

- 6 = Exceptional - Your work shows brilliance and extreme high quality.*
- 5 = Mastery - your work demonstrates excellence in this portion of the activity.*
- 4 = Accomplished - Your work fulfills all of the objectives of this portion of the activity.*
- 3 = Acceptable - Your work is minimally acceptable or needs minor revisions.*
- 2 = Minimum - Your work is either incomplete or requires major revisions.*
- 1 = Not Addressed - Your work did not address or include what was asked for in the r.*
- 0 = Not Turned In - Some portion of the activity was not turned in leaving nothing to s*

Points are awarded to each of the sub-categories (left margin), then their average is put as the total of the main category (right margin). The average of all the main categories will become the overall grade for the activity.

Safety -

- _____ Safety precautions were taken throught the entire process
- _____ Safety equipment was used when necessary
- _____ Safety precautions were documented for using hand tools and machines

Research Paper -

- _____ Overall work performed showed neatness and quality
- _____ Work was logically organized and met all requirements
- _____ Students demonstrated understanding
- _____ Students could make connections between their work and the real world
- _____ Student used proper formatting and citations

Presentation -

- _____ All group members demonstrated understanding
- _____ All group members could make connections between their work and the real world
- _____ Student presentation was professional and well rehearsed
- _____ Presentation met the time requirement
- _____ All students participated equally in the presentation

Design Brief -

- _____ Part One: Extent of research performed (people & information utilized)
- _____ Part Three: Procedures were reviewed and precisely followed
- _____ Part Four: Resource pages were clear, detailed and accurate - particularly the time resou
- _____ Part Five: The data Collection log was clear, accurate and complete
- _____ Part Six: Activity & Student Assessment: Neat, complete and insightful

Team Work -

- _____ Acted as a responsible member of the team during work and testing
- _____ Acted efficiently during work and testing sessions (time)

18 Criteria Activity Total Average _____

Grade Legend

A+ = Above 5	B+ = 4 to 4.4	C+ = 3 to 3.4	D = 1.5 to 2.4
A = 4.5 to 5	B = 3.5 to 3.9	C = 2.5 to 2.9	F = 0 to 1.4

Instructor Comments: On reverse side

1

Biofuel Utilization

For the Teacher

The ideas and concepts discussed in this unit, **Biofuel Utilization**, not only lend themselves to excellent science fair projects but also can be adapted to mathematics, and social studies lessons when used to introduce students to environmental issues concerning limited resources. The Rapa Nui investigation suggested in question 3 at the end of the "Technology Description" section will dramatically illustrate what can happen to a society that is careless in handling its natural resources.

It is important for you as the teacher to emphasize to your students that use of biomass for energy production is much more than burning wood. Critics of biomass like to view it as just another word for incineration and this is very misleading. Having your students research waste water treatment or visiting a waste water treatment plant in your area will demonstrate how biomass is used to not only treat wastewater in the secondary treatment process, but also produce enough natural gas to heat and operate the sewage treatment plant!

Another area of biomass energy research that has stirred a great deal of interest is the production of biodiesel fuels, which can be produced from waste cooking oils. An EPA study of combustion products of pure biodiesel (B100) and a 20% blend of biodiesel (B20) with regular diesel fuel reduced visible smoke and odor and toxic emissions as shown in following table.

The elevated combustion temperature because of the cleaner burning does result in a slight increase in NO_x emissions. Biodiesel also reduces the amount of sulfur emissions.

Emission	B100*	B20*
Carbon Monoxide	-47%*	-12%*
Hydrocarbons	-67%*	-20%*
Particulates	-48%*	-12%*
Nitrogen oxides	+10%*	+2%*
Air Toxics	-60%- 90%	-12%- 20%

**Environmental Protection Agency Draft Technical Report EPA420-P-02-001 (2002)"A Comprehensive Analysis of Biodiesel Impacts on Exhaust Emissions*

B100 and B20 refer to the biodiesel content of the fuel, 100% biodiesel and 20% biodiesel respectively.

The National Renewable Energy Laboratory (NREL) is actively involved in basic research and development with various industrial partners to find cost-effective technology for producing liquid transportation fuels from biomass materials. In addition, gas production using anaerobic processes and pyrolysis technologies are being investigated.

Gasifier technology produces an extremely clean combustible gas using a wide variety of woody fuels that otherwise would not have commercial value. Both electricity and heat are produced for small communities in remote areas lacking access to on-grid electricity. More information about this new biomass technology can be found at www.gocpc.com.

Recent breakthroughs in low cost catalysts for hydrogen production from biomass may result in helping the world make the transition from a fossil fuel to hydrogen based economy.

National Science Education Standards by the National Academy of Sciences

Science Content Standards: 5-8

Science of Inquiry

– Content Standard A

“Understandings about scientific inquiry”

– Content Standard E

“Abilities of technological design”
“Understandings about science and technology”

– Content Standard F

“Personal health”
“Populations, resources, and environments”
“Natural hazards”
“Risks and benefits”
“Science and technology in society”

– Content Standard G

“Science as a human endeavor”
“Nature of science”
“History of science”

Unifying Concepts and Processes

“Evidence, models, and explanation”
“Constancy, change, and measurement”
“Evolution and equilibrium”
“Form and function”
“Systems, order, and organization”
“Evidence, models, and explanation”
“Constancy, change, and measurement”
“Evolution and equilibrium”
“Form and function”

Technology Description

During the course of the last decade biofuels in the form of blended gasoline (Gasohol), and biodiesel have begun to find a place in our energy economy. While better emissions and air quality was the driving force for their use, biomass derived biofuels will be required to offset the loss of dwindling petroleum reserves in the near future.

Since the middle of the 19th century, our nation has primarily invested in coal and petroleum to the extent that we now consume 25% of these nonrenewable resources while only having 2% of the world population. Our ability to adapt to diminishing fossil fuel resources is critical to our survival as a nation.

MTBE

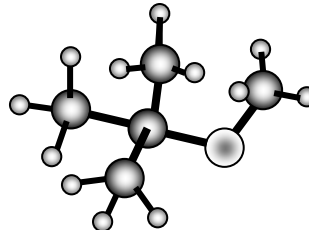

Oil and coal are major contributors to the pollution problems faced by many of our nation’s cities. Smog, acid rain, and airborne particulates can all be traced to some degree to emissions from our cars, trucks, power plants, and factories. Add to that the potential threat of global warming from accumulations of heat trapping carbon dioxide released from 200 million years of captivity and its obvious we need new alternatives for fueling our transportation system.

Biofuels have the potential to offer an attractive alternative since they

originate from sources that utilize *existing* carbon dioxide to create the new fuel source. This results in a zero sum gain since the carbon dioxide returns to the atmosphere when the fuel is burned.

The challenge for biomass technology is to find a biomass raw material that has a high energy content which can be transformed to a usable fuel for as low an energy input cost as possible. Hydrogen, Methanol, and Ethanol can all be produced using biomass technologies. Growth rate, processing time, agricultural costs, etc. all have to be considered when selecting a candidate material for use as a biomass fuel. Previous societies failed to heed these factors and were faced with the loss of biomass resources.



Excess removal of wood products (deforestation) for use as fuel for heating and cooking has resulted in soil erosion and loss of habitat. Proper harvesting and regrowth practices are essential if the potential of biomass as a renewable energy source is going to be realized.

The easiest way to understand the processes involved in biomass becoming a biofuel is to imagine the warmth and glow of a log burning. Today's research focuses on how to

release that energy more efficiently and with fewer emissions. Biofuels offer great versatility. They can extend the utility of conventional fuels, such as blends of gasoline and diesel fuel. Gasification of wood chips from forest thinning projects can supply both heat and electricity. Biofuels can take the form of a biogas that is created from the same kind of bacteria that allows cows to digest grass.



Dave Mussell

Two common sources of biogas!

The above cartoon illustrates that humans also generate biogas. Sometimes what we eat results in some unpleasant biogas experiences.

Resources:

<http://www.veggievan.org/>

<http://www1.eere.energy.gov/biomass/>

<http://www.need.org/needpdf/BIOMASSSecondary.pdf>

Questions to Consider:

1. Why are biofuels potentially a more environmentally friendly source of energy when compared to fossil fuels?
2. In the late 1980's chemicals called oxygenates were added to gasoline to create blended fuel which burned cleaner and helped reduce air pollution in large urban areas. In the last ten years controversy has arisen over use of one oxygenate in particular – MTBE. How has solving one environmental problem created another?
3. Suppose you and your friends were stranded on an island thousands of miles away from the nearest cell phone tower. You have limited biomass resources. Investigate what happened to the people of Rapa Nui and explain how you would do things differently.
4. An average coal or nuclear power plant in the United States produces 1000 MW (Megawatts) of electrical power. By the year 2030, the United States will require 900,000 MW of power. It is estimated that biofuels will be capable of providing 100,000 MW of power. What percentage of power will be provided by biofuels?

Resources:

<http://www.netaxs.com/~trance/rapanui.html>
<http://www.energyquest.ca.gov/>
http://www.mtbepollution.com/About_MTBE/default.htm

Project Ideas

1 Can nuts be used as a fuel source?

Learning Objective: Is the oil content in commercial nut varieties sufficient to develop an agricultural industry based on harvesting nuts as a fuel source?

Controls and Variables: Variety of nut, heat loss to environment, distance of nut to object to heat.

Materials and Equipment: Soft drink can, large paper clips, balance (0.01g accuracy), 100 ml graduate cylinder, mixed nuts, and water. If possible use temperature probe and data logger/calculator setup such as Texas Instruments, TI-83+ and CBL for data collection. Otherwise thermometer and stopwatch will be adequate.

Safety and Environmental

Requirements: Use caution when working with flames.

Suggestions: Bend paper clip to act as a support to hold nut you will burn. Measure rate of temperature rise of water per gram of burning nut material. Soda can is inexpensive vessel to hold water being heated.

Other Ideas: Compare published energy content for nut variety to experimental results. Comparison of fuel efficiency of nut varieties to other fuel sources such as paraffin and kerosene.

2 Can biodiesel reduce pollution?

Learning Objective: Compare the emissions of diesel fuel to pure biodiesel and 20% biodiesel blend to validate pollution reduction.

Controls and Variables: Type and concentration of biodiesel, emission capture system, combustion chamber

Materials and Equipment: Plastic bag (1 gallon), small alcohol burner, glass funnel, plastic tubing, beaker, two-hole stopper, glass tubing, triangular file, good imagination, Calculator/Data logger combination, CO₂ sensor (www.vernier.com)

Safety and Environmental

Requirements: Use caution when working with flames.

Suggestions: Need to develop method for measuring combustion product quantitatively. Carbon Dioxide can be measured with sensor (Rate of production?) or color change of indicator as carbonic acid forms in water.

Other Ideas: Develop a way of measuring particulate emissions using filter paper.

3 Can a model Stirling engine be powered by biodiesel?

Learning Objective: Develop a small working model of a car (similar to a mouse-trap) car powered by a Stirling engine and biodiesel as a fuel source. Compare the performance of your car using different biomass fuel alternatives.

Safety and Environmental

Requirements: As with all experiments with open flames and solvents, work in an appropriate area (fume hood or outdoors) and never leave a flame unattended.

More Project Ideas

Compare energy and soot formation of methyl esters of animals with methanol.

Compare the benefits of various alternative fuels (emissions, cost. Performance)

What is the effect of size on the burning rate of wood?

Can a gasoline engine be modified to run on methane? How efficiently?

Do coal-wood or coal-RDF (refuse-derived fuels) pellets burn cleaner than coal alone?

Wind

For the Teacher

The use of fossil fuels is projected to decline during the lifetime of your students. Renewable energy is that energy that can, during our lifetimes, be renewed, typically with additional energy from the sun. Of course we teach, and it is true, that energy cannot be created. So we are not creating energy, we are simply making use of energy that is sustainable. Drilling and digging fossil fuels out of the ground is not a sustainable activity in the long term. Examples of renewable energy include wind, solar, biomass and hydro-electric.

This unit focuses specifically on wind power. The wind blows due to differences in pressure and temperature between regions. Primarily the sun drives these differences; therefore the sun is even the source of wind power.

Teachers should use this guide to give ideas to students for science fair projects. Or, in the classroom, this can be used to generate interest in hands on experimentation or as extra credit during an energy unit.

Science Content Standards: 5-8

Science As Inquiry

– Content Standard A:

“Abilities necessary to do scientific inquiry”

“Understandings about scientific inquiry”

Physical Science

– Content Standard B:

“Transfer of energy”

Earth and Space Science

– Content Standard D:

“Earth in the solar system”

Science and Technology

– Content Standard E:

“Abilities of technological design”

“Understandings about science and technology”

Science in Personal and Social Perspectives

– Content Standard F:

“Science and technology in society”

Technology Description

Wind energy is another source of energy that has been used for thousands of years. Since earliest recorded history, humans have been harnessing the power of the wind. There is evidence that sailing vessels operated along the Nile River as early as 5000 B.C. And within several centuries before the birth of Christ, simple windmills were used in China, Persia, and the Middle East to pump water and grind grain.

In the American West, millions of windmills were erected during the late nineteenth century, supplying water for farms and ranches. By 1900, small wind systems were developed to generate direct current (dc) electricity, which was stored in banks of batteries. Most of these wind systems were abandoned when inexpensive electricity was extended to rural areas under the rural electrification programs during the 1930s.

Interest in wind power was rekindled following the energy shortages

during the 1970s. Since then, wind machines have evolved into a reliable technology that can supply energy cost-effectively in several regions of the nation. Today's machines use one of two designs: Horizontal-axis and Vertical-axis. Horizontal-axis machines use propeller-like blades on a gearbox and generator, mounted atop a tower. Vertical-axis machines look like two-bladed eggbeaters that rotate around a central, vertical column.

The most common use of wind turbines is in large groups, called windfarms, which can provide enough electricity for small cities. These applications now provide about 1500 MW of electricity, mainly in California and Hawaii.

Wind technology has advanced significantly since its initial implementation. In addition to ascetic improvements, the new megawatt-class wind turbines produce higher quality utility-grade power and can be connected directly to conventional grids. These turbines supply enough power for 300-600 homes and produce as much as 30 times the power of wind turbines of the 1980s.



Picture of wind turbines located at the National Wind Technology Center, Boulder, CO.

Researchers are studying several issues that could help improve the economics and performance of wind machines. By developing new, more efficient blade designs, engineers are helping extend the usefulness of wind technologies into geographical regions with untapped wind resources. And by analyzing the wind flow patterns within a windfarm, scientists hope to make predictions of windfarm performance more reliable.

Resources:

American Wind Energy Association. 122 C Street, NW, Suite 380 Washington, DC 20001 phone (202) 383-2500 fax (202) 383-2505

windmail@awea.org

<http://www.awea.org/>

Free Publications available online

<http://www.awea.org/pubs/complimentary.html>

Wind Power Today and Tomorrow. (2004). 36pp.

<http://www.nrel.gov/docs/fy04osti/34915.pdf>

Small Wind Electric Systems: A U.S. Consumer's Guide. (2004). 27 pp

<http://www.nrel.gov/docs/fy04osti/35893.pdf>

Project Ideas

1 Calculate wind power potential in your city and compare to a typical solar power of 1kW/m²?

Learning Objectives: Understand that energy can not be created or destroyed but can be changed in form. Appreciate the interaction of science and technology and community. Create and use a mathematical model.

Variables: Speed and duration of wind, types and size and numbers of wind turbines.

Special Equipment: None – This is a mathematical model

Specific Resources:

- (1) Lecture Notes from University of Oregon
<http://zebu.uoregon.edu/ph162/14.html>
- (2) Clean Energy: How Solar Energy Works,
http://www.ucusa.org/clean_energy/renewable_energy_basics/how-solar-energy-works.html,
retrieved July 29, 2004
- (3) Melody, Ingrid, Photovoltaics: A Question and Answer Primer, HealthGoods,
http://www.healthgoods.com/Education/Energy_Information/Renewable_Energy/photovoltaics_Q_and_A.htm,
retrieved July 28, 2004
- (4) July 1987, Photovoltaics: Sunlight to Electricity in One Step, British Columbia Ministry of Agriculture and Food,

<http://www.agf.gov.bc.ca/resmgmt/publist/400series/430310-1.pdf>, retrieved July 28, 2004

Special Safety and Environmental Concerns: None

Hints: Compare the sun's average peak power = 1 kW/m² to the wind power available in your area. Calculate wind power ($\frac{1}{2}\rho AV^3$) from turbine (ρ = air density, A = swept area, and V = wind velocity). Record wind speeds over two week period from your local weather reports and convert to average velocity in m/s. Calculate swept area based on wind turbine sizes you can find in resources in meters squared (m²). Find air density values in a reference book. Graph power created versus number of turbines or average wind speed. Compare to how much land you would need to absorb the same amount of sun energy.

Other Ideas: Compare the cost of a given parcel of land used for collecting energy (wind and/or photovoltaics) versus other possible uses.

2 Design and construct a wind vane and an anemometer. Use them to measure and compare wind direction and speed at various sites.

Learning Objectives: Understand how scientific measurements are done, importance of units and accuracy.

Variables: Wind direction, wind speed, sites selected for comparisons

Special Equipment: Wood, nails, plastic, cardboard, ping-pong balls, Popsicle sticks, jar lid, pen

Specific Resources: Search "Building an Anemometer" in your web search engine.

Special Safety and Environmental Concerns: None

Hints: Calibrate vane with compass. Calibrate anemometer (could be done through the window of a car with a parent). Compare different sites for collecting wind energy.

Other Ideas: The design and construction of a wind vane and/or an anemometer for efficiency could be an engineering project.

3 Determine lift and drag forces of various airfoil (wing) designs.

Learning Objectives: Recognize that design is a complex process that involves trade offs such as strength versus weight in airfoil design.

Variables: Airfoils, lifting force, drag force

Special Equipment: Multi-speed fan, cardboard or Styrofoam. For advanced projects: wind tunnel (can be homemade).

Specific Resources:

- (1) Beginners Guide to Aerodynamics, NASA Glenn Research Center <http://www.grc.nasa.gov/WWW/K-12/airplane/bga.html>

- (2) What Makes an Airplane Fly, Aeronautics Learning Laboratory for Science, Technology, and Research, <http://www.allstar.fiu.edu/aero/ftmidfly.htm>

- (3) Encarta Encyclopedia, 2004, "Aerodynamics," http://encarta.msn.com/encyclopedia_761557396/Aerodynamics.html

- (4) FIOLSIM II, NASA Glenn Research Institute, <http://www.grc.nasa.gov/WWW/K-12/airplane/foil4.html>

Special Safety and Environment Concerns: Take care when working with electricity and fans.

Hints: Compare wings of different shapes and sizes. Design a method of measuring lift, i.e., suspend airfoils and use sensitive spring scales to measure drag and lift.

Other Ideas: Advanced students could construct a wind tunnel and measure drag and measure drag and lift forces on various airfoil designs. What are the effects of bugs or ice on lift and drag forces?

4 What propeller size is the most efficient in producing electricity?

Learning Objectives: Understand that design is a complex process that involves trade offs such as strength versus weight in airfoil design.

Variables: Propeller size and materials

Special Equipment: Fan (2-3 speeds), 1-1/2-V dc motor, voltmeter (0-5 V), 100-ohm resistor, insulated wire, propellers (model airplane or one of own design), wind tunnel for advanced students (See Figure 2).

Specific Resources:

- (1) Wind Energy Basic, Wind Energy Development, <http://windeis.anl.gov/guide/basics/index.cfm>, retrieved on July 29, 2004
- (2) Propeller, <http://www.fact-index.com/p/pr/propeller.html>, retrieved on July 28, 2004

Special Safety and Environmental Concerns: Take care when working with electricity and fans.

Hints: Wind tunnels can be constructed of cardboard. Wind speed can be reduced to determine effects. To measure the electricity produced you will need to measure the volts and the amps.

Other Ideas: Advanced students could investigate solidity (high versus low) and number of blades by comparing efficiency and tip speed ratios of different blades. Also, the efficiency of dynamic inducers and cones can be investigated.

5 Can wind energy be used to power a boat into the wind? Will a boat powered by wind travel faster than a sailboat with the same swept area? Will a boat powered by wind travel faster than the wind?

Learning Objectives: Understand that design is a complex process that involves trade offs such as buoyancy, drag, stability, and weight.

Variables: Wind speed, windmill and propeller diameters

Special Equipment: Anemometer, model boats made of wood with propeller blades and shaft

Warning: Keep fingers and faces away from spinning propellers and fan blades.

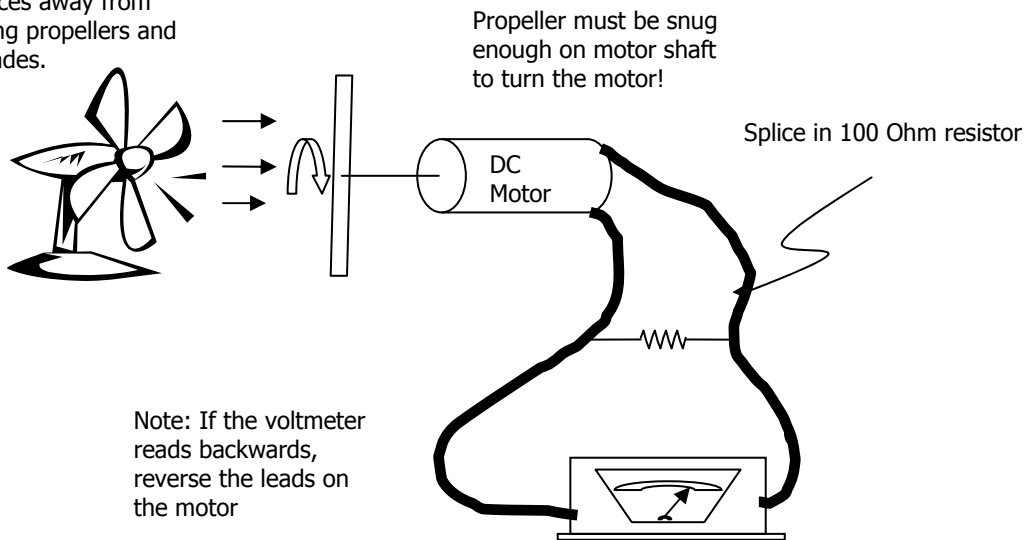

Note: If the voltmeter reads backwards, reverse the leads on the motor

Specific Resources:

- (1) Sailboat Glossary, Seadercraft, http://www.seadercraft.com/sailing_glossary.html, retrieved July 29, 2004
- (2) Search "Building an Anemometer" in your web search engine.

Special Safety and Environmental Concerns: Take care when working with electricity and fans.

Hints: Calibrate vane with compass. Calibrate anemometer (could be done through the window of a car). Attach a string, fishing pool and line, or some kind of device to your boat so that you may retrieve your boat from the water. The propeller used to propel a boat through water should be smaller than the wind propeller (turbine). See Figure 4.

Other Ideas: A similar idea could be applied to a model car. Advanced students could use a large prototype with a system of bearings on the shaft and propellers.

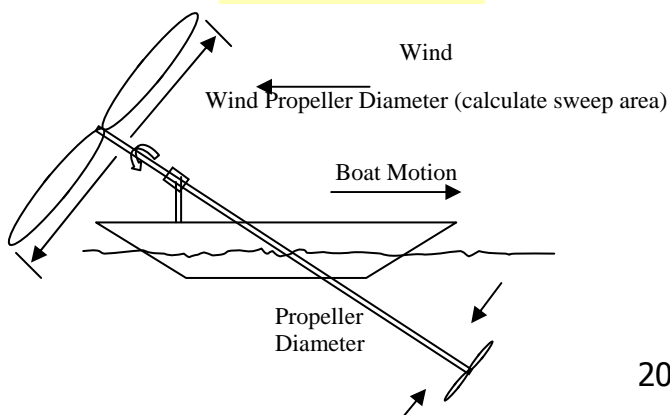
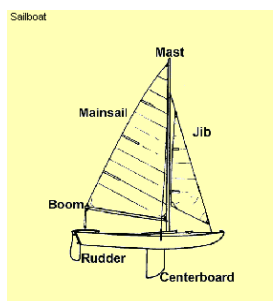

6 What propeller design is most efficient in producing electricity?

Learning Objectives: Understand that design is a complex process that involves trade offs such as strength versus weight in airfoil design. Energy transfer always involves loss of energy to heat.

Variables: Propeller diameter, power developed, wind speed

Special Equipment: Fan (2-3 speeds), 1-1/2-V dc motor, voltmeter (0-5V); 100-ohm resistor, insulated wire, materials for propeller, wind tunnel for advanced students.

Specific Resources:

- (1) Wind Energy Basic, Wind Energy Development, <http://windeis.anl.gov/guide/basic/index.cfm>, retrieved on July 29, 2004
- (2) Propeller, <http://www.fact-index.com/p/pr/propeller.html>, retrieved on July 28, 2004

Special Safety and Environmental Concerns: Take care when working with electricity and fans.

Hints: Set up your experiment as in the sketch for project #4

Other Ideas: The angle of the blades can be varied and compared. The wind speed can be varied and tested. The number of blades can be varied (1, 2, 3, etc.). The materials used in constructing the propellers can be varied.

7 What is the most efficient spacing of wind turbines for “farming” wind in a given unit of space?

Learning Objectives: Realize that design is a complex process. Compare a model to actual results. See how technology interacts with society.

Variables: Wind direction, number and design of the wind turbines, topography

Special Equipment: Fan (2-3 speeds), 1-1/2-V dc motor for each turbine, voltmeter and ammeter for each turbine, 100-ohm resistors, insulated wire, turbine propellers, wind tunnel for advanced students.

Specific Resources:

- (1) Haley, Jay, Landowners Frequently Asked Questions about Wind Development, http://www.eere.energy.gov/wind/poweringamerica/pdfs/wpa/34600_landowners_faq.pdf, retrieved July 28, 2004

Special Safety and Environmental Concerns: Be careful when operating blades.

Hints: Set up each turbine as illustrated in Projected #4 and previous picture. A simple wind tunnel could be constructed of cardboard. This would decrease variations of airflow generated by fan. May need to use clay, Lego trees, or other materials to model desired terrain.

Measure power output to see which spacing is best.

Other Ideas: Total electricity produced could be determined for the model land area. Mathematical calculations could determine total electricity produced for a larger area by extrapolation.

8 What area in your community is the most favorable for using wind as an energy source to generate electricity?

Learning Objectives: Understand the value and usefulness of mathematical models. Understand the conversion of units into common forms.

Use the cost information and power curve for the Bergey Excel 7.5 kW turbine given below to model cost of power given wind speeds in your area.

Turbine	\$ 18,400.00
Tower and Grounding	\$ 11,628.00
Installation	\$ 5,200.00
Shipping	\$ 2,000.00
Total	\$ 37,228.00
O&M per year	\$ 200.00

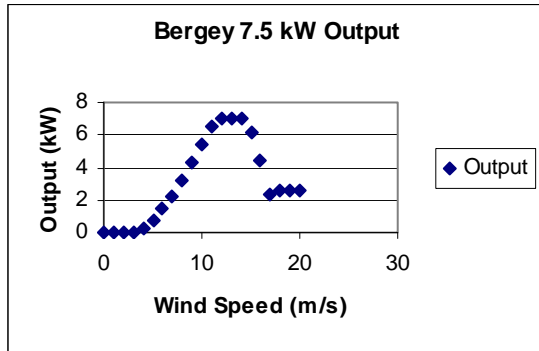

Variables: Wind Speed

Special Equipment: Anemometer (a recording anemometer for more sophisticated research)

Specific Resources:

- (1) Topozone, <http://topozone.com>, retrieved July 28, 2004
- (2) Evaluating Your Wind Resource and Sitting Your Turbine, Department of Energy, http://www.eere.energy.gov/consumerinfo/makeelectricity/eval_wintrb_eval.html, retrieved July 29, 2004
- (3) Search "Building an Anemometer" in your web search engine.

Special Safety and Environmental Concerns: None

Hints: Track wind information in your area for several months. Read Power Curve and find how much power is being generated over time. Divide total cost of wind turbine by power created for 10 years and calculate cost per kW. Compare to your electric bill.

Other Ideas: Does height above ground surface have any effects on wind speed in a given locale?

9 Is solar, wind, or solar and wind the best method to generator electricity?

Learning Objectives: Recognize that design is a complex process requiring tradeoffs. Understand that energy can be transferred to other forms but always involves the loss of some energy.

Variables: Load Size and type(s) of renewable resource

Specific Equipment: Solar Panel, Blade (plastic propeller blade), Wiring (preferably with clamps on the end), Motor (1 or 2), Buzzer, Light (Christmas Bulb), and any other load sources desired.

Specific Resources:

- (1) "Circuits," Encyclopedia, retrieved on July 13, 2004, <http://encyclopedia.thefreedictionary.com/Circuit>.
- (2) "How Solar Cells Work," How Stuff Works, Retrieved on July 13, 2004, <http://www.howstuffworks.com/solar-cell.htm>.

Special Safety and Environmental Concerns: Take care when working with electricity and fans.

Hints: When working with both solar and wind check the individual pieces.

Other Ideas:

Does series or parallel circuits work better in the solar/wind configuration?

More Project Ideas

Compare the efficiency of vertical-axis versus horizontal-axis wind machines.

How does changing the number of blades on a windmill affect the amount of energy it can produce?

How does the number of blades on a wind machine affect the number of revolutions per minute?

How does the shape of the blades on a windmill affect the energy it produces?

At what angle should windmill blades be set for maximum efficiency?

Find the windiest spot on your school playground. Make a map of measured wind versus location, time of year, and time of day.

How well do paper windmills of different design work? Which turns with the least wind?

How does wind vary with height above ground in your neighborhood or school?

What is the relationship between wind speed and electrical energy produced?

Can a wind turbine run on thermal updrafts?

What sail designs are best for boat speed and power?

Credits:

Picture taken at NWTC, May 2004

<http://www.sea.edu/k12lessonplans/k12MadeToSail.htm>

Communications with Ian Baring-Gould (National Wind Technology Center), 6/25/04

Bergey Wind Power
<http://www.bergey.com/>

Hydropower

For the Teacher

Hydroelectricity is the extraction and conversion of energy from water into its most useful form; electricity. Where water flows from a high level to a low level, turbines are used to convert this movement to produce electricity.

Electricity from flowing water is one way in which electricity can be produced. The second way water can be used is by damming rivers to store water until it is needed. The damming of rivers is the most common way of producing electricity. About 20% of the world's electricity comes from this method.

Even though there are no pollutants produced by hydroelectric power there is the environmental and social issues that impact people through the construction and the storage of water by the use of dams.

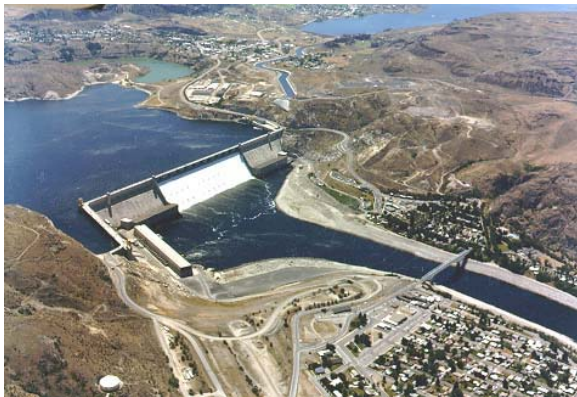

Grand Coulee Dam and power plant

National Science Education Standards by the National Academy of Sciences

Science Content Standards: 5-8

Science As Inquiry

– Content Standard A:

“Understandings about scientific inquiry”

Physical Science

– Content Standard B:

“Properties and change of Properties in matter”
“Transfer of energy”

Earth and Space Science

– Content Standard D:

“Earth in the solar system”

Science and Technology

– Content Standard E:

“Abilities of technological design”
“Understandings about science and technology”

Science in Personal and Social Perspectives

– Content Standard F:

“Science and technology in society”

Technology Description

The basics are the turbines, which generate very reliable power with a very simple design. Some kind of a “runner” or propeller is attached to a shaft, which operates an alternator to generate power when the water turns the runner. There are three types of turbines used in hydroelectric generation: impulse turbines, reaction turbine, and submersible propeller turbines. No matter what the source of the water if you have running water, and it supplies water year around than you can have a year around power supply.

Water turbines are “active power producers” That means if the water is flowing and the turbine is turning then power is produced. The power must be used to charge batteries or be used to operate an electrical device, or the heat build up can damage the turbine. A controller is used to divert the power to batteries or to a diversion load to use the surplus electricity safely.

Impulse turbines operate on the same principle as a toy pinwheel. Water strikes the turbine runner, and pushes it in a circular motion. The water is brought through a pipe and out a small nozzle to force the turbine to turn. Impulse turbines work best when the head is high (20 ft or more). Head is the distance between where the water enters the pipe and where it reaches the turbine.



Impulse Turbine

Reaction turbines require a much larger amount of water flow than impulse turbines, but can operate with as little as two feet of head. This is ideal for use in an area with very flat land, but a large water flow.



Reaction Turbine

The least efficient turbine is the submersible propeller turbine, but has the simplest design. A propeller is mounted on a shaft connected directly to an alternator. When submerged in a fast moving water source, the force of the passing water rotates the propeller.

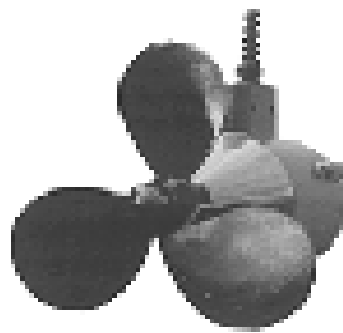

Submersible propeller Turbine

Resources:

United States Department of Energy
<http://www.doe.gov/>

National Renewable Energy Laboratory
<http://www.nrel.gov/>

The Pembina Institute
<http://www.re-energy.ca>

Queensland Department of Education
<http://www.sustainableenergy.qld.edu.au/html/activitysheets.html>

United States Geological Survey
<http://usgs.gov/>

United States Bureau of Reclamation
<http://www.usbr.gov/power/>

Other power.com
<http://www.otherpower.com>

Fords MTM L.L.C.
<http://www.fords-mtm.com>

Micro Hydro Power
<http://www.microhydropower.net>

Voltmeter
<http://www.sciencekit.com/>

Project Ideas

- 1 Does the type or shape of a water turbine affect the efficiency of energy production?

Learning Objective: Designing, construction, and evaluating turbine efficiency.

Controls and Variables: Water speed, size of turbine, Height above turbine, Time

Materials and Equipment:

A cork or similar cylinder (a Styrofoam cylinder will work), Safety razor blades (single blade), knitting needle or similar to be used as a shaft, thread or small twine, different objects to be used as masses, stop watch or watch. Materials for construction can be purchased in most grocery and hardware stores. Specialized equipment is not needed.

Safety and Environmental

Requirements: *Adult supervision is needed in the construction of the turbines. The use of sharp objects can be potentially hazardous.*

Suggestions: When measuring the power produced, lifting of different amounts of mass can be used to evaluate the design

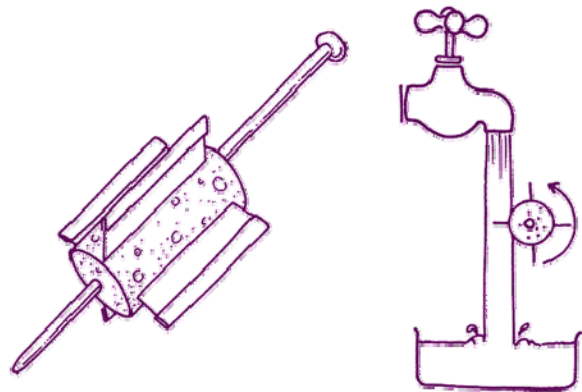

2 Building and Testing a Hydroelectric Generator.

Learning Objective: You will be able to observe for your self-how electricity is produced from the energy of running water.

Controls and Variables: Water speed, height water falls, energy produced.

Materials and Equipment:

Materials list and equipment needed is available at: <http://www.re-energy.ca> click on "water Power" then download: "Water power Electrical Generator" and "Micro-hydro Template Sheet"

Multimeter.

(See resource section - this is not absolutely necessary for this project, but it allows you to measure voltage *and* current.)

Safety and Environmental

Requirements: see precautions on down loaded instructions.

Suggestions: Measure the voltage (amount of potential energy in the electricity) at different heights and with different water speeds, different blade sizes, different water stream sizes,

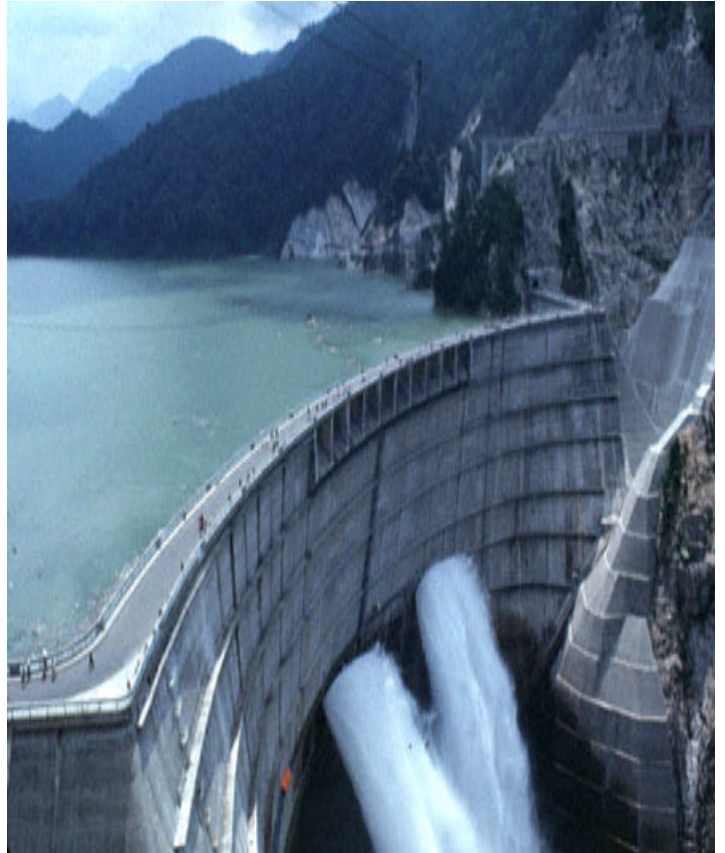

Ocean Power

For the Teacher

The discussion of renewable energy some times focuses on what happens when the sun doesn't shine? What happens when the wind isn't strong enough to produce sufficient power? How can we store the energy we need? What happens when storage is not practical on a large scale for instance supplying energy to a large energy grid? In areas of the country that have available coastline, but are limited in other renewable resources can use the oceans as there renewable sources. We are familiar with the large hydroelectric dams that dot our nation, creating large reservoir and flooding millions of acres of land. By turning to the restless seas we can find a source of energy that is not affected by clouds and the scarcity of wind. By using ocean power, we can increase our need for power with out having to deplete our existing non-renewable resources.

Ocean power is divide into three categories, Wave Energy, Tidal Energy, and Ocean Thermal Energy Conversion (OTEC) Systems. Ocean Energy is estimated to be 2 to 3 million megawatts of power on our world's coastlines.

National Science Education Standards by the National Academy of Sciences

Science Content Standards: 6-8
Science As Inquiry
– **Content Standard A:**

“Abilities necessary to do scientific inquiry”

“Understandings about scientific inquiry”

Physical Science

– **Content Standard B:**

“Properties and changes of properties in matter”

“Motions and Forces”

“Transfer of energy”

Earth and Space Science

– **Content Standard D:**

“Structure of the Earth System”

Science and Technology

– **Content Standard E:**

“Abilities of technological design”

“Understandings about science and technology”

Science in Personal and Social Perspectives

– **Content Standard F:**

“Science and technology in society”

Technology Description

More than 70% of the solar radiation reaching Earth falls on the ocean, heating the upper layers of the seas. This thermal energy, combined with wind and the forces of our solar system causes currents, waves, and tides. Together these forms of thermal and mechanical energy make up a huge energy resource.

The mechanical forms of ocean energy-the tides, waves, and currents-offer significant potential energy in specific regions around the world. Several nations have tried to harness this energy, but low efficiencies and high cost have limited application in

most cases. In recent years the technology has changed the climate for this type of renewable energy. More and more countries are funding research and development.

The Tidal power stations utilize the twice-daily movements of the tides. Various devices are used to convert this motion to turn turbines to produce electrical power.

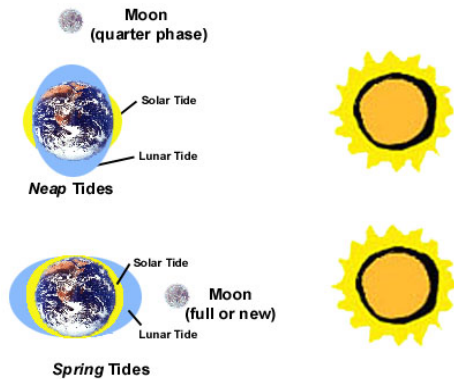

Tidal Energy involves erecting barrage across a tidal basin. A sluice is used to direct the water into a basin, as the ocean level drops the water is allowed to flow back into the ocean. Traditional hydroelectric technologies are used with the redirected water to produce electricity.

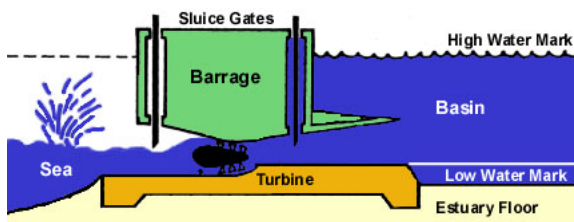

There are various means of capturing this energy. Floats or pitching devices generate electricity from the bobbing or pitching action of the device these can be used on a floating structure or anchored to the sea floor.

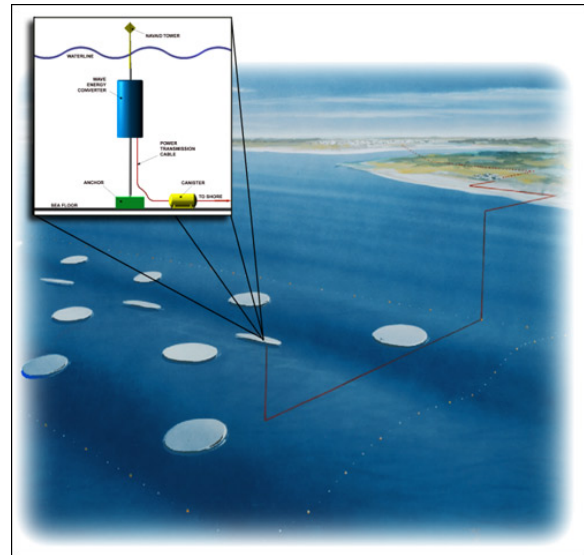

Oscillating Water columns generate electricity by the rise and fall of a vertical shaft. This rising and falling of the column of water drives air into an air turbine. Wave surge or focusing devices allow the sea to be channeled there by pushing the trapped air on top of the water. The air is then forced through a turbine.



An interesting type of generator uses the idea that all fluids behave the same. Using this idea they have produced an underwater turbine that resembles a wind turbine.

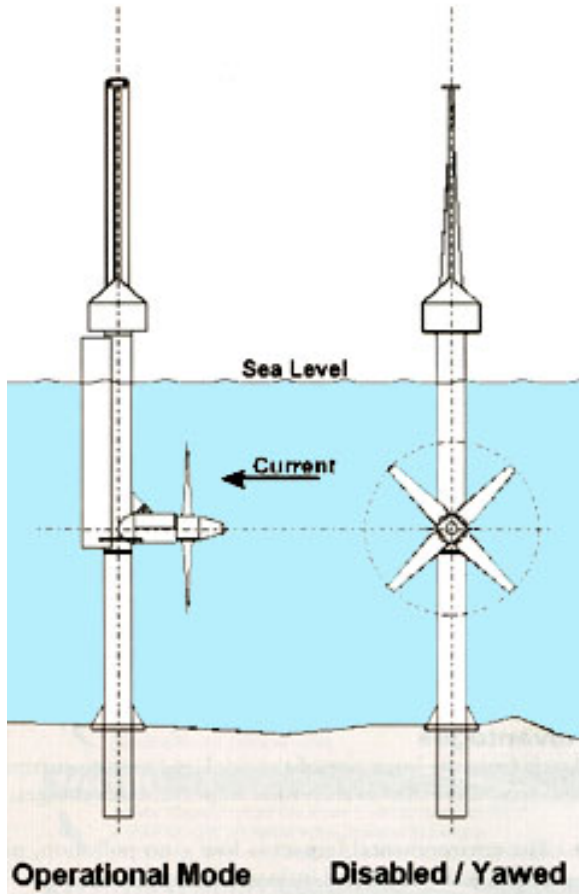

There are Ocean Thermal Energy Conversion (OTEC) System relies on the stored thermal energy difference in the oceans. Each day the sun provides the equivalent of 250 billion barrels of in the form of thermal energy to our oceans

Three types of OTEC systems can be used to generate electricity:

Closed-cycle plants circulate a working fluid in a closed system, heating seawater, flashing it to vapor, routing the vapor through a turbine, and then condensing it with cold seawater.

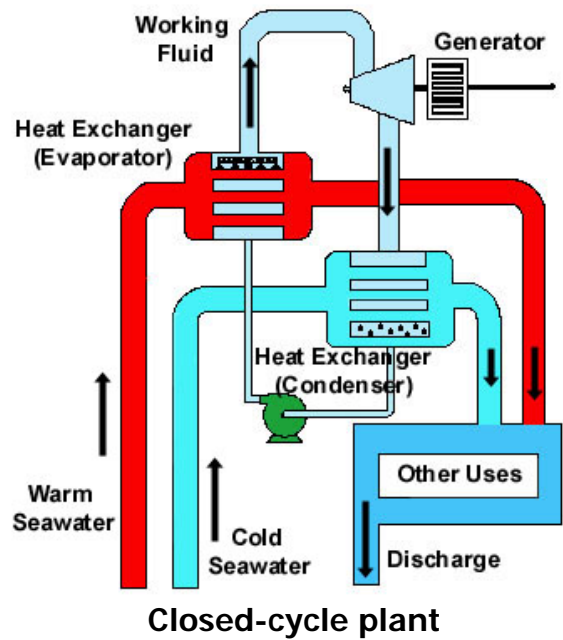

Open-cycle plants flash the warm seawater to steam and route the steam to a turbine.

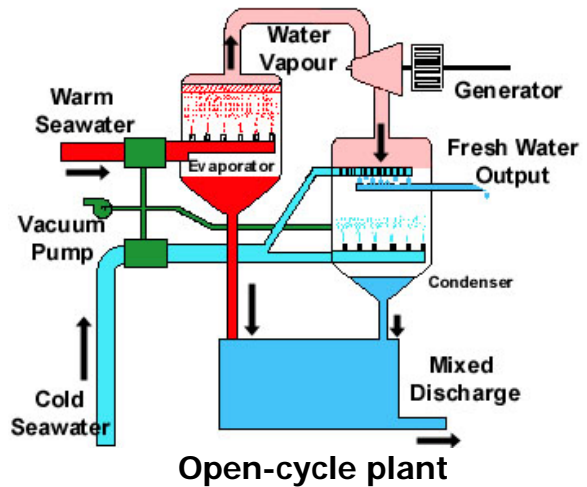

Hybrid plants flash warm seawater to steam and use the steam to vaporize a working fluid in a closed system.

Resources:

U.S. Department of Energy, Energy Efficiency and Renewable Energy
http://www.eere.energy.gov/consumer/renewable_energy/ocean/index.cfm/mytopic=50010

National Renewable Energy Laboratory
<http://www.nrel.gov/>

Ocean power technologies
[Ocean Power Technologies](#)

Resources for Following Projects:

Tubing and stoppers can be found through any scientific supply house.

<http://www.sciencekit.com/>

Project Ideas

1 How can you put the energy of ocean tides to work?

Learning Objective: What affects the way water fills and empties a tidal basin?

Controls and Variables: Volumes of different containers representing different size oceans. Different size containers representing different size basins. Changes in elevation of the ocean and basin, affecting water flow.

Materials and Equipment:

Containers

Plastic milk containers, soda pop containers, water bottles. **With bottoms removed**

Stoppers

Rubber stoppers to fit the containers, **one hole**

Rubber or plastic tubing

(see resource section) Thick walled plastic tubing can replace glass tubing inserted into stoppers.

Safety and Environmental Requirements: *None.*

Suggestions: Vary the height of the ocean bottle to see how fast it will fill the basin bottle. Vary the height of the basin to find out how fast the basin empties into the ocean. How do differences in the sizes of the ocean and the basins affect the flow between them? Use a water wheel to extract the energy from the filled basin, calculate the efficiency and the energy produced. Vary tubing sizes to observe the effects on the efficiency and energy produced.

2 How does an OTEC (ocean thermal energy plant) work?

Learning Objective: You will be able to investigate the principles behind the OTEC.

Controls and Variables:

Variations in ocean temperature, at what temperatures are needed to change liquids to gases and gases to liquids.

Materials and Equipment:

Pulse Glass

<http://www.sciencekit.com/> (62790-00 \$16.45) How liquids can change to gases at low temperatures.

Safety and Environmental

Requirements: *The pulse glass can be fragile care should be used.*

Suggestions: Find the temperature range for the liquid in the pulse glass. Temperatures up to 40 degrees centigrade can be used safely.

3 Can water boil at room temperatures?

Learning Objective: How the boiling points of liquids can be changed.

Controls and Variables: Water temperature, pressure.

Materials and Equipment:

Cincinnati Form Franklin's Flask

<http://www.sciencekit.com/> 68933-01 \$59.25 a less expensive way of observing liquids boiling at low temperatures.

Safety and Environmental

Requirements: *As with all experiments that involve heating and pressure you will need to wear eye protection.*

Suggestions: Try adding table salt to the liquid. Build a model of an open-cycle OTEC plant.

4 Build a wave energy device

Learning Objective: Building different models of wave energy conversion devices.

Controls and Variables: Power generated, wave height, wave period

Materials and Equipment:

If no natural source of waves is available, a wave making machine can be made from a wooden plank that one or two people could push back and forth just under the surface of the water.

Safety and Environmental

Requirements: Use caution when working in a surf zone. Do not leave devices in the surf zone unattended or when high surf is expected.

Suggestions: Many different kind of energy conversions devices have been designed and built. Build your own or design a new device.

Alternative Fuels Used in Transportation

For the Teacher:

The use of energy is a factor in all our lives and that is why it is important for us as teachers to have our students learn about the energy we use now and of new forms of energy that are becoming available. Nonrenewable energy sources are diminishing everyday and it is vital that students learn of renewable energy sources to help them as they grow to become better informed and more responsible to the energy resources they will use.

The use of gasoline for transportation is the most commonly used fuel, however there are multiple alternative fuels that are making their way to the market. These alternative fuels include such things as, Propane, Natural Gas, Electric Hybrids, Hydrogen Fuel Cells, and Bio-diesel. Students will probably have heard of some of these alternative fuels, but may not understand how and why they are better than ordinary gasoline. The projects included in this section are designed to give students the opportunity to create their own investigation and testing with alternative fuels and their relation to transportation.

The projects included will fit easily with regular classroom lessons surrounding scientific inquiry and the scientific method. The projects have



capabilities of crossing multiple education disciplines using studies such as chemistry, physics, economics, and marketing and they involve social interaction as well as group learning.

Alternative fuels are being researched everyday at NREL by top scientists to discover which fuel methods work best, how well they work and how easily they can be distributed to the public. The authors of this section are studying the emissions released from large trucks running on different bio-diesel fuels to compare which blends create lower emissions.

National Science Education Standards by the National Academy of Sciences:

Science Content Standards: 5-8 Science as Inquiry

- Content Standard A:

“Abilities necessary to do scientific inquiry”

“Understandings about scientific inquiry”

Physical Science

- Content Standard B:

“Properties and changes of

properties in matter”

“Transfer of energy”

Earth and Space Science

- Content Standard D:

“Structure of the earth system”

Science and Technology

- Content Standard E:

“Abilities of technological design”

“Understandings about science and technology”

Science in Personal and Social Perspectives

- Content Standard F:

“Populations, resources, and environments”

“Science and technology in society”

Technology Description:

Transportation by cars and trucks radically changed the face of our country over the last hundred years with petroleum providing the fuel for our vehicles. We use about 13 million barrels of oil each day to keep us on the move. Americans drive their personal vehicles about 2.3 trillion miles a year with 98 percent of our vehicles running on petroleum or diesel fuels. United States imports two-thirds of all the petroleum we use; therefore, cheaper and renewable alternative fuels would be desirable to reduce our dependence. In addition to the dependence factor, one also needs to consider the emissions from gasoline-powered vehicles are fairly extensive and include CO, CO₂, NO_x, SO_x, VOCs, OH⁻, and PM. Some of these emissions are known or probable human carcinogens, including benzene (known), formaldehyde, acetaldehyde, and 1,3-butadiene (probable). Gasoline can also impact the environment if spilled, since it spreads

on water surfaces and quickly penetrates porous soils and groundwater.

The idea of alternative fuels has been around about as long as there been vehicles. In the 1880s, Henry Ford built one of his first automobiles to run on ethanol. The alternatives fuels that are being actively explored by the Department of Energy include: methanol; propane; ethanol; compressed and liquefied natural gas; electricity; hybrid electricity; biodiesel; and hydrogen fuel cells. Factors such as cost, fuel distribution, emissions, vehicle systems analysis, energy storage, power and propulsion systems, and advanced power electronics are just some of the considerations in phasing in alternative fuels and advanced vehicle design.

Complete Combustion

Fuel (hydrocarbons) + Air (O₂& N)

⇒ CO₂ + H₂O + N

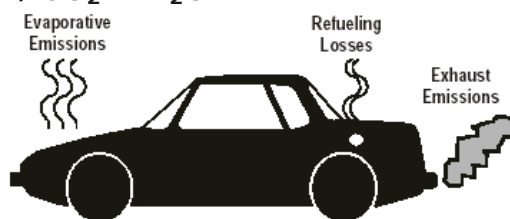

Typical Engine Combustion

Fuel + Air Unburned Hydrocarbons

+ NO_x + CO + CO₂ + H₂O

Improving fuel economy, cost, availability, and emissions are primary goals of research into alternative fuels and transportation.

Alternative Fuels- Methanol

Methanol, or wood alcohol, is a colorless, odorless, toxic liquid. Methanol is the simplest alcohol

(CH₃OH), produced by replacing one hydrogen atom of methane with a hydroxyl radical (OH). Methanol can be produced from natural gas, coal, residual oil, or biomass.



Although vehicles can operate on pure methanol fuel (M100), methanol blended with 15 percent unleaded gasoline—M85— is more practical for real world applications. Because methanol is a liquid fuel, it does not require major changes in the distribution system or in car engines, but no major auto manufacturers offer M85 compatible vehicles at this time. The cost of M85 is equal to or slightly higher than premium blends. M85 has a lower energy content per gallon, so mileage is lower; but power, acceleration and payload capacity are comparable to gasoline. Vehicles using methanol, however, must use a special, expensive lubricant.

Propane

Propane is an energy-rich fossil fuel often called liquefied petroleum gas (LPG). It is colorless and odorless; an odorant called mercaptan is added to serve as a warning agent. Propane is a by-product of petroleum refining and natural gas processing. And, like all fossil fuels, it is nonrenewable. The chemical formula for propane is C₃H₈.

Under normal atmospheric pressure and temperature, propane is a gas. Under moderate pressure and/or lower temperature, however, propane

can easily be changed into a liquid and stored in pressurized tanks. Propane is 270 times more compact in its liquid state than it is as a gas, making it a portable fuel.

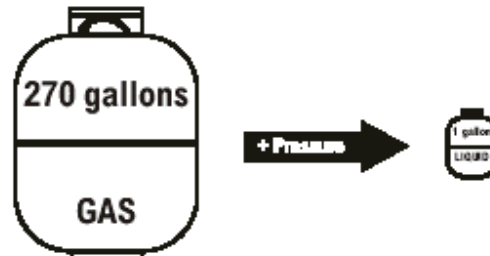

Propane has been used as a transportation fuel for more than half a century and is the most widely used and most accessible alternative fuel. Today about three percent of total propane consumption is used to fuel 270,000 vehicles, mostly in fleets. For fleet vehicles, the cost of using propane is 5 to 30 percent less than for gasoline.

Ethanol

Ethanol is a clear, colorless alcohol fuel made by fermenting the sugars found in grains, such as corn and wheat, as well as potato wastes, cheese whey, corn fiber, rice straw, urban wastes, and yard clippings. There are several processes that can produce alcohol (ethanol) from biomass. The most commonly used processes today use yeast to ferment the sugars and starch in the feedstock to produce ethanol. A new process uses enzymes to break down the cellulose in woody fibers, making it possible to produce ethanol from trees, grasses, and crop residues.

In the 1970s, the oil embargoes revived interest in ethanol as an alternative fuel. Today, more than fifty ethanol plants, mostly in the Midwest, produce over a billion gallons of ethanol.

Gasoline containing ten percent ethanol—E10—is widely used in urban areas that fail to meet standards for carbon monoxide and ozone. Since ethanol contains oxygen, using it as a fuel additive results in up to 25 percent fewer carbon monoxide emissions than conventional gasoline. E10 is not considered an alternative fuel under EPACT, but a replacement fuel.



Methane

Methane, the natural gas we use for heating, cooking, clothes drying, and water heating, can also be a clean burning transportation fuel when compressed (CNG) or liquefied (LNG). Compressed natural gas (CNG) vehicles emit 85-90 percent less carbon monoxide, 10-20 percent less carbon dioxide, and 90 percent fewer reactive non-methane hydrocarbons than gasoline-powered vehicles. (Reactive hydrocarbon emissions produce ozone, one of the components of smog that causes respiratory problems.) These favorable emission characteristics result because natural gas is 25 percent hydrogen by weight; the only combustion product of hydrogen is water vapor. Natural gas is usually placed in pressurized tanks when used as a transportation fuel. Even compressed to 2,400-3,600 pounds per square inch (psi), it still has only about

one-third as much energy per gallon as gasoline. As a result, natural gas vehicles typically have a shorter range, unless additional fuel tanks are added, which can reduce payload capacity. With an octane rating of 120+, power, acceleration and cruise speed are comparable.



Louisville Metropolitan Sewer District Fleet CNG Vehicle

Electricity

In 1891, William Morrison of Des Moines, Iowa, developed the first electric car. By the turn of the century, dedicated electric vehicles (EVs) outnumbered their gasoline-powered counterparts by two-to-one. Today there are about 10,500 dedicated EVs in use in the United States, mostly in the West and South. Researchers are still working on the same problem that plagued those early dedicated EVs—an efficient battery. The batteries limit the range of a dedicated EV, which is determined by the amount of energy stored in its battery pack. The more batteries a dedicated EV can carry, the more range it can attain, to a point. Too many batteries can weigh down a vehicle, reducing its load-carrying capacity and range, and causing it to use more energy. The typical dedicated EV can only travel 50 to 130 miles between charges. This driving range assumes perfect driving conditions and vehicle maintenance. Weather conditions, terrain, and some accessory use can significantly reduce the range.

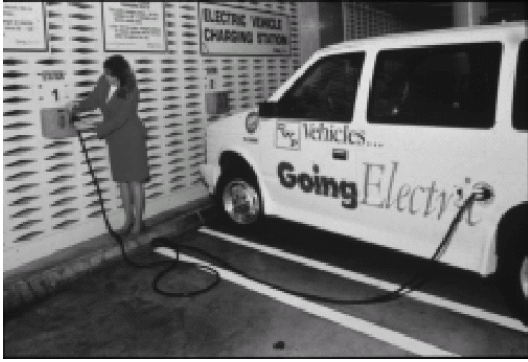

Hybrid Electricity

Hybrid Electric Vehicles (HEVs) may be the best alternative vehicle for the near future, especially for the individual consumer. HEVs offer many of the energy and environmental advantages of the dedicated electric vehicle without the drawbacks. Hybrids are powered by two energy sources—an energy conversion unit (such as a combustion engine or fuel cell) and an energy storage device (such as battery, flywheel, or ultracapacitor). The energy conversion unit can be powered by gasoline, methanol, compressed natural gas, hydrogen, or other alternative fuels. HEVs have the potential to be two to three times more fuel-efficient than conventional vehicles. An HEV battery doesn't have to be recharged. It has a generator powered by the internal combustion engine to recharge the batteries whenever they are low. A regenerative braking system captures excess energy when the brakes are engaged. The recovered energy is also used to recharge the batteries.

Gas-Electric Hybrid

Biodiesel

Biodiesel is a fuel made by chemically reacting alcohol with vegetable oils, fats, or greases, such as

recycled restaurant greases. It is most often used in blends of two percent or 20 percent (B20) biodiesel. It can also be used as neat biodiesel (B100). Biodiesel fuels are compatible with and can be used in unmodified diesel engines with the existing fueling infrastructure. It is the fastest growing alternative transportation fuel in the U.S. Biodiesel contains virtually no sulfur, so it can reduce sulfur levels in the nation's diesel fuel supply. Removing sulfur from petroleum-based diesel results in poor lubrication. Biodiesel is a superior lubricant and can restore the lubricity of diesel fuel in blends of only one or two percent. Biodiesel can also improve the smell of diesel fuel, sometimes smelling like french fries.



Berkeley Curbside Recycling Trucks Now Fueled by Recycled Vegetable Oil

Hydrogen Fuel Cell

In the future, hydrogen may provide a significant contribution to the alternative fuel mix. The space shuttles use hydrogen for fuel. Fuel cells use hydrogen and oxygen to produce electricity without harmful emissions; water is the main by-product. Hydrogen is a gas at normal temperatures and pressures, which presents greater transportation and storage hurdles than liquid fuels. No distribution system currently exists. Today, the predominant method of producing hydrogen is steam reforming of natural

gas, although biomass and coal can also be used as feedstocks.



*SunLine Transit Agency
Hydrogen Fuel Cell Bus*

Resources:

Energy Efficiency and Renewable Energy
<http://www.fueleconomy.gov/>

National Energy Educational
Development
<http://www.need.org>

Energy Efficiency and Renewable Energy
<http://www.eere.energy.gov>

Kentucky Clean Fuels Coalition
www.kentuckycleanfuels.org

U.S. Environmental Protection Agency
www.epa.gov

National Renewable Energy Laboratory -
Department of Energy
www.nrel.gov

Alternate Transportation Fuels
<http://www.need.org/needpdf/AlternativeFuels.pdf>

Energy Correlation to National Science
Education Content Standards
<http://www.need.org/needpdf/Correlation.pdf>

Project Ideas

1 What is the heat content of two alternative fuels?

Learning Objective: You will be able to measure the amount of heat absorbed by water during the combustion of methanol and ethanol in a calorimeter.

Controls and Variables: Volume of water, temperature change in heat sink (100 mL of water), mass of fuel used, and heat content of two fuels.

Materials and Equipment: Economy calorimeter; alcohol burners; ethanol; methanol; & thermometers.

Safety and Environmental Requirements: Safety glasses should be worn at all times. The frame of the economy calorimeter retains heats and care must be taken when moving after testing.

Suggestions:

- Determine the number of chemical bonds in methanol (5) and ethanol (8).

- Correlate the heat content of each fuel related to the number of chemical bonds.
- Students explore why the obtained heat value fall below the actual heat value (ethanol = 7089 cal/g and methanol = 5426 cal/g).
- Do a balance of equations for the combustion of methanol ($2\text{CH}_3\text{OH} + 3\text{O}_2 \Rightarrow 2\text{CO}_2 + 4\text{H}_2\text{O} + \text{energy}$) and ethanol ($\text{C}_2\text{H}_5\text{OH} + 3\text{O}_2 \Rightarrow 2\text{CO}_2 + 4\text{H}_2\text{O} + \text{energy}$).
- Determine the oxygen to fuel ratio for each fuel and how would this ratio change the volume of carbon dioxide produced.

Places To Purchase:

Calorimeter:

<https://www1.fishersci.com/wps/portal/HOME>

(\$25.60 - economy food calorimeter)

<https://www.freyscientific.com>

(\$21.95 – economy food calorimeter)

Homemade calorimeter can be made by using two different size cans with holes through the top of both cans to suspend the smaller can over the flame with glass stir rod. Larger can is a tube and smaller can open only on top to hold water and take temperature readings (note diagram below).

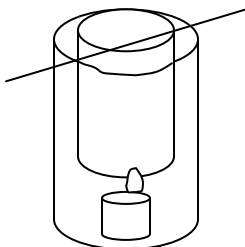

Wickless Leakproof Burner

<https://www1.fishersci.com/wps/portal/HOME>

(\$14.00 – holds 100cc of fuel)

<https://www.freyscientific.com>

(\$13.65 – holds 100cc of fuel)

Flint Glass Alcohol Lamp

<https://www.freyscientific.com>

(\$6.25 – 8 oz. capacity)

<https://www1.fishersci.com/wps/portal/HOME>

(\$6.35 – 8 oz. capacity)

Ethanol

<https://www1.fishersci.com/wps/portal/HOME>

(\$10.80 – 1 liter)

<https://www.freyscientific.com>

(\$8.35 – 1 liter)

Methanol

<https://www1.fishersci.com/wps/portal/HOME>

(\$5.15 – 500 mL)

<https://www.freyscientific.com>

(\$6.65 – 500 mL)

2 What is the economically best choice between purchasing a hybrid or typical gasoline engine automobile?

Learning Objective: You will be able to show which type of engine is the most economical in the long run between a hybrid and typical gasoline engine.

Controls and Variables: The different variables for each automobile will be initial cost, operating cost (gasoline price), and miles per gallon of fuel. Constants should be the amount of driving that would be done in each automobile.

Materials and Equipment: Pen and paper and access to the Internet for research.

Safety and Environmental Requirements: None

Suggestions:

- Payback period is the length of time you must own an energy-efficient vehicle before the decreased operational costs make up for the difference in initial purchase price. Calculate the payback period for a Honda Civic (Hybrid) vs. a Honda Civic (Gasoline) using the following figures:

Honda Civic (Hybrid)
 Initial Cost: \$19,650
 Tax Incentive: \$1500
 Miles per Gallon: 48 mpg
 Honda Civic (Gasoline)
 Initial Cost: \$17,260
 Tax Incentive: \$0
 Miles per Gallon: 40 mpg

	Hybrid	Gasoline
Initial Cost	\$19,650	\$17,260
Tax Incentive	\$1,500	\$0
Fuel Economy	48 mpg	40 mpg

Difference in Initial cost	(+) \$2390	
Difference in cost after tax incentive	(+) \$890	
Fuel economy at a gas rate of \$2.10 per gallon for one year at 10,000 miles	\$438/year	\$525/year

Amount of time till hybrid savings exceed gasoline initial savings 10.2 years

- Investigate the rate at which hybrid vehicles have been decreasing in initial cost. What might be some factors for this decrease? Do they expect hybrid vehicles to someday have a lower initial cost than gasoline engine vehicles?
- Research other types of alternative fuels. Is hybrid more cost efficient than compressed natural gas (CNG), hydrogen fuel cell, propane, or bio-diesel?

3 Determine a plan for large number fleets of automobiles to transition for traditional gasoline engines to alternative fuel engines.

The mayor of a large city in your area has asked your class to develop a plan to reduce emissions created by his fleet — including school buses, public

buses, sanitation trucks, police, emergency vehicles, and the city fleet of automobiles. Divide the project into six parts and in each part develop a plan to present to the mayor, listing recommendations and costs for each type of vehicle and the rationale for each recommendation.

List the recommendations of each part by vehicle category. Where there are several recommendations, debate and defend recommendations until a consensus is reached.

Learning Objective: You will understand different forms of alternative fuels as well as a greater understanding of citywide economics.

Controls and Variables: None

Materials and Equipment: Pen and paper and access to the Internet for research.

Safety and Environmental Requirements: None

Suggestions: Invite area experts to visit the classroom to discuss alternative fuel vehicles.

Present your findings in a formal report to be sent to your local mayor.

4 Quantify the relative amount of CO₂ given off by the methanol vs. ethanol during the combustion process.

Utilize a fish aquarium pump to pull samples of exhaust fumes from above the calorimeter experiments (done in project idea one) and let it

pump the collected gases into a test tube of bromothymol blue solution or red cabbage juice to determine relative CO₂ content. (Bromothymol blue will change from blue to green to yellow in the presence of CO₂)

Learning Objective: You will be able to test for the presence of CO₂ in the combustion of ethanol and methanol and qualitatively compare the two amounts.

Controls and Variables: The different amounts of ethanol and methanol that are used can either be held constant or varied depending on the experiment. Hold the solution of bromothymol blue or red cabbage juice constant through each test.

Materials and Equipment: A fish aquarium air pump with tubing, air pump in sealed container with inlet and outlet air tubes, two test tubes, scale to determine mass of fuel consumed, material from project #1, bromothymol blue solution or red cabbage juice, and stopwatch.

Safety and Environmental Requirements: Safety wear (goggles, lab apron, heat resistant gloves), well ventilated area for burning, and waste container (do not pour ethanol or methanol down the drain or into garbage).

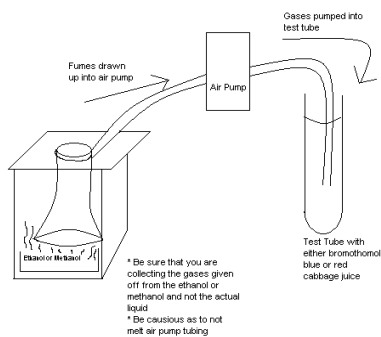

Places to Purchase:

Bromothymol Blue, 0.04% in Ethanol
<http://www.baddley.com/> (\$12.00 – 125 mL)

<http://www.clarksonlab.com/salesaz.htm> (\$14.95 - 5 g powder reagent)

5 What goes into building a hydrogen fuel cell car?

There are many different available models of hydrogen fuel cell cars that can be bought. Try just using the basic parts to build a unique hydrogen fuel cell vehicle.

Learning Objective: You will be able to understand the hydrogen fuel cell process of how water (through electrolysis) is turned into power to run a motor.

Controls and Variables: A simple hydrogen fuel cell vehicle kit will give all the components necessary; everything else is up to you.

Materials and Equipment: Hydrogen fuel cell vehicle kit, some power tools may be necessary when building custom vehicle bodies. You will also need smooth surface to run the vehicles on.

Safety and Environmental

Requirements: Safety protection should be taken when building the cars from scratch as well as protection from small electrical circuits and a moving motor.

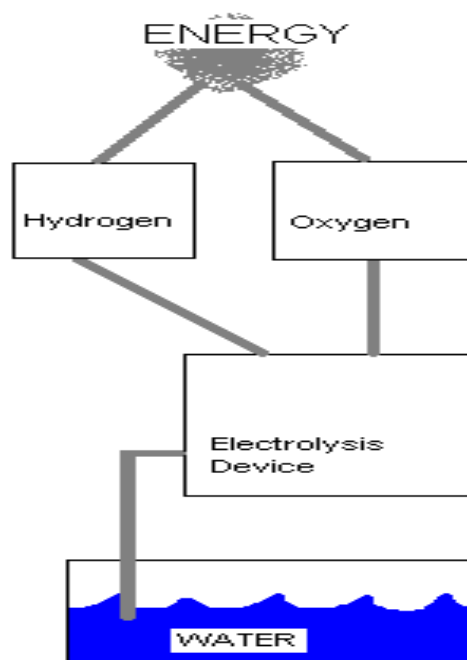

Suggestions:

1. See who can build the fastest vehicle by changing wheels and axis, body types, and gear sizes.
2. Determine the efficiency of the hydrogen fuel cell.

Places to Purchase:

Hydrogen Fuel Cell Kits
<http://electronickits.com/kit/complete/solar/fuelcell.htm>
 (~ \$125)

http://sciencekit.com/category.asp_Q_c_E_427448
 (~ \$220)

References:

<http://www.nap.edu/readingroom/books/nses/html/>

<http://www.nrel.gov>

<http://www.fueleconomy.gov/>

<http://www.need.org/needpdf/AlternativeFuels.pdf>

Photo References:

<http://www.need.org/needpdf/AlternativeFuels.pdf>

Computer-Based Energy Projects

For the Teacher

Although these are science fair projects, all three are easily adaptable to the regular classroom, provided you have computer access. If possible, it would be optimal to team-teach with the computer science teacher at your school as part of a unit on renewable energy. Students can work in groups for any of these projects. In fact, for class-work groups would be preferable. If working in groups, it may be more effective to assign different aspects of the project (to be turned in) to each member of the group.

Project 1: This project lends itself well to a renewable energy unit. While learning about what these energy sources are, students can gain an understanding of their availability throughout the country, and more importantly, which renewable resources can be harnessed in their area. This can also correlate to an analysis of locations in the country where renewables are already being used. The ultimate message for students might be that we have a vast, virtually untapped, resource that would provide clean power. This lesson is highly relevant across the curriculum, particularly in today's political climate due to our country's reliance on foreign oil.

Project 2: With the recent advances in transportation technology, a project that incorporates an investigation of hybrid vehicles is useful for informing students about the latest discoveries, and will likely

be in line with student interests. This project also continues the theme from project three—energy use. Students will gain a valuable understanding of the magnitude of fossil fuel use and how it can be decreased, even *without* buying new technology cars.

Project 3: No unit on energy use and renewable resources is complete without an analysis of the distribution of energy consumption around the world. The best way to adapt this project would be to have one class period of data compilation (from the included websites), and another of discussion.

Project 4: Computer modeling need not be confined to the realm of engineers and programmers. NREL has developed a modeling program, HOMER, which can be simplified enough so that even middle school students could use it. HOMER models renewable, hybrid, or stand-alone systems to allow the user to construct the most economically feasible power system. The website where HOMER can be downloaded also provides tutorials that could be used in the middle school classroom. For high school students, a project in which they model their own homes powered by renewable energy resources would send a very important message about the feasibility (depending on what resources are available in your area) of employing renewable power in small-scale, domestic situations.

*National Science Education
Standards by the National
Academy of Sciences*

Science Content Standards: 9-12

Science As Inquiry

- **Content Standard A:**

"Abilities necessary to do scientific inquiry"

"Understanding about scientific inquiry"

Physical Science

- **Content Standard B:**

"Conservation of energy and increase in disorder"

"Interactions of energy and matter"

Earth and Space Science

- **Content Standard D:**

"Geochemical cycles"

Science and Technology

- **Content Standard E:**

"Abilities of technological design"

"Understandings about science and technology"

Science in Personal and Social Perspectives

- **Content Standard F:**

"Population growth"

"Natural resources"

"Environmental quality"

"Natural and human-induced hazards"

"Science and technology in local, national, and global changes"

Science Content Standards 5-8

Science as Inquiry

- **Content Standard A:**

"Abilities necessary to do scientific inquiry"

"Understanding about scientific inquiry"

Physical Science

- **Content Standard B:**

"Transfer of energy"

Science and Technology

- **Content Standard E:**

"Abilities of technological design"

"Understandings about science and technology"

Science in Personal and Social Perspectives

- **Content Standard F:**

"Populations, resources and environments"

"Natural hazards"

"Risks and benefits"

"Science and technology in society"

Technology Description

In a society where an increasing amount of our information comes from the Internet, students (and teachers) need more exposure to using the Internet as a research and learning tool. Also, as we become more technology-dependent, we need to provide computer-based learning for students so that they may be better adapted for their academic life and beyond. Finally, renewable energy technology is evolving at a pace that could bring it into common household use within the lifetime of our students. This set of projects seeks to combine technology-based learning with the study of renewable energy. Our goal is to provide a learning experience in which students gain a deeper understanding of energy use and renewable energy availability, as well as an appreciation for the feasibility of renewable energy in our society.

References

P. Gilman, T. Lambert, P. Lilienthal; HOMER: The Optimization Model for Distributed Power, July 2003. [Online]. Available <http://www.nrel.gov/homer/>

RETScreen International, July 2003. [Online] Available <http://www.retscreen.net>

Carleton College, "Using Data in the Classroom: Community and Educational Issues," July 2003. [Online] Available http://serc.carleton.edu/research_education/usingdata/index.html

Project Ideas

1 Where are the best renewable and non-renewable energy resources in the US? In the World?

Learning Objective: Students will become familiar with using the Internet as a research tool. Students will learn the best locations for each of the renewable resources

Controls and Variables: None

Materials and Equipment:
Computer with Internet access
Poster-making supplies

Safety and Environmental Requirements: None

Suggestions:

- Create a map showing the locations for the three best energy resources in

a region. The map can be on the scale of county, state, country, continent or world.

- Create a series of maps showing the distribution of several energy resources in a region, with one energy resource depicted in each map.
- If you could power an entire region solely on renewable energy, how would you distribute wind farms, geothermal plants, hydroelectric power, biomass and solar utilities across the region? Create a map showing your plan.

Resources:

1. <http://rredc.nrel.gov/solar/>
2. <http://www.eia.doe.gov/>
3. http://serc.carleton.edu/research_education/usingdata/index.html
4. <http://www.wattsun.com/resources.html>
5. <http://waterdata.usgs.gov/nwis/rt>
6. <http://www.usdams.org/>
7. <http://energy.er.usgs.gov/products/databases/USCoal/index.htm>
8. <http://www.epa.gov/enviro/html/em/index.html>
9. Biomass Resource Information Clearinghouse (see www.nrel.gov)
Hint: use information about US Agriculture production to map location of best biomass resources

2 How much energy do we consume while driving?

Learning Objective:

Students will learn about how much energy we consume for transportation.

Students will analyze which technological advancements can help reduce energy consumption.

Controls and Variables: none

Materials and Equipment:

Computer with Internet access
Poster-making supplies

Safety and Environmental

Requirements: None

Suggestions:

- Analyze the performance of four cars from an environmental perspective. Create a poster that compares the following features for four different car makes: miles per gallon, annual fuel expense and greenhouse gas emissions, nitrogen and sulfur emissions, and other features that affect fuel economy and pollution.
- Considering our current oil consumption, how much could we decrease consumption if everyone drove hybrid-electric cars? How could we further reduce oil consumption if people to maximum advantage of public transportation and carpooling? Show this information on another poster.

Resources:

1. <http://www.fueleconomy.gov/>

2. <http://www.epa.gov/autoemissions/>
3. <http://www.glencoe.com/sec/science/webquest/content/altfuels.shtml>
4. <http://www.glencoe.com/sec/science/webquest/content/hybrid.shtml>
5. <http://www.eere.energy.gov/afdc/>

3 How much energy do we use?

Learning Objective:

Students will understand how energy is used.

Students will understand their own contribution to energy use.

Students will learn about energy-saving technologies.

Controls and Variables: None

Materials and Equipment:

Computer with Internet access
Poster-making supplies

Safety and Environmental

Requirements: none

Suggestions:

- Create a series of maps showing energy usage in a region (county, state, country, etc). Indicate what sector (domestic, industrial, agricultural) uses what fraction of energy in the area you are mapping. How can this region reduce its energy use?
- For a more advanced project, compare energy usage between three regions, indicating the distribution of energy use as described above.
- Most advanced: compare resource availability (fossil fuels, agriculture, renewable energy, if used in that region) in the region with that region's

energy use. Refer to project number one in this chapter for additional websites to use in your research.

- Discuss, orally or written: Why do some countries use more energy per capita than others? How could these countries decrease their energy consumption?

Resources

1. <http://eia.doe.gov/mer/contents.html>
2. <http://www.eia.doe.gov/emeu/consumption/>

4 Are renewable energy resources economically feasible on a small scale?

Learning Objective:

Students will learn how to use a computer program which models small-scale renewable energy system.

Students will analyze the costs associated with powering their own home from renewable sources.

Controls and Variables:

Control – current energy usage and cost

Variable - energy-saving practices, costs associated with renewables, availability of renewable resources, metering options

Materials and Equipment: Computer with Internet access and HOMER version 2.0 (or higher) installed on the hard drive (HOMER can be obtained from the following website; be sure to download version 2.0 or higher.

<http://www.nrel.gov/homer/>)

Safety and Environmental Requirements: none

Suggestions:

- Use the computer program, HOMER, to answer the following questions.
- How much money would you save if your house, which is connected to the utility grid, had renewable power sources as well?
- If you had to choose between connecting your house to the grid or using only renewables, which one is cheaper?
- Use the additional suggestions below to gather all of the necessary data for your project.
- Call your local utility company to find out about net metering options and sellback pricing of domestic watts produced.
- Go through the HOMER tutorials before attempting to set up this project. Tutorials can be accessed on the HOMER website. (<http://www.nrel.gov/homer/>).
- Download resource data files from the HOMER website, contact NREL with questions about HOMER.

OPTIONAL: Use RETScreen software for your simulations. The site listed contains a training manual. (<http://www.retscreen.net/ang/menu.php>)

Compare your results from HOMER with the results you obtained from RETScreen.

Environmental Aspects

For the Teacher

The project ideas proposed in this section are applicable for science fairs, but they could also be modified and performed as classroom activities or demonstrations to introduce or reinforce basic environmental science concepts such as ecosystem balance, nutrient cycling, and energy transformations. Project ideas can also be easily adjusted to fit levels of student knowledge and ability.

Before students begin a science fair project or before a project idea is introduced as a classroom activity, students will need background information on environmental aspects of energy production and use. We have included several resources that can help familiarize students with the environmental aspects of energy. Students should be familiar with the use of fossil fuels for energy, the different forms of pollution created by the continued use of fossil fuels, and why renewable resources may be a better alternative.

At the National Renewable Energy Lab (NREL), scientists not only focus on the production of energy from various renewable resources, but also the elimination of hazardous wastes produced in biomass fuel generation. They work to discover efficient industrial and/or bioremediation methods to reduce or eliminate the need for waste storage, making the production process more efficient and environmentally friendly. The following projects are

aligned with the National Science Education Standards and support the mission of NREL

National Science Education Standards by the National Academy of Sciences

Science Content Standards: 5-8 Science As Inquiry

– Content Standard A:

“Abilities necessary to do scientific inquiry”

“Understandings about scientific inquiry”

Physical Science

- Content Standard B:

“Properties and changes of properties in matter”

“Transfer of energy”

Life Science

- Content Standard C:

“Diversity and adaptations of organisms”

Science and Technology

- Content Standard E:

“Abilities of technological design”

“Understandings about science and technology”

Science in Personal and Social Perspectives

-Content Standard F:

“Populations, resources, and environments”

History and Nature of Science

- Content Standard G:

“Science as a human endeavor”

“Nature of science”

Technology Description

With human population growing exponentially, the demands for energy resources have increased dramatically. The energy needed for our everyday lives is creating environmental concern throughout the world. In all energy changes, there is a loss of energy in the form of heat or other waste, which can pollute the environment. In fact, in some places, we are actually poisoning ourselves with wastes from human activities.



Pollution is anything in the environment that does not normally belong there. Much of the pollution in

our world is linked directly to energy use. Combustion of fossil fuels such as coal, oil, and natural gas in our vehicles, homes, industries, and power plants creates several types of harmful emissions. The harmful pollutants end up in our air, water, and soil, which cause damage to the earth and its organisms, to property, to our health, and to our quality of life. In addition, combustion of fossil fuels releases excess carbon dioxide into the atmosphere, which scientists believe could possibly lead to dramatic changes in the world's climate.

Not only does using fossil fuels as sources of energy create pollutants, but their supplies are also limited. Fossil fuels take millions of years to form from

decaying organic matter. We are using them up at an ever-increasing rate, and they will not be replenished in our lifetime. Finding and using alternative energy resources, such as wind, solar, and biomass, makes sense. Renewable energy resources produce fewer wastes overall and are continuously available because of our sun.

Although we can't always undo the environmental damage, sometimes there are ways to clean up the pollutants. One method to clean wastes from the environment is called **bioremediation**. In the process of bioremediation, microorganisms break down harmful substances and use them as food. A good example of bioremediation that you may be familiar with is the use of microorganisms to help clean up oil spills. New research focuses on the use of microorganisms to clean up wastes so that the earth is a friendly place for all organisms.

The following project ideas focus on the environmental aspects of energy usage. The topics examine environment quality, air, water, and soil pollution, and bioremediation. Most projects can be done with a limited amount of supplies, but the time invested in the projects will vary. By taking a more critical look at the impacts energy usage has on the environment, you will develop a greater appreciation for Earth's balance and its complexity. We hope you become more aware of your own energy consumption and need

References

Books:

- E. McLeish, *Energy Resources: Our Impact on the Planet*. Austin, TX: Raintree Steck-Vaughn, 2002.
- T. Cook, *Environment*. Danbury, CT: Grolier, 2002.
- M. Maslin, *Global Warming: Causes, Effects, and the Future*. Stillwater, MN: Voyageur, 2002.
- K. M. Miller, *What If We Run Out of Fossil Fuels?* Danbury, CT: Children's Press, 2002.

Web Resources:

University of Wisconsin, Board of Regents, "The Why Files: The Science Behind the News," [site] 2003, Search: Energy, Environment and pollution, and Micro world, Available: <http://whyfiles.org/>

US Geological Survey, "Bioremediation: Nature's Way to a Cleaner Environment," [Online document] 1997 Apr 1, Available: <http://water.usgs.gov/wid/html/bioremed.html>

Web Content Producer: [Patricia Noel Williams](#), Site design: [Crabtree + Company](#), "Microbeworld," [site] Available: <http://www.microbeworld.org>

Michigan State University. [Communication Technology Laboratory](#) and the [Center for Microbial Ecology](#).

Office of Fossil Energy, U.S. Department of Energy, "Fossil Fuels...Future Fuels," [Site] Available: <http://www.fe.doe.gov/education/>

U.S. Department of Energy, "Energy Efficiency and Renewable Energy," 2003 Jul. 2, Available: <http://www.eere.energy.gov/>

U.S. Department of Energy, search "Energy Sources" and "Environment," Available: www.energy.gov

The U.S. Environmental Protection Agency, "Browse EPA Topics," [Site index] 2003 June 11, Available: <http://www.epa.gov/epahome/topics.html>

National Oceanic and Atmospheric Administration, "NOAA Education Resources," [site] 2003 June 16, Available: <http://www.education.noaa.gov/>

Website curator: [Robert B. Schmunk](#)
Responsible NASA official: [James E. Hansen](#), "Institute of Climate and Planets," [site] 2003 May 7, Available: <http://icp.giss.nasa.gov>

Materials Resources:

** Indicates materials that can be purchased through any science supply company. Possible science supply companies include:*

*Carolina Biological- www.carolina.com
Sargent-Welch- www.sargentwelch.com
Frey Scientific - www.freyscientific.com*

Project Ideas

1 How clean is your community?

Learning Objective: Did you ever wonder if the water or air in your home or around your community was polluted? In this project you will collect samples of the water or air in and around your home, school, or community over time and compare/contrast the water or air quality in different areas.

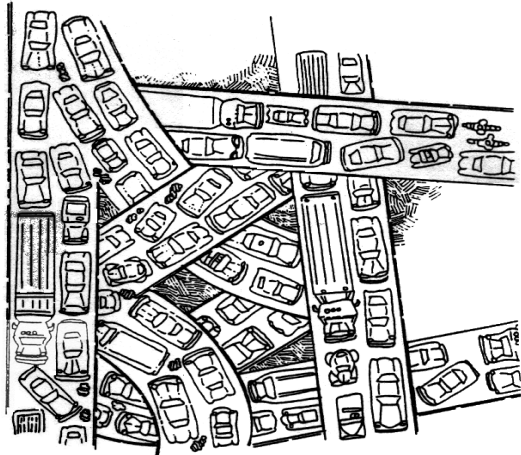

Control and Variables:

Control – For water monitoring, distilled or drinking water; for air monitoring, filtered air

Variables – collection site or source, time of day, season of the year, day of the week

Materials and Equipment:

pH paper; thermometers; water and air testing strips and/or titration kits (science supply company* \$33-300); air collection kits, ozone monitoring (science supply company*, approximately \$125); muffler collection demonstration kits (Carolina Biological, \$100)

Safety and Environmental

Requirements: Wear goggles when using testing kits with solutions and wash hands when completed. Follow all directions and safety precautions that are included with the kits.

Suggestions:

- Collection sites should be checked regularly
- Organisms present in water can be monitored, and particulates in the air can be collected using index cards covered with petroleum jelly.
- Data from global monitoring organizations, like NOAA, can also be compared and analyzed.

2 What are the effects of air pollutants on plants?

Learning Objectives: Have you ever wondered how pollutants from burning fossil fuels affect organisms in the environment? In this project you will monitor pollutant(s) derived from the combustion of fossil fuels and analyze their effect on plants.

Control and Variables:

Control – Unexposed plants

Variables – plant variety, type of air pollutant (e.g. sulfur dioxide, ozone, carbon monoxide, nitric acid), length of exposure, concentration of pollutant

Materials and Equipment: Pollution monitoring kits (science supply company*, starting at \$30); aquaria or plastic bags for individual treatment chambers; plants, seeds, soil, and containers can be purchased from local stores.

Safety and Environmental

Requirements: Follow all safety instructions when generating gases. Initial testing should occur in the presence of an adult with supervision. This should occur under a fume hood or in adequate ventilation. Goggles should be worn when producing gas. Gloves and masks may be worn.

Suggestions

Old aquaria can be sealed with plexiglass and silicon seal. This allows for an accurate measurement of pollution concentration. Valves can be installed in plexiglass so that air plus pollutant can enter or exit.

Plastic bags can be used in place of aquaria for "one shot" applications.

Seeds can be planted and germination rates determined or seedlings planted and growth rates can be monitored.

Carbon dioxide can be generated and the effects of excess gas can be monitored in plants to simulate increased carbon dioxide in the atmosphere.

3 What types of energy sources produce substances that cause acid rain?

Learning Objective: Do all fuels produce acid rain? In this project you will discover how acid rain can be produced by gas wastes from the combustion of energy sources and evaluate if some fuel sources produce more acid rain than others.

Control and Variables:

Control – Liquid without gases being introduced.

Variables– fuel source, combustion time

Materials and Equipment: Combustion set-up (from classroom or high school chemistry lab); water or lime water (calcium hydroxide, science supply company*, \$4) or liquid indicator (cabbage juice or other organic indicators from a science supply company*); solid fuel sources (charcoal, coal, paper, dried cornstalks, wood chips); balance; pH paper;

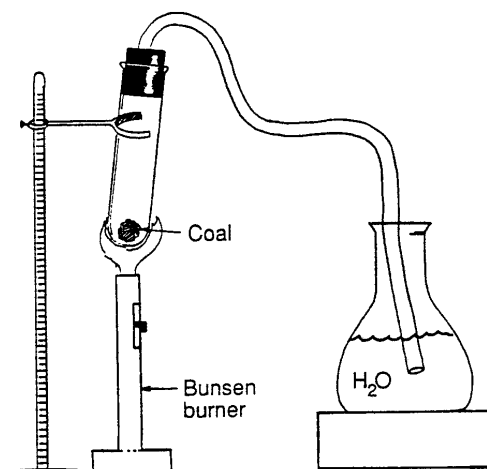

Safety and Environmental

Requirements: Perform burnings under a fume hood or in a setting with adequate ventilation. Wear goggles and be careful to avoid burns. Do not leave the experiment unattended. Do not allow water to suck back into hot test tube.

Suggestions:

- Heat equal volumes/weights of biomass from different sources over the same time period.
- More advanced students can quantify the concentration of the pollutant and identify the pollutant.

How does acid rain affect the growth and survival of plants?

Learning Objective: Do you know how acid rain affects organisms in an ecosystem? In this project you will discover what effect acid rain has on the growth and survival of plants and infer how that may disrupt the health of the entire ecosystem.

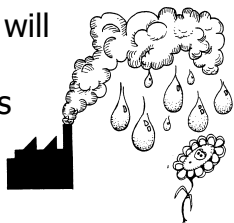

Control and Variables:

Control – Unexposed plants

Variables – Plant variety, age of plant, rain pH, exposure time

Materials and Equipment: pH paper; spray bottle; various concentrations of dilute acids (school chemistry lab or kitchen products); seeds, plants, soil, and containers can be purchased from local stores. Optional: acid rain kit (science supply company*, \$30 and up).

Safety and Environmental

Requirements: Be careful when spraying the “acid rain” on plants and do not point toward your face. Gloves and goggles should be worn during preparation and application.

Suggestions

- Compare plant species, test and select members of the same species with greater tolerance to lower pH.
- Compare germination rates or effects on seedling development.
- Monitor other organisms, such as microorganisms or small aquatic invertebrates, in ponds and streams.

- Monitor nutrients in the soil to see how pH levels affect them.

4 What is the effect of an increase in water temperature on the amount of dissolved oxygen in water?

Learning Objective: You have probably heard the term “global warming.” Do you know what it is, what causes it, and what it may do to the organisms on earth? Why would it be a big deal for factories to discharge clean, but warm



water into a stream? In this project you will investigate the effects of global warming and thermal pollution on organisms living in the water.

Control and Variables:

Control – sample water tested at “normal” temperature (the temperature normal for the environment)

Variables – varying the temperature of water sample, source of water, the amount of oxygen in the water, living organisms in the water

Materials and Equipment: Water samples; thermometer; individual dissolved oxygen kit or chemicals to perform dissolved oxygen tests (science supply company*, \$43).

Safety and Environmental

Requirements: Be sure to follow all directions in the kit. Use goggles when testing with chemical solutions in the laboratory or field.

Suggestions:

- Take water temperatures first.
- Test samples directly in the field, or test samples as quickly as possible after gathering from a water-sampling site.
- Fill all bottles to the top and cap tightly so that no air enters.
- A water bath could be used to slowly heat water samples to measure the effects of varied temperature.
- Range of oxygen requirements could be investigated for invertebrate organisms by observing physiological responses in varying water temperatures.

5 How does the amount of oxygen affect the quality of air when different fuels are burned?

Learning Objective: You already know that oxygen is needed to burn fuel sources. Did you know that burning with low oxygen concentrations also effects the types and amounts of air pollutants? Did you also know that some fuel sources contain more pollutants than others? In this project you will analyze the carbon monoxide emissions from burning solid energy sources.

Control and Variables:

Control – room air

Variables – Amount of oxygen (size or amount of openings in furnace), solid energy source (wood, charcoal, natural gas, coal, paper, old cornstalks, etc.)

Materials and Equipment:

Small metal furnace (see diagram), carbon monoxide detector (purchase

from local hardware store, \$30), solid fuel sources, igniter, optional starter fluid

Safety and Environmental

Requirements: Wear goggles and perform only with adult supervision. Perform combustions under a fume hood or in well ventilated areas outdoors (cemented areas, inside grill). Be careful of burns.

Suggestions:

Allow the fuel source to burn entirely within the furnace.

Compare burning temperatures or calculate the number of joules of energy produced by each fuel source.

Monitor and/or analyze the buildup inside the furnace or ash remains.

Investigate possible uses for the ash waste.

Compare the burning of alcohol with gasoline in furnace and in modified internal combustion engines.

6 How can pollutants in the soil affect the organisms that live there?

Learning Objective: Did you ever wonder what affects spilling or leaching of energy-generating products have on the organisms in the soil? In this project you will investigate the effects common energy products have on microorganisms in the soil.

Control and Variables

Control – “unexposed” soil

Variables – fuel product, amount of fuel, soil type, soil site, amount of soil, exposure time, culture media, respiration conditions (with or without air)

Materials and Equipment: Liquid media: culture tubes or bottles with caps and media ; Solid media: petri plates, media,

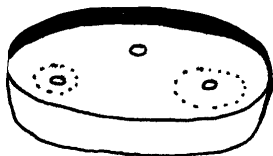

and filter disks; (media available from science classroom or science supply company, \$7-\$50); soil samples, balance, fuel sources/products (gasoline, motor oil, alcohols, engine cleaners, coolants); spectrophotometer for liquid media (high school or university).

Safety and Environmental

Requirements: Store soil sample in refrigerator when not in use. Wear goggles when adding fuels or products to cultures. Wash your hands after setting up cultures. Do not open lids of petri plates. Follow directions when using the spectrophotometer.

Suggestions:

- Solid or liquid media can be used to culture soil microorganisms.
 - Respiratory conditions can be compared.
- Anaerobic conditions can be obtained by filling all tubes/bottles full. Plates can be placed in bags or containers with an oxygen scavenger (\$20-35 Camp Micro Inc. www.campmicro.com)
- Aerobic cultures should be agitated to increase oxygen dispersion.
 - Solid media should be inoculated with liquid cultures.
 - Small filter disks may be used or colony growth can be visually inspected for zones of inhibition.

7 How can microorganisms help clean up pollutants from the environment?



Learning Objective: Did you know that some microorganisms can use pollutants as “food”? Pollutants that some microorganisms can degrade are oils, such as those from oil spills. In this project you will see if microorganisms are capable of bioremediation and examine what conditions are needed for successful “cleanup”.

Control and Variables:

Control – no microorganisms
Variables – type of oil, temperature, type of soils, source of soil, amount of soil, respiratory conditions, light

Materials and Equipment: Soil samples; different oils (motor, machine, vegetable, mineral, available from grocery or auto store); jars and lids; inorganic nutrients



(chemistry classroom); balance; brown paper for oil test.

Safety and Environmental

Requirements: Wear goggles when setting up and collecting data. Oils are **FLAMMABLE!** Keep set up away from open flame.

Suggestions

- Aquaria pump and lid alterations can be used to monitor the effects of aeration on rate of degradation.
- Paper is used to check for degradation. Let oil/water spot on paper dry before you make conclusions.
- pH may be monitored.
- Nutrients can be limited, or added in excess, to monitor effects.
- Advanced students may want to design assays for metabolites or design a cleanup method for potential use in their community.