

HYDROGEN STUDENT DESIGN COMPETITION 2016:

DEVELOPMENT OF A HYDROGEN POWERED MICROGRID FOR GRID SERVICES AND BACKUP

Prof. Michael Fowler
mfowler@uwaterloo.ca

Dr. Azadeh MaroufMashat
azadeh.maroufmashat@uwaterloo.ca

Ushnik Mukherjee

u3mukherjee@uwaterloo.ca

Jonathan Ranisau

jranisau@uwaterloo.ca

Mohammed Barbouti

mbarbout@uwaterloo.ca

Aaron Trainor

ahtraino@uwaterloo.ca

Nidhi Juthani

nnjuthan@uwaterloo.ca

Hadi El-Shayeb

helshaye@uwaterloo.ca

UNIVERSITY OF
Waterloo



Problem Statement

Why?

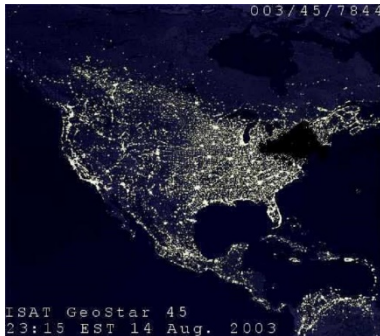

With What?

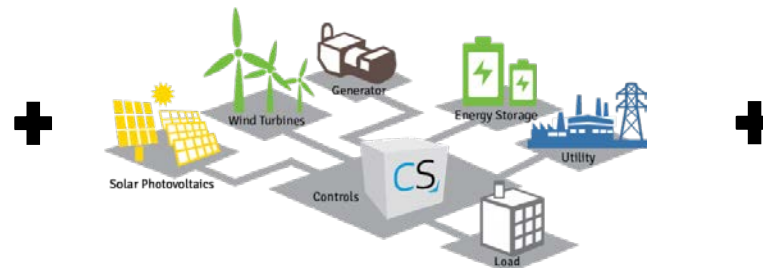

Specific
Objectives

1. Supply 10% Demand over regular operation
2. Supply 90% Demand over 2-day blackout

Our Approach

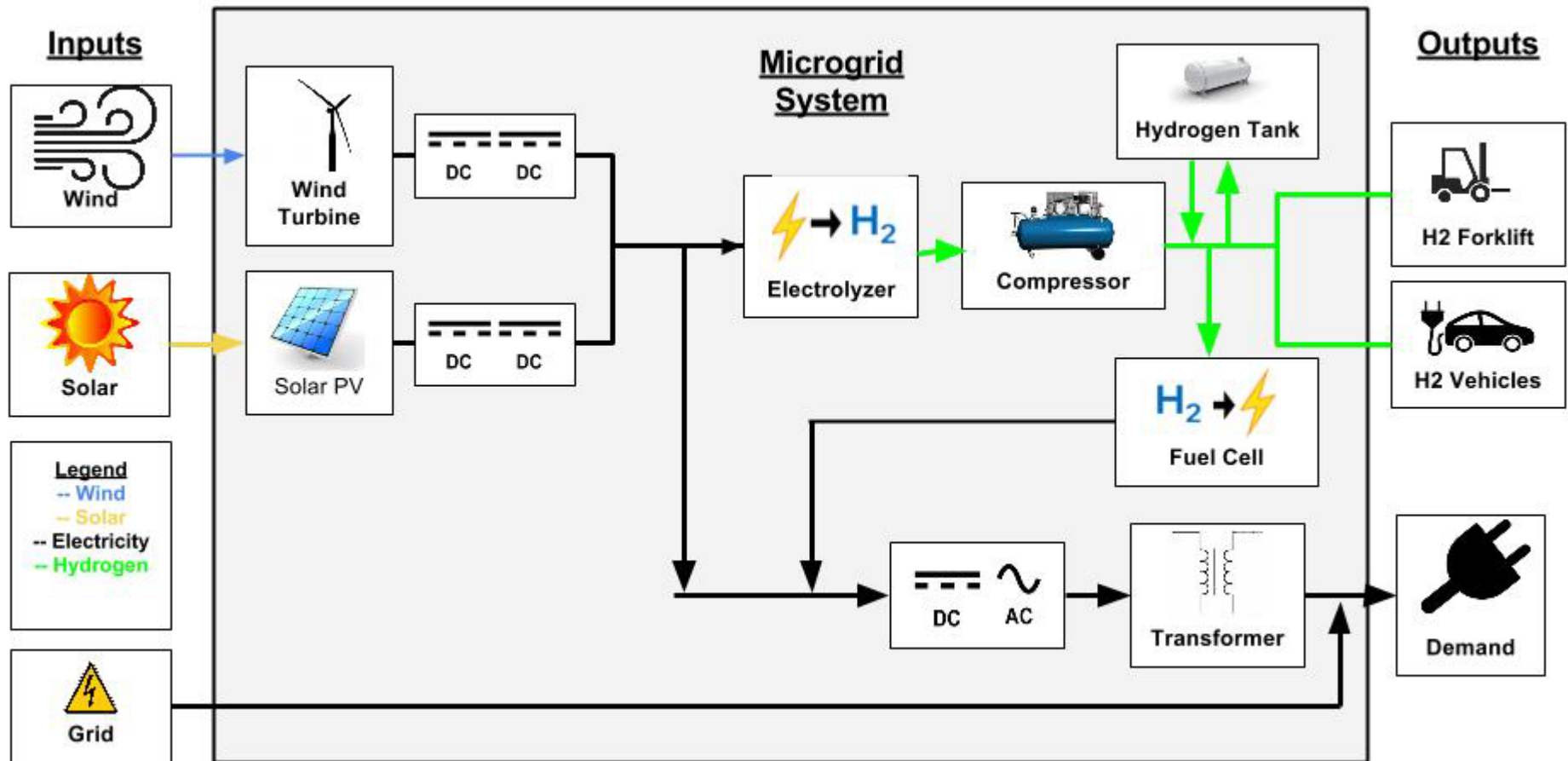

Modeling Approach

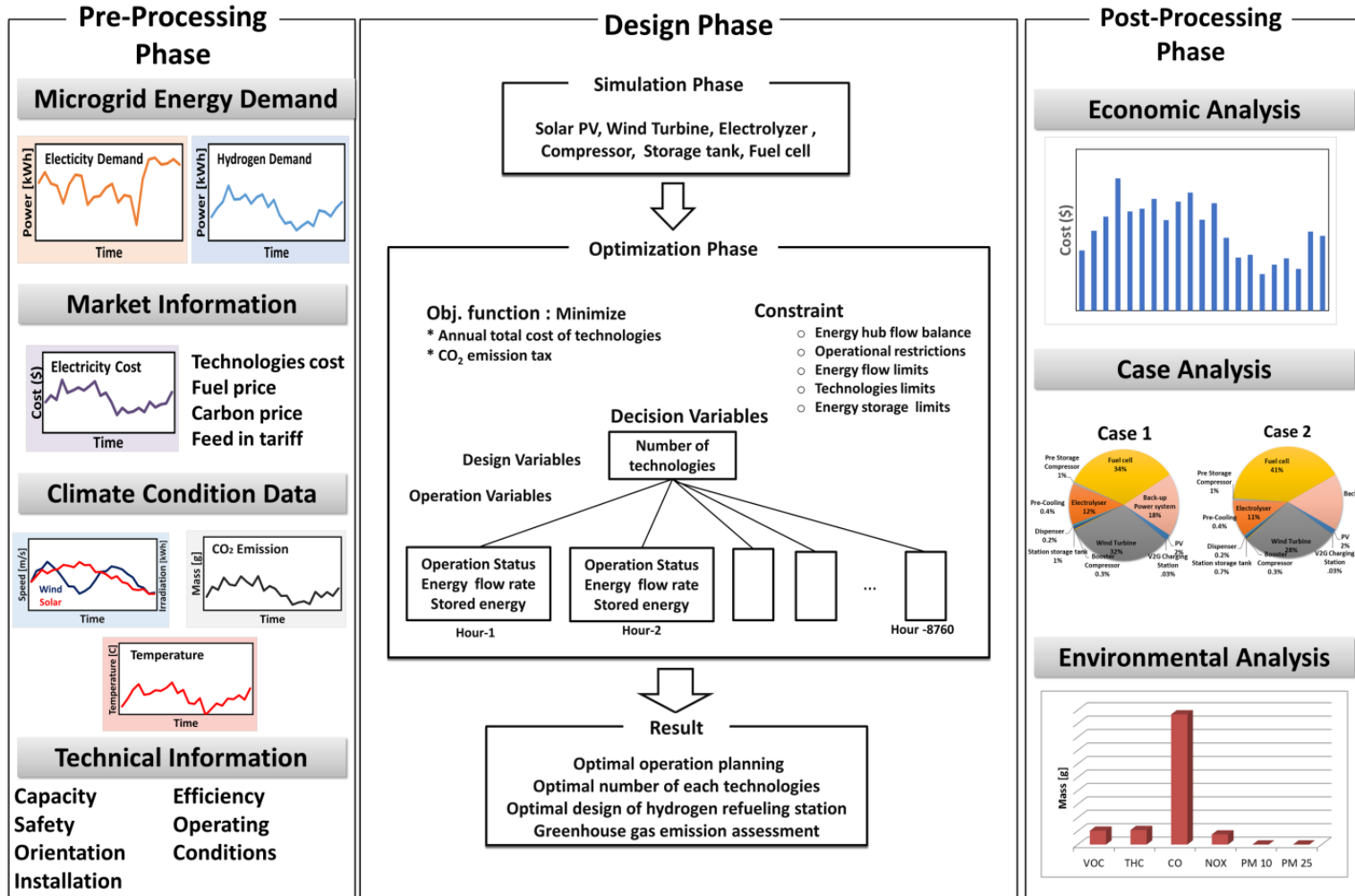

Step 1: Pre-Processing Phase

Siting

Canada's Microgrids

- Bella Coola
- Hartley Bay
- Balzac, Alberta

Cornwall, Ontario

- Food distribution centre
- Climate
- Rural



Step 1: Pre-Processing Phase

Microgrid Demand Data

Electrical Demand

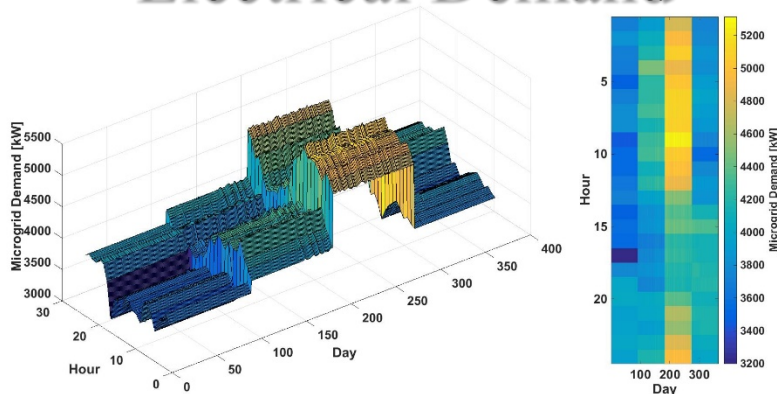

- **Electrical demand:**
 - Food distribution centre
 - Logistics centres
 - Residential Area

Hydrogen Demand

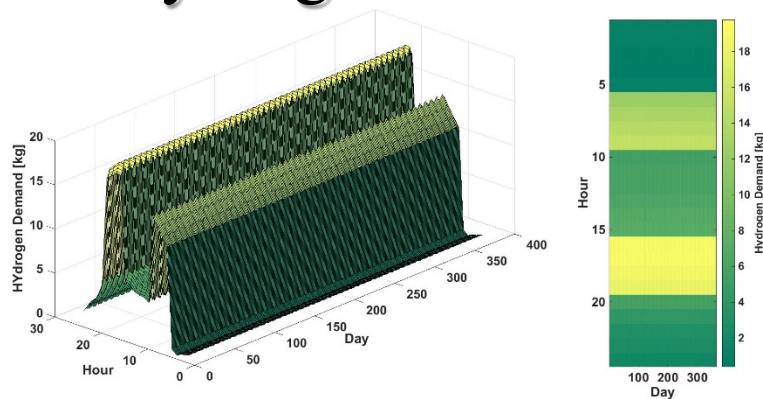

- **Hydrogen demand:**
 - Forklifts
 - Residential FCVs
- **Maximum demand:**
 - Electrical (5314.54 kW)
 - Hydrogen (19.77 kg)

Step 1: Pre-Processing Phase Climate Condition Data

Solar Irradiation

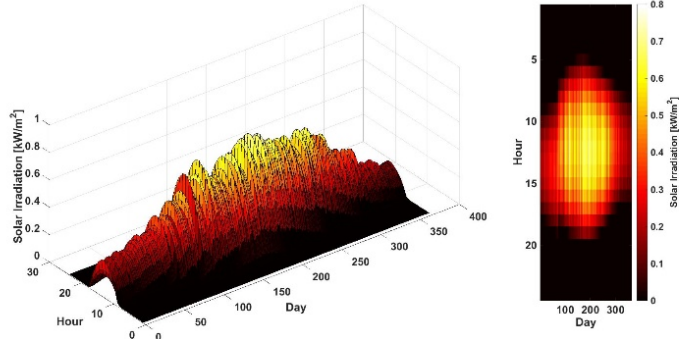

Range: 0.80 kW/m²
Average: 0.16 kW/m²

PV Efficiency

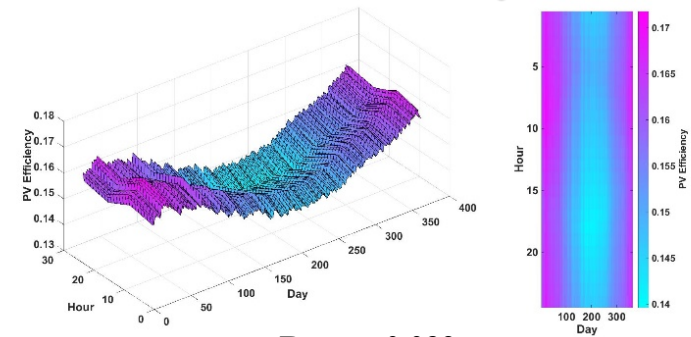

Range: 0.032
Average: 0.15

Temperature

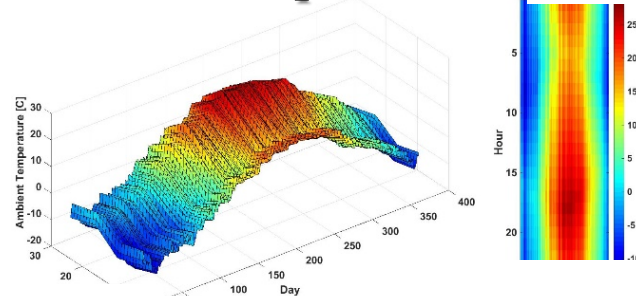

Range: 42.91 °C
Average: 8.79 °C

Wind Speed

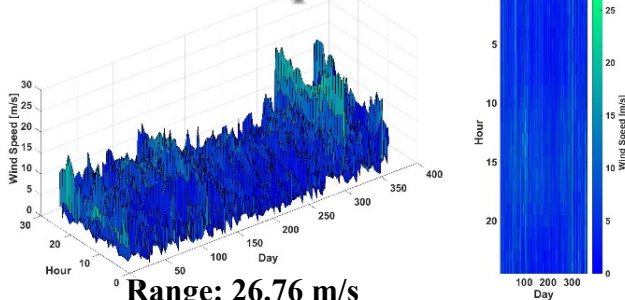

Range: 26.76 m/s
Average: 5.80 m/s

Power Coefficient

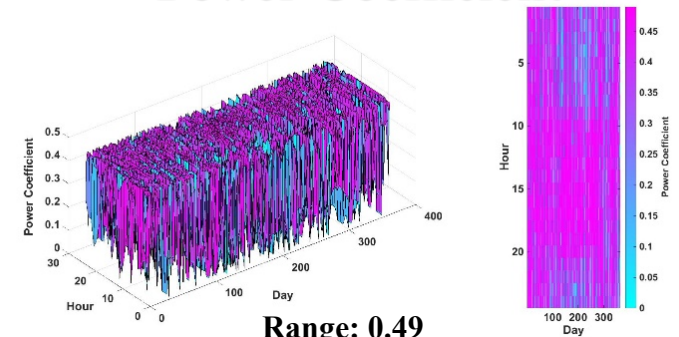

Range: 0.49
Average: 0.38

Step 1: Pre-Processing Phase Infrastructure & Equipment

System	Component	Supplier	Specification
Refueling Station	Electrolyzer	Hydrogenics	1 MW
	Pre-storage Compressor	Fluitron	Discharge - 430 bar
	Storage Tanks	Cp Industries	21.3 kg – 430 bar
	Booster Compressor	HydroPac	Discharge – 875 bar
	Dispensing Station	Two-Hose Dispenser ¹	875 bar
Backup Power System	Pre-storage Compressor	RIX Industries	Discharge – 310 bar
	Storage Tank	(Fabricated) – ASME Steel	89 kg – 172 bar
	Fuel Cell	Hydrogenics	1 MW
	Electrolyzer	Hydrogenics	1 MW
Vehicle-To-Grid	Charger & Parking Spot	AC Propulsions Inc.	20 kW

Vehicle-To-Grid

- FCVs convert hydrogen into electricity in times of grid failure
- Offsets demand required by Microgrid fuel cells during emergencies

¹Parks, G.; Boyd, R.; Cornish, J.; Remick, R. *Hydrogen Station Compression, Storage, and Dispensing Technical Status and Costs*. NREL Technical Report NREL/BK-6A10-58564, May 2014.

Step 2: Design Phase

Simulation

- Yearly energy supply/demand
- Simulation with GAMs

Optimization

- Case Specific Criteria
- Economic Objective

Results

- List of technologies & Infrastructure

Solution

- Optimal number of each component

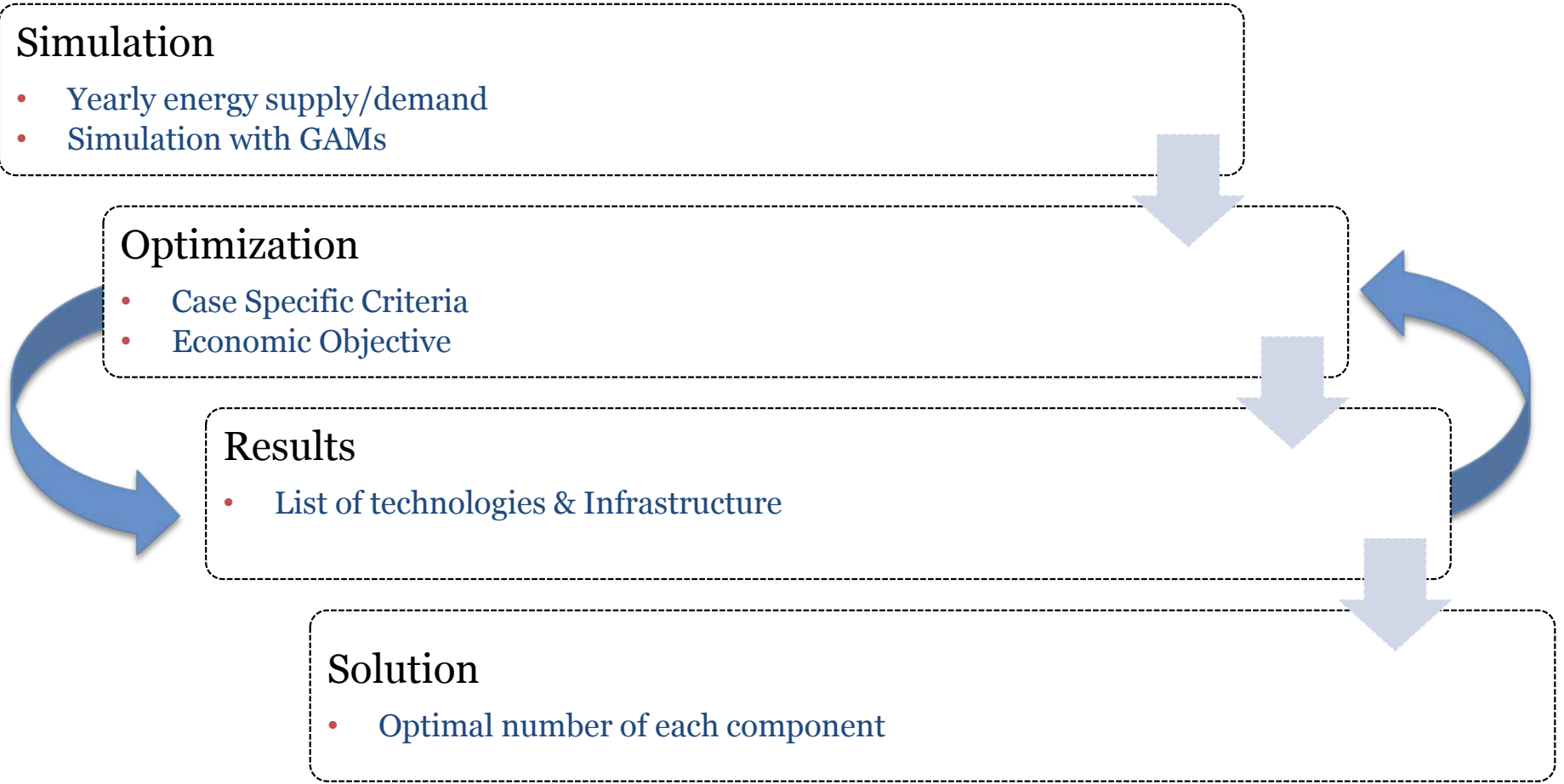

Step 3: Post-Processing Phase

Cases I & II

Case 1: No V2G - \$45,901,525

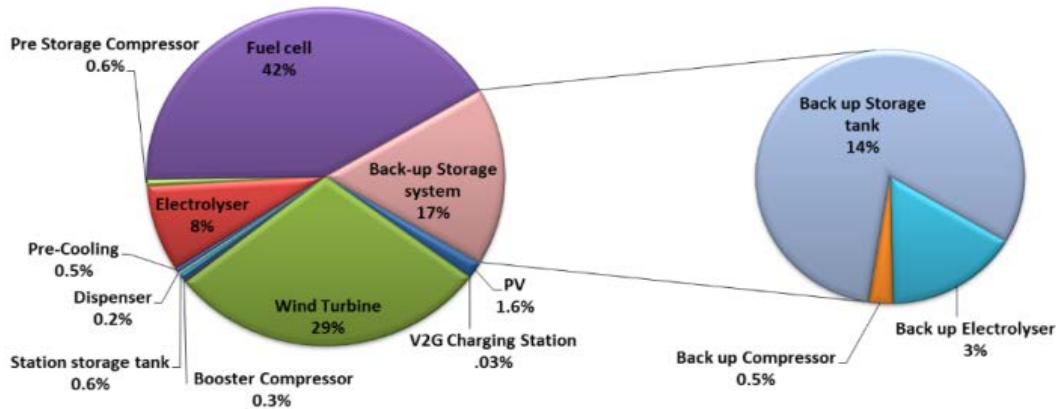

• Case 1:

- 4 Fuel Cells required
- 42% Total Cost

Case 2: Implementing V2G - \$41,249,028

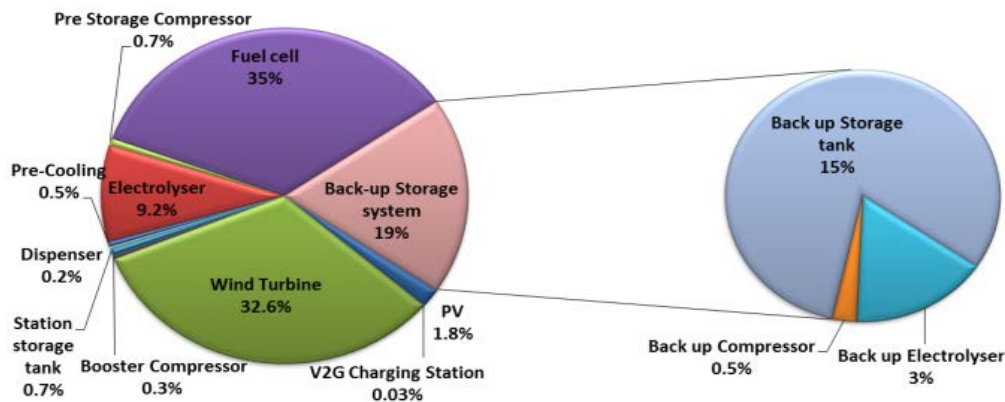

• Case 2:

- 3 Fuel Cells required
- 35% Total Cost

Step 3: Post-Processing Phase

Root Cause Analysis

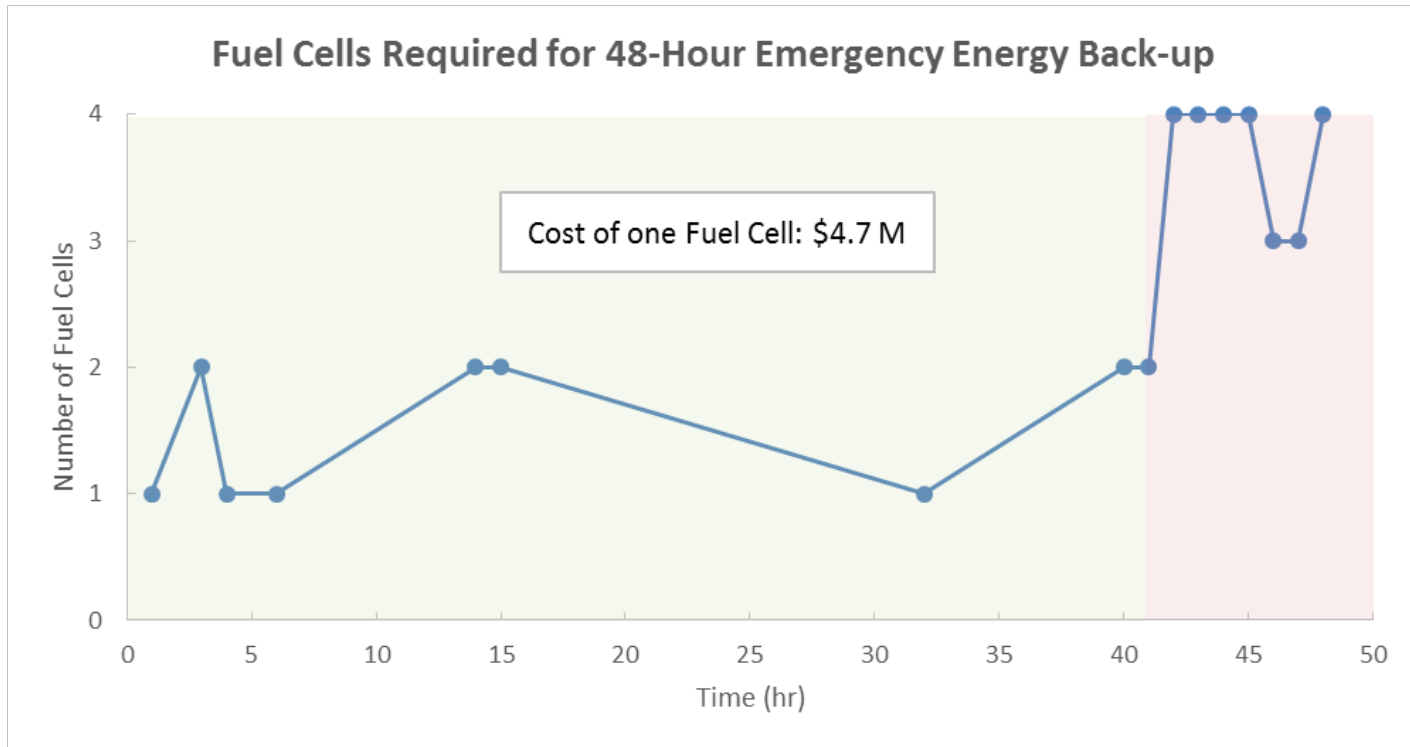

- Overall cost with V2G: \$41.2 million
- Required number of fuel cells exaggerated during worst part of blackout simulation

Step 3: Post-Processing Phase

Cost Analysis for Case II

Scenario	Case	Description	Premium Price			Total Cost USD	Income USD	Economic Offset USD	Environm ental offset USD	Net Present Value USD
			Carbon Trade [\$.kg ⁻¹]	Hydrogen [\$ kg ⁻¹]	FC Electricity [ckWh ⁻¹]					
1	1		N/a	N/a	N/a	44,669,928	845,919	78,349	-	(35,595,326)
2	2		N/a	N/a	N/a	40,017,432	845,919	78,349	-	(30,942,829)
12	2	Selling hydrogen to natural gas pipeline	15	8	50	40,017,432	845,919	2,810,109	47,343	(3,657,189)

- Alternative design scenarios
- Model versatility

Site Layout

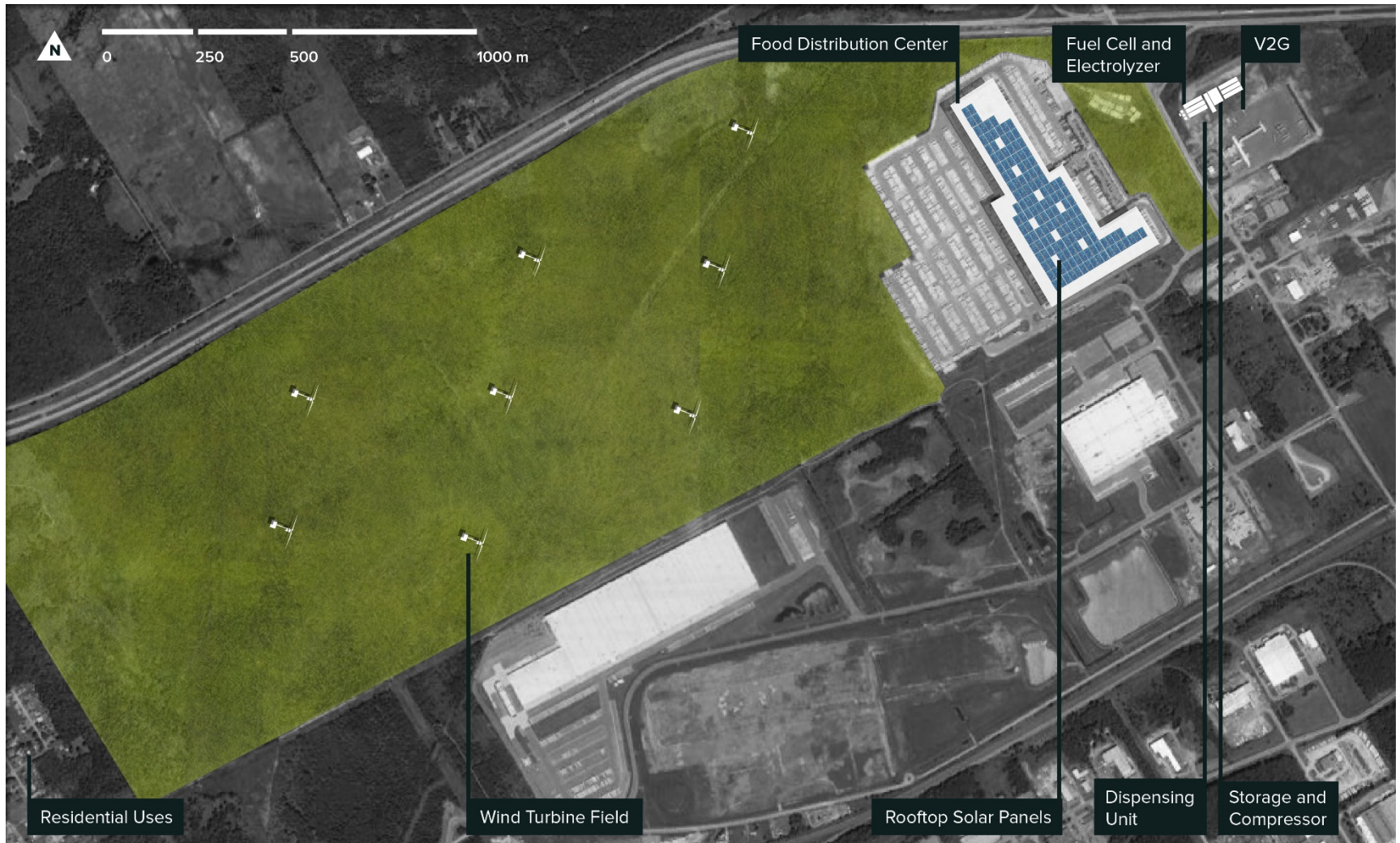

Design of Hydrogen Infrastructure

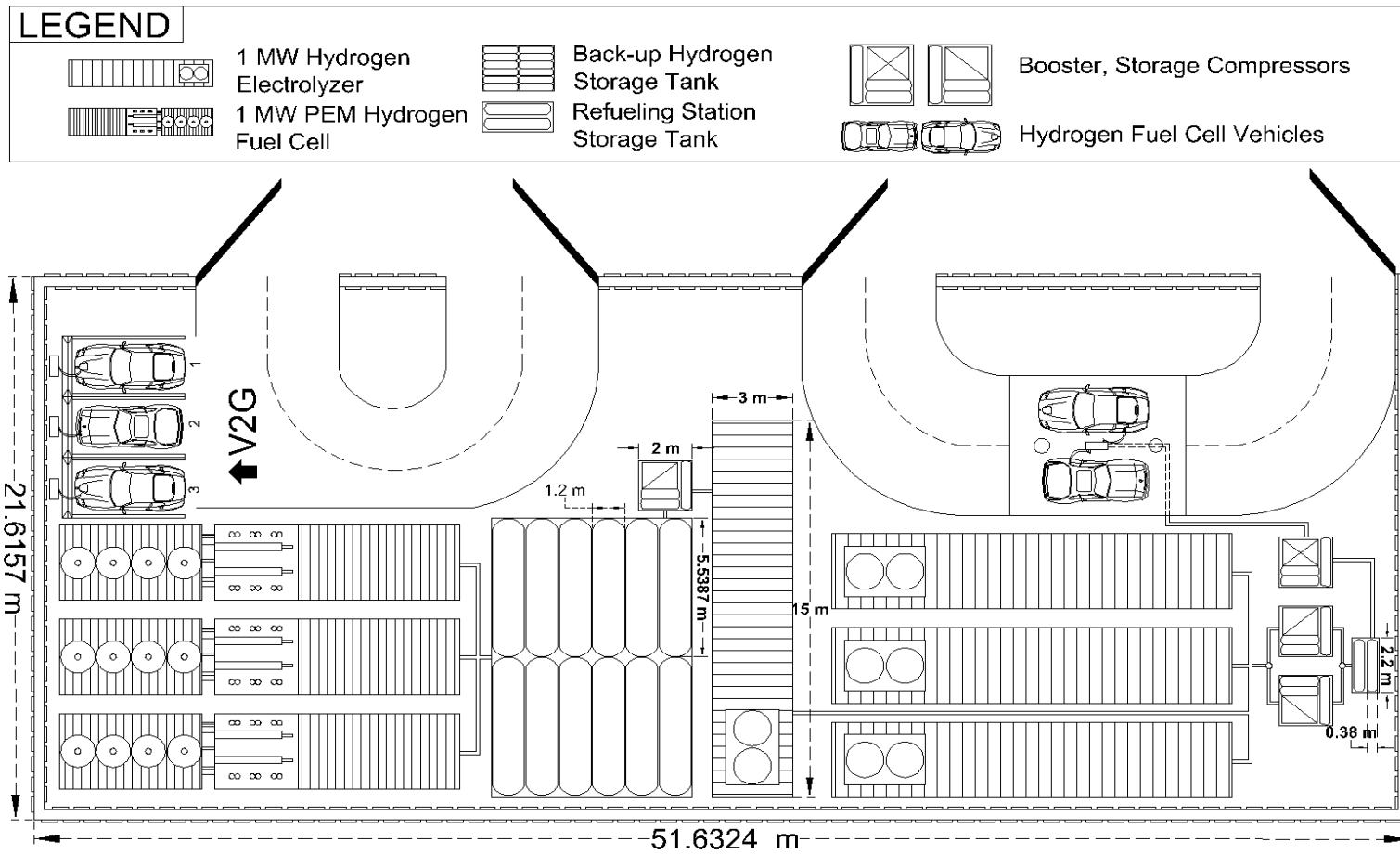

Final Design Image

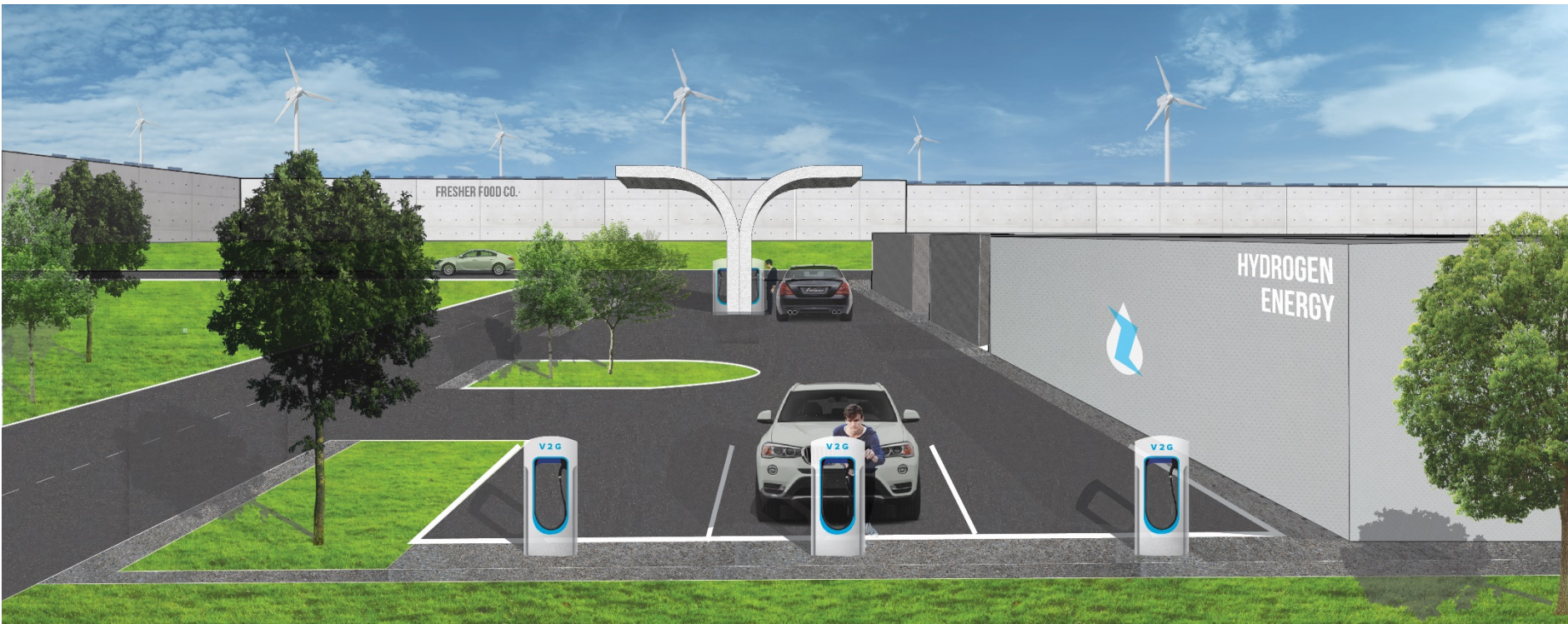

Prof. Fowler

mfowler@uwaterloo.ca

Dr. Azadeh MaroufMashat

azadeh.maroufmashat@uwaterloo.ca

Ushnik Mukherjee

u3mukherjee@uwaterloo.ca

Jonathan Ranisau

jranisau@uwaterloo.ca

Mohammed Barbouti

mbarbout@uwaterloo.ca

Aaron Trainor

ahtraino@uwaterloo.ca

Nidhi Juthani

nnjuthan@uwaterloo.ca

Hadi El-Shayeb

Helshaye@uwaterloo.ca