

# Battery Pack Thermal Design

Advanced Vehicles & Fuels Research  
**Energy Storage**

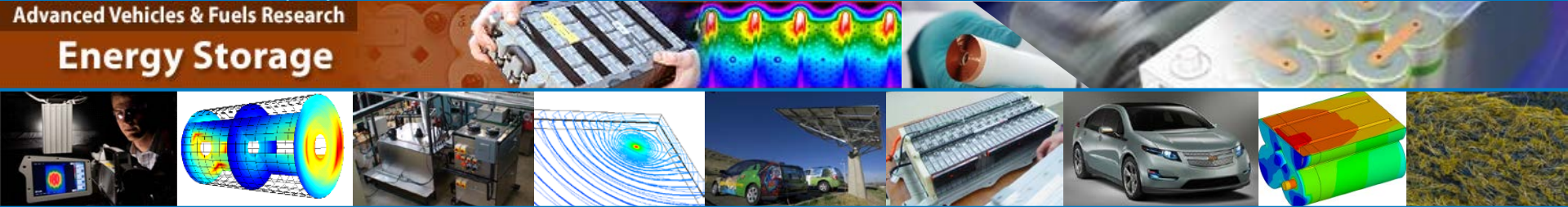

## Ahmad Pesaran

National Renewable Energy Laboratory  
Golden, Colorado

NREL/PR-5400-66960



16th Annual

**advanced automotive  
battery conference**

JUNE 14-17, 2016 | COBO CENTER | DETROIT, MI



# NREL Energy Storage R&D

Collaborating with industry to achieve energy storage targets for different applications

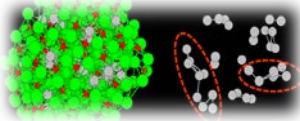
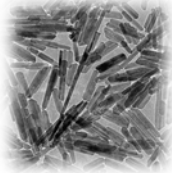

**Materials Synthesis and Processing**  
(Improve energy density and stability)



**Component Testing and Characterization**  
(Evaluate performance, life, and safety)

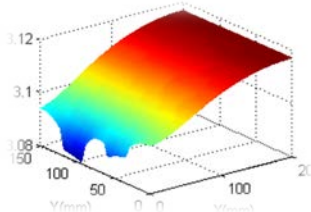

**Multi-physics Battery Modeling**  
(Improve performance, life, and safety)

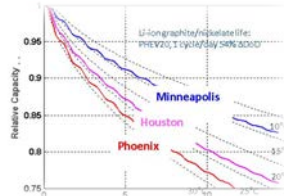

**Diagnostic, Management, and Control**  
(Enhance life utilization)



**System Evaluation and Techno-Economics**  
(Find cost-effective pathways)

# Battery Pack Design

## Selecting a high-performing design is just a start

- **Series and parallel integration of cells to achieve required**
  - Required energy and power
  - Max and min voltage
  - Calendar and cycle life
  - Cost targets
- **Pack must be safe**
  - Mechanical/structural
  - Electrical
  - Thermal
- **Management and Control**
  - Mechanical management – Robust packaging for shock, vibration, crush
  - **Thermal management – Life, performance, safety**
  - Electrical management – Balancing, performance, life, safety
- **Other**
  - Manufacturability
  - Recyclability
  - Diagnostics
  - Maintenance/repair

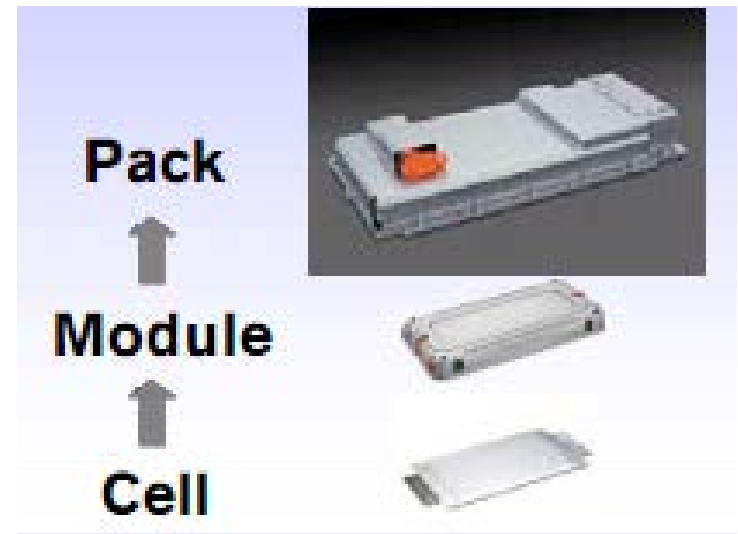

# Battery Thermal Design

---

- **Normal Operation**
  - Normal driving
  - Every day
  
- **Off-Normal Operation**
  - Abuse conditions
  - Rare

# Temperature Impact on LIB

- Lithium-ion batteries (LIB) are the technology of choice for many applications
- LIBs are sensitive to temperature as it impacts life, performance (capacity and resistance), safety, and (eventually) cost

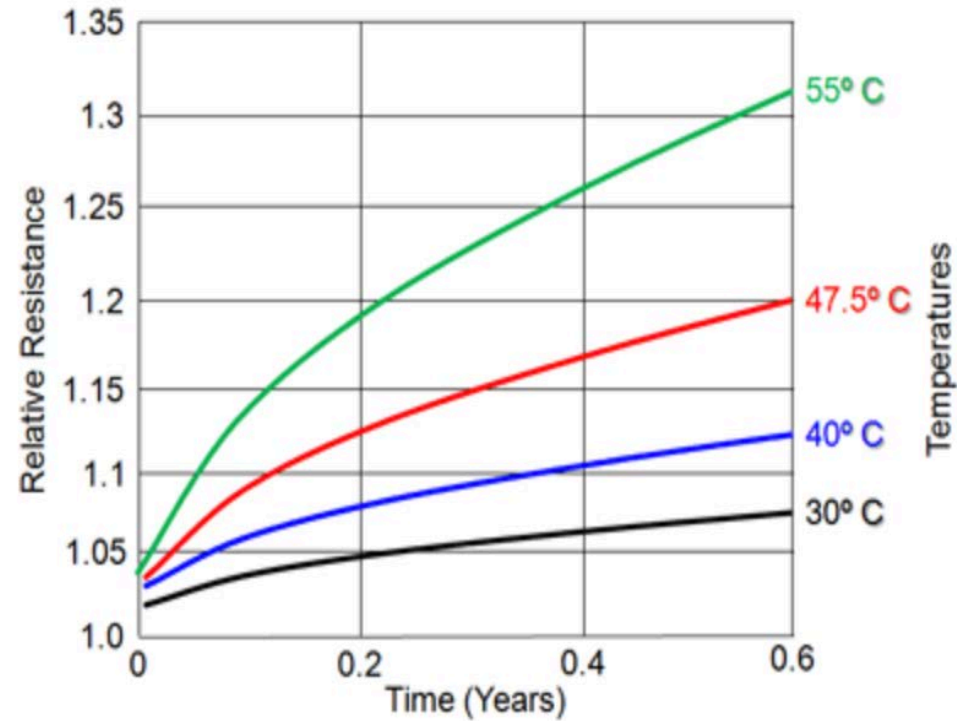
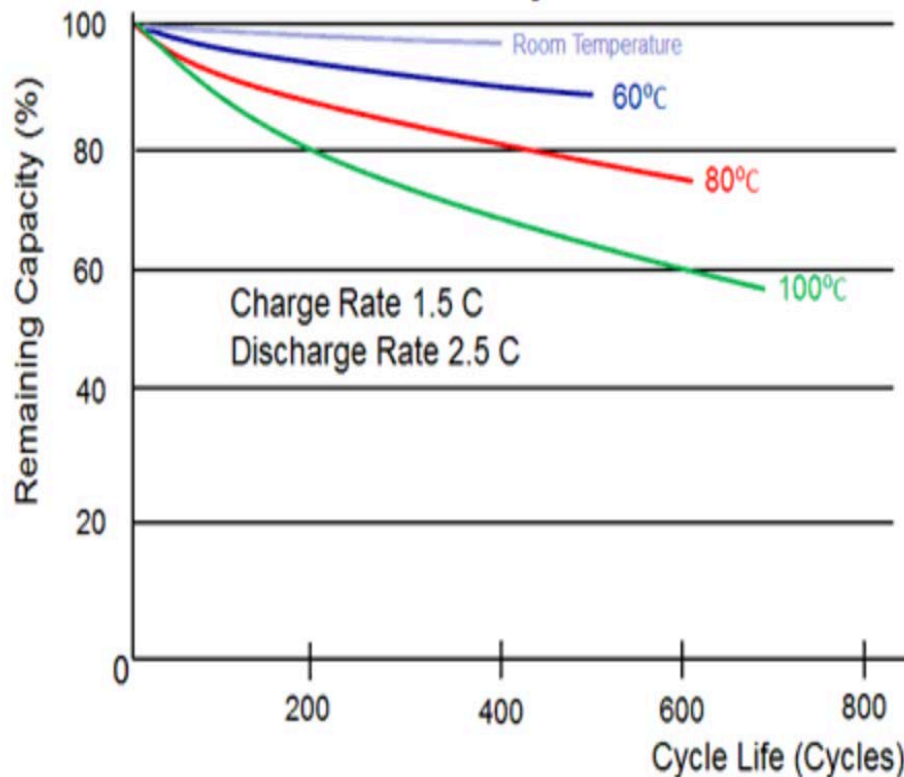

<http://www.mpoweruk.com/life.htm>

# Temperature Impact on xEVs

- Higher temperatures degrade LIBs more quickly
- Low temperatures reduce power and energy capabilities
- Proper temperature control improves reliability, safety, and range

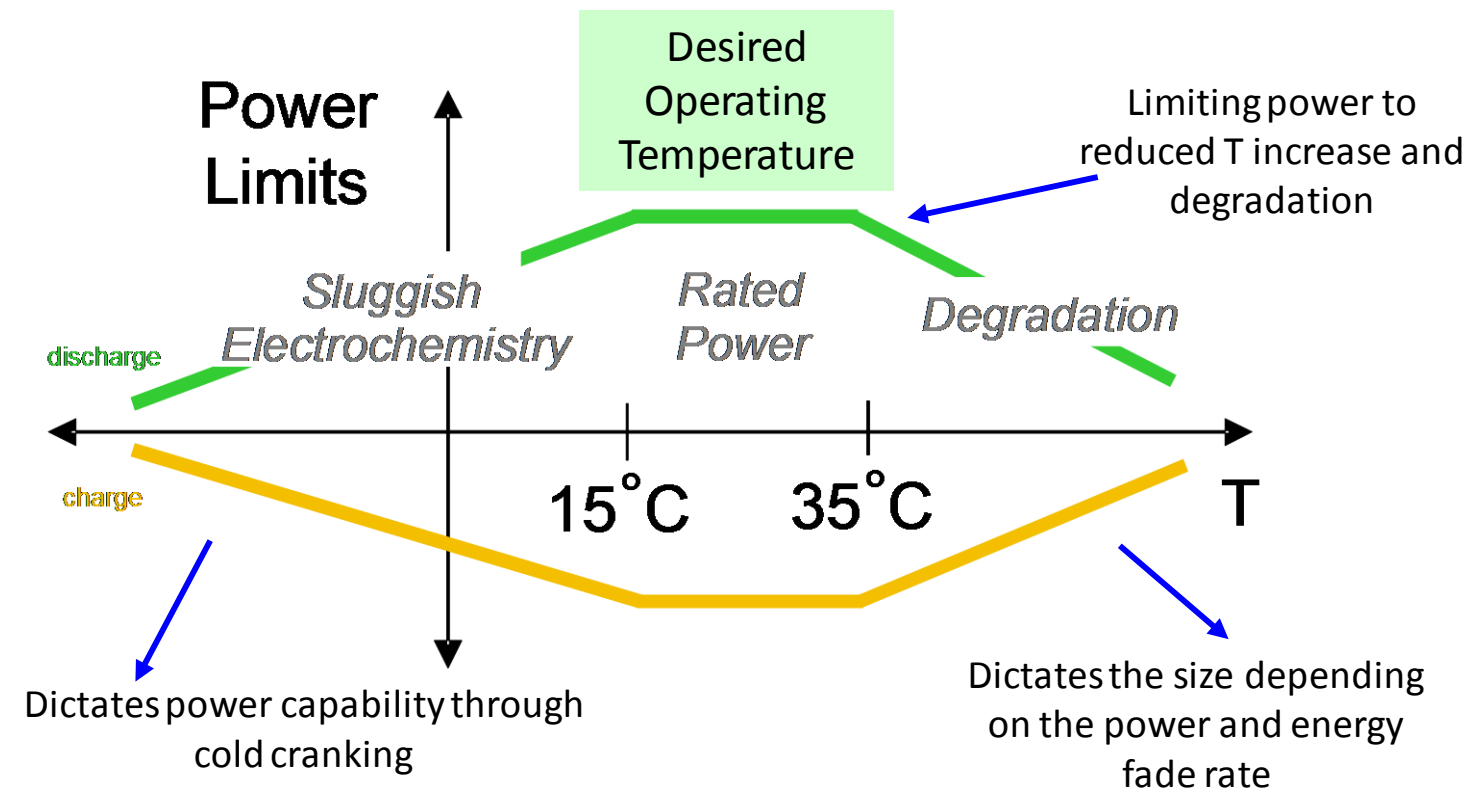

Also limits the electric driving range

Kandler Smith, NREL Milestone Report, 2008

# xEV Thermal Management – Normal Operation

- **Battery thermal management is needed for xEVs to:**
  - Keep the cells in the desired temperature range
  - Minimize cell-to-cell temperature variations
  - Prevent the battery from going above or below acceptable limits
  - Maximize useful energy from cells and pack
- **However, a battery thermal management systems (BTMS) should be designed to:**
  - Minimize increased complexity
  - Added initial cost provide long term value
  - Improve reliability
  - Minimize parasitic losses

# Battery Heat Balance – Lumped Capacitance

Assuming battery is isothermal (has high thermal conductivity)

$$mC_p \frac{dT_s}{dt} = \text{Heat}_{gen} - hA(T_s - T_a) - e\delta A(T_s^4 - T_a^4) - Q_{Ext\_conduction}$$

Rate of  
Temp  
Change

Rate of  
Internal Heat  
Generation

Convection  
Heat Loss

Radiation  
Heat Loss

Conduction  
Heat Loss

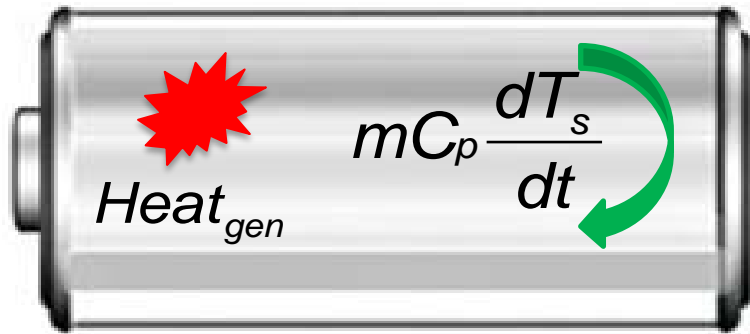

Heat generated ( $\text{Heat}_{gen}$ )  
in a battery consists of:

- Electrochemical reactions
- Phase changes
- Mixing effects
- Joule heating

D. Bernardi, E. Pawlikowski and J. Newman

*J. Electrochem. Soc.* 1985. Volume 132. Issue 1.

$$hA(T_s - T_a) + e\delta A(T_s^4 - T_a^4) + Q_{Ext\_conduction}$$

Method of heat rejection/addition for thermal control

$T_s$  = Battery Temp

$T_a$  = Ambient Temp



# Heat Generation Rate and Specific Heat Impact Battery Temperature Rise

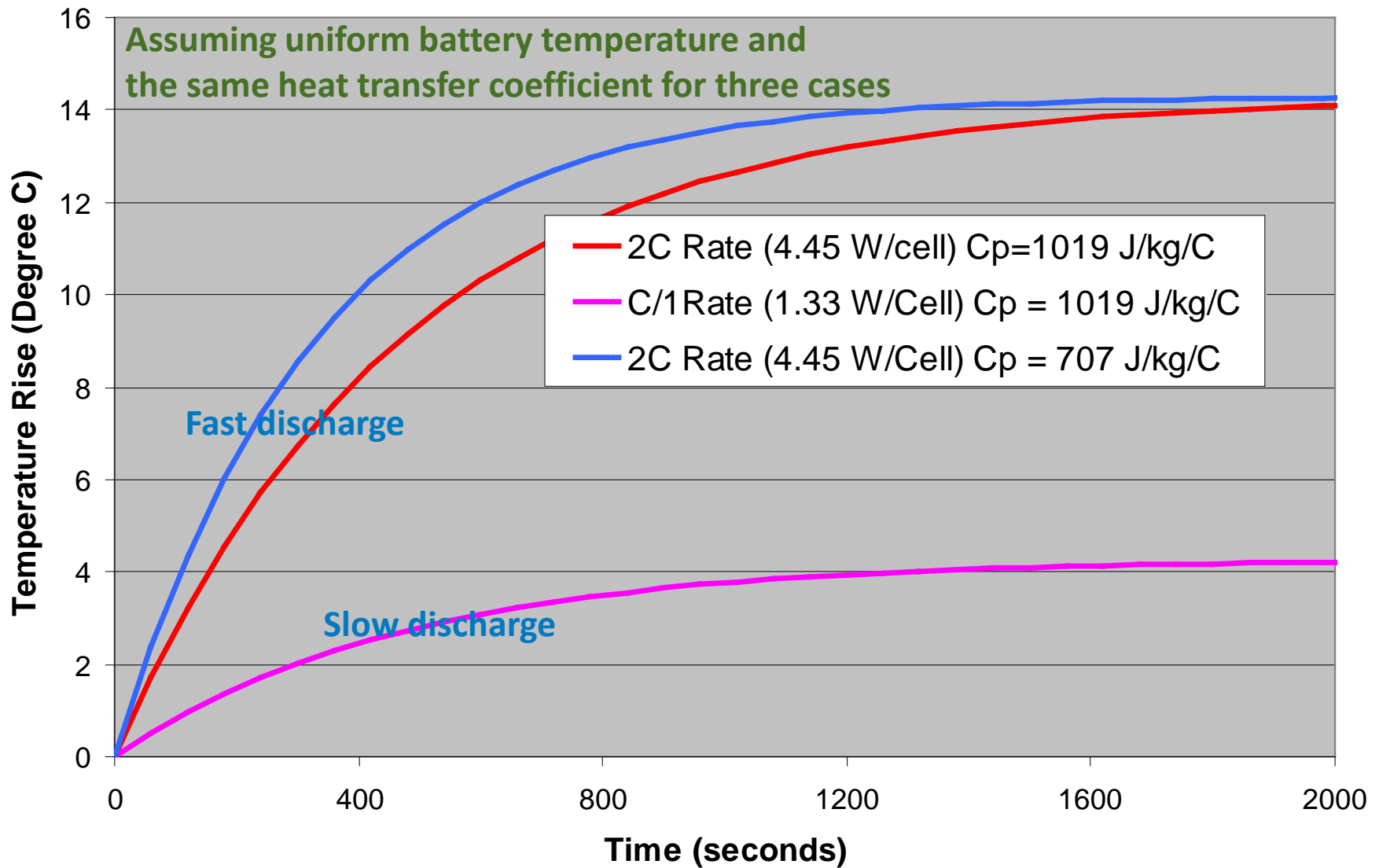

# Battery Heat Transfer – none isothermal

Could be 2 or 3 dimensional in geometry

**Core region**  $\rho C_p \frac{\partial T}{\partial t} = Heat_{gen} + \nabla \cdot k \nabla T$

$k$  : thermal conductivity

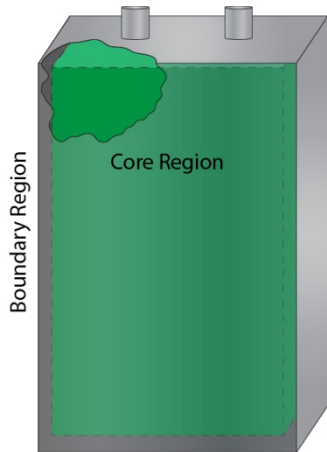
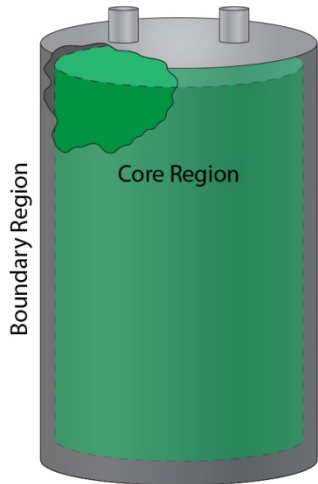

**Case or boundary region**

$$-k_n \frac{\partial T(n)}{\partial n} \Big|_{n=0.L} = h(T_s - T_\infty) + e\delta(T_s^4 - T_\infty^4) + \rho_B C_{p,B} H_B \frac{\partial T_B}{\partial t}$$

Heat flux  
from the  
core

Convection  
from various  
case surfaces

Radiation  
from various  
case surfaces

Heat  
accumulation  
in the case

Johnsee Lee, K. W. Choi, N. P. Yao and C. C. Christianson

*J. Electrochem. Soc.* 1986, Volume 133, Issue 7, Pages 1286-1291

# Example of T Distribution in a 6-cell Module

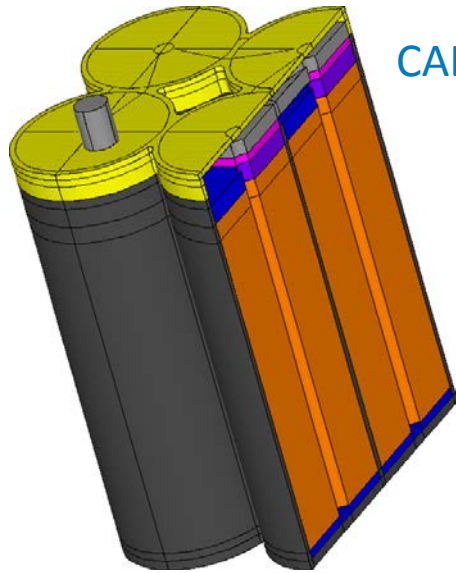

CAD of a 6-cell module

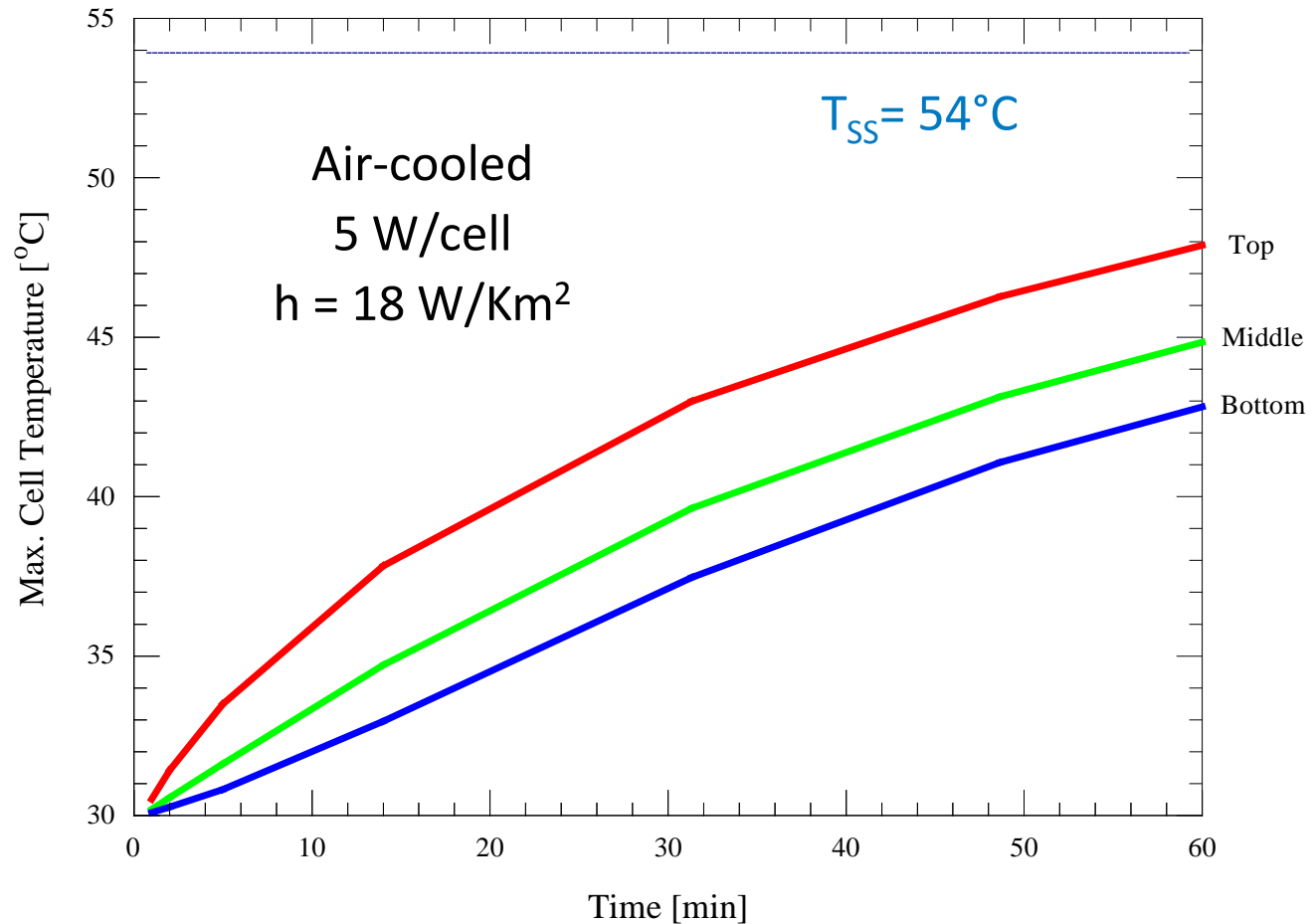
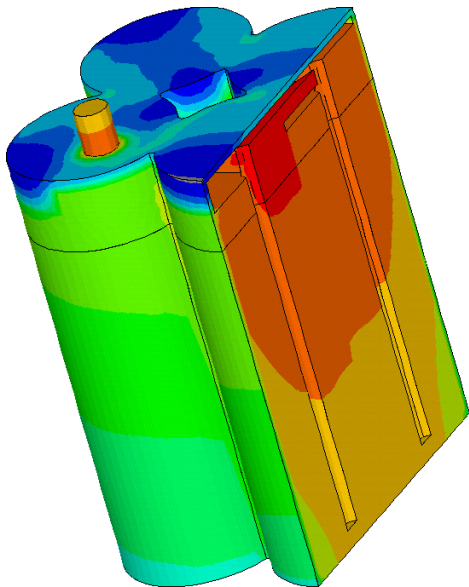

A. Pesaran, A. Vlahinos, S. Burch. Proceedings of the 14th Electric Vehicle Symposium, December 1997

# Heat Transfer in a Battery Pack

Coolant Flow Rate ( $M_c$ ) for each cells in series

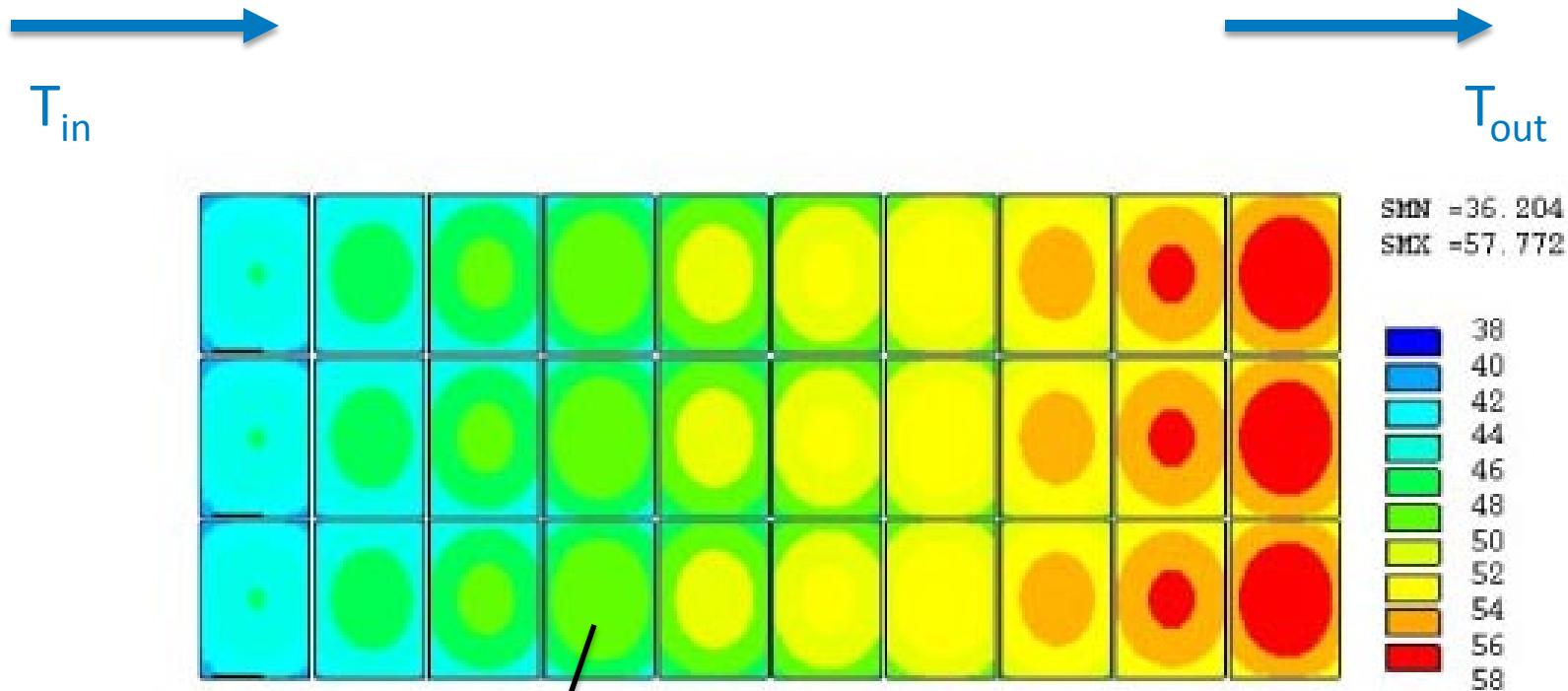

$Q_{Gen}$

$$M_c C_p (T_{out} - T_{in}) = \sum Q_{Gen}$$

(Heat Generation within a cell)

# Information Needed for BTMS Design

- Acceptable temperature range
- Acceptable temperature difference
- Maximum and minimum temperature limits
- Thermo-physical properties
- Battery heat generation rates
- Heat rejection rates from battery
- Configurations and dimensions of cells and proposed BTMS
- Parasitic power needed to push fluids/cooling through BTMS

# Tools for Designing BTMS

- **Experimental Tools**

- Isothermal calorimeters and battery testers
- Infrared thermal imaging
- Thermal conductivity meters
- Set up to measure heat transfer characteristics
- Battery thermal testing loop

- **Modeling Tools**

- First-order/lumped capacitance thermal and fluid models
- 1-D, 2-D, 3-D thermal and fluid-flow performance models
- 3-D electrochemical-thermal model
- Computer-aided engineering software with CFD

# Measuring Heat Generation

- Isothermal conduction calorimeters along with battery testers are best equipment to measure **heat generation** at various current rates, temperatures, and states of charge (SOCs)
- Heat flux gauges measure heat exchanges from a battery and between a constant temperature heat sink

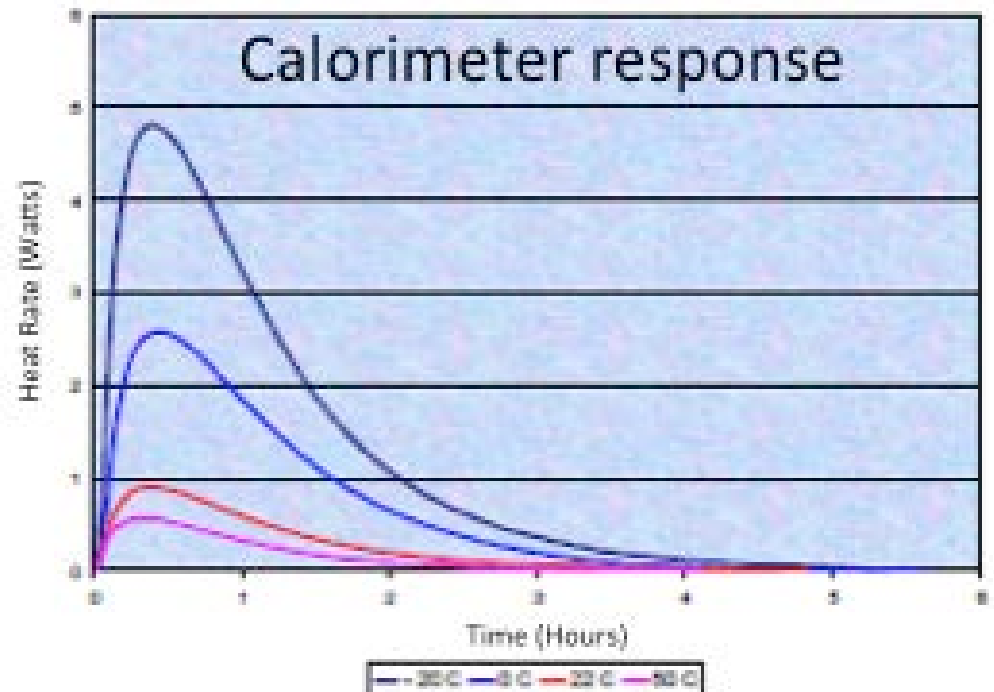

# Example Heat Generation Data for CC Discharge

(from max to min allowable capacity-SOC)

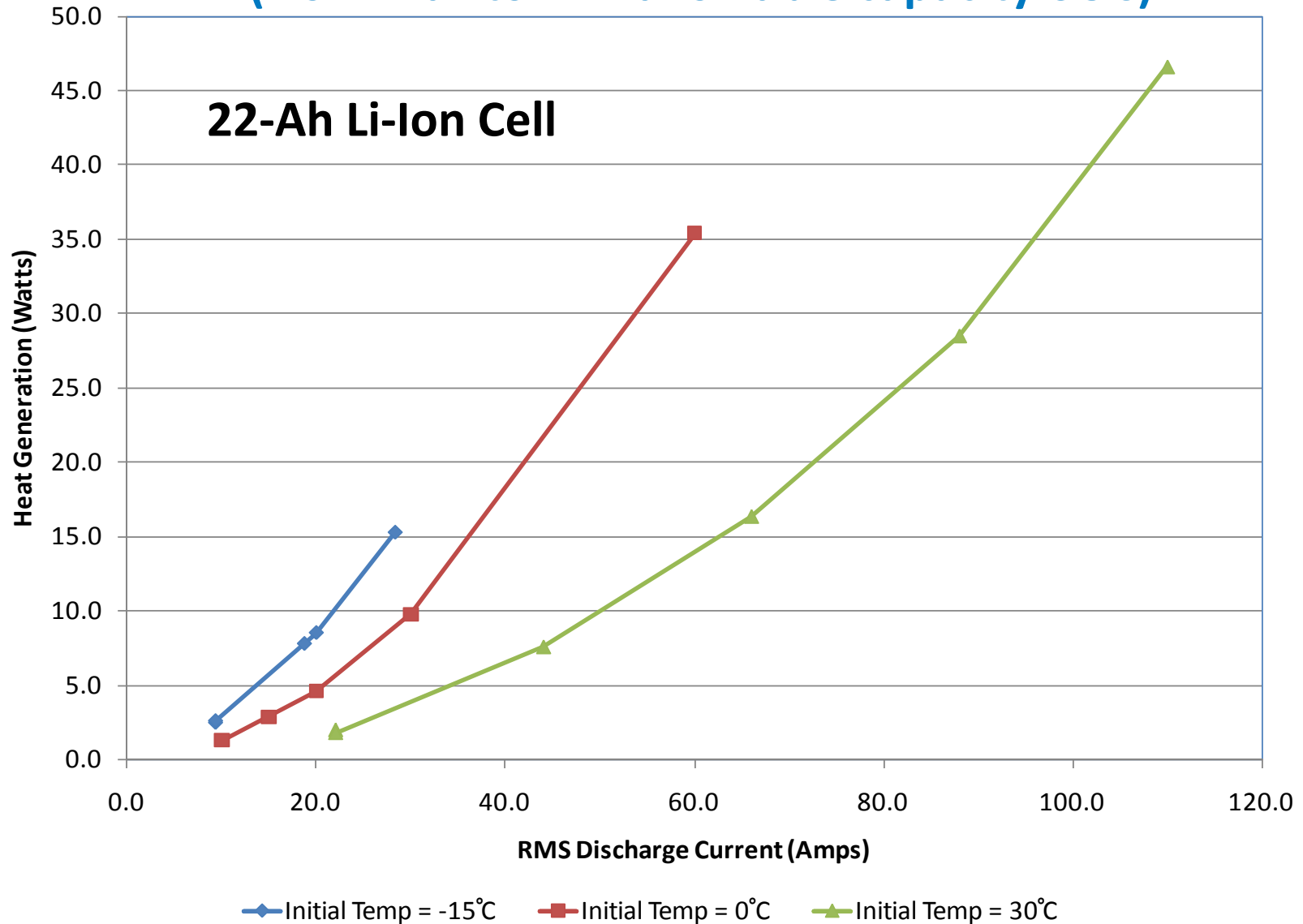



# Infrared Battery Thermal Imaging

- Quickly finds thermal signature of the whole cell under electrical loads
- Helps understand thermal behavior, creates diagnostics, and improves designs
- Could be used as a validation of thermal models
- Thermal signature depends on several factors
  - Geometry, thermal conductivity of case and core,
  - Location of terminals, design of interconnects,
  - Current density, current profile, chemistry, environment

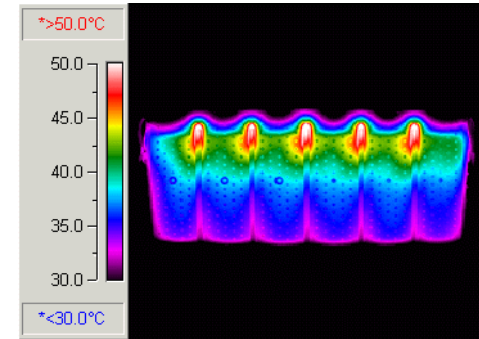
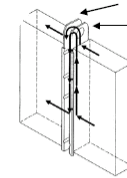

Thermal image of a 6.5-Ah NiMH module from a MY 2002 Prius under 100A CC discharge

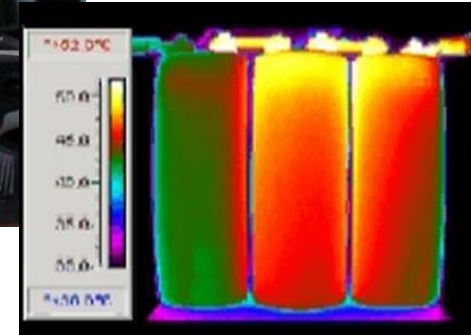
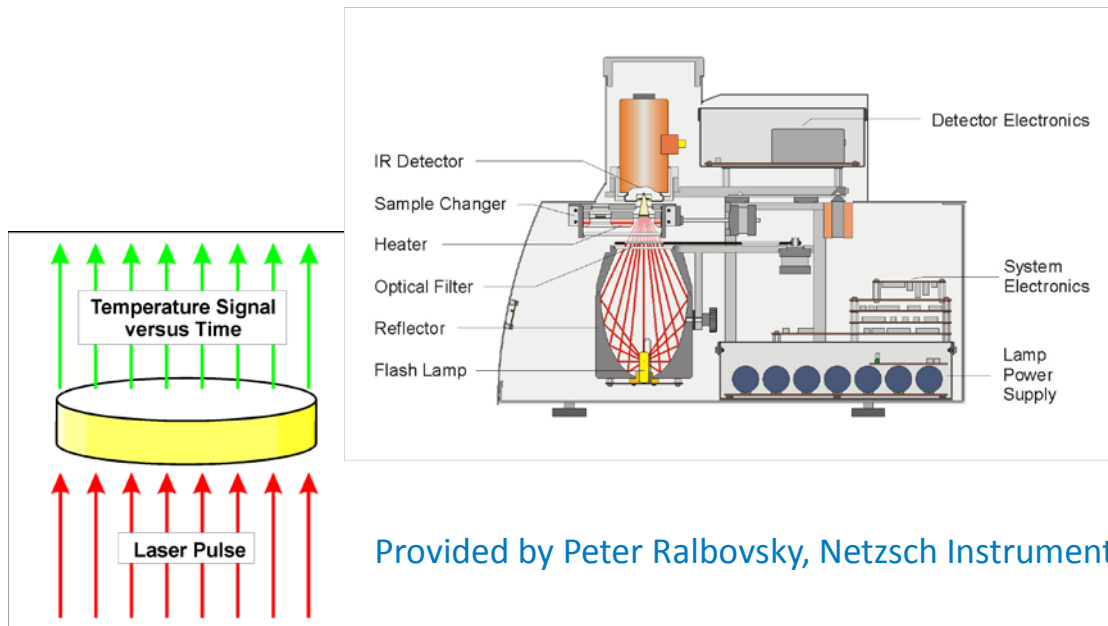

Photo Credits: Matt Keyser, NREL

# Measuring Thermal Conductivity of LIB Components

## Flash Diffusivity Method:



Netzsch LFA 447 Unit



- Measurements have shown that generally the thermal conductivity of a LIB is much lower in-plane than cross-plane  
In plane ~ 0.8 to 1.1 W/m/K    Cross plane ~ 28 to 35 W/m/K

Photo Credit: John Ireland, NREL

# Battery Thermal Testing Loops

- Measuring heat transfer coefficients or conductance

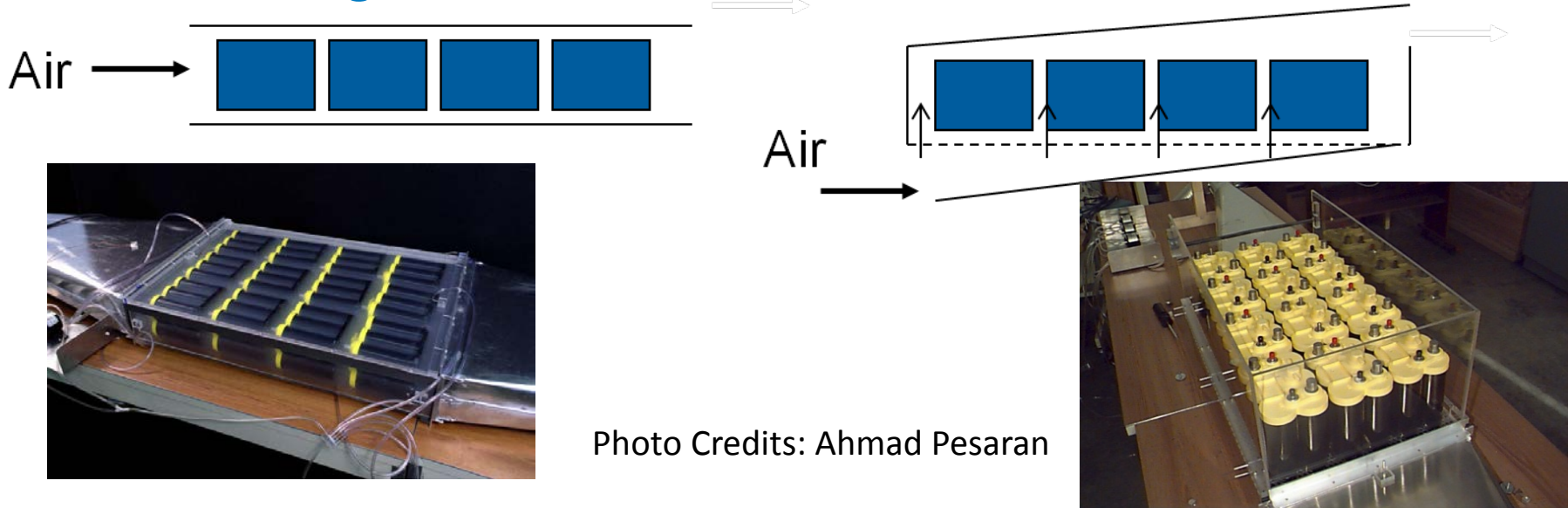

- Hardware in the loop thermal testing

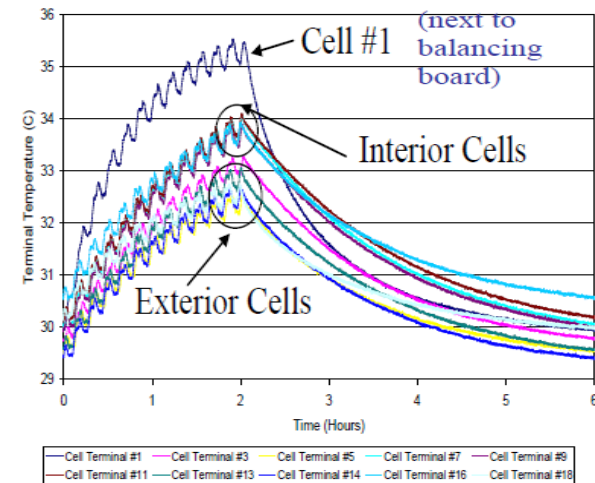
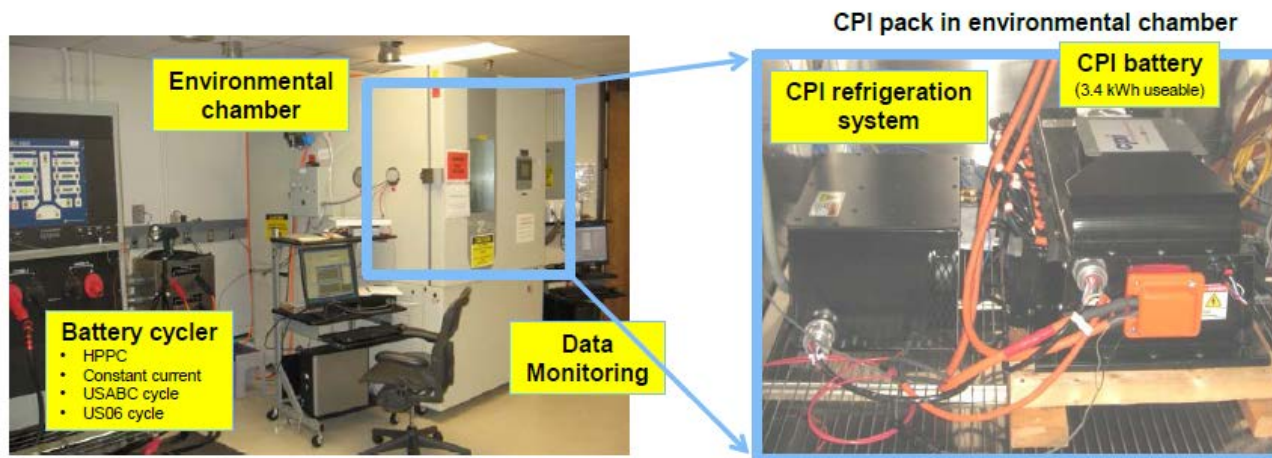
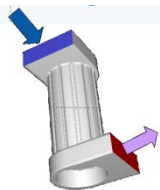

Photo Credits: Kandler Smith, NREL

# Process for Battery Thermal Design



## Cell Characteristics

- Shape and size : Prismatic/Cylinder/Oval, etc.
- Materials/Chemistries
- Voltage/current & heat gen data
- Thermal/Current Paths inside a Cell

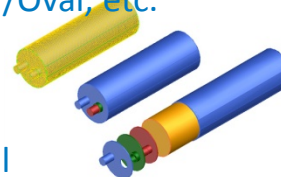

## Module Cooling Strategy

- Coolant Type: Air/Liquid
- Direct Contact/Jacket Cooling
- Serial/Parallel Cooling
- Terminal/Side Cooling
- Module Shape/Dimensions
- Coolant Path inside a Module
- Coolant Flow Rate
- Passive with phase change
- etc.

## Operating Conditions

- Vehicle Driving Cycles
- Control Strategy
- Ambient Temperature
- etc.

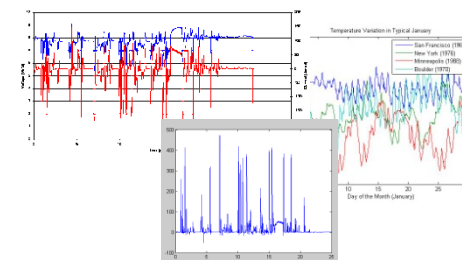
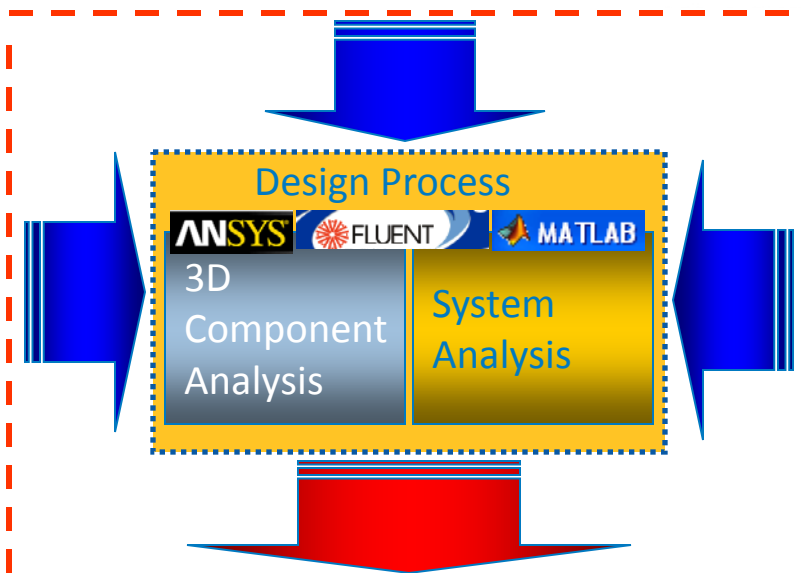

## Battery Thermal Responses

- Temperature History Cells/Module/Pack
- Temperature Distribution in a Cell
- Cell-to-Cell Temperature Imbalance in a Module
- Battery Performance Prediction
- Pressure Prop and Parasitic Power
- etc.

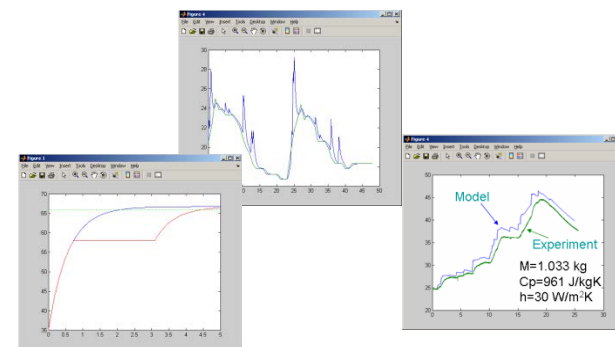
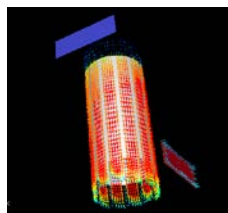
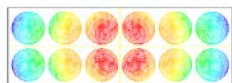

# Computer Aided Engineering of Batteries

- Combines fluid flow, thermal, and electrochemical models in one package

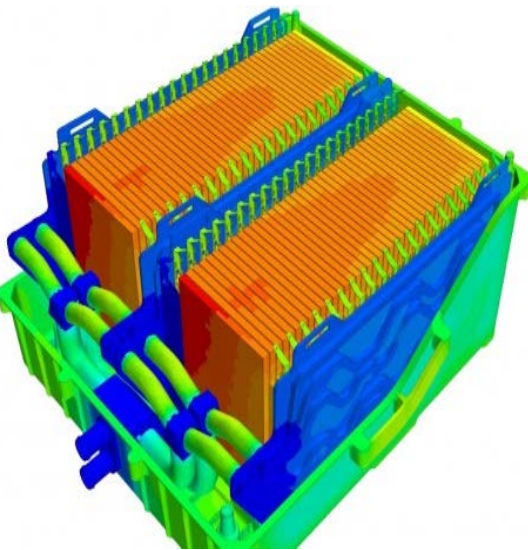

CD-adapco

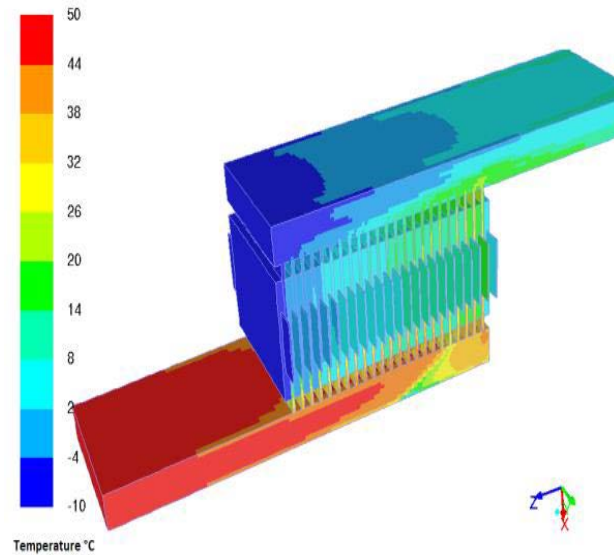

EC Power

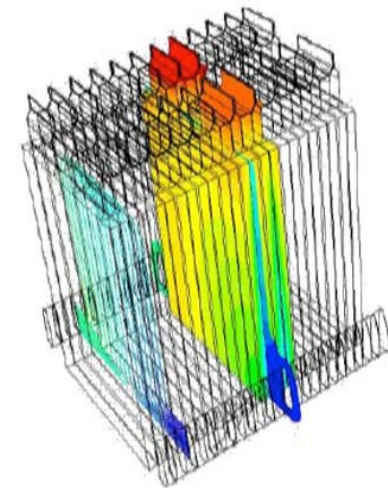

ANSYS

# Battery Thermal Design

---

- **Normal Operation**
  - Normal driving
  
- **Off-Normal Operation**
  - Abuse conditions

# Off-Normal Operation – Examples

- Internal and external short circuit
- Overheating
- Crash induced crush

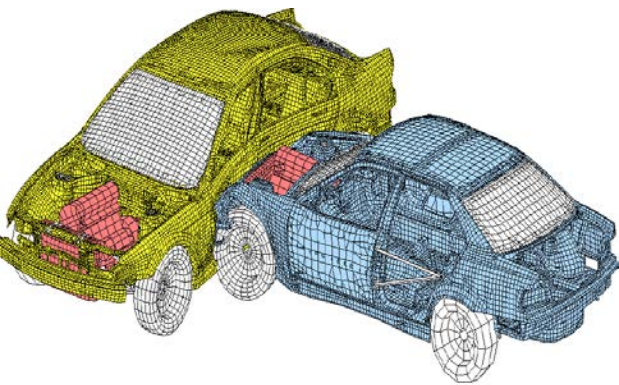
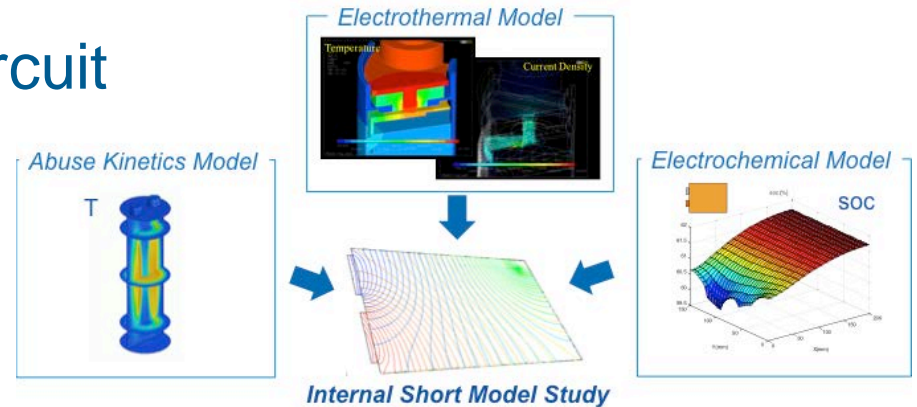

- Sharp object penetration
- Overcharge

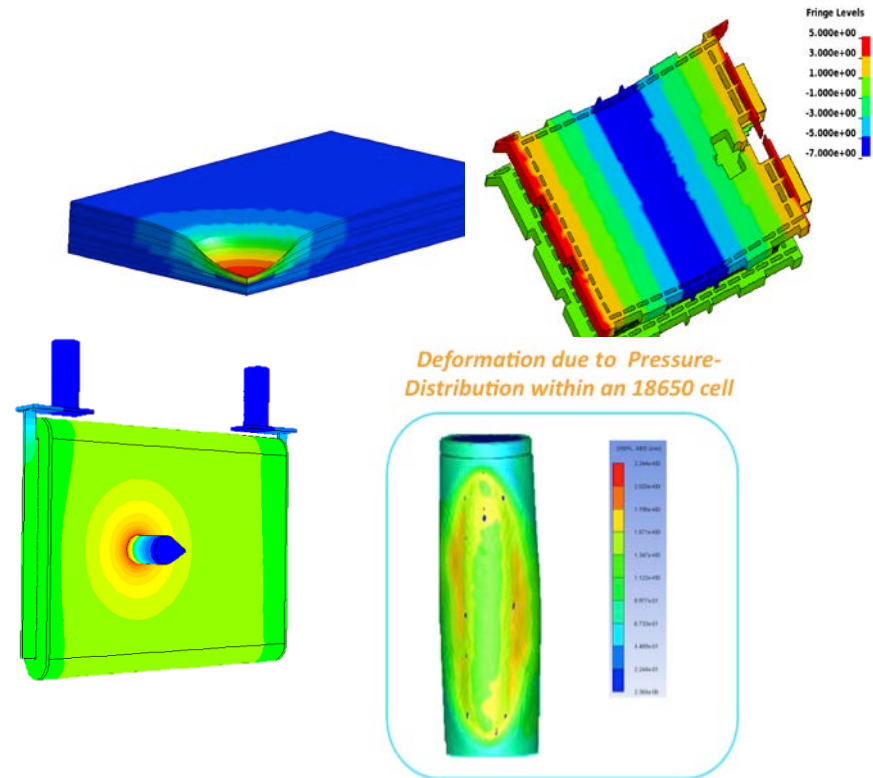

# Accelerating Rate Calorimeter Testing

## Measuring Heat during Thermal Runaway (TR)

*3 Ah jelly roll rapid thermal runaway ( $>10^{\circ}\text{C}/\text{min}$ ) occurs  $20^{\circ}\text{C}$  lower than 2.2 Ah cell*

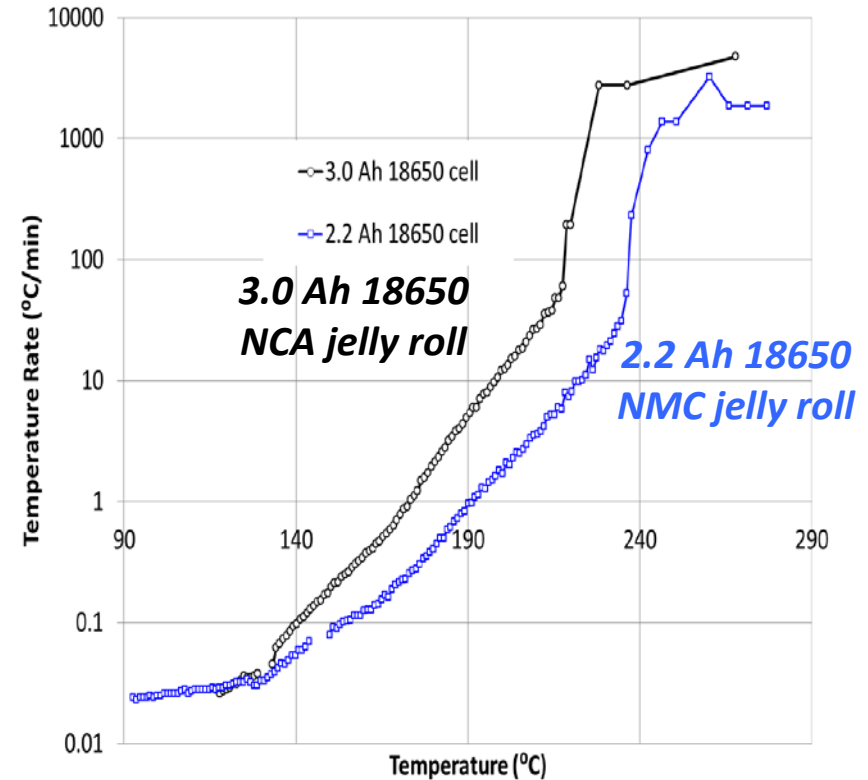

**NREL's THT EV  
Accelerating Rate  
Calorimeter**

Jelly Roll	Weight (g)	Onset Temp ( $^{\circ}\text{C}$ )	Peak Temp( $^{\circ}\text{C}$ )	Venting Temp( $^{\circ}\text{C}$ )	Total Heat Generation (J)	Runaway Enthalpy(kJ/Ah)	Mass Change (g)
18650 3.0 Ah	45.23	111.6	932.4	128.0	31,002.91	10.33	13.27 (29.3%)
18650 2.2 Ah	43.34	91.5	782.7	143.7	25,016.76	11.37	8.97 (20.1%)



# Cell to Cell Thermal Propagation

- Assuming one cell will fail and go to thermal runaway
- Is the design robust to not allow cell to cell propagation?
- How best to test the design?

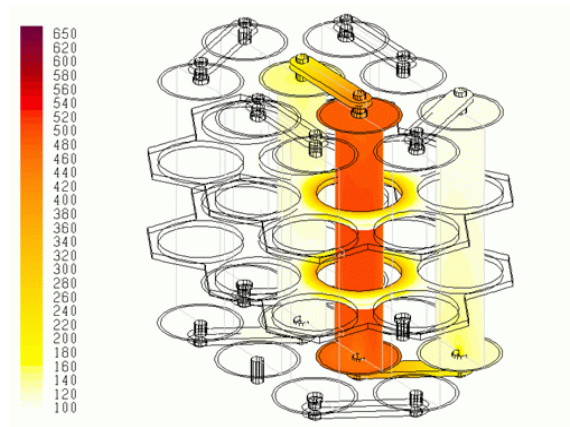
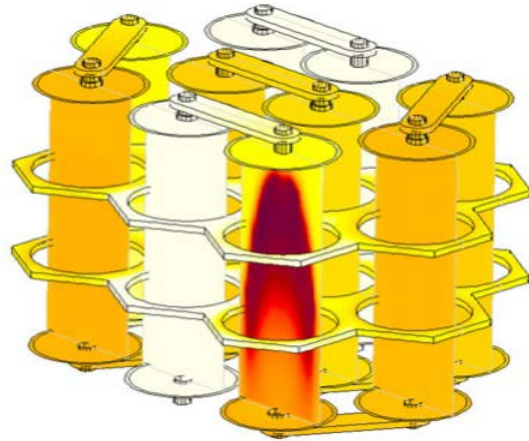
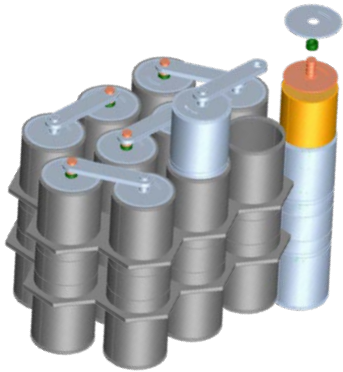

- Cell-Cell Propagation Testing using NREL Battery Internal Short Circuit (ISC) Device

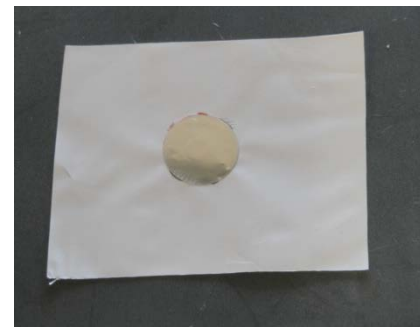

# NREL Battery ISC Device Design

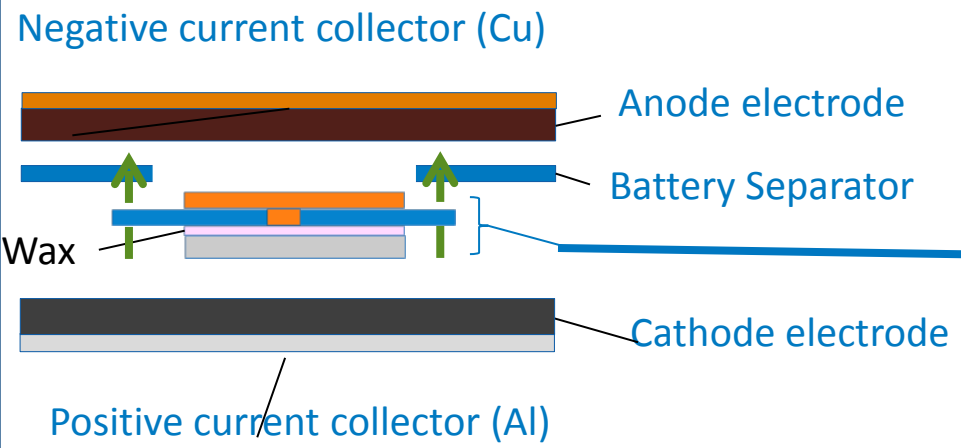

Graphics are not to scale and for illustration only

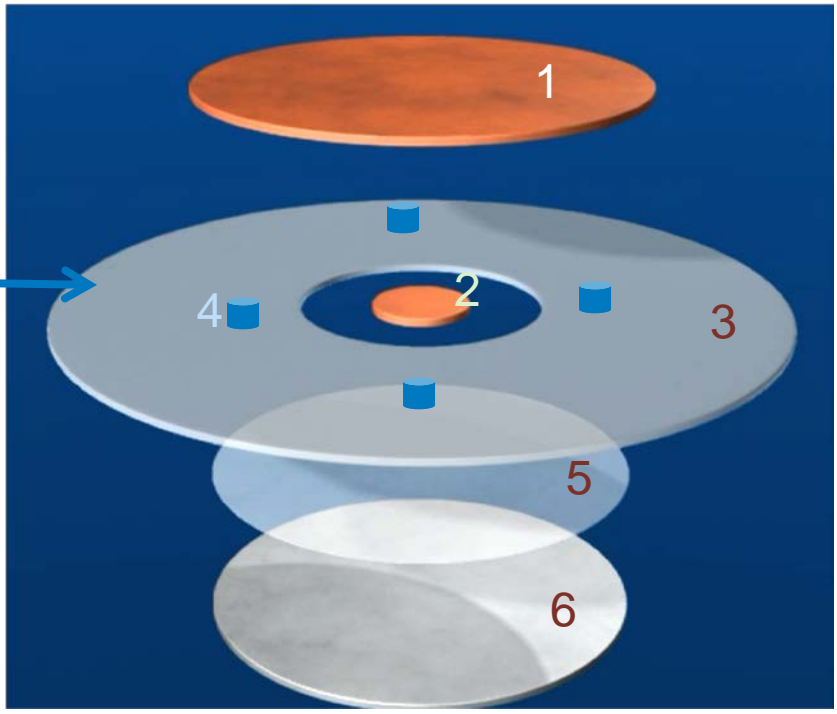

- Top to Bottom:
1. Copper Disc
  2. Copper Puck
  3. Battery Separator
  4. Adhesive/glue
  5. Phase Change Material (wax)
  6. Aluminum Disc

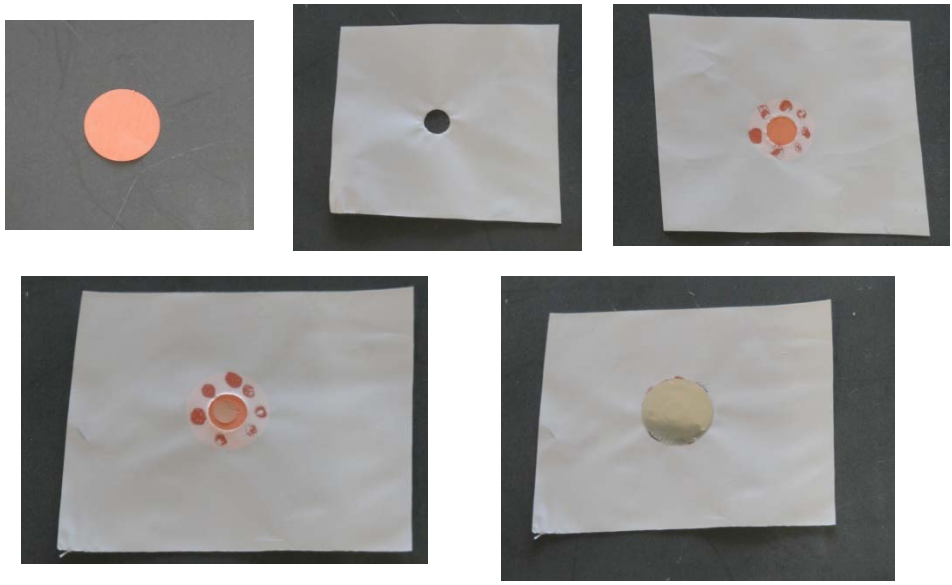

# Evaluation of a Novel Li-ion Packaging Technology

- **Cadenza's large prismatic cell technology for grid storage and PEV**

- Uses commoditized 26mm jelly rolls – “abundant supply chain ”
- Proprietary housing material with thermal quenching ability developed by Morgan Advanced Materials
- Large “cells” ranging from 30Ah to 200Ah in development
- Expected low cost \$125/kWh
- Feature: Ability to survive internal short without cascading allows high energy density



- **Department of Energy/ARPA-E Range Team**

- Cadenza Innovation LLC (Principal), Fiat Chrysler Automobiles, NREL, Samsung SDI NA, Morgan Advanced Materials, Magna Steyer Battery Systems, Alcoa, Karotech LLC, and Impact Design LLC

# Cell to Cell Propagation Study Using ISC Device



- **Intended application for ARPA-E project**
  - Fiat 500e (24kWh original battery)
  - DEMO battery project: 38kWh (in the same volume)
- **Proof-of-concept cells to date for two systems:**
  - 6 jellyrolls in a row: 30Ah (NCM)
  - 23 jellyrolls in an array: 90Ah (NCA)



# ISC Device in a 30Ah NCM cell and a 90 Ah NCA

One cell with internal short circuit device implanted jelly rolls

30Ah "cell"  
consisting of 6 x  
5Ah NCM jelly rolls

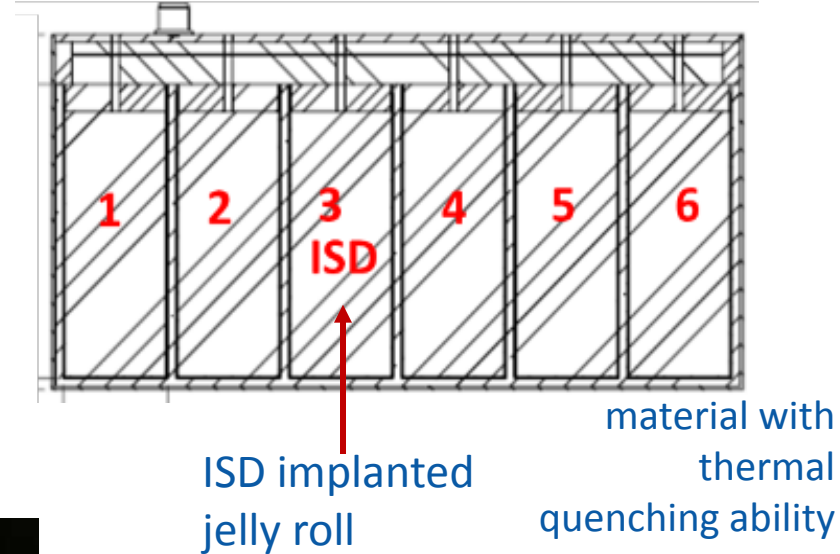
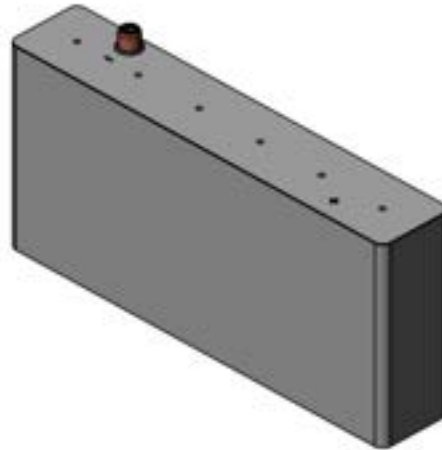

90 Ah "cell"  
consisting of 23 x  
3.9Ah NCA jelly rolls

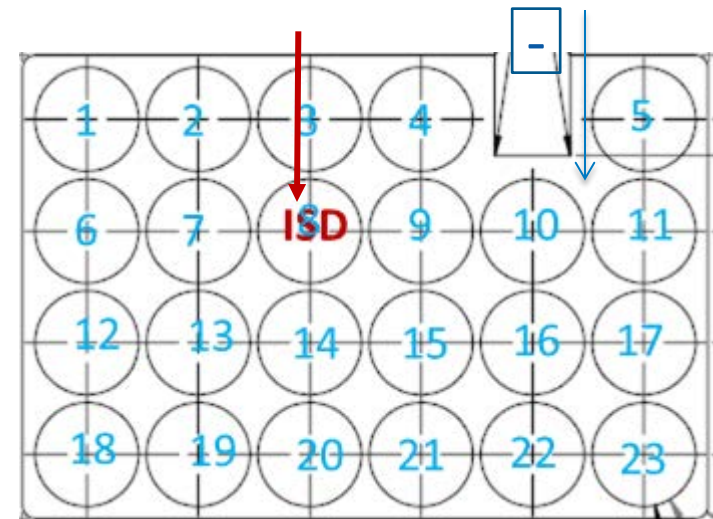

# Experiments Showed No TR Propagations

for 30Ah NCM cell after initiating the internal short circuit

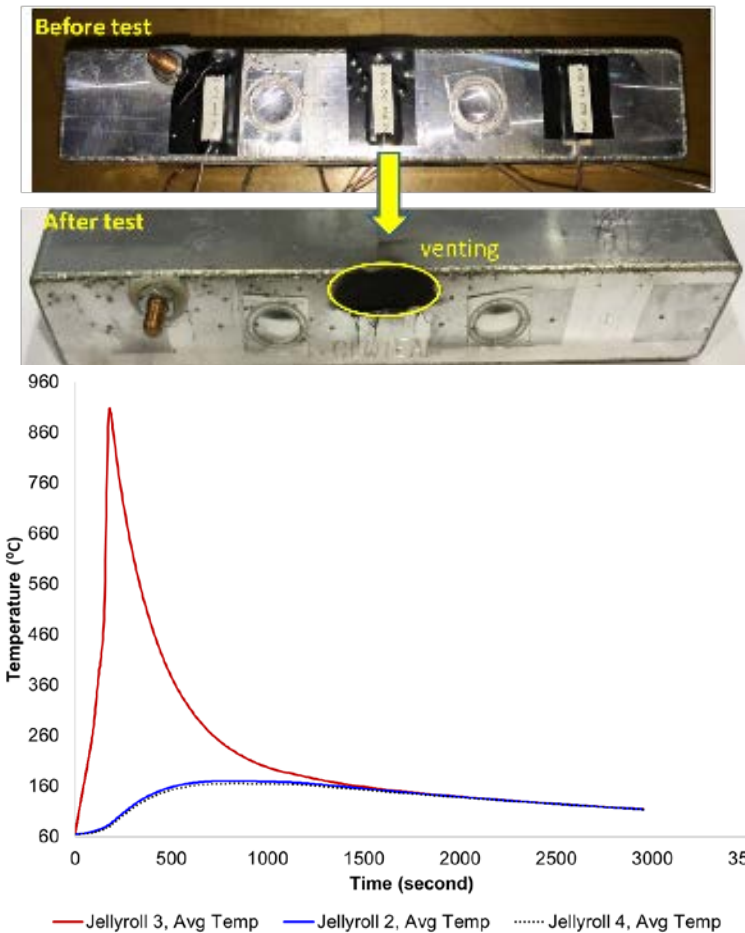
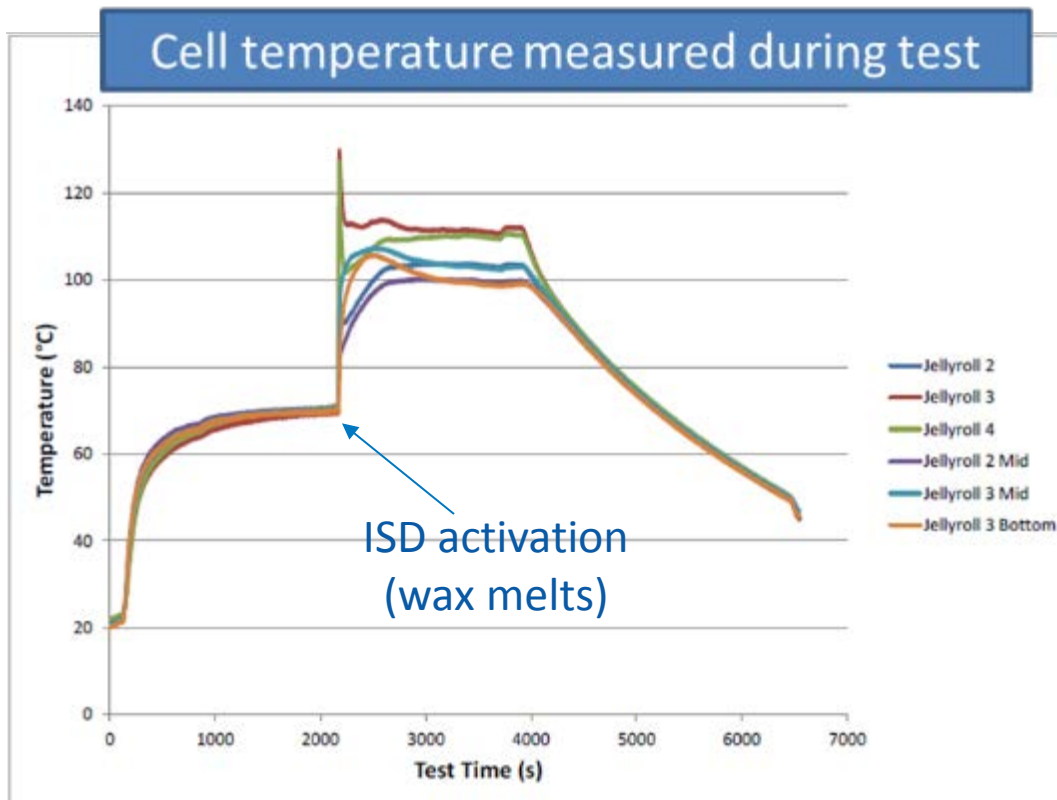

The cell only vented with a max measured cell surface temperature less than 138°C.

# Experiments Showed No TR Propagation in the 90 Ah cell after initiating the ISC (NCA)

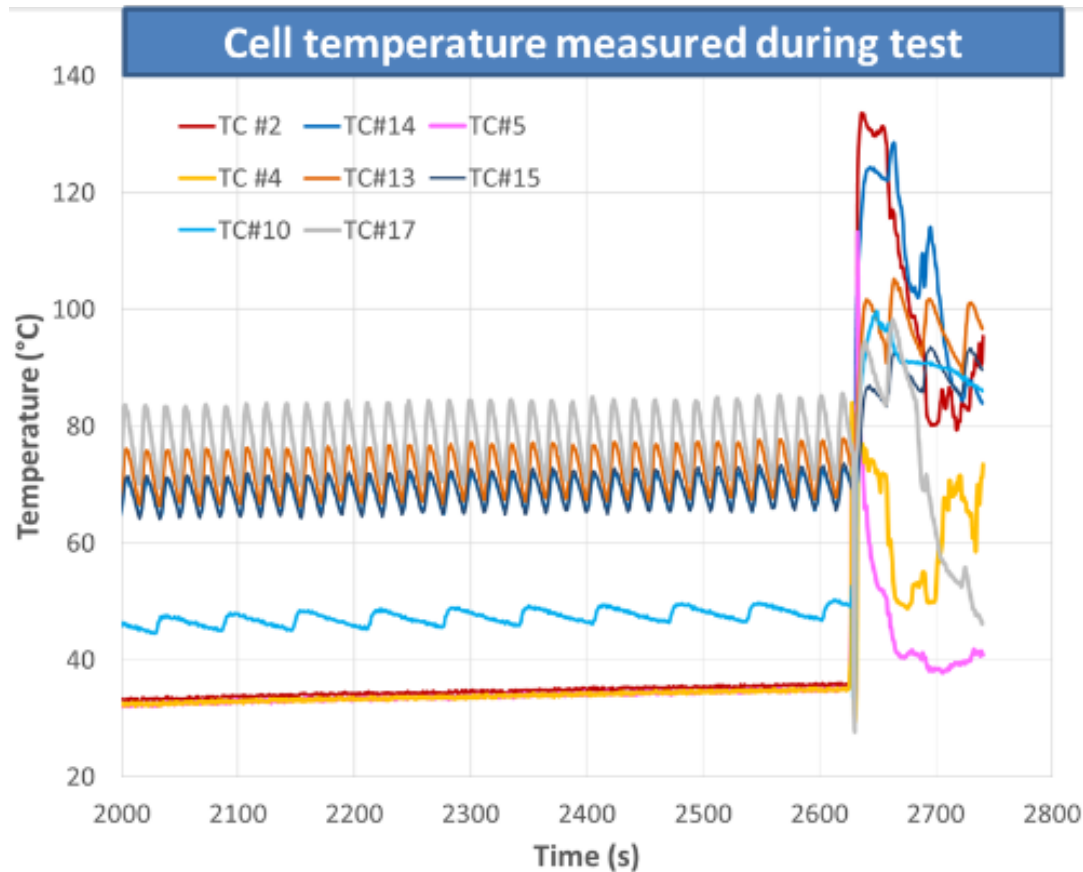

Front of cell after test

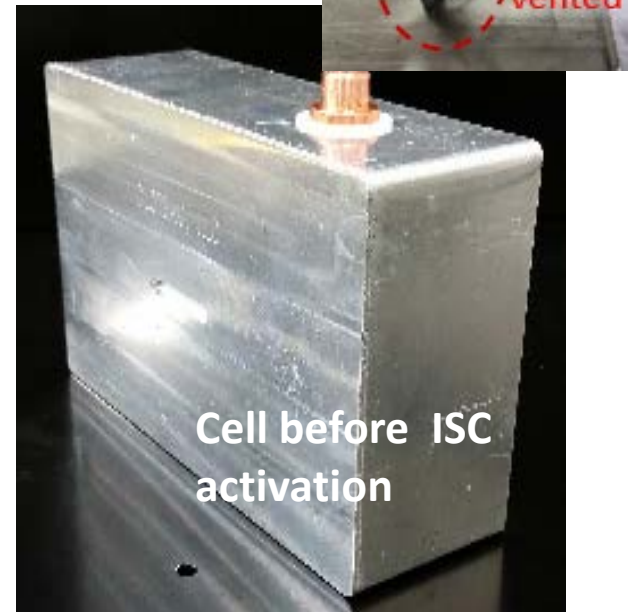

The cell only vented with a max measured cell surface temperature less than 138°C.

# Summary – Battery Pack Thermal Design

- Battery thermal management system essential for xEVs
  - Normal operation during daily driving (achieving life and performance)
  - Off-normal operation during abuse conditions (achieving safety)
- Battery thermal management system needs to be optimized with right tools for lowest cost
- Experimental tools such as isothermal battery calorimeter, thermal imaging, and heat transfer setups are needed
- Thermal models and computer-aided engineering tools are useful for robust designs
- During abusive conditions, designs should prevent cell to cell propagation in a module/pack (keep the fire small and manageable)
- NREL battery ISC device can be used for evaluating robustness of a module/pack to cell-to-cell propagation



# Acknowledgements

## The NREL Team

- Matt Keyser
- Gi-Heon Kim
- Shriram Santhanagopalan
- Kandler Smith
- Chuanbo Yang

## Funding from Department of Energy, Vehicle Technologies Office

- Brian Cunningham
- Dave Howell

