

# Computer Aided Battery Engineering Consortium



**P.I.: Ahmad Pesaran**

**NREL Contributors: Shriram Santhanagopalan, Kandler Smith, Lei Cao, Gi-Heon Kim, Chao Zhang, Chuanbo Yang, Peter Graf**

**Partner Contributors: Stephen Dajka (ANSYS), Partha Mukherjee (TAMU), Elham Sahraei (MIT), Josh Lamb (SNL), Dennis Dees (ANL), Bill Stanko (USCAR)**

**National Renewable Energy Laboratory**

**Vehicle Technologies Office (VTO) Annual Merit Review and Peer Evaluation**

**Washington, D. C.**

**June 7, 2016**

**Project ID # ES294**

**NREL/PR-5400-66509**

This presentation does not contain any proprietary, confidential, or otherwise restricted information.

# Overview – A New Project for FY16

## Timeline

- **Project Start Date: 10/2015**
- **Project End Date: 9/2018**
- **Percent Complete: 17%**

## Budget

- **Total Project Funding: \$1.735M**
  - DOE Share: 100%
  - Contractor Share: 0%
- **Funding Received in FY16: \$1.735M**
- **Subcontractors Funding: \$400K**

## Barriers

- Lack of tools that can simulate battery thermal behavior during crush for improving battery safety
- Lack of fast CAEBAT software
- Lack of microstructure models for electrode design

## Partners

- ANSYS
- ANL
- SNL
- MIT
- Texas AMU
- USCAR-CSWG

# Relevance – Supporting DOE VTO Program

- The DOE's EV Everywhere Grand Challenge aims to produce plug-in electric vehicles (PEVs) as affordable, safe, and convenient for the American family as gasoline-powered vehicles by 2022.
  - PEVs must be as safe as conventional vehicles.
  - PEV batteries must not lead to unsafe situations when crashed
- The 2011–2014 DOE VTO Computer Aided Engineering for Electric Drive Vehicle (CAEBAT) activity was successful in releasing electrochemical-thermal models in commercial software tools.

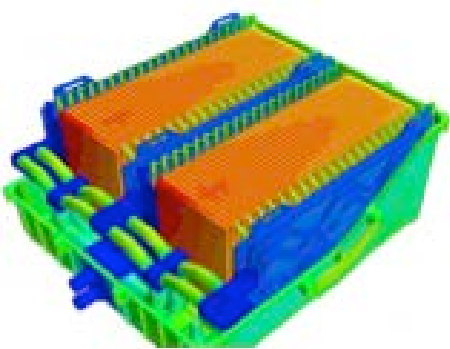

CD-adpaco

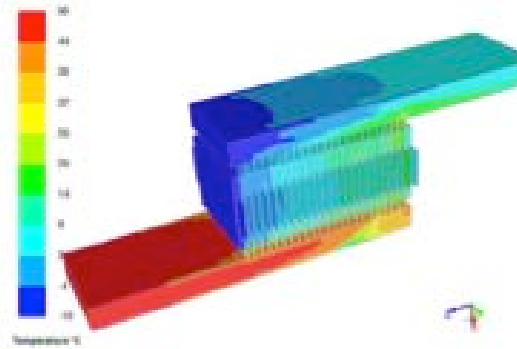

EC Power

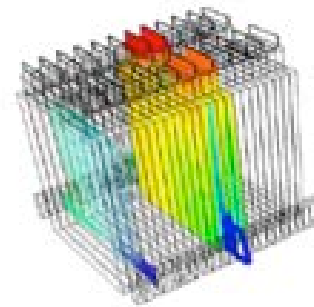

ANSYS

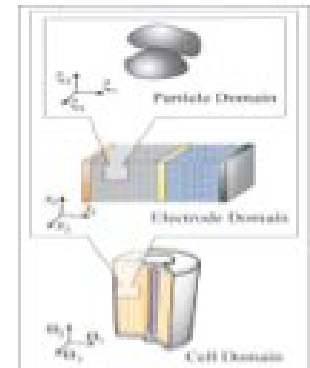

NREL MSMD

# Relevance – Supporting VTO CAEBAT Activity

- FY13-FY14 NREL projects funded under FY13 DOE VTO FOA (dubbed as CAEBAT-II) initiated the following:
  - Linking mechanical models to electrochemical-thermal tools to study crash-induced crush and
  - Speeding up the computational time of running simulations

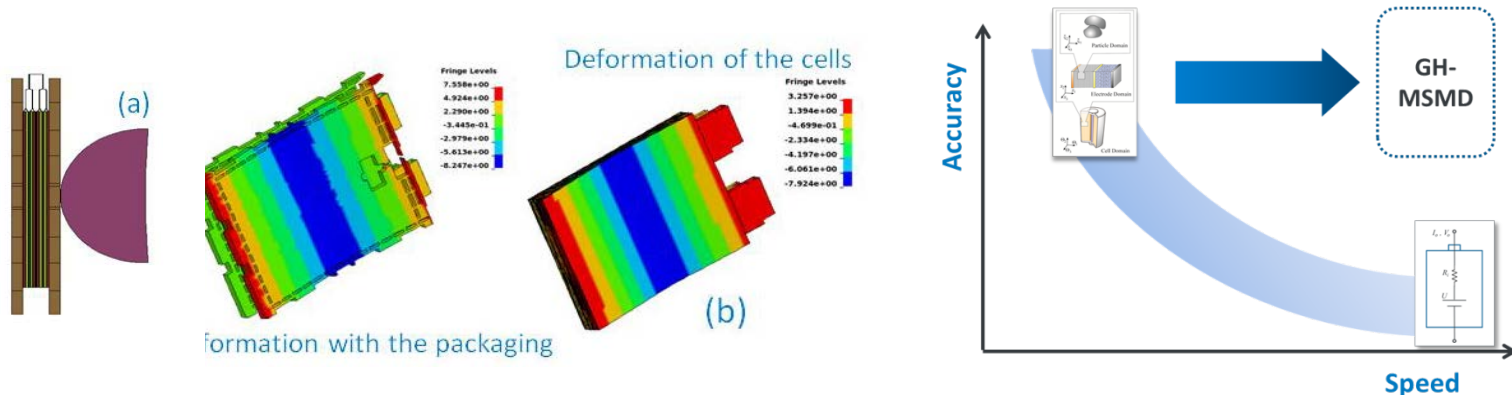

- This FY16 project is based on a proposal awarded under the FY15 VTO FOA (CAEBAT-II) and has started in October 2015.
- The overall goal of all CAEBAT phases is to create CAE tools to reduce the development cycle of safe in-vehicle battery systems, thus reducing costs of batteries and making PEVs affordable.

# Relevance – Project Objectives

Purpose: Assemble a multi-national lab collaborative team including experts from academia and industry to enhance recently developed CAEBAT-II battery crush modeling tools and to develop microstructure models for electrode design – both computationally efficient

## The objectives are to:

- 1. Enhance extremely fast multi-physics battery models*
- 2. Couple mechanical-electro-chemical-thermal (MECT) models more efficiently*
- 3. Develop advanced microstructure models for Li-ion electrodes*

# Key Milestones – by Tasks

Milestone Name/Description	Deadline	Milestone Type
M 1.1 Draft Summary Documentation of GH-MSMD framework	09/31/2016	Annual SMART Milestone
M 1.2 Complete Frequency Domain GH-MSMD formulation	01/31/2017	Quarterly Progress Measure
M 1.3 Present at the DOE Annual Merit Review	04/30/2016	Quarterly Progress Measure
M 1.4 Perform out design evaluation and performance evolution study using newly developed multiphysics GH-constituent models	07/31/2018	Quarterly Progress Measure
M 2.1 Present initial demonstration of simultaneous coupling in MECT model that shows interaction of mechanical deformation with the thermal response	03/31/2016	Milestone (Go/No-Go)
M 2.2 Draft documentation describing the mechanical tests procedure for development and validation of constitutive models for individual battery components	07/31/2017	Annual SMART Milestone
M 2.3 Interim update on mechanical models demonstrating damage propagation across multiple axes of battery cells and battery modules	12/31/2017	Quarterly Progress Measure
M 2.4 Report summarizing model validation for MECT simulations	04/30/2018	Quarterly Progress Measure
M.3.1 Document microstructure model formulation and validation plan	12/31/2015	Quarterly Progress Measure
M 3.2 Present microstructure project update at AMR	06/31/2016	Quarterly Progress Measure
M 3.3 Comparison of microstructural model simulations from both stochastic reconstructed (simulated) and tomographic (measured) geometries	09/30/2017	Quarterly Progress Measure (Go/No-Go)
M 3.4 Validation of electrode microstructure design tool for multiple electrode designs showing < 10% error between models and data	09/30/2018	Annual SMART Milestone

# FY16 Project Milestones

Milestone Name/Description	Due Date	Milestone Type	Status
Develop microstructure model formulation and validation plan	12/31/2015	QPM (Regular)	Compleat
Present initial demonstration of simultaneous coupling approach for connecting mechanical deformations to electro-chemical-thermal models	3/31/2016	Go-No Go QPM (Stretch)	Completed
Attend the DOE Annual Merit Review to update on project progress	6/30/2016	QPM (Regular)	On Track
Draft Summary Documentation of GH-MSMD framework	9/31/2016	Annual SMART (Regular)	On Track

QPM: Quarterly Progress Measure

# Strategy/Approach – End Goals

- Expand upon existing electro-chemical-thermal (ETC) and mechanical-ETC models, make them computationally more efficient, add new physics, develop microstructure models, validate them
- Accelerate developing improved electrode and cells by reducing the number of experiments
- Transfer developed models to commercial software vendors and end-users to reduce the battery development cycle and cost.



# Strategy/Approach – Tasks

- 1. Enhance extremely fast multiphysics battery models** for particle, electrode-, cell-, and pack-level multiscale model simulations based on the innovative GH-MSMD developed under CAEBAT-2. Fabricate and test electrode and cells for model parameter identification and validation.
- 2. Couple mechanical-electro-chemical-thermal (MECT) models efficiently** to predict the thermal-runaway behavior of cells and modules after a crash-induced crush, expanding on the unique approach developed in CAEBAT-2. Perform battery abuse and safety testing for parameterization and validation of models. Obtain insight from automotive crash experts.
- 3. Develop advanced microstructure models** as tools to design battery electrodes through a better understanding of basic physics at the particle and electrode levels. Build upon existing microstructure models. Fabricate and test electrode samples with different characteristics, also obtain tomography images, to build enhanced and validated microstructure models.

# Strategy/Approach: Roles and Responsibilities

- NREL (Gi-Heon Kim ) leads Task 1. *Enhancing extremely fast multiphysics battery models*,
  - ANL fabricates electrode and cells samples and conduct experiments.
  - NREL enhances fast-running MSMD framework to include new physics
- NREL (Shriram Santhanagopalan) leads Task 2. **Coupled Mechanical ETC modeling**
  - MIT performs experiments for mechanical properties
  - ANL fabricates appropriate cells
  - SNL conducts abuse test (crush & circuit)
  - NREL furthers enhance MECT models for cells and modules
  - NREL compare SNL data with models for validation
  - CSWG provide insight battery crush testing and industry perspective
  - The ANSYS team will participate in integrating the MECT models with Fluent and commercializing the solution.

# Strategy/Approach: Roles-Responsibilities

- NREL (Kandler Smith) leads Task 3. *Developing Advanced Microstructure Models* task
  - ANL fabricates electrodes and map microstructure geometry using tomographic imaging
  - ANL conducts experiments on electrode with different characteristics
  - TAMU creates microstructure geometry and link to electrochemical models
  - NREL integrates the microstructure models into the CAEBAT framework
  - NREL/TAMU use the experimental data for validation and further enhancement
- Ahmad Pesaran (NREL) leads the overall project

# Technical Accomplishments – Task 1

1. **Enhancing extremely fast multiphysics battery models** for particle, electrode-, cell-, and pack-level multiscale model simulations based on the innovative GH-MSMD developed under CAEBAT-2. Fabricate and test electrode and cells for model parameter identification and validation

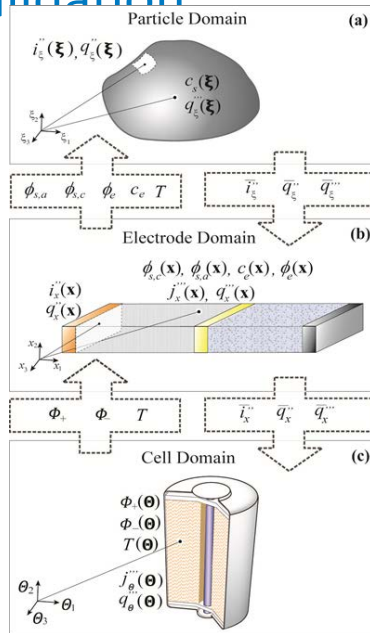

**MSMD**

**MSMD vs GH-MSMD**

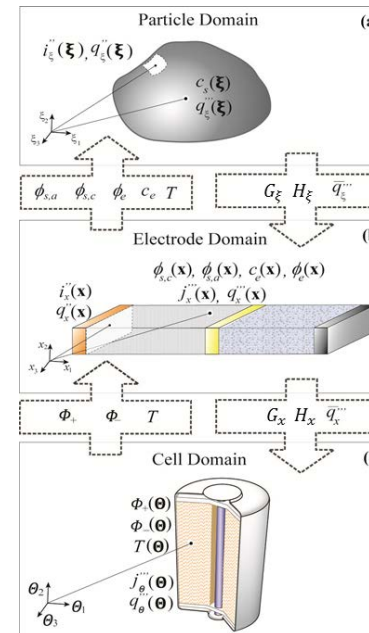

**GH-MSMD**

The diagrams above summarize the model solution variables in each computational domain and the coupling variables exchanged between the adjacent length scale domains in MSMD (left) and in GH-MSMD (right). Even though the solution algorithms are significantly different between the two, the model structures are similar. This comparison signifies the modularity of model framework that the GH-MSMD inherited from the MSMD.

# Benchmark Result of GH-MSMD Implementation

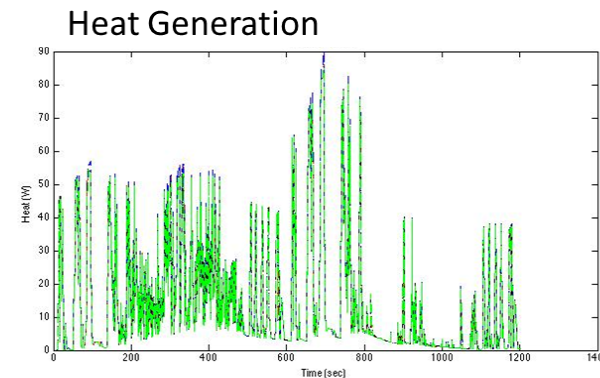
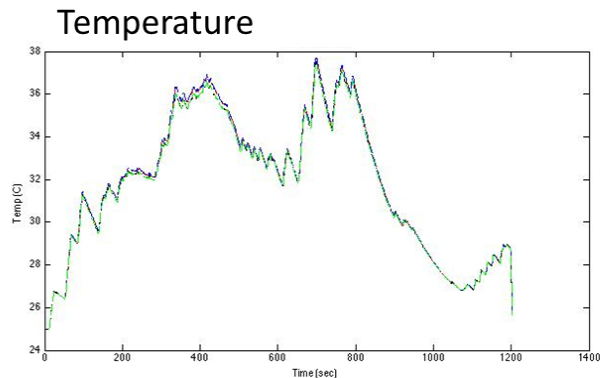
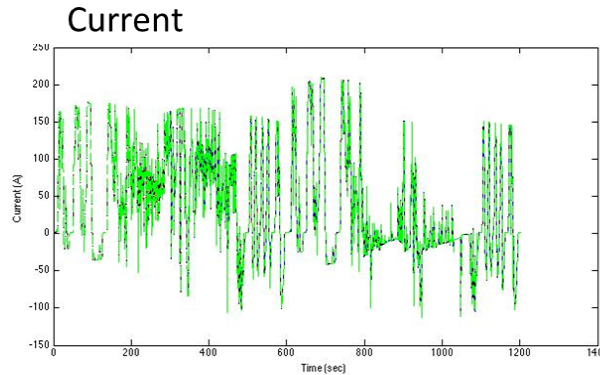
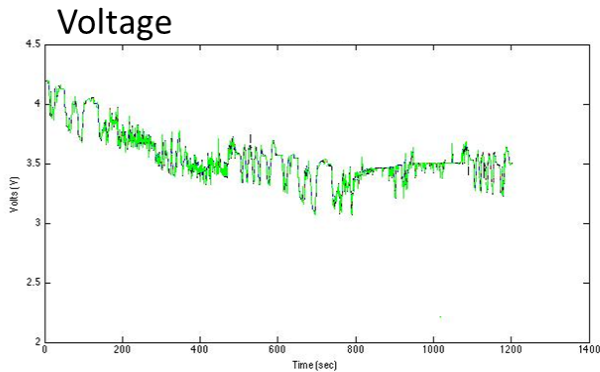

**PHEV10, US06  
Mid-size Sedan  
20 min (1,200 sec) Drive**

Model	Time [sec]
GH-MSMD Ed-LPD	0.74
GH-MSMD Ed-PLM	6.48
MSMD Segregated	654

Figures above present the comparison of electrical and thermal response of a battery for mid-size sedan plug-in hybrid electric vehicle (PHEV10) US06 20 minutes driving power profile from the GH-MSMD and the original MSMD. The model outputs are shown very close to each other. The most efficient GH-MSMD model option runs the 1,200-second simulation only in 0.74 seconds using a personal computer, while the original MSMD runs the same case in 654 seconds.

- A 100~1,000 fold speed up was demonstrated while maintaining solution accuracy.
- Submitted a manuscript (titled *Efficient and Extensible Quasi-Explicit Modular Nonlinear Multiscale Battery Model: GH-MSMD*) to Journal of Power Sources
- Continued development of standard procedure for MSMD/GH-MSMD model parameter identification

# Model Parameter Identification

## *Intrinsically Under-determined Problem*

- Thermodynamic properties
- Kinetics characteristics
- Ion transport characteristics
- Electrical characteristics
- Particle geometry/morphology

- Pore structure characteristics
- Transport limitation in electrolyte
- Ionic conductance
- Electronic conductance in matrices
- N-P balance
- Functional additive effects

- Thermal mass and conductance
- Electrode terminals and current collectors
- Performance evaluation
- Safety evaluation
- Life evaluation

Material Preparation

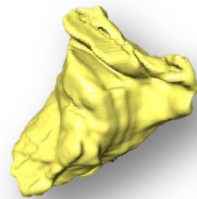

Sample



Design & Process

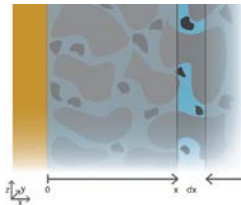

Sample



Prototype

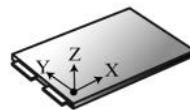

Characterization

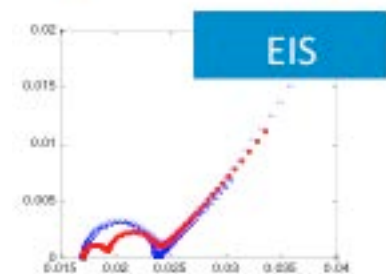
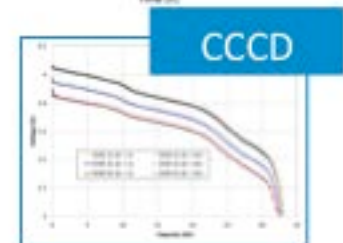
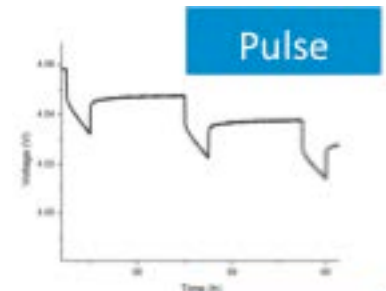

# Challenges: Inconsistency

Diffusivity: GITT vs LS-GITT

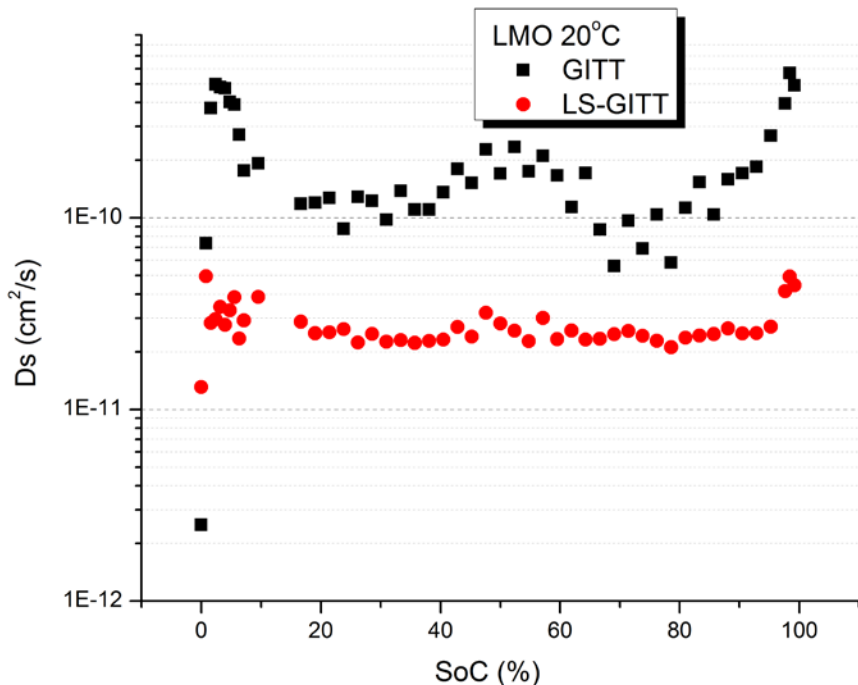

*It is shown that two conventional methods (using different models) yield different **diffusivity** values from an identical experimental data set.*

- Physics-based models are constructed on governing equations describing physicochemical processes in a battery, and require related material properties and design parameters as model inputs.
- On the other hand, standard characterization tests such as GITT and EIS use certain models while acquiring physicochemical properties of battery components.
- Unfortunately, these procedures have been decoupled in practice.

## [APPROCH] Advanced Model-based Battery System Characterization

- Model-based optimization procedures that have been highly desired by battery industry, but limited by the lack of a fully-adaptive, fast-running, high-fidelity, flexible battery model.
- NREL brings high fidelity fast-running models directly into battery system characterization step.

# Approaches : 5 Sub-Tasks

1.1. ***Enhance Baseline Model Capabilities***: GH-baseline models were successfully developed and implemented both in MATLAB and C++ platform. We found that major enhancement of these models are required for better use in application for advanced model-based battery characterization. This subtask includes improving PDM particle network model and enhancing CDM sparse-matrix treatment.

1.2. ***Develop Frequency Domain GH-MSMD Framework***: EIS is one of the frequently used experimental methods for battery characterization and diagnostics. Since the current GH-MSMD has been developed in time-domain, it is difficult to utilize the information produced in frequency domain. In this subtask, frequency-domain GH-MSMD will be developed from the governing equations used in time-domain model, running with the identical model input files.

1.3. ***Develop Physics-based Constituent Models for Design Evaluation and Performance Evolution***: The purely predictive models will only require material characteristics, design parameters, and process parameters to predict the performance and the life of a battery before it is actually made. To meet the eventual goal providing such models, we will develop proper GH-constituent models capturing physicochemical processes.



# Future Work for Task 1

- Enhance Baseline Model Capabilities
- Develop Frequency Domain GH-MSMD Framework
- Develop Physics-based Constituent Models for Design Evaluation and Performance Evolution
- *GH-MSMD Documentation for Battery Community*
- *Fabrication and Characterization*

# Task 2 – Mechanical-ECT Coupling

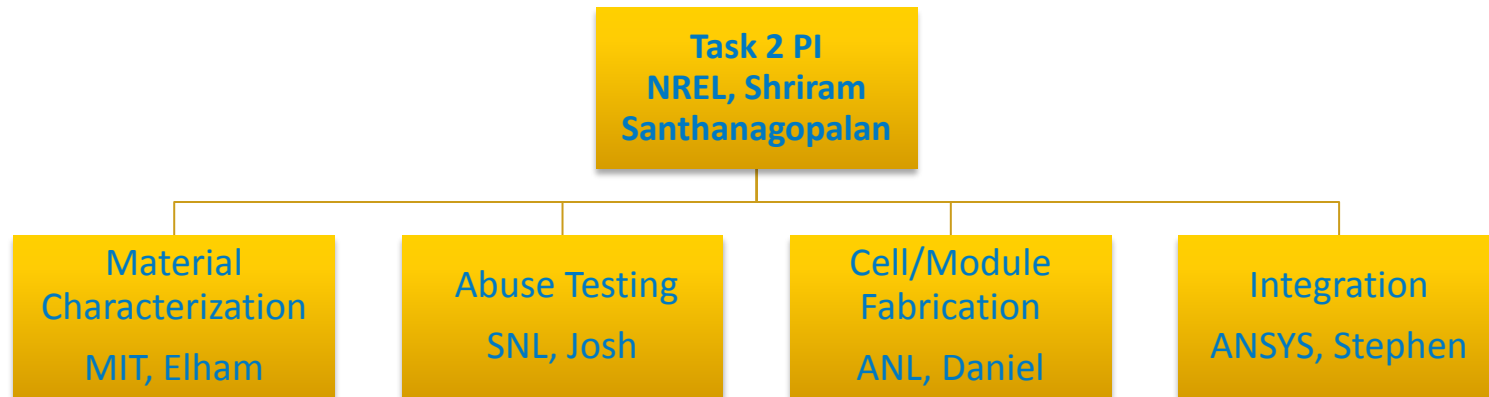

- The main objective of this effort is to develop a physically accurate mechanical-electrochemical-thermal modeling approach to simulate the interplay of mechanical crush with thermal and electrochemical responses of the battery under various abuse scenario.
- To accomplish this, we will expand the unique approach developed in CAEBAT-2 to enable simultaneously coupling of mechanical-electrochemical-thermal behaviors, and accurate modeling of mechanical failure events.
- We will build cell-level models for a subsequent milestone and are collaborating with MIT and SNL to obtain test data to characterize the model parameters as well as to validate cell-level predictions from these models.

# Technical Accomplishment - Task 2

- Developed a material model for simultaneously modeling of mechanical-electrochemical-thermal behavior
- Predicted the electrical short, voltage drop and thermal runaway behaviors followed by a mechanical abuse induced short
- Studied the effect of short resistance on the battery cell performance
- Demonstrating the applicability of the developed model for full pouch cell abuse simulation
- Received first round of data from SNL on abuse test of battery module
- Implementing ABDT tool into standard ANSYS System in Workbench

## Milestone: Identify an Approach to Simultaneously Link Crush Simulations to ECT

- This Milestone was completed in March 2016 showing some initial results on a model geometry. The results indicate a “Go” on this milestone.

# NREL Multi-scale Simultaneously Coupled MECT Model

Macro-scale 3D homogenized mechanical-thermal model

Meso-scale quasi-3D mechanical-thermal model

Pseudo 2D electrochemical-thermal model

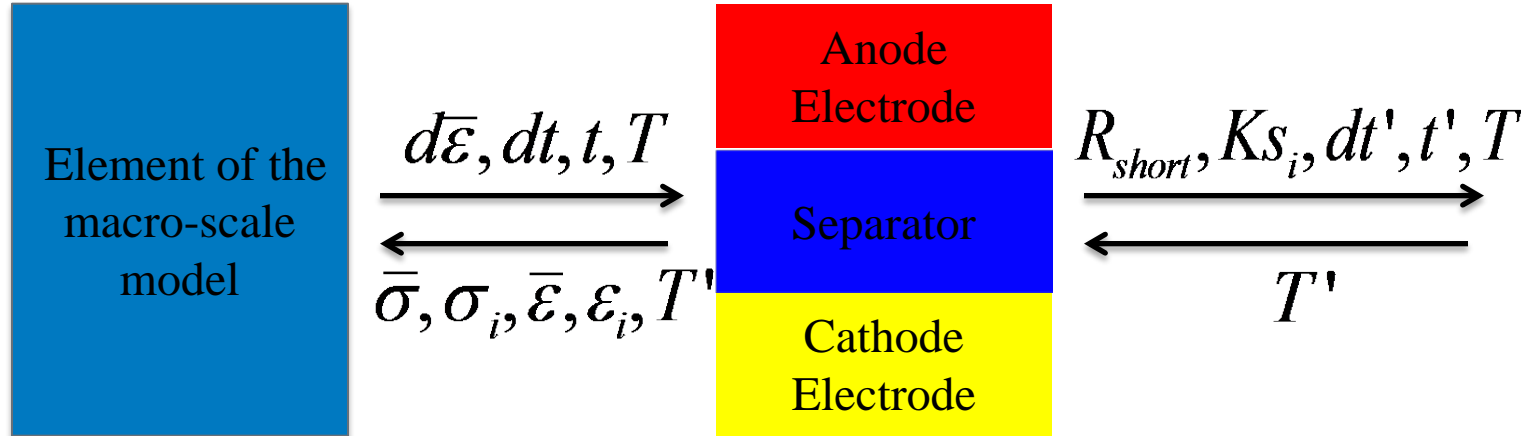

- Short Resistance ( $\Omega \cdot m^3$ )

Different type of shorts can be distinguished by the short area for the different failure modes of separator layer, e.g. tensile failure or shear failure.

$$R_{short} = A_{short} \sum \frac{1}{\kappa_s^{(i)}}$$

- Temperature

Temperature is assumed to be uniform across each LSDYNA macro element. And the temperature rise is calculated based on the generation of joule heating energy and electrochemical reaction heats.

# NREL Single-Element Demonstration of MECT Model

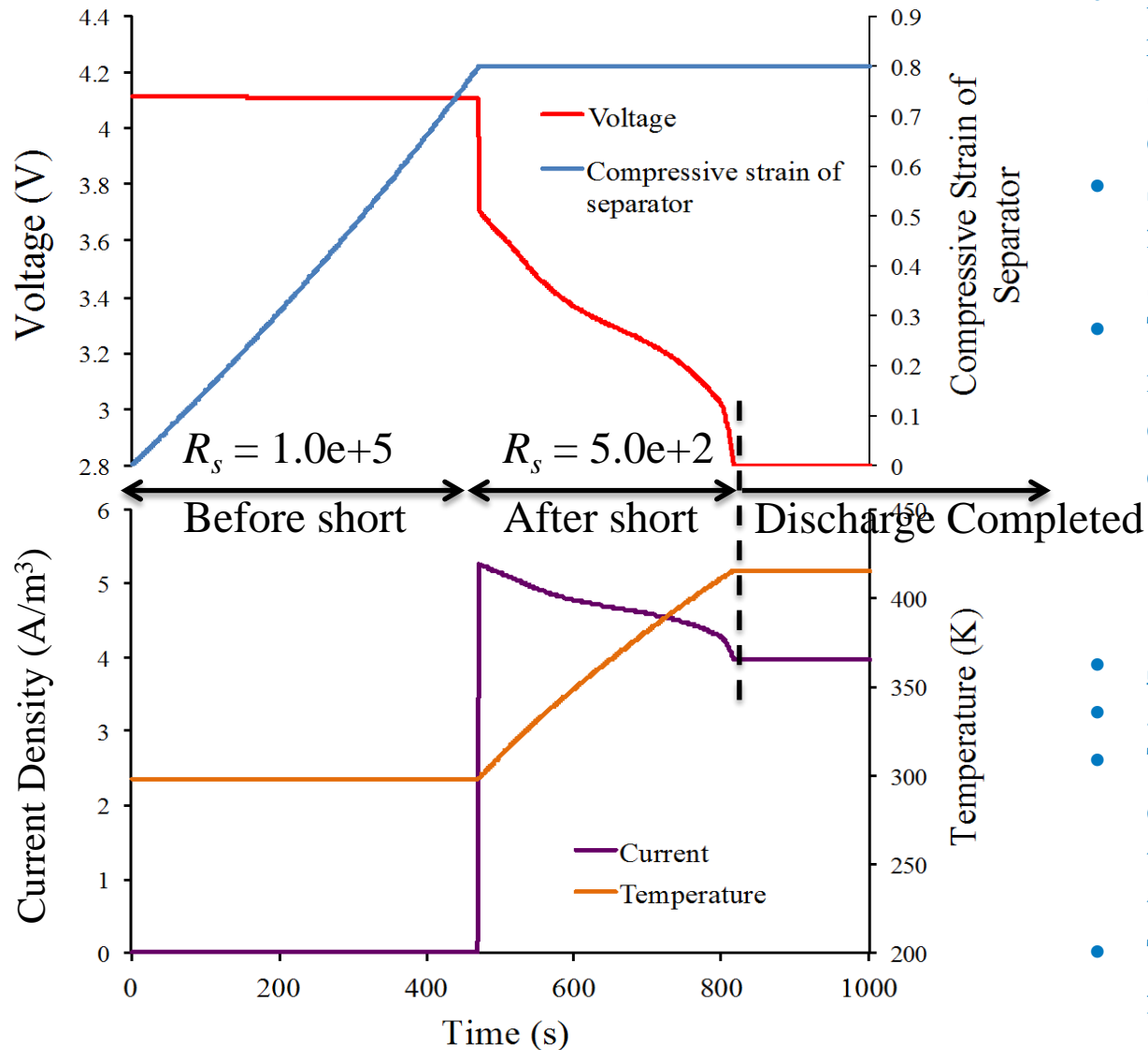

- Linear elastic mechanical response for electrodes and separator were used for demonstration purposes.
- Strain based failure criteria for separator was used to simulate short-circuit.
- The current shows an instant increase and then starts drop due to the decrease in the cell voltage.

- Simulation Conditions:
- 5 Ah LiCoO<sub>2</sub>/graphite cell
- The cell voltage of fully discharged is set to 2.8V and the battery model stops after that.
- The model uses 2 minutes for 10<sup>6</sup> time steps.

# NREL Numerical Study on the Effect of Short Resistance

- The developed MECT model is further utilized here to investigate the effect of short resistance on the battery cell performance

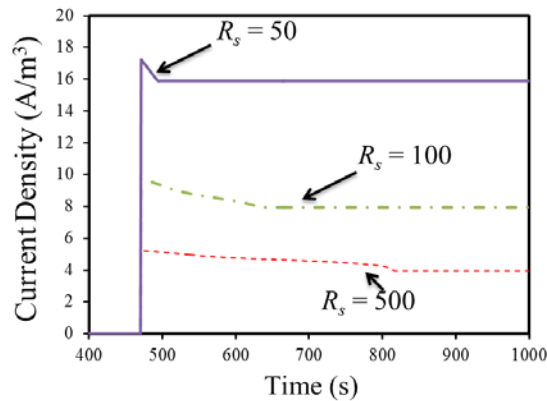

Current Profile

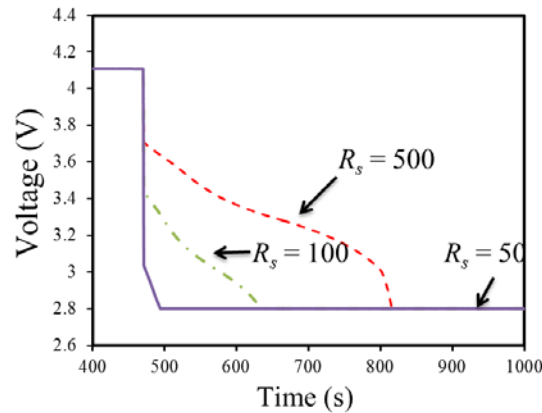

Voltage Profile

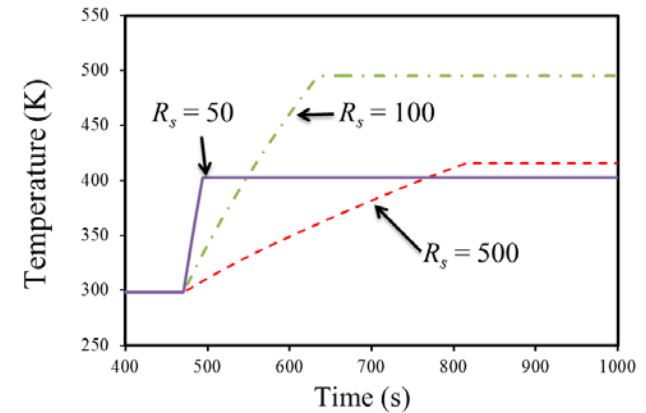

Temperature Profile

- The model captures the effect of short circuit resistance on the subsequent electrical response.
- With the decrease of short circuit resistance, the instantaneous increase of current and voltage drop increases, the discharging completes in a much quicker manner.
- The temperature profile is consistent with the voltage/current evolution profiles, a lower short-circuit resistance does not always produce a higher temperature: there are trade-offs between the cell's energy content, how fast it can be dissipated as heat in the electrochemical models versus heat transfer rates away from the point of generation.

# ANSYS Integration of Mechanical - ECT Coupling

- ANSYS implementing the developed MECT model in ANSYS products, providing technical supports on the coupling method

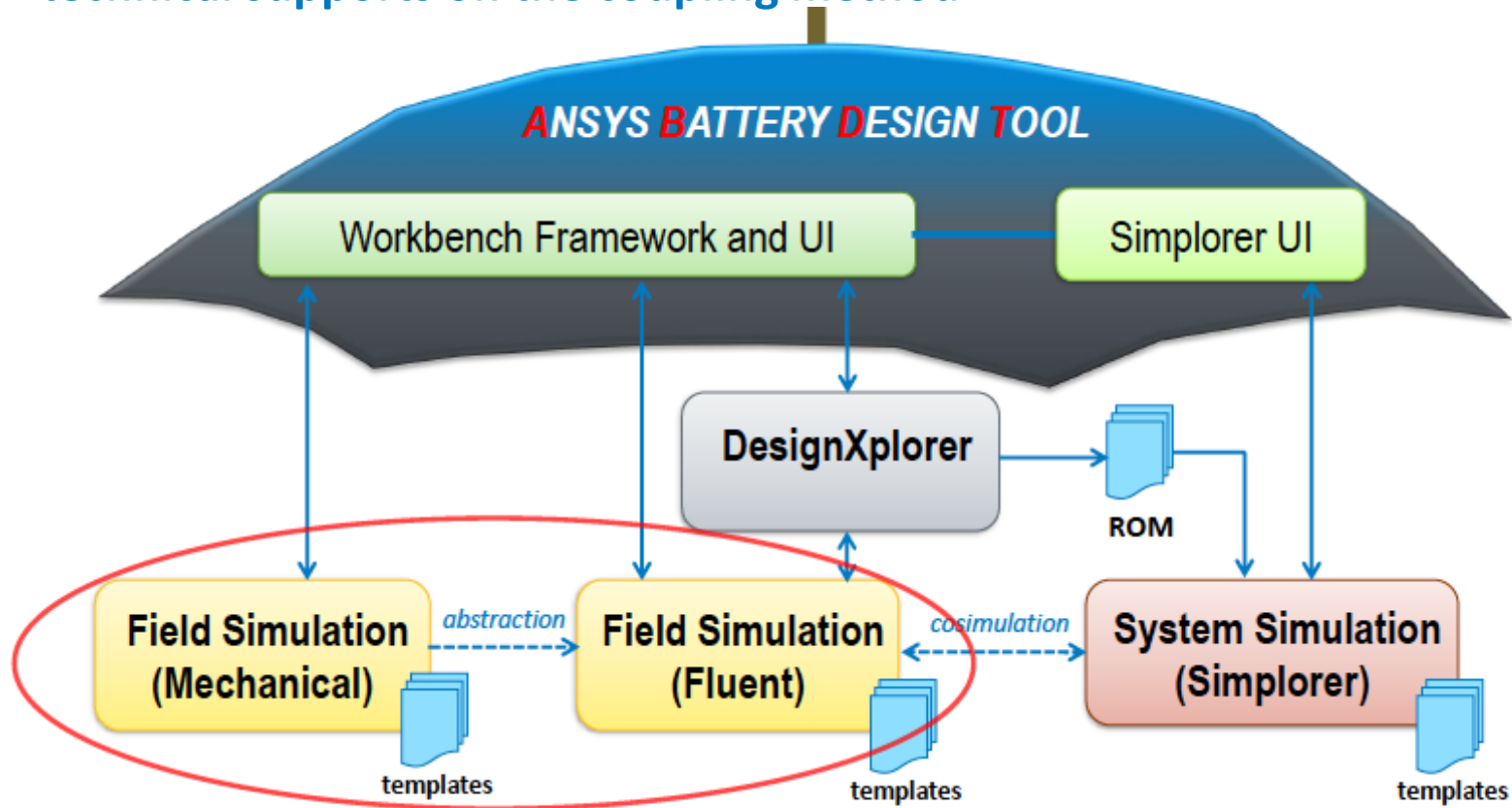

- Convenient “vertical app” around standard ANSYS products
- Plug-and-play with other products via open-standard interfaces

# MIT Mechanical Characterization

- MIT providing experimental and model inputs, to support the mechanical constitutive and fracture modeling of battery cell components

## Micro testing of collectors

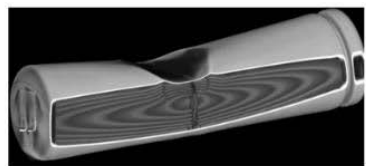
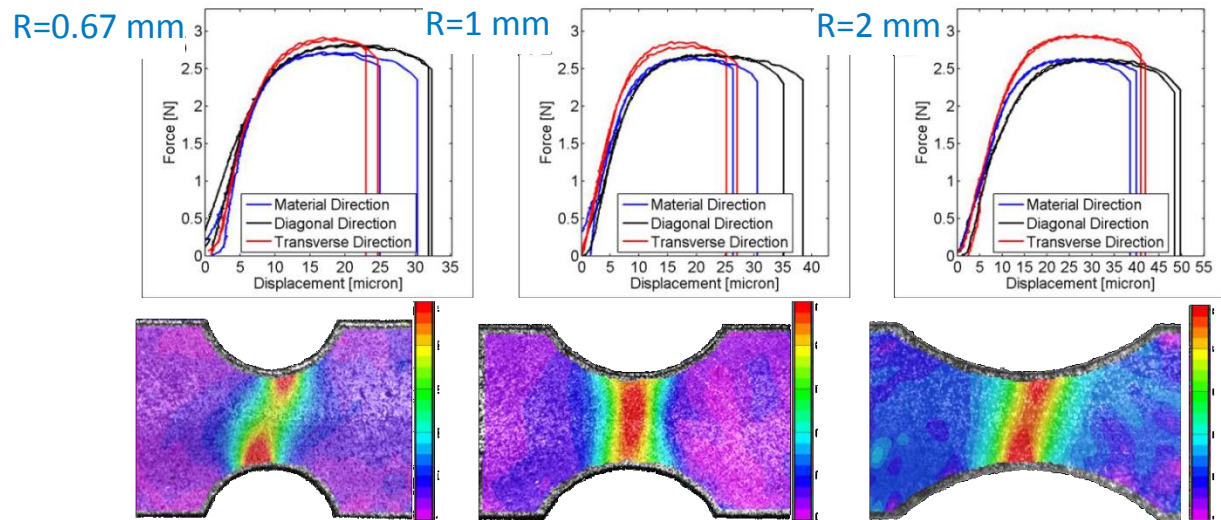
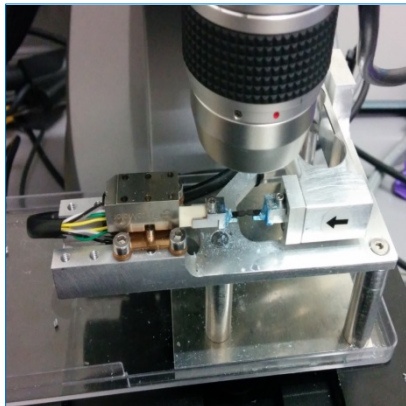

Side View

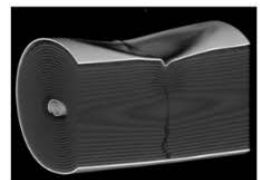

Side View (local/crack location)

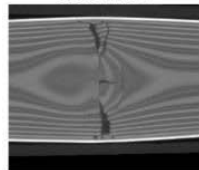

Bottom View (local/crack location)



View of Cross Section

CT images of cell fracture

Fracture modeling

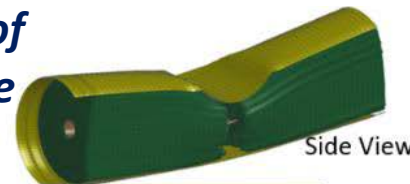

Side View

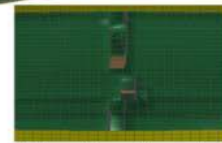

Bottom View (local/crack location)

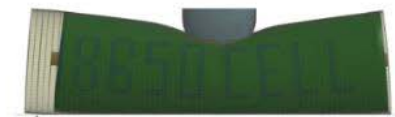

Side View (No Crack)



Top View (Longitudinal Crack)





# SNL Abuse Testing of Batteries

- SNL providing experimental of abuse test of batteries to support MECT model development

## Module Compression

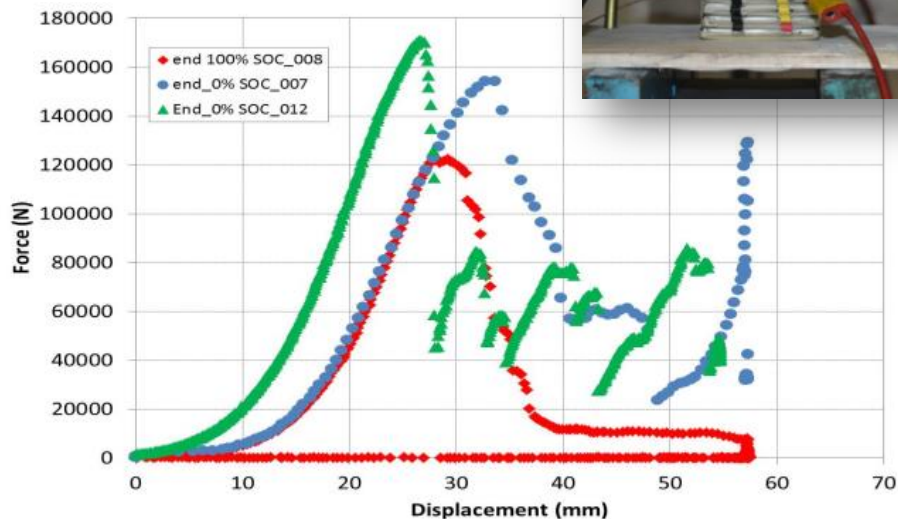

## Analog "pole test"

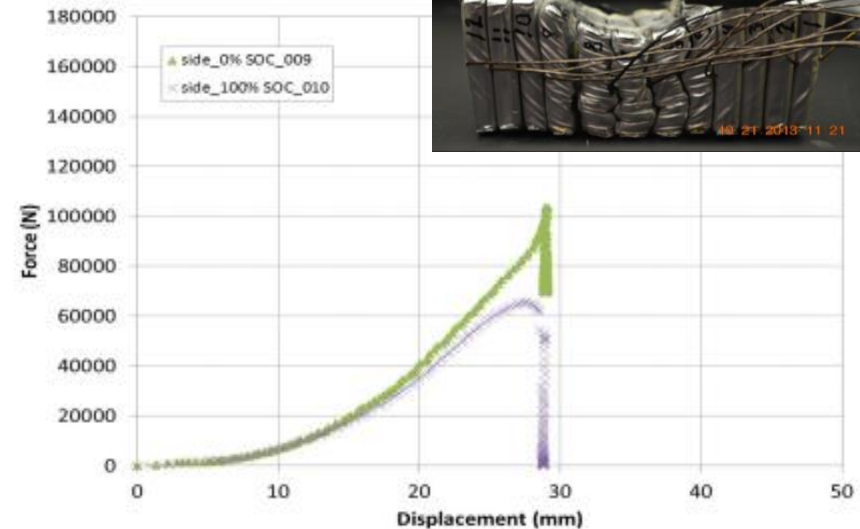

- *Determining coupled failure behavior of batteries during crush/impact testing*
- *Providing module level data support for validation of MECT model*

## CT image of structural failure

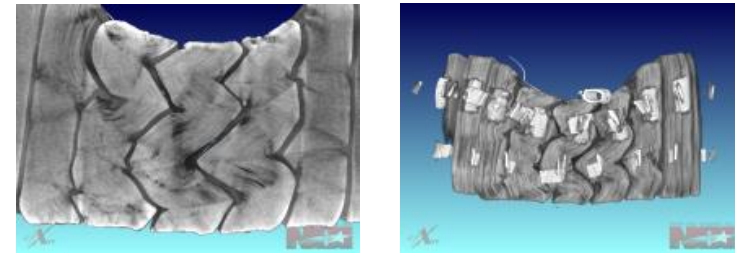

# SNL Abuse Testing Planned

- Single cell end crush – new fixture built for single cell tests
- Failure mode investigation - Crush and CT analysis of charged and discharged packs crushed to predetermined displacement
- Dynamic Testing – drop testing at burn site

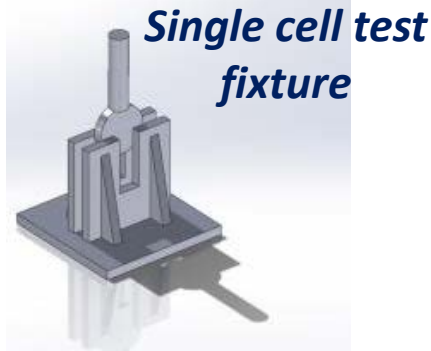

## Single cell test data

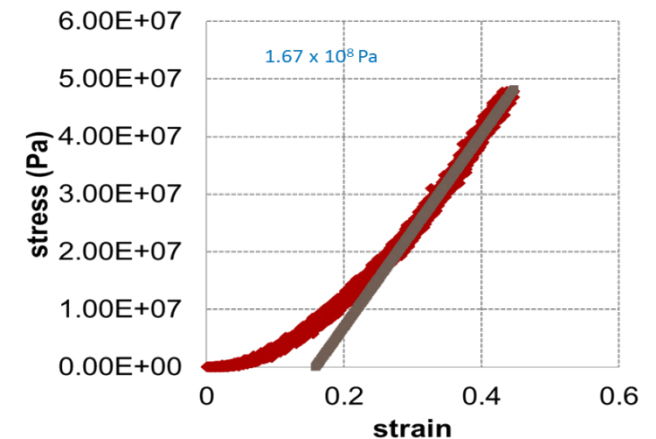
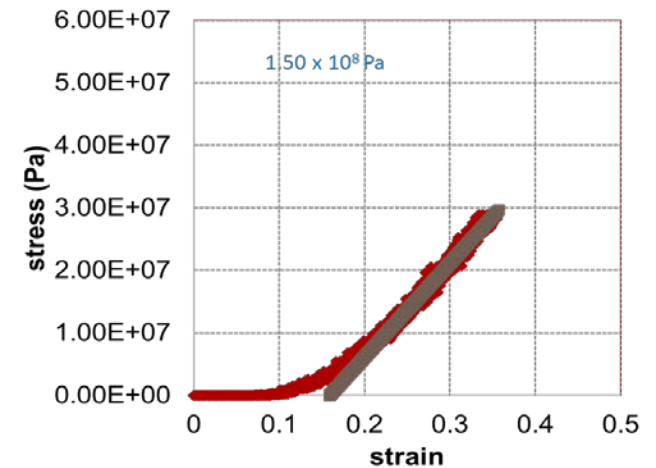

# Future Work – Task 2

- Full cell numerical study using the material model presented in this report.
- Verification compared with existing electrochemical models, for example, ANSYS MSMD model.
- Evolve ABDT into standard Analysis System in Workbench
- Work with MIT on fracture modeling of battery cell components.
- Validation against test data from Sandia.

# Task 3 – Microstructure Modeling

3. *Developing advanced microstructure models* as tools to design battery electrodes through a better understanding of basic physics at the particle and electrode levels. Build upon existing microstructure models. Fabricate and test electrode samples with different characteristics, also obtain tomography images, to build enhanced and validated microstructure models.

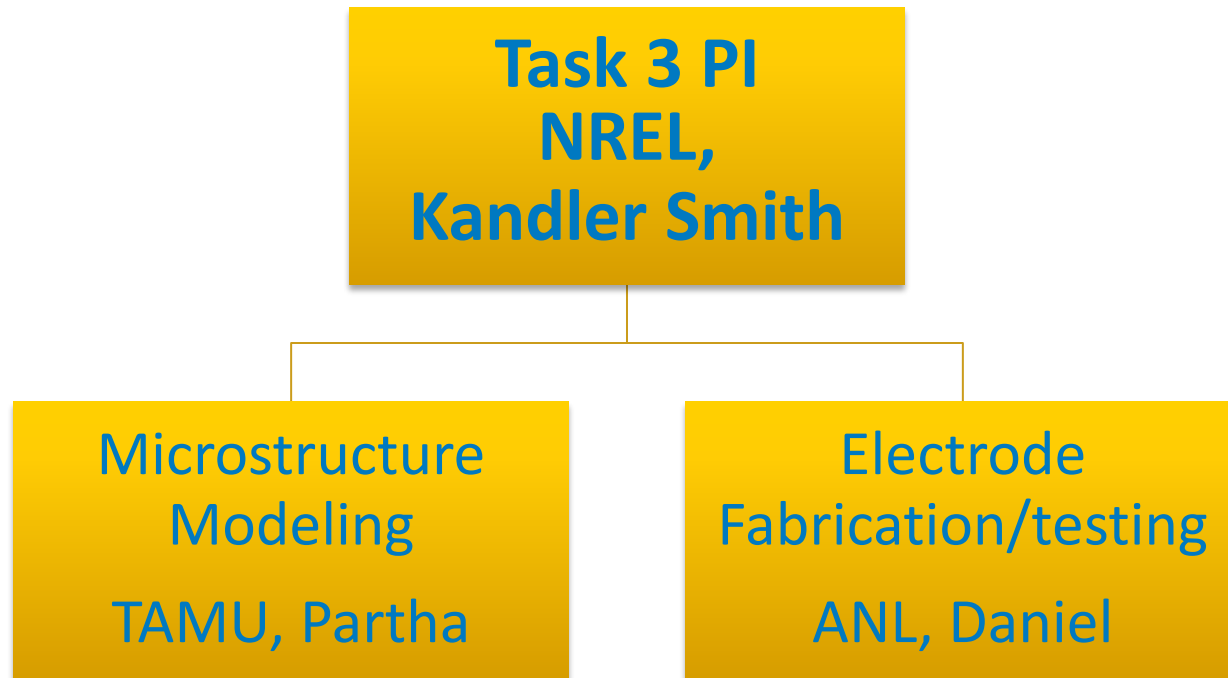

# Overview of 3D Microstructure Modeling

- Create tools to virtually generate realistic microstructure geometries
- Validate virtual geometries using tomography & electron microscopy

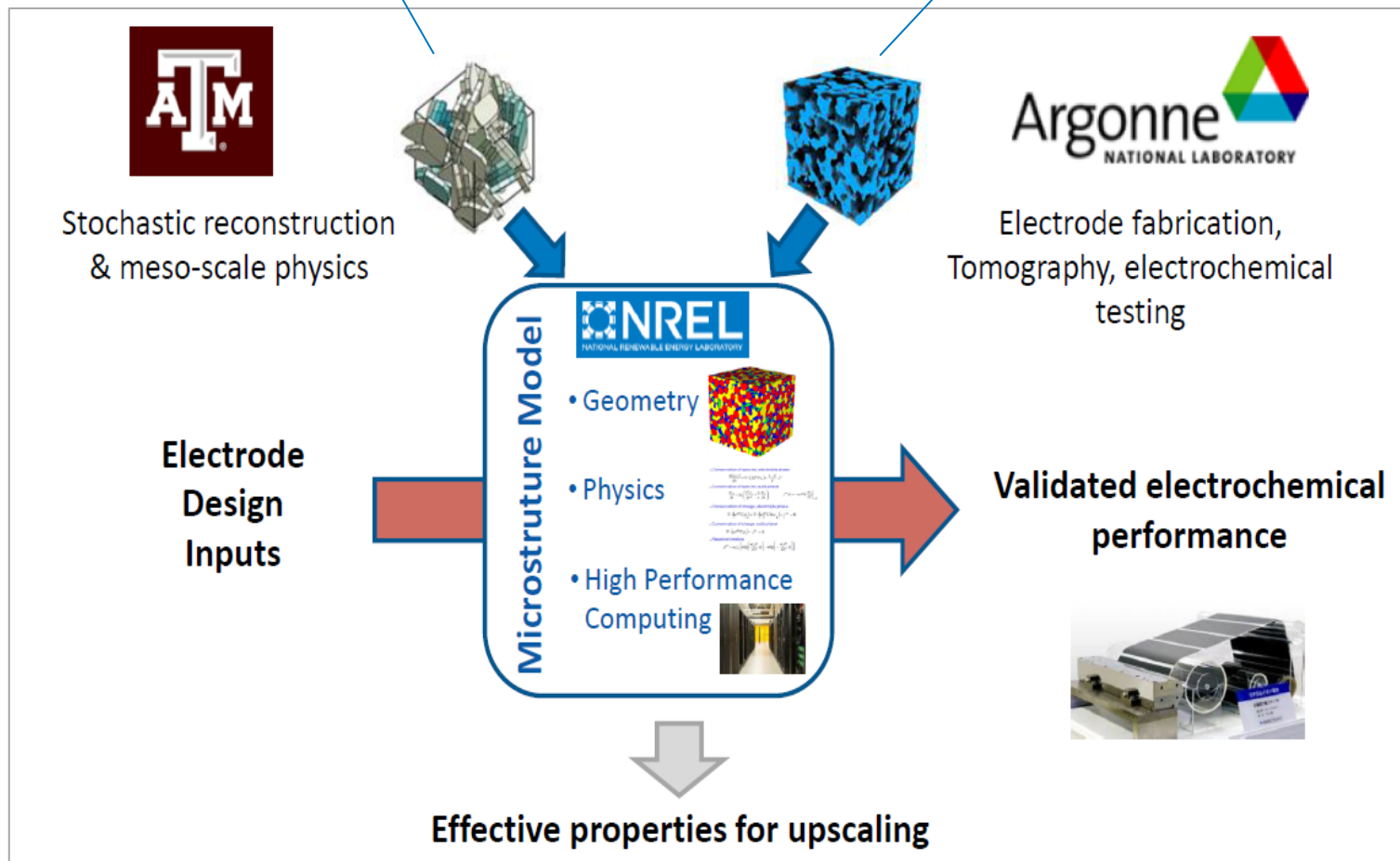

- Bridge to cell and pack CAE toolsets

# Technical Accomplishments – Microstructure

- Defined electrochemical physics of interest for microstructure modeling
- Demonstrated echem simulations on 2D and 3D geometries
- Developed draft experimental test plan with ANL CAMP, complementing ABR programs
- Received first baseline electrode data
- Developing new methodology to automate tomography reconstruction with TAMU
- Prototyping tools for virtual geometry construction with TAMU

# Argonne National Lab Experimental Validation

- ANL providing model inputs (recipe), experimental samples, electrochemical and tomographic measurements
- Initial focus: NMC532/graphite from ABR program
  - Leverage baseline electrochemical datasets already available
- 3 year validation study to include electrode design variants
  - Multiple loading & calendaring conditions for validating microstructure models at several electrode thicknesses & porosities
  - Provides opportunity to explore performance & degradation physics documented from previous ANL-ABR studies and apply knowledge in future design tools

NMC532

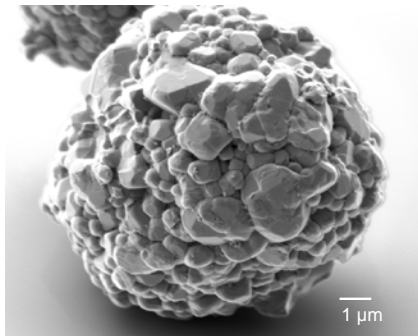

Graphite

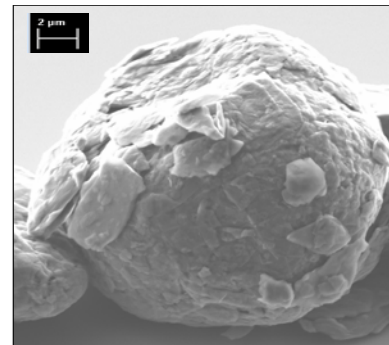

SEM images courtesy of Daniel Abraham & Andy Jansen, ANL CAMP facility

# Texas A&M Geometry Stochastic Reconstruction

Two paths:

1) Image-based, supporting experimental validation



3D simulation  
Validation  
Physics exploration

2) Virtual path, supporting computer-aided design without need for prototype

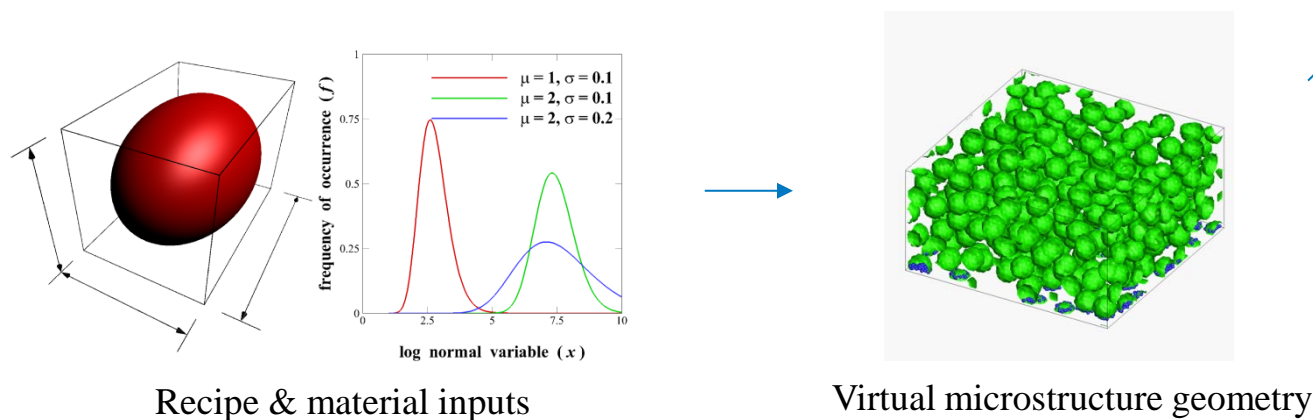



# NREL Electrochemical Simulation Tool Development

Same code solves both 2D and 3D cases  
Scalable for high performance computing,  
3D domains and meshes

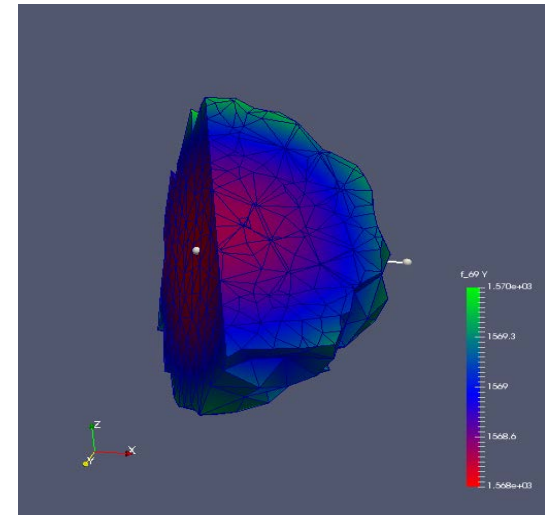
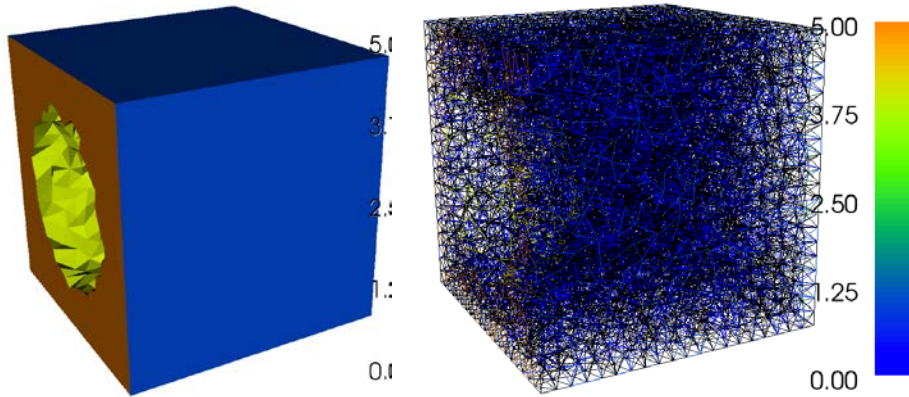

Concentration profile  
Inside solid particle

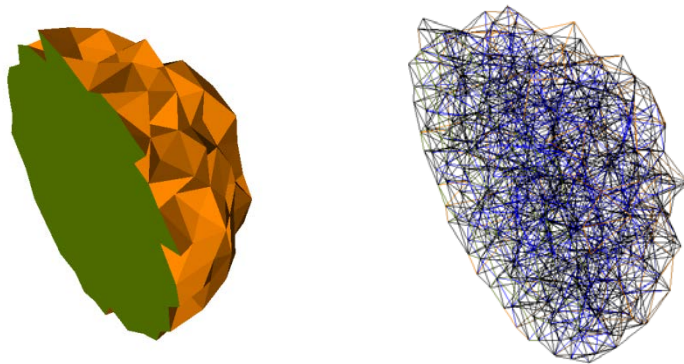

(About 11K degrees of freedom.  
About 10 sec/time step on one core.)

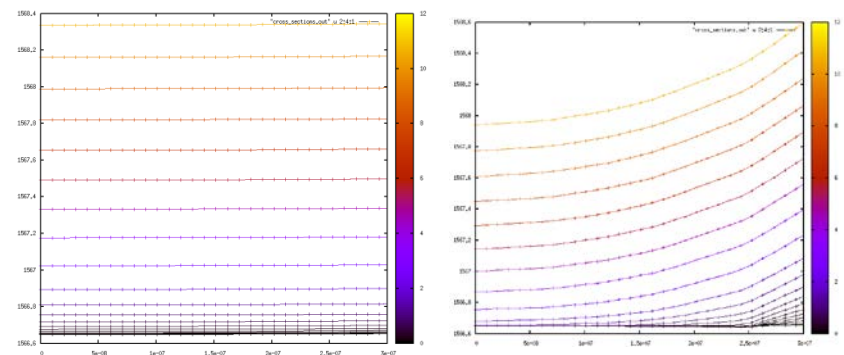

Response to change  
in solid phase diffusivity

# Future Work for Task 3

- Tomographic characterization of baseline electrode geometry
- Electrochemical simulation of baseline electrode microstructure
  - Virtual reconstructed geometry
  - Tomographic reconstructed geometry
- Model enhancements based on baseline electrode model validation study
- Modeling and validation for thick electrode design variants

# Responses to Previous Year Reviewers' Comments

New Project in FY16 so not reviewed last AMR.

# Collaborators and Partners

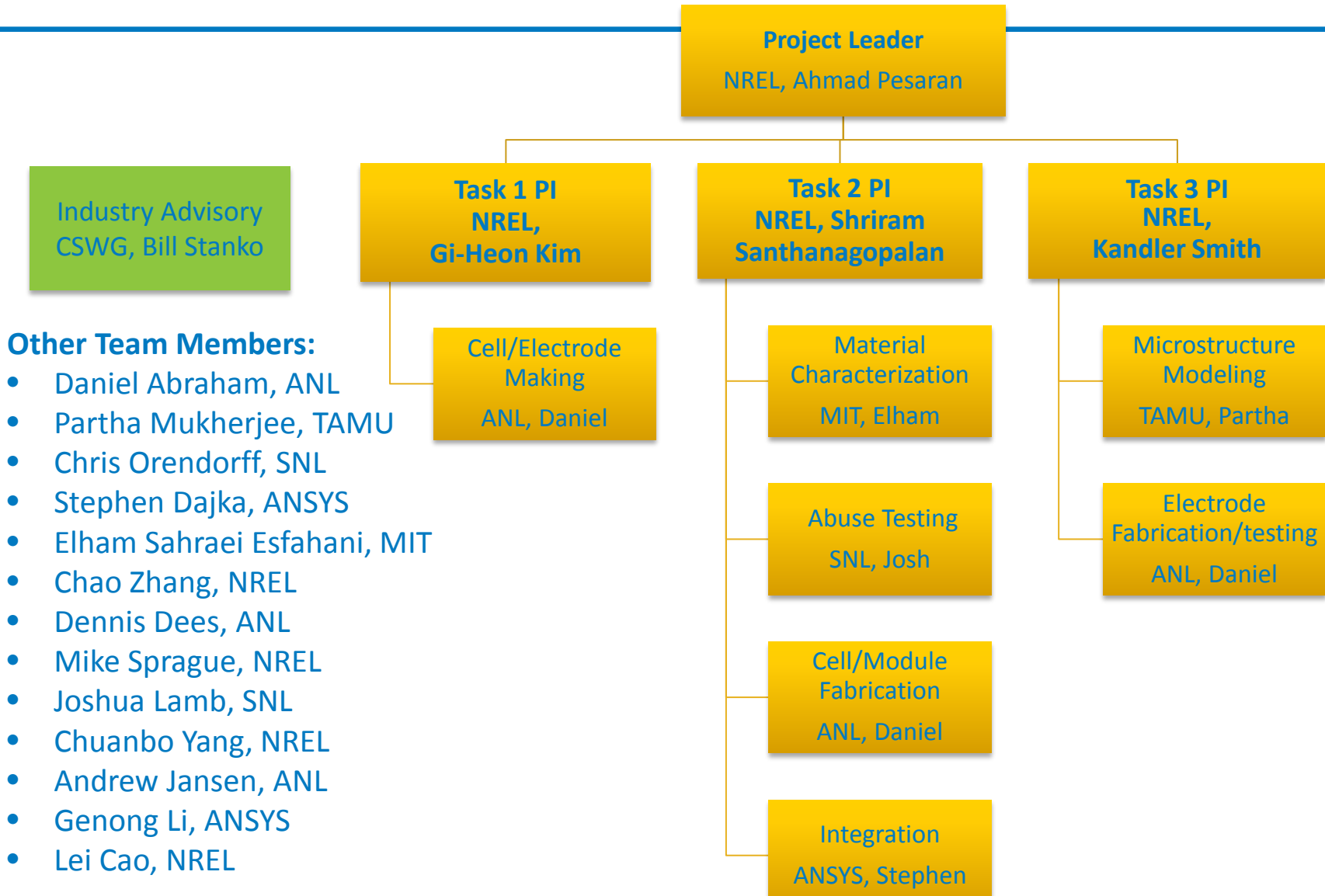

# Summary

- **Task 1. New GH-MSMD provides 100-1000x computation speed-up in battery electrochemical/thermal simulation**
  - Retains modularity of particle, electrode, cell, pack domains
  - Journal article in preparation
  - Speed enables direct full model use in parameter identification
- **Task 2. Simultaneously coupled mechanical-electrochemical-thermal model for mechanical abuse simulation**
  - Enables simultaneous modeling of electrochemical reactions during the short, when necessary
  - Studies the interactions between mechanical failure and battery cell performance
  - Improves the flexibility of the model for various batteries structures and loading conditions
  - Model validation is ongoing to compare with test data from SNL
  - Established ADBT tool in ANSYS
- **Task 3. Microstructural modeling to enhance next gen. electrode designs**
  - 3 year project to validate models for variety of electrodes complementing Advanced Battery Research programs
  - Prototype tools have been developed for echem simulation and geometric reconstruction

# Acknowledgements

- We appreciate support and funding provided by Vehicle Technologies Office at the U.S. Department of Energy
  - Brian Cunningham
  - David Howell

# Technical Back-Up Slides

# NREL MECT Model Mechanical Homogenization

- This example uses linear elastic models for illustrative purposes; but the model can easily accommodate user-defined constitutive models for the mechanical response.
- A generic micro-mechanical model for homogenization of the different layers was introduced to improve computational efficiency of the coupling scheme.
- The constitutive equations when re-organized in specific ways enable easier interpretation of experimentally measurable responses such as in-plane and through-plane stresses.

## Constitutive equations

$$\sigma_{ij} = C_{ijkl} \epsilon_{kl}$$

## Re-organization of matrix components

$$\begin{Bmatrix} \sigma_{11} \\ \sigma_{22} \\ \sigma_{12} \\ \sigma_{33} \\ \sigma_{23} \\ \sigma_{13} \end{Bmatrix} = \begin{bmatrix} C_{11} & C_{12} & C_{16} & C_{13} & C_{14} & C_{15} \\ C_{12} & C_{22} & C_{26} & C_{23} & C_{24} & C_{25} \\ C_{16} & C_{26} & C_{66} & C_{36} & C_{46} & C_{56} \\ C_{13} & C_{23} & C_{36} & C_{33} & C_{34} & C_{35} \\ C_{14} & C_{24} & C_{46} & C_{34} & C_{44} & C_{45} \\ C_{15} & C_{25} & C_{56} & C_{35} & C_{45} & C_{55} \end{bmatrix} \begin{Bmatrix} \epsilon_{11} \\ \epsilon_{22} \\ \epsilon_{12} \\ \epsilon_{33} \\ \epsilon_{23} \\ \epsilon_{13} \end{Bmatrix}$$
  

$$\begin{Bmatrix} \sigma_{=} \\ \sigma_{\perp} \end{Bmatrix} = \begin{bmatrix} C_{=} & C_{\times}^T \\ C_{\times} & C_{\perp} \end{bmatrix} \begin{Bmatrix} \epsilon_{=} \\ \epsilon_{\perp} \end{Bmatrix}$$

Zhang, Chao et al. IJES 2015



# NREL MECT Model Mechanical Homogenization

## Macro-meso mechanical homogenization method

- Given that the thickness of the different layers is several orders of magnitude smaller than the in-plane dimensions, we have the following assumptions for building the effective stress/strain relationships:

$$\bar{\boldsymbol{\varepsilon}}_{\perp} = \boldsymbol{\varepsilon}_{\perp}^{(1)} = \boldsymbol{\varepsilon}_{\perp}^{(2)} = \dots = \boldsymbol{\varepsilon}_{\perp}^{(N)} \quad \bar{\boldsymbol{\sigma}}_{\perp} = \boldsymbol{\sigma}_{\perp}^{(1)} = \boldsymbol{\sigma}_{\perp}^{(2)} = \dots = \boldsymbol{\sigma}_{\perp}^{(N)}$$

$$\bar{\boldsymbol{\varepsilon}}_{\perp} = \boldsymbol{\nu}^{(1)} \boldsymbol{\varepsilon}_{\perp}^{(1)} + \boldsymbol{\nu}^{(2)} \boldsymbol{\varepsilon}_{\perp}^{(2)} + \dots + \boldsymbol{\nu}^{(N)} \boldsymbol{\varepsilon}_{\perp}^{(N)}$$

$$\bar{\boldsymbol{\sigma}}_{\perp} = \boldsymbol{\nu}^{(1)} \boldsymbol{\sigma}_{\perp}^{(1)} + \boldsymbol{\nu}^{(2)} \boldsymbol{\sigma}_{\perp}^{(2)} + \dots + \boldsymbol{\nu}^{(N)} \boldsymbol{\sigma}_{\perp}^{(N)}$$

- Regrouping the terms as discussed in the previous slide provides explicit expressions for the effective stiffness of the cell-sandwich, from properties of individual components (e.g. separator, anode and cathode).

$$\bar{\mathbf{C}}_{\perp} = \left[ \sum_{i=1}^N \boldsymbol{\nu}^{(i)} (\mathbf{C}_{\perp}^{(i)})^{-1} \right]^{-1} \quad \bar{\mathbf{C}}_{\times}^T = \left[ \sum_{i=1}^N \boldsymbol{\nu}^{(i)} \mathbf{C}_{\times}^{(i)T} (\mathbf{C}_{\perp}^{(i)})^{-1} \right]^{-1} \bar{\mathbf{C}}_{\perp}$$

$$\bar{\mathbf{C}}_{\times} = \bar{\mathbf{C}}_{\perp} \left[ \sum_{i=1}^N \boldsymbol{\nu}^{(i)} (\mathbf{C}_{\perp}^{(i)})^{-1} \mathbf{C}_{\times}^{(i)} \right] \quad \bar{\mathbf{C}}_{=} = \sum_{i=1}^N \boldsymbol{\nu}^{(i)} \mathbf{C}_{=} + \sum_{i=1}^N \boldsymbol{\nu}^{(i)} \mathbf{C}_{\times}^{(i)T} (\mathbf{C}_{\perp}^{(i)})^{-1} (\bar{\mathbf{C}}_{\times} - \mathbf{C}_{\times}^{(i)})$$

# NREL MECT Model Verification of Mechanical Homogenization

- Numerical comparison of the full-scale multi-layer model against the efficient macro-meso mechanical homogenization models capture the mechanical response under in-plane tension (main failure mode of cell components) accurately.

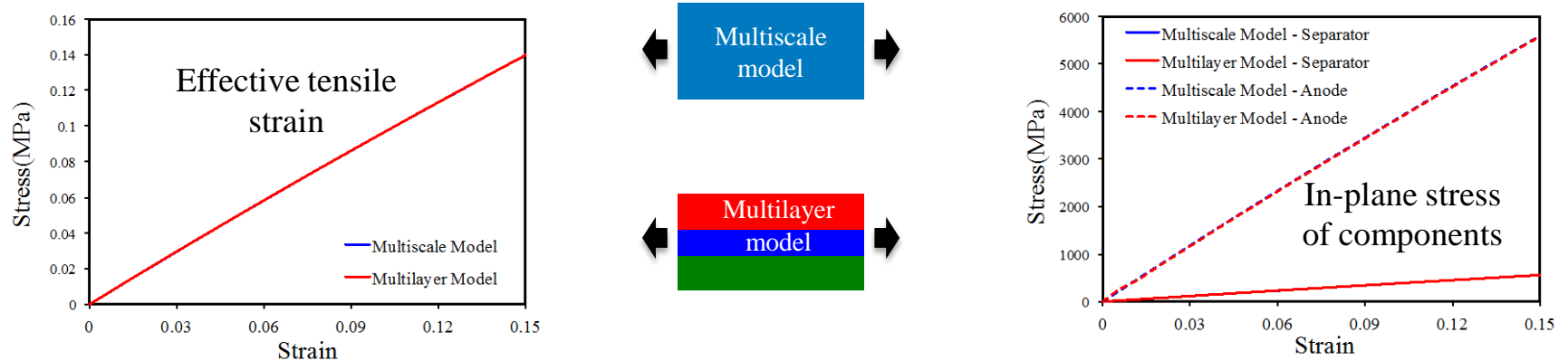

- Other failure modes such as through-thickness compression show the need for more sophisticated mixing rules beyond the linear combination of component properties used in this version.

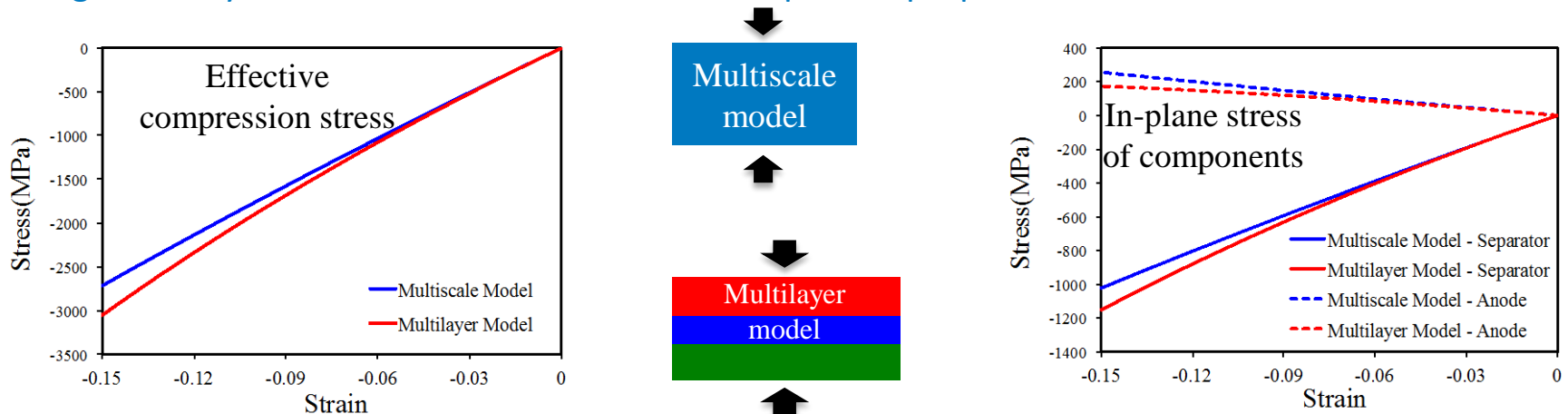

# NREL MECT Model Electrochemical-Thermal Model

## Pseudo 2D electrochemical-thermal model

- The battery model uses the same set of equations from our previous CAEBAT efforts, building on the Newman model.

### Charge Transfer Kinetics at Reaction Sites

$$j^{Li} = a_s i_o \left\{ \exp\left[\frac{\alpha_a F}{RT} \eta\right] - \exp\left[-\frac{\alpha_c F}{RT} \eta\right] \right\} \quad i_0 = k (c_e)^{\alpha_a} (c_{s,\max} - c_{s,e})^{\alpha_a} (c_{s,e})^{\alpha_c} \quad \eta = (\phi_s - \phi_e) - U$$

### Species Conservation

$$\frac{\partial c_s}{\partial t} = \frac{D_s}{r^2} \frac{\partial}{\partial r} \left( r^2 \frac{\partial c_s}{\partial r} \right) \quad \frac{\partial(\hat{\epsilon}_e c_e)}{\partial t} = \nabla \cdot (D_e^{eff} \nabla c_e) + \frac{1-t_+^0}{F} j^{Li} - \frac{i_e \cdot \nabla t_+^0}{F}$$

### Charge Conservation

$$\nabla \cdot (\hat{\sigma}^{eff} \nabla \phi_s) - j^{Li} = 0 \quad \nabla \cdot (\kappa^{eff} \nabla \phi_e) + \nabla \cdot (\kappa_D^{eff} \nabla \ln c_e) + j^{Li} = 0$$

### Energy Conservation

$$\rho c_p \frac{\partial T}{\partial t} = q \quad q = j^{Li} \left( \phi_s - \phi_e - U + T \frac{\partial U}{\partial T} \right) + \hat{\sigma}^{eff} \nabla \phi_s \cdot \nabla \phi_s + \kappa^{eff} \nabla \phi_e \cdot \nabla \phi_e + \kappa_D^{eff} \nabla \ln c_e \cdot \nabla \phi_e$$

### Short Current

$$i_{short} = \frac{\phi_{1,p}|_{lp} - \phi_{1,n}|_0}{R_{short}}$$

# Appendix

$d\bar{\varepsilon}$  : strain increment

$dt$  : time step

$t$  : time

$T$  : temperature

$T'$  : updated temperature

$\varepsilon_i$  : strain of components

$\sigma_i$  : stress of components

$\bar{\varepsilon}$  : effective strain

$\bar{\sigma}$  : effective stress

$dt'$  : mapped time step for electrochemical model

$t'$  : mapped time for electrochemical model

$R_{short}$  : short resistance

$Ks_i$  : conductivity of cell components