



# Significant Enhancement of Computational Efficiency in Nonlinear Multiscale Battery Model for Computer Aided Engineering



**P.I.: Gi-Heon Kim, ES Modeling Task Lead  
National Renewable Energy Laboratory**

**June 9, 2015**

Lab Lead, Ahmad Pesaran

Kandler Smith, Peter Graf, Myungsoo Jun, Chuanbo Yang: **NREL**

Genong Li, Shaoping Li, Amit Hochman, Dimitrios Tselepidakis: **ANSYS**

Project ID #: ES197

This presentation does not contain any proprietary, confidential, or otherwise restricted information.

# Overview

---

## Timeline

---

- **Start Date:** October 2013
- **End Date:** September 2015
- **Percent Complete:** 75%

## Budget

---

- **Total Project Funding:** \$1,218K
  - DOE Share : \$718K
  - TARDEC Share: \$500K
- **Funding Received in FY13:** \$718K
- **Funding Received in FY14:** \$500K

## Barriers in Battery CAE

---

*CAE accelerates product development cycle, reduce cost and improve performance*

- Limited Multiphysics Integrity
- Wide-varied Time & Length Scales
- Instability Caused by Nonlinearity

## Partners

---

- **ANSYS**
  - Physics Business Unit
  - Electronics Business Unit
- **Project Lead: National Renewable Energy Laboratory (NREL)**

CAE = computer-aided engineering

# Relevance

## Background and Motivation

- Physicochemical processes in lithium-ion batteries occur in intricate geometries over a wide range of time and length scales.
- There have been strong needs in the industry to use predictive physics-based models for design, evaluation, and control of batteries and systems.
- In the pursuit of providing such models, NREL pioneered the Multi-Scale Multi-Domain (MSMD) model, overcoming challenges in modeling the highly nonlinear multi-scale response of battery systems.
- However, further improvement in computational efficiency is greatly desired for practical application of the model to variety engineering problems, while the intrinsic nonlinearity of battery physics is resolved properly.

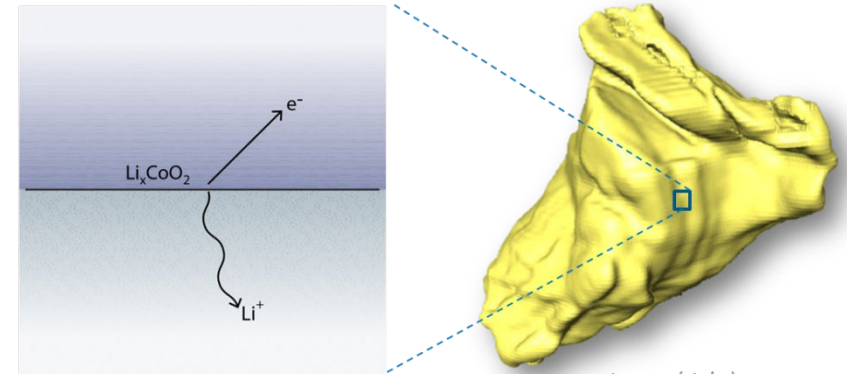

Image (right):  
Wilson et al. 2011, JPS

**Inhomogeneity In Nature:** Local equilibria are significantly separated from system equilibrium during the energy conversion process. Therefore, kinetic response of a battery system is intrinsically inhomogeneous.

# Relevance

## Project Goal

*To improve computation speed of state-of-the-art nonlinear multiscale battery model by a factor of 100 while maintaining its solution accuracy*

## Objectives during the Past Year

- Finalize GH-MSMD framework formulation
- Define GH-constituent model communication protocol
- Identify MSMD baseline sub-models
- Reformulate the baseline models and convert them into GH-constituent models
- Implement GH-MSMD baseline models both in MATLAB and C++ platform
- Perform benchmark test for the GH-MSMD implementation on standard vehicle driving profile
- Develop adaptive reduced order models (ROMs) based on the state variable model (SVM) approach, capturing the dynamic of lithium diffusion and migration and impact on cell response
- Establish an application programming interface (API) to integrate NREL's newly developed model libraries in third party commercial software

**Impact Anticipated** Successful completion of the project is expected to shift the paradigm to using a model for electric-drive vehicle battery system design and evaluation, potentially revolutionizing the standard development process for the entire industry, accelerating the breakthroughs necessary for industry to meet the nation's EV Everywhere Grand Challenge and related targets for the vehicle electrification.

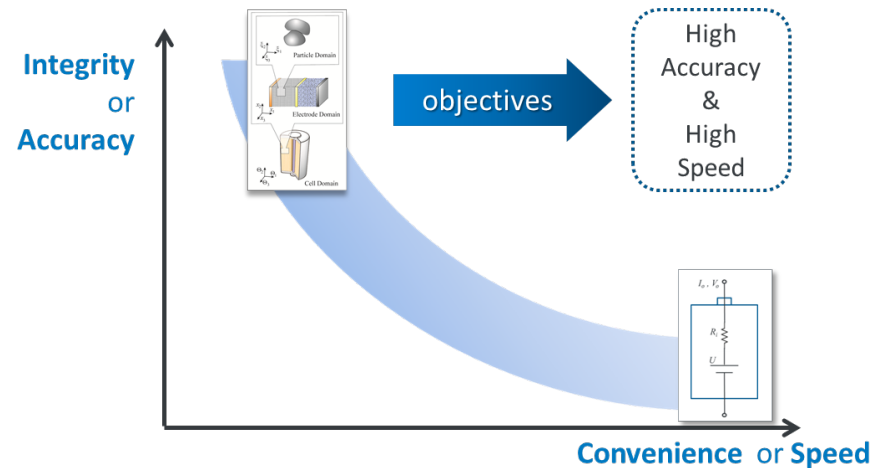

# FY15 Milestones

Month/Year	Description	Status
01/2015	Adaptive ROM Demonstration	met
04/2015	Submission of AMR Presentation	met
08/2015	Model Demonstration Running on ANSYS Platform	on track
09/2015	Annual Milestone Report	on track
Go/No-Go	Achieving 100-fold computation speed	met

# Approach/Strategy

## MSMD Baseline Model Identification

### Particle Domain Model (PDM)

*Discrete Diffusion Particle Model (DDPM) : The model solves solid-phase lithium diffusion dynamics and transfer kinetics in a discrete diffusion particle system. The particles are considered electronically continuous, but ionically discrete. An arbitrary number of quantized discrete particles can be given as a user input. Kinetic, transport, and thermodynamic model parameters of each discrete particle can be independently determined.*

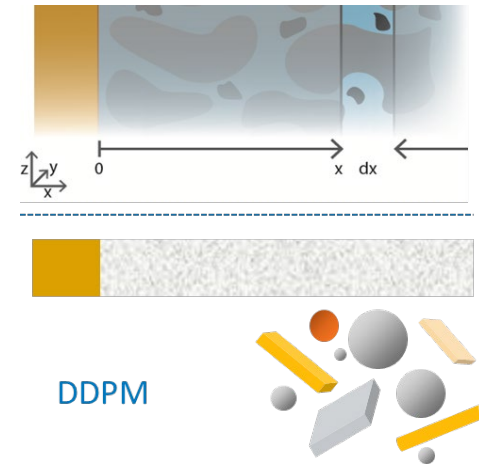

### Electrode Domain Model (EDM)

*1D Porous Electrode Model : The model assumes existence of in-plane ensemble average. Porous media theory is introduced. The ionic, electronic, and species transport properties are modeled with porous media parameters.*

### Cell Domain Model (CDM)

*Single Potential-Pair Continuum (SPPC) Model : The model treats the stratified cell composite as a homogeneous continuum with orthotropic transport properties and resolves temperature and a pair of current collector phase potentials in the volume of the continuum with distinguished in-plane and transverse conductivities for heat diffusion and electrical current conduction.*

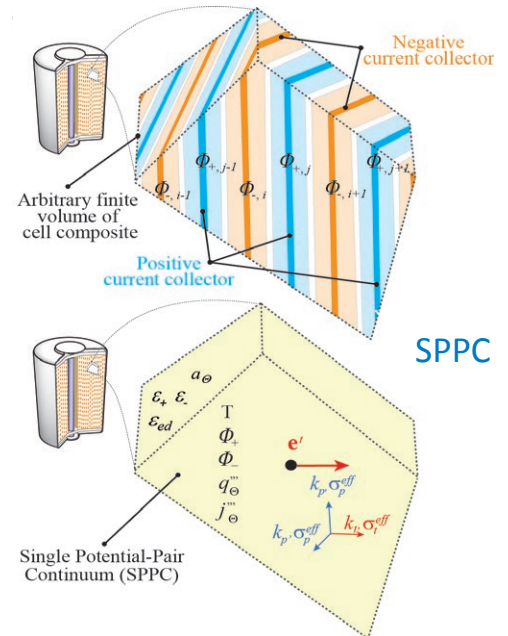

# Approach/Strategy

## Inefficiency Builds up with Inhomogeneity at Each Scale

*PDM Characterization*



**Polarization** caused by kinetic barrier, solid transport limitation, ohmic resistances, and micro-scale inhomogeneity

*EDM Characterization*



+ **Polarization** through electrolyte and composite matrices, and meso-scale inhomogeneity

*CDM Characterization*



+ **Polarization** caused by non-uniform temperature and electric potential fields, and macro-scale inhomogeneity

### [APPROCH] Bottom-Up Sequential Identification

- We suggest a sequential optimization procedure to break the under-determined parameter estimation problem of the whole system into a sequence of fully determined fits to subsets of the parameters.
- This sequential procedure is developed from the fact that the physicochemical processes in batteries occur in significant time scale segregation.

# Approach/Strategy

## Standard Input File Structure Facilitating Multiscale Simulation

	PDM	EDM	CDM
Define Battery			
posptcltbl.inp, negptcltbl.inp	○	○	○
edparm.inp		○	○
cdparm.inp			○
Define Usage			
ELprofl.inp	○	○	○
Setup Model			
setup.inp	○	○	○

- Standard input files define the battery, the usage, and the numeric conditions for model setup.
- The input file structure reflects the MSMD modularity. For example, if you keep the materials and the electrode design the same and only want to change the cell form factor, the “cdparm.inp” needs to be replaced. If you change “edparm.inp” while keeping the others the same, you change the electrode design of a battery. “posptcltbl.inp” and “negptcltbl.inp” define the positive and negative active materials, respectively.



# Approach/Strategy

## MSMD

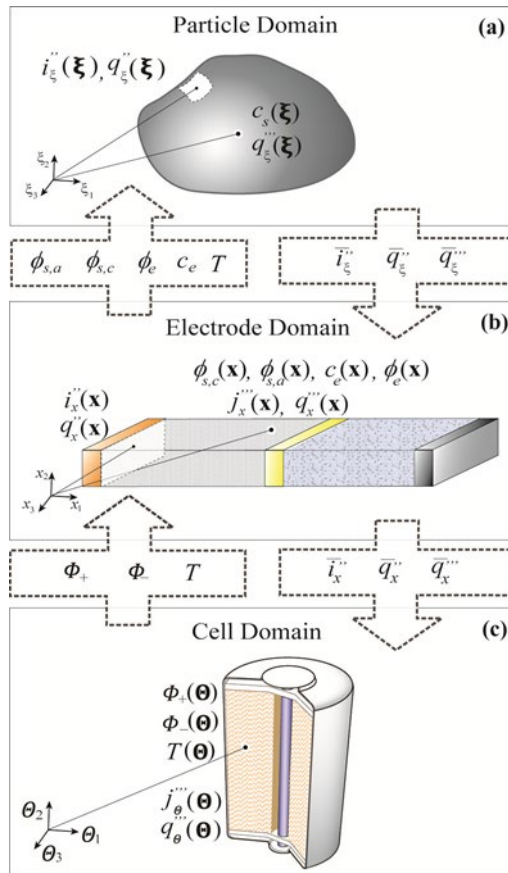

## GH-MSMD

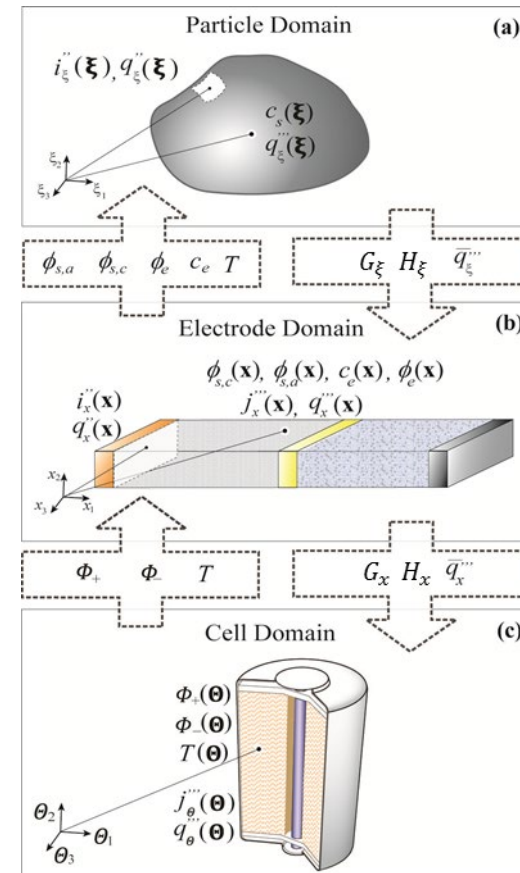

The diagrams above summarize the model solution variables in each computational domain and the coupling variables exchanged between the adjacent length scale domains in MSMD (left) and in GH-MSMD (right). Even though the solution algorithms are significantly different between the two, the model structures are similar. This comparison signifies the modularity of model framework that the GH-MSMD inherited from the MSMD.

# Approach/Strategy

## Adaptive-SVM (A-SVM) Development

### Goals

- Develop a fast, efficient 1D electrochemical model (a.k.a. Newman model) capturing physics of Li-ion battery electrochemical transport and reaction kinetics
- Model should be extensible to any Li-ion porous electrode design and state-of-health parameter set. *Eliminate preprocessing step to re-identify SVM for new designs and during aging.*

### Approach

- Extend previous work<sup>[Smith et al. 2007]</sup> that developed a ROM in SVM form by fitting frequency response of transfer functions representing distributed electrochemical dynamics
- Use numerical and/or analytical approaches to eliminate the cumbersome pre-processing step required to fit frequency responses and compile results into look-up tables usable only for one battery design at one state of health

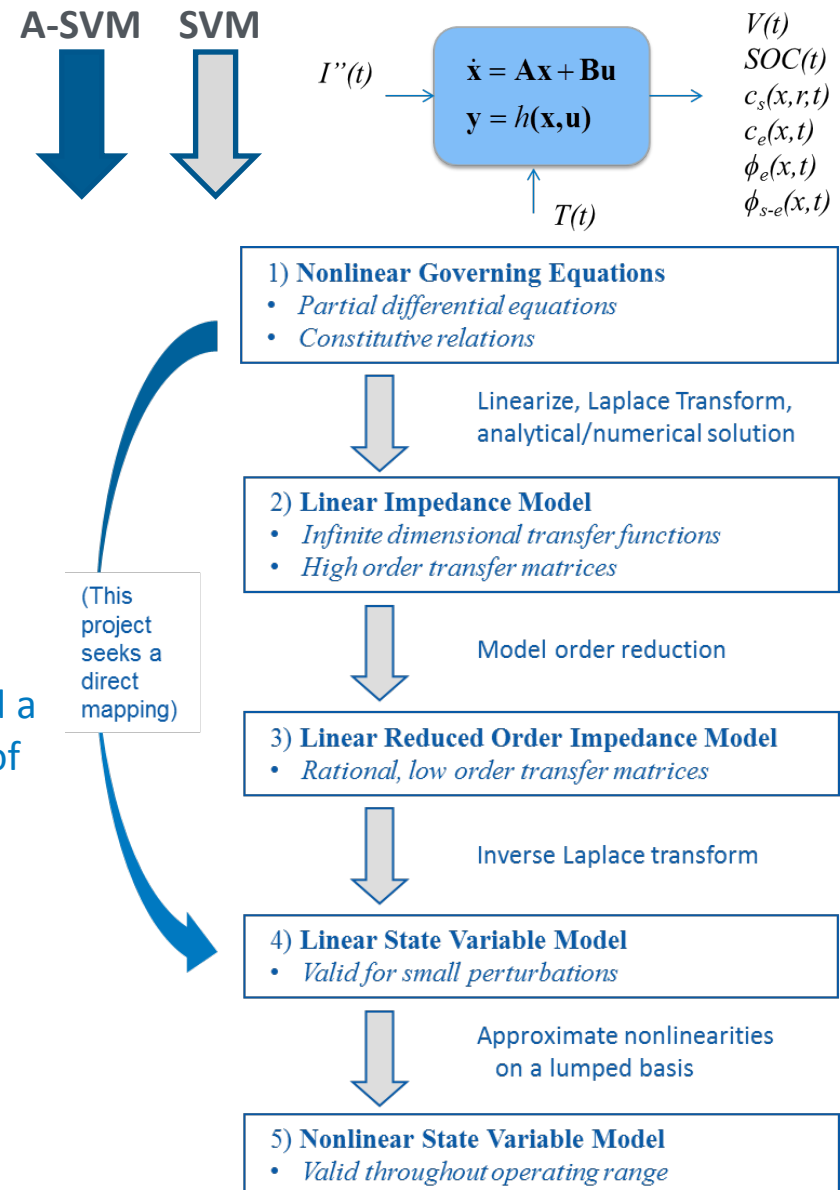

# Approach/Strategy

## EDM Extension and Multiphysics Integration for MSMD-Safety

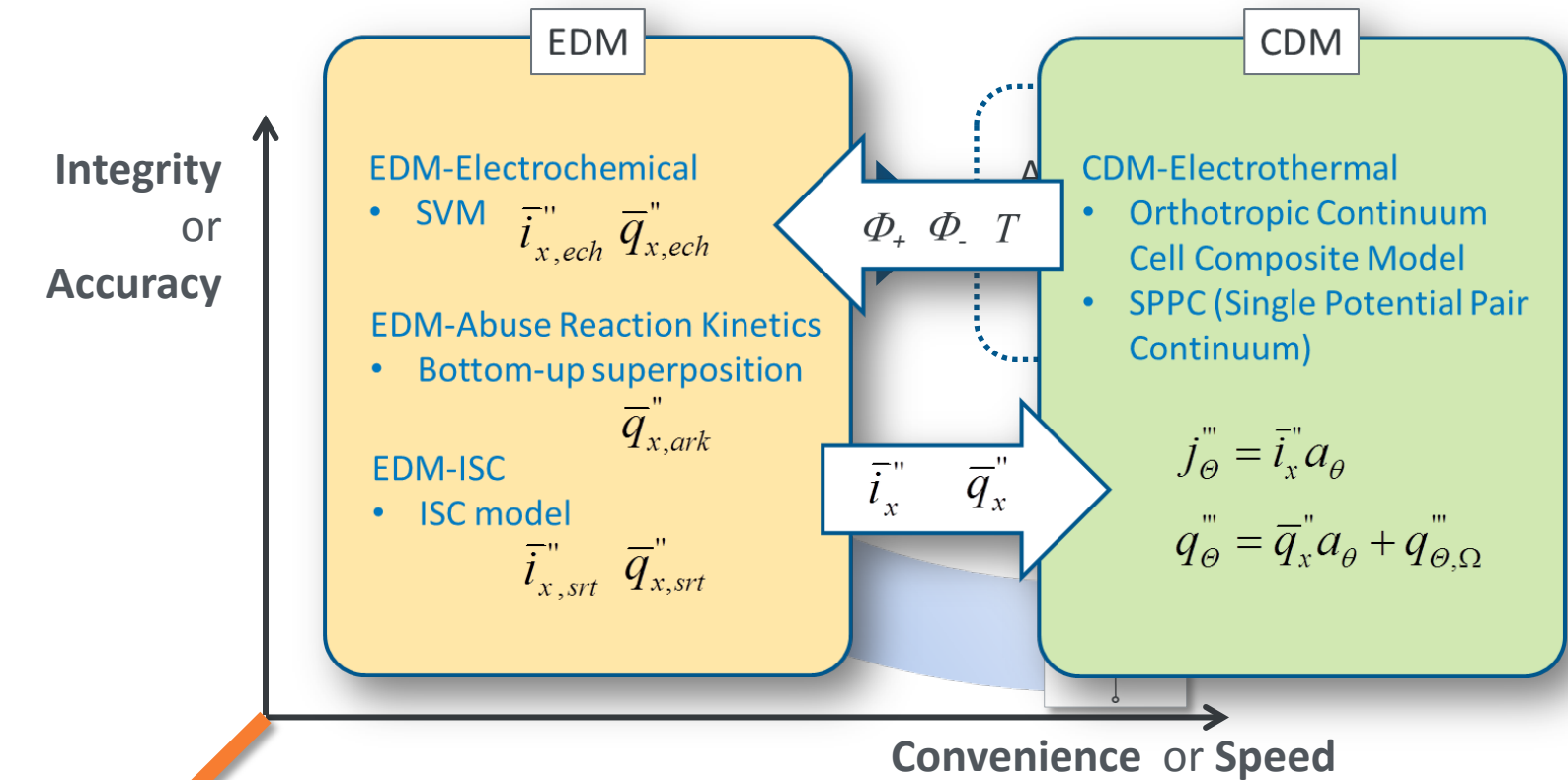

**Applicability** : The 3<sup>rd</sup> dimension of model efficiency improvement

# Technical Accomplishments and Progress

## Benchmark Result of GH-MSMD Implementation at EDM Level

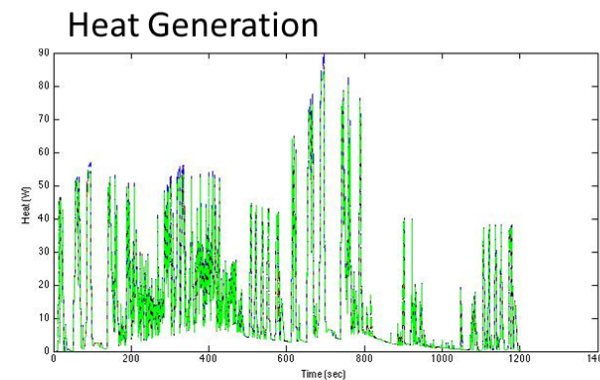
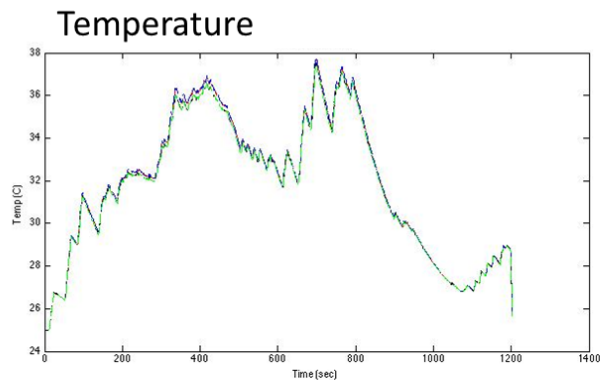
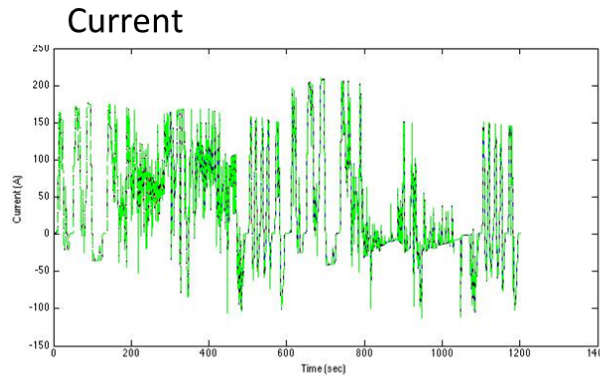
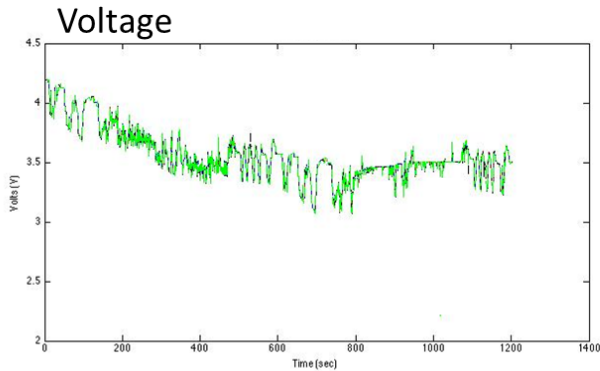

**PHEV10, US06  
Mid-size Sedan  
20 min (1,200 sec) Drive**

Model	Time [sec]
GH-MSMD Ed-LPD	0.74
GH-MSMD Ed-PLM	6.48
MSMD Segregated	651

*Figures above present the comparison of electrical and thermal response of a battery for mid-size sedan plug-in hybrid electric vehicle (PHEV10) US06 20 minutes driving power profile from the GH-MSMD and the original MSMD. The model outputs are shown very close to each other. The most efficient GH-MSMD model option runs the 1,200-second simulation only in 0.74 seconds using a personal computer, while the original MSMD runs the same case in 654 seconds. A 100~1,000 fold speed up was demonstrated while maintaining solution accuracy.*

# Technical Accomplishments and Progress

## A-SVM : Analytical Approach – Summary of Algorithm

Obtain a state-space form of SDF via VECFIT

$$(A_n, B_n, C_n, D_n)$$

$$\left[ \begin{array}{c|c} A_m & B_m \\ \hline C_m & D_m \end{array} \right] = \left[ \begin{array}{ccc|c} A_n - \zeta B_n C_n & -(\zeta/C_{dl})B_n & (\zeta/C_{dl})B_n & 0 \\ -\zeta C_n & -(\zeta/C_{dl}) & \zeta/C_{dl} & 0 \\ 0 & 0 & 0 & 1 \\ \hline -\zeta C_n & -(\zeta/C_{dl}) & \zeta/C_{dl} & 0 \end{array} \right]$$

Derive a state-space form of  $\xi(s)$  by system interconnection formulae

$$(A_\xi, B_\xi, C_\xi, D_\xi)$$

$$\left[ \begin{array}{c|c} A_\xi & B_\xi \\ \hline C_\xi & D_\xi \end{array} \right] = \left[ \begin{array}{ccc|c} A_m & (1/C_{dl})B_m & 0 & 0 \\ 0 & 0 & 0 & 1 \\ 0 & 0 & -1/(R_f C_f) & 1 \\ \hline -C_m & (1/C_{dl})(1 - D_m) & 1/C_f & 0 \end{array} \right]$$

Derive a state-space form of a electrode impedance by system interconnection formulae

$$(A_z, B_z, C_z, D_z)$$

$$A_z = \begin{bmatrix} A_\xi - \frac{6}{A} B_\xi C_\xi & \frac{6m}{A^2} B_\xi C_\xi & \frac{6m}{A^2} B_\xi D_\xi C_\xi & \frac{3H_2}{A} B_\xi C_\xi \\ 0 & A_\xi & B_\xi C_\xi & 0 \\ 0 & 0 & A_\xi & 0 \\ 0 & 0 & 0 & A_\xi \end{bmatrix},$$

$$B_z = \begin{bmatrix} \frac{6m}{A^2} B_\xi D_\xi^2 + \frac{3H_2}{A} B_\xi D_\xi + \frac{H_2}{4} B_\xi \\ B_\xi D_\xi \\ B_\xi \\ B_\xi \end{bmatrix},$$

$$C_z = \left[ -\frac{6\delta}{A^2} C_\xi \quad \frac{6\delta m}{A^2} C_\xi \quad \frac{6\delta m}{A^2} D_\xi C_\xi \quad \frac{3\delta H_2}{A} C_\xi \right],$$

$$D_z = H_1 + \frac{6\delta}{A^2} \left( m D_\xi^2 + \frac{H_2 A}{2} D_\xi + \frac{H_2 A^2}{4!} \right).$$

Model order reduction by balanced truncation

$$(A_z^r, B_z^r, C_z^r, D_z^r)$$

M. Jun, K. Smith, P. Graf, "State-space Representation of Li-ion Battery Porous Electrode Impedance Model with Balanced Model Reduction." *J. Power Sources*, Vol. 273, 2015

# Technical Accomplishments and Progress

## Error-Corrected Time-Domain Series Solution (ETS)

### Recursive Expression

$$\theta_s = \theta_m + \sum_{n=1}^N Q_n(\tau) + e_N(\tau)$$

$$Q_n(\tau + \Delta\tau) = -\frac{2i''_{\zeta}(\tau + \Delta\tau)}{\lambda_n^2} \left[ 1 - e^{-\lambda_n^2 \Delta\tau} \right] + e^{-\lambda_n^2 \Delta\tau} Q_n(\tau)$$

$$e_N(\tau + \Delta\tau) = -2i''_{\zeta}(\tau + \Delta\tau) \left[ \sum_{n=1}^{\infty} \frac{1}{\lambda_n^2} - \sum_{n=1}^N \frac{1}{\lambda_n^2} - \frac{e^{-\lambda_{N+1}^2 \Delta\tau}}{\pi \lambda_{N+1}} + \sqrt{\frac{\Delta\tau}{\pi}} \operatorname{erfc}(\lambda_{N+1} \sqrt{\Delta\tau}) \right] + o(e^{-\lambda_{N+1}^2 \Delta\tau})$$

### Error Comparison vs. SVM: 5C discharge with 40C-max random 1 sec pulses, N=10

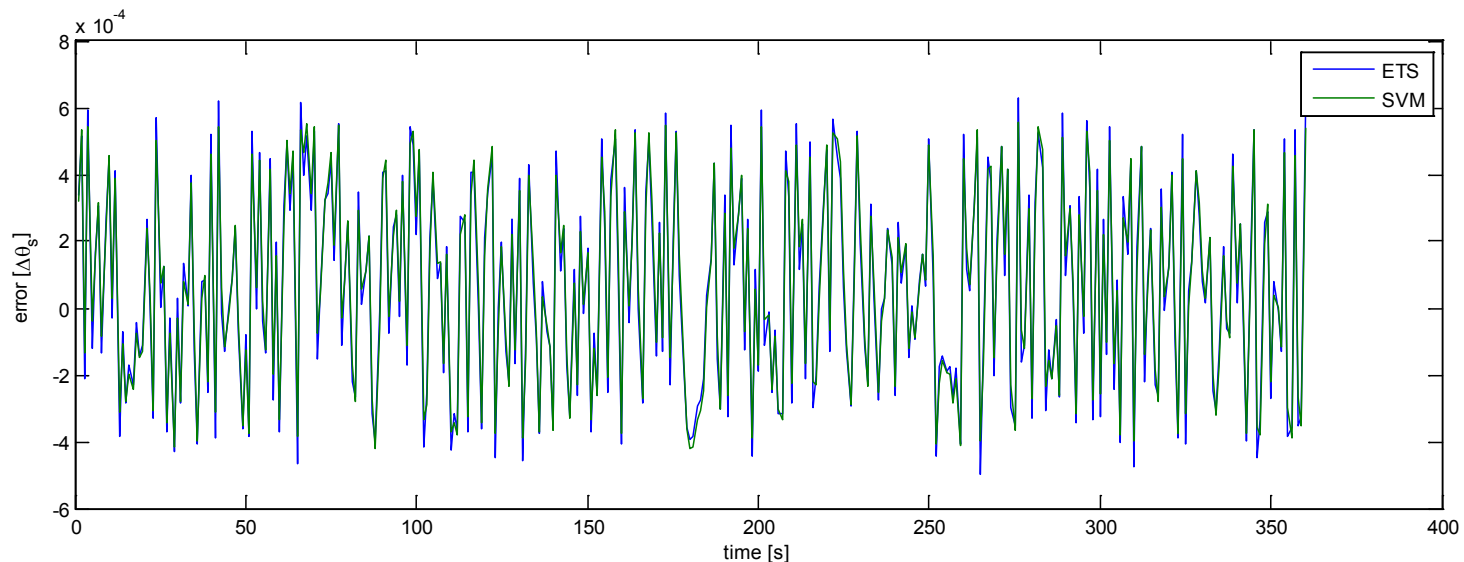

# Technical Accomplishments and Progress

## NREL Custom EDM Library Integration in ANSYS Fluent MSMD Battery Module

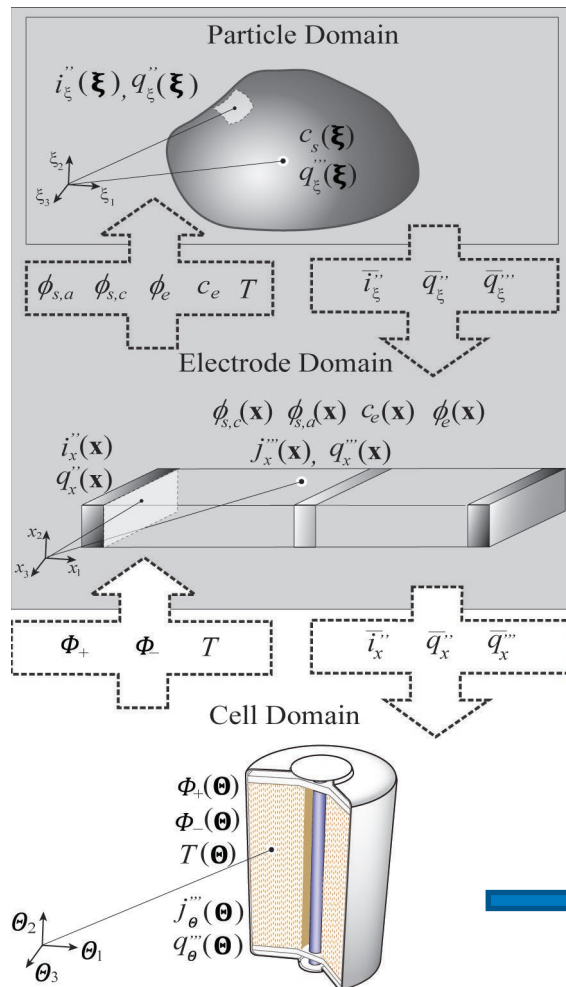

NREL Multiphysics EDM Library  
for Safety Simulation

EDM – Electrochemical : SVM

EDM – Abuse Reaction Kinetics

EDM – ISC

### Linking Protocol

- NREL EDM – Fluent API

### CDM

- The SPPC CDM-electrothermal model in ANSYS Fluent MSMD-module

# Technical Accomplishments and Progress

## Fault Evolution Study

2P1S Subset Configuration with Fins and Cooling Plate

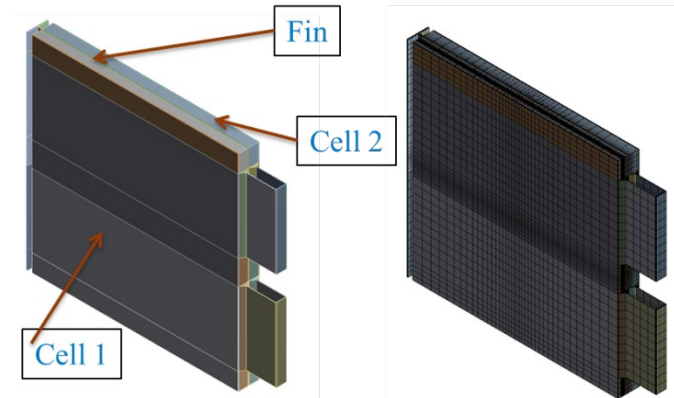

	Case 1	Case 2
Config	1S2P	1S2P
Cell	40 Ah, LCO/Graphite 255mm x 255mm x 10mm	
Initial Short Resistance (mΩ)	222	444
Initial Short Location	Middle of cell#1	

### Case 1 : 222-mΩ Initial Short

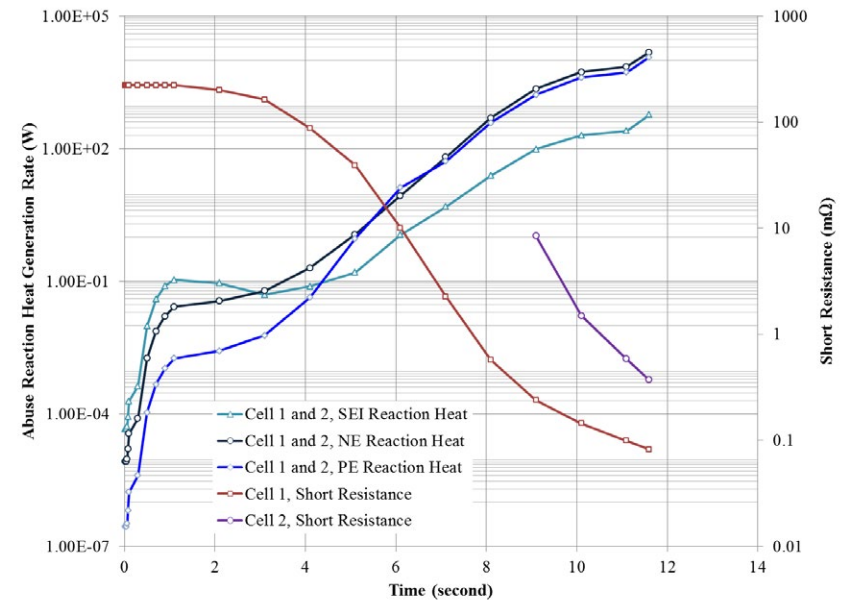
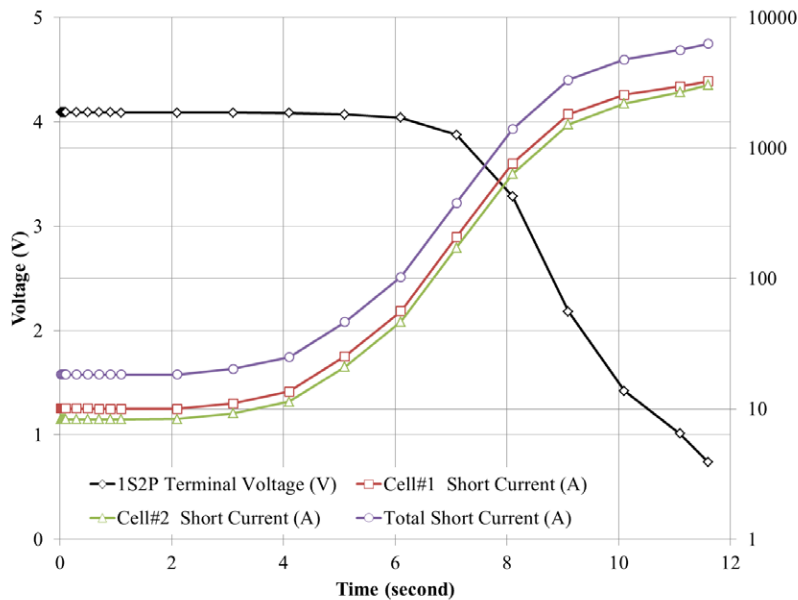



# Technical Accomplishments and Progress

## Fault Evolution Study

### Case 1 : 222-mΩ Initial Short

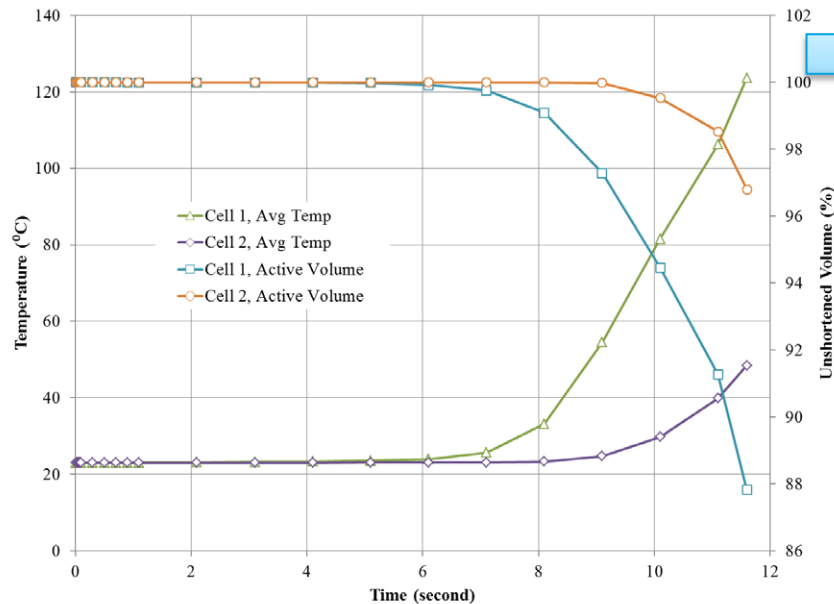

### Short Propagation for Separator Breakdown

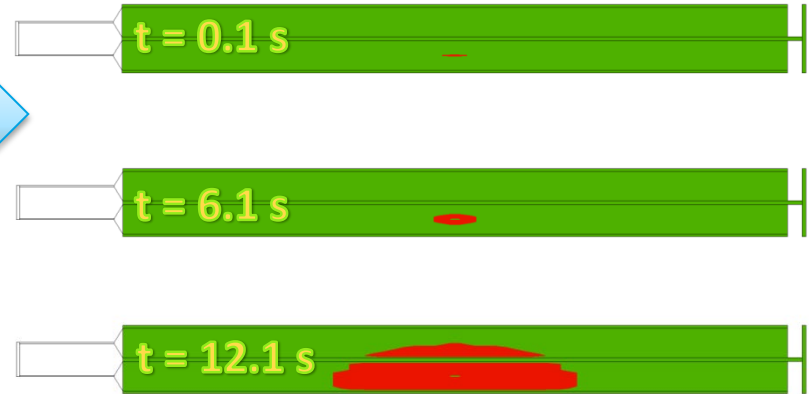

### Surface Temperature

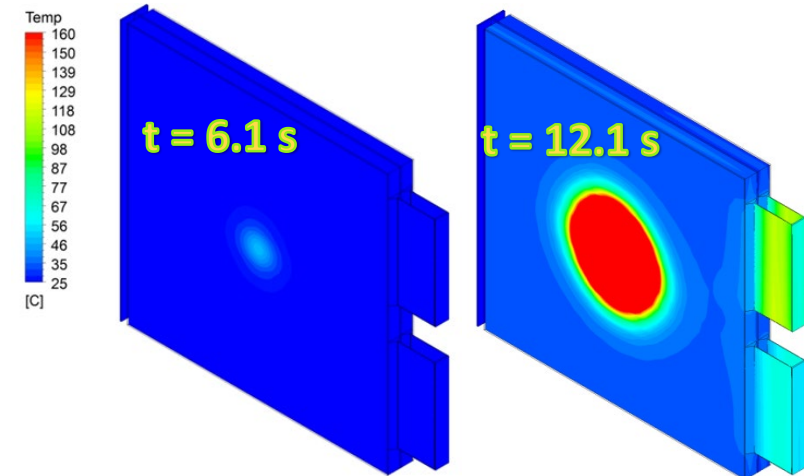

### Electrochemical Reaction Current Density

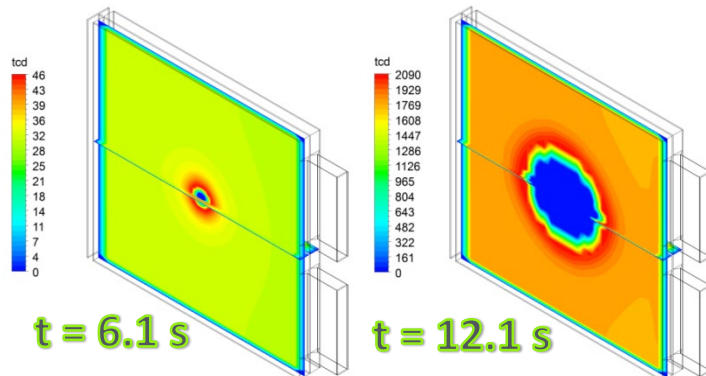

# Technical Accomplishments and Progress

## Fault Evolution Study

### Case 2 : 444-mΩ Initial Short

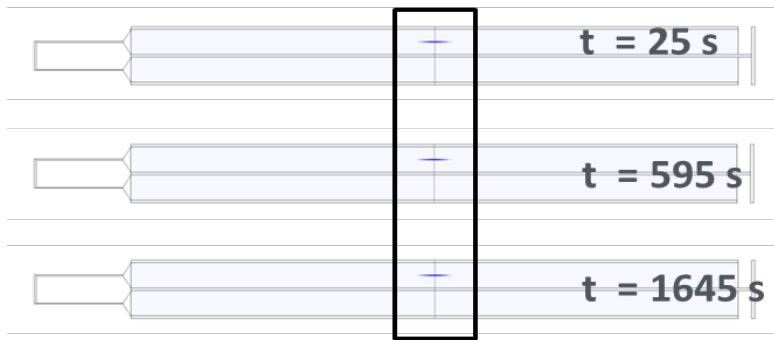

*Effective heat transfer may lower the maximum steady-state temperature when a latent defect exists and prevents or slows down the further growth for a fault for thermal breakdown.*

DOD = depth of discharge

### Temperature

$t = 25$  s  
DOD = 0.08%

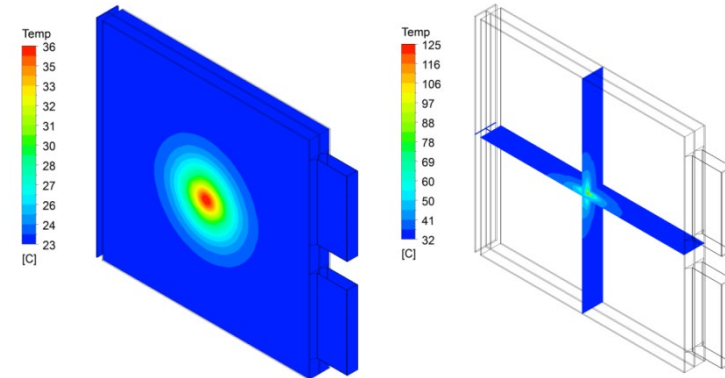

$t = 595$  s  
DOD = 1.9%

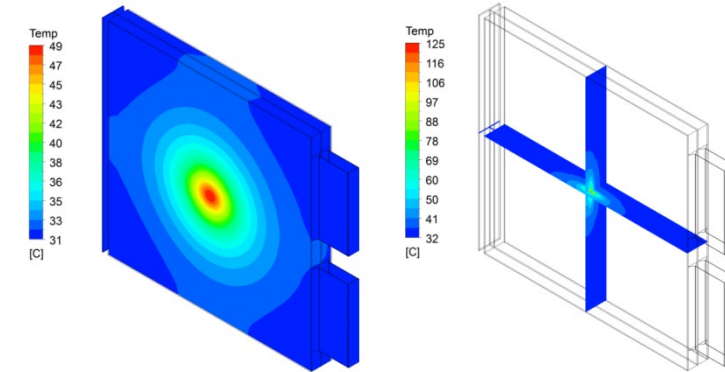

$t = 1645$  s  
DOD = 5.2%

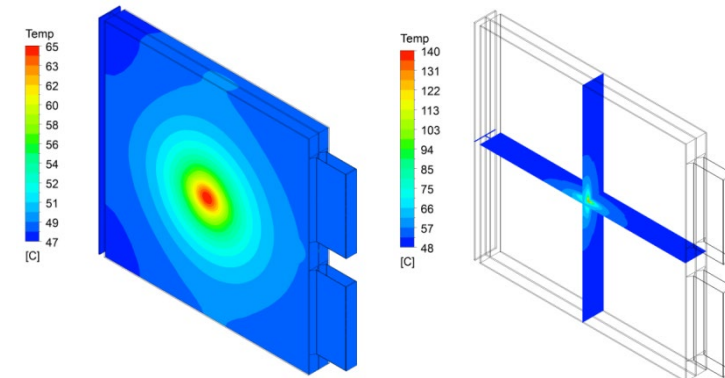

# Response to Previous Year Reviewers' Comments

Q: Reviewer 3 indicated that we suggested the target (i.e., 100 times improvement in computational time), but no discussion of the degree to which progress has been made.

A: The project was in a relatively early stage last year and didn't yet identify the metric to evaluate relative enhancement of the model's computation speed against the baseline full-order model. This year's review includes the benchmark results of GH-MSMD EDM implementation, indicating that we substantially exceeded a 100 times computational speed improvement over the full order model.

Q: Reviewer 3 suggested that it would be nice to have more academic contributions, and Reviewer 1 stated that the project should enable collaboration with universities.

A: The project was originally planned to have a university partner. Later, the university performer, which has dual affiliation in ANSYS, decided to participate through the company for administrative convenience. We will keep looking for opportunities to work with academia in current and future projects.

# Collaboration and Coordination with Other Institutions

---

*To bring immediate benefits to industries, the outcome model should be numerically robust and usable in an engineering environment*

*To leverage what has been accomplished through the previous efforts in the program*

---

## **Partner: ANSYS**

- *The project team will demonstrate intergradation of the outcome models on ANSYS's battery simulation platform. ANSYS developers will support NREL researchers with required software engineering.*
- *With the ANSYS battery simulation software as a platform for the MSMD research, appropriate source code access, prototype versions of ANSYS' tools, developer-level technical support, and advisory consultation on NREL's use will be provided.*
- *From the previous collaboration, ANSYS developers participating in the project have established a profound understanding of the MSMD architecture.*

# Remaining Challenges and Barriers

- Recent benchmark tests for the baseline GH-implementation demonstrated 100 to 1,000 times speed-up. The remaining challenge, however, is to enhance the applicability of the model to various battery engineering problems.
- In order to address varied problems in the industry, interdisciplinary constituent models relating material, design, process, and operational parameters with physicochemical parameters of the GH- baseline models are needed.
- EIS is one of the frequently used methods for battery characterization and diagnostics. Because the current GH-MSMD has been developed in the time domain, it is difficult to utilize the information produced in the frequency domain.
- The modular architecture of GH-MSMD facilitates participation of external expertise across the battery community. Independently developed sub-models can be plugged in the framework to extend the simulation capability. However, unlike the original MSMD, the GH-MSMD protocol is not intuitively understandable.
- Identification of a physics-based battery model is known to be difficult. This anticipated difficulty for development of a physics-based constituent model comes from the fact that characterization of a battery is intrinsically solving an under-determined problem.

# Proposed Future Work

## Rest of FY15

- Complete A-SVM development and implementation
- Continue work on stand-alone C++ code and Fluent-API
- Development of POD-DEIM on electrolyte diffusion equation
- Demonstrate viability of GH-MSMD implementation in Fluent

## Future Project

- There have been strong needs in the industry to use purely predictive physics-based models for design, evaluation, and control of batteries and systems. In the pursuit of providing such models, we will develop physics-based interdisciplinary constituent models working in the GH-MSMD framework.
- Frequency-domain GH-MSMD will be developed from the identical governing equation sets used in the time-domain model, running with the standard input files.
- We will deliberately summarize the GH-MSMD principles and implementation and publicize them to encourage contributions from outside experts.
- We will develop a sequential optimization procedure to break the under-determined parameter estimation problem of the whole system into a sequence of fully determined fits to subsets of the parameters; advanced model-based battery characterization

# Summary

- The GH-MSMD framework formulation was completed.
- MSMD baseline models were identified.
- Baseline MSMD sub-models were reformulated and converted into the GH-constituent model following a specific protocol required in the GH-MSMD framework.
- The model codes were implemented both in MATLAB and C++.
- **A recent benchmark test for the baseline GH-implementation demonstrated 100 to 1,000 times speed-up.**
- A-SVM has been developed based on the SVM approach, capturing the dynamic of Li diffusion and migration and impact on cell response.
- We established an application programming interface (API) to integrate NREL's newly developed model libraries in the third-party commercial software, ANSYS Fluent.