

RECLAMATION

Managing Water in the West

San Luis Reservoir Expansion Draft Appraisal Report

Central Valley Project, California
Mid-Pacific Region



U.S. Department of the Interior
Bureau of Reclamation
Mid-Pacific Region - Planning Division

December 2013

DRAFT



**U.S. Department of the Interior
Bureau of Reclamation
Mid-Pacific Region - Planning Division**

December 2013

Mission Statements

The mission of the Department of the Interior is to protect and provide access to our Nation's natural and cultural heritage and honor our trust responsibilities to Indian Tribes and our commitments to island communities.

The mission of the Bureau of Reclamation is to manage, develop, and protect water and related resources in an environmentally and economically sound manner in the interest of the American public.

San Luis Reservoir Expansion Draft Appraisal Report

**Central Valley Project, California
Mid-Pacific Region**



**U.S. Department of the Interior
Bureau of Reclamation
Mid-Pacific Region - Planning Division**

Table of Contents

1.0 EXECUTIVE SUMMARY	1
2.0 INTRODUCTION.....	4
2.1 Purpose of the Appraisal Study	4
2.2 Need for the Appraisal Study	5
2.3 Authorization for Appraisal Study	5
2.4 Study Area.....	6
3.0 PROBLEMS AND OPPORTUNITIES	8
3.1 Problems.....	8
3.2 Opportunities.....	10
3.3 Objectives.....	11
3.4 Constraints.....	11
4.0 EXISTING CONDITIONS	13
4.1 Facilities	13
4.1.1 Dam Embankment	13
4.1.2 Gianelli Pumping-Generating Plant.....	15
4.1.3 Intake Towers / Trashrack Structures	15
4.1.4 Trashrack Structure Access Bridge.....	17
4.1.5 Spillway	17
4.2 Reservoir Area-Capacity	18
4.3 Related Projects.....	19
4.4 Previous Studies	22
4.5 Influencing Contracts, Agreements, and Conditions	24
5.0 MANAGEMENT MEASURES	27
5.1 Non-Structural Measures.....	27
5.2 Structural Measures.....	28
5.3 Alternatives	30
5.3.1 No Action Alternative.....	30
5.3.2 Conceptual Dam Raise Alternative.....	30

6.0 CONSIDERATIONS FOR STRUCTURAL MODIFICATIONS..... 32

6.1 Intake Towers/Trashrack Structures..... 32

6.2 Trashrack Structure Access Bridge 32

6.3 Spillway..... 32

7.0 WATER OPERATIONS AND BENEFITS FORECAST 34

7.1 Existing Operations 34

7.2 Water Supply Forecast 35

7.2.1 Method 1: Spreadsheet Analysis of CalSim-II Results..... 35

7.2.2 Method 2: CalLite Modeling Analysis 37

7.3 Summary of Results 39

8.0 ENVIRONMENTAL 40

9.0 COST ESTIMATES 41

10.0 FINDINGS AND RECOMMENDATIONS 43

10.1 Findings..... 43

10.2 Recommendations 44

11.0 REFERENCES..... 45

ATTACHMENT A

B.F. Sisk Dam Increased Storage Alternatives, Appraisal Level Study: Technical Memorandum No. VB-86-68313-25

ATTACHMENT B

Sisk Enlargement Appraisal Level Modeling Analysis

Figures

Figure 1. Major facilities of the San Luis Unit and the appraisal study area.....	7
Figure 2. Typical Section of B.F. Sisk Dam.....	14
Figure 3. Close-up of B.F. Sisk Dam and Gianelli Pumping-Generating Plant.....	14
Figure 4. Outlet works intake towers and access bridge.....	16
Figure 5. Overview of B.F. Sisk inlet and outlet structures.....	17
Figure 6. Area-Capacity curves for San Luis Reservoir and O'Neill Forebay.....	18
Figure 7. Locations of CALFED surface storage investigations relative to the Sisk study area.	23
Figure 8. Typical section of the conceptual modification alternative.....	31
Figure 9. Approximate limits of spillway demolition.....	33
Figure 10. A 10 year plot of long-term San Luis reservoir volume.....	34

Tables

Table 1. Maximum additional annual export opportunities by water year type*.....	36
Table 2. Additional export opportunities stored by various capacity increases*.....	37
Table 3. Average Annual Additional Deliveries of CVP and SWP (TAF/yr)*.....	38
Table 4. Change in North-of-Delta Average End of September Storage (TAF).....	38
Table 5. Summary of maximum and minimum estimated water supply benefits.....	39
Table 6. Summary of appraisal level field cost estimates.....	42

Acronyms and Abbreviations

AF	acre-feet
BA	Biological Assessment
BDCP	Bay-Delta Conservation Plan
BO	Biological Opinion
CALFED	CALFED Bay-Delta Program
CA	California Aqueduct
CAS	Corrective Action Study
CEQA	California Environmental Quality Act
COA	CVP/SWP Coordinated Operations Agreement
cfs	cubic-feet per second (ft ³ /s)
CVOO	Reclamation Central Valley Operations Office
CVP	Central Valley Project
CVPIA	Central Valley Project Improvement Act
D-1641	SWRCB Water Right Decision 1641
DMC	Delta-Mendota Canal
DWR	California Department of Water Resources
Delta	Sacramento-San Joaquin Delta
EIR	Environmental Impact Report
EIS	Environmental Impact Statement
ESA	Endangered Species Act
ft ³ /s	cubic feet per second
JPOD	Joint Point of Diversion
M&I	Municipal and Industrial
MAF	million acre-feet
mo	month
NEPA	National Environmental Policy Act
NMFS	National Marine Fisheries Service
OCAP	Operations Criteria and Plan
OMR	Old and Middle River
Reclamation	The U.S. Bureau of Reclamation
RPA	reasonable and prudent alternatives
RWS	reservoir water surface
SLLPIP	San Luis Low Point Improvement Project
SWP	State Water Project
SWRCB	State Water Resource Control Board
TAF	thousand acre-feet
TM	Technical Memorandum
TSC	Reclamation's Technical Service Center
USFWS	U.S. Fish and Wildlife
yr	Year

1.0 EXECUTIVE SUMMARY

The Bureau of Reclamation (Reclamation) developed this Appraisal Report to document studies to increase the storage capacity of San Luis Reservoir (behind B.F. Sisk Dam) to improve the reliability of Central Valley Project (CVP) and State Water Project (SWP) water supplies dependent upon San Luis Reservoir. Seismic risks under the dam and in the Delta, regulatory constraints to operating Delta export facilities, algae blooms at low water levels, and future climate change have and will reduce the reliability of CVP/SWP deliveries dependent upon the San Luis Reservoir.

Reclamation initiated feasibility studies of delivery reliability risks associated with algal blooms and low reservoir levels in 2001 with the San Luis Low Point Improvement Project (SLLPIP) feasibility study, authorized by P.L. 108-361. The SLLPIP Initial Alternatives Information Report identified raising B.F. Sisk (Sisk) Dam as one alternative to the low point problem; however, the alternative was eliminated from study after the Plan Formulation Report (PFR) because more cost-effective solutions seemed available at that time.

In 2006, as a response to studies that determined B.F. Sisk dam poses a potential risk of seismic failure, Reclamation also initiated a Safety of Dams Corrective Action Study (CAS) to determine a course of action to reduce the seismic risks at the dam. Alternatives being evaluated in the CAS include raising the dam and adding abutments, as well as restricting the water level in San Luis Reservoir.

Since then, Delta export facilities have been further restricted to protect threatened and endangered species in the Central Valley, and the State of California has initiated the Bay-Delta Conservation Plan to address the delivery reliability issues related to water exports from the Delta. This effort may or may not fully address delivery reliability issues related to San Luis Reservoir, and additional storage in San Luis Reservoir may be needed to further restore delivery reliability and system flexibility.

Modifications to the dam embankment and dike, spillway, intake towers, and access-bridge would be needed to increase storage capacity within San Luis Reservoir and reduce identified dam safety risks. These modifications have been found to be technically feasible to construct. Attachment A to this Report contains a series of technical memoranda which provided the basis for appraisal level conceptual designs, estimated field costs, and other considerations of the requirements to raise B.F. Sisk Dam which are presented in this report.

In order to generate appraisal level cost estimates for this study, a conceptual dam raise alternative was formulated that considered co-equal objectives of increasing storage and mitigating dam safety risks, while also minimizing impacts to existing facilities. The conceptual

alternative consists of a raise of the reservoir water surface (RWS) by 10 feet and a corresponding raise of the dam crest by 20 feet, increasing reservoir capacity by approximately 130 TAF. This conceptual design included excavation of weaker foundation materials and addition of significant downstream stability berms in several areas around the dam embankment.

Total field costs were estimated to be \$360 million to construct the conceptual design. The excavation and stability berms required for reducing dam safety risks account for approximately 67% of total field costs. Costs of design, design support, construction support and construction support activities are not included in the estimated field cost. The field cost estimates for this study do include estimates for mobilization, design and construction contingencies, and allowance for procurement strategies.

The maximum estimated benefit of increasing the capacity of San Luis Reservoir by 130 TAF (10 foot increase in the water surface elevation), under existing operations and regulations, is 43 TAF of additional average annual Delta exports. Additional studies indicate that, under current operations and regulations, benefits to CVP and SWP water supply and deliveries could potentially be realized with reservoir capacity increases up to 400 TAF (~30-foot RWS raise). For example, a 400 TAF reservoir capacity increase could produce approximately 71 TAF of additional average annual Delta exports and deliveries under current operations and regulations. Based on the results of this report, additional in-depth studies exploring the opportunities for enlarging B.F. Sisk Dam to increase the capacity of San Luis Reservoir as a part of the San Luis Low Point Feasibility Study are warranted.

Further studies would be developed in coordination with Reclamation's Dam Safety Office, the State Department of Water Resources, the Santa Clara Valley Water District, and the San Luis & Delta-Mendota Water Authority, and other entities to ensure development of a feasible solution to the several risks to CVP and SWP water delivery reliability.

Based on the findings of this report, recommendations for further studies include:

- 1) Restore one or more San Luis Reservoir expansion alternatives to the San Luis Low Point Feasibility Studies to determine:
 - a) Actions needed to correct identified dam safety risks
 - b) Technical, environmental, economic, and financial feasibility of increasing south-of-Delta surface water storage capacity under a wide range of future conditions, including climate change and changes in Delta export and conveyance capacity
- 2) Address the following topics during the feasibility study process:
 - a) Refine the area-capacity calculations for an expanded San Luis Reservoir

- b) Consider the need to upgrade the Gianelli pumping plant depending on the height of capacity increasing alternatives analyzed
 - c) Opportunities to enhance recreation in the reservoir
 - d) Upgrade/improve operational representation of San Luis Reservoir in the CALSIM-II and CalLite models
 - e) Consider carryover operations with a larger reservoir to improve dry year delivery benefits
 - f) Complete a constructability evaluation to provide a detailed analysis of possible construction phasing to reduce impacts to CVP and SWP operations during construction
 - g) Complete all necessary updates to geotechnical data and models
 - h) Evaluate operational changes for sharing Delta exports and export opportunities
- 3) Manage land uses within the potentially affected areas to avoid technical and logistical conflicts that may increase the cost of the dam safety and expansion projects
- 4) Develop a cost-share agreement with non-federal partners to fund the feasibility and environmental studies.

2.0 INTRODUCTION

The CVP/SWP, one of the Nation's major water conservation developments, extends from California's Cascade Range in the north to the semi-arid but fertile plains along the Kern River in the south. The CVP/SWP was initially built primarily to protect the Central Valley from water supply shortages and flood damages, but the CVP/SWP also improves Sacramento River navigation, supplies municipal and industrial (M&I) water, generates electric power, conserves fish and wildlife, creates opportunities for recreation, and enhances regional water quality.

B.F. Sisk Dam and San Luis Reservoir are an integral part of the CVP/SWP system which is located on San Luis Creek approximately 12 miles west of Los Banos, California. The entire reservoir is within Merced County, California (Figure 1). San Luis Reservoir has 65 miles of shoreline and controls runoff from about 82 square miles. The dam is an off-stream water storage facility used to store supplemental water for irrigation and domestic water supply. Water is lifted from the O'Neill Forebay into the reservoir for storage by the Gianelli Pumping-Generating Plant, and then water is released back through the pump-generating plant for use and to generate electricity. The dam impounds approximately 2,040,500 AF at the maximum RWS elevation.

The dam was built by Reclamation beginning in February 1963 and was completed in 1967. Releases from the reservoir serve many purposes ranging from domestic supply to power generation to irrigation for both the CVP and SWP. While Reclamation owns the facilities, operations and maintenance (O&M) is jointly performed by the California Department of Water Resources (DWR) and Reclamation.

2.1 Purpose of the Appraisal Study

The purpose of this Appraisal Report is to document the results of an appraisal-level study to determine the nature of water and related resource problems and needs in the study area (section 2.4), formulate and assess preliminary management measures, determine the potential for federal interest, and recommend subsequent actions that may achieve the stated study objectives. Specifically, this study was scoped to focus on evaluation of surface storage measures at San Luis Reservoir rather than demand reduction measures.

The scope of the Appraisal Report is consistent with the Reclamation Manual (USBR 2007), and other relevant Federal water resources planning guidelines such as *Principals and Requirements for Federal Investments in Water Resources* (CEQ, 2013). As such this report uses only existing data and information for determining current and projected needs, will identify at least one potential solution that requires Federal involvement, and provides a preliminary assessment of problems and opportunities, potential management measures and a recommendation to either proceed to feasibility investigation or terminate the study.

2.2 Need for the Appraisal Study

Reclamation has been working since 2001 on the San Luis Low Point Improvement Project (SLLPIP), which is investigating solutions to decreased water delivery reliability that occurs when San Luis Reservoir storage drops to a “low point,” below 300 TAF. During low point times, Reclamation’s San Felipe Unit (which draws water from San Luis Reservoir) can experience supply interruptions due to low reservoir water levels relative to the San Felipe Division’s intake within the reservoir. In 2008 the SLLPIP Initial Alternatives Information Report identified raising B.F. Sisk (Sisk) Dam as one alternative to the low point problem; however, the alternative was eliminated from study after the 2010 Plan Formulation Report (PFR) because more cost-effective solutions seemed viable at that time.

Concurrently, the Mid-Pacific Region continued to evaluate opportunities to reduce the water supply impact of the Central Valley Project Improvement Act (CVPIA), consistent with section 3408(j) Least Cost Yield Increase of CVPIA. Studies completed in 2005 and 2008 under this program (Reclamation 2005, 2008c) indicated that a combination of increased storage, both north and south of the Delta, along with improved Delta conveyance capacity would most efficiently reduce the water delivery impacts of CVPIA.

Additionally, in 2006, as a response to studies that determined Sisk dam poses a potential risk of seismic failure, Reclamation also initiated a Safety of Dams Corrective Action Study (CAS) to determine a course of action to reduce the seismic risks at the dam. Alternatives being evaluated in the CAS include raising the dam and adding abutments, as well as restricting the water level in San Luis Reservoir.

Based upon the earlier yield replacement studies, identified “low point” issues, and identified dam safety risks, the Planning Division embarked upon an appraisal study to develop a project that would both mitigate the dam safety issues and improve deliveries to the San Felipe Unit and CVP/SWP as a whole.

Around the same time that the region initiated the appraisal study, both CVP and SWP contractors began asking about expanding Sisk Dam while improving safety because they saw that additional south-of-Delta storage would be useful to better capture water supplies in the Delta at times when it would not be harmful to protected fish species.

2.3 Authorization for Appraisal Study

Reclamation is authorized to conduct General Planning Activities, such as this Appraisal evaluation, by The Reclamation Act of June 17, 1902, (32 Stat. 388, 43 U.S.C. 391) and acts amendatory thereof and supplementary thereto.

The San Luis authorizing act, Public Law 86-488, 86th Congress, was signed into law on June 3, 1960.

2.4 Study Area

The San Luis Unit (Figure 1), a part of the combined CVP/SWP was authorized for construction in 1960. The principal purpose of the federal portion of the facilities is to furnish supplemental irrigation water supply to some 600,000 acres located in the western portion of Fresno, Kings, and Merced Counties. Deliveries from San Luis Reservoir also flow west out of the reservoir through Pacheco Pumping Plant and Conduit to the San Felipe Division of the CVP, which serves the SCVWD and the SBCWD. The San Felipe Division of the CVP provides supplemental irrigation to 63,500 acres of land, in addition to approximately 132 TAF of water annually for municipal and industrial use.

While Reclamation holds title to all San Luis Unit facilities, the majority of the facilities are operated as joint-use facilities, a combined effort of the federal and state governments, with 55 percent of the total costs contributed by the State of California and the remaining 45 percent by the United States.

The joint-use facilities are O'Neill Dam and Forebay, B.F. Sisk Dam, San Luis Reservoir, William R. Gianelli Pumping-Generating Plant, Dos Amigos Pumping Plant, Los Banos and Little Panoche Reservoirs, and San Luis Canal from O'Neill Forebay to Kettleman City, together with the necessary switchyard facilities.

The Federal-only portion of the San Luis Unit includes the O'Neill Pumping Plant and Delta-Mendota Canal (DMC), Coalinga Canal, Pleasant Valley Pumping Plant, and the San Luis Drain. San Luis Reservoir serves as the major storage reservoir and O'Neill Forebay acts as an equalizing basin for the upper stage dual-purpose pumping-generating plant. Pumps located at the base of O'Neill Dam move water from the CVP DMC through an intake channel and discharge it into the O'Neill Forebay. The SWP California Aqueduct (CA) also flows directly into O'Neill Forebay. The pumping-generating units within the forebay lift the water and discharge it into the San Luis Reservoir. When not pumping, these units generate electric power by reversing flow through their turbines. Water for irrigation is released into the San Luis Canal and flows by gravity to Dos Amigos Pumping Plant where it is again lifted more than 100 feet to permit gravity flow to its terminus at Kettleman City. A State canal system continues to southern coastal areas. During irrigation months water from the CA flows through the O'Neill Forebay into the San Luis Canal instead of being pumped into the San Luis Reservoir. Two detention reservoirs, Los Banos and Little Panoche control cross drainage along the San Luis Canal. The reservoirs also provide recreation and flood control benefits.

Figure 1. Major facilities of the San Luis Unit and the appraisal study area.



3.0 PROBLEMS AND OPPORTUNITIES

Water supply reliability problems associated with the CVP/SWP result from multiple factors that, in combination, have reduced the operational flexibility and delivery reliability of these water projects over time. Regulatory actions pursuant to the Endangered Species Act (ESA), CVPIA, and Clean Water Act, and implementation of the Reasonable and Prudent Alternatives (RPAs) from the 2008/2009 U.S. Fish and Wildlife Service (USFWS) and National Marine Fisheries Service (NMFS) Biological Opinions (BOs) have reduced the ability to export water supplies through the Delta export facilities. Demands within the CVP and SWP Service area developed when more water supplies were available and have increased while the supply availability has declined significantly.

Water resources problems related to San Luis Reservoir operations are described in the following sections.

3.1 Problems

Problems identified during this study fall into three main categories which reflect issues associated with water delivery reliability, operational flexibility, and climate change; each of which are discussed in further detail below.

Water Delivery Reliability

The term “water delivery reliability” can be defined as the annual amount of water that can be expected to be delivered with a certain frequency. Water delivery reliability is generally measured as a probability or likelihood that a contractor will receive a certain amount of water from the CVP/SWP in a particular year (DWR 2012).

Many factors combine to affect CVP/SWP water delivery reliability. These natural and human-created factors may include the availability of source water, regulatory restrictions on CVP/SWP operations, and the effects of climate change. Uncertainty also exists because of the potential for an emergency such as an earthquake striking in or near the Delta, which, if substantial enough, could interrupt CVP/SWP exports from the Delta and/or deliveries from south-of-Delta facilities such as San Luis Reservoir.

Previous reports have confirmed that there is a significant seismic risk to B.F. Sisk Dam due to the close proximity of several active faults (Reclamation 2013b). Failure of B.F. Sisk Dam would completely halt all deliveries from the San Luis Unit, severely impacting CVP and SWP water delivery reliability.

South-of-Delta agricultural water deliveries are becoming increasingly less reliable. During the past decade, initial annual allocations to south-of-Delta agricultural contractors have been as low

as 0% of full contract supplies. Uncertainty in water supply makes it hard for farmers to plan their crops, obtain operating capital, and make other important annual decisions related to their farming operations. Annual allocations of M&I, refuge, and settlement contractors' water deliveries have much higher reliability than agricultural allocations (Reclamation 2008b). Additionally, Reclamation's San Felipe Unit contractors are faced with water delivery reliability risks due to the "low point" problem that is further defined in Section 4.4 of this report.

Operational Flexibility

The term "operational flexibility" can be defined as the ability to manage existing water supplies, consistent with the project authorizations and objectives, in an efficient manner while adapting to continuous changes in regulatory, physical, and hydrologic conditions. Physical limitations include capacity limits and maintenance requirements of the system.

Increased operational flexibility can result from the ability to transfer or convey water supplies among project features, draw from supplemental water supplies, and continuously manage operations among a matrix of integrated project facilities, among other things.

Climate Change

Future increases in air temperature, shifts in precipitation patterns, and sea level rise could affect California's water supply by changing how much water is available, when it is available, and how it is used. Expected impacts to the SWP and CVP include lower south-of-Delta exports, having less surplus water in reservoirs that can be used during shortages, pumping more groundwater to augment reductions in surface water supplies, and an increased risk that insufficient water availability could interrupt SWP and CVP operations.

A recent report by the California Climate Change Center (DWR 2009) used multiple climate projections to assess the future reliability of California's main water supply projects. Mid-century and end-of-the-century impacts were estimated for Delta exports, reservoir carryover storage, groundwater pumping, power supply, and the vulnerability of the CVP/SWP to operational interruptions. This study examined carryover storage for four major SWP and CVP water supply reservoirs: Lake Shasta, Trinity Lake, Lake Oroville, and Folsom Lake. The study concluded that reservoir carryover storage is expected to be reduced by 15%-19% by mid-century and 33%-38% at the end of the century.

These expected reductions in carryover storage reduce water supply reliability by reducing surplus storage that can be used in times of shortages. Additionally, annual Delta exports are expected to be reduced by approximately 7%-10% by mid-century and by 21%-25% at the end of the century. These impacts to carryover storage, water supply reliability, and Delta exports are likely to further reduce water deliveries south of the Delta.

3.2 Opportunities

Water Delivery Reliability

Regulatory restrictions on the CVP/SWP's Delta operations have been among the major factors affecting water delivery reliability (DWR 2012). Increased storage capacity at San Luis Reservoir could provide an opportunity to export more Delta water supplies when environmental and regulatory conditions allow, such as during the rainy season (December – March) when Delta exports are generally less restricted. These increased exports could improve CVP/SWP water supplies to support annual water allocations which in turn would equate to higher water delivery reliability for south-of-Delta contractors. Increasing the volume of water able to be stored in the reservoir would also contribute to reducing the risk of delivery impacts to the San Felipe Unit due to the issues identified in the SLLPIP.

Operational Flexibility

Current CVP/SWP operational flexibility is partially constrained by limited south-of-Delta storage. As previously discussed, throughout the historic hydrologic record there are years when water quality and Delta conditions would allow exports from the Delta but Reclamation has nowhere to store additional water that could be exported. Increased storage at San Luis Reservoir would provide more operational flexibility to the CVP/SWP by enabling optimized export of Delta water when conditions allow. The ability to store these additional exports, when they are available, could contribute to increasing operational flexibility in the following ways:

- Increasing use of water available when not required for in-Delta and Delta outflow needs.
- Managing the timing of water availability to better match demand/water use (seasonally and year-to-year to meet drought needs)
- Providing emergency water supply
- Providing hydropower generation or flexible generation opportunities
- Adapting to loss of snowpack storage
- Supplementing local water supplies, conservation, reuse, and desalination

Ecosystem Restoration

Increased south-of-Delta water supplies, stored in San Luis reservoir, could potentially be delivered to south-of-Delta National Wildlife refuges as part of CVPIA Level 4 water delivery requirements.

3.3 Objectives

A planning objective is a statement of what an alternative plan should try to achieve. Based on the water resources problems and opportunities identified in sections 3.1 and 3.2, the following planning objectives were developed for this study:

- Increase storage capacity of San Luis Reservoir (water supply)
- Increase south-of-Delta deliveries by optimizing Delta export opportunities (operational flexibility and delivery reliability)
- Mitigate for identified seismic risks at B.F. Sisk Dam (dam safety)
- Reduce the frequency of San Luis Low Point events

3.4 Constraints

A constraint is a condition or restriction that limits the extent of a project or planning process and hinders the ability to achieve a particular objective. Several constraints to the stated objectives of this study have been identified, including the following:

Water Supply/Delta Exports

Water for additional storage south-of-Delta is constrained by an overall limited water supply and limited Delta exports under current operating agreements, permits, BOs, and other regulatory requirements. Access to the existing Delta water supply is limited, and is forecast to become more constrained in the future (DWR 2012).

Dam Safety

A series of studies and analyses culminating in the seismic risk analysis that was completed in 2006 determined that there is justification to take action to reduce risk to the downstream public in the vicinity of B.F. Sisk Dam. Consequently, Reclamation, with collaboration from DWR, initiated the Safety of Dams CAS to investigate and determine a course of action to mitigate risk. Reclamation initiated this appraisal study in 2011 to explore the possibility of developing a project that would both mitigate the dam safety risk and improve deliveries to the CVP/SWP.

CalSim-II Modeling

While the CalSim-II model is the most widely accepted model for analyzing CVP and SWP operations, it is a planning model only and does not forecast future operations or water deliveries. The model was created to look at large scale, system-wide, changes in the entire CVP and SWP on a monthly average time step. For this appraisal study, CalSim-II results are only valid as a comparison between operations with and without a proposed action and should not be construed as a forecast of future operations.

Gianelli Pumping Plant

There is an upper limit to the increase in the amount of hydraulic head (i.e. RWS raise) that the existing pumps can accommodate without significant reductions in efficiency or increases in operational risk. Further analysis should consider the potential need to upgrade the pumping plant, depending on the height of raise alternatives analyzed.

Regulatory Requirements

Ongoing reconsultation processes for the 2008 USFWS and 2009 NMFS BOs have resulted in some uncertainty in future CVP and SWP operational constraints. Section 4.5 of this report provides more detail on applicable regulatory requirements.

Operational assumptions for modeling and evaluation of potential benefits included in the appraisal study were derived from the:

- The Reclamation 2008 *Biological Assessment on the Continued Long-Term Operations of the CVP and SWP* (2008 OCAP BA) (Reclamation 2008a)
- The USFWS 2008 *Formal ESA Consultation on the Proposed Coordinated Operations of the CVP and SWP* (2008 USFWS BO) (USFWS 2008)
- The NMFS 2009 *BO and Conference Opinion on the Long-Term Operations of the CVP and SWP* (2009 NMFS BO) (NMFS 2009)
- Coordinated Operations Agreement (COA) between Reclamation and DWR for the CVP and SWP, as ratified by Congress (Reclamation and DWR 1986)

4.0 EXISTING CONDITIONS

This section is intended to provide some description and explanation of the existing facilities, features, and other components of B.F. Sisk Dam and its related structures which would need to be modified in order to construct a dam raise. General design and construction considerations are discussed in this section.

4.1 Facilities

4.1.1 Dam Embankment

B.F. Sisk Dam is a zoned earthfill structure that includes a wide central core (Zone1) with downstream drainage zones (Zones 2 and 4), a drainage blanket (Zones 2 and 4), and a toe drain. A typical section of the Dam is illustrated in Figure 2.

The upstream face of the dam is sloped at 3:1 horizontal to vertical (H:V) above elevation 400 and 8:1 H:V below elevation 400. The downstream face of the dam at the maximum section is sloped at 2:1 H:V above elevation 450, 2.5:1 H:V from elevation 450 to elevation 400, 6:1 H:V from elevation 400 to 290, and 2:1 H:V from elevation 290 to the downstream toe. The dam embankment has seven zones with the central zone consisting of low plasticity clay. The downstream face of the dam is covered by a 2-foot-thick rock blanket and the upstream face is covered by a 3-foot-thick layer of riprap. There is a saddle dike located along the north rim of the reservoir approximately 1,300 feet from the dam.

In September of 1981, four stability berms (three upstream and one downstream) were added as a result of an upstream slope failure caused by rapid drawdown.

Figure 2. Typical Section of B.F. Sisk Dam

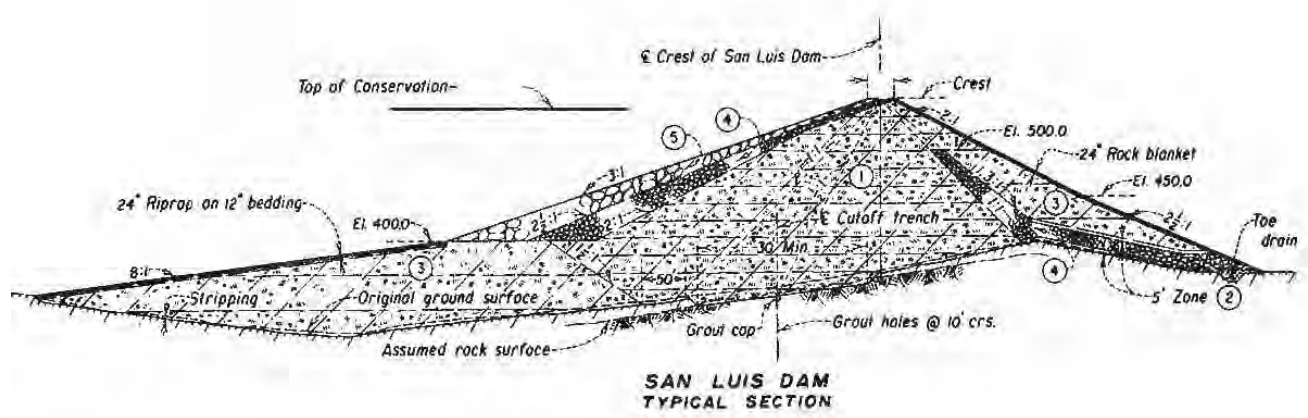

Figure 3. Close-up of B.F. Sisk Dam and Gianelli Pumping-Generating Plant



4.1.2 Gianelli Pumping-Generating Plant

The following paragraphs were taken from the Appraisal-Level Study of Static Stability for Increased Storage Technical Memorandum included as part of Attachment A to this report.

Gianelli Pumping-Generating Plant

The Gianelli Pumping-Generating Plant located at the left, northern, abutment of the dam (Figure 3) and serves as the outlet works for the dam. The outlet capacity of the plant is approximately 16,000 cubic-feet per second (cfs) with a full reservoir. The intakes to the penstocks are located near the left abutment of the dam and consist of a 284-foot-high structure containing four trashrack structures and four parallel 17.5-foot-diameter concrete tunnels/penstocks. The inlet to each tunnel is controlled by a roller-mounted emergency closure gate located in each trashrack structure. The tunnels are approximately 2,230 feet long with the last 1,180 feet of each tunnel containing a steel liner. The concrete tunnels/penstocks bifurcate to eight 11.5-foot diameter steel penstocks, with each steel penstock serving a pump-generator unit in the pump-generating plant. A 156-inch-diameter butterfly valve is located in each of the 11.5-foot-diameter steel penstocks just upstream from its respective pump-generator unit.

Each of the eight pump-generating units has a capacity of 63,000 horsepower as a motor, and 53,000 horsepower as a generator. Each unit features two-speed motor-generators by means of two rotors mounted on the same vertical shaft connected to Francis-type turbines. The lower motor operates at 150 revolutions per minute (rpm) and the upper motor operates at 120 rpm. The 150-rpm-motor is used for heads exceeding 190 feet while pumping and 227 feet while generating. In 1983, Units 1 and 5 were converted from 150 rpm to 156.5 rpm operation to increase efficiency at the higher head encountered when topping off the San Luis Reservoir.

4.1.3 Intake Towers / Trashrack Structures

Four separate trashrack structures, constructed on a common base and controlled by roller-mounted emergency closure gates, are provided at the reservoir end of the outlet tunnels and are joined to the tunnels by sections of conduit. The trashrack structures also serve as intake, discharge, and gate structures. Figure 4 is a profile view, looking north, of the trashrack structures, and their access bridge.

Figure 4. Outlet works intake towers and access bridge



Each trashrack structure consists of a rectangular semi-bell mouth-shaped entrance joining a transition which changes from rectangular to a circular cross section. The entrance opening is a rectangle, 23.0 by 28.5 feet in size, and is vertical to permit seating of a 23.0- by 28.5-foot bulkhead gate. The centers of the entrance openings are at elevation 287.25 which is 38.75 feet below the minimum RWS elevation.

Each trashrack structure is provided with a 17.5- by 22.89-foot roller-mounted gate which operates in slots located 10 feet from the entrance opening. The roller-mounted gates provide emergency closure of the outlet works tunnels in the event of a failure of the penstocks or a malfunction of the butterfly valves installed near the pump turbine units. The emergency gate closure also permits dewatering of the tunnels for inspection, maintenance, and repair. The roller-mounted closure gates are actuated by hydraulic hoists whose pistons are sufficiently long to close the gates with a single thrust. Each hoist is mounted on the top of the trashrack structure in the open position.

A single bulkhead gate is provided to be lowered over the entrance opening of any one of the trashrack structures to permit inspection, maintenance, and repair of the roller-mounted gate seats and guides. A gantry crane provides means of moving the bulkhead gate to a particular trashrack structure and in lowering and raising the gate.

4.1.4 Trashrack Structure Access Bridge

Vehicular and pedestrian access to the trashrack structures is provided by a 16-foot-wide bridge, about 1,060 feet long, which connects the crest of the dam with the left trashrack structure (Figure 4, Figure 5). The trashrack structures are connected by bridges which support the gantry crane.

4.1.5 Spillway

An uncontrolled concrete morning-glory-type spillway is located at the left abutment of the dam near station 139+00 (Figure 5). The full length of the spillway was excavated into bedrock. The upstream 350-foot section is a cut-and-cover conduit through the dam embankment and the left abutment. The remaining approximately 1000 feet to the stilling basin is an open chute. The design discharge capacity for the spillway is 1,030 cfs.

Figure 5. Overview of B.F. Sisk inlet and outlet structures



4.2 Reservoir Area-Capacity

The Technical Record of Design and Construction (Reclamation 1974) indicates San Luis Reservoir has a surface area of 12,700 AF and an approximate capacity of 2,040,500 AF at the current maximum reservoir elevation (Figure 6).

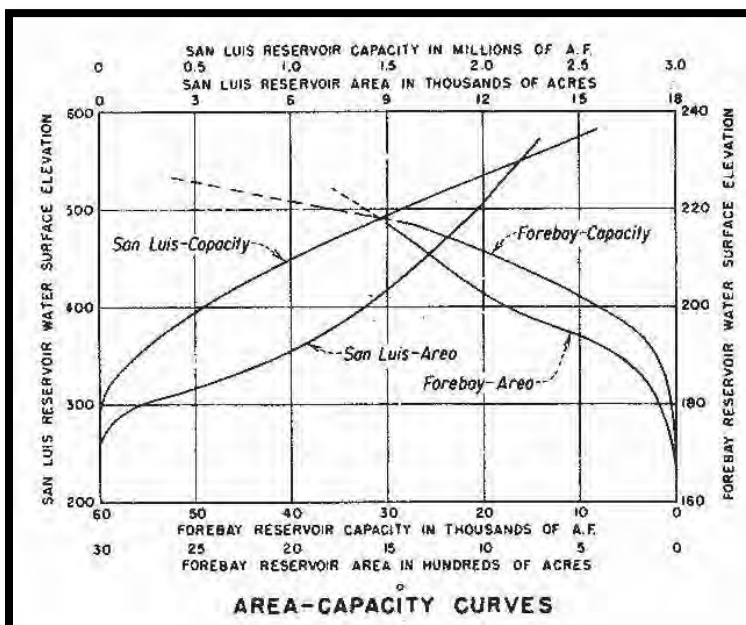

Figure 6. Area-Capacity curves for San Luis Reservoir and O'Neill Forebay

This existing area capacity curve was calculated from a July 1960 aerial topographic survey. A contemporary topographic survey around the reservoir rim would be necessary for a more precise capacity increase calculation. As such, the reported increase in area capacity associated with a 10-foot reservoir raise is approximate. The existing area-capacity curve indicates total capacity of the reservoir with a 10-foot RWS raise would be approximately 2,226,500 AF, an increase of 131,500 AF. Extrapolating the surface area of 12,700 AF vertically 10 feet yields a capacity increase of 127,000 AF. For the purposes of this appraisal-level study, the increase in capacity associated with a 10-foot RWS raise is assumed to be approximately 130,000 AF.

4.3 Related Projects

The purpose of this section is to call attention to other known projects and project proposals which should be considered if a feasibility-level investigation is pursued as a result of this Appraisal Report.

Safety of Dams Corrective Action Study, B.F. Sisk Dam

Studies have determined that B.F. Sisk dam poses a potential risk of seismic failure. As such, Reclamation's Safety of Dams office has initiated a Corrective Action Study (CAS) with DWR to determine a course of action to reduce the risk of dam failure. Current activities include the development of an EIS/EIR, geologic investigations, economic analysis, and preliminary engineering designs of various alternatives. The preliminary cross sections and dam raise designs described within this appraisal study have taken into account the dam safety issues that have been illuminated by the CAS.

The preliminary cost estimates completed for this study include costs for modifications that will be required to attain an appropriate static safety factor for the embankment. Dynamic (seismic) forces were not evaluated as part of this appraisal study. Costs related to dam safety upgrades necessary under static conditions account for approximately one third of the overall costs of the dam raise.

Gianelli Pumping-Generating Plant Refurbishment Project

Increasing demands to run the pumping-generating plant units to meet changing operational needs has led to increased wear and tear of the units. The units operate throughout a wide range of reservoir elevations during a normal water delivery season. Currently, three major refurbishment projects are underway to restore the reliability of the Gianelli Pumping-Generating facility.

Motor-Generator Speed Conversion

The 8 units at Gianelli are unique in that a double motor-generator is mounted on each shaft. The lower motor-generator runs at 150 rpm and the upper runs at 120 rpm to improve efficiency and performance over the large range in head due to fluctuations in San Luis Reservoir. The 150 rpm rotors on Units 1 and 5 were converted to 156.5rpm in the mid-1980s to improve performance when "topping" off the reservoir. Two more units are scheduled for speed conversions as part of an extensive plan to rewind each of the motor-generators.

Pump-Turbines Refurbishment

Over the years, the pump/turbine casings have incurred significant metal loss from normal corrosion and cavitation. DWR has begun the process of refurbishing all of the units.

Butterfly valves Refurbishment/Replacement

Each of the 8 units has a 156-inch butterfly valve and the units are paired into four common penstocks. When one butterfly valve fails, two units are affected. As of early 2013, one valve has been refurbished and was currently being installed back on Unit 5.

The projects listed above are currently in progress and are scheduled to be completed by 2026 at an estimated to cost \$191.8M, of which the federal share is approximately \$84.6M.

Proposed San Luis Reservoir Solar Project

The U.S. Department of Interior has established as a priority the development of renewable energy resources. As such, Reclamation has been collaborating with others to identify and implement renewable energy projects. To achieve that goal a multi-disciplinary team including the Bureau of Reclamation, California Department of Water Resources, and California State Parks and Recreation was recently formed to identify land use constraints associated with developing a utility-scale solar generation facility at B. F. Sisk Dam.

The solar project, as proposed, would be a ground based, tracker mounted solar facility located on land owned by Reclamation and located adjacent to the San Luis Reservoir and the O'Neill Forebay. Between twenty (20) and one hundred (100) megawatts of solar arrays in a multi-phased project would be installed at one or more locations in the area of the San Luis Unit.

San Luis Low Point Improvement Project

San Luis Reservoir is capable of receiving water from both the DMC and the CA, which enables the CVP and SWP to pump water into the reservoir during the wet season (October through March) and release water into the conveyance facilities during the dry season (April through September) when demands are higher. Deliveries from San Luis Reservoir also flow west through Pacheco Pumping Plant and Conduit to the San Felipe Division of the CVP (Figure 1), which includes the SCVWD.

High temperatures and typically low reservoir levels during the summer months create conditions that foster algae growth in the surficial waters of San Luis Reservoir. When the RWS elevation approaches the elevation of the Pacheco Intakes, summer algal blooms cause water quality that is not suitable for municipal and industrial water users relying on existing water treatment facilities in Santa Clara County.

Typically, low point conditions occur when water levels in San Luis Reservoir reach an elevation of 369 feet above mean sea level or reservoir volume of approximately 300 TAF, when the water is approximately 35 feet above the top of the Lower Pacheco Intake. If water levels fall below 369 feet, the San Felipe Division's use of CVP supplies could be limited by algae-related water

quality effects. San Luis Reservoir is the only delivery route for the San Felipe Division's CVP supplies authorized under their current CVP Water Service Contracts.

Reclamation, working with SCVWD, is exploring options to address the low point problem. The SLLPIP considers a Combination Alternative, Water Treatment Facility Upgrade Alternative, and a Bypass Alternative, to reduce the risk of "low point" water levels. These alternatives are being analyzed in a Draft Planning Study and Draft EIS/EIR. Reclamation and its consultant are working with SCVWD to refine the Combination Alternative as the locally preferred plan.

Measures contained in the alternative include:

- Routing CVP Water through the State's South Bay Aqueduct through an exchange of CVP and SWP water;
- Reoperation of Anderson Reservoir to provide additional local supplies;
- Blending San Luis Reservoir deliveries with those from Anderson Reservoir water to improve water quality for local consumptive uses;
- Development of new groundwater extraction capacity in the SCVWD service area; and
- Construction of a new groundwater recharge pond to provide adequate aquifer recharge.

Implementation of this project would provide operational flexibility of the San Luis Reservoir and improve reliability of water deliveries to CVP contractors.

4.4 Previous Studies

This section is intended to provide a brief description of previously completed studies that are related to the problems, opportunities, and objectives of this study.

CALFED Initial Surface Water Storage Screening, Integrated Storage Investigation

This report, published by CALFED (2000b), summarizes the initial screening for potential new surface water storage reservoirs to help meet the objectives of the CALFED Bay-Delta Program. CALFED began the initial screening with a list of fifty-two potential reservoir sites, including consideration of expansion of San Luis. Forty surface storage projects were removed during the initial screening for not significantly contributing to the CALFED multiple purpose objectives, including water supply, flood control, water quality, and ecosystem. The report is clear that those sites not retained for additional CALFED consideration would still be candidates for development by others for other purposes.

Enlarging of San Luis Reservoir was considered and eliminated from further analysis for apparent implementability conflicts. The CALFED program considered a dam raise of 40 feet in order to increase storage by 390 TAF. It was estimated that a total of 16 million cubic yards of material would have to be excavated to allow for the necessary extension of the drain and filter zones on the embankment. It was also hypothesized that the San Luis facility would need to be out of service for nearly 2 years in order to construct the raise. It was this potential long term shut down that rendered a Sisk dam raise not implementable and therefore screened out of further CALFED surface storage investigations. It was concluded that an enlargement of San Luis Reservoir in conjunction with a planned outage for another reason could be very attractive.

CALFED Surface Storage Program

The CALFED Final Programmatic Record of Decision (ROD) (CALFED 2000a) identified five surface storage projects that would contribute to the objectives of the program, including: North-of-the-Delta Off-stream Storage (NODOS) Investigation, Upper San Joaquin River Basin Storage Investigation (USJRBSI), Los Vaqueros Expansion (LVE) Investigation, Shasta Lake Water Resources Investigation (SLWRI), and In-Delta Storage Program (Figure 7). State participation in the In-Delta Storage Program was suspended in July 2006 when state funding was terminated and Reclamation did not receive authority to study the project.

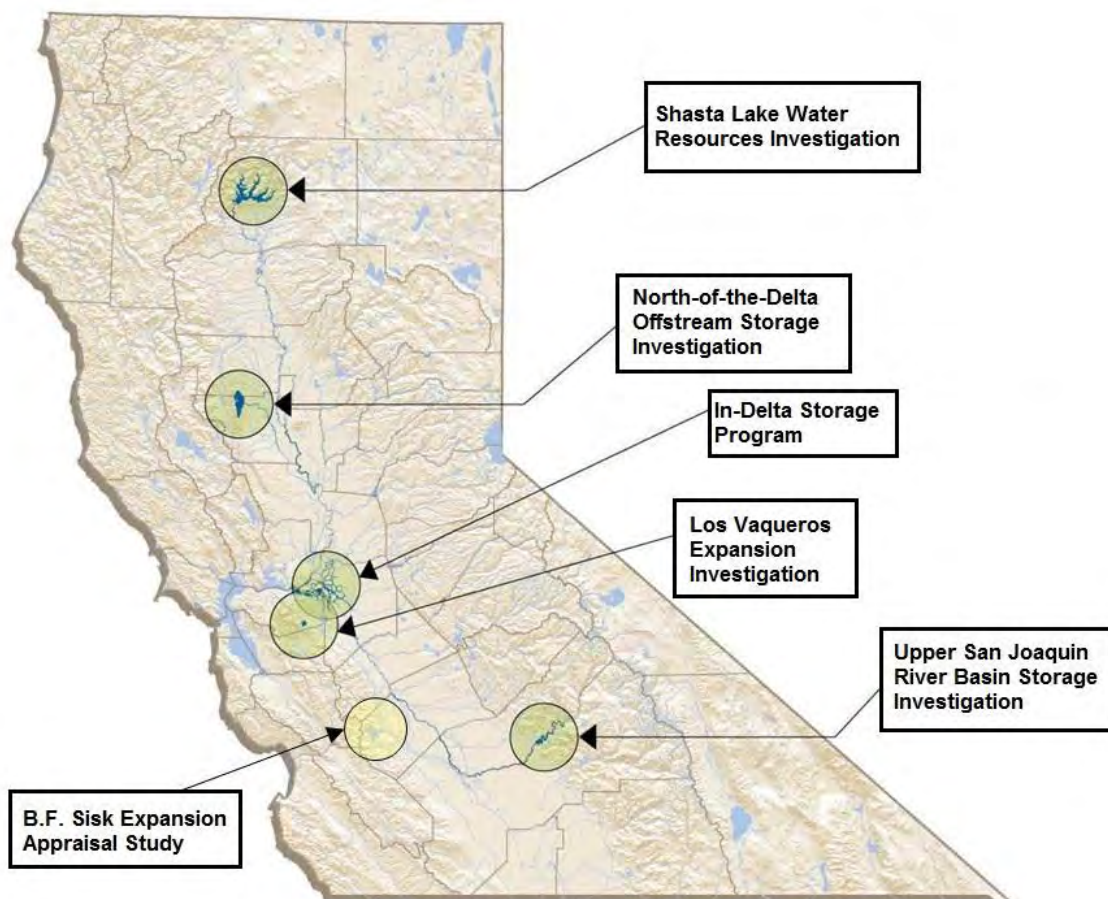

Figure 7. Locations of CALFED surface storage investigations relative to the Sisk study area¹.

The CALFED surface storage investigations are conceived to support multiple objectives that combine ecosystem restoration and water quality improvements with more traditional purposes of water supply reliability, hydropower, and flood protection. Since initiation of the surface storage investigations, the planning, biological, and regulatory conditions have changed significantly, including updated BOs for delta smelt and salmon, Delta export constraints, new State water legislation, and proposed operations contained in the BDCP. The investigations have been adapting to these changes and integrating new information into the feasibility studies and environmental review.

¹ This Appraisal Study is not a CALFED storage investigation, Figure 7 is for geographic reference only.

4.5 Influencing Contracts, Agreements, and Conditions

The following projects, contracts, agreements, and conditions have been considered as having the potential to influence the outcome of this appraisal study and/or being relevant to the conclusions and recommendations which will be included in this report.

State Water Resources Control Board Revised Water Right Decision 1641

The 1995 Bay-Delta Water Quality Control Plan (WQCP) contains current water quality objectives for the San Francisco Bay/Sacramento-San Joaquin Delta Estuary. SWRCB D-1641 (SWRCB 2000) and Water Right Order 2001-05 contain the current water right requirements to implement the 1995 WQCP. D-1641 incorporates water right settlement agreements between Reclamation and DWR and certain water users in the Delta and upstream watersheds regarding contributions of flows to meet water quality objectives. However, the SWRCB imposed terms and conditions on water rights held by Reclamation and DWR that require these two agencies, in some circumstances, to meet many of the water quality objectives established in the 1995 WQCP. D-1641 also authorizes the CVP and SWP to use joint points of diversion (JPOD) in the south Delta, and recognizes the CALFED Operations Coordination Group process for operational flexibility in applying or relaxing certain protective standards.

Joint Point of Diversion

The Joint Point of Diversion (JPOD) refers to the CVP/SWPs' shared use of each other's pumping facilities in the south Delta to export water from the Delta. The CVP and SWP have historically coordinated use of Delta export pumping facilities to assist with deliveries and to aid each other during times of facility failures. In 1978, by agreement with DWR, and with authorization from the SWRCB, the CVP began using the SWP Banks Pumping Plant for replacement pumping (195 TAF per year) for lost capacity at Jones Pumping Plant because of striped bass export restrictions in SWRCB Water Right Decision 1485. In 1986, Reclamation and DWR formally agreed that "either party may make use of its facilities available to the other party for export and conveyance of water by written agreement" and that the SWP would pump CVP water to make up for striped bass protection measures (USBR and DWR 1986).

Coordinated Operations Agreement

The COA defines how Reclamation and DWR share their joint responsibility to meet Delta water quality standards and the water demands of senior water right holders, and how the two agencies share surplus flows (USBR and DWR 1986). The COA defines the Delta as being in either "balanced water conditions" or "excess water conditions." Balanced water conditions are periods when Delta inflows are just sufficient to meet water user demands within the Delta, outflow requirements for water quality and flow standards, and export demands. Under excess water conditions, Delta outflow exceeds the flow required to meet the water quality and flow standards. Typically, the Delta is in balanced water conditions from June to November, and in

excess water conditions from December through May. However, depending on the volume and timing of winter runoff, excess or balanced water conditions may extend throughout the year.

With the goal of using coordinated management of surplus flows in the Delta to improve Delta export and conveyance capability, the COA received Congressional approval in 1986, and became Public Law 99-546. The COA, as modified by interim agreements, coordinates operations between the CVP and SWP, and provides for the equitable sharing of surplus water supply. The COA requires that the CVP and SWP operate in conjunction to meet State water quality objectives in the Bay-Delta estuary, except as specified. Under this agreement, the CVP and SWP can each contract from the other for the purchase of surplus water supplies, potentially increasing the efficiency of combined water operations.

Biological Opinions on Long-term Operation of the Central Valley Project and State Water Project

Since 2004, NMFS and USFWS BOs regarding effects of the proposed long-term operation of the CVP/SWP have been revised twice. On October 22, 2004, NMFS issued a BO regarding effects of the proposed long-term operations for the CVP in coordination with the SWP on winter-run Chinook salmon, spring-run Chinook salmon, Central Valley steelhead, Southern Oregon/Northern California Coast Coho salmon, and Central California Coast steelhead and their designated critical habitats. On February 16, 2005, USFWS issued a BO regarding effects of the proposed long-term operations on delta smelt. The 2004 and 2005 BOs supersede the prior BOs issued by NMFS and USFWS, and contain reasonable and prudent measures and terms and conditions that specify fisheries monitoring actions, spawning gravel augmentation, forecasting of deliverable water, management of cold-water supply within reservoirs, temperature monitoring, adaptive management processes to analyze annual cold-water management, minimization of flow fluctuations, passage at Red Bluff Diversion Dam, operation of gates in the Delta, fish screening at export facilities, and numerous other effects minimization measures. In response to litigation, the 2004 and 2005 BOs were remanded to NMFS and USFWS for revision, but were not vacated.

In August 2008, Reclamation reinitiated consultation with the fishery agencies based on the 2008 *Biological Assessment on the Continued Long-Term Operations of the CVP and SWP* (2008 OCAP BA). In December 2008, the USFWS issued a new BO, *Formal Endangered Species Act Consultation on the Proposed Coordinated Operations of the CVP and SWP*, finding that the long-term operations of the CVP and SWP would jeopardize the continued existence of the Delta smelt. In July 2009, NMFS issued a new BO finding that the same operations would jeopardize populations of listed salmonids, steelhead, green sturgeon and orcas. Because both agencies made jeopardy determinations, both agencies included a reasonable and prudent alternative (RPA) in their BOs.

In response to lawsuits challenging the 2008 and 2009 BOs, the District Court for the Eastern District of California (District Court) remanded the BOs to USFWS and NMFS in 2010 and 2011, respectively. The District Court ordered USFWS and Reclamation to prepare a final BO and associated final NEPA document by December 1, 2013. Similarly, the District Court ordered NMFS and Reclamation to prepare a final BO and associated final NEPA document by February 1, 2016. These legal challenges may result in changes in CVP and SWP operational constraints, if the revised USFWS and NMFS BOs contain new or amended RPAs. Despite this uncertainty, the 2008 and 2009 BOs issued by the fishery agencies contain the most recent estimate of potential changes in water operations that could occur in the near future. Furthermore, it is anticipated that the final BOs issued by the resource agencies will contain similar RPAs. Because the RPAs contained in the 2008 and 2009 BOs have the potential to significantly impact CVP/SWP operations and potential benefits of CVP Operations, they have been implemented in this analysis.

DRAFT

5.0 MANAGEMENT MEASURES

The purpose of this section is to provide a brief discussion of the process to develop management measures to achieve study objectives. The sections to follow briefly describe a range of dam raise concepts and management measures identified during the appraisal study. A management measure is a feature or activity that can be implemented at a specific geographic site to address one or more planning objectives. Measures are the building blocks of which alternative plans are made. Measures become more specific and better defined as planning progresses (IWR 1996).

5.1 Non-Structural Measures

Non-Structural measures could potentially contribute to meeting the objectives of this study. The Safety of Dams CAS has preliminarily evaluated some of the non-structural alternatives discussed below (Reclamation 2013b). The following non-structural measures have been identified which could be studied in further detail if a feasibility level evaluation is pursued.

Reservoir Restrictions / Increased Freeboard

Dam safety risks could potentially be reduced by lowering the reservoir level such that even if the dam were to experience a large crest settlement, a breach leading to failure would not occur. Since B.F. Sisk is an off-stream storage facility, a reservoir restriction is feasibly obtained by not filling (pumping into) the reservoir. This measure would consist only of a change in operations, so it is considered non-structural.

Based on current seismic deformation estimates (Reclamation 2013b) it appears that a permanent restriction of at least 50 feet would be required to reduce the risk to within current Reclamation Public Protection Guidelines. This would require a substantial reallocation and reduction of project water deliveries and would significantly reduce the amount of power which can be generated.

Demand Reduction / Water Use Efficiency

As a means to reduce demands on existing supplies, further studies could investigate the ability of existing Reclamation water reuse and water use efficiency programs to ease demands on the San Luis Reservoir. A water reuse project is a project that reclaims and reuses municipal, industrial, domestic, or agricultural wastewater and naturally impaired groundwater and/or surface waters. Reclaimed water can be used for a variety of purposes such as environmental restoration, fish and wildlife, groundwater recharge, municipal, domestic, industrial, agricultural, power generation, or recreation.

Reclamation's Water Use Efficiency Program offers grant opportunities for water conservation and water use efficiency projects. The goal of the program is to accelerate the implementation of cost-effective actions that provide water management benefits through conservation. Water use

efficiency implementation is intrinsically linked to other benefits such as water quality, water supply reliability, and in stream flows (Reclamation 2013a).

Dredging to Create Additional Storage Capacity

As a non-structural measure, the CAS has preliminarily considered dredging of material from within the reservoir as a means to create additional storage capacity. This measure could be further evaluated in the future and may have merit if existing borrow sources are limited.

Changes in Operations

Further studies could evaluate operational changes at San Luis Reservoir that may improve water delivery reliability, such as adding a carryover storage component.

Groundwater Storage

Further studies could evaluate potential use of groundwater storage opportunities throughout the Central Valley. Groundwater storage could be evaluated for use in conjunction with or as an alternative to more surface water.

Pumping Capacity Restrictions

Non-structural evaluations could consider the benefits and impacts of increased Delta pumping limits during less sensitive times of the year for fish and water quality.

5.2 Structural Measures

Structural measures refer to features that require construction or assembly on-site. Structural measures could potentially contribute to meeting the objectives of this study. The structural measures identified and described below could be studied in further detail if a feasibility level evaluation is pursued.

Downstream Stability Berms

B.F. Sisk Dam is founded on four different geologic units: Panoche Formation (rock), Tulare Formation, Slopewash, and Patterson Alluvium. Previous studies have shown that the undrained strength of the Slopewash and the liquefied strength of the Patterson Alluvium, triggered by seismic loading, result in significant deformations (crest settlement) of the dam at those locations. These dynamically unstable areas can be stabilized with the use of berms located at the downstream toe of the dam and keyed into high strength foundation material.

The berms are constructed by first excavating overburden foundation soils down to either the dense basal gravel layer or bedrock beneath the berm footprint. During this excavation, the rock blanket or slope protection is also removed to the top elevation of the berm. Next, the existing toe drain is removed by excavation. These two operations would expose the existing blanket drain and surrounding filter materials in the downstream face of the dam. Above the blanket drain, the existing Zone 3 shell would be exposed. After completion of the excavations, backfill would be placed and compacted. Incorporated into the primary backfill material is an extension

of the blanket drain that connects to a new toe drain constructed at the toe of the berm. The final step is to place slope protection on the downstream face of the berm.

Downstream Crack Filters

Crest settlement in response to a seismic event can result in two types of failure: dam overtopping and post-earthquake erosion through cracks caused by shaking or settlement. The stability berm and crest raise measures primarily address the overtopping issue. The cracking issue is addressed by a filter being incorporated into the crest raise geometry and added to the upper part of the downstream face of the dam. Significant seismic deformations typically produce cracking of the embankment near the crest. Deformation cracking for embankments on liquefiable foundations is typically limited to depths of about 10 to 25% of the embankment height based on historical performance records of embankment dams. The primary function of the downstream filter zones is to provide a filter to mitigate the potential for internal erosion through post-seismic crest cracks.

Various Crest / Embankment Raises

Crest raise measures include raising the height of the dam to increase the amount of available freeboard and to provide space for additional reservoir storage capacity. Crest raises of various heights could be studied in order to balance needs for additional freeboard and additional storage space. The conceptual structural designs analyzed for this appraisal study built upon existing designs and concepts that were developed as part of a CAS.

Three crest raise methodologies were conceptualized during the CAS that were also evaluated for the appraisal study. The following two concepts were eliminated from further consideration due to the lack of erosion control measures that were shown to cause significant cracking of the dam crest in the event of a large earthquake:

- Steepened upstream and downstream slopes utilizing either a reinforced earth section or soil cement for the upstream and downstream slope faces; and,
- Vertical upstream and downstream slopes using a mechanically stabilized earth (MSE) wall section

A third conceptual design was carried forward in the CAS and is similar to the conceptual design that was developed for the appraisal study.

Alternative Dam Sites

Further studies could consider alternative dam sites within or adjacent to the San Luis Reservoir.

5.3 Alternatives

Alternatives consist of a set of one or more management measures functioning together to address one or more planning objectives. It is not within the scope of an appraisal study to analyze or recommend alternatives; rather, the appraisal study is intended to identify a range of management measures that may be combined into alternatives to be studied further if a feasibility level study is authorized.

Alternatives can consist of structural and/or non-structural measures and also always include a no action alternative in order to describe “future without” conditions. In order to get an appraisal level cost estimate a conceptual dam raise alternative needed to be formulated as a basis for material quantities and construction methods to be estimated. The sections below discuss the no action and a conceptual dam raise alternative which were developed during technical studies completed during the appraisal process.

5.3.1 No Action Alternative

Defining likely without-project conditions (the No Action Alternative) is an important step in federal water resources planning. The without-project conditions aid in accurately defining water resources problems and needs. The without-project conditions serve as a baseline against which alternatives can be evaluated to determine their effectiveness, and to identify resulting impacts. In defining the without-project conditions, changes in parameters are taken into account such as projections related to population, land uses, and new local and regional water resources and programs related to local and regional water resources. Normally only currently adopted projections and/or projects that are either under construction or authorized and funded, would be included in the without-project conditions.

If a feasibility level evaluation is pursued, that study will need to evaluate potential impacts of taking no action. For this study, the CALSIM-II and CalLite baseline models are considered the “with-out project condition” to which the increased storage scenarios were compared.

5.3.2 Conceptual Dam Raise Alternative

The embankment raise concept developed for this study includes two structural components; a crest raise, and downstream stability berms. Both of these components have been included in the appraisal-level studies to maintain consistency with the Safety of Dams CAS. The crest raise component is required to accommodate the additional volume of water and some degree of increased freeboard and the downstream stability berms are necessary to increase static and dynamic stability of the embankment to the appropriate safety factor. In order to raise B.F. Sisk Dam, corresponding modifications to the dam embankment, dike, spillway, intake towers, and access-bridge would be needed.

In this study, a conceptual dam raise alternative was identified based on balancing the need for additional storage while minimizing impacts to existing facilities. This concept was also developed in a way to limit impacts to project costs by limiting the number and types of facilities affected by potential dam expansion construction.

In order to develop appraisal level field cost estimates a conceptual alternative needed to be formulated. The conceptual alternative evaluated for this appraisal study included a 10-foot RWS raise in conjunction with a 20-foot embankment raise.

Figure 8 is a graphic summary and typical section of the proposed modification alternative.

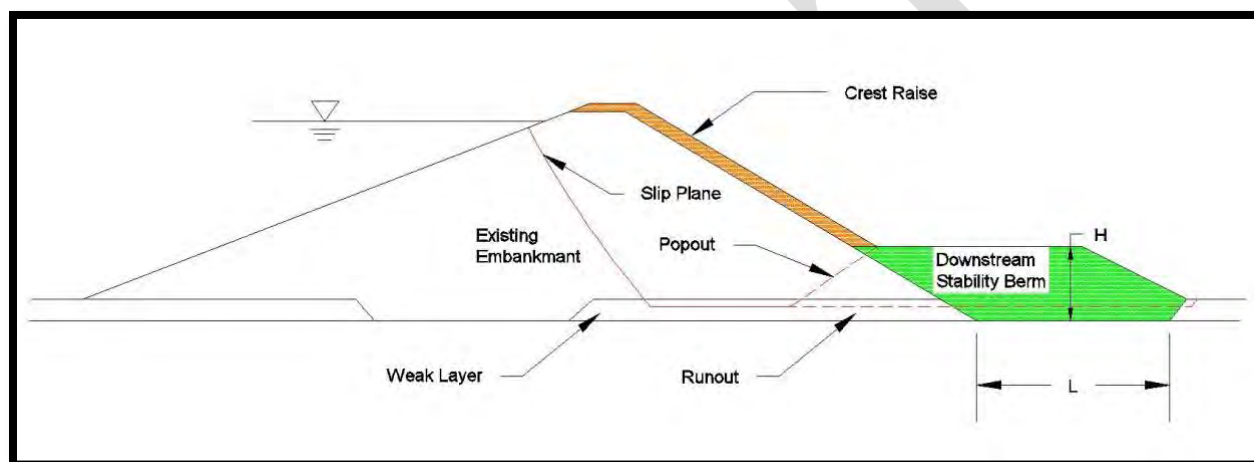

Figure 8. Typical section of the conceptual modification alternative

Construction Considerations

The scope of the proposed modifications will likely require multi-year phasing of the work and thorough coordination between construction contractors. Construction sequencing will be required to allow some of the outlet works intake towers to remain operational while other towers undergo demolition and reconstruction. Due to the location of the intake towers within the reservoir, the limited access, and the desire to maintain water storage during construction, use of a barge will likely be required for demolition and construction of the intake towers.

Construction sequencing will be required for excavation, demolition, and reconstruction of the spillway to ensure the RWS is well below the level of the modifications. Construction may impact several recreation areas around the reservoir. Evaluation of whether these areas can remain open during construction and how they may be impacted by higher water levels should be considered during the feasibility phase of study.

6.0 CONSIDERATIONS FOR STRUCTURAL MODIFICATIONS

The sections below summarize the structural modifications that would be needed to implement the conceptual alternative as described in the previous section (5.3.2).

6.1 Intake Towers/Trashrack Structures

In order to increase the San Luis Reservoir water surface by 10 feet, the existing intake towers would need to be raised a corresponding 10 feet. To accomplish this, the top 16.25 feet of the existing towers would be demolished. The intake tower walls would be extended vertically using forms and cast-in-place concrete. The intake tower operating platform with support corbels would be reconstructed as originally designed.

Prior to demolition of the top of the intake towers, all existing equipment including the roller gate, hoist stem extension, gantry crane, and bulkhead gate would be removed. This equipment would be re-installed after extension of the intake towers is completed.

6.2 Trashrack Structure Access Bridge

The current access bridge deck elevation is at the same elevation as the crest of the dam and the top of the intake tower/trashrack structures. The bridge span would be removed and replaced with a similar-type superstructure at an appropriately raised elevation. The new bridge deck elevation would vary between the intake towers and the abutment. The existing bridge piers would be extended vertically and the new bridge would be founded on the extended piers.

An analysis of the feasibility of raising this access bridge has been carried out and has determined that raising the access bridge is technically feasible. The cost of raising the bridge has been estimated to be on the order of \$11,000,000. Technical Memorandum BFS-8140-STY-2013-1 and cost estimates have been included in Attachment A of this report

6.3 Spillway

The morning glory spillway is located approximately 100 feet upstream of the centerline of the dam near station 139+00, and the access bridge for the intake towers intersects the crest at approximately station 140+50, as shown on Figure 5. The upper 22 feet of the spillway would be demolished. The spillway would then be raised 10 feet. Excavation of the upstream face of the dam would be necessary to expose the top 22 feet of the spillway. The embankment section would be reconstructed after modifications to the spillway structure were completed.

Modifications to the spillway may also involve covering part of the open chute to accommodate the new fill and/or overlay.

Figure 9. Approximate limits of spillway demolition

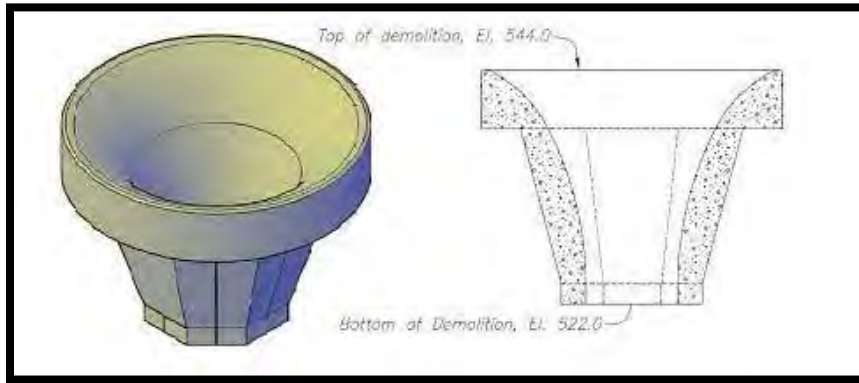

Modifications to the spillway will be required if the dam is raised. The spillway modification will most likely be limited to cutting away the existing upstream opening (Figure 9), raising the spillway, and replacing the spillway opening.

DRAFT

7.0 WATER OPERATIONS AND BENEFITS FORECAST

The purpose of this section is to briefly describe existing operations at San Luis Reservoir and to discuss the methodology and results of the appraisal level estimates of water supply benefits which are presented in this section.

7.1 Existing Operations

The total capacity of San Luis Reservoir, as reported by the Reclamation Central Valley Operations Office (CVOO) in 2013, is 2,028 TAF. The federal share of San Luis Reservoir capacity is 966 TAF and the State share is 1,062 TAF. The Federal share is operated by the Reclamation CVOO while the State share is operated by the SWP Operation Control Office. CVP south-of-Delta water demands primarily include M&I, irrigation, refuge, and other environmental purposes. CVOO operates the reservoir on an annual basis to maximize use of available water to meet CVP contractors' contracts and the requirements of other authorized purposes. Typically, San Luis Reservoir is filled during October through March from available supplies in the Delta and is drawn down from April through September to supplement Delta exports during those high demand months. Water from the Delta is pumped into San Luis Reservoir via the CVP DMC and SWP CA when not needed for direct delivery. The goal is to fill the reservoir to the maximum extent possible with available supplies from the Delta in the wet season. Water previously stored in the reservoir is released through the Pacheco Tunnel to the San Felipe Division and/or through the Gianelli Intake to CVP and SWP contractors south of the Delta. In order to illustrate the variability in annual San Luis operations, Figure 10 depicts a 10-year plot of long-term reservoir volume.

Figure 10. A 10 year plot of long-term San Luis reservoir volume

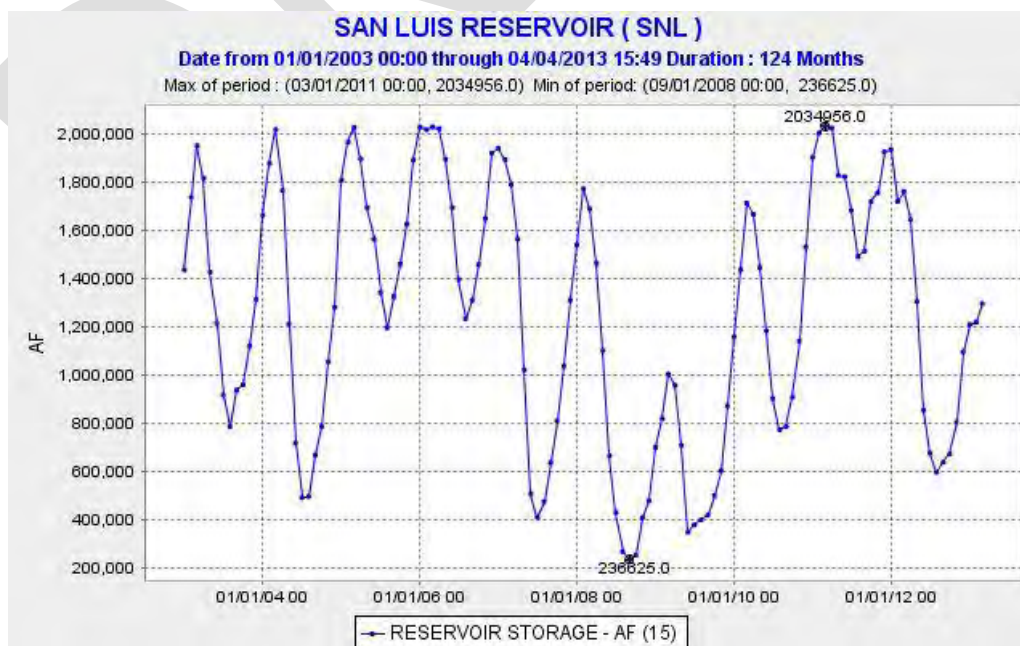

7.2 Water Supply Forecast

This analysis is focused on assessing, at an appraisal level, the capacity of the CVP and SWP to use additional storage in San Luis Reservoir that would be afforded by raising Sisk Dam. Two analysis methods were used in order to bracket the potential water supply benefits: The first method estimates a maximum water supply benefit by using a spreadsheet analysis to post-process results from an existing baseline CalSim-II study. The analysis estimates additional export opportunities that could have been utilized if there was additional storage capacity at San Luis reservoir; the second method estimates a minimum water supply benefit by using the CalLite model to compare with- and without-project scenario to determine average annual additional deliveries that could occur if there were additional storage capacity in San Luis reservoir.

7.2.1 Method 1: Spreadsheet Analysis of CalSim-II Results

Results from a current CalSim-II baseline operations study were evaluated for this method. The baseline study uses an 82 year period of record as input hydrology, and assumes a 2030 land use level of development. The baseline includes the RPAs from the USFWS BO of 2008 and the NMFS BO of 2009. Detailed descriptions of the CalSim-II baseline assumptions are included in Attachment B to this report.

The objective of this modeling approach was to put an upper bound on potential water supply benefits by looking only at the opportunities that currently exist in the Delta for additional water exports if San Luis Reservoir was larger. Because of the large range of potential operations assumptions involved in delivery of additional CVP and SWP water supplies, a much more detailed and in depth modeling to evaluate how much of these additional exports could actually be delivered when needed and to estimate the economic benefits of such deliveries, would be conducted if feasibility studies are conducted.

To determine opportunities for additional exports, the following restrictions were evaluated for each month in the baseline study: Banks and Jones permit and capacity limits, Export/Import ratio control limit, D-1641 and RPA export limits, and Old and Middle River (OMR) flow standards. This method assumes that if the baseline study exports in each month were less than the minimum of all export restrictions, and there was surplus Delta outflow, then there was opportunity for additional exports which could not be realized due to lack of storage. CVP and SWP exports and storage were assumed to be combined, and the split between the projects was not evaluated. Attachment B to this report describes the calculations used.

This analysis recognizes that that while CalSim-II is the best available tool for modeling CVP/SWP operations there may be significant uncertainties in the results due to the use of the model in a predictive mode rather than its usual comparative mode. The results do however

provide an objective estimation of the potential benefits of enlarging Sisk Dam and San Luis Reservoir.

The summary results of analyzing the CalSim-II baseline study for export opportunities are shown in Table 1. A detailed analysis of export opportunities data is provided in Attachment B to this report.

Opportunities for additional exports occur in 17 years (21% of years) and in 37 months (4% of months) of the 82 year period of analysis. The modeling study has indicated that, under existing conditions, if unlimited storage was available in San Luis Reservoir, the CVP and SWP combined could export an annual average 71 TAF of additional water. Approximately 85% of the additional exports would occur in Wet or Above Normal water years (Table 1). The maximum additional monthly export opportunities in the baseline CalSim-II study is 6 TAF.

Table 1. Maximum additional annual export opportunities in baseline CalSim-II study by water year type*

Water Year Type**	Total	Wet	Above Normal	Below Normal	Dry	Critical
Average Annual Additional Export Opportunities in all 82 years (TAF/yr)	71	155	89	35	7	20

* Results assume unlimited storage at San Luis Reservoir under current regulatory conditions

** Water Year Type is Sacramento Valley Index.

To provide additional information for further studies, a simplified analysis was performed to determine how much additional exports could be stored at different increased reservoir sizes. The additional exports were added to the existing storage in the same month in the CalSim-II study, and that total storage was compared to 8 alternative raise sizes. A continuous model over the period of record would be required to most accurately capture all the effects of additional exports, because any additional supply would have to be delivered immediately for the reservoir space to be available in the following month. This simple analysis instead evaluates each month independently, so may overestimate the storable volume. The modeled result of various reservoir storage increases summarized in Table 2. This table also gives some insight into the reservoir size beyond which no additional annual average benefits may be realized under current operations and within the limitations of this analytical approach.

Table 2. Additional export opportunities that can be stored by various reservoir storage capacity increases*

Reservoir Storage Increase (TAF)	130	175	200	300	400	450	500	Unlimited
Average Annual Additional Export Opportunities in all years (TAF/yr)	43	52	56	67	71	71	71	71

* results modeled from baseline CalSim-II study

7.2.2 Method 2: CalLite Modeling Analysis

CalLite 2.01 was used to analyze the potential delivery benefits of raising Sisk Dam. CalLite is a scaled down version of CalSim which replicates CalSim results quite closely with much faster run-time. As with CalSim, it is a long term planning model designed to analyze differences in water supply reliability between a baseline condition and a proposed alternative. Detailed descriptions of the CalLite baseline assumptions are in Attachment B.

In order to constantly adapt to changing physical, environmental, and regulatory conditions, San Luis Reservoir operations are conditionally variable. This posed a particular challenge for this appraisal study because analyzing the benefits of raising Sisk Dam is particularly sensitive to how San Luis operations are represented in the model. Preliminary modeling analyses conducted for this study have highlighted areas where refinements could be made in the model to improve model application if feasibility level studies are conducted. Such refinements would include using available export capacity to fill the reservoir and adjusting the south-of-Delta allocation to allow delivery of the water once it is there.

CalLite runs were conducted with three alternative sizes of an enlarged San Luis Reservoir, with the only change in the model being the defined size of the reservoir. The increase in reservoir size was split proportionally between CVP and SWP so that the ratio of CVP to SWP storage was the same as currently exists. The intent of these runs was to put an approximate lower bound on delivery benefits of enlarging San Luis, since it is unlikely that all of the additional exports detailed in Method 1 could actually be delivered.

Table 3 shows that in the CalLite results, net CVP deliveries increase while net SWP deliveries decrease. From review of model results, the decrease in SWP deliveries is mostly because with a larger San Luis Reservoir, the CVP utilizes more of its equal pumping share under the OMR export constraint in months when OMR flow limits are controlling, thereby reducing SWP pumping in those months. A secondary reason is that with a larger San Luis, CVP can reduce the amount of unused Federal share under COA that is pumped by SWP, compared to the baseline. These shifts in pumping propagate into deliveries.

Table 3. Average Annual Additional Deliveries of CVP and SWP (TAF/yr)*

Reservoir Storage Increase (TAF)	130		300		500	
	SWP	CVP	SWP	CVP	SWP	CVP
CVP Net Change		12		21		30
SWP						
Table A	4		10		15	
Article 21 (Interruptible)	-10		-20		-27	
Carryover	2		3		3	
SWP Net Change		-4		-8		-9
TOTAL (SWP+CVP)		7		13		21

* combined from simplified CalLite studies compared to the 2013 CalLite Baseline

Another reason for the lack of increase in SWP deliveries is that for SWP, an enlarged San Luis often leads to a shift of deliveries from Article 21 (interruptible) to Table A, without increasing overall SWP deliveries. Article 21 deliveries are only made when San Luis is full, which is less likely in the alternatives. There is a benefit to this shift that is not captured in the numbers shown, because Table A deliveries are preferable to Article 21 since they are firm yield on which contractors can depend. Additional analysis and discussion of the modeled benefit forecast is included in Attachment B.

As indicated in Table 4, north-of-Delta storages were not significantly impacted in the alternatives modeled, indicating that north-of-Delta deliveries and operations remained constant. Results from the CalLite studies are summarized in Table 3.

Table 4. Change in North-of-Delta Average End of September Storage in CalLite studies (TAF)

Reservoir Storage Increase (TAF)	130	300	500
CVP Shasta + Folsom + Trinity	0.7	-3.6	-4.2
SWP Oroville	0.4	0.1	0.6
Total	1.1	-3.5	-3.6

7.3 Summary of Results

Table 5 shows a comparison of minimum and maximum water supply benefits that were estimated for a range of alternative reservoir storage increases. Keeping in mind the challenges in modeling San Luis Reservoir operations previously discussed, these results represent the range of possible delivery benefits that could be expected to occur, given additional storage at San Luis reservoir. This approach does not account for system wide changes that would occur as a result of addition of new storage to the CVP/SWP system. Numerous factors including year-to-year delivery patterns for CVP and SWP, management of carryover storage in San Luis, sharing of storage and delivery benefits between CVP and SWP, and carriage water and salinity consequences of increased exports of excess Delta outflow have a significant role in determining the water supply benefits of raising B.F. Sisk Dam.

Table 5. Summary of maximum and minimum estimated water supply benefits

Reservoir Storage Increase* (TAF)	130	300	500
Maximum water supply benefit (TAF/yr)	43	67	71
Minimum water supply benefit (TAF/yr)	7	13	21

*storage increases relate to water surface increases of approximately 10', 20', and 35', respectively

8.0 ENVIRONMENTAL

If a feasibility level investigation is authorized, the study will be subject to all scoping, coordination, environmental analysis, and other considerations required by the National Environmental Policy Act (NEPA) and the California Environmental Quality Act (CEQA) and other pertinent Federal, State, Regional, and local laws and policies. Although a large scale, in-depth, environmental investigation was not within the scope of this appraisal evaluation, no major discernible impacts to the environment were identified during the process of completing the study.

A considerable amount of environmental analysis and coordination has been completed in relation to the Safety of Dams CAS and SLLPIP. Further environmental studies, if feasibility level investigations are pursued as part of this effort, will certainly benefit from the work previously completed under these related programs.

During preliminary study scoping and coordination meetings between Reclamation and DWR it was noted that there have been anecdotal expressions of support from the environmental community, water users, and stakeholders for the study of raising Sisk Dam for the purpose of increasing surface storage.

9.0 COST ESTIMATES

Appraisal-level field cost estimates were made for the conceptual design of a 10-foot RWS raise in conjunction with the 20-foot dam raise. Only construction costs are presented here; that is, no contract, design, or remediation costs, or time escalations are included. The contingency includes 15 percent to cover costs for current “unlisted” items and 25 percent to reflect the uncertainty in the appraisal-level quantities. Detailed estimate worksheets are included in Attachment A. Two estimates were made in an attempt to bracket the uncertainty associated with the potential variability of the dam foundation. The worksheets include costs for two different berm sizes for differing strength assumptions, therefore total costs were reported as a range. For the sake of this appraisal study, costs reported in the estimates to follow represent the high end of estimates completed and should be considered only from an “order of magnitude” perspective. Further development and value analysis of designs and cost estimates could potentially find significant cost savings, however at this appraisal level many construction variables are undefined so contingencies are high and cost estimates are very conservative.

For further details on field cost estimates, fill quantities estimated, and other cost estimation considerations please refer to Attachment A of this report.

The values presented in Table 6 are field cost estimates made at the appraisal level and, as such, should not be used for authorization or as a definitive indicator of total project costs. The estimates only include costs for construction and do not include associated costs for design, investigations, project coordination, contract administration, construction management, environmental studies, mitigation, operation and maintenance costs, etc.

Table 6. Summary of appraisal level field cost estimates

Feature	Cost	% Total Cost
Embankment Modifications:		25%
Crest Raise	\$60,589,000	
Downstream Stability Berm Modifications:		67%
SVS Section	\$28,491,900	
NVS Section	\$39,645,500	
Abutment Sections	\$87,022,500 *	
Dike	\$602,000	
Structure Modifications:		8%
Intake Towers	\$4,080,300	
Spillway	\$590,350	
Bridge	\$11,127,200	
Roller Gate	\$576,875	
Gantry Crane	\$557,200	
Bulkhead Gate	\$875,000	
Subtotal:	\$234,157,825 *	100%
TOTAL ESTIMATED FIELD COSTS:	\$360,000,000 **	

NOTES: (*) Costs marked with an asterisk represent the high end of a range of costs estimated. (**) Total estimated field costs include mobilization (~5%), design contingencies (~15%), allowance for procurement strategies (~3%), and construction contingencies (~25%). See Attachment A for detailed cost estimate worksheets.

Contingencies are considered funds to be used after construction starts and not for design changes during project planning. The purpose of contingencies is to identify funds to pay contractors for overruns on quantities, changed site conditions, change orders, etc. As per the Reclamation Cost Estimating Handbook (Reclamation 1989), appraisal-level estimates should have 25± percent added for contingencies. Based on the current level of design data, geologic information, and general knowledge of the conditions at the various sites, the contingency line item was set at 25± percent of the contract cost for all features. The contingency line item is a rounded value which may cause the dollar value to deviate from the actual percentage shown.

It should be noted that the estimated cost for the crest raise and dam/dike modifications, including the downstream berms needed for static stability, is greater than 90 percent of the field costs. Modifications to the structures account for less than 10 percent of the field costs.

10.0 FINDINGS AND RECOMMENDATIONS

10.1 Findings

This report documents an appraisal-level study of the potential for raising B.F. Sisk Dam with the objective of increasing the storage capacity of San Luis Reservoir. Primary findings of the study are summarized below.

- 1) In order to raise B.F. Sisk Dam, increase storage capacity within San Luis Reservoir, and reduce dam safety risks, modifications to the dam embankment and dike, spillway, intake towers, and access-bridge are needed.
- 2) The necessary modifications have been found to be technically feasible to construct.
- 3) In order to generate field cost estimates, a conceptual dam raise alternative was formulated which consisted of a raise of the RWS by 10 feet and a corresponding raise of the dam embankment crest by 20 feet, increasing reservoir capacity by approximately 130 TAF. This conceptual design includes excavation of weaker foundation materials and addition of significant downstream stability berms in several areas.
- 4) Total estimated field costs are \$360 million to construct the conceptual design described in Section 5.3.2 of this report.
 - a. The costs of design, design support, construction support and construction support activities are not included in the estimated field cost. The field cost estimates for this study do include estimates for mobilization, design and construction contingencies, and allowance for procurement strategies.
 - b. The excavation and stability berms required for reducing dam safety risk account for approximately 67% of total field costs.
- 5) The estimated benefit of increasing the capacity of San Luis Reservoir by 130 TAF (10-foot RWS raise) is up to 43 TAF of additional average annual Delta exports and deliveries under current conditions.
- 6) Under current operations and regulations, benefits to CVP and SWP water supply and deliveries could potentially be realized with reservoir capacity increases up to 400 TAF (~30-foot RWS raise).
 - a. A 400 TAF reservoir capacity increase could produce approximately 71 TAF of additional average annual Delta exports and deliveries under current operations and regulations.

10.2 Recommendations

Based on the technical feasibility of constructing a dam raise at the Sisk site and the modeled potential for water supply and operational benefits, the results of this appraisal study indicate that more in-depth studies exploring the opportunities for enlarging B.F. Sisk Dam to increase the capacity of San Luis Reservoir and mitigate identified safety risks are warranted.

Based on the findings of this Appraisal Report, recommendations for further studies are as follows:

- 1) Seek/confirm authority to initiate feasibility studies to determine:
 - a) Actions needed to correct identified dam safety risks, both with and without capacity increasing alternatives
 - b) Technical, environmental, economic, and financial feasibility of increasing south-of-Delta surface water storage capacity under a wide range of future conditions, including climate change and Delta export and conveyance capacity
 - c) Appropriate allocations of cost of the dam safety modifications and potential water supply benefits
- 2) Address the following topics during the feasibility study process:
 - a) Refine the area-capacity calculations for an expanded San Luis Reservoir
 - b) Consider the need to upgrade the Gianelli pumping plant depending on the height of capacity increasing alternatives analyzed
 - c) Opportunities to enhance recreation in the reservoir
 - d) Upgrade/improve operational representation of San Luis Reservoir in the CALSIM and CalLite models
 - e) Consider carryover operations with a larger reservoir to improve dry year delivery benefits
 - f) Complete a constructability evaluation to provide a detailed analysis of possible construction phasing to reduce impacts to CVP/SWP operations during construction
 - g) Complete laboratory testing and analysis of all and soil samples collected during recently concluded field investigations at the site. Complete corresponding updates to geotechnical data and models.
 - h) Perform a freeboard analysis to determine the minimum amount of freeboard necessary
 - i) Evaluate operational changes for sharing Delta exports and export opportunities
- 3) Manage land uses within the potentially affected areas to avoid technical and logistical conflicts that may increase the cost of the dam safety and expansion projects.
- 4) Develop a cost-share agreement with DWR and others to fund the feasibility and environmental studies.

11.0 REFERENCES

Autobee, Robert, 1996. San Luis Unit, West San Joaquin Division, Central Valley Project. U.S., Department of Interior, Bureau of Reclamation.

CALFED. See CALFED Bay-Delta Program.

CALFED Bay-Delta Program. 2000a. Final Programmatic Environmental Impact Statement/Environmental Impact Report. Prepared by U.S. Department of the Interior, Bureau of Reclamation, U.S. Fish and Wildlife, National Marine Fisheries Service, U.S. Environmental Protection Agency, Natural Resources Conservation Service, U.S. Army Corps of Engineers, and California Resources Agency. Sacramento, California. July.

———. 2000b. Initial Surface Water Storage Screening. Sacramento, CA. August. Available at:http://www.water.ca.gov/storage/docs/Surface%20Storage%20Misc.%20Docs/screen_final_all.pdf.

———. 2000c. Programmatic Record of Decision. Sacramento, CA. August.

California Department of Water Resources (DWR). 2012. The State Water Project: Final Delivery Reliability Report 2011. State of California, California Natural Resources Agency, Department of Water Resources. June 2012.

———. 2009. Using Future Climate Projections to Support Water Resources Decision Making in California. State of California, California Natural Resources Agency, Department of Water Resources. May.

———. 2010. CALFED Surface Storage Investigations Progress Report. State of California, California Natural Resources Agency, Department of Water Resources. November.

CEQ. See Council on Environmental Quality.

Council on Environmental Quality (CEQ), 2013. Principals and Requirements for Federal Investments in Water Resources. 2013.

DWR. See California Department of Water Resources.

IWR. See Institute for Water Resources

Institute for Water Resources. 1996. Planning Manual. IWR Report 96-R-21. US Army Corps of Engineers Water Resources Support Center. November.

NMFS. See National Marine Fisheries Service

- National Marine Fisheries Service. 2004. Biological Opinion on the Long-Term Central Valley Project and State Water Project Operations Criteria and Plan. Southwest Region. Long Beach, California. October.
- . 2009. Biological Opinion and Conference Opinion on the Long-Term Central Valley Project and State Water Project. Southwest Region. Long Beach, California. June.
- SWRCB. See State Water Resources Control Board.
- State Water Resources Control Board. 1978. Water Right Decision 1485. State of California Water Resources Control Board.
- . 1995. Water Quality Control Plan for the San Francisco Bay/Sacramento-San Joaquin Delta Estuary, 95-1 WR. Sacramento, California. May.
- . 1999. Division of Water Rights, California Environmental Protection Agency. A Guide to Water Transfers.
- . 2000. Revised Water Right Decision 1641. In the Matter of: Implementation of Water Quality Objectives for the San Francisco Bay/Sacramento-San Joaquin Delta Estuary; A Petition to Change Points of Diversion of the Central Valley Project and the State Water Project in the Southern Delta; and A Petition to Change Places of Use and Purposes of Use of the Central Valley Project. Sacramento, California. March.
- USBR. See U.S. Department of Interior, Bureau of Reclamation
- U.S. Bureau of Reclamation, 1974. San Luis Unit, Technical Record of Design and Construction, Vol. I through VII. U.S. Department of Interior, Bureau of Reclamation, Denver.
- . 1989. Cost Estimating Handbook. U.S. Department of Interior, Bureau of Reclamation, Denver Office, Construction Division, Engineering Support Branch, Revised March 1989.
- . 2004. 2004 Operations Criteria and Plan (OCAP) Biological Assessment (BA). June.
- . 2005. A CVP Yield Feasibility Investigation Report: The Delivery Impact of CVPIA. Sacramento. May.
- . 2007. Reclamation Manual. U.S. Department of Interior, Bureau of Reclamation, Denver. Available at: <http://www.usbr.gov/recman/>

- . 2008a. Biological Assessment on the Continued Long-Term Operations of the CVP and SWP (2008 OCAP BA). Sacramento.
- . 2008b. Central Valley Project and State Water Project Operations Criteria and Plan Biological Assessment. Sacramento. May.
- . 2008c. Water Supply and Yield Study. Sacramento. March.
- . 2009. Comprehensive Facility Review – B.F. Sisk Dam, Central Valley Project, Mid-Pacific Region, U.S. Department of the Interior, Bureau of Reclamation, Technical Service Center, Denver, Colorado. June.
- . 2010a. Appraisal-Level Construction Considerations, TM No. VB-8313-9, B.F. Sisk Dam, Central Valley Project, Mid-Pacific Region, California, U.S. Department of the Interior, Bureau of Reclamation, Technical Service Center, Denver, Colorado, May 2010.
- . 2010b. Borrow Site Environmental Evaluation Report, Technical Memorandum, North State Resources, Inc. and ICF International, Redding California. February.
- . 2013a. Central Valley Project Water Plan 2013. U.S. Department of the Interior, Bureau of Reclamation, Mid-Pacific Region. Sacramento, CA. February.
- . 2013b. Modification Alternatives Technical Memorandum – Corrective Action Study – Phase 2 Feasibility Level. Technical Memorandum No. VB-R11PD80312-23. B.F. Sisk Dam, Central Valley Project, Mid-Pacific Region. U.S. Department of the Interior, Bureau of Reclamation, Technical Service Center, Denver, CO. March.
- U.S. Department of the Interior, Bureau of Reclamation, and California Department of Water Resources (USBR and DWR). 1986. Agreement Between the United States of America and the State of California for Coordinated Operation of the Central Valley Project and the State Water Project. Sacramento, California. November.
- USFWS. See U.S. Fish and Wildlife Service
- U.S. Fish and Wildlife Service. 2008. Formal Endangered Species Act Consultation on the Proposed Coordinated Operations of the Central Valley Project (CVP) and State Water Project (SWP). Available: http://www.fws.gov/sacramento/es/documents/SWP-VP_OPs_BO_12-15_final_OCR.pdf. Accessed December 17, 2008.

This page intentionally left blank..

ATTACHMENT A

Technical Memorandum No. VB-86-68313-25

B.F. Sisk Dam Increased Storage Alternatives, Appraisal Level Study

NOTE:

DUE TO CONTENT OF SENSITIVE INFORMATION WHICH HAS BEEN LABELED “FOR OFFICIAL USE ONLY” MANY PORTIONS OF ATTACHMENT A ARE NOT AVAILABLE FOR PUBLIC REVIEW. UPON SPECIFIC REQUEST, SOME PORTIONS MAY BE MADE AVAILABLE ON AN AS NEEDED BASIS FROM THE PROJECT MANAGER.

DRAFT

This page intentionally left blank.

RECLAMATION

Managing Water in the West

FOR OFFICIAL USE ONLY

Technical Memorandum No. VB-86-68313-25

B.F. Sisk Dam – Increased Storage Alternatives, Appraisal-Level Study

Central Valley Project, California
Mid-Pacific Region



FOR OFFICIAL USE ONLY



U.S. Department of the Interior
Bureau of Reclamation
Technical Service Center
Denver, Colorado

April 2013

Mission Statements

The mission of the Department of the Interior is to protect and provide access to our Nation's natural and cultural heritage and honor our trust responsibilities to Indian Tribes and our commitments to island communities.

The mission of the Bureau of Reclamation is to manage, develop, and protect water and related resources in an environmentally and economically sound manner in the interest of the American public.

FOR OFFICIAL USE ONLY

Technical Memorandum No. VB-86-68313-25

B.F. Sisk Dam – Increased Storage Alternatives, Appraisal-Level Study

**Central Valley Project, California
Mid-Pacific Region**

FOR OFFICIAL USE ONLY



**U.S. Department of the Interior
Bureau of Reclamation
Technical Service Center
Denver, Colorado**

THIS PAGE INTENTIONALLY LEFT BLANK

FOR OFFICIAL USE ONLY

Technical Memorandum No. VB-86-68313-25
B.F. Sisk Dam – Increased Storage Alternatives
Appraisal-Level Study

Technical Memorandum No. VB-86-68313-23

B.F. Sisk Dam – Increased Storage Alternatives, Appraisal-Level Study

Central Valley Project, California
Mid-Pacific Region

 P.E.

Author: Tonya Hart, P.E.
Geotechnical Engineer, Geotechnical Engineering Group 3, 86-68313

 P.E.

Checked: Tuti Tierney, P.E.
Civil Engineer, Geotechnical Engineering Group 3, 86-68313



Peer Review: Randy Kuzniakowski, P.E.
Civil Engineer, Geotechnical Engineering Group 4, 86-68314

4/5/2013
Date

REVISIONS					
Date	Description	Prepared	Checked	Technical Approval	Peer Review

THIS PAGE INTENTIONALLY LEFT BLANK

Acronyms and Abbreviations

AF	acre-feet
APS	allowance for procurement strategies
bcy	bank cubic yards
BOR	Bureau of Reclamation
CAS	Corrective Action Study
CFR	Comprehensive Facility Review
CMP	Corrugated Metal Pipe
CRB	Consultant Review Board
CY	cubic yards
DWR	California Department of Water Resources
FLAC	Fast Lagrangian Analysis of Continua
FS	factor of safety
ft ²	square foot (feet)
ft ³	cubic foot (feet)
GVS	Great Valley Sequence
IE	Issue Evaluation
km	kilometer(s)
MPRO	Mid-Pacific Regional Office
MSE	Mechanically Stabilized Earth
NVS	North Valley Section
PMP	Project Management Plan
RA	Risk Analysis
RRA	Risk Reduction Analysis
Reclamation	Bureau of Reclamation
RWS	reservoir water surface
SOD	Safety of Dams
SPT	standard penetration test
SVS	South Valley Section
TM	Technical Memorandum
TSC	Technical Service Center
URS	URS Group, Inc.

THIS PAGE INTENTIONALLY LEFT BLANK

Contents

	Page
Executive Summary	1
I. Scope of Work.....	3
II. Background.....	3
A. General	3
B. Dam Embankment.....	4
C. Features	4
III. Reservoir Area-Capacity	6
IV. Design Considerations.....	6
V. Other Crest Raise Alternatives Considered.....	7
VI. Preferred Alternative.....	8
A. Downstream Stability Berms	9
B. Crest Raise.....	10
C. Structure Modifications.....	11
VII. Material Zoning.....	12
A. Downstream Stability Berms	12
B. Crest Raise.....	12
VIII. Quantities and Field Cost Estimates.....	12
IX. Borrow Areas.....	16
A. Borrow Area 1 – Basalt Hill.....	16
B. Borrow Area 6 – O’Neill Forebay.....	18
C. Haul Roads	18
X. Construction Methods.....	21
A. Borrow Area Excavation Methods	21
B. Crest Raise Excavation and Backfill Methods	21
C. Berm Excavation and Backfill Methods	22
XI. Summary	23
XII. Conclusions and Recommendations	24
XIII. Future Needs and Work	26
A. Final Design Data.....	26
B. Reservoir Rim Stability Issue.....	27
References	29

Figures

Appendix A – Cost Estimate Worksheets – Option A

Appendix B – Cost Estimate Worksheets – Option B

Appendix C – TM VB-86-68313-22

Appendix D – TM BFS-8110-STY-2012-1

Appendix E – TM BFS-8140-STY-2013-1

THIS PAGE INTENTIONALLY LEFT BLANK

FOR OFFICIAL USE ONLY

**Technical Memorandum No. VB-86-68313-25
B.F. Sisk Dam – Increased Storage Alternatives
Appraisal-Level Study**

Appendix A
Cost Estimate Worksheets – Option A

FOR OFFICIAL USE ONLY

THIS PAGE INTENTIONALLY LEFT BLANK

FEATURE: B.F. Sisk Dam Modification Appraisal Level Study 20-foot Dam Raise Only, No D/S Berm Middle Estimated <u>Drained</u> Strength Parameters Geotechnical (86-68313)	PROJECT: Central Valley Project, Madera County, California	
	WOID: A176F	ESTIMATE LEVEL: Appraisal
	REGION: MP	UNIT PRICE LEVEL: Oct-12
	FILE: U:\2012 Projects\BF Sisk\002 Completed Sheets\001 Summary BF Sisk - Drained.xlsx\Sht 4A	

PLANT ACCOUNT	PAY ITEM	DESCRIPTION	CODE	QUANTITY	UNIT	UNIT PRICE	AMOUNT
		The quantities on this sheet apply to the following locations. Sections for these locations were not analyzed in Slope/W for static stability. However, because the embankment is founded directly on bedrock (i.e. potentially liquefiable foundation materials were removed during construction), no downstream berm is needed.					
		Stations 0+00 to 31+00					
		Stations 46+00 to 56+00					
		Stations 114+00 to 139+00					
		Stations 149+00 to 165+00					
		Stations 173+00 to 176+00					
		Stations 183+00 to 185+00					
	1	Excavation, Common	86-68313	304,000	yd3	\$4.50	\$1,368,000.00
	2	Zone 1: Selected clay, sand, and gravel compacted by tamping rollers to 6-inch lifts (Assume Borrow Area 6 is sole borrow source for Zone 1 material and is rippable with dozer and processing is required)	86-68313	195,000	yd3	\$18.00	\$3,510,000.00
	3	Processed sand & gravel compacted by vibratory smooth drum rollers in 12-inch to 24-inch lifts (for D/S filter zones & U/S riprap bedding and crack stopper zones) (Assume Basalt Hill is sole borrow source for sand & gravel which must be drilled/blasted and processed)	86-68313	646,000	yd3	\$55.00	\$35,530,000.00
	4	Misc. Fill (Assume Borrow Area 6 is sole borrow source material which is rippable with dozer and minimal processing required)	86-68313	2,170,000	yd3	\$9.30	\$20,181,000.00
SUBTOTAL THIS SHEET							\$60,589,000.00

QUANTITIES		PRICES	
BY Tonya Hart, P.E.	CHECKED Tuti Tierney	BY Greg Akins	CHECKED [Signature] 1/25/13
DATE PREPARED 12/21/12	PEER REVIEW / DATE Randy Kuzniakowski	DATE PREPARED 01/25/13	PEER REVIEW / DATE [Signature] 1/28/13

FEATURE: B.F. Sisk Dam Modification Appraisal Level Study 20-foot Dam Raise Middle Estimated <u>Drained</u> Strength Parameters		PROJECT: Central Valley Project, Madera County, California	
Geotechnical (86-68313)		WOID: A176F	ESTIMATE LEVEL: Appraisal
		REGION: MP	UNIT PRICE LEVEL: Oct-12
		FILE: U:\2012 Projects\BF Sisk\002 Completed Sheets\002 Summary BF Sisk - Undrained.xlsx\Summary 16	

PLANT ACCOUNT	PAY ITEM	DESCRIPTION	CODE	QUANTITY	UNIT	UNIT PRICE	AMOUNT
		Summary: Stations 37+00 thru 180+00 below					
	5	Excavation, Common		507,000	yd3	\$4.50	\$2,281,500.00
	6	Filter		1,414,000	yd3	\$55.00	\$77,770,000.00
		compacted by vibratory smooth drum rollers in 12-inch to 24-inch lifts (for D/S filter zones & U/S riprap bedding and crack stopper zones) (Assume Basalt Hill is sole borrow source for sand & gravel which must be drilled/blasted and processed)					
	7	Misc. Fill		4,475,000	yd3	\$9.30	\$41,617,500.00
		(Assume Borrow Area 6 is sole borrow source material which is rippable with dozer and minimal processing required)					
Sta	37+00						
		Excavation, Common	86-68313	53,000	yd3		Included above
		Filter	86-68313	210,000	yd3		Included above
		Misc. Fill	86-68313	427,000	yd3		Included above
Sta	65+00						
		Excavation, Common	86-68313	147,000	yd3		Included above
		Filter	86-68313	107,000	yd3		Included above
		Misc. Fill	86-68313	669,000	yd3		Included above
Sta	86+00						
		Excavation, Common	86-68313	131,000	yd3		Included above
		Filter	86-68313	276,000	yd3		Included above
		Misc. Fill	86-68313	1,368,000	yd3		Included above
Sta	107+00						
		Excavation, Common	86-68313	90,000	yd3		Included above
		Filter	86-68313	530,000	yd3		Included above
		Misc. Fill	86-68313	1,085,000	yd3		Included above
Sta	147+20						
		Excavation, Common	86-68313	35,000	yd3		Included above
		Filter	86-68313	239,000	yd3		Included above
		Misc. Fill	86-68313	561,000	yd3		Included above
SUBTOTAL THIS SHEET							\$121,669,000.00

QUANTITIES		PRICES	
BY Tonya Hart, P.E.	CHECKED Tuti Tierney	BY Greg Atkins	CHECKED [Signature] 3/22/13
DATE PREPARED 12/21/12	PEER REVIEW / DATE Randy Kuzniakowski	DATE PREPARED 1/25/2013 - revised 3/20/13	PEER REVIEW / DATE [Signature] 3/22/13

FEATURE: B.F. Sisk Dam Modification Appraisal Level Study 20-foot Dam Raise "Best" <u>Drained</u> Strength Parameters Geotechnical (86-68313)	PROJECT: Central Valley Project, Madera County, California <hr/> WOID: A176F ESTIMATE LEVEL: Appraisal REGION: MP UNIT PRICE LEVEL: Oct-12 <hr/> FILE: U:\2012 Projects\BF Sisk\002 Completed Sheets\001 Summary BF Sisk - Drained.xlsx\Sht 4A
--	---

PLANT ACCOUNT	PAY ITEM	DESCRIPTION	CODE	QUANTITY	UNIT	UNIT PRICE	AMOUNT
Sta	169+00						
		Excavation, Common	86-68313	14,000	yd3		Included above
		Filter	86-68313	20,000	yd3		Included above
		Misc. Fill	86-68313	230,000	yd3		Included above
Sta	180+00						Included above
		Excavation, Common	86-68313	37,000	yd3		Included above
		Filter	86-68313	32,000	yd3		Included above
		Misc. Fill	86-68313	135,000	yd3		
		Dike					
	8	Excavation, Common	86-68313	5,000	yd3	\$4.50	\$22,500.00
	9	Filter	86-68313	8,000	yd3	\$55.00	\$440,000.00
		compacted by vibratory smooth drum rollers in 12-inch to 24-inch lifts (for D/S filter zones & U/S riprap bedding and crack stopper zones) (Assume Basalt Hill is sole borrow source for sand & gravel which must be drilled/blasted and processed)					
	10	Misc. Fill	86-68313	15,000	yd3	\$9.30	\$139,500.00
		(Assume Borrow Area 6 is sole borrow source material which is rippable with dozer and minimal processing required)					
SUBTOTAL THIS SHEET							\$602,000.00

QUANTITIES		PRICES	
BY Tonya Hart, P.E.	CHECKED Tuti Tierney	BY Greg Akins <i>Greg Akins</i>	CHECKED <i>[Signature]</i> 1/28/13
DATE PREPARED 12/21/12	PEER REVIEW / DATE Randy Kuzniakowski	DATE PREPARED 01/25/13	PEER REVIEW / DATE <i>NA</i> 1/28/13

FEATURE: B.F. Sisk Dam Static Dam Raise Cost Estimate Outlet Works Intake Towers Middle Estimated <u>Drained</u> Strength Parameters	PROJECT: Central Valley Project, Madera County, California	
	WOID: AF743	ESTIMATE LEVEL: Appraisal
	REGION: MP	UNIT PRICE LEVEL: Oct-12
	FILE: U:\2012 Projects\BF Sisk\002 Completed Sheets\001 Summary BF Sisk - Drained.xlsx\Summary 16	

PLANT ACCOUNT	PAY ITEM	DESCRIPTION	CODE	QUANTITY	UNIT	UNIT PRICE	AMOUNT
		GENERAL SITEWORK					
		Assume the reservoir is low enough for work to commence, and all equipment is removed from the top of the intake towers					
		MOBILIZATION	86-68130	1	LS		Included on summary sheet
		Assume a barge is mobilized for the work					
		INTAKE TOWERS					
	11	Full depth saw cut depth of cut varies from 2' to 3'	86-68130	520	LF	\$240.00	\$124,800.00
	12	Remove and dispose of top of intake towers quantity includes removal of the top 14 - 16 feet of 4 intake towers as well as gantry crane slabs between towers	86-68130	1,200	yd3	\$540.00	\$648,000.00
	13	Furnish, form, and place reinforced concrete 4,500psi @ 28 days	86-68130	1,700	yd3	\$1,500.00	\$2,550,000.00
	14	Cementitious Materials assumed to be 600lbs/yd3	86-68130	510	tons	\$200.00	\$102,000.00
	15	Furnish and place concrete reinforcement assumes 150lbs/yd3	86-68130	255,000	lbs	\$1.50	\$382,500.00
	16	Drill and grout anchor bars assume #9 bars and 2" dia holes 5425 ft of linear drilling (31" per hole) bars included in concrete reinforcement line item	86-68130	2,100	ea	\$130.00	\$273,000.00
SUBTOTAL THIS SHEET							\$4,080,300.00

QUANTITIES		PRICES	
BY Michael Shepherd	CHECKED Jason Schneider, P.E.	BY Greg Akins <i>Greg Akins</i>	CHECKED <i>[Signature]</i> 01/26/2013
DATE PREPARED 11/15/12	PEER REVIEW / DATE Jason Schneider, P.E.	DATE PREPARED 01/25/13	PEER REVIEW / DATE TA 1/28/13

FEATURE: B.F. Sisk Dam Static Raise Cost Estimate Morning Glory Spillway Middle Estimated <u>Drained</u> Strength Parameters	PROJECT: Central Valley Project, Madera County, California	
	WOID: AF743	ESTIMATE LEVEL: Appraisal
	REGION: MP	UNIT PRICE LEVEL: Oct-12
	FILE: U:\2012 Projects\BF Sisk\002 Completed Sheets\001 Summary BF Sisk - Drained.xlsx\Summary 16	

PLANT ACCOUNT	PAY ITEM	DESCRIPTION	CODE	QUANTITY	UNIT	UNIT PRICE	AMOUNT
		GENERAL SITEWORK					
		Assume the reservoir is low enough for work to commence					
		MOBILIZATION	86-68130	1	LS	Included on summary sheet	
		Assume the excavation and demolition equipment is on site (from the intake tower work)					
		SPILLWAY					
	17	Full depth saw cut depth of cut 2'-6"	86-68130	48	LF	\$200.00	\$9,600.00
	18	Excavation of upstream embankment Includes compacted embankment, rip rap bedding, and rip rap	86-68130	1,950	yd3	\$27.00	\$52,650.00
	19	Remove and dispose of top of Spillway quantity includes removal of the top 22ft	86-68130	180	yd3	\$600.00	\$108,000.00
	20	Furnish, form, and place reinforced concrete 4500psi @ 28 days	86-68130	220	yd3	\$1,400.00	\$308,000.00
	21	Furnish and place concrete reinforcement assume 150lbs/yd3	86-68130	33,000	lbs	\$1.50	\$49,500.00
	22	Cementitious Materials 600 lbs/yd3	86-68130	66	tons	\$200.00	\$13,200.00
	23	Drill and grout anchor bars assume # 11 bars and 2.5" dia holes 255 feet of linear drilling (38" per hole) bars included in concrete reinforcement line item	86-68130	80	ea	\$130.00	\$10,400.00
SUBTOTAL THIS SHEET							\$551,350.00

QUANTITIES		PRICES	
BY Michael Shepherd	CHECKED Jason Schneider, P.E.	BY Greg Akins <i>greg akins</i>	CHECKED <i>[Signature]</i> 1/28/2013
DATE PREPARED 11/15/12	PEER REVIEW / DATE Jason Schneider, P.E.	DATE PREPARED 01/25/13	PEER REVIEW / DATE <i>[Signature]</i> 1/28/13

FEATURE: BF Sisk (formerly San Luis) Dam Appraisal Level Study 20 - foot dam raise Intake Tower Access Bridge Middle Estimated <u>Drained</u> Strength Parameters		PROJECT: Central Valley Project, Madera County, California	
WOID: A176F	ESTIMATE LEVEL: Appraisal	REGION: MP	UNIT PRICE LEVEL: Oct-12
FILE: U:\2012 Projects\BF Sisk\002 Completed Sheets\001 Summary BF Sisk - Drained.xlsx\Summary 16			

PLA NT ACC OU	PAY ITE M	DE SC	CODE	QUANTITY	UNIT	UNIT PRICE	AMOUNT
	25	Removal & Disposal of Existing Bridge The existing dam will be raised 20 feet. Since it would be very difficult to raise & reuse the existing bridge superstructure (six spans), it will be removed & replaced with a new bridge. The existing bridge superstructure consists of two steel plate girders (considered fracture critical) supporting a reinforced concrete deck. Reservoir will not be dewatered, so demolition must consider barg access & handling / disposal of structural steel coated with lead paint. To estimate the amount of materials to be removed, the existing bridge superstructure quantities are estimated to be: Reinforced concrete = 400 cy Structural steel = 640,000 lbs	86-68140	1	ls	\$1,150,000.00	\$1,150,000.00
	26	Concrete (4,500 psi @ 28 days) Concrete volume is based on 3 quantities: 1. Pier caps extended vertically 12 ft.=170 cy 2. Superstructure deck = 700 cy 3. Abutment @ dam = 150 cy	86-68140	1,030	yd ³	\$1,400.00	\$1,442,000.00
	27	Cementitious Material (6 sacks/cy)	86-68140	290	tons	\$200.00	\$58,000.00
	28	Reinforcing Steel Specified minimum yield strength = 60 ksi	86-68140	260,000	lbs	\$1.50	\$390,000.00
	29	Structural Steel (bridge superstructure) Structural steel girders conforming to ASTM A709 Grade 50W (Fy = 50 ksi, weathering). See attached drawing for bridge cross section	86-68140	2,500,000	lbs	\$3.00	\$7,500,000.00
	30	Bridge Guardrail (California ST-10) See attached Caltrans Standard Plans B11-68, B11-69 & B11-70 for guard rail details	86-68140	2,370	lf	\$220.00	\$521,400.00
	31	Backfill behind/around abutment	86-68140	170.0	yd ³	\$20.00	\$3,400.00
	32	Compacted backfill behind/around abutment	86-68140	170.0	yd ³	\$20.00	\$3,400.00
SUBTOTAL THIS SHEET							\$11,068,200.00

QUANTITIES		3400	
BY Jesus G. Romero, PE	CHECKED Joseph M. Gemperline, PE	BY Greg Akins <i>g. akins</i>	CHECKED <i>[Signature]</i> 01/23/13
DATE PREPARED 12/07/12	PEER REVIEW / DATE Roman M. Koltuniuk, PE	DATE PREPARED 01/25/13	PEER REVIEW / DATE <i>[Signature]</i> 1/28/13

FEATURE: BF Sisk (formerly San Luis) Dam Appraisal Level Study 20 - foot dam raise Intake Tower Access Bridge Middle Estimated <u>Drained</u> Strength Parameters	PROJECT: Central Valley Project, Madera County, California	
	WOID: A176F	ESTIMATE LEVEL: Appraisal
	REGION: MP	UNIT PRICE LEVEL: Oct-12
	FILE: U:\2012 Projects\BF Sisk\002 Completed Sheets\001 Summary BF Sisk - Drained.xlsx\Summary 16	

PLA NT ACC OU	PAY ITE M	DE SC	CODE	QUANTITY	UNIT	UNIT PRICE	AMOUNT
	33	Epoxy grouted anchors into existing caps 1 in diameter Hilti Adhesive anchor: HIT_HY 150 MAX-SD+HAS. Grouted anchors are spaced at 1'-0" (16 x 5 grid), 80 per pier cap.	86-68140	400	ea	\$50.00	\$20,000.00
	34	Bearing Pads Preformed fabric bearing pads at piers. Size of pads are estimate to be 5" thick x 2'-0" wide by 1'-9" long. Total number of pads = 18	86-68140	18	ea	\$1,500.00	\$27,000.00
	35	Bridge Joint Seals at Expansion Joints Elastomeric expansion device equal to General Tire Co. Transflex Model 1300 or to Watson Bowman & Associates Waboflex-SR Model SR 13 for full width of bridge. 2 1/2" by 2 3/4" Preformed Compression Joint Seals at tower & abutment.	86-68140	60	lf	\$200.00	\$12,000.00
				20	lf		
				40	lf		
SUBTOTAL THIS SHEET							\$59,000.00

ANTITIES		PRICES	
BY Jesus G. Romero, PE	CHECKED Joseph M. Gemperline, PE	BY Greg Akihs <i>gastan</i>	CHECKED <i>[Signature]</i> 01/28/13
DATE PREPARED 12/07/12	PEER REVIEW / DATE Roman M. Koltuniuk, PE	DATE PREPARED 01/25/13	PEER REVIEW / DATE <i>[Signature]</i> 1/20/13

FEATURE: B. F. Sisk Dam Modification Roller Gate re-location and Stem Extension Middle Estimated <u>Drained</u> Strength Parameters		PROJECT: Central Valley Project, Madera County, California	
WOID:		ESTIMATE LEVEL:	Appraisal
REGION: MP		UNIT PRICE LEVEL:	Oct-12
FILE: U:\2012 Projects\BF Sisk\002 Completed Sheets\001 Summary BF Sisk - Drained.xlsx\Summary 16			

PLANT ACCOUNT	PAY ITEM	DESCRIPTION	CODE	QUANTITY	UNIT	UNIT PRICE	AMOUNT	
	36	Site Survey (Pre-Rehab) (assess general conditions and take measurements as needed)	86-68420	1	LS	\$12,000.00	\$12,000.00	
		NOTE: The following quantities are for work on one roller gate, hoist, & associated equipment Total work is for four gates.						
	37	Shut down and lock out unit associated with gate to be removed	86-68420	1	LS	\$5,000.00	\$5,000.00	
	38	Remove hydraulic piping to hoist Crew: 1 supervisor, 1 mechanic Shut valves to hoist Drain oil from piping (15 gallons, 1 Crew HR) Disconnect piping and plug ends (1 Crew HR) Remove piping to hoist 150# (3 Crew HR)	86-68420	1	EA	\$9,500.00	\$9,500.00	
	39	Remove Hydraulic Power Unit (8 Crew HR) Disconnect electrical Remove and store indoors Raise Roller Gate Crew: 1 supervisor, 2 mechanics, 1 laborer	86-68420	1	EA	\$14,500.00	\$14,500.00	
	40	Raise/lock gate by Gov't force (1 Crew HR) Assume contractor assists gov't forces	86-68420	1	LS	\$3,500.00	\$3,500.00	
	41	Remove hoist (18 Crew HR)	86-68420	1	LS	\$21,000.00	\$21,000.00	
	42	Remove intermediate stems (12 Crew HR)	86-68420	1	LS	\$26,000.00	\$26,000.00	
	43	Remove gate (10 Crew HR)	86-68420	1	LS	\$31,000.00	\$31,000.00	
SUBTOTAL THIS SHEET							1	\$122,500.00

QUANTITIES		PRICES	
BY D.L. Read	CHECKED D.M. Drake	BY Greg Akins <i>gajtk</i>	CHECKED <i>[Signature]</i> 1/29/2013
DATE PREPARED 12/10/2012	PEER REVIEW / DATE D.M. Drake	DATE PREPARED 01/25/13	PEER REVIEW / DATE <i>[Signature]</i> 1/28/13

FEATURE: B. F. Sisk Dam Modification Roller Gate re-location and Stem Extension Middle Estimated <u>Drained</u> Strength Parameters	PROJECT: Central Valley Project, Madera County, California WOID: ESTIMATE LEVEL: Appraisal REGION: MP UNIT PRICE LEVEL: Oct-12 FILE: U:\2012 Projects\BF Sisk\002 Completed Sheets\001 Summary BF Sisk - Drained.xlsx\Summary 16
---	--

PLANT ACCOUNT	PAY ITEM	DESCRIPTION	CODE	QUANTITY	UNIT	UNIT PRICE	AMOUNT	
		Install Embedded metalwork						
	44	Furnish and install embedded gate guides	86-68420	1,875	LB	\$13.00	\$24,375.00	
		Install Roller Gate Crew: 1 supervisor, 2 mechanics, 1 laborer						
	45	Install gate (10 Crew HR)	86-68420	1	LS	\$36,000.00	\$36,000.00	
	46	Install intermediate stems (12 Crew HR)	86-68420	1	LS	\$30,000.00	\$30,000.00	
	47	Furnish and install one new intermediate stem (steel - 1,475 # each, 12 Crew HR)	86-68420	1	LS	\$140,000.00	\$140,000.00	
	48	Install hoist (18 Crew HR)	86-68420	1	LS	\$50,000.00	\$50,000.00	
	49	Install hoist (18 Crew HR)	86-68420	1	LS	\$42,000.00	\$42,000.00	
SUBTOTAL THIS SHEET							2	\$322,375.00

QUANTITIES		PRICES	
BY D.L. Read	CHECKED D.M. Drake	BY Greg Akins <i>Greg Akins</i>	CHECKED <i>[Signature]</i> 01/28/2013
DATE PREPARED 12/10//2012	PEER REVIEW / DATE D.M. Drake	DATE PREPARED 01/25/13	PEER REVIEW / DATE <i>[Signature]</i> 1/28/13

FEATURE: B. F. Sisk Dam Modification Roller Gate re-location and Stem Extension Middle Estimated <u>Drained</u> Strength Parameters	PROJECT: Central Valley, California California <table border="1" style="width:100%; border-collapse: collapse;"> <tr> <td style="width:30%;">WOID:</td> <td>ESTIMATE LEVEL: Appraisal</td> </tr> <tr> <td>REGION: MP</td> <td>UNIT PRICE LEVEL: Oct-12</td> </tr> </table> FILE: U:\2012 Projects\BF Sisk\002 Completed Sheets\001 Summary BF Sisk - Drained.xlsx\Summary 16	WOID:	ESTIMATE LEVEL: Appraisal	REGION: MP	UNIT PRICE LEVEL: Oct-12
WOID:	ESTIMATE LEVEL: Appraisal				
REGION: MP	UNIT PRICE LEVEL: Oct-12				

PLANT ACCOUNT	PAY ITEM	DESCRIPTION	CODE	QUANTITY	UNIT	UNIT PRICE	AMOUNT	
		Install Hydraulic Controls						
		Crew: 1 supervisor, 1 mechanic, 1 laborer						
	50	Install Hydraulic Power Unit (6 Crew HR)	86-68420	1	LS	\$23,000.00	\$23,000.00	
	51	Connect piping (16 Crew HR)	86-68420	1	LS	\$21,000.00	\$21,000.00	
	52	Electrically connect HPU, power, & control board 1 electrician (10 HR)	86-68420	1	LS	\$18,000.00	\$18,000.00	
	53	Fill and vent system (6 Crew HR)	86-68420	1	LS	\$15,000.00	\$15,000.00	
	54	Test system:		1	LS	\$19,000.00	\$19,000.00	
	55	Pressure test (6 Crew HR)	86-68420	1	LS	\$12,000.00	\$12,000.00	
	56	Leak test Cylinder (6 Crew HR)	86-68420	1	LS	\$12,000.00	\$12,000.00	
	57	Operational test (6 Crew HR)	86-68420	1	LS	\$12,000.00	\$12,000.00	
SUBTOTAL THIS SHEET							3	\$132,000.00

QUANTITIES		PRICES	
BY D.L. Read	CHECKED D.M. Drake	BY Greg Akins <i>gyth</i>	CHECKED <i>[Signature]</i> 1/28/13
DATE PREPARED 12/10//2012	PEER REVIEW / DATE D.M. Drake	DATE PREPARED 01/25/13	PEER REVIEW / DATE <i>[Signature]</i> 1/28/13

FEATURE: B.F. Sisk Raise Appraisal Study Intake Tower Modifications Mechanical Equipment Group 86-68410 Most Probable Estimate Middle Estimated <u>Drained</u> Strength Parameters	PROJECT: Central Valley Project, Madera County, California <hr/> WOID: A176F ESTIMATE LEVEL: Appraisal REGION: MP UNIT PRICE LEVEL: Oct-12 <hr/> FILE: U:\2012 Projects\BF Sisk\002 Completed Sheets\001 Summary BF Sisk - Drained.xlsx\Summary 16
--	---

PLANT ACCOUNT	PAY ITEM	DESCRIPTION	CODE	QUANTITY	UNIT	UNIT PRICE	AMOUNT
		GANTRY CRANE:					
	58	Remove and dispose exist crane rails All parts are structural steel - 85# ASCE rails, 600 feet, 16,040 lbs. - 585 Rail clips, 293 lbs. - 290 Bearing plates, 1,600 lbs. - 320 - 1/2" Dia. x 12" machine bolts, 640 lbs. - 300 - 1/2" Dia. x 10" welded studs, 600 lbs.	86-68410	19,200	lbs.	\$0.75	\$14,400.00
	59	Furnish and install new crane rails Structural steel, coated - 85# ASCE rails, 600 feet, 16,040 lbs. - 585 Rail clips, 293 lbs. - 290 Bearing plates, 1,600 lbs. - 320 - 1/2" Dia. x 12" machine bolts, 640 lbs. - 300 - 1/2" Dia. x 10" welded studs, 600 lbs.	86-68410	19,200	lbs.	\$9.00	\$172,800.00
	60	Rerope the hoist and provide a new drums to accommodate the additional 10'-0" of height - 1-inch Dia. 6x37 IWRC, galvanized, extra improved plow steel (XIP) - Two new drums, cast steel, coated, 9'-4" long, 24" dia., 1,545 lbs. ea. Assume: - Rope is 4 part	86-68410	1	LS	\$120,000.00	\$120,000.00
				1,300	ft.		
				3,090	lbs.		
SUBTOTAL THIS SHEET							\$307,200.00

QUANTITIES		PRICES	
BY R. Stephen	CHECKED A. Ritt	BY <i>Greg Akins</i>	CHECKED <i>[Signature]</i> 01/28/2013
DATE PREPARED 12/17/12	PEER REVIEW / DATE D. Hulse	DATE PREPARED 01/25/13	PEER REVIEW / DATE <i>[Signature]</i> 1/28/13

FEATURE: B.F. Sisk Raise Appraisal Study Intake Tower Modifications Mechanical Equipment Group 86-68410 Most Probable Estimate Middle Estimated <u>Drained</u> Strength Parameters	PROJECT: Central Valley Project, Madera County, California <hr/> WOID: A176F ESTIMATE LEVEL: Appraisal <hr/> REGION: MP UNIT PRICE LEVEL: Oct-12 <hr/> FILE: U:\2012 Projects\BF Sisk\002 Completed Sheets\001 Summary BF Sisk - Drained.xlsx\Summary 16
--	---

PLANT ACCOUNT	PAY ITEM	DESCRIPTION	CODE	QUANTITY	UNIT	UNIT PRICE	AMOUNT
		GANTRY CRANE:					
	61	Remove, store and reinstall gantry crane after modifications to the intake towers are completed - Gantry crane will have to be disassembled due to width of access bridge - Crane dead weight is 176,000 lbs. - Crane is approx. 40'-0" tall, 40'-0" wide, and 38'-0" long. Assume: - Crane is stored onsite - Crane is fully functional - No modernization is required - Removal and reinstallazation will require the use of a mobile crane, ~20T	86-68410	1	L.S.	\$250,000.00	\$250,000.00
		SUBTOTAL THIS SHEET					\$250,000.00

QUANTITIES		PRICES	
BY R. Stephen	CHECKED A. Ritt	BY <i>Greg Akins</i>	CHECKED <i>[Signature]</i> 01/26/2013
DATE PREPARED 12/17/12	PEER REVIEW / DATE D. Hulse	DATE PREPARED 01/25/13	PEER REVIEW / DATE <i>[Signature]</i> 1/26/13

FEATURE: B.F. Sisk Raise Appraisal Study Intake Tower Modifications Mechanical Equipment Group 86-68410 Most Probable Estimate Middle Estimated <u>Drained</u> Strength Parameters	PROJECT: Central Valley Project, Madera County, California	
	WOID: A176F	ESTIMATE LEVEL: Appraisal
	REGION: MP	UNIT PRICE LEVEL: Oct-12
	FILE: U:\2012 Projects\BF Sisk\002 Completed Sheets\001 Summary BF Sisk - Drained.xlsx\Summary 16	

PLANT ACCOUNT	PAY ITEM	DESCRIPTION	CODE	QUANTITY	UNIT	UNIT PRICE	AMOUNT
		BULKHEAD GATE:					
	62	Remove and reinstall bulkhead gates, lifting frame and storage arms. - (2) Top bulkhead gates, 75,000 lbs. ea., approx. 24'-6" wide x 15'-0" tall - (2) Bottom bulkhead gates, 73,000 lbs. ea., approx. 24'-6" wide x 14'-6" tall - Bulkhead gates are stored in the top of the guides of the intake towers. - Lifting frame, 12,000 lbs., 26'-0" x 16'-6" - (8) Storage arms, 1,200 lbs. ea., fastened to concrete deck by anchor bolts, on top of a grout pad.	86-68410	1	L.S.	\$500,000.00	\$500,000.00
	63	Remove and dispose existing bulkhead guides - Embedded in concrete - Eight at 2,500 lbs. ea., 10'-0" long	86-68410	20,000	lbs.	\$0.75	\$15,000.00
	64	Furnish and install new bulkhead guides - Structural steel, coated, embedded - Eight at 5,000 lbs. ea., 20'-0" long	86-68410	40,000	lbs.	\$9.00	\$360,000.00
SUBTOTAL THIS SHEET							\$875,000.00

QUANTITIES		PRICES	
BY R. Stephen	CHECKED A. Ritt	BY Greg Akins <i>Greg Akins</i>	CHECKED <i>[Signature]</i> 1/28/13
DATE PREPARED 11/29/2012	PEER REVIEW / DATE D. Hulse	DATE PREPARED 01/25/13	PEER REVIEW / DATE <i>[Signature]</i> 1/28/13

FEATURE: B.F. Sisk Dam Modification Appraisal Level Study 20-foot Dam Raise Middle Estimated <u>Drained</u> Strength Parameters Option A	PROJECT: Central Valley Project, Madera County, California	
	WOID: A176F	ESTIMATE LEVEL: Appraisal
	REGION: MP	UNIT PRICE LEVEL: Oct-12
	FILE: U:\2012 Projects\BF Sisk\002 Completed Sheets\001 Summary BF Sisk - Drained.xlsx\Summary 16	

PLANT ACCOUNT	PAY ITEM	DESCRIPTION				AMOUNT
		Subtotal Sheet 2 of 16				\$60,589,000.00
		Subtotal Sheet 3 of 16				\$121,669,000.00
		Subtotal Sheet 4 of 16				\$602,000.00
		Subtotal Sheet 5 of 16				\$4,080,300.00
		Subtotal Sheet 6 of 16				\$551,350.00
		Subtotal Sheet 7 of 16				\$39,000.00
		Subtotal Sheet 8 of 16				\$11,068,200.00
		Subtotal Sheet 9 of 16				\$59,000.00
		Subtotal Sheet 10 of 16				\$122,500.00
		Subtotal Sheet 11 of 16				\$322,375.00
		Subtotal Sheet 12 of 16				\$132,000.00
		Subtotal Sheet 13 of 16				\$307,200.00
		Subtotal Sheet 14 of 16				\$250,000.00
		Subtotal Sheet 15 of 16				\$875,000.00
		Subtotal				\$200,666,925.00
		Mobilization	5%	+/-		\$10,000,000.00
		Subtotal with Mobilization				\$210,666,925.00
		Contract Cost Allowances (Sum of):	18%	+/-		\$39,333,075.00
		Design Contingencies,15% (+/-)				
		APS, 3% (+/-). Type of procurement: Request for Proposal				
		CONTRACT COST				\$250,000,000.00
		Construction Contingencies	25%	+/-		\$60,000,000.00
		FIELD COST (Unit Price Level Oct 2012)				\$310,000,000.00
		Non-Contract Costs				To be determined by the appropriate responsible official
		Escalation to Notice to Proceed (NTP)				To be determined by the appropriate responsible official
		CONSTRUCTION COST				To be determined by the appropriate responsible official
Ref.: For appropriate use and terminology, see Reclamation Manual, Directives and Standards FAC; 09-01, 09-02 and 09-03.						

QUANTITIES		PRICES	
BY See Estimate Sheets	CHECKED See Estimate Sheets	BY Greg Akins	CHECKED [Signature] 3/20/13
DATE PREPARED	PEER REVIEW / DATE See Estimate Sheets	DATE PREPARED 1/25/2013 - revised 3/20/13	PEER REVIEW / DATE [Signature] 3/22/13

FOR OFFICIAL USE ONLY

**Technical Memorandum No. VB-86-68313-25
B.F. Sisk Dam – Increased Storage Alternatives
Appraisal-Level Study**

Appendix B

Cost Estimate Worksheets – Option B

FOR OFFICIAL USE ONLY

THIS PAGE INTENTIONALLY LEFT BLANK

FEATURE: B.F. Sisk Dam Modification Appraisal Level Study 20-foot Dam Raise Middle Estimated <u>Undrained</u> Strength Parameters Option B Geotechnical (86-68313)	PROJECT: Central Valley Project, Madera County, California <hr/> WOID: A176F ESTIMATE LEVEL: Appraisal REGION: MP UNIT PRICE LEVEL: Oct-12 <hr/> FILE: U:\2012 Projects\BF Sisk\002 Completed Sheets\002 Summary BF Sisk - Undrained.xlsx\Sht 1
---	--

PLANT ACCOUNT	PAY ITEM	DESCRIPTION	CODE	QUANTITY	UNIT	UNIT PRICE	AMOUNT
		The cost estimate sheets from B.F. Sisk Dam Appraisal-Level Construction Considerations (TM VB-8313-9; May 2010) were used to establish quantities for preparing this cost estimate. The borrow areas, construction methods, and environmental considerations presented in TM VB-8313-9 are assumed to be the same for this Appraisal-Level study. Additionally, information presented in B.F. Sisk Dam Appraisal-Level Study of Static Stability for Increased Storage report (TM VB-86-68313-22; December 2012) should be reviewed.					
		NOTES:					
		1) Quantities were calculated at specific sections (e.g. stations 37+00, 65+00, 86+00, 107+00 and 147+20) and the dike during this Appraisal-Level study. Quantities at stations 169+00 and 180+00 were taken from VB-8313-9 and were not recalculated during this study. The quantities indicated at each station were assumed to be representative of the location (e.g. station 37+00 represents total quantities between stations 0+00 and 56+00).					
		2) Raise includes removal of 10 feet of the existing crest for penetration into existing Zone 1 core (6 inches of gravel surfacing plus Zone 4, Zone 5 (riprap), and Zone 1).					
		3) Costs associated with escalation to NTP, and non-contract costs are not included; mobilization and allowance for procurement strategies costs are included.					
		4) There is a Corrective Action Study (CAS) underway to address risks of dam failure during a major earthquake. This appraisal-level study evaluated increased storage in San Luis Reservoir based solely on static stability conditions using post-earthquake soil strength parameters. These estimates were prepared to provide a general order-of-magnitude-type cost. This study is not meant to be a stand-alone study, rather it should be reviewed during the CAS.					

QUANTITIES		PRICES	
BY Tonya Hart, P.E.	CHECKED Tuti Tierney	BY <i>Greg Akins</i> Greg Akins	CHECKED <i>[Signature]</i> 1/28/13
DATE PREPARED 12/21/12	PEER REVIEW / DATE Randy Kuzniakowski	DATE PREPARED 01/25/13	PEER REVIEW / DATE <i>[Signature]</i> 1/28/13

FEATURE: B.F. Sisk Dam Modification Appraisal Level Study 20-foot Dam Raise Only, No D/S Berm Middle Estimated <u>Undrained</u> Strength Parameters Geotechnical (86-68313)	PROJECT: Central Valley Project, Madera County, California	
	WOID: A176F	ESTIMATE LEVEL: Appraisal
	REGION: MP	UNIT PRICE LEVEL: Oct-12
	FILE: U:\2012 Projects\BF Sisk\002 Completed Sheets\002 Summary BF Sisk - Undrained.xlsx\Summary 16	

PLANT ACCOUNT	PAY ITEM	DESCRIPTION	CODE	QUANTITY	UNIT	UNIT PRICE	AMOUNT
		The quantities on this sheet apply to the following locations. Sections for these locations were not analyzed in Slope/W for static stability. However, because the embankment is founded directly on bedrock (i.e. potentially liquefiable foundation materials were removed during construction), no downstream berm is needed.					
		Stations 0+00 to 31+00					
		Stations 46+00 to 56+00					
		Stations 114+00 to 139+00					
		Stations 149+00 to 165+00					
		Stations 173+00 to 176+00					
		Stations 183+00 to 185+00					
	1	Excavation, Common	86-68313	304,000	yd3	\$4.50	\$1,368,000.00
	2	Zone 1: Selected clay, sand, and gravel compacted by tamping rollers to 6-inch lifts (Assume Borrow Area 6 is sole borrow source for Zone 1 material which is rippable with dozer and processing is required)	86-68313	195,000	yd3	\$18.00	\$3,510,000.00
	3	Processed sand & gravel compacted by vibratory smooth drum rollers in 12-inch to 24-inch lifts (for D/S filter zones & U/S riprap bedding and crack stopper zones) (Assume Basalt Hill is sole borrow source for sand & gravel which must be drilled/ blasted and processed)	86-68313	646,000	yd3	\$55.00	\$35,530,000.00
	4	Misc. Fill (Assume Borrow Area 6 is sole borrow source for Zone 1 material which is rippable with dozer and minimal processing is required)	86-68313	2,170,000	yd3	\$9.30	\$20,181,000.00
SUBTOTAL THIS SHEET							\$60,589,000.00

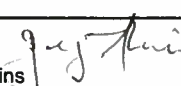
QUANTITIES		PRICES	
BY Tonya Hart, P.E.	CHECKED Tuti Tierney	BY Greg Akins	CHECKED  1/28/13
DATE PREPARED 12/21/12	PEER REVIEW / DATE Randy Kuzniakowski	DATE PREPARED 01/25/13	PEER REVIEW / DATE TH 1/28/13



FEATURE: B.F. Sisk Dam Modification Appraisal Level Study 20-foot Dam Raise "Best" <u>Undrained</u> Strength Parameters Geotechnical (86-68313)	PROJECT: Central Valley Project, Madera County, California	
	WOID: A176F	ESTIMATE LEVEL: Appraisal
	REGION: MP	UNIT PRICE LEVEL: Oct-12
	FILE: U:\2012 Projects\BF Sisk\002 Completed Sheets\002 Summary BF Sisk - Undrained.xlsx\Sht 3B	

PLANT ACCOUNT	PAY ITEM	DESCRIPTION	CODE	QUANTITY	UNIT	UNIT PRICE	AMOUNT
		Summary Station 37+00 to 180+00					
	5	Excavation, Common		1,177,000	yd3	\$4.50	\$5,296,500.00
	6	Filter		1,763,000	yd3	\$55.00	\$96,965,000.00
		compacted by vibratory smooth drum rollers in 12-inch to 24-inch lifts (for D/S filter zones & U/S riprap bedding and crack stopper zones) (Assume Basalt Hill is sole borrow source for sand & gravel which must be drilled/blasted and processed)					
	7	Misc. Fill		5,688,000	yd3	\$9.30	\$52,898,400.00
		(Assume Borrow Area 6 is sole borrow source material which is rippable with dozer and minimal processing is required)					
Sta	37+00						
	10	Excavation, Common	86-68313	260,000	yd3		Included above
	20	Filter	86-68313	274,000	yd3		Included above
	30	Misc. Fill	86-68313	738,000	yd3		Included above
Sta	65+00						
	10	Excavation, Common	86-68313	466,000	yd3		Included above
	20	Filter	86-68313	312,000	yd3		Included above
	30	Misc. Fill	86-68313	1,196,000	yd3		Included above
Sta	86+00						
	10	Excavation, Common	86-68313	131,000	yd3		Included above
	20	Filter	86-68313	276,000	yd3		Included above
	30	Misc. Fill	86-68313	1,368,000	yd3		Included above
Sta	107+00						
	10	Excavation, Common	86-68313	90,000	yd3		Included above
	20	Filter	86-68313	530,000	yd3		Included above
	30	Misc. Fill	86-68313	1,085,000	yd3		Included above
Sta	147+20						
	10	Excavation, Common	86-68313	179,000	yd3		Included above
	20	Filter	86-68313	319,000	yd3		Included above
	30	Misc. Fill	86-68313	936,000	yd3		Included above
SUBTOTAL THIS SHEET							\$155,159,900.00

QUANTITIES		PRICES	
BY Tonya Hart, P.E.	CHECKED Tuti Tierney	BY Greg Akins	CHECKED [Signature] 3/20/13
DATE PREPARED 12/21/12	PEER REVIEW / DATE Randy Kuzniakowski	DATE PREPARED 1/25/2013 - revised 3/20/13	PEER REVIEW / DATE [Signature] 3/22/13

FEATURE: B.F. Sisk Dam Modification Appraisal Level Study 20-foot Dam Raise "Best" <u>Undrained</u> Strength Parameters	PROJECT: Central Valley Project, Madera County, California	
	WOID: A176F	ESTIMATE LEVEL: Appraisal
	REGION: MP	UNIT PRICE LEVEL: Oct-12
	FILE: U:\2012 Projects\BF Sisk\002 Completed Sheets\002 Summary BF Sisk - Undrained.xlsx\Summary 16	

PLANT ACCOUNT	PAY ITEM	DESCRIPTION	CODE	QUANTITY	UNIT	UNIT PRICE	AMOUNT
Sta	169+00						
	10	Excavation, Common	86-68313	14,000	yd3		Included above
	20	Filter	86-68313	20,000	yd3		Included above
	30	Misc. Fill	86-68313	230,000	yd3		Included above
Sta	180+00						
	10	Excavation, Common	86-68313	37,000	yd3		Included above
	20	Filter	86-68313	32,000	yd3		Included above
	30	Misc. Fill	86-68313	135,000	yd3		Included above
		Dike					
	8	Excavation, Common	86-68313	5,000	yd3	\$4.50	\$22,500.00
	9	Filter	86-68313	8,000	yd3	\$55.00	\$440,000.00
		compacted by vibratory smooth drum rollers in 12-inch to 24-inch lifts (for D/S filter zones & U/S riprap bedding and crack stopper zones) (Assume Basalt Hill is sole borrow source for sand & gravel which must be drilled/blasted and processed)					
	10	Misc. Fill	86-68313	15,000	yd3	\$9.30	\$139,500.00
		(Assume Borrow Area 6 is sole borrow source material which is rippable with dozer and minimal processing is required)					
SUBTOTAL THIS SHEET							\$602,000.00

QUANTITIES		PRICES	
BY Tonya Hart, P.E.	CHECKED Tuti Tierney	BY Greg Akins	CHECKED  01/28/13
DATE PREPARED 12/21/12	PEER REVIEW / DATE Randy Kuzniakowski	DATE PREPARED 01/25/13	PEER REVIEW / DATE  1/28/13



FEATURE: B.F. Sisk Dam Static Dam Raise Cost Estimate Outlet Works Intake Towers Middle Estimated <u>Undrained</u> Strength Parameters	PROJECT: Central Valley Project, Madera County, California	
	WOID: AF743	ESTIMATE LEVEL: Appraisal
	REGION: MP	UNIT PRICE LEVEL: Oct-12
	FILE: U:\2012 Projects\BF Sisk\002 Completed Sheets\002 Summary BF Sisk - Undrained.xlsx\Summary 16	

PLANT ACCOUNT	PAY ITEM	DESCRIPTION	CODE	QUANTITY	UNIT	UNIT PRICE	AMOUNT
		GENERAL SITEWORK					
		Assume the reservoir is low enough for work to commence, and all equipment is removed from the top of the intake towers					
		MOBILIZATION	86-68130	1	LS	Included on summary sheet	
		Assume a barge is mobilized for the work					
		INTAKE TOWERS					
	11	Full depth saw cut depth of cut varies from 2' to 3'	86-68130	520	LF	\$240.00	\$124,800.00
	12	Remove and dispose of top of intake towers quantity includes removal of the top 14 - 16 feet of 4 intake towers as well as gantry crane slabs between towers	86-68130	1,200	yd3	\$540.00	\$648,000.00
	13	Furnish, form, and place reinforced concrete 4,500psi @ 28 days	86-68130	1,700	yd3	\$1,500.00	\$2,550,000.00
	14	Cementitious Materials assumed to be 600lbs/yd3	86-68130	510	tons	\$200.00	\$102,000.00
	15	Furnish and place concrete reinforcement assumes 150lbs/yd3	86-68130	255,000	lbs	\$1.50	\$382,500.00
	16	Drill and grout anchor bars assume #9 bars and 2" dia holes 5425 ft of linear drilling (31" per hole) bars included in concrete reinforcement line item	86-68130	2,100	ea	\$130.00	\$273,000.00
SUBTOTAL THIS SHEET							\$4,080,300.00

QUANTITIES		PRICES	
BY Michael Shepherd	CHECKED Jason Schneider, P.E.	BY Greg Akins	CHECKED [Signature] 01/28/13
DATE PREPARED 11/15/12	PEER REVIEW / DATE Jason Schneider, P.E.	DATE PREPARED 01/25/13	PEER REVIEW / DATE [Signature] 1/28/13

FEATURE: B.F. Sisk Dam Static Raise Cost Estimate Morning Glory Spillway Middle Estimated <u>Undrained</u> Strength Parameters	PROJECT: Central Valley Project, Madera County, California	
	WOID: AF743	ESTIMATE LEVEL: Appraisal
	REGION: MP	UNIT PRICE LEVEL: Oct-12
	FILE: U:\2012 Projects\BF Sisk\002 Completed Sheets\002 Summary BF Sisk - Undrained.xlsx\Summary 16	

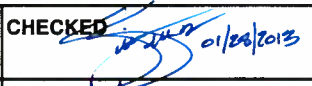
PLANT ACCOUNT	PAY ITEM	DESCRIPTION	CODE	QUANTITY	UNIT	UNIT PRICE	AMOUNT
		GENERAL SITEWORK					
		Assume the reservoir is low enough for work to commence					
		MOBILIZATION	86-68130	1	LS	Included on summary sheet	
		Assume the excavation and demolition equipment is on site (from the intake tower work)					
		SPILLWAY					
	17	Full depth saw cut depth of cut 2'-6"	86-68130	48	LF	\$200.00	\$9,600.00
	18	Excavation of upstream embankment Includes compacted embankment, rip rap bedding, and rip rap	86-68130	1,950	yd3	\$27.00	\$52,650.00
	19	Remove and dispose of top of Spillway quantity includes removal of the top 22ft	86-68130	180	yd3	\$600.00	\$108,000.00
	20	Furnish, form, and place reinforced concrete 4500psi @ 28 days	86-68130	220	yd3	\$1,400.00	\$308,000.00
	21	Furnish and place concrete reinforcement assume 150lbs/yd3	86-68130	33,000	lbs	\$1.50	\$49,500.00
	22	Cementitious Materials 600 lbs/yd3	86-68130	66	tons	\$200.00	\$13,200.00
	23	Drill and grout anchor bars assume # 11 bars and 2.5" dia holes 255 feet of linear drilling (38" per hole) bars included in concrete reinforcement line item	86-68130	80	ea	\$130.00	\$10,400.00
SUBTOTAL THIS SHEET							\$551,350.00

QUANTITIES		PRICES	
BY Michael Shepherd	CHECKED Jason Schneider, P.E.	BY Greg Akins	CHECKED  01/26/2013
DATE PREPARED 11/15/12	PEER REVIEW / DATE Jason Schneider, P.E.	DATE PREPARED 01/25/13	PEER REVIEW / DATE  1/28/13

FEATURE: BF Sisk (formerly San Luis) Dam Appraisal Level Study 20 - foot dam raise Intake Tower Access Bridge Middle Estimated <u>Undrained</u> Strength Parameters	PROJECT: Central Valley Project, Madera County, California	
	WOID: A176F	ESTIMATE LEVEL: Appraisal
	REGION: MP	UNIT PRICE LEVEL: Oct-12
	FILE: U:\2012 Projects\BF Sisk\002 Completed Sheets\002 Summary BF Sisk - Undrained.xlsx\Summary 16	

PLA NT ACC OU	PAY ITE M	DE SC	CODE	QUANTITY	UNIT	UNIT PRICE	AMOUNT
	25	Removal & Disposal of Existing Bridge The existing dam will be raised 20 feet. Since it would be very difficult to raise & reuse the existing bridge superstructure (six spans), it will be removed & replaced with a new bridge. The existing bridge superstructure consists of two steel plate girders (considered fracture critical) supporting a reinforced concrete deck. Reservoir will not be dewatered, so demolition must consider barg access & handling / disposal of structural steel coated with lead paint. To estimate the amount of materials to be removed, the existing bridge superstructure quantities are estimated to be: Reinforced concrete = 400 cy Structural steel = 640,000 lbs	86-68140	1	ls	\$1,150,000.00	\$1,150,000.00
	26	Concrete (4,500 psi @ 28 days) Concrete volume is based on 3 quantities: 1. Pier caps extended vertically 12 ft.=170 cy 2. Superstructure deck = 700 cy 3. Abutment @ dam = 150 cy	86-68140	1,030	yd ³	\$1,400.00	\$1,442,000.00
	27	Cementitious Material (6 sacks/cy)	86-68140	290	tons	\$200.00	\$58,000.00
	28	Reinforcing Steel Specified minimum yield strength = 60 ksi	86-68140	260,000	lbs	\$1.50	\$390,000.00
	29	Structural Steel (bridge superstructure) Structural steel girders conforming to ASTM A709 Grade 50W (Fy = 50 ksi, weathering). See attached drawing for bridge cross section	86-68140	2,500,000	lbs	\$3.00	\$7,500,000.00
	30	Bridge Guardrail (California ST-10) See attached Caltrans Standard Plans B11-68, B11-69 & B11-70 for rail details	86-68140	2,370	lf	\$220.00	\$521,400.00
	31	Backfill behind/around abutment	86-68140	170.0	yd ³	\$20.00	\$3,400.00
	32	Compacted backfill behind/around abutment	86-68140	170.0	yd3	\$20.00	\$3,400.00
SUBTOTAL THIS SHEET							\$11,068,200.00

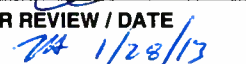
ANTITIES		3400	
BY Jesus G. Romero, PE	CHECKED Joseph M. Gemperline, PE	BY Greg Akins	CHECKED  01/26/2013
DATE PREPARED 12/07/12	PEER REVIEW / DATE Roman M. Koltuniuk, PE	DATE PREPARED 01/25/13	PEER REVIEW / DATE  1/28/13

FEATURE: BF Sisk (formerly San Luis) Dam Appraisal Level Study 20 - foot dam raise Intake Tower Access Bridge Middle Estimated <u>Undrained</u> Strength Parameters	PROJECT: Central Valley Project, Madera County, California <hr/> WOID: A176F ESTIMATE LEVEL: Appraisal REGION: MP UNIT PRICE LEVEL: Oct-12 <hr/> FILE: U:\2012 Projects\BF Sisk\002 Completed Sheets\002 Summary BF Sisk - Undrained.xlsx\Summary 16
---	---

PLA	INT	ACC	DOU	PAY	ITE	M	DE	SC	CODE	QUANTITY	UNIT	UNIT PRICE	AMOUNT
									86-68140	400	ea	\$50.00	\$20,000.00
									Epoxy grouted anchors into existing caps 1in diameter Hilti Adhesive anchor: HIT_HY 150 MAX-SD+HAS. Grouted anchors are spaced at 1'-0" (16 x 5 grid), 80 per pier cap.				
									86-68140	18	ea	\$1,500.00	\$27,000.00
									Bearing Pads Preformed fabric bearing pads at piers. Size of pads are estimate to be 5" thick x 2'-0" wide by 1'-9" long. Total number of pads = 18				
									86-68140	60	lf	\$200.00	\$12,000.00
									Bridge Joint Seals at Expansion Joints Elastomeric expansion device equal to General Tire Co. Transflex Model 1300 or to Watson Bowman & Associates Waboflex-SR Model SR 13 for full width of bridge. 2 1/2" by 2 3/4" Preformed Compression Joint Seals at tower & at abutment.				
										20	lf		
										40	lf		
									SUBTOTAL THIS SHEET			\$59,000.00	

ANTITIES		PRICES	
BY Jesus G. Romero, PE	CHECKED Joseph M. Gemperline, PE	BY Greg Akins <i>g. akins</i>	CHECKED <i>[Signature]</i> 01/28/2013
DATE PREPARED 12/07/12	PEER REVIEW / DATE Roman M. Koltuniuk, PE	DATE PREPARED 01/25/13	PEER REVIEW / DATE <i>[Signature]</i> 1/28/13

FEATURE: B. F. Sisk Dam Modification Roller Gate re-location and Stem Extension Middle Estimated <u>Undrained</u> Strength Parameters		PROJECT: Central Valley Project, Madera County, California	
WOID:		ESTIMATE LEVEL:	Appraisal
REGION:	MP	UNIT PRICE LEVEL:	Oct-12
FILE: U:\2012 Projects\BF Sisk\002 Completed Sheets\002 Summary BF Sisk - Undrained.xlsx\Summary 16			

PLANT ACCOUNT	PAY ITEM	DESCRIPTION	CODE	QUANTITY	UNIT	UNIT PRICE	AMOUNT	
	36	Site Survey (Pre-Rehab) (assess general conditions and take measurements as needed)	86-68420	1	LS	\$12,000.00	\$12,000.00	
		NOTE: The following quantities are for work on one roller gate, hoist, & associated equipment Total work is for four gates.						
	37	Shut down and lock out unit associated with gate to be removed	86-68420	1	LS	\$5,000.00	\$5,000.00	
	38	Remove hydraulic piping to hoist Crew: 1 supervisor, 1 mechanic Shut valves to hoist Drain oil from piping (15 gallons, 1 Crew HR) Disconnect piping and plug ends (1 Crew HR) Remove piping to hoist 150# (3 Crew HR)	86-68420	1	EA	\$9,500.00	\$9,500.00	
	39	Remove Hydraulic Power Unit (8 Crew HR) Disconnect electrical Remove and store indoors	86-68420	1	EA	\$14,500.00	\$14,500.00	
		Raise Roller Gate Crew: 1 supervisor, 2 mechanics, 1 laborer						
	40	Raise/lock gate by Gov't force (1 Crew HR) Assume contractor assists gov't forces	86-68420	1	LS	\$3,500.00	\$3,500.00	
	41	Remove hoist (18 Crew HR)	86-68420	1	LS	\$21,000.00	\$21,000.00	
	42	Remove intermediate stems (12 Crew HR)	86-68420	1	LS	\$26,000.00	\$26,000.00	
	43	Remove gate (10 Crew HR)	86-68420	1	LS	\$31,000.00	\$31,000.00	
SUBTOTAL THIS SHEET							1	\$122,500.00

QUANTITIES		PRICES	
BY D.L. Read	CHECKED D.M. Drake	BY Greg Akins <i>Greg Akins</i>	CHECKED <i>[Signature]</i> 1/28/2013
DATE PREPARED 12/10//2012	PEER REVIEW / DATE D.M. Drake	DATE PREPARED 01/25/13	PEER REVIEW / DATE <i>[Signature]</i> 1/29/13

FEATURE: B. F. Sisk Dam Modification Roller Gate re-location and Stem Extension Middle Estimated <u>Undrained</u> Strength Parameters		PROJECT: Central Valley Project, Madera County, California	
WOID:		ESTIMATE LEVEL: Appraisal	
REGION: MP		UNIT PRICE LEVEL: Oct-12	
FILE: U:\2012 Projects\BF Sisk\002 Completed Sheets\002 Summary BF Sisk - Undrained.xlsx\Summary 16			

PLANT ACCOUNT	PAY ITEM	DESCRIPTION	CODE	QUANTITY	UNIT	UNIT PRICE	AMOUNT	
		Install Embedded metalwork						
	44	Furnish and install embedded gate guides	86-68420	1,875	LB	\$13.00	\$24,375.00	
		Install Roller Gate Crew: 1 supervisor, 2 mechanics, 1 laborer						
	45	Install gate (10 Crew HR)	86-68420	1	LS	\$36,000.00	\$36,000.00	
	46	Install intermediate stems (12 Crew HR)	86-68420	1	LS	\$30,000.00	\$30,000.00	
	47	Furnish and install one new intermediate stem (steel - 1,475 # each, 12 Crew HR)	86-68420	1	LS	\$140,000.00	\$140,000.00	
	48	Install hoist (18 Crew HR)	86-68420	1	LS	\$50,000.00	\$50,000.00	
	49	Install hoist (18 Crew HR)	86-68420	1	LS	\$42,000.00	\$42,000.00	
SUBTOTAL THIS SHEET							2	\$322,375.00

QUANTITIES		PRICES	
BY D.L. Read	CHECKED D.M. Drake	BY Greg Akins <i>gajtk</i>	CHECKED <i>[Signature]</i> 1/28/13
DATE PREPARED 12/10/2012	PEER REVIEW / DATE DM Drake	DATE PREPARED 01/25/13	PEER REVIEW / DATE <i>[Signature]</i> 1/28/13

FEATURE: B.F. Sisk Raise Appraisal Study Intake Tower Modifications Mechanical Equipment Group 86-68410 Most Probable Estimate Middle Estimated <u>Undrained</u> Strength Parameters	PROJECT: Central Valley Project, Madera County, California	
	WOID: A176F	ESTIMATE LEVEL: Appraisal
	REGION: MP	UNIT PRICE LEVEL: Oct-12
	FILE: U:\2012 Projects\BF Sisk\002 Completed Sheets\002 Summary BF Sisk - Undrained.xlsx\Summary 16	

PLANT ACCOUNT	PAY ITEM	DESCRIPTION	CODE	QUANTITY	UNIT	UNIT PRICE	AMOUNT
		GANTRY CRANE:					
	58	Remove and dispose exist crane rails	86-68410	19,200	lbs.	\$0.75	\$14,400.00
		All parts are structural steel					
		- 85# ASCE rails, 600 feet, 16,040 lbs.					
		- 585 Rail clips, 293 lbs.					
		- 290 Bearing plates, 1,600 lbs.					
		- 320 - 3/4" Dia. x 12" machine bolts, 640 lbs.					
		- 300 - 3/4" Dia. x 10" welded studs, 600 lbs.					
	59	Furnish and install new crane rails	86-68410	19,200	lbs.	\$9.00	\$172,800.00
		Structural steel, coated					
		- 85# ASCE rails, 600 feet, 16,040 lbs.					
		- 585 Rail clips, 293 lbs.					
		- 290 Bearing plates, 1,600 lbs.					
		- 320 - 3/4" Dia. x 12" machine bolts, 640 lbs.					
		- 300 - 3/4" Dia. x 10" welded studs, 600 lbs.					
	60	Rerope the hoist and provide a new drums to	86-68410	1	LS	\$120,000.00	\$120,000.00
		accommodate the additional 10'-0" of height					
		- 1-inch Dia. 6x37 IWRC, galvanized, extra improved plow steel (XIP)		1,300	ft.		
		- Two new drums, cast steel, coated, 9'-4" long, 24" dia., 1,545 lbs. ea.		3,090	lbs.		
		Assume:					
		- Rope is 4 part					
SUBTOTAL THIS SHEET							\$307,200.00

QUANTITIES		PRICES	
BY R. Stephen	CHECKED A. Ritt	BY <i>Greg Akins</i>	CHECKED <i>[Signature]</i> 01/28/13
DATE PREPARED 12/17/12	PEER REVIEW / DATE D. Hulse	DATE PREPARED 01/25/13	PEER REVIEW / DATE <i>[Signature]</i> 1/28/13

FEATURE: B.F. Sisk Raise Appraisal Study Intake Tower Modifications Mechanical Equipment Group 86-68410 Most Probable Estimate Middle Estimated <u>Undrained</u> Strength Parameters	PROJECT: Central Valley Project, Madera County, California <hr/> WOID: A176F ESTIMATE LEVEL: Appraisal REGION: MP UNIT PRICE LEVEL: Oct-12 <hr/> FILE: U:\2012 Projects\BF Sisk\002 Completed Sheets\002 Summary BF Sisk - Undrained.xlsx\Summary 16
---	---

PLANT ACCOUNT	PAY ITEM	DESCRIPTION	CODE	QUANTITY	UNIT	UNIT PRICE	AMOUNT
		GANTRY CRANE:					
	61	Remove, store and reinstall gantry crane	86-68410	1	L.S.	\$250,000.00	\$250,000.00
		after modifications to the intake towers are completed					
		- Gantry crane will have to be disassembled due to width of access bridge					
		- Crane dead weight is 176,000 lbs.					
		- Crane is approx. 40'-0" tall, 40'-0" wide, and 38'-0" long.					
		Assume:					
		- Crane is stored onsite					
		- Crane is fully functional					
		- No modernization is required					
		- Removal and reinstallazation will require the use of a mobile crane, ~20T					
SUBTOTAL THIS SHEET							\$250,000.00

QUANTITIES			PRICES		
BY R. Stephen	CHECKED A. Ritt		BY <i>Greg Akins</i>	CHECKED <i>[Signature]</i> 01/28/13	
DATE PREPARED 12/17/12	PEER REVIEW / DATE D. Hulse		DATE PREPARED 01/25/13	PEER REVIEW / DATE <i>[Signature]</i> 1/28/13	

FEATURE: B.F. Sisk Raise Appraisal Study Intake Tower Modifications Mechanical Equipment Group 86-68410 Most Probable Estimate Middle Estimated <u>Undrained</u> Strength Parameters	PROJECT: Central Valley Project, Madera County, California <hr/> WOID: A176F ESTIMATE LEVEL: Appraisal REGION: MP UNIT PRICE LEVEL: Oct-12 <hr/> FILE: U:\2012 Projects\BF Sisk\002 Completed Sheets\002 Summary BF Sisk - Undrained.xlsx\Summary 16
--	---

PLANT ACCOUNT	PAY ITEM	DESCRIPTION	CODE	QUANTITY	UNIT	UNIT PRICE	AMOUNT
		BULKHEAD GATE:					
	62	Remove and reinstall bulkhead gates, lifting frame and storage arms. - (2) Top bulkhead gates, 75,000 lbs. ea., approx. 24'-6" wide x 15'-0" tall - (2) Bottom bulkhead gates, 73,000 lbs. ea., approx. 24'-6" wide x 14'-6" tall - Bulkhead gates are stored in the top of the guides of the intake towers. - Lifting frame, 12,000 lbs., 26'-0" x 16'-6" - (8) Storage arms, 1,200 lbs. ea., fastened to concrete deck by anchor bolts, on top of a grout pad.	86-68410	1	L.S.	\$500,000.00	\$500,000.00
	63	Remove and dispose existing bulkhead guides - Embedded in concrete - Eight at 2,500 lbs. ea., 10'-0" long	86-68410	20,000	lbs.	\$0.75	\$15,000.00
	64	Furnish and install new bulkhead guides - Structural steel, coated, embedded - Eight at 5,000 lbs. ea., 20'-0" long	86-68410	40,000	lbs.	\$9.00	\$360,000.00
SUBTOTAL THIS SHEET							\$875,000.00

QUANTITIES		PRICES	
BY R. Stephen	CHECKED A. Ritt	BY <i>Greg Akins</i>	CHECKED <i>[Signature]</i> 1/24/2013
DATE PREPARED 11/29/2012	PEER REVIEW / DATE D. Hulse	DATE PREPARED 01/25/13	PEER REVIEW / DATE <i>[Signature]</i> 1/28/13

FOR OFFICIAL USE ONLY

**Technical Memorandum No. VB-86-68313-25
B.F. Sisk Dam – Increased Storage Alternatives
Appraisal-Level Study**

Appendix C

TM VB-86-68313-22

Appraisal-Level Study of Static Stability for Increased Storage

FOR OFFICIAL USE ONLY

THIS PAGE INTENTIONALLY LEFT BLANK

RECLAMATION

Managing Water in the West

FOR OFFICIAL USE ONLY

Technical Memorandum No. VB-86-68313-22

Appraisal-Level Study of Static Stability for Increased Storage

**B.F. Sisk Dam
Central Valley Project, California
Mid-Pacific Region**



FOR OFFICIAL USE ONLY



U.S. Department of the Interior
Bureau of Reclamation
Technical Service Center
Denver, Colorado

January 2013

Mission Statements

The mission of the Department of the Interior is to protect and provide access to our Nation's natural and cultural heritage and honor our trust responsibilities to Indian Tribes and our commitments to island communities.

The mission of the Bureau of Reclamation is to manage, develop, and protect water and related resources in an environmentally and economically sound manner in the interest of the American public.

FOR OFFICIAL USE ONLY

Technical Memorandum No. VB-86-68313-22

Appraisal-Level Study of Static Stability for Increased Storage

**B.F. Sisk Dam
Central Valley Project, California
Mid-Pacific Region**

FOR OFFICIAL USE ONLY



**U.S. Department of the Interior
Bureau of Reclamation
Technical Service Center
Denver, Colorado**

THIS PAGE INTENTIONALLY LEFT BLANK

FOR OFFICIAL USE ONLY

Technical Memorandum No. VB-86-68313-22
Appraisal-Level Study of Static Stability for Increased Storage

Technical Memorandum No. VB-86-68313-22

Appraisal-Level Study of Static Stability for Increased Storage

B.F. Sisk Dam
Central Valley Project, California
Mid-Pacific Region

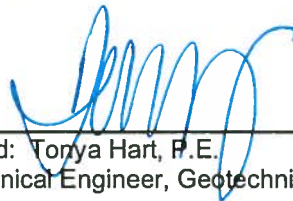
 P.E.

Prepared: Tonya Hart, P.E.
Geotechnical Engineer, Geotechnical Engineering Group 3, 86-68313

 P.E.

Checked: Tuti Tierney, P.E.
Civil Engineer, Geotechnical Engineering Group 3, 86-68313



Peer Review: Randall Kuzniakowski, P.E.
Civil Engineer, Geotechnical Engineering Group 4, 86-68314

1/28/13
Date

REVISIONS					
Date	Description	Prepared	Checked	Technical approval	Peer review

THIS PAGE INTENTIONALLY LEFT BLANK

Acronyms and Abbreviations

BOR	Bureau of Reclamation
CAS	Corrective Action Study
CFR	Comprehensive Facility Review
CRB	Consultant Review Board
DWR	Department of Water Resources
FLAC	Fast Lagrangian Analysis of Continua
FS	factor of safety
ft ²	square foot (feet)
ft ³	cubic foot (feet)
GVS	Great Valley Sequence
IE	Issue Evaluation
km	kilometer(s)
MPRO	Mid-Pacific Regional Office
MSE	Mechanically Stabilized Earth
NVS	North Valley Section
PMP	Project Management Plan
RA	Risk Analysis
Reclamation	Bureau of Reclamation
RWS	reservoir water surface
SOD	Safety of Dams
SPT	Standard Penetration Test
SVS	South Valley Section
TM	Technical Memorandum
URS	URS Group, Inc.

THIS PAGE INTENTIONALLY LEFT BLANK

Contents

	Page
I. Introduction.....	1
II. Background Information.....	1
A. Location and Features	1
B. Previous and Concurrent Studies	2
C. Site Geology	4
1. General	4
2. Stratigraphy.....	4
a. Panoche Formation (Kp).....	4
b. Tulare Formation (QTt)	5
c. Los Banos Alluvium (Ql).....	5
d. San Luis Ranch Alluvium (Qsl).....	5
e. Patterson Alluvium (Qp).....	5
f. Slopewash (Qs).....	5
III. Embankment Materials	6
A. General	6
B. Zone 1.....	6
C. Zone 2.....	6
D. Zone 3.....	6
E. Zone 4.....	7
F. Zone 5.....	7
G. Rock Blanket, Riprap, and Bedding Material	7
H. Stabilization Berms (Zones 6 and 7)	7
IV. Modified Embankment Configuration.....	7
V. Stability Analyses	9
A. General	9
B. Method of Analysis	9
C. Piezometric Data	10
D. Embankment Cross Sections and Locations	12
1. Station 37+00.....	11
2. Station 65+00.....	11
3. Station 86+00.....	11
4. Station 107+00.....	12
5. Station 147+20.....	12
6. Dike.....	12
E. Material Properties	12
VI. Results.....	13
VII. Summary and Discussion.....	19
References.....	21

FOR OFFICIAL USE ONLY

**Technical Memorandum No. VB-86-68313-22
Appraisal-Level Study of Static Stability for Increased Storage**

Tables

Table	Page
1	Material properties used in the limit equilibrium stability analyses 14
2	Results of the parametric study..... 15

Attachments

Attachment

- A Drawings
- B Results of Static Stability Analyses

FOR OFFICIAL USE ONLY

**Technical Memorandum No. VB-86-68313-25
B.F. Sisk Dam – Increased Storage Alternatives
Appraisal-Level Study**

Appendix D

TM BFS-8110-STY-2012-1

*Analysis of Spillway, and Outlet Works Towers and Conduit, and
Gianelli Pumping-Generating Plant*

FOR OFFICIAL USE ONLY

THIS PAGE INTENTIONALLY LEFT BLANK

RECLAMATION

Managing Water in the West

Technical Memorandum No. BFS-8110-STY-2012-1

B.F. Sisk Dam Analysis of Spillway, and Outlet Works Towers and Conduit, and Gianelli Pumping –Generating Plant

Central Valley Project, California
Mid-Pacific Region



SENSATIVE – FOR OFFICIAL USE ONLY



U.S. Department of the Interior
Bureau of Reclamation
Technical Service Center
Denver, Colorado

December 2012

Mission Statements

The mission of the Department of the Interior is to protect and provide access to our Nation's natural and cultural heritage and honor our trust responsibilities to Indian Tribes and our commitments to island communities.

The mission of the Bureau of Reclamation is to manage, develop, and protect water and related resources in an environmentally and economically sound manner in the interest of the American public.

BUREAU OF RECLAMATION
Technical Service Center, Denver, Colorado
Structural Analysis Group, 86-68110

Technical Memorandum No. BFS-8110-STY-2012-1

**B.F. Sisk Dam - Analysis of Spillway, and
 Outlet Works Towers and Conduit, and
 Gianelli Pumping – Generating Plant**

B.F. Sisk Dam
Central Valley Project, California
Mid Pacific Region

Michael A. Shepherd

Prepared: Michael A. Shepherd
 Civil Engineer, Structural Analysis Group 86-68110

Jason Schneider P.E.

Checked: Jason Schneider, P.E.
 Civil Engineer, Waterways and Concrete Dams Group 86-68130

Jason Schneider P.E.

Technical Approval: Jason Schneider, P.E.
 Civil Engineer, Waterways and Concrete Dams Group 86-68130

Walter Heyder P.E.

Peer Review: Walter Heyder P.E.
 Civil Engineer, Waterways and Concrete Dams Group 86-68130

1/26/2013

Date

REVISIONS					
Date	Description	Prepared	Checked	Technical Approval	Peer Review

Table of Contents

	Page
I. Introduction.....	1
A. Purpose.....	1
B. Description of Dam.....	1
II. Static Evaluation	2
A. Considerations.....	2
B. Outlet Works Intake Tower Modification.....	3
C. Outlet Works Conduit.....	4
D. Morning Glory Spillway Modification	4
E. Gianelli Pumping Generating Plant	5
III. Seismic Evaluation	5
A. Outlet Works Intake Towers	6
B. Spillway	9
C. Finite Element Model Results.....	10
D. Dam Safety and Risk Analysis	12
IV. Conclusions.....	14
References	15

FOR OFFICIAL USE ONLY

**Technical Memorandum No. VB-86-68313-25
B.F. Sisk Dam – Increased Storage Alternatives
Appraisal-Level Study**

Appendix E

TM BFS-8140-STY-2013-1

Analysis of Trashrack Structure Access Bridge

FOR OFFICIAL USE ONLY

THIS PAGE INTENTIONALLY LEFT BLANK

RECLAMATION

Managing Water in the West

Technical Memorandum No. BFS-8140-STY-2013-1

B.F. Sisk Dam - Analysis of Trashrack Structure Access Bridge

Central Valley Project, California
Mid-Pacific Region



Sensitive – For Official Use Only



U.S. Department of the Interior
Bureau of Reclamation
Technical Service Center
Denver, Colorado

March 2013

Mission Statements

The mission of the Department of the Interior is to protect and provide access to our Nation's natural and cultural heritage and honor our trust responsibilities to Indian Tribes and our commitments to island communities.

The mission of the Bureau of Reclamation is to manage, develop, and protect water and related resources in an environmentally and economically sound manner in the interest of the American public.

B.F. Sisk Dam - Analysis of Trashrack Structure Access Bridge

**Central Valley Project, California
Mid-Pacific Region**

For further information regarding this Technical Memorandum, contact:

Jesus Romero
303-445-3124
jromero@usbr.gov



**U.S. Department of the Interior
Bureau of Reclamation
Technical Service Center
Denver, Colorado**

BUREAU OF RECLAMATION
Technical Service Center, Denver, Colorado
Water Conveyance Group, 86-68140

Technical Memorandum No. BFS-8140-STY-2013-1

**B.F.Sisk Dam - Analysis of Trashrack
 Structure Access Bridge**

Central Valley Project, California
Mid-Pacific Region

 P.E.
 Prepared: Joseph Gempert, P.E.
 Civil Engineer, Water Conveyance Group, 86-68140

 P.E.
 Checked: Jesus Romero, P.E.
 Civil Engineer, Water Conveyance Group, 86-68140

 P.E.
 Technical Approval: Jesus Romero, P.E.
 Civil Engineer, Water Conveyance Group, 86-68313

 P.E. 3/8/2013
Date
 Peer Review: Roman Koltuniuk, P.E.
 Supervisory Civil Engineer, Structural Analysis Group, 86-68110

REVISIONS					
Date	Description	Prepared	Checked	Technical approval	Peer review

Contents

	Page
Existing Access Bridge.....	7
Bridge Modification	7
Appendix.....	10
PIER 1 Interaction Diagram.....	10

THIS PAGE INTENTIONALLY LEFT BLANK

ATTACHMENT B

San Luis Reservoir Enlargement
Appraisal Level Modeling Analysis

This page intentionally left blank.

San Luis Reservoir Expansion Appraisal Study - Attachment B

Sisk Enlargement Appraisal Level Modeling Analysis – May 2013

Introduction

This analysis is focused on assessing at an appraisal level the capacity of the CVP/SWP system to use the additional storage in San Luis Reservoir that would be afforded by raising Sisk Dam; two analysis methods were used in order to bracket the projected water supply benefits. One, a spreadsheet analysis, post-processed results from an existing baseline Calsim II study and provided a maximum benefit. The other, a direct application of CalLite, followed the classic planning model application approach of comparing with and without-project scenarios and produced a minimum benefit.

Method 1: Spreadsheet Analysis of Calsim II Results

The Method 1 approach was to post-process results from Reclamation's most current Calsim II baseline study. The baseline study uses an 82 year period of input hydrology and 2030 land use level of development. The baseline includes the RPAs recommended by the FWS BO of 2008 and the NMFS BO of 2009. Detailed descriptions of the Calsim II baseline assumptions are in Attachment C. The objective of Method 1 was to put an upper bound on potential delivery benefits, by looking only at the opportunities that currently exist in the Sacramento-San Joaquin delta for additional pumping if San Luis Reservoir was larger. Because of the large range of potential operation assumptions involved in delivery of additional CVP and SWP water supplies, it will take a much more detailed and lengthy modeling study to precisely evaluate how much of this additional pumping could actually be delivered when needed.

To determine opportunities for additional pumping, the following pumping restrictions were evaluated for each month in the baseline study: Banks and Jones permit and capacity limits, Export/Import ratio control limit, D-1641 and RPA export limits, and OMR flow standards. This method assumes that if the baseline study pumping in each month was less than the minimum of all pumping restrictions, and there was surplus delta outflow, then there was opportunity for additional pumping which could not be realized due to lack of storage. CVP and SWP pumping and storage were assumed to be combined, and the split between the projects was not evaluated. Attachment A describes the calculations used.

This analysis recognizes that while Calsim II is the best available tool for modeling CVP/SWP operations, there may be significant uncertainties in the results due to the use of Calsim II in a predictive mode rather than its usual comparative mode. The results do however provide an objective maximum estimate of the potential benefits of enlarging Sisk Dam and San Luis Reservoir.

Results - Method 1

The results of analyzing the Calsim II baseline study for pumping opportunities are shown in Table 1 and Table 2. Detailed pumping opportunities data are provided in Attachment B.

Opportunities for additional pumping occur in 17 years (21% of years) and in 37 months (4% of months) of the 82 year period of analysis. The spreadsheet analysis has indicated that if unlimited storage was available in San Luis Reservoir, then the CVP and SWP combined could pump an annual average 71 TAF of additional water. Approximately 87% of the additional pumping occurred in Wet or Above Normal water years.

Table 1 – Annual Additional PUMPING OPPORTUNITIES in baseline Calsim II study.

Water Year Type*	Total	Wet	Above Normal	Below Normal	Dry	Critical
Total Additional PUMPING OPPORTUNITIES (TAF)	5,833	4,019	1,070	485	20	239
No. of Years with Additional PUMPING OPPORTUNITIES	17	9	3	2	1	2
Avg Annual Additional PUMPING OPPORTUNITIES in additional pumping years (TAF/yr)	343	447	357	243	20	120
Avg Annual Additional PUMPING OPPORTUNITIES in all 82 years (TAF/yr)	71	49	13	6	0	3

* Water Year Type is Sacramento Valley Index.

Table 2 – Monthly Additional PUMPING OPPORTUNITIES in baseline Calsim II study.

	Total
Total Additional PUMPING OPPORTUNITIES (TAF)	5,833
No. of Months with Additional PUMPING OPPORTUNITIES	37
Avg Monthly Additional PUMPING OPPORTUNITIES in additional pumping months (TAF/mo.)	158
Avg Monthly Additional PUMPING OPPORTUNITIES in all months (TAF/mo.)	6

To further quantify these potential delivery benefits, a simplified analysis was performed to determine how much additional pumping could be stored at different increased reservoir sizes.

The additional pumping was added to the existing storage in the same month in the Calsim II study, and that total storage was compared to several different raise sizes. A continuous model over the period of record would be required to most accurately capture all the effects of additional pumping, because any additional pumping would have to be delivered immediately for the reservoir space to be available in the following month. This simple analysis instead evaluates each month independently, so may overestimate the storable volume. This method was used to avoid having to make any assumptions about how the additional pumping would be used, since that is an area of uncertainty that can only be resolved by more detailed modeling. The spreadsheet analysis results of various reservoir size increases and their ability to utilize additional pumping are summarized in Table 3. This table also gives some insight into the reservoir size beyond which no additional annual average benefits can be realized under current operations.

Table 3 –Additional PUMPING OPPORTUNITIES in baseline Calsim II study that can be stored by various reservoir storage capacity increases.

Water surface elevation increase (feet)	10	13	15	22	29	34	37	NA
Reservoir Storage Increase (TAF)	132	175	200	300	400	450	500	Unlimited
Total Additional PUMPING OPPORTUNITIES (TAF)	3,505	4,263	4,632	5,453	5,833	5,833	5,833	5,833
Months with Additional PUMPING OPPORTUNITIES	37	37	37	37	37	37	37	37
Avg Annual Additional PUMPING OPPORTUNITIES in all years (TAF/yr)	43	52	56	67	71	71	71	71

Method 2: CalLite Modeling Analysis

CalLite 2.01 was used to analyze the delivery benefits of raising Sisk Dam. CalLite is a screening model version of Calsim, which replicates Calsim results quite closely with much faster run-time. As with Calsim, it is a long term planning model designed to analyze differences in water supply reliability between a baseline condition and a proposed alternative. Detailed descriptions of the CalLite baseline assumptions are in Attachment C. San Luis Reservoir operations are conditionally variable and sensitive to many environmental and system conditions. Hence, it is difficult to achieve a realistic predictive operation with CalLite/Calsim under the more general long term operating goals of the overall system. This posed a particular challenge for this appraisal study, because analyzing the benefits of raising Sisk Dam is particularly sensitive to how San Luis operations are represented in the model. Preliminary modeling analyses conducted for this study have highlighted areas where refinements could be made in the model to improve model applicability at the Feasibility level – both in using available export capacity to fill the reservoir and in adjusting the South of Delta allocation to allow delivery of the water once it is there. At the present time, however, CalLite/Calsim remains the best available tool for determining how much of the additional pumping analyzed in the previous section could actually be stored and delivered. CalLite runs were conducted with three alternative sizes of an enlarged San Luis, with the only change in the model being the size of the reservoir. The increase in reservoir size was split proportionally between CVP and SWP so that the ratio of CVP and SWP storage was the same as currently exist. The intent of these runs in Method 2 was to put an approximate lower bound on delivery benefits of enlarging San Luis, since it is unlikely that all of the additional pumping detailed in Method 1 could actually be delivered.

Results – Method 2

North of Delta storages were not significantly impacted (Table 4) in the alternatives modeled, indicating North of Delta deliveries and operations are being held constant.

Table 4 – Change in North of Delta Average End of September Storage in CalLite studies

Water surface elevation increase (feet)	10	22	37
Reservoir Storage Increase (TAF)	132	300	500
CVP Shasta + Folsom + Trinity (TAF)	0.7	-3.6	-4.2
SWP Oroville (TAF)	0.4	0.1	0.6
Total (TAF)	1.1	-3.5	-3.6

Results from the CalLite studies are summarized in Table 5.

Table 5 – Average Annual ADDITIONAL DELIVERIES of CVP and SWP combined from simplified CalLite studies compared to the 2013 CalLite Baseline.

Water surface elevation increase (feet)	10		22		37	
Reservoir Storage Increase (TAF)	132		300		500	
CVP (TAF/yr)		12		21		30
SWP						
Table A (TAF/yr)	4		10		15	
Article 21 (Interruptible) (TAF/yr)	-10		-20		-27	
Carryover (TAF/yr)	2		3		3	
SWP Total (TAF/yr)		-4		-8		-9
TOTAL (TAF/yr)		7		13		21

Table 5 shows that in the CalLite results CVP deliveries increase while SWP deliveries decrease to a lesser degree. From review of model results, the decrease in SWP deliveries is mostly because, with a larger San Luis Reservoir, the CVP utilizes more of its equal pumping share under the OMR export constraint in months when OMR flow limits are controlling, thereby reducing SWP pumping in those months. A secondary reason is that with a larger San Luis Reservoir, CVP can reduce the amount of unused Federal share under COA that is pumped by SWP, compared to the baseline. These shifts in pumping propagate into shifts in deliveries. A second reason for the lack of increase in SWP deliveries is that for SWP, an enlarged San Luis Reservoir often leads to a shift of deliveries from Article 21 (interruptible) to Table A, without increasing overall SWP deliveries. Article 21 deliveries are only made when San Luis is full, which is less likely in the alternatives. There is a benefit to this shift that is not captured in the numbers shown, because Table A deliveries are preferable to Article 21 since they are firm yield on which contractors can depend.

Tables 6a-6c show the additional deliveries for three different raise sizes. Results are reported by Water Year Type, with combined CVP/SWP benefits from simplified CalLite studies compared to the 2013 CalLite Baseline.

Table 6a – ADDITIONAL DELIVERIES of CVP and SWP combined from simplified CalLite studies compared to the 2013 CalLite Baseline by Water Year Type – 132 TAF Reservoir Increase

Water Year Type *	Total	Wet	Above Normal	Below Normal	Dry	Critical
Total ADDITIONAL DELIVERIES in Water Year Type (TAF)	615	223	73	268	55	-3
No. of Years	82	26	12	14	18	12
Year Type Annual Average (TAF/yr)	NA	9	6	19	3	0
Period of Record (82 Years) Annual Average (TAF/yr)	7	3	1	3	1	0

* Water Year Type is Sacramento Valley Index.

Table 6b – ADDITIONAL DELIVERIES of CVP and SWP combined from simplified CalLite studies compared to the 2013 CalLite Baseline by Water Year Type – 300 TAF Reservoir Increase

Water Year Type *	Total	Wet	Above Normal	Below Normal	Dry	Critical
Total ADDITIONAL DELIVERIES in Water Year Type (TAF)	1,082	257	212	298	363	-49
No. of Years	82	26	12	14	18	12
Year Type Annual Average (TAF/yr)	NA	10	18	21	20	-4
Period of Record (82 Years) Annual Average (TAF/yr)	13	3	3	4	4	-1

* Water Year Type is Sacramento Valley Index.

Table 6c – ADDITIONAL DELIVERIES of CVP and SWP combined from simplified CalLite studies compared to the 2013 CalLite Baseline by Water Year Type – 500 TAF Reservoir Increase

Water Year Type *	Total	Wet	Above Normal	Below Normal	Dry	Critical
Total ADDITIONAL DELIVERIES in Water Year Type (TAF)	1,687	547	372	347	553	-131
No. of Years	82	26	12	14	18	12
Year Type Annual Average (TAF/yr)	NA	21	31	25	31	-11
Period of Record (82 Years) Annual Average (TAF/yr)	21	7	5	4	7	-2

* Water Year Type is Sacramento Valley Index.

Results - Summary

Table 7 shows a comparison of Additional Pumping Opportunities (Table 3) and the CalLite Additional Deliveries (Table 5) for three raise sizes. Keeping in mind the previously stated challenges in modeling San Luis operations, these results represent the range of possible delivery benefits that could be expected to occur. Where in this range deliveries would fall in a more refined analysis depends on numerous factors, including year-to-year delivery patterns for CVP and SWP, management of carryover storage in San Luis, sharing of storage and delivery benefits between CVP and SWP, and carriage water and salinity consequences of increased pumping of excess Delta outflow.

Table 7 – Maximum and Minimum Project Benefits

Water surface elevation increase (feet)	10	22	37
Reservoir Storage Increase (TAF)	132	300	500
Maximum Project Benefits:			
Avg Annual PUMPING OPPORTUNITIES in all years (TAF/yr)	43	67	71
Minimum Project Benefits:			
Avg Annual ADDITIONAL DELIVERIES in all years (TAF/yr)	7	13	21

Attachment B, Appendix A
Sisk Enlargement Appraisal Level Modeling Analysis – May 2013

Equations used to calculate additional pumping opportunities in Calsim II 2013 baseline study.

(Units are cfs unless otherwise noted)

1	D418	Jones Pumping
2	D419	Banks Pumping
3	D409	1+2
4	C407_CVP	Surplus Delta Outflow – CVP
5	C407_SWP	Surplus Delta Outflow – SWP
6	C407_CVP + C407_SWP	Surplus Delta Outflow - total 4+5
7	BanksAllowOut	Banks permitted pumping capacity
8	JonesAllowOut	Jones permitted pumping capacity
9	Max Total Permit/ Phys Pumping	7+8
10	EIXPCTRL	EI Export Control limit
11	AMJCtrl	Apr/May Jones Control limit (min of D-1641 and Vernalis RPA caps)
12	AMBCtrl	Apr/May Banks Control limit (min of D-1641 and Vernalis RPA caps)
13	AMCtrl	11+12
14	MAXEXP_RPA_CVPDV+MAXEXP_RPA_SWPDV	RPA export limit (min of Fall X2, DCC, Vernalis RPA caps)
15	D418up	Jones pumping in base cycle, used to calc OMR_restriction
16	D419_SWPup	Banks pumping in base cycle, used to calc OMR_restriction
17	comb_exp_dec_	combined export decrease
18	cvp_exp_dec_	cvp export decrease
19	swp_exp_dec_	swp export decrease
20	C408_Lbound	Lower limit on OMR flow
21	C_OMR	OMR flow
22	OMR restriction	OMR restriction: function (15 thru 21)
23	Controlling Pumping Restriction	Minimum of 9, 10, 13, 14, 22
24	Unused Pumping	23-3 (but not negative)
25	Unused Pumping with water to pump	min 6, 24
26	Unused Pumping with water to pump (taf)	25 converted to TAF
27	Original S_SL Total (S11 + S12) (taf)	San Luis Total Storage of Baseline
28	New Storage (taf)	New storage required to hold additional pumped water 26+27

Source: Sisk_PumpingPotential.xlsx

Attachment B, Appendix B
Sisk Enlargement Appraisal Level Modeling Analysis – May 2013

Table B-1

Yearly opportunities for additional pumping in Calsim II 2013 baseline.

Year Type	Water Year	Additional Pumping Opportunities TAF	No. of months
AN	1922		
BN	1923		
C	1924		
D	1925		
D	1926		
W	1927		
AN	1928		
C	1929		
D	1930		
C	1931		
D	1932		
C	1933		
C	1934	199	1
BN	1935		
BN	1936	99	1
BN	1937	386	2
W	1938	425	3
D	1939		
AN	1940		
W	1941		
W	1942		
W	1943		
D	1944		
BN	1945		
BN	1946		
D	1947		
BN	1948		
D	1949		
BN	1950		
AN	1951	254	3
W	1952		
W	1953		
AN	1954		
D	1955		
W	1956	102	2
AN	1957		
W	1958		
BN	1959		
D	1960		
D	1961		
BN	1962		
W	1963		
D	1964		

Table B-1 (Cont.)

Year Type	Water Year	Additional Pumping Opportunities TAF	No. of months
W	1965		
BN	1966		
W	1967		
BN	1968		
W	1969	716	4
W	1970	5	1
W	1971		
BN	1972		
AN	1973		
W	1974		
W	1975		
C	1976		
C	1977	40	1
AN	1978		
BN	1979		
AN	1980	748	2
D	1981		
W	1982	183	2
W	1983	1,511	5
W	1984	759	5
D	1985		
W	1986	232	1
D	1987		
C	1988		
D	1989		
C	1990		
C	1991		
C	1992		
AN	1993	68	1
C	1994		
W	1995	86	2
W	1996		
W	1997		
W	1998		
W	1999		
AN	2000		
D	2001	20	1
D	2002		
AN	2003		

Charts of Pumping Opportunities

Chart B-1 1920's

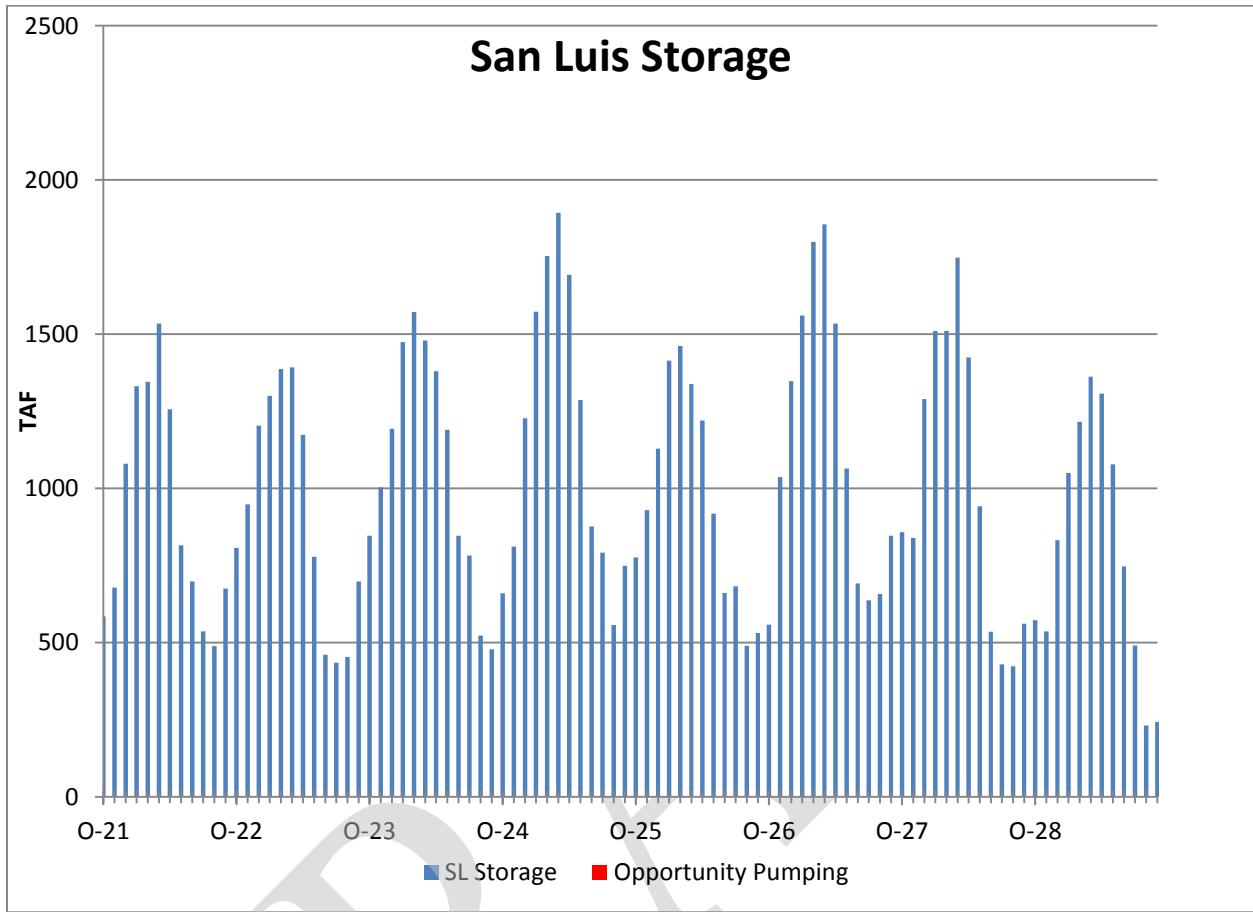

Chart B-2 1930's

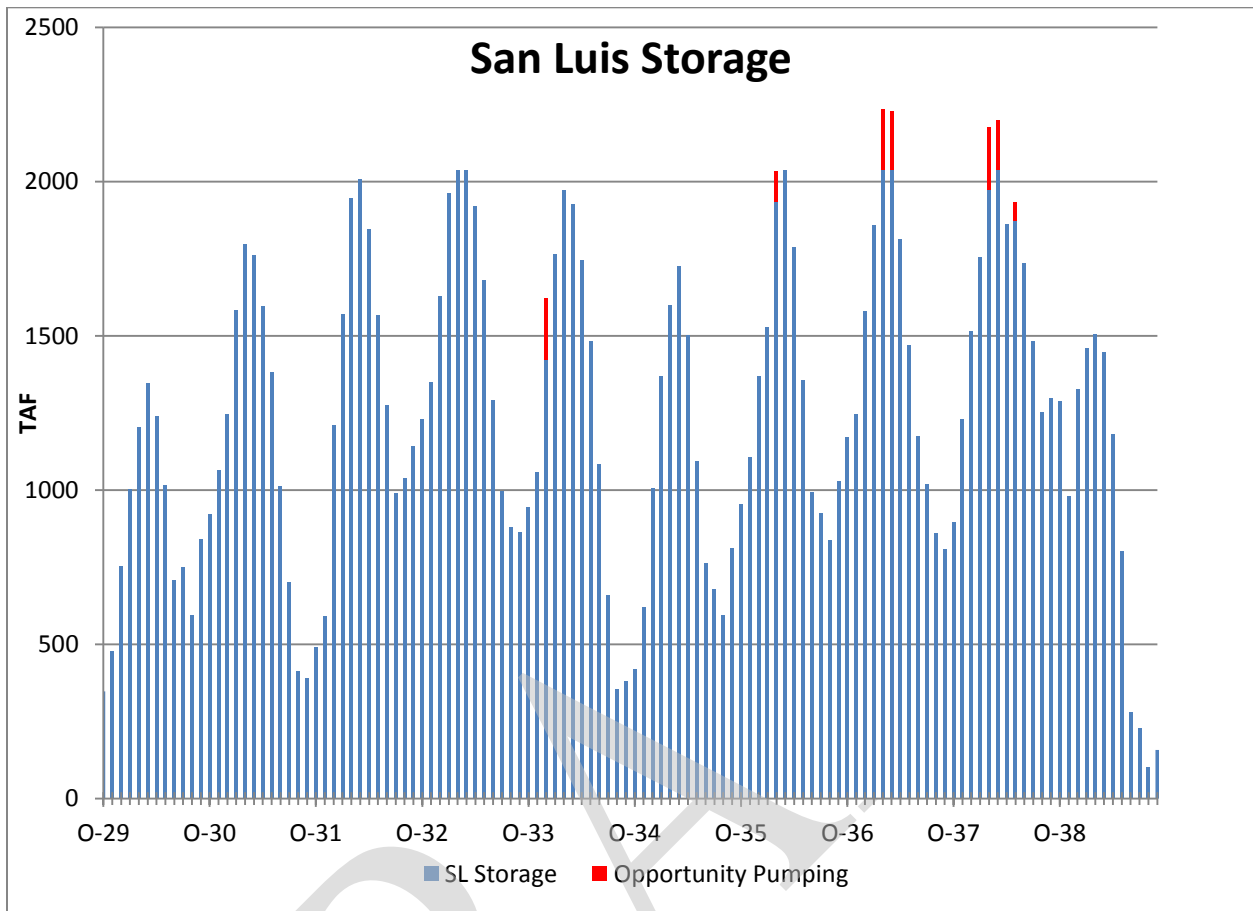
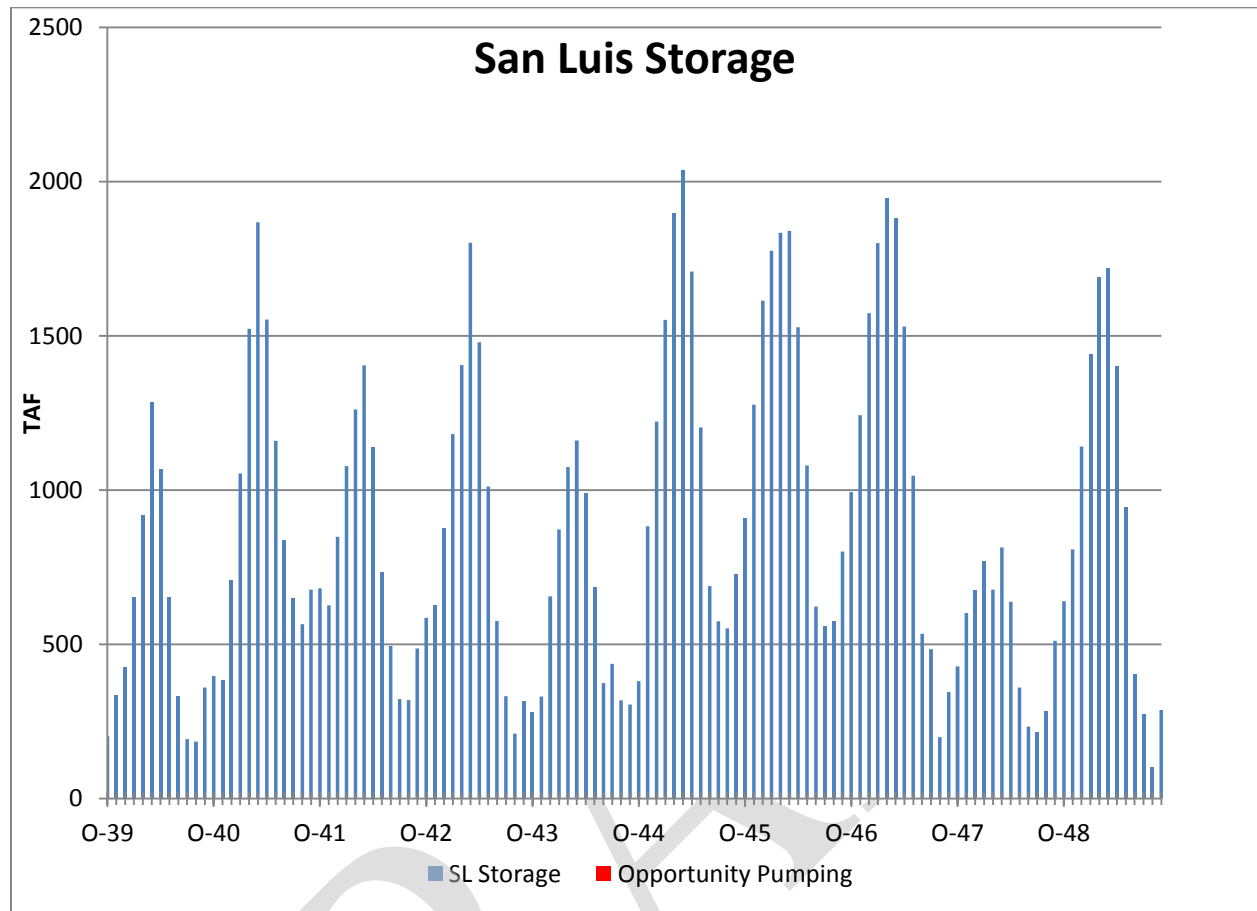

Chart B-3 1940's



DRAFT

Chart 1-4 1950's

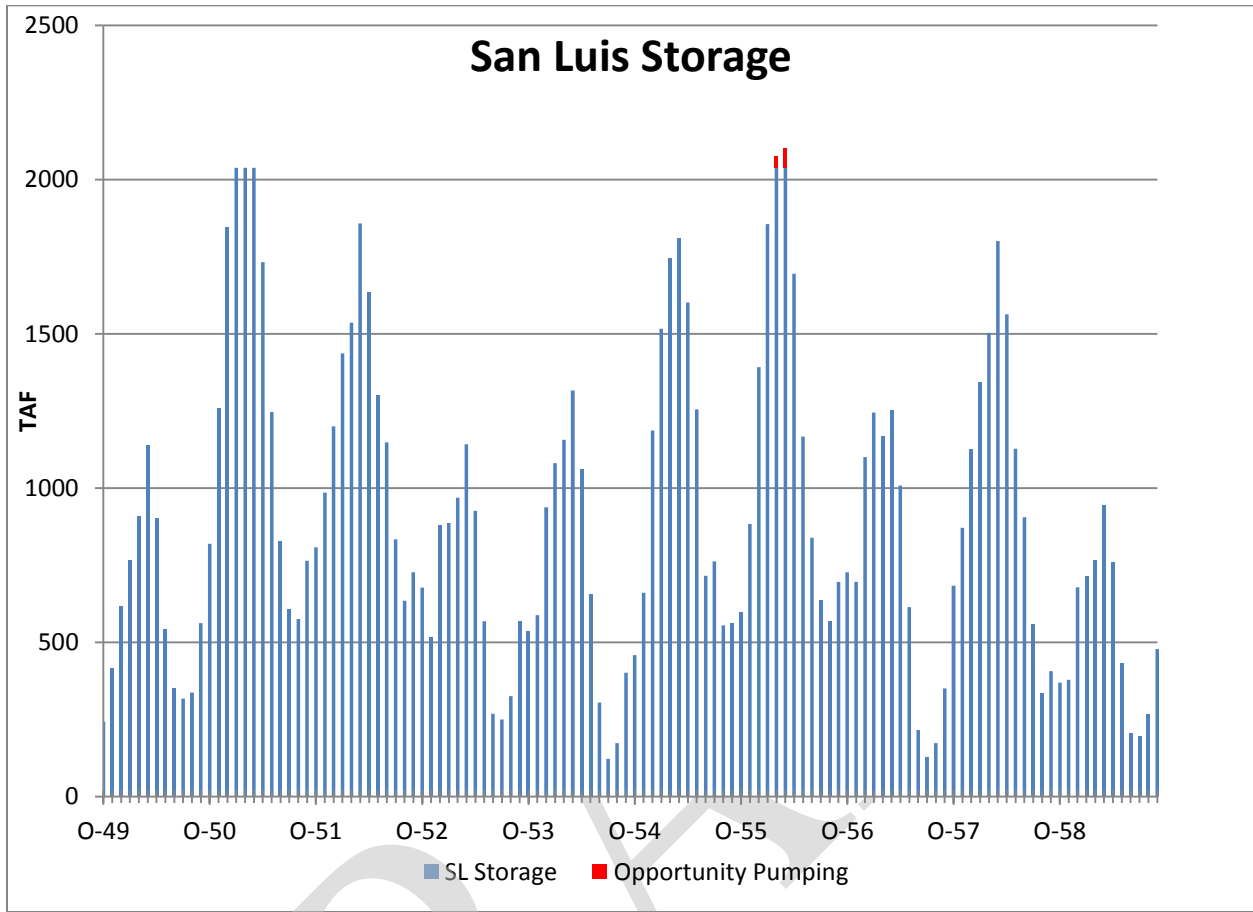

Chart B-5 1960's

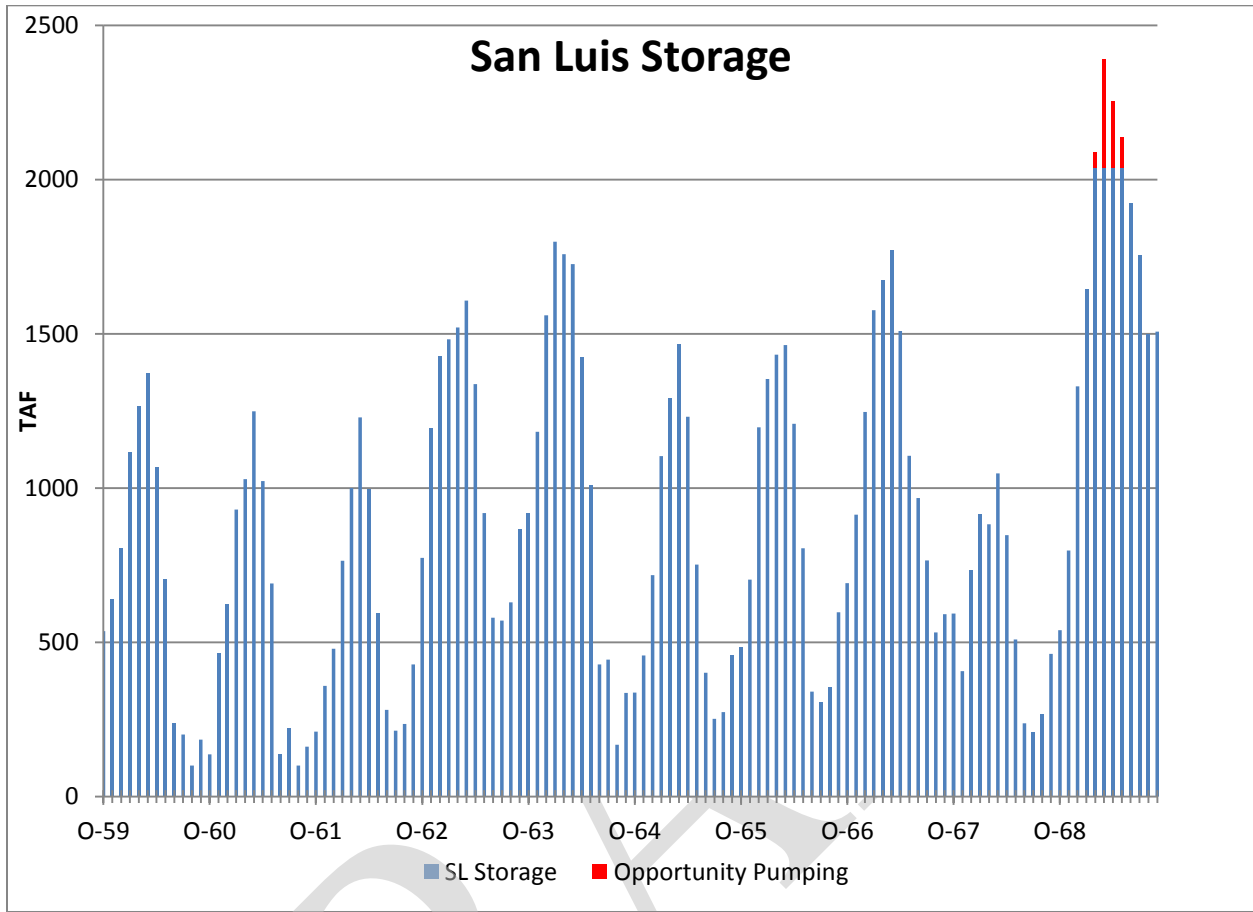

Chart B-6 1970's

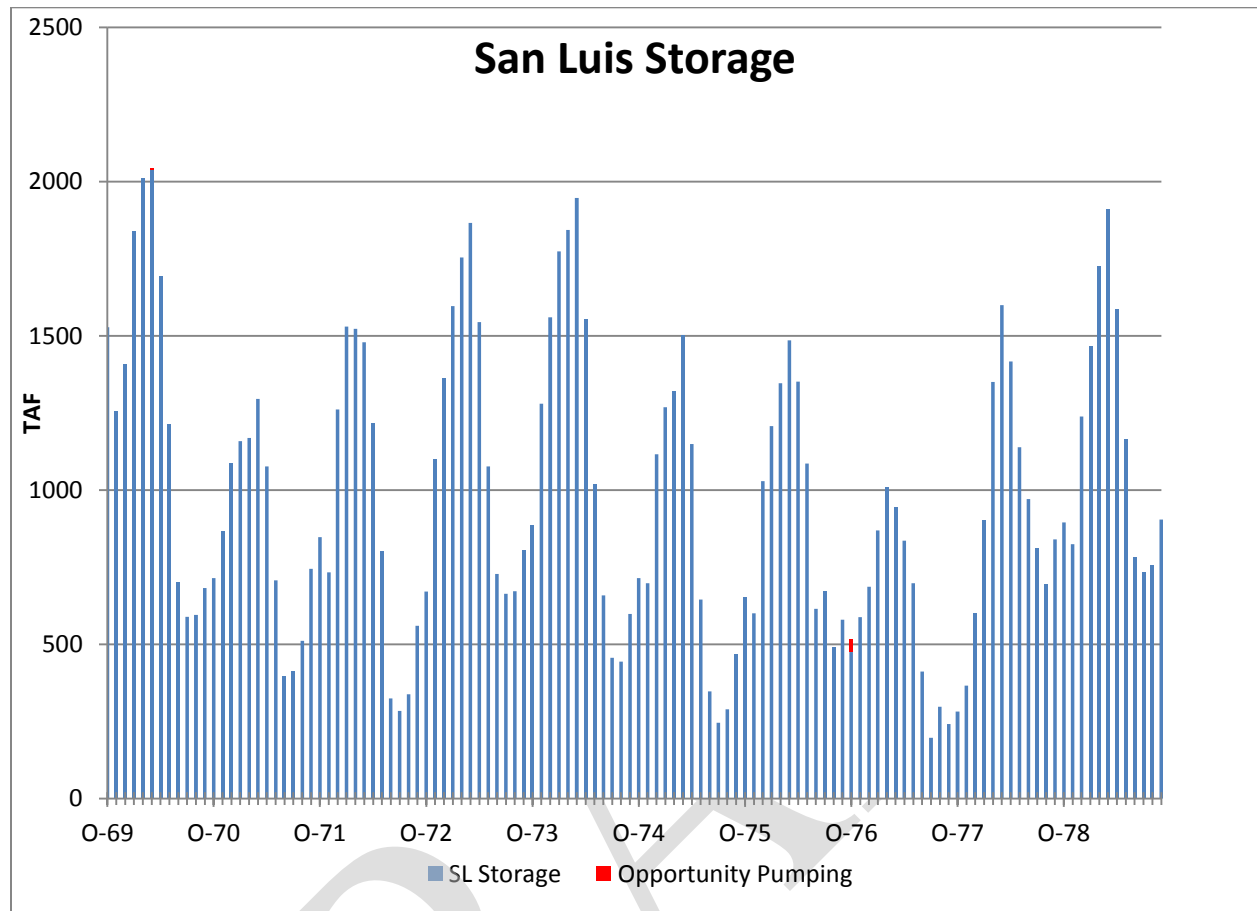

Chart B-7 1980's

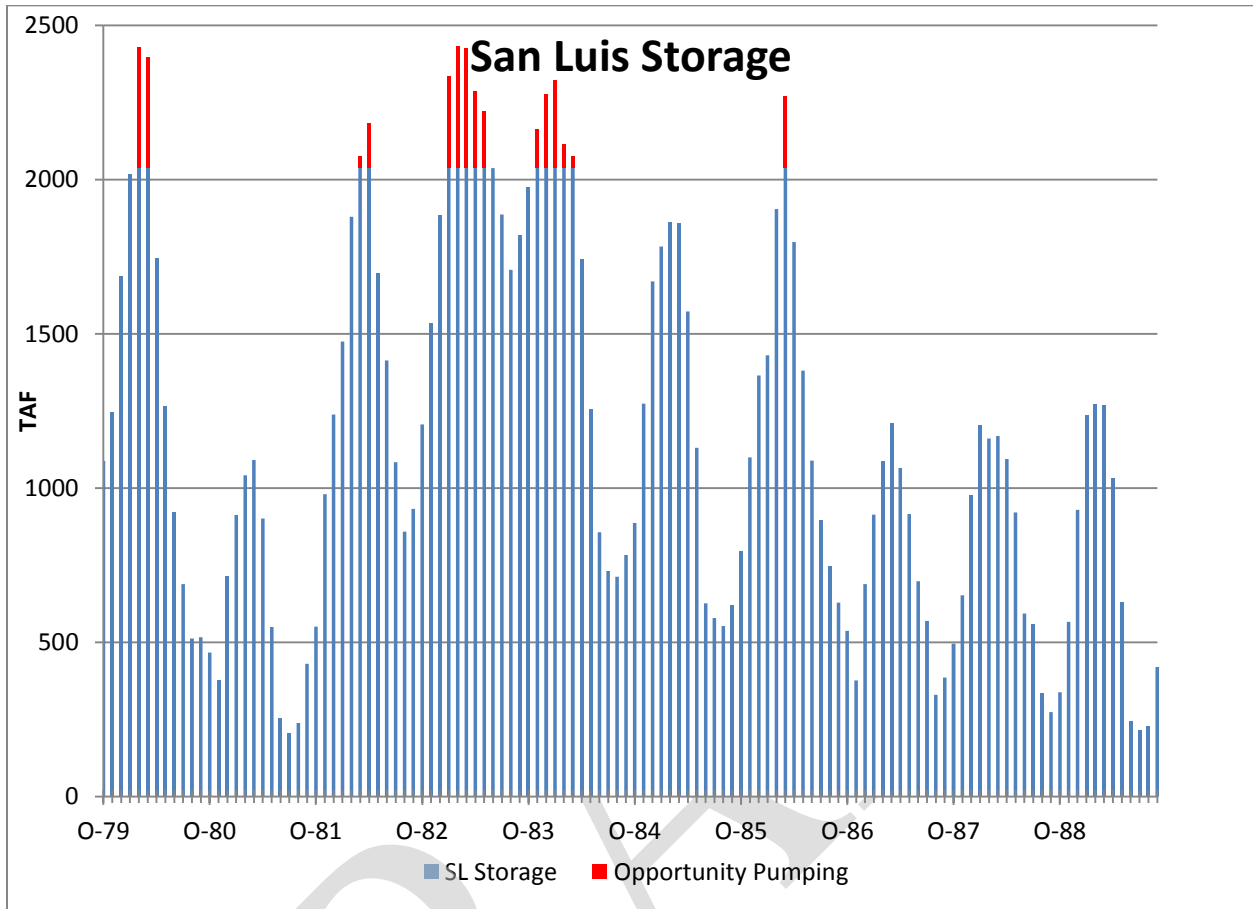

Chart B-8 1990's

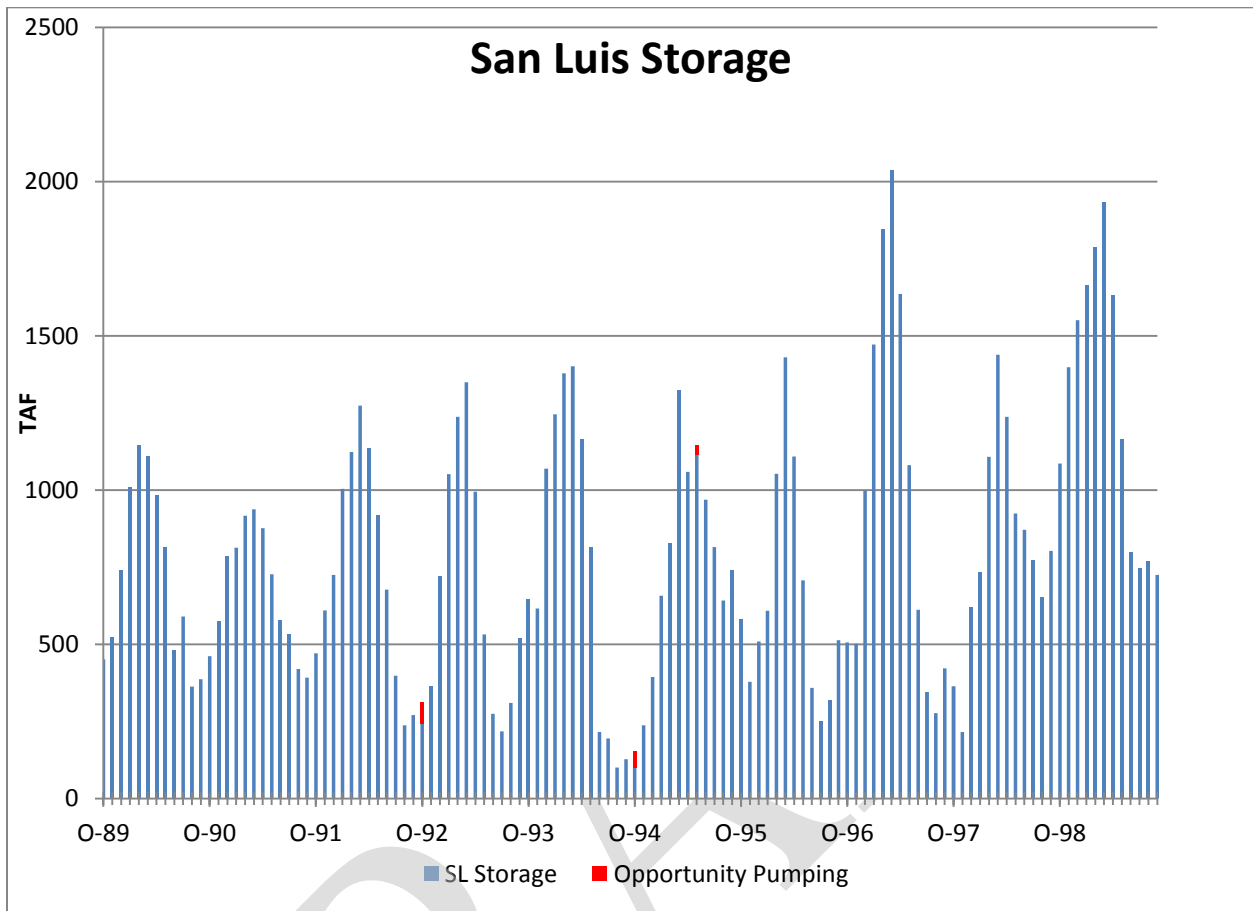
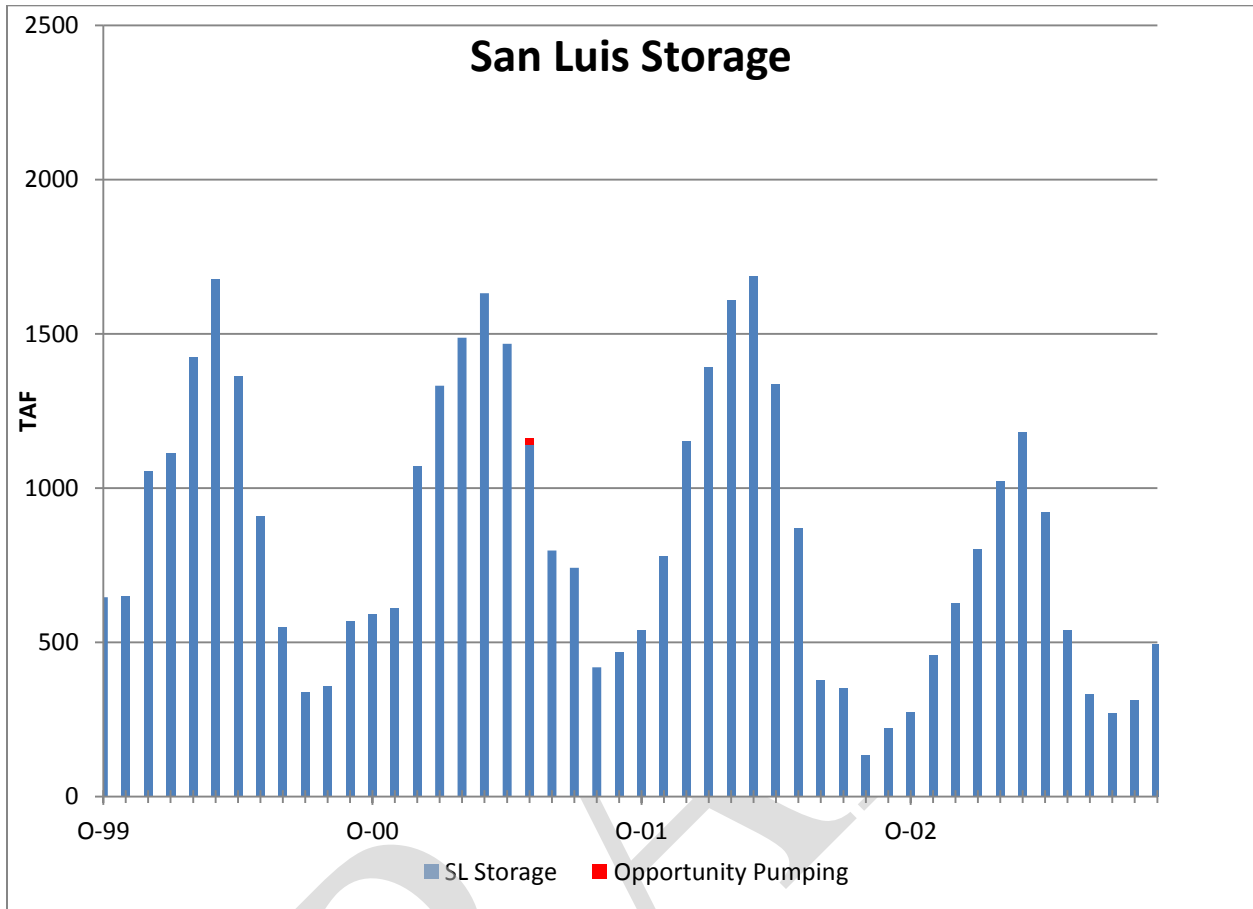

Chart B-9 2000's



Attachment B, Appendix C
Sisk Enlargement Appraisal Level Modeling Analysis – May 2013

Calsim-II Assumptions for Reclamation Jan 2013 Baselines

	Existing Condition ¹	Future Condition ¹
Planning Horizon	2005	2020
Period of Simulation	82 years (1922-2003)	Same
HYDROLOGY		
Level of Development (land use)	2005 Level ²	2030 Level ³
DEMANDS		
North of Delta (excluding the American River)		
CVP	Land-use based, limited by contract amounts ⁴	Land-use based, full build-out of contract amounts
SWP (FRSA)	Land-use based, limited by contract amounts ⁵	Same
Nonproject	Land-use based, limited by water rights and SWRCB Decisions for Existing Facilities	Same
Antioch Water Works	Pre-1914 water right	Same
Federal refuges	Recent historical Level 2 water needs ⁶	Firm Level 2 water needs ⁶
American River Basin		
Water rights	Year 2005 ⁷	Year 2025, full water rights ⁷
CVP	Year 2005, including Freeport Regional Water Project ⁷	Year 2025, full contracts, including Freeport Regional Water Project ⁷
San Joaquin River Basin⁹		
Friant Unit	Limited by contract amounts, based on current allocation policy	Same
Lower basin	Land-use based, based on district level operations and constraints	Same
Stanislaus River basin ^{10 19}	Land-use based, based on New Melones Interim Operations Plan, up to full SEWD deliveries (155 TAF/yr) depending on New Melones Index	Same
South of Delta		
CVP	Demand based on contract amounts ⁴	Same
Federal refuges	Recent historical Level 2 water needs ⁶	Firm Level 2 water needs ⁶
CCWD	195 TAF/yr CVP contract supply and water rights ¹¹	Same ¹¹
SWP ^{5 12}	Variable demand, of 3.0-4.1 MAF/Yr, up to Table A amounts including all Table A transfers through 2008	Demand based on full Table A amounts
Article 56	Based on 2001-2008 contractor requests	Same

Calsim-II Assumptions for Reclamation Jan 2013 Baselines (contd.)

	Existing Condition	Future Condition
Article 21	MWD demand up to 200 TAF/month from December to March subject to conveyance capacity, KCWA demand up to 180 TAF/month and other contractor demands up to 34 TAF/month in all months, subject to conveyance capacity.	Same
North Bay Aqueduct	71 TAF/yr demand under SWP contracts, up to 43.7 cfs of excess flow under Fairfield, Vacaville and Benecia Settlement Agreement	Same
FACILITIES		
System-Wide	Existing facilities	Same
Sacramento Valley		
Shasta Lake	Existing, 4,552 TAF capacity	Same
Red Bluff Diversion Dam	Diversion dam operated with gates out all year, NMFS BO (Jun 2009) Action I.3.1 ¹⁹ ; assume permanent facilities in place	Diversion dam operated with gates out all year, NMFS BO (Jun 2009) Action I.3.1 ¹⁹ ; assume permanent facilities in place
Colusa Basin	Existing conveyance and storage facilities	Same
Upper American River	PCWA American River pump station	Same
Lower Sacramento River	Freeport Regional Water Project	Freeport Regional Water Project
Delta Export Conveyance		
SWP Banks Pumping Plant (South Delta)	Physical capacity is 10,300 cfs but 6,680 cfs permitted capacity in all months up to 8,500 cfs during Dec 15 th - Mar 15 th depending on Vernalis flow conditions ²⁰ ; additional capacity of 500 cfs (up to 7,180 cfs) allowed for reducing impact of NMFS BO (Jun 2009) Action IV.2.1 ¹⁹ on SWP ²¹	Same
CVP C.W. "Bill" Jones Pumping Plant (formerly Tracy PP)	Permit capacity is 4,600 cfs in all months (allowed for by the Delta-Mendota Canal-California Aqueduct Intertie)	Same
Upper Delta-Mendota Canal Capacity	Existing (exports limited to 4,200 cfs plus diversion upstream from DMC constriction) plus 400 cfs Delta-Mendota Canal-California Aqueduct Intertie	Same
Los Vaqueros Reservoir	Enlarged storage capacity, 160 TAF, existing pump location. Alternate Intake Project included ¹⁴	Enlarged storage capacity, 160 TAF, existing pump location. Alternate Intake Project included ¹⁴
San Joaquin River		
Millerton Lake (Friant Dam)	Existing, 520 TAF capacity	Same
Lower San Joaquin River	None	City of Stockton Delta Water Supply Project, 30 mgd capacity

Calsim-II Assumptions for Reclamation Jan 2013 Baselines (contd.)

	Existing Condition	Future Condition
South of Delta (CVP/SWP project facilities)		
South Bay Aqueduct	Existing capacity	SBA rehabilitation, 430 cfs capacity from junction with California Aqueduct to Alameda County FC&WSD Zone 7 point
California Aqueduct East Branch	Existing capacity	Same
REGULATORY STANDARDS		
Trinity River		
Minimum Flow below Lewiston Dam	Trinity EIS Preferred Alternative (369-815 TAF/yr)	Same
Trinity Reservoir end-of-September minimum storage	Trinity EIS Preferred Alternative (600 TAF as able)	Same
Clear Creek		
Minimum flow below Whiskeytown Dam	Downstream water rights, 1963 Reclamation proposal to USFWS and NPS, and USFWS predetermined CVPIA 3406(b)(2) flows ²² , and NMFS BO (Jun 2009) Action I.1.1 ¹⁹	Same
Upper Sacramento River		
Shasta Lake end-of-September minimum storage	NMFS 2004 Winter-run Biological Opinion (1900 TAF in non-critical dry years), and NMFS BO (Jun 2009) Action I.2.1 ¹⁹	Same
Minimum flow below Keswick Dam	SWRCB WR 90-5, predetermined CVPIA 3406(b)(2) flows, and NMFS BO (Jun 2009) Action I.2.2 ¹⁹	Same
Feather River		
Minimum flow below Thermalito Diversion Dam	2006 Settlement Agreement (700 / 800 cfs).	Same
Minimum flow below Thermalito Afterbay outlet	1983 DWR, DFG agreement (750 – 1,700 cfs)	Same
Yuba River		
Minimum flow below Daguerre Point Dam	D-1644 Operations (Lower Yuba River Accord) ¹⁵	Same
American River		
Minimum flow below Nimbus Dam	American River Flow Management as required by NMFS BO (Jun 2009) Action II.1 ¹⁹	Same
Minimum flow at H Street Bridge	SWRCB D-893	Same
Lower Sacramento River		
Minimum flow near Rio Vista	SWRCB D-1641	Same

Calsim-II Assumptions for Reclamation Jan 2013 Baselines (contd.)

	Existing Condition	Future Condition
Mokelumne River		
Minimum flow below Camanche Dam	FERC 2916-029 ¹³ , 1996 (Joint Settlement Agreement) (100 – 325 cfs)	Same
Minimum flow below Woodbridge Diversion Dam	FERC 2916-029, 1996 (Joint Settlement Agreement) (25 – 300 cfs)	Same
Stanislaus River		
Minimum flow below Goodwin Dam	1987 Reclamation, DFG agreement, and flows required for NMFS BO (Jun 2009) Action III.1.2 and III.1.3 ¹⁹	Same
Minimum dissolved oxygen	SWRCB D-1422	Same
Merced River		
Minimum flow below Crocker-Huffman Diversion Dam	Davis-Grunsky (180 – 220 cfs, Nov – Mar), and Cowell Agreement	Same
Minimum flow at Shaffer Bridge	FERC 2179 (25 – 100 cfs)	Same
Tuolumne River		
Minimum flow at Lagrange Bridge	FERC 2299-024, 1995 (Settlement Agreement) (94 – 301 TAF/yr)	Same
San Joaquin River		
San Joaquin River below Friant Dam/Mendota Pool	Interim San Joaquin River Restoration flows	Full San Joaquin River Restoration flows
Maximum salinity near Vernalis	SWRCB D-1641	Same
Minimum flow near Vernalis	SWRCB D-1641 but with Vernalis Adaptive Management Plan single-step standard only, per purchase agreement between Reclamation and Merced ID. NMFS BO (Jun 2009) Action IV.2.1 Phase II flows not provided due to lack of agreement for purchasing water.	SWRCB D-1641 and Vernalis Adaptive Management Plan per San Joaquin River Agreement. ¹⁷ NMFS BO (Jun 2009) Action IV.2.1 Phase II flows not provided due to lack of agreement for purchasing water.
Sacramento-San Joaquin Delta		
Delta Outflow Index (flow and salinity)	SWRCB D-1641 and FWS BO (Dec 2008) Action 4 ¹⁹	Same
Delta Cross Channel gate operation	SWRCB D-1641 with additional days closed from Oct 1-Jan 31 based on NMFS BO (Jun 2009) Action IV.1.2 ¹⁹ (closed during flushing flows from Oct 1-Dec 14 unless adverse water quality conditions)	Same
South Delta exports (Jones PP and Banks PP)	SWRCB D-1641 export limits, not including VAMP period export cap under the San Joaquin River Agreement, Vernalis flow-based export limits in Apr - May as required by NMFS BO (June 2009) Action IV.2.1 Phase II ¹⁹ (additional 500 cfs allowed for Jul-Sep for reducing impact on SWP) ²¹	Same
Combined Flow in Old and Middle River (OMR)	FWS BO (Dec 2008) Actions 1, 2, and 3 and NMFS BO (Jun 2009) Action IV.2.3 ¹⁹	Same

Calsim-II Assumptions for Reclamation Jan 2013 Baselines (contd.)

	Existing Condition	Future Condition
OPERATIONS CRITERIA: RIVER-SPECIFIC		
Upper Sacramento River		
Flow objective for navigation (Wilkins Slough)	NMFS BO (Jun 2009) Action I.4 ¹⁹ ; 3,250 – 5,000 cfs based on CVP water supply condition	Same
American River		
Folsom Dam flood control	Variable 400/670 flood control diagram (without outlet modifications)	Same
Feather River		
Flow at mouth of Feather River (above Verona)	Maintain DFG/DWR flow target of 2,800 cfs for Apr - Sep dependent on Oroville inflow and FRSA allocation	Same
Stanislaus River		
Flow below Goodwin Dam	Revised Operations Plan and NMFS BO (Jun 2009) Action III.1.2 and III.1.3 ¹⁹	Same
San Joaquin River		
Salinity at Vernalis	Grasslands Bypass Project (partial implementation)	Grasslands Bypass Project (full implementation)
OPERATIONS CRITERIA: SYSTEMWIDE		
CVP Water Allocation		
CVP settlement and exchange	100% (75% in Shasta critical years)	Same
CVP refuges	100% (75% in Shasta critical years)	Same
CVP agriculture	100% - 0% based on supply. South-of-Delta allocations are additionally limited due to D-1641, FWS BO (Dec 2008), and NMFS BO (Jun 2009) ¹⁹	Same
CVP municipal & industrial	100% - 50% based on supply. South-of-Delta allocations are additionally limited due to D-1641, FWS BO (Dec 2008), and NMFS BO (Jun 2009) ¹⁹	Same
SWP Water Allocation		
North of Delta (FRSA)	Contract-specific	Same
South of Delta (including North Bay Aqueduct)	Based on supply; equal prioritization between Ag and M&I based on Monterey Agreement; allocations are limited due to D-1641, FWS BO (Dec 2008), and NMFS BO (Jun 2009) ¹⁹	Same

Calsim-II Assumptions for Reclamation Jan 2013 Baselines (contd.)

	Existing Condition	Future Condition
CVP/SWP Coordinated Operations		
Sharing of responsibility for in-basin use	1986 Coordinated Operations Agreement (FRWP and EBMUD 2/3 of the North Bay Aqueduct diversions are considered as Delta export, 1/3 of the North Bay Aqueduct diversion is considered as in-basin use)	Same
Sharing of surplus flows	1986 Coordinated Operations Agreement	Same
Sharing of restricted export capacity for project-specific priority pumping	Equal sharing of export capacity under SWRCB D-1641, FWS BO (Dec 2008), and NMFS BO (Jun 2009) export restrictions ¹⁹	Same
Water transfers	Acquisitions by SWP contractors are wheeled at priority in Banks Pumping Plant over non-SWP users; LYRA included for SWP contractors ²¹	
Sharing of export capacity for lesser priority and wheeling-related pumping	Cross Valley Canal wheeling (max of 128 TAF/yr), CALFED ROD defined Joint Point of Diversion (JPOD)	Same
San Luis Reservoir	San Luis Reservoir is allowed to operate to a minimum storage of 100 TAF	Same
CVPIA 3406(b)(2)		
Policy decision	Per May 2003 Department of Interior decision	Same
Allocation	800 TAF/yr, 700 TAF/yr in 40-30-30 dry years, and 600 TAF/yr in 40-30-30 critical years	Same
Actions	Pre-determined non-discretionary FWS BO (Dec 2008) upstream fish flow objectives (Oct-Jan) for Clear Creek and Keswick Dam, non-discretionary NMFS BO (Jun 2009) actions for the American and Stanislaus Rivers, and NMFS BO (Jun 2009) actions leading to export restrictions ¹⁹	Same
Accounting adjustments	No discretion assumed under FWS BO (Dec 2008) and NMFS BO (Jun 2009) ¹⁹ , no accounting	Same
WATER MANAGEMENT ACTIONS		
Water Transfer Supplies (long term programs)		
Lower Yuba River Accord ²¹	Yuba River acquisitions for reducing impact of NMFS BO export restrictions ¹⁹ on SWP	Same
Phase 8	None	None
Water Transfers (short term or temporary programs)		
Sacramento Valley acquisitions conveyed through Banks PP ²³	Post analysis of available capacity	Same

Calsim-II Assumptions for Reclamation Jan 2013 Baselines (contd.)

Notes:

- ¹ These assumptions have been developed under the direction of the Department of Water Resources and Bureau of Reclamation management team for the Bay Delta Conservation Plan (BDCP) HCP and EIR/EIS. Additional modifications were made by Reclamation for its Jan 2013 baselines.
- ² The Sacramento Valley hydrology used in the Existing Condition Calsim-II model reflects nominal 2005 land-use assumptions. The nominal 2005 land use was determined by interpolation between the 1995 and projected 2020 land-use assumptions associated with DWR Bulletin 160-98 (1998). The San Joaquin Valley hydrology reflects 2005 land-use assumptions developed by Reclamation to support Reclamation studies.
- ³ The Sacramento Valley hydrology used in the Future Condition Calsim-II model reflects 2020 land-use assumptions associated with Bulletin 160-98. The San Joaquin Valley hydrology reflects draft 2030 land-use assumptions developed by Reclamation to support Reclamation studies.
- ⁴ CVP contract amounts have been reviewed and updated according to existing and amended contracts, as appropriate. Assumptions regarding CVP agricultural and M&I service contracts and Settlement Contract amounts are documented in the Delivery Specifications attachments to the BDCP Calsim assumptions document.
- ⁵ SWP contract amounts have been updated as appropriate based on recent Table A transfers/agreements. Assumptions regarding SWP agricultural and M&I contract amounts are documented in the Delivery Specifications attachments to the BDCP Calsim assumptions document.
- ⁶ Water needs for Federal refuges have been reviewed and updated, as appropriate. Assumptions regarding firm Level 2 refuge water needs are documented in the Delivery Specifications attachments to the BDCP Calsim assumptions document. Refuge Level 4 (and incremental Level 4) water is not included.
- ⁷ Assumptions regarding American River water rights and CVP contracts are documented in the Delivery Specifications attachments to the BDCP Calsim assumptions document. The Sacramento Area Water Forum agreement, its dry year diversion reductions, Middle Fork Project operations and "mitigation" water is not included.
- ⁸ Footnote removed.
- ⁹ The new Calsim-II representation of the San Joaquin River has been included in this model package (Calsim-II San Joaquin River Model, Reclamation, 2005). Updates to the San Joaquin River have been included since the preliminary model release in August 2005. The model reflects the difficulties of on-going groundwater overdraft problems. The 2030 level of development representation of the San Joaquin River Basin does not make any attempt to offer solutions to groundwater overdraft problems. In addition a dynamic groundwater simulation is not yet developed for the San Joaquin River Valley. Groundwater extraction/recharge and stream-groundwater interaction are static assumptions and may not accurately reflect a response to simulated actions. These limitations should be considered in the analysis of result
- ¹⁰ The CALSIM II model representation for the Stanislaus River does not necessarily represent Reclamation's current or future operational policies. A suitable plan for supporting flows has not been developed for NMFS BO (Jun 2009) Action III.1.3.
- ¹¹ The actual amount diverted is reduced because of supplies from the Los Vaqueros project. The existing Los Vaqueros storage capacity is 100 TAF, and future storage capacity is 160 TAF. Associated water rights for Delta excess flows are included.
- ¹² Under Existing Conditions it is assumed that SWP Contractors demand for Table A allocations vary from 3.0 to 4.1 MAF/year. Under the Future No Action baseline, it is assumed that SWP Contractors can take delivery of all Table A allocations and Article 21 supplies. Article 56 provisions are assumed and allow for SWP Contractors to manage storage and delivery conditions such that full Table A allocations can be delivered. Article 21 deliveries are limited in wet years under the assumption that demand is decreased in these conditions. Article 21 deliveries for the NBA are dependent on excess conditions only, all other Article 21 deliveries also require that San Luis Reservoir be at capacity and that Banks PP and the California Aqueduct have available capacity to divert from the Delta for direct delivery.
- ¹³ Mokelumne River flows reflect EBMUD supplies associated with the Freeport Regional Water Project.
- ¹⁴ The CCWD Alternate Intake Project, an intake at Victoria Canal, which operates as an alternate Delta diversion for Los Vaqueros Reservoir.
- ¹⁵ D-1644 and the Lower Yuba River Accord are assumed to be implemented for Existing and Future No Action baselines. The Yuba River is not dynamically modeled in CALSIM II. Yuba River hydrology and availability of water acquisitions under the Lower Yuba River Accord are based on modeling performed and provided by the Lower Yuba River Accord EIS/EIR study team.
- ¹⁶ Footnote removed.
- ¹⁷ It is assumed that either VAMP, a functional equivalent, or D-1641 requirements would be in place in 2020.
- ¹⁸ Footnote removed.
- ¹⁹ In cooperation with Reclamation, National Marine Fisheries Service, Fish and Wildlife Service, and CA Department of Fish and Game, the CA Department of Water Resources has developed assumptions for implementation of the FWS BO (Dec 15th 2008) and NMFS BO (June 4th 2009) in CALSIM II.
- ²⁰ Current ACOE permit for Banks PP allows for an average diversion rate of 6,680 cfs in all months. Diversion rate can increase up to 1/3 of the rate of San Joaquin River flow at Vernalis during Dec 15th – Mar 15th up to a maximum diversion of 8,500 cfs, if Vernalis flow exceeds 1,000 cfs.

Calsim-II Assumptions for Reclamation Jan 2013 Baselines (contd.)

Notes (continued):

- ²¹ Acquisitions of Component 1 water under the Lower Yuba River Accord, and use of 500 cfs dedicated capacity at Banks PP during Jul – Sep, are assumed to be used to reduce as much of the impact of the Apr-May Delta export actions on SWP contractors as possible.
- ²² Delta actions, under USFWS discretionary use of CVPIA 3406(b)(2) allocations, are no longer dynamically operated and accounted for in the CALSIM II model. The Combined Old and Middle River Flow and Delta Export restrictions under the FWS BO (Dec 15th 2008) and the NMFS BO (June 4th 2009) severely limit any discretion that would have been otherwise assumed in selecting Delta actions under the CVPIA 3406(b)(2) accounting criteria. Therefore, it is anticipated that CVPIA 3406(b)(2) account availability for upstream river flows below Whiskeytown, Keswick and Nimbus Dams would be very limited. It appears the integration of BO RPA actions will likely exceed the 3406(b)(2) allocation in all water year types. For these baseline simulations, upstream flows on the Clear Creek and Sacramento River are pre-determined based on CVPIA 3406(b)(2) based operations from the Aug 2008 BA Study 7.0 and Study 8.0 for Existing and Future No Action baselines respectively. The procedures for dynamic operation and accounting of CVPIA 3406(b)(2) are not included in the CALSIM II model.
- ²³ Only acquisitions of Lower Yuba River Accord Component 1 water are included.

Key:

Ag = agricultural
 ACOE = Army Corps of Engineers
 BO = Biological Opinion
 BDCP = Bay-Delta Conservation Plan
 CALFED = CALFED Bay-Delta Plan
 CCWD = Contra Costa Water District
 cfs = cubic feet per second
 CVP = Central Valley Project
 CVPIA = Central Valley Project Improvement Act
 DFG = California Department of Fish and Game
 DMC = Delta-Mendota canal
 DWR = California Department of Water Resources
 D-xxxx = Water Right Decision
 EBMUD = East Bay Municipal Utility District
 EIS = Environmental Impact Statement
 FC&WSD = Flood Control and Water Service District
 FERC = Federal Energy Regulatory Commission
 FRSA = Feather River Service Area
 FRWP = Freeport Regional Water Project
 FWS = Fish and Wildlife Service
 KCWA = Kern County Water Agency
 LYRA = Lower Yuba River Accord
 MAF/yr = million acre-feet per year
 M&I = municipal and industrial
 MWD = Metropolitan Water District
 NMFS = National Marine Fisheries Service
 NPS = National Park Service
 PCWA = Placer County Water Agency
 PP = Pumping Plant
 Reclamation = United States Department of the Interior, Bureau of Reclamation
 ROD = Record of Decision
 SBA = South Bay Aqueduct
 SEWD = Stockton East Water District
 SWP = State Water Project
 SWRCB = State Water Resources Control Board
 TAF = thousand acre-feet
 TAF/yr = thousand acre-feet per year
 USFWS = United States Fish and Wildlife Service
 VAMP = Vernalis Adaptive Management Plan
 WR = water right
 yr = year

CalLite Assumptions for Reclamation Baseline

CalLite assumptions are the same as the Calsim II assumptions above, with the following exceptions:

1. Delta Export Conveyance
Los Vaqueros Reservoir - CalLite does not dynamically represent Los Vaqueros, but time series representation is based on existing storage capacity (100 TAF) and existing pump locations.
2. Regulatory Standards
San Joaquin River
San Joaquin River below Friant Dam/Mendota Pool - CalLite does not dynamically represent the SJR, but time series representation is based on Friant operations with no SJR Restoration flows.
3. Regulatory Standards
Sacramento-San Joaquin Delta
South Delta exports (Jones PP and Banks PP) - CalLite has the same export limits as Calsim, but also uses the VAMP period export cap for CVP.
4. CVP/SWP Coordinated Operations
Water Transfers – CalLite has no transfers.
5. Water Management Actions
Lower Yuba River Accord - CalLite has no transfers.
6. Water Management Actions
Water Transfers (short term or temporary programs)
Sacramento Valley acquisitions - CalLite has no transfers.