

INTAKE DIVERSION DAM Yellowstone River, Montana

Fish Protection and Passage Concept Study Report

Water Resources Research Laboratory

Prepared for:
United States Bureau of Reclamation
Montana Area Office

January, 2000



INTAKE DIVERSION DAM Yellowstone River, Montana

Fish Protection and Passage Concept Study Report

Water Resources Research Laboratory

Prepared for:
United States Bureau of Reclamation
Montana Area Office By:
Brent Mefford, Rick Christensen, and
Arthur Glickman

January, 2000

Contents

	<i>Page</i>
Project Description	1
Intake Diversion Dam	1
Diversion Headworks and Canal	2
Hydraulics	2
Water Surface Modeling	3
Fish Protection	6
Barrier Location	6
Barrier Designs	7
Flow Criteria for Fish Barriers	7
Positive Barrier Screen Concept	8
Recommended Screen Design	10
Louver Concept	13
Fish Passage Fishway Concepts	15
Flume and Baffle Fishway Concept	15
Riprap Channel Fishway Concept	17

Figures

1. Location of Intake Diversion Dam, Montana	2
2. View of intake dam and main canal headworks	3
3. Location of survey data points measured for the concept study	4
4. Estimated water surface profiles across intake dam for river and canal flows	5
5. Flow relationship between the river at intake dam and the high flow channel	5
6. View looking upstream toward the main canal headworks	7
7. View looking upstream at the Burns wasteway flow control gates	7
8. Typical layout of a linear flat plate fish screen structure	9
9. Typical layout of a "V" shaped fish screen structure	9
10. Layout of a rotating drum fish screen structure	9
11. Intake fish screen concept design	11
12. Yakima Tieton Canal fishscreen	12
13. Louver style fish barrier, Rhone 1955	14
14. Intake fish louver concept design	16
15. Yellowstone concrete fish ladder	18
16. Yellowstone riprap fish ladder	19

**Appendix A
Water Surface Model Data**

Figure A-1 Yellowstone	21
Figure A-2 Hec-Ras geometry plan showing cross-section locations	22
Figure A-3 Yellowstone reach above dam	23
Figure A-4 Yellowstone reach below dam	24
Figure A-5 River intake canal	25
Table A-1 Hec-Ras water surface profile output for flows given in figure 4	26

**Appendix B
Construction Cost Estimate Sheets**

1. Fish screen facilities screen structure totals sheet	30
2. Fish screening facilities screen option	31
3. Fish screen structure - mechanical	32
4. Fish screen facilities louver structure totals sheet	33
5. Fish screen facilities louver option	34
6. Fish louver structure - mechanical	35
7. Baffled fishway structure	36
8. Rock fishway structure	37

Tables

Table 1. Agency Velocity criteria for screening salmonids	8
---	---

Intake Diversion Dam Fish Protection and Passage Feasibility Report

Intake Diversion Dam and the diversion headworks for the Lower Yellowstone Irrigation District's Main Canal are located on the Yellowstone River about 17 miles north east of Glendive, Montana, figure 1. The affect of the dam and unscreened diversion on the fisheries of the lower Yellowstone River has been the subject of multiple studies by state and federal resource agencies. Entrainment studies by Heibert (2000) show significant numbers of fish are entrained with diversion flow into the canal. Fish population studies conducted by Montana Fish Wildlife and Parks (Stewart, 1986, 1988, 1990, 1991) indicate the dam is a partial barrier to many species and likely a total barrier to some species. The purpose of this study is to present designs for reducing fish entrainment into the canal and increasing fish passage past the diversion dam.

Project Description - Lower Yellowstone Irrigation Project (Reclamation Project Data, 1981)

The Reclamation Service began investigating the project in 1903. A report by a board of consulting engineers, dated April 23, 1904, served as a basis for authorization of the project. The project was authorized by the Secretary of the Interior on May 10, 1904, under the Reclamation Act of June 17, 1902. Construction of a diversion dam, canal headworks and delivery canals were began on July 22, 1905. Water was available for irrigation during the season of 1909.

The Lower Yellowstone Irrigation Project lies in east-central Montana and western North Dakota. The project includes the Lower Yellowstone Diversion Dam, Thomas Point Pumping Plant, the Main Canal, 225 miles of laterals, and 118 miles of drains. The purpose of the project is to furnish a dependable supply of irrigation water for 52,133 acres of fertile land along the west bank of the Yellowstone River. About one-third of the project lands are in North Dakota and two-thirds in Montana.

Water is diverted from the Yellowstone River into the Main Canal by the Lower Yellowstone Diversion Dam near Intake, Montana. It is carried by gravity to the greater portion of the project lands. About 2,300 acres of benchland are irrigated by water pumped from the canal by the Thomas Point Pumping Plant.

Intake Diversion Dam

Intake Dam was originally constructed as a rock-filled timber crib weir about 12 ft high and 700 ft long. The original dam contained 23,000 cubic yards of material. The dam raises the upstream water elevation from about three to five feet depending on river flows. Since the construction of Intake Dam, the structure has required frequent repair to maintain the needed upstream head to divert flow into the canal. Heavy ice and large flood flows work to progressively move riprap material from the dam downstream. A cableway that crosses the river over the crest of the dam is used to place riprap along the dam crest when repairs are required. Over the years, large quantities of rock have been added to the dam to replace rock displaced by the river. Riprap now extends several hundred feet downstream of the dam across the width of the dam.

Diversion Headworks and Canal

The Main Canal diverts to the west side of the Yellowstone River at Intake and extends down the valley to the confluence of the Yellowstone and Missouri Rivers. The canal is 71.6 miles long, unlined and has an initial capacity of about 1,400 ft³/s. The canal headworks is a concrete structure with 11 5-ft-diameter sluice gates, figure 2. There are no trashracks in front of the intake gates. The canal was originally designed with a 30 ft bottom width with 1.5:1 side slopes. The canal is designed to convey its full capacity at a flow depth of about 10 ft. The canal operates from late April through October of each year.

Hydraulics

Flow and water level data for the river and canal were needed to design fish protection and passage structures. For the feasibility level design these data were estimated by conducting a limited site survey and developing a water surface computer model.

A site survey was conducted on April 18 and 19, 1999. The survey was conducted prior to the canal being watered up for the irrigation season. The survey included; measuring cross sections through the canal for a distance of about 1600 ft downstream of the diversion headworks;

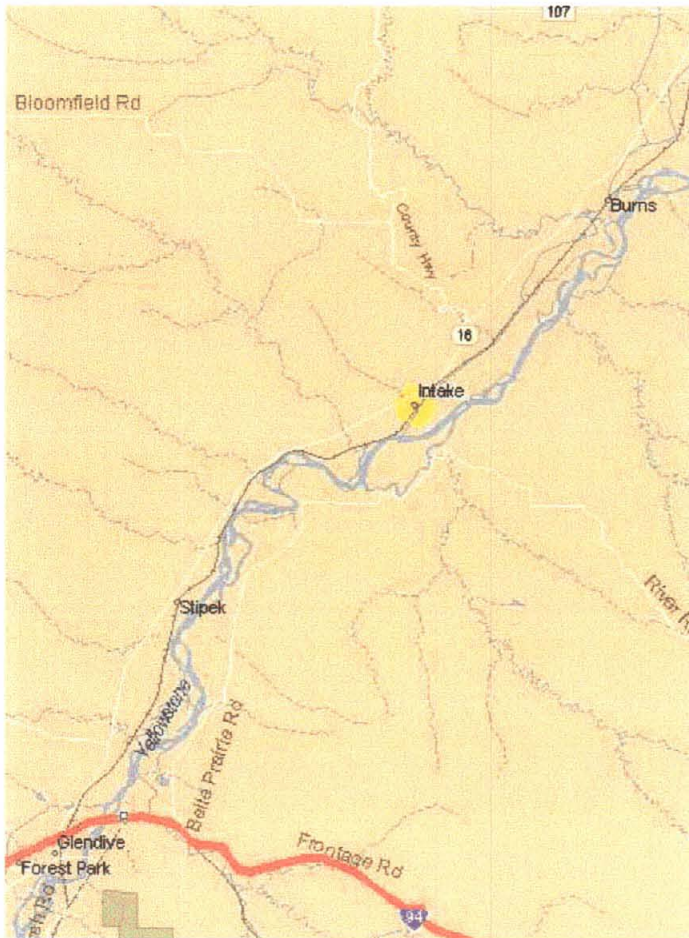

surveying random river bank elevations for a distance of about 1.0 mile upstream and downstream of the diversion dam; and conducting river bathymetry measurements for a distance of about 1.5 miles upstream and downstream of the diversion dam. The land based survey data was obtained using a GIS system referenced to a benchmark located just east of Thirteen Mile Creek at the railroad crossing. River bathymetry data was obtained using a boat mounted ADCP (acoustic doppler current profiler) with a GIS link. The ADCP provided nearly continuous location, flow depth and velocity data along the path taken by the survey boat. The location of all survey data collected are shown on figure 3. Note, no bathymetry data was collected for a distance of about 500 ft downstream of the dam crest due to shallow and turbulent flow conditions.

Figure 1 - Location of Intake Diversion Dam, Montana.

Water Surface Modeling

A water surface flow relationship for the Yellowstone River near Intake Dam was developed using the Corp of Engineers' Hec-Ras program. Hec-Ras is a one dimensional standard step backwater simulation model. The model requires topography cross-sections along the river and canal as input. This data was generated by first creating a contour map of the river, river bank area and canal prism from the survey data, figure A1 of the appendix. Cross section data were cut from the contour model and input into a Hec-Ras geometry file. A plan view of the river section modeled, including the location of cross-sections used in the model, is shown in figure A2. River channel roughness used in the Hec-Ras model was adjusted by calibrating the model against the river water surface profile measured during the topographic survey.

Model output - Flow simulations were conducted for a range of river flows with and without canal diversion. Figure 4 shows water surface profiles across the dam for each river flow modeled. For river flows above 30,000 ft³/s the high flow channel that bypasses the dam to the south is assumed to flow as given in figure 5. River and canal cross sections showing estimated water surface elevations based on the model are given in figures A3 - A5. Table A1 gives estimated water surface elevations and related hydraulic data for the design range of river flows. The estimated rise in the upstream water surface elevation caused by the dam is 3.3 ft to 5.2 ft for flows of 5,000 to 40,000 ft³/s, respectively.

at Sidney
-10 ft of
river
flows
exceed
this
Flow
character
curve

The normal water surface elevation in the canal is estimated to be 1990.8 just downstream of the diversion headworks for flows up to 1,400 ft³/s. At lower canal flows, the canal water surface elevation is assumed to be controlled by downstream check structures. Canal geometry data could not be obtained in the first 100 ft of the canal due to standing water in the canal at the time the field survey was conducted. Therefore, the downstream prism of the canal was extrapolated to the headworks for the model. Near the headworks, the canal prism has changed significantly since construction. The canal width has increased within the first bend and a large scour hole

followed by a deposition berm have formed in the invert downstream of the canal inlet gates. The canal prism beyond 100 ft downstream of the headworks remains similar to the excavated shape with some aggregation of the canal invert and degradation of canal side slopes. The bottom width is still about the original 30 ft. It does not appear the changes in the canal profile have significantly affected the hydraulics of the canal. The original canal design flow depth of 9.8 ft appears to be reasonable.

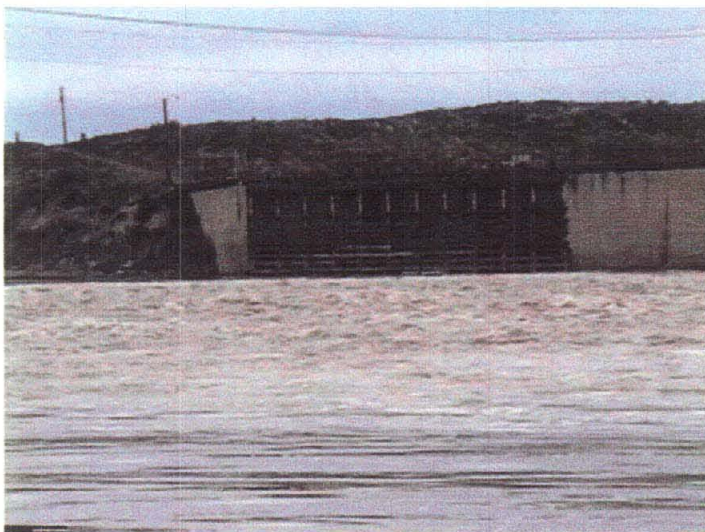

Figure 2 - View of Intake Dam and Main Canal Headworks.

Yellowstone River at Intake Dam

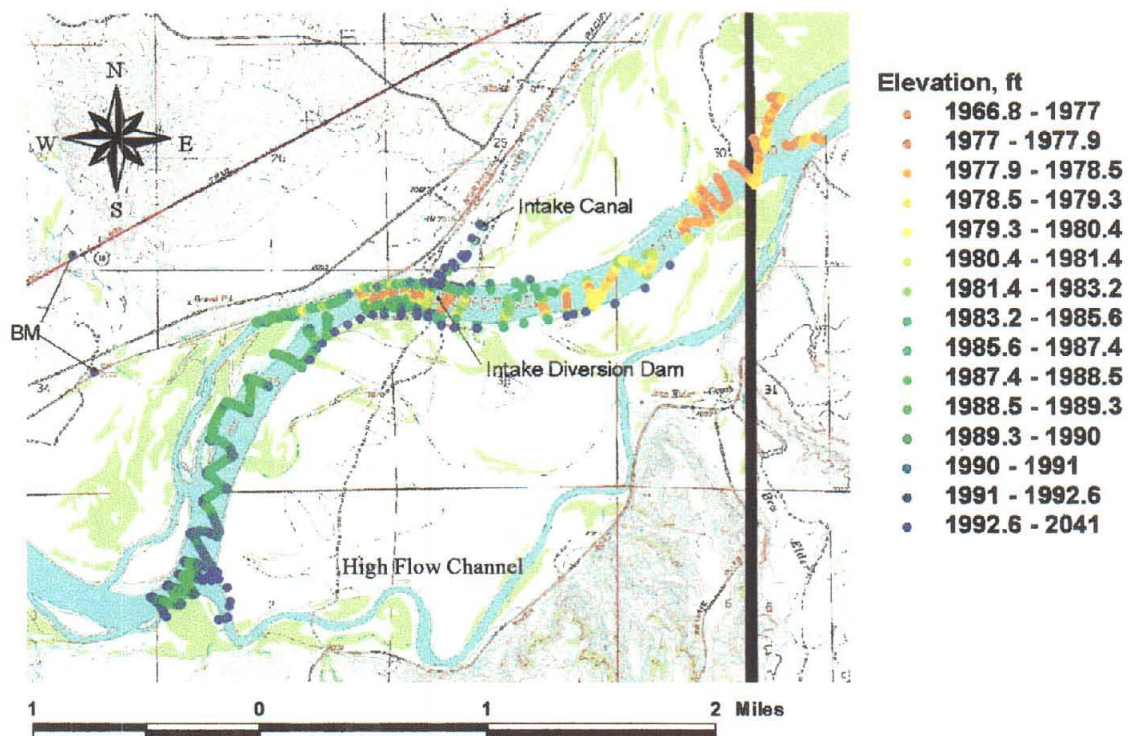

Figure 3 - Location of survey data points measured for the concept study. Ground surface elevations are denoted by the color spectrum shown in the legend. Note, the river has migrated laterally in some locations since the U.S. Geological Survey Map shown as a background was generated.

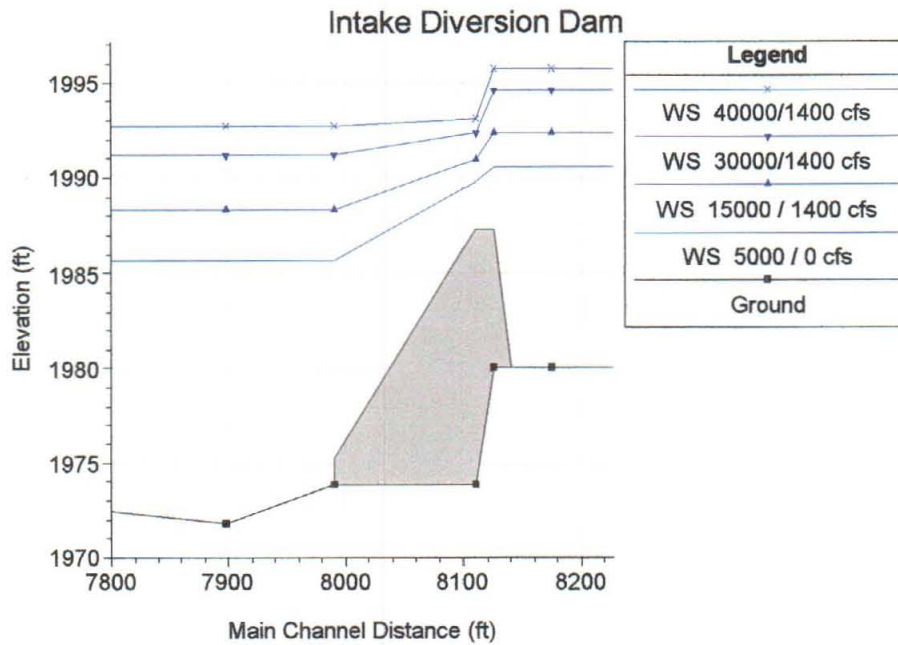

Figure 4 - Estimated water surface profiles across Intake Dam for river and canal flows (ft³/s) of:

River flow upstream of high flow channel	Canal diversion	Flow over dam	Flow downstream of high flow channel return
40,000	1,400	37,400	38,600
30,000	1,400	28,100	28,600
15,000	1,400	13,600	13,600
5,000	0	5,000	5,000

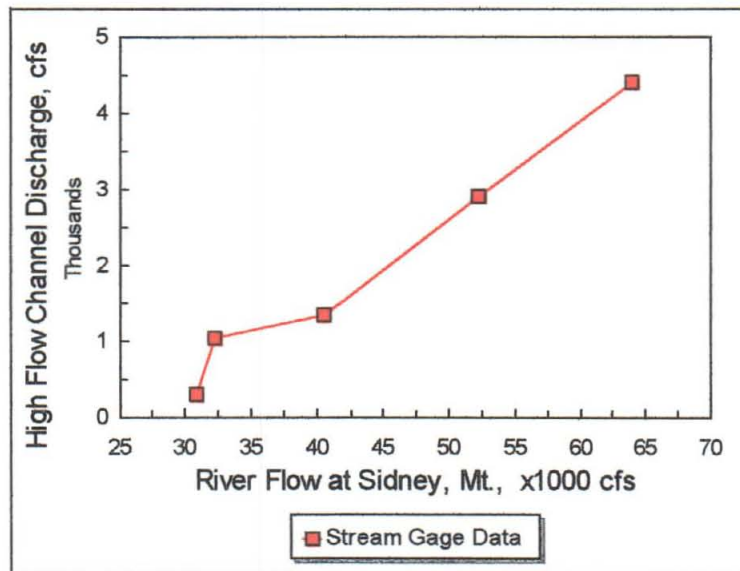

Figure 5 - Flow relationship between the river at Intake Dam and the high flow channel that bypasses the dam. (Phil Stewart MFW&P, 1997).

Fish Protection

Various methods of reducing fish entrainment are used at water diversions. These methods are generally divided into two categories, positive barriers and behavioral barriers. Positive barrier screens prevent all fish larger than fingerling size and a high percentage of fry from passing on downstream. Screens allow water to pass through while guiding fish to escape routes commonly called fish bypasses. Behavioral barriers rely on triggering an avoidance response in fish. Most behavioral barriers use artificially imposed stimulus to guide fish away from diverted flow. The most common behavioral barriers are louvers, strobe lights, sound generators and electric fields. Behavioral barriers vary widely in effectiveness and application, however no behavioral barriers are considered 100 percent effective. Louvers are a coarse mesh structural barrier that are designed to generate flow turbulence that fish can detect and avoid. Light, sound and electric fields are non-structural barriers. In most cases, non-structural barriers have not been proven to be effective substitutions for structural barriers. They should only be considered if structural barriers can not be constructed due to site restrictions or cost.

Barrier Location

A fish protection facility at Intake Diversion Dam could be placed on-river in front of the diversion headworks structure or off-river in the canal downstream of the headworks. Both locations have advantages and disadvantages. On-river fish barriers are generally preferred where applicable because they prevent fish from ever leaving the river. On the down side, on-river means the barrier must be designed to contend with large debris, ice, large changes in river stage and relatively poor access to the barrier for maintenance. An off-river location downstream of the canal headworks has the advantage of being removed from the extremes of flow and debris that occur in the river. The structure can be unwatered for maintenance and inspection each year after the irrigation season. The down side of an off-river location is the uncertainty of fish mortality or injury associated with passing through the headworks gates and the potential for increased predation by predator fish due to the concentration of fish in bypass flows. At Intake Dam, the severity of flood flows, large debris and ice jams favor an off-river fish barrier.

Selecting a location of the structure along the canal is a function of fish bypass construction and residence time of the fish in the canal. Two possible locations for the fish protection structure were considered, either locating the structure near the diversion headworks (herein referred to as the headworks site) or about 8.2 miles further downstream near a canal wasteway at Burns (see figure 1). Locating the structure near the headworks will require improving access along both sides of the canal and constructing a bypass for about 500 ft through a 40 to 60 ft high bluff that parallels the river, figure 6. At the Burns location, the canal is constructed through an area of fill material. The canal sits above the natural topography which provides good access and offers a short fish bypass. The canal wasteway discharges into a natural slough that joins the river about 1 mile from the canal, figure 7. The resource agencies have expressed their desire to return fish to the river as quickly as possible and minimize the need to salvage fish when the canal is shutdown each fall. Therefore, for the purpose of this concept level design the canal headworks location was chosen. If the Burns site is pursued in the future, the fish screen designs proposed for the headworks site will be applicable to Burns. Only site access and the fish bypass would differ.

Improved access to the fish screen structure will be required at the headworks site. Access from the canal bridge crossing leading to the Intake recreation area is anticipated. Roads would be constructed on either side of the canal that slope down to the elevation of the pit protection structure. A turn around area will also be required on both sides. During construction, a temporary canal crossing would likely be constructed to permit large trucks to negotiate the site.



Figure 6 - View looking upstream toward the Main canal headworks. Photo was taken from the access bridge to the Intake boat launch and recreation area. Outline of the screen structure shows the approximate location.

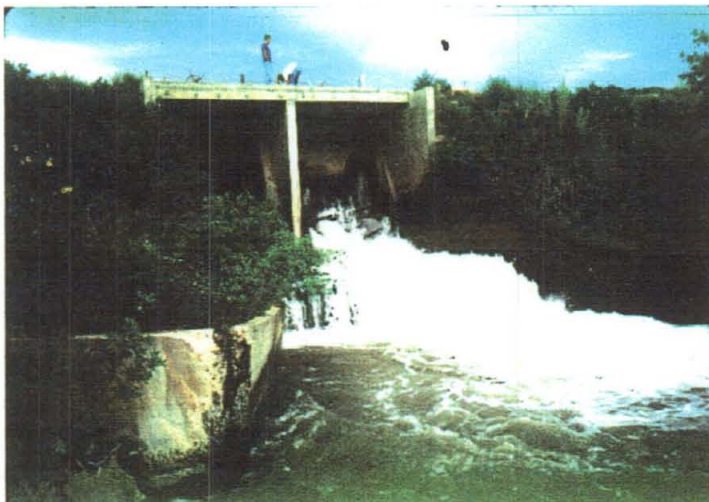

Figure 7 - View looking upstream at the Burns Wasteway flow control gates.

Barrier Designs

Both a positive barrier fish screen and a louver style barrier were carried through the feasibility design and included herein. The two concepts differ in fish protection efficiency, size of structure, debris handling, and construction cost. Both were designed to be located downstream of the diversion headworks and contain similar fish bypasses.

Flow Criteria for Fish Barriers

Primary objectives and hydraulic criteria of a fish barrier must be established prior to selection of a barrier design. Typical fish protection objectives and hydraulic criteria include: fish species, size and swimming strength; barrier approach velocity (velocity measured perpendicular to the barrier face); barrier sweeping velocity (velocity measured parallel to the barrier face); and

barrier design (opening size). Screen opening size and screen velocity criteria for salmon fry and fingerlings have been established by many state and federal agencies - Table 1. Criteria for other species have generally not been established. However, the criteria given in Table 1 is generally applicable to most fish species indigenous to a river environment. Consideration should be given to reducing the barrier approach velocity from the values given if very weak swimming fish are to be protected. Barrier approach velocity and barrier size are directly related. The lower the barrier approach velocity, the larger the structure size.

Table 1. Agency velocity criteria for screening salmonids. (Sources: EPRI 1986; K. Bates, Washington Department of Fisheries, personal communication.)

Agency	Approach velocity (ft/s) ^a		Sweeping velocity ^d
	Fry ^b	Fingerlings ^c	
National Marine Fisheries Service	≤0.4	≤0.8	Greater than approach velocity
California Department of Fish and Game	≤0.33 for continuously cleaned screens: ≤0.0825 for intermittently cleaned screens	Same as fry	At least twice the approach velocity
Oregon Department of Fish and Wildlife	≤0.5	≤1.0	Approach velocity or greater
Washington Department of Fisheries	≤0.4	≤0.8	Approach velocity or greater
Alaska Department of Fish and Game	≤0.5	Same as fry	No criterion
Idaho Department of Fish and Game	≤0.5	≤0.5	Sufficient to avoid physical injury to fish
Montana Department of Fish Wildlife and Parks	≤0.5	≤1.0	No criterion

^aVelocity component perpendicular to and approximately 3 inches in from or the screen face.

^bFish less than 2.36 inches (60 mm) long.

^cFish 2.36 inches (60 mm) or longer.

^dtheoretical velocity vector along and parallel to the barrier face; often considered equal to the average

Positive Barrier Screen Concept

There are two general categories of positive barrier fish screens, fixed and moving screens. Fixed screens designed for open channel diversions are typically designed as a series of flat screen panels positioned nearly vertical. The screens are aligned at an angle to the canal flow to obtain the desired screen area and create a strong sweeping flow parallel to the screen face. A single line of screens (figure 8) or a "V" arrangement (figure 9) can be used. The "V" design allows the structure length to be shortened, but requires the fish bypass be placed mid-channel. The mid-channel bypass is not desirable if large debris is common as it can become wedged in the apex of the "V" and be difficult to remove. A single line screen has a fish bypass positioned at the downstream end of the screen on the channel wall. The screen surface is cleaned by moving a brush or hydraulic spraywash head over the screen. Debris can be either racked vertically up the screen and collected on the screen deck or passed down the length of the screen to the fish bypass to be carried back to the river.

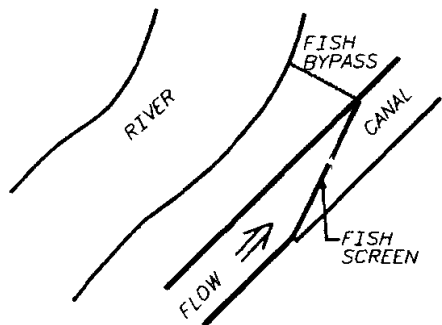

Figure 8 - Typical layout of a linear flat plate fish screen structure.

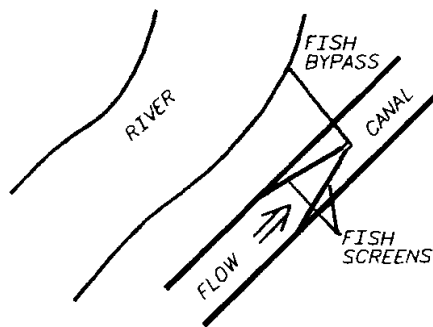

Figure 9 - Typical layout of a "V" shaped fish screen structure.

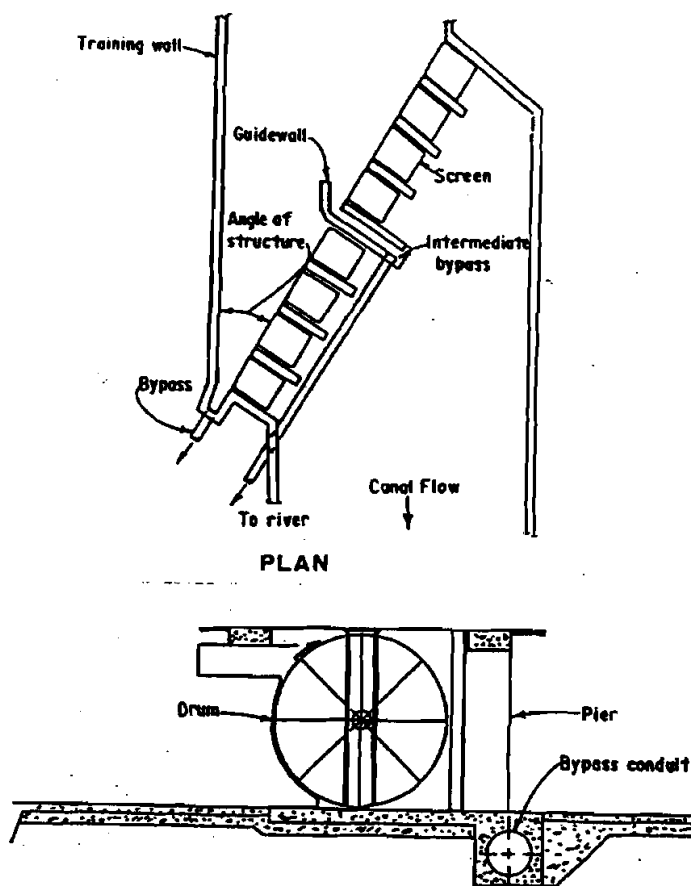

Figure 10 - Layout of a rotating drum fish screen structure. (Liston et al., 1998)

Moving screens are designed to continuously carry small impinged debris over the screen as they rotate. Drum screens are the most common type of rotating fish screen. For a large diversion, a series of drum screens are set end to end between piers angled to the flow, figure 10. The front face of the piers is shaped to conform to the drums which minimizes blockage of fish guidance along the screen faces. The individual drums consist of rigid cylindrical frames covered by screen material. Rubber seals that seat against the piers are attached to both ends of the drums. A bottom seal is fixed to the structure beneath the drum and seats against the drum surface. The drums rotate about their axis. The drums rotate such that the front (upstream) face rises and the back face descends. The drums are operated 0.7 to 0.8 submerged. This submergence is required for proper debris handling. Debris that impinges on the screen is carried over the top by the rotation and washed off the backside by the

through flow. This tends to be a very effective cleaning mechanism making drum screens a good self cleaning design. If the submergence drops much below 0.7, debris tends to not cling to and carry over the drum but instead accumulates along the front face. Larger debris like logs can roll in front of the screen and require manual removal. Drums have been constructed ranging from a few feet up to 20 feet in diameter and from the typical 10 to 12 feet length up to 25 to 30 feet in length.

Recommended Screen Design

A flat plate linear screen structure is recommended as the best screen option for the Main Canal. The layout of the structure is shown in figure 11. The design requires a concrete flume 440 ft long, 55 ft wide and 14 ft deep be constructed within the existing canal prism, figure 11. Within the concrete flume a 300 ft long and 10 ft high screen and baffle structure angles across the channel at a 9.8 degree angle. The screen structure is mounted on a 6 inch high concrete sill. The sill enhances movement of bottom sediments toward the fish bypass entrance and reduces problems of cleaning the screen area near the channel invert.

The screen structure is designed to pass 1,400 ft³/s with a screen approach velocity of 0.5 ft/s. Although several types of screen material are available, 3/32 opening stainless steel wedge wire screen material with about a 50 percent porosity is recommended. This screen material is very durable and will withstand the impact of larger sticks that frequently enter the canal. Wedge wire screen has been in use for many years at other fish screening facilities and has performed very well. The screen is designed with 10-ft-square panels each weighing 2,000 lbs mounted in vertical guides. As shown, the panels would be raised by mobile crane for removal or maintenance. A mobile crane capable of lifting 3,000 lbs (weight of baffle panels) at a 40 ft reach would be required. During initial construction of the screen panels up to four spare screen panels should be made. These could be installed if panels are damaged during the irrigation season.

The screen is expected to cause about 0.3 ft or less of water surface drop (headloss) through the structure. The majority of the headloss in a properly cleaned screen structure occurs at the baffles. Baffles are used to adjust the flow distribution passing through the screen. An even through-screen flow distribution is important to prevent high velocity hot spots from occurring that can cause fish impingement and debris cleaning difficulties. Adjustable baffles are mounted parallel to the screen on the downstream side, see figure 11 section C-C. Baffles are typically 6-inch-wide to 10-inch-wide steel plates with a pin mounted on each end to allow them to be rotated. A typical baffle design used on the Yakima Tieton Canal Fish screen is shown in figure 12. Baffles are designed to create high resistance to the flow in areas where the canal approach velocity is high and low resistance in areas where velocity is low. Flow between two baffles can be adjusted by rotating the baffles to increase or decrease the opening between the baffles. The difference in flow resistance along the structure caused by the baffles then forces a more uniform flow distribution through the fish screen. The greater the non-uniformity of flow velocity approaching the screen structure the tighter the baffles must be closed to even out the flow and the greater the headloss. The upstream bend in the canal and unbalanced inlet gate operation are factors that can create non-uniform flow velocity upstream of the screen.

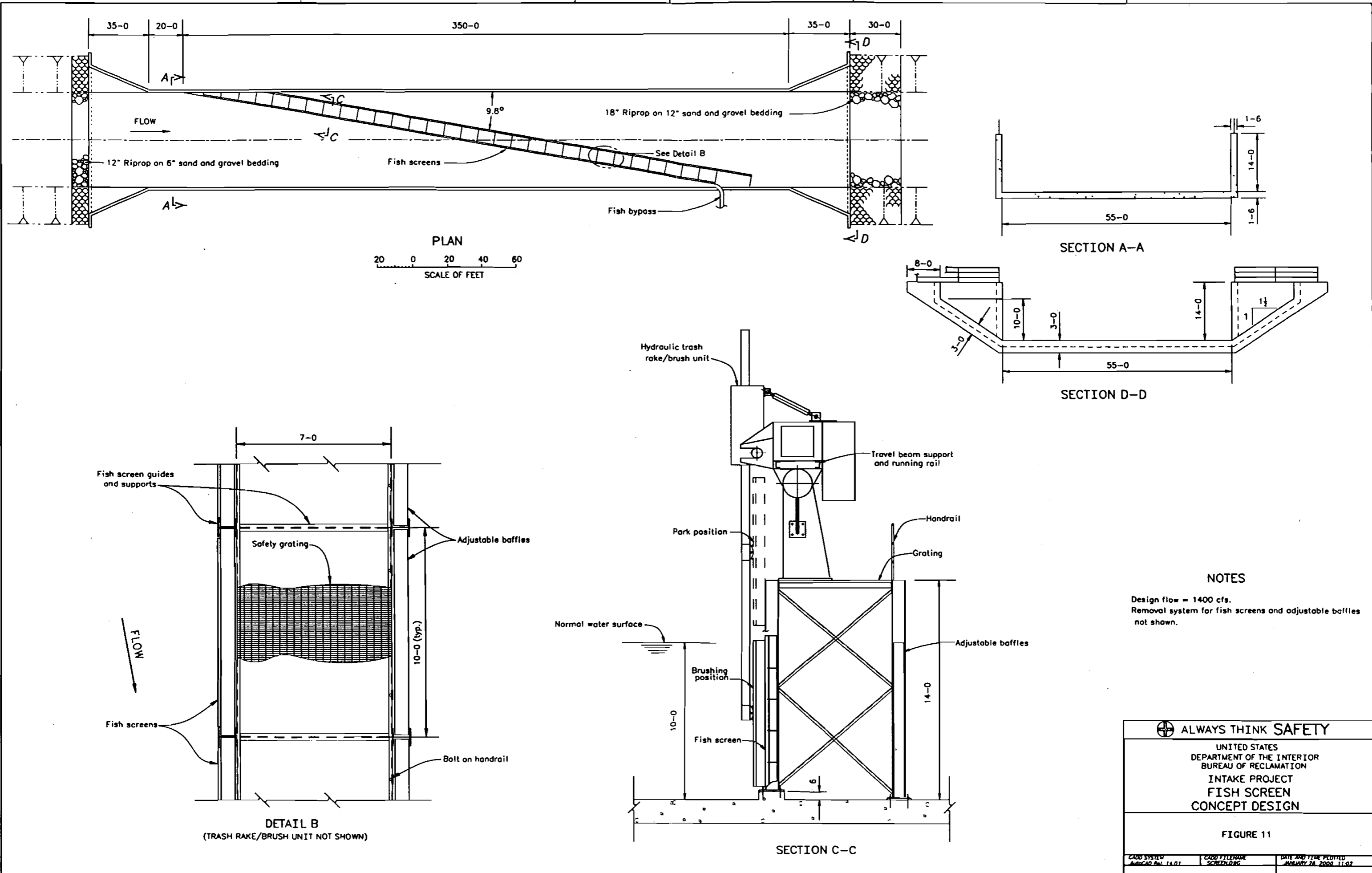

NOTES

Design flow = 1400 cfs.
 Removal system for fish screens and adjustable baffles not shown.

ALWAYS THINK SAFETY		
UNITED STATES DEPARTMENT OF THE INTERIOR BUREAU OF RECLAMATION INTAKE PROJECT FISH SCREEN CONCEPT DESIGN		
FIGURE 11		
CAD SYSTEM AutoCAD Rev. 14.01	CAD TITLENAME SCREEN.DWG	DATE AND TIME PLOTTED FEBRUARY 28, 2000 11:02

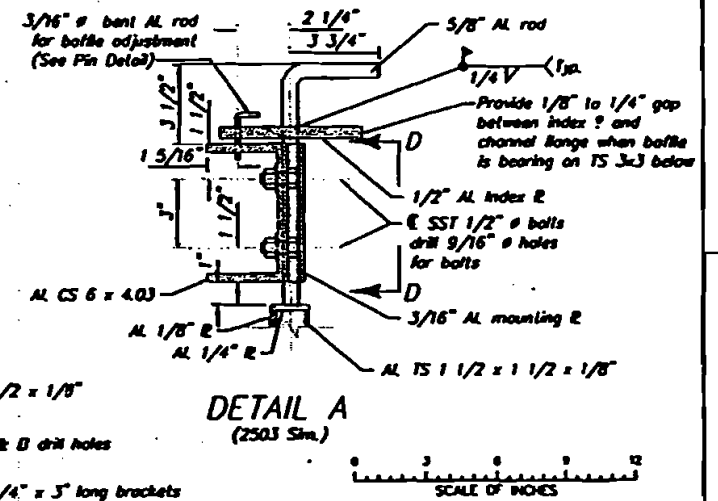
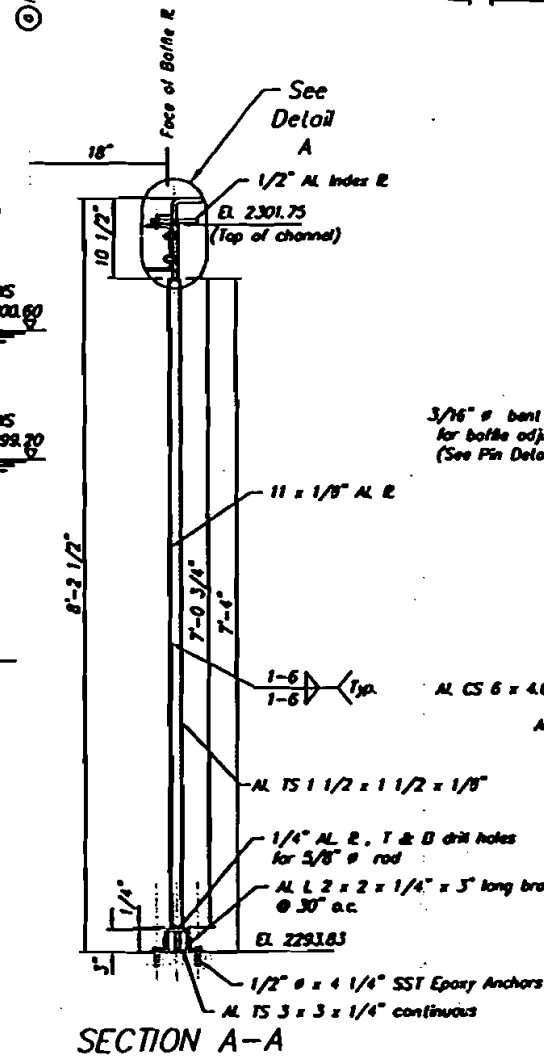
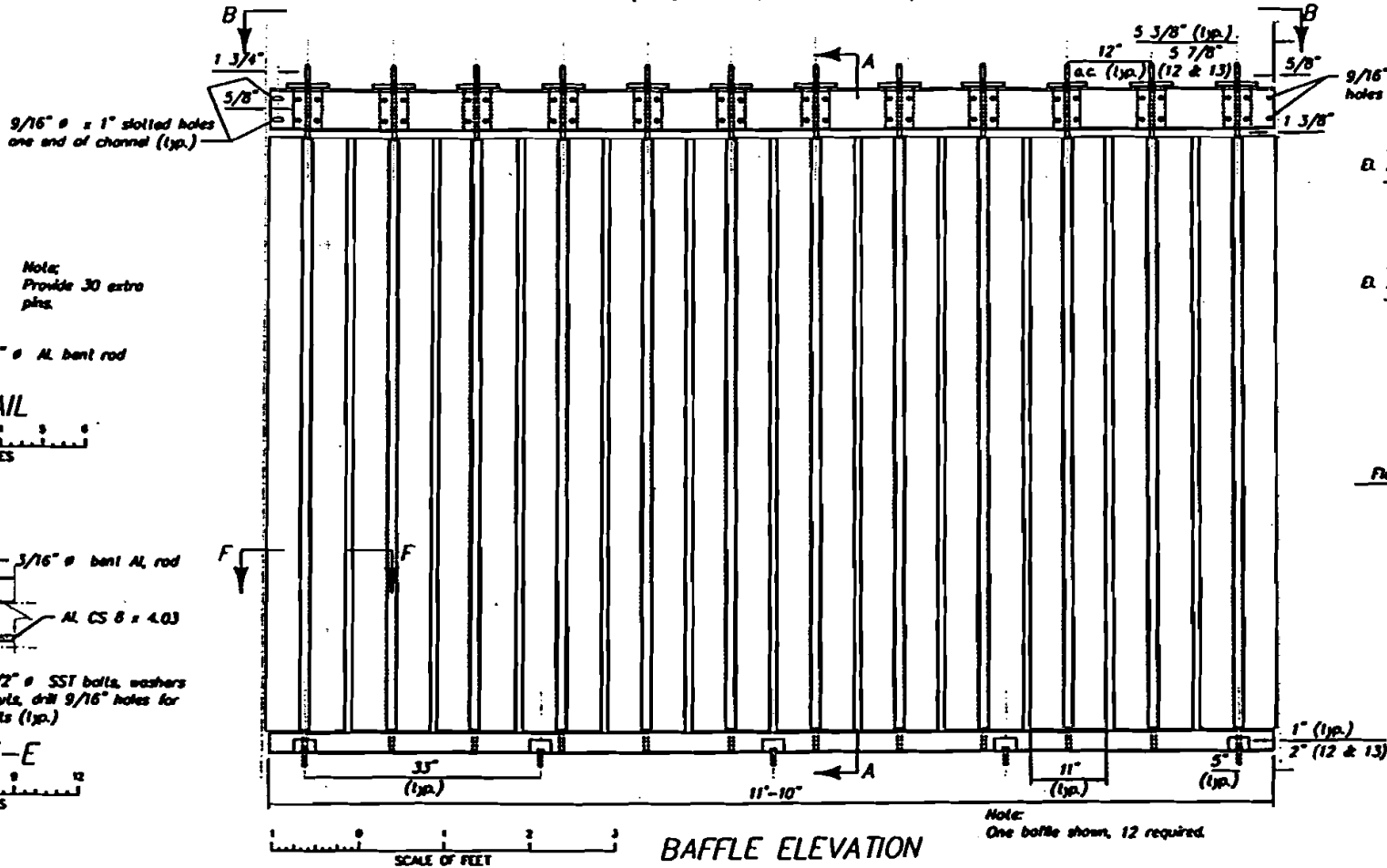
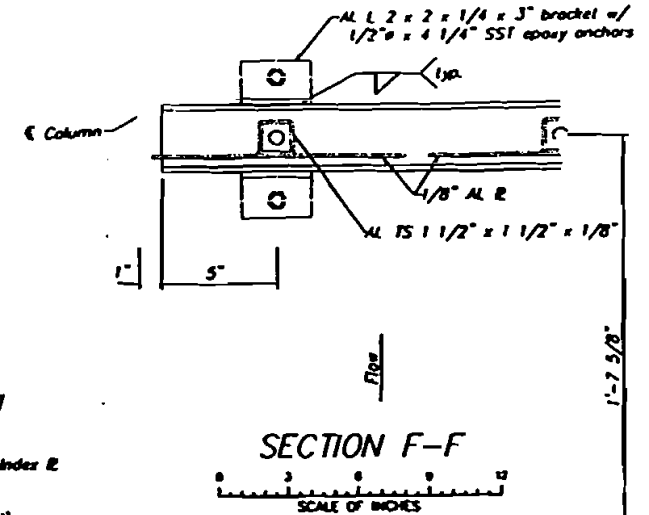
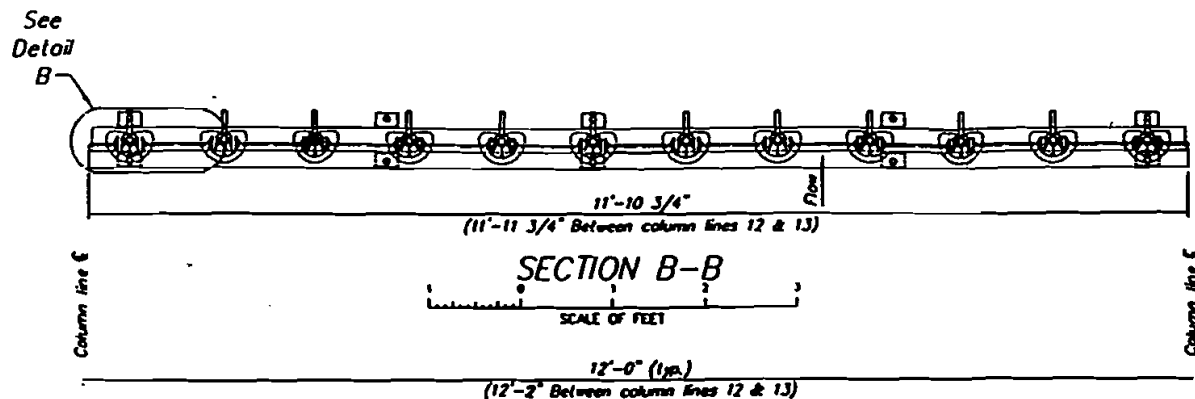
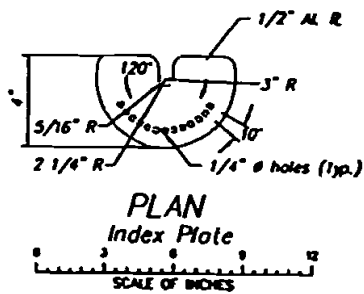

REFERENCE DRAWINGS
 CONCRETE STRUCTURE AND STEEL WORK - 33-100-2505
 PLAN AND DETAILS - 33-100-2505
 STEEL WORK - SECTIONS AND DETAILS - 33-100-2503

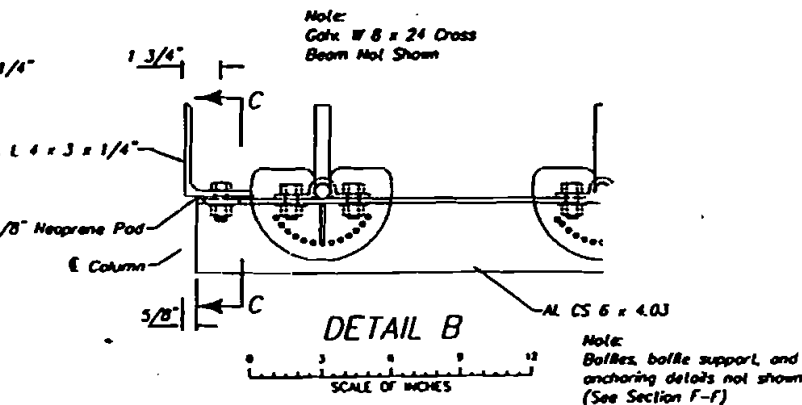
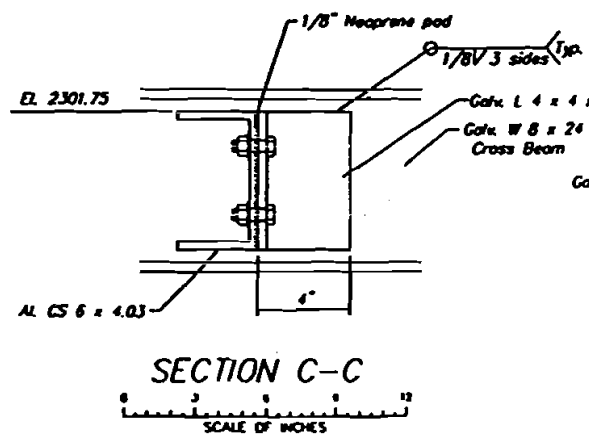
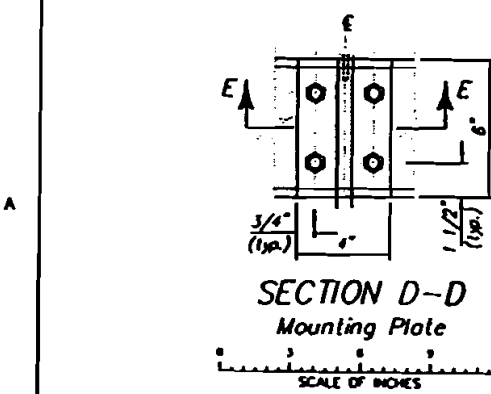
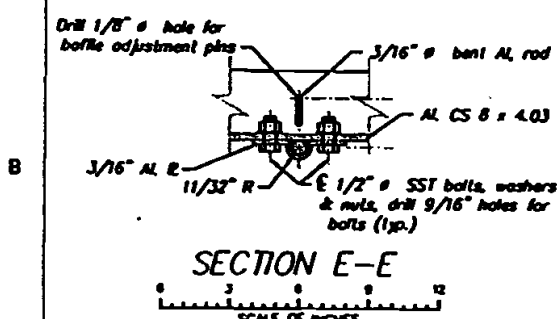
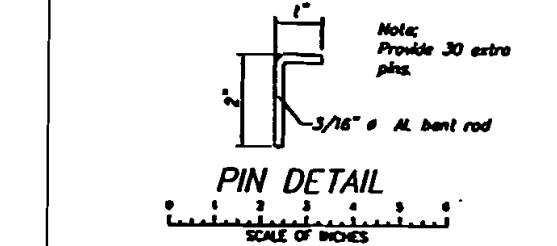

Rev	6/24/98	As-built
NO	EDM	
Rev	8/5/98	General revisions
NO	EDM	
ALWAYS THINK SAFETY		
UNITED STATES DEPARTMENT OF THE INTERIOR BUREAU OF RECLAMATION YAKIMA PROJECT - WASHINGTON PHASE 3 FISH PASSAGE AND PROTECTIVE FACURES YAKIMA TIETON CANAL FISHSCREEN BAFFLE PLANS, DETAILS, SECTION, & ELEVATION		
DESIGNER	CHECKED	
DRAWN	BY	DATE AND TIME PLOTTED
CADD SYSTEM	CADD FILENAME	PROGRAM NUMBER
PLANTAC FILE #	Y2503.DWG	AUGUST 3, 1998 08:32
PLANTAC	DATE	33-100-2504

Figure 12

Flow baffles are typically adjusted during initial startup of the facility to achieve good uniformity of approach flow to the entire screen. The baffles should only have to be adjusted during the first operation of the screen structure following construction. Baffles should not require further adjustment unless normal operating conditions change significantly.

A fish bypass entrance is located at the downstream end of the screen on the south side of the canal. The entrance to the bypass pipe is a 2 ft wide opening the full height of the screen. The bypass then transitions to a 36 inch diameter pipe that passes through a bluff between the canal and river for a distance of 560 ft. The bypass pipe enters the river about 500 ft downstream of the dam. The fish bypass will convey about 50 ft³/s flow at 1400 ft³/s irrigation diversion.

A traveling brush system is proposed for cleaning the fish screen, see figure 11 section C-C. The system shown is typical of commercially available systems. A brush is moved along the screen from upstream to downstream by a rail mounted motor drive system. The brush sweeps debris off the screen and moves it toward the fish bypass entrance where debris is carried by the fish bypass flow back to the river. After reaching the downstream end of the screen the brush retracts out of the flow prior to moving back to the upstream end of the screen. The brush system can be automated to operate based on a time period cycle or based on water surface differential measured across the screen structure.

The screen concept is estimated to cost 5.5 million dollars. An itemized list of component quantities and costs for the screen facility are given in Appendix B, tables B1-B3. There are areas where costs could be reduced pending additional field data collection. The main area is the concrete flume. The drawings and cost estimate assume a full concrete flume is built within the canal. This is shown to ensure stability of the screen structure section. The canal banks adjacent to the screen must be capable of supporting heavy machinery including a mobile crane should a screen panel need to be pulled in the future. If future geology exploration show the material is sufficiently stable, the floor of the concrete flume could be reduced to a 13 ft wide by 300 ft long concrete pad lying under the screen. The flume walls could be shortened to 170 ft long abutments on each side. If a full flume is not needed for channel stability, concrete quantities can be reduced by about 60 percent for the screen structure. This option would cost an estimated 4.7 million dollars.

Louver Concept

A typical louver design of a fish barrier is shown in Figure 13. Reclamation first used louvers to protect fish at the Tracy Fish Salvage Facility near Tracy, California in the 1950's. Many studies of louver fish guidance efficiencies have been conducted at Tracy and other sites. These studies have shown fish protection efficiency using louvers is a function of flow approach velocity, fish size and fish behavior. Studies of louver designs by Rhone and others have resulted in the following general design criteria for louvers.

Approach velocity – 1 ft/s or less (1 ft/s is typical)

Louver bar spacing – 1 inch

Angle of the louver structure to the flow – less than 26 degrees

Angle of the louver bars to the direction of the approach flow – 90 degrees

Guide vanes are located behind the louver bars.

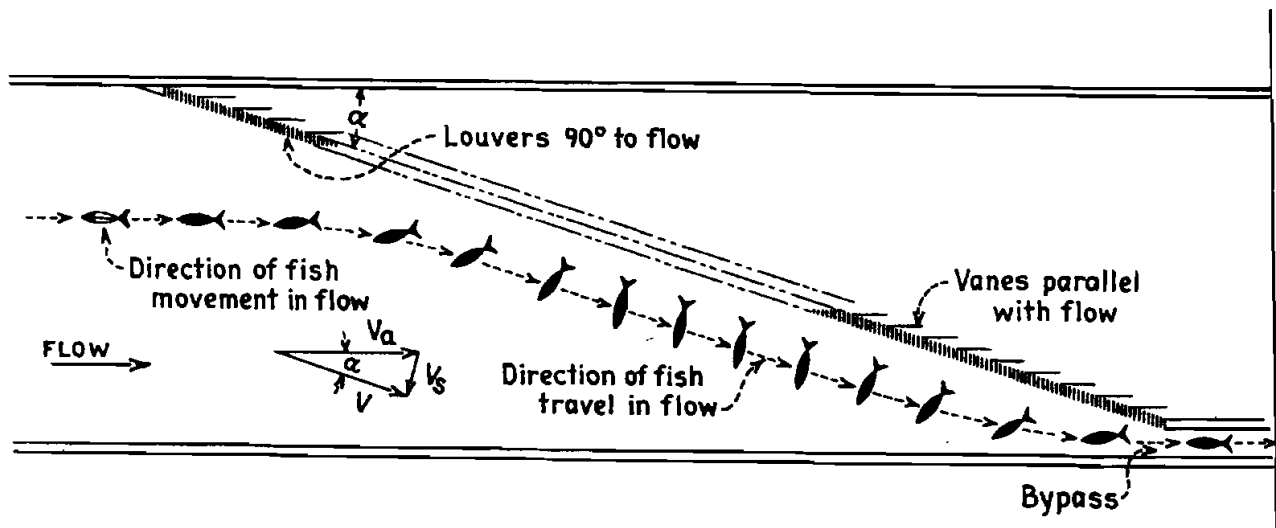

Figure 13 - Louver style fish barrier, Rhone 1955.

The fish protection efficiency of louvers based on the above criteria varies. In general, efficiencies of better than 90% are common for fish of length greater than about 2 to 3 inches. For smaller fish, especially weak swimming species, fish salvage efficiencies of 40 percent or less can occur.

A fish protection structure based on a louver concept was developed for the Main Canal following the above listed general design criteria. The concept design of a louver is shown in figure 14. The layout of the louver is similar to the screen concept. Fish are guided along the louver to the downstream end where they enter a fish bypass that returns them to the river. The louver structure is 265 ft long and 55 ft wide. The louver is set at a 19.9 degree angle to the canal bank. Designing the louver for an approach velocity of 1.0 ft/s compared to the 0.5 ft/s for the screen concept results in the shorter structure length and greater attack angle to the flow. The louver panels and downstream straightening vanes are shown in figure 14, detail B. Straightening vanes redirect flow to a downstream direction, which serves to reduce the energy loss as flow passes through the louver. The louver is designed with removable 10 ft long x 10 high steel panels set in vertical guides. The panels are set on top of a 6 inch high concrete sill. The sill reduces sediment deposition on the seat area of the panels and provides improved guidance to the fish bypass for small fish that move close to the bottom.

Louvers are often designed without automated cleaning devices when trashracks are upstream. At the Main Canal Diversion, there are no trashracks covering the inlet tubes. Recent fish netting studies conducted by Heibert (2000) have shown significant amounts of medium size debris pass through the inlet gates into the canal. This debris would impinge on the louver and require removal. During spring flows when large debris loads are present in the river the louver panels would likely require daily cleaning. Therefore, an automated trashrack rake is proposed for the louver. The rake would clean the upstream louver face by vertically raking over the louver and onto a conveyor belt. The conveyor moves the material to a dump site at to the canal bank.

The louver concept is estimated to cost 3.2 million dollars. An itemized list of component quantities and costs for the louver facility are given in tables B4-B6. Similar to the screen option,

the louver structure cost could be reduced if additional geology data supports constructing less than a full concrete flume. If future geology exploration show the material is sufficiently stable, the floor of the concrete flume could be reduced to a 13 ft wide by 180 ft long concrete pad lying under the louver. The flume walls could be shortened to about 120 ft long abutments on each side. For this scenario, concrete quantities can be reduced by about 50 percent and construction costs reduced to about 2.8 million dollars for the louver structure.

Fish Passage Fishway Concepts

Three fishway concepts were considered for Intake Dam; a flume and baffle fishway, a riprap channel fishway and a long low gradient channel. The flume and baffle fishway and riprap channel fishway concepts are similar in that they are located on the south abutment of Intake dam with slopes of 4 percent and 2 percent respectively. The low gradient fishway channel concept is discussed in the Lower Yellowstone River Fish Passage and Protection Study report (Mefford, January, 1999). This concept would construct a new channel from the toe of Intake Dam in a south westerly direction and join the high flow channel. The resulting fishway would be a 3.6 mile long channel with a slope of about 0.04 percent.

Only the first two fishway concepts are presented herein with concept level designs and cost estimates. To develop a concept level design for the low gradient channel will require additional survey and geological data.

In conjunction with constructing a fishway, it is recommended that the dam crest near the north bank be raised with riprap to discourage fish passage up the north bank. Fish often hug a river bank to escape high velocity flow. At Intake Dam the riprap downstream of the crest appears to be at a flatter slope near the north bank. This could cause two problems for fish passage. First, the existing dam shape may create flow conditions that attract fish to the north bank of the river and away from a future fishway on the south bank. Second, fish passage along the north river bank leads the fish directly in front of the Main Canal headworks where entrainment with the canal diversion flow is likely. Canal entrainment studies by Heibert (January, 2000) support this theory. Heibert's study shows the downstream most gate on the canal headworks entrains the largest percentage of the fish.

Flume and Baffle Fishway Concept

A fishway concept design using a dual-vertical-slot baffle is shown in Figure 14. The fishway uses a series of baffles to break the drop over the dam into smaller increments. The fishway design is based on a design river flow range of 5,000 to 40,000 ft³/s. The estimated stage discharge elevations upstream and downstream of the dam are given in Table A1. The low river condition results in a maximum water surface differential across the dam of 5.2 ft. The criteria used in the baffle fishway concept design are:

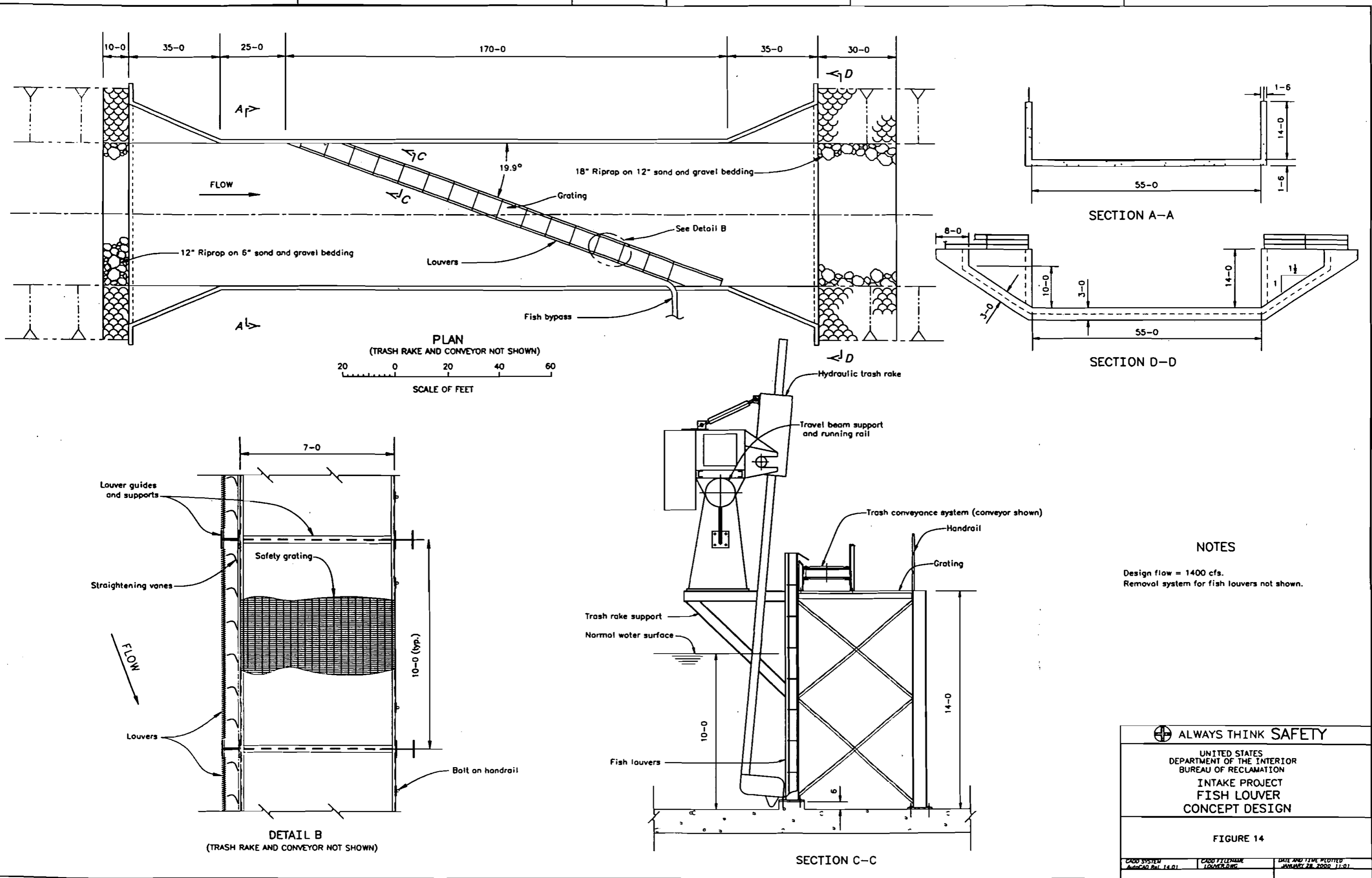

NOTES

Design flow = 1400 cfs.
Removal system for fish louvers not shown.

⊕ ALWAYS THINK SAFETY

UNITED STATES
DEPARTMENT OF THE INTERIOR
BUREAU OF RECLAMATION
INTAKE PROJECT
FISH LOUVER
CONCEPT DESIGN

FIGURE 14

CADD SYSTEM AutoCAD Rev. 14.01	CADD FILENAME LOUVER.DWG	DATE AND TIME PLOTTED JANUARY 28, 2000 11:01
-----------------------------------	-----------------------------	---

Maximum design water surface differential across the dam, 5.2 ft
Maximum design water surface drop per baffle, 0.4 ft
Maximum passage velocity (through slot), 5.1 ft/s
Minimum depth of flow in the fishway , 2.5 ft

The baffle fishway layout shown passes the fishway around the south abutment of Intake dam. The fishway channel is 8 ft wide and 135 ft long. The fishway entrance is at elevation 1983 and the exit at elevation 1988. The concrete channel slopes at four percent through the baffled reaches and contains a 0.013 percent slope where the fishway turns sharply. Removable chevron shaped baffles are shown spaced 10 ft apart. Each baffle is 8 ft tall and contains two 18- inch-wide vertical slots for fish passage. The chevron shaped baffle was recently developed for improving the passage of non-salmonids at Reclamation's Marble Bluff Dam near Reno, Nevada. The chevron baffle design is recommended because it provides a strong downstream guidance within the pools between baffles. This is important when river turbidity is high during peak fish passage periods. A course trashrack would be placed over the fishway exit to prevent large debris from becoming wedged in the fishway channel.

The baffle and concrete flume fishway shown on figure 15 is estimated to cost \$620,000. An itemized cost estimate is given in table B6.

Riprap Channel Fishway Concept

A riprap channel fishway was designed that follows the south river bank. The fishway, shown in figure 16, starts at the dam crest and extends 200 ft downstream along the bank. The fishway design is similar to the recently constructed Huntly Dam fishway near Billings, Mt. The fishway is designed at a 2 percent slope. Chevron shaped boulder arrays are placed within the fishway to create hydraulic drops about every 17 ft along the channel. The boulder arrays are required to maintain sufficient flow depth within the fishway. The boulders also create pools between boulder arrays that provide resting areas for fish. The chevron shape concentrates flow toward the center of the fishway channel and produces higher flow velocity in the center of the channel than at the banks. Each boulder weir will create about 0.4 ft of water surface drop. Stability of a riprap structure is a major design concern. Each year as river flows start to increase in the spring river ice moves some of the riprap on the dam downstream. Some riprap is probably floated out of position by surrounding ice while other riprap is moved by the force of ice jams pushing against the rock. Both mechanisms of moving the rock could effect the stability of rock placed on the fishway. An ungrouted rock fishway would likely require yearly maintenance to replace lost riprap. Grouting of the riprap is a possible solution. However, additional field soils data is needed to determine if the native soils would provide a suitable foundation for a grouted rock structure.

The cost of the ungrouted rock fishway structure design given in figure 16 is \$401,000. An itemized cost estimate is given in Table B7.

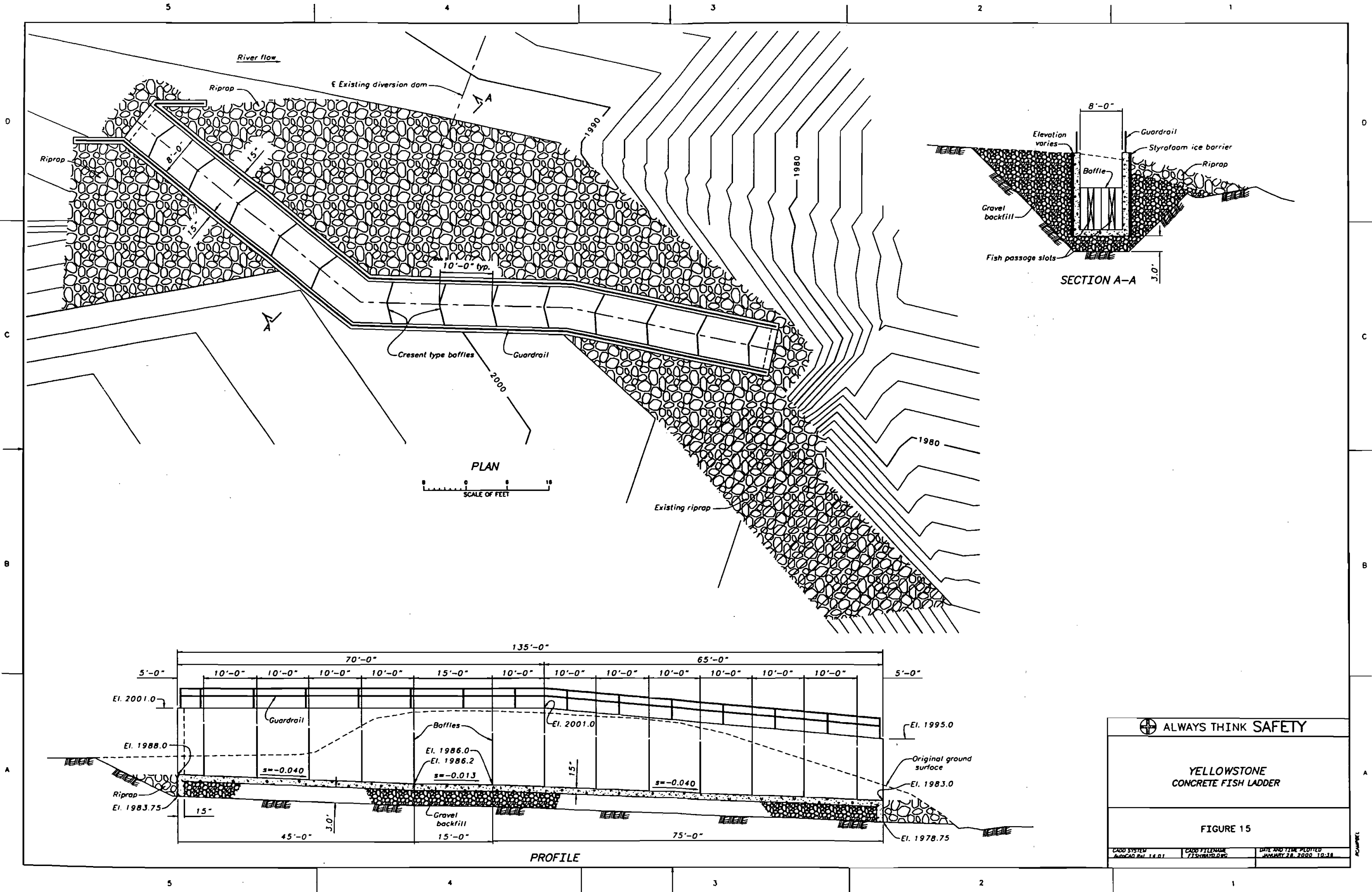

5

4

3

2

1

D

C

B

A

D

C

B

A

River flow

Riprap

Existing diversion dam

1990

1980

1980

Crescent type baffles

Guardrail

PLAN

SCALE OF FEET

Existing riprap

Elevation varies

Guardrail

Styrofoam ice barrier

Riprap

Gravel backfill

Baffle

Fish passage slots

SECTION A-A

135'-0"

5'-0"

10'-0"

10'-0"

10'-0"

10'-0"

15'-0"

10'-0"

10'-0"

10'-0"

10'-0"

10'-0"

10'-0"

10'-0"

10'-0"

10'-0"

10'-0"

10'-0"

10'-0"

10'-0"

10'-0"

10'-0"

5'-0"

EI. 2001.0

EI. 1988.0

EI. 1983.75

s=-0.040

EI. 1986.0

EI. 1986.2

s=-0.013

EI. 2001.0

15'

s=-0.040

EI. 1995.0

Original ground surface

EI. 1983.0

EI. 1978.75

15'

45'-0"

3.0'

15'-0"

Gravel backfill

75'-0"

PROFILE

ALWAYS THINK SAFETY

YELLOWSTONE CONCRETE FISH LADDER

FIGURE 15

CADD SYSTEM: AutoCAD R14.01
 CADD FILENAME: FISHWATER.DWG
 DATE AND TIME PLOTTED: JANUARY 28, 2000 10:38

5

4

3

2

1

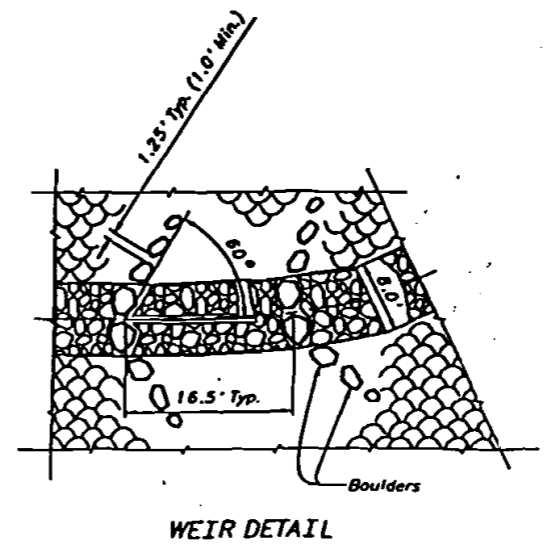
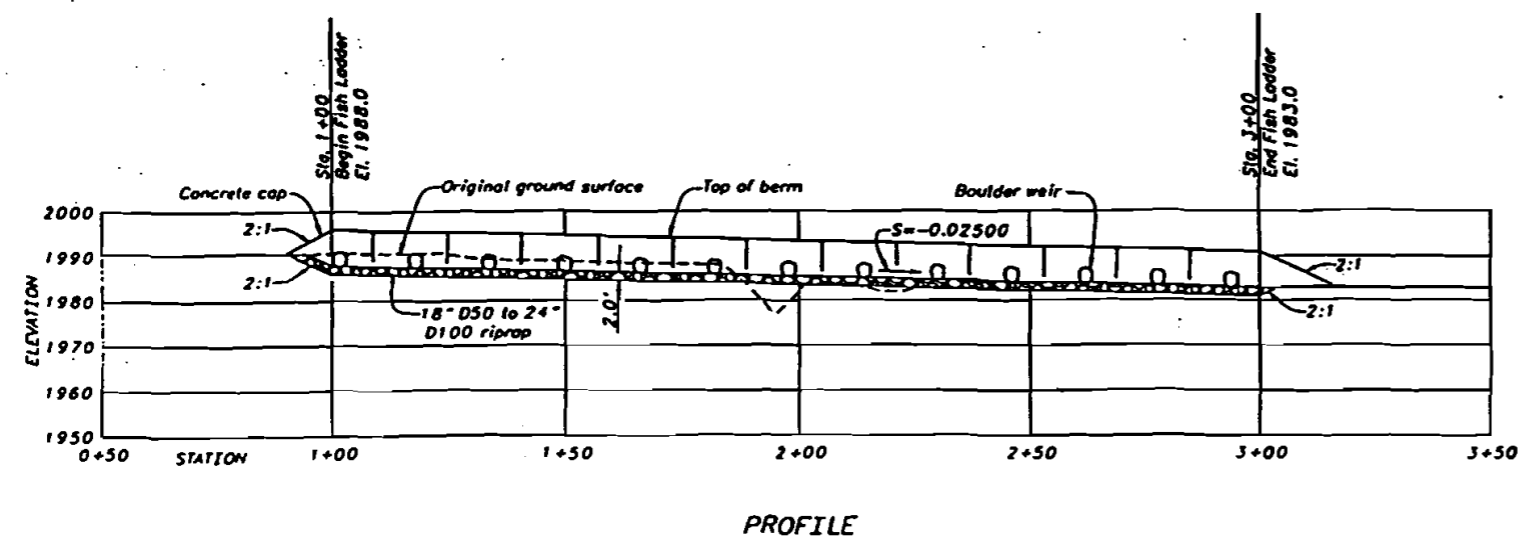
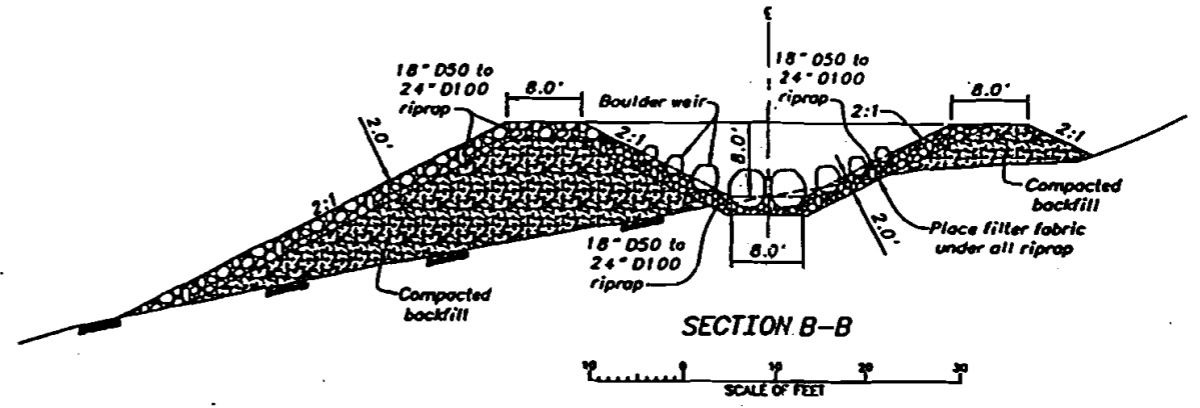
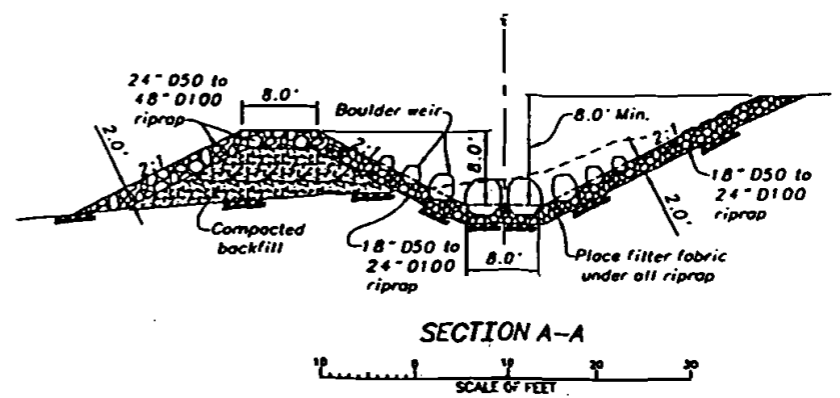
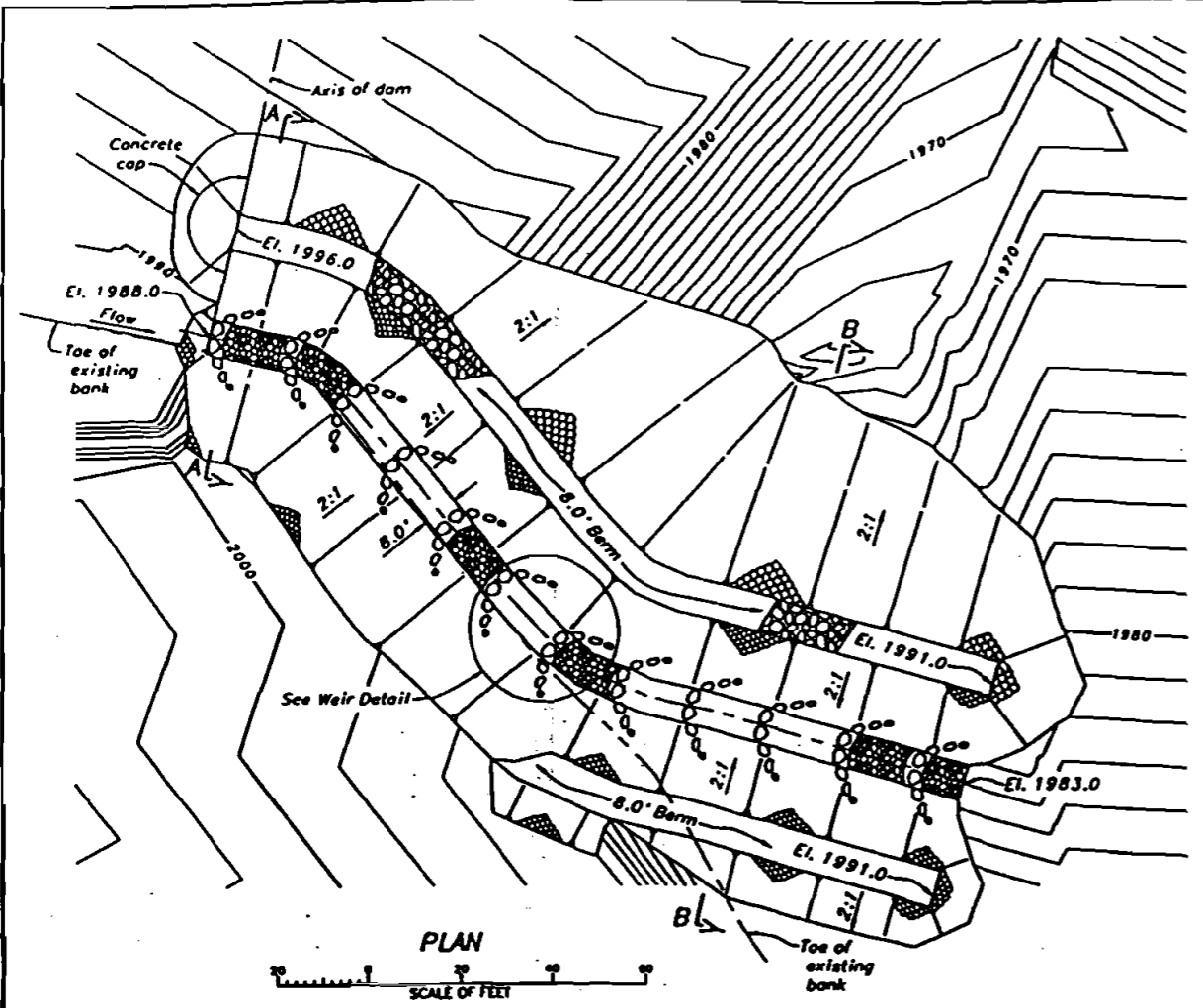

⊕ ALWAYS THINK SAFETY

YELLOWSTONE
RIPRAP FISH LADDER

FIGURE 16

CAD SYSTEM ARCAD 11.0.1	CAD FILENAME RIPRAP.DWG	DATE AND TIME PLOTTED MARCH 23 2009 10:19
----------------------------	----------------------------	--

Appendix A
Water Surface Model Data

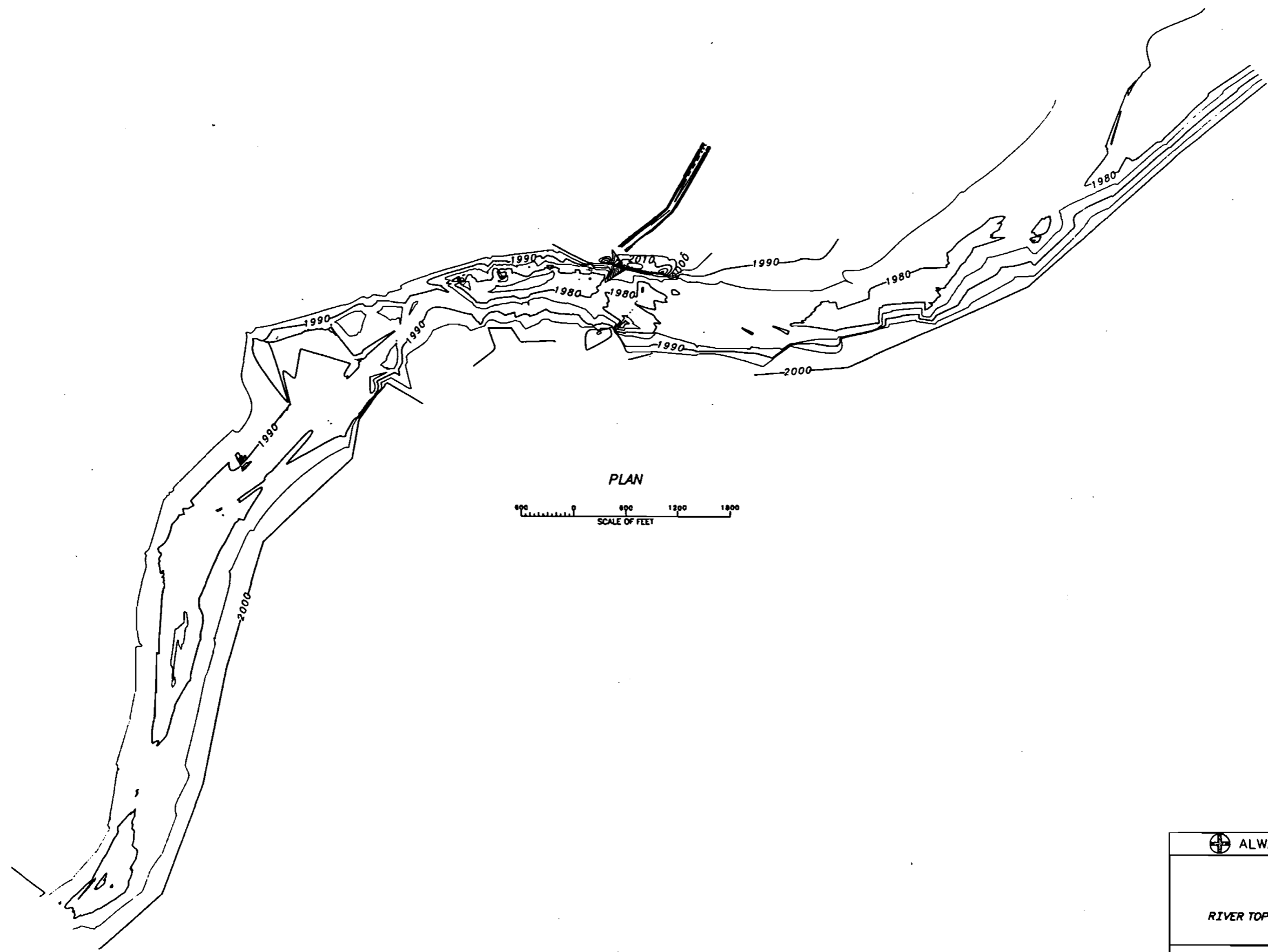

PLAN

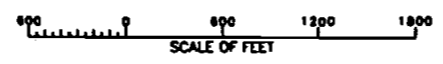

⊕ ALWAYS THINK SAFETY

YELLOWSTONE
RIVER TOPOGRAPHY NEAR INTAKE DAM

FIGURE A1

<small> CAD SYSTEM AutoCAD Rev. 14.01 </small>	<small> CADD TITLEBLOCK 2 CONT.BLOCK </small>	<small> DATE AND TIME PLOTTED MONDAY 28 AUG 2000 10:34 </small>
---	--	--

RCP/REL

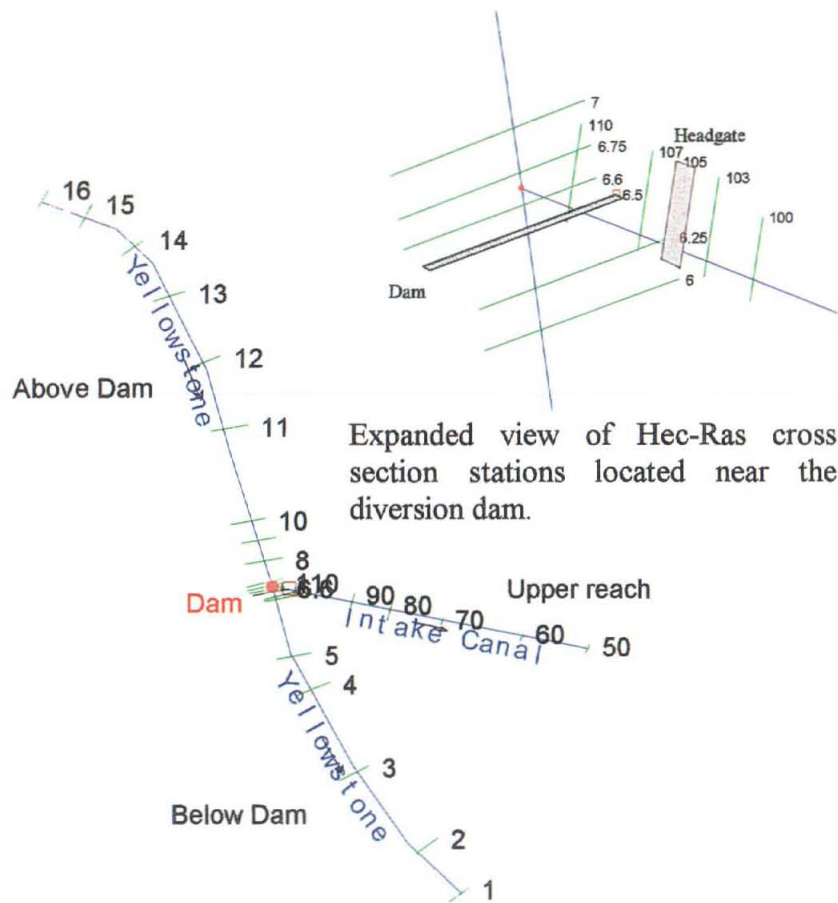

River Reach Sta. Reach Length, ft

Above Dam	16	906.4
Above Dam	15	1179.8
Above Dam	14	1368.7
Above Dam	13	1700.1
Above Dam	12	1590.0
Above Dam	11	2230.5
Above Dam	10	484.9
Above Dam	9	515.7
Above Dam	8	496.9
Above Dam	7	100.0
Above Dam	6.75	70.0
Below Dam	6.6	50.0
Below Dam	6.5	135.0
Below Dam	6.25	93.3
Below Dam	6	1368.0
Below Dam	5	907.7
Below Dam	4	2108.2
Below Dam	3	2243.4
Below Dam	2	1269.0
Below Dam	1	

Figure A2 - Hec-Ras geometry plan showing cross-section locations within the reach of the Yellowstone River modeled

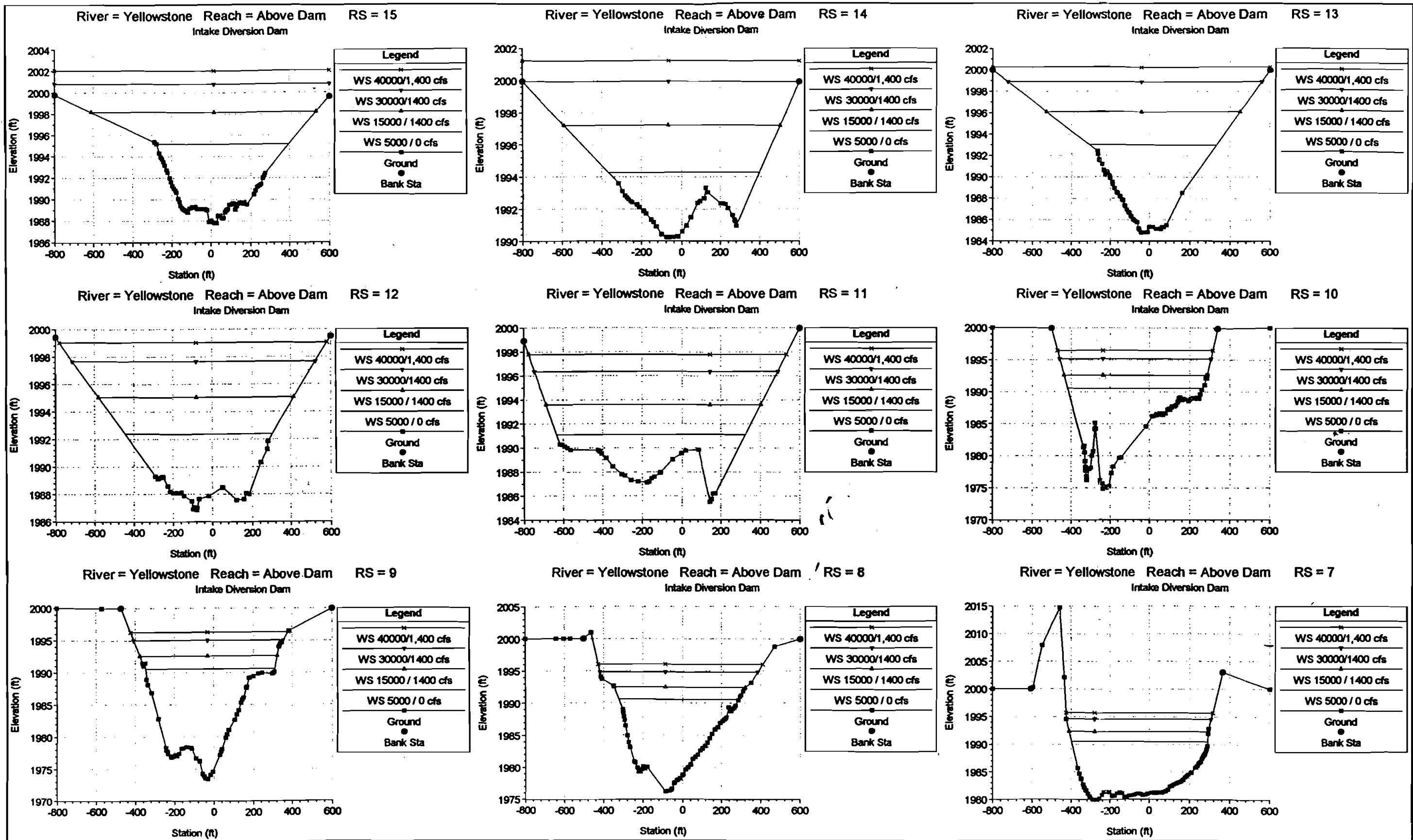

Figure A3 - Hec-Ras model output of Yellowstone River cross-sections upstream of Intake Dam.

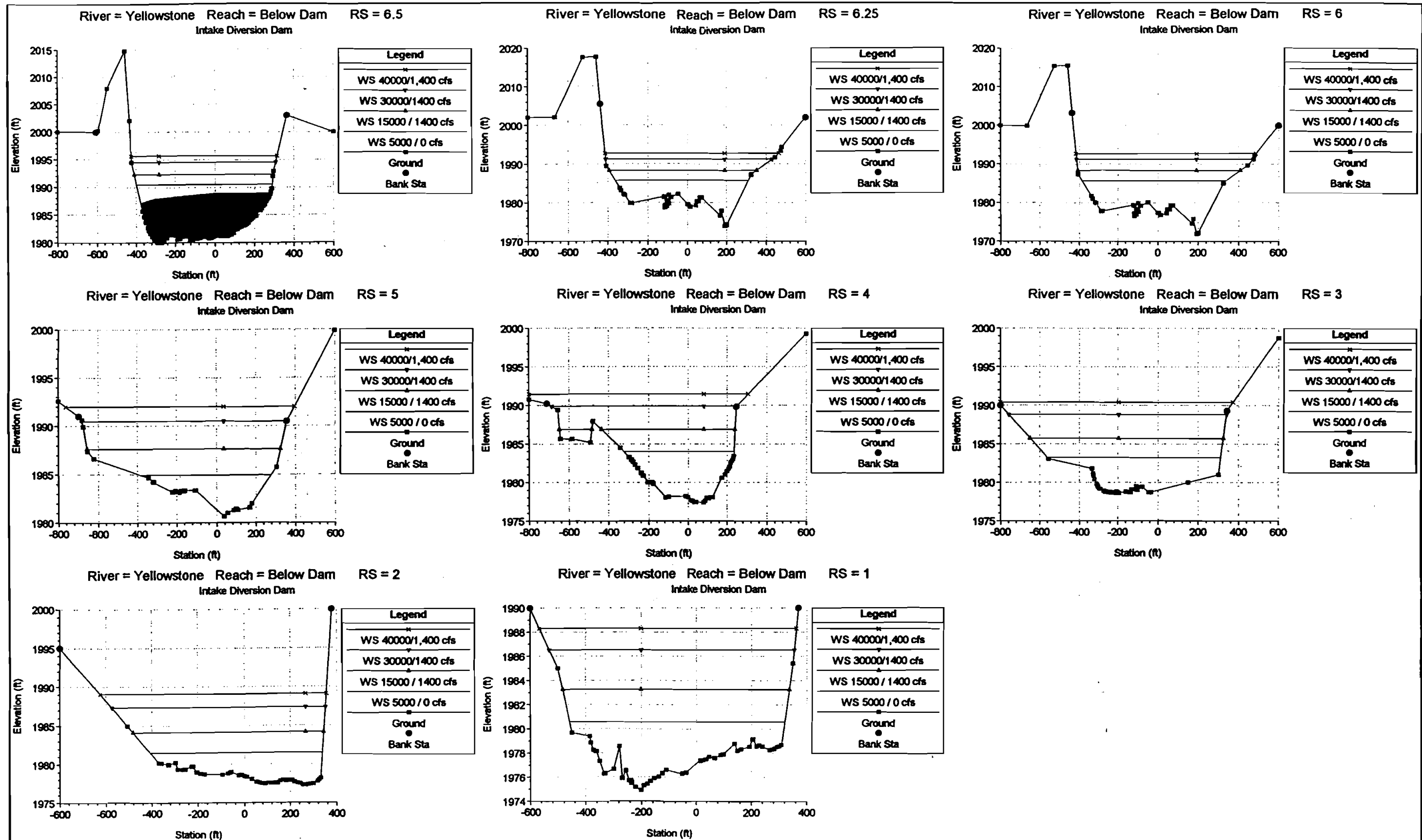

Figure A4 - Hec-Ras model output of Yellowstone River cross-sections downstream of Intake Dam.

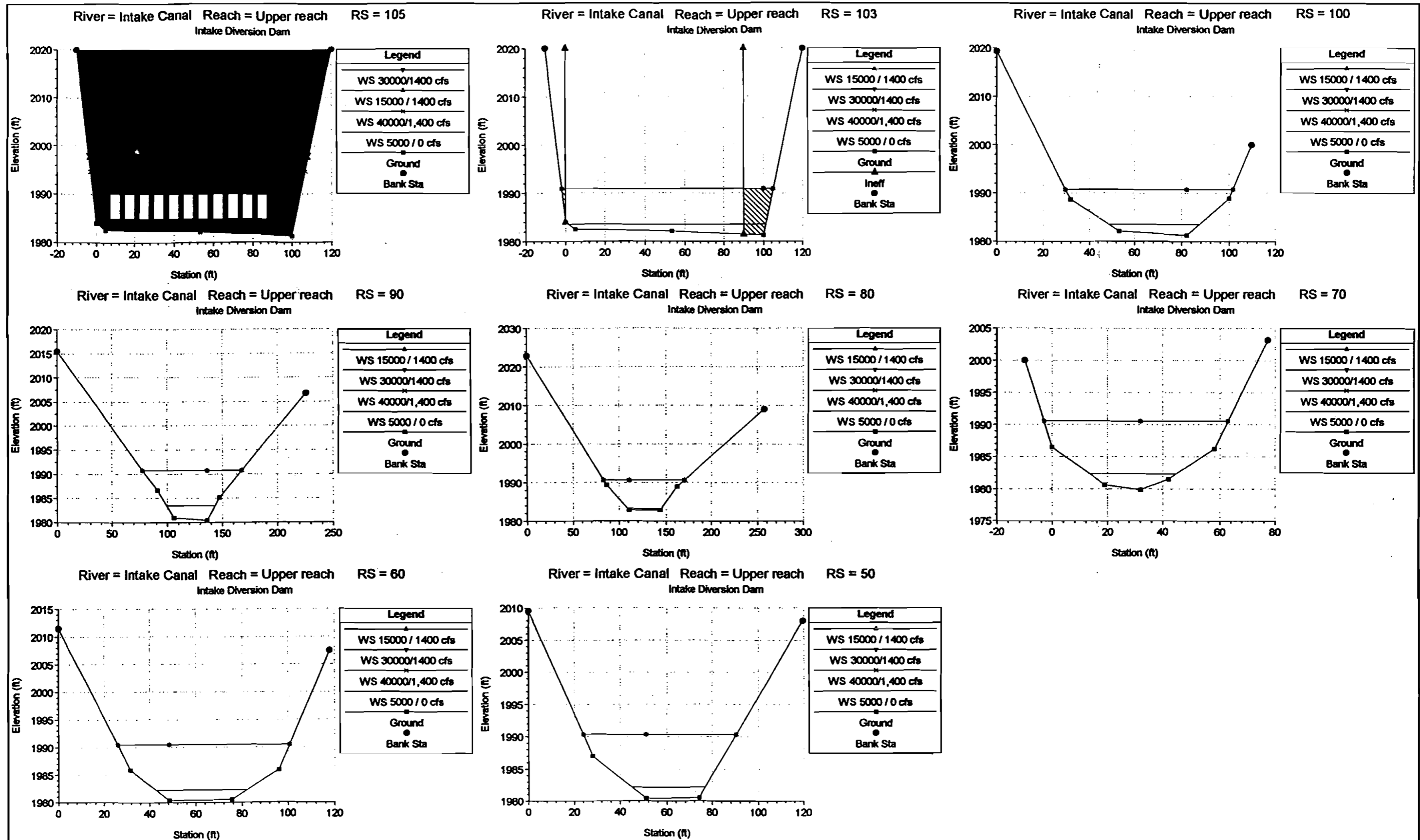

Figure A5 - Hec-Ras model output of Main Canal cross-sections downstream of canal headworks.

Table A-1 - Hec-Ras Water Surface Profile Output for flows given in figure 4.

River	Reach	River Sta	Q Total (cfs)	W.S. Elev (ft)	Vel Chnl (ft/s)	E.G. Elev (ft)	Delta EG (ft)
Intake Canal	Upper reach	110	50.00	1991.27	0.05	1991.27	0.00
Intake Canal	Upper reach	110	1400.00	1997.43	0.86	1997.44	0.00
Intake Canal	Upper reach	110	1400.00	1998.30	0.81	1998.31	0.00
Intake Canal	Upper reach	110	1400.00	1994.68	1.06	1994.70	0.00
Intake Canal	Upper reach	107	50.00	1991.27	0.05	1991.27	7.73
Intake Canal	Upper reach	107	1400.00	1997.43	0.86	1997.44	6.52
Intake Canal	Upper reach	107	1400.00	1998.30	0.81	1998.31	7.39
Intake Canal	Upper reach	107	1400.00	1994.68	1.06	1994.70	3.78
Intake Canal	Upper reach	105 Inline Weir					
Intake Canal	Upper reach	103	50.00	1983.53	0.41	1983.53	0.00
Intake Canal	Upper reach	103	1400.00	1990.87	1.79	1990.92	0.01
Intake Canal	Upper reach	103	1400.00	1990.87	1.79	1990.92	0.01
Intake Canal	Upper reach	103	1400.00	1990.87	1.79	1990.92	0.01
Intake Canal	Upper reach	100	50.00	1983.52	0.82	1983.53	0.01
Intake Canal	Upper reach	100	1400.00	1990.77	2.91	1990.91	0.06
Intake Canal	Upper reach	100	1400.00	1990.77	2.91	1990.91	0.06
Intake Canal	Upper reach	100	1400.00	1990.77	2.91	1990.91	0.06
Intake Canal	Upper reach	90	50.00	1983.51	0.48	1983.51	0.05
Intake Canal	Upper reach	90	1400.00	1990.75	2.43	1990.84	0.07
Intake Canal	Upper reach	90	1400.00	1990.75	2.43	1990.84	0.07
Intake Canal	Upper reach	90	1400.00	1990.75	2.43	1990.84	0.07
Intake Canal	Upper reach	80	50.00	1983.27	3.58	1983.47	1.13
Intake Canal	Upper reach	80	1400.00	1990.63	3.03	1990.77	0.10
Intake Canal	Upper reach	80	1400.00	1990.63	3.03	1990.77	0.10
Intake Canal	Upper reach	80	1400.00	1990.63	3.03	1990.77	0.10
Intake Canal	Upper reach	70	50.00	1982.33	1.01	1982.34	0.09
Intake Canal	Upper reach	70	1400.00	1990.54	2.87	1990.67	0.11
Intake Canal	Upper reach	70	1400.00	1990.54	2.87	1990.67	0.11
Intake Canal	Upper reach	70	1400.00	1990.54	2.87	1990.67	0.11
Intake Canal	Upper reach	60	50.00	1982.24	0.84	1982.25	0.08
Intake Canal	Upper reach	60	1400.00	1990.47	2.47	1990.56	0.09
Intake Canal	Upper reach	60	1400.00	1990.47	2.47	1990.56	0.09
Intake Canal	Upper reach	60	1400.00	1990.47	2.47	1990.56	0.09
Intake Canal	Upper reach	50	50.00	1982.15	1.08	1982.17	
Intake Canal	Upper reach	50	1400.00	1990.33	3.00	1990.47	
Intake Canal	Upper reach	50	1400.00	1990.33	3.00	1990.47	
Intake Canal	Upper reach	50	1400.00	1990.33	3.00	1990.47	
Yellowstone	Above Dam	16	5000.00	1995.81	3.41	1995.99	0.15
Yellowstone	Above Dam	16	15000.00	1998.96	4.37	1999.26	0.16
Yellowstone	Above Dam	16	29500.00	2001.46	5.08	2001.85	0.14
Yellowstone	Above Dam	16	38800.00	2002.64	5.39	2003.06	0.13
Yellowstone	Above Dam	15	5000.00	1995.15	1.68	1995.19	0.03
Yellowstone	Above Dam	15	15000.00	1998.17	2.63	1998.28	0.05
Yellowstone	Above Dam	15	29500.00	2000.82	3.20	2000.98	0.05
Yellowstone	Above Dam	15	38800.00	2002.05	3.55	2002.25	0.05
Yellowstone	Above Dam	14	5000.00	1994.27	2.93	1994.40	0.18
Yellowstone	Above Dam	14	15000.00	1997.20	3.39	1997.38	0.11
Yellowstone	Above Dam	14	29500.00	1999.93	3.77	2000.15	0.09
Yellowstone	Above Dam	14	38800.00	2001.22	4.03	2001.47	0.08

Yellowstone	Above Dam	13	5000.00	1993.02	1.72	1993.06	0.03
Yellowstone	Above Dam	13	15000.00	1996.11	2.77	1996.23	0.05
Yellowstone	Above Dam	13	29500.00	1998.89	3.45	1999.07	0.06
Yellowstone	Above Dam	13	38800.00	2000.26	3.72	2000.48	0.06
Yellowstone	Above Dam	12	5000.00	1992.38	1.96	1992.44	0.05
Yellowstone	Above Dam	12	15000.00	1995.05	3.07	1995.20	0.08
Yellowstone	Above Dam	12	29500.00	1997.66	3.78	1997.89	0.08
Yellowstone	Above Dam	12	38800.00	1999.02	4.06	1999.28	0.08
Yellowstone	Above Dam	11	5000.00	1991.11	2.17	1991.18	0.09
Yellowstone	Above Dam	11	15000.00	1993.62	3.07	1993.77	0.08
Yellowstone	Above Dam	11	29500.00	1996.38	3.65	1996.59	0.07
Yellowstone	Above Dam	11	38800.00	1997.79	3.93	1998.03	0.07
Yellowstone	Above Dam	10	5000.00	1990.58	1.07	1990.60	0.01
Yellowstone	Above Dam	10	15000.00	1992.62	2.46	1992.72	0.02
Yellowstone	Above Dam	10	29500.00	1995.17	3.69	1995.38	0.04
Yellowstone	Above Dam	10	38800.00	1996.47	4.31	1996.76	0.05
Yellowstone	Above Dam	9	5000.00	1990.57	0.87	1990.58	0.00
Yellowstone	Above Dam	9	15000.00	1992.54	2.12	1992.61	0.01
Yellowstone	Above Dam	9	29500.00	1995.02	3.32	1995.19	0.03
Yellowstone	Above Dam	9	38800.00	1996.28	3.93	1996.52	0.03
Yellowstone	Above Dam	8	5000.00	1990.55	0.99	1990.56	0.00
Yellowstone	Above Dam	8	15000.00	1992.44	2.40	1992.52	0.02
Yellowstone	Above Dam	8	29500.00	1994.80	3.67	1995.01	0.04
Yellowstone	Above Dam	8	38800.00	1996.00	4.30	1996.29	0.06
Yellowstone	Above Dam	7	5000.00	1990.52	0.91	1990.54	0.00
Yellowstone	Above Dam	7	15000.00	1992.34	2.21	1992.41	0.02
Yellowstone	Above Dam	7	29500.00	1994.60	3.51	1994.79	0.03
Yellowstone	Above Dam	7	38800.00	1995.74	4.20	1996.01	0.04
Yellowstone	Above Dam	6.75	5000.00	1990.52	0.91	1990.53	
Yellowstone	Above Dam	6.75	15000.00	1992.32	2.21	1992.40	
Yellowstone	Above Dam	6.75	29500.00	1994.57	3.52	1994.76	
Yellowstone	Above Dam	6.75	38800.00	1995.70	4.21	1995.97	
Yellowstone	Below Dam	6.6	4950.00	1990.52	0.90	1990.53	4.83
Yellowstone	Below Dam	6.6	13600.00	1992.32	2.01	1992.38	3.98
Yellowstone	Below Dam	6.6	28300.00	1994.56	3.38	1994.73	3.33
Yellowstone	Below Dam	6.6	37400.00	1995.68	4.06	1995.94	2.97
Yellowstone	Below Dam	6.5	Inline Weir				
Yellowstone	Below Dam	6.25	4950.00	1985.67	1.35	1985.70	0.01
Yellowstone	Below Dam	6.25	13600.00	1988.31	2.46	1988.41	0.03
Yellowstone	Below Dam	6.25	28300.00	1991.20	3.62	1991.40	0.05
Yellowstone	Below Dam	6.25	37400.00	1992.71	4.10	1992.97	0.05
Yellowstone	Below Dam	6	4950.00	1985.67	0.97	1985.69	0.00
Yellowstone	Below Dam	6	13600.00	1988.32	1.91	1988.38	0.01
Yellowstone	Below Dam	6	28300.00	1991.22	2.94	1991.36	0.02
Yellowstone	Below Dam	6	37400.00	1992.73	3.41	1992.91	0.02
Yellowstone	Below Dam	5	4950.00	1984.92	3.54	1985.12	0.22
Yellowstone	Below Dam	5	13600.00	1987.63	3.64	1987.84	0.11
Yellowstone	Below Dam	5	28300.00	1990.49	4.27	1990.77	0.08
Yellowstone	Below Dam	5	37400.00	1992.00	4.55	1992.33	0.07
Yellowstone	Below Dam	4	4950.00	1984.03	1.99	1984.09	0.03
Yellowstone	Below Dam	4	13600.00	1986.88	3.05	1987.03	0.05
Yellowstone	Below Dam	4	28300.00	1989.88	3.97	1990.13	0.06
Yellowstone	Below Dam	4	37400.00	1991.45	4.33	1991.74	0.05
Yellowstone	Below Dam	3	4950.00	1983.21	1.94	1983.27	0.05

Yellowstone	Below Dam	3	13600.00	1985.72	2.80	1985.84	0.05
Yellowstone	Below Dam	3	28300.00	1988.79	3.52	1988.99	0.05
Yellowstone	Below Dam	3	37400.00	1990.44	3.78	1990.66	0.05
Yellowstone	Below Dam	2	4950.00	1981.49	2.31	1981.57	0.07
Yellowstone	Below Dam	2	13600.00	1984.12	3.23	1984.28	0.06
Yellowstone	Below Dam	2	28300.00	1987.35	4.03	1987.60	0.06
Yellowstone	Below Dam	2	37400.00	1989.09	4.30	1989.38	0.06
Yellowstone	Below Dam	1	4950.00	1980.61	2.04	1980.67	
Yellowstone	Below Dam	1	13600.00	1983.25	3.00	1983.39	
Yellowstone	Below Dam	1	28600.00	1986.52	3.91	1986.76	
Yellowstone	Below Dam	1	38600.00	1988.30	4.32	1988.59	

Appendix B
Construction Cost Estimate Sheets

ESTIMATE WORKSHEET

FEATURE: FISH SCREEN FACILITIES SCREEN STRUCTURE TOTALS SHEET	10-Jan-2000	PROJECT: DIVISION: FILE: C:\123R4D\EST\INTAKE\TOTALS.WK4
--	-------------	--

PLANT ACCT.	PAY ITEM	DESCRIPTION	CODE	QUANTITY	UNIT	UNIT PRICE	AMOUNT
		Mobilization and preparatory work					\$190,000
		Screen structure subtotal					\$1,335,500
		Bypass pipeline subtotal					\$325,000
		Outlet structure subtotal					\$35,700
		Mechanical subtotal					\$2,107,750
		Subtotal					\$3,993,950
		Unlisted Items (10%)					\$406,050
		Contract Cost					\$4,400,000
		Contingencies (25%)					\$1,100,000
		Field Cost					\$5,500,000

QUANTITIES		PRICES	
BY	CHECKED	BY	CHECKED
		R. Baumgarten	<i>N. Hyndman</i> 1/10/00
DATE PREPARED	APPROVED	DATE	PRICE LEVEL
		01/10/2000	Appraisal 99

FEATURE: FISH SCREENING FACILITIES SCREEN OPTION	10-Jan-2000	PROJECT: INTAKE
C:\123R4\EST\INTAKE\SCRNEST.WK1		
DIVISION:		
UNIT:		

PLANT ACCT.	PAY ITEM	DESCRIPTION	CODE	QUANTITY	UNIT	UNIT PRICE	AMOUNT
		SCREEN STRUCTURE					
		Concrete		2,200	cy	\$400.00	\$880,000
		Reinforcement		264,000	lbs	\$0.65	\$171,600
		Handrail		12,000	lbs	\$5.00	\$60,000
		Earthwork (15 percent of above)					\$167,000
		riprap		220	cy	\$50.00	\$11,000
		bedding for riprap		140	cy	\$45.00	\$6,300
		2" insulation on the walls		13,200	sf	\$3.00	\$39,600
							Screen Structure Subtotal
							\$1,335,500
		BYPASS PIPELINE (jacking)					
		Carrier pipe: 36 inch dia HDPE		560	ft	\$125.00	\$70,000
		Casing pipe: 42-inch diameter		500	ft	\$450.00	\$225,000
		grout between casing and carrier pipe			ls		\$30,000
							Bypass Pipeline Subtotal
							\$325,000
		OUTLET STRUCTURE					
		Concrete		15	cy	\$600.00	\$9,000
		reinforcement		1,800	lbs	\$0.75	\$1,350
		Earthwork (30 percent of above)					\$3,100
		Cofferdam			ls		\$15,000
		Riprap		100	cy	\$50.00	\$5,000
		Bedding for riprap		50	cy	\$45.00	\$2,250
							Outlet Structure Subtotal
							\$35,700
							Total this Sheet
							\$1,696,200

QUANTITIES		PRICES	
BY A. Glickman	BY R. Baumgarten	CHECKED	
DATE PREPARED	APPROVED	DATE	PRICE LEVEL Appraisal 00

FEATURE:
 13-Apr-2000
FISH SCREEN STRUCTURE
MECHANICAL

PROJECT:
INTAKE PROJECT
DIVISION:
FILE:
 C:\MYFILES\TEST F~1\PROJECTS\MONTANA\INTAKE~1

PLANT ACCT.	PAY ITEM	DESCRIPTION	CODE	QUANTITY	UNIT	PRICE	AMOUNT
	1	Fish screens, 10'W x 10' H, 30 + 4 spares stainless steel (approx. 2000 lbs/panel)		68,000	lbs SS	\$10.00	\$680,000
	2	Adjustable baffles, 10'W x 10'H, 26 + 4 spares steel, (approx. 3000 lbs/panel)		90,000	lbs	\$6.00	\$540,000
	3	Hydraulic trash rake/brushing unit, rail and supports single boom, 310 feet of length (21,000 lbs)		1	LS		\$300,000
	4	Guides, supports, bracing, grating, steel		107,000	lbs	\$4.50	\$481,500
	5	Steel transition to bypass 2'W x 10'H to 36" dia. pipe		8,200	lbs	\$10.00	\$82,000
	6	Isolation, 36" dia. cast iron slide gate at bypass exit		1,500	lbs	\$5.00	\$7,500
	7	Water level measuring equipment		1	LS	\$15,000.00	\$15,000
	8	Stoplog guides at bypass entrance		350	lbs	\$5.00	\$1,750
Subtotal Mechanical-----							\$2,107,750

QUANTITIES		PRICES	
BY R. Christensen	CHECKED	BY R. Baumgarten	CHECKED
DATE PREPARED 12/6/99	APPROVED	DATE 04/13/2000	PRICE LEVEL Appraisal 00

ESTIMATE WORKSHEET

FEATURE:

**FISH SCREEN FACILITIES
 LOUVER STRUCTURE
 TOTALS SHEET**

10-Jan-2000

PROJECT:
INTAKE PROJECT

DIVISION:

FILE:
 C:\123R4D\EST\INTAKE\TOTALS.WK4

PLANT ACCT.	PAY ITEM	DESCRIPTION	CODE	QUANTITY	UNIT	UNIT PRICE	AMOUNT
		Mobilization and preparatory work					\$110,000
		Screen structure subtotal					\$847,900
		Bypass pipeline subtotal					\$325,000
		Outlet structure subtotal					\$35,700
		Mechanical subtotal					\$1,039,650
		Subtotal					\$2,358,250
		Unlisted Items (10%)					\$241,750
		Contract Cost					\$2,600,000
		Contingencies (25%)					\$600,000
		Field Cost					\$3,200,000

QUANTITIES		PRICES	
BY	CHECKED	BY	CHECKED
		R. Baumgarten	<i>N. H. Johnson</i> 1/10/00
DATE PREPARED	APPROVED	DATE	PRICE LEVEL
		01/10/2000	Appraisal 99

ESTIMATE WORKSHEET

FEATURE: FISH SCREENING FACILITIES LOUVER OPTION	10-Jan-2000	PROJECT: INTAKE
		DIVISION:
C:\123R4\EST\INTAKE\LOUVEST2.WK1		UNIT:

PLANT ACCT.	PAY ITEM	DESCRIPTION	CODE	QUANTITY	UNIT	UNIT PRICE	AMOUNT
		SCREEN STRUCTURE					
		Concrete		1,300	cy	\$425.00	\$552,500
		Reinforcement		156,000	lbs	\$0.70	\$109,200
		Handrail		6,600	lbs	\$6.00	\$39,600
		Earthwork (15 percent of above)					\$105,000
		riprap		220	cy	\$50.00	\$11,000
		bedding for riprap		140	cy	\$45.00	\$6,300
		2" insulation on the walls		8,100	sf	\$3.00	\$24,300
					Screen Structure Subtotal		\$847,900
		BYPASS PIPELINE (jacking)					
		carrier pipe; 36 inch dia , HDPE		560	ft	\$125.00	\$70,000
		Casing pipe: 42 inch diameter		500	ft	\$450.00	\$225,000
		Grout between casing and carrier pipe			ls		\$30,000
					Bypass Pipeline Subtotal		\$325,000
		OUTLET STRUCTURE					
		Concrete		15	cy	\$600.00	\$9,000
		reinforcement		1,800	lbs	\$0.75	\$1,350
		Earthwork (30 percent of above)					\$3,100
		Cofferdam			ls		\$15,000
		Riprap		100	cy	\$50.00	\$5,000
		Bedding for riprap		50	cy	\$45.00	\$2,250
					Outlet Structure Subtotal		\$35,700

QUANTITIES		PRICES	
BY A. Glickman		BY R. Baumgarten	CHECKED
DATE PREPARED	APPROVED	DATE 10-Jan-2000	PRICE LEVEL Appraisal 00

ESTIMATE WORKSHEET

FEATURE:

FISH LOUVER STRUCTURE

MECHANICAL

13-Apr-2000

PROJECT:
INTAKE PROJECT

DIVISION:

FILE:
C:\MYFILES\TEST F-1\PROJECTS\MONTANA\INTAKE~1

PLANT ACCT.	PAY ITEM	DESCRIPTION	CODE	QUANTITY	UNIT	UNIT PRICE	AMOUNT
	1	Fish louvers, 10'W x 16' H, 15 + 2 spares steel (approx. 4800 lbs/panel)		81,600	lbs	\$4.00	\$326,400
	2	Conveyor, steel		18,000	lbs	\$6.50	\$117,000
	3	Hydraulic trash raking unit, rail and supports single boom, 160 feet of length (14,200 lbs)		1	LS		\$200,000
	4	Guides, supports, bracing, grating, steel		58,000	lbs	\$5.00	\$290,000
	5	Steel transition to bypass 2'W x 10'H to 36" dia. pipe		8,200	lbs	\$10.00	\$82,000
	6	Isolation, 36" dia. cast iron slide gate at bypass exit		1,500	lbs	\$5.00	\$7,500
	7	Water level measuring equipment		1	LS	\$15,000.00	\$15,000
	8	Stoplog guides at bypass entrance		350	lbs	\$5.00	\$1,750
Subtotal Mechanical - - - - -							\$1,039,650

QUANTITIES		PRICES	
BY R. Christensen	CHECKED	BY R. Baumgarten	CHECKED
DATE PREPARED 12/6/99	APPROVED	DATE 04/13/2000	PRICE LEVEL Appraisal 00

ESTIMATE WORKSHEET

FEATURE: <p style="text-align: center;">10-Jan-2000</p> <p style="text-align: center;">BAFFLED FISHWAY STRUCTURE</p>	PROJECT: <p style="text-align: center;">INTAKE PROJECT</p> <hr/> DIVISION: <hr/> FILE: <p>C:\MYFILES\TEST F~\PROJECTS\MONTANA\FISHWAY.</p>
---	---

PLANT ACCT.	PAY ITEM	DESCRIPTION	CODE	QUANTITY	UNIT	UNIT PRICE	AMOUNT
	1	Fishway flume					
		Concrete		260	yds	\$425.00	\$110,500
		Reinforcement		39,000	lbs	\$0.70	\$27,300
		Handrail		5,050	lbs	\$6.00	\$30,300
		Riprap		400	yds	\$50.00	\$20,000
		Riprap bedding		250	yds	\$45.00	\$11,250
		2" insulation on walls		2,160	sf	\$3.00	\$6,480
		Earthwork (25% of above)					\$51,457
							Flume Structure Subtotal
							\$257,287
	2	Steel Baffles		14,850	lbs	\$3.50	\$51,975
		Guides		5,950	lbs	\$3.00	\$17,850
							Baffle Subtotal
							\$69,825
	3	Cofferdaming					
		assumes earth		1,800	yds	\$25.00	\$45,000
		riprap		220	yds	\$50.00	\$11,000
		dewatering (20% of above)					\$11,200
							Cofferdam subtotal
							\$67,200
							Subtotal
							\$394,312
		Mobilization and preparatory work					\$19,716
		Flume structure					\$257,287
		Baffles and Guides					\$69,825
		Cofferdam					\$67,200
		Subtotal					\$414,028
		Unlisted items(20%)					\$82,806
		Contract Cost					\$496,833
		Contingencies (25%)					\$125,000
		Field Cost					\$621,833

QUANTITIES		PRICES	
BY	CHECKED	BY	CHECKED
B. Mefford			
DATE PREPARED	APPROVED	DATE	PRICE LEVEL
12/6/99		01/10/2000	

FEATURE: 11-Jan-2000 ROCK FISHWAY STRUCTURE	PROJECT: INTAKE PROJECT DIVISION: FILE: C:\MYFILES\TEST F~1\PROJECTSMONTANA\FISHWAY.
--	--

PLANT	PAY	DESCRIPTION	CODE	QUANTITY	UNIT	PRICE	AMOUNT
		1 Fishway channel					
		Excavation		630	yds	\$10.00	\$6,300
		Compacted Backfill		2,650	yds	\$7.50	\$19,875
		Riprap		1,585	yds	\$50.00	\$79,250
		Boulders		125	yds	\$200.00	\$25,000
		Riprap bedding		951	yds	\$45.00	\$42,795
		Geotextile		2,200	syd	\$3.00	\$6,600
							Fishway Structure Subtotal
							\$179,800
		2 Cofferdaming					
		assumes earth		2,000	yds	\$25.00	\$50,000
		riprap		250	yds	\$50.00	\$12,500
		unwatering (20% of above)					\$12,500
							Cofferdam subtotal
							\$75,000
							Subtotal
							\$254,800
		Mobilization and preparatory work					\$12,740
		Subtotal					\$267,540
		Unlisted items(20%)					\$53,508
		Contract Cost					\$321,000
		Contingencies (25%)					\$80,250
		Field Cost					\$401,000

QUANTITIES		PRICES	
BY	CHECKED	BY	CHECKED
B. Mefford			
DATE PREPARED	APPROVED	DATE	PRICE LEVEL
12/6/99		01/11/2000	

References

Stewart, P.A. 1986, 1988, 1990, 1991. Fish Management Surveys. Federal Aid in Fish Restoration, Project F-30-R-22, Montana Department of Fish, Wildlife and Parks., Helena.

Hiebert, S., Wydoski, R., Parks, T., January, 2000. Fish Entrainment at the Lower Yellowstone Diversion Dam, Intake Canal, Montana 1996-1998, Bureau of Reclamation Denver Office and Montana Area Office.

Mefford, B., January 1999. Lower Yellowstone River - Water Diversion Inventory, Fish Passage and Protection Study, Bureau of Reclamation Water Resources Research Laboratory and Montana Fish Wildlife, and Parks.