

RECLAMATION

Managing Water in the West

Leadville Mine Drainage Tunnel Risk Assessment

Leadville Mine and Drainage Tunnel Project, Colorado
Great Plains Region

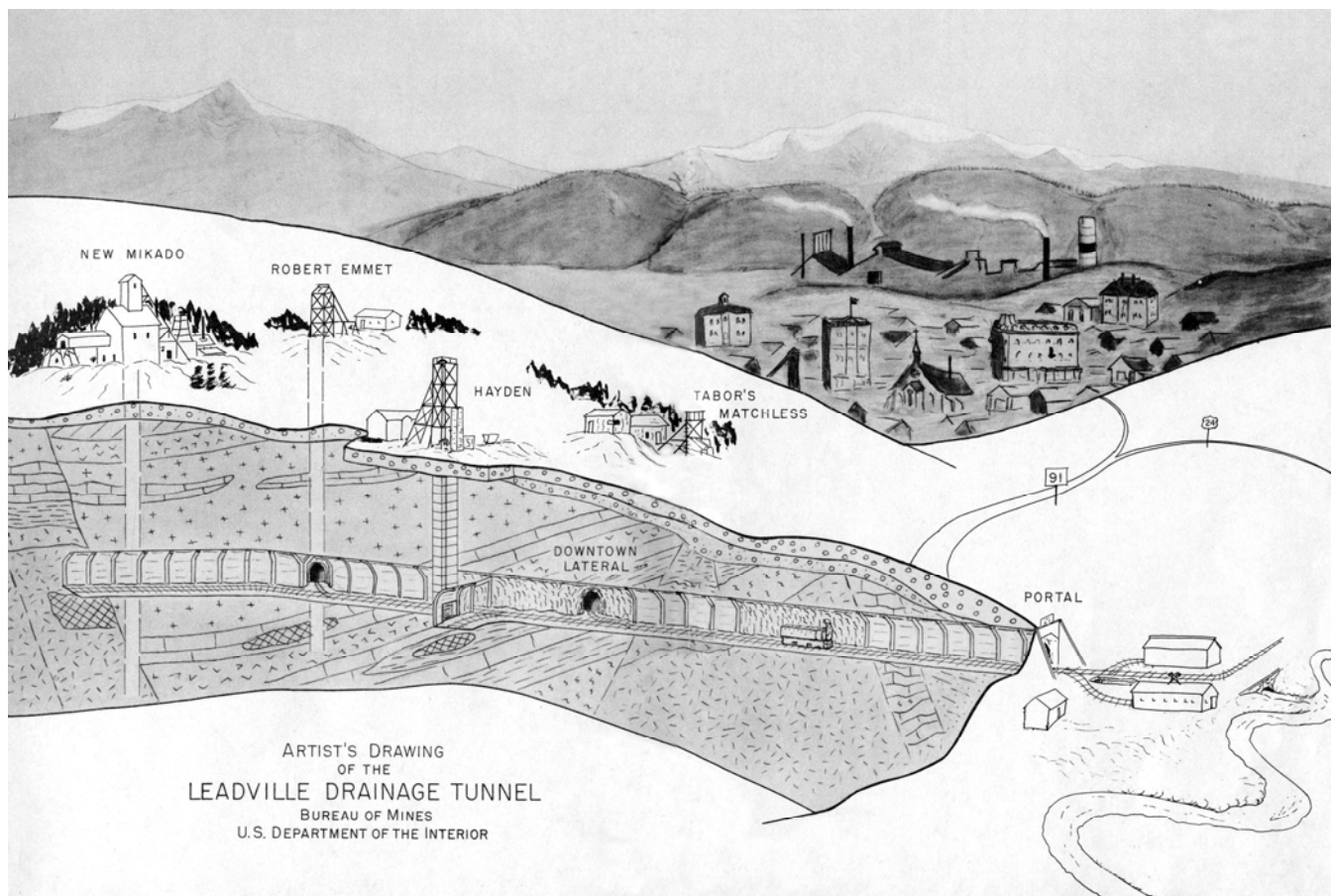

Mission Statements

The mission of the Department of the Interior is to protect and provide access to our Nation's natural and cultural heritage and honor our trust responsibilities to Indian Tribes and our commitments to island communities.

The mission of the Bureau of Reclamation is to manage, develop, and protect water and related resources in an environmentally and economically sound manner in the interest of the American public.

Introduction

The Bureau of Reclamation has completed a study to evaluate the stability and assess the risk associated with the Leadville Mine Drainage Tunnel (LMDT) in Leadville, Colorado. The risk assessment consists of the following four sections:

1. Existing Conditions of the Leadville Mine Drainage Tunnel
2. Results of the Geotechnical and Structural Analysis, Leadville Mine Drainage Tunnel
3. Potential Failure Modes and Effects Analysis, Leadville Mine Drainage
4. Comment Response Document

To complete the risk assessment, Reclamation utilized a similar process to that used to assess risk at its dams, a model that is a global standard for conducting risk assessments. The initial step was to gather available records, review those records and prepare a report detailing the LMDT including its history, details of construction, modifications, and current operations. Next, structural analysis of specific LMDT features was performed. With this information a group of Reclamation specialists gathered in a team setting and completed the risk assessment which included identifying potential failure modes and effects analysis (PFMEA), determining the likely consequences for each failure mode, and identifying opportunities for data gathering, risk reduction, and monitoring which can enhance project safety. The draft assessment was internally peer reviewed.

Finally, it was independently peer reviewed by experts not affiliated with Reclamation, including a geologic hazards specialist from the U.S. Geological Survey, a retired rock mechanics and mining engineering professor from the Colorado School of Mines, and a mining engineer from Leadville. This Consultant Review Board (CRB) confirmed Reclamation's conclusions that it is unlikely there would be a sudden release of water from the Leadville Mine Drainage Tunnel and that there is no imminent public safety hazard.

The risk assessment was released in final draft form on June 30, 2008 after incorporating the CRB comments and suggestions. The public and government agencies were then invited to submit technical comments on the final draft risk assessment to Reclamation. Comments along with Reclamation's responses are included in section 4 of this final risk assessment

Findings

The risk assessment found that a blockage in the tunnel near the Pendery Fault is likely to exist due to a zone of tunnel roof collapse located downstream from the

fault. The blockage is currently stable and is expected to be longer and stronger than Reclamation conservatively estimated in its stability analysis.

Even though it is highly unlikely, the study considered what would happen if the blockage near the Pendery Fault rapidly gave way. This would result in higher water pressure being transmitted to the downstream plug material and engineered bulkheads constructed by Reclamation in 1980 and 1991. Based upon this conservative assumption, this is how the tunnel and surrounding area would respond:

- The higher water pressure and forces on the downstream plug material and constructed bulkhead would not be great enough to move them.
- It would take a significant period of time for the increased water pressure to migrate from the upstream end of the downstream plug near Station 5+92 to the soils around the LMDT near the timber-lattice bulkhead and tunnel liner at Station 4+61. The elevated groundwater levels would likely drain off below ground surface into the surrounding terrace gravels.
- In the remote event that groundwater levels near the timber-lattice bulkhead and tunnel liner at Station 4+61 were to rise to levels which could collapse the concrete tunnel liner, a rapid release of water is not expected. Analysis shows that the elevated water pressure would not generate enough force to push this material out of the tunnel, and erosion of the collapsed material is unlikely.
- It is highly unlikely that the hillside above the portal would become unstable. The soils are too strong for that to occur, even with elevated groundwater conditions.

Summary

Reclamation used multiple layers of conservative assumptions throughout the engineering analysis (such as low soil strengths, neglecting tunnel roughness, considering the upper blockage fails rapidly, and using extremely high groundwater levels). Therefore, conditions are actually more stable than the analyses indicate. If the blockage near the Pendery Fault were to fail, it would likely occur over a time frame of weeks or months, not hours or days. Sensors in the LMDT would provide adequate warning of the changes in the tunnel.

Engineering analysis indicates that neither a rapid release of water nor slope failure is likely to occur. Even when earthquake loadings are added to the slope above the portal, analysis shows that the slopes would remain stable. The consequences of each potential failure mode were evaluated and the residents of Leadville and The Village at East Fork are safe. There could be some seepage of contaminated water into the surrounding rock and soils that would find its way to the Arkansas River.

Recommendations

The risk assessment team recommends Reclamation enhance its activities on site to monitor water pressures in the tunnel and surrounding hillside soils. Specifically, the team recommended adding water pressure monitoring instruments to the monitoring wells at Stations 3+00, 4+70, and 6+35 and connecting them to the existing Early Warning System.

The team also recommends that the Emergency Action Plan for the facility be updated, finalized and exercised. The update to the plan should include information about the new potential failure modes, including the likely indicators of potential failure mode initiation, and establishing clear written directions of actions to be taken.

Reclamation has accepted and is implementing these recommendations.

RECLAMATION

Managing Water in the West

Existing Condition of the Leadville Mine Drainage Tunnel

Leadville Mine and Drainage Tunnel Project, Colorado
Great Plains Region



Mission Statements

The mission of the Department of the Interior is to protect and provide access to our Nation's natural and cultural heritage and honor our trust responsibilities to Indian Tribes and our commitments to island communities.

The mission of the Bureau of Reclamation is to manage, develop, and protect water and related resources in an environmentally and economically sound manner in the interest of the American public.

BUREAU OF RECLAMATION
Technical Service Center, Denver, Colorado

Existing Condition of the Leadville Mine Drainage Tunnel

Leadville Mine and Drainage Tunnel Project, Colorado
Great Plains Region

Geotechnical Engineering: Michael Gobla, Civil Engineer, P.E.
Geotechnical Engineering 86-68311

Date

Engineering Geology: Mark Vandenberg, Geologist, P.G.
Geology, Geophysics, and Seismotectonics 86-68320

Date

Peer Review: Lloyd Crutchfield, P.G., Manager
Structural Engineer, Structural Analysis Group D8110
Geology, Geophysics, and Seismotectonics 86-68320

Date

Contents

	Page
1.0 Introduction.....	1
2.0 History of the Leadville Mine Drainage Tunnel.....	3
2.1. LMDT Background	3
2.2. History Timeline.....	4
2.3. Initial Bureau of Mines Construction	11
2.4. Second Project Bureau of Mines Construction.....	20
2.5. Bureau of Mines Maintenance.....	29
2.6. Transfer to Reclamation	36
2.7. Occurrence and Filling of Sinkholes	36
2.8. Modifications 1978-1980	39
2.9. Modifications 1990-1992	42
2.10. Rock Mass Characterization Study.....	43
2.11. Valve Controlled Bulkhead Study	44
2.12. Inspection March 25, 2008	45
3.0 Geology.....	51
3.1. Regional Geology	51
3.2. Tunnel Stratigraphy	51
3.3. Structure	51
3.4. Hydrogeology	52
3.5. Seismicity	54
3.6. Previous Geologic Investigation.....	54
4.0 Portal Structure Station 0+32.5.....	55
5.0 Tunnel Segments.....	56
5.1. Concrete Lined Segment Station 0+54 to 4+61.....	56
5.2. Timber Bulkhead and Gravel Fill Station 4+60 to 4+66	57
5.3. Bulkhead and Backfill Station 4+66 to 5+00	58
5.4. Glacial Materials Station 5+00 to 6+50.....	58
5.5. State Highway 91 Station 5+64.55	58
5.6. Shallow Bedrock Crown Station 6+50 to 21+00.....	58
5.7. Gray Porphyry Station 21+00 to 22+00	59

5.8. Leadville Limestone Station 22+00 to 22+50	59
5.9. Parting Quartzite Station 22+50 to 24+50.....	59
5.10. Limestone Station 24+50 to 27+55	60
5.11. Porphyry Dike Station 27+55 to 29+63.....	60
5.12. Faults at Station 29+63	60
5.13. Parting Quartzite Station 32+50 to 37+80.....	60
5.14. Limestone Station 37+80 to 40+60	60
5.15. Pendery Fault Station 40+70	60
5.16. Precambrian Granite Station 40+60 to 63+45	61
5.17. Lower Paleozoic Sedimentary Rocks 63+45 to 97+00.....	61
5.18. Downtown Lateral Station 84+70.....	61
5.19. Hayden Lateral Station 89+22.....	62
5.20. Pando Porphyry Station 97+00 to 112+34	62
5.21. Robert Emmet Lateral Station 99+70 to 99+83.....	62
5.22. Mikado Fault to End Station 112+34 to 112+99	62
6.0 LMDT Yard Area Downstream of the Portal	62
6.1. Yard Area	62
6.2. Detention Pond	63
6.3. Water Treatment Plant.....	63
6.4. Sludge Facility	63
6.5. Clearwell and Easement to East Fork - Arkansas River.....	64
6.6. The Village at East Fork.....	64
7.0 Auxilary LMDT Facilities	65
7.1. Extraction Wells at Station 10+25.....	65
7.2. Observation Well at Station 10+25	65
7.3. Additional Observation Wells	66
8.0 References.....	67

Figures

Figure 1. Location of the LMDT at Leadville, Colorado.	2
Figure 2. Surface plant facilities erected for construction of the LMDT. Note the track for disposal of excavated soil and rock turns to the southwest (Elgin and Others, 1949).....	13
Figure 4. Typical sections showing steel rail support and unsupported tunnel segments used in the first LMDT construction project. Illustration taken from (Elgin and Others, 1949).....	17

Figure 5. Plan and geologic section of LMDT from 0 to 6,600 feet from the portal. Illustration taken from (Elgin and Others, 1949).....	19
Figure 6. Plan and geologic section of LMDT from 6,000 to 8,000 feet past the portal, taken from (Salsbury, 1956).....	22
Figure 7. Plan and geologic section of LMDT from 8,000 to 10,000 feet past the portal, taken from (Salsbury, 1956).....	23
Figure 8. Plan and geologic section of LMDT from 10,000 to 11,299 feet past the portal, taken from (Salsbury, 1956).....	24
Figure 9. Timber supports used for a 7.5-foot-wide clear opening in the LMDT, taken from (Salsbury, 1956).	26
Figure 10. Steel supports used for a 7.5-foot and 8.0-foot-wide clear openings in the LMDT, taken from (Salsbury, 1956).....	27
Figure 11. Timber supports used for 8.0-foot-wide clear openings in the LMDT, taken from (Salsbury, 1956). The timber spiles are the wood supports driven into the roof at an upwards angle as shown in the upper portion of section AA.....	28
Figure 12. Photograph showing the inflow to the LMDT through a drillhole connected to the Robert Emmet shaft, taken from (Salsbury, 1956). This is prior to driving the Robert Emmet lateral.	30
Figure 13. Workers digging out a boulder embedded in running ground in sheared quartzite, taken from (Salsbury, 1956). The boulder prevented spiles from being driven.....	31
Figure 14. Plan and section showing condition of the LMDT in 1972 including the location of sinkholes, 1968 injection drill holes, and monitoring wells installed in 1968, taken from (Reclamation, 1976).....	38
Figure 15. Photograph of the bulkhead located at Station 4+66.....	40
Figure 16. Sketch showing flows from vent pipe and compressed air pipe which extend through collapsed material in the LMDT, taken from (Smirnoff and Allen, 1980).	41
Figure 17. Photograph of the LMDT portal structure taken on March 25, 2008..	46
Figure 18. Photograph taken on March 25, 2008 looking at the downstream end of the LMDT showing the concrete center walkway with drainage ditches on either side and steel floor grating.....	46
Figure 19. Photograph taken on March 25, 2008 looking upstream from the Portal area in the LMDT showing the ventilation fan, motor controls, and vent pipe at left, and the electric lights at the upper right.....	47
Figure 20. Photograph taken on March 25, 2008 looking downstream from about midway inside the reinforced concrete lined segment of the LMDT. Note the calcium carbonate stalagmites forming from the slow seepage along a thin roof crack and at a joint in the concrete lining.....	48
Figure 21. This crack located about 3 feet above the LMDT floor is the only one that showed offsetting of the concrete. The offset is about 1/8 inch.	49
Figure 22. Photograph of a weep hole in the reinforced concrete lining which is almost completely blocked by calcium carbonate precipitates.....	49

Figure 23. Photograph taken on March 25, 2008 of the cobble and gravel-filled timber-lattice bulkhead at Station 4+61 of the LMDT. At left is the intake end of the ventilation pipeline.....	50
Figure 24. Plot of water levels in wells along the lower portion of the LMDT alignment.....	53
Figure 25. Plot of water levels in wells along the upper portions of the LMDT alignment.....	53
Figure 26. Construction photograph showing the cobbles behind the timber-lattice bulkhead at Station 4+60 of the LMDT.....	57
Figure 27. Aerial Photograph Showing the LMDT Portal Area Including the Water Treatment Plant, Adjacent Housing, and East Fork of the Arkansas River.....	64
Figure 28. The Village at East Fork. The East Fork of the Arkansas River is to the right of the photograph.....	65
Figure 29. View of Pumphouse and Extraction Wells in the vicinity of Station 10+25. May 28, 2008.....	66

Tables

Table 1. LMDT water flow measurements from (Salsbury, 1956).....	32
Table 2. Steel supports installed in the LMDT in 1953 (Salsbury, 1953).	33
Table 3. Results of five injection drill holes into the LMDT in 1968.	37
Table 4. 2003 Rock Mass Characterization, Well Construction Details	43
Table 5. Material Properties Assumed for the 2005 Bulkhead Study.....	44
Table 6. Seismic loading conditions for the LMDT.	54
Table 7. Observation Wells in and near the LMDT.....	66

Appendices

Appendix A - Geologic Cross-Section along the Leadville Mine Drainage Tunnel

Appendix B - Selected Drawings from Specification 0-SI-60-04100/DC-7804, Treatment Plant and Tunnel Lining, Leadville Mine Drainage Tunnel Project

Drawings

- 1335-D-18 Treatment Plant - Site Plan
- 1335-D-60 Treatment Plan – General Piping Plan and Elevations
- 1335-D-122 Tunnel lining – Alignment and Profile
- 1335-D-123 Tunnel Lining – Typical Tunnel Section, Cutoff Wall, and Timber Bulkhead
- 1335-D-124 Tunnel Lining – Outlet Portal Structure Isometric View, Sections and Detail
- 1335-D-125 Tunnel Lining – Outlet Portal Structure Sections and Details

1.0 Introduction

The Leadville Mine Drainage Tunnel (LMDT) is an underground excavation constructed during World War II and the Korean War to drain groundwater from metal mines located at Leadville in Lake County, Colorado. The LMDT is not a tunnel in the strict sense of the word in that there is not a surface opening at each end of the underground excavation. It actually is a drainage adit of just over two miles in length. The LMDT portal is located about 1.5 miles north of Leadville adjacent to the south bank of the East Fork of the Arkansas River as shown in Figure 1.

Since its construction, the LMDT has experienced partial collapse and blockage of portions of the drainage flow pathway along the tunnel. A reservoir of water, called the “mine pool” has formed in the upper reaches of the LMDT as a result of water being impounded behind the suspected areas of collapse. The water table associated with the mine pool has been rising over the years while the quantity of water draining from the LMDT has declined. Local residents, both local and state officials, and the EPA have expressed safety concerns relating to the possibility of a sudden release of water behind the blockage. Bureau of Reclamation (Reclamation) employees at the LMDT Water Treatment Plant, and neighbors in a small residential community called the Village at East Fork, are located adjacent to the LMDT portal and are potentially at risk from a “failure” of the LMDT. The Bureau of Reclamation, Technical Service Center, with participation by the Great Plains Region and Eastern Colorado Area Office, has been tasked to perform an assessment of the potential for failure of the LMDT.

This report documents the current condition of the LMDT and serves as a factual summary description upon which subsequent investigations will be founded. The report describes the current condition of the LMDT including its history of construction and operation, geologic materials penetrated, dimensions of the excavation, materials of construction, and seepage rates and water table levels experienced. Facilities below the LMDT portal are also described along with a description of the borings drilled along the LMDT alignment for water extraction and water level monitoring.

Existing Condition of the Leadville Mine Drainage Tunnel

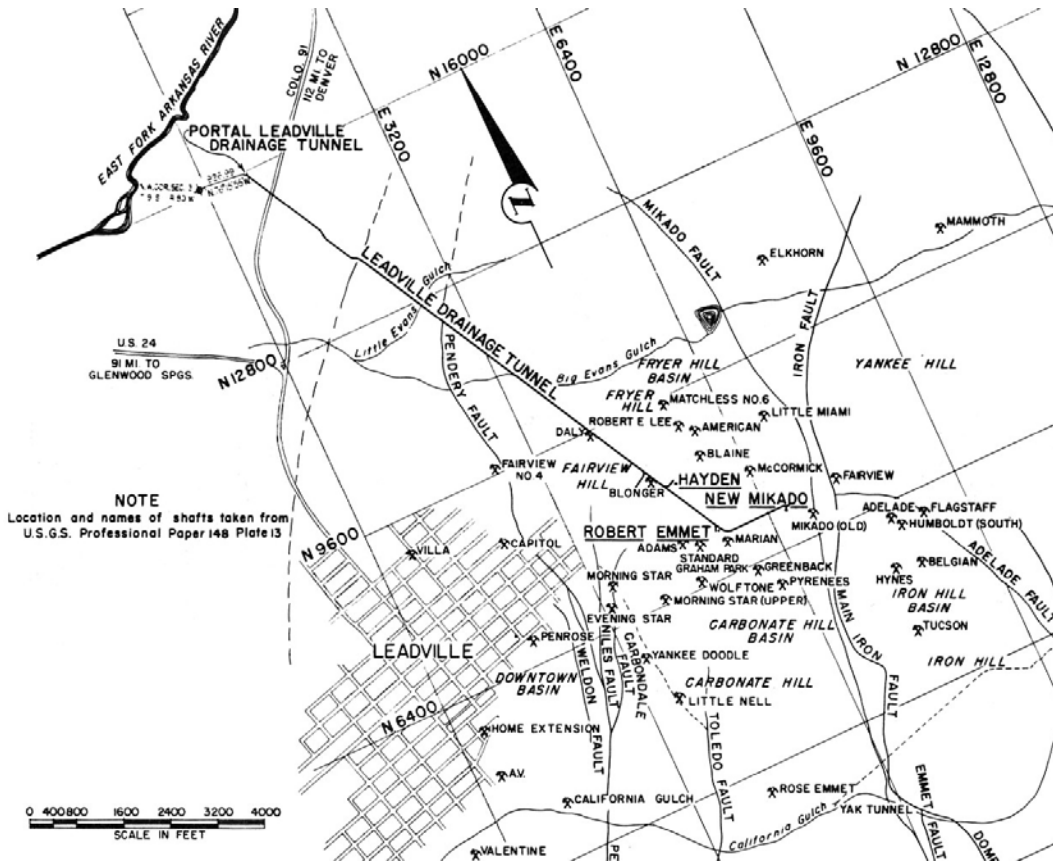

Figure 1. Location of the LMDT at Leadville, Colorado.

2.0 History of the Leadville Mine Drainage Tunnel

The LMDT is an underground excavation constructed during World War II and the Korean War to drain groundwater from metal mines located at Leadville in Lake County, Colorado. The portal area is located about 1.5 miles north of downtown Leadville near the south bank of the East Fork of the Arkansas River. The LMDT is a little more than two miles long and ends in the vicinity of Stray Horse Gulch located about one mile east of downtown Leadville (see Figure 1).

2.1. LMDT Background

The Leadville Mine Drainage Tunnel was constructed by the U.S. Bureau of Mines to drain the Fryer Hill, Downtown, Graham Park, and Iron Hill basins of the Leadville Mining District. Construction took place in two stages between 1943 and 1952. The first stage was terminated in 1945 due to increased costs resulting in fund exhaustion directly attributable to unexpected geologic conditions. The second stage, constructed during the Korean conflict, was driven from 6,600 to 11,299 feet. Historic mine workings of significant aerial extent are drained by the LMDT.

The Bureau of Mines documented areas of collapse and deterioration during their ownership. Deterioration of tunnel support and collapse of the tunnel are believed to have continued as evidenced by the increasing head in the mine pool located upstream of the Pendery Fault. Tunnel supports, including wooden timbers and steel sets, have deteriorated throughout sections of the LMDT.

Reclamation acquired the LMDT in 1959 for water rights associated with the tunnel with the intent of including the drainage water as part of the supply for the Fryingpan-Arkansas Project. Due to more senior existing claims on the water, no water rights were ever obtained by Reclamation. The LMDT drainage discharges into the East Fork of the Arkansas River. The Clean Water Act of 1972 prohibited discharge of any pollutant from a point source without meeting criteria specified in a site specific National Pollutant Discharge Elimination System (NPDES) permit. The LMDT drainage contains metals which were eventually determined to exceed water quality standards. To bring the discharge water into compliance, Reclamation designed and constructed a chemical precipitation water treatment plant using sodium hydroxide. This facility commenced operation in March of 1992. Reclamation operates the facility to remove heavy metals (cadmium, zinc, and iron) from the LMDT drainage water. The design capacity of the water treatment plant is 3.2 million gallons per day (MGD).

In addition to constructing the water treatment plant, Reclamation modified the LMDT in the vicinity of the portal on several occasions. The most significant modifications were during the 1990-1992 construction when a new wood-lattice and gravel-filled bulkhead, a 428-foot-long concrete tunnel liner, an outlet portal structure, and a geomembrane-lined detention pond were installed. Work on access roads to the plant and the small group of homes near the plant was recently completed, providing additional means for entering and exiting the area.

2.2. History Timeline

1860 – Placer gold was discovered bringing fortune seekers to a tributary creek near the headwaters of the Arkansas River. On April 6, 1860, John O'Farrel and his party stopped at noon. He went to the creek to get some water for his coffee. Upon breaking through the snow and ice he found gold lying on the sand bar. The men began working the area. A few days later Abe Lee exclaimed "boys I got all of California here in my pan!" Horace Tabor and Samuel Kellogg came by on April 26th and in two months time took out \$75,000 in gold from their claims. Oro City was the name of the new town at California Gulch where \$1 million in placer gold was recovered that first summer. Ten thousand people moved to Oro City by July of 1860 (Emmons and others, 1927). The rich gold placers were mined out in a few years time and the population fell to about two hundred.

1868 – Hard rock mining for gold commences at the Printer Boy Mine.

1874 – The heavy blue-colored sand, which annoyed the miners for years because it clogged their sluice boxes, is identified as a silver-bearing variety of the lead-carbonate mineral cerussite. A. B. Wood and W. H. Stevens hire prospectors to locate outcrops of rock containing the lead-carbonate silver ore. Silver mining is initiated on a small scale in 1875 on the Lime, Rock, and Dome claims.

1877 – Prospectors discover rich ores of lead and silver on Fryer Hill and in other areas of the district. Mining expands and the population growth results in the establishment of the city of Leadville.

1878 – The first successful smelter, the Harrison Reduction Works, is completed and begins operation. The silver rush continues and the population grows to 15,000.

1880 - The Denver and Rio Grande Railroad reaches Leadville. This enables an acceleration of the silver and lead mining activity.

1895 – The Yak Tunnel is started in California Gulch at an elevation of 10,340 feet to drain the Iron Hill portion of the mining district. Years later, through a series of eastward extensions it eventually reaches a length of approximately 4 miles.

1896 – Labor unrest stops production, the Downtown mines are allowed to flood.

1898 – Pumping of up to 15,000,000 gallons per day is required to drain the mines.

1901-1925 – Notable efforts to drain portions of the mining district include 1901-1907, 1915-1916, and 1923-1925 pumping to lower the water levels in the Fryer Hill, Graham Park, Carbonate Hill, and Downtown areas. These areas are all in the vicinity of the upstream end of the yet to be constructed LMDT.

1912 – The Yak Tunnel is 3.75 miles long, it reaches the Diamond Shaft.

1915-1916 – Pumping the Penrose Shaft starts May 8, 1915. It requires pumping until July, 1916 to unwater the Downtown mine workings. Thereafter a pumping rate of 1,500 gallons per minute (gpm) is needed to keep the workings unwatered.

1917 – The Fryer Hill and Graham Park area mines are unwatered by pumping.

1919 – A labor strike followed by economic decline closes all the Leadville mines except the Penrose. The Graham Park mines flood.

1921 – The Canterbury Tunnel is started near the base of Canterbury Hill at an elevation of 10,063 feet as a community project to explore for undiscovered ore deposits and drain a portion of the Leadville Mining District. Significant inflow of water occurs before the tunnel crosses the Pendery Fault. The Canterbury Tunnel intercepted a water flow in the vicinity of the Pendery Fault averaging about 1300 gal/min throughout the year, and the mine operators in the district recognized a marked reduction in recharge rate (Chapman and Stephens, 1929). Work ceased in 1925 at a length of 4,172 feet, as the exploration results were disappointing.

1923 – The Graham Park mines are unwatered by pumping. The Penrose Shaft pumps stop in November allowing the Downtown mines to flood.

1933 – Mining in the district shuts down, the mines are allowed to flood.

1943 - 1945 – The Bureau of Mines constructs the first segment of the LMDT to Station 66+00 to drain portions of the existing mines in the Leadville Mining District.

1949 – An appropriation of \$750,000 was approved on October 12, 1949 for completion of the LMDT.

1950 - 1952 – A contract is awarded to the Utah Construction Company in September, 1950. The LMDT is completed to Station 112+99 by March 1952.

1953 – Reinforcement of deteriorated timbering was completed along the first 2,500 feet of the LMDT by April 17, 1953. A total of 215 steel sets were placed.

1955 – Inspection identifies a cave-in of two steel sets from Station 40+25 to 40+30. Other problem areas are identified on a profile drawing dated March, 1955. Some repairs were made in May and June between Stations 38+50 and 48+75, and between Stations 65+00 and 66+00.

1956 – First sinkhole on the ground surface above the LMDT is reported in June.

1959 – Reclamation acquires the LMDT in December, 1959 as a potential water source for the Fryingpan-Arkansas Project and accepted "full custody, accountability, and future responsibility" for the LMDT with the stipulation that, "...Reclamation has no present intention of spending any funds on the maintenance and repair of the tunnel."

1966 – A sinkhole is discovered on July 5, 1966 located 125 feet down slope toward the portal from State Highway 91, which crossed the LMDT about 535 feet from the portal. Subsequent investigations find an accompanying cave-in of the tunnel.

1968 – In September a sinkhole develops 15 feet down slope from the edge of State Highway 91. The sinkhole was backfilled and several holes are drilled through the highway and into the tunnel beneath the highway, and were filled and cement grouted. Reclamation installs six observation wells to monitor the groundwater in the vicinity from the portal to Station 6+35.

1972 – On May 25, an explosive device was placed in the air line which passed through collapsed portions of the LMDT to Station 10+00. The blast increased LMDT outflows for a short period of time and then the flows diminished.

1973 – Reclamation awards a contract to clean out first 200 feet of tunnel, install new supports in the second 100 feet, and completely backfill all remaining sinkholes, voids, and un-collapsed portions of the tunnel between approximate Stations 1+25 and 5+00. A bulkhead of treated timbers is also installed at Station 2+00. To accommodate the work, Reclamation purchases and fences approximately 8 acres of land overlying and adjacent to the tunnel portal.

1975 – The Environmental Protection Agency (EPA) issues a NPDES permit to Reclamation because the effluent from the LMDT was determined to be a pollutant containing heavy metals in quantities exceeding applicable water quality standards. Conditions of the permit require effluent monitoring only.

1975 – Reclamation installs a 450 gallon per minute capacity pump at Station 6+35 in an attempt to maintain the groundwater table at a safe level in ground adjacent to the lower portion of the tunnel. This is a temporary fix.

1976 - Water is flowing out of the LMDT at a historic average of 1,570 gallons per minute or about 2,500 acre-feet annually. Numerous sinkholes are observed at the ground surface above the LMDT from Station 2+00 to approximately 6+50 and it is assumed that this portion of the tunnel is almost completely filled with sloughed material. A total of 12 sinkholes have been recorded over the years since 1956. The holes are at different locations along the first 650 feet of tunnel, but none are found from Station 6+50 to 10+00; it is assumed that the tunnel is partially filled with some areas being collapsed, but no sinkholes have ever appeared within this section of the LMDT (Station 6+50 to 10+00).

1976 – Public Law 94-423 (September 28, 1976) authorizes the Department of the Interior to rehabilitate the first 1,000 feet of the LMDT, and to maintain the tunnel in a safe condition, to monitor the quality of the tunnel discharge, and to make investigations leading to recommendations for treatment measures, if necessary, to bring the quality of the tunnel discharge in compliance with applicable water quality standards.

1978 - 1980 – The collapse material from the first 500 feet of the tunnel was excavated and the tunnel opening shored up. A bulkhead, constructed of steel beams and wooden timbers, was installed at Station 4+66.

1978 – Commissioner of Reclamation recommends to Secretary of the Interior on July 7, 1978, that the LMDT be plugged.

1983 – The contaminated mining area at Leadville is placed on EPA's National Priority List (NPL) naming it as the California Gulch Superfund Site. The 18-square-mile area was divided into 12 areas designated Operable Units (OU). The LMDT is hydraulically connected to OU6 and OU12. OU6 addresses contamination in Strayhorse Gulch and OU12 addresses Site-Wide Surface and Groundwater Quality.

1988 – Reclamation's Missouri Basin Regional Engineer completes a study of the tunnel plug from Station 4+66 to Station 6+32 and finds that the resistance would be more than adequate to handle the estimated range in hydraulic pressure based upon the most likely tunnel, soil, and groundwater conditions.

1989 – January, the Sierra Club and Colorado Environmental Coalition sue Reclamation alleging Clean Water Act violations as a result of discharges from the LMDT.

1989 – In February, Reclamation and EPA enter into a Federal Facilities Compliance Agreement (FFCA) in which Reclamation agreed to initiate construction of a treatment plant to treat discharges from the LMDT.

1990 – Consent Decree executed for the lawsuit based on the FFCA.

1990 – Construction of the water treatment plant and lining of a portion of the LMDT is initiated.

1992 – P.L. 102-575 authorized Reclamation to construct a treatment plant in order that water flowing from the Leadville Mine Drainage Tunnel may meet water quality standards, but specified that the plant “shall be constructed to treat the quantity and quality of effluent historically discharged” from the tunnel.

1992 – Reclamation completes construction of the LMDT water treatment facility, and has been treating water continuously since this time. A flow through wood-lattice bulkhead was constructed at Station 4+61. Gravel and cobble backfill was placed immediately behind the bulkhead. The tunnel downstream of the bulkhead was lined with reinforced concrete. Weep holes were installed through the concrete lining to drain surrounding groundwater into the tunnel.

1994 – EPA contracts with Reclamation for data gathering, analysis, design, construction, and oversight technical assistance activities associated with the California Gulch NPL Site.

1998 – Reclamation’s technical assistance to EPA ends.

2000 – EPA begins channeling and routing contaminated surface water from OU6 into the mine pool through a drain installed at the Marian Shaft.

2001 – Reclamation completes an Emergency Action Plan (EAP) for the LMDT and Water Treatment Plant. A safety brochure was developed and distributed to the residents of The Village at East Fork.

2001 – Reclamation installs a water level indicator and other warning systems in and near the LMDT and ties this into the water treatment plant's auto-dialer for employees.

2001 – Reclamation hosts an Open House at the LMDT Water Treatment Plant.

2001 – A structural analysis was completed on the bulkhead at Station 4+61 by the Great Plains Region who found it to be sound with the plates and bolts used for the bearing of the timber members in good condition.

2002 – Two wells were drilled and three existing holes were enlarged along the alignment of the tunnel in 2002 with the purposes of monitoring water levels along the tunnel, obtaining groundwater quality sampling points, and gathering rock quality data along the tunnel. Boreholes LMDT-B1 and –B2 are new monitoring wells constructed by Reclamation at Stations 46+66 and 96+66, respectively. Hayward Baker modified three existing (pre-tunnel construction) test holes along the tunnel alignment at Stations 25+15, 36+77, and 75+05.

2002 – In January, Reclamation’s Eastern Colorado Area Office sends a memorandum presenting a status update of Leadville Mine Drainage Tunnel Activities to the Lake County Board of Commissioners. The memorandum discussed the road work to provide improved egress from the treatment plant and The Village at East Fork, implementation of an EAP, placement of the monitoring well at Station 10+25, and results of a bulkhead strength analysis.

2002 – An audible warning system is installed to alert The Village at East Fork residents in the event of an emergency. The system plays an alert message in Spanish and English.

2002 – In June, Reclamation submits comments to the EPA on the Draft OU6 Focused Feasibility Study, including concerns pertaining to the capacity of the LMDT Water Treatment Plant to adequately treat additional discharge from OU6 and Reclamation’s lack of authority to treat contaminated water pumped from upstream of the proposed LMDT plug.

2003 – Road improvements are completed to the LMDT Water Treatment Plant and The Village at East Fork. These road improvements include the main access road from State Highway 91 and the secondary access road from U.S. Highway 24.

2003 – Reclamation participates with Lake County in a table-top exercise to test the response to a potential problem at the LMDT Water Treatment Plant.

2003 – September 3, EPA releases the final Record of Decision on the OU6 remedy. EPA selects the alternative to plug the LMDT and pump contaminated surface and groundwater to Reclamation’s LMDT Water Treatment Plant for treatment.

2004 – Reclamation participates with Lake County in a functional exercise to practice for a potential problem at the LMDT Water Treatment Plant and test the EAP. An audible test of the emergency warning message was not conducted.

2004 – In February, EPA sends a letter to Reclamation Regional Director Bach, informing Reclamation of EPA’s decision for OU6 and providing an initial draft of a Memorandum of Understanding (MOU) between Reclamation, EPA, and Colorado Department of Public Health and Environment (CDPHE) to implement the remedy.

2004 – Meetings and discussions are held between Reclamation and EPA, highlighting Reclamation’s lack of authority to treat the contaminated water pumped from OU6.

2004 – Rocky Mountain Region Solicitor renders a Legal Opinion that under current law, Reclamation does not have authority to expand its treatment plant so

there will be sufficient capacity to treat surface runoff from OU6 and the mine pool groundwater.

2005 – As part of other studies, the slope stability of the area between the portal and Station 10+25 was analyzed. The results indicated that the gross stability of the portal area to Station 10+25 is adequate for the ground conditions. The slope stability study examined several different groundwater and soil property scenarios.

2005 – Several versions of the draft MOU were sent back and forth between Reclamation, EPA, and CDPHE. In meetings with EPA and the State, Reclamation reiterates its position that if the sole purpose of the LMDT Treatment Plant is to implement OU6 remedy, the plant should be operated by EPA or Colorado.

2006 – EPA, Source-Water Consulting, and the University of Colorado present the results of an extensive study of ground water in the LMDT area titled “Hydrogeologic Characterization of Ground Waters, Mine Pools, and the Leadville Mine Drainage Tunnel, Leadville, Colorado”. In the report, they conclude “The results of this investigation indicate that the LMDT drains only a small volume of mine pool water and a very large volume of regional bedrock and adjacent alluvial groundwater.”

2006 – February, CDPHE submits a request to Senator Allard’s office for legislation, “...that would provide Reclamation the necessary authority to cooperate with EPA and the State of Colorado in implementing the remedy proposed for OU6...” EPA’s opinion was that Reclamation should pay for implementation of part of the remedy.

2006 – Reclamation receives a first draft of legislation from Interior’s Congressional drafting service which included transfer of the treatment plant to EPA. On several occasions, draft legislation and the draft MOU were discussed and revised based on comments and discussions with EPA and Colorado.

2006 – Reclamation proposes a \$30 million trust fund for future operation and maintenance of LMDT Treatment Plant. Colorado requests \$50 million.

2007 – Continued discussions between Reclamation, EPA, and the State of Colorado on draft legislation and draft MOU. Mid-year, discussions stall over the trust fund level disagreement.

2007 – Reclamation meets with EPA, Lake County, State of Colorado, and others to discuss their concerns about the LMDT in October.

2007 – November 8, Reclamation receives a letter from EPA expressing its concerns pertaining to an uncontrolled, potentially catastrophic release of water from the LMDT which could endanger human life and the environment.

2008 – January 14, Reclamation asks EPA for their analysis supporting their concerns regarding an uncontrolled, potentially catastrophic release of water from the LMDT.

2008 – February 8, Reclamation receives a letter from EPA referencing studies completed by Reclamation in the 1970s to support their concerns pertaining to the sudden release of water from LMDT. No additional EPA-sponsored analysis is provided.

2008 – February 13, the Lake County Board of County Commissioners declares a state of emergency due to the LMDT mine pool's elevated level and the abundant snowpack.

2008 – Reclamation initiates a risk assessment to determine the true risk associated with the existing condition of the LMDT in February 2008. The risk assessment is scheduled to be completed by June 30, 2008.

2008 – February 19, Reclamation participates with other Federal, State, and Local agencies at public meeting conducted in Leadville.

2008 – On February 22, Reclamation tests the warning system at the LMDT Water Treatment Plant in conjunction with Lake County Office of Emergency Management.

2008 – February 28, Senate Bill S.2680 is introduced to amend the Reclamation Projects Authorization and Adjustment Act of 1992 to require the Secretary of the Interior to take certain actions to address environmental problems associated with the Leadville Mine Drainage Tunnel in the State of Colorado, and for other purposes. Also on February 28, House of Representatives Bill H.R. 5511 is introduced to direct the Secretary of the Interior, acting through the Bureau of Reclamation, to remedy problems caused by a collapsed drainage tunnel in Leadville, Colorado, and for other purposes.

2008 – On March 10, Reclamation tests the capacity of its water treatment plant. The plant successfully treats a flow rate of 2150 gallons per minute at the current water quality levels. On March 18, flow from the LMDT is 1120 gallons per minute.

2.3. Initial Bureau of Mines Construction

In the summer of 1943, surveys were made to select the portal site and survey the surface topography along the tunnel alignment. The portal site is located near the northwest corner of Section 13, T. 9 S., R. 80 W. of the 6th Principle Meridian, on the Hibsche Placer Claim, Patent Survey No. 399, owned by the Resurrection Mining Company. The Bureau of Mines purchased a portion of the Hibsche

Claim in the portal area. In addition, the Ditch Placer Claim, Patent Survey No. 416, of 9.28 acres was acquired for the waste-rock dump. Access to the portal area was provided by construction of a 1,000-foot-long road by Lake County prior to construction startup.

An expenditure of \$1.4 million was authorized in 1943 for construction of the LMDT and laterals. A cost plus fixed fee contract was awarded to Stiers Brothers Construction Company of St. Louis, Missouri. Construction activity began on December 6, 1943. This construction project is documented in Bureau of Mines Report of Investigations 4493 (Elgin and others, 1949) from which the following details and illustrations are taken.

Little was known about the geology of the first 7,000 feet of the tunnel alignment. A churn drill was used to drill ten holes through the glacial moraine. The 6-inch holes were drilled to tunnel level or to bedrock if it was encountered first. When bedrock was encountered, diamond core drilling was performed to determine the nature of the geologic formation encountered.

A surface plant consisting of nine buildings, a well and water tank, explosives storage, rail lines, and other utilities was soon established as shown on Figure 2. An excavation was cut into the hillside for the portal. A dragline was used to excavate a ditch to carry tunnel drainage to the East Fork of the Arkansas River. The track for dumping the tunnel excavation waste was carried to the southwest as shown on Figure 2.

Agreements were made with mine owners to provide royalty payments for ores to be extracted under the benefit of the drainage provided by the tunnel. Not all owners were willing to sign the agreements; in some cases, condemnation to obtain right of way was employed. A water level survey was conducted to determine the mean water levels in the various basins to be drained. A survey of shafts was initiated in early 1944. Of the 480 shafts examined, only 57 were open to permit water level measurements. Measurements were made on a quarterly basis to observe seasonal variations in water levels.

The amount of water draining from the LMDT was recorded on a daily basis using a Parshall flume weir installed at the portal. A similar weir was installed at the portal of the Canterbury Tunnel and measured every day to determine if driving the LMDT would capture some of the Canterbury flow. Weirs were also installed at California Gulch and the Valentine Shaft for recordation every 15 days.

The LMDT was excavated on a gradient of 0.3 percent, but this was increased to 0.5 percent in the rock section to provide faster water outflow and better flushing action. Caving of the tunnel occurred in August, 1944 from Station 20+50 to Station 21+26. This segment of the tunnel was in gray porphyry where the rock

roof became very thin due to a zone of deeper glacial moraine than anticipated. As a result, it was decided to fill about 50 feet of the tunnel with sand and gravel,

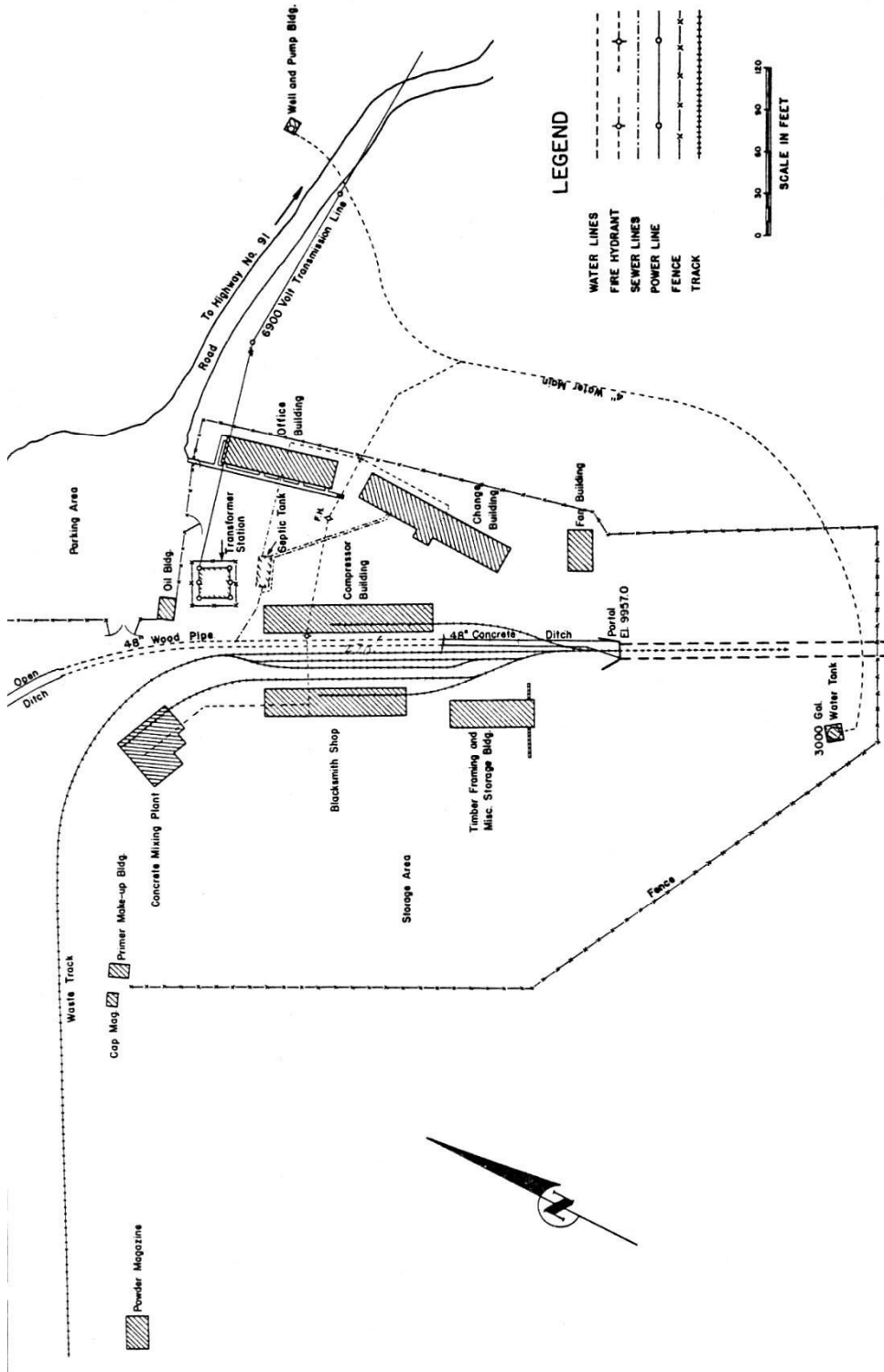

Figure 2. Surface plant facilities erected for construction of the LMDT. Note the track for disposal of excavated soil and rock turns to the southwest (Elgin and Others, 1949).

bulkhead it off, and start a new excavation adjacent to the original alignment. The deviation in alignment begins at Station 16+81 and returns to the original alignment at approximately Station 24+48. The first 335 feet of the LMDT was driven to create a clear opening inside the supports 10 feet wide by 11.5 feet high.

Because of the difficult excavation conditions, the excavated section was reduced to 9 feet wide by 10.5 feet high clear opening. The timber supports are shown in Figure 3. Bedrock in the invert was encountered at Station 3+50. The bedrock contact had a shallow dip such that it took until Station 6+35 for the bedrock to reach to 1.5 feet above the crown (top) of the LMDT excavation. This bedrock was weathered such that it was not until around Station 6+50 that a competent roof was obtained. Drilling and blasting were performed to break the bedrock prior to excavation. Where the rocks were naturally broken or where the roof was in glacial material, spiling was required to support the opening. Spiling is a method of excavation through heavy or caving ground. Spiling involves driving timber or steel roof supports at an angle up into the caved material. The supports are held in place in cantilever fashion by the preceding support set while the ground below the supports is excavated. Once excavated, a timber set is quickly placed to hold the far end of the cantilever in place. This new timber set forms the cantilever support for the next group of spiles to be driven. It is a slow and costly excavation method. Only the bottom was drilled and blasted, and the top was excavated using pneumatic spaders. Switch Stations were cut 4 feet into the right wall on a 250-foot spacing to facilitate switching cars with a “cherry picker.”

The difficulty of excavation resulted in exhaustion of funds with only 6,600 feet of the planned 17,000 feet of tunnel being completed. A total of 4,200 feet of the 6,600 feet of tunnel excavated required support. A total of 3,243 feet of tunnel was supported by timber sets spaced from 2 to 6 feet apart, (see Figure 3), and 957 feet of tunnel was supported by steel rail sets spaced from 3 to 5 feet apart, see Figure 4. The steel sets, consisting of 52-pound rail, were used in areas where the rock required only light support. The 10-inch by 10-inch timbers were used for support in heavy ground. A total of 465 feet of the timber-supported areas were concreted. The concrete was portioned by volume as 1:2.5:3.5 (cement: water: aggregate) with 1.5-inch diameter coarse aggregate. As little water as possible was used because of the tunnel inflows. Calcium chloride was added to the concrete, at a rate of 1 pound per 100 pounds of cement, to accelerate set time. Gunitite was applied to 2,065 feet of the unsupported tunnel to prevent sloughing, and to 335 feet of the supported portions. The gunitite was one part cement to four parts clean, minus 10 mesh sand applied from ¼ to 3 inches thick. Quick setting cement with added calcium chloride (1 pound per 100 pounds of cement) was used to accelerate the set time of the gunitite.

In driving the tunnel into fault zones, or other areas where the ground was extensively broken, holes 15 to 40 feet long were drilled into the face and grouted with neat cement. The cement grout was placed under pressures up to 1,000 pounds per square inch (psi).

The first 30 feet of the excavation encountered stream terrace clay, sand, and gravels. Next water-bearing glacial debris was encountered and the glacial soils produced about 50 gpm of water inflow. The bottom of the tunnel encountered the Weber Formation near Station 3+50. The slope of the bedrock was so gradual that the full face of the tunnel excavation was not entirely in rock until around Station 6+35. At this point, the 1.5 feet of rock above the tunnel was very weathered. Water inflows along this part-rock, part-soil segment increased to approximately 200 gpm. After the full face was in rock, spiling still had to be used because the rock was highly weathered and water inflows increased to 300 gpm. Competent rock did not appear in the crown until approximately Station 6+50. Deeper into the Weber Formation excavation, conditions improved and the face became relatively dry, with tunnel drainage decreasing to 200 gpm and nearly all of it coming from the moraine/bedrock contact area that had been passed. Only top lagging and timber sets spaced 6 feet apart were needed to support the unweathered portion of the Weber. Eventually steel rail sets were substituted because they were easier to install and the ground only required light support.

At 2,100 feet, the tunnel entered a dike of gray porphyry. A large water flow was encountered at Station 21+26 feet which increased to 3,000 gpm and washed over 1,500 cubic yards of mud, sand, and broken rocks into the LMDT. After several hours, the flow eventually subsided to 200 gpm. The debris was cleaned out when caving caused the collapse of six steel sets and another inflow of 3,000 gpm was experienced. This flow subsided after a few hours. Cleaning the tunnel started another inflow so a wooden bulkhead was placed at Station 17+95 to stop the inflow. Test holes revealed that the bedrock over the tunnel was only 4- to 12-feet thick and that the inflows were from the overlying glacial material. A concrete bulkhead with drainage pipes was placed against the wooden bulkhead at Station 17+95 to prevent other inflows and a thick coating of gunite was applied to the tunnel walls and arch roof downstream of the bulkhead.

A parallel bypass tunnel was started at Station 16+81. The junction for the bypass developed heavy pressures. The timber supports were quickly reinforced. Planks were nailed to the timbers and concrete fill was placed behind the planks up to the top of the posts. Reinforcing steel was placed in the turnout arch and a concrete pillar was placed in the widest span of the arch. A 4-inch thick coating of gunite was applied to the turnout and along the tunnel to the bulkhead except for a 14-foot-long interval of tunnel where there was too much water inflow to permit gunite application. Three-segment arch sets to support the concrete walls were placed between the regular sets in the interval of water inflow. Holes were drilled through the concrete walls and grout was pumped in under pressures up to 750 psi to fill all voids. The bypass tunnel was offset to provide a 35-foot-wide pillar between the two excavations. Most of the excavation was performed using spaders to avoid shattering the roof rock by blasting. The porphyry was highly altered, crushed, faulted and had wet walls, but was penetrated and the tunnel drained about 300 gpm. The tunnel walls in the bypass were concreted flush with the timbers and a thick coating of gunite was applied to the arch. Weep pipes

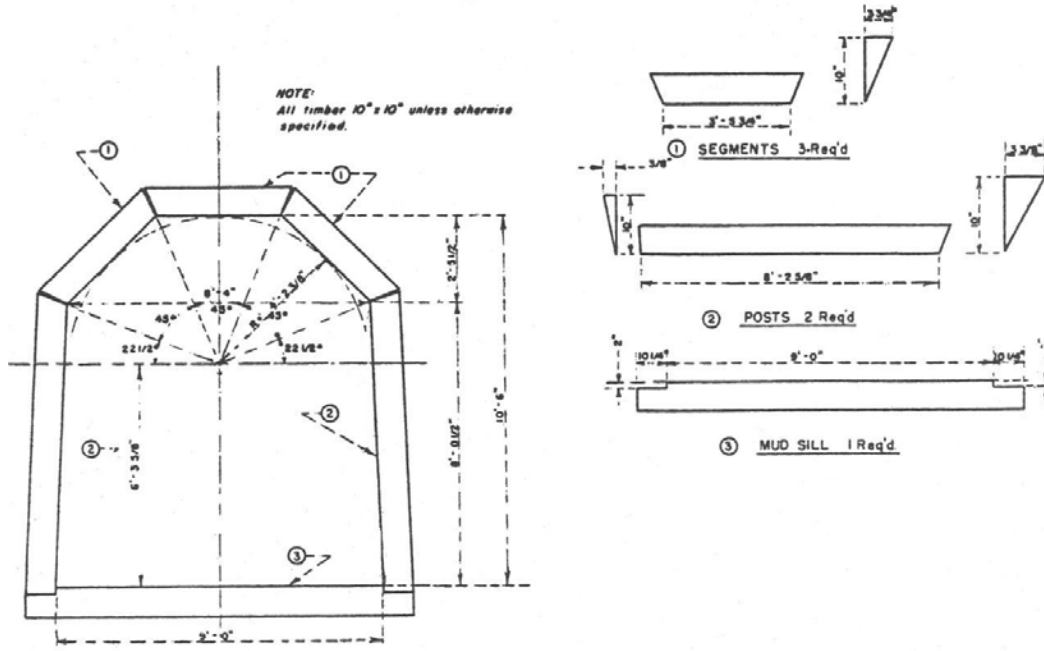

Framing details for standard wood tunnel set.

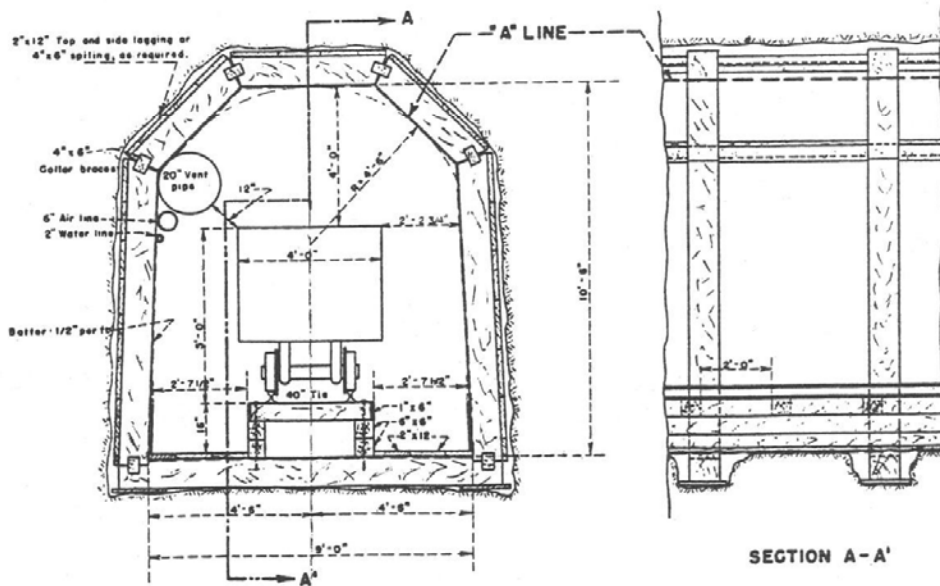
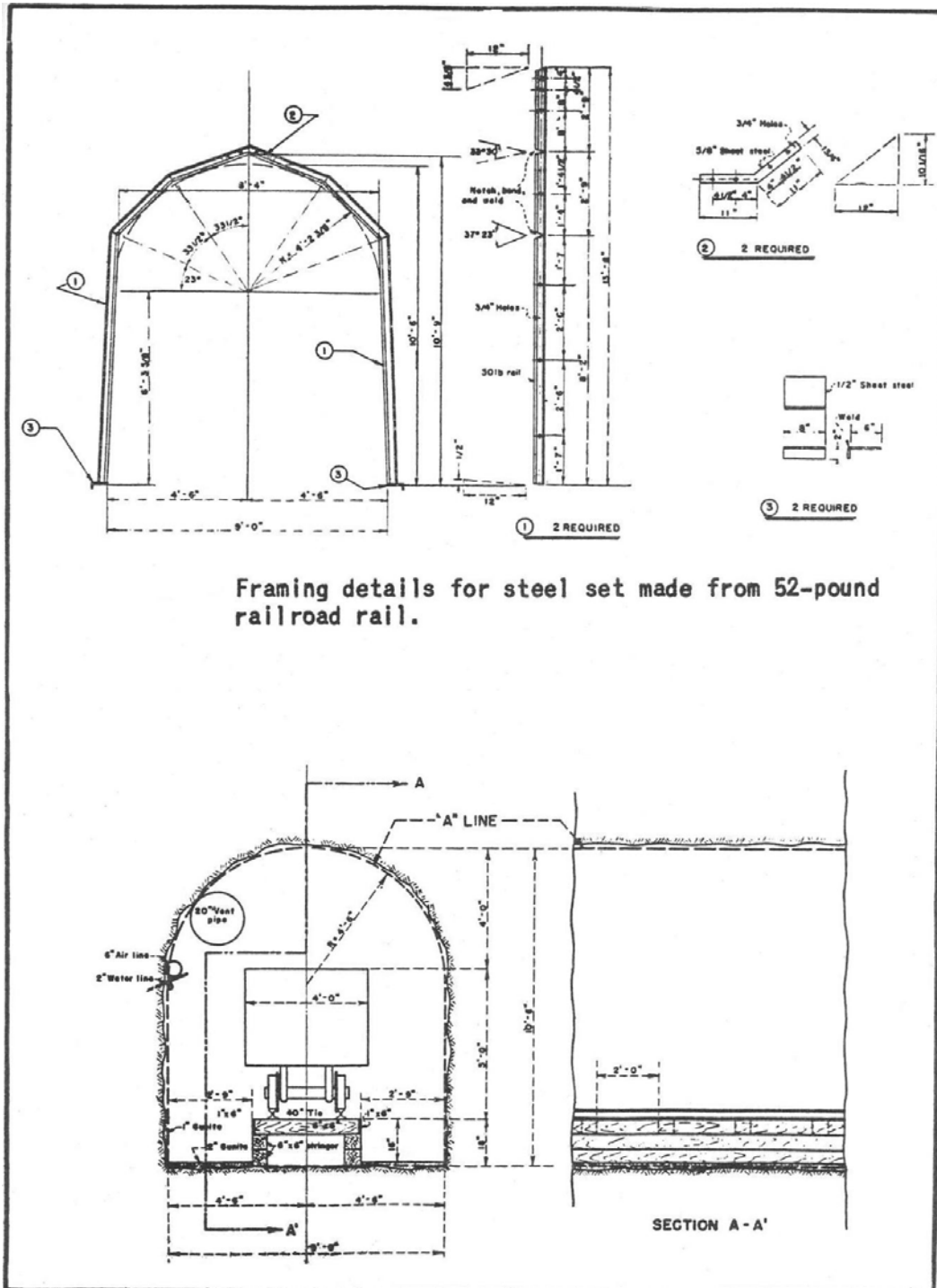

Figure 3. Timber support used in the first LMDT construction project. Illustration taken from (Elgin and Others, 1949).



Framing details for steel set made from 52-pound railroad rail.

Typical unsupported tunnel section.

Figure 4. Typical sections showing steel rail support and unsupported tunnel segments used in the first LMDT construction project. Illustration taken from (Elgin and Others, 1949).

were placed for drainage wherever water was flowing to prevent development of water pressures behind the concrete. Other weep holes were drilled after the concrete had set. Holes were drilled into the tunnel face to probe ahead, and zones of loose rocks or heavy flows were grouted under high pressure ahead of excavation operations to consolidate the ground and reduce water inflows.

At Station 22+00 the tunnel entered the Leadville limestone. Water inflows increased to 500 gpm at the contact with the porphyry. A fault was crossed at Station 22+50 and the tunnel entered fractured quartzite. A large flow of water was experienced but the quartzite was hard, allowing excavation to continue. At Station 23+00 test holes encountered a brecciated water-bearing zone. The tunnel was advanced with spiling and breast boards but a large inflow of water, mud, and rocks broke in at Station 23+28. A temporary timber bulkhead reduced the inflow from 3,000 gpm to 1,100 gpm. The tunnel was concreted for a distance of 35 feet back from the face and grout was pumped in at high pressure through holes drilled in a radial pattern. A thick concrete bulkhead with 4-inch pipes was placed at the face to prevent leakage of grout back into the tunnel. Next, 11 cubic yards of concrete were forced into the area behind the bulkhead. Holes 40 feet long were drilled through the bulkhead, and grouted at up to 300 psi placing 112 tons of cement. After setting, more 40-foot holes were drilled in to check consolidation and to provide weep holes. The tunnel was then advanced 30 feet through the fault zone where fractures from 1/8-inch up to 8-inches in width had been filled with grout. After the fault zone, the excavation entered limestone and shale which were fairly stable.

Another water-bearing, mud-filled breccia zone was detected by drill holes at Station 24+40. This zone was grouted with 1,448 sacks of cement and then it was excavated without difficulty. The bypass tunnel was driven a total of 791 feet and then it returned to the original alignment at Station 24+48. The tunnel continued in limestone and flows increased to 1,300 gpm. White-colored porphyry was encountered at Station 27+55 and test holes reaching the center of the dike produced a flow of over 1,600 gpm.

A large flow of water developed at Station 29+63. From 500 gpm, the flow increased to over 5,700 gpm in four hours time, raising the total tunnel outflow to 7,000 gpm. Over the next 48 hours, flow diminished and nearly stopped when additional flow broke in from the lower left wall. The rock in this area did not require support, but timber sets were installed as a precaution. The watercourse on the left side developed into a cavern with openings as large as 60 feet long, 15 feet wide and 20 feet high. The channel narrowed but persisted until Station 32+00 where it passed below the tunnel grade. Advantage was taken of the hard rock and natural opening to slab 156 feet of the tunnel wide enough for a siding track. Eventually, the watercourse drained and tunnel flow decreased to 1,500 gpm.

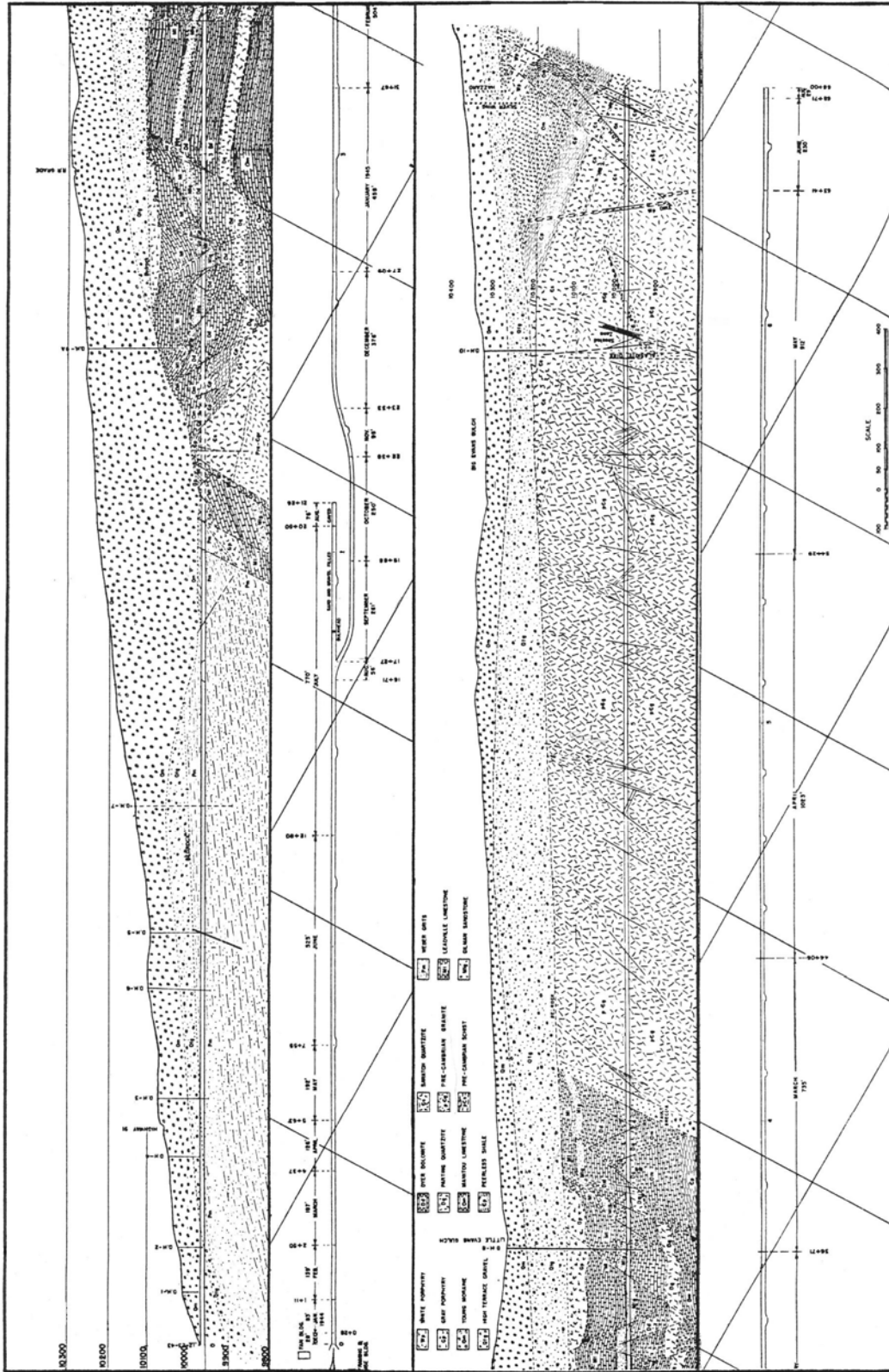

Figure 5. Plan and geologic section of LMDT from 0 to 6,600 feet from the portal. Illustration taken from (Elgin and Others, 1949).

At Station 32+50 the tunnel entered a fractured and highly altered zone which required spiling and breast boards to keep mud and loose rocks from entering the tunnel. No flowing water was encountered in this 300-foot-long altered zone. Better rock was encountered next and required only light support of steel-rail sets and some gunite. At Station 37+80 the limestone was broken by numerous faults which required top spiling for excavation through the zone.

The Pendery Fault was encountered at Station 40+70 and the tunnel excavation entered pre-Cambrian granite. This 40-foot-wide zone was filled with fine breccia and carried some water. It was supported with timber sets on five-foot centers. The granite was fractured and blocky for a few hundred feet past the Pendery Fault and carried a small amount of water. Timber sets were placed to support the blocky ground. After passing Station 44+00 the tunnel was quickly advanced with timber supports only being required in short sections where dikes of altered alaskite and pegmatite rock were penetrated. All of the rock in this area was coated with gunite to prevent sloughing from the decomposing action of water and air. Beyond Station 60+00, the granite was broken by faulting and carried considerable flows of water. Timber supports were necessary.

Cambrian quartzite dipping at 21 degrees was encountered at Station 63+45 and the entire face was in quartzite by Station 64+50. Inflows at the contact of the granite and the quartzite increased the total tunnel flow to 4,000 gpm. All of the fractures in the quartzite were found to carry water. The quartzite did not require support and the fractures dried up. At Station 65+71 a heavy flow broke in from the upper left side of the face washing in fragments of quartzite and white porphyry, filling the tunnel for a distance of 40 feet. A series of four bulkheads were placed on the washed in material to stop the inflow. A 4- by 6-foot pilot tunnel was driven as a top heading starting at Station 65+60. First the tunnel was supported by timber sets on five-foot centers starting 30 feet back from the zone with poor rock. Spiling was required along with breast boards as the top heading was advanced, the lower portion of the tunnel was in hard quartzite, which had to be blasted, while the top was in broken porphyry and quartzite which required full support. At Station 65+90 the rock conditions improved so the top heading was no longer needed. At Station 66+00 orders were given to discontinue operations because of exhaustion of funds. The contract was terminated and all construction activity ceased on August 27, 1945.

2.4. Second Project Bureau of Mines Construction

Metal shortages during the Korean War generated renewed interest in mining at Leadville. On October 12, 1949, an appropriation of \$750,000 was approved for completion of the LMDT. The Utah Construction Company was awarded a cost plus fixed fee contract on August 16, 1950. Details regarding the second project are summarized in Bureau of Mines Report of Investigations 5284 (Salsbury, 1956) from which the following details and illustrations are taken.

Construction commenced in September, 1950. A total of 4,698 feet of main tunnel, 548 feet of laterals, and 23 feet of shaft crosscuts were driven. The LMDT was driven on a heading of S 28 degrees, 53 minutes, 10 seconds E for the first 10,047 feet. Direct connections were made to the Hayden and Robert Emmet Shafts. The Hayden lateral was driven approximately 200 feet, the Downtown lateral was approximately 291 feet, and the Robert Emmet lateral was approximately 60 feet in length.

The mines of Graham Park on the western slope of Iron Hill were drained by the Robert Emmet connection; therefore, a planned direct connection to the Pyrenees Shaft was not completed. Instead, the LMDT alignment was turned due east at 10,047 feet from the portal, and an additional 1,252 feet was driven to cut through the Mikado Fault. This last 1,252-foot-long segment is referred to by the Bureau of Mines as the New Mikado lateral. A short segment of cross-cut was required to connect to the New Mikado Shaft, which was found to be caved at the tunnel level.

The LMDT ended in pre-Cambrian granite 11,299 feet in from the portal. The granite was not expected to be encountered and therefore the LMDT did not effectively drain the area east of the Mikado Fault. The LMDT was completed by March 1952. The geology along the LMDT alignment is shown in Figures 6, 7, and 8.

The Bureau of Mines decided to reduce the size of the excavation to 7.5 feet wide by 8.75 feet high clear opening inside the supports as shown in Figure 9. After some time, the smaller excavation size proved too tight for the drilling operation. In 1951, the excavation width was increased to 8 feet clear opening as shown in Figures 10 and 11. The initial tunnel work was carried on at a grade of 0.3 percent until rock was reached; then it increased to 0.5 percent. During the second project, the grade was reduced to 0.2 percent beyond Station 66+00. The total rise from the portal to the upstream face at Station 112+99 is 25.9 feet.

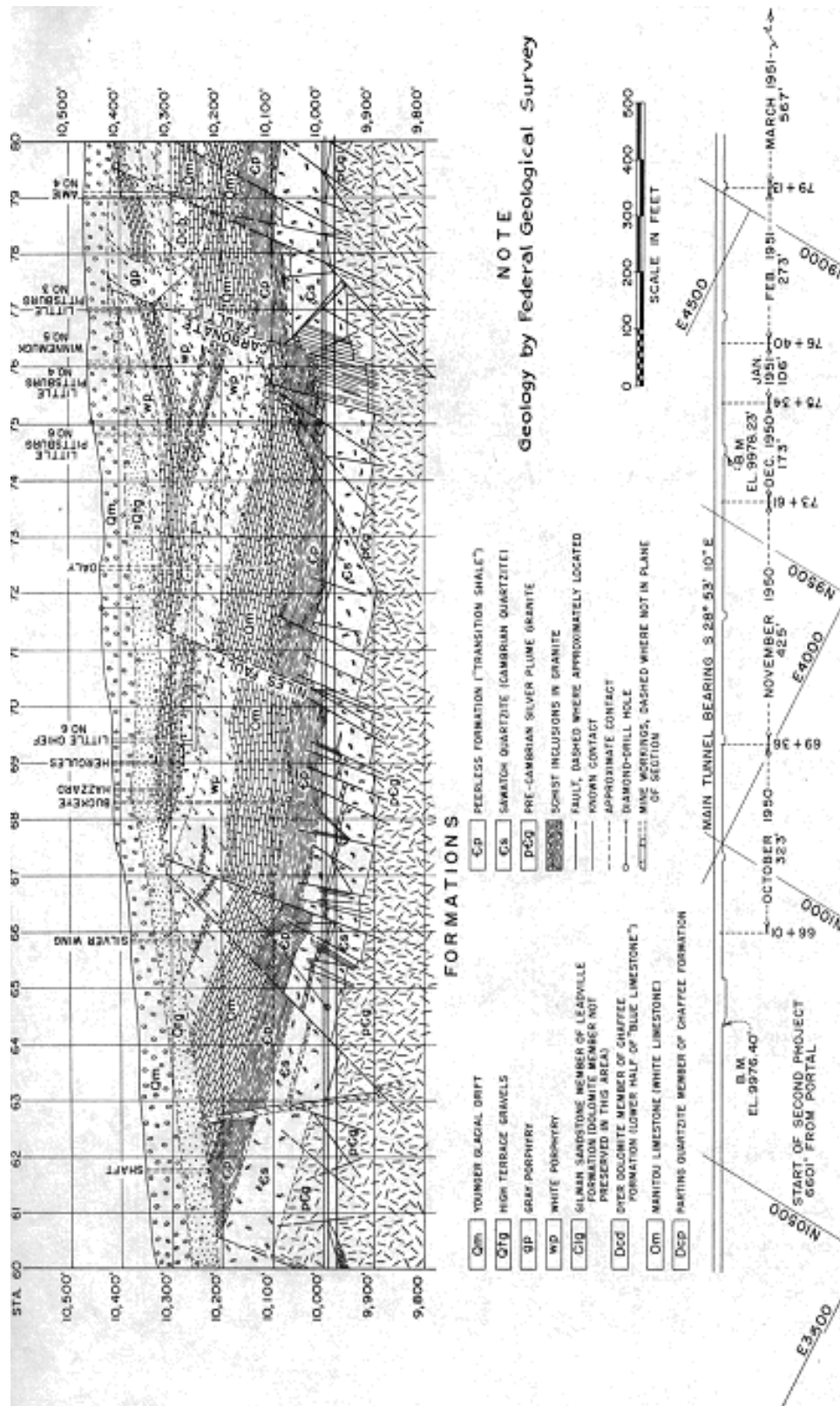

Figure 6. Plan and geologic section of LMDT from 6,000 to 8,000 feet past the portal, taken from (Salsbury, 1956).

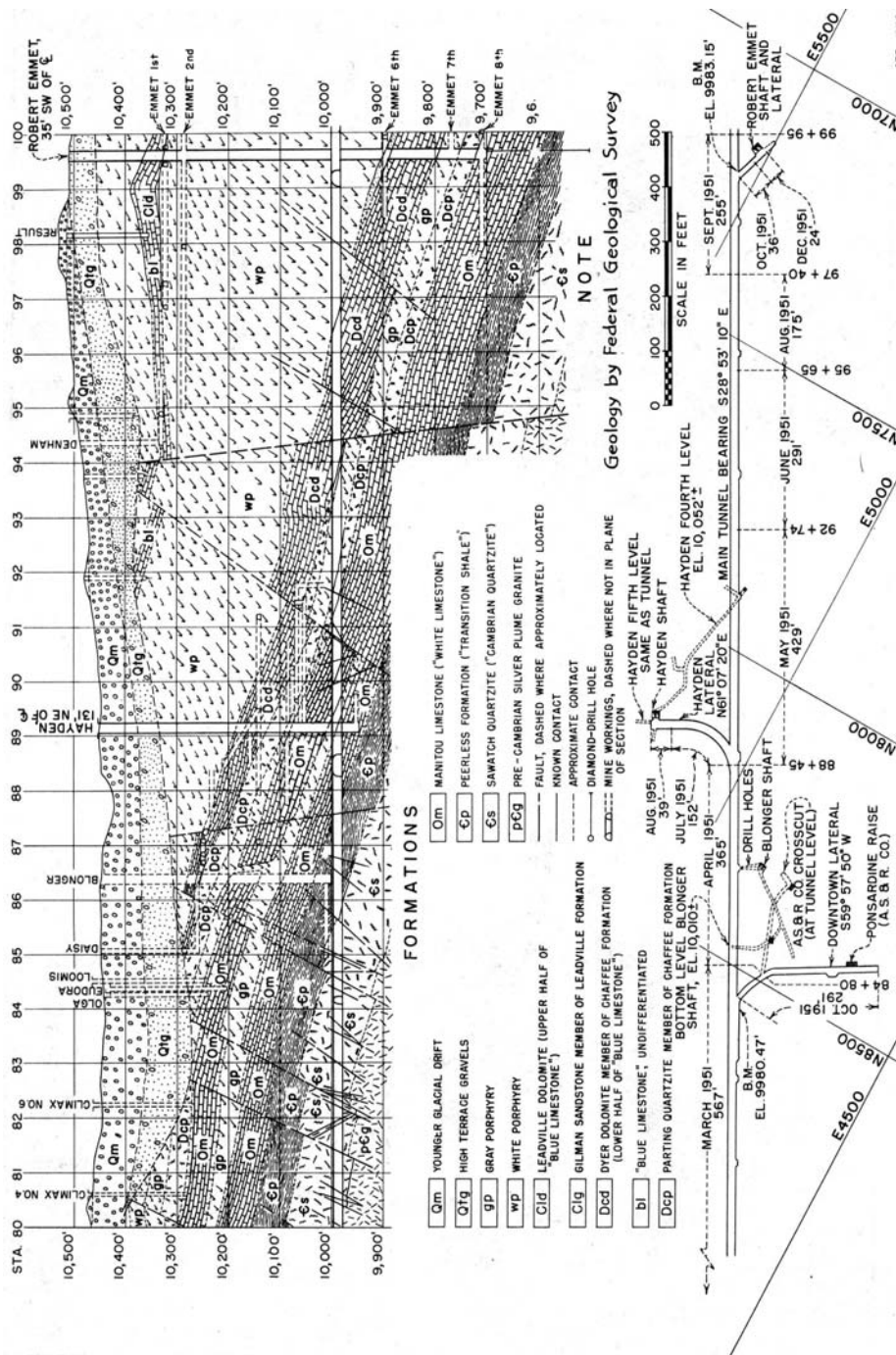

Figure 7. Plan and geologic section of LMDT from 8,000 to 10,000 feet past the portal, taken from (Salsbury, 1956).

Existing Condition of the Leadville Mine Drainage Tunnel

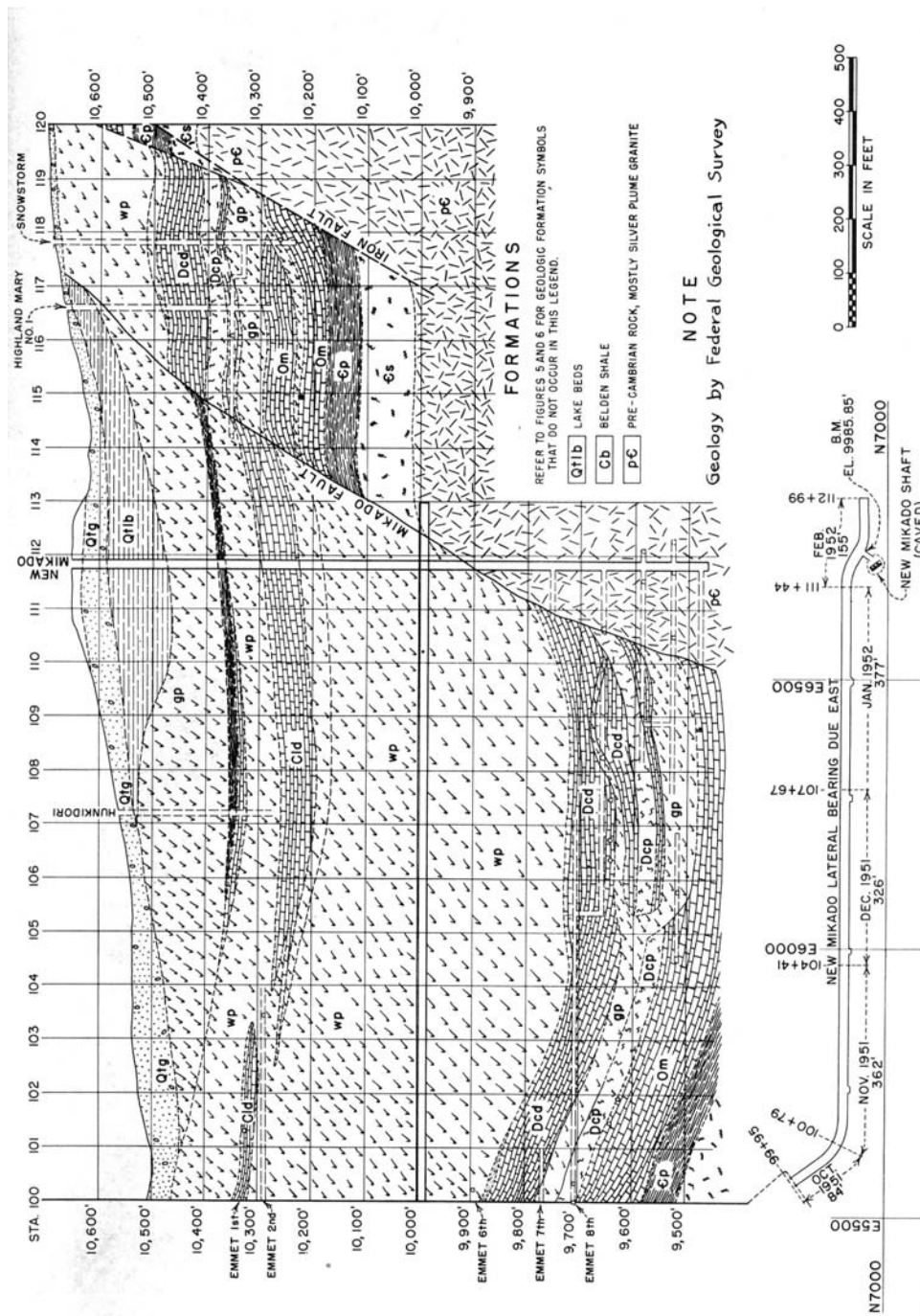

Figure 8. Plan and geologic section of LMDT from 10,000 to 11,299 feet past the portal, taken from (Salsbury, 1956).

Experiences with wet flowing ground were repeated during the second project. Most of the problems were in the quartzite shear zones and in faults and softer formations where heavy water flows were experienced. Again, light to moderate support was provided by installing steel sets, heavy ground required support using 10-inch by 10-inch timber sets, and the caving and running ground required spiling. The timbers in the first project were not treated and were found to be prone to decay. The second project used timbers which were pressure treated with creosote at a rate of 10 pounds per cubic foot of wood. All supports were placed on 5-foot centers to match the rate of advance of each drill and blast round. Transverse track stringers were placed at each set to resist side pressure, but no side pressure was noted between Stations 66+00 and 100+00. Side pressure developed in the New Mikado lateral, and at the Mikado Fault (around 10,600 feet in). Side pressures also developed in areas where the porphyry formation was found to be swelling. No supports were placed in areas of solid ground. Overhead support was essential in some areas such as throughout the blocky porphyry from Station 96+00 to the Mikado Fault. The overhead support was provided as six to twelve 4- x 6-inch lagging placed around the arch portion. Of the 5,240 feet of tunnel and laterals driven during the second project, 3,688 feet were supported.

Ice curtains formed in the winter in the first 600 feet of the tunnel due to the constant drip of seepage. The ditch used beyond Station 66+00 was smaller than that of the first project and had an estimated capacity of 5,000 gpm. The maximum recorded flow through this smaller ditch was 3,765 gpm. The first constant water inflow was encountered near the Daly Shaft at Station 73+55.

Measurements of shaft water elevations in Fryer Hill, Graham Park, and the Downtown basin were resumed for those shafts that remained open during the years 1950, 1951, and 1952. A steady lowering of water levels in the Hayden Shaft was observed. By August, 1951 when actual connection via a 200 foot lateral was made with the LMDT, the Hayden Shaft had been drained virtually to tunnel level through connecting watercourses.

A large inflow at Station 99+70 in July, 1951 was accompanied by a rapid drop in the water level in the Robert Emmet Shaft and other mine workings. The mines of Graham Park, including the Pyrenees, Greenback, Adams, and other shafts are interconnected with the Robert Emmet Shaft. There was an appreciable lag, indicating a minor obstruction of the drainage connections between mines.

A heavy waterflow cut in a limestone fissure in the Leadville limestone at Station 95+65 increased the rate of drainage from the Robert Emmet and other shafts rapidly, see Figure 12. By October 1951 the water level in the Robert Emmet Shaft was only a few feet above the tunnel floor, as determined by pilot holes drilled before actual connection. The flow entering the LMDT from the Robert Emmet Shaft since the connection remained nearly constant at about 400 gpm.

Existing Condition of the Leadville Mine Drainage Tunnel

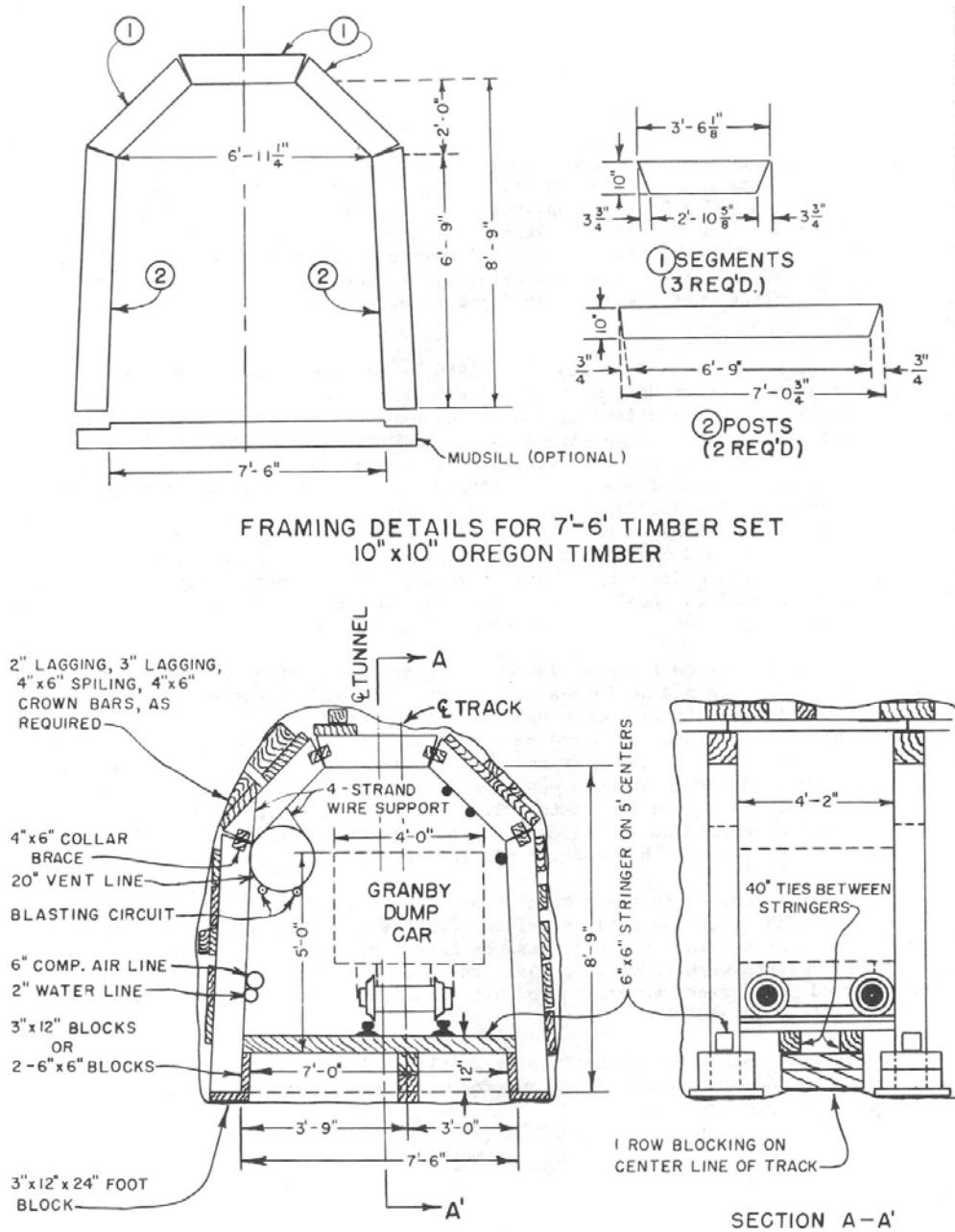

Figure 9. Timber supports used for a 7.5-foot-wide clear opening in the LMDT, taken from (Salsbury, 1956).

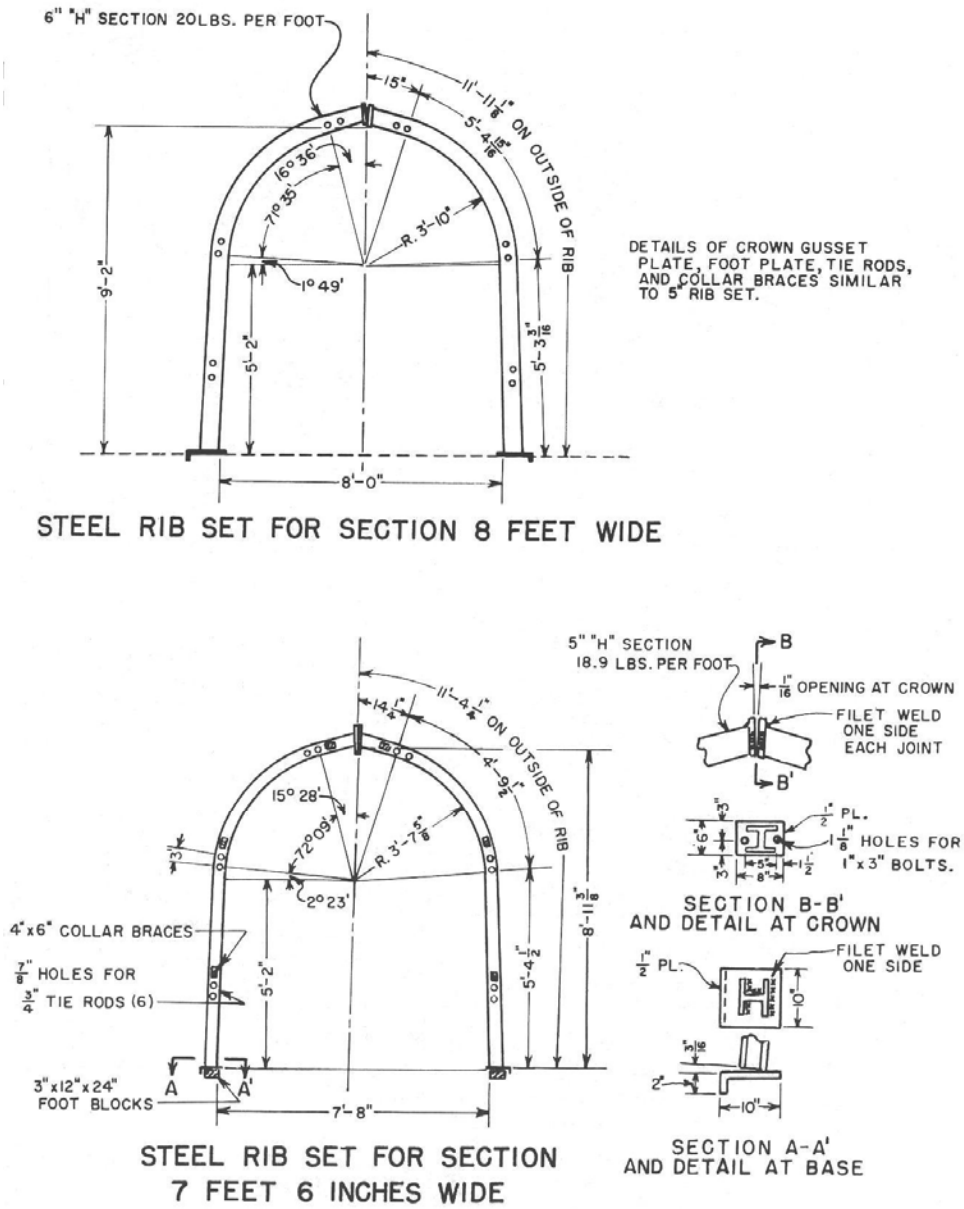
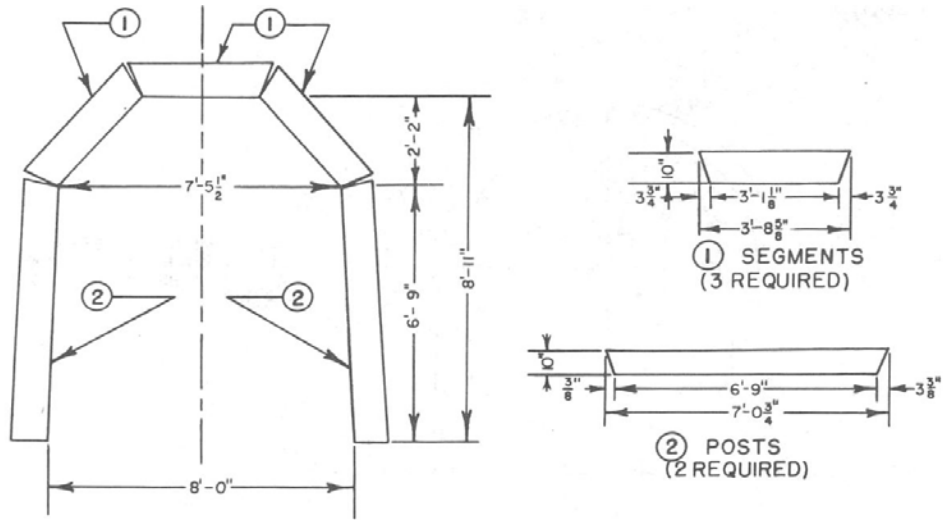
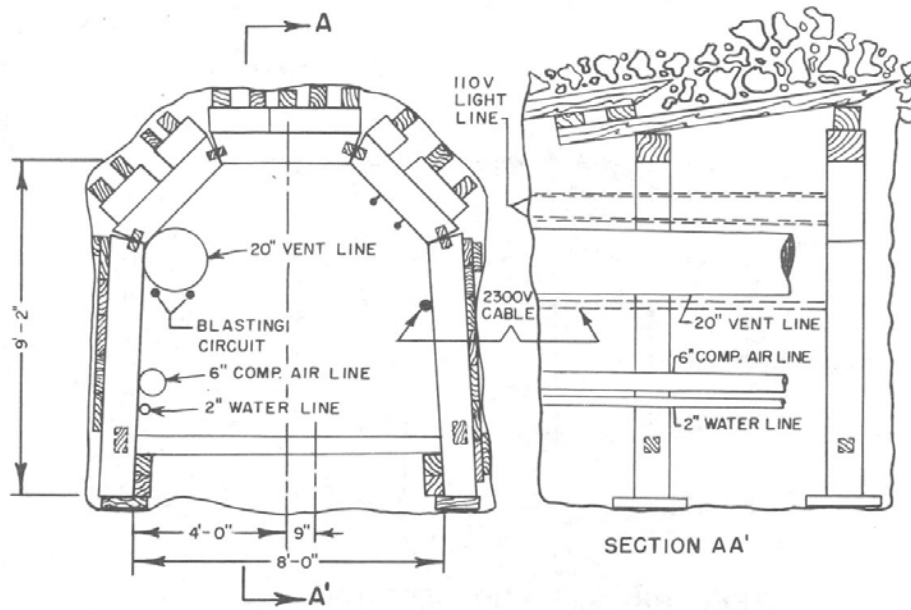

Figure 10. Steel supports used for a 7.5-foot and 8.0-foot-wide clear openings in the LMDT, taken from (Salsbury, 1956).



FRAMING DETAILS FOR 8-FOOT TIMBER SET 10"X10" OREGON TIMBER



SPILING OR CROWN BAR CONSTRUCTION ILLUSTRATED

Figure 11. Timber supports used for 8.0-foot-wide clear openings in the LMDT, taken from (Salsbury, 1956). The timber spiles are the wood supports driven into the roof at an upwards angle as shown in the upper portion of section AA.

The temperature of the flow was 52 degrees F. The water in the New Mikado lateral was 46 degrees F, and 41 degrees F for water flowing from the Daly Shaft at Station 73+57.

The LMDT passed near the Blonger Shaft and under a drift from that mine. Although the LMDT was in quartzite, it was known that weak Peerless shale was only a few feet above the excavation. From Station 84+50 to Station 86+50, numerous test holes were drilled ahead of the excavation to probe for water-filled mine workings. A car pass station was excavated in the LMDT adjacent to the Blonger Shaft and several 50 foot holes were drilled. It is thought that one of these holes penetrated the sump of the shaft but it made no water. In 1952, the American Smelting and Refining Company (ASARCO) drove a connection to the bottom of the Blonger Shaft verifying its location. It was found that the Blonger drift was five feet higher than shown on mine maps and it was completely filled with soft shale and timbers, thus explaining why no water had been encountered when the LMDT was excavated under the drift.

At Station 90+20, a test hole in the face encountered water under pressure. A total of 20 holes ranging from 20 to 40 feet long were drilled to drain the limestone formation. The flow soon diminished and further excavation encountered a fault zone. At the end of the LMDT (Station 112+99), two 40-foot-long holes were drilled ahead. A small flow of water developed indicating that the solid granite continued ahead. Additional information regarding water flows is contained in Table 1.

2.5. Bureau of Mines Maintenance

The cost of the first two LMDT construction projects was put at approximately \$2.0 million (Bureau of Mines, 1952). At the time that the Bureau of Mines announced completion of the LMDT in March 1952, it was also announced that Bureau personnel would be used to replace timber in the older section of the tunnel, perform grouting of some heavy ground, and would lay concrete drainage pipe in ditches where the tunnel floor is fractured in crossing faults. The following maintenance data are taken from numerous Bureau of Mines memos and correspondence regarding the inspection and repair of the LMDT.

Contracts with George E. Davis and James P. Webb starting in December 1952 were awarded to place steel reinforcing between old timber sets (Salsbury, 1953). Cresote-treated lagging was also installed between the sets. The steel was blocked up to the old timber caps, lagging and spiling. The reinforcement of deteriorated timbering was completed along the first 2,500 feet of the LMDT by April 17, 1953, as detailed in Table 2. Two types of steel sets were used. One type consisted of 82 sets of 6-inch H beams. The other type consisted of 158 sets of 4-inch H section horseshoe sets which were excess from a tunnel project near Ft. Collins, Colorado.



Figure 12. Photograph showing the inflow to the LMDT through a drillhole connected to the Robert Emmet shaft, taken from (Salsbury, 1956). This is prior to driving the Robert Emmet lateral.



Figure 13. Workers digging out a boulder embedded in running ground in sheared quartzite, taken from (Salsbury, 1956). The boulder prevented spiles from being driven.

Table 1. LMDT water flow measurements from (Salsbury, 1956).

Date of measurement	Discharge from tunnel, gallons per minute	Remarks	Water level/ in Adams shaft	
			Feet above sea level	Date
Sept. 1946	2,065	End of first project. Face of tunnel at 6,600 feet.	10,163	June 1945
Sept. 1950	1,900	Start of second project.		
Nov. 27, 1950	1,176	Gradual decrease September to November.	10,111	Sept. 30, 1950
Nov. 28, 1950	2,630	"Daily fissure" at 7,357 feet cut.		
Dec. 1950	2,675-1,980	Fluctuating flow as tunnel advanced through small faults and fractures from 7,357 to 7,628 feet.		
Jan.-Apr. 1951	1,980-1,640	Decreasing flow as tunnel penetrated comparatively dry ground.	10,107	Dec. 18, 1950
Apr.-June 1951	1,640-2,480	Gradual increase as heading cut water-bearing fissures in limestone.	10,084	May 20, 1951
July 5, 1951	3,765	Maximum flow recorded during second project; open fissure in white limestone was cut.	10,087	June 20, 1951
July-Sept. 1951	3,765-2,875	Gradual decrease as water level in Graham Park mines was lowered.	10,063	July 20, 1951
Oct. 1, 1951	2,925	Slight increase as drill hole tapped Robert Emmet shaft.	10,020	Aug. 20, 1951
Oct. 1-4, 1951	2,925-3,390	Additional holes drilled into Robert Emmet shaft.	10,013	Sept. 20, 1951
Oct. 4-Dec. 30, 1951	3,390-2,580	Flow decreased as water level in Robert Emmet shaft was lowered.	9,993	Oct. 20, 1951
Dec. 31, 1951	2,580	Connection made to Robert Emmet shaft.	9,988	Nov. 20, 1951
Jan. 1-Feb. 14, 1952	2,580	Nearly constant flow as New Mikado lateral was driven in white porphyry; no new water cut.	9,987	Dec. 20, 1951
Feb. 14, 1952	2,580	Second project completed.		
Aug. 11, 1952	2,825	Maximum flow in 1952 with tunnel in standby condition; seasonal increase.	9,982	Jan. 1, 1952 ^{1/}
May 11, 1953	1,770	Minimum flow in 1953; seasonal decrease.		
Aug. 21, 1953	2,200	Maximum flow in 1953; seasonal increase.		
May 7, 1954	1,460	Minimum flow in 1954; seasonal decrease.		
Aug. 5, 1954	1,850	Maximum flow in 1954; seasonal increase.		
Mar. 3, 1955	1,480	Late winter flow in 1955; seasonal decrease.		

^{1/} This represents the water level in Adams, Robert Emmet, and the mines of Graham Park.
The Robert Emmet shaft could not be measured because of an obstruction.

^{2/} Floor of the Robert Emmet lateral at the shaft is 9,982 feet above sea level.

A total of 215 steel sets, were placed, 75 heavy and 140 light, the remainder, 7 heavy and 10 light were held in reserve for future use. The 6-inch sets were used where there was the most decay of old timber, or where known soft formations were likely to require additional support. Lateral pressure at the portal due to frost heave required 8 heavy sets with spreaders.

Beyond Station 100+00, there was no ventilation and the timber spiling, lagging, and track ties were found to be decaying rapidly. The white porphyry did not continue to swell as originally observed during first excavation except at one point around Station 106+00.

Table 2. Steel supports installed in the LMDT in 1953 (Salsbury, 1953).

Distance from portal in feet	Number of heavy 6-inch steel sets	Number of light 4-inch steel sets	Comments
10 to 45	8		Spreader were included to resist lateral pressure due to frost heave
105		1	
110 to 200	20		
220 to 270	11		
310 to 400		19	
560 to 590		7	
687 to 717		7	
750 to 770	5		At carpass (wide section of LMDT)
795 to 830		8	
855 to 880		6	
985 to 1005		4	
1065 to 1110		9	
1115 to 1210	25		At carpass
1240 to 1473		40	In alternate sets between sets reinforced with rail sets in 1952
1482 to 1509	6		At carpass
1520 to 1645		21	In alternate sets between old 52-pound rail sets
2256 to 2281		6	
2345 to 2355		3	
2365 to 2370		2	
2440 to 2457		4	
2465 to 2475		3	
Totals	75	140	

In August 1953, the tunnel flow was found to be 2,200 gpm. Mining was conducted on the Pittsburgh claim at the tunnel level.

In February, 1954 it was decided to make additional repairs to the LMDT. An inspection on March 4, 1954 found the lagging had failed at Station 109+75. Timber sets at Station 112+30 to 112+40 were showing signs of extreme pressure and the posts had been sinking into the floor. Spreaders were placed above track level to resist side pressure. The flow of water was 1,850 gpm. Additional inspections in March resulted in addition of more work to the project. It was decided to:

1. Clean main tunnel ditch at Downtown lateral, Hayden lateral, Robert Emmet lateral, New Mikado lateral, and elsewhere between Stations 66+00 and 109+70 to lower the water level in the ditch below the track. All muck to go to the waste dump outside the tunnel;
2. Straighten or replace 14 track stringer between Stations 106+35 and 107+00 and reblock the track and at the transition section at Station 110+00;
3. Place treated lagging between Stations 106+15 and 106+70, remove decayed lagging, and remove all debris and muck to the waste dump; and
4. Install three intermediate 10-inch by 10-inch treated timber sets between old sets from Stations 112+30 to 112+40 where the New Mikado lateral crosses the Mikado Fault.

In May, 1954 during the rehabilitation work, it was found that stringers underneath track ties in the Hayden and Robert Emmet laterals had broken and needed replacement. Also, the wooden walkway and the track ties beyond Station 99+24, where the air is stagnant, were found to be in poor condition. The stringers in the Hayden and Robert Emmet laterals were replaced and some walkway near the 3,000 foot siding and in the New Mikado lateral was replaced with creosoted 1-inch by 12-inch boards.

During the December 3, 1954, inspection, five sets, from Stations 106+45 to 106+65 showed side pressure near the base of the sets due to swelling of the altered porphyry rock. The 6-inch by 6-inch spreaders supporting the track were bowed upward and one was broken, the track rails were out of position. Three new spreaders were placed during the inspection at Stations 106+45, 106+55, and 106+65. The flow of water at the portal was 1,520 gpm.

A cave-in was reported in January 1955 at approximately Station 40+35 to 40+40 in the LMDT where 2 sets fell and water 2.5 feet deep formed behind a dam of rock and debris. An arch formed in the roof strata about 20 feet above the track. This section of the LMDT is in the Parting quartzite near the Pendery Fault. The fault is located from Station 40+70 to 40+95. The fault area was previously concreted and was still standing open. The area of the cave-in occurred in a section of 46 sets of continuous timbering from Station 38+50 to 40+75 in the

Parting quartzite. The cause was dry rot of the timber, which deteriorated even though it had been coated with gunnite.

Further inspection showed that the LMDT was also likely to cave-in from Station 65+00 to 66+00 and that the squeeze at Station 106+00 continued for at least 6 sets. Other problem areas were identified on a profile drawing dated March, 1955. Repair was accomplished under contract 14-09-040-1132 with Robert L. Jones of Leadville from May 24 to June 6, 1955. By the time the repair work was under way, the tunnel had caved for 20 feet in length and to a height of 20 feet above the rail level. Six light steel sets were installed on five-foot centers. The open ground above the steel sets was cribbed and lagged. Four heavy steel sets were placed near Station 66+00. The recommended replacement of 46 sets from Station 38+50 to Station 40+75, which showed signs of dry rot was not undertaken except for the six light steel sets that were placed at the location of the cave-in. The recommended repairs to the deformed steel sets located from Station 106+45 to Station 106+65 were not undertaken.

In June, 1956 the Bureau of Mines reports "There is small cave in tunnel about 150 or 200 feet from the portal. There is small hole up on top of the Hill." In September, 1956 a total of 53 10-inch by 10-inch creosoted-timber sets were installed in five locations. Details of the installation were not found but it was stated that most of the critical work identified in 1955 was performed. No work was performed in the Mikado lateral area.

Interest in disposal of the LMDT as surplus property intensified late in 1956. Inspections on December 5 and 6, 1956, found fallen timber blocking and rock at Stations 34+65 and 36+60. These locations were supported by steel rail sets and the timber blocking behind them had rotted out and fallen. The remainder of the LMDT was found to be open to the Hayden Shaft. The inspection did not enter the last 325 feet due to bad air. Four sections of the LMDT were found to be in a critical state of dry rot at Stations: 25+05 to 25+55 needing 10 sets, 28+00 to 28+40 needing 7 sets, 29+40 to 29+70 needing 9 sets, and 38+45 to 38+65 needing 4 sets. Also, timber in poor condition due to dry rot was noted from Station 20+50 to 22+50. At Station 89+35 a steel set was missing and the 10-foot lagging failed with two cars of rock fallen into the tunnel. Numerous areas of rotten lagging about to fail were noted at Stations 66+80, 85+70, 92+80, 93+25, 93+85, 102+50, and 104+50.

The requested repair work from the December 1956 inspection was still on the list of required repairs that were detailed in a June, 1957 inspection along with many more locations needing attention. It is not known if this work was completed. It is estimated that the Bureau of Mines spent over \$50,000 on post-construction maintenance from 1952 until 1959 (Reclamation, 1976).

2.6. Transfer to Reclamation

In December, 1959, Reclamation acquired the LMDT as a potential water source for the Fryingpan-Arkansas Project. Reclamation accepted "full custody, accountability, and future responsibility" for the LMDT with the stipulation that, "...Reclamation has no present intention of spending any funds on the maintenance and repair of the tunnel."

2.7. Occurrence and Filling of Sinkholes

A sinkhole was discovered on the slope above the LMDT on July 5, 1966 located 125 feet down-slope toward the portal from State Highway 91 (Reclamation, 1976). Subsequent investigations found an accompanying cave-in inside the LMDT about 260 feet in from the portal. This collapse prevented access further back into the LMDT but drainage flows continued through the 20-inch diameter steel ventilation pipeline at about 1660 gpm. On September 11, 1968, a cave-in occurred in the LMDT and a 20-foot deep sinkhole developed 15 feet down-slope from the edge of State Highway 91. The highway centerline crosses above LMDT Station 5+64.55. The LMDT was blocked by collapsed material but flow continued to discharge through the caved area via the ventilation pipeline. Reclamation issued specifications No. 700C-690 under a negotiated contract to quickly address the problem.

The sinkhole at the ground surface above LMDT Station 5+18 was backfilled with 175.5 cubic yards of earth backfill. An 8-inch-diameter test well was drilled 60 feet east of the highway and the 9 ft. by 11 ft. tunnel was found to be open. The casing was pulled to the top of the LMDT and water levels were measured to be 23 feet above the top of the tunnel. This water level indicated that the LMDT water discharge through the ventilation pipeline required some head to force the flow through the pipe. The flow was being partially retarded by the collapse.

Five 8-inch-diameter holes were drilled through the highway and adjacent areas along the tunnel alignment as shown in Figure 14. The drill holes encountered voids about half way down to the LMDT and were filled and grouted as detailed in Table 3. The gravel fill was sized from 0.75 to 1.5 inches in diameter. The procedure used was to drill to the level of the LMDT, fill the voids, if any, to the top of the tunnel, then lift the casing while filling with sand until the overlying void was encountered (Griffin and others, 1968). Once the casing was at the overlying void, more gravel fill was placed to fill the void. Next, the casing was left at the top of the gravel-filled upper void to enable grouting. A sand-cement slurry grout was injected to completely fill the upper void.

Next, Reclamation installed six observation wells to monitor the groundwater in the vicinity from the portal to Station 6+35 as shown in Figure 14.

Table 3. Results of five injection drill holes into the LMDT in 1968.

Drill Hole Number	Voids Encountered	Gravel Placed yd³	Grout Placed bags of cement	Condition of LMDT when drill hole reached the bottom
1	5-foot cavity between 61.9 and 66.9 feet above LMDT	7 at upper void	172	Tunnel filled to crown with caved material
2	4-foot cavity between 47.7 and 51.7 feet above LMDT	12 at LMDT, 0.5 at upper void	93	Tunnel filled to within 4 feet of crown with caved material
3	10-foot cavity between 49.7 to 59.7 feet above LMDT	48 at LMDT, 23 at upper void	185	Tunnel open
4	3-foot cavity between 58.4 and 61.4 feet above LMDT	4 at upper void	155	Tunnel filled to crown with caved material
5	1-foot cavity between 74.6 and 75.6 feet above LMDT	0.25 in upper void	5	Tunnel filled to crown with caved material
Totals		94.75	610	

Existing Condition of the Leadville Mine Drainage Tunnel

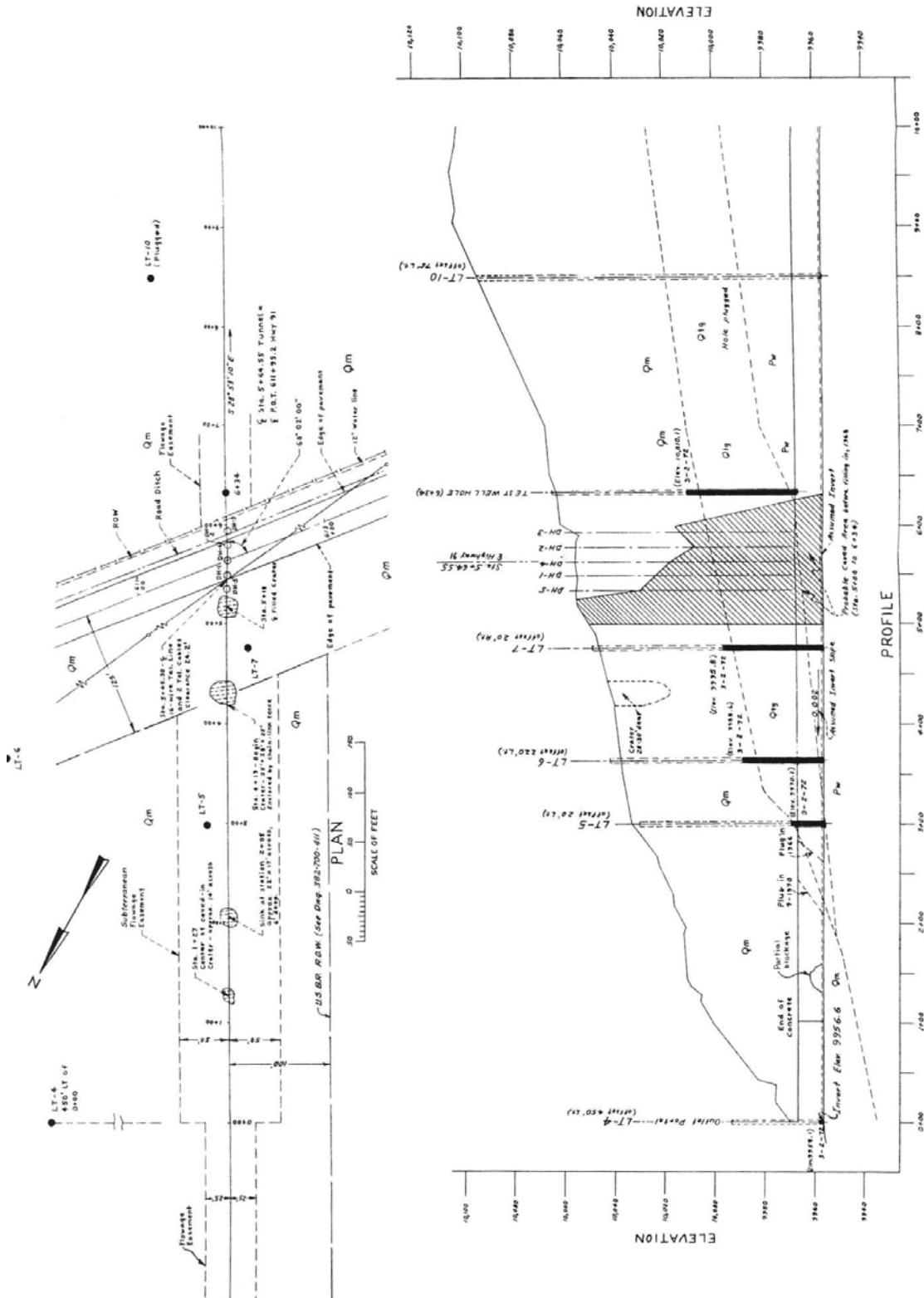

Figure 14. Plan and section showing condition of the LMĐT in 1972 including the location of sinkholes, 1968 injection drill holes, and monitoring wells installed in 1968, taken from (Reclamation, 1976).

In 1972, flow that was coming through the ventilation pipe and the compressed air pipe diminished. The ventilation pipe and the compressed air pipe are from the original construction and they penetrate and carry flow through the collapsed zones and gravel injected portions of the LMDT. In order to reverse the diminishing flows, an explosive was detonated in the 8-inch compressed air pipe at approximate Station 10+00. This had the effect of increasing flows through the two pipes for a short period of time, but the flows eventually diminished again.

Development of other sinkholes and collapses in the tunnel continued to occur away from the highway from Station 2+00 to Station 5+00. In 1973, Reclamation awarded a contract to clean out first 200 feet of tunnel, install new steel 7-foot horseshoe shaped supports from Station 1+00 to Station 2+00, and completely backfill all remaining sinkholes, voids, and un-collapsed portions of the tunnel between approximate Stations 1+25 and 5+00 (Bennett, 1977). This work was performed under specification 700-797 (Reclamation, 1973). To facilitate the backfilling, percussion holes were drilled every 10 feet along the tunnel alignment. Voids in the tunnel and in the overlying soils were backfilled with a total of 450 cubic yards of gravel. A treated-timber bulkhead was installed at Station 2+00. A 24-inch-diameter corrugated metal pipe was installed and connected to the fallen 20-inch ventilation pipe and the 8-inch steel compressed air pipe. New track was installed in the first 200 feet of the LMDT to facilitate the work. Also, to accommodate the work, Reclamation purchased and fenced approximately 8 acres of land overlying and adjacent to the tunnel portal. An additional water observation well was placed at Station 3+40.

In 1975, Reclamation installed a 450 gallon per minute capacity pump in a well at Station 6+35 in an attempt to maintain a lower groundwater table adjacent to the lower portion of the tunnel.

In 1976, it was reported that the track installed in 1973 was in poor condition and that some additional sinkholes had formed since the 1973 work was performed to fill the tunnel (Reclamation, 1976). A total of 12 sinkholes had been observed over the years up until the summer of 1976. Since the more recent sinkholes were away from the highway, Reclamation began a program of erecting safety fencing around the holes rather than backfilling them as had been done in the past.

2.8. Modifications 1978-1980

Public Law 94-423, dated September 28, 1976, authorized Interior to rehabilitate the first 1,000 feet of the LMDT, and to maintain the tunnel in a safe condition, to monitor the quality of the tunnel discharge, and to make investigations leading to recommendations for treatment measures, if necessary, to bring the quality of the tunnel discharge in compliance with applicable water quality standards.

In 1976 seismic refraction surveys were made along the surface overlying the tunnel from Station 4+55 to 10+00 to locate subsurface voids and in 1977 a geologic design data report was prepared in anticipation of additional repair work (Bennett 1977).

Reclamation hired contractors to excavate the LMDT and perform consolidation grouting in the first 500 feet of the tunnel where sinkholes were developing to improve the stability of the tunnel and ground in the area. The collapse material in the first 500 feet of the tunnel was re-excavated and shored up. The excavation work was hampered by heavy water inflows. Several attempts were made in 1979 to drill and install a dewatering well to pump down water in the tunnel to facilitate the excavation work. A well at Station 6+65 was drilled to 98 feet into the tunnel where water 6 feet deep was seen to be flowing. While waiting for well screen, a sinkhole appeared adjacent to the drill rig and the hole was lost. Another hole was drilled at Station 7+22, but at a depth of 113 feet the cable broke and the bit was lost in the hole which was abandoned. There were large cost overruns associated with the construction project. Eventually, the excavation was completed, gravel backfill placed, and a bulkhead, constructed of steel beams and wooden timbers, was installed at Station 4+66, see Figure 15. Records regarding the extent of consolidation grouting performed, if any, have not been found.



Figure 15. Photograph of the bulkhead located at Station 4+66.

On May 9, 1980, prior to completion of the bulkhead shown in Figure 15, Reclamation visually estimated flows from the vent pipe (250 gpm), cast iron air line (250 to 400 gpm), and there was seepage at the face, for a total of 600 to 800 gpm (Smirnoff and Allen, 1980). Figure 16 shows the locations of the vent pipe and air pipe.

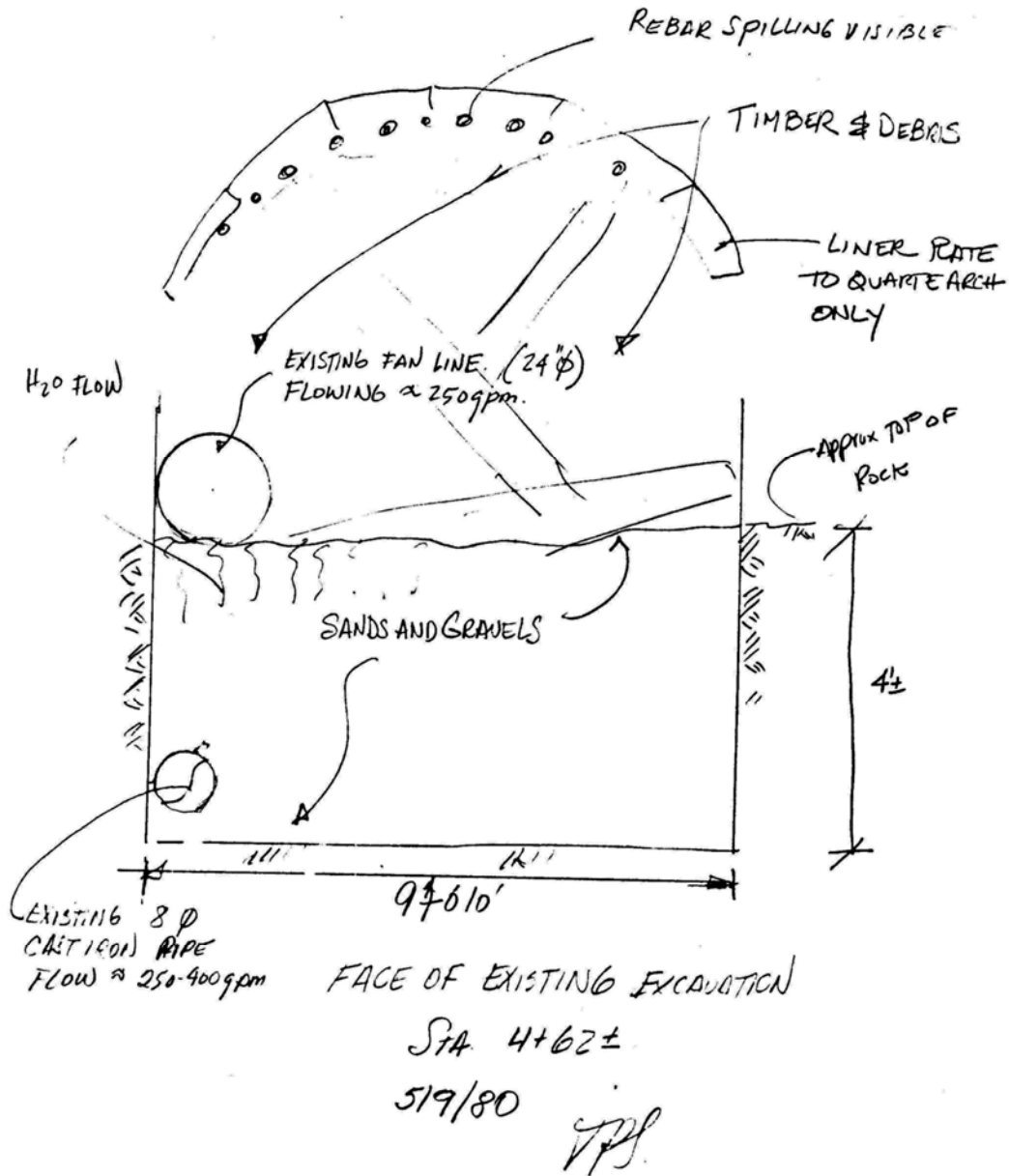

Figure 16. Sketch showing flows from vent pipe and compressed air pipe which extend through collapsed material in the LMDT, taken from (Smirnoff and Allen, 1980).

In 1988, Reclamation's Missouri Basin Regional Engineer completed a study of the tunnel plug and likely collapse zones from Station 4+62 to Station 6+32 and found that the resistance would be more than adequate to handle the estimated

hydraulic pressure based upon the most likely tunnel, soil, and groundwater conditions.

2.9. Modifications 1990-1992

Design of a water treatment plant and lining of a portion of the LMDT was initiated in the late 1980s. Construction ran from 1990 to 1992. In 1992, P.L. 102-575 authorized Reclamation to construct a water treatment plant in order that water flowing from the Leadville Mine Drainage Tunnel may meet water quality standards, but specified that the plant “shall be constructed to treat the quantity and quality of effluent historically discharged” from the tunnel.

The work was covered by specification 0-SI-60-04100/DC-7804 (Reclamation, 1989). Reclamation completed construction of the LMDT Water Treatment Plant in 1992, and it has been treating water continuously since this time. Operation of an extraction well at Station 10+25 plus drainage outflow through the bulkhead now controls the water surface in the lower reaches of the tunnel.

A new portal structure was constructed further back into the hillside which was excavated back to facilitate the installation. The portal has sloping wing walls which extend from Station 0+10 to 0+32.5. The outside face of the portal is at Station 0+32.5 and the portal concrete structure extends back to Station 0+54. The portal is made from one-foot-thick reinforced 4,000 psi concrete. A six-foot-deep drainage sump is included in the structure with two outfall pipes, one to the detention pond and one to the treatment plant.

The concrete tunnel liner is approximately one-foot-thick 4,000 psi concrete with number 5 reinforcement bars. The existing steel sets were left in place embedded 5 inches into the concrete lining. Weep holes were placed through the lower walls of the liner and grout holes were placed into the roof. The existing fill behind the new concrete liner was grouted at 25 psi. The weep holes consist of a 2.5-inch-diameter PVC solid pipe into which a 1.5-inch perforated PVC pipe was inserted. The inserted pipe was wrapped with two layers of geotextile filter fabric prior to insertion into the larger pipe. The geotextile filter fabric also covers the interior end of the inserted pipe.

The existing timber bulkhead at Station 4+66 was left in place. Gravel backfill was placed between the existing bulkhead and a new wood-lattice bulkhead constructed at Station 4+61 to 4+60. Gravel backfill was 1.5 to 2.5 inches in diameter; however, this was problematic in that the flow moved the gravel into spaces between the lattice timbers and caused plugging off of the flow through the new timber lattice. A zone of 3-inch to 12-inch cobbles was instead placed immediately behind the new timber bulkhead at 4+61, which eliminated the plugging of the lattice. The new timber lattice, made of creosote-treated 2 x 12 Douglas Fir, is held together with stainless steel screws. A stainless steel support set was placed immediately in front of the timber lattice structure to lock it in

place. The stainless steel support set is anchored to the concrete liner using ¾-inch-diameter stainless steel bolts.

2.10. Rock Mass Characterization Study

From September until November 2003 Reclamation conducted a drilling program for the EPA to evaluate the geotechnical and hydrologic nature of rock in areas where it might be possible to construct a hydraulic bulkhead in the LMDT as a component of Operable Unit 6 of the California Gulch Superfund Site. Two holes, designated LMDT-B1 and LMDT-B2 were drilled. Hole LMDT-B1 was drilled to evaluate the Precambrian Granite upstream of the Pendry Fault, and hole LMDT-B2 was drilled to evaluate the Pando Porphyry near the Robert Emmet Shaft. Prior to the evaluation, EPA engaged Hayward Baker to enlarge three existing (pre-tunnel construction) test borings and convert them into monitoring wells. The five holes involved in the study are detailed in Table 4.

Table 4. 2003 Rock Mass Characterization, Well Construction Details

Drill Hole	Station	Total Depth Feet	Hole Diameter Inches	Screened Influence Zone
LMDT-B1	46+66	360.0	7-7/8	325.0 to 360.0
LMDT-B2	96+44	534.5	7-7/8	350.0 to 534.5
LDT 25+15	25+15	281.0 tunnel crown	5-3/4	4" pvc pipe open to tunnel
LDT 36+77	36+77	298.0 tunnel crown	5-3/4	4" pvc pipe open to tunnel
LDT 75+05	75+05	470.0 tunnel crown	2-15/16	2" pvc pipe open to tunnel

The two holes drilled by Reclamation drifted off alignment as they went through the rock and failed to intersect the tunnel. Water tests indicated that the holes were near enough to the LMDT to be in hydraulic communication with it. The two new holes were cored and optically logged. Discontinuities were evaluated for strike, dip, openness, infilling, spacing frequency, etc. Plots were prepared in various graphical representations including pole, pole concentrations, contoured poles, rose diagram, contoured pole concentrations, contoured principal planes, and principal planes. The core was photographed and evaluated with regard to Rock Quality Designation, and the Rock Mass Rating and Q System ratings were determined. The report concluded that a hydraulic plug could be constructed in the granite upstream of the Pendry Fault in order to contain and control the mine pool.

2.11. Valve Controlled Bulkhead Study

Reclamation conducted a study for installation of a concrete bulkhead and a valve in the LMDT (Smith and others, 2005). It would have been installed just downstream of the existing lattice bulkhead at Station 4+62 for the purpose of shutting off the LMDT drainage flow for up to seven days to allow for water treatment plant shutdown and maintenance. Water would be allowed to build up in the ground behind the bulkhead provided that water did not back up to the point where it might cause a slope failure or a collapse of the tunnel liner.

Physical and strength properties were identified for use in the evaluation based upon available project data, interviews, and site visits, but no references were given, nor were any strength tests undertaken. The densities, strengths, and other data are assumed values; however, they appear to be reasonable for the type of materials involved. The assumed values are presented in Table 5.

Table 5. Material Properties Assumed for the 2005 Bulkhead Study.

Material	Property	Range of Values	Average Value
Glacial Moraine	Unit Weight, lb/ft ³	115 to 130	125
Glacial Moraine	Cohesion, lb/in ²	2 to 10	5
Glacial Moraine	Friction Angle, degrees	32 to 45	40
Glacial Moraine	Void Ratio, %	10 to 35	25
Glacial Moraine	Porosity, %	15 to 40	30
Glacial Moraine	Permeability, ft/sec	3.2 x 10 ⁻⁵ to 3.2 x 10 ⁻³	3.2 x 10 ⁻⁴
Terrace Gravels	Unit Weight, lb/ft ³	110 to 120	115
Terrace Gravels	Cohesion, lb/in ²	5 to 15	10
Terrace Gravels	Friction Angle, degrees	35 to 41	38
Terrace Gravels	Void Ratio, %	10 to 20	15
Terrace Gravels	Porosity, %	20 to 35	27
Terrace Gravels	Permeability, ft/sec	3.2 x 10 ⁻⁵ to 3.2 x 10 ⁻³	7.0 x 10 ⁻⁴
Weber Formation	Unit Weight, lb/ft ³	142 to 150	146
Weber Formation	Cohesion, lb/in ²	10 to 40	25
Weber Formation	Friction Angle, degrees	50 to 60	55
Weber Formation	Permeability, ft/sec	1.28 x 10 ⁻⁷ to 1.28 x 10 ⁻⁵	1.28 x 10 ⁻⁶

Using the data in Table 5, the slope stability of the hillside between the portal and LMDT Station 10+25 was evaluated using the computer program SLOPE/W. Factors of safety were computed for five cases with different piezometric water surface profiles ranging from the low seen in March 2004 to the historical high observed in the hillside after the 1976 collapse, which was multiplied by 1.6, which brought the piezometric surface to well above historic values. These high water cases were run for average and minimum strength values. The factor of safety determined was 3.74 and 2.59 respectively.

A determination of the likely loading on the concrete tunnel liner was undertaken using the computer program TUNANAL. This evaluation concluded that loading on the tunnel liner is sensitive to the elevation of the groundwater surface and that to maintain a reasonable factor of safety, the existing liner can not withstand any additional hydrostatic load. Continuous pumping from the well at Station 10+25 or another location must continue. A new tunnel lining, grout curtain at the bulkhead, shorter shut down period, and/or other measures may be required if a temporary shutdown of tunnel flows is to be achieved. The valve controlled bulkhead was not constructed.

2.12. Inspection March 25, 2008

On March 25, 2008, an inspection of the LMDT was made by Reclamation geotechnical engineers Michael Gobla and Jack Touseull, and civil engineer Kevin Atwater for the purposes of evaluating the structural integrity of the portal, tunnel liner, and timber lattice bulkhead. The inspection included the portal structure, drainage ditch, reinforced concrete liner, weep holes, and the timber lattice bulkhead. The concrete is sound and relatively fracture free. One lift line located about 3 feet above the door opening was damp as evidenced in the accompanying photograph in Figure 17. A few short hairline cracks were noted in the portal structure. The portal structure is in overall excellent condition.

Entrance to the portal is controlled by a steel door which is normally kept closed and locked. Just inside the LMDT portal is a floor grating with removable panels to allow access to the sump at the end of the two drainage ditches; a concrete walkway divides the ditches, see Figure 18. Beyond the grating, electrical equipment is located on the right side (looking downtunnel) for operation of the lights and ventilation system. The overhead lights, ventilation fan, and ventilation pipeline are shown in Figure 19. All of the equipment was in operating condition at the time of the inspection.



Figure 17. Photograph of the LMDT portal structure taken on March 25, 2008.



Figure 18. Photograph taken on March 25, 2008 looking at the downstream end of the LMDT showing the concrete center walkway with drainage ditches on either side and steel floor grating.



Figure 19. Photograph taken on March 25, 2008 looking upstream from the Portal area in the LMDT showing the ventilation fan, motor controls, and vent pipe at left, and the electric lights at the upper right.

The inside surface of the reinforced concrete tunnel liner in the downstream portion of the tunnel has been coated with a bright white reflective material. The presence of this coating obscures the condition of the concrete. The upstream portion of the reinforced concrete liner (where the liner is under higher soil and water loading) has not been coated. Approximately ten cracks were observed in the concrete lining. The cracks varied from hairline to about 1/16 of an inch wide. The two most significant cracks were found on the left side of the tunnel (looking downstream), one in the crown, (see Figure 20), and one along the wall about 4 feet above the floor. Both of these cracks were about 20 feet long and 1/16-inch wide. A small amount of calcium bearing mineral precipitates are forming from the seepage coming through the cracks. The seepage rates are very slow; at most locations the cracks are wet, but not dripping. The cracks are of little structural concern. Probing with an ice pick it was not possible to dig open the cracks. The concrete is sound and very hard, even right at the edge of the crack. Only one crack near the lattice bulkhead showed minor offsetting of the tunnel lining; at all other cracks, the lining is smooth and even across the crack.



Figure 20. Photograph taken on March 25, 2008 looking downstream from about midway inside the reinforced concrete lined segment of the LMDT. Note the calcium carbonate stalactites forming from the slow seepage along a thin roof crack and at a joint in the concrete lining.

All of the tunnel weep holes show some level of clogging by mineral precipitates. Flow is minimal, and this has been so since their construction. The weep holes were constructed by placing a geotextile-filter-wrapped perforated pipe inside a solid PVC pipe inserted through the concrete liner. Cleaning of the weep holes must be done with care to not rupture the geotextile.

The stainless steel tunnel support was visible just in front of the timber lattice bulkhead. The stainless steel support for the timber lattice has not been affected by its environment and is in like new condition. A regular steel post just downstream of the bulkhead is showing signs of deterioration, but this post is not an essential structural component of the tunnel. It does emphasize the point that the zinc and iron-rich water, even at near neutral pH, is capable of degrading regular steel over a period of time.

Behind the bulkhead are 3- to 12-inch cobbles behind which is a vertical zone of 1 ½ to 2 ½-inch gravel. During construction, finer sized gravel was used for the gravel fill, but when the timber lattice support was installed, it was found that the smaller gravel was carried into the lattice openings by the water flow and it resulted in constricting the drainage flow rate through the timber structure. A change was made to install a vertical zone of cobbles to lie in immediate contact with the timber lattice which is what was observed to be the case.



Figure 21. This crack located about 3 feet above the LMDT floor is the only one that showed offsetting of the concrete. The offset is about 1/8 inch.



Figure 22. Photograph of a weep hole in the reinforced concrete lining which is almost completely blocked by calcium carbonate precipitates.



Figure 23. Photograph taken on March 25, 2008 of the cobble and gravel-filled timber-lattice bulkhead at Station 4+61 of the LMDT. At left is the intake end of the ventilation pipeline.

The timbers and cobbles above the water level have a thin coating of black manganese oxides. The timbers below the level of flowing water are coated with a layer of iron hydroxide precipitates about 1/8-inch thick. The precipitates have a firm but not hard crust, which when broken is soft underneath.

The timber comprising the lattice support structure remains in excellent condition. The 2-by-12-inch boards have maintained alignment and remain in sound condition. The timbers were probed with an ice pick; the tip of the ice pick would only penetrate into the wet timber 1/16 to no more than 1/8 of an inch. Most of the timbers above and all of those below the flow surface were probed with the ice pick.

At the time of the inspection, the tunnel outflow through the bulkhead was approximately 250 gpm. It is concluded that the LMDT structural elements are in excellent condition. Correct materials were specified and installed for this harsh environment. No significant degradation has been observed.

The only features requiring attention are the weep holes. Those showing more than half the pipe being filled with precipitates should be cleaned out. This can be accomplished by drilling/chiseling out the precipitates to remove the inner 1.5-inch diameter perforated pipe and its geotextile wrapping, and then insert new geotextile-wrapped pipe inserts into the 2.5 inch PCV pipes.

3.0 Geology

3.1. Regional Geology

The Leadville Mine Drainage Tunnel lies in the center of the Southern Rocky Mountain physiographic province. Generally, this province consists of greatly elevated, north-south strips of granite flanked by, and sometimes capped by sedimentary rocks. Intermountain basins, such as South Park, are common. The Sawatch Range, lying to the west of the tunnel, has the highest peaks of the Rocky Mountains.

The tunnel portal lies near the headwaters of the Arkansas River between the Sawatch and Mosquito Mountain Ranges. The tunnel itself is driven into the Mosquito Range. The portal and first 635 feet of tunnel lie in a terminal glacial moraine and terrace gravel.

3.2. Tunnel Stratigraphy

The LMDT penetrates the entire stratigraphic section of rocks present in the Fryer Hill and Carbonate Hill basins, including Precambrian granite and sedimentary Cambrian quartzite, Peerless shale, Manitou limestone, Parting quartzite, and Leadville “blue” limestone.

Surficial materials (glacial moraine and terrace deposits), consisting of gravel, cobbles, and boulders in a silt and sand matrix overlie the tunnel. The first several hundred feet (approximate Station 0+50 to 6+35) of the LMDT were constructed within these near-surface deposits.

Refer to Appendix A – *Geologic Cross-Section Along the Leadville Mine Drainage Tunnel* for detailed stratigraphy.

3.3. Structure

The rocks have undergone extensive deformation and tilting and have been intruded by sills and large masses of porphyry. In east-west or southeast-northeast section, the fault blocks of east-dipping sedimentary beds are dropped in steplike fashion to the west. In addition to the main faults, there are many intermediate faults within blocks. Many of the faults, such as the Pendery and Carbonate, are water bearing. The Mikado Fault was not water bearing at the tunnel level, at least where cut. When shear zones accompany faults, problems of support arose in driving through them.

Most the ore bodies are of the replacement type associated with the intrusives, and their placement have been controlled by structural factors such as pre-mineral faults or the damming effect of formations impervious to passage of mineralizing solutions. Post-mineral faulting sometimes displaced or broke up ore bodies, thus complicating exploration and mining.

The rock mass consists primarily of Precambrian granite and metamorphic rocks. Paleozoic sedimentary rocks overlay these basement rocks. The rock mass is heavily faulted, fractured and upturned as a result of the Laramide orogeny. Intrusions into the Precambrian and Paleozoic rocks along faults and between sedimentary rock layers have also occurred. The intrusions formed igneous porphyry bodies and ore deposits.

3.4. Hydrogeology

The LMDT is situated in a large, complex, groundwater system. The location and regional flow of ground water in the Leadville Mining District is directly controlled by the faulted boundaries of the various structural basins. Each basin retained its own ground water and circulation between the basins was not possible because of the presence of impermeable gouge along the faults. Mine workings including stopes, adits, and shafts have radically changed the original groundwater flow system in and around Leadville.

The regional hydrology for engineering purposes can be separated into two water bearing units. They are the unconsolidated surficial material and the bedrock aquifers. The groundwater levels in the surficial aquifer are shallow and generally controlled by the topography. Hydrologic studies, including dye tracer studies, have demonstrated that the fractured bedrock aquifer is hydraulically connected to the upper surficial aquifer. Further, there is an upwelling of bedrock groundwater into the alluvial aquifer that has been confirmed by monitoring in California Gulch. The unconsolidated aquifer is porous and tends to readily transmit ground water. The geometry of the bedrock is a controlling factor in groundwater flow in the surficial aquifer.

Water levels are monitored in several wells present along the LMDT alignment. Refer to Appendix A – Geologic Cross-Section Along the Leadville Mine Drainage Tunnel for locations of wells. Figure 24 shows water levels in wells along the lower portion of the LMDT alignment and Figure 25 shows water levels in wells and the Emmet Shaft along the upper portion.

Existing Condition of the Leadville Mine Drainage Tunnel

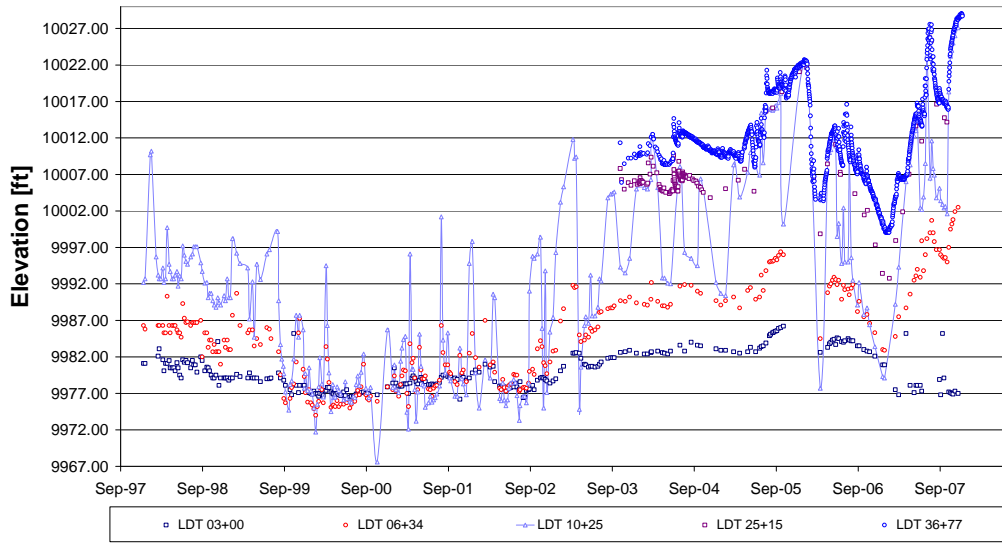

Figure 24. Plot of water levels in wells along the lower portion of the LMDT alignment.

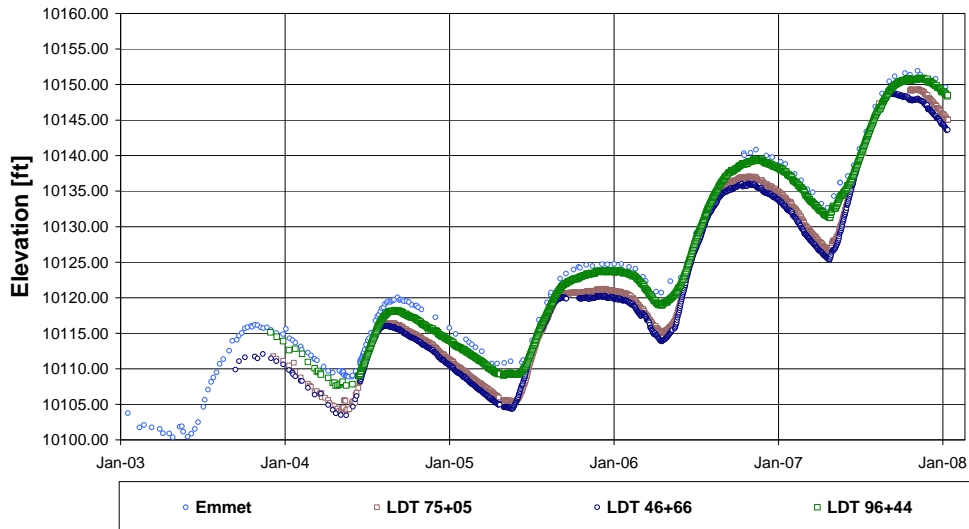

Figure 25. Plot of water levels in wells along the upper portions of the LMDT alignment

3.5. Seismicity

Estimated seismic loadings in the table below were derived from peak horizontal acceleration (PHA) hazard curves for Sugar Loaf Dam that were presented in the Technical Memorandum entitled “Screening/Scoping Level Probabilistic Ground Motion Evaluation for Mount Elbert Forebay, Sugar Loaf, and Twin Lakes Dams, Fryingpan-Arkansas Project, Colorado, 2002”. PHA hazard curves for Sugar Loaf Dam provide reasonable estimates of seismic loading at the Leadville Mine Drainage Tunnel located less than 5 miles from dam.

Table 6. Seismic loading conditions for the LMDT.

Return Period (years)	PHA
500	0.05g
2,500	0.15g
10,000	0.35g

3.6. Previous Geologic Investigation

Ten holes were drilled by the U.S. Bureau of Mines in the 1940s to determine subsurface conditions to be encountered by the first 7,000 feet of tunnel. Of these, six were concentrated in the first 1,100 feet. The holes were churn drilled through the glacial moraine and terrace material to the top of bedrock. The bedrock portion was cored. Logs of these holes are not available; however, much of the information on the geologic cross section (Drawing No. 1335-D-2A) is based on data obtained from the drilling.

With no maintenance, the tunnel deteriorated rapidly, and sections of the tunnel arch supported exclusively by wood sets have collapsed. Some of the voids thus created worked their way to the surface and appeared as sinkholes. The first major sinkhole occurred at Station 4+00 in 1966. In 1968, a cave-in occurred next to State Highway 91. As a part of the emergency repairs, ten holes were drilled. Five of these were used to backfill subsurface voids (including the tunnel) and five were left open for water observation purposes. These holes were entirely in glacial moraine and terrace gravels. Logs are not available.

Again, in 1973, an attempt was made to fill all remaining subsurface voids from Station 2+00 to about Station 5+00. To locate the cavities, percussion holes were drilled at 10-foot intervals. Every place a void was encountered; it was backfilled with gravel (including the tunnel). During this same phase, an additional water observation well was placed at Station 3+40. Logs are not available for any of these holes. All holes were in glacial moraine and terrace gravels.

Four drill holes were completed in 1989 (DH 89-1 through -4) to gather geologic design data for the Treatment Plant. Depths of the four boreholes ranged from 13.0 to 19.8 feet. The holes encountered glacial moraine consisting primarily of sand and gravel with 20 to 25 percent fines with low to no plasticity. Locations of the boreholes are shown on drawing 1335-D-3.

Two wells were drilled and three existing holes were enlarged along the alignment of the tunnel in 2002 with the purposes of monitoring water levels along the tunnel, obtain groundwater quality sampling points, and to gather rock quality data along the tunnel. Boreholes LMDT-B1 and -B2 are new monitoring wells constructed by Reclamation for the EPA at Stations 46+66 and 96+66, respectively. Under contract with the EPA, Hayward Baker modified three existing (pre-tunnel construction) test holes along the tunnel alignment at Stations 25+15, 36+77, and 75+05. The original test holes were core drilled using small diameter diamond bits (AX and BX size). Hayward Baker enlarged the diameter of the existing holes and deepened them to intersect the crown of the tunnel. PVC pipe was installed in the enlarged boreholes to the crown of the tunnel and the annuluses were grouted.

The new boreholes, LMDT-B1 and -B2, failed to directly intercept the tunnel; however, camera inspection revealed connectivity with the tunnel through a series of open joints. Well screens and pea-gravel filter packs were installed adjacent to the tunnel. PVC riser pipes were grouted above the screened intervals.

Reclamation installed a piezometer at LMDT Sta. 10+25, 25 feet left in July 2002 to monitor drawdown adjacent to existing pumping wells installed in the LMDT. The piezometer has dual influence zones, one at the base of surficial materials and the other in the upper portion of bedrock.

4.0 Portal Structure Station 0+32.5

The portal has been rebuilt on several occasions. The current portal structure was constructed during the 1990-1992 modifications. The work was covered by specification 0-SI-60-04100/DC-7804 (Reclamation, 1989).

The original portal was located at LMDT Station 0+00 and the first 30 feet of the LMDT was excavated through river deposits (clay, silt, sand, and gravel). The existing portal was constructed further back into the hillside (Station 0+32.5). The excavation would have removed all of the river deposited soils from around the LMDT.

The portal structure has sloping wing walls, which extend from about Station 0+10 to 0+32.5. The outside face of the portal is at Station 0+32.5 and the portal concrete structure extends back to Station 0+54. The portal structure is made from one-foot-thick reinforced 4,000 psi concrete. A six-foot deep drainage sump is included in the structure with two outfall pipes, one to the detention pond and

one to the treatment plant. The portal structure was inspected on March 25, 2008 and found to be in excellent condition.

The elevation of the LMDT at the portal (door threshold) is 9,958.42 feet. Downstream of the entrance, the ground slopes up about two feet to the elevation of the service yard area. Details regarding the portal structure construction are shown on drawings 1335-D-18 Site Plan, 1335-D-124 Outlet Portal Structure Isometric View, Sections, and Detail, and 1335-D-125 Outlet Portal Structure Sections, and Details (See Appendix B).

5.0 Tunnel Segments

5.1. Concrete Lined Segment Station 0+54 to 4+61

From the back of the portal structure at Station 0+54 to Station 4+61, the LMDT has been lined with reinforced concrete. This portion of the LMDT is surrounded by glacial soil deposits and the liner serves to prevent internal erosion and piping of the soil into the LMDT. From the portal structure to Station 3+50 the LMDT is completely surrounded by glacial soils. At Station 3+50, bedrock (sandstone and shale) was encountered in the floor of the LMDT. From Station 3+50, the bedrock contact rises along the walls of the tunnel with glacial soils remaining in the upper portion of the tunnel. It is not until Station 6+50 that the bedrock reaches the crown of the tunnel excavation. The original excavation was driven at a size of 10-feet wide by 11.5-feet tall clear opening inside the timber supports until Station 3+35, so roughly a 12-feet wide by 12.5 feet tall excavation. The section was reduced to 9-feet wide to 10.5-feet tall clear opening from Station 3+35 to Station 6+00, or a 11-feet wide by 12-feet tall excavation.

Since the liner has been completed, there have not been any more sinkholes occurring above the LMDT alignment. The concrete lining was constructed during the 1990-1992 modifications. The work was covered by specification 0-SI-60-04100/DC-7804 (Reclamation, 1989). Details of the reinforced concrete liner are found on drawing 1335-D-123 Typical Tunnel Section, Cutoff Wall, and Timber Bulkhead. The concrete lining was inspected on March 25, 2008 and found to be in excellent condition with the exception of the weep holes, which are becoming clogged with calcium carbonate precipitates.

The tunnel concrete liner is approximately one-foot thick and incorporates 4,000 psi concrete with number 5 steel reinforcement bars. Number 6 bars were placed at the lower corners. The existing steel sets were left in place embedded 5 inches into the concrete lining. One weakness in the design is that there is only 3 inches of concrete cover over the floor reinforcement in the ditches. The center walkway is an elevated section of concrete which forms the walls of the drainage conveyance ditches on either side. The walkway has a welded wire fabric for reinforcement. Weep holes were placed through the lower walls of the liner and

grout holes were placed into the roof. The existing backfill behind the new concrete liner was grouted at 25 psi.

5.2. Timber Bulkhead and Gravel Fill Station 4+60 to 4+66

During the 1990-1992 modifications, gravel-fill was placed between the existing bulkhead at 4+66 and a new wood-lattice timber bulkhead constructed at Station 4+60 to 4+61. The gravel backfill was 1.5 to 2.5 inches in diameter; however, this was problematic in that the flow moved the gravel and caused plugging off of the flow through the new timber lattice. A vertical zone of 3-inch to 12-inch cobbles was instead placed immediately behind the new timber bulkhead at 4+61 which eliminated the plugging of the lattice. The new timber lattice, made of 2 x 12 inch creosote-treated Douglas Fir, is held together with stainless steel screws. A stainless steel L-shaped support was placed immediately in front of the timber lattice structure to lock it in place. The stainless steel support is anchored to the concrete liner using $\frac{3}{4}$ -inch-diameter stainless steel bolts. Details of the bulkhead construction are shown on drawing 1335-D-123 Typical Tunnel Section, Cutoff Wall, and Timber Bulkhead. Inspection of this bulkhead on March 25, 2008 found it to be in excellent condition.

In a Memorandum (Armer, 2001), the stability of the bulkhead at Station 4+60 was evaluated. It was reported that with flow 2.5 feet above the floor (current condition), the bulkhead had a factor of safety of 3.3. If water flow were to rise to the full height of the LMDT, the factor of safety would be greater than 1.0 for the bulkhead assembly.



Figure 26. Construction photograph showing the cobbles behind the timber-lattice bulkhead at Station 4+60 of the LMDT.

5.3. Bulkhead and Backfill Station 4+66 to 5+00

In the Station 4+66 to 5+00 segment of the tunnel, the bedrock contact continues to rise, reaching half way up the sides of the excavation at Station 5+00. The steel (A-36) and timber bulkhead constructed in 1979 is located at Station 4+66. Behind this bulkhead, any remaining voids were filled with gravel. This segment of the tunnel (to Station 5+00) had previously been filled during the 1973 construction by drilling percussion holes every ten feet from the surface and placing gravel down into the tunnel voids. It is believed that this segment of the LMDT is still filled with a combination of collapsed glacial material and injected gravel.

5.4. Glacial Materials Station 5+00 to 6+50

The Station 5+00 to 6+50 segment of the tunnel has bedrock walls gradually rising from the mid-height to the crown of the tunnel. This segment of the LMDT is mostly filled with collapsed glacial soils. Although reports suggest this entire section of the LMDT was filled with gravel, no conclusive records have yet been found to verify the upper-most 20 feet having been filled. According to the drawing showing conditions in 1972 (Figure 14), the area filled was from Station 5+00 to Station 6+30. The drawing shows the tunnel open beyond Station 6+30 as of 1972. At Station 6+35, a cap of 1.5 feet of weathered bedrock was reported above the crown of the excavation and at this location the small top heading was terminated. An extraction well installed at Station 6+35 penetrates the tunnel and was used for draining the LMDT prior to installing the extraction wells at Station 10+25.

5.5. State Highway 91 Station 5+64.55

The centerline of State Highway 91 crosses over the LMDT at Station 5+64.55. Besides the paved highway, there are buried utilities in the ground adjacent to the highway.

5.6. Shallow Bedrock Crown Station 6+50 to 21+00

Bedrock (Weber Formation) was reported by the Bureau of Mines to have improved at Station 6+50 such that the spiling was discontinued and the spacing of timber supports was increased to 6 feet. The LMDT crosses interbedded sandstones and shales until Station 21+00 where it enters gray porphyry. Because of the problems excavating through the porphyry, a part of the LMDT was abandoned and a bypass tunnel was constructed beginning at Station 16+81. The bypass runs approximately 35 feet to the right (looking up tunnel) from the original alignment and extends to Station 24+48. The turnout, starting at Station

16+81 was concreted and a center pillar was placed as extra support across the wide opening. Holes were drilled through the concrete and grout was pumped in at 750 psi to fill all voids behind the supports.

Two extraction wells penetrate the LMDT near Station 10+25 and an observation well is offset 25 feet from the tunnel alignment.

5.7. Gray Porphyry Station 21+00 to 22+00

At Station 21+00 the tunnel entered a dike of gray porphyry. Advance of 26 feet into the area resulted in a peak water flow of 3,000 gpm, which washed over 1,500 cubic yards of mud, sand, and broken rocks into the LMDT. Attempts to clear the tunnel and continue on were met with similar inflows of water and muck. A wooden bulkhead was placed at Station 17+95 to stop the inflow. Test holes revealed that the bedrock over the tunnel was 4- to 12-feet thick and that the inflows were from the overlying glacial material. A concrete bulkhead with drainage pipes was placed against the wooden bulkhead at Station 17+95 to prevent other inflows and a thick coating of gunite was applied to the tunnel walls and arch roof downstream of the bulkhead. The porphyry was altered and crushed but relatively dry. The walls were concreted flush with the support timbers. At Station 22+00 the Leadville Limestone was encountered.

5.8. Leadville Limestone Station 22+00 to 22+50

Continuing on the bypass alignment, the tunnel was excavated through the Leadville “blue” limestone without problems. Large flows of water were experienced at both contacts (downstream and upstream) of the adjacent rocks with the limestone.

5.9. Parting Quartzite Station 22+50 to 24+50

The Parting quartzite proved to be perhaps the most difficult of all the tunneling conditions. Initially the walls were hard but advance drillholes at Station 23+00 encountered a breccia zone. Spiling was used but a large flow of water and mud broke in at Station 23+28. A timber bulkhead reduced the flows from 3,000 gpm to 1,100 gpm. The tunnel was concreted 35 feet back from the face. A concrete bulkhead was placed against the face, and then grout was pumped in at high pressure through holes drilled in a radial pattern around the outside of the face. Next, 11 cubic feet of concrete was pumped in under pressure behind the concrete bulkhead. Holes were drilled 40 feet through the bulkhead and grouted at 300 psi, placing a total of 2,248 sacks of cement. More breccia zones were encountered. One at Station 24+40 took 1,448 sacks of cement to consolidate. The tunnel eventually turned back to the original alignment at Station 24+48.

5.10. Limestone Station 24+50 to 27+55

Limestone (Manitou) in this segment required only light support with steel rail sets and partial lagging. A 281-foot-deep monitoring well penetrates this segment of the LMDT at Station 25+15.

5.11. Porphyry Dike Station 27+55 to 29+63

Timber sets were required for a distance of 20 feet where an inflow of over 1,600 gpm was experienced.

5.12. Faults at Station 29+63

Two closely spaced faults at Station 29+63 experienced inflows of 5,700, gpm raising the total tunnel outflow to 7,000 gpm (the highest LMDT flow ever recorded). A cavern following the side of the tunnel with openings as large as 60 x 15 x 20 feet was observed. After the water drained out, the cavern sides were hard so 156 feet of the tunnel length was slabbed off to take advantage of the natural cavern openings to create a siding for the track.

5.13. Parting Quartzite Station 32+50 to 37+80

A fractured and altered zone of Parting quartzite rock was encountered from Station 32+50 to 37+80 which required spiling over the arch and some of the sides to prevent mud inflows. A 298-foot-deep monitoring well penetrates the LMDT at Station 36+77.

5.14. Limestone Station 37+80 to 40+60

Limestone (Manitou), highly broken was crossed by spiling. Later maintenance records mention that the parting quartzite is in or just above the roof of the tunnel along much of this segment of the workings.

5.15. Pendery Fault Station 40+70

The Pendery Fault zone was about 40 feet wide and contained fine breccia with some water. It was excavated with timber supports on 5-foot centers. The supports and intervening areas were concreted.

5.16. Precambrian Granite Station 40+60 to 63+45

The Precambrian granite was fractured and blocky and carried some water until Station 44+00 when ground conditions improved. Timber supports were only required in short sections where dikes of altered alaskite and pegmatites were penetrated. All of the rock in the unsupported section were gunited to prevent alteration by water and air. Beyond Station 60+00, the granite was more broken and carried considerable flows of water, so timber supports were required.

5.17. Lower Paleozoic Sedimentary Rocks 63+45 to 97+00

The rocks encountered along this segment include the Manitou Dolomite, Peerless Formation (Station 72+85 to Station 73+60), and Sawatch Quartzite. Generally poor rock requiring support was encountered, although some competent zones were reported. Particularly poor quality broken rock is present between 66+00 to 77+00 and 78+00 to 80+00. At Station 84+50 shale was nearby over the top of the LMDT resulting in heavy ground requiring timber supports.

Abundant faulting and folding is present over the entire reach. Major faults encountered include the Niles Fault at approximate 70+20 and the Carbonate Fault at approximate station 76+30. The Carbonate Fault contained significant water and two to three feet of soft gouge.

The LMDT gradient for drainage changes in this segment from 0.5 percent up to Station 66+00 to 0.2 percent beyond (upstream) of Station 66+00. Heavy water inflows were encountered at the Daly fissure located at Station 73+57. A 470-foot-deep monitoring well penetrates the LMDT at Station 75+05.

No mineralization was reported along the first 7,100 feet of the tunnel. The first signs of lead-zinc mineralization were encountered from Station 71+20 to Station 71+80 in the form of sulfide minerals occurring along the quartzite bedding planes. Slight amounts of mineralization along bedding planes in quartzite were encountered from Station 74+40 to Station 74+50. At Station 84+17 a 2-foot-wide zone of lead and zinc sulfides was encountered.

5.18. Downtown Lateral Station 84+70

The Downtown Lateral was all in quartzite. It was driven without the need for roof supports. A direct connection to a shaft was not made with this lateral, but later ASARCO made a connection with a raise from the Ponsardine Mine.

5.19. Hayden Lateral Station 89+22

The Hayden lateral was driven 191 feet to encounter the Hayden shaft at the 5th level of the Hayden mine workings. This portion of the LMDT is in white limestone.

5.20. Pando Porphyry Station 97+00 to 112+34

When last inspected the Pando Porphyry section of the tunnel (Station 99+83 to 112+34) was still open, but showing signs of lateral pressure. The supports and lagging have been replaced on several occasions in this part of the tunnel due to the swelling nature of the altered porphyry. With a lack of maintenance, it is possible that there is significant failure of supports in this section of the LMDT.

5.21. Robert Emmet Lateral Station 99+70 to 99+83

The LMDT encountered heavy inflows through a limestone fissure at Station 95+65 which began draining the Robert Emmet Shaft well before the Robert Emmet Lateral was initiated.

5.22. Mikado Fault to End Station 112+34 to 112+99

At the Mikado Fault, the LMDT passes from white porphyry into Precambrian granite. Little support was required in this segment of the LMDT. A short drift was excavated to connect with the base of the New Mikado Shaft which was found to be caved at the LMDT elevation. At the end of the LMDT at Station 112+99, two 40-foot long drill holes were drilled into the face beyond the end of the LMDT. Away from the Mikado Fault, it is likely that the portions of the LMDT in granite are still open.

6.0 LMDT Yard Area Downstream of the Portal

6.1. Yard Area

Numerous treatment plant infrastructure components are located in and around the service yard area outside of the portal of the LMDT. The arrangement of the gravel-surfaced yard is shown on drawing 1335-D-18 Site Plan. Besides the water treatment plant and detention pond, there are the clearwell, electrical

transformer, generator for emergency power, storage sheds, monitor wells, and chain link fencing. Access is through a 20-foot wide gate.

6.2. Detention Pond

A geomembrane-lined pond lies on the west side of the service yard and occupies approximately 0.5 acre. It can receive water from the LMDT sump or from the clearwell downstream of the water treatment plant. The detention pond is used to capture water flowing from the LMDT bulkhead during temporary plant shutdowns, and to retain water discharges from the plant which fail to meet NPDES water quality requirements for discharge to the river. It is 6-feet deep and is designed to hold 4 feet of water. Above 4 feet, pond overflow is directed to an overflow intake which has a pipe leading to the river. It has an impermeable 30-mil liner to prevent metals-laden water from percolating through the soil into the groundwater. The pond is surrounded on three sides by monitoring wells. The pond has a maximum volume of 601,100 gallons (Reclamation, 1991). If the pond were to fill, the water would overflow into the Arkansas River untreated. Since its construction, the pond has not spilled to the river.

6.3. Water Treatment Plant

The water treatment plant was constructed in 1990 to 1992. It is located downstream and to the right of the LMDT alignment (looking downstream). The plant is operated to remove CO₂, acidify the water with sulfuric acid to pH 5, neutralize the water using diluted sodium hydroxide, add polymer to settle the floc into sludge, filter and release the treated water. It has remained in continuous operation since 1992.

There are two parallel treatment trains of 1,100 gpm capacity each. The plant has difficulties in May of each year when zinc and other metals loading in the water spikes and must be run at a slower throughput rate. The main problems are the large amounts of sludge generated and the tendency to clog the sand filters. The plant monitors turbidity, pH, temperature, and conductivity of the water. The water inflow rate is measured at the well at Station 10+25, and at the intake sump at the plant. By subtracting the two numbers the inflow from the LMDT bulkhead drainage is computed. On March 25, 2008, the inflows were 750 gpm from the well and 250 gpm from the bulkhead.

6.4. Sludge Facility

After the initial operation of the plant, sludge storage became problematic during winter due to sludge freezing and sticking to containers. To remedy the problem, a sludge storage building was constructed immediately to the east of the water treatment plant.

6.5. Clearwell and Easement to East Fork - Arkansas River

Clean water discharged from the treatment plant is discharged to a below-grade sump located adjacent to the north side of the water treatment plant. The sump is called the “clearwell” and it has a building shell erected over it. Two 14-inch-diameter fiberglass-reinforced pipes convey water from the clear well. One pipe runs to the detention pond to allow capture and storage of water from the plant that does not meet discharge water quality standards. The other pipe runs through an easement to an outfall along the side of the East Fork of the Arkansas River. The location of the clearwell and buried pipes are shown on drawing 1335-D-60.



Figure 27. Aerial Photograph Showing the LMDT Portal Area Including the Water Treatment Plant, Adjacent Housing, and East Fork of the Arkansas River.

6.6. The Village at East Fork

The Village at East Fork is a 72 Space Community located off of Highway 91 in Leadville, Colorado. The community consists of modular homes approximately 10 years old.



Figure 28. The Village at East Fork. The East Fork of the Arkansas River is to the right of the photograph.

7.0 Auxiliary LMDT Facilities

7.1. Extraction Wells at Station 10+25

When sinkholes developed above the tunnel and adjacent to State Highway 91 in the 1970s, Reclamation responded by installing a dewatering well in 1977. The well was replaced by two new wells in 1991 (a primary and backup well), the wells are located at approximate tunnel Station 10+25. The wells and pumps at Station 10+25 provide the primary source of water input to the treatment plant. Stainless steel turbine pumps run by a motors sitting on top of the wells are used to extract water from the LMDT. The pumps have 1500 gpm capacity, but are limited by inflows to the LMDT at this time to around 750 gpm. A control house is located inside a fenced yard area which contains the well heads (see Figure 29). Only one of the wells and pumps is operated at a time. The other is a backup system. The control house contains the programmable motor controls for the pump motors and electronics for relaying data signals from the well and pump sensors to the water treatment plant.

7.2. Observation Well at Station 10+25

An observation well with a piezometer having dual influence zones, one at the base of surficial materials and the other in the upper portion of bedrock, was installed in 2002 to monitor drawdown adjacent to extraction wells at Station 10+25, 25 feet left of LMDT centerline. The observation well at Station 10+25 is located just outside of the fenced area which contains the extraction wells and pumphouse.



Figure 29. View of Pumphouse and Extraction Wells in the vicinity of Station 10+25. May 28, 2008.

7.3. Additional Observation Wells

Additional observation wells have been installed into and near the LMDT for monitoring groundwater levels. Following are additional observation wells at close proximity to the LMDT:

Table 7. Observation Wells in and near the LMDT.

Station	Offset	Surface Elevation	Penetrates Tunnel
3+00	20' Left	Approx. 10,034	No
4+70	20' Right	Approx. 10,046	No
6+35	None	Approx. 10,063	Yes
25+15	None	10,099.50	Yes
36+77	None	10,272.50	Yes
46+66	None	10,320.49	Yes
46+96	None	Approx. 10,321.	Yes
75+05	None	10,452.88	Yes
96+44	None	10,513.64	Yes

8.0 References

- Armer, L. D. (2001) Leadville Mine Drainage Tunnel, Bulkhead Investigation, Leadville, Colorado. Bureau of Reclamation Memorandum from Supervisor, Technical Services Group, Denver, Colorado, June 28, 2001
- Bennett, N. B. (1977) Geologic specifications design data for Leadville Mine Drainage Tunnel, Leadville Mine Drainage Tunnel Project. U.S. Department of the Interior, Bureau of Reclamation, December, 1977, 9 p. plus appendices.
- Bureau of Mines (1952) Bureau of Mines completes Leadville Drainage Tunnel. U.S. Department of the Interior, Bureau of Mines, Advance press release, Denver, Colorado, Feb. 26, 1952, 6 p.
- Chapman, E. P., Stephens, F. A. (1929) Report on the Leadville District and Adjoining Territory. Private report prepared for Asarco. 1929, 262 p.
- Elgin, R. A., Volin, M. E., and Townsend, J. A. (1949) The Leadville Drainage Tunnel; Lake County, Colorado. U.S. Department of the Interior, Bureau of Mines, Report of Investigations 4493, August, 1949, 37 p.
- Emmons, S.F., Irving J.D., and Loughlin, G.F., (1927) Geology of Ore Deposits of the Leadville Mining District, Colorado, U.S. Geological Survey Professional Paper 148.
- Griffin, C. W., Hall, C. E., and Greer, M. J. (1968) Report of Official Travel to Leadville, Colorado, October 13 and 14, 1968, Bureau of Reclamation.
- Reclamation (1973) Schedule, general provisions, specifications and drawings, initial repairs to Leadville Drainage Tunnel. U.S. Department of the Interior, Bureau of Reclamation, Lower Missouri Region, Specifications No. 700C-797, 45 p.
- Reclamation (1976) Report on Leadville Mine Drainage Tunnel. U.S. Department of the Interior, Bureau of Reclamation, Lower Missouri Region in cooperation with the Intermountain Field Operations Center, Bureau of Mines, August 1976, 45 p. plus appendix.
- Reclamation (1989) Solicitation/Specifications 0-SI-60-04100/DC-7804, Treatment Plant and Tunnel Lining, Leadville Mine Drainage Tunnel Project, Colorado, Volumes I, II, and III. U.S. Department of Interior – Bureau of Reclamation, October 1989

Reclamation (1991) Design summary, treatment plant and tunnel lining, Leadville Mine and Drainage Project, Colorado. U.S. Department of the Interior, Bureau of Reclamation, Denver, Colorado, January, 1991, 89 p.

Reclamation (2004) Rock Mass Characterization, Data Summary Report for Leadville Mine Drainage Tunnel, Colorado, U.S. Department of Interior Bureau of Reclamation, Technical Service Center, May 2004, 33 p. plus appendices.

Salsbury, M. H. (1953) Condition of and timbering needs at Leadville Tunnel. U.S. Department of the Interior, Bureau of Mines, Memorandum from Resident Engineer, Leadville Drainage Tunnel, April 21, 1953, 3 p.

Salsbury, M. H. (1956) Leadville Mine Drainage Tunnel – Second Project; Lake County, Colorado. U.S. Department of the Interior, Bureau of Mines, Report of Investigations 5284, December 1956, 50 p.

Smirnoff, T., and Allen, D. (1980) Trip to Leadville Mine Drainage Tunnel Project to observe condition of existing tunnel excavation under Specifications No. DC-7343. Bureau of Reclamation, Engineering and Research Center, Travel Report, May 29, 1980, 2 p.

Smith, K., Atwater, K., Romansky, M., Torres, R., and Sullivan, C. (2005) Special study for Leadville valve controlled bulkhead. Bureau of Reclamation, Technical Service Center, Denver, Colorado, July, 2005, 20 p.

Appendix A: Geologic Cross-Section along the Leadville Mine Drainage Tunnel

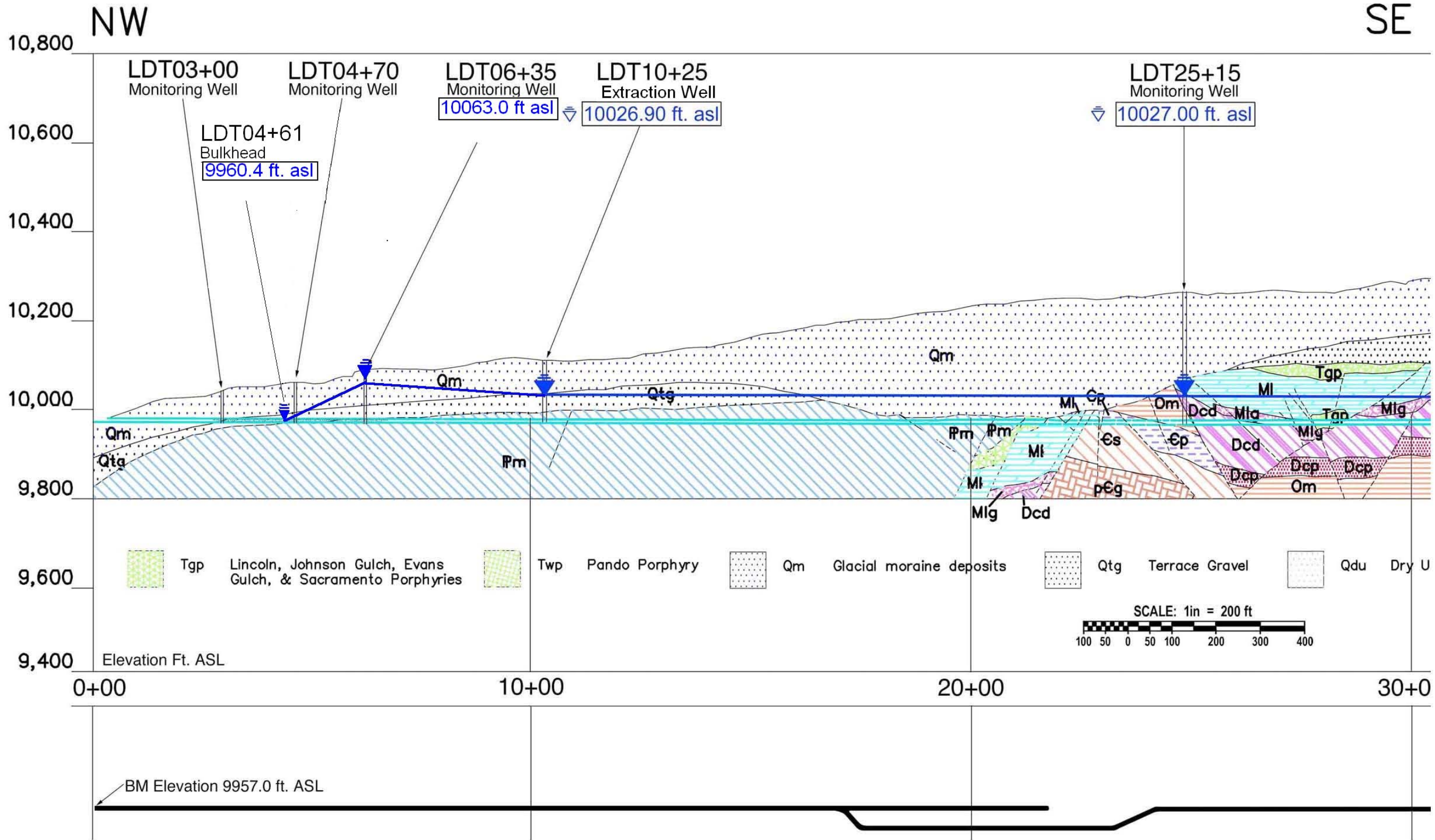

NW

SE

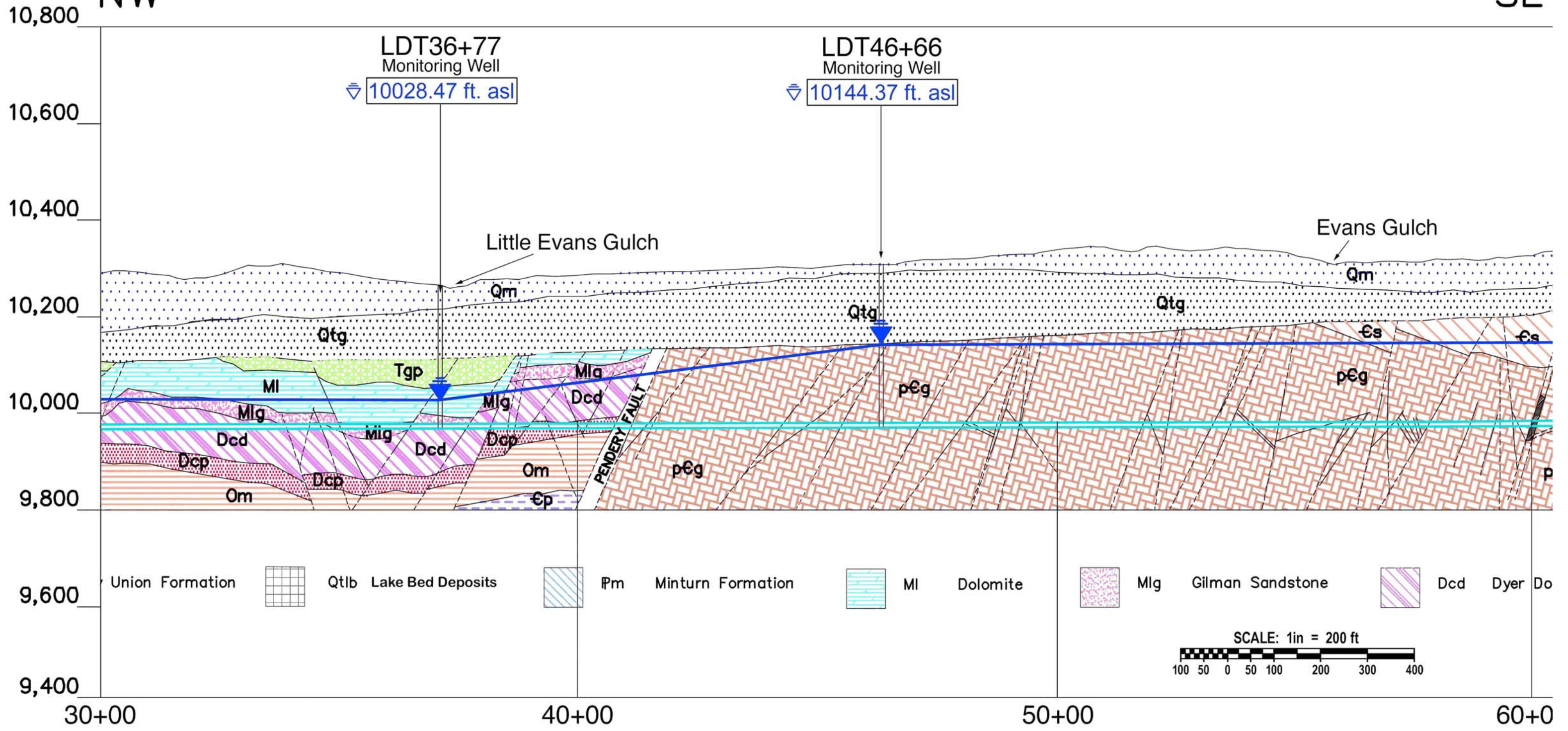

Main Tunnel Bearing S28° 53' 10" E

NW SE

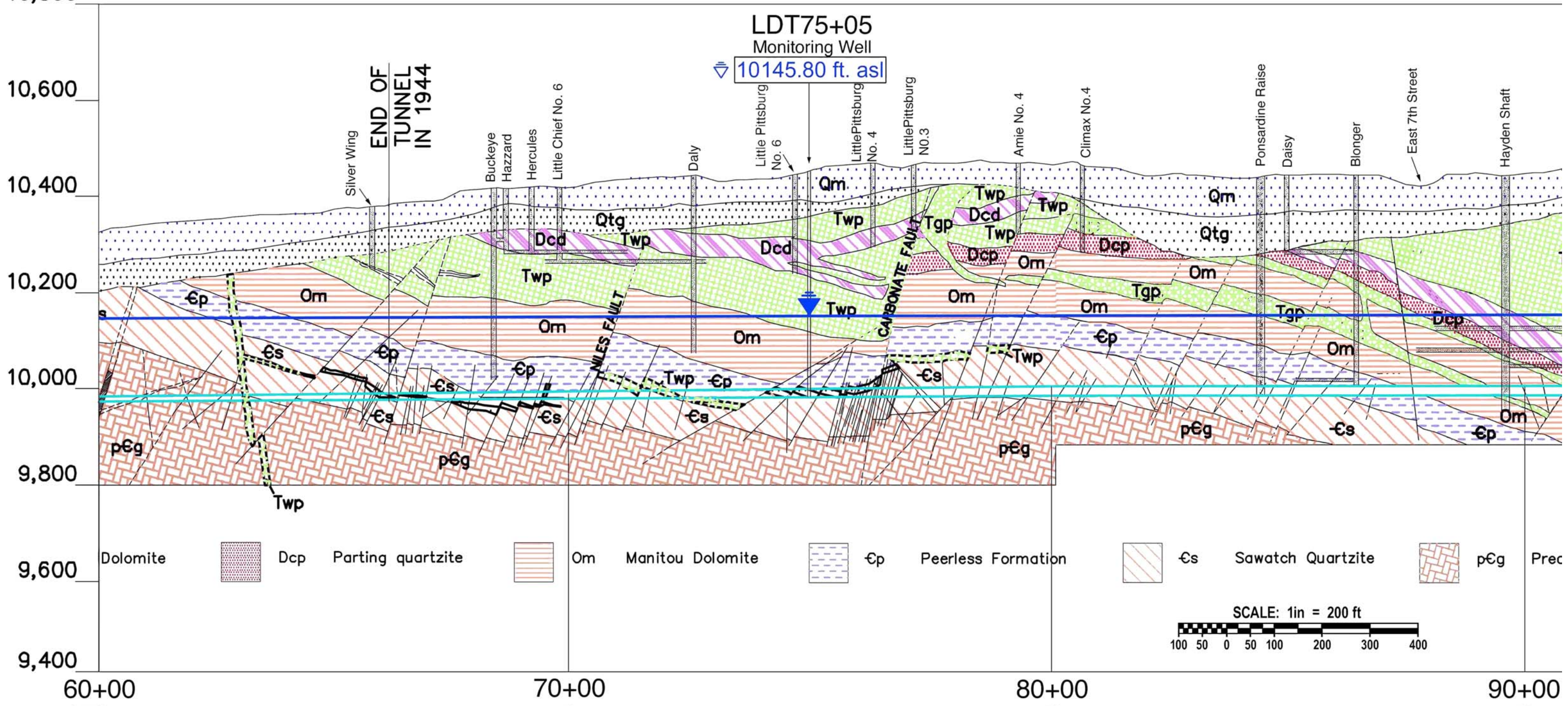

Dolomite
 Dcp
 Parting quartzite
 Om
 Manitou Dolomite
 Ep
 Peerless Formation
 Es
 Sawatch Quartzite
 pEg
 Prec

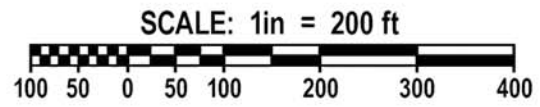

60+00 70+00 80+00 90+00

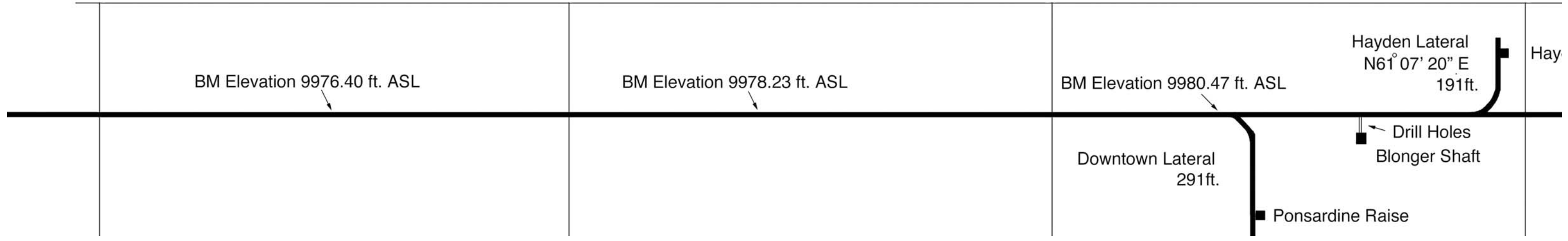

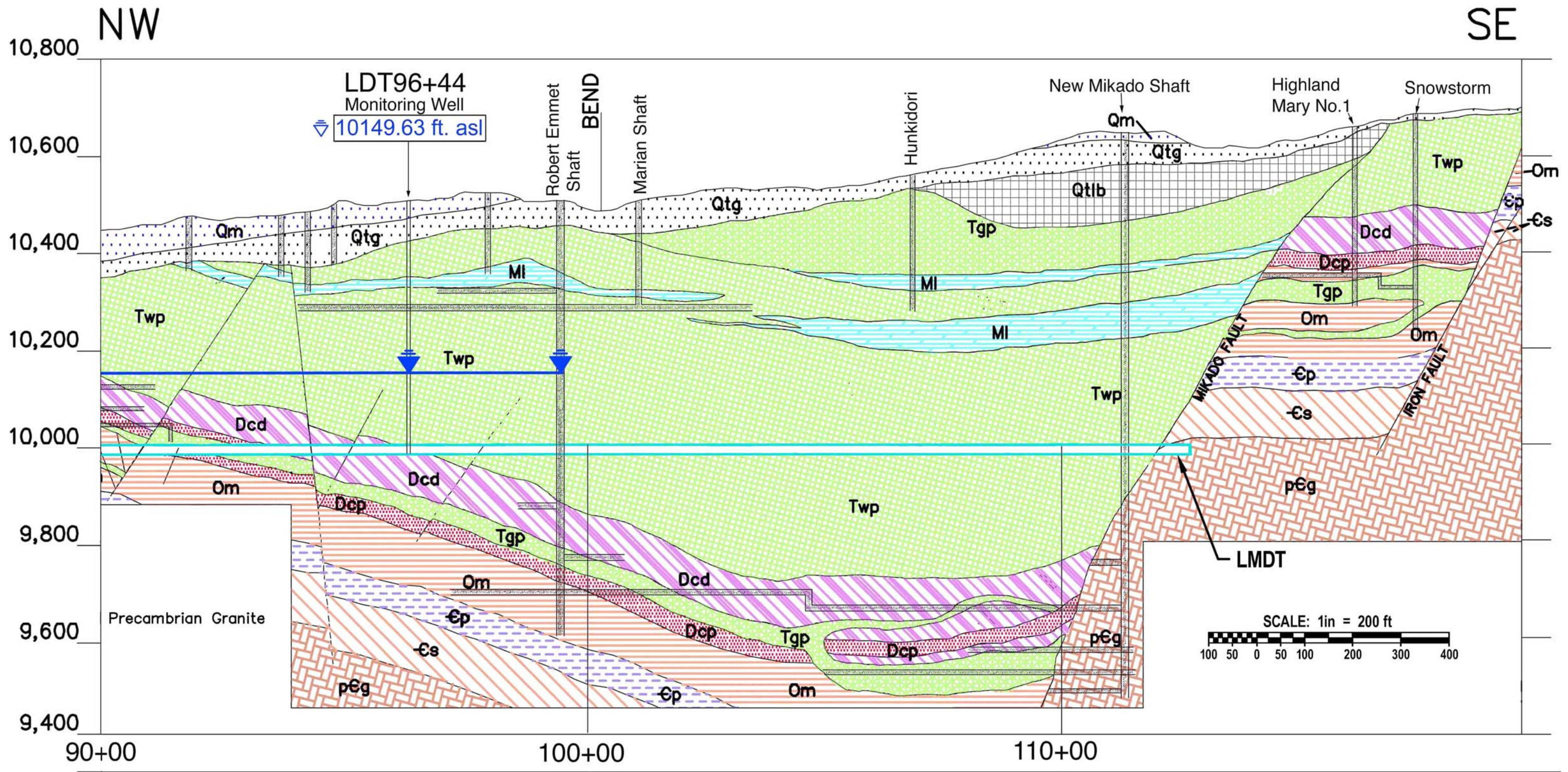

**Appendix B: Selected Drawings from
Specification 0-SI-60-04100/DC-7804-
Treatment Plant and Tunnel Lining,
Leadville Mine Drainage Tunnel**

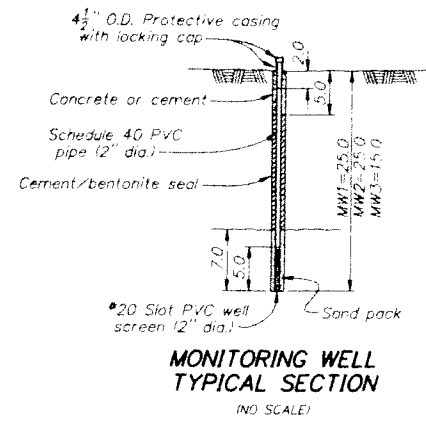
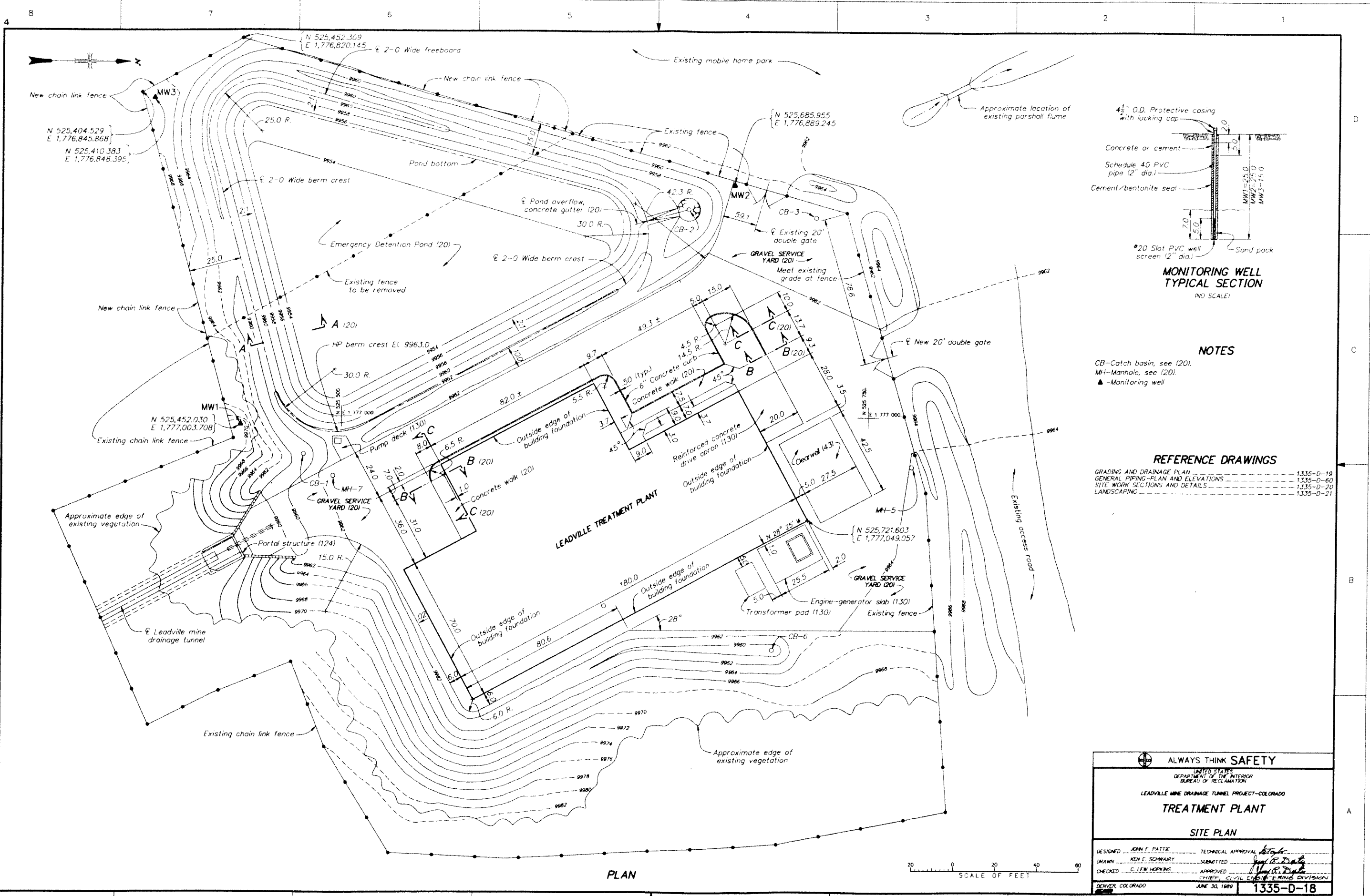

NOTES
 CB-Catch basin, see (20).
 MH-Manhole, see (20).
 ▲ -Monitoring well

REFERENCE DRAWINGS

GRADING AND DRAINAGE PLAN	1335-D-19
GENERAL PIPING-PLAN AND ELEVATIONS	1335-D-60
SITE WORK SECTIONS AND DETAILS	1335-D-20
LANDSCAPING	1335-D-21

ALWAYS THINK SAFETY

UNITED STATES
 DEPARTMENT OF THE INTERIOR
 BUREAU OF RECLAMATION

LEADVILLE MINE DRAINAGE TUNNEL PROJECT-COLORADO

TREATMENT PLANT

SITE PLAN

DESIGNED: JOHN F. PATTE	TECHNICAL APPROVAL: <i>[Signature]</i>
DRAWN: KEN E. SCHWARTZ	SUBMITTED: <i>[Signature]</i>
CHECKED: C. LEW HOPKINS	APPROVED: <i>[Signature]</i>
CHIEF, CIVIL ENGINEERING DIVISION	
DENVER, COLORADO	
JUNE 30, 1989	

1335-D-18

SCHWARTZ
 LEADVILLE SITE
 06/01/89 10:48:42

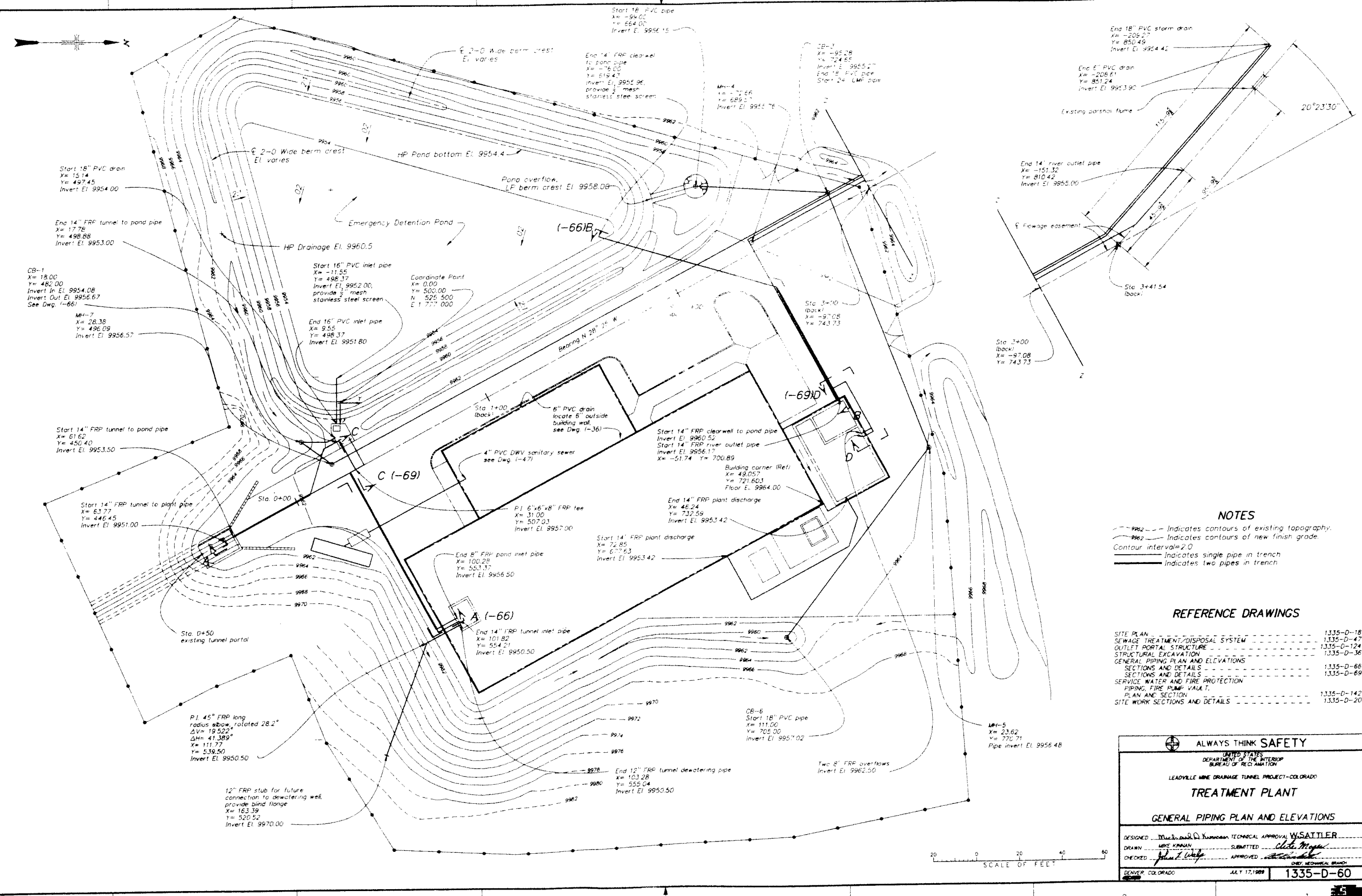

Start 18" PVC drain
X= 15.14
Y= 497.45
Invert El. 9954.00

End 14" FRP tunnel to pond pipe
X= 17.79
Y= 498.88
Invert El. 9953.00

CB-1
X= 18.00
Y= 482.00
Invert In El. 9954.08
Invert Out El. 9956.67
See Dwg. (-66)

Mt-7
X= 28.38
Y= 496.08
Invert El. 9956.57

Start 14" FRP tunnel to pond pipe
X= 61.62
Y= 450.40
Invert El. 9953.50

Start 14" FRP tunnel to plant pipe
X= 63.77
Y= 446.45
Invert El. 9951.00

Sta. 0+50
existing tunnel portal

P.I. 45° FRP long
radius elbow, rotated 28.2°
ΔV= 19.522'
ΔH= 41.389'
X= 111.77
Y= 539.50
Invert El. 9950.50

12" FRP stub for future
connection to dewatering well,
provide blind flange
X= 163.39
Y= 520.52
Invert El. 9970.00

Start 16" PVC inlet pipe
X= -11.55
Y= 498.37
Invert El. 9952.00,
provide 3" mesh
stainless steel screen

End 16" PVC inlet pipe
X= 9.55
Y= 498.37
Invert El. 9951.80

Coordinate Point
X= 0.00
Y= 500.00
N 525.500
E 1 777.000

Sta. 1+00
(back)

P.I. 6" x 6" x 8" FRP tee
X= 31.00
Y= 507.03
Invert El. 9957.00

End 8" FRP pond meet pipe
X= 100.28
Y= 553.13
Invert El. 9956.50

End 14" FRP tunnel inlet pipe
X= 101.82
Y= 554.21
Invert El. 9950.50

Start 14" FRP plant discharge
X= 72.85
Y= 677.63
Invert El. 9953.42

End 12" FRP tunnel dewatering pipe
X= 103.28
Y= 555.04
Invert El. 9950.50

Start 18" PVC pipe
X= -94.00
Y= 664.00
Invert El. 9956.15

End 4" FRP clearwell
to pond pipe
X= -76.00
Y= 619.47
Invert El. 9950.96,
provide 3" mesh
stainless steel screen

Mt-4
X= -72.66
Y= 689.00
Invert El. 9950.76

CB-2
X= -95.28
Y= 724.65
Invert El. 9955.27
End 18" PVC pipe
Start 24" GMI pipe

End 18" PVC storm drain
X= -205.27
Y= 850.49
Invert El. 9954.42

End 6" PVC drain
X= -208.61
Y= 851.24
Invert El. 9953.90

End 14" river outlet pipe
X= -151.32
Y= 810.42
Invert El. 9855.00

Sta. 3+00
(back)
X= -97.08
Y= 743.73

Building corner (Ret)
X= 48.057
Y= 721.603
Floor El. 9964.00

End 14" FRP plant discharge
X= 46.24
Y= 732.59
Invert El. 9953.42

CB-6
Start 18" PVC pipe
X= 111.00
Y= 705.00
Invert El. 9957.02

Mt-5
X= 23.62
Y= 770.71
Pipe invert El. 9956.48

Two 8" FRP overflows
Invert El. 9962.50

NOTES

- 9962 --- Indicates contours of existing topography.
- 9964 --- Indicates contours of new finish grade.
- Contour interval=2.0
- Indicates single pipe in trench
- == Indicates two pipes in trench

REFERENCE DRAWINGS

SITE PLAN	1335-D-18
SEWAGE TREATMENT/ DISPOSAL SYSTEM	1335-D-47
OUTLET PORTAL STRUCTURE	1335-D-124
STRUCTURAL EXCAVATION	1335-D-36
GENERAL PIPING PLAN AND ELEVATIONS	
SECTIONS AND DETAILS	1335-D-66
SECTIONS AND DETAILS	1335-D-69
SERVICE WATER AND FIRE PROTECTION	
PIPING, FIRE PLUMB, VAULT,	
PLAN AND SECTION	1335-D-142
SITE WORK SECTIONS AND DETAILS	1335-D-20

ALWAYS THINK SAFETY

UNITED STATES
DEPARTMENT OF THE INTERIOR
BUREAU OF RECLAMATION

LEADVILLE MINE DRAINAGE TUNNEL PROJECT-COLORADO

TREATMENT PLANT

GENERAL PIPING PLAN AND ELEVATIONS

DESIGNED: <i>Michael D. Kupperman</i>	TECHNICAL APPROVAL: <i>W. Sattler</i>
DRAWN: <i>Mike Kahan</i>	SUBMITTED: <i>John Meyer</i>
CHECKED: <i>John F. White</i>	APPROVED: <i>John Meyer</i>
DENVER, COLORADO	CHIEF, MECHANICAL BRANCH
JULY 17, 1989	1335-D-60

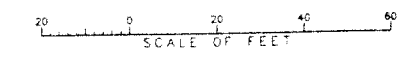

PREPARED BY
 LEADVILLE DISTRICT
 08-71288 082588

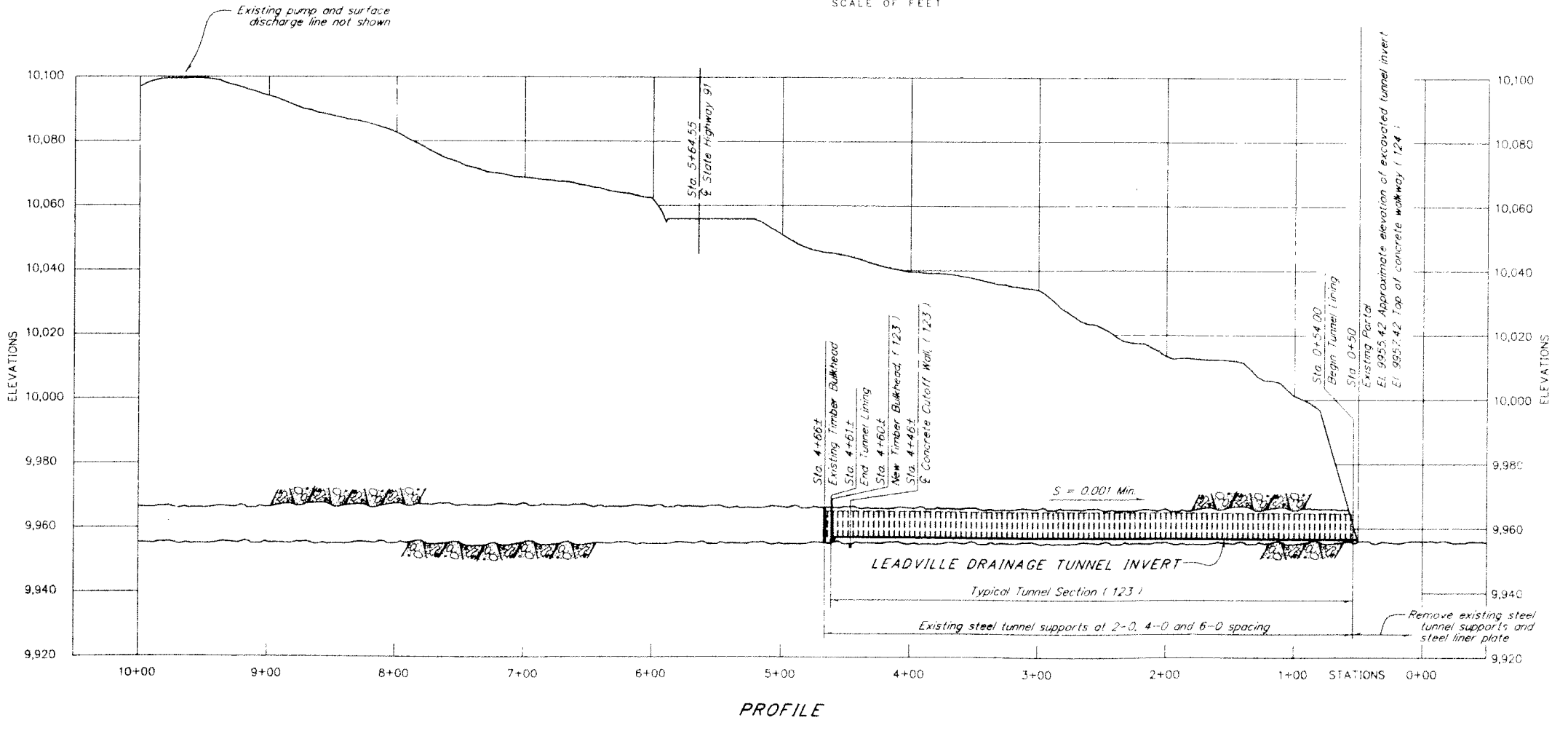
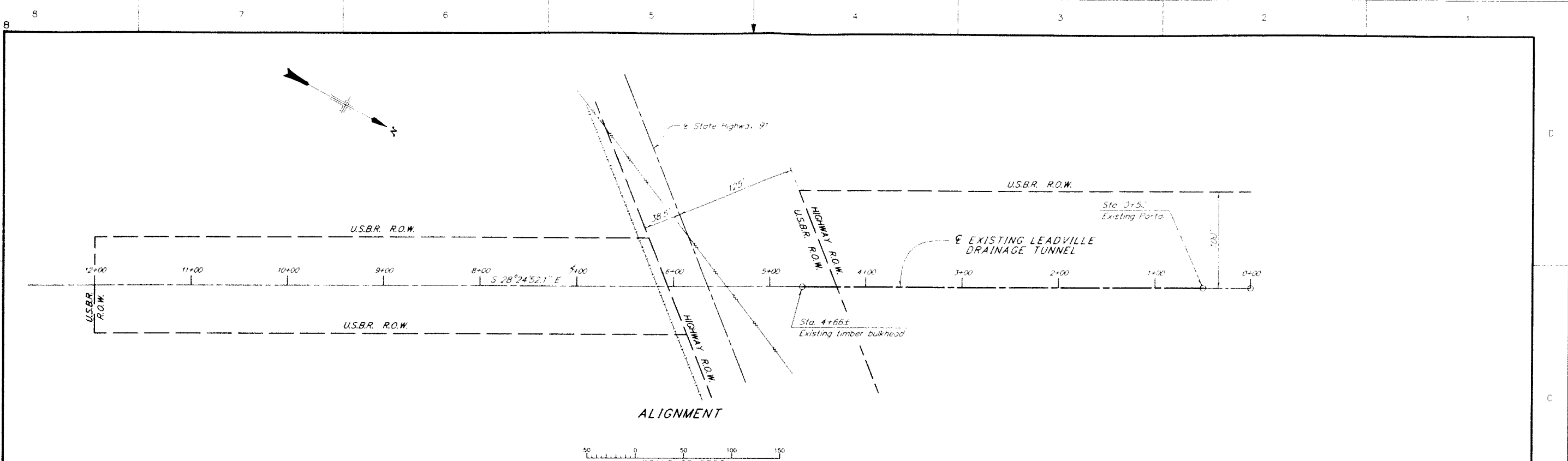

NOTES
 For Typical Tunnel Section, see (123).
 This drawing compiled from project drawings 382-706-4028 and 382-700-290.
 Sta. 0+50 Leadville Drainage Tunnel (this specification) = Sta. 0+38.06 of original Leadville Tunnel (circa 1943).

ALWAYS THINK SAFETY	
<small>UNITED STATES DEPARTMENT OF THE INTERIOR BUREAU OF RECLAMATION</small>	
LEADVILLE MINE DRAINAGE TUNNEL PROJECT - COLORADO	
TUNNEL LINING	
ALIGNMENT AND PROFILE	
DESIGNED: <i>Bob Scully</i>	TECHNICAL APPROVAL: <i>John Steigler</i>
DRAWN: <i>Bob Scully</i>	SUBMITTED: <i>W.D. & J. Shannon</i>
CHECKED: <i>[Signature]</i>	APPROVED: <i>W.D. & J. Shannon</i>
DESIGNED: COLORADO	FEBRUARY 8, 1989
1335-D-122	

LEADVILLE ALIGNMENT, M. DIS. 89/08/89 8944.41

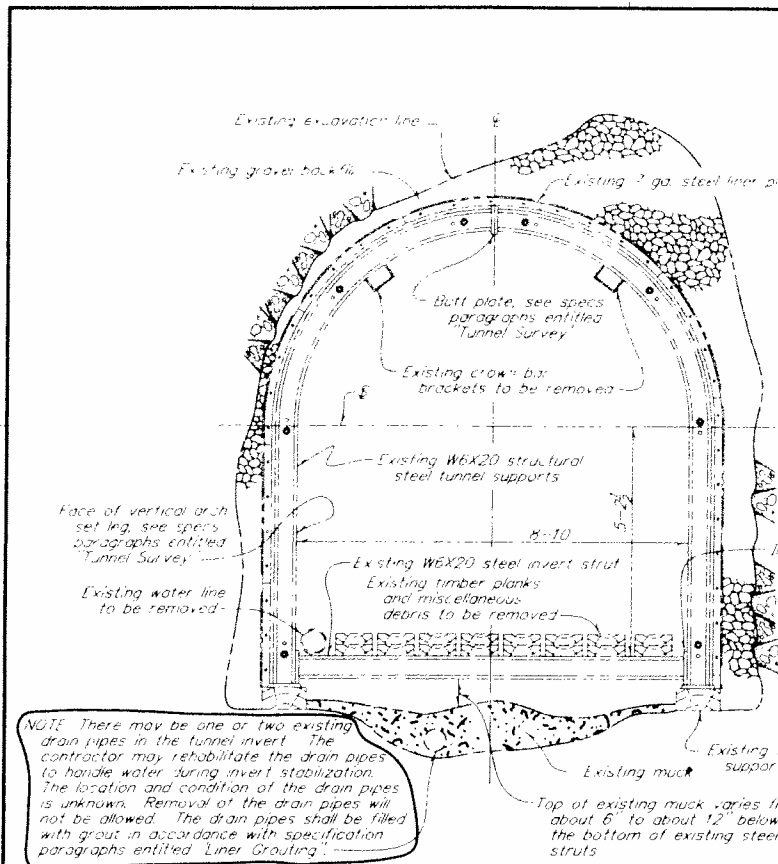

EXISTING TUNNEL SECTION

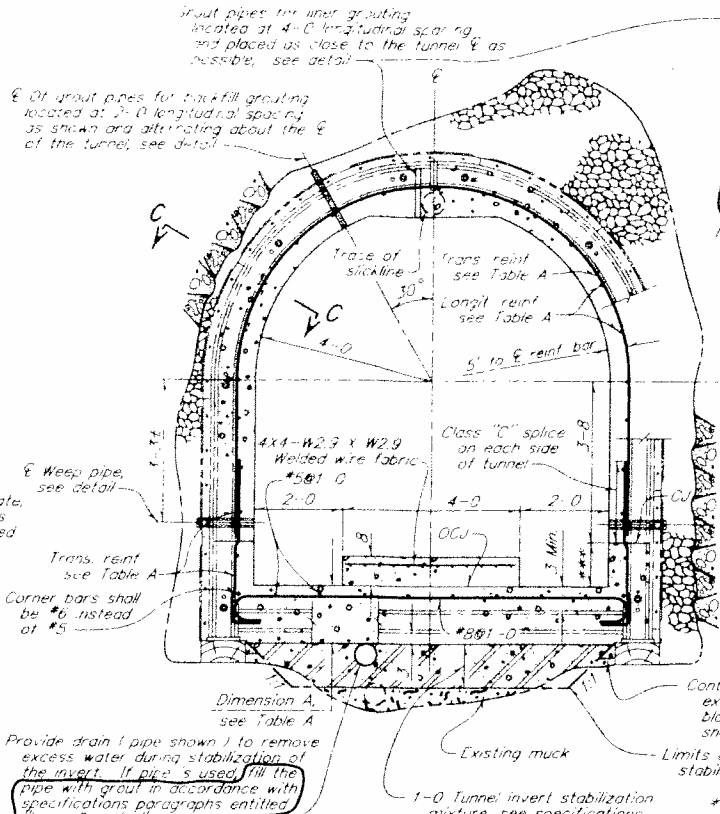
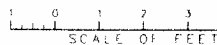

EXISTING TUNNEL SECTION WITH NEW CONCRETE LINING

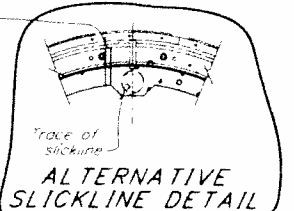

NOTE: The contractor shall maintain a minimum of 3" cover over existing steel ribs and strut when placing concrete tunnel lining. The contractor shall be allowed to place longitudinal bars directly against steel ribs and invert struts.

TABLE A

STATIONS	DIMENSION A	TRANS. REINF.	LONGIT. REINF.
STA. 0+54 to STA. 0+94	1-4 Min.	#7@1'-0"	#7@1'-0"
STA. 0+94 to STA. 4+26	1-0 Min.	#5@1'-0"	#5@1'-0"
STA. 4+26 to End of concrete lining (4+61.1)	1-0 Min.	#5@1'-0"	#8@1'-0"

GROUT PIPE DETAIL FOR LINER GROUTING

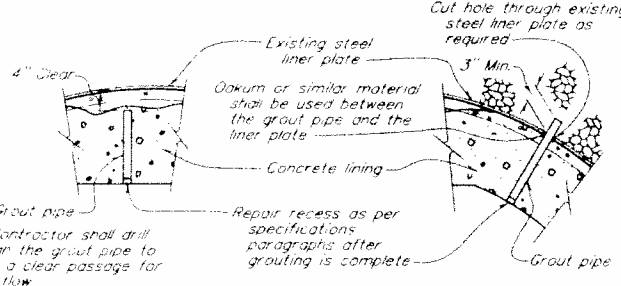

GROUT PIPE DETAIL FOR BACKFILL GROUTING

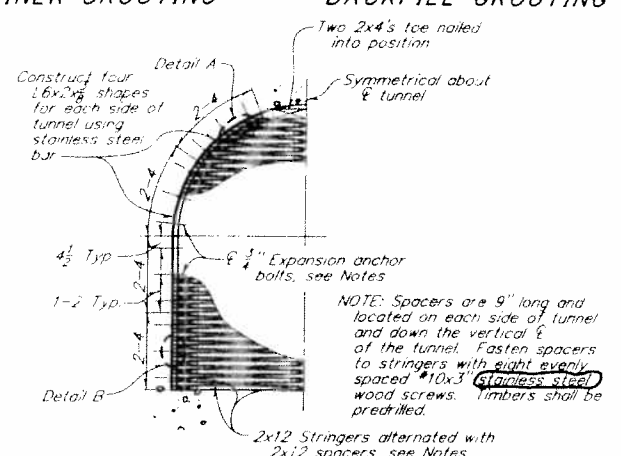

SECTION A-A

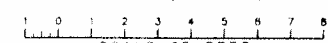

NOTES

For details of water handling during construction, see (160).
 For alignment and profile, see (122).
 For ventilation details, see (156).
 For lighting details, see (158).
 For general concrete outline notes, see 40-D-6517.
 Chamfers are required on all exposed concrete edges, see 40-D-6517.
 For general notes and minimum requirements for detailing reinforcement, Class 60, see 40-D-6263.
 Tunnel lining design is based on a specified compressive concrete strength (f'c) of 4,000 lbs. per square inch at 28 days, and reinforcement with a specified minimum yield strength (fy) of 60,000 lbs. per square inch. Splices for all longitudinal reinforcement bars shall be staggered.
 Backfill grouting pressure shall be 25 pounds per square inch. Liner grouting pressure shall be 20 pounds per square inch. Grouting shall not begin until the floor breakout and the cutoff wall have been placed. Grouting shall be in accordance with the specifications paragraphs.
 2x12 Timber stringers and spacers used in timber bulkhead shall be Douglas Fir-Larch, select structural grade.
 Expansion anchor bolts shall be stainless steel and embedded 9" min. into concrete.
 Holes drilled in L6x2 1/2's shall be 7/8" dia. Holes may be slotted in vertical direction to aid in installation.
 Gravel backfill shall be 1/2" to 2 1/2" nominal size. Gradation shall meet ASTM C 33, size No. 2.
 If the transverse bars are set back from the longitudinal bars to meet cover requirements on the transverse bars, the contractor shall provide a method to stabilize the transverse bar cages and also to tie the transverse bar cages to the longitudinal steel.

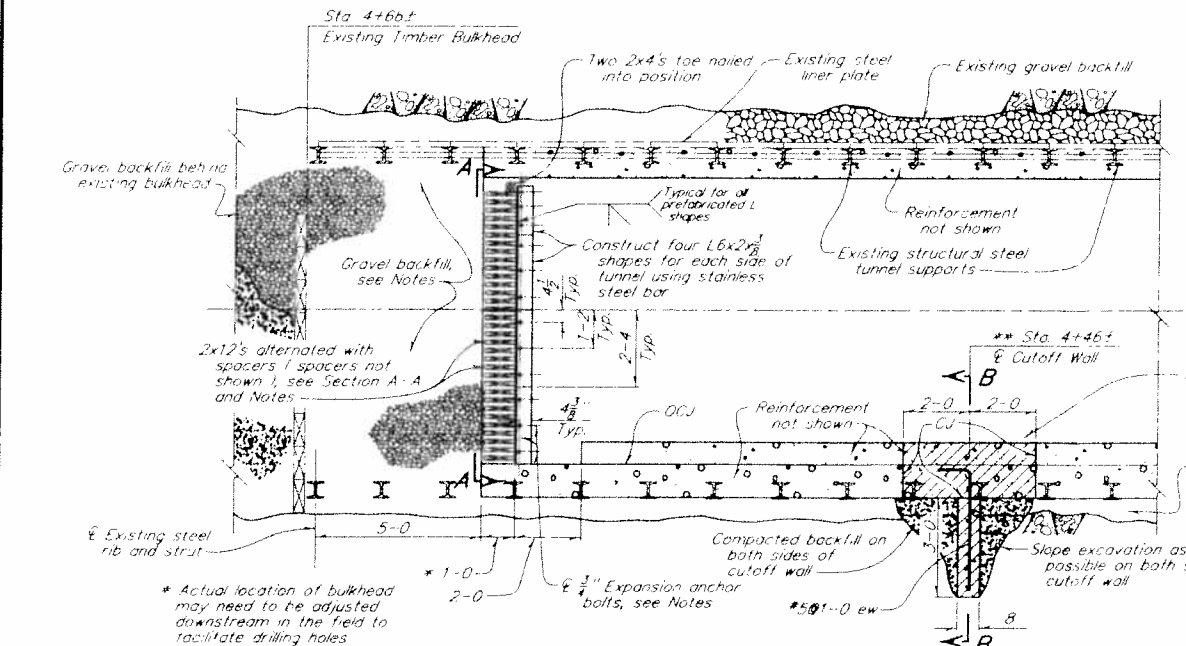

PROFILE OF EXISTING TUNNEL WITH NEW CONCRETE LINING NEAR EXISTING BULKHEAD

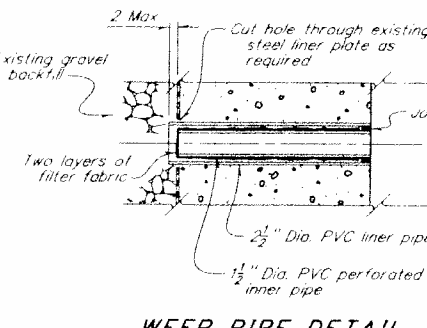

WEEP PIPE DETAIL

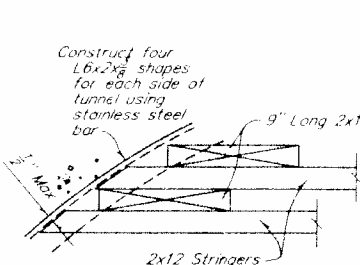
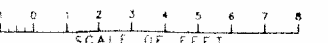

DETAIL A DETAIL B SIMILAR

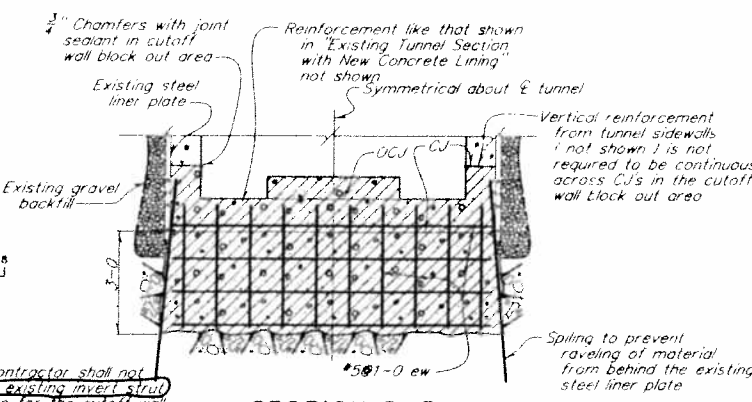

SECTION B-B

ALWAYS THINK SAFETY

UNITED STATES DEPARTMENT OF THE INTERIOR BUREAU OF RECLAMATION

LEADVILLE MINE DRAINAGE TUNNEL PROJECT - COLORADO

TUNNEL LINING

TYPICAL TUNNEL SECTION, CUTOFF WALL, AND TIMBER BULKHEAD

DESIGNED: William Kaufman TECHNICAL APPROVAL: Barbara R. Spitzer
 DRAWN: Bob Scully SUBMITTED: Paul F. Carlson
 CHECKED: John Narvaiz APPROVED: W. L. Long

DENVER, COLORADO FEBRUARY 15, 1985 1335-D-123

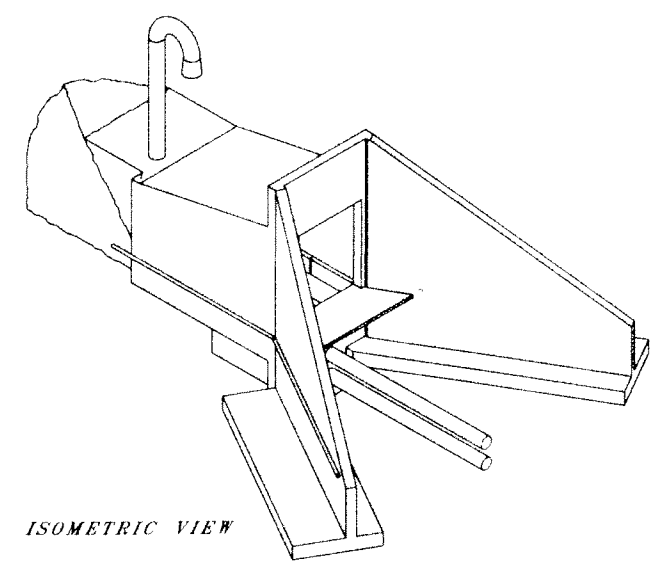
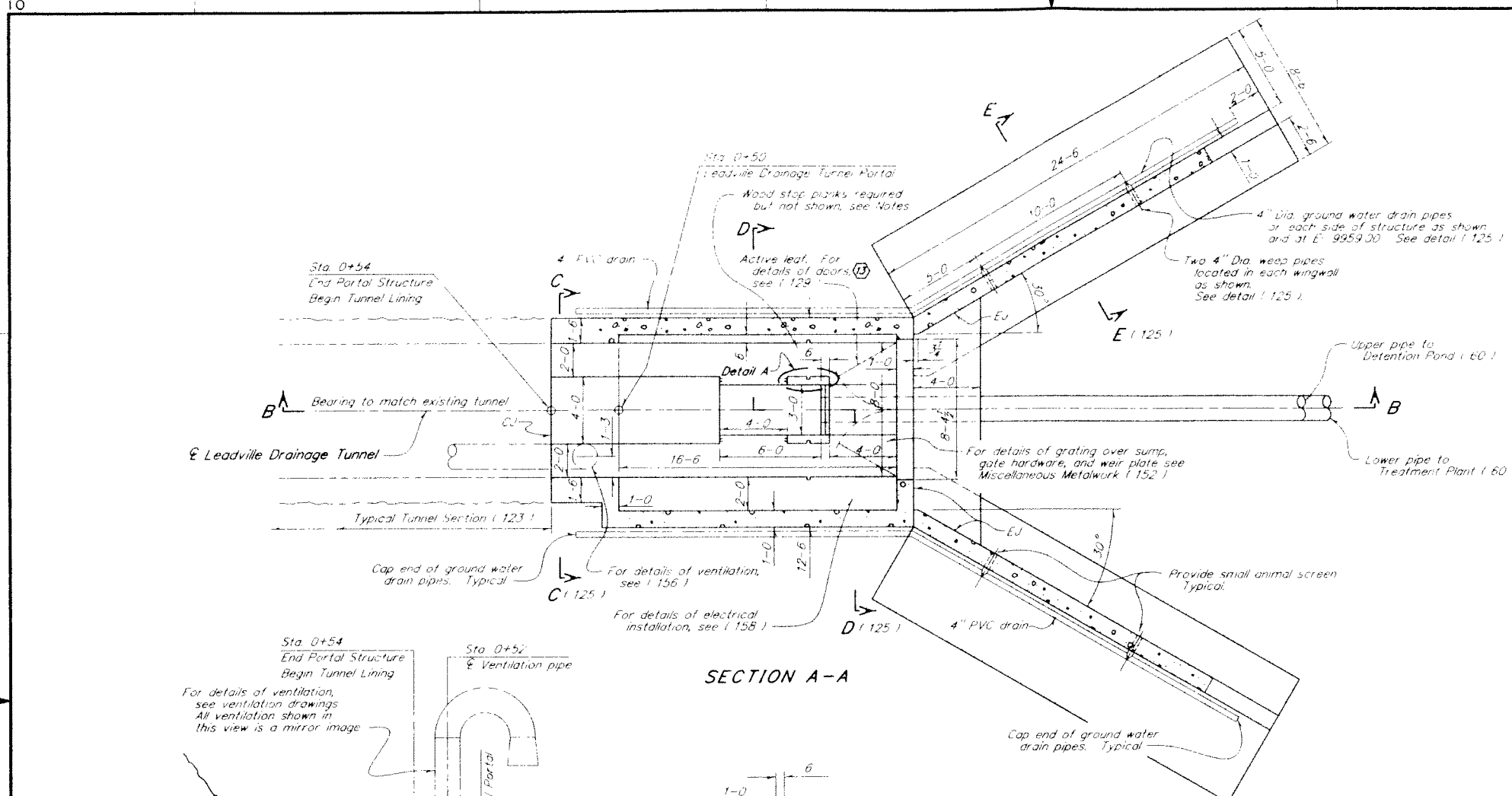

ISOMETRIC VIEW

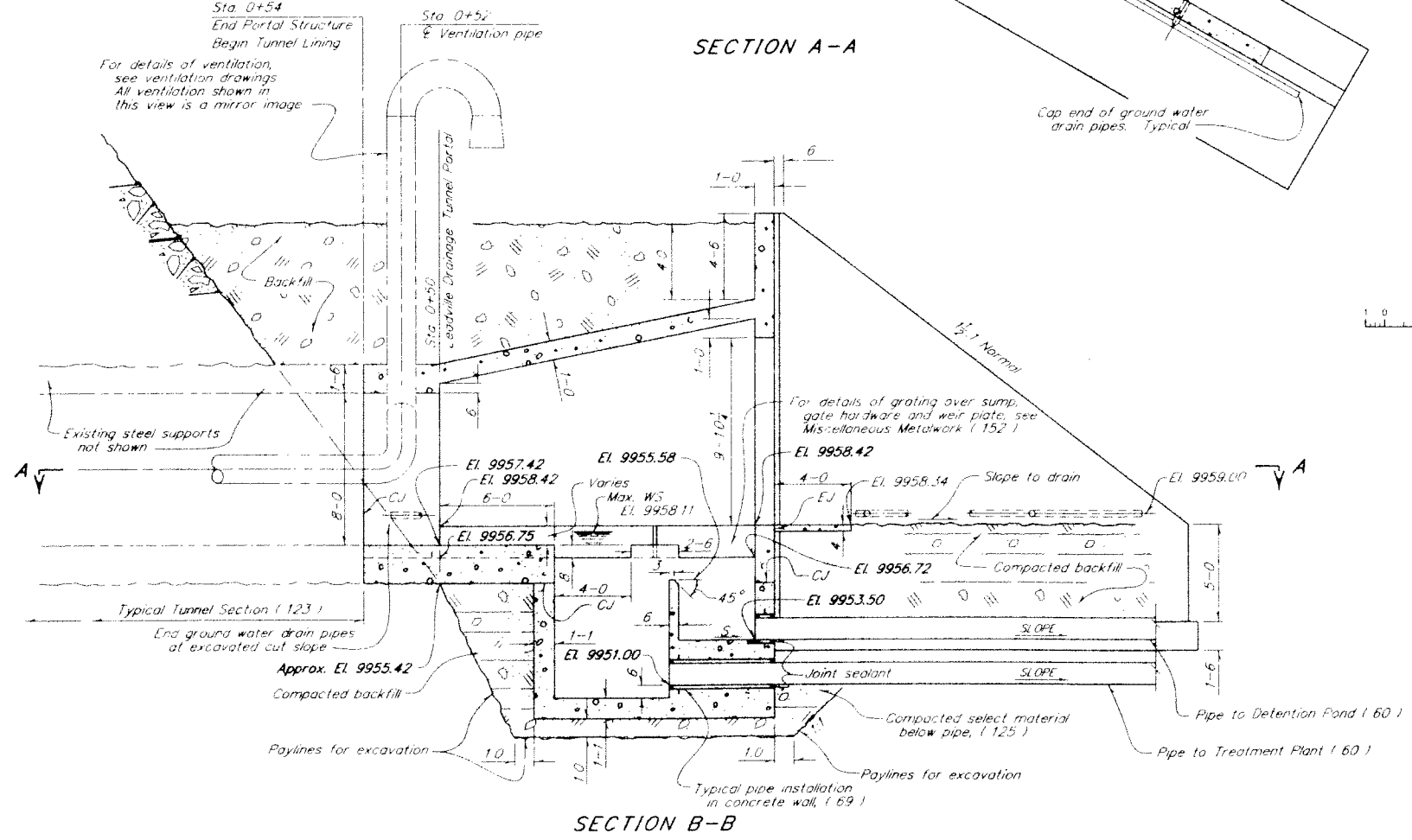

SECTION B-B

LEGEND

Glacial Moraine or Terraced Gravel

Designates door number, 129.

NOTES

For Outlet Portal Reinforcement, see 12c.)
 The contractor shall field check as built conditions of wood stop plank openings and provide wood stop planks to suit.
 Wood stop planks shall be in accordance with specifications paragraphs.
 For general concrete outline notes, see 40-0, BS17.
 Structural design is based on 4,000 pounds per square inch specified compressive concrete strength (f_c) at 28 days.
 Foundation for concrete structures shall be prepared as described in the specifications paragraphs.
 Structures shall be placed entirely on undisturbed earth, sound rock, or thoroughly compacted fill.
 Backfill shall not be placed against the structure below EL 9955.42 until 7 days after last concrete placement below that elevation.
 Backfill shall not be placed against the structure above EL 9955.42 until concrete has reached 28 day strength.
 The contractor shall not use heavy equipment to place backfill on top of structure.

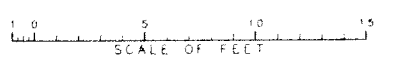

NOTE: Vertical dimensions of sump are not to scale.

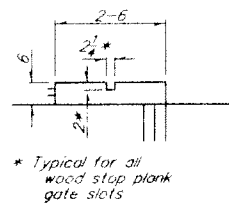

* Typical for all wood stop plank gate slots

DETAIL A

ALWAYS THINK SAFETY	
UNITED STATES DEPARTMENT OF THE INTERIOR BUREAU OF RECLAMATION	
LEADVILLE MINE DRAINAGE TUNNEL PROJECT - COLORADO	
TUNNEL LINING	
OUTLET PORTAL STRUCTURE	
ISOMETRIC VIEW, SECTIONS, AND DETAIL	
DESIGNED: <i>John Stewart</i>	TECHNICAL APPROVAL: <i>John Stewart</i>
DRAWN: <i>Bob Scully</i>	SUBMITTED: <i>K.D. Chapman</i>
CHECKED: <i>John Stewart</i>	APPROVED: <i>W.S. Long</i>
DENVER, COLORADO	MARCH 10, 1989
SHEET 1 OF 2	1335-D-124

LEADVILLE - PORTAL STRUCTURE NO. 514
 10/24/75
 08/28/84

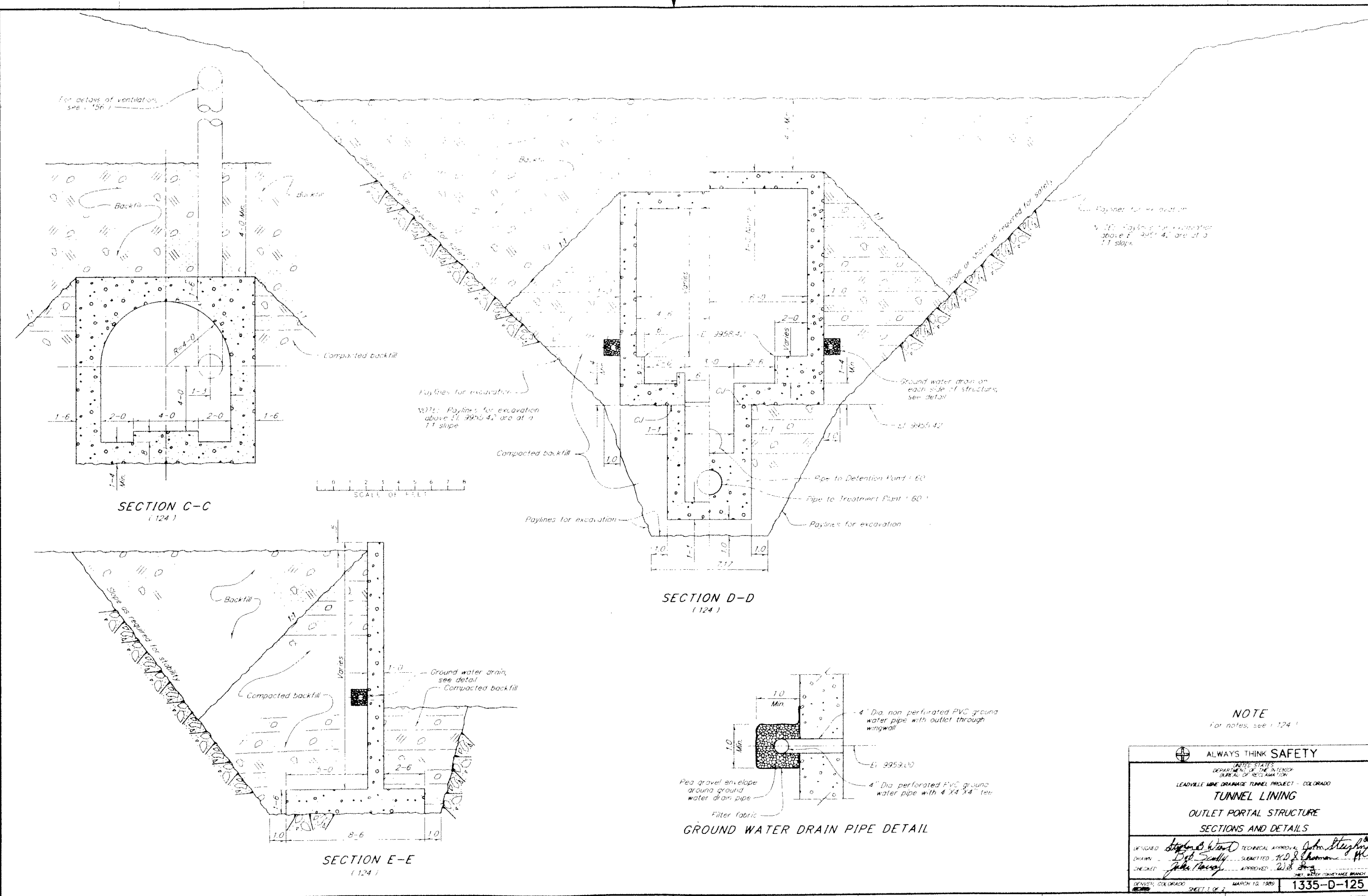

For details of ventilation, see 1241

SECTION C-C
(124)

SCALE OF 1/4" = 1'-0"

SECTION D-D
(124)

SECTION E-E
(124)

GROUND WATER DRAIN PIPE DETAIL

NOTE
For notes, see 1241

<p>ALWAYS THINK SAFETY</p> <p>UNITED STATES DEPARTMENT OF THE INTERIOR BUREAU OF RECLAMATION</p> <p>LEADVILLE MINE DRAINAGE TUNNEL PROJECT - COLORADO</p> <p>TUNNEL LINING</p> <p>OUTLET PORTAL STRUCTURE</p> <p>SECTIONS AND DETAILS</p>	
DESIGNED BY: <i>Stephen B. Wood</i> DRAWN BY: <i>Bob Scully</i> CHECKED BY: <i>Jude Hickey</i>	TECHNICAL APPROVAL: <i>John Stegeman</i> SUBMITTED BY: <i>W.D. & Associates</i> APPROVED BY: <i>W.D. & Associates</i>
DIVISION: COLORADO SHEET: WATER CONVEYANCE BRANCH SHEET 3 OF 3	MARCH 10, 1989 1335-D-125

SECURITY LEADVILLE PORTAL STRUCTURE BR. DISK
 8/16/89 891304

RECLAMATION

Managing Water in the West

Results of Geotechnical and Structural Analysis, Leadville Mine Drainage Tunnel

Leadville Mine and Drainage Tunnel Project, Colorado
Great Plains Region

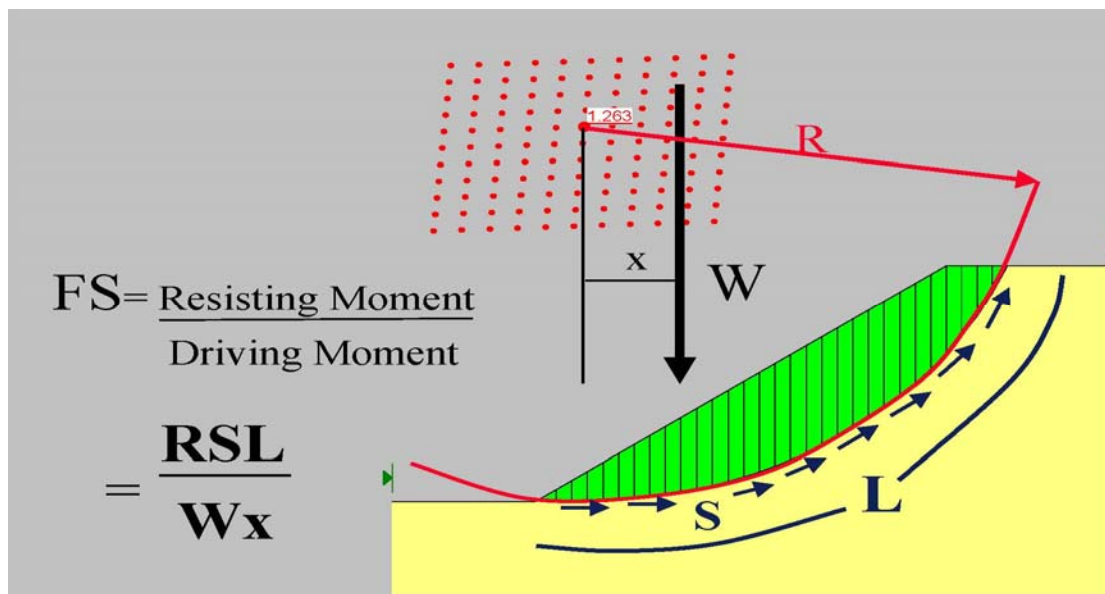

Mission Statements

The mission of the Department of the Interior is to protect and provide access to our Nation's natural and cultural heritage and honor our trust responsibilities to Indian Tribes and our commitments to island communities.

The mission of the Bureau of Reclamation is to manage, develop, and protect water and related resources in an environmentally and economically sound manner in the interest of the American public.

Results of Geotechnical and Structural Analysis, Leadville Mine Drainage Tunnel

Leadville, Colorado
Great Plains Region

Geotechnical Engineering

Prepared By:

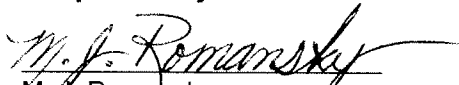
M. J. Romahsky



Roger L. Torres, P.E.

Jack Touseull, P.G., P.E.G., P.E.

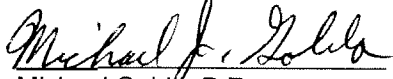
Checked By:



Michael Gobla, P.E.

Technically Approved By:

Michael Gobla, P.E.

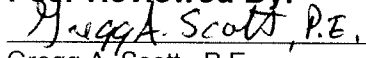
Peer Reviewed By:

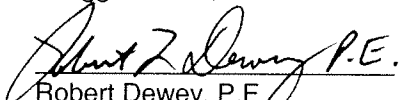
Gregg A. Scott, P.E.



Robert Dewey, P.E.

Civil Engineering

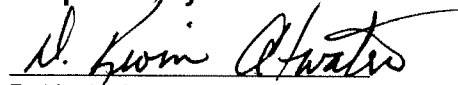
Prepared By:

D. Kevin Atwater

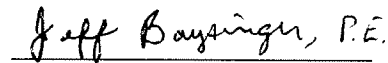
Checked By:

Jeff Baysinger, P.E.

Technically Approved By:

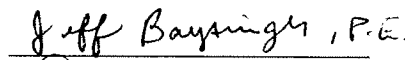
Jeff Baysinger, P.E.

Peer Reviewed By:

David Edwards, P.E.

Contents

	Page
1. Introduction.....	1
1.1. Establishment of the Mine Pool.....	3
1.2. Purpose	4
1.3. Summary of Results.....	6
2. Geotechnical and Structural Analysis.....	7
2.1. Stability of Flow Blockage in the Vicinity of the Pendery Fault.....	7
2.2. Stability of the Porous Plug Above the Timber-Lattice Bulkhead	15
2.3. Stability of Timber-Lattice Bulkhead.....	30
2.4. Stability of Tunnel Lining	35
2.5. Stability of Hillside in Vicinity of Portal.....	39
3. Conclusions.....	44
4. References.....	46

Figures

Figure 1. Location of the LMDT at Leadville, Colorado	2
Figure 2. Excavating to remove a boulder at the top of a collapse zone of shattered quartzite in the LMDT, note the mix of material sizes, taken from (Salsbury, 1956).	10
Figure 3. Required shear strength versus length of tunnel blocked from collapse in LMDT.	13
Figure 4. - Photograph taken in 2001 of the existing Timber Lattice Bulkhead installed in 1991 at Station 4+60 to 4+61. Note clarity of water outflow and 2.5-foot high flow with has been typical since post construction.....	16
Figure 5. Photograph taken on October 25, 1991 of the Timber-Lattice Bulkhead as construction was nearing completion showing the layer of cobbles at Station 4+62 of the LMDT.	17
Figure 6. Photograph taken on August 20, 1990 showing the porous bulkhead located at Station 4+66.	17
Figure 7. Plan and section showing condition of the LMDT in 1972 including the location of sinkholes, 1968 injection drill holes, and monitoring wells installed in 1968, taken from (Reclamation, 1976).....	19
Figure 8. Photograph taken May 21, 2008 showing the reinforced concrete LMDT Portal with 1-ft. thick wing walls.....	22
Figure 9. Driving force versus differential head and safety factor for an instantaneous increase of head at the upstream end (Station 5+92) of the plug	

in the LMDT. The additional resistance from the manmade bulkheads and porous cobble and gravel fills located from Station 4+61 to Station 5+00 are not included in the calculation. 27

Figure 10. Driving force versus safety factor for a diffusion of head along the plug from the upstream end at Station 5+92 to just above the porous fill at Station 5+00. Again the additional resistance provided by the manmade bulkheads and porous cobble and gravel fills located from Station 4+61 to Station 5+00 are not included in the calculation. 28

Figure 11. Water levels measured in wells at Stations 6+35 and 10+25. 30

Figure 12. Plan view of timber beam. 31

Figure 13. View of angle bracket and anchor bolt. 33

Figure 14. Excavation in May, 2008 into the Glacial Moraine at Leadville for installation of a pipeline under Highway 91 along the alignment of the LMDT. Note the steep slopes of the excavation and spoil banks indicating high shear strength of the soil. 40

Tables

Table 1. Required shear strength for assumed blockage lengths. 12

Table 2. Material properties for quartzite debris 14

Table 3. Results of five injection drill holes into the LMDT in 1968. 20

Table 4. Results of bulkhead components analysis. 34

Table 5. Results of Tunnel Lining Analysis. 38

Table 6. Physical Properties, Glacial Moraine (Qm). 40

Table 7. Physical Properties, Terrace Gravels (Qtg) 41

Table 8. Physical Properties, Minturn Formation (Pm). 41

Table 9. Mechanical Properties, Glacial Moraine (Qm). 41

Table 10. Mechanical Properties, Terrace Gravels (Qtg). 41

Table 11. Mechanical Properties, Minturn Formation (Pm). 41

Table 12. Seismic Loading for the LMDT Slope Stability Analysis. 42

Table 13. Piezometric Levels for Slope Stability Analysis LMDT. 42

Table 14. Results of Slope Stability Analysis. 43

Appendices

Appendix A - Drawing no. 1335-D-123 showing the Timber Bulkhead.

Appendix B - Spreadsheet for calculation of the plug stability against blowout for the instantaneous pressure condition.

Appendix C - Spreadsheet for calculation of the plug stability against blowout for the diffused pressure condition.

Appendix D - Slope Stability Calculation Results.

1. Introduction

This report was prepared to document studies performed to evaluate stability of the Leadville Mine Drainage Tunnel (LMDT). The LMDT is an underground excavation constructed by the Bureau of Mines during World War II and the Korean War to drain groundwater from metal mines located at Leadville in Lake County, Colorado (Figure 1). Collapse of the tunnel roof was a common occurrence during and after construction. Eventually a decision was made to place a porous bulkhead against a major zone of collapse near the portal and continue drainage operations at the LMDT using both flow through the bulkhead and by pumping water from extraction wells located upstream of the bulkhead. Expected continued roof collapse in upstream areas of the tunnel, have led to the establishment of impounded water referred to as the “mine pool” due to its connection with flooded and interconnected old mine workings.

The elevation of the mine pool water behind collapsed areas in the LMDT has been rising over the past few years. Area residents, local and state officials, and the EPA have expressed safety concerns relating to the possibility of a sudden release of water behind blockages or a massive slope failure of the hillside above the portal area. A small residential community, The Village at East Fork, is located adjacent to the LMDT portal. Also, the Bureau of Reclamation (Reclamation) operates a Water Treatment Plant located adjacent to the portal of the LMDT. In response to these concerns, Reclamation commissioned a qualitative risk assessment of the LMDT. The assessment of risks has been performed in three major steps which include:

- Determination of the existing condition of the LMDT including its history, details of construction, modifications, and current operations.
- Identification of potential failure modes and effects analysis (PFMEA) including identifying opportunities for data gathering, risk reduction, and monitoring enhancement activities which can enhance project safety.
- Structural analysis of specific LMDT features associated with potential failure modes to better understand the mechanism of failure and the likelihood of occurrence.

Finally, a review and adjustment of the PFMEA was made in light of the analysis results. Separate reports have been prepared for each of the above major steps of investigation. The report titles are:

Existing Condition of the Leadville Mine Drainage Tunnel

Potential Failure Modes and Effects Analysis, Leadville Mine Drainage Tunnel

Results of Geotechnical and Structural Analysis, Leadville Mine Drainage Tunnel

Results of Geotechnical and Structural Analysis, Leadville Mine Drainage Tunnel

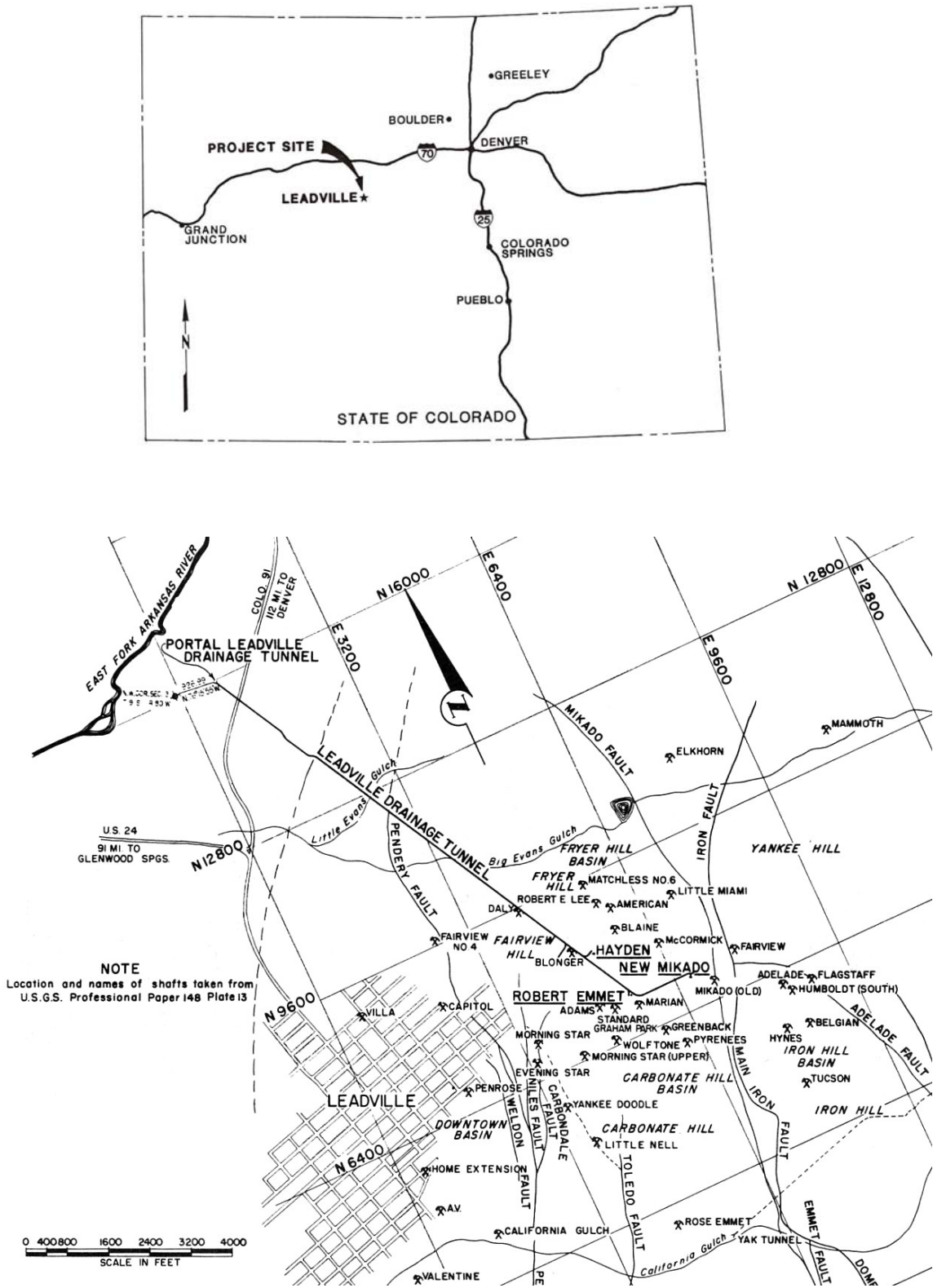

Figure 1. Location of the LMDT at Leadville, Colorado

1.1. Establishment of the Mine Pool

The LMDT has a history of roof collapse both during and after construction. Additional details about the history, operation, and features of the LMDT can be found in a report titled “Existing Condition of the Leadville Mine Drainage Tunnel” (Gobla and Vandeberg, 2008). After construction, the deterioration of the strength of some rock units, timber, and steel supports resulted in additional roof collapses throughout the LMDT which were repaired on an as needed basis until 1968 when a major collapse about 500 feet into the tunnel threatened the overlying Highway 91. The collapse dammed off much of the flow previously draining through the tunnel. Some flow continued to pass through the existing tunnel ventilation and compressed air pipes which were in the zone of collapse. The collapsed area was modified by injection of sand and gravel into the collapsed portions of the tunnel, injection of grout into voids in the overburden above the tunnel, and installation of a porous bulkhead at Station 4+66 to reinforce the downstream side of the collapsed zone, thus forming a porous hydraulic plug to support the overlying highway and hillside and protect against rapid release of the water backed up by the plug. Because this porous plug significantly reduces the transmission of water which was previously free draining from the tunnel, water extraction wells fitted with pumps were installed upstream of the plug to continue drainage operations. In the 1970s there were continued problems with minor sinkholes developing in the lower portion of the LMDT. In 1990-92 a new concrete portal and a reinforced concrete tunnel liner were constructed along the lower reaches of the tunnel to prevent further occurrences of sinkholes. Five feet of additional gravel and cobble fill was placed between the porous bulkhead at Station 4+66 and a second porous “timber lattice” bulkhead was constructed at Station 4+61 and tied to the new concrete tunnel liner.

In response to suspected additional tunnel collapses, a pool of water has been building up within the abandoned mine workings connected to the LMDT. As the water flow from the mine workings is further impeded down the tunnel, the water level rises in hydraulically interconnected mine workings, thus forming a “mine pool.” Extraction wells located at Station 10+25 yield no more than about 750 gpm of water. Monitoring of water elevations along the LMDT alignment shows that there is a differential head of about 119 feet between the groundwater level in observation wells located at Station 36+77 and Station 46+66. This segment of the tunnel between these wells crosses the Pendery Fault. Based upon the geology and history of the LMDT, it is believed that a significant zone of collapse exists just downstream of the fault, just under $\frac{3}{4}$ mile in from the portal, and that this collapse is impeding flow and causing the rise in the mine pool water elevation. It is likely that the zone of collapse is not a complete barrier to flow. Ventilation and compressed air pipelines from the initial construction left inside the tunnel are believed to have been engulfed in the collapse debris in a similar fashion as to what was observed at a collapse further downstream in the tunnel. These conduits likely penetrate through the blockage and transmit limited amounts of water. In summary, there are believed to be at least two major

blockages to flow in the tunnel, a lower blockage and an upper blockage. The lower blockage is the porous plug consisting of two gravel filled bulkheads supporting the overlying and adjoining collapse material below the highway which was stabilized by injection of fill. The upper blockage is believed to be a zone of collapsed rock downstream of the Pendery Fault.

1.2. Purpose

The purpose of this report is to present the results of geotechnical and structural analyses performed to evaluate the structural stability of the LMDT and portal hillside area. A total of seven potential failure modes were identified for the LMDT and documented in a separate report titled “Potential Failure Modes and Effects Analysis, Leadville Mine Drainage Tunnel” (Reclamation, 2008). The seven potential failure modes are summarized below:

Potential Failure Mode No. 1 – Breach in Upstream Tunnel Blockage results in “Blowout” of Downstream Bulkheads

Description

Breach of a tunnel blockage near the Pendery Fault results in increased head and flow in the downstream tunnel which results in breaches of the downstream tunnel blockages and bulkheads. The mine pool is released out the tunnel portal at a high flow rate.

Potential Failure Mode No. 2 – Breach in Upstream Tunnel Blockage results in Rapid Erosion Breach of Downstream Slope Materials

Description

This potential failure mode begins in a similar manner to Potential Failure Mode No. 1, except that as the increased water pressures reach the downstream blockages and bulkheads, they hold. The groundwater levels and flow rates could then rise along the outside of the tunnel. If erosion of the material at the downstream slope face begins, progressive erosion and slumping of material or “piping” could progress upstream through the hillside until a connection was made to the tunnel upstream of State Highway 91, resulting in a rapid release of water. A potential additional complication could involve collapse of the concrete tunnel lining downstream of the bulkheads (from the portal, Station 0+54, to Station 4+61), resulting in sinkholes that shorten the seepage path to the tunnel upstream of the highway.

Potential Failure Mode No. 3 – Breach in Upstream Tunnel Blockage results in High Downstream Groundwater Levels and Slope Instability

Description

Breach of an upstream tunnel blockage near the Pendery Fault could result in increased water pressure in the downstream portion of the tunnel and a rise in the

adjacent groundwater level. Given that the downstream tunnel blockage under State Highway 91 and the bulkheads hold, the groundwater level outside of the tunnel could then rise to unprecedented levels. The increase in pore pressures within the gravel soils near the portal could result in slope instability, and movement of earth materials and water into and adjacent to the tunnel portal area.

Potential Failure Mode No. 4 – Breach in Upstream Tunnel Blockage results in Leakage of Contaminated Water into Downstream Areas

Description

Breach of a tunnel blockage near the Pendery Fault results in higher water pressures in the downstream tunnel and higher groundwater levels above the downstream portion of the tunnel. The blockage under State Highway 91 and bulkheads hold, but water contaminated with heavy metals seeps through the pervious gravels into low lying areas, possibly exiting at Evans Gulch, Little Evans Gulch, or more likely the tunnel portal. It is possible that water could also flow toward California Gulch if the groundwater levels over the downstream portion of the tunnel rose to high enough levels.

Potential Failure Mode No. 5 – Earthquake Triggers Slope Instability near Tunnel Portal

Description

A major earthquake causes instability of a large portion of the slope adjacent to the downstream tunnel portal resulting in impacts to this area. This could be triggered under normal groundwater conditions, or as a result of elevated groundwater conditions due to breach of a blockage upstream near the Pendery Fault.

Potential Failure Mode No. 6 – Seepage Erosion into Tunnel Causes Sinkholes and Loss of the Highway

Description

Under this scenario, high groundwater outside the tunnel would result in a gradient that could carry soil material into the tunnel. The loss of material overlying the tunnel would then result in voids that could stope to the surface, creating sinkholes that would affect State Highway 91. For this to occur, the water pressure outside the tunnel would need to be higher than inside.

Potential Failure Mode No. 7 – Flow at Tunnel Portal Plugs Off, Raising Groundwater and Causing Slope Instability

Description

For this potential failure mode to initiate, impervious fines would need to be carried into the tunnel, filling the voids in the downstream tunnel to the point where drainage through the tunnel is impeded, raising the groundwater level

outside the tunnel and leading to slope instability. The initial water level outside the tunnel would need to be higher than inside the tunnel, and the tunnel would need to be acting as a drain for the slopes near the portal.

A review of the failure modes indicates that elevated groundwater conditions in and adjacent to the downstream portion of the tunnel is a common theme with respect to the loading conditions which might lead to failure. Considering the loading conditions which might reasonably occur, the following are evaluated in this report:

- Stability of a flow blockage in the vicinity of the Pendery Fault
- Stability of the porous plug above the Timber-Lattice Bulkhead
- Stability of the Timber-Lattice Bulkhead
- Stability of the Concrete Tunnel Lining
- Stability of the Hillside above the Portal

1.3. Summary of Results

Based upon the detailed analysis documented in this report, it is concluded that the blockage near the Pendery Fault is likely due to a zone of roof collapse located downstream from the fault. The blockage is stable and currently resists the force exerted by 119 feet of differential head. However, the likelihood of the blockage remaining stable decreases with increased head differential. For that reason, all analyses and potential failure mode assessment conservatively assumes rapid failure of the blockage.

The forces acting on the plug of porous material and lattice bulkhead due to the pressure wave resulting from failure of a blockage near the Pendery Fault would not be great enough to overcome the existing shear strength of the material and move it.

Wells at Station 10+25 and at Station 6+35 would be likely to experience artesian flow conditions and relieve some of the pressure. The amount and height of flow would be limited by head losses in the LMDT and by those caused by the well casing and pumping rates.

It would take a significant period of time for the increased water pressures to seep through the 130-foot-long seepage pathway from the upstream end of the plug near Station 5+92 to the soils around the LMDT near the Timber-Lattice Bulkhead and Tunnel Liner at Station 4+61. The elevated groundwater levels would likely drain off into the surrounding terrace gravels near Station 6+00. If groundwater levels near the bulkheads were to rise unexpectedly, there would be

a warning because this condition would be detected by the groundwater observation well at Station 4+70.

In the very remote event that groundwater levels near the Timber-Lattice Bulkhead and Tunnel Liner at Station 4+61 were to rise to levels which could collapse the tunnel lining, and despite preventative actions a collapse occurred, a blowout is not expected to follow. It is noted that failure of the concrete liner and/or bulkhead would leave a considerable length, (130-feet) of terrace gravels between the point of collapse and the water released from the mine pool, in turn raising the water head in the tunnel downstream from the Pendery Fault.

Failure of the hillside due to slope instability is highly unlikely. Analysis shows that soil strengths would need to be lower than currently estimated for a failure to occur. In conclusion, engineering analysis indicates that neither blowout nor slope failure are likely to occur.

2. Geotechnical and Structural Analysis

The following chapters of this report present the details of the geotechnical and structural analysis of key features associated with the LMDT. First, the stability of a tunnel collapse flow blockage in the vicinity of the Pendery Fault is evaluated. Next, it is assumed that the blockage near the Pendery Fault has failed and the effects upon the manmade and natural porous plug located between Stations 4+61 and 6+30 are analyzed. Then, the structural stability of the Timber-Lattice Bulkhead and the Concrete Tunnel Lining are evaluated. Finally, the slope stability of the hillside around the Portal is analyzed assuming an increase in the groundwater levels near the portal.

2.1. Stability of Flow Blockage in the Vicinity of the Pendery Fault

An increase in the groundwater levels in the upper reaches of the LMDT and the hydraulically connected old mine workings, has been measured and is commonly referred to as the “mine pool.” The elevated groundwater levels are transmitted down the tunnel at least as far as the observation well at Station 46+66. Down station from this point, the groundwater level decreases as indicated by water level measurements from the observation well located at Station 36+77. There is approximately 119-feet of differential head due to the change in groundwater levels between the two observation well locations. A collapse in the tunnel resulting in formation of a flow blockage is believed to have occurred somewhere between the observation wells at Stations 36+77 and 46+66. The Pendery Fault forms a water barrier which apparently prevents water from circumventing the blockage and passing through defects in the rock adjacent to the LMDT.

Concerns manifested that further increases in the mine pool level could increase the differential head and cause a rupture of the blockage leading to adverse consequences near the tunnel portal such as a slope failure or a “blowout” (sudden catastrophic release) of the mine pool.

2.1.1 Location of Flow Blockage

Prior to this study, it was thought that the blockage was due to tunnel roof collapse at the Pendry Fault. Detailed examination of construction and operation records indicate that the area of blockage is unlikely located within the limits of the Pendry Fault, but rather is thought to be in the adjacent area of the tunnel below the fault. This reasoning is threefold.

First, Bureau of Mine’s reports from construction and post construction state that the Pendry Fault portion of the LMDT was reinforced and concreted. Later observations, through downhole camera work, found the tunnel open and well supported by the concrete encased shoring (Gobla and Vandenberg, 2008). The fault area likely remains open due to the level of support provided during tunnel construction.

Second, just downstream of the Pendry Fault, the tunnel had a history of collapse during construction through zones of quartzite which filled the tunnel for long distances with the running ground. During later operations there were several reports of heavy ground, decaying timbers, and minor collapse of supports. The most likely blockage location is just downstream of the fault between Stations 38+50 and 40+70 within the Parting Quartzite where a section of 46 consecutive timber sets showed signs of dry rot during inspections in 1955. In January, 1955 collapse of two sets near Stations 40+35 to 40+40 formed a dam which backed up water 2.5 feet deep in the tunnel and prompted the recommendation to replace all 46 timber sets. Only six light steel sets were placed in the vicinity of the collapse, the recommended replacement of all 46 decayed timber sets was never completed. Thus, a zone of roof collapse likely extends for a significant distance along the tunnel below the fault.

Third, it is unlikely that the Pendry Fault or any of the rock units in this section are pervious enough to rapidly drain the water from the tunnel, thus a collapse is necessary to explain the differential head. The Pendry Fault, encountered from Stations 40+75 to 40+95, is a normal fault. It is steeply dipping to the northwest. Geologic data defines the Pendry Fault as a hydraulic barrier that prohibits the horizontal movement of groundwater across its boundary, but which can transmit flow along (parallel to) the fault. There has been speculation that leakage of mine pool water into California Gulch is presumably occurring along the Pendry Fault; however, it is not likely that there is a significant inflow from the LMDT into this fault. When the fault was encountered during LMDT construction, it was said to have made “some water” which was a surprise to the tunnel builders who were expecting a large inrush of water. Furthermore, across the fault zone, the tunnel was reinforced with concrete which would be a barrier to flow from the

LMDT to the fault. Other underground mine workings contact and penetrate the Pendery Fault, if there is significant flow of mine water along the fault it likely is due to connections with the old mine workings.

2.1.2 Nature of Flow Blockage

Based on the length of tunnel reported to contain dry rot timber supports, a considerable length of tunnel (up to about 200 feet, from Stations 38+50 to 40+75) could be collapsed. This would include both dolomite and quartzite types of rock. The rock downstream of the Pendery Fault is typically more fractured. The dolomite on the downstream, 'Hanging Wall' side of the Pendery Fault was reported to be blocky, and fractured, but was only lightly supported. As the supports deteriorate, loads from the blocky rock may become too much, and a collapse would result. Several zones of fractured dolomite, and a long zone of fractured Parting Quartzite was penetrated by the tunnel excavation downstream of the Pendery Fault.

When the tunnel would collapse during construction, large lengths of the tunnel (reports of 40 to 100 feet) would fill with flowing debris that would eventually stabilize and allow work to resume. Excavation of the inflow debris would often result in resumption of running ground until another blockage to the flow would establish. The tunnel builders eventually learned to bulkhead and inject grout into the inflow debris prior to excavation. Twenty vertical feet of roof collapse is another common dimension referenced in reports. This is the distance that stoping occurred up and beyond the original tunnel crown and typically the entire tunnel and much if not all of the stope was filled with debris.

Debris from the Parting Quartzite is likely non-plastic. A collapse zone in the Parting Quartzite would contain a mixture of blocks, gravel, and sand-sized particles which would likely form a "filter" as the finer particles catch against the coarser particles, making such a zone less susceptible to seepage erosion or piping. Even if the mixture was internally unstable and the fines were washed out, the remaining assemblage of coarse interlocked particles would limit flow through the blockage, and would retain high shear strength, see Figure 2.

The debris was likely deposited through standing water. Side pressure could increase the normal stress and shear strength of the blockage; however, the effects of side pressure from the tunnel walls were not observed in this reach of the tunnel. Therefore side pressures would only be generated by the submerged weight of the collapse debris itself pushing against the tunnel walls. It is assumed that there would not be any significant amount of overburden pressure due to eventual formation of an arch in the fractured rock over the debris pile.

The maximum head on the upstream side of a tunnel blockage likely is limited by the elevation of the top of rock where the overlying pervious terrace gravels would quickly drain away any excess head that would rise above the bedrock interface with the gravels. The exact elevation and location of this hydraulic

control is unknown, as it likely occurs at a low bedrock contour elevation off the tunnel alignment. To date, the highest water elevation observed is approximately 10,150 feet which is 163 feet above the tunnel invert at the monitoring well located at Station 96+44.

Finally, based upon observations of actual flow blockage due to roof collapse further downstream in the LMDT, the 20-inch ventilation pipe is likely to be partially collapsed by the force of the collapse and the thicker 8-inch diameter compressed air pipe may still be intact and carrying significant flow (250 gpm). This would explain how observed turbidity changes and injected dye can be rapidly transmitted to the Water Treatment Plant from the upstream areas of the LMDT, and yet a blockage still exist. Although some flows are allowed to pass through the embedded pipes, the collapse debris could still be impeding most of the flow thus creating the observed differential head.



Figure 2. Excavating to remove a boulder at the top of a collapse zone of shattered quartzite in the LMDT, note the mix of material sizes, taken from (Salsbury, 1956).

2.1.3 Forces Acting on the Flow Blockage

As stated, the blockage is comprised of rock blocks as well as gravel, and sand-sized particles. Fine-grained particles are not expected to be present in appreciable quantity because of the nature of the geology at this location. The actual height and length of the collapse debris mass forming the flow blockage is unknown but likely extends above the tunnel crown and encompasses many of the “dry rot” timber sets. In order to calculate a Factor of Safety (FS), the ratio of the summation of forces resisting divided by the summation of forces driving, would require certain knowledge of the actual length, vertical extent, contact area, weight and frictional resistance of the collapse material. As these are unknown, the forces are also not calculable with certainty. However, determining the minimum shear strength required to maintain a plug in place, while resisting the differential head can begin to express the stability of the blockage with more certainty as fewer inputs are required.

The Shape of the original tunnel excavation immediately downstream of the Pendry Fault in the area where it is assumed that the collapse and subsequent blockage has resulted is a modified horseshoe 11 feet wide and 12.5 feet high. This shape is calculated to have a contact perimeter of 42 feet. The face loading area was calculated to be 125 ft². Based upon water level elevations measured in observation wells at Station 37+77 and 46+66, a differential head of 119 feet exists. Calculations using differential heads of 100 feet and 150 were used to compute the driving force and shearing resistance necessary to maintain a FS of 1.0 against shearing at the perimeter. Values lower than 1.0 indicate potential instability, while those increasingly higher than 1.0 indicate increasing stability.

The driving force on the face of the blockage was computed by multiplying the differential head for each case by the face loading area. Those values are:

- For 100 feet of differential head: $100 \text{ ft.} \times 62.4 \text{ lbs/ft}^3 \times 125 \text{ ft}^2 = 780,000 \text{ lbs}$
- For 150 feet of differential head: $150 \text{ ft.} \times 62.4 \text{ lbs/ft}^3 \times 125 \text{ ft}^2 = 1,170,000 \text{ lbs}$

Next the driving force is divided by the contact area in square inches (contact perimeter times blockage length) to obtain the shear strengths required per square inch of contact area for stability at various assumed blockage lengths. The results are presented in Table 1.

Table 1. Required shear strength for assumed blockage lengths.

Differential Head 100 feet	
Blockage Length feet	Required Shear Strength lb/in ²
10	13
25	5
50	3
100	1
Differential Head 150 feet	
Blockage Length feet	Required Shear Strength lb/in ²
10	19
25	8
50	4
100	2

The results of the calculation are shown graphically in Figure 3 where the data are plotted as required shear resistance vs. length on the y and x axis respectively. Two plots, the upper representing the differential head of 150 feet, and a lower representing the differential head of 100 feet are shown. Both are asymptotic. The curves are down trending with a decrease in required shearing resistance as the length of the blockage (and total frictional contact area) increases. As expected, more shearing resistance is required to hold the larger differential head of 150 feet. Further, the shearing resistance required is seen to decrease as the length of the blockage increases.

For a length of blockage of less than thirty feet, the amount of shear strength required to maintain the blockage in place rapidly increases. At blockages greater than about 50 feet in length, the required shear strength is small and does not change significantly with increasing blockage length. The calculation is a simplification of the actual situation, but is useful in showing the approximate range of frictional shear strength needed for various lengths of blockage to resist the driving force caused by the differential head.

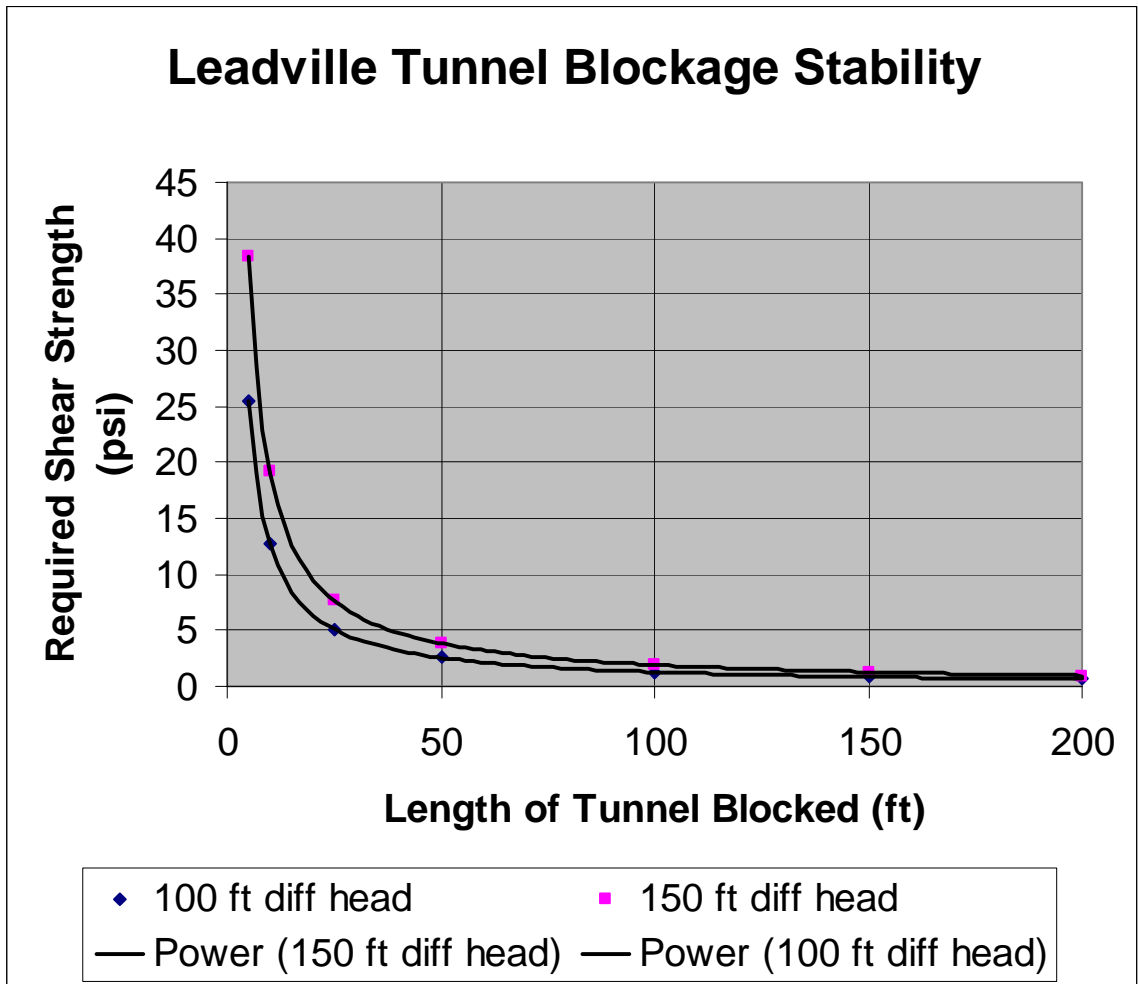

Figure 3. Required shear strength versus length of tunnel blocked from collapse in LMDT.

In reality, the roof of the tunnel above the debris is not likely to provide much frictional resistance before movement starts, if any, due to a lack of a normal force. The sides will provide less resistance than the floor prior to shearing due to differing normal forces. On the other hand, the surfaces of the tunnel in this analysis were characterized as smooth surfaces of uniform shape for the entire length. The actual conditions would be very rough and irregular, thus significantly adding to the shear strength. Also, the debris contains numerous angular rock fragments which would tend to rotate during shearing causing the fill to dilate upon initiation of movement. This would tend to increase the normal forces along the tunnel walls thus adding to the frictional strength. The material above the roof would be sheared at the roof line of the downstream tunnel opening upon movement. This would mobilize additional strength.

The next logical question is, can the required shear strength values indicated actually be achieved by a reasonable length of collapse debris in the tunnel? This question is addressed in the following section of this report.

2.1.4 Likely Strength of the Upper Flow Blockage

The shear strength derived from surface friction prior to movement is equal to the normal force times the tangent of the interface friction angle. Assuming an arched roof forms, there is no overburden pressure acting on the debris in this section of the tunnel other than the debris pile itself. Therefore, the normal force acting on the floor of the tunnel is equal to the submerged weight of the overlying debris. The normal force acting along the sides of the tunnel is equal to the submerged weight of the overlying debris times some factor for the side earth pressure. Also, the normal force along the sides varies from a maximum at the base of the debris pile to no force at the top of the pile. The 11-ft wide by 12.5-ft tall portions of the tunnel which remain intact within and below the collapsed segments will act as a shear key preventing movement of the upper portions of the debris. This would mobilize the strength of the material if movement initiates.

Using this rationale, the likely shear strength due to friction is calculated. The following material properties are assumed for the quartzite debris:

Table 2. Material properties for quartzite debris

Property	Value
Submerged Unit Weight	77.6 lb/ft ³
Friction Angle	35 degrees
Cohesion	0
Coefficient of at rest earth pressure (K ₀)	0.43 (1 – sin Ø)

For a unit length of 1 foot along the tunnel, and assuming a debris pile height of 20 feet, the frictional strength is estimated as:

For the 11-foot wide tunnel floor (assuming a 20-foot high debris pile):

$$F = \text{height} \times \text{submerged weight} \times \text{Tangent of the friction angle} \times \text{width}$$

$$F = 20 \text{ ft.} \times 77.6 \text{ lb/ft}^3 \times \tan(35) \times 11 \text{ ft.} = 11,950 \text{ lbs/ft of tunnel length.}$$

For the tunnel walls (below the roof):

$$P_0 = \frac{1}{2} K_0 \times \text{submerged weight} \times \text{height}^2 \quad (\text{for one wall})$$

$$P_0 = \frac{1}{2} \times 0.43 \times 77.6 \text{ lb/ft}^3 \times (12.5 \text{ ft})^2 = 2,546 \text{ lbs/ft of tunnel length.}$$

$$\text{Double the value for two walls} = 5,092 \text{ lbs/ft of tunnel length.}$$

Total frictional resistance = 11,950 lbs/ft + 5,092 lbs/ft = 17,043 lb/ft of tunnel length or about 3.3 lb/in².

Using the estimated frictional strength, the length of collapse required downstream of a blocked section of tunnel to resist movement of the blockage would be the driving force divided by the frictional resistance per foot of tunnel length. For 100 feet of differential head, the driving force = 100 ft. x 62.4 lbs/ft³ x 125 ft² = 780,000 lbs. The required length of debris in the tunnel to resist this force without movement = 780,000 lbs / 17,043 lbs/ft = 46 feet.

For 120 feet of differential head the driving force = 120 ft. x 62.4 lbs/ft³ x 125 ft² = 936,000 lbs. The required length of debris in the tunnel to resist this force without movement = 936,000 lbs / 17,043 lbs/ft = 55 feet.

For 150 feet of differential head the driving force = 150 ft. x 62.4 lbs/ft³ x 125 ft² = 1,170,000 lbs. The required length of debris in the tunnel to resist this force without movement = 1,170,000 lbs / 17,043 lbs/ft = 69 feet.

The actual length of collapsed material forming a flow blockage is not known, as the differential head increases, the length of blockage required to resist movement increases. However, given that about 40 timber sets exhibiting dry rot were not replaced, the length of collapsed tunnel could easily approach 80 or more feet. Further, if the material began to shear, additional resistance would be generated at the roof line, and at the wall due to the roughness and dilation of the material.

2.2. Stability of the Porous Plug Above the Timber-Lattice Bulkhead

The following portion of this report assesses the stability of the porous plug located between Stations 4+61 and 6+32. The evaluation includes a description of the composition of the plug, its geologic environment, current groundwater conditions, and the effects of a rapid rise in groundwater pressure should the upstream tunnel blockage near the Pendery Fault fail. The results of this assessment play a key role in understanding the likelihood of Potential Failure Modes 1, 2, 3, and 4. Most importantly, this assessment shows that even if the upper blockage fails, the rapid transmission of a pulse of groundwater pressure to the porous plug likely will not result in failure of the bulkhead.

2.2.1 Description of the Porous Plug

The porous plug, which has also been referred to as the “lower blockage” is comprised of a heterogeneous matrix of naturally occurring materials and man-made construction components including two bulkheads with cobble and gravel fill, and over 100-feet of collapsed overburden plus injected sand and gravel fill. This section of the tunnel was excavated through glacial deposits and terrace gravels.

At the downstream end, from Station 4+60 to 4+61 is the Timber Lattice Bulkhead as shown in Figure 4. The timbers are held in place by an L-shaped bracket made of stainless steel which is anchored to the Concrete Tunnel Lining. From Station 4+61 to Station 4+66 there is 5-feet of cobble and gravel fill held in by the Timber Lattice Bulkheads. The fill immediately against the bulkhead on the downstream side is comprised of cobble-size rock as seen in Figure 5.



Figure 4. - Photograph taken in 2001 of the existing Timber Lattice Bulkhead installed in 1991 at Station 4+60 to 4+61. Note clarity of water outflow and 2.5-foot high flow with has been typical since post construction.



Figure 5. Photograph taken on October 25, 1991 of the Timber-Lattice Bulkhead as construction was nearing completion showing the layer of cobbles at Station 4+62 of the LMDT.

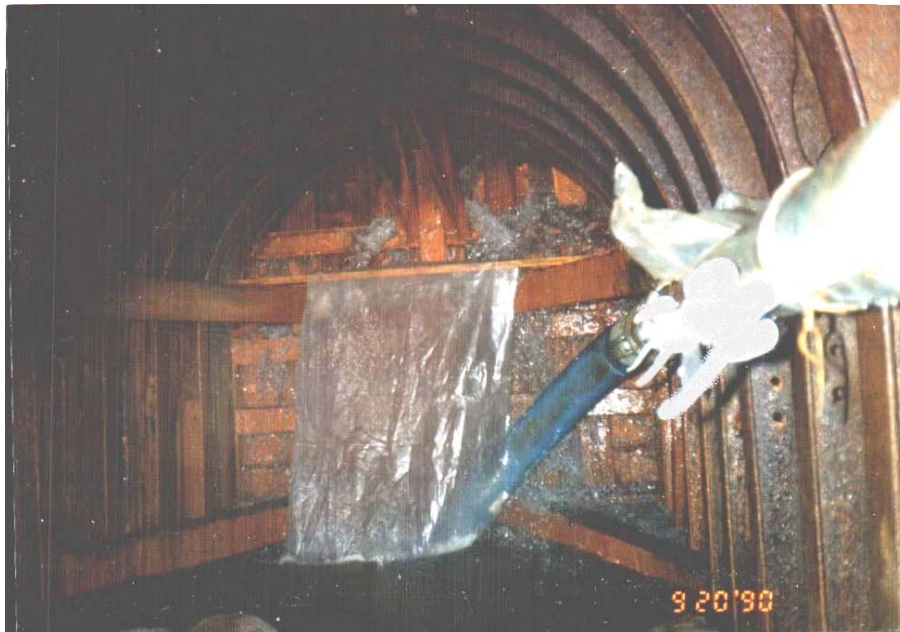

Figure 6. Photograph taken on August 20, 1990 showing the porous bulkhead located at Station 4+66.

At Station 4+66 a porous timber bulkhead was previously constructed in 1980 when the LMDT was excavated back to approximately Station 5+00 (Figure 6), new steel supports were placed, and gravel backfill was installed to bear against the sand-filled collapse zone. The tunnel along this porous plug section was originally excavated to approximately 11 feet wide and 12 feet high (Gobla and Vandenberg, 2008). Various tunnel supports and spacing were used. Both wood and steel sets were used with the only common denominator being the use of wood for blocking and lagging and the use of spiling through bad ground. The exact configuration and location of all the various support members are not documented. Spacing varied and various support members or configurations were changed over the years as maintenance and stability issues occurred.

The tunnel at Station 4+62 has a bedrock bottom and 4-foot-high bedrock side walls, above which the rest of the wall and crown are composed of unconsolidated terrace gravel materials. The bedrock surface slopes up station and by Station 6+35 the entire tunnel is completely in bedrock (Reclamation, 1989). The change from a tunnel roof in terrace gravels to a rock roof is probably the reason why the 1968 surface subsidence and the area of tunnel collapse did not extend further southeast. The thickness of the overlying overburden above the blockage area averages about 100 feet. Most of the blockage in the tunnel is from the 1968 ground subsidence that occurred some where between Station 5+00 and drill hole #2, at about Station 5+75, and extended all the way to the surface (Figure 7).

The interpretation of the length of the collapsed zone was based upon the data from five drill holes and downstream observations in the tunnel. Figure 7 shows the collapse going all the way to Station 6+32. However, no other documentation supports that this was the actual case; no back filling that was done through drill holes other than drill holes 2 and 3, at about Station 5+92, see Table 3. It is possible that this 40 foot area from Station 5+92 to Station 6+32 may have collapsed since then, but it is not known for certain. There is no direct evidence that material is plugging the tunnel any further up station than 5+92.

In 1973, Reclamation awarded a contract to clean out first 200 feet of tunnel, install new steel horseshoe shaped supports from Station 1+00 to Station 2+00, and completely backfill all remaining sinkholes, voids, and un-collapsed portions of the tunnel between approximate Stations 1+25 and 5+00 (Bennett, 1977). A bulkhead of treated timbers was also installed at Station 2+00.

In 1975 Reclamation installed a 1 cubic foot per second (cfs) capacity pump at Station 6+34 in an attempt to maintain the groundwater table at a low level in ground adjacent to the lower portion of the tunnel. This was considered to be a temporary fix. It is interesting to note that this was followed in 1976 by numerous sinkholes at the ground surface above the LMDT from Station 2+00 to approximately 6+50. It is assumed that this portion of the tunnel was almost completely filled with sloughed material.

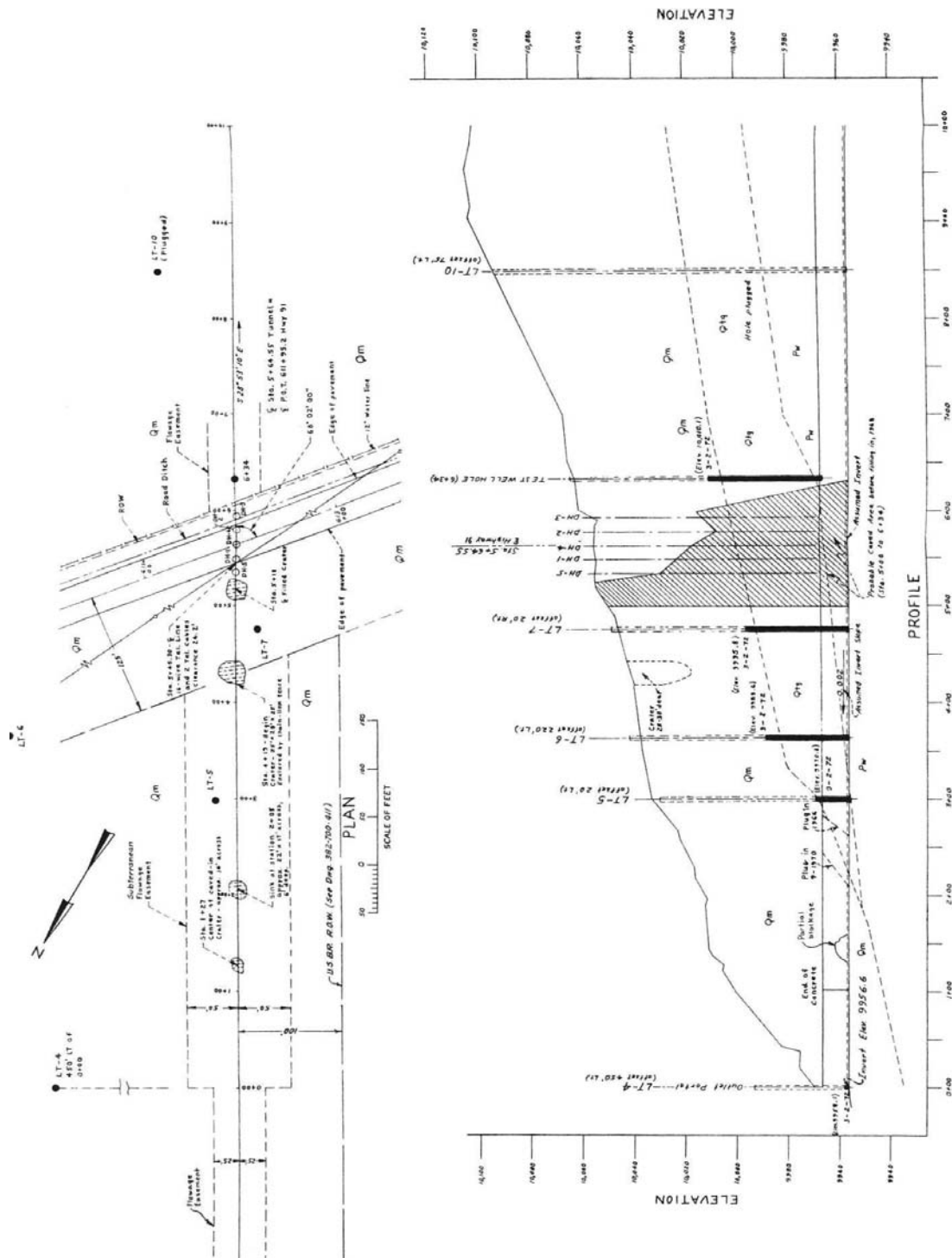

Figure 7. Plan and section showing condition of the LMDT in 1972 including the location of sinkholes, 1968 injection drill holes, and monitoring wells installed in 1968, taken from (Reclamation, 1976).

From 1978 until 1980 the bulkhead at Station 2+00 was removed and the tunnel was excavated back to perform consolidation grouting of the overburden and tunnel support rehabilitation was completed for the first five hundred feet of the tunnel. Records regarding the extent of consolidation grouting performed, if any, have not been found. The project encountered difficulty in drilling a well above the collapse area to reduce water levels in the tunnel. Most of the excavation work to open the tunnel back to Station 5+00 was performed with a constant flow of water and there were some instances of running ground filling the excavation. Eventually the tunnel was opened and the steel sets were improved to Station 5+00. Upstream from Station 5+00 the collapsed fill from 1968 remained. Gravel fill was placed against the collapsed material and continued down to Station 4+66 where a timber bulkhead was installed (Figure 6). The steel sets provide some roughness to the tunnel perimeter and the bulkhead provides some restraining force to downstream movement of the collapsed area infill and the man-made fill placed between Stations 5+00 and 4+67.

Table 3. Results of five injection drill holes into the LMDT in 1968.

Drill Hole Number	Voids Encountered	Gravel Placed yd3	Grout Placed bags of cement	Condition of LMDT at drill hole bottom
1	5-foot cavity between 61.9 and 66.9 feet above LMDT	7 at upper void	172	Tunnel filled to crown with caved material
2	4-foot cavity between 47.7 and 51.7 feet above LMDT	12 at LMDT, 0.5 at upper void	93	Tunnel filled to within 4 feet of crown with caved material
3	10-foot cavity between 49.7 to 59.7 feet above LMDT	48 at LMDT, 23 at upper void	185	Tunnel open
4	3-foot cavity between 58.4 and 61.4 feet above LMDT	4 at upper void	155	Tunnel filled to crown with caved material
5	1-foot cavity between 74.6 and 75.6 feet above LMDT	0.25 at upper void	5	Tunnel filled to crown with caved material
Totals		94.75	610	

Transecting the 1968 collapsed portion of the tunnel is an existing 20-inch ventilation pipe and an 8-inch cast iron pipe along bottom of the east side of the tunnel. The smaller diameter pipe was estimated in 1980 to be passing 250-400 gpm while the larger diameter ventilation pipe was only estimated at 250 gpm. It is probable that the larger diameter, less crush resistant, ventilation pipe has some obstructions. It was noted after the 1968 collapse that flows continued through the 20-inch diameter steel ventilation pipeline at about 3.7 cfs (1660 gpm). Later on, an 8-inch-diameter test well was drilled 60 feet east of the highway and the tunnel was found to be open. The casing was pulled to the top of the LMDT and water levels were measured to be 23 feet above the top of the tunnel. This water level indicated that the LMDT water discharge through the ventilation pipeline required some head to force the flow through the pipe. Therefore, the flow was being partially retarded by the collapse. More importantly is that the combined flow from these two conduits equals most of the flow down at the portal so that the amount of flow through the actual material filling the collapsed area must therefore be minimal.

Based upon what could be observed, the collapse material is a heterogeneous mixture of overburden materials with steel and wooden tunnel segments spread through out the collapsed mass. These large support segments could add to the resistance of the tunnel blockage from being displaced down the tunnel. However, it is known that both the wooden and steel support members disintegrate in the mine environment and therefore could not be depended upon for the long term. Furthermore, these segments may result in voids along the boundary of the segments and the collapsed material if there was inadequate natural compaction against these segments or if these segments weather away.

It should be noted that with the double bulkheads at the downstream end of the collapse area, and the manner in which the gravels and cobbles were placed in between the bulkheads and the collapsed material, that the risk of piping or erosion of fines would be reduced, if not eliminated. In fact, the water seen exiting from the bulk head at Station 4+60 (Figure 4) has remained clean for 18 years and the drainage ditches on either side of the walkway are free of sediments. This is evidence that filters have formed and they are retaining material. The tunnel shows a pressure differential from a maximum at the upstream end of the collapse (around 50 feet of head) to a minimum at the Timber-Lattice Bulkhead, which is exposed to the atmospheric pressure and showing 2.5 feet of head.

It should be noted that the tunnel from Stations 0+54 to 4+61 was supported with steel sets, lined with reinforced concrete and the inside diameter reduced in size to an 8 feet wide by 8.5 feet high, semi-circular arch. Furthermore, the portal area has a massive concrete structure, (Figure 8) and the space behind the concrete tunnel lining was pressure grouted. Therefore, the entire structure together with the bulkhead and reduced cross sectional area would provide additional restraint to the material plugging the larger diameter tunnel from being ejected.

The geology of the LMDT along the porous plug includes three units; Quaternary glacial moraine (Qm), terrace gravels (Qtg), and Permian Minturn Formation (Pm). The glacial moraine consists of gravel, cobbles, and boulders in a silt and sand matrix and it overlies the terrace gravels. The terrace gravels make up the crown and part of the tunnel side walls until at about station 6+35 where the bedrock surface meets at the tunnel crown. Downstream of about station 3+50 the tunnel is completely in alluvial material and gets thicker below the tunnel invert until it is over 100-feet thick at the portal area. The Minturn Formation is interbedded sandstones and shales and makes up the entire tunnel floor along the tunnel plug. At Station 4+62, the lower 4-foot portion of the tunnel wall is bedrock. The height of the bedrock in the walls rises slowly in the upstream direction and, at Station 6+35 the rock reaches the crown of the tunnel.



Figure 8. Photograph taken May 21, 2008 showing the reinforced concrete LMDT Portal with 1-ft. thick wing walls.

2.2.2 Plug Material Properties

Although the material filling the tunnel is of a heterogeneous nature, simplifying assumptions were made in order to conduct an analysis. Other than the pipes that became buried along the length of the blockage, the material in the entire length of the blockage was considered to be uniform, including the bulkhead areas and any fill placed into the upstream collapse area through drill holes.

The tunnel dimensions and area were taken as uniform for the entire length of the blockage. Also, the wall of the tunnel was assumed to be smooth, which represents a more conservative case than actually exists. Approximately 130 feet of plug is known to exist, the drawing of the 1968 collapse and fill suggests that a total of 170 feet of plug could exist.

A plug length of 92 feet was used in stability calculations as a conservative estimate. Since the 1968 collapse extended to the surface and the overburden is unconsolidated, it was assumed that the full overburden load was being seen at the tunnel collapse from Station 5+00 on upstream to the end of the plug. At and below Station 5+00, the tunnel was rehabilitated with closely spaced steel sets and lagging therefore the lower 38 feet of tunnel plug has a roof and will likely not experience full overburden pressure on the backfill. The lower 38 feet of the tunnel fill was not considered to provide strength, a conservative assumption.

The two bulkheads downstream of the blockage were only considered as being important contributors to forming a filter whereby the fines and gravel size fragments could not be easily removed by erosion or piping. Although the bulkheads, and the intervening steel sets would also add shear resistance to the material in the plug, the resistance was not considered and was therefore viewed as another conservative factor in the model.

Physical and strength properties identified for use in the evaluation were based upon a 2005 valve controlled bulkhead study (Smith and others, 2005) which was based upon available project data, interviews, and site visits; however, no strength tests were undertaken. The unit weight, strengths, and other data are assumed values; however, they appear to be reasonably conservative for the types of materials involved.

The unconsolidated overburden was assumed to be all the same and a conservative value of unit weight of 110 lb/ft^3 was used. A higher value of void ratio was used, which corresponds to the glacial moraine and is in agreement with a 1988 study. The friction angle was varied from 30 to just over 46 degrees, with the higher value matching that used in a 1988 analysis of the plug stability (Reclamation 1988). The higher friction angles are possible because the tunnel cross sectional area drops from 119 ft^2 at the blockage to 66.8 ft^2 at the concreted tunnel section. In addition the tunnel side surface would not be totally smooth. An at rest lateral earth pressure coefficient of $1 - \sin\phi$ was assumed.

2.2.3 Plug Hydrogeology

The hydrogeology of the entire area of the LMDT and connected mines is quite complex. It is summarized in a report by Goble and Vandenberg (2008) and detailed in a report by the EPA (2002). The hydrogeology of the tunnel collapses is much simpler as they block or restrict flow down the tunnel alignment and may or may not be completely filling the tunnel. Water flows through the unconsolidated glacial moraine and terrace gravels are much greater than through

the bedrock, except maybe in the areas or directions of intense fracturing or solution channels. The unconsolidated gravelly aquifer is porous and tends to readily transmit groundwater flow. The geometry of the bedrock is a controlling factor in groundwater flow which is towards the river and the portal along the bedrock surface. Rock fractures and solution channels are of little importance in the bedrock formations present (shales and sandstones) along the plug portion of the LMDT.

Observation wells have been placed along and adjacent to the tunnel alignment to measure the head in the tunnel and in the overburden, and provide access for down hole camera observations in the tunnel at a few of the well locations. Also, at Station 10+25 there are two additional wells which are used to pump water from the tunnel to control the head in the tunnel upstream from the tunnel blockage between Station 4+61 and 6+32.

2.2.4 Plug Failure Analysis

The stability issue of the lower tunnel plug was first addressed in a memorandum dated August 22, 1988 from the Regional Engineer, Billings, Montana to the Project Manager in Loveland, Colorado (Reclamation, 2002). The memo concluded that the plug was not likely to blow out and had a considerable factor of safety with respect to existing conditions. After studying the 1988 memorandum, it was decided that the data and conclusions were not adequate. Some of the reasons were:

- All steps of calculations were not shown.
- It did not reference all the sources of data.
- No attention was given to piping or internal erosion.
- The 1988 memorandum covered a plug length of 170 feet even though the evidence suggests it may only be 130 feet long.

The only values that could be verified in the memorandum were the volume of a 170-foot-long plug and the hydraulic driving force. However, the mass of the plug at 995,000 pounds seemed like it was low, but might be the submerged buoyant weight. The mass of the 170-foot long plug should be at least 2.4 million pounds, and have a submerged weight of 1 million pounds. Lastly, the angle of internal friction used was not stated and the amount of shear resistance reported seems high. Since the previous study was poorly documented, and due to renewed concerns about the stability of the tunnel plug, a new stability analysis was carried out.

Tunnel blockage, whether from a natural collapse or a man made plug that then develops a hydraulic head behind it, can fail for one of several reasons. However, the primary reason is usually leaking around the blockage which usually leads to

an erosional failure around or next to the blockage and not a blow out of the obstruction (Abel, 1998), (Harteis and Dolinar, 2006), (Fuenkajorn and Daemen, 1996). No discussion or evaluation of this critical issue was made in 1988.

The upstream end of the plug is not directly visible. On the downstream end there are man made structures from which some data can be obtained. Water flow into the concrete tunnel and monitoring wells located both upstream and downstream of the bulkhead are measured. However, no test data are available for any of the materials in the collapse zone. The upstream limit of the collapse and the extent of the sand and gravel fill (Table 3) into the collapsed material are all mostly derived by anecdotal evidence.

Since the lattice bulkhead was installed (1991), the tunnel flow has been rather consistent and, more importantly, the volume of flow has been less than the capacity of the cast iron and vent pipe conduits that pass through the plug. Therefore, it appears that very little flow is coming directly through the surrounding ground surface or directly through the tunnel blockage. The difference in head seen in boreholes located upstream and downstream of the blockage is usually no more than 10 feet and most of the time the upstream and downstream levels are at about the same elevation. In fact, since the elevation of flow through the Station 4+61 bulkhead is 15-20 feet lower than the two nearby observation wells, groundwater flow is through soils around the tunnel and towards the bulkhead at Station 4+61.

The explanation for this behavior is that the collapsed fill portion of the plug, although somewhat pervious, is believed to be a barrier to water flow. There were fines in the terrace gravels which collapsed into the tunnel and a mix of sand and gravel was injected through boreholes into the fill. The up-station part of the plug is known to impound water. The lower portion of the plug, from Station 5+00 down to Station 4+62, is filled with clean gravels and cobbles. The absence of fines creates a much more porous and very pervious flow medium in the downstream portion of the plug. For the purposes of modeling, it was assumed that the plug is nearly impermeable over the entire cross sectional area for the upstream 92 feet, except for flow in the surrounding soils around the plug or through the two previously mentioned pipes.

It was also assumed that the plug is in contact with the entire perimeter which was conservatively modeled as smooth and uniform, and with constant normal loading. With a heterogeneous collection of material in the plug and no test data, a range of values was examined to analyze any sensitivity in the frictional strength parameter. An angle of internal friction of 46 degrees was selected as a maximum value and a conservative value of 30 degrees was selected as a minimum value. A conservative value of zero was used for the cohesion.

The head of 34 feet that has been experienced over the past several years was selected as a minimum. Maximum head was selected based upon the back calculated value of hydraulic head that would be needed to obtain a factor of safety (FS) equal to 1.0.

The shear resistance provided by the blockage was calculated using:

Shear Stress = (Normal Stress – pore pressure) * tan (phi) Shear stress was assumed to occur along the entire theoretical tunnel perimeter.

Where: Stress normal to the shear surface is broken down into vertical and horizontal surfaces

Pore pressure is the hydraulic head * 62.4 lb/ft³

phi is the angle of internal friction between the blockage material and the tunnel perimeter

The vertical stress from the overburden on the blockage was assumed to not be arching over the blockage since it had failed to the surface and was calculated by:

$$\text{Sigma-v} = \text{Unit weight} * \text{Depth of overburden} / 144 \text{ in}^2$$

Where: Sigma-V is the vertical stress

Unit weight of the overburden material, lbs/ft³

Average depth of overburden in feet

The secondary principal or horizontal stress on the sides of the blockage was calculated by

$$\text{Sigma-H} = \text{Sigma-V} * (1 - \sin\phi)$$

Where: Sigma-H is horizontal stress

The force driving the blockage out was calculated using:

Driving force = Vertical face area of the plug times the hydraulic pressure

Where: Vertical area = nominal area of the semi-circular tunnel shape at the upstream plug end

Hydraulic pressure = the height of the water table above the invert of the tunnel, rather than at the centroid of the face, is another conservative assumption.

The Excel spread sheets in Appendixes B & C summarize the type of calculations that were made. The results are summarized in figures 9 and 10. Figure 9 shows the calculation for the plug considering an instantaneous loading condition. In other words, it assumes that the upper blockage near the Pendery Fault has failed

and a pulse of groundwater pressure is rapidly transmitted down the tunnel to the upstream end of the plug.

As would be expected, the lower the friction angle, the lower the safety factors for a given hydraulic head. As the hydraulic head increases, the safety factor decreases for each value of friction. However, for each pair of curves, with a different friction angle, the two curves when plotted against safety factor are non linear and with increasing hydraulic head converge. At a factor of safety of 1, indicating the driving and resisting forces are equal, the hydraulic head is nearly 220 feet. This is more than 100 feet higher than any groundwater levels ever measured in this part of the LMDT. The calculations show that this pressure pulse can be withstood and the plug will not “blowout.”

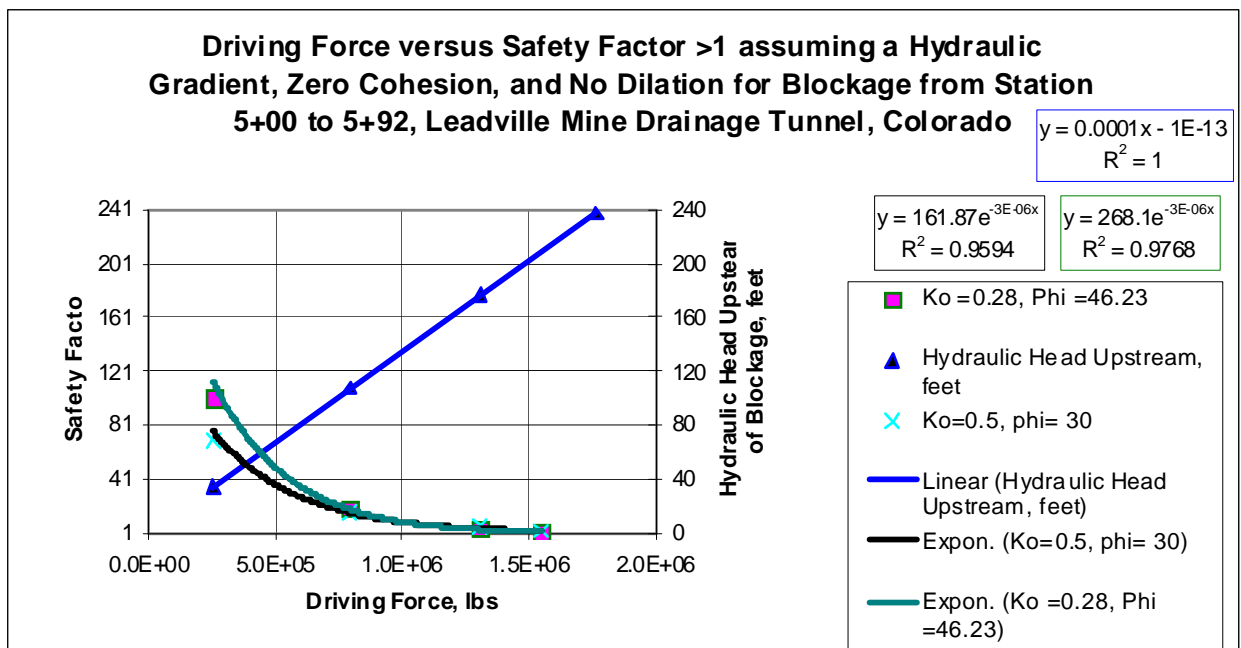

Figure 9. Driving force versus differential head and safety factor for an instantaneous increase of head at the upstream end (Station 5+92) of the plug in the LMDT. The additional resistance from the manmade bulkheads and porous cobble and gravel fills located from Station 4+61 to Station 5+00 are not included in the calculation.

A second calculation was made to consider what would happen over a period of time. In time, the initial rapid increase in water pressure would begin to inject water through the pore space in the plug thus raising the groundwater levels in the surrounding soils. Eventually elevated groundwater conditions could be experienced at a distance away from the upstream end of the plug. An assumption was made that the full upstream hydraulic head would travel to the lower end of the nearly impervious part of the plug at Station 5+00. The calculation is repeated considering a uniform elevated groundwater condition all along the plug from Station 5+92 down to Station 5+00.

The concrete tunnel lining and concrete portal with its supporting wing walls are massive concrete structures. The concrete lining has an internal area smaller than the area containing the plug. Therefore, any mass movement of the plug down into the tunnel alignment would cause dilation of the angular fill and it would be faced with a cross sectional restriction thus generating high frictional resistance. The massive, anchored concrete portal structure and concrete tunnel lining which is attached to preexisting steel tunnel supports, and any of the consolidation grouting behind the concrete lining form a structure which can resist the thrust produced by the frictional loading.

The results shown in Figure 10 for the full hydraulic head across the length of the plug indicate that the conservative factor of safety remains above 1.0 for differential heads up to about 125 feet.

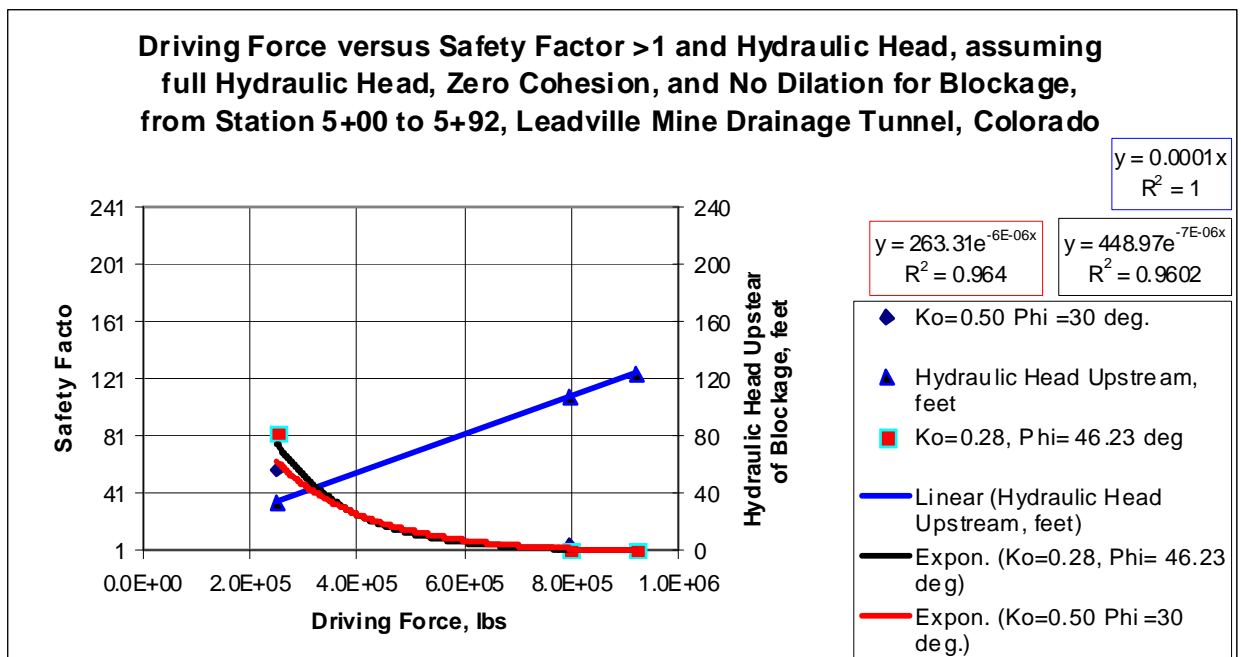

Figure 10. Driving force versus safety factor for a diffusion of head along the plug from the upstream end at Station 5+92 to just above the porous fill at Station 5+00. Again the additional resistance provided by the manmade bulkheads and porous cobble and gravel fills located from Station 4+61 to Station 5+00 are not included in the calculation.

Considering the nature of the surrounding soils it is impossible for such a condition to exist. First of all, the soil overburden is only about 100 feet thick in this area which would limit the groundwater levels above the plug to that height. Pressures beyond that level could not be transmitted downstream along the plug. Instead, the wells near and upstream of the plug would become artesian. Secondly, as the water with elevated pressure at the upstream end of the plug spreads out into the soil, it is likely to drain off laterally as well as towards the bulkhead at Station 4+62; therefore, any elevated water table forming along the plug is going to be attenuated by drainage into the adjacent soil and be

substantially less than the upstream driving head. Considering the situation, it is concluded that a “blowout” of the plug along the tunnel and out the portal is virtually impossible.

2.2.5 Other Potential Failure Modes If the Plug Holds

Other modes of failure modes might be possible if most of the maximum mine pool head were seen at the lower plug and the plug holds. Failure Modes 2, 3, and 4 must be considered.

Failure Mode 2, a seepage erosion breach of the downstream portal slope is also unlikely. First a portion of the elevated groundwater levels will drain to the pervious part of the plug. Since the plug will remain intact, the gravel and cobble fill will continue to act as a filter and allow the water to pass. Even if a hydraulic fracture forms along the side of the tunnel allowing water seepage and higher pressures to reach the lower end of the plug, the flow will still need to pass through the 38 feet of gravel and cobble fill where filtration is expected to be maintained.

For water migrating from the upstream end of the plug towards the toe of the hillside, there is a reasonably low gradient. There is at least 400 feet of soil through which the flow must travel. Regarding the potential for possible piping or backward erosion at the downstream slope, seepage should be looked for and if found evaluated and monitored. Likely seepage exit points would be on the outside of the Portal wing walls, or along the toe of the hillside on either side of the Portal. Therefore, this problem becomes an issue similar to leakage at embankment dams. The appearance of seepage, and monitoring of changes in seepage rates and turbidity with time can be used to determine the stability of seepage areas. Any changes in volume of water or observations of solids moving in the seepage areas can be used to give an early warning and the appropriate course of action taken: evacuation and/or drawdown of the mine pool, and capturing and treating seepage flows. At present there are no known seeps at the downstream toe of the hillside.

Failure Mode 3 deals with elevated groundwater levels causing slope instability of the hillside. This is addressed in a later section of this report. Failure Mode 4, Leakage of contaminated water into downstream areas is possible. If the elevated groundwater spreads out and drains into the surrounding soils as well as to the porous end of the plug, the water in the surrounding soils will likely migrate to the river and not be captured by the LMDT bulkhead flows. If the water elevations of a pressure pulse are high enough, the wells at 10+25 and 6+36 may experience artesian flow to the surface. Therefore under present conditions, some amount of loss of contaminated water into downstream areas could occur if the Pendery Fault area blockage fails.

One final observation was made for the water elevation data for drill holes at Stations 6+34 and 10+25. There appears to be a difference in head between these

two wells, see Figure 11. This would suggest that a small tunnel collapse or blockage may have formed some place between the two wells. Reviewing the history of the tunnel, in 1979 a well was drilled into the tunnel at Station 6+65, but while waiting for delivery of well screen, a sinkhole appeared next to the drill rig and the hole was lost. If there is a blockage in this area, then the risk to the tunnel blockage downstream of Station 6+34 may be reduced even further since the pressure gradient down the tunnel would experience another damping effect from this blockage. This also points out an important fact that given the history of the LMDT, new collapses may form and old ones may grow. As a result, there will be even more barriers to not only impede flow down the LMDT but to create additional hydraulic barriers, which will create additional stepped pressure drops along the drainage path.

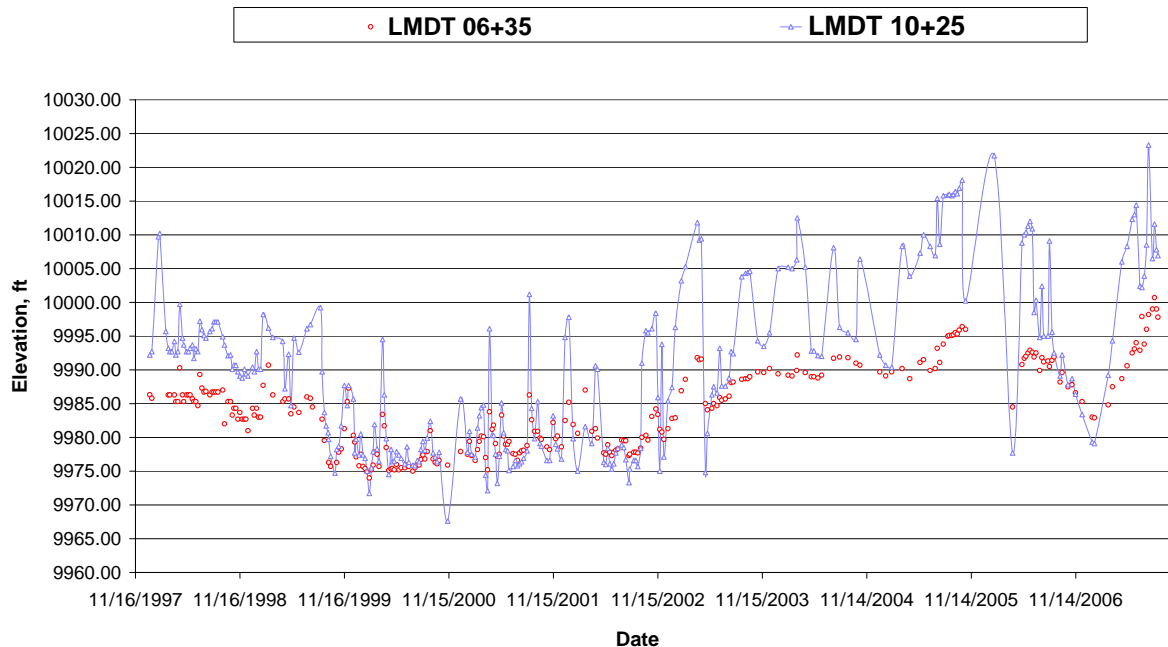

Figure 11. Water levels measured in wells at Stations 6+35 and 10+25.

2.3. Stability of Timber-Lattice Bulkhead

The timber bulkhead at Sta. 4+60 of the Leadville Mine Drainage Tunnel was inspected March 25, 2008. The dimensions and spacing of the timber members of the bulkhead were confirmed to be the same as shown on drawing no. 1335-D-123 (see Appendix A). The timbers were probed with an awl and appeared in good condition.

The size and number of stainless steel anchor bolts were also confirmed the same as shown on drawing no. 1335-D-123. The bolts and stainless steel angle brackets affixed to the concrete also appeared in good condition.

The analysis of the components of the timber bulkhead was based on the following:

- Timber beam (see Figure 12) was assumed simply supported and uniformly loaded.

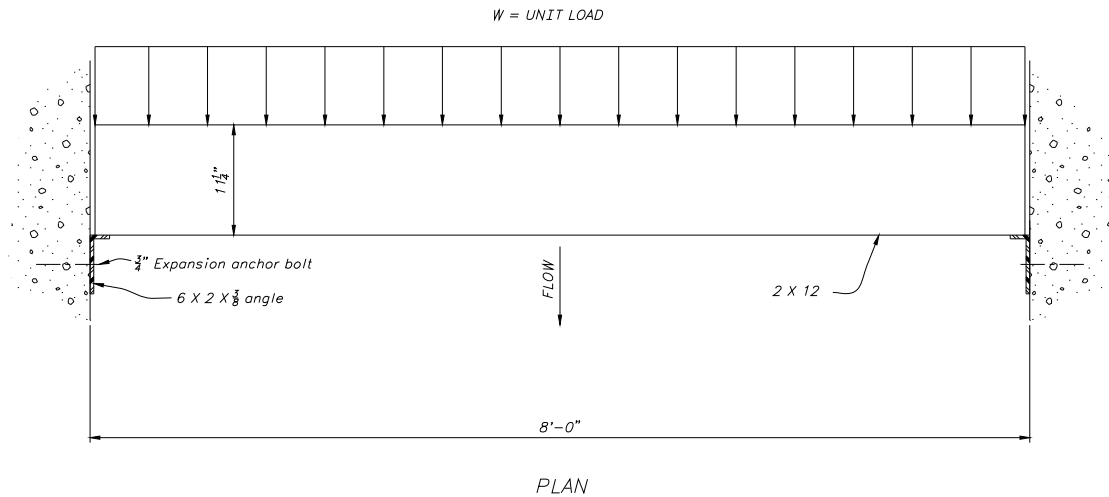

Figure 12. Plan view of timber beam.

- Length of beam for moment and bearing = 7.9 ft.
- Effective length (length – 2 x depth of beam) of beam for shear = 6.0 ft.
- The timber was assumed to be Douglas Fir Larch, select structural grade as shown on drawing no. 1335-D-123. Properties for the timber are from Timber Construction Manual, American Institute of Timber Construction, 2nd ed., 1974. Timber properties follow:
 - Allowable bending stress (repetitive member use) = 2050 lb/in²
 - Allowable horizontal shear stress = 95 lb/in²
 - Allowable compression perpendicular to grain = 385 lb/in²
 - Duration factor (assume 50 years) = 0.96

- Adjustment factor for bending when moisture content exceeds 19% = 0.86
- Adjustment factor for shear when moisture content exceeds 19% = 0.97
- Adjustment factor for compression perpendicular to grain when moisture content exceeds 19% = 0.67
- No reduction in allowable stresses assumed for preservative treatment
- The assumed average factor of safety is 2.5. Ninety-nine out of 100 pieces will have a safety factor greater than 1.25. See Design of Wood Structures—ASD, Breyer, Donald E., Kenneth J. Fridley, David G. Pollock and Kelly E. Cobeen., McGraw-Hill, 5th ed.

The analysis of the $\frac{3}{4}$ -inch diameter expansion anchor bolt was based on the following properties:

- Allowable shear per bolt = 5.65 kips
- Assumed safety factor (ratio of ultimate load to allowable load) = 3.8

The analysis of the 6 x 2 x $\frac{3}{8}$ angle (see Figure 2) was based on the following properties

- Yield strength (F_y) assumed to be 39,000 lb/in² (type 304L)
- Assumed allowable shear stress = 0.4 x F_y
- Assumed allowable bending stress = 0.66 x F_y

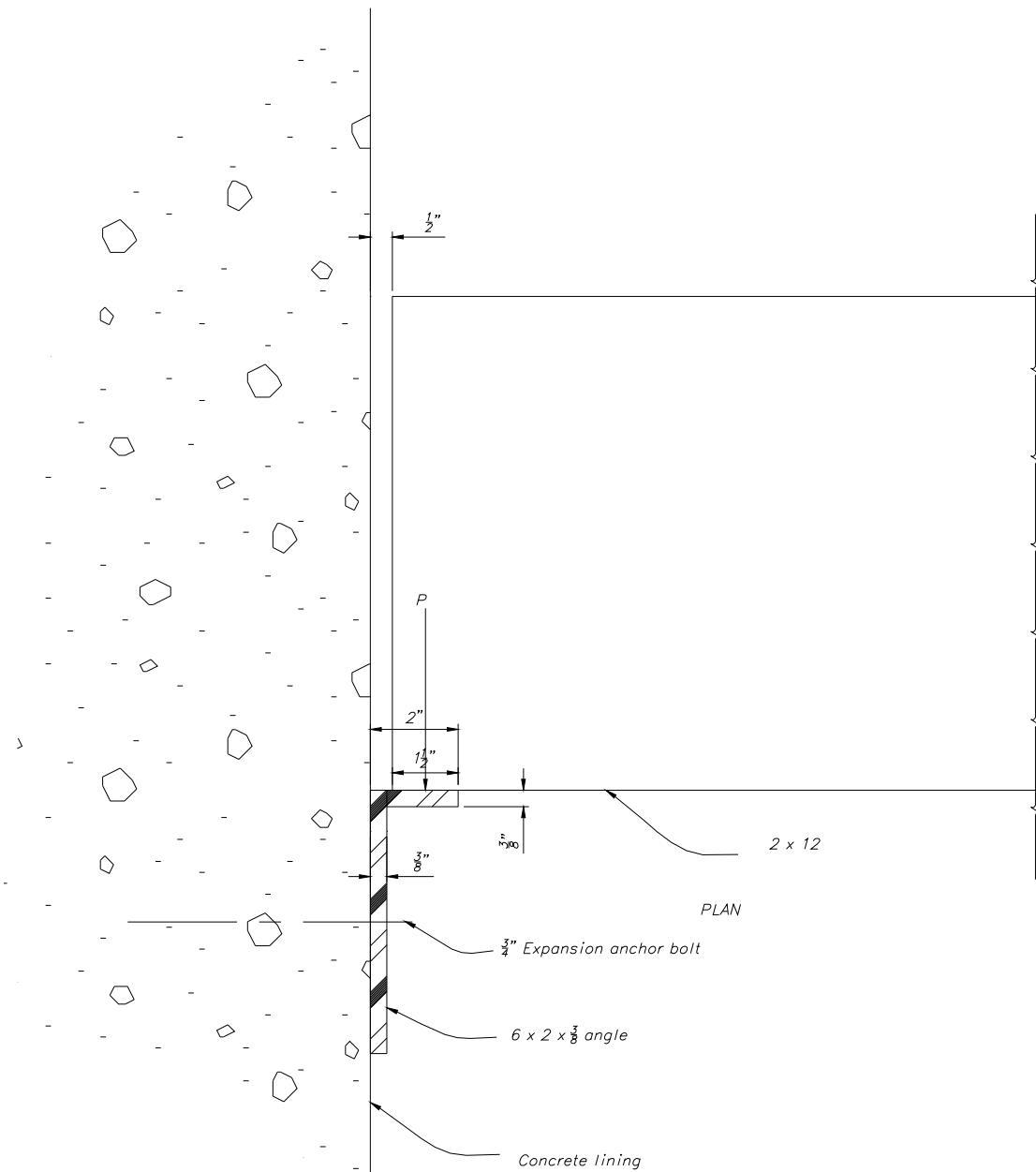

Figure 13. View of angle bracket and anchor bolt.

The soil loading against the bulkhead assumed the following:

- Assumed angle of internal friction = 36 degrees
- Assumed unit weight of moist soil = 115 lb/ft³
- Assumed unit weight of saturated soil = 130 lb/in²
- Assumed Jaky's at-rest coefficient = 0.412
- Assumed effective height of soil against bulkhead = 5.8 feet

The hydrostatic pressure exerted against the timber bulkhead assumed the following:

- Assumed percent of clear area between horizontal beams that is open to flow = 11%
- Assumed no hydrostatic pressure on downstream side of bulkhead

The results of the analysis of the bulkhead components are summarized in the following table:

Table 4. Results of bulkhead components analysis.

Bulkhead Component	Design Head (ft. above invert)	Computed Head at Failure (ft. above invert)	Notes
Timber beams	7.0	21.0 (52.0)	1,2,3,4
Support angles	34.0	52.0	5
Anchor bolts	30.0	116.0	6
<p>Notes:</p> <ol style="list-style-type: none"> 1) Timber beam is assumed to have an average factor of safety of 2.5 for the design head. 2) Timber beam is assumed to fail at an average factor of safety just less than 1.0. 3) The value of computed head at failure shown (not in parenthesis) represents the value that the beam would fail at in compression perpendicular to grain. This failure mode would occur at the bearing of the timber beam on the angle. 4) After the beam has initially failed in compression perpendicular to grain, it was assumed that the wood fibers would densify until the mode of failure finally becomes shear (the value in parenthesis). This should be verified by laboratory test if this value is deemed critical. 5) Support angle is assumed to fail by flexure when yield strength is reached. 6) Expansion bolt is assumed to have a safety factor of 3.8 in shear. 7) Hydrostatic pressure is assumed to develop at the face of the timber lattice; drainage at the interface is ignored. 			

Discussion –

The “design head” represents the height of water (relative to the tunnel invert) that would be considered a safe value for design purposes. The “assumed head at failure” represents the height of water (relative to the invert) where failure could occur for the assumptions outlined above. Reports indicate that historically the water level at the timber lattice never rises more than about 2 or 3 feet above the tunnel invert, regardless of the fact that the water level at Station 10+25 has exceeded 70 feet above the tunnel invert. There is only about 80 feet of unconsolidated materials (terrace gravel and glacial moraine) above the bulkhead. It should be pointed out that this is a conservative analysis and that is unlikely that the “assumed head at failure” values of 52 or 116 could be achieved in these materials. The porous nature of these deposits would most likely be able to dissipate water before reaching these levels. However, adding a support that would resist horizontal loads at the midspan of the beams would be a low cost but effective method of increasing “design head” and “assumed head at failure” of all bulkhead components.

2.4. Stability of Tunnel Lining

The reinforced concrete lining from Sta. 0+54 to Sta. 4+61 of the Leadville Mine Drainage Tunnel was inspected March 25, 2008. The observable concrete (above the shallow water surface in the gutters) was in good condition.

The analysis of the concrete lining was first based on the following:

- Although, drawing no. 1335-D-123 indicated that the spacing of the existing steel ribs and struts could vary from 2’-0” to 6’-0”, the spacing of the steel ribs was assumed to be at 2’-0” and 4’-0” based on the following:
 - On page 56 of the Design Summary, Treatment Plant and Tunnel Lining, Leadville Mine and Drainage Project, Bureau of Reclamation, 1991, it states that “the existing tunnel consists of steel sets placed at 2-ft and 4-ft centers”
 - A check of photographs shows a 4-ft or closer spacing of the steel sets.
 - Jeff Farrar (a Reclamation employee and an inspector of the tunnel construction who was underground when the supports were being placed) said that the spacing of the steel sets were mostly on 2 ft. spacings where the ground was heavy and spiling had to be used, but there may have been some areas with better ground where a 4 ft. spacing was used. Jeff did not believe there were any areas with 6-ft spacings.

- The reinforcement sizes and spacings shown on drawing no.1335-D-123 are assumed as-built. The dimensions of the lining and the location of reinforcement and steel sets shown on the drawing are assumed as-built.

Assumptions made for analyses included:

- The weep holes plug and become inoperable or are overwhelmed by the volume of inflow such that external head exists above the level of weep holes. The former scenario is possible only if routine cleaning of the weep holes is not performed and the latter scenario is viewed as an extreme worst case scenario.
- The earth loading is carried entirely by the initial support (steel sets, liner plate and steel struts). The full capacity of the reinforcement in the concrete lining less any moments and shears resulting from grouting is available to resist external hydrostatic pressures.
- There is no interaction between the external soil mass and the concrete lining; i.e., the stiffness of the soil in keeping the lining from deforming was not included.
- Two sets of assumptions of the residual capacity of the steel sets were assumed:
 - The steel ribs have no residual moment carrying capacity or shear capacity remaining after supporting soil loadings. The steel struts have no moment carrying capacity but full shear capacity after supporting soil loadings.
 - The steel ribs and steel struts have a residual 1/3 of their original moment or 3/5 of their original shear carrying capacity to resist external hydrostatic loading.
- The floor of the concrete lining of the tunnel carries only the dead load of the concrete lining and the grout load. Vertical earth loadings are carried by the initial support.
- The steel strut of the floor carries all the compressive load from the lateral soil pressures
- The concrete has bonded to the steel ribs and steel struts
- The allowable concrete to steel bond stress is 160 lb/in²
- 28-day compressive strength of concrete is 4,000 lb/in²

- Reinforcement bars are Grade 60
- Yield strength (f_y) of steel tunnel supports and steel invert strut is 36,000 lb/in²

During typical designs, load factors above 1.0 (overestimating loads) are used for external loads. Strengths are assumed with factors slightly less than 1.0 (underestimating strengths). The analyses were adjusted for these factors as noted below:

- A load factor of 1.0 combined with the strength reduction factors shown below was used to determine the computed head at failure
- A strength reduction factor for shear of 0.85
- A strength reduction factor for moment of 0.90

The following table summarizes the results of the analyses.

Table 5. Results of Tunnel Lining Analysis.

Spacing of Steel Sets	Original Design Head (ft. above invert) [1]	Computed Head at Failure (ft. above invert) [2][3]	Computed Head at Failure (ft. above invert) [4]
4'-0"	0	20	46
2'-0"	0	25	68

Notes:

[1] The tunnel was not designed to resist external hydrostatic pressure. See the Design Summary, Treatment Plant and Tunnel Lining, Leadville Mine and Drainage Project, Colorado, January 1991 (for specifications No. DC-7804). The author of the design summary writes that the transverse reinforcement was sized using the difference between the design loads (vertical and lateral earth pressures or grouting pressure) and the capacity provided by the steel sets. Additionally, as was done in the specification (DC-7804) it is common practice to not design for external hydrostatic pressure where feasible. This is done by specifying weep holes to keep external hydrostatic pressures from developing against tunnel linings.

[2] Assumes steel ribs and steel struts have no residual strength remaining after supporting soil loadings except for steel struts in shear.

[3] It cannot be determined with reasonable certainty what stresses the backfill grouting actually imparted to the steel supports or steel reinforcement in the floor. Assuming the floor initially acts as a transverse fixed-fixed beam with a uniform foundation pressure distributed across the bottom of the floor equal to the combined loading from the dead load of the concrete lining and a 25 lb/in² backfill grouting pressure over the top 90 degrees of the crown, analysis indicates the floor should have already failed in flexure. This failure would probably manifest itself as local crushing (plastic hinge) at the junction of the floor and the wall but should not constitute a catastrophic failure as the floor would begin to act as a simple beam. It is further assumed following the crushing of the concrete that while the concrete floor would have minimal capacity to resist shear at the junction of the wall and floor, the full shear capacity of the steel strut is available to resist shear. As this mode of failure is assumed not catastrophic, the value shown for assumed head at failure reflects the capacity of the lining elsewhere.

[4] Assumes steel ribs and steel struts have a residual strength of 1/3 their original flexural capacity and 3/5 of their original shear capacity after supporting soil loadings. This reflects the excess capacity of the initial support without regard to any additional flexural capacity provided by the reinforcement embedded in the concrete lining or the shear capacity provided by the concrete itself.

Discussion –

The reinforced concrete lining was placed approximately 11 years after the tunnel supports were erected. This fact is the basis for assuming all earth loadings were carried solely by the initial support. It cannot be ascertained with any certainty how much of a steel support's flexural or shear capacity is used to resist the earth loads. Hence, the set of assumptions noted above was made regarding the residual capacity in bending and shear of the steel ribs and struts.

The assumption that the steel ribs and struts, after resisting the ground loads, have 1/3 of their original capacity to resist moments and 3/5 of their original capacity

to resist shears assumes the original designers used $0.66 f_y$ (f_y is the yield strength of the steel supports) for allowable bending stresses and $0.4 f_y$ for allowable shear stresses..

If the values for original design head or computed head at failure are deemed critical to this study then the location of the steel sets should be verified by non-destructive testing and the original design head or computed head at failure should be compared to a modeled groundwater surface which would be established in the vicinity of the tunnel following a breach of the blockage near the Pendry Fault.

The fact that the water level at the timber lattice bulkhead is never seen to rise more than 2 or 3 feet above the tunnel invert, regardless of the upstream water levels is again an important observation for the tunnel lining stability. This, coupled with the weep holes in the lining, and other potentially conservative analysis assumptions, suggest that the likelihood of reaching a critical failure head is small.

2.5. Stability of Hillside in Vicinity of Portal

Even though there is a lack of specific engineering data regarding the near surface soil and bedrock units in the immediate vicinity of the tunnel portal, this area is likely to remain stable due to the free draining nature of the near surface material, the dip of the contact surface between the near surface material and the bedrock, and the physical size and scale of the portal structure. The pervious terrace gravels in the portal area are underlain by the rock surface of the Minturn formation which slopes away toward the river. The groundwater level in the gravels follows the rock surface, quickly dropping toward the river downstream of about Station 6+35.

Seismic loading contributes little to the risk of slope failure. The simultaneous occurrence of a large earthquake and high groundwater levels in the portal area, both of which are needed to approach unstable slope conditions, is a remote possibility. The earthquake hazard in the Leadville area is not high, and it is unlikely an earthquake would trigger other potential failure modes.

2.5.1 Assumptions and Data

Physical and Mechanical properties were assumed for the three geologic units that would most influence fluid transport and earth loads. The Geologic Units are Glacial Moraine (Qm), Terrace Gravels (Qtg) and bedrock comprised of shales and sandstones of the Minturn Formation (Pm).

The assessment of these properties was accomplished from review of available project data, discussions with project personnel, site visits and published data. Recent excavation for a pipeline installation indicated that the Glacial Moraine is able to stand at steep angles in excavations and in dumped fill embankments, see

Figure 14. This indicates that the material has cohesion and the actual shear strength of this material is likely closer to the maximum value for the range of strengths assumed in the analysis.



Figure 14. Excavation in May, 2008 into the Glacial Moraine at Leadville for installation of a pipeline under Highway 91 along the alignment of the LMDT. Note the steep slopes of the excavation and spoil banks indicating high shear strength of the soil.

The Glacial Moraine (Qm) is a silty to clayey gravel (GM-GC) with cobbles and boulders. The Terrace Gravel (Qtg) is also silty to clayey gravels (GM-GC) without the presence of cobbles and boulders. The Minturn Formation (Pm) is a coarse-grained medium-hard sandstone with interbedded shale.

Physical Properties

The physical properties of each geologic unit are presented below in Tables 6 through 8, Physical Properties.

Table 6. Physical Properties, Glacial Moraine (Qm).

Property		Minimum	Maximum	Average
Unit Weight	lbs/ft ³	115	130	125

Table 7. Physical Properties, Terrace Gravels (Qtg)

Property		Minimum	Maximum	Average
Unit Weight	lbs/ft ³	110	120	115

Table 8. Physical Properties, Minturn Formation (Pm).

Property		Minimum	Maximum	Average
Unit Weight	lbs/ft ³	142	150	146

Mechanical Properties

The mechanical properties of each geologic unit are presented below in Tables 9 through 11, Mechanical Properties.

Table 9. Mechanical Properties, Glacial Moraine (Qm)

Property		Minimum	Maximum	Average
Cohesion	lbs/in ²	2	10	5
Friction Angle	Degrees	32	45	40

Table 10. Mechanical Properties, Terrace Gravels (Qtg).

Property		Minimum	Maximum	Average
Cohesion	lbs/in ²	5	15	10
Friction Angle	Degrees	35	41	38

Table 11. Mechanical Properties, Minturn Formation (Pm).

Property		Minimum	Maximum	Average
Cohesion	lbs/in ²	10	40	25
Friction Angle	Degrees	50	60	55

2.5.2 Seismicity

Estimated seismic loadings used in these studies as pseudo static loadings are presented in the Table 12, Seismic Loading.

Table 12. Seismic Loading for the LMDT Slope Stability Analysis.

Estimated Return Period	Probable Horizontal Acceleration
Years	g
500	0.05
2,500	0.15
10,000	0.35

2.5.3 Slope Stability Cases

Twelve slope stability cases were considered by varying the physical and mechanical properties. The physical and mechanical properties utilized in the analyses were the minimum, maximum, and average properties. All properties (unit weight, cohesion, and friction angle) were varied at the same time. Additionally, the piezometric water surface was conservatively modeled at elevations approximately 40 feet greater than historically observed. Modeled water elevations in wells along the tunnel alignment are shown below in Table 13.

Table 13. Piezometric Levels for Slope Stability Analysis LMDT.

Piezometric Head @ Station	Elevation in Feet
3+00	10023.9
4+70	10040.8
6+35	10056.1
10+25	10,060.0

Effects of earthquake loading were modeled by imposing pseudo static earthquake loadings for three return periods, using the seismic coefficients equal to the peak horizontal ground acceleration 0.05g, 0.15g and 0.35g for 500, 2500 and 10,000 year return periods respectively.

Two additional slope stability cases were also computed. One case is the static stability using the minimum properties and assuming no soil cohesion. The other case is an analysis to determine the yield acceleration under seismic loading. The yield acceleration is that level of seismic loading at which the Factor of Safety is 1.0.

The slope stability analysis computed both static and pseudo static Factors of Safety (FS) for the slope between the portal and LMDT station 10+25 using the computer software SLOPE W (GEO-SLOPE International Ltd). The critical failure surface is determined by an automatic search that initially involves a circular plane, but according to the geologic configuration the surface can be modified to straight line segments.

The analysis results are presented in Table 14.

Factor of Safety values are most influenced by physical and mechanical properties and seismic loading conditions as is indicated by the results of Slope Stability Analysis.

Consideration was also given to the observation that the site shows no indications of previous gross instability, other than the reported localized areas of sinkholes due to collapse in the tunnel. Output files from the SlopeW software are included in Appendix D.

Table 14. Results of Slope Stability Analysis

Seismic Loading Case (Pseudo Static Coefficient)	Factor of Safety using Minimum Material Properties	Factor of Safety using Average Material Properties	Factor of Safety using Maximum Material Properties
Static with cohesion	1.96	3.12	4.44
Static with no cohesion	1.54	2.03	-
0.05	1.68	2.68	3.67
0.15	1.30	2.02	2.59
0.35	0.87	1.22	1.59

Please note that pseudo static stability conditions would exist during an earthquake for just an instant, when the accelerations in the failure mass are as high as the coefficient shown (in the units of acceleration due to gravity). During an earthquake, factors of safety fluctuate. Since liquefaction of the gravelly soils is not considered to be a reasonable possibility at this site, it is only while the factor of safety drops below 1.0 that permanent deformation of the slide mass would occur. Since all pseudo static factors of safety are above 1.0, except for the highest earthquake loading and minimum strength parameters analyzed, very little

to no deformations are expected to be caused by an earthquake even under extremely conservative assumptions.

The minimum factor of safety of 0.87 was obtained by combining the extreme conditions of a maximum seismic loading with minimum soil properties and elevated groundwater in the downstream hillside. Although a result with a Factor of Safety of less than 1.0 was calculated for this case, it does not automatically follow that the hillside will fail even if these conditions were to manifest. For seismic loading one must consider the amount of ground deformation that will occur. Empirical correlations between yield acceleration and calculated “Newmark” type rigid body movements (Jibson, 2007) were used to estimate the likely maximum amount of movement that would occur under the worst-case scenario using the following equation:

$$\log D_N = 0.215 + \log \left[\left(1 - \frac{a_c}{a_{\max}} \right)^{2.341} \left(\frac{a_c}{a_{\max}} \right)^{-1.438} \right] + 0.510$$

where, D_N is the estimated displacement (in centimeters), a_c is the yield or critical acceleration, a_{\max} is the peak earthquake acceleration, and 0.510 is a factor to account for the mean plus one standard deviation of the data. A yield acceleration for the soil mass was calculated to be about 0.197g (the pseudo-static coefficient resulting in a F.S. = 1.0 using lower shear strength and high ground water estimates). Using the yield acceleration and peak earthquake acceleration, the empirical relationship indicates maximum displacements would be on the order of 0.7 inches. It is generally accepted that it takes predicted displacements at least on the order of 6 to 12 inches before stability is considered to be threatened.

Therefore the analysis indicates that the gross stability of the portal area, defined for this study as extending to LMDT Station 10+25 is adequate for the ground conditions, water loading and seismic conditions as currently assumed. Although it is believed that groundwater levels near the portal cannot rise to dangerous levels, it is recommended that the groundwater wells at Stations 3+00, 4+70, and 6+35 be instrumented with pressure transducers and data be tied to the EWS.

3. Conclusions

Based upon the detailed analysis documented in this report, it is concluded that the upper blockage near the Pendery Fault is likely due to a zone of roof collapse located downstream from the fault. This blockage is likely to contain tunnel utility conduits which remained intact in the collapse which still convey some flow directly through this part of the tunnel. The upper blockage is estimated to be stable under the current conditions with 100 to 119 feet of differential head. However, the likelihood of the blockage remaining stable declines with increased head differential. For that reason, all analysis and potential failure modes conservatively assumed rapid failure of the blockage.

If the blockage near the Pendery Fault were to fail, the likelihood of uncontrolled seepage would increase and some property damage could occur, but loss of life would not be expected. A pressure wave would travel down the LMDT and might damage the extraction wells at Station 10+25. Further down the LMDT, it is very unlikely that the failure could cause a “blowout” of the porous plug and Timber-Lattice Bulkhead. The forces acting on the plug of porous material due to the pressure wave would not be great enough to overcome the existing shear strength of the material and move it. Flow down the tunnel from the failure of the upper blockage near the Pendery Fault would be limited by head losses through the system and by the diameter of the casings in the wells at Station 10+25 which would be expected to experience artesian flow conditions. Because the LMDT is full of water below the upper blockage, and the porous plug would hold, a small flow would accompany the pressure pulse, not a massive “blowout” type of flood wave. The well at Station 6+35 is likely to also experience artesian flow. The artesian flow conditions at one or possibly two wells could last for a significant period of time (days to weeks) until the head in the mine pool was lowered.

It is very unlikely that failure of the upper blockage near the Pendery Fault could result in failure of the Timber-Lattice Bulkhead or in failure of the Tunnel Liner. A large mass of soil would need to experience elevated ground water conditions. It would take a significant period of time (days) for the increased water pressures to seep through the 130-foot-long seepage pathway from the upstream end of the plug near Station 5+92 to the soils around the LMDT near the Timber-Lattice Bulkhead and Tunnel Liner at Station 4+62. Although specific seepage modeling has not been performed, it is expected that the mounding groundwater levels would drain off and thus be attenuated by the surrounding Terrace Gravels. If groundwater levels were to rise, this changing condition would be detected by the monitoring well at Station 4+70 and by increased flow at the Timber-Lattice Bulkhead.

In the very unlikely event that groundwater levels near the Timber-Lattice Bulkhead and Tunnel Liner at Station 4+60 were to rise to levels which could collapse the bulkhead or tunnel liner, a “blowout” would not be expected to follow. Rather, some of the surrounding soils would be pushed into the tunnel, but eventually the shear strength of the soil would act against the floor and walls of the lower portion of the LMDT and prevent a “blowout.” It is noted that failure of the liner and/or bulkhead would leave a considerable length, (several hundred feet) of concrete lined tunnel and the massive concrete portal intact. The remaining mass would be able to resist the thrust generated by the force of fill being pushed into the collapsed tunnel opening and eventually a stable plug would form.

Analysis shows that movement of the hillside could only occur in model runs by combining the extreme conditions of elevated groundwater, a maximum seismic loading, and minimum soil properties. None of these conditions are considered to be likely.

The likelihood of the upper blockage near the Pendery Fault remaining stable decreases as the level of the mine pool, and subsequent head differential, increases. If the upper blockage were to fail, the likelihood of uncontrolled seepage would increase and some property damage could occur, but loss of life would not be expected. A more thorough and complete assessment of the likelihood of these combination of events, other failure modes, and the consequences of failure events is presented in the “Potential Failure Modes and Effects Analysis” report (Reclamation, 2008).

4. References

Abel, J. F., (1998) Bulkhead Design for Acid Mine Drainage. Proceedings Western US Mining-Impacted Watersheds, Joint Conference on Remediation and Ecological Risk Assessment Technologies, Denver, Colorado, October 27-29, 1998, 36 p.

Armer, L. D. (2001) Leadville Mine Drainage Tunnel, Bulkhead Investigation, Leadville, Colorado. Bureau of Reclamation Memorandum from Supervisor, Technical Services Group, Denver, Colorado, June 28, 2001.

Bennett, N. B. (1977) Geologic specifications design data for Leadville Mine Drainage Tunnel, Leadville Mine Drainage Tunnel Project. U.S. Department of the Interior, Bureau of Reclamation, December, 1977, 9 p. plus appendices.

Buffington, J. M., Dietrich, W. E., and Kirchner, J. W. (1992) Friction angle measurements on a naturally formed gravel streambed: Implications for critical boundary shear stress. *Water Resources Research*, v. 28, no. 2, Feb., pp. 411-425.

Bureau of Mines (1953) Condition of and timbering needs at Leadville Tunnel. U.S. Department of the Interior, Bureau of Mines, Memorandum from Resident Engineer, Leadville Drainage Tunnel, April 21, 1953, 3 p.

EPA (2002) Ground water hydrology in the vicinity of the Leadville Mine Drainage Tunnel Operable Unit 6 and Affected Areas, Volumes I and II, EPA Region VIII, September 2002.

Fuenkajorn, K. and Daemen, J. J. K. (1996) Sealing of boreholes and underground excavations in rock. Chapman and Hall, London, first ed., 329 p.

Gobla, M. J. and Vandenberg, M. A. (2008) Existing Condition of the Leadville Mine Drainage Tunnel. U.S. Department of the Interior, Technical Service Center, Denver, Colorado, 74 p.

Griffin, C. W., Hall, C. E., and Greer, M. J. (1968) Report of Official Travel to Leadville, Colorado, October 13 and 14, 1968, Bureau of Reclamation.

Harteis, S. and Dolinar, D. (2006) Water and slurry bulkheads in underground coal mines: design, monitoring, and safety concerns. SME Annual Meeting March 27-29, Saint Louis, MO, SME preprint 06-043, Littleton, Colorado, 5 p.

Jibson, R.W. (2007), "Regression Models for Estimating Coseismic Landslide Displacement," Engineering Geology v. 91, pp. 209-218.

Reclamation (1973) Schedule, general provisions, specifications and drawings, initial repairs to Leadville Drainage Tunnel. U.S. Department of the Interior, Bureau of Reclamation, Lower Missouri Region, Specifications No. 700C-797, 45 p.

Reclamation (1976) Report on Leadville Mine Drainage Tunnel. U.S. Department of the Interior, Bureau of Reclamation, Lower Missouri Region in cooperation with the Intermountain Field Operations Center, Bureau of Mines, August 1976, 45 p. plus appendix.

Reclamation (1979) Study of Effects on Plugging the Leadville Drainage Tunnel. U.S. Department of Interior – Bureau of Reclamation, U.S. Geological Survey, and U.S. Bureau of Mines, Special Report, September 1979.

Reclamation (1988) U.S. Department of Interior, Bureau of Reclamation, Memorandum, Leadville Drainage Tunnel, Upcoming Water Level Recovery Test (w/discussion of tunnel plug stability) - Leadville Mine Drainage Tunnel Project, Colorado, 1988

Reclamation (1989) Solicitation/Specifications 0-SI-60-04100/DC-7804, Treatment Plant and Tunnel Lining, Leadville Mine Drainage Tunnel Project, Colorado, Volumes I, II, and III. U.S. Department of Interior – Bureau of Reclamation, October 1989

Reclamation (1991) Design summary, treatment plant and tunnel lining, Leadville Mine and Drainage Project, Colorado. U.S. Department of the Interior, Bureau of Reclamation, Denver, Colorado, January, 1991, 89 p.

Reclamation (2008) Potential Failure Modes and Effects Analysis, Leadville Mine Drainage Tunnel. U.S. Department of the Interior, Technical Service Center, Denver, Colorado, 27 p.

Salsbury, M. H. (1956) Leadville Mine Drainage Tunnel – Second Project, Lake County, Colorado. U.S. Department of the Interior, Bureau of Mines, Report of Investigations 5284, December 1956, 50 p.

Smith, K., Atwater, K., Romansky, M., Torres, R., and Sullivan, C. (2005) Special study for Leadville valve controlled bulkhead. Bureau of Reclamation, Technical Service Center, Denver, Colorado, July, 2005, 20 p.

Smirnoff, T., and Allen, D. (1980) Trip to Leadville Mine Drainage Tunnel Project to observe condition of existing tunnel excavation under Specifications No. DC-7343. Bureau of Reclamation, Engineering and Research Center, Travel Report, May 29, 1980, 2 p.

**Appendix A: Drawing no. 1335-D-123
showing the Timber Bulkhead**

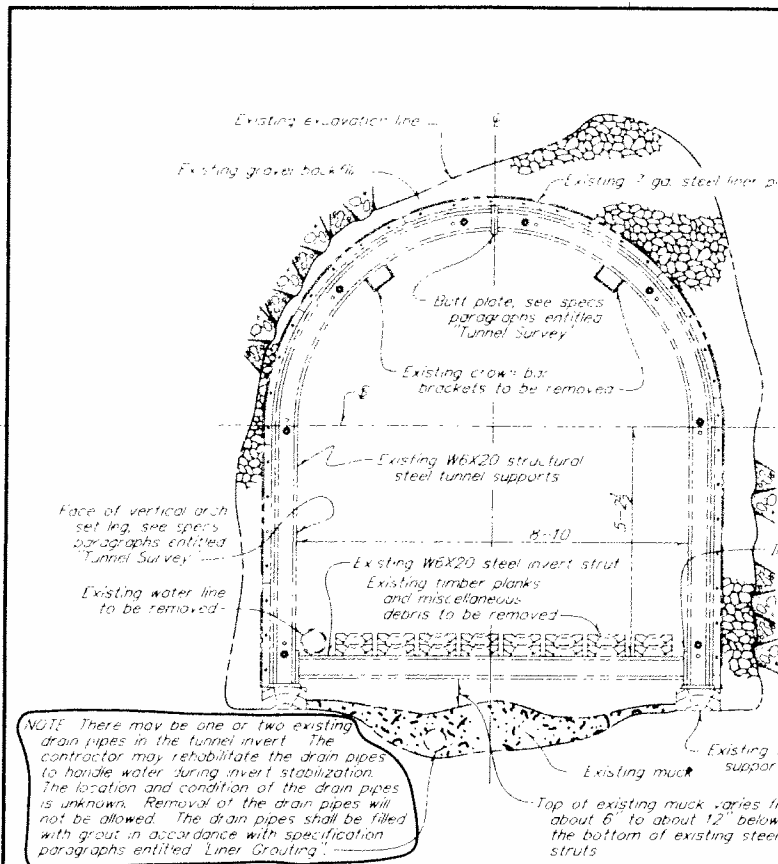

EXISTING TUNNEL SECTION

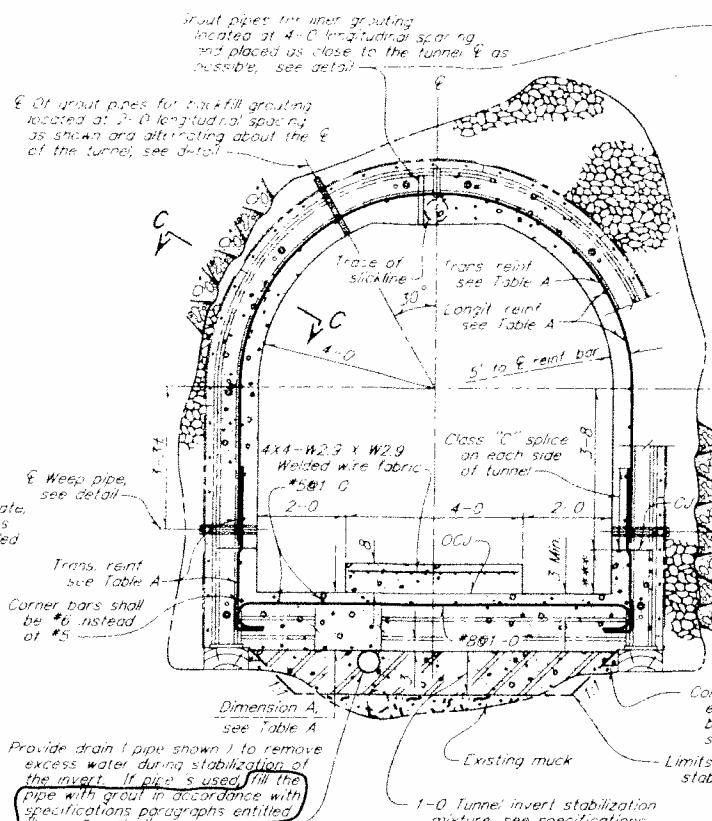
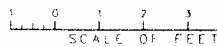

EXISTING TUNNEL SECTION WITH NEW CONCRETE LINING

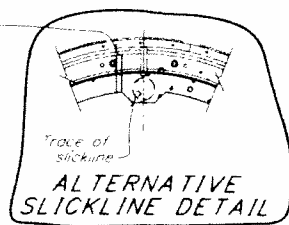

NOTE: The contractor shall maintain a minimum of 3" cover over existing steel ribs and strut when placing concrete tunnel lining. The contractor shall be allowed to place longitudinal bars directly against steel ribs and invert struts.

TABLE A

STATIONS	DIMENSION A	TRANS. REINF.	LONGIT. REINF.
STA. 0+54 to STA. 0+94	1-4 Min.	#7@1-0	#7@1-0
STA. 0+94 to STA. 4+26	1-0 Min.	#5@1-0	#5@1-0
STA. 4+26 to End of concrete lining (4+61.1)	1-0 Min.	#5@1-0	#8@1-0

*** This dimension may vary depending on the final slope of finished invert (0.01 min.). The contractor shall maintain a minimum of 3" cover over existing steel struts.

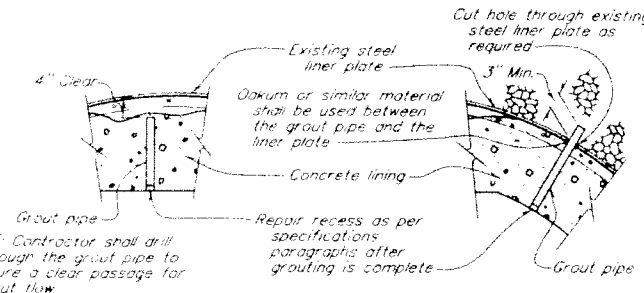

GROUT PIPE DETAIL FOR LINER GROUTING

GROUT PIPE DETAIL FOR BACKFILL GROUTING

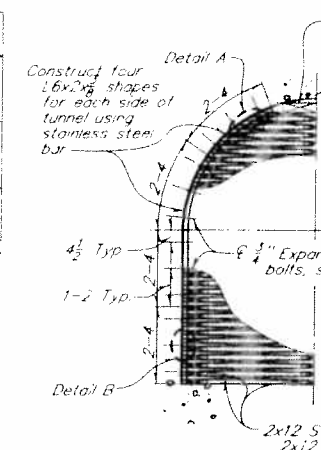

SECTION A-A

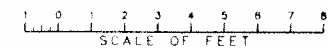

NOTES

For details of water handling during construction, see (160).
 For alignment and profile, see (122).
 For ventilation details, see (156).
 For lighting details, see (158).
 For general concrete outline notes, see 40-D-6517.
 Chamfers are required on all exposed concrete edges, see 40-D-6517.
 For general notes and minimum requirements for detailing reinforcement, Class 60, see 40-D-6263.
 Tunnel lining design is based on a specified compressive concrete strength (f'c) of 4,000 lbs. per square inch at 28 days, and reinforcement with a specified minimum yield strength (fy) of 60,000 lbs. per square inch.
 Splices for all longitudinal reinforcement bars shall be staggered.
 Backfill grouting pressure shall be 25 pounds per square inch. Liner grouting pressure shall be 20 pounds per square inch. Grouting shall not begin until the floor blockout and the cutoff wall have been placed. Grouting shall be in accordance with the specifications paragraphs.
 2x12 Timber stringers and spacers used in timber bulkhead shall be Douglas Fir-Larch, select structural grade.
 Expansion anchor bolts shall be stainless steel and embedded 9" min. into concrete.
 Holes drilled in L6x2's shall be 7/8" dia. Holes may be slotted in vertical direction to aid in installation.
 Gravel backfill shall be 1/2" to 2/4" nominal size. Gradation shall meet ASTM C 33, size No. 2.
 If the transverse bars are set back from the longitudinal bars to meet cover requirements on the transverse bars, the contractor shall provide a method to stabilize the transverse bar cages and also to tie the transverse bar cages to the longitudinal steel.

ALWAYS THINK SAFETY

UNITED STATES DEPARTMENT OF THE INTERIOR BUREAU OF RECLAMATION
 LEADVILLE MINE DRAINAGE TUNNEL PROJECT - COLORADO
TUNNEL LINING
 TYPICAL TUNNEL SECTION, CUTOFF WALL, AND TIMBER BULKHEAD

DESIGNED: William Kaufman TECHNICAL APPROVAL: Barbara R. Spitzer
 DRAWN: Bob Scully SUBMITTED: Paul F. Carlson
 CHECKED: John Narvaiz APPROVED: W. L. Long
 SUPERVISOR OF CONSTRUCTION BRANCH
 DENVER, COLORADO FEBRUARY 15, 1989 1335-D-123

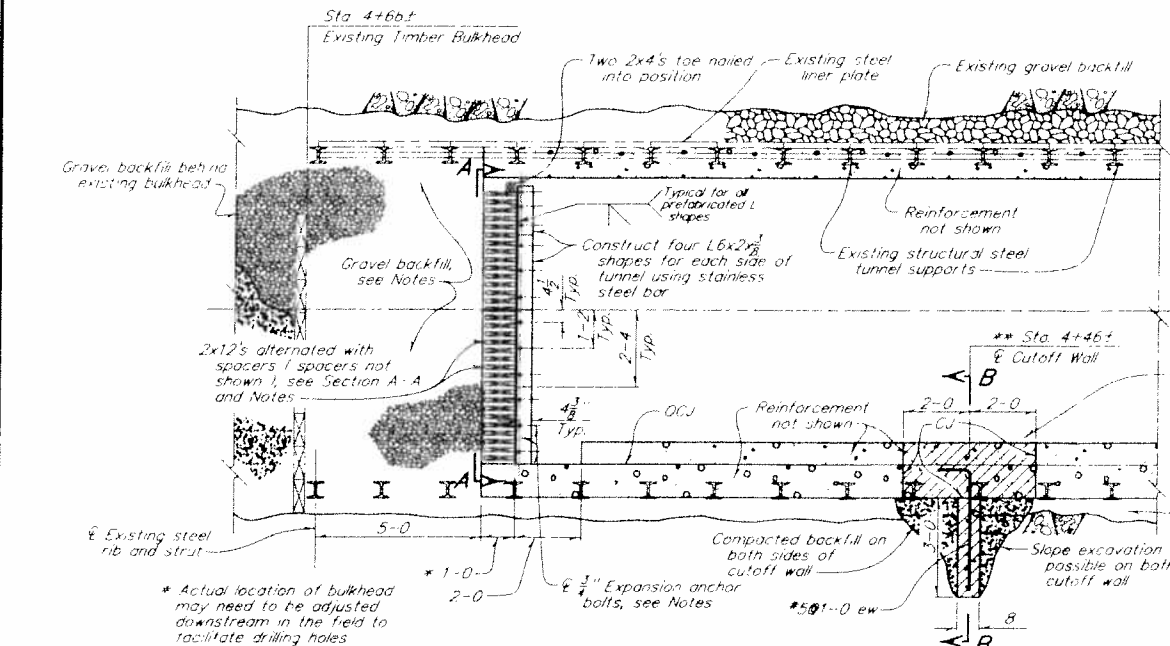

PROFILE OF EXISTING TUNNEL WITH NEW CONCRETE LINING NEAR EXISTING BULKHEAD

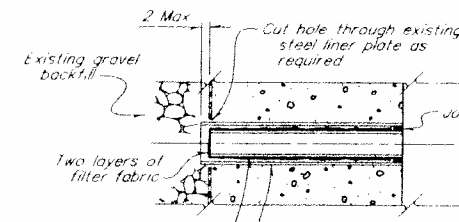

WEEP PIPE DETAIL

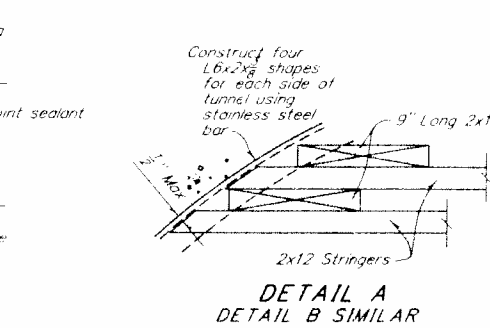
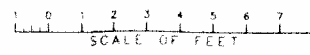

DETAIL A DETAIL B SIMILAR

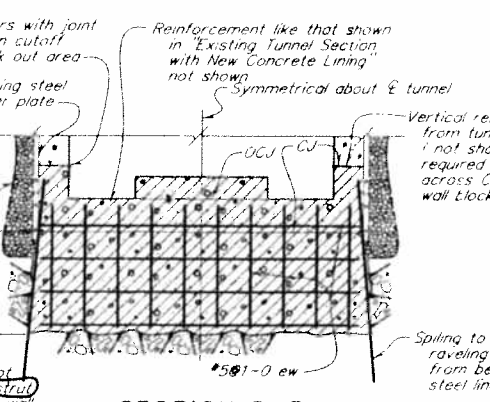

SECTION B-B

NOTE: The contractor shall not remove an existing invert strut or excavate for the cutoff wall until the last concrete placement of the tunnel lining within 25-0 of either side of cutoff wall has attained a compressive strength (f'c) of 4,000.

10-2-89
 D 66E
 ADDED NOTES AND REVISED EXISTING NOTES. ADDED ALTERNATIVE SLICKLINE DETAIL.

**Appendix B: Spreadsheet for
calculation of the plug stability against
blowout for the instantaneous pressure
condition**

5+00 to 5+92 Hydraulic Gradient Through the Tunnel Plug

1988 Calculations

	Square section of Tunnel			Curved section		Total	
	Height, ft	Width, ft	Area, ft ²	radius, ft	Area, ft ²	Area, ft ²	
Cross sectional area of	Inside A-Line	5.21	8.83	46.01	4.42	30.64	76.65
	Area	6.00	8.83	53.00	4.42	30.64	83.64
Outside B-line		5.21	9.83	51.22	4.92	37.97	89.18707
	Area	6.00	9.83	59.00	4.92	37.97	96.97179
Surface Area		10.42	8.83		Length		
		12.00	8.83		4.42	13.88	33.13
					4.42	13.88	34.71

Calculations

Density of material used 2005 and in this report	110 lb _f /ft ³	This number used by this study			
Density of material used 1988	100 lb _f /ft ³				
Collapsed Length of tunnel	92 feet				
Assumed Internal Friction and Poisson's ratio	30 degrees		0.45	Rock Tunnel Wall Height	
Pages 43 and 61 Gobla's report	11 feet wide	R=	5.5	Sta	height, feet
excavation dimensions	12 feet tall	H=	6.5	4+62	4
Max Area of Plug, estimated in this study	119.02 feet ²		46	5+00	5.79
More accurate Volume of Plug this study	10,950 Cu. Feet			5+75	9.32
Hydraulic Driving Force				5+92	10.12
This Study max area & correct head	252,506 pounds			6+34	12
This Study max area & artesian flow @ well 6+34	796,878 pounds				
This Study maximum area & max head	922,685 pounds				

Shear Calculations

Average Depth of Collapse	100 feet				
Average vertical stress this study	76.39 psi				
Average horizontal stress this study	38.19 psi				
Invert elevation 0+00	9957 feet	Jaky Ko=	0.50		
Surface Elevation well 6+34	10,064.30 feet	Sigma H = Sigma V*(1-sin(phi))			
Head and Pressure at well 6+34 for artesian flow	107.30 feet	Sigma H = Sigma V*(1-sin(phi))			
Maximum head elevation Pendry Blockage	10148.81 feet				
Maximum Potential water head at 6+34	191.81 feet				
Maximum hydraulic pressure-Non Leaky Tunnel	83.12 psi		46.50 psi		
Hydraulic head and pressure for uplift/fracturing 2008	176.28 head	Mine pool head 192 feet, 9/13/2007. Doubtful hydraulic fracturing			
Water head and pressure at 6+34 for FS=1	124.24 feet	or uplift may occur where overburden less than about half the head			
shear calculations		Jaky (1948)[1] for normally consolidated soils			
Perimeter of horseshoe tunnel	34.71 feet	Jaky (1948)[1] for normally consolidated soils			

Bottom of horseshoe 8.83 feet 76.39 psi
 Sides of horseshoe tunnel x2 12 feet 53.84 psi
 Top of horseshoe tunnel 13.88 feet
 Shear Equation used in 1988 memorandum
 Shear strength 1988 back calculation for Tan A Reported 22.9×10^6 lbs shear $S=(p-u) \tan \phi$
 Fiction Angle between Rock and fill 30 degrees Input phi value here:
 Corrected Head and pressure 34 feet 14.73 psi
 Shear strength, pounds this study w/1988 area 14,818,187 pounds Used true head. Not used
 Shear strength, this study w/ max area 14,681,664 pounds
 Shear strength, this study uplift head non leaky -7,011,342 pounds Without a leaky tunnel pressure could liftup overburden
 Shear strength, this study max head non leaky 923,240 pounds Without a leaky tunnel pressure could blowout plug or overburden
 Shear strength, this study max head, leaky 3,505,994 pounds With a leaky tunnel pressure could not blowout plug or overburden

Location	Description	Date Completed [MM/DD/YY]	Total Depth [feet]	TOC elevation [ft. ASL]
LDT03+00	Alluvial well 20' off set from LDT, Station 3+00	1976	78	10035.1
LDT04+70	Alluvial well 20' off set from LDT, Station 4+70	1976	92	10048.8
LDT06+34	LMDT Well Previous DWW, Station 06+34	1976	108	10099.7

10,064.30 feet TOC for LDT 06+34 Error in table

Parameters for this study

Water Elev. feet	Water Pressure psi	Head at 6+34 feet	Shear Resistance, lbs	Driving force, lbs	S.F.
9991.00	14.73	34.00	14,681,664	252,506	58.14
10064.30	46.50	107.30	3,505,994	796,878	4.40
10081.24	53.84	124.24	923,240	922,685	1.00

Equation Parameters

B	A		
-0.048710487	967,657	Shear resistance SF=1	922,711
-152464.8116	19865468.06	Head for FS=1	124.24

Check
 lbs 922,711 lbs
 feet

Estimated Driving Force versus Resisting Force for Leadville Tunnel Blockage with a full Hydraulic Gradient from 5+00 to 5+92 with Increasing Head to the Left, Rock Contact Phi = 30 deg., zero cohesion, Internal friction Sediments 30 deg., Ko = 0.5

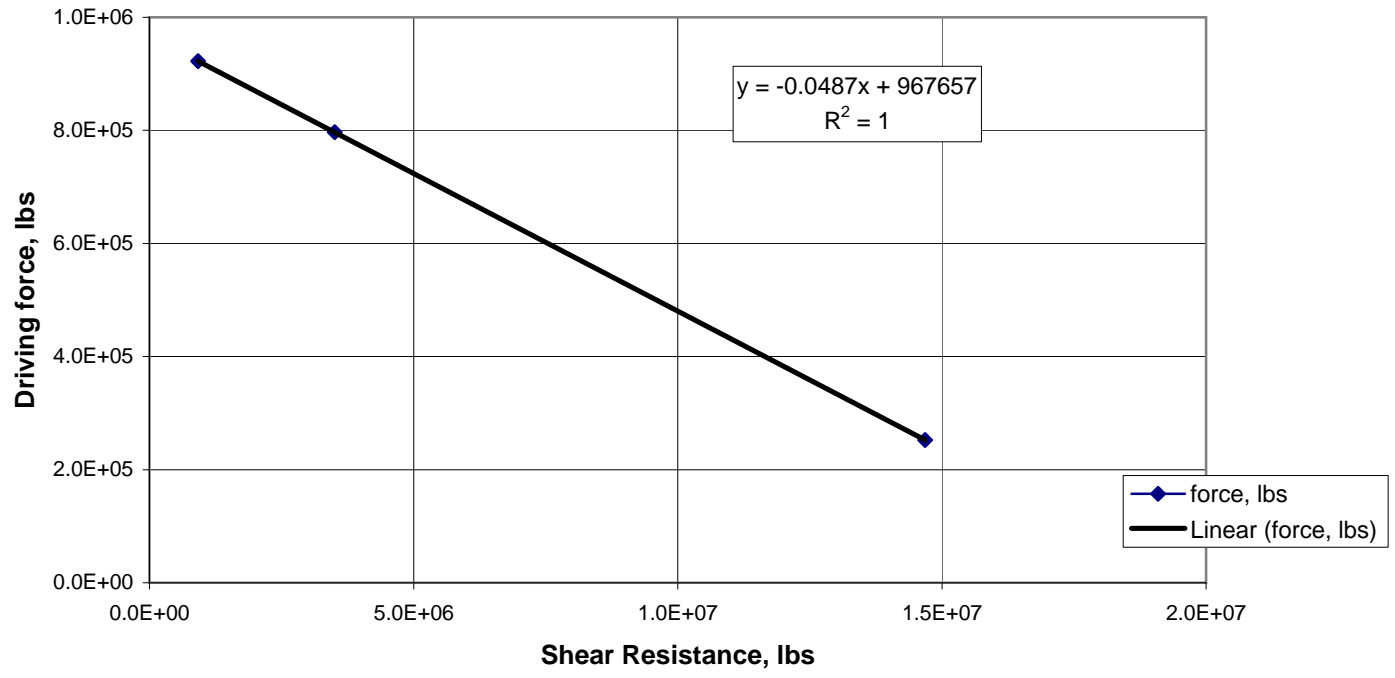

Head versus Shear resistance for Blockage with a full Hydraulic Gradient from Station 5+00 to 5+92, Rock Contact Phi = 30 deg., zero cohesion, Internal friction Sediments 30 deg., Ko = 0.5, Leadville Mine Drainage Tunnel, Colorado

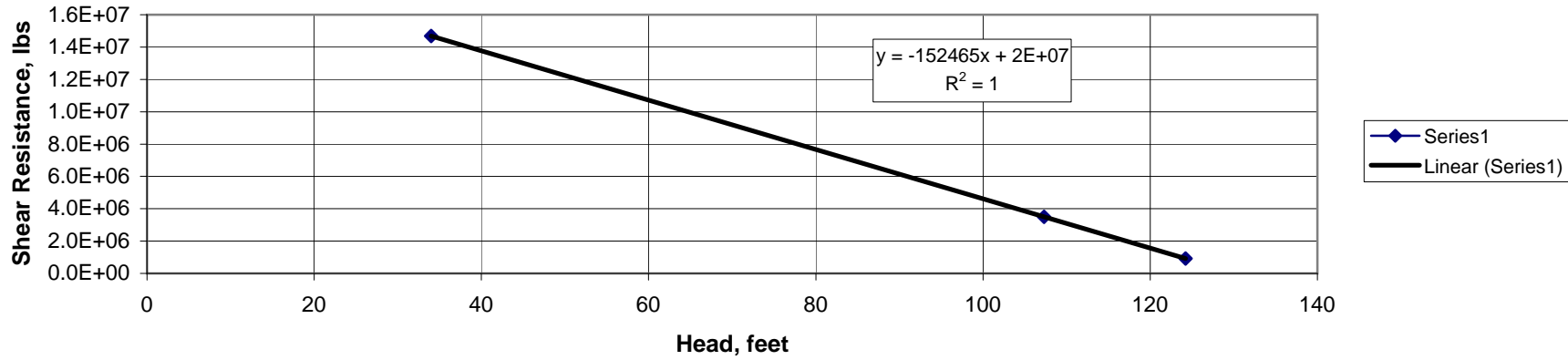

Driving force versus Safety Factor for Blockage from Station 5+00 to 5+92, assumed a full Hydraulic Gradient, Increases to the Right, rock contact phi = 30 deg., zero cohesion, Ko=0.5 sediments internal friction = 30, Leadville Mine Tunnel, Colorado

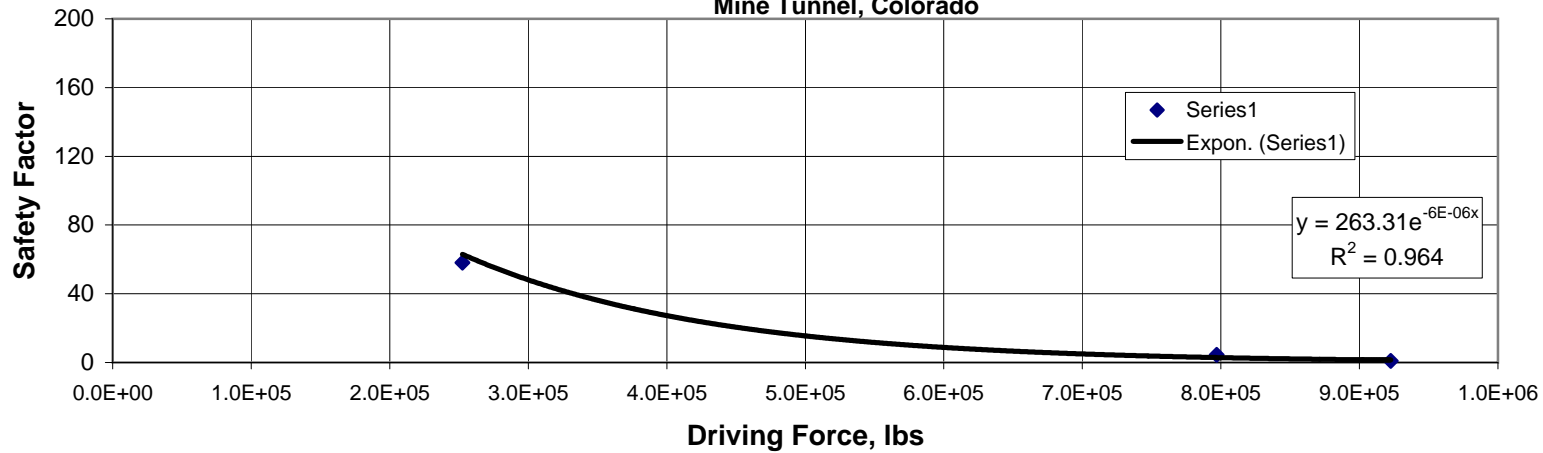

1988 Calculations

5+00 to 5+92

	Square section of Tunnel			Curved section		Total	
	Height, ft	Width, ft	Area, ft ²	radius, ft	Area, ft ²	Area, ft ²	
Cross sectional area of	Inside A-Line	5.21	8.83	46.01	4.42	30.64	76.65
	Area	6.00	8.83	53.00	4.42	30.64	83.64
	Outside B-line	5.21	9.83	51.22	4.92	37.97	89.18707
	Area	6.00	9.83	59.00	4.92	37.97	96.97179
Surface Area					Length		
		10.42	8.83		4.42	13.88	33.13
		12.00	8.83		4.42	13.88	34.71

Calculations

Density of material used 1988	100 lb/ft ³	
Density of material used 2005 and in this report	110 lb/ft ³	This number used by this study
Collapsed Length of tunnel	92 feet	
Assumed Internal Friction and Poisson's ratio	46.23 degrees	0.45
Pages 43 and 61 Gobla's report excavation dimensions	11 feet wide 12 feet tall	Rock Tunnel Wall Height Sta height, feet
Max Area of Plug, estimated in this study	119.02 feet ²	R= 5.5 4+62 4
More accurate Volume of Plug this study	10,950 Cu. Feet	H= 6.5 5+00 5.79
Hydraulic Driving Force		46 5+75 9.32
This Study max area & correct head	252,506 pounds	5+92 10.12
This Study max area & artesian flow @ well 6+34	796,878 pounds	
This Study maximum area & max head	794,501 pounds	
Shear Calculations		
Average Depth of Collapse	100 feet	
Average vertical stress this study	76.39 psi	
Average horizontal stress this study	21.23 psi	
Invert elevation at station 0+00	9957 feet	Jaky Ko = 0.28
Surface Elevation well 6+34	10,064.30 feet	Sigma H = Sigma V*(1-sin(phi)) Jaky Coefficient used
Head and Pressure at well 6+34 for artesian flow	107.30 feet	Sigma H = Sigma V*(1-sin(phi)) Jaky Coefficient used
Maximum head elevation Pendry Blockage	10148.81 feet	
Maximum Potential water head at 6+35	191.81 feet	
Maximum hydraulic pressure-Non Leaky Tunnel	83.12 psi	Head may be incorrect. Appears depth to the water table used as the head. 77 feet was only used to check original calculations.
Hydraulic head and pressure for uplift/fracturing 2008	176.28 feet	46.50 psi
Water head and pressure at 6+35 for FS=1	106.98 feet	Mine pool head 192 feet, 9/13/2007. Doubtful hydraulic fracturing or uplift may occur where overburden less than about half the head
shear calculations		
Perimeter of horseshoe tunnel	34.71 feet	
Bottom of horseshoe	8.83 feet	
Sides of horseshoe tunnel x2	12 feet	76.39 psi
Top of horseshoe tunnel	13.88 feet	46.36 psi
Shear Equation used in 1988 memorandum		S=(p-u) tan Ø
Friction Angle between fill and rock surfaces	46 degrees	
Corrected Head and pressure in 1988	34 feet	
Shear strength, pounds this study w/1988 area	23,976,341 pounds	14.73 psi
Shear strength, this study w/ max area	20,913,668 pounds	Used true head. This was not used
Shear strength, this study max head non leaky	-18,308,588 pounds	Without a leaky tunnel pressure could blowout lift up overburden.
Shear strength, this study max head non leaky	795,598 pounds	Without a leaky tunnel pressure could blowout plug or overburden.
Shear strength, this study max head, leaky	707,385 pounds	With a leaky tunnel pressure could not blowout plug or overburden.

Location	Description	Date Completed [MM/DD/YY]	Total Depth [feet]	TOC elevation [ft. ASL]
LDT03+00	Alluvial well 20' off set from LDT, Station 3+00	1976	78	10035.1
LDT04+70	Alluvial well 20' off set from LDT, Station 4+70	1976	92	10048.8
LDT06+34	LMDT Well Previous DWW, Station 06+34	1976	108	10099.7

10,064.30 feet TOC for LDT 06+34 Error in table

Parameters for this study

Water Elev. feet	Water Pressure psi	Head at 6+34 feet	Shear Resistance, lbs	Driving force, lbs	S.F.	
9991.00		14.73	34.00	20,913,668	252,506	82.8
10064.30		46.50	107.30	707,385	796,878	0.89
10063.98		46.36	106.98	795,598	794,501	1.0

Equation Parameters

B

A

-0.026940747	815,935	Shear resistance SF=1	794,530 lbs	Check	794,530
-275665.5256	30286295.95	794,530 Head for FS=1	106.98 feet		lbs

Estimated Driving Force versus Resisting Force for Leadville Tunnel Blockage from 5+00 to 5+92 with Increasing Head to Left, but with full hydraulic gradient, Rock Contact Phi = 46.23 deg., zero cohesion, Internal friction Sediments 46.23 deg., Ko = 0.5

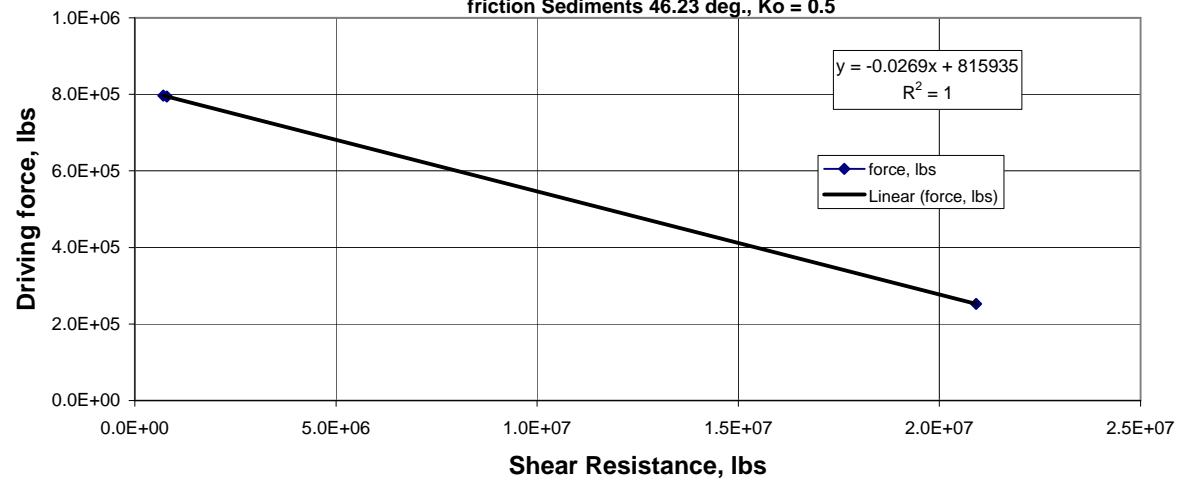

Head, with full hydraulic Gradient through the Leadville Mine Tunnel blockage versus Shear resistance for Blockage from Station 5+00 to 5+92, Phi =46.23 deg., zero cohesion, Internal friction Sediments 46.23 deg., Ko = 0.5

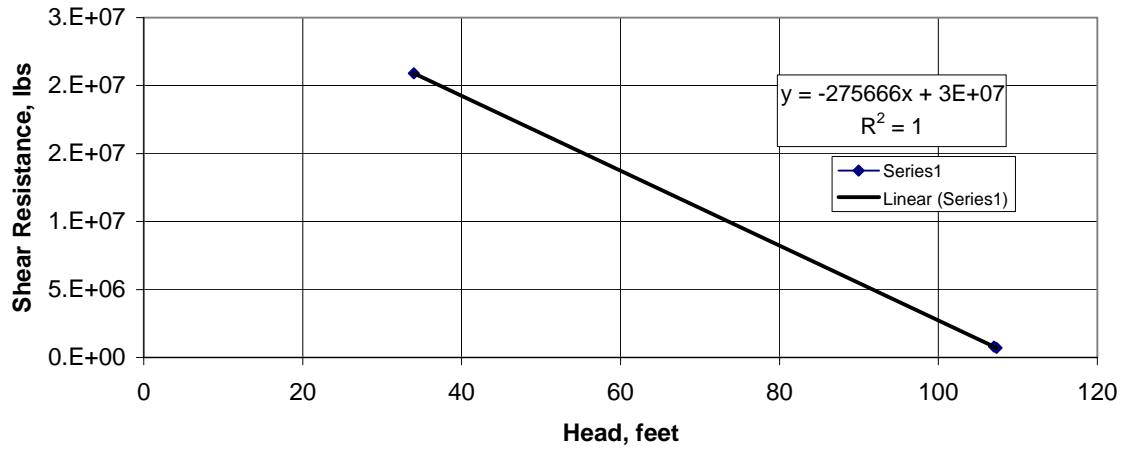

Head, with full hydraulic Gradient through the Leadville Mine Tunnel blockage versus Shear resistance for Blockage from Station 5+00 to 5+92, Phi =46.23 deg., zero cohesion, Internal friction Sediments 46.23 deg., Ko = 0.28

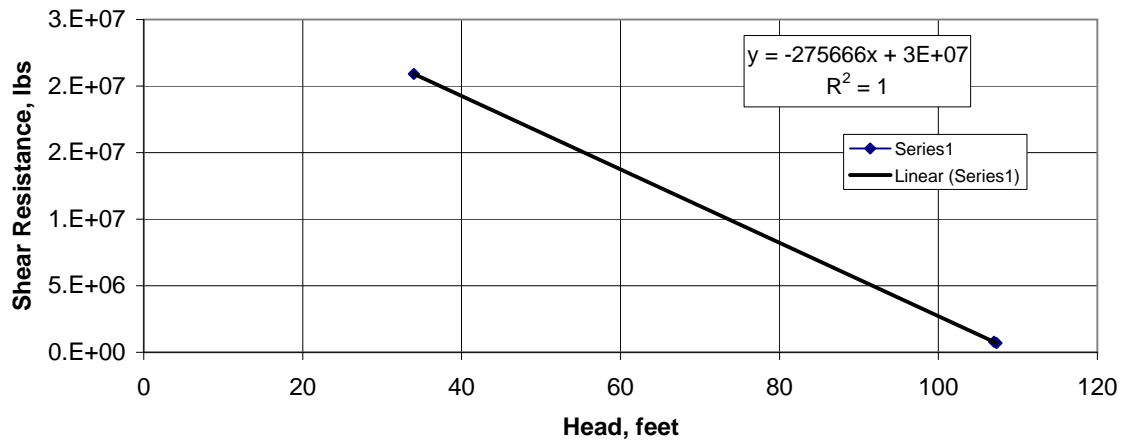

Driving force versus Safety Factor for Leadville Mine Tunnel Blockage with a full hydraulic gradient from Station 5+00 to 5+92 as Head Increases to the Right, rock contact phi = 46.23 deg. zero cohesion, Internal friction Sediments 46.23 deg., Ko = 0.5

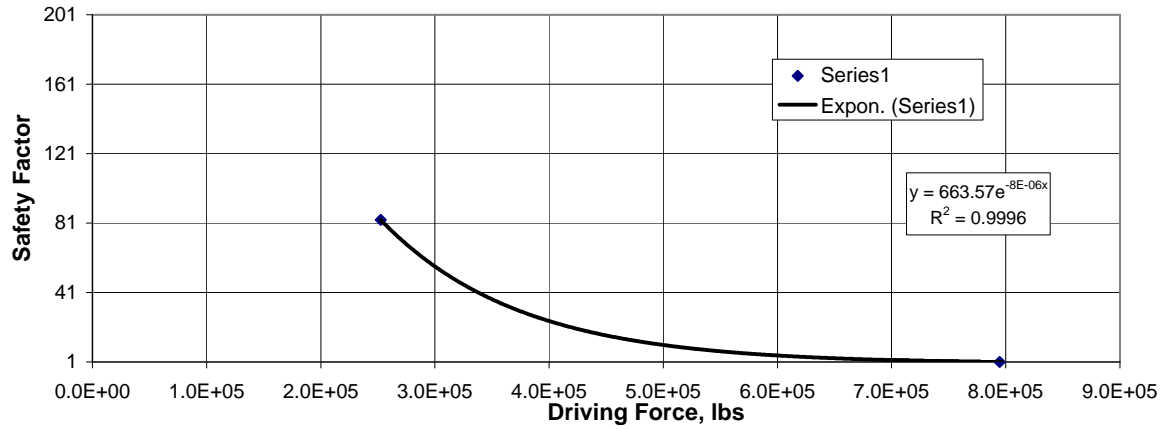

Driving force versus Safety Factor for Leadville Mine Tunnel Blockage with a full hydraulic gradient from Station 5+00 to 5+92 as Head Increases to the Right, rock contact phi = 46.23 deg. zero cohesion, Internal friction Sediments 46.23 deg., Ko = 0.28

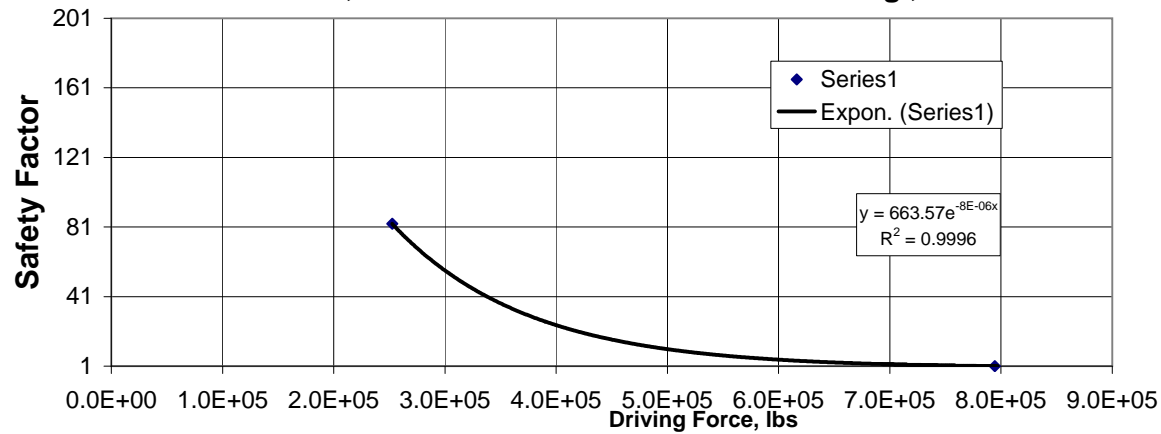

**Driving Force versus Safety Factor >1 and Hydraulic Head, assuming full Hydraulic Head,
Zero Cohesion, and No Dilation for Blockage, from Station 5+00 to 5+92, Leadville Mine
Drainage Tunnel, Colorado**

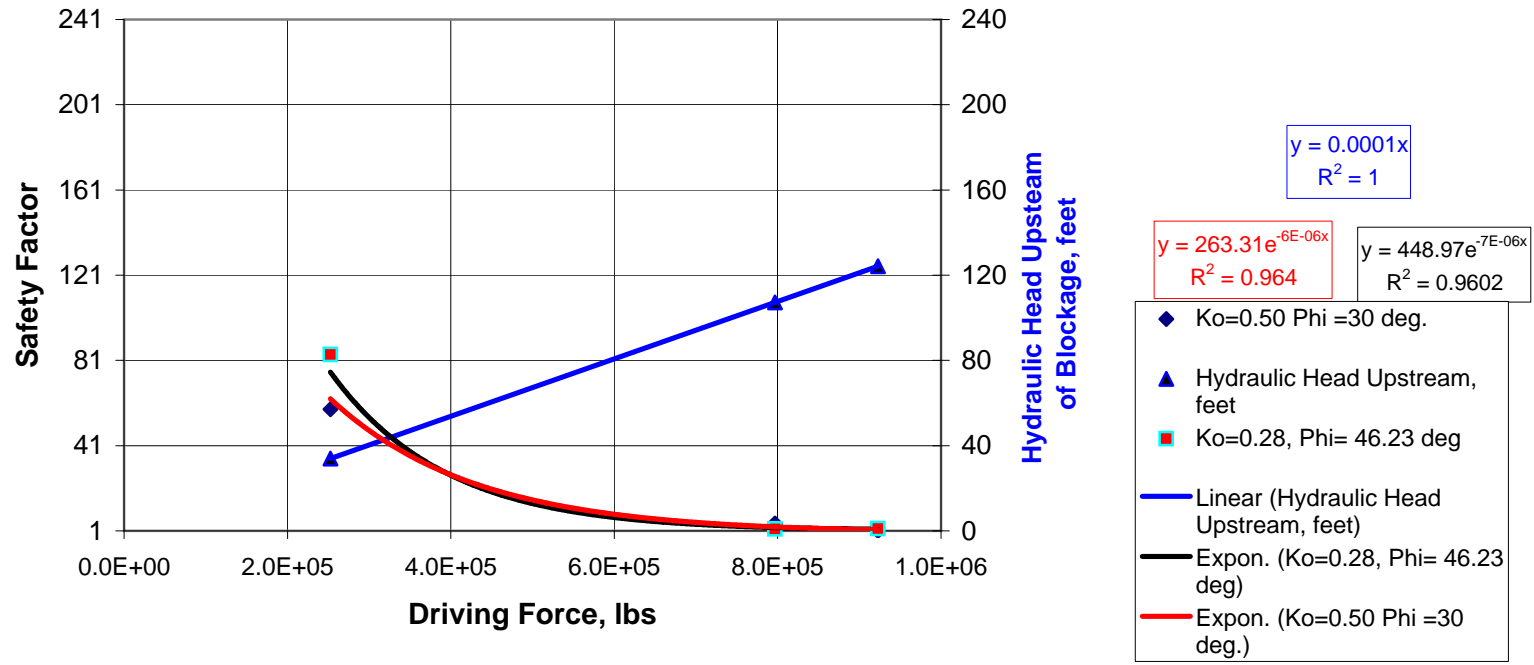

**Appendix C: Spreadsheet for
calculation of the plug stability against
blowout for the diffused pressure
condition**

5+00 to 5+92 Hydraulic Gradient Through the Tunnel Plug

Calculations

	Square section of Tunnel			Curved section		Total	
		Height, ft	Width, ft	Area, ft ²	radius, ft	Area, ft ²	Area, ft ²
Cross sectional area of	Inside A-Line	5.21	8.83	46.01	4.42	30.64	76.65
	Area	6.00	8.83	53.00	4.42	30.64	83.64
	Outside B-line	5.21	9.83	51.22	4.92	37.97	89.18707
	Area	6.00	9.83	59.00	4.92	37.97	96.97179
Surface Area		10.42	8.83		Length		
		12.00	8.83		4.42	13.88	33.13
					4.42	13.88	34.71

Calculations

Density of material used 1988	100 lb _f /ft ³	
Density of material used 2005 and in this report	110 lb _f /ft ³	This number used by this study
Collapsed Length of tunnel	92 feet	
Assumed Internal Friction and Poisson's ratio	30 degrees	0.45
Pages 43 and 61 Gobla's report	11 feet wide	1988 Conservative value inside A-line
excavation dimensions	12 feet tall	R= 5.5
Max Area of Plug, estimated in this study	119.02 feet ²	H= 6.5
More accurate Volume of Plug this study	10,950 Cu. Feet	46
Correct Mass of Collapsed Tunnel plug 1988	1,094,953 lbs	
Hydraulic Driving Force		
This Study max area & correct head	252,506 pounds	
This Study max area & artesian flow @ well 6+34	796,878 pounds	
This Study maximum area & max head	1,763,455 pounds	
Shear Calculations		
Average Depth of Collapse	100 feet	Not used
Average vertical stress this study	76.39 psi	Not used
Average horizontal stress this study	38.19 psi	Jaky Ko=
Invert elevation 0+00	9957 feet	Sigma H = Sigma V*(1-sin(phi))
Surface Elevation well 6+34	10,064.30 feet	Sigma H = Sigma V*(1-sin(phi))
Water head used in 1988 , 6+34 (11/24/1976)	77 feet	
1988 hydraulic pressure	33.37 psi	0.50
Head and Pressure at well 6+34 for artesian flow	107.30 feet	Head may be incorrect. Appears depth to the water table used as
Maximum head elevation Pendry Blockage	10148.81 feet	the head. 77 feet was only used to check original calculations.
Maximum Potential water head at 6+34	191.81 feet	46.50
Maximum hydraulic pressure-Non Leaky Tunnel	83.12 psi	Mine pool head 192 feet, 9/13/2007. Doubtful hydraulic fracturing
Hydraulic head and pressure for uplift/fracturing 2008	176.28 head	76.39

Water head and pressure at 6+34 for FS=1	237.45 feet	102.90
shear calculations		psi
Perimeter of horseshoe tunnel	34.71 feet	psi
Bottom of horseshoe	8.83 feet	psi
Sides of horseshoe tunnel x2	12 feet	$\delta=(p-u) \tan \emptyset$
Top of horseshoe tunnel	13.88 feet	
Shear Equation used in 1988 memorandum		Friction of Jaky (1948)[1] for normally consolidated soils
Fiction Angle between Rock and fill	30 degrees	Jaky (1948)[1] for normally consolidated soils
Corrected Head and pressure in 1988	34 feet	14.73
Shear strength, pounds this study w/1988 area	14,818,187 pounds	Used true h Input phi value here:
Shear strength, this study w/ max area	17,273,566 pounds	46.23
Shear strength, this study uplift head non leaky	6,427,063 pounds	Without a leaky tunnel pr degrees found by back calculation
Shear strength, this study max head non leaky	1,764,083 pounds	Without a le psi
Shear strength, this study max head, leaky	11,685,731 pounds	With a leaky tunnel pressure could not blowout plug or overburden

Location	Description	Date Completed [MM/DD/YY]	Total Depth [feet]	TOC elevation [ft. ASL]
LDT03+00	Alluvial well 20' off set from LDT, Station 3+00	1976	78	10035.1
LDT04+70	Alluvial well 20' off set from LDT, Station 4+70	1976	92	10048.8
LDT06+34	LMDT Well Previous DWW, Station 06+34	1976	108	10099.7

10,064.30 feet TOC for LDT 06+34 Error in table

Parameters for this study

Water Elev. feet	Water Pressure psi	Head at 6+34 feet	Shear Resistance, lbs	Driving force, lbs
9991.00		14.73	34.00	17,273,566
10064.30		46.50	107.30	11,685,731
10133.28		76.39	176.28	6,427,063
10194.45		102.90	237.45	1,764,083
				1,763,455

Equation Parameters

B	A	68.41
-0.097420973	1,935,313	14.66
-76232.40578	19865468.06	4.91
		1.00

1,763,510
237.46 lbs
feet Check
1,763,510 lbs

Estimated Driving Force versus Resisting Force for Leadville Tunnel Blockage from 5+00 to 5+92 with Increasing Head to the Left, but with a gradient, Rock Contact Phi = 30 deg., zero cohesion, Internal friction Sediments 30 deg., Ko = 0.5.

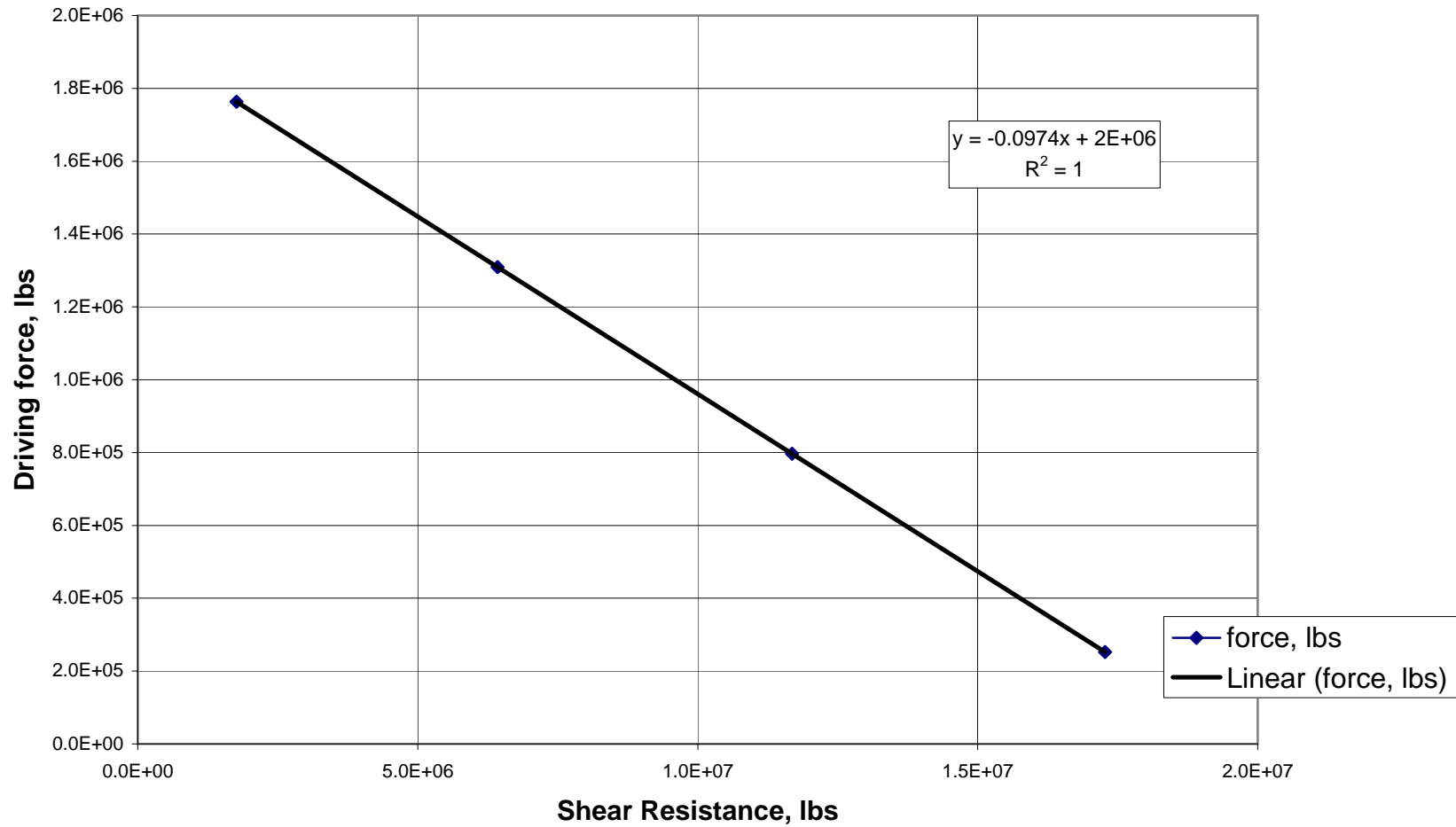

Head versus Shear resistance for Blockage with a Hydraulic Gradient from Station 5+00 to 5+92, Phi =30 deg., Leadville Mine Drainage Tunnel, Colorado

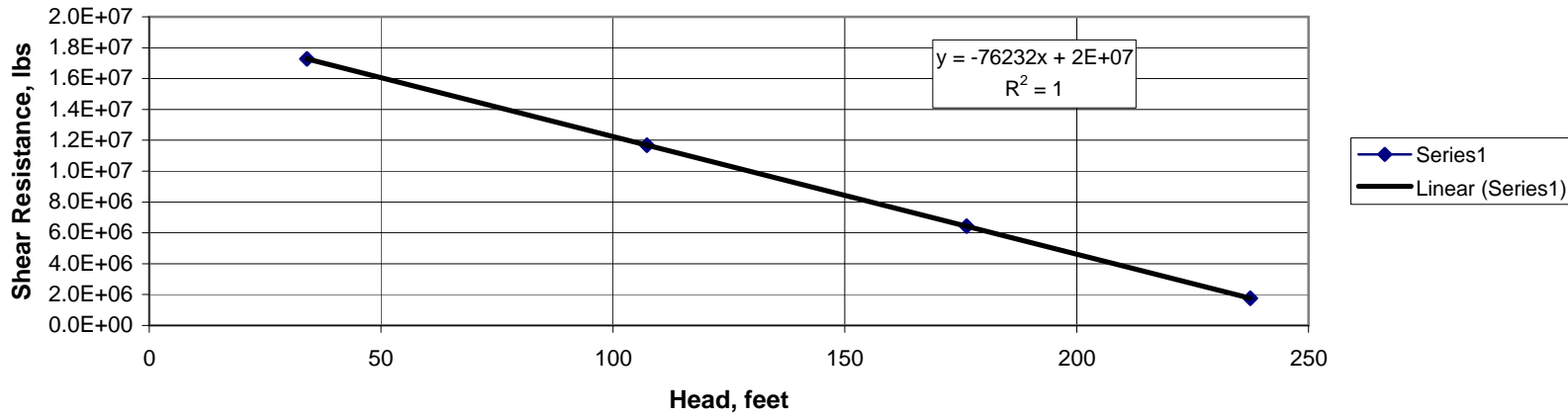

Head versus Shear resistance for Blockage with a Hydraulic Gradient from Station 5+00 to 5+92, Rock Contact Phi =30 deg., zero cohesion, internal friction sediments 30 deg., zero cohesion, Ko=0.5 Leadville Mine Drainage Tunnel, Colorado

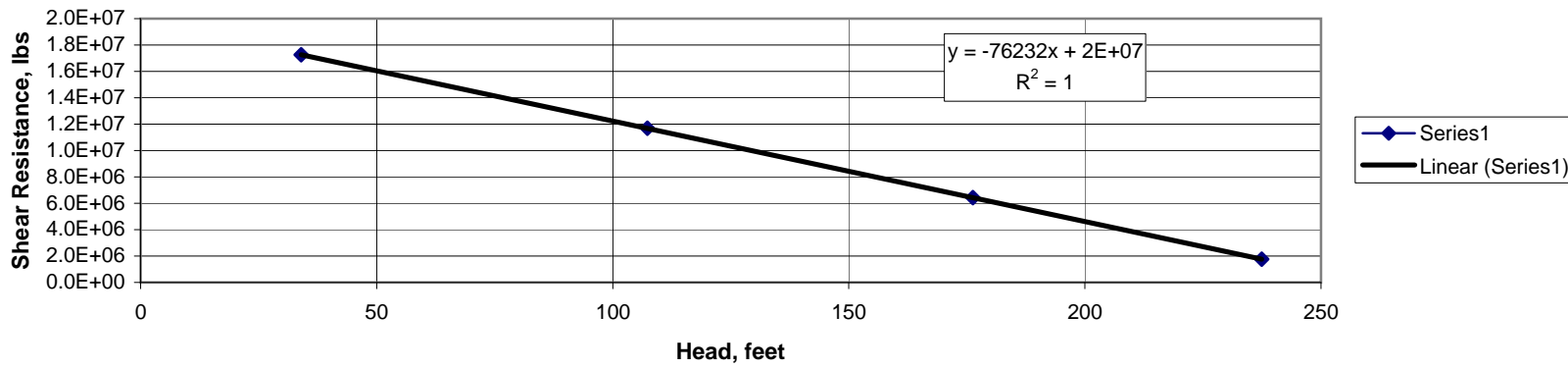

Driving force versus Safety Factor for Blockage from Station 5+00 to 5+92 as Head, assuming a Hydraulic Gradient, Increases to the Right, phi = 30 deg., Leadville Mine Drainage Tunnel, Colorado

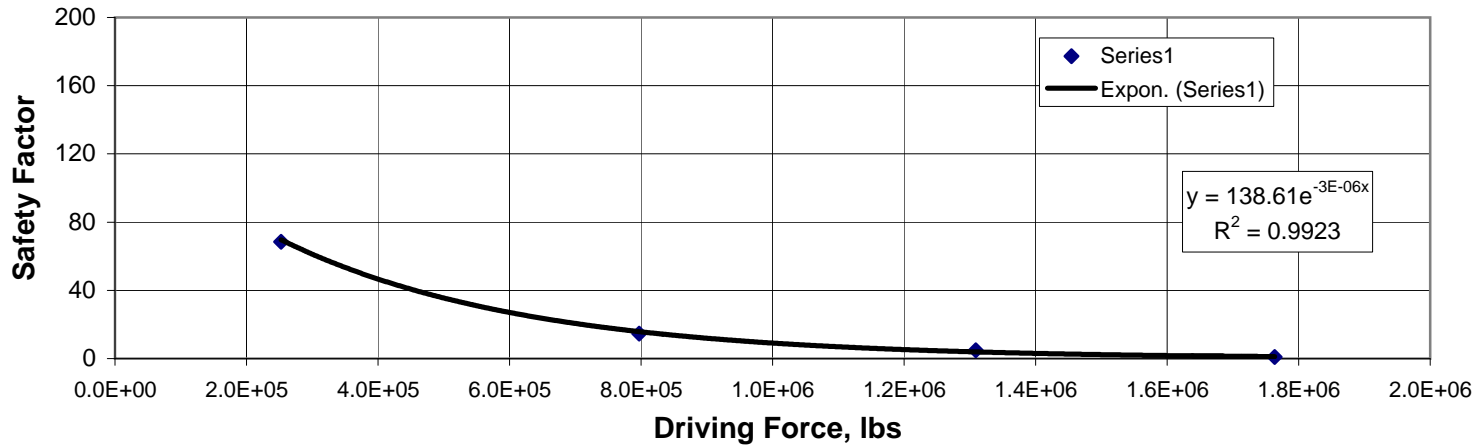

Driving force versus Safety Factor for Blockage from Station 5+00 to 5+92 as Head, assuming a Hydraulic Gradient, Increases to the Right, zero cohesion, internal friction sediments 30 deg., zero cohesion, Ko=0.5 Leadville Mine Drainage Tunnel, Colorado

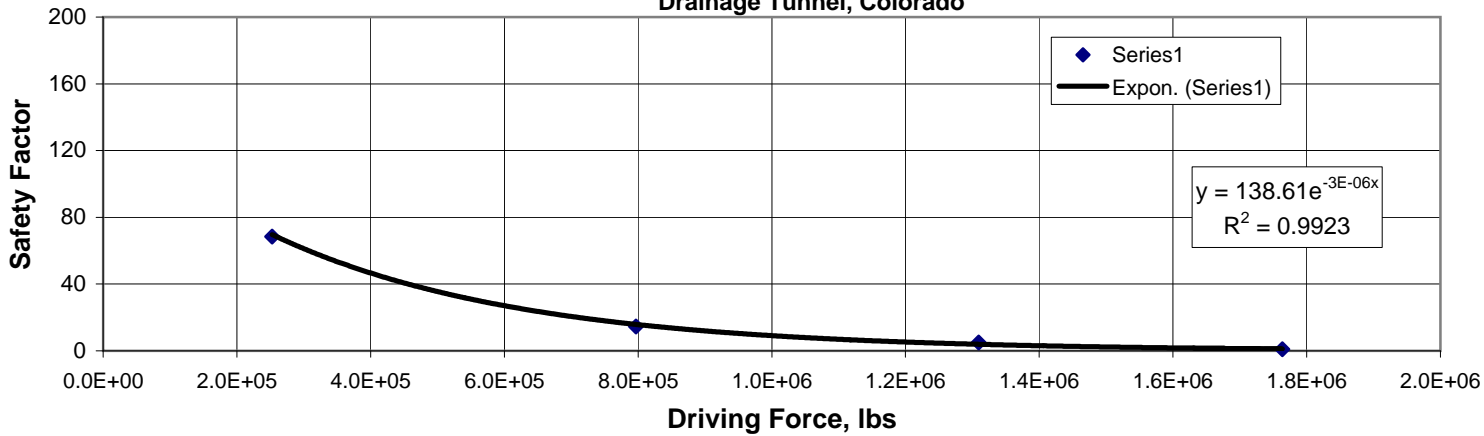

Calculations

	5+00 to 5+92			Curved section		Total	
	Height, ft	Width, ft	Area, ft ²	radius, ft	Area, ft ²	Area, ft ²	
Cross sectional area of	Inside A-Line	5.21	8.83	46.01	4.42	30.64	76.65
	Area	6.00	8.83	53.00	4.42	30.64	83.64
Surface Area	Outside B-line	5.21	9.83	51.22	4.92	37.97	89.187066
	Area	6.00	9.83	59.00	4.92	37.97	96.971789
		10.42	8.83		Length		
		12.00	8.83		4.42	13.88	33.13
					4.42	13.88	34.71

\Calculations

Density of material used 1988	100 lb _f /ft ³	
Density of material used 2005 and in this report	110 lb _f /ft ³	This number used by this study
Collapsed Length of tunnel	92 feet	
Assumed Internal Friction and Poisson's ratio	46.23 degrees	0.45
Area of Plug, estimated in 1988	83.6 feet ²	1988 Conservative value inside A-line
Pages 43 and 61 Gobla's report excavation dimensions	11 feet wide	R= 5.5
	12 feet tall	H= 6.5
Max Area of Plug, estimated in this study	119.02 feet ²	46
More accurate Volume of Plug this study	10,950 Cu. Feet	
Hydraulic Driving Force		
This Study max area & correct head	252,506 pounds	
This Study max area & artesian flow @ well 6+34	796,878 pounds	
This Study maximum area & max head	1,548,528 pounds	

Shear Calculations

Average Depth of Collapse	100 feet	
Average vertical stress this study	76.39 psi	
Average horizontal stress this study	21.23 psi	Jaky Ko = 0.28
Invert elevation at station 0+00	9957 feet	Sigma H = Sigma V*(1-sin(phi))
Surface Elevation well 6+34	10,064.30 feet	
Head and Pressure at well 6+34 for artesian flow	107.30 feet	the head. 77 feet was only used to check original calculations.
Maximum head elevation Pendry Blockage	10148.81 feet	46.50 psi
Maximum Potential water head at 6+35	191.81 feet	Mine pool head 192 feet, 9/13/2007. Doubtful hydraulic fracturing or uplift may occur where overburden less than about half the head
Maximum hydraulic pressure-Non Leaky Tunnel	83.12 psi	
Hydraulic head and pressure for uplift/fracturing 2008	176.28 feet	
Water head and pressure at 6+35 for FS=1	208.51 feet	76.39 psi

shear calculations

90.35 psi

Perimeter of horseshoe tunnel	34.71 feet		
Bottom of horseshoe	8.83 feet		
Sides of horseshoe tunnel x2	12 feet		
Top of horseshoe tunnel	13.88 feet		
Shear Equation used in 1988 memorandum			
Friction Angle between fill and rock surfaces	46 degrees	$\delta=(p-u) \tan \emptyset$	
Corrected Head and pressure in 1988	34 feet	14.73 psi	
Shear strength, pounds this study w/1988 area	23,976,341 pounds	Used true head.	This was not used
Shear strength, this study w/ max area	25,599,982 pounds		
Shear strength, this study max head non leaky	5,988,854 pounds	Without a leaky tunnel pressure could blowout lift up overburden.	
Shear strength, this study max head non leaky	1,546,787 pounds	Without a leaky tunnel pressure could blowout plug or overburden.	
Shear strength, this study max head, leaky	15,496,841 pounds	With a leaky tunnel pressure could not blowout plug or overburden.	

Location	Description	Date Completed [MM/DD/YY]	Total Depth [feet]	TOC elevation [ft. ASL]
LDT03+00	Alluvial well 20' off set from LDT, Station 3+00	1976	78	10035.1
LDT04+70	Alluvial well 20' off set from LDT, Station 4+70	1976	92	10048.8
LDT06+34	LMDT Well Previous DWW, Station 06+34	1976	108	10099.7

10,064.30 feet TOC for LDT 06+34 Error in table

Parameters for this study

Water Elev. feet	Water Pressure psi	Head at 6+34 feet	Shear Resistance, lbs	Driving force, lbs	S.F.	
9991.00		14.73	34.00	25,599,982	252,506	101.4
10064.30		46.50	107.30	15,496,841	796,878	19.4
10133.28		76.39	176.28	5,988,854	1,309,182	4.6
10165.51		90.35	208.51	1,546,787	1,548,528	1.0

Equation Parameters

B	A				
-0.053881494	1,631,871	Shear resistance SF=1	1,548,439		
-137832.7628	30286295.95	1,548,439 Head for FS=1	208.50	Check	
			lbs	1,548,439 lbs	
			feet		

Estimated Driving Force versus Resisting Force for Leadville Tunnel Blockage from 5+00 to 5+92 with Increasing Head to the Left, but with a gradient, Rock Contact Phi = 46.23 deg., zero cohesion, Internal friction Sediments 46.23 deg., Ko = 0.28

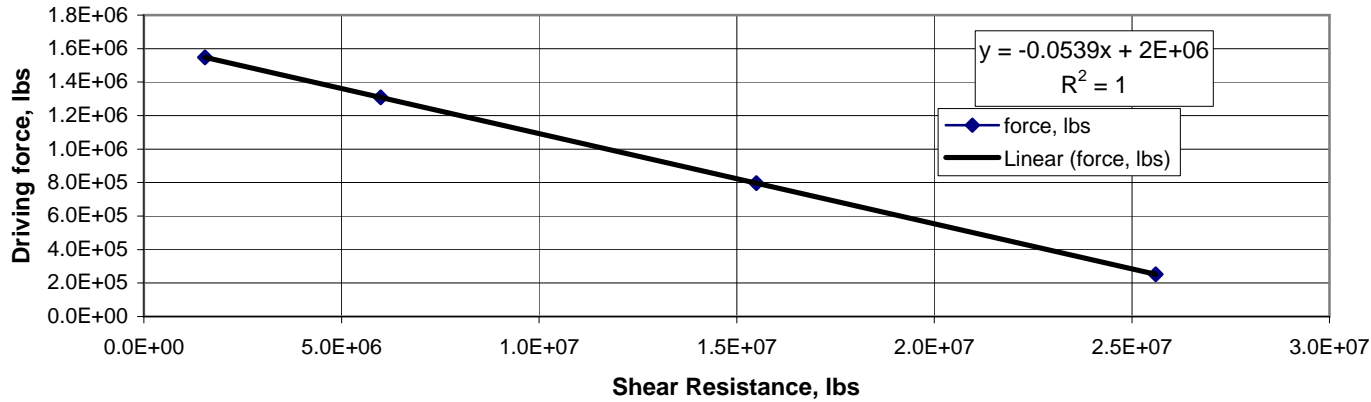

Head, with a Gradient through the Leadville Mine Tunnel blockage versus Shear resistance for Blockage from Station 5+00 to 5+92, Phi =46.23 deg., zero cohesion, Internal friction Sediments 46.23 deg., Ko = 0.28

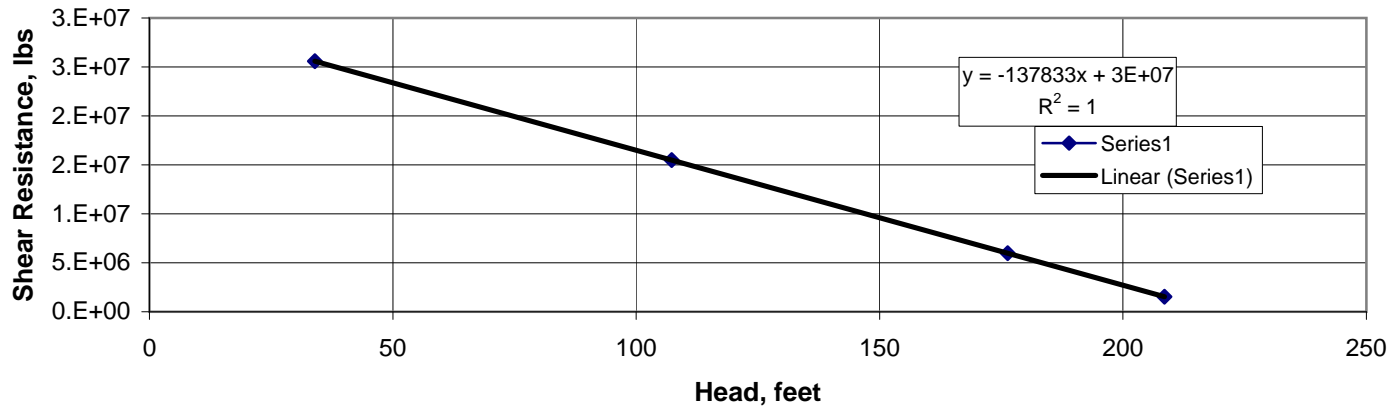

Driving force versus Safety Factor for Leadville Mine Tunnel Blockage with a hydraulic gradient from Station 5+00 to 5+92 as Head Increases to the Right, rock contact phi = 46.23 deg. zero cohesion, Internal friction Sediments 46.23 deg., Ko = 0.28

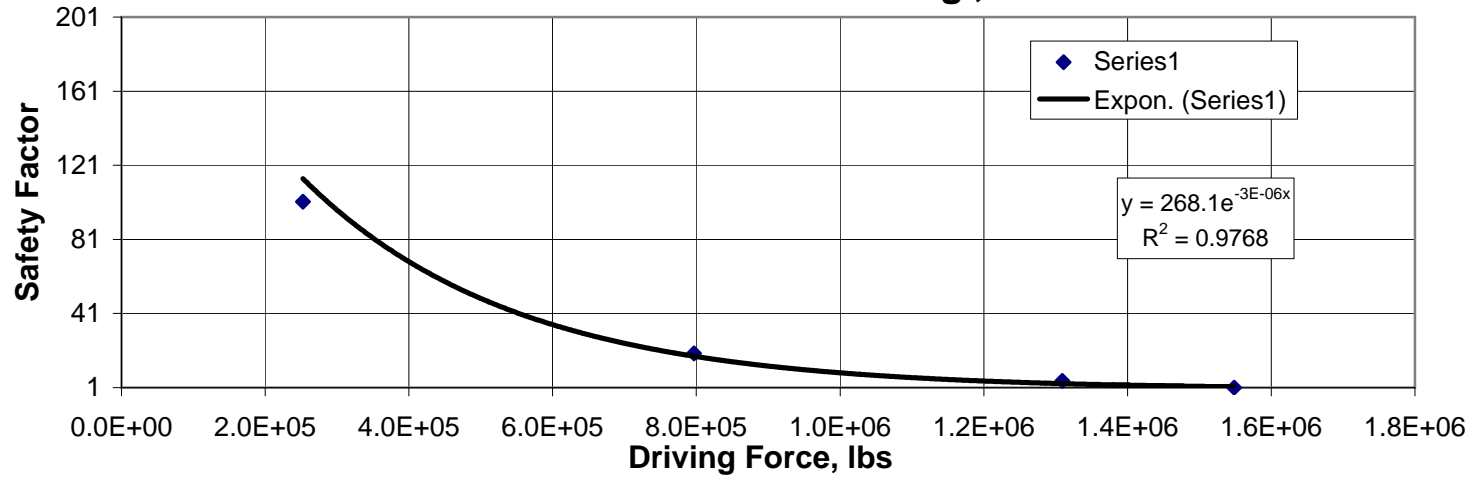

Driving Force versus Safety Factor >1 assuming a Hydraulic Gradient, Zero Cohesion, and No Dilation for Blockage from Station 5+00 to 5+92, Leadville Mine Drainage Tunnel, Colorado

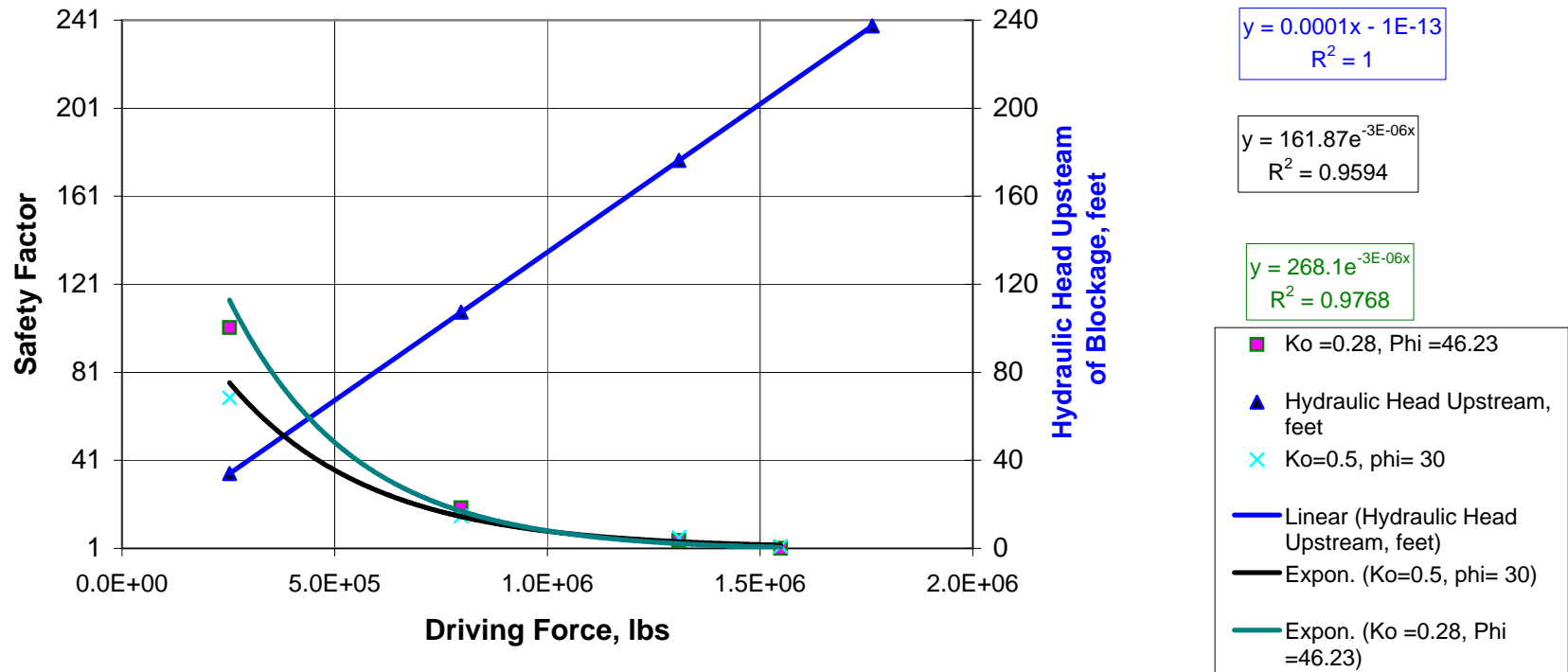

Appendix D: Slope Stability Calculation Results

APPENDIX D - FIGURE 1 LEADVILLE DRAINAGE TUNNEL

STUDY 2008 - SEISMIC COEFFICIENT: 0.000g
SOIL PROPERTIES: MINIMUM
GW at Sta. 10+25: 100 ft above tunnel invert

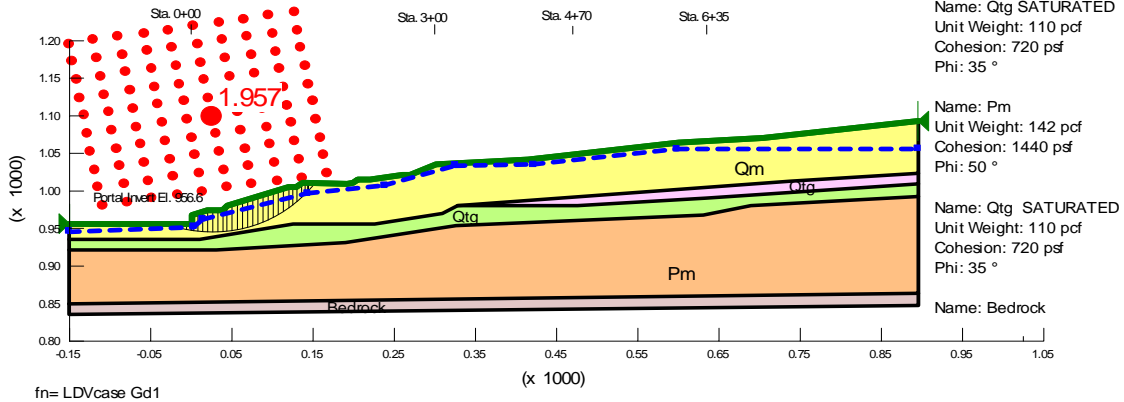

APPENDIX D - FIGURE 2 LEADVILLE DRAINAGE TUNNEL

STUDY 2008 - SEISMIC COEFFICIENT: 0.05g
SOIL PROPERTIES: MINIMUM
GW at Sta. 10+25: 100 ft above tunnel invert

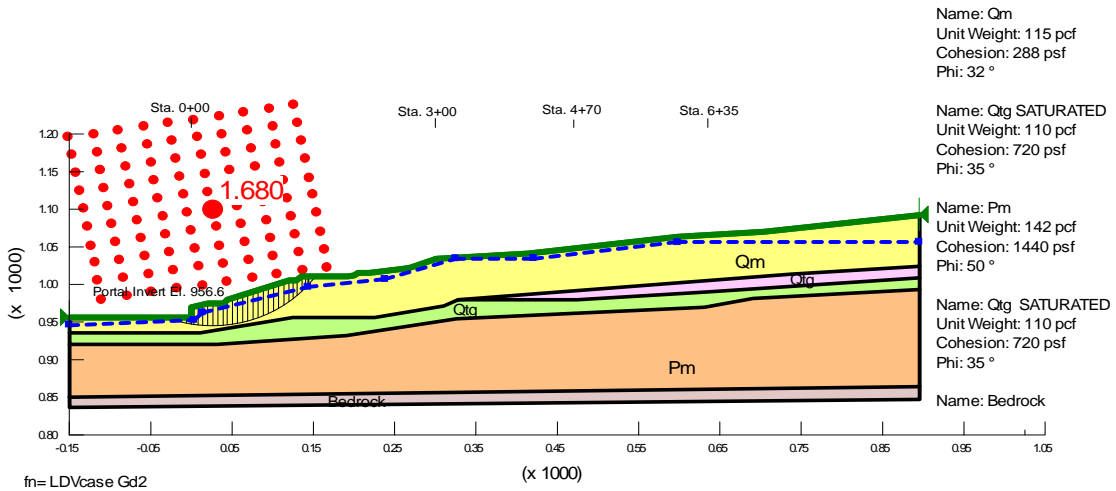

APPENDIX D - FIGURE 3 LEADVILLE DRAINAGE TUNNEL

STUDY 2008 - SEISMIC COEFFICIENT: 0.15g
SOIL PROPERTIES: MINIMUM
GW at Sta. 10+25: 100 ft above tunnel invert

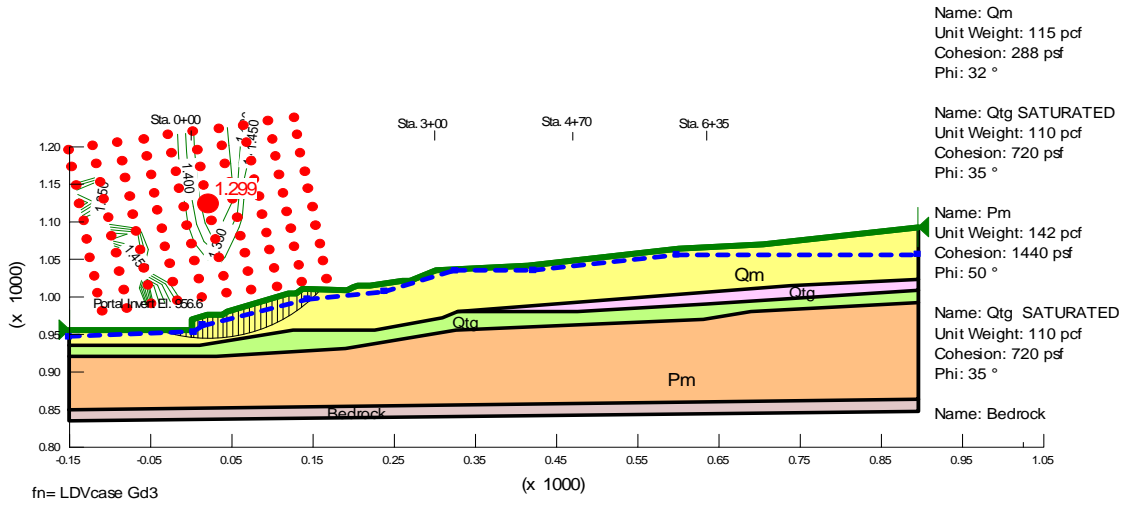

APPENDIX D - FIGURE 4 LEADVILLE DRAINAGE TUNNEL

STUDY 2008 - SEISMIC COEFFICIENT: 0.35g
SOIL PROPERTIES: MINIMUM
GW at Sta. 10+25: 100 ft above tunnel invert

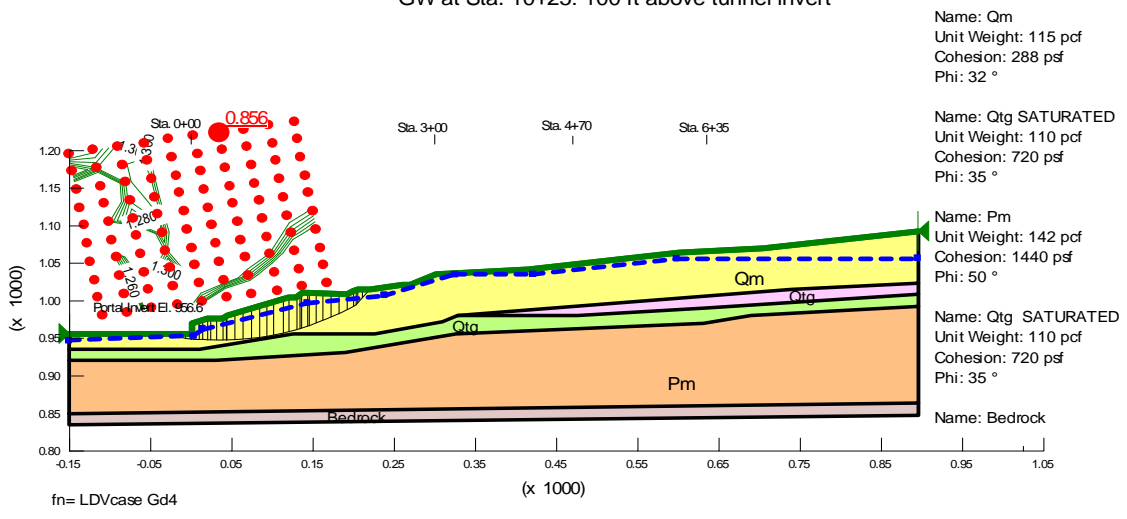

APPENDIX D - FIGURE 5 LEADVILLE DRAINAGE TUNNEL

STUDY 2008 - YIELD ACCELERATION: 0.197g
SOIL PROPERTIES: MINIMUM
GW at Sta. 10+25: 100 ft above tunnel invert

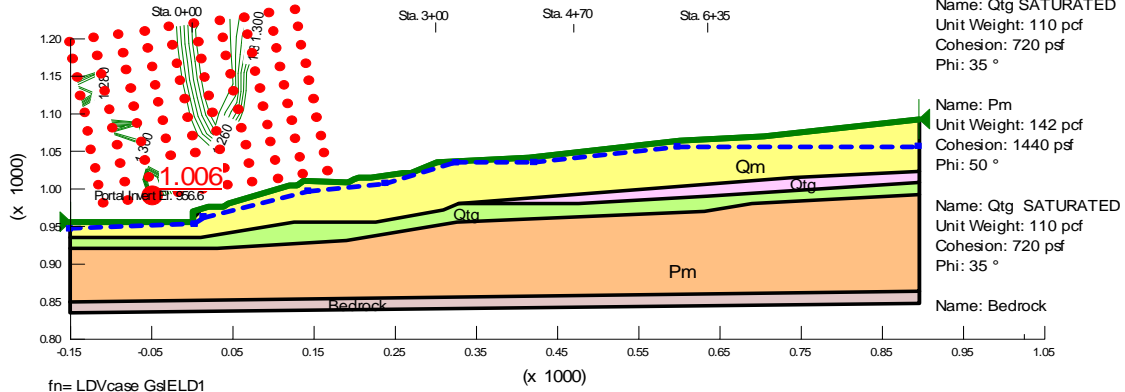

APPENDIX D - FIGURE 6 LEADVILLE DRAINAGE TUNNEL

STUDY 2008 - SEISMIC COEFFICIENT: 0.000g
SOIL PROPERTIES: AVERAGE
GW at Sta. 10+25: 100 ft above tunnel invert

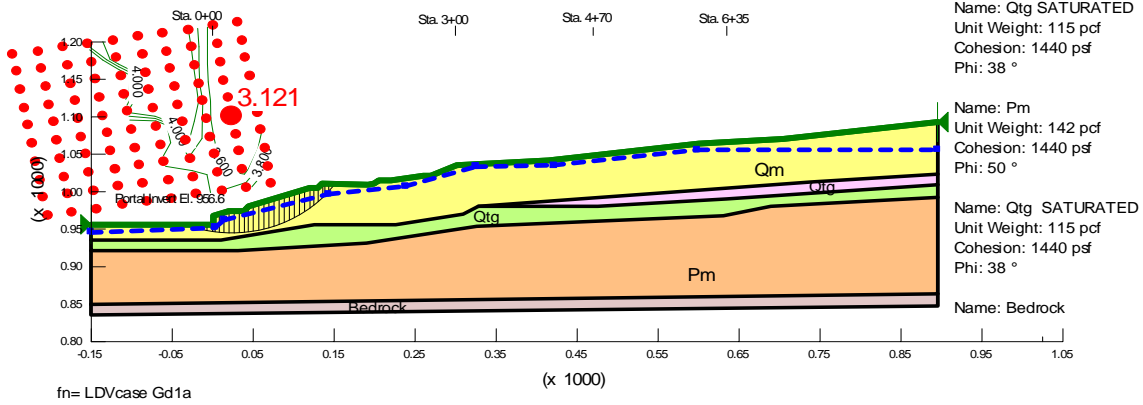

APPENDIX D - FIGURE 7 LEADVILLE DRAINAGE TUNNEL

STUDY 2008 - SEISMIC COEFFICIENT: 0.050g
SOIL PROPERTIES: AVERAGE
GW at Sta. 10+25: 100 ft above tunnel invert

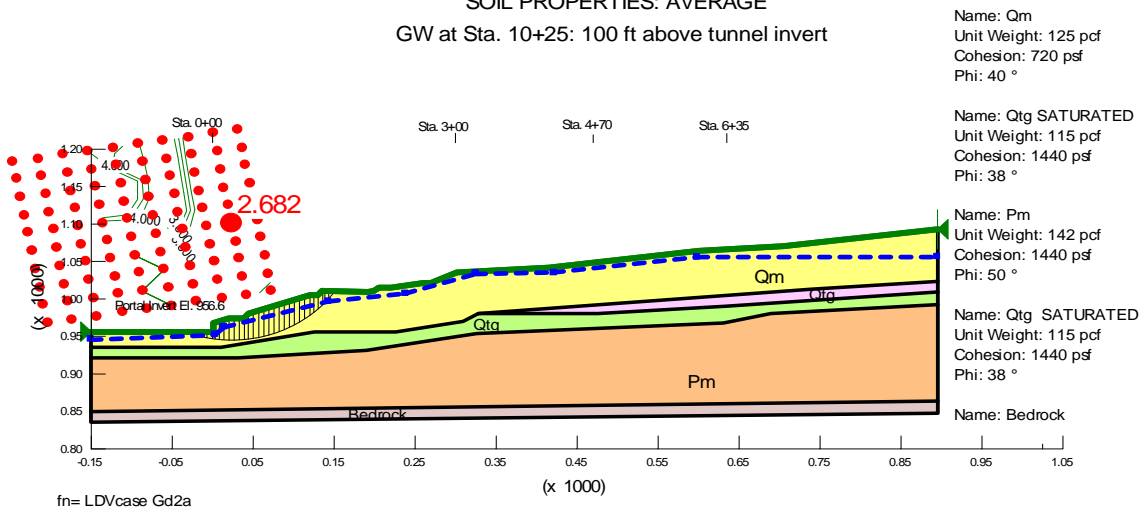

APPENDIX D - FIGURE 8 LEADVILLE DRAINAGE TUNNEL

STUDY 2008 - SEISMIC COEFFICIENT: 0.15g
SOIL PROPERTIES: AVERAGE
GW at Sta. 10+25: 100 ft above tunnel invert

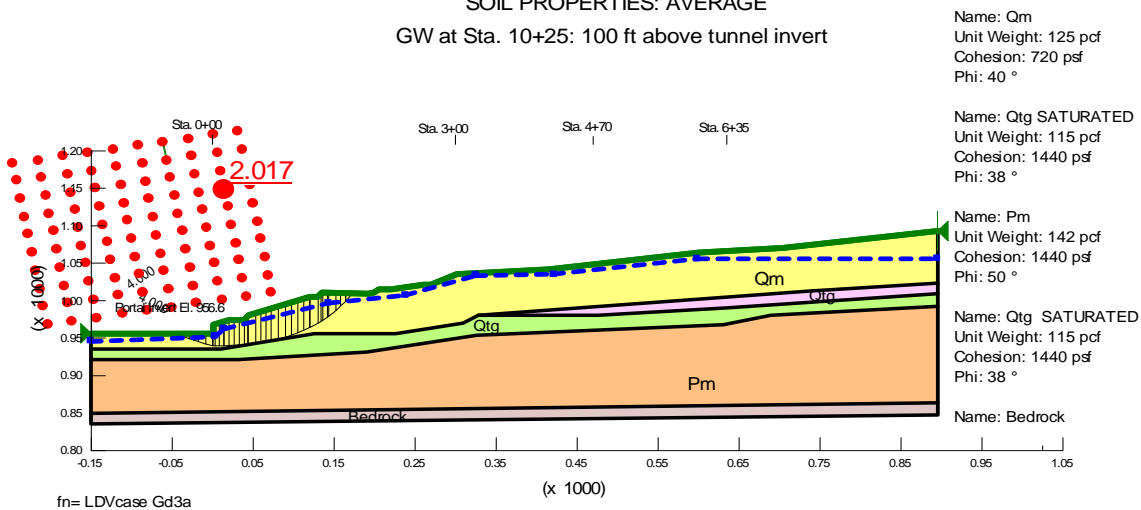

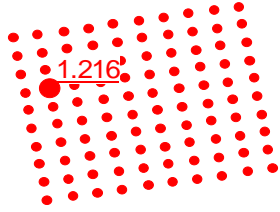

APPENDIX D - FIGURE 9 LEADVILLE DRAINAGE TUNNEL

STUDY 2008 - SEISMIC COEFFICIENT: 0.35g
SOIL PROPERTIES: AVERAGE
GW at Sta. 10+25: 100 ft above tunnel invert

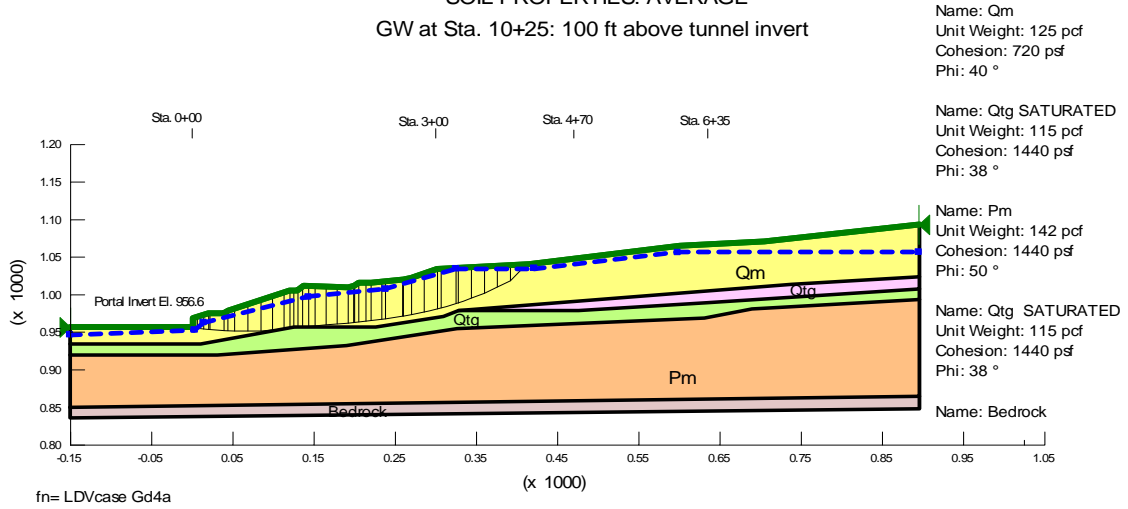

APPENDIX D - FIGURE 10 LEADVILLE DRAINAGE TUNNEL

STUDY 2008 - SEISMIC COEFFICIENT: 0.000g
SOIL PROPERTIES: MAXIMUM
GW at Sta. 10+25: 100 ft above tunnel invert

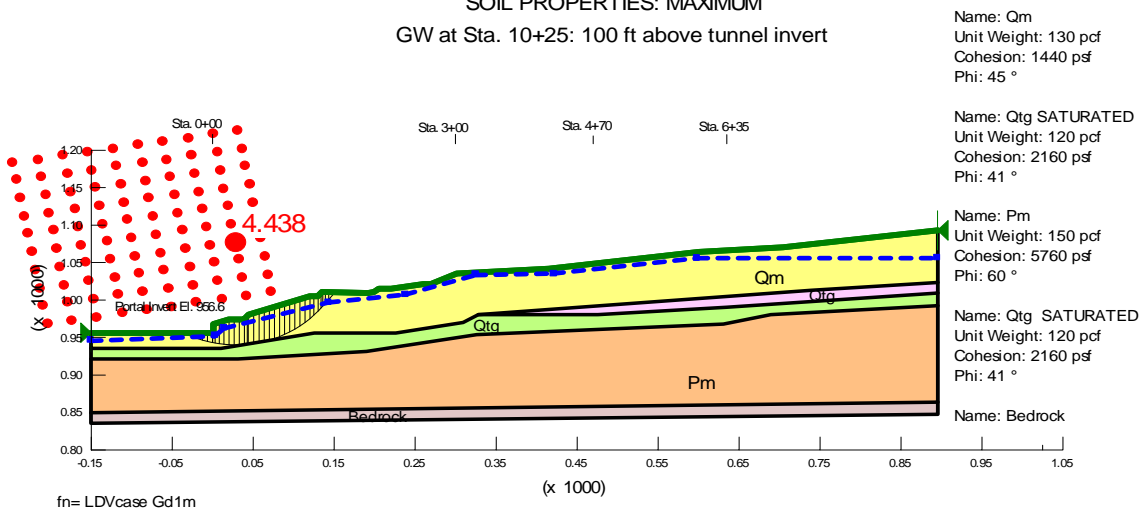

APPENDIX D - FIGURE 11 LEADVILLE DRAINAGE TUNNEL

STUDY 2008 - SEISMIC COEFFICIENT: 0.050g
SOIL PROPERTIES: MAXIMUM
GW at Sta. 10+25: 100 ft above tunnel invert

Name: Qm
Unit Weight: 130 pcf
Cohesion: 1440 psf
Phi: 45 °

Name: Qtg SATURATED
Unit Weight: 120 pcf
Cohesion: 2160 psf
Phi: 41 °

Name: Pm
Unit Weight: 150 pcf
Cohesion: 5760 psf
Phi: 60 °

Name: Qtg SATURATED
Unit Weight: 120 pcf
Cohesion: 2160 psf
Phi: 41 °

Name: Bedrock

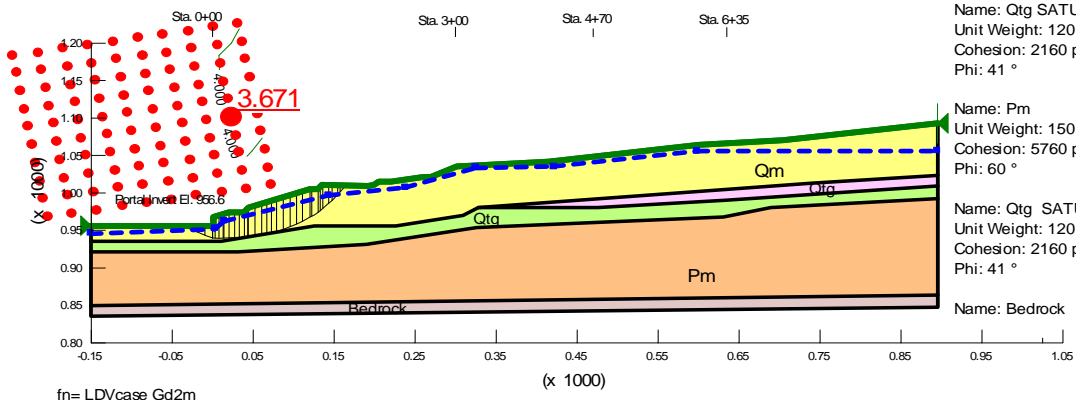

APPENDIX D - FIGURE 12 LEADVILLE DRAINAGE TUNNEL

STUDY 2008 - SEISMIC COEFFICIENT: 0.150g
SOIL PROPERTIES: MAXIMUM
GW at Sta. 10+25: 100 ft above tunnel invert

Name: Qm
Unit Weight: 130 pcf
Cohesion: 1440 psf
Phi: 45 °

Name: Qtg SATURATED
Unit Weight: 120 pcf
Cohesion: 2160 psf
Phi: 41 °

Name: Pm
Unit Weight: 150 pcf
Cohesion: 5760 psf
Phi: 60 °

Name: Qtg SATURATED
Unit Weight: 120 pcf
Cohesion: 2160 psf
Phi: 41 °

Name: Bedrock

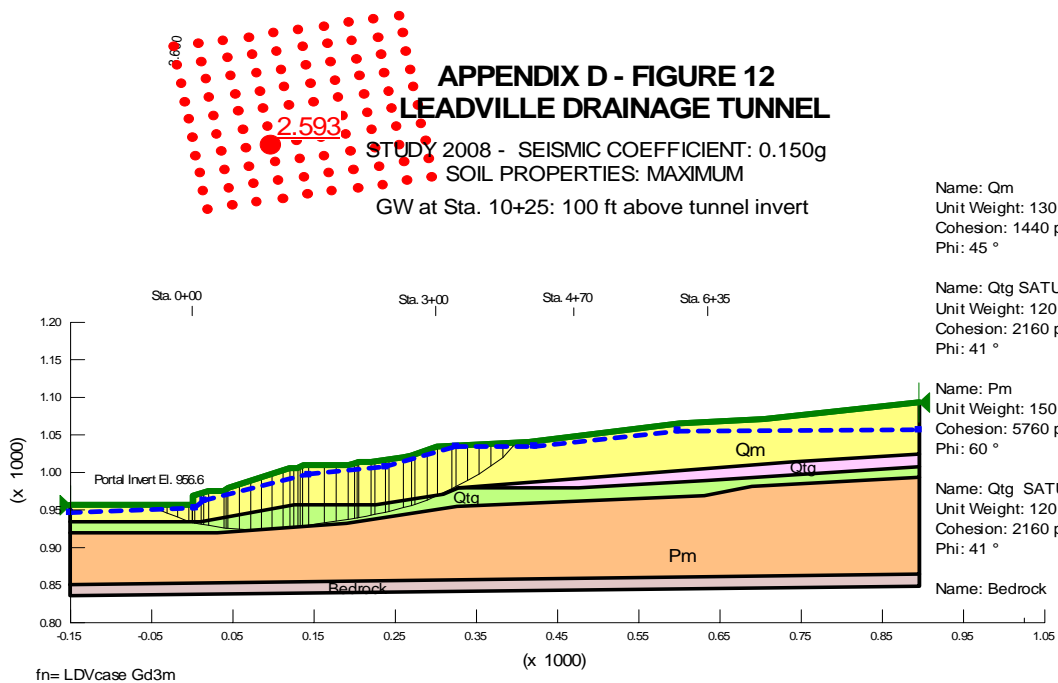

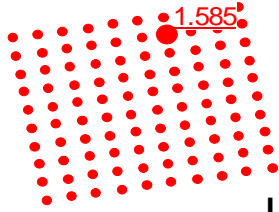

APPENDIX D - FIGURE 13 LEADVILLE DRAINAGE TUNNEL

STUDY 2008 - SEISMIC COEFFICIENT: 0.350g
SOIL PROPERTIES: MAXIMUM
GW at Sta. 10+25: 100 ft above tunnel invert

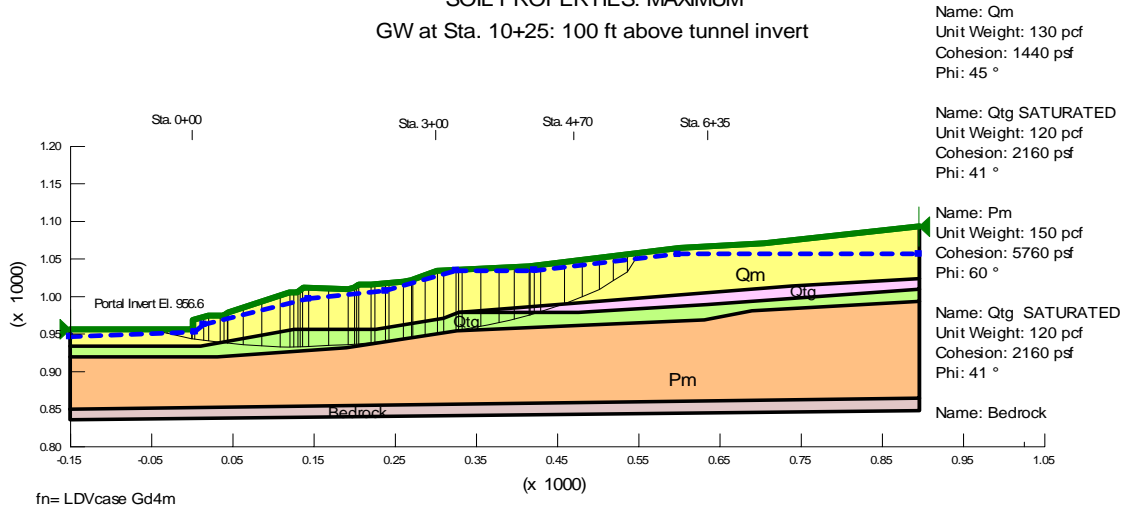

APPENDIX D - FIGURE 14 LEADVILLE DRAINAGE TUNNEL

STUDY 2008 - SEISMIC COEFFICIENT: 0.000g
SOIL PROPERTIES: MINIMUM & NO COHESION
GW at Sta. 10+25: 100 ft above tunnel invert

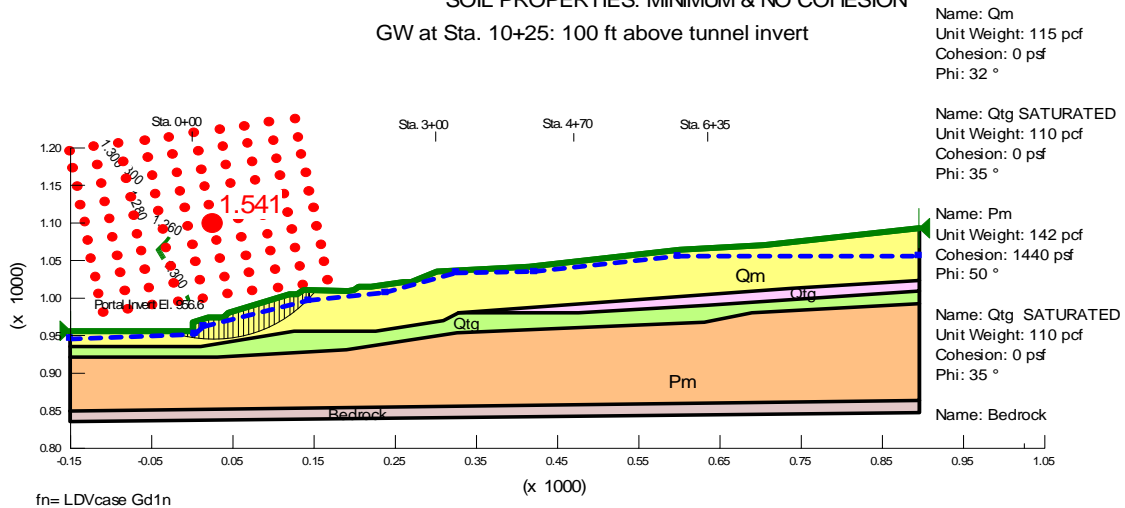

APPENDIX D - FIGURE 15 LEADVILLE DRAINAGE TUNNEL

STUDY 2008 - SEISMIC COEFFICIENT: 0.00g
SOIL PROPERTIES: AVERAGE & NO COHESION

GW at Sta. 10+25: 100 ft above tunnel invert

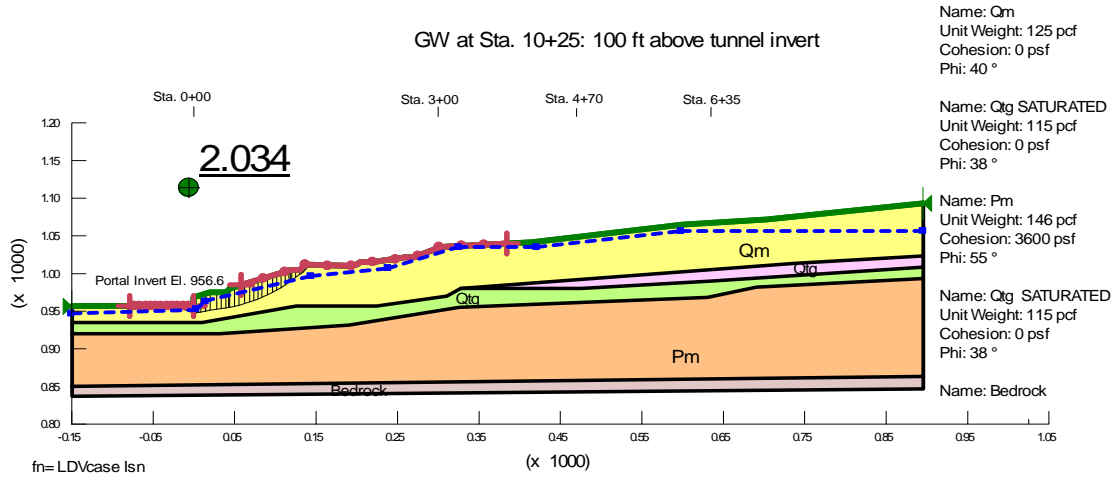

RECLAMATION

Managing Water in the West

Potential Failure Modes and Effects Analysis Leadville Mine Drainage Tunnel

Leadville Mine and Drainage Tunnel Project, Colorado
Great Plains Region

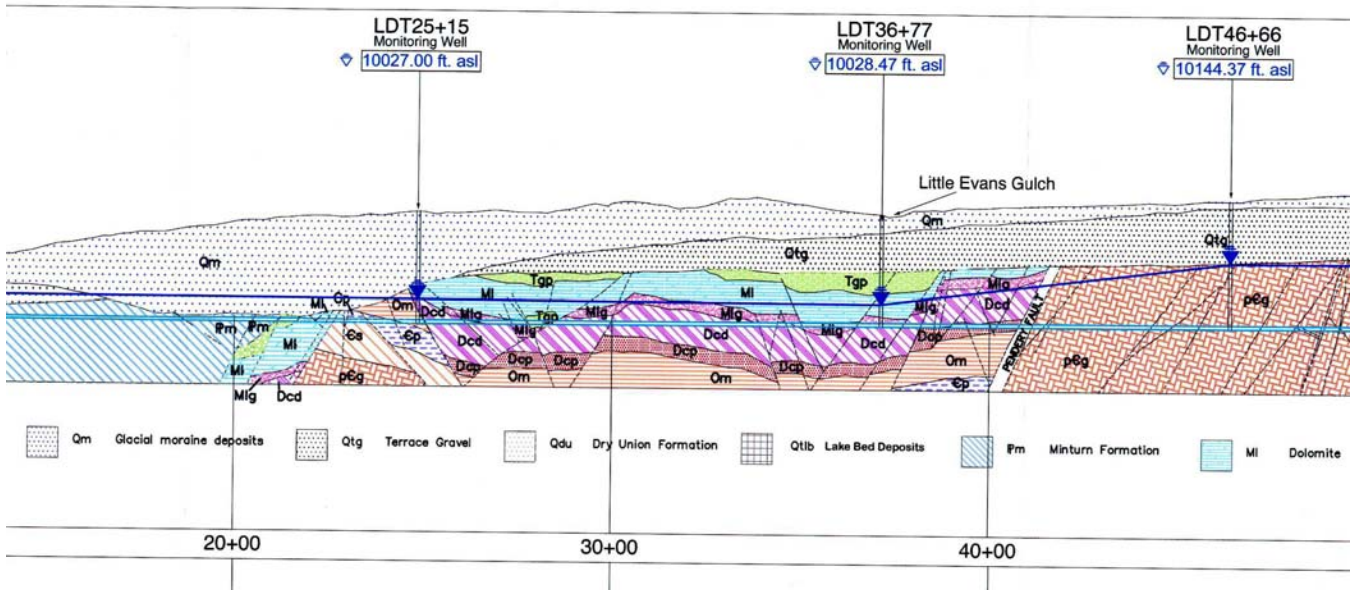

Mission Statements

The mission of the Department of the Interior is to protect and provide access to our Nation's natural and cultural heritage and honor our trust responsibilities to Indian Tribes and our commitments to island communities.

The mission of the Bureau of Reclamation is to manage, develop, and protect water and related resources in an environmentally and economically sound manner in the interest of the American public.

Potential Failure Modes and Effects Analysis

Leadville Mine Drainage Tunnel

Leadville, Colorado
Great Plains Region

Author:	<i>Gregg A. Scott</i>	Certification:	<i>Gregg A. Scott</i>
Author:		Certification:	
Checked:	<i>Mark Vandenberg</i>		
Checked:		Date:	<i>6/26/2008</i>

Authorship, Checking and Certification of this Document

For the purposes of this document the following applies:

Author's Signature. This is the signature of the person or persons with primary responsibility for writing this document. All team members' signatures, such as concurrence, were not required. However, signature of the document by the author(s) does signify that a draft document was provided to team members, and that they had an opportunity to comment on the draft. The author's signature also implies that comments were considered and that any critical issues or influencing factors were incorporated into the document.

Certification Signature. Certification signatures are those of the persons who co-facilitated the risk analysis. These signatures signify that Reclamation methodology, processes, and requirements were followed. In addition, these signatures verify that qualifications of the persons making various probability estimates were appropriate. The purpose of endorsing qualifications is to reduce the potential for inappropriate estimates, or conflicts, arising from limited qualifications that might result in total rejection of risk analysis findings.

Certification signatures also signify that the spirit of the analysis and team dynamics are represented by the document. In other words, any divergent views, critical issues or significant influencing factors have been captured. This is a check of the author's responsibility to fully capture and represent the team's thinking.

Checked Signature. Checking signatures verify that any calculations, figures or tables have been checked. This includes "back-of-the-envelope" calculations performed during the risk analysis but not documented in any place but this report.

Contents

	Page
Description of Study	1
Participants.....	1
Project Description.....	2
Major Findings and Understandings	4
Risk Categorization.....	7
Risk Categorization Matrix for Public Safety	7
Potential Failure Mode Evaluation	9
Evaluation of Blockage Near the Pendery Fault.....	9
Evaluation of Early Warning System	15
Potential Failure Mode No. 1 – Breach in Upstream Tunnel Blockage results in “Blowout” of Downstream Bulkheads	18
Potential Failure Mode No. 2 – Breach in Upstream Tunnel Blockage results in Rapid Erosion Breach of Downstream Slope Materials.....	21
Potential Failure Mode No. 3 – Breach in Upstream Tunnel Blockage results in High Downstream Groundwater Levels and Slope Instability	23
Potential Failure Mode No. 4 – Breach in Upstream Tunnel Blockage results in Leakage of Contaminated Water into Downstream Areas	26
Potential Failure Mode No. 5 – Earthquake Triggers Slope Instability near Tunnel Portal.....	28
Potential Failure Mode No. 6 – Seepage Erosion into Tunnel Causes Sinkholes and Loss of the Highway	30
Potential Failure Mode No. 7 – Flow at Tunnel Portal Plugs Off, Raising Groundwater and Causing Slope Instability	30
Summary	31
References.....	33

Figures

Figure 1a. Geologic Cross Section along Leadville Mine Drainage Tunnel Alignment	34
Figure 1b. Geologic Cross Section along Leadville Mine Drainage Tunnel Alignment (cont.).....	35

Figure 1c. Geologic Cross Section along Leadville Mine Drainage Tunnel
Alignment (cont.)..... 36
Figure 2. Plan Map of Tunnel and Leadville Area 37
Figure 3. Water Levels in the Upstream Tunnel..... 38
Figure 4. Water Levels in the Downstream Tunnel..... 39
Figure 5. Running Ground in the Parting quartzite (approximate date
August/September 1951) 41
Figure 6. Bulkhead at Station 4+66 (date noted on photo)..... 42
Figure 7. Recent Aerial View of Tunnel Portal Area 43
Figure 8. Excavation into the Glacial Moraine at Leadville for installation of a
pipeline under Highway 91 along the alignment of the LMDT (late spring
2008) 44

Tables

Table 1. Risk Categorization Matrix..... 7
Table 2. Risk Categorization Summary by Potential Failure Mode (PFM) 32

Appendix

Appendix A - Event Trees

Description of Study

This report documents the Potential Failure Modes and Effects Analysis (PFMEA) performed for the Leadville Mine Drainage Tunnel (LMDT) near Leadville, Colorado. A PFMEA is an examination of “potential” failure modes and their effects (consequences) for an existing project works by a team qualified to evaluate the structures and site conditions. It is based on a review of existing data and information (including geology, design, analysis, construction, structural behavior, and operations), first-hand input from operations personnel, and site examinations.

The process is conducted in a team setting, where interactions enhance and draw out the breadth of experience brought to the table by a group of qualified individuals, and includes the following:

- Review of all available background material.
- Identification of potential modes of failure.
- Discussion of the likelihood of the potential failure modes, listing the favorable factors (conditions making the probability of failure mode “less likely”) and the adverse factors (conditions that make the probability of failure “more likely”).
- Determining the likely consequences for each potential failure mode.
- Categorizing each potential failure mode according to its likelihood of developing and consequences should it develop, and documenting the rationale behind the categorization.
- Identifying opportunities for risk-reduction, monitoring enhancement, data collection, and/or analyses to enhance the project safety or understanding of the project risks.

“Risk”, by definition, includes both likelihood and consequences. Thus, a **PFMEA is in essence a qualitative risk assessment**, since both the likelihood of the potential failure modes occurring, and the consequences should they occur are examined (but not quantified). The “risk” categorization procedure is discussed in more detail later in this report.

Participants

The following members comprised the PFMEA core team:

Gregg A. Scott, P.E.	Senior Technical Specialist, Facilitator
Michael Gobla, P.E.	Geotechnical Engineer, Co-Team Leader, mining specialty
Richard Wiltshire, P.E.	Geotechnical Engineer, soil mechanics specialty
M. J. Romansky	Geotechnical Engineer, rock mechanics specialty

Mark Vandenberg, P.G. Engineering Geologist, Co-Team Leader, geology specialty
Lloyd Crutchfield Supervisory Engineering Geologist, geology specialty

In addition, the following individuals provided input for specific issues:

Kevin Atwater Civil Engineer, tunnel analysis
Roger L. Torres, P.E. Geotechnical Engineer, slope stability analysis
Jack Touseull, P.E. Geotechnical Engineer, evaluation of tunnel plug (Sta 4+62)
Gene Csuti Electrical/Electronics Engineer/Technician, Leadville Mine Drainage Tunnel Water Treatment Plant

Project Description

The LMDT is an underground excavation constructed during World War II and the Korean War to drain groundwater from metal mines located near Leadville in Lake County, Colorado. Although it was originally operated as an open drain, collapse of a portion of the tunnel roof in 1968 led to installation of a porous bulkhead downstream of the collapse, and an extraction well upstream of the collapse. A water treatment plant was constructed adjacent to the tunnel portal to treat the mine-contaminated drainage flows from both the tunnel and extraction well.

Normal faulting occurs in the Leadville, Colorado mining district along northerly trends, with displacements of several hundred feet. This cuts the district into several irregular compartmentalized blocks. Groundwater flow across the faults is typically restricted by impervious fault gouge. Minerals were deposited along the faults and fissures, and along open bedding planes in sedimentary formations. The largest ore bodies were on top of the “Leadville (Blue) Limestone” in the western part of the district, while smaller gold veins were more prevalent in the eastern part of the district.

Gold was discovered in the Leadville area in 1860. Continued mining in the area through the end of the 19th Century and beginning of the 20th Century resulted in the development of deep underground mines to remove rich ores of silver, lead, and zinc. Constant pumping was required to keep water out of these mines, which eventually became economically impractical. Metal shortages during World War II resulted in renewed interest in these mines for the war effort. The Bureau of Mines was tasked with constructing a drainage tunnel to dewater the mines in preparation for renewed production. A portal site was selected for the drainage tunnel about 1½ miles north of the town of Leadville, and tunneling began in December of 1943. A geologic section along the alignment of the Leadville Mine

Drainage Tunnel (LMDT) is attached as Figure 1, and a plan map of the tunnel and Leadville area is attached as Figure 2.

The first 650 feet of tunnel was excavated through glacial deposits and terrace gravels. At about 30 feet, water bearing glacial deposits were encountered which ultimately produced about 50 gal/min inflow. However, the first significant tunnel inflow occurred along the contact with the Weber shales and sandstones, 350 to 650 feet into the excavation, where a flow of 200 to 300 gal/min was encountered. The first 335 feet of tunnel was constructed as a 10-foot-wide by 11½-foot-high modified horseshoe shape. In an effort to save time and money, the dimensions were reduced to 9-foot-wide by 10½-foot-high thereafter. Tunneling was very slow through the gravel deposits. Tunnel construction encountered additional difficulties in the rock sections. At about Station 21+00 the crown of the tunnel collapsed. An overlying basin filled with loose soil and water allowed “running” ground to enter the tunnel, which necessitated construction of a bypass through this area. Poor tunneling conditions were encountered in areas of faulting and fractured rock. Top headings, temporary bulkheads, advance grouting to control water inflow, heavy timber supports, spiling, gunite, and other ground control measures were used in various combinations through the worst rock. Two piece steel rail sets were used in sections requiring lighter support. The Pendery Fault was crossed at about Station 40+70. At about Station 65+70, a zone with heavy water flow was encountered that washed in fragments of quartzite and white porphyry, filling the tunnel for 40 feet. The tunnel was advanced through this zone to Station 66+00, but at that point all available funds had been expended, and tunneling stopped in 1945.

In September 1950, tunneling resumed due to metal shortages encountered during the Korean War and the possibility that the mines would need to be re-opened. After re-stabilizing portions of the tunnel excavated under the first contract, the tunnel was advanced. Once again, difficulties were encountered in sheared and faulted sections of rock, requiring heavy timber supports similar to those used in the first phase of excavation. Light steel sets were used in sections requiring lighter support. Sections of the tunnel were reduced in size, the smallest cross section being 7½ feet wide by 8¾ feet high. Exploratory holes were drilled in an attempt to connect with the Blonger Shaft, but no water inflow was encountered. Laterals were constructed to connect to the Ponsardine Raise, Hayden Shaft, and Robert Emmet Shaft. A bend in the tunnel occurs near the Robert Emmet Shaft and the tunnel continues easterly, connecting to the New Mikado Shaft at a total length of almost 11,300 feet. The total rise from the portal to the end face is about 26 feet, from approximately elevation 9,970 feet at the portal to 9,996 feet at the Mikado Shaft. The tunnel was completed in 1952. Later that year a connection was driven to the bottom of the Blonger Shaft. The Blonger Drift was found to be completely filled with soft shale and timbers, explaining why no water was encountered during the connection drilling. The Bureau of Mines continued maintenance work, repairing cave-ins and keeping the tunnel open until 1959. However, the benefits of the drainage tunnel were never completely

realized, as mining in this section of the district never really resumed to any significant level.

The Bureau of Reclamation acquired the LMDT in 1959, with the intent of including the water rights associated with the drainage water as part of the supply for the Fryingpan-Arkansas Project. However, these water rights were actually never obtained due to senior claims. In taking over the tunnel, it was stipulated that “Reclamation has no present intention of spending any funds on the maintenance and repair of the tunnel.” However, during the 1960s, surface sinkholes developed due to collapse of the tunnel, threatening State Highway 91 which passes over the tunnel about 535 feet upstream of the portal. Reclamation drilled several holes through the highway and backfilled voids with hydraulic fill and grout. The surface sinkholes were also backfilled.

Prior to construction of the water treatment plant, the tunnel discharged directly into the East Fork of the Arkansas River. The tunnel effluent contains concentrations of heavy metals that exceed water quality standards. As owner of the tunnel, Reclamation was required to bring the discharge into compliance with the Clean Water Act of 1972. Between 1978 and 1979, the collapsed material in the first 500 feet of tunnel was removed, and the tunnel shored up. A bulkhead, constructed of steel beams and wooden timbers, was installed 466 feet from the tunnel entrance (Station 4+66) to reduce tunnel discharge. During 1991 and 1992, the water treatment plant and improvements to the tunnel were constructed by Reclamation. This included a new steel-framed wood-lattice bulkhead backfilled with a gravel and cobble filter at Station 4+61, and concrete lining of the entire tunnel downstream of the bulkhead.

The water treatment plant has operated successfully since its construction, providing clean discharge to the river. However, since about 2003, there has been a gradual rise in the water level near the old mine workings (referred to as the “Mine Pool”), as illustrated in Figure 3. Based on monitoring wells, this higher water level is transmitted down the tunnel at least as far as Station 46+66 (monitoring well LDT 46+66), below which the water level drops (monitoring well LDT 36+77). The water level along the tunnel is also shown in Figure 1. Concerns have been raised that if the difference in water level is due to a blockage caused by tunnel collapse, rupture of the blockage under a continued increase in the Mine Pool level could lead to adverse consequences near the tunnel portal. These concerns prompted this PFMEA study.

Major Findings and Understandings

During the PFMEA session, discussions took place and information was uncovered that resulted in a greater understanding of the conditions and issues related to (1) the LMDT, (2) identified potential failure modes, and (3) the likelihood for adverse consequences. At the conclusion of the session, each

participant was asked to provide their most significant conclusions regarding the study. These are captured below.

- The PFMEA process allowed the team to pull out a lot of information buried in old correspondence, organize the available information, and engage in meaningful discussions. The fact that all team members were able to come to consensus on the major issues is a good indication that, based on the available evidence, conditions are reasonably well understood.
- There likely is a collapse in the tunnel forming a blockage between Stations 36+77 and 46+66. Ground water levels measured in observation wells located at Stations 36+77 and 46+66 indicate to date that a maximum differential hydraulic head of approximately 119 feet is being held back by the blockage. Rather than at the Pendery Fault (Stations 40+70 to 40+95) which was concrete lined, the most likely blockage location is just downstream between Stations 38+50 and 40+70 in the Parting quartzite, where a section of 46 consecutive timber sets showed signs of dry rot in 1955. The rotting timber is credited for ultimate collapse of a 20-foot zone which initiated near Stations 40+35 to 40+40. Six light steel sets were placed in the vicinity of the collapse, but the recommended replacement of all 46 timber sets was never completed. Thus, the blockage could extend for a significant distance along the tunnel. Increased leakage into California Gulch, presumably along fractured rock associated with the Pendery Fault, is further evidence that the tunnel collapse is downstream of the fault. This flow would be expected if tunnel water was getting to the fault zone, which would be more unlikely if the collapsed zone extended through and upstream of the fault.
- The limit on the height of the Mine Pool will likely be controlled by the contact of low rock cover areas with overlying terrace gravels. The gravels are significantly more pervious than the underlying rock formations, and water rising to the contact will be quickly bled off through the gravel along the bedrock contact. The exact location for this water level control is unknown, as it likely occurs somewhere off the tunnel alignment where geologic information is sparse.
- The collapsed section of tunnel under and downstream of Colorado State Highway 91, remedial backfill and grout, double bulkhead, and concrete lining form a long and robust plug in the downstream portion of the tunnel, which is very unlikely to “blow out”, even if the full head from the Mine Pool were to be transmitted to this location.
- A tunnel blockage formed by collapse is likely to have high shear strength due to interlocking of the larger angular fragments, making a shear failure

through the material unlikely. It is estimated that only a few lb/in² of shear strength is needed for tunnel blockage lengths of 50 feet or more (about 5 times the tunnel diameter) to resist the hydrostatic pressure.

- Seepage erosion or “piping” of materials in and adjacent to the tunnel appears to be unlikely. Blockage materials near the Pendery Fault may be “cemented” by metal precipitates. Even if the materials were internally unstable, and the fines washed through, the remaining mixture of coarse angular blocks and gravel size material would limit the amount of flow through the blockage. Materials in the downstream tunnel are contained by the bulkheads and adjacent filter material. This is supported by the fact that water exiting the tunnel through the bulkhead has always been observed to be clean. In addition, the coarser gravels adjacent to the tunnel will convey a lot of water without moving particles.
- Even though there is a lack of specific engineering test data on the geologic materials near the tunnel portal (and test data would be very difficult to obtain in the gravel materials), this area is likely to remain stable. The pervious terrace gravels in the portal area are underlain by the rock surface of the Minturn formation (Weber sandstones and shales) which slopes away toward the river. The groundwater level in the gravels follows the rock surface, dropping toward the river downstream of about Station 6+35 (see Figure 4). The water level at the timber lattice bulkhead has not risen more than about 2 or 3 feet above the tunnel invert, regardless of the fact that the water level at Station 10+25 has exceeded 70 feet above the tunnel invert. Portal slope stability analysis using high groundwater levels approaching a fully saturated condition indicate adequate factors of safety. Considering the actual history of low ground water levels, the factors of safety are considered to be conservative.
- Seismic loading contributes little to the risk at the LMDT. The simultaneous occurrence of a large earthquake and high groundwater levels in the portal area, both of which are needed to approach unstable slope conditions, is a remote possibility. The earthquake hazard in the Leadville area is not high, and it is unlikely an earthquake would trigger other potential failure modes. The combination of sloping bedrock overlain by porous gravels results in a groundwater system where high water levels are very unlikely to occur.
- With recent improvements to the Early Warning System (EWS), there should be plenty of advance warning of dangerously developing conditions. Three separate parameters are tied to an automated alarm: (1) the water level in the well at Station 10+25, (2) the turbidity of the water entering the treatment facility which includes the combined flow from the dewatering well and the tunnel leakage, and (3) the rate of the combined flow entering the treatment facility. If the change in any of these

parameters exceeds the predetermined levels, an automatic alarm call is generated to the plant operators who will quickly evaluate the situation. If the situation is judged to be dangerous, a siren on site will be manually activated to evacuate the area. **However, additional guidance needs to be put in place to help the operators decide when to activate the siren.** The people that would need to be evacuated are in a relatively small area (The Village at East Fork and water treatment plant) near the tunnel portal.

- Although it is believed that groundwater levels near the portal cannot rise to dangerous levels, monitoring is considered to be a prudent risk management activity, and **it is recommended that the ground water wells at Stations 3+00, 4+70, and 6+35 be evaluated to ensure reliable information is being obtained, and if so, instrumented with pressure transducers and the data be tied into the existing Early Warning System (EWS).**

Risk Categorization

A categorization matrix was developed at the beginning of the exercise as a means of ranking the “risk” posed by the potential failure modes in a relative sense. This is shown in Table 1 and described below.

Risk Categorization Matrix for Public Safety

Table 1. Risk Categorization Matrix

CONSEQUENCES OF FAILURE	FAILURE MODE LIKELIHOOD			
	RULED OUT	LOW	MODERATE	HIGH
LEVEL 3 Consequence Category		Low Likelihood Level 3 Consequences	Moderate Likelihood Level 3 Consequences	High Likelihood Level 3 Consequences
LEVEL 2 Consequence Category		Low Likelihood Level 2 Consequences	Moderate Likelihood Level 2 Consequences	High Likelihood Level 2 Consequences
LEVEL 1 Consequence Category		Low Likelihood Level 1 Consequences	Moderate Likelihood Level 1 Consequences	High Likelihood Level 1 Consequences
No Significant Consequences				

Consequence Descriptions

- **No Significant Consequences** – No significant economic consequences or impacts to the downstream population
- **Level 1** – No significant economic impacts to the downstream population; water use may be impacted locally
- **Level 2** – Downstream water use possibly impacted; possible damage to State Highway 91, dwellings in The Village at East Fork, and the water treatment plant downstream of the tunnel portal
- **Level 3** – Major damage possible to State Highway 91, to dwellings in The Village at East Fork, and to the water treatment plant; possible loss of life; downstream water use possibly impacted to a significant extent

Likelihood Descriptions

- **Ruled Out** – The physical conditions do not exist for its development or the likelihood is so remote as to be non-credible
- **Low (Unlikely)** – The possibility cannot be ruled out, but there is no compelling evidence to suggest it has occurred or that a condition or flaw exists that could lead to its development
- **Moderate (Neutral)** – The fundamental condition or defect is known to exist, indirect evidence suggests it is plausible, but evidence is not weighted toward likely or unlikely
- **High (Likely)** – There is direct evidence or substantial indirect evidence to suggest it has occurred and/or is likely to occur

Those potential failure modes that fall into the “Ruled Out” category with respect to likelihood typically require no further action. Those that fall into the “No Significant Consequences” category may require some action if the likelihood is moderate to high, in order to avert erosion of public confidence. Those potential failure modes that fall in the high likelihood and high consequence category in the upper right hand red-shaded box of the risk matrix are the most dangerous, and likely require immediate action. Proceeding diagonally down toward the bottom left corner of the risk matrix, the risks become increasingly less, and so does the need for action. Monitoring is considered to be an appropriate risk management strategy for potential failure modes that fall into the green- or blue-shaded boxes. For potential failure modes that fall into the yellow- or orange-shaded boxes, additional strategies for long-term risk reduction should be considered.

Potential Failure Mode Evaluation

The PFMEA team brainstormed potential failure modes associated with possible adverse impacts to areas downstream of the LMDT. The team then evaluated each potential failure mode in detail, reviewing conditions and factors related to the development of each along with the possible consequences of failure. All potential failure modes were categorized, using judgment and general team consensus, based upon the weight and strength of each piece of favorable or adverse evidence, the performance record related to that failure mode, and the likely magnitude of potential adverse consequences.

During the brainstorming session, it became apparent that there were two key pieces to the likelihood of adverse consequences that could apply to several of the identified potential failure modes. These included: (1) the likelihood that a blockage upstream near the Pendery Fault could rupture, resulting in a rapid increase in the tunnel water pressure downstream of the blockage and a rise in the groundwater level above the downstream portion of the tunnel (which is currently flooded), and (2) the likelihood that the early warning system would fail to provide ample warning of a dangerous condition and a timely evacuation of The Village at East Fork should the need arise. Therefore, these “pieces” of potential failure mode development were evaluated separately. The ultimate classification of the follow-on potential failure modes was then influenced by these evaluations.

In order to show how these two key pieces fit with the other pieces of the potential failure modes, event trees were developed. An event tree shows the progression of events that would need to occur for failure to result. The event trees are contained in Appendix A, and can be used with the potential failure mode descriptions to gain a better understanding of what it would take for a failure condition to manifest.

Evaluation of Blockage Near the Pendery Fault

Description

A blockage due to tunnel collapse near the Pendery Fault fails, resulting in a rapid rise in the downstream tunnel water pressure followed by a rise in the groundwater level above the downstream portion of the tunnel. This could result from: (1) an increase in the upstream Mine Pool level above historical levels due to rapid melting and infiltration of a heavy snowpack, (2) a surge of water upstream of the blockage caused by collapse of abandoned mine workings and drainage paths, or (3) a major earthquake. Failure of the blockage results from either seepage erosion (“piping”) of the blockage debris, or shear failure through the blockage debris under the increased hydrostatic or seismic loading.

Adverse Factors Making the Events “More Likely”

- The differential head drop from Stations 46+66 to 36+77 indicates there is likely a blockage in the tunnel due to roof collapse between these two locations. The team could not envision another mechanism that would lead to a 119-foot head differential.
- Movement of particles across the lens of a borehole camera, which was lowered down boreholes adjacent to the tunnel upstream and downstream of the Pendery Fault, suggested higher velocity flow downstream near Station 36+77 than upstream near Station 46+66, suggesting pooling of water in the upstream area indicative of a blockage and possible sediment deposition.
- Evidence suggests that water is flowing along (parallel to) the Pendery Fault (i.e. increased flows to California Gulch and limited communication of dye tracer tests between the Mine Pool and tunnel portal), indicating there is a possible tunnel blockage downstream of the Pendery Fault.
- Untreated timber supports and blocking were used in areas of heavy ground loads. Bureau of Mines correspondence from 1955 indicates a cave-in near Stations 40+35 to 40+40 in the Parting quartzite was caused by collapse of rotted timber supports. Only 6 sets were replaced in this area, although 46 sets showed signs of dry rot. The timber supports become less effective with time, and may have already collapsed.
- The worst problems with mud and water inflow were encountered in the Parting quartzite. Figure 5, a construction photograph, shows “running” ground encountered in the quartzite. Over time, a tunnel collapse and blockage in this zone would not be unexpected.
- Rock on the hanging wall of a fault is generally more fractured. The dolomite on the downstream (hanging wall) of the Pendery Fault is blocky and likely unstable if the tunnel supports fail.
- Although not large, there is a change in water chemistry between Stations 46+66 and 36+77, which suggests a physical blockage in the tunnel between these locations, with more mixing downstream.
- The debris from the Parting quartzite is likely non-plastic, which would make it more susceptible to seepage erosion. Side pressure, which would increase the normal stress and shear strength of the material comprising the blockage, was not observed during tunneling.
- There is potential for further increases in the Mine Pool head, which would provide an even greater differential head across a tunnel blockage.

- There could be interconnection between the Mine Pool and the tunnel as evidenced by the water levels in the Robert Emmet Shaft closely following the tunnel monitoring wells (Figure 3).
- A major earthquake in the area could increase the hydraulic loading on a tunnel blockage, or reduce the strength of the blockage through settlement and an increase in pore pressures. If the material settled enough, water could flow over the top of the blockage and erode the material down to invert level.
- A large area of the mine workings could collapse suddenly and rapidly raise the water level in the Mine Pool. This occurred at the New Jersey Zinc Co. Sterling Hill mine in the 1980s resulting in an 80-foot increase in water level due to collapse of a stope. If this occurred at the LMDT, a larger head (perhaps with a hydrodynamic component) could be transmitted against the upstream face of the tunnel blockage.

Favorable Factors making the Events “Less Likely”

- The tunnel was reported to be “concreted” and open through the Pendery Fault in 1955; it is unlikely that a collapse has occurred in this zone.
- Based on the length of tunnel reported to contain dry rot timber supports, a considerable length of tunnel (up to about 200 feet, from Stations 38+50 to 40+75) could be collapsed. A long collapse zone would be more stable.
- When the tunnel would collapse during construction, large lengths of the tunnel (50 to 100 feet) would fill with debris and stabilize. This occurred typically in the glacial soil zones, the quartzite, and in fractured porphyry.
- If the Mine Pool water is impounded against a tunnel blockage, mixing of low-pH and pH-neutral water would precipitate clay-size particles that could “cement” the blockage debris, making it more stable.
- A collapse zone in the Parting quartzite would contain a mixture of irregularly shaped blocks, gravel, and sand-sized particles that would likely form a “filter” as the finer particles catch against the coarser particles, making such a zone less susceptible to seepage erosion. Even if the mixture was internally unstable and the fines were washed out, the remaining assemblage of coarse interlocked particles would limit flow through the blockage, and would retain high shear strength.

- Observed failures of concrete bulkheads begin with the onset of leakage along the roof/bulkhead surface. This initial leakage increases as the channel is eroded and enlarged. This typically takes weeks or even months. The same is expected for a collapse “bulkhead”. A gradual increase in water level downstream of the blockage would be observed in the monitoring wells.
- The maximum head on the upstream side of a tunnel blockage is limited by the elevation of the contact between bedrock and the overlying pervious terrace gravels which would quickly drain away any excess head. The exact elevation and location of this control is unknown, as it likely occurs at a low bedrock cover area off the tunnel alignment.
- The apparent rise in the Mine Pool elevation in recent years could be the result of coming out of a drought that gripped the area up until about 2003. Water levels recorded in the Robert Emmet Shaft dating back to 1995 show that the levels were higher (about Elevation 10,140) than the subsequent five years and declining at that time. If earlier data could be found, it might show that in fact the Mine Pool has been at elevated levels in recent decades, similar to those currently observed.
- The seasonal rise in the Mine Pool water elevation is limited by the amount of snowmelt that infiltrates the rock; most of the snowmelt leaves as surface “runoff”. In recent history, the water level at Station 46+66 has not risen more than about 15 feet from the previous year and this occurs over a period of several months. Thus, the differential head should not rise quickly, and there should be time to react if an unusually high infiltration or mine pool level occurs.
- The tunnel downstream of Station 36+77 is full of water. Thus, a wall of muck and water would not shoot down the tunnel if the tunnel blockage were to breach. Rather, an increase in the downstream tunnel pressure followed by a gradual rise in the downstream groundwater levels above the tunnel would be more likely. The downstream water decreases the differential head across the blockage and reduces the potential for piping and shear failure.
- Collapses in the mine workings which contain the Mine Pool were commonplace, and many were inaccessible a few years after they were mined out. The rock was not stable and was not well supported, since only temporary access was needed, and mine economics dictated the minimum needed to extract the rock and ore. This likely provides some impediment to flow through the system.
- There is no reason to believe the LMDT is completely open in other areas. Additional collapsed areas and blockages of the tunnel would limit flows

to the downstream tunnel reaches from the Mine Pool even if a blockage near the Pendery Fault were to breach. For example, based on the water level data in Figure 4, there may be resistance to flow between Stations 10+25 and 6+34 (both intercept the tunnel but appear to record different elevations, although the well at 10+25 is pumped). In addition, in 1979 a well at Station 6+65 was drilled to 98 feet into the tunnel where water 6 feet deep was seen to be flowing. While waiting for well screen, a sinkhole appeared adjacent to the drill rig and the hole was lost.

- The seismic hazard in the Leadville area is not high. Estimated peak horizontal ground surface accelerations are as follows: 500-year = 0.05g, 2,500-year = 0.15g, and 10,000-year = 0.35g. The accelerations experienced underground are expected to be less than these values by at least half (based on experience at other sites, and the fact that in theory ground motions double when reflecting off a horizontal ground surface). The hydrodynamic pressures exerted by the earthquake shaking would act on both sides of the blockage, since it is submerged. Therefore, the chances of an earthquake rupturing the blockage appear to be small.

Likelihood Category

The PFMEA team classified the likelihood of this series of events as **Low to Moderate**, depending on the length of tunnel that is blocked near the Pendery Fault (a long tunnel blockage would lead to a low category, and a short tunnel blockage would lead to a moderate category). Since this is the first series of events for a number of potential failure modes, it should be noted that this controls the likelihood of those modes, and they cannot have a higher likelihood than this.

Rationale (Key Factors)

A blockage of the LMDT due to tunnel collapse downstream of the Pendery Fault is likely. There is a long stretch of poor ground downstream of the Pendery Fault where the timber supports were reported to be in poor condition in the 1950s due to dry rot. In addition, there is a drop in the tunnel water level across this zone. Although a blockage is likely, the chances of breaching the blockage followed by a large rapid increase in the downstream tunnel water pressure and a rise in the groundwater level above the downstream portion of the tunnel are considered to be low to moderate because: (1) the tunnel muck forming the blockage has a low to moderate chance of failing under increased head. It likely consists of a well-graded mixture of rock blocks, gravel, and sand sized particles which will form a “filter”. Even if the fines were to wash out under increased differential head, the coarse angular interlocking rock particles that remain would limit the amount of flow through the zone and would retain high shear strength. The longer the blockage is, the higher the resistance to shearing and the lower the chances of seepage erosion or breach, and (2) there is not an unlimited supply of water in the Mine Pool directly connected to the LMDT. Much of the old mine workings are likely collapsed, and others do not have a direct hydraulic connection to the

LMDT. The amount of water that can infiltrate during any given season is limited, and the level to which the Mine Pool can rise is limited by the elevation of the bedrock contact with the overlying pervious terrace gravels.

Opportunities for Risk Reduction, Monitoring Enhancement, Data Collection, and/or Analysis

Because this represents the initial series of events for a number of potential failure modes, the PFMEA team came up with the following list of potential measures to mitigate or better understand the likelihood of this initial phase of failure mode development. This is not to say that they are all recommended for implementation, but rather they form a list of ideas that can be considered during any future risk mitigation.

- Drill large-diameter holes into the tunnel and examine the extent of tunnel blockage with a remote crawler camera.
- Pump the Mine Pool down to reduce the load on the tunnel blockage (currently planned as an interim risk reduction measure).
- Construct a permanent concrete bulkhead upstream of the Pendery Fault designed to take the load from a maximum level Mine Pool (currently in the planning stages).
- Raise the water pressure in the downstream portion of the tunnel to reduce the differential head across the tunnel blockage (while ensuring the water levels and gradients near the portal remain low).
- Drill holes into the tunnel near the Pendery Fault blockage zone through which gravel and grout are injected to form a tunnel plug capable of withstanding the differential head with more certainty.
- Determine limiting bedrock cover for water levels upstream of blockage.
- Restore drainage from the Canterbury Tunnel. When driven in the 1920's, the Canterbury Tunnel intercepted a water flow in the vicinity of the Pendery Fault averaging about 1300 gal/min throughout the year, and the mine operators in the district recognized a marked reduction in recharge rate.

Evaluation of Early Warning System

Description

The consequences of several potential failure modes were tied to the effectiveness of the Early Warning System (EWS). Therefore, the PFMEA team evaluated the likelihood of the EWS being unsuccessful as a separate part of the failure mode process. With recent improvements to the EWS, it consists of the following features:

- The water level in the dewatering well at Station 10+25 is remotely monitored through electronic instrumentation. If the water level in the well rises more than 70 feet above the tunnel invert, or if there is greater than a 5-foot change in the water level (upward or downward) in any 60 minute period, an alarm is triggered.
- The turbidity of the water entering the water treatment plant is monitored continuously. This water represents combined flows from the dewatering pump at Station 10+25 and from the tunnel through the timber lattice bulkhead. If the turbidity NTU exceeds 30, an alarm is triggered.
- The combined flow entering the water treatment plant from the dewatering well and tunnel bulkhead is monitored continuously. If the flow increases by more than 100 gal/min during any 60 minute period (with no change in operations), an alarm is triggered.
- If an alarm is triggered, an auto-dialer is activated to send out an alarm message to the four water treatment plant staff on call. The auto-dialer calls the first person's pager, waits 2.5 minutes for phone acknowledgement, then calls that person's cell phone and again waits 2.5 minutes for acknowledgement. If that person does not acknowledge the alarm, the auto-dialer proceeds to the next contact on the list. If the alarm has not been acknowledged, the auto-dialer repeats the process a second time. If there is still no response, the auto-dialer begins calling home phone numbers for each of the operators. There is no delay between calls to the home phone numbers. The Mount Elbert Powerplant, which is staffed 24 hours per day 7 days per week, is called if there is no acknowledgement of the alarm after each home phone is called. If it gets to this point, approximately 40 minutes has elapsed since the alarm was triggered. The whole process is repeated if the alarm is not reset at the plant within 90 minutes.

- Once a staff member receives and acknowledges an alarm, they travel to the plant from Leadville to assess the situation, if not already there. If the situation is judged to be serious, the siren is manually activated to evacuate The Village at East Fork. Currently, an Emergency Action Plan has been drafted, but it needs to be finalized to help guide the decision on when to activate the siren.
- The area and hillside near the tunnel portal is inspected daily for signs of seepage, slumping, bulging, or other indications of changing conditions.
- Once the siren is activated, people in The Village at East Fork will need to recognize the danger and evacuate in a quick and orderly fashion. The siren has been tested to ensure that it can be easily heard by residents of The Village at East Fork, and that the populace recognizes what it means.

Adverse Factors making Unsuccessful EWS Initiation “More Likely”

- The water treatment plant is only staffed four days a week, Monday through Thursday during business hours. If an alarm is triggered, most likely someone will need to respond and travel to the plant during off hours.
- The warning system depends on correct operation of a number of electronic components to inform someone that an alarm has been triggered. It is unlikely that all of these components will be 100 percent reliable.
- Once someone responds to an alarm, they must make an evaluation and judgment as to how serious the situation is, and then make a decision as to whether to activate the siren. This takes time and requires a judgment call.
- A final Emergency Action Plan providing guidance on when to activate the siren has not been completed.

Favorable Factors making Unsuccessful EWS Initiation “Less Likely”

- The autodialer system is connected to three sources of power, 1) service power to the plant, 2) direct connection to an uninterruptible power supply, and 3) battery backup with 1.5 hour full-load supply. If one supply is lost, it rotates to the next.
- The autodialer system has four internal checks, 1) auto-dialer power fault, 2) auto dialer battery fault, 3) auto-dialer phone line fault, and 4) auto-dialer card fault. In addition, plant operating personnel verify the

operation and alarm status for the auto-dialer system at the end of each plant shift. They also periodically verify auto-dialer operation and status (by calling the auto-dialer) during evenings and weekends. There have been no cases of auto-dialer failure since construction of the plant.

- The monitoring and alarm system results in approximately 8 to 12 call-outs per year for plant operating personnel (related to plant operations, not tunnel stability issues). All plant personnel live within approximately 40 minutes travel time of the plant. Since implementation of the auto-dialer call out procedures identified above, all alarms have been responded to within approximately 1 hour (or less) of alarm initiation. A call-out has never reached the Mt. Elbert Powerplant.
- There are three independent parameters being monitored to detect a potentially dangerous situation, any one of which could trigger an alarm if it is out of the normal range as defined by the triggering criteria. The chance of detecting a change in conditions is good.
- Public meetings have been held to discuss the siren and what it means. People in The Village at East Fork are aware of what they need to do if the siren goes off.
- There are two evacuation routes out of The Village at East Fork to the main highways. If one gets cut off, people can still get out of the area.
- The alarm thresholds are thought to be set at conservatively low levels, and conditions are not expected to change rapidly. Thus, there should be time to evaluate the situation and make a good call on the need to evacuate.
- A Draft Emergency Action Plan (EAP) has been prepared. (However, it is currently not on site, and needs to include additional information to help guide the decision on when to activate the siren.)

Likelihood Category

The PFMEA team judged there to be a **Low** likelihood that the EWS would fail to provide warning of a dangerous situation in a timely manner. The team also considered the chances of people failing to evacuate once the siren sounded to be **Low**. Since this forms the last step in many of the identified potential failure modes, and would effectively reduce the potential for loss of life to a low likelihood, the highest consequence category for those potential failure modes for which the system provides warning would be Level 2 (i.e. economic damages and impacts to water use).

Rationale (Key Factors)

There appears to be adequate redundancy in the system to trigger an alarm if something changes significantly and transmits a message to someone who can respond. The threshold limits are set low enough that there should be time to react and make a good decision on whether to activate the siren.

Opportunities for Risk Reduction, Monitoring Enhancement, Data Collection, and/or Analysis

The PFMEA team discussed the EWS in detail. The weak link in the system seems to be the decision criteria to be used in deciding when to activate the siren. Although it is expected there would be plenty of time to evaluate the situation and make a decision, in the unlikely chance that things are changing rapidly, additional guidance on making this decision would be helpful to the water treatment plant staff. Review of the Draft EAP to ensure it contains the proper guidance, and timely finalization of the document would be important risk management activities.

Potential Failure Mode No. 1 – Breach in Upstream Tunnel Blockage results in “Blowout” of Downstream Bulkheads

Description

Breach of a tunnel blockage near the Pendery Fault results in an increase in head and flow in the downstream tunnel, which breaches the downstream tunnel blockages and bulkheads, and results in high flows out of the tunnel portal. Since this potential failure mode results from breach of a blockage near the Pendery Fault, and the early warning system is relied upon as mitigation, see also the previous sections that address these issues. The event tree in Appendix A also indicates how these events fit together in the failure progression.

Adverse Factors that Make the Potential Failure Mode “More Likely”

- There is about 119 feet of differential head in the LMDT between Stations 36+77 and 46+66. If a tunnel blockage in this area were to breach, there would likely be increased pressure in the downstream tunnel, perhaps followed by an increase in the groundwater level above the downstream portion of the tunnel.
- According to “design code”, the allowable effective head for the bottom board of the timber lattice bulkhead currently visible in the tunnel is only 19 feet above the tunnel invert (assuming no drainage at the bulkhead).

- A borehole camera inserted into the tunnel at Stations 25+15, 36+77, and 75+05 indicated the tunnel was open in these locations. Thus, there may not be additional blockages to impede the flow of water down the tunnel.
- If the tunnel were completely open, flows of over 449,000 gal/min (1,000 ft³/s) could exit the tunnel portal (assuming over 100 feet of driving head at the Mine Pool).
- The dewatering well at Station 10+25 could be rendered inoperable from the influx of water pressure.

Favorable Factors that Make the Potential Failure Mode “Less Likely”

- It is estimated that over 100 feet of the tunnel is blocked where it passes under State Highway 91 near Station 5+65. The blockage includes collapsed gravel and soil material, and sand and gravel placed in the voids. It is unlikely that this length of tunnel blockage would breach due to an increase in tunnel water pressure upstream.
- Photos indicate the first timber bulkhead near Station 4+66, which is no longer visible in the tunnel, was braced against steel sets placed downstream of the bulkhead, with gravel fill placed upstream (and subsequently also downstream) of the bulkhead. This bulkhead appears to be quite robust, as shown in Figure 6.
- The downstream tunnel below the Pendery Fault area blockage is full of water. A “bore wave” of water and muck will not travel down the tunnel. Rather, the likely impact would be an increase in the downstream tunnel water pressure and perhaps a rise in the groundwater level above the downstream portion of the tunnel.
- The new timber lattice bulkhead at Station 4+61 consists of multiple independent boards, most of which would need to break to release the upstream filter and tunnel blockage material. This is not a water tight bulkhead where hydrostatic pressure can build up behind the boards, but rather a containment system for the upstream pervious filter material, and thus the loading on the boards is not likely to be high. Although “design code” suggests a limiting height on the water pressure the boards should be designed to resist, on the average the boards will likely support about 2½ times the code value even under a water-tight case.
- There could be additional blockages between the Pendery Fault and State Highway 91, especially in the vicinity of shallow bedrock cover (Stations 10+25 to 21+00) and the Leadville Limestone (Stations 22+00 to 22+50) where problems were encountered during tunneling, that would impede

any flow coming down the tunnel. The dewatering well at Station 10+25 has become inoperable on occasion, and a collapse is suspected of being the cause.

- Full flow exiting the tunnel portal would likely not be possible, as it would require transport of all caved and collapsed material downstream to and out of the portal. This material would have to pass through four curves and changes in direction at the Station 21+00 bypass area. In addition, the blockage material in the 11-foot by 12-foot tunnel would need to pass through the 8-foot by 8-foot concrete lined section of the tunnel.
- If a rise in the downstream tunnel water pressure was detected, an attempt at pumping from the dewatering well at Station 10+25 would likely be performed in an effort to lower the water level.
- There are three wells near station 10+25 that would serve as “surge shafts” to relieve transient pressures that might be transmitted to the tunnel blockages and bulkheads. In addition, it is estimated if the ground water would go artesian before enough head could build up to move the blockages.
- Flows through the timber lattice bulkhead have been clear, indicating the filter material is effective in preventing movement of fines through the blockage.

Consequences

Flows out of the tunnel would graze and possibly damage the left side of the water treatment plant (looking downstream), then spread out through the area between the detention pond and the East Fork of the Arkansas River. There are about four dwellings in the direct path between the tunnel portal and the river (see Figure 7). It is anticipated the early warning system would be effective in detecting a change in conditions that could lead to this potential failure mode, and that people in these dwellings would be evacuated well in advance of significant flows impacting this area. However, the dwellings in line between the tunnel portal and the river could suffer significant damage.

Risk Categories

The team considered the likelihood of this potential failure mode developing to be **Low**. If in fact this potential failure mode were to develop, the resulting consequences are judged to be **Level 2**.

Rationale (Key Factors)

The Low likelihood category is based on the fact that over 100 feet of the downstream tunnel is blocked, including two bulkheads installed to retain this material, and the fact that the downstream tunnel is filled with water, preventing a “bore wave” from traveling down the tunnel and colliding with the downstream blockage and bulkhead zone. Although it is expected that the early warning system (EWS) would provide timely evacuation of people from the affected area (see previous evaluation), there would likely be significant economic damage to a few buildings and dwellings, resulting in Level 2 consequences.

Opportunities for Risk Reduction, Monitoring Enhancement, Data Collection, and/or Analysis

While the PFMEA team was assembled and the potential failure mode was fresh in their minds, the following potential actions were identified. Again, it should be noted that these are not all recommended for implementation, but rather provide a list of possible actions to be considered during future risk mitigation activities. In addition to the actions identified previously for the Evaluation of Blockage Near the Pendery Fault, the following were identified:

- Move dwellings currently in direct line with the tunnel portal.
- Move water treatment plant.
- Build a training dike or wall to direct flows around the potentially affected buildings.
- Obtain more information on downstream material and blockages to confirm the strength of this material.
- Add a vertical beam down the center of the timber lattice bulkhead (anchored above and below) to improve its moment capacity.

Potential Failure Mode No. 2 – Breach in Upstream Tunnel Blockage results in Rapid Erosion Breach of Downstream Slope Materials

Description

This potential failure mode begins in a similar manner to Potential Failure Mode No. 1, except that as the increased water pressures reach the downstream blockages and bulkheads, they hold. The groundwater levels and flow rates could then rise along the outside of the tunnel. If erosion of the material at the downstream slope face begins, progressive erosion and slumping of material or “piping” could progress upstream until a connection was made to the tunnel upstream of State Highway 91, resulting in a rapid release of water. A potential

additional complication could involve collapse of the concrete tunnel lining downstream of the bulkheads (from the portal, Station 0+54, to Station 4+61), resulting in sinkholes that shorten the seepage path to the tunnel upstream of the highway. Since this potential failure mode involves the breach of an upstream tunnel blockage and operation of the early warning system, see previous evaluations of these issues. See also the event tree in Appendix A.

Adverse Factors that Make the Potential Failure Mode “More Likely”

- When the sinkholes were repaired near the highway in the 1960s, several areas above the tunnel were grouted to prevent further settlement of the material. These grouted zones could form a “roof” for piping development above the tunnel crown.
- The steel sets placed along with the first timber bulkhead in 1978 and additional sets placed in 1990 are spaced at about four feet maximum. At this spacing, shear failure of the concrete tunnel lining is possible at the intersection between the floor and wall with a rise in groundwater less than that required to saturate the slope.
- If the flows and gradients adjacent to the tunnel are sufficiently large, the soil materials could be erodible.

Favorable Factors that Make the Potential Failure Mode “Less Likely”

- The permeability of the terrace gravels surrounding the tunnel is high and the underlying bedrock surface slopes down away from the tunnel portal area toward the river. This would tend to carry any additional buildup of groundwater down below the tunnel toward the river.
- On occasions when the dewatering well at Station 10+25 has been shut down, the water level has risen as high as 80 feet above the tunnel invert at that location with no change in the water level at the downstream lattice bulkhead (about 2½ feet above tunnel invert), and no observable seepage on the downstream slopes adjacent to the tunnel portal.
- The piping resistance and stability of the terrace gravel and glacial moraine near the tunnel portal are likely quite high. These materials are likely quite broadly graded, such that natural filters would tend to form. If the fines were to erode out, the remaining material would be coarse with high shear strength.
- Movement of materials near the tunnel portal due to seepage has not been observed at this site. The only time material adjacent to the tunnel has been observed to move has been as a result of tunnel collapse.

Consequences

If indeed this potential failure mode were to develop, a large quantity of water would likely flow through the tunnel portal area. It would likely be more spread out than for Potential Failure Mode No. 1. Thus, there would likely be less damage to each individual building, but more dwellings would be affected. Since the early warning system (EWS) is expected to be effective in evacuating people before life-threatening flows materialized, no loss of life is expected.

Risk Categories

The team considered the likelihood of this potential failure mode developing to be **Low**. If it were to develop, the consequences were judged to be **Level 2**.

Rationale (Key Factors)

The Low likelihood of failure is based primarily on the high permeability of the terrace gravel near the portal and the underlying sloping bedrock surface that would tend to drain the excess water below the tunnel. This is evidenced by the water level at the lattice bulkhead (Station 4+61) which doesn't change significantly even with a large increase in the head at Station 10+25. Although there would be economic damage to dwellings in The Village at East Fork should this potential failure mode manifest, the early warning system would most likely result in timely evacuations.

Opportunities for Risk Reduction, Monitoring Enhancement, Data Collection, and/or Analysis

Though not necessarily recommended for implementation, the following list provides possible actions to be considered during any risk mitigation programs:

- Obtain more information on downstream slope material and blockages to confirm the strength and piping resistance of this material.

Potential Failure Mode No. 3 – Breach in Upstream Tunnel Blockage results in High Downstream Groundwater Levels and Slope Instability

Description

Breach of an upstream tunnel blockage near the Pendery Fault could result in increased water pressure in the downstream portion of the tunnel and a rise in the adjacent groundwater level. Given that the downstream tunnel blockage under State Highway 91 and the bulkheads hold, the groundwater level outside of the tunnel could then rise to unprecedented levels. The increase in pore pressures within the gravel soils near the portal could result in slope instability, and movement of earth materials and water into and adjacent to the tunnel portal area.

See also previous evaluations of breach of an upstream tunnel blockage, the early warning system, and the event tree in Appendix A.

Adverse Factors that Make the Potential Failure Mode “More Likely”

- It is uncertain if the dewatering well at Station 10+25 could keep up with the increase in water from the upstream portion of the tunnel, and there is a chance that the well would be disrupted and rendered inoperable by the sudden influx of water pressure.
- The bedrock surface directly under the highway does not appear to slope as steeply as it does closer to the portal; there may be a tendency for higher water levels in this location.
- Shear strength values used in slope stability analyses are assumed values, not based on testing.

Favorable Factors that Make the Potential Failure Mode “Less Likely”

- A pump test performed at Station 6+35 indicated a high permeability in the gravels at about 50 feet/day. With this high permeability and the underlying bedrock surface which slopes away from the portal, it is unlikely that a significant head of water could build up in the portal area.
- Reasonably conservative shear strengths were selected for slope stability analysis based on Reclamation’s experience with gravelly soils. Average friction angles for gravels from Reclamation laboratory testing range from about 34 degrees with more than 12 percent non plastic fines (passing the No. 200 sieve) to 41 degrees for gravels without significant fines¹.
- Excavation for a pipeline in the spring of 2008 resulted in nearly vertical unsupported slopes up to about 25 feet high in the glacial moraine material, indicating high strength with a component of cohesion, as shown in Figure 8. It would be very difficult to collect and test samples of this material, but this excavation reveals a lot about its strength.
- Two-dimensional slope stability analyses for slip surfaces extending through the highway area, and with the groundwater a few feet below the ground surface (i.e. nearly saturated ground conditions) produced the following favorable factors of safety (with no cohesion):

¹ *Design of Small Dams*, Third Edition, U.S. Department of the Interior, Bureau of Reclamation, Government Printing Office, Denver, Colorado, 1987.

Low friction angle estimate 32 degrees for glacial moraine 35 degrees for terrace gravel	Best estimate friction angle 40 degrees for glacial moraine 38 degrees for terrace gravel
1.5	2.0

- It is unlikely the groundwater conditions could ever be as severe as assumed for the slope stability analyses due to the high permeability of the terrace gravel and the tendency for the water to drain away at the portal.
- Using available ground contours, a cross section was sketched from the tunnel downstream of Station 10+25 to the northwest toward dwellings associated with the Village at East Fork. Comparing this section to a section along the tunnel alignment indicated very similar geometry. Thus, the slope stability analyses are applicable to potential slope instability that could impact these dwellings.

Consequences

Several dwellings in The Village at East Fork are “tucked in” near the base of the slope to the left (west) of the tunnel portal. The contours of the slope in this area are such that any large scale slope failures would move directly toward and impact these dwellings. In addition, State Highway 91 would likely be affected.

Risk Categories

The likelihood of failure mode development was judged to be **Low**. The consequences from major slope failure were judged to be **Level 2**.

Rationale (Key Factors)

The primary rationale for the Low likelihood assignment was the slope stability analyses, and the favorable factors of safety that were calculated. Even with reasonably conservative shear strengths and conservative groundwater levels, the analyses indicate the slopes should be stable with a reasonable margin of safety. Although damage to dwellings in The Village at East Fork could occur, chances are good that a rise in groundwater level near the LMDT portal would be detected and the dwellings evacuated before a major slide occurs.

Opportunities for Risk Reduction, Monitoring Enhancement, Data Collection, and/or Analysis

The following list represents possible actions identified by the PFMEA team for consideration during future risk mitigation actions.

- Install horizontal drains in the slopes to the left of the tunnel portal to help ensure their stability under increased groundwater levels.
- Install a monitoring well downslope of the tunnel to the left of the tunnel portal (looking downstream) to measure groundwater levels in the slope above the most vulnerable dwellings. Alternatively, monitor the water

level in the supply well for The Village at East Fork, about 700 feet WSW of the portal.

- Install and maintain additional numerous weep holes in the downstream concrete tunnel lining so that the first 450 feet of tunnel will act as a drain to keep water pressures from building up and destabilizing the slope.
- Move the dwellings closest to the toe of the slope away from this area.

Potential Failure Mode No. 4 – Breach in Upstream Tunnel Blockage results in Leakage of Contaminated Water into Downstream Areas

Description

Breach of a tunnel blockage near the Pendery Fault results in higher water pressures in the downstream tunnel and higher groundwater levels above the downstream portion of the tunnel. The blockage under State Highway 91 and bulkheads hold, but water contaminated with heavy metal concentrations seeps through the pervious gravels into low lying areas, possibly exiting at Evans Gulch, Little Evans Gulch, or more likely the tunnel portal. It is likely that water will also flow up and out of the monitoring wells at Station 10+25 and downstream and across the highway. Water could also flow toward California Gulch if the groundwater levels over the downstream portion of the tunnel rose to high enough levels.

Adverse Factors that Make the Potential Failure Mode “More Likely”

- Monitoring flumes are upslope of the tunnel location in Evans Gulch and Little Evans Gulch. Seepage outbreaks in these areas would not be detected by the flumes.
- The permeable nature of the glacial and terrace gravels would convey water readily.
- The collars of the monitoring wells at Station 10+25 and downstream are lower than the water levels upstream of the Pendery Fault based on recent measurements.

Favorable Factors that Make the Potential Failure Mode “Less Likely”

- Breakout of flows into Little Evans Creek or Evans Creek is unlikely. Little Evans Gulch is about 2,000 feet upstream of State Highway 91, and there is about 200 feet of coarse alluvium over the tunnel at this point. Evans Gulch is downstream of Highway 91, but has historically been a “losing” stream.
- The monitoring well at Station 10+25 would indicate a rise in the groundwater level. This level is monitored 24/7, and changes out of the ordinary will trigger an alarm and investigation.
- The combined flows from the tunnel bulkhead and dewatering well at Station 10+25 are measured as they go into the water treatment plant. An increase in flow due to higher tunnel pressures or groundwater levels would likely show up and trigger an alarm.
- Seepage that surfaces at the toe of the slope near the portal and detention pond would likely be noticed by plant personnel or residents.
- The Water Treatment Plant could likely handle some limited increase in flow, especially near the tunnel portal.

Consequences

There would be no economic damage to dwellings in The Village at East Fork if this potential failure mode were to develop. However, water quality and use could be impacted locally, depending on the amount of water that was leaking into the water courses and the time it took to recognize the issue and handle the surface leakage.

Risk Categories

The likelihood of failure mode development was judged to be Moderate to High, given that a blockage upstream near the Pendery Fault is breached. However, recall that the chances of a blockage at the Pendery Fault breaching were considered to be Low to Moderate. Thus, the overall likelihood for this potential failure mode can be no higher than **Moderate**. The consequences are considered to be **Level 1**.

Rationale (Key Factors)

The primary rationale for the likelihood category is that the downstream tunnel blockage (under State Highway 91) and bulkheads are likely to hold if the tunnel pressure rises, and the groundwater will likely seek other exit points if the downstream groundwater level rises. The most likely exit points would be through the more pervious gravels to low lying areas near the portal.

Opportunities for Risk Reduction, Monitoring Enhancement, Data Collection, and/or Analysis

The PFMEA team identified the following possible actions that could be considered during risk mitigation actions:

- Install flow measuring flumes in Evans Gulch and Little Evans Gulch downslope from the tunnel.
- Install a redundant monitoring well near Station 4+66 (currently planned).
- Ensure material is available locally to allow construction of “sand bag” containment systems with the possibility to pipe contaminated material to areas where it can be handled and treated.

Potential Failure Mode No. 5 – Earthquake Triggers Slope Instability near Tunnel Portal

Description

A major earthquake causes instability of a large portion of the slope adjacent to the downstream tunnel portal resulting in impacts to this area. Based on analysis results, it is extremely unlikely that this could be triggered under normal groundwater conditions. The only conceivable failure scenario the team could imagine involved elevated groundwater conditions near the portal due to breach of a blockage upstream near the Pendery Fault from seismic loading, followed by a major aftershock which could trigger slope instability.

Adverse Factors that Make the Potential Failure Mode “More Likely”

- Using a pseudo-static seismic coefficient of 0.35g (equal to the peak horizontal ground acceleration for a 10,000-year recurrence interval), a high groundwater level near the ground surface, and the lower shear strength estimates (which included 2 lb/in² cohesion), the calculated factor of safety for major slip surfaces near the portal that would extend up to the highway is less than 1.0 (about 0.89). A factor of safety less than 1.0 indicates a limited amount of slippage is possible (for the given extreme set of assumptions).

Favorable Factors that Make the Potential Failure Mode “Less Likely”

- Several unlikely events need to occur concurrently for this potential failure mode to have a reasonable chance of developing (high downstream groundwater levels, a major remote earthquake and aftershock, weak soil conditions, and sufficient displacement to fail the slope).

- Even in the unlikely event that the ground water levels were high, the soil strengths were at the low end of the estimated values, and a 10,000-year earthquake hit the area, the results would not be catastrophic. Given a yield acceleration for the soil mass of about 0.2g (using lower shear strength and high ground water estimates), empirical relationships² indicate maximum displacements would be on the order of 0.7 inches. It is generally accepted that it takes predicted displacements at least on the order of 6 to 12 inches before stability is considered to be threatened.
- The duration of a major earthquake is likely too short to breach a blockage upstream near the Pendery Fault, cause a rise in the downstream groundwater and produce enough displacement to fail the slope. Therefore, an aftershock would be needed to trigger slope instability. Aftershocks are expected to be of smaller magnitude than the main shock in this area of the country.
- With best estimate soil shear strengths, even the peak horizontal ground acceleration for a 10,000-year earthquake produces a pseudo-static factor of safety greater than 1.0. Earthquakes at a 2,500-year recurrence interval and less produce factors of safety greater than 1.0 even with all other assumptions conservative. Slippage is unlikely with a factor of safety greater than 1.0.
- A high groundwater level near the portal is unlikely under any scenario, due the pervious nature of the gravels in this area and the sloping bedrock surface that carries water down under the portal area. Thus, the factors of safety are likely considerably higher than those calculated (which all included a high groundwater level).

Risk Category and Rationale

This potential failure mode was **Ruled Out**. It was not considered plausible since the only way the team could envision it might occur is if a whole series of unlikely events occurred simultaneously: (1) a major remote earthquake occurred with a high level of ground shaking and a strong aftershock, (2) the groundwater in the portal area was high at the time of the earthquake, (3) the strengths in the soil materials in the portal area are lower than presently thought to be the case, and (4) displacements were larger than predicted by current methods.

² Jibson, R.W., "Regression Models for Estimating Coseismic Landslide Displacement," *Engineering Geology* Vol 91, pp. 209-218, 2007.

Potential Failure Mode No. 6 – Seepage Erosion into Tunnel Causes Sinkholes and Loss of the Highway

Description

Under this scenario, high groundwater outside the tunnel would result in a gradient that could carry soil material into the tunnel and through the lattice timber bulkhead. The loss of material between the tunnel and the highway would then result in voids that could stope to the surface, creating sinkholes that would affect State Highway 91. For this to occur, the water pressure outside the tunnel would need to be higher than inside.

Risk Category and Rationale

This potential failure mode was **Ruled Out** without developing lists of Adverse and Favorable Factors. It is considered to be extremely unlikely for the following reasons:

- Filter material was placed behind the timber lattice bulkhead, and seepage exiting at the bulkhead has been clear since its installation in 1992.
- The tunnel under the highway is filled with collapsed gravel material and injected fill. It is unlikely material could move into or through this zone.
- The bulkhead area is monitored; if material were moving through the bulkhead, it would likely be noticed, an evaluation made, and remedial measures taken if appropriate.
- The area between the tunnel and highway has been treated, including injection of cement grout. This treatment is likely to prevent sinkholes from progressing up to the roadway.
- It is not clear how a condition could develop with higher pressures outside the tunnel than inside.

Potential Failure Mode No. 7 – Flow at Tunnel Portal Plugs Off, Raising Groundwater and Causing Slope Instability

Description

For this potential failure mode to initiate, impervious fines would need to be carried into the tunnel, filling the voids in the downstream tunnel blockage and porous bulkhead, and plugging weep holes in the concrete lining to the point where drainage through the tunnel is further impeded, raising the groundwater level outside the tunnel to new highs and leading to slope instability. The initial water level outside the tunnel would need to be higher than inside the tunnel, and the tunnel would need to be acting as a drain for the slopes near the portal.

Risk Category and Rationale

This potential failure mode was **Ruled Out** without developing lists of Adverse and Favorable Factors. It is considered to be extremely unlikely for the following reason:

- There is not a significant tendency for flow to “drain” into the downstream portion of the tunnel; it is likely draining off through the gravel material. Additional plugging of the material in the tunnel would likely have minimal effect on the groundwater level.

Summary

The team assembled to perform the Potential Failure Modes and Effects Analysis (PFMEA) for the Leadville Mine Drainage Tunnel (LMDT) identified seven potential failure modes that could affect the population near the tunnel portal (and possibly downstream). Each potential failure mode was classified according to the likelihood of its development, and the consequences of failure (the two components of “risk”), based on categories developed for this study. Four of the identified failure modes would be initiated by breach of a blockage in the tunnel that likely exists just downstream of the Pendery Fault. The likelihood of a blockage existing and breaching in this area was evaluated separately, and forms a part of the evaluation for these four potential failure modes. The consequences for several of the identified potential failure modes depend on how effective the Early Warning System (EWS) is in (1) detecting impending failure and (2) resulting in evacuation of the potentially affected population. Therefore, the EWS was also evaluated separately, and this evaluation affected the consequence categorization. The event trees contained in Appendix A indicate how these two pieces fit with the other events needed for failure mode development.

The team used its best judgment based on the available information to categorize the potential failure modes. The results of the evaluations are summarized in Table 2. The most uncertainty is associated with the evaluation of a blockage near the Pendery Fault, where it was necessary to infer the likely conditions from other data. It should be noted that three potential failure modes were Ruled Out as being so unlikely as to not be plausible. No potential failure modes with High Likelihood were identified. In general, the risks associated with the project appear to be on the low side (but not negligible). Thus, monitoring appears to be an appropriate risk management strategy. Key conclusions are summarized in the Section of this report titled, “Major Findings and Understandings”. For each potential failure mode, possible risk reduction actions, monitoring enhancements, data collection, and/or analyses were identified that could be used to reduce the risk, confirm the evaluations made by the team, or better understand the risk (see listing associated with each potential failure mode). None of these were considered to be critical to the safe operation of the LMDT facility at this time, but could be considered during risk mitigation studies. The exception is related to the Emergency Action Plan (EAP), which is currently in draft form. Although the

EWS will likely trigger an alarm indicating something has changed significantly, it is not clear that water treatment plant operating personnel will have enough guidance as to how serious the situation might be, and when it is appropriate to activate the siren to evacuate The Village at East Fork. Thus, **it is recommended that the EAP be reviewed by the technical project staff to ensure sufficient guidance is covered, and the EAP be finalized as soon as possible.** Since monitoring is an important risk management activity, **it is recommended that the ground water wells at Stations 3+00, 4+70, and 6+35 be evaluated to determine if reliable information is being collected, and if so instrumented with pressure transducers and the data be tied into the existing Early Warning System (EWS) as soon as possible.**

Table 2. Risk Categorization Summary by Potential Failure Mode (PFM)

CONSEQUENCES OF FAILURE	FAILURE MODE LIKELIHOOD			
	RULED OUT	LOW	MODERATE	HIGH
LEVEL 3 Consequence Category	PFM #5 – Earthquake triggers slope instability			
LEVEL 2 Consequence Category	PFM #6 – Seepage erosion leads to loss of highway PFM #7 – Tunnel drainage plugs leading to slope instability	PFM #1 – Rupture of D/S blockage and bulkheads PFM #2 – Rapid seepage erosion of materials adjacent to portal PFM #3 – Rise in groundwater triggers slope instability		
LEVEL 1 Consequence Category			PFM #4 – Rise in groundwater results in contaminated leakage from ground surface	
No Significant Consequences				
Note: If the Early Warning System is unsuccessful, the consequences for PFM #1, #2, #3, and #7 would elevate to Level 3.				

References

A large number of references were reviewed by team members prior to the PFMEA session. A good summary and listing of these references is contained in a separate report prepared for this study³. In addition, all analyses performed prior and subsequent to the team session⁴ were reviewed to ensure risk estimates were consistent with the results.

³ “Existing Condition of the Leadville Mine Drainage Tunnel,” prepared by Michael Gobla and Mark Vandenberg,” Bureau of Reclamation, Technical Service Center, Denver, Colorado, DRAFT May 2008.

⁴ “Results of Geotechnical and Structural Analysis, Leadville Mine Drainage Tunnel,” prepared by M.J. Romansky, Roger Torres, Jack Touseull, and Kevin Atwater, Bureau of Reclamation, Technical Service Center, DRAFT June 2008.

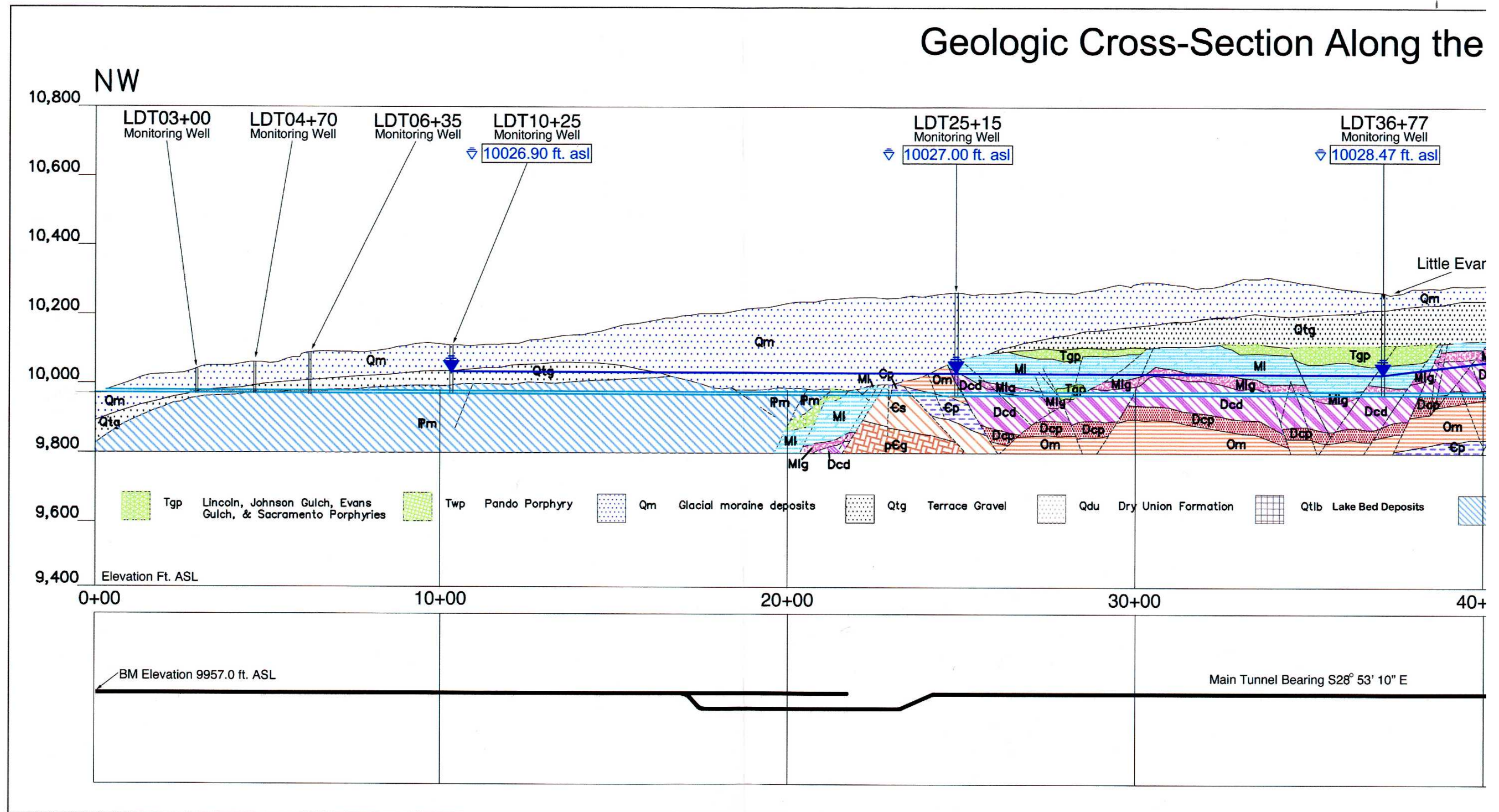

Figure 1a. Geologic Cross Section along Leadville Mine Drainage Tunnel Alignment

the Leadville Mine Drainage Tunnel, Showing Abandoned Mine Workings, and Monitoring Well

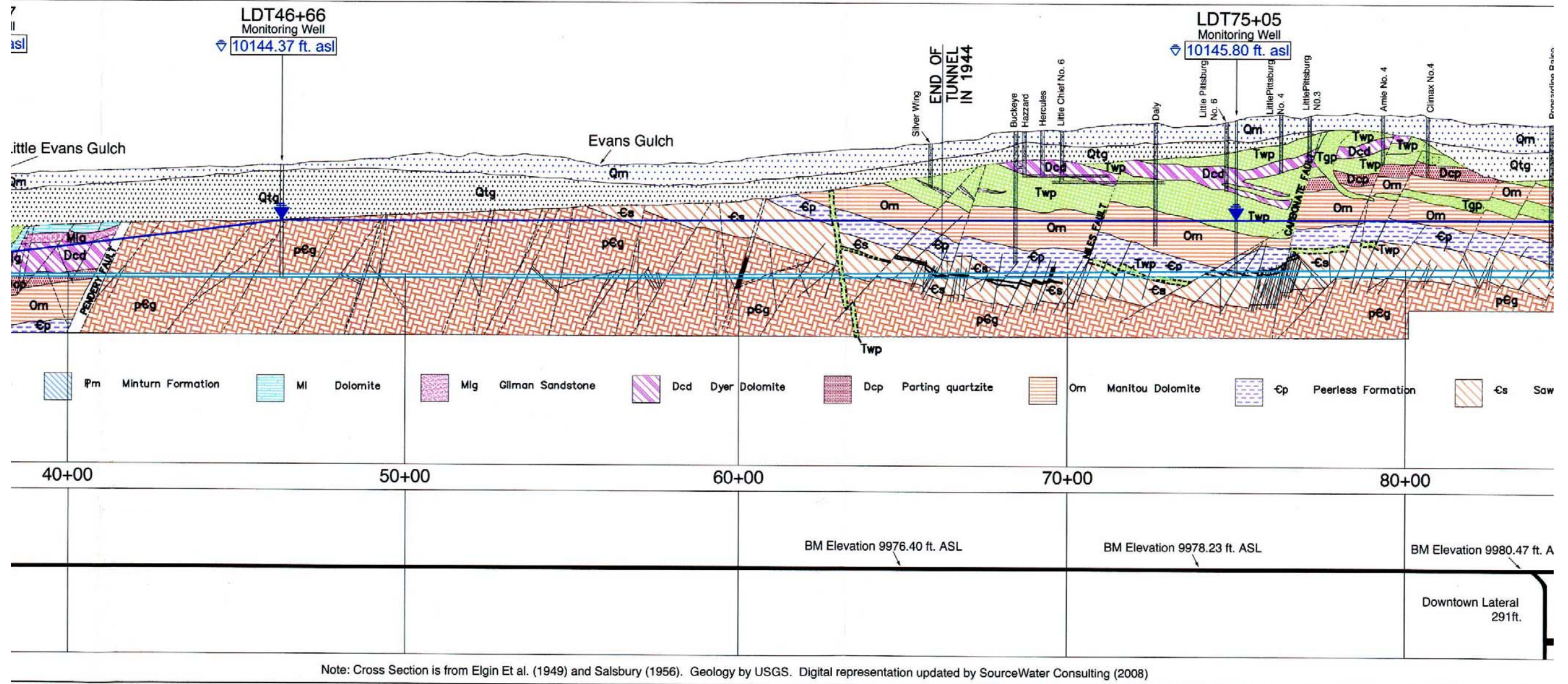

Figure 1b. Geologic Cross Section along Leadville Mine Drainage Tunnel Alignment (cont.)

Monitoring Well Water Levels, January 1st, 2008

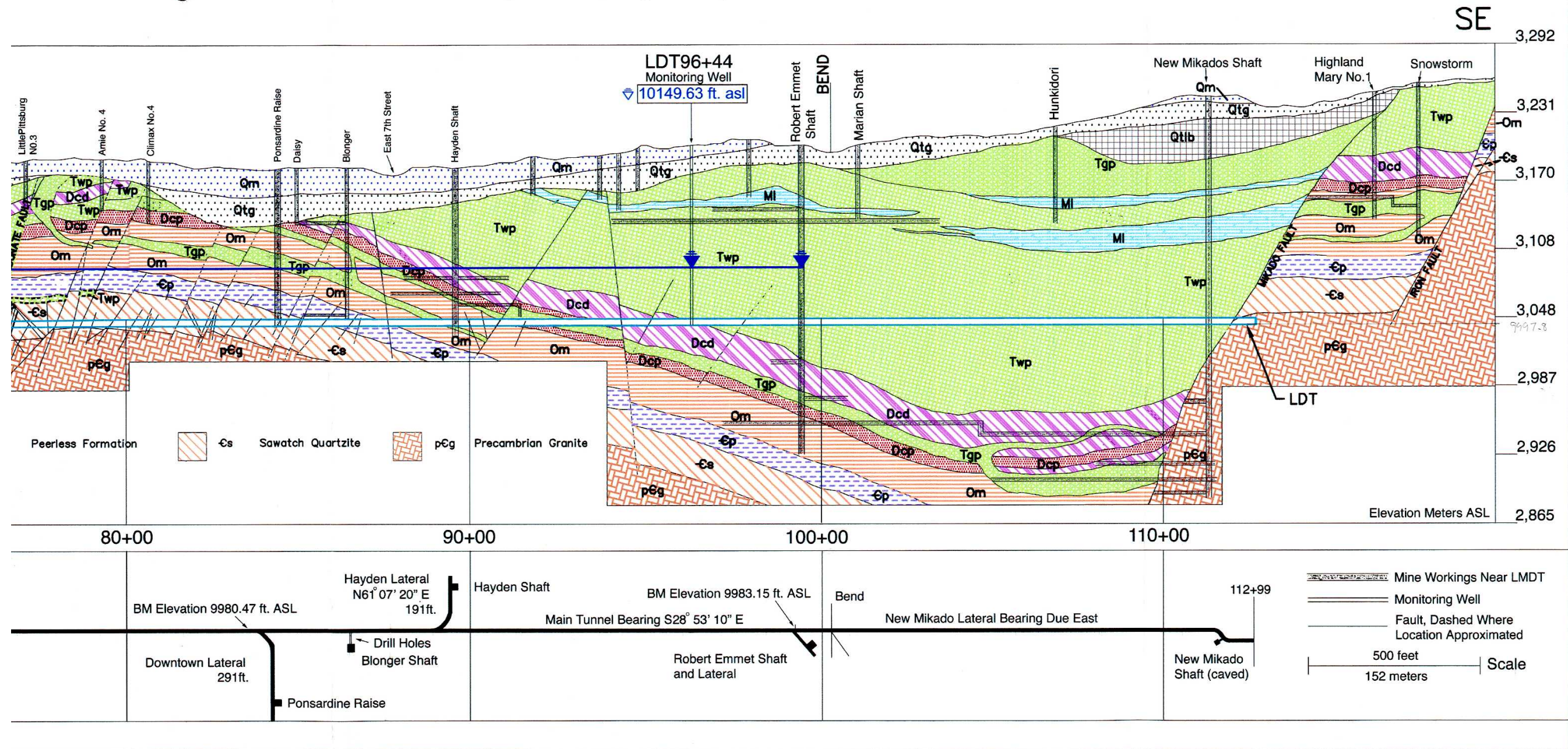

Figure 1c. Geologic Cross Section along Leadville Mine Drainage Tunnel Alignment (cont.)

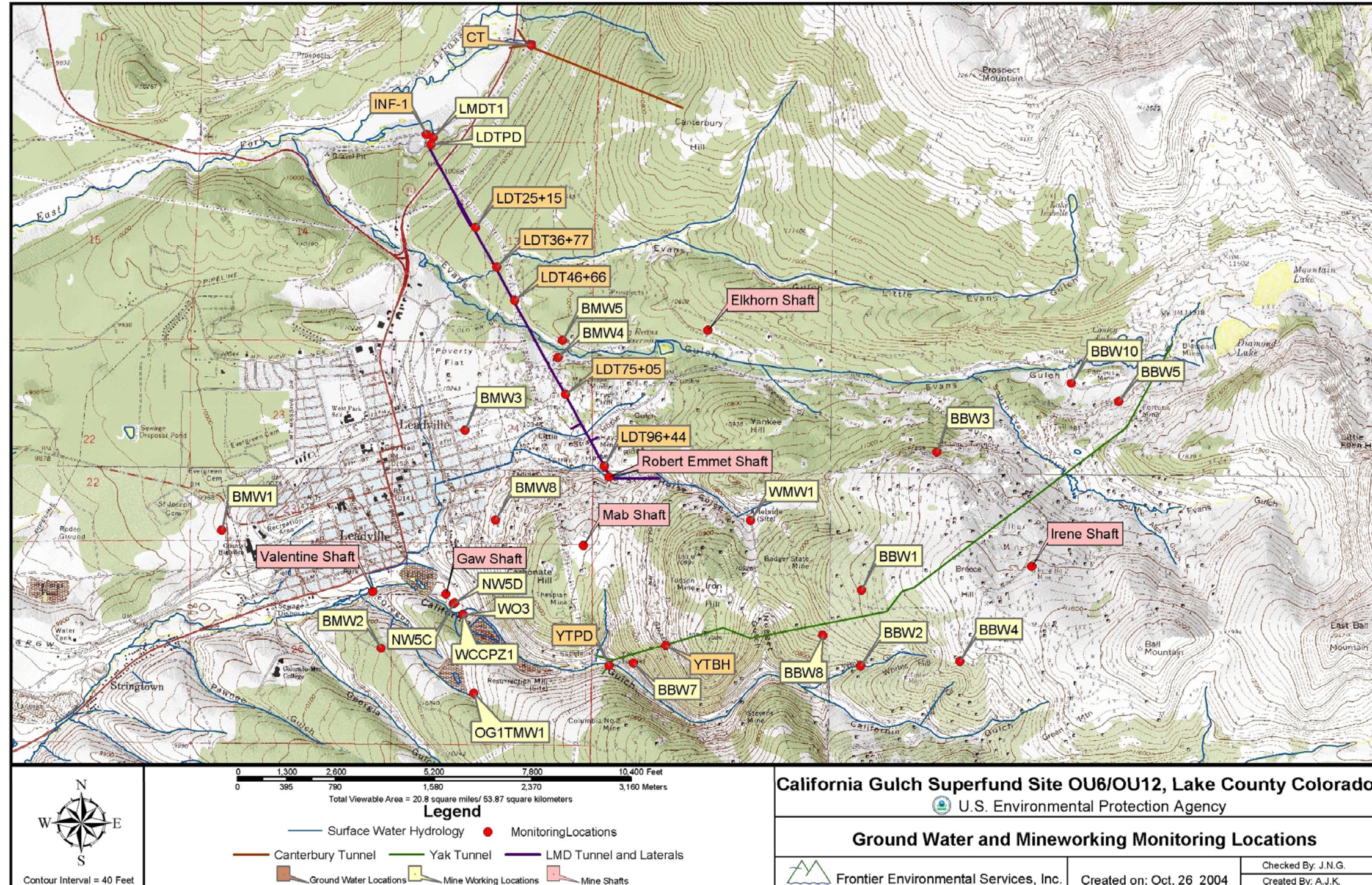

Figure 2. Plan Map of Tunnel and Leadville Area

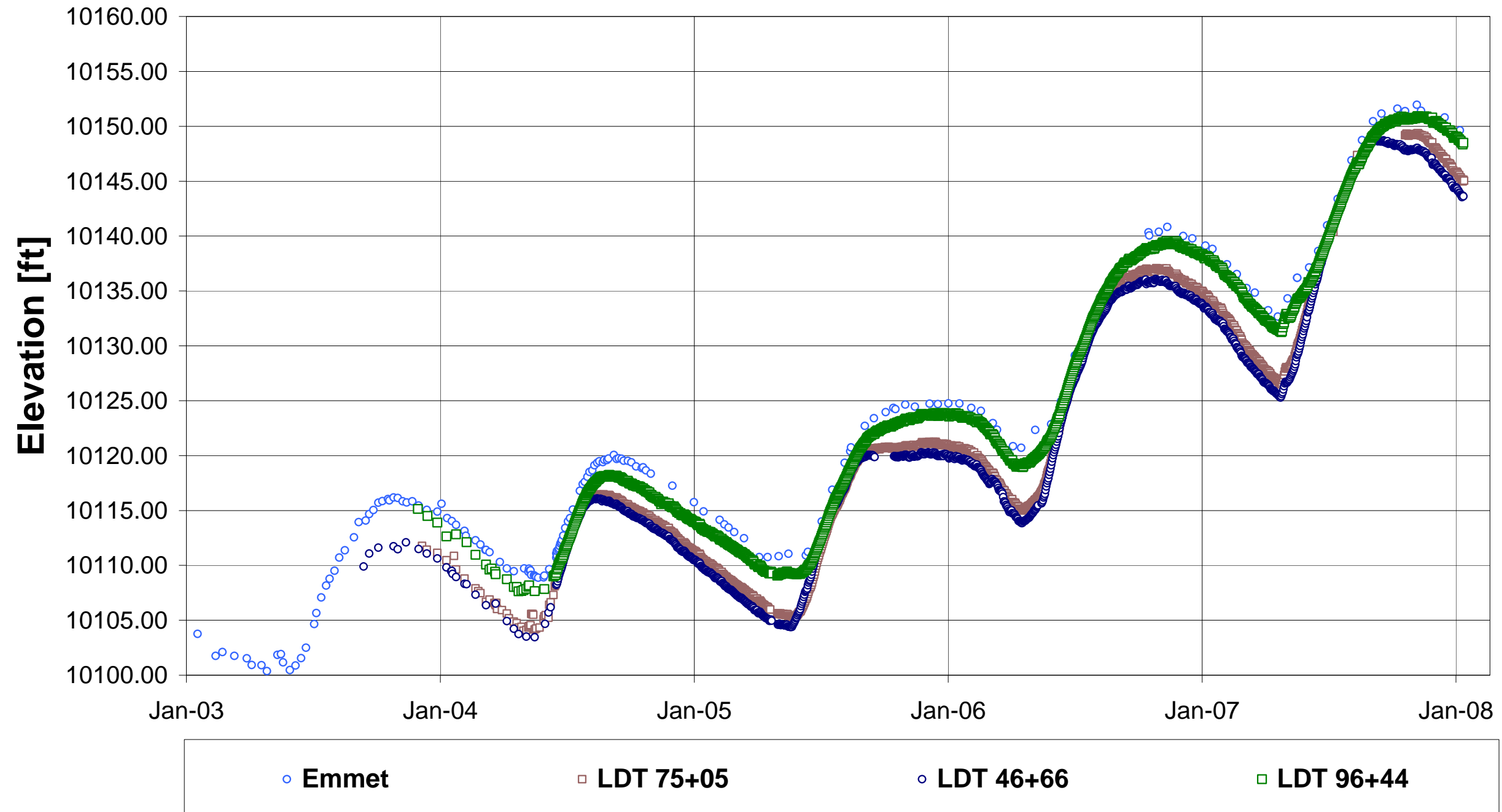

Figure 3. Water Levels in the Upstream Tunnel

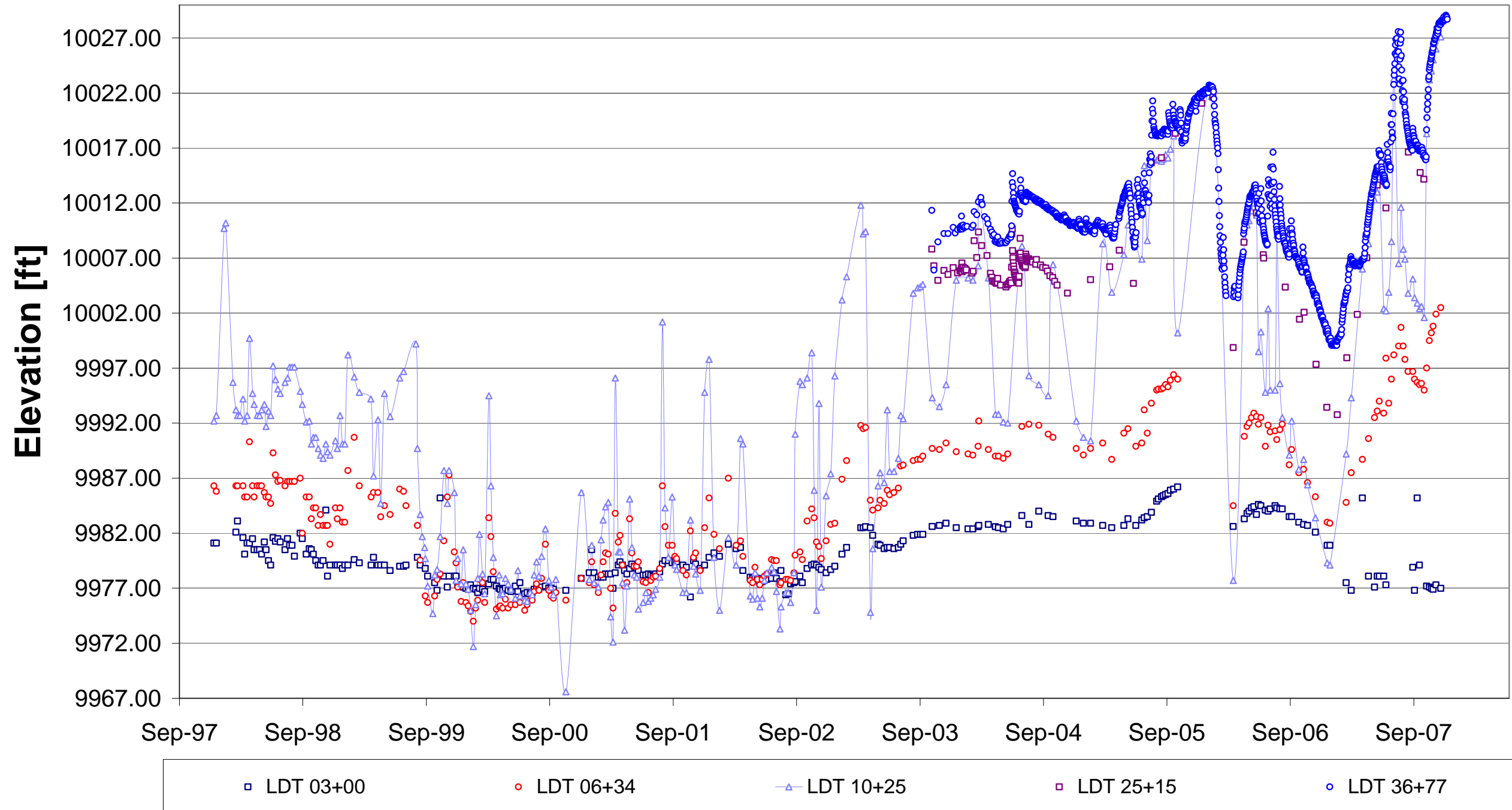

Figure 4. Water Levels in the Downstream Tunnel



Figure 5. Running Ground in the Parting quartzite (approximate date August/September 1951)



Figure 6. Bulkhead at Station 4+66 (date noted on photo)



Figure 7. Recent Aerial View of Tunnel Portal Area



Figure 8. Excavation into the Glacial Moraine at Leadville for installation of a pipeline under Highway 91 along the alignment of the LMDT (late spring 2008)

Appendix A: Event Trees

Potential Failure Modes and Effects Analysis Leadville Mine Drainage Tunnel

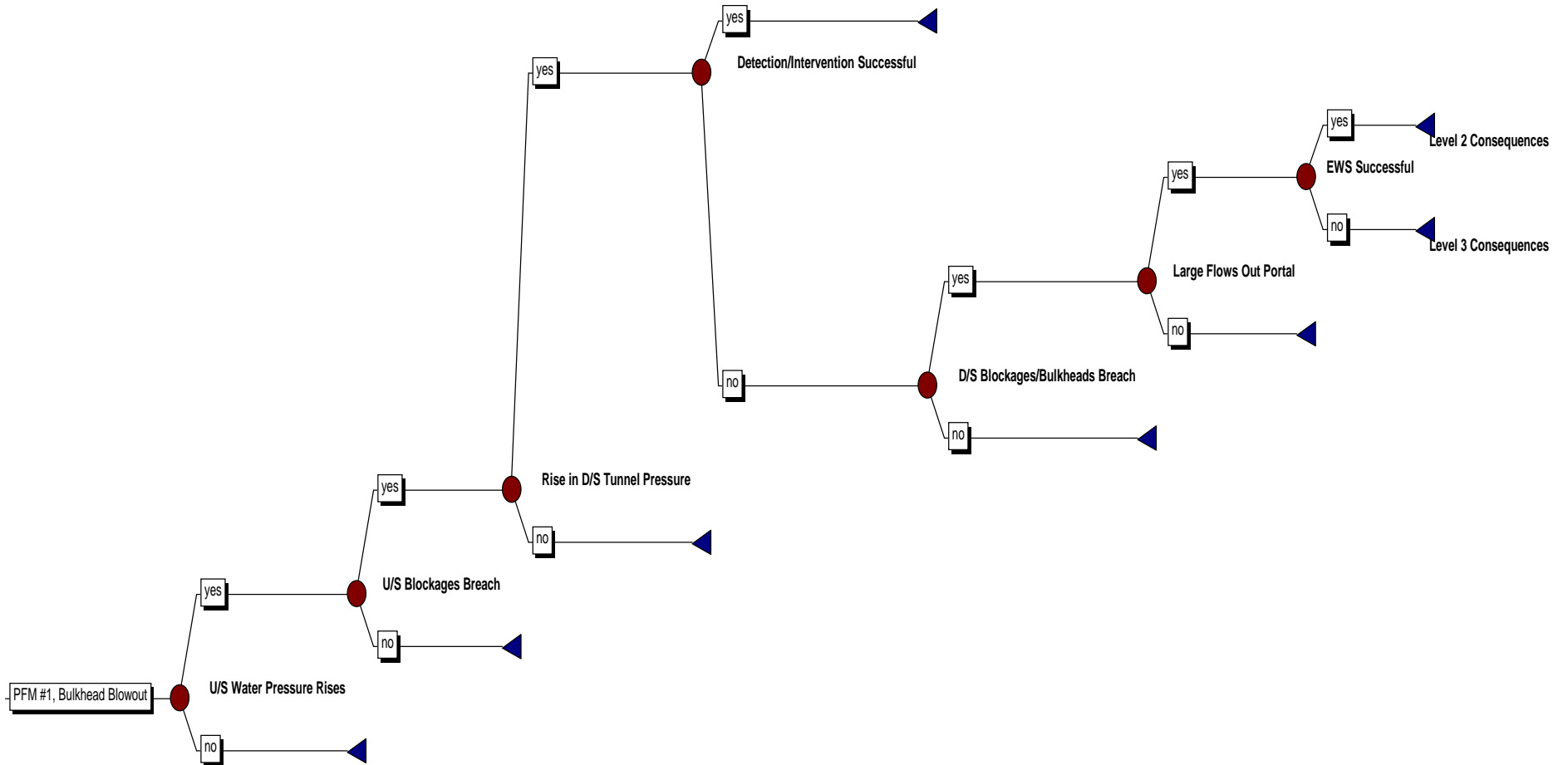

Potential Failure Modes and Effects Analysis Leadville Mine Drainage Tunnel

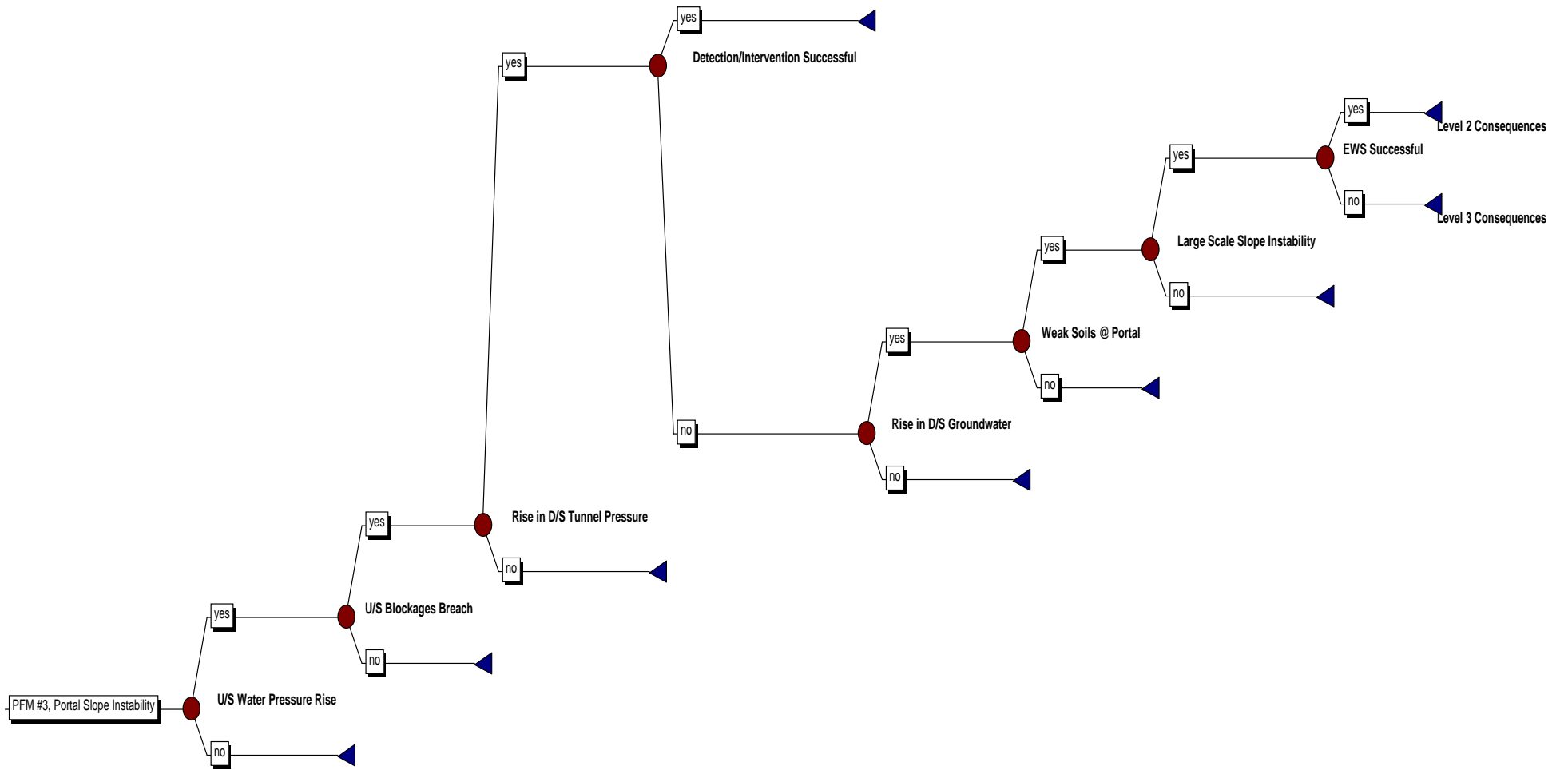

Potential Failure Modes and Effects Analysis Leadville Mine Drainage Tunnel

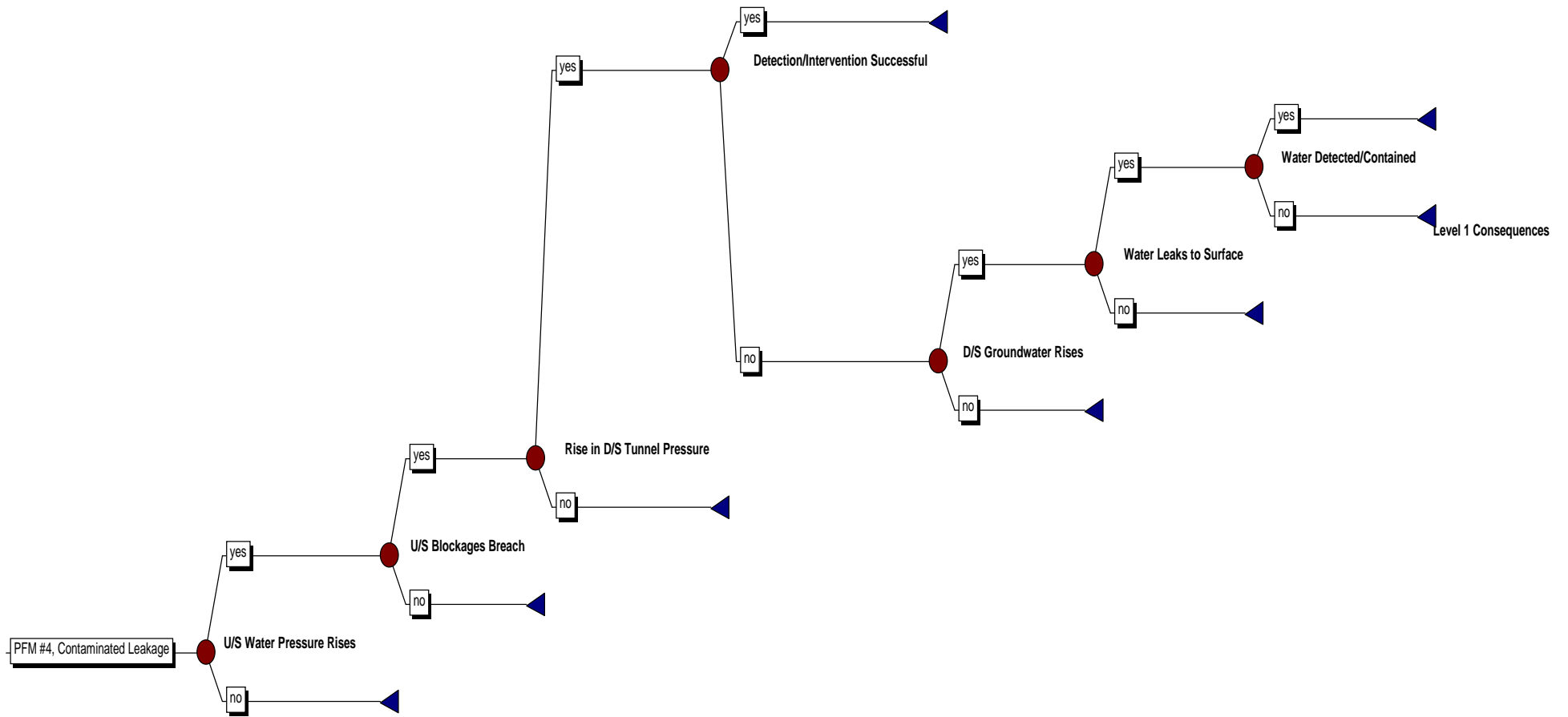

Potential Failure Modes and Effects Analysis Leadville Mine Drainage Tunnel

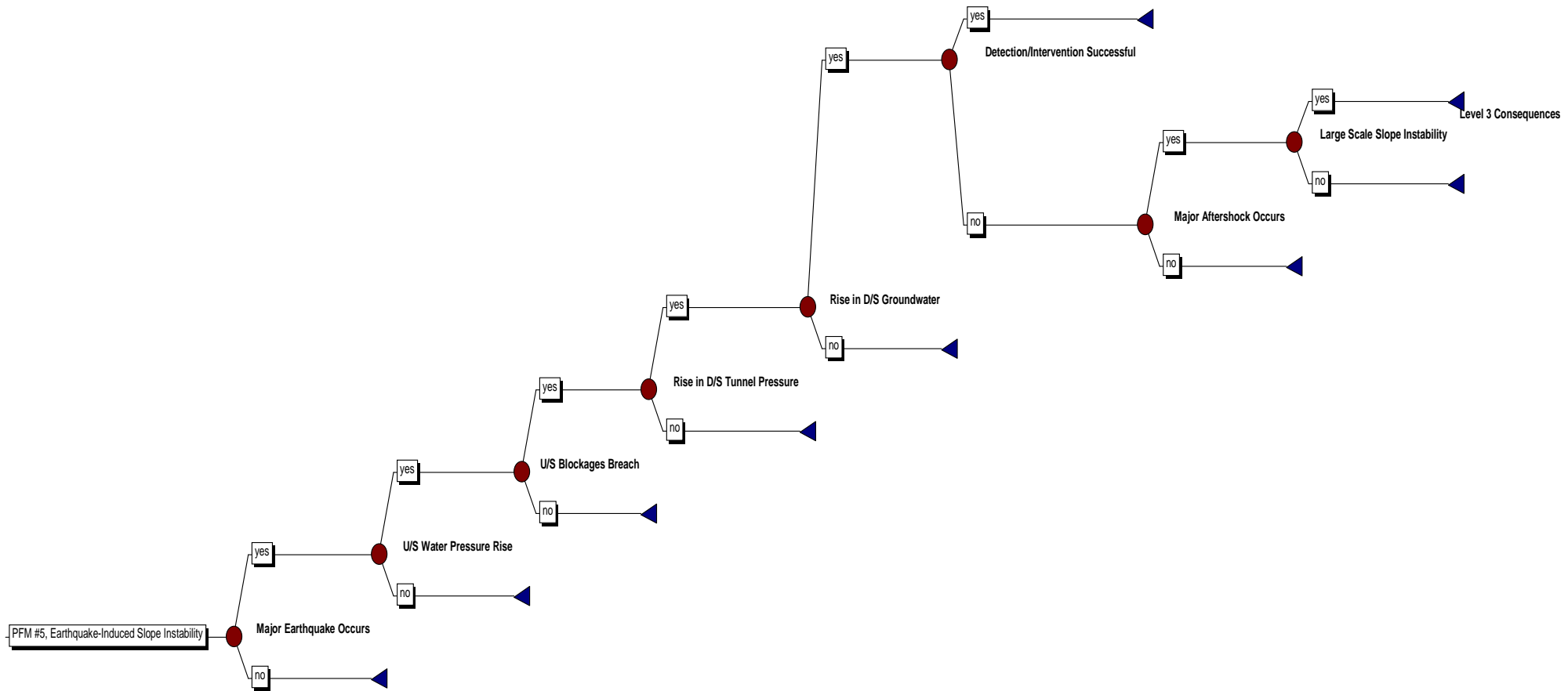

Potential Failure Modes and Effects Analysis Leadville Mine Drainage Tunnel

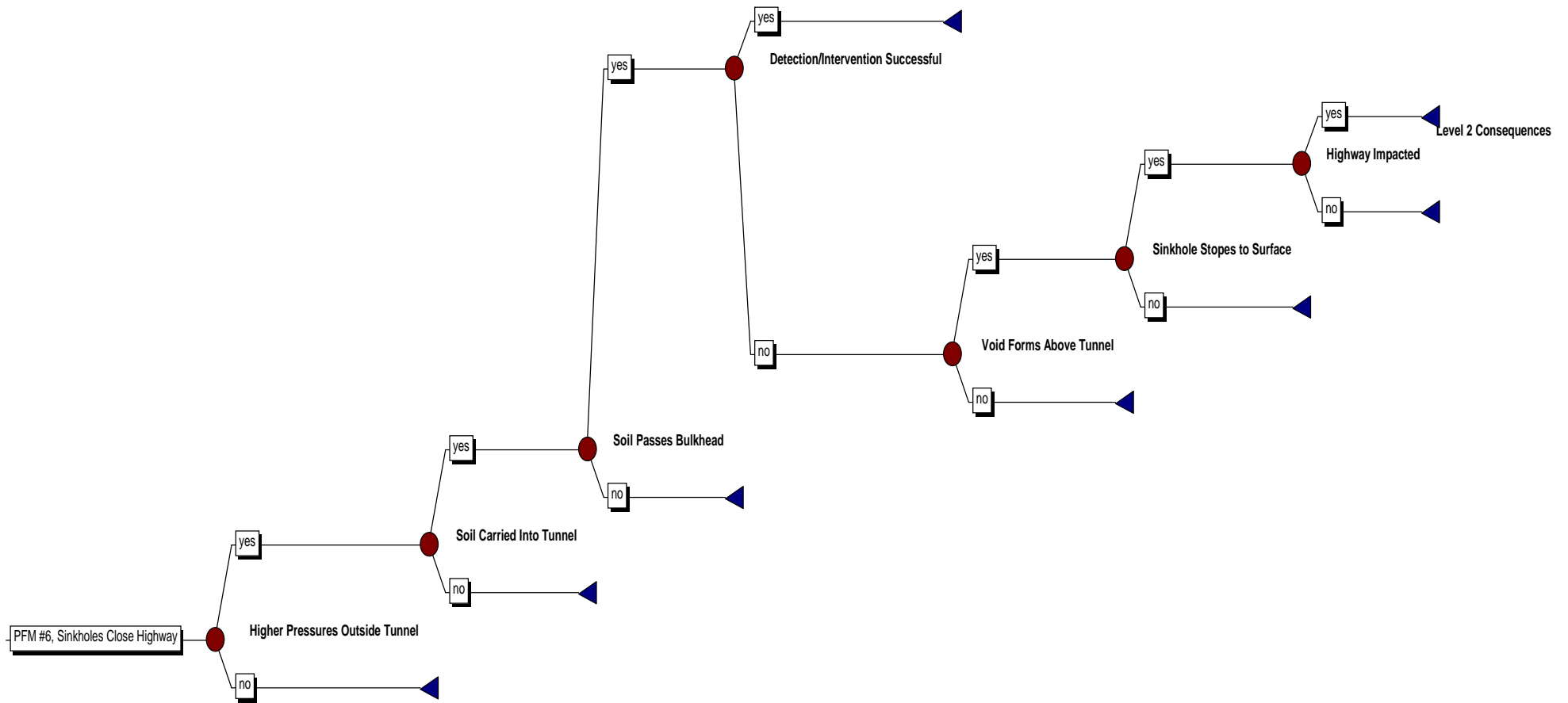

Potential Failure Modes and Effects Analysis Leadville Mine Drainage Tunnel

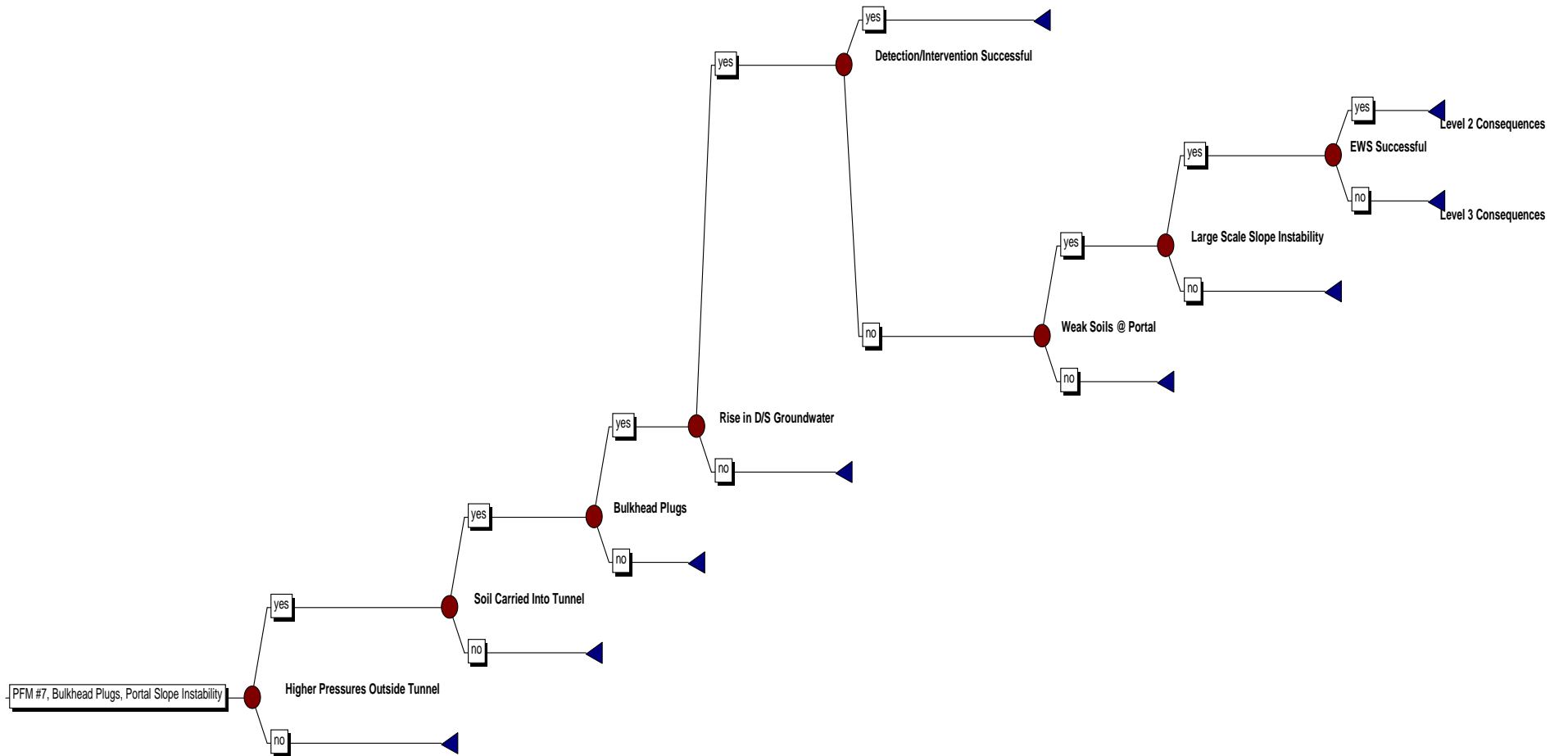

RECLAMATION

Managing Water in the West

Comment Response Document

Leadville Mine Drainage Tunnel Risk Assessment

**Leadville Mine Drainage Tunnel Project, Colorado
Great Plains Region**



For Official Use Only



**U.S. Department of the Interior
Bureau of Reclamation**

October 2008

Mission Statements

The mission of the Department of the Interior is to protect and provide access to our Nation's natural and cultural heritage and honor our trust responsibilities to Indian Tribes and our commitments to island communities.

The mission of the Bureau of Reclamation is to manage, develop, and protect water and related resources in an environmentally and economically sound manner in the interest of the American public.

Comment Response Document Leadville Mine Drainage Tunnel

Leadville Mine Drainage Tunnel Project, Colorado
Great Plains Region

prepared by

Technical Service Center

Authors

Michael Gobla, P.E.

Mark Vandenberg, Geologist, P.G.

Peer Reviewer

Lloyd G. Crutchfield, P.G., Manager
Engineering Geology Group

Acronyms and Abbreviations

ARD	Acid Rock Discharge.
CDPHE	Colorado Department of Public Health & Environment
CRB	Consultant Review Board
EAP	Emergency Action Plan
ECAO	Eastern Colorado Area Office
EPA	Environmental Protection Agency
EWS	Early Warning System
LMDT	Leadville Mine Drainage Tunnel
OU6	Operable Unit 6
PFMEA	Potential Failure Modes Effects Analysis
ROD	Record of Decision
TSC	Technical Service Center
USACE	United States Army Corps of Engineers

Contents

	Page
<i>Introduction</i>	2
<i>Consultant Review Board Comments</i>	3
<i>Mark R. Cole Comments</i>	14
<i>Lake County Board of County Commissioners Comments</i>	16
<i>U.S. Army – Corps of Engineers</i>	22
Summary Review Memorandum by B.J. Bailey, P.G.	23
Review Comments from Steven Jirousek, R.G. (Attachment 1)	25
Review Comments from Joseph A. Kissane, P.G. (Attachment 2).....	32
Review Comments from B.J. Bailey, P.G. (Attachment 3)	37
<i>United States Environmental Protection Agency Comments</i>	46

Introduction

The Lake County Board of County Commissioners passed a resolution declaring the existence of a disaster emergency on Feb. 13, 2008 due to concerns about the stability of blockages that had developed in the Leadville Mine Drainage Tunnel (LMDT). The resolution stated that “...*this elevated groundwater level is an imminent threat to the citizens of Lake County Colorado, public and private property, local domestic water supply, local wastewater treatment plant and the water quality of the Arkansas River Basin...*”

Reclamation’s Technical Service Center (TSC), with participation by the Great Plains Region and Eastern Colorado Area Office (ECAO), responded by attending public meetings and initiating a risk assessment relating to the stability of blockages in the LMDT. A final draft risk assessment report was released in June 2008 and the public was invited to comment. The scope of this effort was limited to an evaluation of the potential for a sudden failure of the blockage and potential impacts to downstream infrastructure and populations in the event of a rapid release of water.

An independent board of consultants was assembled to review Reclamation’s draft risk assessment of the LMDT. A Consultant Review Board (CRB) Meeting was held in Denver, Colorado on June 20, 2008. The CRB was comprised of:

Dr. John F. Able, retired rock mechanics and mining engineering professor from the Colorado School of Mines.

Robert L. Elder, mining engineer from Leadville, CO.

Dr. Randall W. Jibson, geologic hazards specialist from the U.S. Geological Survey

The risk assessment study consists of the following three documents for the Leadville Mine Drainage Tunnel which Reclamation provided to the CRB for their review and comment:

1. Existing Conditions
2. Results of the Geotechnical and Structural Analysis
3. Potential Failure Modes and Effects Analysis

The risk assessment was released in final draft form on June 30, 2008 after addressing the CRB comments and suggestions.

The public and government agencies were then invited to submit technical comments on the final draft risk assessment to Reclamation. Comments were received from:

- Mark R. Cole
- Lake County Board of County Commissioners
- United States Army Corps of Engineers (USACE)
- United States Environmental Protection Agency

This report contains responses to all of the comments in the order they were received. The comments from the CRB are presented first, followed by comments from the public and government agencies. Reclamation questions to the CRB are in bold text. The CRB's responses to these questions are in plain text. Other comments are presented in plain text, and Reclamation's responses immediately follow each comment and are presented in bold and italicized text.

Consultant Review Board Comments

The CRB was asked to consider four questions in preparation of their report. Comments are organized according to the four questions posed to the CRB.

Question 1. Are Reclamation's interpretations of the existing hydrogeology, geotechnical, and structural information reasonable and sound?

The overall interpretations regarding the existing conditions in and around the LMDT appear reasonable and sound. Reclamation's review of the history of the LMDT is detailed and complete, and it provided a valuable framework for the review. The description of the difficult conditions encountered during construction and the intermittent efforts to rehabilitate the tunnel provides a basis for understanding the structural geology and how the current hydrogeologic condition has developed.

The data collected by the multiple monitoring wells have made it possible to reasonably conclude that the LMDT is submerged except on the portal side of the porous bulkhead at Station 4+61. The Pendery Fault and the collapsed-rock bulkhead immediately downstream partially hydrologically separate the tunnel into two parts. Upstream is the mining area, which forms a single interconnected mine pool. The collapse bulkhead greatly retards free flow of water from the mine pool toward the portal. The downstream part of the tunnel contains another collapse zone that was evidenced by a number of chimney collapses to the surface in the roughly 600+ feet from the portal. It is impossible to physically inspect either of the two parts. The data show that the water head in the lower section of

the tunnel has been increasing somewhat, and the water head in the upper section has been increasing considerably more. The water table in the upper section of the tunnel is very close to the level of the rock/terrace gravel contact, which could prevent any further rise in the mine pool because of the higher permeability of the terrace gravels.

Specific comments in response to this question include:

Comment 1. The lack of measured engineering properties (unit weight, shear strength, etc.) of the materials being analyzed in both the tunnel blockages and the slopes at the portal renders the analyses based on these properties somewhat tentative. Are there any geotechnical data from past construction projects for the portal, the treatment plant, or any of the pipelines? Use of conservative strength values to bracket limiting conditions is a reasonable approach to deal with lack of directly measured data, but direct measurement would be preferable.

Reclamation agrees with the CRB and recognizes the lack of measured engineering properties. The first step in the assessment program was to collect available information. The search for data included archives from the Bureau of Mines as well as Reclamation files from the Eastern Colorado Area Office, the Great Plains Regional Office, and the Denver Office. No laboratory testing results were found that would provide direct information for strength determination. Reclamation briefly considered a data collection program to sample and test the critical materials. The presence of numerous cobbles and boulders in the gravels and the lack of access to the terrace gravels and Weber Formation would necessitate collecting very large samples at significant depth to accurately characterize the material properties. Given the perception of potentially imminent failure and the subsequent public concern, Reclamation determined the public would be best served by rapidly determining the potential risk and concluded the only feasible alternative was to evaluate the tunnel using a range of strength values, including multiple layers of conservative assumptions to overcome the lack of site specific information.

Comment 2. There is the lack of consistency in reporting units of water flow: gallons/minute, gallons/day, and cubic feet/second are all used. One unit of measure should be selected, and all reported values should be converted to those units. Alternatively, a parenthetical system could be used to provide consistent unit conversion for flows originally reported in various types of units.

Reclamation agrees with the CRB. The reports have been modified to present units of flow in gallons/minute.

Comment 3. Wherever possible it would be valuable to have the approximate date of the pictures presented. The month and year would be good, but even the approximate year would help in understanding of the gradual changes in the LMDT.

Reclamation agrees with the CRB. Dates have been added to the photograph captions in the final versions of the reports.

Comment 4. If the data exist, extend the January 2008 water-table line on the geologic cross section to the portal from LDT 10+25 by including data from LDT 06+35, LDT 04+70, LDT 03+00, and the water level at the bulkhead at Station 4+61.

Reclamation agrees with the CRB. Construction details (i.e., influence zones, depths of completion, etc.) have been evaluated. Only the well at Station 06+35 penetrates the tunnel—the others are off of the tunnel alignment with influence zones outside the tunnel. The drawing in appendix A of the Existing Conditions Report was updated to show the water level at Station 06+35 and at the tunnel bulkhead.

Comment 5. A critical question is what maximum differential head is physically possible at the upper blockage, and that can only be ascertained by additional geological investigation to determine the geological controls of the local hydrology ([Potential Failure Modes Effects Analysis] PFMEA report, p. 10-12; Results report, p. 9).

One controlling hydrologic condition that might currently exist (posited by [Environmental Protection Agency] EPA hydrologist Mike Wireman) is that part of the Mine Pool discharge could be migrating to outlet points south of the Mining District. This theory is based, in part, on dye-tracer studies in which much of the dye was not recovered in the LMDT discharge. Occasional recovery of dye from the Gaw shaft and surrounding springs in California Gulch further supports this theory. If the southward water migration could be confirmed, it would reduce concerns regarding potential increases in Mine Pool recharge rates. The lower reach of Iowa Gulch is in line with the southerly projection of the Pendery fault complex. Surface elevations in lower Iowa Gulch are quite low relative to present Mine Pool elevations.

Reclamation does not know precisely what the maximum water table level would be, but believes the control on this elevation may be the geologic contact between pervious zones in the bedrock and the overlying gravels. The rate of rise of the mine pool would be limited by the gravel's large water carrying capacity and by the fact that some shafts will experience artesian flow. SourceWater Consulting has noted that seeps and flow from shafts begin in California Gulch when the water level in the LMDT mine pool reaches an elevation of 10,147. The Bureau of Mines previously suggested that a water elevation of 10,160 may be the maximum based upon this level being measured in the Pyrenees shaft prior to the excavation of the LMDT. It is believed that present water levels are near the maximum likely to occur as the hydrologic system is able to overflow out of the top of the mine pool. Placing an exact

value on this elevation is not essential, given the finding that the lower plug and bulkheads can resist considerably higher water levels and the historic evidence that the upper limit is somewhere near elevation 10,160.

Comment 6. The potential for a change in the physical conditions, particularly the rate of recharge of the Mine Pool, should perhaps be addressed in the risk assessment. For example, future periods of high precipitation could increase recharge rates in the Mine Pool. If this occurs, the relief-well pumping rate might need to be increased. The presently planned pumping rate corresponds with the estimated rate at which the LMDT Treatment Plant can process the pump output, and so it seems prudent to find ways to increase Plant throughput or to eliminate a portion of the recharge water.

Reclamation agrees in theory with the CRB that there is potential for change in the current physical conditions and that rate of recharge and rate of pumping/treatment of the Mine Pool may become significant issues in the future. However, Reclamation's goal in the risk assessment program was to assess the risk(s) to the public and others under current conditions. Reclamation recognizes the limitations of the LMDT Water Treatment Plant capacity. However, with the newly installed relief well, proportionally more water from the mine pool is being pumped and treated than in the past. Reclamation supports any effort(s) to reduce or eliminate recharge water from the Mine Pool system.

Question 2. Have the critical potential failure modes been identified, and have the risks for those potential failure modes been reasonably assessed and portrayed?

The critical failure modes have been adequately identified, and the associated risks have been rationally assessed and portrayed in most respects. Specific comments regarding this question are as follows:

Comment 1. At the portal, the slope stability of the west flank of the slope is most critical from a life-safety standpoint because houses are located near the base of this slope. Page 20 of the PFMEA report states that slope profiles at the portal are basically the same regardless of the downslope direction. This should be verified by comparing the analyzed slope profile to at least one profile measured in a westerly direction toward the houses.

The slope profile presented in the analysis is considered to be the steepest, and therefore least stable, slope. Drawing the profile further to the west results in profiles which are similar to or slightly less steep, and therefore equal to or more stable than the slope for analysis. Profiles were sketched in the risk assessment meeting using available topographic contours to verify this conclusion.

Comment 2. A better rationale is needed for the earthquake scenarios analyzed as described on p. 43 of the Results report. It is unclear why each of the three ground-shaking levels are not analyzed for each of the three groundwater levels. The groundwater levels near the portal are relatively insensitive to changes in groundwater levels upslope; therefore, it seems reasonable simply to model the highest groundwater levels (which provides an argument of conservatism) for each of the three earthquake scenarios.

Reclamation agrees with the CRB. In response to this comment, Reclamation reworked the slope stability cases to include an analysis of the three seismic loading conditions using the highest groundwater levels as suggested. The result of the revised analysis is that the hillside will remain stable even under the worst loading conditions.

Comment 3. Some discussion of the seismic performance of the tunnel plugs (collapse bulkheads) should be presented. How will they perform in an earthquake? What are the possible failure modes? Since ground shaking is far less underground, the seismic coefficients used in the surface slope-stability analysis could be reduced significantly in any analysis of the underground bulkheads. The fact that the bulkheads are submerged is also significant. Because of the differential head across the tunnel blockages, the peak predicted earthquake accelerations would apply a smaller design load to the upstream face of a bulkhead that is submerged in water on both sides. Normally, engineered reinforced concrete bulkheads will impound water only on the upstream side. The non-engineered collapse bulkhead downstream of the Pendery Fault, and any other collapse bulkheads except the Station 4+61 porous bulkhead, will be resisted by water pressure on the downstream side.

Reclamation agrees in theory with the CRB. As noted by the CRB, the seismic loading in the underground tunnel will be considerably less than that felt by a soil slope above bedrock. Reclamation ruled out the need for a detailed analysis of earthquake loading on the blockages for two reasons. First, the additional loading to the plugs due to an earthquake would be minimal, far less than what was analyzed for hydrostatic water pressure loading. Second, although there could be some more stress on the blockages due to an earthquake, with water on both sides they are not likely to fail. However, Reclamation decided to consider the worst case which is that the upper blockage could rapidly fail, perhaps as a result of earthquake loading. If failure was due to an earthquake, it would take a minimum of a few minutes for the water pressure to be transmitted down to the lower plug and bulkheads. The severe shaking would be over by the time that the water pressure loading would be seen downstream. Therefore, the analysis performed for the lower plug is a valid representation of the expected response.

Comment 4. Concrete bulkheads, and probably also collapse bulkheads, subject to overloading by whatever cause fail slowly but progressively by erosion after an

initial fracture allows leakage along either the contact between the bulkhead and the adjacent rock or by propagation of fractures induced in the adjacent rock or in the bulkhead. If a leak develops as the result of earthquake loading on any caved-rock bulkhead, it will not be possible to directly observe post-earthquake leakage and erosion or attempt to grout off the leak. However, monitoring wells should provide an indication of any significant increase in leakage through or around the bulkhead downstream of the Pendery Fault. Thus, failure of this type would involve a long time period and gradual increase in water pressure on the portal side of the bulkhead.

Reclamation agrees with the CRB. Reclamation is currently monitoring the water levels on both sides of the blockage near the Pendery Fault. Additionally, Reclamation is monitoring wells in and around the lower tunnel. Reclamation is confident that any significant change in the geohydrologic conditions could be detected and evaluated long before a significant increase in risk could occur.

Comment 5. The Early Warning System (EWS) discussed in the PFMEA report (p. 13-15) needs to be better fleshed out and specified. Specifically, a rigorous protocol should be put in place that specifies objective criteria that dictate issuing a warning. On-call personnel making the final decision should have enough technical expertise to exercise independent judgment, but if the specified criteria are met, the procedure should dictate when to sound the alarm, not just the responsible party's judgment. The technical expertise should be used primarily to verify that the instruments appear to be working correctly and that the reported data are accurate. Auto-dialer and call-down procedures should be reviewed and checked for adequate performance and redundancy, and the time between the auto-dialer being activated and the possible activation of an alarm should be quantified. Local emergency-response personnel should be notified before a warning is sounded so that they can be prepared to assist in the evacuation and overall response. Community exercises should be held at regular intervals to assure that local residents know how to respond to a warning. A planned evacuation route to the west exit from the community should be put in place to avoid coming in proximity to the path of possible water or debris flow from the tunnel or surrounding slopes. Also, both east and west entrances to the community should be kept snow-free to assure access and egress at any time of the year.

Reclamation agrees with the CRB. Reclamation developed and put into use criteria for two interim alarm response levels for use until the Emergency Action Plan (EAP) can be finalized. The initial alarm level activates when relatively minor changes in the piezometric surface, seepage rates, turbidity, or rate of change in parameters occurs. The response for the initial alarm level is the immediate callout of Reclamation personnel to evaluate the change in conditions. The second alarm level activates when very significant changes in the geohydrologic conditions occur. The indicators for this alarm level are based on surface observation and misinterpretation is very unlikely. The

response for the second level is evacuation of everyone in the vicinity of the lower tunnel. Reclamation has completed installation of, and tested, an alarm siren to notify local residents of adverse conditions.

Reclamation is working toward finalizing the Emergency Action Plan (EAP). The EAP will provide detailed information regarding the items identified in the comments, will be exercised as soon as possible after completion, and all site workers will be trained in the procedures once it is available. An in-house tabletop exercise has been conducted and plan finalization and exercise are expected in the near future.

Comment 6. An opportunity for risk reduction that could prove beneficial is the restoration of previous water flow from the Canterbury Tunnel. Parkville Water District is exploring measures to recover water from their adjudicated rights at the Canterbury, either through an intersecting well or by partial rehabilitation of the adit itself. The Colorado Department of Public Health & Environment (CDPHE) has obtained an appropriation from the Colorado Legislature to study possible water flow connections between the Canterbury Tunnel and the Mine Pool. When driven in the 1920's, the Canterbury Tunnel intercepted a water flow in the vicinity of the Pendery fault averaging 1300 gpm throughout the year. As a result, mine operators in the District recognized a marked reduction in recharge rate to both the Graham Park and Downtown basins. Should retapping of the Canterbury water flow be accomplished, the Mine Pool could very well experience a reduction in recharge rate, and the LMDT might receive an additional benefit in reduced saturation of the moraine surrounding its downstream segment.

Reclamation supports others efforts to reduce or eliminate recharge water to the Mine Pool system.

Question 3. Do the analyses adequately represent the expected behavior of the various tunnel components and the LMDT portal slopes?

In general, the analyses adequately model the expected behavior of the tunnel and portal slopes. Addressing the following issues could improve the value of the report and the predictions:

Comment 1. As stated above, the lack of measured shear strengths for materials in the tunnel plugs and the portal slopes somewhat limits the confidence of the results. Is there any potential to measure site-specific physical properties or back-calculate physical properties from site-specific field evidence? Also, when geologic materials are broken or otherwise disturbed, they can swell, which could affect their unit weight, friction angle, cohesion, and bulk permeability. The assumed values used in the analyses are reasonable and most likely represent the actual range of material properties, but direct measurement would increase the overall confidence in the results.

As discussed earlier, Reclamation agrees with the CRB and recognizes the lack of measured engineering properties. Given the perception of potentially imminent failure and the subsequent public concern, Reclamation determined the public would be best served by rapidly determining the potential risk and concluded the only feasible alternative was to evaluate the tunnel using a range of strength values including multiple layers of conservative assumptions to overcome the lack of site specific information.

Comment 2. The maximum height that any collapse chimney breached the overburden above the tunnel to produce a sinkhole at the ground surface could be used in conjunction with the underlying tunnel height to back-calculate a percent swell for the terrace gravel and glacial moraine. See attached figure from Piggott and Eynon (1977).

*Using this for the area around Highway 91 the following is calculated:
 $S\% = 2h(100)/H = 2 \times 12 \times 100 / 100 = 24$ percent, meaning the swell was less than 24 percent because a sinkhole occurred. The Bureau of Mines reported a zone of collapse further up in the tunnel where the overburden was 270 feet above the tunnel, but no surface sinkhole formed. For this area, the calculation is $S = 2 \times 12 \times 100/270 = 9$ percent. Since a sinkhole did not occur, the swell would have been somewhat greater than this value. So the swell is somewhere between 9 percent and 24 percent; it is difficult to be more precise than this.*

Comment 3. Figure 14 in the Results report is a picture demonstrating the high effective angle of friction and probable cohesion for the glacial-moraine material above the LMDT.

Reclamation agrees with the CRB. The caption points out that the steep slopes indicated high soil shear strength. However, Reclamation chose to use more conservative assumptions in regards to the shear strength and friction due to the lack of test data from these materials.

Comment 4. The mass permeability along the tunnel axis of the combined terrace gravels and glacial moraine might be roughly measured during one period of pumping from LDT 10+25 by monitoring the water levels in LDT 25+15 and LDT 06+35 and by monitoring the volume of water withdrawn from LDT 10+25. Figure 4 (Water Levels in the Downstream Tunnel) in the PFMEA report appear to show a relationship between the temporary lowering of the water table in LDT 10+25 with a smaller lowering in the closest monitoring well LDT 06+34.

Reclamation considered creating a very rough estimate of permeability by analyzing pumping rates at Station 10+25 and surrounding wells but elected not to present that data due to significant concerns regarding the accuracy of such analysis. The pumped well at Station 10+25 and monitoring wells at 6+35 and 25+15 are directly in the tunnel. Reclamation feels that analysis of the pumping and drawdown would most likely be primarily influenced by the flow

regime of the tunnel and fractured bedrock system rather than the terrace gravels and glacial deposits.

Comment 5. Much of the information regarding flow paths within the collapsed tunnel is conjectural, such as whether surviving vent lines or compressed air lines are still capable of carrying significant water flow after almost 60 years of deterioration. The actual flow path could be a mixture of surviving pipe lines, sub-track drainage-ditch segments, and piping through voids in surrounding rock formations or moraine.

Reclamation agrees with the CRB that flow path(s) are not completely understood. Reference to open vent lines was taken out of the risk assessment document. However, this does not change the overall evaluation.

Comment 6. There is logical inconsistency in one aspect of the characterization of the material behavior. Page 9-10 of the PFMEA report and page 9 of the Results report state that the material forming the upper blockage likely was deposited in standing water in the tunnel and therefore is in a loose condition. Pages 13 and 15 of the Results then state that, if and when this material begins to shear, the relative movement of angular particles will cause dilation of the mass. This is not true if the material was, in fact, deposited in a loose condition. Loose materials contract when sheared; only dense materials dilate when sheared. Is there direct evidence that the upper plug materials are in a loose state? If not, then perhaps this statement should be deleted.

Reclamation agrees with the CRB. The statement describing the upper plug materials as in a loose state was deleted from the final draft report.

Comment 7. The Results report states (page 44) that even with a factor of safety less than 1.0 in seismic conditions, very little deformation is likely to occur. This assertion is difficult to defend without further analysis. If the claim is going to be made that even if $FS < 1$, it will not fail, then why run the analysis? What result would have been cause for concern? The best way to rectify this is to run a simplified displacement analysis to estimate actual slope displacements during the specified earthquake shaking, and then to evaluate the significance of these displacements. Running such an analysis would require no additional information and could be done rather quickly using published empirical models (Jibson, 2007). Fully documenting likely coseismic displacements, and then evaluating the significance of those displacements, will greatly strengthen the conclusions regarding the effects of earthquakes on the stability of the slopes.

Reclamation agrees with the CRB. An analysis of expected displacements was completed and the results are presented in the report. The calculated movements were small (less than an inch), indicating the slopes are likely to remain stable during and following a major earthquake in the area.

Question 4. Are the risk assessment's conclusions and recommendations comprehensive, reasonable, and supported by the studies?

The conclusions and recommendations of the risk analysis are reasonable and, in general, well supported. However, the following significant issues should be addressed:

Comment 1. The PFMEA report states that “*collapses in the mine workings...likely limit the amount of water actually stored in the Mine Pool, and which would be available to raise downstream water levels...*” (p. 11). Analysis of data from USBM Circular 7125 suggests a possible water volume of 937.2 billion gallons above the LMDT invert at the Robert Emmet shaft when the Mine Pool was at 120 feet above the invert. The current Mine Pool elevation of 167 feet above the invert suggests an even larger water volume. However, if the lower collapse bulkhead is stable, as the risk analyses show, then the volume of water in the Mine Pool should not be the overriding concern.

Reclamation removed the statement from the risk assessment report. However, Reclamation feels that the issue is not central to the risk analysis and that the exact size of the mine pool does not affect the results of the evaluation.

That said, Reclamation feels the statement regarding the mine pool is correct. Reclamation believes collapses within the mines would fill spaces in the mine openings which formerly contained water. The collapses would also have completely blocked some of the flow pathways to the LMDT and partially blocked others. For example, a minor fall creating a pile three feet high would result in a three-foot deep pool of water which would not drain out if this part of the mine pool were lowered. Therefore, it is very unlikely that the entire 937+ billion gallons could suddenly drain out if the LMDT blockages were removed. There would likely be many places in the mine workings where water would be retained due to collapse and partial collapse. Reclamation agrees there is likely still a large volume of mine pool water which could drain out and that flow connection from the LMDT to the Robert Emmet Shaft area is still likely intact.

Comment 2. The following statement in PFMEA report (p. 11) is only correct in the absolute sense that it cannot be wrong as worded: “It is unlikely that all the mine workings are interconnected enough (especially with the possibility of additional collapses) such that the entire Mine Pool would drain quickly as the result of breaching a blockage near the Pendery Fault.” The breaching of a blockage near the Pendery Fault would develop slowly because of the flow resistance from downstream collapse blockages, the bulkhead at Station 4+61 and 4+66, and the backfill injected to fill voids in the multiple collapses of terrace gravels and glacial moraine into the tunnel that produced sinkholes for more than 500 feet upstream from the portal. This positive statement appears to be unduly confident, particularly in view of the extremely close connection between water-

table elevations along the LMDT between Station 46+66 and the Robert Emmet Shaft. Historically, rapid drainages of as much as 3765 gpm occurred when fissures were encountered during tunneling operations (USBM LMDT Second Project Report, 1956). These sudden high water flows were accompanied by a steady drop in the Mine Pool level under adjacent areas, which is evidence of extensive flow connections between much, if not all, of the Mine Pool. These high flows that occurred when the LMDT approached adjacent mine workings in the upstream part of the tunnel suggest that the mine pool could drain rapidly. Again, however, the main issue is the stability of the lower collapse bulkhead, which the analyses show to be quite stable. Also, a hypothetical failure of the upper collapse bulkhead (below the Pendery fault) would most likely occur very slowly, which would retard a rapid draining of the Mine Pool.

Reclamation agrees with the CRB that water levels indicate a connection between the mine workings and the LMDT, and that section of the PFMEA report was modified. The text has been changed to the following: "There is no reason to believe the LMDT is completely open in other areas." Additional collapsed areas and blockages of the tunnel would limit flows to the downstream tunnel reaches from the Mine Pool even if a blockage near the Pendery Fault were to breach. For example, based on the water level data in Figure 4, there may be resistance to flow between Stations 10+25 and 6+34 (both intercept the tunnel but appear to record different elevations, although the well at 10+25 is pumped). In addition, in 1979 a well at Station 6+65 was drilled to 98 feet into the tunnel where water 6 feet deep was seen to be flowing. While waiting for well screen, a sinkhole appeared adjacent to the drill rig and the hole was lost.

Comment 3. The justification for ruling out slope failure during an earthquake needs to be strengthened. If the upper blockage fails and higher pore pressures are transmitted downslope, the higher resulting groundwater conditions could persist for some time. If earthquake shaking is considered a highly unlikely event, then don't analyze it. It appears inconsistent to do a detailed analysis of seismic slope stability and then to dismiss it because it is so unlikely.

Reclamation agrees with the CRB that analysis of a failure mode that has been deemed "ruled out" is generally considered unnecessary and can be confusing for the report's audience. As in other aspects of the analysis, Reclamation preferred to err on the side of conservatism. Reclamation felt maintaining thoroughness of the overall analysis was worth the risk of confusion. Additionally, Reclamation felt it important to be transparent in its analysis and show all of its work. In the extremely unlikely event that a large remote earthquake were to occur immediately after a catastrophic failure of the tunnel blockage, the analysis shows that risk of hillside failure would be minimal. The minimum factor of safety of 0.87 was obtained by combining the extreme conditions of maximum seismic loading with minimum soil properties and elevated groundwater in the downstream hillside. Although a result with a

Factor of Safety of less than 1.0 was calculated for this case, it does not automatically follow that the hillside will fail even if these conditions occur. The amount of ground deformation that would occur was estimated and presented in the report. The analysis indicates maximum displacements would be on the order of 0.7 inches. It is generally accepted that it takes predicted displacements at least on the order of 6 to 12 inches before stability is considered to be threatened.

Comment 4. Conservative to very conservative assumptions were made at every step of the geotechnical and risk analyses. The cumulative conservatism of the overall analysis supports the conclusion that rapid, catastrophic failure of the collapse bulkheads and resulting rapid drainage of the Mine Pool through the portal are extremely unlikely events.

Reclamation agrees with this observation. No additional response required.

Mark R. Cole Comments

Comment 1. The Assessment should be reorganized. You have the three reports in the wrong order. You have data, conclusions, data. I suggest that you place the second chapter "Potential Failure Modes and Effects Analysis Leadville Mine drainage Tunnel" at the end of the report so the organization is data, data, conclusions. It would then appear to be a more professionally done document.

Reclamation agrees with the suggested format. Potential Failure Modes and Effects Analysis has been relocated as suggested.

Comment 2. In the "Potential Failure Modes and Effects Analysis Leadville Mine Drainage Tunnel" I do not know what the Risk categorization means. What does low, moderate and high mean? What is the time frame? A low category may become high if expressed over a long enough time frame. These need to be expressed in some mathematical fashion (probabilities) so the reader has some sense of the risk probabilities involved. Until you express these mathematically they have no meaning.

Assessment of Risk in the PFMEA looked at both likelihood and consequences in a qualitative sense. The consequence descriptors and likelihood descriptors are defined on pp. 7 and 8 of the report. Reclamation believes that the qualitative assessment provided a reasonable estimate of risks associated with the project and that a quantitative risk assessment resulting in numerical values was not practicable at this site.

Comment 3. The consequences should be more detailed. The focus in the Assessment is on the Village at East Fork with little regard to the impacts on the riparian habitat -- erosion, fish, insects, wildlife, drinking water quality down stream. Even though it is a low probability event, if a blowout should occur the impacts are substantially understated in your report because there is approximately a billion gallons of high metal, low pH waters in the mine pool.

This risk assessment focused only on potential impacts to downstream populations and property. Assessment of potential environmental impacts is beyond the scope of this study.

Comment 4. If the height of the mine pool is limited by the bed rock/terrace gravel interface then the flow into the mine pool vs. the flow through the gravels could limit the mine pool height. However, you did not present data to indicate that this is happening. The size of the pipe is very important in this assertion, the volume of flow into the mine pool and the volume of out flow through the gravels will then control the mine pool height. You present no data to show the inflow vs. outflow. As I read the Assessment this assertion is not support by data.

Reclamation does not know precisely what the maximum water table level would be. However, Reclamation believes the control on this elevation may be the geologic contact between pervious zones in the bedrock and the overlying gravels. The rate of rise of the mine pool would be limited by the gravel's large water carrying capacity and by the fact that some shafts will experience artesian flow. Source Water Consulting has noted that seeps and flow from shafts begin in California Gulch when the water level in the LMDT mine pool reaches an elevation of 10,147. The Bureau of Mines previously suggested that a water elevation of 10,160 may be the maximum based upon this level being measured in the Pyrenees shaft prior to the excavation of the LMDT. It is believed that present water levels are near the maximum likely to occur as the hydrologic system is able to overflow out of the top of the mine pool. Placing an exact value on this elevation is not essential given the finding that the lower plug and bulkheads can resist considerably higher water levels, and the historic evidence that the upper limit is somewhere near elevation 10,160.

Comment 5. On page 13 in the "Potential Failure Modes and Effects Analysis Leadville Mine drainage Tunnel" You suggest restoring drainage from the Canterbury Tunnel. There is an assertion that the tunnel flowed "1300 gal/min throughout the year, and the mine operators in the district recognized a marked reduction in recharge rate". What is the source of this data? I had not heard this before.

The source for the flow volume from the Canterbury Tunnel is the "Report on the Leadville District and Adjoining Territory" by Edward P. Chapman and Frank M. Stephens dated 1929. The authors spent 1½ years examining 359 properties, including a detailed examination of the Canterbury Tunnel. Pages

181 through 187 is a detailed discussion of the Canterbury Tunnel including the geology and observed flow of 1300 gpm during the dry part of the year.

Comment 6. The earthquake data is fine as far as it goes. Since earthquakes usually accompany fault movement, what would be the results of movement on the Pendery or associated faults. We are living the Rio Grande Rift Valley where post Pleistocene fault movement is recorded by moraine offset south of Leadville.

Movement along the Pendery Fault would likely cause additional collapse and could reduce the hydraulic connectivity along the LMDT. This would tend to help contain the mine pool.

Comment 7. In the "Results of Geotechnical and Structural Analysis Leadville Mine Drainage Tunnel" you assert that the Pendery Fault is a flow barrier; however, in other sections it is stated that the Pendery Fault will transport water. What "Geologic Data" (p.8) indicates fluid flow along the fault in the vicinity of the tunnel? The drilling records for the tunnel indicate that there was "some" water flow when the fault was crossed. Else where the drillers experienced very large water flows. The Pendery water flow should be consistent between sections of the report.

Construction records state that a significant amount of clayey gouge was encountered at the Pendery fault. This gouge would tend to restrict flow across the fault. The associated fractured zones adjacent to the fault provide a conduit to transmit water. In summary, water flow across (perpendicular to) the fault would be restricted and flow along (parallel to) the fault would be expected.

Lake County Board of County Commissioners Comments

Comment 1. The risk assessment appears to be limited to examining potential failure modes of the LMDT and the potential impact to loss of life and property damage. The BOCC is very concerned about the potential impacts that the impounded mine pool may have elsewhere in the mining district such as seeps and springs into California Gulch and the Arkansas River with associated environmental pollution and degradation of water quality. Little if any attention was paid in the draft risk assessment to the potential environmental consequences of the elevated mine pool. Shouldn't the BOR include an analysis of potential environmental damage resulting from the elevated mine pool for the entire mining district area and surrounding ecosystem, rather than the existing narrow focus on public safety and property damage from a possible catastrophic release/tunnel blowout?

This risk assessment focused only on potential impacts to downstream populations and property. Assessment of potential environmental impacts is beyond the scope and intent of this study.

Comment 2. Page 46, "Results of Geotechnical and Structural Analysis" and subsequent discussion in "Potential Failure Modes" discusses the idea that the likelihood of the blockage remaining stable decreases with increased head differential. It is suggested that though failure may occur it will not likely result in a blowout. It is further suggested that such a failure, though not a catastrophic blowout, may result in property damage but not loss of life. What about environmental damage to the Arkansas River ecosystem and potential effect on drinking water supplies should such a failure occur? Again, the risk assessment is too narrowly focused to the exclusion of environmental concerns.

This risk assessment focused only on potential impacts to downstream populations and property. Assessment of potential environmental impacts is beyond the scope of this study.

Comment 3. It appears the risk assessment conclusions are based upon the current blockage scenario. Additional collapses would surely be expected in the future, which could further affect the risk scenario. Shouldn't the analysis anticipate future collapses and their potential effect on the mine pool? What does BOR intend to do if further collapses occur? Does the BOR intend to perform maintenance of the tunnel to prevent or minimize such future collapses?

Reclamation agrees that additional collapses are likely to occur in the future. However, Reclamation believes that this would reduce the risks of a sudden release of water from the tunnel, which was the focus of this assessment.

Comment 4. The Sherman Tunnel in the Leadville mining district apparently experienced a blowout just this past week. This is an example that such events do actually occur in the mining district. Perhaps the risk assessment team should be informed of this event and may wish to examine it to see if any lessons might be derived from that occurrence.

Engineered bulkheads and placed fill material were not present in the Sherman Tunnel; therefore, Reclamation believes that conditions of the tunnel are not similar enough to draw meaningful comparisons.

Comment 5. The risk assessment does not define the safe level of the impounded mine pool behind the blockage. It would seem this is an important component of the risk analysis especially for decision-making concerning future action. The Independent Review Board made a similar recommendation to which the BOCC concurs.

Reclamation believes that unacceptable risk of a sudden release of mine pool water is not present in any mine pool elevation that could reasonably occur. Reclamation does not know precisely what the maximum water table level would be. However, Reclamation believes the control on this elevation may be the geologic contact between pervious zones in the bedrock and the overlying gravels. The rate of rise of the mine pool would be limited by the gravel's large water carrying capacity and by the fact that some shafts will experience artesian flow. SourceWater Consulting has noted that seeps and flow from shafts begin in California Gulch when the water level in the LMDT mine pool reaches an elevation of 10,147. The Bureau of Mines previously suggested that a water elevation of 10,160 may be the maximum based upon this level being measured in the Pyrenees shaft prior to the excavation of the LMDT. It is believed that present water levels are near the maximum likely to occur as the hydrologic system is able to overflow out of the top of the mine pool. Placing an exact value on this elevation is not essential, given the finding that the lower plug and bulkheads can resist considerably higher water levels, and the historic evidence that the upper limit is somewhere near elevation 10,160.

Comment 6. Since direct observation of the collapse(s) is not possible, the BOCC is still uncertain how stability can be so easily assumed?

Although no direct observation of the Pendery blockage is possible, Reclamation believes the assumptions presented in the analysis are reasonable based on considerable engineering expertise. Additionally, some of the potential failure modes assumed that the upper blockage did indeed fail and even with this conservative assumption analysis showed that the engineered bulkheads would resist the forces and not fail. It is important to emphasize that the lower blockage associated with the engineered bulkheads was observed in the tunnel and by drilling five holes along the collapse fill and injecting gravel to create a stable fill mass.

Comment 7. A continuing theme in the report is that BOR never intended to maintain the tunnel upon acquisition from USBM. This really has no bearing on the actual assessment of risk and is concerning because it seems to indicate a continuing pervasive attitude in the BOR that the tunnel is not fully BOR's responsibility. The history section of the report describes the upstream portion, but then completely ignores it in the analyses and review.

This risk assessment focused only on potential impacts to downstream populations and property. Assessment of issues beyond these potential impacts is beyond the scope of this study.

Comment 8. It appears that BOR considers the contamination problem, which is probably in progress right now, a level 1, no economic impact other than local water use impacts. Actually this impact is greater. Contaminated water reports to the Arkansas River over time. From there it affects area fisheries, tourism and others' judgments of our area from stigmatization due to contamination. The damage to the local economy from contamination could be significant.

This risk assessment focused only on potential physical impacts to downstream populations and property. Assessment of potential environmental impacts from the mine pool is beyond the scope of this study.

Comment 9. Review of upstream water level data indicates there are major blockages above 75+00. BOR will need to include an analysis of these blockages for planning future action, including the permanent fix. Perhaps this was not mentioned in the report because BOR did not deem it relevant to the scope of this risk assessment. Does the BOR intend to perform further analysis of these blockages in regards to the effect on mine pool drainage?

Although Reclamation is not aware of a major blockage near Station 75+00, Reclamation believes that this would have no impact on the conclusions of the risk analysis and does not intend on performing additional analysis in these areas.

Comment 10. It appears measured data was not used for soil properties. All were assumed, and optimistically assumed. For example, the report states that the 25 foot high unsupported vertical slopes in the till near the highway indicate a very strong material. Not necessarily. It does not require high strength to form an unsupported vertical trench face. It definitely indicates a high fines content (silt and clay) and depending on size distribution a higher fines content can create a much weaker material, right at the low end of the assumed strengths or even lower. For the long term, will BOR actually obtain real numbers and adjust the report accordingly, rather than use optimistic assumptions?

Reclamation used a wide range of soil strengths in their slope stability analysis. Assumed soil friction angles were varied from 32 to 45 degrees, which Reclamation believes accurately brackets reasonable soil strengths for the types of soils present. As additional supporting evidence, EPA constructed a temporary reservoir for a pump test using these soils. The very steep slopes of the EPA embankment did not fail when saturated. This behavior is consistent with a mixed soil (containing both granular and cohesive material) and suggests that the actual strength is well above the 32 degree value used in the analysis.

Comment 11. The flow calculation of 7500 gpm in bullet 2, page 17 should be 450,000 gpm. This is a minor unit conversion error. The 1000 cfs is correct.

Reclamation agrees with the BOCC and has corrected the mistake in conversion.

Comment 12. The tunnel analyses indicate the concreted portions near the portal, which hold back the main bulkhead, should already be in failure, and that no additional groundwater pressures can be supported by the tunnel. What are the factors of safety? What will BOR do about it? Will it reinforce the lining? Will BOR open up the Canterbury to relieve the local groundwater pressures? Or does BOR just plan to rely on their assertions that groundwater levels are under control and probably will remain so? Lining instability threatens several of the assumptions for various scenarios.

There is no evidence elevated water pressure is acting against the tunnel liner. At the bulkhead at station 4+61, the hydraulic head is directly observable and is approximately 2.5 feet above the tunnel invert. At the portal, groundwater monitoring wells indicate that there is no head against the liner. Elevated water levels seen in the observation well at station 3+00 does not reflect the head acting against the tunnel liner. The well is offset 20 feet from the alignment and there are weep holes along the tunnel; therefore, the head against the liner is low. We continue to monitor the facility; there is no basis for change.

Comment 13. The assumptions in the report regarding earthquake analyses are not backed up by data or discussion. Again these assumptions affect several areas of the report. Figures developed for the Sugarloaf Dam are used. What were the threat sources for that dam? If it is the Mosquito fault, then this site is a lot closer to the source than the dam is, with resulting seismic potential higher, though the return period would still be low.

The maximum loading is not from the Mosquito fault. The values for Sugarloaf Dam are slightly higher than what would be used at the tunnel location if site-specific seismic loading curves were generated for the LMDT location; therefore, the analysis is appropriate.

Comment 14. The statements about clay and iron hydroxides helping to cement and stabilize the soils are grossly optimistic. It has been observed in old mines that iron hydroxides are simply very weak mush, with a very thin layer of slightly stiffer crust where exposed to air. Clays deposited in a saturated water environment require physical pressure to consolidate, which would not be present to any significant degree in the tunnel environment. If anything, they will form weak layers that inhibit good frictional strength development.

The report statement about “clay-sized particles” forming due to chemical precipitation is misunderstood in this comment. Reclamation is referring to the slow but constant buildup of mineral precipitates formed when lower pH water mixes with higher pH water. These mineral precipitates act to fill voids in the collapsed material, increasing its density and do have a mild cementing effect

over the course of years as the precipitates crystallize. The blockage area below the Pendery Fault is in a chemical mixing zone. Reclamation has observed this cementation effect in other old mines where pH and neutral pH waters mix. This is different than the weak precipitates which form when acid water is exposed to air; however, even those will tend to crystallize and solidify given enough time.

Comment 15. As touched on earlier, the report does not attempt to predict what may physically be the ultimate maximum height of the mine pool or the Canterbury Hill water table for a worst-case analysis. Nor does the current analysis determine how deep a mine pool or water table can safely be handled. Such an analysis could provide guidance for future decisions on what additional actions may need to be taken. Will BOR perform such an analysis?

Reclamation does not know precisely what the maximum water table level would be. However, Reclamation believes the control on this elevation may be the geologic contact between pervious zones in the bedrock and the overlying gravels. The rate of rise of the mine pool would be limited by the gravel's large water carrying capacity and by the fact that some shafts will experience artesian flow. Source Water Consulting has noted that seeps and flow from shafts begin in California Gulch when the water level in the LMDT mine pool reaches an elevation of 10,147. The Bureau of Mines previously suggested that a water elevation of 10,160 may be the maximum based upon this level being measured in the Pyrenees shaft prior to the excavation of the LMDT. It is believed that present water levels are near the maximum likely to occur as the hydrologic system is able to overflow out of the top of the mine pool. Placing an exact value on this elevation is not essential given the finding that the lower plug and bulkheads can resist considerably higher water levels, and the historic evidence that the upper limit is somewhere near elevation 10,160. It should be noted that Reclamation is closely monitoring the differential head at the upper blockage as a part of the LMDT plant operations. If conditions change, evaluation will be made and actions taken such as reducing the pumping rate Station 10+25 and increasing pumping rate from the new well at Station 46+96 to reduce the differential head.

Comment 16. There should be a time line for the emergency action plan to be implemented, including table tops. It has been discussed that table tops be conducted twice a year due to the Village at East Fork mobile home park being so transient. Further, the information distributed by the BOR might possibly also be handled through the school system so the children who are English speaking can interpret the information for their parents.

Reclamation agrees with the BOCC; a timeline for the completing and implementing the emergency action plan is being developed and will be shared with all stakeholders.

Comment 17. Chemicals being stored at the plant need to be addressed in the emergency action plan and the evacuation plan.

Reclamation agrees with the BOCC; storage of hazardous materials is addressed in the Emergency Action Plan.

Comment 18. It may be advisable to have an employee of the plant become a member of the Lake County emergency services council.

Reclamation is looking into the possibility of a staff member becoming a member of the council.

Comment 19. Summary comment: The BOR seems quite intent on not looking at the mine pool problem as a whole in the risk assessment, but rather parceling out one issue of the overall problem involving the LMDT. The dangers of contamination and other issues are given short shrift. The utility of the risk assessment is questionable since it is only looking at one piece of the puzzle. Many assumptions are made without actual data. The agencies, particularly BOR, appear to continue to be very much defending turf rather than demonstrating a willingness to fix the totality of the problem. Does BOR intend to continue to gather better data and to further supplement this report when such data is obtained? Although perhaps given the narrow focus of the report, such additional monies would be better spent on actual physical improvements.

Reclamation does not intend to collect additional data prior to finalizing the Risk Assessment Report. The Final Risk Assessment will be issued with this comment response document attached in September 2008. If Reclamation conducts any additional studies, they will be carried out under subsequent agreements.

U.S. Army – Corps of Engineers

EPA Region 8 asked the USACE to review Reclamation's Final Draft Leadville Mine Drainage Tunnel Risk Assessment report dated June 30, 2008. EPA also had provided the USACE with other EPA documents/reports for background information.

The USACE provided EPA Region 8 with a Review Memorandum dated August 25, 2008. This Review Memorandum included a two-page summary review memorandum by B.J. Bailey, P.G., and three attached individual review memorandums by: Steven Jirousek, R. G.; Joseph A. Kissane, P.G.; and B.J. Bailey, P.G. The review comments provided in these four review memorandums are each restated below and Reclamation's response (in bold italics) to each of the review comments is given below the review comment where judged necessary

and appropriate. It appears that EPA Region 8 asked the USACE to respond to four specific questions, which are included in the summary review memorandum.

Summary Review Memorandum by B.J. Bailey, P.G.

Summary of Conclusions: Based on our review of Risk Assessment, we believe that the remedy selected by the Record of Decision (ROD) appears to be the most acceptable approach to understanding and managing potential risks posed by the Leadville Mine Drainage Tunnel (LMDT). Although all reviewers came to the conclusion that a catastrophic failure of the collapsed portion of the tunnel resulting in the rapid release of mine pool water and collapse debris out of the LMDT is unlikely, it is most probable that the LMDT will continue to deteriorate resulting in less than catastrophic releases.

Reclamation agrees that catastrophic failure of the collapsed portion of the tunnel resulting in the rapid release of Mine Pool water and collapse debris out of the LMDT is unlikely (extremely low). Reclamation also agrees that additional collapses are likely to occur in the future but believes that this could reduce the risks of a sudden release of water from the tunnel, which was the focus of the risk assessment.

Question 1: Determine if implementing the 2003 ROD remedy – engineered plugs and backfilling the tunnel – is still appropriate.

The reviewers believe that the solution of engineered plugs and backfilling the tunnel is still appropriate. The remedy would provide a known engineered structure from which to form the basis of any future risk assessments or evaluations.

Judgment regarding the appropriateness of the selected remedy in EPA's 2003 ROD for Operable Unit 6 (OU6) was not part of Reclamation's Risk Assessment study. Reclamation previously had received a copy of EPA's 2002 Draft OU6 Focused Feasibility Study and had provided EPA with review comments in June 2002. EPA released the OU6 ROD in September 2003 and notified Reclamation of the OU6 remedy selection in a February 2004 letter from EPA. Since then, Reclamation has interacted with EPA a number of times concerning their selected OU6 remedy and the potential effects on Reclamation's Leadville Water Treatment Plant; these interactions included transmittal of Reclamation's February 2006 "Assessment of Remedial Design Concept"(which comments in detail on the engineered tunnel plug and backfilling the lower portions of the LMDT) to EPA.

Question 2: Identify any fatal flaws or poor assumptions in the USBR study.

All reviewers agree that no fatal flaws were noted in the USBR study.

All of the data used in the analyses were based on assumptions. Most appear to be conservative but all of the reviewers agree that the assumptions made concerning the location, length, degree of filling, and the geotechnical properties of the material within the collapsed section of the tunnel on which the Risk Assessment is based, are questionable and not necessarily conservative. Numerous inconsistencies concerning the dynamics of the groundwater within the LMDT and the surrounding area were also identified and present a major concern.

The Risk Assessment report documents the data used in Reclamation's study and the basis for the assumptions made. The independent CRB commented that "The lack of measured engineering properties (unit weight, shear strength, etc.) of the materials being analyzed in both the tunnel blockages and the slopes at the portal renders the analyses based on these properties somewhat tentative." and "Conservative to very conservative assumptions were made at every step of the geotechnical and risk analyses." Reclamation recognizes the lack of measured engineering properties for the soil and rock materials associated with the LMDT and the uncertainty associated with the analysis results. The CRB's second comment seems to disagree with the "questionable and not necessarily conservative" comment made by the USACE. Reclamation agrees with the CRB's conclusion regarding the risk assessment results being conservative. Reclamation agrees that there are numerous inconsistencies associated with the groundwater system beneath OU6 and that it is not completely understood at this time. However, Reclamation believes that this groundwater system, especially the connection between the Mine Pool in the mine workings and the LMDT, is understood to a sufficient degree to support the Risk Assessment's conclusions.

Question 3: Determine if there is another, better, model out there to evaluate the risk at the site.

The reviewers agree that the models used in the Risk Assessment are representative of models currently in use in the mining industry. There was insufficient time to perform market research to evaluate more recent models that may be capable of a more dynamic analysis.

Reclamation agrees that the risk analysis methodology used for this study was appropriate.

Question 4: Evaluate the USBR's conservative assumptions – are they conservative enough?

Although the degree of conservatism varies, the reviewers determined that, with the exception of the collapsed plug, the assumptions were generally conservative. Because there is no actual data collected from the site, the evaluation of the degree of conservatism could change based on future findings.

Reclamation agrees that the assumptions made for this risk assessment study were (generally) conservative. Reclamation also believes that the assumed length of the collapsed tunnel plug just below the Pendery Fault (a minimum of 20 to 50 feet) was relatively conservative as the actual length of the plug could range from 80 to over 200 feet based on tunnel maintenance observations.

**Review Comments from Steven Jirousek, R.G.
(Attachment 1)**

Question 1. Determining if implementing the 2003 ROD remedy - Engineered Plugs and backfilling the tunnel - is still appropriate.

It is my opinion that the risks and consequences presented in the USBR documents do not alter the validity of Final Record of Decision, OU6 California Gulch Superfund Site, Leadville, Colorado (ROD) Alternative 2g. Implementation of a feasible engineered plug design in the LMDT would reduce, although not eliminate the risk of adverse consequences due to changes in the LMDT or mine pool over time. Specific facets of that alternative need to be addressed to ensure the concept is constructible and functions as intended.

Judgment as to the appropriateness of the selected remedy in EPA's 2003 ROD for OU6 was not part of Reclamation's Risk Assessment study. Reclamation has provided EPA with information about concerns and comments on its 2002 Focused Feasibility Study and the 2003 ROD's selected remedy for OU6 at various times since June 2002.

The following comments are regarding the ROD selected alternative 2g.

Comment 1. The USBR Risk Assessment did not directly address compliance with the EPA ROD and focused instead on the immediate concerns expressed by EPA and the local community (USBR's Existing Conditions report refers to a letter from EPA to USBR dated Nov 8, 2007) regarding risks of an uncontrolled potentially catastrophic release of water from LMDT that could endanger human life and the environment. This was USBR's stated purpose for the risk assessment. Based on the request for review the Corps received from EPA, it seems the EPA may have intended a broader view of the assessment of risk from the LMDT than the USBR approach.

Reclamation agrees that the Risk Assessment study focused on concerns regarding the potential for an uncontrolled catastrophic release of water from the LMDT that could endanger the public (life and property loss); these concerns were expressed collectively by EPA in its letter dated November 8, 2007, by the State of Colorado, and by the local community. EPA's 2003 ROD and its selected remedy for OU6 were not addressed by Reclamation's Risk Assessment study.

Comment 2. 2003 Record of Decision referred to discharge of contaminated surface water to the Marion Shaft and ultimately to the LMDT via the Robert Emmet Shaft. The addition of contaminated surface discharge to the mine pool, as a means to convey those waters to the USBR waste water treatment plant at the downstream end of the LMDT, may not be effective due to the known and suspected LMDT blockages. The mine pool may provide temporary storage capacity for diversion of contaminated surface water via the Marion Shaft, but the practice exacerbates the problem of rising mine pool water elevations and may prove to be counterproductive if the mine pool rises high enough that contaminated water moves from the bedrock into the overlying soils and is discharged to the surface untreated.

Reclamation agrees that the discharge of contaminated OU6 surface water to the Marian Shaft and ultimately to the LMDT Mine Pool via the Robert Emmet Shaft exacerbates the existing problem and is probably counterproductive.

Comment 3. Final Record of Decision, OU6 California Gulch Superfund Site, Leadville, Colorado Alternative 2g (selected) calls for construction of a concrete bulkhead in sound bedrock upstream of the Pendery Fault to permanently isolate the mine pool from the LMDT and to then reduce the mine pool elevation by pumping from wells. The ROD does not address in any detail how such a bulkhead is to be constructed. There are significant challenges associated with design and construction of a bulkhead under the conditions present at the site. The feasibility of constructing a bulkhead at the proposed location must be thoroughly considered before advancing to design phases.

Reclamation agrees that there are significant challenges associated with the design and construction of an engineered bulkhead (plug) in the LMDT. Reclamation provided EPA with an assessment of its Remedial Design Concept for the engineered plug and backfilling of the lower portions of the LMDT in a February 2006 document.

Comment 4. Final Record of Decision, OU6 California Gulch Superfund Site, Leadville, Colorado Alternative 2g (selected) calls for lowering the mine pool elevation by pumping from wells after construction of the concrete bulkhead. The contaminated pump discharge would then be conveyed to the USBR waste water treatment plant at the lower end of the LMDT by a buried pipeline. It seems as

though the USBR has mandated limits on the quantity and source of water it can treat. The ROD does not appear to recognize this constraint. Furthermore, the USBR waste water treatment plant has a limited capacity and may not be capable of processing the quantity of contaminated water from the mine pool at the rate necessary during efforts to drawdown the mine pool water elevation. The ROD does suggest modifications could be conducted on the USBR waste water treatment plant to accommodate the significant processing rate needed during mine pool drawdown but the issue of USBR's ability to treat mine pool water remains to be addressed.

Reclamation agrees. One mine pool well and buried pipeline to Reclamation's Leadville Water Treatment Plant have been constructed by EPA with input and assistance from Reclamation.

Comment 5. *Draft Water Hydrology in the Vicinity of the Leadville Mine Drainage Tunnel Operable Unit 6 and Affected Areas* maps of bedrock groundwater elevations for 1992 and 1996 do not show groundwater elevations in the vicinity of the Robert Emmet Shaft (RES) or the upper LMDT that can be compared to the conceptual pre-mining groundwater elevations or those for 1944, 1946, and 1951. It is not possible from the data provided to assess potential changes in the bedrock ground water elevations and their affect on the LMDT in the mine pool area after a suspected blockage occurred in the LMDT near Pendery Fault. I suspect the EPA has this information but was not apparent in the documents reviewed.

This risk assessment focused only on potential impacts to downstream populations and property. Assessment of issues beyond these potential impacts is beyond the scope of this study.

Comment. 6. It is not clear how recent mine pool groundwater elevation increases relate to current measured discharge rates at seeps and springs, and at the timber-lattice bulkhead in the LMDT.

It is not clear from these documents that there has been a commensurate increase in the rate of discharge from any of these points or an increase in the number of discharge locations.

This risk assessment focused only on potential impacts to downstream populations and property. Assessment of issues beyond these potential impacts is beyond the scope of this study.

Question 2. Identifying any fatal flaws or poor assumptions in the USBR Study

No fatal flaws or poor assumptions were identified that would alter the conclusions presented in the USBR risk assessment.

Reclamation agrees.

Question 3. Determining if there is another, better, model out there to evaluate the risk at the site

The process of determining the state of existing conditions in the LMDT, the Potential Failure Modes and Effects Analysis, and the Geotechnical and Structural Analysis of the plausible failure modes seems to be a comprehensive means of identifying and evaluating risks and consequences. The PFMEA process focuses on existing conditions and as implemented has limited application to conditions over long time periods.

Reclamation agrees that its risk assessment process focused on the existing LMDT situation and was appropriate for this study. Reclamation does not believe that the level (pressure head) of the mine pool will rise significantly above the level at the time of the Risk Assessment study, and that the degree of conservatism used in the study should minimize the potential for a dramatically different situation and risk assessment result.

Comment 1. Potential Failure Modes and Effects Analysis is a formal process of assessing risk and their consequences whereby a multi-disciplinary team reviews design, construction, and operations/maintenance documents, etc., and then brainstorms possible failure scenarios and their consequences. Each possible scenario is evaluated and its credibility determined. It is a process the USBR has been using on their facilities for sometime and the Corps of Engineers is beginning to adopt for assessing risk on its dams.

Reclamation agrees.

Comment 2. The Potential Failure Modes and Effects Analysis followed accepted procedure and identified what seem to be the most likely failure modes and addressed the primary safety concerns regarding the LMDT structural failures that were raised in the ROD.

Reclamation agrees that the PFMEA analysis followed accepted procedure and identified the most likely failure modes.

Comment 3. The potential failure modes that were identified and the risk matrix with consequences and likelihood descriptions for each potential failure mode were reasonable.

Reclamation agrees.

Question 4. Evaluating the USBR's conservative assumptions - are they conservative enough?

It is my opinion that the level of conservatism applied by USBR in each aspect of their risk assessment of the LMDT has been appropriate overall.

Reclamation agrees.

Comment 1. The geotechnical and structural analysis of the LMDT as part of the risk assessment was satisfactory. The assumptions made were reasonable based on available information. An appropriate level of conservatism was applied based on the level of uncertainty for each failure mode analysis.

Reclamation agrees.

Comment 2. The analysis of stability of the blockage in the vicinity of the Pendery Fault was reasonable. It seems as though there may be more collapses along the LMDT than just this one and the one near the timber-lattice bulkhead. That condition would make the likelihood of the blockages failing even less and diminish the consequences if any did fail.

Reclamation agrees.

Comment 3. The analysis of the flow blockage above the timber-lattice bulkhead was also reasonable. The amount of water that may be by-passing the lower blockage by flowing out of the LMDT and into the soil could have been more thoroughly described.

Reclamation agrees. Reclamation is not able to directly measure the seepage potentially bypassing the lower blockage in the LMDT. Reclamation believes the terrace gravel deposit probably collects and conveys most of the seepage that may be bypassing the lower blockage in the LMDT. As noted in the PFMEA report on page 21 (under Favorable Factors), a pump test was performed on the well at Station 6+35 and it indicated a terrace gravel permeability of 50 feet/day, which is relatively high. While a two- or three-dimensional seepage analysis to estimate the amount of water that may be bypassing the lower blockage by flowing through the terrace gravel has not been conducted, Reclamation believes that the physical orientation, thickness, and relatively high permeability of the terrace gravel deposit (confined by the overlying lower permeability glacial moraine) should be able to convey a relatively large amount of seepage out toward the East Fork beneath the LMDT Portal.

Comment 4. It seems likely that water impeded by the lower blockage near the timber-lattice bulkhead may flow through the tunnel walls into the gravel soils that make up the walls in that vicinity. It is not clear where that water goes after moving into the soils. If that water were to discharge at the surface as a seep or spring, it does not seem likely that a piping condition or slope instability condition would develop due to the coarse granular nature of the soils; but potentially

contaminated groundwater may discharge to the ground surface or to surface waters in the area.

Reclamation agrees – see the response to Comment. 3 above. Since the last LMDT Portal modifications in 1990-92, no surface seepage or slope instability has been observed. LMDT water not captured by the well at Station 10+25 or flowing through the timber bulkhead could become groundwater and could travel into and through the terrace gravel and glacial moraine deposits beneath the ground surface at the Portal and could then join the surface water in the East Fork.

Comment 5. The effectiveness of weep holes in the concrete tunnel lining was not adequately addressed in the analysis of the stability of the concrete lining. Photographs of the concrete lining indicate significant clogging of some weep holes by mineral deposition. It was not entirely clear if the analysis considered a reduced weep hole efficiency. It is clear however, that even if a segment of the concrete tunnel lining failed, the blockage near the timber-lattice bulkhead would remain stable. The soil above a failed segment of concrete lined tunnel would likely collapse into the tunnel and result in a sink-hole at the ground surface.

Some of the weep holes in the concrete tunnel lining were observed to be clogged as shown in Figure 22 of the Existing Condition report. The Existing Condition report recommended that these weep holes be cleaned out in Section 2.12 (Inspection March 25, 2008) on p. 54. Reclamation is planning to do so. Reclamation agrees that the lower blockage would likely remain stable in the event the concrete tunnel lining failed.

Comment 6. The analysis of the stability of the hillside in the vicinity of the portal was reasonable. The extreme case of high ground water elevation, weak soil strengths, and large seismic event occurring simultaneously is indeed remote. Displacement of the slope toe of less than one foot in the unlikely event the extreme case occurred probably would not result in a catastrophic failure of the slope.

Reclamation agrees.

Comment 7. The primary observations to make are that the Leadville Mine Drainage Tunnel (LMDT) was hurriedly constructed by US Bureau of Mines as part of the war effort in the 1940's and 1950's. It was apparently not designed or constructed for long-term stability as it was constructed using mining techniques for advancing the LMDT and temporary roof support rather than using tunneling methods available at the time. The type of roof support used, wooden timbers and light steel sets, are generally used to provide temporary support and are prone to deterioration in a relatively short time. Consequently, the overall roof stability in the LMDT should be anticipated to deteriorate significantly over time as the support members deteriorate.

Reclamation agrees.

Comment 8. There is ample description of poor roof conditions and difficulties advancing the LMDT during construction and of roof stability maintenance efforts after construction. A cursory assessment of the station by station description in *Existing Condition of the Leadville Mine Drainage Tunnel, Final Draft June 2008*, indicates only about 2,500 feet of LMDT length does not appear to be prone to partial or full collapse based on reported construction problems and anticipated deterioration of roof support members. It seems likely that there are more tunnel blockages present in the LMDT than the two assessed by USBR. Over time much of the length of the LMDT should be anticipated to at least partially collapse. The hydraulic connection between the mine pool and the timber-lattice bulkhead may be anticipated to further diminish as a result.

Reclamation agrees.

Comment 9. Based on descriptions of LMDT construction, there are numerous locations where significant groundwater inflow to the LMDT may be possible downstream of the upper blockage near the Pendery Fault. It is possible much of that water would be unrelated to the mine pool.

Reclamation agrees.

Comment 10. The description of the construction station by station was very helpful in grasping the LMDT condition and geologic setting. There is some question as to the significance of the karst feature that runs sub-parallel to the LMDT near station 29+63 to 32+00. A karst solution opening 60 feet long, 15 feet wide and 20 feet high was encountered. The opening apparently narrowed and plunged into the tunnel floor near station 32+00. What affect, if any does that feature have in the movement of water in the LMDT? How stable is the roof at that location due to the greater span from wall to wall through that section?

The Geologic Cross-Section along the LMDT (four figures) included in Appendix A of the Existing Condition report indicates the bedrock along the Station 29+63 to 32+00 portion of the LMDT is Dyer Dolomite (Dcd). When two closely spaced faults were encountered at Station 29+63, the tunnel construction experienced the largest inflow of water recorded for the LMDT (5,700 gallons per minute). The large cavern that followed the side of the constructed tunnel may or may not be a continuous feature connected to other such features in the Dyer Dolomite. It could be part of a groundwater conduit within the dolomite, bringing some of the water noted under No. 9 above to the LMDT. The report notes that the cavern sides were hard and that 156 feet of the tunnel length was “slabbed off” to create a siding for the track. This would appear to indicate that the rock along this cavern was sufficiently hard and strong to create a relatively stable roof for the tunnel.

Review Comments from Joseph A. Kissane, P.G. (Attachment 2)

The general concept of the 2003 ROD appears to be appropriate, given the parameters and goals of the ROD.

This risk assessment focused only on potential impacts to downstream populations and property. Assessment of issues beyond these potential impacts is beyond the scope of this study.

Comment 1. The U.S. Bureau of Reclamation studies of the conditions include geotechnical considerations and assumptions, some of which are based on the available information, without proposal for subsequent verification. The Bureau of Reclamation's failure mode analysis contains many assumptions to account for unknowns, and most are reasonably conservative. Some of the assumptions are not as likely as others. Among the assumptions, the most significant unverified assumption is the location and extent of the presumed collapse. Some efforts have been made to identify the location using remote camera imagery and borings; however, there is still a level of uncertainty as to the extent of the collapse/plug and the nature of the material that composes it (its composition,) its degree of compaction, and the size distribution of the materials within it.

Because of the Risk Assessment's conclusion that catastrophic failure of the collapsed portion(s) of the tunnel resulting in rapid release of mine pool water and collapse debris out of the LMDT is unlikely (extremely low), Reclamation has determined verification of the various assumptions made is unnecessary. That verification effort would be very expensive and would likely leave many questions unanswered. Reclamation recognizes that it has made many assumptions in the various studies conducted and believes that they were appropriately conservative. The independent CRB commented that "Conservative to very conservative assumptions were made at every step of the geotechnical and risk analyses." Reclamation believes that the length of the upper collapse/plug near the Pendery Fault is not a critical issue, primarily due to the fact that the better characterized lower collapse/blockage above Station 4+61 should be more than capable of preventing the rapid release of water out of the LMDT in the event the upper blockage did breach and release the Mine Pool. Reclamation has significant experience with rockfill and well-graded glacial moraine materials throughout the West and believes that the Risk Assessment has appropriately characterized these materials and how they will perform under the postulated loadings.

Comment 2. The USBR Risk Assessment addresses static conditions as they are believed to exist at present, and it is apparent from the collapse plug that the overall condition of the tunnel is not static in the reasonable future. The majority of the tunnel being unlined and the continued action of environmental stresses on it will continue to act against the long term integrity of the structures. Without

further investigation, it is not known what impacts are likely from collapses or changes in the groundwater regimes, and without further stabilization measures it is very likely that such things will occur.

Reclamation's goal in the Risk Assessment study was to assess the risk(s) to the public and others under current conditions. Reclamation agrees that in the future, the condition of the LMDT, the elevation of the Mine Pool, and groundwater levels around the LMDT in general may change. Reclamation believes that collapses in the LMDT and in the mine workings will continue to occur. However, Reclamation believes that such collapses, especially in the LMDT, would help limit flows to the downstream tunnel reaches from the Mine Pool, even if a blockage near the Pendery Fault were to breach.

Comment 3. In the Section of Major Findings and Understandings of the failure mode analysis, there is a discussion that states: "It is unlikely that the Pendery Fault or any of the rock units of this section are pervious enough to drain the water from this section of the tunnel." Later in the same paragraph, it is stated that: "Increased leakage into California Gulch, presumably along fractured rock associated with the Pendery Fault, is further evidence that the tunnel collapse is downstream of the fault zone." These statements appear to be in conflict, or at least require more explanation.

Reclamation agrees; that portion of the report has been modified.

Comment 4. The discussion of limits on the height of piezometric head within the Mine Pool implies that the head cannot rise above the bedrock/overburden contact, because the relatively high permeability of the overburden gravels. The variable nature of typical moraine deposits and the potential for highly fractured zones within bedrock in faulted areas makes this less than a universal certainty – in spite of the conditions immediately adjacent to the tunnel. In locations that are exclusively terrace gravels, this is likely, as stated; however, it is possible that the head might be greater in some locations under some conditions, and the discussion does state that the location of the water level controls remains unknown.

There are a lot of geologic data regarding the significant extent and thickness of the terrace gravel deposit. The permeability of the terrace gravel was determined by Reclamation using a pump test on the well at Station 6+35 near the LMDT Portal. While that permeability of 50 feet/day for the terrace gravel is only valid for that one location, it is considered representative of the material. Reclamation does not know precisely what the maximum water table level would be, but believes the control on this elevation may be the geologic contact between pervious zones in the bedrock and the overlying gravels. The rate of rise of the mine pool would be limited by the terrace gravel's large water carrying capacity and by the fact that some shafts would experience artesian flow. Source Water Consulting has noted that seeps and flow from shafts begin

in California Gulch when the water level in the LMDT Mine Pool reaches an elevation of 10,147. The Bureau of Mines previously suggested that a water elevation of 10,160 may be the maximum based upon this level being measured in the Pyrenees Shaft prior to the construction of the LMDT. It is believed that present water levels are near the maximum likely to occur as the hydrologic system is able to overflow out of the top of the Mine Pool. Placing an exact value on this elevation is not essential given the finding that the lower collapse/plug and lattice-timber bulkheads can resist considerably higher water levels, and the historic evidence that the upper limit is somewhere near elevation 10,160.

Comment 5. The Risk Assessment addresses static conditions as they are believed to exist in the LMDT at present, and it is apparent from the collapse plug that the overall condition of the tunnel is not static in the reasonable future. The Risk Assessment also tends to reflect an evaluation of the LMDT with little or no evaluation of the conditions of nearby mine shafts and adits and drifts, that may or may not impact the LMDT as conditions change (which they will, to an undetermined extent). The majority of the tunnel being unlined and the continued action of environmental stresses on it will continue to act against the long term integrity of the structure. Without further investigation, it is not known what impacts are likely from collapses or changes in the structural conditions of the LMDT or other nearby mine structures, and/or groundwater regimes, and without further stabilization measures it is very likely that such things will occur.

Reclamation's goal in the Risk Assessment study was to assess the risk(s) to the public and others under current conditions. Reclamation agrees that in the future, the condition of the LMDT, the elevation of the Mine Pool, and groundwater levels around the LMDT in general may change. Reclamation believes that collapses in the LMDT and in the mine workings will continue to occur. However, Reclamation believes that such collapses, especially in the LMDT, would help limit flows to the downstream tunnel reaches from the Mine Pool, even if a blockage near the Pendery Fault were to breach.

Comment 6. The discussion of Major Findings and Understandings uses terms that are subjective when it comes to safety, e.g.: "In addition, the coarser gravels adjacent to the tunnel will convey a *lot* of water without moving particles" and "With recent improvements to the Early Warning System (EWS), there should be *plenty* of advance warning of dangerously developing conditions."

Correct – the study was not a quantitative risk analysis.

Comment 7. A simplified stability analysis was done using a conservative approximation of the size of the collapse plug and the prediction is that the plug is not likely to fail rapidly in a fashion that will cause the engineered plug near the downstream portal to fail. Without additional verification as to the extent and composition of the collapse plug, it is difficult to assess its permanence or

durability. The analysis of failure modes include an assumption that the blockage materials may be materials that may somehow be “cemented” by metal precipitates. Given the acidic nature of the waters, it is also quite possible that the materials are susceptible to leaching or deflocculation of clay minerals present. It may be possible that should the collapse plug be composed of material that will lose its integrity in time, that mass movement in a confined debris-flow may occur causing a plunger effect that could result in heads being applied to the engineered plug that are not anticipated in the risk evaluation done by U.S. Bureau of Reclamation.

Reclamation recognizes the uncertainty associated with the upper collapse plug. However, Reclamation believes that its judgment about the piping failure mechanism for the upper collapse plug is reasonable and appropriate. The CRB agreed with Reclamation’s assessment that even in the unlikely event the upper bulkhead did collapse, it would “... fail slowly but progressively by erosion ...” and “Thus, failure of this type would involve a long time period and gradual increase in water pressure on the portal side of the bulkhead.”

Comment 8. The reports and assessments of the Bureau of Reclamation appear to address the risks and likelihood of catastrophic failure of the collapse plug and implications to the engineered plug downstream and the portal area structures in the short term, if conditions remain essentially as they are, within the parameters of the scenarios presented. The geotechnical and structural conclusions may be valid if the conditions are as modeled – and however likely the assumptions are at the present time, there are possible, even somewhat likely scenarios that could alter those conditions, and thereby alter the outcomes.

Reclamation’s engineering evaluation of the lower collapse plug and the lattice-timber bulkhead included the assumption that the upper collapse plug had breached and that the Mine Pool had been released down the LMDT. The evaluation of the lower collapse plug therefore assumed dramatically higher groundwater levels (up to 100 feet above the tunnel invert at Station 10+25) around the Portal area than have existed since Reclamation constructed the Leadville Water Treatment Plant facility in 1992, as well as three assumed seismic (pseudo-static) loadings with separate slope stability analyses performed. Reclamation believes that these analyses have conservatively estimated how the LMDT Portal area would perform under present conditions as well as possible altered conditions.

Comment 9. The assessments are primarily based on geotechnical and structural consequences of possible movement of material from the collapse plug, and not so much the hydrogeologic or environmental consequences or the consequences beyond the tunnel and associated structures of deviating from the ROD-prescribed action. The majority of the tunnel is unlined. It is very possible that there will be other collapses in the tunnel. Faults and unconformable geologic contacts may contain materials susceptible to erosion in the long term that may not result in

large-scale short-term changes in conditions, but may slowly cause wedges or blocks of rock to move or collapse into the tunnel at other locations. The impact of these collapses goes beyond the impact on the engineered plug and the structures at the portal. Surface subsidence, opening of migration pathways for untreated Mine Pool water, and the connection of the tunnel with previously unconnected sources of other mine-impacted water are just a few possible negative impacts should more collapses occur.

This Risk Assessment focused only on potential impacts to downstream populations and property. Assessment of potential environmental impacts was beyond the scope of this study. Reclamation agrees that additional collapses in the mine workings and the LMDT are likely to occur in the future but believes that this would reduce the risk of a sudden release of water from the tunnel, which was the focus of this risk assessment.

Comment 10. Groundwater regimes are variable – and the Bureau of Reclamation evaluation does not appear to consider the potential changes in groundwater demand, or changes in mining activities and how these might impact the groundwater chemistry or the overall environment if the ROD-prescribed action is not executed.

This Risk Assessment focused only on potential impacts to downstream populations and property. Assessment of potential environmental impacts was beyond the scope of this study.

Comment 11. Risk Reduction Opportunities:

The USBR Failure Modes and Effects Analysis discusses a list of “Opportunities for Risk Reduction, Monitoring Enhancement, Data Collection and/or Analysis”, but includes the caveat that this “is not to say they are all recommended for implementation, but rather they form a list of ideas that can be considered during any future risk mitigation.” Among these that are closest to achieving the apparent goals of the ROD are:

- Drill large diameter holes into the tunnel and examine the extent of blockage with a remote crawler camera (or other remote device).
- Construct a permanent concrete bulkhead upstream of the Pendery Fault designed to take the load from a maximum level Mine Pool.
- Drill holes into the tunnel near the Pendery Fault blockage zone through which gravel and grout are injected to form a tunnel plug capable of withstanding the differential head with more certainty.

Reclamation agrees.

Comment 12. Evaluation of Early Warning System

Regardless of the approach taken, in addition to the improvements in the Early Warning System, the system should include an alarm to signal that any of the automated systems is not operational. Self-tests and manned tests should be included in the O&M, along with calibration checks for all measured parameters.

Reclamation agrees that such non-operational alarms should be included in the Early Warning System, and is working to make such improvements.

Review Comments from B.J. Bailey, P.G. (Attachment 3)

Comment 1. “Existing Condition of the Leadville Mine Drainage Tunnel”

Page 6. Sinkholes are discussed here and throughout the document. It is unclear if the seismic refraction work was concentrated only over the LMDT. The document leads me to believe there is a one-to-one correlation between sinkhole formation and LMDT drainage. I was left with the following questions: are there other sinkholes in the area not related to the LMDT alignment; are the sinkholes predominantly within areas underlain by the limestone units; and are sinkholes located near any other tunnels or shafts within the drainage basin? The fact that a large cavern was discovered adjacent to the tunnel at Sta. 29+63 may indicate the presence of others in the area.

As noted on p. 42 (under 2.8 Modifications 1978-1980), the seismic refraction surveys performed by Reclamation in 1976 “were made along the surface overlying the tunnel from Station 4+55 to 10+00 ...” Experience with the LMDT Portal area since the first sinkhole was discovered in 1956 is a direct correlation between sinkhole development and the flow of drainage water through the LMDT. The glacial moraine material appears to be highly erodible, but the terrace gravel deposit probably filters the glacial moraine material, which probably limits the development of sinkholes at other locations further up the tunnel. The landscape around the Leadville Mining District is populated with prospect holes, numerous mine clams, and related shafts, making it difficult to differentiate between them and any sinkhole features. There may be sinkholes associated with the limestone areas, which appear to be overlain by terrace gravel and glacial moraine materials according to the “Geologic Cross-Section along the Leadville Mine Drainage Tunnel” included in Appendix A and the surface mapping included in the 1927 Emmons report. There may be other limestone unit caverns around the Leadville Mining District besides the one encountered in the Dyer Dolomite at Station 29+63 in the LMDT.

Comment 2. Limestone dissolution is apparently a problem given the condition of the weep holes in the LMDT and the relatively rapid formation of stalactites along cracks (p.51, 52). Clogging of the weep holes could lead to rapid destabilization of the tunnel liner and could also account for the relatively fast deterioration of other support systems. There is no indication that any studies have been done to address the impact of [Acid Rock Discharge] ARD on the dissolution of limestone in particular or on any other rock types such as the shale found in/around the LMDT, including gouge material, has been done.

Correct. The report recommended that these weep holes be cleaned out in Section 2.12 (Inspection March 25, 2008) on p. 54. Reclamation is planning to do so. Reclamation is not planning to conduct such ARD-effect studies.

Comment 3. Page 9. It was mentioned that in 2004 that the Bureau participated with Lake County in a functional exercise to practice for a potential problem at the LMDT Water Treatment Plant and to test the EAP and that no audible test was performed at that time. On p. 11 it states that the warning system was retested in 2008 but does not indicate that an audible test was performed. Was this test ever performed?

Yes - the warning system test performed on February 22, 2008 (mentioned on p. 11) was an audible test. Reclamation has been working with the local community to improve the collective understanding of the Early Warning System and the appropriate responses by our staff at the Leadville Water Treatment Plant, by the public, and by the community's emergency responders.

Comment 4. Page 9. The inadequacy of the treatment plant is mentioned here and elsewhere in the reviewed documents as well as the limited storage in the .5 acre holding pond. This issue needs to be addressed and remedied in the OU12 (Hydrologic OU) document. Much of the water draining from the LMDT is influent from both the alluvial and bedrock aquifers which is diluting the ARD.

Reclamation's Leadville Water Treatment Plant has a long history of operational success for the designed purpose. The facility is currently treating quantities of contaminated water well in excess of sustained historic flows from the LMDT.

Comment 5. Page 10. The result of the 2006 study of ground water in the LMDT area titled "Hydrogeologic Characterization of Ground Waters, Mine Pools, and the Leadville Mine Drainage Tunnel, Leadville, Colorado" done by Source-Water Consulting and the University of Colorado concluded that the LMDT drains only a small volume of mine pool water and a very large volume of regional bedrock and adjacent alluvial groundwater. This has two implications. The first is that the treatment Plant is being overburdened by water that is being contaminated after entering the LMDT and the second is that when ground water falls below a certain level there is potential for mine pool water to leave the tunnel and contaminate

surrounding areas as well as undermine alluvium on surrounding slopes. This is especially true since the first 635 feet of the tunnel is within alluvium.

Reclamation agrees with the first stated implication. The LMDT functions well as a groundwater collection and drainage system. The relatively small amount of LMDT water that is not collected by the well at Station 10+25 or flows through the lattice-timber bulkhead at Station 4+61 for treatment by the Leadville Water Treatment Plant probably flows into the terrace gravel and/or the glacial moraine deposits, which would then convey the groundwater to the East Fork of the Arkansas River. The glacial moraine overlying the terrace gravel around the LMDT Portal has been stable with no evidence of seepage exiting the slope or toe areas since the plant was constructed in 1992. Hence, no undermining of the portal area slopes appears to be occurring and the slope stability analyses have indicated these slopes should remain stable under the very conservative conditions analyzed. Reclamation's monitoring of the LMDT Portal area includes periodic examinations of the slope and toe areas around the portal.

Comment 6. Page 37. Paragraph states "In June, 1956 the Bureau of Mines reports 'There is a small cave in tunnel about 150 or 200 feet from the portal. There is small hole up on top of the Hill.'" This relates to comment above (p.9)

Correct. However, since the LMDT Portal area modifications constructed by Reclamation in 1978-80 and 1990-92, no additional sinkholes have been found at the portal area or along the LMDT.

Comment 7. Page 42. Statement that additional sink holes had formed between the 1973 and 1976 inspections for a total of 12 sinkholes observed. "Since the more recent sinkholes were away from the highway, Reclamation began a program of erecting safety fencing around the holes rather than backfilling them as had been done in the past." There is no indication that additional monitoring was done to evaluate the growth of these sinkholes.

Correct. However, since the LMDT Portal area modifications constructed by Reclamation in 1978-80 and 1990-92, no additional sinkholes have been found at the portal area or along the LMDT.

Comment 8. Page 43. Sta. 6+65 a well drilled 98 feet into tunnel observed 6-ft. of water flowing in tunnel. A sinkhole formed adjacent to drill rig and hole was lost.

Correct. However, since the LMDT Portal area modifications constructed by Reclamation in 1978-80 and 1990-92, no additional sinkholes have been found at the portal area or along the LMDT.

Comment 9. Page 44. This paragraph is a good illustration of my general concerns with all three documents. It refers to “likely” collapse zones which indicates the actual locations of collapsed areas and the quantity of collapsed material within the LMDT is unknown. Also the statement that the tunnel is more than adequate to handle the estimated hydraulic pressure based upon the most likely tunnel, soil, and groundwater conditions. ... is extremely vague. This statement was made in 1988 and makes me question what other assumptions have been carried through as fact.

Reclamation’s stability analyses performed for the Portal area slopes assumed a groundwater condition with the water level 100 feet above the invert at Station 10+25 and almost at the ground surface downstream of that location. This is believed to be a reasonably conservative assessment of possible future conditions in the event the upper collapse blockage were to breach and release the Mine Pool. An appropriate range of material properties was assumed in these analyses. These parameters are believed to reasonably assess the existing and future LMDT Portal conditions with sufficient specificity to allow others like the CRB and the USACE to review and concur with the result of Reclamation’s Risk Assessment study. Reclamation’s various LMDT studies since 1988 have not been based on that earlier evaluation or its information.

Comment 10. Page 47. Table 5 list the material properties assumed for the 2005 bulkhead study. There is no indication of how many values were collected to determine the range, whether or not the average value was a weighted average, and whether or not outliers were included in the calculations. This type of data needs to include this type of information. The paragraph also states that no references were found and that no strength tests were done. This study was done in 2005 so this information should be available. My concern is that this type of unsupported information is carried forward as fact without confirmation.

The “average value” data given in Table 5 do not appear to be the average of the range low and high values, so a better term than “average value” may be appropriate here. Some of the engineers and geologists who authored the 2005 Valve Controlled Bulkhead Study report also participated in this Risk Assessment process; the information from the 2005 study was reevaluated and used in the current study. Reclamation believes the assumed material properties given in Table 5 for the materials encountered by the LMDT’s construction are reasonable and appropriate for this Risk Assessment study. The CRB concurred with Reclamation’s opinion.

Comment 11. Page 69. High quantities of sludge are referenced at the treatment plant. This seems to be an indication that erosion is occurring within the zone the tunnel is draining.

There is no evidence erosion is occurring within the LMDT’s groundwater source areas. The water flowing into the plant is monitored and no eroded

sediments have been found since its startup in 1992. The seepage at the lattice-timber bulkhead has remained clear with no suspended sediments visible, which indicates that the backfill and cobble material placed upstream of the two timber-lattice bulkheads is functioning as a good filter. The sludge is material produced by the Leadville Water Treatment Plant as a result of chemical reaction of sodium hydroxide reagent which is blended with the mine water. The chemical reaction forms a precipitate which is referred to as "sludge".

Comment 12. "Results of Geotechnical and Structural Analysis, Leadville Mine Drainage Tunnel"

Page 4. The last sentence of the paragraph under "Description" touches on one of my main concerns which is the potential collapse of the concrete tunnel liner downstream of the bulkheads and the potential for sinkhole formation. One of the figures included is a photograph of the partially CaCO₃ filled weep holes and stalactites forming along the crown. The deposition is apparently occurring rather rapidly yet there is no indication in the documents that any type of inspection and response plan is either in place or proposed. I am under the impression that inspections tend to occur at irregular intervals with no set plan in place.

Based on the Risk Assessment's conclusions and recommendations, Reclamation has instituted a more detailed periodic LMDT monitoring program that includes the interior of the concrete tunnel section. Section 2.12, p. 54 of The Existing Condition Report recommended that these weep holes be cleaned out in (Inspection March 25, 2008). Reclamation is planning to do so. The water level at the lattice-timber bulkhead has remained steady with a height of about 2½ feet since it was constructed. It is believed that the terrace gravel collects and conveys the water that doesn't flow through the bulkhead downward and toward the river. It would take a significantly higher water level/pressure to create concern about the possibility of collapse of the concrete tunnel liner.

Comment 13. After reviewing the documents, I determined that the best way to present my comments was to discuss my general concerns rather than a paragraph by paragraph discussion. My general comments are:

1. Inconsistency of information. For example, the highest head is usually stated to be 119-ft. but there are also references to the highest head being 163-ft. This is higher than the highest number used in the analysis (150-ft.). In this case, it is apparent that a conservative approach may not have been followed in all cases.

While the groundwater in the Leadville Mining District is very complicated, the Risk Assessment's three reports have attempted to clearly recap the LMDT's history and to convey the monitoring data associated with it and the Mine pool. The 163-foot head was mentioned in the Results report in the fourth paragraph on p. 9. This head value (elevation 10,150) was stated as being the highest

measured head above the tunnel invert at the monitoring well located at Station 96+44. The highest head value of 119 feet was stated in the Results report in the first paragraph under “1.3 Summary of Results” on p. 6 as being the maximum differential head across the upper blockage near the Pendry Fault, as indicated by the monitoring wells at Stations 36+77 and 46+66. As shown in the Existing Condition report, Appendix A (Cross-Section along the Leadville Mine Drainage Tunnel, 2nd figure, the water in the LMDT below the upper blockage was located at elevation 10,028.47, according to the monitoring well at Station 36+77. (The water in the LMDT above the upper blockage was located at elevation 10,144.37, according to the monitoring well at Station 46+66, which calculates to a differential head of 115.90 feet.) The Results report assumed differential heads of 100 and 150 feet to evaluate the stability of the upper blockage, and the value of 150 feet is 30 feet higher than the maximum value observed in these upper blockage monitoring wells so far – a conservative approach.

Comment 14. Numerous inconsistencies make it apparent that the documents were written by multiple writers, which is not unusual, but that no one person was responsible for bringing the documents together into a unified whole. The use of a good technical editor would result in the elimination of many of the inconsistencies noted. It is of particular concern when these inconsistencies occur in the evaluation data.

The Risk Assessment’s three draft reports were written by the Risk Team members. The schedule for producing the draft reports was fairly aggressive and a technical editor was not used at that time. Reclamation plans to perform an appropriate technical review and editing on the final Risk Assessment report, which should eliminate any inconsistencies in how the rather complex data are presented.

Comment 15.

2. Ground water issues: It becomes apparent in the documents that the groundwater within and surrounding the LMDT is either not completely understood or not utilized to its fullest extent.

Information gained from the Mike Wireman Reports clarified many issues. In the Reclamation’s Risk Assessment there is no unified concept of flow into or out of the LMDT or through the blockages. Inconsistencies in their discussions concerning the role of the Pendry fault vary from it being a flow path to a semi-impermeable boundary. Inflow quantities from fracture zones within the Parting quartzite vary from one document to another, inflow being high within the background document to low to nonexistent in the technical analysis document. The potential drainage of the mine pool into the glacial deposits is of particular concern.

The documents indicate that this may be a good thing because it serves as an additional safety factor to reduce the driving force when looking at a potential “blowout” of the tunnel blockages.

EPA’s report by Mike Wireman conveys a lot of information about the groundwater around the Leadville Mining District, primarily the groundwater found below OU6. There remains considerable uncertainty regarding the amounts of water flowing into and out of the LMDT and through the upper blockage near the Pendery Fault. It appears that more water flows parallel to the fault than across the Pendery Fault, except for areas where the fault has been penetrated by mine workings. This has been discussed more thoroughly in Reclamation’s earlier responses to USACE comments in this document. These flow quantities are not a critical aspect of the analysis of the stabilities of the upper and/or lower LMDT collapse blockages or the potential for sudden, catastrophic release of the Mine Pool out the LMDT Portal, which was the primary focus of Reclamation’s Risk Assessment. While Reclamation has stated that it is uncertain as to the maximum elevation to which the Mine Pool may rise, the historic (pre-LMDT) maximum elevation of the Mine Pool in the vicinity of the Robert Emmet Shaft appears to have been about 10,160. Reclamation believes this may be due to the ability of the terrace gravel deposit to drain away Mine Pool water that might otherwise rise above elevation 10,160, thereby creating a greater head differential across the Pendery Fault. Reclamation agrees that limiting the differential head across the Pendery Fault, controlling the potential for a “blowout” of the upper blockage, is a good thing.

Comment 16. The potential for destabilization of the hillside is dismissed by assuming that the flow of the escaping mine pool is toward the river and that the distribution of the water within the surrounding soil/glacial deposits is relatively uniform. These are unsupported assumptions. There is no discussion of the metal loading in the water flow through the LMDT that could contaminate material surrounding the LMDT.

The results of Reclamation’s stability analyses are presented in the Results report and they conservatively indicate little to no potential for static or seismic slope instability of the LMDT Portal hillside. Beyond the LMDT water removed by the well at Station 10+25 and flowing through the lattice-timber bulkhead at Station 4+61, none of the remaining groundwater has exited as seeps on the hillside or along its toe during the 16 years since the concrete lined tunnel and the water treatment plant were completed in 1992. The other monitoring well water levels around the LMDT Portal also show this groundwater situation is under control – this is not an assumption. While the glacial moraine material around the LMDT may have become contaminated by groundwater flow, this may have existed before the tunnel was constructed, and it may still be occurring. However, that potential concern was not included as a task in Reclamation’s Risk Assessment as has been noted earlier in this response document.

Comment 17. There is limited discussion of potential seepage and or piping issues. They do state that no seepage or piping was noted during an inspection but there is no indication that these inspections occur on a regular basis.

This response document has already addressed the USACE's seepage and piping comments. Based on the Risk Assessment's conclusions and recommendations, Reclamation has instituted a more detailed periodic LMDT monitoring program.

Comment 18. Assumptions: While most of the assumptions used appear conservative, some are not. The assumptions I am most uncomfortable with are:

There was no data directly applicable to the site used in the analyses. Apparently the rock within the tunnel was never tested so typical values for that rock type were used. At least some of these estimates need to be confirmed by actual testing of the rock types at the site.

Reclamation recognizes the lack of measured engineering properties for the rock and soil materials associated with the LMDT. Reclamation believes that it has appropriately and conservatively characterized these materials based on the geologic and geotechnical site information available. The lack of access to obtain suitable samples of the rock materials would require time and money to perform the sampling and testing program. Given the perception of potentially imminent failure and the subsequent public concern, Reclamation determined that the public would be best served by rapidly determining the potential risk and concluded the only feasible alternative was to evaluate the tunnel using a range of strength values and multiple layers of conservative assumptions to overcome the lack of site specific information. Given the Risk Assessment results, actual testing of rock (and soil) materials from the site does not appear warranted. The CRB accepted Reclamation's position on this concern.

Comment 19. The actual volume and configuration of the existing blockage of the tunnel is unknown. Some of the analyses used the assumption that quite a bit of the blockage was continuous in length and filled the tunnel from floor to crown which is not a conservative approach. The document discussing the results of the analysis states this directly on page 11, first paragraph of Section 1.3. There is also a statement of page 20 that the extent of the consolidation grouting that was performed is unknown because of missing records.

Reclamation recognizes the uncertainty associated with the upper collapse blockage near the Pendery Fault. The resulting conservative approach was to assume the unlikely event that the blockage failed catastrophically. This conservative assumption was carried forward to all other failure modes analyzed. Catastrophic failure of the blockage would likely greatly increase the pressure in the water-filled tunnel below the blockage. Since the upper collapse

blockage still exists and impounds the Mine Pool, Reclamation's Results report in Section 2.1.3 discusses the likely situation at this upper collapse blockage. Reclamation also recognizes the uncertainty associated with the lower blockage near the LMDT Portal. The Results report statement about the uncertainty regarding the consolidation grouting on page 20 is associated with the remedial measures constructed in 1978-80 below the LMDT's lower collapse blockage.

Comment 20. The assumptions concerning slope failure are unclear but seem to include gradient with no reference to how this was determined. The document gives the general impression that slope failure was not seriously considered.

Figure 7 in the Results report on p. 19 shows the groundwater table indicated by the monitoring wells installed in 1968. The configuration of that groundwater table generally follows the interface between the terrace gravel and the overlying glacial moraine, as well as the ground surface above. The slope stability analyses assumed various groundwater elevations at the well at Station 10+25 and then assumed the groundwater surface sloped toward the river generally following the historic groundwater table noted in 1968. As a conservative assumption, the maximum (worst case) groundwater surface was only a few feet below the sloping ground surface above the tunnel. Results report Section 2.5 presents "Stability of Hillside in Vicinity of Portal", including the material assumptions, piezometric levels assumed (see Table 13), and the stability factor of safety results in Table 14. The lowest static factor of safety, assuming the weakest soil material properties, is a factor of safety of 1.54, which Reclamation considers to be adequate. Only the extremely conservative seismic pseudo-static analysis that assumed the weakest soil material properties and a 0.35g earthquake loading produced a factor of safety below 1.0.

Comment 21. Seismicity is dismissed as of no consequence but the analysis parameters did not include the duration or the range of durations that were used for the analysis. This information needs to be included in the document.

The pseudo-static seismic stability analysis and the empirical correlations between yield acceleration and deformation used to estimate the likely maximum amount of movement (less than one inch) as discussed on p. 43 of the Results report do not involve the duration of earthquake shaking when performing the calculations.

Comment 22. In the conclusions for the analysis document, the third paragraph states that the surrounding terrace gravels would serve to attenuate rising groundwater levels but there is no mention on what effects this would have on the surrounding slopes. It would also be wise to perform a seepage analysis as part of the risk assessment. It would also be important to know the metal loading of the potential seep water.

When Reclamation has turned off the well pump at Station 10+25 for maintenance, the water level has risen to as much as 70 feet above the LMDT invert. During such situations, the level of the water flowing through the lattice-timber bulkhead at Station 4+61 has remained at approximately 2.5 feet above tunnel invert. This information appears to indicate the terrace gravel deposit is capable of handling the seepage flow caused by much higher groundwater levels. The overlying glacial moraine deposit helps to confine the groundwater seepage to remain within the terrace gravel, which must convey it toward the river. The monitoring wells around the LMDT Portal are instrumented and Reclamation would be alerted to a higher groundwater table that might adversely affect the slope stability. A seepage analysis would not refine these groundwater table observations to any great degree. The metals content of the groundwater around the LMDT Portal has already been discussed in this document.

Comment 23. I feel it unlikely that a catastrophic failure would send water and rock shooting out of the portal but it is highly likely that portions of the tunnel will continue to fail. The risk analysis is addressing static conditions but this is a dynamic condition which will change over time. I was disappointed to see that there was no discussion of periodic inspections included as part of the document.

Reclamation agrees that a catastrophic failure with water and rock shooting out of the portal is unlikely. Reclamation agrees that in the future, the condition of the LMDT, the elevation of the Mine Pool, and groundwater levels around the LMDT in general may change. Reclamation believes that collapses in the LMDT and in the mine workings will continue to occur. However, Reclamation believes that such collapses, especially in the LMDT, would help limit flows to the downstream tunnel reaches from the Mine Pool, even if a blockage near the Pendery Fault were to breach. Reclamation has instituted a more detailed periodic LMDT monitoring program.

United States Environmental Protection Agency Comments

Comment 1. The Reclamation Risk Assessment calls for: 1) increased monitoring of water pressure in the tunnel and the hillside soils, 2) connecting water pressure monitoring equipment to the existing Early Warning System, and 3) updating Reclamations's Emergency Action Plan.

EPA supports these recommendations and their implementation.

No response required

Comment 2. The Risk Assessment also provides lists of “possible actions to be considered during future risk mitigation activities.” Included in this list is the installation of permanent plugs in the tunnel.

EPA supports the installation of permanent plugs in the tunnel as well as back filling the first 2000 feet of the tunnel. This would: 1) permanently stabilize the LMDT; 2) ensure that residents and property at the mouth of the tunnel are protected from release; 3) minimize contamination of the Arkansas River water supply and fishery; and 4) protect EPA’s restoration work along the Upper Arkansas River.

No response required

Comment 3. The models used by Reclamation for the Risk Assessment are generally accepted, used by the Industry, and considered appropriate for discerning initial site conditions. However, given the unstable and changing nature of conditions in the LMDT, the use of a more dynamic approach, as well as the use of a probabilistic analysis, would greatly improve the confidence level concerning the findings.

Reclamation believes mine pool levels are reaching their maximum height. Reclamation also believes it is unlikely continued deterioration of the LMDT and other tunnels in the mining district will have an adverse impact on tunnel stability in the lower portion of the LMDT. Reclamation feels attempts to take a more dynamic approach to risk assessment are unwarranted. Additionally, Reclamation believes a probabilistic analysis would be misleading in this case. Reclamation has significant experience in probabilistic risk analysis and believes there must be a large database of similar structural evaluations and experience with their failures for probabilistic analysis to have meaning. No such data base exists.

Comment 4. The Risk Assessment may adequately address conditions in the tunnel as they now exist. However, it does not consider that conditions within the tunnel will worsen with time. There is a significant likelihood that more collapses and dams will form in the tunnel to the point that it will not be effective in conveying water to the tunnel portal.

Reclamation agrees that additional collapses are likely to occur in the future but believes that this would reduce the risks of a sudden release of water from the tunnel which was the focus of this assessment.

Comment 5. The Risk Assessment does not adequately consider the potential for the dewatering well at 10+25 to be damaged or become non-operational by hydraulic pressure associated with a failure of the upper blockage (near the Pendery fault). Failure of the 10+25 dewatering well would reduce the ability to manage tunnel water should the upper blockage fail.

Reclamation agrees and acknowledged that failure of the upper blockage could render the dewatering wells at 10+25 inoperable (see conclusions on page 45 of the Results of Geotechnical and Structural Analysis). Even if this were to occur, Reclamation found the risk of a sudden release of water from the mine pool to be extremely low.

Comment 6. The Risk Assessment in general underestimates the volume of groundwater entering the tunnel above the Pendery fault. It also incorrectly assumes that the water levels will stop rising when the bedrock/glacial sediment boundary is reached, should the upper blockage fail and cause water levels to rise.

Reclamation did not attempt to quantify the volume of groundwater entering or existing in the mine pool. Although these volumes were taken by reference from other documents and not verified, Reclamation does not believe they relate to the risk of a sudden release of water from the mine pool.

Reclamation did recognize that water level in the lower portion of the tunnel is likely to rise above the bedrock/glacial sediment if the upper blockage were to fail. Refer to the conclusions section of the Results of Geotechnical and Structural Analysis Report that states, "If the blockage near the Pendery Fault were to fail,.....The well at Station 6+35 is likely to also to experience artesian flow. The artesian flow condition at one or possibly two wells could last for a significant period of time (days to weeks) until the head in the mine pool is lowered".

Reclamation does not know precisely the maximum potential mine pool elevation, but believes the control on this elevation (assuming upper blockage remains in place) may be the geologic contact between pervious zones in the bedrock and the overlying gravels. The rate of rise of the mine pool would be limited by the gravel's large water carrying capacity and by the fact that some shafts will experience artesian flow. Source Water Consulting has noted that seeps and flow from shafts begin in California Gulch when the water level in the LMDT mine pool reaches an elevation of 10,147. The Bureau of Mines previously suggested that a water elevation of 10,160 may be the maximum based upon this level being measured in the Pyrenees shaft prior to the excavation of the LMDT. It is believed that present water levels are near the maximum likely to occur as the hydrologic system is able to overflow out of the top of the mine pool. Placing an exact value on this elevation is not essential given the finding that the lower plug and bulkheads can resist considerably higher water levels, and the historic evidence that the upper limit is somewhere near elevation 10,160.

Comment 7. The Risk Assessment concluded that there was a low risk of adverse impacts if the upper blockage failed. This was based on the assumption that the tunnel, the Reclamation timber-lattice bulkheads, and the glacial till surrounding the lower reaches of the tunnel would effectively contain and diffuse the water released from the upper tunnel. However, this assumption can not be proven and was not based on site specific data. There is no test data to determine if the glacial till could handle the large inflow of ground water if the upper blockage failed.

Although no specific data regarding the ability of the till to transmit water was available, Reclamation disagrees that specific data was not used. The amount of cover (glacial till) above the tunnel was examined and determined to be capable of withstanding the pressures that would result if the upper blockage were to fail.

Comment 8. The Reclamation Risk Assessment concludes that a blockage length of 55 feet would be required to resist the force required for movement, given a differential hydraulic head of 120 feet (currently at 119 feet). It is impossible to determine the length of the collapse zone below the Pendery fault – there is no sound basis for estimating the length. This significantly constrains the certainty of the conclusions reached in the Risk Assessment.

The assessment states, “The actual length of collapsed material forming a flow blockage is not known, as the differential head increases, the length of blockage required to resist movement increases. However, given that about 40 timber sets exhibiting dry rot were not replaced, the length of collapsed tunnel could easily approach 80 or more feet”. This being said, we disagree that “This significantly constrains the certainty of the conclusions reached in the Risk Assessment”. Reclamation concluded that even if this upper blockage fails that a sudden release of water from the mine pool is highly unlikely.