

Southern Company Interim Policy Lease Application Addendum B

Data Collection Project
Offshore of Tybee Island, Georgia

prepared for:

Bureau of Ocean Energy Management
Outer Continental Shelf Alternative Energy Program
Interim Policy Lease

Mail Stop 4090
381 Elden Street
Herndon, VA 20170-4817

prepared by:



&

Geo-Marine, Inc.



Southern Company IP Lease Application – Addendum B



**Bureau of Ocean Energy Management,
Outer Continental Shelf (OCS) Alternative Energy Program
Interim Policy Lease**

November 2012

INTRODUCTION

In April 2011, Southern Company submitted an Interim Policy Lease Application (2011 Lease Application or Primary Application) to potentially place a single traditional fixed meteorological (met) tower Data Collection Configuration (DCC) on the Outer Continental Shelf (OCS) off the coast of Georgia to collect site-specific wind and environmental data. The 2011 Lease Application fully characterized the potential placement of the DCC on the OCS. In the 2011 Lease Application Southern Company initially identified three OCS blocks of potential lease interest, Brunswick NH 17-02 OCS blocks numbered 6074, 6174 and 6126, ultimately identifying block 6126 as the preferred block to lease for potentially placing a single fixed met tower DCC.

In May 2012, Southern Company submitted Addendum A to the 2011 Lease Application, that fully characterized another data collection technology, the AXYS WindSentinel™, hereafter referred to as Buoy Data Collection Configuration (BDCC), a mobile or moveable single unit alternative technology to potentially be deployed. Because the BDCC is a mobile technology configuration, a single BDCC unit could be deployed and moved around into any of the three previously identified lease blocks (Brunswick NH 17-02 OCS blocks numbered 6074, 6174 and 6126), as discussed in Addendum A.

At this time Southern Company has not decided which data collection technology to deploy (the met tower DCC, the BDCC buoy or possibly both); therefore, to aid in this decision making process, Southern Company requested a Bureau of Ocean Energy Management (BOEM) National Environmental Policy Act (NEPA) review of 1) the deployment and fixed installation of a DCC met tower technology at Brunswick NH 17-02 OCS block 6126, as considered in the 2011 Lease Application; and/or 2) the deployment of a single mobile BDCC buoy to potentially collect data at all three Brunswick NH 17-02 OCS blocks numbered 6074, 6174 and 6126, as considered in Addendum A.

This Addendum B to the 2011 Lease Application is intended to address the comments and information requests BOEM provided in their document entitled “Southern Company Interim Policy Lease Application & Addendum A Comment & Information Request Matrix, June 22, 2012” as provided under Appendix 4B of this Addendum B.

The information (e.g., engineering design, vessel specifications etc.) contained herein is understood to be conceptually accurate and will be refined after site characterization surveys are conducted. Following Lease issuance and prior to installation, this information will be finalized and submitted to BOEM in a detailed Project Plan.

The text of each of the 28 BOEM comment and information requests followed by Southern Company’s individual responses are presented below.

1. Page 18, Primary Application 2.4 – Information Request**BOEM Information Request**

“There is a general description of the height of the tower and the penetration depth of piles but there lacks any description regarding the approximate bottom footprint (page 18 says “a few hundred square feet.” What is the method of installation? Approximate timing/duration of installation time? In some sections they seem to refer to scour protection devices but this information is lacking from section 2.4. A range of types and footprint and overall tower design with illustrations in one location in the document are needed.”

Southern Company Response

The three DCC piles will each be 36 inches in diameter (Addendum B, **Appendix 1B**). The method of installation is provided in section 2.4. The estimated duration of on-site installation is 12 days. Further investigation has revealed that scour protection devices should not be needed (Schellstead, 2012) as with “a small diameter pile, a general rule of thumb is that the maximum scour depth is equal to about twice the pile diameter” (Hughes, 2012). Southern Company wishes to regard all references to the use of scour protection as a possibility should geophysical/geotechnical survey data collection and subsequent engineering design require scour protection. If scour protection is considered, potential scour protection devices or a scour protection plan will be developed for evaluation by BOEM. The tri-pile DCC tower design is the only met-tower design being considered in the Application. The preliminary DCC Assembly Drawings are provided in Appendix 1B.

2. Page 7, Primary Application, Table 1-3 - Comment**BOEM Comment**

“This table seems to imply that the applicant will coordinate ESA and Magnuson-Stevens Act consultations with NMFS. Although the applicant is encouraged to reach out to NMFS, it is BOEM’s responsibility to consult with NMFS. The applicant should consult with NMFS under the MMPA.”

Southern Company Response

Southern Company acknowledges this comment and anticipates being involved when appropriate. Southern Company understands that BOEM is the entity that leads ESA and Magnuson-Stevens Act consultations and these consultations will be initiated by BOEM.

3. Page 7-11, Addendum A, Section 2.4A**BOEM Information Request**

“Similar to the primary lease application there is a good description of biological resources (site characterization). However the specifics regarding the mooring design are lacking. For instance they mention a 5-ton mooring anchor (pg. 7, Section 2.4A) but make no mention of the anchor size, nor the approximate anchor chain sweep, necessary to describe the benthic habitat disturbance or to support their conclusion that the anchor will only impact a “few square meters.” They even have a picture of the anchor with chain on page 32 with no cross reference. A full description of the device and mooring system in one location within the document is necessary.”

Southern Company Response

Site specific data has not been collected and the final mooring design specifications have not been developed. For the purposes of this addendum it is projected that the mooring design would be a standard semi-taught chain and anchor. The dimensions of the 5 ton concrete anchor would be 49” L x 49” W x 48” H (Addendum B, **Appendix 2B**). The projected mooring design would employ a standard 3:1 ratio - chain length to water depth. The water depth at each of the three proposed sites is approximately 50 feet. At this depth the chain would be 150’ long. The maximum potential sweep radius of chain drag would be approximately twice the water depth (~100’). Depending on site characteristics the total area potentially impacted would be approximately 2,918m² (31,415 ft²). Once site characterization surveys are conducted, if it is found that environmentally sensitive areas exist within the estimated anchor chain sweep, Southern Company will contact BOEM to determine the appropriate mitigation. Southern Company’s first option would be to avoid sensitive areas. If it is not possible to avoid sensitive areas, a mooring could be reengineered to mitigate or completely eliminate the potential impact.

4. Page 13-16, Primary Application, Section 2.3 – Information Request**BOEM Information Request**

“The discussion of follow-up with BOEM regarding the potential discovery of “biologically sensitive habitat” should reference the videographic ground-truth option that is mentioned in section 2.3 (page 13) of the main application.”

Southern Company Response

Revised Sections

2.7 Archaeological Resources

While coastal Georgia is known to be rich in archaeological resources (NERRS, 2008), there are no reports or data to suggest that significant archaeological resources are located within the proposed OCS blocks, and therefore, no mitigation relating to archaeological resources should be

necessary. Geo-Marine, Inc. (GMI), on behalf of Southern Company, contacted the Georgia Department of Natural Resources (DNR), Historic Preservation Division (SHPO), and was referred to the Savannah, Georgia USACE underwater archaeologist. The Automated Wreck and Obstruction Information System (AWOIS) database was also queried in an effort to locate any archaeological resources possibly found in the lease block area. These efforts have returned no evidence of any significant archaeological resources within the project area.

Vessels dating from the 15th to 20th centuries are reported within 4.8 km (2.6 NM) of the U.S. Atlantic coast and so have the potential to be present offshore Georgia. Vessel types could include: wooden ships, ironclads, military and war vessels, German submarines, and wind, oar, paddle, pole, steam, and diesel-powered vessels. Since its opening in the mid 1700s, the Port of Savannah has been involved in multiple wars (i.e., Revolutionary War, War of 1812, Civil War, and World Wars I and II; Elliott et al., 2000; Symonds and Clipson, 2001). The naval aspect of these events lends to the potential for archaeological resource sites to be present within the vicinity of the proposed OCS blocks. Additional resources may include ships sunk during periods of conflict and dump or debris scatter, such as brick, rock, and other material from ballast discard (Elliott et al., 2000). Other unreported shipwrecks may have resulted from natural and man-made events and are possibly located in the project area.

Survey design plans will meet requirements and follow protocols as set forth by MMS NTLs (2009) and any new BOEMRE guidelines. If any archaeological resources are identified during surveys, all sea floor disturbing activities will be halted and additional site surveys will be conducted prior to continuation of project activities. Southern Company will contact BOEMRE and USACE to determine the significance of the find and implement a mitigation plan to avoid disturbing the area. All additional survey data collected, including videographic data, will be provided to BOEM prior to commencing with any sea floor disturbing activities.

2.8.2.1 Physical Resources

◆ **Shallow Hazards**

Shallow hazards in the vicinity of the proposed OCS blocks are composed of both submerged and non-submerged obstructions (**Figure 2-10**). Submerged hazards include a variety of unnamed shipwrecks, the Tybee dump site, and other obstructions (USGS, 2000; Captain Segull's Nautical Charts Inc., 2005) while buoys (e.g., NOAA weather buoys) and U.S. Navy Tactical Aircrew Combat System (TACS) support towers constitute non-submerged structures (GDNR, 2001; GDNR, 2010a; NDBC, 2010). Based on existing data there are no known obstructions within the preferred OCS block (6126) and alternative OCS block one (6074). Alternative OCS block two (6174) has two known shipwrecks within the block boundaries.

Possible Impacts Discussion

Construction of offshore installations may impact the marine environment through the alteration or destruction of key habitats and/or archaeologically significant sites. Shipwrecks provide both historical value and an important habitat for commercial and recreational fish species as well as

benthic organisms. Due to their ecological value, shipwrecks may be considered Biologically Sensitive Habitats (BSHs). The lease process does not require a detailed site survey prior to construction unless and until key habitats or archaeologically significant sites are discovered. There is no evidence or data suggesting that BSH or significant historical sites exist in any of the proposed OCS blocks. The MMS Preliminary Draft Lease Stipulations Report stipulates that for any BSH located or discovered within 328 ft of proposed seafloor disturbance or within 3,281 ft of locations in which activities could result in turbidity plumes (e.g., excavation), a detailed site survey must be conducted before any activities begin and at a minimum must include both color videography and still photography. Additionally, in an effort to ensure full habitat delineation, surveys should include a range outside the boundary of the BSH, even if outside the OCS block. Benthic communities and substrate composition must be classified in all site surveys. Furthermore, surveys conducted for a small site must include the entire area (100%) while larger survey sites may be completed using transect methods with no more than 65.6 ft between each transect line (MMS, 2010a).

Based on existing literature there are no known BSH within the proposed preferred OCS block that would trigger MMS Preliminary Draft Lease Stipulations requirements. If BSH is observed during site characterization surveys, Southern Company will notify the USACE and BOEMRE and other appropriate agency personnel to discuss possible impacts and project development plans. All survey data collected, including videographic data, will be provided to BOEM prior to commencing with any sea floor disturbing activities.

5. Information Request

BOEM Information Request

“If possible, BOEM would appreciate any metadata associated with the GIS layers provided by Southern Company.”

Southern Company Response

Southern Company has included the metadata with the submission of this Addendum B.

6. Page 2, Primary Application, Section 1.0 – Information Request

BOEM Information Request

“Clarify what is meant by an ‘alternative DCC’ (if it is in reference to a buoy, this should be explicitly stated).”

Southern Company Response

At the time the Primary Application was compiled Southern Company was aware that alternative wind measurement instrumentation options were emerging, some proven and some not. That is

the reason Southern Company referred to the possibility of an alternative Data Collection Configuration but we were not informed enough to specifically reference a buoy configuration (as we have now done through Addendum A filed after the Primary Lease Application). For place in the time context the reference to “alternative DCC” is correct. Nonetheless, the sentence could be rewritten in hindsight as below. This is not Southern Company’s preference.

Revised Section

1.0 Introduction

This Section provides the background for applying for a Bureau of Ocean Energy Management, Regulation, and Enforcement (BOEMRE) Interim Policy (IP) lease to place a Data Collection Configuration (DCC) on the Outer Continental Shelf (OCS) off the coast of Georgia to collect site-specific wind and environmental data. This lease application is solely for the proposed DCC.

Southern Company Research and Environmental Affairs (Southern Company), with the assistance of Georgia Power Company Environmental Affairs, is proposing to continue research on the wind resources off the coast of Tybee Island, Georgia. This research will follow a study begun in 2005 by Southern Company and the Georgia Institute of Technology, Strategic Energy Institute (GT SEI) to examine the wind power generation potential off the Georgia coast. The publication *SOUTHERN WINDS Summary Report 2007, A study of wind power generation potential off the Georgia coast* (2007 Report) gives the results of this study and provides the foundation for continuing site-specific offshore research and data collection.

In the 2007 Report, the results from an analysis conducted by GT SEI of wind data collected from a nearby Navy platform via the South Atlantic Bight Synoptic Offshore Observational Network (SABSOON), a nearby National Oceanic and Atmospheric Administration (NOAA) buoy and a nearby offshore lighthouse tower were presented. These results showed that an area off the coast of Georgia may be classified as a Class 4 wind regime, which potentially could provide enough energy for an offshore wind farm. The 2007 Report can be downloaded at <http://www.southerncompany.com/planetpower/pdfs/WindReport.pdf>.

Southern Company submitted a confidential nomination of interest to the United States (U.S.) Department of the Interior, Minerals Management Service (MMS), now BOEMRE, regarding the leasing of three block areas on the OCS pursuant to its IP on offshore alternative energy resource assessment and technology testing under Section 388 of the Energy Policy Act of 2005 in order to continue research and collect site-specific offshore data. In response to the nomination, BOEMRE sent correspondence on July 23, 2008, to inform Southern Company it was prepared to engage in a process of negotiation, analysis, and consultation focused on noncompetitive issuance of an alternative energy limited lease authorizing resource assessment in the three specified OCS block areas. The three OCS block areas were selected by Southern Company based on the results of the 2007 Report. These blocks appeared to have minimal logistical and environmental constraints and were in an area expected to have good wind resources with very few conflicts with other known uses.

This lease application has been prepared in accordance with BOEMRE’s *Alternative Energy Program, Interim Policy, Project Application Guidance for Outer Continental Shelf Alternative*

Energy Program, Interim Policy Leases (Project Application Guidance). Furthermore, previously approved BOEMRE lease applications were used as guidelines in developing the technical approach for this application.

If and when BOEMRE approves Southern Company's IP lease application and the lease terms are negotiated and acceptable to both parties, Southern Company intends to select a single preferred block area from the three previously designated OCS block areas in order to install either a meteorological tower or an alternative DCC (Such as a buoy DCC). The data collection equipment to be used in the selected OCS block will be designed and assembled with the necessary instrumentation to measure wind speed, direction, shear, and other characteristics and potentially with instrumentation to collect other environmental data for an as yet-to-be-determined specified time period. This data collected will help Southern Company determine the feasibility of wind generation off the Georgia coast and, thus, complete the study that was begun in 2005.

7. Page 4, Primary Application, Section 1.2 – Information Request

BOEM Information Request

Clarify if an AIS Transponder will be mounted on the meteorological tower.”

Southern Company Response

Yes. An Automatic Identification System Transponder will be installed on the Met Tower.

8. Primary Application, Table 1-3 – Information Request.

BOEM Information Request

“Add the following to Table 1-3 under FAA: 14 CFR Part 77 Marking of Meteorological Evaluation Towers (published in FR Vol. 76, No. 122, June 24, 2011)”

Southern Company Response

Southern Company understands that the June 24, 2011 Federal Register notice cited by BOEM states: "This action announces the FAA's recommended guidance for the voluntary marking of Meteorological Evaluation Towers (METs) erected in remote and rural areas that are less than 200 feet above ground level (AGL)." The MET Southern Company is considering for potential deployment would be greater than 200 feet above ground level (i.e., 260+/- feet above the mean high water line), and as such we do not believe this voluntary guidance would apply. As stated in the 2011 Lease Application at Table 1-3, we anticipate compliance with 14 CFR Part 77 as that regulation relates to FAA requirements for MET structures over 200 feet.

9. Information Request

BOEM Information Request

“The DOD is not on the list of Agency contacts; please clarify if this agency has been contacted regarding proposed action.”

Southern Company Response

As of the filing of the Primary Application or since, the Department of Defense has yet to be contacted regarding the IP Lease Application and any potential subsequent proposed action. At the appropriate time Southern Company will continue stakeholder outreach.

10. Page 13, Primary Application, Section 2.4 – Information Request

BOEM Information Request

“Clarify the number of support vessels that will be used for the installation of the tower described in paragraph 5.”

Southern Company Response

The vessels that will be utilized during installation are provided in Table 2-1 in section 2.6. A total of 5 vessels will be utilized. The “cargo barge” mentioned in section 2.4 paragraph 2 will not be utilized. This change is reflected in the revised section below.

Revised Section

2.4 General Structure and Project Design, Fabrication, and Installation Information

Section 2.4 provides information about the components of the DCC including a description of the sequencing for installing DCC components. Emergency DCC repair contingencies are also discussed.

The four main components of the DCC are the pilings, jacket, platform deck, and tower. The components will be transported and installed utilizing a derrick barge and anchor handling vessel. At the Project site, piles will be lifted into position and driven into the sea bed to the desired depth of approximately 16 m (53 ft) by using either impact or vibratory methods. Installation of the piles will take place using the derrick barge equipped with an 8-part anchoring system. Following pile driving, the jacket will be attached to the piles, leveled, and welded into place. Next, the platform deck will be lifted into position on the pile – jacket assembly and securely welded to the assembly. The platform deck is a three legged tripod structure supporting an individual meteorological tower and is equipped with a deck house, lights, horns, swing ropes, and tower structure legs. Once the platform deck is welded in position, the pre-assembled tower

will be secured to the tower structure legs and erected to the design height of 67 m (220 ft) above the platform deck. FAA lighting and various instruments will be mounted and interconnected to the control console located on the platform deck. Once DCC installation is complete, the entire structure will be inspected and all supporting vessels will be demobilized.

Southern Company will utilize sound engineering practices throughout the design, construction, normal operation and maintenance and in any emergency situation involving the DCC. In the event that unforeseen emergency DCC repairs become necessary as a result of events such as accidental vessel or aircraft collisions, force majeure, vandalism and/or other unplanned events, Southern Company will implement immediate actions including but not limited to the following based upon the nature of the emergency: the DCC will be taken out of service; the necessary personnel to fully access the emergency will be dispatched to the DCC site; the emergency situation will be contained; additional immediate emergency support will be acquired and dispatched to fully control the emergency. Once the immediate emergency situation is contained a DCC damage assessment will be conducted to determine the extent of repair necessary. Depending upon the emergency event and the outcome of the damage assessment Southern Company will decide to repair or decommission the DCC. If DCC repair is selected a Root Cause Analysis may be performed and corrective actions will be implemented. Corrective actions may include DCC engineering, safety, and instrumentation modifications and or the implementation of new operation procedures. Throughout any DCC emergency event Southern Company actions will be undertaken with appropriate BOEMRE consultation.

11. Page 15, Primary Application, Table 2-1 – Information Request

BOEM Information Request

“Table 2 – 1 describes Hours on Site for projected vessel usage. Is this based on 24-hr days or will the vessels be returning to port(s)? Provide similar table for operations and conceptual decommissioning of the DCC.”

Southern Company Response

The hour estimate is based on a 24 hour day. It is planned that the vessels will remain on site until installation is complete unless unforeseen circumstances require them to return to port. The projected vessel usage for operation and decommissioning is provided in Table 2-5 Section 2.8.1.1.

#12. Page 16, Primary Application, Section 2.8.1.1 – Information Request

BOEM Information Request

“Describe all of the vessel activities (number of vessel trips, number of hours vessels will operate, etc.) that will be necessary to support survey activities.”

Southern Company Response

As provided in section 2.8.1.1 Site Assessment Survey Phase, studies may be conducted to collect information on ocean-bottom characteristics. To appropriately survey the 1800m x 1800m grid it is estimated that it will take five (5) twelve hour days. The vessel will likely remain on site until the surveys are complete unless unforeseen circumstances (e.g., inclement weather, equipment modifications, etc) require it to return to the onshore support base.

#13. Page 17, Primary Application, Section 2.8.1.1 – Information Request**BOEM Information Request**

“Describe vessel activities for the routine operational/maintenance phase.”

Southern Company Response

Routine operational/Maintenance vessel activities are provided in section 2.8.1.1 Table 2-5. Vessel activities during routine operation/maintenance will consist of shuttling workers from the maintenance staging base to the DCC. As mentioned in Section 1.2, “The long-term operation and maintenance staging base during the life of the Project will be at Plant Kraft or at another Georgia Power facility located in close proximity” to the project site.

#14. Page 17, 17 Primary Application, Section 2.8.1.1 – Information Request**BOEM Information Request**

“Clarify what is meant by “may exercise the option to remove the DCC and associated equipment...” as described in paragraph 3.”

Southern Company Response

To clarify, Southern Company wants to preserve the opportunity to remove any DCC and associated equipment based upon wind resource measurement data. For example if data reveal unacceptable wind resources for power generation development then removal of the DCC and associated equipment may be a best option.

#15. Page 17, Primary Application, Section 2.8.1.1 – Information Request**BOEM Information Request**

“Please clarify the specific number of days decommissioning will require (paragraph 4).”

Southern Company Response

Decommissioning will require approximately 12 days.

#16. Page 19, Primary Application, Table 2-2 – Information Request**BOEM Information Request**

“An Anchor Handling Vessel from a ‘Louisiana Port’ is listed in Table 2-2 on page 19. Please clarify which port in Louisiana this vessel will utilize, or if this is the base for the vessel.”

Southern Company Response

The anchor handling vessel may be mobilized from a Louisiana port from which it is based. If Coastal Point Energy is utilized, then the anchor handling vessel will be mobilized from the Port of New Orleans.

#17. Page 6 & 22, Primary Application Section 1.2, - Information Request**BOEM Information Request**

“Application states the fabrication will be at an existing shipyard; please identify if this shipyard is in Port Wentworth. Additionally, the project application states the DCC components and equipment will be fabricated on derrick barges (paragraph 5), but on page 22 it states fabrication will be done at an existing shipyard. Clarify if the derrick barges will be used for construction, for fabrication or for transportation to the construction site only.”

Southern Company Response

Fabrication will take place at an existing shipyard in Louisiana. The Application (paragraph 5, Page 6) states that “The fabricated DCC components and equipment on derrick barges will take approximately twelve days to travel from the onshore support base in Georgia to the Project site and to be installed.” As mentioned in paragraph 3, a “probable location for the onshore support base and Project construction staging area will be Plant Kraft in Port Wentworth, Georgia.” The derrick barge will be utilized for transport and installation.

#18. Primary Application, Section 2.8.1.1 – Information Request**BOEM Information Request**

“Please clarify number of vessel trips by project phase for operations. What is the anticipated operational inspection schedule for the DCC (i.e., quarterly inspections or monthly?)

Southern Company Response

The number of vessel trips during the operational phase is provided in Table 2-5. To summarize, Southern Company anticipates that the DCC will be inspected/maintained every 45 to 60 days.

#19. Information Request**BOEM Information Request**

“Provide distances between anchor points, diameter and radii for the proposed Derrick Barge Anchor Pattern.”

Southern Company Response

See the 2011 Lease Application section 2.8.1.1 – Sea Bottom Disturbances, and Appendix A – Proposed Vessels and Anchoring Patterns. To further illustrate the derrick barge anchor pattern, **Addendum B, Appendix 3B** is included in this document.

#20. Page 3, Primary Application, Section 1.2 – Comment**BOEM Comment**

“Southern Company would like to reserve the right to relocate the proposed tower or buoy. This is only possible if all areas to which they want to relocate have been adequately surveyed, Section 106 consultation conducted, and approvals issued.”

Southern Company Response

Southern Company acknowledges the comment.

#21. Page 4, Primary Application, Section 1.2 – Information Request**BOEM Information Request**

“How deep into the seafloor will the proposed met tower extend?”

Southern Company Response

See section 2.4 of the 2011 Lease Application. Note: This is only an estimate. As mentioned in the Appendix B introduction, once site characterization surveys are conducted this information will be finalized and provided to BOEM.

#22. Page 10, Primary Application, Section 2.2 – Comment**BOEM Comment**

“It sounds as though geotechnical survey will be conducted after the geophysical survey and plan submission? If this is accurate, Section 106 consultation will be made dramatically easier.”

Southern Company Response

This is correct. It is Southern Company’s intention to conduct the surveys in this manner.

#23. Page 10, Primary Application, Section 2.2 – Comment**BOEM Comment**

“At a minimum, an 1800-m grid centered on the proposed DCC location will be surveyed. This will only be adequate if the anchor sweep for all construction activities will be located within this grid.”

Southern Company Response

Southern Company acknowledges this comment.

#24. Page 10, Primary Application, Section 2.2 – Comment**BOEM Comment**

Southern Company should understand that side scan sonar is used to identify cultural resources as well.

Southern Company Response

Southern Company acknowledges this comment.

#25. Page13, Primary Application, Section 2.4 – Information Request**BOEM Information Request**

“Need the anchor sweep of all proposed survey, support, construction and other vessels in order to confirm survey has adequately covered all seafloor disturbances.”

Southern Company Response

All seafloor disturbing activities will occur inside of the 1800m x 1800m grid.

#26. Page 15, Primary Application, Section 2.7 – Comment**BOEM Comment**

“Mitigation measures may be identified during Section 106 consultation.”

Southern Company Response

Southern Company acknowledges this comment.

#27. Page 15, Primary Application, Section 2.7 & Addendum A, Section 2.7A – Comment**BOEM Comment**

“If the following statement cannot be supported, then it and associated conclusions should be revised: ‘it is doubtful that any major resources would have gone unrecorded by previous archaeological explorations and projects.’ ”

Southern Company Response

Through this response, in hindsight, Southern Company proposes to have this sentence removed from the proceeding written record as it relates to both the 2011 Lease Application and Addendum A documents.

#28. Page 18, Primary Application, Section 2.8.1.1, Sea Bottom Disturbances – Information Request**BOEM Information Request**

“The footprint is not the only seafloor disturbance; anchoring is also considered a disturbance and must be included within the survey footprint.”

Southern Company Response

See Information Request #25.

REFERENCES CITED

- Captain Segull's Nautical Charts, Inc. 2005. Offshore Coastal Georgia: Tybee Island to Doboy Sound. Chart GA30-2. Portsmouth, Rhode Island: Captain Segull's Nautical Charts, Inc.
- Elliott, R.F., R. Rogers, and D. Crass. 2000. Stemming the tide: A survey of submerged cultural resources programs in the United States with a view toward Georgia. Southern Research, Historic Preservation Consultants, Inc., Ellerslie, Georgia.
- Hughes, S.A. Design of Maritime Structures – Scour and Scour Protection, USACOE. http://www.oas.org/cdcm_train/courses/course4/chap_8.pdf. Accessed 16 October 2012.
- MMS (Minerals Management Service). 2010a. Guidelines for biologically sensitive habitat field surveys and reports. Appendix A in Preliminary Draft Lease Stipulations report.
- NERRS (National Estuarine Research Reserve System). 2008. Sapelo Island National Estuarine Research Reserve Management Plan, 2008-2013. National Oceanic and Atmospheric Administration.
- Schellstede, H.J. Personal Communication between Mr. Herman Schellstede, President of Coastal Point Energy Development, and Mr. Greg Rosier, Geo-Marine, Inc. 16 October 2012.
- Symonds, C.L. and W.J. Clipson. 2001. The Naval Institute historical atlas of the U.S. Navy. Naval Institute Press, Annapolis, Maryland.
- USGS (United States Geologic Survey). 2000. USGS East-coast sediment analysis: Procedures, database, and georeferenced displays. U.S. Geological Survey Open-File Report 00-358. Eastern Publications Group.

Appendix 1B

Met Tower Assembly Drawings

Assembly Drawing

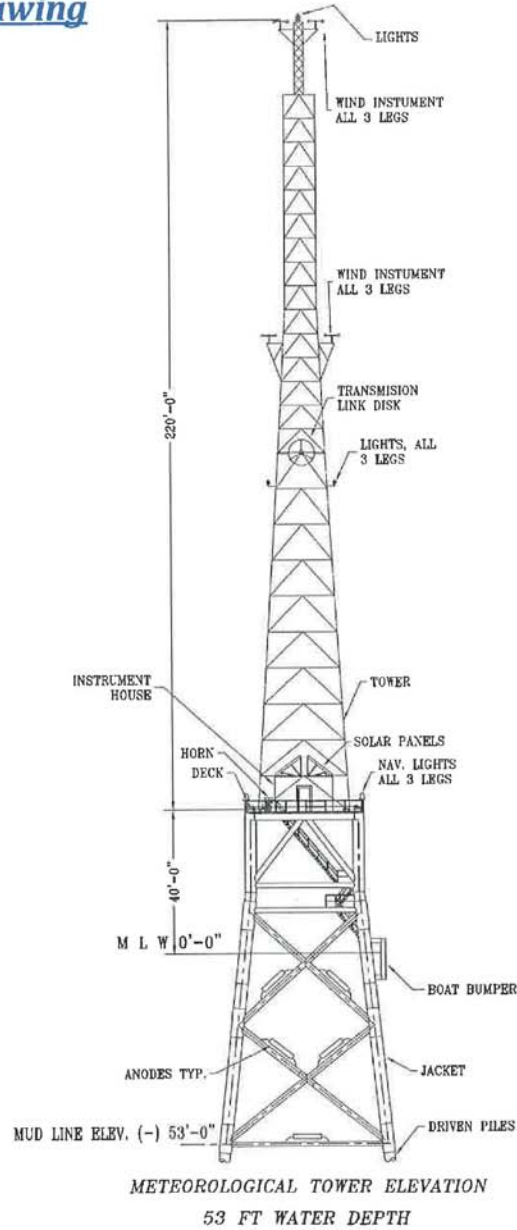

Hermann J. Schellstede & Associates, Inc.
199 Dodge Street
New Iberia, LA 70563 U.S.A.

Meteorological Tower Design, Specifications and Installation
Southern Company Services, Inc.

Proposal No. 5898.02.001 Offshore Georgia Project

Appendix 2B
Buoy Anchor Design

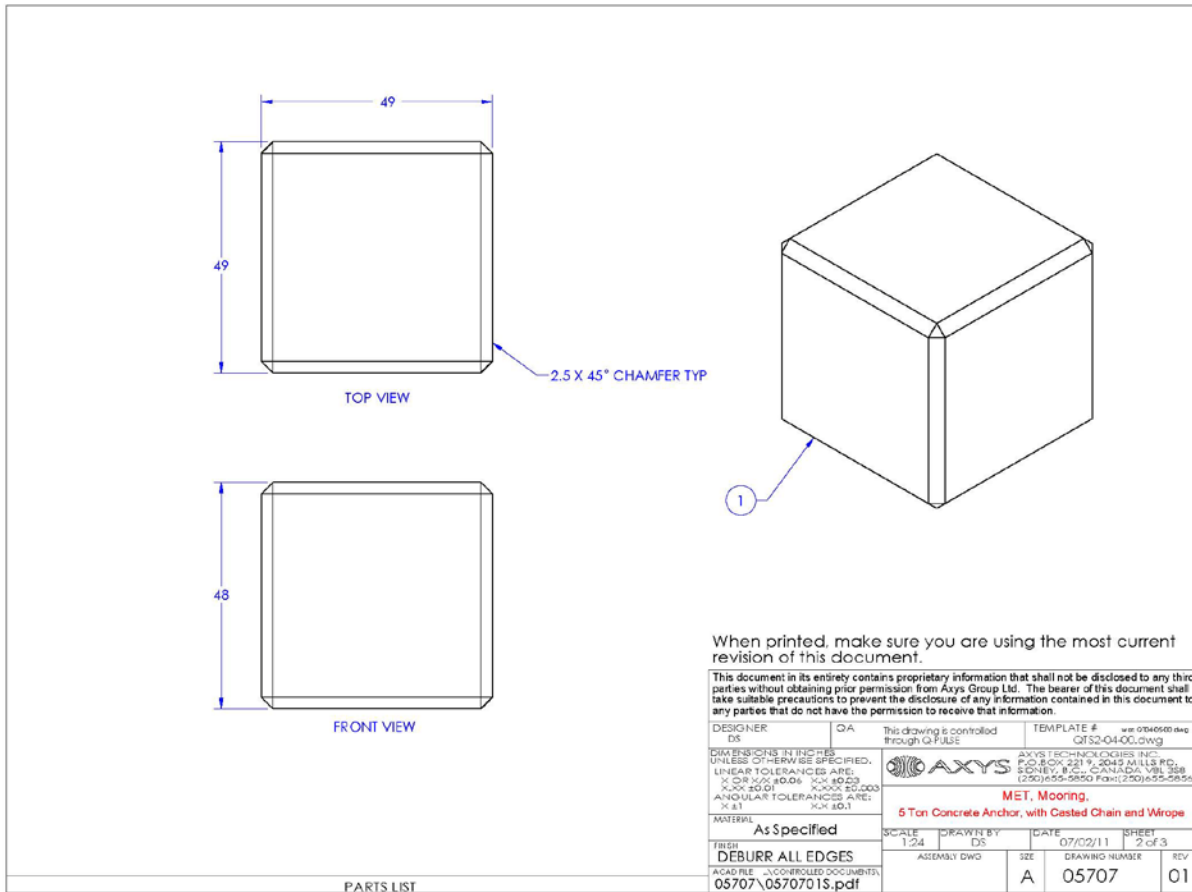

Appendix 3B

Proposed Derrick Barge Anchor Pattern

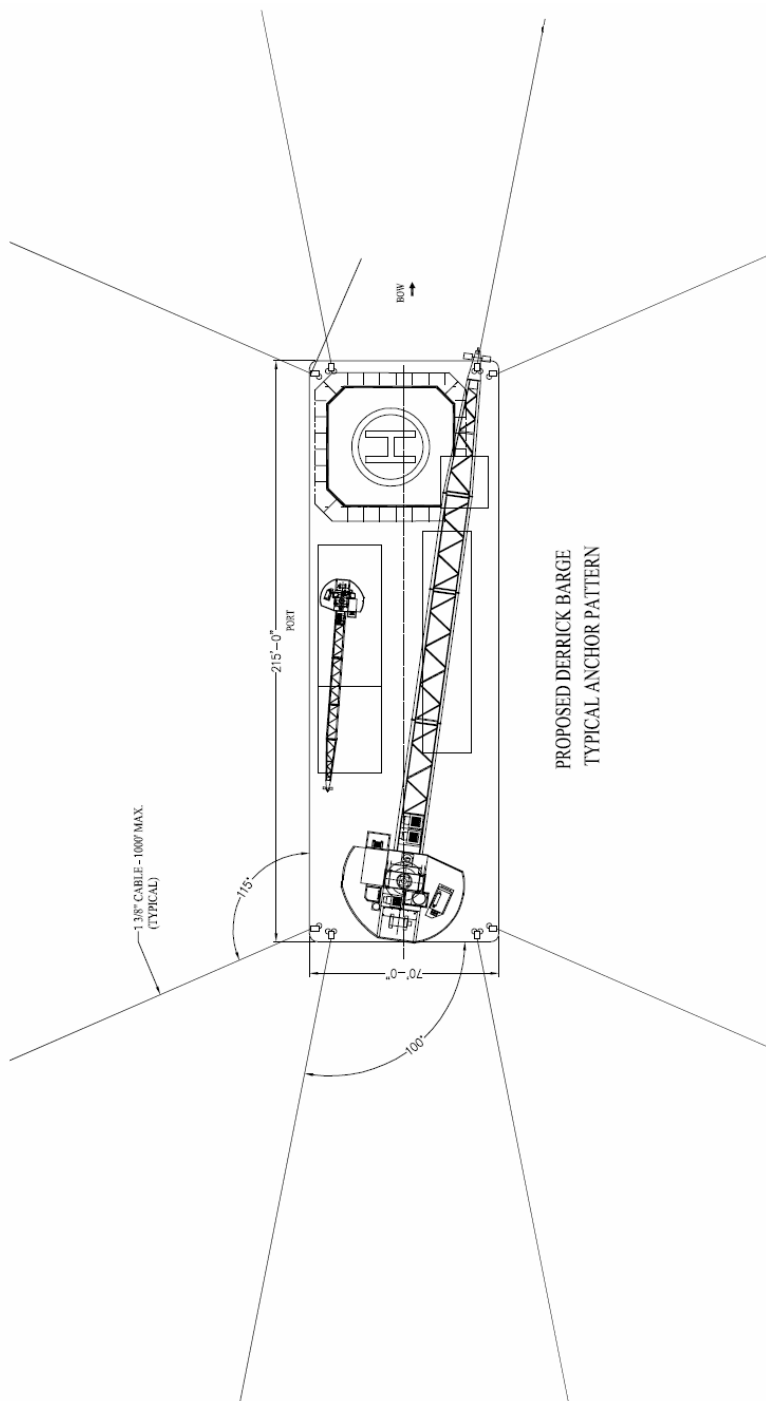

Appendix 4B

**Southern Company Interim Policy Lease Application & Addendum A
Comment & Information Request Matrix
June 22, 2012**

Southern Company Interim Policy Lease Application & Addendum A Comment & Information Request Matrix June 22, 2012						
#	Location			Comment	Type	Reviewer
	Page	Line	Section			
1.	18		Primary Application, 2.4	There is a general description of the height of the tower and the penetration depth of piles but there lacks any description regarding the approximate bottom footprint (page 18 says “a few hundred square feet.” What is the method of installation? Approximate timing/duration of installation time? In some sections they seem to refer to scour protection devices but this information is lacking from section 2.4. A range of types and footprint and overall tower design with illustrations in one location in the document are needed.	Information Request	
2.	7		Primary Application, Table 1-3	This table seems to imply that the applicant will coordinate ESA and Magnuson-Stevens Act consultations with NMFS. Although the applicant is encouraged to reach out to NMFS, it is BOEM’s responsibility to consult with NMFS. The applicant should consult with NMFS under the MMPA.	Comment	
3.	7-11		Addendum A, 2.4A	Similar to the primary lease application there is a good description of biological resources (site characterization). However the specifics regarding the mooring design are lacking. For instance they mention a 5-ton mooring anchor (pg. 7, Section 2.4A) but make no mention of the anchor size, nor the approximate anchor chain sweep, necessary to describe the benthic habitat disturbance or to support their conclusion that the anchor will only impact a “few square meters.” They even have a picture of the anchor with chain on page 32 with no cross reference. A full description of the device and mooring system in one location within the document is necessary.	Information Request	

Southern Company Interim Policy Lease Application & Addendum A Comment & Information Request Matrix June 22, 2012						
#	Location			Comment	Type	Reviewer
	Page	Line	Section			
4.	13-16		Primary Application, 2.3	The discussion of follow-up with BOEM regarding the potential discovery of “biologically sensitive habitat” should reference the videographic ground-truth option that is mentioned in section 2.3 (page 13) of the main application.	Information Request	
5.				If possible, BOEM would appreciate any metadata associated with the GIS layers provided by Southern Company.	Information Request	
6.	2		Primary Application, 1.0	Clarify what is meant by an “alternative DCC” (if it is in reference to a buoy, this should be explicitly stated).	Information Request	
7.	4		Primary Application, 1.2	Clarify if an AIS transponder will be mounted on the meteorological tower.	Information Request	
8.			Primary Application, Table 1-3	Add the following to Table 1-3 under FAA: 14 CFR Part 77 Marking of Meteorological Evaluation Towers (published in FR Vol. 76, No. 122, June 24, 2011)	Information Request	
9.				The DOD is not on the list of Agency contacts; please clarify if this agency has been contacted regarding proposed action.	Information Request	
10.	13		Primary Application, 2.4	Clarify the number of support vessels that will be used for the installation of the tower described in paragraph 5.	Information Request	
11.	15		Primary Application, Table 2-1	Table 2 – 1 describes Hours on Site for projected vessel usage. Is this based on 24-hr days or will the vessels be returning to port(s)? Provide similar table for operations and conceptual decommissioning of the DCC.	Information Request	

Southern Company Interim Policy Lease Application & Addendum A Comment & Information Request Matrix June 22, 2012						
#	Location			Comment	Type	Reviewer
	Page	Line	Section			
12.	16		Primary Application, 2.8.1.1	Describe all of the vessel activities (number of vessel trips, number of hours vessels will operate, etc.) that will be necessary to support survey activities.	Information Request	
13.	17		Primary Application, 2.8.1.1	Describe vessel activities for the routine operational/maintenance phase.	Information Request	
14.	17		Primary Application, 2.8.1.1	Clarify what is meant by “may exercise the option to remove the DCC and associated equipment...” as described in paragraph 3.	Information Request	
15.	17		Primary Application, 2.8.1.1	Please clarify the specific number of days decommissioning will require (paragraph 4).	Information Request	
16.	19		Primary Application, Table 2-2	An Anchor Handling Vessel from a ‘Louisiana Port’ is listed in Table 2-2 on page 19. Please clarify which port in Louisiana this vessel will utilize, or if this is the base for the vessel.	Information Request	
17.	6, 22		Primary Application, 1.2	Application states the fabrication will be at an existing shipyard; please identify if this shipyard is in Port Wentworth. Additionally, the project application states the DCC components and equipment will be fabricated on derrick barges (paragraph 5), but on page 22 it states fabrication will be done at an existing shipyard. Clarify if the derrick barges will be used for construction, for fabrication or for transportation to the construction site only.	Information Request	

Southern Company Interim Policy Lease Application & Addendum A Comment & Information Request Matrix June 22, 2012						
#	Location			Comment	Type	Reviewer
	Page	Line	Section			
18.			Primary Application, 2.8.1.1	Please clarify number of vessel trips by project phase for operations. What is the anticipated operational inspection schedule for the DCC (i.e., quarterly inspections or monthly?)	Information Request	
19.				Provide distances between anchor points, diameter and radii for the proposed Derrick Barge Anchor Pattern.	Information Request	
20.	3		Primary Application, 1.2	Southern Company would like to reserve the right to relocate the proposed tower or buoy. This is only possible if all areas to which they want to relocate have been adequately surveyed, Section 106 consultation conducted, and approvals issued..	Comment	
21.	4		Primary Application, 1.2	How deep into the seafloor will the proposed met tower extend?	Information Request	
22.	10		Primary Application, 2.2	It sounds as though geotechnical survey will be conducted after the geophysical survey and plan submission? If this is accurate, Section 106 consultation will be made dramatically easier.	Comment	
23.	10		Primary Application, 2.2	At a minimum, an 1800-m grid centered on the proposed DCC location will be surveyed. This will only be adequate if the anchor sweep for all construction activities will be located within this grid.	Comment	
24.	10		Primary Application, 2.2	Southern Company should understand that side scan sonar is used to identify cultural resources as well.	Comment	
25.	13		Primary Application, 2.4	Need the anchor sweep of all proposed survey, support, construction and other vessels in order to confirm survey has adequately covered all seafloor disturbances.	Information Request	

Southern Company Interim Policy Lease Application & Addendum A Comment & Information Request Matrix June 22, 2012						
#	Location			Comment	Type	Reviewer
	Page	Line	Section			
26.	15		Primary Application, 2.7	Mitigation measures may be identified during Section 106 consultation.	Comment	
27.	15		Primary Application, 2.7 Addendum A, 2.7 Table 2.14	If the following statement cannot be supported, then it and associated conclusions should be revised: "it is doubtful that any major resources would have gone unrecorded by previous archaeological explorations and projects."	Comment	
28.	18		Primary Application, 2.8.1.1, Sea Bottom Disturbances	The footprint is not the only seafloor disturbance; anchoring is also considered a disturbance and must be included within the survey footprint.	Information Request	