

United States  
Department of  
Agriculture

Forest Service

National Technology &  
Development  
Program

Watershed, Soil, Air Management  
0625 1801—SDDTC  
December 2006



# **Burned Area Emergency Response Treatments Catalog**



## Acknowledgements

The Burned Area Emergency Response Treatments Catalog (BAERCAT) was developed with the support and contributions of numerous individuals. The following regional and national Burned Area Emergency Response coordinators provided direction on the design, format, and content of the BAERCAT.

Bruce Sims (R1)  
Jerry Freeouf (R2)  
Penny Luehring (R3)  
Jeff Bruggink (R4)  
Brent Roath (R5)  
Steve Howes (R6)  
Emanuel Hudson (R8)  
Bonnie Ilhardt (R9)  
Meredith Webster (WO)

Technical review and contribution of drawings, photos, treatment implementation techniques, and effectiveness monitoring was provided by the following USDA Forest Service, BLM, and FHWA individuals. Their participation and willingness to share their time and expertise in the field of Burned Area Emergency Response helps to make the BAERCAT a valuable tool in future BAER assessments and implementation.

Peter Robichaud (RMRS, research engineer)  
Gregory Kuyumjian (R3, hydrologist)  
Annette Parsons (BLM/FS, soil scientist, GIS)  
George Toyama (SDTDC, visual information specialist)  
Mike Nolan (R3, engineer)  
Eric Brown (FHWA hydraulic engineer)  
Donna Sheehy (R1, engineer)  
Ken Hubbert (soil scientist)  
Gregory Napper (SDTDC, engineer)  
Ken Kanaan (R2, soil scientist)  
Annetta Mankins (R5, watershed specialist)  
Cheryl Taylor (R1, hydrologist)  
Jim Fitzgerald (R5, hydrologist)

Technical review of the BAERCAT was conducted by the following individuals from the USDA Forest Service, Department of the Interior, and Ministry of Forest Research. Their comments and experience in BAER provided invaluable input.

Jeff TenPas (R5 soil scientist)  
Tommy John (R2, soil scientist)  
William Fowler (R9, hydrologist)  
Pam Stachler (R9, hydrologist)  
Bill Crane (SDTDC, engineer)  
Doug Hyde-Sato (R3, contract officer)  
Richard Schwab (NPS BAER)  
Mike Smith (R4, hydrologist)  
Jim Bergman (R4, hydrologist)  
Robin Pike (Ministry of Forest Research, British Columbia)  
Scott Miles (R5, soil scientist)  
Rhonda Helzner (R4, hydrologist)





# **Burned Area Emergency Response Treatments Catalog**

Carolyn Napper  
Soil Scientist  
USDA Forest Service

San Dimas Technology &  
Development Center  
San Dimas, California

December 2006

---

Information contained in this document has been developed for the guidance of employees of the U.S. Department of Agriculture (USDA) Forest Service, its contractors, and cooperating Federal and State agencies. The USDA Forest Service assumes no responsibility for the interpretation or use of this information by other than its own employees. The use of trade, firm, or corporation names is for the information and convenience of the reader. Such use does not constitute an official evaluation, conclusion, recommendation, endorsement, or approval of any product or service to the exclusion of others that may be suitable.

The U.S. Department of Agriculture (USDA) prohibits discrimination in all its programs and activities on the basis of race, color, national origin, age, disability, and where applicable, sex, marital status, familial status, parental status, religion, sexual orientation, genetic information, political beliefs, reprisal, or because all or part of an individual's income is derived from any public assistance program. (Not all prohibited bases apply to all programs.) Persons with disabilities who require alternative means for communication of program information (Braille, large print, audiotape, etc.) should contact USDA's TARGET Center at (202) 720-2600 (voice and TDD). To file a complaint of discrimination, write to USDA, Director, Office of Civil Rights, 1400 Independence Avenue, S.W., Washington, D.C. 20250-9410, or call (800) 795-3272 (voice) or (202) 720-6382 (TDD). USDA is an equal opportunity provider and employer.



# Burned Area Emergency Response Treatments Catalog

## Table of Contents

### Chapter 1 Introduction

Starting the BAER Assessment Process .....	1
Areas To Review .....	1
Defining the Emergency .....	2
Treatment Selection .....	2
Land Treatments .....	3
Channel Treatments .....	4
Road and Trail Treatments .....	5
Protection and Safety Treatments .....	6
Summary .....	7
BAER Treatment Selection Tool .....	9

### Chapter 2 Land Treatments

Aerial Hydromulch .....	13
Ground Hydromulch .....	21
Straw Mulch .....	25
Slash Spreading .....	31
Erosion Control Mats .....	35
Log Erosion Barriers .....	41
Fiber Rolls or Wattles .....	49
Silt Fences .....	55
Soil Scarification .....	59
Seeding .....	63
Invasive Plants .....	69
Hazardous-Material Stabilization .....	73
Heritage-Site Stabilization .....	75

### Chapter 3 Channel Treatments

Checkdams .....	81
In-Channel Tree Felling .....	89
Grade Stabilizers .....	93
Stream Channel Armoring .....	97
Channel Deflectors .....	99
Debris Basins .....	101

### Chapter 4 Road and Trail Treatments

Outsloping .....	105
Rolling Dips .....	109
Overflow Structures .....	113
Low-Water Stream Crossings .....	121
Culvert Modification .....	127
Debris Rack and Deflectors .....	131
Riser Pipes .....	139
Catchment-Basin Cleanout .....	145
Storm Inspection and Response .....	149
Trail Stabilization .....	153
Road Decommissioning .....	159

### Chapter 5 Protection and Safety Treatments

Facility-Safety Work .....	161
Flood Warning Systems .....	163
Hazard-Trees and Unstable Rocks .....	165

Protection Enforcement.....	169
Protective Fences and Barriers.....	173
Warning Signs.....	179
<b>References</b> .....	<b>183</b>
<b>Appendix A</b>	
Section 1 Excerpts From “Aerial Helimulching Lessons Learned and Recommendations” .....	191
Section 2 Aviation Safety Plan .....	199
Section 3 Contract Example for BAER Helimulching.....	205
Section 4 Straw Delievery Accounting Form .....	211
Section 5 Helicopter Straw Accounting Form .....	212
<b>Appendix B</b>	
BAER Treatments Sample Contract Specifications by Gregory Napper and Carolyn Napper .....	213
<b>Appendix C</b>	
Low-Water Stream Crossing Calculations .....	235
<b>Appendix D</b>	
BAER Job Hazard Analysis .....	237
<b>Appendix E</b>	
Riprap Class and Size Gradation: Requirements for Riprap .....	243
<b>Appendix F</b>	
Storage Capacity Reference for Contour Felled Log Erosion Barriers by Peter Robichaud.....	245



# Chapter 1 Introduction

---

## **Introduction**

The Burned Area Emergency Response (BAER) treatments catalog presents, instructions, monitoring tools, and references that BAER assessment and implementation teams use to identify appropriate treatments in a BAER emergency. The target audience for this publication is any Federal land management agency BAER assessment and implementation team. The publication is written as instructions to the team. However, other readers with an interest in emergency rehabilitation of fire areas will benefit from this information.

BAER treatments for land, channels, roads/trails, and protection and safety are discussed in the catalog. Readers will learn the primary treatment use, the purpose and objective of the treatment, suitable locations for treatment implementation, and cost factors. Available treatment effectiveness information is provided to share known benefits and limitations of the treatments, although such information may be limited or anecdotal. BAER teams should validate specific treatment effectiveness in the affected area prior to recommending its use.

BAER implementation team members can familiarize themselves with project design and implementation information as they review design considerations, tools and equipment, construction specifications, and safety considerations.

Implementation and effectiveness monitoring recommendations for each treatment are included. Photographs and drawings illustrate the treatments and provide information to facilitate contracting. A draft contract with specifications for each treatment is in the appendix.

Although the BAER catalog provides current comprehensive guidance on BAER treatments numerous variations exist for each treatment. BAER teams must consider the local conditions, climate, resources, geography, vegetation response, storm intensity, and values at risk when prescribing a treatment. A treatment that is highly effective in Washington may not be as effective in Arizona. BAER teams should use the catalog as general guidance for treatment selection and implementation, and work closely with local resource specialists and regional BAER coordinators to ensure that the correct treatment is prescribed and implemented.

## **Starting the BAER Assessment Process**

BAER assessment team composition is determined both by the size of each fire and the nature of values potentially threatened by post-fire effects. Generally, specialists in soils, hydrology, geology, engineering, wildlife, botany, and archeology assess the fire's effects and predict the post-fire effects. Each resource specialist brings a unique perspective to the BAER process, to help the team rapidly determine whether the post-fire effects constitute urgent threats to human life, safety, property, or critical natural and cultural resources and to produce an integrated plan to respond to those threats (FSM 2500-2523).

## **Areas to Review**

The assessment of a burned area includes a review of existing resource documents. Prior to conducting field reviews, the forest supervisor or district ranger briefs the BAER team regarding the fire and known values at risk (FSM 2500-2523). Forest maps are used to identify structures and infrastructure within and downstream of the burned area. Each BAER team member consults appropriate references (such as databases, maps, and inventories) to identify additional values at risk.

# Chapter 1 Introduction

---

Soil-resource and ecological-unit inventories provide baseline information on soil characteristics, including erosion potential, slope class, soil texture, and management limitations. Review of hydrologic records—including historic records of magnitude and duration of events, frequency curves, flood history, and records of past wildfires—help the hydrologist understand a watershed’s response to fire. The access and travel management plan and road management objectives, which are products of the roads analysis process, provide information on roads including jurisdiction, maintenance level, and resource concerns.

Next, the field review focuses on the fire’s effect (i.e., changes in vegetation cover and watershed response) and identifies potential values at risk. The BAER team specialists look at:

- Amount and distribution of high- and moderate-burn severity within each watershed.
- Presence and extent of water-repellent soils.
- Presence and extent of effective soil cover.
- Potential needle-cast from existing vegetation.
- Vegetative recovery timeframe and potential for noxious and invasive plant spread.
- Flood-prone areas and downstream effects.
- Debris-prone areas and downstream effects.
- Flood-source areas and downstream effects.
- Potential for stream diversion at trail and road crossings.
- Channel stability and riparian vegetation conditions.
- Potential for increased erosion or sedimentation.
- Potential for water quality deterioration.
- Barriers to natural water flow (e.g., fencing, stockponds, dams).
- Physical hazards at campgrounds, trailheads, and facilities.
- Capacity and condition of structures at stream crossings.
- Condition of road infrastructure including signs, guardrails, and road delineators.
- Potential hazardous materials contamination created or exposed by the fire.
- Downstream values outside the fire perimeter that may be at risk.
- Potential impacts on road and trail prisms to increased erosion and runoff from adjacent hillslopes.
- Access needs on routes throughout the burned area to facilities, residences, and campgrounds.

## **Defining the Emergency**

The BAER assessment team integrates the information collected from engineering, hydrology, soils, and other resource areas to determine whether the post-fire effects will threaten life, safety, or property, or cause unacceptable degradation to natural or cultural resources. They also determine whether the burned area requires emergency treatments to minimize identified threats. The assessment team identifies the threat or emergency type, location, duration, and extent prior to determining appropriate emergency treatments (Veenis 2000; FSM 2500-2523).

## **Treatment Selection**

Once a BAER team determines that a fire created an urgent need to implement emergency stabilization measures, the treatment selection process begins. The BAER assessment team identifies appropriate treatments and measures that best respond to the potential threats or hazards using reliable and proven land, channel, road/trail, and

# Chapter 1 Introduction

---

protection/safety methods (FSM 2520-2523). Often several treatments are recommended to reduce or mitigate the effect of the threats in a burned area. The BAER team considers numerous treatment-selection factors in consultation with the forest supervisor and leadership team including:

- Nature of downstream values at risk.
- Effectiveness of treatment.
- Treatment combinations (land, channel, road/trail, protection/safety) to reduce risks.
- Timeframe for implementation.
- Personnel and resources available for implementation and monitoring.
- Hazards associated with treatment implementation.
- Ease of treatment implementation.
- Cost effectiveness of treatments.
- Coordination with other Federal, State, and local agencies.

Generally, a combination of land, channel, road/trail, and protection/safety treatments are selected. The synergy of treatments often provides the most effective set of stabilizing factors. Not all treatments are as effective at obtaining the emergency stabilization objectives. A treatment selection tool is provided (table 1) to assist BAER teams in selecting treatments that achieve stabilization objectives. Treatments are ranked 1, 2 or 3 to identify the degree by which they meet the stabilization objective. If the box is blank the treatment does not address the objective. Use table 1 to ensure the appropriate treatment is selected. A brief summary of the considerations and use of the treatments within each category follows.

## Land Treatments

Land treatments stabilize burned areas by preventing or reducing fire's adverse effects. They foster recovery by providing soil cover and reducing erosion, trapping sediment and reducing sedimentation, and/or reducing water repellency and improving infiltration. They also maintain ecosystem integrity by preventing expansion of unwanted species.

### Mulching

Mulching provides immediate ground cover and protects soils from erosion and nutrient capital loss. Mulching can reduce downstream peak flows by absorbing rainfall and allowing water repellency to breakdown. Mulch helps to secure seeds that are either stored in the soil or applied as an emergency treatment by maintaining a favorable moisture and temperature regime for seed germination and growth. Mulching methods include aerial and ground application using straw, woodchips, or fiber materials.

### Erosion barriers

Erosion barriers reduce the slope's length, slow overland runoff, trap sediment, and improve infiltration by installing logs, fiber rolls, or sandbags. Knowing storm type and erosion potential, trapping capacity of each structure, and implementation production rates are critical factors for selecting appropriate erosion barriers.

### Scarification

Scarification increases infiltration and reduces runoff and erosion. Teams need to evaluate the persistence, depth, and pervasiveness of water repellency when recommending scarification methods, such as tilling, ripping, and raking. Teams recommend this treatment with seeding as a tool for seedbed preparation. Hazards to crews implementing this treatment should be considered fully.

# Chapter 1 Introduction

---

<b>Slash spreading</b>	Slash spreading provides soil cover. Teams should identify the amount of soil cover necessary to reduce erosion. Using mechanized equipment, such as hydroax or mastication may provide more cover faster than using hand-held chain saws.
<b>Seeding</b>	Seeding provides a vegetative surface cover to minimize soil and wind erosion. Seeding methods include both aerial and hand application. Seeding may prevent the introduction and increase of noxious and invasive weeds. Because seeding may be ineffective until the second year, teams may recommend applying mulch for first-year effectiveness.
<b>Invasive plants</b>	If noxious and invasive plants were present prior to the fire, the assessment team may consider preventive treatments that include seeding of highly competitive desired species. Appropriate methods for removing or reducing noxious and invasive plants in the burned area (hand removal, and mechanical, biological, and chemical methods) depend on the extent of the population. Biological and chemical treatments can be implemented only if an environmental document is approved for both the area and biological or chemical agent identified (BAER Guidance Paper-Noxious and Invasive Weed Treatment).
<b>Critical-habitat stabilization</b>	Critical-habitat stabilization includes site-specific habitats, such as meadows, riparian areas, and other unique habitats. Methods to stabilize the site, foster recovery, and reduce adverse impacts to the values at risk depend on the habitat.
<b>Hazardous-material stabilization</b>	Hazardous-material stabilization includes methods to stabilize an identified hazardous material onsite. Measures may include rolled erosion control products to prevent erosion or reduce runoff onto or from the site (BAER Guidance Paper-Hazardous Materials).
<b>Heritage-site stabilization</b>	Heritage-site stabilization protects and maintains site integrity. Employing erosion control products, such as mulch, rolled erosion control products, and jute netting; establishing erosion barriers; and removing destabilized trees or other features help maintain site integrity (BAER Guidance Paper-Heritage Resources).
<b>Channel Treatments</b>	Use channel treatments to reduce or mitigate the effect to water quality, loss of water control, slow water velocity, trap sediment, and maintain channel characteristics. Channel treatments may reduce adverse impacts to downstream values at risk including property and critical natural or cultural resources.
<b>Grade stabilizers</b>	Grade stabilizers reduce channel downcutting by establishing grade control, decreasing water velocity, and maintaining width-to-depth ratio. When correctly implemented, grade stabilizers i.e., rocks, logs, or fiber-roll structures are most effective in small watersheds (ephemeral channels).
<b>Checkdams</b>	Checkdams temporarily store sediment and can attenuate peak flow as water is routed through several small basins. Careful hydrologic- and sediment-yield analysis is recommended before prescribing a checkdam of logs, strawbales, and rock/gabion structures.
<b>Debris and sediment basins</b>	Debris and sediment basins temporarily store sediment and can attenuate peak flows. Debris basins are expensive and time consuming to design and build to meet standards for dam construction. However, in areas of high

# Chapter 1 Introduction

---

values at risk, a debris basin may be the most effective treatment. BAER team members should consider size and amount of material to be moved as well as the long-term impacts of construction and maintenance.

## **Channel-debris clearing**

Channel-debris clearing removes debris from the channel and flood-prone area that could dislodge and plug culverts downstream. Prescriptions to clear debris should consider channel and geomorphic processes, as well as fishery values within the system.

## **Stream-channel armoring**

Stream-channel armoring reduces the potential impact from increased peak flows on stream reaches by placing rocks or suitable materials along the banks. Additional methods include rock vanes, in-channel felling, and stream deflectors. These methods reduce streambank erosion and protect both natural resources and property.

## **Road and Trail Treatments**

Road and trail treatments mitigate the fire's effect on the transportation infrastructure and protect life, safety, property, and critical natural or cultural resources. These treatments work in conjunction with land, channel, and protection/safety treatments (BAER Guidance Paper-Roads and Trails Treatments).

## **Rolling dips and waterbars**

Rolling dips and waterbars create additional drainage across roads or trails for anticipated increased runoff. Where the road prism alternates from insloped to outsloped, consider removing berms, and rolling the grade. Use armored dips for roads expecting all-season traffic. For roads with more than a 10-percent slope that can be closed to traffic, dig waterbars into the road and skew them properly to maintain their function.

## **Berm removal**

Berm removal on the outside edges of roads allows water to sheet-flow off the road prism rather than being concentrated. Careful distribution of water minimizes its erosive power.

## **Outsloping**

Outsloping prevents water concentration and channeling by dispersing runoff across the road. The cross-slope of an outsloped road varies from 3 to 5 percent and depends on road profile, maintenance level, and traffic service level.

## **Overside drains**

Overside drains are used to protect the fillslope from erosion where increased runoff is expected from the fire's effect. To prevent fill erosion, armor lead-out ditches with riprap. Corrugated metal downdrains can fail when installed on roads with earthen berms. Use culvert extensions and other downdrain structures to prevent erosion and release runoff onto stable areas.

## **Culverts**

Culverts that are used for roadway drainage (ditch relief culverts) and channel crossings become a watershed emergency when they are damaged in a fire or when their hydraulic capacity is marginal. Stream diversion potential may exist along insloped roads with a continuous road grade. Post-fire sediment and debris flow in channels may plug culverts and increase the diversion-potential risk. Increased storm runoff due to the fire's effects can cause the failure of undersized culverts and lead to erosion of the road fill and deterioration of water quality. Potential treatments include:

# Chapter 1 Introduction

---

<b>Culvert removal</b>	<p>Remove cross-drain culverts that are 24 inches or less and replace with outsloping or rolling dips. For channel-crossing culverts, evaluate whether a low-water stream crossing (unvented ford) would address the emergency and meet resource concerns (access, aquatic species, and water quality). If access is not needed, remove the culvert temporarily and replace after the emergency ceases. Place barricades as needed.</p> <p>Temporarily modifying culverts with risers or slotted drop inlets, adding elevated inlets, or armoring diversion dips below culverts can mitigate plugged culverts. To determine the appropriate modification, analyze each culvert for location, fill depth, access, sediment potential, and values at risk.</p>
<b>Debris structures</b>	<p>Installing structures above a culvert or bridge crossing can protect the facility and prevent plugging. Debris racks and deflectors require inspection and regular maintenance.</p>
<b>Replacement or upgrade</b>	<p>Fire damaged culverts should be replaced or upgraded if increased flow or debris is expected. Upgrades solely to protect the road or trail investment are used only when less costly than repairing damage.</p>
<b>Storm inspection and response</b>	<p>Typically, crews drive the roads during or immediately after storms, checking sediment and debris accumulations and performing thorough, rapid inspection of road-drainage features, culverts, and other structures. The crew is responsible for maintaining culvert function by opening culvert inlets and removing debris.</p>
<b>Trail stabilization</b>	<p>Trail stabilization reduces adverse effects of increased runoff and erosion from fire. Methods include waterbars (rock, log, or rubber), armored stream crossings, and rolling dips.</p>
<b>Road closure</b>	<p>Closing roads is the safest and most effective treatment when a threat to human life is identified. Roads can be closed where an alternative access exists. Closures are implemented with a signed forest order and must be enforced. Possible treatments include gates, jersey barriers, barricades, signs, and closure enforcement.</p> <p>Where closure is impossible, treatments may combine hazard removal, storm inspection and response, culverts modifications, dips, debris racks, warning signs, or flood-warning systems. The combination depends on the location, amount and type of access, and climatic conditions.</p>
<b>Protection and Safety Treatments</b>	<p>Treatments to protect life, safety, and critical natural and cultural resources include flood-warning systems, warning signs, barriers, facility safety work, enforcement protection, and hazard removal.</p>
<b>Flood-warning systems</b>	<p>Flood-warning systems are used when there is a direct and substantial threat to life and a high probability of significant storms capable of producing floods or mass failure. Flood-warning treatments include early-warning systems that are collaboratively identified with the local jurisdiction responsible for public safety (BAER Guidance Paper-Early Warning Systems).</p>
<b>Warning signs</b>	<p>Warning signs alert drivers and recreational users of existing or potentially hazardous conditions created by wildfire incidents. Warning signs use universal symbols and follow <i>Sign and Poster Guidelines for the Forest</i></p>

# Chapter 1 Introduction

---

*Service (EM-7100-15)*. The signs identify the immediate threats to public safety or limit access to protect treated or recovering areas.

## **Protective fencing and barriers**

Protective fencing and barriers limit public and/or livestock access to protect treated or recovering areas where emergency access is not necessary. Barriers also prevent access to hazardous areas (BAER Guidance Paper-Gates, Fences, and Barriers).

## **Protection enforcement**

Protection enforcement is implemented through established patrol areas, signing, and enforcement actions and informs users of temporary changes in effect as a result of a fire.

## **Facility safety work**

Facility safety work includes replacing minor warning or safety control facilities damaged or destroyed by the fire. Treatments are implemented rapidly where human health or safety is at risk and no other protection options exist (BAER Guidance Paper-Facility Replacement).

## **Hazard removal**

Hazard removal includes prevention, control, or removal of contaminated or hazardous material created or exposed by the fire. In addition, hazard-tree and unstable-rock removal prevents risk to human life and property. Removing the hazard is prescribed when access to the area is not administratively controllable (BAER Guidance Paper-Hazardous Tree and Rock Removal).

## **Summary**

The BAER assessment team conducts a rapid assessment of the fire area and downstream values at risk to determine whether the post-fire effects pose a threat to life or property or will cause unacceptable degradation to natural or cultural resources. The teams assess the nature of the threats and their potential impact to recommend appropriate emergency treatments.

BAER assessment and implementation teams can use this catalog in selecting and implementing appropriate treatments for the identified emergency. The following chapters describe land, channel, road and trail, and protection and safety treatments currently available to BAER teams.





# Chapter 1 Introduction

---

## BAER Treatment Selection Tool

Land Treatments								
	Cover Treatments				Barrier Treatments			
	Straw mulch	Hydromulch	Slash spreading	Seeding	Contoured felled log erosion barrier	Fiber rolls	Silt fences	Scarification
Reduces Erosion	x1	x2	x2	x3	x2	x2	x2	x3
Increase Cover	x1	x2	x2	x2*				
Improve Moisture Retention	x1	x2	x3					
Reduce Slope Length					x2	x2	x1	
Slows Runoff Velocity								
Trap Sediment			x3		x2	x2	x1	
Increase Infiltration	x1	x2			x2	x2		x2
Provide a Seedbed	x2	x2						x2
Reduce Noxious Invasive Plant				x2				
Provide Surface Roughness	x1	x3	x2	x2				x2

1= Fully meets objective

2= Partially meets objective

3= Rarely or seldom meets objective

\*= not effective in first year, partially effective year 2

## Chapter 1 Introduction

	Channel Treatments										
	Checkdams			In-channel structures							
	Strawbale checkdams in ephemeral channels	Log checkdam	Rock checkdam	In-channel felling	Grade stabilizer rock	Grade stabilizer log	Streambank armoring	Channel deflectors	Debris and sediment basin		
Trap Sediment Provides Grade Control Reduces Velocities Slows Sediment Delivery Attenuates Peak Flow Reduces Streambank Erosion Durability of Structure Maintenance Needs	x1	x1	x1	x2	x1	x1			x1		
	x2	x2	x2								
	x2	x2	x2								x1
	x3	x2	x2								x1
	x2	x1	x1		x1	x2	x2	x2	x1	x2	x1
	moderate	moderate	low*	low	low	low	low	low	low	low	moderate

- 1= fully meets objective
- 2= partially meets objective
- 3= seldom or rarely meets objective

\*low maintenance when structures are large

## Chapter 1 Introduction

Road and Trail Treatments																
	Storm inspection response	Road Prism Drainage						Culvert Modification					Trail Stabilization			
		Outsloping	Dips	Armored dips	Rock armored overflow structure	Armored low water stream crossing	Metal overside drains	Debris racks deflectors	Risers	Culvert upgrades	Culvert cleanup	Metal end-sections				
Improve Hydraulic Capacity			x1	x1				x1				x1			x1	Trail stabilization
Shortens Flow Length		1x														
Prevents Reduces Plugging of Culverts	x2			1x				x1				x1			x2	
Prevents Reduces Diversion	x3		x1	x1				x1								
Traps Debris												x2				
Reduces Road Erosion		x2		x1			x1	x2							x2	
Disperses Flows		x1			x1											x2
Protects Road Fill		x3		x1			x1							x1		

- 1= fully meets objective
- 2= partially meets objective
- 3= seldom or rarely meets objective

## Chapter 1 Introduction

---

	Minor Facility Safety Work	Hazard Removal	Warning Signs	Protective Fencing and Barriers	Protection and Enforcement	Flood Warning Systems
Reduces Impacts to resources		x1		x2	x2	
Improves Public Safety	x1	x1	x1	x1	x2	x1

1= Fully meets objective

2= Partially meets objective

3= Rarely or seldom meets objective

### Assessment Team Considerations For Emergency Stabilization

#### Primary Treatment Use

Aerial hydromulch provides immediate temporary soil cover to hillslopes inaccessible by ground-based equipment with high-erosion hazard ratings and high- and moderate-burn severity.

#### Description

Hydromulch refers to fiber mulches and soil stabilizers (tackifiers, polymers, and seeds) that, when mixed with water and applied to the soil surface, form a matrix that helps reduce erosion and fosters plant growth (Robichaud 2003).



Figure 1—Aerial application after the Cedar fire, Cleveland National Forest, December 2003.

#### Purpose of Treatment

Aerial hydromulch reduces erosion by providing cover that reduces raindrop impact and absorbs overland flow. Hydromulching binds loose soil and ash to protect downstream water quality. The mulch improves moisture retention, which benefits seeded mixtures.



Figure 2—Treated areas on Cedar fire, December 2003.

## Chapter 2 Land Treatments

### Emergency Stabilization Objective

Aerial hydromulch helps prevent unacceptable degradation to natural resources, including erosion and deterioration of water quality.

### Suitable Sites

Treatment is intended for application in one or more of these situations:

- Areas inaccessible by ground.
- Areas with intermingled high- and moderate-burn severity.
- Soils with a high erodibility factor (K) and or reduced infiltration capability.
- Sparsely forested areas with slopes between 25 and 50 percent.
- Subwatersheds with high values at risk adjacent to or below the treatment area.
- Subwatersheds that supply domestic water and are vulnerable to ash, accelerated erosion, and sedimentation that could disrupt water quality.
- Areas prone to strong winds where dry mulch would be removed.

Aerial hydromulch costs range from \$2,000 to \$3,000 per acre. Application rates vary depending on the fire.

### Cost

Cost factors include:

- Number of seed mixes.
- Helicopter/fixed-wing aircraft turnaround time.
- Helicopter/fixed-wing aircraft production rate.
- Location of staging areas.
- Availability of water close to staging areas.
- Road access for large equipment.



Figure 3—Aerial hydromulching requires close access to water, large staging areas, and close proximity to treatment units.

### Treatment Effectiveness

Aerial hydromulching is a new BAER tool. Current effectiveness monitoring conducted on the Cedar and Hayman fires indicated limited effectiveness of aerial hydromulch to reduce post-fire sediment production rates (Hubbert, unpublished paper; McDonald 2004; Robichaud 2003). Hydromulch effectiveness depends on several factors including application rates, slope length, slope steepness, residual canopy, and mulch components.

Application rates (dry product per unit area) can influence treatment effectiveness. For example, on the Hayman fire, the aerial application rate of 1 ton per acre was intended to provide 70-percent ground cover. Immediately after application, ground cover was 65 percent and declined to 30 percent by the first post-fire year. Measured erosion reduction was only 18 percent in the first post-fire year and 27 percent in the second post-fire year.

Hydromulch applied to slopes of more than 50 percent have varying success rates. On the Cedar fire in California, rilling occurred on slopes of more than 50 percent (Hubbert, unpublished paper). Heavily timbered sites at Cerro Grande lost 40 percent of the application on standing trees (Kuyumjian, personal communication).

Application rates in southern California varied significantly from the prescribed rates. Prescribed application rates were 100-percent broadcast and 50-percent contour strips. Treated strips were 115 feet wide separated by untreated strips 115 feet wide. Actual ground cover was 51 percent for the 100-percent broadcast cover and 30 percent for the 50-percent strip treatment (Hubbert, unpublished paper). There was no first post-fire year erosion reduction in the 50-percent coverage area and a 53-percent reduction in the 100-percent coverage area. In the second post-fire year, there was a 34-percent erosion reduction in the 50-percent coverage area and a 44-percent reduction in the 100-percent coverage area (Robichaud, personal communication).

Cedar fire monitoring found that the intensity of the rain event was an important factor in overland flow, especially when antecedent soil moisture conditions were near or at storage capacity (Hubbert, unpublished paper). Once runoff concentrates, the shear force of the water is greater than the resistive force of the mulch causing it to be displaced. Once exposed, the soil is easily eroded. Hydromulch is more effective on short slope length such as road cuts where concentrated flow is not likely.

Based on the results, hydromulch is not a cost effective erosion control treatment for steep, high-burn severity hillslopes with long slope length.

The effect of hydromulch on native vegetation was monitored on the Cedar fire in southern California. Quantitative findings indicated that vegetation recovery (percent cover) was not hindered by the hydromulch (Hubbert, unpublished paper).

### **Project Design and Implementation Team Information**

**Design** After the BAER assessment team has designated potential treatment areas, review the field sites to ensure suitability. Key design considerations include nontreatment areas, burn severity, slope length, and overall unit size. Units that are very small can be difficult to treat. Delineate the boundary of the treatment units so that they are clearly viewed from the ground and air.

Establish staging areas close to treatment units that have water and adequate space. Include the aviation specialist assigned to the project in this step. The aviation specialist is responsible for writing the aviation

## Chapter 2 Land Treatments

---

safety plan and approving the staging area. Consult with other specialists to ensure that the final treatment areas and staging sites are approved.

### Materials

Evaluate hydromulch components. Hydromulch is a mixture of wood or paper fiber, tackifier, soil binder (polymers), viscosity stabilizer, and water. Manufacturers use various components and ratios of these ingredients. Use a product that will bind to the soil and maintain a strong bonded fiber matrix that is long-lived (greater than 12 months). Hydromulches vary in the length and strength of the fibers as well as effectiveness.

The Hayman fire required seed mixed with woodpulp mulch, water, and a tackifier or polymer to bind the material to the soil, so the seed could sprout. However, different manufacturers used different ratios of the various components that produced different outcomes. Ensure that the material purchased will bind to the soil and maintain a strong bond for greater than 12 months.

### Contracting

Aerial hydromulching requires implementation team coordination with the contracting officer to develop a contract that achieves the emergency stabilization objectives within the allowable timeframe.

Based on a review of recent aerial hydromulch contracts, include the following topics to improve the implementation of the contract.

- Identify the required effective ground cover rather than a fixed application rate.
- Identify how the ground cover will be measured for both depth of material and aerial extent.
- Require that treated-area images are captured and provided to the forest as a contract deliverable.
- Obtain Material Safety Data Sheets from the manufacturer to verify that the pH of the hydromulch is compatible with the pH of the soil.
- Use a coloring agent in the mix to identify treated areas.
- Require that a “satlock” or a global positioning system (GPS) platform compatible with U.S. Department of Agriculture (USDA) Forest Service software is maintained for the spray log (Kuyumjian, personal communication).

### Vehicles and Aircraft

Hydromulching has been performed with both rotary-wing and fixed-wing aircraft (crop-dusters or “air tractors”). Fixed-wing aircraft may be less expensive than helicopters depending on production rates. Consider topography and elevation changes when evaluating aircraft.

### Sikorsky Sky Crane

Two thousand gallons of mulch slurry per minute were placed into the Sikorsky Sky Crane helicopter in Denver. The seed, water, and site-specific tackifier were stored onsite in large tanks. The slurry of seed, mulch, tackifier, and water was mixed in the hydromulching machines and pumped into 10,000-gallon storage tanks before being pumped into the helicopters. To keep the mixture in suspension, the slurry was constantly recirculated.

### Production Rates

Production rates vary based on the number of aircraft flying, proximity to helibase, and weather conditions. The chart below provides information from treated areas.



## Chapter 2 Land Treatments

Fire Name	Acres Treated	Aircraft Type	Production Rate (acres per day)	Total Days	Contact Region and Forest
Trough Fire	6 (experiment)	helicopter	6	1	R-5 Mendocino
Cero Grande	1,450	4 fixed-wing	52	29	R-3 Santa FE
Hayman Fire	1,560	helicopter	50	31	R-2 Pike and San Isabel
Cedar Fire	450	helicopter			R-5 Cleveland

### Construction Specifications

- Require an air operations safety plan and safety officer.
- Use the designated airport/operations manager to facilitate activities at a helibase or designated operation areas.
- Use a load counter at each staging area to track number of loads being applied each day and their turnaround time.
- Use two field inspectors to assess production rate and coverage per treatment area. The number of inspectors may change depending on the number of staging areas and helicopters/aircraft flying to different treatment areas.
- Identify treatment polygons with both GPS and ground-based flagging.
- Select the staging areas. All mulching operations including delivery, storage, and aerial operations are conducted from these designated staging areas.
- Avoid applying hydromulch during excessive rain, wind, or snow. Application will be made only when weather conditions meet Federal Aviation Administration visual flight rules. Flight operations shall comply with all applicable Federal aviation regulations.
- Implement project following the aviation project safety plan.
- Maintain daily operation reports tracking the number of flights, areas treated, application rates, and verification of satisfactory application from ground inspectors.
- Inspect areas to validate ground-cover application rates that are consistent with contract specifications. The following indicators may be evaluated:
  - o Width of swath.
  - o Percent cover.
  - o Depth and uniformity of application.
  - o Avoidance of no-treatment areas (sensitive plant exclusion areas).
  - o Total net acreage treated within a treatment polygon.

### Application of hydromulch

There are many different considerations for aerial application of hydromulch. Below is an example of contract specifications from the Cleveland National Forest in southern California. Consult recent hydromulch contracts used in the area to find out what did and did not work when preparing a contract.

- Apply hydromulch with either a fixed-wing or rotary-wing aircraft. Rotary-wing aircraft shall be Type 1 helitankers equipped with a tank capacity for enough hydromulch mixture to cover 1 acre. The helitanker shall be equipped with a manifold with an agitator to keep the hydromulch mixture in suspension during flight. Fixed-wing or rotary-wing aircraft shall be capable of achieving the desired application rate of the hydromulch mixture.

## Chapter 2 Land Treatments

---

- Use a hydromulch mixture consisting of not less than 2,000 gallons of water per acre, 500 pounds of mulch per acre, and 300 pounds of binder per acre. (Note: this particular contract did not include seed in the hydromulch.)
- Avoid applications within exclusion areas shown on the treatment map, other treatment areas within the polygons that are rockface or rockslope (incapable of vegetation cover), and areas that did not burn.

**Inspection** Use the following methodology to validate correct application areas and rates:

- Stake and flag treatment areas, recording GPS coordinates (inspectors).
- Identify any nontreatment areas within a polygon or adjacent to a polygon by flagging and noting the location (inspectors).
- Walk each polygon to inspect the application AFTER HYDROMULCH IS APPLIED (inspectors).
- Mark thin or missed areas with GPS coordinates and flag on the ground for the pilots.
- Fill in the areas with additional drops (contractor).
- Recheck areas for coverage.
- Place transects randomly throughout the polygon (Spiars, unpublished paper).
- Stake the start and end of the randomly selected transect area.
- Record the location (GPS), aspect, slope type (concave, convex) and percent slope for the site.
- Place a 10-meter tape across the slope.
- Photograph the tape and existing coverage prior to collecting the data.
- Take 10 points per meter for a total of 100 points.
- Record both the presence of cover (Y/N) and the depth of cover to the nearest quarter inch.
- Note ground-cover transects lower than the contract-stated application rate and flag for additional drops.
- Record ground-cover transects that meet the application rate and enter into the sample pool for effectiveness monitoring.
- Record treated area accomplishments daily and note any application problems identified.
- Place cards on the ground to assure that the correct amount is applied. Field crews inspect application rates for both depth of material and aerial extent. Perform random transects to validate application rates.



Figure 4—Hydromulch fibers form a smooth dense mat.



Figure 5—The relative thickness of the aerial hydromulch application.

### Safety

- Conduct project and aviation operations in a safe and effective manner and in full compliance with the aviation project safety plan.
- Mitigate dangers and hazards to the general public from project activities.
- Use dust abatement on staging areas and access roads.
- Provide traffic control on roads with high public use.
- Prevent spread of noxious weeds.
- Ensure that all equipment is free of soil, seeds, vegetative matter, or other debris that could contain or hold noxious weed seed.
- Rehabilitate and revegetate staging areas using a noxious-weed free native-species mix appropriate for the site.
- Mitigate damage or potential damage to private property.

## Chapter 2 Land Treatments

---

### **Treatment Monitoring Recommendations**

#### **Implementation**

- Perform a job hazard analysis (JHA) for each phase of the work including using airplanes and helicopters, driving, and field monitoring in rugged terrain.
- Ensure that safety concerns can be mitigated prior to project implementation.

- Was the treatment implemented as designed?
- Were staging areas or helispots rehabilitated after use?
- Were noxious and invasive weed-detection measures taken?
- Was the correct application rate applied uniformly?

#### **Effectiveness**

- Are there signs of erosion onsite?
- Did the hydromulch stay onsite?
- What is the percent cover provided by the hydromulch?
- Is natural vegetation recovering?

### Assessment Team Considerations for Emergency Stabilization

#### Primary Treatment Use

Hydromulch is used in high-burn severity areas where increased erosion and sediment from the road backslope and adjacent hillslope may endanger life and property. Hydromulching is used in areas where the BAER assessment team has identified an increased risk of invasive and noxious plants along roads.

#### Description

Ground-based hydromulching is applied from the road using truck-mounted applicators that can reach 200 to 300 feet, depending on the equipment. Hydromulch is a slurry applied to hillslopes with or without seed. Hydromulch is an all-inclusive term that includes fiber mulches, soil stabilizers, tackifiers, and polymers that when mixed with water and applied to the soil surface form a matrix that helps reduce erosion and foster plant growth (Robichaud 2000).



Figure 6—Ground application of hydromulch.

#### Purpose of Treatment

Hydromulch protects the soil surface from erosion, reduces adverse impacts to values at risk (water quality, fish habitat), and may reduce noxious and invasive plant establishment.

#### Emergency Stabilization Objective

Hydromulching reduces hillslope erosion and protects identified values-at-risk.

#### Suitable Sites

Hydromulching is intended for use in one or more of these locations:

- Soils with high-burn severity and high-erosion potential.
- Slopes between 25 and 50 percent without effective soil cover.
- Areas without needle-cast or regrowth potential within the first year.
- Areas with high values at risk immediately adjacent to the site or downstream.
- Slopes with less than 25-percent surface rock and soil deeper than 8 inches.

## Chapter 2 Land Treatments

**Cost** Ground hydromulching applied between fiscal year (FY) 2000 and 2003 in the Southwestern Region (R3) cost \$1,675 to \$3,000 per acre (Kuyumjian, personal communication).

**Cost factors include:**

- Availability of hydromulch services.
- Availability and location of water for mix.
- Number of seed mixes.
- Accessibility and road condition.
- Applied rates.

**Treatment Effectiveness**

Quantitative data on the effectiveness of ground-based hydromulch is limited. Effectiveness monitoring from the Hayman fire found ground hydromulching ineffective in reducing erosion because the treatment did not significantly reduce the amount of bare soil (MacDonald 2004).

Laboratory tests of hydromulch plots identified the application rate as the critical element in effectiveness. Field observations indicate slope length is critical to treatment effectiveness. Longer slopes begin to rill as runoff concentrates on the smooth surface. Further monitoring of hydromulch will help determine where and when this costly treatment is most effective.



Figure 7—Treated cutslopes above the highway with vegetation resprouting.

### Project Design and Implementation Team Information

**Design**

After the BAER assessment team designates potential treatment areas, review the field sites to ensure suitability. Key design considerations include slope steepness, slope length, hazard trees, nontreatment areas (rocky areas), and invasive and noxious plant sites.

Review the entire treatment polygon and flag areas of low-burn severity, steep slopes, and rocky areas. Identify on the ground the extent of the treatment unit for the contractor and for implementation monitoring.

## Chapter 2 Land Treatments

### Materials, Tools, and Equipment

The contractor is responsible for supplying all material and equipment including transportation to and from the designated locations. Four-wheel-drive equipment may be necessary depending on road conditions. Road-improvement work may be needed to clear tree limbs and hazard trees to allow a semitruck-size hydromulcher access.

### Design and Construction Specifications

The following is a sample hydromulch specification. Specifications may vary by hydromulch selection. Coordinate hydromulching with an experienced crewmember.

1. Lay out hydromulch area with stakes, flags, and GPS coordinates to delineate treatment polygons.
2. Identify no-treatment areas that may have rocky or shallow soils and clearly delineate for the crew and contractor.
3. Determine treatment mix with an interdisciplinary team to identify whether the application will include seed and fertilizer.
4. Recommend a two-step application for best results. First, apply the seed mix. Second, apply a mulch and tackifier separately. Validate that the two-step practice is used in your area.
5. Meet all Federal and State requirements and guidelines for seed if a seed mixture is included.
6. Apply 1.25 tons of mulch per acre. Validate application rates for site-specific conditions.
7. Apply a Guar-based tackifier at a rate of 75 pounds per acre, or 3 percent of the mulch rate. (Example only, validate for site specific conditions.)
8. Have a maximum discharge distance for the hydroseeder/hydromulcher on level ground of not less than 200 feet from the nozzle. Clearly delineating the upslope boundary of the treatment area helps ensure appropriate application rates.
9. Have a constant hydraulic or gear agitation of the slurry tank in the hydroseeder/hydromulch equipment that provides an even mix of seeds, mulch, and fertilizer.

### Safety

Ground hydromulching uses existing roads that may have other traffic. Develop a road safety and traffic management plan to mitigate hazards. Identify hazards and develop mitigation measures for ground hydromulching. Include the following in the JHA:

- Hazard trees within treatment areas.
- Conditions that make driving unsafe.
- Presence of large equipment on roads with other traffic.

### Treatment Monitoring Recommendations

#### Implementation

- Were contract requirements met for pure live seeds per square foot (If applied in a two step process)?
- Were contract specifications for depth and extent of mulch and tackifier achieved?

#### Effectiveness

- Are there indications of rilling?
- Did sediment reach the road and affect access?
- Did the pure live seed germinate? How much?

## Chapter 2 Land Treatments

---

- Are noxious and invasive plants present in the treated area? Amount and extent?
- Did sediment reach streams or impact values at risk (fish)?
- Was the hydromulching designed for a specific storm event?
- Had the storm event occurred at the time of effectiveness evaluation?
- What was the slope of the treated area?



Figure 8—Treated cutslope with rilling. Longer slope lengths tend to have rilling as the runoff concentrates on the surface.



### Assessment Team Considerations for Emergency Stabilization

#### Primary Treatment Use

Straw mulch provides immediate ground cover and protection to soils from erosion. BAER assessment teams recommend this treatment in areas of moderate- and high-burn severity where erosion potential is high.

#### Description

Straw mulch with weed-free straw helps provide temporary cover to erosion-vulnerable areas as a result of the fire. Straw is applied with helicopters (helimulching) to treat large areas, or by hand for smaller treatment sites. A straw blower pulled behind a light-duty truck is used for roadside application. Straw is applied in contour strips or broadcast to achieve a certain percent of ground cover. Straw mulching is popular due to improved application methods (helicopter) that quickly and efficiently treat large areas prior to precipitation.



Figure 9—Helimulch applications on the Bear fire in northern California.

#### Purpose of Treatment

Straw mulch provides immediate ground cover and protects the soil from erosion and loss of nutrients. Mulch can reduce downstream peak flows by absorbing rainfall and allows prewetting of water repellent soil. Straw helps to secure seeds that are stored in the soil, or applied as an emergency treatment. Straw mulch on burned areas helps maintain a favorable moisture and temperature regime for seed germination and growth.



Figure 10—Straw broadcast from a helicopter provides fast soil cover.

## Chapter 2 Land Treatments

### Emergency Stabilization Objective

Mulch helps reduce surface erosion. Mulch may also reduce water quality degradation offsite.

### Suitable Sites

This treatment is intended for use in one or more of the following locations:

- Areas of high- and moderate-burn severity.
- Slopes up to 65 percent (Mankins, unpublished paper).
- Areas that do not receive high winds.
- Areas that have been identified for seeding.
- Areas with sensitive or rare plants should be avoided.
- Areas in the upper portions of watersheds with high- and moderate-burn severity.
- Areas with some surface roughness to hold mulch, or if surface roughness can be created with felled or limbed trees to avoid redistribution of the straw.

### Cost

Straw helimulching ranged in price from \$250 to \$930 per acre from treatment cost tracking conducted by the Southwestern Region (R3) from FY 2000 to 2003.

Hand application of straw mulch ranged from \$500 to \$1,200 per acre. Application of straw with the strawblower was completed at a cost of \$425 per acre.

Application rates are approximately 1 to 2 tons per acre. This rate provides an average mulch depth of 1 to 2 inches.

### Cost factors include the following variables:

- Type of application (aerial, hand, or machine).
- Proximity from helispot to treatment areas (turnaround time).
- Access for large vehicles to the helispot or staging area.
- Number of days suitable for flying as determined in the aviation plan.
- Size of access areas may require additional staging areas or helispots to be built.
- Availability of experienced crews for both helimulching (helitack crew) and hand application.
- Availability of certified weed-free straw.

### Treatment Effectiveness

Qualitative and quantitative monitoring indicate that mulch is an effective treatment when applied to suitable sites. Effectiveness of straw mulch whether aerially applied or hand spread, is related to the amount of ground cover it provides. Generally, mulch is applied at a rate of 1 ton per acre, which corresponds to about 70-percent ground cover.

After the Hayman fire, in an aerially applied straw mulch site, ground cover was 79 percent after application, 52 percent in the first post-fire year, and 62 percent in the second year. Over time, decreases in mulch cover due to decomposition are offset by the increases in natural vegetation. First post-fire year erosion reduction was 64 percent and second post-fire year reduction was 65 percent (Robichaud, personal communication).

Straw mulch provides greater reduction in erosion than hydromulch. Because straw has longer fiber lengths than hydromulch materials, this treatment requires greater shear force to displace it. Straw can be moved

by runoff; however the straw forms mini-debris dams with interlocking straw that allow it to store sediment and slow velocities. Additionally, straw mulch encourages high soil moisture retention, which can increase natural and introduced seeding survival and recovery.

The most common reason for treatment failure is the wind blowing the mulch offsite or piling the straw so deeply that vegetation is suppressed. Keys to effectiveness include even application and consistent thickness, regardless of treatment method. Steep slopes are avoided because straw will move, especially if the slope is uniform. In occasionally windy areas, assessment teams may consider crimping, using tackifier, or creating surface roughness by felling trees normal to the prevailing winds (Kuyumjian, personal communication).

Other variables include the size, age, and type of straw. Dry straw comes apart easily and does not clump whereas straw that has been sitting baled in the field can develop a crust and will not spread as well. Some contractors rebale the straw for better dispersal. Fluffing the straw with equipment breaks the crust and allows the straw to fall independently. Fluffing also prevents any jarring to the helicopter and pilot as the straw is released (Mankins, unpublished paper).

Problems can arise with straw containing noxious or invasive weeds. Require weed-free straw and include followup monitoring of staging areas and treatment areas to detect any weeds.

Straw mulching combined with seeding improves seed germination by providing an improved growing site. The seed in turn helps stabilize and hold the straw onsite as it grows (Kanaan, personal communication).

### **Project Design and Implementation Team Information**

#### **Design**

After the BAER assessment team has designated potential treatment areas, review the field sites to ensure suitability. Key design considerations include slope steepness, wind, clear identification of nontreatment areas (rocky areas, green, or partially burned trees), staging areas, and helicopter safety in and out of the treatment area (powerlines, homes, highways, or other hazards).

Review the entire treatment polygon and flag and stake on the ground for field monitors. Use GPS points on the treatment area, in the contract, and for subsequent implementation and effectiveness monitoring.

#### **Construction Specifications**

Follow these steps to implement a successful straw-mulch treatment:

#### **Helimulch**

1. Identify the treatment areas with flagging, staking, and/or GPS coordinates.
2. Work with the helicopter manager to review treatment units, identify potential staging areas, and helispots.
3. Work with the helicopter manager and the forest aviation safety officer to develop the aviation safety plan and JHA (see appendix A). In some regions the aviation safety plan is reviewed at the regional office.
4. Obtain heritage resource clearances for any proposed enlargements to staging areas or temporary helispots.

## Chapter 2 Land Treatments

5. Work with contracting officers to obtain bids on certified weed-free straw and a helicopter or fixed-wing aircraft for application (Dean, Web site; Mankins, unpublished paper).
6. Start your mulch project with an experienced project leader.



Figure 11—Helitack crew and equipment help load the cargo nets at the staging area.

### Hand Application

1. Identify the treatment areas with flagging, staking, and/or GPS coordinates.
2. Identify available work crews since this is a labor-intensive treatment.
3. Validate that work can be completed prior to first damaging storm event.
4. Order straw and identify suitable staging areas to reduce the amount of straw that needs to be packed by crewmembers.
5. Use tools such as gloves, pitch forks, and baling hooks to expedite the moving and spreading of straw. Use caution with hooks and pitch forks.
6. Use hand-application treatments for contour-strip mulching or 100-percent broadcast. Ensure that field crews understand the correct application rate.



Figure 12—Crew applying straw by hand.

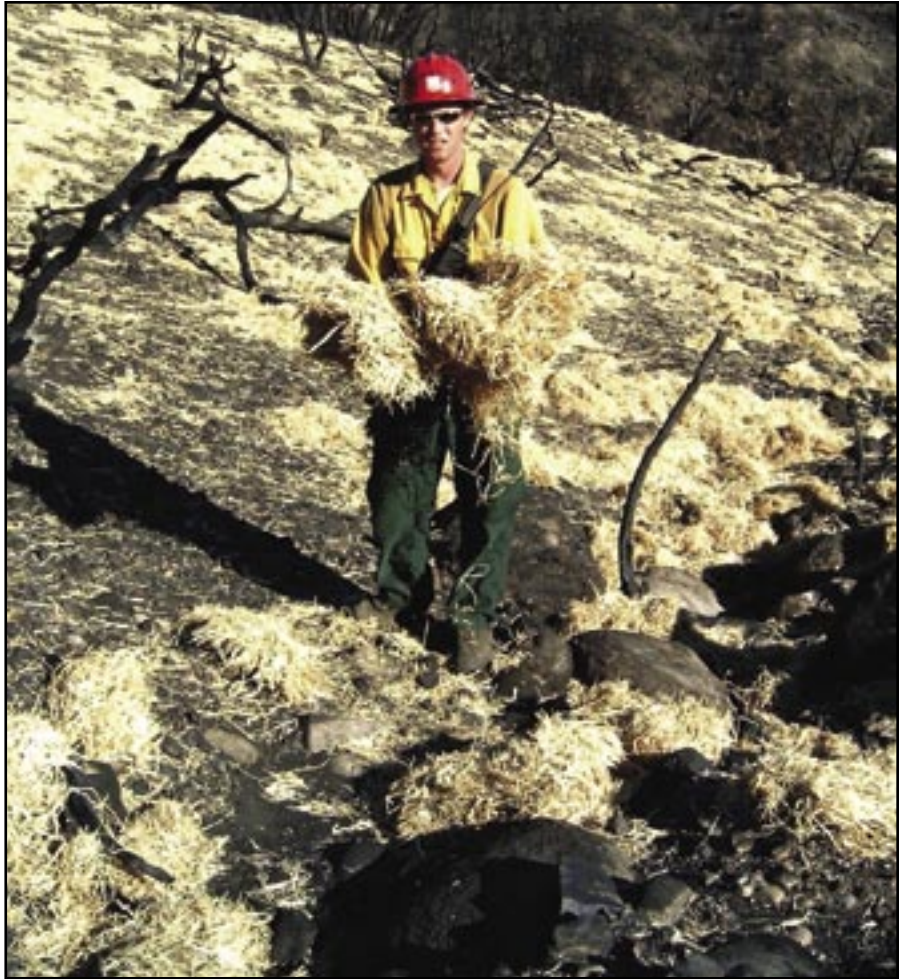

Figure 13—Use gloves and other protective equipment when applying straw.

### Straw Blower Application

Areas above or below roads can be treated with a truck-pulled strawblower. Some forests have a strawblower or the work is contracted. Important considerations for this treatment include identifying the staging areas and straw length for stability on the soil. In some cases a tackifier may be needed.

### Safety

Straw mulching is a hazardous treatment to implement. Consider all the hazards and review and update the JHA daily to avoid injuries. Include the following in the JHA:

- Handling and inhaling straw, may cause eye irritations and skin rashes.
- Lifting heavy bales may cause back strain.
- Helicopter use must follow the aviation safety plan.
- Strawblower use requires additional safety considerations.

### Treatment Monitoring Recommendations

#### Implementation

- Was the treatment implemented as designed?
- What is the percent cover provided by the straw?
- Were staging areas or helispots rehabbed after use?
- Were noxious and invasive weed-detection measures taken?
- Was the correct application rate applied uniformly?

## Chapter 2 Land Treatments

---

### Effectiveness

- Are signs of erosion evident onsite?
- Did the mulch stay onsite?
- What is the percent cover provided by the straw?
- Is natural vegetation recovering?



Figure 14—In windy areas straw will move offsite, leaving the soil prone to erosion.

### Assessment Team Considerations for Emergency Stabilization

#### Primary Treatment Use

Slash spreading provides soil cover to moderate- and high-burn severity areas. The treatment is designed to reduce hillslope erosion by increasing ground cover with available onsite materials. Recent studies by Missoula Technology and Development Center (MTDC) and Rocky Mountain Research Center used onsite small diameter trees to provide effective ground cover. (Groenier, 2004)

#### Description

Slash spreading involves felling, lopping, and scattering submerchantable trees and brush to provide soil cover.



Figure 15—Mechanized equipment can quickly produce slash for effective soil cover.

#### Purpose of Treatment

Slash spreading reduces erosion by providing soil cover.

#### Emergency Stabilization Objective

Slash spreading reduces erosion to prevent the unacceptable degradation of critical natural resources.

#### Suitable Sites

This treatment is intended for use in one or more of the following locations:

- Areas of high- and moderate-burn severity.
- Areas burned but with available slash material onsite.
- Soils with high erosion-hazard ratings.



Figure 16—Completed unit with slash spread uniformly.

## Chapter 2 Land Treatments

**Cost** Cost data for slash treatments in the Southwestern Region (R3) for FY 2000 to 2003 ranged from \$220 to \$1,000 per acre.

**Cost factors include the following variables:**

- Availability of submerchantable trees or brush for slashing.
- Topography of treatment area.
- Ease of obtaining good soil contact with slash material (amount of chain saw work required).

**Treatment Effectiveness** Chain saw-created slash spreading is ineffective in many areas due to the large amount of material needed for adequate soil cover. Burned areas lack enough slash for erosion control. Production rates are slow because extensive chain saw work is needed for good soil contact.

Slash spreading is used in small areas where unique resources and adequate slash are found. Slash spreading protects cultural resources from erosion and can camouflage the sites.

New studies reveal additional opportunities to provide erosion control by engineered wood products or through mastication and onsite shredding of small diameter trees.

Engineered wood mulch was tested for use on burned areas. This type of product consists of a blend of sliced wood strands that provide erosion control over two or more seasons. Rainfall simulation studies completed by Rocky Mountain Research Station indicate the effectiveness of engineered wood mulch. BAER teams have had difficulty procuring the material which sells for about \$60 per 600-pound bale or \$8.75 per 50-pound bale (elwdsystems, Web site).

Use of track-mounted shredders on the Borrego fire and the Clearwater National Forest demonstrate opportunities for shredding to reduce erosion. Track-mounted machines can shred trees 6 to 8 inches in diameter and provide “weed free” erosion control (Groenier, 2004). Equipment varies but generally enables an operator to treat an area within a 20-foot radius from a single position. Track-mounted machines tested in New Mexico exerted less than 4 pounds per square inch of ground pressure (Armstrong, unpublished paper).



Figure 17—Closeup of the slash material generated with heavy equipment.



## Chapter 2 Land Treatments

---

The mulching head is capable of grinding the tree into chips or coarse pieces. Other equipment combinations include an excavator with shredder and a centrifuge blower to distribute the wood. MTDC is conducting studies to review alternative collection and distribution systems including aerial applications to place the material within the treatment unit.

### Project Design and Implementation Team Information

<b>Design</b>	Review the treatment areas in the field to ensure that sites are suitable. Identify any hazards that may have to be removed or avoided prior to implementing treatment. Obtain heritage-resource clearance if heavy equipment is used to implement the treatment.
<b>Tools/Equipment</b>	Slash spreading commonly is implemented with a hotshot crew or a 20-person handcrew with chain saws. Mechanized equipment (hydro-ax) masticates trees into smaller pieces and provides more uniform cover (Kuyumjian, personal communication).
<b>Safety</b>	Slash spreading can be hazardous. Consider all hazards and update the JHA daily to avoid injuries. Include the following in the JHA. <ul style="list-style-type: none"><li>• Hazard associated with tree felling and chain saw operation.</li><li>• Hazards associated with heavy equipment using sharp, high-speed moving parts.</li><li>• Stump-holes and unstable footing.</li></ul>
<b>Treatment Monitoring Recommendations</b>	<b>Implementation</b> <ul style="list-style-type: none"><li>• Was the treatment implemented as designed?</li><li>• Were guidelines followed regarding effective soil coverage?</li></ul> <b>Effectiveness</b> <ul style="list-style-type: none"><li>• Did the slash spreading trap sediment?</li><li>• Did the slash spreading reduce erosion in the treatment area?</li><li>• Did the slash stay onsite?</li><li>• Was the percentage of soil cover known? If so, how much?</li><li>• Was the treatment tested by the design storm at the time of monitoring?</li></ul>



### **Assessment Team Considerations for Emergency Stabilization**

#### **Primary Treatment Use**

Erosion control mats are a temporary erosion control measure for sites at risk from erosion and increased runoff. Erosion control mats treat site-specific resource concerns including heritage sites, water intake facilities, and other critical locations.

#### **Description**

Erosion control mats or rolled erosion control products (RECP) provide soil stability to sites until vegetation can establish. RECPs are either synthetic or organic and temporary or permanent. Organic RECPs are biodegradable and made from a variety of materials including coconut, wood excelsior (aspen), or straw. Material is contained in lightweight netting that lasts from several months to several years. Netless products are currently available. RECPs are tested to meet erosion control standards. Consult with the Erosion Control Technology Council (ECTC) for information on products. Although the products are expensive they are effective when installed correctly.



Figure 18—Erosion mats come in various types depending on site specific needs.

#### **Purpose of Treatment**

Erosion control mats reduce erosion caused by raindrop impact and absorb overland flow. The erosion control mats reduce soil temperature and provide moisture conservation, which fosters site revegetation.

## Chapter 2 Land Treatments

### Emergency Stabilization Objective

Erosion control mats prevent unacceptable degradation of a facility, National Register of Historic Places (NRHP) site, or site officially eligible for listing in the NRHP (BAER Guidance Paper-Heritage Resources).



Figure 19—Erosion mats may be used for heritage sites to provide cover to unique features at risk of erosion.

### Suitable Sites

This treatment is intended for application in one or more of the following situations:

- Areas of high-burn severity with loss of effective soil cover.
- Areas small in size with high values at risk.
- Areas with a persistent hydrophobic layer at or affecting the site.
- Soils with a high erosion hazard rating.
- Areas with increased overland runoff threatening the site or site feature.

### Cost

Costs vary depending on the type of material selected for the site. Contact erosion control product distributors for price estimates. Consult the ECTC (ECTC, Web site) and International Erosion Control Association (IECA, Web site) for a list of distributors.

- Questions for identifying the best product for your specific area include:
  - Treatment area slope gradient.
  - Products' functional longevity.

Most RECPs are priced by the square yard and sold in rolls. Prices range from 35 to 50 cents per square yard to more than \$1 per square yard. Installation is extra.

Cost factors include the following variables:

- Timeframes for vegetative recovery.
- Native seed viability.
- Type of erosion control products.
- Site location and ease of access.

### Treatment Effectiveness

Erosion control products work well on graded or homogenous sites which are uncommon in forested environments. Site preparation is required to provide good contact between the soil and the appropriate erosion control product.

Erosion control products rarely are used for BAER treatments so effectiveness data is limited. Tests conducted at Shasta College in California indicated an 81-percent reduction in soil loss compared to bare soil when RECPs were used (McCullah, 2000). Additional testing information is available from ECTC. Installation requires an experienced crew. Good ground contact also is necessary for an effective treatment.

Some erosion control products can trap animals or affect native plant establishment. Consult the distributors to ensure that the product is appropriate for your site conditions. New RECPs include netless blankets with biodegradable stakes.

### Project Design and Implementation Team Information

#### Design

After the BAER assessment team has designated potential treatment areas, review the sites in the field to ensure site suitability for erosion control mats. Key design considerations include slope uniformity, onsite rocks and debris, runoff control from other sources, and treatment area size.

#### Erosion Control Mat Implementation

Make the soil surface stable, firm, and free of rocks and other obstructions. Install RECPs according to the manufacturer's published installation recommendations or use these minimum guidelines.

1. Install RECPs after applying seed, fertilizer, and other necessary soil amendments, unless soil in-filling of the RECP is required.
2. Use stakes or staples at least 6 inches long to secure RECPs to the soil. Longer anchors may be necessary in sandy, loose, and/or wet soils.
3. Unroll the RECP parallel to the primary direction of flow and place it in direct contact with the soil surface. Do not stretch or allow material to bridge over surface inconsistencies. Overlap edges of adjacent RECPs by 2 to 4 inches.
4. Use a sufficient number of stakes or staples to prevent seam separation. Overlap roll ends of joining RECPs 2 to 6 inches in the direction of flow.

#### Slope Installations

At the top of slope, anchor the RECP using one of these methods:

**Staples.** Install the RECP 3 feet over the shoulder of the slope onto flat final grade. Secure with a single row of stakes or staples on 1-foot centers.

**Anchor trench.** Construct a 6-inch by 6-inch anchor trench. Extend the upslope terminal end of the RECP 3 feet past the anchor trench. Use stakes or staples to fasten the product into the anchor trench on 1-foot centers. Backfill the trench and compact the soil. Apply seed

## Chapter 2 Land Treatments

---

and any soil amendments to the compacted soil and cover with the remaining 1-foot terminal end of the RECP. Secure the terminal end with a single row of stakes or staples on 1-foot centers.

**Check slot.** Construct a stake- or staple-check slot along the top edge of the RECP by installing two rows of stakes or staples 4 inches apart on 4-inch centers. Drive all stake and staple heads flush with soil surface.

After the RECP is fastened at the top of the slope continue with the installation as follows:

1. Fasten all RECPs securely to the soil by installing stakes or staples every 5 to 10 feet depending upon the site's wind conditions.
2. Overlap rolls by 2 to 4 inches in shingle style. Each roll should overlap in the slope's downstream direction.
3. Secure the bottom of each roll with one staple per linear foot.
4. Minimize foot traffic during installation to avoid tears and holes.

### Safety

Erosion control mats require an experienced crew to implement safely. Mitigate hazards and update daily to avoid injuries. Include the following in the JHA:

- Back strains from lifting mats.
- Stump-holes and unstable footing.
- Splinters from stakes to fasten RECPs.



Figure 20—Proper implementation of erosion control mats ensures treatment success.

## Chapter 2 Land Treatments

---

### Treatment Monitoring Recommendations

#### Implementation

- Was the project implemented as designed by heritage resource and watershed specialists?
- Were manufacturer guidelines for installation and application followed according to specifications?
- Was the erosion control product anchored correctly?
- Is there close adhesion to the soil?
- Were staple and stake guidelines followed?

#### Effectiveness

- Did the treatment protect the site from erosion?
- Did the treatment avoid diminishing the integrity of the site?
- Has the area stabilized with vegetation?
- Did the treatment meet other resource objectives for revegetation and wildlife?





### Assessment Team Considerations for Emergency Stabilization

#### Primary Treatment Use

Log erosion barriers (LEBs) are used in timbered areas with moderate- and high-burn severity where hillslope erosion rates are increased significantly from the fire.



Figure 21—High-burn severity areas on the Santa Fe National Forest with available trees that are candidate sites for contour felled LEBs.

#### Description

LEBs (contour felled logs, log terraces, or terracettes) are logs placed in a shallow trench on the contour. LEBs trap sediment if laid in a bricklayer pattern on the hillslope. The potential volume of sediment stored is dependent on slope, size, and length of the felled trees, and proper implementation. LEBs with soil end berms trap more sediment.

## Chapter 2 Land Treatments

### Purpose of Treatment

LEBs reduce erosion by shortening slope length, providing surface roughness, improving infiltration, and trapping sediment (Clifford, unpublished paper).



Figure 22—Contour felled LEB held in place with existing tree and stump.

### Emergency Stabilization Objective

LEBs reduce hillslope erosion and adverse effects to identified values at risk (ecological integrity and water quality).

### Suitable Sites

Use this treatment in one or more of these locations:

- Hillslopes with high- and moderate-burn severity.
- Slopes between 25 and 60 percent.
- Water repellent soils are present.
- Soils with high erosion-hazard ratings.
- Watersheds with high values at risk.

### Cost

LEBs vary in price based on cost factors. LEB-treatment implementation costs summarized by the Southwestern Region (R3) from FY 2000 to 2003 ranged from \$420 to \$1,200 per acre.

Cost factor variables include:

- Treatment-area terrain.
- Site access (vehicle or helicopter).
- Number of logs placed per acre.
- Crew knowledge and experience.

### Treatment Effectiveness

LEBs were the northwest's second most used treatment from the 1970s to the 1990s (Robichaud 2000). However, with cheaper and more effective hillslope treatments, such as helimulching, the use of LEBs has decreased.

Quantitative studies on the sediment-trapping efficiency of LEBs ranged from 6.7 cubic yards per acre to 72 cubic yards per acre with a high density of logs. Research in southern California found soil depths and soil water-holding capacity dictated LEB effectiveness (Wohlegemuth 2001).

### Treatment Monitoring Recommendations

Six paired watershed sites from throughout the Western United States are being monitored for determining effectiveness of contour-felled logs. The storage capacity of each log was determined by calculating storage volume from onsite measurements. Volumes were calculated using the average depths and lengths then discounted for poor ground contact and slope placement. There were an average of 90 logs ha<sup>-1</sup>. Average initial individual log storage was 0.38 m<sup>3</sup>. An ocular estimate for log soil contact was also made.

Findings show the effectiveness of contour felled logs is dependent on rainfall intensity. Observations from numerous rainfall events at these six paired watershed sites indicate that the logs are more effective at trapping sediment if the 10-minute rainfall intensity is low (less than 30 millimeters per hour). With high intensity rainfall (10-minute rainfall intensity greater than 50 millimeters per hour), trap efficiency declines to less than 60 percent, which also decreases by 10 to 15 percent with each successive rain events. Soil end berms increase the storage capacity by about 12 to 15 percent, thus end berms improve their performance. (Robichaud, personal communication)

Measurement of over 3,000 logs suggests several causes for the observed compromises in effectiveness. Some of these factors can be controlled by improved installation strategies and other factors are inherent from settling and downslope runoff. Some observations include:

- 20 percent of the logs were not placed within 5 percent of the hillslope contour.
- 5 percent of the logs rolled due to stake failure.
- 15 percent of the soil end berms failed due to inadequate height and washout caused by runoff.
- 30 percent of the logs were not backfilled with soil to prevent runoff from undermining the log.

BAER implementation teams have reported the following problems with LEBs, which can be avoided with training and implementation monitoring. Common reasons for treatment ineffectiveness include:

- Trees improperly bedded caused runoff and erosion under the log.
- Trees not placed on the contour concentrated runoff and erosion at the ends of the log.
- LEB density (logs per acre) was insufficient for the slope and burn severity.
- LEBs placed on slopes greater than 60 percent.
- Areas with rocks prevented proper installation and accelerated erosion.
- Limbs left untrimmed prevented ground contact and resulted in erosion.
- Crew training was inadequate and resulted in poor implementation.
- Inspection or implementation monitoring was infrequent.



Figure 23—Contour felled LEBs 2 years after treatment.



Figure 24—Contour felled LEB 2 years later that has not trapped any sediment.



Figure 25—Area initially treated with LEBs, but secondary treatment of straw mulch is added to reduce erosion.

### Project Design and Implementation Team Information

#### Design

After the BAER assessment team has designated potential treatment areas, review the field sites to ensure suitability. Key design considerations include standing dead-tree-diameter (8 to 12 inches diameter breast height), site accessibility, and safety. Larger tree diameters can trap and store more sediment but can be unwieldy.

LEBs are used in high-burn severity areas. Review the entire treatment polygon and flag rocky areas, low-burn severity areas, and slopes of more than 60 percent. For slopes less than 20 percent, evaluate the need for LEBs with a BAER team member or the forest soil scientist. Have the archeologist review the area and flag areas to avoid (Ruby, unpublished paper).

#### Tools/Equipment

To ensure safe felling, limbing, trenching, and backfilling each log, select trees that measure 8 to 12 inches diameter breast height. Tree species include conifer, alder, birch, and aspen. Straight trees make firm contact with the soil. Logs should be 10- to 20-feet long. Longer logs are difficult to handle and place correctly.

- Chain saw with complete sharpening and repair equipment (extra chain, file).
- Hazel hoe or mattock for bedding logs.
- Single-bit axe to cut and pound stakes.
- Carpenter level to ensure that logs are on the contour.
- Stakes 12 to 16 inches long to hold logs in position.
- Tape measure.

## Chapter 2 Land Treatments

### LEB Implementation

Demonstrate the correct installation method prior to implementing LEBs. Alert the crew and inspectors on spacing for different slope classes, placing the log on the contour, bedding the log, and establishing the bricklayer pattern. Use soil end berms to improve trapping efficiency (Robichaud, personal communication). Once the demonstration is complete, assign crews and inspectors to treatment areas. (Tracy, unpublished paper)

Crews should work in teams of three with one sawyer, followed at a safe distance by two people trenching and bedding the logs. Total crew size varies depending on the treatment area. Crews should start at the top of the unit and work downslope offsetting the LEBs in a bricklayer pattern.

Installing LEBs is challenging and hazardous work. Hotshot crews are commonly used to install LEBs because of their skills and experience. Contract crews also can be used.

Designate inspectors for unit layout and implementation monitoring. The inspector ensures that LEBs meet construction specifications for spacing, alignment, density, and bedding. Inspectors can use a global positioning system (GPS) to mark treatment areas for subsequent effectiveness monitoring.



Figure 26—Contour felled LEB which has filled with sediment and then failed. Sediment trapping ability of LEBs on steep slopes is limited.

## Chapter 2 Land Treatments

<b>Vehicles/Aircraft</b>	<ul style="list-style-type: none"><li>• Crew carriers can be used to access designated sites.</li><li>• Helicopter access is required occasionally for more remote locations. Ensure that appropriate flight plans and JHA are included.</li></ul>
<b>Production Rates</b>	<p>Production rates vary with the number of LEBs placed per acre. Reducing the number of LEBs to expedite the treatment jeopardizes effectiveness.</p> <p>Specifications require that logs from burned trees 15 to 20 feet in length be placed 10 feet apart on slopes more than 50 percent. For slopes less than 50 percent, trees are placed 15 feet apart. Distance on the contour between the LEBs is 10 feet. Approximately 95 trees per acre are required to meet this specification based on a 20-foot log length that would provide 1,900 linear feet per acre. An estimated 100 to 200 logs per acre at 20-foot length would be required to obtain 2,000 to 4,000 linear feet per acre (see appendix F).</p> <p>The LEB installation rate for a well-trained crew is approximately 1 acre per person-day depending on spacing and linear feet per acre. Experienced crews can treat 3 or more acres per person-day. Validate production rate from recent LEB installation contracts. Be sure to compare slope, spacing, and actual linear feet installed per acre.</p>
<b>Method of Installation</b>	<ol style="list-style-type: none"><li>1. Identify treatment polygons on a map and clearly mark in the field.</li><li>2. Use inspector(s) review each polygon and determine whether the area complies with the specifications. Nonwork areas such as large openings (areas where burn severity will be lower), rocky areas, and slopes more than 60 percent will be identified as bypass areas (Ruby 1995).</li><li>3. Flag the perimeter of each area with a discrete color code, marked on the ground with a wooden stake, and indexed on the stake and on a project map. Record the size of the polygon.</li><li>4. Consult with the cultural resource staff prior to starting the project. Placement of LEBs is a ground-disturbing activity and requires clearance to ensure that resources are avoided and/or protected.</li><li>5. Start installation of LEBs at the top of the treatment area (Schmidt 2003).</li><li>6. Work in teams with one sawyer safely ahead of two individuals to bed the log. Some implementation teams use larger crews with a sawyer and swamper followed by four individuals to bed the log. Team size is determined by safety and efficiency.</li><li>7. Use sawyers to delimb the log to allow for 100-percent contact with the ground.</li><li>8. Check that the log is on the contour with a hand level.</li><li>9. Dig a trench on the contour 3 to 5 inches deep depending on the size of the log to break up water repellant soils.</li><li>10. Place the log in the trench on the contour and backfill the log ensuring that there are no gaps.</li><li>11. Anchor the log with wooden stakes if needed.</li><li>12. Place limbs or branches on the slope and ends of the LEBs for surface roughness and to break up concentrated flows.</li><li>13. Use inspectors to review and approve all work when treatment within a block is complete.</li><li>14. Report daily acreages treated, with acres per person-day and costs.</li><li>15. Track acres treated per block and continue layout on planned work (Tracy, unpublished paper).</li></ol>

## Chapter 2 Land Treatments

### Safety

LEBs are a hazardous treatment. Consider all hazards and review and update the JHA daily to avoid injuries. Include the following in the JHA:

- Chain saw operation and felling trees.
- Hazard trees within treatment areas.
- Stump-holes and unstable footing.

### Treatment Monitoring Recommendations

#### Implementation

- Was the treatment implemented as designed?
- Were specifications for spacing, logs per acre, and bypass areas implemented?
- How many linear feet per acre were implemented?

#### Effectiveness

- Did the LEBs trap sediment?
- Did the LEBs fill with sediment?
- Are there signs of rilling?
- Did water move under the LEB?
- Was there overtopping of the LEB?
- Was the storm event the LEBs were designed for in the burned area report (FS 2500-8)?
- Had storm events occurred at the time of effectiveness evaluation?



Figure 27—Once the LEB fills, sediment will move over or around the log. Soil berms on the sides of LEBs help hold more material behind the log.



### Assessment Team Considerations for Emergency Stabilization

#### Primary Treatment Use

Fiber rolls are used in high-burn severity areas where soil erosion and water quality deterioration are at risk. Fiber rolls are used where LEBs are not practical. They are for intensive treatment of high values at risk including heritage sites.

#### Description

Fiber rolls, commonly called wattles, are prefabricated rolls manufactured from rice straw and wrapped in ultraviolet degradable plastic or jute netting. Fiber rolls are approximately 9 inches in diameter and up to 25 feet long. A 25-foot-long fiber roll weighs 35 pounds. Fiber rolls are designed for low-surface flows not to exceed 1 cubic foot per second. They are not for stream channels or gullies (Morris 2004).



Figure 28—Fiber roll placed across the hillslope. Not all the fiber rolls are on the contour which can accelerate erosion.

#### Purpose of Treatment

Fiber rolls reduce erosion by shortening the slope length to slow overland flow velocity. Fiber rolls trap sediment and provide a seedbed for vegetative recovery. If water repellent soils are present, the installation of the fiber rolls may break through the water repellent layer and can improve infiltration.

#### Emergency Stabilization Objective

Fiber rolls reduce erosion and may reduce adverse effects to identified values at risk (ecological integrity and water quality).

#### Suitable Sites

Use fiber rolls in one or more of these locations:

- Areas of high- and moderate-burn severity.
- Slopes with less than 40 percent of the original ground cover remaining.
- Slopes between 20 and 40 percent.
- Soils not less than 8 inches deep.
- Slopes with less than 25-percent surface rock.

## Chapter 2 Land Treatments

**Cost** Fiber rolls are expensive to implement. Costs vary by project. Fiber-roll treatment implementation costs summarized by the Southwestern Region (R3) from FY 2000 to 2003 ranged from \$1,100 to \$4,000 per acre.

Cost factors include:

- Distance from site to staging area.
- Access to staging area for large-vehicles.
- Experience and availability of crews to install fiber rolls.
- Placement method for fiber-rolls (helicopter or handcrews).
- Vegetation remaining.
- Requirements for fiber-roll spacing.

### Treatment Effectiveness

Limited effectiveness monitoring data is available on fiber rolls. Monitoring of the 2003 Cedar fire used field observations and select photopoints to document the effectiveness.

Findings indicate the need for implementation monitoring to ensure proper location, spacing, and placement of the fiber roll. Do not place fiber rolls in drainages or turn the ends down. Fiber rolls in drainages failed and fiber rolls with the end turned down contributed to rill formation (Hubbert, unpublished paper).

Vertical spacing of fiber rolls remains highly variable. Consult manufacturer guidelines, soil-burn severity maps, and erosion-hazard ratings for slopes.

Fiber rolls can attract small rodents, which in turn attract snakes that can become trapped in the netting. The wildlife biologist can assist in determining wildlife concerns (Kuyumjian, personal communication).



Figure 29—Avoid placing the fiber rolls in drainages.

Specify that fiber rolls are certified weed free for the installation State. Other informal observations of fiber rolls (wattles) and their effectiveness are:

- Fiber rolls provide good germination of seed as compared to the rest of the slope. Breaking up slope length provided germination sites (Morris 2004).
- Fiber rolls had undercutting below the wattle where there was overtopping.

- Fiber rolls function for up to 2 years but remain for several years after filling.
- Fiber rolls are awkward to transport and are difficult to install on steep slopes.
- Fiber rolls work best when placed in a trench with complete ground contact and firm anchoring.
- Fiber rolls are expensive and labor intensive. Ensure that enough experienced crews are available to complete the work in the timeframe required (Robichaud 2000).
- Fiber rolls work well in coarse-grain soils. Tests at San Diego State University Soil Erosion Research Laboratory demonstrated that fiber rolls reduce offsite sediment delivery from bare soil by as much as 58 percent with proper installation (Earth Savers, Web site).

Inspect fiber rolls after each storm event. Fiber rolls are unsuitable in areas with high-intensity, short-duration storm events where they fill quickly with material. Check the past performance of fiber rolls in the area prior to prescribing their use. Further monitoring efforts are needed to fully identify the failure mechanisms.

### Project Design and Implementation Team Information

After the BAER assessment team has designated potential treatment areas, review the field sites for suitability. Key design considerations include site accessibility, vegetation remaining, and correct spacing. Fiber rolls are delivered in large trucks and the closer the trucks can get to the site the lower the cost. In some cases, helicopters can transport the wattles to the treatment area.

**Design** Review the entire treatment polygon and flag rocky areas, low-burn severity areas, and slopes over 45 to 50 percent. For slopes less than 10 to 15 percent, evaluate the need for fiber rolls with a BAER team member or the forest soil scientist. Have the archeologist and wildlife biologist review the area and flag areas to avoid.



Figure 30—Fiber rolls do not reduce erosion but trap sediment on the slope. Where high values are at risk identify the emergency objective and select the treatment which best meets that objective.

## Chapter 2 Land Treatments

### Construction Specifications

1. Lay out a contour line on the slope with a hand level and wire flags.
2. Dig a shallow depression 3 to 5 inches deep with a pulaski or pick and place the fiber roll in it.
3. Place excavated soil downslope of the trench.
4. Place the fiber roll and backfill the upslope length of the fiber roll with the excavated soil. Compact to prevent water from flowing under the fiber roll.
5. Turn the ends of the fiber roll upslope slightly (like a smile) to trap sediment and prevent channeling of flows.
6. Drive a 1- by 2-inch or 2- by 2-inch wooden stake through the center of the fiber roll and at least 6 inches into the ground. Stop 2 inches above the fiber roll. (Stake lengths should be 18 to 24 inches. For rocky soils, rebar has been used, but should be removed after the site is stabilized.)
7. Put four stakes in a 12-foot fiber roll, five stakes in each 20-foot fiber roll, and six stakes for 25-foot fiber roll.
8. Space (horizontal) for fiber rolls depends on normal rainfall intensity, slope steepness, soil characteristics, and the extent of surface cover remaining on the slope.
9. Place wattles 50 feet apart (872 per acre) on moderate-burn severity on slopes of 20 to 50 percent. Place wattles 20 feet apart (2,178 per acre) on high-burn severity slopes. (Natural Resource Conservation Service Web site).
10. Stagger the layout on the slope in a bricklayer pattern starting at the top of the slope with a 12- to 18-inch overlap.



Figure 31—To ensure proper installation, work with experienced crews and inspect as the fiber rolls are installed. Improper installation negates the effectiveness of this treatment.

### Materials

- Contour straw wattles 9 to 12 inches in diameter and 10 to 30 feet in length.
- Wooden stakes, 5- (1 by 2 inch or 2 by 2 inch) 18 to 24 inches long per wattle.

### Tools

- Shovel
- Pulaski
- Hammer
- Hand level
- Flagging

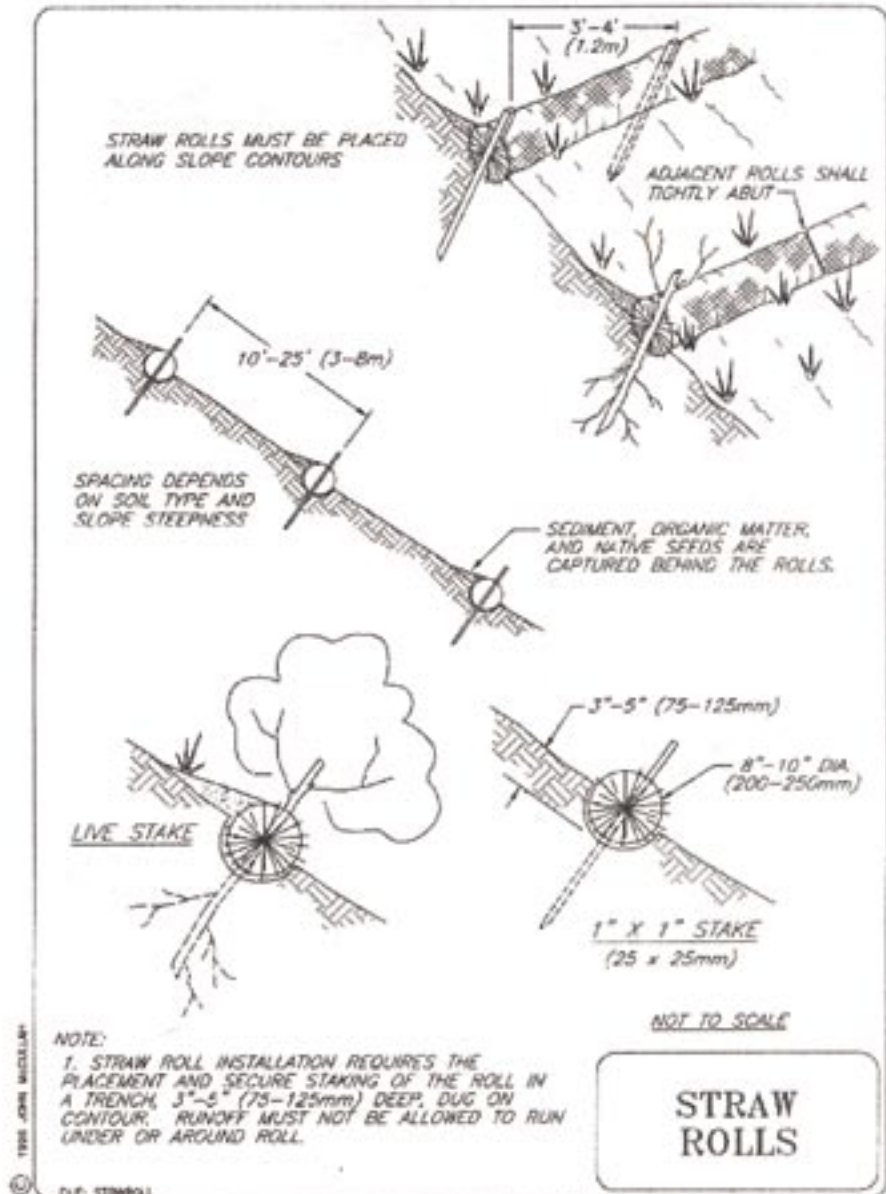

Figure 32—Fiber roll installation guide.

**Safety**

Fiber rolls are implemented safely when the following items are included and mitigated in the JHA.

- Aircraft-safety plan if using any aircraft to move wattles.
- Injuries from stakes, splinters, and traversing rugged ground.
- Allergies to straw.

**Treatment Monitoring Recommendations**

**Implementation**

- Was the treatment implemented as designed?
- Were specifications for spacing, location, and installation of fiber rolls implemented?
- How many linear feet per acre were installed?

### Effectiveness

- Did the fiber rolls trap sediment?
- Are there indications of rilling?
- Were the fiber rolls undercut?
- Was there overtopping of the fiber roll?
- What type of storm event were fiber rolls designed for in the FS-2500-8?
- What storm events had occurred at time of effectiveness evaluation?
- Did the fiber roll trap seeds for revegetation establishment?

### **Assessment Team Considerations for Emergency Stabilization**

**Primary Treatment Use**

Silt fences trap soil and sediment but are used infrequently as a BAER treatment.

**Description**

Silt fences are a geotextile fabric that traps sediment. They are installed with wooden posts or metal T-posts, and are firmly sealed and anchored below groundlevel. Geotextile fabric attached to hogwire adds strength to the fence.



Figure 33—A recently installed silt fence.

**Purpose of Treatment**

Silt fences are used to trap sediment. Place silt fences in areas with high values at risk where other treatments, such as log erosion barriers or fiber rolls may be ineffective. Use silt fences to monitor sediment movement during effectiveness monitoring (Robichaud 2002).

**Emergency Stabilization Objective**

Silt fences trap sediment and protect areas with high values at risk including heritage resources, water quality, and aquatic resources.

**Suitable Sites**

This treatment is intended for use in one or more of the following locations:

- Areas with high values at risk.
- Areas accessible for inspection and maintenance.
- Areas with site-specific resource concerns (heritage sites).

**Cost**

Silt-fence materials are available widely. Material costs are low, \$50 per roll, but labor costs and installation effort and maintenance can increase costs. Installed silt fences range from \$150 to \$250 for each fence. Once the site is stabilized, remove the fences. Removal cost can be paid for with BAER funds.

Cost factors include the following:

- Proximity to vehicle access.
- Size and number of fences.
- Soil characteristics.
- Maintenance frequency.
- Removal of silt fences.

### Treatment Effectiveness

Silt fence effectiveness on reducing erosion is high if the silt fences are installed properly (anchored properly with the bottom of the silt fence keyed into the soil allows water to pass through slowly while trapping sediment) and maintained. Robichaud and Brown (2002) have measured trap efficiency of over 90 percent for silt fences used as a hillslope erosion measurement device. These silt fences were carefully installed with the bottom of the silt fence properly anchored and the end of the silt fence turned upslope to prevent sediment from going around the end. Silt fences, although very effective, require significant installation effort and constant maintenance if they are to remain effective. Contributing areas should not exceed 10,000 square feet, and once they are partially filled they need to be emptied to maintain their effectiveness.



Figure 34—Silt fences are generally used for monitoring treatment effectiveness.

### Project Design and Implementation Team Information

#### Design and Construction Specifications

The following method describes how to implement silt fences as a treatment. Additional information is available for silt fence construction in (Robichaud 2002). Major differences in the design specifications are using wooden stakes and the anchoring method. Both designs work well if implemented correctly.

1. Visit each site to determine exact needs including number of silt fences, spacing, and layout.
2. Stake the locations to ensure that the contributing watershed is not too large to overwhelm the silt fence.
3. Coordinate with other resource specialists (heritage resources) prior to installing the silt fences.
4. Dig an 8-inch trench along the contour.
5. Drive the posts to approximately 16 inches below the soil surface.
6. Unroll the geotextile and wire (if used). Attach the geotextile to the wire with tie wire.
7. Place the fence in the trench and attach to the fence posts.
8. Backfill the trench and tamp to ensure adequate compaction.
9. Inspect the silt fence after every runoff event if possible.



## Chapter 2 Land Treatments

10. Repair any damage immediately.
11. Remove sediment and debris from the fence when visible bulges appear or the silt fence is one-third full.
12. Remove the silt fence after vegetation or other permanent erosion control measures are installed and functional.



Figure 35—Silt fences are effective at trapping sediment but require inspection and maintenance. Silt fences should be removed once the area has stabilized.

### Materials

- Hardwood posts at least 36 inches long with a minimum cross section area of 3 inches, use standard T- or U-section steel posts that weigh at least 1 pound per linear foot.
- Wire-fence material, at least 14-gauge, with openings no larger than 6 by 6 inches.
- Geotextile material (for the fence).
- Tiewire (to attach the fence to the wire).

### Equipment

- Fencepost pounder (for installation).
- Wire cutter.

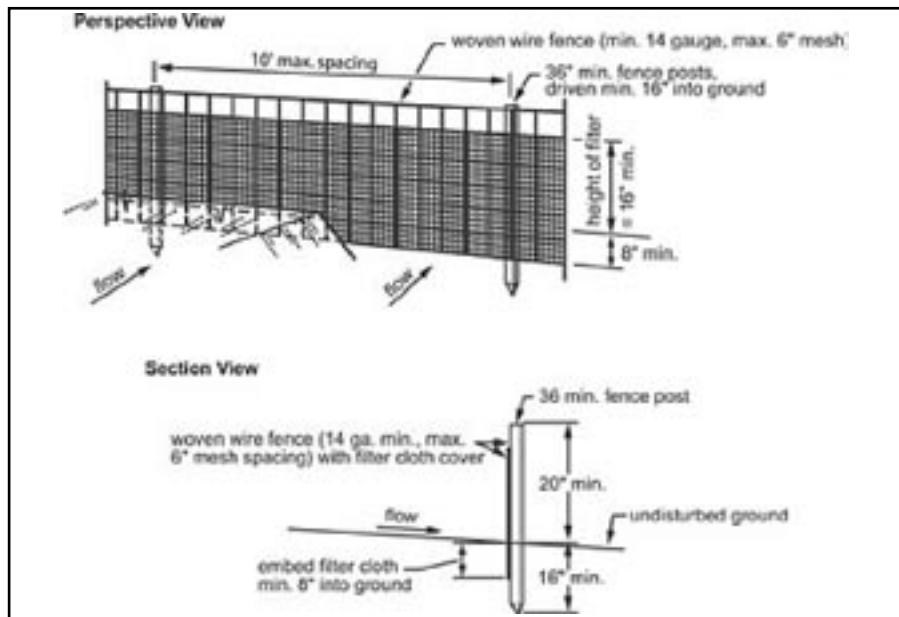

Figure 36—Properly installed and maintained silt fences have a 90-percent trap efficiency.

## Chapter 2 Land Treatments

---

### **Safety**

Include the following items and mitigation on the JHA. Consider all hazards and update daily to avoid injuries.

- Injuring back from the fencepost pounder.
- Ensuring adequate eye protection.
- Cutting wire can cause injury.

### **Treatment Effectiveness**

#### **Implementation**

- Was the silt fence installed as designed?

#### **Effectiveness**

- Did the fence trap sediment?
- Was there a failure of the structure? If so, how? Overtop, endrun, or blowout?
- What was the size of the contributing watershed?
- Was the structure tested by the design storm during monitoring?

### Assessment Team Considerations for Emergency Stabilization

<b>Primary Treatment Use</b>	Soil scarification prepares the seedbed for seeding and improves infiltration. Soil scarification is for areas of high-erosion hazard rating and high-burn severity where values at risk are high.
<b>Description</b>	Scarifying soils to reduce water repellency became popular after the Cerro Grande and Hayman fires. Volunteer groups--anxious to assist in the recovery process--used rakes to break up the shallow hydrophobic conditions and provide a good seedbed. This provided temporary erosion control. Raking was done on the contour both with and without untreated strips. More recent application had an all-terrain vehicle (ATV) with a 4-foot-by-4-foot chain-link harrow with 4-inch-long teeth scarify the ground and create a seedbed. Seed is applied at the same time with the ATV (Kanaan, personal communication).
<b>Purpose of Treatment</b>	Soil scarification reduces overland flow and erosion by increasing infiltration and creating surface roughness. Hydrophobic layers are broken down with scarification. Additionally, seedbed preparation fosters seed germination and growth.
<b>Emergency Stabilization Objective</b>	Soil scarification can reduce erosion by increasing infiltration. Seeding further helps to reduce erosion and stabilize the soil in year two.
<b>Suitable Sites</b>	This treatment is intended for use in one or more of the following locations: <ul style="list-style-type: none"><li>• Areas of high- and moderate-burn severity.</li><li>• Slopes with high erosion potential.</li><li>• Slopes less than 20 percent (with ATVs or small dozer).</li><li>• Slopes between 20 and 40 percent (with handcrews).</li></ul>
<b>Cost</b>	<p>Implementation costs vary depending on application method. Volunteer crews often are willing to prepare the seedbed with rakes. Crew costs are \$245 to \$300 per acre. This cost assumes treating an 8-foot-wide swath on the contour and leaving an untreated area of 20 to 30 feet between raked and seeded areas. Roughly 20 acres per day can be treated by a 20-person crew (Kuyumjian, personal communication).</p> <p>ATV use has considerably lower costs, \$50 per acre with a production rate of 40 acres per day per ATV, for both seeding and scarifying (Kanaan, personal communication).</p> <p>Cost factors include the following:</p> <ul style="list-style-type: none"><li>• Ground-disturbing BAER activity that requires cultural clearance work. The extent of the project and acres to be treated will affect treatment costs.</li><li>• Terrain of treatment site dictates the application method. ATVs are not recommended for slopes of more than 20 percent or in dense stands of timber.</li><li>• Safety issues can increase costs if the site area is very hazardous.</li></ul>

### Treatment Effectiveness

Treating water repellent soils with soil scarification equipment is not uncommon. However, only limited data supports the efficacy of this treatment. In some situations the scarification has worked well and in others it has failed. More recent efforts combined soil scarification with seeding. Ongoing studies of scarification and seeding on the Bobcat fire in Colorado did not reduce sediment yields significantly (MacDonald 2000).



Figure 37—Crews using hand rakes scarify soils and follow with hand seeders. Studies indicate this treatment is not effective.

Effectiveness of soil scarification on reducing erosion by increasing infiltration and breaking up the water repellent soil conditions was monitored on Hayman fire sites. To determine effectiveness of this treatment, research plots were scarified with McLeods by raking on the contour to a depth of 1.5 inches adjacent to control (untreated) plots on 20-percent and 40-percent slopes. There was no difference in ground cover amount among the treated and untreated sites the first 2 years after the fire. Erosion rates from the scarified plots were not statistically different than the control for either the first or second postfire years.

During rainfall events, it was observed that runoff was delayed several minutes as water entered the scarified soil. However, after several more minutes of rainfall, overland flow occurred and carried the soil, which has been loosened by the treatment downslope (Robichaud, personal communication).

BAER specialists that implemented scarification feel the risks in high-burn severity areas outweigh the benefits derived. Other lower risk treatments, including seeding with dry mulch application, should be applied first (Kannan and Kuyumjian, personal communications). Little data is available on the benefit of scarification on seedling establishment (Robichaud, personal communication).

Soil scarification is a tool for assessment teams but it is recommended that other treatment options be pursued prior to recommending this treatment for emergency stabilization.

### Project Design and Implementation Team Information

#### Design and Construction Specifications

After the BAER assessment team has designated potential treatment areas, review the field sites to ensure suitability. Key design considerations include worker safety, high- and moderate-burned areas, nontreatment

## Chapter 2 Land Treatments

areas, and slope class. ATVs and dozers have slope limitations. Lay out treatment areas by comparing slope breaks with burn severity maps. Specific equipment is matched to a treatment area. Identify treatment type in the field. Use GPS coordinates for boundaries for both the contract and subsequent implementation and effectiveness monitoring.

- Identify and lay out proposed treatment polygons with flagging and GPS units to obtain coordinates.
- Obtain cultural resource clearance for treatment areas.
- Identify and remove hazardous snags with a saw team prior to implementing the project.
- Identify staging area for crews, equipment, and material (seed).
- Treat alternating areas on the contour. Treated areas with a handcrew may be approximately 8 feet wide, and areas with an ATV will be as wide as the chain link harrow (approximately 4 feet wide).
- Distance between treated strips depends on the slope.
- Use of ATVs is faster but limited to approximately 20-percent sideslopes.
- Use dozers with ripper shanks on a hydraulic toolbar. Problems can arise with trapping woody material in the shanks which slows production rates considerably.

### Tools/Equipment

This work can be done with handcrews, ATVs, dozers, or volunteer crews. Hazards associated with snags, stump holes, and rugged conditions need full consideration. The JHA should be developed carefully for this treatment.

- Flagging and staking of treatment areas.
- Using rakes or McLeods.
- Using a chain saw.
- Using a hand seeder (belly grinder).
  
- Utility ATV.
- Dozer equipped with tool bar and ripper shanks.
- Chain link harrow with 4-inch-long teeth mounted behind the ATV.
- Seeder mounted on back of ATV.
- Personal protective equipment for ATV riders and hand crews.



Figure 38—Larger equipment is used for deeper ripping to increase infiltration and break through water repellent soils.

## Chapter 2 Land Treatments

### Safety

Soil scarification is a hazardous treatment to implement as crews are exposed to unsafe working conditions. Consider all hazards and update the JHA daily to avoid injuries. Include the following in the JHA.

- Establish communications plan (radios and spare batteries).
- Establish safety officer position, especially with large crews and volunteer groups.
- Know the weather forecast and be alert for hazards, especially windy conditions.
- Work with volunteer groups is fun and challenging. Ensure that the groups have the proper protective equipment, especially boots, for their safety.
- Access by road to remote sites may have snags, heavy equipment, and other hazards. Flag and sign the access to identify the route clearly.

### Treatment Monitoring Recommendations

#### Implementation

- Were treatment specifications met in regard to depth and width of seedbed preparation?

#### Effectiveness

- Are signs of rilling and erosion apparent?
- Did treatment reduce the hydrophobic conditions?
- What were the precipitation events prior to monitoring?
- What design storm was used for the treatment?
- Did treated strips trap sediment from the untreated strips and reduce erosion?



Figure 39—Use of an ATV and a chain harrow to scarify and seed soils.

### Assessment Team Considerations for Emergency Stabilization

#### Primary Treatment Use

Seeding reduces hillslope erosion. Seeding also is prescribed for areas at risk from the spread of invasive and noxious plants.

#### Description

Seed is applied with fixed-wing aircraft or helicopters for large treatment units and with belly grinders for smaller treatment areas. Since seeding is ineffective the first year, it is included with other treatments, such as straw mulching, hydromulching, or soil scarifying.

Previous effectiveness results of seeding alone showed poor results the first year and variable results in subsequent years (Beyers 2003; Janicki 2003; Robichaud 2000). Seed mixes vary from region to region and depend on BAER treatment objectives. Revegetation information available from the fire-effects information system helps assessment teams evaluate natural vegetation recovery rates for a particular species and area.



Figure 40—Loading seed into the aircraft.

#### Purpose of Treatment

Seeding minimizes soil and wind erosion by providing vegetative cover. Seeding may prevent the introduction and increase of noxious and invasive plants. Seeding may help protect threatened and endangered habitat, and reduce sediment delivery and transport to drainages.

#### Emergency Stabilization Objective

Objectives are to reduce erosion and prevent the introduction or spread of noxious and invasive plants (Smith, unpublished paper).

#### Suitable Sites

This treatment is intended for use in one or more of the following locations:

- Areas of high-burn severity.
- Areas within or adjacent to high values at risk.
- Soils without soil cover that are highly erodible.
- Slopes up to 60 percent.
- Areas with potential for spread of known noxious and invasive plants.

## Chapter 2 Land Treatments

---

**Cost** Seeding costs vary depending on the cost factors below. Seeding costs summarized by the Southwestern Region from FY 2000 to 2003 ranged from \$20 to \$170 per acre.

Cost factors include the following variables:

- Availability of seed mix.
- Implementation timeframe.
- Number of landowners involved.
- Elevation and climate.
- Size of fire or complex of fires.
- Aircraft type, fixed-wing or helicopter.
- Topography and terrain.
- Number of species in seed mix.
- Proximity of treatment blocks to staging areas.
- Timing and weather conditions during seeding.

**Treatment Effectiveness** Seeding alone has become less popular as a treatment due to its limited effectiveness. In a review of existing studies on seeding, few studies demonstrate statistically significant decreases in sediment movement (Beyer 2003). In addition, seeding rarely provides any effective cover the first year after the fire. Assessment teams hope that second-year effects warrant the treatment and that soil losses the first year are not too dramatic.

Due to seeding's limited effectiveness, some assessment teams prescribe combining mulching with seeding to provide immediate soil cover. The mulch protects the seeds from drying out and once the seed germinates it holds the straw in place. The combination extends the life of the mulch treatment (Kuyumjian and Kanaan, personal communications).

Robichaud et al (2000) examined nine seeding studies in conifer forests that provided quantitative ground cover data. In the first growing season after the fire, about half of the studies reported less than 30-percent ground cover and only 22-percent reported at least 60-percent ground cover. At least 60- to 70-percent ground cover is needed for erosion reduction (Robichaud et al 2000). Better cover, and thereby better erosion mitigation, can be expected in the second and subsequent years. Several other studies from the Western United States show that the second and, in some cases, third and fourth year erosion rates were not affected by seeding (Roby 1989, Van de Water 1998, Wohlegemuth et al 1998, Wagenbrenner 2003).

### **Project Design and Implementation Team Information**

**Design** Review the BAER assessment team findings on the ground to validate the treatment areas. Use stakes, flags, or GPS coordinates to identify the treatment units.

Identify the applications method: hand seeding, drill seeding, or aerial seeding for large areas. Have the archeologist review the area if ground-disturbing methods are recommended to create a seedbed.





Figure 41—Validating the proper seeding rate with monitoring cards.

Coordinate with the botanist to identify any no-seed areas and delineate accordingly. Work with the botanist to ensure that the seed selected is appropriate. Soil types, climatic factors, timing, natural regeneration, and slope all factor into revegetation objectives. The criteria for selecting seed species includes (Smith, unpublished paper):

- Effectiveness for erosion control.
- Compatibility with other resource objectives.
- Species adaptability.
- Native versus nonnative species.
- Number of species in mix.
- Certified seed.
- Seed laws.

Once the seed method is selected, consult the BAER Web site for information on applying seed with helicopters and fixed-wing aircraft. The lesson plan, *Aerial seeding – Planning and Implementation*, outlines the steps to implement a seeding treatment. Drill seeding also is common in flatter topography. In many cases revegetation is improved by selecting the appropriate time of application and cultivation method, such as drill seeding, aerial, or harrowing.



Figure 42—Helicopter with bucket for applying seed.

### Safety

Seeding is implemented safely when all hazards are mitigated and reviewed daily to avoid injuries. Include the following in the JHA.

- Hazard trees within treatment units.
- Application using helicopters or fixed-wing aircraft.
- Access to treatment units.

### Treatment Monitoring Recommendations

#### Implementation

- Was the treatment implemented as designed?
- Was the correct amount of pure live seed applied?
- Were sensitive or no-seed areas avoided?



Figure 43—Seed germination the first winter.

#### Effectiveness

- Are there signs of rilling or sheet erosion?
- Did the seed germinate and provide effective cover to stabilize the soil?



Figure 44—Seeded area is prone to accelerated erosion during the first year.



### Assessment Team Considerations for Emergency Stabilization

#### Primary Treatment Use

Treating noxious and invasive weeds prevents the serious threat these plants have on ecosystems. Depending on the plant type, and its response to fire, the BAER team may recommend chemical, biological, hand, mechanical, or prevention-seeding to treat invasive plants.

#### Description

Noxious weeds are listed on the Federal and/or State noxious weed lists. Invasive weeds are plants that have been introduced into an environment outside their native range.

Noxious-weed specialists on BAER teams evaluate the potential for spread from existing populations and from proposed BAER activities. Once the weed characteristics are known, the BAER team recommends a method for the threat consistent with forest direction. For example, chemical or biological treatments are allowed only if the affected area has a completed environmental document.

Surveying an area where the threat of noxious or invasive plants is identified is the first step. If noxious or invasive plants occur, remove isolated populations by hand. Where a robust population exists and the BAER team feels the fire's effect has exacerbated the threat to the ecosystem, mechanical or prevention seeding is recommended (BAER Guidance Paper-Noxious and Invasive Weed Treatment).



Figure 45—Invasive plant populations may exist in or adjacent to the area prior to the fire.

#### Purpose of Treatment

Invasive plants are a serious threat to the stability and function of ecosystems. Often these plants rapidly colonize a burned area, reducing other plant abundance and diversity.

#### Emergency Stabilization Objective

Noxious or invasive weeds are treated with BAER funds to stabilize and prevent unacceptable degradation to natural and cultural resources.

#### Suitable Sites

This treatment is intended for use in one or more of the following locations:

- Sites with preexisting weed species in the area or nearby.
- Areas where fire suppression activities may have introduced noxious or invasive weeds.



Figure 46—Ensure that all straw is certified weed free. Know the origin of the material especially if crossing State lines.

**Cost** Costs vary depending on how the population is treated. Common treatment methods are chemical, biological, and hand- and prevention-seeding. Consult with the forest BAER coordinator or the regional BAER coordinator for cost information.

Cost factors include the following variables:

- Treatment methodology selected.
- Site location and access.
- Frequency of detection survey required.
- Size of area for detection survey.

**Treatment Effectiveness** No data on treatment effectiveness is available. If a BAER team is considering treatments, check with the regional BAER coordinator to get informal feedback on effective methods. Effectiveness monitoring of the different methods is needed.

### **Project Design and Implementation Team Information**

**Design** Review the BAER assessment team findings on the ground to validate potential locations. If the BAER team recommended seeding or chemical treatments, establish the treatment areas with flagging, staking, and identifying treatment area coordinates.

If the BAER team recommended a mechanical treatment, ensure that proper archeological clearance is received prior to implementation. Establish treatment area perimeters so that archeologists, botanists, contractors, and contract inspectors know the extent of the treatment areas.

If the plant's response to fire is uncertain, then much of the work is detection. Survey to see whether the plants move into an area or how they reestablish themselves after a fire. Map areas of potential infestation

and establish a detection survey schedule. Identify whether other USDA Forest Service personnel are working in the area and whether with training, they can help with the detection survey. Document the detection survey schedule throughout the year and, if the plants are found in the areas, determine the method of treatment. Submit a funding request to the regional BAER coordinator to implement the treatment method identified (FSM 2500-2523).

<b>Tools/Equipment</b>	Tools and equipment will vary depending on the treatment method used.
<b>Safety</b>	Ensure that a JHA is developed for the treatment method identified. If seeding with an aircraft, follow all direction for airplanes and helicopters ensuring the safety of the pilots, groundcrew, and field monitors.
<b>Treatment Monitoring Recommendations</b>	<b>Implementation</b> <ul style="list-style-type: none"><li>• Was the treatment implemented as designed?</li><li>• Was detection survey set up to establish the post-fire presence of invasive species?</li></ul> <b>Effectiveness</b> <ul style="list-style-type: none"><li>• Was the treatment effective in preventing or eradicating the invasive species?</li><li>• If seeding was used, did it out-compete the noxious or invasive plants?</li></ul>





### Assessment Team Considerations for Emergency Stabilization

#### Primary Treatment Use

Hazardous material stabilizing methods are used when the USDA Forest Service has sole responsibility for the hazardous materials which pose post-fire, health, and safety concerns.

#### Description

Hazardous material treatments include stabilizing or removing toxic materials created (lead battery burns up in the fire and lead is now leaching out) or destabilized by the fire. Use BAER funds when the USDA Forest Service is solely responsible for the hazardous material. The USDA Forest Service is solely responsible for items that it owns, including batteries, vehicles, and buildings. The USDA Forest Service does not own hazardous materials in a recreation residence or at an abandoned mine. If the USDA Forest Service moves or manipulates any hazardous material that it does not own, the USDA Forest Service could become legally responsible for cleanup of the entire site (BAER Guidance Paper-Hazardous Materials).

Treatment preference for emergency stabilization of hazardous materials is:

- Prevent contamination through site stabilization (e.g., erosion control, ground cover, and so on).
- Control contamination by inplace isolation (e.g., barriers, containment measures, and so on).
- Remove hazardous materials.



Figure 47—Hazardous materials may range from large facilities to propane tanks or car batteries.

#### Purpose of Treatment

Treatments are prescribed to prevent or control contamination of the area from the hazardous material.

#### Emergency Stabilization Objective

Objectives include reducing the threat to human health and/or preventing the unacceptable degradation to natural resources including water, soil, or wildlife.

## Chapter 2 Land Treatments

---

<b>Suitable Sites</b>	<p>This treatment is intended for use in one or more of the following locations:</p> <ul style="list-style-type: none"><li>• Sites where the USDA Forest Service has sole responsibility for these hazardous materials.</li><li>• Hazard is directly related to the fire (did not exist, was unknown, or was not hazardous prior to the fire).</li><li>• Hazard poses significant threat to health, safety, or natural resource degradation.</li></ul>
<b>Cost</b>	<p>Treatment cost varies on the method required to prevent, control, or remove the hazardous material. BAER guidance directs treatment prescribed to be the minimum necessary to stabilize the site or relieve significant threats.</p>
<b>Treatment Effectiveness</b>	<p>Effectiveness of hazardous material treatments has not been documented. Further monitoring of the types of methods used to reduce the hazard is needed.</p>
<b>Project Design and Implementation Team Information</b>	
<b>Design</b>	<p>Coordinate any stabilization or removal activities with qualified USDA Forest Service hazmat personnel. For hazardous materials not under USDA Forest Service jurisdiction, such as special-use cabins, refer permittees to State or county hazmat authorities for assistance.</p>
<b>Safety</b>	<p>If hazardous material is removed from the forest, follow applicable Federal, State, and local regulations. Hazardous material must be removed and disposed of with personnel qualified in hazardous material response.</p> <p>Hazardous material stabilization is inherently dangerous. Mitigate all hazards in the JHA to avoid injuries. Include the following in the JHA.</p> <ul style="list-style-type: none"><li>• Unmarked containers with hazardous materials.</li><li>• Unstable ground near mines on forest service lands.</li><li>• Unexploded ordinances in burned areas.</li></ul>
<b>Treatment Monitoring Recommendations</b>	<p><b>Implementation</b></p> <ul style="list-style-type: none"><li>• Was the treatment implemented as designed?</li><li>• Was the treatment implemented in a timely manner?</li></ul> <p><b>Effectiveness</b></p> <ul style="list-style-type: none"><li>• Was the treatment effective in preventing or eliminating the identified threat?</li><li>• Was the treatment the minimum necessary to stabilize the site?</li></ul>

## Chapter 2 Land Treatments

### Assessment Team Considerations for Emergency Stabilization

<b>Primary Treatment Use</b>	Heritage site stabilization protects the qualifying site characteristics from exposure by erosion, overland runoff, sun baking, and mechanical disturbance without displacing or damaging the remains.
<b>Description</b>	<p>Stabilizing treatments protect sites, human remains, and artifacts to maintain site integrity and allow vegetative regrowth. Stabilizing methods vary from erosion control and camouflage to strategic manipulation of potential hazards (felling trees to avoid site impacts). Specific treatments used to stabilize heritage sites include the following:</p> <ul style="list-style-type: none"><li>• Covering sites with rolled erosion control mats.</li><li>• Removing hazard trees to avoid site impacts.</li><li>• Padding human remains to protect remains.</li><li>• Using log deflectors to channel runoff away from site.</li><li>• Using log-grade stabilizers to reduce downcutting at site.</li></ul>
<b>Purpose of Treatment</b>	Heritage site stabilization reduces erosion and maintains site integrity with vegetative or physical stabilization methods.
<b>Emergency Stabilization Objective</b>	Stabilizing heritage sites prevents unacceptable alteration of any National Register of Historic Places (NRHP) qualifying characteristics. These characteristics include its location, design, setting, materials, workmanship, or association from increased erosion, storm runoff, debris flow, or looting (BAER Guidance Paper-Heritage Resources).
<b>Suitable Sites</b>	<p>This treatment is intended for application in one or more of the following locations:</p> <ul style="list-style-type: none"><li>• Areas of high-burn severity.</li><li>• Areas within close proximity to trails and access routes.</li><li>• Areas with little or no remaining vegetative cover.</li><li>• Areas with highly erodible soils.</li><li>• Areas of high cultural significance.</li><li>• Areas where wind-throw would uproot site features.</li><li>• Areas listed or proposed for listing on NRHP.</li></ul>
<b>Cost</b>	<p>Costs vary depending on the size of the area stabilized and the materials available. Hand crews rather than heavy equipment stabilize and disguise sites due to site sensitivity. Mapping the extent of the area at risk defines the extent and the amount of material needed to cover or protect the area.</p> <p>Cost factors include the following variables:</p> <ul style="list-style-type: none"><li>• Crew availability (experienced) to implement the treatment.</li><li>• Site location and ease of access.</li><li>• Material availability.</li><li>• Consultation requirements.</li></ul>
<b>Treatment Effectiveness</b>	A literature search of monitoring records for heritage-site stabilization did not show any results. However, in reviewing the fire's effects on heritage resources, the major factor is heat intensity. Heat intensity depends on fuel loading and fire duration. In areas where fires burn brush and move

quickly through a site, the damage to the soil profile is less and stabilization efforts are effective. Sites burned with high-soil-burn severity are harder to stabilize. Through analysis of the area's soil condition and information on plant community reestablishment, the BAER assessment team can determine the best stabilization technique.

### **Project Design and Implementation Team Information**

**Design** After the BAER assessment team has designated potential treatment areas, review these field sites with the archeologist to ensure suitability. One key design consideration is defining the threat to the site. Will overland flow, flood, erosion, or tree uprooting be the major threat to the site? Once this is established, select the stabilizing treatment with the archeologist.

**Hazard Tree Removal** Hazard tree removal in heritage sites is determined with the archeologist and qualified sawyer. Key design considerations include preventing site damage from falling trees and excessive fuel loading that may threaten the integrity of the site. Review the field sites to determine which trees could adversely impact the site, where the trees could be felled safely, and how the material is removed from the site. In some cases limbs and logs are used for soil cover or log diverters to prevent run-on to the site. Designate a disposal area for material that will not impact the site.

### **Construction Specifications**

1. Map the site and flag the boundary to define the limits.
2. Identify and mark trees to be removed with flags or paint.
3. Flag the disposal area.
4. Designate an area to store all fuel, oil, and tools downhill and outside of the site boundary.
5. Conduct all chain saw fueling, repairing, and sharpening within the designated area.
6. Fell designated trees and use smaller limbs and vegetation for soil cover and camouflaging within the site.
7. Photograph the site after completing the treatment.
8. Monitor the site to evaluate the treatment in regard to reducing adverse impacts from hazard trees.

**Erosion Control Mats** Erosion control mats or blankets are commonly referred to as rolled erosion control products (RECPs). RECPs are effective in reducing erosion and sedimentation when properly implemented. RECPs are either synthetic or organic and come in a variety of materials including coconut, wood excelsior, or straw. New RECPs include net-less blankets with biodegradable stakes. Each manufacturer and distributor has a variety of products available depending on specific site considerations.

RECPs are used to stabilize heritage sites that require immediate soil cover. Key design considerations include run-on from adjacent areas, bedrock areas with low infiltration and high runoff, high-burn severity areas, and presence of water-repellent soils.

### Construction Specifications

1. Make the soil surface stable, firm, and free of rocks and other obstructions.
2. Follow manufacturer's published installation requirements for the specific RECP purchased.
3. Apply seed or fertilizer to the site prior to installing RECP if seeding is recommended by the archeologist and soil scientist.
4. Unroll the RECP parallel to the primary direction of flow and in direct contact with soil surface.
5. Avoid stretching the material.
6. Overlap edge of adjacent RECPs by 2 to 4 inches.
7. Follow the guidelines for number of stakes or staples to prevent seam separation.
8. Overlap roll ends of joining RECPS 2 to 6 inches in the direction of the flow.
9. Photograph and document the area with a site map after completing the treatment.
10. Monitor the site after the first significant storm event to evaluate the treatment and ensure the mats are functioning as designed.

### Log Deflectors

Log deflectors are used primarily in first-order channels where accumulated sediments or debris may direct overland flows towards heritage sites. The channel change is often caused by a sediment fan that deposited in the first-order channels or filled the previous channel. The build up of a sediment fan or channel infilling develops when the time span between wildfires can be measured in centuries. Key design considerations include delineation of the vulnerable area, probable routing locations (where the overland runoff will come from), slope of the area, and a nonthreatening fluvial path to route the runoff (Ruby, unpublished paper). As in any channel modification, the potential to exacerbate the fire's effect can occur if a deflector is not carefully designed by the hydrologist and archeologist.

### Construction Specifications

1. Identify storm runoff pathways.
2. Construct log deflectors across a fluvial path at an angle and gradient that does not accelerate runoff and cause soil erosion.
3. Intersect the log with the diversion point at approximately 120 degrees to achieve a safe change in the runoff's direction without erosion.
4. Have the outlet empty into a well defined channel approximately 100+ degrees.
5. Place the log deflectors along the slope simulating the new channel area before digging the trench.
6. Ensure that the deflectors are placed at an angle that approximated the natural channel pattern. If the angle is too abrupt or too gentle the flows will circumvent the log deflector.
7. Ensure that logs are 6 to 9 inches in diameter on the small end, and straight enough to make secure contact with the soil surface for the entire length of the log.
8. Construct a shallow trench in the soil above the deflector to accommodate the channel flow. The trench may eventually become a part of the permanent channel system as the log deteriorates and the channel stabilizes.

## Chapter 2 Land Treatments

---

9. Map and photograph the site.
10. Monitor the site during or immediately after any runoff event to evaluate the treatment is functioning as designed (Ruby, unpublished paper)

### Protecting Human Remains

### Design and Construction Specifications

If a feature has been uncovered by a fire, take the following steps:

1. Map the site or feature to define the limits.
2. Locate and mark the length and width of the padding limits with flagging.
3. Photograph the site before, during, after padding to maintain a photographic record.
4. Use GPS coordinates to document its location.
5. Cover the site with loose native material without packing it.
6. Cover the feature with 3 to 6 inches of loose soil.
7. Add another lift of soil that is 6 inches deep and moderately packed.
8. Place another 2 inches of loose soil in the area as the landform is worked to restore it to the adjacent area with no apparent depressions or runoff paths.
9. Photograph the padded site.
10. Armor the site with available rock or organic material.
11. Leave approximately 2 to 4 inches between rocks to allow for vegetation growth.
12. Use seed in the area between the rocks to stabilize the site over time.
13. Cover the seed and site with any unburned vegetation or partially burned vegetation to disguise it. Ensure that the camouflage method does not make the site more visible.
14. Use a rolled erosion control product to cover the site if no vegetation is available. Jute netting or a netless erosion control product can be used.
15. Photograph the site after completing the treatment.
16. Monitor the site after the first storm runoff event to evaluate the treatment in regard to soil erosion stability, vegetation stability, and site visibility (Ruby, unpublished paper).

This work is done with hand crews and requires an archeologist to be onsite assisting in the design and project implementation.

#### Tools

- Rakes or McLeods
- Shovels
- Hand seeder
- Wheelbarrow
- Chain saw

#### Equipment

- Camera
- GPS

#### Material

- Flagging and staking for treatment areas.

## Chapter 2 Land Treatments

---

### Safety

Stabilizing heritage sites can be hazardous. Consider all the hazards and review and update daily to avoid injuries. Include the following in the JHA.

- Chain saw operation and tree felling.
- Hazard trees within treatment areas.
- Stump holes and unstable footing.

### Treatment Monitoring Recommendations

#### Implementation

- Was the project implemented as designed?
- Did the treatment disguise the site?
- Did the treatment modify the soil surface to disrupt or remove any erosional paths?

#### Effectiveness

- Did the treatment stabilize the site?
- Did the treatment disguise the site over time?
- Were erosion and storm runoff pathways identified and treated?
- Was the site pilfered or vandalized?





### Assessment Team Considerations for Emergency Stabilization

**Primary Treatment Use**

Checkdams trap sediment and slow water velocities slowing the sediment pulse entering streams.

**Description**

Checkdams can be constructed from straw, log, or rock depending on the location and availability of materials. Strawbale checkdams are a temporary erosion control measure built with three to five strawbales depending on the size of the channel. Strawbale checkdams are placed in ephemeral channels with a moderate gradient to trap and reduce sediment delivered to channels. Log checkdams are built from logs within the fire area. The size, slope, and space between logs determines the amount of material trapped. Rock checkdams are used where there are high values at risk and a rock source is close by.



Figure 48—Strawbale checkdam with energy dissipater.

**Purpose of Treatment**

Checkdams are designed to trap and store sediment mobilized from the hillslope and channel. Properly constructed checkdams prevent downcutting and attenuating peak flows as water is routed through a series of small basins created by the checkdams. The moist deposits of soil, ash, and organic material can serve as fertile sites for vegetative recovery.

**Emergency Stabilization Objective**

Objectives are to reduce water quality deterioration and encourage recovery of vegetation.

**Suitable Sites**

The treatment is intended for use in one or more of the following locations:

- Swales with gentle gradient that allow for sediment storage.
- High-burn severity areas with highly erodible soils.
- Areas with less than 20-percent ground cover, or ineffective cover for that ecosystem.
- Areas with high values at risk.
- Watersheds with small drainage areas, generally less than 5 acres.

## Chapter 3 Channel Treatments

**Cost** Checkdams are inexpensive to construct and range in price from \$150 to \$600 each.

Cost factors include the following variables:

- Treatment location and access.
- Construction material used (log, straw, or rock)
- Movement of bales from the staging area to the treatment sites.
- Availability of strawbales that are certified weed free.
- Maintenance and reconstruction needs.

Strawbale checkdams were popular in the 1990s. They were one of the most common channel treatments implemented. Treatment success varied with ratings of good to poor. However, properly located and installed strawbales can be effective. Strawbale checkdams placed in first order streams with a stream gradient of less than 5 percent were rated favorably by implementers. However, poor ratings were given for improperly installed treatments or when located in large drainages. Strawbale checkdams are more successful in a 2- to 5-year design storm return period where design storm magnitude is within the capacity of the structure.

Problems with strawbale and log checkdams include filling to capacity from only small storms. A large storm event can cause the entire structure to fail requiring reconstruction or maintenance. Successive and frequent storm events can wash out structures. Inspection of the strawbales after storms is recommended to reduce catastrophic failure. It is not uncommon for up to 20 percent of the structures to fail even under good conditions. Failure of structures often resulted in more damage occurring from the treatment.



Figure 49—Strawbale checkdam that filled, overtopped, and created a gully below the structure.

Some implementers found the single-log check dams or log-sill dams to be effective in seasonal and small perennial streams and less risky than the multi-log structures. Field review found up to 20 percent of the structures failed during the first runoff season (Ruby, unpublished paper). More catastrophic failures occurred with larger multi-log structures especially in streams that quickly aggraded (Hubbert, unpublished paper). Water formed a new channel around the end of the log dam even in places where the logs were keyed in 3 feet into the streambank. Failure mechanisms included undercutting and end-runs around the structure.

Rock checkdams are more permanent and can be effective when properly implemented. All types of checkdams appear to work better when implemented in gentle gradients, high in the watershed, and placed in a series. Any checkdam changes the channel gradient and works only to meter out the sediment in a channel rather than preventing it from getting into the channel in the first place.

Assessment teams should consider the burn severity, vegetative response, design storm, values at risk, and ability to implement, inspect, and maintain channel treatments prior to prescribing this work.

### Project Design and Implementation Team Information

**Design** After the BAER assessment team has designated potential treatment areas, review these field sites with the hydrologist and soil scientist to ensure suitability. Key design considerations include watershed size, channel type, slope gradient, burn severity, space requirements, and materials needed.

Identify site access and hazards in and around the work area to determine appropriate mitigation measures.

### Construction Specifications

Implementation of a strawbale checkdam includes the following steps:

1. Survey the site to identify the appropriate placement for each strawbale checkdam.
2. Build strawbale checkdams in a series. Construct the dams upstream from a natural nickpoint (point resistant to erosion). Ideally, the crest of the second spillway below should be at the elevation of the base of the first dam above it. However, water has more energy to undermine the structure if it is dropped from a high elevation. Armor outlets to reduce water's erosive force.
3. Look upstream to determine the existing channel width. The strawbale dam must extend well beyond the existing channel width because the new grade control established by the dam will be higher than the preexisting grade.
4. Place the spillway bale(s) on the flat side after smoothing a shallow trench.
5. Ensure the bales are seated properly, preventing water flow from under the dam.
6. Use wooden stakes to anchor the spillway bales securely into the ground.
7. Use an appropriate hammer to pound the stakes at an angle until they are 2 inches below the surface.
8. Place the side bales upright at a slight skew, to create a "smile" shaped structure. Ensure that the bales extend well beyond the preexisting active channel. The soil surface beyond the end bales must be higher than the maximum depth of flow anticipated over the center of the structure.
9. Push the bales together tightly to prevent gaps between the bales.
10. Use rocks and woody material to close any gaps between the side bales and the spillway bales.
11. Construct an energy dissipator at the base of the spillway bales by anchoring logs with U-shaped rebar or using onsite rocks piled at least two deep against the bales. (Bend the rebar in advance or bend in the field by wrapping it around a small tree trunk.) The energy dissipator should be large enough to receive all water flowing over the dam.
12. Pound the U-shaped rebar into the ground using the hammer.
13. Secure the rebar to the log with 2-inch fence staples.
14. Place any small branches, woody debris, or pine needles on the upstream side of the dam. The small material will be picked up by the water and plug any gaps in the dam.

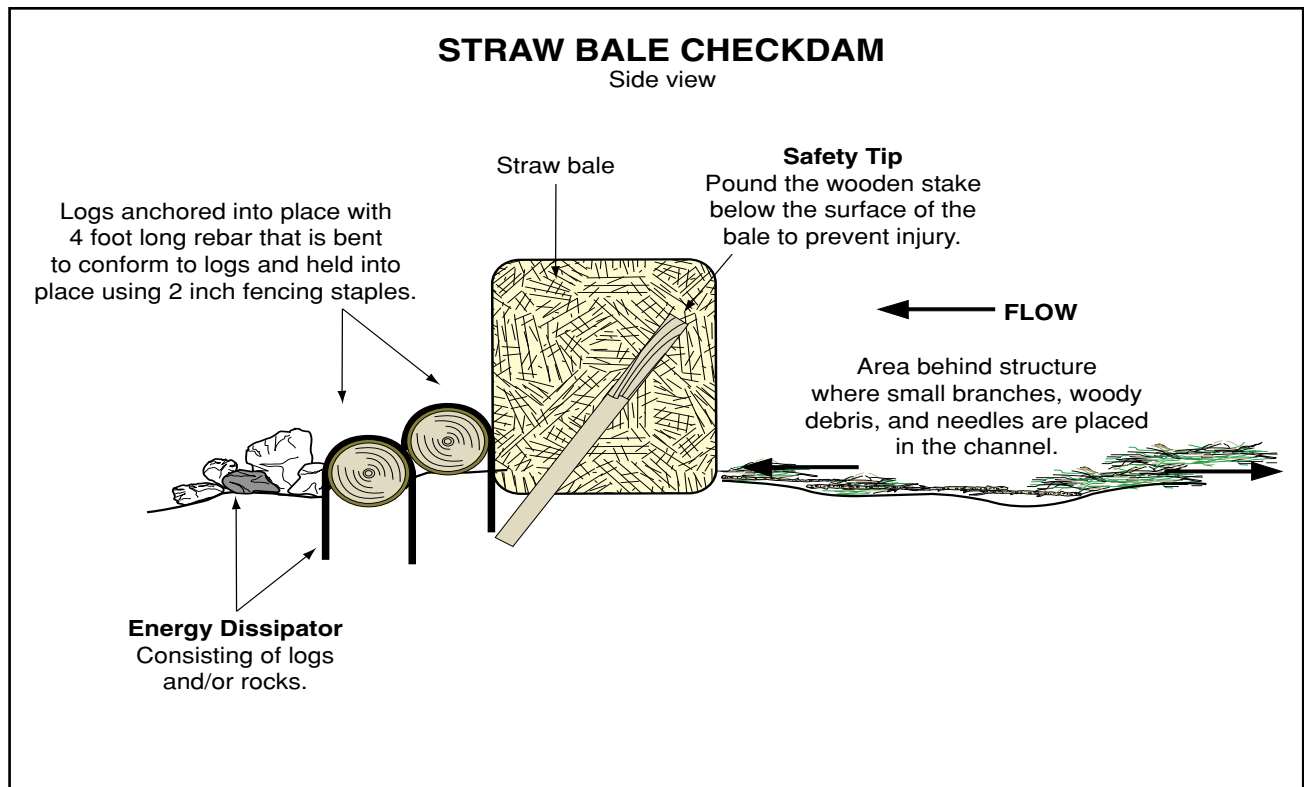

Figure 50—Strawbale checkdam (sideview).

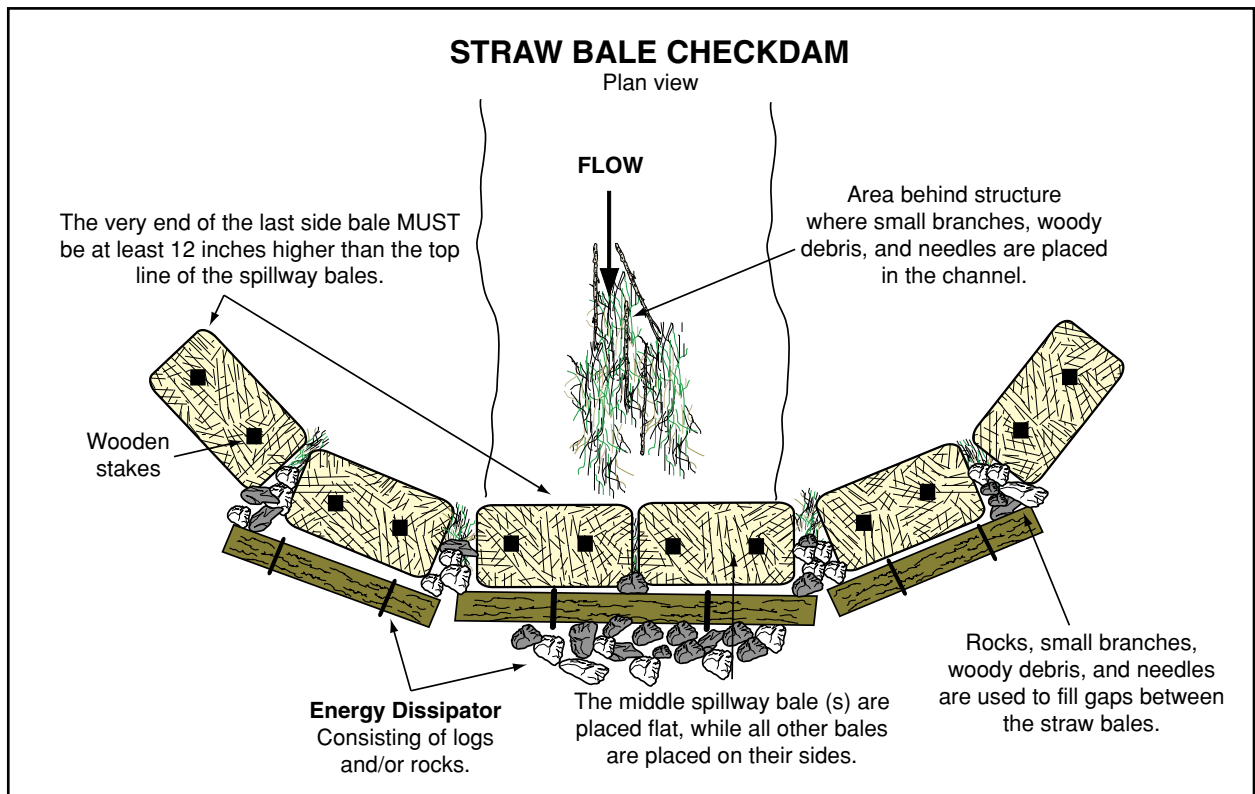

Figure 51—Strawbale checkdam (planview).

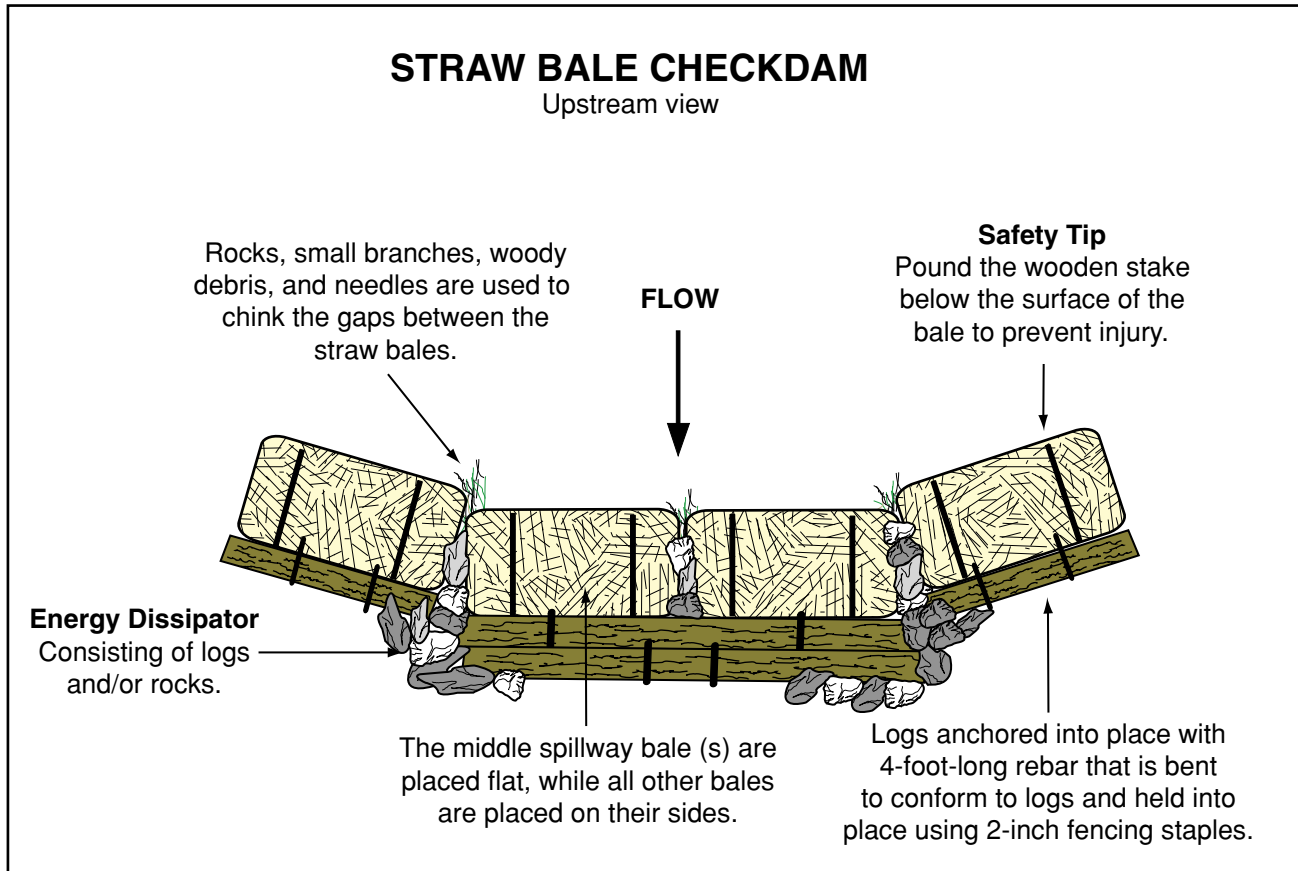

Figure 52—Strawbale checkdam (upstream view).

**Inspection** To ensure the checkdam functions properly, review the following:

1. The crest of the spillway bale must be lower than the bottom edge of the last side bale to trap sediment and prevent water from going around the structure.
2. The energy dissipator must use large enough material to withstand the storm runoff.

**Material/Tools** Items required for a strawbale checkdam include:

**Materials**

1. Certified weed-free strawbales (meet State requirements for noxious and invasive weeds).
2. Wooden contractor stakes, 24 inches long.
3. Rebar to anchor log dissipater, 3/8 inch (See drawing).

**Tools**

1. McLeod rakes.
2. Shovels.
3. Hammer.
4. Eye protection.

## Chapter 3 Channel Treatments

### Log Checkdam Construction Specifications

1. Determine the channel width and cut the log 3 to 4 feet longer to key the log into the channel bank. Streams should not be wider than 6 to 7 feet at bankfull.
2. Excavate a trench 2 to 4 inches deep in the channel.
3. Key the log 2 feet into the channel bank and lay it in the trench.
4. Place two posts on the downstream side of the log to hold it firmly in place.
5. Attach filter cloth to the structure's upstream side to prevent undercutting. Filter cloth should extend up the channel approximately 3 feet and be buried at least 6 inches.
6. Notch the log to provide a spillway and armor the spillway with rocks to serve as an energy dissipator.
7. Inspect and maintain all dams after the first runoff event.

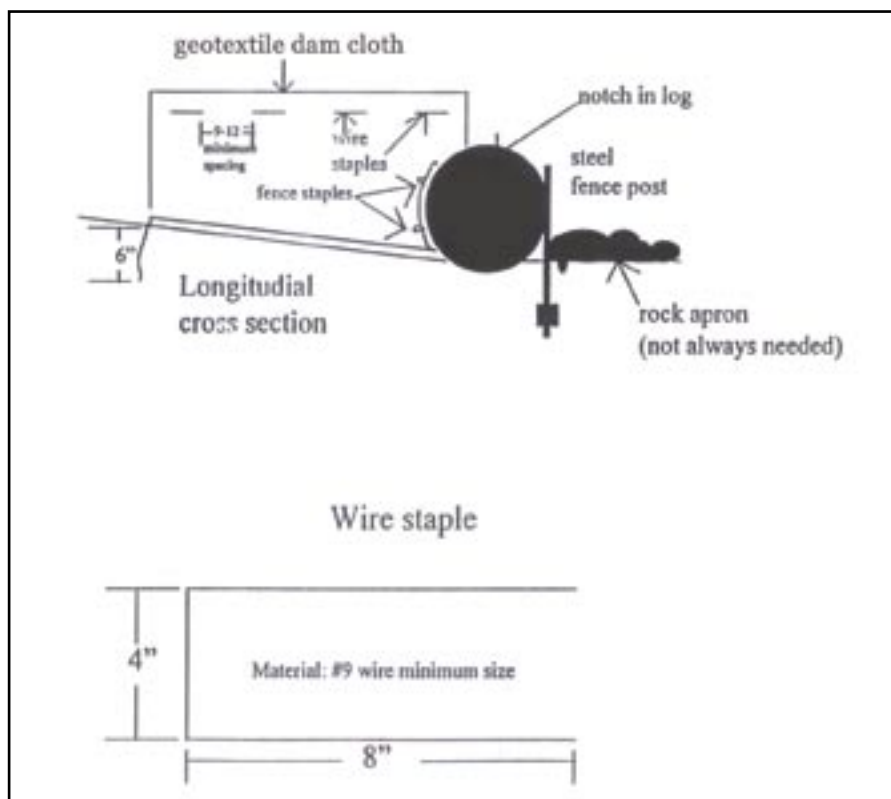

Figure 53—Typical log checkdam structure.

### Safety

Strawbale checkdams are implemented safely if all hazards are mitigated. Review, update, and include the following items in the JHA.

- Hazard trees and snags within treatment areas.
- Stump holes and unstable footing.
- Strawbale lifting and moving.
- Eye protection.
- Allergic reactions from straw.

### Treatment Monitoring Recommendations

### Implementation

- Was the project implemented as designed?
- Were the strawbales properly located?
- Were energy dissipators installed?
- Were there gaps between bales?



Figure 54—Checkdams should be inspected and maintained.

### Effectiveness

- Did the strawbale checkdam fill with sediment?
- Did vegetation grow in the deposits behind the dam?
- Did any downcutting occur downstream from the dam?
- Does the structure need any maintenance for subsequent storm events?



Figure 55—Install checkdams to avoid endruns.



### Assessment Team Considerations for Emergency Stabilization

<b>Primary Treatment Use</b>	In-channel tree felling is prescribed to maintain channel stability and provide fish habitat. In-channel tree felling replaces woody material consumed by the fire. It also is used to treat steep drainages to reduce the risk of in-channel debris flow bulking for several years after a fire (Fitzgerald, unpublished paper).
<b>Description</b>	In-channel tree felling involves directionally felling trees upstream so the tops of the trees are in the channel. The trees are felled at a diagonal along designated channel reaches. The trees are staggered from side to side along the stream in a herringbone design (Ruby, unpublished paper; Fitzgerald, unpublished paper).
<b>Purpose of Treatment</b>	In-channel tree felling traps floatable debris and suspended sediment. Over time, woody material can cause sediment deposition and channel aggradation. Large woody material dissipates stream energy, provides cover for fish, and forms rearing and resting habitats. For seasonal channels the in-channel trees serve as dams to stabilize existing prefire bed material and to trap and store post fire sediment in the short term, while providing long-term channel stability (Fitzgerald, unpublished paper).
<b>Emergency Stabilization Objective</b>	In-channel tree felling reduces effects to critical natural resources (sensitive aquatic species) or downstream values (water quality and or road crossings) by restoring large woody debris to the channel and dissipating stream energy.
<b>Suitable Sites</b>	<p>This treatment is intended for use in one or more of the following locations (Ruby, unpublished paper):</p> <ul style="list-style-type: none"><li>• Areas of high-burn severity where woody material has been consumed.</li><li>• Channels where energy dissipation is necessary.</li><li>• Channels with high values at risk such as road crossings or sensitive aquatic species.</li><li>• Channels with unstable bedload and high sediment-loading potential.</li></ul>
<b>Cost</b>	<p>Little cost data is available for this treatment. The unit cost for directional felling in the Southwest Region (R3) for FY 2000 to 2003 ranged from \$3,500 to \$4,000 per mile of treatment, based on approximately 100 trees felled per mile of channel.</p> <p>Cost factors include the following variables:</p> <ul style="list-style-type: none"><li>• Number of trees designated per mile.</li><li>• Hazard associated with felling trees.</li><li>• Location of treatment area.</li><li>• Amount of large woody material available.</li></ul>
<b>Treatment Effectiveness</b>	The Shasta Trinity National Forest has reviewed the effectiveness of in-channel tree felling for 5 years. The treatment is successful when properly located in a series along the channel. Structures reduce the risk of debris flow bulking and stream channel destabilization, yet are flexible to shift as the stream channel recovers (Fitzgerald, unpublished paper).

## Chapter 3 Channel Treatments

Other effectiveness monitoring of this treatment are by visual observations identifying if the trees are still there and if sediment was trapped.

### Project Design and Implementation Team

#### Design

After the BAER assessment team has designated potential stream reaches for in-channel tree felling, review the areas in the field to ensure the sites are suitable. Key considerations are the availability of suitable trees, ability to safely implement the treatment, and channel characteristics favorable to this treatment (increased sediment load, gradient, and loss of woody material from the fire).

#### Construction Specifications

- Define the treatment areas by staking, GPS coordinates, or flagging.
- Candidate trees are dead and size class is representative of the stream reach.

#### For perennial streams:

- Leave felled trees in one piece with the top attached.
- Space 2 trees per 50 to 100 feet of channel, with 1 tree on each side of the channel for approximately 106 to 212 trees per mile.
- Fell two trees from each side of the channel on top of each other to improve stability.
- Fell trees such that the top quarter to half of the tree is within the high-water level for that channel (Ruby, unpublished paper).

#### For seasonal channels:

- Fell the primary tree across the channel to “plug” the channel.
- Buck the primary tree so the log touches the channel bottom.
- Fell secondary trees to support the primary tree.
- Use trees large enough to hold the expected runoff and debris load (Fitzgerald, unpublished paper).

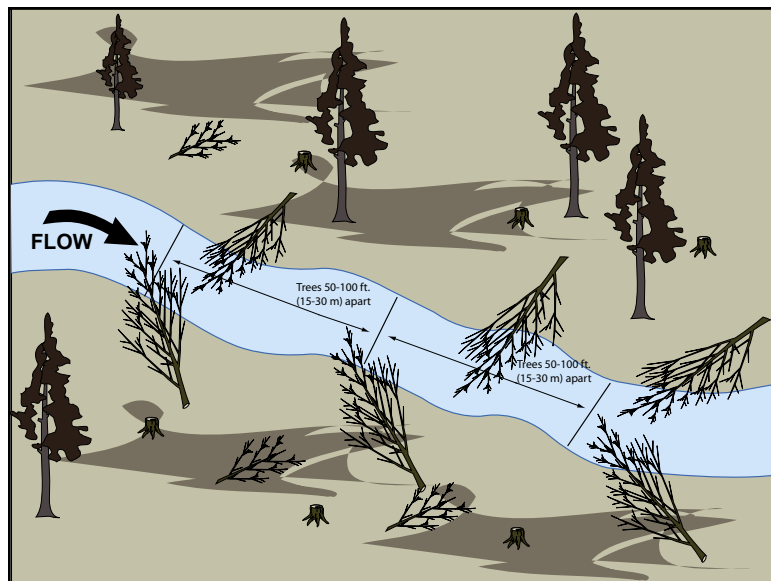

Figure 56—Directional tree felling.

## Chapter 3 Channel Treatments

<b>Tools/Equipment</b>	Tools necessary for implementing in-channel felling include chain saws and PPE.
<b>Safety</b>	<p>In-channel tree felling is implemented safely when hazards are identified and mitigated. Review and update the JHA daily to avoid injuries. Include the following in the JHA.</p> <ul style="list-style-type: none"><li>• Work in and around streams with unstable footing.</li><li>• Muscle and back strain from chain saw operation.</li><li>• Hazards associated with tree felling of potentially unstable trees.</li></ul>
<b>Treatment Monitoring Recommendations</b>	<p><b>Implementation</b></p> <ul style="list-style-type: none"><li>• Was the treatment implemented as designed?</li><li>• Were guidelines followed regarding the spacing, diagonal placement, and percentage of the tree within the high water level?</li><li>• How many trees per acre were placed in the channel?</li></ul> <p><b>Effectiveness</b></p> <ul style="list-style-type: none"><li>• Did the woody material trap sediment?</li><li>• Did the woody material protect identified downstream values (culvert or aquatic habitat)?</li><li>• Were the in-channel trees tested at the time of review according to the design storm parameters?</li></ul> <p>The following tool was developed by hydrologists Bob Blecker and Terry Benoit in 1985 during the Gorda-Rat fire. This dichotomous key modified an earlier debris stability key by Bilby. Review of channels and literature determined that firmly anchored log jams plus large logs should remain in the channel for channel stability, fish habitat, and to stabilize instream bed material.</p>
<b>Stream Channel Debris Removal Key and Guidelines</b>	<p>Debris removal key (use as a dichotomous key starting with couplet 1)</p> <ol style="list-style-type: none"><li>1). a) Debris anchored or buried in the streambed or bank at one or both ends or along the upstream face – LEAVE b) Debris not anchored – Go to 2</li><li>2). a) Debris longer than 30 feet – LEAVE b) Debris shorter than 30 feet – Go to 3.</li><li>3). a) Debris greater than 18 inches in diameter – Go to 4. b) Debris less than 18 inches in diameter – Go to 5.</li><li>4). a) Debris longer than 15 feet – LEAVE b) Debris shorter than 15 feet – Go to 5.</li><li>5). a) Debris braced on downstream side by boulders, bedrock outcrops, or stable pieces of debris – LEAVE b) Debris not braced on downstream side – REMOVE.</li></ol>



## Assessment Team Considerations for Emergency Stabilization

### Primary Treatment Use

Grade stabilizers are designed to prevent channel incising and downcutting. Grade stabilizers provide grade control to systems that may become destabilized from increased storm runoff and velocities.

### Description

Grade stabilizers are constructed from various materials, including logs, rocks, and wood. BAER assessment teams may recommend this treatment in areas where the loss of soil cover and increased runoff would result in channel downcutting. If grade stabilizers are proposed as an emergency treatment, a hydrologist familiar with their design, implementation, and effectiveness should design them to meet the particular site specifications.

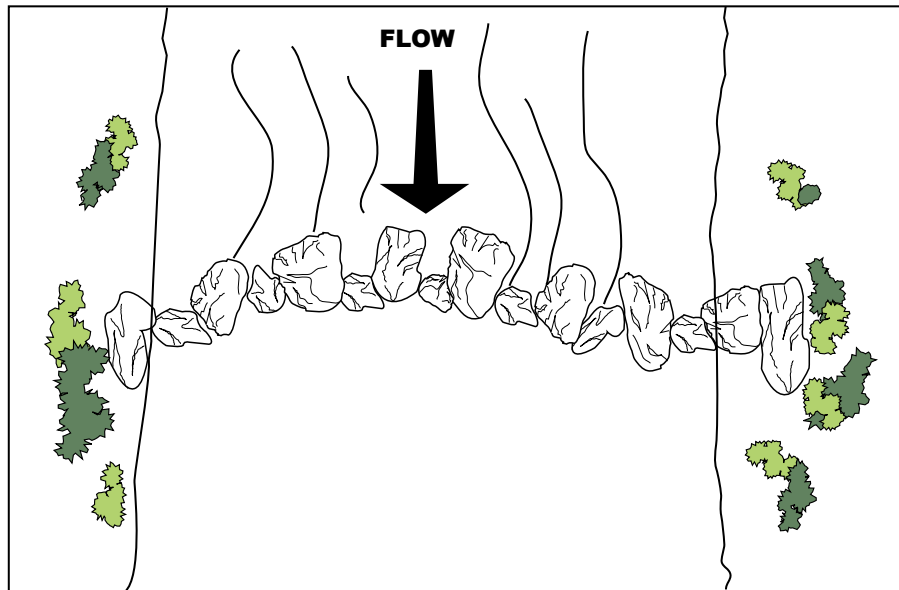

Figure 57—Grade stabilizer is placed at grade to prevent channel incision.

### Purpose of Treatment

Grade stabilizers maintain channel gradient and reduce channel scouring or downcutting from increased overland runoff.

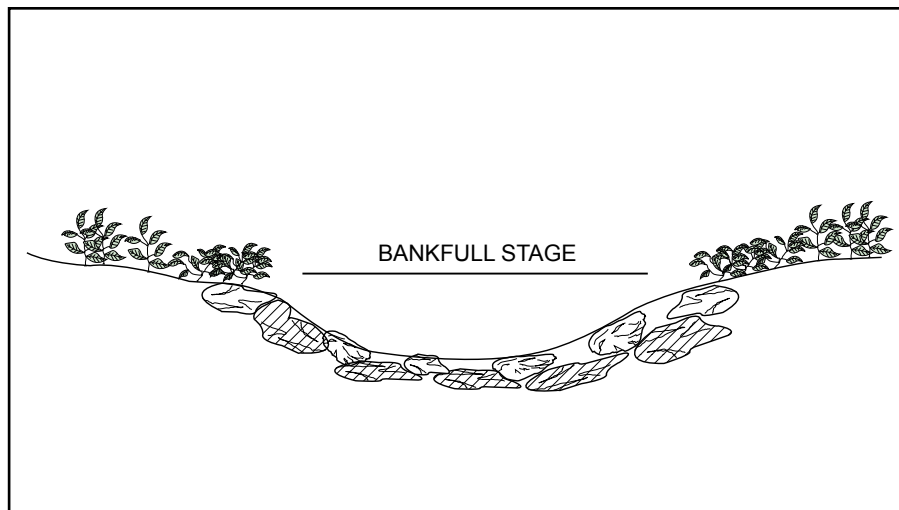

Figure 58—Bankfull view of grade stabilizer.

## Chapter 3 Channel Treatments

### Emergency Stabilization Objective

Objectives are to reduce water quality deterioration and establish grade control in seasonal channels.

### Suitable Sites

This treatment is intended for application in one or more of the following situations:

- Downstream beneficial uses are high.
- Channel indicators of instability exist.
- Watershed has high percentage burn throughout.
- Soil cover loss and woody debris.
- Presence of persistent hydrophobic condition in watershed.
- Seasonal channels with low to moderate flows.
- Channel gradient less than 6 percent.

### Cost

Limited data exists on this treatment because it is seldom used. Costs range from \$250 to \$4,000 per structure depending on materials and installation method.

Cost factors include the following variables:

- Material available.
- Access to sites.
- Availability of skilled workforce.
- Mechanized equipment use (backhoe/excavator).

### Treatment Effectiveness

Little quantitative data is available on grade-stabilizer effectiveness as a BAER treatment. Data collected on BAER treatment effectiveness (Robichaud 2000) found no evidence that grade stabilizers were effective in stabilizing the channel gradient.

In some cases, scouring and downcutting of seasonal channels has occurred after wildfires, but our ability to predict where downcutting may occur is limited. Much of the downcutting that does occur could result from short-duration stormcells over a particular drainage that can be missed easily during the BAER assessment phase.

Occasionally, assessment teams recommend grade stabilizers. This treatment may be most effective for areas of low or moderate flows.

### Project Design and Implementation Team Information

### Design

After the BAER assessment team has designated potential treatment areas, review these field sites with the hydrologist to ensure suitability. Key design considerations include channel gradient, morphology and stability, adjacent hillslope conditions (soil burn severity), and available materials. Obtain any needed State or Federal streambank alteration permits prior to implementation.

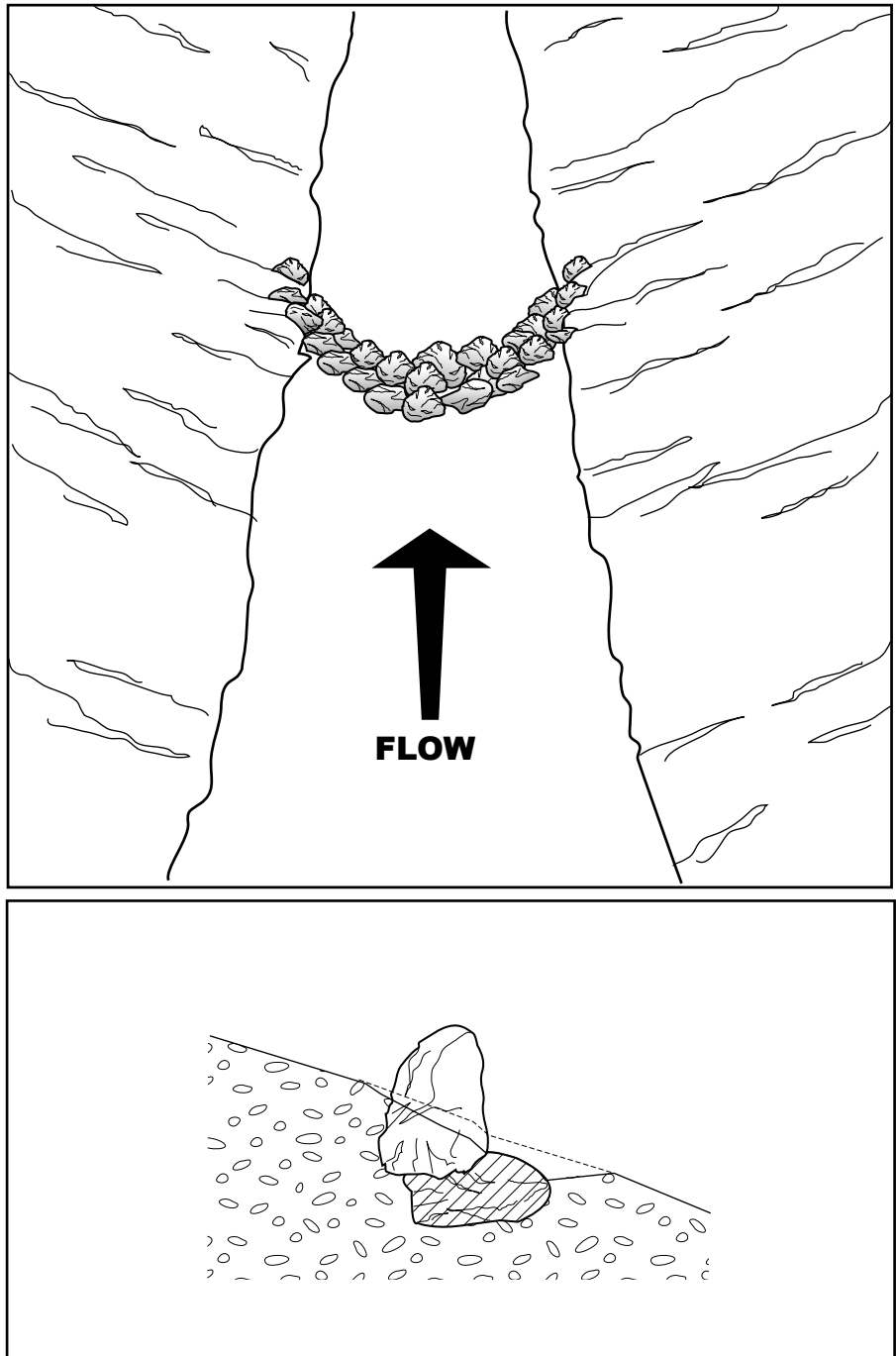

Figure 59—Stream grade can be adjusted and maintained by careful placement of boulders.

## Chapter 3 Channel Treatments

---

### Construction Specifications

Proper design and planning is required when implementing a treatment. Each rock- or log-grade stabilizer will vary depending on the site but basic requirements include:

1. Identify each treatment area by staking, flagging, and marking GPS coordinates.
2. Estimate the size and amount of material required for each structure.
  - a.If using rock for the structure, ensure it is large enough to withstand the erosive force of the stream channel.
  - b.If using wood or logs, estimate the width of the channel for the targeted high flows to ensure the structure is not outflanked with higher flows.
3. Construct the structure at grade, which requires excavation, depending on the materials used.
4. Spread excavated material on the slopes and/or use it to fill around the rocks.
5. Inspect and monitor the structures for any signs of erosion after the first storm event.

### Tools/Equipment

Tools will vary depending on the type of material used.

- Chain saws for use on wood and log structures.
- Backhoes or excavators for placing rock structures.

### Safety

Grade stabilizers are safely implemented when hazards are identified and mitigated. Review and update the JHA daily to avoid injuries. Include the following items in the JHA.

- Hazard trees and snags within treatment areas.
- Work around heavy equipment.
- Rocks or logs on site.
- Chain saw use.
- Road access to the site.

### Treatment Monitoring Recommendations

#### Implementation

- Was the treatment implemented as designed?
- Is the structure at grade?
- Is the structure long enough to avoid outflanking?
- Were State or Federal streambank permit final reports submitted?

#### Effectiveness

- What type of storm events did the structure receive prior to monitoring?
- Are there indications of channel downcutting? If so, are more structures needed?
- Did the structure function as designed?



<b>Assessment Team Considerations for Emergency Stabilization</b>	
<b>Primary Treatment Use</b>	Streambank armoring reduces impacts from increased peak flows from the fire's effects on unstable stream reaches. In some hydrologic systems, streambanks are a major source of sediment after a wildfire.
<b>Description</b>	Armoring is the placement of rock along the streambank to reduce erosion. Armoring may include placement of boulders, riprap, or gabion baskets.
<b>Purpose of Treatment</b>	Streambank armoring is prescribed to reduce erosion and sediment in stream channels.
<b>Emergency Stabilization Objective</b>	Armoring of streambanks moderates the severity of streambank erosion and reduces degradation of water quality.
<b>Suitable Sites</b>	This treatment is intended for use in one or more of the following locations: <ul style="list-style-type: none"><li>• Highly erodible streambanks.</li><li>• Areas with high values at risk.</li></ul>
<b>Cost</b>	Streambank-armoring cost data is unavailable because this treatment is used seldom. However, the forest engineering staff may have identified rock sources.  Cost factors include the following variables: <ul style="list-style-type: none"><li>• Proximity to suitable rock source.</li><li>• Haul distance.</li><li>• Size of material required.</li></ul>
<b>Treatment Effectiveness</b>	No quantitative effectiveness monitoring data exists for this treatment. Qualitative monitoring of streambank-armoring using gabion baskets to protect a well house and pump station performed well (Kuyumjian, personal communication). Assessment teams that prescribe this treatment should consult with the forest watershed and engineering staff to evaluate whether this treatment meets the emergency treatment objectives. When streambank armoring is prescribed, ensure that properly sized material is used. Well-intentioned prescriptions have accelerated streambank erosion downstream of the structure. Assessment and implementation teams should use caution when prescribing this as an emergency treatment.
<b>Project Design and Implementation Team Information</b>	
<b>Design</b>	After the BAER assessment team has designated potential treatment areas, review these field sites to ensure suitability and determine the material required.  Key design considerations include material size and amount. Designers also need to ensure that no erosion occurs at the end of the armoring treatment. Design considerations for transitioning may include energy dissipators and in-channel felling. Obtain any State or Federal stream alteration permits prior to implementation.

## Chapter 3 Channel Treatments

---

<b>Tools/Equipment</b>	Backhoe. Dumptruck. Excavator with a thumb attachment for precise boulder placement or moving large rock. Gabions for necessary mass when large boulders are unavailable.
<b>Safety</b>	In-channel tree felling is implemented safely when hazards are identified and mitigated. Review and update the JHA daily to avoid injuries. Include the following in the JHA. <ul style="list-style-type: none"><li>• Working with heavy equipment.</li><li>• Working in and near a stream zone with unstable footing.</li><li>• Working near hazard trees.</li></ul>
<b>Treatment Monitoring Recommendations</b>	<b>Implementation</b> <ul style="list-style-type: none"><li>• Was the treatment implemented as designed?</li><li>• Were guidelines followed for rock and boulder sizing?</li><li>• Were treatment transitions (energy dissipators) incorporated in the design and implemented?</li><li>• Were stream alteration permit final reports submitted?</li></ul> <b>Effectiveness</b> <ul style="list-style-type: none"><li>• Did the stream-channel armoring prevent streambank erosion?</li><li>• Was the armoring tested at the time of review according to design storm parameters?</li><li>• Were transition structures effective in preventing downcutting and streambank scouring, if used?</li></ul>

### Assessment Team Considerations for Emergency Stabilization

<b>Primary Treatment Use</b>	Channel deflectors protect a structure or infrastructure from increased streamflows caused by the effect of the fire.
<b>Description</b>	Channel deflectors include methods such as j-hooks, rock barbs, and single- or double-wing deflectors (Rosgen 1996). The treatment is designed to direct streamflows and velocities away from unstable banks or high values at risk.
<b>Purpose of Treatment</b>	Channel deflectors protect structures or the transportation infrastructure from increased streamflows and/or flooding.
<b>Emergency Stabilization Objective</b>	Channel deflectors reduce the potential loss or damage to property or infrastructure.
<b>Suitable Sites</b>	This treatment is intended for use in one or more of the following locations: <ul style="list-style-type: none"> <li>• Roads which may parallel stream channels.</li> <li>• Facilities at risk from streambank erosion or flooding.</li> </ul>
<b>Cost</b>	Treatment costs are highly variable depending on the structure installed. Once a structure is selected, consult with the forest watershed staff to obtain cost estimates. Cost factors include the following variables: <ul style="list-style-type: none"> <li>• Structure type installed.</li> <li>• Availability of material (rock, jersey barriers, riprap, logs).</li> <li>• Site location and access availability.</li> </ul>
<b>Treatment Effectiveness</b>	There is no documented effectiveness monitoring data for this treatment, because this treatment is seldom prescribed. If a BAER assessment team prescribes this treatment, a well-developed design is required prior to implementation. In many cases there is inadequate time to conduct surveys and design this treatment prior to the first damaging storm event.

### Project Design and Implementation Team Information

<b>Design</b>	<p>After the BAER assessment team has designated potential treatment locations, review the area in the field to ensure site suitability. Key considerations are available streamflow data, values at risk (if flows increase, what impact is there on a campground, building, or road), availability of materials, and experienced personnel to design and implement the treatment. Use established protocols for the treatment selected and match the treatment to the channel characteristics (Rosgen 1996).</p> <p>Identify appropriate permits required for implementation. Channel deflectors should be in compliance with both State and the United States Army Corps of Engineers Nationwide Permit 37 "Emergency Watershed Protection and Rehabilitation" and Nationwide Permit General Conditions (Kuyumjian, personal communication).</p>
---------------	---

## Chapter 3 Channel Treatments

---

<b>Tools/Equipment</b>	<p>Most channel deflectors are installed with an excavator or backhoe. Excavators with a thumb attachment enable the operator to pick up and place boulders with less impact to the stream. Other equipment includes dumptrucks to haul boulders to the site.</p>
<b>Safety</b>	<p>If this treatment is implemented, work with the forest watershed staff and other resource professionals experienced with implementing these treatments to ensure proper installation.</p> <p>Channel deflectors can be implemented safely if all hazards are mitigated. Review, update, and include the following items in the JHA.</p> <ul style="list-style-type: none"><li>• Heavy equipment working in area..</li><li>• Vehicle traffic on roads to and from the site may require a traffic management plan.</li></ul>
<b>Treatment Monitoring Recommendations</b>	<p><b>Implementation</b></p> <ul style="list-style-type: none"><li>• Was the treatment implemented as designed?</li><li>• Were guidelines followed regarding the size of the material placed and the spacing between channel deflectors?</li><li>• Were stream alteration permit final reports submitted?</li></ul> <p><b>Effectiveness</b></p> <ul style="list-style-type: none"><li>• Did the structures function as designed and help to move the stream flow away from the identified values at risk?</li><li>• Were the structures tested at the time of review by the design storm?</li><li>• Was there damage to the structures (campground, building, road)? If so, are additional treatments necessary?</li><li>• Was there damage to the stream environment?</li></ul>

### Assessment Team Considerations for Emergency Stabilization

#### Primary Treatment Use

Debris basins are emergency structures for areas where a threat to human life and property is identified and an opportunity exists to contain and control expected material. Constructing new debris basins are considered a last resort due to cost, maintenance, and timeframes for engineered design and permit approvals.

#### Description

Debris basins vary in size and type. The basin type refers to whether it is in-channel or off-channel. The type influences the design, construction and operation, and reclamation needs (Van de Water, unpublished paper). In some cases, existing debris basins are cleaned out or enlarged to provide additional capacity.



Figure 60—Small basin created to trap sediment.

#### Purpose of Treatment

Debris basins are constructed to treat either the loss of runoff control and deterioration of water quality or threats to human life and property.

#### Emergency Stabilization Objective

The objectives provide immediate protection from floodwater, floatable debris, sediment, boulders, and mudflows.

#### Suitable Sites

This treatment is intended for use in one or more of the following locations:

- Areas of moderate- to high-burn severity.
- Areas identified with prefire debris flow and landslide hazards.
- Areas where high-value resources are imminently threatened.
- Sites with the capacity to trap the estimated debris flow volume.
- Sites with access available for construction and maintenance.

## Chapter 3 Channel Treatments

---

**Cost** Debris basins are expensive and costs vary from location to location.

Cost factors include the following variables:

- Access to site.
- Size of debris basin.
- Availability of material.
- Frequency of maintenance.
- Proximity to spoils area.
- Type of debris basin, new or existing.
- Site characteristics.

### Treatment Effectiveness

Because debris basins seldom are implemented as a BAER treatment by the USDA Forest Service, no such quantitative information is available on their effectiveness. Current research by the U.S. Department of the Interior, U.S. Geological Survey is working to define treatment effectiveness.

### Project Design and Implementation Team Information

#### Design

After the BAER assessment team has designated potential treatment locations, review the area in the field to ensure site suitability. Prior to designing the structure, explore all other potential treatments that reduce the emergency to an acceptable level (FSH 2509.13 Chapter 26.4).

If a major structure is required, a certified, professional engineer should design the structure. Obtain any State or Federal permits and approval and design the structure to no less than the minimum acceptable design probability of a 100-year flood.

The level of detail of the investigation, design, design reports, and drawings to construct a safe dam depends on the size and hazard assessment classification of the dam (FSM 7500 Chapter 7510).

Current design standards (FSM 7500, Chapter 7520) require the following investigations for all new dams or enlargement of an existing dam.

- Test appropriate size and hazard of the dam.
- Ensure that the factors of safety and allowable shear stresses in the design are appropriate for the construction and operating conditions.
- Identify earthquake hazards, including fault displacement, soil liquefaction, and cracking potential; structure type; structure, abutment, and reservoir slope stability; overtopping effects; and required defensive measures including emergency action plans.
- Use geosynthetic fabric for the dam's structural stability only after consultation with other Federal agency or private engineering consultants experienced in their application.
- Use of outlet works depends on the type of dam and hazard class. Consider requirements for reducing reservoir capacity in the design.
- Use of flashboards with shear pins or failure supports are not permitted in uncontrolled spillways.
- Provide all weather road access for operation and maintenance of high hazard dams.
- Provide instrumentation, where necessary, for measurement of physical changes that could affect dam safety.



Figure 61—Ensure that material from the debris basin can be removed.



Figure 62—Large debris basins may be constructed where there are high values at risk.





## Assessment Team Considerations for Emergency Stabilization

**Primary Treatment Use** Outsloping is used within areas of high- and moderate-burn severity where loss of control of water is a risk.

**Description** Outsloped road templates disperse water and reduce erosion. Outsloping is useful in most locations, particularly for dispersing surface drainage on flat road grades. Outsloping is often combined with other road treatments, including rolling dips and armored crossings to control water.

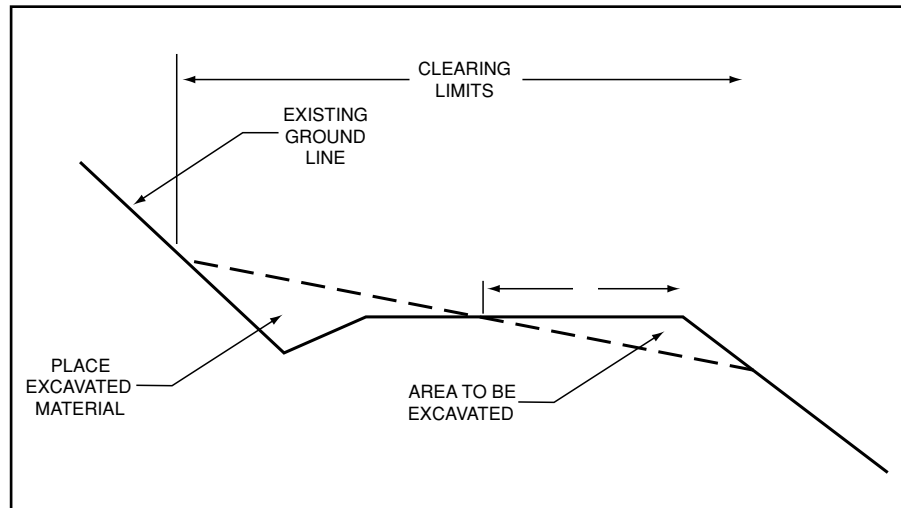

Figure 63—Outsloped road cross-section.

**Purpose of Treatment** Outsloping is a tool to drain water effectively from the road surface while preventing its concentration.

**Emergency Stabilization Objective** Outsloping reduces adverse effects to water quality by dispersing runoff on roads and fillslopes.

**Suitable Sites** This treatment is intended for use in one or more of the following locations.

- Outslope areas that concentrate flows.
- Areas of high- and moderate-burn severity.
- Road grades under 10 percent.
- Areas susceptible to run-on from adjacent burned areas.

**Cost** Outsloping is performed along road segments where concentrated flow can cause adverse effects. Recent watershed contracts cited a cost of \$2 per linear foot.

Outsloping can be contracted or accomplished by available forest road crews.

Cost factors include the following variables:

- Road prism shape (inslope or outslope).
- Size and extent of existing berm.
- Presence and extent of vegetation.

### Treatment Effectiveness

No formal effectiveness monitoring data is available on road outsloping. Informal observations show both immediate and long-term facility and resource benefits, including less sediment delivered to stream channels and reduced road maintenance.

Ensure proper compaction and clearly identify road access needs. Rilling and sheet erosion can occur without proper roadbed compaction. Traffic use during wet road conditions reduces the effectiveness of the treatment.

In areas with highly erodible soils, outsloping roads with unvegetated soils may increase erosion. Other road treatments including rolling dips, armoring, and slope protection may be necessary in these areas.

### Project Design and Implementation Team Information

#### Design

Outsloping is accomplished with an excavator, dozer, grader, and watertruck. The excavator pulls back the fill and places the material in the ditch. The dozer assists in moving and reshaping the road profile and the grader completes the final profile. Use water to moisten the soil for final shaping and compacting. Production rates vary depending on the degree of outsloping and the amount of material to be moved. Contact the forest engineer for updated cost and production rates for work performed on the forest.

#### Construction Specifications

After the BAER assessment team has designated the potential treatment area, review these field sites with the engineer and soil scientist. Key design considerations include the length of road to outslope, erodibility of the fillslope, and treatment locations. Combinations of land, channel, and road treatments reduce or mitigate adverse effects downstream.

1. Perform any necessary clearing and grubbing, excavation and embankment, and erosion control to reshape the roadbed.
2. Construct the roadway to conform to the typical sections shown on the drawings.
3. Shape the roadway to provide drainage of surface water as shown on the drawings. (Often, a crawler-tractor dozer blade is used.)
4. Use an excavator to prevent sidecasting of material outside the traveled way.
5. Protect the cutslopes from undercutting by locating suitable borrow material from the berm or fillslope and place as shown on the drawings.
6. Remove all berms for maximum dispersal of water.
7. Accentuate the existing slope to 4-percent outslope.
8. Finish roadbed to a smooth riding surface with a motorgrader.
9. Ensure sufficient moisture exists to obtain compaction across the full roadway.
10. Remove berms on insloped roads and shape the roadway to outslope short segments.

## Chapter 4 Road and Trail Treatments

---

**Equipment** Heavy equipment (and operators) used to shape the road prism include:

- Dozer – D6.
- Grader –12G.
- Watertruck.
- Service truck.
- Equipment operator.
- Truck driver (watertruck).
- Laborer (swamper).

**Safety** Outsloping can be implemented safely if all hazards are mitigated. Review, update, and include the following items in the JHA:

- Equipment rollover from working near the road edge.
- Accidents from nonoperational backing devices.
- Lack of appropriate warning signs to road users.
- Damage to vehicles from the windrow created between passes.

### Treatment Monitoring Recommendations

#### Implementation

- Was the work performed as designed?
- Were contract requirements met?
  - o Compaction to standard?
  - o Outslope grade at 4 percent?
  - o Was the berm removed?
- Was additional hillslope treatment performed such as mulching to protect the fillslope?

#### Effectiveness

- Are there signs of road-surface rilling?
- Are there signs of sediment delivery to the nearest channel?
- Are there indications of concentrated flow?
- Are there signs of slope failures?
- What storm events occurred prior to monitoring?



### Assessment Team Considerations for Emergency Stabilization

<b>Primary Treatment Use</b>	Rolling dips are implemented in high- and moderate-burn severity watersheds where loss of control of water and subsequent impact to infrastructure has been identified by the BAER assessment team. Rolling dips or armored crossings are used where existing road drainage is inadequate to handle increased runoff, sediment, and debris associated with the effects of the fire. This treatment may be implemented in connection with other road drainage improvement measures.
<b>Description</b>	Roadway dips modify the road drainage by altering the template and allowing surface flows to frequently disperse across the road. Dips are used in two ways: First, on an insloped road the dips take water from the inside of the road and transport it across the road to a designated and armored location that provides a relief. Second, on an outsloped road, frequent rolling dips provide a change in grade to disperse flows (Napper, unpublished paper).
<b>Purpose of Treatment</b>	Rolling dips are used to drain water effectively from the road surface and prevent concentration of water. Rolling dips also provide a relief for surface waterflow on the road and serve as a relief valve in the event of culvert plugging.
<b>Suitable Sites</b>	<p>Rolling dips are used to reduce the risk to the road infrastructure from loss of water control. Rolling dips also reduce adverse effects to soil, water, and aquatic habitat from increased erosion.</p> <p>Rolling dips are used in one or more of the following locations:</p> <ul style="list-style-type: none"><li>• Roads with a continuous grade and infrequent drainage structures.</li><li>• Culverts (below) that have diversion potential.</li><li>• Roads where frequencies between inspection and maintenance may be limited after the fire.</li><li>• Roads with grades less than 12 percent.</li><li>• Roads where outsloping is not feasible.</li></ul>
<b>Cost</b>	<p>In recent Pacific Southwest Region (R5) watershed restoration contracts, rolling dips were implemented to improve road drainage and reduce risk of culvert plugging. Costs for rolling dips ranged from \$390 to \$1,200 per dip.</p> <p>Cost factors include the following variables:</p> <ul style="list-style-type: none"><li>• Material consistency.</li><li>• Production rates (estimate 2 to 4 dips per day depending grade and excavation).</li><li>• Amount of excavation and material movement.</li><li>• Equipment necessary (water may be necessary to ensure appropriate compaction if the road is very dry).</li><li>• Armoring requirements.</li></ul>
<b>Treatment Effectiveness</b>	No formal effectiveness monitoring data exists on rolling dips. Rolling dips and outsloping are common BAER treatments used to disperse flows and prevent stream diversion. Rolling dips are constructed easily with a dozer but often are too short in length, or too shallow to contain the expected

flows. In addition, rolling dips can be compromised by driving through them in wet soils, creating rutting. Treated roads with traffic should be armored to maintain the rolling dips' effectiveness. In addition, BAER implementation teams should pay special attention to locating rolling dips and staking each site.

### Project Design and Implementation Team Information

**Design** After the BAER assessment team has designated potential treatment areas, review these field sites with the engineer to ensure site suitability. Key design considerations include access needs during the emergency period, diversion potential at culverts, road gradient, and slope length.

**Construction Specifications** Clearly identify the locations of the dips using stakes, GPS coordinates, and maps. Consider equipment travel distance between sites and whether the equipment would be transported or walked from each location. Identify logical treatment units that reduce travel time.

- Identify the road segment to be treated and determine spacing guidelines.
- Consider intervals suggested in guides based on erosion hazard rating, road grade, and road design speed.
- Ensure that the existing design (spacing) of dips on the road may be sufficient especially when combined with an outslope or inslope to standard specifications.
- Add dips to create a drivable overflow structure. Dip placement in this application is immediately below or downgrade of the culvert.
- Perform any necessary clearing or grubbing to construct the dips as shown on the drawings.
- Excavate and use borrow material during embankment; excavate drainage; shape the roadway (to 4-percent outslope unless otherwise designated in writing) in the drainage dips. The dip invert shall slope 4-percent greater than the road grade.
- Construct dips with a skew angle to the line perpendicular to the centerline of the roadway, as designated in writing. The typical angle is 30 degrees.
- Recommend armoring the surface and lead out.

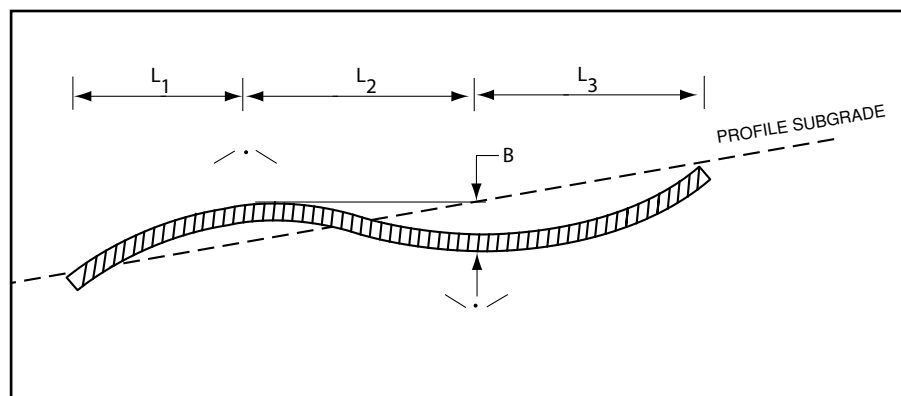

Figure 64—Rolling dip profile. Note: Dip dimensions, L1, L2, L3, and B will be designated in writing and staked on the ground by the engineer.

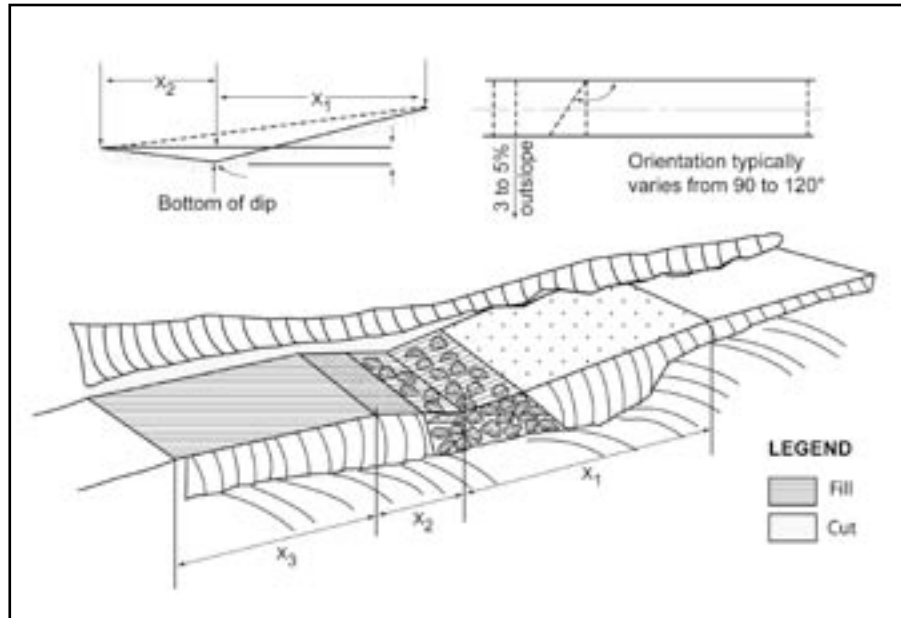

Figure 65—Armored rolling dip.

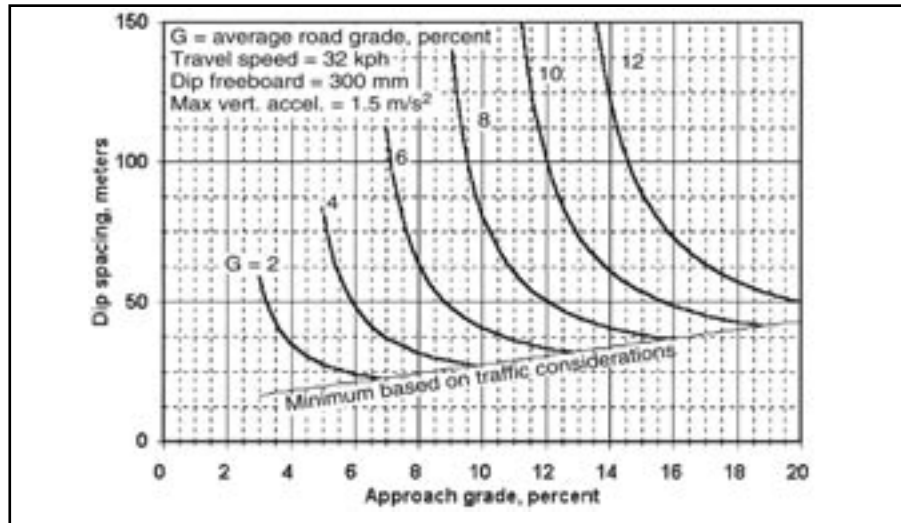

Figure 66—Rolling dip spacing guidelines.

**Tools/Equipment**

Dips are constructed with a dozer, typically a D6 or larger, and may be finished to a smooth driving surface with a motorgrader. A watertruck may be required to provide adequate moisture for compaction. Dips in BAER applications may be armored with rock to reduce rutting.

**Safety**

Rolling dips can be safely implemented if all hazards are mitigated. Review and update the JHA and include the following items:

- Heavy equipment use.
- Equipment rollover risk on unstable ground.
- Accidents from backing.
- Rough road surface during construction.

## Chapter 4 Road and Trail Treatments

### Treatment Monitoring Recommendations

### Implementation

- Was the dip built as designed using the appropriate length, depth, skew, and armoring?

### Effectiveness

- Did the dip carry runoff?
- Are the dips correctly spaced?
- Is the length between dips correct?
- Are the dips correctly located (addressing both road and hillslope runoff)?
- Did the dip prevent diversion potential?
- Did a nearby culvert plug or exceed its capacity?
- Was the armoring outflanked?
- Did sediment deposit in the dip?

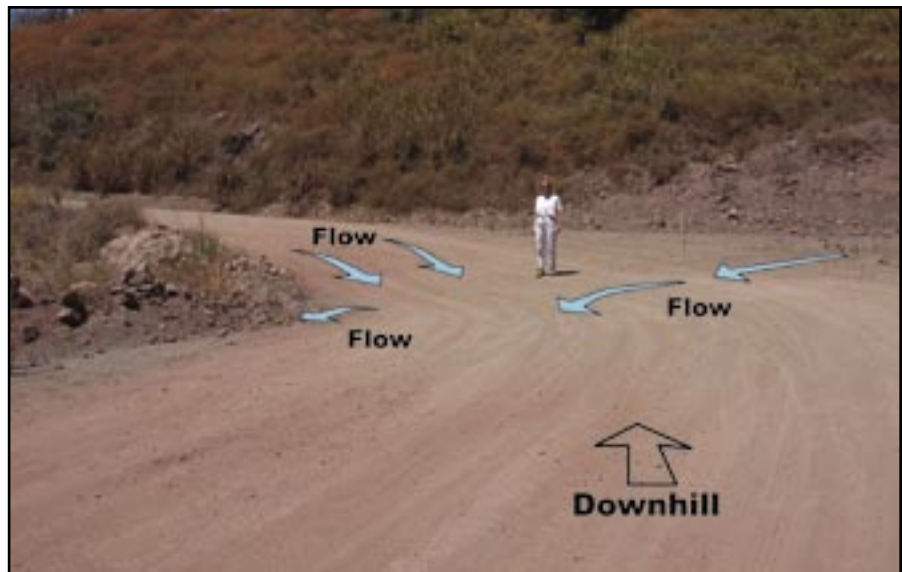

Figure 67—Rolling dip.



Figure 68—Rolling dips must be long enough to accommodate vehicle traffic.



### Assessment Team Considerations for Emergency Stabilization

<b>Primary Treatment Use</b>	Overflow structures are used on roads to control runoff across the road prism and to protect the road fill. Structures are placed in defined channels, or more commonly, in areas between defined channels where increased storm runoff is predicted due to reduced infiltration (Napper, unpublished paper).
<b>Description</b>	<p>Post-fire storm runoff comes from various sources including streams, hillslopes, and defined road drainage structures. Controlling the runoff to avoid culvert failure, maintain access, and prevent road and fillslope erosion is important.</p> <p>The structure used depends on the road design, maintenance, and service level. Typical methods include armored rolling dip, overside drain, or imbricated (overlapped) rock-level spreader.</p>
<b>Purpose of Treatment</b>	Overflow treatments are used to protect the fillslope and reduce erosion from increased storm runoff.
<b>Emergency Stabilization Objective</b>	Overflow structures reduce risk from fillslope erosion and downcutting to the road infrastructure. The structures also reduce adverse effects to soil, water, and aquatic habitat from fillslope erosion.
<b>Suitable Sites</b>	<p>This treatment is intended for use in one or more of the following locations:</p> <ul style="list-style-type: none"><li>• Roads located below high-and moderate-burn severity areas.</li><li>• Road segments that have a long continuous grade and infrequent drainage.</li><li>• Roads that are insloped.</li></ul>
<b>Overflow structures</b>	<p>Armored rolling dips provide increased capacity when hydrologic analysis indicates the current pipe size is too small for the short-term increased storm runoff created by the fire. The dips prevent stream diversion by safely channeling increased flows back into the channel. Armored rolling dips are used instead of culvert upgrading when there are constraints on timing, access, or with the road fill (insufficient roadway cross section to bed a larger pipe).</p> <p>Overside drains (berm drains and down drains) are placed in stream crossings where no culvert or armoring exists and in locations where the embankment (fillslope) needs protection. Berm drains protect embankments in the following situations:</p> <ul style="list-style-type: none"><li>• Burn below the road was moderate or high severity and lacks vegetative cover.</li><li>• Berm is a part of the original road design and removing it is impractical.</li><li>• Overside drains help maintain control of water in a concave topography with berm drains by directing runoff into natural channels.</li></ul> <p>Imbricated rock-level spreaders have been used on high standard roads including State highways and county roads. The imbricated rock-level spreader is a permanent structure that is built with large rock placed in</p>

## Chapter 4 Road and Trail Treatments

---

a stairstep (shingled) design on excavated benches with either little or no grade along the revetment's length (longitudinal axis). The spreader protects the road fill from overland flows (Brown, personal communication).

**Cost** The three types of treatment vary in cost. Cost estimates can be developed based on material and installation requirements.

Armored rolling dips are constructed with a minimum of 10 cubic yards of riprap through the road prism and additional riprap, or in some cases larger material, may be required on the fillslope. Equipment used to place material includes a dozer and backhoe. Prices range from \$500 to \$2,000 per structure depending on the amount of riprap required (Napper, unpublished paper).

Overside drains (berm drains with down drains) are assembled onsite by a crew. To improve effectiveness the berm drains work better when they transition with an asphalt curb.

Imbricated rock-level spreader is built with Class 5 rock at a minimum. Geotextile may also be used to prevent loss of fines. An excavator is used to build the benches and to place the rock.

Cost factors include the following variables:

- Distance from rock source.
- Traffic access needs during construction.
- Size and length of fillslope.

Armored rolling dips are effective low-cost treatments when properly designed and implemented. Consider the anticipated increase in flow and vehicle access needs on the road prior to building the dip. Qualitative monitoring of armored rolling dips found erosion problems when the dip was too short and when insufficient riprap was used on the fillslope.

Overside drains fail if not properly designed, installed, and maintained. The drains fail for several reasons. First, the corrugated metal is more resistant to erosive forces than the surrounding soil, so the overside drain will remain when the surrounding soil erodes. Use an overside drain on paved roads with an asphalt curb in areas of high- and moderate-burn severity where little vegetation remains and root strength will not stabilize a berm. Secondly, maintenance of the drainage structure is required to clear deposited soil, ash, and debris. Finally, install the overside drain with adequate length to protect the fillslope, so discharge does not cause erosion at the slope's toe.

Imbricated rock-level spreaders (rock armored overflow) have been used by the U.S. Department of Transportation Federal Highways Administration (FHWA) to protect fillslopes in areas that burn frequently. Initial qualitative monitoring indicates these structures are effective when they discharge directly onto a highly vegetated/wooded zone. In burn areas, where this is not possible, the bottom tier should be buried to be flush with the existing ground. Armoring or paving the shoulder or berm that discharges into the spreader provides a smooth transition for surface flow and prevents erosion around the structure (Brown, personal communication).

### Project Design and Implementation Team Information

**Design** After the BAER assessment team has designated potential treatment areas, review these field sites with the engineer and hydrologist to ensure the site suitability. Different sites may require different overflow structures. Key design considerations include:

- Vehicle use and access needs.
- Maintenance requirements of the structure.
- Land treatments implemented on the hillslope.
- Size of contributing area.
- Fillslope erodibility.

Analyzing these design considerations allows the designers to mix and match appropriate overflow treatments for the area. If the structure may affect a water feature, obtain needed stream/wetland alteration permits. Use permit exemptions as appropriate for Federal requirements.

### Construction Specifications *Armored rolling dip*

1. Visit each site to determine exact needs. The site geometry determines the amount of material required.
2. Determine the volume of material to be removed to make the crossing and the volume of rock needed for the armoring.
3. Stake the portion of the road prism that will be lowered to provide the flood flow path. Ensure that this staking will place the flow where it will be controlled with the armoring.
4. Determine the rock source. Make arrangements for procuring the rock and ensure that it is sized appropriately.
5. Contact your call-when-needed contractor and arrange for a site visit for the treatment sites. Show the contractor the diagrams and drawings. Ensure that the contractor understands what a successful treatment should look like.
6. Coordinate with other road users to inform them that work is scheduled on these crossings.
7. Stockpile sufficient rock nearby, but out of the way, at each treatment site.
8. Construct the rolling dip ensuring it is deep enough with the rock placement to accommodate increased stormflows (Napper, unpublished paper).

### *Overside Drains*

1. Identify the location for the overside drain.
2. Consider the existing road design and length of contributed area.
3. Match the size of the overside drain to the contributing area.
4. Reinforce the existing berm with an asphalt berm on paved roads and when placing a drain in a dip or low spot.
5. Assemble the overside drain.
6. Anchor the drain at all locations and provide energy dissipation at the outlet to prevent erosion.

### *Imbricated Rock-Level Spreader (Rock armored overflow)*

1. Dig benches in the fillslope to a predetermined depth or until a structurally sound foundation is reached.
2. Line the benches with geotextile to prevent loss of fines during runoff events if rock is not encountered.
3. Design benches with a flat or very mild grade along the longitudinal axis.
4. Slope benches slightly into the face of the excavation for added stability.
5. Place rocks such that joints are staggered and consecutive rows are overlapping.
6. Place the bottom tier of the structure flush to the ground to prevent erosion.
7. Construct a paved shoulder that directs surface flow into the spreader to ensure a smooth transition from paved road to the rock-level spreader (Brown, personal communication).

#### **Equipment/Materials**

The following equipment/material is required

- Excavator with bucket and thumb.
- Dozer – equivalent to a D6.
- Riprap and/or boulders appropriately sized for the specific site.
- Overside drain.

#### **Safety**

Overflow structures can be implemented safely if all hazards are mitigated. Review, update, and include the following items in the JHA.

- Working with heavy equipment.
- Cuts and abrasions from assembling overside drain.
- Walking and working on unstable ground.

#### **Treatment Monitoring Recommendations**

##### **Implementation**

- Was the structure installed as designed?
- Was grade lowered through the rolling dip to provide stormflow passage?
- Were permit final reports submitted or exemption's documented?

##### **Effectiveness**

- Was the structure tested by the design stormflows at the time of monitoring?
- Did the structure pass the stormflows?
- Are there an adequate number of structures for the increased runoff?
- Are there signs of erosion or rilling on the road or toe of slope?
- Are there signs that the riprap material may have moved?
- Is the riprap size sufficient?
- Did the structure receive maintenance?
- Does the structure require maintenance to properly function?

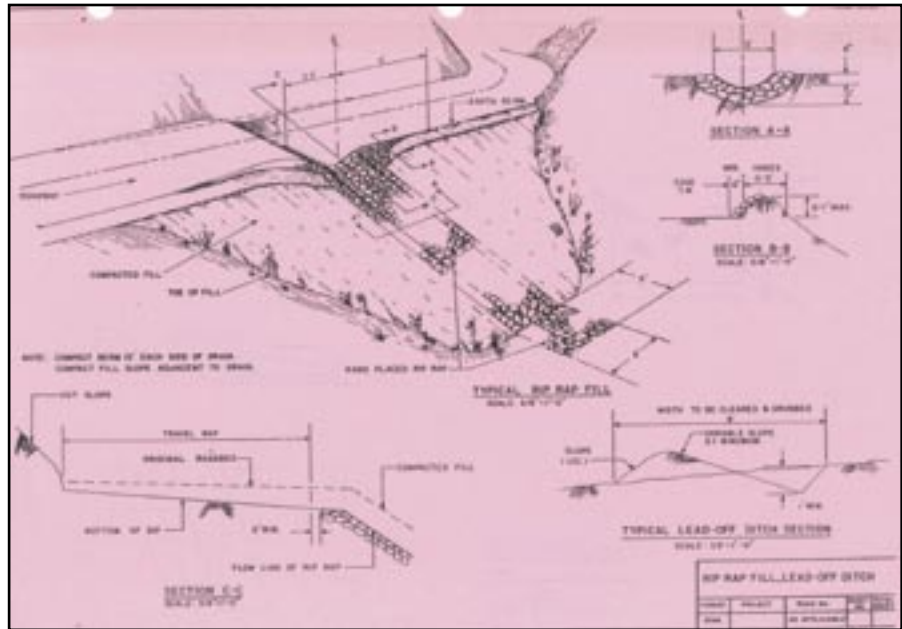

Figure 69—Armored rolling dip (profile view).



Figure 69a—Completed armored rolling dip.



Figure 70—Metal roadside drain.



Figure 71—Failed metal roadside drain.



Figure 72—Rock armor used to replace failed overside drain.



Figure 73—Imbricated rock level spreader is used on paved roads to protect the road fill.



Figure 74—Imbricated rock level spreader used by FHWA in areas that burn often and control of water on the fillslope is critical.



### Assessment Team Considerations for Emergency Stabilization

<b>Primary Treatment Use</b>	A low-water stream crossing (LWSC) protects transportation infrastructure, reduces or eliminates the loss of control of water, and reduces the threat to water quality. LWSCs can be designed to accommodate aquatic passage.
<b>Description</b>	<p>LWSCs temporarily replace culverts during the period of extreme watershed response and eliminate the potential for plugging and stream diversion of a natural channel. There are three common types of LWSCs:</p> <p><b>Natural fords.</b> For most BAER treatments the natural ford crossing is a quick, efficient treatment that responds to the emergency created by the fire. Natural ford crossings eliminate culvert failure from plugging and are easily implemented on roads that meet the site-selection criteria. The natural ford conforms to the streambed or the desired crossing elevation above the streambed. The grades of the roadway approaches are shaped to provide a smooth transition with slopes less than 10 percent. The crossing is constructed of crushed stone, riprap, boulders, pre-cast concrete slabs, or other suitable material.</p> <p><b>Vented ford with pipes.</b> This is a structure with pipes under the crossing that accommodate low flows without overtopping the road. High water will periodically flow over the crossing. Approaches are designed to provide acceptable grades of less than 10 percent by shaping the roadway or adjusting the crossing elevation. The pipes or culverts may be embedded in earth fill, aggregate, riprap, or portland cement concrete. The vented ford works well when fisheries and water quality requirements prohibit vehicles from entering the stream and where bedload is unlikely to plug the culverts.</p> <p><b>Low-water bridge.</b> A flat-slab bridge deck is constructed at about the elevation of the adjacent stream banks, with a smooth cross section designed to allow high water to flow over the bridge surface without damaging the structure. Use the low-water bridge when normal daily flow cannot pass economically or effectively through a vented ford, especially when fish passage is required.</p>
<b>Purpose of Treatment</b>	LWSCs prevent stream diversion and keep water in its natural channel. A LWSC prevents erosion of the road fill and reduces adverse effects to water quality. LWSCs maintain access to areas once storm runoff rates diminish.
<b>Emergency Stabilization Objective</b>	LWSCs or fords reduce the risk to the road infrastructure and adverse effects to water quality and aquatic habitat.
<b>Suitable Sites</b>	<p>The natural ford is appropriate in the following locations (FSH 7709):</p> <ul style="list-style-type: none"> <li>• Use LWSC structures on traffic-service level “C” and “D” roads where water overtops the road continuously or intermittently during and following mild floods.</li> <li>• Roads crossing ephemeral or seasonally flowing channels.</li> <li>• Roads where traffic can be interrupted during periods of mild to severe flooding.</li> <li>• Fisheries and water quality requirements allow vehicles to enter the stream.</li> <li>• The normal daily flow is less than 6 inches deep.</li> </ul>

## Chapter 4 Road and Trail Treatments

---

- Hydrologic analysis requires expensive pipe sizes or pipes that do not fit the roadway cross section.
- Culverts are at risk of plugging and diverting from increased runoff and bedload.
- Road crossings where high sediment delivery is expected.

**Cost** Costs for LWSCs range from \$500 to \$2,500 for an unvented ford. Costs increase for a vented ford or low-water bridge. Consult the forest engineer for updated costs.

Cost factors include the following variables:

- Amount of material to be moved from stream channel.
- Amount of riprap required to armor exposed and erodible slopes.
- Distance from material source (rock plant).
- Depth of fill or embankment.
- Distance to disposal site.
- Use of force account crews or indefinite delivery/indefinite quantity contracts.

**Treatment Effectiveness** Ford crossings effectively eliminate loss of water control at road/stream crossing. Poor design or implementation results in greater damage to the infrastructure and water quality. Common problems include the overall stability of the endwall (also known as fordwall) design. Design the endwall to accommodate increased stormflows and associated bedload and debris. Bury the endwalls deep enough, or provide them with an erosion-resistant splash pad to prevent undermining. When the top of the endwall is placed at stream grade or below, problems with downcutting or aggradation of material above the structure are avoided. If the gradient is too flat through the structure, aggradation may occur requiring maintenance to remove the material deposited. The typical failure is undercutting of the endwall due to insufficient armoring (Napper, unpublished paper).

Informal monitoring indicates that flexible structures (those created with boulders versus grouted) adjust to changes and do not undercut or scour-out from underneath. The boulder or riprap structure has a size gradation of material so voids are not created. The structure is long enough to avoid outflanking with high flows.

Jersey barriers (also known as K-rails) are less effective as an endwall material since they are not flexible. Placing a jersey barrier at grade is more difficult than boulders. Where a culvert is being replaced by a LWCS, establishing the stream grade can be difficult. Look carefully to find clues of the original streambed level masked by years of deposition.

### **Project Design and Implementation Team Information**

**Design** Many design possibilities exist for natural fords. If the stream has a flat slope and a rock or gravel bottom, construct a natural ford by lowering the road grade to the stream bottom.

USDA Forest Service Handbook direction notes the following design considerations: On streams with steep slopes, or with rough, rocky, or soft sandy bottoms, level the bottom with a coarse gravel, or riprap. Install an endwall on the downstream edge of the road to hold the leveling layer in place. The endwall is both long enough and buried below the natural

stream grade to ensure the walls will not be undermined. Allow sufficient length to prevent outflanking when the channel is moving both bedload and debris.

Successful endwalls can be built with:

- Loose boulders.
- Rock-filled gabions.
- Jersey barriers.

### Method of Implementation/ Installation

1. Excavate the existing fill material at the stream crossing.
2. Remove the culvert and any unsuitable material associated with the culvert, including all soft or spongy material.
3. Incorporate suitable excavated material into the roadway on either side of the crossing.
4. Dispose of unsuitable material at designated disposal sites.
5. Reshape the drainage to establish the natural stream channel grade.
6. Look for indications of stream gradient associated with stream cobbles, boulders, and vegetation.
7. Dig a trench for placement of the endwall once the channel is reshaped and stream gradient through the crossing is set.
8. Place the boulders, Jersey barrier, or rock-filled gabions in the trench.
9. Backfill along the trench.
10. Place a graded mix of riprap and boulders below any structure if there is more than an 8-inch drop of water from the structure to prevent scouring. With larger drops, a revetment blanket may be required for spillway armor (Napper, unpublished paper).

### Equipment

Various equipment is required depending on the design of the ford crossing. However, basic equipment to remove the culvert and shape the road grade includes the following:

- Dump trucks (belly dump, semidump).
- Excavator with bucket and thumb attachment.
- Dozer with adjusting blade (D-6 or larger) depending on the amount of material to be moved.

### Safety

A LWSC is implemented safely when hazards are identified and mitigated. Review and update the JHA daily to avoid injuries. Include the following in the JHA.

- Working around moving equipment.
- Lifting heavy rocks or materials may cause muscle and back strain.
- Shifting equipment loads may have potential for rollover.
- Working near hazard trees.
- Working in and near a stream zone with unstable footing.

### Treatment Monitoring Recommendations

#### Implementation

- Was the project implemented as designed?
- What was the size and depth of material placed?
- Is the structure long enough and the ends high enough to avoid potential outflanking?

## Chapter 4 Road and Trail Treatments

- If the road is above the stream grade, were materials placed downstream to protect the fillslope and road embankment?

### Effectiveness

- Was any riprap material moved from the site?
- Was the structure tested at the time of review by the design storm?
- Was the structure outflanked by any flows?
- Was the slope of the road adequate to allow material to move across the structure?
- Are there indications of rilling or headcutting?

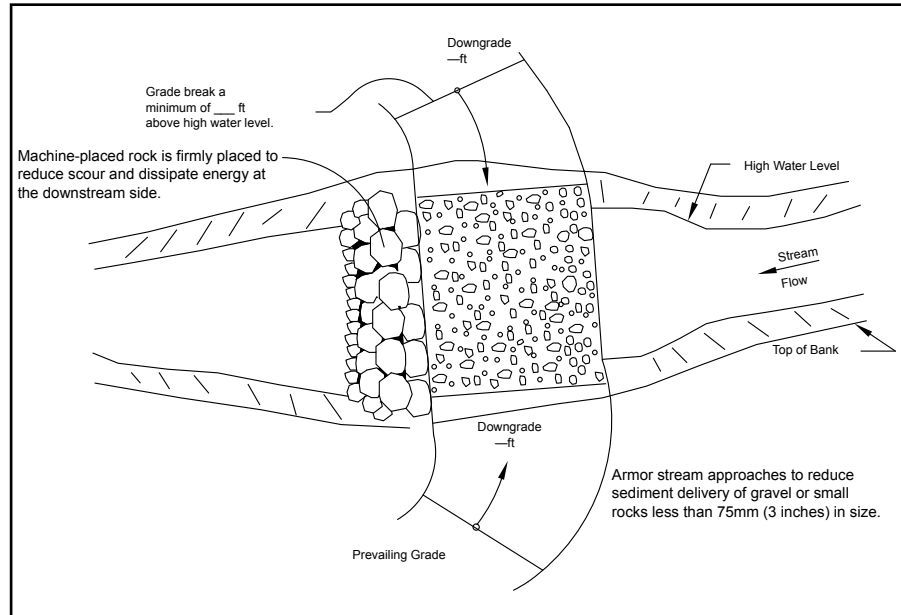

Figure 75—Low-water stream crossing diagram.



Figure 76—Low-water stream crossing replaces a 24-inch culvert.



Figure 77—Ensure adequate length of the endwall and armor the outlet to prevent scouring.



### Assessment Team Considerations for Emergency Stabilization

#### Primary Treatment Use

Culvert modification addresses the flooding and debris concerns identified by the team as a result of the fire. Culvert modification usually involves upgrading the culvert size for increased runoff and associated bedload and debris. Upgrades occur on perennial channels where road access is required and the existing culvert does not meet USDA Forest Service direction for aquatic species passage.

#### Description

Culvert modification replaces fire-damaged culverts or upgrades culverts for increased flow or debris expected as a result of the fire. Upgrades must be compatible with road and trail management plans as well as forest plans and interim direction such as Pacfish/Infish guidelines for culvert sizing. When upgrading is undertaken solely to protect the road or trail investment, the cost for upgrading should be less than the cost to repair damages after they occur (BAER Guidance Paper-Roads and Trails Treatments).

Culvert upgrading design and treatment implementation incorporates each forest's direction for both hydraulic capacity of the culvert and any requirements for aquatic species passage. Given the values at risk, the treatment must be quickly designed and implemented to maintain access and protect aquatic resources. If vehicle access is not needed, temporary culvert removal is an option until the area stabilizes.



Figure 78—Metal end sections are attached to culvert inlets to improve the hydraulic efficiency and reduce the potential for plugging.

#### Purpose of Treatment

The purpose of culvert modification is to increase the flow and debris passage capacity to prevent road damage.

#### Emergency Stabilization Objective

The objectives are to prevent the loss of the road infrastructure and reduce risks to critical natural resources and downstream values.

## Chapter 4 Road and Trail Treatments

---

**Suitable Sites** This treatment is intended for use in one or more of the following locations:

- High-burn severity watersheds.
- Drainages with undersized culverts.
- Road access is required.

**Cost** Culvert upgrades are costly and vary from \$20,000 to \$150,000 per structure.

Cost factors include the following variables:

- Culvert size (diameter and length).
- Culvert type.
- Site access.
- Site hazards.
- Fill (remove and replace).
- Headwall and endwall.
- Inlet reconfigurations.

Effectiveness monitoring of this treatment is only qualitative. The treatment rates 'well' when the new culvert is installed prior to the first rains and withstands the flows and debris associated with the post-firestorm runoff. 'Poor' ratings reflect the inability to perform the upgrade in a timely manner or culverts still not large enough and failing.

### **Project Design and Implementation Team Information**

**Design** After the BAER assessment team has designated potential treatment areas, review these field sites to ensure suitability and determine the best culvert modification for each site. Because the design and construction of each culvert upgrade will vary by location, design teams should include engineers, hydrologists, and fishery biologists. The design team should identify resource objectives to select the best treatment for each site. Consult the contracting officer early and frequently for timely implementation of the treatment.

The design team may select installation of metal end sections on culverts to help channel debris flow to reduce plugging. Metal end sections add approximately 15 percent to the hydraulic efficiency of inlet-controlled culverts.

**Safety** Culvert modifications are implemented safely when hazards are identified and mitigated. Review and update the JHA daily to avoid injuries. Include the following in the JHA.

- Working with heavy equipment.
- Working in and near a stream zone with unstable footing.
- Working near hazard trees.

### **Treatment Monitoring Recommendations**

#### **Implementation**

- Was the project implemented as designed?



### Effectiveness

- Did the structure (including overflow devices) function as designed?
- Does the structure allow aquatic organism passage for all life stages?
- What size storm events had the structure received at the time of monitoring?



Figure 79—This larger pipe was installed to replace an undersized culvert that had failed in the past.



Figure 80—This culvert was modified with two culverts and risers to handle increased flows and potential woody debris.



## Assessment Team Considerations for Emergency Stabilization

### Primary Treatment Use

Debris racks (trash racks) and debris deflectors are structural measures that protect culverts from plugging with debris and causing potential stream diversion. Debris varies in size and includes sediment, rock, small and large limbs, and logs. Debris countermeasures depend on the size and type of debris anticipated from the fire.

A debris deflector is a structure placed at the culvert inlet to route the major portion of the debris away from the culvert entrance. (USDOT FHWA, 2004) Debris deflectors are used for medium (tree limbs or large sticks) to large (logs or trees) floating debris.

A debris rack is a structure placed across the stream channel to collect the debris before it reaches the culvert entrance. Debris racks are usually vertical and at right angles to the streamflow, but they may be skewed with the flow or inclined with the vertical. (USDOT FHWA, 2004) Debris racks are used for small (small limbs or sticks) and medium floating debris.

### Description

A debris rack is a barrier across the stream channel which stops debris too large to pass through a culvert. Debris racks are designed for small and medium floating debris. The storage area must be large enough to retain the anticipated type and quantity of debris expected in one storm or between cleanouts. Debris racks are constructed in sections using heavy rail, steel, wood, or chainlink fence material. Rail and steel construction are stronger and more resilient to stormflows than either wood or chainlink racks.

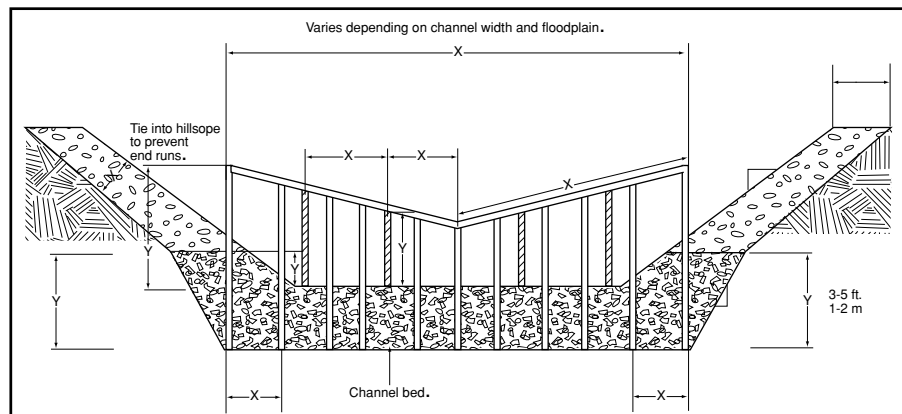

Figure 81—Typical debris rack structure.

Debris deflectors are generally V-shaped structures with the apex pointed upstream. Common designs have the apex as the lowest point of the structure. Deflectors function by diverting medium and large floating debris and large rocks from the culvert inlet to accumulate in a storage area where debris is removed after the flood subsides. The deflector's structural stability and orientation with the flow make it suitable for large culverts, high-velocity flows, and debris consisting of heavy logs, stumps, or large boulders.

## Chapter 4 Road and Trail Treatments

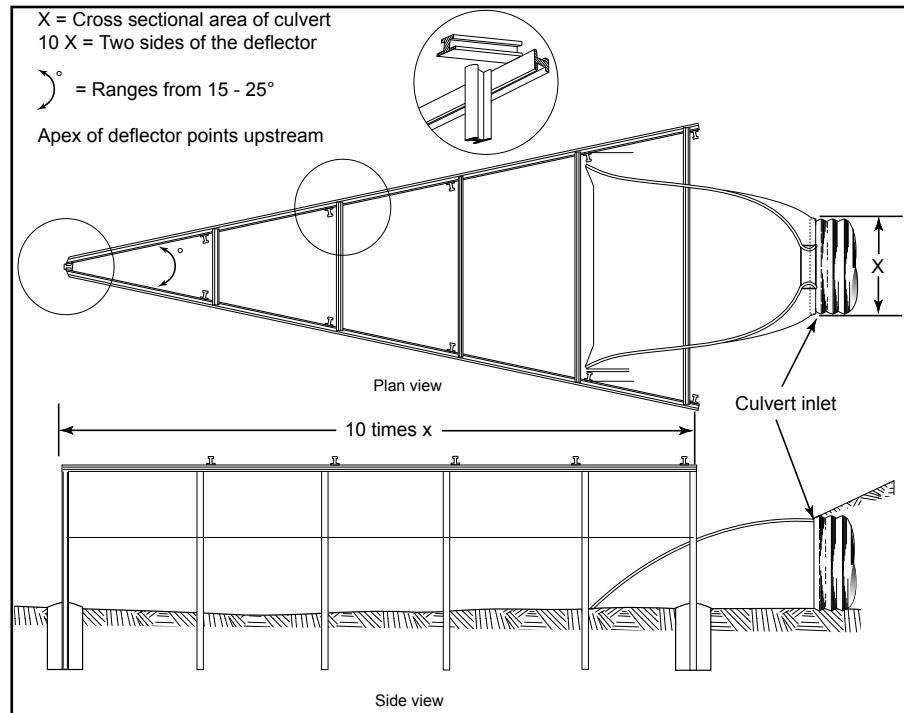

Figure 82—Typical debris deflector structure.

### Purpose of Treatment

Debris structures (racks and deflectors) are designed to protect culverts from catastrophic road failure by catching floatable debris in streams that would plug culverts. Accumulated debris is removed periodically or cut into smaller pieces to pass through the culvert. Debris structures protect downstream habitat by trapping fine and coarse detritus from sheet, rill, gully, channel, and bank erosion behind the structure. All the material behind the debris structure can be removed and placed at a designated location out of the channel.

Debris structures protect the transportation infrastructure, public safety, and downstream resource values.

The treatment is intended for use in one or more of the following locations:

- Drainages at risk of plugging with debris.
- Culverts that can accommodate the storm runoff design capacity but may have increased bedload and debris.
- Movement of both bedload and debris.
- Identification of crossings where stream diversion is possible.
- Downstream infrastructure, public safety, or other resources are at risk.

### Cost

Debris structures vary in price depending on materials. Costs for log debris racks used in the southwest ranged from \$100 to \$4,000 each. The lower cost log debris racks often are constructed with onsite material and built in series up the channel to store more material.

Debris structures constructed with heavy rail or steel range from \$3,000 to \$30,000 or more depending on the size and materials required. A heavy rail or steel structure may be worth the investment, depending on the type of material that is mobilized and the values at risk below.

## Chapter 4 Road and Trail Treatments

Cost factors include the following variables:

- Structural measure required to withstand the anticipated debris and storm runoff (debris deflector or debris rack).
- Site location and access.
- Materials required for implementation.
- Number of structures and locations.
- Availability of knowledgeable crew or contractor.
- Maintenance frequency.



Figure 83—Debris rack effectively trapping material from plugging the culvert.

### Treatment Effectiveness

No quantitative data exists on the effectiveness of debris structures. However, anecdotal information indicates they can be effective with proper implementation and maintenance. Problems can occur if the design structure is too small for the stormflows and associated debris. Effectiveness monitoring of debris structures is needed.

Debris-structure effectiveness depends on identifying anticipated debris type, amount, and maintenance. For BAER teams new to an area, obtaining historical information without someone familiar with the areas is difficult. Discussions with the forest engineer, road crew, and hydrologist may identify areas prone to debris jams. Timely inspection and removal of debris from the debris structures is critical to their success. BAER teams must consider storage capacity above the debris rack or the size of the accumulation area for a debris deflector prior to recommending this treatment.

### Project Design and Implementation Team Information

**Design** After the BAER assessment team has designated potential treatment areas, review each field site to ensure suitability and determine which debris structure is appropriate.

Field survey data should include the following (USDOT FHWA, 2004):

- Classification of the expected debris size.
- Quantity of expected debris.
- Future changes in debris type or quantity due to the fire.
- Stream and watershed characteristics upstream of the site.
- Streamflow velocities in the vicinity of the culvert.
- Direct and indirect evidence related to the delivery potential of floating debris.
- Cross sections of the area available for debris storage at the site.
- Data on the maximum allowable headwater and embankment height for a culvert structure.

Once this information is gathered, the implementation team can identify the type of structure required at each site and materials can be ordered.

### Implementation Specifications

#### Debris Rack

Do not place the debris rack in the plane of the culvert entrance because it will plug easily. "Where a well-defined channel exists upstream of the culvert, the debris rack should be placed upstream from the culvert entrance a minimum distance of two times the culvert diameter. However, they should not be placed so far upstream that debris enters the channel between the rack and the culvert inlet." (USDOT FHWA, 2004) Other guidelines for locating the debris rack include adding the size of the culvert diameter to the fill height and then multiplying that number by 1.5. The final number is the distance from the culvert entrance where the structure should be placed (Kuyumjian, personal communication). In other scenarios the channel type and access to the area may dictate the debris rack's location. Consult with the forest engineer, hydrologist, and geologist when locating the debris rack. If a large debris storage area exists at the rack location, maintenance frequency is reduced and added safety is provided against overtopping the installation during a single storm.

The general dimensions of a trash rack vary from site to site. The straining area of a rack should be at least 10 times the cross-sectional area of the culvert being protected. Vertical bars are spaced from one-half to two-thirds the minimum culvert dimension to allow lighter debris to pass through the rack and the culvert. The overall rack dimensions should be a function of the amount of debris expected per storm, the frequency of storms, and the schedule of expected cleanouts. When a rack is installed at the upstream end of the wingwall, it should be at least as high as the culvert (USDOT FHWA, 2004).

Rack height should allow some freeboard above the expected depth of flow in the upstream channel for the design flood. Racks 10- to 20-feet high have been constructed.

Vertical racks that receive the full impact of floating debris and boulders should have their brace members set in concrete.

### Debris Deflectors

Debris deflectors usually are built of heavy rail or steel sections. However, timber and steel pipe can be used if the debris is light floating or fine detritus. Salvaged railroad rails may be used.

The deflector is built at the culvert entrance and aligned with the stream rather than the culvert so that the accumulated debris does not block the channel. For multiple pipes install a single deflector or individual deflectors can be built over each pipe.

General dimensions for deflectors provided by the FHWA recommends that the angle at the apex of the deflector should be between 15 and 25 degrees, and the total area of the two sides of the deflector should be 10 times the cross-sectional area of the culvert. The deflector's base width and height should be at least 1.1 times the respective dimension of the culvert. The upstream member is vertical on most installations. However, a sloping member at the apex (sloping downstream from bottom of member) reduces the impact of large floating debris and boulders and probably prevents debris from gathering at that point.

"Spacing between vertical members should not be greater than the minimum culvert dimension nor less than one-half the minimum dimension. A spacing of two-thirds the minimum dimension is commonly used. Where headwater from the design flood is expected to be above the top elevation of the deflector and floating debris is anticipated, horizontal members should be placed across the top. The spacing of horizontal members on the top should be no greater than one-half the smallest dimension of the culvert opening." (USDOT FHWA, 2004)

### Equipment

Heavy equipment generally is required for installing a heavy rail or steel structure debris rack or debris deflector. The equipment may include a backhoe or excavator, depending on the size of the debris rack and whether it is prefabricated or welded onsite. A hand crew can build a log debris structure. If the logs are large a backhoe can help expedite the process.

### Safety

Debris structures are implemented safely when hazards are identified and mitigated. Review and update the JHA daily to avoid injuries. Include the following in the JHA.

- Working around moving equipment.
- Working near hazard trees.
- Lifting heavy rocks or materials can cause muscle and back strain.
- Working in and near a stream zone with unstable footing.
- Welding onsite requires eye protection.

### Treatment Monitoring Recommendations

#### Implementation

- Was the project implemented as designed?
- Is the structure placed in the channel away from the culvert opening to prevent plugging?

### Effectiveness

- Did debris move down the channel?
- Did the debris rack prevent the culvert from plugging?
- Did the area receive the design storm event at the time of monitoring?
- Is the culvert functioning as designed?
- Did the treatment protect the road?



Figure 84—Debris racks must be long enough to avoid material from outflanking the structure.



Figure 85—Debris deflector is located at inlet of culvert..

### Assessment Team Considerations for Emergency





Figure 86—Large debris deflector on crossing below a major interstate.



## Stabilization

### Primary Treatment Use

Risers are used to protect transportation infrastructure on roads with large fills where access must be maintained (paved roads, county roads). Risers cannot be used in areas where aquatic passage is required.

### Description

Riser pipes are a low-cost, quickly implemented treatment that provides sediment storage upstream of a crossing that would otherwise plug. Each riser is designed individually to meet the needs and mitigate the risks at a particular crossing. Riser pipes function to sieve debris and allow passage of water. The riser pipe allows accumulation of bedload sediments released from the drainage due to the loss of soil cover and reduced infiltration from water repellent soils. The sediment and ash captured in the basin can be removed with a backhoe or extend-a-hoe and properly disposed (Napper, unpublished paper).

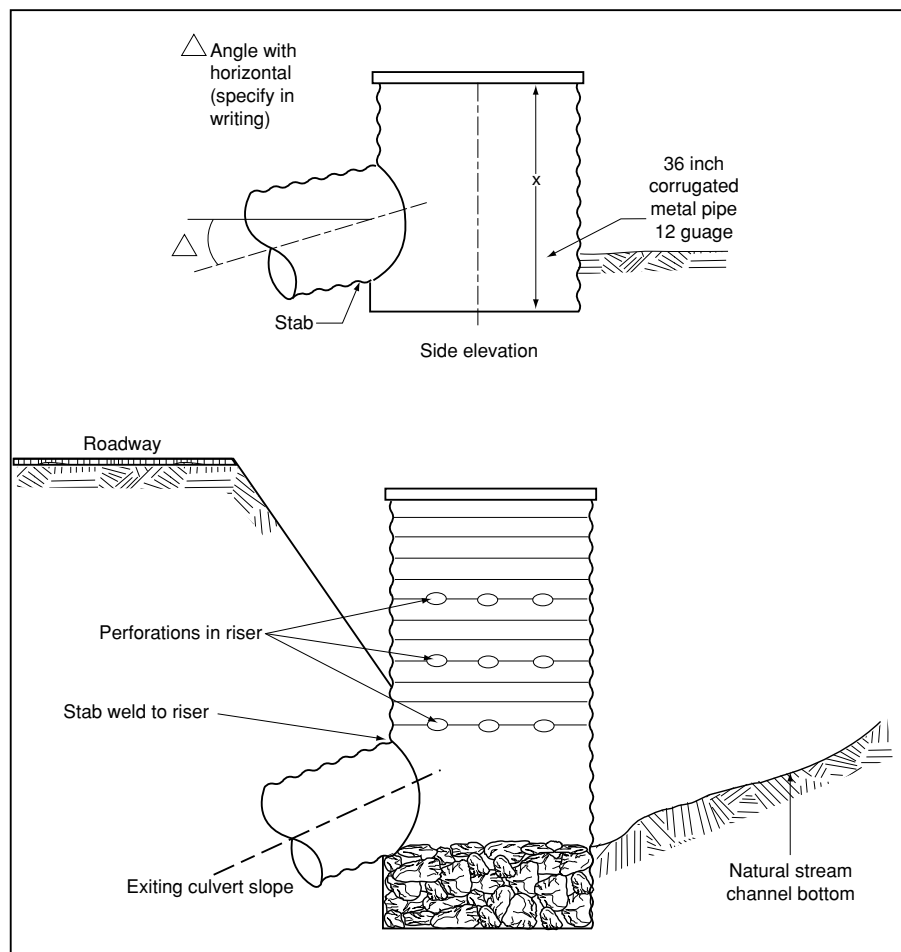

Figure 87—Perforated drop-inlet riser.

### Purpose of Treatment

Riser pipes help prevent culverts from plugging with sediment and floating debris. The pipes capture sediment and reduce downstream impacts to water quality. Riser pipes also reduce peak flows by storing water and sediment.

### Emergency Stabilization Objective

Risers are used to protect the road infrastructure from failure.

## Chapter 4 Road and Trail Treatments

---

- Suitable Sites** Riser installation is intended for application at one or more of the following locations:
- Access at road crossings with a culvert inlet is limited by conventional equipment (backhoe).
  - Access (storm inspection) during the winter and spring is precluded by snow or soft roadbed.
  - Drainages with high-burn severity and erosion predictions indicate a high risk of sediment delivery.
  - Channels (confined) that have high bedload transport.
  - Culverts that range from 18 to 48 inches.
  - Roads that are paved (county roads) and provide access to residences.\*
  - Channels (stream) that have high bedload transport capabilities.\*
  - Channels that are seasonal.

\*Riser pipes are often used by county and State road departments on higher volume roads where they can frequently check and maintain the structures.

- Cost** Risers are inexpensive temporary treatments that can be implemented with a force account road crew or through a construction contract. Contract prices in 2003 for a 36-inch diameter corrugated metal pipe welded to an elbow were \$750 to \$1,400 for labor and material. The riser and elbow were then collared onto the existing culvert.

Cost factors include the following variables:

- Job implemented by force account or contract.
- Culvert size and inlet condition.
- Location and access of site(s).

- Treatment Effectiveness** No effectiveness monitoring data exists for risers aside from anecdotal information. Risers are used by both the USDA Forest Service and county road departments and have performed well when maintained. Problems occur if the structures are not routinely checked and debris removed from the basins. Risers are temporary treatments that are easily disassembled and returned to the forest equipment yard when no longer needed. Risers are installed quickly and at a low cost. They also trap sediment and maintain culvert function effectively.

### **Project Design and Implementation Team Information**

- Design** After the BAER assessment team has designated potential treatment areas, review these sites in the field with the engineer and hydrologist to ensure site suitability. Key design considerations include the following:
- Culvert size.
  - Inlet condition.
  - Riser height.
  - Sediment storage capacity.
  - Maintenance frequency.
  - Sediment disposal areas.
  - Culvert diversion potential (may require placing an armored or rolling dip on the road too).

### **Construction Specifications**

Once the design is complete, stake each site, obtain GPS coordinates for the location, and contact the local force account crew or the call-when-needed contractor to arrange a site visit.

There are several riser-pipe designs and installation methods. Two common methods are discussed below:

#### **Drop-Inlet Design**

The drop-inlet design is the most adaptable and common because there is no direct connection to the existing pipe. The vertical riser is a corrugated metal pipe with a notch cut into the bottom (to the diameter of the pipe being enclosed) and fits over the culvert, effectively sealing off the opening from the surrounding soil. The drop-inlet riser should be no less than 36 inches in diameter. Vertical notches or slits are cut into the riser with the lowest notch opening placed above the area backfilled. As much as one-third of the riser height may be backfilled to stabilize the structure.

Risers over 8 feet in height may require backfilling or anchoring to keep them from moving with the expected flow velocities. Anchors help until the accumulation of a soil surrounding the pipe secures it in place.

Armor the bottom of the riser with large rocks (8 to 12 inches) to protect from scouring. The erosive force of the water pouring in from the sides and top can be powerful. The rock armor must not be higher than the invert of the culvert and should be at least 1-foot thick.

Place a steel grate at the top of the riser to keep floatable debris out. An antivortex collar is used to prevent a vortex from damaging the road fill.

Include a dewatering feature for large risers behind high embankments to relieve the possible buildup of hydrostatic pressures. This feature can be as simple as a few small holes near the bottom of the pipe covered with filter cloth to allow drainage into the riser and through the culvert.

#### **T-Design**

The T-design or elbow attachment requires that a collar be attached to the existing culvert that runs beneath the embankment. The collar connects the existing pipe to the elbow riser. The height of the elbow riser is based on the fill height or the expected accumulation of sediment and debris between maintenance. Because pipe inlets are often damaged, collar installation may require excavation to expose the pipe sufficiently to cut off the damaged section. This riser type has slits and a grate over the top, too.

The angle between the existing pipe and the riser should be less than 90 degrees for efficient flows and maintenance. This riser design in a large fill has the potential to back up water behind the embankment and create a hydrostatic condition. The hydrostatic pressure can be alleviated by installing a section of perforated pipe near the bottom or by perforating the pipe used and wrapping it with filter cloth.

### **Equipment/Materials**

Riser pipes are relatively easy to install, depending on size. Equipment includes the selected riser attachment, backhoe, chain, labor, riprap (for inside the drop-inlet design), grate, and any additional tiedowns to stabilize the riser.

## Chapter 4 Road and Trail Treatments

**Safety** Risers are implemented safely if all hazards are mitigated. Review, update, and include the following items in the JHA.

- Working with heavy equipment.
- Lifting heavy objects.
- Walking and working on unstable ground.

### Treatment Monitoring Recommendations

#### Implementation

- Was the structure installed as designed?
- Were all the design components implemented (anchors, rock armor, relief for hydrostatic pressure, slits, perforations, stability of riser, height of collared T relative to fill)?

#### Effectiveness

- Was the structure tested according to the design storm identified in the 2500-8 at the time of monitoring?
- Was the storage area adequate for the frequency of maintenance and the size of the contributing area?
- Was sediment trapped and did water continue to pass through the structure?
- Was the road infrastructure maintained without loss to the road or access?

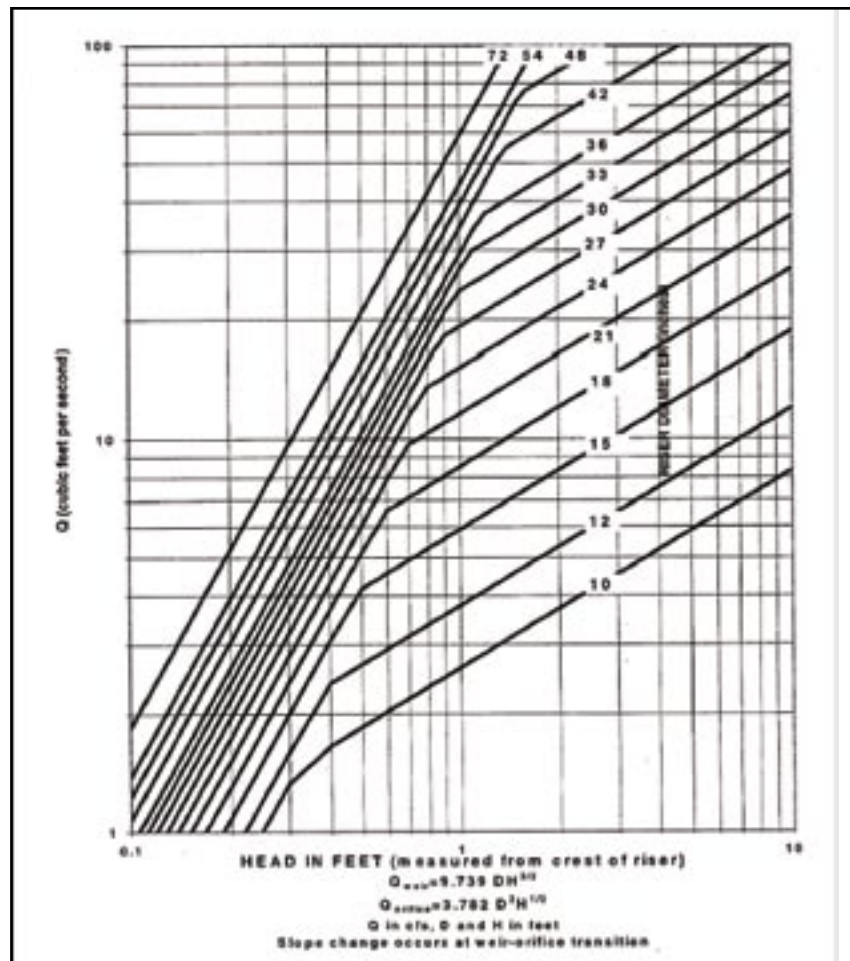

Figure 88—Riser sizing chart.



Figure 89—Tall riser used to prevent plugging of culvert.



Figure 90—Riser is attached to prevent plugging of culvert.



Figure 91—Riser located next to county road and receives frequent maintenance to remove material.



Figure 92—Ensure the openings on the riser are sized to allow water to flow freely into the structure. Small openings can plug with fine detritus.



### Assessment Team Considerations for Emergency Stabilization

<b>Primary Treatment Use</b>	Catchment-basin cleanout is used in stream channels, above culverts, and in catchment basins where the threat of sediment reducing the culvert capacity and creating a flash flood is identified as an emergency.
<b>Description</b>	Catchment-basin cleanout increases the channel capacity for predicted sediment. The size of the catchment basin and the contributing sediment source dictate treatment frequency.
<b>Purpose of Treatment</b>	Catchment-basin cleanout is the removal of organic debris and sediment deposits to prevent them from becoming mobilized in debris flows or flood events.
<b>Emergency Stabilization Objective</b>	Catchment-basin cleanout protects the transportation and facility infrastructure.
<b>Suitable Sites</b>	<p>This treatment is intended for use in one or more of the following locations:</p> <ul style="list-style-type: none"> <li>• Road crossings where existing sediment reduces the culvert capacity.</li> <li>• Streams where fish requirements are not a concern.</li> <li>• Areas with high values-at-risk have been identified.</li> <li>• Locations where clearing can be done prior to the first damaging rain.</li> </ul>
<b>Cost</b>	<p>Catchment-basin cleanout varies from \$200 to \$2,000 for each basin.</p> <p>Cost factors include the following variables:</p> <ul style="list-style-type: none"> <li>• Amount of material removed.</li> <li>• Location of disposal site.</li> <li>• Cost for move-in and move-out.</li> <li>• Frequency of catchment-basin cleanout.</li> </ul>
<b>Treatment Effectiveness</b>	<p>No quantitative effectiveness monitoring data is available on catchment-basin cleanout but anecdotal information suggests the treatment is effective.</p> <p>In many areas the culvert capacity is limited by lack of maintenance. Removing and disposing of material prior to storm events is effective. This treatment does require inspection of the catchment basins between storm events to determine whether additional cleanout is necessary.</p>
<b>Project Design and Implementation Team Information</b>	
<b>Design</b>	After the BAER assessment team has designated potential treatment areas, review these field sites with the forest engineer and hydrologist. Key design considerations include channel gradient, design storm, catchment basin capacity, and material to be removed at each site. Review the burn severity above the catchment basin and determine whether upslope treatments adequately mitigate the sediment delivered to the basin.

## Chapter 4 Road and Trail Treatments

### Construction Specifications

For sediment removal projects identify:

- Sediment disposal areas with stakes and flags.
- Limits of excavation required.
- Vegetation to be left undamaged.

If you are removing a lot of material with numerous trucks, develop a traffic safety plan. Appropriate temporary road closures while equipment is working also may be necessary.

### Equipment

Heavy equipment is used to remove sediment and may include excavators, backhoes, front end loaders, and dumptrucks.

### Safety

Catchment-basin cleanout can be implemented safely if all hazards are mitigated. Review and update the JHA as needed and include the following items in the JHA.

- Traffic safety plan.
- Snag hazards are identified and removed.
- Work involving heavy equipment.

### Treatment Monitoring Recommendations

#### Implementation

- Was the work performed as designed?
- Was the work completed prior to the first storm?
- Were designated disposal areas stabilized?

#### Effectiveness

- Did the culvert plug with sediment?
- Was the structure damaged?
- What storm events had occurred prior to monitoring?



Figure 93—Removing accumulated sediment to ensure culvert capacity prior to seasonal storms can reduce the risk to the transportation infrastructure.



Figure 94—Typical equipment used to cleanout basins include excavators, backhoes, and dumptrucks.



### Assessment Team Considerations for Emergency Stabilization

<b>Primary Treatment Use</b>	Use storm inspection and response (previously called storm patrol) in high- and moderate-burn severity watersheds where access is required (road cannot be stormproofed and closed) and there is a high risk of loss of water control from inadequate drainage structures. Storm inspection/response must be more cost effective than upsizing or modifying existing drainage structures (BAER Guidance Paper-Roads and Trail Treatments).
<b>Description</b>	Storm inspection and response keeps culvert and drainage structures functional by cleaning sediment and debris from the inlet between or during storm events on roads where access is required. Storm inspection and response performed during the storm should meet safety considerations in the JHA (Napper, unpublished paper).
<b>Purpose of Treatment</b>	Storm inspection and response provides needed road access throughout the designated storm season by ensuring road drainage function.
<b>Emergency Stabilization Objective</b>	Storm inspection and response is an efficient measure to protect the transportation infrastructure after a wildfire. The treatment is used in lieu of more costly upgrades that are not feasible due to expense or design timeframe (Napper, unpublished paper).
<b>Suitable Sites</b>	Storm inspection and response is intended for use in one or more of the following locations: <ul style="list-style-type: none"> <li>• Road crossings where loss of control of water or exceedance is identified.</li> <li>• Road access is necessary throughout the storm season.</li> <li>• Road crossings where high sediment and debris is anticipated.</li> <li>• Roads susceptible to landslides.</li> <li>• Roads with all-season surfacing (aggregate or asphalt).</li> </ul>
<b>Cost</b>	Cost estimates can be obtained from estimating force-account salary or from existing construction contracts. Storm inspection is performed with forest road crews, IDIQ contracts, or construction contracts.

Equipment	Rate (per day)	Basis
Backhoe	\$390.00	2005 RSMeans
Front-end loader	\$465.00	2005 RSMeans
Pick-up truck (4 by 4)	\$63.50	2005 RSMeans
Tandem dumptruck (11 metric tons)	\$272.00	2005 RSMeans
4-person crew	\$970.00	2005 RSMeans

Cost factors include the following variables:

- Distance from site to staging area.
- Difficulty with access (downed logs and rocks blocking road).
- Inclement weather slowing productivity.
- Location of disposal site.
- Number of anticipated storm responses.

## Chapter 4 Road and Trail Treatments

---

### Treatment Effectiveness

No formal effectiveness monitoring data exists on storm inspection and response. Informal observations indicate cost effectiveness because many road problems are avoided with timely clearing and cleaning of road crossings.

Problems occur when a dedicated team is not made available to conduct the storm inspection and response. In some cases the patrol area is too large for a forest to do and contracting may be a solution. In accessible areas some forests have used storm patrols instead of installing trash racks or larger culverts.

### Project Design and Implementation Team Information

#### Design

After the BAER assessment team has designated potential treatment areas, review these field sites. Key considerations include access requirements for private inholdings, structures, or facilities. Review the area with the engineer and identify critical areas or structures needing inspection.

Identify any hazards that require mitigation prior to implementation. Determine who will conduct the inspections. Inspection and response is done with force account or contract.

#### Implementation Specifications

- Determine the road inspection response areas.
- Divide the burn into areas or zones to help determine the number of people needed to effectively cover the area.
- Identify the higher elevations versus the lower elevations and plan your strategy for access.
- Identify high-priority areas that may require daily or frequent access.
- Identify surfaced roads and nonsurfaced roads to further decide on where the access will be.
- Identify high-risk structures or high-value areas that are prone to storm damage (Napper, unpublished paper).

#### Equipment/Tools

The following equipment and tools are used for the clearing of structures and restoring drainage function.

##### Equipment

- Backhoe w/extendahoe.
- Dump truck (5- or 10-yard).
- Service truck (4 by 4) with winch.

##### Tools

- Axe or pulaski.
- Barricades.
- Chain saw.
- Come-along.
- Digging bar (large).
- Pitch fork.
- Rake.
- Shovel.
- Signs (hazardous condition).
- Signs (storm warning).
- Tow chain with hooks.

### **Safety**

Storm inspection and response is implemented safely when hazards are identified and mitigated. Review and update the JHA daily to avoid injuries. Make safety first and include the following in the JHA.

- Identify a communications plan (radios and spare batteries).
- Establish safety officer position and authority.
- Know the weather forecast and scout for hazards (trees, high-water, debris flows).
- Drive according to the road conditions, not on the perceived urgency of the task.
- Prepare for bad weather by taking additional food and blankets.

Ensure that work leaders and supervisors know the types and locations of the stabilization treatments. Have the communications and safety plans reviewed by the work leaders on a daily basis. Weather reports are a key element of the safety plan.

Driving on wet roads where rutting will occur defeats the purpose of a road patrol. Walking short distances to specific sites is more prudent. Road patrols should never be performed by only one person.

Road hazards discovered during road inspections should be barricaded immediately and reported.

### **Treatment Monitoring Recommendations**

#### **Implementation**

- Were contract requirements met?
- What was the storm-patrol response time?
- Was material removed from areas identified by the BAER assessment team?

#### **Effectiveness:**

- Were there drainage structure failures?
- Was identified access maintained? If not, for what duration was access restricted?
- What type of storm event mobilized material? (Duration and intensity)
- Size and extent of material mobilized?



Figure 95—Rubber tire backhoes are an integral component of storm inspection and response.



Figure 96—Tracklaying excavators are very effective when moving large amounts of material quickly.



### **Assessment Team Considerations for Emergency Stabilization**

<b>Primary Treatment Use</b>	Use trail stabilization on trails lacking adequate drainage features for anticipated increased runoff.
<b>Description</b>	Trail stabilization methods include rolling dips, rubber belt waterbars, rock waterbars, and rock spillways. The stabilization methods selected may vary but are designed to reduce trail erosion or damage.
<b>Purpose of Treatment</b>	Trail stabilization provides drainage and stability to reduce trail damage or downstream values at risk.
<b>Emergency Stabilization Objective</b>	Stabilization objectives are to reduce loss of property and unacceptable degradation to downstream values.
<b>Suitable Sites</b>	<p>This treatment is intended for use in one or more of the following locations:</p> <ul style="list-style-type: none"> <li>• Trails within or below high-burn severity areas.</li> <li>• Trails with sustained grade through burned areas that lack adequate drainage.</li> <li>• Trail segments that have the potential to deliver sediment to streams.</li> <li>• Trails where previous drainage structures were damaged by the fire.</li> <li>• Stream crossings with diversion potential.</li> </ul>
<b>Cost</b>	<p>Trail stabilization costs in the Southwest Region (R3) from FY 2000 to 2003 ranged from \$1,000 to \$3,000 per mile.</p> <p>Cost factors include the following variables:</p> <ul style="list-style-type: none"> <li>• Number of structures required within the treatment area.</li> <li>• Availability of material onsite.</li> <li>• Crew skill level.</li> <li>• Hazards adjacent to the trail requiring mitigation.</li> </ul>
<b>Treatment Effectiveness</b>	No quantitative data exists on the effectiveness of this treatment. Clearly identify treatment areas so work can be done prior to the first damaging storm event. These treatments require a well qualified crew that can install the structures correctly for adequate drainage.

### **Project Design and Implementation Team Information**

<b>Design</b>	Review the BAER assessment team findings on the ground to validate treatment areas. Place flags, stakes, and/or GPS coordinates at the treatment locations. Determine the materials available and select the appropriate stabilization method for the trail use.
<b>Tools/Equipment</b>	Tools and equipment required depend on the stabilization method used. Basic trail construction equipment is required for most methods. Rubber belt waterbars require purchasing treated timbers, galvanized nails, and a rubber conveyor belt.

# Chapter 4 Road and Trail Treatments

**Safety** Trail stabilization is implemented more safely when hazards are identified and mitigated. Review and update the JHA daily to avoid injuries. Include the following in the JHA.

- Work in remote locations.
- Hazard trees along the trail.
- Trail crossings with unstable footing.
- Objects that require heavy lifting.

**Treatment Monitoring Recommendations**

**Implementation**

- Was the treatment implemented as designed?
- Were an adequate number of drainage structures placed to accommodate the increased runoff.
- Were energy dissipaters used to disperse flows at drainage crossings?
- Was trail outslowing within specification?

**Effectiveness**

- Are there signs of erosion and sediment delivery on the trail?
- How far did the runoff extend down the trail?
- Did the existing drainage structures perform as designed?
- Are more frequent drainage structures necessary?
- At the time of review were the structures tested according to the design storm identified in the FS 2500-8?

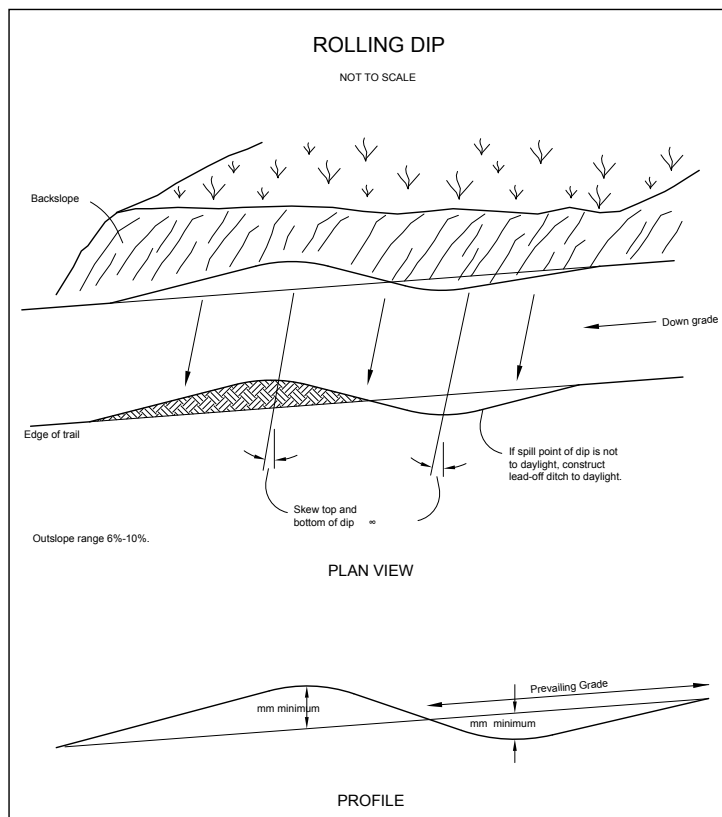

Figure 97—Trail rolling dip.

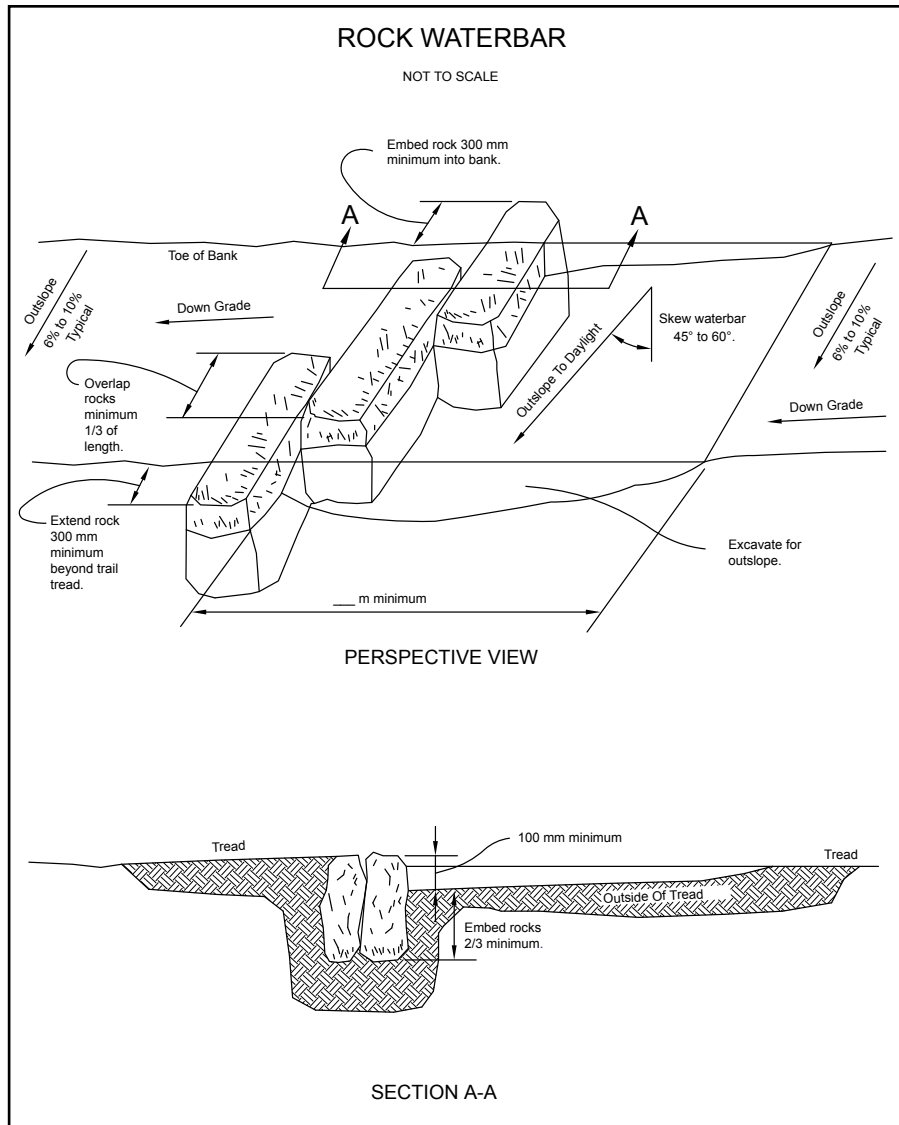

Figure 98—Trail rock waterbar.

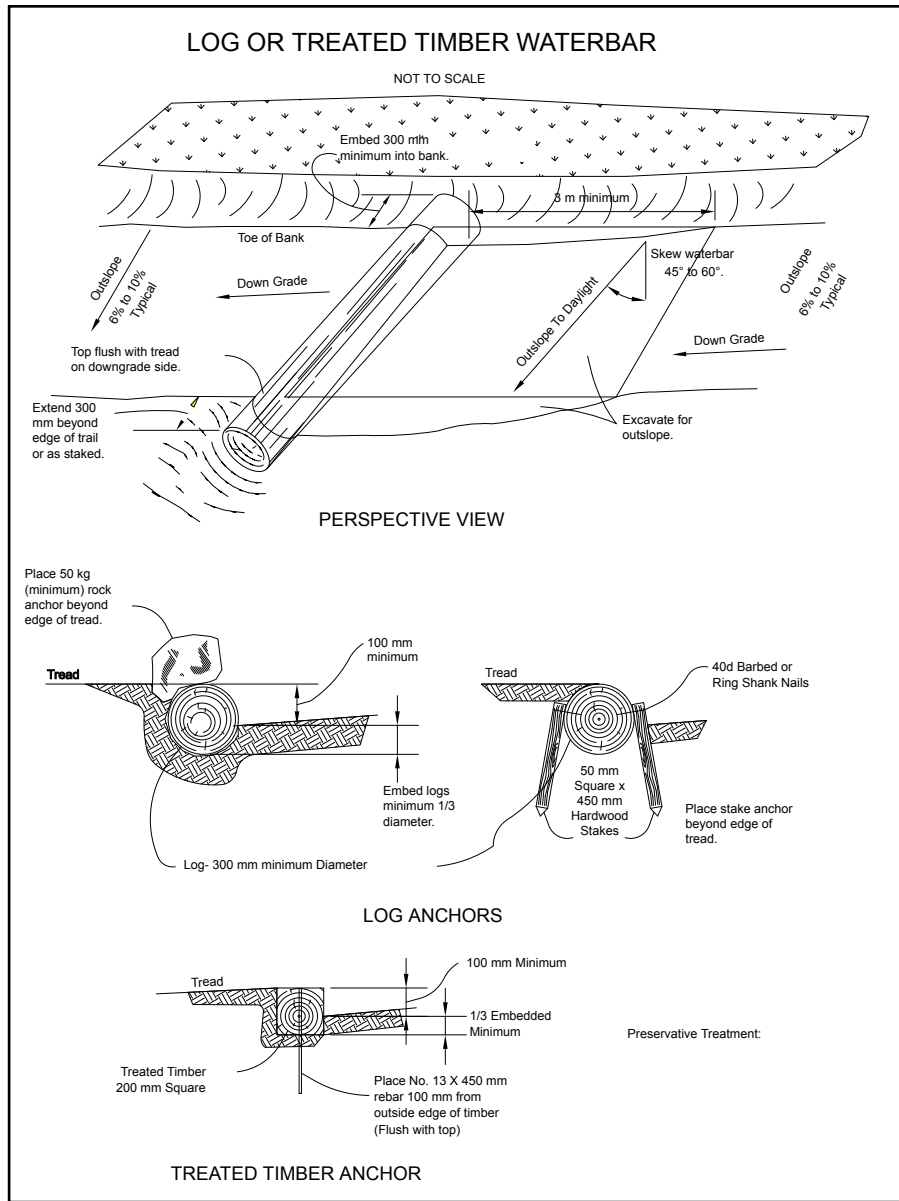

Figure 99—Log or treated timber waterbar for trails.

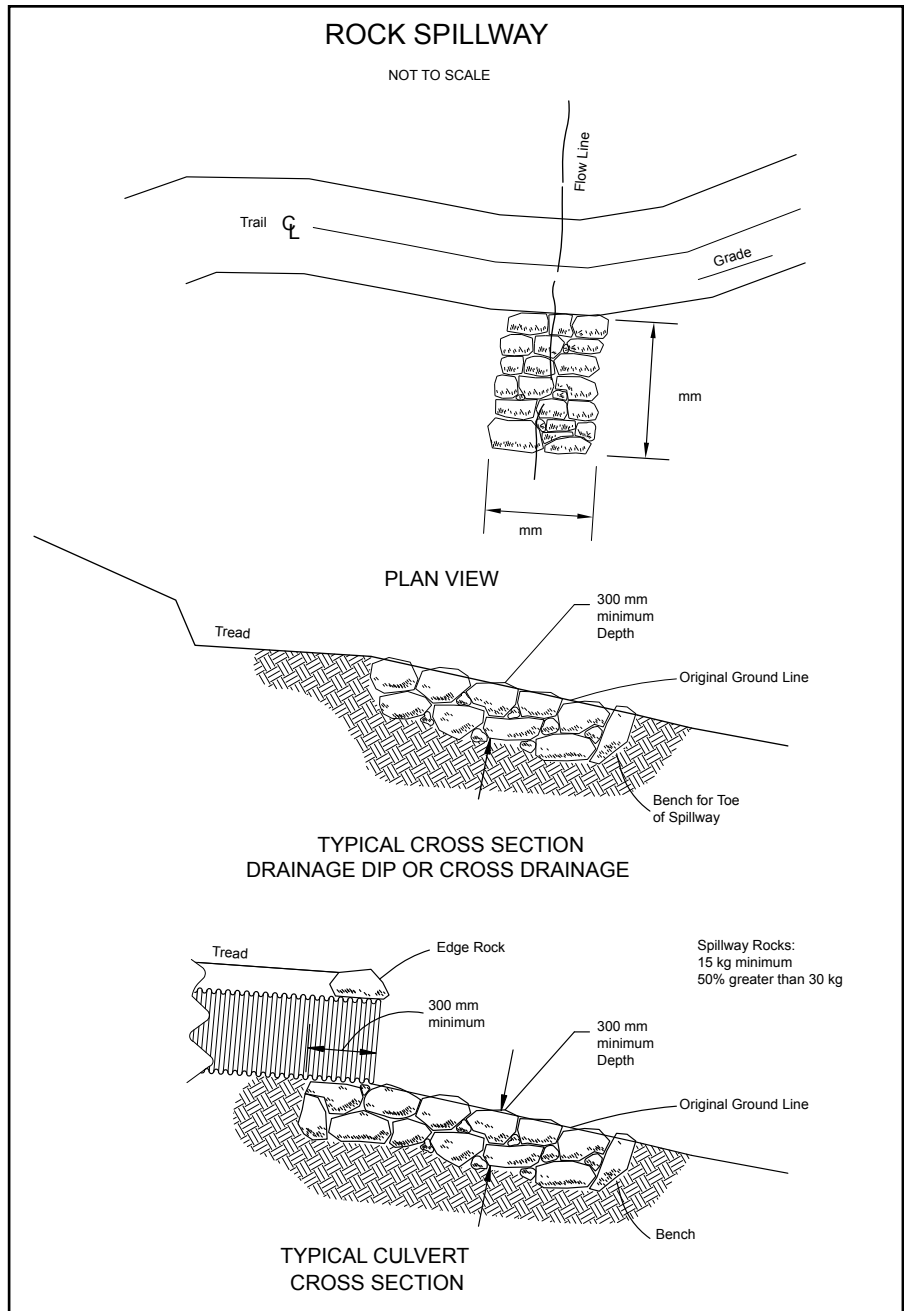

Figure 100—Trail rock spillway.



### Assessment Team Considerations for Emergency Stabilization

<b>Primary Treatment Use</b>	Road decommissioning (as a BAER treatment) is for unauthorized roads (nonsystem, jammer roads) that are destabilized through loss of vegetation and high-burn severity surrounding the unclassified road. This treatment is not used on authorized (system) roads.
<b>Description</b>	Road-decommissioning treatment includes subsoiling (tilling), restoring original hillslope conditions with recontouring of the road fill, restoring drainage through the road prism, and reducing further hillslope erosion. Road decommissioning uses an excavator and or dozer with rippers to pull material into the road and break through compacted soil layers improving infiltration.
<b>Purpose of Treatment</b>	Road decommissioning of unclassified roads improves infiltration, restores hillslope hydrology, and reduces erosion of sidecast material.
<b>Emergency Stabilization Objective</b>	Road decommissioning stabilizes soil, thereby reducing degradation of natural resources and downstream values.
<b>Suitable Sites</b>	<p>This treatment is intended for use in one or more of the following locations:</p> <ul style="list-style-type: none"> <li>• Areas with high-burn severity and high-soil erosion potential.</li> <li>• Roads (unclassified) destabilized by the fire through vegetation loss.</li> <li>• Loss of stabilizing vegetation to hold soil and prevent erosion</li> <li>• Areas where vegetative treatments are unlikely to be effective</li> <li>• Hillslope with multiple unclassified roads (jammer roads)</li> </ul>
<b>Cost</b>	<p>Road decommissioning costs vary depending on the extent of the treatment. Cost estimates for recontouring the road prism in the Northern Region (R1) ranged from \$7,000 to \$8,000 per mile.</p> <p>Costs generally are lower for this treatment because unclassified road prisms tend to be narrow, free of vegetation, and lack large cuts and fills. Equipment can treat these areas faster than in other more traditional road decommissioning restoration treatments.</p> <p>Cost factors include the following variables:</p> <ul style="list-style-type: none"> <li>• Hazard trees (or other hazardous conditions) requiring mitigation prior to implementation.</li> <li>• Costs to move-in and move-out of proposed treatment locations.</li> <li>• Equipment type and size necessary to implement the treatment.</li> </ul>
<b>Treatment Effectiveness</b>	Road decommissioning of unclassified roads and old jammer logging roads was implemented successfully in Region 1. No quantitative data is available on soil-erosion rates but visual inspection reveals that the decommissioned unclassified roads became vegetated within the first year after treatment. Emergency treatment objectives to improve infiltration and reduce erosion by restoring the slope were achieved in the treated areas.

### **Project Design and Implementation Team Information**

**Design** After the BAER assessment team has designated potential treatment areas, review the field sites. Key design considerations include site suitability for the treatment and method of road decommissioning. Heritage resources clearance is required. Identify potential hazards to mitigate before treatment implementation. Starting at the top of the watershed lay out the site with flags, stakes, or GPS coordinates. Determine road length to be decommissioned for each treatment area.

**Tools/Equipment** Road decommissioning typically is implemented with a D-6 dozer (or similar equipment) with winged rippers mounted on the toolbar or an excavator. Equipment size depends on the road width, level and depth of compaction, and equipment availability. The excavator pulls sidecast material and fills to restore the original hillslope. Afterwards, the excavator places debris onto the treated area. Often a dozer and excavator will work together in tandem to implement the treatment. Ensure that the road prism is fractured adequately before pulling the fill material.

**Safety** Road decommissioning is implemented safely when hazards are identified and mitigated. Review and update the JHA daily to avoid injuries. Include the following in the JHA.

- Working in and around heavy equipment.
- Operating on steep slopes.
- Working near hazard trees along the treatment area.

### **Treatment Monitoring Recommendations**

#### **Implementation**

- Was the treatment implemented as designed?
- Were guidelines for tilling depth followed?
- Were any seasonal channels encountered and opened to restore natural drainage patterns?
- Was available woody debris placed on the treated area?

#### **Effectiveness**

- Did the treatment reduce erosion and allow for vegetative recovery?
- Is the slope stabilized through use of the treatment?
- What storm events had occurred prior to monitoring?



### **Assessment Team Considerations for Emergency Stabilization**

<b>Primary Treatment Use</b>	Facility safety work includes a variety of methods to repair minor facilities, such as signs, guardrails, or sanitary facilities where human health or safety is at risk (BAER Guidance Paper-Facility Replacement).
<b>Description</b>	<p>BAER funds are available to replace warning and safety control facilities damaged or destroyed by fire. Treatments include replacing accident and safety signs on or in buildings, campgrounds, and other areas where signs specify hazards to the public or property. Delineators and guardrails can be replaced if the road remains open and an emergency is identified. Road delineators are reflective devices mounted in a series at the side of a roadway to help indicate the roadway alignment and ensure driver safety.</p> <p>Other facility safety work includes replacement of sanitary facilities if human health is at risk, costs are minor, and closure of the facility is not feasible. Fire-damaged buildings can be signed using BAER funds until the facility is repaired.</p>
<b>Purpose of Treatment</b>	Facilities safety work reduces an identified safety or health risk that was created by the fire.
<b>Emergency Stabilization Objective</b>	Emergency facility safety work protects life and property.
<b>Suitable Sites</b>	<p>This treatment is intended for use in one or more of the following locations:</p> <ul style="list-style-type: none"> <li>• USDA Forest Service roads where delineators have been burned.</li> <li>• Sanitary facilities that are damaged but must be kept open for use.</li> <li>• Facilities damaged where human health or safety is at risk and no other treatment options are available.</li> </ul>
<b>Cost</b>	<p>Costs vary depending on the type of facility being replaced. Check with forest resources in watershed, engineering, or facilities to obtain cost information.</p> <p>Cost factors include the following variables:</p> <ul style="list-style-type: none"> <li>• Type of treatment implemented.</li> <li>• Site location.</li> <li>• Suppliers/contractors available to perform work.</li> </ul>
<b>Treatment Effectiveness</b>	Facility safety work is a recent BAER treatment that has no quantitative monitoring information. Anecdotal information on replacement of delineators along a forest road showed a favorable response. Use of BAER funds is limited to minor structures with an identified emergency that could not be treated otherwise.

### **Project Design and Implementation Team Information**

<b>Design</b>	Once the BAER team has identified an emergency related to facility-safety work and that treatment has been approved, repair can begin. Review the BAER assessment team findings on the ground to validate the treatment areas. Use stakes, flagging, or GPS coordinates to identify the treatment area.
---------------	---

## Chapter 5 Protection and Safety Treatments

---

Take necessary precautions to ensure no one is injured while waiting for the treatment to be implemented. Areas may have to be closed temporarily until the treatment can be implemented.

### **Safety**

Facility-safety work is implemented more safely when all hazards are mitigated and reviewed daily to avoid injuries. Include the following in the JHA.

- Hazardous driving conditions.
- Hazardous facilities including burned buildings.
- Unsafe sanitary facilities.

Due to the nature of these treatments, take necessary preventative measures for unsafe areas. Include safety updates and messages to BAER implementation teams as facility-safety work is being performed.

### **Treatment Monitoring Recommendations**

#### **Implementation**

- Was the treatment implemented as designed?
- Was the treatment implemented in a timely manner?
- Were temporary closures or restrictions necessary?

#### **Effectiveness**

- Did the treatment protect human health and safety?

### **Assessment Team Considerations for Emergency Stabilization**

<b>Primary Treatment Use</b>	Flood-warning systems are installed in locations where a direct risk to human life from floods or mass failures is identified.
<b>Description</b>	Flood-warning systems, commonly called early-warning systems (EWS), are installed in burned watersheds on USDA Forest Service lands. EWS provide local emergency networks, such as police, fire, or emergency preparedness organizations with information on rainfall intensity and duration allowing early detection of hazardous conditions. The National Weather Service is responsible for setting thresholds relative to precipitation and issuing flashflood warnings. The USDA Forest Service is involved in procuring and locating the EWS. The local emergency network maintains the EWS. (U.S. Department of Commerce, Web site; ALERT, Web site; Douglas, 2005)
<b>Purpose of Treatment</b>	Warning systems provide notification to people in areas susceptible to flooding or mass failures as a result of the wildfire.
<b>Emergency Stabilization Objective</b>	Warning systems prevent loss of life and/or property from storm runoff and/or debris flows.
<b>Suitable Sites</b>	<p>This treatment is intended for use in one or more of the following locations:</p> <ul style="list-style-type: none"><li>• Watersheds with high- and moderate-burn severity.</li><li>• Watersheds that burned and are adjacent to the urban interface.</li><li>• Areas (burned) above USDA Forest Service, State, and county roads that are not closed and are susceptible to flooding or debris flows.</li></ul>
<b>Cost</b>	<p>Weather station dataloggers vary in price depending on the system selected. New systems with 15 sensors to measure temperature, relative humidity, rainfall, soil moisture, and wind speed are as low as \$400. Four AA batteries power the unit for 1 year. (ONSET, Web site; C Microdog.com, Web site) However, given the importance of this unit in alerting people to potential flooding and other hazards, ensure that the system is reliable and provides information that the National Weather Service can use.</p> <p>Cost factors include the following variables:</p> <ul style="list-style-type: none"><li>• Knowing number of EWS required for the burned area.</li><li>• Selecting areas and installing stations.</li><li>• Accessing identified sites.</li></ul>
<b>Treatment Effectiveness</b>	No documented effectiveness monitoring information exists on EWS. Anecdotal information indicates these systems work best with well established emergency preparedness organizations. Problems can arise when the USDA Forest Service assumes responsibility for maintaining and operating the equipment. It is best to work collaboratively with the local emergency preparedness organization and define roles and responsibilities.

### **Project Design and Implementation Team Information**

**Design** After the BAER assessment team has designated areas susceptible to flashflooding and mass wasting, coordinate with local community emergency response networks. Implementation teams should share documentation and area maps that are threatened by potential floods or mass failures. Local emergency response groups can identify areas where additional precipitation data would improve existing precipitation data coverage. Once additional sites are selected in a collaborative manner, the forest can purchase the EWS and assist in the installation (BAER Guidance Paper-Early Warning System).

**Tools/Equipment** Several weather station dataloggers are available for purchase online. Most new systems are easy to install, run on battery power, and have remote access to data. New wireless transceivers can transmit data to any internet browser for additional cost, but not all areas may have adequate network coverage. Before selecting a unit ensure that the weather station can reliably transmit real time data. Consult the ALERT Web site for information on equipment and the early warning process.

**Safety** Flood warning systems or EWS installation is implemented safely when hazards are identified and mitigated. Review and update the JHA to avoid injuries. Include the following in the JHA.

- Road conditions may be hazardous.
- Work in areas with unstable footing.
- Area has hazard trees near installation.

### **Treatment Monitoring Recommendations**

#### **Implementation**

- Was the EWS installed?
- How many?

#### **Effectiveness**

- Was the EWS data used?
- Did flashflooding or mass failures occur in the area delineated by the BAER team?

### Assessment Team Considerations for Emergency Stabilization

<b>Primary Treatment Use</b>	<p>Treatment of hazard trees and unstable rocks is prescribed to protect life along roads, high-use areas, permanent structures, and recreation areas that cannot be closed during the emergency. BAER assessment teams must identify the appropriate level of response based on risk factors (BAER Guidance Paper-Hazardous Tree and Rock Removal).</p> <p>Note: Hazard-tree removal to protect USDA Forest Service workers or crews implementing BAER treatments is NOT a separate treatment but is included in the unit cost of the BAER treatment being implemented.</p>
<b>Description</b>	<p>Large boulders destabilized by wildfire and severely burned trees pose a preventable risk to public safety. Hazard-tree and unstable-rock areas are identified by the BAER assessment team. An urgent significant hazard is identified when the collapse or breakdown of the burned or unstable object is “highly likely to occur within the year and could result in property damage, personal injury or death.”(BAER Guidance Paper-Hazardous Tree and Rock Removal)</p>
<b>Purpose of Treatment</b>	<p>Hazard-tree and unstable-rock treatments reduce the risk to public safety.</p>
<b>Emergency Stabilization Objective</b>	<p>Remove identified hazards to reduce the threat to life and property from both hazard trees and unstable rocks.</p>
<b>Suitable Sites</b>	<p>This treatment is intended for use in one or more of the following locations:</p> <ul style="list-style-type: none"><li>• Areas of high use.</li><li>• Access routes that cannot be closed.</li><li>• Areas of high values and/or unique resources.</li><li>• Areas adjacent to permanent structures.</li></ul>
<b>Cost</b>	<p>Hazard-tree removal is considered a linear unit and costs are based on a per-mile cost. Actual costs from the Southwest Region (R3) during FY 2000 to 2003 range from \$340 to \$1,200 per mile.</p> <p>Cost factors include the following variables:</p> <ul style="list-style-type: none"><li>• Number of trees to be removed.</li><li>• Diameter of the trees.</li><li>• Density of the trees.</li><li>• Distribution of treatment areas.</li><li>• Need for secondary treatment including placement of trees to ensure safety.</li><li>• Hazard associated with tree removal (risk to chain saw operator).</li></ul> <p>Cost for treating boulders destabilized by wildfire varies by location and treatment method. In some cases, blasting the rock can reduce the risk, in other cases using heavy equipment may remove the threat. Anchoring nets trap and reduce rockfall onto the road. Maintenance of these structures varies with the extent of the hazard.</p>

## Chapter 5 Protection and Safety Treatments

---

### Treatment Effectiveness

Hazard-tree removal and clearing of unstable rocks has not been monitored for treatment effectiveness. Determining the appropriate level of response, by following the criteria used in the BAER Guidance paper, helps assessment teams define the emergency and develop treatment recommendations. Assessment teams should recommend stabilization or removal of hazards that threaten life or property when there are no other protection options.

### Project Design and Implementation Team Information

#### Design

After the BAER assessment team has designated potential treatment areas, validate the field sites. Key design considerations include validating the risk level as low, moderate, or high as defined below.

- Low risk – Areas with no vehicles, no structures, or infrequent use.
- Moderate risk – Areas with intermittent use by people or moving vehicles.
- High risk – Areas of high use with concentration of people, parked vehicles, and permanent structures.

In areas of moderate risk, the appropriate emergency response is to post signs warning of the danger and describing conditions under which the hazard may occur. (See Treatment Warning Signs for appropriate signs.)

For high-risk areas, where closure (both public and administrative) cannot be implemented, validate the treatment recommendation identified by the BAER assessment team.

### Construction Specifications

Treatment of hazard trees is conducted by the USDA Forest Service or contract crews. In some cases heavy equipment can move downed material off the road prism.

- Mark hazard trees within high-risk areas where collapse or breakdown of the tree is expected to occur within the year.
- Review hazards of felling trees.
- Fell and remove any burned hazardous tree that could fall on road, parking area, building, or unique site.
- Place trees on contour (where possible) in locations that do not adversely affect road drainage.

### Tools/Equipment

#### Tools

- Chain saws.
- Extra chain.
- Shovel.
- Blasting materials.

#### Equipment.

- Backhoe.
- Loader.

Removal of unstable rocks is conducted by the USDA Forest Service or contract crews.

- Identify hazard areas subject to rocks and boulder movement.
- Determine whether boulder can be moved to a stable site with heavy equipment.

## Chapter 5 Protection and Safety Treatments

---

- Determine whether boulder can be treated in place if it cannot be moved.

### Safety

Hazard removal is implemented more safely when hazards are identified and mitigated. Review, update and include the following in the JHA.

- Crews operating in area.
- Chain saw operation.
- Road closure plan during operations.
- Vehicles within the area.
- Equipment used for blasting trees and rocks.

### Treatment Monitoring Recommendations

#### Implementation

- Were identified hazard trees removed as specified?
- Were unstable rock hazards removed as specified?

#### Effectiveness

- Were there any losses of life or property occur in the treatment area?
- Do additional threats to life and property exist in the treatment area?
- Is additional hazard-tree removal necessary?
- Did hazard trees fall in this area without impacts to life and property?
- Is additional rock-removal treatment necessary?





### **Assessment Team Considerations for Emergency Stabilization**

<b>Primary Treatment Use</b>	Protection-enforcement treatments are recommended by BAER teams either when enforcing a forest order, or as a stand-alone treatment when no feasible treatment is available.
<b>Description</b>	<p>If the BAER team obtained a forest order for resource protection, the order has to be enforceable. Identify personnel available to enforce the order before placing a forest order (FSH 7709.59 Chapter 20).</p> <p>In situations where the fire's effect is limited and the BAER team does not want to recommend a forest or area closure, the team can recommend patrols and public contact to ensure effective resource protection.</p>
<b>Purpose of Treatment</b>	Reduce adverse impacts to resources by patrolling identified areas when there are no other effective alternatives.
<b>Emergency Stabilization Objective</b>	The objective is to prevent unacceptable degradation of critical natural or cultural resources or downstream values.
<b>Suitable Sites</b>	<p>This treatment is intended for use in one or more of the following locations:</p> <ul style="list-style-type: none"> <li>• Natural recovery areas.</li> <li>• High public-use areas.</li> <li>• Adjacent to off-highway vehicle (OHV) routes.</li> <li>• New areas with forest closure orders.</li> </ul>
<b>Cost</b>	Costs for this treatment depend on the enforcement level required and the patrol frequency to ensure treatment effectiveness. Cost estimates can be made using employee grade levels and vehicle costs.
<b>Treatment Effectiveness</b>	No quantitative effectiveness monitoring of this treatment exists. Anecdotal information indicates protection and enforcement creates public awareness regarding their role in ensuring recovery after a fire. Patrolling and public contact can include the use of volunteer OHV groups, native plant groups, or hiking clubs interested in the forest recovery. If volunteer groups and organizations are used, ensure that adequate time and funding is allocated for training and support and safety concerns are thoroughly addressed.

### **Project Design and Implementation Team Information**

<b>Design</b>	<p>Review the BAER assessment team findings in the field with a law enforcement officer to identify the implementation strategy. Consider the size of the area, values at risk, and key areas for protection and enforcement.</p> <p>Evaluate the potential use of forest OHV patrols, and fire prevention and recreation staff to inform the public about resource concerns created by the fire. In some areas informative signs are used in addition to protection enforcement. A positive message at a kiosk helps achieve public support and provide valuable information.</p>
---------------	--

## Chapter 5 Protection and Safety Treatments

---

For areas that have barricades to protect natural resources or for public safety, a forest order is required. The forest order must be enforceable. Review the areas on the ground with a law enforcement officer to identify the best barricade location to ensure its success (CFR 261.54).

### Safety

Protection enforcement is implemented more safely when hazards are identified and mitigated. Review and update the JHA to avoid injuries. Include mitigation in the JHA for the following:

- Potential confrontations with the public. In some cases, the public may be very frustrated with forest closures or access restrictions.
- Unsafe or rough driving conditions in patrol areas.

### Treatment Monitoring Recommendations

#### Implementation

- Was the protection-enforcement treatment implemented as designed?
- Were informational displays a component of the protection enforcement strategy?
- Was a forest order used according to CFR 261.54 as identified in FSH 7709.59 Chapter 20- Traffic Management?

#### Effectiveness

- Was the frequency of patrol and enforcement commensurate with the use of the area and the emergency identified?
- Was the closure order effective?

### Writing Forest Orders

When a BAER team recommends a barrier to restrict use on a forest road, a written order is required. Orders may be written for individual roads, groups of roads, or for all roads in an administrative unit. Clearly state the prohibition that applies to individual roads.

Review and validate travel management plans, values at risk, and BAER treatment objectives before preparing the order. Show the road restrictions on forest visitor maps.

Post the order to notify road users of the prohibition that applies to the road. Place a copy of the order in ranger district and forest supervisor offices. Bring the prohibition to the attention of affected users through the use of letters, news releases, and informational display boards.

Terminate the order when no longer necessary. The termination can be a fixed date in the original order or a separate termination order.

Remove signs related to the prohibition when the termination goes into effect. Notify users of the termination with similar news releases, letters, and informational displays.

Optional items for inclusion in an order:

- A numbering system.
- A penalty statement (36 CFR 261.1b). If a penalty statement is included, use the wording shown in the example attached.
- A termination date. (FSH 7709.59 chapter 20)

UNITED STATES DEPARTMENT OF AGRICULTURE  
FOREST SERVICE  
P.O. Box 4040  
Foresttown, California 96007  
Order of the Forest Supervisor

SMOKEY NATIONAL FOREST  
FOREST SUPERVISOR'S ORDER NO. 67  
April 2, 1990

Pursuant to 36 CFR 261.50(b), it is hereby ordered that the prohibitions hereinafter set forth apply to FDR 210, Roaring River Road, on the River Ranger District, Smokey National Forest:

1. Parking on the paved part of the roadway.
2. Logging trucks and other trucks with a GVW over 30,000 lbs. being on the road Saturdays and Sundays from Memorial Day to Labor Day and from October 10 to November 1 annually.
3. Logging trucks and other trucks with GVW over 30,000 lbs. being on the road on Memorial Day, July 4, and Labor Day.
4. Commercial timber sale and other vehicles larger than tandem, tri-axle or self-tracking trailer without pilot vehicle.

Violation of this order is prohibited by the provisions of the regulations cited, and under 16 USC 551 and 7 USC 1011(f). Any violation is subject to punishment by a fine of not more than \$500 or imprisonment of not more than six months, or both.

/s/ Samuel Forester  
SAMUEL FORESTER, Forest Supervisor



### **Assessment Team Considerations for Emergency Stabilization**

<b>Primary Treatment Use</b>	Protective fences and barriers protect public safety, BAER treatment areas, and naturally recovering areas from access.
<b>Description</b>	Protective fences and barriers include a variety of methods; gates, fences, boulders, jersey barriers, and logs. The type of fence or barrier selected depends on the access permitted and the size of the area.
<b>Purpose of Treatment</b>	<p>Protective fences and barriers provide public safety, protect BAER treatments, and allow natural vegetative recovery of a burned area (BAER Guidance Paper-Gates, Fences, &amp; Barriers).</p> <p>Roads and areas closed to the public must have a forest order that regulates and controls traffic. Direction for forest orders is in FSH 7709.59 chapter 20-Traffic Management. If use is prohibited on forest development roads, cite 36 CFR 261.54. Traffic rules and orders regulate or control traffic to prevent roadway damage, mitigate unsafe conditions, or to implement a specific resource management activity.</p>
<b>Emergency Stabilization Objective</b>	Protective fences and barriers help prevent threats to human life in unstable areas. These fences protect treated and recovering areas from vehicles, cattle, and other uses that can impede the success of the treatment.
<b>Suitable Sites</b>	<p>This treatment is intended for use in one or more of the following locations:</p> <ul style="list-style-type: none"> <li>• Areas of public use including campgrounds, popular dispersed camping areas, and road segments that are susceptible to rock-fall or flooding as a result of the fire.</li> <li>• Areas where natural barriers have been burned exposing sensitive sites to vehicle or recreational use.</li> <li>• Areas seeded or treated with straw mulch that have an active range allotment.</li> </ul>
<b>Cost</b>	<p>Unit-cost data for fencing in the Southwest Region (3) during FY 2000 to 2003 was \$5,000 per mile. Access gates were \$2,500. Jersey barriers are estimated at \$34 per linear foot. Boulder placement is \$250 to block vehicle access.</p> <p>Cost factors include the following variables:</p> <ul style="list-style-type: none"> <li>• Location of site and access constraints.</li> <li>• Availability of materials in close proximity to site (boulders).</li> <li>• Type of fence (smoothwire, barbed wire, electric).</li> <li>• Type of animal or use that is being restricted may increase costs.</li> <li>• Type of barrier selected.</li> </ul>
<b>Treatment Effectiveness</b>	Monitoring information on fencing to protect treated areas identifies the importance of knowing which grazers are present. Different and more costly fence requirements are necessary when excluding elk versus cattle. Once the type of grazer is identified, the success rate for the fencing treatment increased.

## Chapter 5 Protection and Safety Treatments

---

Identify the type of access allowed to determine appropriate barriers to restrict access. To prevent all-vehicle access on roads, placing jersey barriers and boulders in key locations are effective. If partial access is allowed, a gate with informational signing is effective.

### Project Design and Implementation Team Information

#### Design

After the BAER assessment team has designated potential treatment areas, review the field sites.

For fencing treatments consider the following:

- Type of animal to be excluded?
- Vehicle access needs beyond the site?
- Resource objective (long term) for fencing where forest funds could be used.
- Presence of all terrain vehicles in the area and likelihood of cross-country riding.
- Availability of crews to install fence.
- Type of fence that will address emergency treatment objectives.
- Hazards present within the treatment area that need to be removed prior to installation.
- Design an exit strategy to remove any animals that may enter the enclosure.

Barrier and barricade design considerations include the following:

- Access by large vehicles to the closure site. Can a truck with jersey barriers offload and set the barriers?
- Availability of boulders near the treatment area?
- Level of public use of the area?
- Signs that properly inform users?
- Barrier effectiveness based on local conditions.
- Barrier that prohibits motor vehicle use has an order pursuant to 36 CFR 261.54. (FSM 7731.1 Traffic Management)

#### Tools/Equipment

Basic equipment required for fence construction includes metal fenceposts, wire, wooden braces, and fence staples. A dumptruck, loader, and backhoe are used for most barricades.

#### Safety

Protective fencing and barriers are implemented more safely when hazards are identified and mitigated. Review and update the JHA to avoid injuries. Include the following in the JHA.

- Working with heavy equipment.
- Building fences and avoiding cuts, scrapes, and eye injuries.

#### Treatment Monitoring Recommendations

#### Implementation

- Was the treatment implemented as designed?
- Were informative signs posted?

### Effectiveness

- Did the closure (fence or barricade) keep animals or people out of the area?
- Did the treatment reduce the risk to human life?
- Did the identified emergency occur?
- Did the fence enable the treatment to function as designed?
- Did natural recovery occur?



Figure 101a—Wire fence to restrict access to an area that is naturally recovering.



Figure 101b—Metal fencing to restrict vehicle access to an area that is naturally recovering.



Figure 102—Boulders can serve as barriers to sensitive areas.



Figure 103—Jersey barriers (k-rails) line this road to protect vehicles on the road from debris flows.





Figure 104—Gates prevent access to hazardous areas.



Figure 105—Boulder barricade prevents vehicle entry but allows pedestrian access.



Figure 106—Gate restricts vehicle access to unsafe areas within the burn.



Figure 107—Jersey barriers (K-rail) can be used to limit vehicle access.



Figure 108—Jersey barriers can be removed from the road prism once the emergency is over.

### Assessment Team Considerations for Emergency Stabilization

<b>Primary Treatment Use</b>	Warning signs alert drivers and recreational users of existing or potentially hazardous conditions created by the wildfire.
<b>Description</b>	<p>Warning signs are a component of the overall travel control devices (TCDs) for the burned area (USDA Forest Service-EM7100-15, 2005). TCDs include all signs, signals, markings, and other devices used to regulate, warn, or guide traffic. The purpose of TCDs is to promote road safety by providing for the orderly and predictable movement of all motorized traffic. TCDs use the standards and guidance contained in the Manual on Uniform Traffic Control Devices (MUTCD) for all signs and traffic markings intended to control or regulate use on National Forest System Roads (NFSRs).</p> <p>The MUTCD and FSM 7731.15 -Signing and Traffic Control devices detail specifically the size, shape, color, and marking requirements for TCDs to ensure driver safety. All signs intended for drivers must meet these guidelines. No warning sign should be installed without an engineering study or application of engineering judgment to determine the need for and appropriateness of the sign and correct sign message.</p> <p>Signs designed for pedestrians are also covered in the EM 7100-15 chapter 13 and are not required to meet MUTCD guidelines. Pedestrian warning signs should be retroreflective, if intended to be read at night.</p>
<b>Purpose of Treatment</b>	Warning signs inform the public of potential hazards created by the fire including flooding, falling rock, and debris.
<b>Emergency Stabilization Objective</b>	Objectives are to protect life and property by alerting users to the hazards within the area.
<b>Suitable Sites</b>	<p>This treatment is intended for use in one or more of the following locations:</p> <ul style="list-style-type: none"><li>• Access routes to recreational areas.</li><li>• Trailheads providing access into the burn area.</li><li>• Informational kiosks located near the area affected by the fire.</li><li>• Hazards along access roads that enter the fire area.</li><li>• Roads closed with a forest order.</li></ul>
<b>Cost</b>	<p>Unit cost for warning signs in the Southwest Region (R3) from FY 2000 to 2003 ranged from \$80 to \$300.</p> <p>Cost factors include the following variables:</p> <ul style="list-style-type: none"><li>• Number of signs ordered.</li><li>• Installation costs.</li><li>• Size of signs.</li></ul>
<b>Treatment Effectiveness</b>	No documented monitoring data exists on the effectiveness of warning signs as a treatment. Warning signs frequently are prescribed on key access roads where potential hazards are identified. Warning signs are inexpensive and convey an important message to forest users. Current direction requires an engineering study or application of engineering judgment to determine the need for and appropriateness of the sign and correct sign language. Previous signs often were too lengthy or the message was misunderstood by the public.

### Project Design and Implementation Team Information

**Design** Review the BAER assessment team findings on the ground with an engineer to determine the need for either an engineering study or application of engineering judgment to identify the appropriate sign and correct sign message for the location.

Engineering studies and engineering judgment are terms defined in the MUTCD to denote evaluations that are performed by qualified individuals. For most emergency BAER treatments and signing needs on NFSRs may be determined based on engineering judgment. This less technical type of evaluation consists of a review, evaluation, and decision on the proper application of TCDs. It is advisable to document the analysis process, the date the work was done, and the name and signature of the person making the judgment as a component of the BAER records and sign plan inventory for the road.

The travel management strategy identifies the type of signing necessary. If the management strategy is to discourage use at certain times of the year when the risk is higher, a warning sign is appropriate. If the threat to life in an area is identified, signing combined with a physical closure or barrier may be required. If prohibiting traffic, prepare and enforce a legal order citing the appropriate CFR. Install restrictions as necessary. Sign the area with the appropriate TCD.

Warning signs warn drivers of unexpected conditions on or adjacent to a road and to situations that might not be apparent. Warning signs indicate the need for caution on the part of the vehicle operator and may call for a reduction of speed or a vehicle maneuver that is not consistent with driver expectancy. The following signs are used to identify warnings in or adjacent to a burned area.

Contact the forest or regional sign coordinator on the engineering staff for sign ordering advice, vendors, and order forms. Nonstandard signs must be approved by the regional sign coordinator.

Use the following caution signs for trails and roads.



Warning Information  
signs for trails  
2-inch letters 12 x 24 min

Figure 109—Entering burn area, stay on trail.



Warning Information sign  
Roads less than 35 mph  
4-inch letters 36 x 48

Roads 35-50 mph  
5-inch letters 42 x 60

Figure 110—Entering burn area, stay on roads and trails.

If these signs are warning only and there is no order to keep people on roads and trails use yellow and black signs. If there is a closure order to prohibit off road or trail use, then black and white signs should be used.



FW8-7a Forest Service Standard sign  
Many States have their own supplement such  
as WATCH FOR ROCKS

Figure 111—Falling Rock – FW8-7a Forest Service Standard sign. Many States have their own supplement such as WATCH FOR ROCKS.



FW5-1f

Figure 112—Impassable during high water.

The IMPASSABLE DURING HIGH WATER and FLASH FLOOD AREA signs may be used where unexpected or seasonal high water would prevent passage. Dry washes that drain a large area in desert country are an example of places to use the FLASH FLOOD AREA sign. A depth gauge may be used with either sign but is especially helpful in dry wash installations. An engineering study is recommended before installing depth gauges.



FW5-1g

Figure 113— Flash flood area.

Use individual warning signs at specific locations where the hazard exists. Avoid oversigning as disrespect of the message will occur and signs lose their effectiveness.



Figure 114—Falling rock and debris.

This sign is used for areas of trees, limbs, rocks, stumps that may be coming off the side slope and entering the travelway.



Figure 115—Falling rock and debris flash flood area next \_\_ miles.

### Tools/Equipment

Tools necessary for implementing warning signs include posthole diggers, drills, and screws. Ensure the correct mounting method is used for the appropriate signs.

### Safety

Warning sign installation is implemented more safely when hazards are identified and mitigated. Review and update the JHA to avoid injuries. Include the following in the JHA.

- Working in areas with unstable footing.
- Lifting large signs may cause muscle and back strain.

### Treatment Monitoring Recommendations

#### Implementation

- Were signs installed in all locations as designed?
- Do the signs meet FSM direction for warning signs?

#### Effectiveness

- Did users alter their use of the area as a result of the warning signs?
- Did the identified emergency occur in the areas designated?
- Was a travel management strategy for the burned area identified?
- Was the treatment responsive to the travel management strategy selected (discourage, eliminate, or prohibit)

## References

---

ALERT Saves Lives [Homepage of ALERT], [Online]. (Updated 16 June 2003) Available: <http://alertsyste.ms.org/> [2005, July 21]

Amaranthus, M.; Russell, D. 2004. Revegetating after a wildfire. Erosion Control. November/December. 46-61.

Armstrong, B. 2003 Borrego fire rehabilitation project. Unpublished paper on file at: U.S. Department of Agriculture, Forest Service, San Dimas Technology and Development Center, San Dimas, CA. 7 p.

BAER Guidance Papers. Homepage of Burned Area Emergency Response, Forest Service, U.S. Department of Agriculture. [Online]. Available: <http://fsweb.gsc.wo.fs.fed.us/baer/assess/guidelines.htm>

BAER Training. Homepage of Burned Area Emergency Response. Forest Service, U.S. Department of Agriculture [Online]. Available: <http://fsweb/gsc/wo.fs.fed.us/baer/assess/guidelines.htm>

Becker, R. 2001. Effective aerial reseeding methods: market search report. Gen. Tech. Rep. 01511204 –SDTDC. San Dimas, CA: U.S. Department of Agriculture, Forest Service, San Dimas Technology and Development Center. 19 p.

Brown, E.R. 2005. [E-mail to Carolyn Napper]. March 10. On file at: U.S. Department of Agriculture, Forest Service, San Dimas Technology and Development Center, San Dimas, CA. SWA files.

Beyers, J.L. 2004. Postfire seeding for erosion control: effectiveness and impacts on native plant communities. *Conservation Biology* 18 (4), 947-956.

City of Fort Collins, CO. (2004) *Flood Warning Systems*. [Homepage for City of Fort Collins, CO.], [Online]. Available: <http://www.fcgov.com/stormwater/fwsindex.php> [2005, April 28]

Clifford, T.J. 2001. Contour falling, LEBs, wattles. Unpublished paper on file at: U.S. Department of Agriculture, Forest Service, San Dimas Technology and Development Center, San Dimas, CA. 7 p.

Cochran, R. 2002. Hayman fire H25914 aerial hydromulching August 15 to September 14, 2002 report. Unpublished report on file at: U.S. Department of Agriculture, Forest Service. Pike and San Isabel National Forest, CO. 10 p.

Conservation Technology. (2002) *FEMA Flood Hazard Mitigation Handbook*. [Homepage on Conservation Tech.]. Available: <http://www.conservationtech.com/FEMA-WEB/FEMA-master-web/INDEX.htm> [2005, March 7]

Copstead, R.L.; Johansen, D.K.; Moll, J. 1998. Water/road interaction: introduction to surface cross drains. Gen. Tech. Rep. 9877 1806 –SDTDC. San Dimas, CA: U.S. Department of Agriculture, Forest Service, San Dimas Technology and Development Center. 16 p.

Covert, S.A.; Robichaud, P.R.; Elliot, W.J.; [and others]. 2005. Evaluation of runoff prediction from WEPP-based erosion models for harvested and burned forest watersheds. *American Society of Agricultural Engineers*. 48(3): 1091-1100.

Dean, A.E. 2001. Evaluating effectiveness of watershed conservation treatments applied after the Cerro Grande fire, Los Alamos, New Mexico. Tucson, AZ: University of Arizona. 116 p.

## References

---

- Dean, A.; Clarkin, K. 2003. Helicopter straw mulching: planning and implementation. [Online] Available: [http://fsweb.sdtcd.wo.fs.fed.us/programs/wsa/helimulch\\_etip/june2003etip/index.htm](http://fsweb.sdtcd.wo.fs.fed.us/programs/wsa/helimulch_etip/june2003etip/index.htm) [2003, June].
- DeBano, L.F.; Neary, D.G.; Ffolliott, P.F. 1998. Fire's effects on ecosystems. New York, NY: John Wiley & Sons, Inc. 333 p.
- Douglas, R.H. 2005. [Letter to Western Region WFO Meteorologists in Charge] Flash flood responsibility in burned areas. On File at: U.S. Department of Agriculture, Forest Service, Northern Region, Missoula, MT. BAER Coordinator files.
- Earth Savers. (2004, September 13- last update). [Homepage of Earth Saver Rice Straw Wattles], [Online]. Available: <http://www.earth-savers.com> (2004, September 13).
- Erosion Control Technology Council, [Homepage of ECTC], [Online]. (Copyright 1998-2002) Available: <http://www.ectc.org> (2005, November 17).
- Faust, R. 2004. Aerial helimulching techniques – Trough fire. Unpublished paper on file at: U.S. Department of Agriculture, Forest Service, Mendocino National Forest, Willows, CA.
- Fitzgerald, J. 2005. Herringbone log dams: purpose, installation, and effectiveness. Unpublished paper on file at: U.S. Department of Agriculture, Forest Service, San Dimas Technology and Development Center, San Dimas, CA. 6 p.
- Frazier, J. 2004. [Personal communication]. March 25. Sonora, CA. U.S. Department of Agriculture, Forest Service, Stanislaus National Forest, Supervisor's Office.
- Forest Ecology and Management. 2003. The effects of wildland fire on aquatic ecosystems in the Western USA. Volume 178, Issues 1-2. 3 June 2003
- Forrest, C.; Quigley, M.; Jacobsen, N.;[and others]. 2005. Rapid assessment and mitigation of post-fire impacts. Erosion Control January/February: 66-70.
- FSH 2509.13. Burned-Area Emergency Rehabilitation Handbook. WO Amendment 2509.13-95-5. [Effective 1/12/1995]. Chapter 20--Burned-area survey and emergency treatment strategy.
- FSH 2509.13. Burned-Area Emergency Rehabilitation Handbook. WO Amendment 2509.13-95-5. [Effective 1/12/1995]. Chapter 40--Burned-Area Report.
- FSH 2509.13. Burned-Area Emergency Rehabilitation Handbook. WO Amendment 2509.13-95-5. [Effective 1/12/1995]. Chapter 50--Emergency Treatment Implementation.
- FSH 2509.13. Burned-Area Emergency Rehabilitation Handbook. WO Amendment 2509.13-95-5. [Effective 1/12/1995]. Chapter 60--Monitoring and Evaluation.
- FSM 2500, Watershed and Air Operations. WO Amendment 2500-2004-1. [Effective 5/26/2004]. Chapter 2523 –Emergency Stabilization Burned-Area Emergency Response (BAER).
- FSM 7100. Engineering Operations. WO Amendment 7100-2004-2. [Effective 12/23/2004] Chapter – Zero Code.



## References

---

FSM 7160. Engineering Operations. WO Amendment 7100-2000-1. [Effective 9/15/2000], Chapter 7160 – Signs and Posters.

FSM 7500. Water Storage and Transmission. WO Amendment 7500-2000-1. [Effective 9/11/2000]. Chapter –Zero Code.

FSM 7500. Water Storage and Transmission. WO Amendment 7500-2000-1. [Effective 9/11/2000]. Chapter 7510 – Project Administration.

FSM 7500. Water Storage and Transmission. WO Amendment 7500-2000-1. [Effective 9/11/2000]. Chapter 7520 – Dam planning, Investigation, and Design.

FSH 7509.11. Dams Management Handbook. WO Amendment 7509.11-93-1 [Effective 8/5/93]. Chapter 80 – Planning and Design.

FSM 7700. Transportation System. WO Amendment 7700-2003-2 [Effective 12/16/2003]. Chapter 7710 – Transportation Atlas, Records, and Analysis.

FSM 7700. Transportation System. WO Amendment 7700-2003-1. [Effective 1/14/2003] Chapter 7730 – Operation and Maintenance.

FSH 7709.59 Transportation System Operations Handbook. WO Amendment 7709.59-91-1 [Effective 3/1/91]. Chapter 20 – Traffic Management.

FSH 7709.59 Transportation System Operations Handbook. WO Amendment 7709.59-91-1 [Effective 3/1/91]. Chapter 24 --Road Use Permits.

FSH 7709.56b. Transportation Structures Handbook. WO Amendment 7709.56b-94-1 [Effective 7/27/94], Chapter 6 – Hydraulics.

Groenier, J.S.; Showers, C. 2004 Shredding small trees to create mulch for erosion control. Tech. Tip 0471-2335-MTDC. Missoula, MT: U.S. Department of Agriculture, Forest Service, Missoula Technology and Development Center. 6 p.

Howes, S. 1998. Aerial seeding- planning and implementation. Unpublished paper in Burned Area Emergency Rehabilitation (BAER) Techniques Training Manual. USDA, Forest Service, Pacific Southwest Region.

Hubbert, K.R. 2005. Treatment effectiveness monitoring for Southern California wildfires: 2003 to 2004. Unpublished paper on file at: U.S. Department of Agriculture, Forest Service, San Dimas Technology and Development Center, San Dimas, CA. 215 p.

Imler, B. 2004. [E-mail to Carolyn Napper]. November 17. On file at U.S. Department of Agriculture, Forest Service, San Dimas Technology and Development Center, San Dimas, CA.

Interagency helicopter operations guide. 2002. Boise, ID: NFES-1885. National Interagency Fire Center, Jointly sponsored by U.S. Department of Agriculture, Forest Service and Department of Interior, Bureau of Land Management.

## References

---

Innovative forest products and natural resource services, [Homepage of ELWd Systems], [Online]. (Copyright 2005) Available: <http://elwdsystems.com> [2005, September 15].

International Erosion Control Association, [Homepage of IECA], [Online]. (Copyright 2005) Available: <http://ieca.org> [2005, September 15].

Janicki, A.; Potter, D. 2003. Effects of grass seeding on post-fire erosion in a Sierra Nevada pine-hardwood community. Unpublished paper on file at: U.S. Department of Agriculture, Forest Service, Stanislaus National Forest, Sonora, CA. 20 p.

Johnson, A.S. 2003. Aspen fire 2003 treatment success monitoring report. Unpublished report on file at: U.S. Department of Agriculture, Forest Service, Coronado National Forest, AZ. 21 p.

Keating, J. 2005. Hydroseeding: more to know than H<sub>2</sub>O. *Erosion Control*. January/February: 30-40.

Kuyumjian, G. 2004. [Personal communication]. November 17. Los Alamos, NM: U.S. Department of Agriculture, Forest Service, Santa Fe National Forest, Los Alamos Office.

Kuyumjian, G. 2004. [E-mail to Carolyn Napper]. November 17. On file at U.S. Department of Agriculture, Forest Service, San Dimas Technology and Development Center, San Dimas, CA.

Landloch. 2002. Studies of hydromulch effectiveness. National Centre for Engineering in Agriculture Publication 1000455/1, USQ, Toowoomba.

Lenti, R. 2005. BFM's give you BMPs. *Soil Erosion & Hydroseeding*. March/April: 16-19.

MacDonald, L.H.; Rough, D.; Pietraszek, J.; [and others]. 2004. Post-fire erosion and the effectiveness of burned area rehabilitation treatments, Colorado front range. Poster

Mankins, A. 1998. Straw bale check dams, straw wattle dams, log/rock grade stabilizers. Unpublished paper in Burned Area Emergency Rehabilitation (BAER) Techniques Training Manual. USDA, Forest Service, Pacific Southwest Region.

Mankins, A.; Paulo, J.; Ridley, J. 2005. Helimulching lessons learned and recommendations. Unpublished paper on file at: U.S. Department of Agriculture, Forest Service, Shasta-Trinity National Forest, Redding, CA. 42 p.

Manual on Uniform Traffic Control Devices (MUTCD) [Online]. (2003, November). U.S. Department of Transportation, Federal Highway Administration. Available: <http://mutcd.fhwa.dot.gov/>

McCullah, J.; Vance, H. 2000. Shasta College erosion control blanket study research quantifies erosion from slopes. *Land and Water*. Vol 44-5.

Microdaq.com. (2005) *HOBO Weather Station*. [Homepage for Microdaq.com], [Online]. Available: <http://www.microdaq.com/occ/hws/index.php> [2005, April 28]

Moll, J. 1997. Glossary of water/road interaction terminology. Gen. Tech. Rep. 9777 1806P—SDTDC. San Dimas, CA: U.S. Department of Agriculture, Forest Service, San Dimas Technology and Development Center. 19 p.

## References

---

- Moody, J.A.; Martin, D.A. 2001. Hydrologic and sedimentologic response of two burned watersheds in Colorado. Res. Rep. 01-4122. Denver, CO. US. Department of the Interior, U.S. Geological Survey. Paginated by chapter.
- Morris, L. 2004. Straw wattles...a versatile tool for controlling erosion. *Soil Erosion & Hydroseeding*. January/February. 22-24.
- Natural Resource Conservation Service. (2005, July 7 – last update) *Contour Straw Wattles* [Homepage of Colorado Natural Resources Conservation Service, U.S. Department of Agriculture], [Online]. Available: <http://www.co.nrcs.usda.gov/> [2005, July 7].
- Napper, G.; Rundle, J. 1998. Road treatments. Unpublished paper in Burned Area Emergency Rehabilitation (BAER) Techniques Training Manual. USDA, Forest Service, Pacific Southwest Region
- Noland, M. 2005. [E-mail to Carolyn Napper]. April 29. On file at U.S. Department of Agriculture, Forest Service, San Dimas Technology and Development Center, San Dimas, CA.
- Nyhan, J.W.; Koch, S.; Balice, R.; [and others]. 2001. Estimation of soil erosion in burnt forest areas of the Cerro Grande Fire in Los Alamos, New Mexico. Res. Pap. Los Alamos, NM: U. S. Department of Energy, Ecology Group, Los Alamos National Laboratory. 25 p.
- Onset Computer Corporation. (2005). *HOBO Weather Stations Data Logger Guide*. [Homepage of Onset Computer Corporation], [Online]. Available: [http://www.onsetcomp.com/products/prodcuts\\_pages/weatherstation/ws\\_logger\\_guide.html](http://www.onsetcomp.com/products/prodcuts_pages/weatherstation/ws_logger_guide.html) [2005, April 28]
- Pannkuk, C.K.; Robichaud, P.R. 2003. Effectiveness of needle cast at reducing erosion after forest fires. *Water Resources Research* 39 (12). Abstract.
- Robichaud, P.; Wagenbrenner, J. 2005. Hayman fire rehabilitation treatment monitoring progress report. Unnumbered, Moscow, ID: U.S. Department of Agriculture, Forest Service, Rocky Mountain Research Station. 14 p.
- Robichaud, P.; MacDonald, L.; Freeouf, J.; [and others]. 2003. Postfire rehabilitation of the Hayman fire. Gen. Tech. Rep. RMRS-GTR-114. Moscow, ID: U.S. Department of Agriculture, Forest Service, Rocky Mountain Research Station. 21 p.
- Robichaud, P.R. 2000. Forest fire effects on hillslope erosion: what we know. *Watershed Management Council Newsletter*. 9 (1): p.2-10.
- Robichaud, P.R.; Beyers, J.L.; Neary, D.G. 2000. Evaluating the effectiveness of post-fire rehabilitation treatments. Gen. Tech. Rep. RMRS-GTR-63. Moscow, ID: U.S. Department of Agriculture, Forest Service, Rocky Mountain Research Station. 85 p.
- Robichaud, P.R.; Beyers, J.L.; Neary, D.G. 2001. After the fire, before the storm: post-erosion control efforts explored. *CE News*. February. 9 p.
- Robichaud, P.R.; Brown, R.E. 2002. Silt fences: an economical technique for measuring hillslope soil erosion. Gen. Tech. Rep. RMRS-GTR-94. Moscow, ID: U.S. Department of Agriculture, Forest Service, Rocky Mountain Research Station. 24 p.

## References

---

Roby, K.B. 1989. Watershed response and recovery from the Will fire: ten years of observation. In: Berg, N.H., tech. cord. Proceedings of the symposium on fire and watershed management, October 26-28, 1988, Sacramento, CA. Gen. Tech. Rep. PSW-109, Berkeley, CA: U.S. Department of Agriculture, Forest Service, Pacific Southwest Forest and Range Experiment Station: 131-136.

RSMeans. 2005. Heavy construction cost data. Atlanta: Reed Construction Data. 484 p.

Ruby, E. 1995. Contour log terraces. Unpublished paper on file at : U.S. Department of Agriculture, Forest Service, San Dimas Technology and Development Center. San Dimas, CA. 6 p.

Ruby, E. 1998. Watershed treatment criteria for cultural resource sites. Unpublished paper on file at : U.S. Department of Agriculture, Forest Service, San Dimas Technology and Development Center. San Dimas, CA. 18 p.

Sandberg, D.V.; Ottmar, R.D.; Peterson, J.L.; [and others]. 2002. Wildland fire in ecosystems effects of fire on air. Gen. Tech. Rep. RMRS\_GTR-42-volume 5. Fort Collins, CO: U.S. Department of Agriculture, Forest Service, Rocky Mountain Research Station. 78 p.

San Diego State University. 2001. Results from a study of Profile Products' M-BFM: runoff characteristics and sediment retention under simulated rainfall conditions. Res. Rep. San Diego, CA: San Diego State University, Soil Erosion Research Laboratory. 18 p. plus appendix.

Schmidt, L.J. 2003. Designing log contour basins for maximum effectiveness. Stn. Pap. Stream Notes, July, 2003: Fort Collins, CO: U.S. Department of Agriculture, Forest Service, Rocky Mountain Research Station. 2p.

Shepley, B.; Smith, R.; Jackson, G.L. 2002. Market analysis of erosion control mats. Res. Note FPL-RN-0284. Madison, WI: U.S. Department of Agriculture, Forest Service, Forest Products Laboratory. 9 p.

Smith, D.N. 1998. Invasive plants, weeds/seeding. Unpublished paper in Burned Area Emergency Rehabilitation (BAER) Techniques Training Manual. U.S. Department of Agriculture, Forest Service, Pacific Southwest Region.

Spiars, D.A. 2002. Hayman B.A.E.R. rehabilitation aerial hydro-mulching project site inspection final report. Unnumbered, Pueblo, CO: U.S. Department of Agriculture, Forest Service. Pike and San Isabel National Forest. 5 p.

Taylor, C.L. 2004. [E-mail to Carolyn Napper]. May 4. On file at: U.S. Department of Agriculture, Forest Service, San Dimas Technology and Development Center, San Dimas, CA.

Tiedman, A.R.; Conrad, C.E.; Dieterich, J.H.; [and others]. 1979. Effects of fire on water a state-of-knowledge review. Gen. Tech. Rep. GTR WO-10. Provo, UT: U.S. Department of Agriculture, Forest Service, Provo, UT. 28 p.

Tracy, R.; Ruby, E. 1994. Site selection criteria and project requirements contour log terraces on hillslopes. Unpublished paper on file at: U.S. Department of Agriculture, Forest Service, San Dimas Technology and Development Center, San Dimas, CA. 7 p.

## References

---

U.S. Department of Agriculture, Forest Service, 2005. Sign and poster guidelines for the Forest Service. EM-7100-15.

U.S. Department of Commerce, National Oceanic and Atmospheric Administration National Weather Service. (1992, July) *Flash floods and floods...the awesome power! A Preparedness Guide* [Homepage of National Weather Service and National Oceanic and Atmospheric Administration], [Online]. Available: <http://www.nws.noaa.gov.om.brochures/ffbros.htm>

U.S. Department of Transportation, Federal Highway Administration. 2004. Hydraulic Engineering Circular No. 9 Debris-Control Structures Second edition. FHWA-IF-04-016

U.S. General Accounting Office, Report to Congressional Requesters. 2003. Wildland fires-better information needed on effectiveness of emergency stabilization and rehabilitation treatments. GAO-03-430. Washington, DC: U.S. General Accounting Office. 48 p. plus appendices.

Van de Water, R. 1998. Debris basins. Unpublished paper in Burned Area Emergency Rehabilitation (BAER) Techniques Training Manual. U.S. Department of Agriculture, Forest Service, Pacific Southwest Region.

Van de Water, R. 1998. Post-fire riparian zone management: the Salmon River experience. In: Proceedings, nineteenth annual forest vegetation management conference: wildfire rehabilitation. January 20-22, 1998. Redding, CA: Forest Vegetation Management Conference: 25-40.

Veenis, S. 2000. After the fire. Erosion Control. November/December.

Wagenbrenner, J.W. 2003. Effectiveness of burned area emergency rehabilitation treatments, Colorado Front Range. Fort Collins, CO: Colorado State University. Thesis.

Wells, C.G.; Campbell, R.E.; DeBano, L.F.; [and others]. 1979. Effects of fire on soil a state-of-knowledge review. Gen Tech. Rep. GTR WO-7. Research Triangle Park, NC: U.S. Department of Agriculture, Forest Service, Research Triangle Park, NC 34 p.

Wohlgemuth, P.M.; Hubbert, K.R.; Robichaud, P.R. 2001. The effects of log erosion barriers on post-fire hydrologic response and sediment yield in small forested watersheds, southern California. *Hydrological Processes*. 15: 3053-3066.

Wohlgemuth P.M.; Beyers J.L.; Wakeman C.D; [and others]. 1998. Effects of fire and grass on soil erosion in southern California chaparral. In: Proceedings, nineteenth annual forest vegetation management conference: wildfire rehabilitation. January 20-22, 1998. Redding, CA: Forest Vegetation Management Conference: 41-51.



## Appendix A

---

### Section 1. Excerpts From “Aerial Helimulching Lessons Learned and Recommendations” by Annette Mankins, Jeff Paulo, and Jeff Ridley

#### Key Position Responsibilities

The **contracting officer** is responsible for all operations-connected supply and equipment contracts. An exception is when a helicopter is ordered under a forest-directed exclusive use and/or call when needed (CWN) contract. The helimulching support specialist may function as the contracting officer’s representative (COR) for the rice straw mulch supply contracts, as well as COR for the emergency equipment rental agreement (EERA) contracts. Contract inspectors are designated by the COR for each helispot. Contract equipment inspection is conducted pre- and post-use at the helispot.

**Helimulching support specialist** is responsible for overall aerial straw helimulching application, and reports to the operations section chief or directly to the incident commander. This position is crucial and needs to be filled in the early planning stages of implementation. The helimulching support specialist also coordinates the scheduling and prioritization of helicopter operations with air operations and is responsible for aerial straw mulch activities through the support coordinator, one for each helispot (if more than one helispot is needed).

**Support coordinator** is responsible for overseeing the work activities of the supply receipt and/or load delivery person(s), and the field observer(s). The responsibilities include conducting and coordinating the day-to-day operations and keeping a daily log using ICS form 214s.

The **supply load tech** responsibilities include (1) keeping detailed records of rice straw deliveries, including bills of lading and certifications (see appendix D for a blank Straw Mulch Delivery Accounting form, as well as tracking load weight of each helicopter flight) and (2) total helicopter turn around times (see appendix E for a blank Helimulch Load Tracking form).

The **straw/equipment manager** is responsible for pre- and post-equipment inspections and can be a significant help with specifications of straw, set up of straw on the helispot, tracking straw delivery, and identifying safe and drivable delivery routes. This position also needs to be filled during the implementation planning stage.

The **field observers** position themselves at a safe observation point, and provide direct radio feedback to pilots and/or support coordinators during operational application as to effectiveness, wind drift, and location of current and future aerial straw drops.

**Helimulching air specialist** coordinates the helicopter and pilot activities and is also responsible for coordinating the activities of helispot and helicopter managers, and forest cargo-net crews on a daily basis. The helimulching air specialist is also responsible for writing and coordinating forest and regional approval of the aviation safety plan. They are also responsible for conducting the preoperational and daily safety briefings along with the helispot manager. They report directly to the operations section chief or the incident commander. This position is crucial and needs to be filled in the early stages of implementation.

**Helispot managers** have overall responsibility of the helispot/helibase. This includes safety, daily briefings, personnel, and set up to complete an efficient operation. They work under the direction of the helimulching air specialist and work closely and coordinate daily activities with the support coordinators. They also are responsible for force-account net loading and longline-hooking crews, safety issues, and needs.

**Helicopter managers** are responsible for all management factors in administration involving the helicopter. The helicopter managers work directly with helicopter pilots and are primarily focused on aerial safety considerations and fuel needs.

**Net loading support** personnel are responsible for safely loading and hooking up the straw-filled nets to the helicopter long line.

# Appendix A

---

## Organization Recommendations

- Clarify roles, expectations, and lines of authority before initiating work activities.
- Ensure that a qualified COR is available to manage contract and EERA operations.
- Provide a helimulching technical specialist to train net crews in the safe and proper rigging of nets and hooks.
- Ensure all project personnel are properly trained for the position they are filling. **This cannot be overemphasized.**

## Activities

Force account aerial straw helimulching can best be described by breaking down the work activities into six separate components, including:

- Helispot design.
- Safety and preoperational meeting.
- Net loading.
- Aerial application.
- Rice straw mulch.
- Oversight/monitoring.



# Appendix A

## Helispot Design

The design of the helispot is essential to running a safe and effective operation.

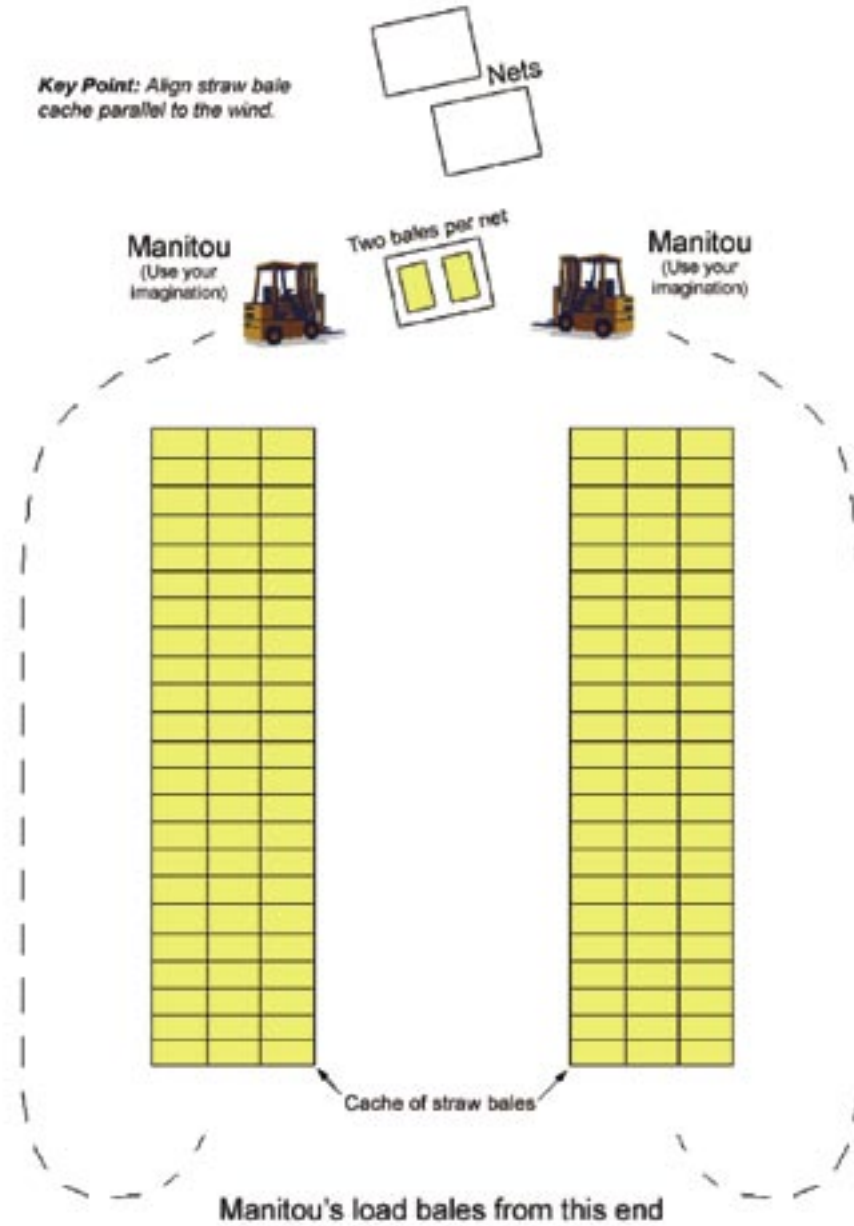

**Figure 2 - Example of an efficient, safe and effective helispot straw loading set-up.**

Recommended equipment and personnel for the straw loading set up is: two Manitou's (each working their own stack or cache of straw), one helicopter manager, one helispot manager, and seven qualified net loading personnel.

When designing a helispot, ensure fuel trucks and double trailers can access the staging area. Ensure there is an ample area for staging straw and net loading operations. There is a lot of equipment activity and helicopter prop wash for ground crews to contend with. If suitable helispot staging areas are not available

## Appendix A

---

on National Forest System lands, provide sufficient lead-time to develop Memorandum of Understandings (MOUs) with other agencies or private landowners. Ideally, have a local contact specialist, or a member of the buying team, versed in agreements, available. If possible, locate the helispot within one air mile of the identified mulch units. Locate more than one helispot if the units are further than one air mile.

Involve helicopter operations personnel early in the process to identifying suitable helispot staging areas and service landing areas.

Provide for a water tender on native surface helispots for dust abatement. Identify water sources in advance of operational activities. Water tenders are not needed on asphalt, or well-hardened helispots or staging areas.

A second piece of equipment is not needed to off-load straw trucks. A Manitou (equipment with a large fork on the front end that can move the bales and also lift and fluff straw after placing in the net) works well.

If possible, design helispots with sufficient safe working areas and safe egress and ingress access points for helicopters so that multiple aircraft might use the same helispot concurrently, if necessary. Do this **ONLY** after consultation with the helicopter manager, and with the concurrence of affected aircraft pilots. Weather factors can vary dramatically from site to site. Identify helispots sufficiently large to hold several days of staged straw to allow for such a contingency. Once the pilots establish an orbiting pattern, and ground crews become sufficiently organized, there should be no appreciable drop in operational productivity or safety by using multiple aircraft on the same helispot.

### Safety and Preoperational Meeting

A project aviation safety plan is prepared by the helimulching air specialist. The plan is required by Interagency Helicopter Operations Guidelines (IHOG). The final plan is prepared, reviewed, and approved by the forest aviation officer, BAER implementation team incident commander, BAER team safety officer, and regional aviation safety officer. See appendix B - Aviation Safety Plan for further information.

Daily briefings are attended by all personnel every morning. The briefings include the daily objectives, and safety. Topics should include; radio frequencies to use, knowledge of field observers, field locations, traffic control, personal protective equipment (PPE) to be worn by all personnel on helispot, personnel that can be located on the "Hot Deck" of the helispot, air hazards, etc. There is also a briefing at night that everyone attends. During this briefing, the team will talk about the daily events, how things went, concerns, and solutions for concerns. The job hazard analysis is prepared by the BAER safety officer and is presented and signed at each morning briefing.

The preoperational briefing can be held the afternoon before the start date to limit "first day flight delays." The briefing is basically a project overview that includes; safety and identified hazards, communications, emergency crash rescue, call tree phone numbers, schedule timeline, start-stop times, and lines of authority. The pilot can observe units from the air with key personnel, talk about basic goals of the project, organization, maps, etc.

The FAA will not provide temporary flight restrictions (TFR) for aerial straw helimulching as is commonly received for fire emergency aerial operations. It is therefore more imperative that pilots, ground, and work crews are very cognizant of aircraft encroaching within the operational air space, so sightings can be immediately reported to air-borne pilots. Use the project information officer to provide public safety information regarding your operations, as well as sign postings in areas frequented by potential conflicts with operational air space, such as airparks and local airports.

### Net Loading

The key elements of this activity include the loading of cargo nets with rice straw mulch, and attaching the net to the helicopter long-line. Typically 100-foot long-lines are used. After loading the bales on to the net, the force account ground crews cut and remove the strings. **The bales should then be "fluffed" by a Manitou (or equivalent) to prevent the safety hazard of the bales shifting in the net during transport causing a jarring effect to the pilot.** The fluffing also helps disperse the straw better and create an effective ground cover with less clumping. The ground crews then attach the helicopter long-line to cargo nets.

## Appendix A

---

**Provide for safety first.** To spread out the work load, provide for more net-tending personnel than you think is necessary and alternate individuals in and out of rotation. Do not allow crews to become complacent, or overly tired, which can lead to accidents.

### Rice Straw

The application material is rice straw for the helimulching treatment under a supply contract. Specifications for the straw are given to the procurement unit. These specifications can include, weed free, stored in a dry environment, delivery needs including dates, times and place, sizes of bales, and double chopped, etc. Specify delivered straw mulch not exceed a moisture content of 20 percent if at all possible. The ideal appears to be in the 11- to 15-percent range. If procurement is done by weight, paying for straw with a high moisture content is undesirable. In addition, “wet” straw does not disperse as well, and the treatment is less effective. This factor may depend on the time of year you are purchasing, critical time limits, and if last years or the new years straw is available. Rice straw is usually baled in late August or early September.

Provide delivery schedule flexibility in the contract. Limited staging space and environmental conditions leading to operational shut-down (excessive winds, fog) can quickly lead to “choking” staging areas with straw if a systematic, set delivery schedule is provided in the contract. Schedule deliveries with a 24- or 48-hour scheduling advance notification window. Also, schedule delivery times to be outside of helispot working hours to alleviate additional congestion. Do this as a contract requirement, unless very large staging areas are available at worksites.

To save on trucking costs, bales are compressed during baling operations to save truckbed space during shipping. Experience shows that bales exceeding baling pressures of over an estimated 450 pounds did not disperse as well during aerial application. Specify a lower maximum cap pressure per pounds/square inch if the straw is still in the field and has not been baled. The baler keeps general records of the baling pressures. Consider making documentation of baling pressure a contract requirement, or at least “cap” acceptable bale pressure. If you use the Manitou equipment to “fluff” the bales then the baling pressure is not as much of a concern.

When designing equipment agreements, provide for fixed hourly and guaranteed minimum daily rates for procured equipment and operators. Establishment of guaranteed minimum daily rates in advance will provide substantial operational flexibility if weather-related and/or nonoperational days occur.

When ordering and working with straw and equipment, a straw manager is essential to guarantee correct straw specifications and delivery options along with equipment prices and abilities to perform as needed.

### Aerial Application

Helicopters must come equipped with a load cell to ensure allowable payloads are not exceeded. Load cells will also help the supply load tech to keep track of weight being delivered with each flight. Load cells include not only the weight of the straw in the net but also the weight of the “sling equipment.” Subtract the weight of the sling equipment (approximately 200 pounds) to come up with exact straw mulch pounds being applied in each load.

Loaded external cargo over flights of public highways is prohibited. Carefully identify suitable helispots where traffic control is not needed, if at all possible. If additional personnel for traffic control are required, additional communication needs, an authorization permit from the State highway department, and procurement of safety signing and cones is needed. This will greatly add to overall operational complexity. Avoid this if possible.

When designing your project, carefully consider the payload capacity and average turn around times for the considered aircraft. Safe payload capacity of the Type II ships could roughly double that of the Type III ship, but operational costs for the Type III are approximately half of those of Type II. Operational air speed is roughly comparable. Thus, overall costs per acre are almost equivalent. In general, consider Type III aircraft only for limited, specialized activity, such small capacity helispots, or in a service capacity, or if the availability of Type II aircraft is very limited.

## Appendix A

---

### **Oversight and Monitoring**

The complexities of operating within two essentially parallel organizations can be initially difficult. The incident commander needs to clarify roles and expectations for primary overhead positions very early in the operation, which will dramatically improve internal communication and lines of authority.

### **Contract Method**

Under the contract method, the contractor provides for all of the logistical needs of the project, including the procurement of helicopters, cargo nets, labor, loading equipment, and straw bales. Treatment areas, unit of measure, technical specifications, payment method, payment units, staging areas, and flight-restrictions are identified. Payment is generally based upon a per acre or job basis.

### **Organization**

The contract is a service contract under Federal Acquisition Regulations (FAR), and entails the use of a contracting officer, COR, and inspectors. The project manager is responsible for the planning phase of the operation. An aviation safety plan and job hazard analysis need to be prepared and approved for the project. Also, air operations and helispot manager positions are needed. Field observers and the supply/load tech positions can be filled if needed.

### **Activities**

See section 3 – Contract Example for BAER Helimulching.

### **Contract and Force Account Methods**

Certain work items must be completed regardless of which method is chosen.

- Aviation safety plan and job hazard analysis must be written and approved.
- Unit boundaries need to be identified on the ground and maps created.
- GPS location of units.
- Helispots/helipads (if more than 1 helicopter is using the site then it is referred to as a helipad) identified and approved.
- Need to improve (cut trees) in support of ingress and egress, before start of project.
- Helispot set-up design.

### **Wrap-up**

There are advantages and disadvantages to each of the treatment methods under consideration. The BAER incident commander will need to select that method most suited to the treatment requirements. The following table compares and contrasts some of the factors to consider in the selection of a treatment method. The comparisons are not absolutes, but are rather on a “relative” scale.

The flexibility of the force account method makes this option a preferred selection if experienced and knowledgeable helimulching personnel are available to implement the project. Also, if the forest or unit does not have a contracting officer available, you may choose the force account method. Time constraints and available personnel are also considerations in the factor of choosing the method of implementing helimulching.

## Appendix A

**Table 1: Treatment method selections... factors to consider.**

<b>Factor</b>	<b>Contract</b>	<b>Force Account</b>
Implementation	Immediate	Immediate
Cost	Higher than force account	Lower than contract
Scale	Better suited to larger (500+ acres, more than 1 helicopter)	Better suited to smaller (<500 acres, 1 helicopter)
Skills needed	Service contract COR, inspectors, helispot managers, field observers	Supply, service (equipment) COR, inspectors, helimulching air and support, support coordinators, field observers, and net loading support
Preflight with project manager/specialists	N/A	Usually done to check unit boundaries and prescriptions
Lines of authority	Linear (simple)	Multilateral (more complex)
Flexibility	Generally inflexible, changes costly	Generally flexible



Appendix A

---

Section 2 – Aviation Safety Plan

***Bear Fire Burned Area Emergency Rehabilitation  
Shasta-Trinity National Forest***

**Helicopter Mulching**

Prepared by: \_\_\_\_\_ Date: \_\_\_\_\_

Helimulching Specialist

Reviewed by: \_\_\_\_\_ Date: \_\_\_\_\_

BAER Helimulching Leader

Reviewed by: \_\_\_\_\_ Date: \_\_\_\_\_

District Ranger

Approved by: \_\_\_\_\_/s/ Stanley A. Kubota\_\_\_\_\_ Date: 11/15/2004

Forest Aviation Officer

Reviewed by: \_\_\_\_\_/s/ Dennis Hulbert\_\_\_\_\_ Date: 11/16/04\_\_

Regional Aviation Officer





## Appendix A

---

### ***Introduction and Objectives***

The 2004 Bear Fire has created flooding problems around the Jones Valley Resort Marina, Jones Valley Boat Launch area along Shasta Lake. The downstream value at risk is the access road into this area.

The objective of this project is to reduce erosion by treating the area with straw mulch. Approximately 230 acres have been selected for treatment with straw mulch applied by helicopter.

### ***Justification***

The area selected for treatment is steep, rocky, and covered with hazard trees. By minimizing ground personnel in the area it will significantly reduce exposure to ground personnel.

### ***Project Description***

#### **General**

The treatment area is located along the road, which is adjacent to Shasta Lake in the Jones Valley Resort area. This road allows access to Shasta Lake, which is highly used for recreation and employment for the surrounding community.

Elevations for the project site will range from 1,000 to 1,500 feet. The project is scheduled for Thursday November 18 thru November 21, weather permitting.

#### **Landing Area**

The site selected for flight operation is the Jones Valley Boat Ramp a 2-acre paved area, elevation 1,114 feet (Lat. 40. 44. 309 x 122. 12. 958). The landing area is in the immediate area of the treatment areas and visual contact with helicopter will be maintained at all times. The access road and boat ramp will be closed off to public access due to public safety. Road guards, boat patrol, and law enforcement will be patrolling to keep public out of the work area. A safe site has been designated in the case of public viewing that is out of the flight operations area. Road guards will allow limited controlled access to authorized personnel and local resort employees on an as need basis. Over flights of buildings, vehicles, people, power lines will not be allowed. A light post stands 40 feet tall in the middle of the parking lot. This pole will be marked and avoided. Small trees will be removed to ensure a proper departure for the helicopter. Helicopter fueling will be conducted at the Jones Valley parking area. A Type 3 engine with crew will be on standby at the site for a fire or medical emergency.

#### **Hazards**

The project area has a small section a power lines that run trough it. The lines are below tree-top level and are visible. The power lines will be identified to the pilot in the preoperational briefing on Wednesday, November 17th. Pilot review of the current Shasta-Trinity Flight Hazard map will be reviewed with the pilot. No mulching drops will be made on power lines and a 50-foot buffer on either side of power lines will be maintained. A NOTAM will be issued to avoid this area. Standing trees are present in the area. Flight altitudes of 100 feet above ground level (AGL) will be maintained while drops are being made. Flight operations will be conducted between civil twilight hours and will be shut down earlier if low light conditions exist. Flight operations will stop each day at 1600 hours to ensure debriefing with pilot can be made and ferry of aircraft to Redding Airport can be accomplished.

#### **Project Operation**

Unless specifically noted and approved all project operations shall be in compliance with the IHOG.

Daily operational briefings and debriefing will begin and end at the designated project site with helimulching specialist, helicopter manager, and all crucial BAER personnel. Problems encountered will be mitigated

## Appendix A

---

before the next operational period begins. The project-briefing checklist will be utilized each day of operation before beginning. If needed a reconnaissance flight will be offered to pilot if need to identify targets of hazards.

Straw mulch will be applied by helicopter using aerial mulching methods developed and approved by San Dimas Technology Development Center. These methods of have been used successfully on the Mendocino, Shasta-Trinity, Six Rivers, Stanislaus, San Bernardino, and Uinta National Forests.

Using these methods straw in loaded into cargo nets according to type and capability of aircraft used.

Three rings will be attached to the releasable hard point of the remote hook. The fourth ring will be attached by an approved tether strap to the long line and not to the remote hook cage.

Release of the remote hook by pilot will invert the net, dumping the straw contents. The net will remain attached to the long line by tether strap and returned to straw base for reload.

Strings on the straw bales will be cut after they are loaded into the net. Straw bales will be dropped from 100 feet AGL with appropriated air speed to ensure proper dispersal of straw. Typical airspeeds for dispersal range from 40 - 60 knots at a height of 100 to 150 feet AGL.

In the event the straw bales do not disperse properly with height and airspeed. A "Manitou" (small Kubota-like tractor) used to move bales into the net, will be used to fluff up straw to reduce compaction of straw. To operate the equipment on the straw base, contractor/nonhelitack personnel must be used under full supervision of helitack. These personnel will use proper PPE in accordance to the IHOG on the straw base during helicopter operations.

Straw bales weigh approximately 1,000 pounds each. Nets and 150-foot long line weighs approximately 250 pounds. Two 1,000-pound bales will be flown at a time.

Specifications on Helicopter are 2,500 pound HOG external jettisonable load at 1,500 feet at 30 degrees Celsius. It will be the pilot's responsibility to perform agency helicopter load calculation utilizing appropriate performance charts to ensure maximum weight limitations are not exceeded on aircraft. Payload weight will be documented on agency manifest form.

### Required Personnel

BAER helimulching specialist- Jeff Ridley has been designated in this position. He was involved with San Dimas in the development of this project. He is responsible for aviation project implementation, training helitack crew on equipment and procedures, and be present for technical knowledge when needed.

A fully qualified helicopter manager will be required for helicopter. The helicopter manager is responsible for contract administration of the helicopter and the overall safe operation of the helicopter on the project. He will also manage the safe operation of personnel and crew on the straw base.

Helitack crew. Four personnel will be needed to load and hook nets at straw base. They are responsible for proper loading and hooking of nets for the project.

Contract equipment operators must be used. They are nonagency personnel and are nonhelitack qualified. They are responsible for loading nets under helitack supervision, and for the safe operation of equipment. They will comply with PPE requirements required according to the IHOG for helicopter operations.

Field observers will be utilized for this project to assist clearing of area of personnel, assist in identifying targets with helicopter pilot by radio and record data. Field observers will not be located in the drop areas.

### Aircraft and Pilot

The aircraft and pilot used to complete this project must be carded and approved for external loads, long line, and mountain flying by the appropriated agency.

## Appendix A

---

### Emergency Crash Rescue

Prestablished incident response plans over the project shall be accordance with the Shasta-Trinity Forest Aviation Plan and the aviation mishap response guide. All aviation mishaps will be coordinated through the Redding ECC by forest repeat tone 13.

### Special Considerations and Equipment

Over flights of personnel, populated areas, power lines, boats will not be permitted.

All external load equipment will comply with agency requirements for the specific project outlined. No swivel will be used with long line equipment.

Helicopter and fuel truck will remain overnight at Redding Airport for aircraft security.

### Communications

All key ground personnel shall be equipped with a programmed radio for the project. Flight following to and from Redding Airport to project site with be done through Redding ECC on forest repeat tone 13. Redding ECC will be notified of beginning and end of flight operations and all flight following for the project will be done locally by helitack and will be conducted in 15-minute intervals. If communications are lost with helicopter, operations will stop to communications are reestablished.

Purpose	Frequency Name	Frequency
<b>Redding Dispatch</b>	<b>Redding</b>	<b>rx 171.575 tx 169.100</b>
Flight following.		
Emergencies	tone 13 (Consider Tone 2)	
Local Flight Following		
Air-to-Ground Communications	Air to Ground	170.000 simplex
Ground Communications	Crew Net	168.200 simplex



# Appendix A

---

## Section 3. Contract Example for BAER Helimulching

Spanish Fire, Mendocino National Forest November 2003

### ***PART 1 – THE SCHEDULE***

#### **SECTION C- DESCRIPTION/SPECIFICATIONS/WORK STATEMENT**

##### **C.1 Description of Work:**

The intent of this contract is to secure services for aerial application via helicopter of certified weed free, double chopped rice straw on 143 acres of high intensity burned area to control erosion in areas burned by the Spanish Fire on the Mendocino National Forest.

The contractor will be responsible for furnishing, storing, loading, hooking, and applying straw by helicopter on designated areas.

The contractor shall provide everything-including but not limited to all equipment, supplies, transportation, labor, and supervision necessary to complete the project, except for that which the contract clearly states is to be furnished by the Government.

Work is to be completed by November 10, 2003.

##### **C.2 Licenses and Insurance:**

Due to the urgency of this procurement, the contractor shall provide the documentation required within one day after contract award, except as provided below. If the contractor fails to provide the documentation within this timeframe, the contract may be terminated for default in accordance with Clause 52.249-8.

**Aircraft Inspection:** Helicopter does not need to be USDA Forest Service carded. Prior to award of contract, the prospective bidder may be required to make all aircraft and straw delivery systems available for inspection at a location selected by the Government and agreeable to the prospective bidder. Failure of the bidder to make all aircraft and equipment available for inspection or failure to provide all required equipment, or meet FAA inspection requirements will be cause for rejection of bid or termination of contract.

**Pilot Certification:** Pilot shall be FAA approved FAR 133 and does not need to be USDA Forest Service carded. The prospective bidder shall provide the contracting officer with the names and certifications of all pilots under this contract. Contractor shall provide proof that all pilots are commercially certified by the FAA to operate the aircraft provided for this contract.

**Straw:** The contractor shall provide a certification of weed free straw to contracting officer prior to the start of work.

##### **C.3 Estimated Start Work Date: November 1, 2003**

##### **C.4. Restriction on Work:**

Work may be performed at any time during the period of the contract, except as outlined in this part. Nothing in this part shall be construed to take away any of the Government's rights under the Suspension of Work Clause (52.212-12). Restrictions are as follows:

1. In accordance with the fire plan, if included in Section J.
2. When the contracting officer (or designated representative) determines that adverse weather has made access too dangerous or that continued vehicular travel would cause unacceptable road damage.

## Appendix A

3. All aerial mulching operations will be limited to daylight hours. No aerial mulching before FAA official sunrise and after sunset.
4. Wind speed is greater than 15 miles per hour.

### C.5 Project Location and Description:

**Location:** The project is located on the Mendocino National Forest. The purpose of this project is to mulch 143 acres of high intensity burn areas to protect soil productivity and the potential for flooding, sediment, and debris flows in riparian areas following the destructive aftermath of the Spanish wildfire, which burned over 6,000 acres.

The Spanish fire is situated on the Grindstone Ranger District. All of the fire is located in the Spanish Creek watershed that drains into the Black Butte River, an anadromous fish stream.

Treatment areas will be covered with a continuous layer of straw.

#### **Identified Helispots**

One staging area is available for a helispot. It is located on private land on Bear Wallow Ridge. The USDA Forest Service has landowner permission to use the site. The County Road will remain open during this contract.

Location 1 staging area is on County Road 311.

Lat. 39° 36' 795" Long. 122° 49' 477"

#### **Helimulching Locations**

Area	Acres	Comments
		<b>Apply an even continuous layer of straw at 1.25 tons per acre.</b> <b>Avoid areas where trees have brown or green needles and rock outcrops.</b>
1	16	Unit has two small drainages.
2	20	Two small streams. Start about 100 feet uphill from the main stream.
3	19	Two small streams. Start about 100 feet uphill from the main stream.
4	15	One steep stream channel below road.
5	7	One steep stream channel 150 feet above and below road.
6	7	One steep stream channel 150 feet above and below road.
7	28	From stream confluence upstream to near upper road. Avoid mulching rock outcrops on west side of channel.
8	31	Mulch the main stream and two side streams.

**Description:** The contractor shall apply mulch onto mountainous terrain ranging from 3,600 to 6,000 feet above sea level. Most work will be between 4,800 and 6,000 feet. Winds are subject to local terrain features and may be unpredictable. Mulching units are not well designated on the ground. Exact latitude/longitude coordinates for locations of mulching units are obtainable from the provided work maps. Mulching areas are certain areas in high intensity burns that are not readily identifiable from the air. The contractor, using the map, unit location, and topography will be responsible for mulching unit boundaries and applying straw within those boundaries. USDA Forest Service ground spotters and some red panel markers will aid the pilot in locating the areas.

**Accessibility:** The general location of the project area may be viewed by 2-wheel drive vehicle by traveling Forest Highway 7 to Alder Springs and taking County Road 311 to Bear Wallow Ridge (towards Logan Basin).

Road 21N06 (Markham Ridge road) traverses the middle of the project area.

Units 2 through 7 are accessible by 2-wheel drive high-clearance vehicle. Units 1 and 8 mulching areas are only accessible by foot or by aerial reconnaissance.

## Appendix A

---

### **C.6 Public Safety:**

The contractor shall provide for public safety when operating by installation of warning signs on roads leading to the operation, which shall contain language indicating the type of operation occurring. Warning signs, meeting the Manual of Uniform Traffic Control Devices (MUTCD), shall be posted according to the MUTCD specifications for the given situation so as to be visible to oncoming traffic.

### **C.7 Government Furnish Property and Personnel:**

**Maps** - Topographic maps with firelines and treatment areas as well as photographs will be provided to the successful bidder.

**Radios:** The Government will provide a portable radio capable of communicating on national forest frequencies for each aircraft.

**COR/Inspector:** The Government will supply personnel to administer the contract and count straw bales going to the various locations.

**Spotters:** The Government will provide spotters to observe the locations and spreading of mulch.

**Fire Engine:** A USDA Forest Service fire engine and/or water tender will be at the location for dust control during flight operations.

**Helibase Manager/ Helicopter Manager:** The USDA Forest Service will provide managers for the project.

### **C.8 Contractor Furnished Equipment:**

The contractor shall provide all labor, equipment, and material necessary to load, service and otherwise support the mulching operation at the project site, including the following:

1. All straw required under the terms of this contract.
2. Aircraft pilot(s) and ground crew personnel trained in loading and hooking nets and mulching by aerial application.

**Personnel:** The contractor shall provide pilots that are commercially certified by the FAA to fly aircraft appropriate to this contract. Proof of certification and flight experience shall be supplied to the contracting officer prior to contract award. The contractor is responsible for providing housing, subsistence, and transportation of contractor's personnel to perform all of the operations related to this contract.

It is recommended that those personnel working near the helicopter should wear nomex clothing, hard hats with chin straps, goggles, leather gloves, and 8-inch top leather boots. The pilot should wear nomex clothing and gloves. If necessary, nomex clothing and hardhats with chinstraps could be supplied by the Forest Service. Contractor to notify Bob Faust (530) 934-1152 three days prior to operations of clothing size for pilot and for crewmembers working around the helicopter.

**Helitack crew:** The contractor will provide a helitack crew to secure nets to the helicopter hooks and block the public from the operational area.

**Straw:** The contractor shall supply, for application, certified weed free rice straw. Straw will be finely chopped (double chopped) roughly 5 to 9 inches in length so that releases from cargo nets and spreads evenly.

Straw will meet the following specifications.

1. Rice straw shall be certified weed free by the County Agriculture Department.
2. Straw bales shall be recently baled. No older than 2 months.
3. Straw needs to be flailed chopped twice to produce straw lengths of 5 to 9 inches.
4. Straw shall be baled at a moisture content less than 13 percent.
  - a. Moisture needs to be measured with a moisture gage.

## Appendix A

---

5. Small bales shall be baled at 60 to 70 pounds per bale or large bales at 800 pounds per bale.
6. Straw shall be stacked on dry ground clear of noxious weeds or tarps/plastic.
7. Straw shall be covered if rain is predicted or occurring

**Nets:** Cargo nets need to have webbing with rings on each corner. Net size needs to be larger than 15 feet square.

**Aircraft:** The contractor shall provide helicopters capable of carrying loads in excess of 1,700 pounds and operating at elevations of up to 6,000 feet.

**Radios:** Radios to interface with victor and forest frequencies.

**Straw Application System:** The contractor shall provide a helicopter equipped with a long line and remote hook, 15 by 15 feet or larger flat 4-point nets (retrievable net system), and necessary rigging. Multiple hooks are necessary to open one net at a time.

**Fuel Truck:** FAA approved fuel supply truck. Operator shall have an external load Class B endorsement.

### C.9 Technical Requirements/Work Method:

**Personnel:** The contracting officers representative has the authority to require the contractor to replace any pilot that fails to carry out the specifications of the contract or is operating aircraft or conducting operations in an unsafe manner.

**Helibases and/or Landings Sites:** The contractor shall be responsible for improving helibases and/or landing sites prior to treatment. The Government shall provide maps of approved heliports and landing sites in the area. Any repairs or rehabilitation of the sites shall be the responsibility of the contractor.

The contractor is responsible for removal and disposal of all debris, which result from the contractors operations. This shall consist of; (but not limited to) baling twine, spilled straw at loading sites or otherwise, pallets and other debris resulting from the mulching operations.

The contractor shall supply a sanitation unit.

The contractor is responsible for all cost incidental to the equipment move-in and move-out.

**Straw:** Receipts from the straw vendor reflecting tons of straw sold must be presented to the contracting officers representative prior to application. The straw shall be delivered in a manner to facilitate even application and capable of extended storage on site for up to several days under variable weather conditions.

The contractor at its own expense shall replace straw not accepted by the Government.

**Straw Delivery and Staging Area:** Straw shall be delivered to the selected staging area. The contractor shall supply a squeeze and operator to unload and stack straw. Onsite straw must be protected from rain and not have a moisture content greater than 13 percent. Straw will not be spread if it is wet.

**Aircraft:** The contractor shall provide helicopters capable of carrying out the terms of the contract. The aircraft shall have the capability of efficiently lifting and operating at speed, and at the altitudes described in C.5. Helicopters should be type II (medium) or equivalent with the same capability.

Helicopters shall be equipped (provided by the contractor) with electronic navigation equipment (GPS) to locate the units. Swath spacing may be done by GPS or visually by the helicopter pilot.

Helicopters shall be equipped with radio communications, air to ground, and shall be maintained during flight operations. The contractor shall provide radio communications equipment in each aircraft for air-to-air communications. The USDA Forest Service will provide a portable radio for air to ground communications with USDA Forest Service personnel. Each aircraft shall also have separate equipment (contractor furnished) for communication between the pilot and the contractors ground personnel.

Contractors operations shall meet industry standards, the approved project aviation safety plan, and the Sequoia National Forest Aviation Management Plan.



## Appendix A

---

The Government or their agent(s) will investigate any accident. Any aircraft involved in any accident shall be deemed to be in sole control of the government and/or its designated agent(s). Access to the accident/incident site and/or aircraft shall be by approval of the contracting officer or designated representative only.

Accidents shall mean destruction or substantial damage to aircraft components and any injury to personnel as defined by the National Transportation Safety Board (NTSB).

Serious incidents shall mean any air to ground mishap, malfunction, or situation involving aircraft or personnel, which results in a deviation from standard procedures and has the potential for resulting in an accident, injury or death.

All wreckage and equipment, which might be involved in an accident related to this contract, shall be under the control of the contracting officer or other persons or agencies designated by the contracting officer until released. Aircraft or pilots involved in any serious incident or accident are suspended from further use until released by the contracting officer.

The contractor agrees to fully cooperate in any investigation and to provide any needed records, statements, or parts in the investigation of any accident of serious incident.

If the Government deems it necessary to disassemble any of the aircraft or its components to detect probable cause of the accident, the Government will be responsible for any costs for disassembling. The contractor will be responsible for any costs involved in reassembly and approval for return-to-service of any item disassembled by the Government.

**Straw Application System:** The contractor shall provide a helicopter equipped with a 50-foot to 150-foot long-line incorporating an electrically operated remote hook.

Flat, 15- by 15-foot or larger, 4-point cargo nets (no self tightening purse strings) capable of loads in excess of 1,500 pounds. Hook carousel need to accommodate 2 to 4 nets. Straw will be spread by releasing one half of the cargo net while flying over firelines and slope units.

Speed and altitude of the helicopter will be dependent on the slope of the land to get adequate straw coverage on the soil. Generally the helicopter will be flying about 200 feet above the ground and at a speed of 30 to 50 miles per hour.

Rigging to allow three of the four points to be released and forth point remaining attached to remote hook or cage.

Initial calibration of the system will be conducted with Government oversight. Test flights measuring straw coverage will be required to obtain the correct calibration for the coverage depth and swath width. All calibration flights shall be at the contractors expense.

**Application Rate Monitoring:** The USDA Forest Service will provide personnel to monitor the location and application rate of treatment. Monitors will need to be able to communicate with the helicopter pilot.

**Mulch Application:** Sequence of areas to be treated and timing for treatment will be determined by the contractor and agreeable to the contracting officer and contracting officer representative. All mulching operations will be limited to daylight hours. No mulching before FAA sunrise or after sunset. Pilots will be restricted to 8 hours of actual flying time per calendar day.

The contracting officer or the COR will use the following criteria to determine when spreading operations will cease.

1. Wind velocity seriously affects normal spreading patterns.
2. Fog, rain or snow making visual inspections inadequate.
3. Surface runoff from rain is excessive.
4. Air turbulence (thermal updrafts, etc.) seriously affects normal spreading patterns.
5. Application being performed under inadequate light conditions.
6. Radio communications not working properly.

## Appendix A

---

7. Rate of application, calibration or coverage are inadequate as determined by the contracting officer or contracting officer representative.
8. The pilot-in-command determines flying conditions are beyond control of the pilot or aircraft capability.

### **IMPORTANT – PLEASE NOTE THE FOLLOWING DISCLAIMER:**

**NOTE:** “It is not the government’s intent to infer, refer, or influence preferences of sources provided. The following list of known sources is provided for informational purposes only and solely due to the urgency of this procurement.”

#### ***Known Straw Suppliers***

Thad Rodgers: Ph (530) - Fax: (530) 934-2445

Joe Carrancho: Ph (530)438-2518 - Fax (530)438-2514

Rick Green (530)934-7225 - Fax (530)934-9666

Ron Kampschmidt (530)934-4500 - Fax (530)934-9575

#### ***Known Helicopter Services***

PJ Helicopters: Ph (530)527-5059 – Fax: (530)527-1730

West Wind Helicopters: Ph (916)645-8117 - Fax: (916)645-9479

Rogers Helicopters: Ph (559)299-4903 - Fax (599)292-5240

Redding Air Service: Ph (530)221-2851

A&P Helicopter: Ph (530) 742-4119

Appendix A

---

Section 4.  
Straw Delivery Accounting Form

Contract Number	Driver	Date	Time	Est. Weight	Weight Tag #	Received By	Remarks



## Appendix B

---

### BAER Treatments Sample Contract Specifications

#### Storm Inspection Response

##### **Work Statement**

Storm inspection/response keeps culvert and drainage structures functional by cleaning sediment and debris from the inlet between or during storms. This work will be accomplished through equipment rental and general labor.

A Storm Patrol unit shall consist of at a minimum two persons in a 4 by 4 vehicle with shovels, chainsaws, winch, and other equipment necessary to clear culverts, restore drainage function, and provide needed access. Available to the storm patrol unit is mechanized equipment with operators that can open plugged culverts, move material from the road, and restore drainage function beyond what can be done with hand tools.

##### **SPS 151(01) Mobilization**

**Description** incorporate 151.01, add the following: Contractors shall be capable of responding with one Storm Patrol Unit within 12 hours of the initial request of the contracting officer.

**Measurement** incorporate 151.02

**Payment** incorporate 151.03, lump sum (ls).

##### **SPS 622(01) Rental Equipment Backhoe w/Operator, Extend-a-Hoe, 4x4**

##### **SPS 622(02) Rental Equipment Dump Truck**

##### **SPS 622(03) Rental Equipment Excavator**

##### **SPS 622(04) Rental Equipment D6 Dozer**

##### **SPS 622(05) Rental Equipment Lowboy**

##### **SPS 622(06) Rental Equipment Service Truck**

**Description** incorporate 622.01,

**Construction Requirements** incorporate 622.02 and add the following:

- a. Locations of drainage failures, possible failures, and washouts shall be reported to the contracting officer.
- b. Plugged drainage structures shall be cleared with hand equipment or mechanically, when it is possible to do so in a safe manner.
- c. Patrolling of roads and clearing drainage structures shall be accomplished in a manner that does not damage the surface of the roads being patrolled, or the drainage structures being maintained.
- d. Personnel assigned to storm patrol shall have contact with the contractor by mobile phone or mobile radio.
- e. The patrol unit shall identify to the contracting officer, problem areas that will require additional heavy equipment to restore proper drainage function.

**Measurement** incorporate 622.02

**Payment** incorporate 622.05 by the hour (hr.)

##### **623(01) General Labor-Laborer**

##### **623(02) General Labor-Laborer, chainsaw with operator**

**Description** reference 623.01

**Measurement** reference 623.02

**Payment** incorporate 623.05, by the hour (hr.)

## Appendix B

---

### **Culvert Modification**

#### **Work Statement**

Culvert modification replaces fire-damaged culverts or upgrades culvert flow for increased capacity or passage of debris expected as a result of the fire. Modifications include upgrading culvert size, attaching metal-end-sections, or placing risers on culvert inlets.

#### **203(01) Removal of Structures and Obstructions-Culvert upgrade/replacement remove CMP 18-36inch**

#### **203(02) Removal of Structures and Obstructions-Culvert upgrade/replacement remove CMP > 36 inch**

**Description** incorporate 203.01

**Material** incorporate 203.02

**Construction Requirements** incorporate 203.04 Remove Material, and 203.05 (a) disposing of material.

**Measurement** incorporate 203.07

**Payment** incorporate 203.08, each (ea).

#### **602(01) Culverts and Drains-Culvert upgrade/replacement Aluminum 36 in-48 in.**

#### **602(02) Culverts and Drains-Culvert upgrade/replacement Aluminum >48**

**Payment** incorporate 602.10, meter (m).

#### **602(03) Culverts and Drains-Culvert Modification Metal end section 18-36 inch**

#### **602(04) Culverts and Drains-Culvert Modification Metal end section >36 inch**

**Payment** incorporate 602.10, each (ea).

#### **SPS 602(05) Culverts and Drains-Riser/elbow, small 36 inch or less**

#### **SPS 602(06) Culverts and Drains-Riser/elbow, large 36 inch or greater**

**Description** This work shall consist of the construction and installation of corrugated metal pipe risers with steel grate covers on existing culverts.

**Materials** incorporate 602.02.

**Construction Requirements** Corrugated metal pipe risers shall be fabricated to the dimensions specified in writing and be of the same type of material and shall have the same coatings as the culvert on which they are to be placed. Corrugated metal pipe risers inlets are fabricated with a stab of the same diameter and material of the existing culvert welded onto the riser and connected to the existing pipe with a collar as shown on the drawings. This weld shall be cold galvanized to prevent corrosion. The stab is welded perpendicular to the riser unless otherwise specified by the engineer in writing. When joining pipes to inlet structures ensure existing pipe is free from damage (i.e. dents) before coupling to the riser. Damage to existing inlets at sites ordered for installing corrugated metal pipe risers will be repaired by the contractor and is an incidental cost to this section.

**Measurement** incorporate 602.09

**Payment** incorporate 602.10, each (ea).

#### **SPS 602(07) Culverts and Drains-Riser pipe extension, small 36 inch or less**

#### **SPS 602(08) Culverts and Drains-Riser pipe extension, large 36 inch or greater**

**Description** Riser pipe extensions are attached to the riser/elbow extending vertically to the designated height. Riser pipes function to sieve debris and allow passage of water. The steel grate cover is attached to the top of the riser pipe extension.

**Material** incorporate 602.02, and 725.12 Frames, Grates, Covers, and Ladder Rungs.

**Construction Requirements** Riser pipe extensions should be 1-foot lower than the fill height. Riser pipe extensions should be perforated with 6 holes per foot of riser height at 6-inch diameter each or as directed by the contracting officer. For riser extensions greater than 8 feet in height, backfill for riser stability as directed by the contracting officer

**Measurement** Incorporate 602.09.

**Payment** Incorporate 602.10, meter (m).

## Appendix B

---

### Debris Rack / Debris Deflector

#### **Work Statement**

A debris rack is a structure placed across the stream channel to collect the debris before it reaches the culvert entrance. Debris racks are constructed with driven piles of various materials including steel H-piles and steel pipe. The design and configuration of the driven piles and appurtenances shall be to the dimensions specified in writing or as shown in the drawings.

Debris deflectors are V-shaped structures with the apex pointed upstream. Deflectors function by diverting medium and large floating debris and large rocks from the culvert inlet to accumulate in a storage area where debris is removed after the flood subsides. Deflectors are constructed with driven piles of various materials including steel H-pipes and steel pipe. The design and configuration of the driven piles and appurtenances shall be to the dimensions specified in writing or as shown in the drawings.

#### **551(01) Driven Piles, Steel H-Piles**

#### **551(02) Driven Piles, Steel Pipe**

**Description** Incorporate 551.01

**Material** Incorporate 551.02

**Construction Requirements** Incorporate 551.03

**Measurement** Incorporate 551.04

**Payment** Incorporate 551.05 meters (m).

#### **SPS 555(01) Steel Structures**

**Description** Incorporate 555.01. This work involves the assembly and welding of the debris structures.

**Material** Incorporate 555.02

**Construction Requirements** Incorporate 555.03 General, 555.14 Welded Connections, 555.18 Welding. Furnish, fabricate and erect the structure as shown in the drawings and at the locations staked on the ground.

**Measurement** Incorporate 555.21

**Payment** Incorporate 555.22 lump sum (ls).

### Low-Water Stream Crossings

#### **Work Statement**

Low-water stream crossings are used to replace culverts where the risk of damage to the culvert, road fill, or access is increased due to the effects of the fire. The low-water stream crossing (natural ford) conforms to the streambed or the designed crossing elevation above the streambed once the culvert is removed.

#### **203(04) Removal of Structures and Obstructions-Remove CMP < 36 inch**

#### **203(05) Removal of Structures and Obstructions-Remove CMP >36 inch**

**Description** incorporate 203.01

**Material** incorporate 203.02

**Construction Requirements** incorporate 203.04 Remove Material, and 203.05 (a) disposing of material.

**Measurement** incorporate 203.07

**Payment** incorporate 203.08, each (ea)

#### **SPS 204(01) Excavation and Embankment –Low-water stream crossing**

**Description** This work includes the excavation of existing fill material at the stream crossing, while providing a vertical alignment that accommodates the design vehicle for the road.

**Construction Requirements** Suitable excavated material shall be incorporated in the roadway on either side of the crossing. Excess excavated material shall be hauled to a designated disposal area under pay item 622(02).

**Measurement** Incorporate 204.16(a) roadway excavation

**Payment** incorporate 204.17 cubic meter (m<sup>3</sup>)

## Appendix B

---

### **SPS 209(01) Structure excavation and Backfill –Low-water stream crossing**

**Description** This work includes the excavation for the low-water crossing endwall within and adjacent to the stream channel, as staked on the ground by the engineer.

**Construction Requirements** incorporate 209.03 Preparation for structure excavation, 209.04 General, 209.05 Channel Preservation, 209.07 Dewatering, and 209.08 Foundation preparations.

**Payment** Measure for payment under 252 (01) Special Rock Embankment and Rock Buttress.

### **251(01) Riprap**

**Description** This work consists of furnishing and placing riprap in the construction of the low-water stream crossing. Incorporate 251.01.

**Material** Incorporate 251.02

**Construction Requirement** Incorporate 251.03 General, 251.04 Placed riprap, and 251.05 keyed riprap.

**Measurement** Incorporate 251.08

**Payment** Incorporate 251.09 cubic meters (m<sup>3</sup>)

### **SPS 252(01) Special Rock Embankment and Rock Buttress –Low-water stream crossing**

**Description** This work consists of furnishing and placing rock keyed into the channel bottom (for endwall) to provide support for the road and riprap above.

**Construction Requirements** Place rock in a stable orientation, ensure all rocks are braced against other rocks and set at the appropriate elevation.

**Measurement** Incorporate 252.05

**Payment** Incorporate 252.06 cubic meter (m<sup>3</sup>).

### **253(01) Gabion and Revetment**

**Description** Gabion structures are for endwall construction and erosion resistant splash pad.

**Materials** Incorporate 253.02

**Construction Requirements** Incorporate 253.03 General, 253.04 Basket Assembly, 253.05 Structure Erection, 253.06 Cell filling, and 253.07 Backfilling.

**Measurement** Incorporate 253.10

**Payment** Incorporate 253.11, cubic meter (m<sup>3</sup>)

### **622(01) Rental Equipment-Dump Truck with operator (min 10 yd capacity, and suitable for hauling boulders).**

**Description** This work includes the hauling of excess material from low water stream crossing site to designated disposal area.

**Payment** Incorporate 622.05, hourly (hr)

## **Surface Drainage Structures**

### **Work Statement**

Surface drainage treatments include outsloping of the road prism or placing rolling dips in the road prism. Both treatments are intended to disperse water and reduce erosion while directing runoff to stable areas. Untreated aggregate is placed on rolling dips to prevent rutting.

### **201(01) Clearing and Grubbing**

**Description** Incorporate 201.01

**Construction Requirements** 201.03 General, 201.04 Clearing, 201.05 Grubbing, and 201.06 Disposal

**Payment** Incorporate 201.09, square meters (m<sup>2</sup>)

### **SPS 204(02) Excavation and Embankment-Outsloping**

**Description** Perform excavation and embankment to change an insloped road to an outsloped road.

**Materials** Incorporate 204.03

**Construction Requirements** Re-shape the roadbed as SHOWN ON THE DRAWINGS. During excavation and embankment, reshape the roadway to 4-percent outslope unless otherwise designated in writing.



## Appendix B

---

Incorporate 204.04 Preparation for roadway excavation and embankment construction, 204.06(a) roadway excavation, 204.10(a) General embankment construction, 204.10(b) embankment within the roadway prism. For the purposes of compaction, operate hauling and spreading equipment uniformly over the full width of each layer. Ensure material is at a moisture content suitable to obtain a mass that will not visibly deflect under the load of the hauling and spreading equipment.

**Measurement** Incorporate 204.16(a) Roadway excavation

**Payment** Incorporate 204.17 cubic meter (m<sup>3</sup>)

### **SPS 204(03) Excavation and Embankment-Rolling Dip**

**Description** Perform excavation and embankment to change the vertical alignment of the road thru the dip to intercept and direct water off the road. Dips must be constructed to provide access for passenger vehicles.

**Construction Requirements** Dip shall be constructed with a skew angle as designated in writing and staked on the ground. Typical angle is 15 degrees. The typical dimensions for dip excavation are shown on the drawings. Outslope the dip at 4 percent unless otherwise designated in writing. Incorporate 204.10(a) General embankment construction, 204.10(b) embankment within the roadway prism

**Measurement** Incorporate 204.16(a) Roadway excavation

**Payment** Incorporate 204.17, each (ea).

### **301(01) Untreated Aggregate Courses**

**Description** Incorporate 301.01

**Materials** Incorporate 301.02

**Construction Requirements** Incorporate 301.03 General, 301.04 Mixing and Spreading, 301.05 Compacting.

**Measurement** Incorporate 301.09

**Payment** Incorporate 301.10, ton.

### **Grade Stabilizer**

#### **Work Statement**

Grade stabilizers are used to prevent channel incision and downcutting. Grade stabilizers provide grade control to stream channels that may become destabilized from increased storm runoff and velocities. Grade stabilizers require excavation across a stream channel to place rocks or other material (logs or wood) at grade.

### **SPS 209(02) Structure Excavation**

**Description** This work includes excavating a trench across the stream channel, in which rocks are placed so that the top of the rocks are at stream grade.

**Construction Requirements** Incorporate 209.03 Preparation for structure excavation, 209.04 General, 209.05 Channel Preservation, 209.07 Dewatering, 209.08 Foundation preparations.

**Payment** No separate payment will be made for this item. Measure for payment under 252(02) Special Rock Embankment and Rock Buttress.

**SPS 252(02) Special Rock Embankment and Rock Buttress** This work consists of furnishing and placing rock keyed into the channel bottom and adjacent area to stabilize stream channel.

**Construction Requirements** Place rock in a stable orientation, ensure all rocks are braced against other rocks and set at the appropriate elevation.

**Measurement** Incorporate 252.05

**Payment** Incorporate 252.06 cubic meter (m<sup>3</sup>).

### **Road Decommissioning**

#### **Work Statement**

Road decommissioning includes subsoiling (tilling), restoring original hillslope conditions with recontouring of the road fill, restoring drainage through the road prism and reducing hillslope erosion. Road decommissioning

## Appendix B

---

is performed on unclassified roads less than 20 feet in width. This work typically requires use of an excavator and or dozer with rippers to pull material into the road and break through compacted soil layers improving infiltration.

### **211(01) Roadway Obliteration**

**Description** Incorporate 211.01 Method 1.

**Construction Requirements** Incorporate 211.02(b) non-rigid material, 211.03 Waterbars and Barriers.

**Payment** Incorporate 211.06, meters (m).

### **Soil Scarification**

#### **Work Statement**

Soil scarification reduces overland flow and erosion by increasing infiltration and creating surface roughness. Water repellant layers are broken down with scarification using mechanized equipment on slopes up to 25 percent. Scarification depth varies with depth and extent of water repellant layers.

### **SPS 622(04) Rental Equipment -D6 Dozer w/Operator, with standard ripper**

**Description** This work involves scarification on the contour with 1-3 rippers depending on site conditions (i.e. brush, downed material, rock).

**Construction Requirements** The configuration of rippers and distances between passes on the contour will be determined by contracting officer.

**Payment** Incorporate 622.05 hourly (hr).

### **Protective Fencing and Barriers**

#### **Work Statement**

Protective fencing and barriers include a variety of methods; gates, fences, boulders, jersey barriers, and logs. The type of fence or barrier selected depends on the access permitted and the size of the area.

### **618(01) Concrete Barrier**

**Description** This work involves placement of precast concrete barriers (jersey barriers) at designated sites to prevent vehicle access and for structure protection.

**Construction Requirements** Incorporate 618.04(c) Precast

**Payment** Incorporate 618.10 each (ea).

### **619(01) Gate**

**Description** This work involves installing gates at designated sites to prevent vehicle access.

**Material** Incorporate 619.02

**Construction Requirements** Incorporate 619.03 Fences and Gates (a) General, 619.03 (c) Wire fences and Gates (5) Gate installation (b) metal gates.

**Payment** Incorporate 619.11 each (ea).

### **619(02) Barb Wire fence**

**Description** This work involves installing barb wire fences to protect recovery of vegetation.

**Material** Incorporate 619.02

**Construction Requirements** Incorporate 619.03 Fences and Gates (a) General, 619.03 (c) Wire fences and Gates (3) Barbed wire and woven wire, (4) Fastening barbed wire and woven wire.

**Payment** Incorporate 619.11 meter (m).

### **619(03) Temporary plastic fence**

**Description** This work involves installing temporary plastic fence at designated sites. **Material** Incorporate 619.02

## Appendix B

---

**Construction Requirements** Incorporate 619.03 Fences and Gates (a) General, 619.06 Temporary fences  
**Payment** Incorporate 619.11 meter (m).

### **SPS 622(05) Rental Equipment-Dump Truck w/Operator (Min 10-yard Capacity, and suitable for hauling boulders)**

**Description** This work involves the hauling of boulders to serve as barriers. Boulders will vary in size, typically no larger than 1.5 meters in the longest dimension.

**Payment** Incorporate 622.05, hourly (hr).

### **SPS 622(06) Rental Equipment-Backhoe w/Operator, Extend-A-Hoe, 4 by 4 (clamshell bucket for gathering and placement of boulders)**

**Description** This work entails the gathering and placement of boulders at designated sites and as shown on the drawings.

**Construction Requirements** Boulders should be placed 1-meter apart, unless otherwise specified in writing. Barriers shall span the entire travel way and beyond as designated in writing and staked on the ground. Boulders should be buried 0.25-0.50 meters in the ground or as designated in writing.

**Payment** Incorporate 622.05, hourly (hr).

## **Facility Safety Work**

### **Work Statement**

Facility safety work includes replacing traffic control signs, delineators, and other safety signs where hazards to the public may exist.

### **633(01) Permanent Traffic Control-Delineators**

**Description** Incorporates 633.01

**Materials** Incorporates 633.02

**Construction Requirements** incorporate 633.03 General, 633.06 Delineators and Object Markers.

**Measurement** Incorporate 633.09(a) for Delineators, each

**Payment** Incorporate 633.10 delineators, each (ea)

### **633(02) Permanent Traffic Control-Traffic Control Signs**

**Description** Incorporates 633.01

**Materials** Incorporates 633.02

**Construction Requirements** incorporate 633.03 General, 633.04 Supports, 633.05 Panels.

**Measurement** Incorporate 633.09(b) for Traffic Control signs and sign systems.

**Payment** Incorporate 633.10 traffic control signs, meters squared (m<sup>2</sup>).

### **635(01) Temporary Traffic Control-Barricades**

**Description** This work consists of furnishing, maintaining, relocating, and removing temporary traffic control devices (barricades) for the protection of the public.

**Materials** Incorporate 635.02.

**Construction Requirements** 635.03 General, 635.05 Barricades

**Measurement** Incorporate 635.26 meter of barricade width.

**Payment** Incorporate 635.27 meter of width (m).

## **Overflow Structures**

### **Work Statement**

Overflow structures are used on roads to control runoff across the road prism and to protect the road fill. Overflow structures include armored rolling dips, and imbricated (overlapped) rock-level spreader. Both treatments protect the road fill with an armored spillway.

## Appendix B

---

### **SPS 204(04) Excavation and Embankment-Armored Rolling Dip**

**Description** Perform excavation and embankment to change the vertical alignment of the road at the road stream crossing to direct water across the road. Dips must be constructed to provide access for passenger vehicles.

**Construction Requirements** Dip shall be constructed as designated in writing and staked on the ground. Dips should be constructed to carry the expected stream volume. The typical dimensions for dip excavation are shown on the drawings. Incorporate 204.10(a) General embankment construction, 204.10(b) embankment within the roadway prism

**Measurement** Incorporate 204.16(a) Roadway excavation

**Payment** Incorporate 204.17, each (ea).

### **301(02) Untreated Aggregate Courses-Armored Rolling Dip**

**Description** Incorporate 301.01

**Materials** Incorporate 301.02

**Construction Requirements** Incorporate 301.03 General, 301.04 Mixing and Spreading, 301.05 Compacting.

**Measurement** Incorporate 301.09

**Payment** Incorporate 301.10, ton.

### **251 (02) Riprap-Armored Rolling Dip**

**Description** This work consists of furnishing and placing riprap in the construction of the spillway for the armored rolling dip. Incorporate 251.01.

**Material** Incorporate 251.02

**Construction Requirement** Incorporate 251.03 General, 251.04 Placed riprap, and 251.05 keyed riprap.

**Measurement** Incorporate 251.08

**Payment** Incorporate 251.09 cubic meters (m<sup>3</sup>)

### **SPS 252(03) Special Rock Embankment and Rock Buttress –Imbricated rock level spreader**

**Description** The imbricated rock level spreader is an overflow device that is keyed into the toe of the fill and includes an overlapping stair stepped spillway up to the road.

**Construction Requirements** Place rock in a stable orientation, ensure all rocks are braced against other rocks and set at the appropriate elevation as shown on the drawings and staked on the ground.

**Measurement** Incorporate 252.05

**Payment** Incorporate 252.06 cubic meter (m<sup>3</sup>).

### **253 (02) Gabions and Revet Mattresses-Gabions**

**Description** Gabion structures can be used to construct overflow structure spillways when large boulders are not readily available.

**Materials** Incorporate 253.02

**Construction Requirements** Incorporate 253.03 General, 253.04 Basket Assembly, 253.05 Structure Erection, 253.06 Cell filling, and 253.07 Backfilling.

**Measurement** Incorporate 253.10

**Payment** Incorporate 253.11, cubic meter (m<sup>3</sup>)

### **Catchment Basin Cleanout**

#### **Work Statement**

Catchment-basin cleanout is used to remove organic debris and sediment immediately in front of culverts, bridges, and other road drainage structures. Material is removed and placed in the designated disposal area.

**622(07) Rental Equipment-Backhoe w/operator**

**622(08) Rental Equipment-Dump truck w/driver**

**622(09) Rental Equipment-Excavator w/operator**

**622(10) Rental Equipment-Dozer w/operator**

## Appendix B

---

### 622(11) Rental Equipment-Service Truck, 4by 4

### 623(03) General Labor-Laborer w/24in chainsaw

### 623(04) General Labor-Laborer

**Description** This work involves the use of any combination of the specified equipment to clean out the catchment basin.

**Construction Requirements** The contracting officer will describe in writing the limits of work areas, areas to be protected, and those areas will be staked on the ground.

**Measurement** incorporate 622.02

**Payment** incorporate 622.05 by the hour (hr.)

## Erosion Control

### **Work Statement**

Erosion control treatments vary depending on the site conditions. Treatments reduce overland flow, foster infiltration, and trap sediment (silt fence, fiber rolls).

### **SPS 157(01) Soil Erosion Control – Hydromulch**

**Description** This work consists of application of hydromulch as a BAER stabilization treatment. Hydromulch refers to fiber mulches; soil stabilizers that when mixed with water and applied to the soil surface form a matrix that helps reduce erosion.

**Materials** Incorporate 713.05 (g) Bonded fiber matrix hydromulch or (h) recycled pulp fiber.

**Construction Requirements** Incorporate 157.03 General, and 157.11 Temporary Turf Establishment. Provide temporary erosion control measures to minimize erosion and sedimentation according to the BAER implementation plan specifications for application rate. Section 107, and Section 157.03.

**Measurement** Incorporate 157.15. Measure hydromulch application by the square meter on the ground surface.

**Payment** Incorporate 157.16 square meter (m<sup>2</sup>).

### **SPS 157(02) Soil Erosion Control –Mulch (Straw)**

**Description** This work consists of application of mulch (straw) as a BAER stabilization treatment. Mulch straw may be from any cereal grain that is certified weed free. **Materials** Incorporate 713.05 (a) Straw.

**Construction Requirements** Incorporate 157.03 General. Apply straw mulch in areas designated in writing at an application rate of 2,700 kilograms per hectare (2,000 pounds per acre). Method of application may be hand spreading or placing with mulch blower equipment.

**Measurement** Measure straw mulch application by the square meter on the ground surface.

**Payment** Incorporate 157.16 square meter (m<sup>2</sup>).

### **SPS 157(03) Soil Erosion Control – Silt Fence**

**Description** This work consists of furnishing, constructing, and maintaining temporary silt fences as a BAER stabilization treatment.

**Material** Incorporate 157.02

**Construction Requirements** Incorporate 157.03 General, 157.05 Filter barriers. Provide temporary erosion control measures to minimize erosion and sedimentation according to the BAER implementation plan, Section 107, and Section 157.03.

**Measurement** Incorporate 157.15

**Payment** Incorporate 157.16, meters (m).

### **SPS 157(04) Soil Erosion Control – Fiber Roll/wattles**

**Description** This work consists of furnishing, constructing, and maintaining fiber rolls/straw wattles as a BAER stabilization treatment.

**Construction Requirements** Incorporate 157.03 General. Provide temporary erosion control measures to minimize erosion and sedimentation according to the BAER implementation plan, Section 107, and Section 157.03.

**Measurement** Incorporate 157.15

**Payment** Incorporate 157.16, meters (m).

## Appendix B

---

### **629(01) Rolled Erosion Control Products and Cellular Confinement Systems-Erosion mat**

**Description** This work consists of furnishing, constructing, and maintaining rolled erosion control products as a BAER stabilization treatment. Incorporate 629.01.

**Material** Incorporate 629.02

**Construction Requirements** Incorporate 629.03 General.

**Measurement** Incorporate 629.08

**Payment** Incorporate 629.09, square meter (m<sup>2</sup>)

### **Hazardous Material Removal**

#### **Work Statement**

Hazardous material removal is the removal of hazardous materials in accordance with federal, state and local regulations for disposal.

### **203(06) Removal of Structures and Obstructions- Hazardous Material**

**Description** This work consists of removing and disposing of hazardous materials.

**Construction Requirements** Incorporate 203.05 Disposing of Material, (d) Hazardous material.

**Payment** Incorporate 203.08, lump sum (ls).

### **Streambank Armoring**

#### **Work Statement**

Streambank armoring is the placement of rock along the streambank to reduce erosion. Armoring may include the placement of boulders, riprap, or gabion baskets.

### **SPS 204(05) Excavation and Embankment-Streambank Armoring**

**Description** Perform excavation and embankment to change the vertical alignment of the road at the road stream crossing to direct water across the road. Dips must be constructed to provide access for passenger vehicles.

**Construction Requirements** Dip shall be constructed as designated in writing and staked on the ground. Dips should be constructed to carry the expected stream volume. The typical dimensions for dip excavation are shown on the drawings. Incorporate 204.10(a) General embankment construction, 204.10(b) embankment within the roadway prism

**Measurement** Incorporate 204.16(a) Roadway excavation

**Payment** Incorporate 204.17, each (ea).

### **SPS 252(03) Special Rock Embankment and Rock Buttress-Streambank Armoring**

**Description** The streambank armor is keyed into the streambank and channel to reduce erosion.

**Construction Requirements** Place rock in a stable orientation, ensure all rocks are braced against other rocks and set at the appropriate elevation as shown on the drawings and staked on the ground.

**Measurement** Incorporate 252.05

**Payment** Incorporate 252.06 cubic meter (m<sup>3</sup>).

### **SPS 253(03) Gabions and Revet Mattresses-Gabions**

**Description** Gabion structures can be used to armor streambanks when large boulders are not readily available.

**Materials** Incorporate 253.02

**Construction Requirements** Incorporate 253.03 General, 253.04 Basket Assembly, 253.05 Structure Erection, 253.06 Cell filling, and 253.07 Backfilling.

**Measurement** Incorporate 253.10

**Payment** Incorporate 253.11, cubic meter (m<sup>3</sup>)

## Appendix B

### PART I – THE SCHEDULE

#### SECTION B – SERVICES AND PRICES

#### BAER

#### Emergency Stabilization Treatments

#### B-1 – SCHEDULE OF ITEMS

Item No.	Description	Unit	Estimated Quantity	Unit Price	Amount
<b>Storm Inspection Response</b>					
SPS 151(01)	Mobilization per project area (per season)	Lump Sum			
SPS 622(01)	Rental equipment-backhoe w/operator, Extend-A-Hoe, 4 by 4	hr			
SPS 622(02)	Rental equipment-dump truck w/operator (Min 10-yard capacity, and suitable for hauling boulders)	hr			
SPS 622(03)	Rental equipment-excavator w/thumb and operator (Cat 325 or equiv.)	hr			
SPS 622(04)	Rental equipment-D6 dozer w/operator or equivalent	hr			
SPS 622(05)	Rental equipment-truck tractor lowboy w/operator (capable of hauling largest equipment listed)	hr			
SPS 622(06)	Rental equipment -service truck, 4 by 4	hr			
623(01)	General labor-laborer(s) (Note: Laborer shall be paid at the rate defined in the wage determination)	hr			
623(02)	General labor-chainsaw w/operator	hr			
<b>Culvert Modification</b>					
203(01)	Removal of structures and obstructions-culvert upgrade/replacement remove CMP 18-36 inch	ea			
203(02)	Removal of structures and obstructions-culvert upgrade/replacement remove CMP >36 inch	ea			
602(01)	Culverts and drains-culvert upgrade/replacement aluminum 36-48 inch	meter			
602(02)	Culverts and drains-culvert upgrade/replacement aluminum > 48 inch	meter			
602(03)	Culverts and drains-culvert modification metal end section 18-36 inch	ea			
602(04)	Culverts and drains-culvert modification metal end section >36 inch	ea			
SPS 602(05)	Culverts and drains-riser/elbow, small 36 inch or less	ea			
SPS 602(06)	Culverts and drains-riser/elbow, large 36 inch or greater	ea			
SPS 602(07)	Culverts and drains-riser pipe extension, small 36 inch or less	meter			
SPS 602(08)	Culverts and drains-riser pipe extension, large 36 inch or greater	meter			





## Appendix B

PART I – THE SCHEDULE  
SECTION B – SERVICES AND PRICES  
**BAER**  
**Emergency Stabilization Treatments**

**B-1 – SCHEDULE OF ITEMS**

Item No.	Description	Unit	Estimated Quantity	Unit Price	Amount
<b>Debris Rack Debris Deflector</b>					
551(01)	Driven piles, steel H-piles	meter			
551(02)	Driven piles, steel pipe	meter			
SPS 555(01)	Steel structures	Lump sum			
<b>Low Water Stream Crossings</b>					
203(04)	Removal of structures and obstructions-remove CMP<36 inch	ea			
203(05)	Removal of structures and obstructions-remove CMP>36 inch	ea			
SPS 204(01)	Excavation and embankment –low water stream crossing(LWSC)	m <sup>3</sup>			
SPS 209(01)	Structure excavation and backfill -LWSC	m <sup>3</sup>			
251(01)	Rip rap -LWSC	m <sup>3</sup>			
SPS 252(01)	Special rock embankment and rock buttress - LWSC	m <sup>3</sup>			
253(01)	Gabion and revetment (for endwall and erosion resistant splash pad)	m <sup>3</sup>			
622(02)	Equipment rental-dump truck w/operator (Min 10- yard capacity, and suitable for hauling boulders)	hr			
<b>Surface Drainage Structures</b>					
201(01)	Clearing and grubbing	m <sup>2</sup>			
SPS 204(02)	Excavation and embankment-outsloping	m <sup>3</sup>			
SPS 204(03)	Excavation and embankment-rolling dip	ea			
301(01)	Untreated aggregate	ton			
<b>Grade Stabilizer</b>					
SPS 209(02)	Structure excavation and backfill(excavation and dewatering)-grade stabilizer	m <sup>3</sup>			
252(02)	Special rock embankment and rock buttress (placing boulders in channel)-grade stabilizer	m <sup>3</sup>			



## Appendix B

### PART I – THE SCHEDULE

#### SECTION B – SERVICES AND PRICES

#### **BAER Emergency Stabilization Treatments**

#### B-1 – SCHEDULE OF ITEMS

Item No.	Description	Unit	Estimated Quantity	Unit Price	Amount
<b>Road Decommissioning</b>					
211(01)	Roadway obliteration, method 1	Meter			
<b>Scarification</b>					
SPS 622(04)	Rental equipment-D6 dozer w/operator, with standard ripper	hr			
<b>Protective Fencing and Barriers</b>					
618(01)	Concrete barrier and precast guardwalls-concrete barrier	ea			
619(01)	Fences, gates, and cattleguards-gate,	ea			
619(02)	Fences, gates, and cattleguards-barb wire	meter			
619(03)	Fences, gates, and cattleguards-temporary plastic fence	meter			
SPS 622(05)	Rental equipment-dump truck w/operator (Min 10-yard capacity, and suitable for hauling boulders)	hr			
SPS 622(06)	Rental equipment-backhoe w/operator, Extend-A-Hoe, 4 by 4 (clamshell bucket for gathering boulders)	hr			
<b>Facility Safety Work</b>					
633(01)	Permanent traffic control-delineators	ea			
633(02)	Permanent traffic control-traffic control signs	m <sup>2</sup>			
635(01)	Temporary traffic control-barricades (meter of barricade width)	m			
<b>Overflow Structures</b>					
204(04)	Excavation and embankment-rolling dip	ea			
301(02)	Untreated aggregate courses	ton			
251(02)	Rip rap	m <sup>3</sup>			
252(03)	Special rock embankment and rock buttress-imbricated rock level spreader	m <sup>3</sup>			
253(02)	Gabions and revet mattresses-gabions	m <sup>3</sup>			



## Appendix B

PART I – THE SCHEDULE  
SECTION B – SERVICES AND PRICES  
**BAER**  
**Emergency Stabilization Treatments**

**B-1 – SCHEDULE OF ITEMS**

Item No.	Description	Unit	Estimated Quantity	Unit Price	Amount
<b>Catchment Basin Cleanout</b>					
622(07)	Rental equipment-backhoe w/operator	hr			
622(08)	Rental equipment-dump truck w/driver	hr			
622(09)	Rental equipment-excavator w/operator	hr			
622(010)	Rental equipment-dozer w/operator	hr			
622(011)	Rental equipment-service truck, 4 by 4	hr			
623(03)	General labor-laborer w/24-inch chain saw	hr			
623(04)	General labor-laborer	hr			
<b>Erosion Control</b>					
SPS 157(01)	Soil erosion control-hydromulch type ____	m <sup>2</sup>			
SPS 157(02)	Soil erosion control-straw	m <sup>2</sup>			
SPS 157(03)	Soil erosion control-silt fence	m			
SPS 157(04)	Soil erosion control-fiber roll (wattles) type____, size ____	m			
629 (01)	Soil erosion control-erosion mat, type ____	m <sup>2</sup>			
<b>Hazardous Material Removal</b>					
203(06)	Removal of structures and obstructions-hazardous material removal, (d) hazardous material	LS			
<b>Streambank Armoring</b>					
SPS 204(05)	Excavation and embankment-streambank armoring	m <sup>3</sup>			
SPS 252(03)	Special rock embankment and rock buttress-rock	m <sup>3</sup>			
SPS 253(03)	Gabions and revet mattresses-gabions	m <sup>3</sup>			

MINIMUM GUARANTEE: 10 percent of total award amount

Price Submitted by:

Name \_\_\_\_\_ Phone \_\_\_\_\_  
Address \_\_\_\_\_ Fax \_\_\_\_\_  
\_\_\_\_\_ e-mail \_\_\_\_\_



## Appendix B

---

### PART I – THE SCHEDULE

## SECTION C – DESCRIPTION AND SPECIFICATIONS

### C- 1 – PROJECT DESCRIPTION AND LOCATION

#### (a) Description of Work

##### STORM INSPECTION AND RESPONSE

Storm inspection/response keeps culvert and drainage structures functional by cleaning sediment and debris from the inlet between or during storms. This work will be accomplished through equipment rental and general labor.

##### CULVERT MODIFICATIONS

Culvert modification replaces fire-damaged culverts or upgrades culvert flow for increased capacity or passage of debris expected as a result of the fire. Modifications include upgrading culvert size, attaching metal-end-sections, or placing risers on culvert inlets.

##### DEBRIS RACK/DEBRIS DEFLECTOR

A debris rack is a structure placed across the stream channel to collect the debris before it reaches the culvert entrance. Debris racks are constructed with driven piles of various materials including steel H-piles and steel pipe. The design and configuration of the driven piles and appurtenances shall be to the dimensions specified in writing or as shown in the drawings.

Debris deflectors are V-shaped structures with the apex pointed upstream. Deflectors function by diverting medium and large floating debris and large rocks from the culvert inlet to accumulate in a storage area where debris is removed after the flood subsides. Deflectors are constructed with driven piles of various materials including steel H-pipes and steel pipe. The design and configuration of the driven piles and appurtenances shall be to the dimensions specified in writing or as shown in the drawings.

##### LOW WATER STREAM CROSSINGS

Low water stream crossings are used to replace culverts where the risk of damage to the culvert, road fill, or access is increased due to the effects of the fire. The low water stream crossing (natural ford) conforms to the streambed or the designed crossing elevation above the streambed once the culvert is removed.

##### SURFACE DRAINAGE STRUCTURES

Surface drainage treatments include outsloping of the road prism or placing rolling dips in the road prism. Both treatments are intended to disperse water and reduce erosion while directing runoff to stable areas. Untreated aggregate is placed on rolling dips to prevent rutting.

##### GRADE STABILIZERS

Grade stabilizers are used to prevent channel incision and downcutting. Grade stabilizers provide grade control to stream channels that may become destabilized from increased storm runoff and velocities. Grade stabilizers require excavation across a stream channel to place rocks or other material (logs or wood) at grade.

##### ROAD DECOMMISSIONING

Road decommissioning includes subsoiling (tilling), restoring original hillslope conditions with recontouring of the road fill, restoring drainage through the road prism and reducing hillslope erosion. Road decommissioning is performed on unclassified roads less than 20 feet in width. This work typically requires use of an excavator and or dozer with rippers to pull material into the road and break through compacted soil layers improving infiltration.

## Appendix B

---

### SOIL SCARIFICATION

Soil scarification reduces overland flow and erosion by increasing infiltration and creating surface roughness. Water repellent layers are broken down with scarification using mechanized equipment on slopes up to 25 percent. Scarification depth varies with depth and extent of water repellent layers.

### PROTECTIVE FENCING AND BARRIERS

Protective fencing and barriers include a variety of methods; gates, fences, boulders, jersey barriers, and logs. The type of fence or barrier selected depends on the access permitted and the size of the area.

### FACILITY SAFETY WORK

Facility safety work includes replacing traffic control signs, delineators, and other safety signs where hazards to the public may exist.

### OVERFLOW STRUCTURES

Overflow structures are used on roads to control runoff across the road prism and to protect the road fill. Overflow structures include armored rolling dips, and imbricated (overlapped) rock-level spreader. Both treatments protect the road fill with an armored spillway.

### CATCHMENT BASIN CLEANOUT

Catchment-basin cleanout is used to remove organic debris and sediment immediately in front of culverts, bridges, and other road drainage structures. Material is removed and placed in the designated disposal area.

### EROSION CONTROL

Erosion control treatments vary depending on the site conditions. Treatments reduce overland flow, foster infiltration, and trap sediment (silt fence, fiber rolls).

### HAZARDOUS MATERIAL REMOVAL

Hazardous material removal is the removal of hazardous materials in accordance with federal, state and local regulations for disposal.

### STREAMBANK ARMORING

Streambank armoring is the placement of rock along the streambank to reduce erosion. Armoring may include the placement of boulders, riprap, or gabion baskets.

(b) Project location. This work will apply to all the project areas identified on the location maps provided in this solicitation. The work will consist of the following items:

(c) Price Range. Between \$xxx and xxx

(d) Site Visit. A site visit to one of the project areas is planned for \_\_\_\_\_

(e) Start Work. The start work date will be determined by the Government. This work will be performed prior to the start of seasonal precipitation.

(f) Period of Performance. (See section F, FAR Clause 52.211-10.)

### C- 2 – GOVERNMENT FURNISHED PROPERTY

Not applicable.

### THE FOLLOWING NOTES WILL APPLY TO ALL WORK AREAS:

1. Work shall only be performed when the probability for rain or runoff is low.



## Appendix B

---

2. Bidders should note that performance and compliance is measured according to metric measures while all payments are measured in Imperial Units.

### C- 3 – STANDARD SPECIFICATIONS

The following standard specifications are incorporated by reference into this solicitation, and any resulting contract. Standard Specifications for construction of roads and bridges on Federal highway projects (FP-03)

<b>SECTION</b>	<b>TITLE</b>
101	Terms, Format, and Definitions
102	Bid, Award, Execution of Contract
103	Scope of Work
104	Control of Work
105	Control of Material
106	Acceptance of Work
107	Legal Relations and Responsibility to the Public
108	Prosecution and Progress
109	Measurement and Payment
151	Mobilization
153	Contractor Quality Control
155	Schedules for Construction Contracts
156	Public Traffic
157	Soil Erosion Control
201	Clearing and Grubbing
203	Removal of Structures and Obstructions
204	Excavation and Embankment
209	Structure Excavation and Backfill
211	Roadway Obliteration
251	Riprap
252	Special Rock Embankment and Rock Buttress
253	Gabions and Revet Mattresses
301	Untreated Aggregate Courses
551	Driven Piles
555	Steel Structures
602	Culverts and Drains
619	Fences, Gates, and Cattleguards
622	Rental Equipment
623	General Labor

Copies of the STANDARD SPECIFICATIONS FOR CONSTRUCTION OF ROADS AND BRIDGES ON FEDERAL HIGHWAY PROJECTS, FP-03, Metric Units. These specifications can be ordered from FHWA.

For information on how to order books, go to the FHWA's website, <http://www.wfl/fha.dot.gov/design/specs/fp03.htm>

### C- 4 – SPECIAL PROJECT SPECIFICATIONS

The following Special Project Specifications are applicable to this contract and are physically included in this section: These Special Project Specifications replace any and all standard specifications not specifically mentioned in Section C-3, above.

<b>SECTION</b>	<b>TITLE</b>
SPS 151(01)	Mobilization
SPS 157 (01) (02) (03) (04)	Erosion Control
SPS 203(04) (05)	Remove CMP
SPS 204(01) (02) (03) (05)	Excavation and Embankment

## Appendix B

---

SPS 209 (01) (02)	Structure Excavation
SPS 252 (01) (03)	Special Rock Embankment
SPS 253 (03)	Gabions and Revet Mattresses
SPS 555(01)	Steel Structures
SPS 602 (01) (02)	Culvert Upgrade
SPS 602(03) (04)	Metal-end-section
SPS 602 (05) (06)	Riser/Elbow
SPS 602 (07) (08)	Riser Extension
SPS 622(01)	Backhoe
SPS 622(02)	Dumptruck
SPS 622(03)	Excavator
SPS 622(04)	Dozer
SPS 622(05)	Lowboy
SPS 622(06)	Service Truck

### C- 5 – DRAWINGS

The following drawings are a part of this solicitation and any resulting contract:

#### Sheet(s)

Title Sheet and Vicinity Map (Cover Sheet)

1 of 1

Area Map(s)

Outslope Road Prism

Install Metal End Section

Low water stream crossing

Riser Pipe

Debris Rack/Debris Deflectors

Calculate Fill Volume

Road Decommissioning

Gates

Install Barriers

Mulching

Dips

# Appendix C

## Low-Water Stream Crossing Calculations

### Low Water Crossing, "Q", and Velocity Calculations

(lwx.xls)

Through Manning's and Chezy Equations;

Ozzie, 1992

**Designer:**       **Date:**

**Project:**       **Sta:**

**Storm Events, "Q" in cfs:**      100 Yr.  ; 50 Yr.  ; 25 Yr.

if known

<u>Input</u>	<u>Variables</u>
"C" Average width of bottom of channel, Feet	0
"a" Slope of Lt. side of channel, % in Dec.	0.5
"b" Slope of Rt. side of channel, % in Dec.	1
"s" Slope of channel, % in Dec.	0.08
"n" Roughness coefficient. ("n" for properly sized riprap = 0.0525)	0.025 <span style="float: right;">bladed ditch</span>
"D" Mean depth of flow in channel for storm flow <i>(May be trial depth until known "Q" is reached)</i>	0.5

<u>Calculated Output</u>	<u>Calculated</u>
Cross-sectional area of flow in sq.ft.	<b>A</b> = <input type="text" value="0.4"/> s.f.
Wetted perimeter in feet	<b>Pw</b> = <input type="text" value="1.8"/> ft.
* Quantity of flow in Cubic Feet per Second, cfs	<b>Q</b> = <input type="text" value="2"/> cfs
* Mean Velocity of stream <i>(May be trial Depth until known "Q" is reached)</i>	<b>Vm</b> = <input style="border: 2px solid red;" type="text" value="5.9"/> ft/sec
Length of wetted side, "a"	<b>La</b> = <input type="text" value="1.1"/> ft.
Length of wetted side, "b"	<b>Lb.</b> = <input type="text" value="0.7"/> ft.



## Appendix D

FS-6700-7 (2/98)		
1. WORK PROJECT/ACTIVITY	2. LOCATION:	3. UNIT
U.S. Department of Agriculture Forest Service	BAER Team	
JOB HAZARD ANALYSIS (JHA) References -- FSH 6709.11 and -- 12 (Instructions on Reverse)	5. JOB TITLE	6. DATE PREPARED
	BAER Team Leader	
7. TASKS/PROCEDURES	8. HAZARDS	9. ABATEMENT ACTIONS
General Air Reconnaissance	No Low level flights without WO approval (<500 feet)	Engineering Controls * Substitution * Administrative Controls * PPE
General Ground Reconnaissance	Footing on steep, rough, uneven terrain; falling trees; heavy vehicle traffic on narrow, winding roads; reburn potential; suppression efforts; dehydration and fatigue; burned out holes.	<b>Is this flight really necessary?</b> Is there another way to do the job? Follow instructions from helitack and the pilot. Ask questions if you do not understand the instructions. Do not fly in hazardous situations. Ask questions of pilots and others to determine what hazardous situations exist. Minimize time in the air. Follow agency guidelines to include flight following and communications. Wear required personal protective equipment (PPE).  Wear eight-inch-high leather boots with lug soles. Stay in communication with incident personnel (division supervisors and BAER Team members). Read daily safety message. Establish Lookouts, Communications, Escape Routes and Safety Zones (LCES). Drive defensively with headlights on. Be aware of suppression efforts within the area you are working in. Be careful not to slip, trip or fall, especially on wet ash. Be aware of possible exposure to hypothermia. Be aware of road conditions. <b>Conduct tailgate safety sessions with your colleagues.</b> Utilize "Six Minutes for Safety" ( <a href="http://www.nifc.gov/sixminutes/dsp_sixminutes.php">http://www.nifc.gov/sixminutes/dsp_sixminutes.php</a> ). Everyone will have a copy of current IAP, know the radio frequency of the division he or she is in, and check in when entering and leaving. If unable to reach the division supervisor, radio Incident Command Post (ICP) Communications or contact the Division Safety Officer (name in ICP).  Learn to identify the plant. Avoid contact as much as possible. If symptoms appear, get medical treatment as needed.  Keep work space clean and take frequent breaks. Clean up your own messes.
Office	Poison ivy  Tight quarters	
General Field Work and Monitoring	General personal safety	<b>Work in pairs. Keep fresh batteries in your radio, and carry an extra battery pack.</b> All personnel within the fire perimeter need a <b>working</b> radio. If needed, get one from ICP-communications if necessary. If folks separate in the field, each individual <b>WILL</b> have a radio. Wear required PPE. Carry reserved energy food or Meals-Ready-to-Eat (MREs). Be prepared to spend the night if necessary.  Let someone know specifically where you will be. Make sure your radio works before you leave. Get it fixed or replaced if necessary.  Be sure someone knows when you have returned. Sign in/ Sign out.

## Appendix D

	Fatigue	Limit shifts to 12 hours or less (going beyond 12 hours is a rare exception). Provide 2:1 work/rest ratios and ensure eight hours off between shifts. Manage for cumulative physical, cognitive or emotional fatigue.
	Sun / hyperthermia	Carry sunglasses. Use sunscreen to prevent sunburn. Consider deferring field work when temperatures exceed 100 degrees F.
	Dehydration	Drink enough water supplemented with electrolyte-based drinks to keep hydrated and prevent heat exhaustion or heat stroke (at least two-three quarts of water per day in summer). Pace yourself when climbing steep, open slopes.
	Hypothermia and cold	Carry extra clothes. Wear layers to prevent sweating and subsequent cooling. Bring rain gear, hat, and warm gloves with you everyday.
	Stream channel surveys	Use extra caution in stream bottoms to prevent falling. Fire-caused stream temperature increases might have already caused rock-slickness to increase.
Field Surveys, Monitoring	Steep slopes and remote worksites	Wear lugged soled shoes with eight-inch tops, with good ankle support. Carry a radio, and leave your itinerary with someone.
Mapping/Inventory Within Fire Perimeter	<b>Working within fire perimeter.</b>	Wear PPE (hard hat, leather boots, NOMEX, fire shelter, goggles, and gloves) at all times. Recognize that the fire is not controlled. Know your ten standard fire orders and 18 "watch out" situations. Area command and the BAER Team Leader will determine on a daily basis whether line-qualified personnel will be needed to escort BAER personnel in high hazard areas.
	Stump and root holes	Keep your eyes on your path of travel. If your attention is diverted, stop and complete the task before proceeding. Excessive amounts of white ash may indicate the presence of a stump or root hole.
	Snags and hazard trees	Size up your surroundings. Avoid work in areas where hazards exist. Be aware of anticipated conditions. Avoid the common BAER condition of spending all of your time looking down, not noticing hazards in the air. Use spot lookouts, and establish safety zones. If the wind is blowing (trees swaying), stop working.
	Slippery and unstable footings	Be extra careful in areas of wet ash, retardant drops, loose rocks and unstable slopes.
	Rattlesnakes and bears	Be aware at all times of the potential for encounters with rattlesnakes and/or bears. Withdraw from the area.
	Personal health and safety	Take care of cuts, bruises and blisters immediately. Report any accidents to the Team Leader and complete an accident report. Take no risks that jeopardize your personal safety or the safety of others.
Storm Events	Lightning	Check weather report, and stay off ridge tops and open slopes during lightning storms. If stuck in the open, keep radio and metallic objects away from you, squat down with only your feet on the ground, using an insulated pad if possible. Keep as

## Appendix D

		much of your body off the ground as possible.
	Fog, smoke; poor visibility, disorientation	Drive with lights on low beam. If fog and/or smoke are so dense as to affect safe driving, cease operations before getting into a situation where safety is compromised.
	Rain	Don't walk on logs; avoid small stems that are parallel to the slope; insure footing. If roads are muddy, stay off roads.
	Wind	Check weather reports; monitor wind events. If trees are swaying, move to a safe area with no trees or snags, or get out of the wind path.
Burned Over Environment	Falling rocks	Don't work directly above or below another person; be wary of rocks.
	Heavy brush	Wear long-sleeved shirt, goggles and gloves
	Insect bites / stings	Wear long-sleeved shirt and hat; use repellent at your discretion. Bees and yellowjackets are a problem in fires. Carry anti-histamine and sting kits for bee stings. If you know you are allergic, carry proper medication and instruct coworkers in administration. <b>Tell your Team Leader about your allergies.</b>
Communication/Coordination with Team Leaders and Suppression Personnel	Loss of repeaters or dead spots	Follow Communications Plan. Notify incident personnel on specific zone when working in field. Be sure to check in with the division supervisor before entering and leaving fire perimeter and/or the division.
Defensive Driving	Vehicle accidents and associated injuries; general driving conditions	Always wear safety belts and make sure everyone else does! Keep windows clean and remove garbage from the cab of the truck. <b>DRIVE WITH THE LIGHTS ON!</b> Forest roads are narrow. Drive defensively, giving yourself enough time and space to react to other drivers or wildlife on the road. If possible, remove hazards from the roadbed rather than try to drive over or around them. Limit driving time to ten hours or less. Stop and take a break if you feel sleepy while driving, or let someone else drive. <b>Don't drive if you feel sick or are taking medication that affects your ability to handle a vehicle.</b>
	Mechanical malfunction; narrow, rough roads, heavy use impacts	Conduct daily preventive maintenance checks. Each vehicle is to have a first aid kit and required equipment. Drive as far to the right as safely possible. Ensure stopping distance is ½ the sight distance on blind curves. Confirm road status, traffic patterns and the presence of heavy equipment before use. Drive defensively. Watch out for public / contractor use of roads.

## Appendix D

Helicopter Operations:		<b>IS THIS FLIGHT REALLY NECESSARY?</b>
1. Approach departure	Rotor and engine exhaust location on different helicopter types pose danger of serious injury	<p>Approach operating helicopter only when instructed to do so by pilot, manager or helitack personnel. All personnel must receive a briefing on the specific type/model of helicopter before working around that helicopter. Each type/model may have different procedures for approach and departure. Standard procedure is as follows:</p> <ol style="list-style-type: none"> <li>1) Approach from the front or front side of helicopter, in a slight crouch and in clear view of the pilot.</li> <li>2) Never go near the rear of the helicopter unless instructed to do so (for models without a tail rotor hazard).</li> <li>3) Allow helitack personnel to carry long objects, or carry them horizontally, low to the ground if authorized to do so.</li> <li>4) Approach/depart helicopters to/from the downhill side (never uphill).</li> </ol>
2. Loading/Unloading	Some aircraft components are fragile and easily broken. Improperly entering or exiting helicopter could adversely shift the position or orientation of the helicopter.	Follow directions of air operations personnel. Open/close doors only when and as instructed. Do not straddle the skid or step immediately adjacent to skid. Use only designated handholds to enter or exit--DO NOT PUT ANY WEIGHT ON THE DOOR. Enter and exit the aircraft in a carefully controlled manner to avoid shifting the aircraft position. Remain seated and belted in until directed otherwise. Secure the seatbelt back inside the helicopter upon exiting.
3. Personal Protective Equipment	Potential for flash fire and potential for serious head trauma in the event of an accident.	For all helicopter flights, PPE must include: Nomex or fire-resistant cotton shirt and trousers, leather or Nomex gloves, leather boots, *Aviator Flight Helmet*, a two-inch overlap of all PPE. *NOTE: Firefighters being transported to a managed helispot may substitute a hardhat with chinstrap and earplugs for the aviator flight helmet.
Mines	Potential exists to encounter open pit mines	Check with local district personnel and map mine hazard areas. Be on the alert for open pit mine areas in all locations. Watch out for hazardous materials.
Fatigue	Potential to affect judgment, work and relationships	Comply with work/rest ratio (two hours of work/ one hour of rest) Comply with days off - 1/14 or 2/21, or time off sooner if deemed necessary by the Team Leader. Recognize that fatigue affects cognitive (decision making) ability; physical ability (balance, stamina, etc). Emotional responses --guard against reacting to fellow workers and others. Ensure that adequate accommodations are available.
Hazardous Materials	Potential exists to encounter burned buildings that contained hazardous materials.	Avoid burned buildings. Be wary around any of the private land, or land bordering private land.



## Appendix D

	Potential exists to encounter areas around private land that may have hazardous materials.	
Employee Security	Potential for disgruntled publics and exposure to non-secure situations	Disengage from a situation where an irate person appears to be in an escalating angry mode. Watch out for unfamiliar objects that may be lethal. Watch out for illegal drug or hazmat sites. <b>Travel in pairs.</b>
Working Relationships	Inappropriate behavior, anger, disorganized effort, poor communications	Always demonstrate mutual respect for others. Guard against reacting to others' emotional anguish; be supportive and understanding. Recognize that fatigue affects cognitive (decision making) ability; physical ability (balance, stamina, etc). Emotional responses --guard against reacting to fellow workers and others
Monitoring of 30-mile Fire Hazard Abatement Plan	Putting employees at risk	Daily report by way of conference call addressing compliance with the 30-Mile Abatement Plan.
10. LINE OFFICER SIGNATURE /s/ Smokey BAER	11. TITLE Deputy Forest Supervisor	12. DATE 0/00/0000

# Appendix D

## JHA Instructions (References-FSH 6709.11 and .12)

The JHA shall identify the location of the work project or activity, the name of employee(s) writing the JHA, the date(s) of development, and the name of the appropriate line officer approving it. The supervisor acknowledges that employees have read and understand the contents, have received the required training, and are qualified to perform the work project or activity.

**Blocks 1, 2, 3, 4, 5, and 6:** Self-explanatory.

**Block 7:** Identify all tasks and procedures associated with the work project or activity that have potential to cause injury or illness to personnel and damage to property or material. Include emergency evacuation procedures (EEP).

**Block 8:** Identify all known or suspect hazards associated with each respective task/procedure listed in block 7. For example:

- a. Research past accidents/incidents
- b. Research the Health and Safety Code, FSH 6709.11 or other appropriate literature.
- c. Discuss the work project/activity with participants
- d. Observe the work project/activity
- e. A combination of the above

**Block 9:** Identify appropriate actions to reduce or eliminate the hazards identified in block 8. Abatement measures listed below are in the order of the preferred abatement method:

- a. Engineering Controls (the most desirable method of abatement). For example, ergonomically designed tools, equipment, and furniture.
- b. Substitution. For example, switching to high flash point, non-toxic solvents.
- c. Administrative Controls. For example, limiting exposure by reducing the work schedule; establishing appropriate procedures and practices.
- d. PPE (least desirable method of abatement). For example, using hearing protection when working with or close to portable machines (chain saws, rock drills portable water pumps)
- e. A combination of the above.

**Block 10:** The JHA must be reviewed and approved by a line officer. Attach a copy of the JHA as justification for purchase orders when procuring PPE.

**Blocks 11 and 12:** Self-explanatory.

## Emergency Evacuation Instructions (Reference FSH 6709.11)

Work supervisors and crew members are responsible for developing and discussing field emergency evacuation procedures (EEP) and alternatives in the event a person(s) becomes seriously ill or injured at the worksite.

Be prepared to provide the following information:

- a. Nature of the accident or injury (avoid using victim's name).
- b. Type of assistance needed, if any (ground, air, or water evacuation)
- c. Location of accident or injury, best access route into the worksite (road name/number), identifiable ground/air landmarks.
- d. Radio frequency(s).
- e. Contact person.
- f. Local hazards to ground vehicles or aviation.
- g. Weather conditions (wind speed & direction, visibility, temp).
- h. Topography.
- i. Number of person(s) to be transported
- j. Estimated weight of passengers for air/water evacuation.

The items listed above serve only as guidelines for the development of emergency evacuation procedures.

### JHA and Emergency Evacuation Procedures Acknowledgment

We, the undersigned work leader and crew members, acknowledge participation in the development of this JHA (as applicable) and accompanying emergency evacuation procedures. We have thoroughly discussed and understand the provisions of each of these documents:

SIGNATURE	DATE	SIGNATURE	DATE
_____	_____	_____	_____
Work Leader			
_____	_____	_____	_____
_____	_____	_____	_____
_____	_____	_____	_____
_____	_____	_____	_____
_____	_____	_____	_____

Work Leader

## Appendix E

### Riprap Class and Size

Class	Rock by Mass	Mass	Approximate
	(in percent)	(in pounds)	Cubic Dimension <sup>(2)(3)</sup> (in inches)
1	20	22 to 33	6 to 8
	30	11 to 22	5 to 6
	40	1 to 11	2 to 5
	10 <sup>(1)</sup>	0 to 1	0 to 2
2	20	55 to 110	8 to 10
	30	22 to 55	6 to 8
	40	2 to 22	3 to 6
	10 <sup>(1)</sup>	0 to 2	0 to 3
3	20	220 to 330	14 to 16
	30	110 to 220	10 to 14
	40	11 to 110	5 to 10
	10 <sup>(1)</sup>	0 to 11	0 to 5
4	20	550 to 770	18 to 20
	30	220 to 550	14 to 18
	40	22 to 220	6 to 14
	10 <sup>(1)</sup>	0 to 22	0 to 6
5	20	1,540 to 2,200	26 to 28
	30	770 to 1,540	20 to 26
	40	55 to 770	8 to 20
	10 <sup>(1)</sup>	0 to 55	0 to 8
6	20	1,870 to 3,530	28 to 34
	30	1,100 to 1,870	22 to 28
	40	110 to 1,100	10 to 22
	10 <sup>(1)</sup>	0 to 110	0 to 10

1. Furnish spalls and rock fragments graded to provide a stable dense mass.
2. The volume of a rock with these cubic dimensions has a mass approximately equal to the specified rock mass.
3. Furnish rock with breadth and thickness at least one-third its length.



## Appendix F

SLOPE	LOG SPACING	LOG DIAMETER	LOGS PER ACRE*	STORAGE CAPACITY	STORAGE CAPACITY**
%	ft	in		yd <sup>3</sup> /acre	ton/acre
10	16	13	129	108	104
10	16	25	129	109	104
10	16	38	129	109	104
10	16	51	129	110	105
10	16	64	129	110	105
10	16	76	129	111	106
10	16	89	129	112	107
10	16	102	129	113	108
10	16	114	129	115	109
10	16	127	129	116	111
10	33	13	64	75	72
10	33	25	64	75	72
10	33	38	64	76	72
10	33	51	64	76	73
10	33	64	64	77	74
10	33	76	64	78	74
10	33	89	64	79	75
10	33	102	64	80	76
10	33	114	64	81	78
10	33	127	64	83	79
10	49	13	43	64	61
10	49	25	43	64	61
10	49	38	43	65	62
10	49	51	43	65	62
10	49	64	43	66	63
10	49	76	43	67	64
10	49	89	43	68	65
10	49	102	43	69	66
10	49	114	43	70	67
10	49	127	43	72	69
10	66	13	32	59	56
10	66	25	32	59	56
10	66	38	32	59	57
10	66	51	32	60	57
10	66	64	32	60	58
10	66	76	32	61	59
10	66	89	32	62	59
10	66	102	32	63	61
10	66	114	32	65	62
10	66	127	32	66	63
10	82	13	26	55	53
10	82	25	26	55	53

## Appendix F

10	82	38	26	56	53
10	82	51	26	56	54
10	82	64	26	57	55
10	82	76	26	58	55
10	82	89	26	59	56
10	82	102	26	60	57
10	82	114	26	61	59
10	82	127	26	63	60
10	98	13	21	53	51
10	98	25	21	53	51
10	98	38	21	54	51
10	98	51	21	54	52
10	98	64	21	55	52
10	98	76	21	56	53
10	98	89	21	57	54
10	98	102	21	58	55
10	98	114	21	59	57
10	98	127	21	61	58
*Logs per unit area are calculated on a average log length of 6.33 meters.					
**Storage capacity by weight is calculated with a bulk density of 1.1342 gcc-1.					

## Appendix F

SLOPE	LOG SPACING	LOG DIAMETER	LOGS PER ACRE	STORAGE CAPACITY	STORAGE CAPACITY
%	ft	in		yd <sup>3</sup> /acre	ton/acre
20	16	13	131	79	76
20	16	25	131	80	76
20	16	38	131	80	77
20	16	51	131	81	77
20	16	64	131	81	78
20	16	76	131	82	78
20	16	89	131	83	79
20	16	102	131	84	81
20	16	114	131	86	82
20	16	127	131	87	83
20	33	13	65	46	44
20	33	25	65	47	44
20	33	38	65	47	45
20	33	51	65	47	45
20	33	64	65	48	46
20	33	76	65	49	47
20	33	89	65	50	48
20	33	102	65	51	49
20	33	114	65	52	50
20	33	127	65	54	51
20	49	13	44	35	34
20	49	25	44	35	34
20	49	38	44	36	34
20	49	51	44	36	35
20	49	64	44	37	35
20	49	76	44	38	36
20	49	89	44	39	37
20	49	102	44	40	38
20	49	114	44	41	40
20	49	127	44	43	41
20	66	13	33	30	28
20	66	25	33	30	29
20	66	38	33	30	29
20	66	51	33	31	29
20	66	64	33	32	30
20	66	76	33	32	31
20	66	89	33	33	32
20	66	102	33	35	33
20	66	114	33	36	34
20	66	127	33	37	36
20	82	13	26	26	25
20	82	25	26	27	25

## Appendix F

20	82	38	26	27	26
20	82	51	26	28	26
20	82	64	26	28	27
20	82	76	26	29	28
20	82	89	26	30	29
20	82	102	26	31	30
20	82	114	26	33	31
20	82	127	26	34	32
20	98	13	22	24	23
20	98	25	22	24	23
20	98	38	22	25	24
20	98	51	22	25	24
20	98	64	22	26	25
20	98	76	22	27	26
20	98	89	22	28	27
20	98	102	22	29	28
20	98	114	22	30	29
20	98	127	22	32	30



## Appendix F

SLOPE	LOG SPACING	LOG DIAMETER	LOGS PER ACRE	STORAGE CAPACITY	STORAGE CAPACITY
%	ft	in		yd <sup>3</sup> /acre	ton/acre
30	16	13	134	70	67
30	16	25	134	70	67
30	16	38	134	70	67
30	16	51	134	71	68
30	16	64	134	72	68
30	16	76	134	73	69
30	16	89	134	74	70
30	16	102	134	75	71
30	16	114	134	76	73
30	16	127	134	77	74
30	33	13	67	37	35
30	33	25	67	37	35
30	33	38	67	37	36
30	33	51	67	38	36
30	33	64	67	39	37
30	33	76	67	39	38
30	33	89	67	40	39
30	33	102	67	42	40
30	33	114	67	43	41
30	33	127	67	44	42
30	49	13	45	26	24
30	49	25	45	26	25
30	49	38	45	26	25
30	49	51	45	27	26
30	49	64	45	27	26
30	49	76	45	28	27
30	49	89	45	29	28
30	49	102	45	30	29
30	49	114	45	32	30
30	49	127	45	33	32
30	66	13	33	20	19
30	66	25	33	20	19
30	66	38	33	21	20
30	66	51	33	21	20
30	66	64	33	22	21
30	66	76	33	23	22
30	66	89	33	24	23
30	66	102	33	25	24
30	66	114	33	26	25
30	66	127	33	28	26
30	82	13	27	17	16
30	82	25	27	17	16

## Appendix F

30	82	38	27	17	17
30	82	51	27	18	17
30	82	64	27	19	18
30	82	76	27	19	19
30	82	89	27	20	20
30	82	102	27	22	21
30	82	114	27	23	22
30	82	127	27	24	23
30	98	13	22	15	14
30	98	25	22	15	14
30	98	38	22	15	14
30	98	51	22	16	15
30	98	64	22	16	16
30	98	76	22	17	16
30	98	89	22	18	17
30	98	102	22	19	19
30	98	114	22	21	20
30	98	127	22	22	21

## Appendix F

SLOPE	LOG SPACING	LOG DIAMETER	LOGS PER ACRE*	STORAGE CAPACITY	STORAGE CAPACITY**
40	16	13	138	65	62
40	16	25	138	65	62
40	16	38	138	66	63
40	16	51	138	66	63
40	16	64	138	67	64
40	16	76	138	68	65
40	16	89	138	69	66
40	16	102	138	70	67
40	16	114	138	71	68
40	16	127	138	73	69
40	33	13	69	32	30
40	33	25	69	32	31
40	33	38	69	32	31
40	33	51	69	33	32
40	33	64	69	34	32
40	33	76	69	35	33
40	33	89	69	36	34
40	33	102	69	37	35
40	33	114	69	38	36
40	33	127	69	39	38
40	49	13	46	21	20
40	49	25	46	21	20
40	49	38	46	21	20
40	49	51	46	22	21
40	49	64	46	23	22
40	49	76	46	23	22
40	49	89	46	24	23
40	49	102	46	26	24
40	49	114	46	27	26
40	49	127	46	28	27
40	66	13	34	15	15
40	66	25	34	15	15
40	66	38	34	16	15
40	66	51	34	16	16
40	66	64	34	17	16
40	66	76	34	18	17
40	66	89	34	19	18
40	66	102	34	20	19
40	66	114	34	21	20
40	66	127	34	23	22
40	82	13	28	12	11
40	82	25	28	12	12
40	82	38	28	13	12

## Appendix F

40	82	51	28	13	13
40	82	64	28	14	13
40	82	76	28	15	14
40	82	89	28	16	15
40	82	102	28	17	16
40	82	114	28	18	17
40	82	127	28	20	19
40	98	13	23	10	9
40	98	25	23	10	10
40	98	38	23	10	10
40	98	51	23	11	10
40	98	64	23	12	11
40	98	76	23	12	12
40	98	89	23	13	13
40	98	102	23	15	14
40	98	114	23	16	15
40	98	127	23	17	17
*Logs per unit area are calculated on a average log length of 6.33 meters.					
**Storage capacity by weight is calculated with a bulk density of 1.1342 gcc-1.					

## Appendix F

SLOPE	LOG SPACING	LOG DIAMETER	LOGS PER ACRE	STORAGE CAPACITY	STORAGE CAPACITY
%	ft	in		yd <sup>3</sup> /acre	ton/acre
50	16	13	143	62	59
50	16	25	143	62	60
50	16	38	143	63	60
50	16	51	143	63	60
50	16	64	143	64	61
50	16	76	143	65	62
50	16	89	143	66	63
50	16	102	143	67	64
50	16	114	143	68	65
50	16	127	143	70	67
50	33	13	72	29	28
50	33	25	72	29	28
50	33	38	72	30	28
50	33	51	72	30	29
50	33	64	72	31	29
50	33	76	72	32	30
50	33	89	72	33	31
50	33	102	72	34	32
50	33	114	72	35	34
50	33	127	72	37	35
50	49	13	48	18	17
50	49	25	48	18	17
50	49	38	48	19	18
50	49	51	48	19	18
50	49	64	48	20	19
50	49	76	48	21	20
50	49	89	48	22	21
50	49	102	48	23	22
50	49	114	48	24	23
50	49	127	48	26	24
50	66	13	36	12	12
50	66	25	36	13	12
50	66	38	36	13	12
50	66	51	36	14	13
50	66	64	36	14	14
50	66	76	36	15	14
50	66	89	36	16	15
50	66	102	36	17	16
50	66	114	36	19	18
50	66	127	36	20	19
50	82	13	29	9	9
50	82	25	29	9	9

## Appendix F

50	82	38	29	10	9
50	82	51	29	10	10
50	82	64	29	11	10
50	82	76	29	12	11
50	82	89	29	13	12
50	82	102	29	14	13
50	82	114	29	15	15
50	82	127	29	17	16
50	98	13	24	7	7
50	98	25	24	7	7
50	98	38	24	7	7
50	98	51	24	8	8
50	98	64	24	9	8
50	98	76	24	10	9
50	98	89	24	11	10
50	98	102	24	12	11
50	98	114	24	13	12
50	98	127	24	14	14









