



**Investigation of Blowout
Main Pass Block 91 Platform A
OCS-G 14576
August 23, 2007**

Gulf of Mexico
Off the Louisiana Coast



U.S. Department of the Interior
Minerals Management Service
Gulf of Mexico OCS Regional Office

**Investigation of Blowout
Main Pass Block 91
OCS-G 14576
August 23, 2007**

Gulf of Mexico
Off the Louisiana Coast

Randall Josey – Chair
Russell Hoshman
Frank Patton
Robert Ranney

Contents

Executive Summary	1
Introduction	3
Authority	3
Background	3
Findings	4
The Incident	4
Post Incident Discoveries	5
Relief Well	7
Well Test Reports and DX Plug Depths	8
Human Factors	8
Conclusions	12
The Incident	12
Causes	13
Contributing Causes	13
Remaining Wells On Site	14
Recommendations	15
Plug and Abandonment Work	15
Safety Alert	15
Appendix	
Attachment 1- Location of Lease OCS-G 14576, Main Pass Block 91.	
Attachment 2- Schematic for well A-1	
Attachment 3 - Cement Bond Log	
Attachment 4 – Schematic for well A-2	
Attachment 5—Schematic for well A-3	

Executive Summary

On January 29, 2007, a casing pressure diagnostic test was performed on the 9 5/8 inch production casing of well OCS-G 14575 Well A-1/A-1D indicating that there was 1950 psig on the production casing and it would not bleed below 250 psig. Well A-1 was capable of producing gas from the production casing. The status of Well A-1 was that the long string was producing 2.1 MMCFD with 1950 psig FTP and 2215 psig SITP. The short string was isolated with a tubing plug. This diagnostic test was not reported to the MMS. The current dual completion in this well utilized a cement packer from 4,925 feet to 6,595 feet with perforations within the cement packer into two producing intervals. On August 23, 2007, an Apache Corporation representative reported gas leaking at the mud line at Main Pass, Block 91, Platform A (MP 91A). No pollution was visible.

It was determined the source of the gas was Well A-1. The communication problem that had existed within Well A-1 had breached the production casing and reached the surface. The maximum observed production casing pressure was 2200 psig. The pressure was only 23% of the minimum internal yield pressure of the 9 5/8 inch production casing and 74% of the next outer casing, the 16 inch surface casing. Once the casing pressure breached the production casing, the magnitude of the casing pressure was more than sufficient to break down the shoe of the 16 inch surface casing at 2,220 feet measured depth. The facts do not provide the necessary information to say definitely how, where or why the failure occurred in the 9 5/8 inch production casing.

Numerous attempts were made to kill the well without success. On September 22, 2007 Main Pass, Block 91, Platform A (MP 91A) structure was found toppled/sunk while returning from storm evacuation for Tropical Depression (TD) Number 10. The Pride Wyoming drilling rig was contracted to drill a relief well, OCS-G 14576 Well No 3. The relief well was drilled intersecting the well bore of Well A-1/A-1D. Well A-1/A-1D was killed with 525 bbls of mud and abandoned with 203 bbls of cement by November 10, 2007.

Main Pass Block 91 Platform “A” sank below the mudline as a result of the Well A-1 blowout along with the three wells located on this platform, Wells A-1/A-1D, A-2/A-2D and A-3/A-3D. It is concluded that the subsidence of Platform “A” may have resulted in casing/tubular buckling for Wells A-1/A-1D, A-2/A-2D and A-3/A-3D. Well A-1/A-1D was killed and abandoned by drilling a relief well. No action has been taken to remedy Wells A-2/A-2D and A-3/A-3D. These wells have the potential of an uncontrolled release of hydrocarbons to the environment.

Apache completed a DSV Survey of the MP 91A toppled platform location from 6/20/2008 to 7/6/2008 using the DSV American Triumph (4 point anchor diving vessel). The survey included mesotech scans of the crater, visual diver inspection of crater and pipelines, diver hand probing of the crater bottom (max 20 feet penetration), and jet lance probing (max 300 feet BSL penetration) deployed from a false rotary on the vessel.

Based on the data collected to date, it is unlikely a surface intervention or recovery of the MP 91A toppled structure will be possible due to technology constraints and concerns for personnel safety. Apache is currently reviewing options for a subsurface intervention on the MP 91A wells (A-2/A-2D and A-3/A-3D).

Introduction

Authority

During a routine field inspection, gas was observed leaking at the mud line on Apache Corporation's (Apache) Platform A, Main Pass Block 91, Lease OCS-G 14576, in the Gulf of Mexico, offshore the State of Louisiana, on August 22, 2007, at approximately 1700 hours. Pursuant to Section 208, Subsection 22 (d),(e), and (f), of the Outer Continental Shelf (OCS) Lands Act, as amended in 1978, and Department of the Interior regulations 30 CFR 250, Minerals Management Service (MMS) is required to investigate and prepare a public report of this accident. By memorandum dated September 17, 2007, the following personnel were named to the investigative panel:

Randall Josey, Chairman - Office of Safety Management, GOM OCS Region;

Russell Hoshman - Technical Assessment & Operations Support Section, GOM
OCS Region;

Frank Patton - New Orleans District, Field Operations, GOM OCS Region;

Robert Ranney - Lafayette District, Field Operations, GOM OCS Region;

The panel members met numerous times throughout the investigation to conduct interviews, review the facts of the incident, draw necessary conclusions, and prepare this report.

Background

Lease OCS-G 14576 is located in Main Pass Block 91 (MP 91), Gulf of Mexico, off the Louisiana Coast. Apache Corporation was the designated Operator of the lease at the time of the incident. (*For lease location, see Attachment 1.*)

Platform A contained Wells A-1/A-1D, A-2/A-2D, and A-3/A-3D. Well A-1 is the well that blew out. Wells A-2/A-2D and A-3/A-3D had DX plugs set once bubbling was noticed at the structure. More information can be found on Wells A-2/A-2D and A-3/A-3D in the "Well Test Reports and DX Plug Depths" section.

Findings

The Incident

Well No. A-1 experienced sustained casing pressure of 2,200 pounds per square inch (psi) which was first noted by Apache Corporation on January 29, 2007. A diagnostic test was run on the production casing of Well No. A-1/A-1D the same day, which revealed the production casing would not bleed below 250 pounds per square inch gradient (psig). Apache Corporation reported this to the Minerals Management Service (MMS) but took no action to correct the situation. Another diagnostic test was performed on August 13, 2007, which revealed the production casing would not bleed below 450 psig, and no action was taken to correct or report the situation to the MMS. Apache first reported the situation to MMS when gas was leaking around the MP 91A platform on August 22, 2007. This was the first indication of possible failed casing. Communication existed on Well No. A-1 between the production casing and the surface after the blowout occurred. On August 27, 2007 the reported pressures on Well A-1 showed 700 psi on the 9 5/8-inch production casing and 0 psi on the 16-inch surface casing. On August 31, 2007 the reported pressures on Well A-1 showed 300 psi on the 9 5/8-inch production casing and 280 psi on the 16-inch surface casing. (*For wellbore schematic of well A-1, see attachment 2.*) The derrick barge *Arapaho* arrived on location late Saturday night, August 25, 2007, after which numerous attempts were made to kill the well without success. One such attempt occurred on August 27, 2007 when 150 barrels (bbls) of seawater with dye (one-half production casing volume) was pumped into the production casing. The gas boil on the water increased substantially, and dye was observed in the boil after only 15 bbls of seawater and dye had been pumped. In a separate attempt 50 bbls of 11.6 ppg calcium chloride fluids, with dye, was bullheaded down the long string with no affect. The derrick barge was demobilized on September 7, 2007, and Well No. A-1 was left flowing to MP 7A platform. The marine vessel *Chantese G* was deployed to the area around MP 91A to detour unauthorized marine traffic from the vicinity of the platform. Helicopter overflights were flown twice daily to monitor the flow at the water line. A seafloor survey was shot from a geophysical vessel, and a site location was selected for drilling a relief well. The Pride Wyoming drilling rig was secured and was being prepared to move on location. Field personnel were evacuated on September 20,

2007 for Tropical Depression Number 10. On September 22, 2007, while returning from the storm evacuation, MP 91A structure was found toppled/sunk. The Pride Wyoming was moved on location October 9, 2007 to drill a relief well. The relief well proved successful by drilling into Well No. A-1/A-1D, and killing same by November 10, 2007.

Post Incident Discoveries

Apache stated in its investigation report that its operators failed to follow Apache's Casing Pressure Management Program. Apache also maintains an access database to track and monitor casing pressure on all of Apache's wells. The database is located on the Apache Regulatory and Safety Website, which serves as Apache facilities home page. Apache stated in the report, that when used correctly, the program provides immediate notification to the Apache Regulatory Department of new or increased casing pressure. Apache did not request a casing pressure departure for this well. Apache failed to provide a diagnostic test for the production casing pressure of 2,180 psi, which is greater than 20 percent of the Minimum Internal Yield Pressure (MIYP). The well would not bleed to zero. The Apache auditor changed the April 2007 comments to reflect notification had been made to MMS on January 29, 2007, but could not produce a diagnostic test or backup paperwork indicating notification had been made. The casing pressure log on the monthly MMS paperwork serves as an additional resource in tracking the casing pressures on all of Apache's wells. As stated in the Apache investigation report, the auditor failed to notify the Apache Regulatory Department pertaining to comments written by the operator on the February 2007 and March 2007 monthly casing pressure log. MMS has no record of the notification, and Apache stated in its report the home office was not notified.

The following statements, based on documentation presented by Apache during the panel interview of personnel on November 27, 2007, list the mechanical and physical events concerning this well. Personnel with Apache in attendance during this interview include Mr. Paul Gluth, Production Engineer Manager for GOM East; Mr. Wade Broussard, Regulatory Foreman; Mr. John Martin, Production Engineer; Mr. Jerry Bordelon, District Production Manager; and Mr. Ronald Christ, Production Superintendent. Minerals Management Service panel members in attendance include Mr. Robert Ranney,

Production Engineer; Mr. Russell Hoshman, Workover Engineer; and Mr. Randall Josey, Safety and Environmental Management Specialist.

- The observed casing pressure was 2,200 psig. This casing pressure was equal to the reported tubing pressure on Well A-1 (LS) and not equal to the tubing pressure on Well A-1D. Communication existed between the casing and the tubing of this well. Apache first noted this pressure on January 29, 2007.
- There was a diagnostic test run on the production casing January 29, 2007 on Well A-1. The production casing bled from 1,950 psig and would not bleed below 250 psig.
- On August 13, 2007 another diagnostic test was performed on Well A-1. The production casing bled from 1,950 psig and would not bleed below 450 psig.
- Gas leaking around the MP 91A platform was first reported by Apache on August 22, 2007. This was the first indication of possible failed casing.
- On August 28, 2007, the long string of Well A-1 was open to production at which time the gas boil at mud line decreased to one-third preproduction size.
- The 9 5/8-inch casing was initially cemented with 1,860 cubic feet of Class H cement. According to the Cement Evaluation Log, the cement was gas cut. There appeared to be large areas of no cement at the depth of each gas zone in the well, indicating that the cement quality was very poor. This trend exists from 7,200 feet MD to the top of the cement. (*See attachment 3 for cement bond log.*)
- The 16-inch, 84 pounds per foot, K-55 casing was run to 2,220 MD/TVD. Estimated gas pressure at the 16-inch shoe was 2,400 psig, assuming a 0.1 psi per foot gas gradient and a surface pressure of 2,200 psig. The pressure at the shoe of the 16-inch surface casing could be 21 pounds per gallon (ppg) mud weight equivalent. Apache's estimated fracture gradient at 2,200 feet for Lease OCS-G 14576 Well No. 3 (Well No. A- 1 relief well) was only 13 ppg.
- The minimum internal yield pressure of the 9 5/8-inch, 47 pounds per foot, P110 casing was 9,440 psig. The maximum observed casing pressure on the 9 5/8-inch casing was 2,200 psig, or 23.3 percent of yield.

- The minimum internal yield pressure of the 16-inch, 84 pounds per foot, K-55 casing was 2,980 psig. The observed casing pressure on the 9 5/8-inch casing was 2,200 psig, or 73 percent of the yield pressure of the surface casing.
- During the recompletion stage performed in April 2003, a cement packer was set in Well No. A-1/A-1D. The long string and short string were perforated within the cement packer and pressure tested to 1,000 psig. The two tubing strings did not have communication with the production casing at that time. The production casing was pressure tested to 1,000 psig. The workover report did not have a notation about a possible casing leak at this time. The top of the cement packer extended 503 feet above the highest perforation.

Relief Well

The relief well, OCS-G 14576 Well No. 3, intersected the wellbore of Well No. A-1/A-1D on November 04, 2007 at 5,391 feet true vertical depth (TVD). While milling into Well No. A-1/A-1D's wellbore, a total of 525 bbls of drilling mud was pumped away, killing Well No. A-1/A-1D. A total of 203 bbls of cement was displaced into the Well No. A-1/A-1D wellbore. The cement was tested to 1,000 psig after it set up. The relief well was (appeared to be) successful at killing and plugging the Well No. A-1/A-1D blowout.

On November 16, 2007, Apache reported that residual bubbling was observed near the platform, and appeared to be an artifact of the underground blowout and not a leak from Well No. A-1/A-1D.

Well Test Reports and DX Plug Depths

1. Well A-2
 - Test dated March 15, 2003, reported production of 290 thousand cubic feet per day (MCF/D); 0 barrels of oil per day (BOPD); and 0 barrels of water per day (BWPD).
 - DX plug was set at 4,567 feet, rotary kelly bushings (RKB), in an X nipple on September 7, 2007.
2. Well A-2D
 - Test dated May 29, 2003, reported 80 MCF/D; 0 BOPD; and 24 BWPD.
 - DX plug was set at 4,597 feet, RKB, in an X nipple on September 7, 2007.
 - See attachment 4 for well bore schematic.
3. Well A-3
 - Test dated August 17, 2007, reported 1,609 MCF/D; 1 BOPD; and 3 BWPD.
 - DX plug was set at 6,056 feet, RKB in an X nipple on September 7, 2007.
4. Well A-3D
 - Test dated March 21, 2003, reported 604 MCF/D; 0 BOPD; and 544 BWPD.
 - DX plug was set at 1,085 feet, RKB in an X nipple on September 7, 2007.
 - See attachment 5 for wellbore schematic.

Human Factors

The human factors will be analyzed by examining the procedural barriers that were in place to prevent an undesirable event, and how the crossing of such barriers contributed to the event. A “barrier” is a single decision point in the chain of events that had the potential to change the final outcome to something more favorable.

- I. Initial Discovery and Notification.
 - A. Barrier - Observation of casing pressure.
 1. This barrier functioned. The Apache operating personnel observed the increase in casing pressure.
 - B. Barrier - Apache operating personnel notify Apache Regulatory Department, who notify the MMS New Orleans District Office and the responsible Apache engineer of the change in the casing pressure.
 1. This barrier functioned. The information was distributed, which now establishes two barriers, either of which may have prevented the event.

- a. The Apache Regulatory Department did not follow-up to ensure proper action was taken.
- b. The MMS would follow-up to ensure proper action was taken.
 - (1) This barrier was compromised at this time by the Apache Regulatory Department when, in the text of their notification, the department stated it would submit diagnostic reports to, and request a departure from, the MMS New Orleans Regional Office. There is no record of the Apache Regulatory Department requesting a departure or submitting a diagnostic report to the Minerals Management Service.
 - (2) The notification also failed to mention that the casing pressure had risen above 20 percent of the MIYP.
- c. The Apache engineer would follow-up to make sure action was taken.

II. Response to Initial Discovery.

A. By the Apache Regulatory Group.

- 1. Barrier - The Apache Regulatory Group requested that the Apache operating personnel send the results of a diagnostic test as soon as it was completed.
 - a. The diagnostic test was performed on January 29, 2007 by the "B" crew, but there is no record that the information was transmitted to the Apache Regulatory Group. This test showed that the casing pressure would not bleed down to zero, a condition that precluded Apache from continuing to produce the well. The MMS Letter to Lessees (LTL) to operators dated January 13, 1994 states, in part, that wells having casings with sustained pressure greater than 20 percent of the minimum internal yield pressure of the affected casing, or pressure that does not bleed to zero through a 1/2-inch needle valve, must be submitted to this office for approval.

b. Neither the above instructions, nor the results of the earlier diagnostic test, were transmitted from the “B” Crew to the “A” Crew. The “A” crew was aware of something, as they requested direction from the Apache Regulatory Group. The Apache Regulatory Group replied, but there is no record of any action being taken by the Apache operating personnel.

2. Barrier - The Apache Regulatory Group did not notice the absence of any response from the Apache operations personnel prior to their being notified on July 10, 2007 by Linear Controls. Linear Controls is an instrumentation company contracted by Apache to provide I&E technicians offshore as well as to manufacture control panels for Apache. They also have a compliance division that handles Apache’s monthly MMS test paperwork. They employ a review for accuracy/errors. In addition, Linear Controls stores all of Apache’s electronic drawing files and documents as part of a database management system/service.

a. The Apache Regulatory Group did not act on the advice from Linear Controls until August 8, 2007.

b. Based on an interview with Apache Regulatory personnel, there is a belief that, in the event a well with sustained casing pressure will not bleed to zero, the decision as to whether the well is allowed to continue to produce lies with the Apache Production Engineer. MMS LTL dated January 13, 1994 states, in part, that wells having casings with sustained pressure greater than 20 percent of the minimum internal yield pressure of the affected casing, or pressure that does not bleed to zero through a 1/2-inch needle valve, must be submitted to this office for approval.

B. Apache Engineer.

1. Barrier - There is no record of any response or action by the Apache Engineer.

C. Apache operating personnel.

1. Barrier - The entry of the casing pressure into the Apache Casing Pressure Management Program would flag the pressure at the platform and at the Apache Lafayette office level. The pressure was entered into the Apache Casing Pressure Management Program, but the flags at neither the local level nor the Apache Lafayette office level were not followed-up on.
2. Barrier - The monthly Casing Pressure Log is reviewed for unacceptable conditions by a contract auditor. The abnormal condition is mentioned on the Casing Pressure Logs for at least three months. This notation is accurate in stating that the casing pressure has equalized with the tubing. However, there is no mention that the casing pressure was above 20 percent of MIYP; that the casing would not bleed down to zero; or that a departure had been obtained from MMS to continue to produce. The auditing firm does not note the lack of a departure or of other supporting documentation until July 10, 2007.

Conclusions

The Incident

On January 29, 2007, a casing pressure diagnostic test was performed on the 9 5/8 inch production casing of well OCS-G 14575 Well A-1/A-1D indicating that there was 1950 psig on the production casing and it would not bleed below 250 psig. Well A-1 was capable of producing gas from the production casing. The status of well A-1 was that the long string was producing 2.1 MMCFD with 1950 psig FTP and 2215 SITP. The short string was isolated with a tubing plug. Communication existed between the long string (A-1) and the production casing. This diagnostic test was not reported to the MMS. The current dual completion in this well utilized a cement packer from 4,925 feet to 6,595 feet with perforations within the cement packer into two producing intervals. The top of the cement packer was extended 503 feet above the highest perforation. When the cement packer was circulated in place, it was originally pressure tested to 1000 psig. No communication existed at that time. On August 23, 2007, an Apache Corporation representative reported gas leaking at the mud line at Main Pass, Block 91, Platform A (MP 91A). No pollution was visible.

It was determined the source of the gas was Well A-1. The communication problem that had existed within Well A-1 had breached the production casing and reached the surface. The maximum observed production casing pressure was 2200 psig. The initial minimum internal yield of the 9 5/8-inch, 47 pounds per foot, P-110 was 9,440 psi. The observed casing pressure on the 9 5/8-inch was 2,200 psig or 23 percent of the internal yield. The pressure was only 23% of the minimum internal yield pressure of the 9 5/8 inch production casing and 74% of the next outer casing, the 16 inch surface casing. Without an additional event or contributing factor, the tubing casing communication would have been contained within the production casing. Once the casing pressure breached the production casing and regardless of the depth that the gas was exiting the production casing, the magnitude of the casing pressure was more than sufficient to break down the shoe of the 16 inch surface casing at 2,220 feet measured depth. The estimated fracture gradient at the shoe of the 16 inch surface casing was 13 pounds per gallon (ppg) mud weight equivalent and the mud weight equivalent of the casing pressure was 21 ppg.

Causes

This panel team has concluded that the evidence in this investigation does not provide the necessary information to say definitely how or why failure occurred. The panel has concluded that the failure was not due to failure at the cement packer. Wild Well Control performed dye tests and pressure tests on August 27, 2007 which the panel believes indicates holes are located above the packer. Wild Well Control pumped 150 barrels (bbls) of seawater with dye (one-half production casing volume) into the production casing. The gas boil on the water increased substantially, and dye was observed in the boil after only 15 bbls of seawater and dye had been pumped, leading this panel to believe the hole in the casing was above the packer. It should be noted that the casing would be gas filled from the well head to as low as the hole in the 9 5/8 inch casing. You can not conclude that the hole in the casing was very shallow because dye appeared at the surface after pumping only 15 bbls of seawater and dye. Water injected into the casing would fall through the gas column. Wild Well Control then bullheaded 50 bbls (2 times the tubing capacity) of 11.6 ppg calcium chloride fluid with dye (kill weight 8.6 ppg) down the long string with no effect on the boil, and no dye observed in the boil, indicating the cement packer had not failed.

Contributing Causes

The original cementing of the 9 5/8-inch casing is considered to be a contributing cause. The cement evaluation logs, produced by Apache, indicate that the cement was gas cut. At the depth of each gas zone in the well, the cement quality is very poor, showing what looks like large areas of no cement. This trend exists from 7,200 feet MD to the top of the cement at 2200 feet. (*See attachment 3 for cement bond log.*)

The Apache operators failed to use Apache's Casing Pressure Management Program which would have raised a red flag where casing pressure is concerned. Had this program been used as intended, the Apache regulatory personnel would have been notified of the sustained casing pressure and could have acted accordingly.

The Apache third-party auditor failed to notify the Apache regulatory personnel of comments noted on the monthly casing pressure log by the Apache operators. The casing pressure log on the Apache monthly MMS paperwork serves as an additional resource in tracking the casing pressures on all of Apache's wells.

Remaining Wells On-Site

Wells Nos. A-2/A-2D and A-3/A-3D have sunk below the mud line and do not meet the MMS regulatory requirements for an abandoned well. The last reported well test on each well indicates gas with little or no oil production. The wells have subsided as a result of the blowout of Well No. A-1. The panel believes, that due to this subsidence, the casings have gone into compression, buckled, and resulted in damage to both the production casing and the long string production tubing.

Recommendations

Plug and Abandonment Work

The MMS should ensure Apache completes plug and abandonment on remaining Wells Nos. A-2/A-2D and A-3/A-3D in accordance with the regulations cited at 30 CFR 250.1715.

Safety Alert

The MMS should also issue a Safety Alert to all lessees and operators containing a brief description of the accident and a summary of the causes leading up to the accident. The following recommendations should also be included in the Safety Alert: (1) Lessees and Operators should review their policies regarding casing pressures; and (2) Lessees and Operators should communicate clearly and in writing what is expected of their field representatives with respect to reporting casing pressures; and (3) Operators are reminded to refer to NTL 2005-G09, Static Casing Pressures Less than 100 psig, dated June 1, 2005, should they experience wells with sustained casing pressure.

APACHE CORPORATION

MAIN PASS BLOCK 91

Set DX, TXA 55

as of 8/03 CURRENT

API: 17-725-40606-00-

OCS-G 14576 WELL A-1 / A-1D

PROPOSED

DIRECTIONAL DATA		
KOP - STRAIGHT HOLE	N/A	RKB
MAX DEV	"	N/A RKB
MAX DOGLEG	"	N/A RKB
DEV AT PERFS	"	N/A RKB
RETURN TO VERTICAL	N/A	RKB

ELEVATIONS		
RKB - MWL		95 FT
RKB - TH		35 FT
WD		37 FT

TUBULARS	SIZE	WT	GRADE	THREAD	DEPTH
DRIVE	36	330			312
SURFACE	70	84	K55		998
PRODUCTION	5-5/8	47	P110		7605
LONG STRING	2-3/8	4.7	L80	BTS8	
SHORT STRING	2-3/8	4.7	L80	BTS8	

WELL HEAD DATA	
TYPE	2-1/16" Dual
WP	5000 psi
TREE CAP	
FLANGE	7-1/16" 5M
THREAD	2-3/8" 8rd
TBG HANGER	
BPV PROFILE	
BTM FLANGE	11" 5M

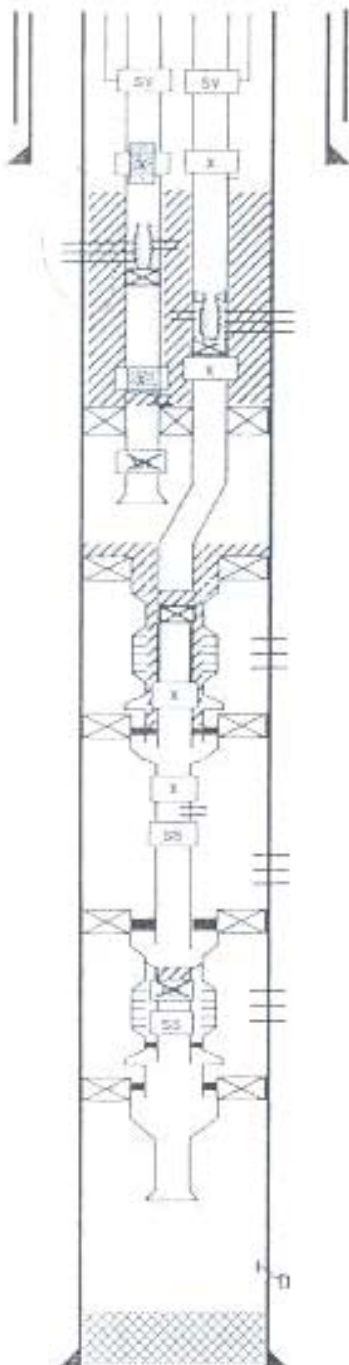

DESCRIPTION OF EQUIPMENT	ID	OD	DEPTH (RKB)				
			SS	LS			
Carnoo TRDP-4E scssvs with FCs SSSV IS NOT HOLDING 703	1.875	4.125	519	589			
SS - DX plug set in X nipple, 8/18/03 (annual plug check)							
X nipples with FCs	1.875	2.625	1995	1964			
Cement Packer from 4925' to 6595' MD (tested to 1000 psi)							
SS- TTWLG assembly w/ 30/50 sand (Pulled pack-off and A-stop)			5401				
SS- Tubing Punch @ 5428' (2" x 4 spf) (to test cement packer)			5428				
FE Sand perfs : 5428' - 5432' (4' x 18 spf)	4		5428	5432			
SS- 1.71" Alpha Bridge Plug (gravel pack base)			5440				
LS- TTWLG assembly with 30/50 sand (Packoff with A-stop on top)			6442				
LS- Tubing punch @ 6470' MD (2" x 4 spf) (to test cement packer)			6470				
GD Sand perfs: 6470' - 6475' (5' @ 18 spf)	5		6470	6476			
LS- 1.71" Alpha Bridge Plug (gravel pack base)			6481				
X-nipple with FC's	1.875	2.625		6554			
SS- X nipple with cml retainer on X-lock	1.875	2.625	6584				
SS- Tubing punch @ 6590' (10" x 4 spf) (circulating hole for cml pkr)			6590				
COMP-SET "D" DUAL PACKER	2.44	8.312	6603	6603			
XN nipple, PX PLUG	1.791	2.025	6614				
WL entry guide	1.990	2.625	6619				
cement plug w/ 52 sxs. (10 bbls) (ETOC @ 6685') (245' plug)							
COMP-SET II HP GRAVEL PACK PACKER	4.750	8.375		6790			
BLANK PIPE (80')	4.950	5.500		6822			
0.008 GA gravel pack screen (41')	4.950	5.500		6901			
1.71" Cast Iron Bridge Plug with 50' cement (TOC @ 6855' MD)				6905			
2-3/8" blast joints (20')	1.990	3.625		6912			
SQUEZZED - GG SAND PERFS : 6930' - 6935' (12 SPF)	5		6930	6935			
X nipple	1.875	3.625		6938			
COMP-SET II HP ISOLATION PACKER	4.750	8.437		6944			
2-3/8" 4.7# L80 BTS8 isolation tubing							
X nipple	1.875	2.687		6994			
Tubing perfs 7020 - 7022', 4 SPF (8960 WLM)							
ISO "A" sliding sleeve (closed), unable to open	1.875	2.687		7034			
ABANDONED - GG STRAY SAND PERFS : 7052' - 7060' (12 SPF)	8		7052	7060			
R/C'd to GG Stray on 9/13/00							
COMP-SET II HP GRAVEL PACK PACKER	4.000	8.375		7072			
2-3/8" 4.7# L80 BTS8 isolation tubing							
ISO "O" sliding sleeve (open), PX PLUG, 10" sd / cml, TOC 7095'	1.875	2.687		7105			
ISO "O" selective sliding sleeve (closed)	1.875	2.687		7130			
BLANK PIPE (20')							
0.008 GA gravel pack screen (19')							
ABANDONED - GH SAND PERFS : 7123' - 7130' (12 SPF)	7		7123	7130			
COMP-PERM II SUMP PACKER	4.750	8.062		7138			
SAND	TVD	BHP	EMW	BHT	SIFP	6974	MD
E1	4880	2182	8.6	134	1634	6974	TVD
FE (BHP 403)	5428	1249	4.4	154	677	7605	MD
GD (BHP 403)	6470	2876	8.8	162	2485	7605	TVD
GG	6930	3090	8.6	156	2406		
GG STRY BHP	7052	3077	8.4	158	2346		
GR	7123	3222	8.7	158	2510		
PLUG BACK						6974	MD
TOTAL DEPTH						7605	MD
FLUID LIH						8.5	ppg CACL
DATE LIH						4/2/1996	
PREPARED BY						B. Erickson	
DATE						10/02/03	

Schematic of well A-1/A-1D

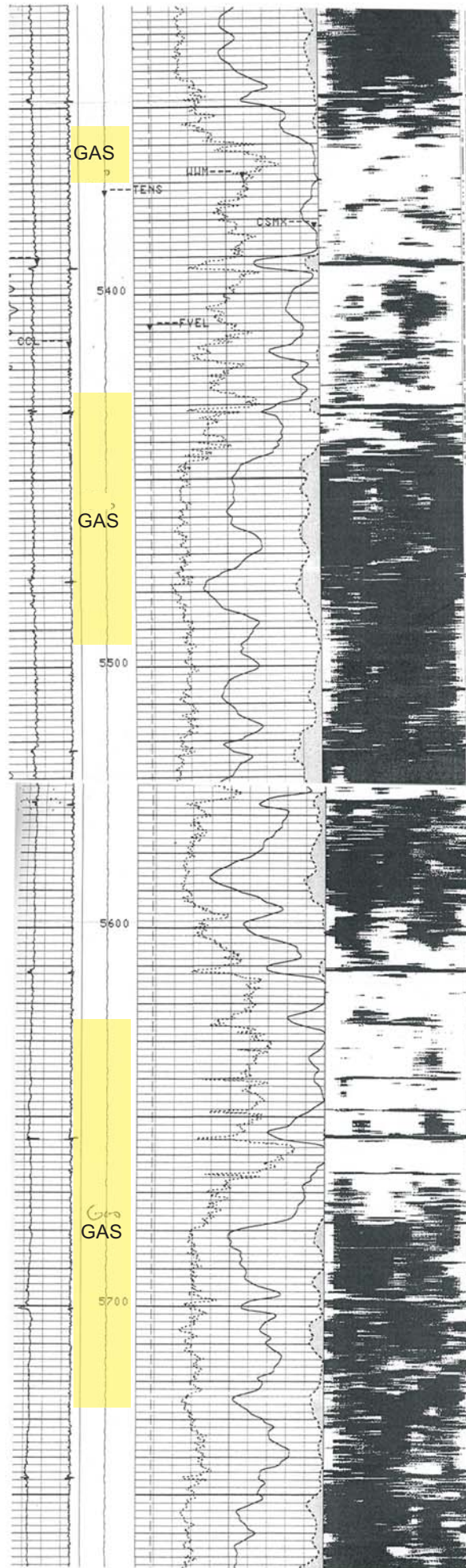

APACHE CORPORATION

MAIN PASS BLOCK 91

DX Plugs, TA SS and LS

as of 9/2007 CURRENT

PROPOSED

API: 17-725-40622-00

OCS-G 14576 WELL A-2 / A-2D

DIRECTIONAL DATA		
KOP		1300 RKB
MAX DEV	33.0 °	2800 RKB
MAX DUELG	6.0 °	2200 RKB
DEV AT PERFS	0.0 °	RKB
RETURN TO VERTICAL		6584 RKB

ELEVATIONS		
RKB - MWL		118 FT
RKB - TH		55 FT
WD		.37 FT

TUBULARS	SIZE	WT	GRADE	THREAD	DEPTH
DRIVE	48				303
CONDUCTION	16	84	K55		1040
SURFACE	10.34	45.5	K55		3735
PRODUCTION	7.58	31.7	P110		9221
LONG STRING	2.3/8	4.7	L80	BT58	
SHORT STRING	2.3/8	4.7	L80	BT58	

WELL HEAD DATA	
TYPE	2-1/16" DUAL
WP	5000 PSI
TREE CAP	
FLANGE	2-1/16" 5M
THREAD	2-3/8" 8/d
TBG HANGER	
BPV PROFILE	
BTM FLANGE	

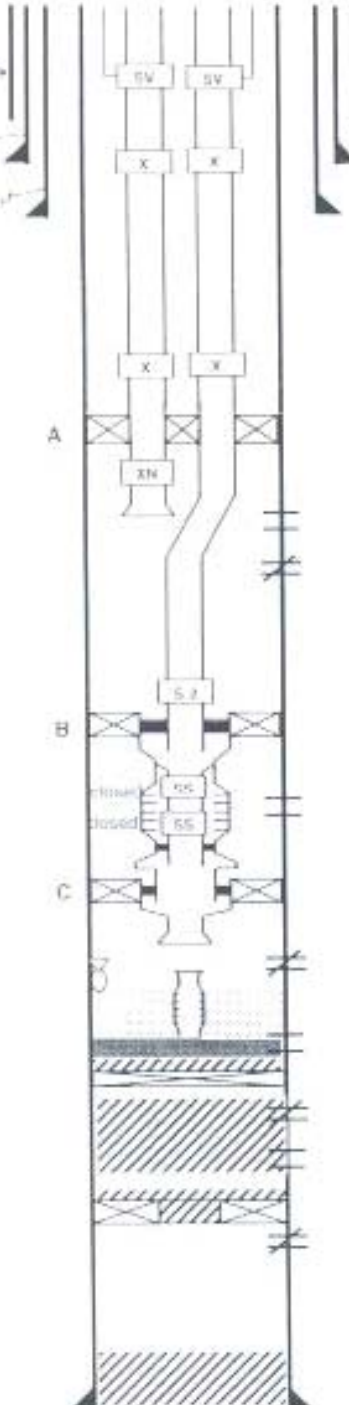

DESCRIPTION OF EQUIPMENT	ID	OD	DEPTH (RKB)					
			SS	LS				
CAMCO TRDP 4E SC55V6 WITH FCS	1.875	4.125	614	644				
X-ripples with FCS	1.875	2.7	3021	1051				
X-ripples (DX plug installed in both ripples 9/707)	1.875	2.7	4567	4590				
EA SAND @ 4440'								
A Comp Set "D" Dual Packer	1.99	6.469	4651	4651				
XN ripple	1.791	2.7	4662					
WL entry guide	1.995	2.700	4668					
EC-1 SAND PERFS : 4850' - 4854' (4' - 12 SPF)								
squeeze perfs. 4877' - 4878'	4		4850	4854				
FB-U SAND @ 5582'								
FD SAND @ 5864'								
GD SAND @ 6970'								
S-2 ripple	1.875	2.700	716					
B Comp-Set gravel pack packer	3.250	6.547	719					
2-3/8" 4 7/8 isolation tubing								
ISO "O" sliding sleeve (closed)	1.875	2.700	727					
ISO "O" selective sliding sleeve (closed)	1.875	2.700	729					
GF SAND PERFS. 7294' - 7300' (6' - 12 SPF)								
C Comp-Perm It Sump packer	4.000	6.500	730					
WL entry guide	1.995	2.700	731					
squeeze perfs. 7346' - 7350'								
3T of lost cap retrieval tool ETOF @ 7501 MD								
TTWL GP Assbly (37' 40# gravel, 6' eml cap on gravel)				751				
GG Stray Sed Perfs 7552' - 7558' (12 SPF) (4' form. sand, TOS @ 7554')	6		7552	7551				
Petal Basket w/ 1lb of cement (TDC @ 7558' MD) as base for GP				757				
250 cement plug ETOC @ 8776 MD (50 sks, 11 1/2 lbs)								
squeeze perfs. 8896' - 8898'								
HF SAND PERFS : 8964' - 8977' (18 SPF)								
EZSV w/ TOC at 9026				904				
squeeze perfs. 9071' - 9085'								
SAND	TVD	BHP	EMW	BHT	SITP	PLUG BACK	9026	MI
EA	4114	1851	8.7	128	1700		8540	TVI
EC-1	4474	2001	8.6	135	1553	TOTAL DEPTH	9221	MI
FB-U	5155	2312	8.7	147	2080		8736	TVI
GF	6810	3081	8.7	177	2400	FLUID LIH	8.7 ppg CACL	
GG str	7066	3049	8.3	180	2342	DATE LIH	10/8/1996	
HF	8478	3835	8.7	207	2988	PREPARED BY	J. C. MARTIN	
						DATE	9/7/2007	

Schematic of well A-2/A-2D

APACHE CORPORATION

MAIN PASS 91 FIELD

DX Plugs, TA SS & LS

as of 09/07 CURRENT

API: 17-725-40650-00-

MP 91 OCS-G-14576 A-3 / A-3D

PROPOSED

DIRECTIONAL DATA		
KOP		4030 RKB
MAX DEV	46.0 °	6203 RKB
MAX DOGLEG	3.3 °	4696 RKB
DEV AT PERFS	44.0 °	RKB
RETURN TO VERTICAL		RKB

ELEVATIONS		
RKB - MWL		109 FT
RKB - TH		50 FT
WD		37 FT

TUBULARS	SIZE	WT	GRADE	THREAD	DEPTH
DRIVE	24				323
CONDUCTOR	16	84	J-55		1318
SURFACE	10-3/4	45.5	J-55	BTC	3850
PRODUCTION	7-5/8	33.7	P-110	LTC	9470
SHORT STR	2-3/8	4.7	N-80	BTS-8	8159
LONG STR	2-3/8	4.7	N-80	BTS-8	7721

WELL HEAD DATA	
TYPE	2 1/16" Dual
WP	5 000 psi
TREE CAP	
FLANGE	1 1/16" 5M
THREAD	2-3/8" stub acctm
TBG HANGER	DCP-FBB
BPV PROFILE	2" HSBPV
BTM FLANGE	9" 10M

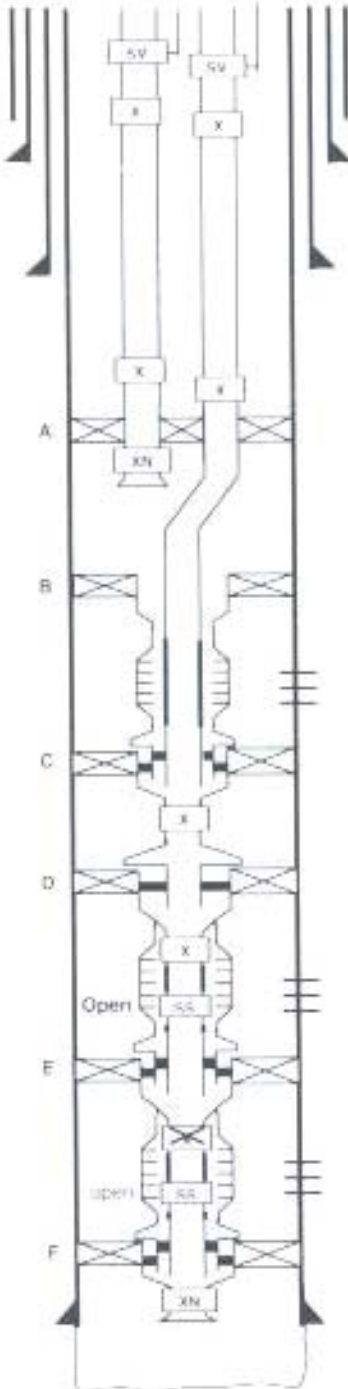

DESCRIPTION OF EQUIPMENT	OD	ID	DEPTH (RKB)				
			SS	LS			
Cameron (Type DCP-FBB) 2.436' ACME Box x 2-3/8" CS Box							
Cameron THHP 4E SCSSV w/ 12 pups	4.125	1.875	502	594			
X-nipple w/ 15' pups (DX plug installed in LS nipple 9/7/07)	2.700	1.875	993	1085			
X-nipple w/ 15' pups (DX plug installed in SS nipple 9/7/07)	2.700	1.875	6056	6086			
A 7-5/8" 33.7-39# OSCA Dual packer	6.489	1.995		6143			
XN nipple w/ 4' pups	2.700	1.791	8154				
WLRG (EOT)	2.700	1.940	8159				
B 7-5/8" 29.7-39# OSCA Comp-Set II "HP" packer	6.437	4.000		6396			
4" NU Bnd P-110 11.6# Blank (56)	4.000	3.476		6474			
4" NU Bnd 8-GA WESCO 316-L Excel SL/HD Screen (36)	4.545	3.550		6471			
Inner- 2-3/8" BTS-8 Blast joint (50')	2.700	1.937	6456				
"GA" sand perfs from 6492 - 6500	8		6492	6500			
Inner- 2.687" x 4' production seals	2.687	1.937	6506				
C 7-5/8" 29.7-33.7# OSCA Comp-Set II "HP" packer	6.547	4.000		6508			
X nipple	2.700	1.875		7439			
D 7-5/8" 29.7-39# OSCA Comp-Set II "HP" packer	6.437	3.250		7471			
Inner- X nipple	2.700	1.875	7521				
Inner- 2-3/8" BTS-8 Blast joint (60')	2.700	1.937	7523				
Inner- ISO-O sliding sleeve [Open]	2.700	1.875	7582				
Inner- 2-3/8" BTS-8 Blast joint (12')	2.700	1.937	7586				
"GG" sand perfs from 7564 - 7586	22		7564	7586			
4" NU Bnd N-80 11# Blank (60')	4.000	3.476		7487			
4" NU Bnd 8-GA WESCO 316-L Excel SL/HD Screen (49)	4.545	3.550		7547			
Inner- 2.687" x 4' production seals	2.687	1.937	7598				
E 7-5/8" 29.7-39# OSCA Comp-Set II "HP" packer	6.437	4.000		7597			
Inner- X nipple (PX plug)	2.700	1.875	7626				
(Temporarily abandoned for later compression reserves)							
Inner- 2-3/8" BTS-8 Blast joint (60')	2.700	1.937	7627				
Inner- ISO-O sliding sleeve [Open]	2.700	1.875	7687				
Inner- 2-3/8" BTS-8 Blast joint (12')	2.700	1.937	7691				
"GG Stray" sand perfs from 7678 - 7688	10		7678	7688			
4" NU Bnd N-80 11# Blank (48')	4.000	3.476		7614			
4" NU Bnd 8-GA WESCO 316-L Excel SL/HD Screen (40)	4.545	3.550		7662			
Inner- 2.687" x 4' production seals	2.687	1.937	7702				
F 7-5/8" 33.7-39# OSCA Comp-Perm II packer	6.250	4.000		7703			
XN nipple w/ 4' pups	2.700	1.791	7716				
WLRG (EOT)	2.700	1.940	7721				
SAND	TVD	BHP	EMW	BHT	SITP	PLUG BACK	9335 MD
FG	5853	2617	8.5	146		862#	TVD
FJ	5993	2680	8.6	148			
GA	6102	2221	7.0	149			
GG (303 BHP)	6957	3049	8.4	168			
GG Stray	7062	2571	7.0	169			
TOTAL DEPTH						8472	MD
						8762	TVD
PACKER FLD						9.7 CaCl	
DATE LIH						na	
PREPARED BY						J. C. MARTIN	
DATE						9/7/2007	

Schematic of well A-3/A-3D