



**Investigation of Fire and Fatality  
East Cameron Block 60  
April 9, 1999**

**Gulf of Mexico  
Off the Louisiana Coast**



**Investigation of Fire and Fatality  
East Cameron Block 60  
April 9, 1999**

**Gulf of Mexico  
Off the Louisiana Coast**

Frank Pausina  
Milford Cole  
Marty Rinaudo

# Contents

---

## **Investigation and Report, 1**

Authority, 1  
Procedure, 1

## **Introduction, 4**

Background, 4  
Brief Description of Accident, 4

## **Findings, 5**

Brief Description of Platform, 5  
Preliminary Activities, 7  
    Originally Scheduled Work, 7  
    Change of Work Scope, 7  
    Crew Change and Communication, 8  
    Safety Meeting, 8  
    Work Detail Deployment, 9  
    FG Scrubber PSV Manifold Replacement, 10  
    Process Drain System Deactivation, 11  
Subcellar Deck Cuts/Accident, 13  
Post-fire Activities, 15  
Sources of Discharge into Sump System, 16  
Alarm History/Analysis, 17  
Procedures and Designated Operator/Contractor Agreements, 19

## **Conclusions, 22**

Accident, 22  
Causes, 23  
    Mechanical, 23  
    Personnel/Procedural/Communication, 25  
    Management, 26

## **Recommendations, 29**

## **Appendix**

Attachment 1, Location of Lease OCS-G 5359, East Cameron Block 60  
Attachment 2, Simplified Partial Flow Schematic of Platform  
Attachment 3, Simplified Flow Schematic of Fuel Gas Scrubber  
Attachment 4, Photograph of Fuel Gas Scrubber  
Attachment 5, Very Simplified Flow Schematic of Fuel Gas Filter  
and Generator Fuel Filter  
Attachment 6, Photograph of Severed HP Separator Drain Line  
on Production Deck  
Attachment 7, Photograph of HP Separator Drain Line with Band Attached

# Investigation and Report

---

## Authority

The fire and fatality that resulted in one fatality, one injury, approximately one million dollars' worth of damage, and the discharge of approximately one barrel of condensate into the sea occurred during construction work on Vastar Resources, Inc.'s (Vastar) Platform A, East Cameron Block 60, Lease OCS-G 5359 in the Gulf of Mexico, offshore the State of Louisiana, on April 9, 1999, at approximately 1337 hours. Pursuant to Section 208, subsections 22 (d), (e), and (f), of the Outer Continental Shelf (OCS) Lands Act, as amended 1978, and the Department of the Interior Regulations 30 CFR Part 250, the Minerals Management Service (MMS) is required to investigate and prepare a public report of this accident. By memorandum dated June 25, 1999, the following MMS personnel were named to the investigative panel

Frank Pausina    New Orleans, Louisiana (Chairman)

Milford Cole    Lake Charles, Louisiana

Marty Rinaudo    Lafayette, Louisiana

## Procedure

At approximately 1600 hours on April 9, 1999, inspectors of the MMS Lake Charles District Office visited the scene of the accident, thereby initiating MMS's investigation of the accident. MMS district personnel visited the accident scene again on April 10, 1999. Panel members visited the accident scene on April 21, 1999.

Panel members and MMS Lake Charles District Office Inspectors met with representatives of Vastar on May 3, 1999, at Vastar's offices located in Lafayette, Louisiana. During the meeting, various details of the accident were discussed.

Vastar's report on the accident was forwarded, as requested, to the panel on May 28, 1999. On January 18, 2000, Vastar faxed to the panel statements taken by Vastar on April 9, 1999, of the following individuals:

Baines Richard - United Production and Construction Services, Inc. (UPCS)

Thomas McGuire - UPCS

Carlton Pete - UPCS

Dale Benoit - Danos and Curole Marine Corporation (D&C)

Louis Bustos - D&C

Rodney Leonard - 2M Radiator and Cooler Services (2M)

Paul Giroir - 2M

On January 20, 2000, the panel conducted interviews with the following witnesses at the New Orleans District Offices:

Glen Birkicht - Vastar (at the time of the accident employed by D&C)

Louis Bustos - D&C

Steve Frantz - Vastar

Bill O'Donnell - Vastar

On January 21, 2000, the panel members conducted an interview with Richard Landry of UPCS at the New Orleans District Offices.

Repeated attempts by the panel to contact Dale Benoit for the purpose of scheduling an interview have failed.

Panel members Cole and Rinaudo revisited the accident scene on February 7, 2000.

On February 11, 2000, the panel interviewed Baines Richard of UPCS at the law offices of Mr. Richard's attorney in Baton Rouge, Louisiana.

Verbatim transcripts of the aforementioned interviews are included in the case file of this investigation.

On March 2, 2000, panel members Pausina and Rinaudo met with Vastar representatives at Vastar's offices in Houston, Texas, to discuss various issues related to the accident.

The Panel members met at various times throughout the investigation, and after having considered all of the information available, produced this report.



## Introduction

---

### **Background**

Lease OCS-G 5359 covers approximately 5,000 acres and is located in East Cameron Block 60, Gulf of Mexico, off the Louisiana coast. *For lease location, see Attachment 1.* The lease was issued effective July 1, 1983. Vastar became the designated operator of the lease in March 1994. At the time of the accident, D&C was contracted to operate the platform.

### **Brief Description of Accident**

On the afternoon of April 9, 1999, a section of the high-pressure separator's drain line was being cut with an electric bandsaw as part of the deactivation of the platform's process drain line system. Construction contract personnel discontinued efforts to complete the severing of the line because of the flow of condensate from the cut. After having attempted to contain the spilled condensate and after having observed no further flow of liquids from the cut, the workers continued to cut the line. During the recutting of the line, condensate, which flowed from the cut, drenched the worker who was operating the saw and was ignited by the saw. The ensuing fire engulfed the worker, who died days later as a result of the burns. Another worker was injured in his attempt to assist the burned worker. The fire caused approximately one million dollars' worth of damage to the platform, and approximately 15 gallons of condensate spilled into the Gulf.



## Findings

---

### **Brief Description of Platform**

The following very brief description of the platform emphasizes those aspects of the platform production flow that more directly relate in varying degrees to the subject accident. Therefore, not all safety devices and pipelines lines will be shown. *For a simplified partial flow schematic of the Platform, see Attachment 2*

Platform A has one producing gas well that flows to a High-Pressure Separator (HP Separator) or Test Separator. When the wells flows to the HP Separator, they also have the option of flowing through a cooling tower. After separation, gas and condensate are routed to the departing sales pipeline. Facility fuel gas is taken off the sales pipeline downstream of the HP Separator.

The fuel gas flow, in route to a Fuel Gas Scrubber (FG Scrubber), flows through an automatic shutdown valve (SDV) and flow safety valve (FSV). The fuel gas then flows through a dual run of a manual block valve (MB Valve), pressure control valve (PCV), and MB Valve per run prior to entering the FG Scrubber. The FG Scrubber dump line consists of an MB Valve, dump valve controlled by an internal dump level controller, SDV, FSV, and MB Valve. The FG Scrubber drain line consists of an MB Valve. The two lines connect on the production deck and flow into the platform's sump system, as depicted in Attachment 2. The FG Scrubber is equipped with a level safety high (LSH), level safety low (LSL), and pressure safety high-low (PSHL), which activate the SDV on the

FG Scrubber dump line and the SDV located upstream of the FG Scrubber. The FG Scrubber also is equipped with a pressure safety valve manifold (PSV Manifold), which allows FG Scrubber blowdown to a High-Pressure Vent Boom (HP Vent Boom). *For a simplified flow schematic of the FG Scrubber, see Attachment 3. For a photograph of the FG Scrubber, see Attachment 4.*

Fuel gas from the FG Scrubber then flows to the Fuel Gas Filter (FG Filter). Immediately upstream of the FG Filter is a dual run of a PCV and FSV per run. The FG Filter is equipped with a PSL. Liquids from the FG Filter enter the sump system through a drain line containing an MB Valve located on the production deck. Gas from the FG Filter powers the platform's pneumatic devices. Gas from the FG Filter also flows to the gas Generator Fuel Filter (Gen. Filter). Liquids from the Gen. Filter enter the sump system through a drain line equipped with an MB Valve located on the main deck. *For a very simplified flow schematic of the FG Filter and Gen. Filter, see Attachment 5.*

For the following discussion of the platform's sump system, refer to Attachment 2. The dump lines of the HP Separator, Test Separator, Low Pressure Accumulator (LP Accumulator), and Skimmer tie into a line, henceforth referred to as the Manifold Drain. The drain lines of the above vessels, together with the Manifold Drain, tie into the sump system as shown in Attachment 2.

**Preliminary  
Activities**

***Originally Scheduled Work***

On March 31, 1999, on East Cameron Block 60 Platform A (Platform A), a leak below the production deck was discovered in the drain line of the test separator. The decision was made by Vastar to repair the leak and also to repair the gas cooler. On April 6, 1999, the UPCS construction supervisor (U-1) met on site with the D&C lead operator (D-1) to determine the job requirements for both the repairs of the leak and the gas cooler. The repair of the leak consisted basically of the replacement of an approximately 20-foot section of the Test Separator drain line. The meeting included in part a walk-through in which pertinent vessels and block valves were identified. U-1 stated that D-1 brought him to each vessel and “We went below in the subcellar and traced them.” According to D-1, hot work was discussed with respect to the welding of the replacement pipe.

***Change of Work Scope***

Later that day on West Cameron Block 71 Platform D, U-1 was informed by a Vastar operations supervisor that the above-referenced scheduled repair of the leaking drain line was changed to include the deactivation of the process drain line system because the process drain lines were no longer being used to drain process vessels into the platform’s sump system. Vastar’s official report on the accident states that the Vastar operations supervisor emphasized that the change in work scope eliminated the need for hot work. U-1 stated that there was no mention of hot work no longer being necessary in the deactivation of the

system. U-1 did not inform D-1 of the change in work scope regarding the process drain line deactivation. The deactivation consisted of cold cutting and flanging the drain lines of the HP Separator, Test Separator, LP Accumulator, Skimmer, and Manifold Drain on the Production Deck.

### ***Crew Change and Communication***

On the morning of April 8, 1999, a D&C crew change took place in which D-1 was replaced by D&C Operator 2 (D-2). D-1 stated that he informed D-2 of the repairs to be performed, namely those that he had discussed with U-1. D-2 stated that he knew of the deactivation from notes and from a conversation with a Vastar employee during his previous hitch. On D-2's only other hitch on the platform, he spent a total of 16 days.

### ***Safety Meeting***

On the morning of April 9, 1999, U-1 and four other UPCS employees, henceforth referred to as U-2, 3, 4, and 5, and two 2M Radiator and Cooler Services (2M) employees arrived on Platform A. On the same morning, a Safety Meeting was attended by the five UPCS employees, the two 2M employees, D-2, and a D&C Roustabout (D-3). The meeting was conducted by D-2 as the lead operator and thus Vastar's representative. U-1 stated that, prior to the safety meeting, he was asked by D-2 "What we were going to be doing?" and "If we did any work there before?" After U-1 replied that he had done several jobs, D-2 said, "You probably know the platform better than I do."

U-2 stated that on the same morning he heard D-2 say that “He was only on the platform two weeks and did not know the platform that well.”

During the safety meeting, only the cold-cutting, i.e., mechanical pipe cutting, of the drain pipes was discussed. While safety meeting documentation indicates discussion took place with respect to hot work, it was discussed only with respect to the erection of the scaffolding, which was to be used for the repair of the gas cooler.

At the safety meeting, a Fire and Safe Work Permit (Hot Work Permit) was initiated and signed for by U-2 and approved and signed by D-2. The permit lists the initiation action for “Welding and Cutting Equipment” only.

#### ***Work Detail Deployment***

Following the safety meeting, U-1, U-2, and U-3 went to the gas cooler, where U-1 gave instructions to U-2 and U-3 regarding the scaffolding erection.

According to the Hot Work Permit, the area around the cooler had already been “sniffed” with a lower explosive limit (LEL) meter with the meter reading zero percent. The 2M employees were waiting for the erection of the scaffolding to begin their work on the cooler.

U-4 and U-5 proceeded to the production deck, where they began to cut the drain lines that, according to U-1, had been flagged for identification purposes.

U-2 said that he did not recall seeing anything flagged.

D-2 shut in the well and proceeded to the FG Scrubber, where they made preparations to replace the FG Scrubber PSV Manifold. D-1 stated that he was aware of the plan to replace the PSV Manifold and that the replacement appeared on a list of other scheduled pipe replacements. D-2 stated that he was aware of the PSV Manifold replacement plans from notes left by D-1 and from conversations with a Vastar employee during his previous hitch. Vastar claims that they were not made aware of the fact that the PSV Manifold was going to be replaced during the time that the process drain line deactivation and the gas cooler repair were going to be performed. U-1 and U-2 stated that no discussion took place during the safety meeting regarding the replacement of the PSV Manifold. Safety meeting documentation lists no reference to work involving the replacement of the FG Scrubber PSV Manifold.

### ***FG Scrubber PSV Manifold Replacement***

The replacement of the FG Scrubber PSV Manifold required the FG Scrubber to be isolated and blown down and the FG Scrubber safety system to be placed in bypass. The devices bypassed at the relay panel were the FG Scrubber PSHL, LSH, and LSL. Once bypassed, the devices will not activate the appropriate SDV's during FG Scrubber upset conditions, which will occur during blowdown

operations. The devices will trip during upset conditions, and the incident will be a part of the alarm history. It should be noted that the bypassing does not directly affect the functioning of the FG Scrubber internal level controller and associated dump valve.

To isolate the FG Scrubber from downstream components, D-2 stated that he closed the MB Valves on both the FG Scrubber dump and drain lines (shaded areas 1 and 2 on Attachment 3). He stated that the MB Valve on the FG Scrubber drain line was already closed. The closing of both valves would effectively achieve downstream isolation. D-2 stated that he red-flagged both lines. To achieve upstream isolation, D-2 stated that he then closed the needle sensing valves for the upstream PCV's (shaded areas 3 and 4 on Attachment 3), believing them to be the incoming block valves (shaded areas 5 and 6). This resulted in both the incoming MB Valves and PCV's remaining open, thereby allowing communication between the FG Scrubber and the HP Separator during the blowdown operations.

D-2 stated that after 20 to 25 minutes of beginning the FG Scrubber blowdown operation, he noticed that the FG Scrubber pressure was not bleeding to zero. He then went back to the location of the needle valves, where he located the incoming MB Valves, which were under insulation material, and closed both. The next significant event according to D-2 was his being told "got fire" by D-3, who was assisting him in the FG Scrubber PSV Manifold replacement.

### ***Process Drain System Deactivation***

At some point that morning, U-1 went to the production deck, where U-4 and U-5 were cutting the aforementioned drain lines, and found that a bandsaw had been used to cut at least one of the lines and that the cut was crooked. He then told U-4 and U-5 to cold-cut the line as he had originally instructed, in order to obtain a straight cut for proper threading. U-1 stated that, because he understood the use of an electrical bandsaw requires a Hot Work Permit and that the existing permit was issued for the welding and cutting operations being performed on the gas cooler, he assumed that U-4 and U-5 had obtained a Hot Work Permit for the use of the bandsaw. He further stated that he was very confident that D-2 and D-3, who were on the production deck, observed the use of the bandsaw.

After leaving the production deck and returning with U-2 and U-3, U-1 saw that the cut on the HP Separator was made too close to the deck and, resultantly, could not be threaded. *For a photograph of the severed HP Separator drain line, see Attachment 6.* The decision was made by U-1 to cut the pipe below the production deck at a location on the subcellar deck. From this point forward, the exact correlation of the movements of U-2 and U-3 with respect to those of U-1 cannot be determined with a great degree of accuracy. U-1 stated that he brought U-2 and U-3 to the subcellar deck and gave them instructions to cut the pipe with an electric bandsaw. U-1 stated that he felt that the previously mentioned assumed permit applied to this pipe as well, since the pipe to be cut at



the subcellar was just an extension of the above pipe for which he assumed the permit to apply. U-2 stated that he and U-3 were sent to the subcellar deck. U-2 also stated that while on the production deck, prior to going to the subcellar deck, he noticed all the pipes had been cut and did not see a bandsaw.

U-1 stated that he then left and returned with the LEL meter to sniff around the sump area on the subcellar deck and found no gas. He stated that he then returned the meter to the cooler area, where it was found by MMS inspectors on the afternoon of the accident. Vastar stated that originally U-1 stated to Vastar that he used the LEL meter as stated above, but then he later “admitted that neither he nor U-3 ever” did so “prior to making the second cut.” The “second cut” will be explained later in the report. U-2 stated that he did not recall seeing the LEL meter being used as U-1 described to the panel. U-1 stated that after returning the meter he returned to the subcellar deck, where he gave directions to U-2 and U-3 as to where to cut the pipe and then left to call the dispatcher regarding some needed flanges.

### **Subcellar Deck Cuts/Accident**

While U-1 was absent, U-2 began to cut the drain line of the HP Separator on the subcellar deck. Interview statements from D-2, U-1, and U-2 regarding various events, some quite significant, occurring from the time of the first cut of the pipe, differ in varying degrees ranging from slightly to totally contradictory.

The following reflects U-1's testimony: By the time he had arrived back at the

subcellar deck, the cut had been made to a depth of approximately 1/4-inch and he was told by U-2 that the line was leaking at the cut but had stopped. Then, approximately 30 seconds later, condensate gushed from the cut “under pressure.” He then instructed U-2 and U-3 to not cut any further and proceeded to the production deck to find the source of the problem, where he informed

D-2, who was working on the PSV Manifold, what had happened. D-2 said in response “...it didn’t come from the fuel gas because I already drained it.” In the interview, U-1 initially said he thought D-2 was referring to the FG Scrubber. However, later in the interview, questions arose as to exactly what vessel D-2 was referring to as having been drained. It appears that D-2 might have been referring to the FG Filter. U-1 said that he saw condensate had sprayed significantly onto the production deck, indicating that condensate had not only exited at the cut but also from the top of the pipe on the production deck. D-2 then said that he would attempt to find the source of the problem. U-1 then went back to the subcellar deck, where he told U-2 and U-3 to not cut any further until the source of the problem was identified and solved. He then saw that the gushing had stopped and that U-2 and U-3 had secured buckets to the line in an attempt to prevent the liquid from pouring into the Gulf. He approximated that two 5-gallon buckets of condensate had been contained. He then went to call the dispatcher again regarding the previously mentioned equipment. While attempting to call the dispatcher, U-1 heard alarms and was told of the accident.

D-2 stated in the interview that U-1 did not come up from the subcellar deck to inform him of the spill and that he did not see any spill on the production deck.

The following reflect U-2's account of the same time period. U-2 stated that the first cut that he had made resulted in the gushing of condensate and that his clothing was soaked with condensate. He then went up to the production deck to inform U-1 of the incident, observed D-3 cleaning condensate from the production deck, found two buckets, and went back to the subcellar deck. U-1 followed him. At some point in time surrounding these series of events, U-2 poured soap and water into the top of the pipe on the production deck. He felt that this produced a safe enough environment for continuing to cut the pipe. He also stated that he assumed, although did not observe, that after the leak initially occurred that some one had sniffed the area with the LEL meter. U-3 then initiated a second cutting of the pipe, at which time condensate again gushed from the pipe, engulfed U-3, and ignited, badly burning U-3. U-2 stated that at that time condensate flowed from the top of the line on the production deck. Condensate in the deck drains on the production deck ignited shortly thereafter. U-2 stated to the panel in effect that he considered the Hot Work Permit issued on the morning of the accident that he signed to apply to all hot work performed anywhere on the platform. When shown the Hot Work Permit and asked about the different categories of hot work appearing on the permit, he responded by stating that in effect he made no distinction between the different categories.

*For a photograph of the HP Separator's drain line with the saw's band*

*attached to the cut, see Attachment 7.*

### **Post-fire Activities**

After burning his hands in unsuccessfully attempting to remove U-3's clothing, U-2 doused U-3 with a fire hose and extinguished U-3's burning clothing. U-2 stated that he activated the platform's Emergency Shutdown System (ESD) and began to fight the fire on the production deck. Statements regarding the fire-fighting efforts on the platform are sketchy at best. U-1 radioed Vastar's EC 71 D platform and notified Vastar of the fire. At some point shortly after the fire began, the decision was made to abandon the platform. A life raft was lowered into the Gulf, and all D&C, UPCS, and 2M personnel on board evacuated the platform at approximately 1400 hours. The men were transferred from the raft to a boat approximately 45 minutes to one hour later and transported to East Cameron Block 42 C Platform (42C). U-3 departed 42C by helicopter at approximately 1510 hours and was flown to a Lafayette hospital, where he arrived at approximately 1700 hours. U-3 was then transported to a Baton Rouge burn center where he died days later. MMS Inspectors Scott Mouton and Edward Runte arrived at the scene by helicopter and put out the fire. U-1 stated that at some time later that day he was told by D-2, "Well, I guess that ends my career in the Gulf."

### **Sources of Discharge into Sump System**

Normally, the possible sources of condensate into the SUMP system are as follows:

1. HP Separator

2. Skimmer
3. LP Accumulator
4. Test Separator
5. Manifold Drain
6. HP Vent Boom
7. Flowlines
8. Diesel Tank
9. Deck Drains
10. Gen. Filter
11. FG Scrubber
12. FG Filter

The first five items are not possible sources of condensate into the sump system at the time of the accident, since all of the drain lines associated with these sources were severed prior to the fire.

Because the manual isolation block valve of the HP Vent Boom's liquid trap and the 1-inch ball valve in the piping from the flowline to the sump were closed, inoperable, and were tested by Vastar after the accident and found to hold pressure, the HP Vent Boom and the flowlines are eliminated as sources of condensate/gas into the sump system.

Because there was no diesel being offloaded onto the platform and there was no evidence of any substantial discharge onto the platform decks, the diesel tank and the deck drains are also eliminated as sources of condensate/gas into the

sump system.

## **Alarm History/Analysis**

The alarm history is an electronic chronological record of safety device events, including the times when safety devices were tripped (ALM), physically acknowledged at the relay panel (ACK), and automatically returned to an untripped status when the upset was eliminated (RTN). For referencing purposes the following alarm history events, E1 through E9, are listed:

E1 - 13:00:35 ALM/FG Scrubber bypass

E2 - 13:09:45 ALM/FG Scrubber PSL

E3 - 13:09:45 ALM/HP Separator PSL

E4 - 13:10:36 ALM/FG Scrubber LSH

E5 - 13:12:16 RTN/FG Scrubber LSH

E6 - 13:18:06 ALM/FG Filter PSL

E7 - 13:36:26 ALM/ultra violet (UV), fire detector

E8 - 13:38:56 ALM/FG Scrubber LSL

E9 - 13:42:15 RTN/FG Scrubber LSL

For example, E1 represents an alarm signaling that the FG Scrubber safety devices have been put in bypass at the relay panel, while E2 represents an alarm signaling the tripping of the FG Scrubber's PSL at 13:09:05 hours because of low pressure.

According to D-1, the alarms indicated on the alarm history resulted in the sounding of a horn, which he heard. U-1 and U-2 stated that they did not hear

any alarms. It should be noted that after a device is put in bypass, the alarm horn will sound only on the first tripping of the device and not thereafter, until such time that the device is removed from bypass mode.

E1 is consistent with D-2's claim to have bypassed the FG Scrubber safety devices. E2 indicates that shortly before that time the blowdown of the FG Scrubber had begun. E3 indicates that pressure is being released from the HP Separator. E4 indicates that liquids have entered the FG Scrubber. E2, E3, and E4 are consistent with communication between the HP Separator and FG Scrubber. Further supporting the apparent communication is the fact that D-2 closed the sensing needle valves of the PCV's between the two vessels and had initially not closed the MB Valves between the vessels. Therefore, it is clear from the alarm history and D-2's testimony regarding his actions with respect to the valves upstream of the FG Scrubber that liquids from the HP Separator flowed to the FG Scrubber during these initial stages of the FGS blowdown.

E5 indicates that liquids flowed from the FG Scrubber during the period between the times of E4 and E5. There are three paths for liquids to follow in leaving the FG Scrubber. One is through the FG Scrubber drain line, another is through the FG Scrubber dump line, and the third is through FG Scrubber PSV Manifold to the HP Vent Boom.

E6 indicates a pressure release in the FG Filter, which can be the result of manually draining the FG Filter or the automatic use of the FG Filter gas for the

platform's instrumentation.

E7 indicates the approximate time of the fire.

E8 indicates that liquids flowed from the FG Scrubber between E5 and E8.

E9 cannot be adequately explained.

**Procedures and  
Designated  
Operator /  
Contractor  
Agreements**

Vastar did not have a generalized set of procedures to be followed for construction work performed on their platforms. Vastar would create specific construction procedures for some projects depending upon the nature of the work to be performed. Some of the factors to be considered in formulating specific procedures for a particular job would include but not necessarily be limited to the complexity of the job and whether or not hot work was scheduled to be performed. Whether or not specific procedures exist, the provisions of Vastar's Safety and Health Manual (SHM) still apply to all construction work. The construction work being performed at the time of the accident was one for which specific procedures did not exist for the reason, according to Vastar, that no hot work was expected to be performed with respect to the construction work. Vastar stated that even though there existed no written procedures for the subject construction work, they assumed that, at the least, the FG Scrubber and other physically possible sources of energy would have either been blinded, disconnected, or double-blocked and bled, as listed in the SHM. None of those three methods was used.

At the time of the accident, a contract existed between Vastar and UPCS, in



which UPCS agreed in essence that they are familiar with Vastar's SHM and that all UPCS employees will comply with the provisions of the manual.

In addition, a contract existed between Vastar and D&C at the time of the accident, in which D&C agreed that they and all under their control would comply with the provisions of the same SHM.

Vastar's SHM states in part that their contractors are responsible for conducting pre-job safety meetings and providing communication with all contract personnel. While the contents of the meetings are not detailed, Vastar's meeting checklist allows for a thorough discussion, including one on simultaneous operations, which was not checked as having been discussed.

The SHM further states in part under the Fire and Safe Work Permit (Hot Work Permit) section that:

- 1) A permit initiator (D-2) is responsible for the details of the job;
- 2) The Operator or Designated Representative (D-2) is responsible for (a) preventing other operations that may conflict with the permitted work and (b) the safety of all personnel under his/her supervision; and
- 3) The person doing the work (U-2) is responsible for understanding the conditions of the permit.

## Conclusions

---

The conflicting and sometimes totally contradictory statements of the witnesses interviewed and the inability of the panel to contact D-3 made the correlation of the activities of the operators and the reconciliation of those activities with physical data very difficult and in some specific areas impossible.

### **Accident**

Based upon the preceding findings, the conclusion of this panel is that at approximately 1336 hours, while U-3 was cutting a section of the HP Separator drain line with an electrically powered bandsaw, condensate was probably released from the FG Scrubber through either the FG Scrubber drain line or dump line into the platform's sump system. The release caused condensate to surge upward through the HP Separator drain line, spray from the cut being made by the bandsaw unto U-3, and flow from the top portion of that drain line onto the production deck. On the production deck, the condensate sprayed onto various vessels and into the deck drains. The electrical component of the band-saw ignited the condensate, resulting in the fire which occurred on both the sub-cellar and production decks and which also caused the injuries to U-2 and U-3.

## Causes

### *Mechanical*

The three most likely sources of condensate/gas into the sump system that were responsible for the gushings of condensate from the cut on the subcellar were the Gen. Filter, FG Filter, and the FG Scrubber.

It is concluded that the Gen. Filter was not the source of condensate/gas into the sump system because the platform had switched to diesel power, the Gen. Filter's MB Valve was on the main deck and relatively significantly distanced from the areas where work was being conducted, and there existed no reason for any work which was being done on the FG Scrubber to have included work on the Gen. Filter.

It is concluded that the first gush occurred between E4 and E5 and was the result of the release of condensate from the FG Scrubber, given that condensate flowed from the FG Scrubber between E4 and E5, and the event preceded the FG Filter PSL alarm.

It is also concluded that the second gush, which immediately resulted in the fire and ultimately the death of U-3, occurred between E5 and E8 and, more specifically, near the time of E7, the time of the UV alarm, and was the result of condensate from either the FG Scrubber or FG Filter. While the alarm history does not disqualify either vessel as the source for the second and fatal

gush, it is the conclusion of the panel that (1) the FG Filter PSL alarm was probably the result of the use of FG Filter gas for the platform's instrumentation; (2) D-2's comment to U-1 concerning D-2's draining of a vessel was with respect to the FG Scrubber, which he drained as a result of his observation of the failure of the FG Scrubber pressure to drop sufficiently during the FG Scrubber blowdown (which was a result of the FG Scrubber's communication with the HP Separator); and, therefore, (3) the source of the second gush was very probably the FG Scrubber.

It is also concluded that the second gush was the result of the release of condensate through the FG Scrubber's drain line. It is believed by the panel that the inlet MB Valves to the FG Scrubber were closed sufficiently prior to the second gush that there existed insufficient influx of liquid into the FG Scrubber to activate the FG Scrubber's internal dump control. It is also concluded that a reflux of liquids from the PSV Manifold is unlikely.

Therefore, **contributing causes** of the accident were D-2's closing of the FG Scrubber's upstream PCV needle sensing valves and the failure of D-2 to close the incoming MV Valves to the FG Scrubber. A **major cause** of the accident was the opening of the FG Scrubber's drain line MB Valve by either D-2 or D-3. A **major cause** of the accident was the decision by U-2 and U-3 to use the electric bandsaw after condensate was seen flowing from the first cut made on the HP Separator drain line on the subcellar deck.

*Personnel/Procedural/Communication*

The failure of D-2 to include a discussion of the maintenance work to be performed on the FG Scrubber PSV Manifold during the safety meeting on the morning of the accident is a **contributing cause** of the accident. Any such discussion could very reasonably be expected to have led to a discussion regarding specific safety issues to be considered with respect to the potential dangers involving the simultaneous operations of cutting drain line pipes and performing maintenance work on a vessel that was a potential source of energy to the drain lines via the sump system. Those issues could have included in part the heightened importance of lock-out/tag-out procedures and the restriction of hot work to those areas for which it was intended by the Hot Work Permit. Furthermore, such a lack of discussion is, in effect, non-compliant with the provisions of Vastar's SHM with respect to safety meetings.

U-1's erroneous assumption that U-4 and U-5 had obtained a Hot Work Permit for the use of the electric bandsaw on the production deck and the further assumption that the presumed permit included the use of the saw on the subcellar deck is a **contributing cause** of the accident.

It is concluded that, at the very least, one of the two D&C employees witnessed the use of the electric bandsaw on the production deck and did nothing to prohibit its further use. The lack of such a prohibiting action is a **contributing cause** of the accident. This also constitutes in effect a violation of Vastar's SHM in that D-2 did not act responsibly with respect to preventing other operations that conflicted with the permitted work nor with respect to the safety of all personnel under his supervision.

It is concluded that D-2 was relatively unfamiliar with the platform to the extent that he either opened the MB Valve on the FG Scrubber drain line or failed to prevent D-3 from doing so without realizing the effect of the opening of the valve with respect to the disposition of the released fluids. Therefore, D-2's unfamiliarity with the platform is a **contributing cause** of the accident and is, in effect, noncompliant with Vastar's SHM for the same reasons given above.

U-2's assumption that the Hot Work Permit issued covered all hot work performed on the platform regardless of location is a **contributing cause** of the accident.

### ***Management***

Vastar communicated the construction work to be performed directly to UPCS and not to D&C, who is the party responsible for the operation of their

platform. This lack of direct communication with D&C led to Vastar's purported lack of knowledge regarding D&C's intention of repairing the FG Scrubber PSV Manifold during the drain deactivation operations conducted by UPCS. Had Vastar scheduled the drain deactivation operation through or in the presence of D&C, their platform operator, Vastar would have been in a position to be made aware of D&C's intention of repairing the FG Scrubber PSV Manifold during the deactivation operation. Such an awareness would have afforded Vastar the opportunity to emphasize to all parties involved the inherent dangers of such simultaneous operations and, therefore, it is reasonable to conclude, would have resulted in a more safely conducted set of simultaneous operations. Therefore, Vastar's method of communication and resultant lack of work coordination is concluded to be a **contributing cause** of the accident.

Vastar's failure to have a specific written procedure for the construction work to be performed is concluded to be a **contributing cause** of the accident.

Written procedures would have confirmed Vastar's expectation with respect to the isolation of energy sources and thereby significantly reduced the possibility of the release of energy into the system.

Because D-2's unfamiliarity with the platform is concluded to be a contributing cause of the accident, D&C's failure to recognize that unfamiliarity and act accordingly are likewise considered to be **contributing**

**causes** of the accident. Given D-2's relative inexperience with the platform (16 days), it is not an unreasonable expectation that D&C verify his ability to act as lead or A-operator on Vastar's behalf, especially in a situation where simultaneous operations were going to be conducted. That verification either did not occur or was misinterpreted.

U-2's misunderstanding of the Hot Work Permit, U-1's assumptions regarding the permits issued, and U-2 and U-3's decision to use the bandsaw after condensate was detected as having flowed from the cut pipe are concluded to represent a serious safety communication problem within UPCS and one which is considered a **contributing cause** of the accident.



## Recommendations

---

The MMS should issue a Safety Alert containing the following to all lessees and operators:

1. A brief description of the accident appearing in this report.
2. A recommendation that designated operators review their established method for communicating proposed multiple work assignments for a particular facility to all involved contractors. Since the coordination of contractor tasks is an essential element of safely conducted operations, the method should be reviewed primarily for the purpose of identifying any realistic potential for miscommunication among contractors. The review should closely examine the role of the facility operating contractor in that communication scheme.
3. A recommendation that designated operators provide specific written procedures for all construction projects, including an emphasis on safety issues.
4. A recommendation that if such an established method does not exist that one be established in accordance with the above-referenced considerations.

5. A recommendation that designated operators review the method by which they monitor all contractors' adherence to all agreed upon safety standards.

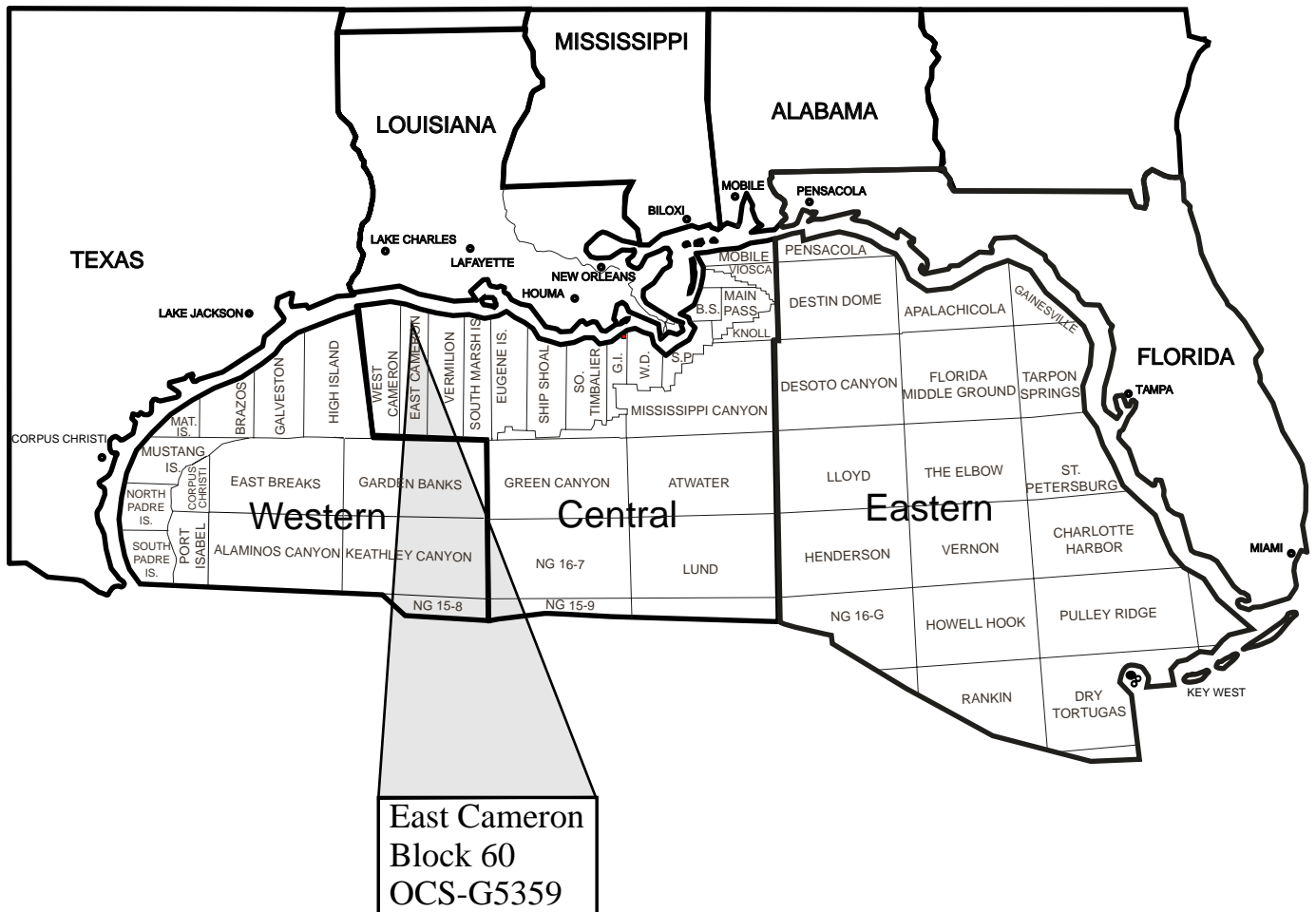

Location of Lease OCS-G 5359,  
East Cameron Block 60

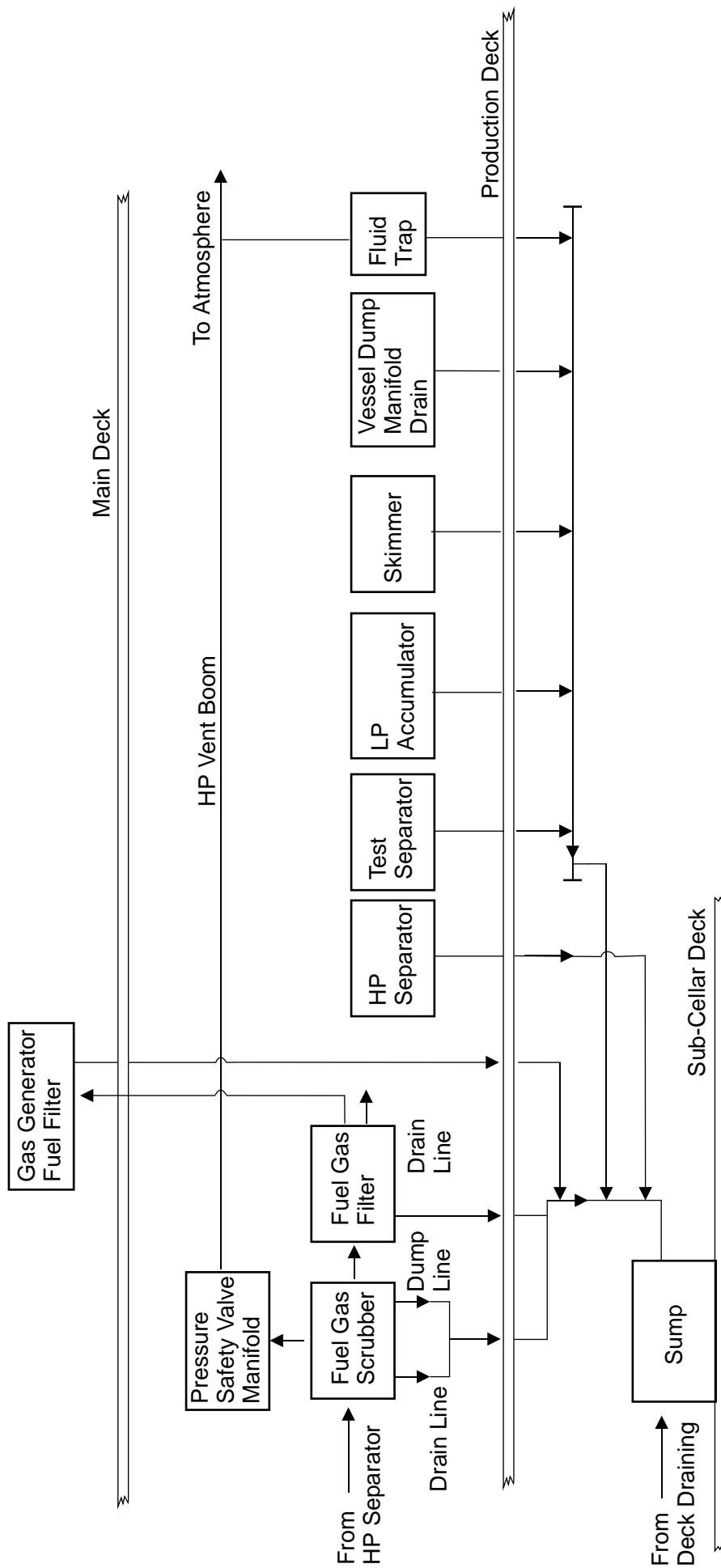

Simplified Partial Flow Schematic of Platform

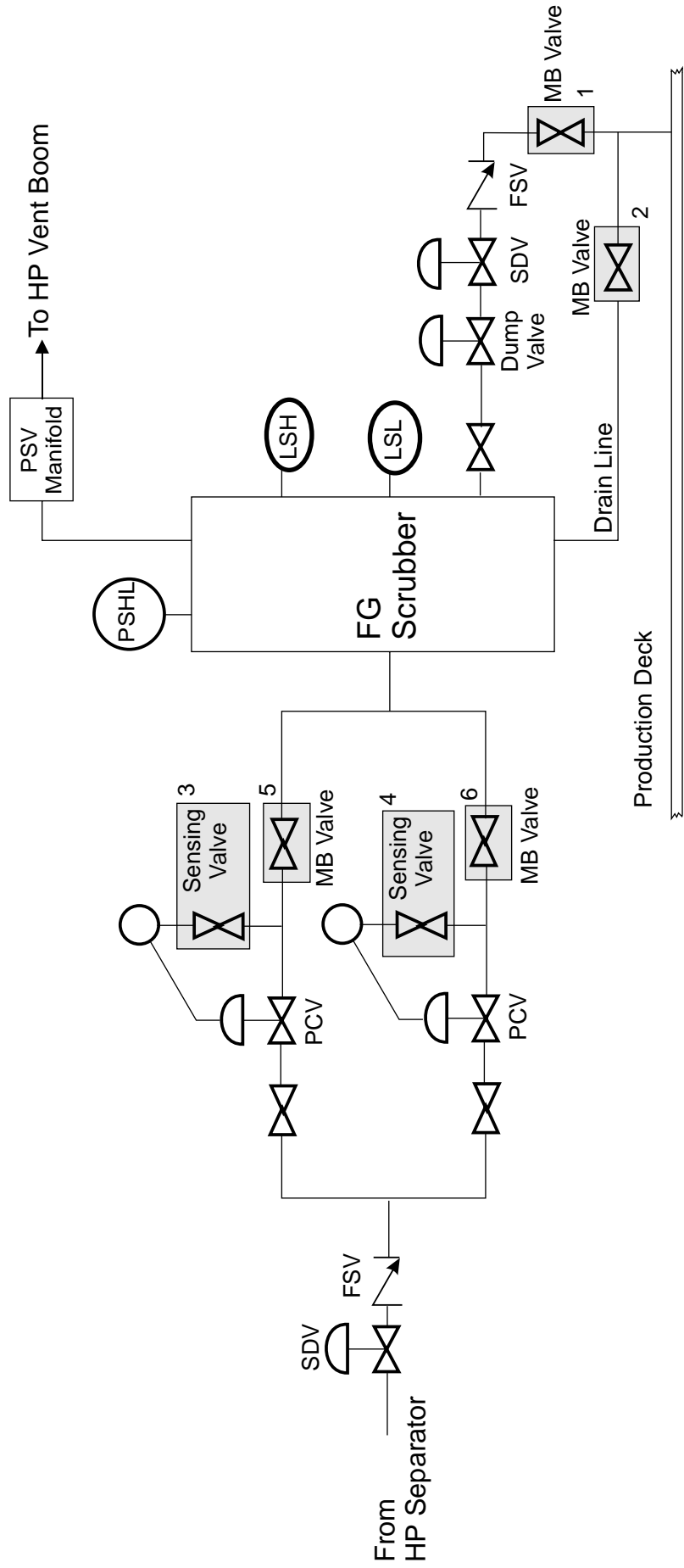

Simplified Flow Schematic of Fuel Gas Scrubber

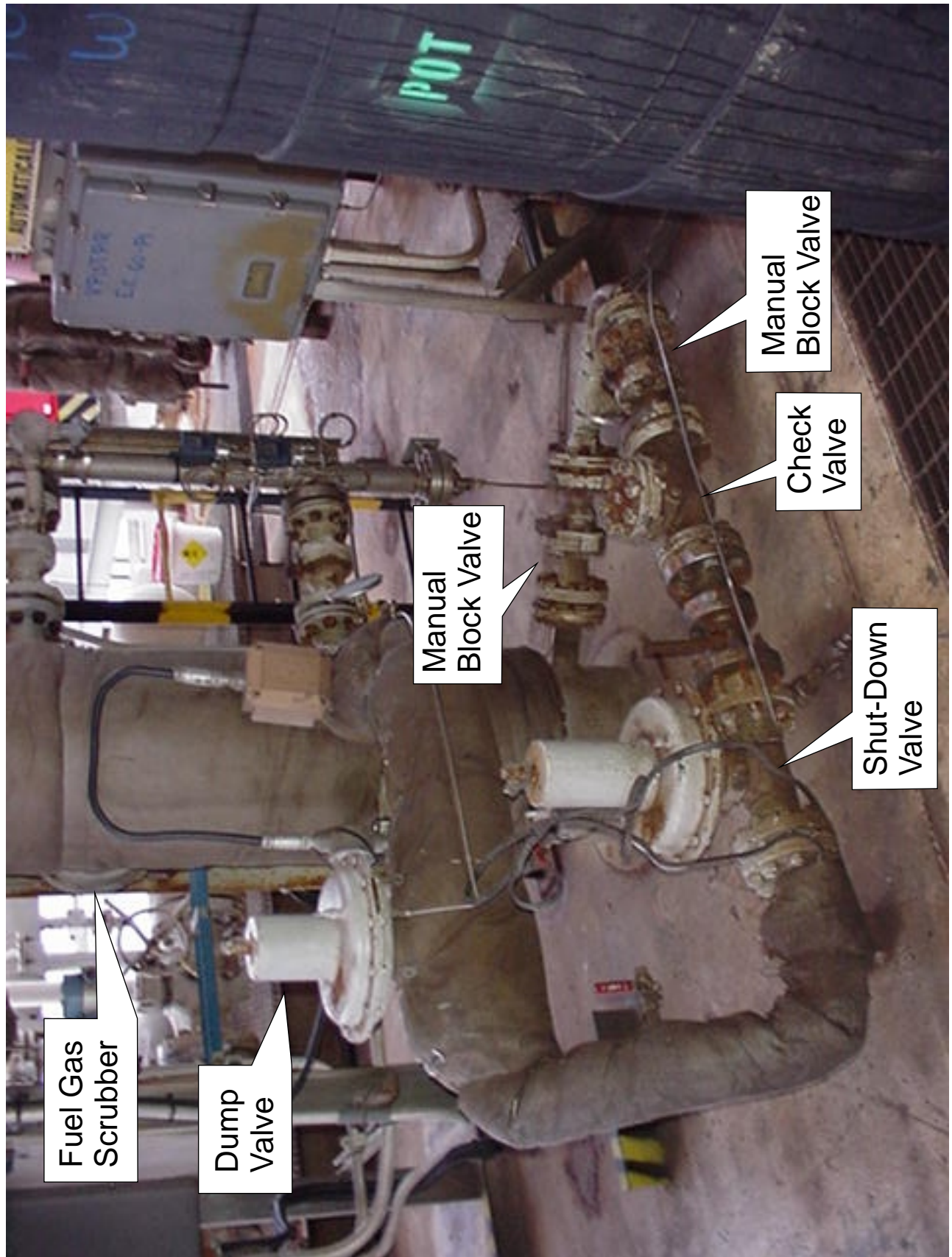

Photograph of Fuel Gas Scrubber

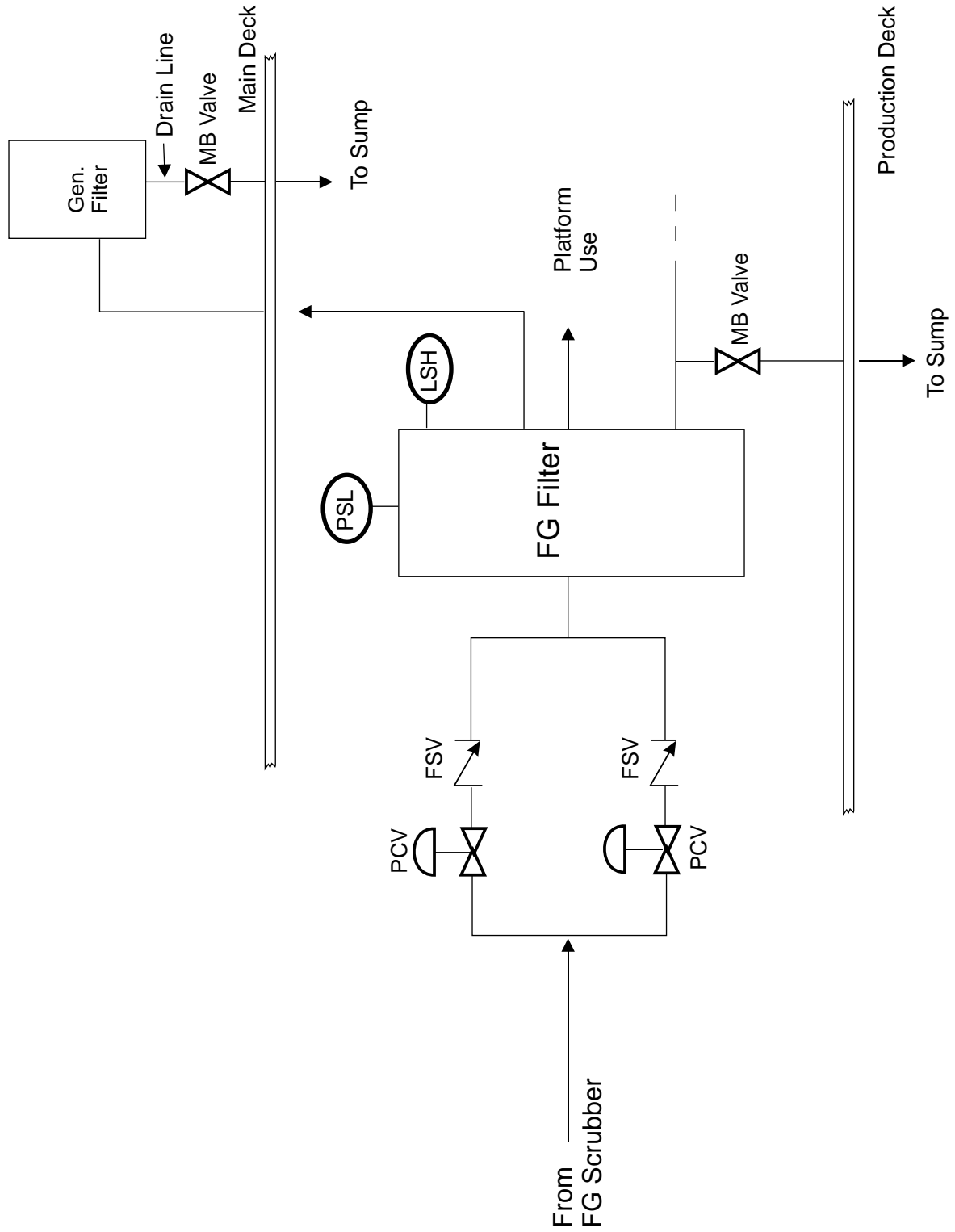

Very Simplified Flow Schematic of Fuel Gas Filter and Generator Fuel Filter





Photograph of Severed HP Separator Drain Line on Production Deck



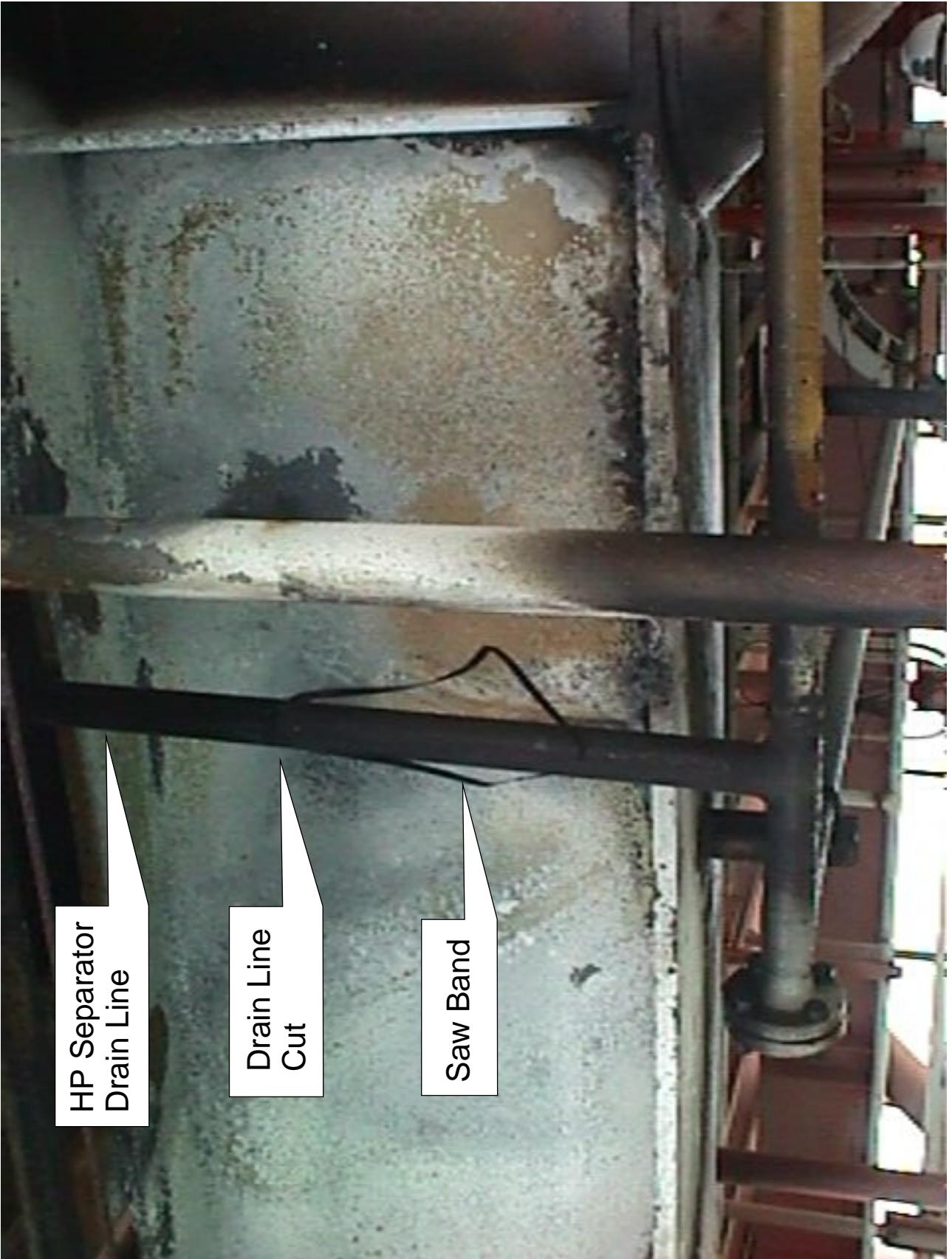

HP Separator  
Drain Line

Drain Line  
Cut

Saw Band

Photograph of HP Separator Drain Line with Band Attached