



*FEMA*  
*Hurricane Recovery*  
*Advisories*



# Roof Underlayment for Asphalt Shingle Roofs



FEMA  
www.fema.gov

## HURRICANE RECOVERY ADVISORY

## Recovery Advisory No. 1

**Purpose:** To provide recommended practices for use of roofing underlayment as an enhanced secondary water barrier in hurricane-prone areas (both coastal and inland).

**Note:** *The underlayment options illustrated here are for asphalt shingle roofs.* See FEMA publication 55, *Coastal Construction Manual*, for guidance concerning underlayment for other types of roofs.

### Key Issues

- Verify proper attachment of roof sheathing before installing underlayment
- Lapping and fastening of underlayment and roof edge flashing
- Selection of underlayment material type

**Note:** This fact sheet provides general guidelines and recommended enhancements for improving upon typical practice. It is advisable to **consult local building requirements** for type and installation of underlayment, particularly if specific enhanced underlayment practices are required locally.

### Sheathing Installation Options

The following three options are listed in order of decreasing resistance to long-term weather exposure following the loss of the roof covering. Option 1 provides the greatest reliability for long-term exposure; it is advocated in heavily populated areas where the design wind speed is equal to or greater than 120 mph (3-second peak gust). Option 3 provides limited protection and is advocated only in areas with a modest population density and a design wind speed less than or equal to 110 mph (3-second peak gust).

### Installation Sequence - Option 1<sup>1</sup>

1. Before the roof covering is installed, have the deck inspected to verify that it is nailed as specified on the drawings.
2. Install self-adhering modified bitumen tape (4 inches wide, minimum) over sheathing joints; seal around deck penetrations with roof tape.
3. Broom clean deck before taping; roll tape with roller.
4. **Apply a single layer of ASTM D 226 Type II (#30) felt.**
5. Secure felt with low-profile, capped-head nails or thin metal disks ("tincaps") attached with roofing nails.
6. Fasten at approximately 6 inches on center along the laps and at approximately 12 inches on center along two rows in the field of the sheet between the side laps.
7. **Apply a single layer of self-adhering modified bitumen complying with ASTM D 1970 over the #30 felt throughout the roof area.**
8. Seal the self-adhering sheet to the deck penetrations with roof tape or asphalt roof cement.

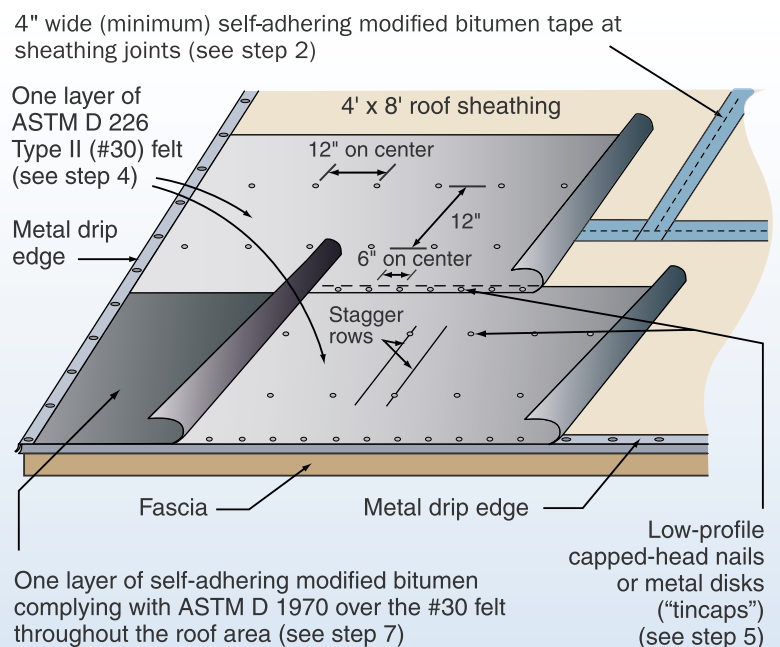

## Installation Sequence – Option 2<sup>1</sup>

1. Before the roof covering is installed, have the deck inspected to verify that it is nailed as specified on the drawings.
2. Install self-adhering modified bitumen tape (4 inches wide, minimum) over sheathing joints; seal around deck penetrations with roof tape.
3. Broom clean deck before taping; roll tape with roller.
4. **Apply two layers of ASTM D 226 Type I (#15) felt with offset side laps.**
5. Secure felt with low-profile, capped-head nails or thin metal disks (“tincaps”) attached with roofing nails.
6. Fasten at approximately 6 inches on center along the laps and at approximately 12 inches on center along a row in the field of the sheet between the side laps.

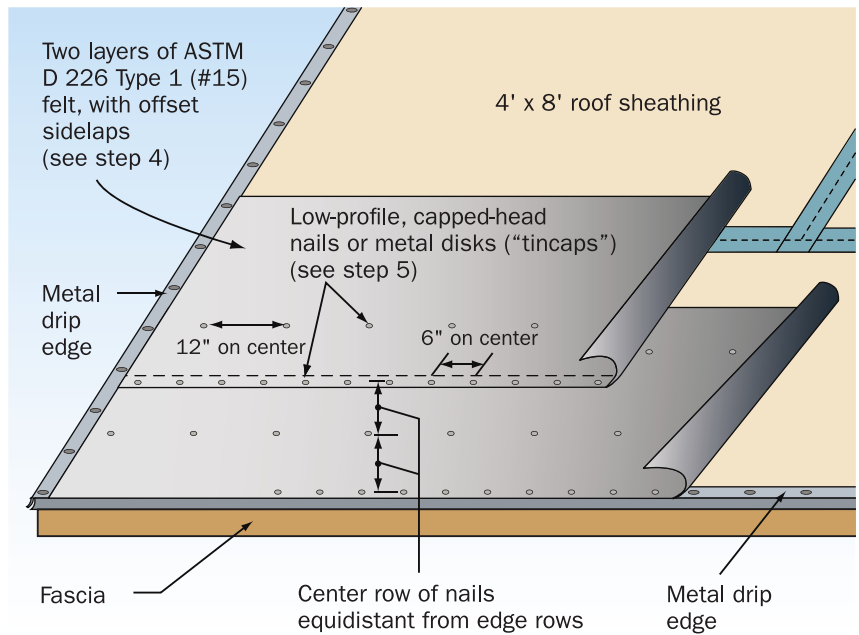

## Installation Sequence – Option 3<sup>1,2</sup>

1. Before the roof covering is installed, have the deck inspected to verify that it is nailed as specified on the drawings.
2. Install self-adhering modified bitumen tape (4 inches wide, minimum) over sheathing joints; seal around deck penetrations with roof tape.
3. Broom clean deck before taping; roll tape with roller.
4. **Apply a single layer of ASTM D 226 Type I (#15) felt.**
5. Tack underlayment to hold in place before applying shingles.

1 **Note:** If the building is within 3,000 feet of saltwater, stainless steel or hot-dip galvanized fasteners are recommended for the underlayment attachment.

2 **Note:** (1) If the roof slope is less than 4:12, tape and seal the deck at penetrations and follow the recommendations given in *The NRCA Roofing and Waterproofing Manual*, by the National Roofing Contractors Association. (2) With this option, the underlayment has limited blowoff resistance. Water infiltration resistance is provided by the taped and sealed sheathing panels. This option is intended for use where temporary or permanent repairs are likely to be made within several days after the roof covering is blown off.

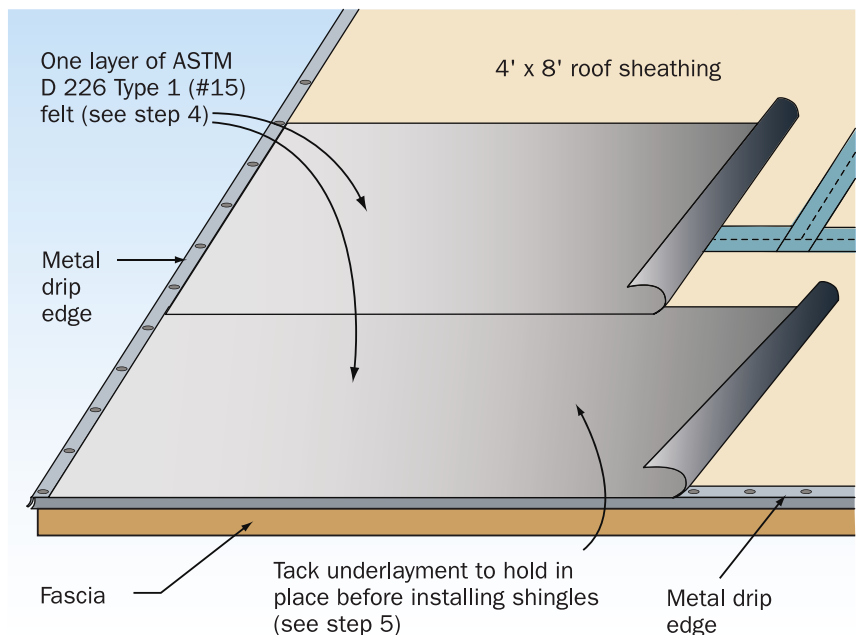

## General Notes

- Weave underlayment across valleys.
- Double-lap underlayment across ridges (unless there is a continuous ridge vent).
- Lap underlayment with minimum 6-inch leg “turned up” at wall intersections; lap wall weather barrier over turned-up roof underlayment.

## Additional Resources

National Roofing Contractors Association (NRCA). *The NRCA Roofing and Waterproofing Manual*. ([www.NRCA.net](http://www.NRCA.net))

# Asphalt Shingle Roofing for High-Wind Regions



**FEMA**  
www.fema.gov

## HURRICANE RECOVERY ADVISORY

## Recovery Advisory No. 2

**Purpose:** To recommend practices for installing asphalt roof shingles that will enhance wind resistance in high-wind, hurricane-prone areas (both coastal and inland).

### Key Issues

- Special installation methods are recommended for asphalt roof shingles used in high-wind, hurricane-prone areas (i.e., greater than 90-mph, 3-second peak gust design wind speed).
- Use wind-resistance ratings to choose among shingles, but do not rely on ratings for performance.
- Consult local building code for specific installation requirements. Requirements may vary locally.
- Always use underlayment. See Fact Sheet No. 1 for installation techniques in hurricane-prone areas.

### Construction Guidance

- 1 Follow shingle installation procedures for enhanced wind resistance.

#### Shingle Installation at Eaves

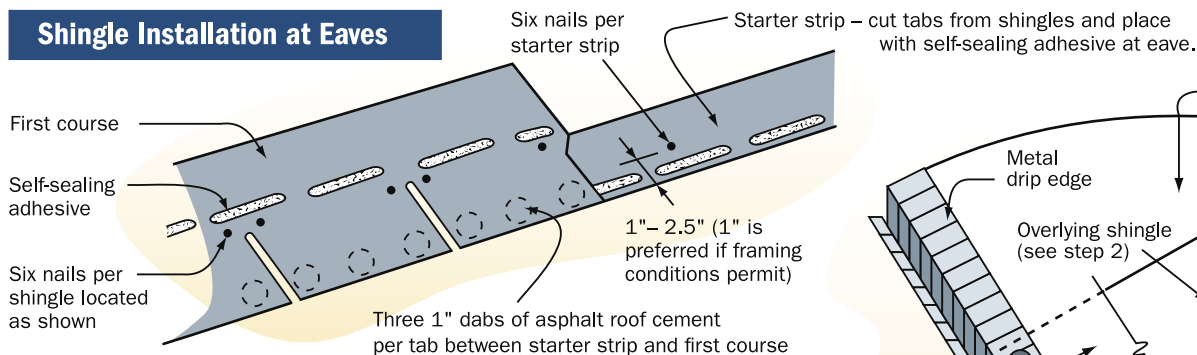

#### Shingle Installation at Hips and Ridges

1. Apply four 1-inch dabs of roof cement to field shingle.
2. **Set pre-cut shingle in place and press down in dabs of roof cement before installing fasteners.**
3. Install fastener on each side of ridge. Note: Because of extra thickness of shingles at hips and ridges, longer nails may be needed.
4. Apply two 1-inch dabs of roof cement to shingle where shown.
5. Repeat steps 2 through 4.

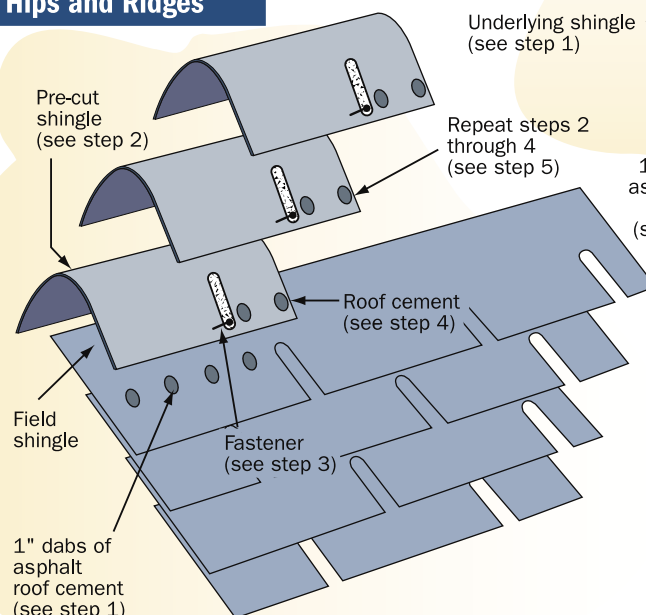

#### Enhanced shingle securement

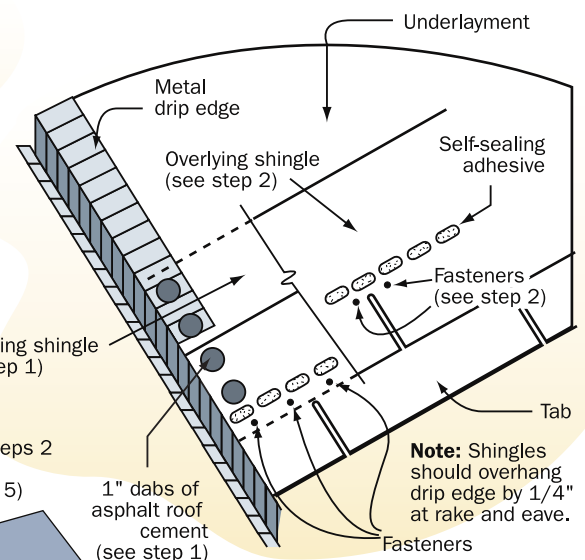

#### Shingle Installation at Rakes

1. Apply two 1-inch dabs of asphalt roof cement on underlying shingle, and two 1-inch dabs on metal drip edge as shown.
2. Set overlying shingle in place and install fasteners except for last fastener at rake.
3. **Press shingle down to set in dabs of asphalt cement before installing final fastener.**
4. Install final fastener at rake edge.
5. Repeat steps for each course.

**2** Consider shingle physical properties.

Properties	Design Wind Speed <sup>1</sup> >90 to 120 mph	Design Wind Speed <sup>1</sup> >120 mph
<b>Fastener Pull-Through<sup>2</sup> Resistance</b>	Minimum Recommended 25 lb at 70 degrees Fahrenheit (F)	Minimum Recommended 30 lb
<b>Bond Strength<sup>3</sup></b>	Minimum Recommended 12 lb	Minimum Recommended 17 lb

1. Design wind speed based on 3-second peak gust.
2. ASTM D 3462 specifies a minimum fastener pull-through resistance of 20 lb at 70° F. If a higher resistance is desired, it must be specified.
3. Neither ASTM D 225 or D 3462 specify minimum bond strength. If minimum bond strength is desired, it must be specified.

Shingle Type	Standard	Characteristics
<b>Organic-Reinforced</b>	ASTM D 225	Relatively high fastener pull-through resistance
<b>Fiberglass-Reinforced</b>	ASTM D 3462	Considerable variation in fastener pull-through resistance offered by different products
<b>SBS Modified Bitumen</b>	A standard does not exist for this product. It is recommended that SBS Modified Bitumen Shingles meet the physical properties specified in ASTM 3462.	Because of the flexibility imparted by the SBS polymers, this type of shingle is less likely to tear if the tabs are lifted in a windstorm.

**3** Ensure that the fastening equipment and method results in properly driven roofing nails for maximum blow-off resistance. The minimum required bond strength must be specified (see **Wind-Resistance Ratings**, below).

**Fastener Guidelines**

- Use roofing nails that extend through the underside of the roof sheathing, or a minimum of 3/4 inch into planking.
- Use roofing nails instead of staples.
- Use stainless steel nails when building within 3,000 feet of saltwater.

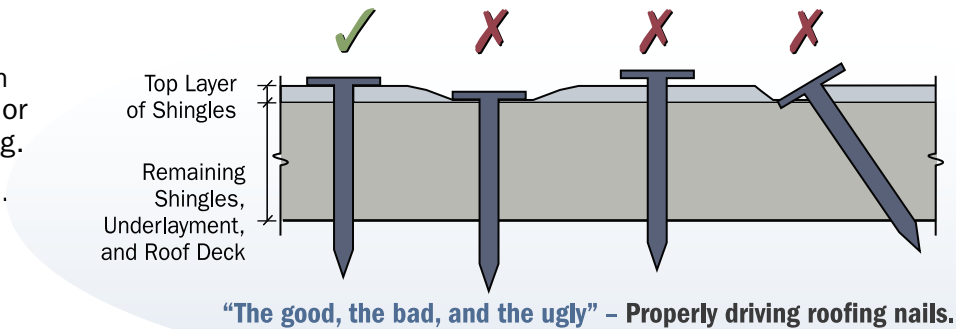

“The good, the bad, and the ugly” – Properly driving roofing nails.

**Weathering and Durability**

Durability ratings are relative and are not standardized among manufacturers. However, selecting a shingle with a longer warranty (e.g., 30-year instead of 20-year) should provide greater durability in hurricane-prone climates and elsewhere.

Organic-reinforced shingles are generally more resistant to tab tear-off, but tend to degrade faster in warm climates. Use fiberglass-reinforced shingles in warm, hurricane-prone climates and consider organic shingles only in cool, hurricane-prone climates. Modified bitumen shingles may also be considered for improved tear-off resistance of tabs. Organic-reinforced shingles have limited fire resistance – verify compliance with code and avoid using in areas prone to wildfires.

After the shingles have been exposed to sufficient sunshine to activate the sealant, inspect roofing to ensure that the tabs have sealed. Also, shingles should be of “interlocking” type if seal strips are not present.

**Wind-Resistance Ratings**

Wind resistance determined by test methods ASTM D 3161 and UL 997 does not provide adequate information regarding the wind performance of shingles, even when shingles are tested at the highest fan speed prescribed in the standard. Rather than rely on D 3161 or UL 997 test data, shingle uplift loads should be calculated in accordance with UL 2390. Shingles having a bond strength (as determined from test method ASTM D 6381) that is at least twice as high (i.e., a minimum safety factor of 2) as the load calculated from UL 2390 should be specified/purchased.

# Tile Roofing for Hurricane-Prone Areas



FEMA  
www.fema.gov

## HURRICANE RECOVERY ADVISORY

Recovery Advisory No. 3

**Purpose:** To provide recommended practices for designing and installing extruded concrete and clay tiles that will enhance wind resistance in hurricane-prone areas (both coastal and inland).

### Key Issues

**Missiles:** Tile roofs are very vulnerable to breakage from wind-borne debris (missiles). Even when well attached, they can be easily broken by missiles. If a tile is broken, debris from a single tile can impact other tiles on the roof, which can lead to a progressive cascading failure. In addition, tile missiles can be blown a considerable distance and a substantial number have sufficient energy to penetrate shutters and glazing, and potentially cause injury. Where the basic wind speed is equal to or greater than 110 mph (3-second peak gust), the wind-borne debris issue is of greater concern than in lower wind speed regions. Note: There are currently no testing standards requiring roof tile systems to be debris impact resistant.

**Attachment methods:** Storm damage investigations revealed performance problems with mortar-set, mechanically-attached (screws or nails and supplementary clips when necessary) and foam-adhesive (adhesive-set) attachment methods. In many instances, the damage was due to poor installation. Investigations revealed that the mortar-set attachment method is typically much more susceptible to damage than are the other attachment methods. Therefore, in lieu of mortar-set, the mechanically-attached or foam-adhesive attachment methods in accordance with this Advisory are recommended.

To ensure quality installation, licensed contractors should be retained. This will help ensure proper permits are filed and local building code requirements are met. For foam-adhesive systems, it is highly recommended that installers be trained and certified by the foam manufacturer.



**Uplift loads and resistance:** Calculate uplift loads and resistance in accordance with the “Design and Construction Guidance” section below. Load and resistance calculations should be performed by a qualified person (i.e., someone who is familiar with the calculation procedures and code requirements).

**Corner and perimeter enhancements:** Uplift loads are greatest in corners, followed by the perimeter and then the field of the roof (see Figure 1). However, for simplicity of application on smaller roof areas (e.g., most residences and smaller commercial buildings), use the attachment designed for the corner area throughout the entire roof area.

**Hips and ridges:** Storm damage investigations have revealed that hip and ridge tiles attached with mortar are very susceptible to blow-off. Refer to the attachment guidance below for improved attachment methodology.

**Quality control:** During roof installation, installers should implement a quality control program in accordance with the “Quality Control” section below.

## Design and Construction Guidance

### 1. Uplift Loads

In Florida, calculate loads and pressures on tiles in accordance with the current edition of the *Florida Building Code* (Section 1606.3.3). In other states, calculate loads in accordance with the current edition of the *International Building Code* (Section 1609.7.3).

As an alternate to calculating loads, design uplift pressures for the corner zones of Category II buildings are provided in tabular form in the Addendum to the Third Edition of the *Concrete and Clay Roof Tile Installation Manual* (see Tables 6, 6A, 7, and 7A).<sup>1</sup>

#### Classification of Buildings

- |                     |   |
|---------------------|---|
| <b>Category I</b>   | - Buildings that represent a low hazard to human life in the event of a failure |
| <b>Category II</b>  | - All other buildings not in Categories I, III, and IV                          |
| <b>Category III</b> | - Buildings that represent a substantial hazard to human life                   |
| <b>Category IV</b>  | - Essential facilities  |

**Note:** In addition to the tables referenced above, the *Concrete and Clay Roof Tile Installation Manual* contains other useful information pertaining to tile roofs. Accordingly, it is recommended that designers and installers of tile obtain a copy of the Manual and the Addendum. Hence, the tables are not incorporated in this Advisory.

## 2. Uplift Resistance

For mechanical attachment, the *Concrete and Clay Roof Tile Installation Manual* provides uplift resistance data for different types and numbers of fasteners and different deck thicknesses. For foam-adhesive-set systems, the Manual refers to the foam-adhesive manufacturers for uplift resistance data. Further, to improve performance where the basic wind speed is equal to or greater than 110 mph, it is recommended that a clip be installed on each tile in the first row of tiles at the eave for both mechanically-attached and foam-adhesive systems.

For tiles mechanically attached to battens, it is recommended that the tile fasteners be of sufficient length to penetrate the underside of the sheathing by  $\frac{1}{4}$ " minimum. For tiles mechanically attached to counter battens, it is recommended that the tile fasteners be of sufficient length to penetrate the underside of the horizontal counter battens by  $\frac{1}{4}$ " minimum. It is recommended that the batten-to-batten connections be engineered.

For roofs within 3,000 feet of the ocean, straps, fasteners, and clips should be fabricated from stainless steel to ensure durability from the corrosive effects of salt spray.

## 3. Hips and Ridges

The *Concrete and Clay Roof Tile Installation Manual* gives guidance on two attachment methods for hip and ridge tiles: mortar-set or attachment to a ridge board. Based on post-disaster field investigations, use of a ridge board is recommended. For attachment of the board, refer to Table 21 in the Addendum to the *Concrete and Clay Roof Tile Installation Manual*.

Fasten the tiles to the ridge board with screws (1" minimum penetration into the ridge board) and use both adhesive and clips at the overlaps.

For roofs within 3,000 feet of the ocean, straps, fasteners, and clips should be fabricated from stainless steel to ensure durability from the corrosive effects of salt spray.

## 4. Critical and Essential Buildings (Category III or IV)

Critical and essential buildings are buildings that are expected to remain operational during a severe wind event such as a hurricane. It is possible that people may be arriving or departing from the critical or essential facility during a hurricane. If a missile strikes a tile roof when people are outside the building, those people may be struck by tile debris dislodged by the missile strike. Tile debris may also damage the facility. It is for these reasons that tiles are not recommended on critical or essential buildings.

If it is decided to use tile on a critical or essential facility and if the tiles are mechanically attached, it is recommended that clips be installed at all tiles in the corner, ridge, perimeter, and hip zones (see ASCE 7-02 for the width of these zones). (See Figure 1)

## 5. Quality Control

It is recommended that the applicator designate an individual to perform quality control (QC) inspections. That person should be on the roof during the tile installation process (the QC person could be a working member of the crew). The QC person should understand the attachment requirements for the system being installed (e.g., the type and number of fasteners per tile for mechanically attached systems and the size and location of the adhesive for foam-adhesive systems) and have authority to correct noncompliant work. The QC person should ensure that the correct type, size, and quantity of fasteners are being installed.

For foam-adhesive systems, the QC person should ensure that the foam is being applied by properly trained applicators and that the work is in accordance with the foam manufacturer's application instructions. At least one tile per square (100 square feet) should be pulled up to confirm the foam provides the minimum required contact area and is correctly located.

If tile is installed on a critical or essential building, it is recommended that the owner retain a qualified architect, engineer, or roof consultant to provide full-time field observations during application.

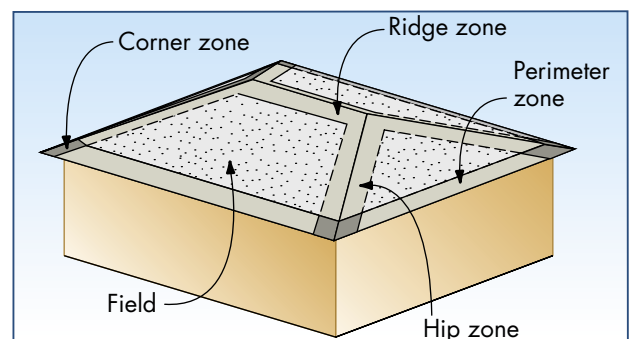

NOTE: See ASCE 7  
for zone width.

Figure 1. For critical and essential facilities, clip all tiles in the corner, ridge, perimeter, and hip zones.

<sup>1</sup> The Manual can be purchased online from the Florida Roofing, Sheet Metal and Air Conditioning Contractor's Association, Inc. at [www.floridarooft.com](http://www.floridarooft.com) or by calling (407) 671-3772. Holders of the Third Edition of the Manual who do not have a copy of the Addendum can download it from this web site.