



## Mitigation Assessment Team Report

# Spring 2011 Tornadoes: April 25-28 and May 22

Building Performance Observations,  
Recommendations, and Technical Guidance

FEMA P-908 / May 2012



FEMA

Any opinions, findings, conclusions, or recommendations expressed in this publication do not necessarily reflect the views of FEMA. Additionally, neither FEMA nor any of its employees makes any warrantee, expressed or implied, or assumes any legal liability or responsibility for the accuracy, completeness, or usefulness of any information, product, or process included in this publication. Users of information from this publication assume all liability arising from such use.

All photographs and figures used in this report were taken by the MAT or developed for this report unless stated otherwise.

Aerial imagery sources (unless otherwise noted in the MAT):

- Post-damage aerial imagery of Alabama and Mississippi: NOAA Imagery, [http://ngs.woc.noaa.gov/storms/apr11\\_tornado/](http://ngs.woc.noaa.gov/storms/apr11_tornado/) (accessed August 16, 2011 through January 23, 2012).
- Post-damage aerial imagery of Missouri: NOAA Imagery, <http://ngs.woc.noaa.gov/storms/joplin/> (accessed August 16, 2011 through January 23, 2012).
- Pre-damage aerial imagery: Google Earth Pro, <http://www.google.com/enterprise/earthmaps/earthpro.html> (accessed August 16, 2011 through January 23, 2012).

A special thanks to the Tuscaloosa County Sherriff's Office and Emergency Management Agency for use of aerial photography taken after the tornado in Tuscaloosa, AL.

# Spring 2011 Tornadoes: April 25-28 and May 22

Building Performance Observations,  
Recommendations, and Technical Guidance

*FEMA P-908 / May 2012*

National Institute of  
Standards and Technology

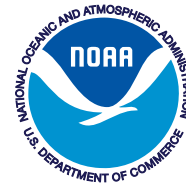

TEXAS TECH UNIVERSITY  
Wind Science & Engineering  
Research Center

THE UNIVERSITY OF  
**ALABAMA**



**FEMA**

---

# Members of the Mitigation Assessment Team

## Chapter Leaders and Authors

### Executive Summary

**Glenn Overcash**

### Chapter 1

**Amit Mahadevia  
Lauren Seelbach**

### Chapter 2

**Jason Senkbeil**  
Amit Mahadevia  
Lauren Seelbach

### Chapter 3

**Erin Ashley**  
Samantha Passman  
Lauren Seelbach

### Chapter 4

**Glenn Overcash**  
John Miller

### Chapter 5

**Dave Conrad**  
John Miller  
Manny Perotin  
Adam Reeder

### Chapter 6

**Tom Smith**  
John Miller  
Manny Perotin  
Jason Senkbeil

### Chapter 7

**Tom Smith**  
Dave Conrad  
Manny Perotin  
Lauren Seelbach  
Laura Seitz  
Scott Tezak

### Chapter 8

**Dave Low**

### Chapter 9

**Scott Tezak**  
Larry Tanner

### Chapter 10

**Glenn Overcash**  
Erin Ashley  
Dave Conrad  
Dave Low  
Samantha Passman  
Tom Smith  
Scott Tezak

### Chapter 11

**Erin Ashley**  
Dave Conrad  
Dave Low  
Glenn Overcash  
Samantha Passman  
Tom Smith  
Scott Tezak

### Appendix G

**Glenn Overcash**

## Team Members

### Team Leader

Paul Tertell, PE, FEMA HQ

### Team Manager

Erin Ashley, Ph.D., URS Group, Inc.

### Team Members

John Battles, PE, CBO, ICC  
Harold Colon, FEMA Region IV  
David L. Conrad, PE, Atkins  
Ron Cower, FEMA  
Bob Franke, FEMA Region VII  
Andrew Herseth, PE, SE, FEMA HQ  
John Ingargiola, EI, CFM, CBO, FEMA HQ  
David Javier, FEMA HQ  
Neal Johnson, AIA, URS Group, Inc.  
Marc Levitan, Ph.D., National Institute of Standards and Technology  
Dave Low, PE, D.K. Low & Associates  
Amit Mahadevia, URS Group, Inc.  
Desiderio Maldonado, PE, Atkins  
John Miller, PE, SE, J&M Engineering  
Glenn Overcash, PE, URS Group, Inc.

Manuel A. Perotin, PE, CFM, Atkins  
John Plisich, FEMA Region IV  
Adam Reeder, PE, Atkins  
Lauren Seelbach, EIT, CFM, URS Group, Inc.  
Laura Seitz, EIT, CFM, URS Group, Inc.  
Jason Senkbeil, Ph.D., University of Alabama  
Randy Shackelford, PE, Simpson StrongTie  
Thomas L. Smith, AIA, RRC, TlSmith Consulting Inc.  
Eric Stafford, PE, T. Eric Stafford & Associates, LLC  
Larry J. Tanner, PE, Texas Tech University  
Paul Tertell, PE, FEMA HQ  
Scott Tezak, PE, TRC Engineering  
John W. van de Lindt, Ph.D., University of Alabama  
Jeff Walker, PE, MCP, ICC  
Erin Walsh, FEMA HQ

### Internal Support

Technical and Management Support:  
Samantha Passman, EIT, URS Group, Inc.

#### Technical Editors:

Susan Ide Patton, URS Group, Inc.  
Ivy Porpotage, URS Group, Inc.  
Amy Siegel, URS Group, Inc.

#### Graphic Artists:

Lee-Ann Lyons, URS Group, Inc.  
Billy Ruppert, URS Group, Inc.

#### Aerial Image Creation:

Kevin McMaster, URS Group, Inc.

### Advisors

Bob Bissell, Region VII  
Ginger Edwards, FEMA Region IV  
Albie Lewis, CEM, Region I  
Robert Lowe, FEMA Region IV



# Dedication

*FEMA and the spring 2011 Tornado Mitigation Assessment Teams dedicate this report to the memory of the victims of the April 25–28, 2011 tornadoes in the southeastern United States and the May 22, 2011 tornado that struck Joplin, Missouri.*

*This report is also dedicated to the families, friends, and communities suffering from their loss.*

**Photographs that appear across the top of the first page of each chapter (from left to right):**  
300-foot latticed cellular tower that collapsed during the tornado event (Tuscaloosa, AL); Glazing damage at patient rooms (St. John's Medical Center, Joplin, MO); FEMA-funded residential safe room (Smithville, MS); Corridor designated as tornado refuge area; debris was blown into it during the tornado (Joplin High School, Joplin, MO); Failed steel column (Fitness Center, Tuscaloosa, AL)



# TORNADO OUTBREAK *of* 2011

IN ALABAMA, GEORGIA, MISSISSIPPI,  
TENNESSEE, AND MISSOURI

## Executive Summary

*The Southeastern and Midwestern portions of the United States experienced historic tornado activity in the spring of 2011.*

During the week of April 18–22, 2011, the meteorological community began to discuss a potentially significant severe weather scenario developing in forecasted model runs for the following week. Several telling meteorological parameters foreshadowed the historical tornado activity that was to follow. The tornado outbreak that ensued resulted in April being ranked the country's most active tornado month on record, with 753 tornadoes. The previous record had been set in April 1974, with 267 tornadoes. From April 25 to 28, 2011 hundreds of tornadoes touched down from Texas to New York, with some of the strongest and most devastating on April 27 occurring in Alabama, Mississippi, Georgia, and Tennessee. According to the National Weather Service (NWS), tornado-caused deaths reached 364 during the month of April, with 321 people killed during the April 25–28 tornado outbreak.

Less than a month later, on May 22, more than 50 tornadoes touched down across an eight-State area, the most powerful of which was a 0.75-mile-wide tornado that cut a 6-mile path through Joplin, MO. The tornado destroyed thousands of homes and caused widespread damage in the city. This historic tornado resulted in 161 fatalities, the most fatalities ever recorded from a single tornado since modern record keeping began in 1950.

While tragic, major catastrophic events and disasters such as the tornadoes of spring 2011 often afford unique opportunities to research how hazards affect the built environment. The maximum winds associated with many of the tornadoes were well above the wind speeds used to design and construct many of the buildings damaged and destroyed during the tornadoes, so significant damage to the built environment would be expected. However, important information can be garnered related to building performance and tornado sheltering after such an event. Damage assessments can also be used to measure the effectiveness of adopted building codes, standards, and practices, and to assess how buildings built to design-level or near design-level respond near the edge of violent tornadoes or along the path of weaker tornadoes.

The Federal Insurance and Mitigation Administration (FIMA) of the U.S. Department of Homeland Security (DHS) is responsible for investigating the effect of such events on the built environment. In response to a request for technical support from the FEMA Regional offices in the impacted states, FEMA deployed a Mitigation Assessment Team (MAT) to investigate the damage and provide technical assistance to the affected communities through their Joint Field Offices established in response to the events. The purpose of the MAT deployment was to assess the performance of buildings, infrastructure, and safe rooms, storm shelters, hardened areas, and tornado refuge areas affected by the tornadoes. The MAT was first sent to Alabama, Mississippi, Georgia, and Tennessee on May 6, 2011 and then re-deployed to Missouri on June 1, 2011. The MAT included FEMA Headquarters and Regional Office engineers, scientists, and communication specialists; representatives from academia; and practicing architects, engineers, and building experts from the design and construction industry.

The MAT investigated the performance of residential buildings, commercial and industrial buildings, critical and essential facilities, and infrastructure, as well as safe rooms, storm shelters, hardened areas, and tornado refuge areas. Additionally, the MAT rated building damage according to the Enhanced Fujita (EF) tornado scale to assess wind speeds exerted on the building. The MAT then developed conclusions and recommendations based on their assessments. This report presents the MAT's field observations, as well as subsequent conclusions and recommendations.

## Observations

The following summarizes the observed damage and overall building performance by type or use of the buildings or structures.

**Residential Construction:** Groups of one-, two-, and multi-family residential buildings provided opportunities for the MAT to compare damage to multiple buildings. Most of the residential building stock affected by the storms were older homes, but some were newer and in compliance with the International Residential Code (IRC). The newer structures generally performed well under design-level wind loading, but the older structures with non-code-compliant construction failed under comparable wind conditions. Additionally, throughout the damaged areas, the MAT observed a lack of above-code design construction practices, which left the buildings vulnerable to damage from the tornadoes.

Damage was progressively more severe with increasing winds, and revealed structural vulnerabilities in buildings, particularly in those subject to winds below the IRC design level of 90 miles per hour



(mph). Not unexpectedly, the damage occurred even in new, code-compliant construction in areas, as wind speeds were estimated to be well above the IRC design level of 90 mph (3-second gust).

**Commercial and Industrial Buildings:** The types of commercial and industrial buildings the MAT visited are normally designed by a design professional. Accordingly, the MAT assessed the design approaches and construction techniques observed in the context of building damage sustained when these structures were exposed to the design-level or higher wind speeds. Buildings designed to the latest edition of the building code have some capacity to resist above-code level wind speeds, but are not able to resist violent winds associated with extreme wind events such as EF4 (associated with 166–200 mph winds) and EF5 (associated with winds over 200 mph) tornadoes. While failed elements of the building envelope contributed to damage, significant portions of commercial and industrial buildings were determined to have collapsed when the load path of the Main Wind Force Resisting System (MWFRS) was disrupted through structural connection failure.

In general, buildings the MAT observed appeared to have been designed and constructed in accordance with the applicable building codes, but experienced failure of the building envelope and structural systems when loaded beyond code parameters.

The MAT noted several commercial and industrial buildings, particularly one- and two-story buildings with long-span roofs that suffered catastrophic failure when small, localized failures progressed to affect larger areas. In some cases, progressive collapse was the result of a lack of redundant stability systems or non-discrete structural systems. Another factor that contributed to complete building collapse was the failure of structural connections when load paths were not continuous, such as with unreinforced masonry (URM).

Some of the commercial buildings had operational plans to direct people to refuge areas. While these operational plans were diligently activated, in most cases, people were directed to places in the building that were not hardened to provide life-safety protection. Further, most of these areas were not evaluated by design professionals to identify their vulnerability to damage and failure from extreme wind events.

**Critical and Essential Facilities:** The critical and essential facilities observed by the MAT included schools, healthcare facilities, first responder facilities (police and fire stations), and Emergency Operations Centers. Most of the buildings were damaged by winds estimated to be at or below design-level wind speeds, and in general performed no better than commercial and industrial buildings.

Since it is of vital importance to communities that critical facilities remain functional during and after tornadoes, the MAT assessed whether the observed critical facilities had areas specifically designed to provide life-safety protection, and if so, whether the areas met the near-absolute protection offered by a safe room designed to FEMA 361, *Design and Construction Guidance for Community Safe Rooms* (FEMA 2008a) or a storm shelter designed to International Code Council (ICC) 500, *Standard for the Design and Construction of Storm Shelters* (ICC/NSSA 2008). The MAT found that none of the observed facilities along the path or in the periphery of the tornadoes had areas specifically designed for life-safety protection. Instead, emergency plans often directed building occupants to interior corridors or restrooms, areas that provided varying degrees of protection.

**Infrastructure:** The MAT assessed tornado damage to communications towers, water treatment and distribution facilities, and one wastewater treatment facility. Communications towers not

only support cell phone service, but are relied on by emergency management agencies and first responders. Disrupted operations of community infrastructure due to electrical service interruption or structural failure frequently delayed recovery efforts. Wind-blown (“wind-displaced”) materials that adhered to latticed communications towers, while presently not accounted for in tower design standards, likely contributed to observed tower collapses. There were numerous examples of how wind-displaced materials may have increased loads on communications towers. Furthermore, the MAT inspected the failure of guy anchors when wind-displaced materials struck the guy wires of a communications tower, resulting in its collapse. The current criteria and guidance for the design of communications towers does not address increased wind pressures when wind forces act on debris that has become entangled with the structure.

The MAT observed water distribution facilities, water towers, and pumping stations rendered inoperable because of power interruption; this led to water loss and decreased water pressure, which in turn exposed communities to a risk of contamination and health hazards resulting from unsanitary conditions.

**Safe Rooms, Storm Shelters, Hardened Areas, and Tornado Refuge Areas:** The MAT observed safe rooms, storm shelters, hardened areas, and tornado refuge areas in residential, commercial and industrial, and critical facilities, as well as stand-alone community tornado refuge areas. All residential and community safe rooms and storm shelters that the MAT observed were built before the adoption of the 2009 International Building Code (IBC) and IRC, which codified the requirements of ICC 500, with the exception of a storm shelter constructed in Seneca, MO. Inspection of safe rooms and storm shelters revealed that many of them had one or more of the following deficiencies:

- + Doors and door hardware not designed or constructed to meet known wind and wind-borne debris impact criteria for life-safety protection
- + Inadequate ventilation
- + Inadequate anchorage of pre-fabricated units
- + Undocumented location
- + Lack of backup system to provide communications capabilities if needed

The MAT heard numerous accounts of homeowners seeking shelter in basements or interior rooms. Similarly, operational plans in critical facilities often designated hallways as refuge areas. While building occupants often consider basements, interior rooms, and hallways as areas of refuge, the MAT noted many instances in which seeking cover in these areas was not a safe option. The MAT observed areas labeled “tornado shelter” that were used as refuge areas but that had not been designed or constructed to provide life-safety protection or evaluated by a design professional to identify vulnerability to damage and failure during an extreme wind event. Although enhanced wind-resistant construction may reduce damage to buildings, only safe rooms or storm shelters hardened to provide life-safety protection from tornadoes can truly provide protection during tornadoes.

The amount of time between the warning and the tornado, which influences where people seek shelter, varied significantly. In the April tornadoes in the Southeast, warnings of the likelihood of a

massive tornado outbreak prompted early school dismissals. The rapidly forming tornado that hit Joplin, however, left residents with less than 20 minutes to seek shelter.

## Recommendations

The MAT's key recommendations in this report are presented in Table ES-1, grouped by topic area.

Table ES-1: Summary of the MAT's Key Recommendations

Topic	Subtopic	Key Recommendations
<b>Codes and Standards</b>	Residential	State and local governments should: <ul style="list-style-type: none"> <li>• Adopt and enforce current model building codes</li> <li>• Increase emphasis on code compliance</li> <li>• Maintain and rigorously enforce the adopted model building code since amendments or lax enforcement practices may weaken the continuous load path of the building</li> </ul>
	Commercial and Industrial	<ul style="list-style-type: none"> <li>• Include failure states and survivability in building codes and standards</li> <li>• Change risk category for large-footprint commercial structures with long-span roofs to Risk Category III in ASCE 7-10<sup>1</sup></li> <li>• Improve design approach in ASCE 7 and IBC to address risk consistently across hazards</li> <li>• ASCE 7 should improve the commentary on code limitations</li> <li>• Clarify risk tolerance in ASCE 7 and IBC</li> <li>• Include best practices for wind design in IBC</li> </ul>
	Critical Facilities	<ul style="list-style-type: none"> <li>• Change code to require newly constructed schools; 911 call stations; emergency operation centers; and fire, rescue, ambulance, and police stations to include a FEMA 361-compliant safe room or ICC 500-compliant storm shelter</li> </ul>
	Tornado Refuge Areas, Hardened Areas, Storm Shelters, and Safe Rooms	<ul style="list-style-type: none"> <li>• The ICC and FEMA should continue to coordinate standards and guidance for storm shelters and safe room design</li> <li>• Improve performance of safe rooms and storm shelters through adoption and enforcement of the 2009 or newer versions of IBC and IRC, which require compliance with ICC 500 for any storm shelter</li> <li>• Change code to require new buildings that do not incorporate a FEMA 361-compliant safe room or ICC 500-compliant shelter to identify the best available refuge area(s)</li> </ul>
<b>Building Type</b>	Residential	<ul style="list-style-type: none"> <li>• Implement voluntary best practices to mitigate damage to one- and two-family residential buildings</li> </ul>

<sup>1</sup> A Risk Category is assigned to buildings based on the risk to human life, health, and welfare associated with potential damage or failure of the building (per ASCE 7-10). The assigned Risk Category, I through IV, dictates the mean return interval for a design event that should be used when calculating the building's resistance to the events. In ASCE 7-05, Risk Categories were called "Occupancy Categories."

Table ES-1: Summary of the MAT's Key Recommendations (continued)

Topic	Subtopic	Key Recommendations
<b>Building Type</b>	Commercial and Industrial	<ul style="list-style-type: none"> <li>• Install a storm shelter or safe room or identify best available refuge areas in large-footprint buildings</li> <li>• For all public buildings, install signage in a conspicuous place at building entrances that states relevant building design parameters and additional signs indicating refuge areas</li> <li>• Place decision-making check lists or flip charts for emergency protocols in prominent locations</li> <li>• Do not use URM in primary or critical support areas of a building</li> <li>• Use screws in deck-to-joist connections instead of puddle welds</li> <li>• Include enhancements to building connections beyond the code requirements</li> <li>• Incorporate redundancy into the MWFRS</li> <li>• Incorporate more redundancy in the design of large-footprint buildings</li> <li>• Use discrete structural systems in large, long-span buildings</li> </ul>
	Critical Facilities	<ul style="list-style-type: none"> <li>• Perform a vulnerability assessment and identify best available refuge areas in existing buildings</li> <li>• Include safe rooms in design of new buildings</li> <li>• Enhance building design to better withstand tornadoes</li> <li>• Strengthen the facility to remain operational following a tornado or high-wind event</li> </ul>
	Infrastructure	<ul style="list-style-type: none"> <li>• Work collaboratively to better understand the risks of wind-displaced materials on communications towers</li> <li>• Work collaboratively to better understand the effects of wind-displaced materials on latticed structures</li> <li>• Provide alternate electrical source</li> <li>• Work collaboratively to better understand communications tower performance</li> </ul>
	Tornado Refuge Areas, Best Available Refuge Areas, Hardened Areas, Storm Shelters, and Safe Rooms	<ul style="list-style-type: none"> <li>• Research travel time to, and use of, safe rooms and storm shelters</li> <li>• Locate safe rooms or storm shelters close to people who will use them</li> <li>• Identify best available refuge areas in buildings without safe rooms</li> <li>• Perform vulnerability assessments of buildings to facilitate planning for high-wind events</li> <li>• Register safe rooms with appropriate local government organizations and provide coordinates of the primary entrance to them</li> <li>• Equip safe rooms, storm shelters, and best available refuge areas with tools to assist occupants when doors and egress routes become damaged, inoperable, or blocked by debris</li> <li>• Equip safe rooms, storm shelters, and best available refuge areas with an alternate means of communication</li> <li>• Provide training on tornado safe rooms, storm shelters, and refuge areas to professional organizations, public officials, emergency managers, building owners/operators and the public</li> </ul>

Table ES-1: Summary of the MAT's Key Recommendations (concluded)

Topic	Subtopic	Key Recommendations
EF Scale		<ul style="list-style-type: none"> <li>• Add DIs to the EF scale guidance</li> <li>• Increase the number of DOD categories for specific DIs</li> <li>• Provide additional guidance for DOD assessment when only a portion of a large building is struck</li> <li>• Modify EF scale DI 2 (One- and Two-family Residences) to remove DOD 5 (“house shifts off foundations”)</li> <li>• Provide photographs with DOD descriptions in EF scale rating guidance</li> </ul>
Post-Tornado Imagery		<ul style="list-style-type: none"> <li>• NOAA should capture post-tornado aerial photographs</li> <li>• NWS should develop EF contours</li> <li>• NWS should enhance the determination of EF ratings at individual structures by including a design professional as part of the QRTs</li> </ul>

**Definitions:**

ASCE = American Society of Civil Engineers

ASCE 7 = *Minimum Design Loads for Buildings and Other Structures* (current edition: ASCE 7-10)

DI = damage indicator

DOD = Degree of Damage

EF = Enhanced Fujita

FEMA = Federal Emergency Management Agency

IBC = International Building Code

ICC = International Code Council

IRC = International Residential Code

MWFERS = main wind force resisting system

NOAA = National Oceanic and Atmospheric Administration

NWS = National Weather Service

QRT = Quick Response Team

URM = unreinforced masonry



TORNADO OUTBREAK  
*of* **2011**

IN ALABAMA, GEORGIA, MISSISSIPPI,  
 TENNESSEE, AND MISSOURI

# Contents

**Executive Summary** ..... i

    Observations ..... ii

    Recommendations..... v

**1 Introduction**..... 1-1

1.1 FEMA Mitigation Assessment Teams ..... 1-2

    1.1.1 Purpose of the 2011 Tornado Mitigation Assessment Team..... 1-2

    1.1.2 Team Composition ..... 1-4

    1.1.3 Methodology ..... 1-4

    1.1.4 Types of Buildings and Structures Assessed by the MAT ..... 1-6

    1.1.5 Involvement of State and Local Agencies ..... 1-9

    1.1.6 Past Tornado MAT Deployments..... 1-9

1.2 Terminology and Background for Tornado Protection Alternatives ..... 1-11

1.3 2011 Tornado Recovery Advisories..... 1-14

1.4 Organization of Report ..... 1-15

<b>2</b>	<b>Meteorological Background and Tornado Events of 2011</b> .....	2-1
2.1	Tornado Prediction .....	2-2
2.2	Enhanced Fujita Scale.....	2-3
2.3	Tornado Winds and Damage Patterns .....	2-4
2.4	National Weather Service Tornado Warning Strategies and Ratings.....	2-6
2.4.1	Tornado Watches and Warnings .....	2-6
2.4.2	NWS EF Rating Assignments .....	2-7
2.5	Tornado Events of Spring 2011.....	2-8
2.5.1	April 25–28, 2011 Tornadoes in the Mid-South Area of the United States .....	2-8
2.5.1.1	April 18–24, 2011.....	2-8
2.5.1.2	April 25, 2011 .....	2-10
2.5.1.3	April 26, 2011 .....	2-11
2.5.1.4	April 27, 2011, 2:00 a.m. to 12:00 p.m. ....	2-11
2.5.1.5	April 27, 2011, 2:30 p.m. to 3:00 p.m.: Philadelphia, MS, Tornado #24, and Cullman, AL, Tornado #38 .....	2-12
2.5.1.6	April 27, 2011, 3:00 p.m.: Hackleburg to Huntsville, AL, Tornado #40 ..	2-13
2.5.1.7	April 27, 2011, 3:30 p.m.: Smithville, MS, Tornado #43 .....	2-14
2.5.1.8	April 27, 2011, 3:38 p.m.: Cordova, AL, Tornado #41/#49 .....	2-15
2.5.1.9	April 27, 2011: Macon County Supercell Thunderstorm, Tornado #46 ...	2-16
2.5.2	May 22, 2011 Storms in Missouri .....	2-17
2.5.2.1	Summary of Synoptic Setting and Mesoscale Environment .....	2-18
2.5.2.2	Damage and Path of the Joplin Tornado .....	2-19
<b>3</b>	<b>Design and Construction Considerations</b> .....	3-1
3.1	Effects of Wind Loading on Structures .....	3-2
3.2	Wind-Borne Debris .....	3-6
3.2.1	Missile Types and Sizes.....	3-8
3.2.2	Wind-Borne Missile Quantity .....	3-11
3.3	Federal, State, and Local Regulations .....	3-13
3.3.1	International Building Code and International Residential Code .....	3-14



3.3.2	International Codes and Storm Shelters.....	3-14
3.3.3	State and Local Codes and Regulations in Areas Visited by the MAT .....	3-15
3.3.3.1	Alabama.....	3-17
3.3.3.2	Georgia.....	3-18
3.3.3.3	Mississippi.....	3-18
3.3.3.4	Tennessee .....	3-18
3.3.3.5	Missouri.....	3-19
<b>4</b>	<b>Observations on Residential Building Performance .....</b>	<b>4-1</b>
4.1	One- and Two-Family Residences.....	4-2
4.1.1	EF Rating Evaluation of Residential Buildings.....	4-3
4.1.2	Description of Progressive Damage for One- and Two-Family Residential Buildings .....	4-4
4.1.3	Loss of Roof Covering and Exterior Siding (DOD 2) .....	4-5
4.1.4	Glazing Damage (DOD 3) .....	4-6
4.1.5	Garage Doors Collapse Inward (DOD 4) .....	4-8
4.1.6	Uplift of Roof Decks (DOD 4).....	4-10
4.1.7	Gable End Walls: Vulnerability Related to Uplift of Roof Deck (DOD 4).....	4-13
4.1.8	Entire House Shifts Off Foundation (DOD 5) .....	4-14
4.1.9	Roof Structure Removed (DOD 6).....	4-15
4.1.10	Collapse of Framed Walls (DOD 6–9) .....	4-18
4.1.11	Wall Framing-to-Foundation Connection Failure: Damage Related to Collapse of Framed Walls (DOD 7–9) .....	4-20
4.2	Multi-Family Residences .....	4-24
4.2.1	EF Rating Evaluation of Multi-Family Residential Buildings .....	4-24
4.2.2	Chastain Manor Apartments (Tuscaloosa, AL).....	4-24
4.2.3	Mercy Village Apartments (Joplin, MO) .....	4-30
4.3	Summary of Conclusions and Recommendations .....	4-35
<b>5</b>	<b>Observations on Commercial and Industrial Building Performance .....</b>	<b>5-1</b>
5.1	Tilt-Up Precast Concrete Walls with Steel Joist Roof System.....	5-5
5.1.1	Description of Construction Method and Load Path .....	5-5

5.1.2	Typical Failure Modes Observed by the MAT.....	5-6
5.1.3	Home Depot (Joplin, MO) .....	5-6
5.2	Load Bearing Masonry with Steel Joist Roof System .....	5-16
5.2.1	Description of Construction Methods and Load Path.....	5-17
5.2.2	Typical Failure Modes Observed by the MAT.....	5-17
5.2.3	Strip Mall – Dry Cleaner, Two Large Retail Stores, and Other Stores (Tuscaloosa, AL).....	5-18
5.2.4	Jefferson Metro Care (Birmingham, AL) .....	5-22
5.2.5	Walmart (Joplin, MO).....	5-27
5.3	Light Steel Frame Buildings .....	5-36
5.3.1	Description of Construction Method and Load Path .....	5-36
5.3.2	Typical Failure Modes Observed by the MAT.....	5-36
5.3.3	Fitness Center (Tuscaloosa, AL).....	5-37
5.3.4	St. Paul’s United Methodist Church (Joplin, MO).....	5-39
5.4	Reinforced Concrete Frame with CMU Infill Walls .....	5-42
5.4.1	Description of Construction Method and Load Path .....	5-43
5.4.2	Typical Failure Modes Observed by the MAT.....	5-43
5.4.3	Ozark Center for Autism (Joplin, MO).....	5-43
5.5	Summary of Conclusions and Recommendations .....	5-48
<b>6</b>	<b>Observations on Critical Facility Performance: Schools.....</b>	<b>6-1</b>
6.1	Building Performance.....	6-4
6.1.1	Alberta Elementary School (Tuscaloosa, AL) .....	6-4
6.1.2	University Place Elementary School (Tuscaloosa, AL) .....	6-10
6.1.3	Ringgold High School and Ringgold Middle School (Ringgold, GA) .....	6-18
6.1.3.1	Ringgold High School .....	6-18
6.1.3.2	Ringgold Middle School.....	6-26
6.1.4	Joplin East Middle School (Joplin, MO).....	6-29
6.1.5	Joplin High School (Joplin, MO) .....	6-35
6.2	Operational Issues.....	6-43
6.2.1	Severe Weather Policy .....	6-45

6.2.2	Severe Weather Communication and Decision Making .....	6-46
6.2.3	Changes for the Future .....	6-47
6.2.4	Summary .....	6-48
6.3	Summary of Conclusions and Recommendations .....	6-48
<b>7</b>	<b>Observations on Critical Facility Performance: Healthcare, First Responder, and Emergency Operations Centers .....</b>	<b>7-1</b>
7.1	Hospitals and Health Care Facilities.....	7-3
7.1.1	Birmingham Nursing and Rehabilitation Center (Birmingham, AL) .....	7-4
7.1.2	LaRocca Nursing Home (Tuscaloosa, AL) .....	7-7
7.1.3	Greenbriar Nursing Home (Joplin, MO) .....	7-12
7.1.4	St. John’s Medical Center (Joplin, MO) .....	7-15
7.2	First Responder Facilities (Police and Fire).....	7-22
7.2.1	Fultondale Municipal Complex (Fultondale, AL) .....	7-22
7.2.1.1	Fire Department.....	7-24
7.2.1.2	Library and “Shelter” .....	7-25
7.2.1.3	Building and Inspections Department.....	7-26
7.2.1.4	City Hall.....	7-28
7.2.1.5	Summary of the MAT EF Ratings for the Fultondale Municipal Complex .....	7-29
7.2.2	Tuscaloosa Fire Station 4 (Tuscaloosa, AL) .....	7-29
7.2.3	Webster’s Chapel Volunteer Fire Department (Wellington, AL) .....	7-34
7.2.4	Smithville Police Department (Smithville, MS) .....	7-37
7.3	Emergency Operations Centers .....	7-42
7.3.1	Tuscaloosa EOC (Tuscaloosa, AL) .....	7-42
7.3.2	Cullman County EOC (Cullman, AL) .....	7-49
7.4	Summary of Conclusions and Recommendations .....	7-51
<b>8</b>	<b>Observations on Infrastructure Performance .....</b>	<b>8-1</b>
8.1	Water Treatment and Distribution Facilities .....	8-2
8.1.1	Tuscaloosa Water Works (Tuscaloosa, AL) .....	8-3

8.1.2	Smithville Water Treatment and Distribution System (Smithville, MS) .....	8-6
8.2	WasteWater Treatment Facilities .....	8-11
8.2.1	Tuscaloosa Waste Water Treatment Plant and Collection System (Tuscaloosa, AL) .....	8-11
8.3	Towers (Communications and Antennas) .....	8-12
8.3.1	Free-Standing Towers .....	8-13
8.3.1.1	Latticed 250-Foot EMS Communications Tower (Tuscaloosa, AL) .....	8-13
8.3.1.2	Latticed 300-Foot Cellular Tower (Tuscaloosa, AL) .....	8-16
8.3.1.3	Solid Cellular Tower, 13th Street (Tuscaloosa, AL) .....	8-19
8.3.2	Guyed Towers .....	8-21
8.3.2.1	300-Foot Guyed Cellular Tower (Smithville, MS) .....	8-21
8.4	Summary of Conclusions and Recommendations .....	8-25
<b>9</b>	<b>Observations on Tornado Refuge Areas, Hardened Areas, and Safe Rooms .....</b>	<b>9-1</b>
9.1	Terminology and Examples .....	9-2
9.1.1	Hardened Areas: Areas Designed to Provide Some Protection .....	9-3
9.1.2	Storm Shelters and Safe Rooms: Areas Designed for Life-Safety Protection .....	9-4
9.2	Tornado Refuge Areas .....	9-7
9.2.1	Tornado Refuge Areas in Residences .....	9-7
9.2.1.1	Core Remnants .....	9-8
9.2.1.2	Basement Areas .....	9-10
9.2.1.3	Tornado Refuge Areas in Multi-Family Buildings or Complexes .....	9-13
9.2.2	Tornado Refuge in Commercial and Industrial Buildings: Planned Tornado Refuge Areas .....	9-14
9.2.2.1	Walmart (Joplin, MO ) .....	9-14
9.2.2.2	Lowe’s Home Improvement Store (Tuscaloosa, AL) .....	9-15
9.2.2.3	Home Depot (Joplin, MO) .....	9-17
9.3	Hardened Structures, Rooms, and Areas Not Designed to Defined Criteria .....	9-18
9.3.1	Hardened Structures for Residential Use .....	9-20
9.3.1.1	Below-Ground Applications .....	9-20
9.3.1.2	Above-Ground Applications .....	9-22

---

9.3.2	Hardened Structures Used as Community Tornado Refuge Areas .....	9-23
9.3.2.1	Above-Ground Applications.....	9-24
9.3.2.2	Below-Ground Applications .....	9-25
9.4	Safe Rooms and Storm Shelters .....	9-26
9.4.1	Above- and Below-Ground Alternatives .....	9-26
9.4.2	Prefabricated versus Site-Built Alternatives .....	9-28
9.4.3	Residential Safe Rooms and Storm Shelters .....	9-29
9.4.3.1	Below-Ground Applications .....	9-29
9.4.3.2	Above-Ground Applications.....	9-31
9.4.4	Non-Residential and Community Safe Rooms .....	9-33
9.4.4.1	Brookwood and Phil Campbell Community Safe Rooms (AL) .....	9-34
9.4.4.2	Brookside Fire Station and Community Safe Room (Brookside, AL) ....	9-37
9.4.4.3	Seneca Intermediate School (Seneca, MO) .....	9-38
9.5	Travel Time to Community Safe Rooms, Storm Shelters, and Tornado Refuge Areas .....	9-42
9.6	Compliance Issues with FEMA 320, FEMA 361, and the ICC 500.....	9-43
9.6.1	Identifying Design Criteria Used for Safe Rooms and Storm Shelters .....	9-43
9.6.2	Accessibility to Safe Rooms and Storm Shelters .....	9-44
9.6.3	Ventilation for Safe Rooms and Storm Shelters .....	9-45
9.6.4	Toilet Facilities for Community Safe Rooms and Storm Shelters.....	9-45
9.6.5	Location and Labeling of Safe Rooms and Storm Shelters .....	9-45
9.6.6	Tools and Other Equipment within Safe Rooms and Storm Shelters .....	9-46
9.7	Summary of Conclusions and Recommendations .....	9-47
<b>10</b>	<b>Conclusions of the 2011 Tornado MAT .....</b>	<b>10-1</b>
10.1	Codes and Standards .....	10-2
10.1.1	Residential Buildings.....	10-2
10.1.2	Commercial and Industrial Buildings.....	10-4
10.1.3	Critical Facilities .....	10-4
10.1.4	Infrastructure Facilities.....	10-5
10.1.5	Tornado Refuge Areas, Hardened Areas, and Safe Rooms.....	10-5

---

10.2	Performance of Residential Buildings .....	10-6
10.3	Performance of Commercial and Industrial Buildings .....	10-7
10.3.1	Communications and Operations .....	10-8
10.3.2	Building Performance/Building Design.....	10-8
10.4	Performance of Critical Facility Buildings .....	10-9
10.5	Performance of Infrastructure Facilities .....	10-11
10.6	Performance of Tornado Refuge Areas, Hardened Areas, and Safe Rooms .....	10-12
10.6.1	General.....	10-12
10.6.2	Residential Safe Rooms and Storm Shelters .....	10-14
10.6.3	Community Safe Rooms, Storm Shelters, and Tornado Refuge Areas.....	10-16
10.7	EF Scale.....	10-17
10.8	Post-Tornado Imagery .....	10-18
<b>11</b>	<b>Recommendations of the 2011 Tornado MAT .....</b>	<b>11-1</b>
11.1	Codes and Standards .....	11-2
11.1.1	Residential Buildings.....	11-2
11.1.2	Commercial and Industrial Buildings.....	11-3
11.1.3	Critical Facilities .....	11-4
11.1.4	Tornado Refuge Areas, Hardened Areas, and Safe Rooms.....	11-4
11.2	Residential Construction .....	11-5
11.3	Commercial and Industrial Construction .....	11-6
11.3.1	Occupant Notification and Operations .....	11-6
11.3.2	Detailing and Connections .....	11-7
11.4	Critical Facilities.....	11-8
11.4.1	Existing Critical Facilities.....	11-9
11.4.2	New Critical Facilities .....	11-10
11.5	Infrastructure Facilities .....	11-10
11.6	Tornado Refuge Areas, Hardened Areas, and Safe Rooms .....	11-11

11.7	EF Scale.....	11-13
11.8	Post-Tornado Imagery .....	11-13

## Appendices

Appendix A	Acknowledgments
Appendix B	References
Appendix C	Acronyms
Appendix D	Glossary
Appendix E	EF Scale Summary
Appendix F	Recovery Advisories for the Spring 2011 Tornadoes
Appendix G	Recommendations for One- and Two-Family Residential Buildings

## List of Figures

### Chapter 1

Figure 1-1:	NOAA SPC Storm Reports for April 25-28, 2011 tornado outbreak.....	1-3
Figure 1-2:	NOAA SPC Storm Report for the May 22, 2011 tornado outbreak.....	1-4
Figure 1-3:	Communities in Alabama, Georgia, Mississippi, Tennessee, and Missouri visited by the MAT in 2011 .....	1-5
Figure 1-4:	HMGP-funded residential safe room in Smithville, MS, that was occupied during the storm, but was not in the tornado path.....	1-8
Figure 1-5:	Cover of FEMA 320.....	1-11
Figure 1-6:	Cover of FEMA 361.....	1-13
Figure 1-7:	Cover of ICC 500 .....	1-14

### Chapter 2

Figure 2-1:	Potential tornado damage pattern .....	2-5
Figure 2-2:	Map of tornado tracks associated with the April 27, 2011 outbreak in Alabama.....	2-9

Figure 2-3: Map of tornado tracks associated with the April 26–27, 2011 outbreak in Mississippi .....2-10

Figure 2-4: Base reflectivity and hook echo for Cullman, AL .....2-12

Figure 2-5: Base reflectivity and hook echo for Hackleburg, AL .....2-13

Figure 2-6: Base reflectivity and hook echo and storm relative velocity for Phil Campbell, AL ..2-14

Figure 2-7: Base reflectivity and hook echo and storm relative velocity for Smithville, MS .....2-15

Figure 2-8: Base reflectivity and hook echo and storm relative velocity for Cordova, AL .....2-15

Figure 2-9: Base reflectivity and hook echo and storm relative velocity for Tuscaloosa, AL .....2-16

Figure 2-10: Base reflectivity and hook echo and storm relative velocity for Pleasant Grove, AL..2-17

Figure 2-11: Joplin, MO, base reflectivity with hook echo and storm relative velocity .....2-19

**Chapter 3**

Figure 3-1: Effects of a breach in a building envelope when the breach is on the windward or leeward side of a building..... 3-3

Figure 3-2: Load path continuity in CMU wall..... 3-4

Figure 3-3: Building failure modes in high-wind event..... 3-5

Figure 3-4: Uplift pressures acting on a building..... 3-5

Figure 3-5: Brick veneer blew off this high school cafeteria during the tornado in Phil Campbell, AL. Note that brick ties do not appear to be at the correct spacing..... 3-6

Figure 3-6: Example of small- and medium-sized missiles commonly observed by the MAT (Tuscaloosa, AL) ..... 3-7

Figure 3-7: Example of medium- to large-sized wind-borne missiles (Tuscaloosa, AL) ..... 3-7

Figure 3-8: Medium-sized missile that struck the roof of a school building (Tuscaloosa, AL) ..... 3-8

Figure 3-9: Large roof beam penetrated the roof of this home (Athens, AL) ..... 3-9

Figure 3-10: OSB damaged the first floor locker in Joplin High School (Joplin, MO) ..... 3-9

Figure 3-11: Small pieces of OSB debris penetrated the roof of a home (Harvest, AL) ..... 3-10



Figure 3-12: Metal sheathing travelled 200 feet as wind-borne debris and landed next to a building outside of the tornado swath (Fultondale, AL) .....	3-10
Figure 3-13: A 2x6 missile penetrated the roof and seat of a car (Joplin, MO) .....	3-11
Figure 3-14: Wind-borne debris consisting of wood framing members and plywood sheathing near the Alberta Elementary School, Tuscaloosa, AL .....	3-11
Figure 3-15: Large quantity of wind-borne debris covering the lawn of a nursing home in Joplin, MO .....	3-12
Figure 3-16: Numerous missiles struck the outer wall of this non-residential building, including several that remained embedded (Tuscaloosa, AL) .....	3-12
Figure 3-17: Large pile of small- and medium-sized wind-borne debris outside of Joplin High School (Joplin, MO) .....	3-13

## Chapter 4

Figure 4-1: Wind-borne asphalt shingle penetrated the gypsum board on both sides of this interior wall at Chastain Manor Apartment Complex (Tuscaloosa, AL) .....	4-4
Figure 4-2: Example of DOD 2 (loss of asphalt shingles) (Tuscaloosa, AL) [MAT EF Rating = 0] .....	4-5
Figure 4-3: Example of DOD 2 (loss of siding) (Tuscaloosa, AL) [MAT EF Rating = 0] .....	4-5
Figure 4-4: Example of DOD 2 (loss of siding) through DOD 6 (large sections of roof structure removed) (Joplin, MO) [MAT EF Rating = 2] .....	4-6
Figure 4-5: Effect of wind on an enclosed building and a partially enclosed building .....	4-6
Figure 4-6: Double-glazed window with outer pane sacrificed, leaving the inner glazing intact (Mercy Village, Joplin, MO) .....	4-7
Figure 4-7: Example of DOD 3 showing window with shattered double-glazing (Harvest, AL) [MAT EF Rating = 2] .....	4-8
Figure 4-8: Example of DOD 4 showing a wide garage door collapsed inward, while narrow garage door to left is intact. (Joplin, MO). [MAT EF Rating = 2] .....	4-9
Figure 4-9: Example of damage including loss of large sections of roof (DOD 6) (Joplin, MO) [MAT EF Rating = 2] .....	4-9
Figure 4-10: Example of how garage door failure (DOD 4) initiated progressive failure, including loss of the garage roof (DOD 6) (Joplin, MO) [MAT EF Rating = 2] .....	4-9

---

Figure 4-11: Example of DOD 4 showing roof decking blown off along eaves and hip (Joplin, MO) [MAT EF Rating = 2] .....	4-10
Figure 4-12: Component and cladding wind pressures .....	4-11
Figure 4-13: Example of DOD 4 showing where roof decking lifted and blew off above damaged soffit (Birmingham, AL) [MAT EF Rating = 2] .....	4-12
Figure 4-14: Example of DOD 4 showing roof decking removed at wide eaves on hip roof (Phil Campbell, AL) [MAT EF Rating = 1] .....	4-12
Figure 4-15: Red circled roof deck nail not connected to rafter (Harvest, AL).....	4-13
Figure 4-16: Example of DOD 4 showing damage to gable end of simple gable roof (Harvest, AL) [MAT EF Rating = 1].....	4-14
Figure 4-17: Example of DOD 5 showing residential building shifted off masonry piers (Cullman, AL) [MAT EF Rating = 2].....	4-14
Figure 4-18: Example of DOD 6 showing failed roof-to-wall connections that resulted in loss of roof structure (Harvest, AL) [MAT EF Rating = 2].....	4-15
Figure 4-19: Example of roof-to-wall connection failure facilitated by non-code-compliant construction (Harvest, AL) [MAT EF Rating = 1] .....	4-15
Figure 4-20: Over-notched rafter found on ground with two toe nails withdrawn from plate (Harvest, AL) [MAT EF Rating = 1].....	4-16
Figure 4-21: Example of DOD 6 showing trusses were connected to walls with small hurricane ties (Phil Campbell, AL) [MAT EF Rating = 2] .....	4-17
Figure 4-22: Example of DOD 6 showing insufficient connection of single roof-to-wall connector (Tuscaloosa, AL) [MAT EF Rating = 2] .....	4-17
Figure 4-23: Example of DOD 6 showing failure of roof framing that resulted in loss of lateral support for the top of this wall (Phil Campbell, AL)[MAT EF Rating = 2] ...	4-18
Figure 4-24: Example of DOD 6 showing pressurization of garage when failure of the garage door/wall removed the support (Harvest, AL) [MAT EF Rating = 2] .....	4-19
Figure 4-25: Example of DOD 6 where most walls remained standing, but under-braced garage entry wall failed (Joplin, MO) [MAT EF Rating = 2] .....	4-19
Figure 4-26: Example of DOD 6 showing under-braced framed sunroom wall failure (Harvest, AL) [MAT EF Rating = 2] .....	4-20
Figure 4-27: Example of wall framing-to-foundation connection failure (Harvest, AL) [MAT EF Rating = 2].....	4-21

Figure 4-28: Example of wall framing-to-foundation connection failure (Harvest, AL) [MAT EF Rating = 2] .....	4-21
Figure 4-29: Wall-to-foundation connection failure (Hackleburg, AL) [MAT EF Rating = 3] .....	4-22
Figure 4-30: Wall-to-foundation failure where bottom plate and concrete nails were pulled out by high winds (Hackleburg, AL) [MAT EF Rating = 3] .....	4-23
Figure 4-31: Wall-to-foundation connection failure (Tuscaloosa, AL) [MAT EF Rating = 4] .....	4-23
Figure 4-32: Aerial view of Chastain Manor Apartments in relationship to the approximate centerline of the tornado damage swath (Tuscaloosa, AL) .....	4-25
Figure 4-33: One-story Chastain Manor Apartments suffered damage varying from roof decking uplift to collapse of roof structure .....	4-26
Figure 4-34: One-story Chastain Manor Apartment unanchored porch column that rotated at top and bottom of column .....	4-27
Figure 4-35: Example of DODs 3 and 4 showing two-story Chastain Manor Apartments with varying roof damage.....	4-27
Figure 4-36: Example of DOD 6 showing two-story Chastain Manor Apartments completely destroyed by the tornado with slabs swept clean .....	4-28
Figure 4-37: Two-story Chastain Manor Apartment steel porch column was blown away and embedded in neighboring hillside .....	4-28
Figure 4-38: Most of the bottom plates were blown off the Chastain Manor leasing office .....	4-29
Figure 4-39: Two-story Chastain Manor Apartment slab with bottom plate pulled over remaining anchor bolt and 1-inch diameter washer .....	4-29
Figure 4-40: Aerial photograph showing Mercy Village prior to tornado .....	4-30
Figure 4-41: Aerial photograph of Mercy Village after the tornado (Joplin, MO) .....	4-31
Figure 4-42: Aerial photograph of Mercy Village after tornado (Joplin, MO) .....	4-32
Figure 4-43: West wall and elevator tower where brick fell off and damaged one-story roof .....	4-33
Figure 4-44: Damage to the gable end wall at south stair tower end. Note third floor wall is missing and second floor wall is bowed outward.....	4-33
Figure 4-45: Damaged glazing on the interior courtyard of north wing building; majority of glazing was damaged.....	4-34

Figure 4-46: Nails through roof sheathing and nail plates have separated from roof trusses because of wind pressures..... 4-35

**Chapter 5**

Figure 5-1: Location of Joplin, MO, buildings described in Chapter 5 ..... 5-3

Figure 5-2: Location of Tuscaloosa, AL, buildings described in Chapter 5 ..... 5-4

Figure 5-3: Location of Jefferson Metro Care medical office in Birmingham, AL..... 5-4

Figure 5-4: Aerial view of Home Depot in Joplin, MO, in relationship to the approximate centerline of the May 22, 2011 tornado damage swath..... 5-7

Figure 5-5: Field east of Home Depot with roof debris..... 5-8

Figure 5-6: Failed puddle welds that connected the metal roof deck to the top chord of the joist..... 5-9

Figure 5-7: Joist girder and column failure..... 5-9

Figure 5-8: Separation at bottom chord to stabilizer plate ..... 5-10

Figure 5-9: Buckled column..... 5-11

Figure 5-10: Bolt failure at interior column resulting from shear and tension. The hooked anchor bolts pulled out of the slab. .... 5-12

Figure 5-11: Joist support pocket at top of a precast wall..... 5-12

Figure 5-12: Failure of joist-to-joist girder connection shown by broken welds..... 5-14

Figure 5-13: The joist seats came free of their bearing locations when both the seat-to-joist weld and the seat-to-embed plate weld broke ..... 5-14

Figure 5-14: Example of weld plate and joist failure. The joist seat was torn from the joist and the anchor studs from embed plate were torn out of the concrete. .... 5-15

Figure 5-15: The panel at the weld plate failed ..... 5-15

Figure 5-16: Example of a weld plate failure. Note the attached joist and the joist pocket at the top of the wall panel. .... 5-16

Figure 5-17: Aerial view showing the locations of the dry cleaner building, fitness center, retail store “A” and retail store “B” (Tuscaloosa, AL)..... 5-18

Figure 5-18: Steel joist in midst of collapsed unreinforced masonry wall at the dry cleaner store (Tuscaloosa, AL).....	5-19
Figure 5-19: Solid steel hot rolled sections left in beam pockets of CMU building section .....	5-20
Figure 5-20: Sequence of failure for CMU wall at the dry cleaner building .....	5-20
Figure 5-21: Global wall instability failure. The CMU blocks are lying loosely on the ground and many have rotated due to the complete separation of all the blocks....	5-21
Figure 5-22: View of steel joist pockets in CMU wall where joists pulled out; the exterior CMU wall fell inwards .....	5-22
Figure 5-23: Steel joists with joist seat and bond beam on top of collapsed wall. Wall fragmentation shows lack of reinforcement in the wall. ....	5-22
Figure 5-24: Aerial view showing the Jefferson Metro Care Facility in relationship to the approximate centerline of the tornado damage swath (Birmingham, AL) .....	5-23
Figure 5-25: Failed bond beam-to-structural steel connection over front windows.....	5-24
Figure 5-26: Roof joist lifted off front and folded over rear half of building .....	5-25
Figure 5-27: Failed roof deck with no connections between the roof deck and the joists.....	5-25
Figure 5-28: This CMU cell was found on the ground adjacent to the structure.....	5-25
Figure 5-29: Bar joist with embed plate and bond beam cell still attached.....	5-26
Figure 5-30: Embed plate with bond beam cell on roof .....	5-26
Figure 5-31: Aerial view of a Walmart in Joplin, MO in relationship to the approximate centerline of the May 22, 2011 tornado damage swath.....	5-27
Figure 5-32: The relatively undamaged west elevation of Walmart after the May 22, 2011 tornado (Joplin, MO).....	5-28
Figure 5-33: Interior of the north half of the Walmart, looking east. Fallen roof structure shown in right side of the picture.....	5-29
Figure 5-34: Destroyed east side of north half of Walmart .....	5-29
Figure 5-35: Interior of the north half of building showing water infiltration collected in bags .....	5-30
Figure 5-36: Interior view from the south half of the building looking toward the east. This shows the boundary of roof damage to the south portion of the building. ....	5-31

Figure 5-37: View of the south half of the building looking north showing roof damage. Note the missing roof membrane..... 5-31

Figure 5-38: Typical connection of two steel joists to joist girder. While the joist seat from one joist remains, the weld failed at the other joist seat connection..... 5-32

Figure 5-39: Joist girder rotated at the column; the bottom chord was not attached to the stabilizer plate ..... 5-32

Figure 5-40: Collapsed column with hooked anchor bolts remains attached to the foundation at the base..... 5-32

Figure 5-41: Roof structure remaining in south half of Walmart (Joplin, MO) ..... 5-33

Figure 5-42: Reinforcing steel in Walmart foundation ..... 5-33

Figure 5-43: Partial collapsed wall in southern half of store ..... 5-34

Figure 5-44: Area of relatively limited damage ..... 5-35

Figure 5-45: Another view of the area shown in Figure 5-44..... 5-35

Figure 5-46: Aerial view of the fitness center in relationship to the approximate centerline of the April 27, 2011 tornado damage swath (Tuscaloosa, AL)..... 5-37

Figure 5-47: Front of fitness center building..... 5-38

Figure 5-48: The anchor bolts of this base plate connection performed well while the weld along the base of the steel column failed ..... 5-39

Figure 5-49: Ductile end column at southwest corner of building. The anchor bolts remained attached to both the foundation and the column..... 5-39

Figure 5-50: Aerial view of St. Paul’s United Methodist Church (Joplin, MO) in relationship to the approximate centerline of the tornado damage swath ..... 5-40

Figure 5-51: Intact PEMB main frames..... 5-41

Figure 5-52: Roof system purlins intact with metal roof clip released ..... 5-41

Figure 5-53: Secondary framing (light gage infill walls) failed while the main frames survived ..... 5-42

Figure 5-54: Aerial view of the Ozark Center for Autism in relationship to the approximate centerline of the tornado damage swath (Joplin, MO) ..... 5-44

Figure 5-55: East elevation of the Ozark Center for Autism showing damage ..... 5-45

Figure 5-56: East elevation from northeast corner of building. The structural core of the taller building performed well, as did the CMU infill. ....	5-45
Figure 5-57: Two-story extension on east side of building shown in Figure 5-56; view shows typical interior layout .....	5-46
Figure 5-58: Roof of the third-story main building.....	5-46
Figure 5-59: Roof section at two-story extension showing how the metal roof deck diaphragm is connected to the joists.....	5-47
Figure 5-60: View of roof of the two-story extension observed from the third floor. Note the failed decking at the corner. ....	5-47
 <b>Chapter 6</b>	
Figure 6-1: Location of Tuscaloosa, AL, critical facilities described in Chapters 6 and 7.....	6-3
Figure 6-2: Location of Joplin, MO, critical facilities described in Chapters 6 and 7.....	6-4
Figure 6-3: Aerial view of tornado track in vicinity of Alberta Elementary School. The center of the damage swath is approximated. ....	6-5
Figure 6-4: Area shown in yellow circle of Figure 6-3. The general location of the tornado refuge areas for the two surviving wings is shown.....	6-6
Figure 6-5: View of the central core area. Refuge areas for the two surviving wings were in the collapsed area. ....	6-6
Figure 6-6: Interior reinforced CMU wall in the central core area where rebar had deficient splice lap .....	6-7
Figure 6-7: Center classroom wing remains standing while the wing to the right collapsed.....	6-8
Figure 6-8: Partially collapsed corridor wall.....	6-8
Figure 6-9: Looking down the corridor of the collapsed classroom wing .....	6-9
Figure 6-10: The reinforced CMU walls around the restroom were left standing, but the rooms were littered with debris .....	6-9
Figure 6-11: University Place Elementary School after the tornado .....	6-10
Figure 6-12: Aerial view of the tornado track in the vicinity of the University Place Elementary School. The center of the damage swath is approximated.....	6-11

Figure 6-13: Close-up of Figure 6-12 showing classroom wings A and B and multipurpose wing (cafeteria, kitchen, and multipurpose room) ..... 6-11

Figure 6-14: View looking south showing damage of the classroom wings and multipurpose wing..... 6-12

Figure 6-15: View looking north showing wall and roof structure damage to classroom wing B and damage to the multipurpose wing..... 6-13

Figure 6-16: View of the second floor damage to classroom wing B..... 6-13

Figure 6-17: View inside the cafeteria .....6-14

Figure 6-18: View toward the cafeteria from within the multipurpose room. The inset shows a multipurpose room girder supported by a concrete column.....6-14

Figure 6-19: Multipurpose room girder. Lack of alignment of the bolt holes in the top and bottom plates (see insets) prevented installation of the anchor bolts. .... 6-15

Figure 6-20: Weld remnants where a joist was attached to the girder and weld remnants where a joist was attached to a bearing plate at a bond beam..... 6-16

Figure 6-21: A strong weld attaching a piece of decking to the joist. The photo on the right shows a weak deck attachment where the weld burnt through the joist. ....6-17

Figure 6-22: Rebar extending out of the slab at the multipurpose room end wall .....6-17

Figure 6-23: View of the Ringgold High School and Ringgold Middle School prior to the April 2011 tornado. NWS EF contour ratings are also shown. .... 6-19

Figure 6-24: Close-up view of Figure 6-23 showing the Ringgold High School prior to the April 2011 tornado..... 6-20

Figure 6-25: View of one of the portable classrooms. The red arrows indicate anchor straps. The strap shown in the inset had corroded through. .... 6-21

Figure 6-26: View of the 2008 auxiliary gymnasium and original gymnasium..... 6-22

Figure 6-27: View of the two gymnasium roofs. The EPDM (black) membrane is over the original gymnasium. Note the displaced rooftop equipment. .... 6-22

Figure 6-28: View of the roof of the 2008 auxiliary gymnasium; inset shows lifted decking ..... 6-23

Figure 6-29: The loss of the roof covering shown in Figure 6-28 led to water intrusion that damaged the floor below..... 6-24

Figure 6-30: View of the aggregate ballasted roof. The fully adhered roof membrane blew away; inset below shows broken windows. .... 6-24



Figure 6-31: The roof covering was blown off of the 2008 art center. The metal wall covering and insulation was also blown off the CMU. ....	6-25
Figure 6-32: At the wrestling facility, metal roof panels were blown off, steel framing was damaged, and a portion of the unreinforced CMU wall collapsed .....	6-25
Figure 6-33: View of the Ringgold Middle School prior to the April 2011 tornado.....	6-26
Figure 6-34: View of the Ringgold Middle School (the inset shows the left portion of the school). The 2008 auxiliary gymnasium and original gymnasium are shown. ....	6-27
Figure 6-35: This wing lost most of its roof decking, and a portion of the brick veneer and unreinforced CMU collapsed .....	6-27
Figure 6-36: View from within a classroom with the collapsed wall shown in Figure 6-35. The deck bulb-tees also blew off.....	6-28
Figure 6-37: Deck panels blew off the original gymnasium .....	6-28
Figure 6-38: EIFS wall failure, glazing damage, and roof deck blow-off .....	6-29
Figure 6-39: Aerial view of the tornado track in the vicinity of the Joplin East Middle School. NWS EF contour ratings are also shown.....	6-30
Figure 6-40: Close-up of Figure 6-39. Major areas of blow-off of the roof membrane and roof deck are shown.....	6-30
Figure 6-41: Interior rooms designated as “shelters” in the middle school’s Tornado Evacuation Plan. The inset shows the “shelter” signage.....	6-31
Figure 6-42: View of the collapsed auditorium roof and both exterior walls .....	6-32
Figure 6-43: View of the gymnasium. The inset shows where the truss was attached to the wall. ....	6-32
Figure 6-44: View of the end of the collapsed truss shown in Figure 6-43 .....	6-33
Figure 6-45: Roof truss and wall debris on the gymnasium floor .....	6-33
Figure 6-46: Brick veneer/insulation/precast concrete wall on the gymnasium floor .....	6-34
Figure 6-47: View of rain infiltration damage in a school corridor .....	6-34
Figure 6-48: Aerial view of the track in the vicinity of the Joplin High School. The center of the damage swath is approximated. NWS EF contour ratings are also shown.....	6-36
Figure 6-49: Close-up of Joplin High School .....	6-37

Figure 6-50: View of a corridor designated as tornado refuge area. The debris was blown into the corridor during the tornado..... 6-38

Figure 6-51: North classroom wing. The inset shows a close-up of the opposite side of the wing..... 6-39

Figure 6-52: Collapse of the exterior brick veneer/reinforced CMU wall and roof assembly into the corridor at the north end of the north classroom wing ..... 6-39

Figure 6-53: Collapsed brick veneer/reinforced CMU..... 6-40

Figure 6-54: View of the collapsed gymnasium. The inset shows the base plate and an anchor bolt that connected the girder support column to the pilaster. .... 6-41

Figure 6-55: Interior view of the second gymnasium ..... 6-41

Figure 6-56: North wall of the auditorium..... 6-42

Figure 6-57: South wall of the auditorium, showing collapse of the masonry infill wall..... 6-42

Figure 6-58: Flowchart depicting severe weather decision making process used by school districts in Alabama..... 6-46

Figure 6-59: Flowchart depicting severe weather decision making process used by the Joplin, MO, School District ..... 6-47

**Chapter 7**

Figure 7-1: Location of Tuscaloosa, AL, critical facilities described in Chapters 6 and 7..... 7-2

Figure 7-2: Location of Joplin, MO, critical facilities described in Chapters 6 and 7..... 7-3

Figure 7-3: Aerial view of the nursing home. Figure shows courtyard where residents were evacuated to and impact of wind-borne debris (Birmingham, AL). .... 7-4

Figure 7-4: Aerial view of the nursing home in relation to the approximate centerline of the tornado damage swath (Birmingham, AL) ..... 7-5

Figure 7-5: View of interior corridors that serve as the residents’ tornado refuge area (Birmingham, AL)..... 7-5

Figure 7-6: This portion of a roof from a nearby house was found across the street from the nursing home (Birmingham, AL)..... 7-6

Figure 7-7: The emergency generator is located near many trees that could easily have damaged the generator and taken it out of service (Birmingham, AL) ..... 7-6

Figure 7-8: Aerial view of the track in the vicinity of the nursing home. Inflow damaged the nursing home and buildings (Tuscaloosa, AL).....	7-7
Figure 7-9: Close-up of the nursing home shown in Figure 7-8 (Tuscaloosa, AL).....	7-8
Figure 7-10: Roof structure and brick veneer were blown off the nursing home (Tuscaloosa, AL).....	7-8
Figure 7-11: Roof structure blown off over resident rooms. The inset is a view from within one of the rooms. The window was broken (Tuscaloosa, AL).....	7-9
Figure 7-12: Interior damage as a result of roof structure blow-off (Tuscaloosa, AL) .....	7-9
Figure 7-13: View of the two-story wing. Most of the windows along this façade were broken (Tuscaloosa, AL).....	7-10
Figure 7-14: Tree-fall damage. Note the boarded-up broken windows. The inset shows a close-up of the tree-fall damage (Tuscaloosa, AL).....	7-10
Figure 7-15: Generator at the southwest side of the facility. Note the roof structure blow-off and wall collapse (Tuscaloosa, AL).....	7-11
Figure 7-16: Aerial view of the track in the vicinity of the nursing home. The center of the damage swath is approximated (Joplin, MO).....	7-12
Figure 7-17: Close-up of Figure 7-16 showing the damaged nursing home. The inset shows the nursing home before the tornado struck (Joplin, MO).....	7-13
Figure 7-18: Aerial view of the nursing home after the tornado (Joplin, MO).....	7-13
Figure 7-19: Only one wall remained standing at the nursing home (Joplin, MO) .....	7-14
Figure 7-20: Aerial view of the track in the vicinity of the St. John’s Medical Center (Joplin, MO) .....	7-15
Figure 7-21: Close-up of Figure 7-20 showing St. John’s Medical Center (Joplin, MO) .....	7-16
Figure 7-22: View of the glazing damage at patient rooms (Joplin, MO) .....	7-17
Figure 7-23: This parking lot was littered with 1½-inch nominal diameter aggregate from the ballasted roof membrane (Joplin, MO) .....	7-17
Figure 7-24: Collapse of a portion of the exterior metal composite foam wall panels at the East Tower addition (Joplin, MO) .....	7-18
Figure 7-25: View of a missing precast concrete wall panel at the loading dock (Joplin, MO) .....	7-19

Figure 7-26: Metal decking blow-off and glazing damage in the administrative area (Joplin, MO) ..... 7-19

Figure 7-27: Exterior wall collapse (EIFS over unreinforced CMU) at an equipment room (Joplin, MO) ..... 7-20

Figure 7-28: Metal decking blow-off and glazing and EIFS damage at the medical office building/outpatient center (Joplin, MO) ..... 7-21

Figure 7-29: Aerial view of tornado track in the vicinity of Fultondale Municipal Complex in Alabama (Fultondale, AL)..... 7-23

Figure 7-30: Tornado winds damaged an emergency generator and a roof, and lifted a roof. The “shelter” entrance is shown (Fultondale, AL). ..... 7-23

Figure 7-31: The apparatus bay doors of the fire department collapsed (Fultondale, AL) ..... 7-24

Figure 7-32: The metal roof panels blew off the apparatus bay of the fire department. The panels unlatched from the clips (Fultondale, AL)..... 7-25

Figure 7-33: The library is on top of the community tornado refuge area. The note in the window directed people to the “shelter” below (Fultondale, AL). ..... 7-26

Figure 7-34: The roof structure of the Buildings and Inspections Department building blew off in one complete section (Fultondale, AL) ..... 7-27

Figure 7-35: Note the inadequate anchorage from the truss nailer that was nailed to the wall top cap block (Fultondale, AL) ..... 7-27

Figure 7-36: The front of the City Hall showing damage to the metal roof covering over the entrance (Fultondale, AL) ..... 7-28

Figure 7-37: Back of the City Hall. Photograph shows the generator that was disabled by a fallen tree (Fultondale, AL)..... 7-29

Figure 7-38: Aerial view of the track in the vicinity of the fire station (Tuscaloosa, AL) ..... 7-30

Figure 7-39: View of the fire station. The apparatus bay, the living quarters, and the nearby heavily damaged apartment buildings are shown (Tuscaloosa, AL). ..... 7-31

Figure 7-40: View of the fire station with adjacent apartment building with unreinforced CMU cells (Tuscaloosa, AL) ..... 7-31

Figure 7-41: View of the living quarters of the fire station from outside. Note the amount and size of wind-borne debris adjacent to the walls (Tuscaloosa, AL). ..... 7-32

Figure 7-42: View of a restroom toward the center of the fire station where occupants took refuge (Tuscaloosa, AL)..... 7-32

---

Figure 7-43: View of the wood-frame apartment building behind the fire station (Tuscaloosa, AL) .....	7-33
Figure 7-44: View of the Webster’s Chapel Volunteer Fire Department in relation to the tornado (Wellington, AL) .....	7-35
Figure 7-45: View of the Webster’s Chapel Volunteer Fire Department after the tornado (Wellington, AL) .....	7-36
Figure 7-46: View of the old apparatus bay of the Webster’s Chapel Volunteer Fire Department. The multipurpose room is indicated (Wellington, AL) .....	7-36
Figure 7-47: View of the back of the building. The debris in the foreground is from the multipurpose room roof and the old apparatus bay (Wellington, AL) .....	7-36
Figure 7-48: Aerial view of the tornado track in the vicinity of the Smithville Police Department (Smithville, MS) .....	7-38
Figure 7-49: Smithville Police Department prior to the tornado (Smithville, MS) .....	7-38
Figure 7-50: Smithville Police Department (close-up of Figure 7-48) showing the room where refuge was taken during the tornado (Smithville, MS) .....	7-39
Figure 7-51: Smithville Police Department. Note the collapsed communications tower (Smithville, MS) .....	7-39
Figure 7-52: The office where two children and an adult took refuge under the desk (Smithville, MS) .....	7-40
Figure 7-53: View of the collapsed east wall and restroom of the Smithville Police Department. Note that some of the restroom walls collapsed (Smithville, MS) .....	7-40
Figure 7-54: Aerial view of the track in the vicinity of the Curry Building city complex (Tuscaloosa, AL) .....	7-43
Figure 7-55: Oblique view of Figure 7-54 showing the Curry Building .....	7-44
Figure 7-56: View of the southeastern end of the Curry Building before the tornado struck. The inset shows post-storm conditions (Tuscaloosa, AL) .....	7-44
Figure 7-57: View of a portion of the collapsed one-story area (Tuscaloosa, AL) .....	7-45
Figure 7-58: View of a portion of a collapsed loading dock area (Tuscaloosa, AL) .....	7-45
Figure 7-59: View of the refuge area (Tuscaloosa, AL) .....	7-47
Figure 7-60: Part of the southern portion of the building. The inset shows a metal door that buckled inward (Tuscaloosa, AL) .....	7-47

Figure 7-61: The door that leads to the EOC area. The inset shows the area above the EOC that collapsed (Tuscaloosa, AL). ..... 7-48

Figure 7-62: An exterior view of the Cullman County government building housing the Water Department and the County EMA facility (Cullman, AL) ..... 7-49

Figure 7-63: Interior view of the emergency operations room of the Cullman County EMA facility (Cullman, AL) ..... 7-50

**Chapter 8**

Figure 8-1: Locations of infrastructure assessed by the MAT in Tuscaloosa, AL ..... 8-2

Figure 8-2: Locations of infrastructure assessed by the MAT in Smithville, MS..... 8-3

Figure 8-3: The approximate centerline of the damage swath in relationship to the Tuscaloosa Water Works storage tower and the DCH Regional Medical Center ..... 8-4

Figure 8-4: Representative damage to overhead electrical lines and substations along the tornado path (Tuscaloosa, AL) ..... 8-5

Figure 8-5: The approximate centerline of the tornado damage swath in Smithville, MS ..... 8-6

Figure 8-6: Smithville Water Treatment Plant and storage tower aerial photograph pre-dates the tornado (Smithville, MS) ..... 8-7

Figure 8-7: Water tower after the tornado (Smithville, MS)..... 8-8

Figure 8-8: Destroyed unreinforced CMU building and damaged metal-framed building (Smithville, MS)..... 8-8

Figure 8-9: Reinforced CMU building housing control equipment (left) and undamaged water treatment control equipment (right) (Smithville, MS)..... 8-9

Figure 8-10: Debris impact damage to Smithville, MS, water tank ..... 8-9

Figure 8-11: Lift pumps and controls of the Smithville, MS, water plant were exposed, but not damaged ..... 8-10

Figure 8-12: Lightly secured chlorine cylinders; some were displaced by high winds (Smithville, MS)..... 8-10

Figure 8-13: Aerial view of the Tuscaloosa Waste Water Treatment Plant in relation to the approximate centerline of the April 27, 2011 tornado damage swath ..... 8-12

Figure 8-14: Aerial view of the approximate centerline of the tornado damage swath in the vicinity of the latticed 250-foot EMS communications tower (Tuscaloosa, AL) .....8-14

---

Figure 8-15: View of toppled EMS communications tower (Tuscaloosa, AL).....	8-14
Figure 8-16: View of the collapsed EMS communications tower; the EOC across 35th Street is also shown (Tuscaloosa, AL) .....	8-15
Figure 8-17: Photograph shows the six-bolt tower base with cracks in concrete foundation cap (Tuscaloosa, AL) .....	8-15
Figure 8-18: Aerial view of the approximate centerline of the tornado damage swath in the vicinity of the 300-foot latticed cellular tower (Tuscaloosa, AL).....	8-17
Figure 8-19: Base for 300-foot latticed cellular tower (Tuscaloosa, AL) .....	8-17
Figure 8-20: View of the 300-foot latticed cellular tower that collapsed during the tornado event (Tuscaloosa, AL) .....	8-18
Figure 8-21: Photograph of the 300-foot cellular tower and the metal building to the southeast before the April 27, 2011 tornado (Tuscaloosa, AL) .....	8-18
Figure 8-22: View of the collapsed 300-foot cellular tower and the destroyed metal building southeast of the tower (Tuscaloosa, AL) .....	8-19
Figure 8-23: Remnants of a trailer that struck the fence surrounding the 300-foot cellular tower (Tuscaloosa, AL).....	8-19
Figure 8-24: Aerial view of the approximate centerline of the tornado damage swath in the vicinity of the solid cellular tower (Tuscaloosa, AL) .....	8-20
Figure 8-25: Aerial view of solid cellular tower left standing after event. Insert shows aerial view of the tower amidst destroyed buildings (Tuscaloosa, AL). .....	8-21
Figure 8-26: Aerial view of the 300-foot guyed cellular tower in relationship to the approximate centerline of the tornado damage swath in Smithville, MS .....	8-22
Figure 8-27: Aerial photograph showing the 300-foot-tall guyed cellular tower after the tornado (Smithville, MS) .....	8-23
Figure 8-28: Guy attachment plate, turnbuckle, and anchor shaft (Smithville, MS) .....	8-23
Figure 8-29: Collapsed 300-foot cellular tower. The triple guy in the foreground is one of the three supports for the temporary tower on the site (Smithville, MS). .....	8-24
Figure 8-30: Wind-displaced building materials wrapped around the 300-foot cellular tower guy (Smithville, MS) .....	8-24
Figure 8-31: The anchor securing one guy was dragged several feet through the ground (Smithville, MS).....	8-25

**Chapter 9**

Figure 9-1: A hardened room in a residential building in Tuscaloosa, AL ..... 9-4

Figure 9-2: Above-ground residential safe room installed in a garage of a home in Joplin, MO, directly impacted by the tornado ..... 9-5

Figure 9-3: These above-ground community safe rooms in Brookwood, AL, were used during the April 27 tornado outbreak, but were not directly impacted by a tornado ..... 9-5

Figure 9-4: Aerial view of tornado damage swath in Crescent Ridge, AL ..... 9-9

Figure 9-5: Core remnants of homes sometimes survive a tornado as shown in this photograph of site-built homes (Crescent Ridge, AL) ..... 9-9

Figure 9-6: The core remnant of a home in Joplin, MO ..... 9-10

Figure 9-7: Manufactured homes destroyed in Crescent Ridge, AL ..... 9-10

Figure 9-8: Tornado refuge area in a Tuscaloosa, AL, basement ..... 9-11

Figure 9-9: Aerial view of the Pleasant Grove, AL, neighborhood ..... 9-12

Figure 9-10: A hardened porch slab over this basement helped to create a tornado refuge area that allowed this family to survive the tornado (Birmingham, AL) ..... 9-12

Figure 9-11: An interior bathroom, often considered a tornado refuge area, was heavily damaged when the tornado struck (Tuscaloosa, AL) ..... 9-13

Figure 9-12: Walmart store in Joplin, MO ..... 9-15

Figure 9-13: Close-up view of the damage at the Walmart store in Joplin, MO ..... 9-15

Figure 9-14: Lowe’s Home Improvement building (Tuscaloosa, AL) ..... 9-16

Figure 9-15: Lowe’s Emergency Response Flipchart (Tuscaloosa, AL) ..... 9-16

Figure 9-16: Home Depot after the May 22, 2011 tornado (Joplin, MO) ..... 9-18

Figure 9-17: Tornado refuge area (training room) of the Home Depot. Note the collapsed tilt-up wall and the wall leaning into the refuge area (Joplin, MO) ..... 9-19

Figure 9-18: Underground shelter that survived a tornado (rated EF2 based on the MAT’s observations) (Smithville, MS) ..... 9-21

Figure 9-19: Below-ground hardened structure used for tornado refuge (Hackleburg, AL) ..... 9-21



Figure 9-20: Above-ground shelter with untested door system; inset shows the inside of the door latch (Smithville, MS) .....	9-22
Figure 9-21: A family shelter with a single deadbolt (Athens, AL) .....	9-23
Figure 9-22: Above-ground hardened structures used as community tornado refuge areas (Amory, MS) .....	9-24
Figure 9-23: Below-ground, hardened structure with poor door and locking system and damaged vent (Smithville, MS) .....	9-25
Figure 9-24: Above-ground safe room that matches the aesthetics of the home (outside Tuscaloosa, AL) .....	9-26
Figure 9-25: Above-ground community storm shelter (Graysville, AL) .....	9-27
Figure 9-26: Below-ground FEMA-funded residential safe room (Tuscaloosa, AL) .....	9-27
Figure 9-27: Site-built FEMA-funded residential safe room (Tuscaloosa, AL) .....	9-28
Figure 9-28: Below-ground FEMA-funded residential safe room (Tuscaloosa, AL) .....	9-29
Figure 9-29: FEMA-funded residential safe room (Smithville, MS) .....	9-30
Figure 9-30: Below-ground garage shelter (Huntsville, AL) .....	9-30
Figure 9-31: ICC 500-compliant storm shelter (Huntsville, AL) .....	9-31
Figure 9-32: Residential safe room that survived the May 22, 2011 Joplin, MO, tornado (rated EF4 based on the MAT's observations) .....	9-32
Figure 9-33: Proximity of the residential safe room shown in Figure 9-32 to the approximate centerline of the Joplin, MO, tornado damage swath.....	9-33
Figure 9-34: Residential safe room (Joplin, MO) .....	9-34
Figure 9-35: Community safe room with exterior and interior locking mechanism; inset shows the three-point interior locking system (Brookwood, AL) .....	9-35
Figure 9-36: FEMA-funded community safe room (Phil Campbell, AL) .....	9-36
Figure 9-37: Interior of the community safe room shown in Figure 9-36 featuring seating, emergency lighting, and ventilation (Phil Campbell, AL).....	9-36
Figure 9-38: A large site-built, below-grade community safe room is housed below this fire station; an unprotected generator is shown (Brookside, AL).....	9-37

Figure 9-39: Interior view of the well-furnished community safe room shown in Figure 9-38 (Brookside, AL) ..... 9-37

Figure 9-40: Seneca Intermediate School (Seneca, MO) ..... 9-38

Figure 9-41: Seneca Intermediate School safe room in the cafetorium ..... 9-39

Figure 9-42: Seneca Intermediate School gymnasium safe room ..... 9-39

Figure 9-43: Doors and ventilation louvers in Seneca Intermediate School community safe room..... 9-40

Figure 9-44: Outside doors and louvers protected by alcoves at the Seneca Intermediate School community safe room ..... 9-40

Figure 9-45: Elevated ventilator in the Seneca Intermediate School community safe room. Inset shows the exterior shroud.-..... 9-41

Figure 9-46: Emergency generator building for the community safe room at the Seneca Intermediate School..... 9-41

**Chapter 10**

Figure 10-1: Concrete nails used in lieu of anchor bolts on residential buildings under construction in the City of Tuscaloosa, AL, after the 2011 tornadoes..... 10-3

Figure 10-2: Lack of anchor bolts on recently constructed slab foundation in Jefferson County, AL ..... 10-4

Figure 10-3: Plywood placed over damaged glazing at this police station (Tuscaloosa, AL) .....10-10

**Chapter 11**

Figure 11-1: IBC/IRC covers ..... 11-2

Figure 11-2: Collapse of exterior CMU/brick veneer wall and roof collapse at the Joplin High School (Joplin, MO). The wall debris fell into the corridor. ....11-9

**Appendix E**

Figure E-1: The EF scale is based on level of typical observed damage ..... E-2

## Appendix G

Figure G-1: Load path elements and height and width limitations for residential buildings covered in Appendix G..... G-4

Figure G-2: Anchor bolt installation guide.....G-13

## List of Tables

### Executive Summary

Table ES-1: Summary of the MAT's Key Recommendations.....v

### Chapter 2

Table 2-1: Fujita Scale Converted to EF Scale ..... 2-4

### Chapter 3

Table 3-1: Wind-Borne Debris and Rolling Debris Classifications ..... 3-8

Table 3-2: Historical Codes for Commercial Buildings..... 3-16

Table 3-3: Historical Codes for Residential Buildings..... 3-16

### Chapter 4

Table 4-1: Degrees of Damage for One- and Two-Family Residences ..... 4-3

Table 4-2: Degrees of Damage for Multi-Family Residences ..... 4-24

Table 4-3: Summary of Conclusions and Recommendations for Residential Building Performance..... 4-36

### Chapter 5

Table 5-1: Summary of Conclusions and Recommendations for Commercial and Industrial Building Performance ..... 5-49

### Chapter 6

Table 6-1: Number of Critical Facilities Observed by the MAT ..... 6-3

Table 6-2: List of School Districts Interviewed by the MAT ..... 6-44

**Chapter 7**

Table 7-1: Summary of Conclusions and Recommendations for Critical Facility Performance..... 7-52

**Chapter 8**

Table 8-1: Summary of Conclusions and Recommendations for Infrastructure Performance..... 8-25

**Chapter 9**

Table 9-1: Summary of Conclusions and Recommendations for Tornado Refuge Area, Hardened Area, and Safe Room Performance ..... 9-47

**Appendix E**

Table E-1: Wind Speeds Used in Fujita Scale Compared to EF Scale.....E-3

Table E-2: EF Scale Damage Indicators ..... E-3

Table E-3: Example – EF Scale DOD for DI No. 2 (Single-Family Residence) ..... E-4

Table E-4: MAT EF Ratings for Sites Visited in Alabama, Georgia, Mississippi, and Tennessee.....E-5

Table E-5: MAT EF Scale Ratings for Sites Visited in Joplin, MO .....E-8

**Appendix G**

Table G-1: Recommended Design Pressures for Doors and Windows ..... G-7

Table G-2: Connector Selection and Installation .....G-10

Table G-3: Roof-to-Wall Connector Requirements.....G-11

Table G-4: Roof-to-Wall Connection Loads .....G-11

Table G-5: Anchor Bolt Spacing Guide ..... G-12

Table G-6: Percentage of Full-Height Sheathing in Maximum Building Dimension (Length) .....G-14

---

Table G-7: Percentage of Full-Height Sheathing in Maximum Building Dimension (Width).....	G-15
Table G-8: Top Plate Splice Guide .....	G-17
Table G-9: Connection Loads at Each End of Exterior Wall Headers .....	G-17
Table G-10: Connector Requirements at Each End of Exterior Wall Headers.....	G-18
Table G-11: Top Plate-to-Stud-Connection Loads.....	G-19
Table G-12: Top Plate-to-Stud Connector Requirements.....	G-19
Table G-13: Stud-to-Stud Connection Requirements.....	G-20
Table G-14: Stud-to-Bottom Plate Connector Requirements.....	G-21





# TORNADO OUTBREAK *of* 2011

IN ALABAMA, GEORGIA, MISSISSIPPI,  
TENNESSEE, AND MISSOURI

# 1 Introduction

*In the spring of 2011, a historic number of powerful and destructive tornadoes struck portions of the United States, causing widespread damage and loss of life. In response to these events, the Federal Insurance and Mitigation Administration (FIMA) of the U.S. Department of Homeland Security's (DHS) Federal Emergency Management Agency (FEMA) deployed building science experts to assess the damage.*

On May 6, 2011 FEMA deployed a Mitigation Assessment Team (MAT) to the States of Alabama, Georgia, Mississippi, and Tennessee to assess the damage caused by an outbreak of tornadoes occurring April 25 through April 28, 2011. A second MAT was deployed on June 1, 2011 to Missouri following the tornado on May 22 in Joplin. This report presents the observations, conclusions, and recommendations in response to those field assessments. The objective of this report is to provide information to communities, businesses, design professionals, and individuals so that they can rebuild safer, more robust structures and minimize loss of life, injuries, and property damage in future tornadoes and high-wind events.

## 1.1 FEMA Mitigation Assessment Teams

Along with responding to disasters and providing assistance to people and communities affected by disasters, FEMA conducts building performance studies after disasters in order to better understand how natural and manmade events affect the built environment. Following a Presidentially declared disaster, FEMA determines the potential need to deploy one or more MATs to observe and assess damage to buildings and structures caused by wind, rain, and/or flooding associated with the storm. FEMA bases this need on estimates from preliminary information of the potential type and severity of damage in the affected area(s) and the magnitude of the expected hazards.

The intent of the building performance studies is to reduce the number of lives lost to future events and minimize the economic impact on the communities where these events occur. The MAT studies the adequacy of current building codes, other construction requirements, and building practices and materials in light of the damage observed after a disaster. MATs are deployed only when FEMA believes the findings and recommendations derived from field observations will provide design and construction guidance that will not only improve the disaster resistance of the built environment in the impacted State or region, but will also be of national significance to all disaster-prone regions. Lessons learned from the MAT's observations are provided in a comprehensive report available to communities to aid their rebuilding effort and enhance the disaster-resistance of building improvements and new construction.

### 1.1.1 Purpose of the 2011 Tornado Mitigation Assessment Team

The outbreak of tornadoes on April 25 through April 28, 2011 and on May 22, 2011 in the Southeastern and Midwestern regions of the country has been cited as the deadliest and most destructive group of tornadoes of its kind according to National Oceanic and Atmospheric Administration (NOAA) National Weather Service (NWS) data<sup>1</sup> in over 50 years. In accordance with its mission of *“supporting our citizens and first responders to ensure that as a nation we work together to build, sustain, and improve our capability to prepare for, protect against, respond to, recover from, and mitigate all hazards...”*<sup>2</sup> FEMA responded to the April tornado outbreak in the Southeastern states of Alabama, Mississippi, Tennessee, and Georgia, and the Joplin, MO, tornado on May 22, 2011 by deploying a MAT composed of national and regional experts to each of the affected areas. Figures 1-1 and 1-2

The National Weather Service (NWS) is one of the six scientific agencies that make up the National Oceanic and Atmospheric Administration (NOAA). It is tasked with providing “weather, hydrologic, and climate forecasts and warnings for the United States, its territories, adjacent waters and ocean areas, for the protection of life and property and the enhancement of the national economy.”

The Storm Prediction Center (SPC) is part of the National Centers for Environmental Prediction (NCEP), which operates under NWS. The SPC is tasked with forecasting the risk of severe thunderstorms and tornadoes in the contiguous United States.

<sup>1</sup> NOAA NWS, 2011 Tornado Information, [www.noaanews.noaa.gov/2011\\_tornado\\_information.html](http://www.noaanews.noaa.gov/2011_tornado_information.html)

<sup>2</sup> FEMA Web site, [www.fema.gov/about/](http://www.fema.gov/about/)



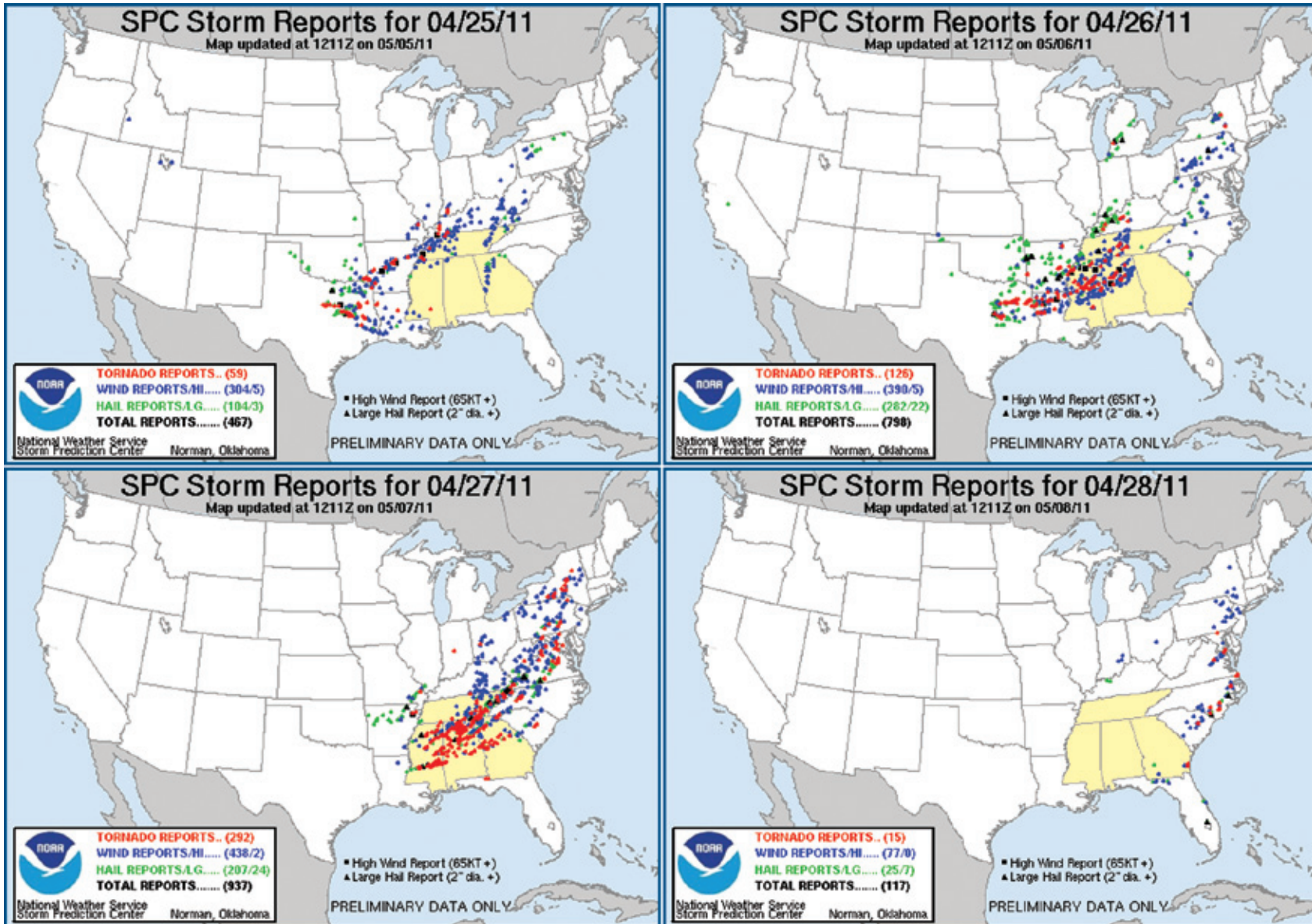
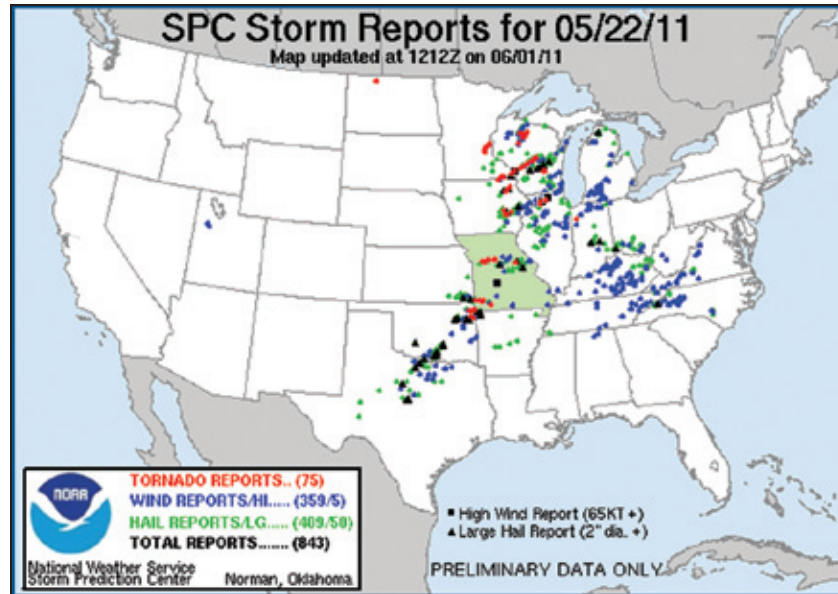

Figure 1-1:  
NOAA SPC Storm Reports for April 25-28, 2011 tornado outbreak  
SOURCE: [HTTP://WWW.SPC.NOAA.GOV](http://www.spc.noaa.gov)

Figure 1-2:  
NOAA SPC Storm Report for  
the May 22, 2011 tornado  
outbreak

SOURCE: [HTTP://WWW.SPC.NOAA.GOV](http://www.spc.noaa.gov)



show NOAA's Storm Prediction Center (SPC) storm reports for each day of the two outbreaks. The reports shown on these maps come from NWS Weather Forecast Offices.

The mission of the MAT was to assess the performance of structures affected by the tornadoes, review safe room and shelter performance in the affected area (in particular the performance of safe rooms and storm shelters that received FEMA mitigation funding for construction), and describe the lessons learned to help future efforts more successfully mitigate damage from tornado events.

### 1.1.2 Team Composition

The MAT included FEMA Headquarters and Regional Office engineers and experts, technical consultants, and construction industry experts. Team members included structural engineers, architects, planners, wind engineers, civil engineers, meteorologists, electrical engineers and communications specialists. The MAT members are listed on the front pages of this document.

The MAT received invaluable support from home and business owners and guides in Alabama, Georgia, Missouri, Mississippi, and Tennessee who assisted the MAT during its deployment. These individuals accompanied the MAT through many of the affected areas, providing valuable insights regarding local communities and their experiences before, during, and after the tornadoes.

### 1.1.3 Methodology

FEMA deployed a MAT to Alabama, Mississippi, Georgia, and Tennessee on May 6, 2011 and to Joplin, MO, on June 1, 2011. The FEMA Region IV Regional Response Coordination Center, joint field offices (JFOs), and State and local government agencies informed the MAT of the tornado paths and preliminary damage data. This information guided the site selection for the field assessments. The members of the MAT visited several sites as a complete team to calibrate findings, after which they

split into three teams to traverse the widespread affected areas across Alabama, Mississippi, Georgia, and Tennessee. This MAT report expands upon the content in previous MAT reports, and focuses on three additional areas: 1) how engineering and construction practices can be changed to reduce the loss of life in tornado events, 2) how damage affected the operation of critical facilities, particularly those involved in first response, and 3) how storm shelters and safe rooms performed in the events.

**Field Assessments:** Field assessments for the April 25–28 tornado events began on May 6 and were conducted through May 13. In Alabama, assessments were made in the communities of Athens, Birmingham, Cordova, Cullman, Hackleburg, Harvest, Huntsville, Phil Campbell, Pleasant Grove, and Tuscaloosa. In Mississippi, assessments were made in the communities of Philadelphia, Raleigh and Smithville. In Tennessee, assessments were made in the communities of Chattanooga, Cleveland, and Dunlap. In Georgia, assessments were made in the community of Ringgold. Field assessments for the May 22 tornado event in Missouri began on June 1 and were conducted through June 4. Assessments were made in the cities of Joplin and Seneca. Figure 1-3 shows all of the communities visited by the MAT.



Figure 1-3:  
Communities in Alabama, Georgia, Mississippi, Tennessee, and Missouri visited by the MAT in 2011

The MAT spent over 12 days in the field conducting site assessments and inspecting damage. All findings were documented through geotagged photographs and field notes, which were then condensed and organized to make the data easier to reference in the final analysis and report. The MAT took thousands of photographs, and compiled extensive field notes of observations made at numerous sites.

**Wind Speed Ratings:** One of the MAT's goals was to determine if building damage observed was preventable, particularly for buildings subjected to the lower wind speeds located at the periphery of the tornado. To accomplish this goal, the MAT related observed building damage to the wind conditions experienced at that site using the Enhanced Fujita (EF) scale. The EF scale is used to classify the intensity of a tornado based on damage observed along its entire track; the scale ranges from EF0 (weakest) to EF5 (most violent). The EF scale is used both to classify the entire tornado track as well as to assess wind speeds experienced by an individual structure based on observed damage to the structure (refer to Sections 2.2, 2.3, and Appendix E for additional information). The MAT assigned structure-specific ratings in order to exercise engineering judgment about whether damage could have been avoided.

EF scale ratings of tornado tracks are developed and published by the NWS. The NWS developed EF contours for the Joplin, MO, tornado and for some of the April 25–28, 2011 tornado outbreak tracks. For the other tracks, the NWS provided a rating for the center of tornado circulation along the track. The MAT report includes figures showing NWS EF contour ratings (when available) superimposed on a NOAA aerial photograph or a pre-tornado photograph. For locations where the NWS did not develop EF contours, the building discussion includes the NWS rating of the track at the center of its circulation in the vicinity of the building. The building discussion also includes the MAT-determined EF rating for the individual sites visited. Besides the MAT, other agencies and groups performed their own determinations on buildings throughout the affected area.

**Aerial Photographs:** Soon after the April 25–28, 2011 tornado outbreak, NOAA shot aerial photographs of portions of many of the tornado tracks. NOAA also shot aerial photographs of the area damaged by the May 22, 2011 Joplin, MO, tornado. Relevant NOAA aerial photographs are included in this report to show the location of buildings visited by the MAT relative to the tornado track and to show other damage in its vicinity. For buildings in locations where NOAA did not obtain aerial photographs, pre-tornado aerial photographs of the building are included for reference.

### 1.1.4 Types of Buildings and Structures Assessed by the MAT

The MAT assessed the overall structural performance and the performance of building envelope elements during its field investigations. If possible, building or facility owners were interviewed to gain insight into how the building occupants reacted during the tornado. The MAT spent considerable time assessing damaged buildings and only minimal time assessing buildings that were totally destroyed. Studying partially destroyed buildings provided the MAT the opportunity to determine why some buildings survived the tornadoes and why some failed. In many cases, the inspection of the damaged buildings revealed weaknesses in building design or construction. As part of their building investigations, the MAT assessed the effects of wind-borne debris (missile) impact on structural performance, as missile impact plays a key role in the success or failure of a building under tornadic wind loads.

The MAT did not look specifically for examples of construction techniques that, though not required by current building codes for this area of the country, are proven to minimize damage in other wind-prone areas (e.g., hurricane areas). These types of practices are often referred to as code-enhanced or *best practices*. The MAT did, however, take note of such practices if observed in the field.

As described below, the structures selected by the MAT for damage assessment included the following five categories: residential building, commercial and industrial building, critical facilities, infrastructure, and personal protection and sheltering structures.

**Residential Buildings:** Although residential construction was not its focus, the MAT visited many residential homes with a variety of construction types. The majority of one- and two-family residential buildings visited were older construction (pre-1970), but some newer homes less than 10 years old were also visited. Many of the single- and multi-family residences visited were unreinforced masonry or wood frame stick-built *non-engineered construction* on slab-on-grade foundations. The MAT attempted to observe residential buildings of all ages, particularly in areas where buildings would have been built under the International Residential Code (IRC), first published in 2000.

**Commercial and Industrial Buildings:** The MAT assessed commercial and industrial buildings of *engineered construction*, including shopping plazas and large footprint stores, throughout the area damaged by tornadoes. The types of commercial and industrial buildings the MAT visited are normally designed by a design professional and included the following:

- + Tilt-up pre-cast concrete walls with steel joists
- + Load-bearing masonry with steel joist
- + Light steel frame
- + Reinforced concrete frame with concrete masonry unit (CMU) infill walls

**Critical Facilities:** The MAT assessed critical facilities including schools, hospitals and healthcare facilities, and facilities used by first responders (police and fire departments and Emergency Operations Centers [EOCs] / Emergency Management Agencies [EMAs]). The MAT report presents the results categorized by use: schools are described in Chapter 6, while other critical facilities are described in Chapter 7. In addition to building performance, the MAT recorded whether the facility was equipped with a safe room or place of refuge and the functional loss resulting from the tornado damage.

**Infrastructure:** The MAT assessed various infrastructure systems in Alabama, Mississippi, and Missouri. The infrastructure systems are categorized in this report by their use: water treatment and distribution facilities, waste water treatment facilities, and towers (both communications and antennae). Both free-standing towers and guyed towers were assessed.

**Personal Protection and Sheltering Structures:** The MAT examined personal protection and sheltering in areas directly in the path of the strong and violent (EF ranking of 2 or greater) tornado vortices and in areas on the periphery of tornadoes. The MAT visited three types of spaces: tornado refuge areas (residential and non-residential), hardened areas, and safe rooms and storm shelters.

Both small individual and larger community safe rooms were observed. Refer to Section 1.2 for definitions of personal protection and sheltering structures.

The residential and non-residential safe rooms and storm shelters observed by the MAT were installed or constructed as above-ground in-residence shelters, above-ground exterior shelters, below-ground in-residence shelters, and below-ground exterior shelters. The MAT visited safe rooms that had been constructed using FEMA Hazard Mitigation Grant Program (HMGP) funds, including underground in-residence safe rooms, above-ground residential safe rooms (such as the safe room shown in Figure 1-4), and community safe rooms. In addition to safe rooms constructed using HMGP funds, the MAT observed more than 16 other tornado refuge areas, hardened structures, storm shelters, and safe rooms of various levels of construction, including underground in-residence shelters, above-ground in-residence shelters, and community shelters.

**Figure 1-4:**  
HMGP-funded residential  
safe room in Smithville, MS,  
that was occupied during  
the storm, but was not in  
the tornado path



### 1.1.5 Involvement of State and Local Agencies

FEMA encouraged the participation of State, county and local government officials, and locally based experts in the assessment process. Their involvement was critical and resulted in:

- + Improving the MAT's understanding of local construction practices
- + Encouraging the MAT to develop recommendations that were both economically and technically feasible for the communities involved
- + Facilitating communication among Federal, State, and local governments and the private sector

The MAT met with local emergency management and government officials in many of the cities and towns they visited. The officials were able to give an overview of the damage in their area and identify key sites to visit. The MAT also coordinated with the FEMA JFOs that had been set up in the area shortly after the tornadoes, and these offices provided invaluable information and resources for the MAT's field activities. The MAT also met with several other groups that had been deployed immediately after the tornadoes and had gathered preliminary data on the damage, including:

- 1) A team assessing the Tuscaloosa damage. The team was funded by the National Science Foundation (NSF) and included representatives from the University of Florida (UF), University of Alabama (UA), Texas Tech University (TTU), Iowa State University, Oregon State University (OSU), South Dakota State University (SDSU), Simpson Strong Tie, and the Applied Technology Council (ATC).
- 2) A team assessing the Joplin damage. The team was funded by the American Society of Civil Engineers (ASCE) and included representatives from UF, UA, OSU, SDSU, and ATC.

Meeting with these teams provided the MAT with valuable information, allowing it to establish a more efficient and effective plan to assess the impacted area. Appendix A lists these and other individuals who assisted the MAT in its field operations and report development.

### 1.1.6 Past Tornado MAT Deployments

Prior to the 2011 MAT deployment, FEMA had deployed two other tornado MATs: one after the April 23–24, 2010 tornado outbreak in Mississippi and one after the May 1999 tornado outbreak in Kansas and Oklahoma. In addition, FEMA deployed a building sciences field team after each of two tornado outbreaks in 2007, one of which occurred in the Southeast and the other in Kansas. Although no MAT report was published after the 2007 tornadoes, Recovery Advisories were published shortly after each event to assist communities in rebuilding efforts.

**Mississippi Tornado Outbreak, April 23–24, 2010:** Beginning the afternoon of Friday, April 23, and continuing through the evening of April 24, 2010 the Arkansas, Louisiana, and Mississippi region experienced severe weather, including multiple tornadoes, from a strong storm system. The most devastating tornado from this event developed in northern Louisiana and caused damage from Tallulah, LA, through eight counties in Mississippi. In response to this tornado outbreak, FEMA deployed a Pre-Mitigation Assessment Team (PMAT) to survey the general building damage

and the performance of the residential and community safe rooms located along the path of the tornado. The PMAT performed site visits and assessments to gather information on the tornado classification, building damage, building performance, and safe rooms. The PMAT's observations, lessons learned, and recommendations regarding the performance of FEMA-funded residential and community safe rooms are presented in their report, *Pre-Mitigation Assessment Team Report – Mississippi Tornado Outbreak, April 23rd – 24th: Damage and Safe Room Performance Observations, Recommendations, and Conclusions* (FEMA 2010b).

**Kansas and Oklahoma Tornado Outbreak, May 3, 1999:** On the evening of May 3, 1999, an outbreak of tornadoes tore through parts of Oklahoma and Kansas, in areas that are considered part of “Tornado Alley,” leveling entire neighborhoods and killing 49 people. The storms that spawned the tornadoes moved slowly, contributing to the development and redevelopment of individual tornadoes over an extended period of time. On May 10, FEMA deployed a MAT to Oklahoma and Kansas to assess damage caused by the tornadoes. The MAT report written following the field assessments, titled FEMA 342, *Building Performance Assessment Report – Oklahoma and Kansas, Midwest Tornadoes of May 3, 1999: Observations, Recommendations and Technical Guidance* (1999a), presents observations, conclusions, and recommendations intended to help communities, businesses, and individuals reduce future injuries and the loss of life and property resulting from tornadoes and other high-wind events. This 1999 MAT investigation led to the development of the First Edition of FEMA 361, *Design and Construction Guidance for Community Safe Rooms* (2000).

**Tornado Outbreaks of 2007:** In the early morning hours of February 2, 2007, a small but devastating outbreak of three tornadoes struck central Florida, impacting the area between Lady Lake and New Smyrna Beach. Two of the tornadoes were rated by the NWS as EF3 and the other was rated EF1. Less than 1 month later, on March 1, 2007, tornadoes hit Alabama and Georgia, causing damage and loss of life. Enterprise, AL, experienced one of the top 10 deadliest tornadoes to impact a school when, in the early afternoon hours, a tornado ripped through a high school, killing eight students. Later that day, a tornado severely damaged a hospital in Americus, GA.

A few months later, on the evening of May 4, 2007, supercell thunderstorms formed across portions of the Midwestern United States, spawning tornadoes in several States. An intense supercell developed southwest of Greensburg, KS, that evening, resulting in the formation of 12 tornadoes. One of these tornadoes formed in northwest Comanche County and within an hour had reached Greensburg, KS, a small community of approximately 1,400 people, and traveled from the town's southern edge to its northwest border. The tornado was rated an EF5 and destroyed or severely damaged the majority of the buildings in Greensburg.

FEMA deployed a building sciences team to the field following each of these tornado outbreaks to assess the damage. In order to provide the most immediate direct feedback to those in the affected areas during the early stages of reconstruction, FEMA published eight tornado Recovery Advisories to provide technical guidance. These can be found on the FEMA Library Web site, under *2007 Tornadoes in Florida Recovery Advisories* and *2007 Tornadoes in Kansas Recovery Advisories*.



## 1.2 Terminology and Background for Tornado Protection Alternatives

As evidenced by this and previous MAT assessments, it is critical to take precautions and seek the best possible protection available to minimize the risk for injury or death in the event of a tornado. A basic understanding of the tornado hazard, as well as an understanding of relevant building codes and construction techniques, is helpful for individuals and communities to better mitigate against tornadoes. This section presents a background of tornado protection terminology and a history of FEMA's role in developing technical guidance.

FEMA has developed specific terminology to differentiate types of tornado refuge areas from other types of "shelters." An understanding of these specific terms and the historic guidance is important since the terms FEMA uses to describe sheltering options are often similar, such as "safe room" and "storm shelter," but have slightly different meanings (see text box on next page). Furthermore, the term "shelter" is used in different ways by different agencies and entities. For instance, the American Red Cross uses the term "shelter" to refer to temporary recovery areas. Similarly, homeless housing is often called "shelters."

Most homes and buildings are typically designed only to the design wind speed prescribed in the codes, and are not designed to withstand tornado-force winds and impact from wind-borne debris. Even homes and buildings constructed in hurricane-prone regions would not survive a direct hit from a violent tornado because they are not designed to resist extreme wind speeds of 200–250 miles per hour (mph), but are only typically designed to resist speeds up to 150 mph. Furthermore, aside from wind-borne debris regions within hurricane-prone regions, design codes do not address impacts from wind-borne debris. Wind-borne debris can cause failure of a critical structural system in a building, which may then cause global failure and endanger its occupants.

FEMA has provided technical guidance on tornado protection since 1980 when it released FEMA TR-83A, *Interim Guidelines for Building Occupant Protection from Tornadoes and Extreme Winds* (1980). Ten years later, FEMA issued additional guidance in FEMA TR-83B, *Tornado Protection: Selecting and Designing Safe Areas in Buildings* (1990). Then, in 1998, FEMA refined their approach to tornado protection and provided technical guidance on how to design and construct a "safe room" that provides near-absolute protection from the wind and wind-borne debris associated with tornadoes. This guidance is presented in the First Edition of FEMA 320, *Taking Shelter from the Storm: Building a Safe Room Inside Your House* (1998).<sup>3</sup>

Most recently updated in 2008, FEMA 320 (Figure 1-5) prescribes safe room designs that homeowners, builders, and



Figure 1-5: Cover of FEMA 320 (FEMA 2008, Third Edition)

<sup>3</sup> The Third Edition of FEMA 320 (released in 2008) is titled *Taking Shelter from the Storm: Building a Safe Room for Your Home or Small Business*. However, readers should be aware that the First and Second Editions of FEMA 320 (released in 1998 and 1999, respectively) were titled *Taking Shelter from the Storm: Building a Safe Room Inside Your House*.

### TERMINOLOGY

**Tornado refuge area** is a general term used to describe any location where people go to seek cover during a tornado. Tornado refuge areas may have been constructed to comply with basic building code requirements (that do not consider tornado hazards). These areas may also have continuous load paths, bracing, or other features that increase resistance to wind loads. It is important for people to know that such an area may not be a safe place to be when a tornado strikes and they still may be injured or killed during a tornado event.

**Best available refuge areas** are areas in an existing building that have been deemed by a qualified architect or engineer to likely offer the greatest safety for building occupants during a tornado. It is important to note that, because these areas were not specifically designed as tornado safe rooms, their occupants may be injured or killed during a tornado. However, people in best available refuge areas are less likely to be injured or killed than people in other areas of a building (FEMA P-431, *Tornado Protection: Selecting Refuge Areas in Buildings* [October 2009]).

**Hardened areas** are designed and constructed to provide some level of protection, but do not necessarily meet International Code Council (ICC) / National Storm Shelter Association (NSSA) *Standard for the Design and Construction of Storm Shelters* (ICC 500) criteria or FEMA guidelines. These areas are commonly referred to by builders and homeowners as **shelters**.

**Storm shelters** provide life-safety protection; they are designed and constructed to meet ICC 500 criteria.

**Safe rooms** provide near-absolute protection; they are designed and constructed to meet the guidelines provided in FEMA 361, *Design and Construction Guidance for Community Safe Rooms* (2008a) or FEMA 320, *Taking Shelter from the Storm: Building a Safe Room for Your Home or Small Business* (2008c).

	Tornado Refuge Area	Best Available Refuge Area	Hardened Area or Room	Storm Shelter	Safe Room
Designed to minimum building code requirements	✓	✓	✓	✓	✓
Evaluated by a design professional and identified as least vulnerable area/room in building		✓		✓	✓
Designed to consider wind speeds or wind-borne debris impacts at some level between code and ICC 500/FEMA criteria			✓		
Designed specifically to provide life-safety protection per ICC 500 or FEMA Criteria				✓	✓
Designed specifically to provide near-absolute protection per FEMA criteria (including operational and emergency planning criteria)					✓

contractors can use to construct safe rooms in homes or small businesses. Design options include safe rooms located in basements or garages, or in an interior room of a new home or small business. Other guidance includes how to modify an existing home or small business to add a safe room in one of these areas. These safe rooms are designed to provide near-absolute protection for their occupants from the extreme winds expected during tornadoes and hurricanes and from flying debris, such as wood studs, that tornadoes and hurricanes usually generate.

In 2000, FEMA released the First Edition of FEMA 361 (Figure 1-6). Updated in 2008,<sup>4</sup> this publication contains guidance for architects, engineers, building officials, local officials and emergency managers, and prospective safe room owners and operators about the design, construction, and operation of safe rooms and storm shelters for extreme-wind events. It presents important information about designing and constructing community safe rooms, including design criteria for wind, wind-borne debris, and flood hazards. The 2008 update to FEMA 361 also includes the technical design criteria used for the prescriptive safe room designs presented in FEMA 320. It includes guidance on shelter management and operations and has checklists to help designers, owners, and emergency management officials ensure safe rooms are correctly designed and constructed. FEMA 361 also has checklists that can be used to evaluate existing buildings that may be used as refuge areas if a FEMA 361-compliant safe room is not available in a community or jurisdiction. The refuge area checklists can help identify how vulnerable different areas of a building are to the effects of wind and wind-borne debris associated with tornadoes or hurricanes.



Figure 1-6: Cover of FEMA 361 (FEMA 2008, Second Edition)

It is important to remember that the building codes and standards used in the United States prior to 2008 did not address life-safety protection from tornadoes or hurricanes. Although the guidance from FEMA and others has existed since the late 1990s, it was not until the release of ICC 500 in 2008 that such criteria were introduced into building standards. Following the release of the ICC 500, the 2009 International Building Code (IBC) and IRC incorporated the standard by reference. This means that if a building is constructed to the 2009 IBC and IRC and there is a portion of the building designated to be a shelter, it must be designed to the criteria of the ICC 500, which has specific provisions on how to provide protection from extreme wind events and wind-borne debris associated with those events (Figure 1-7).

Building codes aim to reduce the level of damage to structures during design wind events but do not address life-safety protection for building occupants in design or extreme wind events.

<sup>4</sup> The Second Edition of FEMA 361 (2008) is titled *Design and Construction Guidance for Community Safe Rooms*.

However, at this time, neither the ICC 500 nor the International Codes (I-Codes) require shelters to be designed or constructed within buildings. ASCE 7, *Minimum Design Loads for Buildings and Other Structures*, also does not address tornadoes as part of the wind design considerations and requirements for buildings or other structures. Therefore, it is imperative that the design community, emergency management officials, and the general public develop a better understanding of the vulnerabilities of existing buildings to tornadoes and other high-wind events.

### 1.3 2011 Tornado Recovery Advisories

Through investigation and observation of the performance of both residential and non-residential buildings, the MAT developed eight new recovery advisories to provide guidance for post-tornado reconstruction; these recovery advisories were published soon after the events and are available online through the FEMA Library Web site<sup>5</sup> and in Appendix F. The set of recovery advisories includes:

- + Recovery Advisory 1: *Tornado Risks and Hazards in the Southeastern United States*
- + Recovery Advisory 2: *Safe Rooms: Selecting Design Criteria*
- + Recovery Advisory 3: *Residential Sheltering: In-Residence and Stand-Alone Safe Rooms*
- + Recovery Advisory 4: *Safe Rooms and Refuge Areas in the Home*
- + Recovery Advisory 5: *Critical Facilities Located in Tornado-Prone Regions: Recommendations for Facility Owners*
- + Recovery Advisory 6: *Critical Facilities Located in Tornado-Prone Regions: Recommendations for Architects and Engineers*
- + Recovery Advisory 7: *Rebuilding and Repairing Your Home After a Tornado*
- + Recovery Advisory 8: *Reconstructing Non-Residential Buildings After a Tornado*

These guidance documents are directed not only toward architects, engineers, and contractors, but also to building owners, homeowners, and State and local government officials. This MAT report supplements the information provided in the recovery advisories and provides more detailed analysis and recommendations.

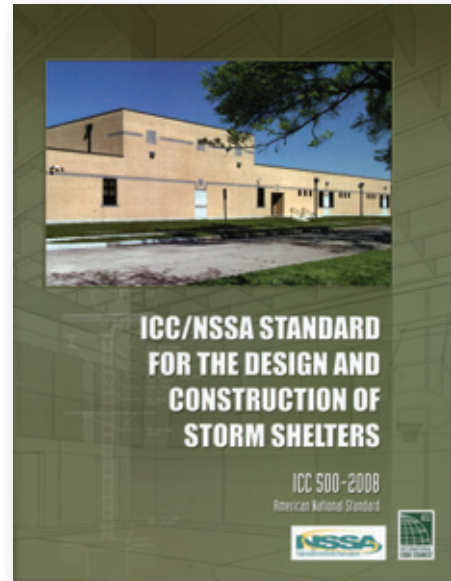

Figure 1-7:  
Cover of ICC 500 (ICC/NSSA 2008)

<sup>5</sup> FEMA Library, Tornado Recovery Advisories, [www.fema.gov/library/viewRecord.do?id=4723](http://www.fema.gov/library/viewRecord.do?id=4723)

## 1.4 Organization of Report

This report is organized in the following manner:

**Chapter 1:** Provides an overview of the purpose and methodology behind the MAT's activities.

**Chapter 2:** Provides a general background on tornadoes and a detailed discussion of the meteorological events that led up to the April 25–28, 2011 tornado outbreak in the mid-south area of the United States and the May 22, 2011 Joplin, MO, tornado.

**Chapter 3:** Presents a discussion of the general causes of observed failures, the regulations that govern construction, and recommended construction practices resulting from the MAT's field investigations.

**Chapter 4:** Presents the MAT's observations on the performance of residential buildings. The MAT assessed one- and two-family residences and multi-family residences.

**Chapter 5:** Presents the MAT's observations on the performance of commercial buildings.

**Chapter 6:** Presents the MAT's observations on the performance of schools.

**Chapter 7:** Presents the MAT's observations on the performance of healthcare and first responder facilities and EOCs.

**Chapter 8:** Presents the MAT's observations on the performance of two infrastructure categories: water treatment and distribution facilities and towers (communications and antennae).

**Chapter 9:** Presents general information and the MAT's observations related to refuge areas, shelters, and safe rooms/storm shelters.

**Chapter 10:** Provides conclusions based on the MAT's observations; this information is intended to assist States, communities, businesses, and individuals who are recovering and rebuilding from the tornadoes.

**Chapter 11:** Provides recommendations intended to assist individual, communities, and businesses through the reconstruction process and to help reduce future damage and impacts from similar tornadic wind events.

**Appendix A:** Lists contributors to the MAT including those who supported preparatory efforts, supported the MAT in the field, and contributed to writing and reviewing the MAT report.

**Appendix B:** Provides the references cited in the report.

**Appendix C:** Provides a list of acronyms and their definitions.

**Appendix D:** Provides a glossary of terms.

**Appendix E:** Provides a background on the development and use of the EF scale, as well as a summary of the EF scale ratings determined by the MAT for structures it accessed.

**Appendix F:** Includes the Recovery Advisories created for the April 25–28, 2011 tornado outbreak in the mid-south area of the United States and the May 22, 2011 Joplin tornado.

**Appendix G:** Provides prescriptive guidance to enhance wood-frame residential building performance when impacted by tornadoes rated EF2 or less or inflow winds associated with tornadoes rated EF3 or greater.



# TORNADO OUTBREAK *of* 2011

IN ALABAMA, GEORGIA, MISSISSIPPI,  
TENNESSEE, AND MISSOURI

## 2 Meteorological Background and Tornado Events of 2011

*The most violent tornadoes, with wind speeds of more than 200 mph near ground level, are capable of tremendous destruction.*

From 1950 through 2006, tornadoes caused 5,506 deaths and 93,287 injuries, as well as devastating personal and property losses.<sup>1</sup> According to tornado occurrence data obtained from the NOAA SPC more than 1,275 tornadoes have been reported nationwide each year since 1997. The number of reported tornadoes has increased over the period 1950–2007 (Simmons and Sutter 2011), attributed in part to better reporting of tornadoes and better technology.

According to the *Glossary of Meteorology* (American Meteorological Society 2000), a tornado is “a violently rotating column of air, pendant from a cumuliform cloud or underneath a cumuliform cloud, and often (but not always) visible as a funnel cloud.”

<sup>1</sup> The majority of the information contained in this section was obtained from the NOAA NWS SPC, <http://www.spc.noaa.gov>. The SPC, part of NWS, is responsible for forecasting the risk of severe thunderstorms and tornadoes in the contiguous United States.

Despite the increase in tornado reports, high intensity tornadoes are still rare. The 2011 tornado season was remarkable for the number of strong and violent tornadoes that impacted populated areas, but it was not the most active tornado year in history (SPC).<sup>2</sup> Super outbreaks similar to the April 27, 2011 and severe and isolated events like the Joplin, MO, tornado have occurred in the past (e.g., April 3–4, 1974). Strong and violent tornadoes such as those in 2011 can be expected to occur with 20–50 year periodicities in tornado-prone regions.<sup>3</sup>

This chapter presents a background on tornadoes and a detailed discussion of the events that led up to the April 25–28, 2011 tornado outbreak in the mid-south region of the United States and the May 22, 2011 Joplin, MO, tornado. This chapter introduces the events on which the observations, conclusions, and recommendations in the following chapters of this report are based. Included are a discussion on tornado prediction; a description of the Enhanced Fujita (EF) scale, the method used to rate tornado intensity based on observed damage; a general description of tornadoes and their associated wind and damage patterns; a discussion of NOAA's NWS tornado warning systems and its method for applying EF ratings to tornadoes; and a narrative of the history, severity, and meteorological events of the spring 2011 tornadoes in Alabama, Georgia, Mississippi, Tennessee, and Missouri.

## 2.1 Tornado Prediction

Meteorologists use several parameters to predict the likelihood and type of severe weather that will occur. Two of the most important parameters for predicting long-track violent tornadoes (LTVTs) are Convective Available Potential Energy (CAPE) and Storm-Relative Helicity (SRH). Since the potential for tornadic storms can be predicted reasonably well using these two parameters, a third parameter, the Energy-Helicity Index (EHI) combines CAPE and SRH. High CAPE values represent an unstable atmosphere and are associated with warm weather and sunny skies. High SRH values reflect the potential for rotating updrafts and are associated with wind shear (changing wind speed and/or wind direction with height in the atmosphere). Generally, when the resulting EHI is greater than 4, there is a good possibility of severe tornadoes (EF2 and greater; refer to Section 2.2 for additional information related to EF scale ratings). Typically, the EHI is in the 5 to 6 range during most large tornadic outbreaks. A summary of these and other severe weather parameters can be found at NOAA's NWS Weather Forecast Office Web site.<sup>4</sup>

**Tornado Season in the Mid-South Region:** Locations in the mid-south, including those areas subjected to the 2011 tornado events, experience their highest CAPE values during the summer months. However, SRH values are typically higher in the cooler months of late fall, winter, and spring, when active frontal systems and undulations in the flow pattern of the upper atmosphere are common. Most severe weather events in the mid-south are therefore characterized by one parameter being much higher relative to the other, and days when high CAPE values coexist with high SRH values are rare. During transitional months in the mid-south region, however, both SRH values and CAPE values can be high. Thus, the mid-south region has two main severe weather/tornado seasons, though tornadoes can occur throughout the year. A peak season occurs from late February

---

2 The most active year on record is 1974 (<http://www.ncdc.noaa.gov/oa/climate/severeweather/tornadoes.html#history>)

3 NOAA National Climatic Data Center, Weather/Climate Events, [http://www.ncdc.noaa.gov/oa/climate\\_research.html](http://www.ncdc.noaa.gov/oa/climate/climate_research.html). See U.S. Storm Events Database.

4 NOAA NWS Weather Forecast Office, Louisville, KY, <http://www.crh.noaa.gov/lmk/soo/docu/indices.php>



through mid-April, and a secondary season sometimes occurs in November. The April 25–28, 2011 outbreak was a little past the mean peak of the spring tornado season in the mid-south region.

**Tornado Season in the Joplin, MO, Region:** The tornado season in Joplin, MO, resembles more of a classic Great Plains regime where peak activity occurs in the spring. May is the peak month for the tornado season in Oklahoma, Kansas, and Missouri, with increased activity commonly occurring from April through June. The probability of tornadoes outside of these 3 months is much lower than it is in the mid-south region.

Tornadoes may travel in any direction, but most move from southwest to northeast or west to east. Unless noted otherwise, the tornadoes that caused the damage observed by the MAT moved from southwest to northeast.

## 2.2 Enhanced Fujita Scale

An important step in classifying tornado intensity was the development of the Fujita scale and the updated EF scale. These tornado intensity rating scales remain an important factor considered by architects and engineers in their evaluation of damage following a tornado. The Fujita scale, originally developed by Dr. Tetsuya T. Fujita in 1971, provided a method to rate tornado intensity by examining the affected area, allowing people to distinguish between weak and strong tornadoes. Since there was no reliable way to accurately determine wind speed of a tornado via instrumentation, the Fujita scale provided a method to rate the intensity of tornadoes based on the damage caused. While the Fujita scale was used for 33 years, it had its limitations. The Fujita scale did not include *damage indicators* (DIs) and did not provide a method to correlate construction quality with the observed variability in damage resulting from similar wind speeds.

The EF scale, a new tornado strength rating model, was published in 2004 in *A Recommendation for an Enhanced Fujita Scale* (TTU 2004) and updated in 2006 (TTU 2006).<sup>5</sup> The 2006 revision to this document updated the steps in assigning an EF scale rating to a tornado event. More detailed information can be found at the TTU Wind Science and Engineering Research Center Web site.<sup>6</sup> In comparison with the Fujita scale, use of the EF scale has led to a more realistic understanding of tornadic wind speeds. It has made it easier to distinguish the areas outside of the central tornado track, which have lesser wind speeds, and areas where wind-resistant design practices may reduce damage.

The EF scale follows the same basic format as the original Fujita scale and also includes six categories, from 0 to 5, representing increasing degrees of wind damage; however, the EF scale was developed using improved examinations of tornado damage to better classify the correlation of tornado damage with associated wind speeds. Table 2-1 lists the 3-second gust speeds based on the original Fujita and EF scale ratings.

<sup>5</sup> Available online from TTU at <http://www.depts.ttu.edu/weweb/Pubs/fscale/EFScale.pdf>

<sup>6</sup> TTU Wind Science and Engineering Research Center Website, [www.wind.ttu.edu](http://www.wind.ttu.edu)

**Table 2-1: Fujita Scale Converted to EF Scale**

Fujita Scale	Fujita Scale: 3-Second Gust (mph)	EF Scale	EF Scale: 3-Second Gust (mph)
F0	45–78	EF0	65–85
F1	79–117	EF1	86–110
F2	118–161	EF2	111–135
F3	162–209	EF3	136–165
F4	210–261	EF4	166–200
F5	262–317	EF5	Over 200

mph = miles per hour; EF = Enhanced Fujita

The EF scale uses 28 DIs to categorize building use and type of construction. Each DI includes damage description categories; each is assigned a number termed the *degree of damage* (DOD), and each has a damage description associated with an expected estimated wind speed. An example of the DOD and damage descriptions for a single-family residence as well as descriptions of the 28 DIs can be found in Appendix E. The DOD includes the expected wind speed as well as a lower- and upper-bound wind speed that would most likely produce the in observed damage. Photographs are included in the supporting documentation for the EF scale in *A Recommendation for an Enhanced Fujita Scale* (TTU 2006) to assist investigators. Appendix E provides additional information on the EF scale, including a list of the DIs and examples of damage description categories.

For information on how the NWS uses the EF scale to derive its tornado ratings, refer to Section 2.4.2.

## 2.3 Tornado Winds and Damage Patterns

The visible funnel cloud associated with and typically labeled the vortex of a tornado is not always the edge of the strongest winds. The radius of highest wind speeds in a tornado can be larger than the visible funnel cloud’s radius. The visible funnel cloud boundary is determined by the temperature and moisture content of the tornado’s inflowing air. It is important to remember that a tornado’s wind speeds cannot be determined just by looking at the tornado. In a tornado, the diameter of the vortex can change with time, so it is impossible to say precisely where a less intense region of the tornado’s wind flow ends and a more intense region begins.

Inflow is rapidly moving air near the surface that is being pulled radially into the vortex. Inflow speeds range from approximately 45–135 mph depending on distance from the vortex and the intensity of the tornado.

Figure 2-1 shows the types of damage that can be caused by the tornadic winds of a violent tornado. In general, as shown in the figure, the severity of the damage varies with distance from the vortex and wind speeds within the vortex. Note, however, that the rotation of a tornado can cause winds flowing into the vortex on one side to be greater than those on other sides. As a result, it is not uncommon for the area of damage on one side of the tornado to be more extensive. The colors in Figure 2-1 illustrate the expected tornado damage near the vortex of the tornado (darkest red) to the periphery of the tornado swath (lightest yellow). The damage expected at each of these wind speeds is explained below:



Figure 2-1: Potential tornado damage pattern

SOURCE: ADAPTED FROM FIGURE 2-2 OF FEMA 342 (1999A)

- + *EF5 wind speeds (dark red)*: Strong frame houses and engineered buildings are lifted from their foundations or are significantly damaged or destroyed. Automobile-sized debris is moved significant distances. Trees are uprooted and splintered
- + *EF4 wind speeds (dark orange)*: Well-constructed homes, as well as manufactured homes, are destroyed, and some structures are lifted off their foundations. Automobile-sized debris is displaced and often tumbles. Trees are often uprooted and blown over.

- + *EF3 wind speeds (light orange)*: Roofs and some walls, especially unreinforced masonry, are torn from structures. Small ancillary buildings are often destroyed. Manufactured homes on nonpermanent foundations can be overturned. Some trees are uprooted.
- + *EF2 wind speeds (yellow)*: Roofs are damaged, including the loss of shingles and some sheathing. Manufactured homes, on nonpermanent foundations can be shifted off their foundations. Trees and landscaping either snap or are blown over. Medium-sized debris becomes airborne, damaging other structures.
- + *EF1 wind speeds (light yellow)*: Minor damage to roofs and broken windows occurs. Larger and heavier objects are displaced. Minor damage to landscaping and trees can be observed.
- + *EF0 wind speeds (light blue)*: Some damage can be seen to poorly maintained roofs. Unsecured light-weight objects, such as trash cans, are displaced.

It is important to note the varying levels of damage to structures between the perimeter and the vortex of the tornado. Many of the mitigation recommendations presented throughout this report and in the Recovery Advisories (Appendix F) would be most effective along the periphery of a violent tornado (in the light blue to light orange range of Figure 2-1 or in the wind speed range of an EF0 to EF2 tornado). Structures located in the dark orange range, between the periphery and the edge of the vortex (in the wind speed range of an EF3 tornado), would benefit from both the mitigation recommendations and adherence to model building codes. For structures directly in the path of a tornado (dark red area of Figure 2-1, or in the wind speed range of an EF4 to EF5 tornado), only engineered shelters would provide near absolute protection to occupants.

## 2.4 National Weather Service Tornado Warning Strategies and Ratings

The NWS was successful in forecasting the events in April and May, 2011 in large part due to improved forecasting ability, particularly after NWS modernization in the mid-1990s. Technological advances in the last 15 years, such as the introduction of Doppler radar, have allowed meteorologists to pinpoint small areas of rotation at the street and block level. Furthermore, improvements in short- and long-term weather forecasting models allow meteorologists a greater lead time for predicting weather conditions that may spawn tornadoes.

### 2.4.1 Tornado Watches and Warnings

When the possibility of a tornado puts people at risk, it is important that they are informed so that they can take precautionary measures to shelter and protect themselves in the event that their home or business is impacted. Currently, the NWS SPC issues watches for large geographic areas where conditions for tornadoes are favorable. The local NWS office then issues warnings when a tornado has been observed by a spotter or when radar indicates strong rotation suggesting the presence of a tornado.

The NWS warning comes in the form of a list of cities and towns that are predicted to be in the path of the storm and the times when the storm will reach a given location. These tornado warnings are disseminated through multiple media sources in different formats in order to convey the information to the public. Residents of communities are alerted about a tornado warning via television, radio, social media, internet, and sirens. Television coverage often includes a tornado polygon of the projected path that is based on the NWS warnings, giving viewers an easily understood graphic representation of the warnings.

### False Alarm Ratios

There are times when a tornado warning is issued, but no tornado touches down. This occurs because radar-indicated rotation within a thunderstorm often does not indicate the actual presence of a tornado. For this reason, the majority of severe weather events and tornado warnings are for weak storms, producing winds with speeds in the EF0 or EF1 range. Often, circulation cannot be confirmed without a spotter in the field, so for these events it is difficult to tell whether or not they are actually tornadoes. The volume of such low intensity events may diminish the value of a warning when one is issued for a more serious storm, similar to those that occurred in the spring of 2011. Statistics documented by the NWS for tornado false alarm ratios in 2008 indicate a rate of 75 percent. The NWS is trying to reduce this number to 70 percent (Brotzge et al. 2011). The false alarm ratio statistics can be misleading because forecasters are not given credit for close calls.

### New Experimental Tornado Warnings

An experimental tornado warning method will be introduced at select NWS field offices beginning April 2, 2012. The traditional tornado warning will be retained in a modified form and two new categories will be added. The experimental warnings will be as follows:

- + **Tornado warning:** A tornado indicated by radar, but not confirmed by field spotters.
- + **Particularly dangerous situation (PDS) tornado warning:** A tornado confirmed on the ground by field spotters or residents.
- + **Tornado emergency:** The highest level of tornado warning; this warning will be issued if a large and potentially violent tornado is about to impact a densely populated area.

The SPC has issued probabilistic forecasts of atmospheric hazards for many years. It issues a three-tiered and color coded probabilistic forecast on its Web site that shows risk categories of slight (light green), moderate (light red), and high (magenta) for areas forecasted to be impacted by severe weather (<http://www.spc.noaa.gov>).

## 2.4.2 NWS EF Rating Assignments

NWS assigns tornado ratings using the EF scale rating system. For events with damage that is potentially greater than EF3 level, the NWS forms a Quick Response Team (QRT) consisting of meteorologists and one or two structural engineers. The QRT conducts a thorough evaluation of damage to structures along the tornado's path and note any unusual observations. Unusual observations include tree debarking, pavement scouring, and other difficult to quantify phenomena associated with very high winds.

The QRT rates EF scale intensities for individual and surrounding structures while using multiple DIs and DODs (refer to Appendix E for additional information DIs and DODs). The data and ratings gathered by the QRT are used by NWS to construct wind speed contours that show wind speed decay from the vortex to the periphery of the damage swath.

For lower intensity tornadoes, the NWS forms a smaller assessment team to conduct a damage survey with specific objectives. The team locates the beginning, end, and widest section of the damage swath, and then rates the maximum intensity of the tornado using multiple DIs and DODs (refer to Section 2.2 for more information on DIs and DODs). The NWS assessment of weaker tornadoes is not as detailed as that performed by a QRT. All assessment personnel, whether QRT or not, undergo training on how to use the EF scale rating system.

The NWS considers several DIs when assigning an EF scale rating to a tornado event. For this reason, structures along the path of a tornado may be assigned several different EF ratings ranging from EF0 to EF5, while the overall tornado intensity may be labeled EF4. For archival purposes, a tornado is officially labeled by the NWS according to its highest intensity along its path.

NWS EF scale training and rating practices can be viewed on the following Web sites:

<http://www.spc.noaa.gov/efscale/>

<http://www.wdtb.noaa.gov/courses/EF-scale/index.html>

## 2.5 Tornado Events of Spring 2011

This section summarizes the events in the mid-south region of the United States from April 25 to 28 and the events in Joplin, MO, on May 22. The information is summarized from post-storm assessments from NWS offices in Jackson, MS; Memphis, TN; Birmingham, AL; Huntsville, AL; and Springfield, MO, unless otherwise noted. Links to specific post-storm assessments are found in the references. EF ratings in this chapter are from NWS post-storm assessments.

### 2.5.1 April 25–28, 2011 Tornadoes in the Mid-South Area of the United States

The following subsections present the events of the April 25–28, 2011 tornadoes in the mid-south area of the United States. The events are presented chronologically, rather than geographically, in order to trace the outbreak from beginning to end using the perspective of those who witnessed the events. The tornado tracks for the April 25–28, 2011 outbreak in Alabama are shown in Figure 2-2 and in Mississippi in Figure 2-3. The tornado tracks from the neighboring States of Tennessee and Georgia are not shown since the tornadoes that impacted those States originated in Alabama and Mississippi, where they caused much greater damage. The names referenced for the tornadoes are those that were widely used by NWS and the media in the aftermath of the tornadoes.

#### 2.5.1.1 April 18–24, 2011

During the week of April 18–22, 2011, the meteorological community began to discuss a potentially significant severe weather scenario developing in forecasted model runs for the following week. As early as Tuesday, April 19, broadcast meteorologists and NWS personnel in Alabama were discussing the possibility of a major severe weather event within 8 days or so. Discussions among forecasters in

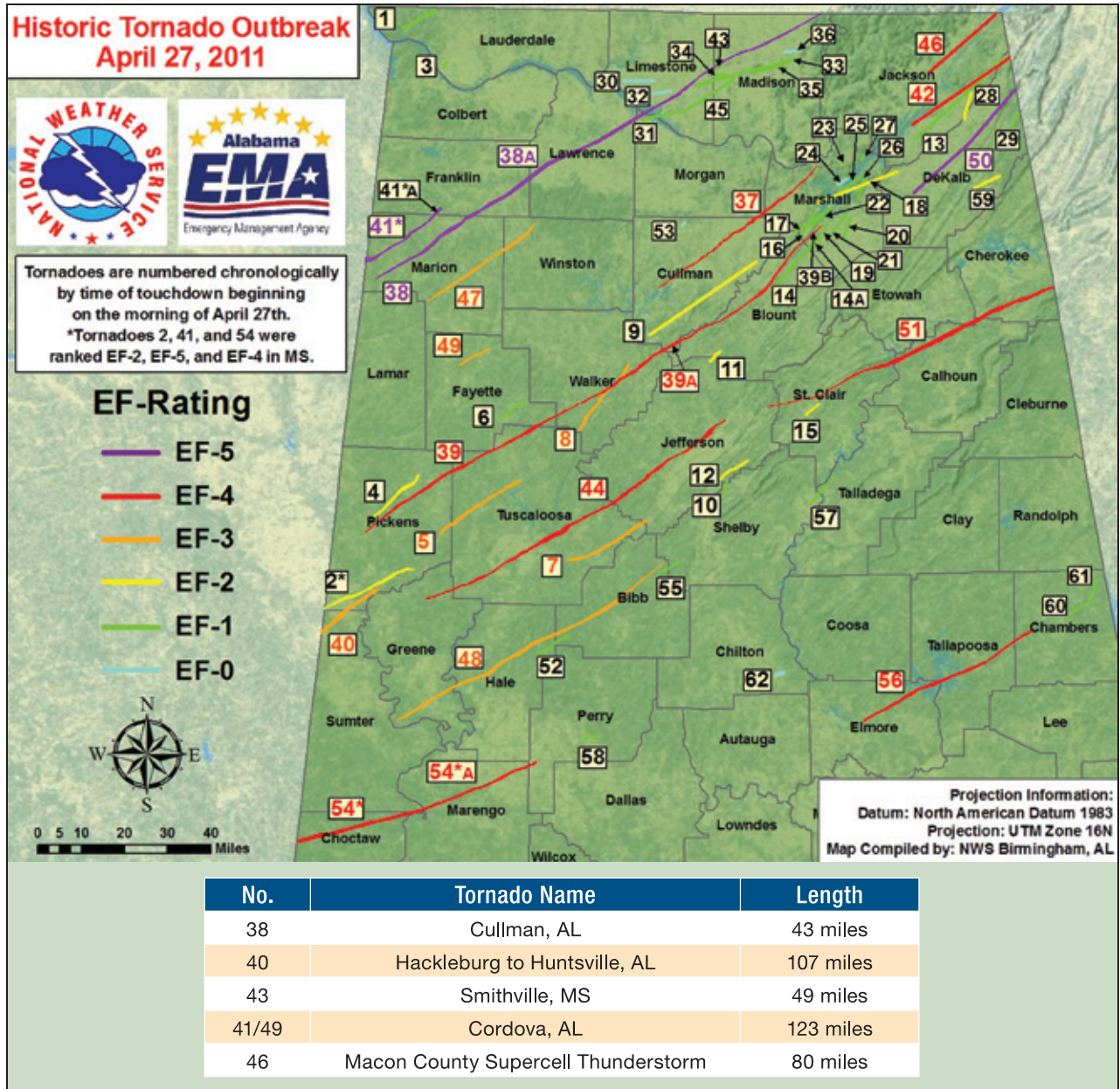

Figure 2-2: Map of tornado tracks associated with the April 27, 2011 outbreak in Alabama

SOURCE: [HTTP://WWW.SRH.NOAA.GOV/BMX/?N=EVENT\\_04272011](http://www.srh.noaa.gov/bmx/?N=EVENT_04272011) APRIL 27, 2011, 12:00 P.M. TO 6:00 P.M

the Southeast escalated throughout the weekend after every model update. Forecasters thought that conditions suggested a very strong potential for supercells with LTVTs.

By Sunday, April 24, forecast soundings and severe weather parameters showed a high combination of CAPE and SRH values for the afternoon of Wednesday, April 27. The corresponding EHI values were forecasted in some areas to have an extremely high value of EHI greater than 9. Generally, when the EHI is over 4, there is a good possibility of strong (EF2 to EF3) and violent (EF4 to EF5) tornadoes. Typically, EHI is in the 5 to 6 range during large outbreaks. On Monday, April 27, when

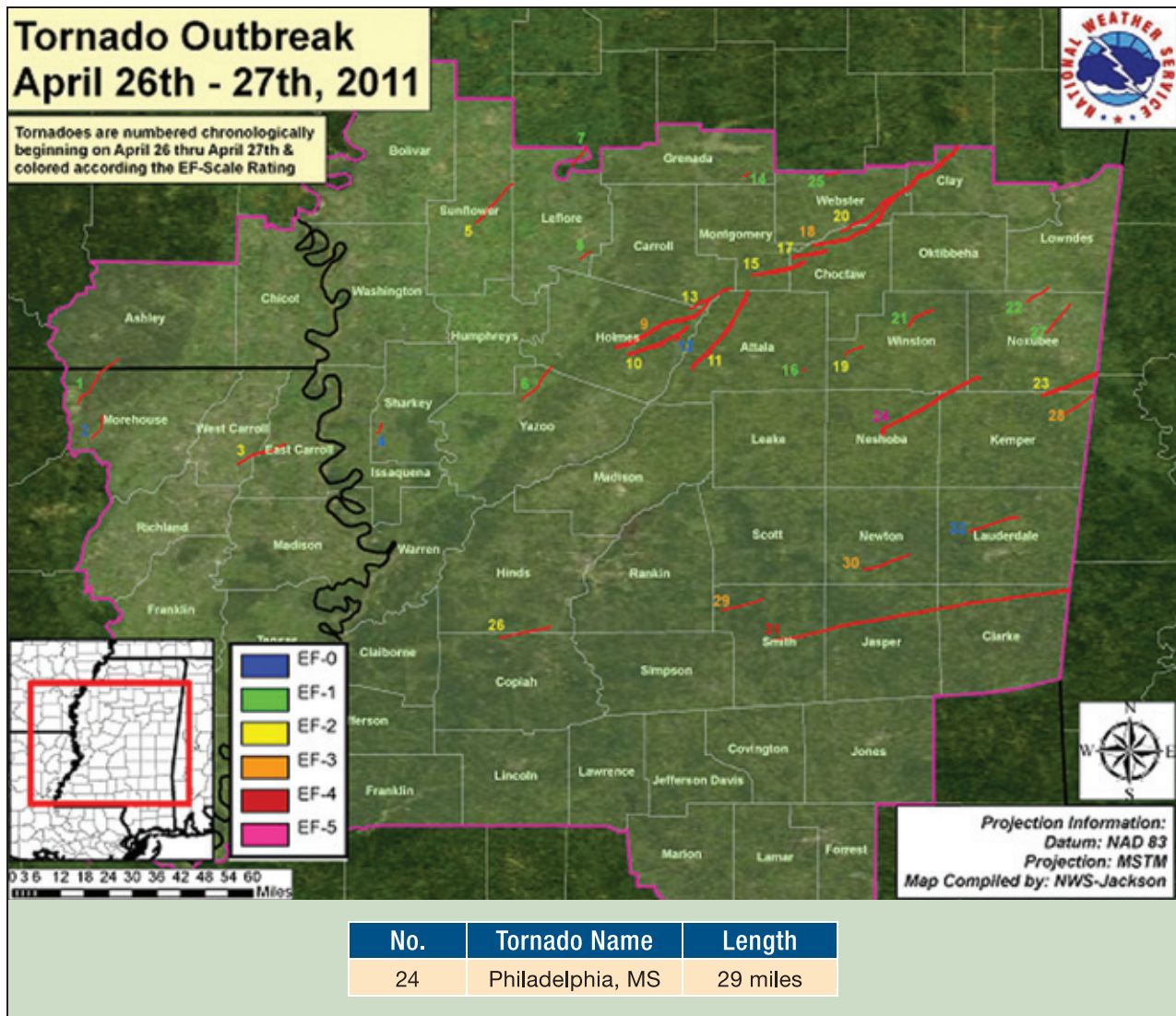

Figure 2-3: Map of tornado tracks associated with the April 26–27, 2011 outbreak in Mississippi

SOURCE: [HTTP://WWW.SRH.NOAA.GOV/JAN/?N=2011\\_04\\_25\\_27\\_SVR](http://www.srh.noaa.gov/jan/?N=2011_04_25_27_SVR)

new model updates showed better agreement in timing and evolution of the event, meteorologists had greater confidence in the development of supercells with LTVT. This began a 48-hour period of warning.

### 2.5.1.2 April 25, 2011

The situation began to materialize in the early morning hours of April 25, when a very strong trough in the upper atmosphere strengthened and moved southward along the leeward side of the Rockies into the Great Plains, bringing cold polar air

***NWS and forecasters successfully predicted the severe tornado event.*** Broadcast meteorologists and NWS personnel began predicting the possibility of severe weather a week before the event (<http://weather.gov>). By 48 hours before the severe tornado events of April 25–28, they were actively warning the public about a historic severe weather day.



from Canada. Unseasonably warm, moist, and unstable air from the Gulf of Mexico was in place throughout much of the southern United States. A 1,000-millibar (mb) surface low was centered just west of Lubbock, TX, at **7:00 p.m. Central Daylight**

A **bow echo** is a bow-shaped line of convective storm cells often associated with swaths of damaging straight-line winds and small tornadoes.

**Time (CDT)**<sup>7</sup> on April 25 in an area of active cyclogenesis. Severe storms began to develop in the diffluent zone to the east of the developing system on the afternoon of April 25 across northeast Texas, southwest Arkansas, and northwest Louisiana. These storms formed into bow echoes that produced high winds and several tornadoes across Arkansas. The atmosphere briefly settled in the early morning hours of April 26 before quickly recharging.

### 2.5.1.3 April 26, 2011

At **7:00 a.m.** on April 26, a 992 mb low was located near Davenport, IA, with a trailing cold front stretching south-southwest into Texas. A secondary surface low developed and deepened over Texas while a jet streak (faster-moving section of the jet stream) promoted uplift in the late afternoon hours. These conditions prompted the SPC to issue a high risk, severe weather outlook for southern Arkansas. High risk warnings are rare and indicate a significantly higher than normal chance for tornadic storms. According to the SPC archives, there were only seven high risk warnings between January 2007 and August 2011.

Numerous tornadoes evolved in Arkansas on the afternoon and evening of April 26 as the storms initially developed as supercells and transitioned into a quasi-linear convective system (QLCS). The QLCS raced eastward into Mississippi and Alabama overnight, evolving into a squall line and knocking out power for thousands. There were hundreds of reports of severe straight-line winds and 21 tornadoes.

### 2.5.1.4 April 27, 2011, 2:00 a.m. to 12:00 p.m.

Linear squall line events normally produce isolated, weaker tornadoes in the EF0 and EF1 range, but some of the early morning (**2:00 a.m. – 3:00 a.m.**) tornadoes in Alabama on April 27 were rated EF2 and EF3. Squall line events are common in Alabama, and the early morning events may have left many residents assuming that the worst of the severe weather had simply arrived half a day early. Furthermore, the morning weather caused numerous power outages, depriving many people of access to local TV meteorologists during the critical afternoon hours.

In the wake of the QLCS/squall line, skies slowly began to clear across northern Mississippi and Alabama, giving way to mostly sunny and very humid conditions with sustained southerly winds of 15 to 25 mph. Despite the clear skies, the forecasted conditions from the model runs of the preceding days were materializing into the perfect combination of instability and wind shear capable of creating the super outbreak of tornadoes on the afternoon of that day.

The SPC issued a PDS (particularly dangerous situation) tornado watch for Mississippi, Alabama, and portions of Tennessee shortly after noon. A 996 mb surface low had formed overnight in Arkansas

<sup>7</sup> All times given as CDT unless otherwise noted.

and was tracking toward Memphis while strengthening. At the same time, a potent shortwave in the upper atmosphere was arriving and promoting further uplift over Mississippi and Alabama during the peak hours of afternoon heating. In the early afternoon, small supercell thunderstorms started to form and take on classic supercell characteristics.

A **PDS tornado watch** provides the same recommended actions to the public, school officials, and emergency managers as other tornado watches. This terminology is often used by meteorologists and even occasionally used when broadcasting storm situations on the air.

A **shortwave trough** (or shortwave) is a disturbance in the mid or upper part of the atmosphere which induces upward motion ahead of it. If other conditions are favorable, this upward motion can contribute to thunderstorm development ahead of a shortwave trough.

(SOURCE: NWS GLOSSARY, [HTTP://NWS.NOAA.GOV/GLOSSARY](http://NWS.NOAA.GOV/GLOSSARY))

**2.5.1.5 April 27, 2011, 2:30 p.m. to 3:00 p.m.: Philadelphia, MS, Tornado #24, and Cullman, AL, Tornado #38**

The first major tornado of the day formed near Philadelphia, MS, at approximately **2:30 p.m.** and tracked northeast for 29 miles while briefly attaining EF5 status (shown as Tornado #24 on Figure 2-3). Though over rural areas, this tornado produced three fatalities when it tossed a manufactured home several hundred yards.<sup>8</sup>

A short time later at **2:43 p.m.**, the 43-mile-long EF4 Cullman, AL, tornado (shown as Tornado #38 on Figure 2-2) formed over Smith Lake and tracked northeast through the heart of Cullman, a city of 15,000. It was characterized by multiple vortices during the first 15 miles of its path. The base reflectivity image for the Cullman, AL, tornado is shown in Figure 2-4. The hook echo is circled in white on the image (Figure 2-4). The tornado continued northeasterly and reached peak intensity over rural areas as it passed north of Fairview, AL. This tornado was the first tornado of the day to be filmed via skycam and broadcast live to residents of north-central Alabama.

**Figure 2-4:**  
Base reflectivity and hook echo (white circle) for Cullman, AL

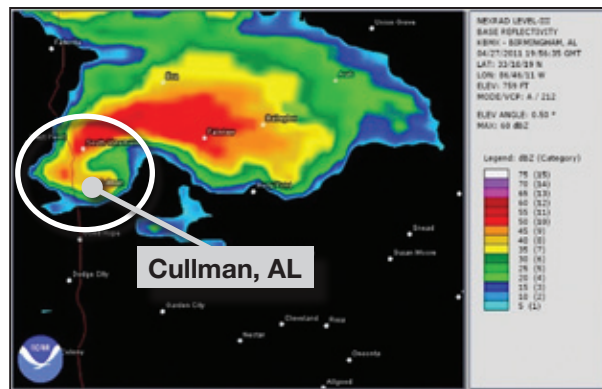

<sup>8</sup> NOAA NWS, Weather Forecast Office, Jackson, MS, Tornado Outbreak April 25–27, 2011, [http://www.srh.noaa.gov/jan/?n=2011\\_04\\_25\\_27\\_svr](http://www.srh.noaa.gov/jan/?n=2011_04_25_27_svr)

**2.5.1.6 April 27, 2011, 3:00 p.m.: Hackleburg to Huntsville, AL, Tornado #40**

Just before **3:00 p.m.**, a discrete supercell rapidly evolved to the west as it crossed the Mississippi/Alabama State line and began to acquire tornadic characteristics on radar. The Hackleburg-to-Huntsville tornado that developed from this supercell tracked an amazing 107 miles before dissipating north of Huntsville, AL. It was rated at EF5 intensity in Hackleburg and Phil Campbell, and possibly reached peak intensity after Phil Campbell near Oak Grove, AL. The NWS justification for the EF5 status was based on numerous pieces of evidence, described below and in the body of this report. According to the SPC database updated in January 2012 (NOAA 2012), the Hackleburg-to-Huntsville tornado caused 72 fatalities, which ranks it as the sixth deadliest single tornado since 1950.

A tornado warning was issued by the NWS Birmingham office at **2:59 p.m.** for the Hackleburg/Phil Campbell area, and at **3:24 p.m.**, a tornado struck the town of Hackleburg, AL (shown as Tornado #40 on Figure 2-2). The base reflectivity radar image showing the hook echo in Hackleburg, AL, is shown in Figure 2-5. In Hackleburg, there was evidence of debris rowing (the piling of debris into rows aligned with wind direction), which occurs in a small percentage of the most violent tornadoes.

**Base reflectivity** is measured by Doppler radar and is related to the power, or intensity, of the reflected radiation sensed by the radar antenna. Base reflectivity is related to rainfall intensity (e.g., drop size and rainfall rate) and hail size (for large values of reflectivity).

**Hook echo** is a radar reflectivity pattern characterized by a hook-shaped extension of a thunderstorm echo, usually in the right-rear part of the storm (relative to its direction of motion). A hook often is associated with a mesocyclone, and indicates favorable conditions for tornado development.

(SOURCE: NWS GLOSSARY, [HTTP://NWS.NOAA.GOV/GLOSSARY/](http://NWS.NOAA.GOV/GLOSSARY/))

The tornado then continued northeast and struck the neighboring town of Phil Campbell 10 minutes later. The base reflectivity and relative velocity radar images for the tornado in Phil Campbell are shown in Figure 2-6. In Phil Campbell, which is located 10 miles northeast of Hackleburg, the damage was similar but more extensive.

In Oak Grove, 20 miles northeast of Phil Campbell, the tornado caused widespread damage, including complete tree debarking in Oak Grove, the most noticeable compared to any other point along its track. Tree debarking is an indication of very intense winds; however, exact wind thresholds for tree debarking depend on tree species and tree health among other factors.

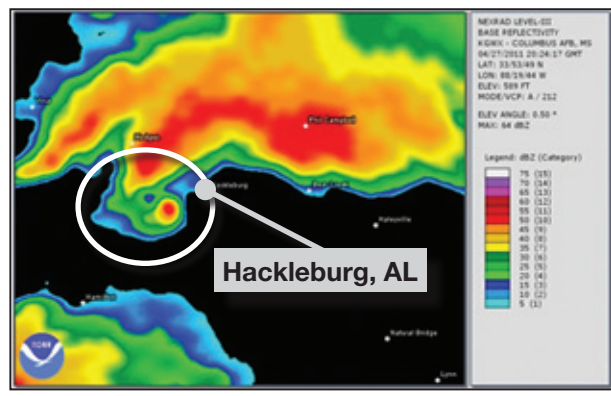

**Figure 2-5:**  
 Base reflectivity and hook echo (white circle) for Hackleburg, AL

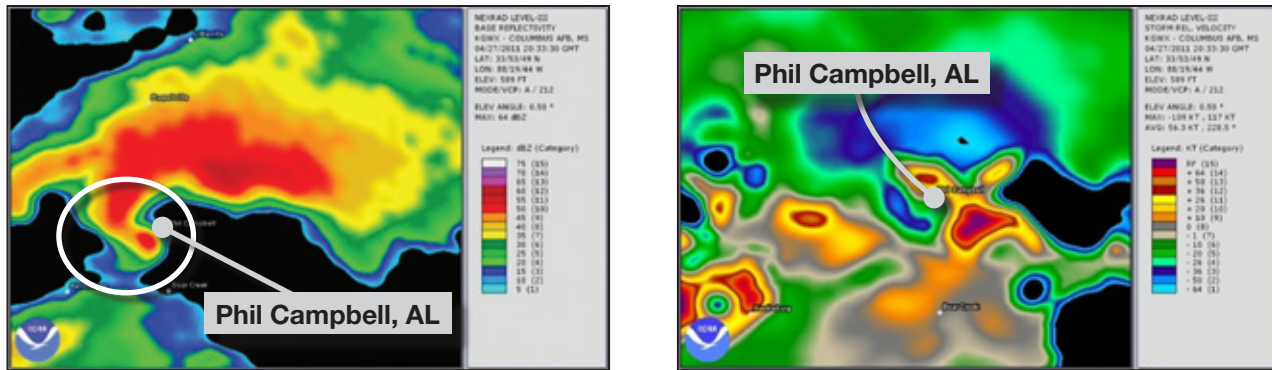

Figure 2-6: Base reflectivity and hook echo (white circle, left) and storm relative velocity (right) for Phil Campbell, AL

Based on NWS damage assessments, the intensity of the tornado fluctuated from EF3 to EF4 as it continued northeast toward Huntsville. The community of Tanner, 28 miles northeast of Oak Grove and approximately 30 miles from the tornado’s end in Huntsville, appears to have experienced increased damage, at least in the upper-end EF4 range. With this tornado, Tanner has been struck by three tornadoes at or above EF4 intensity, twice in a 1974 outbreak and again in the 2011 outbreak. Phil Campbell was also struck in the 1974 outbreak.<sup>9</sup> This represents the most at-or-above EF4 intensity tornado occurrences for a single community.

**2.5.1.7 April 27, 2011, 3:30 p.m.: Smithville, MS, Tornado #43**

Only 25 minutes after the formation of the Hackleburg-to-Huntsville tornado, another storm was developing 20 miles to the southwest over Mississippi, with a track paralleling the Hackleburg storm (shown as Tornado #43 on Figure 2-2). The tornado first appeared north of Amory, MS, and at **3:42 p.m.** the EF5 tornado struck Smithville, MS. The base reflectivity and the relative velocity images for the tornado in Smithville, MS, are shown in Figure 2-7. This tornado was on the ground simultaneously with the EF5 to its east that was over Oak Grove, AL. The total length of the Smithville tornado track was 49 miles and it caused 16 fatalities in Mississippi and 7 in Alabama.<sup>10</sup>

**The SPC successfully predicted the high risk areas.** The area of northeast Mississippi and northwest Alabama was at the center of the SPC’s high risk zone.

The Smithville, MS, tornado crossed into Alabama and struck the community of Shottsville, AL, where it was rated at EF3. The tornado dissipated 6 miles west of Hackleburg, close to the track of the Hackleburg-to-Huntsville tornado.

9 Historical storm event information is available through the NOAA National Climatic Data Center, <http://www.ncdc.noaa.gov/oa/climate/severeweather/extremes.html>

10 NOAA NWS SPC, Annual U.S. Killer Tornado Statistics, <http://www.spc.noaa.gov/climo/torn/fataltorn.html>

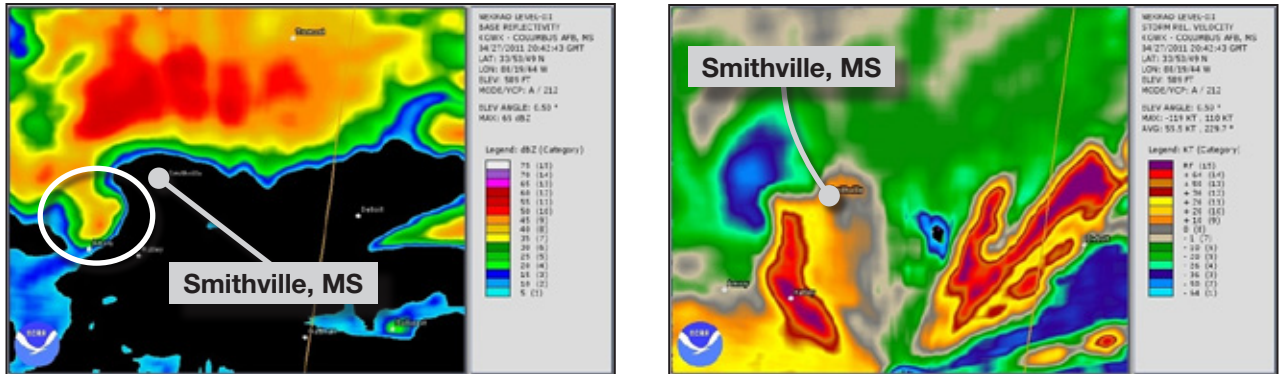

Figure 2-7: Base reflectivity and hook echo (white circle, left) and storm relative velocity on right for Smithville, MS

2.5.1.8 April 27, 2011, 3:38 p.m.: Cordova, AL, Tornado #41/#49

At approximately the same time the Smithville, MS, tornado formed, another tornadic supercell began its 123-mile-long path at **3:38 p.m.**, eventually striking Cordova, AL, 45 miles to the south-southeast in Walker County (this tornado is shown as two tornadoes, #41 and #49, on Figure 2-2). This tornado was ranked EF1 to EF2 for most of its duration, but it briefly escalated into the EF3 to EF4 range after crossing the future I-22 corridor and passing over Cordova, AL, resulting in 13 fatalities.<sup>11</sup> The base reflectivity and the relative velocity images for the tornado in Cordova, AL, are shown in Figure 2-8.

The downtown buildings of Cordova had already been directly impacted by a smaller, but still significant tornado during the early morning hours of April 27, when the squall line (described in Section 2.5.1.3) passed through. Power was still off from that event, leaving the warning siren inoperable during the afternoon. The afternoon Cordova tornado was ranked as an EF3 based on the damage in downtown Cordova. The afternoon track crossed the morning track just 50 yards south of the historic downtown.

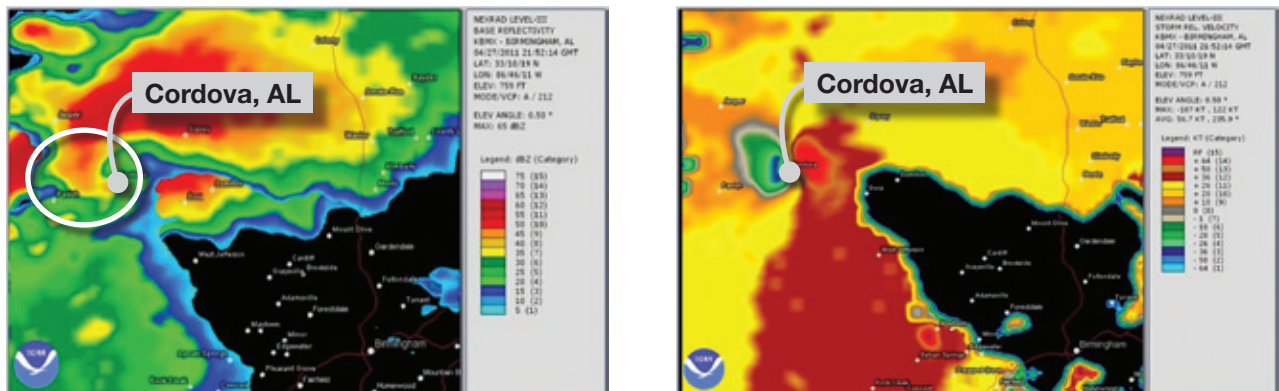

Figure 2-8: Base reflectivity and hook echo (white circle, left) and storm relative velocity on right for Cordova, AL

11 Ibid.

The tornado achieved its maximum intensity of EF4 as it moved northeast of Cordova. It then continued northeast over hilly and rural terrain and, based on reported damage, possibly intensified after dropping off a bluff.

**2.5.1.9 April 27, 2011: Macon County Supercell Thunderstorm, Tornado #46**

The last major tornado of the day causing damage assessed by the MAT was spawned from the Macon County, MS, supercell thunderstorm. A small, discrete supercell developed over Newton County, MS, and looked ordinary for the first 20 minutes of its lifespan. However, there were no storms to the south of this cell to rob it of its inflow, suggesting potential strengthening. Though almost 100 minutes after forming, it was evident that this supercell had a high probability of directly impacting the city center of Tuscaloosa, a city of 83,000 and metropolitan area of almost 150,000 people. TV meteorologists broadcasted a long-range polygon to show what would likely happen over the next hour, and the Birmingham Forecast Office of the NWS provided a 65-minute warning lead time for Tuscaloosa.<sup>12</sup> Incredibly, this supercell thunderstorm would not dissipate until reaching Macon County, NC, almost 7 hours and 30 minutes later, after dropping several tornadoes along its path. Along its 80-mile path through Tuscaloosa and the Birmingham suburbs, it produced 64 fatalities and injured over 1,000 people.<sup>13</sup>

At **4:43 p.m.** the supercell thunderstorm became tornadic just to the southwest of Tuscaloosa, AL (shown as Tornado #46 on Figure 2-2). The base reflectivity and the relative velocity images for the tornado in Tuscaloosa, AL, are shown in Figure 2-9. The storm crossed I-20 near exit 68 at Joe Mallisham Parkway. It entered an industrial area where it damaged and destroyed many buildings, including the large building that housed Tuscaloosa County EMA. The tornado then crossed I-359 and entered the residential areas of Tuscaloosa. A hardened room in a neighborhood was the only structure remaining after debris was cleared (structure is discussed in more detail in Section 9.1.1). The tornado then passed over the busy commercial intersection of 15<sup>th</sup> Street and McFarland Boulevard. At this point, its intensity was rated at EF4 status and it continued to intensify and grow larger as it tracked into the Alberta section of Tuscaloosa.

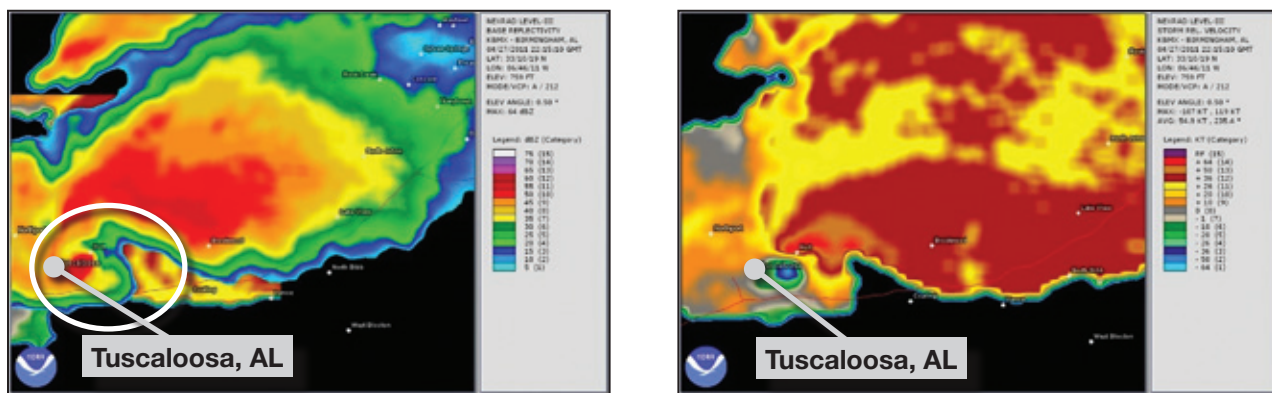

Figure 2-9: Base reflectivity and hook echo (white circle, left) and storm relative velocity on right for Tuscaloosa, AL

12 NWS storm-based warnings and storm reports issued by a Weather Forecast Office can be viewed online at the Iowa Environmental Mesonet, Iowa State University Department of Agronomy, Web site, <http://mesonet.agron.iastate.edu/cow/>

13 NOAA NWS Weather Forecast Office, Birmingham, AL, Tuscaloosa-Birmingham EF-4 Tornado, April 27, 2011, [http://www.srh.noaa.gov/bmx/?n=event\\_04272011tuscbirm](http://www.srh.noaa.gov/bmx/?n=event_04272011tuscbirm)

Alberta Elementary School was severely damaged (see Chapter 6). Most of the older homes in Alberta, as many as 200 or more, were destroyed except for a few interior rooms. Tree debarking was more common here than in other areas struck by this tornado. The tornado then continued into the community of Holt. Most of the older homes in Holt, as many as 200, were completely destroyed while others were left with small interior walls intact. Damage observed in Holt further validated the EF4 rating for the tornado.

The tornado then exited the Tuscaloosa metropolitan area and tracked east-northeast across rural areas before heavily damaging the town of Concord in Jefferson County. After Concord, the tornado passed over the outer sections of Pleasant Grove. The base reflectivity and the relative velocity images for the tornado in Pleasant Grove, AL, are shown in Figure 2-10.

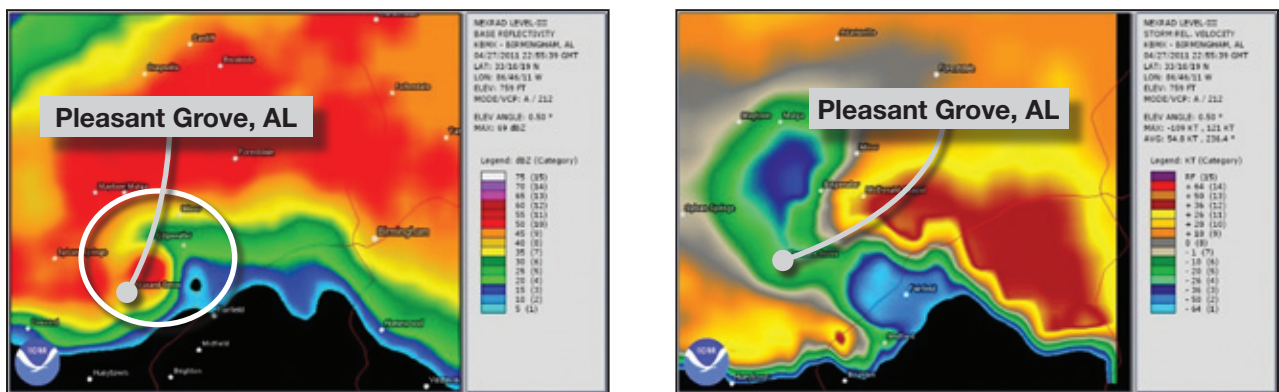

Figure 2-10: Base reflectivity and hook echo (white circle, left) and storm relative velocity on right for Pleasant Grove, AL

The tornado next passed over the industrial area of Pratt City on the northern side of Birmingham, AL. The tornado weakened here, though it still produced extensive damage in Pratt City. The tornado continued to lose intensity, although briefly getting much wider, as it crossed I-65 near exit 266 north of Birmingham. It finally dissipated in Fultondale, AL, where it briefly displayed multiple vortices before lifting.

Although the Tuscaloosa metropolitan area is frequently impacted by tornadoes, the city center had not been directly in the path of a major tornado since 1932. An F4 tornado affected the southern part of the city of Tuscaloosa on December 16, 2000. The April 8, 1998 F5 Oak Grove tornado track was less than 5 miles away from the April 27, 2011 track that devastated Pleasant Grove.<sup>14</sup>

### 2.5.2 May 22, 2011 Storms in Missouri

The May 22 Joplin, MO, tornado resulted in the highest number of fatalities for a single tornado since modern record keeping began in 1950. The official fatality count is 161 including both direct and indirect fatalities (City of Joplin 2011).

<sup>14</sup> Historical storm event information is available through the NOAA National Climatic Data Center, <http://www.ncdc.noaa.gov/oa/climate/severeweather/extremes.html>

Unlike the April 25–28 tornado events in the mid-south, the May 22 Joplin, MO, tornado was an isolated occurrence on a day forecasted by the SPC as having only a moderate risk for tornado activity. Although the threat for severe weather and tornadoes existed, the forecasted conditions were not ideal to produce LTVT. Although there were 51 confirmed tornadoes across an eight-State area that included Missouri, no other tornadoes developed on that day above EF3 intensity. The atmospheric conditions and thunderstorm cell dynamics rapidly evolved during the afternoon hours to produce a complex interaction of circumstances leading to the Joplin, MO, tornado.<sup>15</sup>

### 2.5.2.1 Summary of Synoptic Setting and Mesoscale Environment

In the days before May 22, 2011, meteorologists at the SPC identified conditions favorable for severe weather across a large area of the Great Plains and upper Midwest. A trough in the upper atmosphere was accompanied by a strong 996 mb surface low in eastern South Dakota. A cold front stretched from South Dakota to the Texas Panhandle with advection of warm, moist and unstable air ahead of the front. Several weaker tornadoes touched down in Minnesota and Wisconsin as forecasters had anticipated. An area of diffluence occupied much of the southern Plains in the vicinity of southwest Missouri. By the afternoon of May 22, high CAPE values were in place, and SRH values were increasing ahead of a dry line in Oklahoma.

A mesoscale discussion was issued at **3:48 p.m.** from the SPC indicating the evolving tornado potential over southwestern Missouri with parameters more than sufficient to produce tornadic supercells. A broken line of severe thunderstorms initiated over Kansas and travelled generally southeast toward the Missouri border. Despite the evolving tornadic potential, as indicated by rapidly increasing EHI values immediately before the Joplin tornado, none of the Kansas storms materialized into tornadic cells. The supercell that would ultimately produce the Joplin tornado lacked classic structure as it approached the Missouri border.

Around **4:45 p.m.**, meteorologists observed a smaller storm coming out of Oklahoma and moving toward the northeast. This storm was on a collision course with the unstructured supercell in southeastern Kansas. At **5:05 p.m.**, the two storms collided and merged, as has happened before in numerous severe weather events. When cells merge, often the newly created supercell weakens or dissipates due to disruption of the circulation. However, in other instances in the region, such as the Pierce City, MO, 2003 tornado and the Picher, OK, 2000 tornado, merging cells produce a stronger supercell.

In the May 22, 2011 case, the rapidly rotating smaller cell was ingested by the dying larger cell. The newly created supercell began a transformation and started to acquire a more menacing classic shape. Based on the storm's right-moving tendency and the presence of warm, moist, and unstable air, staff at NWS in Springfield, MO, issued a tornado warning 12 minutes later at **5:17 p.m.**, despite the storm's marginal appearance. A short time later at **5:24 p.m.**, another small cell moving northeast was ingested, and at this point the Joplin supercell began to rapidly intensify and acquire tornadic characteristics.

---

<sup>15</sup> A brief description of the synoptic setting and mesoscale environment for the Joplin tornado, as well as a summary of the NWS damage survey assessment, is located at: NOAA NWS Weather Forecast Office, Springfield, MO, Joplin Tornado Event Summary, May 22, 2011, [http://www.crh.noaa.gov/sgf/?n=event\\_2011may22\\_summary](http://www.crh.noaa.gov/sgf/?n=event_2011may22_summary)



At **5:29 p.m.**, the supercell displayed a hook echo with a velocity couplet (tightly clustered incoming and outgoing winds on radar). The initial touchdown of the multiple-vortex tornado took place at **5:34 p.m.** on the southwestern side of Joplin. A storm relative velocity image was captured at **5:38 p.m.** and a base reflectivity image at **5:43 p.m.** (Figure 2-11).

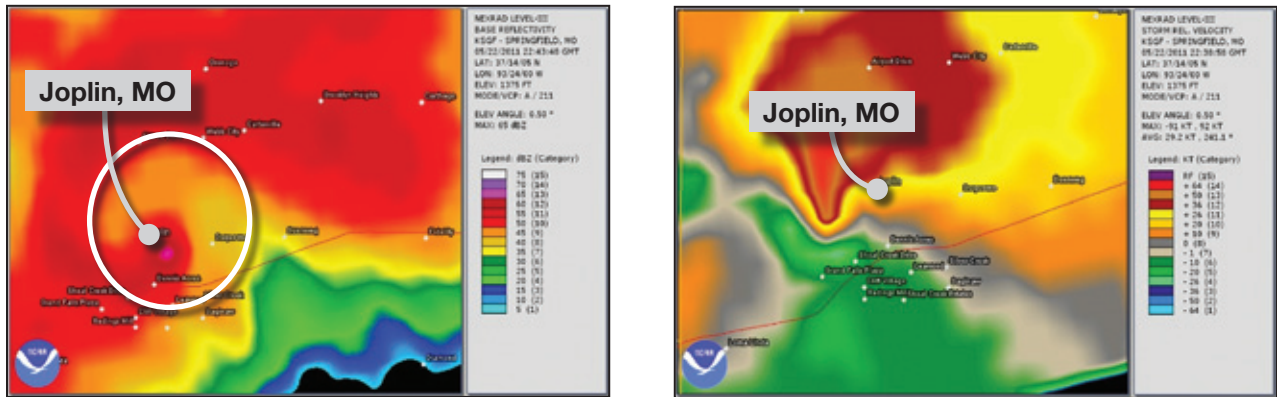

Figure 2-11: Joplin, MO, base reflectivity with hook echo (white circle, left) at 5:43 p.m. and storm relative velocity at 5:38 p.m. (right)

### 2.5.2.2 Damage and Path of the Joplin Tornado

Along its 22-mile path, and especially a 6-mile stretch in Joplin, the 0.75-mile-wide EF5 tornado destroyed and damaged thousands of homes. Numerous commercial buildings, schools, churches, and critical facilities were also destroyed or severely damaged. Joplin had the unfortunate circumstance of being located downwind of the merger collisions that perturbed the ordinary supercell and transformed it into a violent tornadic storm. An NWS assessment team observed damage consistent with previous EF5 tornadoes, including those from the April 27, 2011 outbreak. A full report on their findings can be found at the NOAA NWS, Weather Forecast Office, Springfield, MO, Web site.<sup>16</sup>

The tornado intensified rapidly after touching down near JJ Highway. By the time it entered a new residential area near Sunset Drive, the tornado was evolving from a multiple-vortex structure into a wedge. The sporadic damage on Sunset Drive suggests the possibility of multiple-vortex interaction. The tornado rapidly intensified as it crossed Schifferdecker Avenue and moved east-northeast toward St. John's Regional Medical Center.

Based on damage observed at the St. John's Medical Center, the MAT determined that the center of the tornado most likely passed over the northern parking lot of the hospital, producing a slightly weaker but still significant impact on the hospital. The damage in the parking lot and to buildings just west of the parking lot was extensive. Wind speeds in the parking lot and over adjacent buildings

16 NOAA NWS, Weather Forecast Office, Springfield, MO, Joplin Tornado Event Summary, May 22, 2011, [http://www.crh.noaa.gov/sgf/?n=event\\_2011may22\\_summary](http://www.crh.noaa.gov/sgf/?n=event_2011may22_summary)

to the west of the parking lot are estimated to have been higher than those that directly impacted the hospital (for additional information on the St. John's Medical Center, refer to Section 7.1.4).

St. Mary's Elementary School and Joplin High School were next in the path. Only the large steel cross and a portion of the façade were left of the St. Mary's Elementary School building. Damage at Joplin High School suggested it took a direct hit as indicated by steel fence posts on the softball field facing opposite directions (refer also to Section 6.1.5). NWS rated the damage along this section of the tornado path to be EF4 mixed with some EF5.

The tornado then veered almost due east and crossed the busy commercial intersection of 20<sup>th</sup> Street and Range Line Road. The commercial buildings of Home Depot, Walmart, and Academy Sports were heavily damaged here (refer to Chapter 5 for additional information). Slightly east of this intersection, the tornado veered southeast and began to weaken rapidly before crossing I-44. The storm immediately weakened once it resumed the same east-southeast vector it displayed in Kansas.



# TORNADO OUTBREAK *of* 2011

IN ALABAMA, GEORGIA, MISSISSIPPI,  
TENNESSEE, AND MISSOURI

## 3 Design and Construction Considerations

*During field investigations, the MAT focused on identifying building components and construction practices that performed either poorly or notably well during the tornadoes.*

Most buildings are not designed to withstand the extreme forces caused by the high wind speeds of severe or violent tornadoes (greater than 110 mph), and the vast majority fail when subjected to such conditions. However, the majority of tornadoes recorded in the United States are considered weak (EF1 or below), with maximum wind speeds of 110 mph. Wind speeds associated with EF0 and some EF1 tornadoes are less than or equal to the design wind speeds used in the majority of the United States,<sup>1</sup> and properly designed and constructed structures should perform well under these conditions. In addition to high wind, tornadoes produce large quantities of fast moving wind-borne debris, which contributes to and sometimes causes building failures by penetrating the building envelope and allowing wind inside the structure.

<sup>1</sup> Design wind speeds are higher in hurricane-prone regions of the United States, along the eastern and southeastern coast, than in other areas.

This chapter discusses the effects of wind loading on structures; the types and patterns of wind-borne debris observed in tornadoes; and the Federal, State, and local regulations that govern the areas affected by the tornadoes and the regulatory role in disaster mitigation efforts.

## 3.1 Effects of Wind Loading on Structures

Effects of wind on a building include internal pressurization, increased lateral forces, uplift, and external pressures. Internal pressurization occurs when wind enters a building and lateral forces act either inward, created by the wind blowing directly on the face of a building, or outward, due to suction forces created when low pressure conditions occur inside the building. Most buildings are designed as *enclosed structures* with no large or dominant openings in the envelope that allow wind to enter. However, a breach in this normally enclosed building envelope due to broken windows, failed entry doors, or a failed garage door causes a significant increase in the net effective wind loads acting on the building under strong wind conditions. In such cases, the increased wind load may initiate a partial failure or cause a total failure of the primary structural system. A schematic diagram illustrating the increased loads due to a breach in the building envelope is shown in Figure 3-1.

Internal pressurization due to a breach of the building envelope (i.e., broken windows, failed garage door, missile impact in roof structure, etc.) may contribute to significant structural failures. Maintaining the integrity of the building envelope by limiting the size and number of openings created by the wind event in the building significantly improves the performance of elements in the structural system.

Primary structural systems are those that support the building against lateral and vertical loads. Many buildings observed by the MAT had structural systems that provided continuous load paths for high winds, but that were not sufficient for the extreme lateral and vertical uplift forces generated by tornadic winds. The MAT gathered information to determine whether the observed damage could have been prevented in buildings located in the peripheral areas of the wind field, those not in the direct path of the vortex of the violent tornadoes. Figure 3-2 shows a continuous load path in a CMU wall.

Winds moving around a structure create vertical and lateral forces that act on the building and cause several different failure modes (Figure 3-3). Uplift is a force caused by the wind accelerating around and over buildings and is affected by the geometric changes in the building shape (Figure 3-4).

Model building codes incorporate provisions that take into account the effects of internal pressurization on *partially enclosed buildings*, which are buildings with large permanent openings, by requiring higher design wind loads. Residential structures, considered enclosed structures, are typically not designed to withstand instantaneous wind load increases such as those that occur after an envelope breach.

Some of the damage to buildings noted by the MAT was considered non-structural since only architectural and decorative finishes on the exterior were damaged (Figure 3-5). Engineering

standards such as ASCE 7-05, *Minimum Design Loads for Buildings and Other Structures* (2005), identify these elements as components and cladding and provide guidance for determining wind loads acting on them. ASCE 7-05 is the reference standard for the 2009 I-Codes.

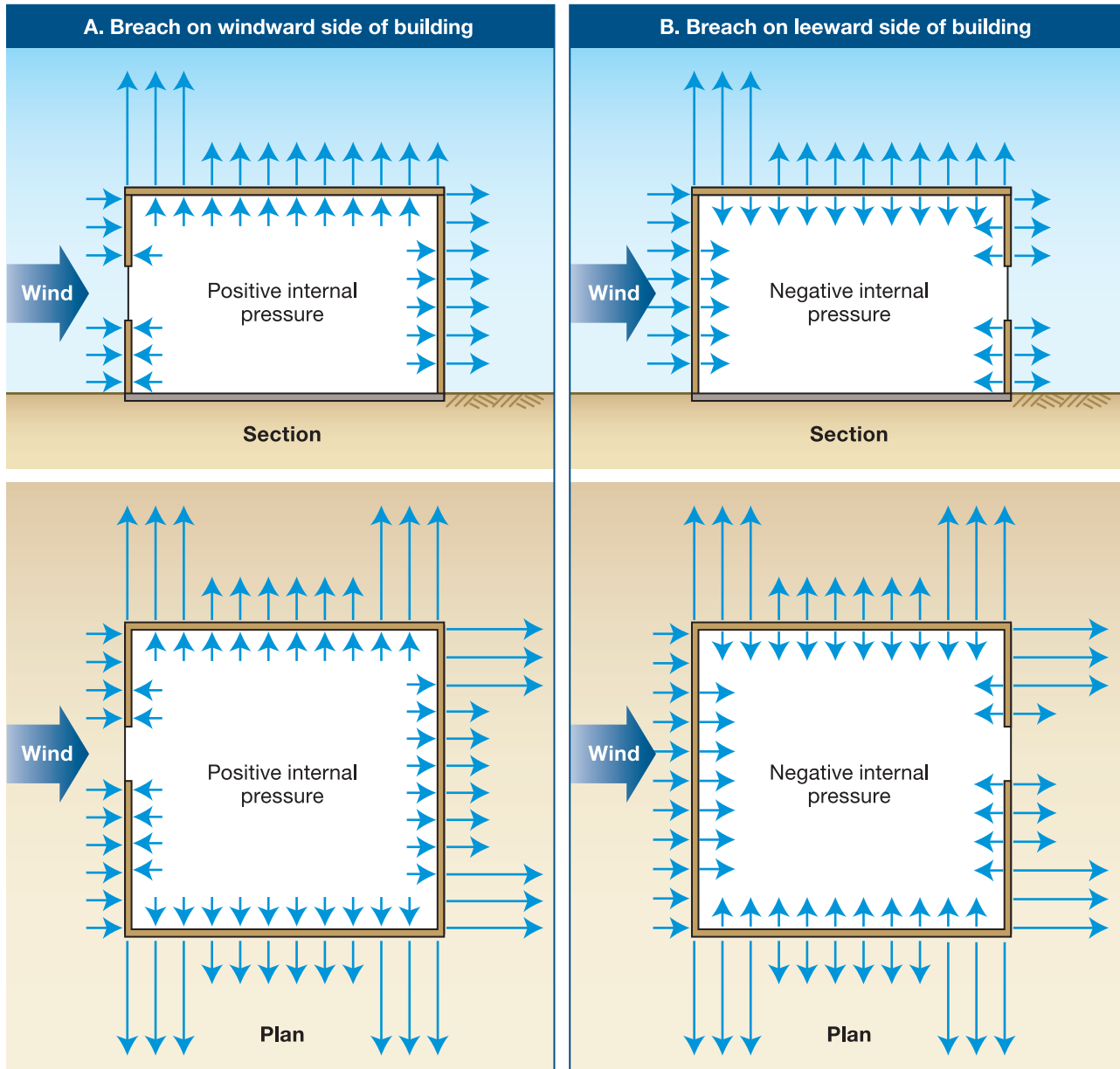
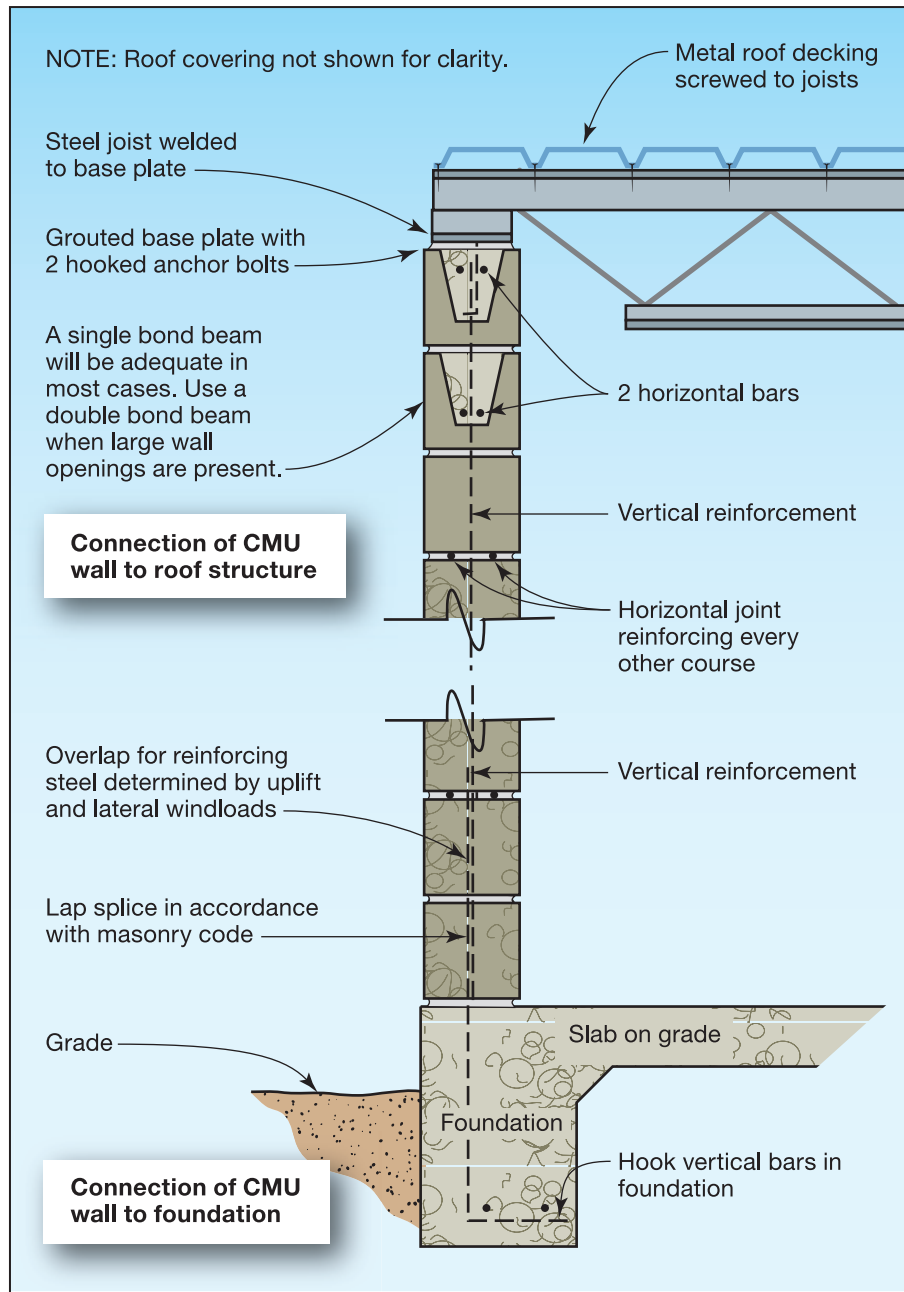

Figure 3-1: Effects of a breach in a building envelope when the breach is on the windward (a) or leeward (b) side of a building, shown in plan and section views

SOURCE: [HTTP://WWW.WBDG.ORG/RESOURCES/ENV\\_WIND.PHP](http://www.wbdg.org/resources/env_wind.php)

**Figure 3-2:**  
**Load path continuity in**  
**CMU wall**  
 SOURCE: FEMA 577, FIGURE 4-26



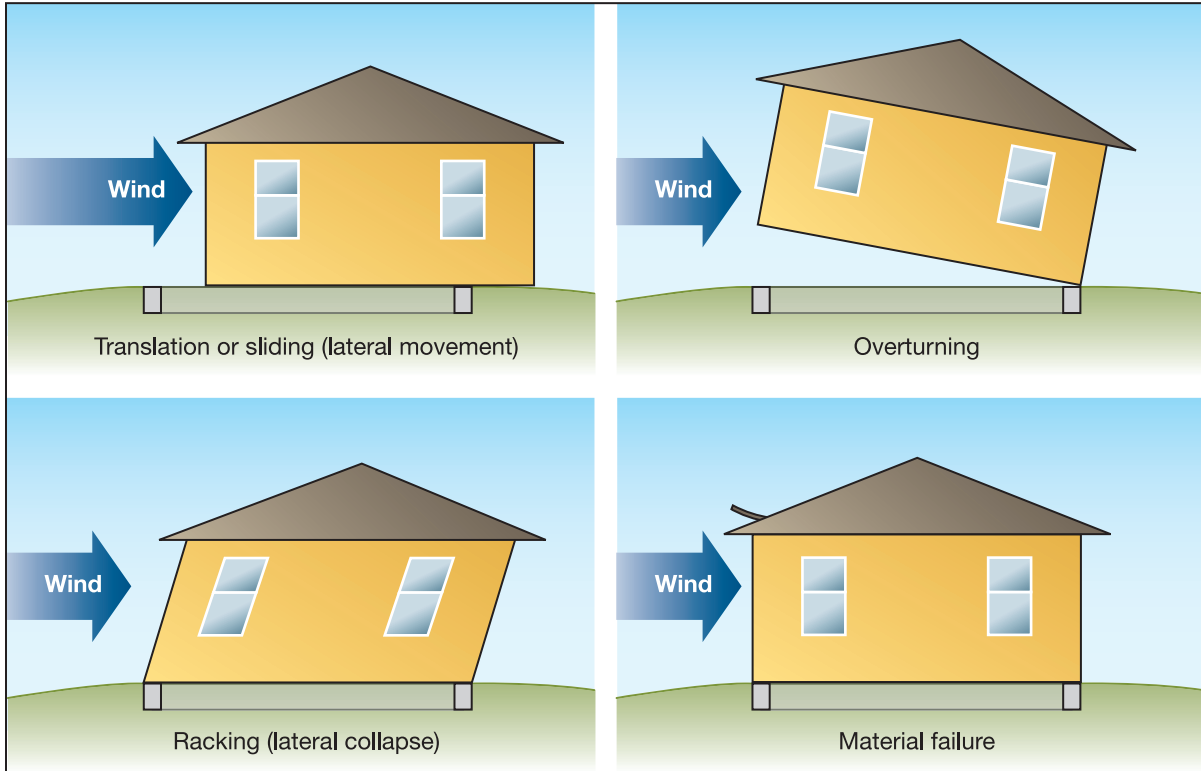

Figure 3-3: Building failure modes in high-wind event

SOURCE: FEMA 342, FIGURE 3-3

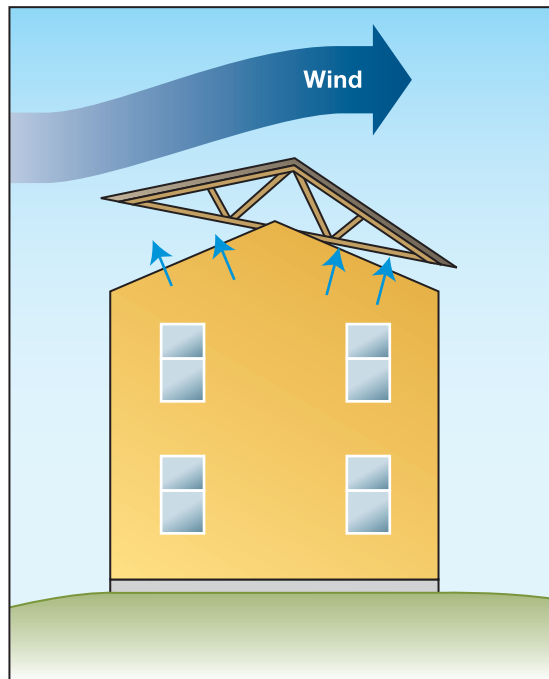

Figure 3-4: Uplift pressures acting on a building



Figure 3-5: Brick veneer blew off this high school cafeteria during the tornado in Phil Campbell, AL. Note that brick ties do not appear to be at the correct spacing, which may have contributed to the failure (shown in red circle in inset).

## 3.2 Wind-Borne Debris

Wind-borne debris, often referred to as missiles, can be generated in a wind storm, but is most common in tornadoes and can cause significant damage. Tornadoes generate some of the largest missiles and propel them with forces unequaled by any other wind storm. Wind-borne debris in tornadoes is a danger to life safety, buildings, and property. It can breach the envelope of a building, resulting in internal pressurization and structural failure, and it can kill or severely injure individuals who are unable to find shelter.

The funnel cloud of a tornado is composed of water vapor and debris carried by both the inflow winds and vortex winds of the storm (see Section 2.3). Smaller missiles (e.g., rocks, pieces of tree limbs, and pieces of shredded wood framing members such as those shown in Figure 3-6) can easily break common window glazing. This causes a rapid change in internal air pressure in a building, putting



stress on the roof-to-wall connections and wall-to-wall or wall-to-floor connections. Medium-sized missiles (e.g., appliances; furniture; heating, ventilation and air-conditioning [HVAC] units; long wooden framing members; and larger tree limbs, also shown in Figure 3-6) can become airborne and cause considerable damage. Large missiles (e.g., propane tanks, trees, and roof trusses such as those shown in Figure 3-7) are often observed as rolling debris, but may also become airborne and can cause major damage to the structural systems of buildings they strike. Section 3.2.1 describes the types, sizes, and quantity of missiles observed by the MAT.



**Figure 3-6:**  
Example of small- and medium-sized missiles commonly observed by the MAT (photograph taken near an apartment complex in Tuscaloosa, AL)



**Figure 3-7:**  
Example of medium- to large-sized wind-borne missiles (photograph shows roof trusses displaced from a nearby building in Tuscaloosa, AL)

### 3.2.1 Missile Types and Sizes

The missile types observed by the MAT varied greatly across the geographic area impacted by the tornados because of the varying intensities of the tornados and the differences in the built environment in affected areas. In residential areas where buildings were primarily wood-frame construction with asphalt shingle roofs, most of the missiles observed were wood framing members, household contents, and brick veneer pieces. Adjacent to wooded areas and in areas with a high tree density, the missiles also included small- to medium-sized pieces of wood from the trees. The missiles in residential areas caused significant damage to the glazing, roofing systems, and exterior cladding of buildings. In non-residential areas, the missiles and wind-borne debris were primarily pieces of wood from trees and building appendages (including awnings, etc.). Table 3-1 lists typical debris observed during the field investigation, its classification, and the typical associated damage.

Table 3-1: Wind-Borne Debris and Rolling Debris Classifications

Missile Size	Typical Composition of Missile	Associated Damage Observed
Small	Rocks, dirt clods, pieces of trees, fragments of buildings (e.g., pieces of wood framing members, bricks)	Broken glazing, broken doors, some damage to light roof coverings
Medium	Appliances, HVAC units, long wood framing members, steel decks, trash containers, furniture, road signs, large tree limbs, fencing	Considerable damage to building envelope and roof structures
Large	Structural columns, beams, joists, roof trusses, large tanks, trees, parts of buildings and appendages (e.g., awnings, decks)	Damage to structural systems

The intensity of the winds in the vortex of a tornado are capable of creating missiles out of nearly any object, from building sections to bits of timber, and projecting these objects with such force as to cause significant damage to buildings and threaten life. The following illustrates the range of missile sizes and resulting missile damage the MAT observed.

Figure 3-8 shows a 2x4 piece of wood that pierced the roof of Alberta Elementary School in Tuscaloosa, AL. The source of this missile was most likely a dislodged piece of the roof framing system from elsewhere at the school (see also Section 6.1.1).



Figure 3-8: Medium-sized missile that struck the roof of a school building (Tuscaloosa, AL)

Figure 3-9 shows a roof truss penetrating a home in Athens, AL, a town just north of Huntsville, AL. The truss most likely originated from the detached garage approximately 100 feet behind this home.



**Figure 3-9:**  
Large roof beam penetrated the roof of this home (Athens, AL)

Figures 3-10 and 3-11 show two instances of oriented strand board (OSB) as debris, one striking a school locker (Figure 3-10) and one impacting the roof of a home in a residential neighborhood (Figure 3-11). Poorly fastened trusses, rafters, and OSB have more potential to generate debris than material that is properly fastened.



**Figure 3-10:**  
OSB damaged the first floor locker in Joplin High School (Joplin, MO)

**Figure 3-11:**  
Small pieces of OSB debris  
penetrated the roof of a  
home (Harvest, AL)



Figure 3-12 shows metal sheathing blown from the roof of the Fultondale Fire Station in Fultondale, AL, and carried nearly 200 feet. Figure 3-13 shows a car in Joplin, MO, with its roof penetrated by a 2x6 framing member. The MAT also observed cars that had become rolling debris during the tornado events, similar to other large debris types.

Seeking refuge in a car during a tornado should only be a last resort.

**Figure 3-12:**  
Metal sheathing travelled  
200 feet as wind-borne  
debris and landed next to  
a building outside of the  
tornado swath  
(Fultondale, AL)





**Figure 3-13:**  
A 2x6 missile penetrated the roof and seat of a car in a residential neighborhood just outside the damage track of the violent tornado in Joplin, MO

### 3.2.2 Wind-Borne Missile Quantity

The missile quantity the MAT observed varied depending on the location of the site and the level of damage in the adjacent areas. Where buildings were totally destroyed, debris and missiles often covered the ground (Figures 3-14 and 3-15). In wooded areas and residential areas that were heavily wooded, passage along the streets was often impossible due to the volume of tree debris present. Many buildings were covered with small puncture marks where the façade was pelted with wind-borne debris. Figures 3-14 through 3-17 show examples of the volume of missiles generated by the tornadoes.



**Figure 3-14:**  
Wind-borne debris consisting of wood framing members and plywood sheathing near the Alberta Elementary School, Tuscaloosa, AL

**Figure 3-15:**  
Large quantity of wind-borne debris covering the lawn of a nursing home in Joplin, MO



**Figure 3-16:**  
Numerous missiles struck the outer wall of this non-residential building, including several that remained embedded (indicated by red circles) (Tuscaloosa, AL)





Figure 3-17:  
Large pile of small- and  
medium-sized wind-borne  
debris outside of Joplin  
High School (Joplin, MO)

### 3.3 Federal, State, and Local Regulations

This section provides background on the Federal, State, and local regulations that govern building construction in the affected areas. Building codes are the technical requirements for design and construction of buildings and structures and are adopted to protect public health, safety, and general welfare. Since the early 1900s and until 2000, model building codes in the United States were developed by three regional model code organizations: Building Officials and Code Administrators International (BOCA), International Conference of Building Officials (ICBO), and the Southern Building Code Congress International (SBCCI). Prior to 2000, there were four primary model building codes adopted throughout the country. These included:

- + National Building Code promulgated by BOCA
- + Uniform Building Code promulgated by the ICBO
- + Standard Building Code (SBC) promulgated by the SBCCI
- + Council of American Building Officials One and Two Family Dwelling Code, promulgated by BOCA, ICBO, and SBCCI

In the early 1990s, the three model code groups formed the ICC, with the intent of creating a single, common set of building, fire, and life-safety codes for the entire United States. The ICC publishes what are known as the *International Codes* (I-Codes), which include the IRC, IBC, and International Fire Code, to name a few. The IBC and IRC specifically address designing buildings for high-wind events such as hurricanes through prescriptive criteria, or they reference ASCE 7, but neither addresses designing for the wind speeds that occur in tornadoes. The IBC and IRC are described more fully in Section 3.3.1.

The adopted building codes and regulations for both residential and non-residential/industrial buildings differ considerably throughout the country. Often, they vary significantly even within a State; one such example is Alabama (described in Section 3.3.3.1 below). The adopted code in each of the affected States at the time of the 2011 tornado outbreak is described in Sections 3.3.3.1 through 3.3.3.5.

### 3.3.1 International Building Code and International Residential Code

The primary codes that address residential, non-residential, and critical facility construction are the IBC and IRC. To better address structural and architectural issues related to moderately high wind events, some State and local governments have adopted the I-codes (IBC and IRC). In addition, ICC 600, *Standard for Residential Construction in High-Wind Regions* (2008), provides guidance for residential construction. This standard specifies prescriptive methods for developing wind-resistant designs and construction details for residential buildings of masonry, concrete, wood-frame, or cold-formed steel-frame construction sited in high-wind regions.

The IBC is primarily a *performance code*, with some prescriptive provisions, that requires buildings and structures to be designed to meet the applicable requirements of the code and various referenced standards. The IRC addresses environmental loads such as high winds using a mostly *prescriptive approach*, so that many one- and two-family houses can be built without individual designs being prepared by architects and engineers. However, buildings and sites that fall outside the scope of the prescriptive limits, which include a maximum height and basic wind speed among other parameters, must be designed for the applicable loads.

Although the IBC and IRC editions published before 2009 do not address the threat of tornadoes, they address wind loading by referencing ASCE 7 (1998 edition or earlier). The current edition of ASCE 7-10, *Minimum Design Loads for Buildings and Other Structures* (2010), has been incorporated into the 2012 I-codes.

### 3.3.2 International Codes and Storm Shelters

It is important to remember that the building codes and standards used in the United States before 2008 did not address life-safety protection from tornadoes or hurricanes. Although guidance from FEMA and others has existed since the late 1990s, it was not until the release of ICC 500 in 2008 that such criteria were introduced into building standards. The ICC 500 standard codifies much, but not all, of the extreme-wind shelter recommendations of FEMA 320 (1998, 1999, and 2008) and FEMA 361 (2000 and 2008). Following the release of the ICC 500, the 2009 IBC and IRC incorporated the standard by reference.

This means that if a building is constructed to the 2009 IBC and IRC, and there is a portion of the building designated to be a shelter, it must be designed to the criteria of the ICC 500, which has specific provisions on how to provide protection from extreme wind events and wind-borne debris associated with those events.

At this time, neither the ICC 500 nor the I-Codes require that shelters be designed or constructed within buildings.

In addition, ASCE 7 does not address tornadoes as part of the wind design considerations and requirements for buildings or other structures.



FEMA 361, which was updated at the same time ICC 500 was released in 2008, uses the same wind speed maps and design process, and references ICC 500 for general building criteria, inspection criteria, and testing standards for debris impact resistance. While the tornado hazard design criteria are the same or can be applied in the same manner for both FEMA 361 and ICC 500 (if an alternative design is not used), certain criteria in the design and construction of a safe room, such as those related to the hurricane hazard (both wind design and wind-borne debris impact criteria), the flood hazard siting criteria, and emergency management considerations are different. Safe rooms constructed in accordance with FEMA 320 (2008a) and FEMA 361 (2008c), meet all criteria of the ICC 500 for storm shelters. Since the two sets of criteria are similar, but not the same in all applications, FEMA uses the term *safe room* to differentiate construction consistent with its criteria from that of ICC 500, which uses the term *storm shelter*. Refer to the text box in Section 1.2 and Chapter 9 for more information regarding safe rooms, storm shelters, and hardened areas.

### 3.3.3 State and Local Codes and Regulations in Areas Visited by the MAT

An understanding of the codes in effect in the areas visited by the MAT is important to the damage assessment. If no codes were in place at the time of the tornado, the performance of structures was interpreted differently than in those locations where codes were in place. For locations where codes were in place before the event, the MAT was able to assess the performance related to specific design requirements in the code, and therefore the success of the code. This section of the report presents a brief history of code adoption in the communities visited by the MAT as well as a discussion of statewide code adoption in the five States visited by the MAT.

Building codes and the materials referenced in the codes change over time. As the building codes evolve, jurisdictions may choose to adopt the newest code, which then takes precedent over the historical code. Buildings that were built, and typically permitted, prior to the adoption of a new code do not need to meet the requirements of the newly adopted code. Therefore, in a single jurisdiction, some buildings may be built to an older code, while other buildings may be built to a newer code.

Tables 3-2 and 3-3 list the building codes in place during the past 5 years for commercial and residential buildings, respectively, in the communities affected by the tornadoes assessed in this report.

Table 3-2: Historical Codes for Commercial Buildings

State	Community	Commercial				
		December 2007	December 2008	December 2009	December 2010	December 2011
AL	Arab	NA	NA	NA	NA	IBC 2006
	Birmingham	IBC 2003	IBC 2003	IBC 2003	IBC 2009	IBC 2009
	Fultondale (Jefferson County)	IBC 2003	IBC 2003	IBC 2003	IBC 2003	IBC 2009
	Huntsville	NA	IBC 2003	IBC 2003	IBC 2003	IBC 2003
	Tuscaloosa	NA	NA	NA	NA	IBC 2009
GA	Ringgold	NA	NA	NA	NA	IBC 2006
MS	Smithville	NA	NA	NA	NA	IBC 2006
MO	Joplin	IBC 2000	IBC 2006	IBC 2006	IBC 2006	IBC 2006
TN	Cleveland	NA	NA	NA	NA	IBC 2006
	Hamilton County	IBC 2003	IBC 2003	IBC 2003	IBC 2003	IBC 2003

SOURCES: ARAB BUILDING DEPARTMENT 2012; CITY OF BIRMINGHAM, AL; CITY OF CLEVELAND, TN; CITY OF HUNTSVILLE, AL; CITY OF JOPLIN, MO; CITY OF TUSCALOOSA, AL; HAMILTON COUNTY, TN; ICC; JEFFERSON COUNTY, AL, 2011; RINGGOLD, GA; SMITHVILLE, MS  
 NA = data not available

Table 3-3: Historical Codes for Residential Buildings

State	Community	Residential				
		December 2007	December 2008	December 2009	December 2010	December 2011
AL	Arab	NA	NA	NA	NA	IRC 2006
	Birmingham	IRC 2003	IRC 2003	IRC 2003	IRC 2009	IRC 2009
	Fultondale (Jefferson County)	IRC 2003	IRC 2003	IRC 2003	IRC 2003	IBC 2009
	Huntsville	NA	IRC 2003	IRC 2003	IRC 2003	IRC 2003
	Tuscaloosa	NA	NA	NA	NA	IRC 2006
GA	Ringgold	NA	NA	NA	NA	IRC 2006
MS	Smithville	NA	NA	NA	NA	IRC 2006
MO	Joplin	IRC 2000	IRC 2006	IRC 2006	IRC 2006	IRC 2006
TN	Cleveland	NA	NA	NA	NA	IRC 2006
	Hamilton County	IRC 2003	IRC 2003	IRC 2003	IRC 2003	IRC 2003

SOURCES: ARAB BUILDING DEPARTMENT 2012; CITY OF BIRMINGHAM, AL; CITY OF CLEVELAND, TN; CITY OF HUNTSVILLE, AL; CITY OF JOPLIN, MO; CITY OF TUSCALOOSA, AL; HAMILTON COUNTY, TN; ICC; JEFFERSON COUNTY, AL 2011; RINGGOLD, GA; SMITHVILLE, MS  
 NA = data not available

### 3.3.3.1 Alabama



Alabama has not adopted a statewide building code for all residential and non-residential buildings.

The Alabama State Building Commission, which has jurisdiction over State-owned buildings, schools (public and private), hotels/motels, and theaters, adopted the 2009 IBC on September 1, 2010. The State made no amendments to the original 2009 IBC. Local amendments, however, are permitted.

The following codes were in effect for new construction for the sites visited at the time of the MAT investigation:

- +Arab, AL: 2000 SBC
- +Birmingham, AL: 2009 IBC, 2009 IRC
- +Fultondale, AL: 2009 IBC, 2009 IRC
- +Huntsville, AL: 2003 IBC, 2003 IRC
- +Tuscaloosa, AL: 2009 IBC, 2006 IRC

**Act 2010-746: Education Appropriations:** On April 30, 2010, Governor Riley signed House Bill 459, *Education Policy*, into law, thereby enacting Act 2010-746, which required any new contract awarded on or after July 1, 2010 for the construction of a new public school (grades kindergarten to twelfth) to include a Building Commission of Alabama-approved safe space or hallway. Pursuant to Act 2010-746, the Building Commission of Alabama adopted ICC 500 (2008) as the minimum building code for safe spaces. Safe spaces are required to comply with the building code requirements for tornado shelters. Compliance with the building code requirements for hurricane shelters is recommended, but not mandatory. Any renovations or additions to existing schools, or the addition of auxiliary buildings to an existing school, are not considered “a new public school” and are exempt.

**Act 2010-185: Alabama Energy and Residential Codes Board:** In 2010, Alabama adopted Act 2010-185, Residential Energy Board, which established the Alabama Energy and Residential Codes Board. The Board has the authority to establish an energy code for non-residential and residential construction; it also has the authority to establish a residential code for one- and two-family dwellings. Because of this authority to adopt such a residential code, the board can potentially affect high-wind load resistance for buildings in Alabama. For the residential building code, the Board has adopted the 2009 IRC with several amendments. This State code only applies to jurisdictions that newly adopt a code and those that have an existing code and intend to update it after the effective date of the State code. Additionally, there is no time limit for jurisdictions that currently implement codes to update to the new State code. However, when a jurisdiction does decide to update its code, it must, at a minimum, comply with the State code. Jurisdictions may amend the State code once they have adopted it to incorporate more stringent requirements.

### 3.3.3.2 Georgia



Georgia has adopted a statewide building code for all residential and non-residential buildings.

The State of Georgia has a statewide code for all residential and non-residential buildings. The Official Code of Georgia Annotated §8-2-20(9) (B) identifies 10 State minimum standard codes, which the Board of Community Affairs has adopted. The State codes consist of a base code and a set of amendments specific to Georgia. Eight of the 10 State minimum

standard codes are mandatory throughout Georgia. For residential construction, the base code currently in effect is the 2006 IRC with 2007, 2008, 2009, 2010, and 2011 State amendments. For non-residential construction, the base code is the 2006 IBC with 2007, 2009, and 2010 State amendments. The adopted IRC and IBC with the State amendments are 2 of the 10 “minimum standard codes.” For the areas the MAT visited, specifically Ringgold, GA, these codes are adopted for new construction.

### 3.3.3.3 Mississippi



Mississippi has not adopted a statewide building code for all residential and non-residential buildings.

Mississippi has not adopted a statewide building code, although it requires State buildings to meet the requirements set forth in the 1997 SBC, which is mandatory for all jurisdictions. Building code adoption and enforcement is primarily the responsibility of local jurisdictions.

In 2006, Bill 31-11-33 created the Mississippi Building Code Council. The Mississippi Building Code Council requires that five coastal counties—Jackson, Harrison, Hancock, Stone, and Pearl River—enforce, on an emergency basis after a disaster event, all of the wind and flood mitigation requirements prescribed by the 2003 IBC and 2003 IRC. None of these counties were affected by the storms described in this report.

After the April 25–28 tornado events, the Town of Smithville, MS, adopted the 2006 IBC and 2006 IRC at their May 24, 2011 meeting. To enforce the codes, the town contracted professional services to conduct building inspections. The 2006 IRC applies to residences that either are being totally rebuilt or have minor repairs being made following the storm damage. Non-residential structures have to comply with the 2006 IBC.

### 3.3.3.4 Tennessee



Tennessee has adopted a statewide building code for all residential and non-residential buildings.

Of the affected areas the MAT visited in Tennessee, only the City of Cleveland in Bradley County and Hamilton County (including the City of Chattanooga as an incorporated city within this county) have local building codes per the State’s definition. Cleveland has adopted the 2006 IBC and

2006 IRC, each with local amendments. Hamilton County (including the City of Chattanooga) has adopted the 2003 IBC and 2003 IRC. The rest of the affected areas did not have a locally adopted building code and would fall under the 2009 IRC statewide requirement for new residential construction and residential construction undergoing a change of use.

Tennessee adopted the 2006 IBC as a statewide code in 2008, but excluded Chapter 11 (Accessibility and Electrical Components) and Chapter 27 (Equipment and Systems). On October 1, 2010, the State adopted the 2009 IRC with several amendments. The 2009 IRC applies to new construction and residential buildings for which the use is going to change. Cities and counties are allowed to opt out of the residential building code requirements via passage of a resolution to exempt the city or county by a two-thirds vote. Additionally, if a region of the State already has a residential building code enforcement program in place that is current within 7 years of the latest edition, they can file to become an exempt jurisdiction and are permitted to continue to operate under their current building codes. Currently, most highly populated areas in Tennessee fall under this category and are therefore exempt from enforcing the 2009 IRC. Local jurisdictions reserve the right to amend the code, if adopted.

The metropolitan area of the City of Nashville and Davidson County adopted both the 2006 IBC and the 2006 IRC with local amendments. Since they have a residential building code in place with their enforcement of the 2006 IRC and local amendments, they did not fall under the requirement to enforce the 2009 IRC as of October 1, 2010.

Tennessee has not adopted a standard regarding safe rooms.

### 3.3.3.5 Missouri



Missouri has not adopted a statewide building code for all residential and non-residential buildings.

Like Mississippi, building codes in Missouri are adopted and enforced at the local level, though the 2000 IBC and 2000 IRC are effective statewide for State buildings. The State of Missouri Division of Facilities Management, Design and Construction have published a *Designer Information Packet* (2007)<sup>2</sup> for State buildings.

As a note, the City of St. Joseph, MO, passed an ordinance prior to the tornadoes requiring manufactured home communities to provide storm shelters for their residents. All storm shelters in the city are required to meet Americans with Disabilities Act requirements and the design criteria set forth by the current version of FEMA 361 (2008a).

The City of Joplin has actively adopted building codes since 1961. Joplin adopted the 2006 IBC and IRC in 2008. After the May 22, 2011 tornado event, the Public Works Department passed an ordinance requiring measures beyond code requirements to ensure safety in high-wind events. The new ordinance changes the required spacing of foundation anchor bolts from 6 feet on-center to 4 feet on-center; the bolts must also line up with the rebar required in concrete block cells. The

<sup>2</sup> Available online at the Missouri Office of Administration Web site, [http://oa.mo.gov/fmdc/dc/fmdc\\_dip/index.htm](http://oa.mo.gov/fmdc/dc/fmdc_dip/index.htm)

new ordinance also requires additional hurricane fasteners on every rafter end and on trusses; where fastening had been required by previous code on every other truss every 4 feet, the code was amended to include fastening on every truss member.



# TORNADO OUTBREAK *of* **2011**

IN ALABAMA, GEORGIA, MISSISSIPPI,  
TENNESSEE, AND MISSOURI

## 4 Observations on Residential Building Performance

*The MAT observed residential building performance across the area impacted by the April 25–28, 2011 tornado outbreak and the May 22, 2011 Joplin, MO, tornado.*

According to data assembled by NOAA’s NWS SPC, of all reported tornadoes in the United States between 1950 and 2006, nearly 95 percent have been rated as the equivalent of EF2 or less (up to 135 mph for 3-second gust) (FEMA 2008a). While the April 25–28, 2011 tornado outbreak and May 22, 2011 Joplin tornado were extraordinary in scale and number of lives lost, the majority of residential damages observed, described, and documented by the MAT was determined to have resulted from wind speeds estimated to be 135 mph or less based on the EF scale damage ranking indicators. Winds of this magnitude generate substantial forces that can result in significant damage, but could be mitigated through enhanced wind-resistant construction procedures.

While past MATs have focused primarily on building performance, this MAT was also tasked with gathering damage information needed to determine tornado ratings using the EF scale when possible (refer to Appendix E for more detail). Not all observed one- and two-family residences

were rated by the MAT. In some cases, ratings were not assessed due to limited accessibility that prevented thorough observations. The NSF-funded *Damage Study and Future Direction for Structural Design Following the Tuscaloosa Tornado of 2011* includes EF scale contour maps developed from extensive post-event DOD data collection and subsequent EF ratings (Prevatt et al. 2011b).

The EF scale assigns each damage indicator (DI) with specific damage description categories called degrees of damage (DOD) to estimate tornado wind speeds. Refer to Section 2.2 and Appendix E for additional information.

Photographs in this chapter that were taken from sites that were rated include the assigned DOD and EF rating. It is important to note, however, that engineering judgment was exercised when assigning the wind speeds that range between a specified lower and upper bound. In some cases, the observed DODs were considered to be inflated by poor construction practices or failure to adhere to the model building codes. Accordingly, wind speeds selected in such cases fall into the lower bound prescribed by the EF scale and may result in a lower EF rating by the MAT. Furthermore, images of a particular DOD may not always be the highest DOD observed at a particular site. In some cases, a photograph of a lower DOD is included in this report to better illustrate a specific failure mode. Figure captions will indicate when an EF rating provided for an image is inconsistent with the illustrated DOD.

This chapter is divided into two parts. The first describes observed damage to one- and two-family residences organized by the type of damage defined in eight DOD categories (2 through 9). The second describes damage to two multi-family residential complexes presented as detailed case studies.

## 4.1 One- and Two-Family Residences

The main purpose of presenting one- and two-family residential damage observations in the order of EF scale and DODs is to illustrate the order of progressive failures and the need to maintain continuous load path connections to mitigate high-wind damage. More specifically, DOD observations advance our understanding of the relationship between wind speeds and damages, and how certain damages may be greatly reduced or avoided altogether through enhanced design practices. The following section briefly describes the EF scale-prescribed damage for residential buildings and progressive damage observed by the MAT, and is followed by detailed descriptions of observed damage of residential buildings grouped by the following eight DODs.

- +Loss of roof covering and siding (DOD 2)
- +Glazing damage (DOD 3)
- +Uplift of roof decks (DOD 4)
- +Gable end walls: vulnerability related to uplift of roof deck (DOD 4)
- +Garage doors collapse inward (DOD 4)
- +House shifts off foundations (DOD 5)



■+Roof structure removed (DOD 6)

■+Collapse of framed walls (DOD 7–9)

Trigger mechanisms or vulnerable features that appeared to initiate the observed failure mode are described when applicable. Likewise, observed damage that is not explicitly listed as a DOD is included with the category most closely related to that failure mode.

#### 4.1.1 EF Rating Evaluation of Residential Buildings

The MAT’s investigation of residential buildings and subsequent wind-speed determinations use the prescribed EF scale for “One- and Two-Family Residences between 1,000 and 5,000 square feet with typical wood framed construction” as outlined in *A Recommendation for an Enhanced Fujita Scale* (TTU 2006). One- and two-family residential structures are designated as DI 2 in the EF scale system and are accompanied by a specific list of DODs with which wind speeds can be estimated through observed damage. Based on a progression of damage from minimal visible damage to complete destruction, observed DODs specific to one- and two-family residences are shown in Table 4-1. A second DOD table for DI 5, which illustrates the progression of multi-family residential damages, is provided in Section 4.2.1.

Table 4-1: Degrees of Damage for One- and Two-Family Residences

DOD	Damage Description	Lower- and Upper-Bound Wind Speed Range (3-second gust in mph)	Expected Wind Speed (3-second gust in mph)
1	Threshold of visible damage	53–80	65
2	Loss of roof covering material (<20%), gutters, and/or awning; loss of vinyl or metal siding	63–97	79
3	Broken glass in doors and windows	79–114	96
4	Uplift of roof deck and loss of significant roof covering material (>20%); collapse of chimney; garage doors collapse inward; failure of porch or carport	81–116	97
5	Entire house shifts off foundation	103–141	121
6	Large sections of roof structure removed; most walls remain standing	104–142	122
7	Exterior walls collapsed	113–153	132
8	Most walls collapsed except small interior rooms	127–178	152
9	All walls collapsed	142–198	170
10	Destruction of engineered and/or well-constructed residence; slab swept clean	165–220	200

SOURCE: TTU 2006

**Definitions:**

DOD = degree of damage                      mph = miles per hour

## 4.1.2 Description of Progressive Damage for One- and Two-Family Residential Buildings

The first group of damages addressed—loss of roof covering and exterior siding, or DOD 2—typically precedes other phases. While nonstructural, damage to these elements can allow water intrusion which may weaken other systems and damage building contents. Damaged roof and wall covering elements may also become wind-borne debris that can cause building damage (Figure 4-1), injuries, and death.

**Figure 4-1:**  
Wind-borne asphalt shingle penetrated the gypsum board on both sides of this interior wall at Chastain Manor Apartment Complex (Tuscaloosa, AL)



The second group of damages addressed—glazing damage and garage doors collapse inward, or DODs 3 and 4—often accelerate the disintegration of the structure through wind pressurization of the interior. Whether the result of wind-borne debris shattering glazing or wind pressure causing garage doors to collapse, a breach in the building envelope subjects it to increased pressurization and allows the intrusion of wind-driven rain. Other common building envelope vulnerabilities include, but are not limited to, soffits, doors, and gable end walls.

The third group of damages addressed—uplift to roof decks, included with DOD 4—begins with the uplift of roof decking and may coincide with, but frequently follows, breaching of the attic level building envelope. The loss of roof decking weakens the roof structure's ability to resist in-plane shear forces, and often results in the failure of the roof structure (DOD 6). Further contributing to the loss of the roof structure are failed roof-to-wall connections. When the roof structure is removed, lateral support (bracing) for the walls is lost. Collapse of exterior and interior walls constitute the later stages of overall structural failure (DOD 7–9), which typically progresses from the top down due to the loss of lateral support after the roof structure fails. This near-final phase of destruction is facilitated by the breakdown of connections between floors and walls, or by under-braced exterior walls that cannot resist in-plane shear forces.

### 4.1.3 Loss of Roof Covering and Exterior Siding (DOD 2)

The MAT observed widespread loss of roof covering and siding; this was evident on both lightly damaged residential buildings and those with more advanced stages of wind-induced damage. Nearly all observed roof coverings were asphalt shingles (Figure 4-2). Figures 4-3 and 4-4 illustrate exterior walls with sections of vinyl siding peeled off by high winds.



Figure 4-2:  
Example of DOD 2 (loss  
of asphalt shingles)  
(Tuscaloosa, AL; photograph  
courtesy of Tuscaloosa  
County EMA)  
[MAT EF Rating = 0]



Figure 4-3:  
Example of DOD 2 (loss of  
siding) (Tuscaloosa, AL;  
photograph courtesy of  
Tuscaloosa County EMA)  
[MAT EF Rating = 0]

Figure 4-4:  
Example of DOD 2 (loss of siding) through DOD 6 (large sections of roof structure removed) (Joplin, MO)  
[MAT EF Rating = 2]



#### 4.1.4 Glazing Damage (DOD 3)

The MAT frequently observed damage to window and door glazing in residential buildings. Most glazing types are extremely vulnerable to the wind-borne debris prevalent in tornadoes. Once the glazing is compromised, the building envelope is breached. This leads to increased pressurization of the interior, which increases stresses in structural components and connections between components that can, in some cases, initiate a chain reaction of structural failures in the building. Figure 4-5 illustrates the increased forces from pressurization on a partially enclosed building with a breached building envelope as compared to the enclosed building.

Figure 4-5:  
Effect of wind on an enclosed building and a partially enclosed building

SOURCE: FEMA P-55, 2011

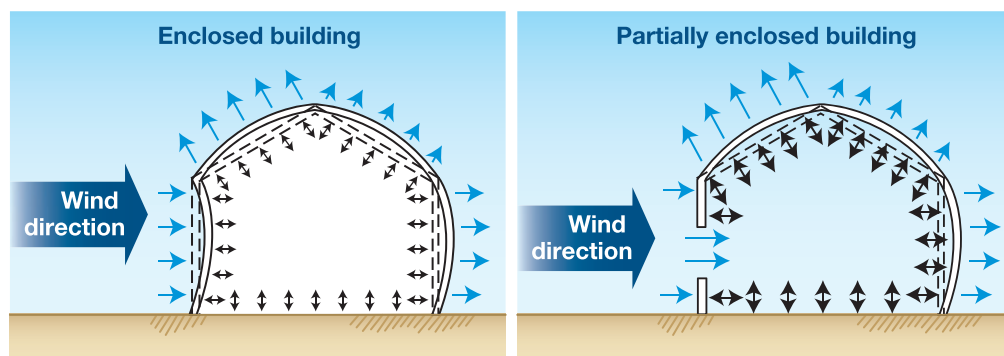

The MAT observed some buildings that benefitted from the installation of insulated glazing units (i.e., double-paned windows), where the outer pane was sacrificed but the inner pane remained intact, as illustrated in Figure 4-6. Energy code changes that require increased efficiency are leading to more double- and triple-paned glazing units in new residential construction. However, most windows of this type were not designed to provide extra protection from wind-borne debris and were breached on impact, as shown in Figure 4-7.



**Figure 4-6:**  
Double-glazed window with outer pane sacrificed (remaining fragments are circled in red), leaving the inner glazing intact (Mercy Village, Joplin, MO); refer also to Section 4.2.3 for a case study of Mercy Village

Figure 4-7:  
Example of DOD 3 showing  
window with shattered  
double-glazing (Harvest, AL)  
[MAT EF Rating = 2]<sup>1</sup>



#### 4.1.5 Garage Doors Collapse Inward (DOD 4)

The MAT observed many failed overhead garage doors. Garage doors, particularly older double garage doors, are especially vulnerable to the effects of wind pressure. Older garage doors were not manufactured and rated to resist high winds. Wind pressure rated garage doors are now available, and may be code compliant while not meeting the wind pressure demands of some tornadoes.

Positive wind pressure against the doors can lead to inward deflection as shown in Figure 4-8. Garage doors can also fail under negative wind loads. In Figure 4-8 the wider double door (16 feet or 18 feet wide) incurs a greater resultant force under the same wind pressure than the adjacent single door (8 feet or 9 feet wide) because of its larger area. Therefore, the threshold for failure of the larger, similarly constructed double garage door is lower than that of the smaller single door. In addition to the actual garage door failing, the lifting and track hardware is vulnerable to failure under wind pressures too.

Residential buildings whose garage doors collapse often exhibit progressive collapse in and above the garage that exceeds the damage elsewhere because of increased pressurization when the garage door fails. Figures 4-9 and 4-10 illustrate this effect; note the extensive damage above the garage in both homes—the ceiling and roof assembly are completely blown off—compared to the opposite side of the buildings, where some of the ceiling and roof remain intact.

<sup>1</sup> More extensive building damage not apparent in this image resulted in a higher site DOD and EF scale rating.



Figure 4-8:  
Example of DOD 4 showing a wide garage door collapsed inward, while narrow garage door to left is intact. Note also the wind-borne missile in roof above (Joplin, MO). [MAT EF Rating = 2]<sup>2</sup>



Figure 4-9:  
Example of damage including loss of large sections of roof (DOD 6) apparently initiated from garage door failure (DOD 4) (Joplin, MO) [MAT EF Rating = 2]



Figure 4-10:  
Example of how garage door failure (DOD 4) initiated progressive failure, including loss of the garage roof (DOD 6) (Joplin, MO) [MAT EF Rating = 2]

<sup>2</sup> More extensive building damage not apparent in this image resulted in a higher site DOD and EF scale rating.

### 4.1.6 Uplift of Roof Decks (DOD 4)

Many roof decks were observed to have separated from rafters or roof trusses. Most often, roof decking was in the form of 4-foot x 8-foot x ½-inch (nominal) OSB sheathing panels. In some older construction, nominal 1-inch x 8-inch planks were observed to comprise the roof deck.

When isolated areas of the roof were observed to be missing decks, as shown in Figure 4-11, the missing portions were often at corners, along roof overhangs, and along hips and/or ridges (Zones 2 and 3 as shown in Figure 4-12), where uplift pressures are greatest. Figure 4-13 shows a home where the roof decking separated above the eaves in an area where vinyl soffit material has been blown away, leading to increased pressures on adjacent roof decking. Nails between the decking and rafter or truss failed to resist uplift forces and allowed the decking to be pulled away from the structural framing. Roof decking above wide overhangs is particularly vulnerable to wind damage, as illustrated in Figure 4-14.

**Figure 4-11:**  
Example of DOD 4 showing roof decking blown off along eaves and hip (Zone 2 in Figure 4-12), where uplift pressures are greater than in the field of the roof (Joplin, MO) [MAT EF Rating = 2]<sup>3</sup>



<sup>3</sup> More extensive building damage not apparent in this image resulted in a higher site DOD and EF scale rating.



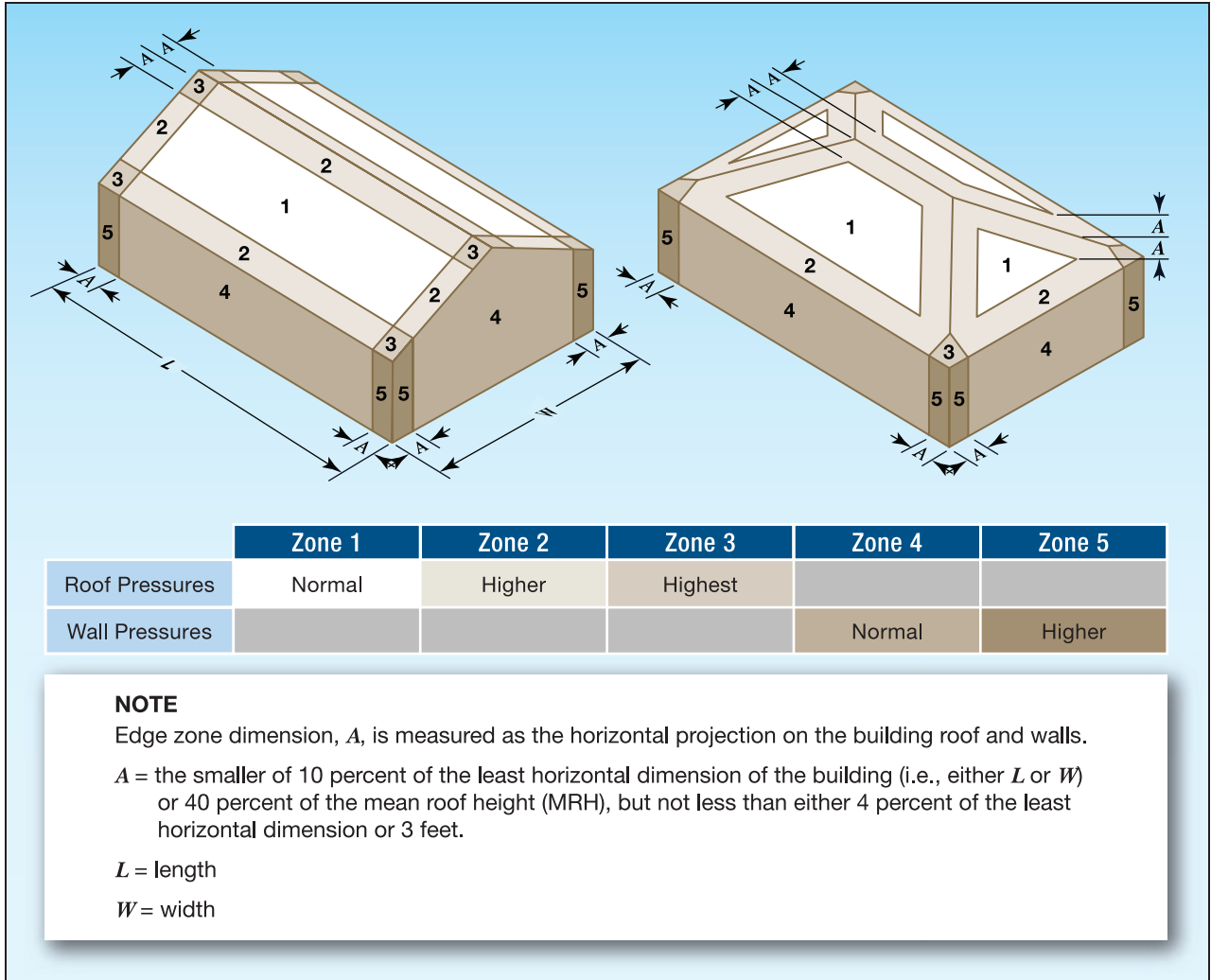

Figure 4-12: Component and cladding wind pressures

SOURCE: FIGURE 8-20 OF FEMA P-55 (2011A)

Figure 4-13:  
Example of DOD 4 showing where roof decking lifted and blew off above damaged soffit in roof Zone 2 (see Figure 4-12) (Birmingham, AL) [MAT EF Rating = 2]<sup>4</sup>



Figure 4-14:  
Example of DOD 4 showing roof decking removed at wide eaves on hip roof (Phil Campbell, AL) [MAT EF Rating = 1]



Poor construction methods can also decrease resistance to wind uplift. Figure 4-15 shows a residence where at least one of the roof deck nails along the panel edges failed to penetrate the rafter below. The expected performance is subsequently rendered weaker than intended by the building code or design professional. Improper spacing of fasteners and the use of improperly sized fasteners result in the same effect.

<sup>4</sup> More extensive building damage not apparent in this image resulted in a higher site DOD and EF scale rating.



Figure 4-15:  
Red circled roof deck nail not  
connected to rafter (edge  
shown with red dashed line)  
(Harvest, AL)

#### 4.1.7 Gable End Walls: Vulnerability Related to Uplift of Roof Deck (DOD 4)

The MAT observed gable end wall failure on many residential buildings with roof deck loss. While not specifically included in the DODs for One- and Two-Family Residences (Table 4-1), this failure mode compromises the building envelope. Once the attic level envelope is breached, increased pressurization can initiate or accelerate roof deck separation. Gable end walls that lack adequate bracing are susceptible to failure from wind pressures. In Figure 4-16, the roof area adjacent to the failed gable end wall lost more roof decking than the rest of the roof.

Figure 4-16:  
Example of DOD 4 showing  
damage to gable end of  
simple gable roof  
(Harvest, AL)  
[MAT EF Rating = 1]



#### 4.1.8 Entire House Shifts Off Foundation (DOD 5)

The MAT observed few instances of entire houses shifting off of their foundations. Framing-to-foundation connection failure was most often observed to follow wall collapse (DOD 7 through 9) and accordingly, those observations are included in Section 4.1.11. The older house depicted in Figure 4-17 was observed to have shifted off the raised pier and beam foundation. This house had no continuous exterior foundation walls, which provide more area for bottom plate anchorage than isolated piers. Further contributing to the observed failure of the bottom plate-to-foundation anchorage was the lack of bracing or connectivity between the top of the exterior piers.

Figure 4-17:  
Example of DOD 5 showing  
residential building shifted  
off masonry piers  
(Cullman, AL)  
[MAT EF Rating = 2]



### 4.1.9 Roof Structure Removed (DOD 6)

When roof decking resists uplift pressure and transfers those forces through fasteners to rafters or trusses, that load must be transferred from the rafter or truss to the framed wall below and from there to the foundation in a continuous load path. Failure to transfer uplift through roof-to-wall connectors results in the loss of the roof structure, as shown in Figure 4-18.

The “birds-mouth” notched rafters spanning from hip to wall in Figure 4-19 separated from the plate and outlookers, and shifted toward the building corner. They were framed onto a single plate across the top of the joists below, a configuration that, while common, is not prescribed in the 2009 IRC, and requires special attention in the application of roof-to-wall connectors and roof-to-ceiling tie-backs. The rafter shown in Figure 4-20 was found nearby and observed to have two small toe nails withdrawn from the plate. Even with proper nailing, the rafter shown in Figure 4-20 would likely have become the next weak link at this location by failing under stress because of improper or non-code-compliant notching. Cutting and notching limitations for sawn lumber rafters are found in Section R802.1.7 of the 2009 and 2012 IRC.



**Figure 4-18:**  
Example of DOD 6 showing failed roof-to-wall connections that resulted in loss of roof structure (Harvest, AL)  
[MAT EF Rating = 2]



**Figure 4-19:**  
Example of roof-to-wall connection failure facilitated by non-code-compliant construction: notched rafters, known as “bird’s mouth,” (red circle) displaced when roof-to-wall connections failed; red arrow indicates rafter bearing plate, yellow arrow indicates outlooker (Harvest, AL)  
[MAT EF Rating = 1]

**Figure 4-20:**  
Over-notched rafter found on ground with two toe nails withdrawn from plate (red circle) (Harvest, AL)  
[MAT EF Rating = 1]



Metal connectors designed to transfer uplift forces from the rafter or truss to the wall below greatly enhance connectivity and were observed to outperform toe nail-only connections. In order to transfer uplift and lateral loads consistent with their maximum design capacities, metal connectors must be installed per the manufacturer's instructions.

Applications of metal connectors not in accordance with manufacturers' installation instructions, including insufficient nailing and using the wrong nail size, can lead to the connection not performing to design capacity. For example, a 6d box nail as shown in Figure 4-21 has a withdrawal capacity of 96 pounds when face-nailed into a Southern Yellow Pine #2 double 2x4 top plate, as compared with 217 pounds for a 10d common nail.

Spacing of roof-to-wall connectors is also critical to the performance of roof-to-wall connections. The house shown in Figure 4-22 had a roof-to-wall connector on the indicated roof truss, but not on the adjacent one. While it used to be typical for designers to specify rafter-to-wall connectors at every other or every third rafter to meet the design requirements of basic design wind speeds, the greater loads exerted during tornadoes can render this minimal design-level connector schedule ineffective, even with correctly installed hardware.



Figure 4-21:  
Example of DOD 6 showing trusses were connected to walls with small hurricane ties. Red circle indicates area of inset photograph. Inset shows gauge indicating undersized 6d box nail remaining in roof-to-wall connector; the yellow circle indicates the appropriate nail size of 8d. (Phil Campbell, AL). [MAT EF Rating = 2]



Figure 4-22:  
Example of DOD 6 showing insufficient connection of single roof-to-wall connector on remaining chord of roof truss at left (red circle) and none on truss at right (Tuscaloosa, AL) [MAT EF Rating = 2]

### 4.1.10 Collapse of Framed Walls (DOD 6–9)

When roof and ceiling or roof truss-to-wall connections fail and leave the top of the framed wall unsupported, walls become especially vulnerable to collapse. Therefore, the roof/ceiling or floor connection to the top and bottom of the framed wall is critical to maintain stability and prevent wall collapse. Figure 4-23 shows a home where the roof system was blown off, removing the lateral support for the top of the wall and allowing it to be blown in.

Figure 4-23:  
Example of DOD 6 showing failure of roof framing that resulted in loss of lateral support for the top of this wall (red arrow) (Phil Campbell, AL)  
[MAT EF Rating = 2]



The floor system above the garage shown in Figure 4-24 separated from the framed exterior walls, allowing both the floor and walls to collapse. As shown in the inset to Figure 4-24, the double top plate of the garage entry wall was pulled away either with the fallen floor system or collapsed portion of the garage entry wall. The deeper floor system above the garage, which was installed to span the garage without intermediate support, appeared to be framed onto a lower top plate that interrupted the continuity of the top plate and weakened the connection to the adjacent walls.

Walls with inadequate bracing were observed to be especially vulnerable to collapse under in-plane shear forces. Garage entry walls, like that shown in Figure 4-25, often have a small percentage of full-height sheathed lengths with respect to the overall wall length and often collapse before other exterior walls collapse. Any exterior wall that lacks code-compliant (2009 and 2012 IBC R602.10) lengths of full height solid sheathed (or alternatively braced) sections is susceptible to failure from in-plane shear.

**Continuous load paths** can be improved by extending the continuous wood panel wall sheathing across the floor system and bottom plate and/or by using metal straps to connect the wall to floor and floor to sill. At the second floor band, extend wall sheathing from upper and lower walls to meet at the band midpoint. Proprietary wall hold-down hardware (described in Appendix G, Section G3.3) is another effective attachment option.





Figure 4-24: Example of DOD 6 showing pressurization of this garage from failure of the garage door/wall removed the support for the second story floor system (red circle). Inset shows where top plate of garage entry wall separated with floor or wall (red circles). Note former location of entry wall top plate—separated and missing from top of studs—is lower than the interior wall top plate due to deeper floor system (Harvest, AL). [MAT EF Rating = 2]



Figure 4-25: Example of DOD 6 where most walls remained standing, but under-braced garage entry wall failed (Joplin, MO) [MAT EF Rating = 2]

Under-braced framed wall collapse was not exclusive to walls with overhead garage doors, however. The MAT also observed openings in framed walls that had large windows or entry doors. Figure 4-26 shows what appears to have been a sunroom. In this instance, wall collapse may have been further enabled by a weak connection between the wall, raised floor system, and bottom plate. Often the bottom plate of the wall is merely nailed to the raised floor system.

**Figure 4-26:**  
Example of DOD 6 showing under-braced framed sunroom wall failure. Note long window bottom on right (red arrow) and the failure of nailed wall-to-floor connection on left wall (yellow arrow) (Harvest, AL). [MAT EF Rating = 2]



#### 4.1.11 Wall Framing-to-Foundation Connection Failure: Damage Related to Collapse of Framed Walls (DOD 7–9)

As noted in Section 4.1.8, the MAT observed that failures of framing-to-foundation connections often followed wall collapse. Examples of failed connections included bottom plates of framed walls attached directly to stem walls and slabs. Failure of foundation anchorage was observed along the exterior stem walls of garage slabs in newer houses where walls were framed atop CMU, as shown in Figures 4-27 and 4-28. The homes shown in Figures 4-27 and 4-28 are located in the same community. Figure 4-27 shows the top of the garage stem wall with the wall bottom plate missing. In Figure 4-28, the bottom plate of the wall remained connected to the top row of CMUs, but the top row of CMU separated from the foundation wall below because there was no reinforcement or other tension connection within the CMU wall. Furthermore, the MAT observed the absence of grout in the cells of the damaged CMU walls in both of these homes, including locations where anchor bolts should have been installed.



Figure 4-27:  
Example of wall framing-  
to-foundation connection  
failure. Wall and bottom  
plate separated from  
foundation where anchorage  
of collapsed framed wall  
failed because anchors  
lacked embedment in grout.  
Note CMU wall with no  
reinforcement or solid grout  
(Harvest, AL).  
[MAT EF Rating = 2]



Figure 4-28:  
Example of wall framing-  
to-foundation connection  
failure. Bottom plate remains  
connected to top row of  
CMU, but CMU wall failed  
due to lack of reinforcement  
for continuous load path  
(Harvest, AL).  
[MAT EF Rating = 2]

Other bottom plate-to-slab foundation connection failures were observed where bottom plates were attached to the concrete slab foundation using only concrete nails (often called cut nails), as shown in Figures 4-29 and 4-30. The illustrated wall-to-slab failure is typical in that either the plate was separated from the slab by lifting around the nails (nails remained embedded), like in Figure 4-29, or the nails pulled out of the concrete with the plate leaving behind small cones of missing concrete, as shown in Figure 4-30. This damage was rated EF3 due to missing walls, but the damage may have occurred in part due to poor connections rather than solely to high winds.

Proper installation of **foundation anchorage** is critical for a foundation to perform as intended under design conditions.

Non-code-compliant foundation attachments were observed to fail prematurely when exposed to high winds.

Although the residence in Figures 4-29 and 4-30 appears to be older construction, the MAT observed recently constructed dwellings were also observed to have driven nails used to attach bottom plates to masonry or poured concrete foundations instead of IRC-required anchor bolts. Figure 4-31 shows a newly constructed residential building in Tuscaloosa, AL (completed December 2010) where the bottom plates in some areas had been secured with only concrete cut nails. Concrete nails provide significantly less resistance to uplift and lateral forces than similarly spaced ½-inch-diameter anchor bolts with 7 inches of minimum embedment.

Figure 4-29:  
Wall-to-foundation connection failure where concrete nails remained in stained concrete slab and bottom plate (missing) pulled over the heads of the nails (red circles) (Hackleburg, AL) [MAT EF Rating = 3]





Figure 4-30:  
Wall-to-foundation failure where bottom plate and concrete nails were pulled out by high winds. Shallowly embedded concrete nails pulled small cones of concrete up with bottom plate (red circles) (Hackleburg, AL).  
[MAT EF Rating = 3]



Figure 4-31:  
Wall-to-foundation connection failure. Note slab failure along right edge where the bottom plate separated and the nail was removed (red arrow). A remaining cut nail is indicated by the red circle. (Tuscaloosa, AL).  
[MAT EF Rating = 4]

## 4.2 Multi-Family Residences

The MAT visited only a few multi-family residences in the post-event investigations. The MAT observations at Chastain Manor in Tuscaloosa, AL, and at Mercy Village Apartments in Joplin, MO, are presented below as case studies in building performance of multi-family residential buildings. Some of the buildings at Chastain Manor were in the direct path of a powerful tornado—rated by the NWS as an EF4 in this vicinity—and suffered significant damage. While a direct hit from an EF4 tornado is rare, the observations from Chastain Manor illustrate the value of on-site safe rooms and storm shelters and comprehensive emergency operations planning, particularly for residential dwellings in tornado-prone regions. Conversely, Mercy Village did not take a direct hit and incurred fewer damages by comparison. Furthermore, the MAT observed that damage at Mercy Village seemed to be less severe than surrounding buildings and consequently reviewed the construction drawings after the site visit. The following sections discuss the MAT’s findings.

### 4.2.1 EF Rating Evaluation of Multi-Family Residential Buildings

Table 4-2 shows the DODs for multi-family residences (DI 5) and their respective wind speeds.

Table 4-2: Degrees of Damage for Multi-Family Residences

DOD	Damage Description	Lower- and Upper-Bound Wind Speed Range (3-second gust in mph)	Expected Wind Speed (3-second gust in mph)
1	Threshold of visible damage	63–95	76
2	Loss of roof covering (<20%)	82–121	99
3	Loss of roof decking; significant loss of roof covering (>20%)	107–146	124
4	Uplift or collapse of roof structure leaving most walls standing	120–158	138
5	Most top story walls collapsed	138–184	158
6	Almost total destruction of top two stories	155–205	180

SOURCE: TTU 2006

**Definitions:**

DOD = degree of damage                      mph = miles per hour

### 4.2.2 Chastain Manor Apartments (Tuscaloosa, AL)

**Location of Facility in Tornado Path:** The MAT observed Chastain Manor, a senior living community in northeastern Tuscaloosa, AL. Figure 4-32 shows an aerial view of Chastain Manor after the tornado. The NWS rated the center of the tornado circulation in the vicinity of the Chastain Manor buildings as an EF4. According to the property developer,<sup>5</sup> approximately 22 of the 25 leased units were occupied when the tornado struck; there were two reported fatalities. The apartment community had only opened in December 2010, and fewer than half of the available units were leased at the time of the tornado strike.

<sup>5</sup> TBG Residential, 3825 Paces Walk, SE, Suite 100, Atlanta, GA 30339

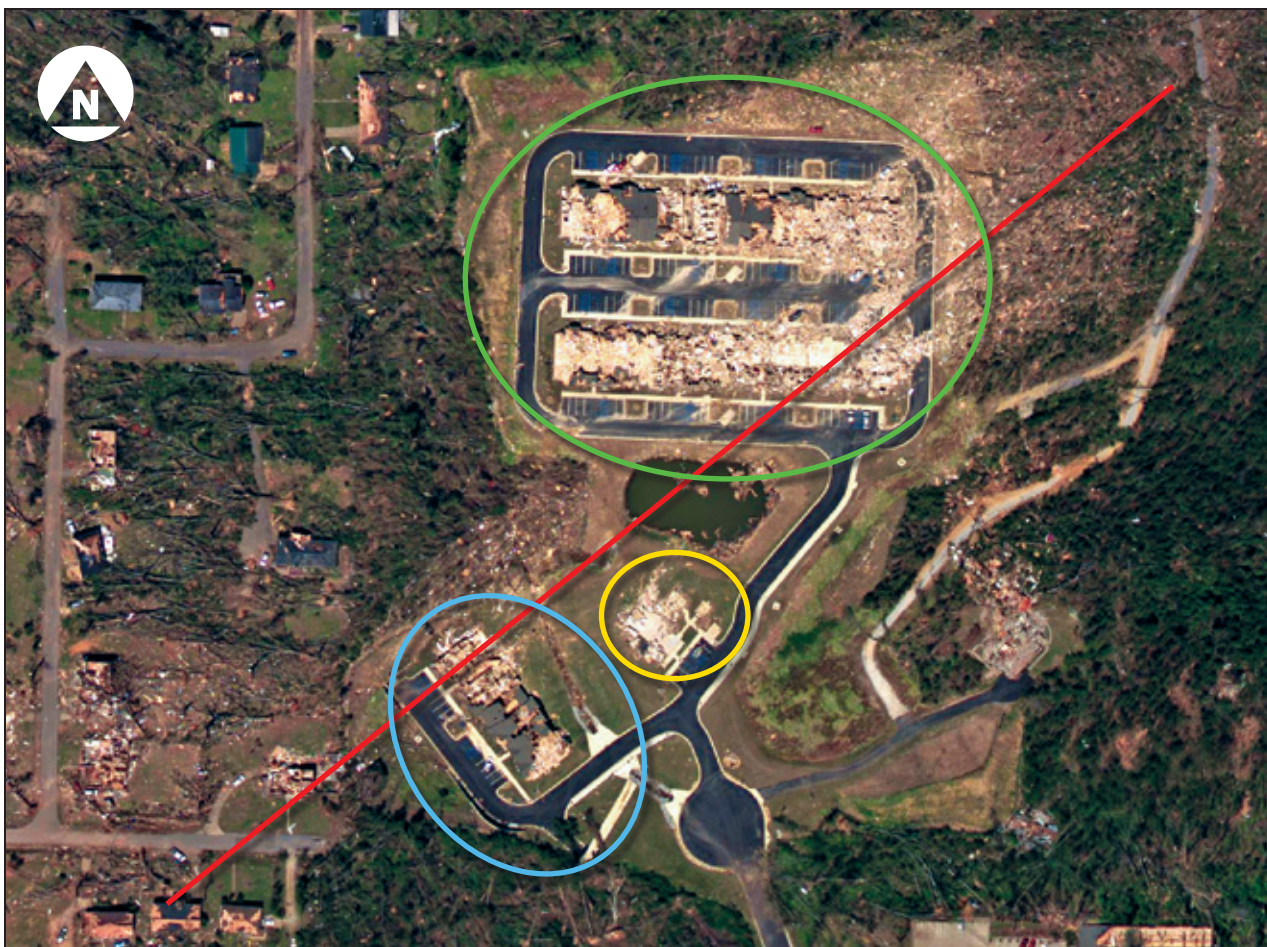

Figure 4-32: Aerial view of Chastain Manor Apartments in relationship to the approximate centerline of the tornado damage swath (red line).<sup>6</sup> The green circle indicates the two-story apartment buildings, the yellow circle shows the location of the leasing office, and the blue circle shows the location of a one-story apartment building (Tuscaloosa, AL). SOURCE: ALL AERIAL PHOTOGRAPHS ARE FROM NOAA IMAGERY ([HTTP://NGS.WOC.NOAA.GOV/STORMS](http://ngs.woc.noaa.gov/storms)) UNLESS OTHERWISE NOTED

**Facility Description:** Chastain Manor is a 56-unit senior apartment home community that opened in December 2010. Unlike Mercy Village, the MAT did not have access to construction drawings for Chastain Manor. The complex is divided into two sets of dwellings, including a set of one-story units and a set of two-story units. A small one-story leasing office foundation was situated between the two sets of dwellings.

The single row of connected one-story units was on the property's higher ground, with shared, open entranceways between units. Basic construction consisted of pre-engineered wood roof trusses that spanned from front to back. Main roof trusses were supported by girder trusses at each end in some areas and by exterior bearing walls in others. All roof trusses were attached with hurricane framing connectors where supported by framed walls. Single-story walls—mostly non-load-bearing because

<sup>6</sup> The red line in this and all similar figures represents the center of the damage swath. The track location is approximated by the MAT based on post-event aerial photographs. The actual centerline of the vortex is offset from the centerline of the damage.

of the girder trusses described above—were framed with 2x4 studs at 16 inches on center atop slab-on-grade foundations. Exterior walls were sheathed with 7/16-inch wood structural panels. The units had porch columns that the MAT observed lacked any positive connection to the slab below.

The two rows of two-story apartment buildings on the lower-lying terrain had shared, open entranceways and stairs between the units. Basic construction was similar to the one-story units with respect to roof framing and framed walls, but the foundations differed somewhat. Although the two-story building foundations were slab-on-grade (similar to the one-story building), some units were separated by masonry retaining walls necessitated by grade changes, so that slabs separated by the retaining wall were at different elevations. Exterior porches of the two-story units were constructed with suspended concrete slab floors in the upper units supported by steel beams on 4¼-inch (outside) diameter standard steel pipe columns. Each observed column (upper and lower) was originally attached to the concrete slab with four ½-inch-diameter expansion bolts through ½-inch-thick steel base plates. The embedment depth, while modest at approximately 2 inches, was more substantial than the one-story unit's porch columns.

**General Wind Damage:** The wind damage observed by the MAT varied significantly across Chastain Manor despite the similarity in the layout of the units (within each set of buildings), materials used, and construction method.

In the one-story units, observed damage ranged from uplift of roof decking (DOD 3) for a few connected units at one end of the building to uplift or collapse of roof structure with most walls standing (DOD 4) for the remainder of the building (Figure 4-33). Where they remained intact, the unanchored porch columns in the one-story units were rotated and/or out of plumb (Figure 4-34).

As indicated by the green circle in Figure 4-32, the units at the northeast end of the two-story apartment buildings were bisected by the center of the tornado and sustained the greatest damage. For the selected DI 5, observed damage to the two-story apartment buildings varied from uplift of roof decking (DOD 3) as shown on several units in Figure 4-35 to complete destruction (DOD 6) as shown by the slab swept clean (Figure 4-36). Despite the enhanced column connection in the two-story units (shown in Figure 4-35), some of the porches were destroyed by the tornado, and two columns were found embedded in the adjacent hillside (Figure 4-37).

**Figure 4-33:**  
One-story Chastain Manor Apartments suffered damage varying from roof decking uplift to collapse of roof structure







Figure 4-34:  
One-story Chastain Manor  
Apartment unanchored porch  
column that rotated at top  
and bottom of column (red  
circles)



Figure 4-35:  
Example of DODs 3 and 4  
showing two-story Chastain  
Manor Apartments with  
varying roof damage. Note  
upper and lower steel pipe  
porch columns (red circles).

**Figure 4-36:**  
Example of DOD 6 showing two-story Chastain Manor Apartments completely destroyed by the tornado with slabs swept clean



**Figure 4-37:**  
Two-story Chastain Manor Apartment steel porch column (shown in-place in Figure 4-34) was blown away and embedded in neighboring hillside



Bottom plates in the leasing office (Figure 4-38) and two-story apartment buildings (Figure 4-36) were removed from the thickened slab foundation in multiple locations. In some areas, the bottom plates were stripped away from the foundation, leaving the anchor bolts embedded in the foundation with washers still attached (Figure 4-39). The washers used between the anchor nut and plate were 1 inch in diameter. While the washer size for the bottom plate anchor is not specified in Section 2308.6 of the 2012 IBC, high-wind areas along the coast are required to use 3-inch-square washers, which significantly increase resistance to plate uplift.



Figure 4-38:  
Most of the bottom plates  
were blown off the Chastain  
Manor leasing office



Figure 4-39:  
Two-story Chastain Manor  
Apartment slab with bottom  
plate pulled over remaining  
anchor bolt and 1-inch  
diameter washer; red circles  
indicate where bolt and plate  
were connected prior to  
damage

**MAT EF Rating:** Using DI 5 (Apartments, Townhouses, and Condos), the MAT selected DOD 6 for the two-story units at Chastain Manor, which were the most damaged at the site. Applying the expected wind speed range for DOD 6 (155–205 mph), the MAT derived the tornado intensity as EF4 (166–199 mph) based on the observed building damage for the two-story units. Hence, the estimated wind speed experienced by the building greatly exceeded the basic design wind speed of 90 mph.

### 4.2.3 Mercy Village Apartments (Joplin, MO)

**Location of Facility in Tornado Path:** The MAT visited the Mercy Village Apartments located in Joplin, MO. Figure 4-40 shows an aerial view of the apartments prior to the tornado, and Figure 4-41 shows an aerial view of the apartments after the tornado. The Mercy Village Apartment building was approximately 1,100 feet from the center of the tornado damage swath, rated by the NWS as EF5 in this location. According to Mercy Housing, Inc. management,<sup>7</sup> approximately 60 out of the total 70 apartment residents were at home when the tornado passed by. There were no reported fatalities.

**Facility Description:** Mercy Village Apartments, a 66-unit retirement community on the campus of St. John's Regional Medical Center, is a three-story, wood-frame apartment building. The construction drawings were produced in 2003, so the apartment building is approximately 7 or 8 years old. The drawings indicate the building was engineered to the requirements of the 2000 IBC.

Figure 4-40:  
Aerial photograph showing  
Mercy Village (red circle)  
prior to tornado

SOURCE: © GOOGLE EARTH



<sup>7</sup> Jennifer Erixon, Mercy Housing Inc., 1999 Broadway, Suite 1000, Denver, CO 80202.



Figure 4-41:  
Aerial photograph of Mercy Village (red circle) after the tornado; red line indicates the approximate centerline of the tornado damage swath (Joplin, MO)

The layout of the building is “L” shaped with a central core on the northwest corner and wings extending in perpendicular directions. One wing is oriented north-south and the other east-west. The exterior of the building is a combination of brick veneer and fiber cement board siding. Basic construction consists of pre-engineered wood roof trusses at 24 inches on center that are attached to framed walls at each end with metal hurricane framing (roof-to-wall) connectors. The bottom chords of gable end trusses were observed to be braced at 48 inches on center. Braces extend 9 feet back from end walls and are attached to blocking between the trusses. As configured, the described bracing was designed to resist potential inward or outward deflection of the gable end truss bottom chords and served to protect the integrity of the roof envelope.

Elevated floors between units are framed with 18-inch-deep pre-engineered wood floor trusses spaced at 16 inches on center and spanning from exterior walls to the center corridors. Floor framing between corridors is 2x10 floor joists at 16 inches on center. Exterior walls were observed to be framed with 2x4 studs at 16 inches on center and sheathed with 7/16-inch wood structural panels. Interior walls are similarly framed, but sheathed with 5/8-inch thick gypsum board. Designated interior shear walls are reinforced and attached to adjoining structural elements with proprietary hold-down hardware and metal straps. One side of the transverse shear walls has a resilient channel against the stud for sound attenuation, which negated approximately half of the design-intended shear wall capacity. Exterior walls were observed to be attached to the foundation with anchor bolts.

**General Wind Damage:** The MAT observed wind damage to Mercy Village Apartments that included damage to siding and brick veneer, structural damage to stair towers and dormers, glazing damage, roof covering damage, and roof decking damage. Since most of the exterior envelope remained functional, the damage to the interior spaces was limited to areas where the exterior envelope was compromised. Units where glazing was destroyed suffered damage. The damage to the corridors was primarily from water infiltration. Figure 4-42 shows the locations of the damaged areas at the Mercy Village Apartments.

Figure 4-42:  
Aerial photograph of Mercy Village after tornado showing building areas identified in “General Wind Damage” (Joplin, MO)

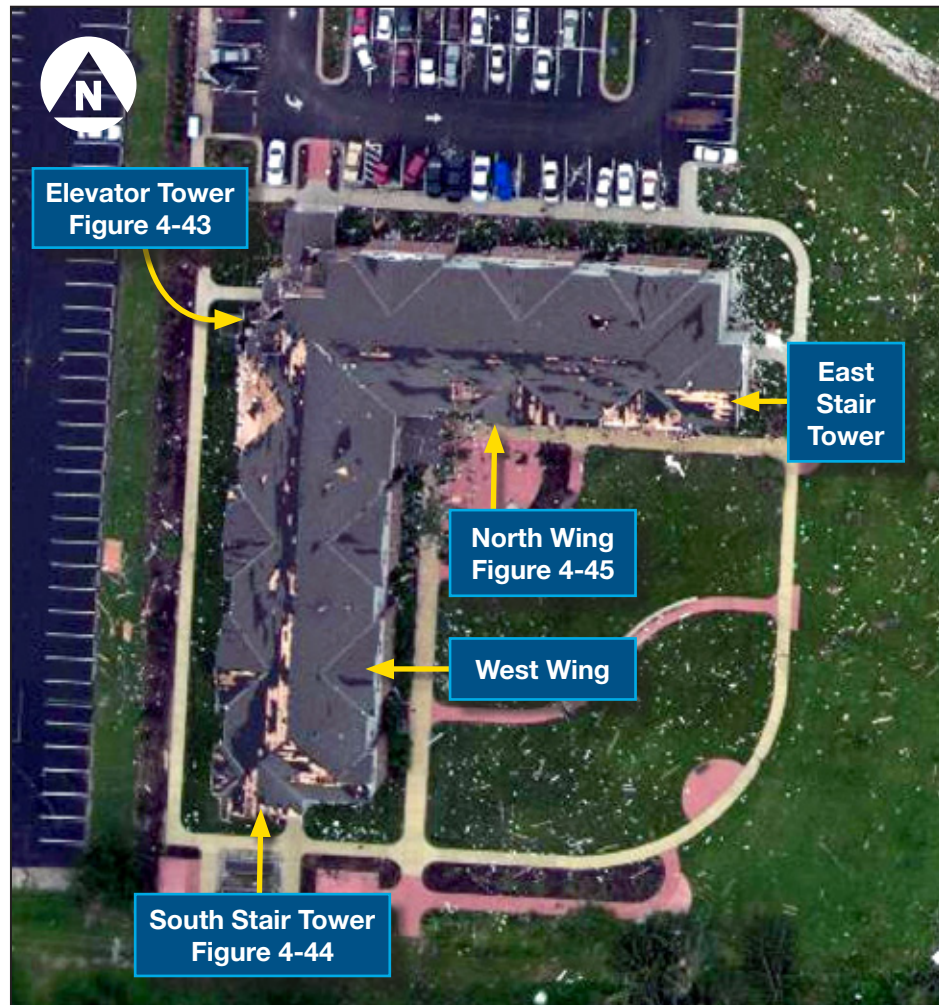

Sections of brick veneer fell off the elevator tower and caused damage to the single-story roof sections around the main entrance, maintenance room, and bathrooms, as shown in Figure 4-43. Aside from the elevator tower, damage to the brick veneer was minimal. The observed brick veneer damage was likely caused by debris impact and did not appear to indicate building movement relative to the foundation (or any significant movement of the building below the third floor). The brick veneer was attached with adjustable wall ties at 16 inches on center vertically and 32 inches on center horizontally as specified.

A section of wall between the third floor and roof was blown away at both stair towers (located at the each end of the building). Additionally, the gable end walls at both tower ends were either missing or suffered extensive damage, as shown in the south stair tower in Figure 4-44. A short section of wall that extended from the end of the stair tower back to the building was still present at each end, but was unsecured and no longer vertically plumb. The stair stringers and landings separated slightly from the perimeter wall above the second floor, and the end wall bowed outward at both stair towers. Similarly, the gable face of the easternmost dormer on the south wall of the east wing was missing. Much of the dormer roof decking was also blown off.



Figure 4-43:  
West wall and elevator tower where brick fell off and damaged one-story roof (red circle)



Figure 4-44:  
Damage to the gable end wall at south stair tower end. Note third floor wall is missing and second floor wall is bowed outward (red arrow).

The gable end wall of the east stair tower (not shown in Figure 4-44) was damaged, but remained intact, due in part to the truss bracing described in the previous section (Facilities Description). The truss braces on the east stair tower appeared to have held the building together long enough to prevent more extensive roof damage in that area.

Nearly all of the glazing on the north wing was damaged by wind-borne debris or wind pressure, as shown in Figure 4-45, and about half the windows on the west wing had damaged glazing. In many of the rooms where glazing was damaged on the third floor, especially on the north wing, the roof appeared to have lifted slightly off the walls and been set back down. The MAT did not observe any horizontal displacement. The MAT inferred the lifting movement from cracks observed between the interior walls and the ceiling.

Sections of roof decking were missing in various locations at the building, but the vast majority of the building's roof decking remained intact. There were some locations where 2x4 nail plates (a.k.a. "sleepers") were installed between the top chord of the trusses and the sheathing to address truss misalignment that occurred during construction. In these locations the nail plates had pulled away from the top chord of the trusses, as shown in Figure 4-46 and the inset, because of decreased nail penetration in the truss chord. Although the roof decking remained tight against the nail plates, there was inadequate nail capacity between the nail plates and truss top chords to resist the required tributary area uplift. Where the decking was directly attached to the trusses, it remained tight and secure.

**MAT EF Rating:** Using DI 5 (Apartments, Townhouses, and Condos), the MAT selected DOD 3 for this facility. Using the expected wind speed range for DOD 3 (107–146 mph), the MAT derived the tornado rating as EF2 (110–137 mph) based on damage to the building. Hence, the estimated wind speed experienced by the building was above the basic wind speed of 90 mph that the building was

**Figure 4-45:**  
Damaged glazing on the interior courtyard of north wing building; majority of glazing was damaged







Figure 4-46: Nails through roof sheathing and nail plates have separated from roof trusses (red circles) because of wind pressures. Inset shows close-up of 2-inch nail withdrawal where nail plates separated from the roof truss.

designed to withstand. The NWS rated the core of the track in the vicinity of Mercy Village as an EF5, which is above the MAT EF2 rating for this building. Mercy Village was approximately 1,100 feet away from the centerline of the tornado; accordingly, wind speed decay would result in a lower speed at the facility.

### 4.3 Summary of Conclusions and Recommendations

Table 4-3 provides a summary of the conclusions and recommendations for Chapter 4, *Observations on Residential Building Performance*, and provides section references for supporting observations. Additional commentary on the conclusions and recommendations is presented in Chapters 10 and 11.

**Table 4-3: Summary of Conclusions and Recommendations for Residential Building Performance**

Observation	Conclusion (numbered according to Chapter 11)	Recommendation (numbered according to Chapter 12)
<p>Examples of recent non-compliant (IRC) construction:</p> <ul style="list-style-type: none"> <li>• Over-notched rafters lacking connection to floor diaphragm: Figures 4-19, 4-20 (Section 4.1.9)</li> <li>• Discontinuous top plate: Figure 4.24 (Section 4.1.10)</li> <li>• UngROUTED CMU below missing bottom plate anchors: Figure 4-27 (Section 4.1.11)</li> <li>• Bottom plate attachment with cut nails: Figure 4.31 (Section 4.1.11)</li> </ul>	<p><b>Conclusion #1</b>  <b>Failure to adopt a current version of code or having no uniform code leaves residential buildings vulnerable to wind damage.</b>  <b>At the time of publication of this report, current codes are the 2012 or 2009 IRC.</b></p>	<p><b>Recommendation #1</b>  <b>Adopt and enforce current model building codes.</b>  <b>At the time of publication of this report, current codes are the 2012 or 2009 IRC.</b></p>
<p>Examples of non-compliant (IRC) bottom plate attachment:</p> <ul style="list-style-type: none"> <li>• Figure 4-31 shows a newly constructed residential building in Tuscaloosa, AL (completed December 2010) where the bottom plates in some areas had been secured with only concrete cut nails. (Section 4.1.11)</li> <li>• Additional examples of IRC exceptions to bottom plate attachment in Figures 10-1 and 10-2</li> </ul>	<p><b>Conclusion #2</b>  <b>Failure to adhere to the structural provisions of the model building code as written can result in buildings that are vulnerable to structural damage.</b></p>	<p><b>Recommendation #2</b>  <b>Increase emphasis on code compliance.</b></p> <p><b>Recommendation #3</b>  <b>Maintain and rigorously enforce the adopted model building code since amendments or lax enforcement practices may weaken the continuous load path of the building.</b></p>
<p>Examples subcategorized by specific failure modes in following rows</p>	<p><b>Conclusion #9</b>  <b>Voluntary implementation of better design and construction practices could mitigate damage.</b></p> <p>Improved design and construction and implementation of details and techniques that are already required in coastal high-wind regions will significantly reduce property damage caused by tornadoes rated EF2 or less (i.e., estimated wind speeds of 135 mph or less) and to buildings located at the periphery of more severe events.</p>	<p><b>Recommendation #15</b>  <b>Implement voluntary best practices to mitigate damage to one- and two-family residential buildings.</b></p> <p>Prescriptive guidance is provided in Appendix G to enhance performance of components, cladding, and critical load path connections observed to have failed during the spring 2011 tornado events. The prescriptive guidance is intended to improve building performance as described in the following rows.</p>

Table 4-3: Summary of Conclusions and Recommendations for Residential Building Performance (continued)

Observation	Conclusion (numbered according to Chapter 11)	Recommendation (numbered according to Chapter 12)
<p>Examples of roof or wall covering that became wind-borne debris endangering surrounding buildings and their occupants as shown in Figure 4-1 (Section 4.1.2)</p> <p>Examples of damage that wall or roof covering that likely led to water intrusion in Figures 4.2 and 4.3 (Section 4.1.3)</p> <p>Examples of unprotected glazing and wide garage doors (16 or 18 feet wide): Figure 4-6, 4-7, 4-8 (Section 4.1.4 and 4.1.5)</p> <p>Examples of increased damages resulting from breaching of the building envelope: Figures 4-9 and 4-10 (Section 4.1.5)</p> <p>Examples of damages that appeared to be triggered by increased pressurization resulting from damaged soffits and gable end walls: Figures 4-13 and 4-16 (Section 4.1.6)</p> <p>Example of poorly fastened roof deck to roof structure that appeared to play a role in the loss of roof decking: Figure 4-15 (Section 4.1.6)</p> <p>Examples of failed roof to wall connections are shown in Figures 4-18 through 4-22 (Section 4.1.9)</p>	<ul style="list-style-type: none"> <li>• <b>Loss of Roof and Wall Covering:</b> Roof and wall covering blown away by high winds and uplift forces became wind-borne debris that endangered surrounding buildings and their occupants. Buildings that suffered roof covering loss were often further damaged by water intrusion.</li> <li>• <b>Component Damage:</b> Component damage, whether shattered glazing or collapsed garage doors, often led to other structural and non-structural damage because of increased pressurization and water intrusion that followed breaching of the building envelope. Unprotected glazing and wide garage doors (16 or 18 feet wide) were particularly vulnerable as was expected from previous MAT assessments.</li> <li>• <b>Uplift of Roof Decking:</b> Loss of roof decking often appeared to be triggered by increased pressurization resulting from damaged soffits, window failures, and gable end walls. Poor fastening of roof decking to the roof structure also appeared to play a role in the loss of roof decking.</li> <li>• <b>Loss of Roof Structure:</b> The weak link most often identified as responsible for loss of roof structure was the roof-to-wall connection.</li> </ul>	<ul style="list-style-type: none"> <li>• <b>Improve roof and wall coverings per Section G.3.1.</b></li> <li>• <b>Increase awareness of glazing damage and strengthen garage doors per Section G.3.1.</b></li> <li>• <b>Strengthen roof decking (sheathing) attachment per Section G.3.2.</b></li> <li>• <b>Strengthen roof-to-wall connections per Section G.3.2.</b></li> </ul>

**Table 4-3: Summary of Conclusions and Recommendations for Residential Building Performance (concluded)**

Observation	Conclusion (numbered according to Chapter 11)	Recommendation (numbered according to Chapter 12)
<p>Examples of wall collapse observed to result from failed attachment of floor and ceiling systems to walls: Figures 4-23 and 4-24 (Section 4.1.10)</p> <p>Examples of wall collapse observed to result from inadequate bracing of framed walls: Figures 4-25 and 4-26 (Section 4.1.10)</p> <p>Examples of failure of wall connection to foundation: Figures 4-27 through 4-31 (Section 4.1.11)</p>	<ul style="list-style-type: none"> <li>• <b>Wall Collapse:</b> Wall collapse was observed to result from failed attachment of floor and ceiling systems to walls and inadequate bracing of framed walls.</li> <li>• <b>Failure of Wall Bottom Plate Attachment:</b> Foundations typically performed adequately, but in some instances the connection of walls to the foundations system failed because of inadequate connection of the bottom plate.</li> </ul>	<ul style="list-style-type: none"> <li>• <b>Improve wall performance through sheathing attachment, hold-down installation and better top plate splicing per Section G.3.3.</b></li> <li>• <b>Improve wall-to-floor connections and bottom plate attachment per Section G.3.3.</b></li> </ul>
<p>Example of the exceptional case where DOD 5 preceded DOD 6: Figure 4-17 shows example of house shifting off of foundation prior to loss of roof structure and wall collapse (Section 4.1.9).</p>	<p><b>Conclusion #43</b> <b>Order of DOD choices for DI 2 (One- and Two-Family Residences) in the EF rating scale does not follow observed damage patterns.</b></p> <p>As noted in Chapter 4, most residences rated by the MAT followed the order of DODs prescribed by the EF scale closely, with the exception of DOD 5 (Entire House Shifts off Foundation). It was very unusual for DOD 5 to precede DOD 6. In the one documented case (Figure 4-17), the observed residence was older construction.</p>	<p><b>Recommendation #45</b> <b>Modify EF scale DI 2 (One- and Two-Family Residences).</b></p> <p>Based on the MAT’s observations for DI 2 (One- and Two-Family Residences), DOD 5 (“entire house shifts off foundation”) was rarely witnessed, unlike DODs 4 and 6, and should be eliminated from the list of DODs.</p>



## TORNADO OUTBREAK *of* **2011**

IN ALABAMA, GEORGIA, MISSISSIPPI,  
TENNESSEE, AND MISSOURI

# 5 Observations on Commercial and Industrial Building Performance

*The MAT visited numerous tornado-damaged commercial and industrial buildings to assess building performance and reasons for failures.*

This chapter describes the results of the MAT's observation of commercial and industrial buildings damaged during the April 25–28, 2011 tornadoes in the mid-south of the United States and the May 22, 2011 tornado that struck Joplin, MO. It provides a general description of the damage observed across the impacted area and provides seven case studies with detailed damage descriptions. This chapter evaluates commercial and industrial building structural designs and the effects of various design decisions and construction techniques on a building's resistance to tornado damage. The MAT's observations focused on the Main Wind Force Resisting System (MWFRS) of the observed building, with special attention on continuous load paths and structural connections. Although failures may have propagated from secondary building elements or the building envelope, it was

the failure of the MWFRS or portions of the critical load paths that resulted in loss of significant sections of building or partial to full building collapses, in several instances causing loss of life.

### Summary of Primary Failure Modes Observed by the MAT

The major structural failures observed by the MAT were caused directly by extreme wind loads that exceeded the design strength of the building structural systems. Many of the failures observed by the MAT were likely a combination of the MWFRS being overloaded by secondary building elements or by insufficient load path connections of the MWFRS. The term failure is used in this chapter to mean a structural material or building structural system that was loaded beyond its resistance capacity. In this context, failure does not imply a design failure occurred; it means that the building or component was challenged by a force larger than it was capable of resisting.

The larger commercial buildings observed by the MAT were designed to function as enclosed buildings. Portions of the building shells were designed to act as both the envelope and the MWFRS that transfers loads into the foundation in lieu of internal bracing. Therefore, when damage to the roof and walls occurred, damage to the MWFRS also occurred. When the building envelope of this type of building is breached, the resulting pressurization effectively changes the enclosed building into a partially enclosed building (refer to Section 3.1 for additional information). Once the building is effectively a partially enclosed building, the key structural components experience significantly higher wind loading than they were designed to resist. The MAT observed buildings that were damaged at wind speeds lower than the design wind speed because of increased pressurization.

### Role of Existing Building Code

It is important to note that current building code wind speeds do not represent the influence from tornados. ASCE 7-10 does not provide requirements for minimum design loads specific to all tornadic events, but does address tornados in the Commentary. Section C26.5.4 *Limitation* (p. 513) as follows:

“It is recognized that tornadic wind speeds have a significantly lower probability of occurrence than the basic wind speeds. In addition, it is found that in approximately one-half of the recorded tornados, gust speeds are less than the gust speeds associated with basic wind speeds.”

Thus while the forces from tornados of lesser intensities, such as those rated EF0 and EF1, fall within the design parameters of wind speeds represented in the current ASCE 7 standard, the forces from very strong tornados (EF3, EF4, and EF5) are well above the forces currently required for building design (refer to Section 2.2 and Appendix E for more information on the EF rating scale). Many of the damaged commercial and industrial buildings observed by the MAT were large structures. The buildings appeared to have been designed in accordance with the governing codes in effect at the time they were built. Therefore, it is most likely that the dramatic building failures observed by the MAT were not the result of poor design or construction, but rather the result of forces being applied to these buildings that were above the expected design parameters.

## Organization of Chapter

The observed failures of commercial and industrial buildings (summarized in Sections 5.1, 5.2, 5.3, and 5.4) were more closely associated with the construction type of the building rather than the use of the building. Therefore, this chapter is organized by building construction type rather than by building use. The location of each building described in this MAT report is shown in Figures 5-1 through 5-3 with each building location shown in relationship to the centerline of the tornado damage swath.

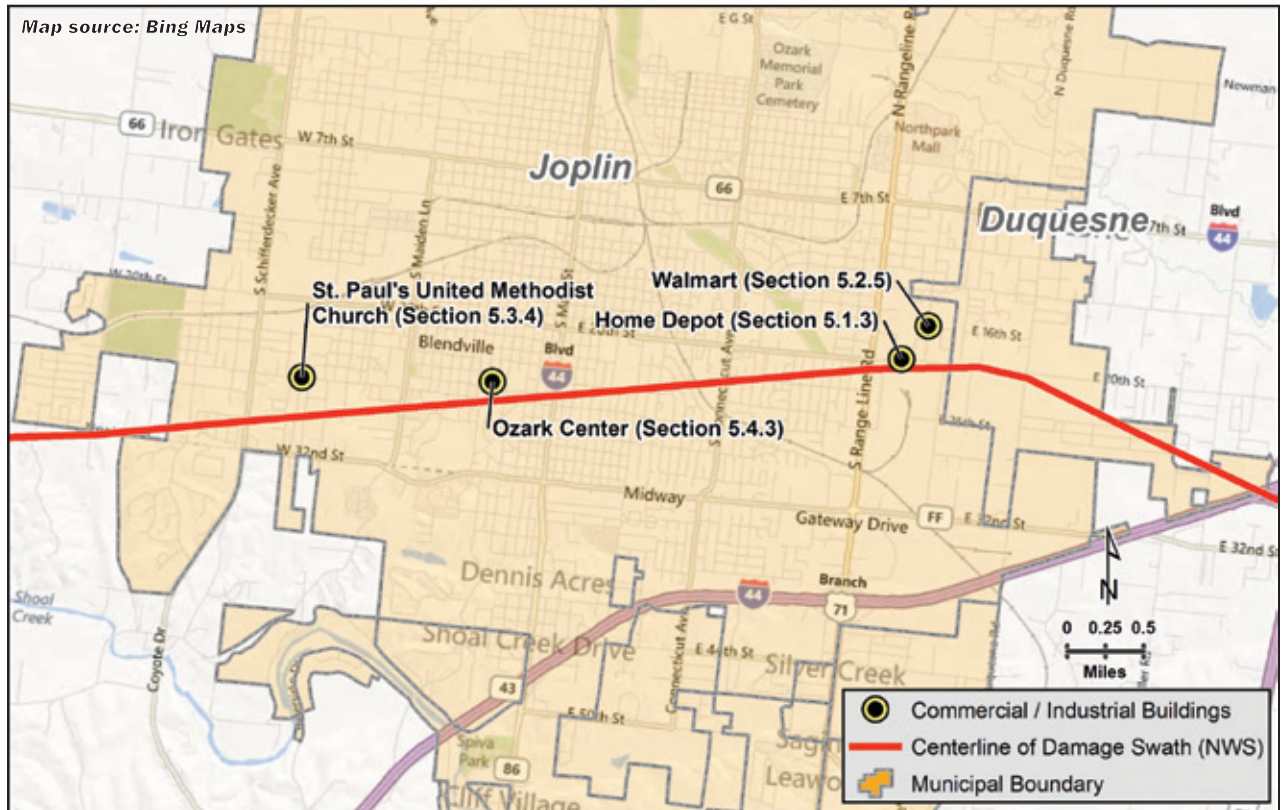

Figure 5-1: Location of Joplin, MO, buildings described in Chapter 5

SOURCE FOR TORNADO TRACK: [HTTP://WWW.CRH.NOAA.GOV/SGF/?N=EVENT\\_2011MAY22\\_SUMMARY](http://www.crh.noaa.gov/sgf/?N=EVENT_2011MAY22_SUMMARY)

This chapter summarizes five building types and the typical failures observed by the MAT specific to each building type. Where significant time was spent evaluating a particular site or issue, additional information is provided for that location as a case study. The types of structural failure conditions observed by the MAT were common across various locations due to common commercial construction methods and the consistency of materials manufacturing.

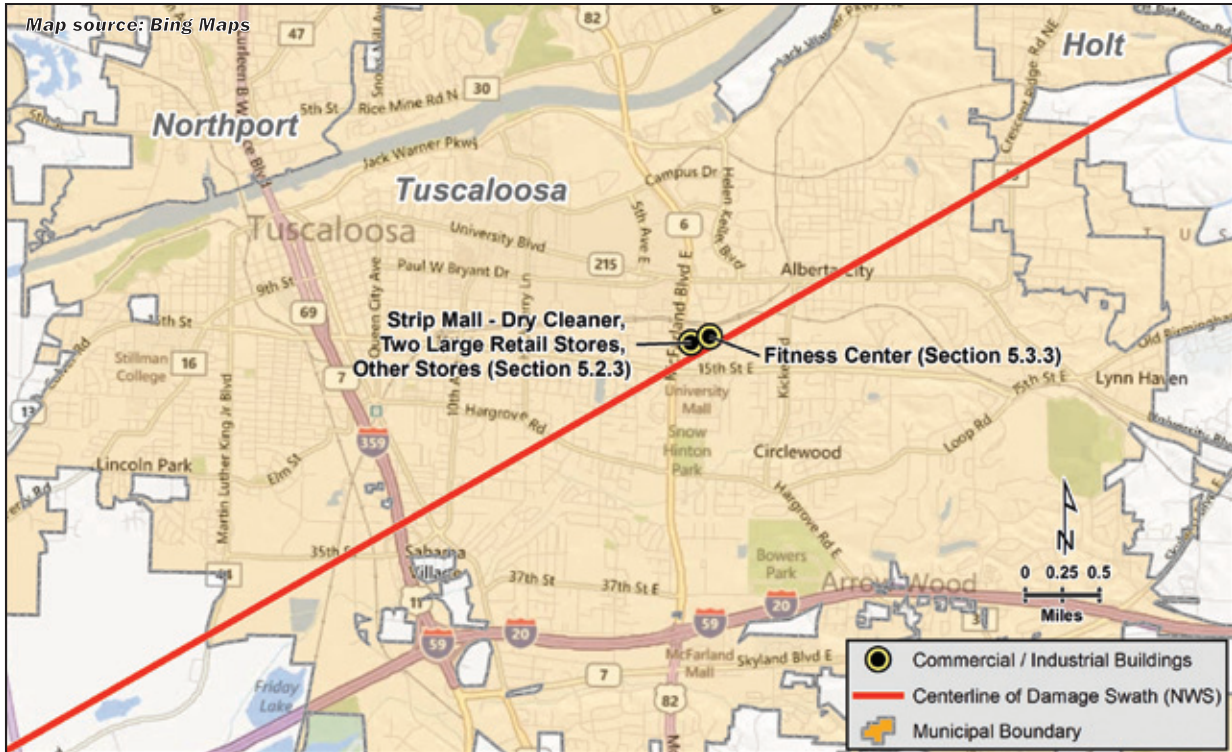

Figure 5-2: Location of Tuscaloosa, AL, buildings described in Chapter 5

SOURCE FOR TORNADO TRACK: [HTTP://WWW.SRH.NOAA.GOV/SRH/SSD/MAPPING/](http://www.srh.noaa.gov/srh/ssd/mapping/)

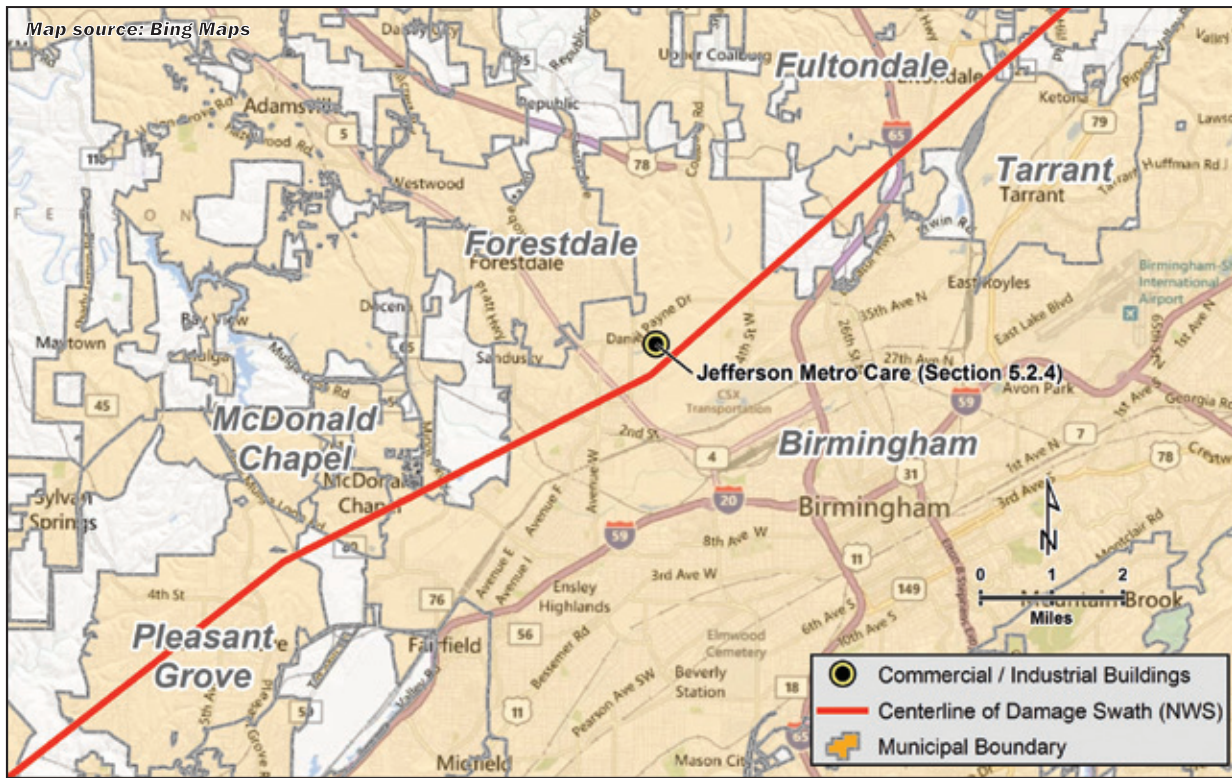

Figure 5-3: Location of Jefferson Metro Care medical office in Birmingham, AL, described in Section 5.2.4

SOURCE FOR TORNADO TRACK: [HTTP://WWW.SRH.NOAA.GOV/BMX/?N=EVENT\\_04272011TUSCBIRM](http://www.srh.noaa.gov/bmx/?N=EVENT_04272011TUSCBIRM)



## 5.1 Tilt-Up Precast Concrete Walls with Steel Joist Roof System

The MAT observed several damaged buildings constructed using tilt-up precast walls with a steel joist roof system. This type of building construction is described in Section 5.1.1 and its typical failure modes in Section 5.1.2. One of these, a Home Depot, was assessed in detail and is presented as a case study in Section 5.1.3.

### 5.1.1 Description of Construction Method and Load Path

Following the tornado in Joplin, MO, the Tilt-Up Concrete Association formed a task force to investigate claims made by an article that criticized the failure and failure modes of tilt-up concrete wall construction during the tornado. Their report, *Analysis of Damage from Historic Tornado in Joplin, Missouri, U.S.A. on May 22, 2011, a Report to the Technical Committee of the Tilt-Up Concrete Association by the Natural Disaster Task Force*, was published in January 2012.

The construction erection procedures of precast concrete and tilt-up concrete panel construction are similar in process. These construction practices were developed to eliminate the use of difficult, expensive, and time-consuming vertical forming of wall elements. In these casting methods, concrete wall panels are made by placing concrete in forms that are laid flat on a casting bed. The panel is then either brought to the project site or picked up from its onsite casting bed and “tilted” into place. During construction, the panels are braced until the connections and load transferring systems are in place.

The tilt-up method reduces the scaffolding work associated with masonry work or poured concrete lifts associated with cast-in-place methods. This construction is typically used for long span roof systems and high ceilings, and is therefore commonly used in large commercial super-centers (supermarkets, household goods, and building material supply stores), as well as warehouses, industrial buildings, agricultural facilities and other high-ceiling single-story applications.

Tilt-up concrete panels are typically relatively thin, usually 7 to 12 inches thick. The individual panels may be multi-story, and some designs have reached heights of 50 feet and higher. Wall panels are typically supported on concrete foundations and may be connected to the floor slab with a cast-in-place perimeter strip between the wall and the slab. Although in many applications panels do not need anchorage due to their heavy weight, the code requires a minimum of two ties per panel and connections that rely solely on friction from gravity may not be used. Interior column and frame systems are commonly used for intermediate support of multiple stories or roof systems. Roof systems in these types of structures may rest on a corbel formed into the wall panel or, more commonly, may be attached with embedded weld plates and brackets at the top of the tilt-up concrete panels.

The load paths of these buildings are straightforward because of the small number of elements involved, which makes the relatively few connections and components in the building very important. The elements of these types of diaphragm structures are connected in a system that allows the various loads to be transferred from element to element down to the foundations:

- + Uniform vertical loads are carried by the roof deck to the joists. Vertical point loads are taken directly to the joists. Horizontal loads are distributed to the roof deck and gathered at shear walls.

- + The joists then transfer the loads through the joist seats to the joist girders at panel points. In some cases, the joists transfer the loads through their seats to beams or walls.
- + The joist girders then transfer loads to either columns or walls. The walls sit on foundations and convey the accumulated forces directly via contact and anchorage.

The connections between these building elements are therefore critical due to the loads flowing through them. Horizontal and vertical uplift loads on the roof deck are typically transferred via puddle welds to the joists that support the deck, or to collector elements at the walls. Welds are also used to transfer forces from joists to joist girders, joists to walls, joist girders to columns, joist girders to walls, and to connect columns to base plates.

### 5.1.2 Typical Failure Modes Observed by the MAT

Structural failure and catastrophic collapse of this building type was observed in several locations. One example of tilt-up construction, a Home Depot, was assessed in detail and is presented as a case study (Section 5.1.3). Although some failures may have been the result of overload on the long span roof systems, the more common condition observed was the failure of the roof deck-to-joist connections and the roof-to-wall panel connections. These connection failures in the MWFRS diaphragm and at the top of the wall allowed the large sections of wall panels to collapse.

Due to the open nature of most buildings using this construction method, the collapse of the very heavy full-height floor-to-roof wall panels did not produce interior pockets of space where occupants could take cover and survive during catastrophic structural failures. Significant damage to building interiors and resulting injury to occupants occurred when these buildings' non-redundant main structural support systems were overloaded. When one panel failed, the loads shared by the adjacent wall panels increased markedly, resulting in the propagation of failure to more of the wall panels, sometimes leading to complete collapse of the exterior walls and roof.

A typical 9-inch-thick x 25-foot-wide x 30-foot-high panel weighs about 84,000 pounds.

### 5.1.3 Home Depot (Joplin, MO)

The 108,000-square-foot Home Depot, located in Joplin, MO, is a typical example of a tilt-up concrete building destroyed by a very intense tornado. According to a local Home Depot representative, there were seven fatalities. Twenty-eight people in the store survived.

**Location of Facility in Tornado Path:** The MAT inspected the Home Depot in Joplin, MO (location shown in Figure 5-1), which was destroyed during the tornado. Figure 5-4 shows the building after the tornado and its location in relationship to the centerline of the tornado damage swath. The NWS rated the center of the tornado circulation in the vicinity of the building as an EF4 to EF5.

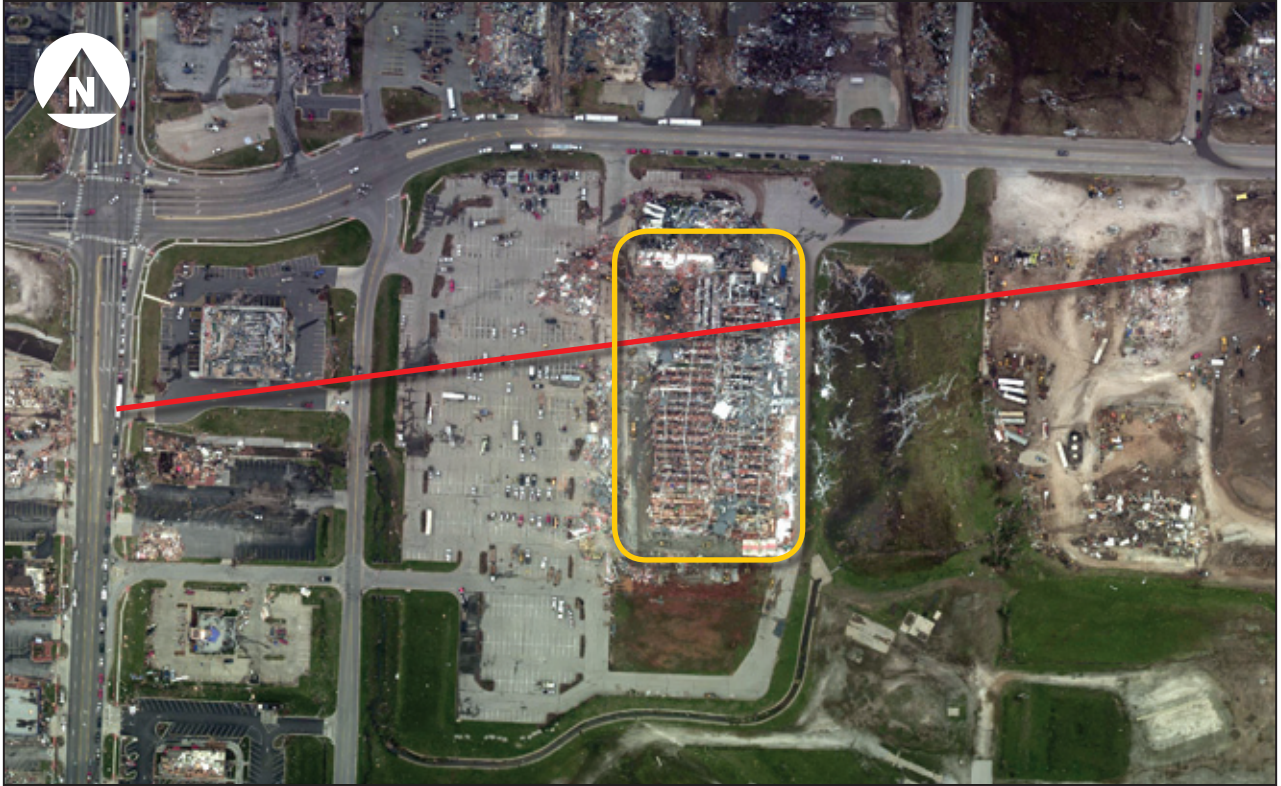

Figure 5-4: Aerial view of Home Depot (yellow circle) in Joplin, MO, in relationship to the approximate centerline of the May 22, 2011 tornado damage swath (red line)<sup>1</sup> (Joplin, MO)

SOURCE: ALL AERIAL PHOTOGRAPHS ARE FROM NOAA IMAGERY ([HTTP://NGS.WOC.NOAA.GOV/STORMS](http://ngs.woc.noaa.gov/storms)) UNLESS OTHERWISE NOTED

**Facility Description:** The Home Depot had a footprint of 240 feet by 450 feet. The structural system for this large building used the following structural and roof covering elements:

- + Membrane roofing
- + Insulation board
- + Metal roof deck
- + Open web steel joists
- + Open web steel joist girders
- + Square tube columns supporting joist girders
- + Precast concrete exterior walls
- + Shallow foundations

<sup>1</sup> The red line in this and all similar figures represents the center of the damage swath. The track location is approximated by the MAT based on post-event aerial photographs. The actual centerline of the vortex is offset from the centerline of the damage.

**General Wind Damage:** After the tornado, some of the precast concrete walls were still standing in the northeast corner of the building and partially along the southwest side. The remainder of the wall panels had collapsed. Some of the wall panels had collapsed inwards, while others had collapsed outwards.

### Roof System

The connection failures and loss of lateral support of the structural elements led to the total collapse of the roof structure, which in turn led to the collapse of the walls. Large portions of the roof membrane, insulation board, and metal deck diaphragm were lifted from the building and moved outside of the building footprint to the open field east of the Home Depot (Figure 5-5). The roof on the front (east) bay remained attached to the joists inside the collapsed foot print.

As previously noted, the roof deck is typically connected to the joists by puddle welds. An example of a failed puddle weld used to connect the metal deck to the top chord of the steel joists is shown in Figure 5-6. The MAT noted this type of connection on each of the metal deck structures observed at the Home Depot. The roof metal deck acted as a lateral diaphragm and was the primary load-carrying system for lateral loads in the building. Once the roof deck connections failed the steel open web bar-joists and joist girders lost their lateral support and became unstable.

One of the advantages of the steel joist system is that it is a more cost effective system than a traditional steel system of wide flange beams and girders. The joists are lightweight and they can be widely spaced and be used on long spans. The system is primarily designed to carry downward vertical loads and can carry horizontal loads that are parallel to the length of the joist.

A disadvantage of the system is that the combination of the elements used in constructing the joists and joist girder and its length create members that have little horizontal capacity when loaded laterally in an un-braced condition, as was the case described above when the roof deck connection failed. This weakness is also evident in the joist girders, which became un-braced when the connection between the joists and joist girders failed. Figures 5-7 and 5-8 demonstrate the lack of rigidity in an un-braced joist system.

**Figure 5-5:**  
Field east of Home Depot  
with roof debris (Joplin, MO)





Figure 5-6:  
Failed puddle welds that  
connected the metal roof  
deck to the top chord of the  
joist (red arrows) (Joplin,  
MO)



Figure 5-7:  
Joist girder and column  
failure. The column-to-joist  
girder is shown by the red  
arrow (Joplin, MO).

Another common practice in the industry is not welding the bottom chord to the stabilizer plate on joist girders at the column support. The bottom chord was not connected at the Home Depot and the MAT noted several instances of separation at this location (Figure 5-8). In some buildings, the bottom chord is welded if the system is designed as a moment frame system, but if analysis determines that the structure is adequate for the design loads without welding the bottom chord,

it is appropriate and encouraged to not make this connection rigid. Alternatively, welding the bottom chord at this location can help keep the bottom chord from buckling provided the connection is capable of resisting the tension induced at this point by the uplift of the joist. However, complications can occur if the construction sequence gets out of order and if snow loads are expected. The bottom plate must be welded after all the dead loads are in place to prevent damage to the lower chord as it deflects and rotates to carry the dead load. If the bottom chord is to be welded to the stabilizer plate, this must be indicated on the plans and considered in the girder design as a special loading condition. Yet another option is to use a loose fit bolt in a slotted hole in lieu of a welded connection at the stabilizer plate.

When single-story, large footprint and multi-story commercial buildings fail during tornadoes, large amounts of debris may be generated at the building sites (see Figures 5-7, 5-12, 5-16, 5-21, and 5-34). To address the structural concerns related to this, FEMA 361 and the ICC 500 provide design criteria to account for debris on the roofs of safe rooms and storm shelters and also state that falling and collapse hazards need to be considered with designing, siting, and constructing these protective areas. FEMA 361 and this publication also provide guidance on operational considerations that state equipment and communication systems should be maintained within safe rooms and tornado refuge areas to assist with the rescue and extraction of individuals from such areas when a building collapse occurs.

**Figure 5-8:**  
Separation at bottom chord  
to stabilizer plate (red arrow)  
(Joplin, MO)



### Interior Columns

The interior columns at the Home Depot were hollow structural steel (HSS) tube sections located on a grid approximately 40 feet x 50 feet, a common industry practice for lightweight steel frames. The columns were attached to the foundations with a 4-bolt base plate that was welded to the column and a 4-bolt connection at the top to the joist girders.

The column elements performed well while the column tops were pulled to the east by the roof translation. Once the roof deck and steel joist connections broke, the lateral and uplift loads on the columns were reduced and the translation stopped.

The MAT observed a column that buckled against the racking system (Figure 5-9). Some columns failed when the hooked anchor bolts for the column pulled out of the concrete. Other columns experienced failure at the base plate due to shear and tension (Figure 5-10). As the column rotated, the force on the compression side of the base plate sheared the bolts and the tension side pulled the hooked anchor bolts free. The code allows the use of hooked anchor bolts when columns are subject to compression only. When anchor bolts are subject to tension a more positive anchorage is created by using headed anchor bolts in lieu of hooked anchor bolts.



Figure 5-9:  
Buckled column (Joplin, MO)

**Figure 5-10:**  
Bolt failure at interior column resulting from shear and tension. The hooked anchor bolts pulled out of the slab (red arrow) (Joplin, MO).



### Exterior Walls

The exterior walls of the Home Depot building were precast tilt-up concrete panels. In this type of construction, the connection at the base of the wall is a steel plate or angle welded to an embedded steel plate in the footing and the wall. The roof connections consist of an embedded steel plate in the wall connected to the roof members. Where the steel joists are perpendicular to the wall, there are pockets or a ledger angle where the wall panels support the joists. Figure 5-11 shows an example of a failed joist support pocket at the Home Depot building.

**Figure 5-11:**  
Joist support pocket at top of a precast wall. The red arrow points to weld marks from the connection to the framing member seat on the embedded plate. The yellow arrow points to the light blue insulation layer between the concrete shells (Joplin, MO).





Figure 5-11 also shows that the panels of the Home Depot building were insulated, which means there were two layers of concrete with a layer of insulation in the center. The two layers of concrete are usually connected by ties and concrete ribs at the perimeter and sometimes in the center of the panel. This detail was not exposed, however, and the MAT was unable to observe the connection.

The design dictates whether there are other connections along the vertical joints between individual wall panels. The MAT did not observe any panel-to-panel connections in the Home Depot building.

For wall panels parallel to the steel joists, the connection to the roof diaphragm is provided by a deck support angle attached to the wall panel with bolts or weld plates. The roof deck is then attached to this angle. There are more substantial connections from the joist girders to the wall panels than from joists to wall panels. There is also an additional connection where the joist bridging attaches to the wall. The bridging is provided by the steel joist supplier. This connection is often very small and lightly designed as the required bridging member sizes are also small. This bridging is one of the methods used to keep the bottom chords from buckling as it reduces the un-braced length of the chord.

When the connections between the panels and the roof system fail or the roof system becomes unstable due to loss of the diaphragm, the panels became tall cantilevered walls. Exterior tilt-up walls are not typically designed to withstand this condition, and certainly not when subjected to large lateral forces created by high winds. With high wind pressures, they can become unstable and collapse. It is worth noting that they do not fail in bending, which is typically the worst design loading condition and occurs during the initial construction lifting operation. Instead, they collapse by failing to resist rotation about the bottom of the panel when subjected to lateral loading.

The MAT observed several types of failures of the roof-to-wall connections at the Home Depot building including failures of the joist girder-to-wall connections, failure of the joist-to-joist girder connection (Figure 5-12), failure at joist seats (Figure 5-13), and failures of the weld plates (Figures 5-14 to 5-16). These kinds of failures were part of a chain of failures that led to the collapse of most of the walls.

In the area shown in Figure 5-12 the product racking system maintained some integrity as the building structural elements failed; this area could possibly have been used as a location to take refuge as an option of last resort. However, the level of protection would have been poor, as protection from both wind-borne debris and store contents would have been minimal.

Figure 5-12:  
Failure of joist-to-joist girder connection shown by broken welds (yellow arrow); red arrow shows location where bridging angle is touching insulation bundles (Joplin, MO)



Figure 5-13:  
The joist seats came free of their bearing locations when both the seat-to-joist weld (yellow arrow) and the seat-to-embed plate weld (red arrow) broke (Joplin, MO)





Figure 5-14:  
Example of weld plate and joist failure. The joist seat was torn from the joist (red arrow) and the anchor studs from embed plate were torn out of the concrete (yellow arrow) (Joplin, MO).



Figure 5-15:  
The panel at the weld plate failed (red arrow) (Joplin, MO)

Figure 5-16:  
Example of a weld plate failure. Note the attached joist (red arrow) and the joist pocket at the top of the wall panel (yellow arrow) (Joplin, MO)



## Foundations

The foundations for the Home Depot were not damaged by the tornado event. The MAT did not note any movement of the interior foundations. The anchor bolt failures (described in *Exterior Walls* above) occurred before there was any movement of the foundation.

**MAT EF Rating:** Using DI 12 (Large Isolated Retail Building), the MAT selected DOD 7 (“complete destruction of all or a large section of the building”) for this building. Using the expected wind speed for DOD 7, the MAT derived the tornado ranking as EF4 (165–170 mph winds). Therefore, the estimated wind speed experienced by the building was well in excess of the 90 mph code design requirements for this location. The MAT EF4 rating for the Home Depot is the same as the NWS rating of EF4 for the center of the tornado circulation at this location.

**Functional Loss:** The Home Depot in Joplin, MO, is a complete loss.

## 5.2 Load Bearing Masonry with Steel Joist Roof System

The MAT observed numerous buildings constructed using load bearing masonry walls with steel joists as the roof system. This type of building construction is described in Section 5.2.1 and its typical failures modes in Section 5.2.2. Detailed case studies for the buildings are presented in Section 5.2.3 through Section 5.2.5.

## 5.2.1 Description of Construction Methods and Load Path

**Older masonry construction:** Masonry construction varies depending on the type and size of the concrete blocks and whether the masonry system is reinforced. Older construction is often unreinforced or inadequately reinforced and is more likely to collapse in what are current design wind speeds. Owners and operators of older buildings constructed prior to the implementation of current building codes can either retrofit the masonry with reinforcement to allow for better performance or should be aware that occupants in these buildings will need to seek more substantial buildings during high-wind events. Refer to Chapter 9 for information on refuge areas and safe rooms/storm shelters.

**Bond beams in multiple story construction:** Reinforced and unreinforced masonry walls can be used in multiple-story construction. Intermediate stories and roof systems can be attached to a grouted bond beam or corbel constructed into the masonry wall. Steel joists or trusses may span between these walls to create floors. Roof trusses are attached at the top of the wall using either a top plate or they may rest on top of a bond beam. The bond beam is intended to serve two purposes: lateral load transfer along the length of the wall or vertical load transfer from the roof system.

**Wall-to-footing/wall-to-roof connections:** In order to provide load path continuity at the connection between the masonry wall and footings, some physical connection must be made between the reinforcing steel in the footing and in the wall. Reinforcing steel is used for this connection since the tensile strength of masonry and grout materials is extremely low and it can only be relied on for compression. Reinforcing steel used to make the wall-to-footing connection must be of a sufficient size and length (development length) to transfer the loads. Similarly the wall-to-roof connection needs to be able to provide a complete load path into the wall reinforcement from the roof elements.

## 5.2.2 Typical Failure Modes Observed by the MAT

**Older masonry construction:** Inevitably, many of the older buildings the MAT observed collapsed during the tornado outbreak. These failures were observed not only in the direct path of the tornado, but also on the tornado periphery where wind speeds were lower and somewhat closer to design level wind speeds.

**Bond beams in multiple story construction:** The MAT checked the top sections of toppled walls for the presence of bond beams. Failures of the bond beams were noted by the MAT in buildings located along periphery areas of the tornado damage swath, suggesting either wall or roof loads larger than the wall system was designed to transfer or a concrete strength that was insufficient.

**Wall-to-footing/wall-to-roof connections:** Failures observed by the MAT occurred in two primary locations: the roof-to-wall connection or at the footing-to-wall connection. The MAT found reinforcing steel in walls and footings to be spaced too infrequently or it was absent altogether in some cases. Where present, development lengths of failed sections of wall were measured and found to be inadequate.

### 5.2.3 Strip Mall – Dry Cleaner, Two Large Retail Stores, and Other Stores (Tuscaloosa, AL)

**Location of Facility in Tornado Path:** The MAT observed a small strip mall in Tuscaloosa, AL (location shown in Figures 5-2 and 5-17), which was destroyed during the April 27, 2011 tornado. This strip mall contained a dry cleaner, two large retail stores, a fitness center and other businesses. The dry cleaner was located on the far west end of the strip mall, retail store “A” was located at the northeast end of the mall, and retail store “B” was adjacent to and south of the first store. The fitness center is described in detail in Section 5.3.3.

The dry cleaner was very near the centerline of the tornado damage swath; the NWS rated the center of the tornado circulation in this location as an EF4. The MAT made detailed observations of the dry cleaner, described below.

**Facility Description:** The dry cleaner building had a footprint of roughly 150 feet by 160 feet. The structural and roof covering systems for this building used the following elements:

- +Membrane roofing
- +Insulation board

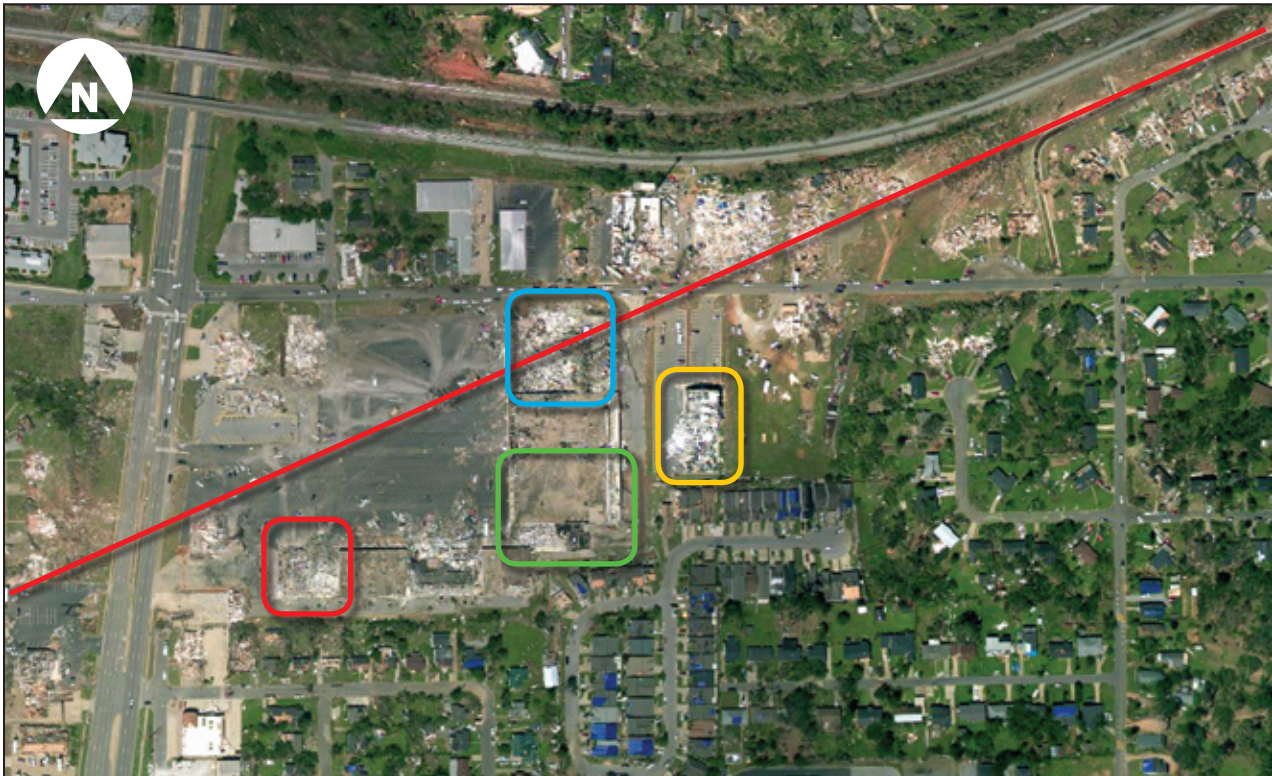

Figure 5-17: Aerial view showing the locations of the dry cleaner building (red box), fitness center (yellow box), retail store “A” (blue box) and retail store “B” (green box) in relationship to the approximate centerline of the April 27, 2011 tornado damage swath (red line) and (Tuscaloosa, AL)

- + Metal roof deck
- + Open web steel joists
- + Unreinforced CMU exterior walls
- + Shallow Foundation

**General Wind Damage:** After the tornado, only one exterior wall and two interior walls of the dry cleaner were left standing. Most of the CMU walls collapsed inward on the building and the roof was either torn away or collapsed in on the building.

### Exterior Unreinforced CMU Walls

The exterior walls on the dry cleaner building were constructed of unreinforced CMU. The walls had some horizontal joint wire reinforcing but no vertical reinforcing or grouted cells. The walls on the front and rear of the building failed, collapsing inward on the building. The connections at the roof failed causing the walls to behave as a tall cantilever wall, which caused the bending stresses to exceed the material stress capacity. Figure 5-18 shows collapsed unreinforced masonry walls. The wall shared with the adjoining building was left standing, as were a few of the smaller interior walls. These walls were supported by roofing from two sides. Since the roof was left mostly intact on the other side of the wall, the wall had some lateral support and remained standing.

The connection at the base of the wall typically consists of reinforcing steel that is embedded into the foundation and then extended up into the CMU cells. The cells are then grouted, locking the reinforcing in place and allowing it to transfer both lateral and uplift load. The walls of the dry cleaning building did not have any visible steel connection between the base of the CMU wall and the foundation. The CMU walls relied on the block mortar joints and self-weight to support the wall. Figure 5-19 shows the lack of reinforcing in the entire wall and also at the connection between the base of the CMU wall to the foundation. The failure sequence is captured in Figures 5-20 and 5-21.



Figure 5-18:  
Steel joist (red arrow)  
in midst of collapsed  
unreinforced masonry wall  
at the dry cleaner store  
(Tuscaloosa, AL)

**Figure 5-19:**  
Solid steel hot rolled sections (red arrow) left in beam pockets of CMU building section. These supported the steel joists shown in Figure 5-18. Also note lack of reinforcement in the wall and wall-to-foundation connection (Tuscaloosa, AL).



**Figure 5-20:**  
Sequence of failure for CMU wall at the dry cleaner building: wall buckling and initial separation (red arrow) was followed by complete separation of wall from bond beam (yellow arrow) and then by collapse of wall (green arrow) (Tuscaloosa, AL)







Figure 5-21: Global wall instability failure. The CMU blocks are lying loosely on the ground and many have rotated (yellow arrow) due to the complete separation of all the blocks. Note lack of reinforcement in the wall and especially between wall and footing (red arrow). Inset shows a close-up view of the separation of the blocks (Tuscaloosa, AL).

### Exterior Unreinforced CMU Walls: Roof System

The roof connection consisted of an embedded steel plate attached to the bond beam connected to the roof members. Where the steel joists were perpendicular to the wall there were typically pockets or a ledger angle where the joists were supported (Figure 5-22). This connection tied into a bond beam running along the front and back walls of the dry cleaner building. When the wall failed and collapsed (Figure 5-23), the bond beam also failed and collapsed, bringing the bar joist roof system down with it.

**MAT EF Rating:** Using DI 10 (Strip Mall), the MAT selected DOD 8 (“collapse of exterior walls; closely spaced interior walls remain standing”) for this building. Using the expected wind speed for DOD 8, the MAT derived the tornado ranking as EF3 (140–150 mph winds). Therefore, the estimated wind speed experienced at the building was well in excess of the 90 mph building code design requirements for this location. The MAT EF3 rating for the dry cleaner is lower than the NWS rating of EF4 for the center of the tornado circulation near this location; however, the building was not located directly in the core of the track.

**Functional Loss:** The dry cleaner building is a complete loss as the exterior walls and roof were destroyed. The two large retail stores are also complete losses.

Figure 5-22:  
View of steel joist pockets in CMU wall where joists pulled out (red arrows); the exterior CMU wall fell inwards, shown in the foreground (Tuscaloosa, AL)



Figure 5-23:  
Steel joists with joist seat and bond beam on top of collapsed wall (red arrow). Wall fragmentation shows lack of reinforcement in the wall (Tuscaloosa, AL).



#### 5.2.4 Jefferson Metro Care (Birmingham, AL)

**Location of Facility in Tornado Path:** The MAT visited the Jefferson Metro Care facility in Birmingham, AL (location shown in Figure 5-24), which was destroyed during the April 27, 2011 tornado. The Jefferson Metro Care facility was located just north of the centerline of the tornado damage swath. The NWS rated the center of the tornado circulation in the vicinity of this facility as EF2.



Figure 5-24: Aerial view showing the Jefferson Metro Care Facility (red box) in relationship to the approximate centerline of the April 27, 2011 tornado damage swath (red line) (Birmingham, AL)

**Facility Description:** The Jefferson Metro Care building had a footprint of roughly 130 feet by 75 feet. The structural and roof covering system for this building used the following elements:

- + Built-up roofing
- + Insulation board
- + Metal roof deck
- + Open web steel joists
- + Steel beam girders
- + CMU with brick veneer exterior walls
- + Shallow foundation

**General Wind Damage:** Most of the exterior walls of the facility withstood the tornado, but a large portion of the northwest roof was damaged when the building envelope was breached at the front windows. Inflow winds resulted in high uplift forces on the roof. The windows along the front exterior walls were blown in by windward pressure.

### Exterior CMU Walls with Brick Veneer

The exterior walls of the Jefferson Metro Care building were constructed of CMU with a brick veneer. The MAT was unable to inspect the reinforcement in the majority of the walls that did not fail.

The roof connection to the exterior walls consisted of an embedded steel plate attached to bond beams. The roof joists were then welded to the steel embed plates. This connection tied into a bond beam running along the front and back walls of the building. The bond beam was supported by, but not connected to, a steel beam over the front windows. The bond beam along the front of the building broke away from the steel beam when the roof system was torn away, as shown in Figure 5-25. The interior joist seats tore away from their support on interior steel beams when they folded over the roof toward the rear of the building.

**Figure 5-25:**  
Failed bond beam-to-  
structural steel connection  
over front windows (red  
arrow) (Birmingham, AL)



### Roof System

The roof consisted of an open web steel bar joist system with a metal roof deck and membrane roofing. Most of the roof failures were a result of failure of the welds for the metal deck diaphragm, bar joists, and main structural beams. Figures 5-26 and 5-27 show the failed roof deck connections. Once struck by high winds, the roof decking was pulled off the bar joists as it was pulled over toward the rear of the building.

Another failure identified was the lack of continuity between the roof structure and the walls. Figure 5-28 shows where a bond beam cell has been stuffed with paper to limit the flow of the grout indicating a serious quality control issue during construction. Figure 5-29 shows a similar condition where the CMU cell is still attached to the steel joist but detached from the wall. Figure 5-30 shows a CMU bond cell that was torn from both the wall and the steel joist.



Figure 5-26:  
Roof joist lifted off front (red arrow) and folded over rear half of building (yellow arrow) (Birmingham, AL)



Figure 5-27:  
Failed roof deck with no connections between the roof deck and the joists (red arrows) (Birmingham, AL)



Figure 5-28:  
This CMU cell was found on the ground adjacent to the structure (shown upside down). The bond beam cell is sealed with paper to keep grout from flowing into lower cells (red arrow) and thus there was no connection to lower elements. The embed plate can be seen attached (yellow arrow) (Birmingham, AL).

Figure 5-29:  
Bar joist with embed  
plate and bond beam cell  
still attached (red arrow)  
(Birmingham, AL)



Figure 5-30:  
Embed plate with bond beam  
cell (red arrow) on roof  
(Birmingham, AL)



**MAT EF Rating:** Using DI 9 (Small Professional Building), the MAT selected DOD 7 (“uplift or collapse of entire roof structure”) for this building. Using the expected wind speed for DOD 7, the MAT derived the tornado rating as a high EF1 (100–105 mph winds). Therefore, the estimated wind speed experienced by the building was in excess of the 90 mph building code design requirements for this location.

The nearest damage survey point assessed by NWS had a rating of EF2. The Jefferson Metro Care building falls within the swath projected from NWS for an EF1 rating, which matches the EF rating derived by the MAT.

**Functional Loss:** The main floor experienced moderate damage from wind-borne debris and water damage after the roof system was torn away from the front part of the building. This damage rendered the building uninhabitable. The tenant, Jefferson Metro Care, relocated to another nearby facility to resume their practice. The building will need significant repairs to the roof and interior before it can be fully functional.

### 5.2.5 Walmart (Joplin, MO)

**Location of Facility in Tornado Path:** The MAT inspected the Walmart in Joplin, MO, which was severely damaged during the May, 2011 tornado. Figure 5-1 shows the location of the Walmart with respect to the tornado damage swath in Joplin. Figure 5-31 shows the building after the tornado and the tornado damage swath in the vicinity of the building. The Walmart was located just north of the centerline of the tornado damage swath. The NWS rated the center of the tornado circulation in the vicinity of the Walmart as EF5. According to a local Walmart representative, there were three deaths among the 200 occupants who were inside the facility during the tornado.



Figure 5-31: Aerial view of a Walmart in Joplin, MO (red box) in relationship to the approximate centerline of the May 22, 2011 tornado damage swath (red line) (Joplin, MO)

**Facility Description:** The Walmart building footprint was approximately 180,000 square feet, 300 feet x 600 feet. The structural and roof covering system consisted of the following elements:

- +Membrane roofing
- +Insulation board
- +Metal deck roof
- +Open web steel joists
- +Open web steel joist girders
- +Square tube columns supporting joist girders
- +Exterior reinforced CMU walls
- +Shallow foundations

**General Wind Damage:** The north portion of the Walmart building remained standing (Figure 5-32) with the majority of its roof structure in place. The south portion of the building lost its roof structure and some of the exterior walls collapsed. At the time the MAT visited, site cleanup of the interior space had been in progress for several days and most of the store contents had been removed.

Figure 5-32:  
The relatively undamaged west elevation of Walmart after the May 22, 2011 tornado (Joplin, MO)



## Roof System

There are two damage levels that occurred within this structure.

North half of building: Within the west side of the north half of the building, the structure remained relatively undamaged, though water infiltration occurred in two places. The roof membrane was compromised, which allowed water infiltration. The exterior envelope of the structure was also compromised, at the north entry on the west side, which allowed water into the interior space via the doors.

The east side of the building within the north half was compromised. The east wall and roof were destroyed beginning at approximately the loading docks on the east side (Figures 5-33 and 5-34). The failures resulted in significant water infiltration. Figure 5-35 is looking north inside the space; note the water level inside the Walmart bag in the lower right corner of the photograph.





Figure 5-33:  
Interior of the north half of  
the Walmart, looking east.  
Fallen roof structure shown  
in right side of the picture  
(red arrow) (Joplin, MO).



Figure 5-34:  
Destroyed east side of north  
half of Walmart (note loading  
dock facing south) (Joplin,  
MO)

Figure 5-35:  
Interior of the north half  
of building showing water  
infiltration collected in bags  
(red arrow) (Joplin, MO)



South half of building: The south half of the building was hardest hit as it was closest to the tornado track. The roof system, including structural members, failed and compromised the integrity of the load carrying systems.

Puddle welds were used to connect the steel roof deck to the top chords of the steel joists. The MAT observed many instances where this connection failed. Figure 5-36 shows the deck supporting the steel joist since the joist girder is no longer there. Figure 5-37 is taken from the outside of the roof portion of the building looking north; the insulation board is still in place on much of the roof, but the roof membrane is missing.

The typical connection of steel joists to joist girders is provided by welds from the joist seat to the girder top chord. Figure 5-38 shows the failure of these welds in this roof assembly. Another industry practice is not welding the bottom chord to the stabilizer plate on joist girders at the column support. This allows for slight flexural movement and rotation at the supports of the girders as they get loaded and unloaded. If the system is designed as a moment frame system this is often welded. At the Walmart, the bottom chord was not welded. Without the bottom chord being welded all of the torsional resistance of the joist must occur at the top chord angle seat connection. The MAT observed several instances of separation such as shown in Figure 5-39.



Figure 5-36:  
Interior view from the south half of the building looking toward the east. This shows the boundary of roof damage to the south portion of the building. Note deck supported by steel joist (Joplin, MO).



Figure 5-37:  
View of the south half of the building looking north showing roof damage. Note the missing roof membrane (Joplin, MO).

### Interior Columns

The interior columns were steel HSS (tube) sections. The MAT observed several instances where the columns were leaning at a severe angle, but were still attached to the foundation, indicating good anchorages that survived large deformations. Figure 5-40 shows a column that is bent completely over, but is still attached to the foundation. Figure 5-41 shows the roof structure that remained standing in the south portion of the building.

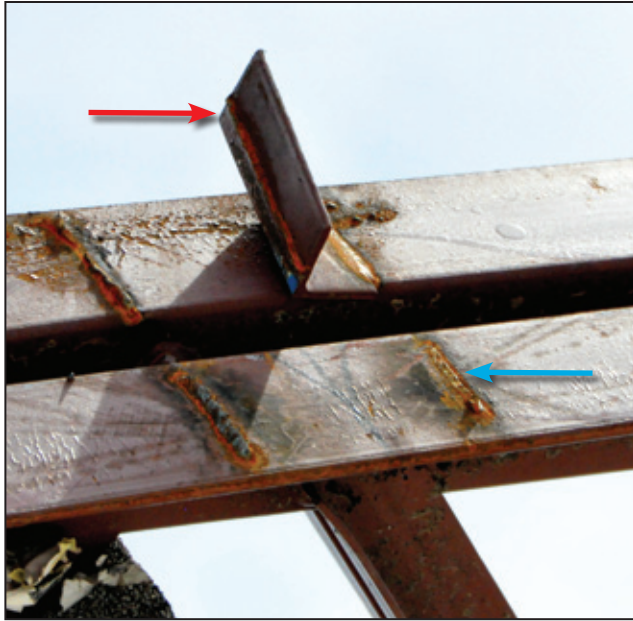

Figure 5-38: Typical connection of two steel joists to joist girder. While the joist seat from one joist remains (red arrow), the weld failed at the other joist seat connection (blue arrow) (Joplin, MO).



Figure 5-39: Joist girder rotated at the column; the bottom chord was not attached to the stabilizer plate (shown by red arrow). The joists were attached with welds to the joist girder top chord. This weld connection failed in the location shown (yellow arrow) (Joplin, MO).

Figure 5-40:  
Collapsed column with hooked anchor bolts remains attached to the foundation at the base (Joplin, MO)





Figure 5-41:  
Roof structure remaining in south half of Walmart. The red arrow shows the location of a column embedded in the wall (Joplin, MO).

### Exterior Walls

The exterior walls of the Walmart were reinforced CMU. In the northwest portion of the building the walls performed adequately (Figure 5-41, upper right side). The walls on the south half of the building and northeast half of the building collapsed. The connections at the roof failed and caused the walls to behave as a tall cantilever wall which caused the bending stresses in the wall and the shear and moment stresses at the base of the wall to exceed the material stress capacity.

The connection at the base of the wall typically consists of reinforcing steel embedded into the foundation and then extended into the CMU cells. The cells are then grouted, locking the reinforcing in place and allowing it to transfer both uplift and lateral loads. Figure 5-42 shows reinforcing cast into the foundations.



Figure 5-42:  
Reinforcing steel in Walmart foundation (Joplin, MO)

The roof-to-wall connection for a CMU wall system is similar to the connections for a precast tilt-up wall system. The connections consist of an embedded steel plate connected to the roof members. Where the steel joists are perpendicular to the wall there are pockets or a ledger angle where the joists are connected. The walls that are parallel to the joists are connected to the roof diaphragm with a deck support angle attached to the panel with bolts or weld plates and the deck is attached to the angle. There are more substantial connections at the joist girders. An additional connection also occurs where the joist bridging attaches to the wall, which is provided by the steel joist supplier. This connection is often neglected as the typical bridging member sizes are small or are poorly connected to the joists and girders reducing the effectiveness of the roof in resisting load reversals and uplift.

The roof connections at Walmart were of this typical design. The joists were connected to the walls by welding to embedded steel plates grouted into the CMU. The joist girders were supported on columns embedded in the walls (Figure 5-41 red arrow). The Walmart roof joists were connected to the joist girders with welds at the joist seat to top chord connections (Figure 5-39).

In some areas of the store, the roof and walls stayed intact enough that refuge could be found. The MAT observed a relatively undamaged space located in the southern end of the Walmart (Figures 5-43 through 5-45). Although the performance may have been circumstantial, this smaller space could have been a candidate for an area of refuge and designed/constructed accordingly.

**Figure 5-43:**  
Partial collapsed wall in southern half of store (note deck support angle at top of wall); area of limited damage shown by red arrow (Joplin, MO)





Figure 5-44:  
Area of relatively limited damage. Photograph was taken looking north (Joplin, MO).



Figure 5-45:  
Another view of the area shown in Figure 5-44. Photograph was taken looking east (Joplin, MO).

**MAT EF Rating:** Using DI 12 (Large Isolated Retail Building), the MAT selected DOD 6 (“inward or outward collapse of exterior walls”) for this building. Using the expected wind speed for DOD 6, the MAT derived the tornado rating as EF4 (165–175 mph winds). Therefore, the estimated wind speed experienced by the building was well in excess of the 90 mph building code design requirements for this location. The MAT EF4 rating for the Walmart is lower than the NWS rating of EF5 for the center of the tornado circulation near the building.

**Functional Loss:** The Walmart in Joplin is a complete loss.

## 5.3 Light Steel Frame Buildings

The MAT observed damaged buildings that were constructed using light steel frames. This type of building construction is described in Section 5.3.1 and its typical failure modes in Section 5.3.2. Two buildings of this construction type were assessed by the MAT and are described in detail in Sections 5.3.3 and 5.3.4. A lack of wind resistance was observed in the roof purlins and the frame-to-foundation connection in this light steel frame construction.

### 5.3.1 Description of Construction Method and Load Path

Light steel frame construction is common for commercial buildings. These buildings are typically only one or two stories. They range from steel stud framing systems, which are constructed in a manner similar to wood framed buildings, to pre-engineered steel rigid frame truss buildings (i.e., pre-engineered metal building [PEMB]) that are fabricated offsite and erected on foundation slabs and covered with light gauge steel panels.

**Steel stud framing systems:** Steel stud framing systems are commonly used for either light steel framed buildings or infill walls for other building systems. These walls are typically braced by using steel straps or angles attached to the outside of wall systems. The interior of the walls are usually gypsum wallboard and the exterior is covered with brick veneer, an exterior insulation and finishing systems (EIFS), or textured paneling systems. Steel framing also allows for large openings for glazing or doors, making it common for commercial store fronts. Roof systems are either wood or steel truss systems and depend on larger steel sections to carry loads down the framing system and into the foundation.

**Pre-engineered metal buildings:** PEMBs consist of a series of pre-engineered trusses, which are a set of columns and roof beams fabricated into a continuous steel frame section or “bent”. These sections are bolted to a foundation or slab by anchor bolts. The walls and roof are framed with a system of channels or z-shaped purlins (for roofs) and girts (for walls) before being covered with light gauge steel panels. Due to the extent of prefabrication available, these buildings can be quickly constructed for a relatively low cost. The frames resist lateral loading along the column and beam lines, but as these loads are applied, significant loads are transferred to the foundations of the building.

### 5.3.2 Typical Failure Modes Observed by the MAT

Light steel frame buildings have been developed to make this construction type economical to build. These structures often experience significant structural damage in high-wind events because there is no redundancy in their design and they are best suited where only normal downward vertical loads are the primary design loads. Failures observed by the MAT typically occurred either in the base plate/anchor bolt system or the anchor bolt pulling out of the foundation

High winds often damage the exterior finish or glazing of light steel frame buildings. Most of the exterior finish or glazing failures observed by the MAT in light steel frame buildings were the result of unprotected glazing or insufficient attachment of exterior cladding or veneers to the structural frame. Once the glazing is breached, the building interior is exposed to wind pressures, which subject the lightly built roof system to increased uplift loads.



### 5.3.3 Fitness Center (Tuscaloosa, AL)

**Location of Facility in Tornado Path:** The MAT inspected a fitness center in Tuscaloosa, AL, which was destroyed during the tornado. The location of this building is shown in Figure 5-2. Figure 5-46 shows the building after the tornado and the tornado damage swath in the vicinity of the building. This building was just east of the buildings discussed in Section 5.2.3. The fitness center was located on the southern periphery of the centerline of the tornado damage swath. The NWS rated the center of the tornado circulation in the vicinity of this building as an EF4.

**Facility Description:** The footprint of the building that sustained the most damage was roughly 90 feet by 130 feet. The structural and roof covering system consisted of the following elements:

- + Metal roofing and siding
- + Metal roof purlins
- + Insulation
- + Secondary metal framing
- + Steel clear-span moment frame system
- + Shallow foundations

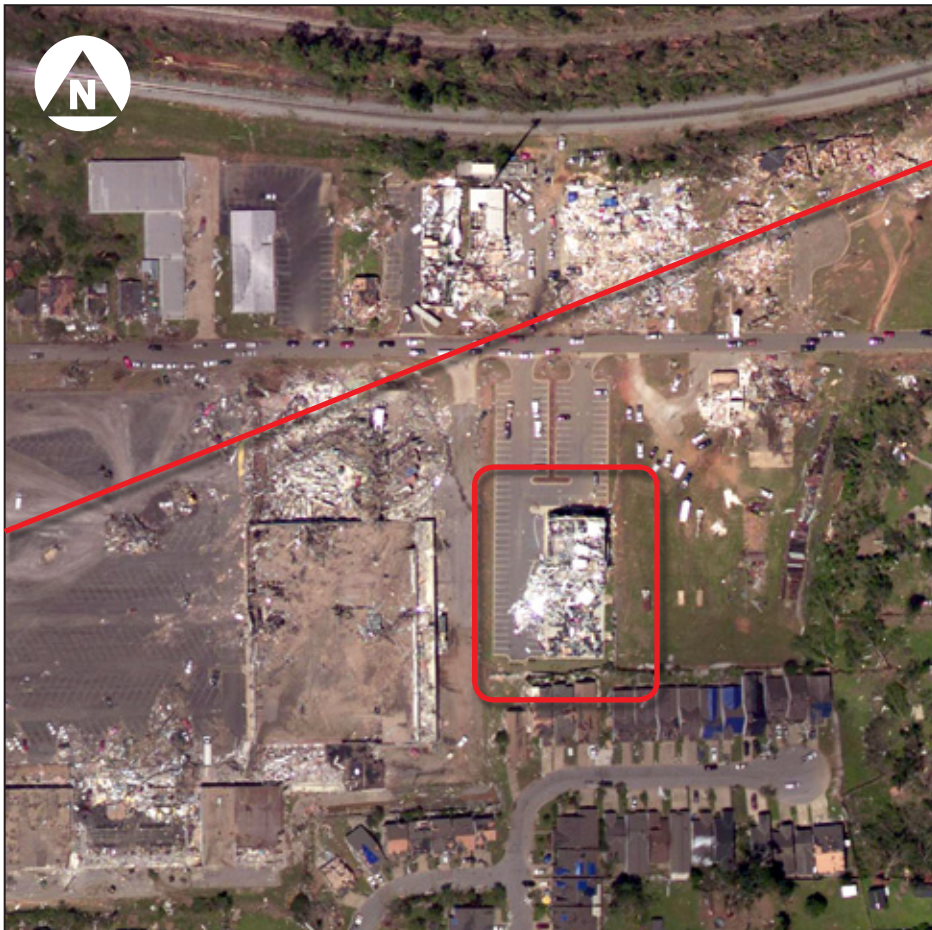

Figure 5-46:  
Aerial view of the fitness center (red box) in relationship to the approximate centerline of the April 27, 2011 tornado damage swath (red line) (Tuscaloosa, AL)

**General Wind Damage:** The southern part of the building was completely destroyed, while some of the northern part of the building was left standing (Figure 5-47). The failures observed were due to a breach of the building envelope from inflow winds that then resulted in excessive wind pressures being exerted on the MWFRS.

**Figure 5-47:**  
Front (north side) of fitness center building  
(Tuscaloosa, AL)



The MWFRS of the north end of this building performed well relative to the buildings in the immediate surroundings and exhibited ductility through much of the failure, providing cavities in which people could survive. The main column frame anchorages to the foundation performed well in the context of extreme overload (Figure 5-48). The column tore free from the base plate at the weld leaving the base plate and anchor rods in place. The steel anchor rods and base plates were stressed to the point of full yield—characterized by exaggerated deformation—which led to a failure of the welds to the columns (Figure 5-49).

**MAT EF Rating:** Using DI 21 (Metal Building Systems), the MAT selected DOD 7 (“progressive collapse of rigid frames”) for this building. Using the expected wind speed for DOD 7, the MAT determined the tornado rating as EF3 (140–145 mph winds). Therefore, the estimated wind speed experienced by the building was well in excess of the 90 mph building code design requirements for this location.

The MAT EF3 rating for the fitness center is somewhat lower than the NWS rating of EF4 for the portion of the tornado track near the building. The nearest NWS survey point was a small retail building approximately 1,000 feet west of the fitness center. The fitness center was not in the center of the tornado track and accordingly, wind speeds away from the center would result in a lower speed at the building.

**Functional Loss:** Most of the fitness center building in Tuscaloosa was destroyed.



Figure 5-48:  
The anchor bolts of this base plate connection performed well while the weld along the base of the steel column failed (red arrow) (Tuscaloosa, AL)



Figure 5-49:  
Ductile end column at southwest corner of building (red arrow). The anchor bolts remained attached to both the foundation and the column (Tuscaloosa, AL).

### 5.3.4 St. Paul's United Methodist Church (Joplin, MO)

**Location of Facility in Tornado Path:** The MAT inspected St. Paul's United Methodist Church in Joplin, MO, which was heavily damaged during the tornado. The church was located on the periphery of the tornado track; the NWS rated the center of the tornado circulation in the vicinity of the church as EF2. Figure 5-1 shows the location of the building relative to the tornado damage swath. Figure 5-50 shows a close-up aerial view of the building and its proximity to the tornado damage swath.



Figure 5-50: Aerial view of St. Paul's United Methodist Church (red box) (Joplin, MO) in relationship to the approximate centerline of the May 22, 2011 tornado damage swath (red line) (Joplin, MO)

**Facility Description:** The footprint of the building that sustained the most damage was roughly 11,700 square feet with dimensions of 90 feet by 130 feet. The structural and roof covering system consisted of the following elements:

- +Metal roof decking
- +Metal roof purlins
- +Insulation
- +Secondary metal framing
- +Steel clear-span moment frame system
- +Shallow foundations

**General Wind Damage:** The southern wing of the St. Paul's United Methodist Church complex was heavily damaged to the point of being substantially destroyed. The MWFRS used for the building exhibited good performance and was left standing as well as several interior walls (Figure 5-51). However, the roof, siding, and end walls were completely removed. The damage to these building envelope elements was due to the breaching of the building envelope from tornado winds, which

resulted in a failure of these secondary elements relieving the internal wind pressure from the MWFRS (Figure 5-52). The primary main column frames and their anchorage to the foundation performed very well (Figure 5-53).



Figure 5-51:  
Intact PEMB main frames  
(red arrow) (Joplin, MO)



Figure 5-52:  
Roof system purlins intact  
with metal roof clip released  
(red arrows) (Joplin, MO)

Figure 5-53:  
Secondary framing (light gage infill walls) failed (yellow arrow) while the main frames survived (red arrow) (Joplin, MO)



**MAT EF Rating:** Using DI 21 (Metal Building Systems), the MAT selected DOD 3 (“metal roof or wall panels pulled from the building”) for this building. Using the expected wind speed for DOD 3, the MAT derived the tornado ranking as EF1 (100–105 mph winds). Therefore, the estimated wind speed experienced by the building was in excess of the 90 mph building code design requirements for this location. The MAT EF1 rating for the church is lower than the NWS rating of EF2 for the center of the tornado circulation near the building.

**Functional Loss:** The southern wing of the St. Paul’s United Methodist Church complex will need to be completely rebuilt. Although large portions of the MWFRS remained intact, the secondary elements suffered severe damage. This exposed the interior to major wind damage that will require full reconstruction.

## 5.4 Reinforced Concrete Frame with CMU Infill Walls

The MAT inspected one building constructed using a concrete frame with CMU infill walls. This type of building construction is described in Section 5.4.1 and its typical failure modes in Section 5.4.2. The MAT findings for the building are described in Section 5.4.3. The building was located outside of the periphery of the tornado damage swath; the NWS rated the center of the tornado circulation in the vicinity of this building as EF4 to EF5. The damage may have been due to the building being taller than any of the surroundings and therefore more exposed to the high winds.

### 5.4.1 Description of Construction Method and Load Path

Reinforced concrete frame buildings are commonly used in multi-story commercial and industrial buildings. The building's primary structural elements are cast-in-place concrete, which creates a large heavy structural frame. The structural elements are the floor system, the beams or joists for the floors, the columns, and the foundations. This construction typically results in substantial redundancy in the structural systems.

### 5.4.2 Typical Failure Modes Observed by the MAT

The failures observed by the MAT in reinforced concrete frame buildings were limited to the secondary elements and the building envelope. The MWFRS of the buildings remained undamaged by the tornado winds.

### 5.4.3 Ozark Center for Autism (Joplin, MO)

**Location of Facility in Tornado Path:** The MAT inspected the Ozark Center for Autism in Joplin, MO, which was damaged during the tornado. The building is located just outside the periphery of the tornado damage swath; the NWS rated the center of the tornado circulation in the vicinity of this facility as EF4 to EF5 (Figure 5-1). Figure 5-54 shows a close-up aerial view of the building after the tornado and its relationship to the tornado damage swath.

**Facility Description:** The building footprint of the Ozark Center for Autism is approximately 450 feet x 250 feet. The structural and roof covering systems include:

- + Standing seam metal roof
- + Ballasted roof covering (original system)
- + Poured-in-place concrete roof and floor slabs
- + CMU elevator and stair shafts
- + Poured-in-place concrete columns
- + CMU infill walls
- + Exterior furring and metal wall panels over the CMU
- + Steel roof trusses (east extension)

**General Wind Damage:** The structural core of the Ozark Center for Autism was not significantly damaged; the structural systems on this building performed very well. The building envelope, however, was heavily damaged. The primary damage occurred to the roofing materials and glazing (Figure 5-55). The metal architectural panel siding on the building failed, as would be expected in this type of event.

After the tornado, the damage to the building consisted of:

- + Loss of exterior skin
- + Loss of roof



Figure 5-54: Aerial view of the Ozark Center for Autism (red circle) in relationship to the approximate centerline of the May 22, 2011 tornado damage swath (red line) (Joplin, MO)

- + Loss of exterior glazing
- + Water damage to the building interior
- + Loss of exterior building walls at the two-story extension

### Building Construction

The Ozark Center is a three-story main building that has a two-story extension on the east side (Figure 5-56). Figure 5-57 shows the typical interior layout of the main building with a perimeter beam and column system. There are two rows of center columns in the two-story extension. The slab is thickened between the rows of center of columns at each level. The remainder of the building is cast-in-place concrete.





Figure 5-55:  
East elevation of the Ozark  
Center for Autism showing  
damage to glazing and siding  
(Joplin, MO).



Figure 5-56: East elevation from northeast corner of building. The structural core of the taller building performed well, as did the CMU infill. The wing in the nearside of the figure is a two-story extension. Wood wall-framing debris can be seen in the foreground (Joplin, MO).

Figure 5-57:  
Two-story extension on east side of building shown in Figure 5-56; view shows typical interior layout (Joplin, MO)



### Roof System

The roof system on the main building consists of a poured-in-place concrete roof deck that was subsequently covered over by adding steel purlins attached to the roof deck at approximately 5 feet on center. The original concrete roof deck was undamaged. The MAT observed clips in place that would accept new roof material, most likely a metal roof deck system. The connection of the roof material to the purlins had failed and the roof material was not observed at the site (Figure 5-58).

Figure 5-58:  
Roof of the third-story main building. The roof overbuild purlins are shown with green arrows while the roof clips that unlatched are shown by red arrow (Joplin, MO).



The roof framing system at the two-story extension is constructed with engineered steel girders and steel joists that span between them. A metal roof deck is connected to the joists (Figure 5-59) and a ballasted roof system is placed over that. The same layered roof construction was used on the three-story main building.

A portion of the deck in the northeast corner of the two-story extension failed when the puddle weld connections failed, but the core structure remained in place (Figure 5-60).



Figure 5-59:  
Roof section at two-story extension showing how the metal roof deck diaphragm is connected to the joists (Joplin, MO)



Figure 5-60:  
View of roof of the two-story extension observed from the third floor. Note the failed decking at the corner (red arrow) (Joplin, MO)

### Floor System

The floor system is a reinforced poured-in-place concrete slab that spans between the perimeter beams and interior columns. It is approximately 6½ inches thick with a dropped section between the center columns. The MAT did not observe any damage to the floor system.

### Exterior Walls

The exterior walls of the main building consisted of a 4-foot-high CMU wall that was framed between the concrete columns. The CMU walls did not show signs of distress. The glazing that spanned from the top of the CMU walls to the underside of the concrete beam above was destroyed.

The exterior walls of the two-story extension were wood-framed walls with studs spaced at approximately 16 inches on center; these walls were destroyed. Portions of the wood can be seen in the foreground of Figure 5-56.

### Building Beams and Columns

The building layout is on column lines that are 21 feet x 17 feet. The two center columns are approximately 6 to 8 feet apart. The MAT did not observe any damage to the concrete beam-and-column structural frame system.

**MAT EF Rating:** Using DI 17 (Low-Rise Building), the MAT selected DOD 5 (“uplift of lightweight roof structure”) for this Ozark Center. Using the expected wind speed for DOD 5, the MAT derived the tornado ranking as EF3 (150-mph winds). Therefore, the estimated wind speed experienced by the building was well in excess of the 90 mph building code design requirements for this location.

The MAT EF3 rating for this building is substantially higher than the NWS rating of EF0 for this area. The NWS rated the center of the tornado circulation for this tornado as an EF5, but the Ozark center was outside the swath derived by the NWS. It is clear, however, the building incurred damage from tornado wind speeds. It is possible that the height of the building contributed to the damage, as it is considerably higher than the surrounding structures.

**Functional Loss:** The Ozark Center will need repairs to non-structural elements, as the main structure performed well and remained intact.

## 5.5 Summary of Conclusions and Recommendations

Table 5-1 summarizes the conclusions and recommendations for Chapter 5, *Observations on Commercial and Industrial Building Performance*, and provides references for supporting observations. Additional commentary on the conclusions and recommendations is presented in Chapters 10 and 11.

Table 5-1: Summary of Conclusions and Recommendations for Commercial and Industrial Building Performance

Observations	Conclusions (numbered according to Chapter 10)	Recommendations (numbered according to Chapter 11)
<p>Specific failure states and building survivability that could be addressed in the codes are seen in:</p> <ul style="list-style-type: none"> <li>• Home Depot (Section 5.1.3)</li> <li>• Fitness Center (Section 5.3.3)</li> </ul>	<p><b>Conclusion #3</b> Wind provisions of the current codes and standards are insufficient to manage building performance in overload events.</p>	<p><b>Recommendation #4</b> Include failure states and survivability in building codes and standards.</p>
<p>Large-footprint commercial structures with long-span roofs that would have possibly benefited from being Risk Category III under ASCE 7-10:</p> <ul style="list-style-type: none"> <li>• Home Depot (Section 5.1.3)</li> <li>• Walmart (Section 5.2.5)</li> </ul>	<p><b>Conclusion #3</b> Wind provisions of the current codes and standards are insufficient to manage building performance in overload events.</p>	<p><b>Recommendation #5</b> Change risk category for large-footprint commercial structures with long-span roofs to Risk Category III under ASCE 7-10.<sup>2</sup></p>
<p>Tornado hazard was not adequately addressed in the codes and standards used for construction:</p> <ul style="list-style-type: none"> <li>• Home Depot (Section 5.1.3)</li> <li>• Strip Mall (Section 5.2.3)</li> <li>• Jefferson Metro Care (Section 5.2.4)</li> <li>• Walmart (Section 5.2.5)</li> <li>• Fitness Center (Section 5.3.3)</li> </ul>	<p><b>Conclusion #3</b> Wind provisions of the current codes and standards are insufficient to manage building performance in overload events.</p>	<p><b>Recommendation #6</b> Improve design approach in ASCE 7 and IBC to address risk consistently across hazards.</p>
<p>Buildings that experienced wind loads that exceeded design wind loads:</p> <ul style="list-style-type: none"> <li>• Home Depot (Section 5.1.3)</li> <li>• Walmart (Section 5.2.5)</li> <li>• Fitness Center (Section 5.3.3)</li> </ul>	<p><b>Conclusion #3</b> Wind provisions of the current codes and standards are insufficient to manage building performance in overload events.</p>	<p><b>Recommendation #7</b> ASCE 7 should improve the commentary on code limitations.</p>
<p>Building codes and standards do not have clear risk tolerances defined, leading to misinformed decisions when seeking shelter from a tornado:</p> <ul style="list-style-type: none"> <li>• Home Depot (Section 5.1.3)</li> <li>• Walmart (Section 5.2.5)</li> </ul>	<p><b>Conclusion #3</b> Wind provisions of the current codes and standards are insufficient to manage building performance in overload events.</p>	<p><b>Recommendation #8</b> Clarify risk tolerance in ASCE 7 and IBC.</p>

<sup>2</sup> A Risk Category is assigned to buildings based on the risk to human life, health, and welfare associated with potential damage or failure of the building (per ASCE 7-10). The assigned Risk Category, I through IV, dictates the mean return interval for a design event that should be used when calculating the building's resistance to the events. In ASCE 7-05, Risk Categories were called "Occupancy Categories."

**Table 5-1: Summary of Conclusions and Recommendations for Commercial and Industrial Building Performance (continued)**

Observations	Conclusions (numbered according to Chapter 10)	Recommendations (numbered according to Chapter 11)
<p>Buildings that could have potentially benefited from redundancy of the MWFRS, ductility of connections, resilience, alternate load paths, design for load reversal, robust perimeter element design, continuity of boundary elements, good connectivity, and inclusion of discrete MWFRS components:</p> <ul style="list-style-type: none"> <li>• Home Depot (Section 5.1.3)</li> <li>• Strip Mall (Section 5.2.3)</li> <li>• Jefferson Metro Care (Section 5.2.4)</li> <li>• Walmart (Section 5.2.5)</li> <li>• Fitness Center (Section 5.3.3)</li> <li>• St. Paul's United Methodist Church (Section 5.3.4)</li> <li>• Ozark Center for Autism (Section 5.4.3)</li> </ul>	<p><b>Conclusion #3</b>  <b>Wind provisions of the current codes and standards are insufficient to manage building performance in overload events.</b></p>	<p><b>Recommendation #9</b>  <b>Include best practices for wind design in IBC.</b></p>
<p>Buildings that did not have a best available refuge area identified, a FEMA 361 or ICC 500-compliant safe room or storm shelter:</p> <ul style="list-style-type: none"> <li>• Home Depot (Section 5.1.3)</li> <li>• Strip Mall (Section 5.2.3)</li> <li>• Jefferson Metro Care (Section 5.2.4)</li> <li>• Walmart (Section 5.2.5)</li> <li>• Fitness Center (Section 5.3.3)</li> </ul>	<p><b>Conclusion #3</b>  <b>Wind provisions of the current codes and standards are insufficient to manage building performance in overload events.</b></p>	<p><b>Recommendation #16</b>  <b>Install a storm shelter or safe room or identify best available refuge areas in large-footprint buildings.</b></p>
<p>Lack of adequate signage provided to building users and occupants regarding building's design capacity:</p> <ul style="list-style-type: none"> <li>• Home Depot (Section 5.1.3)</li> <li>• Walmart (Section 5.2.5)</li> </ul>	<p><b>Conclusion #10</b>  <b>There was inadequate signage in commercial buildings.</b>  There is a lack of adequate signage in large commercial buildings to give building users and occupants a better understanding of a building's design capacity.</p>	<p><b>Recommendation #17</b>  <b>For all public buildings, install signage in a conspicuous place at building entrances.</b></p>
<p>According to management personnel interviewed by the MAT at a Lowes in Tuscaloosa, AL, flip charts helped the response of the store operators during the high stress and confusion of the tornados event by providing emergency protocols. Flip charts could have been potentially helpful for:</p> <ul style="list-style-type: none"> <li>• Home Depot (Section 5.1.3)</li> <li>• Strip Mall (Section 5.2.3)</li> <li>• Jefferson Metro Care (Section 5.2.4)</li> <li>• Walmart (Section 5.2.5)</li> <li>• Fitness Center (Section 5.3.3)</li> </ul>	<p><b>Conclusion #11</b>  <b>Emergency operations flip charts can aid in decision making.</b></p>	<p><b>Recommendation #18</b>  <b>Place decision-making check lists or flip charts in prominent locations.</b></p>

**Table 5-1: Summary of Conclusions and Recommendations for Commercial and Industrial Building Performance (concluded)**

Observations	Conclusions (numbered according to Chapter 10)	Recommendations (numbered according to Chapter 11)
Buildings which used unreinforced masonry as primary support: <ul style="list-style-type: none"> <li>Strip Mall (Section 5.2.3)</li> </ul>	<b>Conclusion #12</b> <b>URM performed poorly as primary support.</b>	<b>Recommendation #19</b> <b>Do not use URM in primary or critical support areas of a building.</b>
The MAT noted that the connections between primary structural members on many buildings were the initial point of failure of the structural systems: <ul style="list-style-type: none"> <li>Home Depot (Section 5.1.3)</li> <li>Walmart (Section 5.2.5)</li> <li>Ozark Center for Autism (Section 5.4.3)</li> <li>Jefferson Metro Care (Section 5.2.4)</li> </ul>	<b>Conclusion #13</b> <b>Connections between primary structural members were often the initial point of failure.</b>	<b>Recommendation #20</b> <b>Use screws in deck-to-joist connections instead of puddle welds.</b>
Buildings that could have potentially benefited from enhancements to building connections beyond code requirements: <ul style="list-style-type: none"> <li>Home Depot (Section 5.1.3)</li> <li>Walmart (Section 5.2.5)</li> <li>Ozark Center for Autism (Section 5.4.3)</li> <li>Jefferson Metro Care (Section 5.2.4)</li> </ul>	<b>Conclusion #13</b> <b>Connections between primary structural members were often the initial point of failure.</b>	<b>Recommendation #21</b> <b>Include enhancements to building connections beyond the code requirements.</b>
Large-footprint commercial structures with long span roofs which progressively collapsed: <ul style="list-style-type: none"> <li>Home Depot (Section 5.1.3)</li> <li>Walmart (Section 5.2.5)</li> </ul>	<b>Conclusion #14</b> <b>Lack of redundant stability systems or non-discrete structural systems contributed to progressive collapse.</b>  This type of failure occurred in large-footprint commercial structures with long-span roofs occurred when small local failures progressed to larger areas of failure.	<b>Recommendations #22, #23, and #24</b>  <b>(#22) Incorporate redundancy in the MWFRS.</b>  <b>(#23) Incorporate more redundancy in the design of large-footprint buildings.</b>  <b>(#24) Use discrete structural systems in large, long-span buildings.</b>







## TORNADO OUTBREAK *of* **2011**

IN ALABAMA, GEORGIA, MISSISSIPPI,  
TENNESSEE, AND MISSOURI

# 6 Observations on Critical Facility Performance: Schools

*The MAT observed a total of 41 critical facilities in the path of tornado tracks or track periphery areas across five States.*

Critical facilities include schools, healthcare facilities, police and fire stations, and emergency operations centers (EOCs). Critical facilities are vitally important to communities that have been struck by tornadoes. Functional schools are needed to provide educational continuity and they are often used to provide space for recovery operations. Functional hospitals and other healthcare facilities are needed to treat injuries and provide routine on-going care to the community. Functional police and fire stations and EOCs are needed to manage their normal mission, along with response and recovery operations after an event.

The tornadoes in April and May of 2011 significantly affected many critical facilities, totally destroying some of them and severely interrupting the operations of several others. Some of the observed facilities were damaged by winds that were below current design wind speeds. Most of the critical facilities observed did not perform any better than commercial buildings and several performed poorly. The damage to these buildings resulted in occupant deaths and injuries, and put many other occupants at risk of injury. Building damage also placed additional burdens on

response and recovery personnel as they endeavored to provide assistance to their communities after the event.

Chapters 6 and 7 describe the performance of some of these critical facilities. The facilities that are discussed in Chapters 6 and 7 were selected to document lessons learned, both good and bad. Some of these facilities are representative of various issues, such as common tornado vulnerabilities of older buildings. Other facilities are discussed because of their unique attributes.

In addition to describing facility performance, Chapters 6 and 7 also report on operational issues associated with tornado watches and warnings issued by the NWS. Because of different strategies that may be implemented for schools versus healthcare, police and fire stations, and EOCs, schools are addressed in this chapter and the other facilities are addressed in Chapter 7. See Section 6.2 for discussion of operational issues in the respective chapters.

### General Discussion on Critical Facilities

Critical facilities are Category III and IV buildings as defined in the 2009 IBC (Section 1604, *General Design Requirements*, Table 1604.5) and ASCE 7-05 (Section 1.5, *Classification of Buildings and Other Structures*, Table 1-1). Category III and IV buildings include, but are not limited to, hospitals and other medical facilities, fire and police stations, primary communications facilities, EOCs, schools, shelters, and power stations and other facilities required in an emergency. FEMA considers critical facilities as those buildings that are essential for the delivery of vital services or protection of a community (FEMA 2007a).

The 2009 edition of the IBC has only two special wind-related provisions pertaining to Category III and IV buildings:

- + *Importance Factor*: The Importance Factor for these buildings is 1.15, rather than the 1.0 factor that is used for most other types of buildings. Using the 1.15 Importance Factor effectively increases the wind design loads by 15 percent.
- + *Wind-borne debris loads*: For buildings located within wind-borne debris regions (as defined in ASCE 7-05) of hurricane-prone regions, exterior glazing is required to be impact resistant. For Category III and IV buildings located where the basic wind speed is 130 mph or greater, the glazing is required to resist a larger momentum missile load than the glazing on other types of buildings.

This provision is not applicable to the facilities observed by the MAT, because none of the facilities were located in a hurricane-prone region.

### Critical Facilities Observed by the MAT

All of the 41 observed critical facilities were located where the basic (design) wind speed prescribed in IBC 2009 is 90 mph. Table 6-1 lists the type and total number of critical facilities observed by the MAT. The locations of the Tuscaloosa and Joplin critical facilities described in this report are shown on Figure 6-1 (April 25–28 tornado event) and Figure 6-2 (May 22, Joplin, MO, tornado event); the schools described in this chapter are highlighted.

Table 6-1: Number of Critical Facilities Observed by the MAT

Facility Type	Alabama	Georgia	Mississippi	Tennessee	Joplin, Missouri	Total Number of Facilities Observed by MAT	Total Number of Facilities Described in MAT Report
Schools (Section 6.1)	9	2	1	2	6	20	6
Hospitals/healthcare (Section 7.1)	3	0	0	0	2	5	4
Police, Fire (Section 7.2)	10	0	2	0	3	15	4
EOCs (Section 7.3)	2*	0	0	0	0	2	2
<b>Total</b>	<b>23</b>	<b>2</b>	<b>3</b>	<b>2</b>	<b>11</b>	<b>42</b>	<b>16</b>

\* The Cullman County EOC, AL, was visited but was not in the tornado track (see Section 7.3.2).

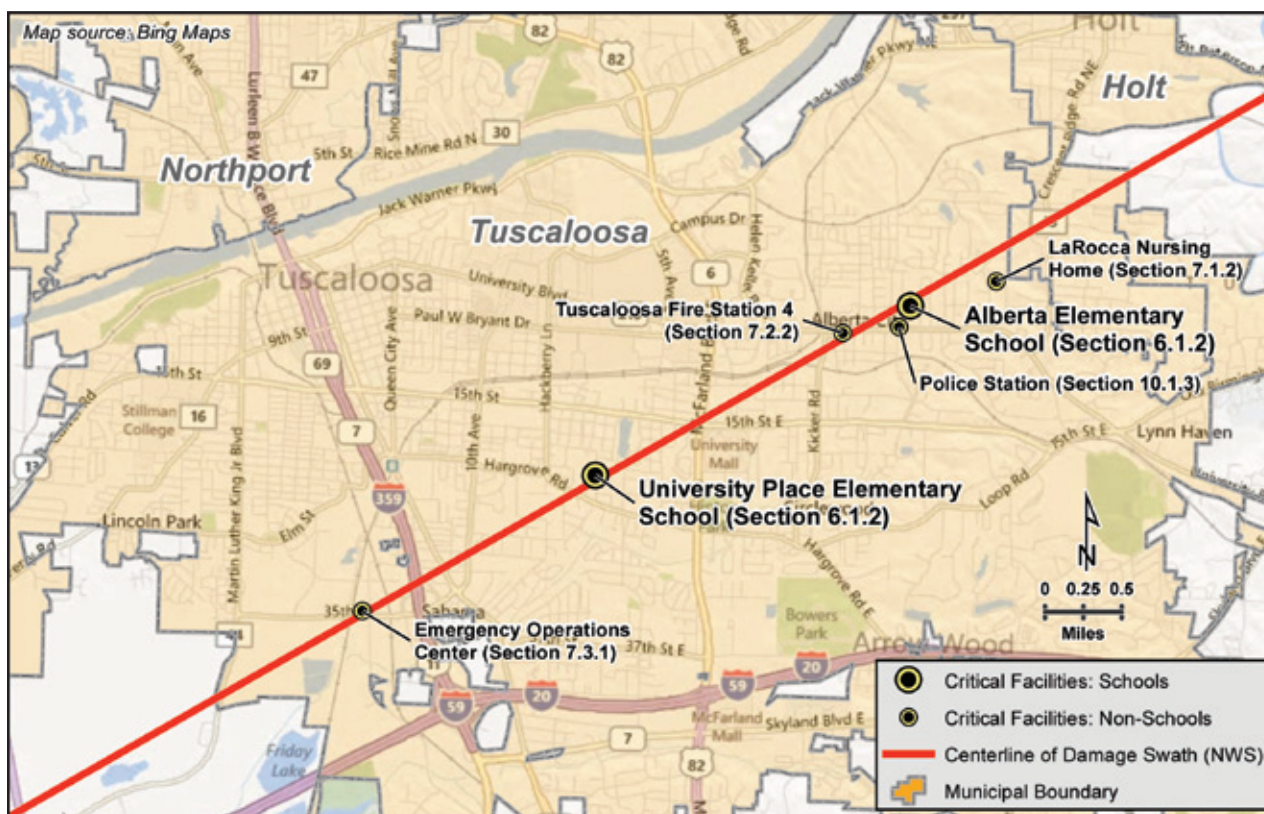

Figure 6-1: Location of Tuscaloosa, AL, critical facilities described in Chapters 6 and 7. The EOC (southwestern end of tornado track shown, red line) is approximately 4.7 miles from the LaRocca Nursing Home (northeastern end of tornado track shown).

SOURCE FOR TORNADO TRACK: [HTTP://WWW.SRH.NOAA.GOV/SRH/SSD/MAPPING](http://www.srh.noaa.gov/srh/ssd/mapping)

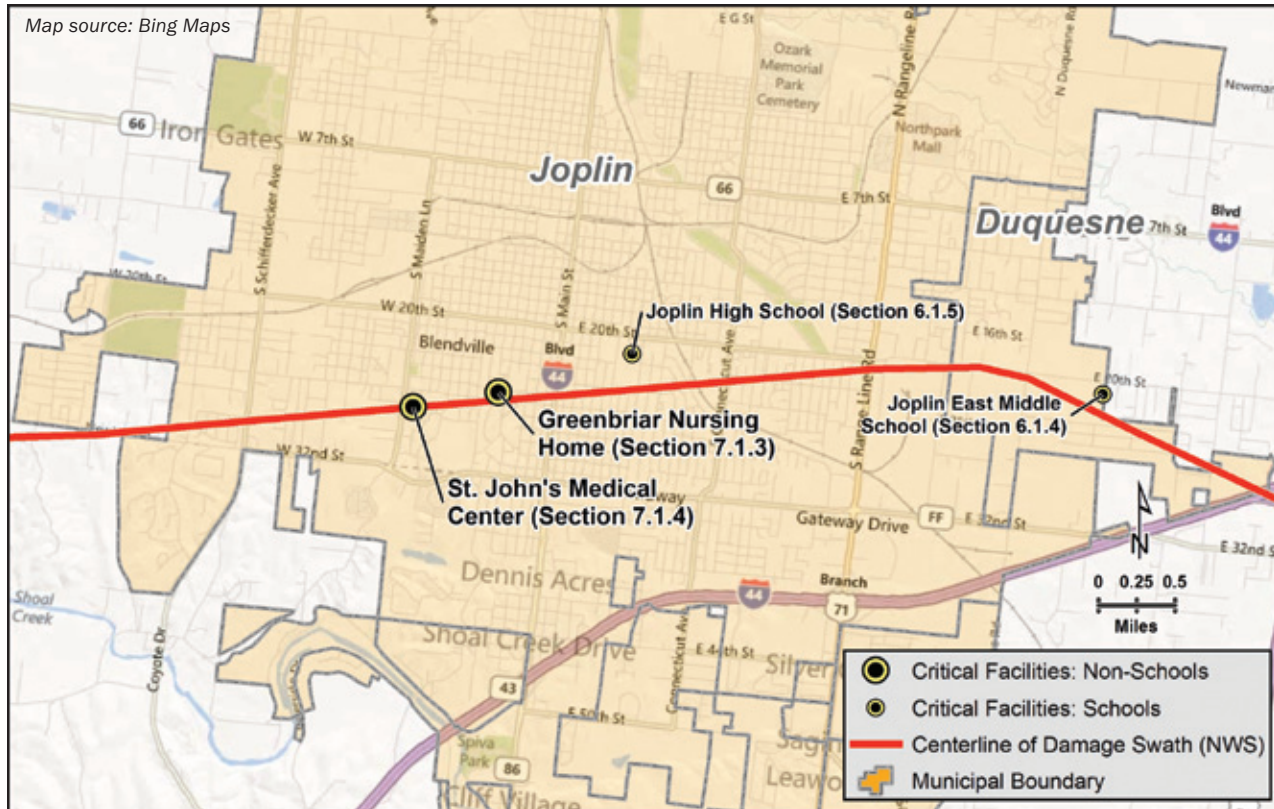

Figure 6-2: Location of Joplin, MO, critical facilities described in Chapters 6 and 7. It is approximately 4.5 miles from the St. John's Medical Center (western end of tornado track) to the East Joplin Middle School (eastern end of tornado track).

SOURCE FOR TORNADO TRACK: [HTTP://WWW.CRH.NOAA.GOV/SGF/?N=EVENT\\_2011MAY22\\_SUMMARY](http://www.crh.noaa.gov/sgf/?N=EVENT_2011MAY22_SUMMARY)

In addition to the 41 critical facilities that were in tornado tracks or track periphery, the MAT visited some additional facilities that were outside of the tracks or track periphery. Some of these additional critical facilities were not struck by high winds, and thus were not damaged. However, some of these additional critical facilities were damaged by thunderstorm winds. None of the observed schools located outside of tracks or track periphery are discussed in this report.

## 6.1 Building Performance

In addition to their traditional role as educational facilities, schools can play an important role in providing space for recovery after a tornado. Thus, their loss of use can affect a community's ability to rapidly respond to the needs of disaster victims, as well as hamper resumption of school activities.

### 6.1.1 Alberta Elementary School (Tuscaloosa, AL)

**Location of Facility in Tornado Path:** The location of the Alberta Elementary School is shown in Figure 6-1. Figure 6-3 shows an aerial view of the tornado track in the vicinity of the school. The NWS rated the center of the tornado circulation in the vicinity of the school as an EF4. According to

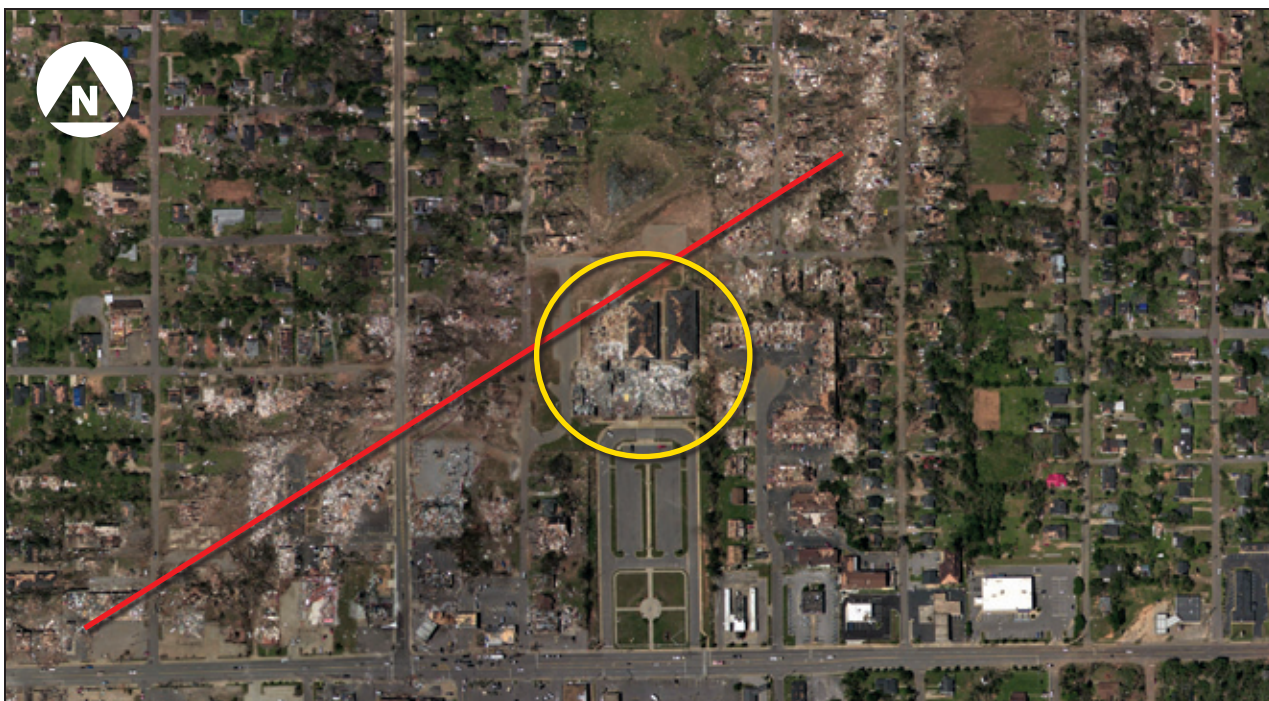

Figure 6-3: Aerial view of tornado track in vicinity of Alberta Elementary School (yellow circle). The center of the damage swath is approximated by the red line<sup>1</sup> (Tuscaloosa, AL).

SOURCE: ALL AERIAL PHOTOGRAPHS ARE FROM NOAA IMAGERY ([HTTP://NGS.WOC.NOAA.GOV/STORMS](http://ngs.woc.noaa.gov/storms)) UNLESS OTHERWISE NOTED

a representative of the school district, the school was not occupied when the tornado struck because the NWS warnings were issued well in advanced of the tornado.

**Facility Description:** The Alberta Elementary School opened in 2002. The one-story school had three classroom wings and a central core area. The central core area included the cafeteria, kitchen, media center, multipurpose room, music room, and offices. The wings and core area had 4:12 sloped roofs composed of asphalt shingles over plywood decking over wood roof trusses. The exterior walls were load bearing. At the wings and portions of the core, the exterior walls were brick veneer over steel studs. Other portions of the exterior core walls were brick veneer over reinforced CMU.

According to the contract drawings, the building was designed in accordance with the 1994 SBC. However, the wind loads were based on the 1995 edition of ASCE 7 using a basic wind speed of 90 mph, Importance Factor of 1.15, and Exposure B.<sup>2</sup>

The school had severe weather tornado refuge areas identified on floor plans that were posted in corridors. The refuge areas for the two surviving wings were located in the central core area (shown by the red arrow in Figure 6-4).<sup>3</sup>

- 1 The red line in this and all similar figures is intended to represent the center of the damage swath. The track location is approximated by the MAT based on post-event aerial photographs. The actual centerline of circulation is offset from the centerline of the damage.
- 2 The basic wind speed, Importance Factor, and Exposure for this facility are the same in both the 1995 and 2005 editions of ASCE 7.
- 3 Presumably the tornado refuge area in the wing of the school that was destroyed was also located in the central core area where all the buildings converged, but the MAT was unable to confirm this.

**General Wind Damage:** One classroom wing and most of the central core collapsed (Figures 6-4 to 6-6, 6-9, and 6-10). The tornado refuge areas for the two surviving wings were destroyed (Figure 6-5). Figure 6-5 shows a portion of the collapsed central core area and the two wings that survived. The MAT judged the limited damage at the surviving wings to be due to shielding provided by the third wing and core area, rather than increased strength of these two wings.

**Figure 6-4:** Area shown in yellow circle of Figure 6-3. The classroom wings are indicated by “W” and the core area by “C.” The general location of the tornado refuge areas for the two surviving wings is shown by the red arrow. Yellow arrows indicate remnants of corridors between the core and wings. The blue arrows indicate restroom remnants. The yellow box indicates kitchen remnants (Tuscaloosa, AL).



**Figure 6-5:** View of the central core area. Tornado refuge areas for the two surviving wings were in the collapsed area (red circle). The yellow arrows indicate the two surviving wings (Tuscaloosa, AL).



Several of the interior walls in the core area were reinforced CMU. Most of these walls collapsed. At the wall shown in Figure 6-6, the rebar was spaced at 4 feet on center. The rebar that was in the collapsed portion had only about 2 inches of embedment into the grouted CMU that is still in place and does not significantly strengthen the joint between the base of the wall and the floor or provide resistance to toppling. Similar splice laps were noted at exterior walls.



Figure 6-6:  
Interior reinforced CMU  
wall in the central core area  
where rebar had deficient  
splice lap. Inset shows a  
close-up of the deficient  
splice lap (Tuscaloosa, AL).

Figure 6-7 shows one of the surviving classroom wings. All of the exterior windows and the glass vision panels in the exit doors were broken (there were eight windows along each of the long walls). This wing also lost a substantial amount of underlayment and asphalt shingles. The wing to the left of the area shown in the photograph lost a significant amount of deck sheathing at the far (south) end and several trusses were missing. Figure 6-8 shows the corridor in the surviving wing shown in Figure 6-7. A portion of the corridor wall partially collapsed.

Figure 6-7:  
Center classroom wing  
remains standing while the  
wing to the right (red arrow)  
collapsed (Tuscaloosa, AL)



Figure 6-8:  
Partially collapsed  
corridor wall (red arrow)  
(Tuscaloosa, AL)



Figure 6-9 shows the view looking down the corridor of the classroom wing that collapsed. The remnant shown by the red arrow is a restroom in the core area. The remnant shown by the blue arrow is the corridor between the collapsed wing and core. Figure 6-10 shows the reinforced CMU restroom remnant in the collapsed wing. The entire restroom area was open to the sky and there was a substantial amount of debris within the rooms. Although corridors and restrooms are sometimes the best available refuge areas, injury or death may occur in corridors and restrooms that are not specifically designed as safe rooms or storm shelters as shown in Figures 6-8 through 6-10 and as discussed in Chapter 9.





Figure 6-9: Looking down the corridor of the collapsed classroom wing; red arrow indicates a bathroom in the core remnant and yellow arrow indicates a corridor that remained standing (Tuscaloosa, AL)



Figure 6-10: The reinforced CMU walls around the restroom were left standing, but the rooms were littered with debris (as shown in the inset). The wall with the brick veneer (red arrow) was an exterior wall (Tuscaloosa, AL).

**MAT EF Rating:** Using DI 15 (Elementary School), the MAT selected DOD 10 (“total destruction of a large section of building or entire building”) for the school. Using the expected wind speed for DOD 10, the MAT derived the tornado rating as EF4 (166–200 mph) based on damage to this building. Hence, the estimated wind speed experienced by the building was substantially above the basic wind speed of 90 mph the building was designed for. As shown in Figure 6-3, this building is near the center of the damage swath. The MAT EF4 rating for this building correlates with the NWS rating of EF4 for the center of the tornado circulation.

The MAT judged the wind damage at this school to be due to its subjection to wind speeds substantially above the design wind speed.

**Functional Loss:** The building will need to be reconstructed before school can resume at this location. According to the school district's Web site, the students were temporarily housed at another school for the 2011–2012 school year. The goal is to have the new Alberta facility ready for occupancy in the fall of 2012.

### 6.1.2 University Place Elementary School (Tuscaloosa, AL)

**Location of Facility in Tornado Path:** The location of the University Place Elementary School is shown in Figure 6-1. Figure 6-11 shows a view of the school after the tornado. Figure 6-12 shows an aerial view of the tornado track in the vicinity of the school. The NWS rated the center of the tornado circulation in the vicinity of the school as an EF4. According to a representative of the school district, the school was not occupied when the tornado struck because the NWS warnings were issued well in advanced of the tornado.

**Figure 6-11:** University Place Elementary School after the tornado. The red arrow shows the collapsed second story of one of the classroom wings. Several broken windows were boarded up at the time of the MAT visit (blue arrow) (Tuscaloosa, AL).



**Facility Description:** The University Place Elementary School opened in 1997. A gymnasium was added in 2008. The original building had two two-story classroom wings, a two-story media center and office area, cafeteria, kitchen, and multipurpose room, as shown in Figure 6-13. All areas had 3:12 sloped metal roof panels attached to steel roof deck supported by steel roof joists. The exterior walls are brick veneer over CMU bearing walls. The bearing walls of the classroom wings are unreinforced. The bearing walls of the media center and multipurpose wing are reinforced. The joists were welded to a plate that had two headed studs embedded into a single bond beam with two #4 horizontal steel reinforcing bars. The second floor assembly was precast, pre-stressed hollow-core slabs with a concrete topping. The slabs rest on the CMU; there is no tie between the slabs and CMU. According to the contract drawings, the building was designed in accordance with the 1991 SBC, using a basic wind speed of 70 mph (fastest-mile).<sup>4</sup> For this building, the wind loads derived from the 1991 SBC for the roof structure are similar to those derived from the 2005 edition of ASCE 7.

<sup>4</sup> A 70 mph fastest-mile equates to about a 90 mph 3-second peak gust.



Figure 6-12: Aerial view of the tornado track in the vicinity of the University Place Elementary School (yellow circle). The center of the damage swath is approximated by the red line (Tuscaloosa, AL).

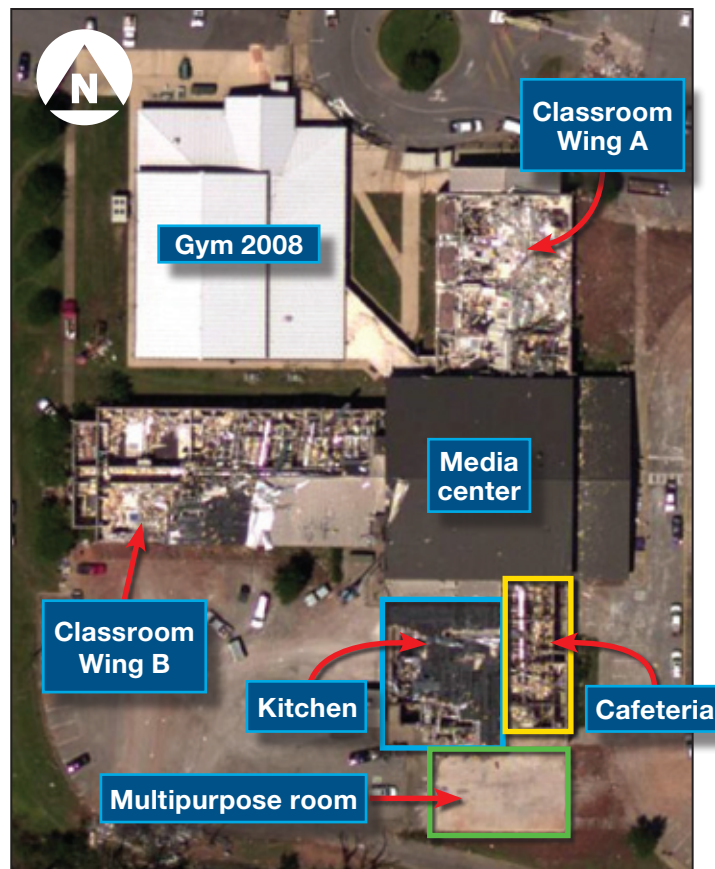

Figure 6-13: Close-up of Figure 6-12 showing classroom wings A and B and multipurpose wing (cafeteria, kitchen, and multipurpose room)<sup>5</sup> (Tuscaloosa, AL)

<sup>5</sup> The multipurpose room debris was removed before the MAT visited this site.

The gymnasium is a pre-engineered metal building. Some of the walls are brick veneer over CMU, while other walls are metal panels. According to the contract drawings, the building was designed in accordance with the 2003 IBC, using a basic wind speed of 90 mph, Importance Factor of 1.15, and Exposure C.

The school did not have a tornado safe room or storm shelter. The first floor corridors in the two classroom wings were the designated refuge areas. The corridors ran down the center of each wing. Each wing had a pair of standard exit doors with glass vision panels at the end of the corridor.

**General Wind Damage:** Several exterior windows were broken (Figure 6-11). Most of the exterior and interior walls of the second floor of classroom wing A collapsed (Figures 6-11, 6-13, and 6-14). About 75 percent of the roof decking of classroom wing B blew off (Figures 6-13 and 6-14) and about 25 percent of the roof joists also blew off of this wing. Some of the second floor exterior wall of classroom wing B also collapsed (Figure 6-15 and 6-16).

The multipurpose wing was also heavily damaged. At the cafeteria, all of the roof decking and several of the roof joists were blown off (Figure 6-17). At the kitchen, much of the roof decking and some roof joists were blown off (Figure 6-18). Some brick veneer and exterior CMU also collapsed. The multipurpose room was destroyed (Figure 6-18). There were two girders at the multipurpose



Figure 6-14: View looking south showing damage of the classroom wings (red arrows) and multipurpose wing (blue oval). The yellow arrow indicates damaged walkway canopy (Tuscaloosa, AL).

PHOTOGRAPH COURTESY OF TUSCALOOSA COUNTY SHERIFF'S OFFICE



Figure 6-15: View looking north showing wall and roof structure damage to classroom wing B (red arrow) and damage to the multipurpose wing (blue oval) (Tuscaloosa, AL)

PHOTOGRAPH COURTESY OF TUSCALOOSA COUNTY SHERIFF'S OFFICE



Figure 6-16:

View of the second floor damage to classroom wing B (red arrow in Figure 6-15). The inset shows a joist welded to a plate that was anchored to a bond beam where one of the headed studs broke off (red arrow). Hollow core slabs are shown, indicated by the yellow arrow (Tuscaloosa, AL).



Figure 6-17:  
View inside the cafeteria  
(Tuscaloosa, AL)



Figure 6-18:  
View toward the cafeteria  
(yellow arrow) and kitchen  
(red arrow) from within the  
multipurpose room. The  
inset shows a multipurpose  
room girder supported by a  
concrete column that is still  
in place (Tuscaloosa, AL).

room. The girders were supported by concrete columns (Figure 6-18 inset). One remained in place (Figure 6-18) and one blew away or collapsed (Figure 6-19).

The contract drawings indicate that the two multipurpose room girders were to be attached to the concrete columns with two  $\frac{3}{4}$ -inch diameter anchor bolts. At the failed girder shown in Figure 6-19, the girder bearing plate consisted of two plates that were welded together. There were two holes that were large enough to accommodate  $\frac{3}{4}$ -inch bolts in the bottom plate (Figure 6-19 top left inset). However, there was only one slotted hole in the top plate (Figure 6-19 bottom inset). Because of inadequate hole alignment, it was not possible for the girder plates to be anchored by  $\frac{3}{4}$ -inch bolts. Both ends of the girder were similar. Apparently the girder simply rested on top of the concrete column. The contract drawings also show a C-shaped plate that was to be anchored to the concrete column with headed studs. The bottom chord of the girder was to slip between the top and bottom of the C. The girder was not to be attached to the C. The C-shaped plate was not installed at the girder chord shown in the Figure 6-18 inset.



**Figure 6-19:**  
Multipurpose room girder. Lack of alignment of the bolt holes in the top and bottom plates (see insets) prevented installation of the anchor bolts (Tuscaloosa, AL).

Several joist connections were observed. Figure 6-20 shows where a joist was welded to the girder shown by the yellow ovals on the left photograph of Figure 6-20. The right photograph of Figure 6-20 shows where a joist was welded to a bearing plate that was anchored to a bond beam. All of the observed welds were of poor quality.



Figure 6-20: The yellow ovals on the left photograph show weld remnants where a joist was attached to the girder. The red ovals on the right photograph show weld remnants where a joist was attached to a bearing plate at a bond beam (Tuscaloosa, AL).

Several deck welds were observed. Weld quality was variable, even within a few feet along a given joist. The weld in the left photograph of Figure 6-21 was quite strong—the decking tore. In the right photograph of Figure 6-21, however, the weld burnt through the joist flange and therefore this weld provided little attachment. Weld quality variability was also observed by MATs after the 1999 tornado outbreak (FEMA 342) and several hurricanes.<sup>6</sup>

Figure 6-22 shows what remains of the exterior end wall of the multipurpose room. A reinforced CMU bearing wall was present where the rebar extends through the slab. In this area, the rebar extends 5½ to 7 inches out of the slab; hence, it had deficient splice overlap with the rebar in the CMU. The contract drawings specified a 1-foot 10-inch-overlap for vertical splices.

The gymnasium (Figure 6-14) experienced only slight damage. There was some gutter damage, and most of the canopy walkway roof blew away (Figure 6-14). The MAT judged the damage to be due to the location of the gymnasium with respect to the tornado track, rather than building strength.

<sup>6</sup> FEMA P-424, Design Guide for Improving School Safety in Earthquakes, Floods, and High Winds, recommends a screw attachment be specified, rather than puddle welds, because screws are more reliable and much less susceptible to workmanship problems (2010a).





Figure 6-21: Red arrow shows a strong weld attaching a piece of decking to the joist (the dark area shown by the yellow arrow is a shadow). The photo on the right shows a weak deck attachment where the weld burnt through the joist (Tuscaloosa, AL).



Figure 6-22:  
Rebar extending out of the slab at the multipurpose room end wall (Tuscaloosa, AL)

**MAT EF Rating:** Using DI 16 (Junior or Senior High School),<sup>7</sup> the MAT selected DOD 10 (“most interior walls of top floor collapsed”) for the school. Considering the observed workmanship issues, the MAT assessed the wind speed as between the expected and lower-bound wind speeds for DOD 10. Hence, the MAT derived the tornado rating as EF3 (136–165 mph) based on damage to this building. Therefore, the estimated wind speed experienced by the building was substantially above the basic wind speed of 90 mph the building was designed for.

As shown in Figure 6-12, this building is near the center of the damage swath. The NWS rated the center of the tornado circulation in the vicinity of the school as an EF4, which is above the MAT EF3 rating of the school. Because the school is on the left side of the center of the circulation, the wind speed at the school should be less than the wind speed at the center of circulation.<sup>8</sup>

The MAT judged the wind damage at this school to be due to its subjection to wind speeds substantially above the design wind speed. Poor workmanship issues also contributed to the building damage.

**Functional Loss:** The school will need to be reconstructed before school can resume at this location. According to the school district’s Web site, the students are temporarily housed at a former elementary school for the 2011–2012 school year.

### 6.1.3 Ringgold High School and Ringgold Middle School (Ringgold, GA)

**Location of Facilities in Tornado Path:** The Ringgold Middle and High Schools are near one another (Figure 6-23). Both schools were damaged during the April 2011 tornado outbreak. The NWS EF contour ratings (see Section 1.1.3 for additional information) in the vicinity of the schools are shown on Figure 6-23. The area was under tornado watches for most of the day the tornado struck. According to a representative of the school district, students and staff were dismissed early due to the weather forecast. The schools were not occupied when the tornado struck.

The NWS developed EF rating contours for the Ringgold and Joplin tornadoes. EF contours were not developed by NWS for the Tuscaloosa tornado.

#### 6.1.3.1 Ringgold High School

**Facility Description:** The high school was constructed in 1973. Eleven classrooms were added in 1977 and nine were added in 1985. A second (auxiliary) gymnasium, administrative offices, and an art center were added in 2008. Figure 6-24 is a view of the high school prior to the tornado.

<sup>7</sup> Because this school has two stories, the Junior or Senior High School DI was judged to be more appropriate than the elementary school DI.

<sup>8</sup> The wind speed is higher on the right side of the center of circulation than it is on the left side.

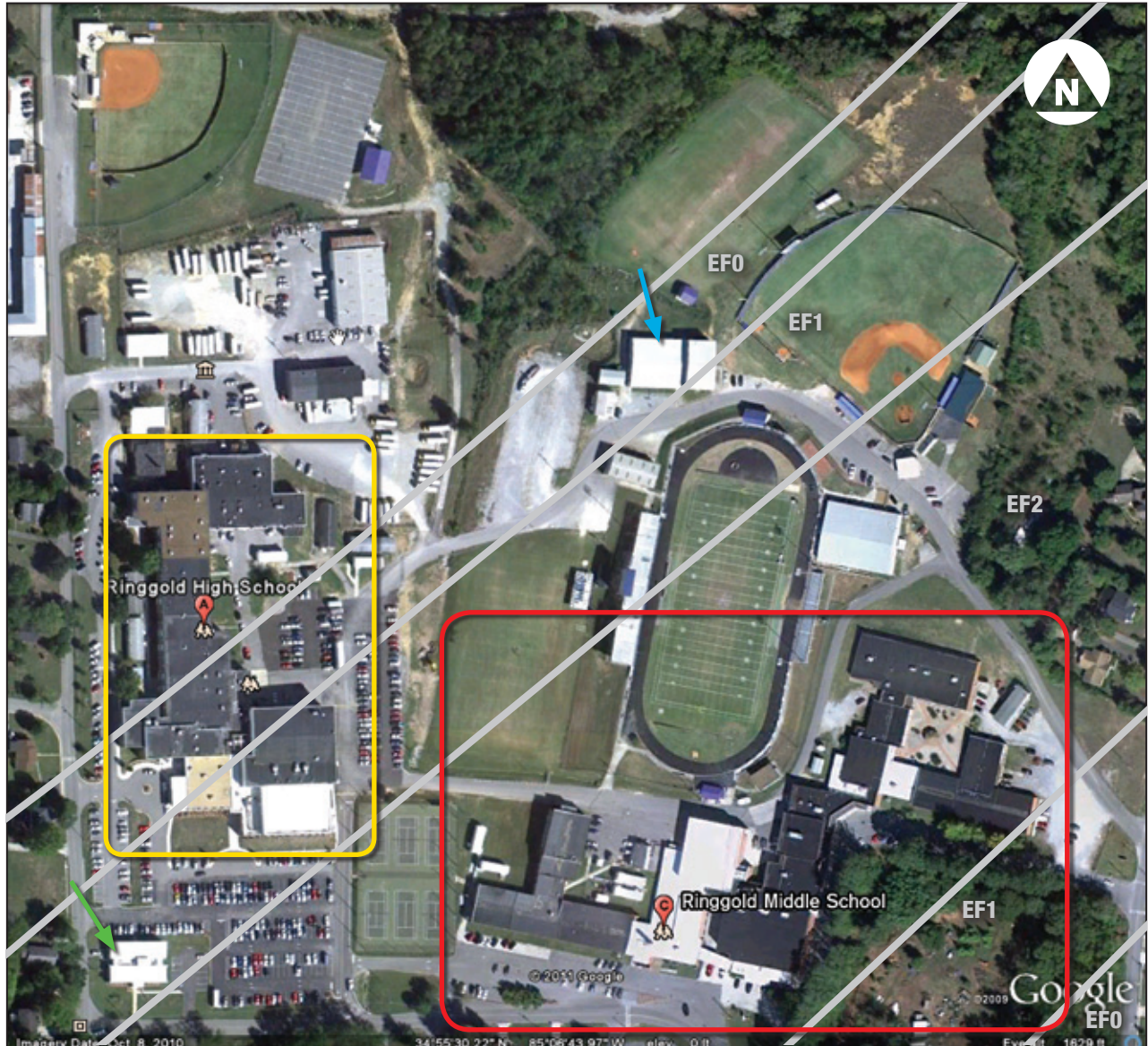

Figure 6-23:<sup>9</sup> View of the Ringgold High School (yellow box) and Ringgold Middle School (red box) prior to the April 2011 tornado. The art center and cheerleading/wrestling facility are shown by the green and blue arrows. NWS EF contour ratings are also shown (Ringgold, GA).

SOURCE: © GOOGLE EARTH

<sup>9</sup> NOAA did not take post-tornado aerial photographs of this location, so a pre-storm image is used here for reference.

Figure 6-24:  
Close-up view of Figure 6-23  
showing the Ringgold High  
School prior to the April 2011  
tornado (Ringgold, GA)

SOURCE: © GOOGLE EARTH

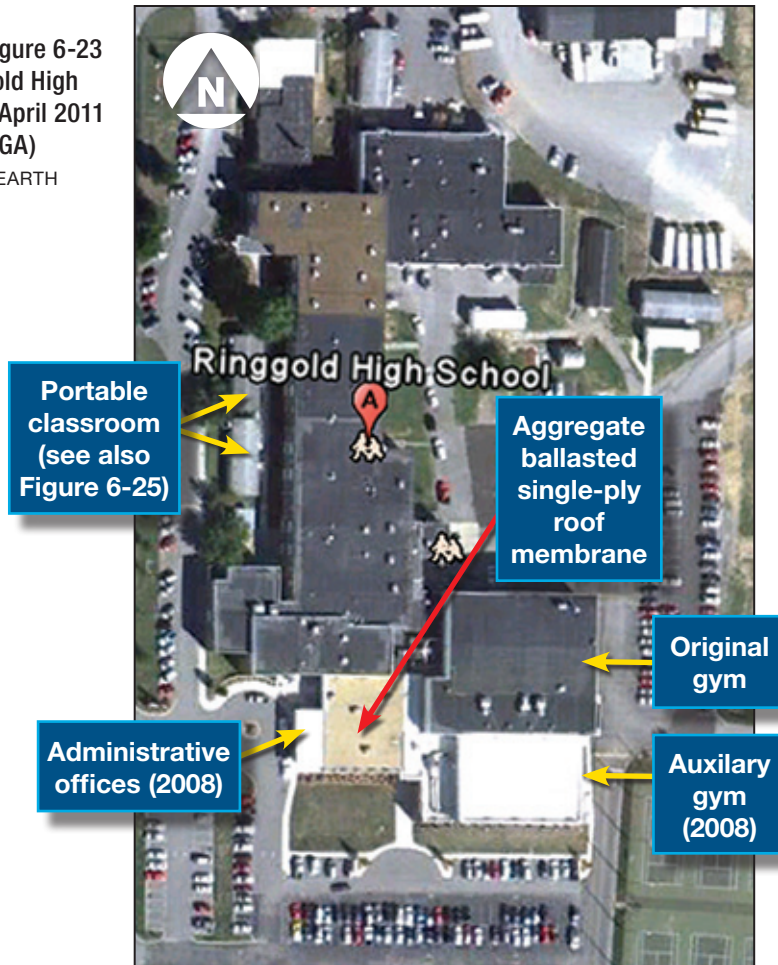

One of the classroom wings has two stories and another has one story. Most of the roof assemblies were fully adhered single-ply roof membrane systems over steel roof decks supported by steel roof trusses; there were also some aggregate ballasted single-ply membranes. The exterior walls of the school are primarily brick veneer over CMU, but some portions are exterior insulation and finishing systems (EIFS) over metal studs over CMU. There were four portable classrooms on the campus. Two classrooms on the west side of the high school were not damaged (Figure 6-25). Although they were not damaged, the MAT observed them to gather data on their condition and potential for becoming sources of wind-borne debris, and to assist in determining the EF rating. The portable classrooms were supported by stacked CMU and anchored down using an embedded anchor and galvanized metal strapping typical of manufactured homes. The MAT noted some of these anchors were in poor condition, some were loose, and one was completely corroded through (Figure 6-25 inset). Due to the condition of the foundation and anchorage straps, it is assumed that wind speeds around the portable classrooms were minimal since no shifting on the foundations appeared to have occurred.

The other two portable classrooms were double-wide units. They were also located on the west side of the high school. One classroom moved off its foundation and had extensive roof and wind-borne debris damage. The other classroom also had extensive roof and wind-borne debris damage. Both of these classrooms were demolished prior to the MAT site visit.



Figure 6-25:  
View of one of the portable classrooms. The red arrows indicate anchor straps. The strap shown in the inset had corroded through (yellow arrow) (Ringgold, GA).

The school did not have a tornado safe room or storm shelter. However, as part of the emergency preparedness plan, tornado refuge areas throughout the building were pre-determined in coordination with the fire department, sheriff's office, the local emergency manager, and school system personnel. According to a rehabilitation contractor project manager, the following areas were to be used as tornado refuge areas during severe weather events: lower-level corridors, restrooms, and the band and chorus rooms. The band and chorus rooms did not have exterior windows. Doors along the corridor had glass vision panels. A pair of standard exit doors with glass vision panels and tempered glass lites above led from the corridor to the exterior. The MAT was unable to determine the amount of reinforcement in the CMU walls. It was also unclear what ceiling/floor system separated the refuge areas from the gymnasium above. After the tornado, the refuge areas were found to be free from damage and debris.

**General Wind Damage:** The tornado struck the south end of the high school (Figure 6-26). The most significant damage was to the gymnasium roofs (Figures 6-27 and 6-28), which resulted in water infiltration that caused damage to the wood floor. The wood gymnasium floor was then demolished (Figure 6-29).

Figure 6-26:  
View of the 2008 auxiliary gymnasium (red arrow) and original gymnasium (yellow arrow on right). The yellow arrow on left indicates the location of a ballasted roof system. Most of the windows within the red oval were broken. The black band (included in the red box) is where EIFS blew off. The insets show the classroom wings that are beyond the gymnasium (left inset) and first floor glazing damage (right inset) (Ringgold, GA).



Figure 6-27:  
View of the two gymnasium roofs. The red arrow shows the 2008 auxiliary gymnasium (see also Figures 6-26 and 6-28). The EPDM (black) membrane is over the original gymnasium. Note the displaced rooftop equipment. The red box shows a portion of the middle school beyond. The inset shows wind-borne debris damage to the EPDM roof (Ringgold, GA).



The roof of the original gymnasium shown in Figure 6-27 had a fully adhered ethylene propylene diene monomer (EPDM) membrane over wood fiberboard over an aggregate surface built-up roof. The primary failure mode was EPDM lifting and peeling. However, as shown by the inset at Figure 6-27, areas of the membrane were punctured by wind-borne debris. The old built-up roof acted as a secondary membrane and likely prevented little if any water from leaking into the gymnasium. However, rain entered the gymnasium where the rooftop equipment shown in Figure 6-27 was blown off the curb. Gas lines were broken at the displaced rooftop equipment shown in Figure 6-27. Damage to the EIFS was noted (Figure 6-26); in some areas the metal studs blew away, while in other areas the EIFS's gypsum board substrate blew away. There were also several broken windows.

The roof of the 2008 auxiliary gymnasium had a fully adhered single-ply membrane over polyisocyanurate insulation over an acoustical steel deck (Figure 6-28). The primary failure mode was membrane lifting and peeling. As shown in the inset at Figure 6-28, some of the decking lifted.

A lower roof adjacent to the 2008 auxiliary gymnasium (see Figures 6-24 and 6-26 for location) had an aggregate ballasted EPDM roof system (Figure 6-30). The winds were such that most of the aggregate on this roof was not scoured. However, the windows shown in the Figure 6-30 inset were likely broken by the roof aggregate. An adjacent roof had a fully adhered single-ply membrane over polyisocyanurate insulation over steel deck. This roof membrane blew away (oval area at Figure 6-30).

In addition to the above damage, the 2008 art center (shown in Figures 6-23 and 6-31) and the cheerleading/wrestling facility (shown in Figures 6-24 and 6-32) were damaged.



Figure 6-28:  
View of the roof of the  
2008 auxiliary gymnasium  
(see also red arrow in  
Figure 6-27); inset shows  
lifted decking (red circle)  
(Ringgold, GA)

Figure 6-29:  
The loss of the roof covering shown in Figure 6-28 led to water intrusion that damaged the floor below. The damaged floor needed to be removed and replaced (Ringgold, GA).



Figure 6-30:  
View of the aggregate ballasted roof. The fully adhered roof membrane blew away; inset below (red box) shows broken windows (Ringgold, GA).







**Figure 6-31:**  
The roof covering was blown off of the 2008 art center. The metal wall covering and insulation was also blown off the CMU. The art center was subsequently demolished (Ringgold, GA).



**Figure 6-32:**  
At the wrestling facility, most of the metal roof panels were blown off, much of the steel framing was damaged, and a portion of the unreinforced CMU wall collapsed. This facility was subsequently demolished (Ringgold, GA).

**MAT EF Rating:** Using DI 16 (Junior or Senior High School), the MAT selected DOD 6 (“damage to or loss of wall cladding”) for the school. Using the expected wind speed for DOD 6, the MAT derived the tornado rating as EF1 (86–110 mph) based on damage to this building. Hence, the estimated wind speed experienced by the building was not substantially above the current basic wind speed of 90 mph.

As shown in Figure 6-23, the NWS derived the rating as EF1 at the southern end of the high school, which correlates with the MAT EF1 rating for this building.

Some of the wind damage at this school was due to damage from wind-borne debris. The MAT judged other building damage to be due to inadequate wind resistance.

**Functional Loss:** According to a representative of the school district, the high school was repaired in time for the start of the 2011–2012 school year. A replacement cheerleading/wrestling field house was constructed and ready for occupancy in November. A replacement art center will be incorporated into a pending theater project that was in the planning stage prior to the tornado.

### 6.1.3.2 Ringgold Middle School

**Facility Description:** The middle school was constructed in 1955. Nine classrooms were added in 1978 and four were added in 1985. A second (auxiliary) gymnasium was added in 2008. Figure 6-33 is a view of the middle school prior to the tornado.

Figure 6-33:  
View of the Ringgold Middle School prior to the April 2011 tornado (Ringgold, GA)

SOURCE: © GOOGLE EARTH

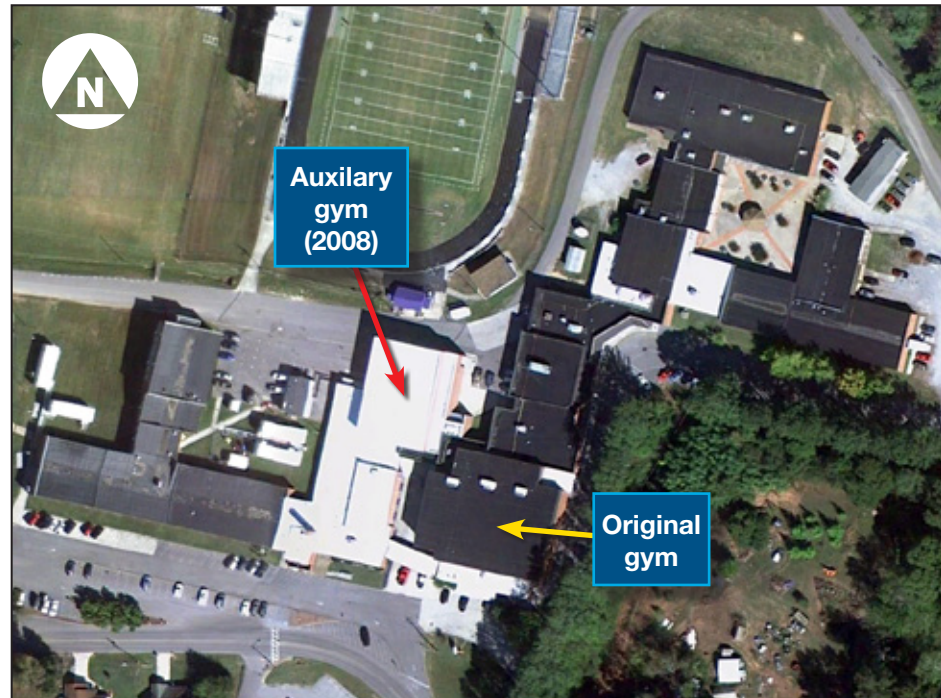

One of the classroom wings has two stories, but most of the school is one story. Some of the roof decks are poured gypsum, others are cementitious wood-fiber, and the 2008 auxiliary gymnasium has a metal deck. The facility has a structural steel frame. Most of the exterior walls are brick veneer over CMU. Some walls are EIFS over metal studs.

There were six portable classrooms on the campus (one of which was a double-wide unit). The double-wide unit and two of the single-wide units were destroyed. The other three units had extensive roof and wind-borne debris damage. These three classrooms were demolished prior to the MAT's site visit.

The school did not have a tornado safe room or storm shelter. However, as part of the emergency preparedness plan, tornado refuge areas throughout the building were pre-determined in coordination with the fire department, sheriff's office, the local emergency manager, and school system personnel. After the tornado, the refuge areas were found to be free from damage and debris.

**General Wind Damage:** The damage experienced by the middle school illustrates the common wind vulnerabilities in schools of this era. The roof membrane blew off much of the building. Most of the gypsum roof deck blew off the portion of the classroom wing shown by the blue oval in Figure 6-34. Other damage is shown in Figures 6-35 to 6-38.



Figure 6-34: View of the Ringgold Middle School (the inset shows the left portion of the school). The 2008 auxiliary gymnasium (yellow arrow) and original gymnasium (red arrow) are shown. Most of the roof deck was lost in the area shown by the blue oval. The yellow box indicates an area where walls and glazing were damaged (Ringgold, GA).



Figure 6-35: This wing lost most of its roof decking, and a portion of the brick veneer and unreinforced CMU collapsed (Ringgold, GA)

The cementitious wood-fiber deck panels blew off the original gymnasium along one perimeter, resulting in standing water on the gymnasium floor (Figure 6-37). Cementitious wood-fiber panels also blew off over some of the classrooms and overhang shown in Figure 6-38. Figure 6-38 also shows a wall that blew in (the damaged wall is shown in the blue oval of Figure 6-34). The wall was EIFS over metal studs. The stud track was attached to a concrete sill with powder-driven fasteners spaced at  $23\frac{1}{2}$  inches and  $26\frac{1}{2}$  inches. The fasteners only had about  $\frac{3}{8}$  inch of embedment. The two windows adjacent to the wall opening and the window at the right of Figure 6-38 were broken, as were several other windows at this wing.

**MAT EF Rating:** Using DI 16 (Junior or Senior High School), the MAT selected DOD 6 (“damage to or loss of wall cladding”) for the school. Considering the building age and observed damage, the MAT assessed the wind speed as between the expected and lower-bound wind speeds for DOD 6. Hence, the MAT derived the tornado rating as EF1 (86–110 mph) based on damage to this building. Therefore, the estimated wind speed experienced by the building was not substantially above the current basic wind speed of 90 mph.

As shown in Figure 6-23, the NWS derived the rating as EF2 at the middle school, which is different from the MAT EF1 rating for this school.

Figure 6-36:  
View from within a classroom. The yellow arrow shows the area of the collapsed wall that is shown in Figure 6-35. In this area, the deck bulb-tees also blew off. The inset shows an area of this wing where some form-board (yellow arrow), a bulb-tee (blue arrow), and the gypsum deck (red arrow) were still in place (Ringgold, GA).



Figure 6-37: Deck panels blew off the original gymnasium. The inset shows the resulting standing water on the wood floor (Ringgold, GA).

INSET PHOTOGRAPH COURTESY OF CATOOSA COUNTY PUBLIC SCHOOLS



Figure 6-38:  
EIFS wall failure, glazing  
damage, and roof deck blow-  
off (Ringgold, GA)

Some of the wind damage at this school was due to damage from wind-borne debris. The MAT judged other building damage to be due to inadequate wind resistance, which is reflective of the codes, standards, and design practices in the era when the majority of this school was constructed.

**Functional Loss:** According to a representative of the school district, the sixth and seventh grade students were able to return to their classrooms at the start of the 2011–2012 school year. However, the eighth grade students temporarily attended the high school while repairs were made to their classrooms. Two single-wide and one double-wide portable classrooms were brought to the site for the chorus and band.

#### 6.1.4 Joplin East Middle School (Joplin, MO)

**Location of Facility in Tornado Path:** The location of the Joplin East Middle School is shown in Figure 6-2. Figure 6-39 shows an aerial view of the tornado track in the vicinity of the school as well as the NWS EF contour ratings in the vicinity of the school. The school was not occupied when the tornado struck (the tornado occurred on Sunday evening).

**Facility Description:** The Joplin East Middle School opened in 2009. The one-story school is over 130,000 square feet, with approximately 45 classrooms, an auditorium, four computer labs, a library, and a gymnasium (Figure 6-40). The auditorium and gymnasium had a single-ply roof membrane over polyisocyanurate insulation over steel roof deck supported by a steel roof structure. The auditorium and classroom wing (primarily one story) had brick veneer over reinforced CMU bearing walls. The gymnasium had brick veneer over insulation installed over precast concrete walls.

The middle school had a Tornado Evacuation Plan with six interior rooms designated as areas of “Tornado Safe Shelter” (Figure 6-41). Although these designated areas may have been the planned tornado refuge areas, they did not possess the wind pressure and wind-borne debris resistance specified in FEMA 361 (2008a) or ICC 500 (2008). Hence, they were not safe rooms or storm shelters (refer to Chapter 9 for additional discussion of safe rooms capable of providing life-safety protection for occupants).

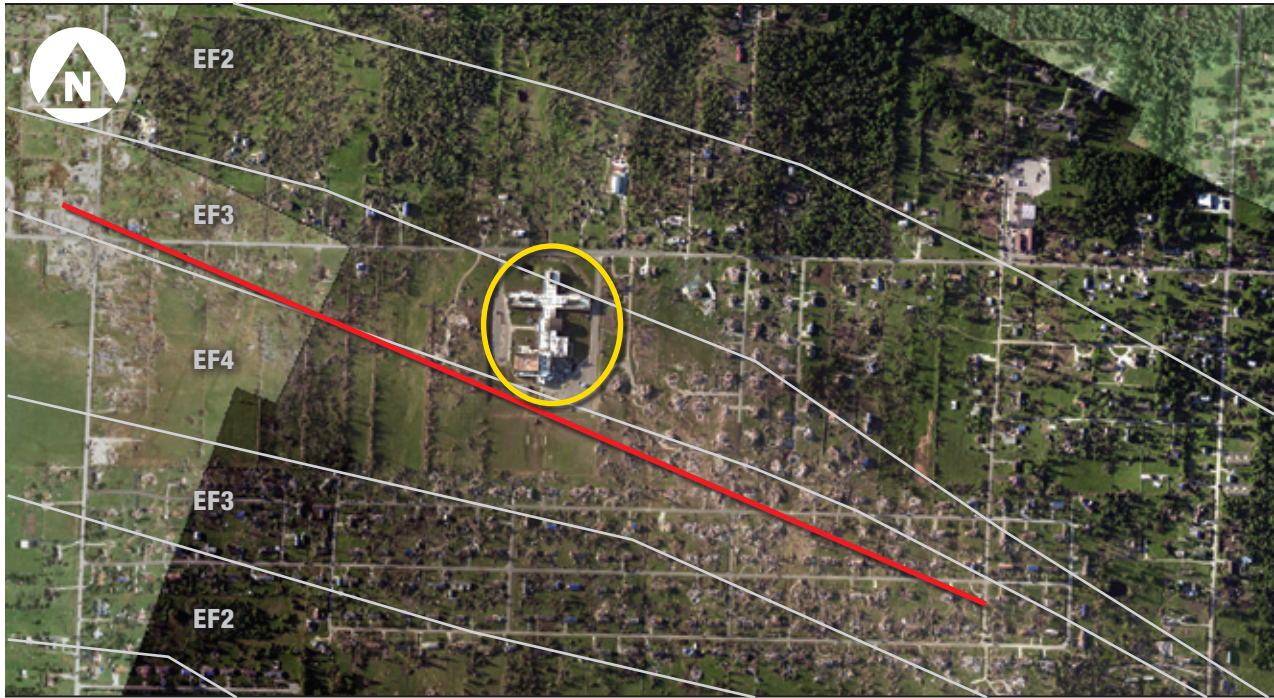

Figure 6-39: Aerial view of the tornado track in the vicinity of the Joplin East Middle School (yellow circle). The center of the damage swath is approximated by the red line. NWS EF contour ratings are also shown (Joplin, MO).

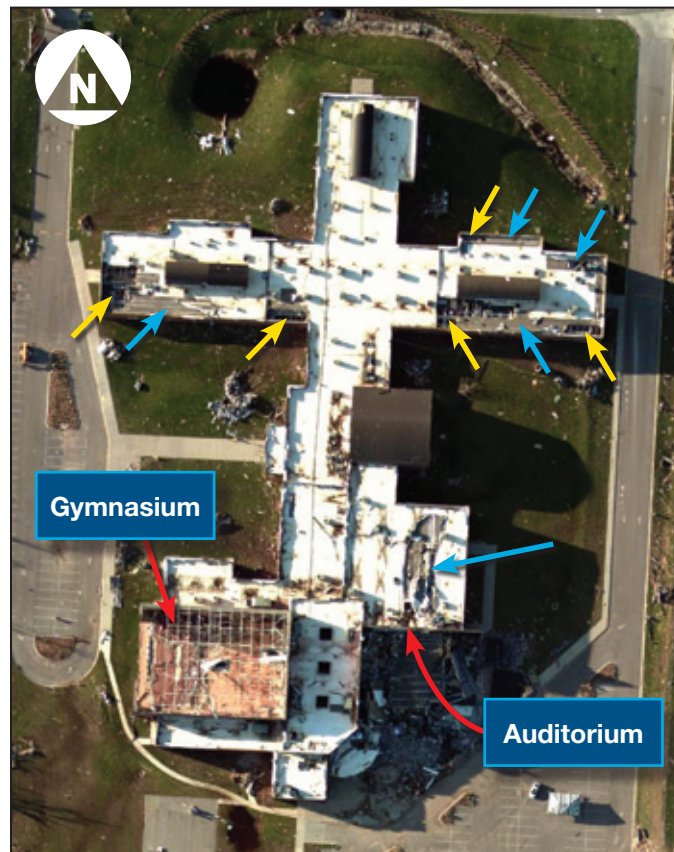

Figure 6-40: Close-up of Figure 6-39. Major areas of blow-off of the roof membrane and roof deck are shown by the blue and yellow arrows (Joplin, MO).

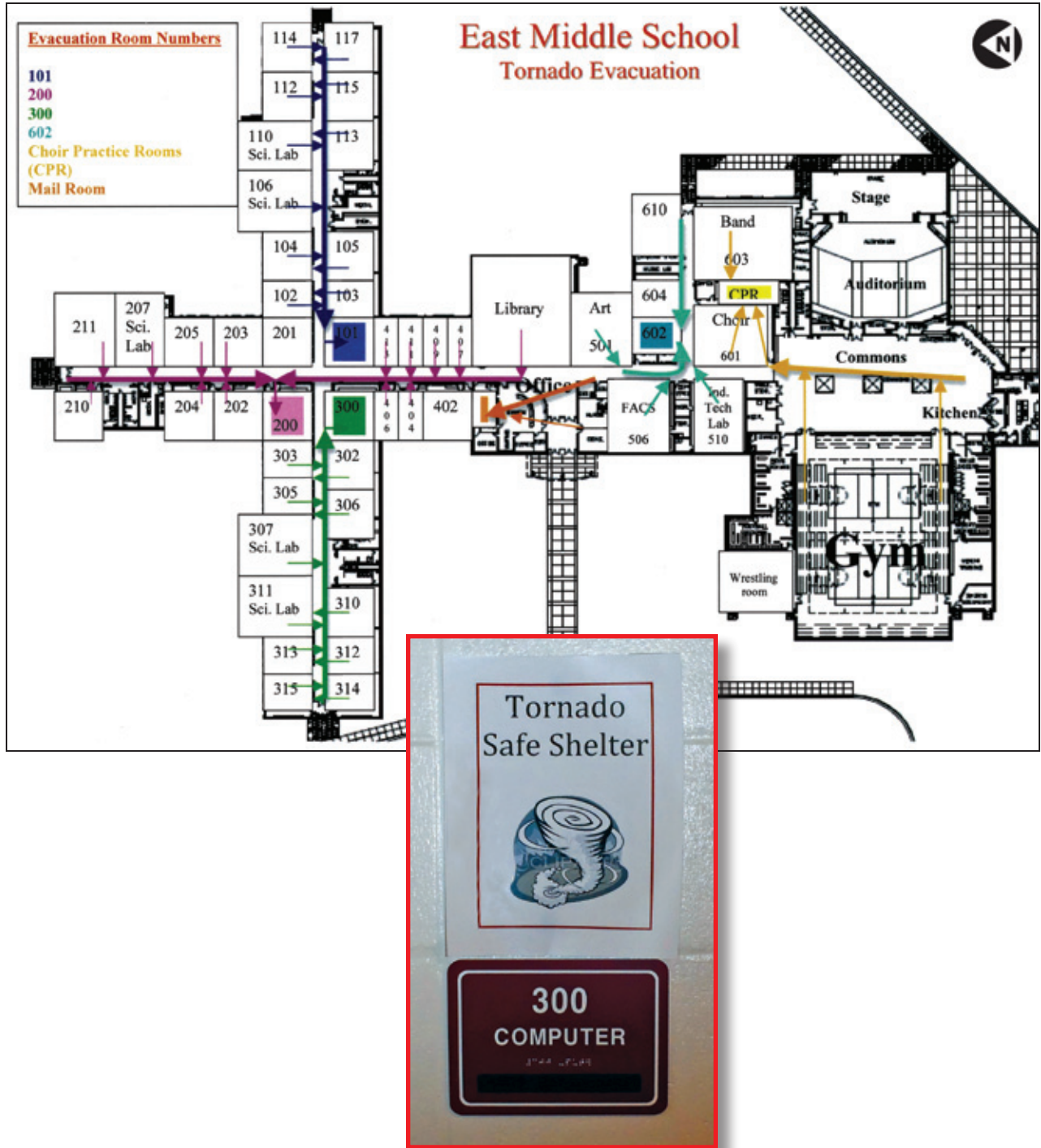

Figure 6-41: Interior rooms designated as “shelters” in the middle school’s Tornado Evacuation Plan. The inset shows the “shelter” signage (Joplin, MO).

**General Wind Damage:** Figure 6-40 shows an aerial view of the damage at the middle school. The most severe damage occurred on the southern end of the school, where the auditorium and gymnasium were located, while the northern end suffered less damage. The auditorium roof and the two exterior walls collapsed (Figure 6-42). At the gymnasium, two roof trusses and an exterior wall collapsed inward upon loss of lateral bracing (Figures 6-43 to 6-46).

**Figure 6-42:**  
View of the collapsed auditorium roof and both exterior walls (Joplin, MO)



**Figure 6-43:**  
View of the gymnasium. The red box in the inset shows where the truss was attached to the wall. The yellow circle indicates the end of the collapsed truss shown in Figure 6-45 (Joplin, MO).







Figure 6-44:  
View of the end of the collapsed truss (yellow circle) shown in Figure 6-43 (Joplin, MO)



Figure 6-45:  
Roof truss and wall debris on the gymnasium floor (Joplin, MO)

**Figure 6-46:**  
Brick veneer/insulation/  
precast concrete wall on the  
gymnasium floor (Joplin, MO)



The remainder of the middle school received damage from wind-borne debris, including glazing damage, as well as water damage due to damaged roof covering, decking, and rooftop equipment (Figures 6-40 and 6-47). The rain intrusion caused damage to the HVAC equipment, ceiling boards, floor coverings, and furnishings.

**Figure 6-47:**  
View of rain infiltration  
damage in a school corridor  
(Joplin, MO)



**MAT EF Rating:** Using DI 16 (Junior or Senior High School), the MAT selected DOD 7 (“collapse of tall masonry walls at gym, cafeteria, or auditorium”) for the middle school. Considering the building age and observed damage, the MAT assessed the wind speed as between the expected and upper-bound wind speeds for DOD 7. Hence, the MAT derived the tornado rating as EF2 (111–135 mph) based on damage to this building.<sup>10</sup> Therefore, the estimated wind speed experienced by the building was above the basic wind speed of 90 mph the building was designed for.

As shown in Figure 6-39, the NWS derived the rating as EF3 at the middle school, which is different from the MAT EF2 rating for this school.

The MAT judged the wind damage at this school to be due to its subjection to wind speeds substantially above the design wind speed and to wind-borne debris.

**Functional Loss:** According to the repair contractor that was on-site during the MAT’s visit, power was restored within 10 days to most of the northern/classroom portion of the building and crews began repairs in an effort to have the facility functional by the start of the 2011–2012 school year. However, repairs were not completed in time due to the extensive damage. According to the school district’s Web site, an industrial park warehouse was converted into a temporary school for the start of the 2011–2012 school year.

### 6.1.5 Joplin High School (Joplin, MO)

**Location of Facility in Tornado Path:** The location of the Joplin High School is shown in Figure 6-2. Figure 6-48 shows an aerial view of the tornado track in the vicinity of the school, as well as the NWS EF contour ratings in the vicinity of the school. The school was not occupied when the tornado struck since the tornado occurred on Sunday evening.

**Facility Description:** Joplin High School opened in 1968 and extensively renovated in 2003, including the addition of the library/media center. The school had one- and two-story classroom wings, two gymnasiums, a performance auditorium, cafeteria, library/media center, and a 1,300-square-foot television station (Figure 6-49). The north classroom wing contained a basement classroom section whose corridor was relatively undamaged during the tornado.

The high school had several construction systems:

- + The north classroom wing had a built-up membrane roof system over lightweight insulating concrete over metal decking. The exterior wall consisted of brick veneer over unreinforced masonry infill walls. The exterior masonry extended approximately 4 feet above the floor. There was EIFS over metal studs between the masonry and floor or roof above.
- + An addition to the north classroom wing had a membrane roof system over steel roof deck supported by steel joists. Exterior walls were brick veneer over reinforced CMU.

<sup>10</sup> A team deployed by ASCE observed both the Joplin Middle School and High School (Prevatt et al. 2011a). This team performed a failure analysis by calculating estimated loads and resistance to determine EF ratings. The MAT’s approach used the DI/DOD EF rating system. It should be understood that both methodologies involve some uncertainties, and therefore ratings of wind speed can vary.



Figure 6-48: Aerial view of the track in the vicinity of the Joplin High School (yellow circle). The center of the damage swath is approximated by the red line. NWS EF contour ratings are also shown (Joplin, MO).

- + The library/media center had a membrane roof system over steel deck supported by pre-engineered bowstring trusses supported by steel columns. End walls were CMU bearing walls.
- + The one-story classroom wing along the west side of the courtyard had a membrane roof system over steel deck supported by steel joists. The exterior walls were brick veneer over reinforced CMU bearing walls. The primary gymnasium had a built-up roof system over steel deck over steel joists supported by girders spanning east to west. The girders were supported on steel columns that were supported on concrete pilasters. The roof at the west wall was supported by steel columns at approximately 15 feet on center. There was brick veneer over unreinforced CMU between the columns.
- + The second gymnasium had a membrane roof system over steel deck over steel joists that spanned between joist girders. The exterior load-bearing walls were brick veneer over reinforced CMU.
- + The auditorium had a membrane roof system over steel deck over steel joists supported by a structural steel frame system. Infill walls were brick veneer over unreinforced CMU.

The high school did not have a tornado safe room or storm shelter. The lower level corridors on the northwest wing were the designated tornado refuge areas (Figure 6-50). The tornado blew some debris such as insulation and other building materials into the corridor, but the overall condition of this area of the building was relatively undamaged.

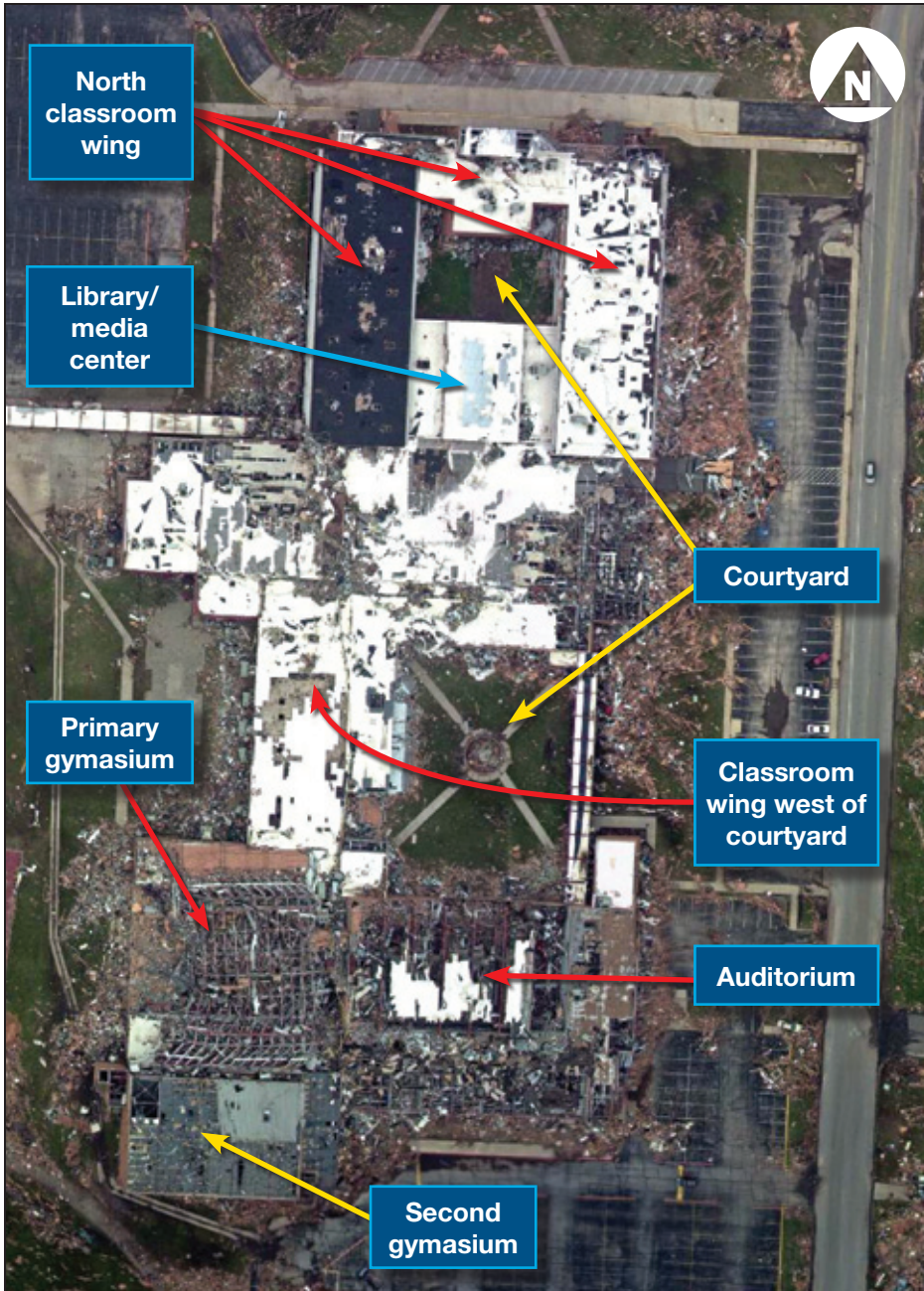

Figure 6-49:  
Close-up of Joplin High  
School shown on Figure 6-48  
(Joplin, MO)

**Figure 6-50:**  
View of a corridor designated as tornado refuge area. The debris was blown into the corridor during the tornado (Joplin, MO).



**General Wind Damage.** As shown in Figure 6-49, the primary gymnasium collapsed and portions of the auditorium collapsed. The long roof spans and unreinforced masonry infill walls contributed to the collapses at these areas. In other parts of the building, the exterior wall collapsed, the roof covering was damaged, and some glazing was damaged as described below.

North classroom wing: Extensive exterior wall damage occurred at this wing (Figure 6-51). In most locations the connection of the stud tracks to the CMU and floor or roof slab failed. In some instances the unreinforced masonry wall also failed. The roof system was damaged but most of the roof deck remained in place.

The exterior reinforced masonry wall and roof structure at the second floor corridor at the north end of this wing collapsed (Figure 6-52). The wall and roof assembly debris fell into the corridor (Figure 11-2). This portion of the building appeared to be an addition.

Library/media center: A portion of the roof covering was destroyed, which resulted in interior water damage. Some exterior glazing was also broken.

Classroom wing along the west side of courtyard: The east masonry wall collapsed into the courtyard (Figure 6-53). The CMU was connected with rebar dowels into the footing; at the top of the wall the CMU was connected to a ledger angle that was welded to the roof deck. There was an approximately 2-foot-tall parapet above the ledger angle. The majority of the angle stayed connected to the CMU, with the welded connections between the deck and angle failing. The angle was installed with expansion bolts into ungrouted cells. There was no connection between the exterior walls and the interior classroom transverse walls. This discontinuity in the load path contributed to the collapse of the exterior wall.



Figure 6-51:  
North classroom wing. The  
inset shows a close-up of  
the opposite side of the wing  
(Joplin, MO).



Figure 6-52:  
Collapse of the exterior brick  
veneer/reinforced CMU wall  
and roof assembly into the  
corridor at the north end of  
the north classroom wing  
(Joplin, MO)

**Figure 6-53:**  
Collapsed brick veneer/  
reinforced CMU. The red  
arrow indicates where  
the ledger angle is still  
connected to the CMU.  
The yellow arrow indicates  
where the angle's expansion  
bolts pulled out of the CMU  
(Joplin, MO).



**Primary gymnasium:** The gymnasium shown in Figure 6-54 collapsed. The west wall was approximately 37 feet tall—it fell into the gymnasium. The connection between the pilasters and columns that supported the roof girders failed. The columns were connected with two 1½-inch diameter bolts, each 3 feet long, as shown in the inset at Figure 6-54. Most of the steel roof deck blew off. Only a small portion of it remained within the gymnasium space. Collapse of the brick veneer/unreinforced CMU end wall and blow-off of the roof decking caused the failure. Once the integrity of the load path was disrupted, there was a progressive failure.

The second gymnasium, to the south of the primary gymnasium, had most of its metal roof panels blown off (Figure 6-55). The gymnasium had a wood floor.

**Auditorium:** The steel roof deck and several of the steel joists blew off (Figure 6-56). Portions of the 25-foot-tall brick veneer/unreinforced CMU wall collapsed (Figures 6-56 and 6-57).





Figure 6-54:  
View of the collapsed gymnasium. The inset shows the base plate (red arrow) and an anchor bolt (yellow arrow) that connected the girder support column to the pilaster (Joplin, MO).

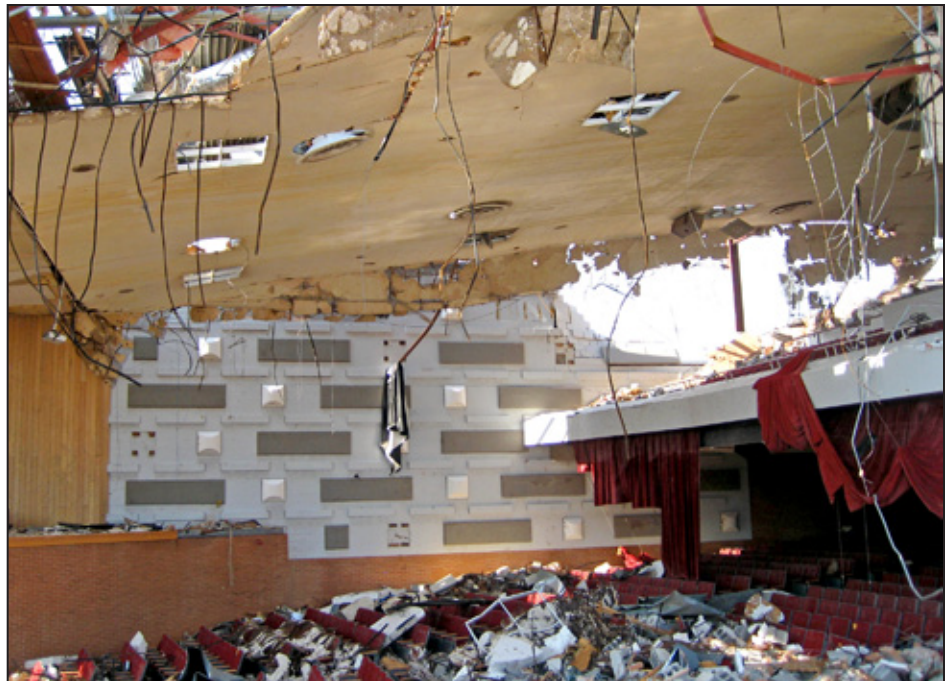

Figure 6-55:  
Interior view of the second gymnasium (Joplin, MO)

Figure 6-56:  
North wall of the auditorium  
(Joplin, MO)



Figure 6-57:  
South wall of the  
auditorium, showing  
collapse of the masonry  
infill wall (Joplin, MO)



**MAT EF Rating:** Using DI 16 (Junior or Senior High School), the MAT selected DOD 11 (“complete destruction of all or a large section of building”) for the high school. Considering the building age and the observed damage, the MAT assessed the wind speed to be the lower-bound wind speed for DOD 11.<sup>11</sup> Hence, the MAT derived the tornado rating as EF3 (136–165 mph) based on damage to this building.<sup>12</sup> Therefore, the estimated wind speed experienced by the high school was substantially above the basic wind speed of 90 mph.

As shown in Figure 6-48, NWS derived the rating as EF4 at the southern end of the high school, which is different from the MAT EF3 rating for this school.

The MAT judged the wind damage at this school to be due to its subjection to wind speeds substantially above the design wind speed and to wind-borne debris.

**Functional Loss:** According to a representative of the school district, school resumed in August 2011 in a temporary facility. The existing high school will be demolished and replaced with a new building.

## 6.2 Operational Issues

On March 1, 2007 at 1:12 p.m., a tornado struck a school in Enterprise, AL, resulting in the deaths of eight students (FEMA 2008a). During the tornado, students had sought refuge in hallways, away from windows, an area that is commonly used as a tornado refuge area in schools. In this case, the refuge area sought out by students and teachers in the Enterprise, AL, school was vulnerable to collapse. Following this tornado event and the school tragedy, the NWS published the results of their post-tornado investigation, in which it was determined that school officials in Enterprise had made appropriate safety decisions based on the information available. The report notes that due to multiple severe weather warnings throughout that day, there was no safe period of time in which they could have enacted an early dismissal. In their recommendations, the NWS stated that the benefits of using hardened safe rooms should be promoted, especially in non-residential buildings where many people gather, such as schools (NOAA 2007b).

In the violent tornadoes of April and May 2011, several schools were directly impacted. Fortunately, none of the schools were occupied at the time the tornadoes struck. The 2007 incident in Enterprise, AL, and the several near misses in the spring of 2011 brought to the forefront the importance of identifying a decision-making process for school administrators in the event of a tornado warning. To better understand current school decision-making processes in tornado-prone regions, members of the MAT held interviews with 10 school districts (Table 6-2) that were impacted in spring of 2011.

---

11 DOD 11 is for complete destruction of all or a large section of building. As shown on Figure 6-49, much of the southern end of the school collapsed. The collapsed areas were the primary gymnasium and auditorium. DOD 7 is “collapse of tall masonry walls at gym, cafeteria, or auditorium.” However, in the judgment of the MAT, DOD 11 was appropriate based on proximity of and damage to these two areas.

12 A team deployed by ASCE observed both the Joplin Middle School and High School (Prevatt et al. 2011a). This team performed a failure analysis by calculating estimated loads and resistance to determine EF ratings. The MAT used the DI/DOD EF rating system. It should be understood that both methodologies involve some uncertainties, and therefore ratings of wind speed can vary.

Table 6-2: List of School Districts Interviewed by the MAT

Location	Number of Students
<b>Alabama</b>	
Decatur City	8,450
Huntsville City	23,000
Walker County	8,000
Tuscaloosa County	18,000
Marion County	3,524
Cullman City	3,017
Limestone County	9,018
<b>Georgia</b>	
Catoosa County	11,009
<b>Mississippi</b>	
Monroe County	2,300
<b>Missouri</b>	
Joplin	7,911

The MAT asked representatives from each school district a series of questions related to school operational decisions during severe weather. These questions, grouped into three categories, were:

■+ Severe Weather Policy

- + What is the official severe weather policy in your school district?
- + Does the policy vary for different types of severe weather?
- + Who makes the final decision and how long is the process?
- + Is the decision based on hazardous weather probability and does it include input from local NWS or TV personnel or others?
- + Are there other factors that influence the decision?

■+ Severe Weather Communication and Decision Making

- + Is it the preference of the district to dismiss students early or keep them at school?
  - + Does that depend on the type of severe weather?
- + Approximately how many students are in after-school programs?

■+ Are there areas of refuge designated in each school?

- + Where are these areas?

The interviews conducted by the MAT revealed that school district response plans for severe weather ranged from taking refuge within the school, early dismissal/delayed start, and closing the school.

Among the school districts interviewed, it was noted that regardless of the type of severe weather, the safe transportation of students was a common factor in decision making. Depending on the size of the district and the area covered, buses may require 45 minutes to 2 hours to complete their routes. Therefore, most of the districts interviewed stated that they prefer to dismiss school early if severe thunderstorm and tornado events are expected to occur near the end of the school day, and delay the start of school if such events are expected to occur in the morning.

## 6.2.1 Severe Weather Policy

The fundamental decision faced by school district personnel on days when tornadoes are forecasted is whether to dismiss students or have them take refuge at school. The following discussion presents some of the challenges that schools face and a summary of the findings for the 10 school districts interviewed by the MAT.

The school districts indicated that taking shelter within the school is the preferred option for schools that have a FEMA 361-compliant safe room or an ICC 500-compliant storm shelter. Of the 10 districts interviewed, only two stated they had safe rooms compliant or nearly compliant with FEMA 361(2008a) and a third district is in the process of applying for school safe rooms. During field assessments, the MAT found safe rooms at two of the 12 schools in one district and two of the 18 schools in the other.

The school districts stated that *schools without a compliant safe room or storm shelter* must follow the district's severe weather policy regarding whether to keep students in the school or dismiss them. The following is a summary of the actions taken in the school districts interviewed:

■+ **Early dismissal:** Seven of the 10 districts interviewed by the MAT stated that their policy is to dismiss students early, if possible. Based on the interviews, early dismissal is scheduled to provide ample time for busses to transport students to their residences in advance of impending severe weather. This approach disperses students over a wide area and decreases liability for school districts. Although the probability of a point location such as a school being directly hit by a tornado is lower than the probability of numerous homes being struck in an area, there was a general perception on the part of the school districts that the chances of a large number of student fatalities is lower when students are in their own residences versus gathered in one location at school.

■+ **Sheltering in schools:** When dismissing students early is not possible due to rapidly changing weather conditions, students and staff must take cover in portions of buildings that were not designed to withstand tornadoes.

The school districts indicated that parents are permitted to pick up their children at their discretion in these situations. Students remaining in the schools are directed to take refuge in an area identified by the school.

FEMA Recovery Advisory 6, *Critical Facilities Located in Tornado-Prone Regions: Recommendations for Architects and Engineers* (Appendix F) provides guidance on identifying best available refuge areas.

The school districts that were interviewed stated that they are reviewing their severe weather policies to decide what is best for their given situation. For example, in the Catoosa County, GA, school district (Ringgold, GA), students who reside in manufactured homes or poorly constructed homes

are encouraged to stay at school, while others are either picked up by their parents or dismissed early. Another consideration cited by school districts is whether there might be more student fatalities when students are sent home than kept at school, as children who are sent home early may have to make severe weather safety decisions on their own if their parents are not at home.

## 6.2.2 Severe Weather Communication and Decision Making

**Alabama School Districts:** The communication process used by the Alabama school districts was very consistent among those the MAT interviewed (Figure 6-58). The NWS field offices in Huntsville and Birmingham coordinate webinars and webcasts that are broadcast to State and County EMA personnel. The County EMA personnel then communicate directly with school superintendents, school transportation and facilities managers, or school severe weather decision teams. In smaller districts, the superintendent often makes cancellation decisions directly, while in larger districts, severe weather teams or facility managers make the decision. Sometimes district officials attend webinar sessions with County EMA personnel, while in other cases, County EMA personnel report to district officials who do not attend the webinar. In both cases, the line of communication starts with the NWS, and the urgency of the situation as it pertains to school closing is then relayed by State and County EMA, though these agencies do not directly make decisions regarding school cancellations. No specific severe weather thresholds or criteria exist for school cancellation; however, the districts report considerable pressure to monitor the proceedings of neighboring districts.

**Figure 6-58:**  
Flowchart depicting severe weather decision making process used by school districts in Alabama

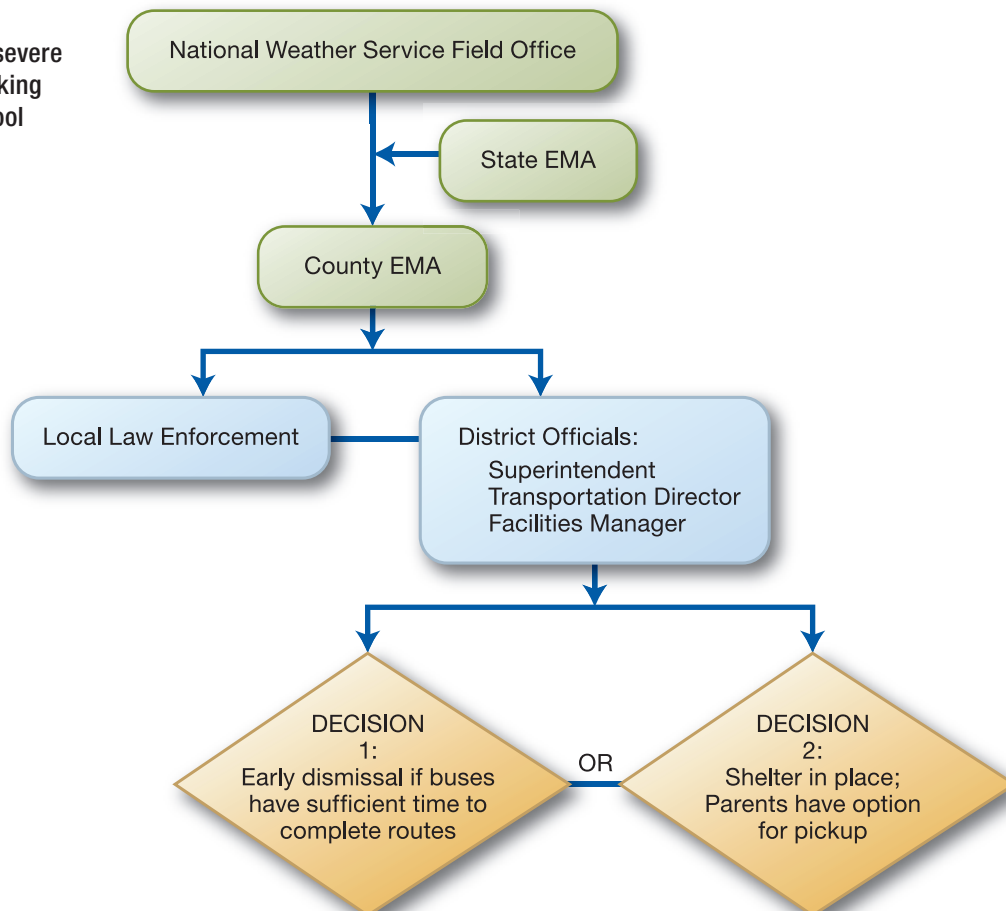

**Joplin School District:** The Joplin, MO, district uses a severe weather team (SWT) of four individuals, each responsible for a school zone of several facilities (Figure 6-59). Each SWT member contacts five to six facilities to tell them to take refuge, with an estimated total phone time of 10 minutes. Refuge is sought if winds are forecasted to exceed 75 mph or if the facility is under a tornado warning. The individual schools monitor weather Web sites and a NOAA weather radio on severe weather days, and they work in conjunction with the district's SWT. The principal of a school can decide to direct the students and faculty to designated areas within the school before getting a call from the SWT. After the storm has passed, SWT members call facilities to provide the all-clear.

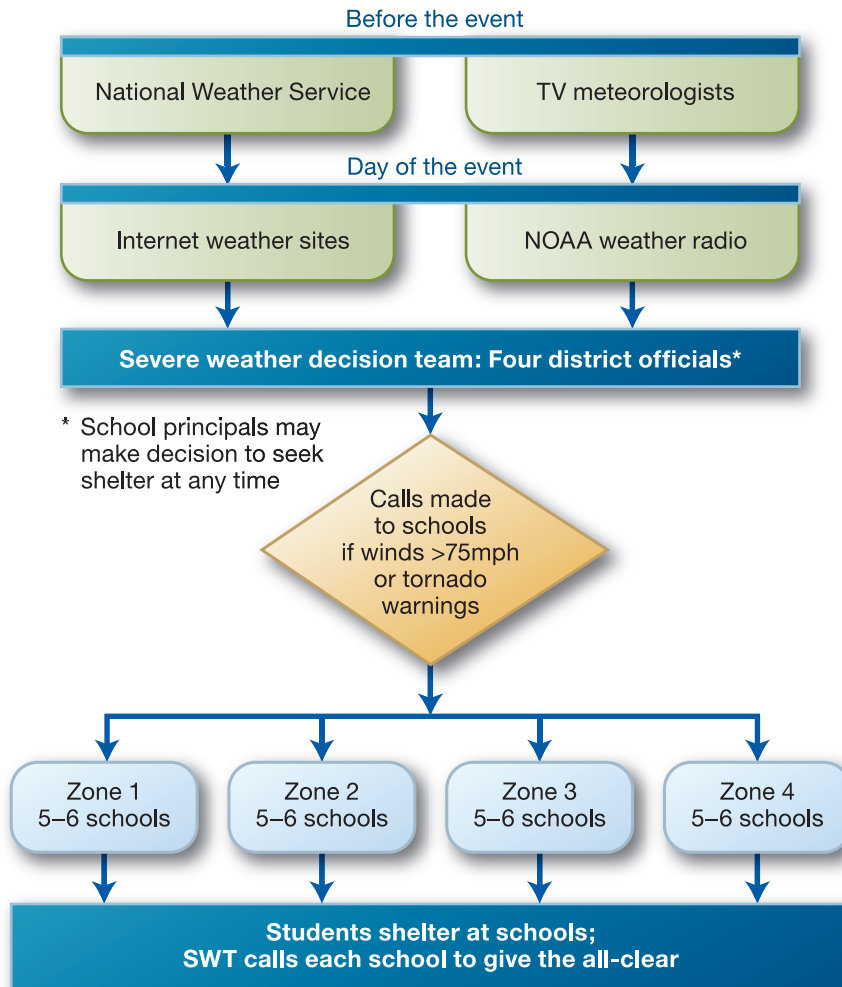

**Figure 6-59:** Flowchart depicting severe weather decision making process used by the Joplin, MO, School District

### 6.2.3 Changes for the Future

Out of the 10 districts interviewed, seven are satisfied with their tornado safety plans and do not intend to change them as a result of the events of spring 2011. Of these seven districts, one plans to increase communication with neighboring districts on days when tornadoes are forecasted. Another district is conducting more frequent drills, increasing focus on communication, and evaluating refuge areas.

In one Alabama district, the 2011 tornadoes resulted in discussions with law enforcement and utilities about severe weather information dissemination during and after the event. In this Alabama district, power was knocked out by severe weather on the morning of the April 27th, which disrupted normal avenues of communication. After the tornado, law enforcement and utilities personnel communicated with the schools. Thus, although the district may deem their policy satisfactory for actions to take before a tornado, they may need to adopt contingency plans for operating after a tornado.

The remaining three districts—Tuscaloosa County, AL; Monroe County, MS; and Joplin, MO— are planning to make changes in the future. According to a representative from Tuscaloosa County, the county is seeking hazard mitigation assistance for eight FEMA 361-compliant school safe rooms to be incorporated into existing and future building plans, which represents 25 percent of the schools in the district. In Smithville, MS (Monroe County School District), there are plans to construct a dual-purpose gymnasium and FEMA 361-compliant safe room that can be used by the entire district. In Joplin, MO, FEMA 361-compliant safe rooms were constructed at temporary locations for the schools that were destroyed by the tornado. At other schools in Joplin, schools have cleared basements to use as tornado refuge areas; however, not all students can fit into the basement areas. The schools plan to house students in interior rooms during tornado events as a last resort.

## 6.2.4 Summary

The MAT noted the following based on its interviews with school districts located in the impacted areas:

- + School officials give considerable thought to closure decisions and the safety of students. This high level of attention results from: 1) the school district’s responsibility for protecting students and staff, and 2) the school district’s interest in having a strategy that minimizes liability.
- + In the districts interviewed, there were no uniform severe weather thresholds or criteria for making school cancellation decisions.
- + In the districts interviewed, there were no existing criteria in use for evaluating areas of the schools used for refuge during tornadoes.

## 6.3 Summary of Conclusions and Recommendations

Table 7-1 provides a summary of the conclusions and recommendations for Chapters 6 and 7, and provides section references for supporting observations. Additional commentary on the conclusions and recommendations is presented in Chapters 10 and 11.





## TORNADO OUTBREAK *of* **2011**

IN ALABAMA, GEORGIA, MISSISSIPPI,  
TENNESSEE, AND MISSOURI

# 7 Observations on Critical Facility Performance: Healthcare, First Responder, and Emergency Operations Centers

*The MAT observed a total of 41 critical facilities in the path of tornado tracks or track periphery areas across five States.*

A general discussion of critical facilities pertinent to both chapters is presented in the introduction to Chapter 6. This chapter presents information on healthcare facilities, first responder (police and fire) facilities, and EOCs.

All of the 41 observed critical facilities were located where the basic (design) wind speed prescribed in IBC 2009 is 90 mph. Table 6-1 lists the type and total number of critical facilities observed by the MAT. The locations of the Tuscaloosa and Joplin critical facilities described in this report are shown on Figure 7-1 (April 25–28, 2011 tornado event) and Figure 7-2 (May 22, 2011 tornado event); the facilities described in this chapter are highlighted.



Figure 7-1: Location of Tuscaloosa, AL, critical facilities described in Chapters 6 and 7. The EOC (southwestern end of tornado damage swath shown, red line) is approximately 4.7 miles from the LaRocca Nursing Home (northeastern end of tornado damage swath shown).

SOURCE FOR TORNADO TRACK: [HTTP://WWW.SRH.NOAA.GOV/SRH/SSD/MAPPING](http://www.srh.noaa.gov/srh/ssd/mapping)

In addition to the 41 critical facilities that were in tornado tracks or track periphery areas, the MAT visited some additional facilities that were outside of the tracks or track periphery. Some of these additional critical facilities were not struck by high winds, and thus were not damaged. However, some of these additional critical facilities were damaged by thunderstorm winds.

Sections 7.1.1 and 7.3.2 describe two facilities that were not struck by

The National Institutes of Standards and Technology (NIST) established a research team to study of the impacts of the disaster in Joplin, MO.

The objectives of the NIST technical study include:

- Determine the characteristics of the wind hazard from the tornado
- Determine the pattern, location and cause of injuries and fatalities, and how these numbers were affected by emergency communications and the public response to those communications
- Determine the performance of residential, commercial and critical (police stations, firehouses, hospitals, etc.) buildings
- Determine the performance of lifelines (natural gas, electrical distribution, water, communications, etc.) as they relate to maintaining building operation
- Make recommendations, if warranted, for improvements to building codes, standards and practices based on the findings of the study

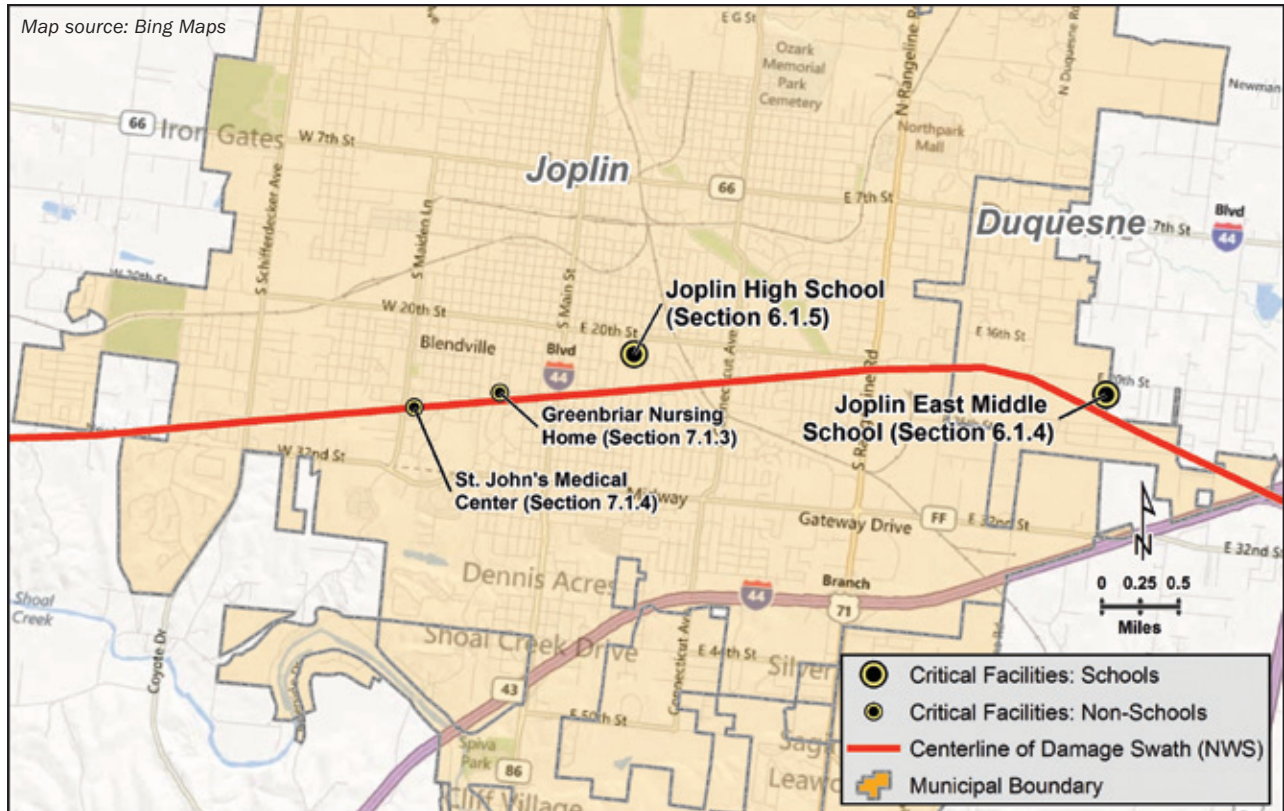

Figure 7-2: Location of Joplin, MO, critical facilities described in Chapters 6 and 7. The St. John's Medical Center (western end of tornado damage swath, red line) is approximately 4.5 miles from the East Joplin Middle School (eastern end of tornado damage swath).

SOURCE FOR TORNADO TRACK: [HTTP://WWW.CRH.NOAA.GOV/SGF/?N=EVENT\\_2011MAY22\\_SUMMARY](http://www.crh.noaa.gov/SGF/?N=EVENT_2011MAY22_SUMMARY)

tornadoes. Section 7.1.1 describes a healthcare facility located just outside of a tornado periphery area; although not struck by the tornado, the facility response to the near miss provided an opportunity to learn some operational issues. Section 7.3.2 describes an EOC that was not in the tornado path. It is included because it has design enhancements intended to allow the facility to remain operational even if struck by a violent tornado. Except for the critical facilities discussed in Sections 7.1.1 and 7.3.2, none of the observed critical facilities outside of the tornado tracks or track periphery areas are discussed in this report.

## 7.1 Hospitals and Health Care Facilities

Health care facilities are at the front line of community protection, especially during and after a natural disaster event. Their capacity to continue to provide services to existing patients, and to respond to the needs of victims following a disaster, depends not only on protecting the integrity of the structure and the building envelope, but on the facilities' ability to carry out their intended functions with little or no interruption. Continued and uninterrupted operation of health care facilities, regardless of the nature of the disaster, is one of the most important elements of a community's continuity of operations (COOP) and disaster recovery program.

### 7.1.1 Birmingham Nursing and Rehabilitation Center (Birmingham, AL)

**Location of Facility near Tornado Path:** The Birmingham Nursing and Rehabilitation Center was not damaged. Figure 7-3 shows a view of the nursing home after the tornado. Figure 7-4 shows an aerial view of the tornado track. This facility was a few hundred yards from the periphery of a tornado that NWS rated as an EF2 at the center of circulation.

**Lessons Learned:** Although the facility was not damaged, this event provided useful lessons. The MAT was advised by facility personnel that the facility has periodic training for various hazards, and in certain events, the facility is required to evacuate all occupants. The staff can evacuate all the residents in less than 10 minutes.

As the tornado approached the facility, the staff believed there was a natural gas leak in the building due to an intense gas smell in the air. The smell was thought to be coming from their facility. However, the gas smell was actually from lines in nearby neighborhoods that had been broken by the tornado. The gas was driven into surrounding areas ahead of the storm. Being unaware of the approaching tornado, and believing that they were in imminent danger due to a gas leak in the facility, the occupants were moved in a matter of minutes to an outdoor courtyard (Figure 7-3).

Figure 7-3:  
Aerial view of the nursing home. The red arrow shows the courtyard where residents were evacuated to. The blue arrows show impact locations of wind-borne debris (Birmingham, AL).  
SOURCE: © GOOGLE EARTH

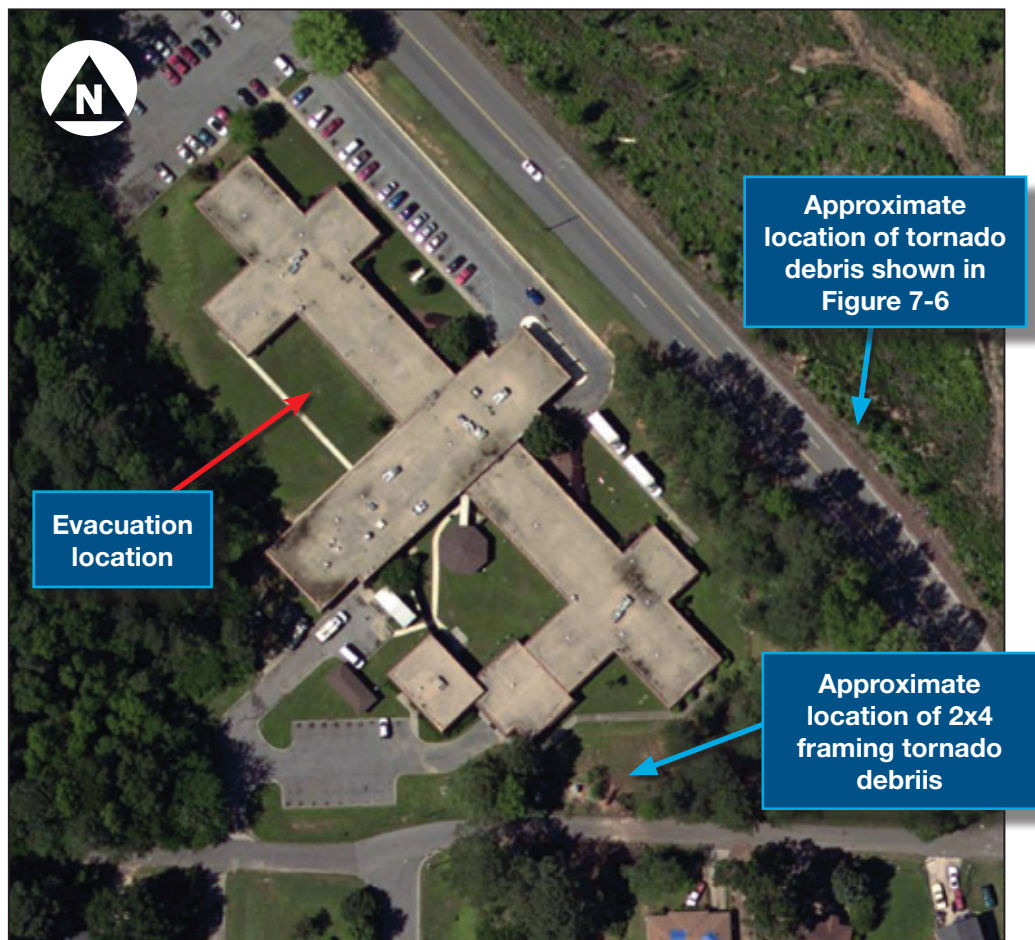

Soon after the facility was evacuated, the facility director realized that a tornado was nearby and on an apparent intercept path with the nursing home (Figure 7-4). The occupants were moved back into the facility corridors, which were designated as the tornado refuge areas for the facility (Figure 7-5).

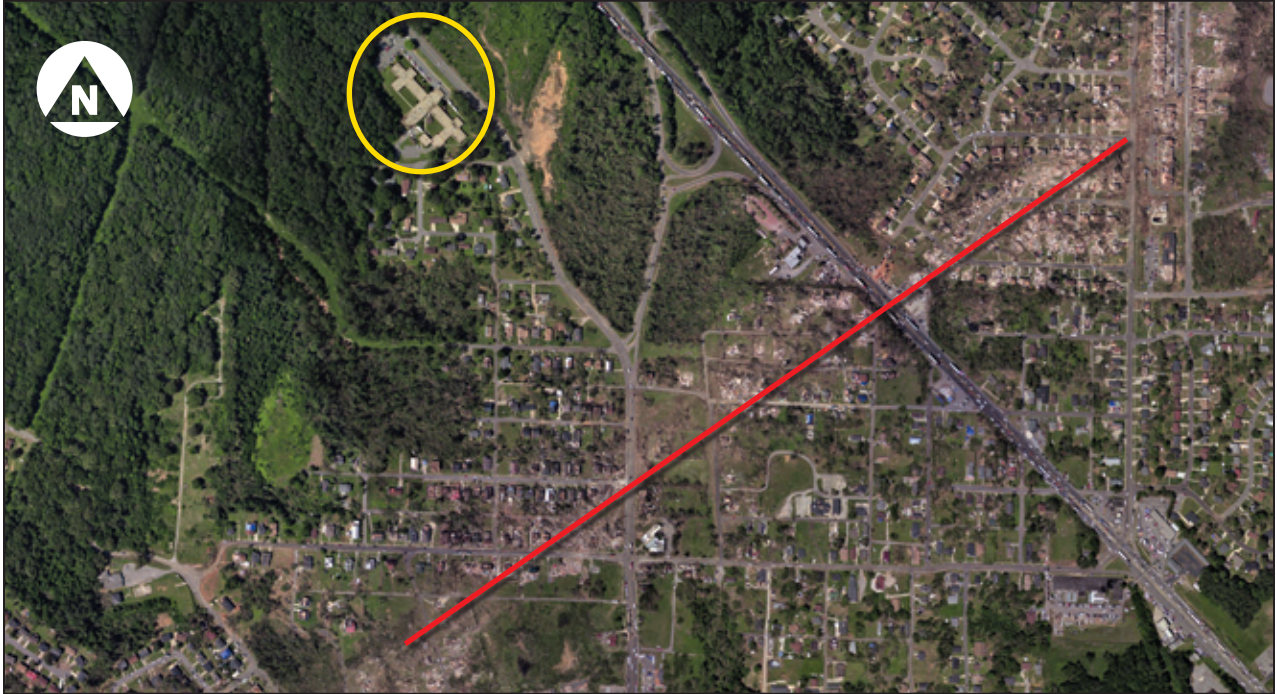

Figure 7-4: Aerial view of the nursing home (yellow circle) in relation to the approximate centerline of the tornado damage swath, shown by the red line<sup>1</sup> (Birmingham, AL)

SOURCE: ALL AERIAL PHOTOGRAPHS ARE FROM NOAA IMAGERY ([HTTP://NGS.WOC.NOAA.GOV/STORMS](http://ngs.woc.noaa.gov/storms)) UNLESS OTHERWISE NOTED



EF contours were not developed by NWS for sites in Birmingham, Tuscaloosa, and Fultondale, AL, and Smithville, MS, described in Chapter 7.

Figure 7-5:  
View of interior corridors that serve as the residents' tornado refuge area (Birmingham, AL)

<sup>1</sup> The red line in this and all similar figures is intended to represent the center of the damage swath. The track location is approximated by the MAT based on post-event aerial photographs. The actual centerline of circulation is offset from the centerline of the damage.

Although the facility did not experience tornado damage, wind-borne debris landed near the nursing home as shown in Figures 7-3 and 7-6.

**Figure 7-6:**  
This portion of a roof from a nearby house was found across the street from the nursing home. The roof portion is approximately 10 feet x 20 feet. The damage potential for a missile of this size is very high (Birmingham, AL).



The nursing home had an emergency generator that was located outdoors (Figure 7-7). Although it was not damaged during this event, the generator was susceptible to tree fall and wind-borne debris damage.

**Figure 7-7:**  
The emergency generator (red arrow) is located near many trees that could easily have damaged the generator and taken it out of service (Birmingham, AL)



## 7.1.2 LaRocca Nursing Home (Tuscaloosa, AL)

**Location of Facility in Tornado Path:** The location of LaRocca Nursing Home is shown in Figure 7-1. Figure 7-8 shows an aerial view of the tornado track in the vicinity of the nursing home. The NWS rated the center of the tornado circulation in the vicinity of the nursing home as an EF4. There were 68 occupants (including residents and staff) in the facility when the tornado struck. No injuries occurred at this facility (DeMonia 2011).

**Facility Description:** This older skilled nursing facility had capacity for 75 residents. A portion of the northern wing had two floors. The remainder of the facility was one story. The steep-slope roofs had asphalt shingles over 1x6 plank decking supported by rafters. The exterior bearing walls were wood studs with 1x6 plank boards, wood fiberboard sheathing, and brick veneer. The facility did not have a storm shelter or safe room.

**General Wind Damage:** Portions of the roof structure were blown off of four areas (Figures 7-9 to 7-12). Some brick veneer was blown off (Figure 7-10), several windows were broken (Figures 7-11 and 7-13), tree-fall caused roof structure and wall damage (Figure 7-14), and some exterior walls collapsed (Figure 7-15).

The facility had two emergency generators, one on the north side of the facility and the other on the southwest. Both generators were outdoors. Had the wall collapsed outward rather than inward, the generator shown in Figure 7-15 may have been taken out of service.



Figure 7-8: Aerial view of the track in the vicinity of the nursing home (yellow circle). The center of the damage swath is approximated by the red line. Inflow damaged the nursing home and buildings within the blue box (Tuscaloosa, AL).

Figure 7-9:  
Close-up of the nursing home shown in Figure 7-8. Red arrows indicate where the roof structure was blown off (Figures 7-10 to 7-12). The yellow arrow indicates a tree on the roof (Figure 7-14). The blue arrow indicates the generator shown in Figure 7-15 (Tuscaloosa, AL).

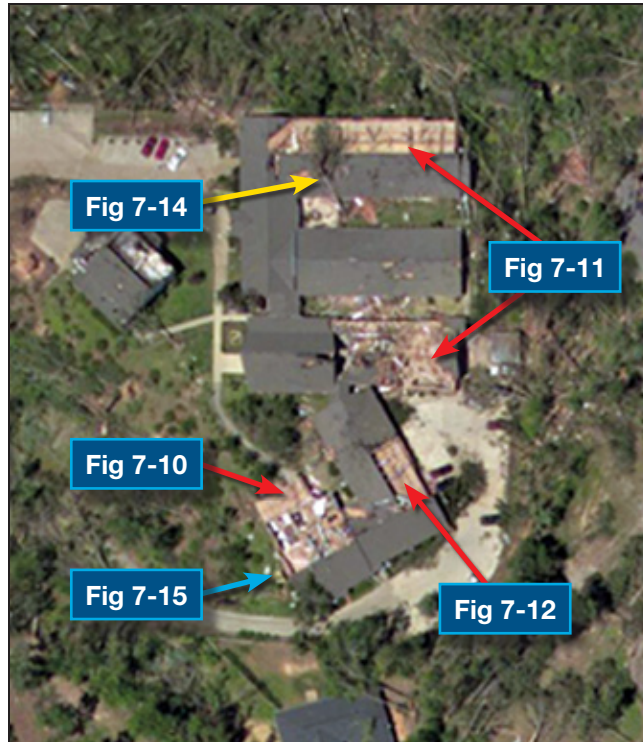

Figure 7-10:  
Roof structure and brick veneer were blown off the nursing home (Tuscaloosa, AL)







Figure 7-11: Roof structure blown off over resident rooms. The inset is a view from within one of the rooms. The window was broken. (Tuscaloosa, AL).



Figure 7-12: Interior damage as a result of roof structure blow-off (Tuscaloosa, AL)

Figure 7-13:  
View of the two-story wing. Most of the windows along this façade were broken (Tuscaloosa, AL).



Figure 7-14:  
Tree-fall damage. Note the boarded-up broken windows. The inset shows a close-up of the tree-fall damage (Tuscaloosa, AL).



Figure 7-15:  
Generator at the southwest side of the facility (red arrow). Note the roof structure blow-off and wall collapse (Tuscaloosa, AL).

**MAT EF Rating:** Using DI 5 (Apartments, Condominiums, and Townhouses; Three Stories or Less), the MAT selected DOD 4 (“uplift or collapse of roof structure leaving most walls standing”) for this facility.<sup>2</sup> Considering the age of the facility and observed damage, the MAT assessed the wind speed as between the expected and lower-bound wind speeds for DOD 4. Hence, the MAT derived the tornado rating as EF2 (111–135 mph) based on damage to this building. Therefore, the estimated wind speed experienced by the building was above the current basic wind speed of 90 mph.

The NWS rated the center of the tornado circulation in the vicinity of the nursing home as EF4, which is above the MAT EF2 rating of this building. As shown in Figure 7-8, the nursing home is away from the center of circulation. Accordingly, wind speed decay would result in a lower speed at the nursing home.

Some of the wind damage at this nursing home was due to wind-borne debris. The MAT judged other building damage to be due to wind speeds substantially above the design wind speed, as well as inadequate wind resistance, which is reflective of the codes, standards, and design practices in the era when this nursing home was constructed.

**Functional Loss:** Prior to the late afternoon tornado strike, the residents were moved into corridors that were designated for use during tornadoes (DeMonia 2011). There were no injuries during the tornado.

It was not possible to evacuate the residents immediately after the tornado had passed because both of the roads from the facility to the street were blocked by several fallen trees. Residents were moved to portions of the building that were not badly damaged. It was the following morning before one of the roads was cleared and the residents and staff evacuated.

<sup>2</sup> There is no DI for nursing homes. The type of construction listed for DI 5 is applicable to this nursing home.

### 7.1.3 Greenbriar Nursing Home (Joplin, MO)

**Location of Facility in Tornado Path:** The location of the Greenbriar Nursing Home is shown in Figure 7-2). Figure 7-16 shows an aerial view of the track in the vicinity of the nursing home. Figure 7-17 shows the nursing home before and after the tornado. The NWS EF contour ratings in the vicinity of the nursing home are shown on Figure 7-16. According to a representative of the nursing home, there were approximately 89 residents and 20 staff in the facility at the time the tornado struck.

**Facility Description:** This skilled nursing facility was built in 1965. It had a maximum occupancy of 120 residents. The 30,311-square-foot building had one core area and four wings. Figure 7-17 shows the nursing home before and after the tornado. The building was constructed with unreinforced CMU with brick veneer walls supporting wood roof trusses.

The facility did not have a storm shelter or safe room. Residents and staff used the central hallway as a tornado refuge area.

**General Wind Damage:** Almost the entire building was destroyed (Figures 7-17 to 7-19). According to witnesses, the tornado blew open the exterior doors and imploded the windows, leading to roof blow-off and wall collapse.



Figure 7-16: Aerial view of the track in the vicinity of the nursing home (yellow circle). The center of the damage swath is approximated by the red line (Joplin, MO).



Figure 7-17:  
Close-up of Figure 7-16 showing the damaged nursing home. The inset shows the nursing home before the tornado struck (Joplin, MO).

INSET SOURCE: © GOOGLE EARTH



Figure 7-18:  
Aerial view of the nursing home (red oval) after the tornado (Joplin, MO)

**Figure 7-19:**  
Only one wall remained  
standing at the nursing home  
(Joplin, MO)



**MAT EF Rating:** Using DI 9 (Small Professional Building),<sup>3</sup> the MAT selected DOD 9 (“total destruction of entire building”) for this facility. Considering the building age and observed damage, the MAT assessed the wind speed as between the expected and lower-bound wind speeds for DOD 9. Hence, the MAT derived the tornado rating as EF3 (136–165 mph) based on damage to this building. Therefore, the estimated wind speed experienced by the building was substantially above the current basic wind speed of 90 mph.

As shown in Figure 7-16, NWS derived the rating as EF5 at the nursing home, which is above the MAT EF3 rating of this building. The actual wind speed of the tornado at this site may have been higher than an EF3. However, since the expected wind speed for total destruction of a DI 9 facility is 157 mph, a determination of a higher wind speed could not be made with a facility of this type of construction. To assess whether higher winds may have occurred, a stronger facility (such as the hospital discussed in Section 7.1.4) would need to be evaluated.

The MAT judged wind damage at this nursing home to be due to it being subjected to wind speeds that were substantially above the design wind speed.

**Functional Loss:** According to a representative, the nursing home had a maximum occupancy of 120 residents; at the time the tornado struck, there were approximately 89 residents and 20 staff. There were 16 fatalities. Ten residents and one staff member died immediately, and five additional residents later died of their injuries. One quadriplegic victim died outside of the building when struck by wind-borne debris. Following the tornado, residents were evacuated to other facilities in the area. The nursing home will be completely rebuilt.

<sup>3</sup> There is no DI for nursing homes. The type of construction listed for DI 9 is applicable to this nursing home. However, DI 9 is for buildings less than 5,000 square feet. Therefore, using DI 9 for this size of nursing home may underestimate the wind speed.

## 7.1.4 St. John's Medical Center (Joplin, MO)

**Location of Facility in Tornado Path:** The location of the St. John's Medical Center is shown in Figure 7-2. Figure 7-20 shows an aerial view of the tornado track in the vicinity of the hospital. The NWS EF contour ratings in the vicinity of the hospital are shown on Figure 7-20. According to a representative of the hospital, it was occupied by staff and approximately 180 patients when the tornado struck. Five patients lost their lives and a number of patients and staff were injured.

**Facility Description:** The St. John's Medical Center was constructed in 1968, with a second East Tower added in 1985 (Figure 7-21). The hospital had 367 beds and its emergency care department was level II trauma certified. The original tower had a concrete frame with cast-in-place concrete floors and a built-up roof. The East Tower addition had a steel frame with cast-in-place concrete floors, a single-ply membrane roof system, an aggregate ballasted roof system on the three-story portion of the addition, and precast concrete wall panels. The towers were joined by a steel superstructure with elevator shafts. The emergency room was located along the northwest corner of the hospital in the original tower; most of the surgery rooms and the intensive care unit (ICU) were in the East Tower addition. The one-story building that housed an emergency generator and switchgear had a steel deck, steel roof joists, and EIFS over unreinforced CMU exterior walls.

The hospital had an electronic medical records system with the data stored in the medical office building/outpatient center, which was connected to the hospital via a tunnel. The data were routinely backed up to an offsite location outside of the area impacted by the tornado.

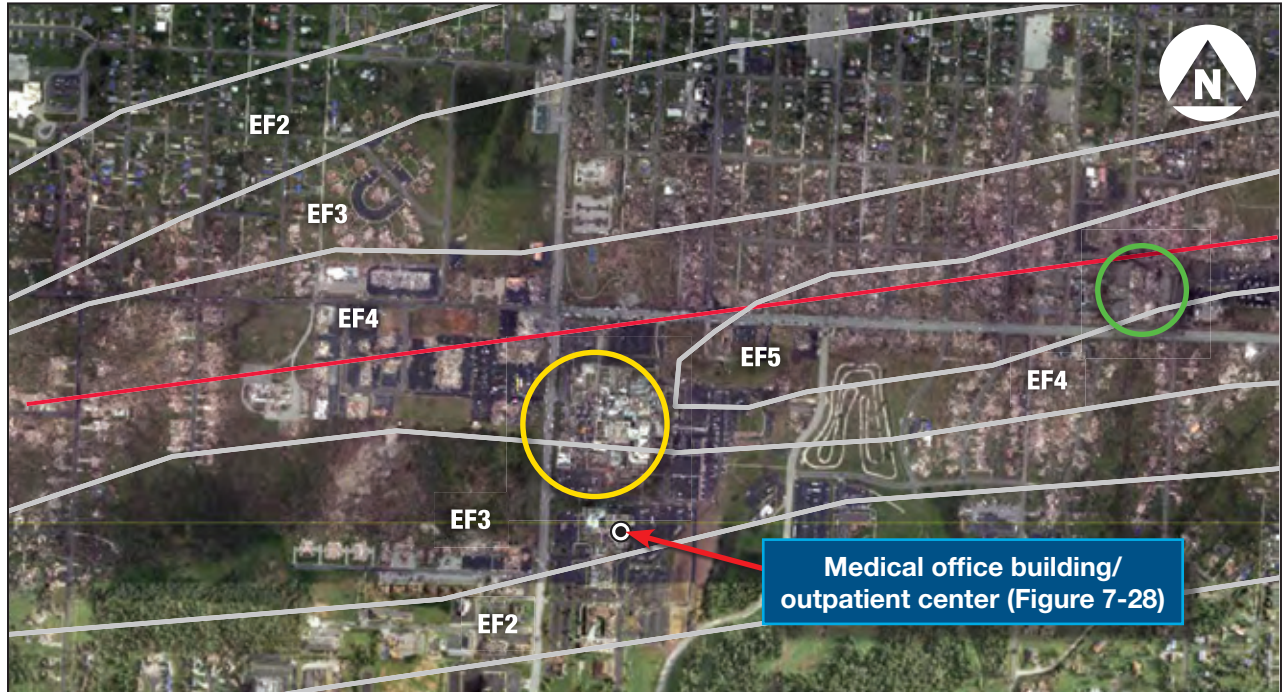
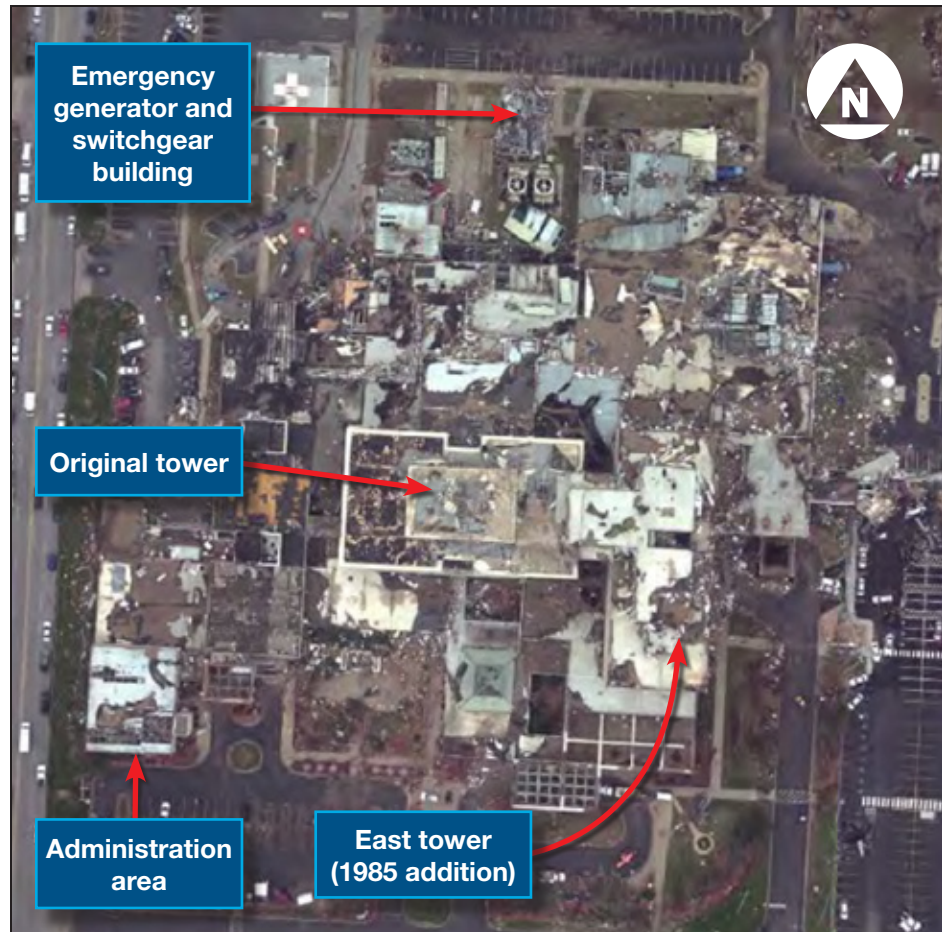

Figure 7-20: Aerial view of the track in the vicinity of the St. John's Medical Center (yellow circle). The blue arrow indicates the medical office building/outpatient center (shown in Figure 7-28). The center of the damage swath is approximated by the red line. The location of Greenbriar Nursing Home (Section 7.1.3) is indicated by the green circle (Joplin, MO).

Figure 7-21:  
Close-up of Figure 7-20  
showing St. John's Medical  
Center (Joplin, MO)



The hospital did not have a tornado safe room or storm shelter. The hospital's tornado procedure entailed moving patients into corridors, except in the ICU, where patients and hospital personnel were to remain in the unit and seek protection to the extent possible. Evacuation sleds were available to help move patients down stairwells and corridors during an emergency in the event elevators were not working.

**General Wind Damage:** Most of the exterior windows were broken, which resulted in injuries to patients and staff as well as extensive interior damage (Figure 7-22). See also Figure 5 in Tornado Recovery Advisory No. 5, *Critical Facilities Located in Tornado-Prone Regions: Recommendations for Facility Owners* (FEMA 2011c) in Appendix F.

There was extensive blow-off of roof membranes on both towers and lower-level roofs, and some roof decking blow-off on the lower-level roofs (Figure 7-21), blow-off of roof aggregate (Figure 7-23), collapse of brick veneer walls at the original tower (Figure 7-24 inset), collapse of metal wall panels at the East Tower addition (Figure 7-24), and collapse of a precast concrete wall panel at the loading dock (Figure 7-25). A hospital representative told the MAT that engineers working on behalf of the hospital determined that the structural steel frame of the East Tower addition had been twisted by the tornado.





Figure 7-22:  
View of the glazing damage  
at patient rooms (Joplin, MO)



Figure 7-23:  
This parking lot was littered  
with 1½-inch nominal  
diameter aggregate from the  
ballasted roof membrane.  
(Joplin, MO).

Figure 7-24:  
Collapse of a portion of the exterior metal composite foam wall panels at the East Tower addition (red arrows). The inset shows collapsed brick veneer at the Original Tower. Most of the glazing shown in this photograph was broken (Joplin, MO).





Figure 7-25:  
View of a missing precast  
concrete wall panel (red box)  
at the loading dock  
(Joplin, MO)

Several of the lower-level areas, including an equipment room and an administrative area, had metal roof decking blown off (Figures 7-26 and 7-27). Some exterior walls also collapsed (Figure 7-27).



Figure 7-26:  
Metal decking blow-off  
and glazing damage in the  
administrative area  
(Joplin, MO)

**Figure 7-27:**  
Exterior wall collapse (EIFS over unreinforced CMU) at an equipment room (Joplin, MO)



The water main and natural gas lines had been labeled at some point prior to the tornado and were closed soon after the event, thereby avoiding flooding, fire, and explosion.

The hospital had two emergency generators, one within the original tower and the other within the building shown in Figure 7-21. The generator/switchgear building collapsed, which resulted in total loss of electrical power throughout the hospital. This building is shown in Figures 12 and 13 of Tornado Recovery Advisory No. 6, *Critical Facilities Located in Tornado-Prone Regions: Recommendations for Architects and Engineers* (FEMA 2011b) in Appendix F. The generator in the original tower did not function because the switchgear was severely damaged by the building collapse.

The medical office building/outpatient center, which housed the medical records server, experienced significant glazing damage, EIFS puncture by wind-borne debris, EIFS blow-off, and roof membrane and roof decking blow-off (Figures 7-21 and 7-28). The on-site medical records server did not survive, but the data were remotely backed up.

**MAT EF Rating:** Using DI 20 (Institutional Building), the MAT selected DOD 10 (“collapse of some top story exterior walls”) for the hospital. Using the expected wind speed for DOD 10, the MAT derived the tornado rating as EF3 (136–165 mph) based on damage to this building. Hence, the estimated wind speed experienced by the building was substantially above the current basic wind speed of 90 mph.

Using DI 17 (Low-Rise Building, 1–4 Stories), the MAT selected DOD 6 (“significant damage to exterior walls and some interior walls”) for the medical office building/outpatient center. Considering the building age and observed damage, the MAT assessed the wind speed as between the expected and lower-bound speeds for DOD 6. Hence, the MAT derived the tornado rating as EF 3 (136–165



Figure 7-28: Metal decking blow-off and glazing and EIFS damage (red arrows) at the medical office building/outpatient center. Inset shows a close-up of the damage (Joplin, MO).

mph) based on damage to this building. Therefore the estimated wind speed experienced by this building was substantially above the current basic wind speed of 90 mph.

As shown in Figure 7-20, the NWS derived the rating as EF3 at the medical office building/outpatient center, which correlates with the MAT EF3 rating for this building. The NWS derived the rating as EF5 at one portion of the hospital and EF4 at other portions, which are different from the MAT EF3 rating for this building.

The MAT judged wind damage at this hospital to be due to wind-borne debris and its subjection to wind speeds substantially above the design wind speed.

**Functional Loss:** According to a representative, the hospital was occupied by staff and approximately 180 patients when the tornado struck. Five patients lost their lives during evacuation efforts and a number of patients and staff were injured as well.

With loss of all electrical power and other significant damage to the building, it was necessary to evacuate the hospital. The emergency lighting in the stairways and corridors was powered by the emergency generator. With loss of the generators, and in the absence of battery-powered exit lighting as a secondary back-up, patients were evacuated down dark stairways and through dark corridors. The hospital was evacuated in about 1½ hours. Patients were either moved to an initial emergency triage area that was set up near the heliport or to another hospital in town.

Within a week, a temporary 60-bed hospital was established across the parking lot from the existing hospital. On January 3, 2012, construction of a new 825,000-square-foot hospital began to replace the former St. John's Medical Center at a new location in Joplin. The new hospital is scheduled to be completed by 2015, with an estimated construction cost of \$345 million. Demolition of the existing hospital is expected to take 5 months, and hospital officials plan to donate the land to the City. Hospital personnel expressed the importance of having electronic patient records, which eased the process of evacuating patients to other hospitals and enabled the quick transition to the temporary 60-bed hospital.

## 7.2 First Responder Facilities (Police and Fire)

Police and fire rescue facilities are critical to disaster response because an interruption in their operation as a result of building or equipment failure may prevent rescue operations, evacuation, assistance delivery, or general maintenance of law and order, which can have serious consequences for the community.

### 7.2.1 Fultondale Municipal Complex (Fultondale, AL)

**Location of Facility in Tornado Path:** Figure 7-29 shows an aerial view of the tornado track in the vicinity of the Fultondale Municipal Complex. The NWS rated the center of the tornado circulation in the vicinity of this complex as an EF2.

The Fultondale municipal complex has four major buildings (Figure 7-30): 1) Fire Department, 2) Library/"Shelter," 3) Building and Inspections Department, and 4) City Hall (which houses the police station, jail, and natural gas utility offices). According to a representative of the complex, citizens seeking refuge from the tornado were in the library when the tornado struck. The jail was also occupied during the event. The Municipal Complex was damaged in several locations.

- + The Fire Department lost the entire roof structure over the apparatus bay.
- + The Library/"Shelter" had damage to the siding and mansard. The entrance to the "Shelter," referred to hereafter as a tornado refuge area, is shown by the yellow arrow in Figure 7-30.
- + The roof structure of the Buildings and Inspections Department was lifted off and came to rest upside down in the area indicated by the blue oval at Figure 7-30.
- + The City Hall and Police Station had roof damage to the porte-cochere (red box in Figure 7-30), and the emergency generator was taken out of service by a fallen tree (red arrow).

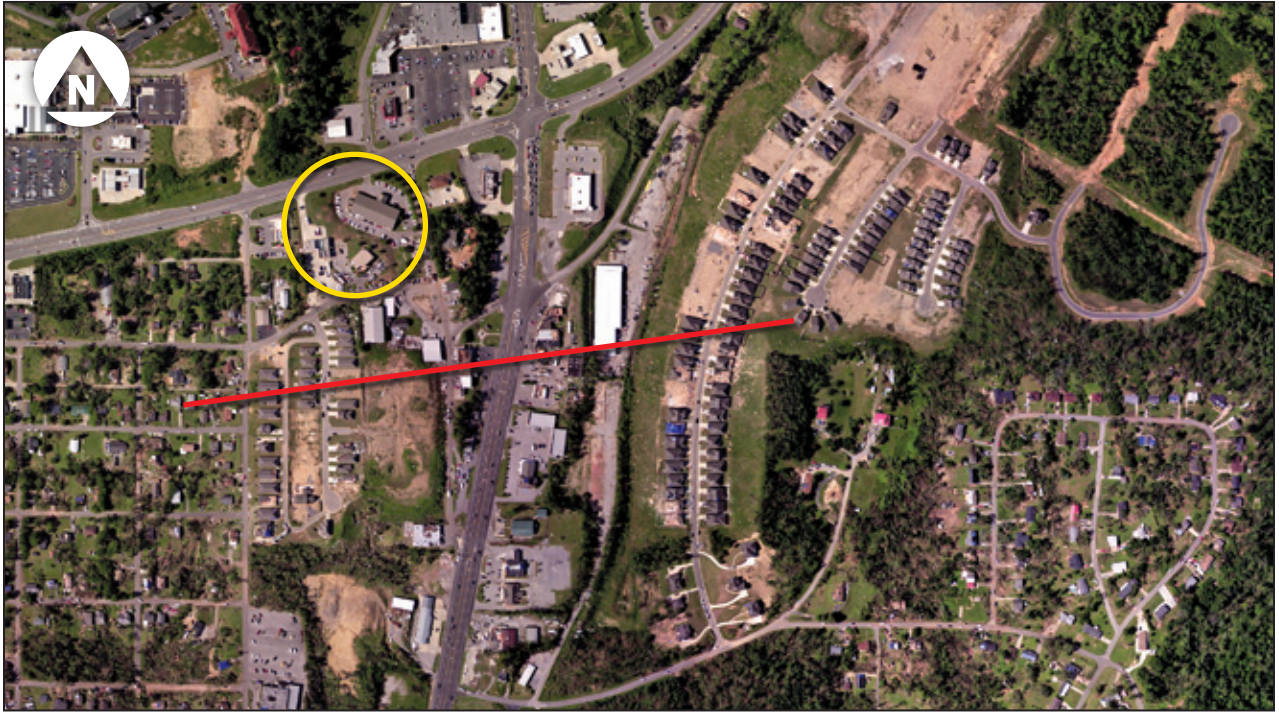

Figure 7-29: Aerial view of tornado track in the vicinity of Fultondale Municipal Complex in Alabama (yellow circle). The center of the damage swath is approximated by the red line (Fultondale, AL).

SOURCE: © GOOGLE EARTH



Figure 7-30: Tornado winds damaged an emergency generator (red arrow) and a roof (red box), and lifted a roof (final location shown by blue box). Yellow arrow shows the “shelter” entrance (Fultondale, AL).

SOURCE: © GOOGLE EARTH

### 7.2.1.1 Fire Department

**Facility Description:** The fire department is a PEMB that was built around 1995. The walls have brick veneer cladding over the frame.

**General Wind Damage:** The apparatus bay doors collapsed, most of the metal roof covering blew off, and some of the metal fascia blew off (Figures 7-31 and 7-32).

**MAT EF Rating:** Using DI 21 (Metal Building Systems),<sup>4</sup> the MAT selected DOD 3 (“metal roof or wall panels pulled from the building”) for this facility. Using the expected wind speed for DOD 3, the MAT derived the tornado rating as EF1 (86–109 mph) based on damage to this building. Hence, the estimated wind speed experienced by the building was not substantially above the current basic wind speed of 90 mph.

The MAT judged the wind damage at this fire station to be due to inadequate wind resistance.

**Functional Loss:** According to a representative of the complex, two pieces of apparatus that received minor damage were freed from the damaged building and were in service in less than 2 hours. Several more hours were required to free the balance of the equipment. Although damaged, the building remained useable after debris removal. The building will need substantial work to bring it back into full service.

Figure 7-31:  
The apparatus bay doors of  
the fire department collapsed  
(Fultondale, AL)



<sup>4</sup> There is no DI for fire stations. DI 21 was deemed appropriate for this facility.





Figure 7-32:  
The metal roof panels blew off the apparatus bay of the fire department. The panels unlatched from the clips, shown at another angle in the inset (Fultondale, AL).



### 7.2.1.2 Library and “Shelter”

**Facility Description:** The library was built in the early to mid-1970s. The Fultondale Community “Shelter” is located in the daylight basement of the library. The tornado refuge area was well publicized and was used by up to 150 people during the day of the storms. The refuge area has glass doors and a window wall system (Figure 7-33) that do not possess the wind pressure and wind-borne debris resistance specified in FEMA 361(2008a) or ICC 500 (2008). Therefore, the glazing presents a potential hazard to the occupants. Because of the glazing vulnerability, this area is considered a tornado refuge area rather than a storm shelter or safe room (refer to Section 9.1 for additional information).

**General Wind Damage:** The library had minimal damage to the metal panel fascia at the entrance vestibule (Figure 7-33). There was also some brick veneer damage on the side of the building that faced the fire station. This damage was minor and easily repaired.



Figure 7-33:  
The library is on top of the community tornado refuge area. The note in the window (red circle) directed people to the “shelter” below (Fultondale, AL).

**MAT EF Rating:** Using DI 17 (Low-Rise Building, 1–4 Stories), the MAT selected DOD 1 (“threshold of visible damage”) for this facility. Using the expected wind speed for DOD 1, the MAT derived the tornado rating as EF0 (65–85 mph) based on damage to this building. Hence, the estimated wind speed experienced by the building was below the current basic wind speed of 90 mph.

The MAT judged the wind damage at this building to be due to inadequate wind resistance, which is reflective of the codes, standards, and design practices in the era when this facility was built.

**Functional Loss:** The building did not experience a loss of function.

### 7.2.1.3 Building and Inspections Department

**Facility Description:** The Buildings and Inspections Department building was constructed in the late 1970s to house a medical response vehicle. The building has CMU bearing walls and a wood truss roof system.

**General Wind Damage:** The roof structure lifted off the walls and flipped over in one complete piece into the side yard (Figures 7-30 and 7-34). The top course of the CMU wall was made from cap blocks and not a bond beam (Figure 7-35). The trusses were attached to a wooden plate that was nailed into the cap blocks. The cap blocks had no positive anchorage to the main wall. The wall also appeared to be unreinforced masonry and was damaged.



Figure 7-34: The roof structure of the Buildings and Inspections Department building blew off in one complete section (red arrow). The yellow oval area is shown in Figure 7-35 (Fultondale, AL).



Figure 7-35: Note the inadequate anchorage from the truss nailer (red arrow) that was nailed to the wall top cap block (blue arrow). The inset shows a close-up. Also note the lack of anchorage between the top cap block and the main wall (Fultondale, AL).

**MAT EF Rating:** Using DI 9 (Small Professional Building), the MAT selected DOD 7 (“uplift or collapse of entire roof structure”) for this facility. Considering the building age and observed damage, the MAT assessed the wind speed as the lower-bound wind speed for DOD 7. Hence, the MAT derived the tornado rating as EF1 (86–110 mph) based on damage to this building. Therefore, the estimated wind speed experienced by the building was not substantially above the current basic wind speed of 90 mph.

The MAT judged the wind damage at this building to be due to inadequate wind resistance, which is reflective of the codes, standards, and design practices in the era when this building was constructed.

**Functional Loss:** According to a representative of the complex, the building was determined to be a total loss. After the tornado, the department temporarily relocated to the basement of the library.

#### 7.2.1.4 City Hall

**Facility Description:** The City Hall was built in 1985. It is a single-story, light-framed building with a truss roof.

**General Wind Damage:** The City Hall lost its metal roof covering over the portecochere (Figure 7-36). The emergency generator was taken out of service by a fallen tree. The tree caused the generator to shift, which broke the natural gas fuel line (Figure 7-37).

A properly protected generator should not be taken out of service by a fallen tree. FEMA Recovery Advisory No.6, *Critical Facilities Located in Tornado-Prone Regions: Recommendations for Architects and Engineers* (Appendix F), provides recommendations for architects and engineers including enhancements to generators to avoid interrupted operations.

**MAT EF Rating:** Using DI 17 (Low-Rise Building, 1–4 Stories), the MAT selected DOD 2 (“loss of roof covering (<20%)”) for this facility. Considering the building age and observed damage, the MAT assessed the wind speed to be between the expected and lower-bound wind speeds for DOD 2. Hence, the MAT derived the tornado rating as EF0 (65–85 mph) based on damage to this building. Therefore, the estimated wind speed experienced by the building was below the current basic wind speed of 90 mph.

The MAT judged the small amount of wind damage at this building to be due to inadequate wind resistance, which is reflective of the codes, standards, and design practices in the era when this facility was built. The damage to the generator was due to a tree that was too close to the generator.

**Functional Loss:** According to a representative of the complex, the loss of City power and damage to their emergency generator resulted in no lighting (other than flashlights) or ventilation in the jail area. Once the natural gas line to the generator was repaired, the building operated on emergency power. Municipal power was restored approximately 3 days after the tornado. The building damage was minor and easily repaired.

**Figure 7-36:**  
The front of the City Hall showing damage to the metal roof covering over the entrance (Fultondale, AL)





Figure 7-37:  
Back of the City Hall. The red arrow points to the generator that was disabled by a fallen tree (Fultondale, AL).

### 7.2.1.5 Summary of the MAT EF Ratings for the Fultondale Municipal Complex

For two of the Fultondale Municipal Complex buildings, the MAT derived an EF0 rating. An EF1 rating was derived for the other two buildings.

As can be seen in Figure 7-30, the four buildings are near one another; hence, they likely experienced similar wind speeds. The buildings may have experienced different wind loads due to differences in angle of attack, shielding, or exposure. However, the different EF ratings may be due to uncertainties in the accuracy of the wind speeds associated with the different DIs and DODs. The NWS rated the center of the tornado circulation in the vicinity of the complex as an EF2, which is above the MAT EF0 and EF1 ratings of the complex. As shown in Figure 7-29, the complex is on the left periphery of the center of circulation. Accordingly, the wind speed at the complex should be less than the wind speed at the center of circulation.<sup>5</sup>

### 7.2.2 Tuscaloosa Fire Station 4 (Tuscaloosa, AL)

**Location of Facility in Tornado Path:** The location of Tuscaloosa Fire Station 4 is shown in Figure 7-1). Figure 7-38 shows an aerial view of the tornado track in the vicinity of the fire station. The NWS rated the center of the tornado circulation in the vicinity of the fire station as an EF4. According to a representative of the fire department, four fire station personnel were in the building when the tornado struck—none were injured.

**Facility Description:** This fire station, which opened in 1952, had a modified bitumen roof membrane system over a cast-in-place concrete deck. Some of the exterior walls were brick (which appeared to be bearing walls). Other exterior walls were stucco over wire lath over furring over what appeared to be cast-in-place concrete. The apparatus bay had two sectional doors at the front and back of the bay.

The facility did not have a storm shelter or safe room.

<sup>5</sup> The wind speed is higher on the right side of the center of circulation than it is on the left side.



Figure 7-38: Aerial view of the track in the vicinity of the fire station (yellow circle). The center of the damage swath is approximated by the red line (Tuscaloosa, AL).

**General Wind Damage:** The MAT also observed nearby apartment buildings when they visited this fire station because the fire station's specific construction type is not covered in the EF rating system. Therefore, damage to two nearby apartment buildings was used to determine EF ratings (as discussed later).

**Apartment Buildings:** The two nearby apartment houses were heavily damaged (Figure 7-39). The apartment house shown by the left yellow arrow lost its entire wood roof structure, and a portion of the unreinforced CMU wall collapsed. The wood-frame apartment house shown by the right yellow arrow lost the roof structure, and several of the exterior and interior walls on the second floor collapsed.

**Fire Station:** At the fire station, all four apparatus bay doors were blown away, all of the exterior windows were broken, the roof membrane was punctured in a few areas, some of the cap sheet was blown away, and some rooftop equipment was blown away.

Figure 7-40 is a view of the fire station and the adjacent apartment building. The inset shows where a section of stucco and lath was broken away by wind-borne debris. The marks on the wall indicate the amount of debris that impacted this area. Figure 7-41 is a view of the fire station living quarters. All of the windows were broken. Fire station personnel took refuge in the rest room shown in Figure 7-42. Figure 7-43 shows the wood-framed apartment building behind the fire station.



Figure 7-39: The fire station is within the red circle. The apparatus bay is indicated by the blue arrow, and the living quarters are indicated by the green arrow. The yellow arrows indicate the nearby heavily damaged apartment buildings (Tuscaloosa, AL).

PHOTOGRAPH COURTESY OF TUSCALOOSA COUNTY SHERIFF'S OFFICE

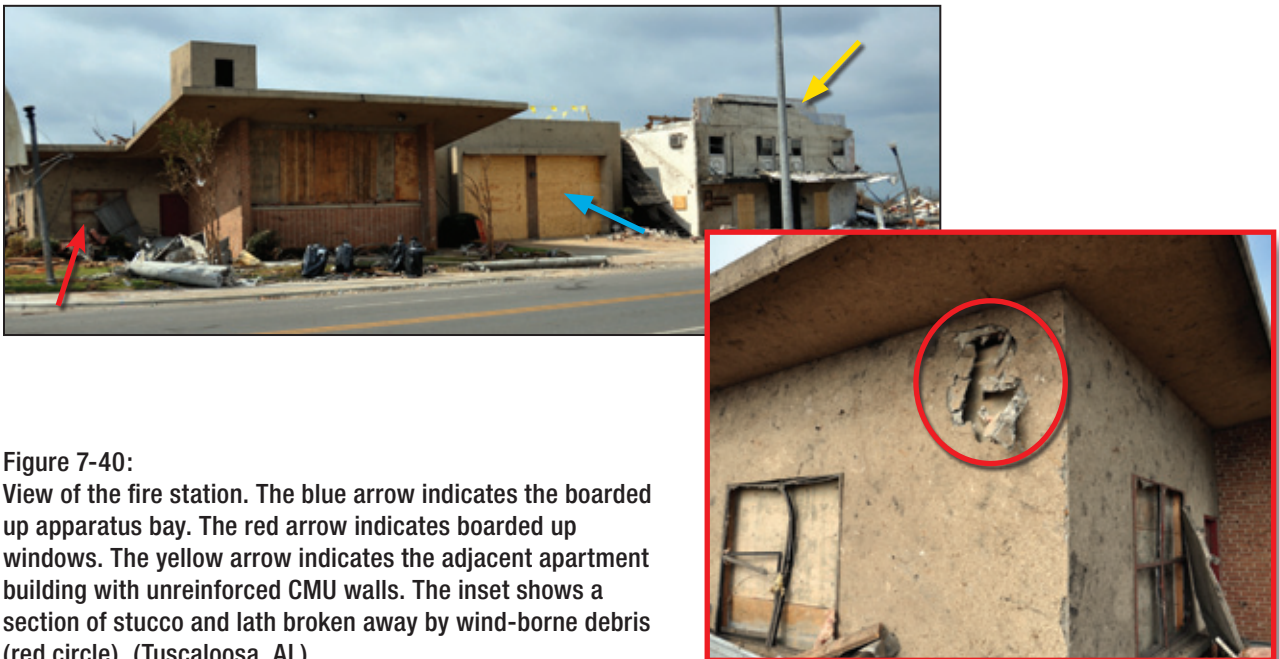

Figure 7-40: View of the fire station. The blue arrow indicates the boarded up apparatus bay. The red arrow indicates boarded up windows. The yellow arrow indicates the adjacent apartment building with unreinforced CMU walls. The inset shows a section of stucco and lath broken away by wind-borne debris (red circle). (Tuscaloosa, AL).

Figure 7-41:  
View of the living quarters of the fire station from outside; inset shows the interior. Note the amount and size of wind-borne debris adjacent to the walls (Tuscaloosa, AL).



Figure 7-42:  
View of a restroom toward the center of the fire station where occupants took refuge. Note the mattress that was taken into the room for additional protection (Tuscaloosa, AL).







Figure 7-43: View of the wood-frame apartment building behind the fire station. The inset shows the far end of the building. The walls were brick veneer over wood fiberboard over wood studs (Tuscaloosa, AL).

**MAT EF Rating:** Because of this fire station's unusual type of construction, none of the DIs were judged appropriate for it. Therefore, two nearby apartment buildings were used instead, and they were rated as follows:

Masonry apartment building: Using DI 7 (Masonry Apartments or Motel), the MAT selected DOD 5 ("collapse of top story walls") for this facility. Considering the building age and observed damage, the MAT assessed the wind speed to be between the expected and lower-bound wind speeds for DOD 5. Therefore, the MAT derived the tornado rating as EF2 (111–135 mph) based on damage to this building.

Wood-frame apartment building: Using DI 5 (Apartments, Condominiums, and Townhouses; Three Stories or Less), the MAT selected DOD 5 for this facility. Considering the building age and observed damage, the MAT assessed the wind speed to be between the expected and lower-bound wind speeds for DOD 5. Therefore, the MAT derived the tornado rating as EF3 (138–167 mph) based on damage to this building.

As can be seen in Figure 7-38, the wood-frame apartment building with the EF3 rating was closer to the center of the tornado circulation than the masonry apartment building with the EF2 rating, so the difference in the ratings may be due to wind speed decay. However, the difference may also be due to uncertainties in the accuracy of the wind speeds associated with the DODs.

Based on the apartment building EF ratings, the fire station either experienced EF2 or EF3 winds. Hence, the estimated wind speed at the fire station was either above or substantially above the current basic wind speed of 90 mph.

The NWS rated the center of the tornado circulation in the vicinity of the fire station as EF4, which is above the MAT EF2 or EF3 ratings of the fire station. As shown in Figure 7-38, the fire station is to the left of the center of circulation. Accordingly, the wind speed at the fire station should be less than the wind speed at the center of circulation.

The damaged glazing was due to wind-borne debris. The damage to the apparatus bay doors was due to either wind-borne debris, or more likely, wind pressures that were substantially above the pressures the doors were designed for. The MAT judged the good performance of the structural system to be due to the use of concrete.

**Functional Loss:** According to a representative of the fire department, one fire engine and one personal vehicle were in the apparatus bay when the tornado struck. The engine was damaged to an extent that it was not usable for emergency response. Fire station personnel therefore provided assistance to the community on foot. The personal vehicle was totaled.

For about the first week after the tornado, the damaged fire station was used to provide services. Then for about two weeks, personnel from this station operated out of Fire Station 6. After that time period, a temporary station was set up about two blocks from Fire Station 4. The temporary station consisted of a mobile office and a canvas apparatus bay.

A new facility will be built for Fire Station 4 at another location. Plans for the damaged fire station have yet to be determined at the time of this report.

### 7.2.3 Webster's Chapel Volunteer Fire Department (Wellington, AL)

**Location of Facility in Tornado Path:** An aerial view of the Webster's Chapel Volunteer Fire Department prior to the tornado is shown in Figure 7-44. The NWS EF contour ratings in the vicinity of the fire station are shown on Figure 7-44. According to a representative of the fire department, the fire station was occupied shortly before the tornado struck, but the occupants left the station before the tornado struck and sought refuge in a church across the street, which was outside of the tornado track and not damaged.

**Facility Description:** The Webster's Chapel Volunteer Fire Department was originally designed as a school several decades ago. When the facility was converted to a fire station, there was only one apparatus bay. A new apparatus bay was added circa 2007 (Figure 7-45). The original building was wood-frame construction with brick veneer walls. The multipurpose room had an aggregate surface built-up roof system over a cementitious wood-fiber deck. The older apparatus bay had a wood roof structure and unreinforced CMU walls. The new apparatus bay is a PEMB with metal roof and wall panels.

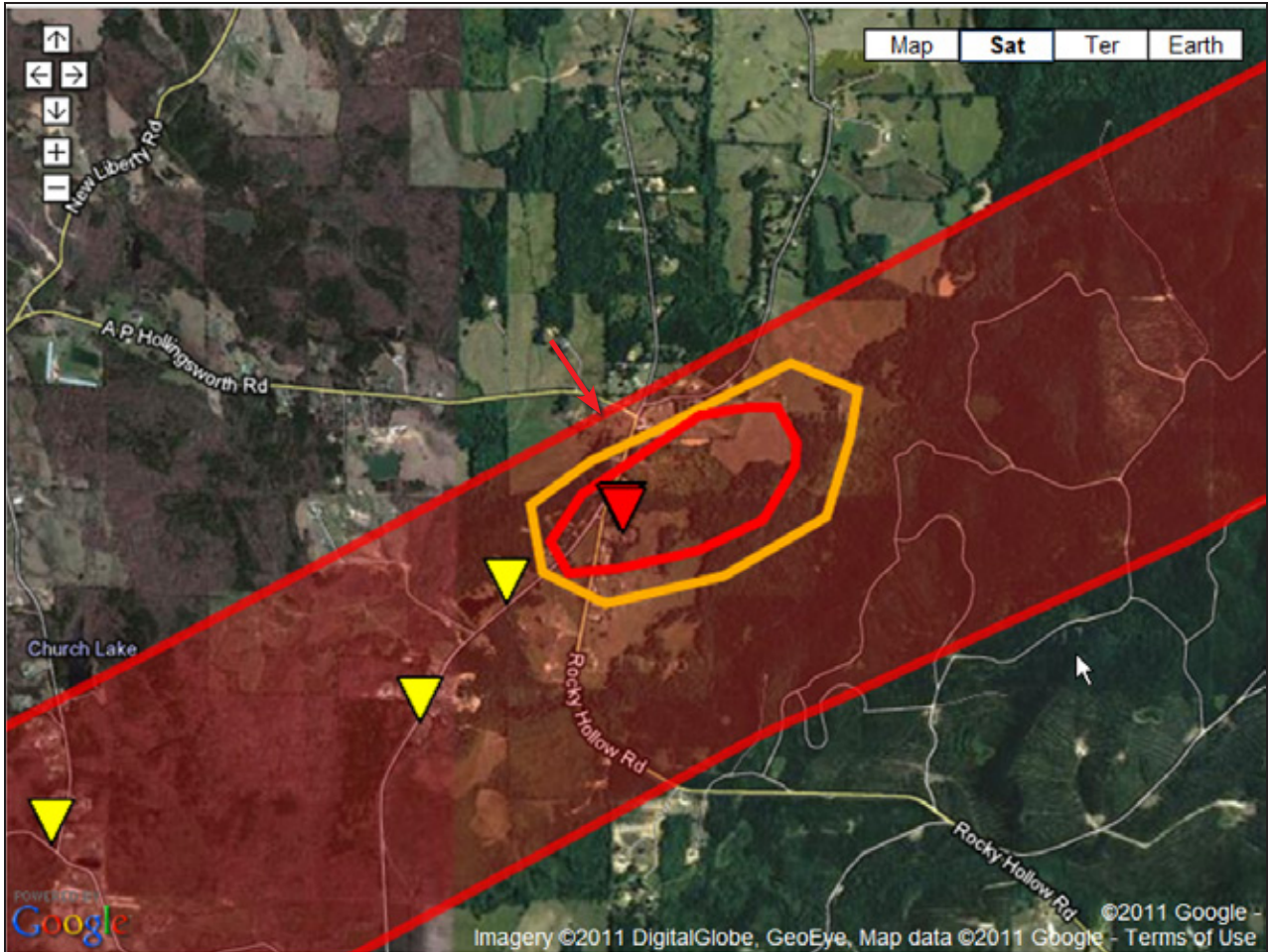

Figure 7-44: View of the Webster's Chapel Volunteer Fire Department (red arrow) in relation to the tornado.<sup>6</sup> The red triangle indicates the location of two houses where NWS rated the tornado as EF4. The yellow triangles indicate the locations of houses where NWS rated the tornado as EF2 (Wellington, AL).

SOURCE: © GOOGLE EARTH

SOURCE OF TORNADO TRACK: NOAA ([HTTP://NGS.WOC.NOAA.GOV/STORMS](http://ngs.woc.noaa.gov/storms))

The facility did not have a storm shelter or safe room.

**General Wind Damage:** The tornado struck the corner of the building where the multipurpose room and old apparatus bay were located. At the old apparatus bay, the rolling doors blew in on the equipment, the roof structure blew off, and part of the back wall collapsed (Figure 7-46). The roof membrane was blown off the multipurpose room, a few windows were broken, and portions of the roof structure and exterior wall were blown away on the backside of the building (Figure 7-47). The new apparatus bay had some wind-borne debris damage (inset at Figure 7-45), but this portion of the building did not experience high winds.

<sup>6</sup> NOAA did not take post-tornado aerial photographs of this tornado. Therefore, a pre-storm image was used for this figure.

Figure 7-45:  
View of the Webster’s Chapel Volunteer Fire Department after the tornado. The new apparatus bay is indicated by the red arrow. The older apparatus bay is indicated by the yellow arrow. The inset shows wind-borne debris damage at the back side of the new apparatus bay. The green arrows indicate plywood debris that penetrated the metal wall panel sidelaps (Wellington, AL).



Figure 7-46:  
View of the old apparatus bay of the Webster’s Chapel Volunteer Fire Department. The multipurpose room is indicated by the red arrow (Wellington, AL).



Figure 7-47:  
View of the back of the building. The old apparatus bay is shown by the yellow arrow and the new bay by the red arrow. Roof structure and wall damage occurred within the red box. The debris in the foreground is from the multipurpose room roof and the old apparatus bay (Wellington, AL).



**MAT EF Rating:** Only the old apparatus bay portion of the facility was rated. Using DI 14 (Automobile Service Building),<sup>7</sup> the MAT selected DOD 6 (“uplift or collapse of roof structure”) for this facility. Considering the facility age and observed damage, the MAT assessed the wind speed as near the lower-bound wind speed for DOD 6. Hence, the MAT derived the tornado rating as EF1 (86–110 mph) based on damage to this building. Therefore, the estimated wind speed experienced by the building was not substantially above the current basic wind speed of 90 mph.

As shown in Figure 7-44, the NWS derived the rating as EF1 in the vicinity of the fire station, which correlates to the MAT EF1 rating.

The MAT judged the wind damage at this fire station to be due to inadequate wind resistance, which is reflective of the codes, standards, and design practices in the era when this building was constructed.

**Functional Loss:** According to a representative of the fire department, all three pieces of equipment in the old apparatus bay were significantly damaged and were therefore not available for response and recovery operations.

## 7.2.4 Smithville Police Department (Smithville, MS)

**Location of Facility in Tornado Path:** Figure 7-48 shows an aerial view of the tornado track in the vicinity of the Smithville Police Department. Figure 7-49 shows the building prior to the tornado. The NWS rated the center of the tornado circulation in the vicinity of the police department as an EF5. According to a representative of the police department, there were seven people in the building at the time the tornado struck, five of whom were injured by the tornado damage. None of the injuries was life threatening.

**Facility Description:** The Smithville Police Department was constructed in 1962. It was previously the town’s health department building. The building was constructed of unreinforced CMU with brick veneer. The building had brick veneer over 4-inch-wide CMU walls. Truss wire was noted with 8 inches-on-center shear reinforcement.

The facility did not have a storm shelter or safe room.

**General Wind Damage:** During the storm, the roof of the police department was blown off, and large portions of the walls on the north, east, and south sides of the building collapsed (Figure 7-50). Figure 7-51 shows a photograph taken directly after the tornado. To the left side of the figure, a portion of the building’s walls can be observed. Figure 7-52 shows the damage to the police station looking south from the back (north) side of the building. The collapse of the east wall, which is also depicted in Figure 7-53, can be noted in Figure 7-49.

---

<sup>7</sup> There is no DI for fire stations. The type of construction listed for DI 14 is applicable to this fire station.



Figure 7-48: Aerial view of the tornado track in the vicinity of the Smithville Police Department (yellow circle). The center of the damage swath is approximated by the red line (Smithville, MS).

Figure 7-49:  
Smithville Police Department  
prior to the tornado  
(Smithville, MS)

SOURCE: © GOOGLE EARTH





Figure 7-50:  
Smithville Police Department  
(close-up of Figure 7-48).  
The red arrow indicates the  
room where refuge was  
taken during the tornado  
(Smithville, MS).



Figure 7-51:  
Smithville Police  
Department. Note the  
collapsed communications  
tower (red arrow) (Smithville,  
MS).

PHOTOGRAPH COURTESY OF TIM  
BURKITT, FEMA

**Figure 7-52:**  
The red arrow indicates the office where two children and an adult took refuge under the desk (Smithville, MS)

PHOTOGRAPH COURTESY OF DARWIN HATHCOCK, CHIEF OF POLICE



**Figure 7-53:**  
View of the collapsed east wall (red arrow) and restroom (blue arrow) of the Smithville Police Department. Note that some of the restroom walls collapsed (Smithville, MS).

PHOTOGRAPH COURTESY OF DARWIN HATHCOCK, CHIEF OF POLICE





**MAT EF Rating:** Using DI 9 (Small Professional Building),<sup>8</sup> the MAT selected DOD 8 (“collapse of exterior walls; closely spaced interior walls remain standing”) for this facility. Considering the building age and observed damage, the MAT assessed the wind speed to be between the expected and lower-bound wind speeds for DOD 8. Hence, the MAT derived the tornado rating as EF2 (111–135 mph) based on damage to this building.<sup>9</sup> Therefore, the estimated wind speed experienced by the building was above the current basic wind speed of 90 mph.

The NWS rated the center of the tornado circulation in the vicinity of the Smithville Police Department as an EF5, which is different from the MAT EF2 rating of this building. As shown in Figure 7-48, the police department was on the right side of the center of the damage swath, and hence the right side of the center of circulation, where the wind speed is the highest. It is likely that there was wind speed decay between the center of circulation and the police station. The MAT judged the wind damage at this police station to be due to wind speeds that were above the design wind speed and inadequate wind resistance, which is reflective of the codes, standards, and design practices in the era when this police station was constructed.

**Functional Loss:** According to a representative of the police department, there were seven people in the building at the time the tornado struck—four employees and three civilians, including one adult and two children—who came to the police station to seek refuge. One occupant injured his arm and shoulder when winds tore a door from his grasp, while another sustained injuries from debris.

Communications for emergency response after the tornado were hampered by the collapse of the communications tower at the police department. The department had a hand-held walkie-talkie, but communication with the Smithville Fire Department, Monroe County Sheriff’s Department, the 911 call center, and the Amory Police Department was not possible because of tornado damage at these other sites. The patrol car radios did not work because they had gotten wet. The cell phone circuits were also jammed. The Smithville Police Department was unable to let other emergency personnel know how bad the damage was and what their immediate needs were.

The police officers had no working or accessible equipment. The patrol cars were destroyed. Without equipment, the officers used pieces of wood as pry bars to try to rescue people trapped in cars and rubble. Doors from houses were used as backboards to transport the injured.

The facility did not have an emergency generator on site, but did have access to generators that could have been set up if needed.

As a result of the tornado, the Smithville Police Department lost complete functionality at its original location and has been relocated to the town hall, where it shares the space with the mayor’s office. The town has plans to rebuild a facility that will house the police, fire, water, and town hall services in one building.

---

<sup>8</sup> There is no DI for police stations. The type of construction listed for DI 9 is applicable to this facility.

<sup>9</sup> It should be noted that the walls of the police station that were still standing immediately following the tornado were demolished several days later, before the MAT and other assessment teams arrived. The demolition caused another damage assessment team to derive an EF4 rating for this facility using DI 9, DOD 9 (“total destruction of entire building”), and the upper-bound wind speed. As evidenced by the damage photographs provided to the MAT, the selection of DOD 9 and an EF4 rating was not reflective of conditions immediately after the tornado.

## 7.3 Emergency Operations Centers

EOCs function as the physical location at which the coordination of information and resources to support incident management (on-scene operations) activities normally takes place.<sup>10</sup> The command and response personnel must remain on duty, in full readiness for action both during and in the aftermath of a disaster. In addition to personnel and resources, EOCs house the information and communications systems that provide feedback to the emergency managers to help them make decisions about efficient and effective deployment of resources. They also relay information to local residents, storm shelters, media, and other first responders, while providing continuity of government and COOP. The loss of an EOC can severely affect the overall response and recovery in the area. For these reasons, the performance of these facilities in tornadoes is of utmost importance.

### 7.3.1 Tuscaloosa EOC (Tuscaloosa, AL)

**Location of Facility in Tornado Path:** The Tuscaloosa EOC was housed in the Curry Building city complex. Figure 7-54 shows an aerial view of the tornado track in the vicinity of the Curry Building city complex. The NWS rated the center of the tornado circulation in the vicinity of the Curry Building as an EF4. According to a representative of the city, there were approximately 15 people in the EOC at the time the tornado struck, none of whom was injured.

The EOC was located on the ground floor of the southeast corner (red circle in Figures 7-54 and 7-55). Figure 7-56 is a view of the EOC before and after the tornado.

**Facility Description:** The Tuscaloosa County EMA was housed in the Curry Building city complex, which was constructed in 1967 as a textile manufacturing plant and later used as an automotive parts manufacturing facility. The Curry Building city complex also housed the Environmental Services Department and general storage.

Most of the southern end of the complex (which housed the EOC) was a two-story steel-framed building with a built-up roof over steel decking. The exterior walls were unreinforced CMU with brick veneer. The first floor had a daylight basement. Most of the second floor had a high bay (equivalent to two stories).

Most of the remainder of the building (in the yellow rectangle in the Figure 7-54 inset), was a one-story steel-framed building with a built-up roof over steel decking. Some of the exterior walls were unreinforced CMU with brick veneer, while others were metal panels. There were several loading dock doors on the north and west sides of the building.

The Curry Building did not have a tornado safe room or storm shelter. However, there was a tornado refuge area within the EOC and another tornado refuge area shown by the blue circle at the Figure 7-54 inset and at Figure 7-55.

**General Wind Damage:** Most of the area shown in the yellow rectangle in the Figure 7-54 inset collapsed (Figures 7-57 and 7-58).

---

<sup>10</sup> Definition for EOC from the National Response Framework (<http://www.fema.gov/emergency/nrf/glossary.htm#E>)



Figure 7-54: Aerial view of the track in the vicinity of the Curry Building city complex (blue rectangle). The center of the damage swath is approximated by the red line. The yellow circle indicates the EOC's collapsed communications tower. The red arrows indicate damaged buildings. In the inset, the red oval shows the EOC and the blue circle shows a tornado refuge area. Most of the area in the yellow rectangle collapsed (Tuscaloosa, AL).



Figure 7-55: Oblique view of Figure 7-54 showing the Curry Building. The green circle indicates the EOC's emergency generator. The red circle shows the ground floor of the southeast corner, the location of the EOC. The blue circle shows the tornado refuge area.

PHOTOGRAPH COURTESY OF TUSCALOOSA COUNTY SHERIFF'S OFFICE

Figure 7-56:  
View of the southeastern end of the Curry Building before the tornado struck. The EOC is located on the ground floor of the red box. The floor above the EOC collapsed (green line). The building to the left of the EOC (blue X) collapsed. The inset shows post-storm conditions (Tuscaloosa, AL).

SOURCE: © GOOGLE EARTH

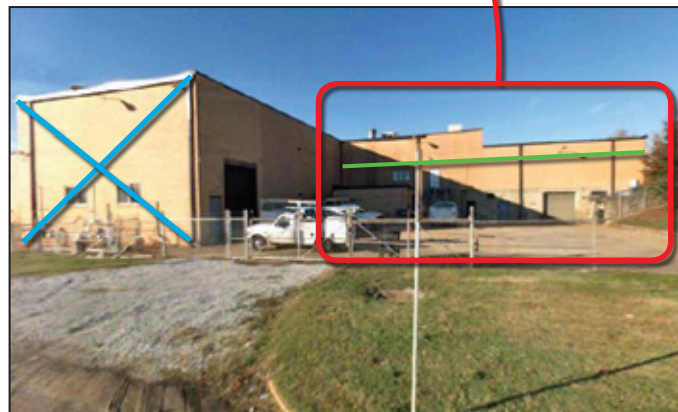



Figure 7-57:  
View of a portion of the  
collapsed one-story area  
(Tuscaloosa, AL)



Figure 7-58:  
View of a portion of a  
collapsed loading dock area  
(Tuscaloosa, AL)

There was a tornado refuge area in a portion of the first floor in the southwest corner of the building (red oval, Figure 7-59). This area was marked with a sign reading “emergency shelter” that had a tornado graphic. The exterior walls in this area were concrete and had adequate strength to resist tornado wind forces. However, the rolling door, personnel door with glass vision panel, and the wall louver lacked sufficient wind pressure and wind-borne debris impact resistance for the area to be considered a safe room or storm shelter. The floor above this refuge area collapsed, indicated by the blue oval, and the roof decking blew off adjacent to this area as indicated by the red arrow. Further along the building, a portion of the roof structure and exterior wall collapsed as indicated by the blue arrow.

Most of the steel decking and some joists were blown off of the southern portion of the building (Figure 7-60) and much of the brick veneer/CMU wall collapsed. The metal door shown at the inset was buckled inward by CMU debris.

Figure 7-61 is a close-up of the Figure 7-56 inset, showing the EOC area.

**MAT EF Rating:** Using DI 23 (Warehouse Building), the MAT selected DOD 7 (“total destruction of a large section of building or entire building”) for the portion the facility that housed the EOC (i.e., the southern portion of the complex). Considering the building age, the MAT assessed the wind speed to be between the expected and lower-bound wind speeds for DOD 7. Hence, the MAT derived the tornado rating as EF3 (136–165 mph) based on damage to this portion of the building. Therefore, the estimated wind speed experienced by the building was substantially above the current basic wind speed of 90 mph.

The NWS rated the center of the tornado circulation in the vicinity of the Curry Building city complex an EF4, which is different from the MAT EF3 rating of the EOC portion of this building. As shown in Figure 7-54, the EOC was on the right side of the center of the damage swath and hence, the right side of the center of circulation, where the wind speed is the highest. It is likely that there was wind speed decay between the center of circulation and the EOC.

The MAT judged the poor wind performance of the Curry Building city complex to be due to wind speeds that were substantially above the design wind speed and inadequate wind resistance, which is reflective of the codes, standards, and design practices in the era when this building was constructed. The good performance of the structural system at the EOC and refuge area was judged to be due to the use of concrete.

**Functional Loss:** According to a representative of the city, there were approximately 15 people in the EOC at the time the tornado struck, including a worker and two family members who were in the Environmental Services Department prior to taking refuge in the EOC. Although the area housing the EOC did not comply with FEMA 361 (2008a) or ICC 500 (2008) criteria for safe rooms and storm shelters, the exterior concrete walls and concrete slab of the second floor provided a level of occupant protection during this event and none of the occupants were injured.

The emergency generator did not come on when normal power was lost because the lines connecting it to the EOC were severed during the storm. The EOC was flooded because the fire sprinkler system was damaged during the tornado. The EOC also lost communications because a large nearby communications tower collapsed (Figure 7-54 and Section 8.3.1.1).



Figure 7-59:  
View of the refuge area (red oval). Note the rolling door, personnel door, and louver wall openings (yellow arrows). The floor above the refuge area (blue oval) collapsed and the roof decking in the adjacent area (red arrow) blew off. A portion of the roof structure and exterior wall collapsed (blue arrow) (Tuscaloosa, AL).



Figure 7-60: Part of the southern portion of the building. The inset shows a metal door that buckled inward (Tuscaloosa, AL).



Figure 7-61:  
The door with the red arrow leads to the EOC area. The inset shows the area above the EOC that collapsed (Tuscaloosa, AL).



The EOC lost complete functionality as a result of the tornado. The EOC had no functionality for approximately an hour after the tornado, at which point they set up at the Tuscaloosa Police Department for several hours. Following this, the EMA was relocated to the UA EOC until approximately May 3, at which point it was moved to a temporary location at the Alabama Fire College. A new permanent location will be required.

The Environmental Services Department is planning to build a new building and a recycling plan on the site of the collapsed Curry Building city complex. The Department temporarily moved into modular buildings across the street after the tornado. Destruction of the Department's facility hampered pickup of recyclables and trash in the first days after the tornado.



### 7.3.2 Cullman County EOC (Cullman, AL)

This facility was not struck by the Cullman tornado on April 27, 2011. Although the facility was not damaged, it is presented in this chapter because of special enhancements that were incorporated into its design in order to avoid facility disruption if struck by a tornado.

In 2008, the Cullman County EMA moved into its new facility in the basement of the newly constructed Cullman County Water Department Building.<sup>11</sup> The EMA portion of the facility was designed as a safe room in accordance with FEMA 361 (2000) to resist the wind pressures and wind-borne debris associated with EF5 tornadoes (Figure 7-62): wind speeds of 250 mph (3-second gust) and debris impact from a 15-pound 2x4 board missile traveling horizontally at 100 mph.

The design criteria were selected by the County and the architect to ensure that EMA staff would be safe and that operations would be maintained if the facility were impacted by a tornado.

The EMA portion of the facility occupies approximately 6,250 square feet and includes a reception area, an operations room that is approximately 1,000 square feet (Figure 7-63), bath rooms, two conference rooms, six offices, storage facilities, a communications closet, and a large multi-purpose room. All these areas are located within the reinforced concrete basement of the building. Two stairwells and one elevator provide access to the below-grade portions of the facility. The stairwells are also constructed of reinforced concrete and spiral downward from the above-grade entrance to the operations room. The emergency generator, air handler, and heating system for the facility are located within a special room in the above-ground portion of the facility. The walls and roof of the room protecting the generator were constructed from reinforced concrete to also meet the FEMA 361 (2000) criteria.



Figure 7-62:  
An exterior view of the Cullman County government building housing the Water Department (above grade) and the County EMA facility (below grade) (Cullman, AL)

<sup>11</sup> The facility was designed by Harris & Associates Architects and Planners, Birmingham, AL.

Figure 7-63:  
Interior view of the  
emergency operations room  
of the Cullman County EMA  
facility (Cullman, AL)



FEMA 361 (2000) design elements and criteria implemented by the owner and architect include:

- + A design wind speed of 250 mph and wind-borne debris impact protection for the EOC portion of the facility and also for the generator room.
- + Wind-borne debris protection of the openings in the generator and mechanical room area to resist a 15-pound 2x4 missile traveling horizontally at 100 mph. This was created with concrete baffle walls. Use of concrete wall baffles allowed the use of traditional louvers between the baffles.
- + Protection of fuel storage. This was achieved by placing the large tank for the generator below ground (including all piping connecting the tank to the generator).
- + Protection of building systems (for example, the heating and air handling systems) by locating the equipment within the same protected space as the generator. Note: the cooling systems for the facility were not in the protected space. Since the EOC is located below grade, it was determined that protecting the cooling system was not critical and that the facility could function for a short period of time if this system were not available.
- + Location of all communications systems, switches, and computer servers for both the EMA and the Water Department within the lower level.
- + Provision of food and water storage within the lower level.
- + Provision of a large multipurpose conference room within the lower-level area that holds over 100 operational personnel for use by the EMA or others responding to an event.

- + High ceilings and multiple layers of lighting. These elements give the facility a light and open feel in spite of the fact that it is totally underground with no natural lighting. The underground facility maintains a more constant temperature with less difficulty and cost than an above-ground facility.
- + Provision of space for additional staff when needed for emergency response. During times of full activation, such as was experienced on April 27, 2011, the two full-time Cullman County EMA staff members were joined by more than 20 people. Representatives from the local emergency response community rotated through on 12-hour shifts to assist the EMA personnel. This included both paid and volunteer response agencies. Staff can also be supplemented as needed by administrative personnel from other county departments such as the Revenue Commission, etc. The multipurpose space adjacent to the EOC on the lower level provides protected space for the county staff plus any additional emergency responders who may be at the facility during an event.

According to the architect, the portions of the facility designed to the FEMA 361 (2008a) criteria were constructed for approximately \$200 per square foot for a total cost of roughly \$1,250,000. By contrast the upper floor of the facility (used for other Cullman County offices) was constructed at a cost of approximately \$120 per square foot. If constructed to the building code in effect at the time, the EMA portion of the facility would have cost approximately 50 percent less. Implementing the FEMA 361 criteria for the selected portions of the facility ended up accounting for approximately 65 percent of the total building cost. By choosing to spend an additional 25 percent on the facility, the owner and architect were able to achieve both personal protection for the 25 County staff and also provide continuity of operations during events. Additionally, based on FEMA 361 criteria regarding the number of occupants, the multipurpose room can provide protection for the facility staff as well as up to 300 additional persons (if needed).

The construction of this facility shows how a community, with no Federal funding assistance, was able to implement the best-available guidance on tornado-resistant construction to design and construct a building that provides life-safety protection for the EMA staff , and also provides for continuity of operations if struck by a tornado.

## 7.4 Summary of Conclusions and Recommendations

Table 7-1 provides a summary of the conclusions and recommendations for Chapters 6 and 7, and provides section references for supporting observations. Additional commentary on the conclusions and recommendations is presented in Chapters 10 and 11.

**Table 7-1: Summary of Conclusions and Recommendations for Critical Facility Performance**

Observation(s)	Conclusion	Recommendation
<p>Schools which sustained damage and did not have a FEMA 361-compliant safe room or ICC 500-compliant storm shelter:</p> <ul style="list-style-type: none"> <li>• Alberta Elementary School (Section 6.1.1)</li> <li>• University Place Elementary School (Section 6.1.2)</li> <li>• Ringgold High School and Ringgold Middle School (Section 6.1.3)</li> <li>• Joplin East Middle School (Section 6.1.4)</li> <li>• Joplin High School (Section 6.1.5)</li> </ul> <p>911 call stations, EOCs, or fire, rescue, ambulance, and police stations that sustained damage and did not have a FEMA 361-compliant safe room or ICC 500-compliant storm shelter:</p> <ul style="list-style-type: none"> <li>• Fultondale Municipal Complex (Section 7.2.1)</li> <li>• Tuscaloosa Fire Station 4 (Section 7.2.2)</li> <li>• Webster’s Chapel Volunteer Fire Department (Section 7.2.3)</li> <li>• Smithville Police Department (Section 7.2.4)</li> <li>• Tuscaloosa EOC (Section 7.3.1)</li> </ul>	<p><b>Conclusion #4</b>  <b>IBC-compliant facilities can be susceptible to building damage.</b></p>	<p><b>Recommendation #10</b>  <b>Propose IBC code change.</b>            Submit IBC code change proposal to require a FEMA 361-compliant safe room or ICC 500-compliant storm shelter in all areas where shelter design wind speeds are 250 mph or greater for all new kindergarten through 12<sup>th</sup> grade schools.</p> <p><b>Recommendation #11</b>  <b>Propose IBC code change</b>            Submit IBC code change proposal to require a FEMA 361-compliant safe room or ICC 500-compliant storm shelter in all areas where shelter design wind speeds are 250 mph or greater for all 911 call stations, emergency operation centers, and fire, rescue, ambulance, and police stations.</p>
<p>Older facilities with significant wind-resistance vulnerabilities:</p> <ul style="list-style-type: none"> <li>• Ringgold High School and Ringgold Middle School (Section 6.1.3)</li> <li>• Joplin High School (Section 6.1.5)</li> <li>• Webster’s Chapel Volunteer Fire Department (Section 7.2.3)</li> <li>• Smithville Police Department (Section 7.3.4)</li> </ul>	<p><b>Conclusion #16</b>  <b>Older facilities were susceptible to damage from weak tornadoes.</b>            Older facilities were subject to considerable building damage and disruption of facility operations when struck by even weak tornadoes</p>	<p><b>Recommendation #25</b>  <b>Perform a vulnerability assessment.</b></p>
<p>Facilities lacking of adequate signage, for example:</p> <ul style="list-style-type: none"> <li>• Joplin East Middle School (Section 6.1.4)</li> <li>• Fultondale Municipal Complex’s Library (Section 7.2.1)</li> <li>• Tuscaloosa EOC (Section 7.3.1)</li> </ul>	<p><b>Conclusion #17</b>  <b>There was a lack of adequate signage directing occupants to refuge areas.</b>            (See also Conclusions #8 and #28)</p>	<p><b>Recommendation #26</b>  <b>Identify best available refuge areas.</b></p>

**Table 7-1: Summary of Conclusions and Recommendations for Critical Facility Performance (concluded)**

Observation(s)	Conclusion	Recommendation
<p>Critical facilities in path of tornado track with lack of FEMA 361-compliant safe room or ICC 500-compliant shelter:</p> <ul style="list-style-type: none"> <li>• Alberta Elementary School (Section 6.1.1)</li> <li>• University Place Elementary School (Section 6.1.2)</li> <li>• Ringgold High School and Ringgold Middle School (Section 6.1.3)</li> <li>• Joplin East Middle School (Section 6.1.4)</li> <li>• Joplin High School (Section 6.1.5)</li> <li>• LaRocca Nursing Home (Section 7.1.2)</li> <li>• Greenbriar Nursing Home (Section 7.1.3)</li> <li>• St. John's Medical Center (Section 7.1.4)</li> <li>• Fultondale Municipal Complex (Section 7.2.1)</li> <li>• Tuscaloosa Fire Station 4 (Section 7.2.2)</li> <li>• Webster's Chapel Volunteer Fire Department (Section 7.2.3)</li> <li>• Smithville Police Department (Section 7.2.4)</li> <li>• Tuscaloosa EOC (Section 7.3.1)</li> </ul>	<p><b>Conclusion #5 and #18</b></p> <p><b>(#5) Many of the critical facilities observed lacked safe rooms and/or storm shelters.</b></p> <p><b>(#18) There was a lack of safe rooms and storm shelters in critical facilities.</b></p>	<p><b>Recommendation #27</b></p> <p><b>Include safe rooms in design of new facilities.</b></p>
<p>Critical facilities with glazing damage, for example:</p> <ul style="list-style-type: none"> <li>• Alberta Elementary School (Section 6.1.1)</li> <li>• Ringgold High School and Ringgold Middle School (Section 6.1.3)</li> <li>• Joplin High School (Section 6.1.5)</li> <li>• LaRocca Nursing Home (Section 7.1.2)</li> <li>• St. John's Medical Center (Section 7.1.4)</li> <li>• Tuscaloosa Fire Station 4 (Section 7.2.2)</li> </ul>	<p><b>Conclusions #15</b></p> <p><b>Glazing is susceptible to damage.</b></p>	<p><b>Recommendation #28</b></p> <p><b>Enhance building design to better withstand tornadoes.</b></p>
<p>Critical facilities that did not remain operational following a tornado:</p> <ul style="list-style-type: none"> <li>• Alberta Elementary School (Section 6.1.1)</li> <li>• University Place Elementary School (Section 6.1.2)</li> <li>• Ringgold High School and Ringgold Middle School (Section 6.1.3)</li> <li>• Joplin East Middle School (Section 6.1.4)</li> <li>• Joplin High School (Section 6.1.5)</li> <li>• LaRocca Nursing Home (Section 7.1.2)</li> <li>• Greenbriar Nursing Home (Section 7.1.3)</li> <li>• St. John's Medical Center (Section 7.1.4)</li> <li>• Fultondale Municipal Complex (Section 7.2.1)</li> <li>• Tuscaloosa Fire Station 4 (Section 7.2.2)</li> <li>• Webster's Chapel Volunteer Fire Department (Section 7.2.3)</li> <li>• Smithville Police Department (Section 7.2.4)</li> <li>• Tuscaloosa EOC (Section 7.3.1)</li> </ul>	<p><b>Conclusion #4</b></p> <p><b>IBC-compliant facilities can be susceptible to building damage.</b></p>	<p><b>Recommendation #29</b></p> <p><b>Strengthen facilities to remain operational.</b></p>





## TORNADO OUTBREAK *of* **2011**

IN ALABAMA, GEORGIA, MISSISSIPPI,  
TENNESSEE, AND MISSOURI

# 8 Observations on Infrastructure Performance

*Natural hazards not only damage buildings but can also damage and disrupt a community's infrastructure. Infrastructure damaged during disaster events can have a widespread effect on a community's ability to recover and significantly delay its return to normal functioning.*

While MATs have historically concentrated on the performance of buildings, this MAT also assessed the performance of some utilities that were affected by the tornadoes, including water treatment and distribution facilities and towers (communications and antennae). The MAT also visited a wastewater treatment facility that performed well during and after the event and determined that lessons applicable to similar facilities could be learned.

The MAT assessed infrastructure in Tuscaloosa, AL, and Smithville, MS. The Tuscaloosa facilities the MAT visited are shown in Figure 8-1. The Smithville facilities are shown in Figure 8-2.

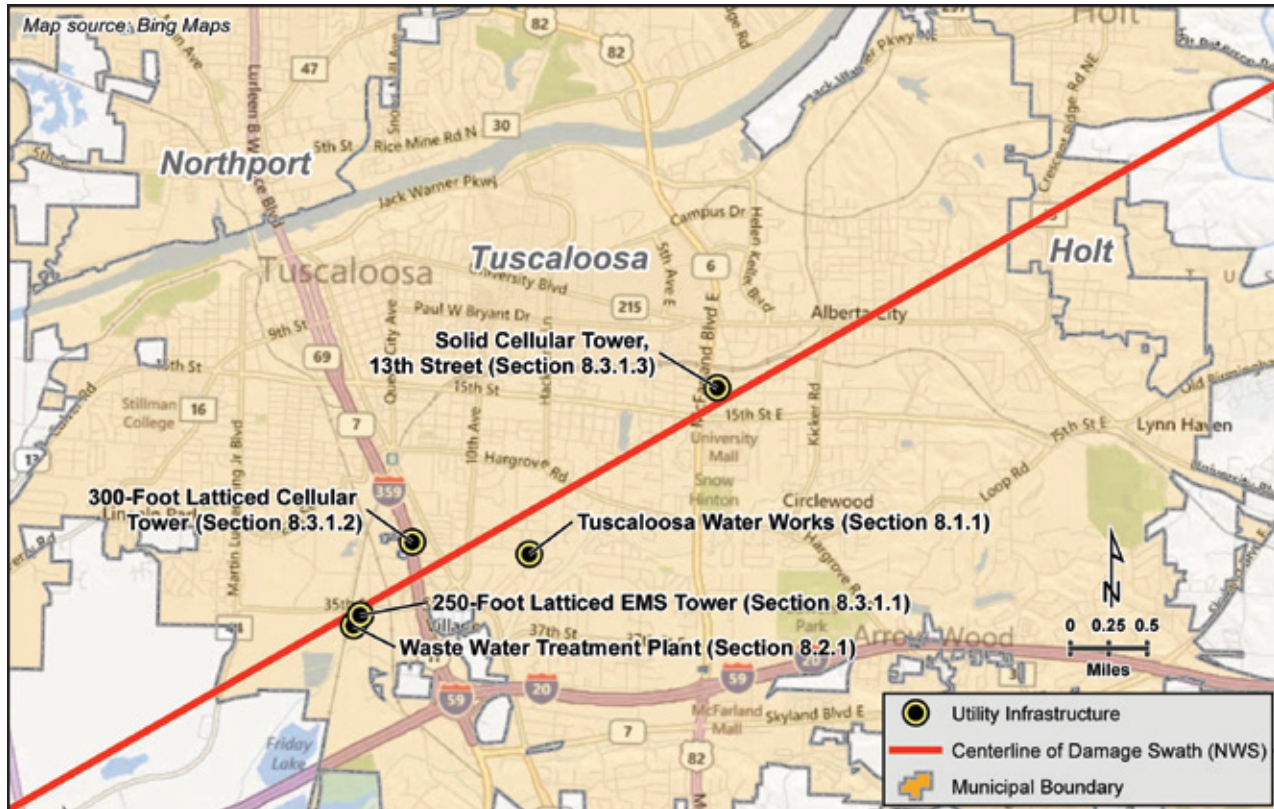

Figure 8-1: Locations of infrastructure assessed by the MAT in Tuscaloosa, AL

SOURCE FOR TORNADO TRACK: [HTTP://WWW.SRH.NOAA.GOV/SRH/SSD/MAPPING](http://www.srh.noaa.gov/srh/ssd/mapping)

The MAT visited several infrastructure facilities and assessed tornado damage and its effects on those facilities; however, the MAT did not provide EF ratings for the structures for two reasons. First, no EF scale DIs are established for some of the infrastructure types the MAT visited, and second, the effects of high winds on the infrastructure were not always the result of direct damage to the infrastructure, but rather to the utilities that served the infrastructure. Most notably, the high winds did not damage the water treatment and distribution systems the MAT observed, but did damage the electric lines that fed those systems; therefore, the most serious consequences of the tornadoes on those facilities were not from direct damage, but from the loss of electrical power.

## 8.1 Water Treatment and Distribution Facilities

Water treatment and distribution facilities typically consist of a water source, a treatment facility, and a system of water distribution pipelines that deliver treated water to customers. Depending on the relative elevations between the water sources and the customers and the geographical location of those customers, water storage towers and water pumping stations may also be present. Water towers can be vulnerable to high-wind events, particularly when the amount of water stored in them is low, and water treatment facilities and water pumping stations can be vulnerable to service interruptions when electrical power is lost. Long-duration service interruptions can be devastating to a community trying to recover from a natural hazard event. Service interruptions can also lead to



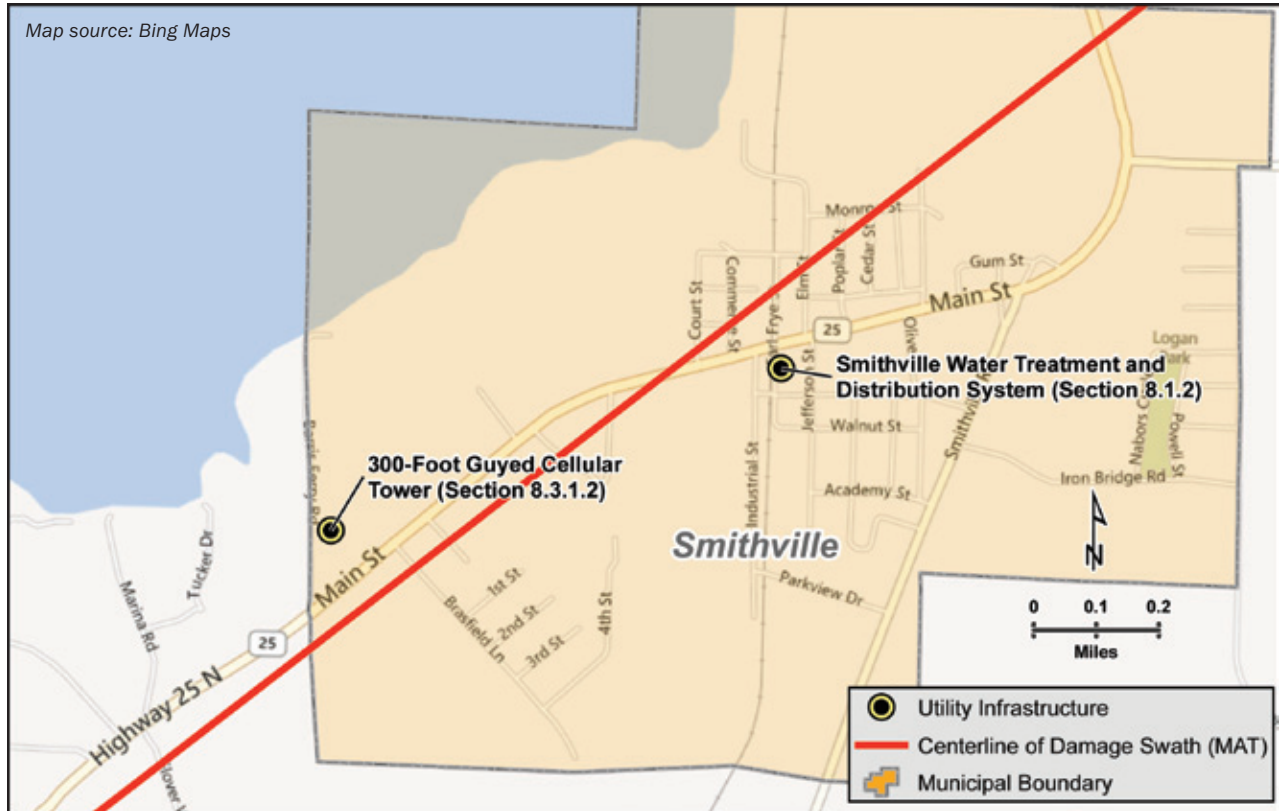

Figure 8-2: Locations of infrastructure assessed by the MAT in Smithville, MS. The NWS track is not shown since it varied greatly from MAT observations.

SOURCE FOR TORNADO TRACK: MAT-DERIVED

contamination of the treated water and create significant health hazards. Following the devastating April 2011 tornadoes, the MAT visited two water treatment facilities, one in Tuscaloosa, AL, and one in Smithville, MS.

### 8.1.1 Tuscaloosa Water Works (Tuscaloosa, AL)

The Tuscaloosa Water Works is part of the Tuscaloosa Water Works and Sewer Department. According to their Web site, the Tuscaloosa Water Works delivers more than 10 billion gallons of water to their customers annually. They serve over 200,000 customers in the City of Tuscaloosa and surrounding communities of Carrols Creek, Coaling, Coker, Englewood-Hulls, Foster-Ralph, Mitchell, and Peterson.

**Location of Facility in Tornado Path:** Figure 8-3 shows an aerial view of the tornado damage swath. NWS rated the center of the tornado circulation as EF4 in the vicinity of one of the Tuscaloosa Water Works storage towers and the DCH Regional Medical Center, a local hospital served by the Tuscaloosa Water Works that suffered reduced water pressure after the tornado.

**Facility Description:** The Tuscaloosa Water Works system has 575 miles of water mains that are 4 inches in diameter or larger and 3,684 public fire hydrants. The Tuscaloosa Water Works collects



**Figure 8-3:**  
Aerial view showing the approximate centerline of the damage swath (red line)<sup>1</sup> in relationship to the Tuscaloosa Water Works storage tower (yellow circle, top inset) and the DCH Regional Medical Center (yellow circle, bottom inset)

SOURCE: ALL AERIAL PHOTOGRAPHS ARE FROM NOAA IMAGERY ([HTTP://NGS.WOC.NOAA.GOV/STORMS](http://ngs.woc.noaa.gov/storms)) UNLESS OTHERWISE NOTED



<sup>1</sup> The red line in this and all similar figures represents the center of the damage swath. The track location is approximated by the MAT based on post-event aerial photographs. The actual centerline of the vortex is offset from the centerline of the damage.

water from the Ed Love Lake and the smaller Jerry Platt Lake. The Ed Love plant can treat up to 45.7 million gallons per day (MGD). The Jerry Platt plant can treat up to 14 MGD. Water is treated at two treatment plants, pumped into 13 storage towers, and fed to customers. The system can store 25.4 million gallons of treated water, 20.6 million gallons of which are stored in tanks; the remaining quantity is stored in the distribution piping.

Emergency power at the Ed Love plant consists of two 1,500-kilovolt-ampere diesel generators that allow the plant to fully function while normal power is lost. There are 23 booster pumps in 8 booster pump stations that fill the storage tanks and control system pressure. The pumps range in size from 25 to 100 horsepower. The pumps are powered by overhead electrical lines from the local electrical utility; no emergency generators are in place to provide alternate power to the pumps.

**General Wind Damage and Functional Loss:** The Tuscaloosa Water Works storage towers were outside of the tornado's swath and were not damaged. However, tornadic winds along the track destroyed hundreds of buildings and other structures in Tuscaloosa. The tornado winds also destroyed miles of overhead electrical transmission and distribution lines and damaged or destroyed electrical substations. Power to the area was interrupted, and several water service lines were broken when buildings were destroyed by the tornado. Figure 8-4 shows representative damage to overhead lines and substations. Shortly after the storm, line breaks contributed to large amounts of water loss, but the larger water line breaks were isolated within hours, so water losses through line breaks were quickly minimized. Smaller line breaks were isolated within 2 to 3 days.

Electrical power, however, was not restored for several days, and without power to drive the lift pumps that fill tanks and booster pumps for system pressure, the storage tanks drained and system pressures dropped. Water service was affected, including water service to critical facilities. For example, approximately 7 hours after the storm, the normal 90 pounds per square inch (psi) of water pressure normally provided to DCH Regional Medical Center (location shown in Figure 8-3) dropped to 25 psi. With the reduced water pressure, toilets on upper floors would not flush and the low water-pressure levels required the hospital to shut down a boiler supplying steam to their central sterilization equipment. Without sterilization equipment, surgical procedures were curtailed.



Figure 8-4:  
Representative damage to  
overhead electrical lines  
and substations along the  
tornado path  
(Tuscaloosa, AL)

## 8.1.2 Smithville Water Treatment and Distribution System (Smithville, MS)

Smithville, MS, is supplied by a 42 MGD water treatment and distribution system. Surrounding areas are supplied by a separate rural water treatment and distribution system. The urban and rural systems serve approximately 450 clients each. The rural system was not damaged by the tornadoes and was not inspected. Observations of the system in Smithville proper are described below.

**Location of Facility in Tornado Path:** A tornado touched down west to southwest of Smithville and travelled east to northeast. NWS rated the center of the this tornado circulation as EF5. The approximate centerline of the tornado damage swath is shown in Figure 2-2 (tornado #43) and below in Figure 8-5. Figure 8-5 also shows the location of the Smithville Water Treatment Plant and storage tower, as well as the location of a 300-foot-tall guyed cellular tower that collapsed (discussed in Section 8.3.2.1).



Figure 8-5: Aerial view showing the approximate centerline of the tornado damage swath in Smithville, MS (red line), the Smithville Water Treatment and Distribution System Plant (blue circle), and the 300-foot-tall cellular tower discussed in Section 8.3.2.1 (yellow circle)

**Facility Description:** The Smithville Water Treatment and Distribution System Plant is shown in Figure 8-6. The water for the urban system is drawn from two wells, treated, stored in an underground clear well, and then pumped into a large storage tank (Figure 8-7). From the storage tank, treated water is gravity-fed to customers. Treatment consists of aeration, sand filtration, chlorination, and pH control. Since the well water is high in dissolved iron, it is also treated for iron removal. The wells, treatment plant, lift pumps, and storage tower are all on Earl Frye Street in Smithville.

Water is pumped from the treatment facility clear well to the storage tank with two 20-horsepower lift pumps. The pumps are operated lead/lag (i.e., only one pump operates at a time). The pumps are supplied by overhead electrical lines. The facility does not have any emergency or standby generators for alternate power.

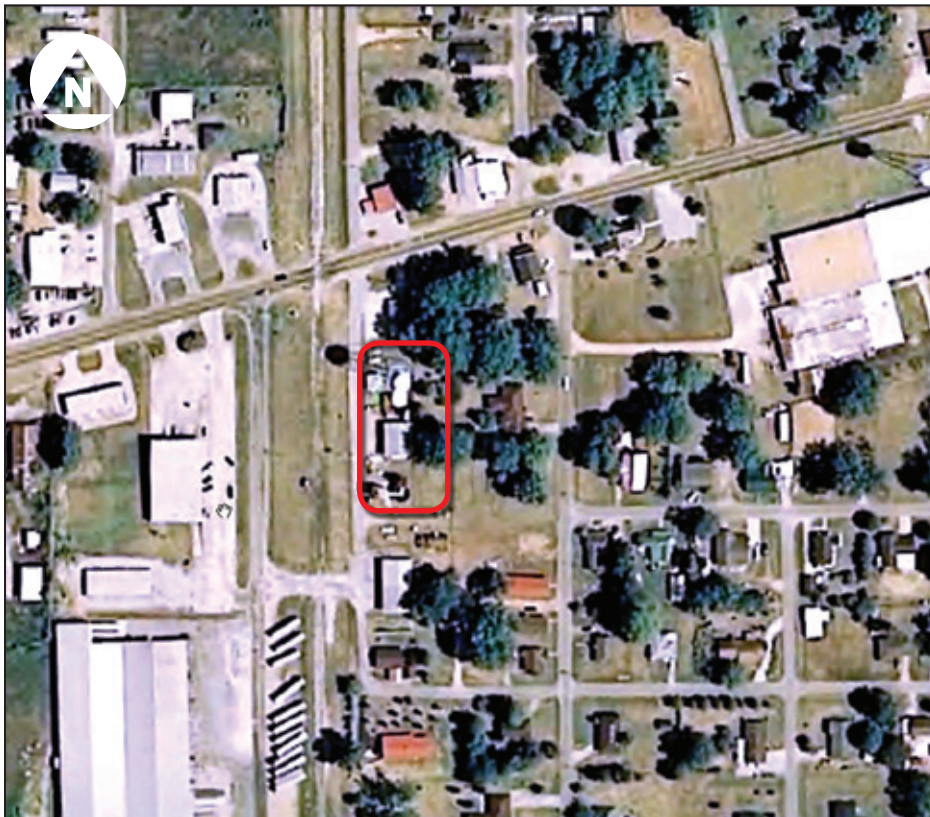

**Figure 8-6:** Smithville Water Treatment Plant and storage tower (red box) aerial photograph pre-dates the tornado (Smithville, MS)

SOURCE: © GOOGLE EARTH

**General Wind Damage:** At the Smithville Water Treatment and Distribution System Plant, the tornado destroyed a small building constructed of unreinforced CMU and damaged a small storage building constructed of metal frames and metal wall and roof panels (Figure 8-8). The buildings were used for secondary non-critical functions like maintenance and storage, and the damage did not significantly affect operations.

Figure 8-7:  
Water tower after the  
tornado (Smithville, MS)



Figure 8-8: Destroyed unreinforced CMU building (left) and damaged metal-framed building (right) (Smithville, MS)

The water treatment control equipment was in a building constructed of reinforced masonry (Figure 8-9). While close to the other buildings and exposed to similar winds, the stronger reinforced building was not extensively damaged.



Figure 8-9:  
Reinforced CMU building housing control equipment (left) and  
undamaged water treatment control equipment (right) (Smithville, MS)



The storage tower was struck by large pieces of wind-borne debris (Figure 8-10). The debris impacted the tank itself and a compression strut that provides lateral bracing and support for the tower legs. At the time of the MAT visit, the impacted area of the tank was not repaired, but the damaged compression strut had been straightened and reinforced. System operators did not know whether the repairs were completed under the direction of a design professional.



Figure 8-10: Debris impact damage to Smithville, MS, water tank: photograph on left shows where debris struck the water tank itself (red circle) and photograph on right shows the repaired compression strut that was damaged by wind-borne debris (red box)

Water pumps and pump controllers were located outside (Figure 8-11). Even though wind-borne debris was widespread in the area, they were not damaged. However, high-pressure chlorine cylinders were stored outside and only lightly secured with small-gage chain (Figure 8-12). Some cylinders were dislodged and displaced nearly 100 yards by the tornadic winds.

**Figure 8-11:**  
Lift pumps and controls of the Smithville, MS, water plant were exposed, but not damaged



**Figure 8-12:**  
Lightly secured chlorine cylinders; some were displaced by high winds (Smithville, MS)





**Functional Loss:** While critical equipment was not damaged (even though much of it was exposed), the tornado destroyed overhead electrical lines and disrupted power to the Smithville, Water Treatment and Distribution System Plant. The tornado also broke fire hydrants and destroyed most of the buildings in town. The destruction of buildings damaged much of the water service piping laterals that supplied individual customers.

Chlorine is a hazardous material and 40 CFR 355.30 triggers emergency planning requirements when more than 100 pounds of chlorine is stored. Containers of chlorine should be protected from exposure to weather, extreme temperatures changes, and physical damage, and they should be stored separately from flammable gases and vapors and combustible substances.

The damage to distribution piping and water service piping laterals resulted in rapid water loss. Since there were no emergency or alternate power supplies serving the lift pumps, the storage tank drained rapidly, and there was a loss of system pressure in the distribution system. The loss of system pressure can allow groundwater to enter distribution piping and contaminate the treated water in the system. Although operators stated that they did not know if water contamination occurred after the tornado, the water treatment and distribution system plant issued “Boil water before use” orders to its customers as a precautionary measure. During the MAT’s visit 11 days after the event, distribution and service line breaks had been repaired or isolated, and system pressure was restored. Operators of the system were awaiting water test results before lifting the “Boil water before use” orders.

## 8.2 WasteWater Treatment Facilities

A functioning wastewater treatment facility is critical for recovery after a natural disaster. Long-term loss of a wastewater treatment facility can create significant health hazards. The MAT interviewed the director of the Tuscaloosa Waste Water Treatment Plant. The plant managed to continue running after the tornado even though the facility experienced wind damage and normal power supply to the plant was lost.

### 8.2.1 Tuscaloosa Waste Water Treatment Plant and Collection System (Tuscaloosa, AL)

The Tuscaloosa Waste Water Treatment Plant treats effluent from the entire city and surrounding service areas. The plant has a current capacity of 30 MGD, but plans to add an additional 15 MGD in 2013.

**Location of Facility in Tornado Path:** The location of the Tuscaloosa Waste Water Treatment Plant is shown in Figure 8-1. Figure 8-13 shows an aerial view of the centerline of the tornado damage swath in the vicinity of the Tuscaloosa Waste Water Treatment Plant.

**Facility Description:** The Tuscaloosa Waste Water Treatment Plant is a 30 MGD plant that serves Tuscaloosa and surrounding areas. Power for the water treatment facility is normally provided by the local electrical utility from overhead distribution lines. The treatment plant itself has on-site emergency diesel generators that allow the plant to operate during prolonged power outages. Also, approximately 50 of the 60 remote lift stations that pump untreated effluent to the treatment plant are equipped with emergency generators.



Figure 8-13: Aerial view of the Tuscaloosa Waste Water Treatment Plant (yellow rectangle) in relation to the approximate centerline of the April 27, 2011 tornado damage swath (red line)

**General Wind Damage and Functional Loss:** The director of the Tuscaloosa Water Works and Sewer Department stated that the tornado disrupted the normal utility power to the plant and remote lift stations, and caused damage to roof systems, doors, and windows at the treatment plant. While normal power was lost, the system continued to operate on emergency power during and after the event with no overflow or discharge of untreated effluent. Some of the remote lift stations lacked emergency power, and effluent had to be pumped into trucks for transportation to the central treatment plant. The loss of doors, windows, and roof coverings allowed water to enter the treatment plant building, but the water entry did not disrupt operations.

### 8.3 Towers (Communications and Antennas)

Communications towers support antennae that serve cellular phones, emergency management systems (EMSs), fire, police, and other critical functions. Since the number and type of antennae mounted on any given tower varies greatly, the functional effects of losing a tower can only be determined on a case-by-case basis.

Towers fall into two general categories: guyed towers and free-standing towers. Guyed towers use a system of steel cables that provide lateral support for a single vertical mast. One end of each cable is connected to the tower, and the other end is connected to earth anchors or concrete foundations. Guy wires are usually installed in sets of three, with each guy wire spaced 120 degrees from adjacent wires. Guy wires are tensioned so that the lateral loads on the mast are balanced, and the mast itself is exposed only to compression loads. The mast in a guyed tower is typically quite slender since the mast is primarily loaded in compression, and lateral wind loads are resisted by the guy wires.

Free-standing towers can be either latticed structures or solid structures. Solid structures are not solid through their cross-sections but rather their interiors are hollow and their outer surfaces solid. Unlike guyed towers, free-standing towers do not rely on guy wires and anchors for lateral support. For a free-standing tower to function, it must be strong enough to resist all lateral loads imposed on it from a design event. It must also be able to transfer those loads to a suitable foundation and the foundation must be large enough and strong enough to transfer all applied loads to the supporting soils below. Without guys, free-standing towers must have a wide footprint and large foundations to prevent overturning and toppling.

### 8.3.1 Free-Standing Towers

The MAT assessed two latticed towers: a 250-foot tower used by the Tuscaloosa EMS and a 300-foot cellular tower. It also evaluated a solid cellular tower near a retail center in Tuscaloosa, AL (see Section 5.2.3); although the MAT did not visit this tower, it evaluated the tower's performance by reviewing photographs taken from a helicopter during a flyover 3 days after the tornado struck the area.

#### 8.3.1.1 Latticed 250-Foot EMS Communications Tower (Tuscaloosa, AL)

The Tuscaloosa EOC (described in Section 7.3.1), which was destroyed by the tornado, was served by a free-standing, latticed, 250-foot-tall communications tower. The tower supported antennae for fire, police, and the EOC. The 250-foot EMS tower was located at N33.177933° and W87.563561°.

**Location of Facility in Tornado Path:** The location of the EMS communications tower is shown in Figure 8-1. Figure 8-14 shows an aerial view of the centerline of the tornado damage swath near the EMS communications tower. The EMS communications tower was within 1,000 feet of the center of the tornado damage swath.

**Facility Description:** The EMS communications tower was relatively new, having been constructed within the last 2 years. The tower was a triangular-based latticed steel structure on concrete foundations. The tower bases were spaced 20 feet apart and constructed with six 7/8-inch-diameter anchor bolts on poured concrete foundation caps. The size and depth of the foundation could not be determined visually.

**General Wind Damage and Functional Loss:** The EMS communications tower collapsed during the storm and fell across the road that separates it from the EOC. By the time of the MAT's visit, the tower had been removed, and only its concrete base remained. The tower was, however, photographed by EMS staff from the ground the day of the event (Figure 8-15) and from a helicopter 3 days after the tornado struck it on April 27 (Figure 8-16).

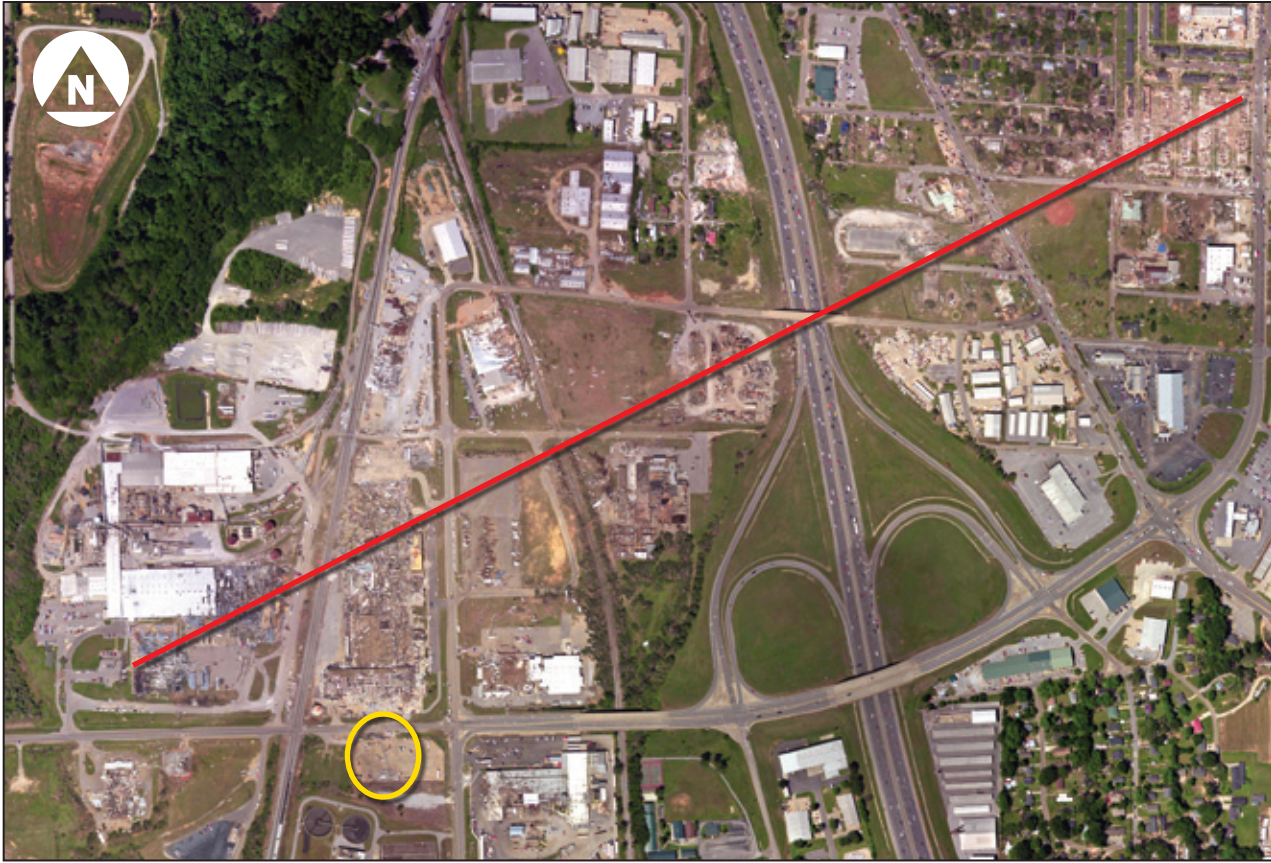

Figure 8-14: Aerial view of the approximate centerline of the tornado damage swath (red line) in the vicinity of the latticed 250-foot EMS communications tower (yellow circle) (Tuscaloosa, AL)

Figure 8-15:  
View of toppled EMS communications tower taken by EMS personnel after the tornado. Note the wind-displaced material (discussed in text) adhered to the tower (Tuscaloosa, AL).

PHOTOGRAPH COURTESY OF TUSCALOOSA COUNTY SHERIFF'S OFFICE





Figure 8-16: View of the collapsed EMS communications tower (yellow oval); the EOC across 35th Street is also shown (red oval) (Tuscaloosa, AL). The communications tower was cut, and the debris that was across the road was removed (yellow triangle).

PHOTOGRAPH COURTESY OF TUSCALOOSA COUNTY SHERIFF'S OFFICE

The MAT noted fresh shear cracks in the concrete foundation bases (Figure 8-17). The cracks resulted from tensile loading in the tower/base connection and suggest that bending occurred in the concrete tower base.



Figure 8-17: Photograph shows the six-bolt tower base with cracks in concrete foundation cap (red oval) (Tuscaloosa, AL)

Wind-displaced materials adhered to the latticed EMS communications tower (Figure 8-16). The adhered materials consisted of chain link fence fabric and webbing interwoven into the fabric. The adhered materials created nearly solid surface areas that increased the amount of surface area exposed to wind pressures, thereby increasing the wind loads on the tower.

The MAT could not determine if the wind-displaced materials adhered to the EMS communications tower before or after it collapsed. Since fencing is generally not an engineered structure, and communications towers are generally extensively engineered, it is highly likely that the fencing was displaced before the tower collapsed. If this was the case, any displaced fencing material that wrapped around the tower would have increased wind loads and could have contributed to the tower failure.

In this section, the MAT introduces a new term: **wind-displaced materials**. Historically these materials have been referred to as wind-borne debris.

While both wind-displaced materials and wind-borne debris are created by high-wind events, their effects on downwind structures are very different. Wind-borne debris tends to puncture building envelopes, while wind-displaced materials tend to wrap around or adhere to downwind structures and can increase wind loads on those structures.

ASTM E1996, *Standard Specification for Performance of Exterior Windows, Curtain Walls, Doors, and Impact Protective Systems Impacted by Windborne Debris in Hurricanes* (2009), which is referenced in the wind-borne debris requirements of the 2012 IBC, specifies missile types and sizes ranging from small steel balls that simulate roof surface aggregate to large 2x4 framing members that simulate debris from destroyed upwind structures. However, there is no specification for materials that do not puncture building envelopes, termed here as “wind-displaced materials” (see text box). Currently there is no consensus standard on wind-displaced materials and no guidance on how to treat their effects on wind loading of structures.

### 8.3.1.2 Latticed 300-Foot Cellular Tower (Tuscaloosa, AL)

A 300-foot latticed cellular tower was located approximately 0.6 mile northeast of the EMS communications tower. Like the EMS communications tower, the cellular tower was a latticed style free-standing tower. Unlike the EMS tower, the cell tower was older and appeared to have been in service for years. The 300-foot cellular tower was located at N33.184515° and W87.557541°.

**Location of Facility in Tornado Path:** The location of the latticed 300-foot cellular tower is shown in Figure 8-1. Figure 8-18 shows an aerial view of the centerline of the tornado damage swath in the vicinity of the 300-foot latticed cellular tower; also shown is the location of the EMS communications tower 0.6 mile to the southwest (described in Section 8.3.1.1). The 300-foot cellular tower was approximately 500 feet north of the center of the tornado damage swath.

**Facility Description:** The bases of the 300-foot latticed cellular tower were spaced 30 feet apart and consisted of six 1½-inch diameter anchor bolts set in cast-in-place concrete (Figure 8-19).

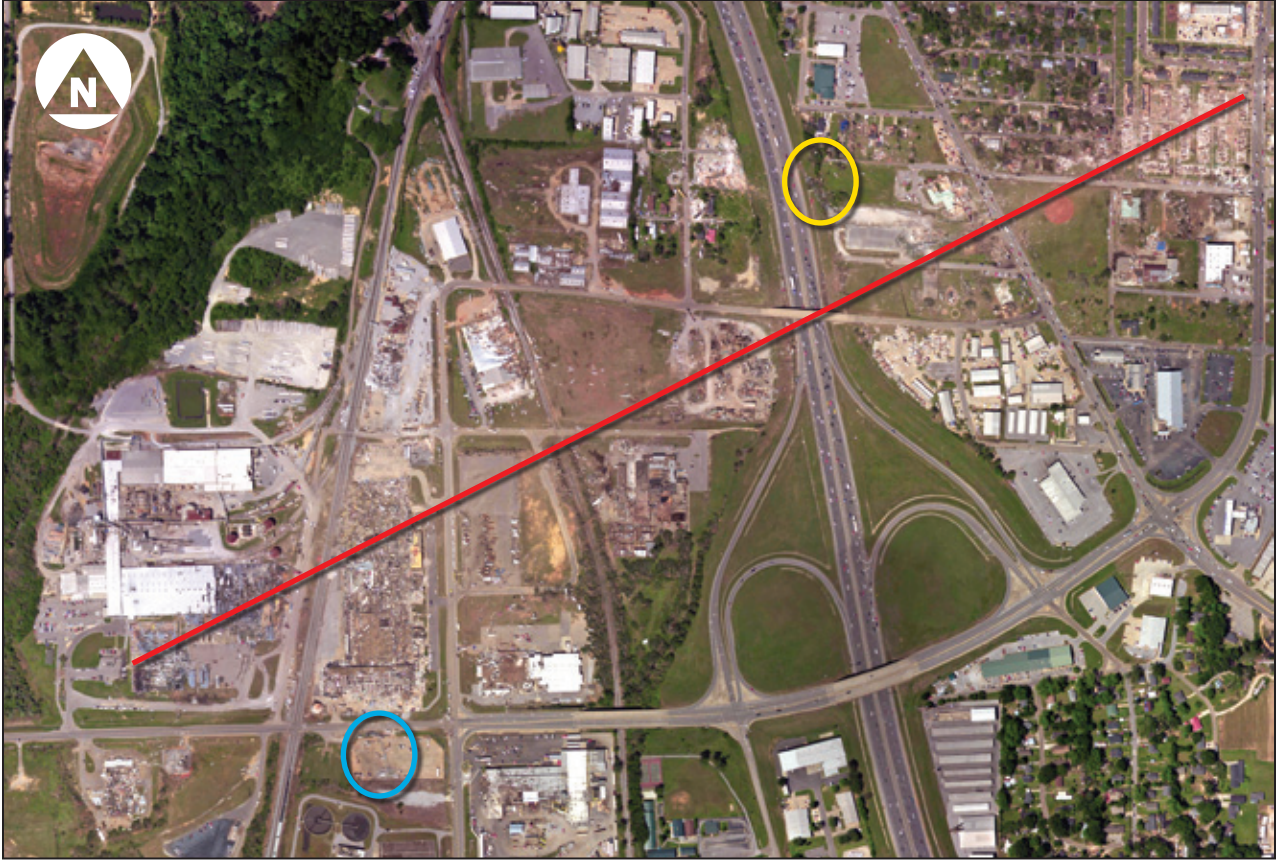

Figure 8-18: Aerial view of the approximate centerline of the tornado damage swath (red line) in the vicinity of the 300-foot latticed cellular tower (yellow oval). Also shown is the 250-foot EMS tower described in Section 8.3.1.1 (blue oval) (Tuscaloosa, AL).



Figure 8-19: Base for 300-foot latticed cellular tower (Tuscaloosa, AL)

**General Wind Damage and Functional Loss:** The 300-foot latticed cellular tower was completely destroyed by the April 27, 2011 tornado. Figure 8-20 shows the collapsed cellular tower.

**Figure 8-20:**  
View of the 300-foot latticed cellular tower that collapsed during the tornado event (Tuscaloosa, AL)



No wind-displaced building materials were seen physically adhered to the fallen latticed tower. However, a large metal building southeast of the tower had been destroyed (Figures 8-21 and 8-22), and large sections of metal panels were scattered throughout the area. The MAT also observed a trailer frame leaning against the fence surrounding the cell tower base (Figure 8-23). These observations suggest that the storm created large amounts of wind-borne debris and wind-displaced sheathing in the vicinity of the tower and wind-displaced material likely struck the tower.

**Figure 8-21:**  
Photograph of the 300-foot cellular tower (yellow oval) and the metal building to the southeast (blue box) before the April 27, 2011 tornado (Tuscaloosa, AL)

SOURCE: © GOOGLE EARTH

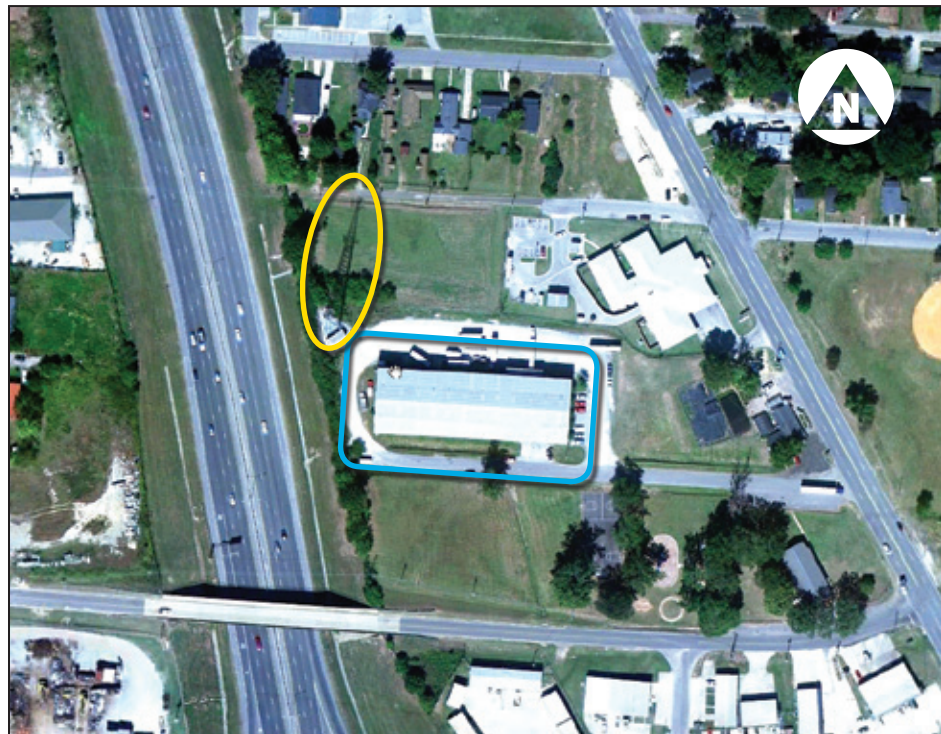





**Figure 8-22:**  
View of the collapsed 300-foot cellular tower (yellow oval) and the destroyed metal building southeast of the tower (blue box) in relation to the approximate centerline of the tornado damage swath (red line) (Tuscaloosa, AL)

PHOTOGRAPH COURTESY  
OF TUSCALOOSA COUNTY  
SHERIFF'S OFFICE



**Figure 8-23:**  
Remnants of a trailer that struck the fence surrounding the 300-foot cellular tower (Tuscaloosa, AL)

### 8.3.1.3 Solid Cellular Tower, 13<sup>th</sup> Street (Tuscaloosa, AL)

A solid cellular tower near 13<sup>th</sup> Street in Tuscaloosa, AL, was not visited during the MAT field reconnaissance, but was assessed by reviewing aerial photographs taken during a flyover 3 days after the April 27, 2011 tornado event. While this limited assessment did not provide detailed information on the performance of the tower, it allowed the MAT to make the observations described below. Web-based data from Google Earth Pro (licensed) indicate that the tower is located at N33.201454° and W87.521943°. Although this tower was within the tornado damage swath, the cellular tower did not collapse during the event.

**Location of Facility in Tornado Path:** The location of the solid cellular tower is shown in Figure 8-1. Figure 8-24 shows an aerial view of the centerline of the tornado damage swath in the vicinity of the solid cellular tower. The cellular tower is within 500 feet of the centerline of the tornado damage swath in an area where the storm caused extensive damage and destruction to nearby buildings.

**Facility Description:** Oblique aerial photographs taken during a flyover 3 days after the event show that the tower is free-standing (i.e., not guyed) and of a solid style, tapered-steel construction (Figure 8-25). Although the aerial photographs do not allow precise measurements of tower height, the MAT estimates the tower to be approximately 300 feet tall based on its height relative to nearby buildings.

**General Wind Damage and Functional Loss:** The aerial photographs show that the tower withstood the event without collapsing.



Figure 8-24: Aerial view of the approximate centerline of the tornado damage swath (red line) in the vicinity of the solid cellular tower left standing after the tornado (yellow circle) (Tuscaloosa, AL)

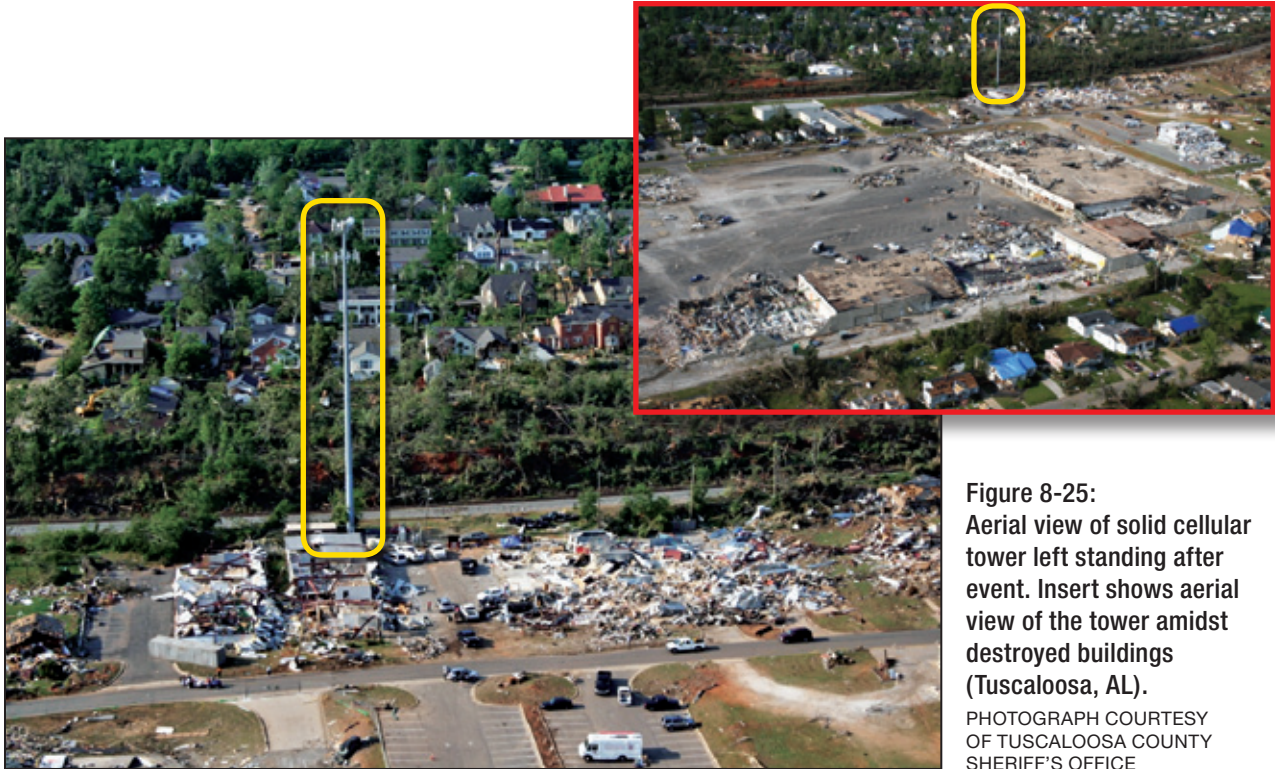

Figure 8-25:  
Aerial view of solid cellular tower left standing after event. Insert shows aerial view of the tower amidst destroyed buildings (Tuscaloosa, AL).

PHOTOGRAPH COURTESY  
OF TUSCALOOSA COUNTY  
SHERIFF'S OFFICE

## 8.3.2 Guyed Towers

Like all towers, guyed towers can fail during high-wind events such as tornadoes. High winds can create forces that exceed a tower's strength and can create wind-borne debris that damages portions of it. High winds can also create wind-displaced materials that can adhere to a tower's mast or guys, increasing the wind loads the tower must resist to avoid failure. In addition, guyed towers are at risk because all guys and anchors must be functional for the tower to remain stable. The loss of even one guy can result in tower collapse.

### 8.3.2.1 300-Foot Guyed Cellular Tower (Smithville, MS)

The MAT inspected a 300-foot guyed cellular tower in Smithville, MS. The 300-foot guyed tower is located approximately three-quarters of a mile west-southwest of the Smithville water tower (described in Section 8.1.2) and 1.25 miles west-southwest of the center of town. The guyed tower is situated in an open field approximately 450 feet northwest of Highway 25.

**Location of Facility in Tornado Path:** The 300-foot-tall guyed cellular tower is shown in Figure 8-2 and 8-26. The centerline of the tornado damage swath is approximately 200 yards southeast of the tower. There were few buildings near the tower, but the MAT noted wind-borne debris and wind-displaced materials littering the cellular tower site.



Figure 8-26: Aerial view of the 300-foot guyed cellular tower (yellow circle) in relationship to the approximate centerline of the tornado damage swath (red line) in Smithville, MS. The Smithville water tower shown in Figures 8-5 through 8-7 is northwest of the guyed tower and circled in blue for reference.

**Facility Description:** The guyed tower was laterally supported by three sets of earth anchors. The guys and anchors were oriented approximately at 60 degrees (east-northeast), 180 degrees (south) and 300 degrees (west-northwest), as shown in Figure 8-27.

The mast was connected to each of the guy anchors with five galvanized guys (both 5/16- and 7/16-inch-diameter guys were used) and turnbuckles (Figure 8-28). The ground anchor shafts were 2 inches in diameter. The MAT could not determine if each of the three anchor shafts terminated in an earth anchor or in a buried concrete mass.

**General Wind Damage and Functional Loss:** The tower collapsed during the event (Figure 8-29), and by the time the MAT visited the site 11 days after the event, preliminary clean-up activity had occurred and a temporary tower had been erected on site. The upper portion of the collapsed tower had been moved to clear the access road to the site.

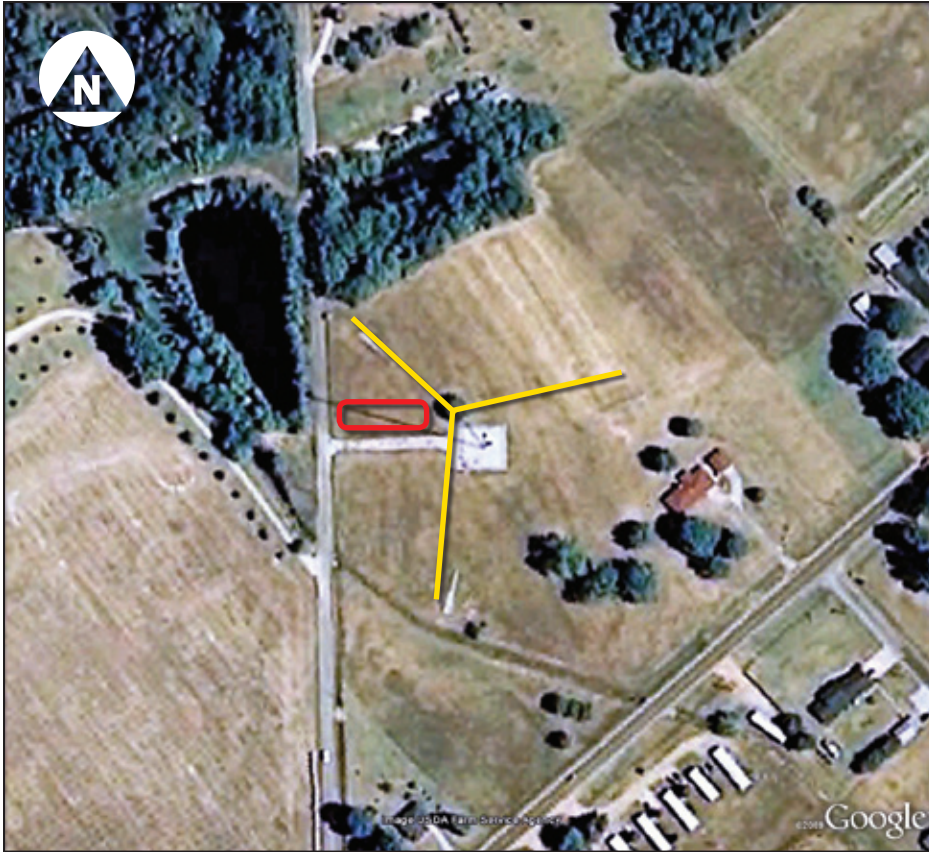

Figure 8-27:  
Aerial photograph showing the 300-foot-tall guyed cellular tower after the tornado; the yellow lines show the location of the original guys, and the red box shows the position of the tower remnants observed by the MAT (Smithville, MS)  
SOURCE: © GOOGLE EARTH



Figure 8-28:  
Guy attachment plate, turnbuckle, and anchor shaft (Smithville, MS)



Figure 8-29: Collapsed 300-foot cellular tower (blue box). The triple guy in the foreground (red oval) is one of the three supports for the temporary tower on the site (Smithville, MS).

Wind-displaced building components struck and adhered to the south guy (Figure 8-30). The anchor that secured those guys failed and was dragged several feet through the ground (Figure 8-31).

The remnants of the tower indicate that it fell to the west. The location of the fallen tower, the presence of the wind-displaced materials adhered to the southern guy, and the failure of the guy anchor suggest that wind-displaced materials overloaded the southern anchor, and the failure of the southern anchor caused the tower to collapse.

Figure 8-30:  
Wind-displaced building materials wrapped around the 300-foot cellular tower guy (Smithville, MS)





Figure 8-31:  
The anchor securing one guy was dragged several feet through the ground (Smithville, MS)

## 8.4 Summary of Conclusions and Recommendations

Table 8-1 provides a summary of the conclusions and recommendations for Chapter 8, *Observations on Infrastructure Performance*, and provides section references for supporting observations. Additional commentary on the conclusions and recommendations is presented in Chapters 10 and 11.

Table 8-1: Summary of Conclusions and Recommendations for Infrastructure Performance

Observation(s)	Conclusion	Recommendation
<p>Failed towers due at least in part to wind-displaced materials:</p> <ul style="list-style-type: none"> <li>Latticed 250-Foot EMS Communications Tower (Section 8.3.1.1)</li> <li>Latticed 300-Foot Cellular Tower (Section 8.3.1.2)</li> <li>300-Foot Guyed Cellular Tower (Section 8.3.2.1)</li> </ul>	<p><b>Conclusions #6 and #21</b></p> <p><b>(#6) Wind-displaced materials affected communications towers.</b></p> <p><b>(#21) Wind-displaced materials affected tower performance.</b></p>	<p><b>Recommendations #30 and #31</b></p> <p><b>(#30) Work collaboratively to better understand the risks of wind-displaced materials on communications towers.</b></p> <p><b>(#31) Work collaboratively to better understand the effects of wind-displaced materials on latticed structures.</b></p>

**Table 8-1: Summary of Conclusions and Recommendations for Infrastructure Performance (concluded)**

Observation(s)	Conclusion	Recommendation
<p>Reliance of systems on utility power to operate lift or booster pump resulted in loss of system pressure when portions of electrical distribution systems were destroyed:</p> <ul style="list-style-type: none"> <li>• Tuscaloosa Water Works in Alabama (Section 8.1.1)</li> <li>• Smithville, MS, water treatment and distribution system (Section 8.1.2)</li> </ul>	<p><b>Conclusion #19</b>  <b>Lost utility power caused loss of system function.</b></p>	<p><b>Recommendation #32</b>  <b>Provide an alternate electrical source.</b></p>
<p>Failed communications and cellular towers:</p> <ul style="list-style-type: none"> <li>• Latticed 250-Foot EMS Communications Tower (Section 8.3.1.1)</li> <li>• 300-Foot Guyed Cellular Tower (Section 8.3.2.1)</li> </ul>	<p><b>Conclusion #20</b>  <b>Guy anchors failed when struck by wind-displaced materials.</b></p>	<p><b>Recommendation #33</b>  <b>Work collaboratively to better understand communications tower performance.</b></p>





## TORNADO OUTBREAK *of* **2011**

IN ALABAMA, GEORGIA, MISSISSIPPI,  
TENNESSEE, AND MISSOURI

# Observations on Tornado Refuge Areas, Hardened Areas, and Safe Rooms

*Although hurricanes in the Southeast have received most of the attention in recent years, the threat and risk from tornadoes in the central and eastern portions of the United States is real.*

A total of 11,629 tornadoes were recorded by NOAA's SPC for the 60-year study period from 1950 through 2010 (NOAA 2011). Between 2000 and 2011, Alabama alone experienced 636 tornadoes with an associated 296 fatalities, and Missouri experienced 668 tornadoes with an associated 234 fatalities. For occupants of buildings not hardened to meet FEMA or ICC criteria to provide life-safety protection from tornadoes, it is critical to adequately plan how to minimize loss of operations and loss of life.

During severe weather, building occupants should be moved to a location in the building that is best protected from potential wind-borne debris and least susceptible to collapse. While these areas do

not provide near-absolute protection (unless designed as safe rooms), they may reduce the number of occupants injured or killed. Appropriate tornado refuge areas should be identified by architects, engineers, or design professionals familiar with FEMA 361 and FEMA P-431, *Tornado Protection: Selecting Refuge Areas in Buildings* (2009b) (refer also to Section 1.2). These tornado refuge areas are usually interior locations with short-span roof systems, reinforced masonry or concrete walls, and no glazed (glass) openings. The tornado refuge areas that typically perform the best during tornadoes are corridors, small interior rooms, and restrooms. Although homeowners and building owners may have identified such areas for use during severe weather and implemented construction measures to improve their performance, these areas have not generally been designed specifically to provide occupant protection. In the absence of access to a safe room, tornado refuge areas are typically a “last choice” or “only option” for those seeking protection. It is important to note that tornado refuge areas do not guarantee safety and offer only limited protection from wind and wind-borne debris; however, if they are identified correctly, they offer the most protection for building occupants seeking refuge during tornadoes and are better than no protection at all. Additional information identifying refuge areas during tornadoes is provided in this chapter.

This chapter describes the differences between tornado refuge areas, hardened areas, storm shelters, and safe rooms (Section 9.1). It includes the MAT’s field observations made after the April 25–28, 2011 tornado outbreak and the May 22, 2011 Joplin, MO tornado event regarding each of these types of protection areas (Sections 9.2 to 9.4). Section 9.5 presents observations related to travel time to places where individuals sought shelter during the tornadoes, and Section 9.6 presents observations related to compliance issues of both residential and community shelter areas not constructed to the stated criteria of the FEMA guidelines or ICC 500 standard.

## 9.1 Terminology and Examples

Buildings and portions of buildings that protect people during a tornado can be classified into four levels; in order of increasing level of protection, these levels of protection range from “minimal protection afforded” to “designed to provide near-absolute life-safety protection.”

- + **Tornado refuge areas** are constructed to regular building code requirements, but may also have continuous load paths, bracing, or other features that increase resistance to wind loads. It is important for people to know that such an area may not be a safe place to be when a tornado strikes and they still may be injured or killed during a tornado event.
- + **Best available refuge areas** are areas in an existing building that have been deemed by a qualified architect or engineer to likely offer the greatest safety for building occupants during a tornado (defined in accordance with FEMA P-431). It is important to note that occupants of such areas may be injured or killed during a tornado since these areas are not specifically designed as tornado safe rooms. However, people in

The MAT uses the terms “**safe room**” and “**storm shelter**” to describe only those hardened structures that meet the FEMA or ICC criteria for life-safety protection (see Section 1.2). Other structures, buildings, or portions thereof that have been described by their users as “shelters” but are not designed to accepted criteria for life-safety protection are identified here as **hardened rooms**, hardened structures, or tornado refuge areas.

the best available refuge areas are less likely to be injured or killed than people in other areas of a building.

- + **Hardened areas or rooms** are constructed for protection, but not specifically to set criteria. The difference between a hardened area and a best available refuge area is that specific portions of the area are designed to carry or resist higher loads from wind or wind-borne debris.
- + **Storm shelters/safe rooms** are constructed to meet criteria set forth in FEMA 320, FEMA 361, or ICC 500<sup>1</sup>

The MAT's observations for the types of structures described above are presented in Sections 9.2 to 9.5. However, it is important that the public and possible users of storm shelters and safe rooms understand that the levels of protection provided by structures designed according to ICC 500 and FEMA guidance documents is notably more complete and safer than the level of protection provided by a building or structure in which part of the criteria set for the in those documents is implemented. Sections 9.1.1 and 9.1.2 provide observations from the field assessments to further define how these types of structures are different.

### 9.1.1 Hardened Areas: Areas Designed to Provide Some Protection

Some structures or portions of buildings observed by the MAT were designed and constructed to provide some level of protection, but did not meet the FEMA or ICC criteria; in some cases, this is because they were constructed prior to publication of the safe room guidance. These types of areas are often referred to as *shelters* by those who seek refuge in them. These **hardened areas** typically provide an improved level of protection for occupants from building or structural failure, but often do not follow FEMA or ICC design criteria. It is important to note that, beyond the basic ability to provide life-safety protection, hardened areas typically do not account for many of the other human factors addressed by ICC and FEMA criteria for storm shelters and safe rooms. Such factors include adequate space for occupants, ventilation, water, toilets, and other design elements to meet occupant needs.

Figure 9-1 shows a hardened room or “shelter” constructed in a residence in Tuscaloosa, AL, just weeks before the April 27, 2011 tornado. The home was directly in the path of the tornado as it moved through the Forrest Lake neighborhood of Tuscaloosa. This hardened room in the home did not collapse during the event, but the wooden door to its interior provided minimal protection from wind forces and wind-borne debris impacts. (The hardened room was not used during the tornado because the owners were not at home when the tornado struck Tuscaloosa.) Because the door did not meet the criteria from FEMA or ICC, the room should not be called a safe room or storm shelter because this component is not designed or tested to provide the same level of life-safety protection as the rest of the structure.

---

<sup>1</sup> The 2008 versions of FEMA 320, FEMA 361, and ICC 500 are intended in this chapter unless another date is specified.

Figure 9-1:  
A hardened room in a  
residential building in  
Tuscaloosa, AL



## 9.1.2 Storm Shelters and Safe Rooms: Areas Designed for Life-Safety Protection

*Storm shelters* are structures, buildings, or portions of buildings that have been designed and constructed to meet ICC 500 criteria and offer protection from extreme weather events, such as tornadoes and hurricanes. Storm shelters provide life-safety protection for their occupants. By contrast, a *safe room* is a hardened structure or area of a building that has been designed and constructed to provide near-absolute protection against both wind forces and the impacts from wind-borne debris, as defined in the FEMA safe room publications. In addition to providing life-safety protection from wind and wind-borne debris, structures built to the FEMA safe room criteria meet and exceed all of the design criteria in the ICC 500 and also consider other emergency management related performance criteria. Because of this, FEMA states that a safe room offers “near-absolute protection” in severe weather events, an even higher level of protection than that provided by storm shelters. Examples of a FEMA residential and community safe room are presented in Figures 9-2 and 9-3, respectively.

*“Near-absolute protection means that, based on our [FEMA’s] current knowledge of tornadoes and hurricanes, the occupants of a safe room built according to this guidance [FEMA 361] will have a very high probability of being protected from injury or death.”*

SOURCE: FEMA 361, PG. 1-2 (2008 EDITION)

While safe rooms and storm shelters can provide the same or different levels of protection, the FEMA criteria for near-absolute protection can provide a different (and higher) level of protection depending on the design criteria used. The level of occupant protection provided by a space specifically designed as a safe room is intended to be much greater than the protection provided by buildings that comply with the minimum requirements of building codes. With respect to the storm shelter criteria from the ICC, the FEMA safe room criteria provide the same or slightly higher level



Figure 9-2:  
Above-ground residential safe room installed in a garage of a home in Joplin, MO, directly impacted by the tornado (rated EF4 based on the MAT's observations)



Figure 9-3:  
These above-ground community safe rooms in Brookwood, AL, were used during the April 27 tornado outbreak, but were not directly impacted by a tornado

of protection than the criteria set forth in the ICC 500 and consequently, the FEMA criteria can be said to meet or exceed the design requirements of ICC 500 in all instances. The level of protection provided by a safe room or storm shelter is a function of the design wind speed, resulting wind pressure used in designing it, and wind-borne debris impact criteria.

■+ **Storm shelters** are designed and constructed in accordance with ICC 500 and offer greater protection than traditional buildings and homes because they have been designed to provide life-safety protection. However, they do not meet all the criteria of FEMA 320 and FEMA 361 and are not considered safe rooms.

To date, NWS has not recorded any wind event exceeding the maximum design criteria provided in FEMA 320 and FEMA 361 (250 mph, 3-second gust, 33 feet above grade).

■+ **Safe rooms** are hardened structures that are specially designed and constructed in accordance with FEMA 320 and FEMA 361 guidelines. Safe rooms provide “near-absolute protection” in extreme weather events, including tornadoes and hurricanes. “Near-absolute protection” means that, based on our current knowledge of tornadoes and hurricanes, the occupants of a safe room will have a very high probability of being protected from injury or death per FEMA 320.

Safe rooms and storm shelters are typically interior rooms or spaces within a building, but they may also be entirely separate buildings or structures designed and constructed to protect their occupants from tornadoes or hurricanes. Safe rooms may be constructed above or below ground. Safe rooms and storm shelters can be used as dual-function rooms within a building or home, where the room may normally be used as a training room, hallway, or closet.

The fact that an engineering design standard (ICC 500) is referenced and heavily used as part of a much larger emergency management program shows FEMA’s commitment to use voluntary consensus standards to the maximum extent possible in carrying out its programs. FEMA continues to educate designers, emergency management officials, property owners, and people in the community seeking to find protection from tornados on the benefits of FEMA 320, FEMA 361, and ICC 500 and how they complement one another.

When compared, the technical guidance for tornado hazards is essentially the same between ICC 500 and FEMA 361 for community storm shelters and safe rooms, but there are some differences when comparing criteria for hurricane hazards for wind, wind-borne debris, and flood design criteria. For residential applications, ICC 500 provides performance design criteria to be met. This allows for residential tornado and hurricane storm shelters to be designed for different wind speeds. In contrast, FEMA 320 guidance provides a prescriptive solution designed for the highest wind speed and wind-borne debris criteria shown on the tornado and hurricane hazard maps included in the ICC and FEMA documents. Further, the FEMA 320 criteria also specify the use of more stringent criteria than ICC 500. As a result, the prescriptive FEMA 320 safe room designs can be used for small community safe rooms, thereby expanding their applicability and usefulness.

In all cases, where differences exist, FEMA criteria are more stringent than the ICC 500 storm shelter criteria. Further, both the FEMA 320 and 361 documents provide important information about the planning, operation, and maintenance of a safe room while ICC 500 (an engineering standard) does not address those issues. Unfortunately, this does not diminish the reality that when the engineering design standard (ICC 500) and the FEMA technical guidance (FEMA 320 and FEMA 361) provide different levels of protection it may lead to some confusion for designers, emergency management officials, property owners, and people in the community seeking to find or provide life-safety protection from tornadoes.

## 9.2 Tornado Refuge Areas

The MAT was able to find only a few safe rooms and storm shelters along the more than 300 tornado tracks (or damage swaths) of the April 25–28, 2011 tornado events in the mid-south of the United States or in the May 22, 2011 Joplin, MO, tornado. This was surprising because it had been more than 10 years since FEMA began publishing technical guidance for the design and construction of safe rooms and storm shelters. Many people were forced to find any protection they could wherever they found themselves when the tornadoes struck.

The NWS and local meteorologists should be credited for their **forecasting success** in providing important and useful storm information that allowed many people to take appropriate action to either find a safe room or move out of the path of the tornadoes before the event struck in their community.

Although some people taking refuge in areas of their homes in Alabama, Georgia, and Mississippi perished, the MAT believes the number of fatalities would have been significantly higher if these tornado refuge areas were occupied when the storms struck. The MAT observed many tornado refuge areas that had collapsed or filled with broken glass from windows shattered by wind-borne debris that would have been unsafe had they been occupied. However, for the tornado events of April 25–28, 2011 the NWS was able to provide long warning times and notifications. As a result, many people who would have taken refuge in an inappropriate place either found safer refuge or moved out of the path of the tornado.

The tornado that struck Joplin, MO on May 22, however, formed rapidly and descended on the city with little advanced warning. Numerous critical facilities, many commercial buildings, and thousands of homes were damaged by the tornado. There were fatalities in tornado refuge areas used during this event.

This section discusses the MAT's observations of buildings (or the areas of buildings) where people took refuge when no safe rooms, storm shelters, or hardened areas were available. The performance of the buildings in the direct path, or near the path, of strong or violent tornadoes was poor, as expected. Residential buildings are not designed to provide resistance to wind loads or consider only minimal wind loads in their design. Non-residential structures, while designed to consider some level of wind resistance, generally do not provide resistance to extreme wind loads. For more detailed discussions and observations related to building performance, see Chapters 4, 5, 6, and 7 of this report for residential buildings, commercial and industrial buildings, schools, and critical facilities, respectively.

### 9.2.1 Tornado Refuge Areas in Residences

The MAT was informed that many residents took refuge in their homes. This occurred for a number of reasons, including minimal warning time and the perception of their home being the safest location. In most cases, the homes did not have a safe room and there was no nearby community safe room or storm shelter. When such a place is not available within or near a home, homeowners are forced to take refuge in the best available spaces they can identify.

If homeowners cannot find shelter in a specifically designed safe room or storm shelter during a tornado, building occupants should take refuge either in the central areas of their homes or in

the basements (if available). If no basement is available, the central area of the home is typically the portion most likely to survive tornado impacts and provides the best tornado refuge area in a home. This is evidenced by core remnants of residential buildings that survive tornado events. The performance of core remnants observed by the MAT is described in Section 9.2.1.1. The performance of basements is discussed in Section 9.2.1.2.

### 9.2.1.1 Core Remnants

In general, the basement is often the least vulnerable area during a tornado. However, if a house has no basement, the MAT's observations indicate that the best place for an individual to go in their home is the central or core areas of the home. Although the location of the core varies from home to home, areas with multiple wall intersections, stairways, or near bathrooms or kitchens are most often the building core. These portions of homes typically perform better than other areas when exposed to extreme winds from tornadoes; areas with multiple wall intersections provide additional strength to resist wind loads if the walls (and sometimes ceiling systems) are connected together.

**Site-Built Housing:** Based on the MAT's observations in all the impacted States, the cores of site-built homes provided the most redundant portions of the structure (see Chapter 4 for detailed discussions on residential building performance). Figures 9-4 and 9-5 illustrate this concept. Some residents in site-built homes in Crescent Ridge, AL, took refuge in the core areas of their homes and survived the tornado event, even when their homes were largely destroyed. Unfortunately, many of the core remnants observed by the MAT could not protect the occupants in this hard-hit community, which was one of the first areas to be impacted by the Macon County Supercell Thunderstorm (see Figure 2-2 in Chapter 2). This single tornado was associated with 61 reported fatalities across these two cities, 43 of which were in the Tuscaloosa area.<sup>2</sup> According to the FEMA JFO approximately one-third of the 43 people killed by this tornado were in Crescent Ridge. The NWS rated the center of the tornado circulation as EF4 in this portion of its track. The approximate centerline of the tornado damage swath is shown in Figure 9-4. This tornado struck both site-built and manufactured homes in the Crescent Ridge neighborhood, resulting in a significant loss of life.

Figure 9-6 shows another example of how a portion of a building may remain standing even after most of the building is destroyed by a violent tornado. No individuals took refuge in this home, but this core remnant survived the impact of the May 22, 2011 Joplin, MO, tornado. The NWS rated the center of the tornado circulation as EF4 in the vicinity of this building.

**Manufactured Housing:** Manufactured housing in Crescent Ridge, AL, did not withstand the tornado that struck the neighborhood. Damage in this neighborhood was ranked as EF4 by the MAT (see Appendix E for additional detail). Although the design and construction of manufactured housing improved greatly after HUD requirements were changed in 1994, manufactured housing is not constructed to survive a tornado event. The long, narrow dimension of the units and different means and methods of securing the units to foundations are a few of the factors that have contributed to overturning and other failures of manufactured home units. Figure 9-7 shows several manufactured homes in the Crescent Ridge, AL, area after the tornado. These homes were displaced off their foundations and also experienced significant damage to the units themselves. No core remnants remained.

---

<sup>2</sup> NOAA's NWS SPC, Annual U.S. Killer Tornado Statistics, <http://www.spc.noaa.gov/climo/torn/fatalorn.html>.





Figure 9-4: Aerial view of tornado damage swath in Crescent Ridge, AL (approximate centerline of swath is indicated by red line).<sup>3</sup> Core remnants of homes shown in Figures 9-5 are identified with red arrows. The damaged manufactured homes in Figure 9-7 are identified with a yellow arrow.

SOURCE: ALL AERIAL PHOTOGRAPHS ARE FROM NOAA IMAGERY ([HTTP://NGS.WOC.NOAA.GOV/STORMS](http://ngs.woc.noaa.gov/storms)) UNLESS OTHERWISE NOTED



Figure 9-5: Core remnants of homes sometimes survive a tornado as shown in this photograph of site-built homes where a closet (red arrow in left photograph) and a bathroom behind a kitchen (red arrow in right photograph) remained standing after the tornado (Crescent Ridge, AL)

<sup>3</sup> The red line in this and all similar figures is intended to represent the center of the damage swath. The track location is approximated by the MAT based on post-event aerial photographs. The actual centerline of circulation is offset from the centerline of the damage.

**Figure 9-6:**  
The core remnant of a home  
in Joplin, MO



**Figure 9-7:**  
Manufactured homes  
destroyed in Crescent Ridge,  
AL (location shown in  
Figure 9-4)



### 9.2.1.2 Basement Areas

Basement areas typically provide better protection than above-ground areas because one or more walls (or a room within the basement) are below ground and will not be affected by wind forces or wind-borne debris. However, basements are vulnerable to damage from the collapse of the structure above unless the ceiling of the basement (or the floor above) is designed to provide protection if the house above collapses.

Figure 9-8 shows an interior basement storage room in a Tuscaloosa, AL, home. This unique home was re-constructed in the 1940s from two old cabins that had been re-located to the site. Placed atop a hillside, the masonry foundation supporting the cabins created a walkout basement. When the family constructed the basement, they set aside the storage room to be used during tornadoes. With heavy timber construction and one wall built into the hillside, this space offered some level of protection. Damage in the neighborhood of this home was ranked as EF2 by the MAT (see Appendix E for additional detail). Although not specifically designed for protection, the family



Figure 9-8:  
Tornado refuge area in a  
Tuscaloosa, AL, basement

occupied the basement during the tornado, and the storage room provided the family a place to take cover when a tornado passed over their neighborhood.

The Pleasant Grove neighborhood outside Birmingham, AL, was directly struck by a tornado (Figure 9-9). The NWS rated the center of the tornado circulation as EF4 in this portion of its track. Many homes in this neighborhood were destroyed, resulting in several fatalities.<sup>4</sup> In several of the destroyed homes, residents sought refuge in their basements, but they were not always safe.

Figure 9-10 shows a home that had a heavily reinforced porch slab over a storage area in their basement; the slab was voluntarily constructed with reinforcing steel and with a slab depth thickness of 9 inches to provide protection during a tornado. The family sought refuge in the storage area under the front porch. The home was completely destroyed by the tornado, but the family survived in the portion of the walk-out basement where the reinforced concrete roof deck was placed.

<sup>4</sup> NOAA's NWS SPC, Annual U.S. Killer Tornado Statistics, <http://www.spc.noaa.gov/climo/torn/fataltorn.html>.



Figure 9-9: Aerial view of the Pleasant Grove, AL, neighborhood.  
NOTE: TRACK DAMAGE CENTERLINE IS NOT IN THE FRAME SHOWN HERE.

Figure 9-10:  
A hardened porch slab over this basement helped to create a tornado refuge area that allowed this family to survive the tornado; location shown in Figure 9-9 (Birmingham, AL)



It is important to note, however, that not all basement areas should be considered “safe” during a tornado just because they are below ground. According to local residents, a few doors down from the home shown in Figure 9-10, a fatality occurred when people sought shelter in the basement and the concrete floor above collapsed into the basement space.

### 9.2.1.3 Tornado Refuge Areas in Multi-Family Buildings or Complexes

In multi-family residential situations, it is important to understand the limitations for potential tornado refuge areas. Figure 9-11 shows a new, multi-unit residential complex in Tuscaloosa, AL, after it was struck directly by a tornado as it tracked through the city. The NWS rated the center of the tornado circulation as EF4 in this portion of its track; its track is shown as tornado #46 on Figure 2-2. Most of the complex was destroyed. The inset photograph shows an interior bathroom in a first floor unit of the complex. Although areas like this are often used as tornado refuge areas, the damage to the space and the debris inside it illustrate the limitations of such refuge areas. Though the bathroom may have provided a place of refuge in this portion of the building that was badly damaged, but did not collapse, the space was not safe. The ceiling (floor structure for the upper floor) blew off, a piece of framed lumber was thrown into the bathroom, and an asphalt shingle (red arrow) penetrated the wall. It is important to note that other similarly constructed areas were completely destroyed by the tornado.

***Taking refuge does not guarantee safety or survival.*** While some refuge areas may survive a direct hit by a tornado, thereby protecting the occupants, other identical refuge areas may collapse and result in fatalities.



Figure 9-11: An interior bathroom (inset), often considered a tornado refuge area, was heavily damaged when the tornado struck the development of Chastain Manor. An asphalt shingle penetrated the wall (red arrow) (Tuscaloosa, AL).

## 9.2.2 Tornado Refuge in Commercial and Industrial Buildings: Planned Tornado Refuge Areas

The MAT visited a number of sites that had formally designed areas within their building for use during tornadoes. These areas performed no better than the typical commercial and industrial construction described in Chapter 5 of this report because they were not constructed to resist high wind loads. In all cases, the designated areas had been identified and were part of a formal plan, but the buildings (and designated areas for use during tornadoes) weren't designed or constructed to provide additional protection. Further, the MAT did not find any indication that these designated areas had been evaluated to understand and document their vulnerability to high winds and wind-borne debris impact.

In commercial and industrial buildings, post-disaster assessments by the MAT and NSF team following the April 25–28, 2011

and May 22, 2011 tornado events suggested that administrative officials or others involved in local planning often identified designated areas or tornado refuge areas without the guidance of a qualified architect or engineer. While it was clear that an effort was made to protect the occupants, many of these designated areas were not evaluated for their ability to provide resistance to or protection from wind and wind-borne debris and were vulnerable. These designated areas were located in:

- + Large spaces, such as gymnasiums or auditoriums
- + Areas near exterior windows and doors
- + Areas surrounded by wall systems subject to collapse in high-wind events

Additionally, in some cases the designated areas had insufficient space for all of the building occupants or were in locations where it would be difficult to move occupants in a reasonable period of time.

### 9.2.2.1 Walmart (Joplin, MO)

Although not a public shelter or designated community tornado refuge area, a Walmart store in Joplin, MO, had a disaster plan that provided guidance on where to take refuge during a tornado. Over 200 people sought refuge inside the store during the May 22, 2011 tornado. The damage swath centerline of the tornado that devastated Joplin was located just a few hundred feet from the building (Figures 9-12 and 9-13). The NWS rated the center of the tornado circulation as EF4 in this portion of its track. Employees gathered everyone inside the store in break rooms, rest rooms, and

In the tornado-prone region of the United States, **many schools have designated refuge for students and faculty during tornadoes**. Several of the schools visited by the MAT had designated refuge areas. The observations on the performance of tornado refuge areas in schools are presented in Chapter 6. An example of a school with a community safe room meeting the FEMA criteria is presented in Section 9.4.4.3.

In addition to schools, other critical facilities often have designated areas for use during tornadoes. The observations on the performance of tornado refuge areas in other critical facilities are presented in Chapter 7.

See also Recovery Advisories 5, 6, and 8 in Appendix F for additional information regarding refuge areas in schools and critical facilities.



Figure 9-12: Walmart store in Joplin, MO



Figure 9-13:  
Close-up view of the damage  
at the Walmart store in  
Joplin, MO

in the customer service desk area near the back of the store. Part of the store's tornado refuge area was constructed of reinforced CMU walls. Once the tornado struck, the front doors and roof were torn away from the building and part of the roof structure collapsed (see Section 5.2.5 for further discussion of the building). According to a local Walmart representative, there were three fatalities inside the store. The fatalities occurred near the center of the store, away from the reinforced exterior walls of the store.

### 9.2.2.2 Lowe's Home Improvement Store (Tuscaloosa, AL)

The Lowe's Home Improvement store in Tuscaloosa, AL (Figure 9-14), was a site where individuals who heard the tornado warning gathered to seek refuge. Although it was not impacted by a tornado, the MAT visited the site. The Lowe's store had an emergency response flipchart that clearly described the action to be taken by store employees during an emergency, including tornadoes (Figure 9-15). The tornado procedure included what to do for a tornado watch, tornado warning, response procedure, and post-tornado procedures.

Figure 9-14:  
Lowe's Home Improvement  
building (Tuscaloosa, AL)



Figure 9-15:  
Lowe's Emergency Response  
Flipchart (Tuscaloosa, AL)





The store manager had been advised of an updated procedure recently issued by Lowe's corporate officials after a tornado struck a Lowe's store in North Carolina just weeks before. The response plan originally called for customers inside the store to be moved to the center aisles of the building, away from exterior walls and windows. In the updated plan, employees were instructed to move everyone to the front of the store into areas with multiple walls defining the space. At this store location, the front of the store was identified in the updated response plan as the designated area for use during tornado events. These smaller rooms were identified in the hopes they would provide better protection for employees and patrons based on similar areas of the North Carolina store performing better during a tornado. This part of the store was primarily unreinforced CMU construction and drop ceiling. The MAT could not determine if this portion of the building had been assessed for use as a tornado refuge area or evaluated to be a best available refuge area.

Many existing buildings, both publicly and privately owned, do not have a safe room or storm shelter. Occupants in these buildings must either leave the building or take refuge in the best available tornado refuge area. The technical guidance in FEMA 361 recommends that ***all tornado refuge areas be evaluated by a design professional*** to identify the vulnerability of the refuge areas to high winds and wind-borne debris and to evaluate the residual risk associated with using these areas for tornado refuge. Additional information on this topic is presented in FEMA Recovery Advisories 2, 5, and 6 issued for this event (see Appendix F).

During the April 27, 2011 tornado event, the Lowe's store housed around 50 customers and residents from the surrounding area who came to the store seeking refuge, as well as employees at work at the time. The store manager moved everyone to the front area of the building and had the occupants congregate in the break rooms and meeting rooms. Power was lost for a short time during the storms, but auxiliary (generator) power turned on. Employees also had battery-powered flash lights to ensure they had enough light to see, as the storage rooms had no windows.

The Lowe's emergency response plan for responding to a tornado event appeared to have been well executed at this store, although the building was not struck or impacted directly by a tornado. The store manager put the response plan into action quickly and followed it to eliminate confusion among the work staff.

### 9.2.2.3 Home Depot (Joplin, MO)

The Home Depot in Joplin, MO, was struck by a direct hit from a very intense tornado on May 22, 2011 (Figure 9-16). The NWS rated the center of the tornado circulation as EF4 to EF5 in the vicinity of this building. Individuals in the area who heard the tornado warning attempted to seek refuge at this store. As discussed in Section 5.1.3 of this report, the roof of the store was torn off and the building's massive concrete tilt-up panels collapsed, resulting in seven fatalities in different locations in the store.

Employees listened to the weather radio and followed the standard emergency plan put in place by the company. As part of the emergency plan, all doors in the store were locked in an attempt to secure the building and reduce the risk of inflow of air, which could compromise the roof system of the building by causing uplift. There were two fatalities at the front of the store. People from the



Figure 9-16: Home Depot after the May 22, 2011 tornado (Joplin, MO)

surrounding area were trying to take refuge inside the building right up to the time the tornado struck it.

In accordance with the emergency plan, all shoppers and employees in the store were gathered in the employee lounge and training area at the back of the store. The MAT was unable to determine if this area was designated as a best available refuge area for use during tornadoes by a design professional or if a formal assessment of the tornado refuge area was conducted. The 28 people who took refuge in the training room survived the storm.

The area of the store where employees and shoppers congregated was constructed of metal stud framing and dry wall. This area was not a hardened structure and could have potentially been crushed had the tilt-up panels fallen on top of the room. Figure 9-17 shows a picture of the remaining structure around the training area. The wall composed of metal studs and drywall can be seen leaning inward (yellow arrow). The photograph also shows the tilt-up panels that collapsed outward beside this area (red arrow).

### 9.3 Hardened Structures, Rooms, and Areas Not Designed to Defined Criteria

This section discusses the MAT's observations of buildings where people took refuge in hardened structures or portions of buildings. In all cases, the buildings were designed to provide some level of hardening, but the MAT was unable to obtain details of the design wind speed used, the debris impact criteria used, or if any operational or emergency management plans were included



Figure 9-17:  
Tornado refuge area (training room) of the Home Depot. Note the collapsed tilt-up wall (red arrow) and the wall leaning into the refuge area (yellow arrow) (Joplin, MO).

in the design process. Further, the MAT noted one or more deficiencies in all of the hardened areas described in this section that prevented them from being categorized as safe rooms or storm shelters. The most common deficiency observed was with door assemblies; specifically, the doors were not capable of withstanding wind forces and wind-borne debris associated with tornadoes. When such doors fail (as occurred in several cases), the occupants are exposed to the tornado and are not as protected as originally intended.

The Wind Science and Engineering Research Center at TTU is one entity that performs **testing on doors** for use in tornado safe rooms and storm shelters. For more information on doors and door hardware that has passed the debris impact test, see <http://www.depts.ttu.edu/weweb>.

Many people interviewed by the MAT had the perception that the only safe place to be during a tornado was in a below-ground structure. Although below-ground shelters have afforded their occupants reasonable protection from violent storms for centuries, this is not accurate, and above-ground safe rooms and storm shelters can also provide life-safety protection when designed and constructed properly. However, for either type of structure or room to protect occupants, all exposed portions must resist debris impacts, and the structures or rooms must have robust doors and locking systems that are easily operated in a high-wind environment. This means any door system used must be tested for wind and debris impact-resistance, or prescriptive solutions that have been shown to pass the FEMA and ICC 500 criteria must be used. The specifications for a prescriptive solution to constructing debris impact-resistant doors are presented in FEMA 320. The solution specifies using three hinges and three points of latching, though variations on the number of hinges attaching doors is becoming more common as more products are tested to the ICC criteria.

The advantage of above-ground hardened structures and rooms is that they are more accessible to young, old, and handicapped people than below-ground structures. The complete exterior of the safe room or storm shelter (including the door assembly) must be designed to resist the violent wind pressures as well as the debris impacts associated with high-wind events. Doors on above-ground structures used for occupant protection are particularly vulnerable and must resist debris with minimal damage after impact (see Chapter 8 of ICC 500). The MAT observed dozens of below-ground and above-ground “shelters” and hardened structures in Alabama and Mississippi. In Joplin, MO, only above-ground structures and rooms were observed. The MAT speculates that this is because of the existence of old mining tunnels under portions of the City of Joplin, but there may be other reasons below-ground structures were not observed. Research into why a certain type of structure was selected for protection is beyond the scope of the MAT.

There are several sources for **information on securing safe room and storm shelter doors**. FEMA 320 provides a prescriptive design for door construction (with hinges and latching systems) that can resist wind and wind-borne debris associated with tornadoes. This solution meets the testing requirement of the ICC 500 for residential safe rooms.

Although three hinges and three latching mechanisms are no longer required per the ICC 500, most doors and systems that have passed the debris impact and wind pressure tests have multiple (or continuous) hinges and multiple latches. As of this publication, no single dead bolt acting as the lone closure mechanism has passed the ICC 500 tests for wind and wind-borne debris resistance.

### 9.3.1 Hardened Structures for Residential Use

The structures presented in the following sections did not meet the FEMA or ICC criteria for safe rooms or storm shelters. Although these structures provided some protection, the occupants were at risk due to the poor construction of the door assemblies or door latching systems.

#### 9.3.1.1 Below-Ground Applications

Although constructed of a hardened concrete shell, the “shelter” shown in Figure 9-18 was protected by plywood doors clad with light steel, a single point locking system, and a vent system that was vulnerable to impacts. It is unknown how many occupants using this structure survived, but the adjacent home was destroyed when the tornado passed over Smithville, MS. Although the Smithville tornado was rated higher at different locations along its track (see Section 2.5.1.7 of this report), the MAT derived the tornado rating as EF2 at this location based on damage to this building.

The Hackleburg, AL, below-ground structure shown in Figure 9-19 seemed to be relatively new. The MAT was unable to determine how many sought refuge here, but there was evidence in the shelter that it was used. Damage in the neighborhood of this home was ranked as EF3 by the MAT (see Appendix E for additional detail). Though the structure was mostly underground and had a reinforced concrete roof structure, the door was constructed of wood planks and locked with a chain held by bent nails. This type of door and method of connection is inadequate to resist wind loads and wind-borne debris; occupants who took refuge here were still at risk because of the low quality and characteristics of this door assembly.



Figure 9-18: Underground shelter that survived a tornado (rated EF2 based on the MAT's observations). Inset shows the location of shelter (Smithville, MS).

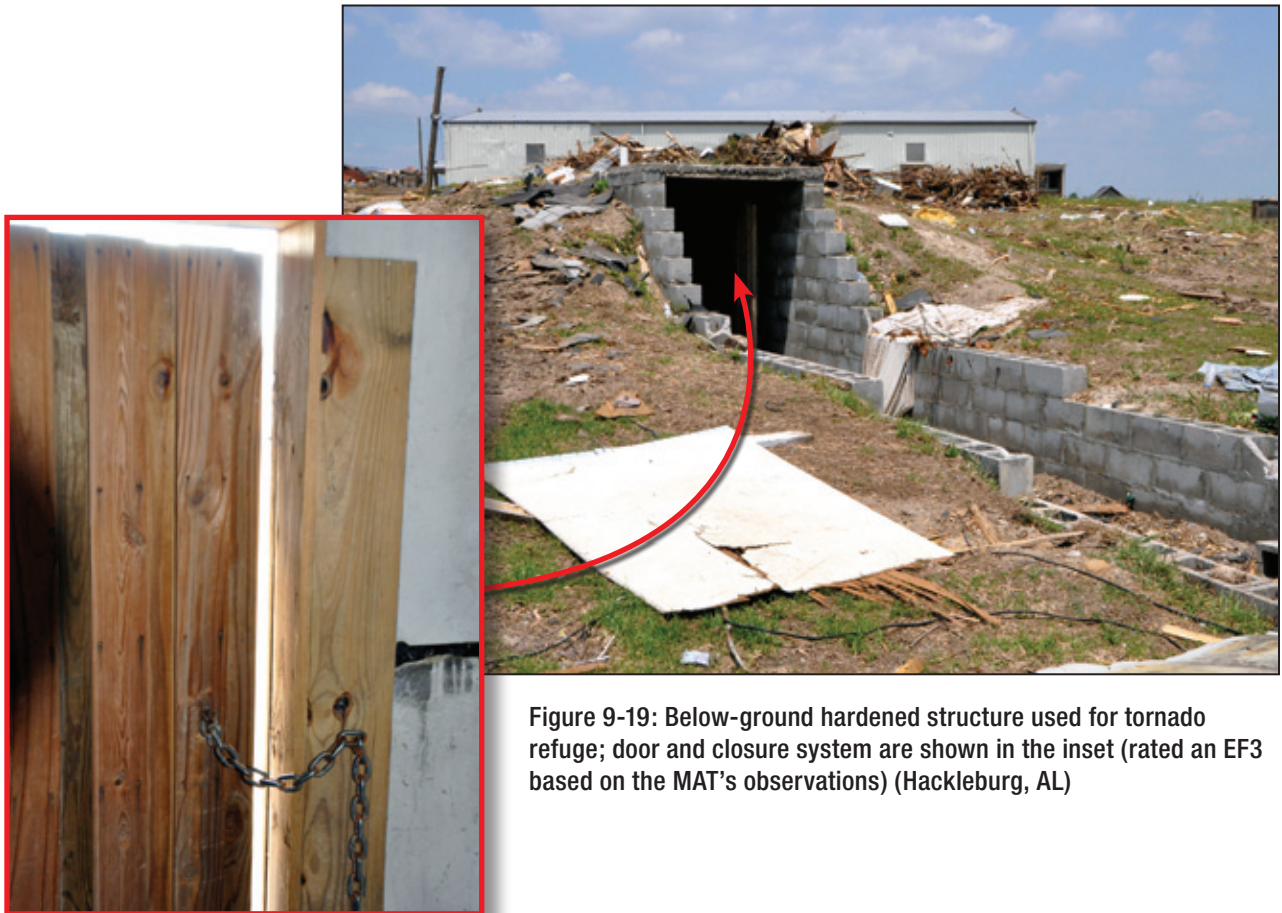

Figure 9-19: Below-ground hardened structure used for tornado refuge; door and closure system are shown in the inset (rated an EF3 based on the MAT's observations) (Hackleburg, AL)

### 9.3.1.2 Above-Ground Applications

A husband and wife took shelter in their above-ground concrete shelter in Smithville, MS, shown in Figure 9-20. Although the small town of Smithville was devastated by a tornado that reached EF4 intensity in places along its track, this home was on the periphery of the vortex and suffered little damage. The clam-shell concrete structure was anchored to the ground with steel bands and earth anchors. Although the concrete walls were sufficiently thick at 6½ inches, the door system was untested, and the locking system could open when impacted by debris or subjected to high wind pressures. The door locking mechanism used three points of connection on the non-hinge side of the door (as suggested in FEMA 320), but the three individual mechanisms used to keep the door in the closed position were not identified as having been tested to the FEMA or ICC debris impact resistance criteria. Because these latching mechanism were light weight and the door did not appear to be reinforced around the latch points, the door was vulnerable to being forced open from wind or wind-borne debris. Further, this structure did not appear to be anchored to resist wind loads (other than the grounding force resulting from its dead weight).

The MAT observed another example of an above-ground “shelter” in Athens, AL (Figure 9-21). A family survived the tornado in a hardened room they had constructed within a shop building east of their home. The hardened room (approximately 8 feet tall, and 6 feet by 9 feet in plan) was constructed with a reinforced CMU wall structure and concrete roof deck. The shop building was totally destroyed by the tornado, as was most of their home. The NWS rated the center of the



Figure 9-20:  
Above-ground shelter with  
untested door system; inset  
shows the inside of the door  
latch (Smithville, MS)



Figure 9-21:  
A family shelter with a single  
deadbolt (Athens, AL)

tornado circulation in the vicinity of this building as EF3. The design of the structure was consistent with the FEMA 320 guidelines with the exception of the door assembly. The door and latching mechanism was not a tested assembly and had only one deadbolt; at the time of this publication, no door latch configuration with one bolt has passed the ICC 500 or the FEMA 361 debris impacting testing criteria.

Although this room successfully provided safe refuge for the family, they were still at risk from high winds and wind-borne debris because of the door system used. The performance of this structure may not have been successful if the door had been impacted by wind-borne debris that caused the door system to fail. Occupants are often unaware of residual risks that remain in these otherwise robustly constructed structures and rooms when structures intended to provide protection from tornadoes are not constructed to the FEMA or ICC criteria.

### 9.3.2 Hardened Structures Used as Community Tornado Refuge Areas

The MAT observed several hardened structures used by communities as tornado refuge areas. The hardened structures presented in this section did not meet the FEMA or ICC criteria for safe rooms or storm shelters. Although these structures provided some protection, the occupants were at risk

because of the poor construction of the door assemblies or door latching systems. Unless otherwise noted, the MAT was not able to verify if these hardened structures had been evaluated by design professionals for vulnerabilities to high winds or use as tornado refuge areas.

### 9.3.2.1 Above-Ground Applications

The Town of Amory, MS, was directly struck by the tornadoes of April 25–28, 2011, but its sirens were sounded by their 911 facility and many took refuge in the concrete above-ground structures shown in Figure 9-22. These structures were not in the damage swath of the tornado that struck Amory. It is unknown how many residents occupied these structures during the several days when tornado watches were in effect. Each unit is 13 feet x 13 feet wide and 7.5 feet tall. Although conduit and switch receptacles for lighting were present in the concrete structures when the MAT visited, no wiring or fixtures had been installed. The doors were hollow metal commercial grade with three deadbolts, but it is unknown if they were FEMA-compliant and tested door assemblies. Although the intended use of these structures was clear, the MAT could not verify the design criteria used for these structures and if they were evaluated to any standards or guidelines for tornado protection.



Figure 9-22: Above-ground hardened structures used as community tornado refuge areas. Insets show electrical boxes ready for wiring and fixtures (left) and door assemblies (right) (Amory, MS).



### 9.3.2.2 Below-Ground Applications

In Smithville, MS, a hardened, underground structure (Figure 9-23) was designated as the “community shelter” to be used during tornadoes. The structure reportedly held 10 individuals during the April 27, 2011 tornado event, rated EF3 by the NWS. Although the structure was robust and constructed from reinforced concrete, the doors were inadequate and did not provide the appropriate level of protection. The doors were constructed of two layers of plywood with a thin sheet steel cladding and only one locking point. This structure also had only one vent for fresh air; the vent was damaged by debris during the storm.

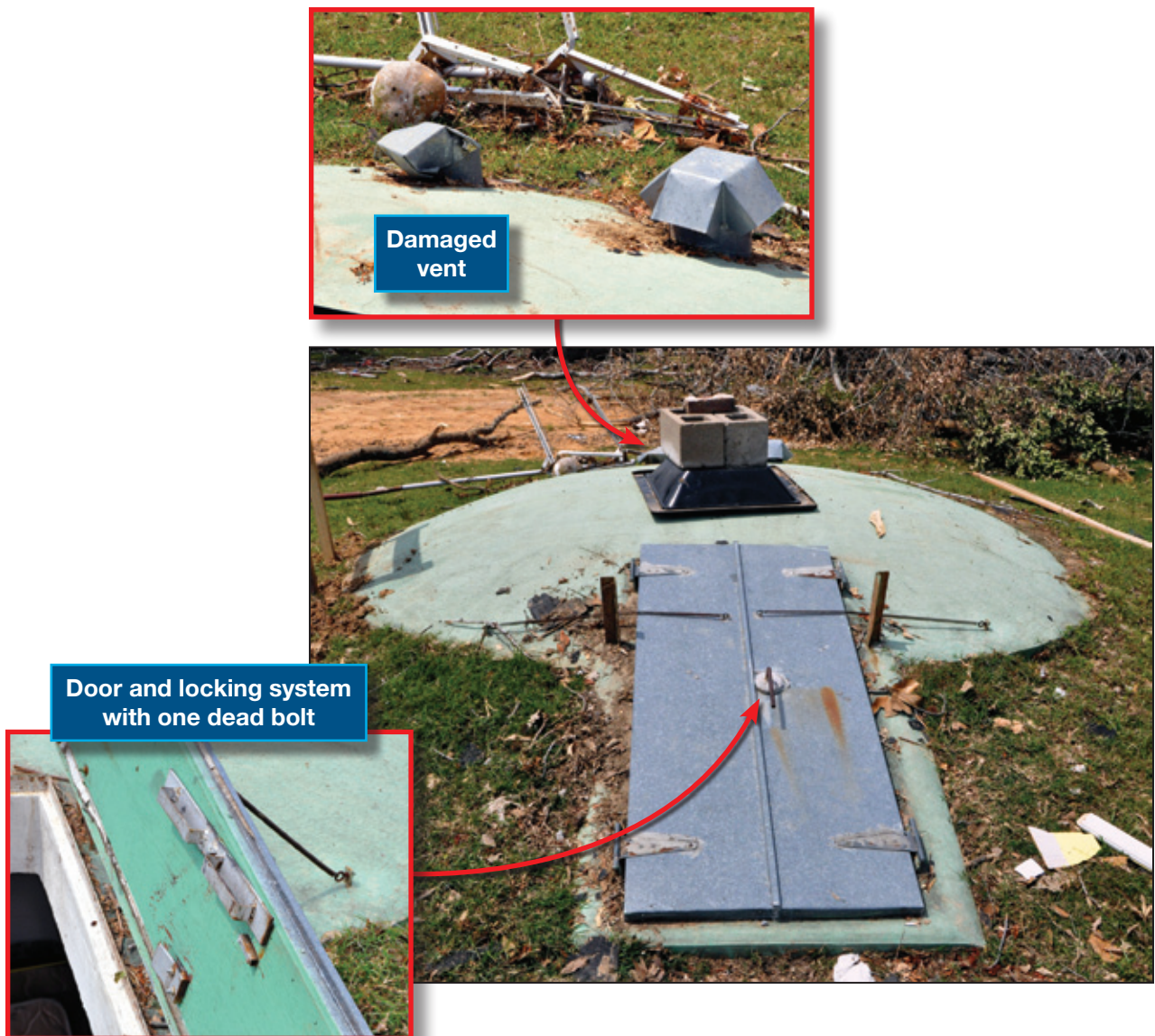

Figure 9-23: Below-ground, hardened structure with poor door and locking system (inset on lower left) and damaged vent (upper inset) (Smithville, MS)

## 9.4 Safe Rooms and Storm Shelters

The MAT observed safe rooms that were compliant with FEMA 320 and FEMA 361 criteria and storm shelters that were compliant with ICC 500 criteria in Alabama and Joplin, MO. Refer to Section 1.2 for a detailed description of the differences between safe rooms and storm shelters.

Safe rooms and storm shelters can be above-ground or below-ground. They can also be site-built or prefabricated structures. The MAT observed all of these types of safe rooms during the field assessments after the April 25–28, 2011 and May 22, 2011 tornadoes.

### 9.4.1 Above- and Below-Ground Alternatives

There are two general types of safe rooms and storm shelters: above-ground and below-ground. Both types were observed during the field observations. Both above-ground and below-ground safe rooms and storm shelters can be stand-alone structures away from the home or building, or they can be rooms or areas in the home, such as a bedroom, a bathroom, or a closet. Wherever it is located, it is specially designed to provide life-safety protection for the people who live in the house or building. Above-ground safe rooms are particularly desirable for those who have a disability or difficulty climbing down into a below-ground area.

Figure 9-24 shows an above-ground safe room that was added to the exterior of an existing home in Tuscaloosa, AL. This home was not in the path of the tornado that struck Tuscaloosa, but the safe room was used by the resident during the storms. The safe room was placed at-grade on the back porch of the home and matched the existing siding and aesthetics of the home. This particular design was chosen because the homeowner's mother had limited mobility and would not be able to access a below-ground safe room in the event of an emergency. This safe room was constructed with FEMA funds.

Figure 9-25 shows an above-ground community storm shelter in Graysville, AL. The structure is adjacent to a church and available for residents of the surrounding area to use in the event of a tornado.

**Figure 9-24:**  
Above-ground safe room  
that matches the aesthetics  
of the home (outside  
Tuscaloosa, AL)





Figure 9-25:  
Above-ground community  
storm shelter (Graysville, AL)

A common safe room design is a stand-alone residential safe room installed below the ground surface outside a house or building. Small stand-alone safe rooms can be constructed to accommodate the occupants of one house, a few houses, or a small apartment building. Building a stand-alone safe room underground can be desirable because it does not take up any additional space within the home or building, and the grade of the surrounding land may lend itself favorably to this design. Figure 9-26 is an example of a below-ground safe room built into the side slope of the back yard of a home in Tuscaloosa, AL. This safe room, constructed in 2008 and funded in part through FEMA grant programs, was placed about 20 feet away from the home and could be reached quickly during a storm. This particular model is large enough to accommodate 10 people comfortably. It is a prefabricated unit, and the door and portions of the safe room that are above ground were tested to show compliance with FEMA 320 criteria. This safe room was occupied during the April 25–28, 2011 tornado outbreak, but this site was not struck by a tornado.



Figure 9-26:  
Below-ground FEMA-  
funded residential safe room  
(Tuscaloosa, AL)

## 9.4.2 Prefabricated versus Site-Built Alternatives

Safe rooms and storm shelters can be prefabricated or site-built, depending on the needs of the owner and the specific site limitations. If constructed correctly to FEMA or ICC criteria, both types can provide life-safety protection. Safe rooms built within existing homes or as part of new construction projects tend to be site-built because there is usually limited access to position a prefabricated safe room or storm shelter. Figure 9-27 is an example of a residential site-built safe room constructed in the master bedroom closet of an existing home in Tuscaloosa, AL, using one of the designs presented in FEMA 320. The above-ground, wood-frame safe room with steel sheathing was used (see Drawing No. AG-06, sheet 11 of 18 [FEMA 1999b]). This safe room was constructed in 2002, funded in part through FEMA grant programs. The safe room was completely contained by the existing structure and very well concealed. The residents of this home used the safe room during the April 25–28, 2011 tornado outbreak, but this site was not struck by a tornado.

The MAT observed many configurations of both above- and below-ground prefabricated safe rooms used during the April 25–28, 2011 and May 22, 2011 tornado outbreaks. Several examples of prefabricated safe rooms (with space for 3 to 12 occupants) are discussed in Sections 9.4.3 and 9.4.4.

**Figure 9-27:**  
Site-built FEMA-funded  
residential safe room  
(Tuscaloosa, AL)



### 9.4.3 Residential Safe Rooms and Storm Shelters

Many residential safe rooms were successfully used during the April 25–28, 2011 and May 22, 2011 tornado outbreaks. All but one of the safe rooms observed were prefabricated units. Homeowners told the MAT they had chosen to install a prefabricated safe room because of the speed of installation and lower cost of the structure. When the safe rooms were constructed as in-home- and garage-installed safe rooms, these alternative locations provided the occupants the most protected access during the tornadoes as they were not required to go outdoors.

#### 9.4.3.1 Below-Ground Applications

In Tuscaloosa, AL, four people survived an EF2 tornado (as rated by the NWS) in the below-ground FEMA-funded safe room shown in Figure 9-28. The grab bar to the right of the safe room was bent by a fallen tree that trapped the family in the safe room until a neighbor cut the tree away from the door. This safe room was installed in 2001 and complies with the FEMA 320 criteria for residential safe rooms in place at the time.

The concrete below-ground safe room shown in Figure 9-29 was in a rural area outside of Smithville, MS, and provided shelter for the occupants of a manufactured home. On April 27, 2011 the homeowner and nine other family members and neighbors, as well as one dog and two cats, took shelter in this FEMA-funded safe room. The shelter had a tested door assembly. Though the area was not struck by the storm, the occupants were comforted and protected by their safe room.

The MAT observed the below-ground garage storm shelter shown in Figure 9-30 in Huntsville, AL. This area of Huntsville was placed under two separate tornado warnings on April 27. The homeowner and his wife retreated to their storm shelter on both occasions. This house was not ultimately affected by the tornadoes, though it sustained damage when a tree fell on it as a result of the strong winds from the storm. Though not a FEMA-funded safe room, the shelter is ICC 500-compliant and



Figure 9-28:  
Below-ground FEMA-  
funded residential safe room  
(Tuscaloosa, AL)

Figure 9-29:  
FEMA-funded residential  
safe room (Smithville, MS)



Figure 9-30:  
Below-ground garage shelter  
(Huntsville, AL)



manufactured by a member of the NSSA. The homeowner, not being an Alabama native, said that he feared “the infamous tornadoes of the southeast” and was intent on having a shelter. He reported that he felt very safe in his new storm shelter.

#### 9.4.3.2 Above-Ground Applications

In the Village of Providence in Huntsville, AL, the MAT found the small and unique above-ground storm shelter shown in Figure 9-31. The shelter was not funded by FEMA, but was ICC 500-compliant and was constructed and installed by an NSSA member company. A husband and wife sought shelter here during both tornado warnings issued on April 27, 2011 for the Huntsville area.

Amidst the massive destruction of the violent tornado that struck Joplin, MO, on May 22, 2011 the MAT discovered the safe room shown in Figure 9-32; its location is shown in Figure 9-33. A family of two walked out of their safe room, only to find their home and their neighborhood totally destroyed. The safe room was anchored to the concrete slab where the garage once stood. The safe room door was locked with multiple locking points and used four hinges. This shelter design was tested at TTU. Installed with no FEMA or Federal funding assistance, the safe room effectively protected the occupants during the historic May 22, 2011 Joplin, MO, EF4 tornado event.



Figure 9-31:  
ICC 500-compliant storm  
shelter (Huntsville, AL)



Figure 9-32:  
Residential safe room that survived the May 22, 2011 Joplin, MO, tornado (rated EF4 based on the MAT's observations). The upper inset shows the inside of the safe room.





Figure 9-33: Proximity of the residential safe room shown in Figure 9-32 (circled in yellow in the inset) to the approximate centerline of the Joplin, MO, tornado damage swath (red line). The safe room was located 0.5 mile west of the heavily damaged St. John's Medical Center (shown by yellow box and described in Section 7.1.4.)

TTU assisted the manufacturer of the in-residence safe room shown in Figure 9-34 in researching and developing its design and performed all the debris impact testing to meet the residential safe room criteria set forth in FEMA 320 and FEMA 361. The home and its safe room were on the periphery of the violent May 22, 2011 Joplin, MO, tornado. The NWS rated the center of the tornado circulation in the vicinity of this home as EF2. The roof structure of the home was lifted up and glazing damage occurred.

#### 9.4.4 Non-Residential and Community Safe Rooms

Similar to residential safe rooms, the MAT observed both site-built and prefabricated non-residential safe rooms. However, for community safe rooms, the prefabricated safe rooms observed all had a maximum occupancy of 100 to 150 people (but often fewer). Larger community safe rooms are typically site-built structures. Steel panels were the predominant materials used in the prefabricated community safe rooms observed by the MAT, while reinforced concrete and reinforced masonry were the predominant materials used in the site-built community safe rooms.

Figure 9-34:  
Residential safe room  
(Joplin, MO)

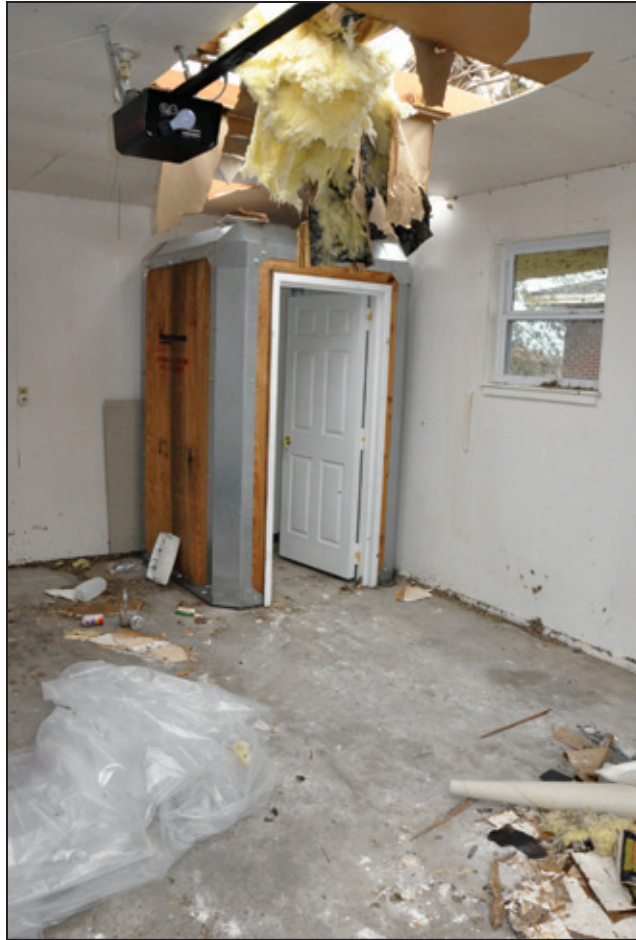

#### 9.4.4.1 Brookwood and Phil Campbell Community Safe Rooms (AL)

The MAT visited three community safe rooms in Alabama. The two above-ground safe rooms were prefabricated structures, while the one below-ground safe room was site-built with reinforced concrete. Although none of these safe rooms was directly hit by a tornado, they each provided safety and comfort to their occupants during the April 25–28, 2011 tornado outbreak.

##### Brookwood, AL

In 2007, in response to past tornado activity in the town, the Town of Brookwood installed an above-ground safe room in its Town Park. Figure 9-35 shows the safe room, which is also promoted on the town Web site. The safe room was used by members of the community for most of the day on April 27, 2011. The town was in the warning areas for the tornadoes that day, but was not directly struck. Because the safe room was in the Town Park, most residents who used the safe room drove there on the day of the event. Town officials stated that the safe room was filled to “standing room only” for a good portion of the day. Power in the town was lost several times during the day, but the safe room was supported by a generator (protected from wind-borne debris by a steel structure) that functioned properly and provided electricity to the safe room. The Brookwood safe room had a restroom for occupant comfort.



Figure 9-35:  
Community safe room with exterior and interior locking mechanism; inset shows the three-point interior locking system (Brookwood, AL)



### Phil Campbell, AL

The community of Phil Campbell, AL, was struck by a violent tornado on April 27, 2011. The NWS rated the center of the tornado circulation for this tornado as EF4. Hundreds of homes were damaged or destroyed, and 27 lives were lost according to a local representative. On top of a hill, away from most of the devastation, was Phil Campbell's FEMA-funded community safe room (Figure 9-36), which housed 60 residents on the day of the storm. The safe room door and panel system was tested in the Debris Impact Test Facility at TTU and meets FEMA 361 debris impact guidelines. The safe room and door is heavy gauge steel and the shelter is partially buried into the hill. An emergency generator (located in the box outside the door of the safe room) supplies electricity for lighting and the mechanical ventilation system. The generator is protected by an impact-resistant enclosure, and the ventilation system is protected from debris impacts with heavy steel shrouds. Figure 9-37 shows the inside of the safe room and the seating arrangement.

The temporary communications tower shown in Figure 9-36 was installed after the tornadoes struck the town. The tower should not be connected to the safe room because the structure was not designed to provide foundation support for guy wires for a communications tower.

Figure 9-36:  
FEMA-funded community  
safe room; guy wires for the  
temporary communications  
tower should not be attached  
to the structure (Phil  
Campbell, AL)



Figure 9-37: Interior of the community safe room shown in Figure 9-36 featuring seating, emergency lighting (green arrows), and ventilation (red arrows); inset is a close-up of the entrance door (Phil Campbell, AL)

#### 9.4.4.2 Brookside Fire Station and Community Safe Room (Brookside, AL)

The MAT visited a below-ground community safe room constructed beneath the Brookside Fire Station in Brookside, AL (Figures 9-38 and 9-39). The safe room was known throughout the community to be at this location and was used by approximately 150 individuals during the April 25–28, 2011 tornado outbreak. Although the town was not struck by a tornado that day, many of the occupants reportedly drove over 5 miles to get to the safe room after watching the day’s events unfold on television.



Figure 9-38:  
A large site-built, below-grade community safe room is housed below this fire station; the red arrow indicates an unprotected generator (Brookside, AL)



Figure 9-39:  
Interior view of the well-furnished community safe room shown in Figure 9-38 (Brookside, AL)

The safe room was constructed in 2008 and funded in part through FEMA grant programs. The fire station and other municipal functions were relocated to this site because of repetitive flooding of the town buildings. The safe room was designed during the fire station design process and is part of the building. It is constructed below grade from reinforced concrete walls with a pre-cast concrete roof deck. The roof deck is the floor system for the fire station offices and dispatch area located above in a non-hardened structure.

There are two entrances to the safe room, one of which has a lift so disabled occupants can access it. The structure can shelter over 300 occupants. The safe room has tools, equipment, bedding, and other support elements in adequate supply for the safe room occupants. Although an emergency generator is on site for backup power, it is not protected from wind-borne debris (red arrow in Figure 9-38). Figure 9-39 shows the interior of the safe room.

#### 9.4.4.3 Seneca Intermediate School (Seneca, MO)

After suffering damage from a tornado in May of 2008, the City of Seneca, MO, built a new Intermediate School (Figure 9-40). Using FEMA HMGP funding, the school designed the cafeteria and gymnasium as a FEMA 361 community safe room (Figures 9-41 and 9-42). This safe room was also constructed to comply with the new ICC 500 storm shelter standard; it was the only safe room visited by the MAT designed to both criteria.

Figure 9-40:  
Seneca Intermediate School  
(Seneca, MO)



Though the community of Seneca, MO, was not hit by a tornado on May 22, 2011 the MAT inspected this new community safe room as a case study of good community safe room construction:

- + The walls are constructed from pre-cast, insulated concrete panels and the roof structure is constructed from precast concrete double tee's (Figure 9-42)
- + All doors are tested FEMA 361 assemblies (Figure 9-43) and the louvers above doors are protected by alcove entries (Figure 9-44)

- + Elevated ventilation units are protected on the outside wall with heavy steel shrouds (Figure 9-45)
- + The generator building was similarly constructed with heavy wall and roof construction, tested doors, and steel shrouds over ventilation openings (Figure 9-46)



Figure 9-41:  
Seneca Intermediate School  
safe room in the cafeteria



Figure 9-42:  
Seneca Intermediate School  
gymnasium safe room



Figure 9-43:  
Doors and ventilation louvers in Seneca Intermediate School community safe room



Figure 9-44:  
Outside doors and louvers (red arrow) protected by alcoves at the Seneca Intermediate School community safe room





Figure 9-45:  
Elevated ventilator in the Seneca  
Intermediate School community safe room.  
Inset shows the exterior shroud.



Figure 9-46:  
Emergency generator  
building for the community  
safe room at the Seneca  
Intermediate School

## 9.5 Travel Time to Community Safe Rooms, Storm Shelters, and Tornado Refuge Areas

To better understand the time and distances that people traveled to these safe rooms, shelters and places of tornado refuge during the storms, the MAT interviewed the owners, operators, and some users of community safe rooms, storm shelters, and other areas used to take refuge from tornadoes (including both hardened structures and best available tornado refuge areas). The MAT interviewed staff at schools and commercial businesses, as well as community safe room operators. This effort was intended to collect data and possible gaps in knowledge that experts in social sciences or behavior analysis may find useful in researching travel time issues and people’s considerations when deciding whether to seek shelter or remain in place.

At the time of publication of this report, FEMA technical and policy guidance on safe rooms states:<sup>5</sup> “The distance from the safe room for the at-risk population is based on a maximum walking travel time of 5 minutes or a maximum driving travel distance of approximately 0.5 mile... whether walking or driving, prospective safe room occupants must be able to safely reach the facility within 5 minutes of receiving a tornado warning or notice to seek shelter.”

This guidance was observed to have been followed at most schools in Mississippi, Alabama, and Missouri visited by the MAT that had safe rooms and best available tornado refuge areas. For all schools discussed in Chapter 6, the tornado refuge areas could be reached by the facility, staff, and students within 5 minutes, and the distances to the safe rooms were ½ mile or less.

The MAT visited several commercial businesses in the tornado warning areas and along the paths of the April 25–28, 2011 tornadoes in Tuscaloosa and Birmingham, AL. Staff at the Hobby Lobby, Lowe’s Home Improvement, and Home Depot stores in Tuscaloosa said that, to the best of their knowledge, the people who took refuge within their facility during the event were either inside or near the store when they decided to take refuge in the buildings. This finding is consistent with the MAT’s discussions with Joplin, MO, business owners and employees after the May 22, 2011 tornado.

Unlike staff of schools and commercial businesses who reported receiving occupants from areas immediately adjacent to their facility, operators of community safe rooms, storm shelters, and tornado refuge areas outside the larger cities reported that many individuals traveled longer distances to seek refuge from the tornadoes. The operators of community safe rooms in Brookside, Brookwood, and Phil Campbell, AL, indicated that occupants reported travelling “miles” and that some had driven to the safe room seeking refuge; no log was kept to record where occupants came from. The operators of hardened structures used during the event in Smithville, MO, and Armory, AL, reported similar information.

While none of the MAT’s findings are conclusive about the risk and vulnerability accepted by individuals that travel to a safe room, storm shelter, or best available tornado refuge area (hardened or not), the variation in the travel patterns and the behaviors reported were not unexpected. However, the MAT is concerned that not all of the observed behavior was the safest reaction to an impending tornado event; specifically, more study is needed to quantify (if possible) how many people drove to

---

5 HMA Unified Guidance, Part IX, Section C.4.1.2, page 111, <http://www.fema.gov/library/viewRecord.do?id=4225>.

a safe room or best available tornado refuge area. Further study is also needed to understand what risks people took, both knowingly and unknowingly, for themselves and their families when they decided to travel great distances within a warning area or along/across a tornado's path, instead of sheltering in place when they became aware of the tornado threat.

## 9.6 Compliance Issues with FEMA 320, FEMA 361, and the ICC 500

The MAT observed a number of well-constructed shelters and safe rooms constructed to FEMA criteria, but only one that was also stated to be constructed to the ICC 500 standard. They also observed a number of safe rooms with compliance issues. In some cases, the safe room was compliant except for a minor element; unfortunately, even a small deviation from the criteria can endanger occupant lives. Consequently, many of the shelters and hardened structures the MAT observed were selected for presentation in this chapter to demonstrate that these structures could be brought into compliance with the FEMA and ICC criteria with only slight modifications.

Note that all the hardened structures the MAT observed were constructed to either the FEMA 320 and FEMA 361 criteria or to unidentified or unknown criteria. The MAT identified only one storm shelter designed to be compliant with the ICC 500 standard; this was the Seneca Intermediate School community safe room in Missouri, which was designed specifically to meet both the FEMA and the ICC criteria (see Section 9.4.4.3). However, as the FEMA and ICC 500 criteria are very similar (and essentially identical for wind and wind-borne debris protection in tornado-prone areas), compliance issues identified in this section are evaluated based on both sets of criteria.

The following section describes ICC 500 and FEMA safe room and storm shelter design and construction elements that were not followed in at least one facility observed by the MAT. The description of each element is followed by a summary of the specific MAT observations related to that element. This information is provided because people may be at risk during a tornado event and unaware of their vulnerability.

### 9.6.1 Identifying Design Criteria Used for Safe Rooms and Storm Shelters

**Compliance Criteria:** Wind pressure design criteria are given by different guides, codes, and standards. The wind pressure criteria specify how strong the safe room must be. The design wind speed is the primary factor in determining the magnitude of wind pressure a building is designed to withstand. FEMA's safe room publications and ICC 500 use the same wind speed hazard maps to recommend design wind speeds ranging from 130 to 255 mph, depending on location. The only exception to this is for residential tornado safe rooms as described in FEMA 361, which requires that residential safe rooms be constructed to resist 250 mph wind speeds. The designs presented in FEMA 320 were designed for the most severe wind and debris condition, those associated with a 250-mph wind speed. Therefore, a safe room designed to the FEMA criteria would be designed to resist tornado (or hurricane) wind speeds in any of the different regions defined by the wind speed hazard maps. This approach was chosen by FEMA to provide a set of designs for home owners and small business that would meet and exceed the design criteria regardless of geographic location. FEMA performed an analysis of costs and materials for each of their prescriptive designs to arrive at this approach. The results did not support development of separate prescriptive designs for each wind speed. These safe room and storm shelter design wind speeds are in contrast to the minimum

required design wind speed of 90 mph for most tornado-prone areas of the country, as stated in the 2009 IRC and the 2009 IBC (codes that establish the minimum requirements for residential and other building construction).

The FEMA 320 safe room designs reflect considerable feedback from stakeholders that pre-engineered prescriptive solutions are highly desirable and simplify the safe room design process. As such, safe room designs in FEMA 320 include easy-to-follow construction plans and specifications.

When designing a safe room, it is also critical to consider wind-borne debris load criteria. The “Tornado Missile Testing Requirements” in FEMA 361 are guidance for missile-resistance requirements for residential and community safe rooms that provide near-absolute protection.

In addition to the safe room’s structural performance requirements, the following operational, maintenance, and human factors must be considered for a successful safe room: electric generator, lighting, emergency provisions, occupancy duration, and more described in FEMA 361 and ICC 500. Each of these items is further elaborated in FEMA 361 and ICC 500. Not all items must be considered for a residential safe room, but they are especially important when designing a community safe room.

**MAT Observation:** Although most community safe room operators and residential safe room owners the MAT visited provided documentation of the design criteria used, the MAT did not observe any posted signs or labels stating the criteria to which the safe rooms were designed in any of the community safe rooms. Only a few of the prefabricated residential safe rooms had a label stating the design criteria or NSSA member compliance.

## 9.6.2 Accessibility to Safe Rooms and Storm Shelters

**Compliance Criteria:** A safe room designer should consider the time needed for occupants of a building to reach the safe room or storm shelter. Safe rooms and storm shelters are only useful if users are able to make it inside safely before a tornado strikes. The following elements should be considered:

- + Safe room users with disabilities may need assistance to access the safe room and may take longer to reach it. Wheel-chair users may require special accommodations along the route to the safe room to reduce the amount of time needed to reach it.
- + Clearly posted signs and labels indicating the purpose of the safe room or storm shelter and its location will make it easier to find.
- + It is essential that the path to the safe room remain clear to allow orderly access to it.
- + Adequate interior dimensions of the safe room and shelter to house the number of users expected. FEMA and ICC both recommend a square foot area per occupant to ensure an appropriate minimum area. The area requirements vary depending on the number of standing and seated occupants and the number of wheel-chair-bound occupants a community safe room can safely hold.

**MAT Observation:** Accessibility requirements were considered in the larger community safe rooms visited by the MAT (Seneca Intermediate School in Missouri and the Brookside, AL, Fire Department community safe room). The Brookside, AL, safe room had a lift to assist disabled or impaired occupants with access to and from the safe room. However, the MAT could not determine whether the smaller Alabama community safe rooms in Phil Campbell, Brookwood, and Graysville had additional space for disabled occupants or whether access for them was considered.

### 9.6.3 Ventilation for Safe Rooms and Storm Shelters

**Compliance Criteria:** Tornado community and residential safe rooms should be ventilated by natural means or mechanical ventilation in accordance with FEMA 361 or ICC 500 for storm shelters. If mechanical ventilation is provided, it must be protected from the wind pressures and wind-borne debris criteria used for the protected space. Further, the ventilation system should be capable of providing the minimum mechanical ventilation rate required by local building code provisions and should also be connected to a backup power system in the event that primary power is lost.

**MAT Observation:** While all the community safe rooms the MAT observed had passive ventilation systems or mechanical ventilation systems, only the Seneca Intermediate School (in Missouri) and the Brookwood and Brookside community safe rooms (in Alabama) were observed to have mechanical systems protected and supported with backup power systems.

### 9.6.4 Toilet Facilities for Community Safe Rooms and Storm Shelters

**Compliance Criteria:** Safe rooms and storm shelters should contain toilets within the protected space. While this is not a design requirement for life-safety protection, this criterion is included to ensure the successful operation and management of safe rooms and storm shelters.

**MAT Observation:** The MAT observed that compliance with providing toilets in the safe rooms varied. The large safe rooms at the Seneca Intermediate School (in Missouri) and in the community safe room in Brookside, AL, had toilet facilities within the protected space. However, no toilets were observed in the smaller Alabama community safe rooms in Graysville.

### 9.6.5 Location and Labeling of Safe Rooms and Storm Shelters

**Compliance Criteria:** Safe rooms and storm shelters should be located such that those intending to seek refuge in the safe room or shelter are not exposed to additional hazards while traveling to or occupying the shelter. Users should be able to safely reach the safe rooms or storm shelter with minimal travel time. Therefore, community safe rooms should be located in a central area such that all designated users can access it quickly. Users should not have to cross obstructions such as creeks, fences, busy roads, or railroad tracks to reach the shelter. Safe rooms and storm shelters should be located outside of floodprone areas. When possible, safe rooms should be located away from structures and objects that could collapse onto it, such as communications towers, roof-mounted equipment, and immediately adjacent multi-story buildings. Similarly, safe rooms should be located such that they avoid nearby electrical transmission or distribution lines that can collapse onto, or very near, the structure. If it is not possible for a safe room to meet any of these criteria, a design and/or operational solution to adequately overcome the shortcoming should be provided.

The MAT recommends local emergency management agencies ***maintain a list of community and residential safe rooms*** to allow them to efficiently locate and check on the safety of the occupants after the storm.

Preferably, every community should have GPS coordinates of the main entrances for all safe rooms in the community. This information will help locate and perform rescue operations after an event, if needed. The presence of debris can

make it impossible for occupants to exit a safe room and difficult for rescue workers to locate. The MAT had difficulty finding some safe rooms located in and amongst the piles of debris on large properties because it did not have the exact coordinates of the main entrance.

Some cities have voluntary storm shelter / safe room registries so that emergency personnel can check on the shelter occupants without being notified.

Safe rooms and storm shelters should be accurately labeled and also identified on posted floor plans. This is especially important for visitors who may not know where the safe room is located or the extent of the protected space within a larger building. Operators of community safe rooms should register their safe rooms with their local emergency management agencies (sometimes it might be police or fire departments) with the exact coordinates of the location of the main entrance of their safe room.

**MAT Observation:** Following the April 25–28, 2011 tornado outbreak, the community of Madison, AL, created such a registry noting the locations of all of safe rooms and storm shelters.

### 9.6.6 Tools and Other Equipment within Safe Rooms and Storm Shelters

**Compliance Criteria:** FEMA guidance on safe rooms recommends that tools, communication devices, and other ancillary equipment be stored within the safe room. This equipment is not intended for life-safety protection, but to support the successful operation of the safe room during a hazard event. Every safe room and storm shelter, both residential and community, should have a supply of tools to help occupants exit the safe room after an event. Since the ICC 500 is an engineering standard, these operational items are not discussed or required for life-safety protection.

**MAT Observation:** Tools were not needed by any of the community safe room occupants to exit after the tornado events because none of the safe rooms observed by the MAT were in structures destroyed by the tornadoes. However, if safe rooms had been located within the numerous damaged businesses visited by the MAT, the occupants would likely have had difficulties exiting the safe rooms since many of the buildings had completely collapsed.

In Tuscaloosa, AL, a family was trapped in their below-ground safe room when a tree fell across the door (see Section 9.4.3.1). The family had to wait for assistance and for the tree to be removed before they could leave the safe room. In another residential safe room in Smithville, MS, the latching mechanism was damaged by debris during the tornado and not operational from inside the safe room. Tools for opening such a damaged locking mechanism were not present in the safe room; storing such tools in a safe room is, however, recommended by in FEMA's guidance documents.

## 9.7 Summary of Conclusions and Recommendations

Table 9-1 provides a summary of the conclusions and recommendations for Chapter 9 and provides section references for supporting observations. Additional commentary on the conclusions and recommendations is presented in Chapters 10 and 11.

**Table 9-1: Summary of Conclusions and Recommendations for Tornado Refuge Area, Hardened Area, and Safe Room Performance**

Observations	Conclusions	Recommendations
<p>ICC 500 and FEMA technical guidance provide similar levels of protection (see Terminology and Examples, Section 9.1)</p>	<p><b>Conclusion #27</b>  <b>Design and construction guidance for storm shelters and safe rooms is consistent, though somewhat different in scope.</b>            FEMA adds different requirements pertaining to using ICC 500 within the context of an emergency management program.</p>	<p><b>Recommendation #12</b>  <b>Continue to coordinate standards and guidance for storm shelters and safe room design.</b></p>
<p>With the exception of the Seneca Intermediate School in Seneca, MO, all of the safe rooms and storm shelters inspected by the MAT, for both residential and community uses, were constructed prior to the publication of the ICC 500. Many of the observed safe rooms and storm shelters were deficient when measured against the ICC 500 standard.</p> <p>Refer to:</p> <ul style="list-style-type: none"> <li>• Hardened structures, rooms, and areas not designed to defined criteria (Section 9.3)</li> <li>• Identifying design criteria used for safe rooms and storm shelters (Section 9.6.1)</li> </ul>	<p><b>Conclusion #7</b>  <b>State of ICC 500 adoption and enforcement.</b>            Many of the observed safe rooms and storm shelters were deficient when measured against the ICC 500 standard.</p>	<p><b>Recommendation #13</b>  <b>Improve performance of safe rooms and storm shelters through code adoption and enforcement.</b></p>
<p>The MAT observed many existing buildings that did not have:</p> <ul style="list-style-type: none"> <li>• a FEMA 361-compliant safe room,</li> <li>• an ICC 500-compliant storm shelter,</li> <li>• a designated evaluated by a design professional to be a best available refuge area, or</li> <li>• a tornado refuge area</li> </ul> <p>Refer to:</p> <ul style="list-style-type: none"> <li>• Terminology and examples (Section 9.1)</li> <li>• Tornado refuge areas in commercial and industrial buildings: Planned tornado refuge areas (Section 9.2.2)</li> </ul>	<p><b>Conclusion #7</b>  <b>State of ICC 500 adoption and enforcement.</b>            Many of the observed safe rooms and storm shelters were deficient when measured against the ICC 500 standard.</p>	<p><b>Recommendation #13</b>  <b>Improve performance of safe rooms and storm shelters through code adoption and enforcement.</b></p>

**Table 9-1: Summary of Conclusions and Recommendations for Tornado Refuge Area, Hardened Area, and Safe Room Performance (continued)**

Observations	Conclusions	Recommendations
<p>Several schools visited by the MAT had designated refuge areas, however, aside from the Seneca Intermediate School, the MAT did not observe any schools with safe rooms constructed to the ICC 500 standard (refer to Section 9.4.4 and 9.2.2).</p>	<p><b>Conclusion #22</b>  <b>2010 Alabama State school tornado safe room requirement.</b>            FEMA supports the State of Alabama Building Commission and Alabama House Bill 459 that requires new school buildings constructed after July 2010 to provide mandatory safe spaces for tornado protection in all K-12 public schools.</p>	<p><b>Recommendation #10</b>  <b>Propose IBC code change.</b>            Refer to Chapter 11 for proposed language for submittal to IBC regarding shelters in schools.</p>
<p>People may travel great distances to get to a community safe room or storm shelter which exceed the ½-mile maximum travel distance advocated in FEMA publications (refer to Section 9.5, Travel time to community safe rooms, storm shelters, and tornado refuge areas)</p>	<p><b>Conclusions #24 and #26</b>  <b>(#24) People traveled excessive distances to community shelters and safe rooms.</b>  <b>(#26) Guidance for identifying how to provide community-wide protection is lacking.</b> There is a lack of guidance as to how far people can and should travel safely to access a safe room or storm shelter.</p>	<p><b>Recommendations #34 and #35</b>  <b>(#34) Research travel time to, and use of, safe rooms and storm shelters.</b>  <b>(#35) Locate safe rooms or storm shelters close to people who will use them.</b></p>
<p>The MAT observed areas within exiting non-residential buildings labeled as “tornado shelters.” However, these areas were not designed and constructed in compliance with FEMA 320/361 or ICC 500 to provide a clear level of protection from tornadoes. While it may result from a lack of understanding of the terminology used in safe room guidance such as FEMA 320/361 and ICC 500, such mislabeling may mislead and endanger potential occupants during a tornado event.</p> <p>Refer to:</p> <ul style="list-style-type: none"> <li>• Terminology and examples (Section 9.1)</li> <li>• Location and labeling of safe rooms and storm shelters (Section 9.6.5)</li> </ul>	<p><b>Conclusions #8 and #28</b>  <b>(#8 and #28) There is a lack of proper labeling and signage.</b> There is a lack of proper labeling and signage for the areas where people seek to take cover from tornadoes.</p>	<p><b>Recommendation #14</b>  <b>Submit proposed IBC code change.</b>            Refer to Chapter 11 for proposed language for submittal to IBC regarding identification of best available refuge areas.</p>



**Table 9-1: Summary of Conclusions and Recommendations for Tornado Refuge Area, Hardened Area, and Safe Room Performance (continued)**

Observations	Conclusions	Recommendations
<p>The MAT observed lack of best available refuge areas sited in buildings:</p> <ul style="list-style-type: none"> <li>• Terminology and examples (Section 9.1)</li> <li>• Location and labeling of safe rooms and storm shelters (Section 9.6.5)</li> <li>• Tornado refuge areas (Section 9.2)</li> <li>• Identifying design criteria used for safe rooms and storm shelters (Section 9.6.1)</li> </ul>	<p><b>Conclusions #25, #26, and #8 and #28</b></p> <p><b>(#25) There is a poor understanding of public actions/movement patterns during tornadoes.</b> Public actions/movement patterns during the April 27 tornadoes and the Joplin tornado are not understood.</p> <p><b>(#26) Guidance for identifying how to provide community-wide protection is lacking.</b> Guidance is needed to help public to select a large, community safe room vs. one of the many smaller, dispersed safe rooms across a community</p> <p><b>(#8) and (#28)</b></p> <p><b>There is a lack of proper labeling and signage.</b></p>	<p><b>Recommendations #36 and #34</b></p> <p><b>(#36) Identify best available refuge areas.</b></p> <p><b>(#34) Research travel time to, and use of, safe rooms and storm shelters.</b></p>
<p>Tornado refuge areas in large, single-story commercial buildings and retail buildings did not perform well (see Section 9.2.2).</p>	<p><b>Conclusion #37</b></p> <p><b>Tornado refuge areas located in large, single-story buildings performed poorly.</b></p> <p>Tornado refuge areas located in large, single-story buildings did not perform well</p>	<p><b>Recommendations #36 and #37</b></p> <p><b>(#36) Identify best available refuge areas.</b></p> <p><b>(#37) Perform vulnerability assessments.</b></p>
<p>Almost none of the residential safe rooms and storm shelters observed by the MAT in the five affected States were registered or listed with local emergency management agencies or police/fire departments. Furthermore, the MAT had difficulty locating FEMA-funded safe room even when latitudes and longitudes were provided (see Section 9.6.5).</p>	<p><b>Conclusions #29 and #31</b></p> <p><b>(#29) There were unregistered safe rooms.</b></p> <p><b>(#31) Some safe rooms were difficult to locate with given coordinates.</b></p>	<p><b>Recommendation #38</b></p> <p><b>Register safe rooms.</b></p>

**Table 9-1: Summary of Conclusions and Recommendations for Tornado Refuge Area, Hardened Area, and Safe Room Performance (concluded)**

Observations	Conclusions	Recommendations
<p>Many safe room owners did not coordinate with their local government, so first responders did not necessarily know the locations of private and individual safe rooms and storm shelters. Also, few community safe rooms were equipped with alternate communication systems as recommended in FEMA 361 (see Sections 9.6.5 and 9.6.6).</p>	<p><b>Conclusions #36, #39, and #30</b></p> <p><b>(#36) Safe room locations were not documented and occupants had no ability to communicate from within.</b> In many locations, first responders did not know the locations of private and individual safe rooms and storm shelters. This is a concern because safe rooms can be hidden beneath debris and difficult to locate after a storm, and occupants may have no means of communication with first responders.</p> <p><b>(#39) There was a lack of alternate means of communication in community safe rooms.</b></p> <p><b>(#30) Safe rooms and storm shelters lacked tools to open or dismantle door if blocked.</b> Most safe rooms and storm shelters did not have tools available should the doors and egress routes become damaged, inoperable, or blocked by debris.</p>	<p><b>Recommendations #39 and #40</b></p> <p><b>(#39) Equip safe rooms, storm shelters, and best available refuge areas with tools to assist occupants when doors and egress routes become damaged, inoperable, or blocked by debris.</b></p> <p><b>(#40) Equip safe rooms, storm shelters, and best available refuge areas with an alternate means of communication.</b></p>
<p>Evidence of technical inadequacies and public misconceptions regarding tornado safe rooms and storm shelters.</p> <p>Refer to:</p> <ul style="list-style-type: none"> <li>• Above-ground applications (Sections 9.3.1.2, 9.3.2.1, 9.4.1, 9.4.3.2)</li> <li>• Ventilation for safe rooms and storm shelters (Section 9.6.3)</li> <li>• Terminology and examples (Section 9.1)</li> <li>• Location and labeling of safe rooms and storm shelters (Section 9.6.5)</li> <li>• Hardened areas: areas designed to provide some protection (Section 9.1.1)</li> <li>• Tornado refuge areas in residences (Section 9.2.1)</li> <li>• Hardened structures, rooms, and areas not designed to defined criteria (Section 9.3)</li> <li>• Safe rooms and storm shelters (Section 9.4)</li> </ul>	<p><b>Conclusions #23, #8 and #28, #32, #33, #34, #35, and #38</b></p> <p><b>(#23) Above-ground safe rooms performed as well as those below ground.</b> The public has misconceptions that above-ground safe rooms are not as safe as below-ground safe rooms.</p> <p><b>(#8) and (#28) There was a lack of proper labeling and signage.</b></p> <p><b>(#32) Safe room door quality observed was often inadequate.</b></p> <p><b>(#33) Safe room door hardware observed was often inadequate.</b></p> <p><b>(#34) There was a lack of adequate ventilation in shelters.</b></p> <p><b>(#35) Safe rooms were observed that had inadequate or no anchoring.</b></p> <p><b>(#38) There was inadequate doors and door hardware on safe rooms/ storm shelters.</b></p>	<p><b>Recommendation #41</b></p> <p><b>Provide training.</b></p>



# TORNADO OUTBREAK *of* **2011**

IN ALABAMA, GEORGIA, MISSISSIPPI,  
TENNESSEE, AND MISSOURI

# 10 Conclusions of the 2011 Tornado MAT

*The conclusions in this report are based on the MAT's damage observations and assessments, an evaluation of relevant codes and regulations, and meetings with Federal, State, and local officials and other interested parties.*

Discussions with subject matter experts, State emergency management agencies from the five affected States, the Alabama Safer Schools Initiative, and local government representatives in the areas hit by the tornadoes were essential in verifying data observed in the field to prepare these conclusions. The conclusions of this report, upon which the recommendations in Chapter 11 are based, are intended to assist States, communities, businesses, and individuals who are recovering and rebuilding from the tornadoes by providing insight into protection of life and property.

## 10.1 Codes and Standards

This section summarizes the MAT's conclusions related to the effectiveness of model building codes and standards based on performance assessments of residential buildings, commercial and industrial buildings, critical facilities, infrastructure, and safe rooms and storm shelters damaged during the spring 2011 tornado outbreak.

The adoption and enforcement of a building code results in safer buildings and improved chances of survival should a tornado strike in the future. It is important to note that building code adoption will not prevent damage to buildings when strong tornadoes strike unless that building had extremely high wind design concepts applied. However, adopting and enforcing building codes and standards demonstrates the community's commitment to improving the quality of design and construction of structures and its belief that citizens' investment in their homes and businesses is important to protect.

### 10.1.1 Residential Buildings

**Conclusion #1 – Failure to adopt a current version of code or having no uniform code leaves residential buildings vulnerable to wind damage:** Much of the residential damage occurred in municipalities that had either no adopted building code (Hackleburg, AL) or outdated codes (Harvest, AL [2003 IRC] and Phil Campbell, AL [1998 SBC]) at the time of the tornado strikes. **At the time of publication of this report, current codes are the 2012 or 2009 IRC.** As of the publication of this report, Alabama and Missouri do not require individual communities to adopt a uniform residential building code. Three of the 17 Alabama communities the MAT visited had no residential building code whatsoever, and five others reported local adoption of residential building codes that predated the 2009 IRC. Adopting and enforcing any model building code is better than none, but as a rule, the more recent the code, the better. Since its introduction in 2000, the IRC has continuously improved its load path provisions, as demonstrated by the expanded wall bracing section in 2006, and has continued to evolve in subsequent editions.

While adopting the most recent version of the IRC does not affect existing building stock (unless building additions are considered), it does establish a benchmark for new construction. Furthermore, adopting model building codes at a statewide level protects individual communities that are unable to adopt newer building codes through their own community processes. In their 2012 report, *Cultivating a State of Readiness*, the Tornado Recovery Action Council of Alabama encourages the adoption of a statewide building code to save lives, increase cooperation between agencies, improve delivery of services, and reduce the negative economic impacts of future storms.

The newly published 2012 IRC contains enhanced provisions for mitigating wind damage for basic 90 mph (3-second gust) wind speed zones, including increased wall bottom plate-to-stud connections and new tables for rafter and roof truss-to-wall uplift resistance requirements, both of which improve a structure's resistance to wind forces by enhancing the continuous load path. Table 802.11 in the 2012 IRC provides prescriptive values for both low- and high-sloped roofs in wind Exposure Categories B and C.

**Conclusion #2 – Failure to adhere to the structural provisions of the model building code as written can result in buildings that are vulnerable to structural damage:** Buildings are made more

vulnerable to damage when local communities weaken the structural provisions of the adopted model building code with amendments or do not rigorously enforce the structural provisions of adopted code. Allowing the continuous load path of a building to be compromised—either in the form of amendments or through enforcement practices—increases the likelihood of structural failure when buildings are exposed to high winds.

An example of non-rigorous enforcement of structural provisions would be allowing bottom wall plates to be attached with concrete nails or cut nails instead of IRC-specified anchor bolts. One reason concrete nails are used to anchor the bottom plate is because they are much easier to use than anchor bolts. Use of anchor bolts requires more planning than concrete nails because anchor bolts have to be embedded in the foundation before the framing is erected. However, concrete nails provide significantly less resistance to uplift and lateral forces than 0.5-inch-diameter anchor bolts with 7 inches of minimum embedment spaced a maximum of 6 feet on-center, as required by code, and therefore the substitution of concrete nails for anchor bolts significantly weakens the connection of the exterior framed wall to the foundation.

Failure of the connection between the wall bottom plate and foundation was observed in newly constructed residential buildings in Alabama, where concrete nails were used for bottom plate attachment (refer to Figure 4-30). Follow-up analysis revealed that the City of Tuscaloosa allows the use of concrete nails for attaching the bottom plate to foundations in lieu of using anchor bolts as required by the IRC. The City of Tuscaloosa continued to permit bottom plates to be nailed to foundations even after the April 2011 tornadoes (Figure 10-1).

The MAT also observed new residential construction in Jefferson County, AL, that was non-code-compliant in the connection of the framed wall plate to the foundation (Figure 10-2).



Figure 10-1: Concrete nails (red circles in left photograph) used in lieu of anchor bolts (absent in both photographs) on residential buildings under construction in the City of Tuscaloosa, AL, after the 2011 tornadoes

Figure 10-2:  
Lack of anchor bolts on recently constructed slab foundation in Jefferson County, AL. Note that an anchor bolt is installed at the corner, but cut nails are installed elsewhere.



## 10.1.2 Commercial and Industrial Buildings

**Conclusion #3 – Wind provisions of the current codes and standards are insufficient to manage building performance in overload events:** The MAT observed numerous instances of failure that occurred when various levels of overload were experienced by the structure. With the exception of storm shelter design and construction per ICC 500, the wind load provisions of the code do not address tornadic events. The ASCE commentary to the wind load provisions speak to the limitations of the wind provisions with respect to tornadoes, but this language is not clear.

## 10.1.3 Critical Facilities

**Conclusion #4 – IBC-compliant facilities can be susceptible to building damage:** Buildings built to the current IBC are still susceptible to significant building damage and disruption if struck by strong or violent tornadoes, as evidenced by the damage sustained by Joplin East Middle School (see Section 6.1.4).

**Conclusion #5 – Many of the critical facilities observed lacked safe rooms and/or storm shelters:** The MAT visited 41 critical facilities located in the path of tornado tracks or track peripheries. None of these facilities had an area designed as a FEMA 361 tornado safe room or an ICC 500 shelter.<sup>1</sup>

<sup>1</sup> Unless otherwise specified, this chapter references the 2008 versions of FEMA 320, FEMA 361, and ICC 500.

First responders typically stay in their buildings to facilitate post-disaster community response and are at risk when there are no safe areas to go to during tornadoes (see Section 7.2).

### 10.1.4 Infrastructure Facilities

**Conclusion #6 – Wind-displaced materials affected communications towers:** The MAT observed that wind-displaced materials can collect on communications towers and increase the wind loads on those towers. Chapter 8 describes how latticed free-standing towers are vulnerable to the effects of wind-displaced materials that increase the tower’s exposure to wind by adhering to the tower surface. Two cases are summarized where those increased loads likely contributed to observed tower collapse.

Section 2.6.9.1 of ANSI/TIA-222-G *Structural Standard for Antenna Supporting Structures and Antennas* (2009) uses Effective Projected Area (EPA) method to determine wind loads. With the EPA method, the sum of the areas of antennae and their supporting structures that are perpendicular to the wind direction is totaled. The total projected area is first scaled by a drag coefficient. Next, the drag coefficient, the EPA, and the design wind speed are used to determine wind loads on the tower and its components. When wind-displaced materials adhere to a latticed tower, the tower’s EPA increases, and wind loads on the tower also increase. Presently, ANSI/TIA-222-G does not address the increase in EPA and wind loads from wind-displaced materials that adhere to latticed structures. There is no guidance in ASCE 7-10 in either the standard or the commentary that deals with the issue of increased loads caused by wind-displaced materials.

### 10.1.5 Tornado Refuge Areas, Hardened Areas, and Safe Rooms

**Conclusion #7 – State of ICC 500 adoption and enforcement:** With the exception of the Seneca Intermediate School in Seneca, MO, all of the safe rooms and storm shelters inspected by the MAT, for both residential and community uses, were constructed prior to the publication of the ICC 500. Many of the observed safe rooms and storm shelters were deficient when measured against the ICC 500 standard. Sections 10.6.2 and 10.6.3 describe some of the more common inadequacies in greater detail. Communities can improve the quality of new safe rooms and storm shelters by adopting and enforcing ICC 500 by itself or through the provisions of the 2009 or 2012 I-Codes. Those editions of the IBC (Section 423) and IRC (Section 323) require that “in addition to other applicable requirements in [the] code, storm shelters shall be constructed in accordance with the ICC/NSSA-500.”

**Conclusion #8 – There is a lack of proper labeling and signage:** The MAT observed areas within existing non-residential buildings labeled as “tornado shelters.” However, these areas were not designed and constructed in compliance with FEMA 320/361 or ICC 500 to provide a clear level of protection from tornadoes. While it may result from a lack of understanding of the terminology used in safe room guidance such as FEMA 320/361 and ICC 500, such mislabeling may mislead and endanger potential occupants during a tornado event.

## 10.2 Performance of Residential Buildings

The MAT inspected various degrees of damage to residential buildings. The primary difference between whether a building suffered only minor damage, such as loss of siding or shingles, or total destruction, such as a slab swept clean, was tornado strength and location of the building with respect to the storm swath. Simply put, greater wind pressures led to greater damage. An illustration of this difference is described in Sections 4.2.1 and 4.2.3 using the contrast in damage between Chastain Manor Apartments (Tuscaloosa, AL) and Mercy Village Apartments (Joplin, MO).

While these factors, as well as variables related to building code adoption and enforcement, and construction materials and methods, directly influence building performance, they are often beyond the control of individual homeowners. The best means of providing life-safety protection for building occupants is to have quick-response access to a safe room compliant with FEMA 361 or a storm shelter compliant with ICC 500 (see Section 10.6).

### Implementing and enforcing current codes and standards resulted in enhanced building performance

in several locations, one such being Mercy Village Apartments in Joplin, MO (described in Section 4.2.3). The level of detailing and engineering incorporated into the construction of the apartment building contributed to its enhanced performance under tornado-force winds.

The load paths and structural systems used in the construction of the Mercy Village project allowed the transfer of the high wind loads to the foundations. The building suffered damage, but the structural integrity of the gravity systems remained stable and protected the building inhabitants.

**Conclusion #9 – Voluntary implementation of better design and construction practices could mitigate damage:** The MAT did not observe many instances of enhanced wind-resistant construction in the residences damaged by the tornadoes. As stated in Chapter 4, according to NOAA tornado statistics from 1950 to 2006, almost 95 percent of all recorded tornadoes were EF2 or less. Some of the damage observed by the MAT resulted primarily from tornadoes rated as EF2 or less or to buildings located in the periphery of a more severe event. This damage can be mitigated through voluntary implementation of recommended best practices for wind-resistant construction.

The design wind speed in the current model building codes for all areas the MAT observed is 90 mph. Since model building code minimum requirements for continuous load path connections increase with design wind speeds, designing buildings to withstand higher wind loads will increase their resistance to wind damage. While it is neither economical nor practical to construct an entire home that is resistant to tornadoes of all strengths, improved design and construction and implementation of details and techniques that are already required in coastal high-wind regions will significantly reduce property damage caused by tornadoes rated EF2 or less (i.e., estimated wind speeds of 135 mph or less). An example of such improved building performance was observed after Hurricane Katrina, where the MAT noted that buildings designed and constructed to resist wind loads greater than 90 mph, as prescribed in ASCE 7 and the I-codes for coastal areas, performed better than the general building stock (FEMA 2006).



The following conclusions focus on the types of residential building damage observed by the MAT that could be mitigated if enhanced wind design and construction practices already used in hurricane-prone regions are voluntarily applied to tornado-prone regions with lower model building code design wind speeds. These types of damage included:

- + *Loss of Roof and Wall Covering*: Roof and wall covering blown away by high winds and uplift forces became wind-borne debris that endangered surrounding buildings and their occupants as shown in Figure 4-1. Buildings that suffered roof covering loss were often further damaged by water intrusion.
- + *Component Damage*: Component damage, whether shattered glazing or collapsed garage doors, often led to other structural and non-structural damage because of increased pressurization and water intrusion that followed breaching of the building envelope (Figures 4-9 and 4-10). Unprotected glazing and wide garage doors (16 or 18 feet wide) were particularly vulnerable (Figures 4-7 and 4-8), as was expected from previous MAT assessments.
- + *Uplift of Roof Decking*: Loss of roof decking often appeared to be triggered by increased pressurization resulting from damaged soffits and gable end walls (Figures 4-13 and 4-16). Poor fastening of roof decking to the roof structure also appeared to play a role in the loss of roof decking as shown in Figure 4-15.
- + *Loss of Roof Structure*: The weak link most often identified as responsible for loss of roof structure was the roof-to-wall connection (Figures 4-18 through 4-22).
- + *Wall Collapse*: Wall collapse was observed to result from failed attachment of floor and ceiling systems to walls (Figures 4-23 and 4-24) and inadequate bracing of framed walls (Figures 4-25 and 4-26).
- + *Failure of Wall Bottom Plate Attachment*: Foundations typically performed adequately, but in some instances the connection of walls to the foundation system failed because of inadequate connection of the bottom plate, as shown in Figures 4-27 through 4-31.

### 10.3 Performance of Commercial and Industrial Buildings

The MAT noted that, during the tornado events, people came from other locations to take refuge in commercial buildings because they perceived them to be safer than other types of buildings. However, in many cases, this perception was unfounded and misguided. Although multi-story framed structures did not experience disproportionate damage or collapse (although there was significant glazing damage), single-story commercial buildings did; the MAT inspected many failures of such buildings. Further, not all building owners and operators understood that commercial structures may not be safe in certain environmental or climatic conditions, such as during violent weather. The MAT's conclusions on communications and operations, as well as building performance as a function of design, are presented in the section that follows.

Refer to Section 10.1.3 (Codes and Standards: Critical Facilities) for conclusions on the susceptibility of IBC-compliant critical facilities.

### 10.3.1 Communications and Operations

**Conclusion #10 – There was inadequate signage in commercial buildings:** In an effort to increase survivability and lower injury and loss of life, building users and occupants need a better understanding of a building’s design capacity and limits through adequate signage. Increased awareness of relevant building design parameters such as importance factor, design wind speed, ground snow load, seismic criteria, rain fall intensity criteria, and other relevant information will help individuals decide where to take refuge and the attendant risks.

**Conclusion #11 – Emergency operations flip charts can aid in decision making:** According to management personnel the MAT interviewed at a Lowes in Tuscaloosa, AL, flip charts helped the response of the store operators during the high stress and confusion of the tornadoes event by providing emergency protocols. Use of a preplanned strategy helps manage the people instead of having to make decisions about issues that they are not trained or educated in, specifically building performance. The use of a tool such as a flip chart allows the store operator to rely on the best information available while leaving the issues of engineering and risk analysis to people with those skill sets.

### 10.3.2 Building Performance/Building Design

**Conclusion #12 – URM performed poorly as primary support:** Buildings that used unreinforced masonry in the exterior walls and primary load carrying system did not perform well (see Figure 5-18). Unreinforced masonry should not be used in any primary load support system or any critical area of a building used for the protection of people.

**Conclusion #13 – Connections between primary structural members were often the initial point of failure:** The MAT noted that the connections between primary structural members on many buildings were the initial point of failure of the structural systems (see Figure 5-6 and Figure 5-8). Puddle welds that attached the roof deck to the joists were found to have inconsistent performance. This is consistent with past findings of roof deck connection performance in high-wind events.

Additionally, the performance of the primary structural member connections could be improved to be more robust and ductile. It is neither difficult nor expensive to increase the design load capacity of these connections. However, it is sometimes more involved to properly construct and inspect the connections.

**Conclusion #14 – Lack of redundant stability systems or non-discrete structural systems contributed to progressive collapse:** The MAT inspected several one- and two-story, large-footprint commercial structures with long-span roofs that suffered catastrophic failure when smaller portions of the structure were progressively overloaded and failed. These smaller local failures then progressed to larger areas of failure that then led to entire building collapse. Buildings with non-redundant structural systems that served multiple functions (such as weather barrier and stability) did not perform well. Such failures were observed in several locations in Alabama and Missouri. Per ASCE 7, buildings should be designed to not experience disproportionate collapse.

## 10.4 Performance of Critical Facility Buildings

The MAT visited a total of 41 critical facilities in the path of tornado tracks or track periphery areas across five States. The tornadoes in April and May of 2011 significantly affected many critical facilities, totally destroying some of them and severely interrupting the operations of several others. Critical facilities such as schools, healthcare facilities, police and fire stations, and EOCs are vitally important to communities that have been struck by tornadoes. Functional schools are needed for educational continuity and they are often used as space for recovery operations. Functional hospitals and other healthcare facilities are needed to treat injuries and provide routine ongoing care to the community. Functional police and fire stations and EOCs are needed to manage their normal mission, along with response and recovery operations after an event.

**Conclusion #15 – Glazing is susceptible to damage:** Damage to critical facilities constructed since the adoption of the IBC is still possible because of wind-borne debris that damages the glazing and building envelope. Although the design wind speed for IBC-compliant facilities in the areas visited by the MAT is greater than EF0 speeds and only slightly below upper EF1 speeds, such facilities were observed to be susceptible to extensive glazing damage (as illustrated by Figures 6-26 and 10-3)<sup>2</sup> and facility disruption due to wind-borne debris generated by the weaker tornadoes. IBC design wind speeds and glazing requirements only apply to the wind-borne debris regions in hurricane-prone areas along the Nation’s coastlines.

Figure 10-3 shows a police station in Tuscaloosa, AL (see Figure 7-1 for location) that experienced roof covering damage and extensive glazing damage. Most of the exterior windows were impacted by wind-borne debris (primarily aggregate from a built-up roof). The debris chipped and cracked the glazing, as shown in the Figure 10-3 inset, but because the glazing was bullet resistant, the glazing remained in the frame. Figure 10-3 shows plywood (red arrows) placed over the damaged glazing.

**Conclusion #16 – Older facilities were susceptible to damage from weak tornadoes:** The MAT observed older critical facilities with significant wind-resistance vulnerabilities.<sup>3</sup> Unless mitigated, older facilities are susceptible to considerable building damage and disruption of facility operations if struck by even weak tornadoes. Ringgold High School and Ringgold Middle School (see Section 6.1.3), Webster’s Chapel Volunteer Fire Department (see Section 7.2.3), and the Smithville Police Department (see Section 7.3.4) are all examples of older critical facilities that demonstrated significant wind-resistance vulnerabilities when struck by weak tornadoes.

**Conclusion #17 – There was a lack of adequate signage directing occupants to refuge areas:** The MAT noted many critical facilities with no signage directing occupants to refuge areas in the building. The MAT observed some critical facilities that had tornado refuge areas identified by signs. In some instances, the signage indicated the refuge area was a “shelter” even though the area had not been designed as a FEMA 361 safe room or an ICC 500 storm shelter. Joplin East Middle School (see Section 6.1.4), the Fulondale Municipal Complex’s Library and “Shelter” (see Section 7.2.1), as well as the Tuscaloosa EOC (see Section 7.3.1) all had signage that indicated the marked

<sup>2</sup> Although the facilities shown in Figures 6-27 and 10-3 were constructed prior to the publication of the IBC, the exterior glazing in IBC-compliant buildings is no more resistant to wind-borne debris than the glazing in older buildings in locations where the basic wind speed is 90 mph.

<sup>3</sup> Older facilities are those for which codes, standards, design, and construction practices did not adequately address non-tornadic wind resistance.



**MAT EF Rating:** Using DI 9 (Small Professional Building), the MAT selected DOD 3 (“broken windows, including clear story windows or skylights”) for the Tuscaloosa, AL, police station.<sup>1</sup> Using the expected wind speed for DOD 3, the MAT derived the tornado rating as EF1 (86–110 mph) based on the damage to this building. Hence, the estimated wind speed experienced by the building was not substantially above the current basic wind speed of 90 mph.



1. There is no DI for police stations. The type of construction listed for DI 9 is applicable to this facility.

Figure 10-3: Red arrows show plywood placed over damaged glazing at this police station; inset shows chipped glazing and illustrates the quantity of wind-blown roof aggregate that struck the facility. Because of the building damage, a mobile command vehicle (yellow arrow) was brought to the site (Tuscaloosa, AL).

refuge area was a “shelter.” However, none of these refuge areas had been designed as a FEMA 361 safe room or an ICC 500 storm shelter.

**Conclusion #18 – There was a lack of safe rooms and storm shelters in critical facilities:** The MAT inspected 41 critical facilities in tornado tracks or along the track periphery. None of these facilities had an area designed as a FEMA 361 tornado safe room or an ICC 500 storm shelter. First responders typically stay in their buildings to facilitate post-disaster community response and are at risk when there are no safe areas to go to during tornadoes (see Section 7.2).

## 10.5 Performance of Infrastructure Facilities

The tornadoes not only damaged buildings, but also disrupted community infrastructure. The MAT inspected damage to public utilities, including water distribution systems, waste water treatment plants, and communications towers.

**Conclusion #19 – Lost utility power caused loss of system function:** The MAT noted that when water treatment and distribution systems relied exclusively on utility power, the systems failed when utility power was lost. When tornadoes destroyed portions of the electrical utilities' distribution systems, the reliance of the systems on utility power to operate lift pumps to fill storage tanks or booster pumps to increase water distribution pressures resulted in the tanks draining and the loss of system pressure. Both the Tuscaloosa Water Works in Alabama (Section 8.1.1) and the Smithville, MS, water treatment and distribution system (Section 8.1.2) were affected in this manner.

**Facilities with sufficient back-up power supply remained functional.**

The Tuscaloosa Waste Water Treatment Plant (Section 8.2.1) was able to continue operations after the tornado in the region knocked out its local power source. The facility was equipped with enough emergency generators to sustain enough of the lift stations to prevent overflow or discharge of untreated effluent.

**Conclusion #20 – Guy anchors failed when struck by wind-displaced materials:** The MAT inspected the failure of guy anchors when wind-displaced materials struck the guy wires of a guyed communications tower, resulting in tower collapse. With guyed structures, all anchors must function to make the tower structurally stable. The lack of structural redundancy inherent in guyed towers makes them particularly vulnerable to collapse when one or more guys or their anchors fail. The 300-foot guyed cellular tower in Smithville, MS experienced that mode of failure (Section 8.3.2.1).

**Conclusion #21 – Wind-displaced materials affected tower performance:** There were numerous examples of how wind-displaced materials can increase loads on communications towers. Wind-displaced materials were observed to have adhered to latticed free-standing towers. Once adhered, the wind-displaced materials increased the area of the latticed towers exposed to wind loads and increased the total wind forces on the towers themselves. While insufficient data were available to confirm that the wind-displaced materials *caused* tower collapse, wind-displaced material increased wind loads on the tower and likely *contributed* to tower collapse. Examples include:

**Solid free-standing cell towers survived**

the event that destroyed guyed and latticed cell towers. One such tower, discussed in Section 8.3.1.3, did not collapse even though it was located near the center of the tornado track, where maximum winds generally occur.

- +A 250-foot EMS communications tower in Tuscaloosa, AL (Section 8.3.1.1) that collapsed during the tornado had wind-displaced materials adhered to the latticed tower. Collapse of the EMS tower disrupted communications and impeded response and recovery in the Tuscaloosa County.
- +A 300-foot free-standing cellular tower in Tuscaloosa, AL (Section 8.3.1.2) also collapsed. While there were no wind-displaced materials noted that were physically adhered to the fallen latticed tower, there were large amounts of debris surrounding the tower. This suggests that some wind-displaced materials may have struck the tower but were dislodged after the tower fell.

Solid free-standing towers are less affected by wind-displaced materials than other types of towers since their entire surface is already exposed to wind pressures and therefore the wind loads are not increased even when materials adhere to the towers. Solid towers are less vulnerable to wind-displaced materials since ANSI/TIA-222-G requires solid free-standing cell towers to be designed to resist higher wind loads (due to greater EPAs) than latticed towers. Also, since they are free-standing, solid towers do not rely on vulnerable guys and anchors for structural stability.

The few numbers of cellular towers assessed prevent the MAT from drawing definitive conclusions about tower performance. However, based on the fact that solid cellular towers must be designed with near-maximum EPAs and do not rely on guys for support, properly designed solid cellular towers should perform better than latticed or guyed towers during wind events that create high winds and wind-displaced materials.

## 10.6 Performance of Tornado Refuge Areas, Hardened Areas, and Safe Rooms

The MAT observed several community safe rooms and storm shelters constructed to criteria that have been in place since 2000, but only one that had been constructed since the release of the 2008 safe room and storm shelter guidance. Numerous residential safe rooms and storm shelters throughout the areas were impacted by the tornadoes. More can be done to promote the design and construction of safe rooms and storm shelters in all building types and uses to provide life-safety protection during tornadoes.

Refer also to Sections 10.3 (Commercial and Industrial) and 10.4 (Critical Facilities) for specific sheltering conclusions related to those building types.

### 10.6.1 General

The best life-safety protection from tornadoes is a safe room or storm shelter, specifically one designed and tested to the FEMA criteria (FEMA 320 / FEMA 361 or the ICC 500 standard). There were no fatalities in any of the observed safe rooms or storm shelters, and none of the occupants of these specially designed structures were injured in spite of the strength of the tornadoes. Although the residential and community safe rooms had generally been designed, constructed, and tested to meet FEMA 320/361 guidelines, there were numerous compliance issues with signage, doors, ventilation, and square footage space allocation.

The performance of tornado refuge areas, hardened rooms, safe rooms, and storm shelters highlights the need for the construction of more safe rooms and storm shelters in tornado-prone regions. The following statements related to the use and performance of safe rooms and storm shelters are based solely on the MAT's observations. Specific conclusions related to residential and community safe rooms and storm shelters are presented in the following sections.

**Conclusion #22 – 2010 Alabama State school tornado safe room requirement:** FEMA supports the State of Alabama Building Commission and Alabama House Bill 459 that requires new school buildings constructed after July 2010 to provide mandatory safe spaces for tornado protection in all

K-12 public schools. The Building Commission further identified the ICC 500 as the standard to which the safe spaces are to be constructed for providing protection from tornadoes.

**Conclusion #23 – Above-ground safe rooms performed as well as those below ground:** Despite broad public perception to the contrary, above-ground safe rooms, when constructed properly, provide the same level of protection and perform just as well as below-ground safe rooms.

**Conclusion #24 – People traveled excessive distances to community shelters and safe rooms:** People may travel great distances to get to a community safe room or shelter, especially when they have ample warning time as was the case in many communities on April 27, 2011. Travel distances to community safe rooms and shelters on that day were reported to be between 5 and 10 miles, greatly exceeding the ½-mile maximum driving distance or 5-minute maximum walking time advocated by FEMA. Whether walking or driving, prospective safe room occupants must be able to safely reach the facility within 5 minutes of receiving a tornado warning or notice to seek shelter.

**Conclusion #25 – There is a poor understanding of public actions/movement patterns during tornadoes:** Based on statistics from the NOAA SPC, over 65 percent of all fatalities on April 27, 2011 occurred in homes, 6 percent occurred in commercial/public buildings, and 3 percent occurred in vehicles. By comparison, 40 percent of the fatalities on May 22, 2011 in Joplin, MO, occurred in homes, 42 percent in commercial/public buildings, and 9 percent in vehicles.

While the time of day and day of the week definitely influenced where people were when the tornado struck, it is difficult to establish if movement patterns related to sheltering were consistent during the April 27 tornadoes (which included both large tornadoes with atypical warning times, many upwards of 60 minutes as well as rapidly forming tornadoes with minimal to no warning times). During the Joplin tornado, which was a large tornado with warning times at or below average, a much higher percentage of fatalities occurred outside the home. Although greater availability of safe rooms or storm shelters in non-residential buildings may have prevented loss of life during this event (which provided less than 20 minutes warning time), behavioral studies and research are lacking to help explain or predict the movements of people during tornadoes.

**Conclusion #26 – Guidance for identifying how to provide community-wide protection is lacking:** Based on the MAT's observations, the determination of whether or not to protect a vulnerable community using a single, large safe room or storm shelter (versus smaller, dispersed safe rooms and storm shelters) is currently based on conjecture and anecdotal evidence. Behavior during storms that spawn tornadoes is not well studied. There is a lack of data and research that clearly states or defines the risk individuals take when they travel long distances to seek refuge during a tornado. Technical storm elements and social science (behavioral) issues such as warning time, presence of multiple funnel clouds, track variation movement patterns across the tornado path, lack of safe areas at current location, and the time available to make the decision to shelter or seek shelter are examples of inputs to the decision making process that warrant further study. Currently, there is a lack of consistent guidance on how to provide protection when the potential occupants are traveling more than 5 minutes (walking time). As such, it is up to the community to determine if they will support or promote the use of a single, large community safe room, dispersed smaller community safe rooms, or smaller private and residential safe rooms throughout the community.

**Conclusion #27 – Design and construction guidance for storm shelters and safe rooms is consistent, though somewhat different in scope:** The ICC 500 for storm shelters and the FEMA technical

guidance (FEMA 320 and FEMA 361) for safe rooms provide the same or nearly identical levels of protection for tornado hazard protection. Notable differences exist between the documents for hurricane hazard protection, but a review of the hurricane provisions was beyond the scope of this tornado MAT report. Both these documents provide important guidance and FEMA continues to educate designers, emergency management officials, property owners, and people in the community seeking to find protection from tornados on the benefits of FEMA 320, FEMA 361 and ICC 500 and how they complement one another. The fact that FEMA references an engineering design standard (ICC 500) and uses it as part of their much larger emergency management program shows FEMA's commitment to use voluntary consensus standards to the maximum extent possible in carrying out its programs.

ICC 500 is an engineering standard and in its first edition; it does not provide a commentary to support the requirements of the standard. The standard is adopted by reference by the 2009 and 2012 I-Codes. By comparison, the technical criteria from the FEMA guidance documents—although not ANSI-certified consensus standards—include an extensive commentary addressing not just design considerations, but also operational and maintenance issues of safe rooms. While the FEMA documents are not adopted by the I-Codes, the FEMA criteria may be adopted by a jurisdiction to govern the construction safe room and storm shelters. The authority having jurisdiction must clearly state who is responsible for reviewing and accepting the design of and construction of a safe room or storm shelter to ensure compliance with the technical criteria or standard.

**Conclusion #28 – There is a lack of proper labeling and signage:** There were areas within existing non-residential buildings labeled as “tornado shelters.” However, these areas were not designed and constructed in compliance with FEMA 320/361 or ICC 500 to provide a clear level of protection from tornadoes. Such labeling may result from a lack of understanding of the terminology used in safe room guidance (such as FEMA 320/361 and ICC 500). This labeling can, however, mislead and endanger potential occupants during a tornado event.

**Conclusion #29 – There were unregistered safe rooms:** There is a potential for people to become trapped in their safe rooms (see Section 9.4.3.1). While most community safe rooms and storm shelters are managed by local or county governments (as they are public facilities), almost none of the residential safe rooms and storm shelters observed by the MAT in the five affected States were registered or listed with local emergency management agencies or police/fire departments.

**Conclusion #30 – Safe rooms and storm shelters lacked tools to open or dismantle door if blocked:** Most safe rooms and storm shelters did not have tools available to open or dismantle the door from within should egress routes become damaged, inoperable, or blocked by debris.

**Conclusion #31 – Some safe rooms were difficult to locate with given coordinates:** The MAT had difficulty locating FEMA-funded safe rooms even when latitudes and longitudes were provided. It seemed that coordinates were either incorrect or outdated, and had not been verified in the field prior to the tornado.

## 10.6.2 Residential Safe Rooms and Storm Shelters

There were design and construction issues observed with the residential safe rooms, storm shelters, and tornado refuge areas assessed by the MAT. For best available tornado refuge areas, it is difficult



to ensure that “above code” improvements are implemented correctly. The MAT observed numerous attempts to construct hardened rooms that were misidentified as “tornado shelters” where voluntary compliance with the criteria and standards from FEMA and ICC was not achieved. An opportunity exists for communities to enable improved compliance with the safe room and storm shelter criteria by adopting the ICC 500 as a minimum standard for storm shelter construction (alone or along with adoption of the latest edition of the IRC).

All of the safe rooms or storm shelters inspected by the MAT during the field visits were constructed prior to any adoption of the 2009 I-codes and ICC 500, which require building departments to be involved in the design, construction, and installation of safe rooms and storm shelters. However, there were numerous discrepancies noted between the observed construction and the FEMA guidance documents on safe rooms or the ICC 500 criteria, that going forward, need to be corrected. The most common deficiencies in the residential safe rooms and storm shelters noted during the field assessments are described below.

**Conclusion #32 – Safe room door quality observed was often inadequate:** Doors that did not meet the FEMA or ICC criteria were the most dominant deficiency in residential safe rooms. Door quality was lacking in many observed residential safe rooms and storm shelters. Many of the doors would not pass the debris impact tests from FEMA 320/361 and ICC 500, and many that were installed had not been tested to show compliance with the criteria. The presence of substandard doors places occupants at risk. If substandard doors fail, the occupants in these areas can be exposed to wind and wind-borne debris.

**Conclusion #33 – Safe room door hardware observed was often inadequate:** Door hardware, specifically latching mechanisms, was observed to be inadequate in many older shelters and hardened rooms (but also in some new storm shelters and safe rooms). FEMA 320 requires three hinges and three latches. FEMA 361 recommends six points of connection (typically three hinges and three latching mechanisms), but allows for other alternatives if the door and door hardware are tested to meet stated debris impact criteria. ICC 500 requires only that the door and door hardware be tested to meet stated debris impact criteria. Most of the older doors (both above- and below-ground) installed in hardened rooms and older shelters had inadequate latching; these doors performed with varying levels of success during the storms.

**Conclusion #34 – There was a lack of adequate ventilation in shelters:** Ventilation pipes and vents were altered or removed in many older below-ground shelters. This is an unsafe practice and places occupants at risk.

**Conclusion #35 – Safe rooms were observed that had inadequate or no anchoring:** A few prefabricated safe rooms were installed but not anchored to a foundation; specifically, the structures observed were heavy, precast concrete safe rooms. Although these safe rooms/storm shelters are massive and stated by sellers and manufactures to be FEMA- and ICC-compliant structures, they must still be restrained to resist high wind forces. The MAT was unable to obtain documentation to show these structures were adequately anchored to resist overturning.

**Conclusion #36 – Safe room locations were not documented and occupants had no ability to communicate from within:** Many tons of debris can be blown on top of or around a safe room or storm shelter during a tornado. Many safe room owners did not coordinate with their local government, so first responders may not have known the locations of private and individual safe

rooms and storm shelters. Furthermore, safe room and storm shelter occupants were not always able to communicate with first responders from within their safe rooms and storm shelters when egress was disabled or blocked by debris.

### 10.6.3 Community Safe Rooms, Storm Shelters, and Tornado Refuge Areas

There were design and construction issues with the community safe rooms, storm shelters, and tornado refuge areas inspected by the MAT. The MAT deployed after the April 25–28, 2011 tornadoes observed numerous safe rooms and storms shelters where voluntary compliance with the criteria and standards from FEMA and ICC was not achieved. An opportunity exists to improve compliance with the safe room and storm shelter criteria by adopting the ICC 500 and a minimum standard for storm shelter construction (alone or along with adoption of the latest edition of the IRC). Further, the few non-stand-alone designated “tornado shelters” or designated refuge areas the MAT observed were in portions of buildings that were not constructed to any higher level of protection than the other portions of the building. The MAT could not verify if any of these areas had been evaluated or assessed for their vulnerability to tornadoes prior to their use as a tornado refuge area.

All of the safe rooms and storm shelters inspected by the MAT during the field assessments were constructed prior to any adoption of the 2009 I-codes and ICC 500 (in which building departments would have been required to be involved in the design, construction, and installation of the structures). The lone exception was the Seneca Intermediate School in Seneca, MO (see Section 9.4.4.3). The most common shortcomings of tornado refuge areas and deficiencies in the community safe rooms and storm shelters noted during the field assessments are described below.

**Conclusion #37 – Tornado refuge areas located in large, single-story buildings performed poorly:** Tornado refuge areas in large, single-story commercial buildings and retail buildings did not perform well. Although some winds were at or above design wind speeds, disproportionate collapses (and almost complete collapses) occurred in several instances (refer to Section 10.3). Although emergency planning efforts by building owners and operators identified specific areas to be used during a tornado event, the MAT could not verify whether any of these areas were defined as best available refuge areas by design professionals who specifically identified vulnerability to wind and wind-borne debris.

**Conclusion #38 – There was inadequate doors and door hardware on safe rooms/storm shelters:** Some FEMA-funded community safe rooms were observed to have inadequate doors and door hardware, similar to problems the MAT observed with residential safe rooms and storm shelters. This is a compliance issue that building departments would have been required to evaluate during the design, construction, and installation of the structures had the construction of these protected spaces been required by the State or local building code.

Most tornado refuge areas the MAT observed also had doors that would not pass the FEMA/ICC criteria (tests) for wind and debris-impact resistance. These weak doors and door systems place occupants at risk during a tornado.

**Conclusion #39 – There was a lack of alternate means of communication in community safe rooms:** Few community safe rooms were equipped with alternate communication systems as

recommended in FEMA 361. Where alternative means of communication were observed, not all safe rooms provided backup power for these systems in the event power was lost during the event.

## 10.7 EF Scale

At each site visited, the MAT independently determined an EF scale rating based on one of the 28 DIs and DOD described in *A Recommendation for an Enhanced Fujita Scale* (TTU 2006), which was officially adopted by NOAA/NWS and first used in February of 2007. Information on the EF scale is provided in Chapter 2 and Appendix E. The following conclusions relate to the EF scale rating system based on the MAT's observations.

**Conclusion #40 – DI lists are incomplete:** To effectively use the EF scale, the construction description should reasonably match the building or structure being rated. There were some types of buildings, such as fire stations, that did not have specifically assigned DIs. Therefore, the MAT used DI 14 (Automobile Service Building) or DI 21 (Metal Building System), depending on which construction type was most closely approximated, to rate fire stations. By contrast, schools are accounted for reasonably well in the existing format, and are separated into DI 15 (Elementary School) and DI 16 (Junior or Senior High School).

**Conclusion #41 – DOD categories are inadequate for specific DIs:** For some of the current 28 DIs, there are up to 12 DOD indicators, allowing the user to choose the specific level of damage based on observations. However, for some DIs, such as free-standing towers, there are only two DOD indicators. Freestanding communications towers (DI 25) were rated by the MAT. The existing format of the EF scale only lists three DODs under DI 25, which limits the number of estimated wind speeds that can be deduced. While free-standing towers have a limited number of possible failure modes and related DODs, other DIs such as DI 5 (Apartments, Condominiums, and Townhouses) have more DODs to better rate tornado wind speeds.

**Conclusion #42 – The process for assessing varying DODs in the same DI is not well explained in EF guidance:** Large buildings, such as Ringgold High School in Ringgold, GA, often exhibited marked differences in damage from one portion of the building to another because the tornado only struck a portion of the building. The lack of guidance for how to assess large buildings where only a portion of the building is struck can make the application of the EF scale different among different users. For example, DI 16, DOD 5, is for "... significant loss of roofing material (>20%) ...". If only one end of a large building is struck, the roof covering damage in that area could exceed 20 percent, but could be less than 20 percent of the total for the entire roof area. In this case, if the DOD were applied only to the portion of the building that was struck, then DOD 5 would be applicable. But if the DOD was applied to the entire building, then DOD 2 would be applicable (assuming the only damage was to the roof covering).

**Conclusion #43 – Order of DOD choices for DI 2 (One- and Two-Family Residences) in the EF rating scale does not follow observed damage patterns:** As noted in Chapter 4, most residences rated by the MAT followed the order of DODs prescribed by the EF scale closely, with the exception of DOD 5 (Entire House Shifts off Foundation). It was very unusual for DOD 5 to precede DOD 6. In the one documented case (Figure 4-17), the observed residence was older construction.

**Conclusion #44 – Photographs of DODs would aid in determining EF ratings:** *A Recommendation for an Enhanced Fujita Scale* (TTU 2006) does not include photographs for each of the DOD indicators, making it difficult for users to accurately interpret the guidance and evaluate structure damage.

## 10.8 Post-Tornado Imagery

Following the tornadoes, the NWS released aerial photographs and rated the intensity of the tornadoes along the tracks in certain locations. The following conclusions relate to the post-tornado imagery and the MAT's observations. These conclusions are not based on field observations, but rather the MAT's observations in developing this report and working with the information collected in the field.

**Conclusion #45 – Post-tornado NWS aerial photographs were helpful in conducting damage analysis:** The NOAA post-tornado aerial photographs were helpful to the MAT. The photographs provide context for wind performance of a given building with respect to building location within or on the periphery of the tornado track. The aerial photographs also show other damage in the vicinity of a given building. The view from the air provided insights that could not be discerned from ground-based observations.

**Conclusion #46 – EF contours provided by NWS were useful:** Having EF contours of the track was helpful to the MAT. Where contours were provided, a direct comparison between the NWS EF contour rating and the MAT EF rating for a specific building could be made. Development of EF contours is also important for risk modeling of facilities and other structures such as nuclear power plants, safe rooms, and power transmission lines.

**Conclusion #47 – Accuracy of EF ratings used to develop track contours is important:** For risk modeling, in addition to developing EF contours, it is important that the EF ratings for the contours be accurate. Accurate wind speed determination is difficult for two reasons: 1) there is some uncertainty of the wind speed for given DODs, and 2) accurate selection of the wind speed between the lower- and upper-bound speeds associated with the DODs requires specialized knowledge. The MAT derived an EF rating for several buildings; the MAT's ratings for most of these buildings were different from the NWS track rating or contour rating in the vicinity of the building. The difference may be a function of the MAT's specialized knowledge of structural performance.



## TORNADO OUTBREAK *of* **2011**

IN ALABAMA, GEORGIA, MISSISSIPPI,  
TENNESSEE, AND MISSOURI

# 11 Recommendations of the 2011 Tornado MAT

*The tornadoes of April 25–28, 2011 and May 22, 2011 were devastating in their intensity, severity, and loss of life and property.*

While the events of April and May 2011 cannot be undone, the affected communities can commit to planning for future tornadoes through promoting sustainable and tornado-resistant construction. The recommendations in this report are based solely on the MAT's observations, assessments, analysis, and conclusions. These recommendations are intended to assist individuals, communities, and businesses through the reconstruction process and to help reduce future damage and impacts from other tornadic wind events.

At a minimum, as communities begin to rebuild homes, businesses, and critical facilities, there are several ways they can reduce the effects of future tornadoes, including:

- + Design buildings to the most current building codes and engineering standards to improve building performance and reduce damage

- + Construct residential and community safe rooms to provide safe refuge in the event of a strong or violent wind storm or tornado

Specific recommendations are included in the following subsections. Mitigating future losses, however, will not be accomplished by simply reading this report; mitigation is achieved when a community actively seeks and applies methods and approaches that will lessen the DOD, injuries, and loss of life in future tornadoes. For example, the Tornado Recovery Action Council of Alabama is encouraging the adoption of a statewide building code to mitigate future losses (2012). These recommendations can be used across the United States and for other disasters, as applicable, to prepare, plan, and design for mitigating deaths and damages in similar hazard events.

## 11.1 Codes and Standards

This section provides MAT recommendations related to codes and standards intended to improve building performance of residential, commercial, industrial, and critical facilities. In addition to property protection, the MAT provides recommendations for requirements related to personal protection.

### 11.1.1 Residential Buildings

**Recommendation #1 – Adopt and enforce current model building codes:** State and local officials should adopt and enforce a current edition of a model building code (current codes at the time of publication of this report are the 2012 or 2009 IRC, Figure 11-1) for all new residential construction. The minimum requirements of the code should be kept intact, including the criteria set forth in ASCE 7, the ICC 500, and Chapter 3 of the IRC. Where the State is deficient in model code adoption, the local jurisdictions should adopt and enforce the latest model building codes. Some jurisdictions may qualify for HUD Community Development Block Grants and FEMA HMGP opportunities to establish inspection departments.



Figure 11-1: IBC/IRC

As an interim step to code adoption, engineers should design and builders should build to the latest model building codes. Designers, builders, and owners should consider voluntary implementation of these codes in jurisdictions where they are not adopted by government authorities.

**Recommendation #2 – Increase emphasis on code compliance:** Where codes are in place, more emphasis should be placed on code compliance. Homebuilders and code enforcement agencies should consider developing an active education and outreach program with contractors to emphasize the importance of code compliance for wind resistance.

**Recommendation #3 – Maintain and rigorously enforce the adopted model building code since amendments or lax enforcement practices may weaken the continuous load path of the building:** Minimum requirements of the IRC and IBC that specify prescriptive connections along the critical load path from roof, through walls, into floor systems, and into the foundation should not be

weakened through local amendments or enforcement practices. Weakening the critical load path threatens the integrity of buildings and endangers their occupants unnecessarily.

### 11.1.2 Commercial and Industrial Buildings

**Recommendation #4 – Include failure states and survivability in building codes and standards:**

For a coherent design approach, structural loads need to be addressed and presented in a clear, consistent philosophy of design. Failure states and building survivability also need to be addressed in the codes. Wind design provisions important for building resistance to high-wind events such as tornadoes should be discussed in ASCE 7, and wind design methodologies should be developed for use by practitioners.

**Recommendation #5 – Change risk category for large-footprint commercial structures with long-span roofs to Risk Category III in ASCE 7-10:** Classify one- and two-story, large-footprint commercial structures with long-span roofs as Risk Category III under ASCE 7-10 to protect the large number of people that may occupy these structures at any given time.

**Recommendation #6 – Improve design approach in ASCE 7 and IBC to address risk consistently across hazards:** The codes and standards need a coherent approach to risks, threats, and hazards. The ASCE 7 standard does not have a clearly articulated design approach as part of the document. If clear and consistent designs with predictable and acceptable performance are to be achieved our codes and standards must clearly state the basis for their development and implementation. Therefore, the MAT recommends that ASCE 7 and IBC undertake the task of capturing a better design approach that treats risk consistently across hazards. Part of the code and standard performance objective must be to prevent building collapse even in extreme events. A building may be rendered a complete functional and economic loss, but it should not collapse. This area of code improvement implies a more sophisticated approach that is partially captured by the development of performance-based design methods. Performance-based design methods should be expanded to more areas of ASCE 7 and the IBC, particularly as they relate to the wind hazard.

**Recommendation #7 – ASCE 7 should improve the commentary on code limitations:** The current codes and standards that govern building design do not clearly express how they handle tornado loads. The narrative that explains the limitations does not clearly state what elements of tornado risk or exposure are covered. ASCE 7 should make clear, unambiguous statements in the commentary about code limitations. These statements should clarify whether tornadoes are dealt with in the process, and if not, why. The commentary discussion needs to objectively explain the rationale for the decision.

**Recommendation #8 – Clarify risk tolerance in ASCE 7 and IBC:** ASCE 7 and the IBC should begin the discussion of risk tolerance so that probability-based design of building performance can be better understood, communicated and implemented.

**Recommendation #9 – Include best practices for wind design in IBC:** The IBC should develop a best practices section for wind design similar to the seismic portion of the code. This section can incorporate details and systems that enhance building performance in extreme wind events. Expansion of this discussion may incorporate concepts that are familiar to seismic designers and also address progressive collapse. Best practices for extreme wind design include redundancy of the

MWFRS, ductility of connections, alternate load paths, design for load reversal, robust perimeter element design, continuity of boundary elements, good connectivity, and inclusion of discrete MWFRS components.

### 11.1.3 Critical Facilities

**Recommendation #10 – Propose IBC code change:** The MAT recommends submitting the following IBC code change proposal regarding schools:

“In areas where the shelter design wind speed for tornadoes per Figure 304.2(1) of ICC 500 (2008) is 250 mph, all new kindergarten through 12<sup>th</sup> grade schools with 50 or more occupants in total, per school, shall have a FEMA 361-compliant safe room or an ICC 500-compliant storm shelter.”

**Recommendation #11 – Propose IBC code change:** Submit the following IBC code change proposal regarding fire and police stations, 911 call centers, and EOCs:

“In areas where the shelter design wind speed for tornadoes per Figure 304.2(1) of ICC 500 (2008) is 250 mph, all new 911 call stations, emergency operation centers, and fire, rescue, ambulance, and police stations shall have a FEMA 361-compliant safe room or an ICC 500-compliant storm shelter.”

### 11.1.4 Tornado Refuge Areas, Hardened Areas, and Safe Rooms

**Recommendation #12 – Continue to coordinate standards and guidance for storm shelters and safe room design:** The ICC and FEMA should continue to work together to establish standards and guidance that are complementary. There are design elements based on emergency management considerations in the FEMA guidance related to the operations and maintenance of storm shelters or safe rooms that are not appropriate for inclusion in the ICC 500, as it is an engineering standard. As FEMA programs continue to fund the design and construction of safe rooms, there are valuable lessons in engineering and construction, in addition to the operational aspects of its safe room program, that could be incorporated into the ICC standard.

The primary reason to keep the FEMA guidance and ICC 500 documents separate is to ensure that emergency management considerations receive appropriate attention during design and construction. While most technical elements in the documents are the same, some remain different. These few differences, less notable in the tornado hazard areas as compared to the hurricane hazard areas, need to be understood and explained to designers, emergency management officials, property owners and managers, and people in communities seeking protection from tornadoes. This outreach is necessary to minimize potential confusion that may exist. As the ICC enters its next cycle of standards development, it should develop a commentary for the ICC 500 that discusses assumptions and limitations of the standard. Further, as FEMA continues to provide guidance in its publications and policies, ICC and FEMA should continue to work together to develop a common message on life-safety protection from tornadoes.



**Recommendation #13 – Improve performance of safe rooms and storm shelters through code adoption and enforcement:** The 2009 and newer versions of both the IBC and IRC require compliance with the ICC 500 for any plan-designated storm shelter. The ICC 500 includes testing standards for storm shelter and safe room components. Components for newly constructed storm shelters and safe rooms, including elements such as doors, door hardware, ventilation, and anchorage, should be verified as compliant with ICC 500 as part of enforcing the aforementioned model building codes.

**Recommendation #14 – Submit proposed IBC code change:** The MAT recommends submitting the following IBC code change proposal regarding identification of best available refuge areas:

“For new buildings that do not incorporate a FEMA 361-compliant safe room or an ICC 500-compliant shelter, the floor plan shall indicate the best available refuge area(s).

- + “The best available refuge area(s) shall be capable of accommodating the building’s occupant load based on the allowable square footage per occupant prescribed in ICC 500.
- + “When signage is provided to identify the refuge area, the terminology should read: “Best Available Refuge Area.
- + “Exception: If building occupants have access to a community FEMA 361-compliant safe room or an ICC 500-compliant shelter, this provision is not applicable.”

## 11.2 Residential Construction

**Recommendation #15 – Implement voluntary best practices to mitigate damage to one- and two-family residential buildings:** The MAT recommends implementing the voluntary best practices for one- and two-family residential construction listed in this section and described further in Appendix G; these best practices will greatly reduce tornado damage to new and rebuilt one- and two-family residential buildings that are exposed to wind loads associated with weaker (i.e., EF0, 1, and 2) tornadoes. Since the decision to implement best practices for enhanced building performance is cost-based, and therefore ultimately lies with the consumer (prospective homeowner), the MAT recommends that designers and builders offer enhanced performance option packages for new residential buildings. These options should be clearly presented so that the potential homeowner understands that improved wind resistance does not equate to “windproof.”

The guidance for improved building performance presented in Appendix G is intended solely for enhanced property protection and should not be construed in any way as an alternative to sheltering. Consequently, occupants of residential buildings in tornado-prone regions should have a tornado emergency operations plan in place, and whenever possible, have practiced this plan through drills to quickly access their safe room, storm shelter, or best available storm refuge.

Prescriptive guidance is provided in Appendix G, per specific sections referenced below, to enhance performance of components, cladding, and critical load path connections observed to have failed during the spring 2011 tornado events. The prescriptive guidance in Appendix G is intended to:

- + Improve roof and wall coverings per Section G.3.1
- + Increase awareness of glazing damage and strengthen garage doors per Section G.3.1
- + Strengthen roof decking (sheathing) attachment per Section G.3.2
- + Strengthen roof-to-wall connections per Section G.3.2
- + Improve wall performance through sheathing attachment, hold-down installation, and better top plate splicing per Section G.3.3
- + Improve wall-to-floor connections and bottom plate attachment per Section G.3.3

## 11.3 Commercial and Industrial Construction

For new commercial and industrial buildings, the MAT recommends that architects and engineers consider the following approaches to improve building performance related to communications and operations, and to detailing and connections.

### 11.3.1 Occupant Notification and Operations

**Recommendation #16 – Install a storm shelter or safe room or identify best available refuge areas in large-footprint buildings:** In buildings where there can be a significant number of people, there should be a designated area that has been evaluated for its vulnerability to damage from tornadic winds and wind-borne debris where occupants can take refuge during a high-wind event. This space could be a break room, an office, or any other space with sufficient floor space for the occupants. Because best available refuge areas do not guarantee safety, the space should be designed to FEMA 361 or ICC 500 criteria.<sup>1</sup>

**Recommendation #17 – For all public buildings, install signage in a conspicuous place at building entrances** (similar to maximum occupancy signs from the fire department): The resulting information may lead to the decision to abandon a structure and find more suitable refuge in certain situations. Signs should:

- + Include relevant building design parameters such as importance factor, design wind speed, ground snow load, seismic criteria, rain fall intensity criteria, and if the building is constructed from URM.
- + Prominently display “Best Available Storm Refuge Area – Maximum Occupancy of” with the maximum occupancy on the sign.

---

<sup>1</sup> This chapter references the 2008 versions of FEMA 320 and 361, as well as ICC 500, unless another date is specified.

- + Be of similar size and placement as the occupancy limitation signs currently used and placed in all buildings.

**Recommendation #18 – Place decision-making check lists or flip charts in prominent locations:**

Such check lists or flip charts help people make critical decisions in times of high stress and are a preferred method of ensuring that consistent and good decisions are made in high-stress situations. Checklists or flip charts should be located where building occupants can easily find them. An example of a flip chart is shown in Figure 9-15.

### 11.3.2 Detailing and Connections

**Recommendation #19 – Do not use URM in primary or critical support areas of a building:** All masonry used in a building as a support wall or shear wall should be reinforced and tied into the adjacent structural elements to ensure ductile and robust performance in overload conditions, as URM has been known to fail in extreme events. URM is not allowed in parts of the country that are subject to increased seismic performance requirements due to its poor behavior in extreme events and insufficient ductility (FEMA 2009). The MAT recommends that all masonry for retail and commercial buildings be reinforced. This will ensure positive connections and a clear load path that is not dependent on gravity alone for the integrity of the building during an extreme wind event. Critical areas of buildings lacking reinforcement should be upgraded to include reinforcement and a continuous load path.

**Recommendation #20 – Use screws in deck-to-joist connections instead of puddle welds:** Several past MAT studies and damage assessments from FEMA, as well as other FEMA guidance documents, recommend the use of screws instead of puddle welds in the deck-to-joist connection. (See FEMA 342; FEMA P-424; FEMA 543, *Design Guide for Improving Critical Facility Safety from Flooding and High Winds: Providing Protection to People and Buildings* [2007]; and FEMA 577, *Design Guide for Improving Hospital Safety in Earthquakes, Floods, and High Winds: Providing Protection to People and Buildings* [2007], for more context.) The screws provide a more reliable and consistent connection than puddle welds and have been shown to perform better in high-wind events. The MAT recommends the use of screws in accordance with observed failures during spring 2011 deployment and past FEMA reports and assessments.

**Recommendation #21 – Include enhancements to building connections beyond the code requirements:** Design improvements can be achieved in new construction by incorporating enhancements that go beyond code requirements. Improving the performance of building connections is a low-cost improvement that can increase design strength and ductility. Until better criteria are established by a rational means, design non-residential buildings as Risk Category III structures under ASCE 7-10.

**Recommendation #22 – Incorporate redundancy in the MWFRS:** To reduce high-wind damage to buildings with long-span roofs and tall walls and limit the progression of a failure, building designers should incorporate redundancy in the MWFRS. Specifically:

- + Design redundant features to limit the area supported by each element to a relatively uniform shape (aspect ratio no greater than 2).

- +Limit the maximum area supported by a bracing system to 40,000 square feet. The area should be large enough that it does not severely affect building operations and flow.
- +Design redundant support, or minimize deflections, such that a column or wall could be damaged and the structural system would not collapse.
- +Provide lateral load resistance in tall walls with more than one means of support at both the top and bottom of the walls.
- +Account for the break in continuity at the expansion/contraction joint when designing the MWFRS wall system.

**Recommendation #23 – Incorporate more redundancy in the design of large-footprint buildings:**

To limit the extent of a progressive collapse from failure of a small element or from a non-redundant system, more redundant systems should be incorporated into the design of large-footprint buildings. The limiting area should be large enough to permit use of the space without substantially affecting the operations and flexibility of the facility. Single-purpose structural stability systems should also be considered. Additional ductility and continuity measures at the perimeter of the structure would allow load distribution to other elements in the event of massive overloads (see Figure 5-48).

**Recommendation #24 – Use discrete structural systems in large, long-span buildings:** To improve building performance, designers should consider solutions that provide for discrete service of components. For example, a building can be designed so that it could lose the roof and not lose stability from the loss of the diaphragm critical to the MWFRS. Although such solutions may add construction cost by removing efficiency of design, they will result in a more robust, redundant system. The greater construction costs may be regained in lower risk and loss profiles.

An example of such a design would be installing a roof deck that provides weather protection, but is separated from the MWFRS and not used as the shear diaphragm. Another example would be including a wall system that does not provide vertical support and shear resistance, but acts solely as an environmental barrier. Such a wall could be lost, and the MWFRS would not be compromised.

## 11.4 Critical Facilities

Design enhancements can be made to both existing critical facilities and those in the planning stage that can be incorporated into the construction documents. Design enhancements beyond IBC requirements are necessary to minimize damage from tornadoes. Design enhancements (including provisions pertaining to electrical power and communications) are also necessary to ensure COOP after a tornado strike.

The MAT prepared several Tornado Recovery Advisories in the wake of the April 25–28, 2011 and May 22, 2011 tornado events. FEMA Recovery Advisory No. 5, *Critical Facilities Located in Tornado-Prone Regions: Recommendations for Facility Owners* (Appendix F), provides recommendations for owners of critical facilities. FEMA Recovery Advisory No. 6, *Critical Facilities Located in Tornado-Prone Regions: Recommendations for Architects and Engineers* (Appendix F), provides recommendations for architects and engineers. These recommendations pertain to both existing and new critical facilities. The

recommendations address best available refuge areas, safe rooms, strengthening new facilities to minimize tornado damage, and enhancements to avoid interrupted operations.

The MAT's key recommendations for improving the performance and operation of existing and new critical facilities during and after a tornado are described below (refer also to the Recovery Advisories in Appendix F).

### 11.4.1 Existing Critical Facilities

**Recommendation #25 – Perform a vulnerability assessment:** A team of architects and engineers should perform a high-wind vulnerability assessment of existing facilities. Findings from such an assessment can lay the groundwork for planning and budgeting capital improvement projects and for developing contingency plans that address facility disruptions that result from a tornado or other natural hazard event, as illustrated in Figure 11-2. Figure 11-2 shows a collapsed CMU/brick veneer wall and collapsed roof structure at Joplin High School (see also Section 6.1.5).



Figure 11-2:  
Collapse of exterior CMU/  
brick veneer wall and roof  
collapse at the Joplin High  
School (Joplin, MO). The wall  
debris fell into the corridor.

**Recommendation #26 – Identify best available refuge areas:** Best available refuge areas should be identified in all critical facilities that do not have areas designed and constructed as safe rooms or storm shelters. Best available refuge areas do not guarantee safety; they are, however, the safest areas available for building occupants. A design professional familiar with tornado risk should assess existing buildings and identify the best available refuge areas. Once identified, the locations of the best available refuge areas should be clearly marked with a permanent sign that reads “*Best Available Refuge Area.*”

## 11.4.2 New Critical Facilities

**Recommendation #27 – Include safe rooms in design of new facilities:** One or more safe rooms should be incorporated into new designs to provide occupant protection. FEMA 361 provides comprehensive guidance for the design of safe rooms. If a safe room is not incorporated, the architect or engineer should identify the best available refuge area(s), and specify that those area(s) should have a permanent sign that reads “*Best Available Refuge Area.*”

**Recommendation #28 – Enhance building design to better withstand tornadoes:** By using design strategies and building materials that are used in hurricane-prone regions, critical facilities can be built to be more wind resistant to most tornadoes (i.e., EF0–EF3). Detailed recommendations for three levels of enhancement to minimize building damage are given in FEMA Recovery Advisory No. 6.

**Recommendation #29 – Strengthen facilities to remain operational:** For critical facilities that should remain operational if struck by a violent tornado (i.e., EF4 and EF5), designers should follow the detailed recommendations related to the MWFRS, the building envelope, HVAC, water, sewer, and emergency power provided in FEMA Recovery Advisory No. 6.

If, because of the additional expense, the owner determines that a critical facility does not need to be operational if struck by a violent tornado, then this reduced building performance should be clearly considered and addressed in emergency operations plans. Other critical facilities (that are not expected to be impacted by the same tornado) should be identified from which to continue critical operations. Appropriate planning, emergency plans, and cooperative agreements, typically referred to as COOP Plans, should be put in place. For facilities such as EOCs that are determined to be critical in providing effective emergency response, owners should budget facility enhancements to avoid interrupted operations even if struck by violent tornadoes.

## 11.5 Infrastructure Facilities

The MAT assessed the performance of water treatment facilities, water distribution facilities, wastewater treatment facilities, and communications towers. It is important that these facilities stay operational after a disaster to provide clean water, sanitation, and communications for the people and emergency responders of the community. The following are recommendations for enhancing infrastructure performance based on the MAT’s observations.

**Recommendation #30 – Work collaboratively to better understand the risks of wind-displaced materials on communications towers:** The authors of ANSI/TIA-222, *Structural Standard for Antenna Supporting Structures and Antennas* (2005), should investigate the risks that wind-displaced materials pose to communications towers and develop methods in that standard to address those risks.

**Recommendation #31 – Work collaboratively to better understand the effects of wind-displaced materials on latticed structures:** The ASCE should provide commentary in Chapter 29 of ASCE 7 on the effects of wind-displaced materials clinging to latticed structures so that designers can consider the possible increases in wind loads on those structures.

**Recommendation #32 – Provide an alternate electrical source:** For water distribution systems that are fed only from utility power systems and that rely on electrically driven pumps to fill storage tanks or boost system pressures, alternate power supplies should be provided. Alternate power supplies may be from on-site standby generators or from temporary portable generators brought to the site after an event. If temporary portable generators are used, provisions should be installed to allow operators to quickly and safely connect the generators to the pump stations before tanks drain or system pressures significantly affect operations.

**Recommendation #33 – Work collaboratively to better understand communications tower performance:** Stakeholders should collaborate to better understand tower performance.

## 11.6 Tornado Refuge Areas, Hardened Areas, and Safe Rooms

Safe rooms are the best means of providing near-absolute protection for individuals who are attempting to take refuge during a tornado. Whether a safe room is constructed by a homeowner for protection of his or her family or is constructed as a group or community safe room, all safe rooms should be designed and constructed in accordance with either FEMA 320 or FEMA 361.

The following are recommendations for personal protection based on the MAT's observations and conclusions.

**Recommendation #34 – Research travel time to, and use of, safe rooms and storm shelters:** Travel time and safe room use research should be sponsored by FEMA, NIST, NSF, NWS, or other Federal entities who have the resources to investigate both the technical and social science issues that are part of the decision-making process of where and how to take shelter from a tornado. How far individuals will travel to find a safe place or shelter from tornadoes is a topic that is not well documented, and as a result, people may be making decisions to find shelter during an event in which there is no time (due to a short warning time period). This complex issue requires further study to better answer the question of how to provide safe rooms, storm shelters, and safe places of refuge at the community level and how to most effectively communicate needed tornado response activities to their community.

Safe rooms and storm shelters constructed in compliance with FEMA guidance and ICC 500 provide **life-safety protection** to building occupants. Refer to Sections 11.3 (Commercial and Industrial) and 11.4 (Critical Facilities) for specific sheltering recommendations related to those building types. Also, refer to Recovery Advisory Nos. 2, 3, and 4 in Appendix F.

**Recommendation #35 – Locate safe rooms or storm shelters close to people who will use them:** Safe rooms and storm shelters should be provided as close to the specific population being protected as possible. This reduces the risk to occupants who have to walk, run, drive, or otherwise travel to the safe room or storm shelter. Safe rooms within the actual building where the occupants are located provide life-safety protection while minimizing the risk to individuals who are attempting to access the space.

**Recommendation #36 – Identify best available refuge areas:** Best available refuge areas should be identified in all non-residential buildings that do not have safe rooms. Best available refuge areas

do not guarantee safety; they are, however, the safest areas available within the existing space for building occupants.

A design professional familiar with tornado risk analysis should assess existing buildings and identify the best available refuge areas. Once identified, the location(s) of the best available refuge area(s) should be clearly marked with a permanent sign. This sign should not use the term “shelter” or “safe room” since those terms should be used only for areas that meet the criteria set forth in FEMA 320, FEMA 361, or ICC 500. If a design professional is not used to identify the space, the area should be referred to only as a tornado refuge area. Tornado refuge areas offer the least amount of protection from a tornado and may not offer any better protection than typical construction.

**Recommendation #37 – Perform vulnerability assessments:** For existing, non-residential buildings, a team of architects and engineers should perform a vulnerability assessment. Findings from such an assessment can lay the groundwork for planning and budgeting capital improvements and for developing contingency plans that address facility disruptions that result from a natural hazard event.

**Recommendation #38 – Register safe rooms:** All safe rooms, storm shelters, and refuge areas within a community should be registered or noted on a list with local emergency management and first responders. The coordinates for the primary entrance to the safe room, storm shelter, or best available refuge area should be provided to help responders locate the structures in the event debris has hidden them or buildings, street signs, etc. have been destroyed. This applies to FEMA-funded safe rooms as well.

**Recommendation #39 – Equip safe rooms, storm shelters, and best available refuge areas with tools to assist occupants when doors and egress routes become damaged, inoperable, or blocked by debris:** All safe rooms, storm shelters, and best available refuge areas should be equipped with whatever tools are necessary for occupants to open or dismantle the door from inside in the event that egress is blocked or the door is damaged.

**Recommendation #40 – Equip safe rooms, storm shelters, and best available refuge areas with an alternate means of communication:** Safe room and storm shelter owners and operators should plan for potential disruptions to both wired and wireless communications systems. Community safe rooms and storm shelters in particular may require backup power to operate alternate communication systems.

**Recommendation #41 – Provide training:** Training on tornado safe rooms, storm shelters, and refuge areas needs to be expanded for professional organizations and should continue for public officials, emergency managers, building owners/operators, and the public. This training should include both technical issues, such as how to perform a vulnerability assessment and identify the best available area for storm refuge in an existing building, as well as non-technical issues, such as travel time and decision-making during tornado warnings as discussed in this report.



## 11.7 EF Scale

Based on the MAT's observations and conclusions about the current EF scale provided in *A Recommendation for an Enhanced Fujita Scale* (TTU 2006), the MAT recommends that the EF scale guidance be modified as follows:

**Recommendation #42 – Add DIs:** While the current 28 DIs encompass most buildings, some common building types, such as fire stations and churches, are not included. The MAT recommends that guidance on the EF scale be updated by adding DIs for common building types that are not currently included

**Recommendation #43 – Increase the number of DOD categories for specific DIs:** The MAT recommends that the DODs for all DIs be reevaluated for consistency and expanded upon where appropriate. Specifically, the number of DODs for communications towers needs to be increased. Any updates should be reflected in published guidance on the EF scale.

**Recommendation #44 – Provide additional guidance for DOD assessment when only a portion of a large building is struck:** For large buildings where only a portion of the building is struck, guidance should be provided that instructs users on the appropriate DOD selection. Any updates should be reflected published guidance on the EF scale.

**Recommendation #45 – Modify EF scale DI 2 (One- and Two-family Residences):** Based on the MAT's observations for DI 2 (One- and Two-family Residences), DOD 5 (“entire house shifts off foundation”) was rarely witnessed, unlike DODs 4 and 6, and should be eliminated from the list of DODs.

**Recommendation #46 – Provide photographs with DOD descriptions in EF rating guidance:** The MAT recommends that photographs be added to published guidance on the EF scale to illustrate each DOD in each DI.

## 11.8 Post-Tornado Imagery

Based on the MAT's observations and conclusions about the current methods for capturing post-tornado imagery and using graphics to display tornado intensity, the MAT recommends that the process be modified as follows:

**Recommendation #47: NOAA should capture post-tornado aerial photographs:** When tornado damage is potentially greater than EF3, the MAT recommends that NOAA shoot aerial photographs soon after the event. Opportunities to coordinate post-tornado aerial photograph missions between FEMA and NOAA to better capture perishable forensic evidence should be explored.

**Recommendation #48 – NWS should develop EF contours:** The MAT recommends that the NWS develop EF contours for all tracks that are rated.

**Recommendation #49 – NWS should enhance the determination of EF ratings at individual structures by including a design professional as part of the QRTs:** QRTs were deployed to many of the sites visited by the MAT in spring 2011, but only the Birmingham, AL area QRT included an engineer. The MAT recommends that a design professional be included in NWS QRTs to improve damage analysis of individual structures after a tornado and to support the documentation of NWS tornado ratings.

TORNADO OUTBREAK  
of **2011**

IN ALABAMA, GEORGIA, MISSISSIPPI,  
TENNESSEE, AND MISSOURI

# A Acknowledgments

*The Federal Emergency Management Agency would like to acknowledge the contributions of the following people to the Mitigation Assessment Team study of the areas affected by the tornadoes of Spring 2011:*

## FEMA Contributors

Jacob Anderson  
Gerald Bonney  
Lisa Booth  
Gregory Bosko  
Sandy Bridges  
Michael A. Brown  
Ronald Broxton  
Michael F. Byrne, FCO DR-1971  
Luletha Cheatham  
Fellece Coleman  
Roger Faris  
Richard Flinn  
Katy Goolsby-Brown  
Tara Hallmark  
Donna Hamilton  
Aaron Hartwell  
Auco Ho  
Sandra Knight, Ph.D., PE  
Edward Laatsch, PE  
Lois Lopez  
Patricia McArthur  
Elaine McNeil  
Laura McSweeney  
Winfield W. Montague, FCO DR-1972  
Ray Morgan

Patrick L. Neichter, PE  
Jose Francisco Oporto  
Wesley Parker  
Gloria Phillips  
Terry Quarles, FCO DR-1972  
Carl Rea  
Christopher Smith  
Jonathan "Ed" Smith  
Mark South  
Jody Springer  
Gary Swagart, PE  
John Synnott  
Gracia Szczech, FCO DR-1973  
Norman Thidemann  
Evelyn Tirado  
Elizabeth Turner, FCO DR-1980  
John Van Zweden  
Maria Vorel  
James Walke, PE  
Darrell Walker  
Ronald C. Wanhanen, PE  
Steiner Wilanger  
Charles Williams  
Lynda Williams  
Gregory Wilson

## Other Contributors

**Mattie Banks**

Birmingham Nursing and Rehabilitation Center, Birmingham, AL

**Gary Box**

Business Retention and Expansion Coordinator, Joplin Chamber of Commerce, Joplin, MO

**John Brook**

Fire Marshal, City of Tuscaloosa, Tuscaloosa, AL

**Donald Burgess, Ph.D.**

National Weather Service

**Chris Canoles**

Senior Director, Loss Prevention, The Home Depot

**Gregory Carbin**

Warning Coordination Meteorologist, National Weather Service, Norman, OK

**Bill Coulbourne, PE**

Director, Wind and Flood Hazard Mitigation, Applied Technology Council

**Thang Dao, Ph.D.**

Post-Doctoral Scholar, University of Alabama, Tuscaloosa, AL

**Shane Daugherty**

Director, Tuscaloosa Environmental Services, Tuscaloosa, AL

**John De Block**

Warning Coordination Meteorologist, National Weather Service, Birmingham, AL

**Gary Ehrlich**

Program Manager, Structural Codes & Standards, National Association of Home Builders, Upper Marlboro, MD

**Jennifer Erixon**

Senior Vice President, Real Estate Development and Asset Management, Mercy Housing Mountain Plains, Joplin, MO

**Mathew Francis, PE**

URS Group, Inc., Germantown, MD

**Gary Goggins**

Meteorologist, National Weather Service, Birmingham, AL

**Barry Gooden**

Warning Coordination Meteorologist, National Weather Service, Atlanta, GA

**Andrew Graettinger, Ph.D.**

Associate Professor, Civil, Construction, and Environmental Engineering, University of Alabama, Tuscaloosa, AL

**David Grau, Ph.D.**

Assistant Professor, Civil, Construction and Environmental Engineering, University of Alabama, Tuscaloosa, AL

**Billy Green**

Deputy Director, Tuscaloosa County Emergency Management Agency, Tuscaloosa, AL

**Rakesh Gupta, Ph.D.**

Professor, Wood Engineering and Mechanics, Oregon State University, Corvallis, OR

**Darwin Hathcock**

Chief of Police, Smithville Police Department, Smithville, MS

**Samuel Hensen, PE**

Engineering Manager, Simpson Strong Tie, McKinney, TX

**Larry Holcomb**

Director of Maintenance, Bradley County Schools, Cleveland, TN

**Ben Jennings, PE**

Structural Engineer, J&M Engineering, Springfield, MO

**Jeff Johnson**

Executive Director of Facilities, Tuscaloosa City Schools, Tuscaloosa, AL

**Michael Johnson**

Director of Buildings, Joplin School District, Joplin, MO

**Omar Kapur**

URS Group, Inc., Germantown, MD

**Vassiliki Koumoudis**

URS Group, Inc., Germantown, MD

**Erica Kuligowski, Ph.D.**

National Institute of Standards and Technology, Gaithersburg, MD

**James G. LaDue**

Meteorologist, Warning Decision Training Branch, National Weather Service, Norman, OK

**Kayed I. Lakhia, AIA, LEED AP, CFM**

URS Group, Inc., Boca Raton, FL

**Eric Letvin, PE, Esq., CFM**

National Institute of Standards and Technology, Gaithersburg, MD

**Philip Line, PE**

Director, Structural Engineering, American Wood Council, Leesburg, VA

**Julie Liptak**

Greenhorne & O'Mara, Laurel, MD

**Phyllis Little**

Director, Cullman County Emergency Management Agency, Cullman, AL

**Frank Lombardo**

National Institute of Standards and Technology, Gaithersburg, MD

**Bobbie Misner**

Greenbriar Nursing Home, Joplin, MO

**John Moyers**

Tennessee Emergency Management Agency, Nashville, TN

**Robert Norton**

Regional Vice President, Support Services/Facilities, St. John's Health System, Springfield, MO

**Richard Okulski**

Warning Coordination Meteorologist, National Weather Service, Memphis, TN

**Lynn Iliff Onstot**

Public Information Officer, City of Joplin Public Affairs, Joplin, MO

**Kelly Park, Ph.D.**

Structural Engineer, Hazard Mitigation Department, Greenhorne & O'Mara, Laurel, MD

**Shiling Pei, Ph.D., PE**

Assistant Professor, Structural Engineering, South Dakota State University, Brookings, SD

**Clif Penick**

City Facility Manager, Tuscaloosa, AL

**Long Phan**

National Institute of Standards and Technology

**David O. Prevatt, Ph.D., PE**

Assistant Professor, Civil and Coastal Engineering, University of Florida, Gainesville, FL

**Damon Raines**

Director of Operations, Catoosa County Public Schools, Catoosa County, GA

**Mitch Randles**

Fire Chief, Joplin Fire Department, Joplin, MO

**Brian Reading, PE**

Senior Engineer, APA – The Engineered Wood Association, Charlotte, NC

**Denia Reese**

Superintendent, Catoosa County Public Schools, Catoosa County, GA

**Thomas Reynolds, PE**

URS Group, Inc., Germantown, MD

**David Roberts**

Director of Construction, DCH Regional Medical Center, Tuscaloosa, AL

**Jeff Roberts**

Tuscaloosa Fire Station 4, Tuscaloosa, AL

**Steve Runnels**

Warning Coordination Meteorologist, National Weather Service, Springfield, MO

**Thomas Schmidlin, Ph.D.**

Professor, Department of Geography, Kent State University, Kent, OH

**Corey Schultz, AIA**

PBA Architects, Wichita, KS

**Adrienne Sheldon, PE, CFM**

URS Group, Inc., Germantown, MD

**Tilt-Up Concrete Association**

National Disaster Task Force, Mount Vernon, IA

**Tuscaloosa County, AL, Sheriff's Office**

**Bryan Wert, PE**

Branch Engineer, Simpson Strong Tie Co., Inc.

**Steve Wilmoth, Ph.D.**

Superintendent of Schools, Seneca R-7 School District, Seneca, MO

**Jimmy Yeung, Ph.D., PE**

Greenhorne & O'Mara, Laurel, MD





# TORNADO OUTBREAK of 2011

IN ALABAMA, GEORGIA, MISSISSIPPI,  
TENNESSEE, AND MISSOURI

## B References

- AMS (American Meteorological Society). 2000. *Glossary of Meteorology*. Boston: American Meteorological Society. Second Edition.
- ANSI/TIA (Telecommunications Industry Association). 2009. *Structural Standard for Antenna Supporting Structures and Antennas*, ANSI/TIA-222-G-2, Addendum 2. December.
- ANSI/TIA. 2005. *Structural Standard for Antenna Supporting Structures and Antennas*, ANSI/TIA-222-G. August.
- Arab Building Department. 2012. Telephone conversation with the author, May 2.
- ASCE. 2010. *Minimum Design Loads of Buildings and Other Structures*. ASCE Standard ASCE 7-10.
- ASCE. 2005. *Minimum Design Loads of Buildings and Other Structures*. ASCE Standard ASCE 7-05.
- ASCE. 1995. *Minimum Design Loads of Buildings and Other Structures*. ASCE Standard ASCE 7-95.
- ASTM International. 2009. *Standard Specification for Performance of Exterior Windows, Curtain Walls, Doors, and Impact Protective Systems Impacted by Windborne Debris in Hurricanes*, ASTM E1996. West Conshohocken, PA.
- Barnes, Lindsey R., Eve C. Grunfest, Mary H. Hayden, David M. Schultz, Charles Benight, 2007. "False Alarms and Close Calls: A Conceptual Model of Warning Accuracy." *Weather and Forecasting*, 22:1140–1147.
- Brotzge, J., S. Erickson, H. Brooks, 2011. "A 5-yr Climatology of Tornado False Alarms." *Weather and Forecasting*, 26:534–544.
- City of Birmingham, AL. "2007 Technical Code." <http://www.birminghamal.gov/planning/2007/2007TechnicalCode.pdf>.
- City of Birmingham, AL. "Technical Codes, 2010 Editions." <http://www.birminghamal.gov/DYS/citysite/pdf/pep/TECHNICAL%20CODE%20OF%20THE%20CITY%20OF%20BIRMINGHAM%202010.pdf>.

- City of Cleveland, TN. "Building Plans Review, Permits and Inspections, Frequently Asked Questions." Handout. <http://www.cityofclevelandtn.com/CommunityDev/Frequently%20asked%20Questions.pdf>.
- City of Huntsville, AL. "Codes Adopted by the City of Huntsville and Admentments to the Technical Codes," ORDINANCE NO. 05-80. [http://www.hsvcity.com/inspection/documents/CODES\\_ADOPTED\\_BY\\_CITY\\_OF\\_HUNTSVILLE\\_and\\_ADMENDMENTS.pdf](http://www.hsvcity.com/inspection/documents/CODES_ADOPTED_BY_CITY_OF_HUNTSVILLE_and_ADMENDMENTS.pdf).
- City of Joplin, MO. "Building Code and Enforcement, City of Joplin." Handout.
- City of Joplin. 2011. *Joplin, Missouri hit by EF-5 Tornado on May 22, 2011*. Fact Sheet – December 5, 2011. City of Joplin, Public Information Office: Joplin, MO.
- City of Ringgold, GA. "Building Inspection Department." <http://www.catoosa.com/depts/plan-zoning/BuildingInspection.htm>, accessed May 1, 2012.
- City of Tuscaloosa, AL. "Inspection Services, Codes." <http://www.ci.tuscaloosa.al.us/index.aspx?NID=290>.
- DeMonia, Robin. 2011. "Alabama tornadoes: Nursing home disaster plans under review." *The Birmingham News*: Birmingham, AL. July 22.
- DeRenzis, Andrew; Kochkin, Vladimir; and Ehrlich, Gary. 2010. *Evaluation of Wood Sole Plate Anchorage to Concrete under Monotonic and Cyclic Loading*, Prepared by the National Home Builders Research Center and published by ASCE. March.
- FEMA (Federal Emergency Management Agency). 2011a. *Coastal Construction Manual: Principles and Practices of Planning, Siting, Designing, Constructing, and Maintaining Residential Buildings in Coastal Areas*. FEMA P-55. August. Fourth Edition.
- FEMA, 2011b. *Critical Facilities Located in Tornado-Prone Regions: Recommendations for Architects and Engineers*, Recovery Advisory 6, Recovery Advisories from the Tornado MATs for Alabama, Mississippi, Tennessee, Georgia, and Missouri. August.
- FEMA, 2011c. *Critical Facilities Located in Tornado-Prone Regions: Recommendations for Facility Owners*, Recovery Advisory 5, Recovery Advisories from the Tornado MATs for Alabama, Mississippi, Tennessee, Georgia, and Missouri. July.
- FEMA, 2011d. *Rebuilding and Repairing Your Home After a Tornado*, Recovery Advisory 7, Recovery Advisories from the Tornado MATs for Alabama, Mississippi, Tennessee, Georgia, and Missouri. August.
- FEMA, 2011e. *Reconstructing Non-Residential Buildings After a Tornado*, Recovery Advisory 8, Recovery Advisories from the Tornado MATs for Alabama, Mississippi, Tennessee, Georgia, and Missouri. August.
- FEMA, 2011f. *Residential Sheltering: In-Residence and Stand-Alone Safe Rooms*, Recovery Advisory 3, Recovery Advisories from the Tornado MATs for Alabama, Mississippi, Tennessee, Georgia, and Missouri. June.
- FEMA, 2011g. *Safe Rooms and Refuge Areas in the Home*, Recovery Advisory 4, Recovery Advisories from the Tornado MATs for Alabama, Mississippi, Tennessee, Georgia, and Missouri. June.

- FEMA, 2011h. *Safe Rooms: Selecting Design Criteria*, Recovery Advisory 2, Recovery Advisories from the Tornado MATs for Alabama, Mississippi, Tennessee, Georgia, and Missouri. June.
- FEMA, 2011i. *Tornado Risks and Hazards in the Southeastern United States*, Recovery Advisory 1, Recovery Advisories from the Tornado MATs for Alabama, Mississippi, Tennessee, Georgia, and Missouri. June.
- FEMA. 2010a. *Design Guide for Improving School Safety in Earthquakes, Floods, and High Winds*. FEMA P-424. December.
- FEMA. 2010b. *Pre-Mitigation Assessment Team Report – Mississippi Tornado Outbreak, April 23rd – 24th: Damage and Safe Room Performance Observations, Recommendations, and Conclusions*. Unnumbered publication. July.
- FEMA. 2009a. *Hazard Mitigation Assistance for Safe Rooms*, Mitigation Interim Policy MMR-2-09-1, April 30.
- FEMA. 2009b. *Tornado Protection: Selecting Refuge Areas in Buildings*. FEMA P-431. October.
- FEMA. 2009c. *Unreinforced Masonry Buildings and Earthquakes: Developing Successful Risk Reduction Programs*. FEMA P-774. October.
- FEMA. 2008a. *Design and Construction Guidance for Community Safe Rooms*. FEMA 361. August. Second Edition.
- FEMA. 2008b. *Hazard Mitigation Assistance for Safe Rooms*, Mitigation Interim Policy MMR-2-07-1, March 7.
- FEMA. 2008c. *Taking Shelter From the Storm: Building a Safe Room For Your Home or Small Business*. FEMA 320. August. Third Edition.
- FEMA. 2007a. *Design Guide for Improving Critical Facility Safety from Flooding and High Winds: Providing Protection to People and Buildings*. FEMA 543. January.
- FEMA. 2007b. *Design Guide for Improving Hospital Safety in Earthquakes, Floods, and High Winds: Providing Protection to People and Buildings*. FEMA 577. June.
- FEMA. 2006. *Hurricane Katrina in the Gulf Coast: Mitigation Assessment Team Report, Building Performance Observations, Recommendations, and Technical Guidance*. FEMA 549. July.
- FEMA. 2000. *Design and Construction Guidance for Community Shelters*. FEMA 361. July. First Edition.
- FEMA. 1999a. *Building Performance Assessment Team Report: Oklahoma and Kansas, Midwest Tornadoes of May 3, 1999*. FEMA 342. October.
- FEMA. 1999b. *In-Residence and Small Business Safe Room Designs*. Drawing No. AG-06, sheet 11 of 18.
- FEMA. 1999c. *Taking Shelter from the Storm: Building a Safe Room Inside Your House*. FEMA 320. October. Second Edition.
- FEMA. 1998. *Taking Shelter from the Storm: Building a Safe Room Inside Your House*. FEMA 320. October. First Edition.
- FEMA. 1990. *Tornado Protection: Selecting and Designing Safe Areas in Buildings*. FEMA TR-83B. June.
- FEMA. 1980. *Interim Guidelines for Building Occupant Protection From Tornadoes and Extreme Winds*. TR-83A. September.

- Fujita, T.T. 1971. *Proposed characterization of tornadoes and hurricanes by area and intensity*. Satellite and Mesometeorology Research Project Report 91, the University of Chicago: Chicago, IL.
- Hamilton County, TN. Undated. "Hamilton County Building & Zoning." <http://www.hamiltontn.gov/inspect>, accessed May 1, 2012.
- ICC (International Code Council). 2012a. International Building Code. Birmingham, AL.
- ICC. 2012b. International Residential Code for One- and Two-Family Dwellings. Birmingham, AL.
- ICC. 2009a. International Building Code. Birmingham, AL.
- ICC. 2009b. International Residential Code for One- and Two-Family Dwellings. Birmingham, AL.
- ICC. 2008. *Standard for Residential Construction in High-Wind Regions*, ICC 600. Birmingham, AL.
- ICC. 2003a. International Building Code. Birmingham, AL.
- ICC. 2003b. International Residential Code for One- and Two-Family Dwellings. Birmingham, AL.
- ICC. Undated. Alabama Code Adoption Information. <http://www.iccsafe.org/gr/Documents/al.htm>, accessed May 1, 2012.
- ICC and NSSA (National Storm Shelter Association). 2008. *Standard for the Design and Construction of Storm Shelters*, ICC 500. Birmingham, AL.
- Jefferson County, AL. 2011. "ORDINANCE NO. 1800, An ordinance to adopt a Building Code for Jefferson County, Alabama." <http://jeffconline.jccal.org/inspectionervices/main/IS-BuildingCode.pdf>.
- Natural Disaster Taskforce. 2012. *Analysis of the Damage from Historic Tornado in Joplin, Missouri, U.S.A. on May 22, 2011*, a Report to the Technical Committee of the Tilt-Up Concrete Association: Mount Vernon, IA. Report 201-12-01. January 12.
- NOAA (National Oceanic and Atmospheric Administration). 2012. *2011 Tornado Fatality Information*. National Weather Service, Storm Prediction Center, Severe Weather Database, updated in January 2012. <http://www.spc.noaa.gov/climo/torn/2011eadlytorn.html>.
- NOAA. 2011. *Storm Prediction Center Warning Coordination Meteorologist's Page*. National Weather Service, Storm Prediction Center. <http://www.spc.noaa.gov/wcm>.
- NOAA. 2007a. *NOAA Service Assessment on Enterprise Tornado Demonstrates Need to Build Hazard Resilient Communities*. November 29. Available at: [http://www.noaanews.noaa.gov/stories2007/20071129\\_tornado.html](http://www.noaanews.noaa.gov/stories2007/20071129_tornado.html).
- NOAA. 2007b. *Service Assessment: Tornadoes in Southern Alabama and Georgia on March 1, 2007*. National Weather Service. November. Available at: [http://www.nws.noaa.gov/os/assessments/pdfs/AL-GA\\_tornadoes07.pdf](http://www.nws.noaa.gov/os/assessments/pdfs/AL-GA_tornadoes07.pdf).
- Prevatt, David O.; Coulbourne, William; Graettinger, Andrew; Pei, Shiling; Gupta, Rakesh; and Grau, David. 2011a. *The Joplin Tornado of 2011 – Damage Survey and Case for Tornado-Resilient Codes*. September 26.
- Prevatt, David O.; van de Lindt, John W.; Graettinger, Andrew; Coulbourne, William; Gupta, Rakesh; Pei, Shiling; Hensen, Samuel; and Grau, David. 2011b. *Damage Study and Future Direction for Structural Design Following the Tuscaloosa Tornado of 2011*. July 27.

- 
- Simmons K.M. and D. Sutter. 2011. *The Economic and Societal Impacts of Tornadoes*. Boston: American Meteorological Society.
- State of Missouri, Division of Facilities Management. 2007. *Designer Information Packet*. State of Missouri, Office of Administration, Division of Facilities Management, Design and Construction. April. [http://oa.mo.gov/fmdc/dc/fmdc\\_dip/index.htm](http://oa.mo.gov/fmdc/dc/fmdc_dip/index.htm).
- SBCCI (Southern Building Code Congress International). 1998. Standard Building Code. Janesville, WI.
- SBCCI. 1994. Standard Building Code. Janesville, WI.
- SBCCI. 1991. Standard Building Code. Janesville, WI.
- Tilt-Up Concrete Association. 2012. *Analysis of Damage from Historic Tornado in Joplin, Missouri, U.S.A. on May 22, 2011*, a Report to the Technical Committee of the Tilt-Up Concrete Association by the Natural Disaster Task Force. Report 201-12-01. January 12.
- Tornado Recovery Advisory Council of Alabama. 2012. *Cultivating a State Of Readiness: Our Response to April 27, 2011*. January. [http://tracalabama.org/wp-content/uploads/2012/01/TRAC\\_Report.pdf](http://tracalabama.org/wp-content/uploads/2012/01/TRAC_Report.pdf).
- Town of Smithville, MS. "Long-Term Recovery, Smithville Recovery News, Building Permits." Last modified June 21, 2011. <https://sites.google.com/site/smithvillelcr/hot-news-1/headline1>, accessed May 1, 2012.
- TTU (Texas Tech University). 2004. *A Recommendation for an Enhanced Fujita Scale*, Submitted to The National Weather Service and Other Interested Users, June 2004, Wind Science and Engineering Center, Texas Tech University: Lubbock, TX.
- TTU. 2006. *A Recommendation for an ENHANCED FUJITA SCALE (EF-Scale)*, Submitted to The National Weather Service and Other Interested Users, October 10, 2006, Revision 2, Wind Science and Engineering Center: Lubbock, TX.



TORNADO OUTBREAK  
*of* **2011**

IN ALABAMA, GEORGIA, MISSISSIPPI,  
TENNESSEE, AND MISSOURI



# Acronyms

<b>Acronym</b>	<b>Definition</b>
<b>ASCE</b>	American Society of Civil Engineers
<b>ASTM</b>	ASTM International
<b>ATC</b>	Applied Technology Council
<b>BOCA</b>	Building Code Administrators International
<b>C&amp;C</b>	components and cladding
<b>CAPE</b>	Convective Available Potential Energy
<b>CDT</b>	Central Daylight Time
<b>CMU</b>	concrete masonry unit
<b>COOP</b>	Continuity of Operations
<b>CWA</b>	County Warning Area
<b>dbZ</b>	decibels of Z
<b>DHS</b>	U.S. Department of Homeland Security
<b>DI</b>	damage indicator
<b>DOD</b>	degree of damage
<b>EF</b>	Enhanced Fujita
<b>EHI</b>	Energy Helicity Index
<b>EIFS</b>	exterior insulation and finishing systems
<b>EMA</b>	Emergency Management Agency

<b>EMS</b>	Emergency Management System
<b>EOC</b>	Emergency Operations Center
<b>EPDM</b>	ethylene propylene diene monomer
<b>FAR</b>	false alarm ratio
<b>FEMA</b>	Federal Emergency Management Agency
<b>FIMA</b>	Federal Insurance and Mitigation Administration
<b>HMGP</b>	Hazard Mitigation Grant Program
<b>HVAC</b>	Heating, ventilation, and air-conditioning
<b>HSS</b>	hollow structural steel
<b>IBC</b>	International Building Code
<b>ICBO</b>	International Conference of Building Officials
<b>ICC</b>	International Code Council
<b>ICU</b>	intensive care unit
<b>IRC</b>	International Residential Code
<b>ISO</b>	Insurance Services Office
<b>LASD</b>	Los Angeles Sherriff's Department
<b>LSU</b>	Louisiana State University
<b>LTVT</b>	long-track violent tornadoes
<b>MAT</b>	Mitigation Assessment Team
<b>mb</b>	Millibar
<b>MGD</b>	million gallons per day
<b>mph</b>	miles per hour
<b>mrh</b>	mean roof height
<b>MRI</b>	mean recurrence interval
<b>MWFRS</b>	Main Wind Force Resisting System
<b>NOAA</b>	National Oceanic and Atmospheric Administration
<b>NSF</b>	National Science Foundation
<b>NSSA</b>	National Storm Shelter Association
<b>NWS</b>	National Weather Service
<b>OSB</b>	oriented strand board
<b>OSU</b>	Oregon State University



<b>PDS</b>	particularly dangerous situation
<b>PEMB</b>	pre-engineered metal building
<b>PMAT</b>	Pre-Mitigation Assessment Team
<b>psi</b>	pounds per square inch
<b>QLCS</b>	quasi-linear convective system
<b>QRT</b>	Quick Response Team
<b>SBC</b>	Standard Building Code
<b>SBCCI</b>	Southern Building Code Congress International
<b>SDSU</b>	South Dakota State University
<b>SPC</b>	Storm Prediction Center
<b>SRH</b>	Storm-Relative Helicity
<b>TTU</b>	Texas Tech University
<b>UA</b>	University of Alabama
<b>UF</b>	University of Florida
<b>URM</b>	unreinforced masonry



TORNADO OUTBREAK  
*of* **2011**IN ALABAMA, GEORGIA, MISSISSIPPI,  
TENNESSEE, AND MISSOURI**D**  
**Glossary**

**Accessory structures:** Accessory structures are also called appurtenant structures. An accessory structure is a structure on the same parcel of property as a principal structure and the use of which is incidental to the use of the principal structure. For example, a residential structure may have a detached garage or storage shed for garden tools as an accessory structure. Other examples of accessory structures include gazebos, picnic pavilions, boathouses, small pole barns, storage sheds, and similar buildings.

**Advection:** The transfer of a property of the atmosphere, such as heat, cold, or humidity, by the horizontal movement of an air mass.

**Base reflectivity:** One of the three fundamental quantities (along with base [radial] velocity and spectrum width) that a Doppler radar measures. Reflectivity is related to the power, or intensity, of the reflected radiation that is sensed by the radar antenna. Base reflectivity is expressed on a logarithmic scale in units called dBZ (decibels of Z, where Z represents the energy reflected back to the radar). The term “base” refers to the product being “basic,” with little advanced processing performed on the data. Base reflectivity is related to rainfall intensity (e.g., drop size and rainfall rate) and hail size (for large values of reflectivity).

**Basic wind speed:** Three-second gust wind speed at 33 feet above the ground in Exposure C. (Exposure C is flat open terrain with scattered obstructions having heights generally less than 30 feet. See “Exposure category.”) Note: Since 1995, American Society of Civil Engineers (ASCE) standard ASCE 7 has used a 3-second peak gust measuring time. A 3-second peak gust is the maximum instantaneous speed with a duration of approximately 3 seconds. A 3-second peak gust wind speed could be associated with either a given windstorm (e.g., a particular storm could have a 40-mph peak gust speed), or a design level event (e.g., the basic wind speed prescribed in ASCE 7).

**Best available refuge area:** Per Federal Emergency Management Agency (FEMA) 431, *Tornado Protection: Selecting Refuge Areas in Buildings* (2009), a “best available refuge area is” an area in an existing building that have been deemed by a qualified architect or engineer to likely offer the greatest safety for building occupants during a tornado. It is important to note that, because these areas were not specifically designed as tornado safe rooms, their occupants may be injured or killed during a tornado. However, people in the best available refuge areas are less likely to be injured or killed than people in other areas of a building.

**Bond beam:** A structural member along the top of a bearing wall used to support and distribute roof loads. Bond beams are either reinforced concrete or reinforced masonry units.

**Bow echo:** A bow-shaped line of convective storm cells that is often associated with swaths of damaging straight-line winds and small tornadoes.

**Building:** A walled and roofed structure. A building includes not only the structure, but also the non-structural elements that complete a building, including walls, roof, glazing, interior finishes, and exterior finishes.

**Building envelope:** The entire exterior surface of a building, including roof and wall covering, exterior glazing and doors, skylights, and other components enclosing the building.

**Building footprint:** Land area occupied by the building.

**Communications tower:** A structure that supports antennae for cellular phones, Emergency Management Services, fire, police, and other critical functions.

**Components and cladding (C&C):** ASCE 7-10 describes C&C as elements of the building envelope that do not qualify as part of the Main Wind Force Resisting System (MWFRS). These elements include roof sheathing, roof coverings, exterior siding, windows, doors, soffits, fascia, and chimneys and include components of some MWFRS elements such as the chords of roof trusses.

**Continuous load path:** The condition required to resist loads acting on a building. The continuous load path starts at the point or surface where loads are applied (i.e., the building envelope), moves through the building, continues through the foundation, and terminates where the loads are transferred to the soils that support the building.

**Convective Available Potential Energy (CAPE):** One of two important parameters necessary to predict long-track violent tornadoes (LTVTs). High CAPE values represent an unstable atmosphere and are associated with warm weather and sunny skies. Locations in the mid-south experience their highest CAPE values during the summer months.

**Corbel:** A structural feature resembling a bracket that projects from a wall and supports a beam or ceiling.

**Critical facility:** A facility that is essential for the delivery of vital services or protection of a community. Critical facilities include, but are not limited to, hospitals, emergency operation centers, fire and police stations, schools, and primary utility facilities. Critical facilities are Category III and IV buildings as defined in ASCE 7.

**Cyclogenesis:** The development or strengthening of a circulating area of low pressure in the atmosphere which results in the development of a cyclone.

- Damage indicator (DI):** A category for buildings, structures, and trees used to estimate wind speeds on the Enhanced Fujita (EF) scale. The EF scale currently has 28 DIs, each of which have several degrees of damage (DODs).
- Debris rowing:** A phenomenon that occurs when wind-borne debris is spread in straight lines as a result of a tornado.
- Degree of damage (DOD):** Numbered level of damage for each DI used in estimating wind speeds on the EF scale. For each DI, several DODs are identified, increasing sequentially from slight visible damage to complete destruction of the particular DI.
- Design wind speed:** see “Basic wind speed.”
- Diffluent zone:** An area where wind spreads laterally in a fan-like pattern from a central axis parallel to the flow along the axis.
- Emergency Operations Center (EOC):** The physical location at which the coordination of information and resources to support incident management (on-scene operations) activities normally takes place. An EOC may be a temporary facility or may be located in a more central or permanently established facility, perhaps at a higher level of organization within a jurisdiction. EOCs may be organized by major functional disciplines (e.g., fire, law enforcement, and medical services), by jurisdiction (e.g., Federal, State, regional, tribal, city, county), or some combination thereof.
- Energy Helicity Index (EHI):** An index that incorporates CAPE and Storm Relative Helicity (SRH), two important parameters in the prediction of LTVTs.
- Enhanced code construction:** Construction that exceeds minimum building code requirements. Also commonly referred to as “Code-Plus” and “Fortified.” The exact meaning varies geographically because different States and communities have adopted and amended different building codes, or different editions of those codes, and thus have different minimum design and construction requirements.
- Enhanced Fujita (EF) scale:** A tornado strength rating model implemented by the National Weather Service (NWS) in 2007 that has six categories, from zero to five, representing damage from increasing wind speeds. The EF scale is an improvement of the previous Fujita scale that better relates wind speeds to levels of damage observed after a tornado. The EF scale contains 28 DIs for the type of building, structure or tree; each DI includes DODs, which are damage descriptors associated with an expected estimated wind speed.
- Exposure Category:** Wind exposure categories defined in ASCE 7 based on the terrain and obstructions surrounding a building. There are three exposure categories: Exposure Category B is for buildings in urban/suburban areas surrounded by low- to mid-rise buildings and/or wooded areas; Exposure Category C is for buildings in open terrain with scattered obstructions having heights generally less than 30 feet (includes the shoreline in hurricane-prone regions); and Exposure Category D is for buildings at the shoreline (except in hurricane-prone areas) with wind flowing over open water for at least 1 mile.
- Federal Emergency Management Agency (FEMA):** Independent agency created in 1979 to provide a single point of accountability for all Federal activities related to disaster mitigation and emergency preparedness, response, and recovery.

**Federal Insurance and Mitigation Administration (FIMA):** A component of FEMA which manages the National Flood Insurance Program (NFIP) and other programs designed to reduce future losses from natural disasters to homes, businesses, schools, public buildings, and critical facilities.

**Funnel cloud:** As defined by the National Oceanic and Atmospheric Administration (NOAA), a condensation funnel extending from the base of a cloud, associated with a rotating column of air that is not in contact with the ground. This is different from a tornado because it is not in contact with the ground and does not have a debris cloud.

**Gable end wall:** The vertical triangular end of an exterior wall above the eave line formed under a gable roof.

**Glazing:** Glass or transparent or translucent plastic sheet used in windows, doors, and skylights.

**Guy wire:** A tensioned cable used to add stability to a structure, such as a tower.

**Hardened area:** Areas that are designed and constructed to provide some level of protection, but do NOT necessarily meet International Code Council (ICC) / National Storm Shelter Association (NSSA) Standard for the Design and Construction of Storm Shelters (ICC 500) criteria or FEMA guidelines. These areas are commonly referred to by builders and homeowners as “shelters.”

**Hip roof:** A roof type composed of four sloping sides. A hip roof does not have any gable ends.

**Hook echo:** A radar reflectivity pattern characterized by a hook-shaped extension of a thunderstorm echo, usually in the right-rear part of the storm (relative to its direction of motion). A hook is often associated with a mesocyclone and indicates favorable conditions for tornado development.

**Importance Factor:** A multiplier that accounts for the degree of hazard to human life and damage to property. Importance Factors are given in ASCE 7-05 and earlier versions of the standard. Note: In ASCE 7-10, the Importance Factor was eliminated for wind loads because the degree of hazard to human life and property damage is accounted for by selecting the proper wind speed map.

**Jet streak:** The region in the jet stream where the wind speeds are highest.

**Linear bow echo:** A large convective system shaped like an archery bow on the radar; systems with this shape can produce severe straight-line winds and occasionally tornadoes.

**Long-track violent tornado (LTVT):** A strong tornado that stays on the ground for a relatively long time, creating a long track.

**Low-sloped roofs:** A category of roofs generally made of weatherproof membrane installed on slopes of 3:12 or less.

**Main Wind Force Resisting System (MWFRS):** ASCE 7-10 defines the MWFRS as an assemblage of structural elements designed to provide support and stability for the overall structure. The MWFRS consists of the foundation; floor supports (e.g., joists, beams); columns; roof rafters or trusses; and bracing, walls, and diaphragms that help transfer loads.

**Masonry infill wall:** A wall consisting of either steel or concrete frames with masonry inset between the openings.

- Mean recurrence interval (MRI):** An estimate of time between events with a common level of intensity; an estimate of the amount of time that would elapse between two wind events of the same strength.
- Mesoscale:** A meteorological phenomenon larger than microscale and storm-scale cumulus systems, but smaller than synoptic weather-scale systems; 10 to 1,000 kilometers in horizontal extent.
- Mitigation:** Any sustained action taken to reduce or eliminate long-term risk to people and property from hazards and their effects.
- Multiple vortex structure:** A type of tornado in which two or more columns of spinning air have a common center of rotation.
- National Oceanic and Atmospheric Administration (NOAA):** An agency within the United States Department of Commerce that specializes in the conditions of the oceans and atmosphere. NOAA reports daily weather forecasts, severe storm warnings, and climate monitoring to fisheries management, coastal restoration, and supporting marine commerce entities.
- National Weather Service (NWS):** One of six agencies in NOAA that produce weather, hydrologic, and climate forecasts and warnings for the United States, its territories, adjacent waters, and ocean areas for the protection of life and property and the enhancement of the national economy.
- Near-absolute protection:** The level of protection for which, based on our current knowledge of tornadoes and hurricanes, the occupants of a safe room will have a very high probability of being protected from injury or death.
- Occupancy Category:** For the purpose of applying the environmental loads of flood, wind, snow, earthquake, and ice, buildings and other structures are classified in ASCE 7-05 into one of four Occupancy Categories based on how they are used. Category I buildings are those that pose low hazard to human life if failure occurs; essential facilities are classified as Category IV. In ASCE 7-10, these are now called “Risk Categories.”
- Particularly dangerous situation (PDS):** A type of watch issued that implies an increased risk of severe and life-threatening weather, such as a major tornado outbreak.
- Prescriptive measures:** Guidance that has been predetermined and calculated for specific circumstances.
- Primary structural system:** A structural system that supports the building against all lateral and vertical loads.
- Quasi-linear convective system (QLCS):** A group of thunderstorms in a linear arrangement; also known as a “squall line.” Development of a QLCS depends on the cold pool produced by the storm and the environmental shear. The movement of the two components creates horizontal velocity that can create tornadoes.
- Redundancy:** The practice of using system components that, when another critical component fails, can resist the loads of the first component as well as its own; redundancies increase the reliability of structural performance.
- Retrofit:** Any change or combination of adjustments made to an existing building that is intended to reduce or eliminate damage to that building from natural hazards.

**Right mover:** A thunderstorm that moves appreciably to the right relative to the main steering winds and to other nearby thunderstorms. Right movers are typically associated with a high potential for severe weather. (Supercells are often right movers.)

**Risk Category:** A term defined in ASCE 7-10 based on the risk to human life, health, and welfare associated with potential damage or failure of the building. These Risk Categories dictate which design event MRI is used when calculating the building's resistance to these events. In ASCE 7-05, these are called "Occupancy Categories."

**Roof assembly:** An assembly of interacting roof components including roof deck, vapor retarder (if present), insulation, and membrane or primary weatherproof roof covering.

**Roof deck:** The structural component of a roof assembly that supports the roof system.

**Roof system:** A system of interacting roof components generally consisting of a membrane or primary roof covering and roof insulation (not including the roof deck) designed to weatherproof and sometimes improve the building's thermal resistance.

**Safe room:** A specially designed hardened structure that meets FEMA criteria and provides "near-absolute protection" from extreme wind events. The level of protection provided by a safe room is a function of the design wind speed and resulting wind pressure used in designing it, and of the wind-borne debris load criteria. To be considered a safe room, the structure must be constructed as detailed in the prescriptive plans in FEMA 320, *Taking Shelter From the Storm: Building a Safe Room For Your Home or Small Business* (2008), (for homes and small businesses) or designed and constructed to FEMA 361, *Design and Construction Guidance for Community Safe Rooms* (2008), (for communities) guidelines. FEMA 361 also contains guidance for homes and small businesses.

**Shortwave trough:** Also called "shortwave." A disturbance in the middle or upper part of the atmosphere that induces upward motion ahead of it. If other conditions are favorable, the upward motion can contribute to thunderstorm development ahead of a shortwave trough.

**Sill plate:** The bottom of the wall that provides the connection point between the wall and the foundation below.

**Squall line event:** According to NOAA, a squall line event is a line of active thunderstorms, either continuous or with breaks, including contiguous precipitation areas resulting from thunderstorms.

**Steep-slope roof:** A category of roofing that generally includes water-shedding types of roof coverings installed on slopes exceeding 3:12.

**Storm Relative Helicity (SRH):** One of two important parameters necessary to predict LTVTs. High SRH values promote rotating updrafts and are associated with wind shear (changing wind speed and wind direction with height in the atmosphere).

**Storm relative radial velocity:** Base velocity with the average motion of all storm centroids subtracted out. Storm relative radial velocity can be useful in finding mesocyclones or other circulation patterns. It is characterized on the Doppler radar by a tight couplet of green and blue colors moving toward the radar and red and orange colors moving away.



- Storm shelter:** Structures, buildings, or portions thereof designed and constructed to meet International Code Council (ICC) standard ICC-500 guidelines and provide life-safety protection from extreme weather events, such as tornadoes and hurricanes. Unlike safe rooms, storm shelters do not meet all FEMA criteria and are not considered to offer “near-absolute protection” in these weather events. Storm shelters can be for homes, small businesses, or communities.
- Structure:** A part of a building or a freestanding constructed element, such as a roof system, tower, or platform.
- Supercell:** According to NOAA, potentially the most dangerous of the convective storm types. Storms possessing this structure have been observed to generate the vast majority of long-lived strong and violent (F2 to F5) tornadoes, as well as downburst damage and large hail. It is defined as a thunderstorm consisting of one quasi-steady to rotating updraft that may exist for several hours.
- Synoptic weather observation:** A surface weather observation of sky cover properties, such as, the state of the sky, cloud height, atmospheric pressure (reduced to sea level), temperature, dew point, wind speed and direction, amount of precipitation, and other special phenomena made periodically for the same area.
- Tilt-up wall construction:** A type of construction during which pre-cast panels, usually concrete, are lifted (tilted) into place on a concrete foundation. These walls may be self-supporting or part of a steel load-bearing framework.
- Tornado:** A violently rotating column of air, often visible as a funnel cloud, suspended from a cumuliform cloud or underneath a cumuliform cloud.
- Tornado outbreak:** An event that occurs when 6 or more tornadoes occur within approximately 24 hours in the same region from the same synoptic-scale weather system.
- Tornado track:** The path that the tornado follows or is predicted to follow.
- Tornado refuge area:** Any location where people go to seek cover during a tornado. Tornado refuge areas may have been constructed to comply with basic building code requirements (that do not consider tornado hazards). These areas may also have continuous load paths, bracing, or other features that increase resistance to wind loads. It is important for people to know that such an area may not be a safe place to be when a tornado strikes and they still may be injured or killed during a tornado event.
- Tributary area:** The area of the floor, wall, roof, or other surface that is supported by the element. The tributary area is formed by one-half the distance to the adjacent element in each applicable direction.
- Trough:** An elongated region of relatively low atmospheric pressure often associated with fronts, but not usually associated with a closed circulation.
- Uplift:** An upward force caused by winds perpendicular to the uplift direction caused by a sudden change in wind direction caused by an object blocking the airstream (i.e., a building). Uplift can occur on structural and non-structural components from wind forces.
- Velocity couplet:** A tornado vortex signature that appears on the Doppler radar as side-by-side velocities—one inbound and one outbound. It is also known as “gate-to-gate shear.”

**Vortex:** The core of the tornado. In this region of the tornado, the winds are complicated and include the peak at-ground wind speeds, but are dominated by the tornado's strong rotation. It is in this region that strong upward motions occur that carry debris upward, as well as around the tornado.

**Vulnerability assessment:** An assessment that is focused on building and operational weaknesses when impacted by a particular hazard event. Results of the assessment would be used to determine what mitigation activities would most likely reduce the vulnerability.

**Wedge structure:** A profile formed by a large single-vortex tornado that resembles a wedge stuck in the ground. Sometimes a wedge can be so wide that it appears to be a large block of low-hanging clouds.

**Wind-borne debris (missiles):** Debris that becomes airborne during a wind event.

**Wind field:** The spatial three-dimensional pattern of winds in a region.

TORNADO OUTBREAK  
*of* **2011**IN ALABAMA, GEORGIA, MISSISSIPPI,  
TENNESSEE, AND MISSOURI **EF Scale Summary**

Currently, tornado intensity is classified using the “Enhanced Fujita” (EF) scale, which improves upon the original Fujita scale. The Fujita scale, originally developed by Dr. Tetsuya T. Fujita in 1971 (Fujita 1971), provided a method to rate tornado intensity by examining the affected area. Since there was no reliable method to accurately determine the wind speed of a tornado, the method allowed people to distinguish between weak and strong tornadoes using the damage caused by the tornado. The Fujita scale was updated and superseded by the EF scale, published in 2004 in *A Recommendation for an Enhanced Fujita Scale* (TTU 2004) and clarified in 2006 (TTU 2006).<sup>1</sup> The 2006 revision to this document clarified the steps in assigning an EF scale rating to a tornado event. More detailed information can be found at the TTU Wind Science and Engineering Research Center Web site.<sup>2</sup>

The EF scale is an important factor considered by architects and engineers in their evaluation of damage following a tornado. Its use has made it easier to distinguish those areas that are outside of the center of the tornado circulation and which experience lesser wind speeds; these are areas where wind-resistant design practices may reduce damage. It was important for the Mitigation Assessment Team (MAT) to document the EF scale rating at each damaged building it visited, as the increased clarity provided by the EF scale allows the MAT to better evaluate and recommend wind-resistant design practices that may be applicable for certain wind speeds.

The EF scale is presented similarly to the original Fujita scale. The EF scale includes six categories, from 0 to 5, that represent increasing degrees of wind damage (see Figure E-1). The wind speed correlation estimates for each category were improved upon from the estimates used in the original Fujita scale. Table E-1 shows the relationship between the 3-second gust speeds of the original Fujita scale and the EF scale.

<sup>1</sup> Available online from TTU at <http://www.depts.ttu.edu/weweb/Pubs/fscale/EFScale.pdf>.

<sup>2</sup> TTU Wind Science and Engineering Research Center Web site, [www.wind.ttu.edu](http://www.wind.ttu.edu).

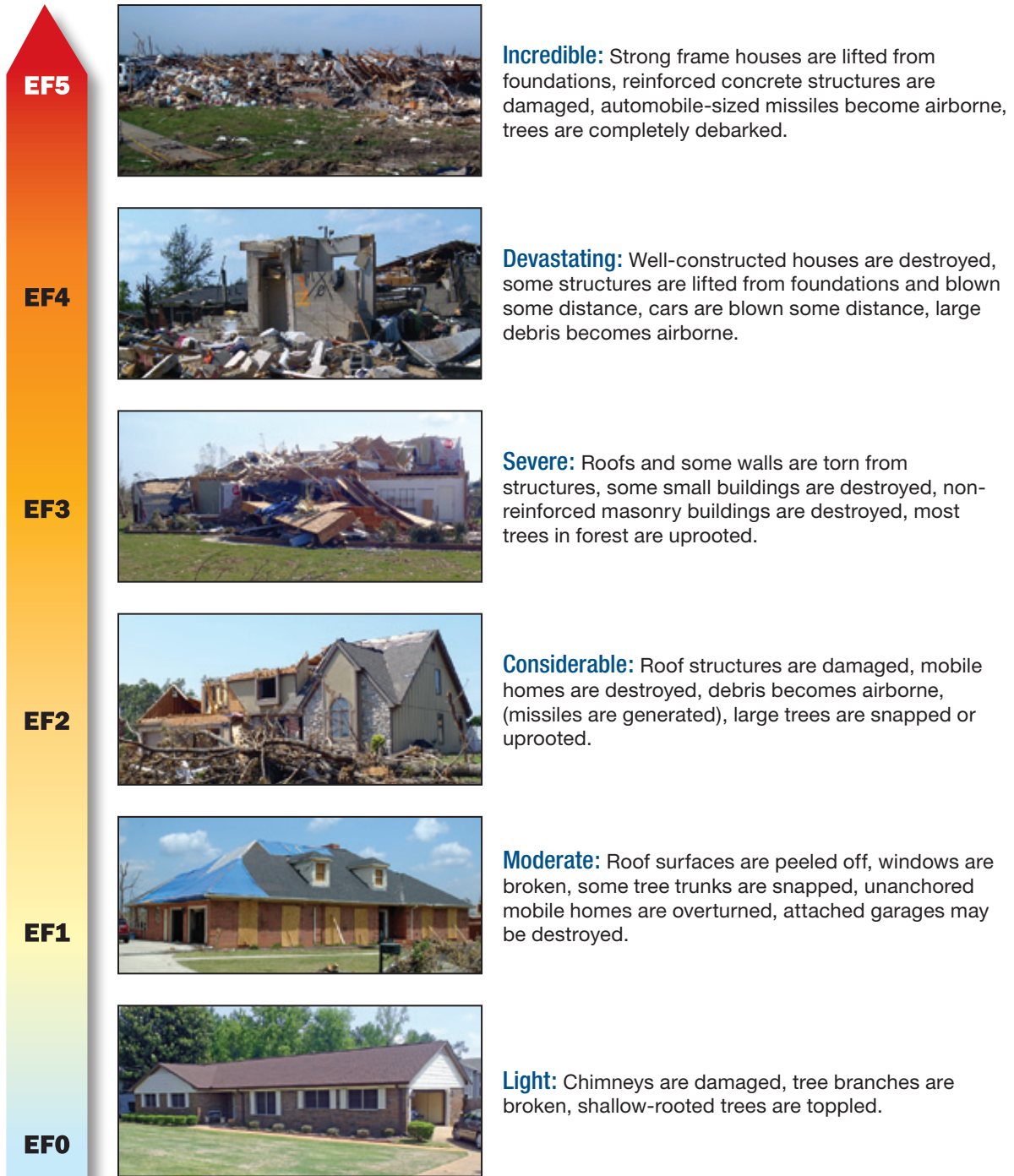

Figure E-1: The EF scale is based on level of typical observed damage

Table E-1: Wind Speeds Used in Fujita Scale Compared to EF Scale

Fujita Scale	Fujita Scale: 3-Second Gust (mph)	EF Scale	EF Scale: 3-Second Gust (mph)
F0	45–78	EF0	65–85
F1	79–117	EF1	86–110
F2	118–161	EF2	111–135
F3	162–209	EF3	136–165
F4	210–261	EF4	166–200
F5	262–317	EF5	Over 200

mph = miles per hour; EF = Enhanced Fujita

The EF scale uses 28 damage indicators (DIs) to categorize building use and type of construction (Table E-2). Each DI includes damage description categories; each is assigned a number termed the degree of damage (DOD), and each has a damage description associated with an expected estimated wind speed. Table E-3 shows an example of the DOD and damage descriptions for a single-family residence. The DOD includes the expected wind speed that would most likely produce the observed damage. Photographs are included in the supporting documentation for the EF scale in *A Recommendation for an Enhanced Fujita Scale* (TTU 2006) to assist investigators.

Table E-2: EF Scale Damage Indicators

DI No.	Damage Indicator (DI)	Use
1	Small Barns or Farm Outbuildings (SBO)	Residential
2	One- to Two-Family Residences (FR12)	
3	Manufactured Home – Single Wide (MHSW)	
4	Manufactured Home – Double Wide (MHDW)	
5	Apartments, Condos, Townhouses [three stories or less] (ACT)	
6	Motel (M)	Commercial and Retail Structures
7	Masonry Apartment or Motel Building (MAM)	
8	Small Retail Building [fast food restaurant] (SRB)	
9	Small Professional Building [e.g., doctor’s office, branch bank] (SPB)	
10	Strip Mall (SM)	
11	Large Shopping Mall (LSM)	
12	Large, Isolated Retail Building [e.g., K-Mart, Wal-Mart] (LIRB)	
13	Automobile Showroom (ASR)	
14	Automobile Service Building (ASB)	Schools
15	Elementary School [single story; interior or exterior hallways] (ES)	
16	Junior or Senior High School (JHSH)	Professional Buildings
17	Low-Rise Building [1–4 stories] (LRB)	
18	Mid-Rise Building [5–20 stories] (MRB)	
19	High-Rise Building [more than 20 stories] (HRB)	
20	Institutional Building [e.g., hospital, government, or university] (IB)	

**Table E-2: EF Scale Damage Indicators (concluded)**

DI No.	Damage Indicator (DI)	Use
21	Metal Building Systems (MBS)	Metal Buildings and Canopies
22	Service Station Canopy (SSC)	
23	Warehouse Building [tilt-up walls or heavy timber construction] (WHB)	
24	Transmission Line Towers (TLT)	Towers/Poles
25	Free-Standing Towers (FST)	
26	Free-Standing Light Poles, Luminary Poles, Flag Poles (FSP)	
27	Trees: Hardwood (TH)	Vegetation
28	Trees: Softwood (TS)	

EF = Enhanced Fujita, DI = damage indicator

SOURCE: RECOMMENDATION FOR AN ENHANCED FUJITA SCALE (TTU 2006)

**Table E-3: Example – EF Scale DOD for DI No. 2 (Single-Family Residence)**

DOD	Damage Description	Lower- and Upper-Bound Wind Speed Range (3-second gust in mph)	Expected Wind Speed (3-second gust in mph)
1	Threshold of visible damage	53–80	65
2	Loss of roof covering material (<20%), gutters, and/or awning; loss of vinyl or metal siding	63–97	79
3	Broken glass in doors and windows	79–114	96
4	Uplift of roof deck and loss of significant roof covering material (>20%); collapse of chimney; garage doors collapse inward; failure of porch or carport	81–116	97
5	Entire house shifts off foundation	103–141	121
6	Large sections of roof structure removed; most walls remain standing	104–142	122
7	Exterior walls collapsed	113–153	132
8	Most walls collapsed except small interior rooms	127–178	152
9	All walls collapsed	142–198	170
10	Destruction of engineered and/or well-constructed residence; slab swept clean	165–220	200

EF = Enhanced Fujita, DOD = degree of damage, DI = damage indicator

(a) The differences between “expected,” “upper bound,” and “lower bound” wind speeds are relatively complex. When assessing typical DIs, professionals familiar with wind effects on buildings and familiar with building sciences should be consulted.

SOURCE: RECOMMENDATION FOR AN ENHANCED FUJITA SCALE (TTU 2006)

After a tornado event, assessment teams rate the intensity of the tornado based on observed damage to individual buildings, structures, or other DIs (as shown in Table E-2) using damage descriptions for each DI (such as the example shown in Table E-3) to determine the appropriate DOD. Structures along the path of a tornado may be assigned several different EF ratings ranging from EF0 to EF5, based on their location within the center of the tornado circulation. Several DIs must be considered when assigning an EF scale rating for a tornado event; therefore, although the EF rating assigned

to individual structures may vary along the path of a tornado, the overall tornado intensity is assigned a single rating. For archival purposes, a tornado is officially labeled by the NWS according to its highest intensity along its path.

To assign an accurate EF scale ranking to a tornado event, several DIs must be rated.

The EF scale is still evolving and may be revised based on field observations made by post-tornado assessment teams. For instance, the MAT noted in its report that the EF scale currently does not include listings for all possible DIs, nor does it include photographic documentation of all DODs (refer to Section 10.7 and Section 11.7 of the MAT report). A focus of the MATs and other storm researchers is to provide additional data that can be incorporated in future updates and refinements to the EF scale and the EF methodology.

Using the EF methodology, the MAT evaluated buildings it visited. The EF ratings given by the MAT for sites visited in Alabama, Georgia, Mississippi, and Tennessee are shown in Table E-4 and for Joplin, MO, in Table E-5. Characteristics such as building age, code built to, siting, construction methods, etc. can affect the amount of damage caused by a tornado; these characteristics can therefore cause a deviation (either lower or higher) between the observed damage and resulting DOD rating and the expected wind speed assigned in the EF scale.

Table E-4: MAT EF Ratings for Sites Visited in Alabama, Georgia, Mississippi, and Tennessee

MAT EF Scale Ratings by Location: AL, GA, MS, TN						
Municipality	Location	Latitude	Longitude	Analysis		
				DI	DOD	EF Rating
<b>Alabama</b>						
<b>Athens</b>	McCulley Mill Road residence near shelter	34.76957	-86.8635	2	6	<b>2</b>
<b>Birmingham</b>	Apartment building	33.53808	-86.8907	5	4	<b>2</b>
<b>Cullman</b>	3rd Street NE historic residence	34.17959	-86.8325	2	7	<b>2</b>
	Three-story church/school	34.17846	-86.8339	20	7	<b>2</b>
<b>Hackleburg</b>	Ray Road residence adjacent to Hackleburg Community Shelters	34.28556	-87.8208	2	8	<b>3</b>
	Hackleburg Police Station	34.27583	-87.8272	9	8	<b>2</b>
	Hackleburg School Complex: Elementary, Junior High, and High School	34.28111	-87.8331	15	7	<b>2</b>
	Hackleburg Fire Department	34.27556	-87.8275	21	3	<b>1</b>
<b>Harvest</b>	Doris Avenue single-family home adjacent to manufactured home	34.82223	-86.7746	2	2	<b>0</b>
	Placid Drive residence #1	34.83972	-86.7347	2	4	<b>1</b>
	Placid Drive residence #2	34.84028	-86.7350	2	6	<b>2</b>
	Doris Avenue single-wide manufactured home	34.82216	-86.7741	3	7	<b>1</b>
	Lockhart Road double-wide manufactured home	34.81996	-86.7711	4	1	<b>0</b>

Table E-4: MAT EF Ratings for Sites Visited in Alabama, Georgia, Mississippi, and Tennessee (continued)

MAT EF Scale Ratings by Location: AL, GA, MS, TN						
Municipality	Location	Latitude	Longitude	Analysis		
				DI	DOD	EF Rating
<b>Alabama (continued)</b>						
<b>Fultondale</b>	Residential neighborhood	33.60716	-86.7947	2	6	<b>1</b>
	Fultondale Fire Station	33.60909	-86.7995	21	3	<b>1</b>
<b>Phil Campbell</b>	Stalcup Circle residences	34.34583	-87.7075	2	6	<b>2</b>
	Phil Campbell Middle and High School	34.34944	-87.7078	16	8	<b>2</b>
<b>Pleasant Grove</b>	Safe Room at 10th Street residence	33.48378	-86.9874	2	2	<b>0</b>
	6th Way residence	33.49162	-86.9818	2	8	<b>4</b>
	12th Street residence #1	33.48031	-86.9975	2	9	<b>4</b>
	12th Street residence #2	33.48035	-86.9988	2	9	<b>4</b>
	12th and 13th Streets residences	33.48030	-86.9975	2	10	<b>4</b>
<b>Rainsville</b>	Plainview Schools:					
	High school	34.48156	-85.8222	16	3	<b>1</b>
	Elementary school	34.48156	-85.8222	15	5	<b>1</b>
<b>Tuscaloosa</b>	5th Street residence	33.21083	-87.4831	2	2	<b>0</b>
	Two-family residences:					
	Building 40	33.18619	-87.5522	2	3	<b>1</b>
	Main structure on 10th Avenue	33.18482	-87.5523	2	8	<b>3</b>
	Crescent Lane residence on top of ridge	33.21556	-87.4886	2	9	<b>4</b>
	Hardened area "shelter" at 16th Street E residence	33.19662	-87.5317	2	9	<b>4</b>
	Manufactured housing park:					
	Unit B	33.20566	-87.4927	3	3	<b>0</b>
	Unit A	33.20566	-87.4927	3	7	<b>1</b>
	Apartment buildings at 5th Avenue E	33.19377	-87.5301	5	2	<b>1</b>
	LaRocca Nursing Home	33.21063	-87.4925	5	4	<b>2</b>
	Chastain Manor Apartments:					
	Townhouses (one-story)	33.21199	-87.4954	5	4	<b>3</b>
	Townhouses (two-story)	33.21193	-87.4945	5	6	<b>4</b>
	Apartment building behind Fire station 4	33.20632	-87.5097	5	5	<b>3</b>
	Tuscaloosa Police Station	33.20689	-87.5039	9	3	<b>1</b>
	Retail stores "A" and "B"	33.19993	-87.5240	12	7	<b>4</b>



Table E-4: MAT EF Ratings for Sites Visited in Alabama, Georgia, Mississippi, and Tennessee (concluded)

MAT EF Scale Ratings by Location: AL, GA, MS, TN						
Municipality	Location	Latitude	Longitude	Analysis		
				DI	DOD	EF Rating
<b>Alabama (concluded)</b>						
<b>Tuscaloosa (concluded)</b>	Armed Forces Reserve Center:					
	Building behind main building with service bays	33.18652	-87.5515	14	4	<b>1</b>
	Low-rise building	33.18676	-87.5514	17	4	<b>1</b>
	Alberta Elementary School	33.20796	-87.5025	15	10	<b>4</b>
	University Place Elementary School	33.19301	-87.5393	16	10	<b>3</b>
	Fitness center	33.20053	-87.5217	21	7	<b>3</b>
	Curry Building city complex EOC	33.17961	-87.5629	23	7	<b>3</b>
	Communications Tower at 35th Street	33.17793	-87.5637	25	3	<b>2</b>
<b>Georgia</b>						
<b>Ringgold</b>	Middle school	34.92238	-85.1127	16	6	<b>1</b>
	High school	34.92234	-85.1130	16	6	<b>1</b>
<b>Mississippi</b>						
<b>Smithville</b>	Brasfield Lane residence adjacent to below-ground shelter	34.06278	-88.4072	2	6	<b>2</b>
	Gum Street residence in front of old cellar/shelter	34.07111	-88.3917	2	6	<b>2</b>
	Below-ground shelter at Poplar Street residence	34.07083	-88.3958	2	9	<b>4</b>
	Community shelter at manufactured housing park at Commerce and Dunlap Streets	34.06972	-88.3997	3	9	<b>3</b>
	Police Station	34.06889	-88.3982	9	8	<b>3</b>
	Fire Station	34.06722	-88.3981	21	3	<b>1</b>
	Cell tower	34.06444	-88.4103	25	2	<b>3</b>
<b>Tennessee</b>						
<b>Cleveland</b>	Blue Springs Elementary School	35.08809	-84.9094	15	6	<b>1</b>

Table E-5: MAT EF Scale Ratings for Sites Visited in Joplin, MO

MAT EF Scale Ratings by Location: Joplin, MO					
Location	Latitude	Longitude	Composite		
			DI	DOD	EF Rating
Safe Room at Alabama Avenue residence	37.06656	-94.4861	2	4	1
Safe Room at Adele Avenue residence	37.0614	-94.5391	2	9	3
Mercy Village Apartments	37.06009	-94.5263	5	3	2
Greenbriar Nursing Home	37.06294	-94.5209	9	9	3
Walmart	37.0729	-94.4716	12	6	4
Home Depot	37.06958	-94.4744	12	7	4
East Joplin Middle School	37.06764	-94.4489	16	7	2
Joplin High School	37.06757	-94.5054	16	11	3
Ozark Center for Autism - Jackson Ave	37.06397	-94.5218	17	5	3
St. John's Medical Center	37.05933	-94.5322	20	10	3
St. Paul's United Methodist Church	37.06271	-94.5441	21	3	1

T O R N A D O   O U T B R E A K  
*of* **2011**IN ALABAMA, GEORGIA, MISSISSIPPI,  
TENNESSEE, AND MISSOURI**F** Recovery Advisories for  
the Spring 2011 Tornadoes

FEMA has prepared a series of new Recovery Advisories (RAs) that present guidance for safe room and refuge areas, facility operations, and the design and reconstruction of buildings in areas subject to tornadoes. Eight advisories have been prepared and are included in this appendix:

- RA1.** Tornado Risks and Hazards in the Southeastern United States
- RA2.** Safe Rooms: Selecting Design Criteria
- RA3.** Residential Sheltering: In-Residence and Stand-Alone Safe Rooms
- RA4.** Safe Rooms and Refuge Areas in the Home
- RA5.** Critical Facilities Located in Tornado-Prone Regions:  
Recommendations for Facility Owners
- RA6.** Critical Facilities Located in Tornado-Prone Regions:  
Recommendations for Architects and Engineers
- RA7.** Rebuilding and Repairing your Home After a Tornado
- RA8.** Reconstructing Non-Residential Buildings After a Tornado

These advisories are also available online at <http://www.fema.gov/library/viewRecord.do?id=4723>



# Tornado Risks and Hazards in the Southeastern United States



FEMA

## TORNADO RECOVERY ADVISORY

RA1, June 2011

### Purpose and Intended Audience

The purpose of this Tornado Recovery Advisory is to provide background on the tornado hazard in the Southeast. The general population, homeowners and renters, policy makers, local officials, builders, and building departments should understand that tornado occurrence in the Southeast is not a rare event. In fact, of the top 20 States in tornado frequency, 5 are in the Southeast.

This advisory also identifies FEMA resources that can be used to help design and construct portions of almost any building type (including residences) to provide safe refuge from tornadoes, or to help minimize damage caused by these wind events.

#### This Recovery Advisory Addresses:

- Recent events
- Tornado occurrence outside “Tornado Alley”... how great is the risk?
- Assessing your risk
- Can a building survive a tornado? Yes!
- Weather radios

### Recent Events

In the late afternoon of April 27, 2011, a large outbreak of tornadoes struck Mississippi, Tennessee, Alabama, and portions of Georgia. The National Oceanic and Atmospheric Administration (NOAA) estimated there were approximately 190 tornadoes that touched down between 8:00 a.m.

EDT April 27 and 8:00 a.m. EDT April 28, a record high for a single storm system. Three of the tornadoes were rated by the National Weather Service (NWS) as EF5, 11 were rated at EF4, 21 at EF3, and the remainder at EF2 and below on the Enhanced Fujita Scale. Fatalities for the events in April totaled 361<sup>1</sup> and hundreds more were injured, making April 27<sup>th</sup> the fourth deadliest day for tornadoes on record.<sup>2</sup> Total damage estimates are still being compiled from this event, but early estimates are that the insured loss for the storms could reach \$6 billion, with Alabama accounting for 70 percent of that loss.<sup>3</sup>

On May 22, 2011, Joplin, Missouri, a town of 50,000 people, was devastated by a large tornado. NWS estimated that the tornado was an EF5 (greater than 200 mph) tornado. At the time of publication of this Recovery Advisory, 141 people from Joplin have been confirmed dead and 750 people reported as injured. The Joplin tornado is the deadliest single tornado since modern recordkeeping began in 1950 and is ranked eighth among the deadliest tornadoes in U.S. history.<sup>4</sup> Total damage estimates could reach \$3 billion.<sup>5</sup>

The National Weather Service uses the Enhanced Fujita Scale (EF Scale) to categorize tornado severity based on observed damage. The scale ranges from EF0 to EF5. See <http://www.spc.noaa.gov/efscale> for further information on the EF Scale.

EF Scale	3-Second Gust Speed (mph)
EF0	65–85
EF1	86–110
EF2	111–135
EF3	136–165
EF4	166–200
EF5	Over 200

1 NOAA, 2011. <http://www.spc.noaa.gov/climo/torn/fatalorn.html> accessed 5/27/11

2 NOAA, 2011. [http://www.noaa.gov/news/april\\_2011\\_tornado\\_information.html](http://www.noaa.gov/news/april_2011_tornado_information.html) accessed 5/17/11

3 Gow, Lauren. May 17, 2011. “US tornado insured losses could reach \$6bn” in Global Reinsurance

4 SOURCE: [http://www.crh.noaa.gov/sgf/?n=event\\_2011may22\\_summary](http://www.crh.noaa.gov/sgf/?n=event_2011may22_summary) accessed 5/27/11

5 SOURCE: [http://money.cnn.com/2011/05/24/news/economy/tornado\\_joplin/index.htm](http://money.cnn.com/2011/05/24/news/economy/tornado_joplin/index.htm) accessed 5/27/11

## Tornado Occurrence Outside “Tornado Alley”... How Great Is the Risk?

“Tornado Alley” is an area of the heartland of the United States known for its tornado activity. Although the exact extent of Tornado Alley can be debated, most scientists agree that Texas, Oklahoma, and Kansas are well known for tornado risk and make up a large portion of Tornado Alley.

What most people may not be aware of is the amount of tornadic activity outside of Tornado Alley. FEMA Region IV has eight States subject to tornadoes and six subject to hurricanes (refer to Figure 1 and Table 1).

Although hurricanes have received most of the attention in recent years in the Southeast, the threat and risk of tornadoes is real. Table 1 below shows the number of tornadoes occurring in each of the States in FEMA Region IV. A total of 11,629 tornadoes were recorded by NOAA’s Storm Prediction Center for the 60-year study period from 1950 through 2010. Between 2000 and 2010, Alabama alone experienced 636 tornadoes.

Except for in the States of Mississippi and Alabama, tornadoes occurring in the Southeast are typically weak to moderately strong (EF0, EF1, EF2, and EF3 tornadoes). However, these weaker tornadoes can be as deadly as the stronger (EF4 or EF5) tornadoes. For example, more than 50 of the 78 deadliest tornadoes that occurred in Florida between 1882 and 2007 were EF3 or weaker. Further, tornadoes are not always single events; sometimes several tornado outbreaks result from a large storm system.

In addition to the April 27, 2011, outbreak, other notable outbreaks in the Southeast include:

### The Super Outbreak of April 3–4, 1974

- 148 tornadoes responsible for 330 fatalities
- Approximately 5,484 injuries
- Approximately \$600 million (1975 dollars) in damages
- Tornadoes affected 13 States from Alabama to Michigan

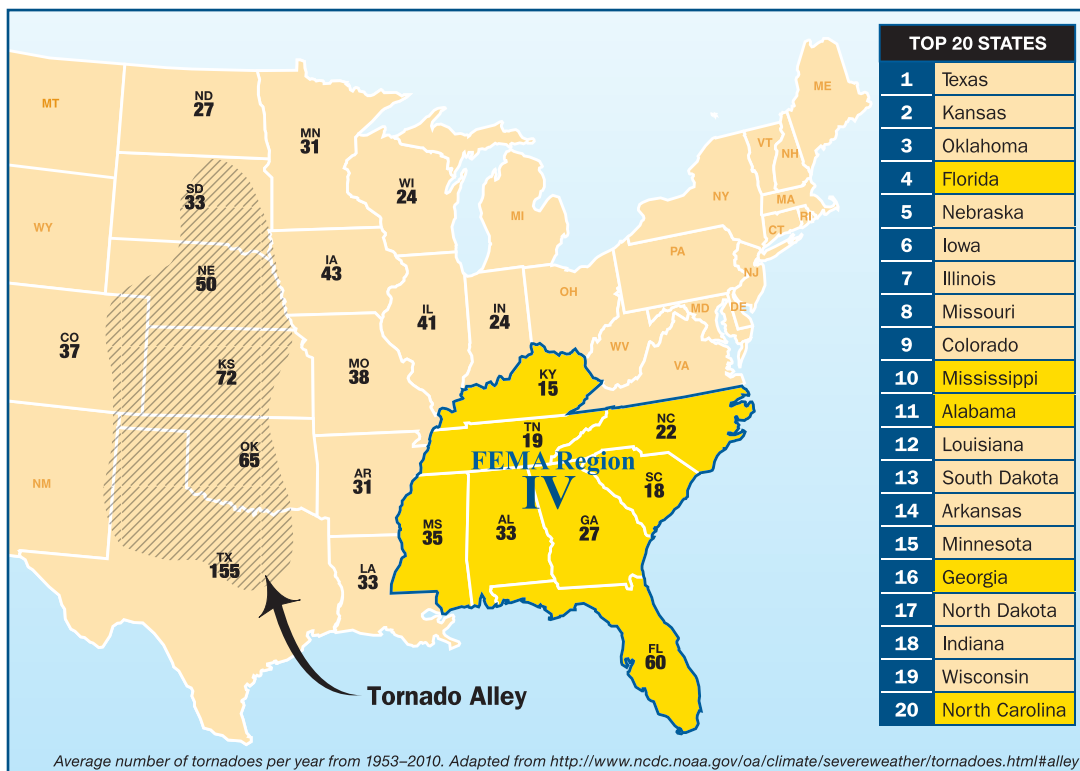

Figure 1: Average number of tornadoes per year in FEMA Region IV and Tornado Alley

Table 1: Tornado occurrences in FEMA Region IV

States in FEMA Region IV	Total Tornado Occurrences (1950–2010)	Total Fatalities (1950–2010)	Total Injuries (1950–2010)	Fatality Rank
Alabama	1,695	441	6,808	4
Florida	3,052	161	3,307	16
Georgia	1,381	190	4,059	14
Kentucky	741	180	3,310	15
Mississippi	1,790	443	6,223	2
North Carolina	1,116	114	2,536	17
South Carolina	894	60	1,693	23
Tennessee	960	399	5,114	5
<b>TOTAL</b>	<b>11,629</b>	<b>1,988</b>	<b>33,050</b>	

Values do not include Spring 2011 tornadoes.  
SOURCE: TornadoHistoryProject.com, which compiles NOAA Storm Prediction Center data found at <http://www.spc.noaa.gov/wcm/#data>

### **The Carolinas Outbreak of March 28, 1984**

- 22 tornadoes responsible for 57 fatalities
- Approximately 1,250 injuries
- Approximately \$200 million (1984 dollars) in damages
- 37 percent of fatalities occurred in manufactured homes

### **The Palm Sunday Outbreak of March 27, 1994**

- 27 tornadoes responsible for 42 fatalities
- Approximately 491 injuries
- Approximately \$107 million (1994 dollars) in damages
- Tornadoes hit Alabama, Georgia, South Carolina, and North Carolina

### **The Enterprise, Alabama Tornado of March 1, 2007**

- 8 fatalities and 50 injuries in Enterprise High School
- The fatalities occurred when walls and roof structure collapsed onto a group of students huddled in the hallway in a crouched position
- Tornado estimated at an EF4

In 2010, the Alabama Building Commission passed a bill (Act 2010-746 Safe Space) requiring that all new K-12 school construction projects awarded after July 1, 2010, provide a storm shelter that complies with the ICC-500 storm shelter standard. This was in large part due to the tragic events of March 1, 2007, when a tornado destroyed the Enterprise High School, killing 7 students and 1 teacher.

## **Assessing Your Risk**

To determine if you have a low, moderate, or high tornado risk, use the Frequency map (Figure 2) to determine how many tornadoes were recorded per 2,470 square miles for the area where your building is located. Find the row in Table 2 that matches that number. Next, look at the Wind Speed map (Figure 3) and note the design wind speed (130 mph, 160 mph, 200 mph, 250 mph) for your building location. Find the matching column in Table 2 and find the box that lines up with both the number of tornadoes per 2,470 square miles in your area and your wind speed. The color in that box tells you the level of your risk from extreme winds and helps you decide whether to build a safe room. A safe room is the preferred method of wind protection in high-risk areas.

*Example:* If your building is located in Birmingham, Alabama, you would see that Birmingham is in an area shaded red on the Frequency map (Figure 2). According to that map, the number of tornadoes per 2,470 square miles in the Birmingham area is >15. On the Wind Speed map (Figure 3), Birmingham is within the dark blue area, identified by the map key with a design wind speed of 250 mph. The box in the Risk Table (Table 2) where the frequency >15 row and the 250 mph wind speed column meet is shaded dark blue, which shows that the building is in an area of high risk.

Note that some areas of low or moderate risk, shown as pale blue or medium blue on Table 2, are within the region of the United States that is also subject to hurricanes (see Figure 3). If you live in this hurricane-prone region, your risk is considered high even if Table 2 shows a moderate or low risk.

## **Can a Building Survive a Tornado? Yes!**

Tornado safe rooms can be designed and constructed to protect occupants from winds and wind-borne debris associated with all tornadoes (EF0–EF5). Buildings designed and constructed above basic code requirements (aka “hardened” buildings) and newer structures designed and constructed to modern, hazard-resistant codes can resist the wind load forces from weak tornadoes (EF1 or weaker). Furthermore, even when stronger tornadoes strike, not all damage is from the rotating vortex of the tornado. Much of the damage is from straight-line winds rushing toward and being pulled into the tornado itself. Many newer homes and commercial buildings designed and constructed to modern codes, such as the *International Residential Code* and *International Building Code* (2009 editions and newer), have load paths that better resist high-wind forces (specified in building codes for hurricane resistance) and may survive without structural failure. The damage to these newer homes and buildings is often to the cladding and exterior systems: roof covering, roof deck, exterior walls, and windows.

For most building uses, it is economically impractical to design the entire building to resist tornadoes. However, portions of buildings can be designed as safe rooms to provide occupant protection from tornadoes. For information on designing safe rooms to resist the strongest tornadoes and hurricane events, see the Tornado Recovery Advisory RA2 titled “Safe Rooms: Selecting Design Criteria” (updated in 2011). For residential safe rooms, see the Tornado Recovery Advisory RA3 titled “Residential Sheltering: In-Residence and Stand-Alone Safe Rooms” (updated in 2011).

Unless a building has a specifically designed safe room, or occupants have access to a community safe room nearby, building owners should work with a qualified architect or engineer to identify the best available refuge areas in the building. For more information on best available refuge areas, see *Tornado Protection: Selecting Refuge Areas in Buildings* (FEMA P-431, 2009) and the Extreme-Wind Refuge Area Evaluation Checklists in *Design and Construction Guidance for Community Safe Rooms* (FEMA P-361, Appendix B1, 2008).

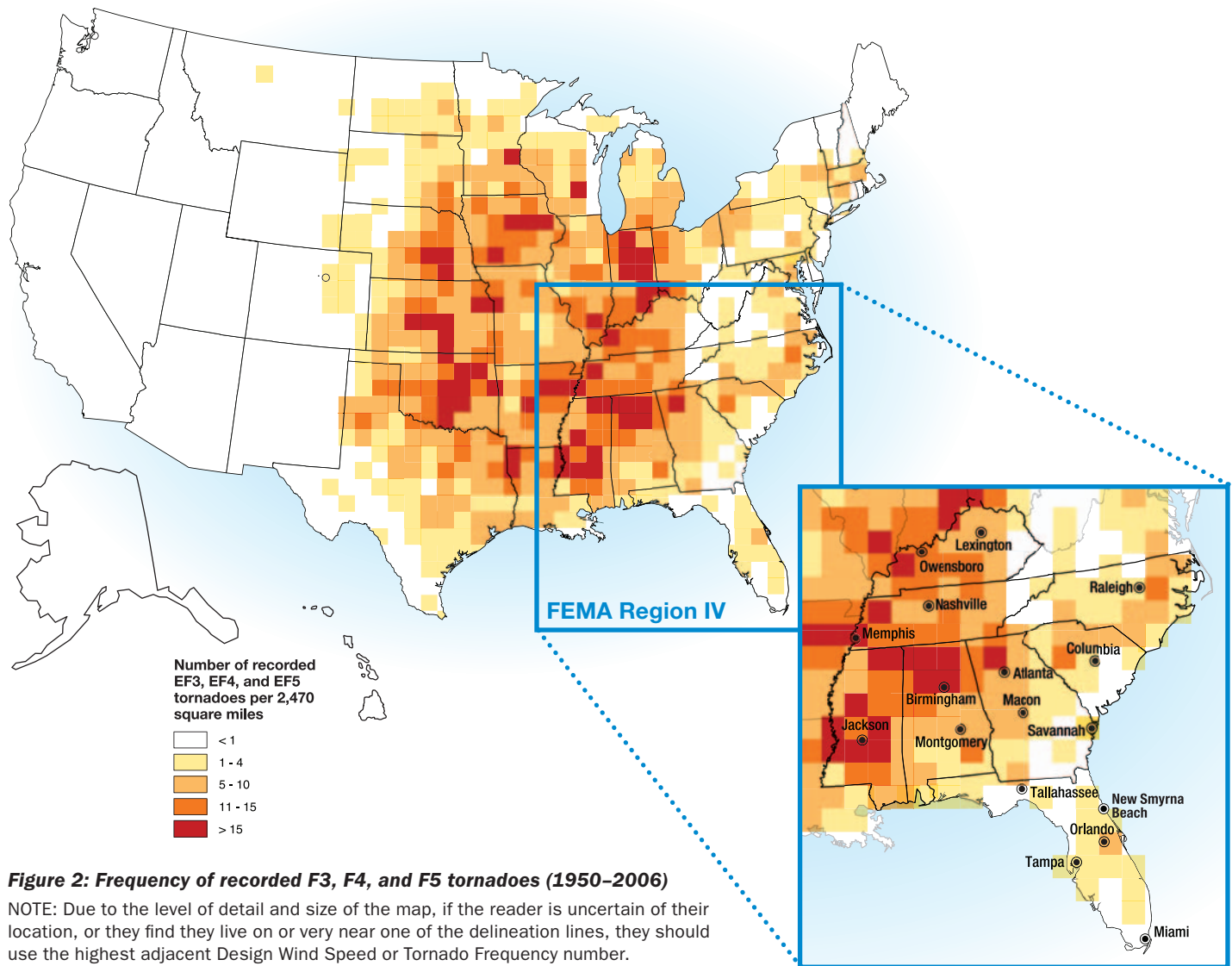

**Figure 2: Frequency of recorded F3, F4, and F5 tornadoes (1950–2006)**

NOTE: Due to the level of detail and size of the map, if the reader is uncertain of their location, or they find they live on or very near one of the delineation lines, they should use the highest adjacent Design Wind Speed or Tornado Frequency number.

SOURCE: FEMA 320, *Taking Shelter From the Storm: Building a Safe Room For Your Home or Small Business*, August 2008, 3rd Edition

**Table 2: Levels of risk during high-wind events**

Number of Tornadoes per 2,470 Square Miles (see Figure 2)	Design Wind Speed (see Figure 3)			
	130 mph	160 mph	200 mph	250 mph
<1	LOW Risk	LOW Risk ★	LOW Risk ★	MODERATE Risk
1–5	LOW Risk	MODERATE Risk ★	HIGH Risk	HIGH Risk
6–10	LOW Risk	MODERATE Risk ★	HIGH Risk	HIGH Risk
11–15	HIGH Risk	HIGH Risk	HIGH Risk	HIGH Risk
>15	HIGH Risk	HIGH Risk	HIGH Risk	HIGH Risk

- LOW Risk** – Sheltering from high winds is a matter of preference.
- MODERATE Risk** – Shelter should be considered for protection from high winds.
- HIGH Risk** – Shelter is the preferred method of protection from high winds.



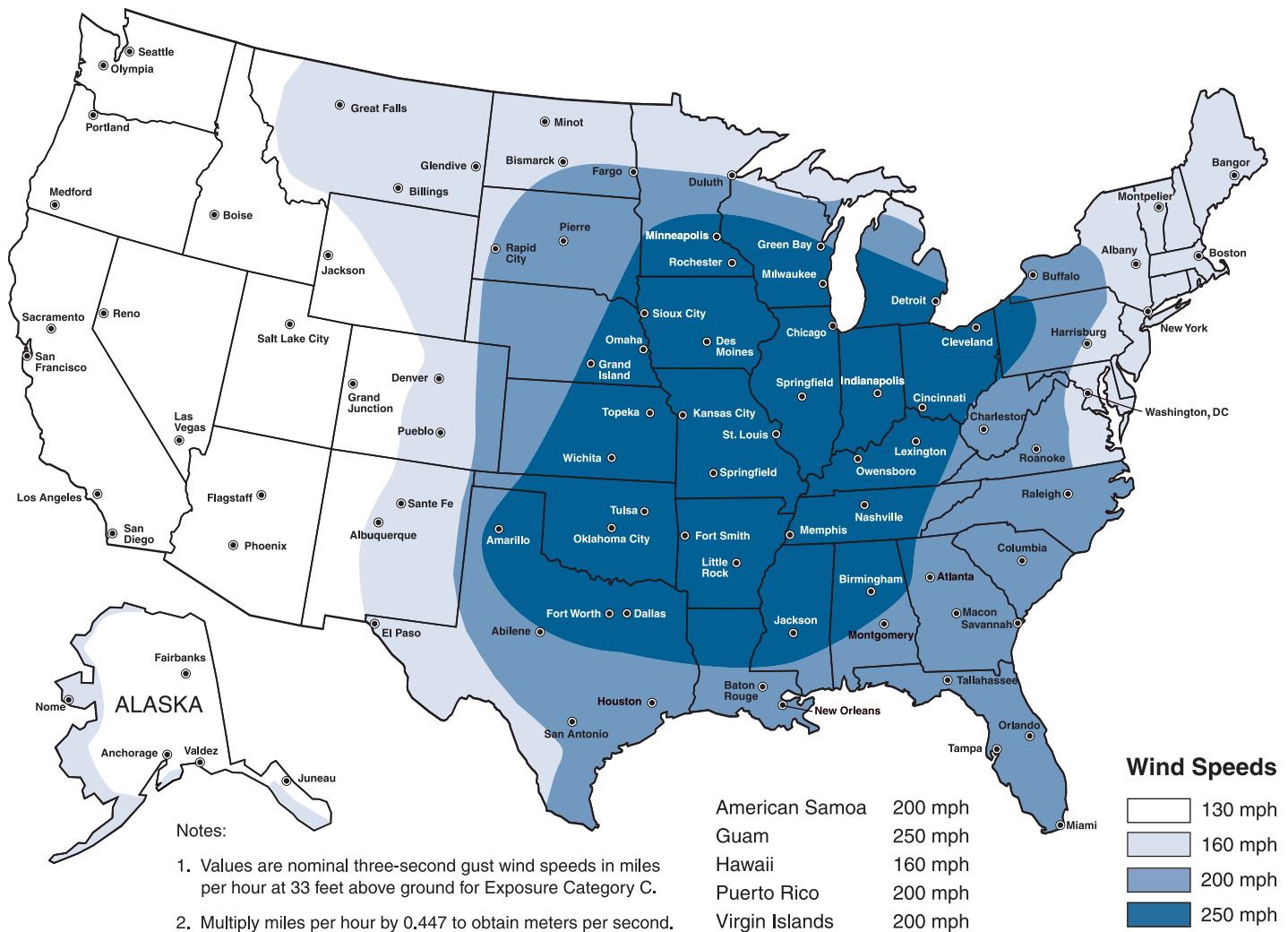

**Figure 3: Tornado safe room design wind speeds in the United States**

SOURCE: FEMA 361, *Design and Construction Guidance for Community Safe Rooms*, August 2008, 2nd Edition

## Weather Radios

Everyone living or working in tornado-prone areas should have a weather radio at their home or place of work. A weather radio is particularly important for those living in areas that do not have storm warning sirens.

The NOAA Weather Radio (NWR) is a nationwide network of radio stations broadcasting continuous weather information directly from a nearby NWS office. NWR broadcasts NWS warnings, watches, forecasts, and other hazard information 24 hours a day, as well as post-event information for all types of hazards, both natural and technological.

NOAA Weather Radios are available at electronics stores across the country and range in cost from \$25 up to \$100 or more, depending on the quality of the receiver and number of features. The NWS does not endorse any particular make or model of receiver.

### Features to look for in a NOAA Weather Radio

- The most desirable feature is an alarm tone. This allows you to have the radio turned on, but silent until a special tone is broadcast before watch and warning messages of an imminent life-threatening situation.
- Specific Area Message Encoding (SAME) technology, a NOAA Weather Radio feature available since the mid-1990s, is capable of providing detailed, area-specific information. Unlike other NOAA Weather Radios, the SAME feature will filter out alerts that do not affect your immediate area.

- The NOAA Weather Radio should be operated on batteries when electrical service may be interrupted. Look for radios with an AC adapter and battery compartment.
- The radio should be tunable to all seven NWR frequencies. For the latest list of frequencies and transmitter locations, check the NOAA Weather Radio Web site <http://www.weather.gov/nwr>.
- The hearing and visually impaired can receive watches and warnings by connecting weather radio alarms to other kinds of attention-getting devices, like strobe lights, pagers, bed-shakers, personal computers, and text printers.

Automated Spanish translation systems are available for use on transmitters serving a significant Hispanic population to broadcast Spanish translations of all emergency weather and natural hazard messages immediately after the official Emergency Alert System (EAS) warning is issued. For more information in Spanish, please visit the NOAA Web site <http://www.weather.gov/nwr/indexsp.htm>.

### **Other Methods to Receive Forecasts, Watches, and Warnings:**

- Tune in to your local radio and television stations for the latest weather forecasts, watches, and warnings. In the event of power loss, battery-operated weather radios can be an interim solution to receive forecasts, watches, and warnings.
- NWS products and services are also available on the Internet at <http://www.weather.gov/nwr>. Delivery of data across the Internet, however, cannot be guaranteed because of potential interruption of service.
- Another low-cost method for receiving the NWS's essential information is available on a wireless data system called the Emergency Managers Weather Information Network (EMWIN). This system presents the information directly on your home or office computer. Users may set various alarms to be alerted to particular information, whether for their local area or adjacent areas. For more information, visit the EMWIN Web site <http://www.weather.gov/emwin/index.htm>.

FEMA is in the process of introducing the Personal Localized Alerting Network (PLAN), which will allow customers with certain types of mobile devices, such as smartphones, to receive emergency alerts specific to their location. Some cities are planned to be online by the end of 2011, and large portions of the United States should have the service by mid-2012. This service will enable certain national, State, and local agencies to send customers alerts for public safety emergencies like tornado warnings and watches. Customers with PLAN-capable devices will be notified by text message of emergencies relevant to their geographic area.

## **National Weather Service StormReady Program**

In addition to the guidance and outreach offered by FEMA, the National Weather Service has established the StormReady Program to help communities prepare for extreme weather events. The StormReady Program, established in 1999, helps communities establish the communication and safety skills and awareness to reduce impacts from extreme events. This is done by strengthening local safety programs and helping communities with advanced planning, education, and awareness. Through this program, the National Weather Service also provides a number of publications and other forms of information on various types of natural hazards. Visit <http://www.stormready.noaa.gov> for more information.

## **Useful Links and Resources**

***Taking Shelter from the Storm: Building a Safe Room For Your Home or Small Business*** (FEMA 320), August 2008, 3rd Edition. <http://www.fema.gov/library/viewRecord.do?id=1536>

***Design and Construction Guidance for Community Safe Rooms*** (FEMA 361) August 2008, 2nd Edition. <http://www.fema.gov/library/viewRecord.do?id=1657>

***Tornado Protection: Selecting Refuge Areas in Buildings*** (FEMA P-431), FEMA, October 2009, 2nd Edition. <http://www.fema.gov/library/viewRecord.do?id=1563>

National Storm Shelter Association (NSSA). <http://www.NSSA.cc>

***ICC/NSSA Standard for the Design and Construction of Storm Shelters*** (ICC-500), June 2008. [http://www.iccsafe.org/Store/Pages/Product.aspx?id=8850P08\\_PD-X-SS-P-2008-000001](http://www.iccsafe.org/Store/Pages/Product.aspx?id=8850P08_PD-X-SS-P-2008-000001)

# Safe Rooms: Selecting Design Criteria



FEMA

**TORNADO RECOVERY ADVISORY**

RA2, June 2011

## Purpose and Intended Audience

The intended audience for this Tornado Recovery Advisory is anyone involved in the planning, policy-making, design, construction, or approval of safe rooms, including designers, emergency managers, public officials, policy or decision-makers, building code officials, and home or building owners. Homeowners and renters should also refer to the Tornado Recovery Advisory No. 3 titled “Residential Sheltering: In-Residence and Stand-Alone Safe Rooms” (updated in 2011). The purpose of this advisory is to identify the design guidance, code requirements, and other criteria that pertain to the design and construction of safe rooms for tornadoes and hurricanes. Different safe room and storm shelter criteria offer different levels of protection to safe room occupants.

### This Recovery Advisory Addresses:

- How safe room construction is different from typical building construction
  - Structural systems
  - Wind-borne debris resistance
- Safe rooms vs. storm shelters
- Selecting refuge areas in buildings



**Community safe room being constructed to FEMA 361 criteria in Wichita, KS.**

## How Safe Room Construction is Different from Typical Building Construction

A safe room is typically an interior room, space within a building, or an entirely separate building, designed and constructed to protect its occupants from tornadoes or hurricanes. Safe rooms are intended to provide near-absolute protection against both wind forces and the impact of wind-borne debris. The level of occupant protection provided by a space specifically designed as a safe room is intended to be much greater than the protection provided by buildings that comply with the minimum requirements of building codes. Until the 2009 International Codes adopted the International Construction Code/National Storm Shelter Association (ICC/NSSA) *Standard for the Design and Construction of Storm Shelters* (ICC-500), the model building codes did not cite design and construction criteria for life safety for sheltering, nor do they provide design criteria for tornado-resistant construction. Information about the ICC shelter criteria and FEMA safe room criteria that provide life-safety protection can be found in other guidance documents referenced in this recovery advisory.

The term “hardened” refers to specialized design and construction applied to a room or building to allow it to resist wind pressures and wind-borne debris impacts during a high-wind event and serve as a shelter.

Safe rooms typically fall into two categories: residential safe rooms and community (non-residential) safe rooms.

- There are two general types of residential safe rooms: in-residence safe rooms and stand-alone safe rooms, located adjacent to or near a residence. An ***in-residence safe room*** is a small, specially designed (“hardened”) room, such as a bathroom or closet, designed as a place of refuge for the people who live in the house. A ***stand-alone residential safe room*** is similar in function and design, but it is a separate structure installed outside the house, either above or below the ground surface. Refer also to Tornado Recovery Advisory No. 3 titled “*Residential Sheltering: In-Residence and Stand-Alone Safe Rooms*” (updated in 2011).
- A ***community safe room*** is intended to protect a larger number of people: anywhere from approximately 16 to several hundred individuals. Community safe rooms include not only public safe rooms but also private safe rooms for businesses and other organizations.
- Guidance on designing and constructing safe rooms can be found in FEMA 320, *Taking Shelter from the Storm: Building a Safe Room For Your Home or Small Business* (2008) and FEMA 361, *Design and Construction Guidance for Community Safe Rooms* (2008).

## Structural Systems

The primary difference in a building’s structural system when designed for use as a safe room, rather than for conventional use, is the magnitude of the wind forces that it is designed to withstand.

Buildings are designed to withstand a certain wind speed (termed “basic [or design] wind speed”) based on historic wind speeds documented for different areas of the country. The highest design wind speed used in conventional construction is near the coastal areas of the Atlantic and Gulf Coasts and is in the range of 140–150 mph, 3-second gust in most locations. By contrast, the design wind speed recommended by FEMA<sup>1</sup> for safe rooms in these same areas is in the range of 200–250 mph, 3-second gust; this design wind speed is intended to provide “near-absolute protection.”

Wind pressures are generally calculated as a function of the square of the design wind speed. As a result, the structural systems of a safe room are designed for forces up to almost eight times higher than those used for typical building construction. Consequently, the structural systems of a safe room (and the connections between them) are very robust.

## Wind-Borne Debris Resistance

Wind-borne debris, commonly referred to as missiles, causes many of the injuries and much of the damage from tornadoes and hurricanes. Windows and the glazing in exterior doors of conventional buildings are not

If glazing is present in a tornado safe room, it should be protected by an interior-mounted shutter that can be quickly and easily deployed by the safe room occupants, or be designed to resist the wind-borne debris impact and wind pressure tests cited in FEMA 361 and prescribed in ICC-500, Chapter 8.

required to resist wind-borne debris, except for buildings in wind-borne debris regions.<sup>2</sup> Impact-resistant glazing can either be laminated glass, polycarbonate, or shutters. The American Society of Civil Engineers (ASCE) Standard 7 missile criteria were developed to minimize property damage and improve building performance; they were not developed to protect occupants. To provide occupant protection, the criteria used in designing safe rooms include substantially greater wind-borne debris loads and will be detailed later in this recovery advisory.

The roof deck, walls, and doors of conventional construction are also not required by the building code to resist wind-borne debris. However, the roof deck and walls around a safe room space, and the doors leading into it, must resist wind-borne debris if the space inside is to provide occupant protection. Additional information regarding the different levels of wind-borne debris loads is provided below.

1 FEMA 361, *Design and Construction Guidance for Community Safe Rooms*, Second Edition (August 2008)

2 ASCE 7, American Society of Civil Engineers Standard 7, *Minimum Design Loads for Buildings and Other Structures* (2010)

## Safe Rooms vs. Storm Shelters

Safe rooms and storm shelters provide different levels of protection depending on the design criteria used. The level of protection provided by a safe room is a function of the design wind speed (and resulting wind pressure) used in designing it, and of the wind-borne debris load criteria. In addition to FEMA 320 and FEMA 361, the International Construction Code/ National Storm Shelter Association (ICC/NSSA) *Standard for the Design and Construction of Storm Shelters* (ICC-500) provides design and construction criteria for storm shelters. FEMA's safe room criteria and ICC-500's storm shelter criteria are similar, with a few differences such as citing with respect to flood hazards and the horizontal missile impact test speed for the hurricane hazard. While the two criteria are similar, FEMA changed the name of its guidance from "shelters" to "safe rooms" when ICC-500 was released to avoid confusion. In addition, FEMA 361, which was updated at the same time ICC-500 was released, references ICC-500 for certain criteria in the design and construction of a safe room, such as testing standards for missile impact and wind pressure resistance.

**Design wind speed and wind pressure criteria:** Wind pressure criteria are given by different guides, codes, and standards. The wind pressure criteria specify how strong the safe room must be. The design wind speed is the major factor in determining the magnitude of the wind pressure that the building is designed to withstand. In FEMA's safe room publications and ICC-500, the same wind speed hazard maps are used to recommend design wind speeds ranging from 130 to 255 mph. The 2009 *International Residential Code* and the 2009 *International Building Code*, which establish the minimum requirements for residential and other building construction, include design wind speeds ranging from 90 to 150 mph throughout most of the country. Table 1 provides a comparison of safe room/shelter design criteria options.

**Wind-borne debris load criteria:** Table 2 presents wind-borne debris criteria given in various guides, codes, and standards. Table 2 shows the different test missiles and the corresponding momentum they carry with them as they strike a safe room. The first entries on the table (Tornado Missile Testing Requirements) are the FEMA missile guidance for residential and community safe rooms that provide near-absolute protection.



**HMGP funds were used for this Public Safety Complex constructed so that the entire facility is compliant with FEMA 361 criteria. Robert J. Curry Public Safety Complex, Gulfport, MS.**



**HMGP-funded community safe room constructed in the basement of a new fire station in Brookside, AL.**

**Table 1. Wind Safe Room/Shelter Design and Construction Codes, Standards, Guidance Comparison<sup>1</sup>** (page 1 of 2)

Title or Name of Document	Code, Regulation, Standard, or Statute?	Wind Hazard	Wind Map
<p><b>FEMA Safe Room Publications:</b>  <b>FEMA 320</b> Taking Shelter from the Storm: Building a Safe Room For Your Home or Small Business (2008)  <b>FEMA 361</b> Design and Construction Guidance for Community Safe Rooms (2008)</p>	FEMA guidance document, not a code or standard. "Best Practice" for high-wind safe rooms	Tornado and Hurricane	<p><b>FEMA 320:</b> Hazard map, maximum wind hazard speed of 250 mph used for design  <b>FEMA 361:</b> Map with four wind speed zones for design (wind mri<sup>2</sup> is 10,000–100,000 years). This map is often referred to as the "FEMA 361 map"</p>
<p><b>International Code Council/National Storm Shelter Association (ICC/NSSA)</b> High Wind Shelter Standard (ICC-500)</p>	Consensus standard for shelter design and construction. Incorporated by reference into the 2009 IBC and IRC.	Tornado and Hurricane	<p><b>Tornado:</b> Uses FEMA 361 map  <b>Hurricane:</b> Uses revised ASCE 7 map with contours at 10,000 year mri with minimum shelter design wind speed of 160 mph, maximum approximately 255 mph</p>
<p><b>Florida State Emergency Shelter Program (SESP)</b> – Florida's interpretation of the American Red Cross (ARC) 4496 Guidance. Note: shelters in this category range from EHPA-recommended design levels, shown in this row, to the code requirement levels (next row), to the ARC 4496 requirements (see below).</p>	Guidance in the Florida Building Code (FBC) "recommending" above-code requirements for EHPAs. See also Appendix G of the Florida SESP report for detailed design guidance.	Hurricane	FBC map, based on ASCE 7-05 (maps basically equivalent); mri is 10–100 years in coastal areas and adjusted with importance factor
<b>ASCE 7-10</b>	2010 edition of ASCE standard on minimum design loads for buildings and other structures.	Hurricane	ASCE 7-10 departs from previous editions and provides multiple wind maps for various "building risk categories" (which are based on occupancy type). The maps have wind speeds based on different mri.
<b>FBC 2000, IBC/IRC 2000 through 2009, ASCE 7-98 through 2005</b>	Building code and design standards for regular (non-shelter) buildings. Some additional guidance is provided in commentary.	Hurricane	ASCE 7 has its own wind speed map based on historical and probabilistic data; mri is 50–100 years in coastal areas and adjusted with importance factor
<p><b>Institute for Business and Home Safety (IBHS) Fortified Home Program</b> – intended as guidance to improve the performance of residential buildings during natural hazard events, including high-wind events. Not considered adequate for sheltering.</p>	Guidance provided to improve performance of regular (non-shelter) buildings in high winds	Tornado and Hurricane	ASCE 7 or modern State building code map
<b>FBC EHPAs</b> – code requirements for public "shelters" (FBC Section 423.25)	Statewide code requirements for EHPAs	Hurricane	The minimum requirement is based on ASCE 7 (maps basically equivalent); mri is 50–100 years in coastal areas and adjusted with importance factor; the missile impact criteria for openings, walls, and roof as provided in SSTD 12, <sup>3</sup> must also be met
<b>Building Codes: Pre-2000</b>	Building code and design standards for regular (non-shelter) buildings	Hurricane	Each of the older codes used their own published wind contour maps
<b>ARC 4496</b> Standards for Hurricane Evacuation Shelter Selection	Guidance for identifying buildings to use as hurricane evacuation shelters	Hurricane	ASCE 7-98 or ANSI A58 structural design criteria
<b>Other:</b> Information for selecting areas of refuge/last resort	Guidance from FEMA and others for selecting best-available refuge areas	Tornado and Hurricane	None

NOTES:

1. The wind shelter guidance and requirements shown here are presented from highest to least amount of protection provided
2. Mean recurrence intervals (mri) for wind speeds maps are identified by the code or standard that developed the map. Typically, the mri for non-shelter construction in non-hurricane-prone areas is 50 years and in hurricane-prone regions, approximately 100 years.
3. Standard Building Code/Standard 12 – Test Standards for Determining Resistance from Windborne Debris

**Table 1. Wind Safe Room/Shelter Design and Construction Codes, Standards, Guidance Comparison<sup>1</sup> (page 2 of 2)**

Wind Design Coefficient Considerations <sup>4,5</sup>	Debris Impact Criteria <sup>6</sup>	Remarks
<p><b>FEMA 320:</b> N/A – prescriptive design guidance for maximum hazard</p> <p><b>FEMA 361:</b> Use FEMA 361 wind speed map with four zones. Calculate pressures using ASCE 7 methods and use <math>I=1.0</math>, <math>K_d=1.0</math>, Exposure C, no topographic effects, <math>G_{Cpi}=\pm 0.55</math> (this will account for atmospheric pressure change [APC])</p>	<p>Test all safe rooms with the representative missile (missile speed dependent on site design wind speed):</p> <p><b>FEMA 320:</b> 15 lb 2x4 at 100 mph (horizontal) and 67 mph (vertical)</p> <p><b>FEMA 361 Tornado:</b> 15 lb 2x4 at 80-100 mph (vertical) and 2/3 of this speed (horizontal)</p> <p><b>FEMA 361 Hurricane:</b> 9 lb 2x4 at 0.1 times the wind speed (horizontal) and 0.5 times the wind speed (vertical)</p>	<p><b>FEMA 320:</b> Intent is to provide “near-absolute protection.” No certification is provided.</p> <p><b>FEMA 361:</b> Intent is to provide “near-absolute protection.” Safe room operations guidance is provided. Occupancy issues are addressed. Wall section details provided. No certification is provided.</p>
<p><b>Tornado:</b> Use FEMA 361 wind speed map. Calculate pressures using ASCE 7 methods and use <math>I=1.0</math>, <math>K_d=1.0</math>, Exposure C with some exceptions, <math>K_{zt}</math>=need not exceed 1.0, <math>G_{Cpi}=\pm 0.55</math> or <math>\pm 0.18+APC</math></p> <p><b>Hurricane:</b> Use revised ASCE 7 map and methods and use <math>I=1.0</math>, all other items as per ASCE 7, no APC consideration required.</p>	<p>Test shelters with representative missile (missile speed dependent on site design wind speed):</p> <p><b>Tornado:</b> 15 lb 2x4 at 80–100 mph (vertical) and 2/3 of this speed (horizontal). <b>Hurricane:</b> 9 lb 2x4 at 0.1 times the wind speed (horizontal) and 0.4 times the wind speed (vertical)</p>	<p>Intent is to provide a standard for the design and construction of high-wind shelters. Will not use term “near-absolute protection.” Occupancy, ventilation, and use issues are also addressed. Shelter operations guidance is provided in the commentary only (commentary is a separate document—not a consensus document).</p>
<p>Recommends that designer add 40 mph to basic wind speed identified on map, Exposure C, <math>I=1.15</math>, <math>K_d=1.00</math>, <math>G_{Cpi}</math> as required by design (typically <math>\pm 0.18</math>), but recommends <math>\pm 0.55</math> for tornado shelter uses.</p>	<p>In wind-borne debris region (120 mph+): Small – pea gravel; Large – 9 lb 2x4 at 75 mph (horizontal), up to 60 feet above grade, but recommends 15 lb 2x4 at 50 mph (horizontal)</p>	<p>The building, or a portion of a building, is defined as an essential facility and as a shelter. Designer is required to submit signed/sealed statement to building department and State offices stating the structure has been designed as a shelter (EHPA plus added recommended criteria).</p>
<p>Method is basis of most wind pressure calculation methods. All items in design process are site-specific. Unlike ASCE 7-05, ASCE 7-10 does not use importance factor in wind calculation.</p>	<p>Uses the same reference as ASCE 7-05 for debris impact criteria (ASTM E 1996), with wind zones modified to account for higher basic wind speeds (see C26.10 of ASCE 7-10 for more information).</p>	<p>The 2009 model I-codes reference ASCE 7-05. However, ASCE 7-10 will be referenced in the 2012 IBC. The 2010 Florida Building Code references ASCE 7-10.</p>
<p>Method is basis of most wind pressure calculation methods. All items in design process are site-specific. Use <math>I=1.15</math> for critical and essential facilities.</p>	<p>In wind-borne debris region (120 mph+): Small – pea gravel; Large – 9 lb 2x4 at 34 mph (horizontal) and areas &gt; 130 mph: 9 lb 2x4 at 55 mph (horizontal), up to 60 feet above grade. Note: 2006 IBC requires the 9-lb 2x4 (large) missile to be tested at 55 mph for critical and essential facilities</p>	<p>Code requires increased design parameters only for buildings designated as critical or essential facilities.</p>
<p>Based on regional hazards, recommendations are provided to improve and strengthen the load path and the performance of the building exterior.</p>	<p>Window and glazing protection is recommended for most hurricane-prone areas, not just areas with a basic wind speed of 120 mph and greater.</p>	<p>This program provides design and construction guidance to improve building performance for high-wind events. Compliance will likely improve building performance but does not imply that the building is safe or that it is appropriate to use as a shelter.</p>
<p>Use basic wind speed at site as identified on FBC wind speed map, use exposure at site, use Category III (Essential Buildings), use wind loads in accordance with ASCE 7.</p>	<p>Use the missile impact criteria for the building enclosure, including walls, roofs, glazed openings, louvers, and doors, per SBC/SSTD 12.</p>	<p>The building or a portion of a building is defined as an essential facility and as an EHPA. Designer is required to submit signed/sealed statement to building department and State offices stating the structure has been designed as an EHPA.</p>
<p>Typically these older codes provided a hurricane regional factor for design wind speeds, but little attention was paid to components and cladding</p>	<p>Not required for all buildings. Where required, the Standard Building Code<sup>7</sup> developed and recommended debris impact standards for use in hurricane-prone regions.</p>	<p>These codes specified limited hazard-resistant requirements. Some guidance was provided with SSTD 10 from SBCCI for the design and construction of buildings in high-wind and hurricane-prone regions. Buildings constructed to these early codes were not required to have structural systems capable of resisting wind loads.</p>
<p>None</p>	<p>None</p>	<p>Provides guidance on how to select buildings and areas of a building for use as a high-wind shelter or refuge area. Does not provide or require a technical assessment of the proposed shelter facility.</p>
<p>None</p>	<p>None</p>	<p>Best available refuge areas should be identified in all buildings without shelters. FEMA 431, <i>Tornado Protection: Selecting Refuge Areas in Buildings</i>, provides guidance to help identify the best available refuge areas in existing buildings. Because best available refuge areas are not specifically designed as shelters, their occupants may be injured or killed during a tornado or hurricane.</p>

NOTES (continued):

4. ASCE 7-05 Building Design Loads for Buildings and Other Structures (2005) is the load determination standard referenced by the model building codes. The wind design procedures used for any shelter type in this table use one of the wind design methods as specified in ASCE 7-05, but with changes to certain design coefficients that are identified by the different codes, standards, or guidance summarized in this table.
5. From ASCE 7 method:  $I$  = importance factor;  $K_d$  = wind directionality factor;  $G_{Cpi}$  = internal pressure coefficient
6. Roof deck, walls, doors, openings, and opening protection systems must all be tested to show resistance to the design missile for the FEMA, ICC, and FL EHPA criteria
7. From the Southern Building Code Congress International, Inc. (SBCCI)

**Table 2. Wind-Borne Debris Criteria**

Guidance, Code, or Standard Criteria for the Design Missile	Debris Test Speed (mph)	Large Missile Specimen	Momentum at Impact (lbf s)
<b>Tornado Missile Testing Requirements</b>			
FEMA 320/FEMA 361	100 (maximum)	15# 2x4	68
	80 (minimum)	15# 2x4	55
International Code Council (ICC) ICC-500 Storm Shelter Standard	100 (maximum)	15# 2x4	68
	80 (minimum)	15# 2x4	55
<b>Hurricane Missile Testing Requirements</b>			
FEMA 320/FEMA 361	128 (maximum)	9# 2x4	53
	80 (minimum)	9# 2x4	33
ICC 500 Storm Shelter Standard	102 (maximum)	9# 2x4	42
	64 (minimum)	9# 2x4	26
Florida State Emergency Shelter Program (SESP) Criteria and Emergency Operations Center (EOC) Design Criteria	50 (EOC recommended)	15# 2x4	34
	55 (EHPA recommended)	9# 2x4	23
	34 (EHPA minimum)	9# 2x4	14
IBC/IRC 2009, ASCE 7-10, Florida Building Code, ASTM E 1886/E 1996	55	9# 2x4	23
	34	9# 2x4	14

**NOTES:**

IBC/IRC – International Building Code/International Residential Code

lbf-s – Pounds (force) seconds

EHPA – Enhanced Hurricane Protection Area

## Using Wind Shelter Design and Construction Codes: An Example

Table 3 shows comparative data for two locations using the design criteria presented in Table 1. Where no guidance is provided for sheltering or basic construction, “N/A” (not applicable) is stated. Where the requirement is not required, “Not required” is stated.

## Selecting Refuge Areas in Buildings

Building owners should be aware of any existing public shelters near their building. For instance, new schools in many States are required to include an ICC-500-compliant storm shelter. If no sheltering options are located nearby, building owners should consider whether their building can be retrofitted for a shelter or safe room. While it is recommended that a safe room be installed, this may not solve the immediate problem of needing to identify the best available refuge areas in a building.

During severe weather, building occupants should be moved to a location in the building that is protected from potential wind-borne debris and the least susceptible to collapse. While these areas do not provide near-absolute protection (unless designed as safe rooms), they may limit the number of occupants injured or killed. Appropriate refuge areas should be identified by architects, engineers, or design professionals familiar with FEMA 361 (2008) and FEMA P-431, *Tornado Protection: Selecting Refuge Areas in Buildings* (2009). These refuge areas are usually interior locations with short-span roof systems, reinforced masonry walls, and no glass openings.

Post-disaster assessments following April 2011 Tornado Outbreak demonstrated that administrative officials or others involved in local planning efforts often identified refuge areas without the guidance of an experienced design professional. While it was clear that an effort was made to protect the occupants, many of these refuge areas were located in large spaces—such as gymnasiums or auditoriums—or in areas near exterior windows and doors. Additionally, many of the selected refuge areas were observed to be surrounded by wall systems subject to collapse in high-wind events. In some cases, the refuge areas had insufficient space for all of the building occupants, or were in locations which would be difficult to move the occupants to in a reasonable period of time. While there were no reports of fatalities in the refuge areas studied, it was likely because the areas were not occupied when the storms struck because many of refuge areas had collapsed or filled with broken glass from windows shattered by wind-borne debris.

Administrative officials interviewed in several communities after the April 2011 Tornado Outbreak indicated that they had been unable to obtain the expertise of a design professional in selecting the appropriate refuge area. The reason cited was liability concerns on the part of the design professional. To ease this concern,



**Table 3. Design Criteria Comparison**

Shelter Design Standard, Code, or Document	Data <sup>1</sup>	Example Location # 1: Miami, FL	Example Location #2: Joplin, MO
<b>FEMA 361</b> <sup>2</sup>	Design wind speed	200 mph (tornado) 225 mph (hurricane)	250 mph
	Pressure on windward wall	107 psf <sup>3</sup> (tornado) 135 psf (hurricane)	167 psf
	Pressure on roof section	239 psf (tornado, suction) 303 psf (hurricane, suction)	374 psf (suction)
	Test missile momentum at impact	61 lb <sub>f</sub> -s (tornado) 46 lb <sub>f</sub> -s (hurricane)	68 lb <sub>f</sub> -s
<b>ICC-500</b>	Design wind speed	200 mph (tornado) 225 mph (hurricane)	250 mph
	Pressure on windward wall	107 psf (tornado) 135 psf (hurricane)	167 psf
	Pressure on roof section	239 psf (tornado, suction) 303 psf (hurricane, suction)	374 psf (suction)
	Test missile momentum at impact	61 lb <sub>f</sub> -s (tornado) 37 lb <sub>f</sub> -s (hurricane)	68 lb <sub>f</sub> -s
<b>FBC EHPA/SESP</b> (using + 40 mph recommendation)	Design wind speed	186 mph	N/A
	Pressure on windward wall	106 psf	N/A
	Pressure on roof section	238 psf (suction)	N/A
	Test missile momentum at impact	34 lb <sub>f</sub> -s	N/A
<b>ASCE 7-10</b> (ASTM E 1996)	Design wind speed	170 mph	115 mph
	Pressure on windward wall	77 psf	35 psf
	Pressure on roof section	173 psf (suction)	79 psf (suction)
	Test missile momentum at impact	14 lb <sub>f</sub> -s	Not required
<b>ASCE 7-05/IBC 2009</b> (ASTM E 1996) <sup>4,5</sup>	Design wind speed	150 mph	90 mph
	Pressure on windward wall	69 psf	25 psf
	Pressure on roof section	155 psf (suction)	56 psf (suction)
	Test missile momentum at impact	14 lb <sub>f</sub> -s	Not required
<b>IBHS</b>	Design wind speed	150 mph	90 mph
	Pressure on windward wall	69 psf	25 psf
	Pressure on roof section	155 psf (suction)	56 psf (suction)
	Test missile momentum at impact	14 lb <sub>f</sub> -s	Not required
<b>FBC EHPA</b>	Design wind speed	146 mph	N/A
	Pressure on windward wall	66 psf	N/A
	Pressure on roof section	147 psf (suction)	N/A
	Test missile momentum at impact	23 lb <sub>f</sub> -s	N/A
<b>Pre-2000 Building Codes</b>	Design wind speed	140 mph and less	90 mph and less
	Pressure on windward wall	< 40 psf (varies)	< 15 psf (varies)
	Pressure on roof section	< 120 psf (varies)	< 45 psf (varies)
	Test missile momentum at impact	Not required by all codes	Not required
<b>ARC 4496</b>	Design wind speed	N/A	N/A
	Pressure on windward wall	N/A	N/A
	Pressure on roof section	N/A	N/A
	Test missile momentum at impact	N/A	N/A
<b>Areas of Last Resort</b>	Design wind speed	Unknown	Unknown
	Pressure on windward wall	Unknown	Unknown
	Pressure on roof section	Unknown	Unknown
	Test missile momentum at impact	Not required	Not required

NOTES:

1. Wind pressures were calculated based on a 40-foot x 40-foot square building, with a 10-foot eave height and a 10-degree roof pitch, partially enclosed
2. For a combined tornado/hurricane safe room, the more restrictive criteria apply. FEMA 320 criteria are based on a 250-mph wind speed regardless of location
3. psf – Pounds per square foot; lb<sub>f</sub>-s – Pounds (force) seconds
4. Non-storm shelter wind design criteria
5. IBC/IRC 2000, 2003, and 2006 editions and ASCE 7-98 have similar wind design criteria

engineers are encouraged to add the following information and qualifiers to their contract and their findings report:

- The identified area should be considered by building owners as only a “best available area of refuge” and occupants could still be injured or killed
- The findings should include:
  - The level of testing completed during the identification of the area
  - The total number of occupants the area can hold
  - The approximate maximum safe wind speed for the best available refuge area
  - The timeframe before which the area should be re-evaluated
  - An outline of potential modifications that could be made to the structure to improve its performance in high-wind events
- State that changes to the building may make the refuge area no longer the best available refuge area

Agreement between the client and the design professional on these points may ease some of the liability concerns. Administrators and facilities managers for buildings with large occupancies should also review FEMA P-431 (2009) and the refuge area evaluation checklists presented in Appendix B of FEMA 361.

## Operating a Safe Room

In addition to the safe room’s structural performance requirements, the following operational, maintenance, and human factors criteria must be considered for a successful safe room:

- Standby power (e.g., generator)
- Protection of critical support systems such as a generator
- Occupancy duration
- Ventilation
- Minimum square footage per occupant
- Egress
- Distance and travel time for occupants traveling to the safe room
- Access for disabled occupants
- Special needs requirements
- Lighting
- Emergency provisions (food, water, sanitation management, emergency supplies, communication equipment)
- Operations and maintenance plans for the safe room

Each of these items is further elaborated in FEMA 361 and ICC-500. Not all items must be considered for a residential safe room, but they are especially important when designing a community safe room.

## Useful Links and Shelter Resources

***Taking Shelter from the Storm: Building a Safe Room For Your Home or Small Business*** (FEMA 320), August 2008, 3rd Edition <http://www.fema.gov/library/viewRecord.do?id=1536>

***Design and Construction Guidance for Community Safe Rooms*** (FEMA 361), August 2008 2nd Edition <http://www.fema.gov/library/viewRecord.do?id=1657>

***Tornado Protection: Selecting Refuge Areas in Buildings*** (FEMA P-431), October 2009 2nd Edition <http://www.fema.gov/library/viewRecord.do?id=1563>

***ICC/NSSA Standard for the Design and Construction of Storm Shelters***, International Code Council and the National Storm Shelter Association (ICC-500), June 2008 [http://www.iccsafe.org/Store/Pages/Product.aspx?id=8850P08\\_PD-X-SS-P-2008-000001#longdesc](http://www.iccsafe.org/Store/Pages/Product.aspx?id=8850P08_PD-X-SS-P-2008-000001#longdesc)

**National Storm Shelter Association** (NSSA); <http://www.NSSA.cc>

# Residential Sheltering: In-Residence and Stand-Alone Safe Rooms



FEMA

## TORNADO RECOVERY ADVISORY

RA3, June 2011

### Purpose and Intended Audience

The purpose of this advisory is to inform homeowners, renters, apartment building owners, and manufactured home park owners about in-residence and stand-alone safe rooms.

#### This Recovery Advisory Addresses:

- Consider a safe room for your home
- In-residence safe room construction and retrofitting options
- Recommendations for sheltering options for when you cannot place a safe room within your home
- Safe room doors
- Refuge areas
- Emergency supply kits and weather radios
- Registering your safe room with local officials

### Consider a Safe Room for Your Home

The purpose of having a safe room in or near your home is to protect you and your family from injury or death from extreme winds. Safe rooms are intended to allow occupants to survive tornadoes and hurricanes with little or no injury. To determine your exposure to tornadoes, refer to FEMA 320, *Taking Shelter from the Storm: Building a Safe Room For Your Home or Small Business* (2008). This publication can help you decide whether to construct a safe room to protect you and your family from injury or death during a tornado or hurricane.

Additional information is provided in the Tornado Recovery Advisory (RA) No. 1 titled "Tornado Risks and Hazards in the Southeastern United States" (updated in 2011).

After determining that you live in a tornado- or hurricane-prone region, it is important to understand the risks. Most homes, even new ones constructed according to current building codes, do not provide adequate protection for occupants seeking refuge from tornadoes. A tornado or hurricane can cause much greater wind and wind-borne debris loads on your house than those on which building code requirements are based. Only specially designed and constructed safe rooms, which are voluntarily built above the minimum code requirements, offer near-absolute protection during a tornado or hurricane.

Safe rooms should not be constructed where flood waters have the potential to endanger occupants within the safe room. Safe rooms in areas where flooding may occur during hurricanes should not be occupied during a hurricane. However, occupying such a safe room during a tornado may be acceptable if the safe room will not be flooded by rains associated with other storm and tornado events. Consult your local building official or local National Flood Insurance Program representative to determine whether your home, or a proposed stand-alone safe room site, is susceptible to local, riverine, or coastal flooding.

### In-Residence Safe Room Construction and Retrofitting Options

Constructing a safe room within your home puts it as close as possible to your family. While a safe room on the exterior of your home may provide adequate protection, it does require your family to be exposed to the

weather elements while traveling to the safe room. A safe room may be either installed during the initial construction of a home or retrofitted afterward. As long as the design and construction requirements and guidance are followed, the same level of protection is provided by either type of safe room.

### New Construction

FEMA 320 contains detailed drawings and specifications that can be used by a builder or contractor to construct a safe room in your home. The designs provided are for safe rooms constructed of wood, masonry, or concrete. All of them are designed to resist 250 mph (3-second gust) wind speeds and impacts from wind-borne debris. Pre-fabricated safe rooms are also available for installation when first building your home. The basic cost to design and construct a safe room during the construction of a new house is approximately \$6,000; larger, more refined, and more comfortable designs may cost more than \$15,000.

It is relatively easy and cost effective to add a safe room when first building your home. For example, when the home is constructed with exterior walls made from concrete masonry units (CMU, also commonly known as “concrete block,” see sketch this page ), the protection level in FEMA 320 can be achieved by strengthening the safe room area’s exterior walls with additional steel reinforcement and grout. The safe room is easily completed by adding interior walls constructed of reinforced CMU, a concrete roof deck over the safe room, and a special safe room door, as shown under construction in the bottom photograph.



**CMU was used for the exterior walls at this house under construction (New Smyrna Beach, FL).**

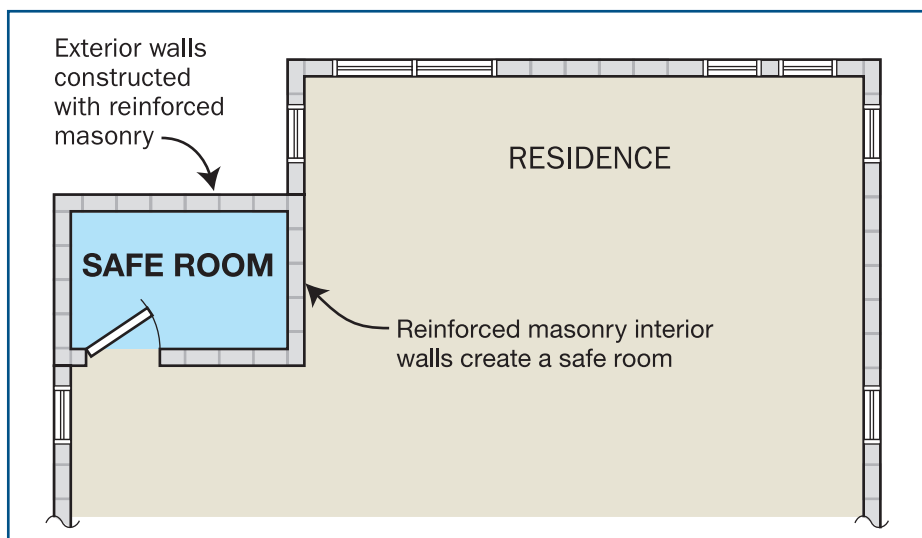

**Sketch of floor plan showing location of safe room area in house.**



**View of an in-residence safe room under construction. Steel reinforced and fully grouted CMU surround the safe room space (New Smyrna Beach, FL).**

## Retrofitting Existing Houses

FEMA 320 contains general guidance for retrofitting a house by adding a safe room. Building a safe room in an existing house will typically cost 20 percent more than building the same safe room in a new house while under construction. Because the safe room will be used for life safety, and because your home might be exposed to wind loads and debris impacts it was not designed to resist, an architect or engineer should be employed to address special structural requirements, even if inclusion of an architect or engineer in such a project is not required by the local building department.

The design drawings provided in FEMA 320 are also appropriate for use in small businesses, fire and police stations, and other public areas where small groups of people may be seeking life-safety protection from extreme winds and wind-borne debris.

## Recommendations for Sheltering When You Cannot Place a Safe Room Within Your Home

There are many reasons that homeowners or renters may not be able to install a safe room within their home. These could include lack of permission (the resident does not own the home or does not have rights to modify or change the home), lack of available space, or lack of technical or economic practicality. In those cases, a stand-alone safe room can be designed and constructed outside of a residence. Stand-alone safe rooms can provide the same level of protection against high winds and wind-borne debris as in-residence safe rooms.

For more information about pre-fabricated and stand-alone safe rooms and storm shelters, contact the National Storm Shelter Association (<http://www.nssa.cc>)

### Small Stand-Alone Safe Rooms

Some site-built homes, and most manufactured homes, do not lend themselves to the structural modifications and retrofitting required to install or construct an in-residence safe room. In these instances, a stand-alone safe room may be constructed (either above grade, partially above grade or below grade) near the residence. Small stand-alone safe rooms can be constructed to accommodate the occupants of one house, a few houses, or a small apartment building. The photograph from Tuscaloosa, AL, shows how a stand-alone safe room provides refuge for the residents.

### Community Safe Rooms

A community safe room can be constructed to accommodate the occupants of several apartments or homes (site-built or manufactured homes). The small safe room designs in FEMA 320 were revised in 2008 and expanded for applications of up to 16 individuals and are suitable for use by business, public facilities, and others when a small, community safe room is desired. The design criteria for these prescriptive designs are presented in FEMA 361, Design and Construction Guidance for Community Safe Rooms (2008). For additional information about community safe rooms, refer to the Tornado Recovery Advisory No. 2 titled "Safe Rooms: Selecting Design Criteria" (updated in 2011). Many different types of safe rooms can be designed and



*View of a pre-fabricated safe room that serves a residence (Tuscaloosa, AL).*

constructed to meet the needs of small or large groups of residents. A safe room may be constructed to be used solely as a shelter or it may be designed as a multi-use building, such as a clubhouse, school, or recreation center. A safe room may also be constructed above-grade, below-grade, or partially below-grade as shown in the photograph from Brookwood, AL. Selecting the right type of safe room will be a collective decision made by the residents, funding agencies, and property owners and managers. For information on community safe rooms for larger populations, including planning and operational issues, see FEMA 361.



**View of a partially below-grade community safe room (Brookwood, AL).**

## Safe Room Doors

When building a safe room, it is very important to pay extra attention to the safe room door. Door construction has been found to be a common weakness in safe rooms' ability to withstand high wind pressures and missile impacts. Door failures are typically due to the type of door construction and door hardware. Standard door construction that meets minimum code requirements is not sufficient to withstand the extreme wind forces and the wind-borne debris impacts often seen in extreme wind events. It is imperative that the walls, ceilings, and doors of a safe room be able to withstand the impacts of missiles carried by extreme winds.

Safe room doors are tested by laboratories for their ability to withstand the pressures associated with high-wind events and missile impacts. To meet the criteria set forth in FEMA 320 for residential and small community safe rooms, doors must resist wind pressures and wind-borne debris impacts in tests set forth in the International Construction Code/National Storm Shelter Association (ICC/NSSA) *Standard for the Design and Construction of Storm Shelters* (ICC-500), for a 250 mph safe room design wind speed and impacts from a 15-pound 2x4 sawn lumber member traveling horizontally at 100 mph (additional design restrictions apply).

Research by the NSSA has shown that steel doors with 14-gauge (or heavier) skins are able to withstand the standard missile impact test. Such doors in widths up to 3 feet, typical of what is found in a residential safe room, are capable of withstanding wind loads associated with wind speeds up to 250 mph when they are latched with three hinges and three deadbolts. At the time of this publication, there has not been a wood door that has successfully passed the pressure or missile impact

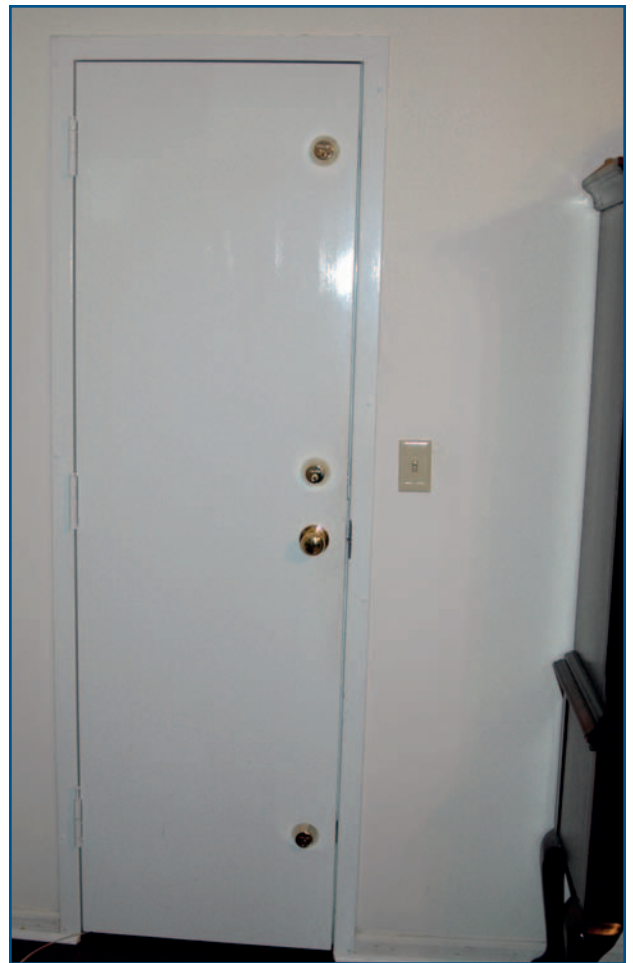

**Photograph of safe room door with three deadbolts and three hinges.**

tests using the design criteria for 250 mph winds. Testing has been performed on various sized doors, and guidance on choosing an appropriate safe room door can be found in Appendix F of FEMA 361 (2008).

## Refuge Areas

Occupants of dwellings that do not have in-residence safe rooms or access to stand-alone or community safe rooms should identify the best available refuge area in their home before an emergency happens. When people identify and take refuge in the best available space within a building, they are less likely to be injured or killed. However, it is important to remember that “best available refuge areas” are not specifically designed as safe rooms, so occupants can be injured or killed during a tornado or hurricane event if the high winds breach the building.

The lowest floor of a building is usually the safest. Upper floors receive the full strength of the winds. Occasionally, tornado funnels hover near the ground but hit only upper floors. Belowground space is almost always the safest location for a refuge area. The following criteria should be considered when identifying the best available refuge area in your home:

- Choose a location that is large enough for all the residents of the home. It is recommended that each person be provided with a minimum of 5 square feet of space in the refuge area. Additional space will need to be accounted for if the residents of the home are wheelchair users or bedridden. Guidance is provided in FEMA P-431, *Tornado Protection: Selecting Refuge Areas in Buildings* (2009).
- Avoid locations with high ceilings. These spaces often have long-span roofs that can collapse under the forces imposed by tornado winds.
- Choose the lowest floor of the residence. A basement is preferable, or first floor if there is no basement).
- Avoid taking refuge in basements with exterior doors or large windows (i.e., walk-out basement). If no other viable option exists, take shelter in a basement area that is away from windows and exterior doors.
- Choose a small interior room without windows (i.e., none of the room’s walls is an exterior wall), such as a bathroom or closet, preferably with only one door.



**View of remnants of an interior room of a house that survived a strong tornado (Tuscaloosa, AL).**



**Avoid selecting a refuge area that is near a masonry chimney (Moore, OK).**

- Choose a room located away from masonry chimneys, trees, or power poles.
- Keep the room relatively free of clutter so you and the other residents can enter and remain in the room for up to several hours.

Homeowners and renters should also refer to the Tornado Recovery Advisory No. 2 titled “Safe Rooms: Selecting Design Criteria” (updated in 2011).

## Emergency Supply Kits and Weather Radios

FEMA 320 includes information on preparing a family emergency plan and an emergency supply kit for a shelter. Further, all individuals living or working in tornado-prone areas should have a battery-powered weather radio in their home or place of work. For more information about weather radios, see Tornado Recovery Advisory No. 1 titled “Tornado Risks and Hazards in the Southeastern United States” (updated 2011).

## Registering Your Safe Room with Local Officials

FEMA recommends that the local fire department, local emergency management agency (EMA), and other relevant local officials be given the location of the safe room. Providing the latitude and longitude coordinates of the entrance to the safe room to local officials can be vital in post-disaster recovery efforts. In the event that debris is surrounding or on top of the safe room, this will allow them to check on the safe room to make sure the occupants are not trapped inside.

## Useful Links and Resources

***Taking Shelter from the Storm: Building a Safe Room For Your Home or Small Business*** (FEMA 320), August 2008, 3rd Edition <http://www.fema.gov/library/viewRecord.do?id=1536>

***Design and Construction Guidance for Community Safe Rooms*** (FEMA 361), August 2008, 2nd Edition <http://www.fema.gov/library/viewRecord.do?id=1657>

***Tornado Protection: Selecting Refuge Areas in Buildings*** (FEMA P-431), FEMA, October 2009, 2nd Edition <http://www.fema.gov/library/viewRecord.do?id=1563>

**National Storm Shelter Association** (NSSA); <http://www.NSSA.cc>



# Safe Rooms and Refuge Areas in the Home



FEMA

## TORNADO RECOVERY ADVISORY

RA4, June 2011

### Purpose and Intended Audience

The intended audience for this Tornado Recovery Advisory is homeowners or home builders. Homeowners and renters should also refer to the Tornado Recovery Advisory No. 3 titled “Residential Sheltering: In-Residence and Stand-Alone Safe Rooms” (updated in 2011). The purpose of this advisory is to identify the different types of safe rooms and provide a brief overview of areas of refuge.

### This Recovery Advisory Addresses:

- How safe room construction is different from typical home construction
  - Which guidance should be followed
  - What constitutes a safe room
- Refuge areas in the home



*An example of an above-ground, in-residence safe room that successfully protected two people (Joplin, MO).*

### How Safe Room Construction is Different from Typical Home Construction

A residential safe room is a space, either within a home or an entirely separate structure, designed and constructed to protect its occupants from tornadoes or hurricanes. The safe room may be located above or below ground. Safe rooms are intended to provide protection against both wind forces and the impact of wind-borne debris. Near-absolute life-safety protection is the level of occupant protection provided by a space specifically designed as a safe room and constructed to meet criteria set forth by FEMA; this is much greater than the protection provided by buildings that comply with the minimum requirements of building codes. Although the FEMA guidance on safe rooms has been available since 1998, building codes did not begin to provide design and construction criteria for life-safety protection from wind events until 2009. When constructed to meet the criteria set forth in the building codes, hardened areas are called storm shelters. Design criteria for storm shelters are similar to criteria for safe rooms, but differences do exist. Information about safe room criteria and storm shelter criteria can be found in other guidance documents referenced in this recovery advisory. A slightly higher level of protection is provided when safe rooms are constructed to meet the FEMA criteria, and owners may be eligible for FEMA grant programs to fund the design and construction of the safe room.

A safe room is a room or structure specifically designed and constructed to resist wind pressures and wind-borne debris impacts during an extreme-wind event for the purpose of providing life-safety protection.

Safe rooms typically fall into two categories: residential safe rooms and community (non-residential) safe rooms.

- **Residential Safe Rooms:** There are two general types of residential safe rooms: in-residence safe rooms and stand-alone safe rooms (located adjacent to, or near, a residence). An *in-residence safe room* is a small, specially designed (“hardened”) room, such as a bathroom or closet that is intended to provide a protected area for the people who live in the house. A *stand-alone safe room* is similar in function and design, but it is a separate structure installed outside the house, either above or below the ground surface. FEMA guidance is available in FEMA 320, *Taking Shelter from the Storm: Building a Safe Room For Your Home or Small Business* (2008).
- **Community Safe Rooms:** Some areas construct community safe rooms that provide protection for a large number of people—from 16 to as many as several hundred individuals. Criteria for designing and constructing a safe room can be found in FEMA 361, *Design and Construction Guidance for Community Safe Rooms* (2008).



**A small area located inside a detached garage used as a refuge area during a tornado (Athens, AL).**

The following should be considered when identifying the best available refuge area in your home:

- Choose a location that is large enough for all the residents of the home to be seated. Account for additional space if the residents of the home are wheelchair users or bedridden.
- Choose the **lowest** floor of the residence. A basement is preferable, or first floor if there is no basement. Below-ground space is almost always the safest location for a refuge area.
- Choose a small interior room without windows (i.e., none of the room’s walls is an exterior wall), such as a bathroom or closet, preferably with only one door.
- Choose a room located away from masonry chimneys, trees, or power poles.
- Avoid locations with high ceilings. These spaces often have long-span roofs that can collapse under the forces imposed by tornado winds.
- Avoid taking refuge in basements with exterior doors or large windows (i.e., walk-out basement). If no other viable option exists, choose an area that is away from windows and exterior doors.
- Keep the room relatively free of clutter so you can remain in the space for up to several hours.

## Selecting Refuge Areas in the Home

If there are no hardened areas within or near a home to use during high wind events, homeowners should consider whether their house can be retrofitted for a safe room. If this is not a viable option, homeowners should identify the best available refuge areas in their home. People in manufactured homes should seek shelter in a community safe room.

## Useful Links and Safe Room Resources

***Taking Shelter from the Storm: Building a Safe Room For Your Home or Small Business*** (FEMA 320), August 2008, 3rd Edition <http://www.fema.gov/library/viewRecord.do?id=1536>

***Design and Construction Guidance for Community Safe Rooms*** (FEMA 361), August 2008, 2nd Edition <http://www.fema.gov/library/viewRecord.do?id=1657>

**ICC/NSSA Standard for the Design and Construction of Storm Shelters**, International Code Council and the National Storm Shelter Association (ICC-500), June 2008 [http://www.iccsafe.org/Store/Pages/Product.aspx?id=8850P08\\_PD-X-SS-P-2008-000001#longdesc](http://www.iccsafe.org/Store/Pages/Product.aspx?id=8850P08_PD-X-SS-P-2008-000001#longdesc)

**Additional information from FEMA Building Science** can be found at <http://www.fema.gov/rebuild/buildingscience> and <http://www.fema.gov/plan/prevent/saferoom>

# Critical Facilities Located in Tornado-Prone Regions: Recommendations for Facility Owners



FEMA

TORNADO RECOVERY ADVISORY

RA5, July 2011

## Purpose and Intended Audience

Critical facilities are emergency operations centers (EOCs), fire and police stations, hospitals, nursing homes, schools, and other buildings that are essential for the delivery of vital services or protection of a community. Tornado damage investigations and other research have shown us techniques for protecting occupants of critical facilities struck by tornadoes, as well as maintaining continuity of operations for those facilities. The 2011 tornadoes that struck the southeast United States specifically highlighted the importance of properly selecting the best available refuge area in existing facilities as well as the importance of minimizing collapse hazards, such as tree fall and other nearby objects. The purpose of this advisory is to inform critical facility owners of enhancements that can be made both to existing facilities and those still in the planning stage. With this awareness, facility owners can budget for desired enhancements and request that these enhancements be incorporated into the construction documents.

## This Recovery Advisory Addresses:

- Best available refuge areas
- Tree fall and other collapse hazards
- Safe rooms
- Strengthening new facilities to minimize damage from tornadoes
- Enhancements to avoid interrupted operations

## Existing Buildings

Critical facility owners should hire the services of a qualified architect or engineer to evaluate their existing building. The evaluation should determine whether the facility adequately protects occupants, operations, and the facility itself from tornadoes and other appropriate hazards. The evaluation should identify the best available refuge areas in the existing facility. Any needed enhancements can be incorporated into capital improvement planning and budgeting. Lack of adequate planning can result in loss of operation and possible loss of life when buildings are inadequately hardened or lack a best available refuge area for occupants (Figure 1).

## Best Available Refuge Areas

In regions of the United States subject to tornadoes, identifying the best available refuge areas within buildings is essential for the safety of building occupants. **Safe rooms** specifically designed



**Figure 1: An EOC in Tuscaloosa, AL, that saw a loss of operations but remained intact even though the story above it collapsed (Tornado 2011)**

PHOTO COURTESY OF THE TUSCALOOSA COUNTY SHERIFF'S OFFICE.

and constructed to resist wind-induced forces and the impact of wind-borne debris provide the best protection. However, findings from investigations of past tornadoes show that many critical facilities contain rooms or areas that may afford some degree of protection from all but the most extreme tornadoes (i.e., an EF4 and EF5 tornado). The **best available refuge areas** should be identified in buildings that do not have areas designed and constructed to serve as safe rooms. Giving building occupants a best available refuge area in a building greatly reduces the risk of injury or death. Best available refuge areas do not guarantee safety; they are, however, the safest areas available for building occupants.

Interior areas with short-span roof systems, such as corridors and small rooms (e.g., restrooms), are often the best available refuge areas. However, as shown in Figure 2, this is not always the case. It is therefore recommended that owners of critical facilities hire a qualified architect or structural engineer familiar with tornado risk analysis to assess existing buildings and identify the best available refuge areas.

The architect's or engineer's systematic review of a building may reveal some problems (such as doors with glass vision panels) within the best available refuge area that can be economically mitigated to improve the refuge area. Areas that include such doors or other problems could still be considered the best available refuge areas despite the vulnerability of the glass. However, known problems should be addressed to the extent possible. Examples of corrective actions include replacing any doors that contain windows or replacing the existing glazing with impact-resistant glazing.

### Collapse Hazards

Collapse hazards can include parts of the building, communication towers and equipment, chimneys, poles, and trees. Collapses can break windows and rupture roof coverings of critical facilities, damage components such as emergency generators and HVAC equipment needed for the operation of a critical facility, and cause structural damage to buildings (Figure 3). Collapse hazards must be addressed in design and sheltering decisions to avoid injuries or death and to ensure operational requirements of a critical facility are met. Potential collapse hazards can be evaluated using the checklists in Appendix B of FEMA 361, *Design and Construction Guidance for Community Safe Rooms* (2008) and the results can be used to evaluate the best available refuge areas.

Guidance documents for identifying best available refuge areas are referenced in FEMA Recovery Advisory No. 6, *Critical Facilities in Tornado-Prone Regions: Recommendations for Architects and Engineers*.

Enhanced Fujita Scale	
EF0	65–85 mph winds
EF1	86–110 mph
EF2	111–135 mph
EF3	136–165 mph
EF4	166–200 mph
EF5	>200 mph



**Figure 2: Debris in an elementary school restroom in Tuscaloosa, AL (Tornado 2011)**

**Figure 3: Collapse of a large communications tower onto a building in Joplin, MO (Tornado 2011)**

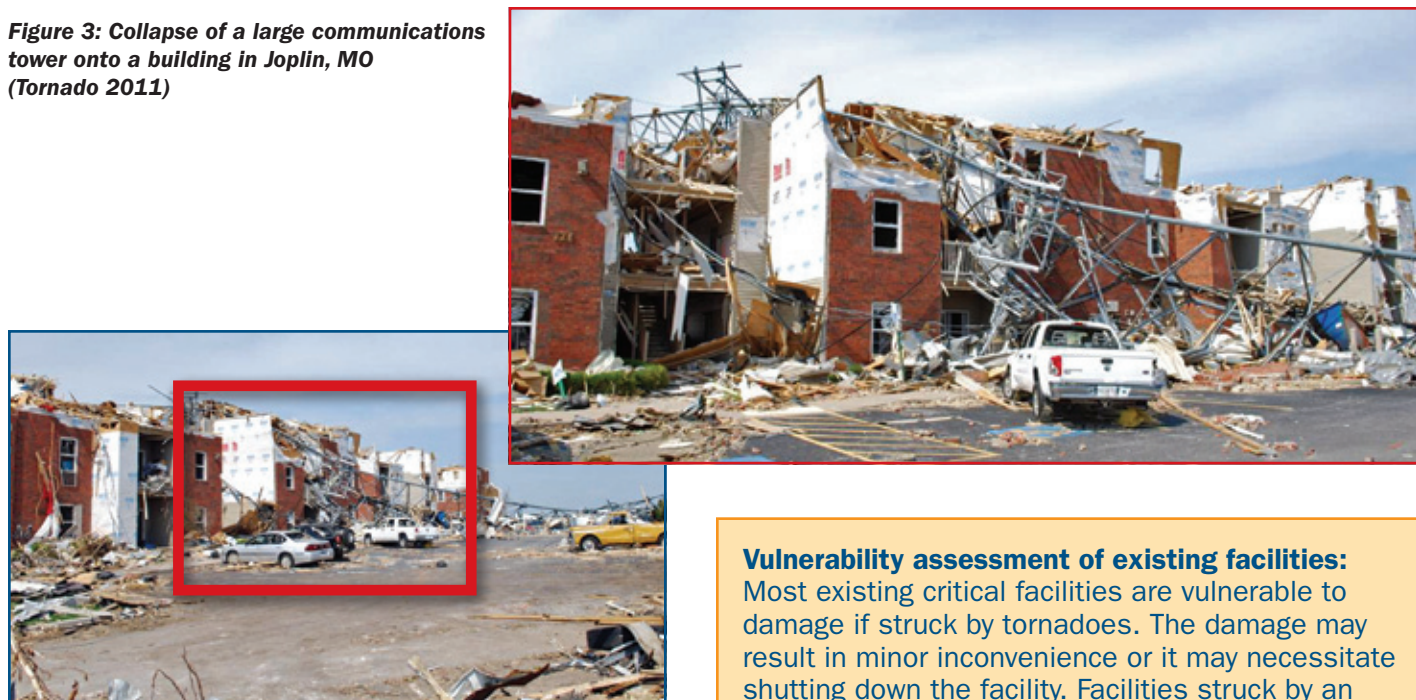

Proper maintenance and placement of trees will minimize damage to critical facilities and surrounding buildings. Trees should be placed such that the distance between the critical facility and the tree is greater than the height the tree will reach when it is fully grown. Trees with wounds, decay, structural defects, known internal trunk voids, severed roots, and soil compaction are prime targets for storm damage. These defects are often a result of damage from a lawnmower or weed trimmer and can be avoided with proper, careful lawn maintenance.

New trees should be planted at the correct depth. Trees planted too deep can develop stem girdling, where the tree roots encircle the stem and weaken it just below the ground, making it more likely to snap off at the stem-girdled point in the event of a forceful wind. In addition, mature trees should be pruned to correct defects, such as multiple leaders and weak branch attachments. Prune trees as soon as the defect is detected because younger trees will heal faster from the pruning.

## **New Buildings and Additions to Existing Buildings**

During planning and budgeting for a new facility or making additions to existing facilities, a designer or space planner normally helps the facility owner develop a program for types of spaces, size of space, equipment needed, parking, and many other elements. For critical facilities in areas prone to tornadoes, owners should consider building safe rooms, strengthening their facility to minimize damage, and enhancing their facility to avoid interruption of operations (see also Recovery Advisory No. 6 for the associated design and construction guidance).

### **Safe Rooms**

All new critical facilities should include one or more safe rooms (depending on facility size) to provide occupant protection. When adding on to an existing facility that does not have a safe room, facility owners should budget for a safe room within the addition (see Figure 4). If possible, the safe room should be sized to accommodate the number of occupants in the existing building and the addition.

Safe rooms are typically dual-function rooms. During normal times, the safe room may function as a training room, restroom, hallway, or other such purpose. When tornadoes threaten, the specially designed and

### **Vulnerability assessment of existing facilities:**

Most existing critical facilities are vulnerable to damage if struck by tornadoes. The damage may result in minor inconvenience or it may necessitate shutting down the facility. Facilities struck by an EF4 or EF5 tornado will normally not be operational unless the facility was designed to remain operational if struck.

A vulnerability assessment can be conducted by a team of architects and engineers. Findings from such an assessment can lay the groundwork for planning and budgeting capital improvements or developing contingency plans that address facility disruption.

constructed safe room serves to protect the building occupants. The additional cost of making a room serve a dual function as a safe room varies. Excluding interior finishes and furnishings in the safe room area, a cost of \$200 per square foot for budgeting is usually sufficient to cover design fees and construction.<sup>1</sup>

Safe rooms afford building occupants near absolute protection. However, facility operations that are housed outside of a safe room are normally susceptible to tornado damage and disruption. To minimize damage or to ensure continuity of operations, additional design and construction measures are needed as recommended below.



**Figure 4: The addition to this school was designed to serve as a safe room (Wichita, KS)**

If Federal funding for the design and construction of a safe room is sought, the technical information in FEMA 361 (2008) must be adhered to as part of the funding requirements of the FEMA safe room policy. FEMA policy on the eligibility of the design and construction of safe rooms for Federal funding is provided in FEMA Mitigation Interim Policy MRR-2-09-1, *Hazard Mitigation Assistance for Safe Rooms*, dated April 30, 2009.

### Strengthening New Facilities to Minimize Damage from Tornadoes

By using design strategies and building materials that are used in hurricane-prone regions<sup>2</sup>, facilities can be built to be more resistant to tornadoes. Therefore, facility owners should consider budgeting for strengthening new buildings or additions to minimize damage and disruption from nearby weak and strong tornadoes and from violent tornadoes that are on the periphery of the facility. With appropriate strengthening and selection of building materials and systems, the cost of tornado repairs and the potential for disruption of operations (see Figure 5) will likely be reduced. Even when constructing a facility using stronger systems, a safe room should be included in the facility to protect occupants during an EF4 or EF5 tornado that strikes the facility.

### Enhancement to Avoid Interrupted Operations

Designing a facility to ensure it will remain operational if struck by a violent tornado is expensive. Therefore, when considering the costs and benefits of designing for continuity of operations, it may be more cost effective to design to minimize building damage and/or provide safe rooms. If, because of the additional expense, the owner determines

that a critical facility does not need to be operational if struck by a violent tornado, then this reduced building performance should be clearly considered and addressed in emergency operations plans. Other critical facilities should be identified (that are not expected to be impacted by the same tornado) from which to continue critical operations. Appropriate planning, emergency plans, and agreements should be put in place. For facilities such as Emergency Operations Centers that are determined to be critical in providing effective emergency response, owners should budget facility enhancements to avoid interrupted operations even if struck by violent tornadoes.

Specific design recommendations pertaining to continuity of operations are provided in FEMA Recovery Advisory No. 6, *Critical Facilities in Tornado-Prone Regions: Recommendations for Architects and Engineers*.

<sup>1</sup> Section 2.3 and Table 2-4 in FEMA 361 (2008), provides additional information on safe room costs.

<sup>2</sup> For more information on constructing buildings hurricane-prone regions, refer to FEMA P-424, *Design Guide for Improving School Safety in Earthquakes, Floods, and High Winds* (2010); FEMA 543, *Design Guide for Improving Critical Facility Safety from Flooding and High Winds* (2007); and FEMA 577, *Design Guide for Improving Hospital Safety in Earthquakes, Floods, and High Winds* (2007).



Specific design recommendations for minimizing building damage are provided in FEMA Recovery Advisory No. 6, *Critical Facilities in Tornado-Prone Regions: Recommendations for Architects and Engineers*.

**Figure 5: Most of the exterior glass in this Joplin, MO, hospital was broken (Tornado 2011)**

Vulnerability assessment of new facilities: As part of the planning process for new facilities, other natural hazards (flood, seismic, and wildfire) should be considered in addition to the tornado hazard. FEMA P-424 (2010), 543 (2007), and 577 (2007) provide guidance on conducting vulnerability assessments. If the building design does not ensure continuity of operations, contingency plans should be developed that address facility disruption.



## Useful Links and Resources

**2007 Tornado Recovery Advisories.** FEMA. 2007. <http://www.fema.gov/library/viewRecord.do?id=2631>

**Hazard Mitigation Assistance for Safe Rooms** FEMA. April 2009. Mitigation Interim Policy, MRR-2-09-1. <http://www.fema.gov/library/viewRecord.do?id=3634>

HMA Unified Guidance FY 10. FEMA. 2009. <http://www.fema.gov/library/viewRecord.do?id=3649>

HMA Unified Guidance FY 11. FEMA. 2010. <http://www.fema.gov/library/viewRecord.do?id=4225>

**Recovery Advisory No. 6, Critical Facilities in Tornado-Prone Regions: Recommendations for Architects and Engineers.** FEMA. 2011.

**Taking Shelter from the Storm: Building a Safe Room For Your Home or Small Business** (FEMA 320). August 2008, 3rd Edition. <http://www.fema.gov/library/viewRecord.do?id=1536>

**Design and Construction Guidance for Community Safe Rooms** (FEMA 361). August 2008, 2nd Edition. <http://www.fema.gov/library/viewRecord.do?id=1657>

**Design Guide for Improving School Safety in Earthquakes, Floods, and High Winds** (FEMA P-424). December 2010, Second Edition. <http://www.fema.gov/library/viewRecord.do?id=1986>

**Tornado Protection: Selecting Refuge Areas in Buildings** (FEMA P-431). October 2009, Second Edition. <http://www.fema.gov/library/viewRecord.do?id=1563>

**Design Guide for Improving Critical Facility Safety from Flooding and High Winds** (FEMA 543). January 2007. <http://www.fema.gov/library/viewRecord.do?id=2441>

**Design Guide for Improving Hospital Safety in Earthquakes, Floods, and High Winds** (FEMA 577). June 2007. <http://www.fema.gov/library/viewRecord.do?id=2739>

**ICC/NSSA Standard for the Design and Construction of Storm Shelters** (ICC-500), June 2008. [http://www.iccsafe.org/Store/Pages/Product.aspx?id=8850P08\\_PD-X-SS-P-2008-000001](http://www.iccsafe.org/Store/Pages/Product.aspx?id=8850P08_PD-X-SS-P-2008-000001)





# Critical Facilities Located in Tornado-Prone Regions: Recommendations for Architects and Engineers



FEMA

**TORNADO RECOVERY ADVISORY**

RA6, August 2011

## Purpose and Intended Audience

Critical facilities are emergency operations centers (EOCs), fire and police stations, hospitals, nursing homes, schools, and other buildings that are essential for the delivery of vital services or protection of a community. Tornado damage investigations and other research have helped to identify techniques for protecting occupants of critical facilities struck by tornadoes, as well as maintaining continuity of operations for those facilities. The 2011 tornadoes that struck the southeast United States specifically highlighted the importance of properly selecting the best available refuge areas in existing facilities as well as the importance of minimizing collapse hazards, such as tall trees and other nearby objects.

The purpose of this advisory is to inform architects and engineers of design enhancements that can be made to both existing facilities and facilities in the planning stage. With this awareness, desired enhancements can be incorporated into construction documents.

The interim information in this Recovery Advisory is intended to assist during the recovery and redevelopment of tornado-damaged areas and to minimize future tornado damage and interruption of operations. This information was developed because of the lack of design guidance on this topic.

## This Recovery Advisory Addresses:

- Existing Buildings
  - Best available refuge areas
  - Tree fall and other collapse hazards
- New Buildings and Additions to Existing Buildings
  - Safe rooms
  - Strengthening new facilities to minimize damage from tornadoes
  - Enhancements to avoid interrupted operations



### Standard of Care

Critical facilities have facility and operational requirements that should be met in addition to building code requirements. Building codes do not stipulate expected building performance for tornadoes. The designer should discuss expectations for acceptable building damage, operational requirements, and occupant safety with the facility owner to ensure the full range of solutions for any special requirements is considered.

### Multi-hazard Design

This Recovery Advisory addresses the tornado hazard. However, critical facilities may be damaged—and continuity of operations may be impaired—by other natural hazards such as flooding, seismic events, and wildfire. When performing vulnerability assessments and design work on critical facilities, all natural hazards that can affect the facility should be considered and accounted for.

## Terminology: Safe Rooms and Shelters

“Safe rooms” are defined as buildings or portions thereof that comply with FEMA 361, *Design and Construction Guidance for Community Safe Rooms* (2008).

“Shelters” are defined as buildings or portions thereof that comply with International Code Council (ICC), ICC 500, *ICC/NSSA Standard on the Design and Construction of Storm Shelters* (2008).

FEMA 361 and the ICC 500 criteria are quite similar. All safe room criteria in FEMA 361 meet the shelter requirements of the ICC 500. However, a few design and performance criteria in FEMA 361 are more restrictive than those in the ICC 500.

A summary of the primary differences between FEMA 361 and ICC 500 is presented in Recovery Advisory No. 2, *Safe Rooms: Selecting Design Criteria* (June 2011). The 2009 edition of the International Building Code (IBC) references ICC 500 for the design and construction of hurricane and tornado shelters. However, although ICC 500 specifies shelter criteria, it does not require shelters.

FEMA’s MRR-2-09-1, *Hazard Mitigation Assistance for Safe Rooms*, dated April 30, 2009, sets forth eligibility requirements for Pre-Disaster Mitigation Program and Hazard Mitigation Grant Program safe room projects and requires adherence to FEMA 361. Also refer to the appropriate State Hazard Mitigation Officer for additional information (<http://www.fema.gov/about/contact/shmo.shtm>).

## Existing Buildings

Although safe rooms specifically designed and constructed to resist wind-induced forces and the impact of wind-borne debris provide the best protection, buildings can have rooms or areas that afford some degree of protection from all but the most extreme tornadoes (i.e., an EF4 or EF5 tornado on the Enhanced Fujita scale). In buildings that do not have areas designed and constructed to serve as safe rooms, the goal of the architect or engineer should be to select the **best available refuge areas**. Giving building occupants a best available refuge area in a building greatly reduces the risk of injury or death. Best available refuge areas do not *guarantee* safety; they are, however, the safest areas available for building occupants. Interior areas with short-span roof systems, such as corridors and small rooms (e.g., restrooms), are often best available refuge areas. However, as shown in Figures 1 and 2, this is not always the case. It is therefore recommended that qualified architects or engineers familiar with tornado risk analysis follow the guidance in FEMA P-431, *Tornado Protection: Selecting Refuge Areas in Buildings* (2009), and the checklists in Appendix B of FEMA 361, to identify best available refuge areas. It is recommended that the best available refuge area(s) have a permanent sign installed that states “Tornado Refuge Area.”

An architect’s or engineer’s systematic review of a building may reveal some problems (such as doors with glass vision panels as shown in Figure 3) within the best available refuge area that can be economically mitigated to improve the refuge area.

### Vulnerability Assessment of Existing Facilities

Most existing critical facilities are vulnerable to damage if struck by tornadoes. The damage may result in minor inconvenience or it may necessitate shutting down the facility. Facilities struck by a violent (EF4 and EF5) tornado will normally not be operational unless the facility was designed to remain operational if struck.

A vulnerability assessment can be conducted by a team of architects and engineers. Findings from such an assessment can lay the groundwork for planning and budgeting capital improvements or developing contingency plans that address facility disruption.



Figure 1: Debris in a school corridor in Joplin, MO (2011 Tornado)



**Figure 2: Collapsed concrete masonry unit (CMU) walls at a Joplin, MO, school restroom (2011 Tornado)**



**Figure 3: Broken vision panel at an elementary school corridor in Tuscaloosa, AL (2011 Tornado)**

Areas that include such doors or other problems could still be considered the best available refuge areas despite the vulnerability of the glass. However, known problems should be addressed to the extent possible. An example of a corrective action would be to replace doors that have vision panels with new door/vision panel assemblies that resist the test Missile E load specified in ASTM E 1996, when tested in accordance with ASTM E 1886. For more information on the test Missile E, see Section 6.3.3.3 of FEMA P-424, *Design Guide for Improving School Safety in Earthquakes, Floods, and High Winds* (2010).

### Collapse Hazards

Position poles, towers, and trees with trunks larger than 6 inches in diameter away from new buildings, additions to existing buildings, and primary site access roads so that they do not hit or block access to the facility if they topple.

When evaluating critical facilities to determine the best available refuge areas, architects and engineers should identify **potential collapse hazards** using the checklists in Appendix B of FEMA 361. Collapse hazards can include parts of the building, communication towers and equipment, chimneys, poles, and trees that can damage buildings with light-frame construction, break windows, and rupture roof coverings (Figures 4 and 5). Refer also to Recovery Advisory No. 5, *Critical Facilities in Tornado-Prone Regions: Recommendations for Facility Owners* (2011).



**Figure 4: Collapse of a large communications tower onto a building in Joplin, MO (2011 Tornado)**



**Figure 5: Tree-fall damage at a critical facility in Tuscaloosa, AL (2011 Tornado)**

## New Buildings and Additions to Existing Buildings

Architects and engineers designing new critical facilities or additions to existing facilities should consider including a safe room to protect occupants, making enhancements that will minimize building damage, and designing the facility to remain operational even if it is struck by a violent tornado.

### Safe Rooms

For all new critical facilities, the facility design should incorporate one or more safe rooms (depending on facility size) to provide occupant protection. When adding on to an existing facility that does not have a safe room, incorporate safe rooms within the addition. Size the safe room to accommodate the number of occupants in the existing building and the addition. Note that if temporary buildings will be used to accommodate increases in occupancy (for example, schools with portable classrooms), space should be designed in the safe room to account for these potential changes in safe room occupancy.

FEMA 361 provides comprehensive guidance for the design of safe rooms, as well as for quality assurance and quality control for their design and construction. FEMA 320, *Taking Shelter from the Storm: Building a Safe Room for Your Home or Small Business* (2008), provides prescriptive solutions for safe rooms that will shelter 16 or fewer occupants. If a safe room is not incorporated, it is recommended that the architect or engineer identify the best available refuge area(s) and that a permanent sign be installed that states “Tornado Refuge Area.”

#### Flood Hazards

See FEMA 361 Sections 3.2.1, 3.6, and 4.4.3 for information regarding flood hazards.

## Minimizing Building Damage by Enhancing Building Resistance

By using design strategies and building materials that are used in hurricane-prone regions, critical facilities can be built to be more resistant to most tornadoes (i.e., EF0–EF3). FEMA’s design guide series (see textbox) provides recommendations for facilities located outside of hurricane-prone regions; these recommendations should be considered minimum baseline recommendations for all critical facilities. The design guides also provide above-baseline recommendations for facilities located within hurricane- and tornado-prone regions.

New buildings and building additions can be strengthened to minimize building damage and disruption from weak (EF0–EF1) and strong (EF2–EF3) tornadoes that pass directly over the facility, and from violent (EF4–EF5) tornadoes on the periphery of the facility. With appropriate strengthening and selection of building materials and systems, the cost of tornado repairs and the potential for disruption of operations will likely be reduced. When strengthening buildings, it is recommended that a safe room(s) also be included in the critical facility to protect occupants in case a violent tornado (i.e., EF4 or EF5) passes over or near the facility.

#### FEMA Design Guides

Wind design recommendations for critical facilities located both inside and outside of hurricane- and tornado-prone regions can be found in the following FEMA publications:

- FEMA P-424, *Design Guide for Improving School Safety in Earthquakes, Floods, and High Winds* (2010)
- FEMA 543, *Design Guide for Improving Critical Facility Safety from Flooding and High Winds* (2007)
- FEMA 577, *Design Guide for Improving Hospital Safety in Earthquakes, Floods, and High Winds* (2007)

### Enhancement Levels

FEMA recommends three enhancement levels. As the enhancement level increases, so does the level of protection from damage, disruption, and cost. Note that none of the enhancement levels ensure continuity of services such as electrical power or communications (see *Continuity of Operations* below). Table 1 provides a summary of the provisions to minimize building damage by enhancement level.

## Level 1 Enhancements

Weak tornadoes (EFO and EF1) have wind speeds that are below or somewhat above the 90-mph basic wind speed,<sup>1</sup> which is the design wind speed throughout most of the continental United States. Hence, buildings that comply with the International Building Code should exhibit good structural, door, and wall performance when struck by weak tornadoes. However, weak tornadoes can generate wind-borne debris that can break unprotected glazing and puncture many types of door, wall, and roof assemblies, which can result in significant interior damage and disruption. When the Level 1 enhancement recommendations are followed, the potential for debris and water to enter the building, if struck by weak tornadoes, is low.

**Level 1 Enhancement Recommendations:** In addition to the baseline recommendations in the FEMA P-424, 543, and 577 chapters that discuss high winds, design the roof deck, exterior doors, exterior glazing, and exterior walls to resist complete penetration by the test Missile E specified in ASTM E 1996. In addition, follow the roof system recommendations in P-424 (Section 6.3.3.7), 543 (Section 3.4.3.4), or 577 (Section 4.3.3.8) for hurricane-prone regions to reduce the potential for wind-borne debris-induced roof leakage. Figure 6 shows one of the recommended roof systems: sprayed polyurethane foam (SPF) over structural concrete. The strong tornado that struck this building did not debond the SPF from the concrete. Although wind-borne debris caused numerous gouges in the foam, the building did not leak because gouged SPF is not susceptible to leakage unless the foam is completely penetrated.

For fire stations, it is additionally recommended that apparatus bay doors and their connections to the structure be designed for a basic wind speed of 150 mph (plus an importance factor of 1.15).<sup>2</sup>

Brick veneer, aggregate roof surfacing, roof pavers, slate, and tile cannot be effectively anchored to prevent them from becoming missiles if a strong or violent tornado passes near a building with these components. To reduce the potential number of missiles, and hence reduce the potential for building damage and injury to people, it is recommended that these materials not be specified for critical facilities in tornado-prone regions.

## Level 2 Enhancements

Strong tornadoes (EF2 and EF3) have wind speeds that are below or near the Level 2 enhancements design wind speed. Hence, when Level 2 recommendations are followed, buildings should not experience structural failure or door or wall collapse when struck by strong tornadoes. However, debris from an EF3 tornado may penetrate the building and result in extensive interior water and perhaps wind damage.

**Table 1: Summary of Provisions to Minimize Building Damage by Enhancement Level**

Enhancement Levels	Recommendations
Level 1	<ul style="list-style-type: none"> <li>Resist test Missile E</li> <li>Special roof system</li> <li>Avoid listed roof and wall coverings</li> <li>Design fire station apparatus bay doors for a basic wind speed of 150 mph</li> </ul>
Level 2	<ul style="list-style-type: none"> <li>Level 1 enhancement recommendations</li> <li>Design for basic wind speed of 150 mph</li> </ul>
Level 3	<ul style="list-style-type: none"> <li>Level 2 enhancement recommendations</li> <li>Special roof deck and exterior walls</li> </ul>



**Figure 6: Although struck by a strong tornado, the SPF roof system of this Plainfield, IL, building did not blow off (1990 Tornado)**

### Brick Veneer

If brick veneer is selected, the veneer should not be depended on to resist debris because of the high potential for collapse of the veneer.

<sup>1</sup> The 90-mph basic wind speed is based on the 2005 edition of American Society of Civil Engineers ASCE 7, *Minimum Design Loads for Buildings and Other Structures*. If ASCE 7-10 is used, the equivalent basic wind speed for Risk Category III and IV buildings is 120 mph.

<sup>2</sup> The 150-mph basic wind speed is based on ASCE 7-05. If ASCE 7-10 is used, the equivalent basic wind speed for Risk Category III and IV buildings is 200 mph. (Note: The importance factor is built into the ASCE 7-10 maps; hence, the 1.15 importance factor is not used in the ASCE 7-10 pressure calculation equation.)

**Level 2 Enhancement Recommendations:** The facility should be designed to incorporate Level 1 enhancements and to a basic wind speed of 150 mph (plus an importance factor of 1.15) for the main wind-force resisting system (MWFRS), the building envelope, and rooftop equipment.

Note: The basic wind speed in south Florida is nearly 150 mph, and as a result, numerous products and systems are available that have been tested for pressures associated with this wind speed.

### Level 3 Enhancements

With incorporation of Level 3 enhancements, penetration of the roof deck or walls by EF3 debris is unlikely, but debris may penetrate doors or glazing. Designing with Level 3 enhancements also minimizes the potential for interior water and wind damage from strong tornadoes. However, significant interior damage could occur (though not within the safe room) if the core of a violent tornado (EF4 or EF5) passes over or near the building.

**Level 3 Enhancement Recommendations:** Facility design should incorporate Levels 1 and 2 enhancements as well as the following:

- Roof deck – A minimum 4-inch-thick, cast-in-place, reinforced concrete deck is the preferred deck. Other recommended decks include minimum 4-inch-thick structural concrete topping over steel decking and precast concrete with an additional minimum 4-inch-thick structural concrete topping.
- Exterior walls – A minimum 6-inch-thick, cast-in-place concrete wall reinforced with #4 rebar at 12 inches on center each way is the preferred wall. Other recommended walls are a minimum 8-inch-thick, fully grouted CMU reinforced vertically with #5 rebar at 40 inches on center and minimum 6-inch-thick precast concrete that is reinforced equivalent to the recommendations for cast-in-place walls.

Note that the above reinforcing recommendations are based on wind-borne debris resistance. More reinforcing steel may be required in the wall to carry wind loads, depending on the design and geometry of the wall.

The benefit of the Level 3 enhancement deck recommendation is illustrated by the fire station shown in Figure 7, which was struck by a strong tornado. The apparatus bay doors collapsed (red arrow), and all of the unprotected glazing was broken. However, the walls and cast-in-place concrete roof deck remained in place. Interior damage was substantial as a result of the glazing failures. If the Level 3 enhancement door, glazing, and rooftop equipment recommendations had been followed, this station would likely have had little, if any, interior damage. The adjacent unreinforced CMU apartment building (red circle) experienced blow off of the wood roof structure and collapse of some exterior CMU walls.

### Hospitals and Nursing Homes

Designing to at least the Level 1 enhancement recommendations is particularly important for hospitals and nursing homes. Designing these facilities to the Level 3 enhancement recommendations is preferable. Sometimes tornado warning time is ample for occupants to reach a safe room; however, at times an approaching tornado is not noticed until a few minutes before it strikes. In those instances with little or no warning of an impending tornado strike, maintaining building envelope integrity is crucial to providing protection to patients, residents, and staff, and to minimizing disruption of services.



**Figure 7: Fire station with a cast-in-place concrete roof deck in Tuscaloosa, AL. The apparatus bay doors (red arrow) collapsed and the adjacent building (red circle) was damaged (2011 Tornado).**



**Figure 8: Collapse of the second-floor roof structure, interior walls, and exterior walls of a school in Tuscaloosa, AL (2011 Tornado)**

The performance of the fire station in Figure 7 is in stark contrast to the school shown in Figure 8, which did not have any of the Level 1, 2, or 3 enhancements. The school was struck by the same strong tornado as the fire station, but the school's steel deck/steel joist roof structure blew away, and the exterior CMU/brick veneer walls and interior walls on the second floor collapsed.

## Continuity of Operations

Designing a facility to ensure it will remain operational if struck by a violent tornado is expensive. Therefore, when considering the costs and benefits of designing for continuity of operations, designing to minimize building damage and/or provide safe rooms may be more cost effective. Facilities such as EOCs that are determined to be critical in providing effective emergency response should be designed to avoid interrupted operations even if struck by violent tornadoes. The following practices will reduce the chances of interrupted operations related to building damage or loss of municipal utilities (i.e., water, sewer, and electrical power).

### Follow Recommendations in FEMA 361

If the entire facility must remain operational, FEMA 361 recommendations should be applied to the entire building. However, if only a portion of the building must remain operational, the recommendations can be applied only to that portion.

Figure 9 shows an example of an EOC (red oval) located in a portion of the first floor of a large building.<sup>3</sup> The collapsed second floor of this facility did not need to remain operational; hence, if a similar facility were being constructed, designing the second floor in accordance with FEMA 361 would not be necessary.

### Avoid Water Leakage

Critical facilities can be housed either on a top floor, with a roof overhead, or a bottom or intermediate floor with another story overhead. Avoiding water leakage is important for both scenarios. For critical facilities with a roof overhead, either of the following options is recommended:

- A modified bitumen roof membrane that is torch-applied to a primed concrete roof deck. Over this membrane, apply roof insulation, gypsum roof board, and another roof membrane as recommended in FEMA P-424 (Section 6.3.3.7), 543 (Section 3.4.3.4), or 577 (Section 4.3.3.8).
- A minimum 4-inch-thick SPF roof system over a concrete roof deck. The SPF should be coated rather than protected with an aggregate surfacing.

For critical facilities with a floor slab overhead, as shown in Figure 9, collapse of an upper level could allow water to leak into the critical facility. If water-sensitive equipment or operations are within the critical facility, the following is recommended.

- Design a false ceiling between the equipment or operations and the floor slab above. Design a waterproof membrane over the top of the false ceiling to prevent leakage into the water-sensitive area below.

<sup>3</sup> The building shown in Figure 9 was not FEMA 361 compliant.

## Vulnerability Assessments

As part of the planning process for new facilities, other natural hazards (flood, seismic, and wildfire) should be considered in addition to the tornado hazard. FEMA P-424, 543, and 577 provide guidance on conducting vulnerability assessments. If the building design does not ensure continuity of operations, contingency plans should be developed that address facility disruption.



**Figure 9: An EOC in Tuscaloosa, AL, that remained intact even though the story above it collapsed (Tornado 2011)**

## Design to Protect the Heating, Ventilation, and Air Conditioning

FEMA 361 provides recommendations pertaining to protecting heating, ventilation, and air conditioning (HVAC) equipment for safe rooms. Safe rooms, however, are normally occupied for relatively short durations, whereas critical facilities are normally needed for continuous long-term operation after a tornado. Therefore, additional provisions for ventilation and/or cooling may be required depending on facility operational requirements.

Maintaining functioning HVAC equipment in facilities that must either remain operational during an event or be able to be made operational shortly after an event can be challenging. Portions of commercial HVAC systems are typically inside the building, but portions that transfer heat to the environment are located outside and are, therefore, vulnerable to damage from wind and wind-borne debris (Figures 10 and 11).

To protect HVAC components outside buildings from horizontal wind-borne debris, wind- and debris-resistant walls can be designed around the equipment. Vertical debris protection is more difficult to achieve. Baffling, as shown in FEMA 361 (Section 3.3.2.e and Figure 7-12) to protect doors from direct debris impact, can be used to prevent damage to exterior equipment. However, baffling can restrict air flow and thereby reduce the cooling capacity of HVAC equipment. The effects of baffling should be considered in the system design.

Geothermal loops transfer heat to the earth and are, therefore, protected from wind and wind-borne debris. Although retrofitting existing systems to use geothermal loops is often not practical, installing geothermal systems during original construction can produce HVAC systems that meet the wind pressure and wind-borne debris criteria in FEMA 361.

An alternative to protecting equipment from debris is to rely on a temporary system, especially in situations when cooling is not needed immediately after an event. In this scenario, portable chiller units, cooling towers, or DX units could be brought to the site if a tornado damages the equipment. If temporary systems will be used, facility owners should source the equipment in advance, and design professionals should specify preinstallation for the power and control connections, as well as the associated piping and duct connections.

### Ensure Water Supply

Depending on facility operational requirements, drinking water or other water needs (such as for hand washing and fire protection) may be satisfied by stored water bottles, a water storage tank within the facility, or a well that is protected by an enclosure that meets the wind pressure and wind-borne debris criteria in FEMA 361.

### Ensure Sewer Service

FEMA 361 recommends self-contained, chemical-type receptacles/toilets to provide sewer service for safe rooms. However, the recommendations in FEMA 361 may be inadequate for critical facilities that do not have to access to functional municipal sewer service for days or weeks after a tornado. For these facilities, a temporary storage tank that can be pumped out by a local contractor should be designed.

FEMA has observed critical facilities that were flooded by backflow from surcharged sewer systems as a result of loss of electrical power to sewage lift stations or storm-damaged sewage treatment plants. Sewer backflow valves can be installed in the sewage discharge line to avoid this problem. However, because sewage will also



Figure 10: ACC units vulnerable to wind and wind-borne debris



Figure 11: Cooling tower vulnerable to wind and wind-borne debris



not be able to leave the building from the primary discharge line, provisions should be made for diversion to a temporary storage tank.

### Make Provisions for Emergency Power

FEMA 361 provides recommendations pertaining to emergency power. However, because critical facilities may have to rely on emergency generators for several days or weeks after a tornado, designers of critical facilities should also refer to the electrical power recommendations in FEMA P-424 (Section 6.3.5.1). Following these recommendations will minimize the loss of needed emergency power (see Figures 12 and 13). These recommendations also pertain to dual fuel generators.<sup>4</sup>



**Figure 12:** This Joplin, MO, building housing the switchgear (red arrow) and emergency generator (Figure 13) collapsed (2011 Tornado)



**Figure 13:** The steel deck/steel joist roof structure and unreinforced CMU walls of this Joplin, MO, building collapsed onto the emergency generator (2011 Tornado)

### Minimizing Operational Disruption in Hospitals

Hospitals present special challenges because of the need for glazing in patient rooms. The following options should be considered to minimize disruption of operations in hospitals.

**Adhere to FEMA 361:** To ensure continuity of operations, designers could follow the recommendations provided in Continuity of Operations above, including specifying that the entire building, including all exterior glazing, meet the tornado wind-borne debris and wind pressure criteria in FEMA 361.

Note: The test missile used for safe room design has much greater momentum than test Missile E (68 versus 22 pounds force per second). Glazing assemblies that have passed the Missile E testing are readily available, and a few assemblies are available that meet the tornado test missile. Known assemblies that have passed the tornado test missile requirement employ polycarbonate glazing. In some assemblies, a pane of glass is on the exterior side of the polycarbonate. The glass protects the outer surface of the polycarbonate from scratches, but the inner surface is susceptible to scratching.

Note: Safe rooms that have a few small windows protected by a shutter on the inside of the room have been designed. However, expecting a shutter within each patient room to always be closed before a tornado event is impractical.

**Implement Level 3 enhancement recommendations:** To minimize operational disruption, the Level 3 enhancement recommendations could be implemented in patient rooms, lobbies, and other areas where exterior glazing is necessary. In other areas of the facility (such as the emergency room, lab, radiology department, surgery department, and the physical plant), the recommendations provided in Continuity of Operations above could be implemented. By taking this approach, some exterior glazing might be breached if a violent tornado passed over or near the hospital, but much of the facility would have a high potential of remaining operational.

<sup>4</sup> After a tornado, main natural gas lines may need to be turned off to prevent fires. If a critical facility has a gas-fired generator, it may not be operational unless it has a secondary diesel fuel source.

## Useful Links and Resources

**Recovery Advisories from the Tornado MATs for Alabama, Mississippi, Tennessee, and Georgia.** FEMA. 2011. Available from: <http://www.fema.gov/library/viewRecord.do?id=4723>.

- Tornado Recovery Advisory No. 1 – *Tornado Risks and Hazards in the Southeastern United States*
- Tornado Recovery Advisory No. 2 – *Safe Rooms: Selecting Design Criteria*
- Tornado Recovery Advisory No. 3 – *Residential Sheltering: In-Residence and Stand-Alone Safe Rooms*
- Tornado Recovery Advisory No. 4 – *Safe Rooms and Refuge Areas in the Home*
- Tornado Recovery Advisory No. 5 – *Critical Facilities Located in Tornado-Prone Regions: Recommendations for Facility Owners.*

**Taking Shelter from the Storm: Building a Safe Room for Your Home or Small Business** (FEMA 320), August 2008, Third Edition. <http://www.fema.gov/library/viewRecord.do?id=1536>.

**Design and Construction Guidance for Community Safe Rooms** (FEMA 361), August 2008, Second Edition. <http://www.fema.gov/library/viewRecord.do?id=1657>.

**Design Guide for Improving School Safety in Earthquakes, Floods, and High Winds** (FEMA P-424), December 2010, Second Edition. <http://www.fema.gov/library/viewRecord.do?id=1986>.

**Tornado Protection: Selecting Refuge Areas in Buildings** (FEMA P-431), October 2009, Second Edition. <http://www.fema.gov/library/viewRecord.do?id=1563>.

**Design Guide for Improving Critical Facility Safety from Flooding and High Winds** (FEMA 543), January 2007. <http://www.fema.gov/library/viewRecord.do?id=2441>.

**Design Guide for Improving Hospital Safety in Earthquakes, Floods, and High Winds** (FEMA 577), June 2007. <http://www.fema.gov/library/viewRecord.do?id=2739>.

**ICC/NSSA Standard on the Design and Construction of Storm Shelters**, International Code Council (ICC) and National Storm Shelter Association (NSSA) (ICC 500), June 2008, Country Club Hills, IL. [http://www.iccsafe.org/Store/Pages/Product.aspx?id=8850P08\\_PD-X-SS-P-2008-000001#longdesc](http://www.iccsafe.org/Store/Pages/Product.aspx?id=8850P08_PD-X-SS-P-2008-000001#longdesc).

# Rebuilding and Repairing Your Home After a Tornado



FEMA

## TORNADO RECOVERY ADVISORY

RA7, August 2011

### Purpose and Intended Audience

The purpose of this advisory is to identify which standard of construction should be used when repairing houses damaged in high-wind events (see Figure 1). The intended audience for this Tornado Recovery Advisory is homeowners or home builders. The advisory explains how to determine which building code is appropriate, describes how to incorporate best practices into construction, and lists resources for installing residential safe rooms. Homeowners and renters should also refer to Tornado Recovery Advisory No. 3, *Residential Sheltering: In-Residence and Stand-Alone Shelters* (updated in 2011).

### This Recovery Advisory Addresses:

- Determining the Appropriate Building Code
- Incorporating Best Practices
- Protecting Building Occupants by Installing Residential Safe Rooms

### Determining the Appropriate Building Code

Building codes are used in many jurisdictions as a minimum standard of construction practice to provide occupants with an improved level of safety from natural hazards, fire, and poor air quality. Building codes are instituted when either the State or a local jurisdiction adopts them. Most building codes are based on one of the current prevailing model building codes published by the International Code Council (ICC).

Houses constructed in hurricane-prone regions may be constructed to the ICC 600, *Standard for Residential Construction in High-Wind Regions*, in addition to the International Residential Code. ICC 600 provides a prescriptive approach for building and repairing houses in regions where the design wind speed is above 90 mph (3-second gust) and, for some construction methods, up to 150 mph. Even if the design wind speed for your location is 90 mph or less, designing to the ICC 600 standard may improve the performance of your house in a high-wind event such as a weak tornado. Although constructing to a higher standard may not eliminate all damage to the building, it may reduce damage from high-wind storm events.

While building codes can be adopted at the State, county, or local jurisdiction (city) level, in some areas of the United States, no building codes are adopted or enforced. Where building codes are not adopted and enforced, residential construction quality may not be ensured by plan reviewers or a building inspector. In these areas, the building owner should hire a qualified professional to conduct inspections and verify that the work is being done properly.



**Figure 1: A house that lost large sections of the roof and the garage due to internal pressurization.**



## Incorporating Best Practices

Best practices are design or construction practices that go beyond the minimum code requirements of the latest model codes to improve building performance. An example of a best practice is adding metal connectors to a structure to improve the transfer of loads through the house from the roof system to the foundation. Construction details and material selection can result in a house with improved resistance to wind pressures and wind-borne debris. Resources for best practices include the ICC 600 standard and FEMA P-499, *Home Builder's Guide to Coastal Construction* (FEMA 2010), which is a technical fact sheet series for improving house performance in high-wind regions. The FEMA P-499 fact sheets are appropriate for use throughout the country, and they provide best practice recommendations for a variety of building systems.

Best practices can be incorporated not only into new construction, but also into existing homes. Houses can be retrofitted either as part of the repair process, such as when replacing the roof covering, or as part of an independent retrofit project. FEMA P-804, *Wind Retrofit Guide for Residential Buildings* (FEMA 2010), describes how to improve a house's performance during high-wind events. The guide outlines three levels of building performance and describes groups of retrofits that can reduce damage to a house. In addition, proper application of the retrofit packages described in FEMA P-804 may result in insurance premium rate reductions in certain areas of the country.

When constructing a new home or repairing a damaged house, certain practices should be considered. Table 1 lists building components that are commonly observed to fail during high-wind events and provides recommended practices to avoid these failures. The failure of these components often results in damage from wind-blown rain and, in some cases, pressurization of the house, which may lead to the loss of walls or the entire structure. While this list is not all-inclusive, it addresses some of the most common and inexpensive preventive measures.

**Table 1. Upgrades to Prevent Common Building Component Failures**

Building Component	Typical Failure	Recommended Practice
Asphalt Shingles	<p>Shingles blown off in high-wind events, exposing the roof to wind-blown rain</p> 	<p>Use shingles rated for 90+ mph wind and use a minimum of four nails per shingle; preferred use is six nails per shingle (Source: FEMA P-499, Fact Sheet 7.3)</p>
Windows and Doors	<p>Windows and doors can be dislodged from the walls</p> 	<p>Make sure windows and doors are properly shimmed and nailed into the framed opening using nails of sufficient length to tie the window and door frames into the adjacent studs (Source: FEMA P-499, Fact Sheet 6.1)</p>

Building Component	Typical Failure	Recommended Practice
Baseplate or Sillplates	<p>Uplift of the wall systems and shear failures</p> 	<p>Make sure there are anchor bolt connections between the plate and the foundation at least every 4 feet (Source: FEMA P-499, Fact Sheet 4.3)</p>
Roof-to-Wall Connections	<p>Uplift of the roof systems and either significant damage or loss of the entire roof</p> 	<p>Ensure there is a continuous load path from the roof to the foundation using metal connectors that are approved for use with the applicable basic wind speed (Source: FEMA P-499, Fact Sheets 4.1, 4.2, and 4.3)</p>
Sheathing	<p>Penetration of fiberboard sheathing and rigid insulation board by wind-borne debris in even weak tornadoes</p> 	<p>Use oriented-strand board (OSB) or plywood to prevent penetration from wind-borne debris and racking (Source: FEMA 342, Chapter 8)</p>
Garage Doors	<p>Buckling of doors either outward or inward</p> 	<p>Select doors designed for higher wind speeds (Source: FEMA P-804, Chapter 4)</p>

Building Component	Typical Failure	Recommended Practice
Brick Veneer	<p>Brick veneers pull away from the wall systems</p> 	<p>Attach veneers with brick ties to the wall framing at adequate spacing as shown in FEMA P-499 (Source: FEMA P-499, Fact Sheet 5.4)</p>
Vinyl Siding	<p>Vinyl siding pulls off wall sheathing</p> 	<p>Use vinyl siding rated for high wind applications and attach it to the wall framing as noted in FEMA P-499 (Source: FEMA P-499, Fact Sheet 5.3)</p>
Gable End Walls	<p>Gable end walls collapse or rotate, causing loss of the roof system, causing failure of hinges and possibly large sections of the building, and causing walls to buckle</p> 	<p>Improve the gable end wall bracing details with additional connections and by improving the load path with additional framing and metal connectors (Source: FEMA P-804, Chapter 4)</p>

## Protecting Building Occupants by Installing Residential Safe Rooms

When reconstructing after a tornado event, homeowners may want to consider installing a residential safe room to protect building occupants in the event of a future tornado. A safe room can be an interior room, a space within a building, or an entirely separate building designed and constructed to protect its occupants from tornadoes and hurricanes. Safe rooms are intended to provide protection against both wind forces and the impact of wind-borne debris.

Additional information on safe rooms can be found in Recovery Advisory No. 3, *Residential Safe Rooms: In-Residence and Stand-Alone Safe Rooms* (updated in 2011).

## Useful Links and Resources

**2011 Tornado Recovery Advisories.** FEMA. 2011. <http://www.fema.gov/library/viewRecord.do?id=4723>

**Recovery Advisory No. 3, Residential Safe Rooms: In-Residence and Stand-Alone Safe Rooms.** FEMA. 2011. <http://www.fema.gov/library/viewRecord.do?id=4723>

**Recovery Advisory No. 5, Critical Facilities Located in Tornado-Prone Regions: Recommendations for Facility Owners.** FEMA. 2011. <http://www.fema.gov/library/viewRecord.do?id=4723>

**Taking Shelter from the Storm: Building a Safe Room for Your Home or Small Business** (FEMA 320). August 2008, Third Edition. <http://www.fema.gov/library/viewRecord.do?id=1536>

**Midwest Tornadoes of May 3, 1999: Observations, Recommendations, and Technical Guidance** (FEMA 342). October 1999. <http://www.fema.gov/library/viewRecord.do?id=1423>

**Home Builder's Guide for Coastal Construction** (FEMA P-499). December 2010, Second Edition. [http://www.fema.gov/rebuild/mat/mat\\_fema499.shtm](http://www.fema.gov/rebuild/mat/mat_fema499.shtm)

**Wind Retrofit Guide for Residential Buildings** (FEMA P-804). December 2010. <http://www.fema.gov/library/viewRecord.do?id=4569>

**Standard for Residential Construction in High-Wind Regions.** ICC 600, International Code Council (ICC). 2008. Country Club Hills, IL.

**International Residential Code for One- and Two-Family Residences** (IRC) ICC. 2009. Country Club Hills, IL.

**ICC/NSSA Standard for the Design and Construction of Storm Shelters** (ICC-500), June 2008. [http://www.iccsafe.org/Store/Pages/Product.aspx?id=8850P08\\_PD-X-SS-P-2008-000001](http://www.iccsafe.org/Store/Pages/Product.aspx?id=8850P08_PD-X-SS-P-2008-000001)





# Reconstructing Non-Residential Buildings After a Tornado



FEMA

**TORNADO RECOVERY ADVISORY**

RA8, August 2011

## Purpose and Intended Audience

The purpose of this advisory is to identify which standard of construction should be considered for repairing buildings damaged in high-wind events (see Figure 1). The intended audience for this Tornado Recovery Advisory is architects, engineers, builders, and building owners. This advisory explains how to determine which building code is appropriate, incorporating best practices into construction, common building failures and how to avoid them, and resources for installing shelters and safe rooms.

### This Recovery Advisory Addresses:

- Determining the appropriate building code
- Incorporating best practices
- Common building failures and recommendations to mitigate them
- Protecting building occupants by installing shelters and safe rooms

## Determining the Appropriate Building Code

Building codes are used in many jurisdictions as a minimum standard of construction practice to provide occupants with an improved level of safety for natural hazards, fire, and air quality. Building codes are instituted when either the State or a local jurisdiction adopts them. Most building codes are based on a model building code.

The current prevailing model building code is the family of International Building Codes produced by the International Code Council (ICC). Codes are typically updated on a predetermined cycle of reviews. Codes from the ICC are updated on a 3-year cycle, and most governmental bodies are using a code based on the 2003, 2006, or 2009 ICC building codes. At the time of this publication, the 2012 ICC building codes have been published, but few local jurisdictions have adopted this version of the code yet. Building codes typically use a performance approach, which means that construction practices are based on a specific building's design and location. In addition to construction methods, building codes also usually dictate administrative practices such as permitting, reviews, and inspections.

Design loads are calculated using design standards or other design guidance referenced by the codes. With only a few exceptions, the International Building Code (IBC) requires the use of American Society



**Figure 1: A business damaged by roof damage and water intrusion from a weak tornado**

### Standard of Care

Critical facilities have facility and operational requirements that should be met in addition to building code requirements. Building codes do not stipulate expected building performance for tornadoes. The designer should discuss expectations regarding acceptable building damage, operational requirements, and occupant safety with the facility owner to ensure the full range of requirements is considered.

of Civil Engineers (ASCE) 7, *Minimum Design Loads for Buildings and Other Structure*, to calculate wind and other loads on buildings.

Even if there is no building code enforced in the jurisdiction where you are building, it is still important to construct to a building code to provide a minimum standard of care. While building permits in these areas may be required, building inspections may not be conducted, and it may be necessary to hire a qualified professional to conduct inspections to verify that the work is being done properly. The latest version of the International Codes (2012) is recommended as a minimum code.

## Incorporating Best Practices

Best practices are design or construction practices that go beyond minimum code requirements to improve building performance. Four options should be considered for increasing the design loads on buildings: increasing the occupancy category, increasing the design wind speed, designing as a partially enclosed building, or designing as if in a hurricane-prone region. Each of these methods will effectively result in a building that can withstand higher wind pressures and/or improve debris impact resistance. Increasing the building occupancy category typically only results in minimal increases in wind resistance; the other methods will improve building performance more substantially.

**Increasing Design Wind Speed:** ASCE 7 promulgates the minimum loading requirements for building design. To improve wind resistance, higher wind loads can be calculated using the calculations in ASCE 7. For an Occupancy Category II building in a non-hurricane-prone area, the standard design wind speed is 90 mph, but increasing the design wind speed to 115 mph will result in a 63 percent increase in velocity pressures and be consistent with similar buildings using the ASCE 7-10 wind speeds. In addition to using a higher design standard for loads, improved construction methods and materials can also improve building performance. Even small practices—such as slightly increasing reinforcing steel sizes and increasing development and lap splice lengths—can greatly improve building performance.



**Designing as a Partially Enclosed Building:** In most cases, buildings are designed to function as an enclosed structure, meaning that it is designed to only allow minimal air into the building even during a high wind event. Once windows or doors are broken by windborne debris, wind pressures can greatly increase and cause significant structural damage to the building. Designing exterior and load-bearing walls, roof systems, and the foundation to resist the increased wind pressures will result in significant improvements to the building structure performance. The recent edition of the International Building Code has tables and charts for these wind speeds and wind pressures that can aid in building detailing.



**Designing as if in a Hurricane-Prone Region:** The design strategies and building materials used in hurricane-prone areas result in buildings that are more resistant to most tornadoes (i.e., Enhanced Fujita [EF] 0–EF3). With appropriate strengthening and selection of building materials and systems, both the potential for disruption of operations and the cost of repairs after a tornado event can be reduced. If the costs associated with loss of function or business interruption are significant, then a higher standard of construction may be appropriate. Building performance can also be improved with engineering techniques introduced through some of the observations noted for critical facilities (see Recovery Advisory No. 6, *Critical Facilities Located in Tornado-Prone Regions: Recommendations for Architects and Engineers* [FEMA 2011] for additional information).

## Common Building Failures and Recommendations to Mitigate Them

Table 1 describes the typical failures observed after the 2011 tornadoes. The table also provides recommended practices to reduce these failures in buildings subjected to weak tornadoes and minimize them for buildings on the periphery of stronger tornadoes.

**Table 1. Building Failures and Recommendations**

Building Component	Typical Failure	Recommended Practice
Superstructure		
Pre-Engineered Buildings	<p>Failure of endwall trusses and endwall truss bracing.</p> 	<p>Size the endwall trusses to resist wall loads and verify that anchor bolts are sized to resist lateral loading. (Source: FEMA 489)</p>
Masonry Buildings	<p>Collapse of unreinforced masonry walls.</p> 	<p>Fully grout walls and increase reinforcement to resist lateral loads and uplift loads on the roof system. (Source: FEMA P-424)</p>
Roof Coverings and Roof Systems		
Ballasted Roofs	<p>Ballasted roof systems can become wind-borne debris and damage surrounding objects.</p> 	<p>Select an alternative ballasting system or fully adhere ballast to the roof system. (Source: FEMA P-424)</p>

Building Component	Typical Failure	Recommended Practice
<p>Roof Truss Connections</p>	<p>Loss of roof trusses from uplift loads. Trusses typically fail at the connection with the wall system, either through poor grouting of anchor bolts or insufficient embedment.</p> 	<p>Improve connection of roof trusses to prevent failure from uplift loads. Verify that the load path is continued through the wall system into the foundation. (Source: FEMA P-424)</p>
<p>Double Tee Connections</p>	<p>Double tees shift due to uplift loads and failures at angle iron welds or insufficient anchor bolts, allowing the double tee to slip off the corbel.</p> 	<p>Ensure that anchor bolts provide sufficient strength to prevent uplift. (Source: FEMA P-424)</p>
<p>Gable End Walls</p>	<p>Insufficient attachment of gable end walls results in building pressurization, loss of the roof system, and possibly large sections of the building.</p> 	<p>Improve the gable end wall bracing details with additional connections and strengthen the load path. (Source: FEMA P-804)</p>

Building Component	Typical Failure	Recommended Practice
Building Envelope		
Metal Sheeting	<p>Loss of wall coverings due to insufficient girts.</p> 	<p>Increase framing between trusses to reduce loads on metal sheeting. Increase metal sheeting thickness to resist the potential for pulling off connectors. (Source: FEMA 489)</p>
Brick Veneer	<p>Wall failures resulting from insufficient brick ties.</p> 	<p>Increase number of brick ties, properly attach ties to the wall system, and sufficiently embed ties into the brick veneer. (FEMA P-499, Fact Sheet 5.1)</p>
Exterior Insulation and Finishing System (EIFS)	<p>Loss of large sections of EIFS due to impact of wind-borne debris.</p> 	<p>Reduce vulnerability of EIFS by using it in locations that are high enough to prevent damage from wind-borne debris. (Source: FEMA 424)</p>
Rooftop Equipment	<p>Damage to rooftop equipment, typically by wind-borne debris or as a result of insufficient anchorage.</p> 	<p>Protect exterior equipment from wind-borne debris. Evaluate connections to rooftop or slab. (Source: FEMA 424)</p>

Building Component	Typical Failure	Recommended Practice
Roll-up Door Systems  	Buckling of roll-up door systems, typically due to either positive or negative pressures. Door tracks and rollers can fail in high winds.	Specify a door system for a higher wind speed than the minimum required by code. (Source: FEMA 489)

Two common building types that failed in the recent tornadoes were masonry buildings and pre-engineered buildings. Both of these building types are common and have aspects that put them at risk of significant damage in high-wind events.

**Masonry Buildings:** Masonry buildings can be constructed as either reinforced or unreinforced masonry. The most common failure noted is with unreinforced masonry walls. The lack of reinforcement makes them particularly susceptible to collapse. Unreinforced walls are commonly observed in older construction, but numerous examples of more recently constructed buildings that contained little or no reinforcement were observed after the 2011 tornadoes. Due to the lack of rigidity, unreinforced masonry walls tend to bow and collapse in high-wind events. The lack of reinforcement also makes the roof system particularly susceptible to uplift.

Failure of reinforced masonry walls is also not uncommon. The failures noted after the 2011 tornadoes were because the wall systems either contained too little reinforcement or insufficient splices or development lengths in the bars. The walls failed in large sections and pulled away from the foundation or slab due to insufficient splice designs. Poor connections between roof systems and wall systems were also noted to cause failure of reinforced masonry walls.

**Pre-Engineered Buildings:** Pre-engineered buildings can sustain significant loss of exterior sheeting, and in some cases, failure of the frame. Exterior sheeting should be sufficiently supported to resist deflection from high winds; additional girts and purlins may be required. Increasing the thickness of the exterior sheeting can reduce the potential for sheeting pulling off connectors. Endwall trusses of pre-engineered buildings should be designed to resist wall loads, and anchor bolts should be sized to resist uplift from high wind loads.

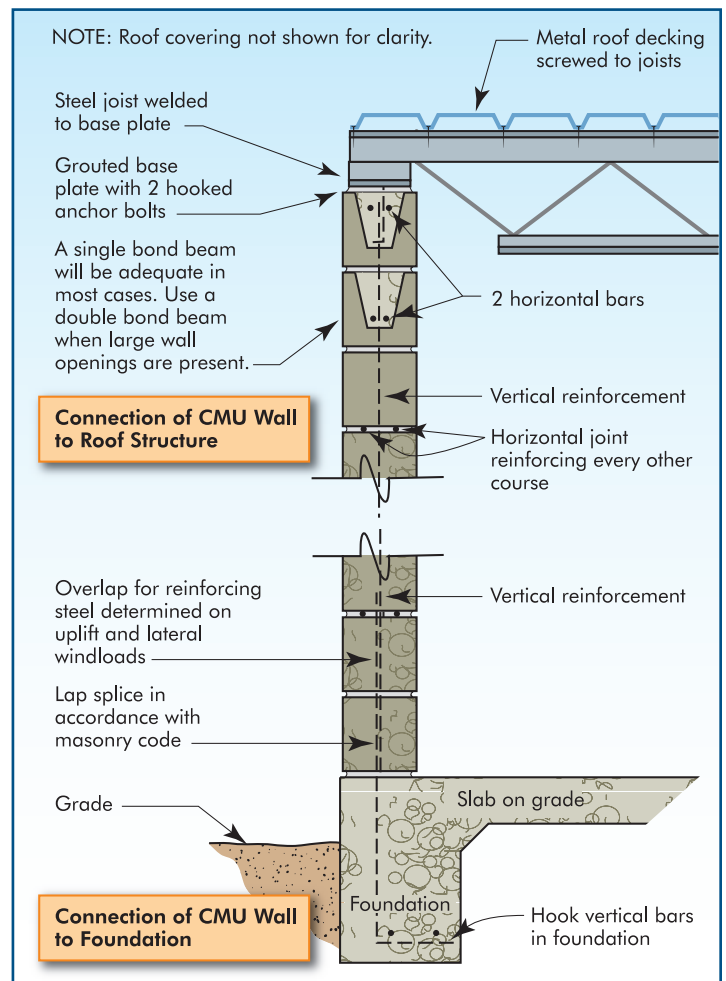

**Figure 2: Example of a masonry wall detail, incorporating many construction best practices. Source: FEMA P-424, Design Guide for Improving School Safety in Earthquakes, Floods, and High Winds (FEMA 2010)**

## Protecting Building Occupants by Installing Shelters and Safe Rooms

When reconstructing after a tornado event, building owners may want to consider installing a safe room or shelter to protect occupants in the event of a future tornado. The distinction between a safe room and a shelter is described in the following text box.

More information on the construction of safe rooms can be found in the FEMA 2011 Recovery Advisory No. 2, *Safe Rooms: Selecting Design Criteria*.

A **shelter** (including safe rooms) is typically an interior room, space within a building, or an entirely separate building, designed and constructed to protect occupants from tornadoes or hurricanes. Shelters are intended to provide protection against both wind forces and the impact of wind-borne debris.

### Useful Links and Resources:

**Minimum Design Loads for Buildings and Other Structures**, American Society of Civil Engineers (ASCE), 2005. ASCE Standard ASCE/SEI 7-05.

**Minimum Design Loads for Buildings and Other Structures**, American Society of Civil Engineers (ASCE), 2010. ASCE Standard ASCE/SEI 7-10.

**Recovery Advisories from the Tornado Mitigation Assessment Teams (MATs) for Alabama, Mississippi, Tennessee, and Georgia**. FEMA. 2011. Available from: <http://www.fema.gov/library/viewRecord.do?id=4723>.

- Recovery Advisory No. 1, *Tornado Risks and Hazards in the Southeastern United States*
- Recovery Advisory No. 2, *Safe Rooms: Selecting Design Criteria*
- Recovery Advisory No. 6, *Critical Facilities Located in Tornado-Prone Regions: Recommendations for Architects and Engineers*

**Taking Shelter from the Storm: Building a Safe Room For Your Home or Small Business (FEMA 320)**, August 2008, 3rd Edition. <http://www.fema.gov/library/viewRecord.do?id=1536>

**Design Guide for Improving School Safety in Earthquakes, Floods, and High Winds (FEMA P-424)**, 2010. <http://www.fema.gov/library/viewRecord.do?id=1986>

**Building Performance Assessment Report. Oklahoma and Kansas, Midwest Tornadoes of May 3, 1999 – Observations, Recommendations and Technical Guidance (FEMA 342)**, October 1999. <http://www.fema.gov/library/viewRecord.do?id=1423>

**Design and Construction Guidance for Community Safe Rooms (FEMA 361)**, August 2008, 2nd Edition. <http://www.fema.gov/library/viewRecord.do?id=1657>

**Home Builder's Guide for Coastal Construction (FEMA P-499)**, December 2010, Second Edition. [http://www.fema.gov/rebuild/mat/mat\\_fema499.shtm](http://www.fema.gov/rebuild/mat/mat_fema499.shtm)

**Wind Retrofit Guide for Residential Buildings (FEMA P-804)**, December 2010. <http://www.fema.gov/library/viewRecord.do?id=4569>

**ICC/NSSA Standard for the Design and Construction of Storm Shelters (ICC-500)**, June 2008. [http://www.iccsafe.org/Store/Pages/Product.aspx?id=8850P08\\_PD-X-SS-P-2008-000001](http://www.iccsafe.org/Store/Pages/Product.aspx?id=8850P08_PD-X-SS-P-2008-000001)

**International Building Code (IBC)**, ICC. 2009. Country Club Hills, IL.





# TORNADO OUTBREAK *of* **2011**

IN ALABAMA, GEORGIA, MISSISSIPPI,  
TENNESSEE, AND MISSOURI

## Recommendations for One- and Two-Family Residential Buildings

### G.1 Purpose and Audience

This appendix provides prescriptive guidance for enhanced construction techniques to improve performance of wood-frame residential structures when impacted by tornadoes rated EF2 or less. Accordingly, the following guidance addresses only the effects of increased wind loading resulting from tornadoes and does not consider other loading conditions such as seismic, snow, flood, or any other loads. The intended users of this appendix are building designers, homebuilders, and homeowners in the tornado-prone regions of the United States. The use of this guidance is intended to be coordinated with recommendations of the building design professional to produce a complete building design resistant to anticipated loads.

One of the goals of the committee that developed this appendix was to make the guidance simple and cost effective, and thereby foster mitigation. The building performance of one- and two-family residential wood-frame buildings during a high-wind event will be significantly elevated over code-level practices through the voluntary implementation of guidance provided in this appendix. While implementing the following guidance is voluntary, the Mitigation Assessment Team (MAT) strongly advises users to take a comprehensive approach to incorporating enhancements as applicable to ensure continuity of the building's load path.

The following guidance is not intended to replace the governing building code, as it does not address all aspects of construction. Instead, enhanced construction techniques presented in this

section should be implemented in accordance with provisions of the governing building code to enhance building performance during high-wind events. If a building code has not been adopted by the authority having jurisdiction, then enhanced construction techniques in this appendix should be implemented in accordance with the requirements of the current version of the International Residential Code (IRC).

While implementing the voluntary mitigation actions proposed in this appendix for one- and two-family residential buildings will greatly enhance their performance when impacted by tornadoes rated EF2 or less, there is no substitute for a personal protection plan that includes access to a safe room in the event of a tornado emergency.

## G.2 Background and Applicability

The guidance in this appendix is adapted from existing guidance for high-wind regions. The primary sources referenced are Technical Fact Sheets from Federal Emergency Management Agency (FEMA) P-499, *Home Builder's Guide to Coastal Construction* (2010), the *Wood Frame Construction Manual (WFCM) Guide to Wood Construction in High Wind Areas for One- and Two-Family Dwellings, 130 mph, Exposure B* (AWC 2006), and the International Code Council's (ICC's) ICC 600-2008, *Standard for Residential Construction in High-Wind Regions*. These documents provide guidance for high-wind resistance that, when implemented in high-wind hazard areas in accordance with the applicable building code, result in enhanced performance for one- and two-family residential buildings.

It is important to note, however, that important differences exist between hurricanes and tornadoes. Hurricane-force winds affect broad areas of coastline, and the probability of their site-specific occurrence is better understood than that of tornadoes. Strengthening buildings by maintaining load path continuity and reinforcing connections has proven successful for mitigating hurricane wind damage and provides a good model for mitigating tornado wind damage.

In areas with relatively low mapped wind speeds, one way to reduce damage caused by tornadoes rated EF2 or less is to design to higher wind speeds. Because of the current lack of standards

The guidance for improved building performance presented in this appendix is intended solely for enhanced property protection and should not be construed in any way as an alternative to sheltering.

The guidance in Appendix G is intended to strengthen new construction. FEMA P-804, *Wind Retrofit Guide for Residential Buildings*, provides guidance on retrofitting existing residential buildings to reduce their vulnerability to damage from high-wind events and wind-driven rain intrusion. Users should note that grant opportunities described in FEMA P-804 may not be available for homes located outside of hurricane-prone regions.

Basic mapped wind speeds in ASCE 7-10 for Category II structures (residential buildings) are higher than those in ASCE 7-05 because they represent ultimate wind speeds or strength-based design wind speeds. Load factors for wind in ASCE 7-10 are also different from those in ASCE 7-05. In ASCE 7-10, the wind load factor in the load combinations for strength design is 1.0; in ASCE 7-05, the load factor is 1.6. The allowable stress design load factor in the load combinations for wind is 0.6; in ASCE 7-05, the load factor is 1.0.

or guidance on designing to loads associated with tornado events, and to facilitate complementary design of buildings or parts of buildings that fall outside the scope of this appendix, the wind pressures in Appendix G are based on an ASCE 7-05 wind speed of 130 mph (3-second gust) using Exposure Category B. Exposure Category B includes urban and suburban areas, wooded areas, and other terrain with numerous closely spaced obstructions the size of single-family dwellings. Residential buildings in Exposure Category C, which is defined as open terrain with scattered obstructions, are outside the scope of this appendix.

As noted in Chapter 4, tornadoes rated EF2 or less often damage window and door glazing in residential buildings, which can lead to increased pressurization of the building. Although the prescriptive solutions presented in this appendix maintain the assumption of an enclosed building consistent with the primary sources referenced above, this condition is unlikely to be met for wind speeds in excess of 110 mph (ASCE 7-05, 3-second gust) unless impact-resistant glazing is installed (described more fully in Section G.3.1.4, Glazing (Doors and Windows)). For added protection of building structures without impact-resistant glazing that are subject to wind speeds in excess of 100 mph (3-second gust), a designer may choose to design for higher wind speeds or increased pressures associated with a partially enclosed building classification as described in ASCE 7.

The guidance in this appendix related to roof-to-wall, wall systems and connections is limited to the following:

- + One- and two-family wood-frame residential buildings with no more than two stories.
- + Mean roof heights ( $H_{max}$ ) and roof spans ( $W_{max}$ ) limitations as shown in Figure G-1. Continuous load path elements that are addressed in this appendix are also shown on Figure G-1.
- + Percentage of full-height wall sheathing and building aspect ratios, as described in Tables G-6 and G-7.
- + Openings in floors and ceilings that are the lesser of 12 feet or half the relative building dimension. Vaulted or cathedral ceilings are outside the scope of this appendix.
- + Load bearing exterior wall height limited to 10 feet. Refer to Section 4 (Walls) of *Wood Frame Construction Manual (WFCM) Guide to Wood Construction in High Wind Areas for One- and Two-Family Dwellings, 130 mph, Exposure B* for complete wall framing schedules.<sup>1</sup>

The enhanced construction techniques described in this appendix are considered applicable for buildings with dimensions and characteristics outside the scope of those listed above, but the building design process must consider modifications to account for differences in building dimensions and characteristics.

---

<sup>1</sup> The American Wood Council guide is available at [http://www.awc.org/pdf/WFCM\\_130-B-Guide.pdf](http://www.awc.org/pdf/WFCM_130-B-Guide.pdf).

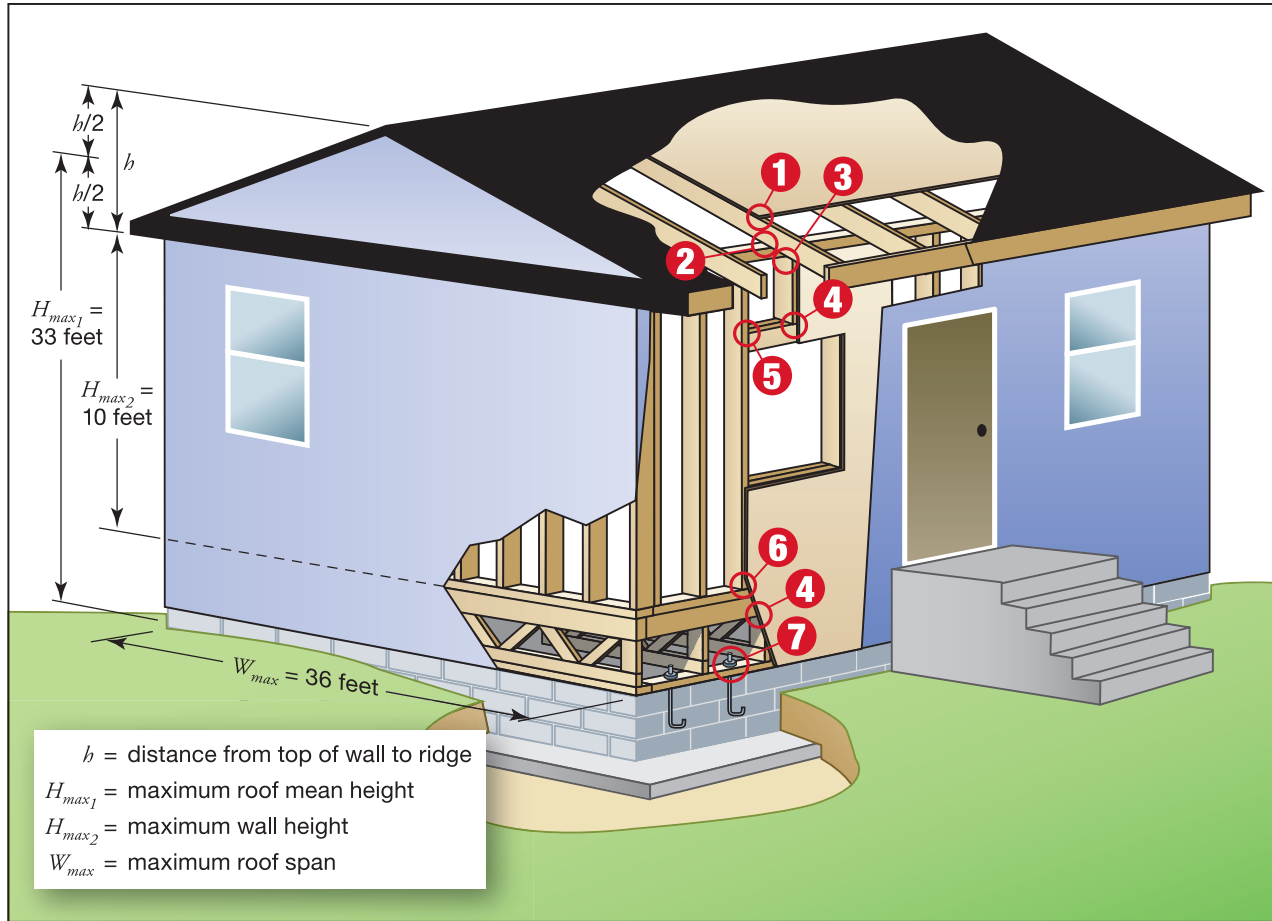

- 1** Roof sheathing connection (G3.2)

**2** Rafter or truss to plate (G3.2, Table G-3, G-4)

**3** Plate to stud (G3.3, Table G-11, G-12)

**4** Wall sheathing connection (G3.3, Table G-6, G-7)
- 5** Header connection (G3.3, Table G-9, G-10)

**6** Stud to plate (G3.3, Table G-14)

**7** Sill anchorage (G3.3, Table G-5)

**Figure G-1: Load path elements and height and width limitations for residential buildings covered in Appendix G**  
 ADAPTED: COURTESY, AMERICAN WOOD COUNCIL, LEESBURG, VA

### G.3 Discussion of Recommendations

The following recommendations include construction specifications and details for enhanced building performance related to the following building components and systems:

#### G.3.1 Building Envelope Components

- +Roof coverings
- +Wall coverings
- +Masonry veneer attachment

- + Glazing (doors and windows)

- + Garage doors

### G.3.2 Roof Systems and Connections

- + Roof decking and decking attachment

- + Soffits

- + Roof-to-wall connections

### G.3.3 Wall Systems and Connections

- + Sill plate attachment

- + Wall sheathing

- + Top plate splices

- + Openings in walls

- + Wall-to-floor connections

## G.3.1 Building Envelope Components

The following section provides guidance for roof coverings, wall coverings, masonry veneer attachment, glazing (doors and windows), and garage doors.

### G.3.1.1 Roof Coverings

The performance of asphalt shingle roof coverings can be improved by following the guidance in [Technical Fact Sheet 7.3, “Asphalt Shingle Roofing for High Wind Regions,”](#) found in FEMA P-499, *Homebuilder’s Guide to Coastal Construction* (2010). Specific information includes physical properties of the shingle to consider when selecting a product and the effectiveness of different wind-resistance-ratings for asphalt shingles. Proper shingle installation at eaves, rakes, hips, and ridges are also illustrated along with fastener guidelines. Other Technical Fact Sheets in P-499 also provide relevant guidance: [Technical Fact Sheet 7.4, “Tile Roofing for High Wind Regions,”](#) and [Technical Fact Sheet 7.6, “Metal Roof Systems in High-Wind Regions,”](#) provide similar high-wind region guidance for installing tile and metal roofs, respectively, and [Technical Fact Sheet 7.2, “Roof Underlayment for Asphalt Shingle Roofs,”](#) recommends best practices for installing roof underlayment for asphalt shingle roofs to act as an enhanced secondary water barrier.

### G.3.1.2 Wall Coverings

The performance of wall coverings and sidings in high winds can be improved by following the recommendations in FEMA P-499, [Technical Fact Sheet 5.3, “Siding Installation in High Wind Regions;”](#) it covers vinyl, wood, and fiber cement siding. Figures are included that depict key differences between vinyl siding rated for high winds and standard vinyl siding. The proper method of fastening to achieve the desired performance is also illustrated. Detailed guidance includes figures showing how to install both wood siding and fiber cement siding.

### G.3.1.3 Masonry Veneer Attachment

The performance of masonry brick veneer can be improved by following the guidelines in FEMA P-499 [Technical Fact Sheet 5.4, “Attachment of Brick Veneer in High-Wind Regions.”](#) The Fact Sheet includes figures that show poor versus good installation techniques and includes recommended vertical spacing of brick ties with 8d ring shank nails based on wind speed. Users should select a wind speed of 130 mph for brick ties and attachment to be consistent with other guidance provided in this appendix.

### G.3.1.4 Glazing (Doors and Windows)

Section 301.2.1.2 of the 2009 and 2012 IRC requires glazed openings to be protected from impact in areas designated as wind-borne debris regions, which are located along hurricane-prone coastlines. To protect glazing from wind-borne debris impact, the IRC specifies the use of impact-resistant coverings, such as shutters, and impact-resistant glazing. Shutters are not a practical option in tornado-prone regions because of the lead time needed to cover the glazed openings. While impact-resistant glazing may be cost prohibitive for elective installation in non-coastal tornado-prone regions, homeowners should be aware that glazing products that provide greater protection against risk associated with wind-borne debris are available. Specifically, wind-borne debris risks incurred without impact-resistant glazing include damage from water intrusion, injury from incoming missiles and shattered glazing, and a decreased level of performance because of increased pressurization.

FEMA P-499 [Technical Fact Sheet 6.2, “Protection of Openings – Shutters and Glazing,”](#) provides guidance for the use of impact-resistant glazing. To qualify as impact-resistant, the glazing has to comply with the testing requirements specified in ASTM E1886 and ASTM E1996 or other approved test methods and performance criteria. There are two typical kinds of precut impact-resistant glazing: laminated glazing systems and polycarbonate systems:

- + *Laminated glazing systems* typically consist of assemblies fabricated with two or more panes of glass and an interlayer of a polyvinyl butyral (or equivalent) film laminated into the glazing assembly. During impact testing, the laminated glass in the system can fracture, but the interlayer must remain intact to prevent water and wind from entering the building.
- + *Polycarbonate systems* typically consist of plastic resins molded into sheets that provide lightweight, clear glazing panels with high impact-resistance qualities. The strength of the polycarbonate sheets is much higher than non-laminated glass (i.e., more than 200 times stronger) and acrylic sheets or panels (i.e., more than 30 times stronger).

While protection from impact is important, glazing must also resist wind pressures. Wind pressure resistance of glazing can be improved by installing glazing products designed to resist the design pressures shown in Table G-1. For the glazed components to perform as rated, they must be installed in accordance with manufacturer’s installation instructions. The supplier should provide verification that window and door products are rated to meet or exceed the positive and negative pressures in Table G-1 and that the test values comply with one of the following testing standards:

- +ANSI/AAMA/NWWDA 101/I.S.2
- +ANSI/AAMA/WDMA 101/I.S.2/NAFS

■+ANSI/WDMA/CSA 101/I.S.2/A440

■+Florida Building Code Testing Protocol TAS 202

Products must be permanently labeled or marked to facilitate verification.

**Table G-1: Recommended Design Pressures for Doors and Windows**

Minimum Window Size	Pressure (psf)*	Minimum Door Size	Pressure (psf)*
2 ft 4 in. x 5 ft	30.2, -32.8 (-40.3)	2 ft 6 in. x 7 ft	29.4, -32 (-38.7)**
2 ft 4 in. x 7 ft	29.5, -32.1 (-39.0)	3 ft x 7 ft	29.0, -31.6 (-38.0)
2 ft 8 in. x 5 ft	29.9, -32.5 (-39.8)	5 ft x 7 ft	28.1, -30.7 (-36.2)
2 ft 8 in. x 7 ft	29.2, -31.8 (-38.4)	6 ft x 7 ft	27.7, -30.2 (-35.3)

psf = pounds per square foot    ft = feet    in. = inches

\* Pressures for doors and windows are derived from Table 602(1) of ICC 600 (2008) for 130 mph 3-second gust.

\*\* Number in parentheses represents the applicable negative pressure when the component is installed within 4 ft of wall corner.

### G.3.1.5 Garage Doors

The performance of garage door openings can be greatly improved by installing enhanced pressure-resistant overhead garage doors in accordance with the following (per ICC 600-2008 Table 602(3) for 130 mph 3-second gust):

■+Single garage doors (minimum size 7 feet high x 9 feet wide) should resist minimum design pressures of +26.7 psf, -30.2 psf.<sup>2</sup>

■+Double doors (minimum size 7 feet high x 16 feet wide) should resist minimum design pressures of +25.6 psf, -28.5 psf.

Pressure-rated garage doors should comply with the testing standards of ANSI/DASMA 108. Although some manufacturers provide wind speed and exposure ratings for their products, labels on many garage doors do not include wind speed or wind pressure ratings. While ANSI/DASMA 108 does not require wind speed or wind pressure ratings to be included on the product labeling, it does require that the positive and negative pressure used in testing be recorded on the ANSI/DASMA 108 *Test Report Form* and that the model number, description, and operating hardware be documented. If the label attached to the door does not list the positive and negative pressure rating, consult the *Test Report Form* to determine whether the garage door meets the minimum design pressures indicated above.

In addition to the door itself, practical guidance on the issue of track depth (enough to avoid wheels pulling out of the track) and proper fastening of the track to the framing at each end of the door

<sup>2</sup> Single and double garage door pressures listed assume minimum 2-foot wall length at each end of door opening.

opening is provided in DASMA TDS 156 and 161. Both Technical Data Sheets and other guidance related to garage access systems are available at the DASMA Web site.<sup>3</sup>

## G.3.2 Roof Systems and Connections

The following section provides guidance for roof systems and connections, roof decking and decking attachment, soffits, and roof-to-wall connections

### G.3.2.1 Roof Decking and Decking Attachment

The performance of roof decking—also referred to as roof sheathing—can be improved by following the guidance in FEMA P-499 Fact Sheet 7.1, “Roof Sheathing Installation.” Fact Sheet 7.1 provides guidance on roof decking and roof decking attachment. Insufficient fastening can lead to total building failure in a high-wind event. During wind loading, the highest uplift forces occur at the roof corners, edges, and ridgelines.

FEMA P-499 Fact Sheet 7.1 states that wood structural panel sheathing with a minimum thickness of 15/32 inch is typically required for roof decking in coastal high-wind areas. Wood structural panel sheathing may be either oriented strand board (OSB) or plywood. Sheathing panels should be rated “Exposure 1” or better.

The sheathing panels should be installed with consecutive rows staggered by half the panel length as shown in [FEMA P-499 Fact Sheet 7.1](#). Sheathing panels should be no shorter than 4 feet long. Unless otherwise indicated by the panel manufacturer, leave a 1/8-inch gap between panel edges to allow for expansion due to changes in moisture content.

An 8d common nail (shank diameter of 0.131 inch, length of 2½ inches) is the minimum size for fastening sheathing panels. Additionally, full round heads are recommended to reduce the potential for head pull-through. Deformed-shank (i.e., ring- or screw-shank) nails provide a cost effective performance improvement over smooth-shank nails and are recommended for fastening the roof sheathing to the framing. Wood structural panel roof sheathing should be attached to roof framing with 8d ring shank nails spaced at 6 inches on center (o.c.) at panel edges and at intermediate framing. For roof sheathing within 4 feet of gable ends, fasteners should be spaced at 4 inches o.c. at panel edges and at intermediate framing. Roof sheathing should also be attached at 4 inches o.c. to blocks shown with Connector S in Table G-3. Top surface of full-height block should be in-plane with top surface of rafter or truss.

Proper fastener spacing is imperative on all sheathing panels. Loss of just one panel in a high-wind event can lead to total building failure. The builder should visually inspect work after installation to ensure that fasteners have hit the framing members. If the building design specifications require installing fasteners at less than 3 inches o.c., they should be staggered. To limit occurrence of splitting of roof framing members, 3-inch nominal roof framing members should be used at adjoining panel edges for fastener spacing less than 3 inches o.c., as required per 2012 IBC Section 2306.2.

---

<sup>3</sup> The Door and Access Systems Manufacturers Association International Web site, <http://www.dasma.com/pubtechdata.asp>.



FEMA P-499 Technical Fact Sheet 7.1 provides further guidance on preserving the integrity of roof decking around ridge vents and ladder framing at gable overhangs.

### G.3.2.2 Soffits

Soffits are particularly vulnerable to damage from high wind pressures at the edges of the building envelope. Loss of the soffit material can cause accelerated building damage due to pressurization of the attic envelope. Soffit failure can be mitigated by implementing the installation guidance in [FEMA P-499 Fact Sheet 7.5, “Minimizing Water Intrusion through Roof Vents in High-Wind Regions.”](#)

### G.3.2.3 Roof-to-Wall Connectors

Each roof truss and rafter should be attached to the framed wall double top plate with a connector designed to resist the loads for the corresponding roof truss or rafter span and spacing. Table G-3 includes recommended hardware and hardware configurations (including blocks shown on Connector S) to resist uplift and shear forces along with the number and type of nails required to resist lateral loads associated with each roof span and truss or rafter spacing condition.

If the connectors specified in Table G-2 are unavailable, users should refer to the uplift capacity values provided in Table G-4 to determine the required capacity for alternate hardware. All three connection categories listed in Table G-3—Uplift (per Connector E, F, G, H, and I), Shear (per Connector S and blocks), and Lateral (per truss or rafter to plate attachment nailing)—are required at each roof member. For example, roof truss members spaced at 24 inches on center and spanning 32 feet would require, per Table G-3: Connector H, Connector S (with blocks), and three 16d sinker toe nails.

#### WARNING

Roof-to-wall connection failure appeared to accelerate damage to whole structures inspected by the MAT; this type of failure is a critical initiation phase of progressive collapse during a tornado.

Recent research at Iowa State University has found a 2–3 times increase over hurricane wind speeds in uplift pressure due to the inflow and updraft of tornado winds. The possible increase in uplift pressure has not been accounted for in any of the pressure values shown in this appendix.<sup>4</sup>

Table G-2 specifies the model numbers and installation specifications for connectors identified throughout this appendix; it is also referenced in Tables G-6, G-7, G-10, G-12, G-13, and G-14.

<sup>4</sup> “Tornado-Induced Wind Loads on a Low-Rise Building,” Dr. Partha Sarkar, *Journal of Structural Engineering*, 2010.

**Table G-2: Connector Selection and Installation**

Connector Type	Simpson Strong-Tie Co.		USP Structural Connectors	
	Model Number	Total Number (and Size) of Fasteners	Model Number	Total Number (and Size) of Fasteners
<b>A</b>	CS20	(10d common)	RS250	(10d common)
<b>B</b>	CS16	(10d common)	RS150	(10d common)
<b>C</b>	A34	8 (8d x1½)	MP34	8 (8d x1½)
<b>D</b>	A35	12 (8d x1½)	MPA1	12 (8d x1½)
<b>E</b>	H2.5A	10 (8d x1½)	RT7	10 (8d x1½)
<b>F</b>	H8	10 (10d x1½)	RT8A	10 (10d x1½)
<b>G</b>	LTS12	12 (10d x1½)	RT8A	10 (10d x1½)
<b>H</b>	MTS12	14 (10d x1½)	MTW12	14 (10d x1½)
<b>I</b>	H10A	18 (10d x1½)	MTW12	14 (10d x1½)
<b>J</b>	MTS12	14 (10d x1½)	RT8A	10 (10d x1½)
<b>K</b>	MTS12	14 (10d x1½)	MTW12	14 (10d x1½)
<b>L</b>	H2.5A	10 (8d x1½)	RT3A	8 (8d x1½)
<b>M</b>	SSP	4 (10d common)	RT3A	8 (8d x1½)
<b>N</b>	SP4	6 (10d x1½)	6 10d x1½ SPT4	6 (10d x1½)
<b>O</b>	SPH4	10 (10d x1½)	SPTH4	10 (10d x1½)
<b>P</b>	HTT5	26 (16d x2½*)	PHD4A	10 (WS3 ¼x3 screws)
<b>Q</b>	HDU11-SDS2.5	30 (SDS ¼x2½ screws)	PHD8	24 (WS3 ¼x3 screws)
<b>R</b>	HD9B**	3 (⅞-inch bolts)	UPHD8***	24 (WS3 ¼x3 screws)
<b>S</b>	RBC	12 10d x1½	RBC	12 (10d x1½)

\* Substitution of 16d common nail is acceptable

\*\* Must be fastened to minimum of three studs

\*\*\* Must be fastened to minimum of three studs or 4x4

Note: Because not all contractors are familiar with the type of structural connectors shown in Appendix G tables, the names of two companies that manufacture connectors have been included. This list of companies is not, however, exhaustive. Additionally, this list is not intended to express a preference for those manufacturers and/or their products by the United States government nor is it an endorsement of those manufacturers and/or their products.

SOURCE: RANDY SHAKELFORD, PE (PERSONAL COMMUNICATION)

Table G-3: Roof-to-Wall Connector Requirements

Truss or Rafter Spacing	Roof Framing Span (ft)				Connections Required in Addition to Uplift Connector	
	24	28	32	36	Connector Type* (Shear)	Truss or Rafter-to-Plate Attachment (Lateral)
16 in. o.c.	E	F	F	G	S**	Three 10d sinker toe nails**
24 in. o.c.	H	H	H	I	S**	Three 16d sinker toe nails**

  

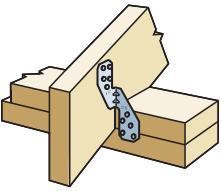

**Connector E**

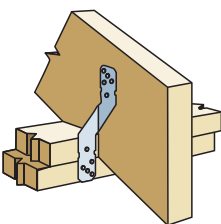

**Connector F (G Similar)**

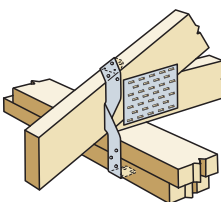

**Connector H**

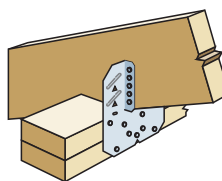

**Connector I**

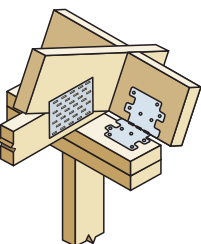

**Connector S\*\***

in. = inch    ft = feet    o.c. = on center

\* Reference Table G-2 for model number and fasteners

\*\* Uplift connector not shown for clarity. Connector S with blocking between rafters or trusses should be used in addition to uplift connectors and truss or rafter to plate attachment nail schedule.

SOURCE (NOT INCLUDING HARDWARE SPECIFICATIONS): COURTESY, AMERICAN WOOD COUNCIL, LEESBURG, VA

Table G-4: Roof-to-Wall Connection Loads

Truss or Rafter Spacing	Roof Framing Span (ft)				Shear (lb)	Lateral (lb)
	24	28	32	36		
16 in. o.c.	Uplift (lb)				109	247
24 in. o.c.	442	499	247	611	164	370
24 in. o.c.	664	748	370	917		

in. = inch    ft = feet    o.c. = on center    lb = pounds

SOURCE: COURTESY, AMERICAN WOOD COUNCIL, LEESBURG, VA

### G.3.3 Wall Systems and Connections

The following section provides guidance for sill plate attachment, wall sheathing, top plate splices, openings in walls, and wall-to-floor connections

#### G.3.3.1 Sill Plate Attachment

To strengthen the connection between the sill plate and foundation, the treated sill plate should be attached to masonry or concrete foundations with 5/8-inch-diameter anchor bolts and 0.229-inch x 3-inch x 3-inch washers in accordance with Table G-5 and installed as shown in Figure G-2. To determine the appropriate building aspect ratio required, refer to the image in Table G-5.

**Table G-5: Anchor Bolt Spacing Guide**

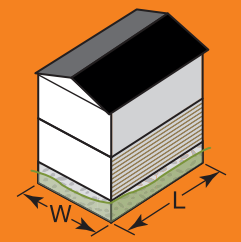

Foundation Supporting:	Stemwall Foundation Aspect Ratio (L/W)						Slab-on-Grade Foundation
	1.00	1.25	1.50	1.75	2.00	2.25	
	5/8-in. Anchor Bolt Spacing						
<b>One story</b>	58 in.	51 in.	43 in.	36 in.	32 in.	28 in.	24 in.
<b>Two-story</b>	40 in.	32 in.	27 in.	23 in.	20 in.	18 in.	24 in.

in. = inches  
 SOURCE: COURTESY, AMERICAN WOOD COUNCIL, LEESBURG, VA

**G.3.3.2 Wall Sheathing**

All framed walls, including gable end walls, should be continuously sheathed with wood structural panels having a minimum nominal thickness of 7/16 inch. According to APA’s *Building for High Wind Resistance in Light-Frame Wood Construction* (2011, page 3), “the most effective way to provide lateral and uplift continuity is to attach adjacent wall sheathing panels to one another over common framing.” In order to determine the attachment schedule for wood structural panels, the following information must be determined from the construction drawings:

1. Building aspect ratio (see figures embedded in Tables G-6 and G-7).
2. Percentage of full height sheathing in the wall to be constructed by dividing the total length of that wall *not* containing openings (i.e., wall sections sheathed over full height) by the total wall line length.

The next step is to use Table G-6 or G-7 to find the required attachment schedule, hold-down hardware, and bottom plate-to-frame connector for information determined in Steps 1 and 2. Table G-6 and Table G-7 provides the attachment schedule for 7/16-inch OSB wall sheathing, wall hold-down hardware, and wall bottom plate to frame hardware. Note that the percentages indicated in Tables G-6 and G-7 are the maximum allowed for the selected aspect ratio and attachment schedule; wall conditions with percentages for the closest spaced attachment schedule in excess of those shown are outside the scope of the guidance in this appendix. While the performance of residential buildings outside the scope of these limits and provisions may be enhanced through the most conservative guidance in this appendix, a registered design professional should be consulted.

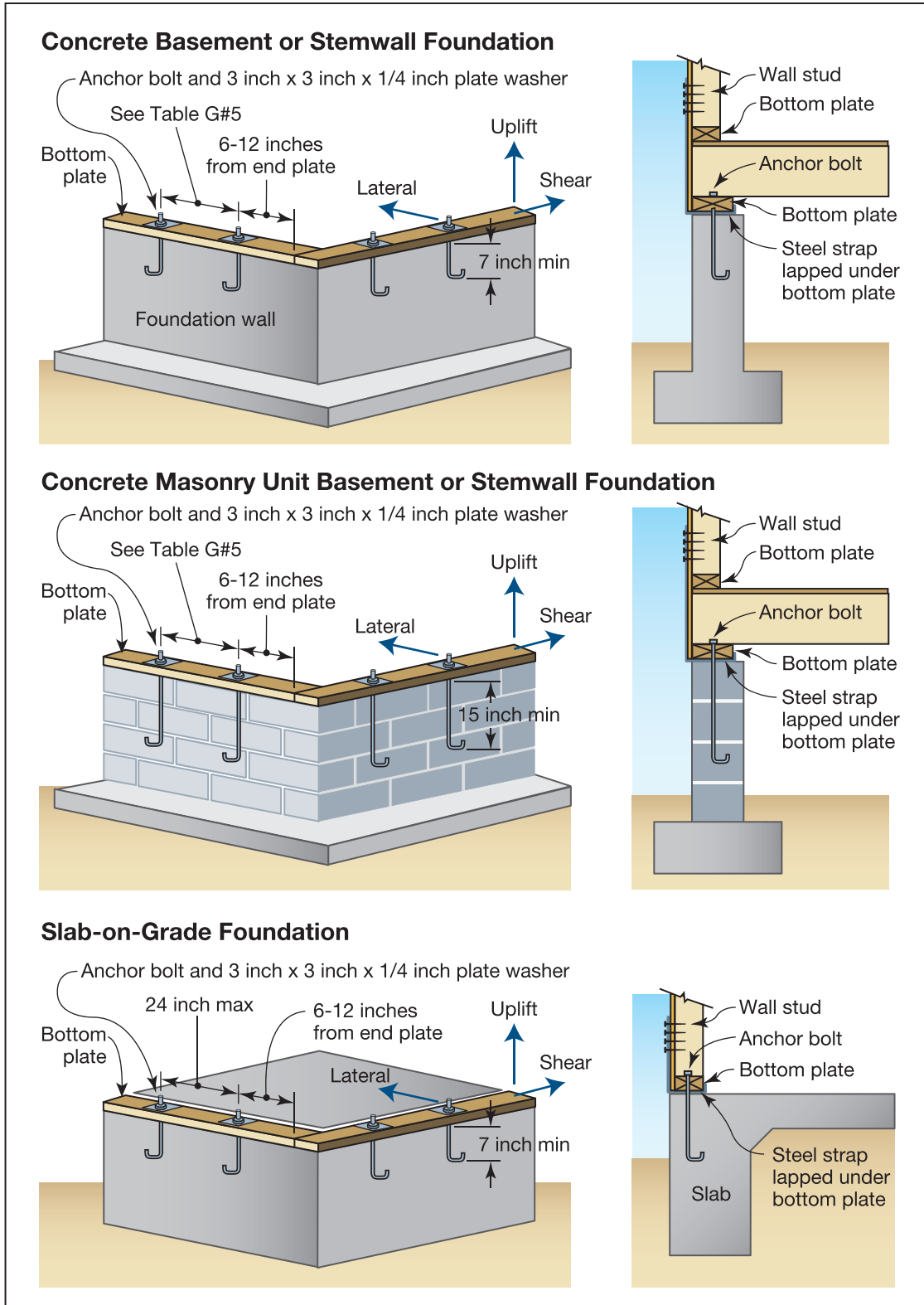

Figure G-2: Anchor bolt installation guide

SOURCE: COURTESY, AMERICAN WOOD COUNCIL, LEESBURG, VA

Table G-6: Percentage of Full-Height Sheathing in Maximum Building Dimension (Length)

Shear Wall Line Beneath	Building Aspect Ratio (L/W)	Percent Full-Height Sheathing on Each Exterior Wall Line		
 <p><b>Roof and Ceiling</b></p>	1.00	43%	34%	28%
	1.25	36%	28%	23%
	1.50	31%	24%	20%
	1.75	27%	21%	17%
	2.00	24%	18%	15%
	2.25	22%	17%	14%
 <p><b>Roof, Ceiling, and One Floor</b></p>	1.00	78%	65%	56%
	1.25	68%	55%	47%
	1.50	60%	48%	41%
	1.75	54%	43%	36%
	2.00	49%	38%	32%
	2.25	44%	35%	29%
<p><b>Attachment Schedule for 7/16-in. Wood Structural Panel Sheathing, Plate-to-Floor, and Hold-down Requirements at Each Wall End</b></p>	Edge nail spacing (8d common nail)	6-in. o.c.	4-in. o.c.	3-in. o.c.
	Field nail spacing (8d common nail)	6-in. o.c.	6-in. o.c.	6-in. o.c.
	Bottom plate-to-floor shear connection (16d common nails)	436 plf (3/ft)	590 plf (3/ft)	730 plf (4/ft)
	Hold-down loads and model #	4,360 lb Connector P*	5,900 lb Connector Q*	7,300 lb Connector R*
				
<p><b>Connector P (Simpson)</b></p>		<p><b>Connector Q**</b></p>		<p><b>Connector R (Simpson)</b></p>
<p>in. = inches    o.c. = on center    ft = foot    plf = pounds per linear foot</p> <p>* Refer to Table G-2 for model number and fasteners</p> <p>** Connector P and R (United Steel Products [USP]) are similar to Connector Q</p> <p>SOURCE (NOT INCLUDING HARDWARE SPECIFICATIONS): COURTESY, AMERICAN WOOD COUNCIL, LEESBURG, VA</p>				

Table G-7: Percentage of Full-Height Sheathing in Maximum Building Dimension (Width)

Shear Wall Line Beneath	Building Aspect Ratio (L/W)	Percent Full-Height Sheathing on Each Exterior Wall Line		
 <p><b>Roof and Ceiling</b></p>	1.00	43%	34%	28%
	1.25	51%	41%	34%
	1.50	58%	47%	40%
	1.75	65%	53%	45%
	2.00	71%	58%	50%
	2.25	76%	63%	54%
 <p><b>Roof, Ceiling, and One Floor</b></p>	1.00	78%	65%	56%
	1.25	89%	75%	65%
	1.50	98%	83%	73%
	1.75	NP	91%	81%
	2.00	NP	98%	87%
	2.25	NP	NP	93%
<p><b>Attachment Schedule for 7/16-in. Wood Structural Panel Sheathing, Plate-to-Floor, and Hold-down Requirements at Each Wall End</b></p>	Edge nail spacing (8d common nail)	6-in. o.c.	4-in. o.c.	3-in. o.c.
	Field nail spacing (8d common nail)	6-in. o.c.	6-in. o.c.	6-in. o.c.
	Bottom plate-to-floor shear connection (16d common nails)	436 plf (3/ft)	590 plf (3/ft)	730 plf (4/ft)
	Hold-down loads and model #	4,360 lb Connector P*	5,900 lb Connector Q*	7,300 lb Connector R*



**Connector P (Simpson)**

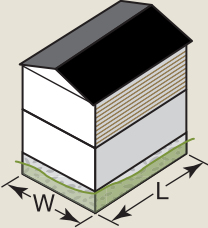
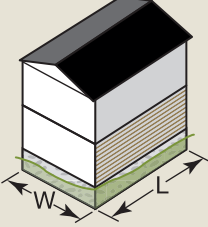
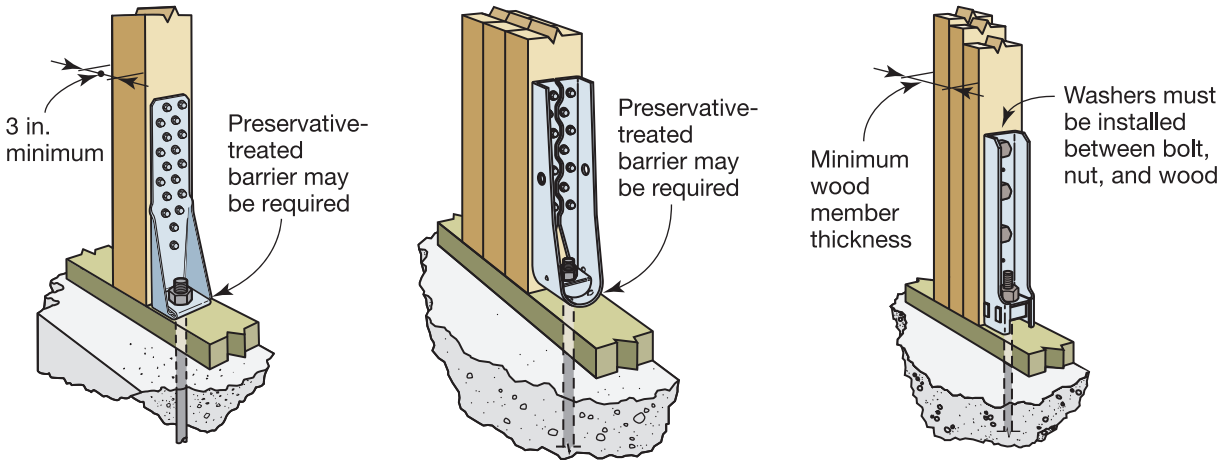
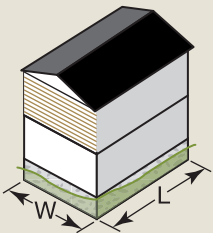
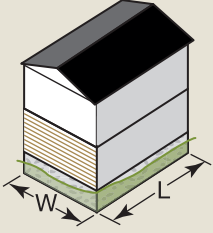
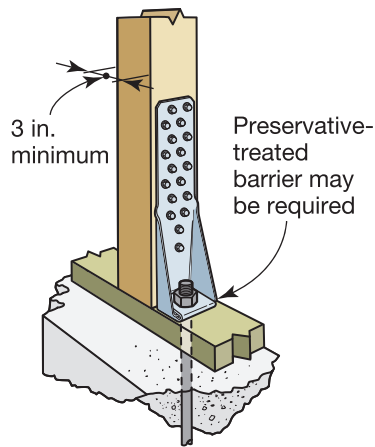
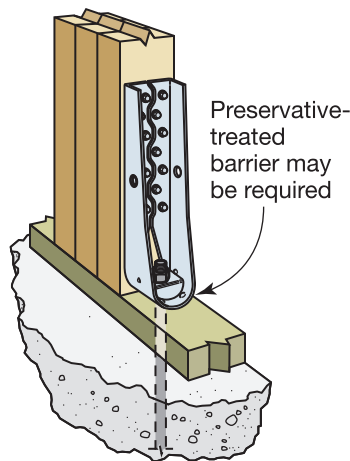

**Connector Q\*\***

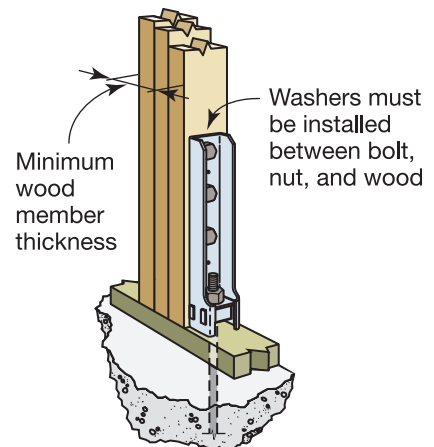

**Connector R (Simpson)**

NP = Not Permitted    in. = inches    o.c. = on center    ft = foot    plf = pounds per linear foot

\* Refer to Table G-2 for model number and fasteners

\*\* Connector P and R (United Steel Products [USP]) are similar to Connector Q

SOURCE (NOT INCLUDING HARDWARE SPECIFICATIONS): COURTESY, AMERICAN WOOD COUNCIL, LEESBURG, VA

**EXAMPLE****Given:**

- + One-story house with building length (L) = 60 feet, building width (W) = 30 feet
- + Both 30-foot-long framed walls contain one 3-foot-wide door and one 6-foot-wide double window

**Find:**

- + Sheathing attachment schedule for 30-foot-long walls
- + Hold-down hardware for 30-foot-long walls

**Solution:**1. *Find the sheathing attachment schedule*

- + Determine building aspect ratio: L: W = (60 feet:30 feet) = 2
- + Determine percent full-height sheathing (P) in wall using the given values:

W = Building width in feet = 30 feet

T = Total width of openings in wall in feet = 3 feet + 6 feet = 9 feet

$$P \left[ = \frac{[W - T]}{W} = \frac{[30 - 9]}{30} \right] = 0.70, \text{ or } 70 \text{ percent}$$

- + Using Table G-7 (for (W)) select the row in the upper portion of the table showing the building aspect ratio (L/W) = 2.00, as determined above.
- + Find the appropriate column for wall sheathing nailing pattern using the percentage for the full-height sheathing calculated above, where P = 70 percent.

Select the second column (58 percent < 70 percent < 71 percent) to determine the nailing schedule, which for this example is 4-inch spacing of edge nails and 6-inch spacing of field nails (8d common nails).

2. *Find the recommended hold-down hardware*

- + Find the hold-down hardware for the column indicated in the previous section. As shown in Table G- 7, Connector Q is recommended for each wall end that has a minimum required capacity of 5900 pounds when installed per manufacturer's installation instructions.
- + Using the row in the same column labeled "Bottom plate-to-floor shear connection (16d common nails)," determine the plate-to-floor shear load connection. For this example, three 16d common nails per foot are required to transfer shear loads between the bottom plate of the wall and the solid floor band.



### G.3.3.3 Top Plate Splices

To maintain the integrity of framed walls when a top plate splice is required, attach the double top plates together per Table G-8. Please note that the maximum roof span of 36 feet (per Figure G-1) and the maximum aspect ratio of 2.25 (per Tables G-5, G-6, and G-7) limit overall building length to a maximum of 81 feet.

Table G-8: Top Plate Splice Guide

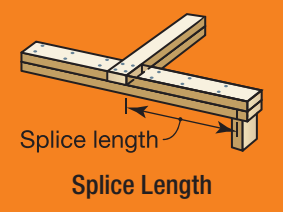

Splice Length	Building Dimension of Wall Containing Top Plate Splice (ft)								
	24	28	32	36	40	50	60	70	80
	Number of 16d Common Nails per Each Side of Splice								
<b>2 ft</b>	8	NP	NP	NP	NP	NP	NP	NP	NP
<b>4 ft</b>	8	10	12	14	16	NP	NP	NP	NP
<b>6 ft</b>	8	10	12	14	16	20	24	NP	NP
<b>8 ft</b>	8	10	12	14	16	20	24	28	32

ft = feet    NP = Not permitted  
 SOURCE: COURTESY, AMERICAN WOOD COUNCIL, LEESBURG, VA

### G.3.3.4 Openings in Walls

Wall openings disrupt the continuous load path required to transfer wind forces through framed walls. Enhanced building performance of framed walls is achieved by installing uplift connector hardware around wall openings. Headers and plates at wall openings should be attached to the framed wall studs at each end with connectors designed to resist the uplift and lateral loads shown in Table G-9 for the corresponding header spans. Table G-9 also shows the number of full-height studs required at each end. Install hardware around framed wall openings as recommended in Table G-10. Please refer to Table G-2 for hardware specifications.

Table G-9: Connection Loads at Each End of Exterior Wall Headers

Header Span	Number of Full-Height Studs	Uplift Load (lb)	Lateral Load (lb)
<b>3 ft</b>	2	689	278
<b>4 ft</b>	2	918	370
<b>5 ft</b>	3	1,148	463
<b>6 ft</b>	3	1,377	555
<b>8 ft</b>	3	1,836	740
<b>10 ft</b>	4	2,295	925

lb = pounds    ft = feet  
 SOURCE: COURTESY, AMERICAN WOOD COUNCIL, LEESBURG, VA

**Table G-10: Connector Requirements at Each End of Exterior Wall Headers**

Header Span	Number of Full-Height Studs	Uplift Connector Type* (#)**	Lateral Connector Type
3 ft	2	A (10)	C
4 ft	2	A (12)	C
5 ft	3	B (14)	D
6 ft	3	B (18)	D
8 ft	3	A × 2 (12 each)	C × 2
10 ft	4	B × 2 (14 each)	D × 2

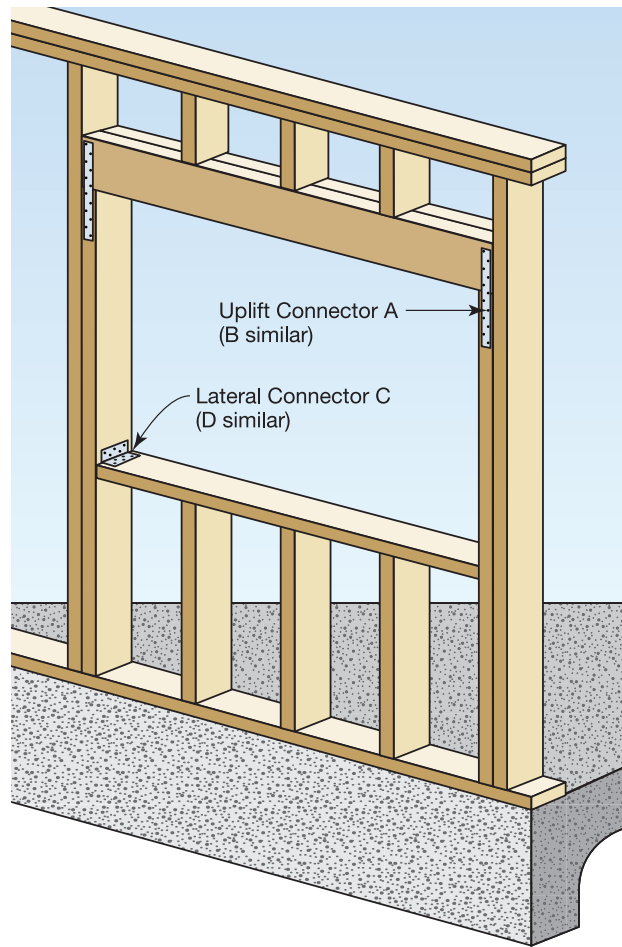

ft = feet

\* Refer to Table G-2 for model number and fasteners

\*\* (#) = Number of nails required in each end of strap

SOURCE: ADAPTED (WITHOUT HARDWARE SPECIFICATIONS) COURTESY, AMERICAN WOOD COUNCIL, LEESBURG, VA

### G.3.3.5 Wall-to-Floor Connection

Table G-11 shows the uplift and lateral loads to resist between the top plate and framed wall stud based on stud spacing and roof span. As previously noted in the section on wall sheathing, APA recommends attaching adjacent wall sheathing panels to one another, over common framing, to provide lateral and uplift continuity. To this end, wood wall sheathing panels should be extended upward from the first-floor walls and downward from the second-floor walls to meet at the midpoint of the second-floor band joist. Likewise, the wood wall sheathing panels from the first-floor walls should be extended downward to lap the sill plate at the foundation level. Connector requirements to resist wall-to-wall uplift loads are shown in Tables G-12 to G-14, and hardware specifications are shown in Table G-2. The number of 16d common nails (through single plate adjacent to stud) required to resist lateral loads is shown in Tables G-12 to G-14.

Table G-11: Top Plate-to-Stud-Connection Loads

Stud Spacing	Roof Framing Span (ft)				Lateral (lb)
	24	28	32	36	
	Uplift (lb)				
12-in. o.c.	331	375	416	458	185
16-in. o.c.	442	499	555	611	247
24-in. o.c.	664	748	833	917	370

in. = inches ft = feet lb = pounds

SOURCE: COURTESY, AMERICAN WOOD COUNCIL, LEESBURG, VA

Table G-12: Top Plate-to-Stud Connector Requirements

Stud Spacing	Roof Framing Span (ft)				Lateral No. of 16d Common Nails (end-nailed)
	24	28	32	36	
	Connector Type*				
12-in. o.c.	E	E	E	E	2
16-in. o.c.	E	F	F	J	2
24-in. o.c.	K	K	K	I	3

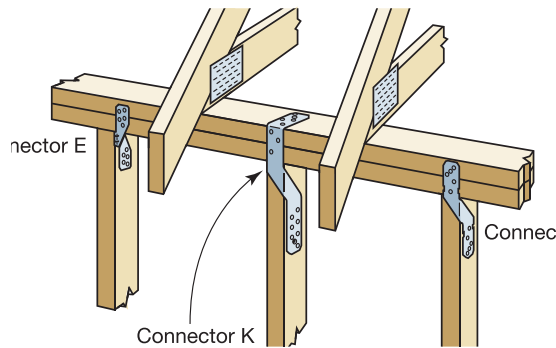

in. = inches ft = feet o.c. = on center

\* Refer to Table G-2 for model number and fasteners

SOURCE: ADAPTED (WITHOUT HARDWARE SPECIFICATIONS) COURTESY, AMERICAN WOOD COUNCIL, LEESBURG, VA

Table G-13: Stud-to-Stud Connection Requirements

Stud Spacing	Roof Framing Span (ft)				Lateral
	24	28	32	36	No. of 16d Common Nails (end-nailed)
	Number of 10d Common Nails in Connector A*				
12-in. o.c.	4	4	6	6	2
16-in. o.c.	6	6	6	8	2
24-in. o.c.	8	8	10	10	3

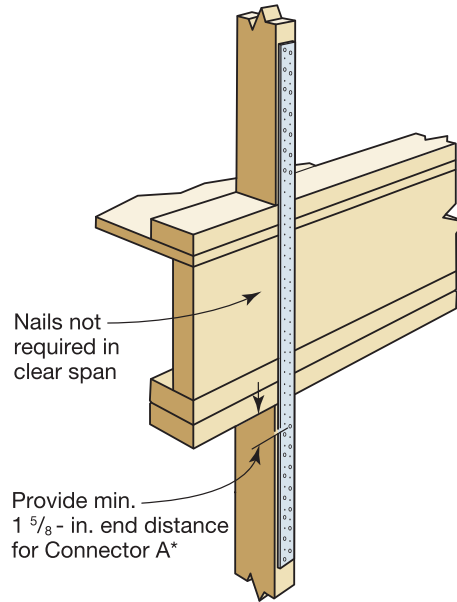

in. = inches    ft = feet    o.c. = on center

\* Install half the nails in each end of the strap to studs. Cut strap cut to length so that required number of nails can be installed in each end. Refer to Table G-2 for model number and fasteners.

SOURCE: ADAPTED (WITHOUT HARDWARE SPECIFICATIONS) COURTESY, AMERICAN WOOD COUNCIL, LEESBURG, VA

Table G-14: Stud-to-Bottom Plate Connector Requirements

Stud Spacing	Roof Framing Span (ft)				Lateral
	24	28	32	36	No. of 16d Common Nails (end-nailed)
<b>12-in. o.c.</b>	L	L	M	M	2
<b>16-in. o.c.</b>	M	M	N	N	2
<b>24-in. o.c.</b>	N	N	N	O	3

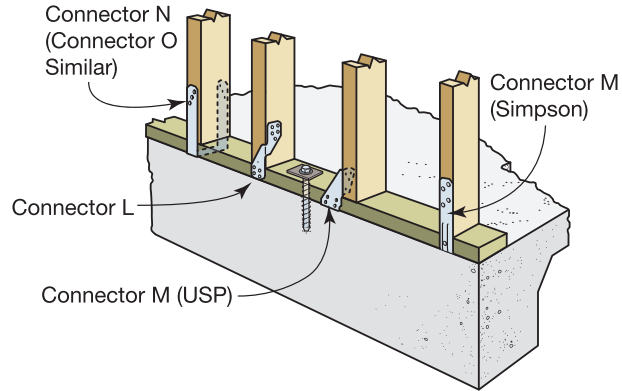

in. = inches ft = feet o.c. = on center

\* Refer Table G-2 for model number and fasteners.

SOURCE: ADAPTED (WITHOUT HARDWARE SPECIFICATIONS) COURTESY, AMERICAN WOOD COUNCIL, LEESBURG, VA

## G.4 References

- ANSI/AAMA/NWWDA (American National Standards Institute/American Architectural Manufacturers Association/National Wood Window and Door Association). 1997. *Voluntary Specifications for Aluminum, Vinyl (PVC) and Wood Windows and Glass Doors*, ANSI/AAMA/NWWDA 101/I.S.2.
- ANSI/AAMA/WDMA (Window and Door Manufacturers Association). 2002. *Voluntary Performance Specification for Windows, Skylights and Glass Doors*, ANSI/AAMA/WDMA 101/I.S.2/NAFS.
- ANSI/DASMA (Door & Access Systems Manufacturers Association). 2005. Standard Method for Testing Sectional Garage Doors and Rolling Doors: Determination of Structural Performance Under Uniform Static Air Pressure Difference, ANSI/DASMA 108.
- ANSI/WDMA/CSA (Canadian Standards Association). 2005. NAFS – North American Fenestration Standard/Specification for Windows, Doors, and Skylights, ANSI/WDMA/CSA 101/I.S.2/A440.
- APA (The Engineered Wood Association). 2011. *Building for High Wind Resistance in Light-Frame Wood Construction*. August. [http://www.apawood.org/level\\_c.cfm?content=pub\\_searchresults&pK=Form%20M310&pF=Yes](http://www.apawood.org/level_c.cfm?content=pub_searchresults&pK=Form%20M310&pF=Yes).
- ASCE. 2005. *Minimum Design Loads of Buildings and Other Structures*. ASCE Standard ASCE 7-05.
- ASTM International. 2009. *Standard Specification for Performance of Exterior Windows, Curtain Walls, Doors, and Impact Protective Systems Impacted by Windborne Debris in Hurricanes*, ASTM E1996. West Conshohocken, PA.
- ASTM International. 2005. *Standard Test Method for Performance of Exterior Windows, Curtain Walls, Doors, and Impact Protective Systems Impacted by Missile(s) and Exposed to Cyclic Pressure Differentials*, ASTM E1886. West Conshohocken, PA.
- AWC (American Wood Council). 2006. *Wood Frame Construction Manual (WFCM): Guide to Wood Construction in High Wind Areas for One- and Two-Family Dwellings, 130 mph, Exposure B*. In cooperation with the International Code Council. American Forest & Paper Association, Inc.: Washington, DC.
- DASMA. 2003. *Connecting Garage Door Jambs to Building Framing*. Technical Data Sheet 161. Cleveland, OH. December 2.
- DASMA. 2001. *Wood Horizontal and Vertical Back Jamb Detail Guidelines*. Technical Data Sheet 156. Cleveland, OH. August 1.
- FEMA. 2010a. “[Asphalt Shingle Roofing for High Wind Regions](#),” Technical Fact Sheet 7.3, *Home Builder’s Guide to Coastal Construction*. FEMA P-499. December.

- FEMA. 2010b. “[Attachment of Brick Veneer in High Wind Regions](#),” Technical Fact Sheet 5.4, *Home Builder’s Guide to Coastal Construction*. FEMA P-499. December.
- FEMA. 2010c. *Home Builder’s Guide to Coastal Construction*. FEMA P-499. December.
- FEMA. 2010d. “[Metal Roof Systems in High-Wind Regions](#),” Technical Fact Sheet 7.6, *Home Builder’s Guide to Coastal Construction*. FEMA P-499. December.
- FEMA. 2010e. “[Minimizing Water Intrusion through Roof Vents in High-Wind Regions](#),” Technical Fact Sheet 7.5, *Home Builder’s Guide to Coastal Construction*. FEMA P-499. December.
- FEMA. 2010f. “[Protection of Openings – Shutters and Glazing](#),” Technical Fact Sheet 6.2, *Home Builder’s Guide to Coastal Construction*. FEMA P-499. December.
- FEMA. 2010g. “[Roof Sheathing Installation](#),” Technical Fact Sheet 7.1, *Home Builder’s Guide to Coastal Construction*. FEMA P-499. December.
- FEMA. 2010h. “[Roof Underlayment for Asphalt Shingle Roofs](#),” Technical Fact Sheet 7.2, *Home Builder’s Guide to Coastal Construction*. FEMA P-499. December.
- FEMA. 2010i. “[Siding Installation in High Wind Regions](#),” Technical Fact Sheet 5.3, *Home Builder’s Guide to Coastal Construction*. FEMA P-499. December.
- FEMA. 2010j. “[Tile Roofing for High-Wind Areas](#),” Technical Fact Sheet 7.4, *Home Builder’s Guide to Coastal Construction*. FEMA P-499. December.
- FEMA. 2008. *Design and Construction Guidance for Community Safe Rooms*. FEMA 361. August. Second Edition.
- ICC. 2012. International Residential Code for One- and Two-Family Dwellings. Birmingham, AL.
- ICC. 2009. International Residential Code for One- and Two-Family Dwellings. Birmingham, AL.
- ICC. 2008. *Standard for Residential Construction in High-Wind Regions*, ICC 600. Birmingham, AL.
- ICC. 2007. *Criteria for Testing Impact & Nonimpact Resistant Building Envelope Components Using Uniform Static Air Pressure*. Florida Building Code Testing Application Standard (TAS) 202-94.
- Sarkar, Partha, 2010. “Tornado-Induced Wind Loads on a Low-Rise Building,” *Journal of Structural Engineering*.

