

Protocol P07

Test Method for Determining the Creep Compliance, Resilient Modulus and Strength of Asphalt Materials Using the Indirect Tensile Test Device

Version 1.1

August 2001

Prepared by:

FHWA-LTPP Technical Support Services Contractor
LAW PCS
A Division of Law Engineering and Environmental Services, Inc.
12104 Indian Creek Court, Suite A
Beltsville, Maryland 20705-1242

Prepared for:

Office of Infrastructure R&D
Long-Term Pavement Performance Team, HRDI-13
Federal Highway Administration
6300 Georgetown Pike
McLean, Virginia 22101
(202) 493-3079



U.S. Department of Transportation
Federal Highway Administration



Long-Term Pavement Performance
Serving your need for durable pavements

LTPP PROTOCOL: P07
For LTPP Test Designation: AC07
**TEST METHOD FOR DETERMINING THE CREEP COMPLIANCE, RESILIENT
MODULUS AND STRENGTH OF ASPHALT MATERIALS USING THE INDIRECT
TENSILE TEST DEVICE**

1. SCOPE

1.1 General

This LTPP program protocol describes procedures for determination of Creep Compliance, Resilient Modulus (M_r), and Strength of hot mix asphalt concrete (HMA) using indirect tensile test techniques. This protocol is partially based on test standards AASHTO TP9-94 (Edition 1B), ASTM D4123, and the procedures outlined in Section 4.4 (Roque, et al) of this protocol.

This protocol describes three distinct procedures for the determination of (1) creep compliance, (2) resilient modulus, and (3) tensile strength. This procedure requires three test specimens obtained from the same general area of the pavement test section. Each specimen is subject to creep compliance at -10, 5, and 25 °C (14, 41, and 77 °F), resilient modulus determinations at 5, 25, and 40 °C (41, 77, and 104 °F) and a strength test at 25 °C (77 °F). Therefore, three replicate test results are obtained for each specimen set.

The methods described are only applicable to core samples from HMA pavement layers. For LTPP, samples tested under this procedure are nominally 100 mm (4 in) core samples. It should be noted that this test procedure could be adapted for use with 150 mm (6 in) diameter specimens or laboratory compacted specimens. However for LTPP purposes, testing is restricted to the above criteria.

1.2 Summary of Test Method

1.2.1 Creep Compliance - The tensile creep compliance is determined by applying a static compressive load of fixed magnitude along the diametral axis of a cylindrical specimen. The resulting horizontal and vertical deformations measured near the center of the specimen are used to calculate tensile creep compliance as a function of time. Loads are selected to keep the material's response in the linear viscoelastic (LVE) range. This is accomplished by keeping horizontal deformations below 0.089 mm (0.0035 in)¹. Horizontal and vertical deformations are measured in the central region of the specimen, away from the localized stress concentrations caused by the loading conditions. The creep compliance test is performed on each specimen at temperatures of -10, 5, and 25 °C (14, 41, and 77 °F).

¹For a 100 mm (4 in) specimen

1.2.2 Resilient Modulus - A cyclic stress of fixed amplitude, with a duration of 0.1 seconds followed by a rest period of 0.9 seconds, is applied to the test specimen. During testing the specimen is subjected to a dynamic cyclic stress and a constant stress (seating load). Loads are selected to keep horizontal deformations between 0.038 and 0.089 mm (0.0015 and 0.0035 in)². The deformation responses of the specimen are measured near the center of the specimen and used to calculate both an instantaneous and total resilient modulus (M_{Ri} and M_{Rt} respectively). Instantaneous resilient modulus is calculated using the recoverable horizontal deformation that occurs during the unloading portion of one load-unload cycle. Total resilient modulus is calculated using the total recoverable deformation, which includes both the instantaneous recoverable and the time-dependent continuing recoverable deformation during the unload or rest-period portion of one cycle. The resilient modulus test is performed on each specimen at temperatures of 5, 25, and 40 °C (41, 77 and 104 °F).

1.2.3 Tensile Strength - The tensile strength is determined by loading the specimen along its diametral axis at a fixed deformation rate until failure occurs. Failure is defined as the point after which the load no longer increases. The maximum load sustained by the specimen is used to calculate the indirect tensile strength. For LTPP testing, the point at which the first crack develops in the failure plane is also identified and recorded. This portion of the test procedure is performed at 25 °C (77 °F).

1.2.4 Testing Sequence - Each test specimen is tested in the following sequence:

1. Creep Compliance -10 °C (14 °F)
2. Resilient Modulus 5 °C (41 °F)
3. Creep Compliance 5 °C (41 °F)
4. Resilient Modulus 25 °C (77 °F)
5. Creep Compliance 25 °C (77 °F)
6. Resilient Modulus 40 °C (104 °F)
7. Tensile Strength 25 °C (77 °F)

1.3 Significance and Use

The values of creep compliance can be used as indicators of the relative quality of asphalt materials, as well as, to generate stiffness estimates for pavement design and evaluation models. The test can also be used to investigate the effects of temperature, load magnitude, and creep loading time on asphalt material properties.

²For a 100 mm (4 in) specimen

When used in conjunction with other physical properties, the creep compliance can contribute to the overall mixture characterization and could well be a key factor for determining mixture suitability for use as a highway paving material under a variety of loading and environmental conditions.

The value of resilient modulus determined from this protocol procedure is a measure of the elastic modulus of HMA materials recognizing certain non-linear characteristics. Resilient modulus values can be used with structural response analysis models to calculate the pavement structural response to wheel loads, and with pavement design procedures to design pavement structures.

The resilient modulus test provides a means of characterizing pavement construction materials including surface, base, and subbase HMA materials under a variety of temperatures and stress states that simulate the conditions in a pavement subjected to moving wheel loads.

The indirect tensile strength test at 25 °C (77 °F) is used to determine the tensile strength, failure strain and the fracture energy of the specimens used for creep compliance and resilient modulus testing.

1.4 Sample Storage

Specimens of HMA materials for use in this testing shall be kept in an environmentally protected (enclosed area not subjected to the natural elements) storage area at temperatures between 5 and 24 °C (40 and 75 °F). Each specimen shall have a label or tag that clearly identifies the material, project number/test section from which it was recovered, and the sample number.

1.5 Units

In this protocol, the International System of Units (SI - The Modernized Metric System) is regarded as the standard. Units are expressed first in their "hard" metric form followed, in parenthesis, by their U.S. Customary unit equivalent.

2. GENERAL SPECIFICATIONS

2.1 Testing Prerequisites

This testing procedure shall be conducted after; (1) approval by the FHWA Contracting Officer's Technical Representative (COTR) to begin testing, (2) approval of Form L04 by the FHWA LTPP RCOC, (3) visual examination and thickness determination of asphaltic concrete (AC) cores and thickness determination of layers within AC cores using Protocol P01, (4) final layer assignment based on the P01 test results (corrected Form L04, if needed), and (5) bulk specific gravity testing of the specimens to be used for this testing have been

completed according to Protocol P02. To attain approval under item (1), the laboratory must: (a) submit and obtain approval of the Quality Assurance/Quality Control (QA/QC) plan for LTPP Protocol P07 testing, (b) demonstrate that their testing equipment meets or exceeds the specifications contained in this protocol, and (c) successfully complete all applicable requirements of the FHWA LTPP P07 Start-up and Quality Control Procedure.

2.2 Sample Size

This testing shall be conducted on 102 mm (4 in) diameter asphalt concrete specimens that are between 25 (minimum) and 51 mm (maximum) (1.0 and 2.0 in) in thickness. The desired thickness for testing is 51 mm (2 in).

2.3 Test Core Locations and Assignment of Laboratory Test Numbers

This test shall be performed on specimens obtained from c-type, 102 mm (4 in) diameter core holes as dictated by the sampling plans for the particular LTPP section. The testing will be performed on asphalt layers with a thickness greater than 25 mm (1.0 in). Generally, samples are retrieved from the approach (stations 0+000m -) and/or leave (stations 0+152m +) ends of a test section but it is possible that for forensic or other studies specimens may be retrieved from within the pavement section. Test results shall be reported separately for samples obtained at the approach, within and leave end of the test section as follows:

(a) Beginning of the Section (stations 0+000m -): Core specimens that are retrieved from areas in the approach end of the test section (stations preceding 0+000m (0+00)) shall be assigned Laboratory Test Number "1".

(b) End of the Section (stations 0+152m +): Core specimens that are retrieved from areas in the leave end of the test section (stations after 0+152m(5+00)) shall be assigned Laboratory Test Number "2".

(c) Within the Section (stations 0+000m - 0+152m): Core specimens that are retrieved from areas within the test section (stations 0+000m - 0+152m (0+00 - 5+00)) shall be assigned Laboratory Test Number "3".

If any of the test specimens obtained from the specified core locations are damaged or untestable, other cores within the same grouping and same layer that have not been identified for other testing can be substituted for this testing. Test specimens from one area (approach, within or leave) of an LTPP section may not be substituted for test specimens from another area. An appropriate comment code shall be used in reporting the test results and any specimen substitution.

3. DEFINITIONS

The following definitions are used throughout this protocol:

- (a) **Layer:** that part of the pavement produced with similar material and placed with similar equipment and techniques. The layer thickness can be equal to or less than the core thickness or length.
- (b) **Core:** an intact cylindrical specimen of pavement materials which is removed from the pavement by drilling and sampling at the designated core location. A core may consist of, or include, one or more different layers.
- (c) **Test Specimen:** that part of the layer which is used for, or in, the specified test. The thickness of the test specimen can be equal to or less than the layer thickness.
- (d) **Creep:** the time-dependent part of strain resulting from stress. A typical load versus deformation graph for creep testing is shown in Figure 1.

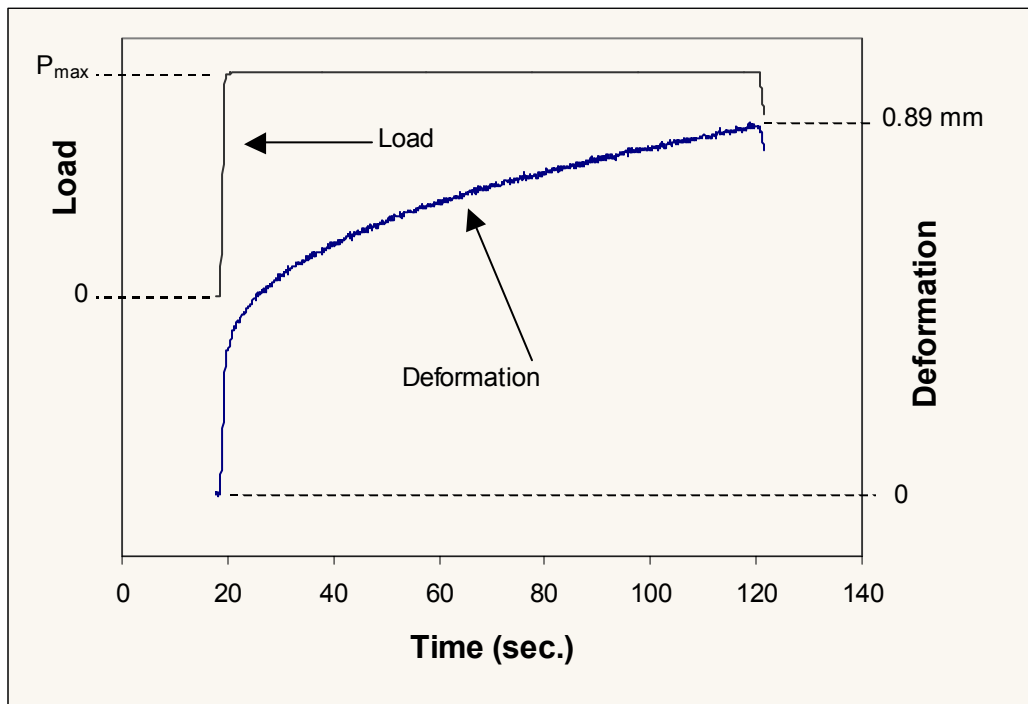

Figure 1. Typical creep test

- (e) **Creep Compliance:** the time-dependent strain divided by the applied stress.
- (f) **Poisson's Ratio, ν :** the absolute value of the ratio of transverse strain to the corresponding axial strain resulting from uniformly distributed axial stress below the proportional limit of the material.

(g) Haversine Shaped Load Form: the required load pulse form for the resilient modulus portion of the P07 test. The load pulse is of the form $[(1 - \cos\theta)/2]$, and the cyclic load (P_{cyclic}) is varied from a seating load (P_{contact}) to the maximum load (P_{max}), as shown in Figure 2.

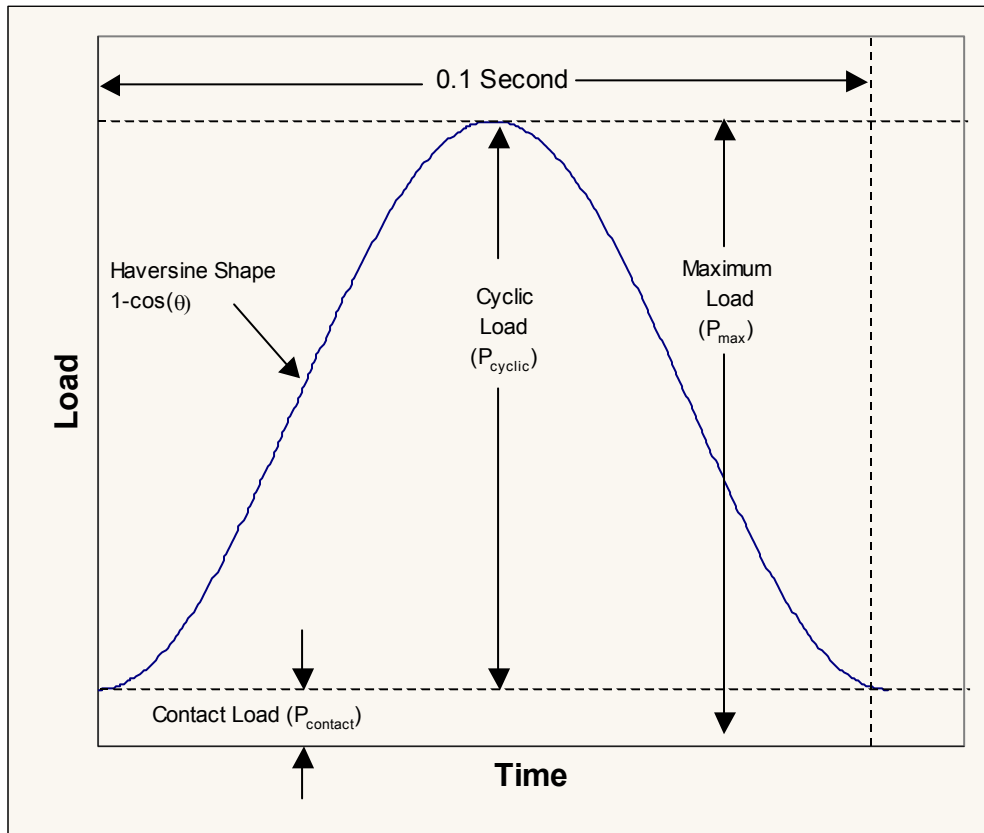

Figure 2. Definition of load pulse terms

(h) Maximum Applied Load (P_{max}): the maximum total load applied to the sample, including the contact and cyclic loads.

$$P_{\text{max}} = P_{\text{contact}} + P_{\text{cyclic}}$$

(i) Contact Load (P_{contact}): the vertical load placed on the specimen in order to maintain contact between the loading strip and the specimen:

(j) Cyclic Load (Resilient Load, P_{cyclic}): load applied to a test specimen which is used to calculate the resilient modulus.

$$P_{\text{cyclic}} = P_{\text{max}} - P_{\text{contact}}$$

(k) Instantaneous Resilient Modulus: determined from the deformation-time plots (both horizontal and vertical) using the instantaneous resilient deformation, obtained in the

manner indicated in Figure 3 and described herein. For each cycle, two regression lines are used to determine the instantaneous and total deformations. The range for regression line 1 starts at the 5th point after the maximum deformation value and ends at the 17th point after the maximum deformation (13 points total). The range for regression line 2 includes the last 299 points of the cycle and the first point from the following cycle. For each cycle, the instantaneous deformation is calculated by subtracting the deformation value at the intersection of regression lines 1 and 2 from the maximum deformation. A typical deformation versus time graph for resilient modulus testing is shown in figure 4.

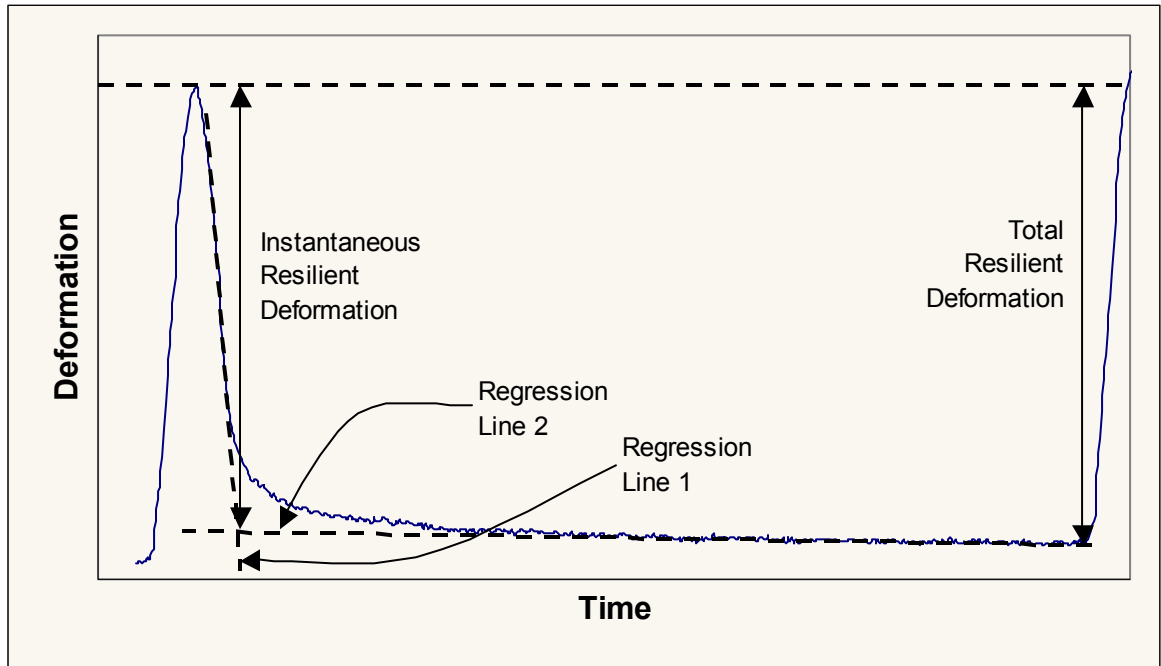

Figure 3. Instantaneous and total resilient deformations

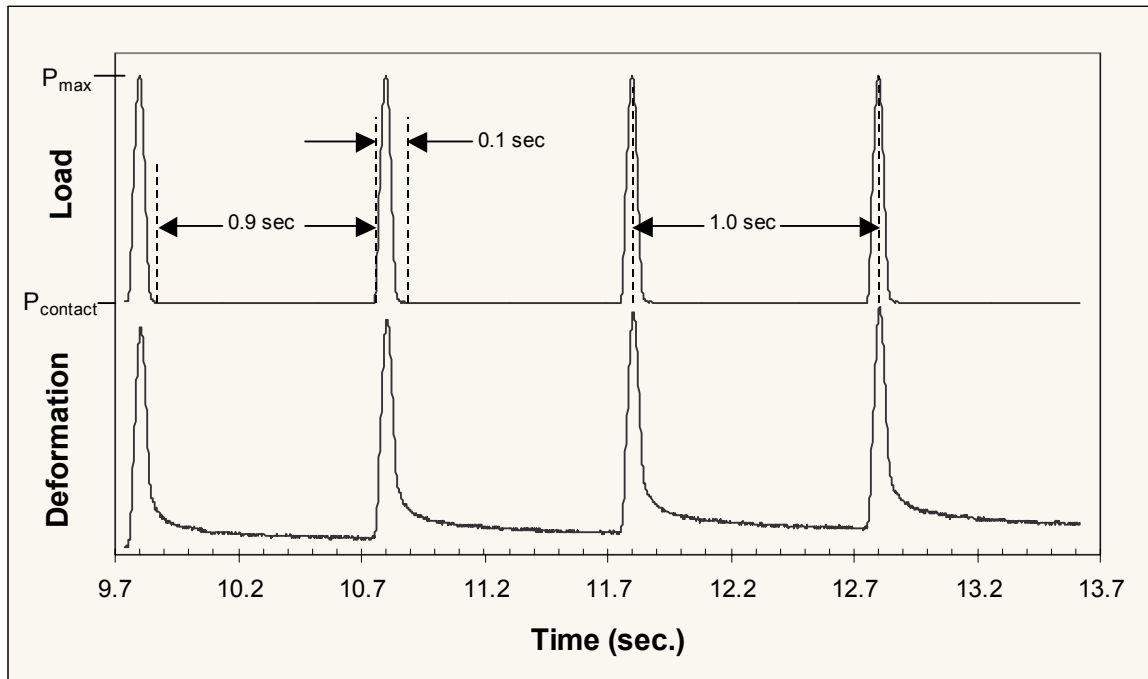

Figure 4. Typical resilient modulus test

(l) Total Resilient Modulus: determined from the deformation-time plots using the total resilient deformation, obtained in the manner indicated in Figure 3 and described herein. For each cycle, the total deformation is calculated by the deformation value of regression line 2 at the first point of the next cycle from the maximum deformation. This value includes both the instantaneous recoverable deformation and the time-dependent continuing recoverable deformation during the rest-period portion of one cycle.

(m) Tensile Strength: the strength shown by a specimen subjected to tension, as distinct from torsion, compression, or shear. A typical load versus deformation plot for indirect tensile strength testing is shown in Figure 5.

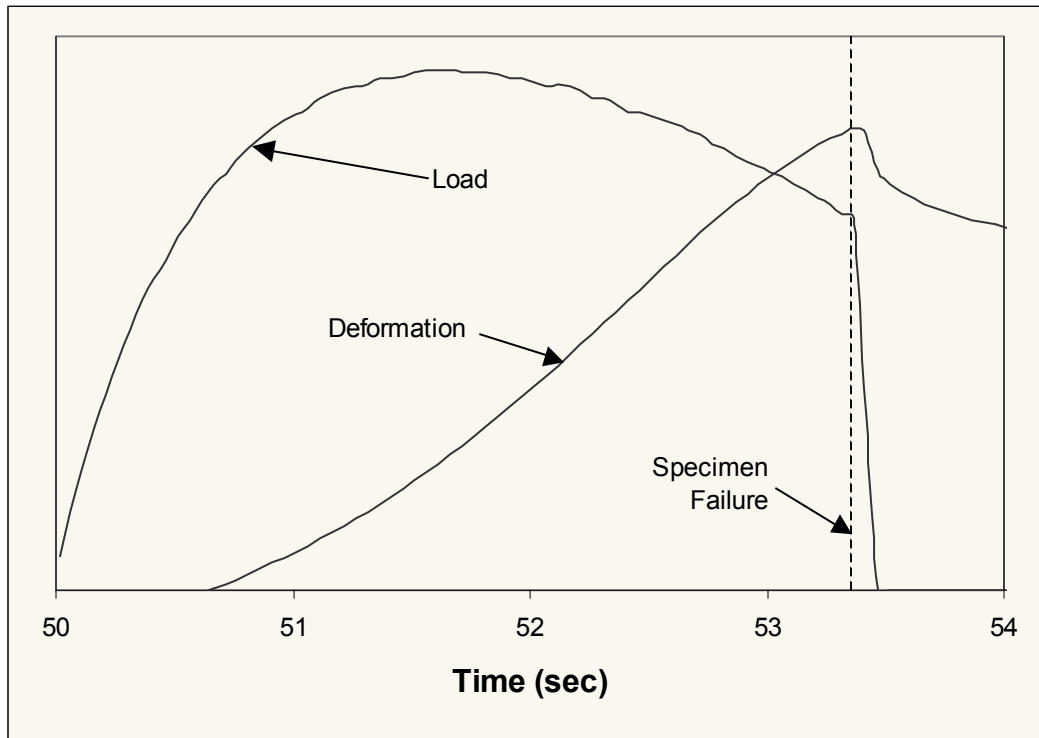

Figure 5. Typical indirect tensile test

4. APPLICABLE DOCUMENTS

4.1 LTPP Protocols

- P01 Visual Examination and Thickness of Asphaltic Concrete Cores.
- P02 Bulk Specific Gravity of Asphaltic Concrete.

4.2 AASHTO Standards

- TP9-94 (Edition 1B) Standard Test Method for Determining the Creep Compliance and Strength of Hot Mix Asphalt (HMA) using the Indirect Tensile Test Device, September 1994.

4.3 ASTM Standards

- D4123 Indirect Tension Test for Resilient Modulus of Bituminous Mixtures

4.4 Other

- Evaluation of SHRP Indirect Tension Tester to Mitigate Cracking in Asphalt Concrete Pavements and Overlays, Roque, Reynaldo, et al, August 1997.

5. APPARATUS

5.1 Loading Device

The testing machine shall be a top loading, closed-loop, servo-hydraulic testing machine. The loading device shall be capable of providing a fixed or constant load with a resolution of at least 4.45N (1 lbf) and constant rate of ram displacement between 12 and 75 mm/minute (0.5-3 in/minute). The test machine should also be capable of applying a haversine shaped load pulse over the range of load durations, load levels, and rest periods described in this protocol (nominally 0.1 second in duration followed by a rest period of 0.9 seconds). The load frame should be capable of handling a minimum of 22,240 N (5,000 lbf).

5.2 Diametral Loading Heads and Specimen Restraint System

Diametral loading heads, equipped with concave steel loading strips having a radius of curvature equal to the nominal radius of the test specimen (nominally 102 mm [4 in]) are required to apply load to the specimen. The loading strip shall be 13 mm (0.5 in) wide. For LTPP testing purposes, the diametral loading heads and specimen restraint system is as specified in Appendix A (Test Equipment Specifications) of this protocol. Typical diametral loading heads are shown in Figure 6.

NOTE: The loading heads have been designed to be interchangeable so that either 102 mm (4 in) or 152 mm (6 in) diameter samples can be tested. The appropriate loading strip can be used by simply rotating the upper and lower loading platens 180 degrees. The upper loading platen was designed to rotate freely under load to accommodate specimens that are not perfectly cylindrical (e.g., field cores).

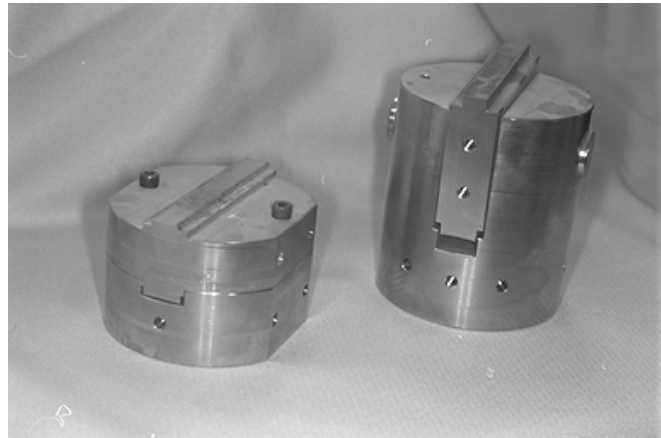

Figure 6. Typical loading heads

The vertical plates on the lower loading head serve as a specimen restraint system. When the specimen is broken during the strength test, these plates keep the two halves from falling and reduces the potential for damage of the deformation measurement system. The specimen restraint system is adjustable to accommodate 102 mm (4 in) and 152 mm (6 in) diameter specimens. An aluminum block designed to align the upper and lower loading platens is shown in Appendix A of this protocol. This alignment unit is necessary because, unlike a typical resilient modulus loading frame that has the upper and lower loading platens permanently

affixed, the upper and lower loading platens in this system are independent of each other. Therefore, this block was designed to align the upper and lower loading strips during initial installation and periodically to check and adjust the alignment.

5.3 Gauge Points

Eight gage points are required per specimen. The gage points must be magnetic (e.g. low carbon steel). Detailed specifications for the gage points are contained in Appendix A. Typical gage points are shown in Figure 7.

5.4 Contact Point Template

A template for marking the contact point where the loading heads would be perfectly aligned with the gage points. Detailed specifications for this device are contained in Appendix A of this protocol.

5.5 Gage Point Mounting System

A gage point mounting system is required. This device is used to mount the gage points precisely on cylindrical test specimens. Detailed specifications for this device are contained in Appendix A of this protocol. A typical gage point mounting device is shown in Figure 9.

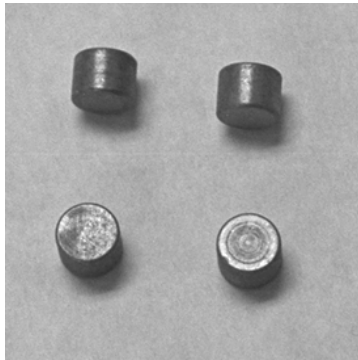

Figure 7. Typical gauge points

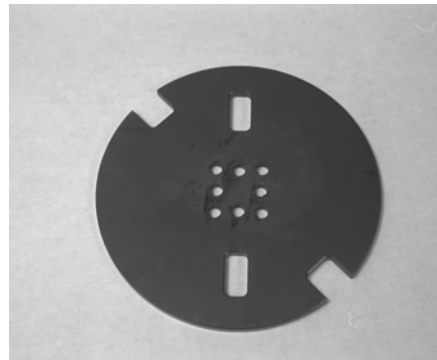

Figure 8. Typical contact point template

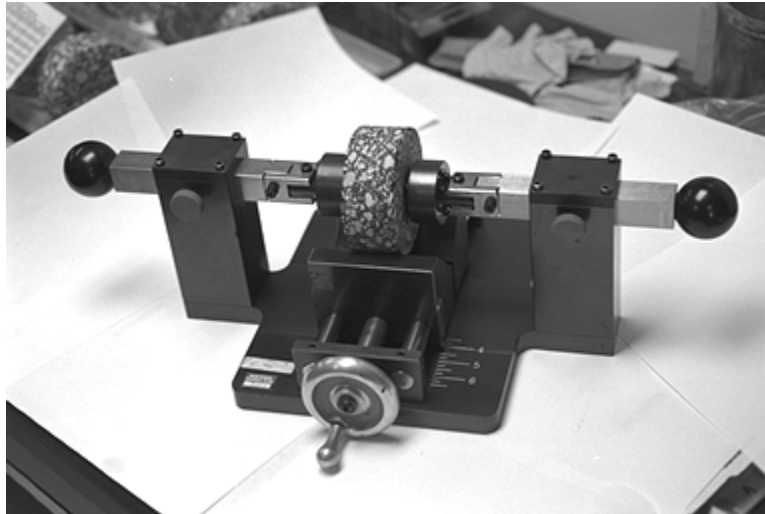

Figure 9. Typical gauge point mounting device

5.6 Temperature Control System

The temperature-control system should be capable of maintaining temperature control within ± 0.2 °C (± 0.4 °F) (measured near the center of the chamber), at settings ranging from -10 to 40 °C (14 to 104 °F). The system shall include a temperature-controlled cabinet large enough to house the diametral loading heads and specimen constraint system as well as three test specimens.

The chambers shall be capable of a minimum temperature change rate of ± 15 °C/hour (± 27 °F/hour). A thermally sealed access port for thermocouple or electrical feed through is also required. In addition, it is preferred that the test chamber or an adjacent preconditioning chamber be large enough to house up to 25 test specimens during production testing operations.

5.7 Measurement and Recording System

The measuring and recording system shall include sensors for measuring and simultaneously recording horizontal and vertical deformations on both faces of the specimen and the load applied to the specimen. The system shall be capable of recording horizontal deformations with a resolution of 0.00025 mm (0.000010 in). The system shall also be capable of recording vertical deformations with a resolution of 0.0005 mm (0.000020 in). Load cells shall be accurately calibrated with a resolution of 5 N (1 lbf) or better. In all cases, the noise in the recording system should be less than the accuracy of the deformation measurement devices being used.

5.7.1 Recorder - The measuring or recording devices must provide real time deformation and load information and should be capable of monitoring readings at a minimum of 500 points/second. These parameters shall be

recorded on an analog to digital or digital data acquisition system. The data acquisition system must be able to record time, temperature, load, and four deformation measurement devices.

5.7.2 Deformation Measurement - The values of vertical and horizontal deformation shall be measured with 25 mm (1 in) gage point mounted extensometers with a full scale travel of 0.5 mm (0.02 in.). The extensometers must be capable of performing within the temperature range prescribed in this test procedure.

Extensometer Response Checks. The extensometers shall be calibrated every two weeks, or after every 50 resilient modulus tests, as per manufacturer specifications.

5.7.3 Load Measurement - The repetitive loads shall be measured with an electronic load cell with a capacity 22,000 N (5,000 lbf) and a sensitivity of ± 5 N (± 1 lbf). The capacity of the load cell shall be matched as closely as possible to the expected testing load ranges to allow adequate feedback response, especially for haversine loading conditions.

During periods of resilient modulus testing, the load cell shall be monitored and checked once a month with a calibrated proving ring or independent load cell to assure that it is operating properly.

5.8 Specimen Sawing Apparatus

A specimen sawing device will be used to cut parallel, smooth and plane top and bottom faces for the asphalt cores. A water-cooled masonry saw has been found to perform this function adequately.

5.9 Humidity Cabinet

A chamber that can control to $\pm 5\%$ relative humidity is necessary to condition specimens. This cabinet or chamber must be large enough to accommodate the number of specimens expected to be tested over 3 days.

5.10 Data Reduction and Analysis System

An automated data reduction and analysis system is necessary to process the data generated by this test procedure. Manual data reduction and analysis is possible but impractical. For LTPP testing, a series of software programs have been developed to process and analyze the data. Appendix B of this procedure outlines the algorithms used in data analysis.

6. TEST SPECIMEN PREREQUISITES

6.1 General Specifications

Cores for test specimen preparation, which may contain one or more testable layers, must have smooth and uniform vertical (curved) surfaces. Cores that are obviously deformed or have any visible cracks must be rejected. Irregular top and bottom surfaces shall be trued up as necessary. Individual layer specimens shall be obtained by cutting with a water-cooled masonry saw.

Each specimen shall represent a single AC layer at one end of the test section. If the field core includes two or more different AC layers, the layers shall be separated at the layer interface by sawing. Any testable layers as identified in the P01 test (Form T01B) shall be separated. Layers that contain more than one lift of the same material placed under the same contract specification may be tested as a single specimen. The traffic direction symbol shall be marked on each layer after cutting to maintain the correct orientation. Layers too thin to test (less than 25 mm [1.0 in]), as well as any thin surface treatments, shall be removed and discarded.

All samples from a single area of the test section (before, within or end) that are candidates for this test shall be assembled, and the bulk specific gravity test results reviewed. Of this group of test candidates, the three specimens with the closest bulk specific gravities should be selected.

6.2 Specimen Thickness

The test specimens designated for M_R testing shall be sawn from the appropriately numbered cores as described above in thickness no greater than 51 mm (2.0 in) in preparation for resilient modulus testing.

The desired thickness for testing is approximately 51 mm (2.0 in). If the thickness of a particular AC layer scheduled for testing is 76 mm (3.0 in) or more, then the 51 mm (2 in) specimen to be used for testing shall be obtained from the middle of the AC layer by sawing the specimen.

The thickness of each test specimen shall be measured to the nearest 0.25 mm (0.01 in) prior to testing. The thickness shall be determined by averaging four measurements located at quarter points around the sample perimeter, and 13 to 25 mm (0.5 to 1 in) in from the specimen edge.

6.3 Specimen Diameter

The diameter of each test specimen shall be determined prior to testing to the nearest 0.25 mm (0.01 in) by averaging diametral measurements. Measure the diameter of the specimen at mid-height along (1) the axis parallel to the direction of

traffic and (2) the axis perpendicular (90 degrees) to the axis measured in (1) above. The measurements shall be averaged to determine the diameter of the test specimen. Core diameters shall be no less than 97.8 mm (3.85 in) or more than 105.4 mm (4.15 in).

6.4 Diametral Axis

Marking of the diametral axis to be tested shall be performed using the loading head contact template described in Appendix A. The axis shall be parallel to the traffic direction symbol (arrow) or "T" marked during the field coring operations. This diametral axis location can be rotated slightly, if necessary, to avoid contact of the loading strips with abnormally large aggregate particles or surface voids. Rotation of the test axis is also required if the surfaces to be loaded taper by more than 0.127 mm (0.005 in) from parallel.

6.5 Sample Preparation

Saw at least 6 mm (.25 in) from both sides of each test specimen to provide smooth, parallel surfaces for mounting the measurement gages. Measurements taken on cut faces yield more consistent results and gage points can be attached more firmly. If the sample is too thin (less than 25 mm (1.0 in)) to accommodate the sawing operation, then the sawing operation is not performed.

Determine the bulk specific gravity of the specimen in accordance with LTPP Protocol P02 except that if the water absorbed by the specimen exceeds 2 percent, substitute a thin, adherent, water resistant plastic wrap membrane for the paraffin coating.

Specimens shall be stored in a cabinet at a constant relative humidity of 50 percent for 3 days prior to testing to ensure uniform moisture conditions.

Epoxy four gage points to each flat face of the specimen (4 per face) using the gage point mounting system. On each flat face of the specimen, two gage points shall be placed along the vertical and two along the horizontal axes with a center to center spacing of 25.0 ± 0.2 mm ($1.0 \pm .1$ in). The location of the gage points on each face shall be identical. The gage points shall be affixed to the specimen with suitable epoxy (e.g. "Zap-a-gap" has been used successfully). Figure 10 illustrates a specimen with gauge points mounted. Mount the extensometers onto the test specimen, as shown in Figure 11.

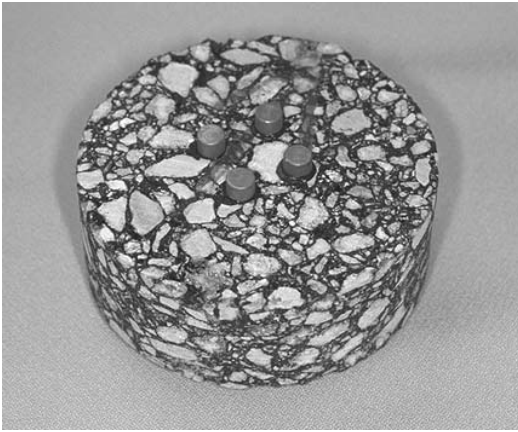

Figure 10. Asphalt specimen with gauge points mounted

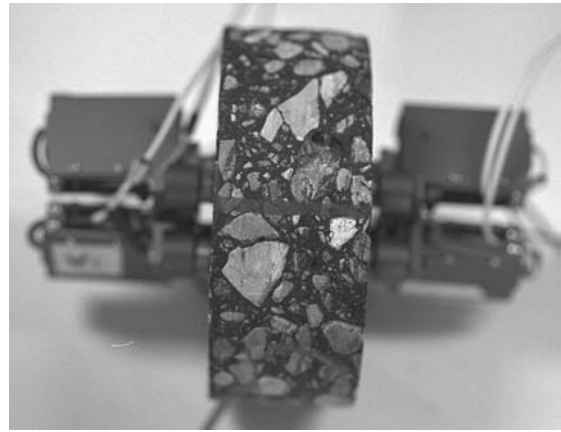

Figure 11. Asphalt specimen with extensometers mounted

7. TEST PROCEDURE

7.1 General

The asphalt cores shall be placed in a controlled temperature cabinet/chamber and brought to the specified test temperature. Unless the core specimen temperature is monitored in some manner and the actual temperature is known, the core samples shall remain in the cabinet/chamber for a minimum of 24 hours prior to testing at 5 °C (41 °F) and 25 °C (77 °F). Specimens shall be held at 40 °C (104 °F) for a minimum of three hours, but not exceeding six hours, prior to testing. All specimens should be stored in an environment where the temperature is maintained between 5 and 21 °C (40 and 70 °F) until they are to be conditioned for testing.

Each specimen is tested in the following sequence:

1. Creep Compliance -10 °C (14 °F)
2. Resilient Modulus 5 °C (41 °F)
3. Creep Compliance 5 °C (41 °F)
4. Resilient Modulus 25 °C (77 °F)
5. Creep Compliance 25 °C (77 °F)
6. Resilient Modulus 40 °C (104 °F)
7. Tensile Strength 25 °C (77 °F)

Mount and center the deformation devices on the sample and zero or rebalance the electronic measurement system.

7.2 Alignment and Specimen Seating

At each temperature, insert the test specimen into the loading device and position it so that the load strip alignment mark on the test specimen lines up with the loading

strips. The alignment of the front face of the specimen can be checked by insuring that the specimen load strip alignment markings are centered on the top and bottom loading strips. If necessary, the rear face of the specimen can be similarly aligned by using a mirror. A specimen mounted in the loading device is shown in Figure 12.

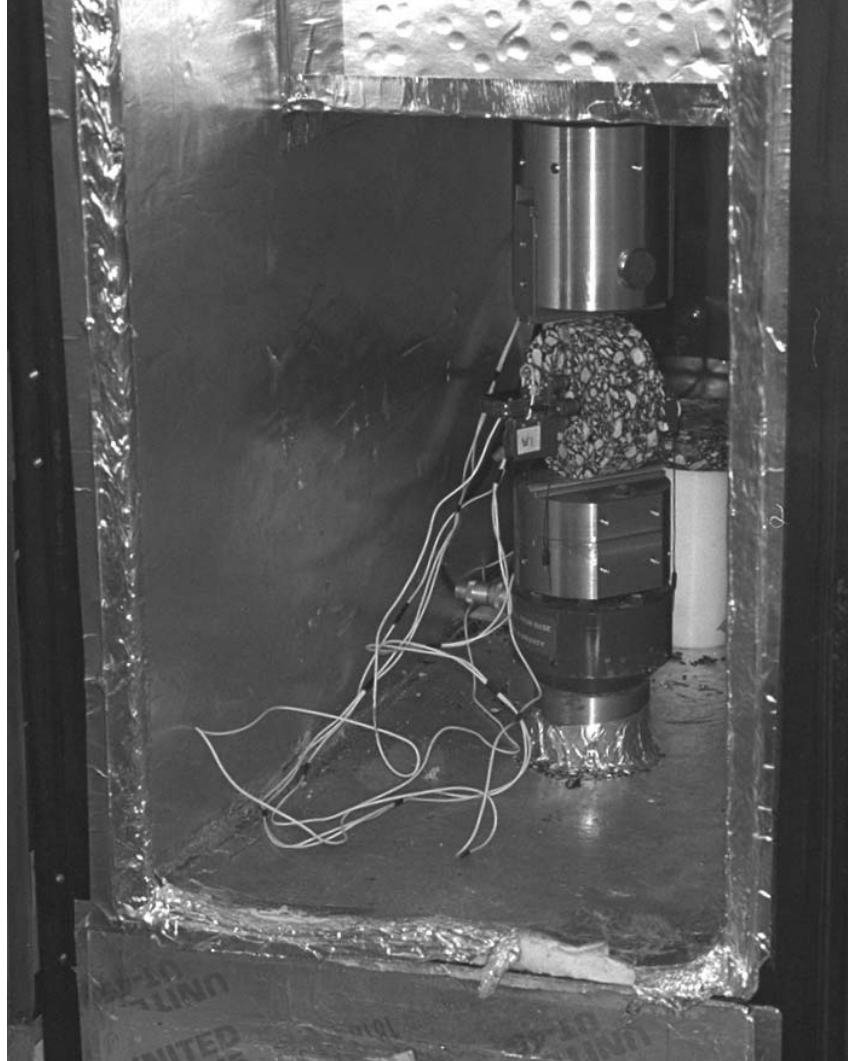

Figure 12. Specimen mounted in loading device

The contact surface between the specimen and each loading strip is critical for proper test results. Any projections or depressions in the specimen-to-strip contact surface which leave the loading strips in a non-contact condition over a length of more than 19 mm (0.75 in) shall be reason for rotating the test axis or rejecting the specimen. In instances where significant non-contact is suspected, machinists dye shall be used to check the specimen-to-strip contact area. If no suitable replacement specimen is available that meets this criteria, the test shall be conducted on the designated specimen. Code 39 shall be used to document this situation. Prior to performing the test procedure at a given temperature, the extensometers shall be

stable. For resilient modulus and indirect tensile strength testing, stability is defined as the horizontal extensometers not drifting by more than 50 micro-strain over 100 seconds. Prior to performing creep compliance testing, stability is defined as the horizontal extensometers not drifting by more than 10 micro-strain over 100 seconds. If these tolerances are not met, it is an indication that the specimen has not stabilized at the test temperature.

7.3 Creep Compliance Determination

After extensometer stability is achieved, apply a static load of fixed magnitude (± 2 percent), without impact to the specimen, that produces a horizontal deformation of 0.038 to 0.089 mm (0.0015 to 0.035 in) after 100 ± 2 s. If either deformation limit is exceeded, stop the test and allow a minimum recovery time of 3 minutes before reloading at a different level. These limits prevent both non-linear response, characterized by exceeding the upper limit, and significant problems associated with noise and drift inherent in sensors when violating the lower strain limit. Collect data at 10 Hz. Return to the initial load level.

7.4 Resilient Modulus Determination

After stability is achieved, zero or rebalance the deformation measurement devices and apply a repeated haversine waveform load to the specimen with a period of 0.1 second followed by a rest period of 0.9 seconds. Use a load that produces a peak horizontal deformation between 0.038 and 0.089 mm (0.0015 and 0.0035 in). If the deformations fall outside these limits, stop the test and allow a minimum recovery time of 3 minutes before reloading at a different level. As explained previously, these limits prevent both non-linear response, characterized by exceeding the upper limit and significant problems associated with noise and drift inherent in sensors when violating the lower limit. Collect data at a uniform rate of 500 points per load cycle.

Once the appropriate load is achieved, testing may commence. The specimen shall be cycled (loaded and unloaded) until deformation and load data are obtained for a minimum of three load cycles. The response haversine waveform shall be matched as closely as possible to the command wave form by adjusting the feedback controls of the system.

7.5 Tensile Strength Determination

This test is only performed at 25°C (77°F) after all other testing is complete, as it will destroy the sample. After stability is achieved, zero the deformation measurement devices. Apply a load to the specimen at a constant rate of 50 mm (2 in) of ram displacement per minute. Record the vertical and horizontal displacement of the sample and the load until the load begins to decrease. Stop the

test as soon as this occurs in order to prevent damage to the deformation measurement devices from a sudden failure of the specimen. Collect data at a rate of 2 Hz.

8. DATA ANALYSIS AND CALCULATIONS

For the purposes of LTPP testing, data analysis and calculations are performed using software developed by Dr. Reynaldo Roque. The software used to perform these calculations is titled as follows: MRFHWA.EXE - used to calculate resilient modulus test results. ITLTFHWA.EXE - used to calculate creep compliance and indirect tensile test results. Documentation accompanying the software describes its use. In addition, Appendix B outlines the analysis methodology used by the software, and Appendix C provides sample calculations.

9. REPORT

The report shall consist of a hard copy of Form T07, and electronic copies of all data files referenced on Form T07 submitted on an accompanying diskette.

9.1 Form T07 - Sample Summary Information

Form T07 contains general information about each test specimen. Fill out Form T07 as described below. Items 1 through 6 shall be the same for each specimen. Items 7 through 44 shall be filled out for each of the three specimens undergoing testing.

9.1.1 Item 1 – State Code

9.1.2 Item 2 – SHRP ID

9.1.3 Item 3 – Layer Number

9.1.4 Item 4 – Field Set

9.1.5 Item 5 – Test No (Generally all three specimens will have the same Test No. However space has been left to record the Test No for each specimen independently in case three adequate specimens with the same Test No were not provided to the lab.)

9.1.8 Item 6 - Sample Area (SPS sections only) (As with Test No, the Sample Area should be the same for all three specimens)

9.1.9 Item 7 – Location Number

9.1.10 Item 8 – LTPP Sample Number

- 9.1.11 Item 9 - Average Specimen Thickness, mm.
- 9.1.12 Item 10 - Average Specimen Diameter, mm.
- 9.1.13 Item 11 - Bulk Specific Gravity (from Test AC02).
- 9.1.14 Item 12 – Comment 1. This comment shall be in accordance with the codes listed on pages E.1-3 (GPS) or E.2-3 (SPS) of the LTPP Laboratory Materials Testing Guide.
- 9.1.15 Item 13 – Comment 2. This comment shall be in accordance with the codes listed on pages E.1-3 (GPS) or E.2-3 (SPS) of the LTPP Laboratory Materials Testing Guide.
- 9.1.16 Item 14 – Comment 3. This comment shall be in accordance with the codes listed on pages E.1-3 (GPS) or E.2-3 (SPS) of the LTPP Laboratory Materials Testing Guide.
- 9.1.17 Item 15 – Other Comments. This field shall be used to document situations for which there is no corresponding code on pages E.1-3 or E.2-3 of the LTPP Laboratory Materials Testing Guide
- 9.1.18 Item 16 – Data Filename, Test 1. This shall be the name of the raw data file generated during resilient modulus testing at the first test temperature.
- 9.1.19 Item 17 – Test 1 Temp. (°C). This shall be the temperature at which the first resilient modulus test was run.
- 9.1.20 Item 18 - Data Filename, Test 2. This shall be the name of the raw data file generated during resilient modulus testing at the second test temperature.
- 9.1.21 Item 19 – Test 2 Temp. (°C). This shall be the temperature at which the second resilient modulus test was run.
- 9.1.22 Item 20 - Data Filename, Test 3. This shall be the name of the raw data file generated during resilient modulus testing at the second test temperature.
- 9.1.23 Item 21 – Test 3 Temp. (°C). This shall be the temperature at which the first resilient modulus test was run.

- 9.1.24 Item 22 – Analysis Filename. This shall be the name of the resilient modulus output file generated by the “MRFHWA” software.
- 9.1.25 Item 23 –Data Filename, Test 1. This shall be the name of the raw data file generated during creep compliance testing at the first test temperature.
- 9.1.26 Item 24 - Test 1 Temp. (°C). This shall be the temperature at which the first creep compliance test was run
- 9.1.27 Item 25 –Data Filename, Test 2. This shall be the name of the raw data file generated during creep compliance testing at the second test temperature.
- 9.1.28 Item 26 - Test 2 Temp. (°C). This shall be the temperature at which the second creep compliance test was run.
- 9.1.29 Item 27 –Data Filename, Test 3. This shall be the name of the raw data file generated during creep compliance testing at the third test temperature.
- 9.1.30 Item 28 - Test 3 Temp. (°C). This shall be the temperature at which the third creep compliance test was run.
- 9.1.31 Item 29 – Analysis Filename. This shall be the name of the creep compliance output file generated by the “ITLTFHWA” software.
- 9.1.32 Item 30 – Data Filename. This shall be the name of the raw data file generated during the indirect tensile strength test.
- 9.1.33 Item 31 – Test Temp (°C). This shall be the temperature at which the indirect tensile strength test was run.
- 9.1.34 Item 32 – “.OUT” Filename. This shall be the name of the output file containing indirect tensile strength and poisons ratio generated by the “ITLTFHWA” software. By default this file has a “.out” extension.
- 9.1.35 Item 33 – “.STR” Filename. This shall be the name of the output file containing the stress versus strain information calculated by the “ITLTFHWA” software. By default this file has a “.str” extension. (Currently this data is not used by LTPP.)
- 9.1.36 Item 34 – “.FAM” Filename. This shall be the name of the output file containing the initial tangent modulus, failure strain and fracture energy

calculated by the “ITLTFHWA” software. By default this file has a “.fam” extension. (Currently this data is not used by LTPP.)

9.2 Electronic Data files

The electronic data files shall be located on a clearly labeled diskette accompanying form T07, and the filenames shall be as recorded on form T07. One complete test sequence will generate 26 data files. The breakdown is as follows:

- 9 Resilient modulus raw data files
(one for each specimen at each temperature)
- 9 Creep compliance raw data files
(one for each specimen at each temperature)
- 3 Indirect tensile strength test raw data files
(one for each specimen)
- 1 Resilient modulus analysis file
- 1 Creep compliance analysis file
- 3 Indirect tensile strength test analysis files

9.2.1 File Naming convention

9.2.1.1 Raw Data Files

As a result of testing performed using this procedure, 21 raw data files are generated. Raw data files are files that contain time, load, deformation, and temperature information for each test procedure. The data files are named in the following manner:

12345678.dat

Slots 1, 2, 3, and 4 are used to assign a number to each sample. This number shall be assigned sequentially by the laboratory, and shall be unique to the specimen under test. Slots 5 and 6 of the file are used to designate the test performed; “rm” for resilient modulus, “cp” for creep compliance, or “ts” for indirect tensile strength. Slots 7 and 8 are used to designate the test temperature; “-0” for -10EC, “05” for 5EC, “25” for 25EC, and “40” for 40EC. All files have a “.dat” extension to designate it is a raw data file.

Table 1 contains an example of the number and naming of data files resulting from one test sequence.

Table 1. Example Data File Names

Test	Temperature	Specimen 1	Specimen 2	Specimen 3
Resilient Modulus	5°C	6042rm05.dat	6043rm05.dat	6044rm05.dat
	25°C	6042rm25.dat	6043rm25.dat	6044rm25.dat
	40°C	6042rm40.dat	6043rm40.dat	6044rm40.dat
Creep Compliance	-10°C	6042cp-0.dat	6043cp-0.dat	6044cp-0.dat
	5°C	6042cp05.dat	6043cp05.dat	6044cp05.dat
	25°C	6042cp25.dat	6043cp25.dat	6044cp25.dat
Indirect Tensile Strength	25°C	6042ts25.dat	6043ts25.dat	6044ts25.dat

9.2.1.2 Analysis Files

The analysis files are created by running the “MRFHWA” software on the resilient modulus data files, and the “ITLTFHWA” software on the creep compliance and indirect tensile strength data files. The analysis files generated by these programs by default have the same first eight characters as the specimen 1 data file, but a different extension. Table 2 contains example analysis filenames for the set of raw data files contained in Table 2

Table 2. Example Analysis File Names

Contents	Filename
Resilient Modulus	6042rm05.mro
Creep Compliance	6042cp-0.out
Indirect Tensile Strength	6042ts25.out
Stress vs. Strain	6042ts25.str
Initial tangent modulus, fracture energy and failure strain	6042ts25.fam

9.2.2 File Structure

As these files are to be analyzed and uploaded to the LTPP Information Management System (IMS) using automated software, strict adherence to the standard file structures presented here is critical.

9.2.2.1 Raw Data File Structure

Each raw data file shall contain seven tab-delimited columns containing the following information:

Column 1 – horizontal deformation, sample face 1, in.

Column 2 – vertical deformation, sample face 1, in.

Column 3 – horizontal deformation, sample face 2, in.

Column 4 – horizontal deformation, sample face 2, in.

Column 5 – applied load, lb.

Column 6 – time, seconds

Column 7 – environmental chamber temperature, EF

Each raw data file corresponds to an asphalt specimen that has undergone the Resilient Modulus, Creep Compliance, or Indirect Tensile testing; all of the data files follow roughly the same format. Each data file contains a number of rows that contain data for each sampling point taken during the testing process. The specific format for each data file type is as follows:

9.2.2.1.1 Resilient Modulus Data File

For resilient modulus testing, five test cycles are collected at a sampling rate of 500 points per second, resulting in a data file with approximately 2500 rows. The first thirteen rows contain header information that is not essential for the calculations. The fourteenth and fifteenth rows are the data names and units; the data are arranged in columns below the data names and units. The data is organized in columns 1 through 7; there should be exactly 2562 rows of data. The first column (rows 16 – 2577) contains deformation data collected from the first horizontal extensometer. The second column (rows 16 – 2577) contains deformation data collected from the first vertical extensometer. The third column (rows 16 – 2577) contains deformation data collected from the second horizontal extensometer. The fourth column (rows 16 – 2577) contains deformation data from the second vertical extensometer. The fifth column (rows 16 – 2577) contains load data obtained throughout the test. The sixth column (rows 16 – 2577) contains the time at which the corresponding data values are recorded; the total nominal time duration of each test should

be 5 seconds. The environmental chamber temperature is shown in the seventh column (rows 16 – 2577).

9.2.2.1.2 Creep Compliance Raw Data File

Creep compliance testing requires a sampling rate of 10 points per second for 100 seconds, and these data files nominally contain a little over a thousand rows of data (1000 rows of testing data and a few pre-test and post-test data points). Each data file corresponds to an asphalt specimen that has undergone the creep compliance testing. The first 5 rows of each data file contain header information that is not essential for the calculations. Row 6 includes the data labels for each data type and row 7 includes the units for each data type. The data is organized in columns 1 through 7; there should be exactly 1039 rows of data. The first column (rows 8 – 1046) contains deformation data collected from the first horizontal extensometer. The second column (rows 8 – 1046) contains deformation data collected from the first vertical extensometer. The third column (rows 8 – 1046) contains deformation data collected from the second horizontal extensometer. The fourth column (8 – 1046) contains deformation data from the second vertical extensometer. The fifth column (rows 8 – 1046) contains load data obtained throughout the test. The sixth column (rows 8 – 1046) contains the time at which the corresponding data values are recorded; the total nominal duration of each test should be 100 seconds. The environmental chamber temperature is shown in the seventh column (rows 8 – 1046).

9.2.2.1.1 Indirect Tensile Strength Raw Data File

Indirect tensile strength testing requires data collection at no less than twenty points per second for the duration of the test. The number of rows in these files fluctuate based upon the response (strain to failure) of the test specimen. Each data file corresponds to an asphalt specimen that has undergone the indirect tensile testing. The first 6

rows of each data file contain header information that is not essential for the calculations. Row 7 includes the data labels for each data type and row 8 includes the units for each data type. The data is organized in columns 1 through 7. The first column contains the deformation data collected from the first horizontal extensometer. The second column contains the deformation data collected from the first vertical extensometers. The third column contains the deformation data collected from the second horizontal extensometer. The fourth column contains the deformation data from the second vertical extensometer. The fifth column contains the load data obtained throughout the test. The sixth column contains the time at which the corresponding data values are recorded. The environmental chamber temperature is shown in the seventh column.

9.2.2.2 Analysis File Structure

The analysis files shall be generated by the “MRFHWA” and “ITLTFHWA” programs, and shall be submitted by the lab with no modifications.

Appendix A

Test Equipment Specifications

A1. LOAD HEADS

A1.1 Bottom Load Heads

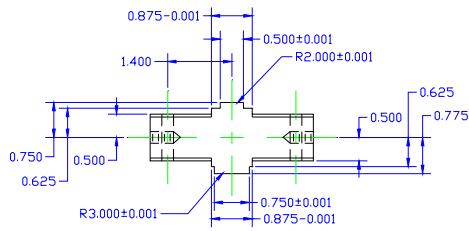
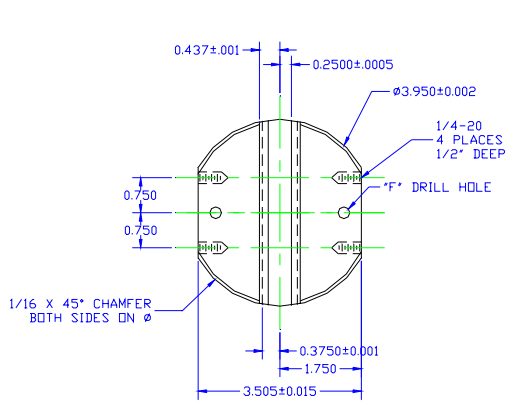

Part load1_a
Material SST 17_4PH
Concave surfaces H.T. to H1075
Number Required 2

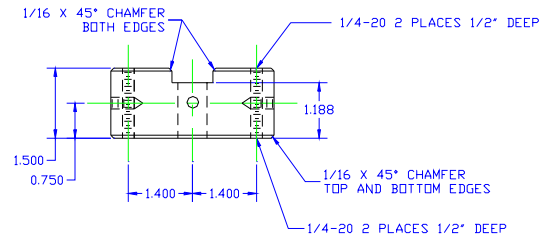
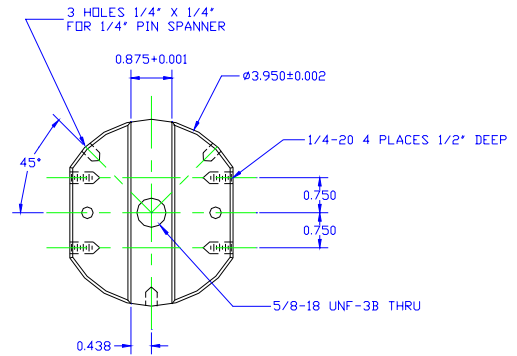

Part load1_b
Material SST
Number Required 1

DRILL AND TAP HOLES BEFORE
HEAT TREATING ALL PARTS

A1.2 Bottom Load Head Subassembly

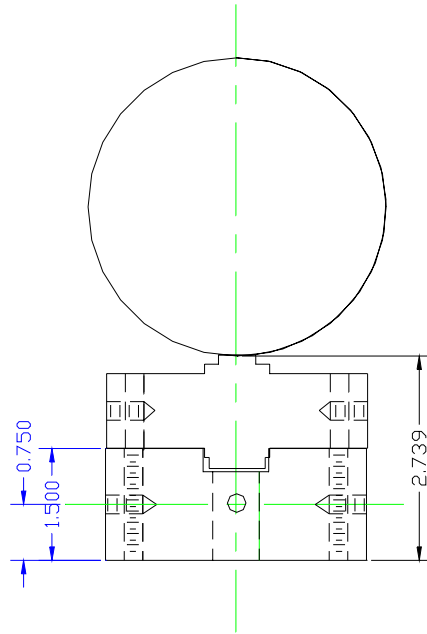

Part load1_b
Material SST
Number Required 1

A1.3 Top Load Head

Part load2_a
 Material SST 17_4PH
 Concave Surfaces H.T. to H1075
 Number Required 2

Drill and Tap 4 - 1/4-20 Holes
 and Rough Bore 1.125 Hole
Before Heat Treating

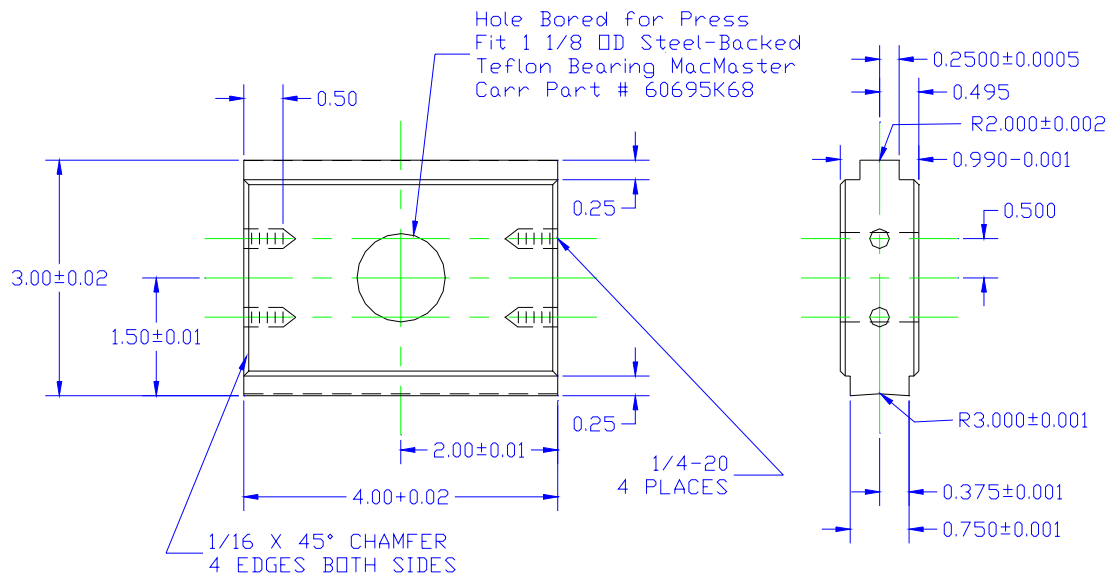

A1.3 Top Load Head Swivel Block

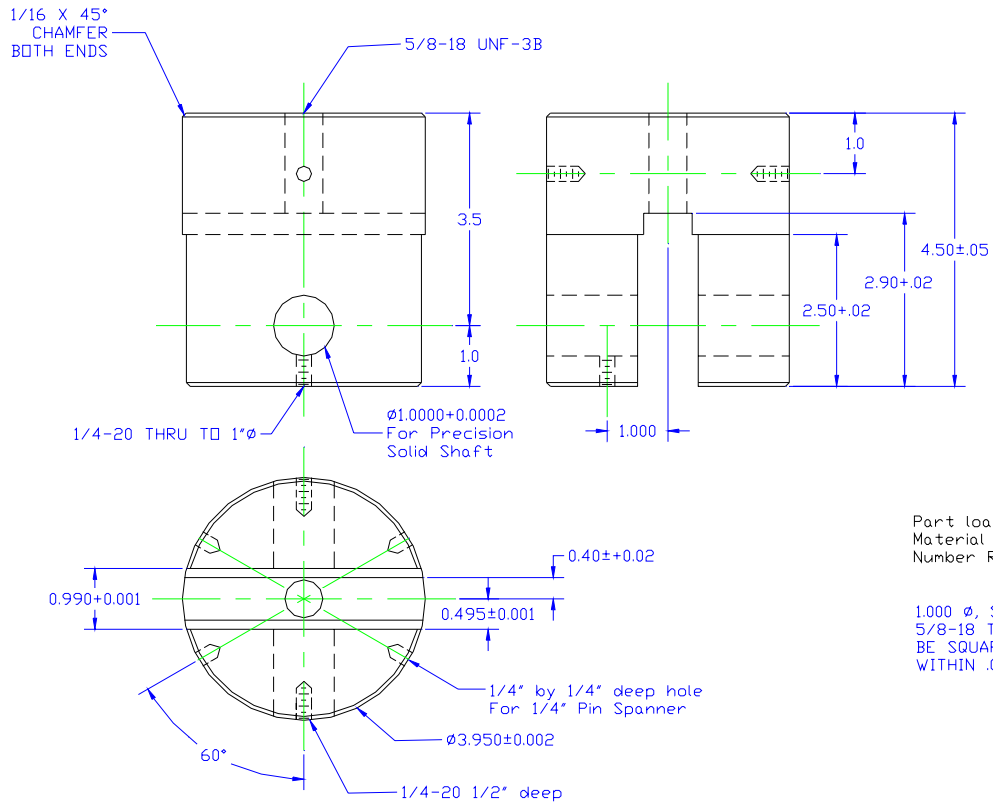

Part load3_a
Material SST
Number Required 1

1.000 Ø, SLOT AND
5/8-18 TAPPED END TO
BE SQUARE AND PARALLEL
WITHIN .002"

A2. LOAD RODS

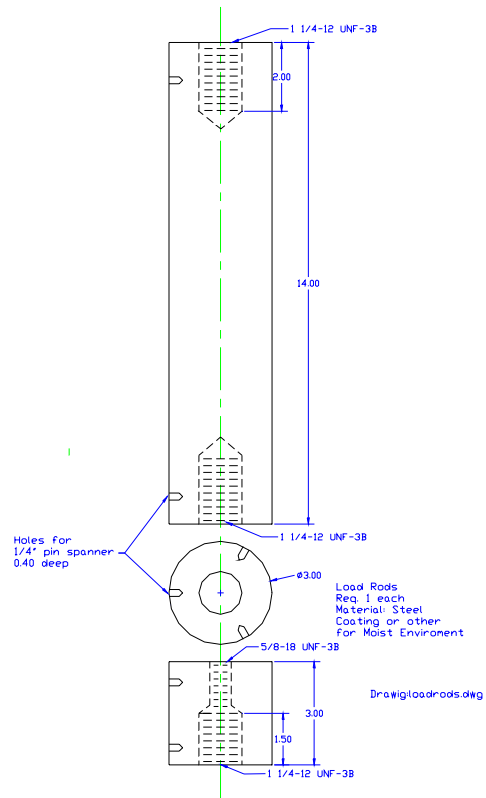

A3. GAUGE POINT MOUNTING TEMPLATE

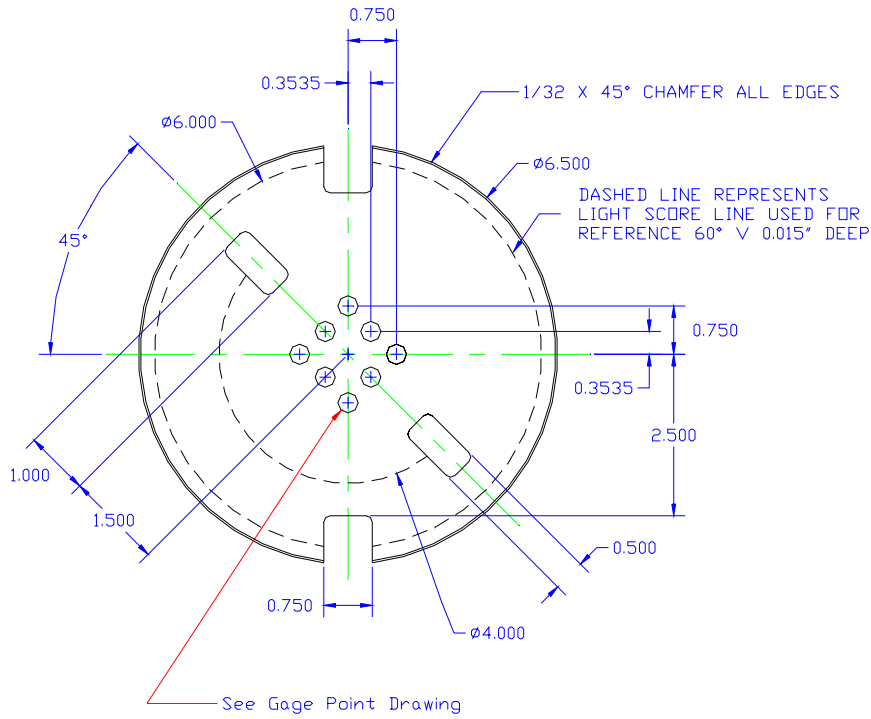

Sample Alignment Fixture
Material 3/16 AL
2 Required
Drawing: FHWA\P07\template.dwg
Braun Intertec
Thor stangebye 7/7/98
942-1791

A6. GAUGE POINT MOUNTING DEVICE

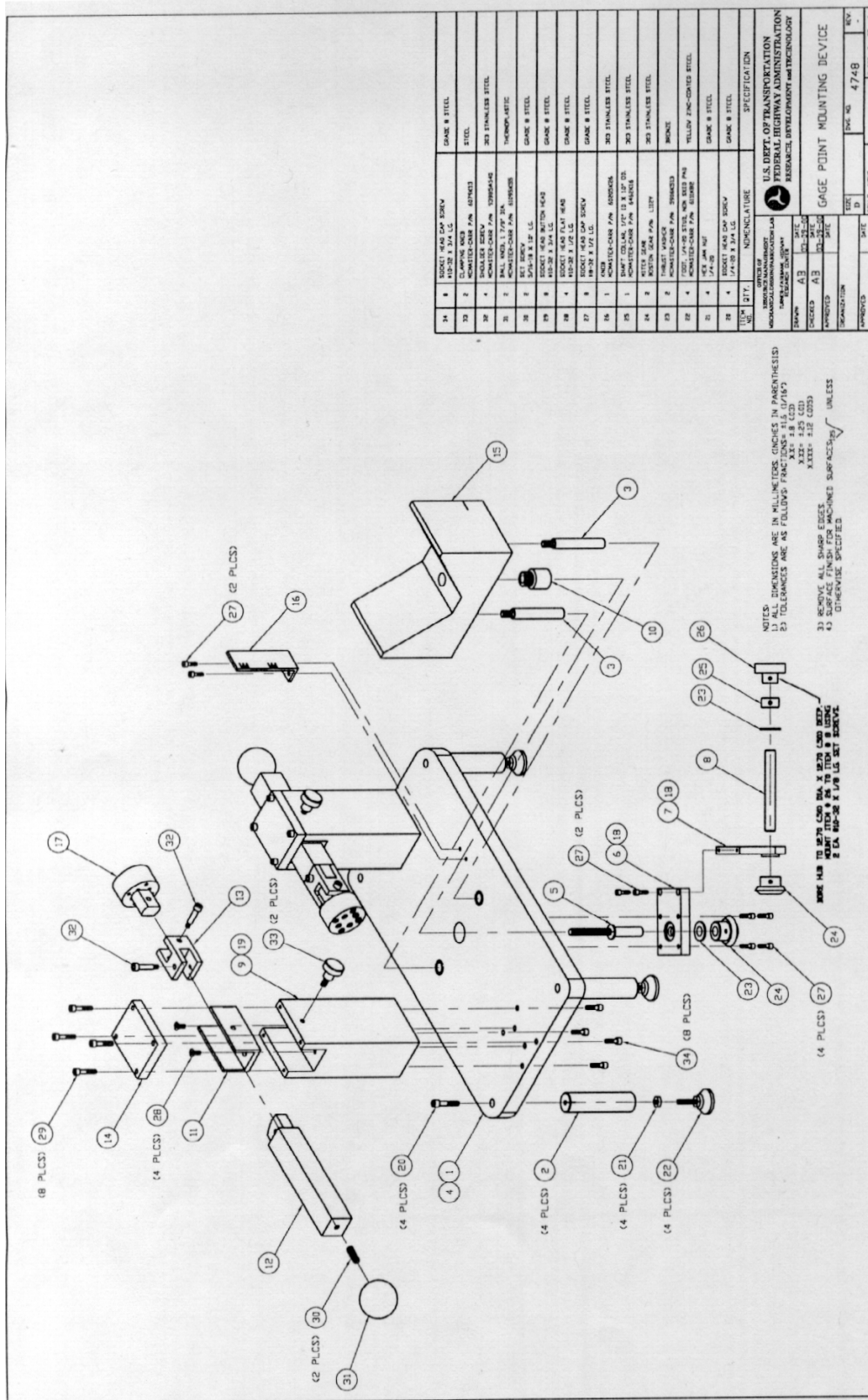

ITEM NO.	DESCRIPTION	QUANTITY	MATERIAL
14	ROCKET HEAD CAP SCREW	8	GRADE 8 STEEL
15	WASHER	4	STEEL
16	CLAMPING BRACKET	4	303 STAINLESS STEEL
17	ROCKET HEAD CAP SCREW	4	303 STAINLESS STEEL
18	WASHER	4	303 STAINLESS STEEL
19	WASHER	4	303 STAINLESS STEEL
20	ROCKET HEAD CAP SCREW	4	303 STAINLESS STEEL
21	WASHER	4	303 STAINLESS STEEL
22	WASHER	4	303 STAINLESS STEEL
23	ROCKET HEAD CAP SCREW	4	303 STAINLESS STEEL
24	WASHER	4	303 STAINLESS STEEL
25	WASHER	4	303 STAINLESS STEEL
26	ROCKET HEAD CAP SCREW	4	303 STAINLESS STEEL
27	WASHER	2	303 STAINLESS STEEL
28	ROCKET HEAD CAP SCREW	4	303 STAINLESS STEEL
29	WASHER	4	303 STAINLESS STEEL
30	ROCKET HEAD CAP SCREW	2	303 STAINLESS STEEL
31	WASHER	2	303 STAINLESS STEEL
32	ROCKET HEAD CAP SCREW	2	303 STAINLESS STEEL

U.S. DEPT. OF TRANSPORTATION
 FEDERAL HIGHWAY ADMINISTRATION
 RESEARCH, DEVELOPMENT AND TECHNOLOGY

PROJECT NO. 477-B

DATE: 10/20/00

REV: 1

SCALE: 1:1

FIGURE NO. 1

DESCRIPTION: GAUGE POINT MOUNTING DEVICE

Appendix B

Data Analysis Algorithms

B1. INTRODUCTION

This appendix contains the algorithms used to determine the resilient modulus, creep compliance and indirect tensile strength for specimens tested using the P07 testing protocol. The algorithms presented herein are based upon the data format, data sampling rates and file structures used for LTPP P07 testing purposes. If formats, sampling rates or file structures used are different than outlined herein, the algorithms should be modified appropriately.

These algorithms are based upon the methods developed by Dr. Reynaldo Roque *et. al.* and documented in the report referenced in Section 4.4 of this protocol. Dr. Roque and his colleagues developed two programs, MRFHWA to reduce and analyze resilient modulus data, and ITLTFHWA to reduce and analyze creep compliance and indirect tensile strength data. The user's guide for the software is available as a separate document. The data analysis methods used in MRFHWA and ITLTFHWA are documented in this appendix. Appendix C of this document contains a step-by-step example of the calculations presented herein.

This appendix is divided into four sections as follows:

- B1. Introduction
- B2. Resilient Modulus Data Analysis Algorithm
- B3. Creep Compliance Data Analysis Algorithm
- B4. Indirect Tensile Strength Analysis Algorithm

B2. RESILIENT MODULUS DATA ANALYSIS ALGORITHM

An outline of the resilient modulus data analysis algorithm that is used in the “MRFHWA” software, and described in the report by Roque *et. al.* is presented in section B2.2. The algorithm is described graphically in section B2.3

B2.1 Subscript Convention

For the purpose of clarity, a subscript convention has been developed. The subscript ‘i’ represents the specimen number (i = 1, 2, or 3), the subscript ‘j’ represents the cycle number (j = 1, 2, or 3), and the subscript ‘k’ represents the specimen face (k = 1 or 2). Thus a variable may have up to three subscripts of the following form: $X_{i,j,k}$.

B2.2 Analysis

A separate analysis must be performed for each of the three temperatures.

B2.2.1 Select Cycles

For each of the three specimens, determine which three cycles of the five recorded in the data file shall be used for analysis. Find the maximum load (Pmax) of the first recorded cycle in the data file. If the maximum occurs at or after 150 points from the start of the file, then the first three cycles recorded in the data file shall be used for subsequent analysis. If the maximum occurs less than 150 points from the start of the file, then the second, third and fourth cycles recorded in the test shall be used. From now on, regardless of which cycles have been selected for analysis, they shall be referred to as cycles 1, 2 and 3, respectively.

B2.2.2 Calculate Contact Load (Pcontact_i)

For each of the three specimens calculate the contact load. Only one contact load shall be calculated for each specimen as follows:

- (1) Determine the point at which the maximum load (Pmax) occurs for cycle 1.
- (2) Select the range of cells from 80 points before Pmax to 30 points before Pmax (50 points total)

(3) Average the load values in the selected range as follows:

$$\text{Eq. B1 : } P_{\text{contact } i} = \frac{\sum_{y=x-80}^{x-30} P_y}{50}$$

where: $P_{\text{contact } i}$ = the contact load for specimen i , lbs.

P_y = the load at point y , lbs.

x = the point at which $P_{\text{max } i,1}$ occurs

B2.2.3 Determine Cycle Start and End Points

For each cycle j on each specimen i , determine the start and end points as follows. Determine P_{max} for cycle j

- (1) Starting at P_{max} , and moving to the left, the start of cycle j is defined as the last data point for which the load is greater than $P_{\text{contact } i} + 6$ lbs. This value shall be referred to as $sp_{i,j}$.
- (2) Starting at P_{max} and moving to the right, the end point for cycle j is defined as the last data point for which the load is less than $P_{\text{contact } i} + 6$ lbs. This value shall be referred to as $ep_{i,j}$.

B2.2.4 Determine the Cyclic Load

For each cycle j on each specimen i , determine the cyclic load ($P_{\text{cyclic } i,j}$) as follows:

$$\text{Eq. B2 : } P_{\text{cyclic } i,j} = P_{\text{max } i,j} - P_{\text{contact } i}$$

where: $P_{\text{cyclic } i,j}$ = the cyclic load for cycle j of specimen i , lbs.

$P_{\text{max } i,j}$ = the maximum load for cycle j of specimen i , lbs.

$P_{\text{contact } i}$ = the contact load of specimen i , lbs

B2.2.5 Calculate the maximum deformations :

On each of the two sawn faces of the sample, deformations are measured in the horizontal and vertical axes. Thus for each sample there will be a total of four deformation vs. time traces. From each of these traces, pick

off the maximum deformation for each of the three cycles, within the cycle start and end points defined in section B2.2.3. These deformations will be referred to in the following format:

$$\{\mathbf{H},\mathbf{V}\}_{\max_{i,j,k}}, \text{ inches}$$

where $\{\mathbf{H},\mathbf{V}\}$ refers to the axis in which the deformation was measured (horizontal or vertical) and subscripts i, j and k refer to the specimen, cycle and face, as defined in section B2.1.

B2.2.6 Determine minimum deformations :

For $\{\mathbf{H},\mathbf{V}\}_{\max_{i,j,k}}$ calculated in section 4.2.5 there will be two corresponding minimum deformations: Total and Instantaneous, as shown in Figure 3 of the main body of this procedure. To calculate these minimum deformations two regression lines must be developed. These minimum deformations shall be referred to in the following format:

$$\{\mathbf{H},\mathbf{V}\}_{\min\{\mathbf{I},\mathbf{T}\}_{i,j,k}}, \text{ inches}$$

where $\{\mathbf{H},\mathbf{V}\}$ refers to the axis in which the deformation was measured (horizontal or vertical), $\{\mathbf{I},\mathbf{T}\}$ refers to the type of deformation (instantaneous or total) and subscripts i, j and k refer to the specimen, cycle and face, as defined in section B2.1.

To calculate $\{\mathbf{H},\mathbf{V}\}_{\min\{\mathbf{I},\mathbf{T}\}_{i,j,k}}$, two regression lines must be developed from the deformation vs. time trace.

B2.2.6.1 Regression Line 1

- (1) Starting at $\{\mathbf{H},\mathbf{V}\}_{\max_{i,j,k}}$ and moving to the right, select the 5th through 17th data points (13 data points total).
- (2) Perform a least squares linear regression on deformation vs. time for the selected data points. The resulting equation shall be as follows:

Eq. B3

$$\text{Deformation} = m_1 \times (\text{Time}) + b_1$$

Where: $m_1 =$ the slope of regression line 1, and

$b_1 =$ the Y-intercept of regression line 1

B2.2.6.2 Regression Line 2

- (1) Starting at the start point of cycle **j+1** and moving to the left, select first 300 data points (300 data points total).
- (2) Perform a least squares linear regression on deformation versus time for the selected data points. The resulting equation shall be as follows:

Eq. B4
$$\text{Deformation} = m_2 \times (\text{Time}) + b_2$$

Where: $m_2 =$ the slope of regression line 2, and
 $b_2 =$ the Y-intercept of regression line 2

B2.2.6.3 Calculate $\{\mathbf{H}, \mathbf{V}\}_{\min I_{i,j,k}}$

$\{\mathbf{H}, \mathbf{V}\}_{\min I_{i,j,k}}$ is the deformation at the intersection of regression lines 1 and 2.

Eq. B5
$$\{H, V\}_{\min T_{i,j,k}} = m_2 \times \left(\frac{b_2 - b_1}{m_1 - m_2} \right) + b_1$$

B2.2.6.4 Calculate $\{\mathbf{H}, \mathbf{V}\}_{\min T_{i,j,k}}$

$\{\mathbf{H}, \mathbf{V}\}_{\min T_{i,j,k}}$ is the deformation calculated from regression line 1 and the first point of cycle **j+1**

Eq. B6
$$\{H, V\}_{\min T_{i,j,k}} = m_2 \times (sp_{i,j+1}) + b_2$$

B2.2.7 Calculate the total and instantaneous recoverable deformations

The total and instantaneous recoverable deformations shall be referred to as $\Delta\{\mathbf{H}, \mathbf{V}\}_{T_{i,j,k}}$ and $\{\mathbf{H}, \mathbf{V}\}_{I_{i,j,k}}$ respectively.

$$\text{Eq. B7} \quad \Delta\{H, V\} \{I, T\}_{i,j,k} = \{H, V\} \max_{i,j,k} - \{H, V\} \min \{I, T\}_{i,j,k}$$

B2.2.8 Calculate average thickness and diameter

$$\text{Eq. B8} \quad t_{avg} = \frac{\sum_{i=1}^3 t_i}{3}$$

$$\text{Eq. B9} \quad d_{avg} = \frac{\sum_{i=1}^3 d_i}{3}$$

Where: t_{avg} = the average thickness for all the specimens, inches
 t_i = the thickness of specimen i , in
 d_{avg} = the average thickness for all the specimens, inches
 d_i = the diameter of specimen i , in

B2.2.9 Calculate the average cyclic load

$$\text{Eq. B10} \quad P_{avg_j} = \frac{\sum_{i=1}^3 P_{cyclic_{i,j}}}{3}$$

Where: P_{avg_j} = the average cyclic load for cycle j , lbs.
 $P_{cyclic_{i,j}}$ = the cyclic load for cycle j of specimen i , lbs.

B2.2.10 Calculate the deformation normalization factors

$$\text{Eq. B11} \quad C_{norm_{i,j}} = \left(\frac{t_i}{t_{avg}} \right) \times \left(\frac{d_i}{d_{avg}} \right) \times \left(\frac{P_{cyclic_{i,j}}}{P_{avg_j}} \right)$$

Where $C_{norm_{i,j}}$ = the deformation correction factor for cycle j of specimen i ,
 t_i = the thickness of specimen i , in.
 t_{avg} = the average thickness of the specimens, in.

d_i = the diameter of specimen i , in.
 d_{avg} = the average diameter of the specimens, in.
 $P_{cyclic_{ij}}$ = the cyclic load for cycle j of specimen i , lb.
 P_{avg_j} = the average cyclic load for cycle j lb.

B2.2.11 Calculate the normalized deformations

Eq. B12

$$\Delta\{H,V\}\{I,T\}n_{i,j,k} = (C_{norm_{i,j,k}}) \times (\Delta\{H,V\}\{I,T\}_{i,j,k})$$

Where: $\Delta\{H,V\}\{I,T\}n_{i,j,k}$ = the normalized deformation for face k and cycle j of specimen i , in.
 $C_{norm_{i,j}}$ = the deformation correction factor for cycle j of specimen i ,
 $\in \{H,V\}\{I,T\}_{i,j,k}$ = the deformation for face k and cycle j of specimen i , in.

B2.2.12 Average deformation data sets

There are 12 deformation data sets. A deformation data set consists of all the recoverable deformations calculated for a given axis $\{H,V\}$, measurement point $\{I,T\}$ and cycle j . Average the deformation data sets by one of the following methods:

B2.2.12.1 Method 1: Normal Analysis

For each deformation data set, remove the highest and lowest deformation and average the remaining four. This average shall be referred to as $\Delta\{H,V\}\{I,T\}n_{avg_j}$

B2.2.12.2 Method 2: Variation of Normal Analysis

For each deformation data set, remove the tow highest and the two lowest deformations and average the remaining two. This average shall be referred to as $\Delta\{H,V\}\{I,T\}n_{avg_j}$

B2.2.12.3 Method 3: Individual Analysis

For each deformation data set, remove any deformations and average the remaining deformations. This average shall be referred to as $\Delta\{H,V\}\{I,T\}navg_j$

B2.2.13 Calculate Poisson's ratios

Eq. B13
$$\nu\{I,T\}_j = -0.1 + 1.480 \times \left(\frac{\Delta H\{I,T\}navg_j}{\Delta V\{I,T\}navg_j} \right) - 0.778 \times \left(\frac{\Delta HInavg_j}{\Delta VInavg_j} \right)$$

B2.2.14 Calculate the cycle averaged deformations

Eq. B14
$$\Delta\{H,V\}\{I,T\}ncycleavg = \frac{\sum_{j=1}^3 \Delta\{H,V\}\{I,T\}navg_j}{3}$$

B2.2.15 Calculate the resilient modulus correction factors

Eq. B15
$$Cmr\{I,T\} = 0.6345 \times \left(\frac{\Delta V\{I,T\}ncycleavg}{\Delta H\{I,T\}ncycleavg} \right) - 0.332$$

B2.2.16 Calculate resilient modulus

Eq. B16
$$M_r\{I,T\}_j = \frac{l \times Pavg_j}{\Delta H\{I,T\}navg_j \times davg \times tavg \times Cmr\{I,T\}}$$

B2.2.18 Repeat sections B2.2.1 through B2.2.17 for each temperature

B2.3 Resilient Modulus Data Analysis Algorithm Flowchart

B2.3.1 Main Procedure

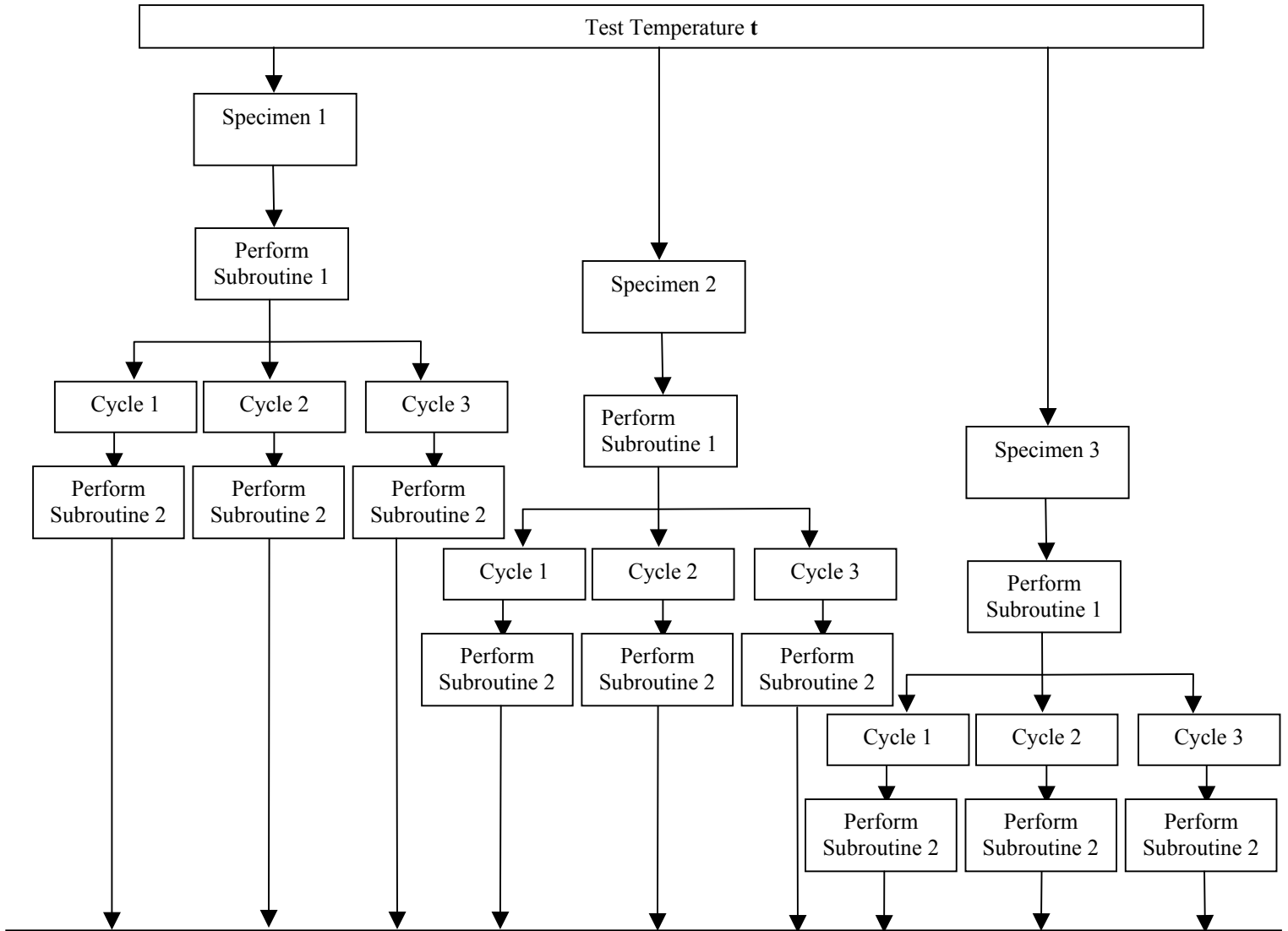

Here's what you have calculated so far:

Specimen	Cycle	P _{eyclic}	Face 1 Deformations				Face 2 Deformations			
			Total		Instant.		Total		Instant.	
			Hor.	Vert.	Hor.	Vert.	Hor.	Vert.	Hor.	Vert.
1	1	P _{eyclic} _{1,1}	$\Delta HT_{1,1,1}$	$\Delta VT_{1,1,1}$	$\Delta HI_{1,1,1}$	$\Delta VI_{1,1,1}$	$\Delta HT_{1,1,2}$	$\Delta VT_{1,1,2}$	$\Delta HI_{1,1,2}$	$\Delta VI_{1,1,2}$
	2	P _{eyclic} _{1,2}	$\Delta HT_{1,2,1}$	$\Delta VT_{1,2,1}$	$\Delta HI_{1,2,1}$	$\Delta VI_{1,2,1}$	$\Delta HT_{1,2,2}$	$\Delta VT_{1,2,2}$	$\Delta HI_{1,2,2}$	$\Delta VI_{1,2,2}$
	3	P _{eyclic} _{1,3}	$\Delta HT_{1,3,1}$	$\Delta VT_{1,3,1}$	$\Delta HI_{1,3,1}$	$\Delta VI_{1,3,1}$	$\Delta HT_{1,3,2}$	$\Delta VT_{1,3,2}$	$\Delta HI_{1,3,2}$	$\Delta VI_{1,3,2}$
2	1	P _{eyclic} _{2,1}	$\Delta HT_{2,1,1}$	$\Delta VT_{2,1,1}$	$\Delta HI_{2,1,1}$	$\Delta VI_{2,1,1}$	$\Delta HT_{2,1,2}$	$\Delta VT_{2,1,2}$	$\Delta HI_{2,1,2}$	$\Delta VI_{2,1,2}$
	2	P _{eyclic} _{2,2}	$\Delta HT_{2,2,1}$	$\Delta VT_{2,2,1}$	$\Delta HI_{2,2,1}$	$\Delta VI_{2,2,1}$	$\Delta HT_{2,2,2}$	$\Delta VT_{2,2,2}$	$\Delta HI_{2,2,2}$	$\Delta VI_{2,2,2}$
	3	P _{eyclic} _{2,3}	$\Delta HT_{2,3,1}$	$\Delta VT_{2,3,1}$	$\Delta HI_{2,3,1}$	$\Delta VI_{2,3,1}$	$\Delta HT_{2,3,2}$	$\Delta VT_{2,3,2}$	$\Delta HI_{2,3,2}$	$\Delta VI_{2,3,2}$
3	1	P _{eyclic} _{3,1}	$\Delta HT_{2,1,1}$	$\Delta VT_{3,1,1}$	$\Delta HI_{3,1,1}$	$\Delta VI_{3,1,1}$	$\Delta HT_{3,1,2}$	$\Delta VT_{3,1,2}$	$\Delta HI_{3,1,2}$	$\Delta VI_{3,1,2}$
	2	P _{eyclic} _{3,2}	$\Delta HT_{2,2,1}$	$\Delta VT_{3,2,1}$	$\Delta HI_{3,2,1}$	$\Delta VI_{3,2,1}$	$\Delta HT_{3,2,2}$	$\Delta VT_{3,2,2}$	$\Delta HI_{3,2,2}$	$\Delta VI_{3,2,2}$
	3	P _{eyclic} _{3,3}	$\Delta HT_{2,3,1}$	$\Delta VT_{3,3,1}$	$\Delta HI_{3,3,1}$	$\Delta VI_{3,3,1}$	$\Delta HT_{3,3,2}$	$\Delta VT_{3,3,2}$	$\Delta HI_{3,3,2}$	$\Delta VI_{3,3,2}$

1

Calculate average thickness (tavg) and diameter (davg) for each specimen:
 $t_{avg} = (t_1 + t_2 + t_3)/3$
 $d_{avg} = (d_1 + d_2 + d_3)/3$

Calculate average cyclic load (Pavg_j) for each cycle:
 $P_{avg,j} = P_{cyclic_{1,j}} + P_{cyclic_{2,j}} + P_{cyclic_{3,j}}$

Calculate Cnorm_{i,j} for each specimen and cycle:
 $C_{norm_{i,j}} = (t_i / t_{avg}) * (d_i / d_{avg}) * (P_{cyclic_{i,j}} / P_{avg,j})$

Calculate normalized deformations ($\Delta\{H,V\}\{I,T\}_{norm_{i,j,k}}$):
 $\Delta\{H,V\}\{I,T\}_{norm_{i,j,k}} = C_{norm_{i,j}} * \Delta\{H,V\}\{I,T\}_{i,j,k}$

Here's what you have calculated so far:

Specimen	Cycle	Pcyclic	Cnorm	Face 1 Normal. Deformations				Face 2 Normal. Deformations			
				Total		Instant.		Total		Instant.	
				Hor.	Vert.	Hor.	Vert.	Hor.	Vert.	Hor.	Vert.
1	1	Pcyclic _{1,1}	Cnorm _{1,1}	$\Delta HTn_{1,1,1}$	$\Delta VTn_{1,1,1}$	$\Delta HIn_{1,1,1}$	$\Delta VIn_{1,1,1}$	$\Delta HTn_{1,1,2}$	$\Delta VTn_{1,1,2}$	$\Delta HIn_{1,1,2}$	$\Delta VIn_{1,1,2}$
	2	Pcyclic _{1,2}	Cnorm _{1,2}	$\Delta HTn_{1,2,1}$	$\Delta VTn_{1,2,1}$	$\Delta HIn_{1,2,1}$	$\Delta VIn_{1,2,1}$	$\Delta HTn_{1,2,2}$	$\Delta VTn_{1,2,2}$	$\Delta HIn_{1,2,2}$	$\Delta VIn_{1,2,2}$
	3	Pcyclic _{1,3}	Cnorm _{1,3}	$\Delta HTn_{1,3,1}$	$\Delta VTn_{1,3,1}$	$\Delta HIn_{1,3,1}$	$\Delta VIn_{1,3,1}$	$\Delta HTn_{1,3,2}$	$\Delta VTn_{1,3,2}$	$\Delta HIn_{1,3,2}$	$\Delta VIn_{1,3,2}$
2	1	Pcyclic _{2,1}	Cnorm _{2,1}	$\Delta HTn_{2,1,1}$	$\Delta VTn_{2,1,1}$	$\Delta HIn_{2,1,1}$	$\Delta VIn_{2,1,1}$	$\Delta HTn_{2,1,2}$	$\Delta VTn_{2,1,2}$	$\Delta HIn_{2,1,2}$	$\Delta VIn_{2,1,2}$
	2	Pcyclic _{2,2}	Cnorm _{2,2}	$\Delta HTn_{2,2,1}$	$\Delta VTn_{2,2,1}$	$\Delta HIn_{2,2,1}$	$\Delta VIn_{2,2,1}$	$\Delta HTn_{2,2,2}$	$\Delta VTn_{2,2,2}$	$\Delta HIn_{2,2,2}$	$\Delta VIn_{2,2,2}$
	3	Pcyclic _{2,3}	Cnorm _{2,3}	$\Delta HTn_{2,3,1}$	$\Delta VTn_{2,3,1}$	$\Delta HIn_{2,3,1}$	$\Delta VIn_{2,3,1}$	$\Delta HTn_{2,3,2}$	$\Delta VTn_{2,3,2}$	$\Delta HIn_{2,3,2}$	$\Delta VIn_{2,3,2}$
3	1	Pcyclic _{3,1}	Cnorm _{3,1}	$\Delta HTn_{3,1,1}$	$\Delta VTn_{3,1,1}$	$\Delta HIn_{3,1,1}$	$\Delta VIn_{3,1,1}$	$\Delta HTn_{3,1,2}$	$\Delta VTn_{3,1,2}$	$\Delta HIn_{3,1,2}$	$\Delta VIn_{3,1,2}$
	2	Pcyclic _{3,2}	Cnorm _{3,2}	$\Delta HTn_{3,2,1}$	$\Delta VTn_{3,2,1}$	$\Delta HIn_{3,2,1}$	$\Delta VIn_{3,2,1}$	$\Delta HTn_{3,2,2}$	$\Delta VTn_{3,2,2}$	$\Delta HIn_{3,2,2}$	$\Delta VIn_{3,2,2}$
	3	Pcyclic _{3,3}	Cnorm _{3,3}	$\Delta HTn_{3,3,1}$	$\Delta VTn_{3,3,1}$	$\Delta HIn_{3,3,1}$	$\Delta VIn_{3,3,1}$	$\Delta HTn_{3,3,2}$	$\Delta VTn_{3,3,2}$	$\Delta HIn_{3,3,2}$	$\Delta VIn_{3,3,2}$

2

2

Develop Trim Data Sets (Trim_{g,h})

Trim Data Sets

Set 1: Cycle1, Total Horizontal Deformation	Set 2: Cycle1, Instant Horizontal Deformation	Set 3: Cycle1, Total Vertical Deformation	Set 4: Cycle1, Instant Vertical Deformation	Set 5: Cycle 2, Total Horizontal Deformation	Set 6: Cycle 2, Instant Horizontal Deformation
Trim _{1,1} = ΔHTn _{1,1,1} Trim _{1,2} = ΔHTn _{2,1,1} Trim _{1,3} = ΔHTn _{3,1,1} Trim _{1,4} = ΔHTn _{1,1,2} Trim _{1,5} = ΔHTn _{2,1,2} Trim _{1,6} = ΔHTn _{3,1,2}	Trim _{2,1} = ΔHIn _{1,1,1} Trim _{2,2} = ΔHIn _{2,1,1} Trim _{2,3} = ΔHIn _{3,1,1} Trim _{2,4} = ΔHIn _{1,1,2} Trim _{2,5} = ΔHIn _{2,1,2} Trim _{2,6} = ΔHIn _{3,1,2}	Trim _{3,1} = ΔVTn _{1,1,1} Trim _{3,2} = ΔVTn _{2,1,1} Trim _{3,3} = ΔVTn _{3,1,1} Trim _{3,4} = ΔVTn _{1,1,2} Trim _{3,5} = ΔVTn _{2,1,2} Trim _{3,6} = ΔVTn _{3,1,2}	Trim _{4,1} = ΔVIn _{1,1,1} Trim _{4,2} = ΔVIn _{2,1,1} Trim _{4,3} = ΔVIn _{3,1,1} Trim _{4,4} = ΔVIn _{1,1,2} Trim _{4,5} = ΔVIn _{2,1,2} Trim _{4,6} = ΔVIn _{3,1,2}	Trim _{5,1} = ΔHTn _{1,2,1} Trim _{5,2} = ΔHTn _{2,2,1} Trim _{5,3} = ΔHTn _{3,2,1} Trim _{5,4} = ΔHTn _{1,2,2} Trim _{5,5} = ΔHTn _{2,2,2} Trim _{5,6} = ΔHTn _{3,2,2}	Trim _{6,1} = ΔHIn _{1,2,1} Trim _{6,2} = ΔHIn _{2,2,1} Trim _{6,3} = ΔHIn _{3,2,1} Trim _{6,4} = ΔHIn _{1,2,2} Trim _{6,5} = ΔHIn _{2,2,2} Trim _{6,6} = ΔHIn _{3,2,2}
Set 7: Cycle 2, Total Vertical Deformation	Set 8: Cycle 2, Instant. Vertical Deformation	Set 9: Cycle 3, Total Horizontal Deformation	Set 10: Cycle 3, Instant Horizontal Deformation	Set 11: Cycle 3, Total Vertical Deformation	Set 12: Cycle 3, Instant. Vertical Deformation
Trim _{7,1} = ΔVTn _{1,2,1} Trim _{7,2} = ΔVTn _{2,2,1} Trim _{7,3} = ΔVTn _{3,2,1} Trim _{7,4} = ΔVTn _{1,2,2} Trim _{7,5} = ΔVTn _{2,2,2} Trim _{7,6} = ΔVTn _{3,2,2}	Trim _{8,1} = ΔVIn _{1,2,1} Trim _{8,2} = ΔVIn _{2,2,1} Trim _{8,3} = ΔVIn _{3,2,1} Trim _{8,4} = ΔVIn _{1,2,2} Trim _{8,5} = ΔVIn _{2,2,2} Trim _{8,6} = ΔVIn _{3,2,2}	Trim _{9,1} = ΔHTn _{1,3,1} Trim _{9,2} = ΔHTn _{2,3,1} Trim _{9,3} = ΔHTn _{3,3,1} Trim _{9,4} = ΔHTn _{1,3,2} Trim _{9,5} = ΔHTn _{2,3,2} Trim _{9,6} = ΔHTn _{3,3,2}	Trim _{10,1} = ΔHIn _{1,3,1} Trim _{10,2} = ΔHIn _{2,3,1} Trim _{10,3} = ΔHIn _{3,3,1} Trim _{10,4} = ΔHIn _{1,3,2} Trim _{10,5} = ΔHIn _{2,3,2} Trim _{10,6} = ΔHIn _{3,3,2}	Trim _{11,1} = ΔVTn _{1,3,1} Trim _{11,2} = ΔVTn _{2,3,1} Trim _{11,3} = ΔVTn _{3,3,1} Trim _{11,4} = ΔVTn _{1,3,2} Trim _{11,5} = ΔVTn _{2,3,2} Trim _{11,6} = ΔVTn _{3,3,2}	Trim _{12,1} = ΔVIn _{1,3,1} Trim _{12,2} = ΔVIn _{2,3,1} Trim _{12,3} = ΔVIn _{3,3,1} Trim _{12,4} = ΔVIn _{1,3,2} Trim _{12,5} = ΔVIn _{2,3,2} Trim _{12,6} = ΔVIn _{3,3,2}

3

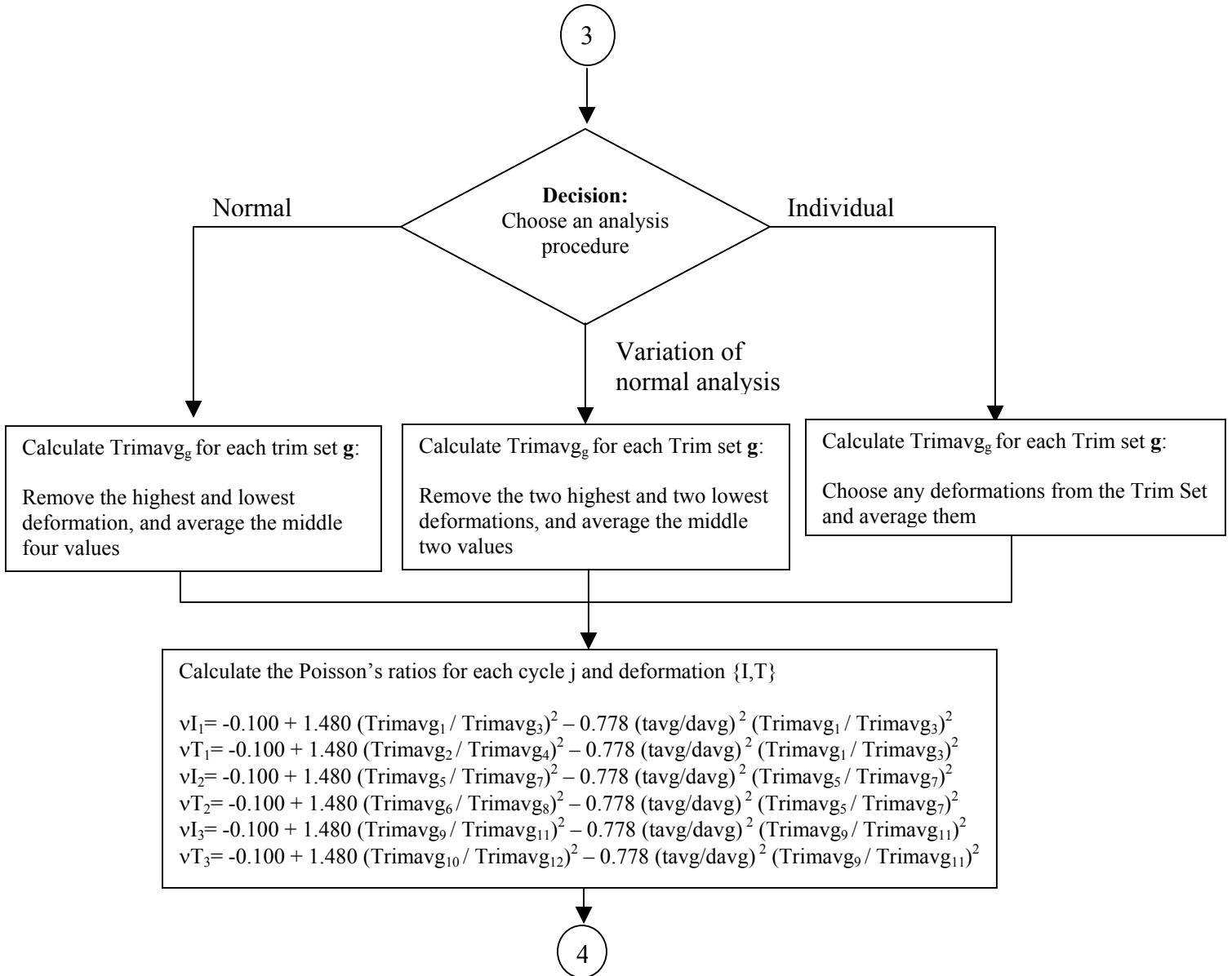

4

Calculate the cycle averaged trim deformation ($\Delta\{H,V\}$ {I,T} trimavg) for each orientation {H,V} and deformation {I,T}:

$$\begin{aligned}\Delta H T \text{trimavg} &= (\text{Trimavg}_1 + \text{Trimavg}_5 + \text{Trimavg}_9) / 3 \\ \Delta H I \text{trimavg} &= (\text{Trimavg}_2 + \text{Trimavg}_6 + \text{Trimavg}_{10}) / 3 \\ \Delta V T \text{trimavg} &= (\text{Trimavg}_3 + \text{Trimavg}_7 + \text{Trimavg}_{11}) / 3 \\ \Delta V I \text{trimavg} &= (\text{Trimavg}_4 + \text{Trimavg}_8 + \text{Trimavg}_{12}) / 3\end{aligned}$$

Calculate resilient modulus correction factors ($C_{mr}\{I,T\}$):

$$\begin{aligned}C_{mrI} &= 0.6345 * (\Delta H I \text{trimavg} / \Delta V I \text{trimavg})^{-1} - 0.332 \\ C_{mrT} &= 0.6345 * (\Delta H T \text{trimavg} / \Delta V T \text{trimavg})^{-1} - 0.332\end{aligned}$$

Calculate instantaneous and total resilient modulus ($MR\{I,T\}_j$) for each Cycle **j**

$$\begin{aligned}MRT_1 &= (\text{gauge length} * P_{avg_1}) / (\text{Trimavg}_1 * \text{davg} * \text{tavg} * C_{cmplT}) \\ MRI_1 &= (\text{gauge length} * P_{avg_1}) / (\text{Trimavg}_2 * \text{davg} * \text{tavg} * C_{cmplI}) \\ MRT_2 &= (\text{gauge length} * P_{avg_2}) / (\text{Trimavg}_5 * \text{davg} * \text{tavg} * C_{cmplT}) \\ MRI_2 &= (\text{gauge length} * P_{avg_2}) / (\text{Trimavg}_6 * \text{davg} * \text{tavg} * C_{cmplI}) \\ MRT_3 &= (\text{gauge length} * P_{avg_3}) / (\text{Trimavg}_9 * \text{davg} * \text{tavg} * C_{cmplT}) \\ MRI_3 &= (\text{gauge length} * P_{avg_3}) / (\text{Trimavg}_{10} * \text{davg} * \text{tavg} * C_{cmplI})\end{aligned}$$

Report the following:

Cycle	vI_j	vT_j	MRI_j	MRT_j
1	vI_1	vT_1	MRI_1	MRT_1
2	vI_2	vT_2	MRI_2	MRT_2
3	vI_3	vT_3	MRI_3	MRT_3

B2.3.2 Subroutine 1

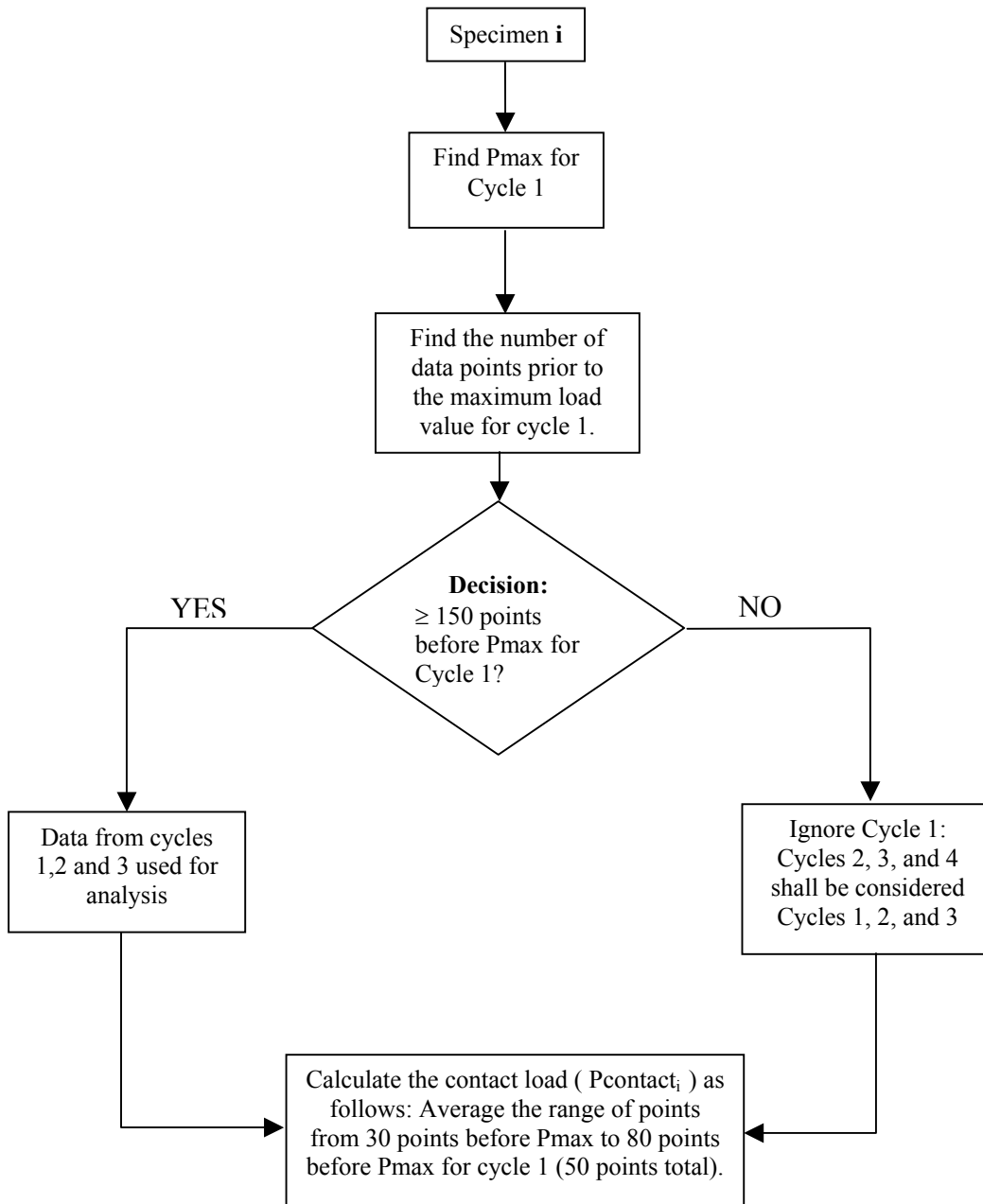

B2.3.3 Subroutine 2

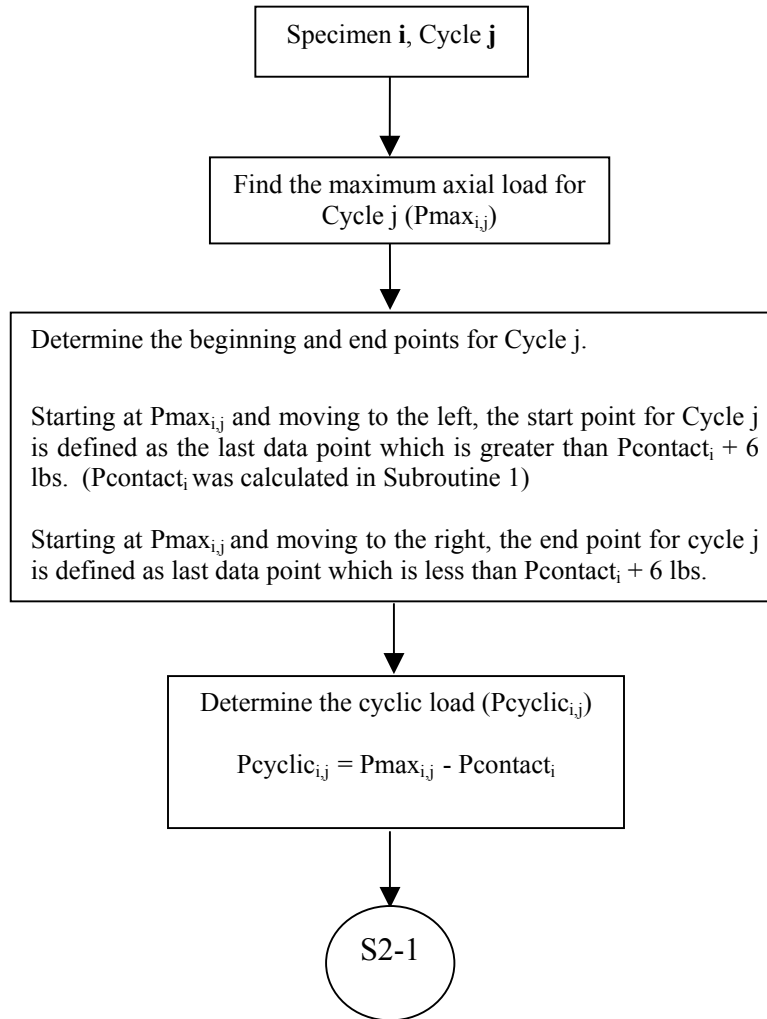

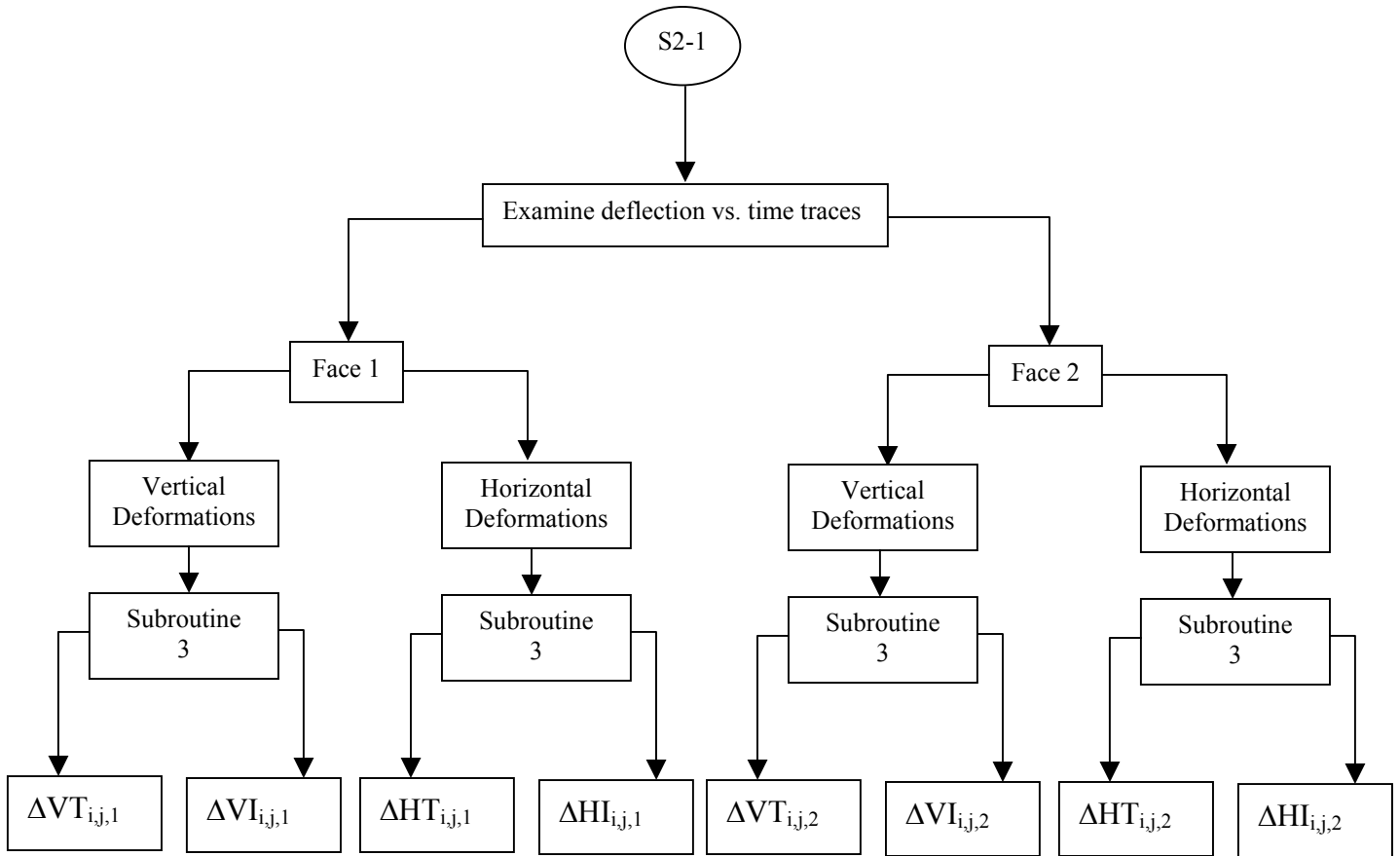

B2.3.4 Subroutine 3

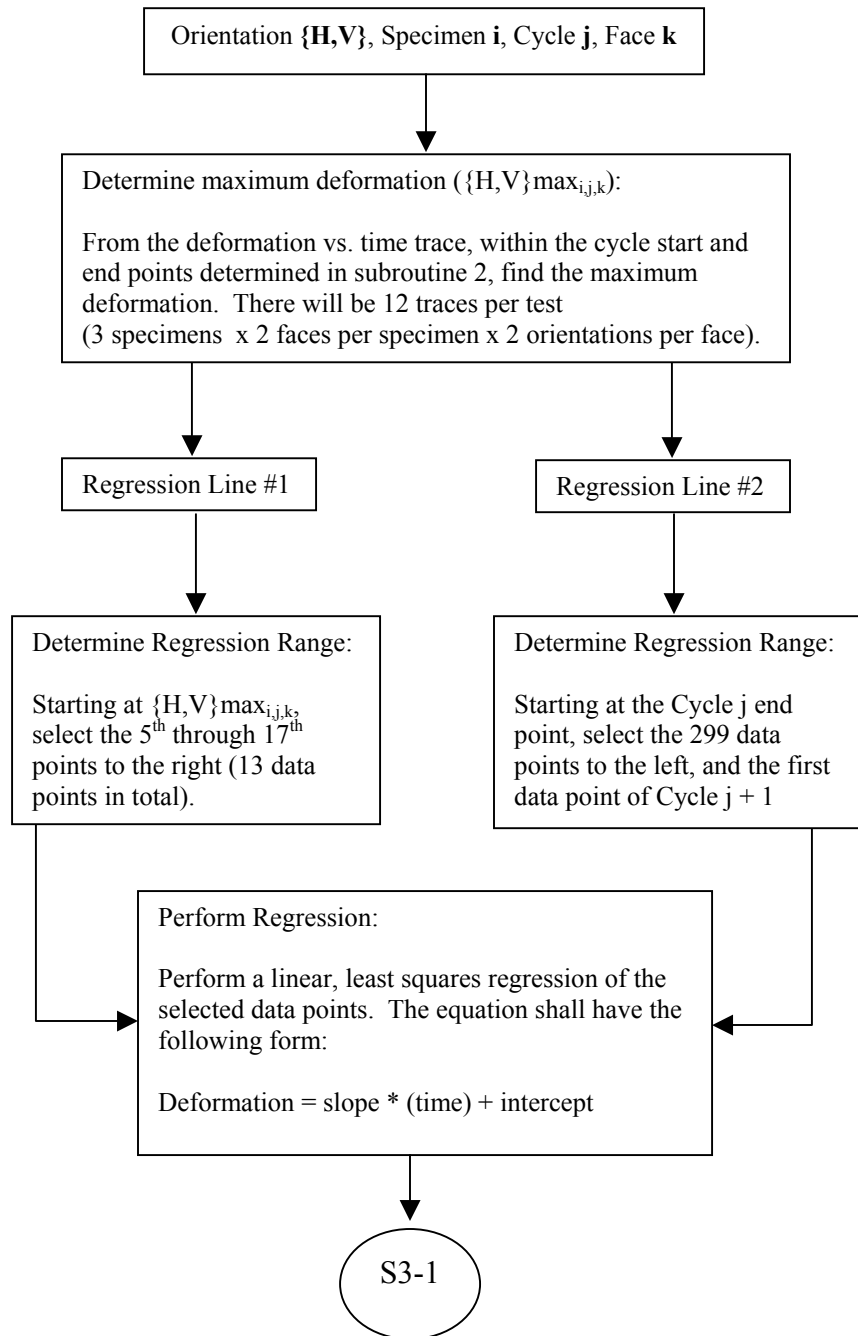

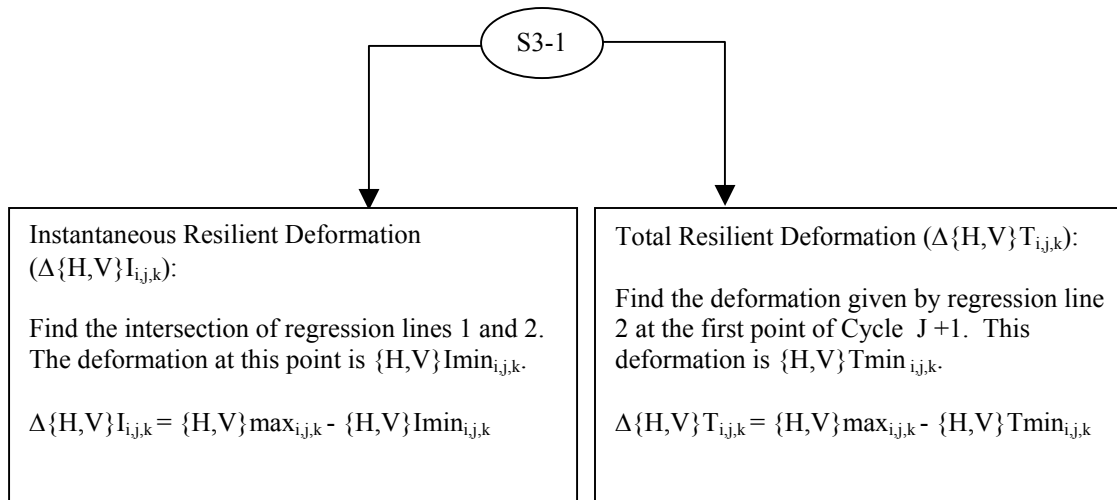

B3. Creep Compliance Data Analysis Algorithm

An outline of the creep compliance data analysis algorithm that is used in the “ITLTFHWA” software, and described in the report by Roque *et. al.* is presented in section B3.2. The algorithm is described graphically in section B3.3.

B3.1 Subscript Convention

For the purpose of clarity, a subscript convention has been developed. The subscript ‘i’ represents the specimen number ($i = 1, 2, \text{ or } 3$), the subscript ‘j’ represents the creep time ($j = 1, 2, 5, 10, 20, 50, \text{ or } 100$), and the subscript ‘k’ represents the specimen face ($k = 1 \text{ or } 2$). Thus a variable may have up to three subscripts of the following form: $X_{i,j,k}$.

B3.2 Analysis

A separate analysis must be performed for each of the three temperatures at which creep compliance data is collected.

B3.2.1 Determine the creep test start point

The 10th data point in the file is always assumed to be the starting point of the test. **It is essential that when the test is performed that exactly 10 data points are collected prior to the initial application of the creep load otherwise this analysis algorithm will produce erroneous results. Since the data sampling rate should be constant at 10 Hz, the creep load should be applied exactly 1 second after the data acquisition is initiated.**

B3.2.2 Determine initial extensometer readings

Determine the extensometer reading ($\{H,V\}_{\min_{i,k}}$) at the starting point of the creep test for each specimen **i** and face **k**. The starting point was defined in Section B3.2.1.

B3.2.3 Determine the extensometer reading for each creep time **j**

The Table B2 indicates the data point that corresponds to a certain creep time **j** for each face **k** of each specimen **i**.

Table B 2. Extensometer reading data points

Extensometer reading at time j	Data Point
$\{H,V\}_{i,1,k}$	20 th point in data file
$\{H,V\}_{i,2,k}$	30 th point in data file
$\{H,V\}_{i,5,k}$	60 th point in data file
$\{H,V\}_{i,10,k}$	110 th point in data file
$\{H,V\}_{i,20,k}$	210 th point in data file
$\{H,V\}_{i,50,k}$	Average 505 th point through 515 th point (11 points total)
$\{H,V\}_{i,100,k}$	1010 th point in data file

For a 100-second creep test, the deformations at 50 seconds are used to calculate the Poisson's ratio for the experiment. To prevent a spike in the data from influencing the Poisson ratio value, the average of the 505th point through the 515th point (11 points total) is taken as the deformation at 50 seconds.

B3.2.4 Calculate deformations for each creep time **j**, face **k**, and orientation $\{H,V\}$ of each specimen **i**.

Eq. B20

$$\Delta\{H,V\}_{i,j,k} = \{H,V\}_{i,j,k} - \{H,V\}_{\min_{i,k}}$$

Where: $\Delta\{H,V\}_{i,j,k}$ = the deformation for creep time **j** of face **k** of each specimen **i**, in.

$\{H,V\}_{i,j,k}$ = the extensometer reading for creep time **i** of face **k** of each specimen **i**, in.

$\{H,V\}_{\min_{i,k}}$ = the extensometer reading at the start of the creep test for each face **k** of each specimen **i**, in.

B3.2.5 Determine the axial load ($P_{i,j}$) for each creep time **j** of each specimen **i**.

Table B 3. Axial load data points

Axial load at time j	Data Point
$P_{i,1}$	20 th point in data file
$P_{i,2}$	30 th point in data file
$P_{i,5}$	60 th point in data file
$P_{i,10}$	110 th point in data file
$P_{i,20}$	210 th point in data file
$P_{i,50}$	510 th point in data file
$P_{i,100}$	1010 th point in data file

B3.2.6 Determine the average axial load (P_i) on specimen **i**.

Eq. B21

$$P_i = \frac{\sum_{t=1,2,5,10,20,50,100} P_{i,t}}{7}$$

where: P_i = the average axial load for specimen **i**, lbs.

$P_{i,t}$ = the axial load for specimen **i** at time = t , lbs.

B3.2.7 Calculate the average specimen thickness (t_{avg}), the average specimen diameter (d_{avg}), and the average axial load (P_{avg}).

Eq. B22

$$t_{avg} = \frac{\sum_{i=1}^3 t_i}{3} \quad d_{avg} = \frac{\sum_{i=1}^3 d_i}{3} \quad P_{avg} = \frac{\sum_{i=1}^3 P_i}{3}$$

where: t_{avg} = the average specimen thickness, in.

d_{avg} = the average specimen diameter, in.

P_{avg} = the average axial load, lbs.

t_i = the thickness of specimen **i**, in.

d_i = the diameter of specimen **i**, in.

P_i = the axial load for specimen **i**, lbs.

B3.2.8 Calculate the deformation normalization factor ($Cnorm_i$) for each specimen **i**.

Eq. B23

$$Cnorm_i = \left(\frac{t_i}{tavg} \right) \times \left(\frac{d_i}{davg} \right) \times \left(\frac{Pavg}{P_i} \right)$$

Where: $Cnorm_i$ = the deformation normalization factor for specimen **i**.

$tavg$ = the average specimen thickness, inches.

$davg$ = the average specimen diameter, inches.

$Pavg$ = the average axial load, lbs.

t_i = the thickness of specimen **i**, inches.

d_i = the diameter of specimen **i**, inches.

P_i = the axial load for specimen **i**, lbs.

B3.2.9 Calculate the normalized deformations ($\Delta\{H,V\}norm_{i,j,k}$) for time **j** and face **k** of each specimen **i**.

Eq. B24

$$\Delta\{H,V\}norm_{i,j,k} = (Cnorm_i) \times (\Delta\{H,V\}_{i,j,k})$$

where: $\Delta\{H,V\}norm_{i,j,k}$ = the normalized deformations for time **j** and face **k** of specimen **i**, inches.

$\Delta\{H,V\}_{i,j,k}$ = the deformation for creep time **j** of face **k** of each specimen **i**, inches.

$Cnorm_i$ = the deformation normalization factor for specimen **i**.

B3.2.10 Average deformation data sets

There are 14 “trim” data sets. A deformation data set consists of all the recoverable deformations calculated for a given orientation $\{H,V\}$, and time **j**. Average the deformation data sets by one of the following methods:

B3.2.10.1 Method 1: Normal Analysis

For each trim data set, remove the highest and lowest deformation and average the

remaining four. This average shall be referred to as $\Delta\{H,V\}_{trimavg_j}$ for time **j**.

B3.2.10.2 Method 2: Variation of Normal Analysis

For each trim data set, remove the two highest and the two lowest deformations and average the remaining two. This average shall be referred to as $\Delta\{H,V\}_{trimavg_j}$ for time **j**.

B3.2.10.3 Method 3: Individual Analysis

For each trim data set, remove any deformations and average the remaining deformations. This average shall be referred to as $\Delta\{H,V\}_{trimavg_j}$ for time **j**.

B3.2.11 Calculate the Poisson's Ratio at time = 50.

Eq. B25

$$\nu = -0.10 + 1.45 \left(\frac{\Delta H_{trimavg_{50}}}{\Delta V_{trimavg_{50}}} \right)^2 - 0.778 \left(\frac{\Delta H_{trimavg_{50}}}{\Delta V_{trimavg_{50}}} \right)^2 \left(\frac{t_{avg}}{d_{avg}} \right)^2$$

Where: ν = the Poisson's Ratio

$\Delta H_{trimavg_{50}}$ = the average horizontal trimmed deformation at time = 50, in.

$\Delta V_{trimavg_{50}}$ = the average vertical trimmed deformation at time = 50, in.

t_{avg} = the average specimen thickness, in.

d_{avg} = the average specimen diameter, in.

B3.2.12 Calculate the creep compliance correction factor ($Compl_y$) for each time **j**.

Eq. B26

$$C_{cmpli} = 0.6354 \left(\frac{\Delta H_{trimavg_j}}{\Delta V_{trimavg_j}} \right)^{-1} - 0.332$$

Where: C_{cmpl_j} = the creep compliance correction factor at time **j**.

$\Delta H_{trimavg_j}$ = the average horizontal trimmed deformation at time **j**, in.

$\Delta V_{trimavg_j}$ = the average vertical trimmed deformation at time **j**, in.

B3.2.13 Calculate the creep compliance for each time **j**.

Eq. B27

$$D_j = \left(\frac{\Delta H_{trimavg_j} \times d_{avg} \times t_{avg} \times C_{cmpl_j}}{P_{avg} \times GL} \right)$$

where: D_j = the creep compliance at time **j**, 1/psi

$\Delta H_{trimavg_j}$ = the average horizontal trimmed deformation at time **j**, in.

d_{avg} = the average specimen diameter, in.

t_{avg} = the average specimen thickness, in.

C_{cmpl_j} = the creep compliance correction factor at time **j**.

P_{avg} = the average axial load, lbs.

GL = the extensometer gage length (1 inch for a nominal 4 inch specimen diameter, 1.5 inches for a nominal 6 inch specimen diameter).

B3.3 Creep Compliance Data Analysis Flow Charts

B3.3.1 Main Procedure

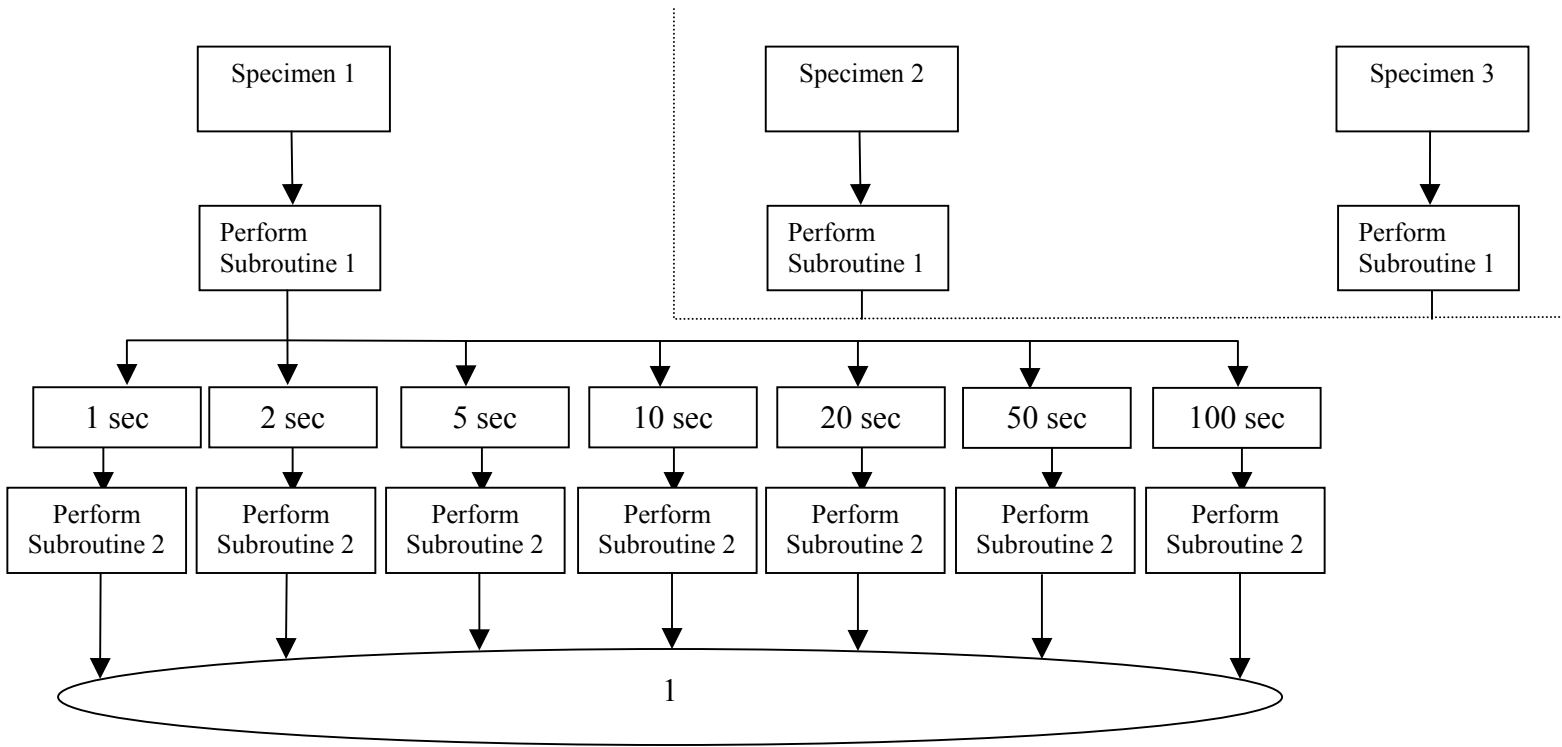

1

Here's what you have calculated so far:

Specimen	P	Time (sec)	Face 1		Face 2	
			Horiz.	Vertical	Horiz.	Vertical
1	P ₁	1	$\Delta H_{1,1,1}$	$\Delta V_{1,1,1}$	$\Delta H_{1,1,2}$	$\Delta V_{1,1,2}$
		2	$\Delta H_{1,2,1}$	$\Delta V_{1,2,1}$	$\Delta H_{1,2,2}$	$\Delta V_{1,2,2}$
		5	$\Delta H_{1,5,1}$	$\Delta V_{1,5,1}$	$\Delta H_{1,5,2}$	$\Delta V_{1,5,2}$
		10	$\Delta H_{1,10,1}$	$\Delta V_{1,10,1}$	$\Delta H_{1,10,2}$	$\Delta V_{1,10,2}$
		20	$\Delta H_{1,20,1}$	$\Delta V_{1,20,1}$	$\Delta H_{1,20,2}$	$\Delta V_{1,20,2}$
		50	$\Delta H_{1,50,1}$	$\Delta V_{1,50,1}$	$\Delta H_{1,50,2}$	$\Delta V_{1,50,2}$
		100	$\Delta H_{1,100,1}$	$\Delta V_{1,100,1}$	$\Delta H_{1,100,2}$	$\Delta V_{1,100,2}$
2	P ₂	1	$\Delta H_{2,1,1}$	$\Delta V_{2,1,1}$	$\Delta H_{2,1,2}$	$\Delta V_{2,1,2}$
		2	$\Delta H_{2,2,1}$	$\Delta V_{2,2,1}$	$\Delta H_{2,2,2}$	$\Delta V_{2,2,2}$
		5	$\Delta H_{2,5,1}$	$\Delta V_{2,5,1}$	$\Delta H_{2,5,2}$	$\Delta V_{2,5,2}$
		10	$\Delta H_{2,10,1}$	$\Delta V_{2,10,1}$	$\Delta H_{2,10,2}$	$\Delta V_{2,10,2}$
		20	$\Delta H_{2,20,1}$	$\Delta V_{2,20,1}$	$\Delta H_{2,20,2}$	$\Delta V_{2,20,2}$
		50	$\Delta H_{2,50,1}$	$\Delta V_{2,50,1}$	$\Delta H_{2,50,2}$	$\Delta V_{2,50,2}$
		100	$\Delta H_{2,100,1}$	$\Delta V_{2,100,1}$	$\Delta H_{2,100,2}$	$\Delta V_{2,100,2}$
3	P ₃	1	$\Delta H_{3,1,1}$	$\Delta V_{3,1,1}$	$\Delta H_{3,1,2}$	$\Delta V_{3,1,2}$
		2	$\Delta H_{3,2,1}$	$\Delta V_{3,2,1}$	$\Delta H_{3,2,2}$	$\Delta V_{3,2,2}$
		5	$\Delta H_{3,5,1}$	$\Delta V_{3,5,1}$	$\Delta H_{3,5,2}$	$\Delta V_{3,5,2}$
		10	$\Delta H_{3,10,1}$	$\Delta V_{3,10,1}$	$\Delta H_{3,10,2}$	$\Delta V_{3,10,2}$
		20	$\Delta H_{3,20,1}$	$\Delta V_{3,20,1}$	$\Delta H_{3,20,2}$	$\Delta V_{3,20,2}$
		50	$\Delta H_{3,50,1}$	$\Delta V_{3,50,1}$	$\Delta H_{3,50,2}$	$\Delta V_{3,50,2}$
		100	$\Delta H_{3,100,1}$	$\Delta V_{3,100,1}$	$\Delta H_{3,100,2}$	$\Delta V_{3,100,2}$

Calculate average specimen thickness (T_{avg}), diameter (D_{avg}) and axial load (P_{avg}):

$$T_{avg} = (T_1 + T_2 + T_3) / 3$$

$$D_{avg} = (D_1 + D_2 + D_3) / 3$$

$$P_{avg} = (P_1 + P_2 + P_3) / 3$$

2

2

Calculate the deformation normalization factors for each specimen i (C_{norm_i})
 $C_{norm_i} = (T_i / T_{avg}) * (D_i / D_{avg}) * (P_{avg} / P_i)$

Calculate the normalized deformations for each orientation $\{H,V\}$ specimen i , time j and face k ($\Delta\{H,V\}_{norm_{i,j,k}}$):
 $\Delta\{H,V\}_{norm_{i,j,k}} = C_{norm_i} * \Delta\{H,V\}_{i,j,k}$

Here's what you have calculated so far

Specimen	P	Cnorm	Time (sec)	Face 1		Face 2	
				Horiz.	Vertical	Horiz.	Vertical
1	P ₁	Cnorm ₁	1	$\Delta H_{norm_{1,1,1}}$	$\Delta V_{norm_{1,1,1}}$	$\Delta H_{norm_{1,1,2}}$	$\Delta V_{norm_{1,1,2}}$
			2	$\Delta H_{norm_{1,2,1}}$	$\Delta V_{norm_{1,2,1}}$	$\Delta H_{norm_{1,2,2}}$	$\Delta V_{norm_{1,2,2}}$
			5	$\Delta H_{norm_{1,5,1}}$	$\Delta V_{norm_{1,5,1}}$	$\Delta H_{norm_{1,5,2}}$	$\Delta V_{norm_{1,5,2}}$
			10	$\Delta H_{norm_{1,10,1}}$	$\Delta V_{norm_{1,10,1}}$	$\Delta H_{norm_{1,10,2}}$	$\Delta V_{norm_{1,10,2}}$
			20	$\Delta H_{norm_{1,20,1}}$	$\Delta V_{norm_{1,20,1}}$	$\Delta H_{norm_{1,20,2}}$	$\Delta V_{norm_{1,20,2}}$
			50	$\Delta H_{norm_{1,50,1}}$	$\Delta V_{norm_{1,50,1}}$	$\Delta H_{norm_{1,50,2}}$	$\Delta V_{norm_{1,50,2}}$
			100	$\Delta H_{norm_{1,100,1}}$	$\Delta V_{norm_{1,100,1}}$	$\Delta H_{norm_{1,100,2}}$	$\Delta V_{norm_{1,100,2}}$
2	P ₂	Cnorm ₂	1	$\Delta H_{norm_{2,1,1}}$	$\Delta V_{norm_{2,1,1}}$	$\Delta H_{norm_{2,1,2}}$	$\Delta V_{norm_{2,1,2}}$
			2	$\Delta H_{norm_{2,2,1}}$	$\Delta V_{norm_{2,2,1}}$	$\Delta H_{norm_{2,2,2}}$	$\Delta V_{norm_{2,2,2}}$
			5	$\Delta H_{norm_{2,5,1}}$	$\Delta V_{norm_{2,5,1}}$	$\Delta H_{norm_{2,5,2}}$	$\Delta V_{norm_{2,5,2}}$
			10	$\Delta H_{norm_{2,10,1}}$	$\Delta V_{norm_{2,10,1}}$	$\Delta H_{norm_{2,10,2}}$	$\Delta V_{norm_{2,10,2}}$
			20	$\Delta H_{norm_{2,20,1}}$	$\Delta V_{norm_{2,20,1}}$	$\Delta H_{norm_{2,20,2}}$	$\Delta V_{norm_{2,20,2}}$
			50	$\Delta H_{norm_{2,50,1}}$	$\Delta V_{norm_{2,50,1}}$	$\Delta H_{norm_{2,50,2}}$	$\Delta V_{norm_{2,50,2}}$
			100	$\Delta H_{norm_{2,100,1}}$	$\Delta V_{norm_{2,100,1}}$	$\Delta H_{norm_{2,100,2}}$	$\Delta V_{norm_{2,100,2}}$
3	P ₃	Cnorm ₃	1	$\Delta H_{norm_{3,1,1}}$	$\Delta V_{norm_{3,1,1}}$	$\Delta H_{norm_{3,1,2}}$	$\Delta V_{norm_{3,1,2}}$
			2	$\Delta H_{norm_{3,2,1}}$	$\Delta V_{norm_{3,2,1}}$	$\Delta H_{norm_{3,2,2}}$	$\Delta V_{norm_{3,2,2}}$
			5	$\Delta H_{norm_{3,5,1}}$	$\Delta V_{norm_{3,5,1}}$	$\Delta H_{norm_{3,5,2}}$	$\Delta V_{norm_{3,5,2}}$
			10	$\Delta H_{norm_{3,10,1}}$	$\Delta V_{norm_{3,10,1}}$	$\Delta H_{norm_{3,10,2}}$	$\Delta V_{norm_{3,10,2}}$
			20	$\Delta H_{norm_{3,20,1}}$	$\Delta V_{norm_{3,20,1}}$	$\Delta H_{norm_{3,20,2}}$	$\Delta V_{norm_{3,20,2}}$
			50	$\Delta H_{norm_{3,50,1}}$	$\Delta V_{norm_{3,50,1}}$	$\Delta H_{norm_{3,50,2}}$	$\Delta V_{norm_{3,50,2}}$
			100	$\Delta H_{norm_{3,100,1}}$	$\Delta V_{norm_{3,100,1}}$	$\Delta H_{norm_{3,100,2}}$	$\Delta V_{norm_{3,100,2}}$

3

3

Develop the trim data sets ($\Delta\{H,V\}_{trim_j}$)

A trim data set consists of all the normalized deformations for a given time j and specimen orientation $\{H,V\}$

$\Delta H_{trim_j} = \{\Delta H_{norm_{1,j,1}}, \Delta H_{norm_{1,j,2}}, \Delta H_{norm_{2,j,1}}, \Delta H_{norm_{2,j,2}}, \Delta H_{norm_{3,j,1}}, \Delta H_{norm_{3,j,2}}\}$

$\Delta V_{trim_j} = \{\Delta V_{norm_{1,j,1}}, \Delta V_{norm_{1,j,2}}, \Delta V_{norm_{2,j,1}}, \Delta V_{norm_{2,j,2}}, \Delta V_{norm_{3,j,1}}, \Delta V_{norm_{3,j,2}}\}$

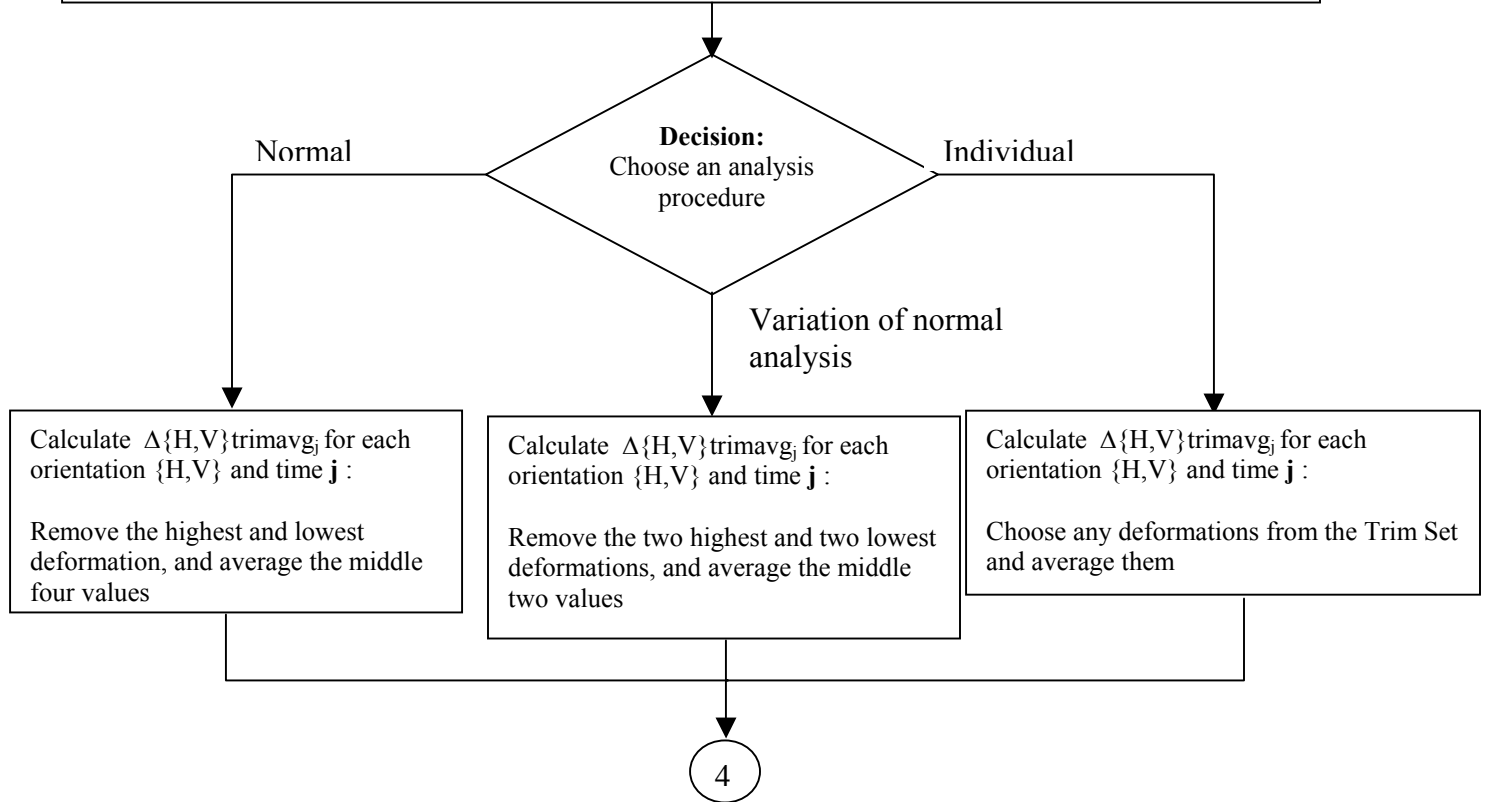

4

Calculate Poisson's Ratios at time **50** (v_{50}):

$$v_{50} = -0.10 + (1.48 - 0.778 * (T_{avg} / D_{avg})^2) * (\Delta H_{trimavg_{50}} / \Delta V_{trimavg_{50}})^2$$

Calculate the creep compliance correction factors for each time **j** (C_{cpl_j}):

$$C_{cpl_j} = 0.634 * (\Delta V_{trimavg_j} / \Delta H_{trimavg_j})$$

Calculate creep compliance at each time **j** (D_j):

$$D_j = (\Delta H_{trimavg_j}) * (D_{avg}) * (T_{avg}) * (C_{cpl_j}) / ((P_{avg}) * (\text{gauge length}))$$

Report the following:

Time (sec)	D_j
1	D_1
2	D_2
5	D_5
10	D_{10}
20	D_{20}
50	D_{50}
100	D_{100}

v_{50}

B3.3.2 Subroutine 1

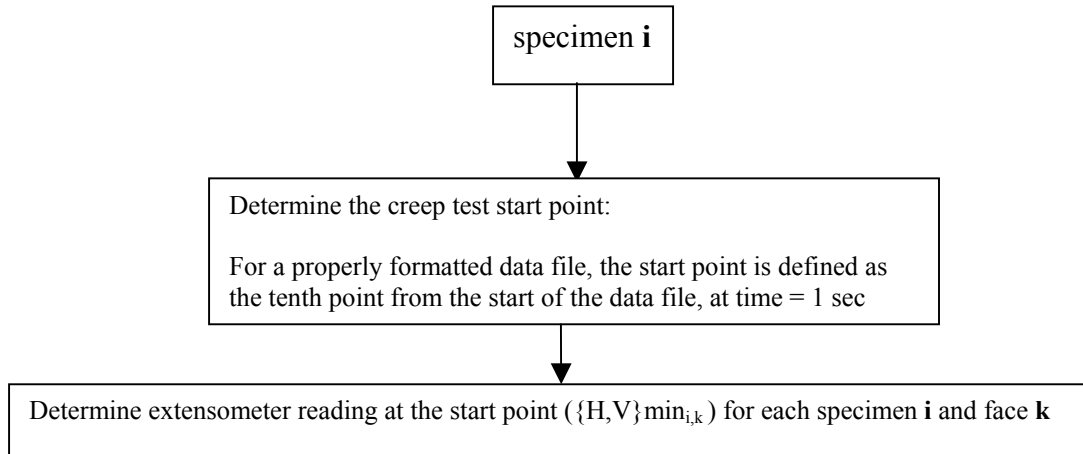

B3.3.3 Subroutine 2

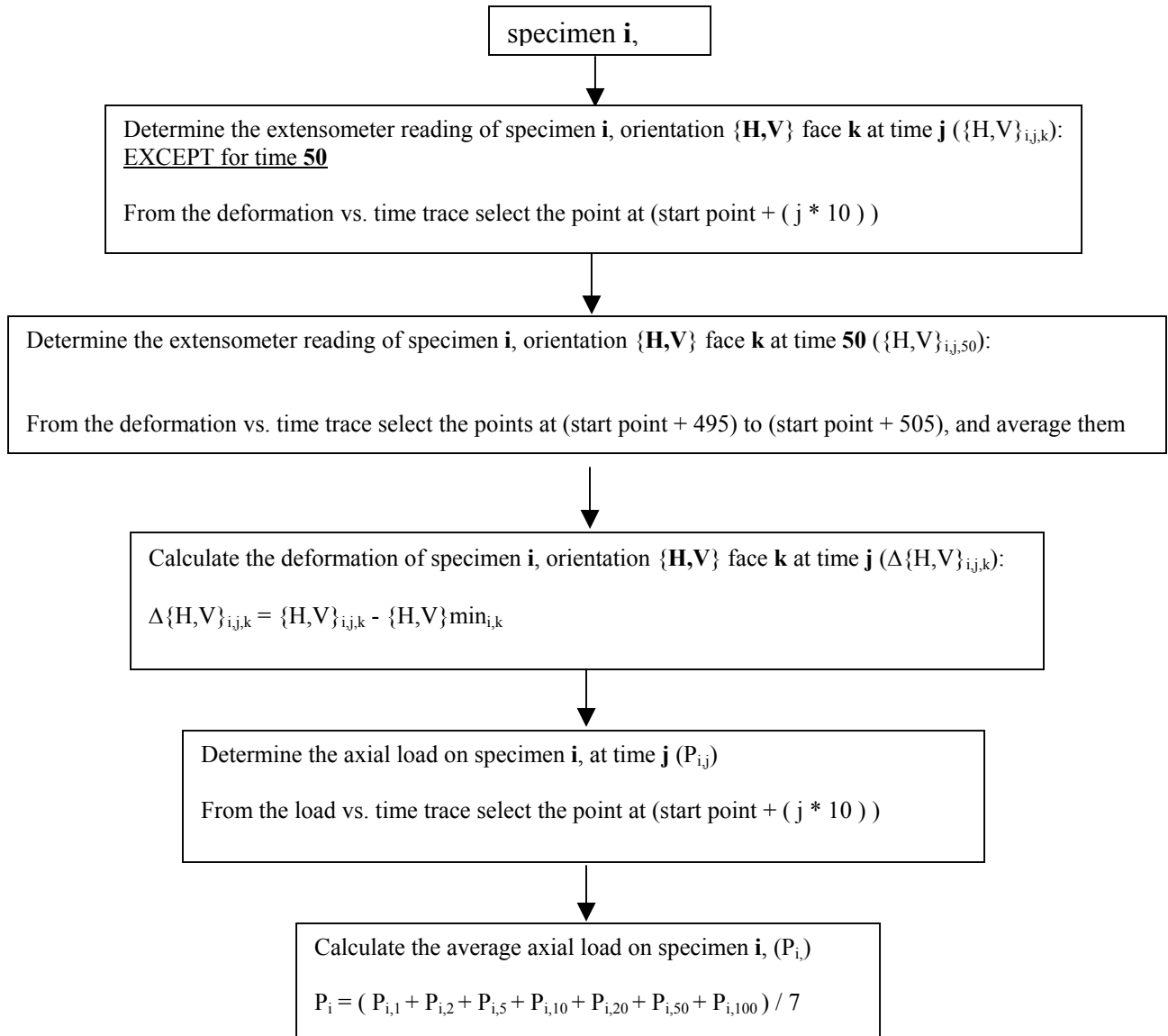

B4. INDIRECT TENSILE STRENGTH DATA ANALYSIS ALGORITHM

An outline of the indirect tensile strength algorithm that is used in the “ITLTFHWA” software, and described in the report by Roque et. al. is presented in section B4.2. The algorithm is described graphically in section B4.3

B4.1 Subscript Convention

For the purpose of clarity, a subscript convention has been developed. the subscript ‘i’ represents the specimen number (i = 1,2 or 3), the subscript ‘j’ represents the specimen face (j =1 or 2) and the subscript ‘t’ represents the time at which a value was measured. Thus a variable may have up to three subscripts of the following form: $X_{i,j,t}$.

B4.2 Analysis

B.4.2.1 Invert Load Values

For each of the three specimens, multiply all load values by -1 , so that compression values are positive.

B.4.2.2 Determine Cycle Start Time (ts_i):

For specimen **i**, determine the time at which the load cycle starts. The load cycle start time is defined as the first time **t** that satisfies the following two requirements:

- 1) The load must continuously increase over the three data points subsequent to ts_i , as shown below:

Eq. B28:
$$P_{i,ts_i+1.5} > P_{i,ts_i+1.0} > P_{i,ts_i+0.5} > P_{i,ts_i}$$

- 2) The load must increase by at least 40 lbs over the three data points subsequent to ts_i , as shown below:

Eq. B29:
$$P_{t+1.5} - P_t > 40lbs.$$

B4.2.3 Zero the Time Values

For each specimen **i**, subtract ts_i from each time value, so that the load cycle starts at $t = 0$.

B4.2.4 Zero the Load Values

For each specimen **i**, subtract the initial load value, $P_{i,0}$ from each load value, so that the load at the time the cycle starts is 0.

B4.2.5 Calculate the Deformation Zero Value ($\{H,V\}_{s_{i,j}}$)

For each specimen **i**, face **j**, and orientation $\{H,V\}$, the deformation zero value is equal to the average of the 10 deformation values prior to the load cycle start, as shown below:

Eq. B30:
$$\{H,V\}_{s_{i,j}} = \frac{\sum_{t=1}^{10} \{H,V\}_{i,j,\frac{-t}{2}}}{10}$$

B4.2.6 Zero the Deformation Values

For each specimen **i**, face **j**, and orientation $\{H,V\}$, subtract $\{H,V\}_{s_{i,j}}$ from the respective deformation value.

B4.2.7 Determine the Failure Load (P_{i,tf_i})

B4.2.7.1 Determine $tf_{i,j}$

For each specimen **i**, and face **j**, determine the time where $V_{i,j,t} - H_{i,j,t}$ is at a maximum ($tf_{i,j}$).

B4.2.7.2 Determine Time of Specimen Failure (tf_i)

For each specimen **i**, the time of specimen failure (tf_i) is the minimum of $tf_{i,1}$ and $tf_{i,2}$.

B4.2.7.3 Determine the Failure Load (P_{i,tf_i})

For each specimen **i**, the failure load is the load **P** corresponding to time tf_i .

B4.2.9 Determine the Deformations at Half the Failure Load $\Delta\{H,V\}_{i,j}$

B4.2.9.1 Determine the Time of Half Failure Load (th_i)

For each specimen **i**, th_i is the time that satisfies the following equation:

Eq. B31
$$P_{i,th_i} = \frac{P_{i,tf_i}}{2}$$

B4.2.9.2 Determine Deformations at Time th_i

For each specimen i , face j and orientation $\{H,V\}$, select the deformations at time th_i . This value shall be referred to as $\Delta\{H,V\}_{i,j}$.

B4.2.10 Calculate the Average Specimen Thickness and Diameter

Calculate the average specimen thickness (T_{avg}) and diameter (D_{avg}) as shown below:

Eq. B32
$$T_{avg} = \frac{T_1 + T_2 + T_3}{3}$$

Eq. B33
$$D_{avg} = \frac{D_1 + D_2 + D_3}{3}$$

B4.2.11 Calculate the Deformation Normalization Factors (C_{norm_i})

For each specimen i , calculate the deformation normalization factors as shown below:

Eq. B34
$$C_{norm_i} = \frac{T_i}{T_{avg}} + \frac{D_i}{D_{avg}}$$

B4.2.12 Calculate the Normalized Deformations ($\Delta\{H,V\}_{norm_{i,j}}$)

Eq. B35
$$\Delta\{H,V\}_{norm_{i,j}} = C_{norm_i} \times \Delta\{H,V\}_{i,j}$$

B4.2.13 Average deformation data sets

There are 2 “trim” data sets. A deformation data set consists of all the normalized deformations calculated for a given orientation $\{H,V\}$. Average the deformation data sets by one of the following methods:

B4.2.13.1 Method 1: Normal Analysis

For each trim data set, remove the highest and lowest deformation and average the remaining four. This average shall be referred to as $\Delta\{H,V\}_{trimavg}$.

B4.2.13.2 Method 2: Variation of Normal Analysis

For each trim data set, remove the two highest and the two lowest deformations and average the remaining two. This average shall be referred to as $\Delta\{H,V\}_{trimavg}$.

B4.2.13.3 Method 3: Individual Analysis

For each trim data set, remove any deformations and average the remaining deformations. This average shall be referred to as $\Delta\{H,V\}_{trimavg}$.

B4.2.14 Calculate Poisson's Ratio (ν)

Eq. B36

$$\nu = -0.10 + 1.48 \left(\frac{\Delta H_{trimavg}}{\Delta V_{trimavg}} \right)^2 - 0.778 \left(\frac{\Delta H_{trimavg}}{\Delta V_{trimavg}} \right)^2 * \left(\frac{T_{avg}}{D_{avg}} \right)^2$$

B4.2.15 Calculate "Used" Poisson's Ratio (ν_{used})B4.2.15.1 Case 1: $\nu > 0.5$

If the ν calculated in step B4.2.14 is greater than 0.5, then $\nu_{used} = 0.5$.

B4.2.15.2 Case 2: $\nu < 0.05$

If the ν calculated in step B4.2.14 is less than 0.05, then $\nu_{used} = 0.05$.

B4.2.15.3 Case 3: $0.05 < \nu < 0.5$

If the ν calculated in step B4.2.14 is between 0.05 and 0.5, then $\nu_{used} = \nu$.

B4.2.16 Calculate the Stress Correction Factors

For each specimen **i**, calculate the stress correction factors as follows:

$$\text{Eq. B37} \quad CSX_i = 0.948 - 0.1114 \left(\frac{T_i}{D_i} \right) - 0.2963 v_{used} + 1.463 \left(\frac{T_i}{D_i} \right) v_{used}$$

B4.2.17 Calculate the Indirect Tensile Strength

For each specimen **i**, calculate the indirect tensile strength as follows:

$$\text{Eq. B38} \quad ITS_i = \frac{2P_{i,fi} CSX_i}{\pi T_i D_i}$$

B4.2.18 Calculate the Average Indirect Tensile Strength

$$\text{Eq. B39} \quad ITS_{avg} = \frac{ITS_1 + ITS_2 + ITS_3}{3}$$

B4.3 Indirect Tensile Strength Analysis Flowcharts

B4.3.1 Main Procedure

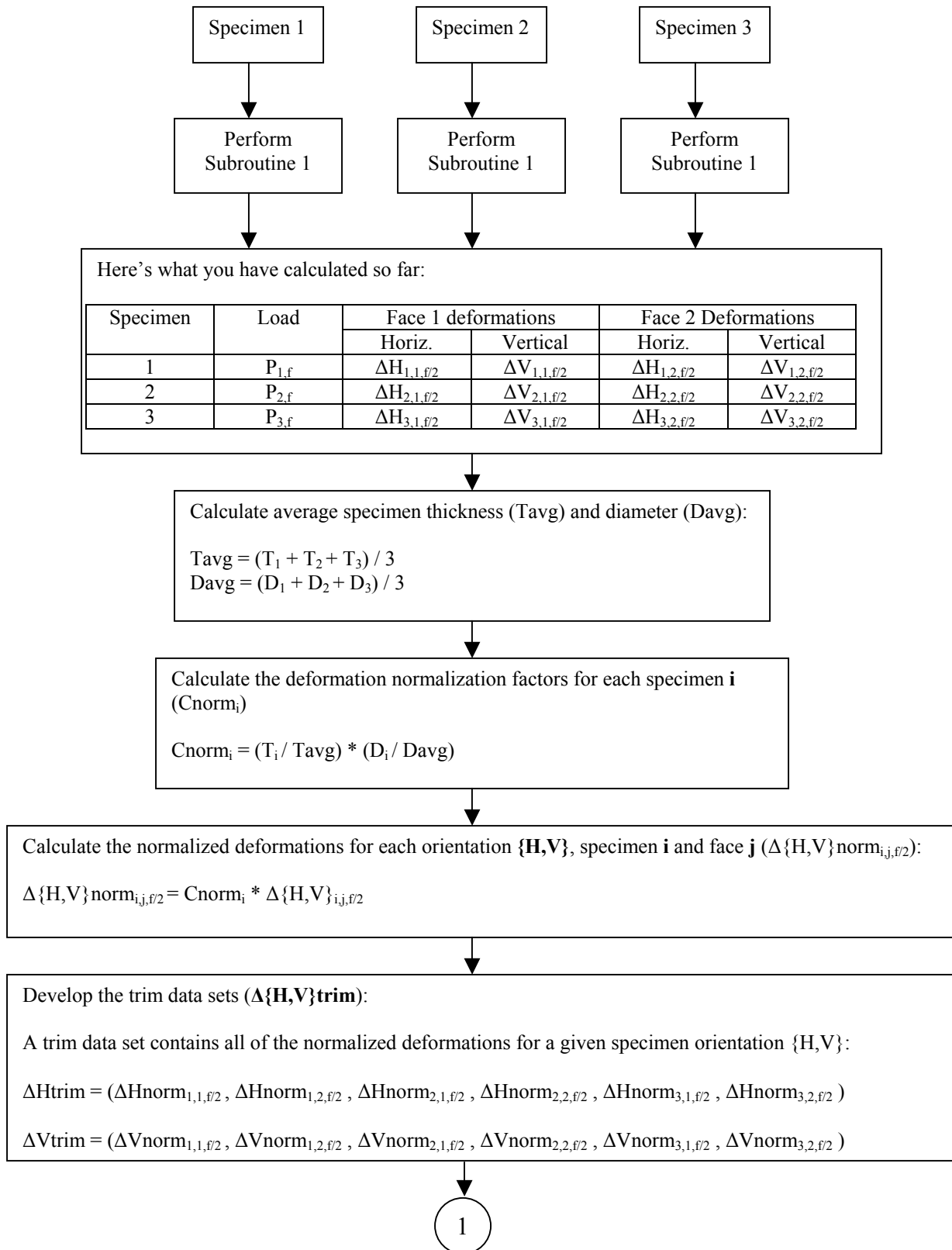

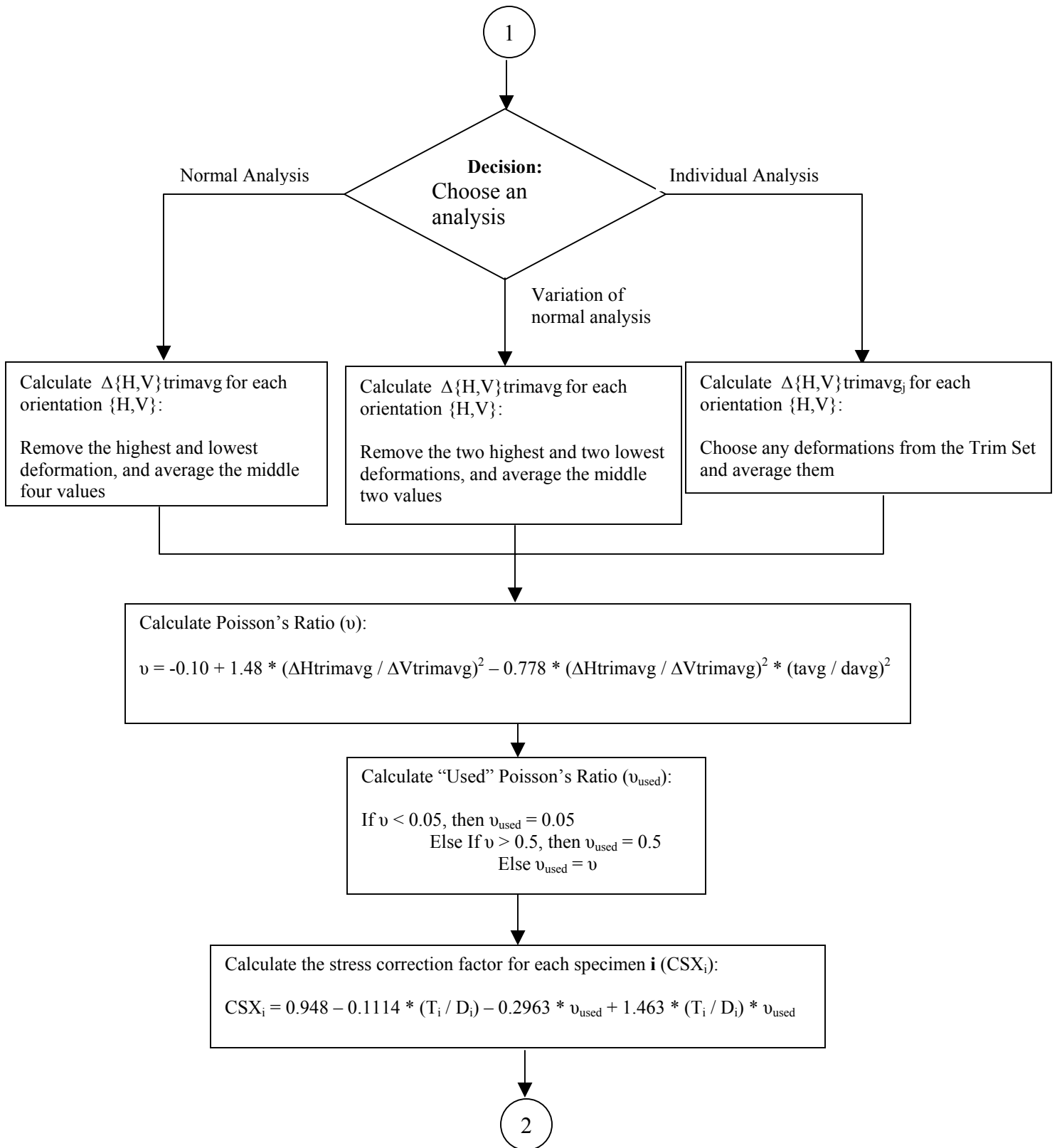

2

Calculate the indirect tensile strength for each specimen *i* (ITS_{*i*}):
$$ITS_i = (2 * P_{i,f} * CSX_i) / (\pi * T_i * D_i)$$

Calculate the average indirect tensile strength (ITS_{avg}):
$$ITS_{avg} = (ITS_1 + ITS_2 + ITS_3) / 3$$

Report the following:

ITS ₁
ITS ₂
ITS ₃
ITS _{avg}
<i>v</i>
<i>v</i> _{used}

B.4.3.2 Subroutine 1

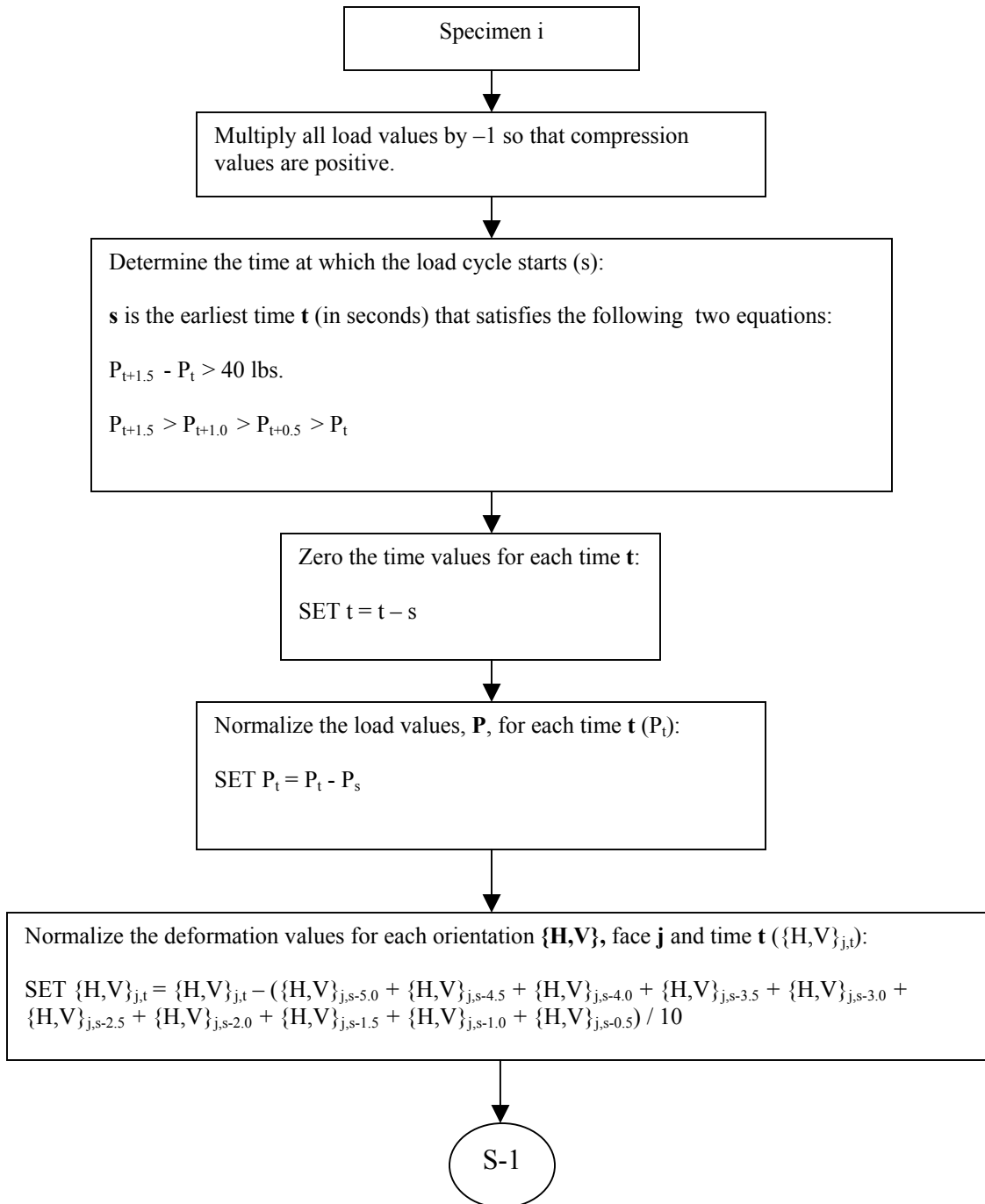

S-1

Find the time at which maximum difference between the vertical and horizontal deformations occurs for each face **j** (f_j):
 f_j is the time t where $\{V\}_{j,t} - \{H\}_{j,t}$ is at a maximum

Select the minimum of f_1 and f_2 (f). This is the time of the specimen failure.

Select the load **P** at time **f** (P_f). This is the specimen failure load

Find the time at which the load is one-half the failure load ($f/2$):

$f/2$ is the time t that satisfies the following equation:

$$P_{f/2} = (P_f) / 2$$

Select the deformations for each orientation $\{H,V\}$ and face j ($\Delta\{HV\}_{j,f/2}$)

LTPP LABORATORY MATERIAL HANDLING AND TESTING
 LABORATORY MATERIAL TEST DATA
 CREEP COMPLIANCE, RESILIENT MODULUS AND INDIRECT TENSILE STRENGTH
 LAB DATA SHEET T07 - SAMPLE SUMMARY INFORMATION

*ASPHALT CONCRETE LAYER (ASPHALTIC CONCRETE PROPERTIES)
 LTPP TEST DESIGNATION AC07/LTPP PROTOCOL P07*

LABORATORY PERFORMING TEST: _____

LABORATORY IDENTIFICATION CODE: ____ _

1. STATE CODE: ____ _ 2. SHRP ID: ____ _

3. LAYER NO: ____ 4. FIELD SET: ____

DATA ITEM	SPECIMEN 1	SPECIMEN 2	SPECIMEN 3
5. TEST NO			
6. SAMPLE AREA (SA-)			
7. LOCATION NO			
8. LTPP SAMPLE NO			
9. AVG. THICKNESS (mm)			
10. AVG. DIAMETER (mm)			
11. BULK SPECIFIC GRAVITY			
12. COMMENT 1			
13. COMMENT 2			
14. COMMENT 3			
15. Other Comments			

1. STATE CODE: ____ ____

2. SHRP ID: ____ ____ ____ ____

3. LAYER NO: ____

4. FIELD SET: ____

DATA ITEM	SPECIMEN 1	SPECIMEN 2	SPECIMEN 3
RESILIENT MODULUS TEST			
16. DATA FILENAME, TEST 1	. DAT	. DAT	. DAT
17. TEST 1 TEMP. (°C)			
18. DATA FILENAME, TEST 2	. DAT	. DAT	. DAT
19. TEST 2 TEMP. (°C)			
20. DATA FILENAME, TEST 3	. DAT	. DAT	. DAT
21. TEST 3 TEMP. (°C)			
22. ANALYSIS FILENAME	. MRO		
CREEP COMPLIANCE TEST			
23. DATA FILENAME, TEST 1	. DAT	. DAT	. DAT
24. TEST 1 TEMP. (°C)			
25. DATA FILENAME, TEST 2	. DAT	. DAT	. DAT
26. TEST 2 TEMP. (°C)			
27. DATA FILENAME, TEST 3	. DAT	. DAT	. DAT
28. TEST 3 TEMP. (°C)			
29. ANALYSIS FILENAME	. OUT		
INDIRECT TENSILE STRENGTH TEST			
30. DATA FILENAME	. DAT	. DAT	. DAT
31. TEST TEMP. (°C)			
32. ".OUT" FILENAME	. OUT		
33. ".STR" FILENAME	. STR		
34. ".FAM" FILENAME	. FAM		

GENERAL REMARKS: _____

SUBMITTED BY, DATE

CHECKED AND APPROVED, DATE

LABORATORY CHIEF

Affiliation: _____

Affiliation: _____