



U.S. Department
of Transportation

**Federal Highway
Administration**

FHWA-SA-96-062

Air Void Analyzer Evaluation

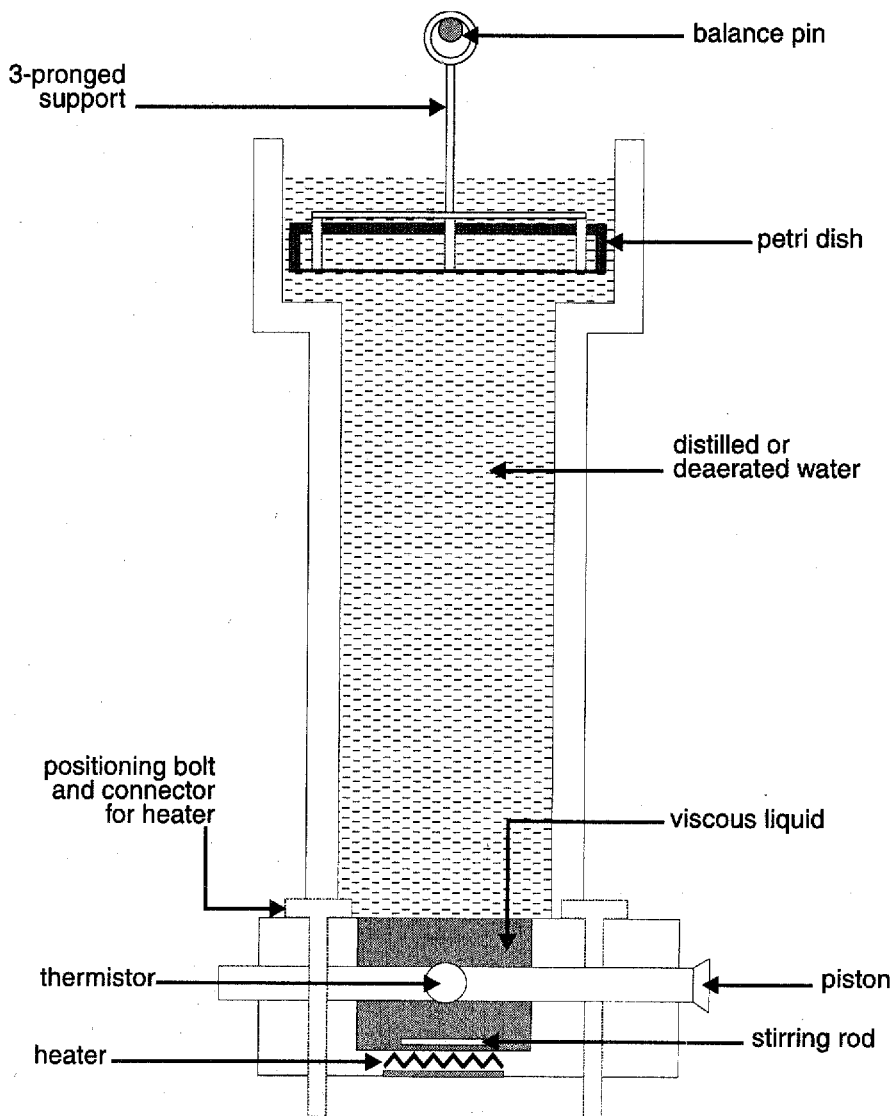

May 1996

NOTICE

This publication is disseminated under the sponsorship of the Department of Transportation in the interest of information exchange. The report does not constitute a standard, specification, or regulation. The United States Government does not endorse products or manufacturers. Trade or manufactures' names appear in the publication only because they are considered essential to the object of this document.

Technical Report Documentation Page

1. Report No. FHWA-SA-96-062	2. Government Accession No.	3. Recipient's Catalog No.	
4. Title and Subtitle Air Void Analyzer Evaluation		5. Report Date May 1996	
		6. Performing Organization Code	
7. Author(s) Donald D. Magura Construction Technology Laboratories, Inc.		8. Performing Organization Report No.	
9. Performing Organization Name and Address		10. Work Unit No. (TRAIS)	
		11. Contract or Grant No.	
12. Sponsoring Agency Name and Address Office of Technology Applications FHWA 400 7th Street, SW HTA-21 Washington, DC 20590		13. Type of Report and Period Covered	
		14. Sponsoring Agency Code	
15. Supplementary Notes			
16. Abstract <p>The Air Void Analyzer (AVA) is a device that permits testing of a sample of fresh concrete and that obtains data regarding air void parameters of air content, specific surface, and spacing factor. Duration of the test is a maximum of 25 minutes. A computer records measured data and calculates the air void parameters. Results are available immediately after the test. The evaluation was conducted to obtain first-hand experience in the use of the device, to use the equipment with a variety of concrete mixes, and obtain data for comparison of results obtained by the ASTM C457 modified point-count method on hardened concrete from the same batch.</p> <p>A total of 26 AVA tests were conducted on concrete at two laboratories and on concrete used in construction at two locations. Concrete from the same batches were also subjected to measurement of the air void system according to ASTM C457. From the tests the following observations can be made:</p> <ul style="list-style-type: none"> • The AVA did not indicate the same air content as an air pressure meter or as determined by ASTM C457. The AVA air content was always on the order of 2% less than the air content by the pressure meter and by ASTM C457. • The spacing factor was about the same by either the AVA or ASTM C457. • The specific surface calculated by the AVA was greater than that from the ASTM C457 test, i.e., the AVA indicated smaller air voids than indicated by the ASTM C457 procedure. <p>The AVA has demonstrated that it can provide information that characterizes the air void system. Use of the AVA system may require some calibration to durable concrete. Nonetheless, if the AVA is used to measure air void parameters in trial batches or in production mixes and correlated to freeze-thaw tests or to known durable concrete mixes, the system can be applicable in quality control and assessment of concrete mixes.</p>			
17. Key Words air-entrained concrete, air voids, air content, spacing factor, specific surface		18. Distribution Statement	
19. Security Classification (of this report) Unclassified	20. Security Classification (of this page) Unclassified	21. No. of Pages 131	22. Price

Contents

AIR VOID ANALYZER (AVA) EVALUATION	1
BACKGROUND	1
INTRODUCTION	1
DEVELOPMENT OF THE AVA	2
AVA OPERATION	3
EVALUATION PLAN	4
EVALUATION TESTS	5
TEST RESULTS	6
PRESENTATION OF DATA	8
Air Content	8
Specific Surface	8
Spacing Factor	8
ANALYSIS OF DATA	9
AVA OPERATION	9
DISCUSSION	10
Operational Features	11
Technical Features	11
CONCLUDING REMARKS	12
REFERENCES	13
APPENDIX A. FINAL REPORT	31
1. Scope of the Report	33
2. Description of Subtask 2.1.	33
2.1. Introduction	33
2.2. Principle of the FCAA Test Method	34
2.3. Aim of the Subtask 2.1.	38
2.4. Test Procedure	38
3. Tests Performed	39
3.1. Batching of Concrete and FCAA Testing	39
3.2. Testing According to ASTM	39
4. Analysis of the Test Results	40
4.1. Reliability of the Results	40
4.2. Correlation Between the FCAA Results and the ASTM Results	43
5. Calculation of Chord and Void Distributions	46
5.1. Aim and Results	46
5.2. Mathematics of the 2D and 3D Transformations	48
5.2.1. Measurement Results	48
5.2.2. Transformation from 3D to 2D	49
5.2.3. Transformation from 2D to 3D	50
6. Conclusions	54
7. References	55
APPENDIX B. AVA OPERATIONS MANUAL	83
Air Void Analyzer	85
Disclaimer	85
Applicable Law	85
Principle of Operation	85

Description of the Measuring Equipment.....	86
Details of the Operation.....	93
Setting Up the Equipment	93
Sampling	96
Measuring Program	102
Measuring Ranges	108
Shut Down	109
Recalculation Program	110
File Management.....	110
Exporting Data to Spreadsheet	110
Preparation for Transport	114
Quick Check List.....	115
To set up	115
To shut down	115
Do's and Don'ts	116
Supplies and Accessories.....	117
Comments and/or Suggestions for Improvements	118
APPENDIX C. CONCRETE MIX DETAILS	119
APPENDIX D. EVALUATION RESPONSES	125

Figures

AIR VOID ANALYZER (AVA) EVALUATION

1. Schematic of riser column	15
2. Riser column and AVA cabinet	16
3. Agitation of sample	17
4. Test under way	18
5. Sheet 1 of AVA output	19
6. Sheet 2 of AVA output	20
7. AVA #3.1 vs. AVA #3.3 air content	21
8. AVA #3.1 vs. AVA #3.3 specific surface	22
9. AVA #3.1 vs. AVA #3.3 spacing factor	23
10. Air pressure meter vs. ASTM C457 air content	24
11. Air pressure meter vs. AVA air content	25
12. Air pressure meter - 2% vs. AVA air content	26
13. ASTM C457 vs. AVA air content	27
14. ASTM C457 vs. AVA specific surface	28
15. ASTM C457 vs. AVA spacing factor	29

APPENDIX A. FINAL REPORT

2.C.	36
18. Regression curve and 95% confidence intervals	45
1. Schematic of riser column	56
2C.	59
3.	59
4.	60
5. DBT-ASTM analysis compared to CSTC-ASTM analysis	61
6. DBT-ASTM analysis compared to CSTC-ASTM analysis	62
7. DBT-ASTM analysis compared to CSTC-ASTM analysis	63
8. Regression curve and 95% confidence limits	64
9. Regression curve and 95% confidence limits	65
10. Regression curve and 95% confidence limits	66
11. Regression curve and 95% confidence limits for a single measurement and the mean of 5 measurements	67
12. Regression curve and 95% confidence limits for a single measurement and the mean of 5 measurements	68
13. Regression curve and 95% confidence limits for a single measurement and the mean of 5 measurements	69
14. Regression curve and 95% confidence limits for a single measurement and the mean of 5 measurements	70
15. Regression curve and 95% confidence limits for a single measurement and the mean of 5 measurements	71
16. Regression curve and 95% confidence limits for a single measurement and the mean of 5 measurements	72
17. Regression curve and 95% confidence limits for a single measurement and the mean of 5 measurements	73
18. Regression curve and 95% confidence limits for a single measurement and the mean of 5 measurements	74
19. Regression curve and 95% confidence limits for a single measurement and the mean of 5 measurements	75

20. Regression curve and 95% confidence limits	76
21. Regression curve and 95% confidence limits	77
22. Regression curve and 95% confidence limits	78
23. Measured ASTM s.o. calculated FCAA chord distribution	79
24. Calculated 3-D void distribution (ASTM) compared to measured FCAA void distribution	80
25.	81
26.	81

APPENDIX B. AVA OPERATIONS MANUAL

1a. AVA equipment with computer and printer	88
1b. AVA Cabinet with riser column, buoyancy recorder, piston and syringe	89
2a. Schematic diagram of riser column (front view)	90
2b. Schematic diagram of riser column (side view)	91
2c. Schematic diagram of measuring equipment (side view)	92
2d. Schematic diagram of measuring equipment (front view)	92
3. Removal of air bubbles from riser column	94
4. Insertion of viscous liquid into bottom of riser column	95
5. Equipment to take a sample of the mortar fraction of the concrete	96
6. The syringe is rotated so that the piston is held fast in the keyways of the aluminum holder	97
7. The "bird cage" holder is lowered into the concrete under vibration	98
8. After the "bird cage" has been vibrated all the way down, the syringe is pushed smoothly down into the concrete under vibration	99
9. Removal of the filled syringe and "bird cage" from the concrete	100
10. The syringe is removed from the "bird cage"	101
11. Fitting the syringe holding the mortar sample onto the end of the piston	101
12.	103
13.	103
14.	104
15.	105
16.	105
17.	109
18.	111
19.	111

Tables

AIR VOID ANALYZER (AVA) EVALUATION

- 1. Outline of evaluation tests 5
- 2. Air void data comparison 7

APPENDIX A. FINAL REPORT

- 1. Anova: Single-Factor analysis 41
- 2. Standard Deviation of the DBT Results 42
- 3. Standard Deviation of the CSTC Results 42
- 4. Outcome of the regression analysis 44
- 5. 3D to 2D transformation for a hypothetical poly-dispersed air void system consisting of only 4 air void sizes 52
- 6. 2D to 3D transformation for the hypothetical air void distribution of table 5 53

APPENDIX C. CONCRETE MIX DETAILS

- C.1 Detroit Concrete Mixes 120
- C.2 Wisconsin Concrete Mixes 121
- C.3 University of Texas Concrete Mixes 122
- C.4 Iowa Concrete Mixes 124



AIR VOID ANALYZER (AVA) EVALUATION

BACKGROUND

The resistance of concrete to distress caused by freezing and thawing is enhanced by having entrained air in the concrete. Standard specifications generally call for an air content of 4 to 7 percent to be measured when concrete is placed. In current construction practice, air content generally is measured using the method and air pressure meters presented in ASTM C231.⁽¹⁾ It is recognized that some of the air measured in this way may be entrapped and not contribute to the freeze-thaw resistance. It is also recognized that the entrained air voids produce a satisfactory air void system when their size and spacing are within certain limits. The size of the air voids is expressed by the specific surface parameter, α , the ratio of the surface area of the air voids to their volume. The spacing is described by the spacing factor parameter, \bar{L} , which relates to the maximum distance in the cement paste from the periphery of a void. These characteristics of the air void system are determined according to ASTM C457, the microscopical method that uses hardened concrete specimens.⁽²⁾ Thus, currently approved meters can measure the overall air content of fresh concrete, but, the air void characteristics can only be measured using hardened concrete specimens.

In a quality assurance program or in mix development by trial batching, it is desirable to measure the air void characteristics quickly and economically, preferably using the fresh concrete. The Air Void Analyzer (AVA) is a system that is proposed to measure the air content, specific surface, and spacing factor using fresh concrete with results "comparable" to ASTM C457.⁽³⁾

INTRODUCTION

The AVA was developed in Europe in the early 1990s under a BRITE/EURAM Project (see appendix A) by a team headed by Dansk Beton Teknik (DBT).⁽³⁾ The AVA offers the benefits described above. The Federal Highway Administration (FHWA) Office of Technology Applications (OTA) purchased one unit in August, 1993 for evaluation.

Evaluation of the AVA was not conducted as a research project, but, rather was designed to:

- Use the equipment in a variety of conditions.
- Operate the system using a variety of concrete mixes.
- Become familiar with the AVA operation.

- Demonstrate the AVA to interested parties and potential users.
- Collect data for assessment of the system compared to ASTM C457.

This report includes:

- A description of the AVA process and equipment.
- An outline of the evaluation plan and activities.
- Data from the verification tests.
- Evaluation comments.
- Discussion and concluding remarks.

This report is not the final assessment of the AVA. Presentation and discussion are based on the activities to date. Evaluation will continue and, as noted below, modifications have been made to the AVA since its original release; there may be other changes in the future. Consequently, information is presented to document the chronology of the activities and the versions of the AVA software and viscous liquid.

DEVELOPMENT OF THE AVA

Conceptually, the AVA operates as follows:

- A 20-cc sample of mortar is obtained from the concrete. Sampling is made using a wire cage to screen out aggregates larger than 6 mm.
- The principal piece of AVA equipment consists of a plexiglas cylinder (riser column) filled at its base with a viscous (glycerine-based) liquid and topped with water. (See figures 1 and 2.)
- The mortar is injected into the viscous liquid and stirred for 30 seconds to release the air voids. (See figure 3.)
- The air bubbles rise through the viscous liquid and water at rates depending on their size. (See figure 4.)
- The air bubbles are collected at the top of the water column beneath a submerged, inverted petri dish.
- The petri dish is suspended from a bracket attached to a sensitive balance.
- The change in suspended mass of the petri dish and bracket caused by buoyancy of the air bubbles is recorded by a computer for 25 minutes after the 30-second stirring period.

- Knowing the viscosity of the system and using Stoke's Law, the size of the air bubbles with time are computed and the air void parameters are calculated according to the theory developed by DBT.
- The DBT theory excludes from the calculations air voids larger than 3 mm in diameter.

The DBT report included as appendix A presents the theoretical basis and description of the AVA concept. Also presented in the report are comparisons of air content, specific surface, and spacing factor obtained by using the AVA and the ASTM C457 method on the same concrete. To ensure good control of specimens for the test, concrete beams were cast. Five AVA samples were taken at even spacing along each beam. Once the beam had hardened, five slices of concrete were cut from the beam adjacent to the locations of the AVA samples for use in the ASTM test method. Tests were conducted at two laboratories.

The DBT report states that the standard deviation of the AVA results is of the same order of magnitude as the standard deviation of the ASTM results. Regression analysis of the AVA versus ASTM data for specific surface and spacing factor showed the relationship was a line with a slope of very nearly 1. The slope of the regression line for air content was on the order of 0.7 to 0.8 and was attributed to the fact that the AVA counted only entrained air bubbles, while in conducting the ASTM tests, coarser, entrapped bubbles were counted. The DBT report also reports: "While voids of a very small diameter will continue to rise after this period (25 minutes), neglecting them is considered acceptable as such very small voids would anyhow not have been measured in the ASTM analysis as they will probably be closed by precipitation in the concrete anyway."

AVA OPERATION

The AVA operations manual is included as appendix B.⁽⁴⁾ The manual contains schematic diagrams, photos of each step in the operation with descriptive text, and sample computer printouts of test data. A computer controls operation of the system. The AVA software records data, performs various timing operations, and computes the air void parameters. When the unit was delivered to the FHWA in August 1993, the AVA was operated with software Version #3.1. The FHWA received an updated software Version #3.3 in November 1993. Except for a few tests, as will be indicated later, all data collected using Version #3.1 were recalculated using Version #3.3. In April 1994, the software was updated to Version #3.4, which also included a modification to the formulation of the glycerine-based special liquid. Software Version #3.4 and the new

special liquid were first used in June 1994, for the tests in Iowa and are employed currently.

Figures 5 and 6 give a sample of the data output. Identification information and mix characteristics must be input to the computer. These items are indicated by \surd in figure 5. Further details and definitions of input data are listed on page 102 of the operations manual, appendix B.

The AVA test takes a maximum of 25 minutes to complete after stirring of the mortar sample stops. The software is designed to stop the test earlier if the change in buoyancy is ≤ 5 mg for 3 minutes. To maintain control of the viscosity, the test must be conducted with the temperature of the special liquid and water between 22 °C and 25 °C. The AVA is designed to be accurate only for air contents in the range of 3.5 percent to 10 percent (appendix B, page 108). If the temperature or air content limits are exceeded during the test, the computer printout indicates if either or both limits are exceeded.

EVALUATION PLAN

The AVA system is based on a theoretical time-buoyancy relationship. The relationship is sensitive to the viscosity of the special liquid and water in the riser column, and temperature must be controlled. One of the objectives was to determine if there is an effect on the viscosity and calculations when some materials or combinations of materials in a concrete mix are present, such as various admixtures, cement of varied sources/types, or types of aggregates.

In concept, the evaluation plan was to use the AVA in different environments and to test concrete mixes with different proportions, materials, and material sources. At the same time, companion cylinders would be made from the same concrete and later used in the ASTM C457 examination for air void parameters. A pressure meter would be used to measure the air content. The slump would be measured according to ASTM C143.⁽⁵⁾

In this evaluation, the target for concrete mixes was:

1. Mixes normally used in pavements with moderate air content and no admixtures.
2. Mixes with high and low air contents.
3. Mixes with fly ash.

4. Mixes with silica fume.
5. Mixes with a superplasticizer.

The intent was to try to include in the evaluation a range of concrete mixes that are used throughout the country. In addition, comments and observations on the operation and performance of the system would be solicited from users or individuals to whom the AVA was demonstrated.

EVALUATION TESTS

The AVA evaluation tests were conducted to meet the aims of the evaluation plan. Table 1 outlines the evaluation tests. The tests were conducted at four locations. The range of geographical location exposed the AVA to diverse material characteristics and

Table 1. Outline of evaluation tests.

DETROIT—EUROPEAN CONCRETE PAVEMENT DESIGN FOR I-75 RECONSTRUCTION
Seven samples were tested from two mixes produced in batch plants for use in a paving project. Air content was in the 6% range to meet project specifications. A WRDA was used.
WISCONSIN—WISCONSIN DOT MATERIALS LABORATORY, MADISON
Ten mixes were tested in the laboratory. These mixes were typical of those used by WIDOT in pavements and structures. The only admixture was an A/E agent. Air content was the principal variable in these tests and ranged from 2.9 to 10.3%.
TEXAS—BALCONES RESEARCH CENTER, UNIVERSITY OF TEXAS, AUSTIN
Fourteen mixes were tested in the laboratory. Using a 5-bag control mix without A/E, three mixes were tested at high, medium, and low air contents. Subsequently, seven mixes with nominal A/E were tested with high and low amounts of fly ash, silica fume, and superplasticizer added separately. A 7-bag mix also was tested at three different air contents.
IOWA—HIGHWAY 21 WHITE-TOPPING, WILLIAMSBURG
One sample was tested from each of two batches produced in a plant for use in a paving project. The concrete, prepared for slip-formed placement, had a 40-mm slump and about 7% air content.

mix proportions. The range of locations also resulted in a variety of combinations of materials and admixtures. The tests in Detroit and Iowa were made at sites of actual paving construction and used samples from the concrete being placed in the roadway.

Tables C.1 to C.4, appendix C, present details of the concrete mixes. They also list slump and air content for the fresh concrete. An air pressure meter was used to determine the air content for all mixes. The air pressure meter available locally at each site was used, thus, the air pressure meter was different at each location of AVA testing.

TEST RESULTS

Table 2 lists results of the evaluation tests. (Note: these data were used in the graphs presented in figures 10 to 15). The AVA and ASTM C457 values for air content, specific surface, and spacing factor are included. The pressure meter air content also is listed for each concrete mix. The Detroit, Wisconsin, Texas, and Iowa ASTM C457 examinations were performed by a commercial laboratory in Richmond, VA. A 60x microscope was used in the ASTM C457 examinations.

As noted in the section on AVA Operation (page 3), the original software, Version #3.1, was modified to Version #3.3. Much of the data had been collected using Version #3.1. It was possible to simply take the #3.1 data and have the new Version #3.3 software to recalculate the data. To review the impact of changing software versions, the original #3.1 data were compared to the new #3.3 data. The air content, specific surface, and spacing factor are plotted in figures 7, 8, and 9, respectively. It is seen that with the exception of a few values at the higher range of the specific surface, the three parameters for both Versions #3.1 and #3.3 are not greatly different. Thus, the seven tests indicated in table 2 as being calculated by Version #3.1 should be close to the data if it had been recalculated using #3.3. The Iowa data was collected and calculated using Version #3.4 and the new viscous liquid. Because the viscosity of the new liquid was changed, data collected using Versions #3.1 and #3.3 could not be recalculated using the new #3.4 software.

In the analysis of data, results using the ASTM C457 procedure are the standard to which results from the AVA are compared. As indicated in table 2, the four sets of data were made counting only the air void sections <3 mm. This was done to approach the AVA data that is based on the system's theory of omitting air voids ≥ 3 mm. It must be noted here that although the AVA and ASTM C457 concrete samples were made from the same batch of concrete, the concrete for each was treated somewhat differently. The concrete for the AVA sample usually was placed in the bowl from a spare air pressure meter. The concrete was rodded as would be done when

Table 2. Air void data comparison.
Air Void Analyzer vs ASTM C457

See notes following table 2.

ID	Air Content, %			Specific Surface, 1/mm		Spacing Factor, mm	
	PM	AVA	C457	AVA	C457	AVA	C457
DETROIT¹							
D1	6.6	5.13	7.15	39.2	30.5	0.13	0.14
	5	2.16	4.09/4.14	27.5	21.9/16.1	0.27	0.25/0.35
D3	6.8	3.2	7.01	28.4	21.8	0.20	0.15
D4*	6.8	2.83	7.23/6.16	32.8	23.5/14.8	0.20	0.18/0.32
D5*	6.6	4.23	7.42	37.1	26.2	0.13	0.12
D6	7	3.32	6.91	42.3	24.0	0.15	0.19
D7*	6.4	2.65/3.06	6.76/6.50	40.0/33.5	23.5/20.1	0.15/0.17	0.13/0.16
TEXAS¹							
Test Batch	2	0.38	1.97	8.1	8.1	1.73	0.85
AE 5&6*	10.2/10	7.66/7.12	8.98	22.5/23.2	19.2	0.15/0.15	0.16
AE 7&8	6.5	4.87	7.50	24.1	14.4	0.18	0.22
AE 9&10	4.5	4.31/4.01	5.19	19.5/15.1	12.7	0.25/0.33	0.35
FA 1&2	7	6.27/6.15	7.49	25.3/20.1	14.5	0.14/0.18	0.23
FA 3&4	8	4.75/5.78	8.51	19.8/20.4	18.5	0.23/0.20	0.15
SF 1&2	5.2	3.94/3.21	5.25	23.8/31.9	13.0	0.22/0.18	0.31
SF 3&4	3.5	4.33	5.41	16.9	16.2	0.32	0.27
SF 5&6	3	1.71	6.12	24.5	14.3	0.35	0.31
SP 1&2	2	0.63	1.96	44.1	13.5	0.26	0.47
SP 3&4	7.5	7.65/8.55	8.82	22.9/22.9	15.6	0.13/0.11	0.18
7AE 1&2	6.5	5.60/5.98	5.63	26.6/36.3	15.1	0.18/0.13	0.29
7AE 3&4	7.5	5.63/3.48	8.97	31.6/19.5	21.9	0.15/0.30	0.14
7AE 5&6*	8.5	7.97	7.96	37.6	23.4	0.10	0.13
IOWA¹							
Iowa 1	7	3.12	5.65	28.4	25.2	0.19	0.17
Iowa 2	7	3.12	8.17	22.6	21.3	0.24	0.15
WISCONSIN¹							
W2*	10.3	10.0	9.56	25.4	14.7	0.10	0.18
W3	5.7	5.69	7.14	25.3	13.4	0.18	0.26
W8	4.7	3.15	5.15	22.8	19.9	0.26	0.25

Notes for table 2:

AVA data are based on software Versions #3.3 and #3.4; tests with * are based on AVA Version #3.1.

1. AVA data are based on only counting air voids <3 mm. ASTM C457 was made using the modified point-count method excluding air void sections ≥ 3 mm.

an air content test was to be conducted. The vibrating bird cage was then inserted at the center of the bowl to obtain the AVA sample. The cylinders for the ASTM C457 tests were 100 mm x 200 mm and rodded and tapped according to ASTM C192.⁽⁶⁾

PRESENTATION OF DATA

Because the AVA is a new concept with quite different hardware than previously used for air content and air void parameter determinations, comparisons and observations will be made to put the AVA in perspective to the well-known methods.

Air Content

Air content determined by air pressure meter (PM) versus that determined by ASTM C457 and the AVA is shown in figures 10 and 11, respectively. The AVA data, compared to the PM data in figure 11, show that the air content measured by the AVA virtually are always less than the PM air contents measurement. As an indication of the relative amount the AVA air content deviates from the PM readings, the PM air contents presented in figure 11 were reduced arbitrarily by 2 percent to represent entrapped air and plotted versus the AVA air contents. The results, shown in figure 12, illustrate that the AVA air content is on the order of 2 percent less than the PM air content measurement.

The direct comparison of ASTM C457 versus AVA air content is shown in figure 13. From the previous relationships shown in figures 11 and 12, the AVA indicates an air content about 2 percent less than the air content determined by ASTM C457.

Specific Surface

For a given air volume, the specific surface is an indicator of the number and size of the spherical air voids in the concrete. Being based on the surface area-volume ratio, a numerically larger value of the specific surface indicates a relatively smaller air void. Figure 14 presents a comparison of the ASTM C457 data versus the AVA specific surface values.

Spacing Factor

The spacing factor is a parameter related to the maximum distance in the cement paste to the periphery of an air void. The smaller distances are associated with more durable concrete. Figure 15 plots the relationship between the ASTM C457 spacing factor and that measured by the AVA.

ANALYSIS OF DATA

The basis for evaluating the AVA was to compare the data generated from AVA tests using fresh concrete to air pressure meter results using fresh concrete, and the quantities determined by the ASTM C457 method using hardened concrete. The air pressure meter test is the customary method used in the field for quality control of the air content. ASTM C457 is the standard method for measuring air void characteristics and has been the authoritative technique. From the evaluation tests conducted to date, neither ASTM C457 nor the air meter are directly equivalent to the AVA, nor, would it necessarily be expected to have exact equivalency between the methods.

The AVA discounts the voids ≥ 3 mm and it also was indicated in the DBT report that some of the very small air voids would not be measured, but, that these small air voids would not be visible and would not be accounted for by the ASTM C457 method. The new AVA software Version #3.4, with the new formulation of the viscous liquid, is intended to overcome what may be perceived as a shortcoming in measuring the small air voids. Only the two Iowa tests used the new AVA setup and there is no significant indication by the data to comment about performance of the new system.

Paragraph 5.5 of ASTM C457 states that air-entrained concrete designed by ACI 201.2R or ACI 211.1, the specific surface, α , is usually in the range 23.6 to 43.3 mm^{-1} and the spacing factor, \bar{L} , in the range 0.10 to 0.20 mm.^(7,8) Excluding the comparison with ASTM C457, data from the AVA tests show the AVA equipment is capable of measuring α and \bar{L} in these ranges.

AVA OPERATION

The AVA operations manual included as appendix B gives the principles and details of operation. Also presented in the manual is a quick check list, instructions for shutting down the system, and a list of do's and don'ts. These latter three items provide reminders that should be considered each time the unit is used. Photos of the computer screen provide direct images of what will be seen during computer input-output. The manual is more than adequate to use the equipment properly and to conduct a test.

An evaluation form prepared specifically for the AVA obtained information regarding its use. This form was sent to Wisconsin and Texas and their responses are included in appendix D. The

following is a summary of significant items from the responses and includes observations from OTA/FHWA experience at the other locations:

- As noted, the AVA depends on the test being conducted with the temperature between 22 °C and 25 °C. In a protected environment such as an ordinary office or laboratory, the system works well. It is not well-suited to field conditions such as might be found in the usual construction site trailers. However, field trailers were used in Detroit and Iowa. By using the heating system, space heaters and/or the AVA base heater, the water and viscous liquid temperature was adjusted upward as needed and tests were completed successfully. Similarly, the trailer air conditioning and/or storage of the water and viscous liquid in the refrigerator cooled the fluids to the proper operating temperatures.
- The balance measuring the change in buoyancy of the petri dish is very sensitive and vibrations affect its recording of weight. Consequently, the AVA needs to be placed on a solid table where vibrations are not transferred through the floor. Because of the flexibility of the field trailer, activity in the trailer was halted during the test periods in Detroit and Iowa.
- At times, it was difficult to obtain a good sample with the syringe. In low slump, harsh mixes, generating a good mortar by the vibrating bird cage was not easy. When the mix was "sticky," the sample did occasionally pull out of the syringe as the syringe was withdrawn from the concrete. Even with good mortar, air bubbles could be entrapped in the syringe, thus, adding the complication of estimating the volume of the sample.
- The software could be made more user friendly because if a keying error is made, the system "locks up." If this occurs at the end of the test, test data will be lost. With deliberate use, however, the system works well.
- No attempt in this evaluation was made to extract a concrete sample for the AVA test from freshly placed and finished pavement. A portable, battery-powered percussion drill would be needed to conduct this type of sampling.

DISCUSSION

The AVA offers a new approach to measuring the air void parameters associated with identifying durable concrete. The benefit of the AVA is that tests can be made quickly on fresh concrete. AVA system measurement of the air void parameters is intended to be equivalent to ASTM C457 results.⁽³⁾ *This evaluation*

was conducted to assess the performance of the AVA operationally and technically. It was intended in this evaluation to employ the system in much the same way as would potential users.

Operational Features

The time required for the AVA test in a field quality assurance program is relevant to maintain control of construction materials. AVA tests can be conducted on about a 1-hour cycle. An AVA test takes a maximum of 25 minutes. Cleaning the riser column and initializing the AVA in less than one-half hour is not difficult. A second test can be started about 1 hour after the first test is started. Depending on location of the concrete to be tested, and if there is any help to obtain samples, the 1-hour cycle is easily achieved and maintained. On the other hand, the ASTM C457 requires time for the concrete to harden, time and equipment to obtain cores, to prepare the samples, and to perform the ASTM C457 procedure. Conduct of the ASTM C457 also requires personnel training to prepare the sample and to perform the procedure.⁽⁸⁾ Overall, the AVA is quicker and easier to conduct than an ASTM C457 test.

Technical Features

The AVA uses a very small sample (20 cc) of the concrete, which is extracted to represent the actual concrete batch; consequently, the quality of the sample is extremely important to the quality of the AVA results. The AVA uses a vibratory cage to screen out aggregate larger than 6 mm. The percussion drill has a rotational frequency of about 2500 rpm that at this level of vibration should not affect the air void system.

Changes have been made to the AVA software and to the viscous liquid properties since the original issue to measure the fine air voids within the 25-minute test limit. Only two evaluation tests (Iowa) were made with the new AVA version; results did not disclose unusual characteristics compared to the earlier AVA tests.

The DBT work (appendix A) showed that their AVA data and that obtained using ASTM C457 had acceptable correlation except for the air content. Comparing the AVA values with the ASTM C457 quantities where only the air void sections <3 mm were counted in this evaluation, the following observations can be made:

- The AVA did not indicate the same air content as an air pressure meter or as determined by ASTM C457. The AVA air content was always on the order of 2 percent less than the air content by the pressure meter and by ASTM C457.

- The spacing factor was about the same with either the AVA or ASTM C457.
- The specific surface calculated by the AVA was greater than that from the ASTM C457 test, i.e., the AVA indicated smaller air voids than did the ASTM C457 procedure.

CONCLUDING REMARKS

Figures 13, 14, and 15 present the principal information for the evaluation of the AVA. In an attempt to make the ASTM C457 data and AVA data somewhat comparable, air void sections >3 mm, as viewed in the ASTM C457, procedure were not counted. However, it appears that performing ASTM C457 by this procedure is not a comparable measurement; it was not the intent of this evaluation to use extraordinary research techniques and pursue more intricate procedures with more sophisticated equipment.

The AVA has demonstrated that it can provide information that characterizes the air void system. Use of the AVA system may require some calibration to durable concrete. The AVA air content will be different from air pressure meter values and may be different from the specific surface and spacing factor determined by standard ASTM C457 procedures. Nonetheless, if the AVA is used to measure air void parameters in trial batches or in production mixes and correlated to freeze-thaw tests or to known durable concrete mixes, the system can be applicable in quality control and assessment of concrete mixes.

REFERENCES

1. ASTM C231-91: *Standard Test Method for Air Content of Freshly Mixed Concrete by the Pressure Method*, Annual Book of ASTM Standards, Vol. 04.02.
2. ASTM C457-90: *Standard Test Method for Microscopical Determination of Parameters of the Air-Void System in Hardened Concrete*, Annual Book of ASTM Standards, Vol. 04.02.
3. *Determination of the Air Void Structure Before Compaction of the Concrete*, Subtask 2.1, BRITE/EURAM Project No: BE-3376-89, Dansk Beton Teknik.
4. *Air Void Analyzer*, Hansson Consulting, Waterloo, Ontario, Canada.
5. ASTM C143-90a: *Standard Test Method for Slump of Hydraulic Cement Concrete*, Annual Book of ASTM Standards, Vol. 04.02.
6. ASTM C192-90a: *Standard Practice for Making and Curing Concrete Test Specimens in the Laboratory*, Annual Book of ASTM Standards, Vol. 04.02.
7. *Guide to Durable Concrete (ACI 201.2R-92)*, ACI Manual of Concrete Practice, Part 1.
8. *Standard Practice for Selecting Proportions for Normal, Heavyweight, and Mass Concrete (ACI 211.1-91)*, ACI Manual of Concrete Practice, Part 1.
9. R. Pleau, P. Plante, R. Gagne, and M. Pigeon, *Practical Considerations Pertaining to the Microscopical Determination of Air Void Characteristics of Hardened Concrete (ASTM C457 Standard)*, Cement, Concrete, and Aggregates, ASTM, Volume 12, Number 1, pp 3-11, 1990.

FIGURES

Note: Data shown in figures 10 to 15 are taken from table 2.

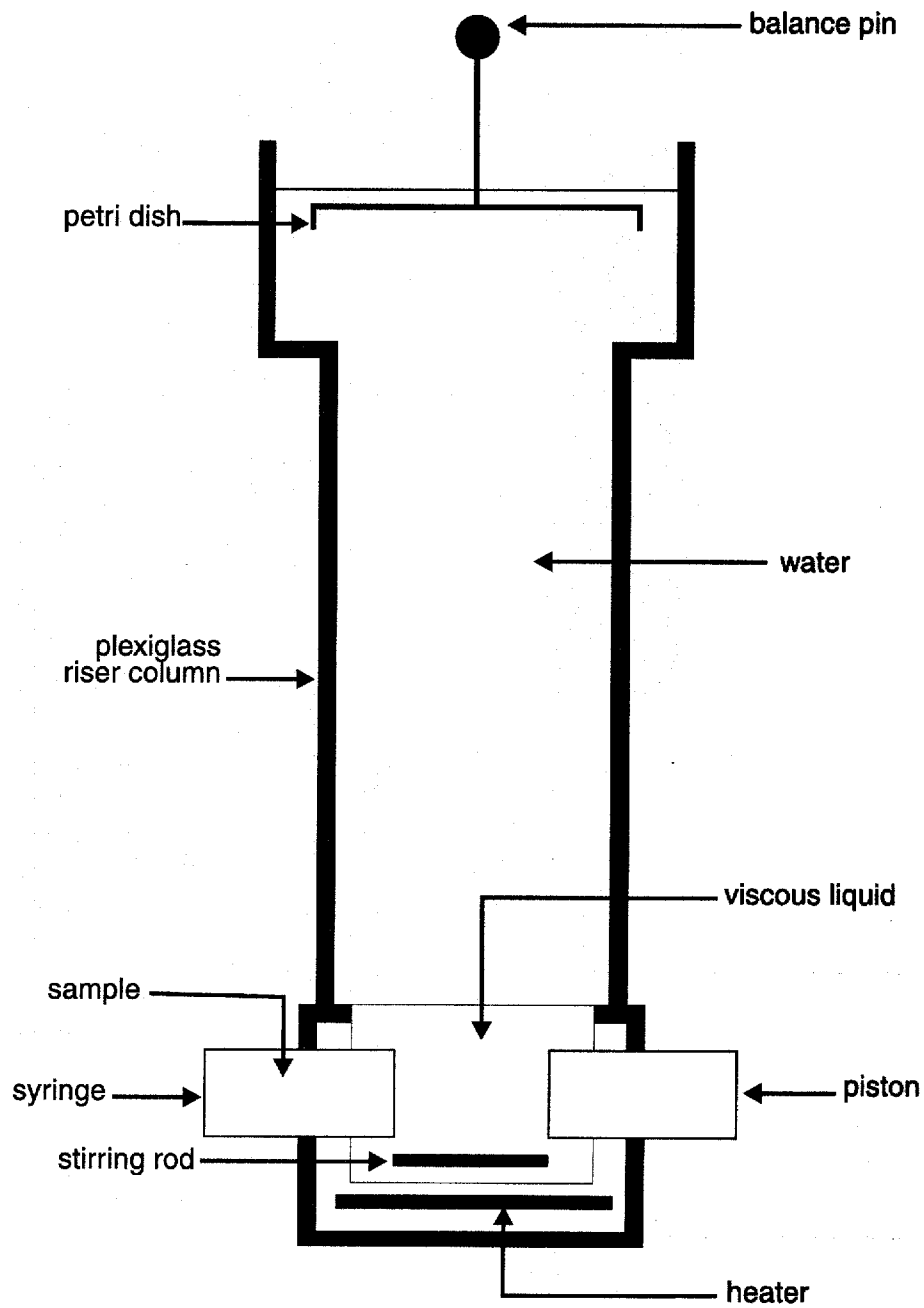

Figure 1.
Schematic of riser column

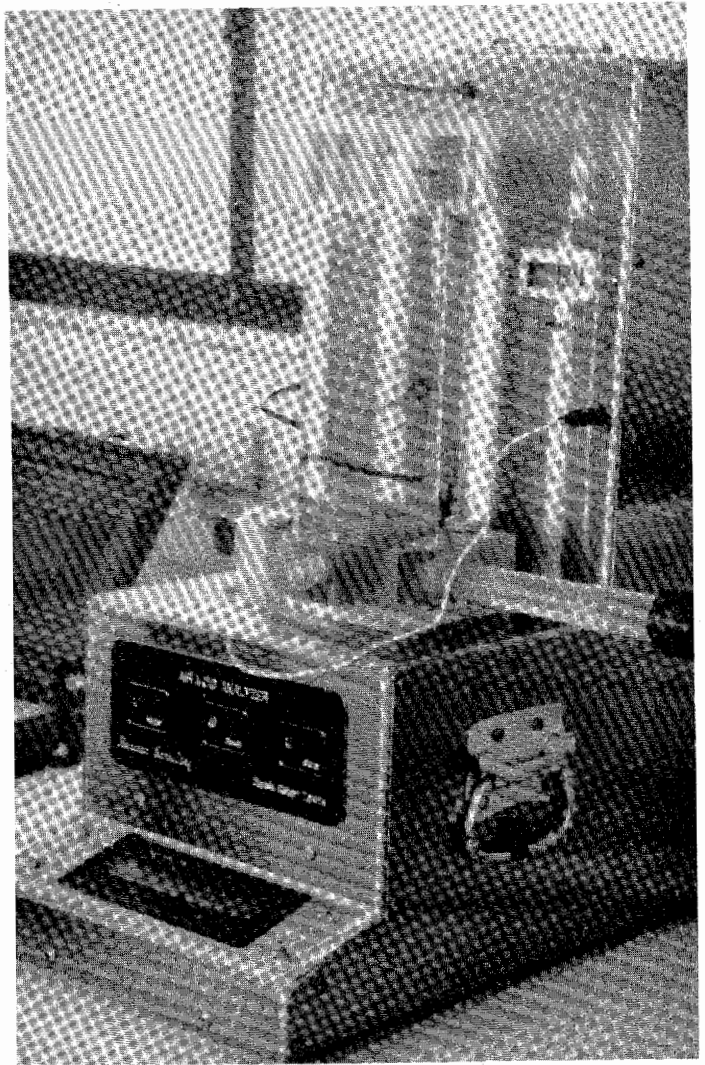

Figure 2.
Riser column and AVA
cabinet

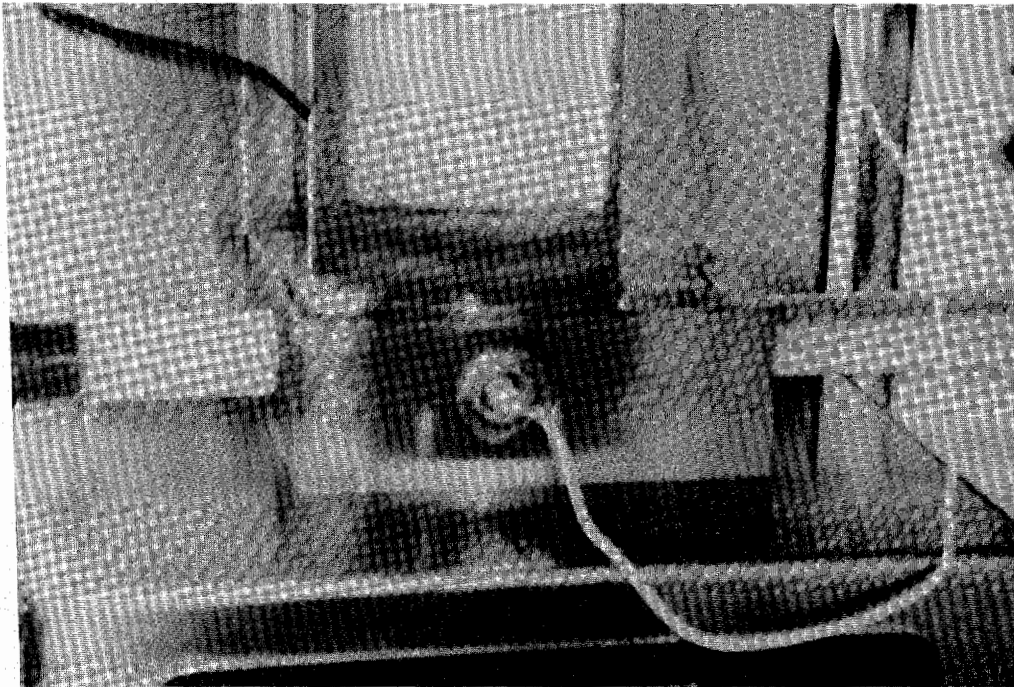

Figure 3.
Agitation of sample

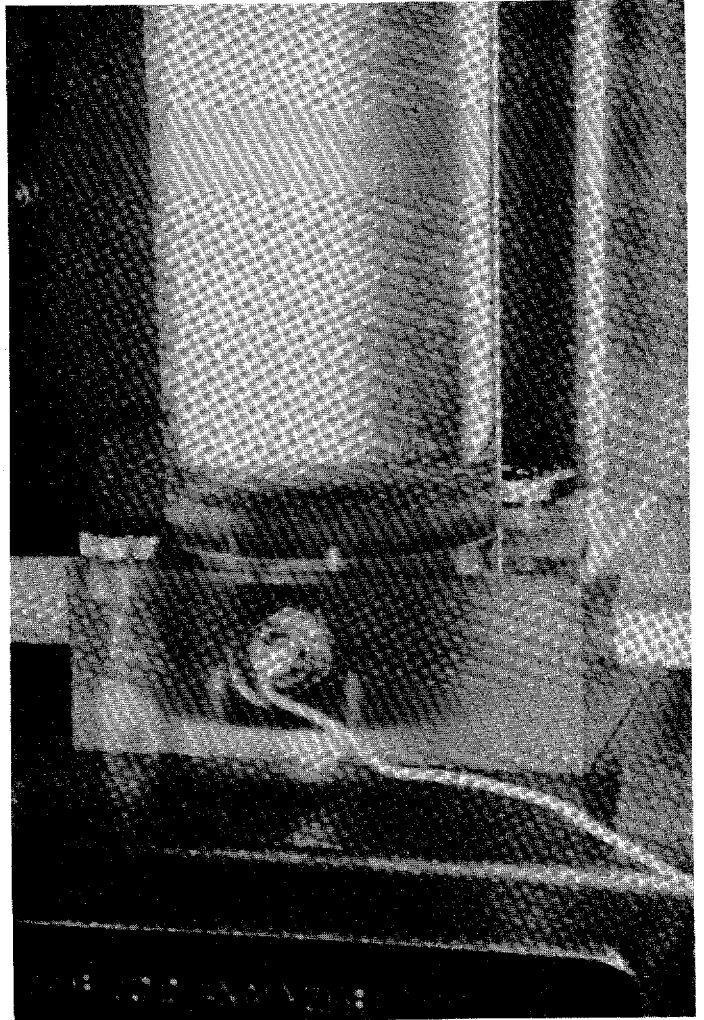
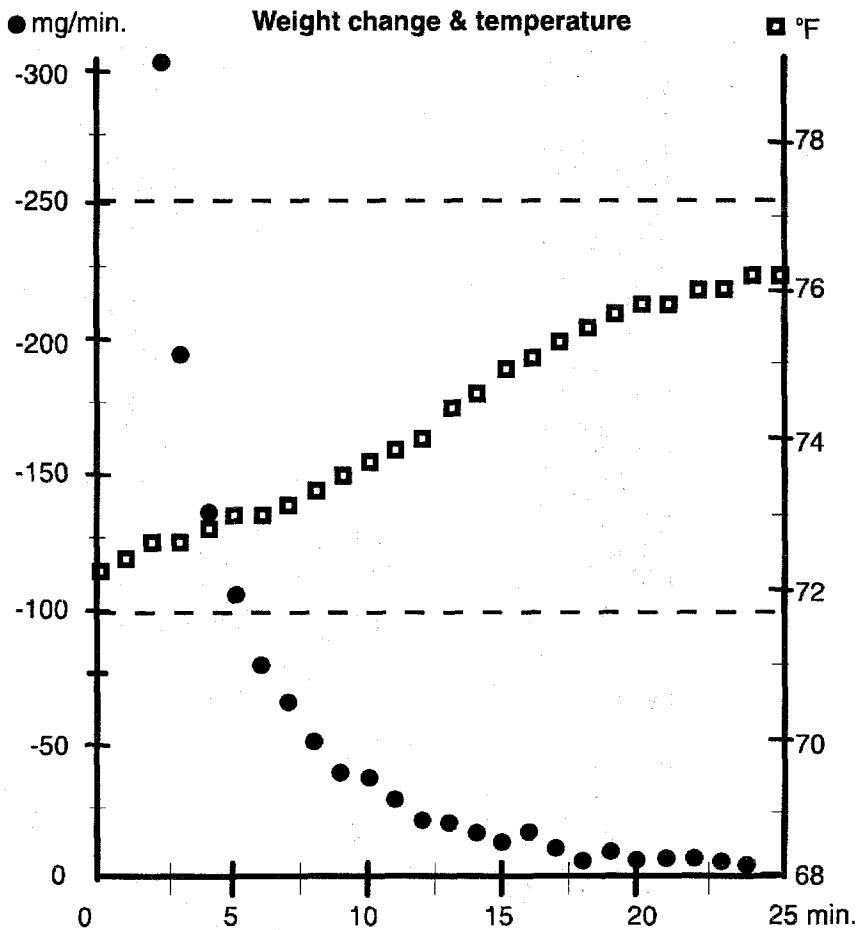

Figure 4.
Test under way

Air Void Analyzer, Series NA3/S
 Dansk Beton Teknik A/S, Denmark
 Hansson Consulting, Canada

Date: March 16, 1994 12:08 PM
 Case no.: 7 Bag A/E Test ✓
 Sample no.: 3 ✓



Sampler:
 Gary W. Klein ✓

Ordered by:
 FHWA ✓

Sample taken:
 BRC-18B ✓

Mortar <6 mm: 54.4 % ✓

Paste: 30 % ✓

Expected air: 7.5 % ✓

Sample volume: 20 cm³ ✓

Results: Recalculated - August 15, 1994 03:33 PM

Chord length		< 2.0 mm	< 0.65 mm	< 0.35 mm
Air in concrete		5.63 %	5.07 %	4.14 %
Air in paste		18.3 %	16.5 %	13.5 %
Air in putty		15.5 %	13.9 %	11.4 %
Specific surface	803 in. ⁻¹	31.6 mm ⁻¹	Corresponding to ASTM C457	
Spacing factor	0.0059 in.	0.15 mm		

Comments: 2.25oz/100&.75 add,SLU-2.5%,PMT-7.5 ✓

FEDERAL HIGHWAY ADMINISTRATION
 Office of Technology Applications

Signature: _____

Figure 5.
 Sheet 1 of AVA output

Air Void Analyzer, Series NA3/S
 Dansk Beton Teknik A/S, Denmark
 Hansson Consulting, Canada

Date: March 16, 1994 12:08 PM

Case no.: 7 Bag A/E Test

Sample no.: 3

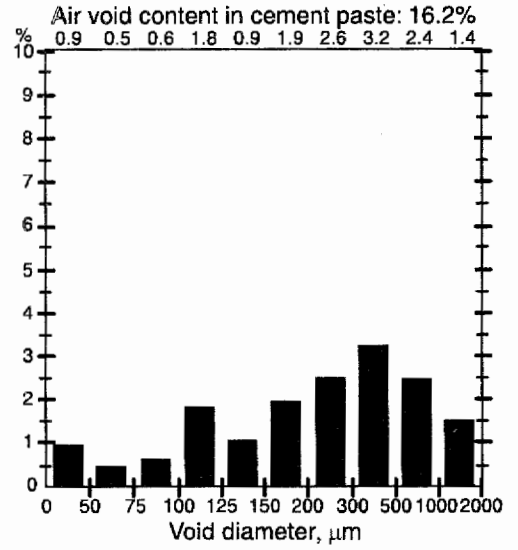
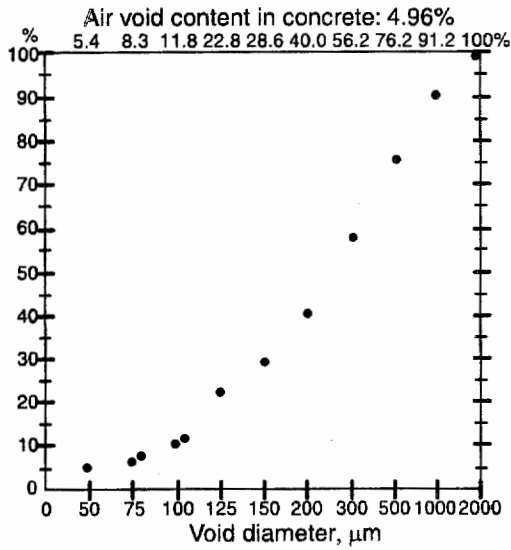

Comments: 2.25oz/100&.75 add,SLU-2.5%,PMT-7.5

Recalculated: August 15, 1994 03:33 PM

FEDERAL HIGHWAY ADMINISTRATION
 Office of Technology Applications

Signature: _____

Figure 6.
 Sheet 2 of AVA output

AVA AIR CONTENT

AVA VERSION #3.1 vs #3.3

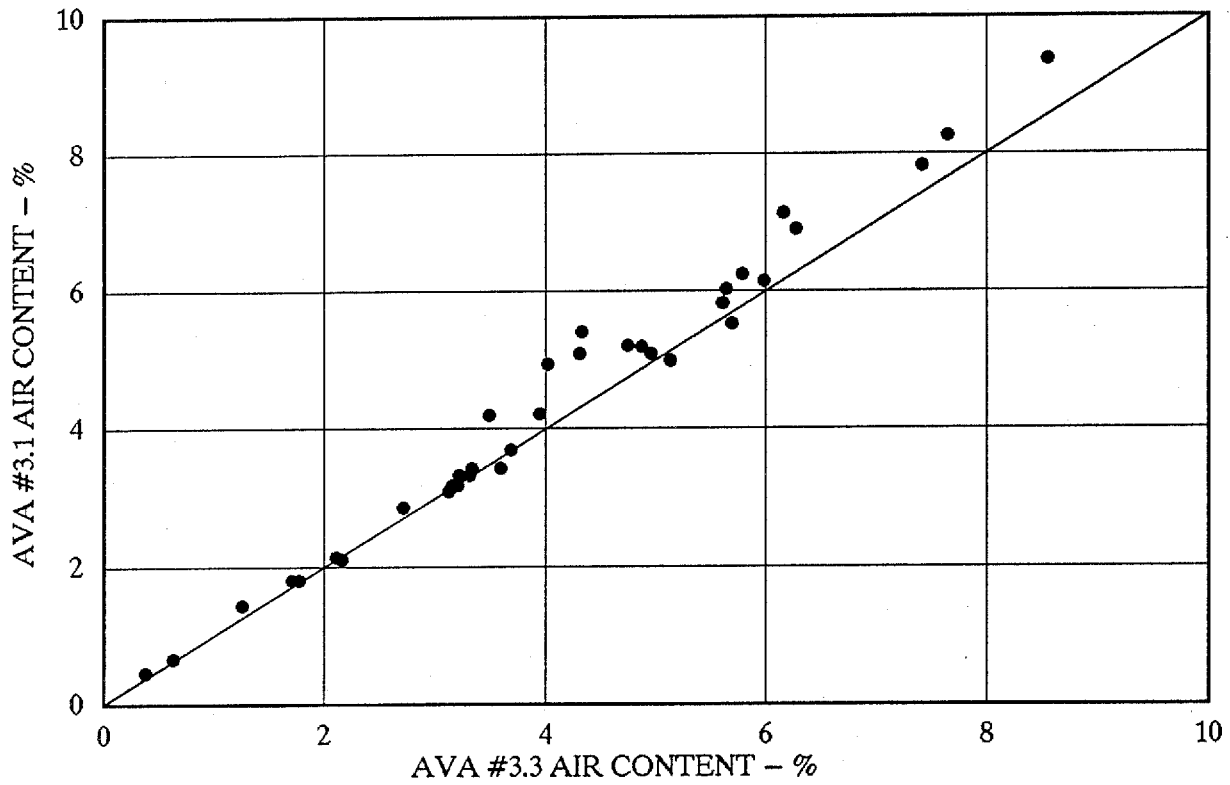

These data were originally collected on AVA #3.1 and recalculated using AVA #3.3

Figure 7.
AVA #3.1 vs. AVA #3.3
air content

AVA SPECIFIC SURFACE

AVA VERSION #3.1 vs #3.3

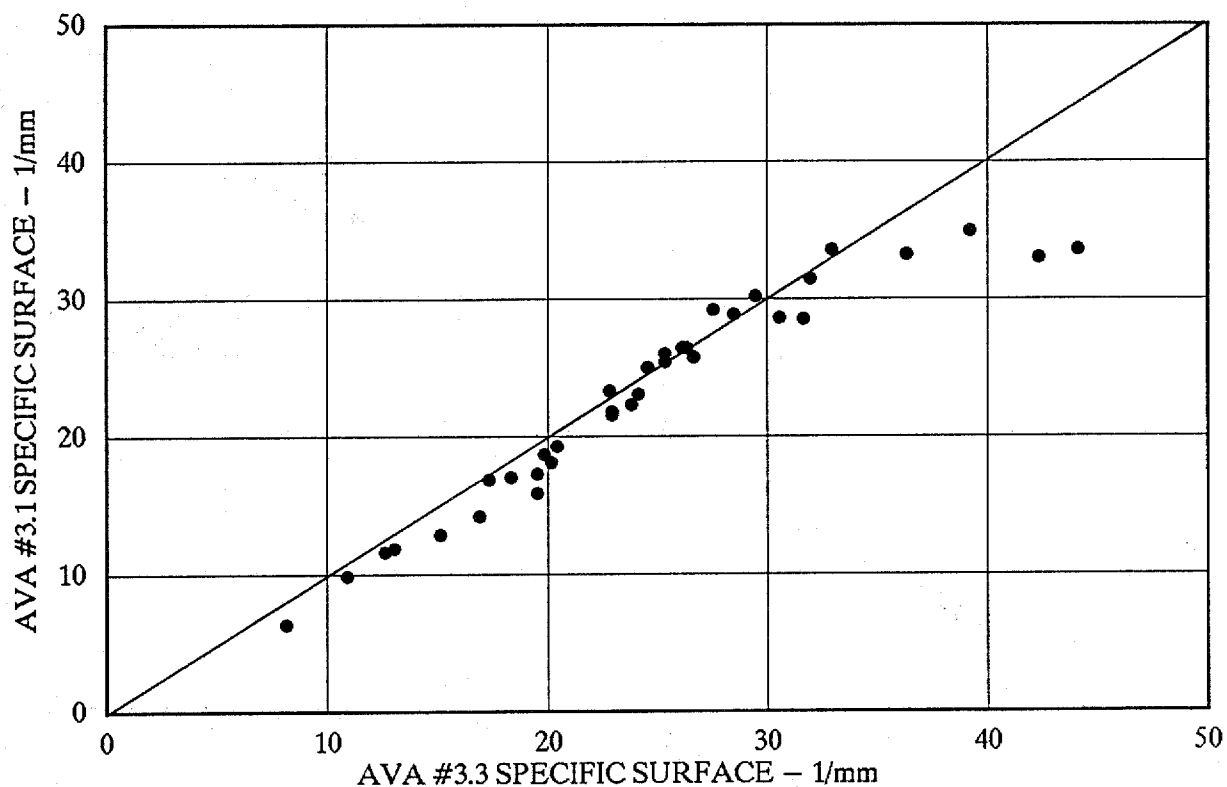

These data were originally collected on AVA #3.1 and recalculated using AVA #3.3

Figure 8.

AVA #3.1 vs. AVA #3.3
specific surface

AVA SPACING FACTOR

AVA VERSION #3.1 vs #3.3

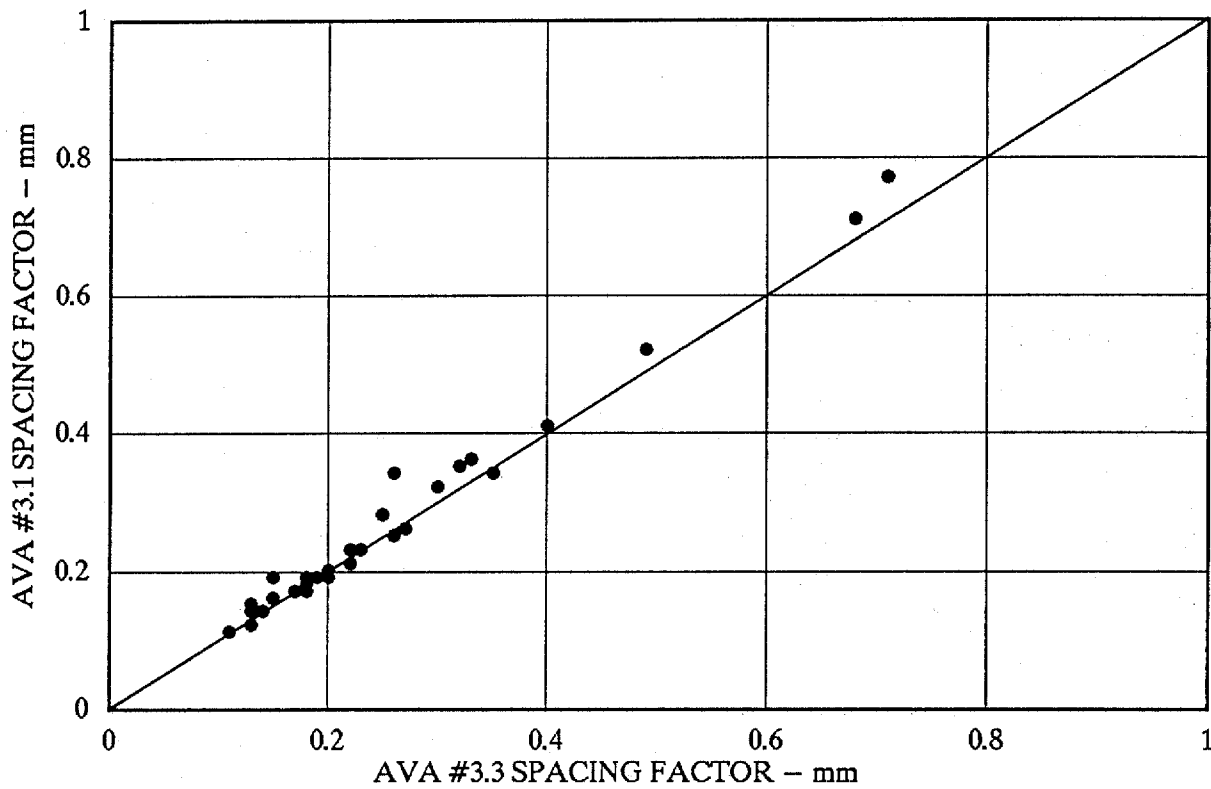

These data were originally collected on AVA #3.1 and recalculated using AVA #3.3

Figure 9.
AVA #3.1 vs. AVA #3.3
spacing factor

AIR CONTENT OF CONCRETE

PRESSURE METER vs ASTM C457

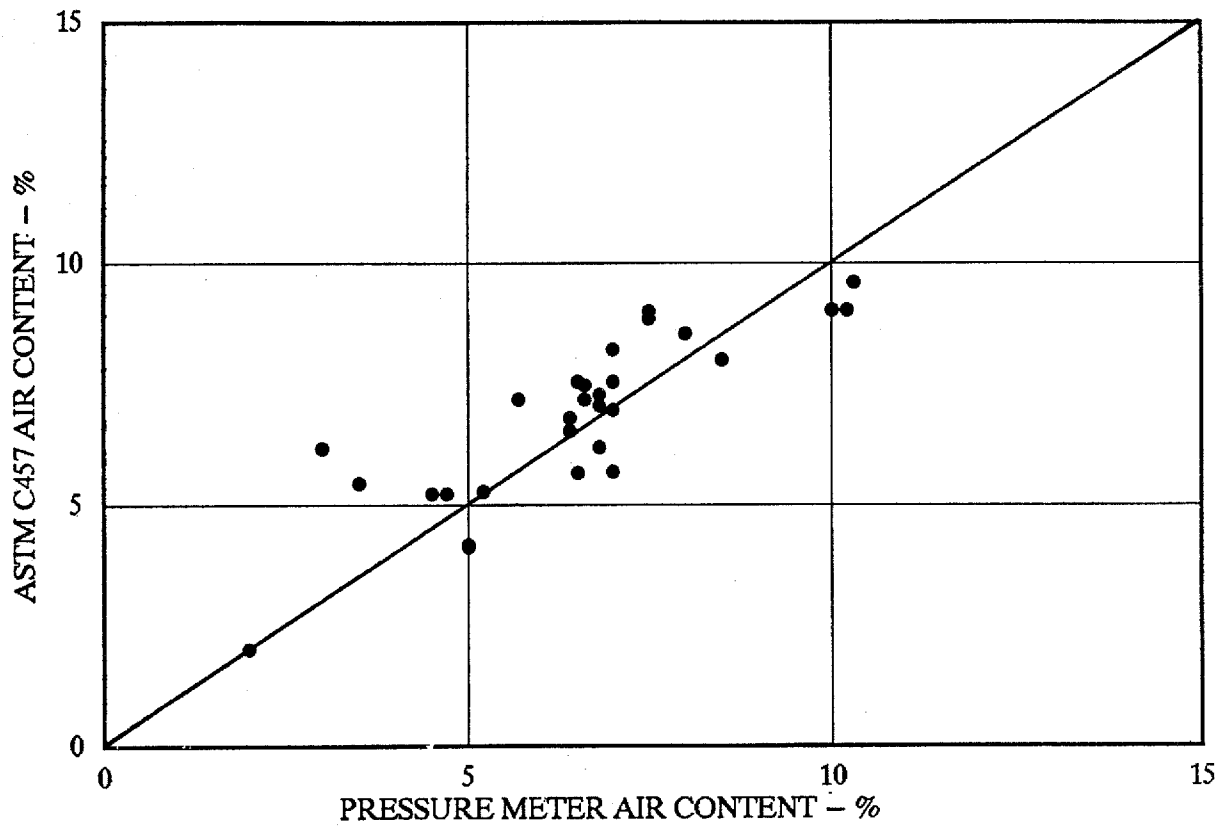

Figure 10.
Air pressure meter vs.
ASTM C457 air content

AIR CONTENT OF CONCRETE

PRESSURE METER vs AVA

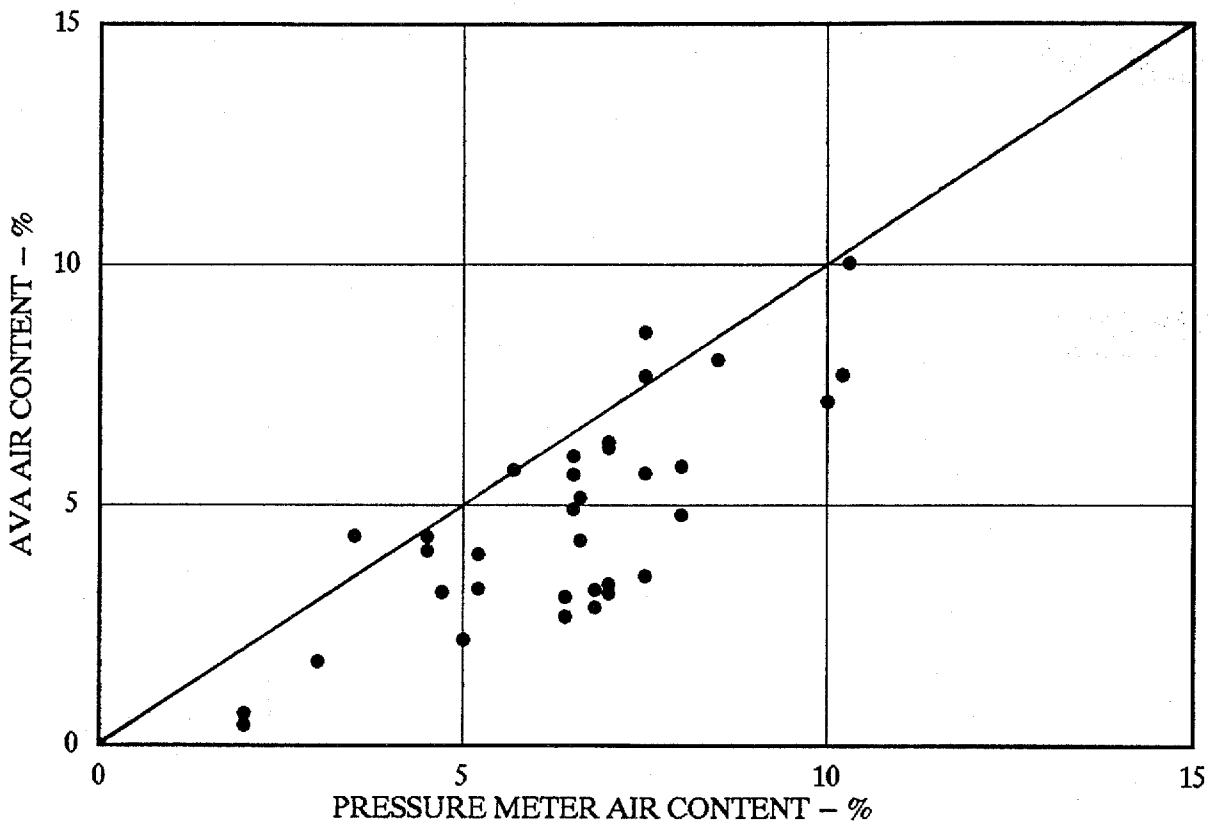

Figure 11.
Air pressure meter vs.
AVA air content

AIR CONTENT OF CONCRETE

PRESSURE METER vs AVA

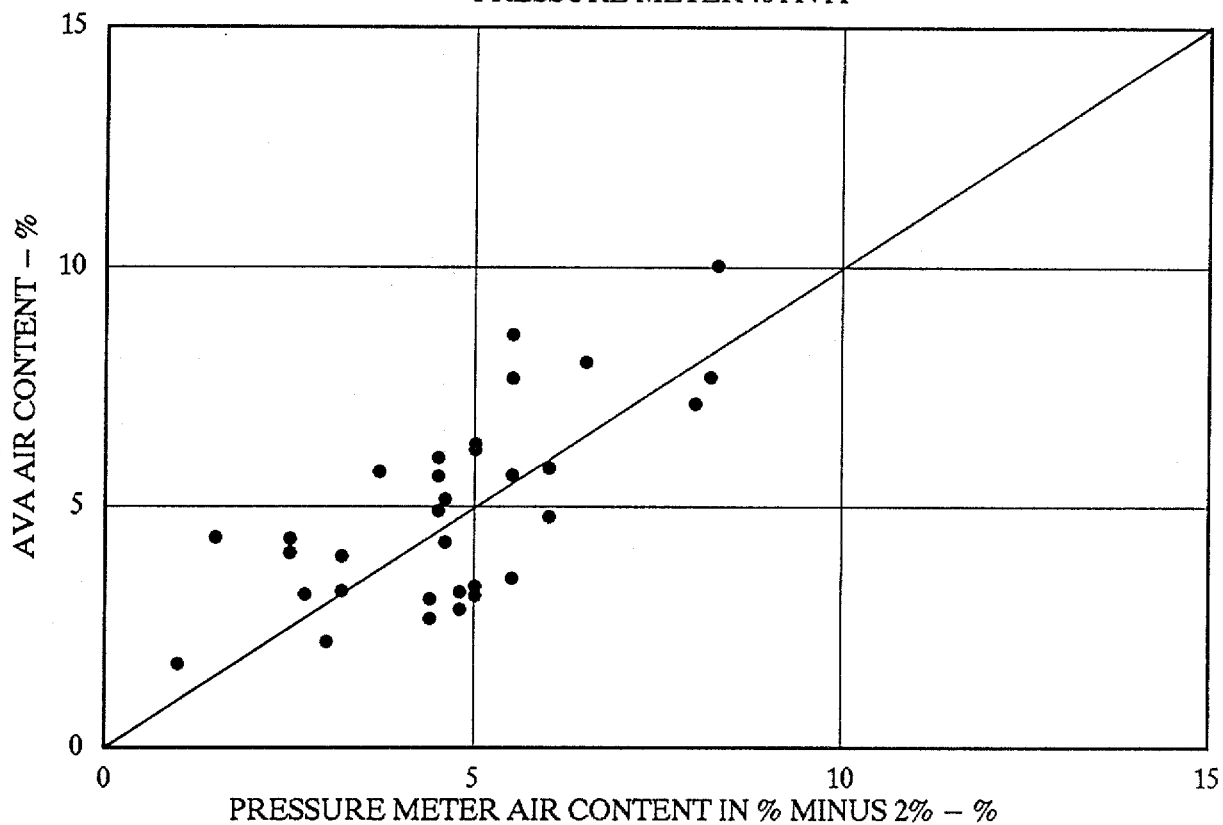

Figure 12.
Air pressure meter - 2%
vs. AVA air content

AIR CONTENT OF CONCRETE

ASTM C457 vs AVA

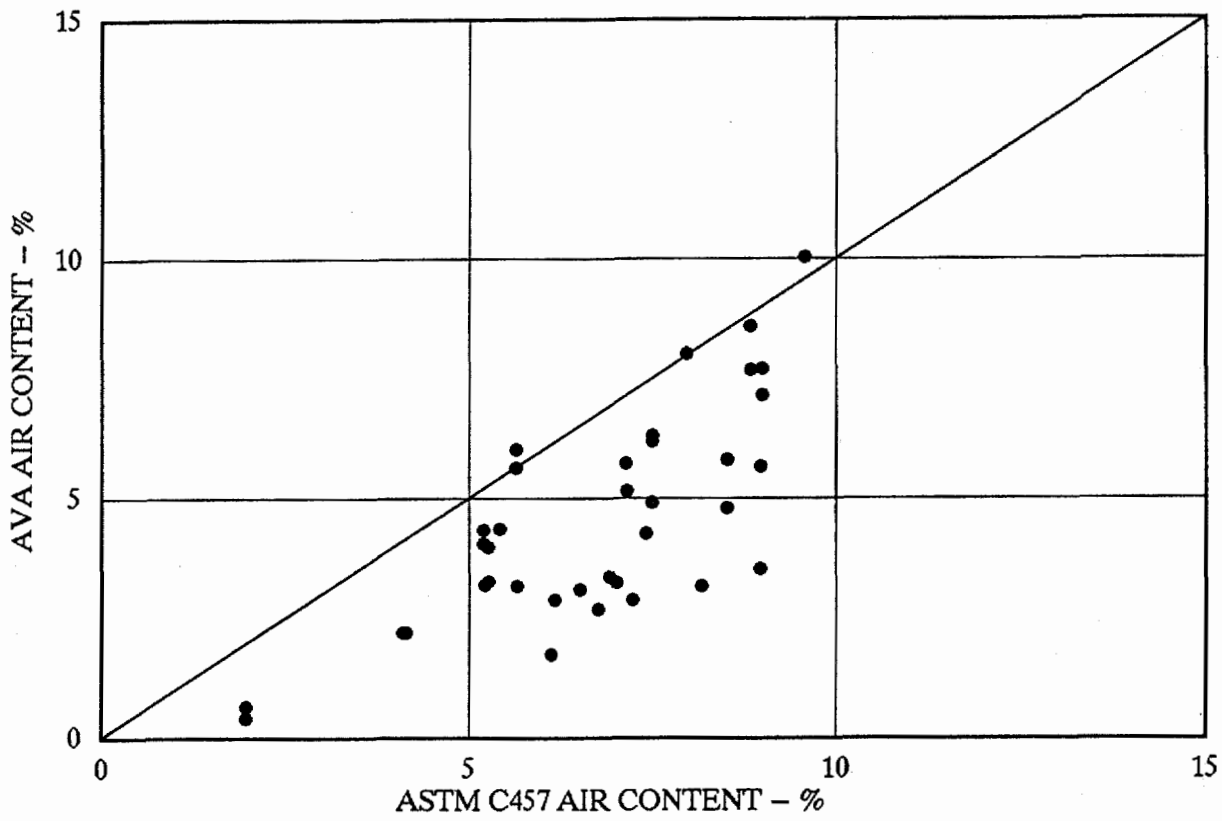

Figure 13.
ASTM C457 vs. AVA air
content

SPECIFIC SURFACE OF AIR VOIDS

ASTM C457 vs AVA

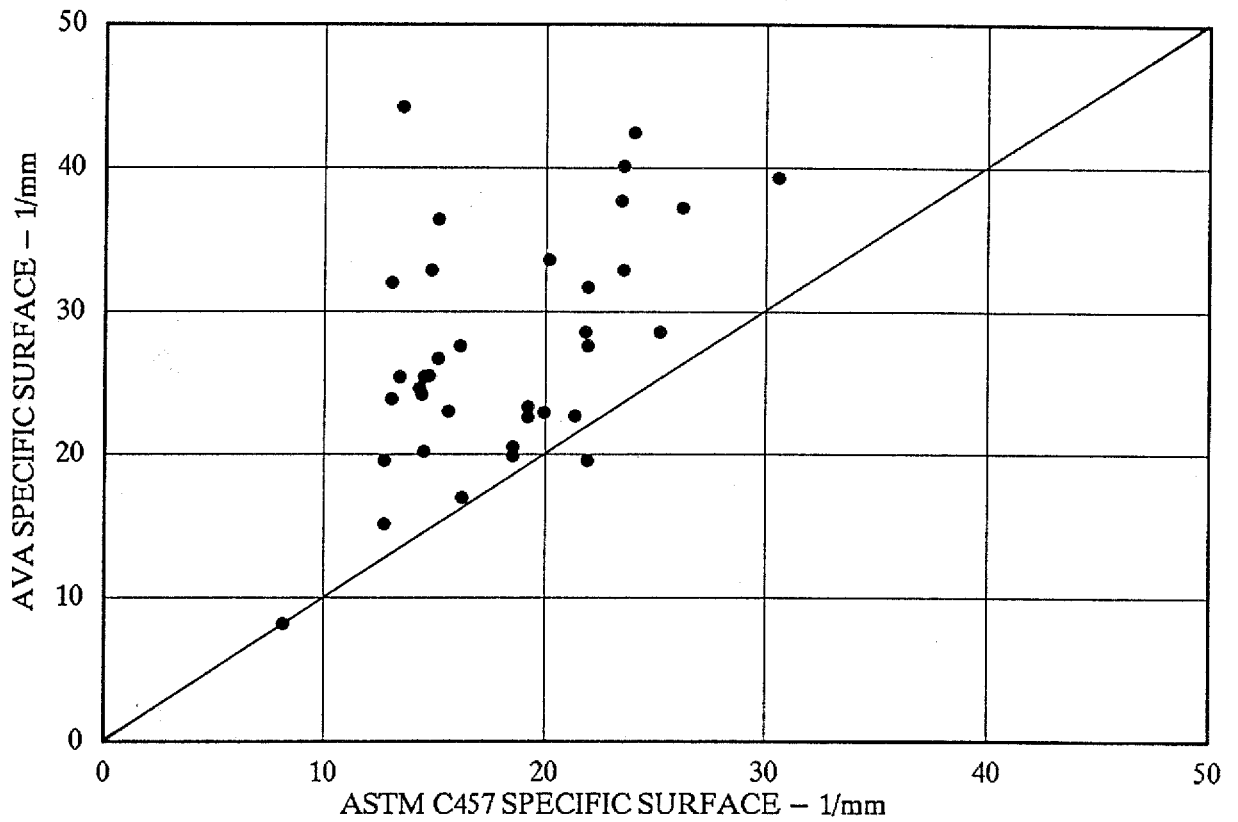

Figure 14.
ASTM C457 vs. AVA
specific surface

SPACING FACTOR OF AIR VOIDS

ASTM C457 vs AVA

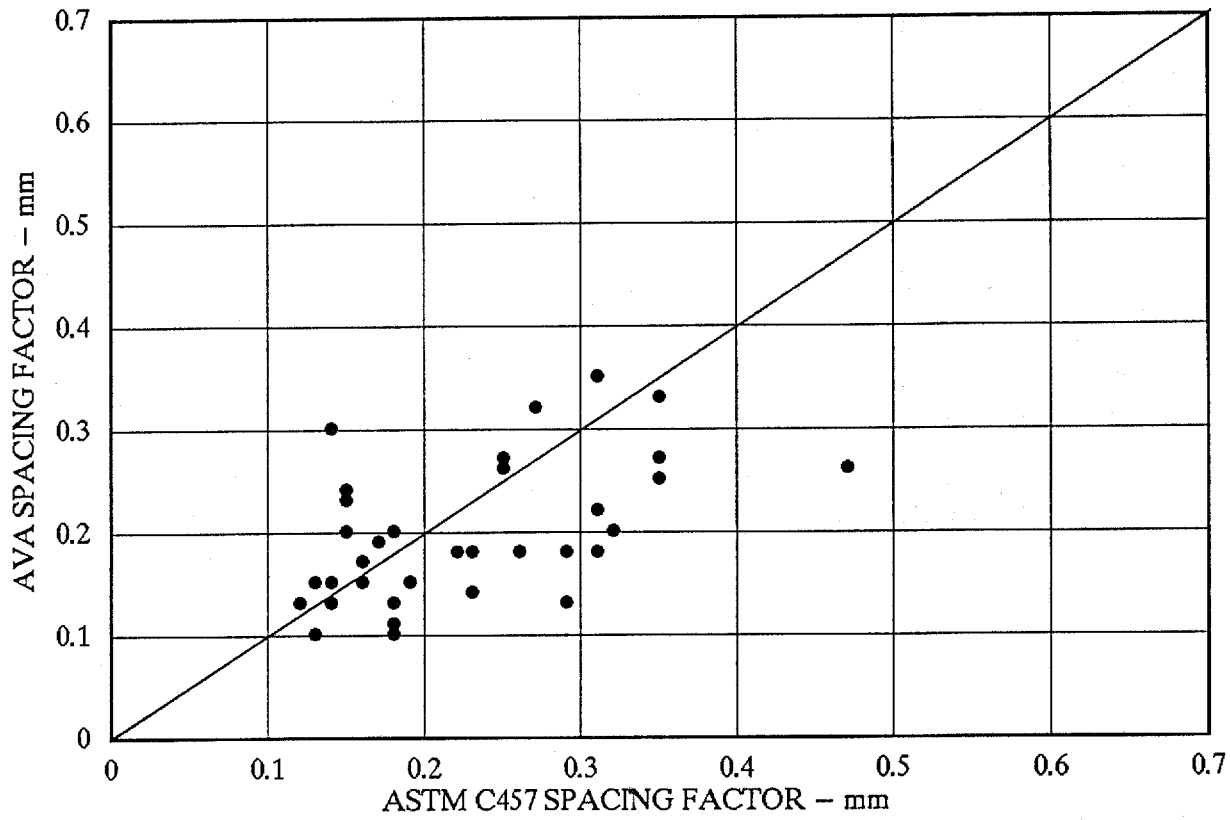

Figure 15.
ASTM C457 vs. AVA
spacing factor



APPENDIX A

BRITE/EURAM PROJECT No: BE-3376-89

Contract No: CT90-0358

March 1991 - February 1994

**QUALITY ASSURANCE OF CONCRETE BASED ON TESTING
OF THE FRESH, STILL PLASTIC MATERIAL**

FINAL REPORT

(First Draft)

Subtask 2.1.:

**Quantitative and Qualitative Determination of the Air Void
Structure in Fresh Concrete**

**Determination of the Air Void Structure Before Compaction
of the Concrete**

BRITE EURAM PROJECT No: BE-3376-89

Contract No: CT90-0358

March 1991 - February 1994

**QUALITY ASSURANCE OF CONCRETE BASED ON TESTING
OF THE FRESH, STILL PLASTIC MATERIAL**

Partners:

- DBT: Dansk Beton Teknik (DK, prime proposer)
- CSTC-WTCB: Centre Scientifique et Technique de la Construction Wetenschappelijk en Technisch Centrum voor het Bouwbedrijf (B)
- CUR: Civieltechnisch centrum Uitvoering Research en regelgeving (NL)
- FORCE: Force Institutterne (DK)
- INTRON: Instituut voor materiaal - en milieuonderzoek (NL)

Task 2:

**QUANTITATIVE AND QUALITATIVE DETERMINATION OF THE AIR VOID
STRUCTURE IN FRESH CONCRETE**

Subtask 2.1.:

**DETERMINATION OF THE AIR VOID STRUCTURE BEFORE COMPACTION OF THE
CONCRETE**

FINAL REPORT

(First Draft)

1. Scope of the Report

This report is the final research report of subtask 2.1. of the project BE-3376-89. The report describes the work performed in relation to subtask 2.1. and gives the conclusions of the research. For full details on all aspects of the research (concrete compositions, raw measurement data,...) Reference is made to the relevant progress reports.

2. Description of Subtask 2.1.

2.1. Introduction

It is generally recognized that the *air void structure* of concrete is a critical parameter for the durability of concrete subjected to frost/thaw action and deicing salts. Indeed when water saturated concrete is exposed to freezing, the resulting expansion of the pore water can produce stresses which are sufficient to crack and spall the concrete. It has been shown [1], that a system of air voids well dispersed throughout the cement paste of the concrete can provide space for the expansion of the freezing water thereby reducing or eliminating the internal stresses.

Traditionally the air void structure of concrete is characterized and assessed in terms of the total *air content* (A), the *specific surface* (α) and the *spacing factor* (\bar{L}) of the air bubbles. More recently also the *micro air content* (A_{300}) has been recognized to be an important factor.

A vast amount of experiments have demonstrated that for a good frost/thaw resistance a sufficient amount of voids with diameters in the range of 5 - 300 μm should be present. Voids with larger diameters do not contribute to the frost resistance. Expressed in terms of the traditional characteristics of the air void structure the following conditions must be met:

- *the specific surface* (i.e. the ratio of the surface area of the voids to the volume of the voids) *should be equal or larger than 25/mm*
- *the spacing factor of the voids* (i.e., as defined by Powers, a measure for the maximum distance from a point in the paste to the nearest void) *should be equal or less than 200 μm .*

These values are now quite generally included in specifications for frost resistant concrete as for example in ENV 206 [2]. Having specified a required air void system, it is of course then necessary to be able to determine whether or not the concrete meets the specifications.

Microscopical examination of the concrete in accordance with ASTM C457 [3] or similar guide-lines [4] is actually the only

method which is used for doing so. Such microscopic analyses can of course only be carried out on hardened concrete. Consequently they are not suited for application in a QA system. With regard to the microscopic analyses following serious disadvantages can be enumerated:

- At the time of analysis the concrete must be hardened and as such it is too late to rectify any possible problems which have occurred.
- Sample preparation requires coring, sectioning, grinding and polishing. This is time consuming and costly. Moreover it can sometimes be very difficult to produce a representative section because for example, aggregates could be porous and such porosities will be wrongly measured as air voids in an automated assessment.
- Manually operated optical microscopic analysis are both tedious and time consuming and may be subjected to a relative high degree human variability.

Realizing that for QA of air entrained concrete a very rapid and reliable analysis method was needed the Fresh Concrete Air void Analysis technique (FCAA) was developed as a principle by DBT in 1988. The FCAA technique was designed so as to give the same information as is provided by the ASTM C457 Standard Practice while avoiding the disadvantages of the latter procedure.

A major advantage of the FCAA technique is indeed that samples can taken at any time, for example, at the batching plant, on arrival at the construction site an even after placement and compaction of the concrete. Of course in order to determine the air void parameters corresponding to those obtained on a core of the hardened concrete the samples should be taken after final compaction. Nevertheless, the procedure is non-destructive as it removes only a very small amount of concrete mortar which can easily and immediately be replaced.

2.2. Principle of the FCAA Test Method

The FCAA technique or “riser column method” for the determination of the characteristics of the air void structure of concrete functions according to the following principles:

- A sample of the mortar fraction of the concrete is taken from a representative area of the concrete by vibrating a wire cage into the concrete. This causes the mortar to enter the cage while excluding all aggregates larger than the wire spacing which has been fixed at 6 mm. A syringe is subsequently inserted into the mortar in the cage giving a 20 cc sample for analysis of the air void structure.

-
- The 20 cc sample is injected from the syringe into the bottom of a riser column filled with a special liquid and water (fig. 1). The mortar is gently stirred for 30 sec. to release the air voids which were developed in the fresh concrete by the addition of an air entraining agent (together with eventually entrapped air) into the viscous liquid at the bottom of the column.
 - The properties of this viscous liquid are such that upon transfer from the mortar to the liquid the resulting bubbles in the mortar retain their original size and neither coalesce nor disintegrate into a number of smaller bubbles. The bubbles then rise through the liquid at rates dependent on their size (according to Stokes Law) and enter a column of water above the liquid. The viscosity of the liquid determines the rise speed of the bubbles of different size and provides a measurable separation in time between the appearance at the top of the column of the bubbles of different size rising from the same layer of the liquid.
 - The air bubbles rising through the column of water are collected under a submerged bowl which is attached to a balance. A computer which is connected to the balance records the buoyancy (B) of the bowl as a function of time.
 - In the early stages of the measurement, the size distribution of the air bubbles arriving under the bowl range from a few mm down to a few μm . For each succeeding period the maximum size of the bubbles decreases as all the larger bubbles, which rises fastest, have already risen to the top of the column. This is illustrated schematically for three bubble sizes in fig. 2a,b,c whereas in practice all bubble sizes have to be considered.

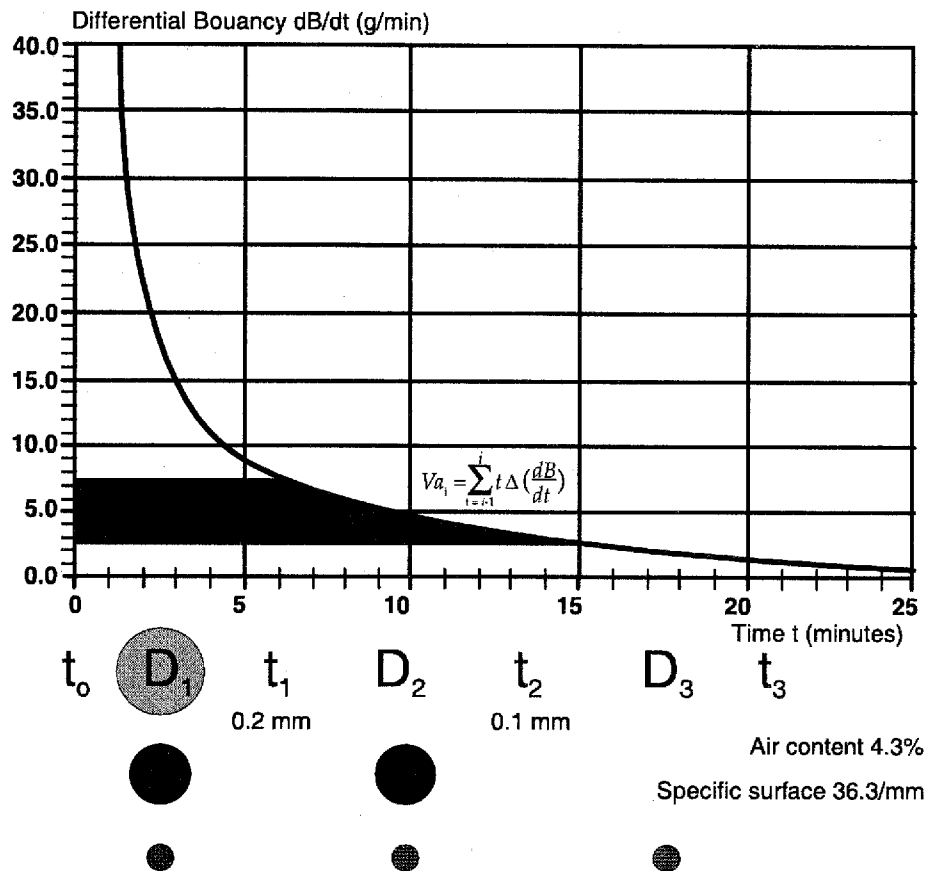

Figure 2.C.

- The measurement procedure continues for 25 min. which is assumed to be an appropriate time period to give the air void parameters comparable to those obtained by the ASTM C457 practice with acceptable accuracy (target +/- 10%). While voids of a very small diameter will continue to rise after this period, neglecting them is considered acceptable as such very small voids would anyhow not have been measured in the ASTM analysis as they will most probably be closed by precipitation in the concrete anyway.
- The computer processes the monitored balance readings and calculates on the basis of the recorded data the following air void parameters specified by the ASTM C457 standard:
 - the volume of air voids with a diameter smaller than 3 mm (as volume % of paste and using the concrete recipe data as volume % of concrete)
 - the specific surface of the air bubbles in 1/mm
 - the spacing factor according to Powers in mm.

These parameters have been calculated to correspond to those that would be obtained from a linear traverse measurement on a plane surface of the hardened concrete analyzed according to ASTM C457 practice.

In addition the computer can print:

- a graph giving the cumulative fraction of volume of voids versus the void diameter
- a bar chart of the actual void volume in different ranges of void diameters.

The calculation of the parameters of the air-void distribution relies, as already has been said, on the fact that the air-bubbles rise through the liquid at rates dependent on their size according to Stokes Law. A well known time interval t_{i-1}, t_i is associated to each considered void class D_{i-1}, D_i . The volume of air (V_{a_i}) of the voids in

this class can be calculated as $V_{a_i} = \sum_{t=i-1}^i t \Delta \left(\frac{dB}{dt} \right)$ where $\frac{dB}{dt}$

represents the recorded differential buoyancy (g/min.). The total volume of air in the sample is found by summing the individual contribution of each void class and is equal to $V_a = \sum V_{a_i}$. The

specific surface of the air-void structure is by definition equal to

$\alpha = \frac{1}{V_a} \sum \alpha_i V_{a_i}$ where $\alpha_i = 6/D_i$ is the specific surface of voids with diameter D_i .

Knowing the volume of the sample (V_s ; normally 20cc) and the composition of the concrete the content of air found in the sample V_a can now be recalculated to the real air content of the concrete A . The following relation applies

$$A = \frac{M_o \frac{V_a}{V_o}}{M_o \frac{V_a}{V_o} + 100} 100\% \text{ where } V_o = V_s - V_a \text{ and } M_o = \frac{M}{100 - A_e} 100\%$$

with M the content of mortar, aggregate $<6\text{mm}$ and A_e the expected air content. The specific surface is independent of the sample size and composition and needs no modification. Knowing A and α the spacing factor can now be calculated; the well known definitions of Powers directly applies.

2.3. Aim of the Subtask 2.1.

The aim of subtask 2.1 of the project is to gather, as a basis for general acceptance of the FCAA technique, the necessary data to prove that the results obtained by testing the fresh concrete according to this technique are reliable and correlate well, irrespective of the type of concrete, with the results obtained by analyzing the same concrete after hardening in accordance with the general accepted ASTM C457 standard practice.

The work done at DBT and CSTC in relation to subtask 2.1 is complementary in this sense that at DBT and CSTC different concrete compositions (representative for a range of European concretes) are being tested. The test procedure for testing the concretes is the same for all concretes and is the same in both laboratories.

2.4. Test Procedure

For each of the examined concretes the test procedure adopted is as follows:

- Approximately 40l of concrete is batched or sampled and subsequently cast and compacted by vibration in a beam-mould (600x100x150 mm or 600x120x120 mm). The compaction applied was only for the purpose of preparing the test specimens and was not intended to simulate the effects of normal handling and consolidation of the concrete. A profound study of these aspects will indeed be studied in subtask 2.2.
- Out of each beam 5 samples of 20 cc fresh concrete are collected. The samples are taken in points evenly distributed over the length of the beam (fig.3). The samples are stored at 5-8°C to extend the setting time of the paste and are analyzed using the FCAA technique. The precaution of cooling the samples is taken because the analysis covers a period of 2 ½ - 3 hours and a complete mixing of the mortar samples with the analysis liquid during the stirring period is essential.
- The FCAA sampling holes in the beam are closed with fresh concrete mortar and the beam is cured for at least 48 hours. Adjacent to the locations where the fresh mortar samples were taken 5 slices (100x100x20 mm) of the beam are produced. These sections are later analyzed according to ASTM C457.

3. Tests Performed

3.1. Batching of Concrete and FCAA Testing

An extensive series of tests has been carried out both at DBT and CSTC. At first trial mixes were batch at CSTC in order to select the proper compositions for air entrained concretes. Pilot testing was performed at DBT to verify the principle of the testing method.

On the basis of the observations made during the pilot testing the software of the computer monitoring the balance readings was slightly adapted at DBT (cfr.5.). Some adjustments of the software appeared indeed to be necessary for correcting some minor deviations which occurred for concretes with extreme air void properties, i.e. very low or very high specific surface.

At CSTC an air void analyser leased from DBT equipped with the original version of computer software was used through the testing.

In the actual round of testing performed by DBT and CSTC at both laboratories 27 different concretes were assessed using the FCAA testing technique, so a total of 270 FCAA tests were performed. The air void characteristics (air content, specific surface) of the tested concretes ranged over a very wide range of values. Fig. 4 gives an indication in this respect. Full detail on the performed test can be found in the relevant progress reports.

3.2. Testing According to ASTM

As a reference method for assessing the air void structure of the concretes the ASTM C457 standard practice for the microscopic analysis of concrete was to be used.

To be even more precise the measurements were to be performed according to the linear traverse (Rosiwal) method [3]. For aggregates with a maximum size of about 25 mm the method consist in measuring and counting air void chords over a length of minimum 2413 mm on a contrast impregnated plane polished concrete section measuring at least 88x88 mm.

It should be stated here that the preparation of the specimens and the analysis according to this standard are performed using automated equipment of a different nature in both laboratories. It was therefore essential to establish that the analysis according to ASTM were performed on a comparative level at DBT and CSTC.

In this respect at first a number of tests were carried out to calibrate the ASTM results obtained at DBT and CSTC. Samples were exchanged and the obtained results compared. Rather severe

unforeseen difficulties in obtaining the same results appeared to occur. The differences which were observed were not only caused by simple malfunction of equipment or operation of such, but appeared also to be related to specimen preparation quality etc. Some of the disadvantages of the ASTM analysis mentioned in the introduction came clearly into the picture.

Subsequently it has been very time consuming to reach an acceptable starting point for the research. A delay which fortunately does not affect the completion of the research was inevitably experienced.

Using a calibration "floating glass sample" the measuring equipments were tested for accuracy, very satisfactory results were obtained in the end (deviations less than 2% for a specific surface of 50/mm).

Training of the CSTC staff was put into practice and a common procedure of preparation was established. So the problems have been overcome and both laboratories were then able to carry out this analysis in accordance with international state-of-the-art. Currently overall quality assurance of the testing is performed through the participation of DBT in international round robin test for testing in accordance with ASTM C457.

An indication of the actual obtained level of agreement in the execution of the ASTM analysis is given in the figures 5, 6 and 7. The results are to be considered as very satisfactory. The deviations observed in fig. 6 in the large chord size intervals being inevitably and not relevant as being governed by the presence of entrapped air voids.

4. Analysis of the Test Results

4.1. Reliability of the Results

As a first general point regarding the fresh concrete air void analysis it has to be pointed out that at some occasion it appeared impossible to correctly analyze the fifth sample which had been taken. The reason for this was obvious the fact that in the 3 hours which generally elapsed before the fifth sample could be analyzed (albeit that the samples were cooled down) some setting of the mortar had taken place. In order to verify whether or not the time of analysis had some influence on the test results "single-factor analysis of variance" tests were run on the obtained results. For this purpose the results were classified according to the order of analysis in 5 groups. As an example the outcome of such an analysis performed the specific surface test results obtained at DBT is given in table 1. The five groups considered are named FCAA_SS1 to FCAA_SS5., where SS stands for specific surface.

From the ANOVA table it appears that there is no significant difference between the groups ($F=0.5 < F_{crit}=2.4$). The same conclusions could be draw for all the ANOVA tables constructed.

Table 1: Anova: Single-Factor analysis

DBT FCAA Specific Surface results.

Summary

<i>Groups</i>	<i>Count</i>	<i>Sum</i>	<i>Average</i>	<i>Variance</i>
FCAA_SS1	24.0	699.8	29.2	47.7
FCAA_SS2	26.0	723.9	27.8	62.2
FCAA_SS3	26.0	717.5	27.6	57.2
FCAA_SS4	25.0	683.2	27.3	62.4
FCAA_SS5	20.0	596.1	29.8	47.8

ANOVA

Source of Variation

	<i>SS</i>	<i>df</i>	<i>MS</i>	<i>F</i>	<i>P-value</i>	<i>F_{crit}</i>
Between Groups	104.8	4.0	26.2	0.5	0.8	2.4
Within Groups	6487.9	116.0	55.9			
Total	6592.7	120.0				

Secondly the standard deviation of each 5 FCAA test results was studied and compared to the standard deviation of each 5 ASTM results. The following figures were obtained (table 2 & 3).

Table 2: Standard Deviation of the DBT Results

	FCAA		ASTM	
	Mean	St. Dev.	Mean	St. Dev.
Air content (%)	0.6	0.28	0.6	0.35
Specific Surface (1/mm)	1.7	0.65	1.5	0.63
Spacing Factor (mm)	0.013	0.0079	0.012	0.0071

Table 3: Standard Deviation of the CSTC Results

	FCAA		ASTM	
	Mean	St. Dev.	Mean	St. Dev.
Air content (%)	0.6	0.48	0.9	0.54
Specific Surface (1/mm)	2.7	1.83	2.9	1.66
Spacing Factor (mm)	0.035	0.0605	0.020	0.0216

Statistical F-tests and t-tests were run in order to evaluate if the difference which were observed were significant. Generally speaking the result indicated that for the ASTM and the FCAA results obtained in one and the same laboratory no significant difference existed. Between the laboratories however a significant difference could be observed. Indeed the standard deviation on the results was except for the air content significantly higher at CSTC than at DBT. The reason for this is undoubtedly that at CSTC in general concretes with a lower air content and lower slump have been tested than was the case at DBT.

As a conclusion toward the reliability of the FCAA results it can thus be stated that the standard deviation on the results is of the same order of magnitude than the standard deviation on the ASTM results (cfr. fig.8).

As is apparent form the figures 9 and 10 the correlation of the standard deviation on the individual results with other parameters

of the concrete (slump, air content, etc.) appeared to be not very significant.

At last it should be mentioned that in very stiff concretes the sampling procedure has give rise to some problems. Indeed for concretes with a slump below 1 cm it appeared not at all easy to get the syringe correctly filled up with mortar.

4.2. Correlation Between the FCAA Results and the ASTM Results

As a final stage in the evaluation of the FCAA results regression analysis have been performed between the ASTM results and the corresponding FCAA results.

For each of the parameters of the air void structure (i.e. the air content, specific surface, spacing factor) the regressions lines have been calculated between:

- the individual ASTM data points and the individual FCAA data points (this has been done for the full data set and for a restricted data set which contains only the results which were in the working range of the DBT air void analyser, ($ASTM_i$ - $FCAA_i$).
- the mean results of each 5 ASTM measurement and the individual FCAA data points ($ASTM_m$ - $FCAA_i$)
- the mean results of each 5 ASTM measurements and the mean results of each 5 FCAA measurements ($ASTM_m$ - $FCAA_m$).

The figures 11 to 22 give the outcome of the analysis. Along with the regression lines on each figure the 95% confidence limits of the regression are indicated, this for a single measurement (dotted lines) and for the mean of 5 measurements (full lines).

The following essential parameters (table 4) were obtained.

Table 4: Outcome of the regression analysis

Regression	Air content		Specific surface		Spacing factor	
	Slope	Confidence interval (%)	Slope	Confidence interval (1/mm)	Slope	Confidence interval (mm)
ASTM _i *-FCAA _i *	0.62	+/-0.85 +/-1.87	0.84	+/-3.14 +/-6.92	0.99	+/-0.022 +/-0.049
ASTM _i -FCAA _i	0.58	+/-0.84 +/-1.84	0.90	+/-2.48 +/-5.44	0.99	+/-0.018 +/-0.039
ASTM _m -FCAA _i	0.78	+/-0.30 +/-1.62	1.06	+/-2.02 +/-4.43	1.16	+/-0.014 +/-0.031
ASTM _m -FCAA _m	0.80	+/-1.31	1.07	+/-2.96	1.16	+/-0.023

In the table 4 an asterisk (*) indicates that the full data set has been used and the subscript (i) respectively the subscript (m) indicates that the individual values respectively the mean values have been considered. Concerning the confidence interval in most cases two values are indicated. The smallest of both values applies for the 95% confidence limits for the mean of 5 values while the other one applies for the 95% confidence limits for a single observation.

From the figures and the table it is evident that as far as concerns the specific surface and the spacing factor a very good correlation exist between the mean value of the 5 ASTM results and individual FCAA results. As an example fig. 18 shows for the specific surface that if a concrete which has a mean specific surface of 35.0/mm were to be analyzed with the air void analyser:

- we can state with 95% of confidence that the mean value of five performed FCAA analysis will fall in the range $35.0-2.02 < FCAA_SS_m < 35.0+2.02$
- while with the same confidence we can state that the individual results will all fall in the range $35.0-4.43 < FCAA_SS_i < 35.0+4.43$.

As such the targets which were fixed at the beginning of the research appear to be largely met for the specific surface. The same can be observed for the spacing factor.

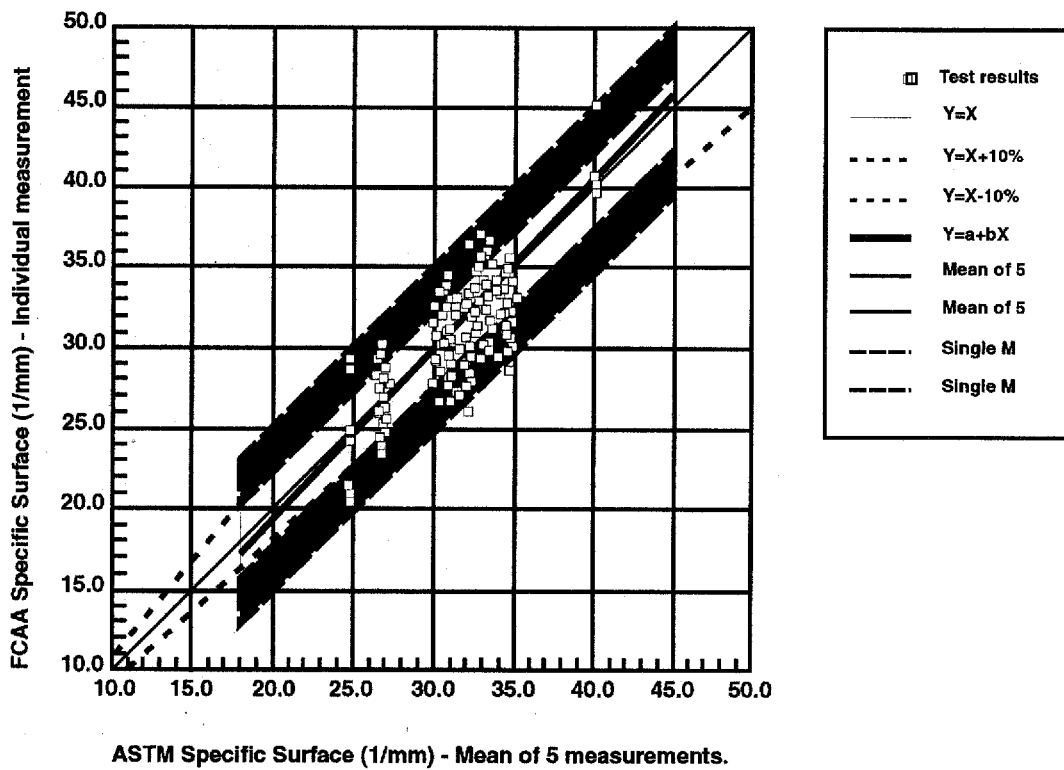
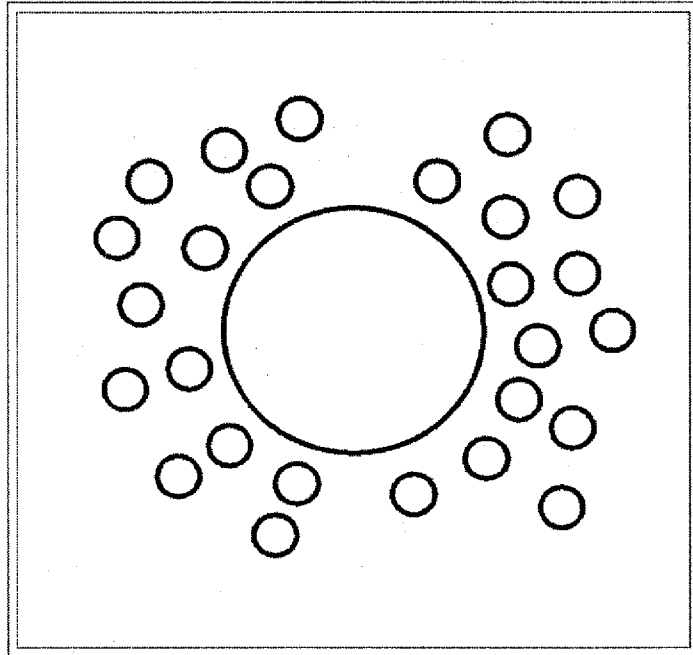

Figure 18.
Regression curve and 95% confidence intervals.

In relation to the air content the situation appears at first glance less favorable. However it should be remarked here that the apparent discrepancy is logic and caused by the fact that the air void analyser does not take account of air bubbles larger than 3 mm. In this way the air void analyser does not take account of entrapped air which explains the deviation between the measured ASTM air content and the measured FCAA air content (cfr. 5). It is important to stress here that anyhow the DBT freshvoid air analyser does not have the purpose of functioning as an air meter and will always fail to do so simply because the size of the sample is statistically too small to have the ability to take properly account of large air voids. The latter however does not have any consequences on the use of the DBT fresh void analyser for assessing the air void structure of concrete as big air voids anyhow do not contribute to the frost resistance of the concrete and as a whole really do not change in reality the spacing factor of the air bubbles as may be evident from following figure.



The presence of a big air void does in reality not really change the spacing of the small air voids.

5. Calculation of Chord and Void Distributions

5.1. Aim and Results

In the preceding section there has been dealt with the comparison and correlation of the air content, the specific surface and the spacing factor (i.e. the traditionally used characteristics of the air void structure of concrete) determined using respectively the ASTM and the FCAA technique. Of course it would be very instructive to be able to compare even more directly the both methods by looking at the results they yield in relation to the real volumetric air content distribution in the concrete.

As such this is not readily possible. Indeed in the ASTM technique the raw measurement data which is used for the calculation of the characteristics of the air void structure is the "distribution of chords" measured on a plane polished concrete section (cfr. 3.2.). In the FCAA technique the raw data consist in the "distribution of air voids" (cfr. 2.2). As the former is 2-D information and the latter 3-D information it is obvious that a direct comparison can not be made.

However, using the 2-D chord distribution information as input the corresponding 3-D void distribution can be calculated [5,6,7]. Conversely, using the 3-D void distribution information as input the corresponding 2-D chord distribution may be obtained.

Suitable calculation procedures in this respect have been reviewed. A 3-D to 2-D conversion was implemented at DBT and used to analyze the FCAA data. A 2-D to 3-D conversion has been implemented at CSTC. The mathematics of these procedures are dealt with in the next section.

At DBT a comparison was made between the measured 2-D ASTM chord distributions and the calculated 2-D FCAA chord distributions. Mean values of 5 measurements were used for this purpose and all chord distributions were recalculated to 1.000 chords. It was on the basis of these comparisons that the original FCAA software has been modified. Modification was done in such a way that for all measured values of specific surface a good fit was obtained between the ASTM and FCAA 2-D chord distributions. It is to be mentioned that these adjustments have not caused essential changes in the specific surfaces since there has been changes in both ends of the air void size scale.

As an example fig. 23 shows the chord distribution curves respectively for the FCAA measurements and the ASTM measurements on sample 92-098. It appears that for this sample the respective curves fit each other very well. For some other samples a small deviation may be found between the two curves. This appears however only to be the case for the rough air void systems with a specific surface of approximately 15/mm which is typically for concretes with a large amount of entrapped air and air contents above 10% (which is actually out of the working range of 3-10% of the air void analyser).

Fig. 24 gives as an example the results of the 2-D to 3-D conversions which have been applied at CSTC. For the sake of comparison the total air content has in this figure been normalized to 1. It is noted that the fit of the two curves is rather good, except again for the large air void diameters. This observation is in agreement with what has been found at DBT. Using the 2-D to 3-D conversion it is now also possible to study the correlation between the micro air content determined in an ASTM analysis with the one recorded by the FCAA.

5.2 Mathematics of the 2D and 3D Transformations

5.2.1. Measurement Results

The procedure for analyzing a polished concrete section according to the linear traverse (Rosiwal) method is fully described in [3] and [4]. Essentially the method consists in measuring along a series of regularly spaced lines of transverse the

- total length of traverse (T_{tot})
- the total length of traverse across air voids (T_v , i.e. the sum of the individual chord lengths)
- the number of void sections intersected (N).

Out of these measurement results the essential parameters of the air void structure (A , a) can be calculated as follows:

$$A = \frac{T_v}{T_{tot}}$$

$$\alpha = \frac{4N}{T_v} = \frac{4}{\bar{l}} \text{ where } \bar{l} = \frac{T_v}{N} \text{ is the average chord length.}$$

The former two relations are generally valid relations known from stereology. They do not imply any assumption on the shape of the voids. For a mono-dispersed system of spherical air voids with diameter D the relation for a is very simple to prove. It is indeed very easily verified that for a sphere of diameter D :

the specific surface $\alpha = \frac{6}{D}$ and

the average chord length $\bar{l} = \frac{2}{3} D$.

If not only the sum of the chord lengths is recorded but also the individual chord lengths the latter can be classified in a certain number of discrete chord classes. The chord length distribution can now be drawn. Generally this is done in a graph representing the cumulative number of chord per unit length of traverse (N_v) in function of the chord length; an example is given in fig. 5.

As explained in section 2.2 the FCAA technique allows to assess directly the distribution of the air content in function of the diameter of the air voids. An example of such a distribution is given in fig. 24. The essential parameters of the void system can be calculated using the following relations:

$$A = \sum_{i=1}^n A_i \quad \alpha = \frac{1}{A} \sum_{i=1}^n \alpha_i A_i$$

Where A_i is the air content of the voids with diameter D_i and

$\alpha_i = \frac{6}{D_i}$ their specific surface.

The question is now how the distribution of chords is related to the distribution of voids and how if one of the distributions is known the other one can be obtained by simple mathematical calculations.

5.2.2. Transformation from 3D to 2D

First the determination of the distribution of chords from information of the distribution of voids will be dealt with. Let us assume we are dealing with a poly-dispersed system of spherical air voids with diameters $D_1, D_2, \dots, D_1, D_1, \dots, D_n$ and related air void content distribution $A_1, A_2, \dots, A_1, A_1, \dots, A_n$.

Considering only the air voids with diameter D_j we know from simple geometrical considerations (fig. 25) that the distance from the centre of a bubble with diameter D_j to any chord with length l_j

is equal to $x(l_j, D_j) = \sqrt{\left(\frac{D_j}{2}\right)^2 - \left(\frac{l_j}{2}\right)^2}$

As such we know that on a given line of traverse the number of chords with length between D_j and l_j per unit length of line of traverse i.e. $N_L(l_j, D_j)$ is as shown on fig. 26 equal to the number of bubbles which are located in the cylinder with the considered line of traverse as axis and radius $x(l_j, D_j)$. This number of bubbles is

equal to $\pi x(l_j, D_j)^2 N_V(D_j)$ and thus $N_L(l_j, D_j) = \frac{\pi}{4} (D_j^2 - l_j^2) N_V(D_j)$

where $N_V(D_j)$ is the number of bubbles with diameter D_j per unit volume of concrete. As the air content of the voids with diameter

D_j is A_j it follows that $N_V(D_j)$ is equal to $N_V(D_j) = \frac{A_j}{\frac{\pi D_j^3}{6}} = \frac{6A_j}{\pi D_j^3}$

By simple subtraction we obtain that the number of chords with length between l_{i-1} and l_i per unit length of line of traverse coming from bubbles with diameter D_j is equal to:

$$N_i(l_{i-1}, l_i, D_j) = N_i(l_{i-1}, D_j) - N_i(l_i, D_j) = \frac{\pi}{4} (l_i^2 - l_{i-1}^2) N_v(D_j) \text{ which of course only holds for } D_j > l_i > l_{i-1}$$

The same reasoning of course applies for the other void diameters and evidently the number of chords in each considered chord length class l_{i-1}, l_i is simply obtained by summing the contributions of all void diameter classes $> l_{i-1}$. As such the chord distribution is found to be:

$$N_i(l_{i-1}, l_i) = \sum_{j=i}^n N_i(l_{i-1}, l_i, D_j) = \frac{\pi}{4} (l_i^2 - l_{i-1}^2) \sum_{j=i}^n N_v(D_j)$$

An example calculation of how to obtain the chord distribution from the air void distribution is given in table 5 for a hypothetical poly-dispersed air void system consisting of only 4 air void sizes.

5.2.3 Transformation from 2D to 3D.

Next let consider the calculation of the air void distribution from the distribution of chords. In the relevant literature four methods have been identified i.e. SPEKTOR'S method [5], LORD and WILLIS method [6], CHAN and FULLMAN's method [7] and a method of unknown origin described in the CEN TC 104 N83 document [4]. The basic premises are the same for the four methods, however the ways of attacking the problem are quite different. In [5] a relative simple geometrical-statistical approach is followed; in [6] both a formal mathematical derivation and a purely geometrical analysis is employed; in [7] the derivation is undertaken in concise differential notation and at last in [4] a purely statistical approach is forwarded. Anyhow the four methods yield essentially the same working formula. In what follows the derivation of this working formula will be developed exploiting further the relations which have been developed in the preceding section 5.2.2.

It has been shown that: $N_i(l_{i-1}, l_i) = \frac{\pi}{4} (l_i^2 - l_{i-1}^2) \sum_{j=i}^n N_v(D_j)$ and

$$\text{so } \sum_{j=i}^n N_v(D_j) = \frac{4N_L(l_{i-1}l_i)}{\pi(l_i^2 - l_{i-1}^2)}$$

$$\text{By simple recursion it follows } \sum_{j=i}^n N_v(D_j) = \frac{4N_L(l_i l_{i+1})}{\pi(l_{i+1}^2 - l_i^2)}$$

Subtracting former equations it is found that

$$N_v(D_j) = \frac{4}{\pi} \left(\frac{N_L(l_{i-1}l_i)}{(l_i^2 - l_{i-1}^2)} - \frac{N_L(l_i l_{i+1})}{(l_{i+1}^2 - l_i^2)} \right)$$

which after multiplication with the volume of the void and substitution of D for l gives:

$$A_i = \frac{2}{3} D_i^3 \left(\frac{N_L(D_{i-1}D_i)}{(D_i^2 - D_{i-1}^2)} - \frac{N_L(D_i D_{i+1})}{(D_{i+1}^2 - D_i^2)} \right)$$

So using this equation it is possible to determine the void distribution A_i if the chord distribution N_L is known.

It has to be stressed however that the air void distribution which will be obtained is not unique as it depends on the range of chord classes which has been chosen. It is indeed observed that it is explicitly assumed that the voids have diameters which coincide with the (arbitrary) chosen chord classes. For a particular choice in some cases negative air contents may even be found for certain void diameters. This has of course no physical meaning and should inspire an alternative chord range classification. To our opinion this aspect is not enough stressed in [4] and should be further evaluated.

Table 5: 3D to 2D transformation for a hypothetical poly-dispersed air void system consisting of only 4 air void sizes.

Void Distribution					
D_j (mm)	1.500	0.350	0.293	0.143	
A_j	0.005	0.010	0.020	0.010	0.045
$N_v(D_j)$	0.002829	0.445448	1.518548	6.531204	
$6/D_j$	4.00	17.14	20.48	41.96	
A_j/A	0.111	0.222	0.444	0.222	
$6A_j/AD_j$	0.44	3.81	9.10	9.32	22.68

Chord Distribution

l_{i-1}	l_i	$N_L(l_{i-1}, l_i, D_j)$	$N_L(l_{i-1}, l_i, D_j)$	$N_L(l_{i-1}, l_i, D_j)$	$N_L(l_{i-1}, l_i, D_j)$	$N_L(l_{i-1}, l_i)$
0.000	0.007	0.000000	0.000017	0.000058	0.000251	0.000327
0.007	0.023	0.000001	0.000168	0.000572	0.002462	0.003204
0.023	0.037	0.000002	0.000294	0.001002	0.004309	0.005606
0.037	0.053	0.000003	0.000504	0.001717	0.007387	0.009611
0.053	0.067	0.000004	0.000588	0.002004	0.008618	0.011213
0.067	0.083	0.000005	0.000840	0.002862	0.012311	0.016018
0.083	0.097	0.000006	0.000882	0.003006	0.012927	0.016819
0.097	0.113	0.000007	0.001176	0.004007	0.017235	0.022426
0.113	0.127	0.000007	0.001176	0.004007	0.017235	0.022426
0.127	0.143	0.000010	0.001511	0.005152	0.022160	0.028833
0.143	0.157	0.000009	0.001469	0.005009		0.006488
0.157	0.173	0.000012	0.001847	0.006297		0.008156
0.173	0.187	0.000011	0.001763	0.006011		0.007785
0.187	0.203	0.000014	0.002183	0.007442		0.009639
0.203	0.217	0.000013	0.002057	0.007013		0.009083
0.217	0.233	0.000016	0.002519	0.008587		0.011122
0.233	0.247	0.000015	0.002351	0.008015		0.010381
0.247	0.263	0.000018	0.002855	0.009732		0.012605
0.263	0.277	0.000017	0.002645	0.009017		0.011678
0.277	0.293	0.000020	0.003191	0.010877		0.014088
0.293	0.307	0.000019	0.002939			0.002957
0.307	0.323	0.000022	0.003527			0.003549
0.323	0.337	0.000021	0.003233			0.003253
0.337	0.350	0.000020	0.003125			0.003144
0.350	1.5	0.004728				0.004728
1.5	2					
2						
					N_L	0.255141
					A/N_L	0.176
					$4N_L/A$	22.68

In table 6 the 2D to 3D transformation has been applied on the hypothetical air void distribution of table 5. Some evidence of what has been said about the impact of the choice of the considered chord range classes is put forward.

Table 6: 2D to 3D transformation for the hypothetical air void distribution of table 5.

Chord classes					Chord classes				
l_{i-1}	l_i	$N_L(l_{i-1}, l_i)$	A_i	$\alpha_i A_i / A$	l_{i-1}	l_i	$N_L(l_{i-1}, l_i)$	A_i	$\alpha_i A_i / A$
0.000	0.007	0.000327			0.000	0.010	0.000667		
0.007	0.023	0.003204	0.0000	0.00	0.010	0.020	0.002002		
0.023	0.037	0.005606			0.020	0.030	0.003337		
0.037	0.053	0.009611			0.030	0.050	0.010679		
0.053	0.067	0.011213			0.050	0.070	0.016018		
0.067	0.083	0.016018			0.070	0.090	0.021358		
0.083	0.097	0.016819			0.090	0.110	0.026697		
0.097	0.113	0.022426			0.110	0.130	0.032037	0.0028	2.82
0.113	0.127	0.022426			0.130	0.150	0.026855	0.0073	6.49
0.127	0.143	0.028833	0.0100	9.32	0.150	0.170	0.009886		
0.143	0.157	0.006488			0.170	0.190	0.011122		
0.157	0.173	0.008156			0.190	0.210	0.012358		
0.173	0.187	0.007785			0.210	0.230	0.013594		
0.187	0.203	0.009639			0.230	0.250	0.014830		
0.203	0.217	0.009083			0.250	0.270	0.016065		
0.217	0.233	0.011122			0.270	0.290	0.017301	0.0166	7.60
0.233	0.247	0.010381			0.290	0.310	0.006311	0.0035	1.48
0.247	0.263	0.012605			0.310	0.330	0.004507		
0.263	0.277	0.011678			0.330	0.350	0.004788	0.0100	3.80
0.277	0.293	0.014088	0.0200	9.10	0.350	0.370	0.000032		
0.293	0.307	0.002957			0.370	0.390	0.000034		
0.307	0.323	0.003549			0.390	0.410	0.000036		
0.323	0.337	0.003253			0.410	0.430	0.000037		
0.337	0.350	0.003144	0.0100	3.81	0.430	0.450	0.000039		
0.350	1.5	0.004728	0.0050	0.44	0.45	1.5	0.004550	0.0050	0.44
1.5	2				1.5	2			
2					2	10			
	N_L	0.255141	0.0450	22.68		N_L	0.255141	0.0451	22.64
	A/N_L	0.176				A/N_L	0.176		
	$4N_L/A$	22.68				$4N_L/A$	22.68		

6. Conclusions

- Due to severe unforeseen practical problems in obtaining between the partners the same results in the reference measurements according to ASTM the research has been substantially delayed. However the problems have been overcome and as such the impact on the research has been limited to a delay which fortunately did not affect the completion of the project
- As far as concerns the determination of the specific surface and the spacing factor of the air void system the riser column method can readily be considered as a very reliable method (and the only one available) for assessing fresh air entrained concrete. The 95% confidence limits for the specific surface and the spacing factor fall well within the goals which have been fixed at the beginning of the research. Also the slope of the regression lines is close to 1 which means that the FCAA technique yields results which are identical to the ASTM results.
- For the Air content however the slope of the regression line is only in the order of 0.7 to 0.8 which means that the riser column method reports a smaller air content than the one measured according to ASTM. Obvious the reason for this apparent discrepancy is the fact that the FCAA does only take into consideration entrained air and does not take into account coarse bubbles of entrapped air. This is also observed considering the 2-D to 3-D conversion of the ASTM results. As such this is not unlogic and it may be concluded that for the determination of the total air content in a concrete the size of the FCAA sample (20cc) is not sufficient. For this purpose the 8.000 cc volume of the pressuremeter is required.
- The results available prove that the measuring principle can be used with the expected accuracy for European concretes with a slump greater than 1 cm. For very stiff concretes with slumps of 0-1cm it is found necessary to look closer into details of the sampling. Indeed collecting of the samples seems to constitute a problem for such concretes which has an influence on the dispersion of the results obtained.
- Making abstraction of the delay which was encountered the second stage of the research (i.e. subtask 2.2.) Can now proceed as has been planned.

7. References

1. T.C. POWERS. The Physical Structure and Engineering Properties of Concrete. The Portland Cement Association (1958).
2. ENV 206. Concrete - Performance, production, placing and compliance criteria (1990).
3. ASTM C 457. Standard Practice for Microscopical Determination of Air-Void Content and Parameters of the Air-Void System in Hardened Concrete. The American Society for Testing and Materials (1982).
4. CEN/TC 140 N83 document. Admixtures for Concrete, Mortar and Grout. Test Methods: Determination of Air Void Characteristics in Hardened Concrete (1991).
5. A.G. SPEKTOR. Analysis of Distribution of Spherical Particles in Non-Transparent Structures. *Zavod. Lab.* 16(2):173 (1950).
6. G.W. LORD and T.F. WILLIS. Calculation of Air Bubble Size Distribution from Results of a Rosiwal Traverse of Aerated Concrete, *ASTM Bull.* No. 177:56 (1951).
7. J.W. CAHN and R.L. FULLMAN. On the Use of Lineal Analysis for Obtaining Particle Size Distribution Functions in Opaque Samples. *Trans. AIME*,206:610 (1956).

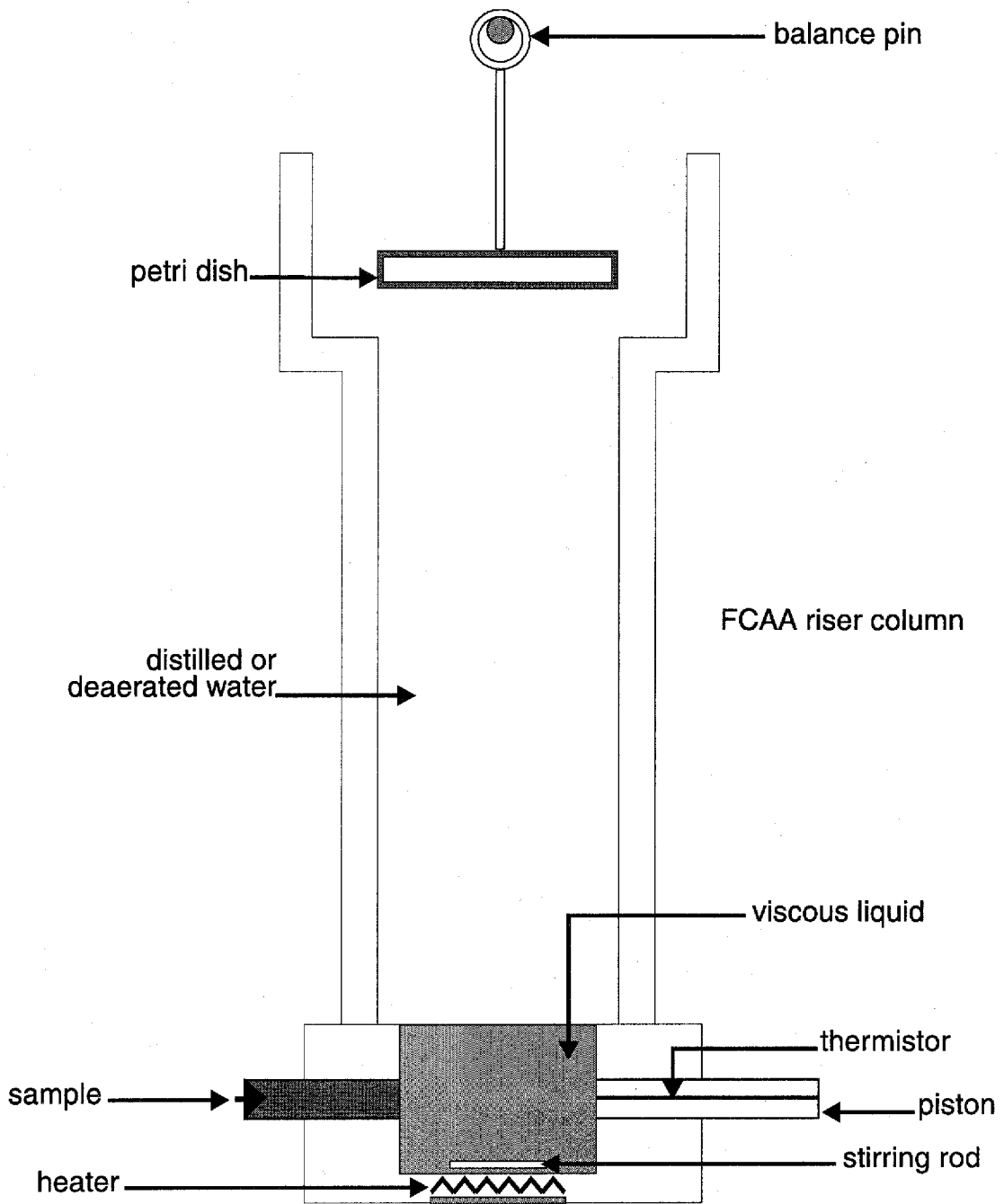
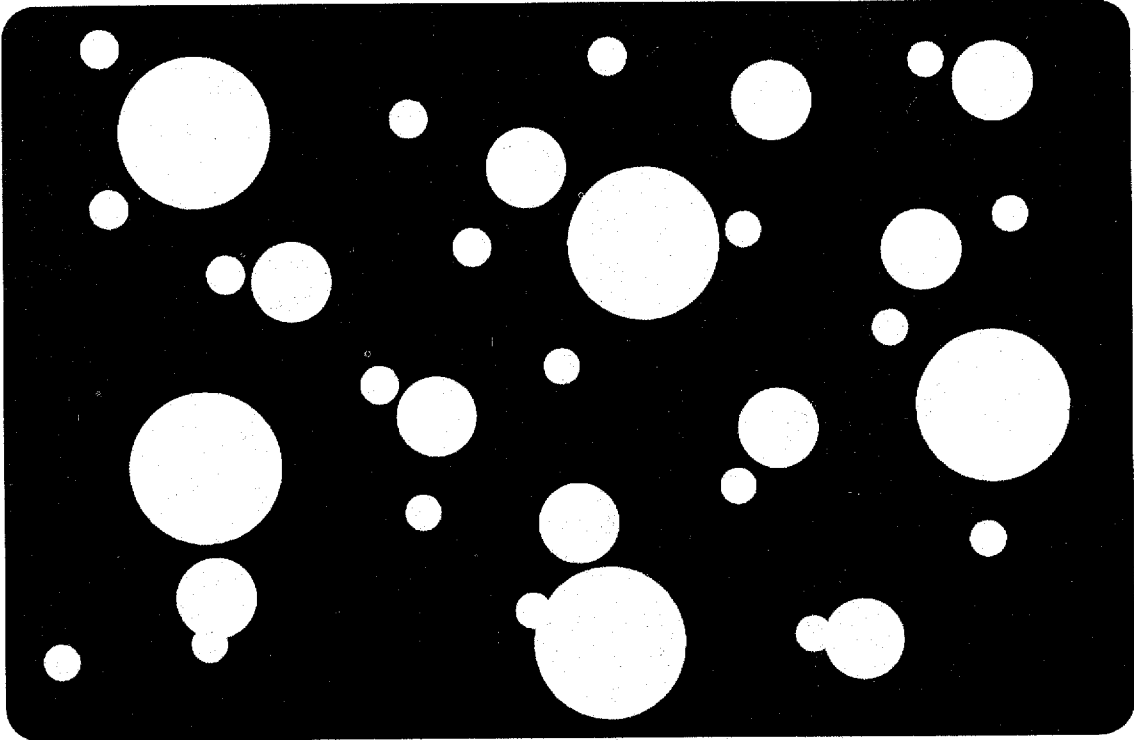
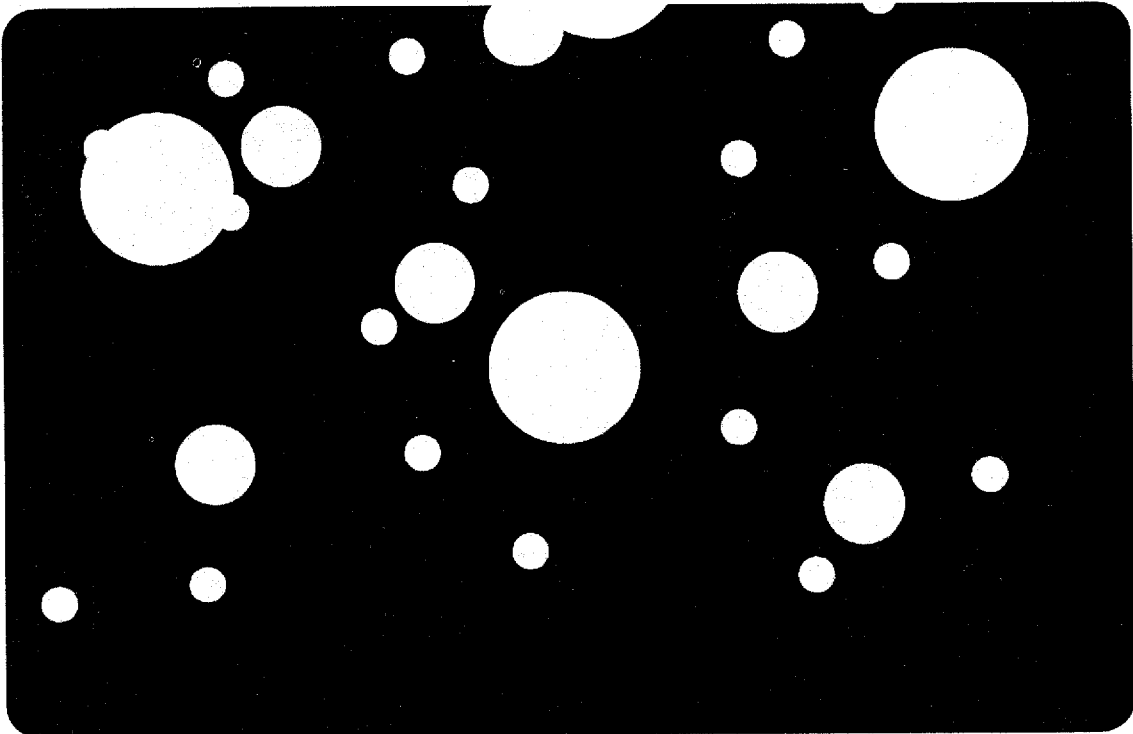

Figure 1.
Schematic of riser column



t_0



$t_0 - t_1$

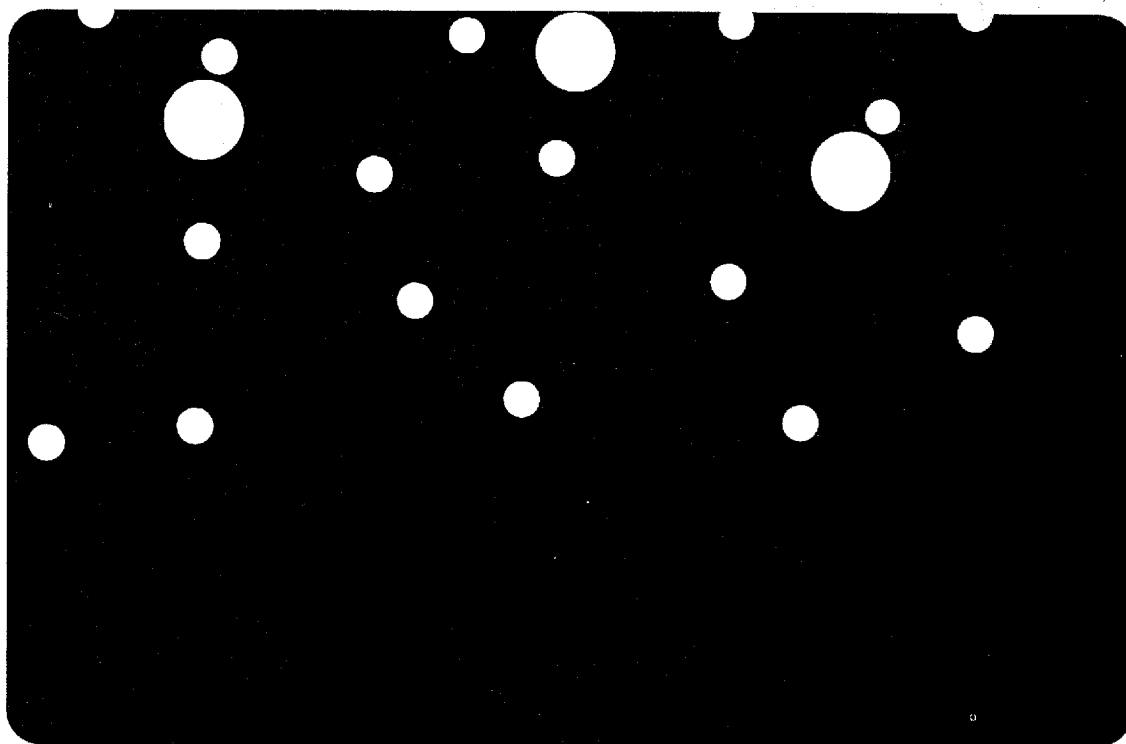

$t_1 - t_2$

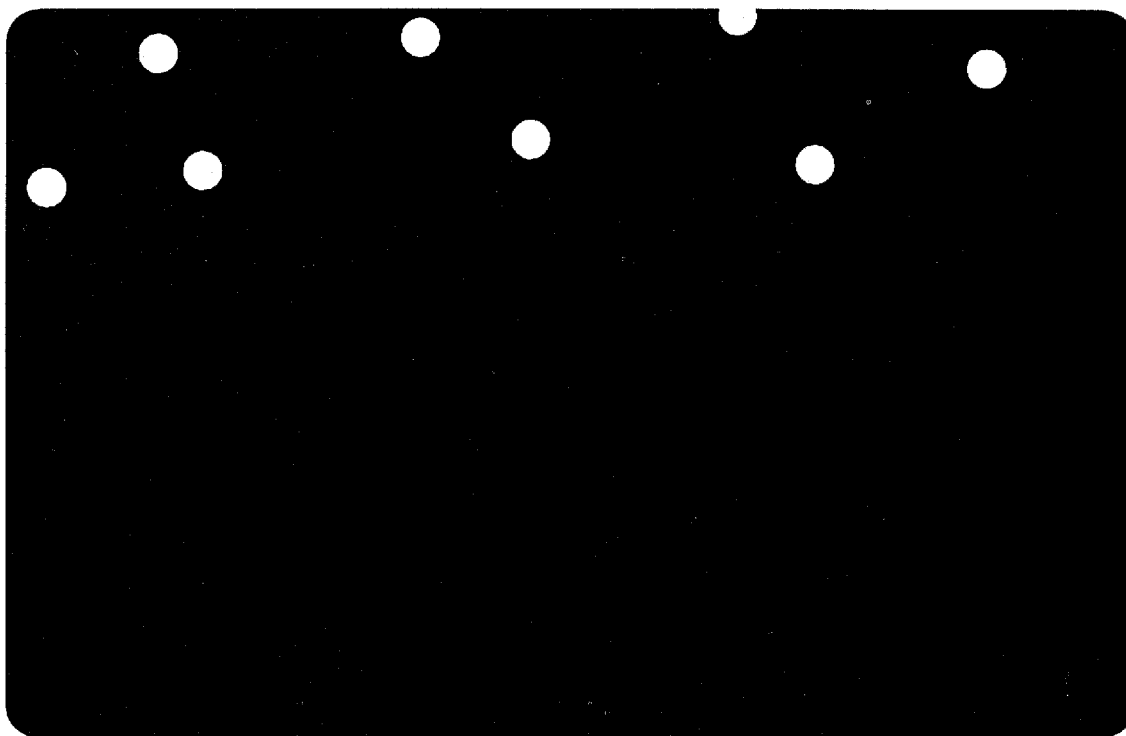

$t_2 - t_3$

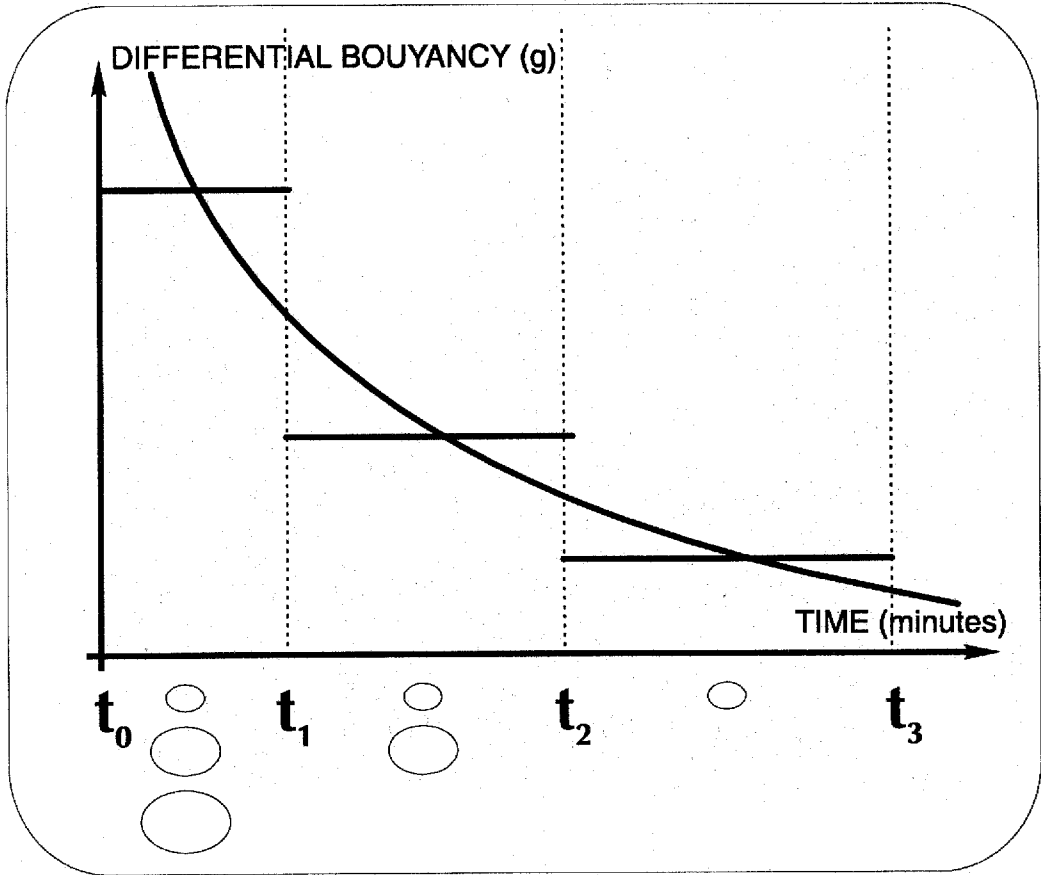

Figure 2C.

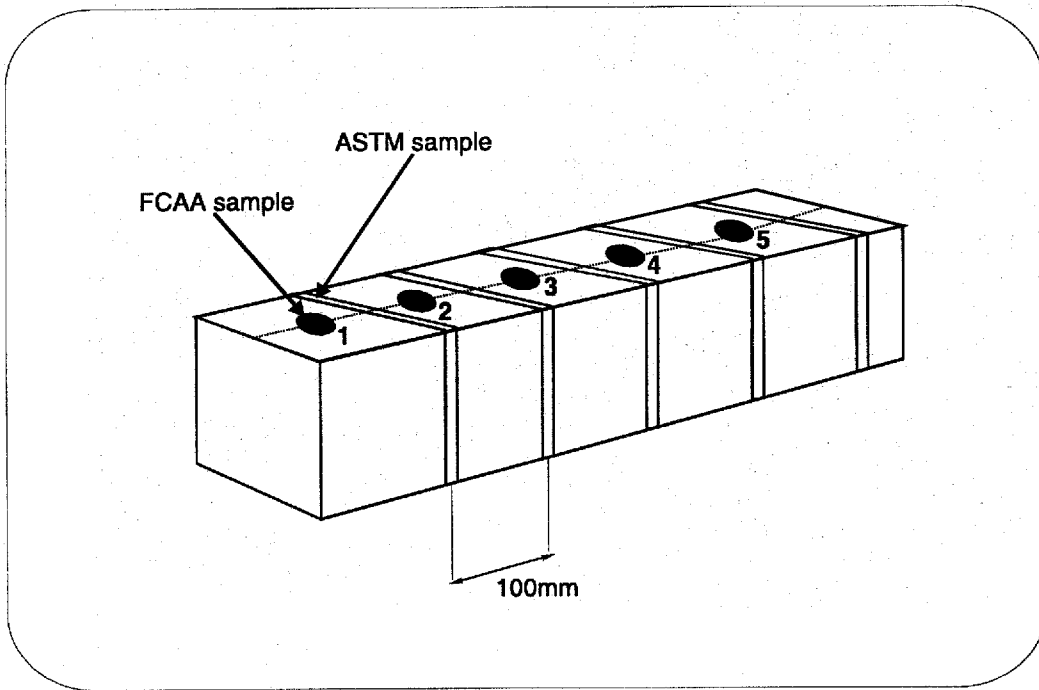

Figure 3.

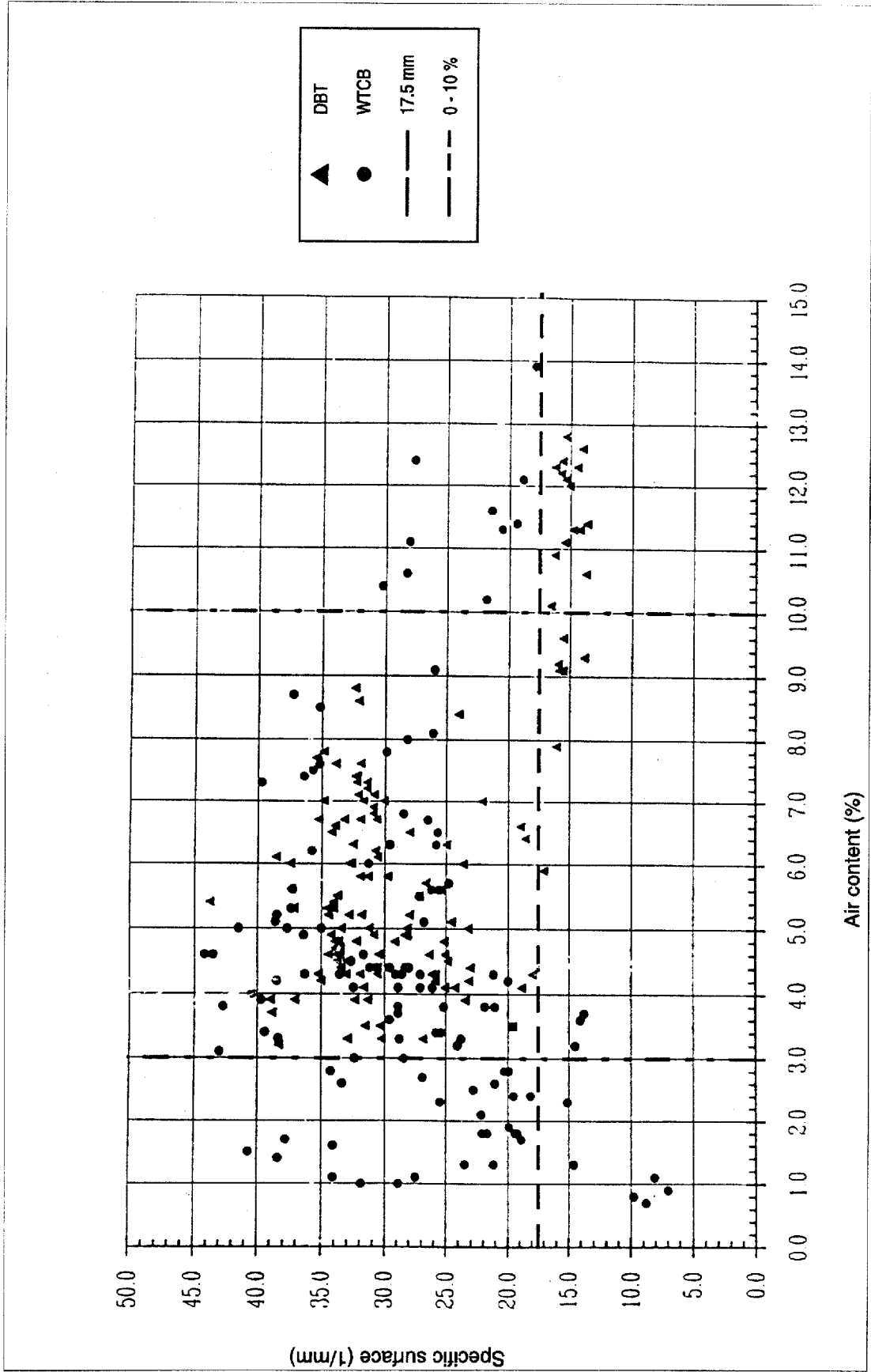

Figure 4.

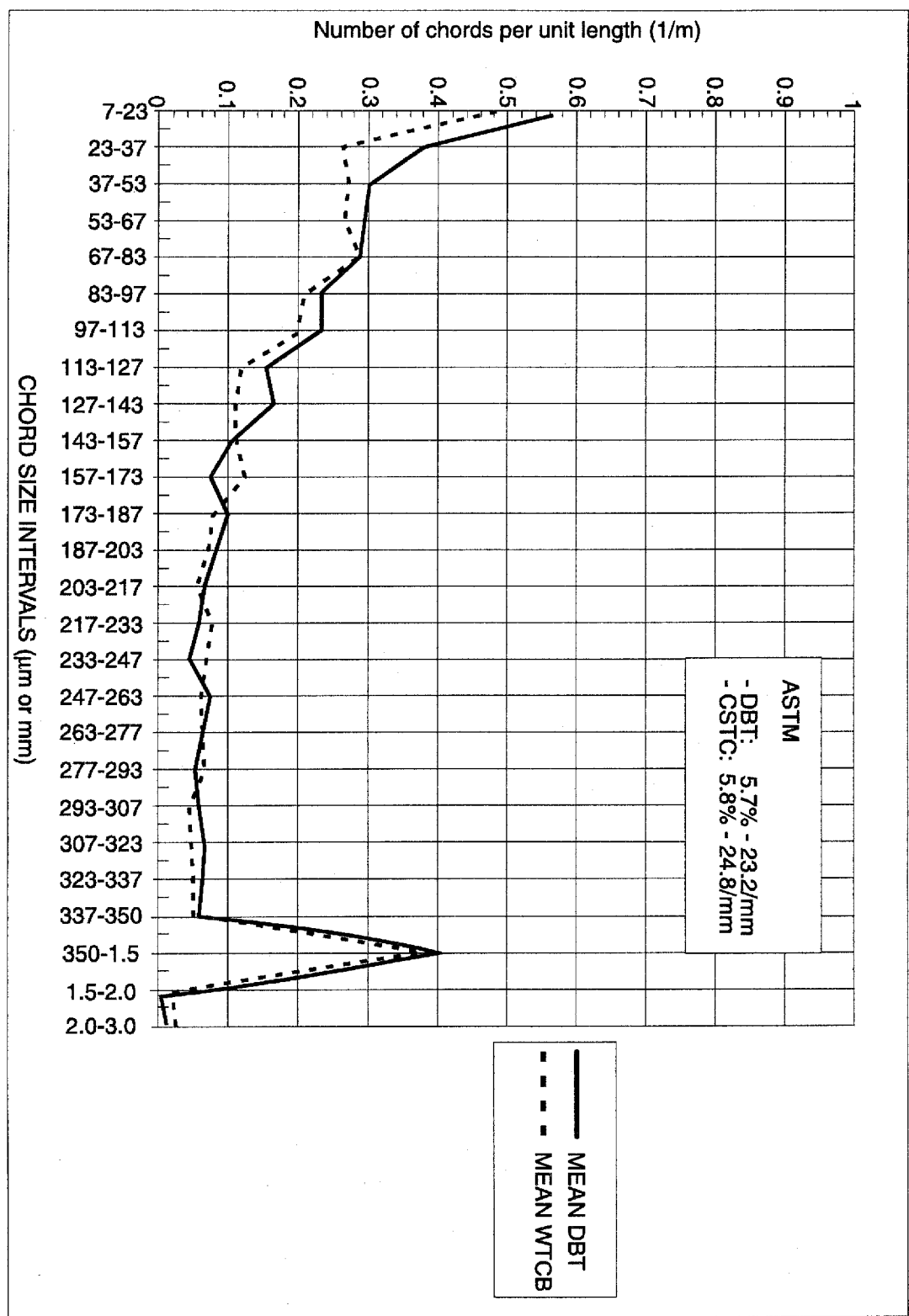

Figure 5.
DBT-ASTM analysis compared to CSTC-ASTM analysis

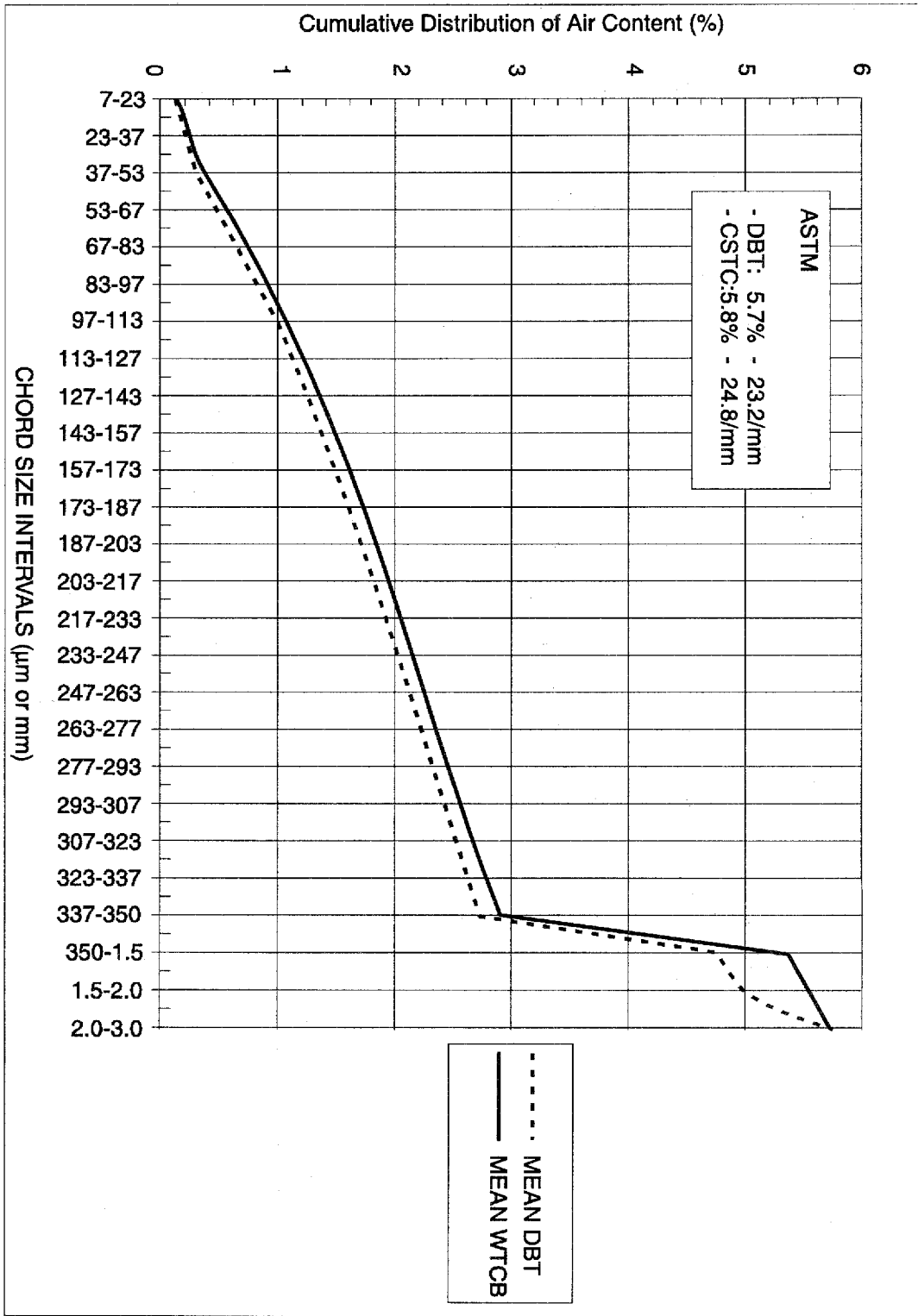
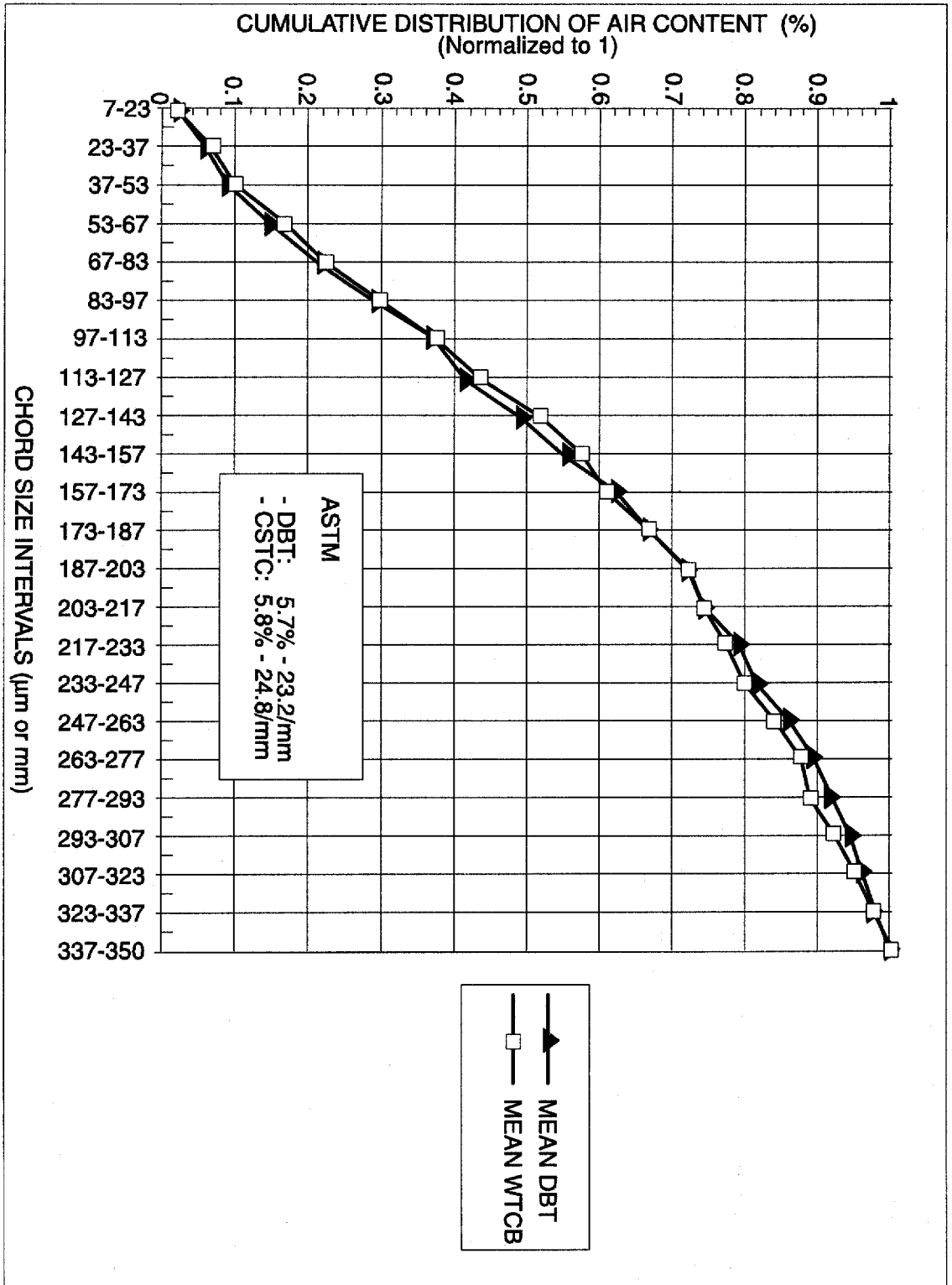

Figure 6.
DBT-ASTM analysis compared to CSTC-ASTM analysis



DBT-ASTM analysis compared to CSTC-ASTM analysis

Figure 7.

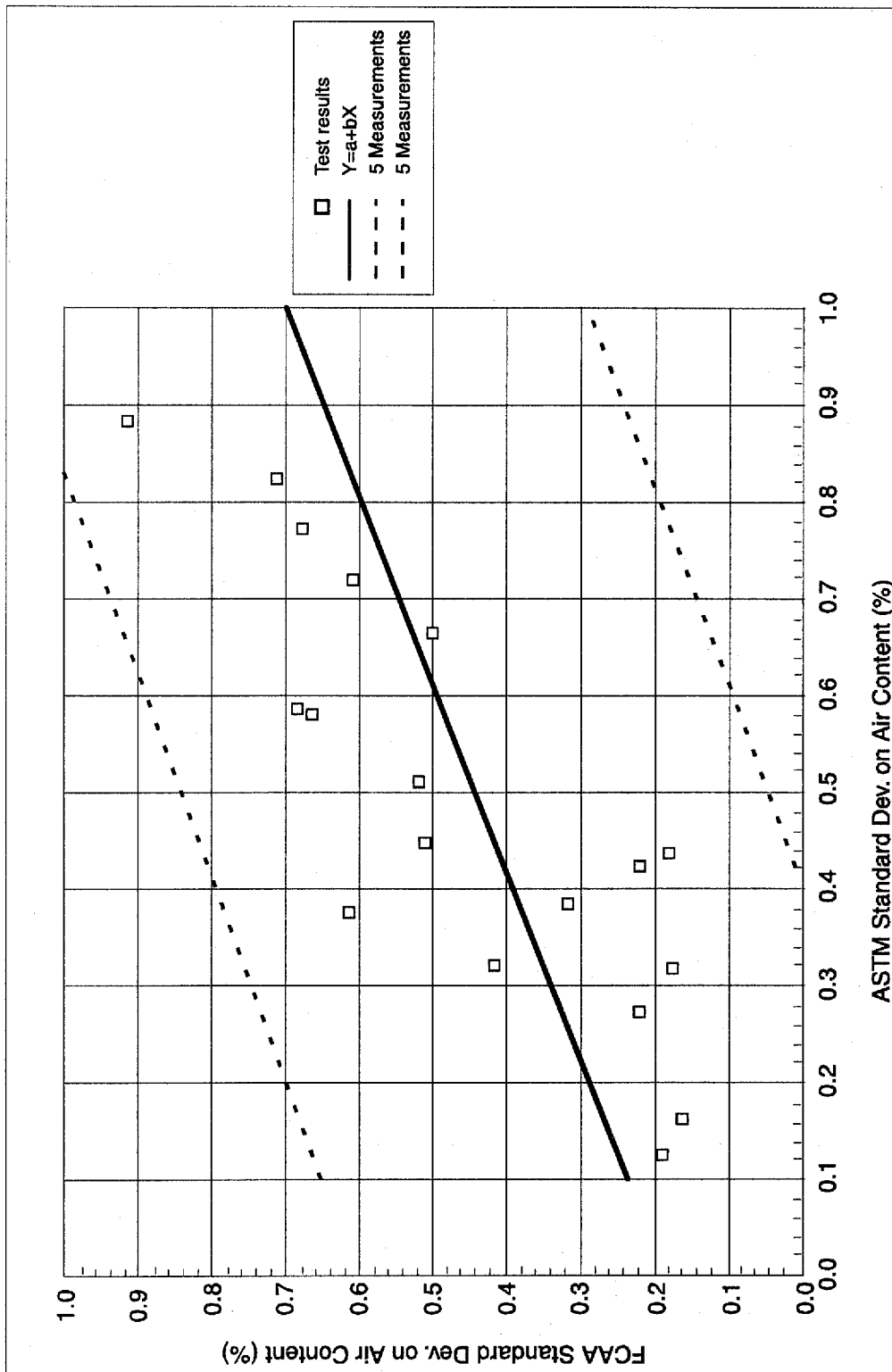

Figure 8.
Regression curve and 95% confidence limits

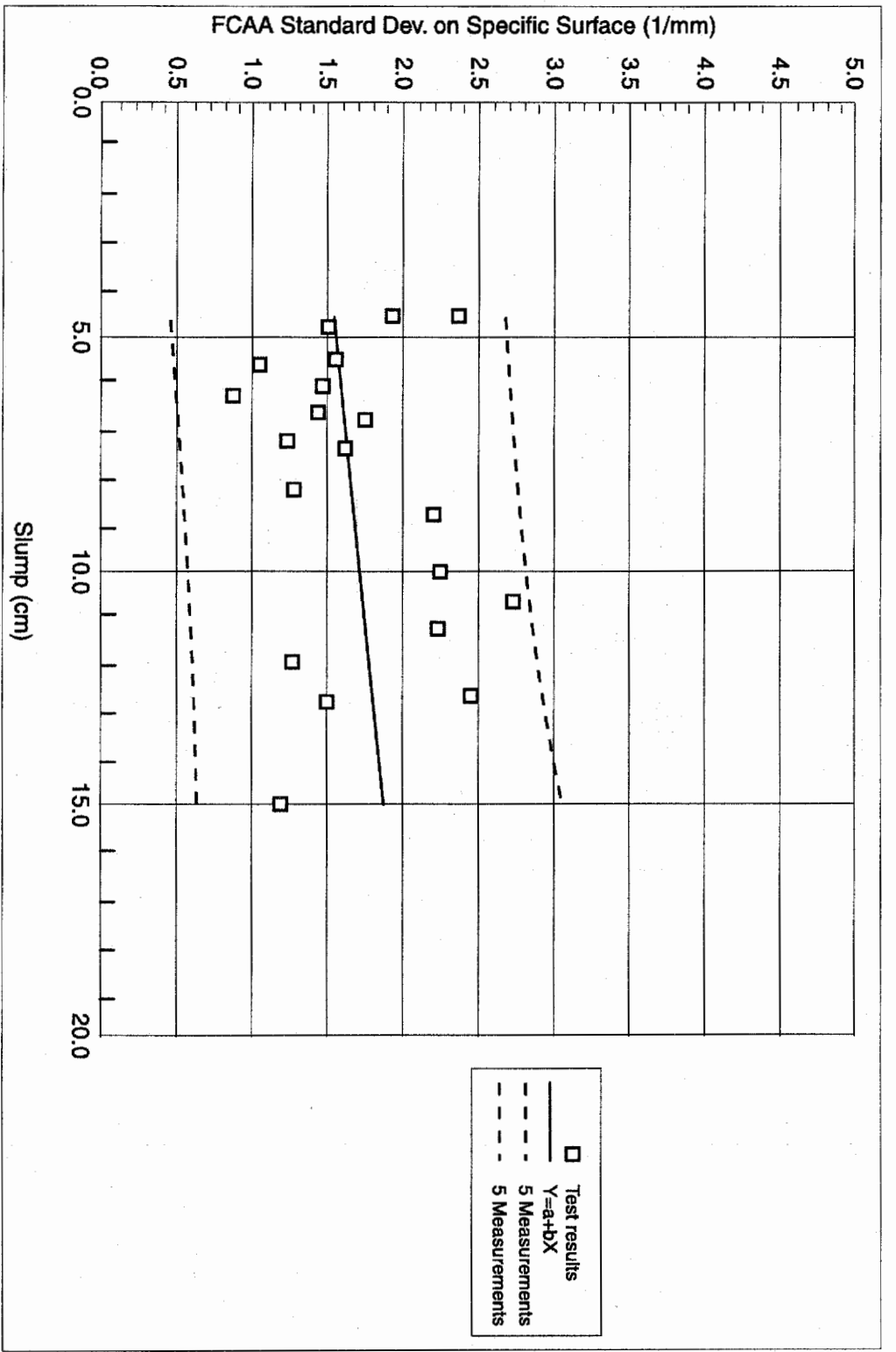

Figure 9.
Regression curve and 95% confidence limits

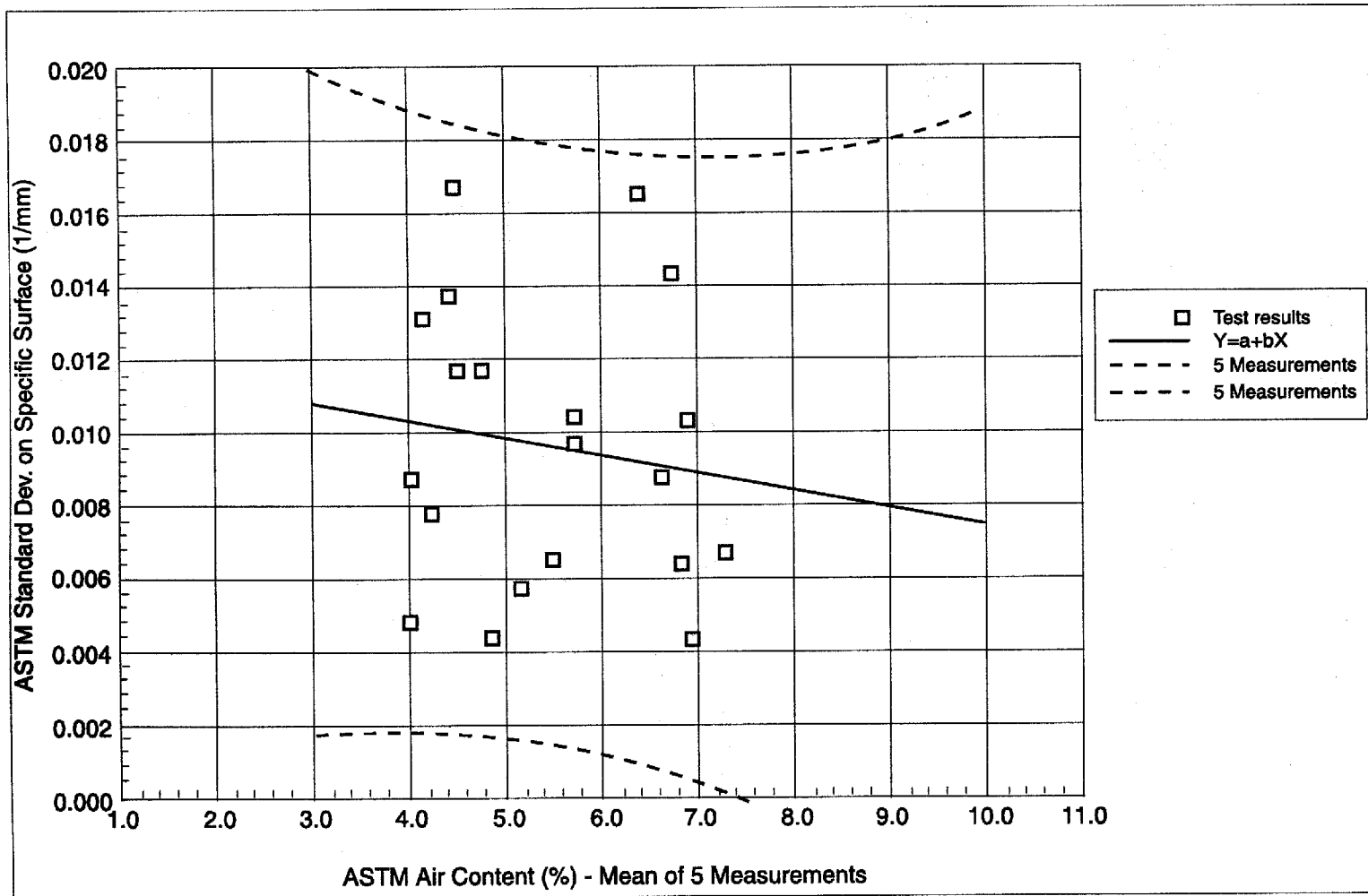
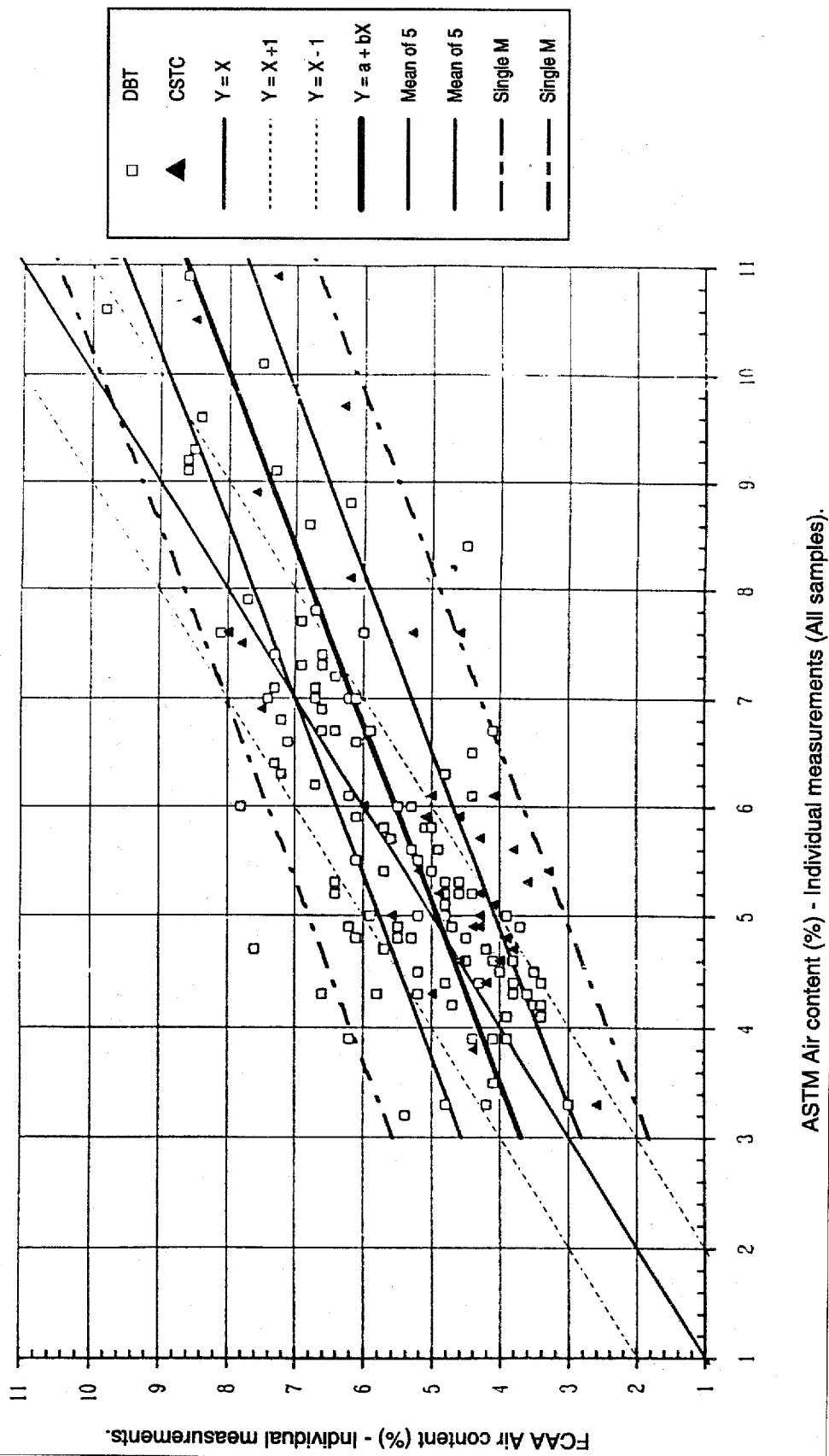

Figure 10.
Regression curve and 95% confidence limits



ASTM Air content (%) - Individual measurements (All samples).

Figure 11.

Regression curve and 95% confidence limits for a single measurement and the mean of 5 measurements

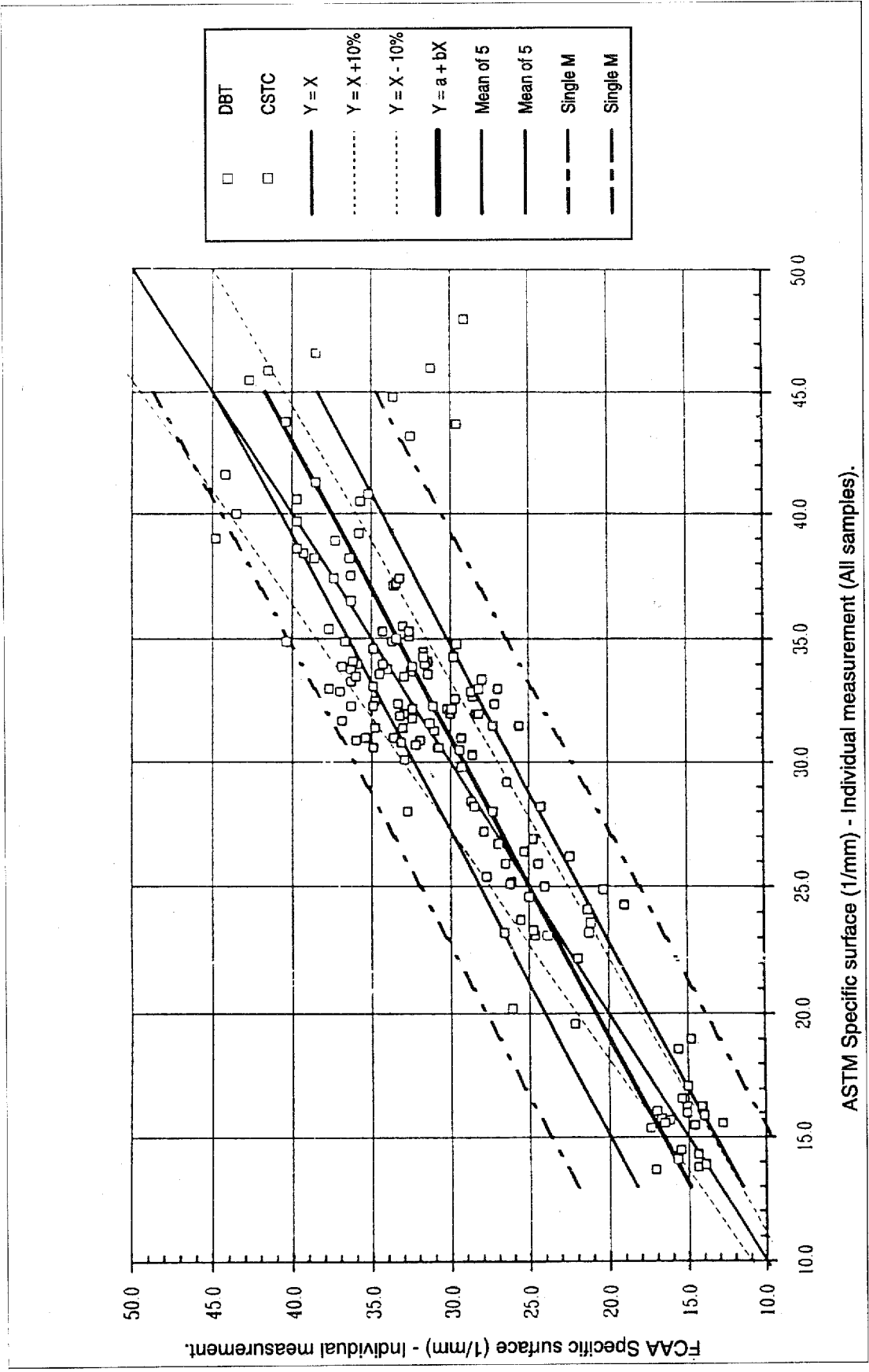

Figure 12. Regression curve and 95% confidence limits for a single measurement and the mean of 5 measurements

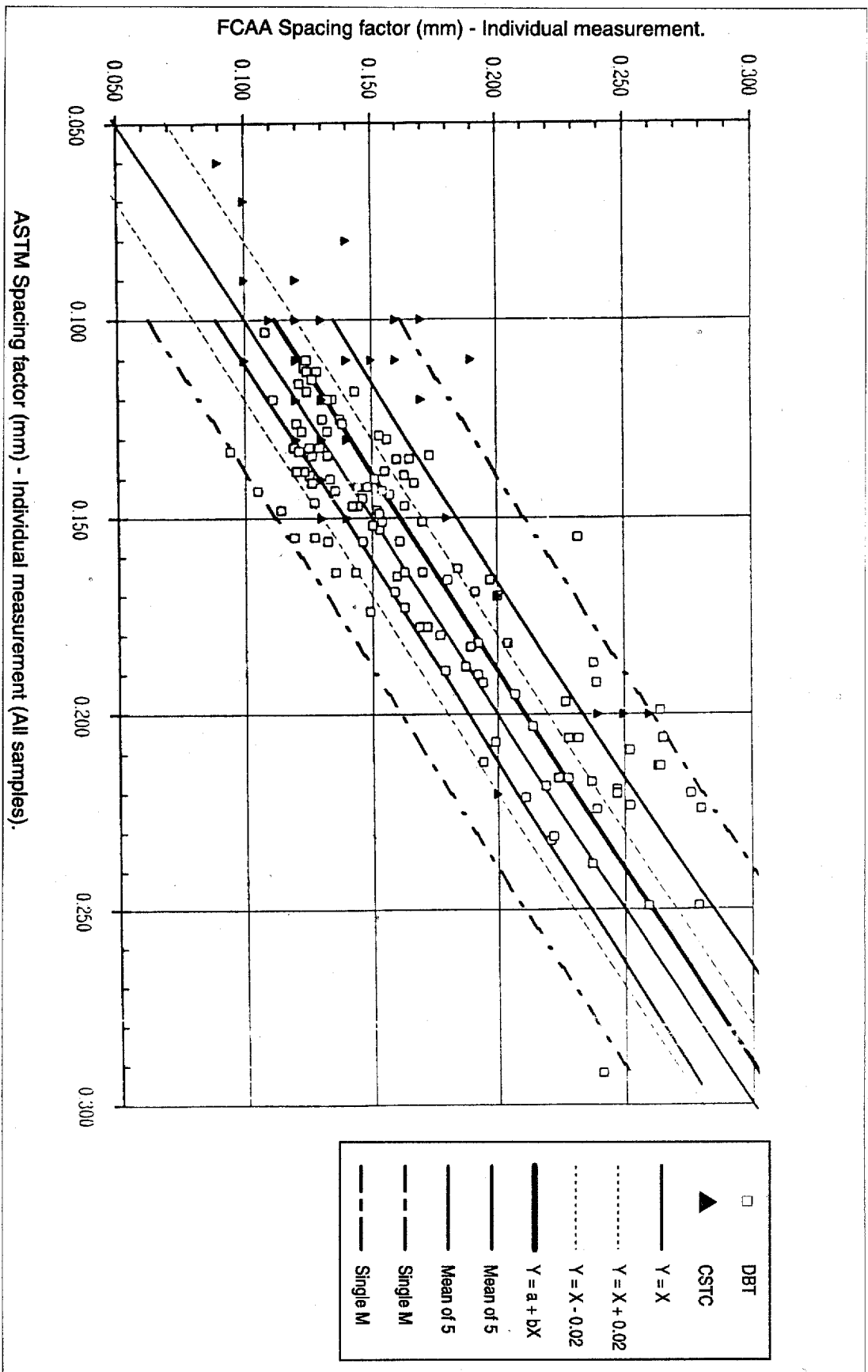

Figure 13.
Regression curve and 95% confidence limits for a single measurement and the mean of 5 measurements

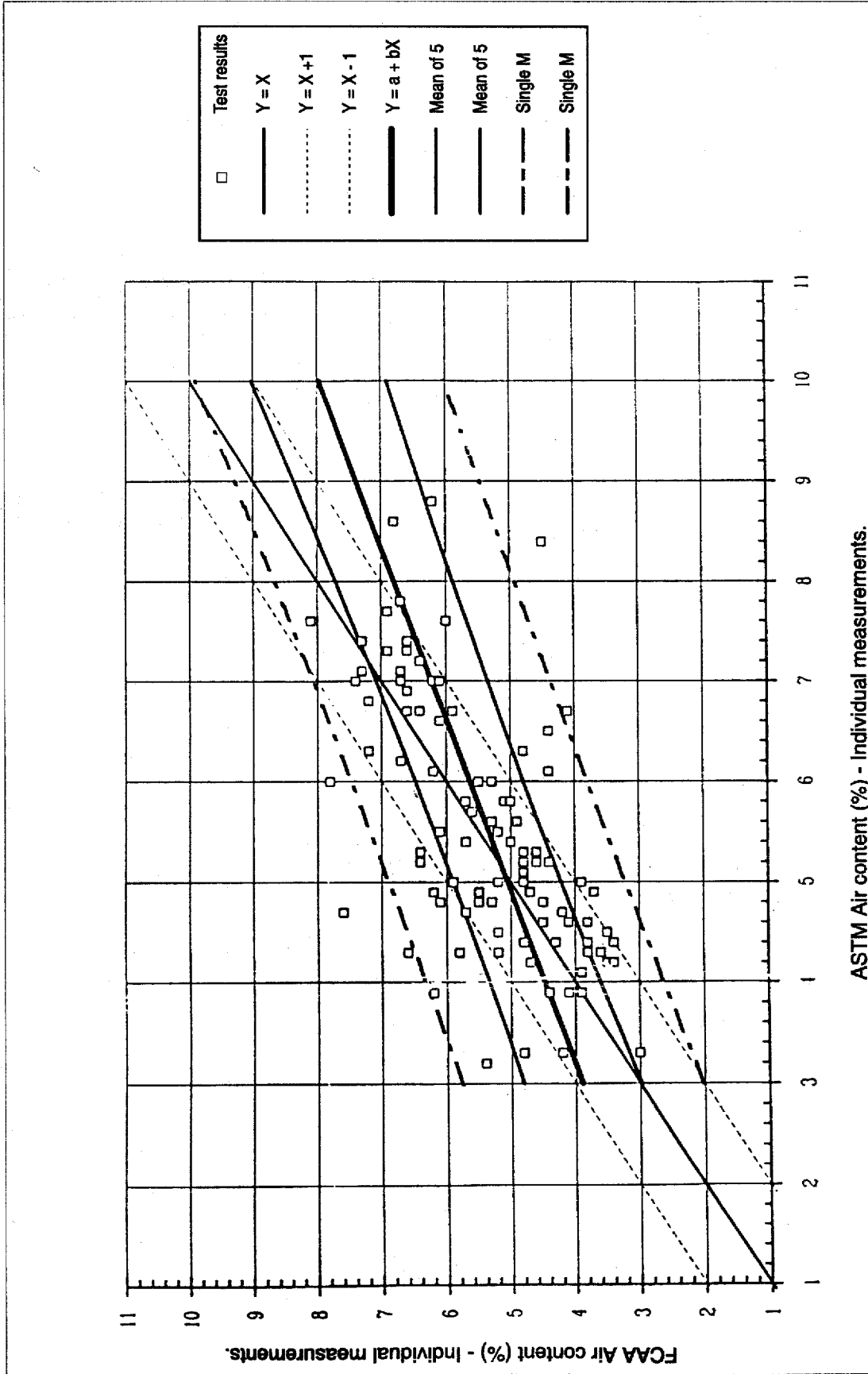

Figure 14.

Regression curve and 95% confidence limits for a single measurement and the mean of 5 measurements

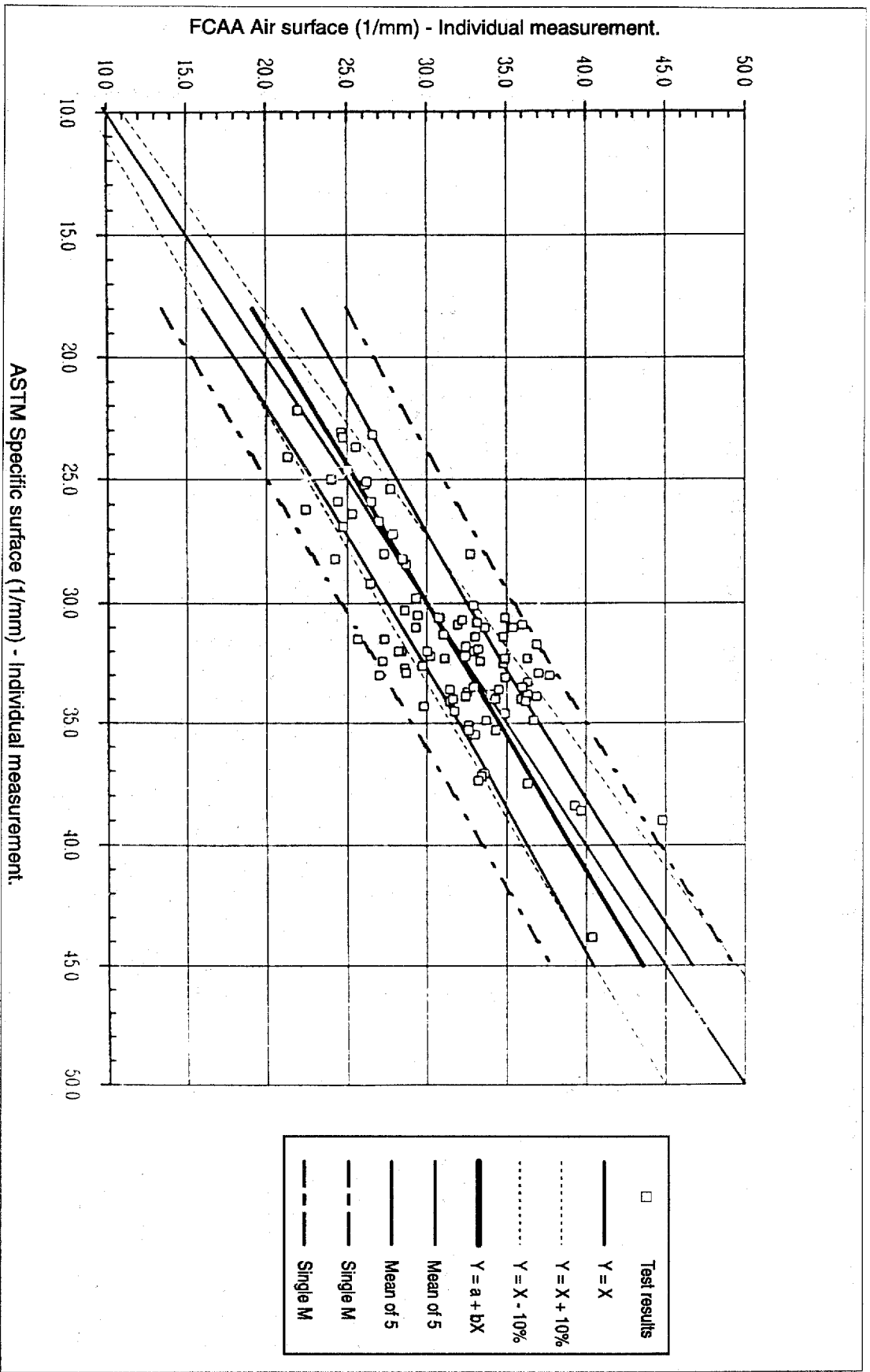

Figure 15.
Regression curve and 95% confidence limits for a single measurement and the mean of 5 measurements

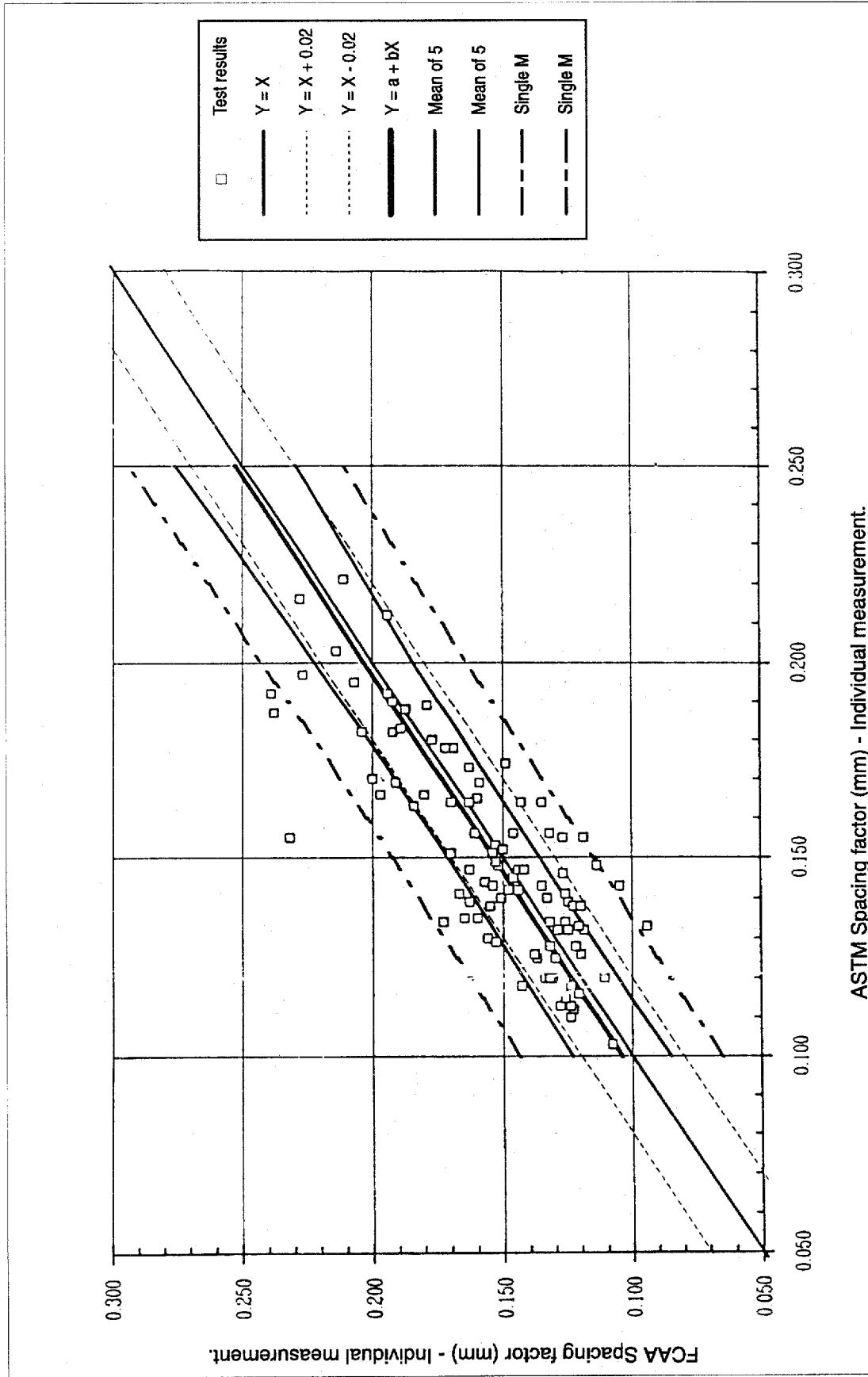

Figure 16.

Regression curve and 95% confidence limits for a single measurement and the mean of 5 measurements

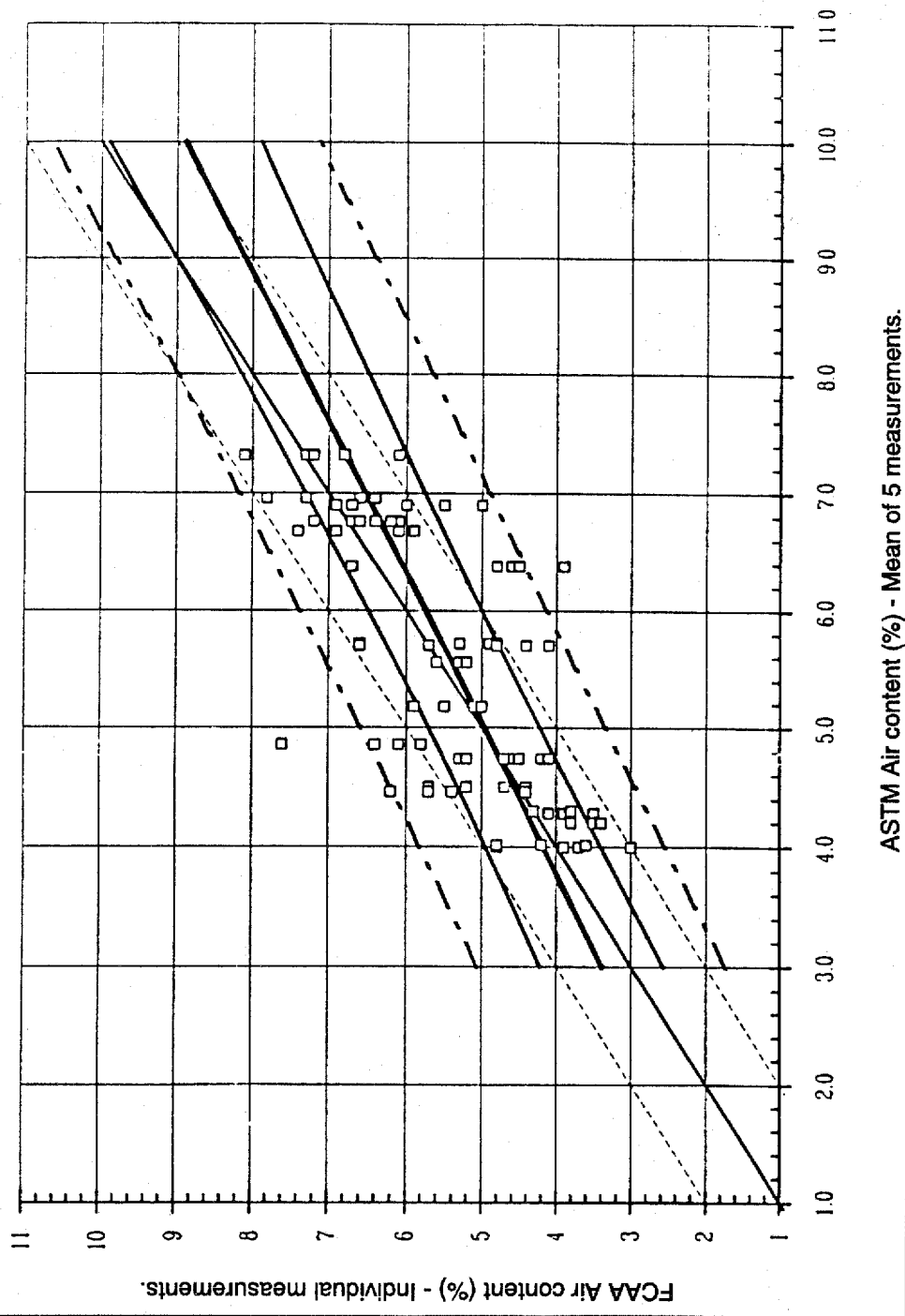

Figure 17. Regression curve and 95% confidence limits for a single measurement and the mean of 5 measurements

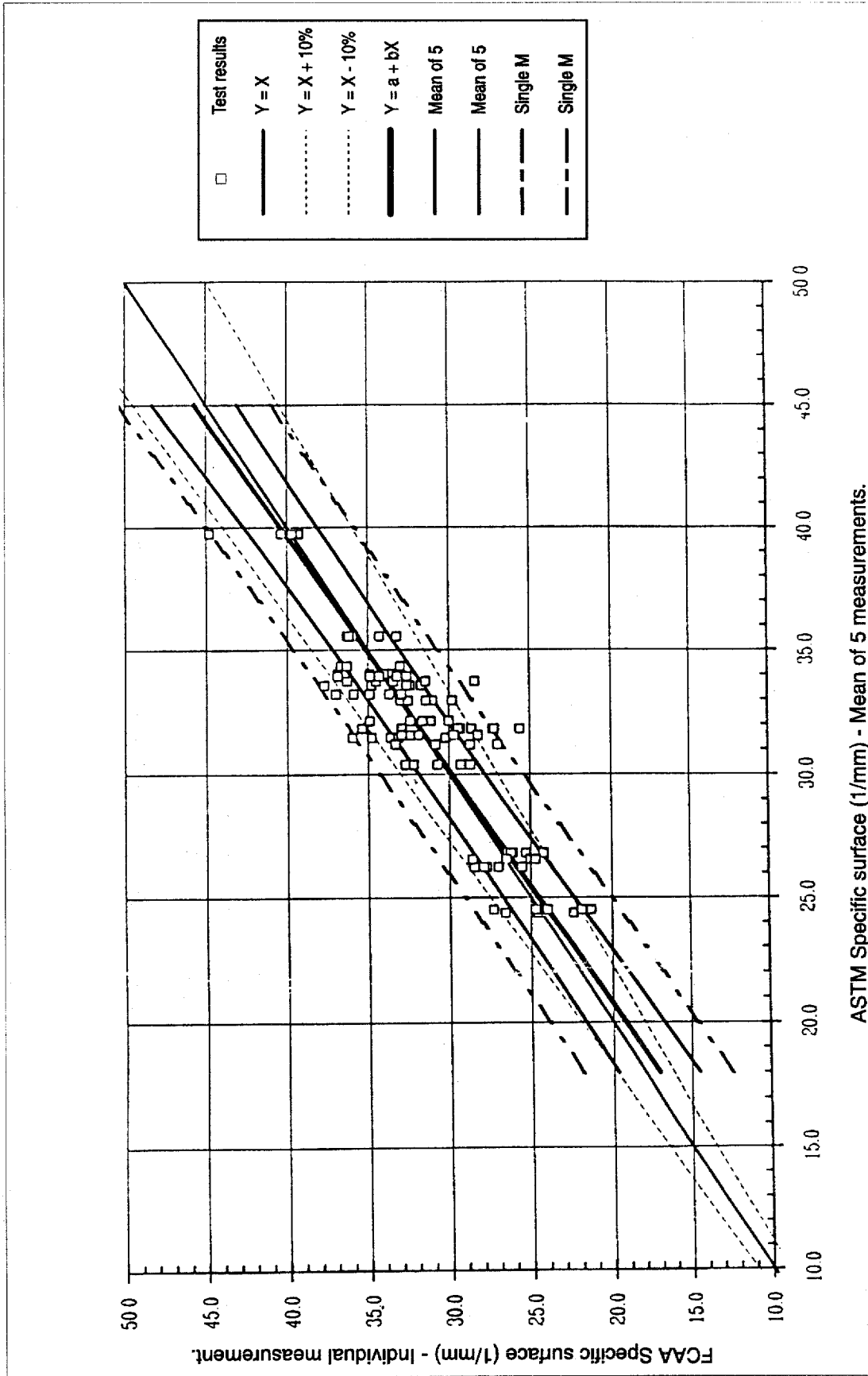

Figure 18. Regression curve and 95% confidence limits for a single measurement and the mean of 5 measurements

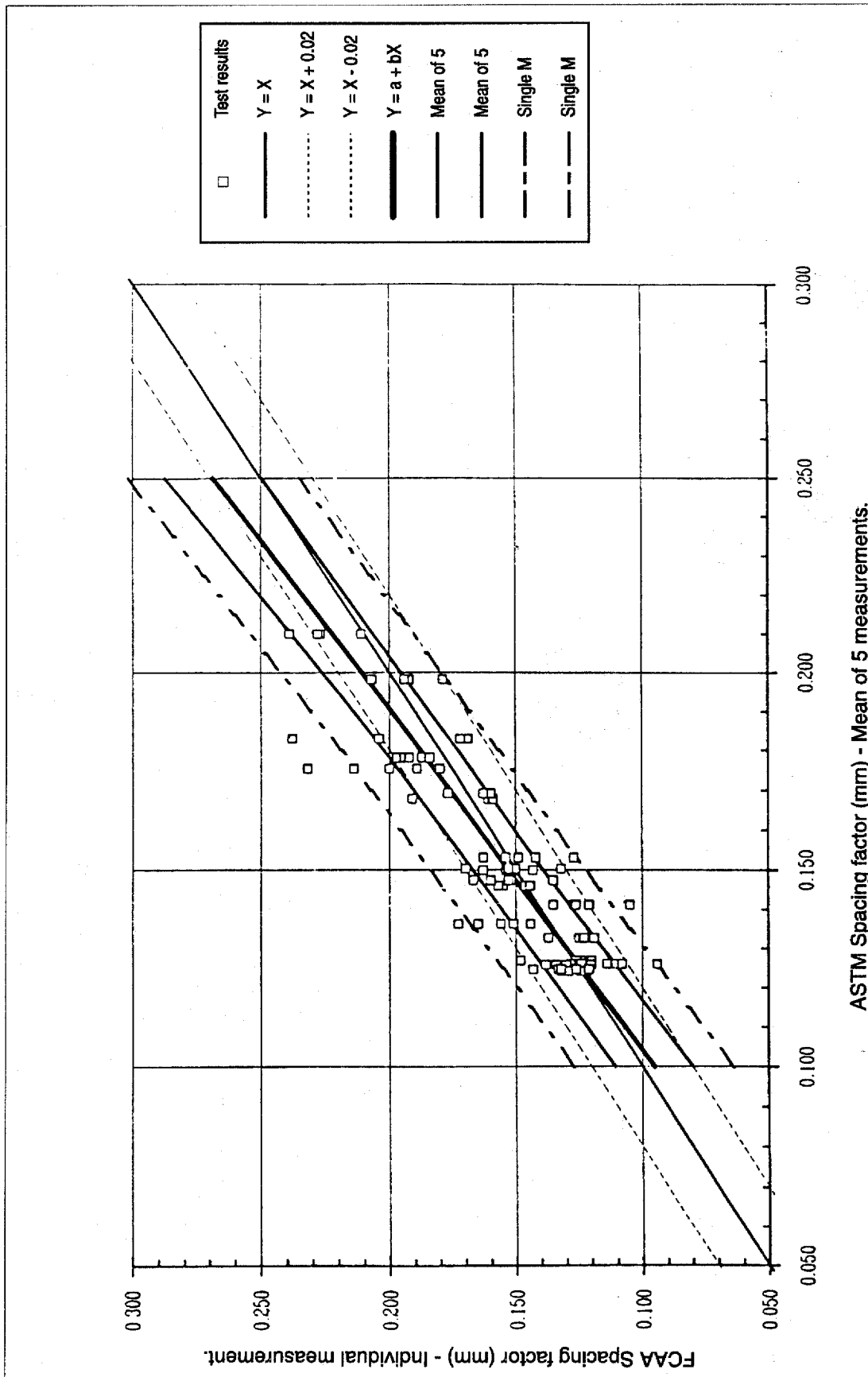

Figure 19. Regression curve and 95% confidence limits for a single measurement and the mean of 5 measurements

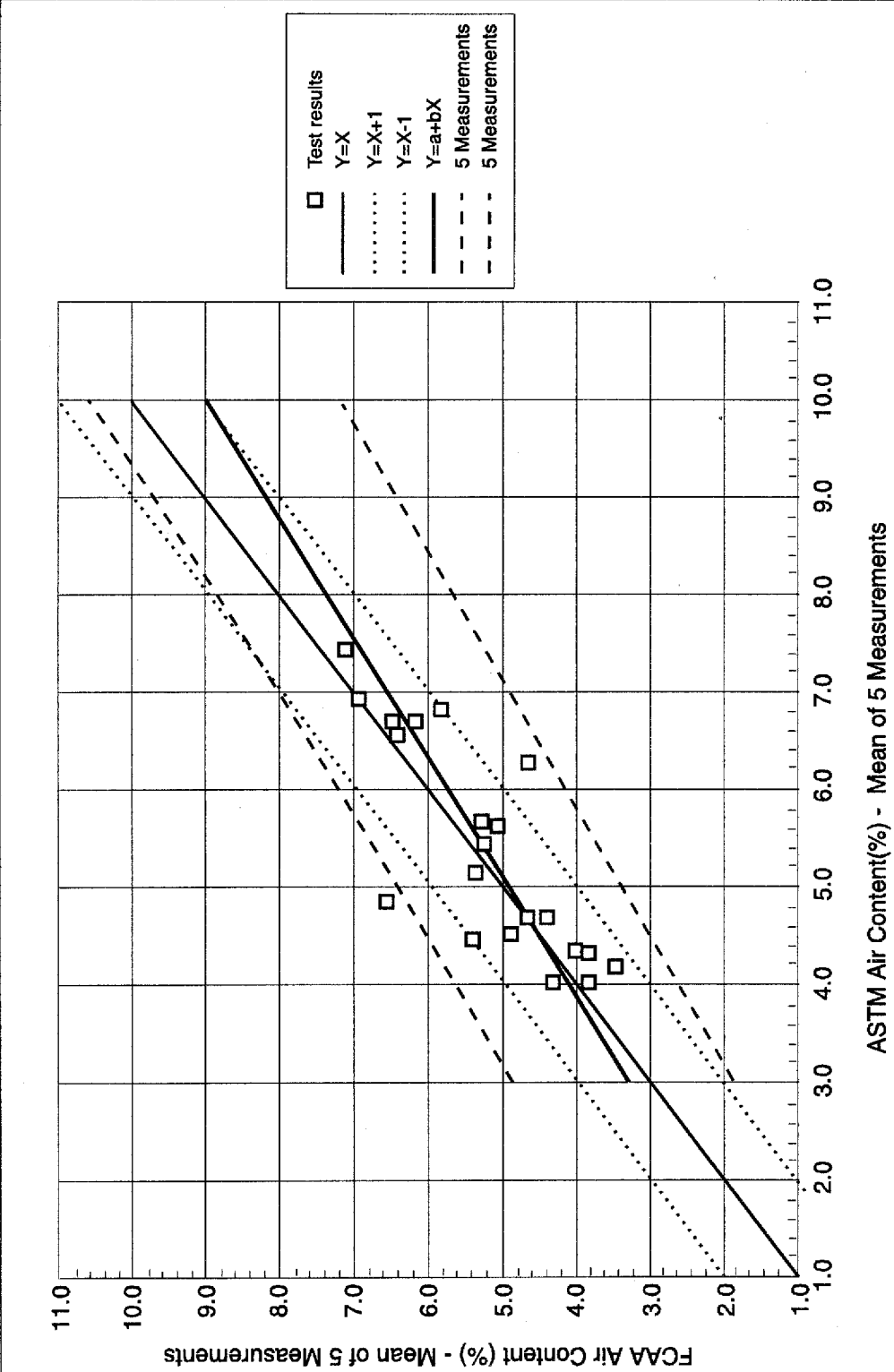

Figure 20.
Regression curve and 95% confidence limits

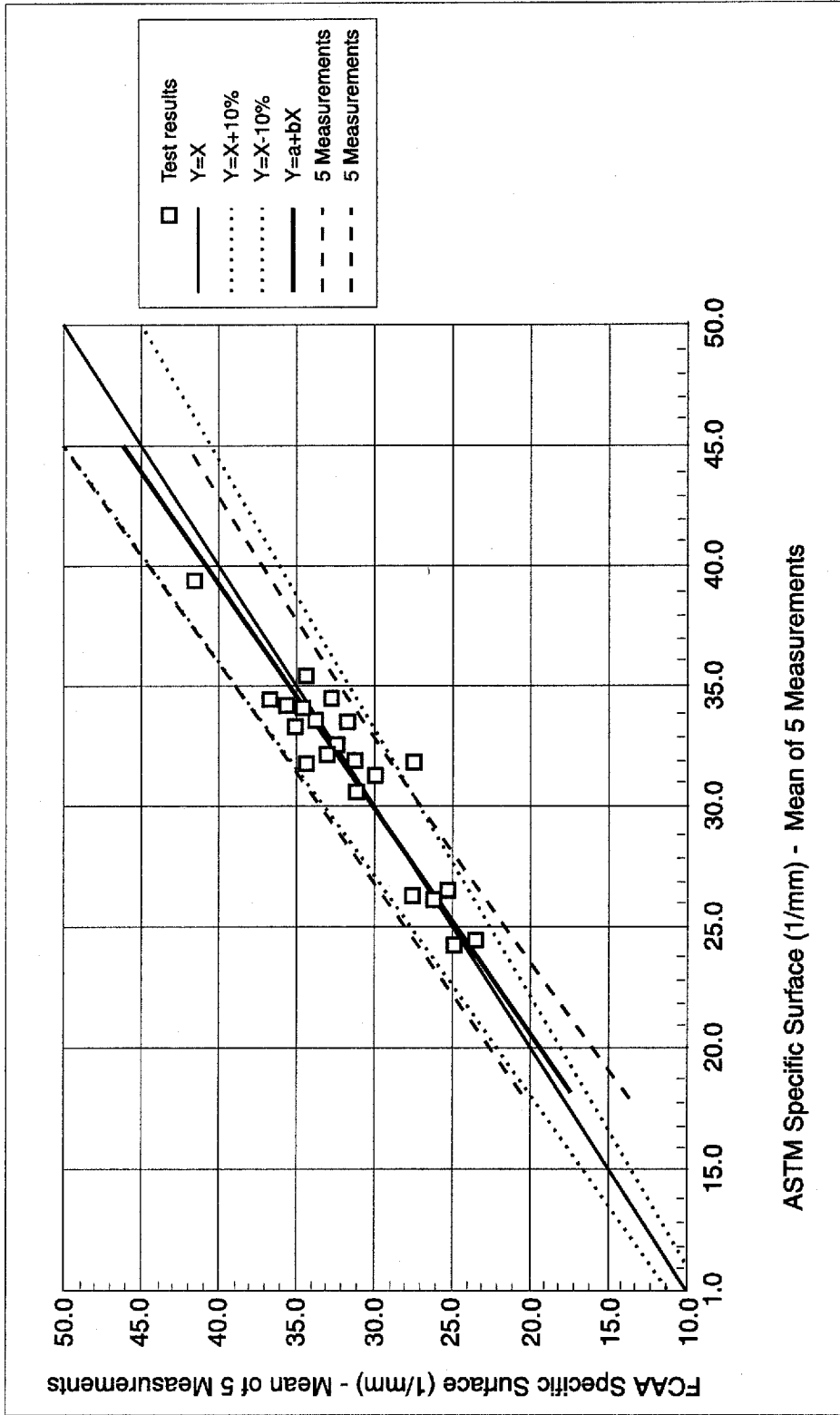

Figure 21.
Regression curve and 95% confidence limits

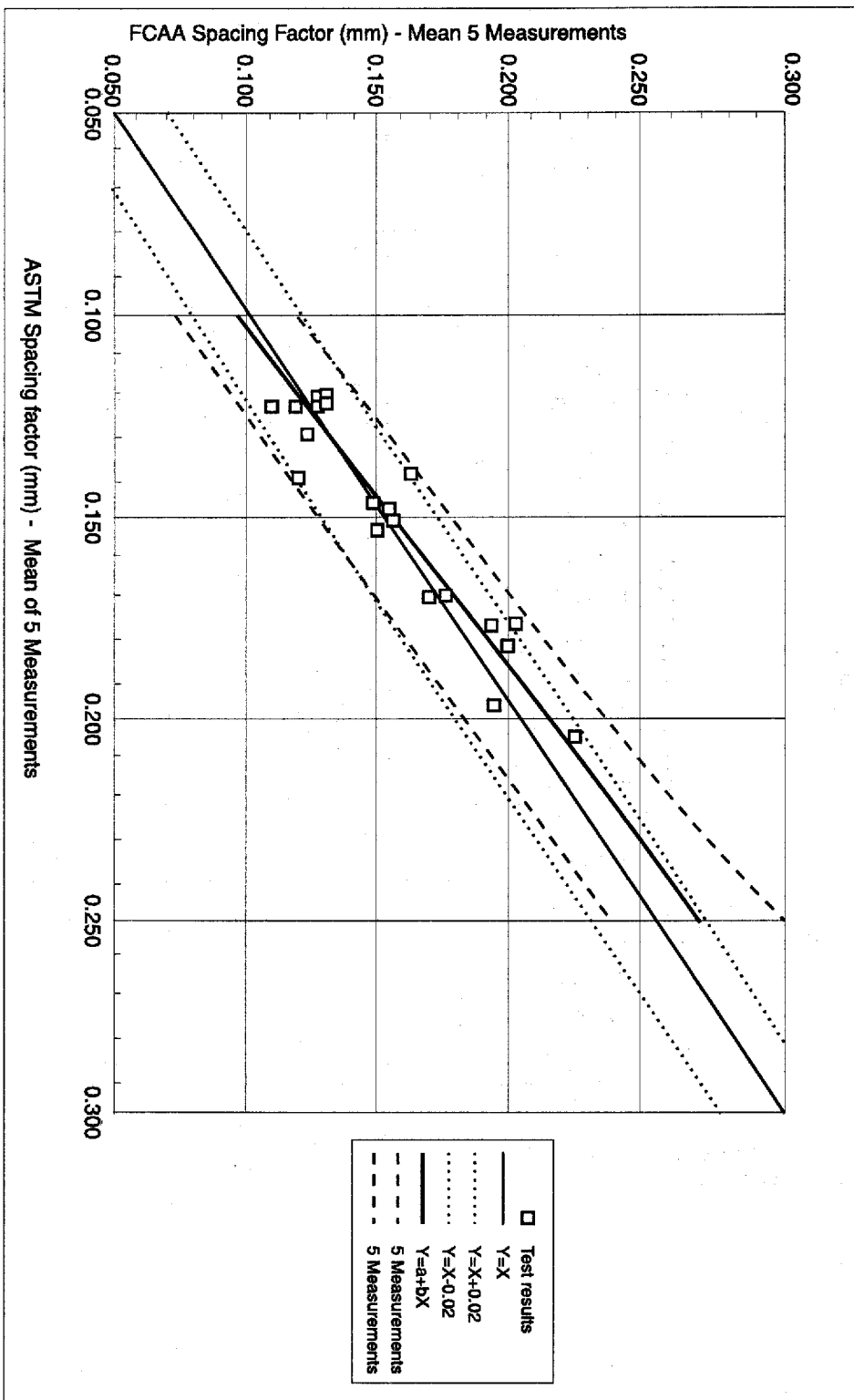

Figure 22.

Regression curve and 95% confidence limits

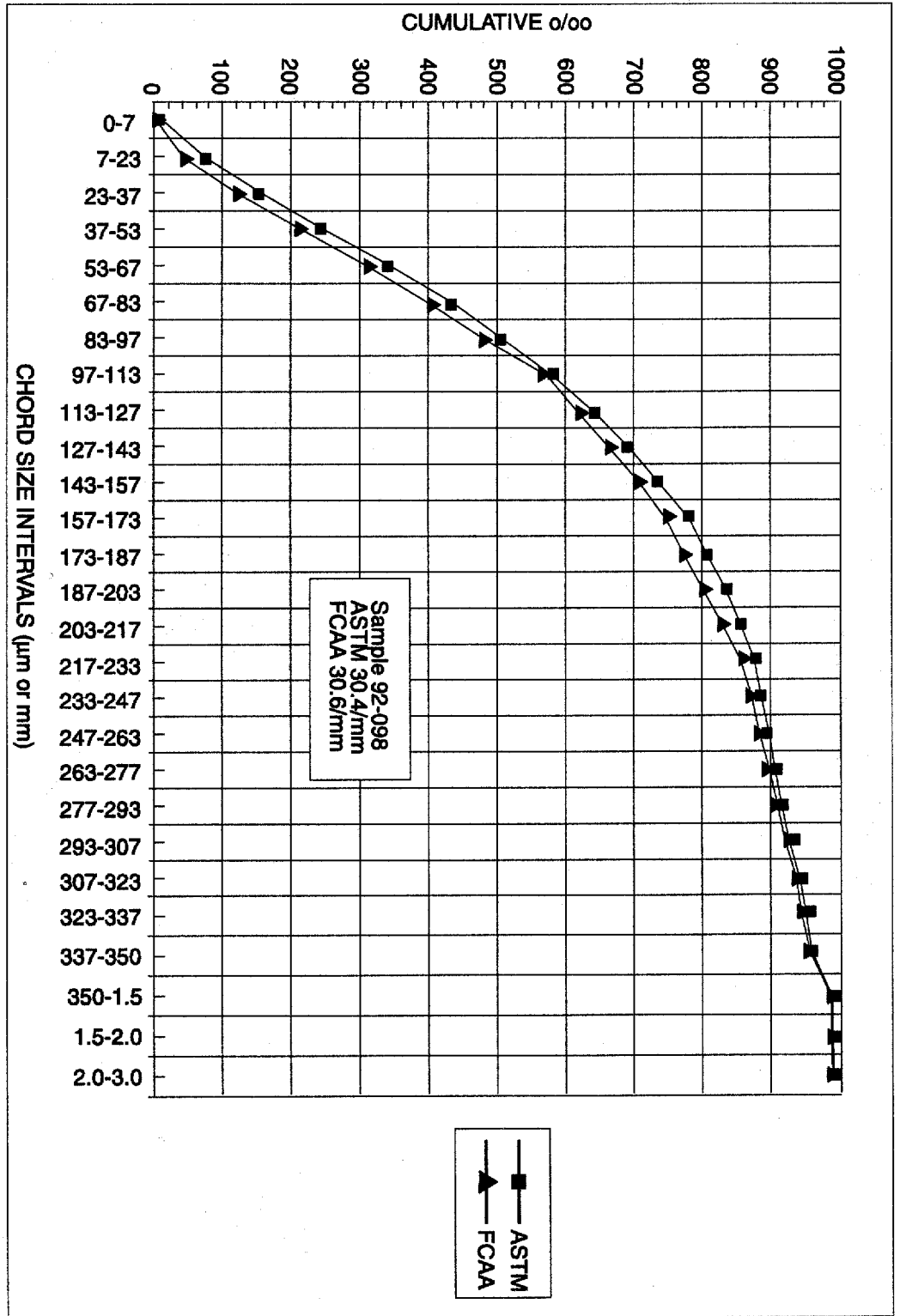

Figure 23.
Measured ASTM versus calculated FCAA chord distribution

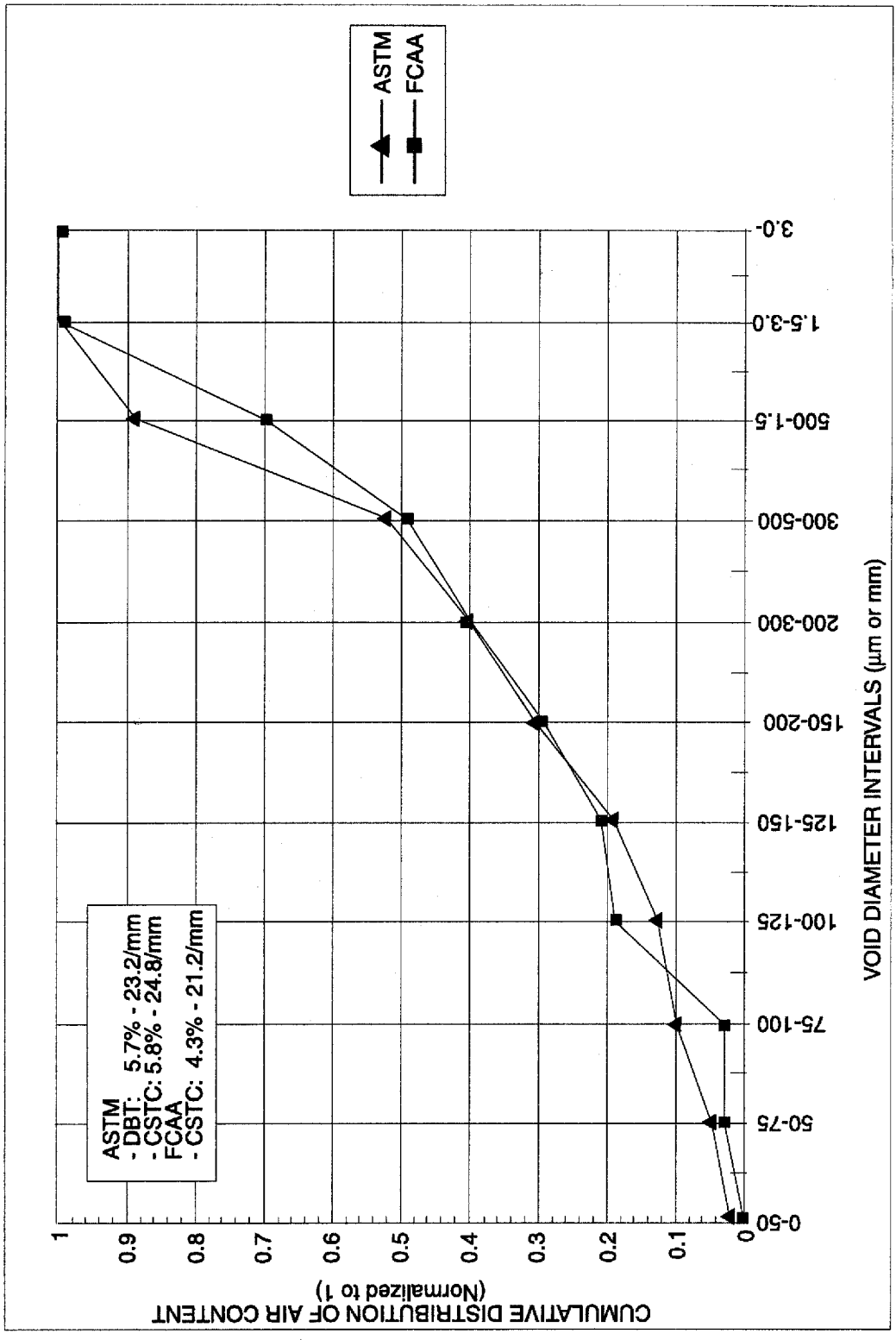

Figure 24. Calculated 3-D void distribution (ASTM) compared to measured FCAA void distribution

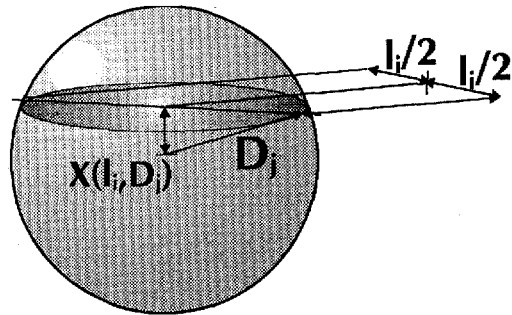

Figure 25.

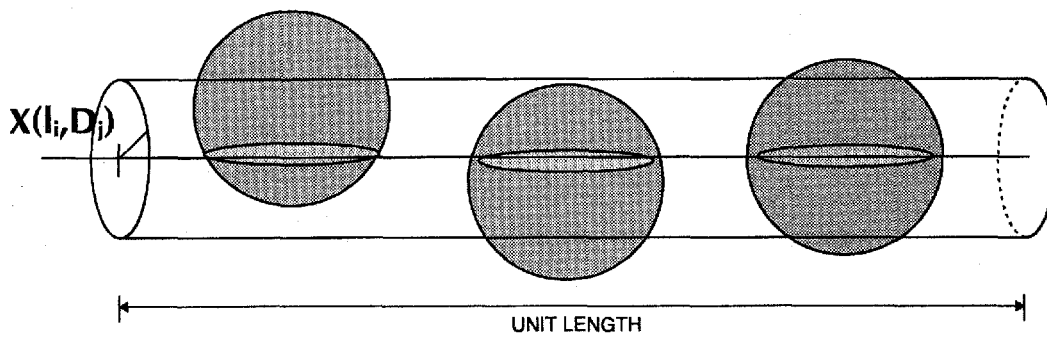

Figure 26.

APPENDIX B

Air Void Analyzer

**Quality Assurance for
Fresh Concrete**

**Hansson Consulting
261 Old Post Road
Waterloo, Ontario
Canada N2L 5B8**

**Ph: 519/884-8986
Fax: 519/884-9824**



Air Void Analyzer

Disclaimer

The air void analysis technique has been developed to determine the standard ASTM air void parameters in fresh (plastic) samples of **air entrained concrete** with a slump no less than 0.25 inches (1 cm) and with entrained air contents (ie. Air in voids < 3mm) between 3.5% and 10% by volume of the concrete.

The results of an analysis carried out with DBT Air Void Analyzer will, under normal conditions (ie. correctly sampled material, correctly performed testing within the specified temperature range and using the analysis liquid with the correct viscosity) be within 15% of the true values for that concrete. This deviation is primarily due to lack of homogeneity of the air void structure (spacing factor and specific surface) in normal concrete.

Due to these unavoidable deviations in concrete and due to our inability to control the user's sampling and testing procedure, Dansk Beton Teknik A/S and Hansson Consulting decline all responsibility for the consequences of the use of results obtained with the Air Void Analyzer.

Applicable Law

All agreements relating to the purchase and operation of the Air Void Analyzer shall be interpreted according to the laws of Ontario, Canada.

Principle of Operation

The air voids developed in the fresh concrete by the addition of an air entraining agent (together with the entrapped air) are released into a viscous liquid, the properties of which allow the resulting bubbles to retain their original size and neither coalesce nor disintegrate into a number of smaller bubbles. The bubbles then rise through the liquid at rates dependent on their size (according to Stokes Law) and enter a column of water above the liquid. The viscosity of the liquid slows the initial rise of the bubbles and provides a measurable separation in time between the appearance at the top of the column, of bubbles of different sizes rising from the same layer of the liquid. The bubbles rise through the column of water and collect under a submerged buoyancy recorder which is attached to a balance. The change in buoyancy is recorded as function of time and, on the basis of previous empirical calibration,

can be related to the number of bubbles of different size. From this data, the following air void parameters¹ specified by ASTM Standard Practice 457² are calculated:

- air content in voids of diameter <3.0mm, <1.0mm and <0.5mm (as volume % of concrete and as volume % of paste)
- spacing factor in mm
- specific surface in mm⁻¹

These parameters have been calculated to correspond to those that would be obtained from linear traverse measurements on a plane surface of the hardened concrete making the assumptions used in the ASTM 457 practice, namely (i) that the average measured chord length is equal to 2/3 of the true void diameter and (ii) for calculations of specific surface and spacing factor, that the voids are all of the same size and that they are located at the lattice points of a regular cubic array.

In addition, the data can be presented as (i) a graph of cumulative fraction of voids (as volume % of concrete) versus the true void diameter and (ii) a bar chart of the actual void volume (as % of the paste volume) in different ranges of void diameter.

¹The total air content of the concrete is not given because the number of large (entrapped) air voids will not be statistically meaningful in a 20 ml sample.

²ASTM 457: Standard Practice for Microscopic Determination of Air-Void Content and Parameters of the Air-Void System in Hardened Concrete, Annual Book of ASTM Standards, Vol.04.02.

Description of the Measuring Equipment

A. Transport container with the following:

- I. Riser column, as shown in Figs. 1a and b, 2a and 2b, and consisting of:
 - i) acrylic column with rectangular bottom plate
 - ii) positioning bolt and nut which also acts as heater connector
 - iii) 24V, 4W heating element
 - iv) hole for piston and injection of mortar sample
 - v) stirrer rod
 - vi) temperature sensor
 - vii) piston
 - viii) o-rings

Also indicated in Fig. 2a and 2b, is the buoyancy recorder consisting of the inverted petri dish suspended from the balance arm.

II. Cabinet, also shown in Figs. 1 and Figs. 2c and 2d with (i) display panel for balance readings, (ii) indicator lamps on the front panel for electrical power heater and stirrer, (iii) sockets at the front for two temperature sensors and (iv) sockets at the back for computer and electrical power. The cabinet contains:

- i) Balance
- ii) Balance pan
- iii) Lever column
- iv) Balance arm
- v) Bushing for balance arm
- vi) Magnetic stirrer
- vii) Data acquisition unit
- viii) Electron circuitry

III. Accessories consisting of:

- i) percussion drill
- ii) mortar sampler
- iii) 5 plastic syringes
- iv) plastic bucket
- v) digital thermometer
- vi) immersible heating element
- vii) flask for inserting viscous liquid in bottom of riser column
- viii) litre bottle for heating liquid
- ix) brush for removing air bubbles from walls of riser column
- x) plexiglas plate with hole

B. Computer case containing:

- i) Macintosh Powerbook145 computer
- ii) A.C. battery recharger
- iii) Diconix 180si printer
- iv) A.C. battery recharger
- v) printer/computer connector cable
- vi) 1 serial cable and 1 SCSI cable

C. Portable/cooler with AC battery charger and bottles for water and viscous liquid

D. Supply of special (blue) viscous liquid (glycerin based, MSDS attached)

Also required are (i) a supply of distilled water or water that has been drawn and left to stand for at least 24 hrs. to allow the excess dissolved air to escape and (ii) access to 110V power.

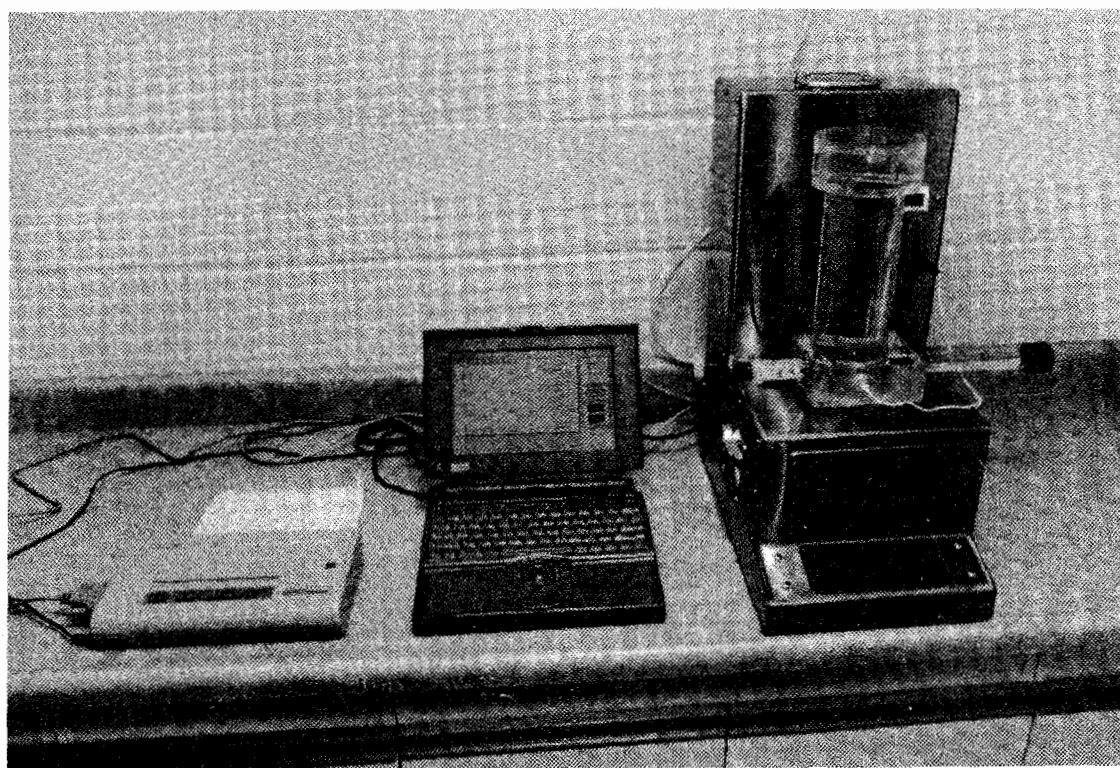

Figure 1a.
AVA equipment with
computer and printer

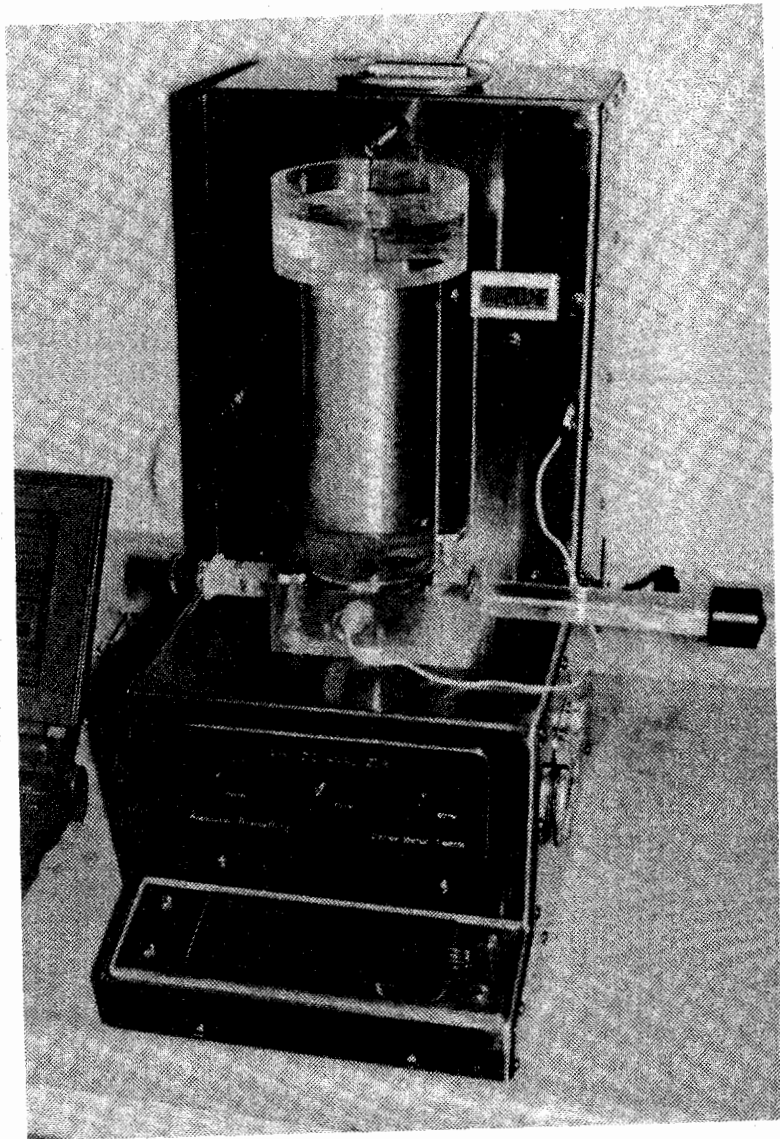

Figure 1b.
AVA Cabinet with riser
column, buoyancy
recorder, piston
and syringe

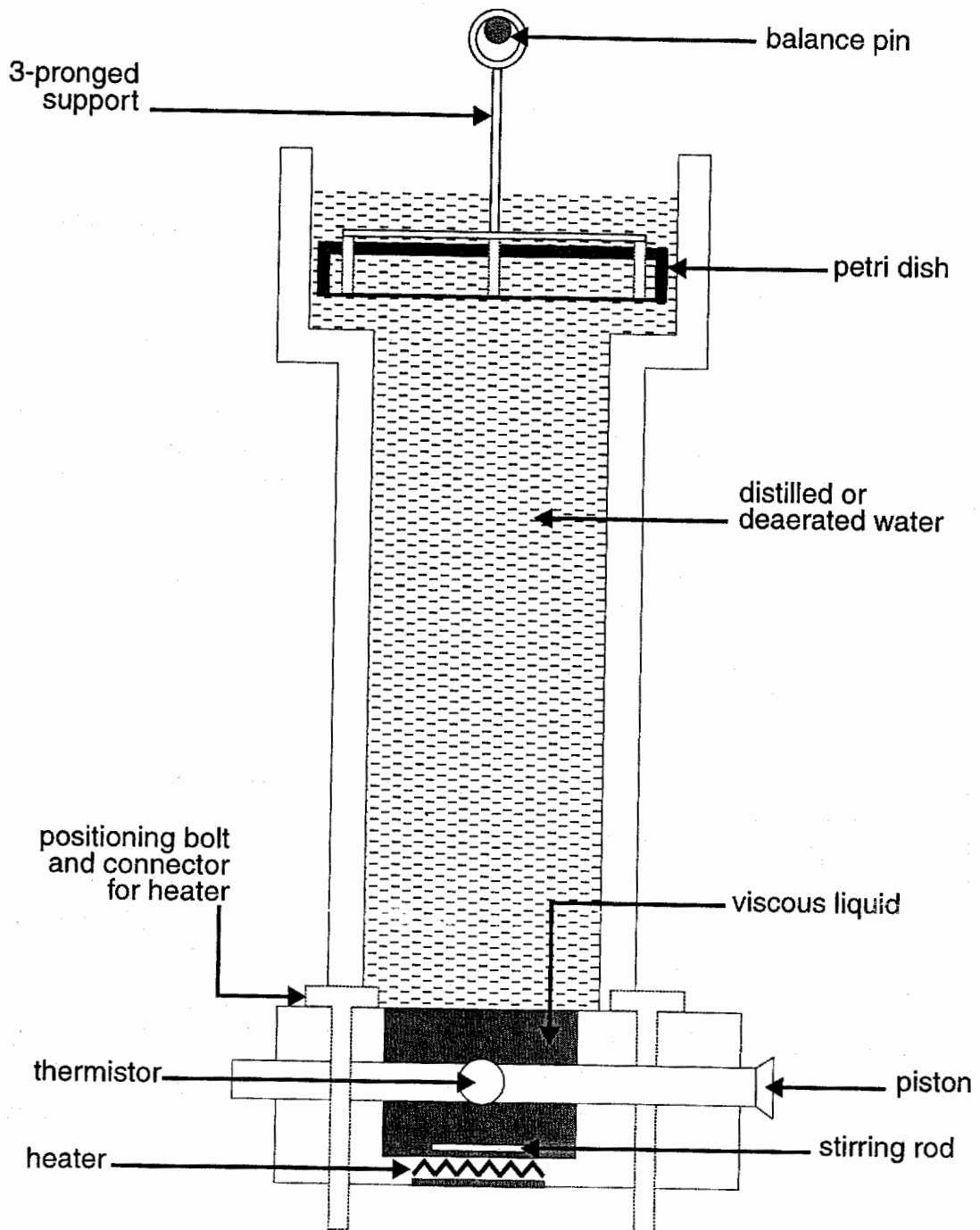

Figure 2a.
Schematic diagram
of riser column
(front view)

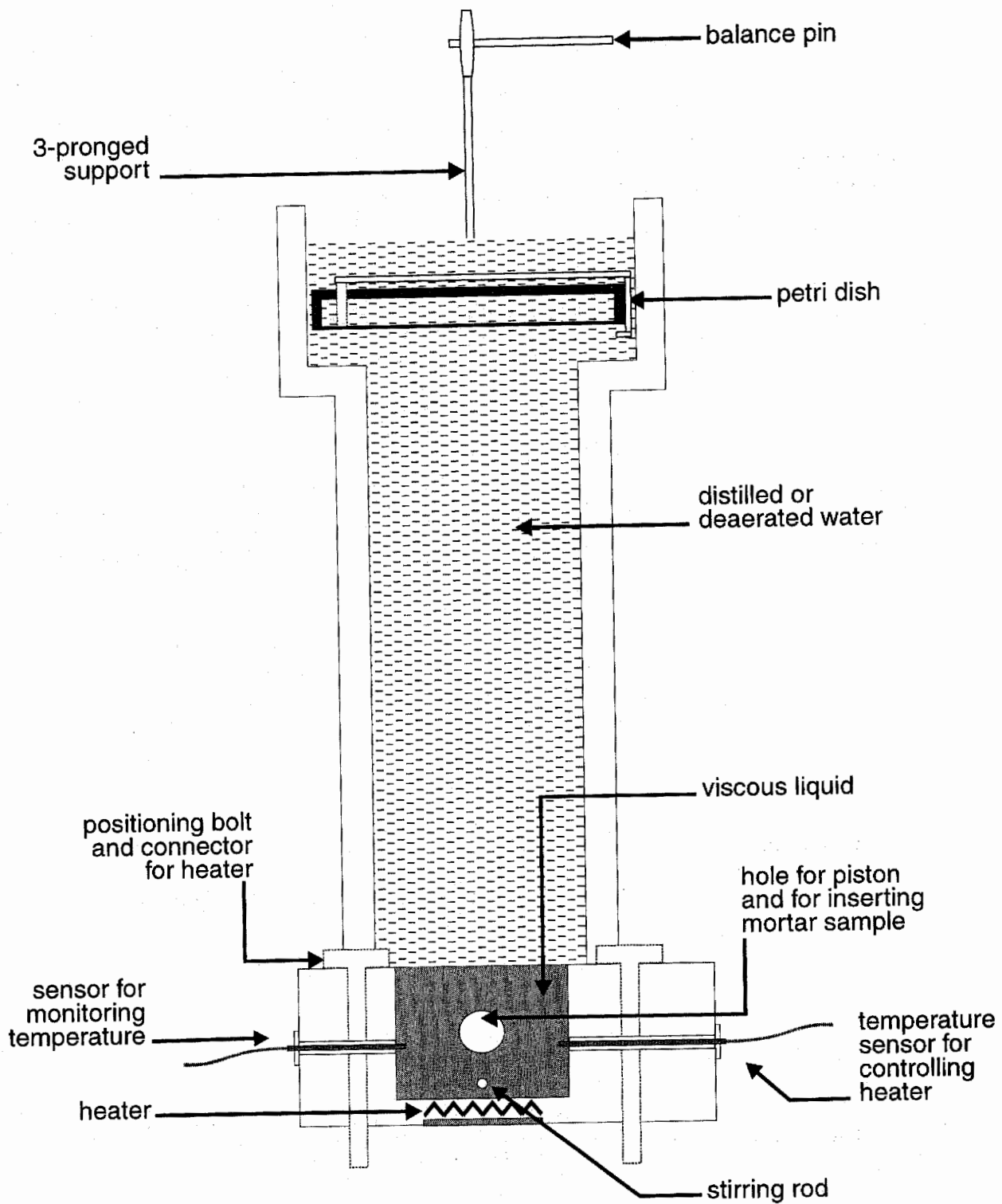

Figure 2b.
Schematic diagram
of riser column
(side view)

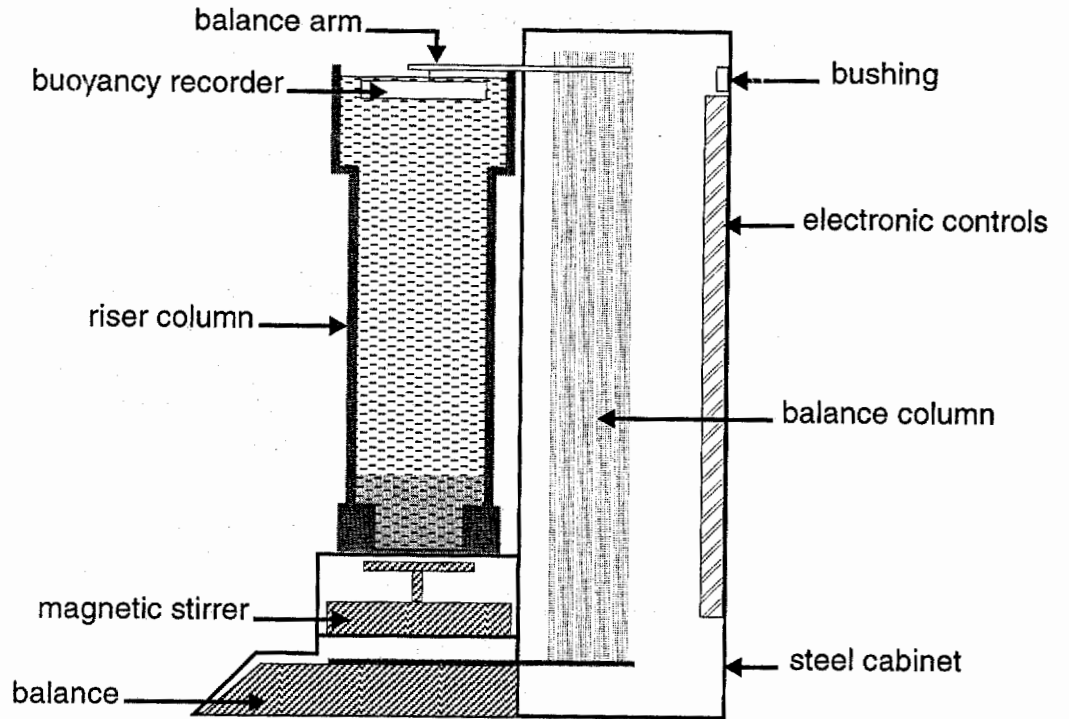

Figure 2c.
Schematic diagram of
measuring equipment
(side view)

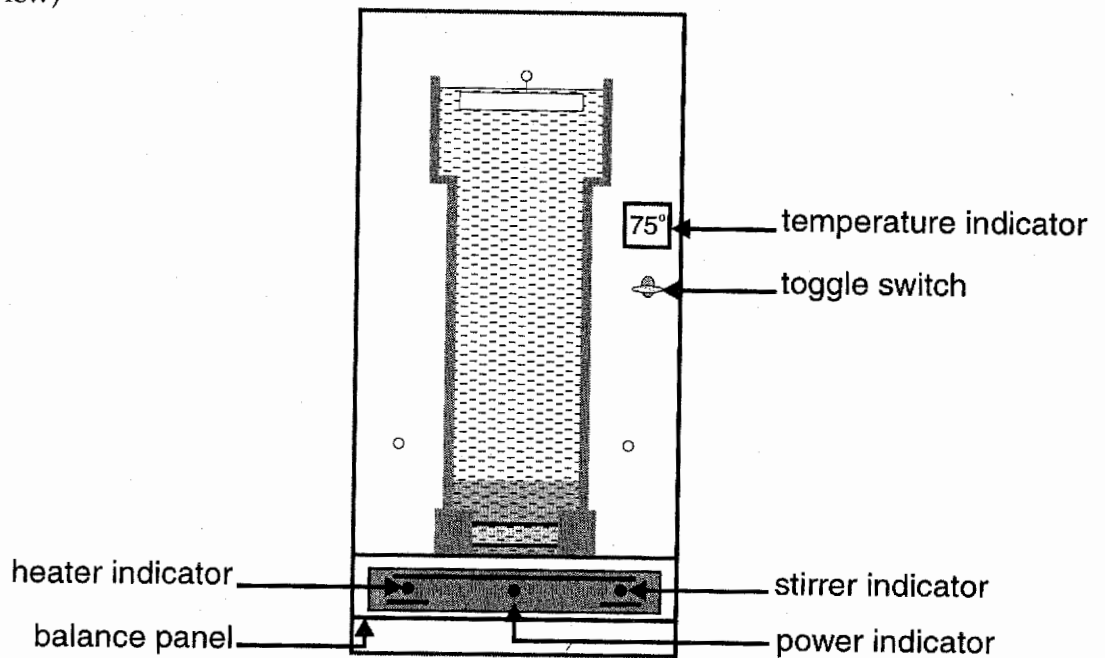

Figure 2d.
Schematic diagram of
measuring equipment
(front view)

Details of the Operation

Setting Up the Equipment

It should be remembered that the equipment contains delicate electro-mechanical components and should be handled accordingly.

The stainless steel cabinet must be placed on a stable base to avoid vibrations which could result in erroneous readings. Since the weight change readings are very small (fractions of a gram), they can also be influenced by windy conditions and, therefore, due protection from the elements is recommended. If the equipment has been stored or transported at temperatures different from the ambient temperature, it should be allowed to stabilize at the ambient temperature before use.

(Note 1: computer diskettes should not be placed on the cabinet because the magnetic stirrer can destroy the contents)

The printer and the two cables from the cabinet are connected to the computer.

(Note 2: care must be taken to ensure that these connections are tight and, where appropriate, the screw fasteners are also tight.)

The heating element, which has been set to 73.5F (23°C), is mounted in the bucket a little above the bottom and the bucket is half filled with the distilled water or de-aerated water. The special liquid is poured into the liter plastic bottle and placed in the bucket so that it too will be heated. In hot weather, if the temperature of the available water and the special liquid is >77°F (25°C), some water and liquid should be chilled in the cooler provided and used to reduce the temperature to the required range.

When the liquids are in the temperature range of 71° - 77°F (22° - 25°C), they are introduced into the riser column as follows:

- the stirring rod is placed at the bottom of the column;
- the water is poured into the column to a level ~ 0.25 - 0.40 in. (~ 1.0 - 1.5 cm) above the upper, wider section;
- air bubbles on the inside of the column are removed with the brush (Fig. 3);
- 200 ml of the special liquid is poured into the flask (to the blue line);

- the flask is lowered to the bottom of the riser column (Fig. 4) and then is raised $\sim 1/4$ in. (~ 1 cm) while the bottom valve is still resting on the bottom of the column. With the flask in this position, the liquid is allowed to run slowly into the bottom of the column. When the liquid has stopped running out, the bottom valve is *closed* and the flask is gently raised out of the water.

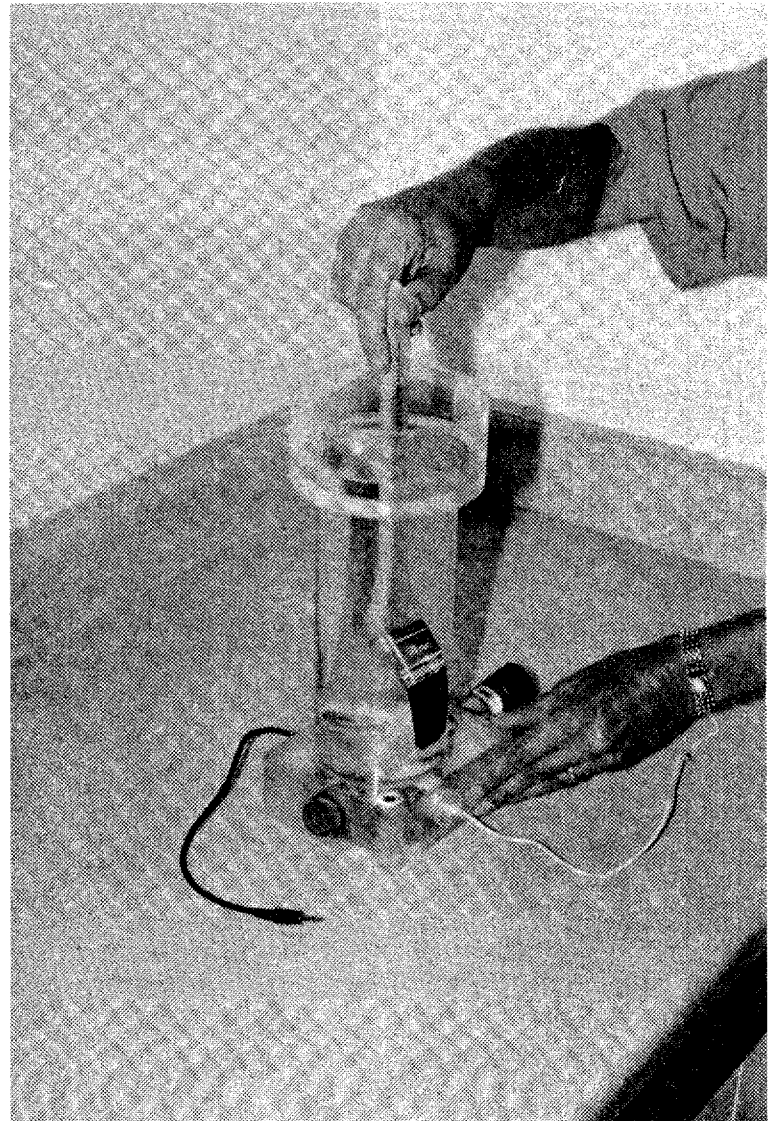

Figure 3.
Removal of air bubbles
from riser column

The riser column is mounted on the measuring equipment, as shown in Figs. 1 and 2, and fixed in the two bushings which also act as connectors between the heating element at the bottom of the column and the power supply.

(Note 3: the heating element must be covered with liquid before the power is switched on. When the knurled clamping nuts are loosened, the contact is broken.)

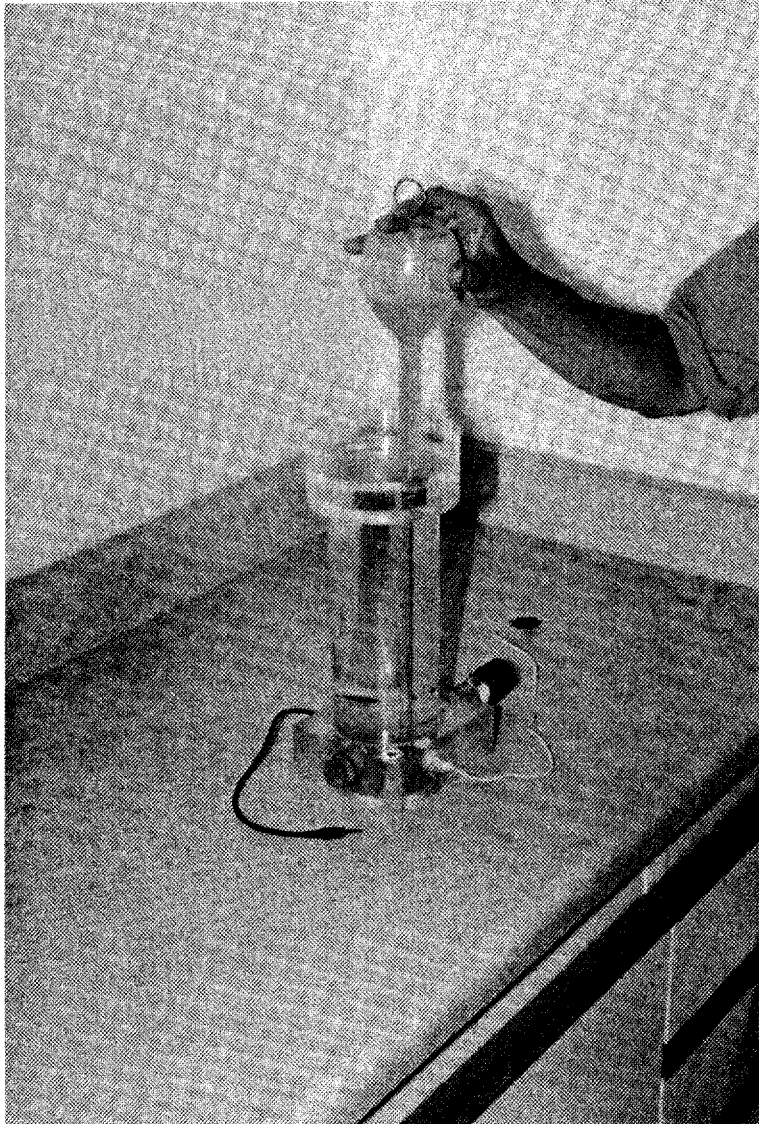

Figure 4.
Insertion of viscous
liquid into bottom of
riser column

The buoyancy recorder (the glass petri dish) is mounted at the top of the riser column (as shown in Figs. 1 and 2) as follows:

- It is lowered into the water at an oblique angle with the hole at the top so that the trapped air can escape.
- The balance arm is unscrewed from the back plate and gently pulled out to its full extension while rotating.
- The buoyancy recorder is then hung in the groove on the balance pin so that it is centered with respect to the column and does not touch the column

The two temperature sensor leads are connected as follows: the white lead from the front of the column is connected to the socket under the temperature display on the right of the front plate of the

cabinet; the black lead from the back of the column is connected to the socket on the left of the front plate of the cabinet.

(Note 4: these leads must not be reversed.)

The power is turned on at the switch at the rear of the cabinet. The temperature of the liquid is then immediately displayed on the meter on the cabinet.

Sampling

The sampling equipment, shown in Fig. 5, consists of:

- percussion drill (2600-2800 r.p.m.)
- aluminum holder with vibrator
- wire "bird cage"
- plexiglas plate with 40 mm hole
- 5 graduated plastic syringes

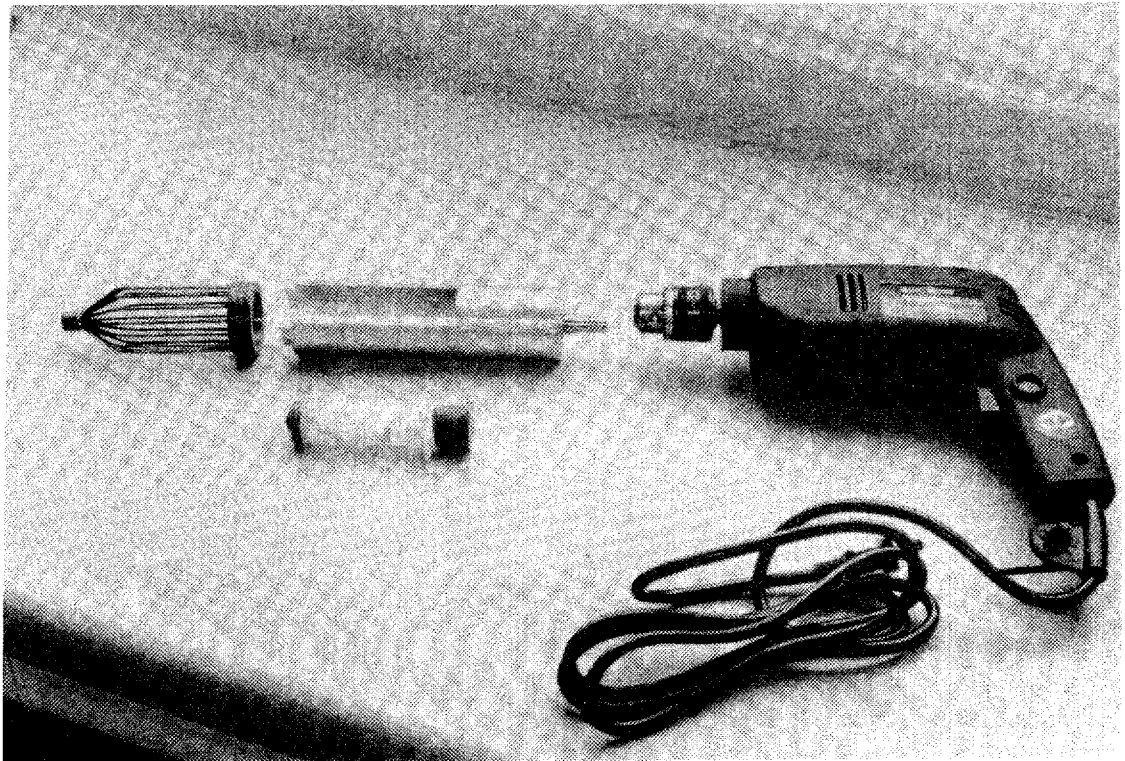

Figure 5.
Equipment to take a
sample of the mortar
fraction of the concrete

The aluminum forked holder is attached to the drill and the "bird cage" is mounted onto the holder by lightly pressing the prongs of the fork together. The syringe is inserted between the prongs and fixed in position by rotating the piston 90° into the keyways in the holder, Fig. 6.

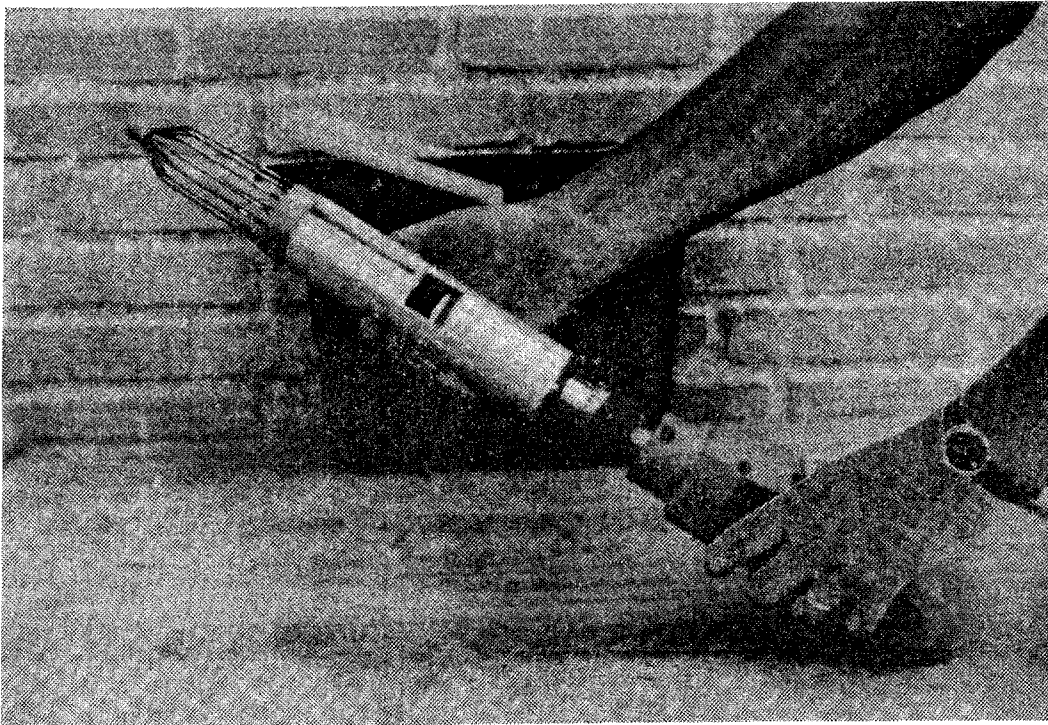

Figure 6.

The syringe is rotated so that the piston is held fast in the keyways of the aluminum holder

The percussion drill is used at the maximum rate and the sample is taken from a location that is representative of the treatment to which the concrete is exposed, but never right in a vibrator track.

The plexiglas plate is placed on the concrete surface with good contact to the concrete. The aluminum holder is gripped in one hand and the drill is started at full speed—this starts the vibration of the sampler.

The vibrating "bird cage" is lowered through the hole in the plate into the concrete, Fig. 7, and the vibrations cause the mortar (ie. the concrete excluding the aggregate >6 mm) to fill the bird cage. At this time care must be taken that the mortar under the plate does

not flow towards the hole in the plate as there is then a risk of filling the bird cage with surface mortar. This is avoided by pushing the plate against the concrete with adequate pressure and by ensuring that air bubbles under the plate do not move towards the hole.

When the "bird cage" has been vibrated all the way down into the concrete, the tip of the syringe must be immersed in the mortar (ie. the mortar must fill the "bird cage"). The syringe is then pushed smoothly down into the concrete under vibration (3-4 sec.), Fig. 8.

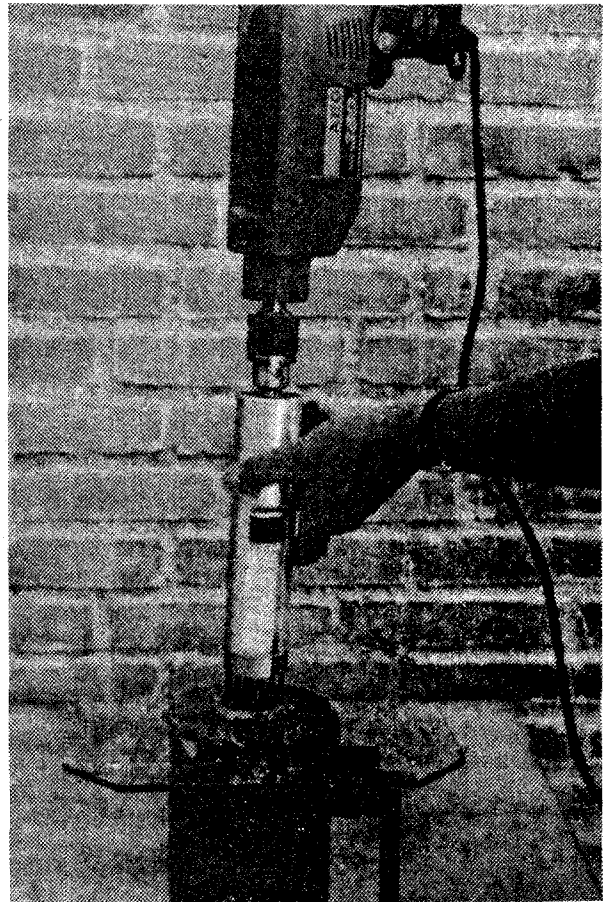

Figure 7.
The "bird cage" holder is lowered into the concrete under vibration

A little of the special liquid may be poured into the ring to prevent air from the outside entering the syringe. When the syringe has been introduced completely into the mortar, the drill is stopped and the sampler is removed from the concrete, Fig. 9.

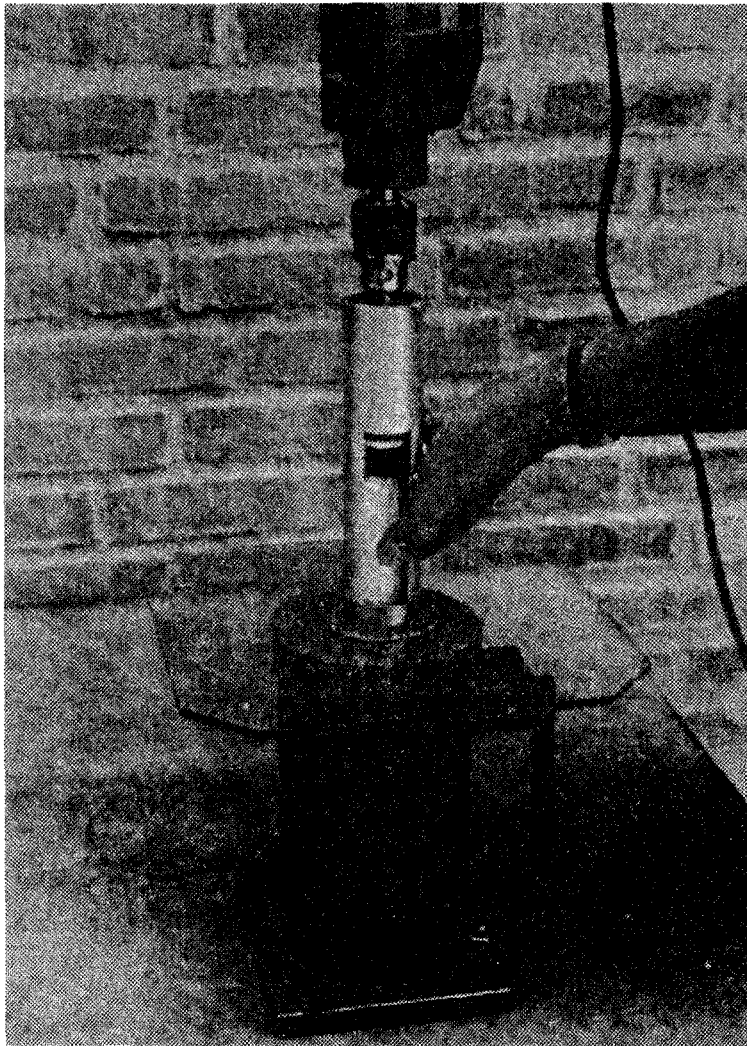

Figure 8.
After the "bird cage"
has been vibrated all
the way down, the
syringe is pushed
smoothly down into the
concrete under vibration

The Syringe can be removed by rotating the piston 90° out of the keyways in the fork. The "bird cage" is removed from the holder by lifting it off while pressing the prongs of the fork together, Fig. 10.

The outside of the syringe is rinsed in water and the piston is pushed forward to the 30 cc mark so that 20 cm³ remain. The excess mortar is "cut off" and the piston is withdrawn 1 mm.

The samples should be taken as soon as the concrete is compressed. If several samples are to be taken at the same time, those which cannot be analyzed immediately should be cooled to 50° - 60°F (10° - 15°C) so that setting is delayed as much as possible. A sample may be used as long as it can be dispersed completely by the magnetic stirring rod.

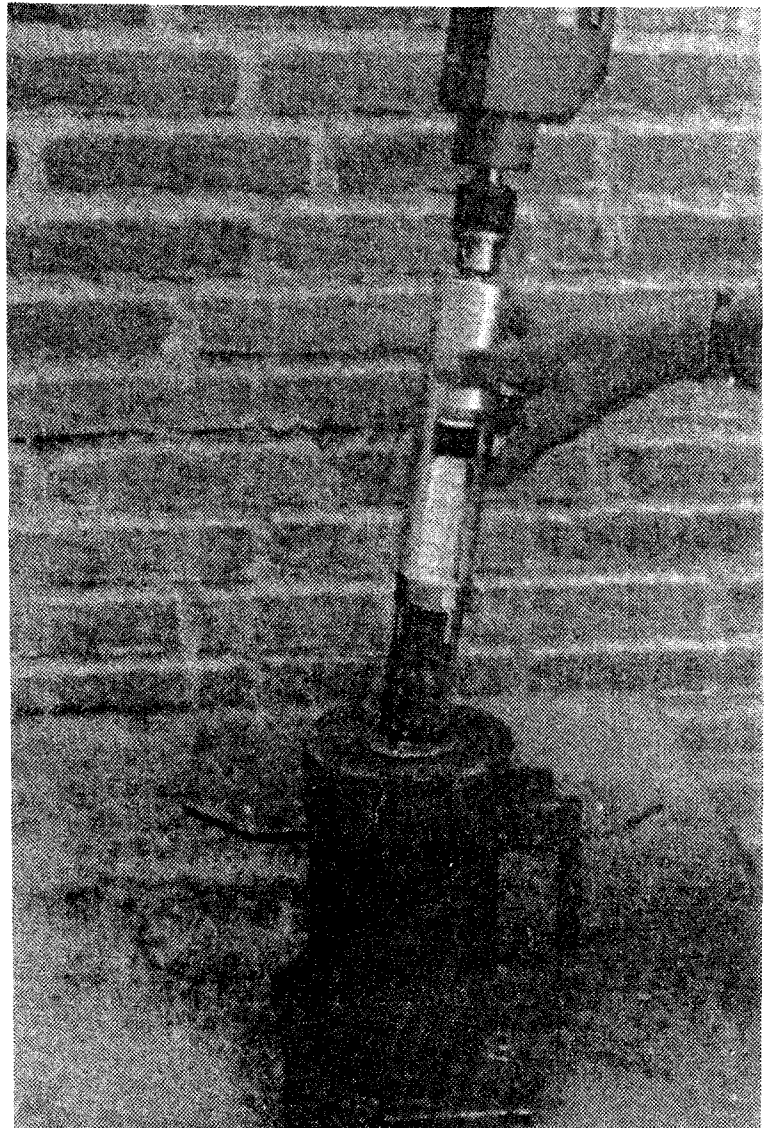

Figure 9.
Removal of the filled
syringe and "bird cage"
from the concrete

The syringe is placed against the end of the riser column piston so that the end of the piston fits ~1 mm into the syringe, Fig. 11. The piston and syringe are twisted and moved through the two O-rings so that the end of the syringe is flush with the inside of the bottom chamber. The piston is withdrawn so that its end is flush with the opposite side of the chamber.

(Note 5: at this time, the air which had been trapped between the piston and the mortar will rise into the buoyancy recorder. If this is significant in volume, it might tilt the petri dish and, therefore, should be removed before the mortar is injected into the column. This may be done by pushing and rotating the balance arm back into the cabinet and tilting the petri dish so that the air can escape from the hole.)

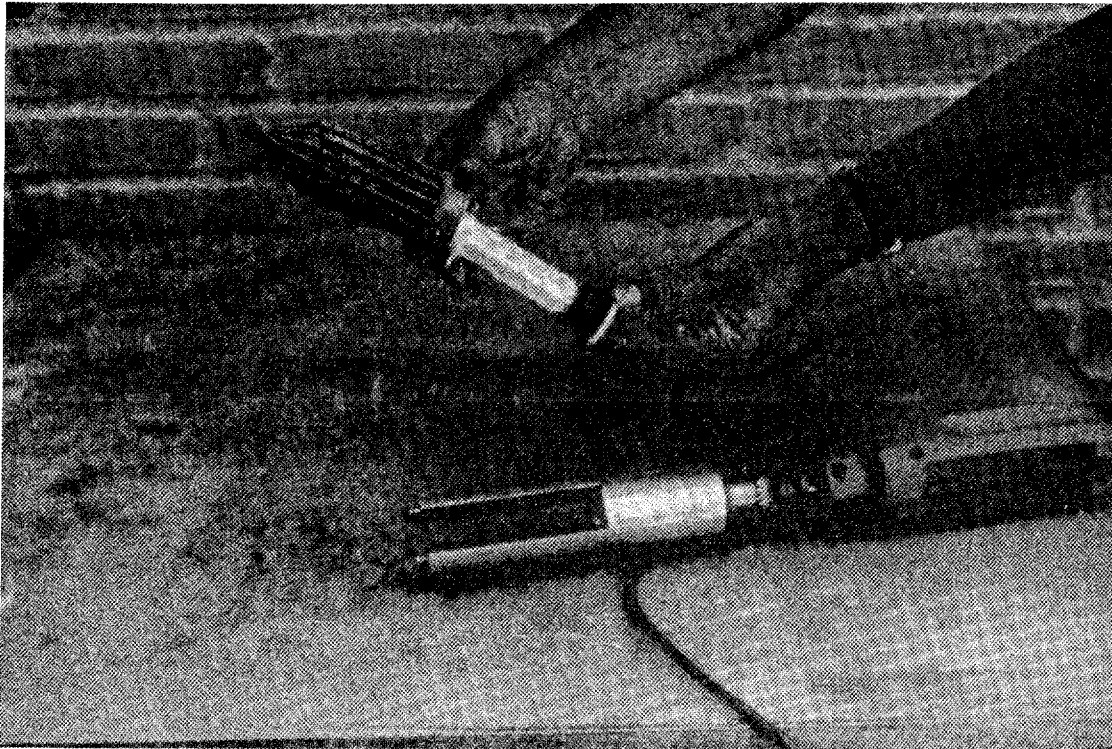

Figure 10.
The syringe is removed
from the "bird cage"

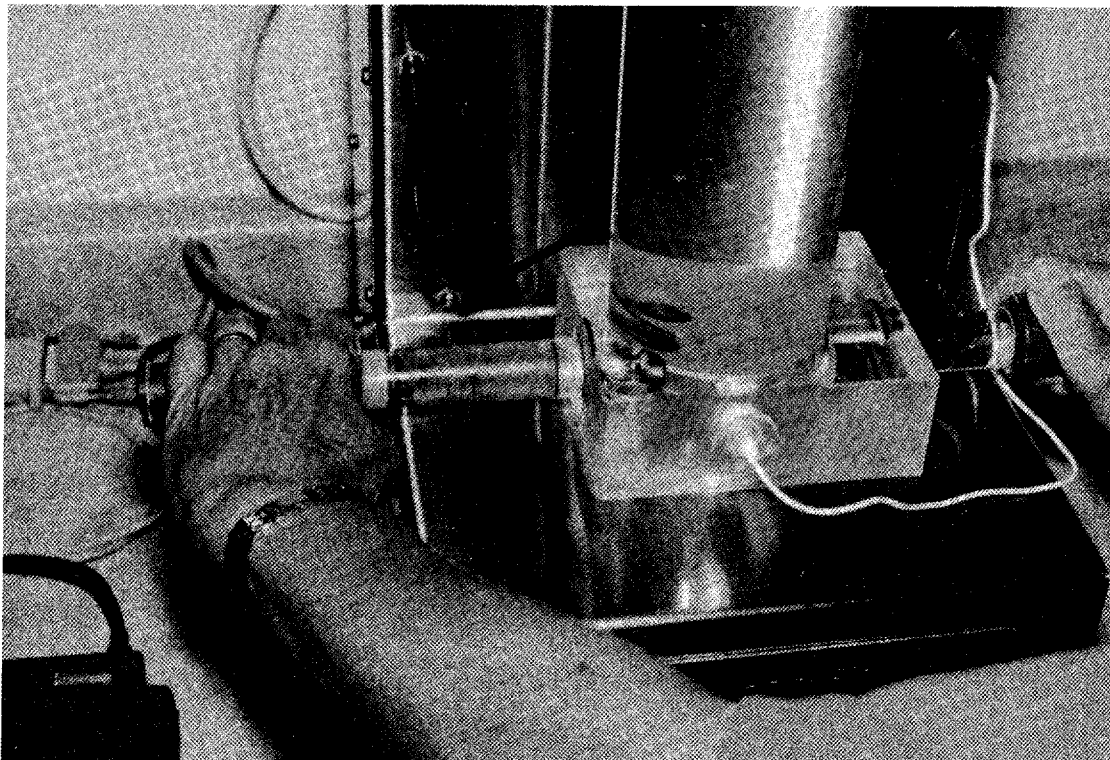

Figure 11.
Fitting the syringe holding
the mortar sample onto the
end of the piston

Measuring Program

- All connections to the computer must be made and the power switches on the AVA equipment and on the printer *must* be turned ON **before the computer is turned on**. Paper is inserted into the printer and the printer "on-line" switch is pressed. Because the measurements take some time, it is recommended that the computer is not used on battery alone but that the battery charger is always connected during measurements.
- The computer is turned on at the switch on the back panel.
- The temperature scale—Fahrenheit or Celsius—is selected by the toggle switch above the temperature meter on the front of the equipment, Fig. 2;
- The measurement program is opened by double clicking on the icon labeled "AVA-FWHA #3.1" (Fig. 12) using the track ball;
- The question written at the bottom of the screen (Fig. 13) is answered by pressing **y** or **n** followed by the **return** key.
- A **y** answer will cause the display to change to that shown in Fig. 14 and the following input data should be keyed in and is displayed at the bottom of the screen as it is typed.

(Note 6: the data will be stored in the computer in a file identified by a combination of the case number and the sample number.)

- **Sampler** (ie. name of operator)
- **Ordered by:**
- **Sample taken** (ie. location of tests)
- **Case No:** this should be a maximum of 30 digits or characters
- **Sample No.** This should be a maximum of 30 digits or characters
- **Mortar <6.0 mm%** is calculated as the sum of the volume percentages of all constituents in the mix except the aggregates >6 mm and the expected air volume.
- **Paste vol. %** is calculated as the sum of the volume percentages of cement + pozzolans + water + additives.
- **Expected air vol.%** is given in %.
- **Sample vol. cm³** is given in cubic centimetres and is usually 20 cm³.



Figure 12.

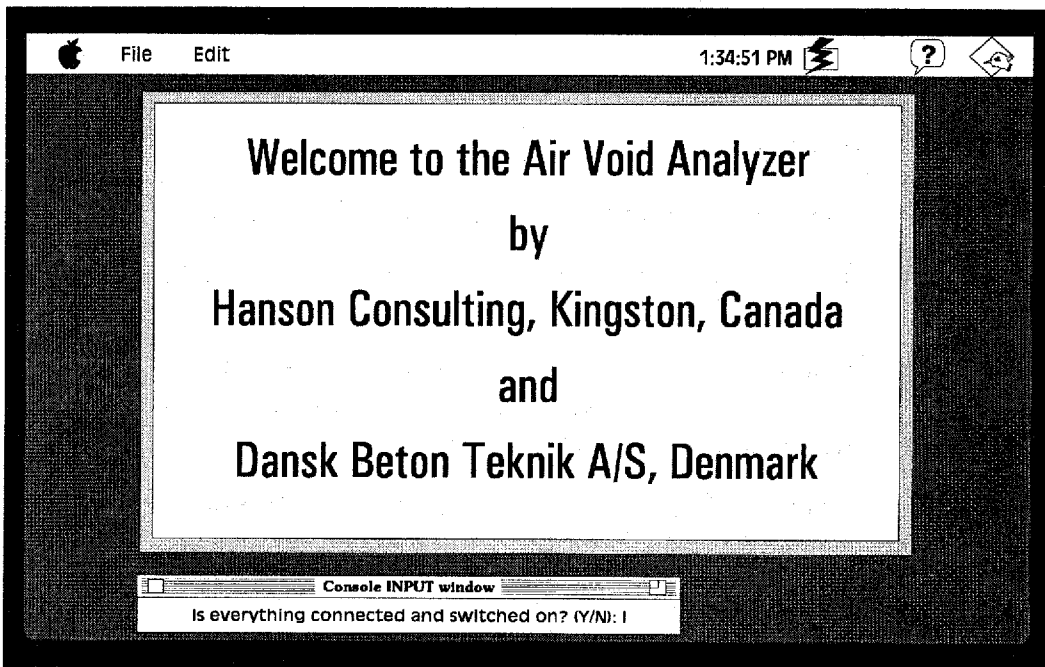

Figure 13.

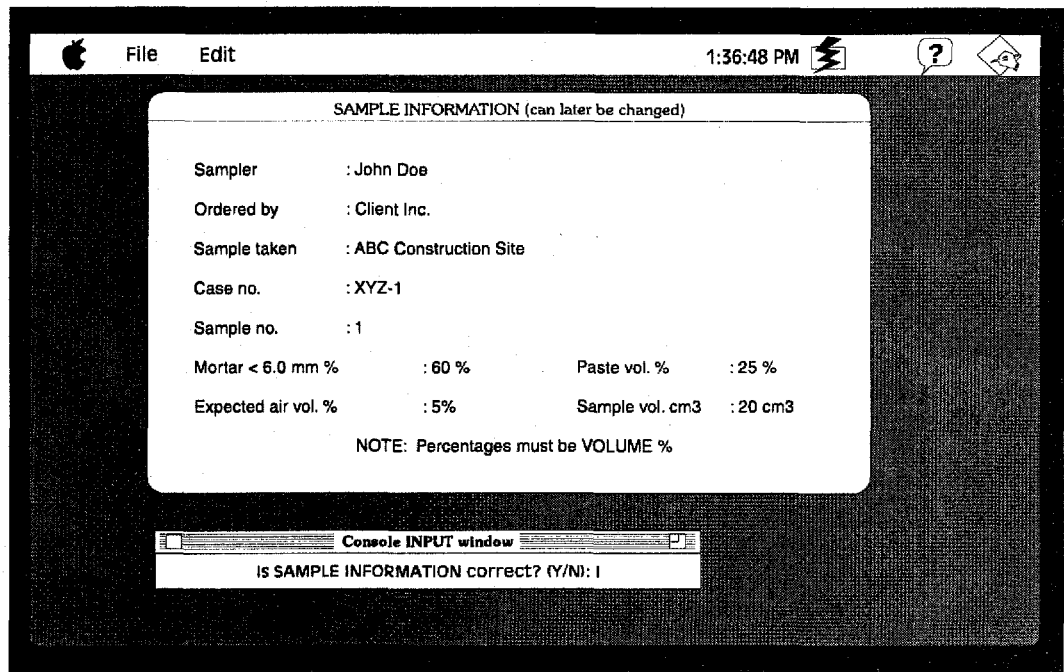

Figure 14.

- If the information keyed in is correct press **y** and **return**. If it is not correct, press **n**, **return** and, where appropriate, **y** or **n** to change the incorrect parameter(s).
- The screen image changes, as shown in Fig. 15, to display the temperature and weight and the temperature of the liquid in the riser column is determined. When the temperature is in the specified range, the mortar sample is injected into liquid.

(Note 7: the liquids should be in the correct temperature range before they are introduced into the riser column. The built-in heater is designed only to maintain the liquids within the correct temperature range during the measurements and is inadequate to heat the liquids from a lower temperature within a reasonable time.)

- The question "insert sample and start measurement?" may then be answered **y** and the measurements are initiated. At this point, the balance is automatically set to zero, the stirrer is operated for 30 s (during which time the stirrer indicator light on the cabinet will be illuminated and the stirrer box on the computer screen will be highlighted, as shown in Fig. 16) and the balance and temperature values are recorded. The heater may start at any time during the measurements if the temperature falls and will be displayed by the left hand indicator light on the cabinet and by the heater box on the computer screen.

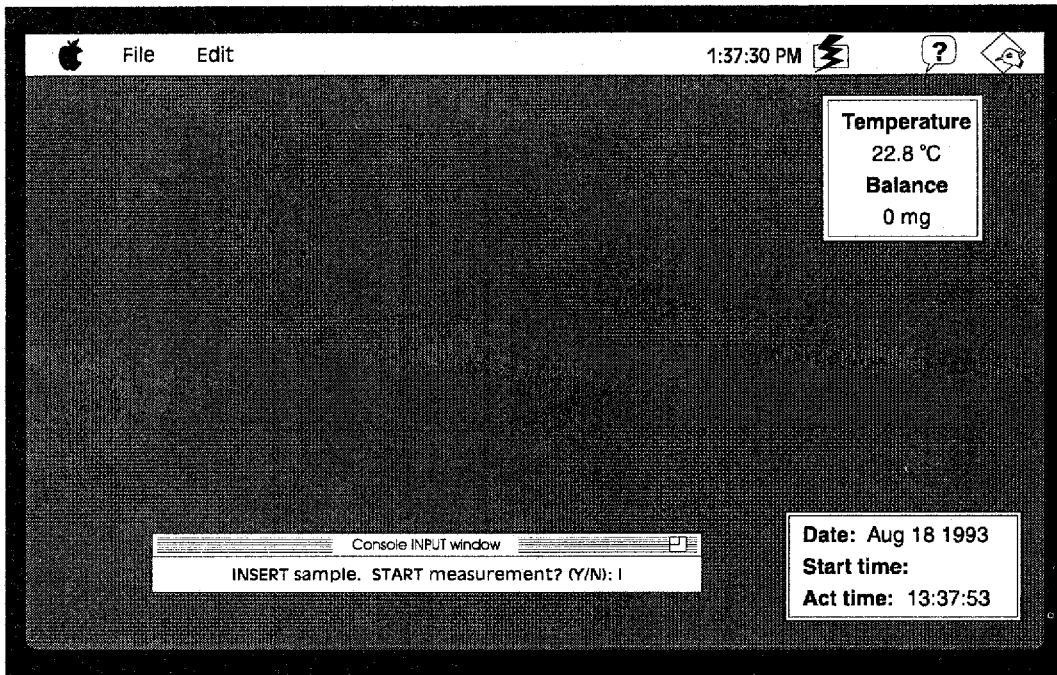

Figure 15.

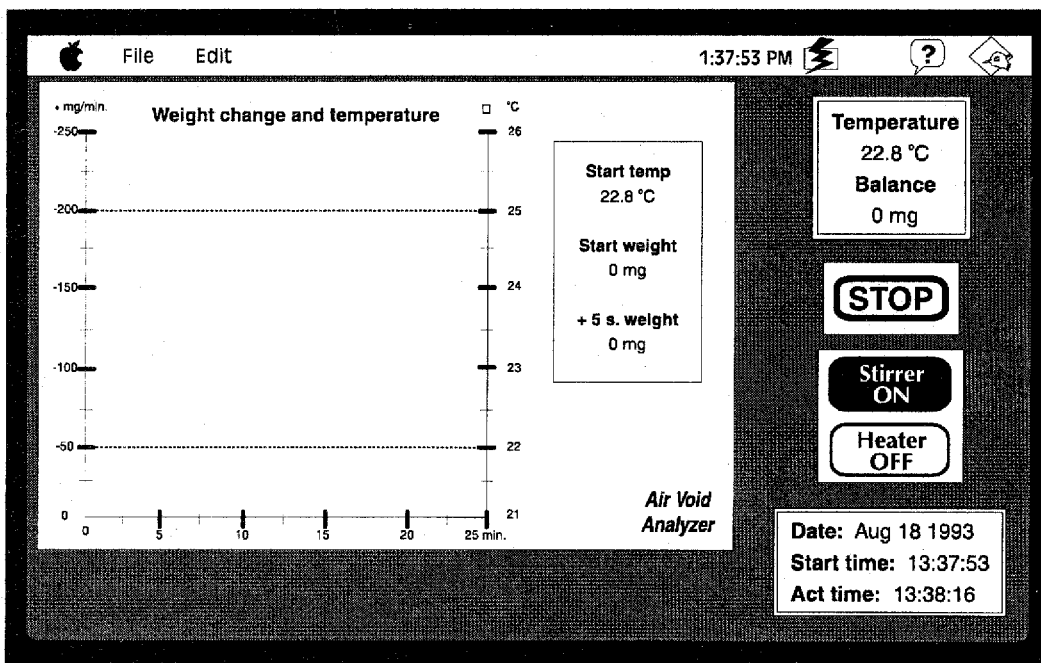
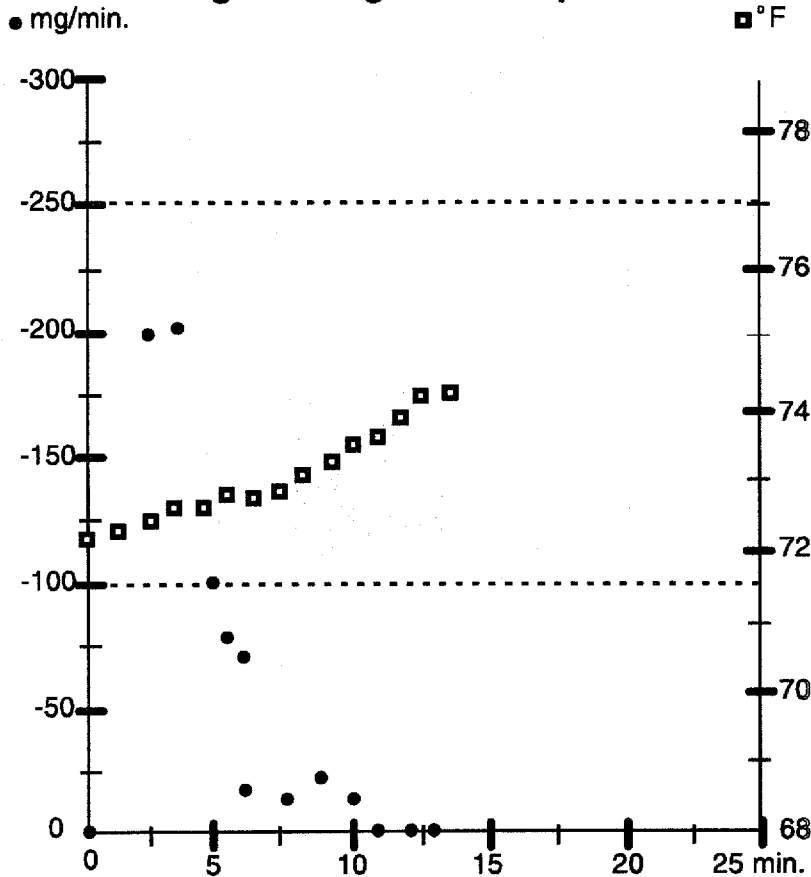

Figure 16.

Air Void Analyzer, Series NA3/S
 Dansk Beton Teknik A/S, Denmark
 Hansson Consulting, Canada

Date: August 23, 1993 01:04 PM
 Case no.: XYZ
 Sample no.: 1

Weight Change and Temperature



Sampler:
John Doe

Ordered by:
ABC Construction Inc.

Sample taken:
Anytown USA

Mortar <6 mm: 60 %

Paste: 30 %

Expected air: 5 %

Sample volume: 20 cm³

Results:

Void Diameter	< 3.0 mm	< 1.0 mm	< 0.5 mm
Air in concrete	3.94 %	2.82 %	2.65 %
Air in paste	12.9 %	9.29 %	8.75 %
Air in putty	11.5 %	8.22 %	7.74 %
Specific surface	21.7 mm ⁻¹		
Spacing factor	0.26 mm		

Comments: This is a test run

FEDERAL HIGHWAY ADMINISTRATION
 Office of Technology Applications

Signature: _____

Air Void Analyzer, Series NA3/S
Dansk Beton Teknik A/S, Denmark
Hansson Consulting, Canada

Date: August 23, 1993 01:04 PM
Case no.: XYZ
Sample no.: 1

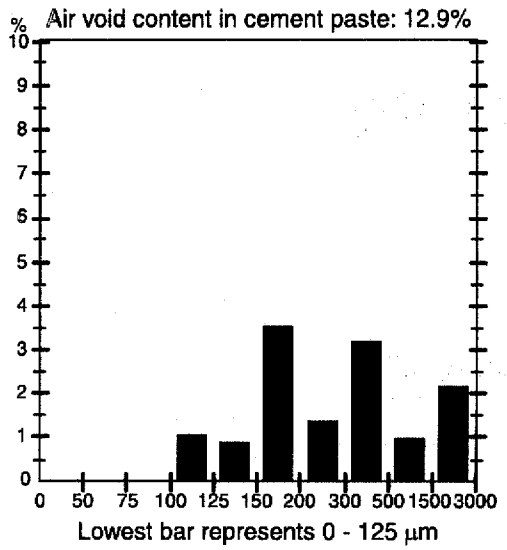
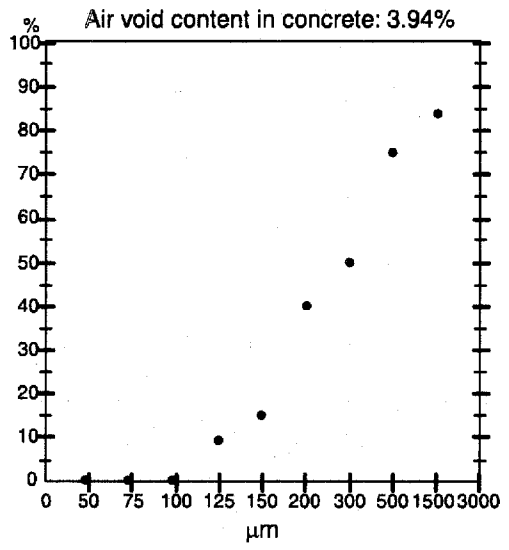

Comments: This is a test run

FEDERAL HIGHWAY ADMINISTRATION
Office of Technology Applications

Signature: _____

The measurements will continue for 25 min. or until the change in buoyancy is ≤ 5 mg for three consecutive minutes. Measurement may also be discontinued manually at any time by pointing the arrow on the screen on **stop** box and holding down the trackball button for 2 s or longer. Even if the program is stopped manually, the results can be stored and used to calculate the air void parameters.

An automatic stop of the measurements at times < 25 min. does not mean that the small voids are either not missing or not counted: while the *average* void size decreases in each measuring period, voids of all size ranges are collected in each period and the presence of small voids at earlier times is taken into account in the calculation of the results.

When the measurements are complete, the air void parameters are computed and the results are displayed on the computer screen as shown in Fig. 17 (except that the actual numbers for the air void parameters will appear where the ">>>>%" and "nano%" are shown in the figure). Any necessary corrections to the input data may be made at this time and the results will be re-calculated and displayed. They are also automatically stored and may be printed out if so desired. If a print-out is not required, click on the **cancel** box on the following *two* screens. Two files are created for each set of results and have the name of the Case No. and Sample No. with suffixes of AVADAT and AVASPS. The former allows the data to be printed out as in the original print-out and to be used to recalculate the results if the input information is incorrect. The latter is in a format which allows the data to be transferred to a spreadsheet.

(Note 8: if an unexpected error occurs at any time, the computer and equipment should be turned off and the experiment be started again from the beginning. This may be caused, for example, by the SCSI connector not being fully inserted or by electrical interference. Because of this possibility, it is recommended that two samples be taken from each location.)

Measuring Ranges

For the results of the measurements to be correct, it is essential that the temperature during the measuring procedure remains within the range for which the system is calibrated (71° - 77° F or 22° - 25° C). If the temperature is out of range, it will be noted on the screen and on the print out.

The air content must also be within certain limits: if it is too low, the weight changes will be too unreliable while if it is too high,

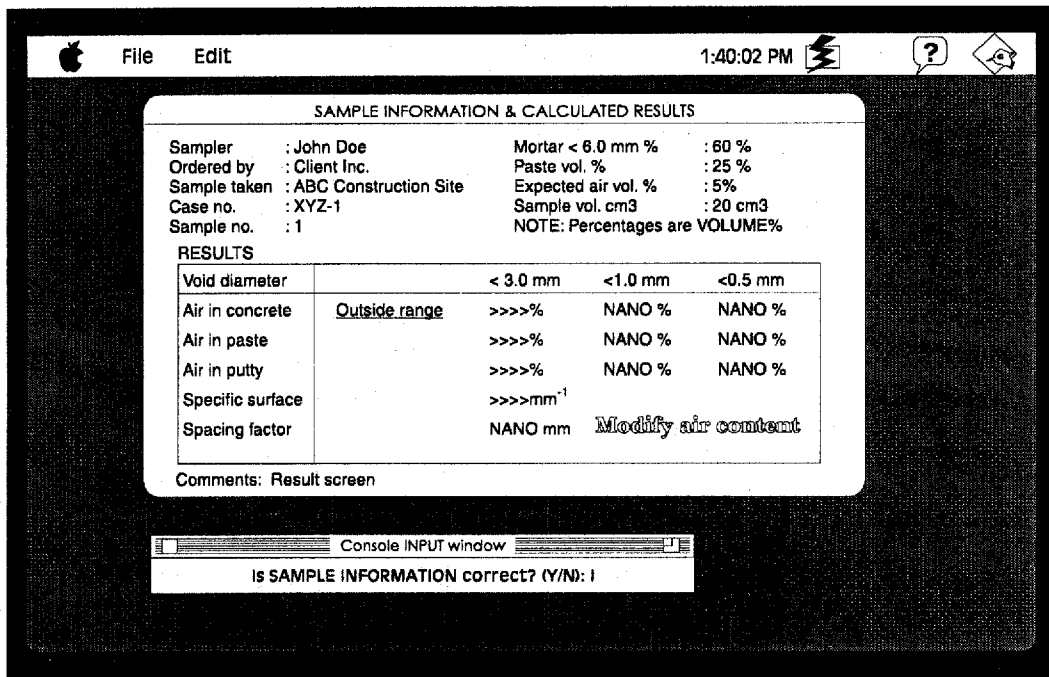

Figure 17.

turbulence may arise in the liquid. If the air is < 3.5% or >10% (by vol. of concrete) it will be noted on the screen display as in Fig. 17 except that the actual numbers for the air void parameters will appear where the ">>>>%" and "nano%" are shown in the figure. These warnings will be repeated on the print out.

Shut Down

The computer should be switched off *before* the AVA equipment and the printer. It is recommended that the computer be **shut down** at the end of each experiment rather than set to **sleep**. This will ensure that any problems encountered in the previous experiment will not be carried over to the following one.

(Note 9: if the switch on the main power rack is turned off and the computer is left connected, the computer battery will be discharged! Therefore, the charging lead for the computer must be disconnected when the main power switch is off.)

The riser column and petri dish should be dismantled and rinsed thoroughly in water at the end of each experiment. The piston, 'O'-rings and plastic syringe may be smeared with a small amount of stopcock grease if necessary. As the magnetic stirrer is not coated, it should not be left in water.

The AVA equipment should be turned off when not in use for a longer time to avoid the build up of heat in the cabinet.

Recalculation Program

If the input data is found to have been incorrect, the results can be corrected at any time by the **Recalculation** program which is operated as follows.

- Double click on the icon "AVA-REC #3.1", Fig. 12, to open the program
- Double click on the desired file ending in AVADAT, Fig. 18
- The input data will be displayed on the screen and you will be asked if you wish to correct each in turn.
- After keying in the correct data, the results are automatically recalculated and displayed on the screen, as shown in Fig. 19. They are stored in two new files with the suffix REC added to the original file name. The original files remain as they were.
- The new data may be printed out at this time if desired. An example of the recalculated print-out is given on pages 112 and 113.

(Note 10: this recalculation program can be used without the computer being connected to the AVA equipment. However, if it is connected to the equipment and/or printer, these MUST be turned on before the computer is turned on.)

File Management

It is recommended that files with incorrect data be trashed to avoid future confusion and that all files from one construction (or set of experiments) be moved to a separate folder.

Exporting Data to Spreadsheet

The data is stored as standard spreadsheet input ASCII file with a comma as separator.

For example, to open the file in the spreadsheet program *Excel*, double click on the *Excel* icon, click on the **file** menu and on **open**. Click on the **text** box in the dialogue window and on the comma as the column delimitator. Click **OK** then double click on the desired data file name ending in AVASPS. The data will then appear on the screen in the spreadsheet format.

The corresponding procedure for other spreadsheet programs, such as *Lotus 123*, will not be exactly the same. Please read the spreadsheet program instruction manual for importing an ASCII data file.

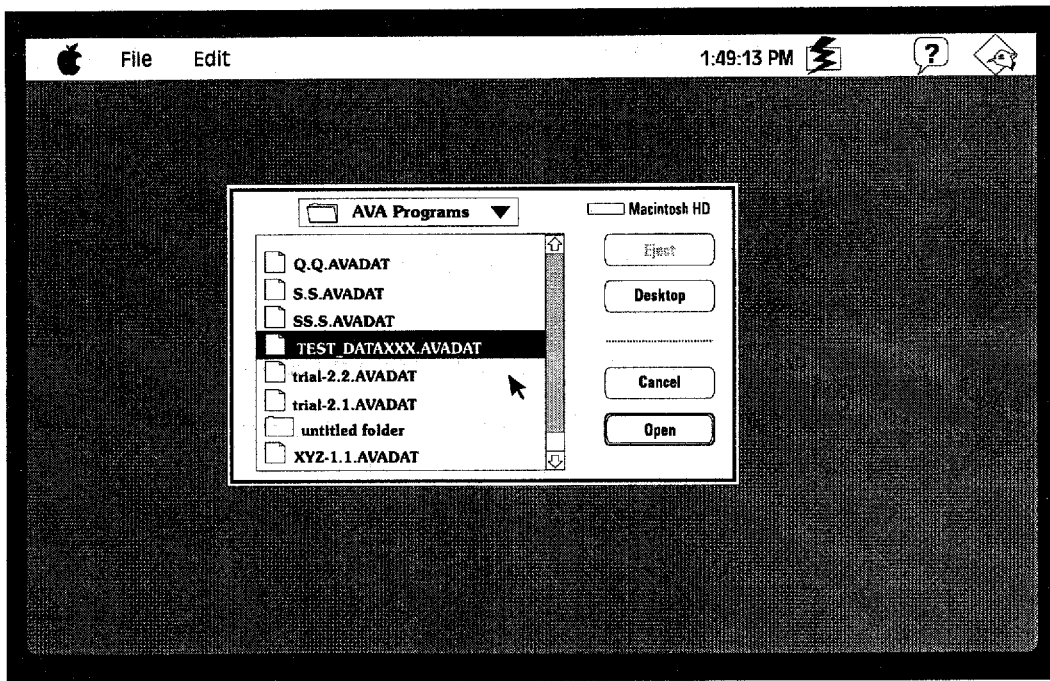

Figure 18.

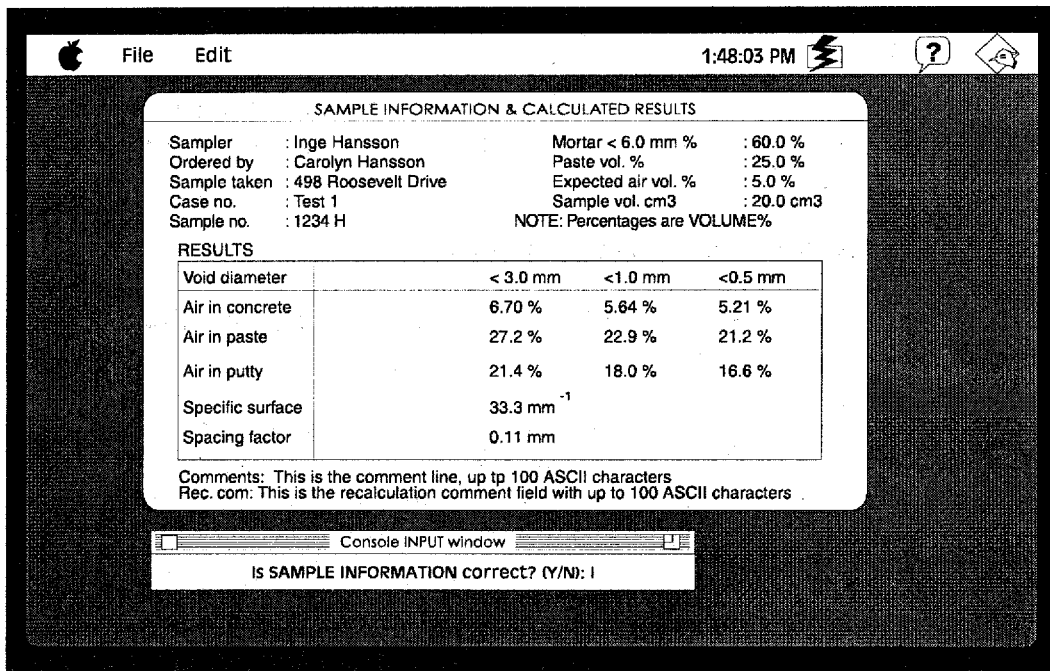

Figure 19.

Air Void Analyzer, Series NA3/S
 Dansk Beton Teknik A/S, Denmark
 Hansson Consulting, Canada

Date: July 12, 1992 04:59 PM

Case no.: 1

Sample no.: 1234 H

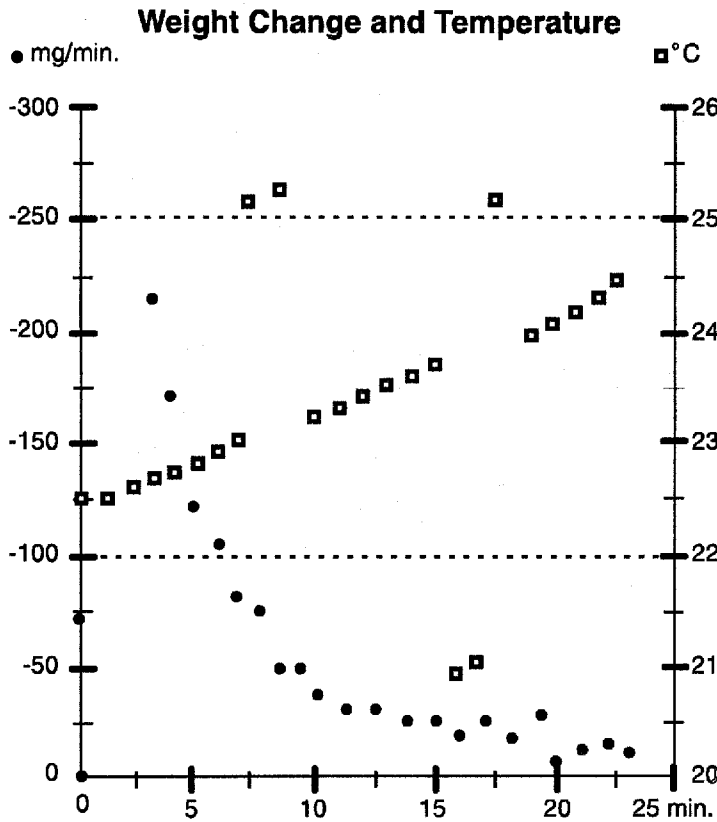

Sampler:
Inge Hansson

Ordered by:
Carolyn Hansson

Sample taken:
498 Roosevelt Drive

Mortar <6 mm: 60.0 %

Paste: 25.0 %

Expected air: 5.0 %

Sample volume: 20.0 cm³

Results: Recalculated - August 22, 1993 10:45 AM

Void Diameter	< 3.0 mm	< 1.0 mm	< 0.5 mm
Air in concrete	6.70 %	5.64 %	5.21 %
Air in paste	27.2 %	22.9 %	21.2 %
Air in putty	21.4 %	18.0 %	16.6 %
Specific surface	33.3 mm ⁻¹		
Spacing factor	0.11 mm		

Comments: This is the comment line, up to 100 ASCII characters

This is the recalculation comment field with up to 100 ASCII characters

FEDERAL HIGHWAY ADMINISTRATION
 Office of Technology Applications

Signature: _____

Air Void Analyzer, Series NA3/S
Dansk Beton Teknik A/S, Denmark
Hansson Consulting, Canada

Date: July 12, 1992 04:59 PM
Case no.: Test 1
Sample no.: 1234 H

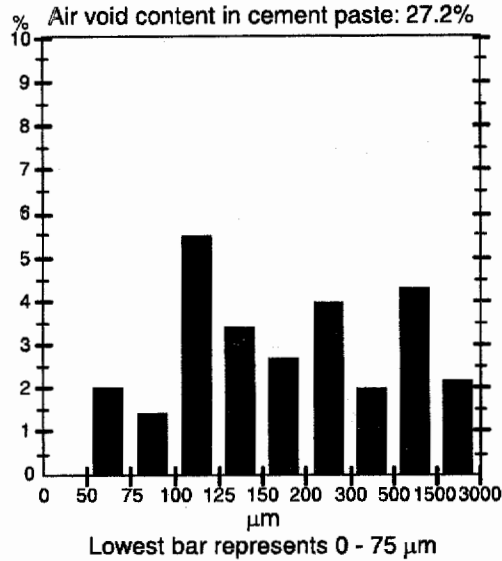
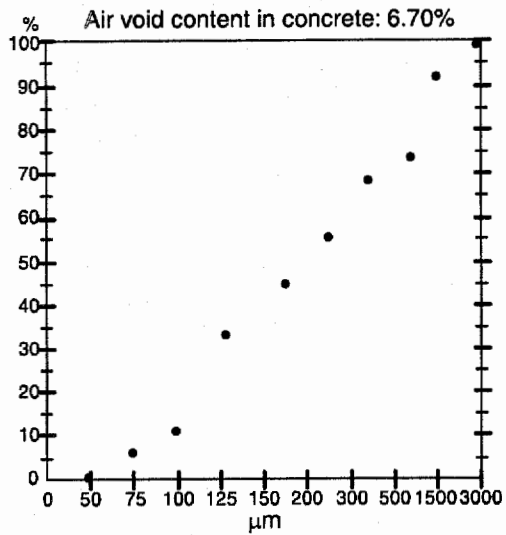

Comments: This is the comment line, up to 100 ASCII characters
This is the recalculation comment field with up to 100 ASCII characters
Recalculated: August 22, 1993 10:36 AM

FEDERAL HIGHWAY ADMINISTRATION
Office of Technology Applications

Signature: _____

Preparation for Transport

When the measurements are finished, the equipment is packed for transport as follows. The buoyancy recorder and the riser column are removed and rinsed. If the equipment has been used for a long time, they may be coated with a thin deposit which can be removed with a weak acid. All parts should subsequently be thoroughly rinsed with water to remove all traces of the acid.

The balance arm which supports the buoyancy recorder is rotated and pushed back and screwed into a bushing at the back of the equipment cabinet. The rubber stopper is placed on the end of the arm so that it is then fixed at both ends.

Care should be taken that the electrical leads to the two temperature sensors in the riser column are not sharply bent. Avoid blows and impact during transport.

Quick Check List

To set up

1. Set the water and special liquid to heat (or cool) to 71° - 77°F (22°-25°C).
2. Set up the equipment and connect it and the printer to the computer.
3. Put piston and stirrer rod in riser column.
4. Fill riser column with water to ~1/4" above the top flange.
5. Remove bubbles from inside column with brush.
6. Insert special liquid into bottom of column.
7. Set column on AVA cabinet.
8. Fasten riser column with knurled nuts to connect the heater.
9. Connect white temperature sensor lead to right hand socket and black sensor lead to left hand socket.
10. Mount the buoyancy recorder on the balance arm and make sure it is not touching the column.
11. Take sample of mortar from representative volume of concrete.
12. Insert syringe into riser column while withdrawing piston.
13. Remove excess air from the petri dish if necessary.
14. Turn on AVA equipment and printer.
15. Insert paper and set printer on-line.
16. Turn on the computer, open the measuring program and key in the data.
17. When the temperature is in the correct range, inject the mortar into the riser column and *immediately* start the measuring program.
18. When the measurements are complete, correct the input data if necessary and print out the results if desired.

To shut down

1. Switch off the computer, *then* switch off the printer and equipment.
2. Remove the riser column and rinse it and the petri dish. Dry the stirrer rod.
3. For transport, fix the balance arm rigidly by screwing into the bushing on the inside of the back panel of the cabinet and fixing it at the front with the rubber stopper.

Do's and Don'ts

1. **Do** connect the printer and AVA equipment to the computer and switch them on before switching on the computer (otherwise the associated power surges could damage the computer).
2. **Do** make sure the cables (especially the SCSI) are tightly connected.
3. **Do** connect the battery charger cable to the computer when making the measurements (because the battery could run low during a measurement).
4. **Don't** leave the computer battery charger cable plugged into the power panel when the panel is switched off (otherwise the battery will discharge)
5. **Don't** put computer diskettes on the AVA equipment (because the magnetic stirrer could erase the contents of the diskette).
6. **Do** allow the equipment to stabilize to the ambient temperature. To check this, turn on the equipment and wait until the balance readings do not drift with time over a period of about 10 min.
7. **Do** heat the water and special liquid to the correct temperature range before filling the riser column (the internal heater is designed to maintain the temperature not to heat the liquids).
8. **Do** remember to put the stirrer rod in the riser column before filling the column with water and liquid.
9. **Do** make sure the buoyancy recorder does not touch the column during the measurements.
10. **Don't** start the program with an empty riser column (otherwise the heater may burn out).
11. **Do** *shut down* the computer rather than set it to *sleep* between measurements (to avoid carrying over any problems to the next measurements).
12. **Do** switch off the computer *before* switching off the printer and AVA equipment (again, the power surges could damage the computer).
13. **Don't** leave the AVA equipment switched on for prolonged periods when not being used (because the heat built up could damage the electronics).

Supplies and Accessories

The following supplies and accessories are available from:

Hansson Consulting
261 Old Post Road
Waterloo, Ontario
Canada N2L 5B8

Ph: 519/884-8986
Fax: 519/884-9824

1. Special viscous liquid
2. Syringes
3. Petri dishes

Comments and/or Suggestions for Improvements

Mail or Fax to:

Hansson Consulting
261 Old Post Road
Waterloo, Ontario
Canada N2L 5B8

Ph: 519/884-8986
Fax: 519/884-9824

Signed: _____

Company: _____

Date: _____

APPENDIX C

Concrete Mix Details

TABLE C.1 - AVA EVALUATION

Detroit Concrete Mixes

European Surface Mix (E-S) - Quantities are for one cu. m. batch
Water = 166 kg. Cement = 446 kg. W/C = 0.37 A/E = 511 ml
Coarse agg. = 1162 kg. Fine agg. = 596 kg. WRDA = 874 ml

European Base Mix (E-B) - Quantities are for one cu. m. batch
Water = 144 kg. Cement = 349 kg. W/C = 0.41 A/E = 286 ml
Coarse agg. = 1011 kg. Fine agg. = 774 kg. WRDA = 673 ml

Mix ID	Slump, mm.	PM Air, %	Components
D1	50	6.6	E-S
D2	45	5.0	E-S
D3	40	6.8	E-B
D4	40	6.8	E-S
D5	25	6.6	E-B
D6	45	7.0	E-S
D7	40	6.4	E-B

TABLE C.2 - AVA EVALUATION

Wisconsin Concrete Mixes

Control Mix (CM) - Quantities are for one cu. m. batch			
Water = 144 kg. Cement = 362 kg. W/C = 0.40			
Coarse agg. = 1060 kg. Fine agg. = 744 kg.			
Mix ID	Slump, mm.	PM Air, %	Components
WIS 1	50	3.9	CM + A/E = 247 ml W increased to 171 kg.
WIS 2*	150	10.3	CM + A/E = 353 ml W increased to 171 kg.
WIS 3*	85	5.7	CM + A/E = 282 ml W increased to 161 kg.
WIS 4	65	4.6	CM + A/E = 353 ml W increased to 153 kg.
WIS 5	30	3.5	CM + A/E = 424 ml W increased to 145 kg.
WIS 6	40	4.8	CM + A/E = 883 ml W increased to 145 kg.
WIS 7	15	2.9	CM + A/E = 883 ml W increased to 145 kg.
WIS 8*	30	4.7	CM + A/E = 1765 ml W increased to 145 kg.
WIS 9	30	3.4	CM + A/E = 282 ml W increased to 161 kg.
WIS 10	60	6.0	CM + A/E = 706 ml W increased to 149 kg.

* Only mixes 2, 3, and 8 had cylinders made for ASTM C457 examination.

TABLE C.3 - AVA EVALUATION**University of Texas Concrete Mixes**

5 Bag* Control Mix (CM) - Quantities are for one cu. m. batch

Water = 166 kg. Cement = 279 kg. W/C = 0.60

Coarse agg. = 959 kg. Fine agg. = 895 kg.

Mix ID	Slump, mm.	PM Air, %	Components
Test Batch	75	2	Control Mix (CM)
A/E #5 & 6	190	10.2/10	CM + A/E = 182 ml
A/E #7 & 8	180	6.5	CM + A/E = 91 ml W reduced to 151 kg.
A/E #9 & 10	75	4.5	CM + A/E = 45 ml W reduced to 151 kg.
Fly Ash #1 & 2	125	7	CM + A/E = 137 ml 15% fly ash replacement W reduced to 151 kg.
Fly Ash #3 & 4	100	8	CM + A/E = 126 ml 35% fly ash replacement W reduced to 149 kg.
S. Fume #1 & 2	70	5.2	CM + A/E = 182 ml 15% silica fume added W increased to 179 kg.
S. Fume #3 & 4	65	3.5	CM + A/E = 283 ml 35% silica fume added W increased to 232 kg.
S. Fume #5 & 6	65	2.5	CM + A/E = 364 ml 35% silica fume added S. Plas. = 273 ml W increased to 202 kg.
S. Plas. #1 & 2	255	2	CM + A/E = 182 ml S. Plas. = 455 ml W increased to 170 kg.
S. Plas. #3 & 4	165	7.5	CM + A/E = 455 ml S. Plas. = 1092 ml W reduced to 151 kg.

* In English units

TABLE C.3 - AVA EVALUATION

University of Texas Concrete Mixes (cont.)

7 Bag* Control Mix (CM) - Quantities are for one cu. m. batch

Water = 175 kg. Cement = 390 kg. W/C = 0.45

Coarse agg. = 959 kg. Fine agg. = 696 kg.

Mix ID	Slump, mm.	PM Air, %	Components
A/E #1 & 2	90	6.5	CM + A/E = 381 ml W reduced to 169 kg.
A/E #3 & 4	65	7.5	CM + A/E = 572 ml W reduced to 165 kg.
A/E #5 & 6	65	8.5	CM + A/E = 889 ml W reduced to 173 kg.

* In English units

TABLE C.4 - AVA EVALUATION

Iowa Concrete Mixes

Iowa Mix - Quantities are for one cu. m. batch

Water = 145 kg. Cement = 289 kg. Fly Ash = 52 kg.

W/C+FA = 0.43 A/E = 166 ml WRDA = 890 ml

Coarse agg. = 984 kg. Fine agg. = 809 kg.

Mix ID	Slump, mm.	PM Air, %	Components
Iowa 1	40	7	Iowa Mix
Iowa 2	40	7	Iowa Mix

APPENDIX D

Evaluation Responses



FEDERAL HIGHWAY ADMINISTRATION
ENGINEERING APPLICATIONS DIVISION

EVALUATION OF AIR VOID ANALYZER PROCESS AND EQUIPMENT

AGENCY NAME: Univ. of Texas at Austin/CMRG

CMRG Construction Materials Research Group

A. Information Provided:

1. Was the information in the operations manual adequate? Yes No

(Comment)

Basically easy to understand, except taking samples.

2. Was the demonstration/training clear and sufficient? Yes No NA

(Comment)

I did not receive any training or a demonstration

3. Were verbal communications with FHWA staff clear? Yes No

(Comment)

Talks with the consultant were very helpful, should have called more often

4. Would more hands-on training with an instructor be useful? Yes No

(Comment)

There is always something lost in a written translation. Better to be shown.

5. Additional suggestions:

Follow the step by step instructions exactly. The step by step checklist must be followed to the letter. Start the test with the temperature at the low range - can heat but cannot cool. If the temperature is approaching upper range then put a bag of ice around cylinder to keep cool.

FEDERAL HIGHWAY ADMINISTRATION
ENGINEERING APPLICATIONS DIVISION

EVALUATION OF AIR VOID ANALYZER PROCESS AND EQUIPMENT (Cont.)

AGENCY NAME: University of Texas - Austin / CMRG

B. Equipment Use:

1. How long did you have the equipment?

Weeks 2 weeks

2. Did one operator/team usually run the test?

Yes No

3. If the answer to 2 is no, did the operator/teams have generally the same experience in running tests, ie., temperature control, steps in the test, computer use, etc.?

Yes No

(Comment)

4. How many individual tests were conducted?

Number 50

5. List any problems and suggestions for improvement:

- Do use the same syringe for more than 4 tests. It loses its seal and allows air bubble to form between the top of the tube and the rubber bulb.

- Drill with more rpms.

- Brush that does allow air pockets between stem and bristles.

6. List desirable features:

- A thermometer on the AVA that works.

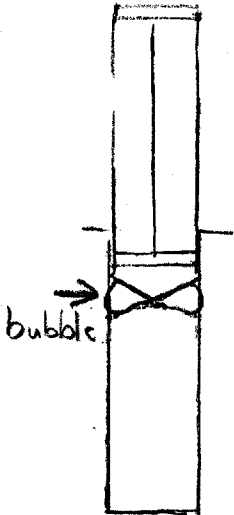

FEDERAL HIGHWAY ADMINISTRATION
ENGINEERING APPLICATIONS DIVISION

EVALUATION OF AIR VOID ANALYZER PROCESS AND EQUIPMENT (Cont.)

AGENCY NAME: UT-Texas-Austin / CMRG

C. Procedure Evaluation:

1. Do you consider the procedure reliable? Yes No
(Comment)

Below 3.0mm - yes. the tests run on the same
sample gave similar and consistent results. - Total Air - No.

2. Do you feel this test can replace linear traverse measurements? Yes No NA

(Comment) I do not have the results of the linear
traverse tests to compare my results but I would think the
AVA is more accurate - less room for human error -

3. Should there be more development work? Yes No NA
(Comment)

Below 3.0mm - No

Total Air - YES. Results from AVA did not always match
4. Other comments: Pressure test.

THE HISTORY OF THE

... ..

... ..

... ..

... ..

... ..

... ..

... ..

... ..

... ..

... ..

... ..

... ..

... ..

... ..

... ..

... ..

... ..

... ..

... ..

... ..

FEDERAL HIGHWAY ADMINISTRATION
ENGINEERING APPLICATIONS DIVISION

EVALUATION OF AIR VOID ANALYZER PROCESS AND EQUIPMENT

AGENCY NAME: WISCONSIN DOT

A. Information Provided:

1. Was the information in the operations manual adequate? Yes No
(Comment) *N/A - WE ONLY HAD THE UNIT IN FOR TWO DAYS OF DEMOS WITH A TRAINED FHWA OPERATOR. WE NEVER OPERATED THE UNIT OURSELVES.*

2. Was the demonstration/training clear and sufficient? Yes No
(Comment)

3. Were verbal communications with FHWA staff clear? Yes No
(Comment)

4. Would more hands-on training with an instructor be useful? Yes No
(Comment)

5. Additional suggestions:

FEDERAL HIGHWAY ADMINISTRATION
ENGINEERING APPLICATIONS DIVISION

EVALUATION OF AIR VOID ANALYZER PROCESS AND EQUIPMENT (Cont.)

AGENCY NAME: WISCONSIN DOT

B. Equipment Use:

1. How long did you have the equipment?

2 DAYS
~~Weeks~~

2. Did one operator/team usually run the test?

Yes No

N/A

3. If the answer to 2 is no, did the operator/teams have generally the same experience in running tests, ie., temperature control, steps in the test, computer use, etc.?
(Comment)

Yes No

N/A

4. How many individual tests were conducted?

Number 10-12

5. List any problems and suggestions for improvement:

HAD PROBLEMS OBTAINING SAMPLES OF LOW-SLUMP
PAVING MIXES WITHOUT ENTRAPPING LARGE POCKETS
OF AIR IN THE SYRINGE

6. List desirable features:

APPEARS TO GIVE ACCURATE AIR SYSTEM SIZE DISTRIBUTION
DATA IN REAL TIME ON A ~~WET~~ MIX
FRESH

FEDERAL HIGHWAY ADMINISTRATION
ENGINEERING APPLICATIONS DIVISION

EVALUATION OF AIR VOID ANALYZER PROCESS AND EQUIPMENT (Cont.)

AGENCY NAME: WISCONSIN DOT

C. Procedure Evaluation:

1. Do you consider the procedure reliable? Yes No
(Comment)

YES - WHEN A GOOD SAMPLE IS OBTAINED

2. Do you feel this test can replace linear traverse measurements? Yes No
(Comment)

WE STILL HAVEN'T SEEN THE
COMPARISON TESTING RESULTS

3. Should there be more development work? Yes No
(Comment)

YES - SAMPLING TECHNIQUE NEEDS IMPROVEMENT
FOR LOW-SLUMP PAVING MIXES.

4. Other comments:

THE AVA APPEARS TO BE A GOOD TOOL FOR LABORATORY
RESEARCH AND FOR TUNING UP PROJECT MIXES AT START-UP.

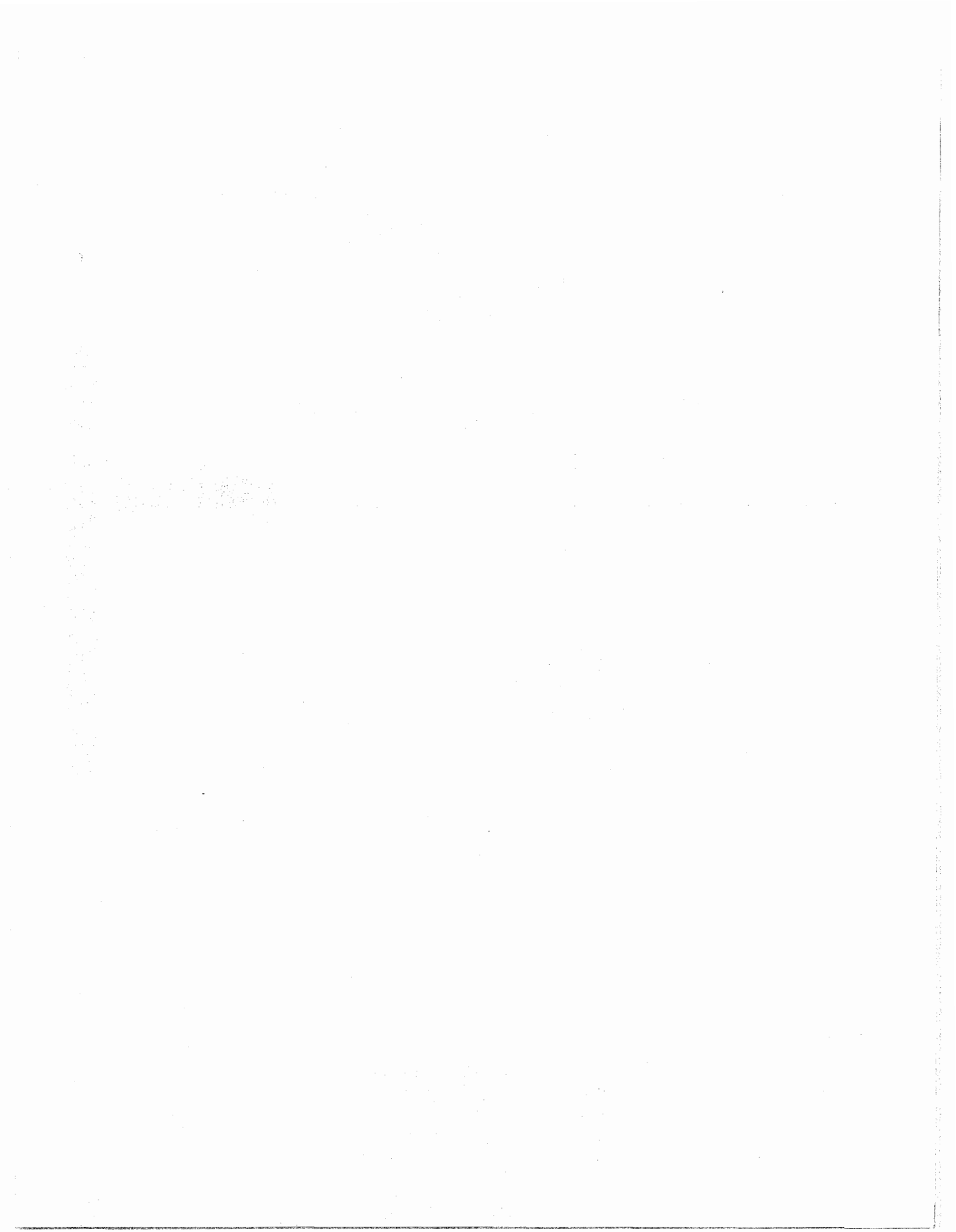









HTA-13/7-96(500)QE