

**Puerto Rico Demonstration Project:
Replacement of Bridge No. 1828 on
PR-140 in Barceloneta, Puerto Rico**

**Final Technical Brief
August 2015**

HIGHWAYS FOR LIFE

Accelerating Innovation for the American Driving Experience.



U.S. Department of Transportation
Federal Highway Administration

FOREWORD

The purpose of the Highways for LIFE (HfL) pilot program is to accelerate the use of innovations that improve highway safety and quality while reducing congestion caused by construction. **LIFE** is an acronym for **L**onger-lasting highway infrastructure using **I**nnovations to accomplish the **F**ast construction of **E**fficient and safe highways and bridges.

Specifically, HfL focuses on speeding up the widespread adoption of proven innovations in the highway community. Such “innovations” encompass technologies, materials, tools, equipment, procedures, specifications, methodologies, processes, and practices used to finance, design, or construct highways. HfL is based on the recognition that innovations are available that, if widely and rapidly implemented, would result in significant benefits to road users and highway agencies.

Although innovations themselves are important, HfL is as much about changing the highway community’s culture from one that considers innovation something that only adds to the workload, delays projects, raises costs, or increases risk to one that sees it as an opportunity to provide better highway transportation service. HfL is also an effort to change the way highway community decision makers and participants perceive their jobs and the service they provide.

The HfL pilot program, described in Safe, Accountable, Flexible, Efficient Transportation Equity Act: A Legacy for Users (SAFETEA-LU) Section 1502, includes funding for demonstration construction projects. By providing incentives for projects, HfL promotes improvements in safety, construction-related congestion, and quality that can be achieved through the use of performance goals and innovations. This report documents one such HfL demonstration project.

Additional information on the HfL program is at www.fhwa.dot.gov/hfl.

NOTICE

This document is disseminated under the sponsorship of the U.S. Department of Transportation in the interest of information exchange. The U.S. Government assumes no liability for its contents or use thereof. This report does not constitute a standard, specification, or regulation.

The U.S. Government does not endorse products or manufacturers. Trade and manufacturers’ names appear in this report only because they are considered essential to the object of the document.

1. Report No.	2. Government Accession No	3. Recipient's Catalog No	
3. Title and Subtitle Puerto Rico Demonstration Project: Replacement of Bridge No. 1828 on PR-140 in Barceloneta, Puerto Rico		5. Report Date August 2015	
7. Authors Hyung Suk Lee, Ph.D., P.E.		6. Performing Organization Code	
9. Performing Organization Name and Address Applied Research Associates, Inc. 100 Trade Centre Drive, Suite 200 Champaign, IL 61820		8. Performing Organization Report No.	
12. Sponsoring Agency Name and Address Office of Infrastructure Federal Highway Administration 1200 New Jersey Avenue, SE Washington, DC 20590		10. Work Unit No. (TRAIS) C6B	
		11. Contract or Grant No.	
		13. Type of Report and Period Covered Final Technical Brief	
		14. Sponsoring Agency Code	
15. Supplementary Notes Contracting Officer's Representative: Julie Zirlin Contracting Officer's Task Manager: Ewa Flom			
16. Abstract As a part of the HfL initiative, the FHWA provided a \$95,000 grant to the Puerto Rico Highway and Transportation Authority (PRHTA) to replace Bridge No. 1828 on Puerto Rico Highway 140 (PR-140) in Barceloneta Municipality. The innovation employed on this project is the use of a geosynthetic reinforced soil-integrated bridge system (GRS-IBS) for the construction of the bridge abutment. The project is currently under construction. PRHTA previously used GRS-IBS on twin bridges (Bridge No. 1121 and 1122) on PR-2, but the current project is the Authority's first GRS-IBS project for a bridge that is actually constructed over water. According to the latest construction schedule, this project is anticipated to be complete by August 20, 2015. Currently, the GRS-IBS foundation and the prestressed void slab have been installed, and an asphalt overlay remains to be worked on.			
17. Key Words Highways for LIFE, geosynthetic reinforced soil, integrated bridge system, GRS-IBS		18. Distribution Statement No restriction. This document is available to the public through the Highways for LIFE website: http://www.fhwa.dot.gov/hfl/	
Security Classif.(of this report) Unclassified	19. Security Classif. (of this page) Unclassified	20. No. of Pages 19	21. Price

SI* (MODERN METRIC) CONVERSION FACTORS				
APPROXIMATE CONVERSIONS TO SI UNITS				
Symbol	When You Know	Multiply By	To Find	Symbol
LENGTH				
(none)	mil	25.4	micrometers	µm
in	inches	25.4	millimeters	mm
ft	feet	0.305	meters	m
yd	yards	0.914	meters	m
mi	miles	1.61	kilometers	km
AREA				
in ²	square inches	645.2	square millimeters	mm ²
ft ²	square feet	0.093	square meters	m ²
yd ²	square yards	0.836	square meters	m ²
ac	acres	0.405	hectares	ha
mi ²	square miles	2.59	square kilometers	km ²
VOLUME				
fl oz	fluid ounces	29.57	milliliters	mL
gal	gallons	3.785	liters	L
ft ³	cubic feet	0.028	cubic meters	m ³
yd ³	cubic yards	0.765	cubic meters	m ³
NOTE: volumes greater than 1000 L shall be shown in m ³				
MASS				
oz	ounces	28.35	grams	g
lb	pounds	0.454	kilograms	kg
T	short tons (2000 lb)	0.907	megagrams (or "metric ton")	Mg (or "t")
TEMPERATURE (exact degrees)				
°F	Fahrenheit	5 (F-32)/9 or (F-32)/1.8	Celsius	°C
ILLUMINATION				
fc	foot-candles	10.76	lux	lx
fl	foot-Lamberts	3.426	candela per square meter	cd/m ²
FORCE and PRESSURE or STRESS				
lbf	poundforce	4.45	Newtons	N
lbf/in ² (psi)	poundforce per square inch	6.89	kiloPascals	kPa
k/in ² (ksi)	kips per square inch	6.89	megaPascals	MPa
DENSITY				
lb/ft ³ (pcf)	pounds per cubic foot	16.02	kilograms per cubic meter	kg/m ³
APPROXIMATE CONVERSIONS FROM SI UNITS				
Symbol	When You Know	Multiply By	To Find	Symbol
LENGTH				
µm	micrometers	0.039	mil	(none)
mm	millimeters	0.039	inches	in
m	meters	3.28	feet	ft
m	meters	1.09	yards	yd
km	kilometers	0.621	miles	mi
AREA				
mm ²	square millimeters	0.0016	square inches	in ²
m ²	square meters	10.764	square feet	ft ²
m ²	square meters	1.195	square yards	yd ²
ha	hectares	2.47	acres	ac
km ²	square kilometers	0.386	square miles	mi ²
VOLUME				
mL	milliliters	0.034	fluid ounces	fl oz
L	liters	0.264	gallons	gal
m ³	cubic meters	35.314	cubic feet	ft ³
m ³	cubic meters	1.307	cubic yards	yd ³
MASS				
g	grams	0.035	ounces	oz
kg	kilograms	2.202	pounds	lb
Mg (or "t")	megagrams (or "metric ton")	1.103	short tons (2000 lb)	T
TEMPERATURE				
°C	Celsius	1.8C+32	Fahrenheit	°F
ILLUMINATION				
lx	lux	0.0929	foot-candles	fc
cd/m ²	candela per square meter	0.2919	foot-Lamberts	fl
FORCE and PRESSURE or STRESS				
N	Newtons	0.225	poundforce	lbf
kPa	kiloPascals	0.145	poundforce per square inch	lbf/in ² (psi)
MPa	megaPascals	0.145	kips per square inch	k/in ² (ksi)

*SI is the symbol for the International System of Units. Appropriate rounding should be made to comply with Section 4 of ASTM E380. (Revised March 2003)

TABLE OF CONTENTS

INTRODUCTION.....1
 HIGHWAYS FOR LIFE DEMONSTRATION PROJECTS.....1
 PROJECT OVERVIEW2

PROJECT DETAILS.....3
 PROJECT BACKGROUND AND LOCATION3
 PROJECT DESCRIPTION4
 PROJECT INNOVATIONS4
 NEW BRIDGE SPECIFICATION5
 GRS-IBS DESIGN.....5
 BIDDING INFORMATION6
 PROJECT SCHEDULE INFORMATION.....7

HIGHWAYS FOR LIFE PERFORMANCE GOALS..... 11
 CONSTRUCTION CONGESTION11
 SOUND AND SMOOTHNESS.....11
 USER SATISFACTION11

ACKNOWLEDGMENTS12

LIST OF FIGURES

Figure 1. Map. Approximate location of Bridge No. 1828 on PR-140.	3
Figure 2. Map. Detailed map of project location.	3
Figure 3. Photo. Existing Bridge No. 1828 on PR-140.	4
Figure 4. Diagram. Front view of GRS abutment.	5
Figure 5. Diagram. GRS abutment section view of Bridge No. 1828.	6
Figure 6. Photo. Excavation of east abutment.	7
Figure 7. Photo. GRS-IBS installation on east abutment.	8
Figure 8. Photo. Excavation of west abutment.	8
Figure 9. Photo. Construction of GRS-IBS on west abutment.	9
Figure 10. Photo. Installation of pre-stressed void slab.	9
Figure 11. Photo. New Bridge No. 1828 after completion of void slab install.	10

LIST OF TABLES

Table 1. Bid comparison summary.	6
---------------------------------------	---

ABBREVIATIONS AND SYMBOLS

EDC	Every Day Counts
FHWA	Federal Highway Administration
GRS	geosynthetic reinforced soil
HfL	Highways for LIFE
IBS	integrated bridge system
IRI	International Roughness Index
OBSI	onboard sound intensity
OSHA	Occupational Safety & Health Administration
PRHTA	Puerto Rico Highway and Transportation Authority
SAFETEA-LU	Safe, Accountable, Flexible, Efficient Transportation Equity Act: A Legacy for Users

INTRODUCTION

HIGHWAYS FOR LIFE DEMONSTRATION PROJECTS

Highways for LIFE (HfL) is the Federal Highway Administration's (FHWA) initiative to advance longer-lasting and promote efficient and safe construction of highways and bridges using innovative technologies and practices. The HfL program provides incentive funding to highway agencies to try proven but little-used innovations on eligible Federal-aid construction projects. The HfL team prioritizes projects that use innovative technologies, manufacturing processes, financing, contracting practices, and performance measures that demonstrate substantial improvements in safety, congestion, quality, and cost-effectiveness. An innovation must be one the applicant State has never or rarely used, even if it is standard practice in other States. Recognizing the challenges associated with deployment of innovations, the HfL program provides incentive funding for up to 15 demonstration construction projects a year. The funding amount typically totals up to 20 percent of the project cost, but not more than \$5 million.

The HfL program promotes project performance goals that focus on the expressed needs and wants of highway users. They are set at a level that represents the best of what the highway community can do, not just the average of what has been done. The goals are categorized into the following categories:

1. Safety

- a. Work zone safety during construction—Work zone crash rate equal to or less than the preconstruction rate at the project location.
- b. Worker safety during construction—Incident rate for worker injuries of less than 4.0, based on incidents reported on Occupational Safety and Health Administration (OSHA) Form 300.
- c. Facility safety after construction—Twenty percent reduction in fatalities and injuries in 3-year average crash rates, using preconstruction rates as the baseline.

2. Construction Congestion

- a. Faster construction—Fifty percent reduction in the time highway users are impacted, compared to traditional methods.
- b. Trip time during construction—Less than 10 percent increase in trip time compared to the average preconstruction speed, using 100 percent sampling.
- c. Queue length during construction—A moving queue length of less than 0.5 miles in a rural area or less than 1.5 miles in an urban area (in both cases at a travel speed 20 percent less than the posted speed).

3. Quality

- a. Smoothness—International Roughness Index (IRI) measurement of less than 48 inches/mile.
- b. Noise—Tire-pavement noise measurement of less than 96.0 A-weighted decibels (dB(A)), using the onboard sound intensity (OBSI) test method.

4. User Satisfaction

- a. User satisfaction—An assessment of how satisfied users are with the new facility compared to its previous condition and with the approach used to minimize disruption during construction. The goal is a measurement of 4 or more on a 7-point Likert scale.

PROJECT OVERVIEW

As a part of the HfL initiative, the FHWA provided a \$95,000 grant to the Puerto Rico Highway and Transportation Authority (PRHTA) to replace Bridge No. 1828 on Puerto Rico Highway 140 (PR-140) in Barceloneta Municipality. The innovation employed on this project is the use of a geosynthetic reinforced soil-integrated bridge system (GRS-IBS) for the construction of the bridge abutment. The project is currently under construction. This technical brief documents the available project information.

PROJECT DETAILS

PROJECT BACKGROUND AND LOCATION

Figure 1 shows a map with the approximate location of the project, and Figure 2 shows a detailed location in satellite view.

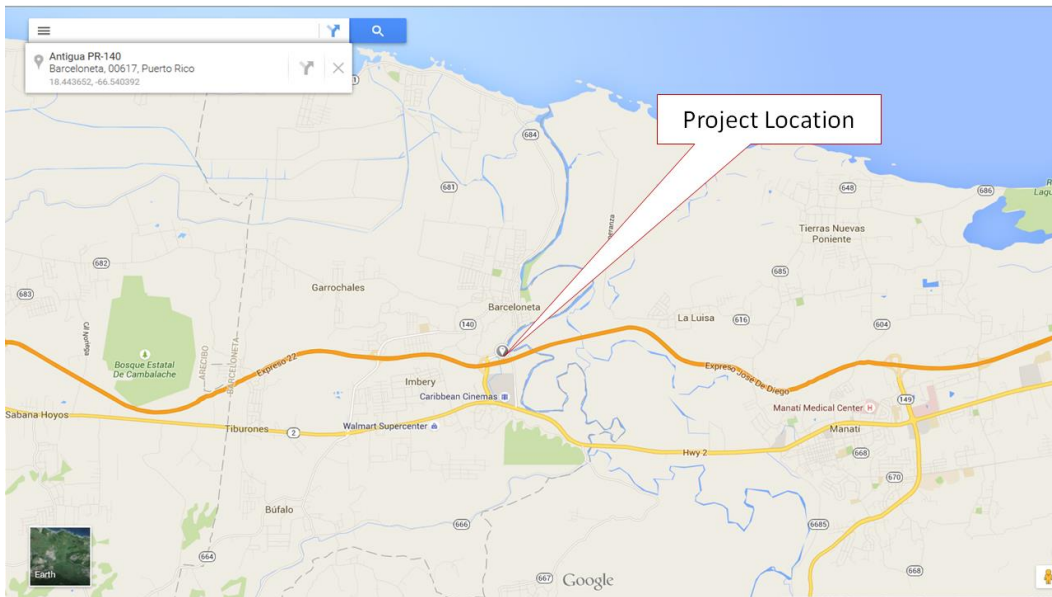

Figure 1. Map. Approximate location of Bridge No. 1828 on PR-140.



Figure 2. Map. Detailed map of project location.

PROJECT DESCRIPTION

Existing Bridge

Figure 3 shows the existing bridge, just prior to being demolished. The existing structure is a single-span bridge with a reinforced concrete slab.



Figure 3. Photo. Existing Bridge No. 1828 on PR-140.

PROJECT INNOVATIONS

The key innovation on this project is the use of GRS-IBS for reconstruction of the bridge abutments. GRS-IBS is an accelerated bridge construction technique which was also selected as one of FHWA's Every Day Counts (EDC) initiatives. The GRS-IBS technology provides support to the bridge through the use of alternating layers of compacted granular fill and sheets of geosynthetic fabric reinforcement. Compared to traditional construction techniques, GRS-IBS technology results in a reduced environmental footprint, as it eliminates the need for deep/pile foundations that are abrasive to the environment.

PRHTA decided to use the GRS-IBS technology for the current project for the following reasons:

1. Reduced construction duration: PRHTA anticipates that the GRS-IBS technology will significantly shorten the construction duration, thereby reducing the duration of the roadway closure for the reconstruction of the bridge.

2. Reduced cost: PRHTA anticipates 20 to 30 percent reduction in the bridge construction cost through the use of GRS-IBS.
3. This is the second GRS-IBS project in Puerto Rico but the first for a bridge that is actually constructed over water.

NEW BRIDGE SPECIFICATION

Figure 4 shows the proposed front view of the GRS-IBS abutment. The new bridge is expected to have a single span and will be constructed with nine prestressed void slabs. The out-to-out width of the bridge is 11.36 meters (37.3 ft), and the effective width excluding the barriers is 10.15 meters (33.3 ft).

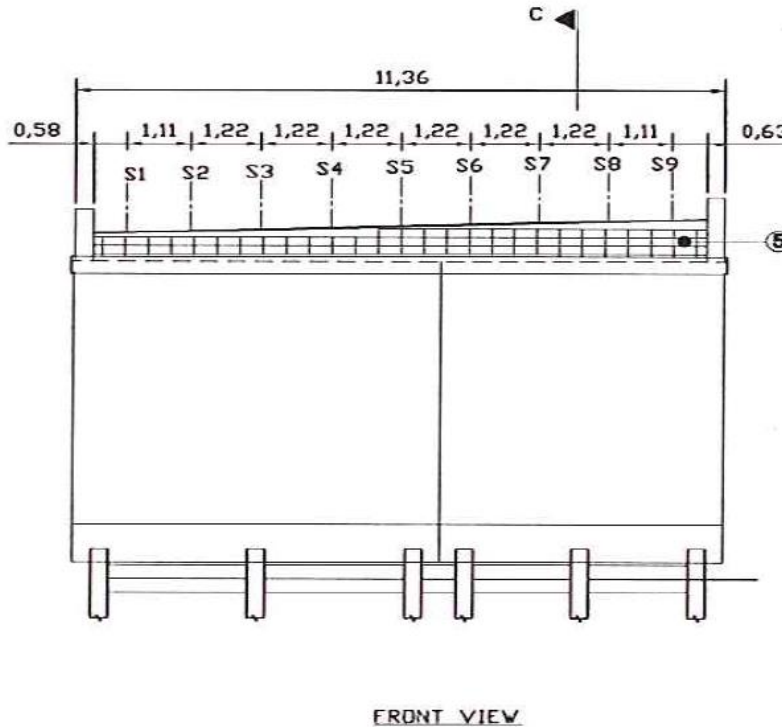

Figure 4. Diagram. Front view of GRS abutment.

GRS-IBS DESIGN

Figure 5 shows the proposed typical section view of the GRS-IBS abutment. The reinforced soil foundation was 1.52 meters (5.0 ft) deep. The GRS was designed to consist of 24 individual layers, with a total depth of 4.72 meters (15.5 ft) for the east abutment and 4.66 meters (15.2 ft) for the west abutment.

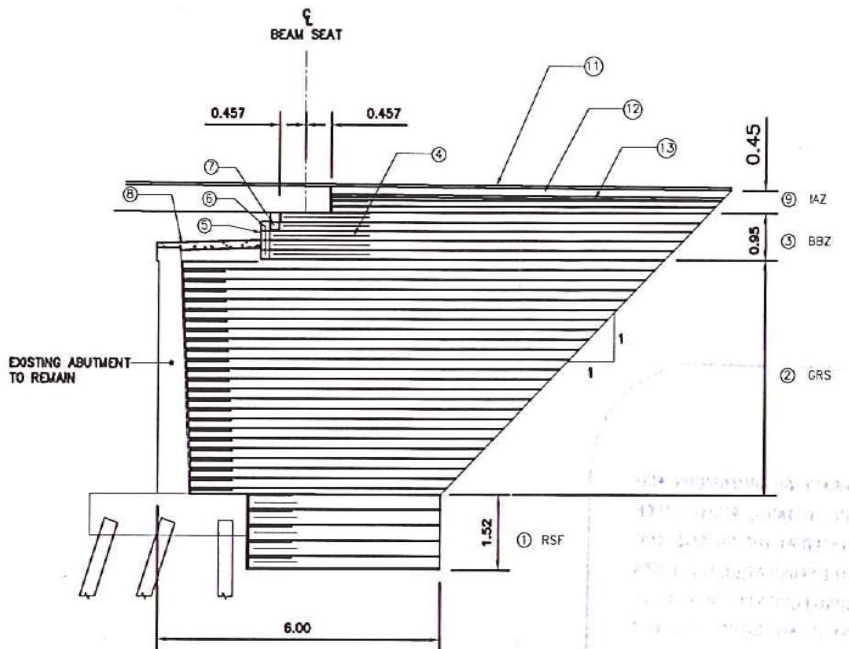

Figure 5. Diagram. GRS abutment section view of Bridge No. 1828.

BIDDING INFORMATION

Table 1 summarizes the bids received for this project. The lowest, winning bid of \$850,000.00 was submitted by LPC&D, Inc.

Table 1. Bid comparison summary.

Bidder	Construction Bid	% Over Low Bid
Estimated Construction Cost	\$988,802.04	-
LPC&D, Inc.	\$850,000.00	0%
Maglez Engineering & Contractors Corp.	\$886,227.25	4%
Constructora Rodriguez Sevilla, Inc	\$910,440.00	7%
Del Valle Group, S.P.	\$919,000.00	8%
Ferrovial Agroman, S.A.	\$938,420.00	10%
Constructora Hartmann, S.E.	\$991,600.00	17%
Gill Engineering Group, Inc.	\$994,418.00	17%
Tamrio, Inc.	\$965,322.00	14%
CD Builders, Inc.	\$1,029,755.00	21%
Desarrolladora JA, Inc.	\$1,033,659.20	22%
Gonzalez Martinez & Assoc.	\$1,034,334.47	22%
CC Construction Corp.	\$1,328,529.00	56%

PROJECT SCHEDULE INFORMATION

The project was awarded on June 19, 2013. The final contract was signed on September 4, 2013, and the notice to proceed was provided to the contractor on September 16, 2013. The original construction was planned for 180 calendar days with a completion date of March 14, 2014. However, the construction schedule was revised, and the new estimated completion date is August 20, 2015. The delay in the project was not related to the GRS technology but was due to other contractual issues.

To date, the GRS-IBS foundation and the prestressed void slab have been installed, and an asphalt overlay remains to be worked on. Figures 6 through 11 show photos taken during construction.



Figure 6. Photo. Excavation of east abutment.



Figure 7. Photo. GRS-IBS installation on east abutment.



Figure 8. Photo. Excavation of west abutment.



Figure 9. Photo. Construction of GRS-IBS on west abutment.



Figure 10. Photo. Installation of pre-stressed void slab.



Figure 11. Photo. New Bridge No. 1828 after completion of void slab install.

HIGHWAYS FOR LIFE PERFORMANCE GOALS

The primary objective of acquiring data on HfL performance goals such as safety, construction congestion, and quality is to quantify project performance and provide an objective basis from which to determine the feasibility of the project innovations and to demonstrate that the innovations can be used to do the following:

1. Achieve a safer work environment for the traveling public and workers.
2. Reduce construction time and minimize traffic interruptions.
3. Produce a high-quality project and gain user satisfaction.

Since this project is still ongoing, the HfL performance goals are yet to be measured. The following subsections provide additional information on some of the significant factors that influence the HfL performance goals.

CONSTRUCTION CONGESTION

Because of lower traffic volumes across the project location, PRHTA anticipated no queuing on this project.

SOUND AND SMOOTHNESS

Due to the short length of the project, PRHTA does not plan to collect smoothness and noise data after construction is completed. However, it is anticipated that the GRS-IBS technology, along with the use of broadcast aggregates, will reduce the differential settlement typically observed at the bridge joints which will improve the ride quality, pavement noise, and user satisfaction.

USER SATISFACTION

Although PRHTA had planned to promote this project in the media and public TV stations owned by the government, no information has been provided regarding the outreach activities.

ACKNOWLEDGMENTS

The project team acknowledges the invaluable insights and guidance of Highways for LIFE Team Leader Byron Lord and Program Coordinator Ewa Flom, who served as the technical panel on this demonstration project. Their vast knowledge and experience with the various aspects of construction, technology deployment, and technology transfer helped immensely in developing both the approach and the technical matter for this document. The team also is indebted to PRHTA Engineers José R. Rodriguez, Francisco Padua, Victor Gracia, Carlos Ortiz, and Noel Rosario, and FHWA Engineers Evelyn Colon, Miguel Rodriguez, Maribell Perez, and Daniel Alzamora, for their advice and assistance during this project.