

GB454  
U5  
no. 5  
c. 5

ANDRE SZUWALSKI

US-CE-C Property of the  
United States Government

# NOTES ON TIDAL INLETS ON SANDY SHORES

by

Morrrough P. O'Brien

GITI REPORT 5

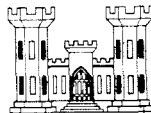

February 1976

Prepared for  
U. S. Army Coastal Engineering Research Center  
under  
Contract DACW72-71-C-0005

by

University of California, Berkeley  
Berkeley, California 94720

## GENERAL INVESTIGATION OF TIDAL INLETS

A Program of Research Conducted Jointly by

U. S. Army Coastal Engineering Research Center, Fort Belvoir, Virginia  
U. S. Army Engineer Waterways Experiment Station, Vicksburg, Mississippi

Department of the Army  
Corps of Engineers

Research Library  
US Army Engineer Waterways  
Experiment Station  
Vicksburg, Mississippi

2169090  
afm

GB454  
U5  
no. 5  
c. 5

FOREWORD

This report results from work performed under contract DACW72-71-C-0005 between the Coastal Engineering Research Center (CERC) and the University of California at Berkeley. It is one in a series of reports from the Corps of Engineer's General Investigation of Tidal Inlets (GITI), which is under the technical surveillance of CERC and is conducted by CERC, the U.S. Army Engineer Waterways Experiment Station (WES), other government agencies, and by private organizations.

The report was prepared by M.P. O'Brien; the contract principal investigator for the University of California was J.W. Johnson; and the CERC contract technical monitors were R.P. Savage and C. Mason.

Dean O'Brien did not write these notes for publication; they were intended only to help a graduate student define his research program. Nevertheless, it was felt by CERC that its potential use by others warranted publication.

Technical Directors of CERC and WES were T. Saville, Jr. and F.R. Brown, respectively.

Comments on the publication are invited.

Approved for publication in accordance with Public Law 166, 79<sup>th</sup> Congress, approved 31 July 1945, as supplemented by Public Law 172, 88<sup>th</sup> Congress, approved 7 November 1963.



G. H. HILT  
Colonel, Corps of Engineers  
Director  
Waterways Experiment Station

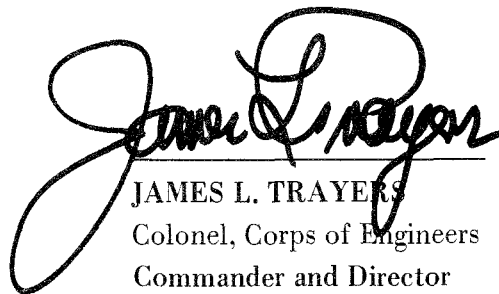

JAMES L. TRAYERS  
Colonel, Corps of Engineers  
Commander and Director  
Coastal Engineering Research Center

## PREFACE

1. The Corps of Engineers, through its Civil Works program, has sponsored, over the past twenty-three years, research into the behavior and characteristics of tidal inlets. The Corps' interest in tidal inlet research stems from its responsibilities for navigation, beach erosion prevention and control, and flood control. Tasked with the creation and maintenance of navigable U.S. waterways, the Corps routinely dredges millions of cubic yards of material each year from tidal inlets that connect the ocean with bays, estuaries, and lagoons. Design and construction of navigation improvements to existing tidal inlets are an important part of the work of many Corps offices. In some cases, design and construction of new inlets are required. Development of information concerning the hydraulic characteristics of inlets is important not only for navigation and inlet stability but also because inlets control the daily exchange of water between bay and ocean. Accurate predictions of the effects of storm surges and runoff also require an understanding of inlet hydraulics during extreme conditions.

2. A research program, the General Investigation of Tidal Inlets program, was developed to provide quantitative data for use in design of inlets and inlet improvements. It is designed to meet the following objectives:

To determine the effects of wave action, tidal flow, and related phenomena on inlet stability and on the hydraulic, geometric, and sedimentary characteristics of tidal inlets; to develop the knowledge necessary to design effective navigation improvements, new inlets, and sand transfer systems at existing tidal inlets; to evaluate the water transfer and flushing capability of tidal inlets; and to define the processes controlling inlet stability.

3. The GITI is divided into three major study areas: inlet classification, inlet hydraulics, and inlet dynamics.

a. The objectives of the inlet classification study are to classify inlets according to their geometry, hydraulics, and stability, and to determine the relationships that exist among the geometric and dynamic characteristics and the environmental factors that control these characteristics. The classification study keeps the general investigation closely related to real inlets and produces an important inlet data base useful in documenting the characteristics of inlets.

b. The objectives of the inlet hydraulics study are to define the tide-generated flow regime and water-level fluctuations in the vicinity of coastal inlets and to develop techniques for predicting these phenomena. The inlet hydraulics study is divided

into three areas: idealized inlet model study, evaluation of state-of-the-art physical and numerical models, and prototype inlet hydraulics.

- (1) The idealized inlet model. The objectives of this model study are to determine the effect of inlet configurations and structures on discharge, head loss, and velocity distribution for a number of realistic inlet shapes and tide conditions. An initial set of tests in a trapezoidal inlet was conducted between 1967 and 1970. However, in order that subsequent inlet models are more representative of real inlets, a number of "idealized" models representing various inlet morphological classes are being developed and tested. The effects of jetties and wave action on the hydraulics are included in the study.
  - (2) Evaluation of state-of-the-art modeling techniques. The objectives of this portion of the inlet hydraulics study are to determine the usefulness and reliability of existing physical and numerical modeling techniques in predicting the hydraulic characteristics of inlet/bay systems, and to determine whether simple tests, performed rapidly and economically, are useful in the evaluation of proposed inlet improvements. Masonboro Inlet, N.C., was selected as the prototype inlet which would be used along with hydraulic and numerical models in the evaluation of existing techniques. In September 1969 a complete set of hydraulic and bathymetric data was collected at Masonboro Inlet. Construction of the fixed-bed physical model was initiated in 1969, and extensive tests have been performed since then. In addition, three existing numerical models were applied to predict the inlet's hydraulics. Extensive field data were collected at Masonboro Inlet in August 1974 for use in evaluating the capabilities of the physical and numerical models.
  - (3) Prototype inlet hydraulics. Field studies at a number of inlets are providing information on prototype inlet/bay tidal hydraulic relationships and the effects of friction, waves, tides, and inlet morphology on these relationships.
- e. The basic objective of the inlet dynamics study is to investigate the interactions of tidal flow, inlet configuration, and wave action at tidal inlets as a guide to improvement of inlet channels and nearby shore protection works. The study is subdivided into four specific areas: model materials evaluation, movable-bed modeling evaluation, reanalysis of a previous inlet model study, and prototype inlet studies.
- (1) Model materials evaluation. This evaluation was initiated in 1969 to provide data on the response of movable-bed model materials to waves and flow to allow selection of the optimum bed materials for inlet models.

- (2) Movable-bed model evaluation. The objective of this study is to evaluate the state-of-the-art of modeling techniques, in this case movable-bed inlet modeling. Since, in many cases, movable-bed modeling is the only tool available for predicting the response of an inlet to improvements, the capabilities and limitations of these models must be established.
- (3) Reanalysis of an earlier inlet model study. In 1957, a report entitled "Preliminary Report: Laboratory Study of the Effect of an Uncontrolled Inlet on the Adjacent Beaches" was published by the Beach Erosion Board (now CERC). A reanalysis of the original data is being performed to aid in planning of additional GITI efforts.
- (4) Prototype dynamics. Field and office studies of a number of inlets are providing information on the effects of physical forces and artificial improvements on inlet morphology. Of particular importance are studies to define the mechanisms of natural sand bypassing at inlets, the response of inlet navigation channels to dredging and natural forces, and the effects of inlets on adjacent beaches.

4. This report presents an edited collection of memoranda prepared over the past forty years on several aspects of inlet hydraulic and sedimentary characteristics, and is being published because of its general value to the GITI, as well as for its potential use in stimulating other researchers studying tidal inlets.

## CONTENTS

	Page
SYMBOLS AND DEFINITIONS . . . . .	6
<b>I INTRODUCTION . . . . .</b>	<b>7</b>
1. Nature of the Problem . . . . .	7
2. Previous Studies . . . . .	9
<b>II EQUILIBRIUM FLOW AREA . . . . .</b>	<b>9</b>
<b>III ELEMENTS OF THE HYDRAULIC REGIMEN . . . . .</b>	<b>11</b>
1. Short, Frictionless Inlet Channel . . . . .	11
2. Small, Deep Lagoon . . . . .	12
3. Long Inlet Channel . . . . .	13
4. Long Lagoon or Estuary . . . . .	13
5. Narrow, Deep Inlet Channel with Large Friction Losses . . . . .	14
6. Short, Deep Inlet Channel to a Large, Shallow Lagoon . . . . .	14
<b>IV POWER AVAILABLE FOR MAINTENANCE OF FLOW AREA . . . . .</b>	<b>14</b>
<b>V VALUE OF TIDAL PRISM IN MAINTAINING INTERIOR CHANNELS . . . . .</b>	<b>16</b>
<b>VI STABLE CHANNELS AND STABLE INLETS . . . . .</b>	<b>16</b>
<b>VII TRACTIVE FORCE CONSIDERATIONS . . . . .</b>	<b>18</b>
<b>VIII SETUP IN A LAGOON BY WAVE ACTION . . . . .</b>	<b>19</b>
<b>IX WAVE REFRACTION BY CURRENTS AT AN INLET . . . . .</b>	<b>19</b>
<b>X SUGGESTED STUDIES . . . . .</b>	<b>20</b>
1. Field Measurements . . . . .	20
2. Model Studies . . . . .	22
<b>LITERATURE CITED . . . . .</b>	<b>26</b>

## FIGURES

1 Schematic inlet flow . . . . .	21
2 Schematic flow orthogonal . . . . .	21
3 Submerged beach configuration . . . . .	23
4 Submerged trough configuration . . . . .	24
5 Attached breakwater configuration . . . . .	24
6 Perched beach configuration . . . . .	24
7 Pilot channel configuration . . . . .	24

## SYMBOLS AND DEFINITIONS

$A_c$	. . . . . minimum area of the channel below MSL (square feet)
$a_o$	. . . . . ocean amplitude (feet)
$b$	. . . . . average width of inlet (feet)
$c$	. . . . . discharge coefficient
$d_b$	. . . . . depth of the bay (feet)
$d_c$	. . . . . channel depth (feet)
$\frac{dh_b}{dt}$	. . . . . time rate of change of the bay water level (feet per second)
$F$	. . . . . fraction of potential energy used to overcome friction and velocity head
$f$	. . . . . silt factor
$g$	. . . . . acceleration of gravity (foot per second-second)
$g_w$	. . . . . the weight per unit mass of water (pounds per cubic foot)
$h_b$	. . . . . bay water-surface elevation (feet)
$H_o$	. . . . . deepwater wave height (feet)
$h_s$	. . . . . ocean water-surface elevation (feet)
$L_b$	. . . . . length of the bay (feet)
$L_c$	. . . . . channel length (feet)
$L_o$	. . . . . deepwater wavelength (feet)
$m$	. . . . . wetted perimeter (feet)
$P$	. . . . . tidal prism (cubic feet)
$Q_f$	. . . . . flow (cubic feet per second)
$Q_L$	. . . . . gross littoral transport (cubic yards per year)
$R$	. . . . . hydraulic radius of channel (feet)
$R_t$	. . . . . the tidal range ( $2a_o$ ) (feet)
$S$	. . . . . slope of water surface (foot per foot)
$T$	. . . . . tidal period (second)
$T_t$	. . . . . duration of tide cycle
$T_w$	. . . . . wave period (second)
$V$	. . . . . velocity in the channel (feet per second)
$V_{cr}$	. . . . . critical velocity for stability (feet per second)
$y$	. . . . . average depth (feet)

# NOTES ON TIDAL INLETS ON SANDY SHORES

by  
*M. P. O'Brien*

## I. INTRODUCTION

### 1. Nature of the Problem.

Sandy shorelines approach an average equilibrium configuration, in planform and in profile, under the influence of wave climate, tides and tidal currents, and local winds acting on the material which forms the shore. The tides and tidal currents vary in a predictable sequence, but waves and local winds may randomly occur, and shorelines may exhibit corresponding random deviations from an average configuration. The more active area of most shorelines is found in and near inlets where strong currents move material stirred up by wave action. Inlets are major features of sandy shorelines, and referred to in this study as channels connecting the ocean with lagoons and estuaries.

Previous studies of the equilibrium configuration of shorelines are lacking in quantitative data on the average long-term wave exposure, and data on the daily, seasonal, and annual variations in wave intensity and direction. The observations of wave characteristics made by ships at sea have been recorded at the National Weather Records Center, Asheville, North Carolina. Programs for analyzing the data have been developed, and the results are available in summaries of synoptic meteorological observations published by the U.S. Naval Weather Service Command. Wave hindcasts for important ocean locations have also been prepared from synoptic weather charts, and wave gages at the shore have recorded wave height and period over extended time periods. Therefore, the raw data and the techniques exist by which wave climate can be reconstructed for comparison with observed shoreline changes.

A long-range objective is to relate the configurations of shorelines and the temporal variations in configuration, to the waves, winds, tides, and currents. A short-range objective is to explain quantitatively the behavior of inlets and adjacent shores.

Analysis of the gross characteristics of inlets in many parts of the world reveals sufficient behavioral similarity to indicate that a more detailed study may yield quantitatively valid relationships, applicable to inlets on all sandy coasts.

The earliest analysis of inlets concerned surveys of the shifting and shallow channels to provide maps for mariners. Surveys have been made at frequent intervals at many inlets throughout the world; for some inlets, records go back more than a century. Nevertheless, there are few inlets with sufficient data to permit analysis of the hydraulic and morphological characteristics of the inlet channel and adjacent shore and bottom.

Improvement of inlet channels by dredging and later stabilization with fixed structures was a prerequisite to the growth of ocean transport. Empirical and local engineering efforts were necessary because there was no related science as a guide. Each inlet seemed unique



and little experience gained at one could be applied to another. The long-term trend of changes in channels and shoals was the best guide to future action; radical innovations were often ineffective. Hydrographic surveys were the trusted technique of the harbor engineer, and the dredge and jetty were the tools to carry out his plans of improvement.

Deficiencies in the data regarding the dynamics of inlets are understandable because studies were made primarily for navigational purposes, and there was an inadequate theoretical basis for either planning field observations or the productive use of the data.

In recent years, available data on inlets have been subjected to analysis and empirical correlation with sufficiently promising results, supporting the conclusion that a program of field observations, theoretical analysis, and laboratory experiments will provide a knowledge of inlet behavior. This knowledge will permit engineers to design inlets with as much certainty as other hydraulic systems, and give scientists a quantitative understanding of the function of inlets in the geomorphology of the shore zone.

Several environmental factors influencing the occurrence and configuration of inlets are:

a. *Tides.* The volume of water passing through the inlet over a complete floodtide or ebbtide is known as the *tidal prism*, and is the dominant factor in determining the flow cross section of the inlet.

The ratio of the tidal range to the depth of the inlet, and the dependent variation in flow cross section between high water and low water, express an absolute size characteristic of inlets. Small inlets are not dynamical models of large inlets when subjected to the same tidal variations. The tidal range in the lagoon or estuary is controlled by the ocean tide, the hydrographic characteristics of the inlet, and the depth and planform of the lagoon.

b. *Wave Climate and Longshore Transport.* The shape of an inlet, and the configuration of the interior and exterior deltas are influenced by the wave-induced sand transport alongshore towards the inlet, and by the scouring action of tidal currents. At some level of intensity of wave-induced sand transport, this scouring action is overpowered by the wave-induced sand transport, closing the inlet.

Information on the annual rate of longshore sand transport near an inlet is usually reported as the *net* difference between the upcoast and downcoast transport rates. This net difference is generally the small difference between two large quantities, each of which may be subjected to large daily, seasonal, and annual variations. The long-term net direction and rate of transport probably control the position of an inlet. The maximum longshore transport rates in both directions probably determine the transport capacity closing an inlet.

c. *Freshwater Runoff.* If freshwater discharge is minor, the interior body of water is usually termed a *lagoon* or *bay*; if the discharge is large, it is termed an *estuary*. The freshwater flow affects the balance between ebbtide and floodtide flows and the capacity of an inlet to reopen after closing. If present, a river system may contribute sediment to the tidal basin. The salinity distribution in the lagoon or estuary depends upon the tidal prism, and the mixing process with the freshwater inflow.

d. *Characteristics of Lagoon.* The depth and planform of the lagoon or estuary may affect its tidal range and tidal prism because the tide wave traverses the lagoon at a speed dependent on the depth. The surface of the lagoon may be assumed to be horizontal only if the wave traverses the lagoon in a short-time interval as compared with the duration of ebbs and floods.

## 2. Previous Studies.

Harbor engineers have long recognized the importance of tidal currents in maintaining navigation channels. Stevenson (1886) recognized that the flow areas of tidal channels were a linear function of the tidal volumes upstream. His equation was:

$$\frac{a'' - a'}{c'} = \frac{a' - a}{c} .$$

Here  $a''$ ,  $a'$ , and  $a$  are the flow areas at three sections, and  $c'$  and  $c$  are the intermediate high water capacities. The relationship was in agreement when applied to the River Tay below Newburgh and to Belfast Lough. Many authors adhered to the concept that the tidal prism is the primary agent in maintaining the channels in lagoons and estuaries.

A study of the Sacramento-San Joaquin River Delta (U.S. Congress, 1934) showed the flow areas of interior channels depended upon the upstream tidal volume as *unrestricted* (1.08 square foot per acre-foot of mean tidal prism) and *restricted* by rocky shore (0.82 square foot per acre-foot of mean tidal prism). The study indicated the geometry of Pacific coast inlets connecting bay and ocean is a function of the tidal prism. All dimensions of a tidal inlet (minimum flow area), and the distance from throat to crest of outer bar (depth over outer bar) were approximate linear functions of the tidal prism. The flow area of the throat (minimum area) showed the least scatter of data points, but all the dimensions of an inlet were related to the tidal prism.

Brown (1928) presented a method for calculating the hydraulic conditions in an inlet channel, which yielded good results when applied to Absecon Inlet, New Jersey.

An element missing from earlier studies and observations of inlet characteristics was an appraisal of the effect of the local ocean wave climate on the dynamics and morphology of the area seaward of the inlet throat. This deficiency occurred because the wave climate (average, seasonal variation, extreme, etc.) was not defined in quantitative terms.

The following sections summarize observations, theories, and analyses which the author has made since 1929 when first exposed to the problems of inlet analysis and design.

## II. EQUILIBRIUM FLOW AREA

O'Brien (1931) reported that the minimum area of the inlet channel below mean sea level (MSL),  $A_c$ , in square feet, is related to the tidal prism on a *diurnal* or *spring tide*,  $P$ , in cubic feet, when the inlet is in equilibrium with its hydraulic environment, approximately as:

$$\frac{P}{A_c} = 2.1 \times 10^3 P^{0.15} . \quad (1)$$

These prism area relationships were first developed using data for Pacific coast inlets. The diurnal range was used because the "long runout" after higher high water (HHW), which is characteristic of Pacific coast tides, was believed to have played the major role in determining the throat area of these inlets.

The field data on the tidal prism used to develop equation (1) ranged from 1.1 by  $10^7$  cubic feet at Pendleton Boat Basin to 1.25 by  $10^{11}$  cubic feet at Delaware Bay, and were believed to be accurate within  $\pm 10$  percent of the flow area and  $\pm 15$  percent of the tidal prism.

O'Brien (1969) showed that these relationships apply to other coasts as well. The available data for unimproved inlets in the range of P between 3.0 by  $10^8$  cubic feet at Punta Banda, Mexico, and 1.25 by  $10^{11}$  cubic feet at the Delaware Bay entrance, also agreed reasonably well with the relationship,

$$\frac{P}{A_c} = 5.0 \times 10^4 \text{ (ft) .} \quad (2)$$

The data considered in these relationships should be reworked to relate the flow area to the tidal prism on a *mean tidal range*.

These relationships seem questionable for the following reasons:

(a) There appears to be no effect of the sand size forming the channel and adjacent shores.

(b) The tide range enters only as it affects the tidal prism. The percentage variation in flow area between high water (HW) and low water (LW) is large at small inlets subjected to a large tidal range.

(c) The net and gross longshore transport rates do not affect the relationships.

(d) Lagoons with two inlets conformed when the summation of the flow areas was used.

(e) The inlets to both lagoons and estuaries followed the same relationship with no effect of freshwater flow or sediment transport.

It does not seem possible that these influences would be completely ineffective in altering the throat area. Some considerations bearing on this point are:

(a) There was scatter in the field data which may not have been due entirely to errors in determining the flow area or the tidal prism. Reanalysis of the data to examine deviations from a best-fit curve may uncover effects of these neglected factors. Some data points differ from the equation by a greater percentage than by uncertainty in the flow area or prism.

(b) The data were derived from surveys which were generally made in good weather and under average hydraulic conditions. If the throat flow area is determined by a balance between scouring tidal currents which carry material seaward or landward through the inlet, and littoral transport by waves and sediment transport by river flow toward the throat, the surveys may have missed the variations in throat area.

(c) Studies of the configuration of the bottom seaward of the throat showed that all dimensions were a function of the tidal prism. The throat area showed the least scatter when plotted against the tidal prism. Analysis of the dynamics of this zone, especially friction losses, may indicate other factors, such as the depth and length of the outer bar are controlling under certain circumstances.

The equilibrium relationship cited is a first approximation only, and the next effort should be directed towards quantitative understanding of deviations from the relationship.

If the flow area is determined by the tidal prism, the area would be in a constant process of adjustment because of the continual variation of the tidal range and the related prism. Is the area greater at spring range than at neap tide? What is the required time period for an entrance to adjust to a different tidal prism?

### III. ELEMENTS OF THE HYDRAULIC REGIMEN

The geometry of the flow channels at coastal inlets is very complex. The ocean tide contains harmonics and is not a simple sine wave. The friction losses in the flow channels are proportional to the squares of the local velocities, and the tide curve of the lagoon or estuary is correspondingly complex. Quantitative analysis of the flow required simplifying assumptions; a few simple, idealized situations are discussed to illustrate the elements of the problem.

#### 1. Short, Frictionless Inlet Channel.

Each small increment of the floodtide or ebbtide reaches the lagoon end and is reflected in a short time as compared with the duration of the phase, that is:

$$\frac{L_c}{\sqrt{gd_c}} \ll \frac{T}{2} \quad (3)$$

where

$$\begin{aligned} L_c &= \text{channel length (foot) ,} \\ d_c &= \text{channel depth (foot) ,} \\ g &= \text{acceleration of gravity (foot per second-second) ,} \\ T &= \text{tidal period (second) .} \end{aligned}$$

Flow in the channel may be considered as a series of steady, uniform states. The volume of water stored in the lagoon per unit time is equal to that passing through the inlet or,

$$A_b \frac{dh_b}{dt} = A_c \cdot V \quad (4)$$

where

$$\begin{aligned}
 A_b &= \text{surface area of the bay (square foot) ,} \\
 A_c &= \text{channel cross-sectional area (square foot) ,} \\
 \frac{dh_b}{dt} &= \text{time rate of change of the bay water level, } h_b \text{ ,} \\
 V &= \text{velocity in the channel (foot per second) .}
 \end{aligned}$$

The tide level in the lagoon,  $h_b$ , will be in phase and of equal range (except for the loss of velocity head), with that in the ocean:

$$h_b = h_s = a_o \sin \sigma t \text{ ,} \quad (5)$$

where

$$\begin{aligned}
 \sigma &= 2\pi/T \text{ ,} \\
 h_s &= \text{ocean water surface elevation ,} \\
 a_o &= \text{ocean amplitude, i.e., half-tidal range.}
 \end{aligned}$$

Solving equation (4) for  $V$ ,

$$V = \frac{A_b}{A_c} \cdot \frac{dh_b}{dt} \text{ .} \quad (6)$$

Differentiating equation (5) and substituting into equation (6),

$$V = \frac{2\pi A_b a_o}{A_c T} \cdot \cos \sigma t \text{ .} \quad (7)$$

At  $t = 0$ ,  $h_s = 0$ , and  $V = V_{max}$ , i.e., the maximum tidal current occurs at midtide. At  $t = T/4$ ,  $h_s = a_o$ , and  $V = 0$ , i.e., slack water occurs at HW and LW.

## 2. Small, Deep Lagoon.

If the horizontal dimensions of the lagoon are small and the depth large, the time required for the tide wave to traverse the lagoon will be small when compared to the duration of the tidal phase or,

$$\frac{L_b}{\sqrt{gd_b}} \ll \frac{T}{2} \text{ ,} \quad (8)$$

where

$$\begin{aligned} L_b &= \text{length of the bay (foot)} , \\ d_b &= \text{depth of the bay (foot)} . \end{aligned}$$

Assuming the surface of the bay remains horizontal during the tidal cycle, HW and LW occur almost simultaneously over the entire surface. The tidal prism will be:

$$P = \int_{-a_b}^{a_b} A_b \cdot dh_b , \quad (9)$$

where

$$\begin{aligned} A_b &= \text{surface area of bay at tidal elevation, } h_b , \\ a_b &= \text{bay tidal amplitude, i.e., half-tidal range} . \end{aligned}$$

If the shores of the lagoon are steep, the area will be approximately constant and the tidal prism may be found by:

$$P = 2A_b a_b . \quad (10)$$

### 3. Long Inlet Channel.

If the inlet channel is long, several effects will be introduced:

(a) There will be a lag in the tide in the lagoon due to the traverse time of the tidal wave through the channel.

(b) The mass of water will be accelerated by a difference in head at the ends of the channel.

(c) Friction losses may become large at the strength of current.

### 4. Long Lagoon or Estuary.

If the tidal basin is of a length that the phases of the tide do not occur simultaneously over the entire area, the tidal prism must be found either by use of measured velocity-time histories,

$$\int_0^{T/2} V \cdot A_c dt ,$$

or by considering the volume changes and phase differences in various parts of the bay, then, summing the volumes over the entire region.

### 5. Narrow, Deep Inlet Channel with Large Friction Losses.

If the channel has large friction losses and a small nonerodible cross section with a small volume of flow into the lagoon,  $a_b \rightarrow 0$ , the velocity in the channel would be:

$$V = C\sqrt{RS} = C\sqrt{d_c \frac{(a_o \sin \sigma t)}{L_c}}. \quad (12)$$

For  $t = T/4$ ,  $V = V_{max}$ , the strength of the current would occur at high and low tide, and slack water would occur at midtide,  $t = 0$  and  $t = T/2$ .

### 6. Short, Deep Inlet Channel to a Large, Shallow Lagoon.

If the channel has fixed banks so the flow area is not enlarged by the current, and

$$\frac{L_b}{\sqrt{gd_b}} \gg \frac{T}{4}, \quad (13)$$

flow into and out of the lagoon would produce tidal changes approaching zero with distance from the inlet.

The hydraulic characteristics of real inlets fall between the preceding six examples, and although the assumptions made to simplify the equations of motion seem to involve extreme deviations from reality, such idealizations may prove useful if field and laboratory measurements yield corrective coefficients which can be categorized.

## IV. POWER AVAILABLE FOR MAINTENANCE OF FLOW AREA

Tidal inlets attain an equilibrium configuration which represents a balance between the sand movement towards the entrance by wave action plus tidal currents and the scouring effect of the ebbtide and floodtide currents through the inlet throat.

The potential energy which might be applied for scouring the channel is the product of the weight of the tidal prism and the tidal range; however, not all of this energy is applied. The fraction of the energy available depends upon the head losses in the inlet channel.

The longshore transport rate along a straight beach is proportional to the longshore component of wave power per unit length of wave crest. Near an inlet, tidal currents and the curvature of the shore make equations for straight shorelines inapplicable. However, the longshore transport near an inlet probably depends primarily upon wave power. As an hypothesis to be tested by field and laboratory studies, assume that an inlet reaches a configuration which depends upon the ratio of the tidal power dissipated in the inlet to the wave power producing local longshore transport.

The power supplied by the total prism is:

$$\text{Tidal power} = \frac{\gamma F P 2a_o}{T_t} ,$$

where

$$\begin{aligned} \gamma &= \text{unit weight of water (pounds per cubic foot) ,} \\ F &= \text{fraction of potential energy used to overcome friction and velocity head ,} \\ T_t &= \text{duration of tide cycle .} \end{aligned}$$

The wave power per foot of shore for waves approaching normal to shore is:

$$\frac{\gamma L_o H_o^2}{16 T_w} ,$$

where

$$\begin{aligned} L_o &= \text{deepwater wavelength (foot) ,} \\ H_o &= \text{deepwater wave heights (foot) ,} \\ T_w &= \text{wave period (second) .} \end{aligned}$$

The total wave power available over the width of the throat section  $b$  can then be defined as:

$$\frac{\gamma b L_o H_o^2}{16 T_w} . \tag{16}$$

Therefore, the ratio of the tidal prism power to wave power,  $I$ , is proportional to:

$$\frac{P R_t}{g_w b T_w T_t H_o^2} , \tag{17}$$

where

$$\begin{aligned} g_w &= \text{the weight per unit mass of water ,} \\ P &= \text{tidal prism (cubic foot) ,} \\ R_t &= \text{the tidal range (} 2a_o \text{) .} \end{aligned}$$



The concept is that some criterion, such as I, will determine whether an inlet will close or open under wave action of intensity ( $T_w, H_o$ ).

Closure of an inlet will require a finite time. Experimentally, each value of P, R,  $T_t$ ,  $T_w$ , and  $H_o$  should be maintained until no further change occurs; then  $H_o$  should be increased to a higher value and the elapsed time should be measured until a new equilibrium is reached as the inlet closes. For closure, the total elapsed time will be difficult to measure accurately; if the model is shut down at intervals and the throat area measured, the elapsed time to reduce the area to half the original value may be a useful parameter.

The concept of closure assumes that the flow area at equilibrium depends upon the wave energy represented by ( $T_w H^2$ ). In a model experiment, this quantity can be measured. In the field, it can only be approximated from information regarding the wave climate at each location.

Galvin (1972) has found an upper envelope for the gross littoral transport given by:

$$Q_L = 2H^2 \quad . \quad (18)$$

Here  $Q_L$  is cubic yards per year and H is the mean annual wave height in feet. This relationship may be sufficiently accurate if there is not a large scatter of the field data. However, available surveys of inlets are made at a particular point in time, usually in the summer, and the effect of wave intensity on flow area is not likely to be discovered by using the annual average of H and  $T_w$  to compute I. If the inlet flow area responds rapidly to wave intensity, the values of H and  $T_w$  preceding the survey may be required for comparison with the small-scale results.

## V. VALUE OF TIDAL PRISM IN MAINTAINING INTERIOR CHANNELS

The flow areas of the channels in San Francisco Bay, adjacent inland waters, and channels in the three Oregon estuaries (Goodwin, Emmett, and Glenne, 1970) are approximate linear functions of the average tidal prism above the section considered.

These facts point to the importance of locating as much of the tidal prism as possible at the maximum distance from the inlet. Dredging shoals between LW and HW in the shallow upper reaches of a lagoon or estuary will not only aid in the maintenance of navigation channels but will also improve the water exchange and flushing ability of the lagoon or estuary.

## VI. STABLE CHANNELS AND STABLE INLETS

Lacey (1929) found in India that nonsilting, nonscouring irrigation channels in alluvium followed the relationship:

$$\begin{aligned} Q_f f^2 &= 3.8 (V_{cr})^6 \quad , \\ 5 &< p_c f^2 < 3,000 \quad , \\ 1 &< V_{cr} < 4 \quad , \end{aligned} \quad (19)$$

where

$$\begin{aligned}
 Q_f &= \text{flow (cubic feet per second) ,} \\
 f &= \text{silt factor ,} \\
 &= 2.0 \text{ heavy sand,} \\
 &= 1.6 \text{ to } 1.4 \text{ coarse sand ,} \\
 &= 1.3 \text{ medium sand ,} \\
 &= 1.0 \text{ standard silt ,} \\
 V_{cr} &= \text{critical velocity for stability (feet per second) ,} \\
 A_c &= \text{flow area (square feet) .}
 \end{aligned}$$

The rate of sediment transport, if any, was unknown. At the minimum flow area of a tidal inlet at strength of current, the maximum velocity is approximated by:

$$V_{max} = \left( \frac{\pi}{T} \right) \frac{P}{A_c} , \quad (20)$$

and the maximum discharge ( $Q_{max}$ ) is given by:

$$Q_{max} = \frac{\pi}{T} P .$$

Substituting these relationships in equation (19) with  $V_{max} = V_{cr}$ , and  $Q_{max} = Q$ :

$$\frac{P}{A_c} = \left( \frac{T}{\pi} \right)^{5/6} \left( \frac{f^2}{3.8} \right)^{1/6} P^{1/6} . \quad (21)$$

For coarse sand,  $f = 2.0$  and  $(f^2/3.8)^{1/6}$ , approaches 1.0 and

$$\frac{P}{A_c} = 2.97 \times 10^3 P^{1/6} . \quad (22)$$

For standard silt,  $f = 1.0$

$$\frac{P}{A_c} = 2.37 \times 10^3 P^{1/6} . \quad (23)$$

Replotting the data for unimproved and improved inlets, Johnson (1973) found

$$\frac{P}{A_c} = 2.4 \times 10^3 P^{0.15} . \quad (24)$$

This agreement may be entirely fortuitous, but it does warrant further study.

Lacey (1929) also found that the wetted perimeter of channels,  $m$ , in nonsilting, nonscouring equilibrium followed the relationship

$$m = 2.7 Q^{1/2} , \quad (25)$$

and was approximately equal to the surface width at MSL of a tidal inlet. The maximum rate of flow at a tidal inlet on each phase of the tide is approximately:

$$Q_{max} = \frac{\pi}{T} P .$$

Therefore, the inlet width,

$$b \cong 2.7 \frac{\pi^{1/2}}{T} P^{1/2} = 2.23 \times 10^{-2} P^{1/2} . \quad (26)$$

The area of the inlet is ( $b \cdot y$ ), where  $y$  is the average depth and  $b$  is the average width. For unimproved inlets (O'Brien, 1969), the area and tidal prism are related empirically by:

$$\frac{P}{A_c} = 5.0 \times 10^4 \text{ ft} . \quad (27)$$

Solving for  $A_c$  and substituting  $b$  from equation (26),

$$A_c = \frac{P}{5.0 \times 10^4} = b \cdot y = 2.23 \times 10^{-2} P^{1/2} ,$$

and

$$y = 8.97 \times 10^{-4} P^{1/2} \text{ (ft)} . \quad (28)$$

## VII. TRACTIVE FORCE CONSIDERATIONS

The tractive force,  $\tau$ , averaged over the wetted perimeter,  $m$ , of  $A_c$  is:

$$\frac{\tau}{w} = R_h S \cong y s ,$$

where

$$\begin{aligned} y &= \text{average depth} , \\ R_h &= \text{hydraulic radius} . \end{aligned}$$

Using Manning's equation for the friction coefficient and computing the tractive force at the time of  $V_{max}$ ,

$$\frac{\tau_{max}}{m} = \left( \frac{n}{1.49} \right)^2 \cdot \frac{V_{max}^2}{y^{1/3}} .$$

Inserting the value of  $V_{max}$  for inlets in equilibrium,  $V_{max} = P/A_c (\pi/T)$ ,

$$\frac{\tau_{max}}{m} = 0.45 \left( \frac{n\pi P}{TA} \right)^2 y^{-1/3} , \quad (29)$$

which, for Johnson's (1973) relationship between  $A_c$  and  $P$  (equation 24), yields:

$$\frac{\tau_{max}}{m} = 2.6 \times 10^6 p^{0.30} \left( \frac{n\pi}{T} \right)^2 y^{-1/3} . \quad (30)$$

The friction coefficient may depend primarily on ripple dimensions; however, the ripple size may depend upon the sand size and the hydraulic conditions.

Since the flow area of an inlet is a quantity required for design, and since this area is directly related to the tidal prism, the use of tractive force or other intermediate criteria in studying the flow area would introduce an unnecessary step. However, development of equation (30) illustrates the relationship that results from the assumption that the tractive force at strength of current is the same at all inlets in equilibrium.

### VIII. SETUP IN A LAGOON BY WAVE ACTION

Mean sea level in a lagoon is frequently assumed to be the same as in the ocean; most determinations of MSL have been made in protected waters, some in lagoons.

Waves moving towards shore project a flux of momentum which causes a setup inside the breaker line amounting to  $KH_s$ , where  $K$  ranges from 0.1 to 0.2 (Saville, 1955).

Near an inlet this phenomenon should have several effects, including: (a) generation of hydraulic gradient along the surf zone, sloping downward towards the inlet, and (b) generation of a setup of the average lagoon water level, an amount probably less than  $KH_s$  on the open coast. This effect may be too small to measure in inlet models, but an effort to do so should be made. Wave-induced setup would be additive to any superelevation of the lagoon surface due to friction losses in the inlet channel.

### IX. WAVE REFRACTION BY CURRENTS AT AN INLET

Waves are refracted by currents and the depth in the vicinity of an inlet. Waves meeting an ebbtide decrease in length and velocity, and increase in steepness. A wave crest straight and parallel to shore will be bowed outward by both the ebbtide current and the bar. The increase in steepness due to both ebbtide current and decreased depth may cause breaking.

Waves moving shoreward into a floodtide increase in length and velocity, and decrease in steepness. The current bows the wave crest inward, whereas the shoaling over the bar without currents, has an opposite effect.

Refraction by currents is an integral component of the dynamics of an inlet and not an independent variable to be studied separately. However, the effect is probably substantial in shaping the bar.

## X. SUGGESTED STUDIES

### 1. Field Measurements.

There are enough field data available for future office studies. However, after analyses of the data have defined the areas of uncertainty, carefully planned fieldwork should be conducted on selected inlets.

One limitation of existing data is that hydrographic surveys are made during calm weather, frequently during the summer, and there is little information available regarding the condition of inlets after wave attack. This is a severe restriction on the validity of the data and may account for the absence of an effect of littoral transport on flow area.

Several types of field data studies are:

*a. Material.* The flow area does not appear dependent upon the size of material forming the beaches and bottom. Do all inlets tend to select the same materials to line the throat section? Is the relationship between grain size, shape, and specific gravity, and the critical orbital velocity such that the bed is fluid, and the area is determined only by hydraulic factors? Is there an actual variation of area with grain characteristics masked by the scatter of the data?

Samples have been collected at enough inlets to begin answering these questions. Samples from the throat section, the outer and inner bar, and at mean tide on adjacent beaches should be obtained to appraise whether the throat section is lined selectively or is like the materials found elsewhere. What is the critical velocity which will start motion of the materials found on the bottom at the throat section?

*b. Hydraulic Analysis.* An inlet is a nozzle. Can a "standard" nozzle be defined and a discharge coefficient be computed from the tidal flow and the instantaneous head difference between bay and ocean? Considering the bottom contours around an inlet, can the flow area perpendicular to the flow be defined well enough to represent the flow area as a function of distance from the throat as on line a-a' (Fig. 1), and define the "nozzle" as the area between the orthogonals to the flow at 2A and 1.5A (Fig. 2)? If the instantaneous tide is known at these two points, a discharge coefficient could be defined by:

$$C = \frac{Q_f}{A \sqrt{2g\Delta h}} .$$

Can C be computed from hydraulic considerations? Does C vary in some orderly manner with the dimensions of the inlet, such as distance from 2A on the oceanside to 1.5A on the bay side?

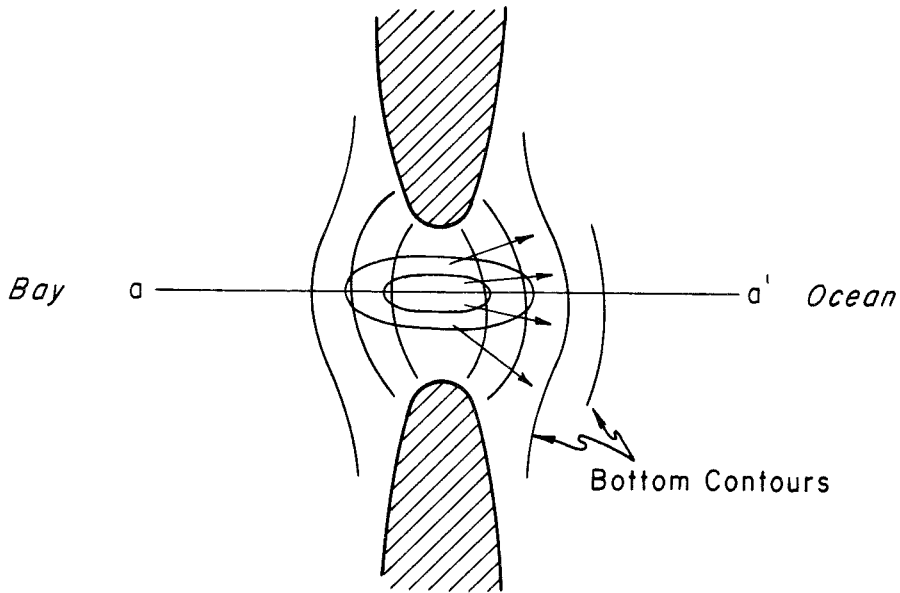

Figure 1. Schematic inlet flow.

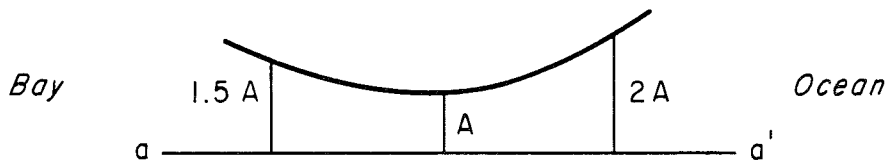

Figure 2. Schematic flow orthogonal.

A discharge coefficient estimated from the geometry would aid tidal calculations for the bay.

$$Q_f = (\text{area of bay}) (\text{rate of rise or fall in bay}).$$

A study of the hydraulic conditions at inlets requires a knowledge of the geometry of the inlet, i.e., width at throat section, maximum depth, shape, etc. Are the relationships between these quantities for an inlet similar to Lacey's (1929) relationships for stable channels in alluvium?

At many inlets the depth at low tide is of the same magnitude as the tidal range, and the flow area varies widely with tide level. What are the phase relationships between tide elevation, flow area, and current velocity? Assuming that a discharge coefficient could be defined and measured, how would it vary with tidal elevation?

Studies of the geometry of inlets might identify some categories which could be modeled in fixed bed to determine discharge coefficients, using for validation a few inlets with available field hydraulic data.

Caldwell (1955) classified the bays behind inlets according to depth, length, and the velocity of tide propagation from the U.S. Coast and Geodetic Survey Tide Tables and Current Tables. He showed the phase relationship between strength of current and tide stand depends on these factors. The subject needs quantitative analysis in connection with the inlet proper, because phase relationship between tide stand, area, and velocity at the inlet proper must affect the sediment movement.

c. *Sand Movement.* Caldwell (1966) states that 23 percent of the sand moving along the shore of New Jersey enters the inlets and remains. This conclusive data and other data relating to sand transport of inlets should be reviewed. Are inlets traps for littoral transport? Over how long a period can an inlet receive material until it chokes up and is closed? Is this process a factor in the life cycle of an inlet?

The original correlation of area and prism (O'Brien, 1931) was based on the long runout and the diurnal range of Pacific coast inlets because this seemed to be the factor which would sweep material out and keep an inlet open. The west coast inlets did not seem to be characterized by inner bars such as are found at Atlantic and gulf inlets. Does this difference exist and, if so, what causes it?

The tidal volumes in and out of an inlet balance over an integral number of tidal cycles, but the velocities and the sediment carrying capacity of the tidal currents may be unbalanced, with a net resultant in or out. The tidal current is approximately proportional to  $R/\Delta t$  where  $R$  = range, and  $\Delta t$  = duration of phase. The capacity to move material per unit width is proportional to some exponent  $x$  of the velocity. Summation over a month or a season of the quantity  $\Sigma (R/\Delta t)^x \Delta t$  for all the ebbtides and floodtides would indicate whether there was a tendency for material to move in or out. This result would apply to all the inlets subjected to these same tidal variations.

A refinement of this approach would be to consider the variations in sediment transport capacity with width, area, and velocity during ebbtides and floodtides at a particular inlet.

## 2. Model Studies.

Some laboratory data suggest that the characteristics of the material used are not a major factor in movable bed models. However, there are many other experiments showing that size, specific gravity, angle of repose, porosity, shape, and other characteristics affect the equilibrium slopes and other features of a shore. The tremendous spread in the data on littoral transport rates suggests that material characteristics, as well as some other factors, may be responsible for this scatter. Before studying the details of inlet configuration in movable bed models, the similitude relationships should be tested for a series of models of different horizontal and vertical scales and with different materials.

A few specifications for these idealized models to test the scaling laws are :

- (a) Three horizontal dimensions for each configuration from the smallest (so small that it probably will not scale) to the largest model that the tank, flow system, and wave generator will handle.

(b) Design so that the vertical scale can be changed by little more than changing the depth of water.

(c) Fixed bed plus patches or mounds of movable material, to achieve well-defined equilibrium quickly.

(d) Measurements, mostly photographic, with a minimum of direct measurement and sampling. The rate of approach to equilibrium is important, and photographs of patches of sand against a white background seem feasible to this end.

(e) No tide. Reflections of waves should be to scale and may be permitted unless water sloshes out of tank.

(f) Suggested configurations are:

(1) Pocket of sand held between two vertical submerged walls (Fig. 3.).

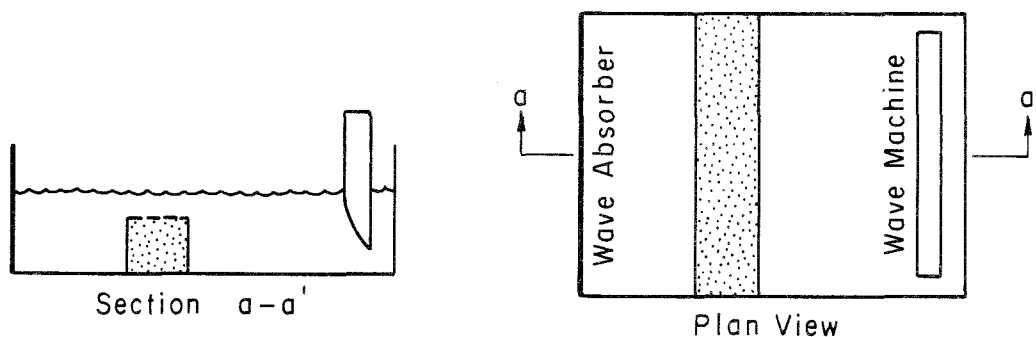

Figure 3. Submerged beach configuration.

(2) Same as (1) with sand banked against outside of wall on machine side. At maximum vertical scale, initial slope angles should be less than angle of repose.

(3) Trough filled with sand in front of cylinder or other shape extending above water surface (Fig. 4).

(4) Santa Barbara breakwater-simplified (Fig. 5).

(5) Perched beach (Fig. 6).

(6) Sample inlet; no waves (Fig. 7). Barrier of material with small pilot channel. For each vertical scale and each material, establish increasing rates of steady flow and measure the flow area for each steady flow. Mound of material with slopes where the steepest is less than angle of repose.

(7) Inlet with flow and waves. Same as (6) but with wave generator on downstream side of barrier.

(8) Same as (7) but with two jetties to fill width of channel. Same flows and waves as (7).

(g) Auxiliary tests and studies.

(1) Materials used:

Sieve analysis.

Settling velocity.



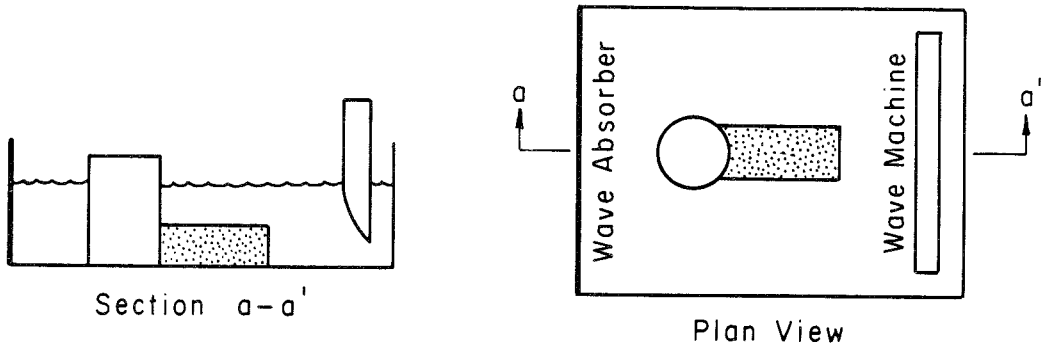

Figure 4. Submerged trough configuration.

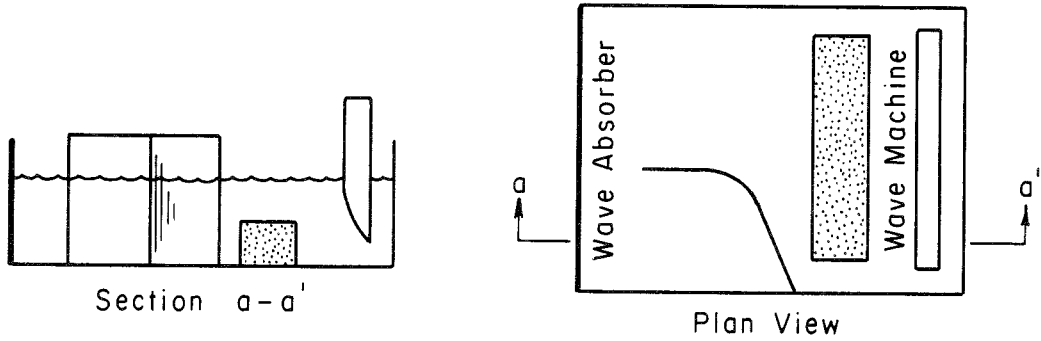

Figure 5. Attached breakwater configuration.

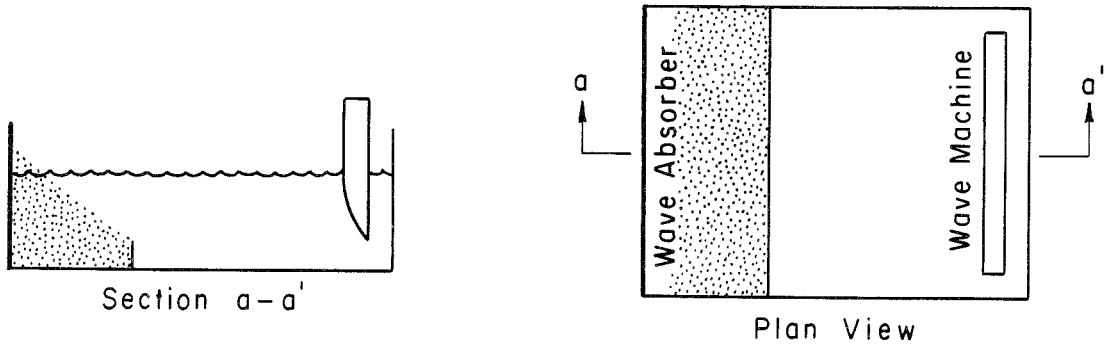

Figure 6. Perched beach configuration.

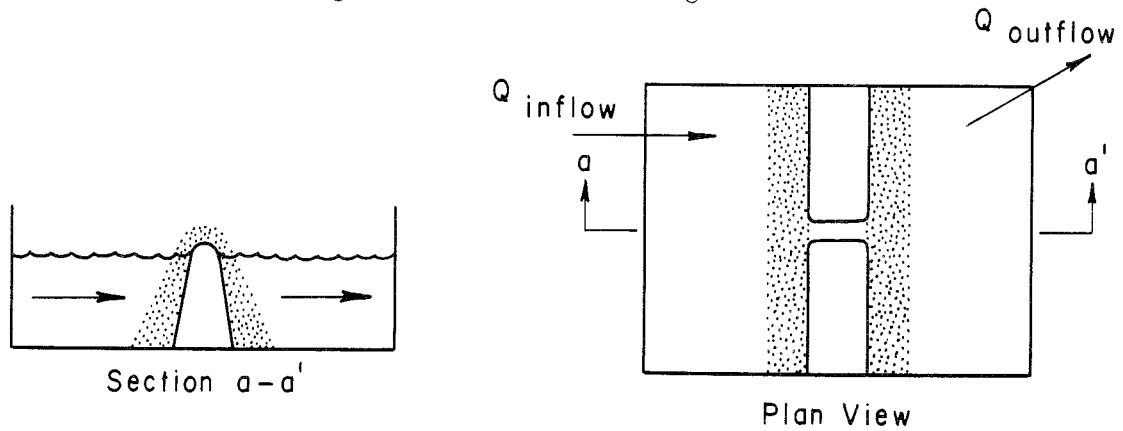

Figure 7. Pilot channel configuration.

Specific gravity.  
Angularity.  
Porosity.  
Angle of repose underwater.  
Steady velocity to start motion.  
Orbital velocity to start motion.  
Microphotograph.

(2) Temperature may be important and should be recorded.

(3) Scale waves in distorted models.

(h) Idealized models.

(1) Movable bed in zone affected by currents and waves:

With and without jetties.

No tide at first.

Steady ebbtide flow at different rates.

Waves. Variations in direction, height, and period.

Objective. Equilibrium flow area; equilibrium configuration of shore.

Two horizontal scales.

(2) Compare results of different tide regimes.

Steady ebbtide flow followed by steady floodtide flow, both at  $Q_{max}$ .

Step wise from maximum ebbtide flow to maximum floodtide flow and return to ebbtide flow.

Sinusoidal variations at different cycle times. Total duration of ebbtide and floodtide the same in all cases.

(i) Inlet models. Assuming that model scaling studies have been encouraging regarding the validity of movable bed models, the next step would be to reproduce to model scale some small existing inlets where the wave environment is simple and known, and if possible to reproduce each one to two horizontal scales (and as many vertical scales as necessary). Possible locations include the boat basin at Camp Pendleton, Bolinas Bay, Santa Cruz, and Moss Landing, California.

## LITERATURE CITED

- BROWN, E. I., "Inlets on Sandy Coasts," *Proceedings of the American Society of Civil Engineers*, Vol. 54, 1928, pp. 505–553.
- CALDWELL, J. M., "Coastal Processes and Beach Erosion," *Journal American Society of Civil Engineers*, Vol. 53, No. 2, 1966, pp. 142–157 (also CERC Reprint R 1-67, NTIS AD 652 025).
- CALDWELL, J. M., "Tidal Currents at Inlets in the United States," Hydraulics Division Separate No. 716, American Society of Civil Engineers, June 1955.
- GALVIN, C. J., Jr., "A Gross Littoral Drift Rate Formula," *Proceedings, 13<sup>th</sup> Conference on Coastal Engineering*, ASCE, Vancouver, B.C., 1972, pp. 953–970.
- GOODWIN, C. R., EMMETT, E. W., and GLENNE, B., "Tidal Study of Three Oregon Estuaries," Bulletin 45, Engineering Experiment Station, Oregon State University, Corvallis, Ore., May 1970.
- JOHNSON, J. W., "Characteristics and Behavior of Pacific Coast Tidal Inlets," *Journal Waterways, Harbors, and Coastal Engineering Division*, Vol. 99, No. WW3, 1973, pp. 325–339.
- LACEY, G., "Stable Channels in Alluvium," *Proceedings, Institute of Civil Engineers*, Vol. 229, 1929, pp. 250–285.
- O'BRIEN, M. P., "Estuary Tidal Prisms Related to Entrance Areas," *Civil Engineer*, Vol. 1, No. 8, 1931, pp. 738–739.
- O'BRIEN, M. P., "Equilibrium Flow Areas of Tidal Inlets on Sandy Coasts," *Journal of Waterways and Harbors Division*, ASCE, Vol. 95, No. WW1, Feb. 1969, pp. 43–52.
- SAVILLE, T., "Laboratory Data on Wave Runup and Overtopping on Shore Structures," TM 64, U.S. Army, Corps of Engineers, Beach Erosion Board, Washington, D.C., Oct. 1955.
- STEVENSON, T., *The Design and Construction of Harbours*, Adam and Charles Black, Edinburgh, 1886.
- U.S. CONGRESS, "Sacramento, San Joaquin and Kern Rivers, California," HD No. 191, 73<sup>rd</sup> Congress, 2<sup>nd</sup> Session, Washington, D.C., 1934.