

Slide-In Bridge Construction Implementation Guide

Planning and Executing Projects with the Lateral Slide Method

FINAL REPORT

DECEMBER 2013



FOREWARD AND ACKNOWLEDGEMENTS

The Slide-In Bridge Construction (SIBC) Implementation Guide was developed for Federal Highway Administration's (FHWA) Every Day Counts Initiative as an innovative Accelerated Bridge Construction technique to shorten project delivery, reduce user impacts, and enhance roadway safety. This document provides a general guideline for state Departments of Transportation (DOTs) to implement the SIBC method for common bridge replacements.

The SIBC Guide was authored by Utah DOT and Michael Baker Corporation.

Technical Working Group contributors include Colorado DOT, Iowa DOT, Massachusetts DOT, Nevada DOT, H. Boyle Engineering, Horrocks Engineers, Klophaus LLC, Garver LLC, Ralph L. Wadsworth Construction, W.W. Clyde, and URS Corporation. Additional contributors of projects and photos include Indiana DOT, Oregon DOT, Missouri DOT, and Slayden Construction.

Timothy Cupples, P.E.
Office of Asset Management
FHWA

DISCLAIMER

The U.S. Department of Transportation / FHWA disseminates this document as an exchange of information. FHWA assumes no liability for its content or use thereof. This guide does not constitute a standard, specification, or regulation, nor does FHWA endorse any particular products or manufacturers.

TABLE OF CONTENTS

CHAPTER 1 – INTRODUCTION OF SLIDE-IN BRIDGE CONSTRUCTION	1-1
1.1 DESCRIPTION	1-1
1.2 BENEFITS	1-2
1.2.1 Safety.....	1-2
1.2.2 Project Schedule.....	1-3
1.2.3 Mobility Impacts	1-3
1.2.4 Project Costs.....	1-4
1.2.5 Quality.....	1-4
1.2.6 Constructability	1-4
1.3 COMMON APPLICATIONS	1-4
1.4 LIMITATIONS	1-8
1.4.1 Right-of-way (ROW) / Staging Area.....	1-8
1.4.2 Geometric Constraints	1-8
1.4.3 Lack of SIBC Experience	1-9
1.4.4 Profile Changes	1-10
1.4.5 Utility Impacts.....	1-10
CHAPTER 2 – OWNER CONSIDERATIONS	2-1
2.1 ROLES AND RESPONSIBILITIES	2-1
2.2 COST CONSIDERATIONS	2-2
2.2.1 Cost Considerations that May Decrease Total Cost	2-3
2.2.2 Cost Considerations that May Increase Total Cost.....	2-3
2.3 PROJECT DELIVERY	2-5
2.3.1 Level of Detail	2-6
2.3.2 Specifications.....	2-7
2.4 PUBLIC RELATIONS	2-7
2.4.1 Public Information prior to Finalizing the Construction Schedule.....	2-7
2.4.2 Comprehensive PI Communication	2-7
2.4.3 Public Support Benefits.....	2-8
2.5 SELECTION PROCESS	2-9
CHAPTER 3 – DESIGN CONSIDERATIONS	3-1
3.1 BRIDGE LAYOUT	3-1
3.1.1 Abutment Types.....	3-3
3.1.1.1 Semi-Integral Abutments.....	3-3
3.1.1.2 Integral Abutments	3-5
3.1.1.3 Seat-Type Abutments	3-5
3.1.1.4 Geosynthetic Reinforced Soil (GRS).....	3-5
3.1.2 Foundation Solutions	3-7
3.1.3 Re-use of Existing Substructure	3-10
3.1.4 Superstructure	3-10
3.2 SIBC LOADS ON PERMANENT BRIDGE	3-11
3.3 DESIGN OF TEMPORARY WORKS AND SLIDE SYSTEM	3-11
3.3.1 Design Considerations.....	3-11
3.3.2 Temporary Works Materials and Foundations	3-13

3.4	BRIDGE TO ROADWAY CONNECTION.....	3-14
3.4.1	Approach Slab	3-14
3.4.2	Sleeper Slab	3-15
3.4.3	Joints.....	3-16
3.4.4	Backfill.....	3-16
3.4.5	Roadway Tie-in Design.....	3-16
3.4.6	Parapet Barrier Connections.....	3-17
3.5	TOLERANCES.....	3-17
3.5.1	Construction Tolerances	3-17
3.5.2	Final Tolerances	3-18
3.6	SPECIFICATION DEVELOPMENT.....	3-18
CHAPTER 4 – CONSTRUCTION CONSIDERATIONS		4-1
4.1	TYPES OF SLIDE SYSTEMS	4-1
4.1.1	Industrial Rollers	4-1
4.1.2	Teflon Pads.....	4-2
4.1.3	Hydraulic Jack.....	4-4
4.1.4	Winches / Mechanical Pulling Devices	4-6
4.1.5	Post-tensioned (PT) Jacks	4-7
4.2	SCHEDULE CONSIDERATIONS	4-8
4.2.1	Partial Demolition with Phased Bridge Slide.....	4-8
4.2.2	Bridge Demolition.....	4-9
4.2.3	Bridge Slide Time.....	4-9
4.2.4	Bridge and Roadway Tie-in.....	4-9
	4.2.4.1 Bridge Layout	4-10
	4.2.4.2 Approach Slabs.....	4-10
	4.2.4.3 Roadway Tie-in	4-11
4.2.5	Detailed Schedule.....	4-11
4.3	SPECIAL PROVISIONS AND SUBMITTAL REQUIREMENTS	4-12
4.4	CHECKLIST OF CONSTRUCTION CONSIDERATIONS.....	4-13

APPENDICES

- Appendix A: Case Studies
- Appendix B: Additional References
- Appendix C: Sample Plans
- Appendix D: Sample Special Provisions

LIST OF FIGURES

Figure 1-1	Overhead View of the West Mesquite SIBC Project, Nevada	1-1
Figure 1-2	Eliminated Phased Construction at the I-80; Echo Road SIBC Project, Utah	1-3
Figure 1-3	SIBC for a Large Truss Bridge on the Milton-Madison Bridge Project, Indiana/Kentucky	1-5
Figure 1-4	SIBC for a Small Stream Crossing for the SR-66 over Weber River Bridge Project, Utah.....	1-5
Figure 1-5	SIBC with Constraints Limiting Traffic Control Options at the OR-38 Bridge Project, Oregon	1-7
Figure 1-6	Difficult Construction Conditions and Site Constraints along the OR-38 Bridge Project, Oregon	1-9
Figure 1-7	SIBC with New Bridge Constructed Higher and then Lowered to the Existing Profile	1-10
Figure 2-1	SIBC that Avoided Use of Temporary Crossovers on I-80; 2300 E. Bridge Project, Utah.....	2-2
Figure 2-2	PI Efforts Attracted the Public to the Sellwood SIBC Project, Oregon	2-8
Figure 3-1	Precast Abutment Installation	3-1
Figure 3-2	Three-Span Overpass Bridge Converted to a Single-Span on the I-80 Echo Road Bridge Project (Before).....	3-2
Figure 3-3	Three-Span Overpass Bridge Converted to a Single-Span on the I-80 Echo Road Bridge Project (After)	3-3
Figure 3-4	Typical Semi-integral Abutment Detail.....	3-4
Figure 3-5	Typical Geosynthetic Reinforced Soil (GRS) Abutment Detail	3-6
Figure 3-6	GRS System for the I-84 Echo SIBC Project, Utah.....	3-6
Figure 3-7	New Abutment Constructed under Existing Structure for the I-80; 2300 E. Bridge Slide, Utah.....	3-7
Figure 3-8	Typical Micropile Detail.....	3-8
Figure 3-9	Straddle Abutment on the I-80 Echo Road Bridge Project, Utah	3-9
Figure 3-10	SIBC Using Existing Substructure on the I-44 Gasconade River Bridge Project, Missouri	3-10
Figure 3-11	Temporary Support to Permanent Substructure Connection	3-12
Figure 3-12	Temporary Support Using Driven Piles on the I-80 Atkinson Bridge Project, Utah.....	3-14
Figure 3-13	Inverted “T” Precast Sleeper Slab on the I-80 Echo Road Bridge Project, Utah.....	3-15
Figure 4-1	Industrial Rollers Used during SIBC	4-1
Figure 4-2	Concrete End Diaphragm on Teflon Pads in Sliding Track System	4-3
Figure 4-3	Slide Shoes Used with Vertical Jacks.....	4-3
Figure 4-4	Teflon Pads with Stainless Steel Wrapped Shoes on End Diaphragm	4-4
Figure 4-5	Hydraulic Jack System Produces Smooth Bridge Movement	4-5
Figure 4-6	Winch System Used to Slide a Bridge over a River	4-6
Figure 4-7	PT Jacks on Threaded High-Strength Bars Push Bridge into Place	4-7
Figure 4-8	SIBC Showing Partial Demolition on the Existing Bridge while Maintaining Traffic	4-9
Figure 4-9	Approach Slab Constructed in Staging Area with the Bridge	4-11

LIST OF TABLES

Table 1-1	Common Applications of Slide-In Bridge Construction	1-6
Table 2-1	Cost Considerations that May Decrease Total Cost with SIBC	2-3
Table 2-2	Cost Considerations that May Increase Total Cost with SIBC	2-4
Table 2-3	Bid Cost Comparison Utilizing Phased Construction with Crossovers for the I-80 Wanship SIBC Project	2-5
Table 2-4	Issues for the Owner to Address When Considering SIBC	2-9
Table 4-1	Checklist of Construction Considerations	4-13

LIST OF ACRONYMS

AADT	Annual Average Daily Traffic
AASHTO	American Association of State Highway and Transportation Officials
ABC	Accelerated Bridge Construction
CM/GC	Construction Manager/General Contractor
DB	Design-Build
DBB	Design-Bid-Build
DOT	Department of Transportation
FHWA	Federal Highway Administration
GRS	Geosynthetic Reinforced Soil
LOS	Level-of-service
LRFD	Load and Resistance Factor Design
MOT	Maintenance-of-traffic
OSHA	Occupational Safety and Health Administration
PBES	Prefabricated Bridge Elements and Systems
PI	Public information
PT	Post-tensioned
RE	Resident engineer
QC	Quality control
ROW	Right-of-way
SIBC	Slide-In Bridge Construction
UDOT	Utah Department of Transportation
VMS	Variable Message Sign

Chapter 1

INTRODUCTION OF SLIDE-IN BRIDGE CONSTRUCTION

1.1 DESCRIPTION

With approximately 25% of the Nation's 607,380 bridges requiring rehabilitation, repair, or total replacement, Slide-In Bridge Construction (SIBC) offers a cost-effective technique to rapidly replace an existing bridge while reducing impacts to mobility and safety. SIBC is an Accelerated Bridge Construction (ABC) technology that reduces the on-site construction time associated with building bridges. Through the Every Day Counts initiative, state highway agencies are working with the Federal Highway Administration (FHWA) to develop this SIBC Implementation Guide. The purpose of this guide is to demonstrate the advantages of SIBC and document how state and local agencies can implement SIBC in typical bridge replacements as a part of their standard business practices.

SIBC allows for construction of a new bridge while maintaining traffic on the existing bridge. The new superstructure is built on temporary supports adjacent to the existing bridge (see Figure 1-1). Once construction is complete, the road is closed, the existing bridge structure is demolished or slid to a staging area for demolition, and the new bridge is slid into its final, permanent location. Once in place, the roadway approach tie-ins to the bridge are constructed. The replacement time ranges from overnight to a week several weeks. A variation of this method is to slide the existing bridge to a temporary alignment, place traffic on the temporary alignment, and construct the new bridge in place.

Figure 1-1
Overhead View of the West Mesquite SIBC Project, Nevada



SIBC provides an effective alternative to phased construction, crossovers, lane reductions, or use of temporary bridges. Although the lateral slide requires a short-term full closure of traffic, owners and the public typically prefer the limited impacts of a single short-term closure when compared to the extended traffic impacts associated with phased construction.

Sliding a constructed bridge is not a new concept and has been successfully implemented in many projects nationwide. Most often, these projects have been large bridges with high traffic volumes and limited construction options. Railroad bridges have also used SIBC in the past because of strict operation limitations to bridge closures. SIBC's application to smaller, routine bridges is relatively new and underutilized. However, state agencies and FHWA have successfully employed SIBC with small bridge replacements as an innovative option to minimize impacts to the traveling public.

1.2 BENEFITS

There are several fundamental benefits to using SIBC, as compared with phased construction, which include:

- Enhanced safety
- Shortened on-site construction time
- Reduced mobility impacts
- Potentially reduced project costs
- Improved quality
- Improved constructability

This guide describes these benefits in greater detail in the following sections.

1.2.1 Safety

Safety is a primary concern during bridge construction for both the traveling public and construction workers. Approximately 44% of bridge construction worker injuries involve a vehicle traveling through a work zone. Of those work zone injuries, approximately two-thirds are fatal (Occupational Safety and Health Administration [OSHA], 1984-2010). SIBC greatly reduces the interaction between construction workers and vehicular traffic by moving the work zone away from live traffic. This result reduces exposure to work zone accidents and increases safety for construction workers and the traveling public.

Construction of the bridge on temporary supports is an extra step not required in traditional construction. Qualified engineers must design the temporary supports and falsework according to American Association of State Highway and Transportation Officials (AASHTO) Guide Specifications for Bridge Temporary Works. In addition, the condensed timeframe of the bridge slide and approach roadway tie-in is very challenging with multiple activities occurring simultaneously. The contractor must provide well-defined schedules, safety briefings, and avoid worker fatigue to maintain safety on the site.

1.2.2 Project Schedule

SIBC significantly shortens on-site construction time when compared with phased construction. Typical phased bridge construction builds one-half of the structure and then the other half. Consequently, this method requires twice the mobilization time, concrete cure times, and other inefficiencies.

SIBC allows construction of the entire superstructure at one time. In certain circumstances, it also allows construction of the substructure simultaneously with the superstructure, which provides additional time savings. Although some additional time is required to build the temporary supports, overall SIBC accommodates faster delivery of a project.

1.2.3 Mobility Impacts

Reduced mobility impacts are one of the greatest benefits of SIBC. Phased construction can require long-term lane restrictions, lane closures, interstate crossovers, and detours, in addition to the general disruption caused by construction activities for prolonged durations. These requirements of phased construction create traffic delays, driver distractions, and ultimately increased user costs for businesses and the public. SIBC provides a relatively simple, cost-effective form of ABC to minimize these impacts.

Figure 1-2
Eliminated Phased Construction at the I-80; Echo Road SIBC Project, Utah

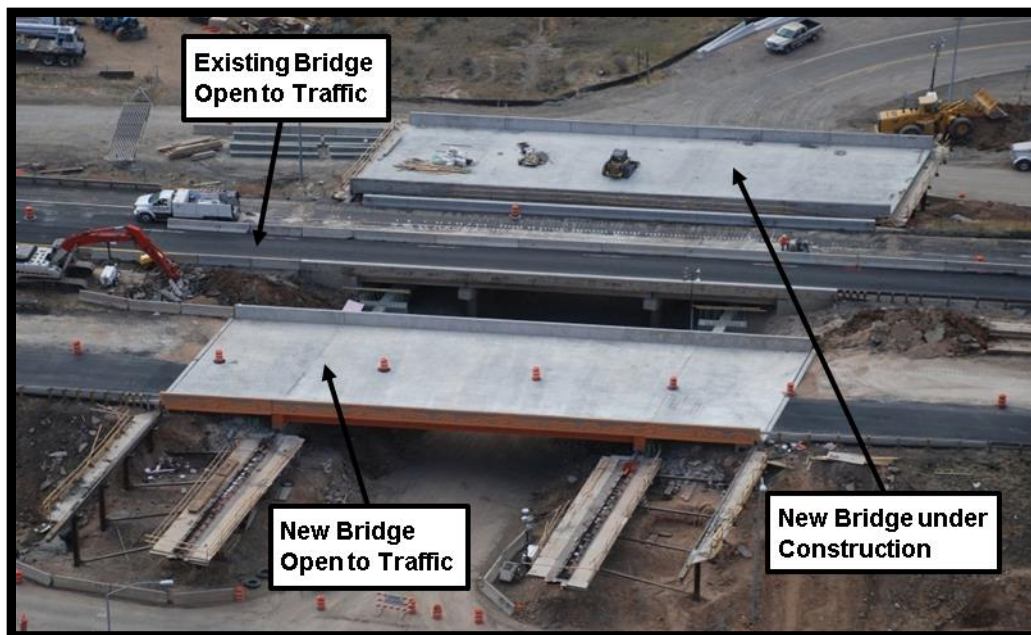

Phased construction of a bridge or a pair of interstate bridges can take seven to 24 months. In comparison, SIBC can eliminate phased construction and decrease lane impacts to a brief full closure (see Figure 1-2). Recent SIBC projects have required road closures that last from just seven hours to seven days. When performed during off-peak hours and with proper communication to the public (see Section 2.4.2), the traveling public and businesses experience minimal mobility impacts.

The Utah Department of Transportation (UDOT) conducted post-construction surveys of residents and businesses that confirmed a majority support of SIBC and other ABC construction efforts, even when short periods of full closure and higher construction costs were required. The transportation system is a tool that the public and economy expect to be accessible and maintained while minimizing impacts using innovative techniques such as SIBC.

1.2.4 Project Costs

SIBC provides a cost-effective means of bridge construction when considering total project costs rather than merely bridge construction costs. Owners, designers, and contractors can experience significant savings in maintenance-of-traffic (MOT), project administration, environmental mitigation, railroad flagging costs, and inflation. SIBC also dramatically reduces user costs associated with detours or extended work-zone traffic delays.

The cost of the actual bridge slide is associated with the superstructure's weight, width, and distance moved. Because the required equipment is relatively simple and is readily available, the cost of the slide is low when compared with other bridge construction costs. For additional information about the costs associated with SIBC, see Section 2.2.

1.2.5 Quality

Implementing SIBC can improve quality by eliminating deck construction joints and girder camber problems associated with phased construction. This production environment also reduces pressure to use faster concrete cure times. In addition, obtaining a full wet cure and blanketing and heating for cold weather cure is typically easier when the superstructure is constructed off-line. Finally, construction workers on SIBC projects face greatly reduced traffic risks, which may facilitate greater focus and attention to construction quality.

1.2.6 Constructability

With SIBC, the new superstructure is built adjacent to the existing superstructure. All traffic remains on the existing superstructure until the construction of the new superstructure is completed. This approach provides for not only a safer work environment for construction workers but also greater ease in construction. Construction work is not required to be immediately adjacent to the traffic. There is additional room for girder sets, deck concrete placement, and equipment access, and the entire bridge is constructed at once instead of connecting phases together. However, substructure construction can be challenging. For additional information on various techniques that address the challenge of constructing substructures under existing bridges, see Section 3.1.

1.3 COMMON APPLICATIONS

SIBC has been applied to bridge construction projects for more than a century. For example, an article published in 1915 in *Engineering News and the Railway Age Gazette* chronicles the successful sliding of three truss spans, weighing a combined 3,500 tons. This bridge slide took only 10 minutes and 17 seconds, completing the bridge closure between train passages. SIBC is applicable to virtually any type of bridge with virtually any length, from large signature bridges to simple slab bridges (see Figure 1-3 and Figure 1-4).

Figure 1-3
SIBC for a Large Truss Bridge on the Milton-Madison Bridge Project, Indiana/Kentucky



Figure 1-4
SIBC for a Small Stream Crossing for the SR-66 over Weber River Bridge Project, Utah



While owners, designers, and contractors can use SIBC in many bridge applications, Table 1-1 presents the most common applications of SIBC that are particularly beneficial and cost-effective.

**Table 1-1
Common Applications of Slide-In Bridge Construction**

Application	Description	Reason
More traffic over the bridge than under the bridge	SIBC typically has greater benefits for bridges where the roadway over the bridge has a lower annual average daily traffic (AADT) than the roadway under the bridge.	If traffic volume on the bridge is a significant issue, SIBC reduces the mobility impacts and user costs. However, for traffic under the bridge, SIBC still requires closures for beam and deck placement on the new bridge, and closure during the existing bridge demolition, new bridge slide, and for post-slide demolition removal and cleanup.
High user cost location	SIBC is generally applicable when user costs are a major consideration.	With fewer detours and work-zone traffic delays, SIBC results in lower user costs than traditional construction.
Elevated safety concerns	SIBC is generally applicable for bridges with extended duration impacts, complex traffic shifts, or other safety concerns.	SIBC increases safety by constructing the superstructure away from traffic, not reducing lane widths, and avoiding merges and potentially confusing lane configurations.
Long detour or no available detour	SIBC is generally applicable for bridge replacements that require a long detour or where no detour route is available due to geography or construction on adjacent routes.	SIBC significantly reduces the duration that a detour is required for the traveling public. If a short-term bridge closure can be sustained without the need for a detour, then SIBC provides a viable solution when no detour is available.
Temporary bridge avoidance	SIBC is generally applicable when a temporary bridge is either unfeasible or cost-prohibitive.	SIBC allows for a short closure period and avoids the need for a temporary bridge to maintain traffic during construction.
No phased construction	SIBC is generally applicable for bridge replacements where phased construction is not permitted or not desired.	If phased construction is not an option due to structure type, constructability issues, or schedule, SIBC provides a viable solution.
Limited on-site construction time	SIBC is generally applicable when the on-site time during construction is limited.	SIBC generally reduces the construction duration when compared to phased construction. This streamlined construction timeframe provides an effective solution to sensitive environments, work required in railroad ROWs, and highly populated commerce, residential, or recreation areas.

Application	Description	Reason
Narrow bridge	SIBC is generally applicable for bridges with a limited width.	A narrow bridge may make traffic control during phased construction unfeasible or unsafe. SIBC precludes the need for extended periods of traffic control on the bridge.
Railroad bridge	SIBC is generally applicable for bridges that carry railroad traffic.	Closure of a railroad bridge stops all related train traffic until the bridge is reopened, which greatly affects the transport of both people and products. SIBC reduces the duration of the bridge closure for railroad bridges.
Replacement bridge shorter than existing	SIBC is generally applicable for replacement bridges that are shorter than the existing.	SIBC facilitates the construction of new substructures under the existing bridge while it remains in service to minimize closure time.
Site conditions and geometric constraints	SIBC is generally applicable for bridges with site conditions or geometric constraints that preclude traffic shifts.	SIBC does not require traffic shifts. Therefore, it is a favorable alternative for bridges with site constraints that preclude traffic shifts.

Figure 1-5 and Figure 1-6 illustrate examples of geometric constraints that made SIBC a favorable alternative. The Oregon Route 38 project, extending from Elk Creek to Hardscrabble Creek, had significant site constraints. The project included the construction of two bridges, each on opposite ends of the same tunnel, with one bridge starting almost immediately after exiting the tunnel, as shown in Figure 1-5.

Figure 1-5
SIBC with Constraints Limiting Traffic Control Options at the OR-38 Bridge Project, Oregon



This geometric constraint made traffic shifts extremely difficult to complete, and SIBC provided a viable solution. The lateral slide eliminated costly realignments, costly temporary bridges, and most of the single-lane restrictions. The slides were completed within the allowed 57-hour closure window for each bridge. Additional case studies of actual applications of SIBC are presented in Appendix A.

1.4 LIMITATIONS

In addition to the benefits and common applications presented in Sections 1.2 and 1.3, the project team must consider several limitations when selecting SIBC. Some of the limitations are not as challenging as initially perceived by new users of the technology.

For example, there is a concern that sliding the bridge may cause structural damage to the girders or deck. However, forces from sliding bridges are similar to typical temperature loads due to the low friction systems and slow rate of load application used to move the bridge. Other loads associated with the move, including vertical jacking for placement of slide elements and from deviations in slide path elevations are similar to forces from bearing replacement activities.

Many owners view a short-term full bridge closure with a temporary traffic detour as prohibitive from the perspective of the traveling public. However, post-construction surveys of residents and businesses reveal high levels of satisfaction with SIBC projects. The traveling public generally prefers a few days of bridge closure over months of traffic delays or detours.

Conversely, some limitations are very challenging including:

- Limited right-of-way (ROW) for staging
- Geometric constraints
- Lack of SIBC experience
- Profile changes
- Utility impacts

These challenges must be evaluated during the planning phases of an SIBC project and are described in greater detail in the following sections.

1.4.1 Right-of-way (ROW) / Staging Area

A common limitation for the application of SIBC is lack of ROW. SIBC involves the construction of a new superstructure adjacent to the existing bridge. Thus, a larger staging area is required adjacent to the existing bridge than with traditional construction. If the land immediately adjacent to the existing bridge is not available, then SIBC may not be a viable construction alternative.

1.4.2 Geometric Constraints

In addition to limited ROW, geometric constraints adjacent to the existing bridge either preclude the use of SIBC or make it challenging. For example, if existing structures or utility poles are

located immediately adjacent to the existing bridge, there may not be sufficient space to construct the new superstructure.

Another geometric constraint is poor geometry or unfavorable terrain immediately adjacent to the existing bridge. If the terrain is steep, then the bridge is highly skewed with large cross-slopes, or other non-conductive terrain constraints are present. These conditions make SIBC more difficult. Conversely, the geometric constraints may also be the reason SIBC is needed to provide a solution with minimal impacts to the public. Figure 1-6 provides an example of a difficult terrain constraint where SIBC was implemented. Significant shoring may be required for such cases in which the geometry or terrain makes SIBC particularly challenging.

Figure 1-6

Difficult Construction Conditions and Site Constraints along the OR-38 Bridge Project, Oregon



1.4.3 Lack of SIBC Experience

Another challenge to the use of SIBC is lack of experience with SIBC. The first use of a new method typically increases bid prices due to risk and pricing of unfamiliar construction methods. However, SIBC is a relatively simple construction method, and after one or two applications, designers and contractors can accurately bid the SIBC projects.

Careful planning before the bridge slide mitigates a lack of experience for the owner, designer, and contractor. Develop specifications that outline required submittals and define allowed parameters to deliver a successful SIBC project. Moreover, consulting with other owners, designers, and contractors who have had successful SIBC experiences reduces potential errors during an owner's first bridge slide.

1.4.4 Profile Changes

SIBC is generally not as effective when the profile across the bridge is being raised since the approach roadway work typically controls the schedule. However, SIBC can be applied when the profile under the bridge is changed. SIBC can also be used when the new bridge must be constructed at a higher profile but is then lowered and slid into place at the existing profile. An example of such an application is in Figure 1-7. As illustrated, the new bridge must be constructed at a higher elevation than the existing bridge to satisfy the required vertical clearance in the temporary location. After the superstructure and abutments construction are complete, the first step is to lower the new bridge to the required elevation. The second step is then to slide the bridge into the final horizontal position.

Figure 1-7
SIBC with New Bridge Constructed Higher and then Lowered to the Existing Profile

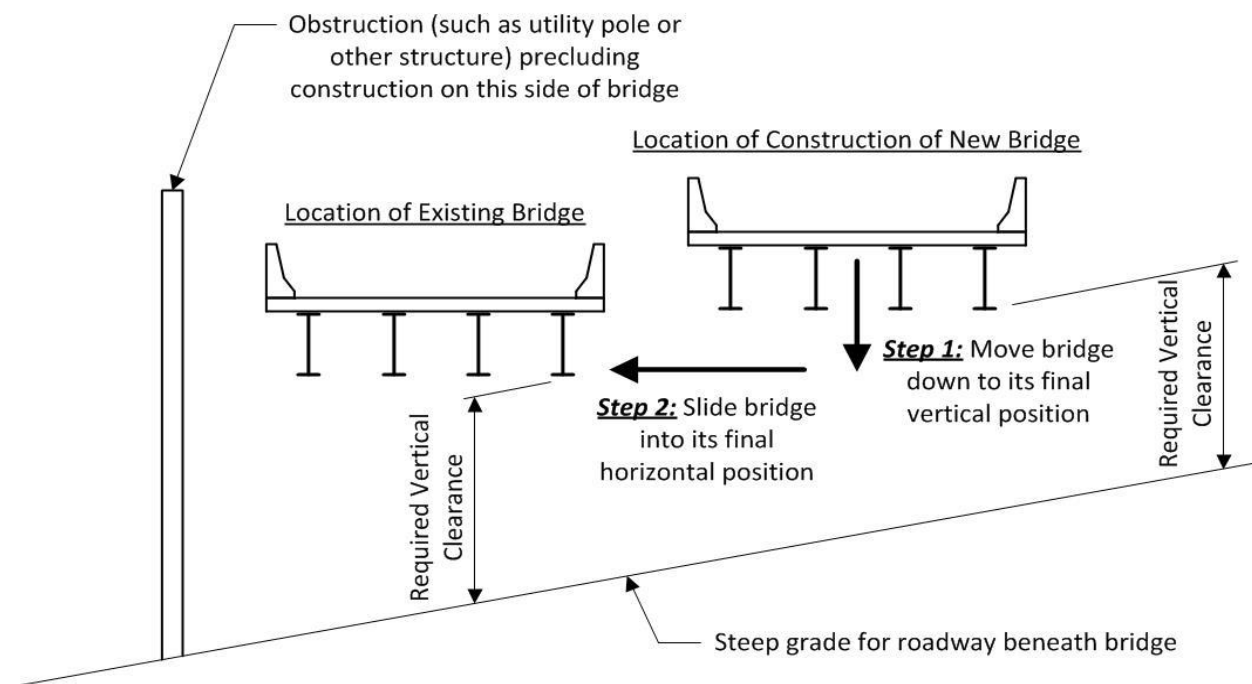

1.4.5 Utility Impacts

The presence of overhead or underground utilities creates challenges during SIBC implementation. When viewing the project site, survey the location of the utilities to determine potential constraints and/or required ROW.

Utilities located on the bridge can increase the project closure times due to the complications of moving and reconnecting the utilities. For example, if a large water line or a high-pressure gas line is present on the bridge and if closure of those utilities is required to facilitate the slide, it may be necessary to schedule the slide during non-peak hours to minimize impact to the public. This interruption in utility service will need to be carefully planned and communicated to customers before the slide takes place.

Chapter 2

OWNER CONSIDERATIONS

2.1 ROLES AND RESPONSIBILITIES

The owner must analyze the project site to assess SIBC feasibility. Verify if there is room either in the median or outside of the bridge to construct the new bridge without major impacts such as buildings, major utilities, roadways, or ramps that cannot be temporarily realigned. Also, consider site environmental constraints such as wetlands, cultural resources, or other constraints that preclude construction activities in the areas adjacent to the existing bridge. Constraints such as these may make SIBC cost prohibitive. Smaller constraints such as lack of ROW, minor utilities, difficult existing terrain, or ramp conflicts with room to temporarily realign may add cost to the project and require additional up-front planning to mitigate, but are not roadblocks to SIBC.

The owner defines expectations for both full and partial closure times, including closure duration and specific days during which the bridge can or cannot be closed. Reasonable closure times are project specific. Activities that affect closure duration include the demolition time, the number of bridge spans to move, required substructure work post-demolition, utility connections, and approach slab and roadway tie-in work. In general, the actual sliding of a bridge span into place takes two to eight hours depending on experience, tolerances, and equipment operation. The additional time required is based on the other activities required.

In addition, the owner must define expectations for impacts to the feature under the bridge, be it a roadway, waterway, railroad, or other feature. SIBC still requires the construction of the bridge, including girder sets and deck placement over the cross-street. Closures for these activities along with preparation time for the slide, sliding the bridge into place, and cleanup of the demolition will require full or partial closures of the feature intersected.

The owner must define incentives and disincentives related to the closure time. Establish disincentives for exceeding the allowed time carefully. An extremely high disincentive may entice the contractor to rush the slide and tie-in work potentially reducing the quality, or the risk of the disincentive may be bid into the job, increasing the cost. Conversely, a low disincentive may increase the risk that the contractor will not prepare and plan enough to meet the deadline, or the penalties will be bid into the project permitting traditional construction. One successful approach is an hourly graduated disincentive. This approach still motivates the contractor to finish on time, but allows for some contingency to complete the project successfully for all parties even if a little additional time is needed.

The owner must focus greater attention on the specifications and submittals with SIBC than might be necessary when using traditional construction. SIBC requires more submittals than with traditional construction, and the owner must ensure that all submittal requirements are well defined. The owner must be prepared for the increased number of submittals to provide a thorough review.

The owner must have an understanding of what is expected during the slide, including the temporary supports and the components and materials used for the slide. The owner must also provide or require the contractor to provide a strategic and comprehensive public involvement plan. Since the bridge is fully closed for a short duration, it is critical that the scheduled times and duration of the closure be communicated effectively to the traveling public (see Section 2.4).

2.2 COST CONSIDERATIONS

When considering the application of SIBC for a specific project, it is important to compare total project costs rather than strictly the bridge costs. Using SIBC to eliminate temporary crossovers (Figure 2-1) or temporary bridges reduces the actual project bid price. In addition, items such as project administrative costs and construction inspection and engineering costs are reduced when the project schedule is significantly reduced. Soft costs, such as user costs, are savings that cannot be applied directly to the project, but are important benefits of SIBC. The following sections present detailed cost considerations.

Figure 2-1
SIBC that Avoided Use of Temporary Crossovers on I-80; 2300 E. Bridge Project, Utah



2.2.1 Cost Considerations that May Decrease Total Cost

Several cost considerations often result in savings when using SIBC. These considerations reduce the total cost for SIBC when compared with other construction methods (see Table 2-1).

Table 2-1
Cost Considerations that May Decrease Total Cost with SIBC

Cost Consideration	Explanation
MOT (Maintenance-of-traffic) (Hard Bid Cost)	In most cases, SIBC significantly reduces traffic control costs. This includes reduction in temporary striping and barrier, lane shifts, and reducing MOT to only a small site-specific area during construction of the bridge. The overall project schedule reduction also reduces MOT maintenance costs.
Crossovers, Temporary Bridges, or Temporary Bypass (Hard Bid Cost)	These items can add significant cost to a project. If SIBC can eliminate these items from the project, these cost savings can offset the cost of SIBC.
Mobilization and Project Overhead (Hard Bid Cost)	Building the bridge in a single phase instead of multiple phases reduces mobilization costs. Reduced project schedule duration reduces contractor administrative on-site costs.
Project Construction Engineering and Inspection (Hard Project Cost)	A reduction in overall project construction schedule similarly reduces the duration of construction engineering and inspection costs.
DOT Administration and Management (Hard Project Cost)	DOT administrative costs associated with the bridge construction are generally reduced due to the reduced schedule.
User Costs (Soft Project Cost)	SIBC can dramatically reduce user costs associated with extended detours or extended work-zone traffic delays. Savings in user costs can be realized even with relatively short detours or low AADTs.

2.2.2 Cost Considerations that May Increase Total Cost

Similarly, there are also several cost considerations that result in additional expenses when using SIBC. These considerations increase the total cost for SIBC, when compared with other construction methods. Table 2-2 presents these cost considerations.

**Table 2-2
Cost Considerations that May Increase Total Cost with SIBC**

Cost Consideration	Explanation
Cost of slide equipment (Hard Bid Cost)	The cost of the slide is a function of the superstructure weight, width, and distance moved. However, because the required equipment is relatively simple and is readily available, the cost of the slide equipment is relatively inexpensive.
Labor for slide (Hard Bid Cost)	Similarly, the labor cost for the slide is also required for SIBC but not for traditional construction. However, since the slide is relatively simple and of short duration, the labor costs associated with the slide are relatively inexpensive.
ROW (Right-of-way) (Hard Bid Cost)	SIBC requires the construction of the new superstructure adjacent to the existing bridge. If this area is not within the existing roadway ROW, additional costs may be associated with temporary easements.
Temporary supports (Hard Bid Cost)	SIBC requires temporary supports to construct the new superstructure adjacent to the existing bridge. The cost of temporary supports varies greatly, depending on the existing conditions at the construction site and the temporary support requirements.
Risk / Disincentives (Hard Bid Cost)	The contractor may increase the bid for risk associated with the disincentives for meeting the accelerated closure schedule.
Risk / New Technology (Hard Bid Cost)	The contractor may increase the bid for risk associated with being unfamiliar with the construction process. This may include risk for needing additional labor, equipment, or overtime than what was planned.
Engineering (Hard Bid Cost)	Modifications to the plans are often required to accommodate the contractor's slide scheme. The modifications must be engineered and documented in the plan set.

Table 2-3 compares the actual bid of the I-80; Wanship SIBC project of (two) 87-foot single span interstate sister bridges with an alternative bid of the same project not using SIBC. The bid item, "Bridge Move" captured the bridge sliding system and temporary support costs. The item, "Temporary Retaining Walls" captured the costs of soil nail walls to support the slope cut next to the existing abutments to allow installation of the new abutments under the existing bridge.

The contractor that executed this SIBC project developed alternative bid items that would have been required to construct a crossover on interstate and construct the bridges one at a time while reducing traffic lanes from two in each direction to one in each direction divided by barrier.

**Table 2-3
Bid Cost Comparison Utilizing Phased Construction with Crossovers
for the I-80 Wanship SIBC Project**

Bid Item	Unit of Measure	Qty	Unit Cost	Total	Comments
Removal of SIBC Bid Items					
Bridge Move	Each	-1	\$312,000	-\$312,000	N/A
Temporary Retaining Walls	LS (lump sum)	-1	\$210,000	-\$210,000	Shore Existing Abutment
Subtotal				-\$522,000	
Traditional Construction Bid Items					
Crossovers (Place and Remove)	Each	2	\$172,000	\$344,000	N/A
Additional Mobilization	LS	1	\$5,000	\$5,000	N/A
Additional General Conditions	Month	3	\$23,500	\$70,500	N/A
Additional Traffic Control	Month	3	\$11,000	\$33,000	N/A
Temporary Barrier	LF (linear foot)	4,800	\$13	\$62,400	N/A
Temporary Retaining Walls	LS	1	\$30,000	\$30,000	Temp. Shore at Phase Line
Temporary Striping	LS	1	\$18,000	\$18,000	Temp. Striping, Remove, Replace
Subtotal				\$562,900	
Approximate Savings with SIBC (see details below)				\$40,900	

This example demonstrates that SIBC cost was almost equal to the cost of traditional construction, as the \$40,900 in 'savings' may be lost to permanent abutment and foundation costs that may have been bid higher due to construction under the existing superstructure. In addition, SIBC reduced Construction Engineering and Inspection by three months, lane reductions from two to one lane in each direction, and lane restrictions from six months to two days with one overnight interstate closure. For this project, SIBC created savings for both owner and user alike providing a feasible ABC solution.

2.3 PROJECT DELIVERY

The owner must designate the project as Design-Bid-Build (DBB), Design-Build (DB), or Construction Manager/General Contractor (CM/GC) prior to project delivery. DB and CM/GC project deliveries are very effective for SIBC projects for multiple reasons. These delivery methods allow the contractor and designer to collaborate during the design process and development of details. This collaboration allows the contractors to optimize the bridge type

and slide system based on their experience and skill sets, modify the bridge design as required to accommodate the slide, and assist in development of MOT layout.

Many states are restricted in the use of DB and CM/GC and need to procure projects through the traditional DBB method. SIBC projects have been completed using DBB project delivery. The keys to success for DBB projects are:

- Providing a bridge design and layout with a viable SIBC option
- Maintaining flexibility from the owner and engineer in evaluating alternative details that do not match typical practices but provide equivalent performance
- Producing specifications that clearly define the owner and engineer expectations, design requirements, and submittal obligations
- Preparing to address unforeseen issues as a team through strong partnering and coordination to assure project success

2.3.1 Level of Detail

For an SIBC DBB project, the designer does not know exactly how the contractor will build the bridge and implement the slide. Therefore, there are several options regarding the level of detail to be included in the design documents.

The first option is to provide no details regarding the slide. Design documents can show the bridge as though it was constructed in place. However, the special provisions can permit or require a slide, with the contractor developing all details that relate to the actual slide. This option provides no slide details on which the contractor can bid, it may require that the contractor hire an engineer during the bid phase, and it may result in an increased bid price for the bridge. It transfers the entire risk to the contractor and will most likely require the contractor's engineer to modify design details of the permanent structure to facilitate SIBC.

The second option is to show a viable slide procedure on the design documents using schematic drawings rather than detailed drawings. This option requires the designer to demonstrate that the slide will work, provides the contractor with a potential solution, and provides the contractor with enough information to estimate a bid. However, it also allows the contractor to use a different slide procedure and requires the contractor to develop final design calculations and details for the selected slide procedure.

A third option is to prescribe the only permissible slide procedure and to show all details related to the slide on the contract documents. This option requires the designer to do all design work related to the slide, provides the contractor a detailed procedure on which to bid, and puts all responsibility for detailing the slide on the designer. This option prevents the contractor from using a different procedure and transfers most of the construction means and methods risk to the designer. This method works well with the CM/GC and DB processes where the contractor is part of the design team.

SIBC projects have been successfully implemented using all three of these approaches. The general consensus of the SIBC Technical Working Group implemented in the production of this guide agreed that the second option was probably the best approach for a DBB project. By

providing a viable slide procedure, the engineer addresses most of the details required to slide the bridge and provides the contractor a biddable plan set, only needing engineering support to cost out significant changes. The final modifications to accommodate the contractor's chosen system are often minor when a slide plan is provided with the plan set.

2.3.2 Specifications

The project specifications detail the responsibilities of the owner, designer, and contractor and clearly assign responsibilities regarding design calculations, design drawings, special provisions, and quantities. Section 3.6 further discusses specifications.

2.4 PUBLIC RELATIONS

One of the major advantages of SIBC is the substantial reduction in impacts to the traveling public. Months of lane reductions, crossovers, backed up traffic, and possibly detours are reduced to a week, weekend, or one night of full closure to replace the bridge. Most surveys and public research show that the public prefers the short-term inconvenience of a full weekend closure rather than the long-term inconvenience of partial closures and detours. However, a short-term closure has a significant impact on the public if they are not aware of or planning for its temporary traffic impacts. A key part of making an SIBC project successful is the application of a comprehensive public information (PI) plan.

A comprehensive PI plan allows the public to make alternative plans for the closure period. If there is a short detour route available, the project team can notify and prepare the public for longer travel times during the brief closure period. If the detour route is considerable, the public can plan non-date critical events around the closure period, avoiding travel delays during the bridge slide.

2.4.1 Public Information prior to Finalizing the Construction Schedule

Communication with the community prior to setting the construction schedule and date(s) for the roadway closure is vital. Consider events that draw an excessive amount of traffic, such as large art, cultural, concert, or sporting events that could be impacted by the closure. Plan the closure period around these events.

Another task is to research the traffic counts in the area. Choose a closure night or period that has the least amount of traffic and then, select the detour route and closure period that provides the best level-of-service (LOS).

2.4.2 Comprehensive PI Communication

The PI plan must consider and communicate with all groups that the SIBC project area may affect. The first group to consider is the local traveling public. Contact the local public through local news media outlets, DOT's website, mailed or e-mailed notifications, press releases, and public meetings.

The project team can provide brochures to businesses and organizations along and adjacent to the bridge site. Coordination with regional and national stakeholders, such as the trucking industry, is also necessary if the closure is on the interstate system or a heavily used highway. Circulating project information and potential impacts to these groups allow for alternative travel planning and reduced traffic impacts.

One to two weeks before the closure period, post messages on permanent and portable Variable Message Signs (VMS). This final measure of communication alerts the traveling public near the bridge site daily or frequently of the upcoming closure and traffic detours.

2.4.3 Public Support Benefits

A strong PI plan has additional benefits for the DOT. Comprehensive effort and planning reduce impacts to the traveling public and encourages public support. In order to appreciate project efforts, the public has to be aware of the effort. A strong PI plan not only minimizes traffic during the move, it also advertises the effort the DOT contributes to the project.

Public support can diminish delays to the project schedule and help to move SIBC projects forward. Surveys of the public executed by UDOT show that the public is very supportive and appreciative of efforts to minimize impacts during SIBC and similar ABC projects. As safety permits, invite the public to observe the SIBC process (see Figure 2-2). Coordinate with local businesses and communities to help promote the project. Innovative options could include shopping sales and discounted hotel rooms to correlate with the bridge slide. These efforts encourage the public to become excited about the bridge replacement instead of dreading it.

Figure 2-2
PI Efforts Attracted the Public to the Sellwood SIBC Project, Oregon

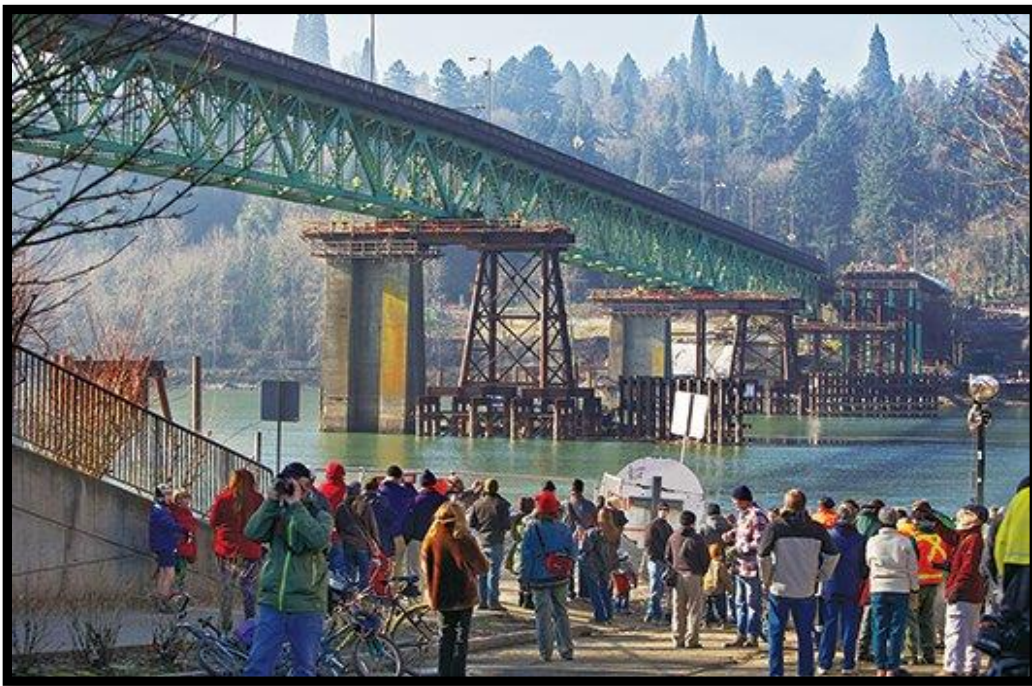

2.5 SELECTION PROCESS

Owners must consider a number of factors during the selection process to determine whether SIBC is a viable option. Table 2-4 presents a series of questions for the owner to consider regarding potential SIBC projects. The more questions an owner can answer, "Yes," the more applicable SIBC may be for that specific bridge.

**Table 2-4
Issues for the Owner to Address When Considering SIBC**

Question	Yes	No	Not Sure
Is there more traffic over the bridge than under the bridge?			
Can the feature crossed accommodate impacts from traditional construction?			
Are mobility impacts and other user costs a significant issue for this bridge construction project?			
Are there safety concerns related to constructing this bridge, such as extended duration impacts, complex traffic shifts, or a limited sight distance approaching the work zone?			
Would a long detour be required for an extended period of time using traditional construction?			
Is this a bridge for which no detour route is available?			
Is a temporary bridge either unfeasible or cost-prohibitive?			
Is the use of phased construction not permitted or not desired for this bridge construction project?			
Is on-site construction time limited for this bridge construction project?			
Is this bridge too narrow to permit safe phased construction on the bridge?			
Can the replacement bridge span be shortened to accommodate new substructures built under the existing structure?			
Are there site conditions or geometric constraints that would preclude traffic shifts or crossovers?			
Are there railroad impacts?			

Chapter 3

DESIGN CONSIDERATIONS

3.1 BRIDGE LAYOUT

SIBC accommodates multiple abutment, span configuration, foundation, and superstructure types. This section discusses recent SIBC experience and successful solutions developed for common highway bridge replacement projects.

The number of spans and length of a bridge impacts the time frame required for bridge replacement using SIBC. If the new bridge is equal to or greater than the length of the existing bridge, it is more difficult to perform substructure work ahead of the bridge demolition. Typically, abutments are installed after the existing bridge is removed. Additional closure time is required to install footings or deep foundations, abutment seats and wingwalls, bents (if required), and connections to the temporary supports to prepare for the move. Alternatively, foundations and abutments can be placed ahead of time during night closures and covered with fill or steel plates each day to allow traffic to resume.

Prefabricated Bridge Element Systems (PBES) for the abutment are an effective way to combine multiple ABC methods to accelerate bridge replacement (see Figure 3-1). Once the existing bridge is removed, drive the piles, place the precast abutment and wingwall pieces over the piles, and grout into place. A similar approach can be used with a bent. Then make connections to the temporary supports for SIBC to proceed. Additional innovations such as using off-peak lane closures to drive piling ahead of the full closure and demolition further accelerates the closure period.

Figure 3-1
Precast Abutment Installation



When the new bridge has a shorter span than the existing bridge, new abutments can be constructed under the existing bridge while it remains in service. This approach accelerates the overall project schedule since the superstructure and substructure are constructed simultaneously and reduces the required closure period since the new abutments are ready as soon as the existing bridge is demolished.

Converting common three-span interstate overpass bridges with fill slopes up to stub abutments into new single-span bridges is an ideal application of this method (see Figure 3-2 and Figure 3-3). Install temporary or permanent soil nail walls to retain the excavation around the existing bridge foundation. Construct the new abutments under the existing bridge in the fill slope area while the existing bridge remains in service. Then replace the three-span structure with a single-span structure using newer, more efficient girder shapes, higher strength materials, and an overall shorter bridge length to maintain the vertical clearance. There are challenges associated with construction of the abutment foundation under the existing bridge, which are discussed in Section 3.1.2.

Figure 3-2
Three-Span Overpass Bridge Converted to a Single-Span
on the I-80 Echo Road Bridge Project (Before)



Figure 3-3
Three-Span Overpass Bridge Converted to a Single-Span
on the I-80 Echo Road Bridge Project (After)



3.1.1 Abutment Types

3.1.1.1 Semi-Integral Abutments

Semi-integral abutments accommodate SIBC well. The solid end diaphragm provides a large, rigid member to jack up the bridge and mount the various sliding systems. The continuous diaphragm allows rollers or sliding shoes (Section 4.1) anywhere along the abutment (not just underneath the girders). The simple abutment seat accommodates construction under the existing bridge or streamlines precast abutment sections.

After the bridge is slid into place, remove the slide system and set the abutment diaphragm on the permanent bearings. Cover the gap between the seat and diaphragm for waterproofing and place the approach slab and/or roadway fill up against the end diaphragm. Figure 3-4 illustrates a typical semi-integral abutment detail.

Figure 3-4
Typical Semi-integral Abutment Detail

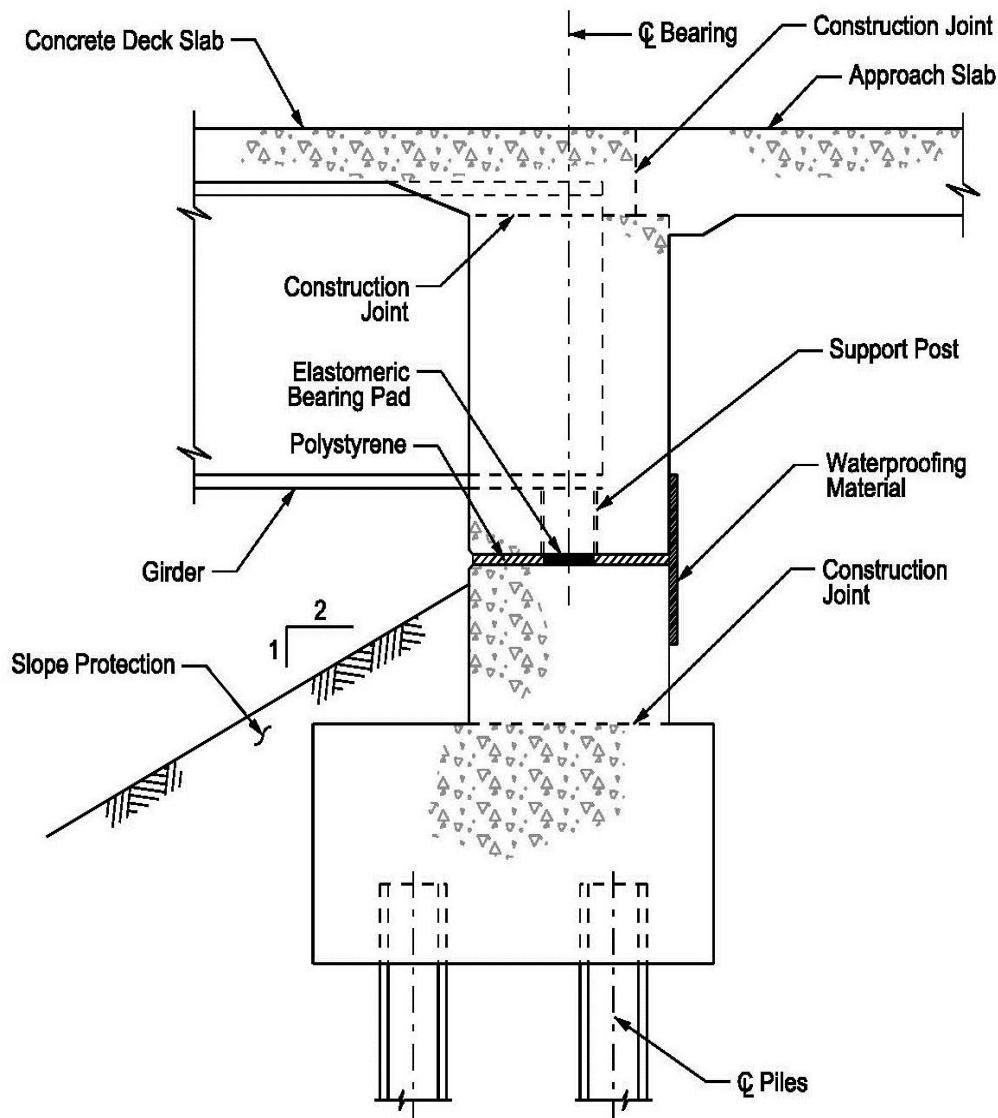

The performance of semi-integral abutments is the same as if installed in traditional bridge construction. Typical performance concerns include service life of the material covering the gap between the seat and diaphragm and service life of bearings, regardless of the construction method. Limit transverse movement with shear keys on the abutment seat or with wingwalls cast after the bridge move is complete. The rigid end diaphragm provides excellent engagement of the backfill behind the abutment to resist longitudinal seismic forces. Additional restraints, such as seismic bolsters, on the girders to engage the abutment and limit longitudinal movement are also viable.

3.1.1.2 Integral Abutments

Integral abutments are very effective for short span highway bridges. However, integral abutments involve additional closure time to place reinforcement and place and cure concrete or grout to connect the abutment diaphragm to the abutment seat after the bridge slide. The details required to make abutments integral are complex and more costly than semi-integral abutments.

3.1.1.3 Seat-Type Abutments

Traditional seat-type abutments provide many of the same advantages of the semi-integral abutments for sliding. However, the top of the back wall elevation is required to be at the same grade as the roadway, which prohibits fully constructing this abutment type under the existing bridge. Also, the presence of back walls on each abutment creates fixed obstructions at both ends of the bridge and requires tighter tolerances to slide the bridge between them.

3.1.1.4 Geosynthetic Reinforced Soil (GRS)

Geosynthetic Reinforced Soil (GRS) abutments are a relatively new type of system. GRS uses closely spaced (i.e., less than 12 inches) alternating layers of compacted granular fill material and geosynthetic reinforcement constructed behind facing elements. A GRS abutment consists of three main components – the reinforced soil foundation, abutment, and integrated approach. GRS is also used to construct the integrated approach to transition from the approaches to the superstructure. This bridge system therefore alleviates the “bump at the bridge” issue caused by differential settlement between bridge abutments and approach roadways. Figure 3-5 illustrates a typical GRS abutment detail, and Figure 3-6 displays a GRS system implemented in an SIBC project.

GRS is a fast, cost-effective method of bridge support that blends the roadway into the superstructure to create a jointless interface between the bridge and the approach. It also eliminates the need for concrete or grout cure time since there is no abutment seat or foundation connection. GRS has been employed successfully on an SIBC project in Utah that converted a three-span bridge into a shorter single-span bridge. The new superstructure was used as a temporary bridge adjacent to the existing bridge while the existing bridge was removed and GRS abutments were constructed. Then the new bridge was slid into place onto the new GRS abutments.

Figure 3-5
Typical Geosynthetic Reinforced Soil (GRS) Abutment Detail

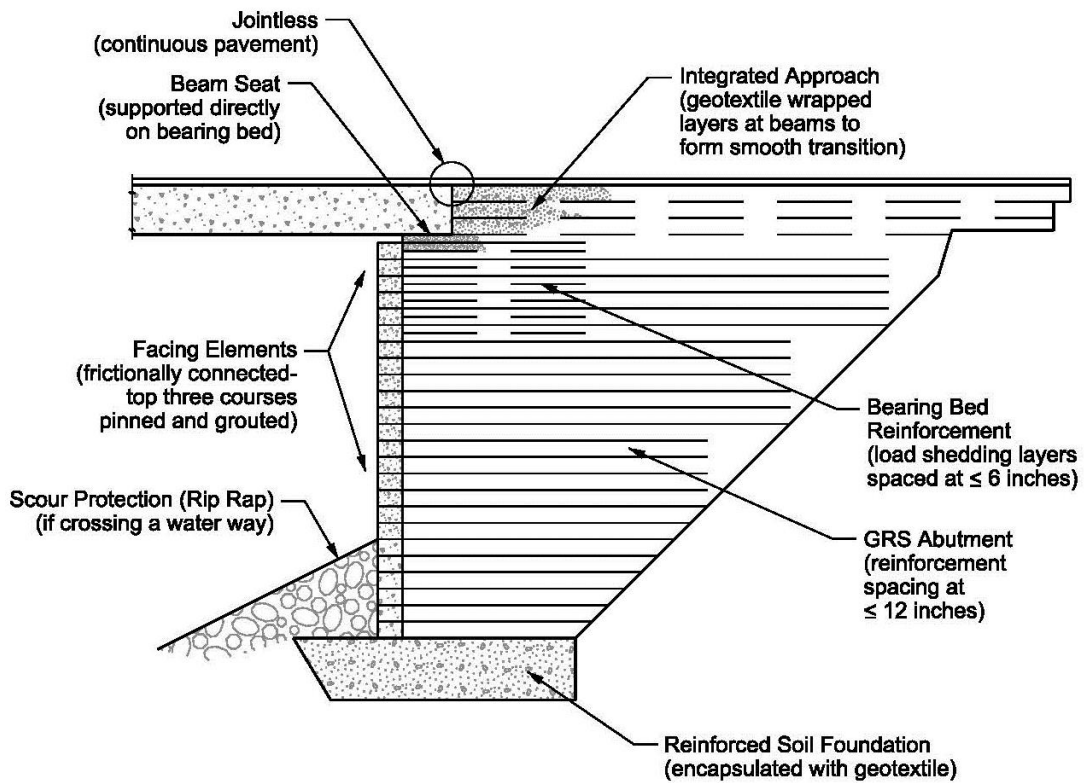

Figure 3-6
GRS System for the I-84 Echo SIBC Project, Utah



3.1.2 Foundation Solutions

For SIBC projects, designing the new bridge with a shorter span length than the existing bridge enables the new abutments to be constructed underneath the existing bridge prior to its demolition (see Figure 3-7). The fill must be excavated and retained against the existing abutment using permanent or temporary means such as soil nails. Installing the substructure under the existing bridge creates challenges for foundation installation.

Figure 3-7
New Abutment Constructed under Existing Structure for the I-80; 2300 E. Bridge Slide, Utah



Spread footings are the simplest and most cost effective foundation alternative when soil conditions permit. Spread footings do not require excessive headroom during construction, and performance is the same as a traditional construction project.

When deep foundations are required, traditional piles cannot be driven under the existing bridge due to limited vertical clearance. One solution is micropiles. A micropile is a small diameter pile (typically less than 12 inches) that is drilled and grouted (see Figure 3-8). Micropiles can be used in areas with low headroom due to their smaller size and segmental installation, which allow the use of smaller equipment. Micropiles typically require about 10 to 12 feet of headroom. A new abutment or bent with micropiles constructed near an existing foundation must avoid conflicts with any existing battered piles.

Figure 3-8
Typical Micropile Detail

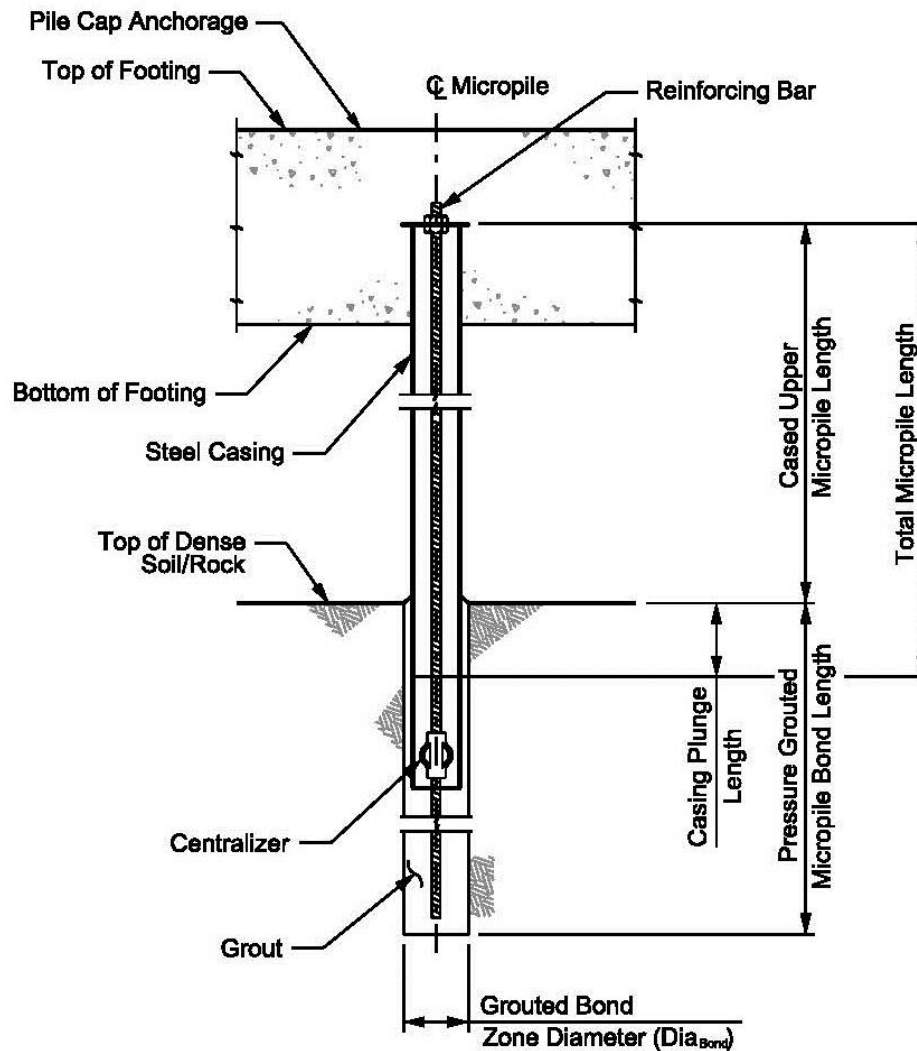

Another solution is the use of a straddle abutment or bent. A straddle abutment uses a pile group or drilled shaft installed outside of the existing bridge footprint on both ends. A straddle bent uses the same concept to install foundations outside the existing bridge footprint. The abutment or bent is designed to span between the two foundations. Straddle abutments eliminate the installation and cost of micropiles, but can increase material costs to accommodate the abutment seat span. The span of the straddle abutment is a function of the width of the existing bridge and skew. Straddle abutments are most effective on narrow bridges and minimal skews to minimize the design span. Figure 3-9 shows a straddle abutment for twin bridges. In this scenario, the spanning element is continuous across the median to reduce initial quantities and permit future widening.

When using a straddle system, consider deflection of the spanning element (seat) during the slide and in the final configuration. Excessive deflections of the seat can cause sliding supports on the end diaphragm to lose contact with the abutment seat and require the end diaphragm to

span between the two adjacent sliding supports that still have contact. One solution to this is to design the end diaphragm to span over one slide support that loses contact. Another solution is to design the end diaphragm stiffness to allow flexibility and redistribution of the loads as the seat deflects. Deflection of the spanning element can be mitigated using deep beam design and configuration of the piles in the pile groups to minimize end rotation at the pile caps. Self-weight deflection can be mitigated using post-tensioning.

Figure 3-9
Straddle Abutment on the I-80 Echo Road Bridge Project, Utah



Final loads and deflections are controlled by locating the bearing points to minimize the load to the center of the abutment beam. With a continuous end diaphragm, the bearing points do not need to be under each girder. Avoiding bearing points in the center of the abutment beam can minimize permanent moment loads and deflections. Also, evaluate the effect of the moment transferred to the pile groups and the abutment loads and deflection between the pile groups in the lateral direction.

An additional solution for deep foundations is to core through the existing deck and drive the piles through the hole in the deck. This method allows for typical pile arrangements and minimizes quantities. The primary concerns are traffic control with additional impacts to traffic, covering or patching of the core hole, and the potential to damage existing girders.

3.1.3 Re-use of Existing Substructure

Another alternative is to re-use the existing substructures for SIBC projects (see Figure 3-10). This method is cost effective and is especially applicable in climates that afford long-term service life of the existing substructures, as well as in low seismic areas.

When using this method, it is especially important to obtain a detailed and accurate survey of the existing substructure rather than relying on as-built drawings. 3D or LiDAR has been used to obtain extensive detail of existing bridges. Give special attention to the conditions that cannot be seen until after the demolition of the existing superstructure.

In addition, the engineer must ensure that the existing abutments will work with the selected slide system and the new superstructure configuration. Adjust any existing pedestals or beam seats to match the required elevations for the slide and new superstructure.

Figure 3-10
SIBC Using Existing Substructure on the I-44 Gasconade River Bridge Project, Missouri



3.1.4 Superstructure

Virtually any superstructure and girder type can be used for an SIBC project. Concrete and steel girder bridges have both been used for many SIBC applications. Steel girder bridges are generally lighter than concrete girder bridges. However, as long as the engineer accounts for the superstructure weight during the design of the slide system, there are no significant disadvantages to sliding a concrete girder bridge. The force required to move a bridge is simply

the superstructure weight multiplied by the coefficient of friction. Therefore, a heavier superstructure requires a larger sliding system to provide more force and support heavier loads on the sliding apparatus. Recent project experience has shown the greatest advantage to a lighter superstructure is reducing the foundation loads to minimize the substructure challenges discussed in the previous sections.

3.2 SIBC LOADS ON PERMANENT BRIDGE

Common concerns with SIBC are that moving a bridge will cause stresses, cracking, and reduction in the bridge's service life when compared to traditional in-place construction. In general, loads from the SIBC process are similar to normal service life loads.

The main source of nonstandard bridge loading and stresses are associated with deflections in the abutment seat, end diaphragm, or deck due to variations in support elevations or jacking the end diaphragm to insert or remove sliding equipment. Many of these stresses are similar to what a normal bridge would experience during bearing replacement.

Design the slide system and superstructure elements to accommodate variations in support elevations during the slide. This includes adding stiffness to the elements to minimize deflections and strength to span slide supports that lose contact due to deflections. It also includes designing to accommodate the deflections and redistribution of stresses when elements encounter elevation differences. Design any components of the bridge that may see tension forces due to these loadings to meet crack control rebar stress requirements using Strength I (STR I) loading and the appropriate crack control exposure factor.

3.3 DESIGN OF TEMPORARY WORKS AND SLIDE SYSTEM

The design and layout of the temporary works usually lie within the contractor's responsibilities on a traditional DBB delivery. The contractor must employ a qualified engineer to provide the required engineered and stamped calculations and drawings per the specifications. Using DB or CM/GC delivery allows the engineer to also design the temporary works and slide system along with assuring the bridge design is detailed to accommodate the slide. Calculate design loads for temporary supports according to the AASHTO Guide Specifications for Bridge Temporary Works. When the bridge is used as a bypass in its temporary location, the temporary substructure will support the bridge with live traffic. Design the temporary substructure according to the current AASHTO Load and Resistance Factor Design (LRFD) Bridge Specifications as indicated for temporary bridges. Coordinate with the owner to determine if extreme event loading checks are required.

3.3.1 Design Considerations

Types of bridge slide systems are discussed in more detail in Chapter 4. In general, bridges are slid on either industrial roller supports or lubricated Teflon coated bearing pads. The lateral force required to move the bridge is a calculation of the structure weight times the coefficient of friction. The kinetic coefficient of friction during the slide can be as low as 1% to 2%. The static

coefficient to start the slide can be significantly higher – in the range of 5% to 15%. Rollers usually provide a consistent and lower static coefficient. Lubricated Teflon pad static coefficients vary depending on how they are implemented. If lubricated Teflon pads are placed under the bridge shortly before the slide, the coefficient will be in the lower range. If the bridge is constructed on the Teflon pads (i.e., the bridge has been sitting on the pads for two to three months), the lubrication will ‘press’ out of the voids over that time frame, and the static coefficient will be in the upper range requiring significantly more force to break the bridge free when starting the slide. Unit loading on Teflon also affects its coefficient of friction.

Sliding forces must also account for real world conditions. Abnormalities in the sliding surface or overstressed Teflon in used bearing pads can cause tearing of the Teflon. Debris in the slide track or path can cause resistance to the rollers. Binding of the bridge rollers or slide system due to one end diaphragm getting ahead of the other can cause increased forces. Horizontal forces of 10% to 20% of the vertical loading have been used. Project specific details may require a higher design load.

The temporary supports and slide system work in conjunction with the permanent substructure to slide the bridge into place. Defining the load path for the sliding forces is an important first step when designing the temporary supports. The bridge is ‘pushed’ into place with a system that anchors itself and pushes from the temporary supports, or is ‘pulled’ into place from a system anchored on the permanent substructure or anchored independently.

When a hydraulic jack is used to push the bridge into place, the push jack anchors itself to a slide track on the temporary support to push the bridge into place. Usually, the slide track and temporary supports are connected to the permanent substructure to transfer this force through the permanent substructure. Figure 3-11 shows an example of this connection.

Figure 3-11
Temporary Support to Permanent Substructure Connection

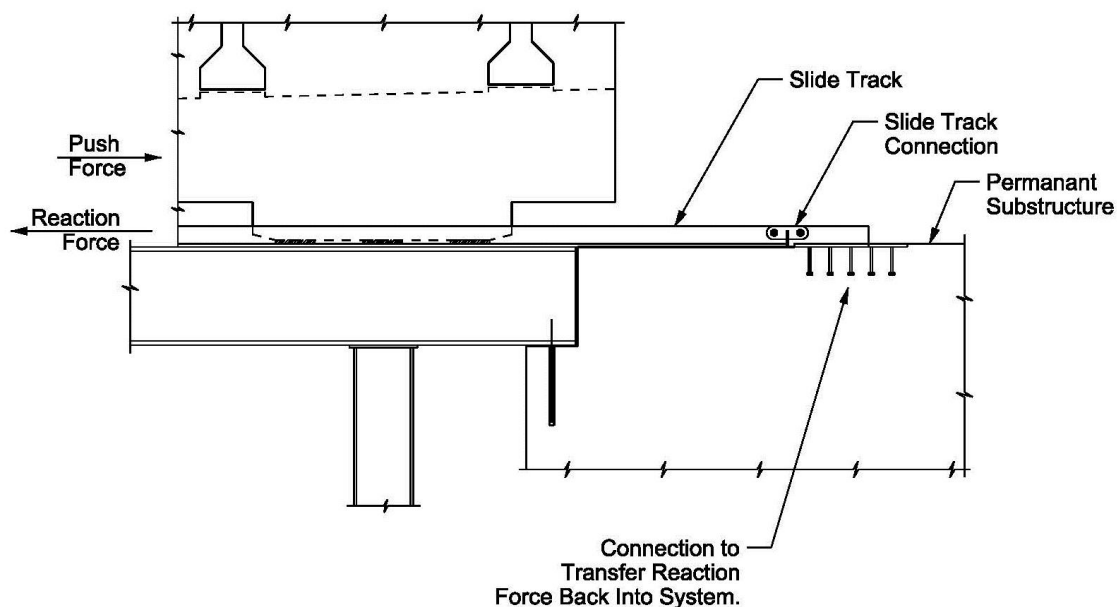

Design this connection for the expected tension and shear forces. Consider transverse forces that may occur if the slide shoes begin to exert transverse forces on the slide track due to rotation of the bridge system caused by non-uniform move distances of the abutments.

Design the connection between the temporary support and permanent substructure to avoid differential deflection. As the bridge moves across this interface, a very large point load can develop just before crossing from the temporary support to permanent substructure. Even a small deflection can cause problems with the slide, especially if rollers are being used. One solution that has been used is to seat the end of the temporary support into the permanent substructure as shown in Figure 3-11. This figure shows a connection from a steel temporary structure to a concrete abutment seat. In this example, the temporary support beam bears on the permanent substructure and has reinforcing dowels to control the transverse movement/forces. The slide track connection in the abutment seat provides a connection between the slide track and permanent abutment to transfer the load through the system.

Design the temporary supports for applicable construction loading. If the bridge is lifted to install or remove sliding equipment, design the supports to account for where the jacks are placed relative to the column locations and centerline of the temporary supports. Account for eccentric and point loads in the design. The engineer must also design the temporary supports for bearing loads from the bridge as they move across the temporary support. The loads will act along multiple positions as the bridge slides into place.

3.3.2 Temporary Works Materials and Foundations

Temporary supports have been constructed using various materials such as steel I-beams or pipes creating rigid frames, falsework frames, and concrete beam seats constructed on fill. Materials are selected based on cost and availability of material, the contractor's preference, and what works best with the selected slide system. Temporary supports are usually connected to the permanent substructures to transfer forces and for stability. They must be able to support construction loads, lateral loads, and provide a safe support system for bridge work.

Temporary support foundations depend on the soil conditions. Owners should provide geotechnical borings in the areas of anticipated temporary supports to assist the contractor in bidding the temporary supports. Driven piles extending as columns up to the support beam have been used successfully on multiple SIBC projects (see Figure 3-12). This configuration minimizes settlement and provides lateral resistance at the base of the columns. Calculate expected settlement and deflection of the system when the full bridge load is applied to determine the elevation to initially set the temporary support. Design the final system to provide elevation differences no greater than the differentials for which they are designed as discussed in Section 3.2.

Figure 3-12
Temporary Support Using Driven Piles on the I-80 Atkinson Bridge Project, Utah

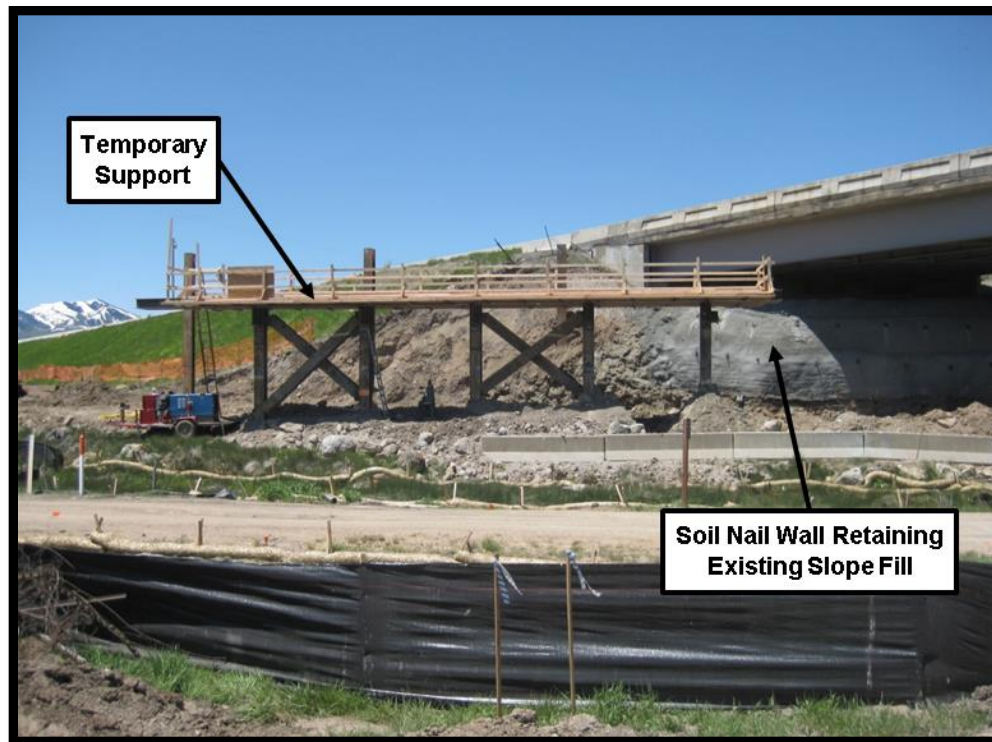

3.4 BRIDGE TO ROADWAY CONNECTION

3.4.1 Approach Slab

There are multiple methods to install approach slabs with SIBC. These include cast-in-place installation, precast approach slab panels, eliminating the approach slabs if the bridge span and state standards allow (or by using a GRS abutment), or sliding the approach slab into place with the bridge. Cast-in-place and precast approach slabs both require additional time to install after the bridge slide.

Sliding the approach slab with the bridge allows for cast-in-place construction of the approach slab using traditional detailing and fast installation of the approach slab to accommodate an overnight closure. This method leaves a gap from under the approach slab to approximately the top of the abutment seat and requires the approach slab to be designed to fully span from the bridge to the end seat on the sleeper slab. The bridge can be opened to traffic before this area is backfilled.

After the bridge is slid into place and the waterproofing membrane is installed on the backside between the abutment seat and end diaphragm, this gap area is backfilled. Backfill options include normal structural fill, self-consolidating material (i.e., graded rock or gravel), geofam, and flowable concrete fill (flowfill). It is not possible to place fill to completely fill the void underneath the approach slab. A solution is to install flowfill during the final lift using pumps and

hoses to bring the fill directly up against the bottom of the approach slabs. Even with this approach, gaps may remain. In addition, shrinkage of flowfill or settlement may leave gaps. The potential lack of support requires the approach slab to span from the abutment to the end approach slab support.

3.4.2 Sleeper Slab

State DOTs determine if sleeper slabs are required. The sleeper slab is either a beam or inverted “T” shape that supports the end of the approach slab (see Figure 3-13). The stem wall, or inverted “T,” provides a concrete-to-concrete interface for joint installation between the stem wall and approach slab and allows asphalt pavement installation up to the backside of the stem wall. When using the method of sliding the approach slab in with the bridge, the sleeper slab provides a level surface for the approach slab to slide on when it is moved with the bridge.

Figure 3-13
Inverted “T” Precast Sleeper Slab on the I-80 Echo Road Bridge Project, Utah



Once the roadway is closed, the area for the sleeper slab must be prepared. If the new sleeper slab is behind the existing bridge abutment, demolition of the existing approach slab and/or excavation of the existing roadway will be required to install the sleeper slab. If the new sleeper slab is in front of the existing abutment in the slope fill area, installation and compaction of fill material may be required to set the sleeper slab.

Sliding the approach slab on a sleeper slab with the bridge is most often used when a very short (one to three days) closure time is required. In these cases, the sleeper slabs are precast to allow quick installation after the roadway closure. Design precast sleeper slabs with lengths that can be lifted and installed with a backhoe or rubber tire crane. Recent SIBC projects have limited the length to 20 to 30 feet and approximately 15 to 20 tons. The section lengths must also accommodate the partial bridge slide distances if a phased slide approach is used as

discussed in Section 4.2.1. Connecting the sections of sleeper slabs has potential advantages and disadvantages. Some perceive that connecting them with rebar and grout after installation will help prevent differential settlement and gaps or elevation differences forming at the joints. The other view is that the gaps and elevation differences will be minimal. The internal forces that would cause these gaps would not be resisted by grout and rebar and would essentially fail the concrete and 'pop' the bar out, causing maintenance issues.

Provide a minimum of ½-inch extra top clear cover to reinforcement on the approach slab and sleeper slab stem. This extra clearance allows for concrete grinding to smooth the approach slab to sleeper slab stem transition if the elevations do not match as designed. Also, provide a slope on top of the sleeper slab stem to match the roadway slope.

Using the inverted "T" sleeper slab vs. a flat beam provides both advantages and disadvantages. The inverted "T" allows roadway backfill to be placed and compacted while the bridge is being moved into place, providing a shorter closure period. However, the stem also creates constraints on both ends of the approach slabs. This method makes accurate installation of the sleeper slabs very important since installing them too close would result in the approach slabs running into the stems. Recent SIBC projects have designed for a minimum 2-inch to 2.5-inch gap between the approach slab and sleeper slab stem to provide enough tolerance to slide the bridge into place.

3.4.3 Joints

Minimizing the duration of bridge closure is a primary goal for SIBC projects. The required speed of the joint installation depends on the bridge closure requirements established for the project. When the method of sliding the approach slab with the bridge on a precast sleeper slab is used, the gap between the end of approach slab and stem of the sleeper slab will most likely vary slightly in width. Specify a joint that accommodates a variable opening width.

One example of a joint that accommodates variable widths is the traditional foam backer rod with silicone joint. This joint facilitates quick installation and accommodates a variable gap width. Installation must be done on properly cleaned and prepared surfaces using the correct thickness of silicone to maximize the service life of this joint. If the roadway is closed for a longer period of time, joint options such as compression seals and strip seals could be used.

3.4.4 Backfill

Proper backfill and compaction of soils under and near the sleeper slab is essential to a successful SIBC project. If backfill or compaction is not completed properly, localized settlement can occur, which will create a bump at the roadway to approach slab resulting in poor ride quality.

3.4.5 Roadway Tie-in Design

Pavement overlays, camber left in the bridge, and deflections that were over-estimated or under-estimated will cause bridge site-specific anomalies in the profile. It is important that the

bridge profile and the roadway tie-in be designed based on accurate survey data of the roadway and bridge rather than the as-built drawings.

Design the roadway tie-in geometry considering the length of roadway reconstruction or grinding. For example, trying to fit a large idealized vertical curve over the bridge area may not provide elevations that tie-in well at specific locations of approach slab or abutment ends. Consider how much adjustment the contractor must make in the roadway, and tie profiles directly into fixed elevations at the end of the grinding or reconstruction limits.

3.4.6 Parapet Barrier Connections

After the slide is completed, connect the parapet on the bridge with the guardrail on the adjoining roadways. The engineer must plan this detail to be as simple as possible so it can be completed quickly. Precast transition pieces can be used to connect the bridge parapet with the roadway guardrail after the bridge is in place.

If a permanent guardrail connection cannot be completed quickly, a temporary barrier protection can be provided so the bridge can be opened to traffic before all final guardrail tie-ins are completed. A temporary barrier can be set in front of the transition, such that traffic can be opened with a reduced shoulder.

3.5 TOLERANCES

The engineer must work with the owner to define acceptable tolerances. Restrictive, unrealistic requirements drive up the project costs. However, if the tolerances are not restrictive enough, the final product may not meet expectations.

3.5.1 Construction Tolerances

An important component to a successful SIBC project is for the contractor to perform frequent, routine quality control (QC) survey checks before proceeding to the next stage. Include scheduled QC checks and reporting requirements in the project specifications. Suggested survey requirements include the top of temporary supports prior to end diaphragm and girder construction, the top of girders prior to deck placement, the top of the deck prior to finalizing the approach slab forming and end elevation, and the approach slab end elevation and final precast sleeper slab dimensions prior to setting the bottom of the sleeper slab grade. At each of these stages, adjustments can be made to the next stage to counteract errors or accumulations of field tolerances.

Horizontal control and tolerances are also very important. Final survey of the centerline of bearing is important prior to the slide to set the precast sleeper slab at the proper bearing (if used). Projecting these as-built conditions and comparing them to the bearings and skews in the plans is important in identifying potential issues that require additional research prior to roadway shutdown and sliding. Items such as a minimum gap between the approach slab and sleeper slab stem (as suggested in Section 3.4.2) provide additional tolerance during the move.

3.5.2 Final Tolerances

The final tolerances for an SIBC project should not be more restrictive than the final tolerances for a traditional construction project. Establishing tighter final tolerances for an SIBC project is not necessary, and it can be counter-productive. Unnecessarily restrictive final tolerances can increase the bid price and increase the duration of a bridge closure, both of which are not in the interest of the owner or the traveling public. As a general principle, there is not much difference between the tolerances needed for an SIBC project and the tolerances required for traditional construction.

3.6 SPECIFICATION DEVELOPMENT

The specifications must clearly define the goals, limitations, and requirements of the SIBC. The engineer must clearly define in the project specifications what is expected of the contractor during the construction process in terms of design, submittals, and project execution.

The specifications should answer the following questions:

- Is SIBC required on this project? Can the contractor use any method to meet a performance specification or is SIBC required per a prescriptive specification?
- What are the requirements for calculations and drawings associated with the slide details and temporary supports?
- What are the shop drawing submittal requirements?
- How much flexibility does the contractor have in developing the slide details?
- How much flexibility does the contractor have in developing the details for the temporary supports?
- What are the tolerance requirements for the contractor?
- What are the bridge closure duration requirements? Are there any specific days or times that are permitted or not permitted?
- Are there any incentives or disincentives?
- What limitations are being placed on the contractor? What is the contractor not allowed to change?
- Define a process allowing the contractor to request revisions to any of the above questions.

The specifications provide guidelines and limitations for how far the contractor can deviate from the project documents. Specific owner requirements must be defined. Additional information about special provisions and submittal requirements is provided in Section 4.3.

Chapter 4

CONSTRUCTION CONSIDERATIONS

4.1 TYPES OF SLIDE SYSTEMS

This section discusses methods that have been used historically and recently for SIBC projects. Example plan sets and shop drawings of some of these methods are also included in the Appendix C.

There is not always an “appropriate” or “better” system for each SIBC bridge move. Geometry, weight, tolerances, and ultimately contractor experience and preference contribute to the decision. Each of the following examples of SIBC slide systems presents advantages and challenges.

4.1.1 Industrial Rollers

Industrial rollers are simple in concept. Construct the bridge on temporary supports and prepare the new or rehabilitated permanent substructure, then place industrial rollers under the girders or end diaphragm of the new bridge. Roll the new bridge into place using a push/pull system. Figure 4-1 demonstrates the SIBC system using industrial rollers.

Figure 4-1
Industrial Rollers Used during SIBC



Advantages:

- Concept is simple and system is inexpensive
- Industrial rollers are readily available to purchase or rent
- Rollers move with the new bridge and can be used with or without a continuous end diaphragm

Challenges:

- Large point load occurs under each roller
- Roller path must be clean and clear
- Binding or jamming of rollers may occur if not aligned properly
- Transitions from temporary supports to permanent substructures must be smooth
- Sliding system needs the ability to start and stop the bridge from rolling since rollers have a low dynamic coefficient of friction
- Rollers typically allow for movement in only one direction and do not allow for final adjustments perpendicular to the movement of the bridge

Solutions:

- Apply elastomeric pads between the rollers and girders or end diaphragm to act as “shocks,” which distribute the load to the rollers over uneven surfaces
- Carefully survey and construct rolling surfaces to confirm roller path is free from debris and inconsistencies
- Build strong, smooth, and flush connections between temporary supports and permanent substructures to avoid drops/bumps and assist longitudinal movement

4.1.2 Teflon Pads

The Teflon pad method uses elastomeric or cotton duck bearing pads topped with Teflon to slide the bridge into place (see Figure 4-2, Figure 4-3, and Figure 4-4). There are multiple ways to employ Teflon pads. One is to line the pads along the temporary supports and permanent substructures. The pads remain stationary, and the bottom of the bridge diaphragm becomes the sliding surface. Slide shoes or sliding blocks can be cast into the end diaphragm and wrapped with a sliding surface such as stainless steel. Then slide the bridge along these pads, distributing loads from the shoe to multiple pads at any time. With this method, the final sliding pads on which the bridge stops can be left in place to act as the final bearings for a semi-integral abutment design (see Section 3.1.1 for abutment types).

The Teflon pads can also be part of a prefabricated slide system. Several heavy lifter contractors have prefabricated systems that use a track and an integrated hydraulic cylinder system (see Section 4.1.3) that pushes the bridge on the Teflon pads in the track system from the temporary supports to its final location. The track system can push the bridge on its end diaphragm (Figure 4-2) or on sliding shoes with jacks (Figure 4-3) to allow vertical lifting and lowering of the bridge also.

Figure 4-2
Concrete End Diaphragm on Teflon Pads in Sliding Track System

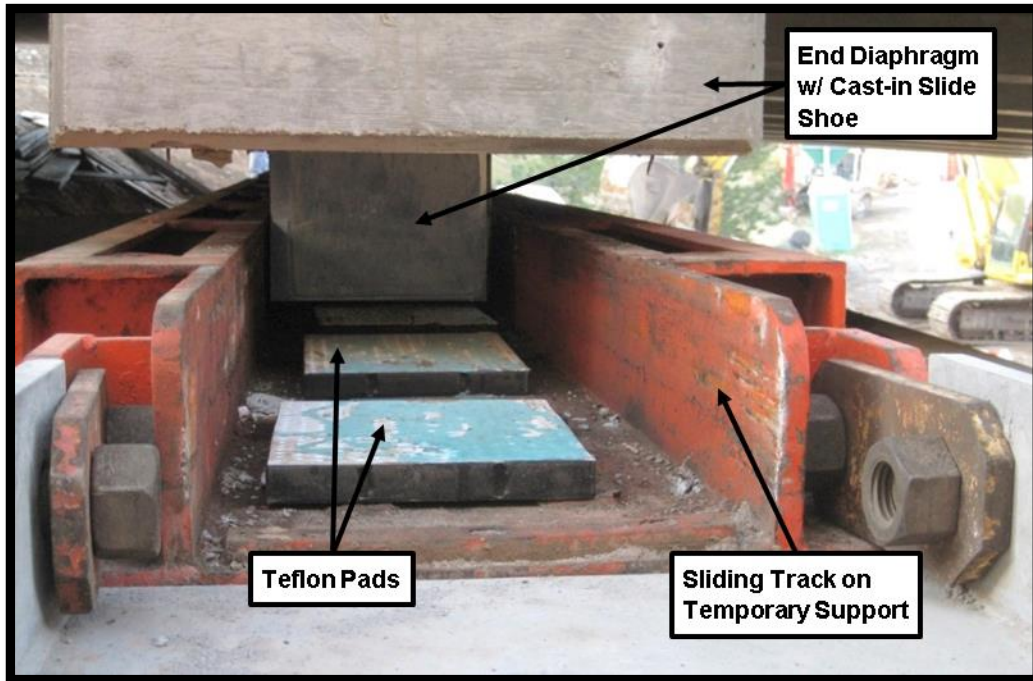

Figure 4-3
Slide Shoes Used with Vertical Jacks



Figure 4-4
Teflon Pads with Stainless Steel Wrapped Shoes on End Diaphragm



Advantages:

- System is relatively inexpensive
- Contractor can slide the bridge with the right equipment for Teflon pads or subcontract to a heavy lifter with a prefabricated system
- Teflon pads allow for transverse and longitudinal movement providing some ability to “steer” the bridge to its final location

Challenges:

- Pads can bind at the slide interface either tearing/damaging the pad or causing the pad to slide along with the bridge
- Bridge can drift in the transverse direction if forces are loaded unevenly or if abutments have a downhill slope

Solutions:

- Lubricate the top side of the pad surface with dish soap or similar substance
- Provide a roughened surface on the bottom side to resist movement of the pads
- Keep additional Teflon pads on-site
- Provide guides for the bridge to resist drifting (see Figure 4-2)

4.1.3 Hydraulic Jack

The hydraulic jack system consists of a hydraulic jack that pushes the bridge into place (see Figure 4-5). There is usually one jack per abutment or bent. Jacks are usually instituted along

with Teflon pads and a sliding track system to provide an anchor to push against and guide the bridge to its final alignment. To execute the slide, the jacks extend to full stroke to push the bridge forward while anchoring against the slide tracks or temporary supports. Then the jacks retract and pull back towards the bridge, reset the anchoring, and push the bridge forward again.

Advantages:

- Bridge moves smoothly
- Ability to sync jacks together while pushing evenly, or run jacks independently to adjust the bridge position
- Some jacks can pull the bridge backwards (with the correct anchoring) to make location adjustments
- Ability to measure/observe hydraulic pressures to know if jacks are exceeding expected force to determine obstructions or impedances

Challenges:

- Bridge movement is slower/non-continuous with the jack resetting each time
- Risk of slide system malfunction is possible with multiple hydraulic pumps, motors, hoses, and controls
- Coordination of separate mechanical systems is required at each push location

Solutions:

- Create equipment checks, contingency plans, and communication protocol between both abutments and the jack operator

Figure 4-5
Hydraulic Jack System Produces Smooth Bridge Movement

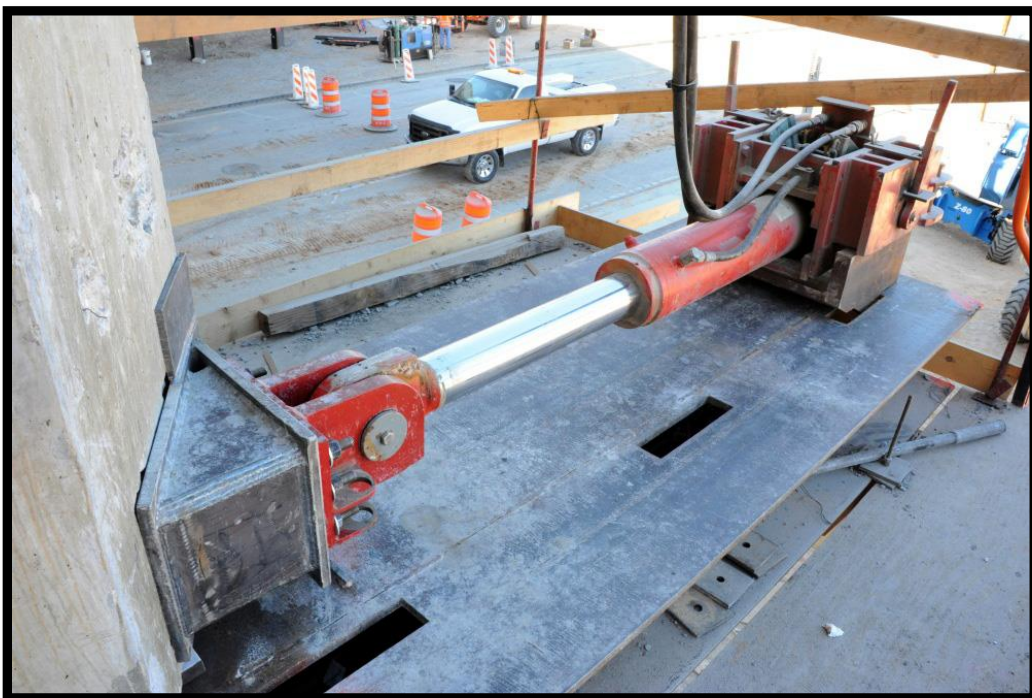

4.1.4 Winches / Mechanical Pulling Devices

Using a mechanical pulling device such as a winch or crane can pull the bridge along rollers or Teflon pads to its final position (see Figure 4-6). Separate pulling devices can be used at each pulling location (i.e., each abutment), or a system of pulleys can be used to allow one mechanical pulling device to pull simultaneously on multiple points.

Figure 4-6
Winch System Used to Slide a Bridge over a River



Advantages:

- Contractor can implement this simple device without the cost of a proprietary prefabricated slide system
- If using one pulling device with a pulley system, the bridge is uniformly moved on all pull points

Challenges:

- No ability to “back up” the bridge without a separate pull system set up on the opposite side of the structure
- Limited ability to control forward motion as cables only work with tension

Challenges (Cont.):

- System requires an independent anchoring point, such as a mount for the winch or crane, which can require additional room that may not be available on the site
- Limited ability to “steer” the bridge to its final location
- Differences between static and dynamic friction, combined with cable flexibility, can cause a jerky movement

Solutions:

- Set-up a separate pull system on the back side of the bridge to back up
- Move the bridge slowly, particularly when using rollers, to reduce the challenge of stopping the bridge slide
- Use stops and guides on the abutment to decrease forward momentum and drifting during the slide
- Install winch mounts to the permanent substructure or a crane dead man to anchor the pull system

4.1.5 Post-tensioned (PT) Jacks

Post-tensioned (PT) jacks are small jacks used to pull a PT strand or threaded high-strength bar (see Figure 4-7). Use these jacks to pull an anchored PT strand or bars and push the bridge into place on rollers or Teflon pads.

Figure 4-7
PT Jacks on Threaded High-Strength Bars Push Bridge into Place

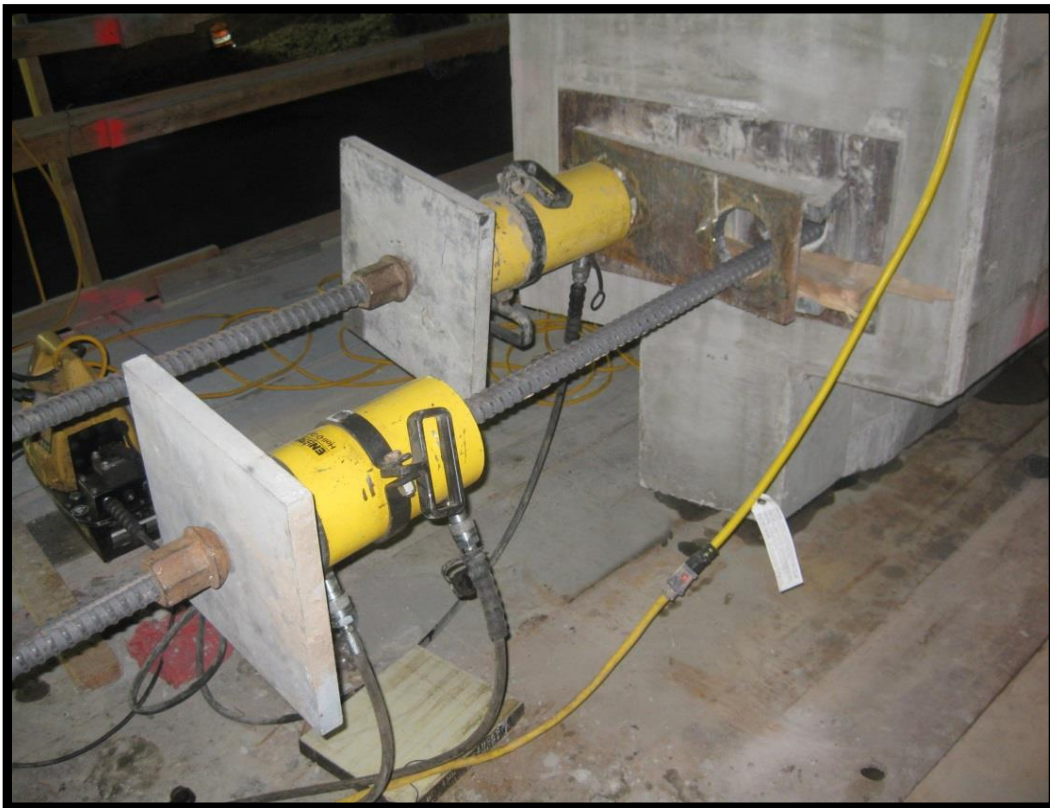

Advantages:

- Contractor can implement this simple system without the cost of a proprietary prefabricated slide system
- One jack can be used at each pull point to “steer” the bridge

Challenges:

- Requires abutment/end diaphragm designs that allow anchoring of the PT strands/bar and transfer from a pulling force on the strand to a pushing force on the bridge
- Using a PT jack at each push point requires coordination to maintain a straight push
- No ability to “back up” the bridge without a separate pull system set up on the opposite side of the structure

Solutions:

- Anchor the PT strands/bar to the end diaphragm to transfer the pushing force through to the bridge
- Set-up a separate pull system on the back side of the bridge to back up

4.2 SCHEDULE CONSIDERATIONS

Determining the amount of time to allow for the bridge slide is critical. Typically, the owner wants to complete the SIBC as quickly as possible, limiting the impacts of the full closure required to execute the slide. However, enough time must be provided to safely and accurately complete the slide and any associated approach work. The following sections present project elements to consider while developing closure time restrictions to produce an accurate construction schedule and reduce risk.

4.2.1 Partial Demolition with Phased Bridge Slide

The most straightforward approach to SIBC is to construct the replacement bridge, close the entire roadway to remove the existing bridge, and then slide the new bridge into place. State DOTs have applied variations to this approach that have reduced risk and full closure time while still realizing the full benefits from SIBC.

In contrast, the partial demolition with phased bridge slide approach reduces traffic to a single lane over the bridge approximately a day before the scheduled full closure. Ideally, this lane reduction would be implemented during low traffic demand (i.e., Saturday). Then perform a partial demolition of the existing bridge along a saw cut. While the existing bridge is still maintaining a single lane of traffic, the new bridge is partially slid into place (see Figure 4-8). This approach allows the contractor to resolve any issues with the slide system ahead of time before the critical stage of the existing bridge being fully demolished. Then when the full closure is implemented, the remaining slide and roadway tie-in operations can be completed more quickly. Although applying this method can result in longer impacts to the underpass cross-street, it allows for a shorter full closure period with reduced risk to the project team.

Figure 4-8
SIBC Showing Partial Demolition
on the Existing Bridge while Maintaining Traffic



4.2.2 Bridge Demolition

Bridge demolition can vary based on bridge type, size, and possible constraints such as geography or environmental concerns that require special operations while demolishing the bridge. Examine site conditions when developing an estimate of demolition time. One approach to minimize closure time of the roadway crossing the bridge is to allow additional closure time of the cross-street. This approach provides for full cleanup of the demolition after the bridge slide has been completed and opened to traffic.

4.2.3 Bridge Slide Time

Winch pull and hydraulic jack push systems have slid 50-foot to 70-foot wide single-span interstate bridges into place as quickly as two hours. Other items such as the demolition time, substructure installation or preparation, and post-slide tie-in work require additional schedule time.

4.2.4 Bridge and Roadway Tie-in

Bridge and roadway tie-in work typically require the most amount of time. Variations in site conditions, bridge design, and roadway will impact the time required for this activity.

4.2.4.1 Bridge Layout

As discussed in the Chapter 1 checklist (see Table 2-3), new bridges constructed shorter than the existing bridge allow new abutments to be built ahead of time under the existing bridge, which substantially shortens the required closure time. Consequently, after the bridge demolition, no time is required to install new foundations or abutment seats since they are already in place and ready for the slide.

If new abutments are installed after the bridge demolition, there are several approaches to minimize construction time. Install deep foundations (i.e., piles) prior to the bridge demolition with short-term nighttime lane closures or full closures, then cover openings with temporary pavement or plating over the damaged roadway. Install precast bridge elements after demolition.

4.2.4.2 Approach Slabs

Approach slabs are one of the biggest challenges in minimizing the scheduled closure times. Casting approach slabs in place after placement of the bridge require additional time to finalize grading, set rebar, place the concrete, and most significantly, provide cure time for the concrete. Precast approach slabs also take a considerable amount of time. Exact grading and preparation of the approach slab location is required to set the panels. Sometimes moving, re-picking, and resetting the precast sections is required. Installing and grouting connections, along with cure time extend the closure time. If not managed properly, these finishing details quickly impact schedule, making it difficult to achieve an overnight closure.

One solution was to construct the approach slab in the staging area with the bridge, and then slide it into place with the bridge (see Figure 4-9). This solution has proven to be very fast and successful, but not without a few challenges to consider. Sliding the approach slab with the bridge requires a grade beam or sleeper slab to slide on. This component cannot be installed until after the road closure, thus adding to the closure time. The contractor must be very meticulous in setting this beam, as proper compaction of base material is required to prevent future settlement, and exact grade must be set to match the grade of the abutment and the bridge. Ensure the approach slab can slide in with the bridge while maintaining contact with the sleeper slab/grade beam and avoiding the rise or drop of the slab relative to the bridge.

An additional challenge is that some DOTs require an inverted “T” shaped sleeper slab when used with asphalt paving to produce a concrete-to-concrete interface to install the joint between the approach slab and sleeper slab stem wall. This type of sleeper slab installation is critical in all three X, Y, and Z coordinates. The stem on the sleeper slab is a constraint on either end of the bridge that increases the tolerance risk during the move.

Figure 4-9
Approach Slab Constructed in Staging Area with the Bridge

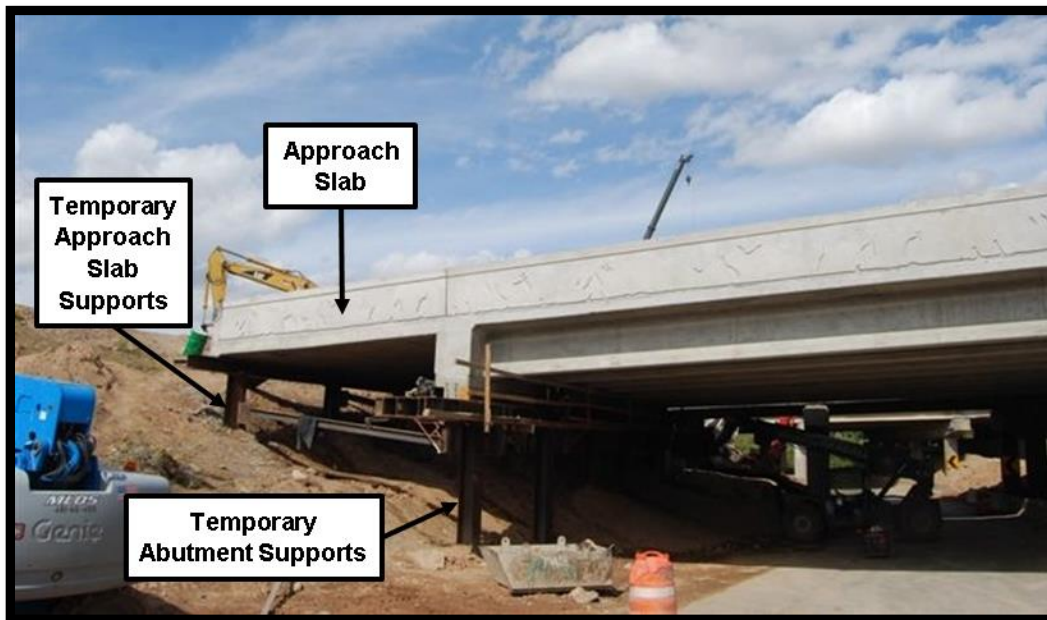

4.2.4.3 Roadway Tie-in

The roadway tie-in is also a critical part of the SIBC process. Carefully consider the amount of roadway work conducted along with the bridge replacement. If significant roadway geometry needs to be addressed along with the bridge replacement, the benefits of SIBC can be negated by the amount of roadway construction time and impacts. Conversely, if a bridge is simply replaced without addressing the tie-in and ride quality sufficiently, a bridge with poor riding quality can result. A balance must be maintained with these two aspects.

As discussed in the Chapter 1 checklist (see Table 2-3), SIBC may not be the appropriate choice if significant roadway work is required. Give proper attention to the roadway tie-in. In a short-term closure for a bridge slide, the primary focus is often on the bridge slide with the roadway tie-in as a secondary priority to be quickly completed before the closure period ends. However, to obtain a high quality tie-in, follow correct fill lift heights, compaction, and paving tie-ins. The owner should also consider allowance of lane closures at night or off-peak hours to provide sufficient time for and attention to grinding and asphalt tie-in after the bridge move. The contractor/designer should allow for long enough tie-in length to fit the full size compaction equipment behind the abutment.

4.2.5 Detailed Schedule

An SIBC project requires a large amount of work to take place in a limited area and short amount of time. This scenario requires extensive planning and a detailed schedule to keep all parties on task and avoid delays or conflicts with different working groups. The contractor, in conjunction with the owner should develop a detailed schedule (i.e., 15-minute intervals) for the duration of the move. This schedule plan will assure that work crews, inspectors, and engineers

are on-site and available when needed to keep all processes moving forward. It will also immediately help identify adjustments required, which can be communicated to the project team and the PI (public information) team if needed.

4.3 SPECIAL PROVISIONS AND SUBMITTAL REQUIREMENTS

SIBC projects require additional specifications and submittals than traditional construction. Example specifications are included in Appendix D. The following is a summary of some items to consider:

- Detailed shop drawings and information of all equipment and material used for sliding the bridge; this includes capacities, operational details, and a schematic demonstrating the slide operation
- Modifications or revisions to the concept slide method and bridge presented in the contract plans; this includes changes to permanent structure supports, end diaphragm modifications, construction joints, or other changes to the bridge
- Detailed plans of the construction staging area; this includes grading plans, mitigation of conflicts with existing features, and bridge clearance to existing cross-street traffic
- Detailed shop drawings and calculations for the temporary supports; this includes accounting for all bridge loads and sliding loads, foundation design, fabrication details, connection details, deflection calculations and allowances, and all design criteria and loading assumptions
- Geotechnical calculations supporting all temporary foundation loads
- A monitoring plan to verify horizontal and vertical control points throughout construction of the bridge elements and to monitor horizontal and vertical alignments during the slide
- Overall schedule of the bridge slide time frame, including a detailed hour-by-hour schedule for critical closure and bridge slide activity times

In addition, a communication plan, escalation plan, and contingency plan should be developed for the project.

The communication plan is very important since the contractor, contractor's engineer, resident engineer (RE), and engineer will all be involved in project elements such as submittals, decisions, and changes. A clear submittal and communication path must be established to keep these project elements in order. But, it is also important for the contractor's engineer to be able to discuss these project elements with the engineer without having to go through the contractor and RE and risk losing items in translation. SIBC requires an effort by the project team to communicate among the entire group to expedite answers and generate solutions for a successful project.

The escalation plan is important during the bridge slide activity. Once a roadway is shut down, the goal is to complete the slide and open the roadway up as quickly as possible. When issues arise, decisions need to be made as quickly as possible. When a decision surpasses the RE's expertise or authority, the team members needed for information or decisions should be on-site or available so the project continues as efficiently as possible.

Contingency plans help to identify the ‘what-ifs.’ Items to consider include standby equipment for critical equipment pieces in case of failure, alternate traffic signing or routing in case the slide-in is not completed on time, and alternate dates for the slide in case construction does not proceed as required.

4.4 CHECKLIST OF CONSTRUCTION CONSIDERATIONS

Following is a checklist of common items to require or perform during the slide-in of a bridge.

Table 4-1
Checklist of Construction Considerations

Checklist Items
✓ Detailed hourly schedule during road closure period
✓ Communication / escalation plan to facilitate quick decision making
✓ Safety plan to cover multiple activities occurring in a small area and address worker fatigue
✓ Survey checks to verify horizontal and vertical alignments throughout the slide
✓ Survey and visual monitoring for deflection of temporary and permanent supports
✓ Final bearing adjustments or shimming required by construction tolerances or deflections to provide full contact through all superstructure supports
✓ Proper installation and compaction of roadway and approach tie-in material
✓ Ability for concrete / pavement grinding if required for final tie-in adjustments
✓ Correct installation and connection of roadside safety features to the bridge
✓ Contingency plan for equipment failure, material issues, and extended closure period

Appendix A: Case Studies

Massena Bridge, Iowa

Construction Year:	2013
Owner:	Iowa DOT
Contractor:	Herberger Construction
Designer:	Iowa DOT
Contracting Method:	Design-Bid-Build (DBB)
SIBC Construction Type:	Hillman rollers with PT jacks

Project Details

The Massena Lateral Bridge Slide Project replaced the existing 40' x 30' steel I-beam bridge constructed in 1930, with a new 120' x 44' single-span pre-stressed girder bridge. The new bridge increases the structural and hydraulic capacity, improves roadway conditions, and enhances safety by providing a wider roadway. The Iowa DOT implemented SIBC in the design details and required the use of SIBC in the project specifications. Since the new bridge was longer than the existing bridge, the design provided precast abutment seats and wingwalls to be installed on driven piles. This approach allowed for fast installation of the abutments after demolishing the existing bridge. Iowa DOT designed the bridge using semi-integral abutments to accommodate the SIBC process. Specifications limited the road closure to nine days and provided an offsite detour during that period.

The contractor used a system of post-tension jacks and rods to pull the bridge on Hillman rollers from the temporary to permanent abutments. The rollers were placed under the end diaphragm on elastomeric pads to provide flexure between the bridge and the rollers. A C-channel guide was placed on the temporary and permanent abutments as a guide for the rollers. Once the bridge was in place, jacks were used to remove the slide system and place the abutment diaphragm on permanent bearings. Iowa DOT has additional project information, pictures, and videos of the Massena Bridge at: <http://www.iowadot.gov/MassenaBridge/index.html>.



I-80; Wanship Bridge, Utah

Construction Year:	2012
Owner:	UDOT
Contractor:	Ralph L. Wadsworth
Designer:	UDOT-Bridge Design, Michael Baker Corp.-SIBC Design
Contracting Method:	Design-Bid-Build (DBB)
SIBC Construction Type:	Teflon pads with PT jacks

Project Details

This project replaced the existing 3-span eastbound and westbound bridges over SR-32 on I-80 near Wanship, UT with new single span bridges. The project included bridge replacement, overlaying I-80 several miles in each direction, and reconstruction and lowering of SR-32. By implementing SIBC, UDOT eliminated the need for construction of costly interstate cross-overs and simply detoured traffic on alternate routes for the one night closure required for each bridge installation. Substandard vertical clearance with a history of bridge hits required vertical clearance improvement. UDOT made a decision to lower SR-32 profile instead of raising I-80 profile to allow SIBC to be used and to minimize impacts to I-80.

This design used full height cantilever abutments on spread footings that were constructed under the existing bridge while it remained in service. Wingwalls were constructed with block-outs to allow installation of the bridge with the block-outs filled in after the slide. Semi-integral abutments were used and the approach slabs were slid in with the bridge on sleeper slabs. Due to the existing and new bridge geometry, the sleeper slabs were located directly over the existing abutment. Enough of the existing abutment was removed to provide a minimum of 2 ft. of granular backfill between the top of the existing abutment and bottom of the sleeper slab. Slight adjustments were made to the abutment and end diaphragm details from the contract drawings to accommodate the slide system. A graduated disincentive was used for closure time penalties.



US-34 over Republican River, Bridge Replacement

Construction Year:	2012
Owner:	CDOT
Contractor:	Lawrence Construction Company
Designer:	Tsiouvaras Simmons Holderness (TSH)
Contracting Method:	Design-Bid-Build (DBB) (A + B Time Format)
SIBC Construction Type:	Rollers with hydraulic jacks

Project Details

The project replaced a four-span bridge with a single span bridge carrying US-34 over the Republican River near Wray, Colorado. The bridge site had significant constraints, including an adjacent railroad to the north and irrigation structures to the south. A construction detour would have required a 70-mile long detour through Kansas and Nebraska. To solve these challenges, a solution was developed to construct the bridge superstructure adjacent to the existing bridge and directly above the irrigation structures. The abutments were constructed in place inside concrete vaults that allowed traffic to pass overhead during all construction activities except the caisson drilling. The bridge was then rolled into place during a short roadway closure. Details of the rolling operation were coordinated with contractors, material suppliers, and heavy lifting experts. Project documents were produced in A + B format to encourage the contractor to minimize the construction schedule.

The final construction closure of US-34 was limited to three days with the roll in of the bridge taking 90 minutes. The bridge construction and roll in operation went smoothly. The river hydraulics of the site required significant channel work that could only be constructed after the old bridge was removed and prior to the new bridge being rolled into its final location. Determining a faster construction method for the river work would have significantly reduced the required closure time. A video of the US-34 Bridge slide is at:

<http://www.youtube.com/watch?v=z5EaZjQ7nw>.



I-80; Summit Park Bridges, Utah

Construction Year:	2011
Owner:	UDOT
Contractor:	Ralph L. Wadsworth
Designer:	UDOT and Michael Baker Corp.
Contracting Method:	Construction Manager/General Contractor (CM/GC)
SIBC Construction Type:	Teflon pads and hydraulic jacks

Project Details

SIBC was used to replace eastbound and westbound three-span bridges over Aspen Drive near Summit Park with more efficient single-span bridges. The Summit Park bridges span a busy commuter corridor between Park City and Salt Lake City, and the SIBC method resulted in fewer traffic interruptions and safer environment for both workers and commuters. The wider, clear span permitted new wildlife to cross under the bridges and improved pedestrian mobility. The CM/GC delivery method allowed the contractor and designer to work together to develop the bridge design with all SIBC details fully developed.

The new abutments were constructed under the existing bridges while they remained in service. Micropiles were used for the deep foundations, which allowed pile installation under the existing bridges. The bridges were slid using Teflon pads with hydraulic push jacks on a track system. The approach slabs were constructed and slid into place with the bridge. The contractor completed the bridge slides overnight during the weekends (one night per bridge) to minimize traffic interruptions. Additional nighttime lane closures were permitted for grinding and asphalt overlay of approximately 400 feet on either side of the bridge for roadway tie-ins.



I-80; 2300 East Bridge, Utah

Construction Year:	2009
Owner:	UDOT
Contractor:	Ralph L. Wadsworth
Designer:	Michael Baker Corp.
Contracting Method:	Design-Build (DB)
SIBC Construction Type:	Teflon pads and hydraulic jacks

Project Details

This project required the replacement of the existing three-span eastbound and westbound bridges over 2300 East on I-80. The DB RFP outlined a closure time of 18 hours in each direction to completely remove and replace the new structures before restoring traffic to full service. The contractor team developed an SIBC solution to meet this requirement, including sliding the approach slabs in with the new bridge.

Each bridge was constructed adjacent to the existing bridge on elevated shoring towers while the substructure was constructed underneath the existing structures. The westbound bridge was constructed four feet higher than its final position to provide vertical clearance in its temporary location. It was lowered onto the sliding tracks to its final position prior to sliding. The existing bridge was partially demolished on a Friday night to allow one lane of traffic during Saturday while the new bridge was partially slid into place. The contractor then slid the new bridge completely into place in less than eight hours during the full closures on Saturday night and opened to all lanes of traffic on Sunday. The existing pavement was PCCP, so a minimum amount of PCCP was removed to install the bridge with asphalt 'plugs' placed between the PCCP and sleeper slab. This short tie-in length created a challenge to provide a smooth roadway to bridge transition between two rigid elements. A video of the 2300 East Bridge move is located at: <http://www.youtube.com/watch?v=IMDIMdAKHcs>.



Appendix B: Additional References

American Association of State Highway and Transportation Officials (AASHTO)
(most recent) Guide Design Specifications for Bridge Temporary Works

American Association of State Highway and Transportation Officials (AASHTO)
(most recent) LRFD Bridge Construction Specifications

American Association of State Highway and Transportation Officials (AASHTO)
(most recent) LRFD Bridge Design Specifications

Federal Highway Administration (FHWA)
2010-2012 Every Day Counts Initiative. Retrieved from
<http://www.fhwa.dot.gov/everydaycounts/>

Occupational Safety and Health Administration [OSHA]
1984-2010 Bridge Construction Worker Injuries, Type 1622

Appendix C: Sample Plans

BRIDGE AND APPROACHES - PPCB LETTING DATE
BRF-092-2(36)--38-15 4-16-2013

CASS COUNTY

CASS COUNTY - DESIGN NO. 113

CONVENTIONAL SIGNS

	DIVIDED HIGHWAY
	PAVED ROAD
	BITUMINOUS ROAD
	GRAVEL ROAD
	INTERSTATE HIGHWAY
	UNITED STATES HIGHWAY
	STATE HIGHWAY
	COUNTY HIGHWAY
	RAILROAD
	PIPELINE
	AIRPORT
	HYDROLOGY
	BRIDGE
	STATE BOUNDARY
	COUNTY BOUNDARY
	CORPORATE LIMIT LINE
	TOWNSHIP LINE
	SECTION LINE

Iowa Department of Transportation
Highway Division

PLANS OF PROPOSED IMPROVEMENTS ON THE
PRIMARY ROAD SYSTEM
CASS COUNTY
BRIDGE AND APPROACHES - PPCB
IA 92 OVER SMALL STREAM
1 MI. WEST OF IA 148

THE IOWA DEPARTMENT OF TRANSPORTATION STANDARD SPECIFICATIONS FOR HIGHWAY AND BRIDGE CONSTRUCTION, SERIES 2012, PLUS APPLICABLE GENERAL SUPPLEMENTAL SPECIFICATIONS, DEVELOPMENTAL SPECIFICATIONS, SUPPLEMENTAL SPECIFICATIONS AND SPECIAL PROVISIONS SHALL APPLY TO CONSTRUCTION WORK ON THIS PROJECT.

Massena Bridge, Iowa

DESIGN NO. 113

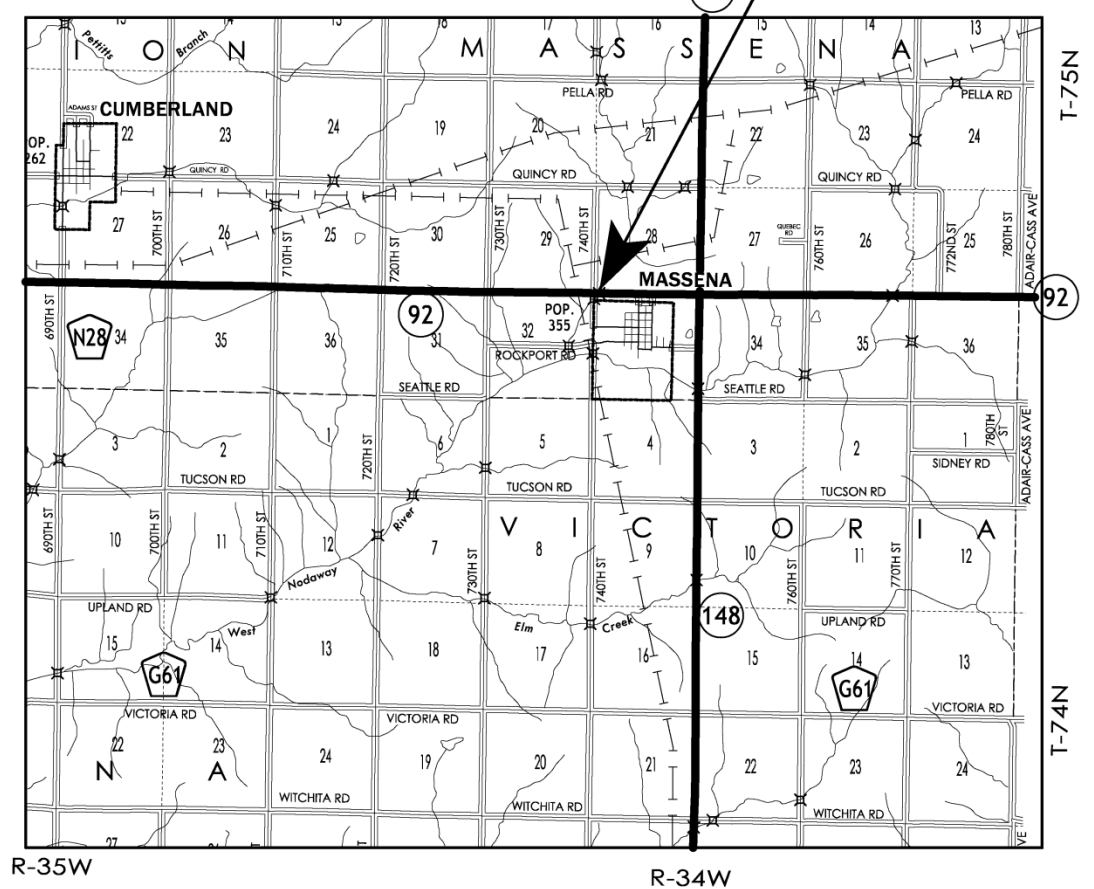

LOCATION MAP

PROJECT DIRECTORY NAME: 1509201009

ENGLISH STANDARD BRIDGE PLANS

STANDARD	ISSUED	REVISED

TOTAL SHEETS	57
PROJECT NUMBER	BRF-092-2(36)--38-15
R.O.W. PROJECT NUMBER	
PROJECT IDENTIFICATION NUMBER	09-15-092-010

INDEX OF SHEETS

NO.	DESCRIPTION
1	TITLE SHEET
2	ESTIMATE SHEET - DESIGN 113
2-26	DESIGN 113
SPS.1	SOIL PROFILE SHEET
C.1	ESTIMATE SHEET FOR ROADWAY
A.1-X.3	ROADWAY SHEETS

REVISIONS

--	--

IOWA ONE CALL
1-800-292-8989
www.iowaonecall.com
811 Know what's below. Call before you dig.

STANDARD ROAD PLANS

STANDARD ROAD PLANS ARE LISTED ON SHEET NUMBER C.2

DESIGN DATA RURAL

2012 AADT	1460	V.P.D.
2032 AADT	1830	V.P.D.
DHV		V.P.H.
TRUCKS	16	%
Total Design ESALs		

INDEX OF SEALS

SHEET NO.	NAME	TYPE
I	JAMES S. NELSON	STRUCTURAL DESIGN
I	STEVEN L. SEIVERT	HYDRAULIC DESIGN
SPS.1, CS.1	ROBERT L. STANLEY	GEOTECHNICAL DESIGN
A.1	PAUL W. FLATTERY	ROADWAY DESIGN
BRIDGE STANDARDS	NORMAN L. McDONALD	STRUCTURAL DESIGN

HYDRAULIC DESIGN

I hereby certify that this engineering document was prepared by me or under my direct personal supervision and that I am a duly licensed Professional Engineer under the laws of the State of Iowa.

Signature: Steven L. Seivert Date: 2-1-2013

Printed or Typed Name: Steven L. Seivert

My license renewal date is December 31, 2014

Pages or sheets covered by this seal: SHEETS 6 AND 7 OF 57

STRUCTURAL DESIGN

I hereby certify that this engineering document was prepared by me or under my direct personal supervision and that I am a duly licensed Professional Engineer under the laws of the State of Iowa.

Signature: James S. Nelson Date: 2-1-2013

Printed or Typed Name: James S. Nelson

My license renewal date is December 31, 2013

Pages or sheets covered by this seal: SHEETS 1 THRU 26 OF 57

ESTIMATED BRIDGE QUANTITIES

ITEM NO.	ITEM CODE	ITEM	UNIT	TOTAL	AS BUILT QUAN.
1	2104-2710020	EXCAVATION, CLASS 10, CHANNEL	CY	560.0	
2	2401-6745625	REMOVAL OF EXISTING BRIDGE	LS	1.00	
3	2402-2720000	EXCAVATION, CLASS 20	CY	239	
4	2403-0100010	STRUCTURAL CONCRETE (BRIDGE)	CY	198.0	
5	2404-7775005	REINFORCING STEEL, EPOXY COATED	LB	47,380	
6	2407-0563120	BEAMS, PRETENSIONED PRESTRESSED CONCRETE, BTC120	EACH	6	
7	2408-7800000	STRUCTURAL STEEL	LB	3,118	
8	2414-6424110	CONCRETE BARRIER RAILING	LF	284.0	
9	2501-0201517	PILES, STEEL, HP 14 X 117	LF	2,090	
10	2507-3250005	ENGINEERING FABRIC	SY	1,833.0	
11	2507-6800061	REVTMENT, CLASS E	TON	1,628.0	
12	2507-8029000	EROSION STONE	TON	52.0	
13	2526-8285000	CONSTRUCTION SURVEY	LS	1.00	
14	2533-4980005	MOBILIZATION	LS	1.00	
15	2599-9999005	PRECAST ABUTMENT FOOTING	EACH	2	
16	2599-9999005	PRECAST WINGWALLS	EACH	4	
17	2599-9999010	PREFABRICATED BRIDGE SUPERSTRUCTURE MOVE	LS	1.00	
18	2601-2638650	BRIDGE WING ARMORING - EROSION STONE	SY	19.4	

ESTIMATE REFERENCE INFORMATION

ITEM NO.	ITEM CODE	DESCRIPTION
1	2104-2710020	EXCAVATION, CLASS 10, CHANNEL
2	2401-6745625	REMOVAL OF EXISTING BRIDGE INCLUDES THE REMOVAL OF THE EXISTING ARTICULATING BLOCK MAT.
3	2402-2720000	EXCAVATION, CLASS 20
4	2403-0100010	STRUCTURAL CONCRETE (BRIDGE) INCLUDES FURNISHING AND PLACING SUBDRAIN (INCLUDING EXCAVATION), FLOODABLE BACKFILL, POROUS BACKFILL, GEOTEXTILE FABRIC, NEOPRENE WATER STOP, WATER FLOODING, AND SUBDRAIN OUTLET AT ABUTMENTS AND TOE OF BERM.
5	2404-7775005	REINFORCING STEEL, EPOXY COATED
6	2407-0563120	BEAMS, PRETENSIONED PRESTRESSED CONCRETE, BTC120 COARSE AGGREGATES FOR PRESTRESSED CONCRETE BRIDGE UNITS SHALL BE IN ACCORDANCE WITH THE REQUIREMENTS OF SECTION 4115 CLASS III DURABILITY. GRADATION OF THE COARSE AGGREGATE SHALL BE IN ACCORDANCE WITH THE REQUIREMENTS OF ARTICLE 2407.02, A, OF THE STANDARD SPECIFICATIONS. INCLUDES 24 BEARING PADS. SEE DESIGN SHEET 14 FOR ADDITIONAL DETAILS. IF ADDITIONAL BEARING PADS ARE NEEDED FOR THE CONTRACTORS MEANS AND METHODS OF PREFABRICATED BRIDGE SUPERSTRUCTURE MOVE THEY SHALL BE INCIDENTAL AND NO ADDITIONAL PAYMENT WILL BE MADE. INCLUDES COIL TIES AT BEAM ENDS.
7	2408-7800000	STRUCTURAL STEEL INCLUDES 8 DRAINS AT 106 LB EACH = 848 LBS. INCLUDES INTERMEDIATE DIAPHRAGMS AT 1543 LBS. INCLUDES 12 STEEL BEARINGS AT 727 LBS. SEE DESIGN SHEET 13 FOR DETAILS.
8	2414-6424110	CONCRETE BARRIER RAILING IF PLACEMENT OF CONCRETE IS DONE BY THE SLIPFORMING METHOD, CLASS BR CONCRETE IS REQUIRED. CAST-IN-PLACE BARRIER RAILS SHALL USE CLASS C MIX. PRICE BID FOR THIS ITEM SHALL INCLUDE THE COST OF CAST-IN-PLACE FORMS IF REQUIRED FOR PLACEMENT OF THE CONCRETE.
9	2501-0201517	PILES, STEEL, HP 14 X 117 INCLUDES FURNISHING AND INSTALLING 132 WELDED STUDS OR 66 ANCHOR ROD ASSEMBLIES. SEE DESIGN SHEET 9 FOR ADDITIONAL DETAILS.

ESTIMATE REFERENCE INFORMATION

ITEM NO.	ITEM CODE	DESCRIPTION
10	2507-3250005	ENGINEERING FABRIC ENGINEERING FABRIC SHALL BE MATERIAL AS SPECIFIED FOR EMBANKMENT EROSION CONTROL IN ACCORDANCE WITH ARTICLE 4196.01,B,3, OF THE STANDARD SPECIFICATIONS.
11	2507-6800061	REVTMENT, CLASS E ESTIMATED AT 1.6 TON/CY.
12	2507-8029000	EROSION STONE ESTIMATED AT 1.6 TON/CY.
13	2526-8285000	CONSTRUCTION SURVEY --
14	2533-4980005	MOBILIZATION --
15	2599-9999005	PRECAST ABUTMENT FOOTING THIS ITEM INCLUDES ALL COSTS FOR FURNISHING AND PLACING THE PRECAST ABUTMENT FOOTING INCLUDING (QUANTITIES FOR TWO FOOTINGS) 43 CY STRUCTURAL CONCRETE (BRIDGE), 7.8 CY STRUCTURAL CONCRETE (MISC.), 9342 LB EPOXY COATED REINFORCING STEEL AND 49 LF OF 27" DIAMETER CMP. INCLUDES THE COST TO TEMPORARILY SUPPORT THE PRECAST FOOTING UNTIL THE STRUCTURAL CONCRETE (MISC.) IN THE PILE VOID HAS OBTAINED THE SPECIFIED STRENGTH FOR RELEASE. THE METHOD OF MEASUREMENT AND BASIS OF PAYMENT WILL BE FOR EACH PRECAST ABUTMENT FOOTING FURNISHED AND PLACED.
16	2599-9999005	PRECAST WINGWALLS THIS ITEM INCLUDES ALL COSTS FOR FURNISHING AND PLACING THE PRECAST WINGWALLS INCLUDING (QUANTITIES FOR FOUR WINGWALLS) 22.4 CY STRUCTURAL CONCRETE (BRIDGE), 4 CY STRUCTURAL CONCRETE (MISC.), 4012 LB EPOXY COATED REINFORCING STEEL, 3" DIAMETER PVC PIPE AND EXPANDING FOAM, AND 28 LF OF 27" DIAMETER CMP. INCLUDES THE COST TO TEMPORARILY SUPPORT THE PRECAST WINGWALLS UNTIL THE STRUCTURAL CONCRETE (MISC.) IN THE PILE VOID HAS OBTAINED THE SPECIFIED STRENGTH FOR RELEASE. THE METHOD OF MEASUREMENT AND BASIS OF PAYMENT WILL BE FOR EACH PRECAST WINGWALL FURNISHED AND PLACED.
17	2599-9999010	PREFABRICATED BRIDGE SUPERSTRUCTURE MOVE SEE SPECIAL PROVISIONS FOR PREFABRICATED BRIDGE SUPERSTRUCTURE MOVE. INCLUDES FURNISHING AND INSTALLING STAINLESS STEEL SOLE PLATE ASSEMBLY.
18	2601-2638650	BRIDGE WING ARMORING - EROSION STONE INCLUDES FURNISHING AND PLACING ENGINEERING FABRIC, EROSION STONE, AND ALL REQUIRED EXCAVATING, SHAPING AND COMPACTING FOR WING ARMORING.

NOTE:
ROADWAY QUANTITIES SHOWN
ELSEWHERE IN THESE PLANS.

DESIGN FOR 0° SKEW
**120'-0 x 44'-0 PRETENSIONED
 PRESTRESSED CONCRETE BEAM BRIDGE**
 120'-0 SINGLE SPAN
QUANTITIES
 STA. 1134+61.00 (1A 92) FEBRUARY, 2012
CASS COUNTY
 IOWA DEPARTMENT OF TRANSPORTATION - HIGHWAY DIVISION
 DESIGN SHEET NO. 1 OF 25 FILE NO. 30484 DESIGN NO. 113

GENERAL NOTES:

IT IS THE INTENT OF THIS DESIGN TO CONSTRUCT A 120'-0" x 44'-0" PRETENSIONED PRESTRESSED CONCRETE BEAM BRIDGE, SKEWED 0°, ON IA 92 AT STATION 1134+61.00.

THIS DESIGN IS FOR THE REPLACEMENT OF THE EXISTING 40'-0" x 30'-0" STEEL I-BEAM BRIDGE, DESIGN NO. 7747. PLANS OF THE EXISTING STRUCTURE WILL BE MADE AVAILABLE TO THE CONTRACTOR. CONTACT THE OFFICE OF CONTRACTS - HIGHWAY DIVISION - IOWA D.O.T. - AMES.

THE LUMP SUM BID FOR "REMOVAL OF EXISTING BRIDGE" SHALL INCLUDE REMOVAL OF THE EXISTING 40'-0" x 30'-0" STEEL I-BEAM BRIDGE AND ARTICULATING BLOCK MAT.

REMOVALS SHALL BE IN ACCORDANCE WITH SECTION 2401, OF THE STANDARD SPECIFICATIONS.

THIS BRIDGE IS DESIGNED FOR HL-93 LOADING, PLUS 20 LBS. PER SQUARE FOOT OF ROADWAY FOR FUTURE WEARING SURFACE.

FAINT LINES ON PLANS INDICATE THE EXISTING STRUCTURE.

UTILITY COMPANIES WHOSE FACILITIES ARE SHOWN ON THE PLANS OR KNOWN TO BE WITHIN THE CONSTRUCTION LIMITS SHALL BE NOTIFIED BY THE BRIDGE CONTRACTOR OF THE STARTING DATE.

IT SHALL BE THE BRIDGE CONTRACTOR'S RESPONSIBILITY TO PROVIDE SITES FOR EXCESS EXCAVATED MATERIAL. NO PAYMENT FOR OVERHAUL WILL BE ALLOWED FOR MATERIAL HAULED TO THESE SITES.

THE BRIDGE CONTRACTOR WILL BE THE ONLY CONTRACTOR AT THE SITE AND IS RESPONSIBLE FOR THE COMPLETION OF ALL WORK AS DETAILED AND NOTED IN THESE PLANS.

CONCRETE BARRIER RAILS PLACED USING THE SLIPFORM METHOD WILL REQUIRE THE USE OF A CLASS BR CONCRETE IN ACCORDANCE WITH ARTICLE 2513.03, A, 2, OF THE STANDARD SPECIFICATIONS. CAST-IN-PLACE BARRIER RAILS SHALL USE CLASS C MIX. CLASS D CONCRETE IS NOT PERMITTED FOR CONCRETE BARRIER RAILS (CAST-IN-PLACE OR SLIPFORMED METHOD).

KEYWAY DIMENSIONS SHOWN ON THE PLANS ARE BASED ON NOMINAL DIMENSIONS UNLESS STATED OTHERWISE. IN ADDITION, THE BEVEL USED ON THE KEYWAY SHALL BE LIMITED TO A MAXIMUM OF 10 DEGREES FROM VERTICAL.

A SCRAPE SAMPLE WAS TAKEN FROM A BEAM OF THIS BRIDGE TO GET AN INDICATION OF THE EXISTENCE OF AND LEVEL OF TOTAL CHROMIUM AND TOTAL LEAD. ANALYSIS OF TOTAL LEAD ON THIS SAMPLE WAS <25 PARTS PER MILLION (PPM) (INCLUDES <0.010 PPM LEACHABLE). ANALYSIS OF TOTAL CHROMIUM ON THIS SAMPLE WAS 29.1 PPM (INCLUDES <0.030 PPM LEACHABLE). THESE ANALYSES SHOW THE EXISTENCE OF THESE TWO TOXIC CONSTITUENTS. LEVELS INDICATED BY THESE TESTS COULD CREATE CONDITIONS ABOVE REGULATORY LIMITS FOR HEALTH AND SAFETY REQUIREMENTS. NO OTHER CONSTITUENTS WERE ANALYZED. THE BIDDER SHOULD NOT RELY ON THE DEPARTMENT'S TESTING AND ANALYSIS FOR ANY PURPOSE OTHER THAN AS AN INDICATION OF THE EXISTENCE OF THESE TWO TOXIC CONSTITUENTS.

THE BRIDGE CONTRACTOR IS TO CLEAR AND/OR SHAPE THE CHANNEL WITHIN THE APPROXIMATE LIMITS SHOWN ON THE "SITUATION PLAN" AND "LONGITUDINAL SECTION ALONG CENTERLINE ROADWAY" ON DESIGN SHEETS 5, 6 AND 7.

CLASS 20 EXCAVATION QUANTITIES ARE BASED ON THE ASSUMPTION THAT THE CHANNEL EXCAVATION IS COMPLETED PRIOR TO STARTING CONSTRUCTION OF THE ABUTMENTS.

SPECIFICATIONS:

DESIGN: AASHTO LRFD 5TH ED. SERIES OF 2010, EXCEPT AS NOTED IN THE CURRENT IOWA BRIDGE DESIGN MANUAL.

CONSTRUCTION: IOWA DEPARTMENT OF TRANSPORTATION STANDARD SPECIFICATIONS FOR HIGHWAY AND BRIDGE CONSTRUCTION, SERIES 2012, PLUS APPLICABLE GENERAL SUPPLEMENTAL SPECIFICATIONS, DEVELOPMENTAL SPECIFICATIONS, SUPPLEMENTAL SPECIFICATIONS AND SPECIAL PROVISIONS SHALL APPLY TO CONSTRUCTION WORK ON THIS PROJECT, INCLUDING:

SPECIAL PROVISIONS FOR PREFABRICATED BRIDGE SUPERSTRUCTURE MOVE.
DEVELOPMENTAL SPECIFICATIONS FOR STRUCTURAL CONCRETE (4500 PSI (31 MPa) OR GREATER).
DEVELOPMENTAL SPECIFICATIONS FOR CONSTRUCTION PROGRESS SCHEDULE

DESIGN STRESSES:

DESIGN STRESSES FOR THE FOLLOWING MATERIALS ARE IN ACCORDANCE WITH THE AASHTO LRFD BRIDGE DESIGN SPECIFICATIONS, 5TH ED. SERIES OF 2010, EXCEPT AS NOTED IN THE CURRENT IOWA BRIDGE DESIGN MANUAL.

REINFORCING STEEL IN ACCORDANCE WITH SECTION 5, GRADE 60.
CONCRETE IN ACCORDANCE WITH SECTION 5, $f'_c = 4,000$ PSI, EXCEPT
PRECAST FOOTING AND WINGWALL CONCRETE IN ACCORDANCE WITH SECTION 5, $f'_c = 5,000$ PSI, AND
PRESTRESSED CONCRETE BEAMS, SEE DESIGN SHEET 19.
STRUCTURAL STEEL IN ACCORDANCE WITH SECTION 6 ASTM A709 GRADE 36, AND GRADE 50.

PILE NOTES:

THIS PROJECT USES THE LOAD AND RESISTANCE FACTOR DESIGN (LRFD) METHODOLOGY FOR DETERMINING PILE CONTRACT LENGTH AND NOMINAL AXIAL BEARING RESISTANCE. NOMINAL AXIAL BEARING RESISTANCES WILL BE LARGER THAN BEARING VALUES IN THE PAST, BUT CONSTRUCTION CONTROL BLOW COUNTS WILL BE APPROXIMATELY THE SAME. A WEAP ANALYSIS AND BEARING GRAPH WILL BE PREPARED BY THE OFFICE OF CONSTRUCTION THAT GIVES THE RELATIONSHIP BETWEEN REQUIRED NOMINAL AXIAL BEARING RESISTANCE AND BLOW COUNT.

FOR THE CONTRACTOR'S BIDDING PURPOSES, PARTICULARLY FOR THE SIZING OF THE PILE DRIVING HAMMER, THE APPROXIMATE PREVIOUS DESIGN METHODOLOGY BEARING VALUES AT END OF DRIVE (EOD) ARE GIVEN BELOW. THESE VALUES SHALL NOT BE USED FOR CONSTRUCTION CONTROL AND ARE GIVEN ONLY FOR COMPARATIVE PURPOSES.

THE PREVIOUS DESIGN BEARING FOR THE WEST ABUTMENT PILES WOULD HAVE BEEN ABOUT 82 TONS.

THE PREVIOUS DESIGN BEARING FOR THE EAST ABUTMENT PILES WOULD HAVE BEEN ABOUT 82 TONS.

SUGGESTED CONSTRUCTION SEQUENCE FOR CRITICAL CLOSURE:

1. DEMOLISH EXISTING BRIDGE.
2. BERM GRADING / DRIVE PILING / PLACE REVETMENT
3. PLACE PRECAST ABUTMENT AND WINGWALL FOOTINGS
4. MOVE PREFABRICATED BRIDGE SUPERSTRUCTURE
5. FLOODED BACKFILL
6. BRIDGE APPROACH PAVING
7. PAVED SHOULDER / GUARDRAIL / LONGITUDINAL GROOVING

THE SUGGESTED CONSTRUCTION SEQUENCE FOR CRITICAL CLOSURE IS A GENERAL LIST OF MAJOR ACTIVITIES AND NOT AN EXHAUSTIVE LIST OF ALL NECESSARY ACTIVITIES.

VALUE ENGINEERING PROPOSALS:

CONTRACTORS MAY DEVELOP ALTERNATIVE CONSTRUCTION PROPOSALS THAT ALLOW THE STATE TO BENEFIT FROM REDUCED COSTS, WHILE MAINTAINING THE SAME OR REDUCED ABC CONSTRUCTION SCHEDULE FOR THE PROJECT. THE CONTRACTOR SHALL ALSO PERFORM ANY NECESSARY REDESIGN OF BRIDGE COMPONENTS RESULTING FROM THE CHANGES. ONLY ALTERNATE DESIGNS THAT UTILIZE A PREFABRICATED BRIDGE CONSTRUCTED OFF-ALIGNMENT AND MOVED TO THE FINAL POSITION WILL BE ACCEPTED FOR REVIEW UNDER THE VALUE ENGINEERING PROPOSAL. THESE DESIGNS MUST PROVIDE THE REQUIRED PERFORMANCE, RELIABILITY, QUALITY AND CONSTRUCTABILITY.

CHANGES TO THE PREFABRICATED BRIDGE SUPERSTRUCTURE MOVE SYSTEM (E.G. PTFE SLIDE, ROLLERS, SPMT, HEAVY LIFT) ARE NOT SUBJECT TO THE COST SAVINGS SHARING REQUIREMENTS OF VALUE ENGINEERING PROPOSALS AND SHALL BE SUBMITTED PER THE REQUIREMENTS OF THE SPECIAL PROVISION FOR PREFABRICATED BRIDGE SUPERSTRUCTURE MOVE.

CONCRETE FORMS ARE REQUIRED TO REMAIN IN PLACE 5 DAYS OR LONGER IN ACCORDANCE WITH ARTICLE 2403.03, M, 2, OF THE STANDARD SPECIFICATIONS, EXCEPT THE MINIMUM CONCRETE FLEXURAL STRENGTH REQUIRED BEFORE REMOVAL OF FORMS SHALL BE 575 PSI.

THESE BRIDGE PLANS LABEL ALL REINFORCING STEEL WITH ENGLISH NOTATION (50# IS $\frac{5}{8}$ INCH DIAMETER BAR). ENGLISH REINFORCING STEEL RECEIVED IN THE FIELD MAY DISPLAY THE FOLLOWING "BAR DESIGNATION". THE "BAR DESIGNATION" IS THE STAMPED IMPRESSION ON THE REINFORCING BARS, AND IS EQUIVALENT TO THE BAR DIAMETER IN MILLIMETERS.

ENGLISH SIZE	3	4	5	6	7	8	9	10	11
BAR DESIGNATION	10	13	16	19	22	25	29	32	36

BRIDGE DECK DIMENSIONS TABLE

NO.	ITEM	UNIT	QUANTITY
1	DECK LENGTH	L.F.	121.8
2	MINIMUM DECK WIDTH	L.F.	47.2
3	MAXIMUM DECK WIDTH	L.F.	47.2
4	DECK AREA	S.F.	5749

1. DECK LENGTH IS MEASURED FROM FACE-TO-FACE OF PAVING NOTCHES ALONG THE CENTERLINE OF THE ROADWAY.
- 2, 3. DECK WIDTHS ARE MEASURED FROM OUT-TO-OUT OF DECK PERPENDICULAR TO THE CENTERLINE OF ROADWAY.
4. DECK AREA IS TO BE BASED ON THE FACE-TO-FACE PAVING NOTCH DISTANCE AND OUT-TO-OUT DECK DIMENSIONS.

SHOP DRAWING SUBMITTALS

SHOP DRAWINGS SHALL BE SUBMITTED FOR THE FOLLOWING ITEMS SHOWN IN THE TABLE BELOW. (NOTE ADDITIONAL SHOP DRAWINGS MAY BE REQUIRED IN ACCORDANCE WITH ARTICLE 1105.03 OF THE STANDARD SPECIFICATIONS.)

SUBMITTAL REQUIREMENTS FOR SHOP DRAWINGS SHOULD BE IN ACCORDANCE WITH ARTICLE 1105.03, OF THE STANDARD SPECIFICATIONS, FOR HIGHWAY AND BRIDGE CONSTRUCTION OF THE IOWA DEPARTMENT OF TRANSPORTATION.

1	DECK DRAIN DETAILS
2	INTERMEDIATE DIAPHRAGM DETAILS
3	LAMINATED NEOPRENE BEARINGS
4	SOLE PLATE
5	PRECAST LIFTING LOCATIONS AND ANCHOR DETAILS
6	PRECAST ABUTMENT FOOTING SUPPORT METHOD
7	PREFABRICATED BRIDGE SUPERSTRUCTURE MOVE SUBMITTALS

DESIGN HISTORY AT THIS SITE

DES. NO.	TYPE OF WORK
8030	ORIGINAL DESIGN
7747	RAISE AND WIDEN
167	FLOOR REPAIR
288	RETROFIT RAIL
497	BRIDGE DECK OVERLAY
1308	SCOUR COUNTERMEASURE
113	BRIDGE REPLACEMENT

TRAFFIC CONTROL PLAN

NOTE: THE ROADWAY WILL BE CLOSED TO THRU TRAFFIC ONLY DURING CRITICAL CLOSURE PERIOD. REFER TO THE TRAFFIC CONTROL PLAN SHOWN ELSEWHERE IN THESE PLANS.

DESIGN FOR 0° SKEW
120'-0" x 44'-0" PRETENSIONED
PRESTRESSED CONCRETE BEAM BRIDGE
120'-0" SINGLE SPAN

GENERAL NOTES

STA. 1134+61.00 (IA 92) FEBRUARY, 2012

CASS COUNTY

IOWA DEPARTMENT OF TRANSPORTATION - HIGHWAY DIVISION
DESIGN SHEET NO. 2 OF 25 FILE NO. 30484 DESIGN NO. 113

SUBSTRUCTURE PRECASTING

PRECASTING MATERIALS AND PROCEDURES SHALL CONFORM TO SECTION 2407 OF THE STANDARD SPECIFICATIONS AND MATERIALS I.M. 570 LRFD. SITE CASTING SHALL CONFORM TO ALTERNATE SITE CASTING PROVISIONS LISTED ON DESIGN SHEET 4.

REMOVAL AND STORAGE:

ALL PRECAST ELEMENTS SHALL BE REMOVED FROM THE FORMS IN SUCH A MANNER THAT NO DAMAGE OCCURS TO THE ELEMENT. FORM REMOVAL SHALL CONFORM TO THE REQUIREMENTS OF ARTICLE 2407.03.F OF THE STANDARD SPECIFICATIONS. ANY MATERIALS FORMING BLOCKOUTS IN THE PRECAST ELEMENTS SHALL BE REMOVED SUCH THAT DAMAGE DOES NOT OCCUR TO THE PRECAST ELEMENTS OR THE BLOCKOUT. PRECAST ELEMENTS SHALL BE STORED IN SUCH A MANNER THAT ADEQUATE SUPPORT IS PROVIDED TO PREVENT CRACKING OR CREEP-INDUCED DEFORMATION (SAGGING). DURING STORAGE FOR LONG PERIODS OF TIME (LONGER THAN ONE MONTH), ALL PRECAST ELEMENTS SHALL BE CHECKED AT LEAST ONCE PER MONTH TO ENSURE CREEP-INDUCED DEFORMATION DOES NOT OCCUR.

LIFTING AND HANDLING:

LIFTING AND HANDLING CALCULATIONS DESIGNED BY A PROFESSIONAL ENGINEER REGISTERED IN THE STATE OF IOWA SHALL BE SUBMITTED. THE PRECAST FABRICATOR SHALL SUBMIT LIFTING LOCATIONS AND LIFTING ANCHOR DETAILS FOR APPROVAL BY ENGINEER PRIOR TO USE. THE LIFTING ANCHORS SHALL BE HOT-DIPPED GALVANIZED. THE LIFTING ANCHORS SHALL BE REMOVED OR CUT FLUSH WITH THE PRECAST SUBSTRUCTURE. HOLES SHALL BE PATCHED WITH AN APPROVED GROUT. STEEL CUT FLUSH WITH THE CONCRETE SHALL BE REPAIRED IN ACCORDANCE WITH MATERIALS IM 410 - "REPAIR OF DAMAGED HOT DIP GALVANIZED COATINGS."

ALL PRECAST ELEMENTS SHALL BE HANDLED IN SUCH A MANNER AS NOT TO DAMAGE OR OVERSTRESS THE PRECAST ELEMENTS DURING LIFTING OR MOVING. LIFTING ANCHORS CAST INTO THE PRECAST ELEMENTS SHALL BE USED FOR LIFTING AND MOVING THE PRECAST ELEMENTS AT THE FABRICATION PLANT AND IN THE FIELD. THE ANGLE BETWEEN THE TOP SURFACE OF THE PRECAST ELEMENTS AND THE LIFTING LINE SHALL NOT BE LESS THAN SIXTY DEGREES, WHEN MEASURED FROM THE TOP SURFACE OF THE PRECAST ELEMENTS TO THE LIFTING LINE. DAMAGE CAUSED TO ANY PRECAST ELEMENTS SHALL BE REPAIRED AT THE EXPENSE OF THE CONTRACTOR TO THE SATISFACTION OF THE ENGINEER.

TRANSPORTATION:

ALL PRECAST ELEMENTS SHALL BE TRANSPORTED IN SUCH A MANNER THAT THE PRECAST ELEMENTS WILL NOT BE DAMAGED OR OVERSTRESSED DURING TRANSPORTATION. PRECAST ELEMENTS SHALL BE PROPERLY SUPPORTED DURING TRANSPORTATION SUCH THAT CRACKING OR DEFORMATION (SAGGING) DOES NOT OCCUR. IF MORE THAN ONE PRECAST ELEMENT IS TRANSPORTED PER VEHICLE, PROPER SUPPORT AND SEPARATION MUST BE PROVIDED BETWEEN THE INDIVIDUAL PRECAST ELEMENTS. PRECAST ELEMENTS SHALL LIE HORIZONTAL DURING TRANSPORTATION, UNLESS OTHERWISE APPROVED.

REPAIRS:

REPAIRS OF DAMAGE CAUSED TO THE PRECAST ELEMENTS DURING FABRICATION, LIFTING AND HANDLING, OR TRANSPORTATION SHALL BE ADDRESSED ON A CASE-BY-CASE BASIS. DAMAGE WITHIN ACCEPTABLE LIMITS OF THE PRECAST ELEMENTS SHALL BE REPAIRED USING MATERIALS I.M. 570 LRFD AT THE FABRICATION PLANT AT THE EXPENSE OF THE FABRICATOR. REPETITIVE DAMAGE TO PRECAST ELEMENTS SHALL BE CAUSE FOR STOPPAGE OF FABRICATION OPERATIONS UNTIL THE CAUSE OF THE DAMAGE CAN BE REMEDIED. ALL PROPOSED REPAIRS SHALL BE APPROVED BY THE ENGINEER IN ADVANCE.

DESIGN FOR 0° SKEW
120'-0" x 44'-0" PRETENSIONED
PRESTRESSED CONCRETE BEAM BRIDGE
120'-0" SINGLE SPAN
SUBSTRUCTURE PRECAST NOTES
STA. 1134+61.00 (1A 92) FEBRUARY, 2012
CASS COUNTY
IOWA DEPARTMENT OF TRANSPORTATION - HIGHWAY DIVISION
DESIGN SHEET NO. 3 OF 25 FILE NO. 30484 DESIGN NO. 113

ALTERNATE SITE CASTING:

IF THE CONTRACTOR ELECTS TO PRECAST THE ABUTMENT FOOTINGS AND WINGWALLS AT A TEMPORARY CASTING FACILITY, CASTING SHALL COMPLY WITH SECTION 2403 OF THE STANDARD SPECIFICATIONS, DEVELOPMENTAL SPECIFICATIONS FOR STRUCTURAL CONCRETE 4500 PSI (31 MPa) OR GREATER, AND THE PROVISIONS LISTED BELOW:

A. EQUIPMENT.

USE EQUIPMENT MEETING THE REQUIREMENTS OF SECTION 2001 AND THE FOLLOWING:

1. CASTING BEDS.

FOR PRECAST CONCRETE, USE CASTING BEDS RIGIDLY CONSTRUCTED AND SUPPORTED SO THAT UNDER THE WEIGHT (MASS) OF THE CONCRETE THERE WILL BE NO VERTICAL DEFORMATION OF THE BED.

2. FORMS.

USE FORMS FOR PRECAST TRUE TO THE DIMENSIONS AS SHOWN IN THE CONTRACT DOCUMENTS, TRUE TO LINE, MORTAR TIGHT, AND OF SUFFICIENT RIGIDITY TO NOT SAG OR BULGE OUT OF SHAPE UNDER PLACEMENT AND VIBRATION OF CONCRETE. ENSURE INSIDE SURFACES ARE SMOOTH AND FREE OF ANY PROJECTIONS, INDENTATIONS, OR OFFSETS THAT MIGHT RESTRICT DIFFERENTIAL MOVEMENTS OF FORMS AND CONCRETE.

B. CURING.

1. USE A METHOD OF CURING THAT PREVENTS LOSS OF MOISTURE AND MAINTAINS AN INTERNAL CONCRETE TEMPERATURE AT LEAST 40°F (4°C) DURING THE CURING PERIOD. OBTAIN THE ENGINEER'S APPROVAL FOR THIS METHOD.

2. WHEN USING ACCELERATED HEAT CURING, DO SO UNDER A SUITABLE ENCLOSURE. USE EQUIPMENT AND PROCEDURES THAT WILL ENSURE UNIFORM CONTROL AND DISTRIBUTION OF HEAT AND PREVENT LOCAL OVERHEATING. ENSURE THE CURING PROCESS IS UNDER THE DIRECT SUPERVISION AND CONTROL OF COMPETENT OPERATORS.

3. WHEN ACCELERATED HEAT IS USED TO OBTAIN TEMPERATURES ABOVE 100°F (38°C):

I. RECORD THE TEMPERATURE OF THE INTERIOR OF THE CONCRETE USING A SYSTEM CAPABLE OF AUTOMATICALLY PRODUCING A TEMPERATURE RECORD AT INTERVALS OF NO MORE THAN 15 MINUTES DURING THE ENTIRE CURING PERIOD.

II. SPACE THE SYSTEMS AT A MINIMUM OF ONE LOCATION PER 100 FEET (30 M) OF LENGTH PER UNIT OR FRACTION THEREOF, WITH A MAXIMUM OF THREE LOCATIONS ALONG EACH LINE OF UNITS BEING CURED.

III. ENSURE ALL UNITS, WHEN CALIBRATED INDIVIDUALLY, ARE ACCURATE WITHIN ±5°F (3°C).

IV. DO NOT ARTIFICIALLY RAISE THE TEMPERATURE OF THE CONCRETE ABOVE 100°F (38°C) FOR A MINIMUM OF 2 HOURS AFTER THE UNITS HAVE BEEN CAST. AFTER THE 2 HOUR PERIOD, THE TEMPERATURE OF THE CONCRETE MAY BE RAISED TO A MAXIMUM TEMPERATURE OF 155°F (71°C) AT A RATE NOT TO EXCEED 25°F (15°C) PER HOUR.

V. LOWER THE TEMPERATURE OF THE CONCRETE AT A RATE NOT TO EXCEED 40°F (22°C) PER HOUR BY REDUCING THE AMOUNT OF HEAT APPLIED UNTIL THE INTERIOR OF THE CONCRETE HAS REACHED THE TEMPERATURE OF THE SURROUNDING AIR.

4. IN ALL CASES, COVER THE CONCRETE AND LEAVE COVERED UNTIL CURING IS COMPLETED. SIDE FORMS AND PANS FORMING THE UNDERSIDE OF CHANNEL SHAPES MAY BE REMOVED DURING THIS PERIOD IF THE COVER IS IMMEDIATELY REPLACED. DO NOT, UNDER ANY CIRCUMSTANCES, REMOVE UNITS FROM THE CASTING BED UNTIL THE STRENGTH REQUIREMENTS ARE MET.

C. REMOVAL OF FORMS.

IF FORMS ARE REMOVED BEFORE THE CONCRETE HAS ATTAINED THE STRENGTH WHICH WILL PERMIT THE UNITS TO BE MOVED OR STRESSED, REMOVE PROTECTION ONLY FROM THE IMMEDIATE SECTION FROM WHICH FORMS ARE BEING REMOVED. IMMEDIATELY REPLACE THE PROTECTION AND RESUME CURING AFTER THE FORMS ARE REMOVED. DO NOT REMOVE PROTECTION ANY TIME BEFORE THE UNITS ATTAIN THE SPECIFIED COMPRESSIVE STRENGTH WHEN THE SURROUNDING AIR TEMPERATURE IS BELOW 20°F (-7°C).

ALTERNATE SITE CASTING: CONT'D

D. TOLERANCES.

LIMIT VARIATION FROM DIMENSIONS SHOWN IN THE CONTRACT DOCUMENTS TO NO MORE THAN 1/8 INCH (3 MM). FOR OVERRUNS, GREATER DEVIATION MAY BE ACCEPTED IF, IN THE ENGINEER'S OPINION, IT DOES NOT IMPAIR THE SUITABILITY OF THE MEMBER FOR ITS INTENDED USE, UNLESS SHOWN ELSEWHERE IN THESE PLANS.

E. HANDLING AND STORAGE.

1. WHEN LIFTING AND HANDLING PRECAST UNITS, SUPPORT THEM AT OR NEAR THE POINTS DESIGNATED IN THE APPROVED SHOP/WORKING DRAWINGS.

2. DO NOT LIFT OR STRAIN UNITS IN ANY WAY BEFORE THEY HAVE DEVELOPED THE STRENGTH SPECIFIED. IN STORAGE, SUPPORT UNITS AT POINTS ADJACENT TO THE BEARINGS.

3. DURING FABRICATION, STORAGE, HANDLING, AND HAULING TAKE CARE TO PREVENT CRACKING, TWISTING, UNNECESSARY ROUGHNESS, OR OTHER DAMAGE. IN PARTICULAR, DO NOT ALLOW TIEDOWNS TO COME IN DIRECT CONTACT WITH CONCRETE SURFACES. DO NOT SUBJECT UNITS TO EXCESSIVE IMPACT. REPLACE AT NO ADDITIONAL COST TO THE CONTRACTING AUTHORITY UNITS THAT ARE, IN THE ENGINEER'S OPINION, DAMAGED IN A WAY TO IMPAIR THEIR STRENGTH OR SUITABILITY FOR THEIR INTENDED USE.

F. FINISH.

FINISH ALL SURFACES WHICH WILL BE EXPOSED IN THE FINISHED STRUCTURE AS PROVIDED IN ARTICLE 2403.03, P, 2, B, AND ENSURE THEY ARE FREE OF HONEYCOMB OR SURFACE DEFECTS. SUBMIT STRUCTURAL REPAIR PROCEDURES TO THE ENGINEER FOR APPROVAL.

DESIGN FOR 0° SKEW
120'-0 x 44'-0 PRETENSIONED
PRESTRESSED CONCRETE BEAM BRIDGE
120'-0 SINGLE SPAN
ALTERNATE SITE CASTING NOTES
STA. 1134+61.00 (1A 92) FEBRUARY, 2012
CASS COUNTY
IOWA DEPARTMENT OF TRANSPORTATION - HIGHWAY DIVISION
DESIGN SHEET NO. 4 OF 25 FILE NO. 30484 DESIGN NO. 113

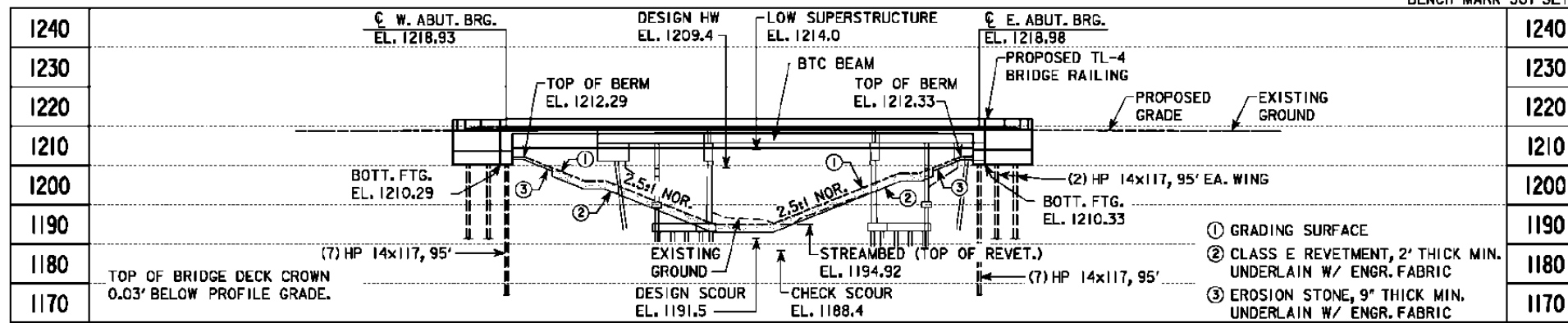

LONGITUDINAL SECTION ALONG CENTERLINE OF APPROACH ROADWAY

NOTES:

- THE PROPOSED BRIDGE IS STRAIGHT WITH GUTTERLINES PARALLEL TO THE LINE BETWEEN CENTERLINE ABUTMENT BEARINGS AT CENTERLINE IA 92.
- EXIST. ARTICULATING BLOCK MAT BELOW THE EXIST. BRIDGE IS TO BE REMOVED.
- TL-4 BARRIER RAIL 34" HEIGHT
- LOW SUPERSTRUCTURE ELEVATION IS CALCULATED AT THE CENTER OF THE CHANNEL.

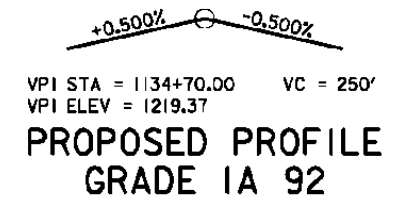

HYDRAULIC DATA

DRAINAGE AREA = 7.1 SQ. MI.
 STREAM SLOPE = 10.7 FT./MI.
 Q₂ = 599 CFS
 STAGE = EL. 1202.6
 CHANNEL VELOCITY = 2.1 FPS
 Q₅₀ = 2,880 CFS
 STAGE = EL. 1209.4
 BACKWATER = 0.5 FT.
 AVG. BRIDGE VELOCITY = 3.5 FPS
 Q₁₀₀ = 3,473 CFS
 STAGE = EL. 1210.7
 BACKWATER = 0.6 FT.
 AVG. BRIDGE VELOCITY = 3.8 FPS
 CALCULATED DESIGN SCOUR = EL. 1191.5

Q₅₀₀ = 4,666 CFS
 STAGE = EL. 1213.7
 AVG. BRIDGE VELOCITY = 3.9 FPS
 CALCULATED CHECK SCOUR = EL. 1188.4

ROADWAY OVERTOP 1218.0
 STA. 1130+72
 AVG. LOW WATER STAGE = EL. 1196.8
 DATE OF SURVEY 1/7/2011

DISCHARGES PER
 U.S.G.S. REPORT 87-4132 REGION 2.

TRAFFIC ESTIMATE

2012 AADT	1,460	V.P.D.
2032 AADT	1,830	V.P.D.
202. DHV		V.P.H.
TRUCKS	16	%
TOTAL DESIGN ESALs		

LOCATION

IA 92 OVER SMALL STREAM
 T-75 N R-34 W
 SECTIONS 28 & 33
 MASSENA TOWNSHIP
 CASS COUNTY
 BRIDGE MAINT. NO. 1563.45092
 FHWA NO. 017841
 LATITUDE 41.258376°
 LONGITUDE -94.776114°

CURVE DATA

PI STA. 1132+21.40
 Δ = 0° 15' 00.00" (RT)
 T = 300.00'
 L = 600.00'
 E = 0.33'
 R = 137,509.65'
 PC STA. 1129+21.40
 PT STA. 1135+21.40

TYPICAL APPROACH SECTION

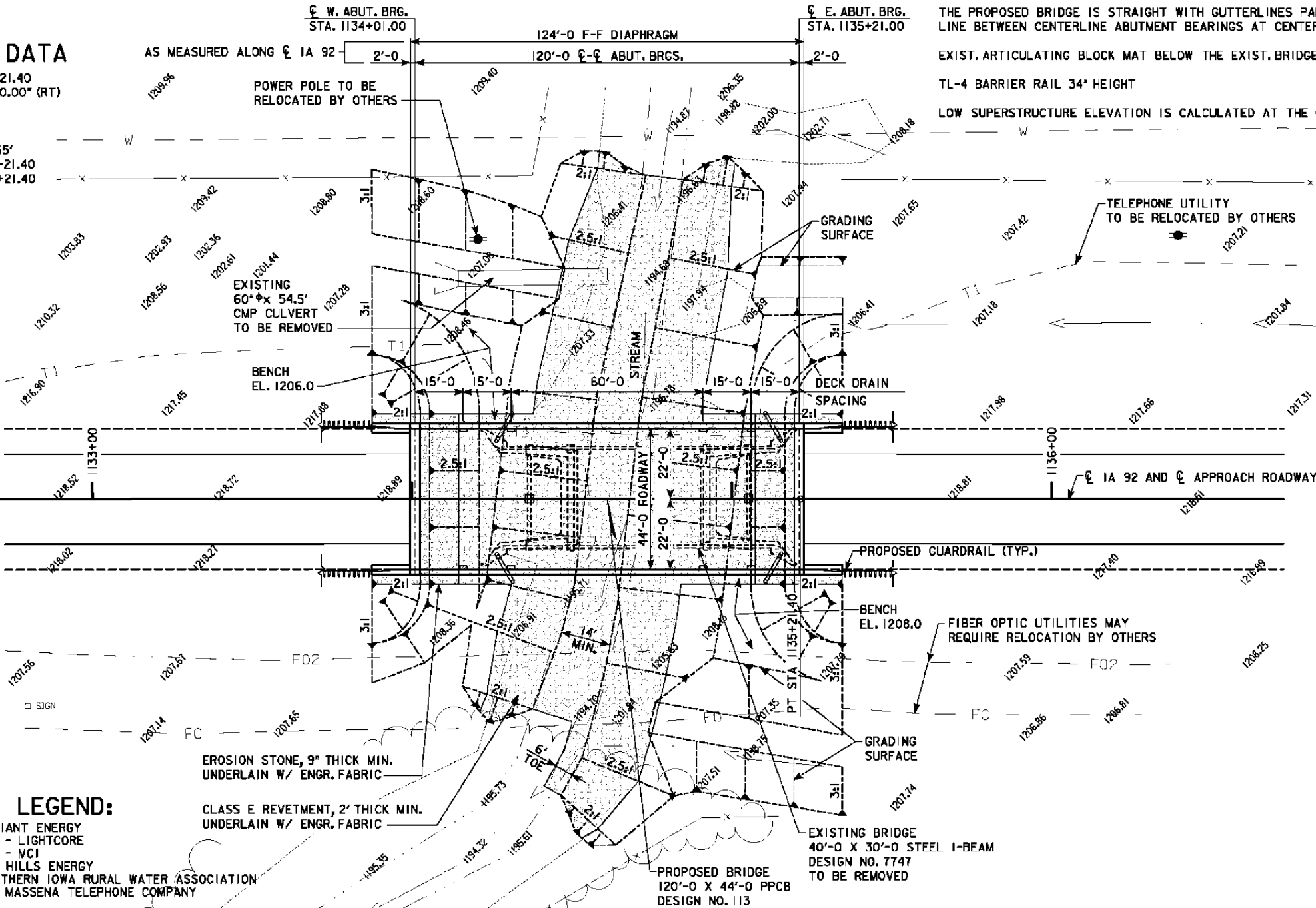
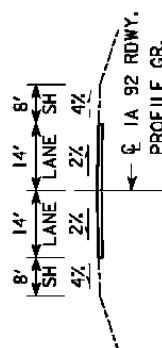

SITUATION PLAN

UTILITIES LEGEND:

- POWER - ALLIANT ENERGY
- FO FIBER OPTIC - LIGHTCORE
- FO2 FIBER OPTIC - MCI
- G-HP GAS - BLACK HILLS ENERGY
- W WATER - SOUTHERN IOWA RURAL WATER ASSOCIATION
- TI TELEPHONE - MASSENA TELEPHONE COMPANY

EROSION STONE, 9" THICK MIN.
 UNDERLAIN W/ ENGR. FABRIC

CLASS E REVETMENT, 2' THICK MIN.
 UNDERLAIN W/ ENGR. FABRIC

EXISTING BRIDGE
 40'-0 X 30'-0 STEEL I-BEAM
 DESIGN NO. 7747
 TO BE REMOVED

PROPOSED BRIDGE
 120'-0 X 44'-0 PPCB
 DESIGN NO. 113

DESIGN FOR 0° SKEW
**120'-0 x 44'-0 PRETENSIONED
 PRESTRESSED CONCRETE BEAM BRIDGE**
 120'-0 SINGLE SPAN
SITUATION PLAN
 STA. 1134+61.00 (IA 92) FEBRUARY, 2012
CASS COUNTY
 IOWA DEPARTMENT OF TRANSPORTATION - HIGHWAY DIVISION
 DESIGN SHEET NO. 5 OF 25 FILE NO. 30484 DESIGN NO. 113

BENCH MARK 501 SET RR SPIKE IN SOUTH SIDE OF POWER POLE STA 1138+51.59 82.94' LT EL. 1210.986

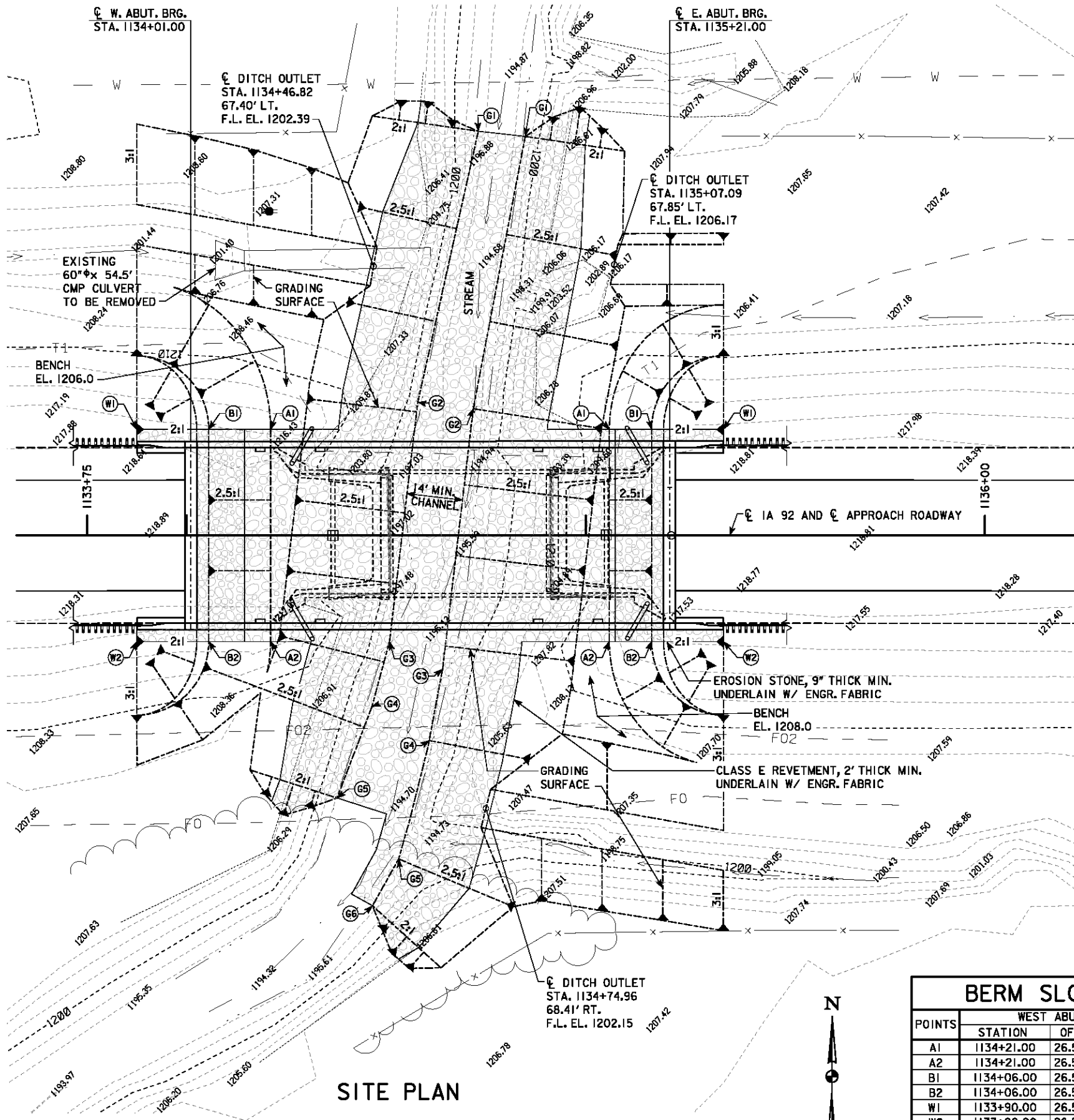

ESTIMATED BERM ARMORING QUANTITIES				
LOCATION	REVETMENT CL. E (TON)	EROSION STONE (TON)	ENGINEERING FABRIC (SY)	EXCAVATION (CY) **
BERM/BANK LINING - WEST SIDE	760	26	850	272
BERM/BANK LINING - EAST SIDE	868	26	983	288
TOTALS	1,628	52	1,833	560

** EXCAVATION QUANTITY CALCULATED FROM PROPOSED GRADING SURFACE FOR THE EMBEDMENT OF CLASS E REVETMENT AS SHOWN IN THE DETAILS.

GRADING CONTROL - WEST		GRADING CONTROL - EAST	
G1	1134+73.04, 101.24' LT, EL. 1195.0	G1	1134+84.81, 99.93' LT, EL. 1195.0
G2	1134+57.89, 33.34' LT, EL. 1195.0	G2	1134+71.79, 31.73' LT, EL. 1195.0
G3	1134+50.81, 26.60' RT, EL. 1195.0	G3	1134+64.09, 33.51' RT, EL. 1195.0
G4	1134+46.40, 42.92' RT, EL. 1195.0	G4	1134+60.74, 51.39' RT, EL. 1195.0
G5	1134+37.66, 65.79' RT, EL. 1195.0	G5	1134+53.08, 81.07' RT, EL. 1195.0
		G6	1134+46.52, 92.78' RT, EL. 1195.0

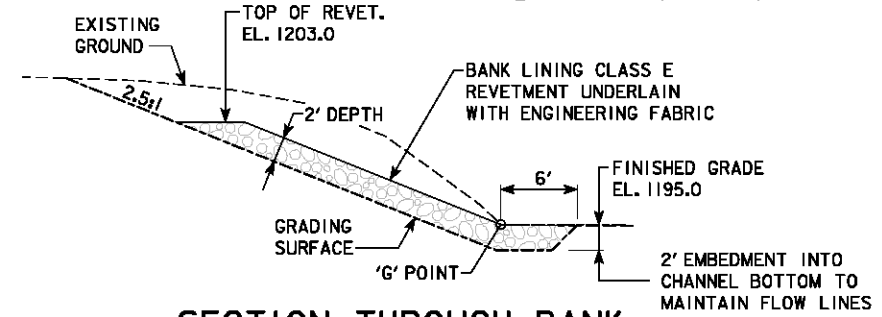

SECTION THROUGH BANK LINING REVETMENT

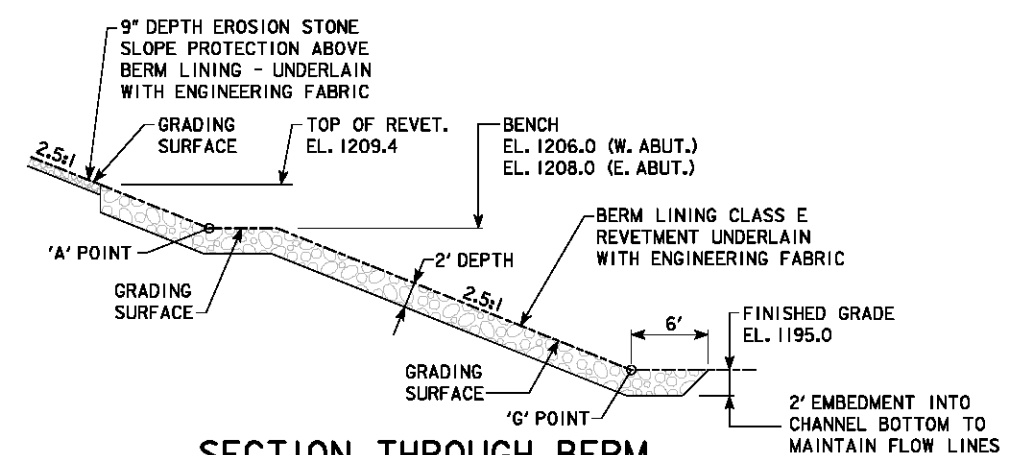

SECTION THROUGH BERM LINING REVETMENT

BERM SLOPE LOCATION TABLE						
POINTS	WEST ABUTMENT			EAST ABUTMENT		
	STATION	OFFSET	ELEV.	STATION	OFFSET	ELEV.
A1	1134+21.00	26.58' LT	1206.00	1135+05.90	26.58' LT	1208.00
A2	1134+21.00	26.58' RT	1206.00	1135+05.90	26.58' RT	1208.00
B1	1134+06.00	26.58' LT	1212.29	1135+16.00	26.58' LT	1212.33
B2	1134+06.00	26.58' RT	1212.29	1135+16.00	26.58' RT	1212.33
W1	1133+90.00	26.58' LT	1218.34	1135+32.00	26.58' LT	1218.39
W2	1133+90.00	26.58' RT	1218.34	1135+32.00	26.58' RT	1218.39

BERM SLOPE ELEVATIONS REFLECT THE GRADING SURFACE

DESIGN FOR 0° SKEW
**120'-0 x 44'-0 PRETENSIONED
 PRESTRESSED CONCRETE BEAM BRIDGE**
 120'-0 SINGLE SPAN
SITUATION PLAN
 STA. 1134+61.00 (IA 92) FEBRUARY, 2012
CASS COUNTY
 IOWA DEPARTMENT OF TRANSPORTATION - HIGHWAY DIVISION
 DESIGN SHEET NO. 6 OF 25 FILE NO. 30484 DESIGN NO. 113

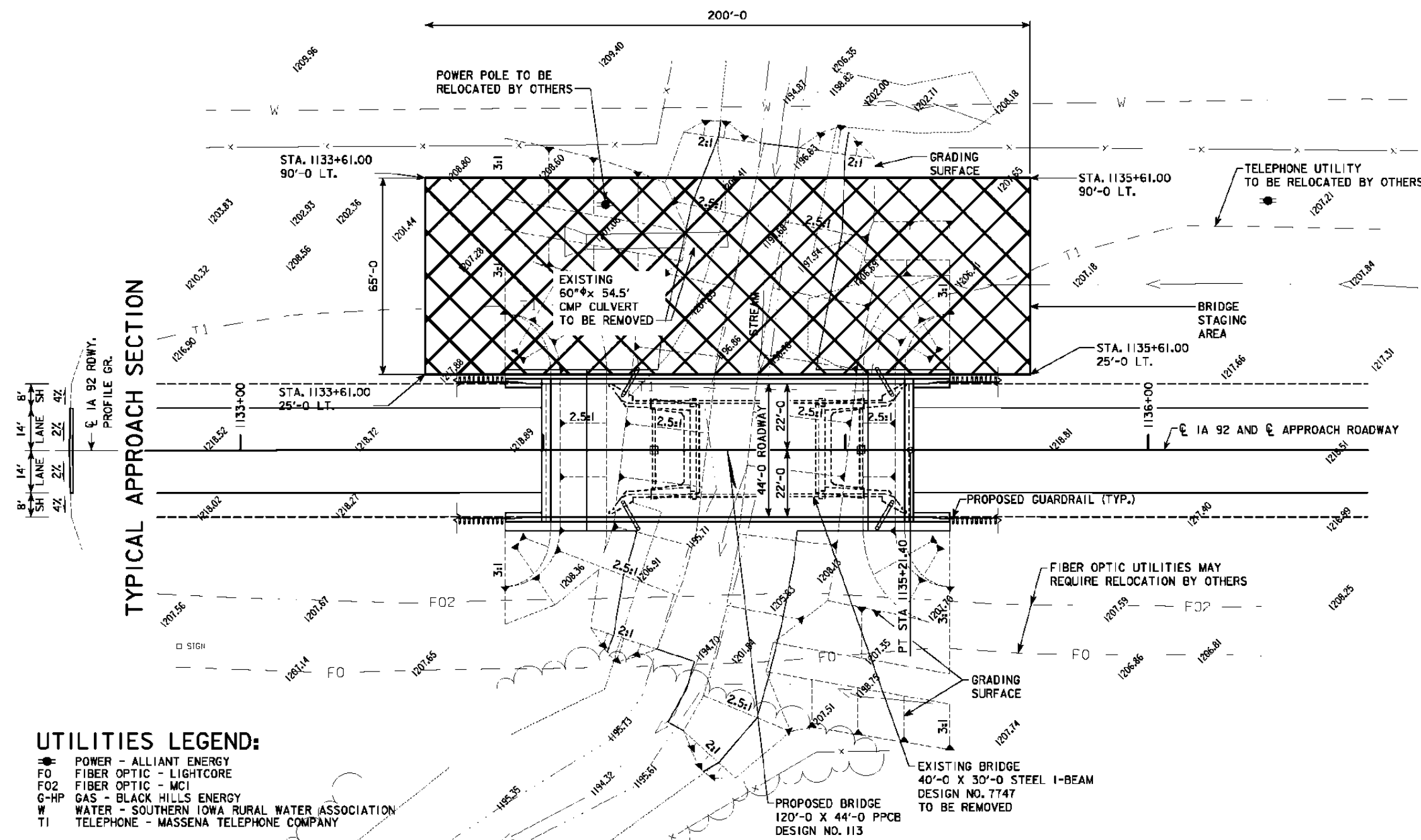

TYPICAL APPROACH SECTION

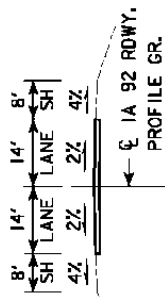

- UTILITIES LEGEND:**
- ☛ POWER - ALLIANT ENERGY
 - FO FIBER OPTIC - LIGHTCORE
 - F02 FIBER OPTIC - MCI
 - G-HP GAS - BLACK HILLS ENERGY
 - W WATER - SOUTHERN IOWA RURAL WATER ASSOCIATION
 - T1 TELEPHONE - MASSENA TELEPHONE COMPANY

DESIGN FOR 0° SKEW
**120'-0" x 44'-0" PRETENSIONED
 PRESTRESSED CONCRETE BEAM BRIDGE**
 120'-0" SINGLE SPAN
BRIDGE STAGING PLAN
 STA. 1134+61.00 (IA 92) FEBRUARY, 2012
CASS COUNTY
 IOWA DEPARTMENT OF TRANSPORTATION - HIGHWAY DIVISION
 DESIGN SHEET NO. 7 OF 25 FILE NO. 30484 DESIGN NO. 113

BRIDGE STAGING PLAN

NOTE: ABUTMENT FOOTING PILES SHALL BE DRIVEN WITH PILE WEBS PARALLEL TO ϕ OF APPROACH ROADWAY.
 WING PILES SHALL BE DRIVEN WITH PILE WEBS PERPENDICULAR TO ϕ OF APPROACH ROADWAY.

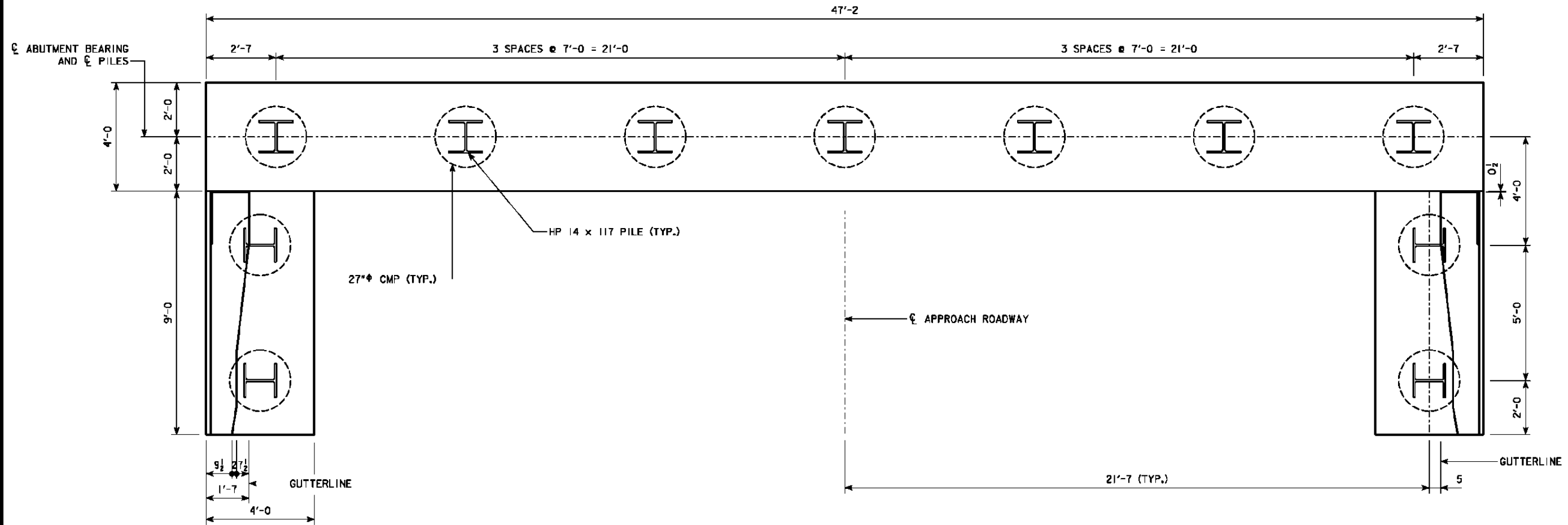

ABUTMENT AND WING WALL PILE PLAN

ABUTMENT NOTES:

THE CONTRACT LENGTH OF 95'-0" FOR THE EAST AND WEST ABUTMENT PILES IS BASED ON A COHESIVE SOIL CLASSIFICATION, A TOTAL FACTORED AXIAL LOAD PER PILE (PU) OF 237 KIPS AND A GEOTECHNICAL RESISTANCE FACTOR (PHI) OF 0.65.

THE NOMINAL AXIAL BEARING RESISTANCE FOR CONSTRUCTION CONTROL WAS DETERMINED FROM A COHESIVE SOIL CLASSIFICATION AND A GEOTECHNICAL RESISTANCE FACTOR (PHI) OF 0.65.

THE REQUIRED NOMINAL AXIAL BEARING RESISTANCE FOR EAST AND WEST ABUTMENT PILES IS 182 TONS AT END OF DRIVE (EOD) OR RETAP. THE PILE CONTRACT LENGTH SHALL BE DRIVEN AS PER PLAN UNLESS PILES REACH REFUSAL. CONSTRUCTION CONTROL REQUIRES A WEAP ANALYSIS WITH BEARING GRAPH.

MINIMUM CLEAR DISTANCE FROM FACE OF CONCRETE TO NEAR REINFORCING BAR IS TO BE 2" UNLESS OTHERWISE NOTED OR SHOWN.

FINAL PILE HEAD POSITION SHALL NOT DEVIATE FROM THE LOCATION DESIGNATED IN THESE PLANS BY MORE THAN 3" IN ANY DIRECTION IN ORDER TO ALLOW THE PRECAST ABUTMENT FOOTING AND WINGS TO BE INSTALLED.

ESTIMATED WEIGHT OF ONE PRECAST ABUTMENT FOOTING WITH KEEPER BLOCK IS 42.2 TONS.

THE METHOD OF SUPPORTING THE PRECAST ABUTMENT FOOTING DURING ERECTION SHALL BE SUBMITTED TO THE ENGINEER PRIOR TO THE ERECTION. SPECIAL EMPHASIS IS PLACED ON THE CONTRACTORS METHOD OF ELEVATION CONTROL.

THE PRECAST ABUTMENT FOOTING SUPPORT SHALL NOT BE REMOVED UNTIL 4000 PSI COMPRESSIVE STRENGTH HAS BEEN ACHIEVED.

THE STRUCTURAL CONCRETE (MISC.) USED TO FILL THE ABUTMENT PILING ENCASEMENTS SHALL BE CLASS D CONCRETE WITH A HIGH RANGE WATER REDUCER. THE MAXIMUM SLUMP ACHIEVED WITH WATER SHALL BE 2 INCHES. THE HRWR SHALL BE ADDED AT THE POUR SITE. THE MAXIMUM ALLOWABLE SLUMP AFTER ADDITION OF THE HRWR SHALL BE 7 INCHES. COARSE AGGREGATE SHALL BE 1/2 INCH TOP SIZE.

THE CONTRACTOR MAY EMPLOY METHODS SUCH AS THE USE OF A NON-CHLORIDE ACCELERATOR OR SUPPLEMENTAL HEATING AND PROTECTION TO INCREASE EARLY STRENGTH GAIN.

OTHER MIXES MAY BE CONSIDERED PROVIDED THEY HAVE BEEN REVIEWED AND APPROVED BY THE DISTRICT MATERIALS ENGINEER.

ESTIMATED QUANTITIES

ITEM	UNITS	QUANTITY
CLASS 20 EXCAVATION	CY	239
PILES - HP 14 x 117 -- 22 @ 95'	LF	2090

NOTE: 11 - HP 14 x 117 STEEL BEARING PILING REQUIRED AT EACH ABUTMENT.

NOTE: BARRIER RAIL NOT SHOWN IN DETAILS.

DESIGN FOR 0° SKEW
**120'-0" x 44'-0" PRETENSIONED
 PRESTRESSED CONCRETE BEAM BRIDGE**
 120'-0" SINGLE SPAN
ABUTMENT DETAILS
 STA. 1134+61.00 (1A 92) FEBRUARY, 2012
CASS COUNTY
 IOWA DEPARTMENT OF TRANSPORTATION - HIGHWAY DIVISION
 DESIGN SHEET NO. 6 OF 25 FILE NO. 30484 DESIGN NO. 113

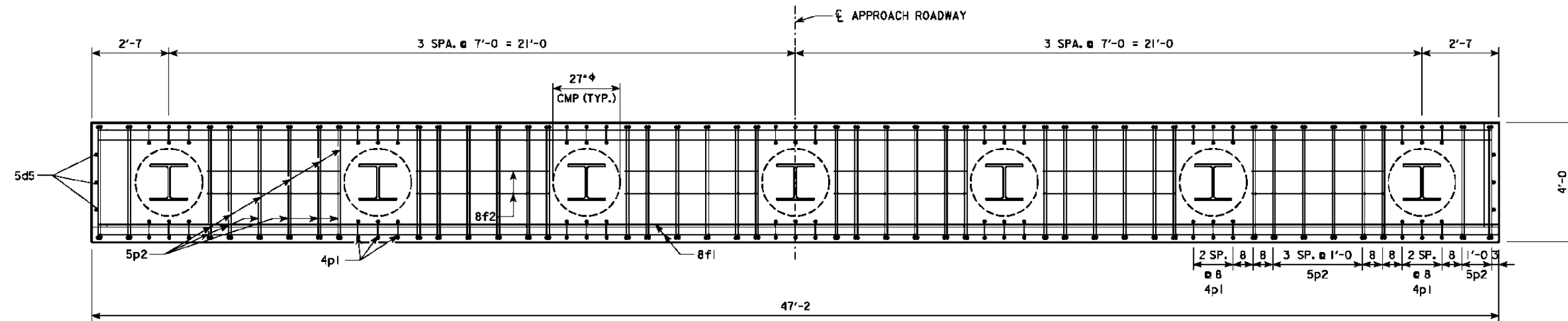
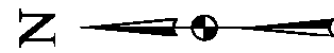

ABUTMENT PLAN VIEW

ABUTMENT KEEPER BLOCK
REINFORCEMENT NOT SHOWN FOR CLARITY

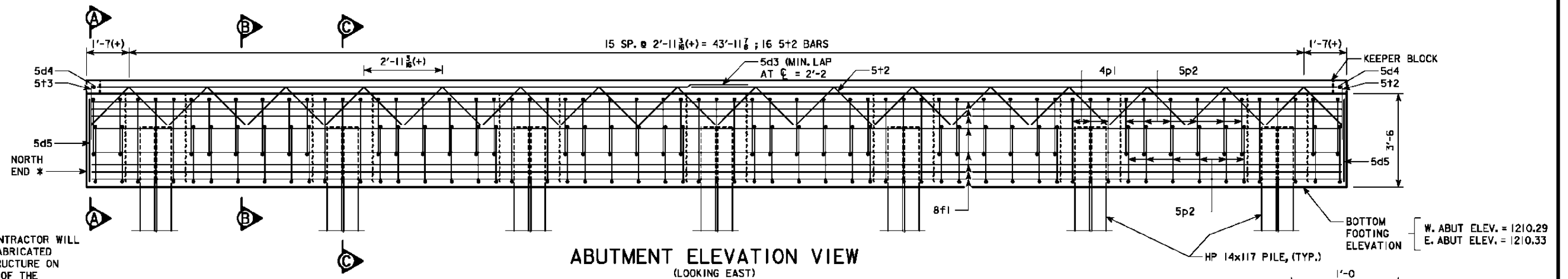

ABUTMENT ELEVATION VIEW

(LOOKING EAST)

* ASSUMES THE CONTRACTOR WILL STAGE THE PREFABRICATED BRIDGE SUPERSTRUCTURE ON THE NORTH SIDE OF THE EXISTING BRIDGE.

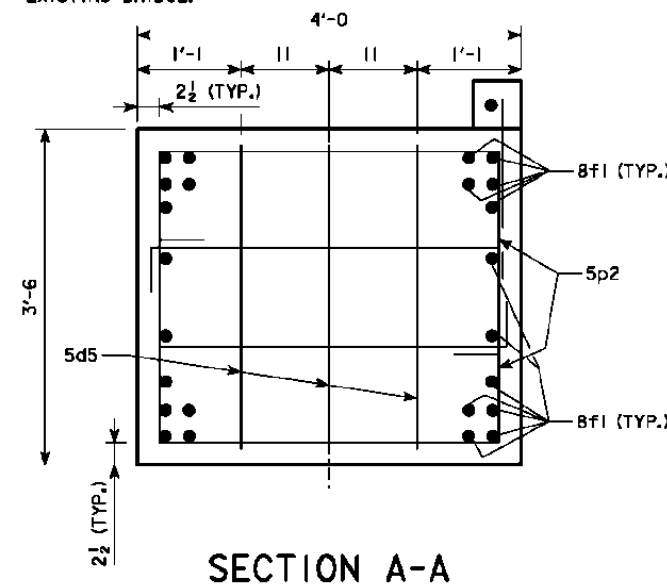

SECTION A-A

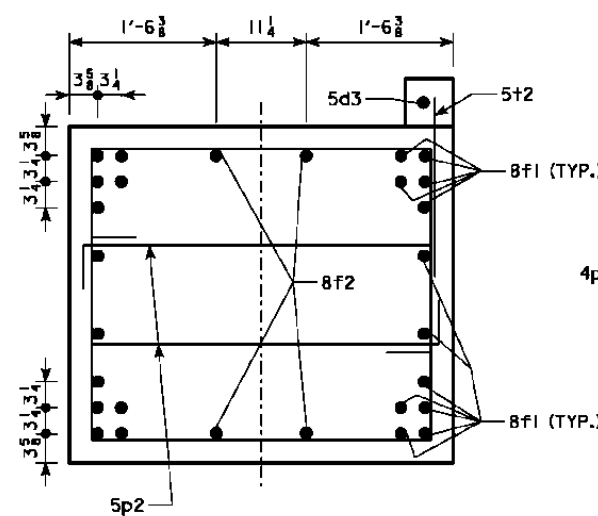

SECTION B-B

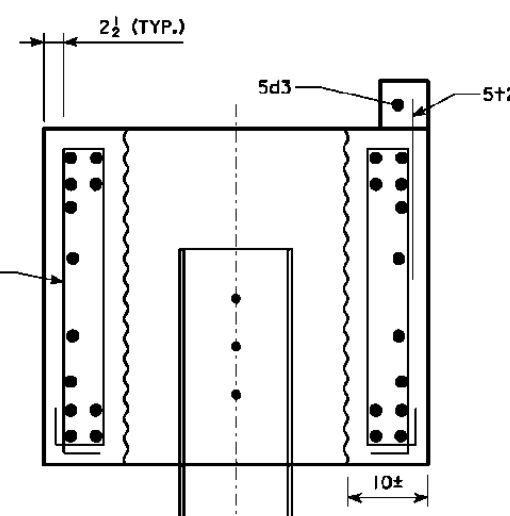

SECTION C-C

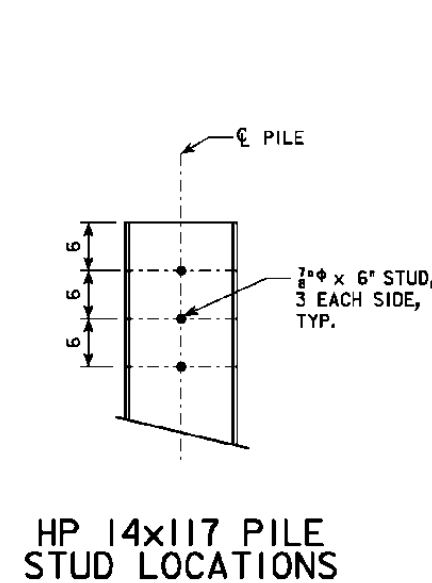

HP 14x117 PILE STUD LOCATIONS

NOTE: SEE DESIGN SHEET 10 FOR QUANTITIES

DESIGN FOR 0° SKEW
**120'-0 x 44'-0 PRETENSIONED
 PRESTRESSED CONCRETE BEAM BRIDGE**
 120'-0 SINGLE SPAN
PRECAST ABUTMENT FOOTING DETAILS
 STA. 1134+61.00 (1A 92) FEBRUARY, 2012
CASS COUNTY
 IOWA DEPARTMENT OF TRANSPORTATION - HIGHWAY DIVISION
 DESIGN SHEET NO. 9 OF 25 FILE NO. 30484 DESIGN NO. 113

BENT BAR DETAILS

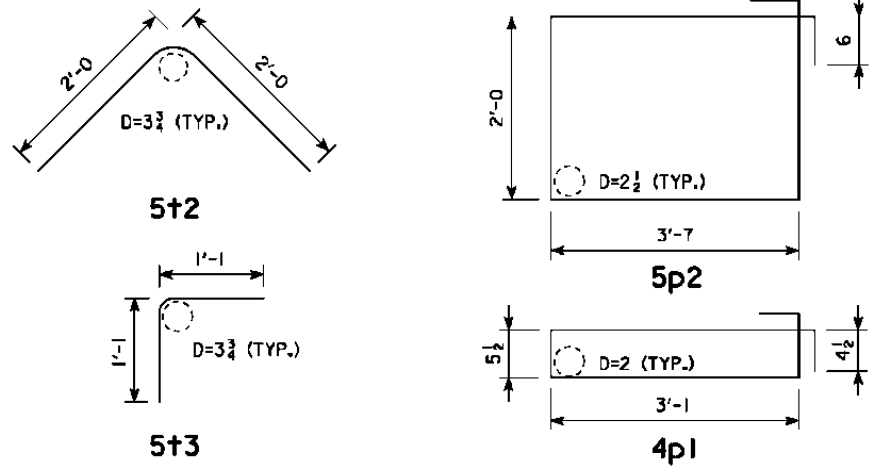

NOTE: ALL DIMENSIONS ARE OUT TO OUT.
D = PIN DIAMETER.

REINFORCING BAR LIST - ONE ABUTMENT

BAR	LOCATION	SHAPE	NO.	LENGTH	WEIGHT
5d3	KEEPER BLOCK LONGITUDINAL	—	2	24'-5	51
5d4	KEEPER BLOCK LONGITUDINAL	—	2	3'-0	6
5d5	ABUTMENT FOOTING END VERTICAL	—	6	3'-2	20
8f1	ABUTMENT FOOTING LONGITUDINAL	—	24	46'-9	2996
8f2	ABUTMENT FOOTING LONGITUDINAL	—	24	4'-5	283
4p1	ABUTMENT FOOTING HOOP	□	42	7'-10	220
5p2	ABUTMENT FOOTING HOOP	□	80	12'-2	1015
5+2	KEEPER BLOCK TIE	┌	18	4'-0	75
5+3	KEEPER BLOCK DOWEL	┌	2	2'-2	5
TOTAL (LBS.)					4671

CONCRETE PLACEMENT QUANTITIES

WEST PRECAST ABUTMENT FOOTING	21	
EAST PRECAST ABUTMENT FOOTING	21	
PILE POCKETS - STRUCTURAL CONCRETE (MISC.)	7.8	
WEST KEEPER BLOCK	0.5	
EAST KEEPER BLOCK	0.5	
TOTAL (CU YDS.)		50.8

ESTIMATED QUANTITIES

ITEM	UNITS	QUANTITY
STRUCTURAL CONCRETE (BRIDGE)	CY	43
STRUCTURAL CONCRETE (MISC.)	CY	7.8
EPOXY COATED REINFORCING STEEL 2 @ 4671	LB	9342
27"φ CMP	LF	49

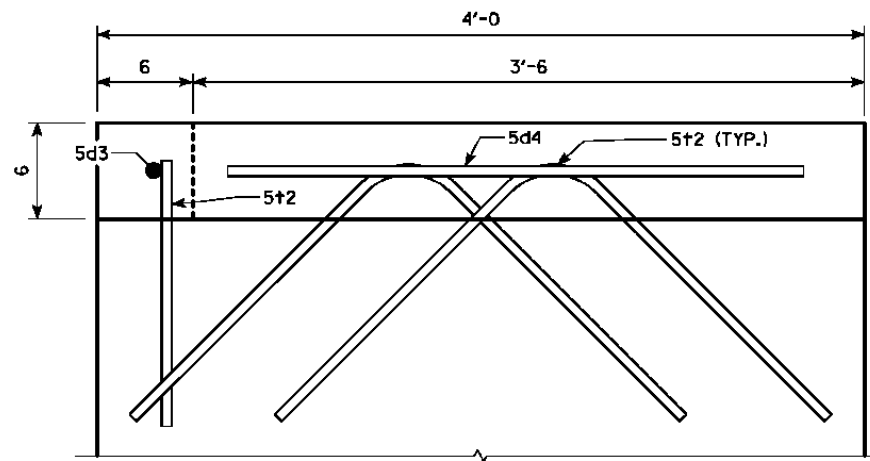

KEEPER BLOCK REINFORCING DETAIL
SOUTH END *

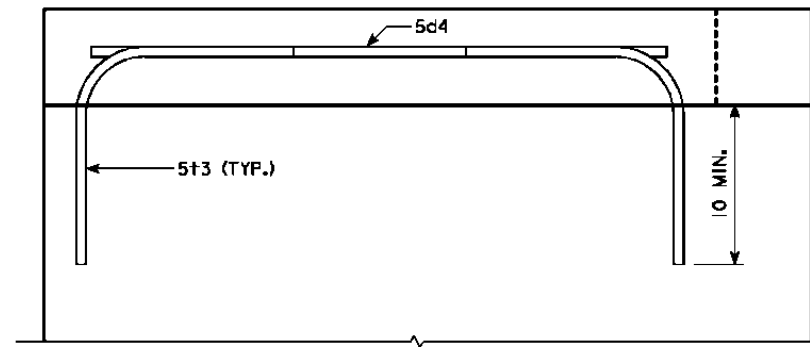

KEEPER BLOCK REINFORCING DETAIL
NORTH END *

THE 5+3 BARS SHALL BE SET IN DRILLED HOLES. HOLES ARE TO BE 10" DEEP. THE DOWELS SHALL BE INSTALLED IN ACCORDANCE WITH THE MANUFACTURER'S RECOMMENDATIONS. USE A POLYMER GROUT SYSTEM IN ACCORDANCE WITH ARTICLE 2301.03,E OF THE STANDARD SPECIFICATIONS.

PRECAST ABUTMENT FOOTING NOTES:

ALL 27"φ CMP ARE GALVANIZED CORRUGATED STEEL PIPE, TYPE 1, 16 GAGE IN ACCORDANCE WITH STANDARD SPECIFICATIONS 4141 AND MATERIALS I.M. 441

NOTE: SEE DESIGN SHEET 9 FOR DETAILS.

DESIGN FOR 0° SKEW
120'-0 x 44'-0 PRETENSIONED
PRESTRESSED CONCRETE BEAM BRIDGE
120'-0 SINGLE SPAN
ABUTMENT FOOTING QUANTITIES
STA. 1134+61.00 (1A 92) FEBRUARY, 2012
CASS COUNTY
IOWA DEPARTMENT OF TRANSPORTATION - HIGHWAY DIVISION
DESIGN SHEET NO. 10 OF 25 FILE NO. 30484 DESIGN NO. 113

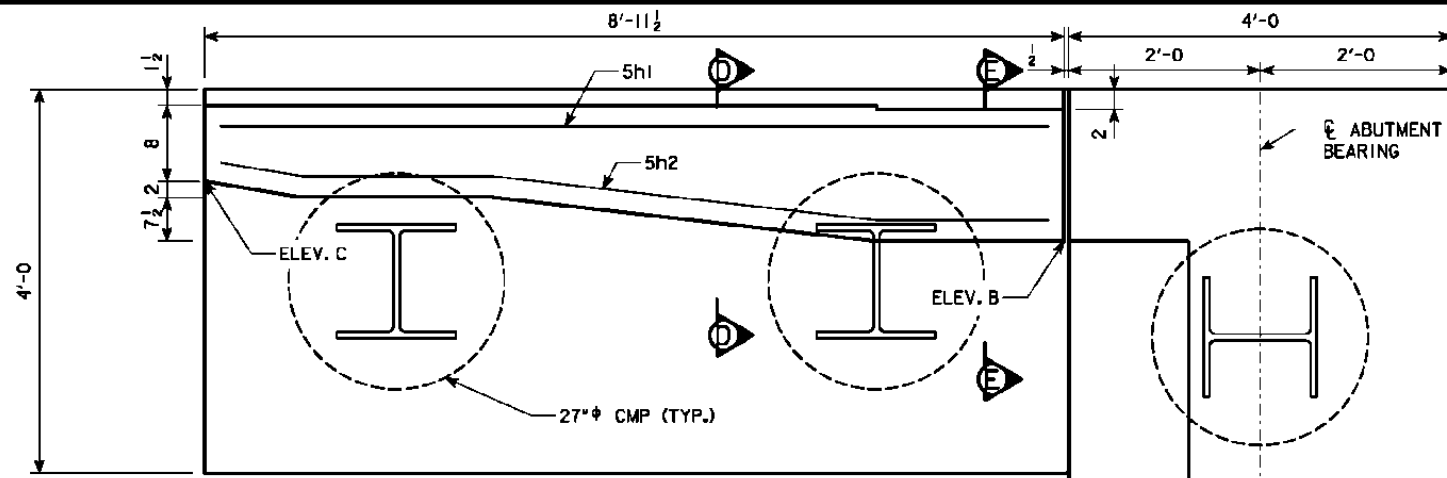

LOCATION	ELEV. B	ELEV. C
NORTHEAST	1218.56	1218.53
SOUTHEAST	1218.56	1218.53
NORTHWEST	1218.52	1218.48
SOUTHWEST	1218.52	1218.48

THE CONTRACTOR MAY NEED TO ADJUST THE WINGWALL FOOTING ELEVATION DUE TO CONSTRUCTION TOLERANCES. THE GOAL IS A LEVEL TRANSITION OF THE TOP OF BARRIER RAIL ALONG THE PROFILE GRADE.

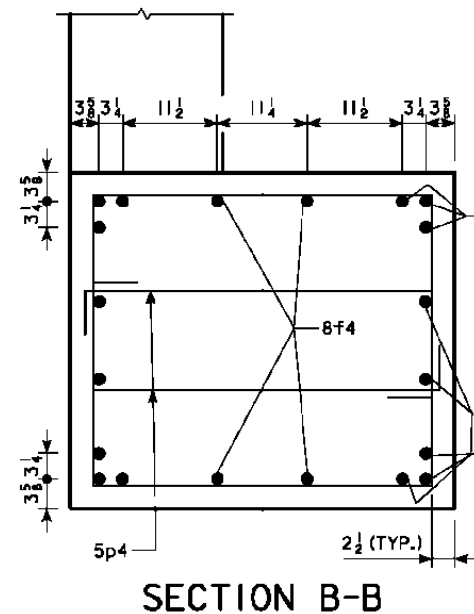
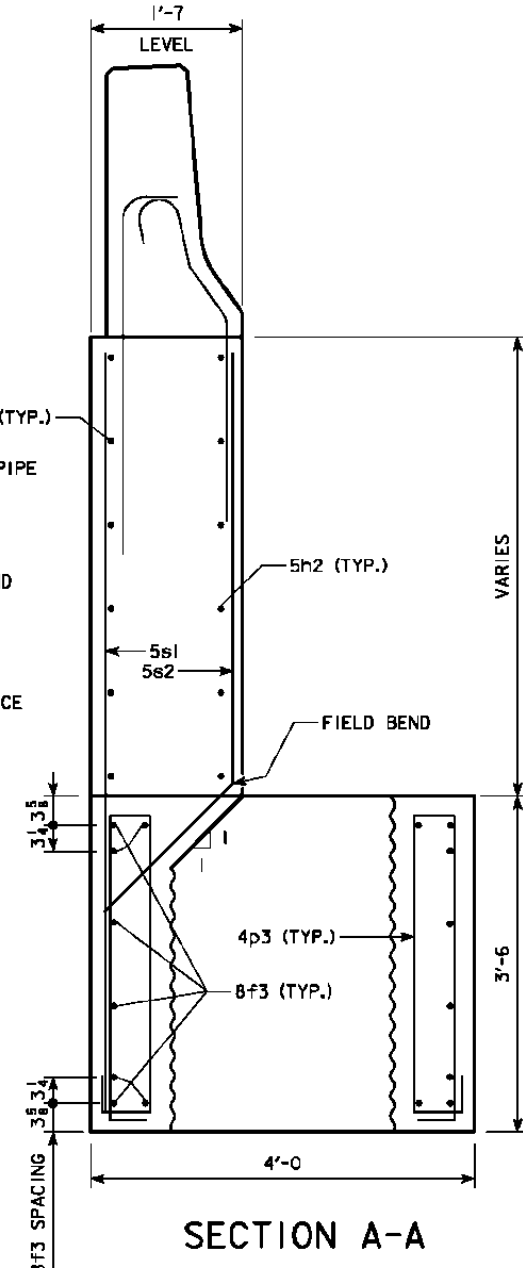
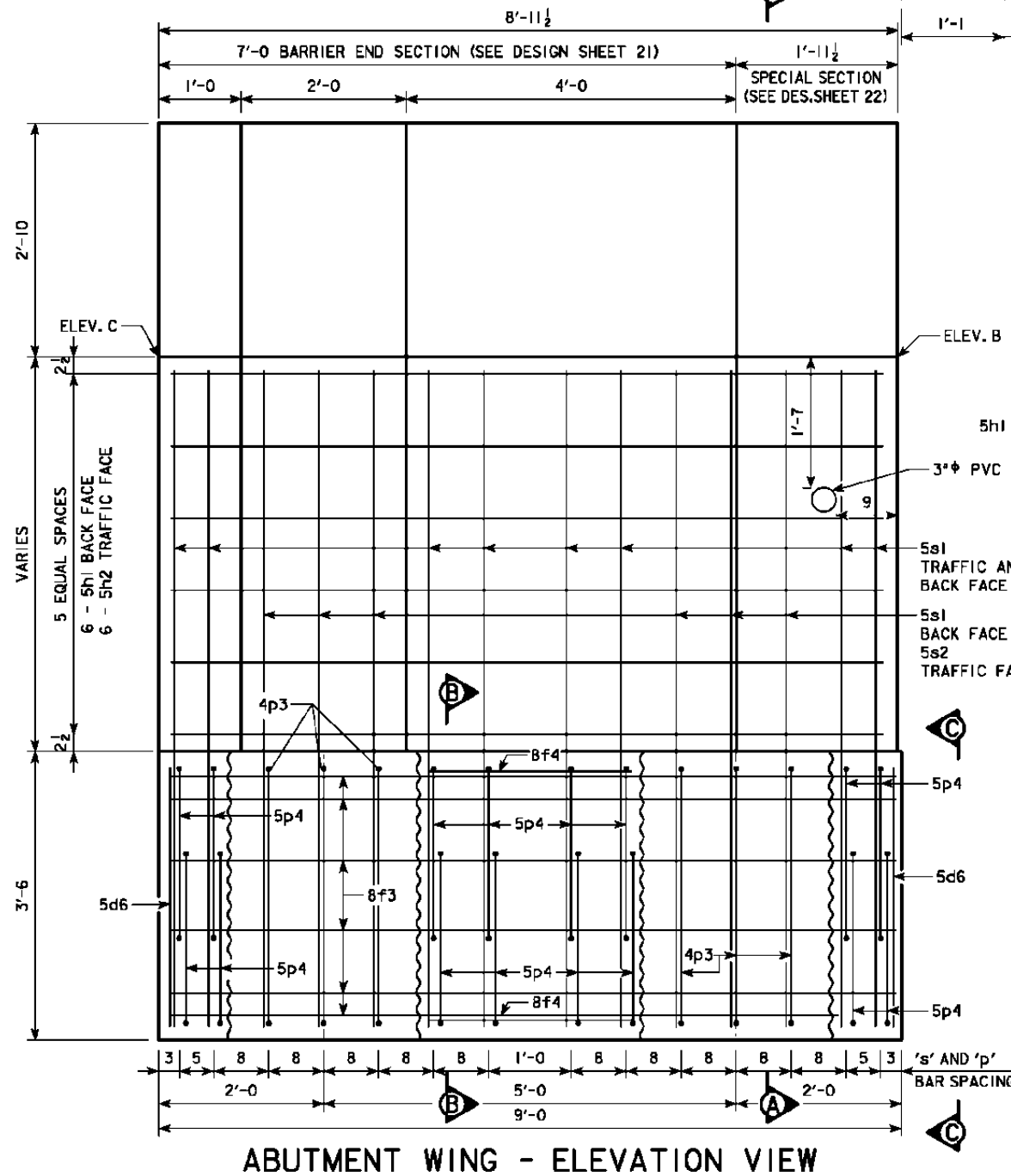

SECTION B-B

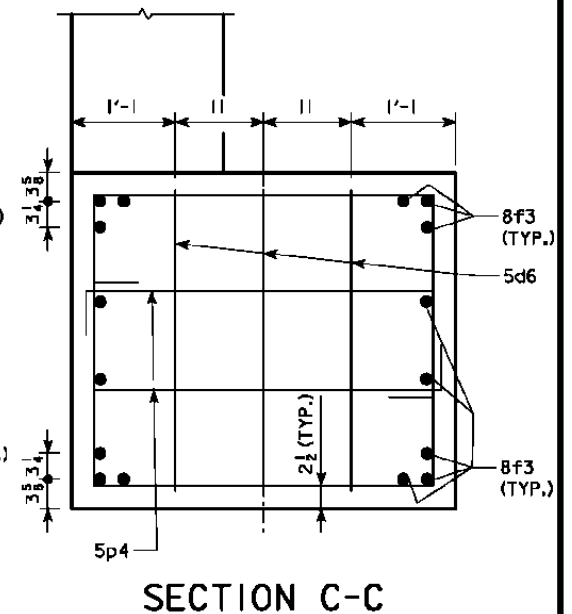

SECTION C-C

NOTE: PLUG 3" PVC PIPE WITH EXPANDING FOAM PRIOR TO BACKFILLING BEHIND ABUTMENTS.

BOTTOM FOOTING ELEVATION
 W. ABUT. ELEV. = 1210.29
 E. ABUT. ELEV. = 1210.33

SEE DESIGN SHEET 12 FOR SECTION D-D AND E-E.

DESIGN FOR 0° SKEW

120'-0" x 44'-0" PRETENSIONED PRESTRESSED CONCRETE BEAM BRIDGE

120'-0" SINGLE SPAN

WING WALL DETAILS

STA. 1134+61.00 (IA 92) FEBRUARY, 2012

CASS COUNTY

IOWA DEPARTMENT OF TRANSPORTATION - HIGHWAY DIVISION

DESIGN SHEET NO. 11 OF 25 FILE NO. 30484 DESIGN NO. 113

BENT BAR DETAILS

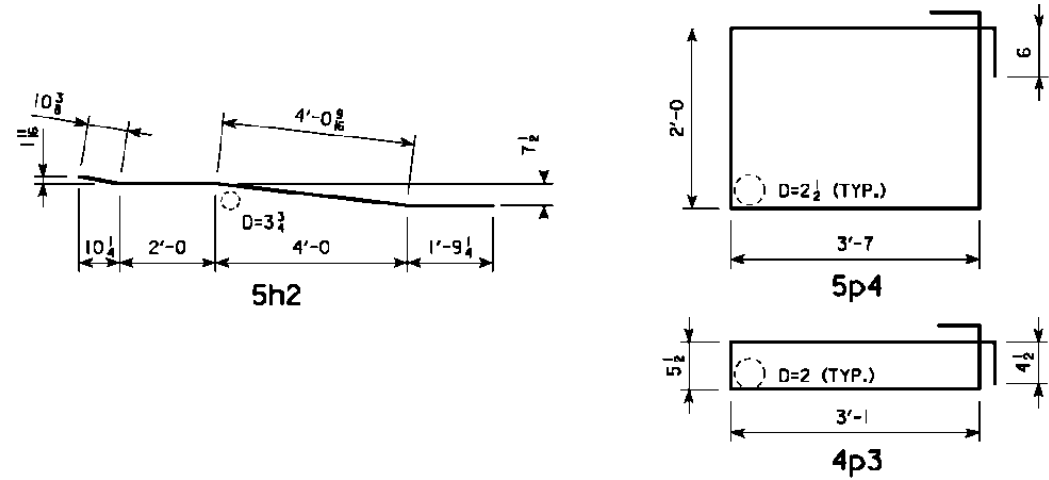

NOTE: ALL DIMENSIONS ARE OUT TO OUT.
D = PIN DIAMETER.

REINFORCING BAR LIST - ONE WINGWALL

BAR	LOCATION	SHAPE	NO.	LENGTH	WEIGHT
5d6	WING FOOTING END VERTICAL	—	6	3'-2	20
8f3	WING FOOTING LONGITUDINAL	—	16	8'-8	370
8f4	WING FOOTING LONGITUDINAL	—	4	2'-5	26
5h1	HORIZONTAL BACK FACE	—	6	8'-7	54
5h2	HORIZONTAL TRAFFIC FACE	—	6	8'-8	54
4p3	WING FOOTING HOOP	□	12	7'-10	63
5p4	WING FOOTING HOOP	□	16	12'-2	203
5s1	VERTICAL BOTH FACES	—	22	7'-6	172
5s2	VERTICAL TRAFFIC FACE	—	6	6'-6	41
TOTAL (LBS.)					1003

CONCRETE PLACEMENT QUANTITIES

ITEM	QUANTITY	UNITS
PRECAST WINGWALLS ^Δ	4 @ 5.6 CY	22.4
PILE POCKETS - STRUCTURAL CONCRETE (MISC.)	4 @ 1.0 CY	4.0
TOTAL (CU YDS.)		26.4

ESTIMATED QUANTITIES

ITEM	UNITS	QUANTITY
STRUCTURAL CONCRETE (BRIDGE)	CY	22.4
STRUCTURAL CONCRETE (MISC.)	CY	4.0
EPOXY COATED REINFORCING STEEL	4 @ 1003 LBS.	4012
27" ϕ CMP	LF	28

^Δ BARRIER RAIL CONCRETE IS NOT INCLUDED.

ESTIMATED WEIGHT OF ONE PRECAST WING WALL WITH BARRIER RAIL IS 13.1 TONS.

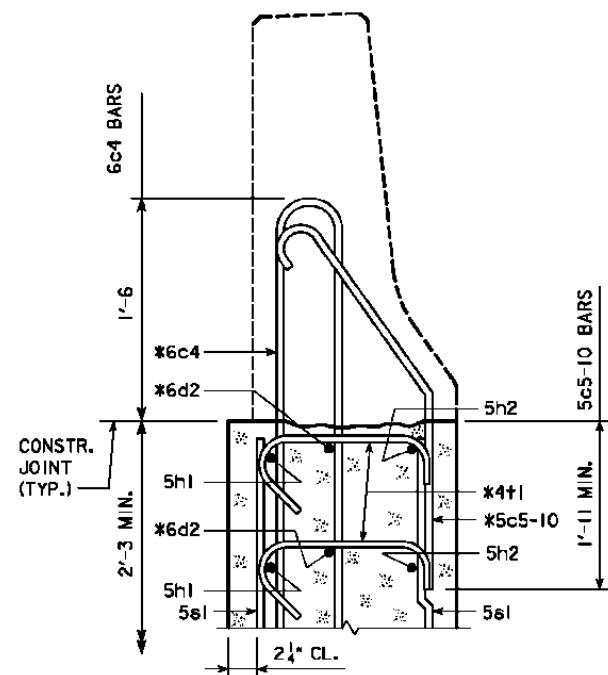

SECTION D-D

* BARRIER RAIL END SECTION BARS TO BE PLACED WITH ABUTMENT WING.

SEE END SECTION DETAILS IN THESE PLANS FOR DETAILS OF BARRIER RAIL END SECTION. REINFORCING BARS 6c3, 6c4, 5c5-10, 6d2 & 4t1 ARE INCLUDED IN THE SUPERSTRUCTURE QUANTITIES.

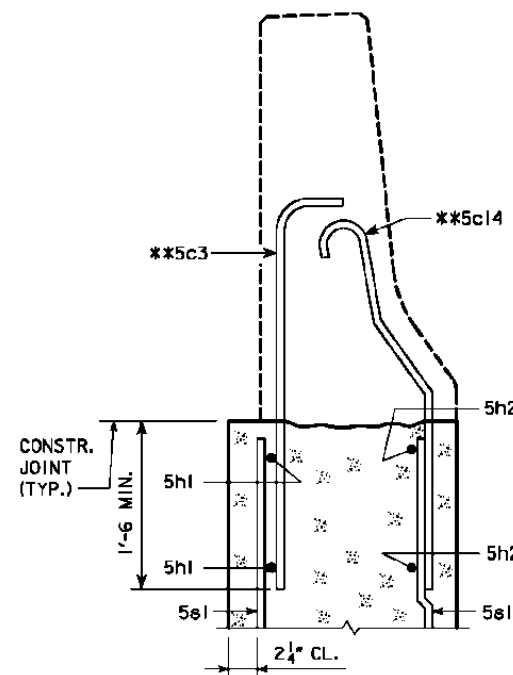

SECTION E-E

** BARRIER RAIL SPECIAL SECTION BARS TO BE PLACED WITH ABUTMENT WING.

SEE BARRIER RAILS DETAILS IN THESE PLANS. REINFORCING BARS 5c3 AND 5c14 ARE INCLUDED IN THE SUPERSTRUCTURE QUANTITIES.

SEE DESIGN SHEET 11 FOR LOCATION OF SECTION D-D AND E-E.

DESIGN FOR 0° SKEW
**120'-0 x 44'-0 PRETENSIONED
 PRESTRESSED CONCRETE BEAM BRIDGE**
 120'-0 SINGLE SPAN
WING WALL QUANTITIES
 STA. 1134+61.00 (1A 92) FEBRUARY, 2012
CASS COUNTY
 IOWA DEPARTMENT OF TRANSPORTATION - HIGHWAY DIVISION
 DESIGN SHEET NO. 12 OF 25 FILE NO. 30484 DESIGN NO. 113

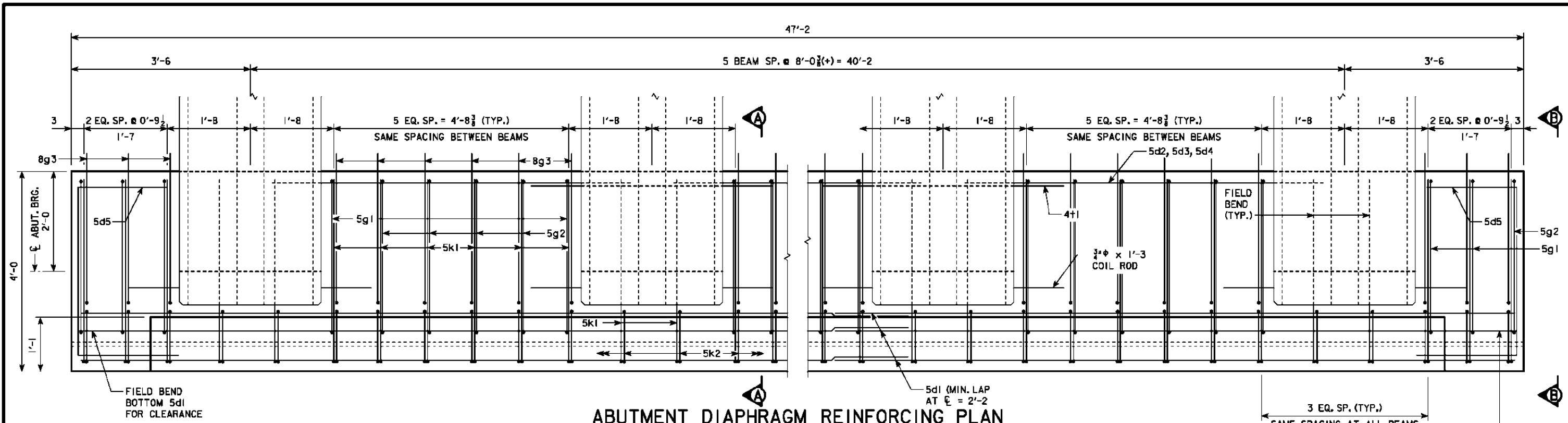

ABUTMENT DIAPHRAGM REINFORCING PLAN

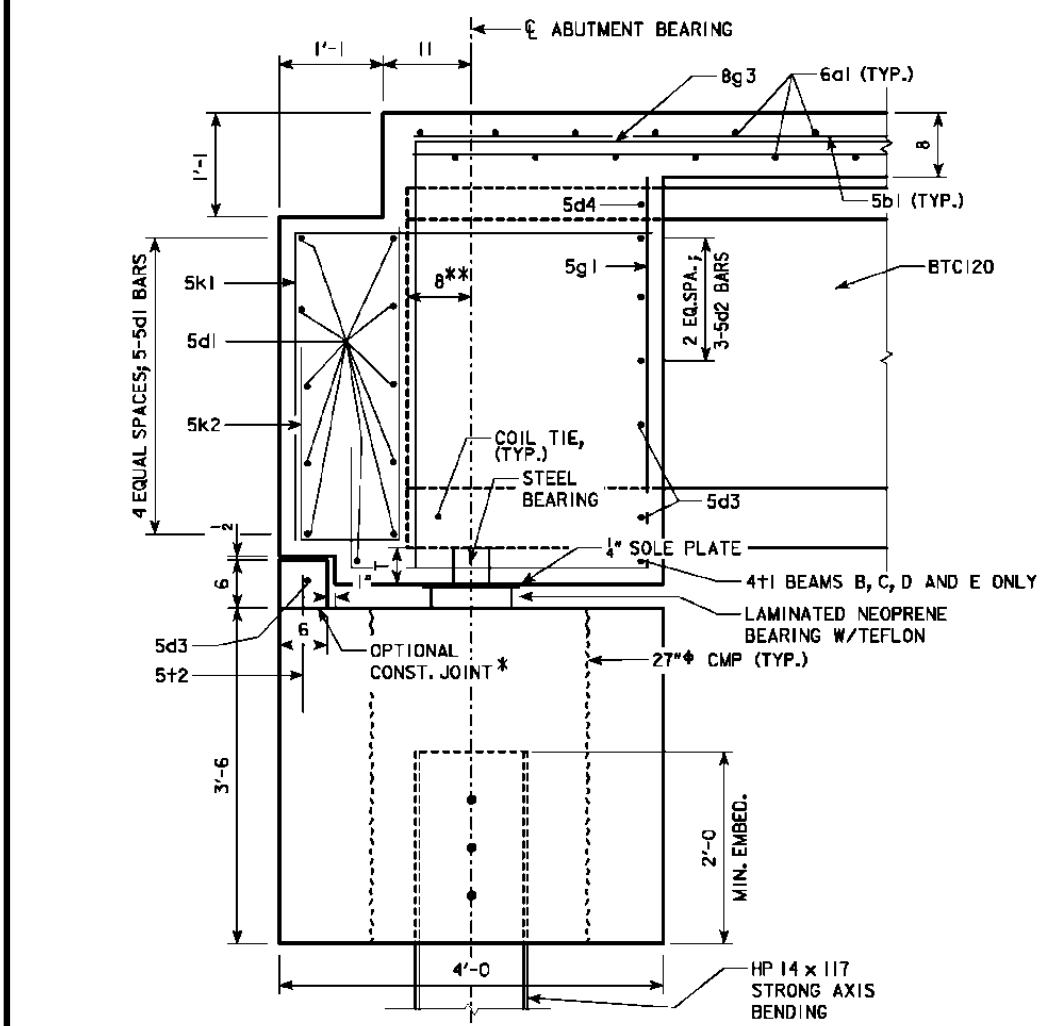

DIAPHRAGM REINFORCING SECTION A-A

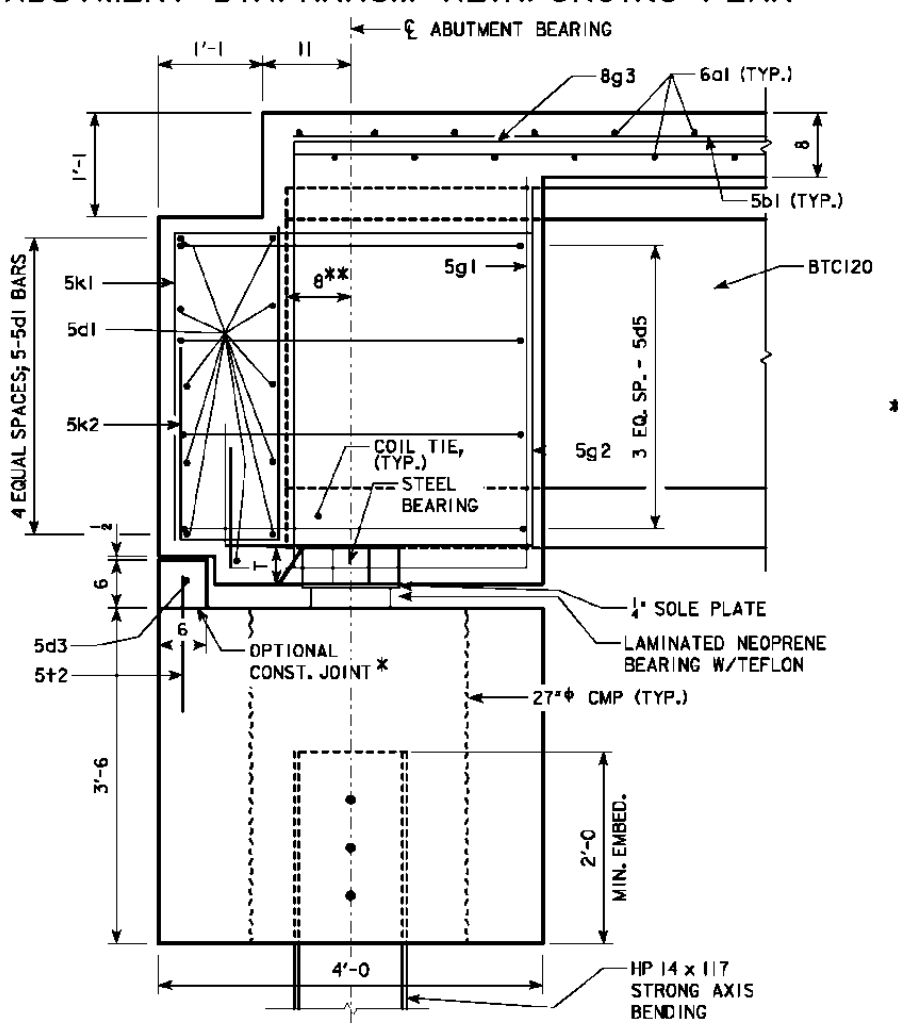

DIAPHRAGM REINFORCING SECTION B-B
END KEEPER BLOCK NOT SHOWN FOR CLARITY

STEEL BEARING	
BEAM LINE	STEEL BEARING THICKNESS (T) (IN.)
C, D	4.5
B, E	2.5
A, F	0.5

** END OF BEAM TO \bar{C} BEAM BEARING DIMENSION

STEEL BEARING - 3 x 2'-4 1/2 x T
WEIGHT OF THE STEEL BEARING INCLUDED IN THE BID ITEM "STRUCTURAL STEEL".

* OPTIONAL CONSTRUCTION JOINT ON EAST AND WEST ENDS AND SOUTH SIDE OF PRECAST ABUTMENT FOOTING. INTENTIONALLY ROUGHEN OPTIONAL CONSTRUCTION JOINT SURFACE TO 1/4" AMPLITUDE. SEE KEEPER BLOCK DETAIL ON DESIGN SHEET 10 FOR ADDITIONAL INFORMATION.

SEE DESIGN SHEET 14 FOR BEARING PAD DETAILS.
SEE DESIGN SHEET 18 FOR COIL TIE LOCATION.

DESIGN FOR 0° SKEW
120'-0 x 44'-0 PRETENSIONED PRESTRESSED CONCRETE BEAM BRIDGE
 120'-0 SINGLE SPAN
ABUTMENT DIAPHRAGM DETAILS
 STA. 1134+61.00 (IA 92) FEBRUARY, 2012
CASS COUNTY
 IOWA DEPARTMENT OF TRANSPORTATION - HIGHWAY DIVISION
 DESIGN SHEET NO. 13 OF 25 FILE NO. 30484 DESIGN NO. 113

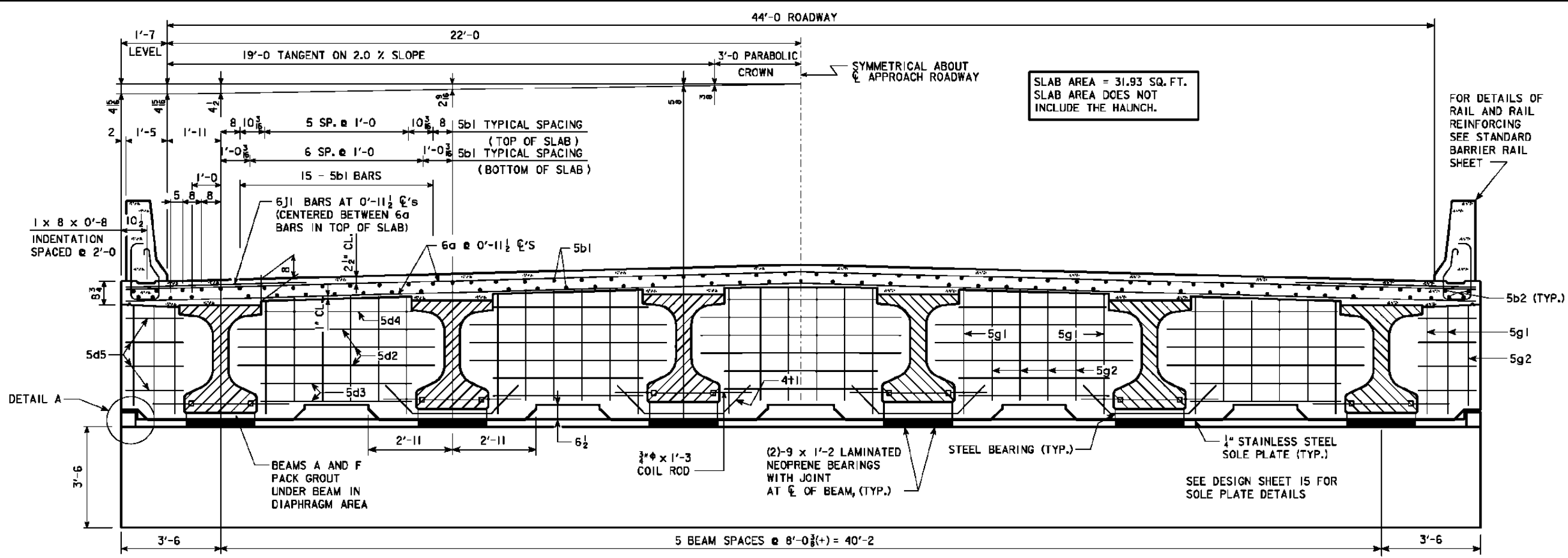

SECTION NEAR ABUTMENT

SUPERSTRUCTURE NOTES:

THE FLOOR SLAB AS SHOWN INCLUDES 1/2" INTEGRAL WEARING SURFACE.
 THE ABUTMENT DIAPHRAGM CONCRETE IS TO BE PLACED MONOLITHICALLY WITH THE FLOOR SLAB.
 ALL BEAMS ARE TO BE SET VERTICAL.
 FORMS FOR THE SLAB AND BARRIER RAIL ARE TO BE SUPPORTED BY THE PRESTRESSED CONCRETE BEAMS.
 CLEAR DISTANCE FROM FACE OF CONCRETE TO NEAR REINFORCING BAR SHALL BE 2 INCHES UNLESS OTHERWISE NOTED OR SHOWN.
 ALL SLAB AND DIAPHRAGM REINFORCING IS TO BE WIRED IN PLACE AND ADEQUATELY SUPPORTED BEFORE CONCRETE IS PLACED.
 TOP TRANSVERSE REINFORCING STEEL IS TO BE PARALLEL TO AND 2 1/2" CLEAR BELOW TOP OF SLAB. BOTTOM TRANSVERSE REINFORCING STEEL IS TO BE PARALLEL TO AND 1" CLEAR ABOVE BOTTOM OF SLAB. TOP AND BOTTOM REINFORCING STEEL IS TO BE SUPPORTED BY INDIVIDUAL BAR CHAIRS SPACED AT NOT MORE THAN 3'-0" CENTERS LONGITUDINALLY AND TRANSVERSELY, OR BY CONTINUOUS ROWS OF BAR HIGH CHAIRS OR SLAB BOLSTERS SPACED 4'-0" APART. I.M. 451.01 REQUIREMENTS SHALL APPLY FOR BAR CHAIRS, BAR HIGH CHAIRS, AND SLAB BOLSTERS.
 COST OF BEARING PADS IS TO BE INCLUDED IN THE PRICE BID FOR "PRETENSIONED PRESTRESSED CONCRETE BEAMS".
 TRANSVERSE SLAB REINFORCING MAY BE SPLICED WITH ONE LAP LOCATED AS FOLLOWS:
 TOP BAR - LAP MIDWAY BETWEEN BEAMS (MIN. LAP = 1'-10").
 BOTTOM BARS - LAP OVER BEAMS (MIN. LAP = 1'-10").
 PAYMENT FOR REINFORCING BARS SHALL BE BASED ON NO SPLICES, AND NO ALLOWANCE SHALL BE MADE FOR THE ADDITIONAL LENGTH OF BAR REQUIRED FOR THE USE OF SPLICES.

ESTIMATED WEIGHT OF THE PREFABRICATED BRIDGE SUPERSTRUCTURE IS 721 TONS. THE ESTIMATED WEIGHT IS A SERVICE WEIGHT (UNFACTORED) BASED ON AN 8" THICK DECK, 1 1/2" AVERAGE THICKNESS HAUNCH AND THE DIMENSIONS AND DETAILS SHOWN IN THESE PLANS. THE CONTRACTOR SHALL CONSIDER CONSTRUCTION LIVE LOADS, ADDITIONAL DEAD LOADS (FALSEWORK, FORMWORK, ETC.) AND CONSTRUCTION VARIANCES/TOLERANCES FOR CALCULATING THE PREFABRICATED BRIDGE SUPERSTRUCTURE MOVE WEIGHT.

BEARING PAD ORIENTATION

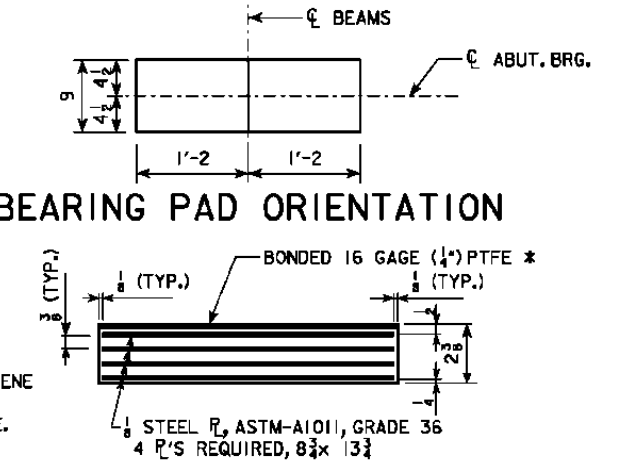

BEARING PAD DETAIL

* IF THE CONTRACTOR CHOOSES A PREFABRICATED BRIDGE MOVE SYSTEM THAT DOES NOT REQUIRE SLIDING THE BRIDGE USING THE STAINLESS STEEL AND PTFE, THE PTFE SURFACE CAN BE OMITTED AND THE LAMINATED NEOPRENE BEARING USED FOR THE FINAL BEARING CONDITION. IF PTFE IS OMITTED ADJUST PRECAST FOOTING ELEVATION ACCORDINGLY.
 SEE DESIGN SHEET 18 FOR DETAILS OF INTERMEDIATE DIAPHRAGMS.

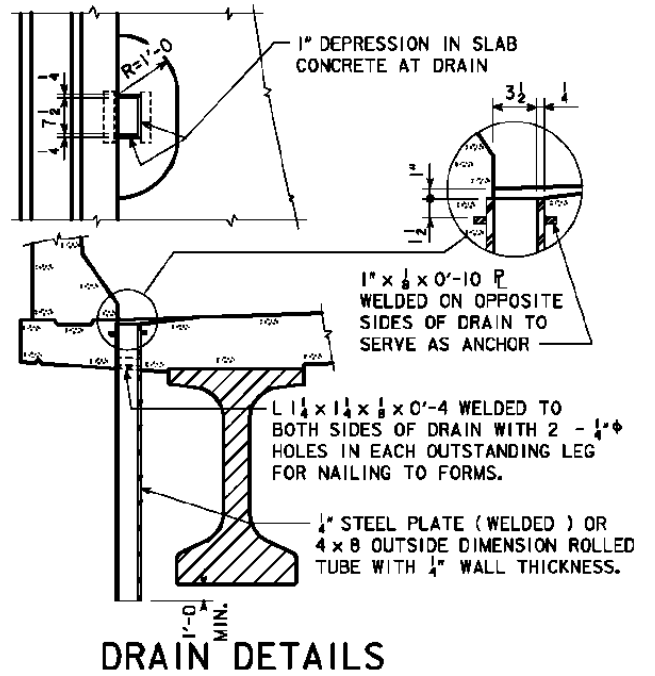
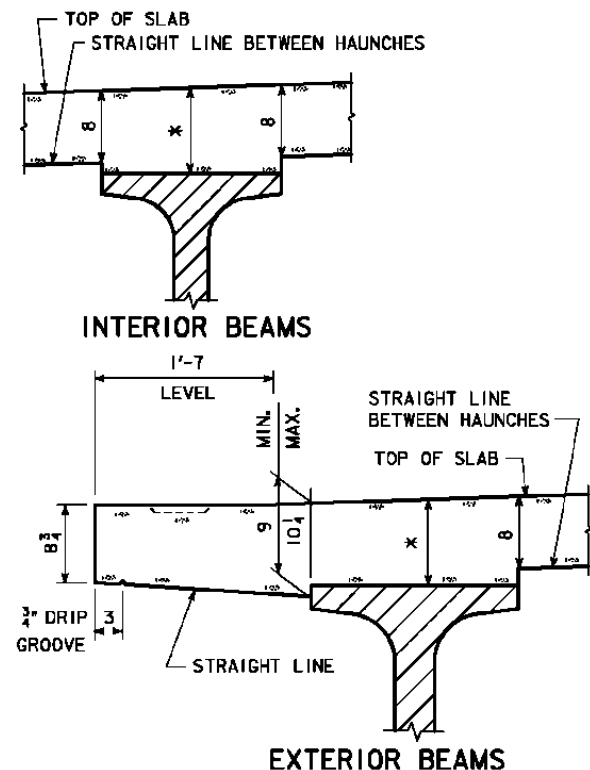

NOTE:
 DRAINS ARE TO BE GALVANIZED. 8 DRAINS REQUIRED. SEE "SITUATION PLAN" FOR LOCATION. WEIGHT OF DRAINS IS INCLUDED IN THE QUANTITY FOR "STRUCTURAL STEEL". WEIGHT IS BASED ON ROLLED TUBE.

DATA FOR ONE DRAIN	
BEAM SIZE	BTC
DRAIN WEIGHT (LBS.)	106
DRAIN LENGTH (FT.)	5'-5 1/2

DESIGN FOR 0° SKEW
120'-0" x 44'-0" PRETENSIONED PRESTRESSED CONCRETE BEAM BRIDGE
 120'-0" SINGLE SPAN
SUPERSTRUCTURE DETAILS
 STA. 1134+61.00 (1A 92) FEBRUARY, 2012
CASS COUNTY
 IOWA DEPARTMENT OF TRANSPORTATION - HIGHWAY DIVISION
 DESIGN SHEET NO. 14 OF 25 FILE NO. 30484 DESIGN NO. 113

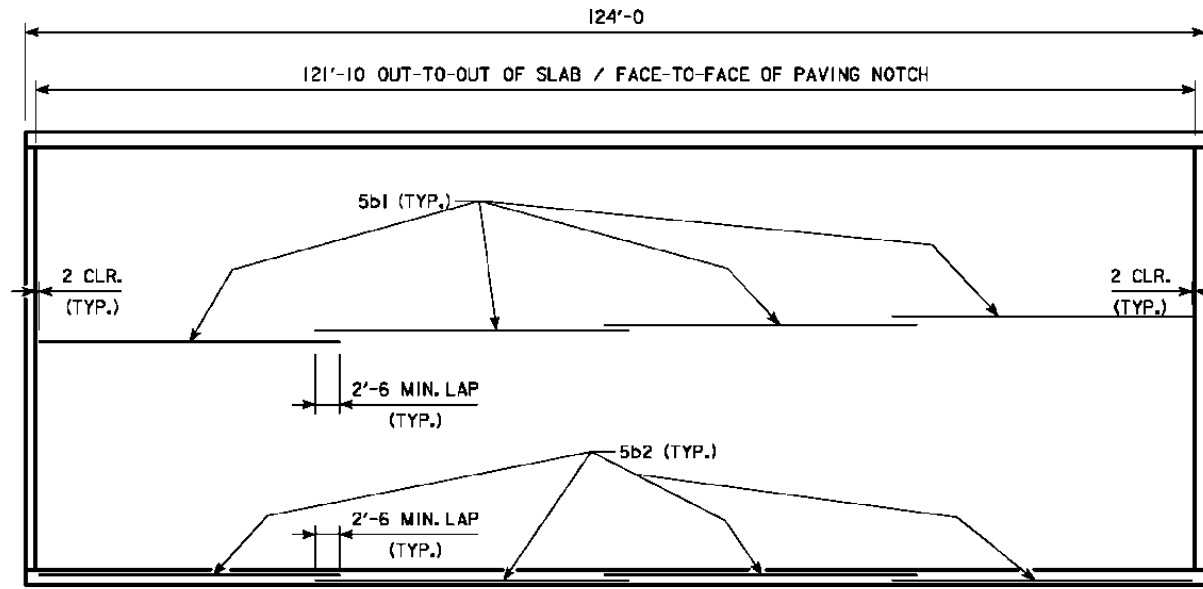

SLAB LONGITUDINAL REINFORCING LAYOUT

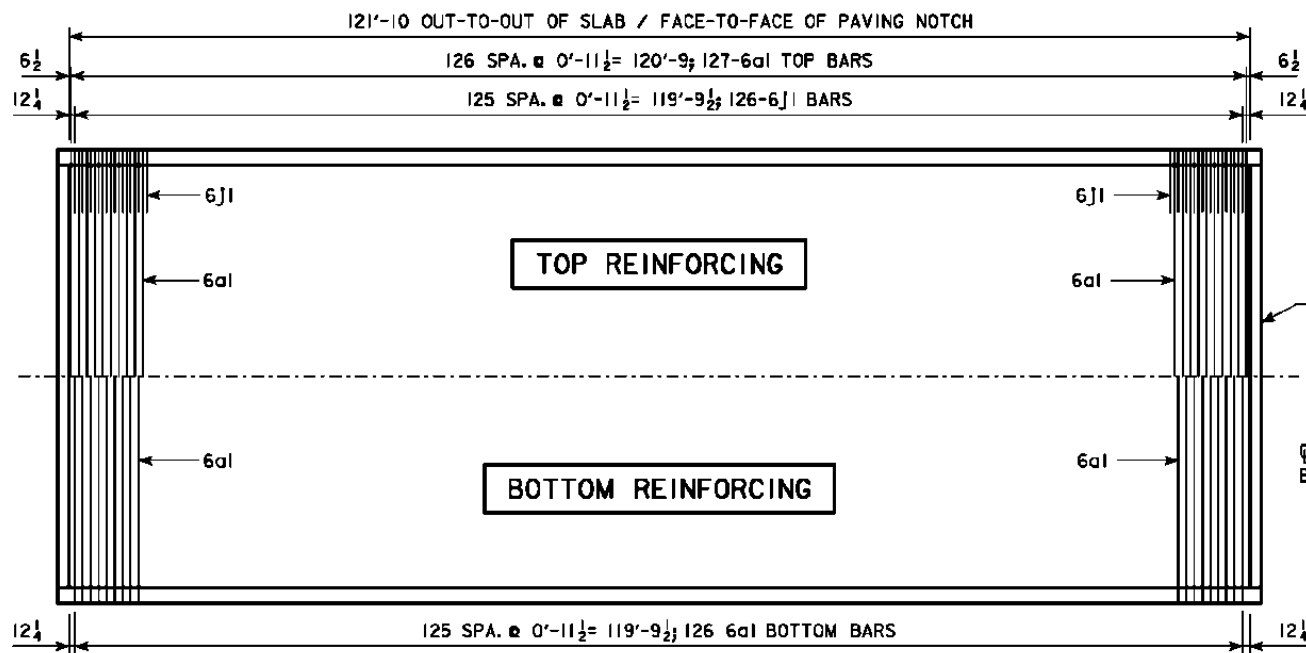

CONCRETE PLACEMENT DIAGRAM

NOTE: THE INTENT IS FOR THE CONCRETE DECK SLAB AND DIAPHRAGMS TO BE PLACED IN ONE SECTION. ALTERNATE PROCEDURES FOR PLACING SLAB CONCRETE MAY BE SUBMITTED FOR APPROVAL TOGETHER WITH A STATEMENT OF THE PROPOSED METHOD AND EVIDENCE THAT THE CONTRACTOR POSSESSES THE NECESSARY EQUIPMENT AND FACILITIES TO ACCOMPLISH THE REQUIRED RESULTS.

BENT BAR DETAILS

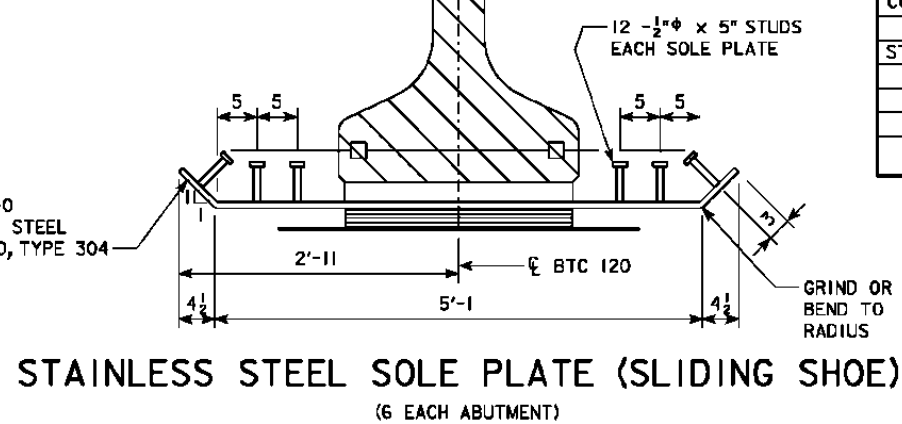
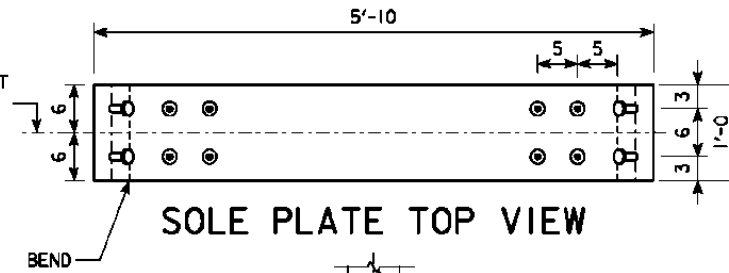
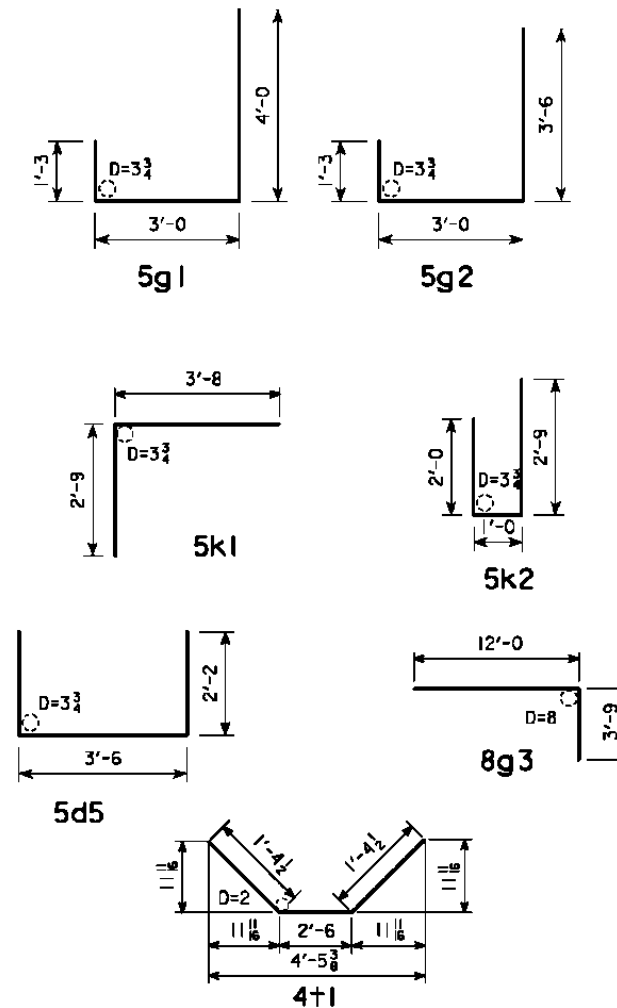

REINF. BAR LIST-ONE SUPER. & TWO DIAPHRAGMS

BAR	LOCATION	SHAPE	NO.	LENGTH	WEIGHT
6a1	SLAB TRANSV. TOP & BOTT.	—	253	46'-10"	17797
5b1	SLAB LONGIT. TOP & BOTT.	—	356	32'-3"	11975
5b2	SLAB LONGIT., UNDER BARRIER RAIL	—	32	32'-10"	1096
5d1	ABUT. PAVING NOTCH	—	44	24'-7"	1128
5d2	ABUT. DIAPH. LONGIT.	—	30	7'-0"	219
5d3	ABUT. DIAPH. LONGIT.	—	20	5'-2"	108
5d4	ABUT. DIAPH. LONGIT.	—	10	4'-10"	50
5d5	ABUT. DIAPH. ENDS	□	16	7'-10"	131
5g1	ABUT. DIAPH. VERT. F.F.	┘	28	8'-3"	241
5g2	ABUT. DIAPH. VERT. F.F.	┘	44	7'-9"	356
8g3	ABUT. DIAPH. VERT. B.F.	┘	72	15'-9"	3028
6j1	TOP OF SLAB TRANSV. (AT RAIL)	—	252	6'-3"	2366
5k1	PAVING NOTCH	┘	96	6'-5"	643
5k2	PAVING NOTCH	┘	96	5'-9"	576
4+1	UNDER BEAMS AT ABUTMENTS	┘	8	5'-3"	28
BARRIER RAIL - SEE DESIGN SHT. NO. 22					7638
REINFORCING STEEL EPOXY COATED - TOTAL (LBS.)					47380

CONC. PLACEMENT QUANTITIES

LOCATION	QUANTITY
SECTION 1, SLAB & ABUT. DIAPH.	198
TOTAL (CU. YDS.)	198

ESTIMATED QUANTITIES

ITEM	UNIT	QUANTITY
STRUCTURAL CONCRETE (BRIDGE)	CU. YD.	198
REINFORCING STEEL EPOXY COATED	LBS.	47380
PRETENSIONED PRESTRESSED CONCRETE BEAMS	EACH	6
STRUCTURAL STEEL		
DIAPHRAGMS		
STEEL BEARINGS		
DECK DRAINS		
1543	727	848
LBS.		3118

DESIGN FOR 0° SKEW
120'-0" x 44'-0" PRETENSIONED PRESTRESSED CONCRETE BEAM BRIDGE
 120'-0" SINGLE SPAN
SUPERSTRUCTURE DETAILS
 STA. 1134+61.00 (IA 92) FEBRUARY, 2012
CASS COUNTY
 IOWA DEPARTMENT OF TRANSPORTATION - HIGHWAY DIVISION
 DESIGN SHEET NO. 15 OF 25 FILE NO. 30484 DESIGN NO. 113

TOP OF SLAB ELEVATIONS **													
LOCATION	C.L. W. ABUT. BRG.												C.L. E. ABUT. BRG.
	LINE 1	LINE 2	LINE 3	LINE 4	LINE 5	LINE 6	LINE 7	LINE 8	LINE 9	LINE 10	LINE 11	LINE 12	LINE 13
GUTTER LINE	1218.52	1218.55	1218.57	1218.59	1218.60	1218.61	1218.62	1218.62	1218.62	1218.61	1218.60	1218.58	1218.57
BEAM LINE A	1218.56	1218.59	1218.61	1218.63	1218.64	1218.65	1218.65	1218.66	1218.65	1218.65	1218.64	1218.62	1218.60
BEAM LINE B	1218.72	1218.75	1218.77	1218.79	1218.80	1218.81	1218.81	1218.82	1218.81	1218.81	1218.80	1218.78	1218.76
BEAM LINE C	1218.88	1218.91	1218.93	1218.95	1218.96	1218.97	1218.98	1218.98	1218.97	1218.97	1218.96	1218.94	1218.93
CL. APPROACH ROADWAY *	1218.93	1218.96	1218.98	1219.00	1219.01	1219.02	1219.03	1219.03	1219.03	1219.02	1219.01	1218.99	1218.98
BEAM LINE D	1218.88	1218.91	1218.93	1218.95	1218.96	1218.97	1218.98	1218.98	1218.97	1218.97	1218.96	1218.94	1218.93
BEAM LINE E	1218.72	1218.75	1218.77	1218.79	1218.80	1218.81	1218.81	1218.82	1218.81	1218.81	1218.80	1218.78	1218.76
BEAM LINE F	1218.56	1218.59	1218.61	1218.63	1218.64	1218.65	1218.65	1218.66	1218.65	1218.65	1218.64	1218.62	1218.60
GUTTER LINE	1218.52	1218.55	1218.57	1218.59	1218.60	1218.61	1218.62	1218.62	1218.62	1218.61	1218.60	1218.58	1218.57

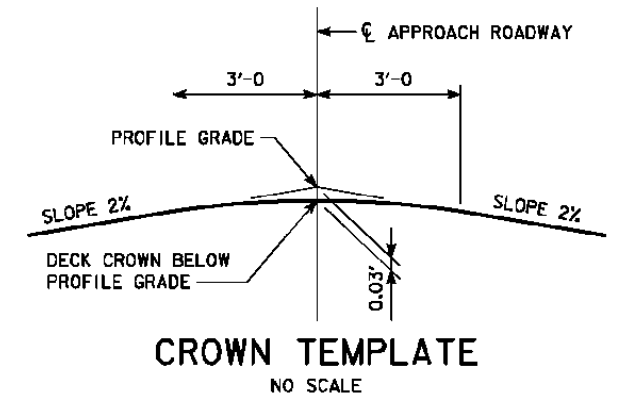

* DEDUCTED 0.03' TO CALCULATE TOP OF SLAB ELEVATION AT THE PROFILE GRADE LINE. SEE CROWN TEMPLATE DETAIL.

** ELEVATIONS GIVEN ARE FOR THE BRIDGE IN ITS FINAL LOCATION. THE CONTRACTOR IS RESPONSIBLE FOR ANY ADJUSTMENTS/CONVERSIONS NECESSARY DUE TO THE BRIDGE SUPERSTRUCTURE BEING CONSTRUCTED OFF ALIGNMENT ON TEMPORARY WORKS. THE CONTRACTOR SHALL SUBMIT TO THE ENGINEER A PLAN FOR ELEVATION CONTROL IF ADJUSTMENTS/CONVERSIONS ARE NECESSARY.

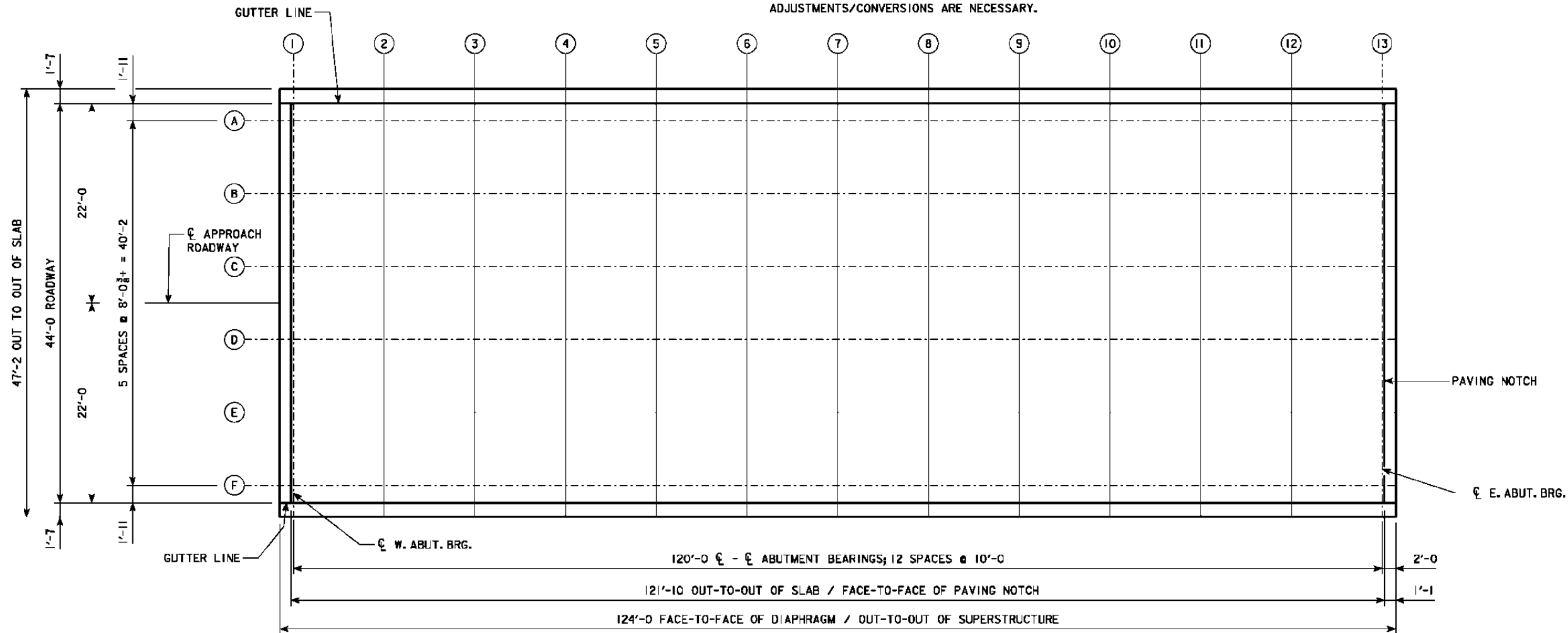

TOP OF SLAB ELEVATIONS LAYOUT

DESIGN FOR 0° SKEW
**120'-0" x 44'-0" PRETENSIONED
 PRESTRESSED CONCRETE BEAM BRIDGE**
 120'-0" SINGLE SPAN
TOP OF SLAB ELEVATIONS
 STA. 1134+61.00 (1A 92) FEBRUARY, 2012
CASS COUNTY
 IOWA DEPARTMENT OF TRANSPORTATION - HIGHWAY DIVISION
 DESIGN SHEET NO. 16 OF 25 FILE NO. 30484 DESIGN NO. 113

REVISED 06-12 - THE ALLOWABLE FIELD HAUNCH MAX. & MIN. WAS CHANGED TO INCHES & DECIMALS OF FEET. NOTE & NOTE 1 WERE CHANGED. THE SLAB HAUNCH LOCATIONS EXAMPLE WAS REPLACED WITH A NOTE. ENGLISH\MISCELLANEOUS\BRIDGES\1066 - THIS SHEET ISSUED 02-08.

LOCATION	C.L. W. ABUT. BRG.												C.L. E. ABUT. BRG.
	LINE 1	LINE 2	LINE 3	LINE 4	LINE 5	LINE 6	LINE 7	LINE 8	LINE 9	LINE 10	LINE 11	LINE 12	LINE 13
BEAM LINE A	1217.89	1218.05	1218.17	1218.27	1218.34	1218.38	1218.40	1218.39	1218.35	1218.29	1218.20	1218.08	1217.94
BEAM LINE B	1218.05	1218.21	1218.33	1218.43	1218.50	1218.54	1218.56	1218.55	1218.51	1218.45	1218.36	1218.24	1218.10
BEAM LINE C	1218.22	1218.37	1218.49	1218.59	1218.66	1218.71	1218.72	1218.71	1218.68	1218.61	1218.52	1218.40	1218.26
BEAM LINE D	1218.22	1218.37	1218.49	1218.59	1218.66	1218.71	1218.72	1218.71	1218.68	1218.61	1218.52	1218.40	1218.26
BEAM LINE E	1218.05	1218.21	1218.33	1218.43	1218.50	1218.54	1218.56	1218.55	1218.51	1218.45	1218.36	1218.24	1218.10
BEAM LINE F	1217.89	1218.05	1218.17	1218.27	1218.34	1218.38	1218.40	1218.39	1218.35	1218.29	1218.20	1218.08	1217.94

* ELEVATIONS GIVEN ARE FOR THE BRIDGE IN ITS FINAL LOCATION. THE CONTRACTOR IS RESPONSIBLE FOR ANY ADJUSTMENTS/CONVERSIONS NECESSARY DUE TO THE BRIDGE SUPERSTRUCTURE BEING CONSTRUCTED OFF ALIGNMENT ON TEMPORARY WORKS. THE CONTRACTOR SHALL SUBMIT TO THE ENGINEER A PLAN FOR ELEVATION CONTROL IF ADJUSTMENTS/CONVERSIONS ARE NECESSARY.

	BEAM LINE	C. W. ABUT. BEARING												C. E. ABUT. BEARING	
		LINE 1	LINE 2	LINE 3	LINE 4	LINE 5	LINE 6	LINE 7	LINE 8	LINE 9	LINE 10	LINE 11	LINE 12	LINE 13	
ANTICIPATED DEFLECTION DUE TO SLAB (IN.)	ALL	0	1.51	2.75	3.72	4.40	4.82	4.96	4.82	4.40	3.72	2.75	1.51	0	
CROSS SLOPE ADJUSTMENTS (IN.)	ALL	± 5/16"													
ALLOWABLE FIELD HAUNCH (IN. & FT.)	MAX.	ALL	2 1/2" (0.208)												
	MIN.	ALL	- 3/16" (-0.016)												

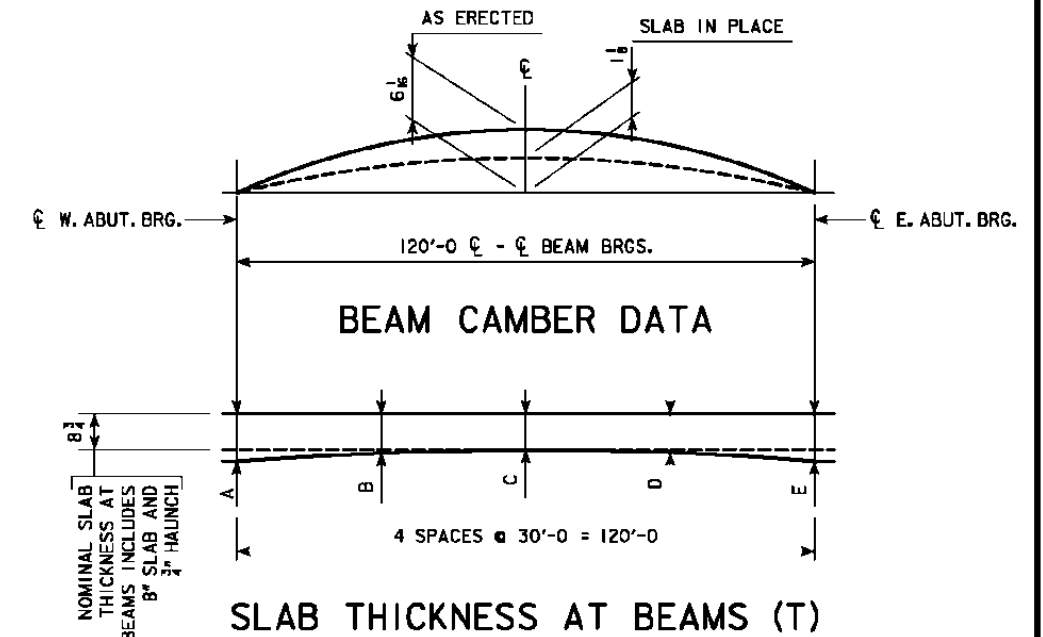

	A	B	C	D	E
BEAM LINE A	9 1/8	8 5/16	8 7/8	8 15/16	9 1/8
BEAM LINE B	9 1/16	8 3/4	8 11/16	8 7/8	9 1/16
BEAM LINE C	9	8 3/8	8 3/4	8 13/16	9
BEAM LINE D	9	8 3/8	8 3/4	8 13/16	9
BEAM LINE E	9 1/16	8 7/8	8 15/16	8 7/8	9 1/16
BEAM LINE F	9 1/8	8 5/16	8 7/8	8 15/16	9 1/8

ESTIMATED SLAB THICKNESS AT BEAMS VARIES DUE TO THE HORIZONTAL TOP OF ABUTMENT FOOTING AND BEARING THICKNESSES CHOSEN.

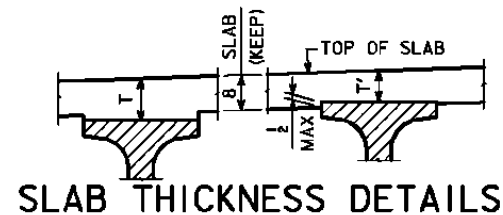

NOTE: THE SLAB THICKNESS (T) AT BEAMS IS BASED ON THE ANTICIPATED BEAM CAMBER AND DEFLECTIONS. THESE VALUES ARE USED BY THE DESIGNER TO SET BEAM ELEVATIONS AND ESTIMATE CONCRETE QUANTITIES. REFER TO THE HAUNCH DATA DETAILS SHEET FOR ADDITIONAL INFORMATION TO AID THE CONTRACTOR IN SETTING THE FIELD HAUNCHES REQUIRED FOR CONSTRUCTION.

NOTE: HAUNCH LOCATIONS ARE AT THE SAME LOCATION AS THE ENCIRCLED LETTERS AND NUMBERS SHOWN ON SLAB ELEVATIONS SHEET.

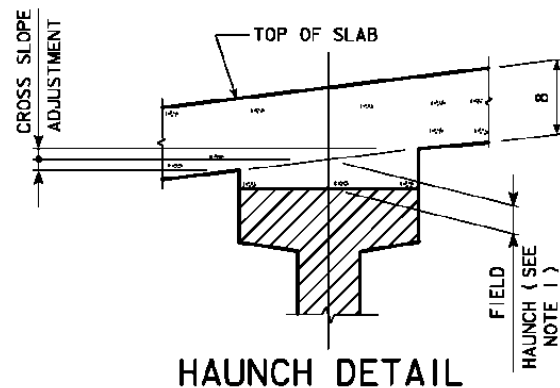

NOTE: BRIDGE SEAT ELEVATIONS ARE SET BASED ON THEORETICAL CAMBER AND BEAM DEFLECTIONS. THESE BRIDGE SEATS WILL PROVIDE A THEORETICAL BEAM HAUNCH WITHIN DESIGN PARAMETERS. FIELD HAUNCHES ARE DETERMINED USING SURVEYED TOP OF BEAM ELEVATIONS AND "BEAM LINE HAUNCH ELEVATION" DATA. ALLOWABLE MAXIMUM AND MINIMUM "FIELD HAUNCH" VALUES ARE GIVEN IN INCHES AND DECIMALS OF FEET IN THE "MISCELLANEOUS DATA" TABLE. "CROSS SLOPE ADJUSTMENT" VALUES WILL AID THE CONTRACTOR IN DETERMINING ACTUAL FORMED HAUNCH DIMENSIONS AT THE EDGES OF THE TOP FLANGE.

NOTE 1: TO CALCULATE FIELD HAUNCH REQUIRED AT EACH LOCATION, SURVEY THE BEAM TOPS CONSISTENT WITH THE SPACINGS SHOWN ON THE "TOP OF SLAB ELEVATIONS LAYOUT". SUBTRACT THE SURVEYED BEAM SHOT FROM THE "BEAM LINE HAUNCH ELEVATION". THIS VALUE WILL BE THE HAUNCH NEEDED (SEE "FIELD HAUNCH" IN HAUNCH DETAIL). THE "BEAM LINE HAUNCH ELEVATION" INCLUDES ADJUSTMENTS FOR SLAB THICKNESSES AND ANTICIPATED DEFLECTIONS. NO ADDITIONAL CALCULATIONS ARE REQUIRED. IF THE FIELD HAUNCH EXCEEDS THE MAXIMUMS AND MINIMUMS SHOWN IN INCHES AND DECIMALS OF FEET IN THE MISCELLANEOUS DATA TABLE, ADJUSTMENTS TO THE GRADE OR ADDITIONAL HAUNCH REINFORCEMENT WILL BE REQUIRED.

DESIGN FOR 0° SKEW
**120'-0" x 44'-0" PRETENSIONED
 PRESTRESSED CONCRETE BEAM BRIDGE**
 120'-0" SINGLE SPAN
SLAB HAUNCH DATA DETAILS
 STA. 1134+61.00 (1A 92) FEBRUARY, 2012
CASS COUNTY
 IOWA DEPARTMENT OF TRANSPORTATION - HIGHWAY DIVISION
 DESIGN SHEET NO. 17 OF 25 FILE NO. 30484 DESIGN NO. 113

REVISION 12-10 - ALTERNATE SECTION C-C ADDED OUTSIDE OF BORDER SHEET. STANDARD NUMBER CHANGED TO 1036-BTCW. ENGLISHBEAMS.DGN 1036C# - THIS SHEET ISSUED 09-03.

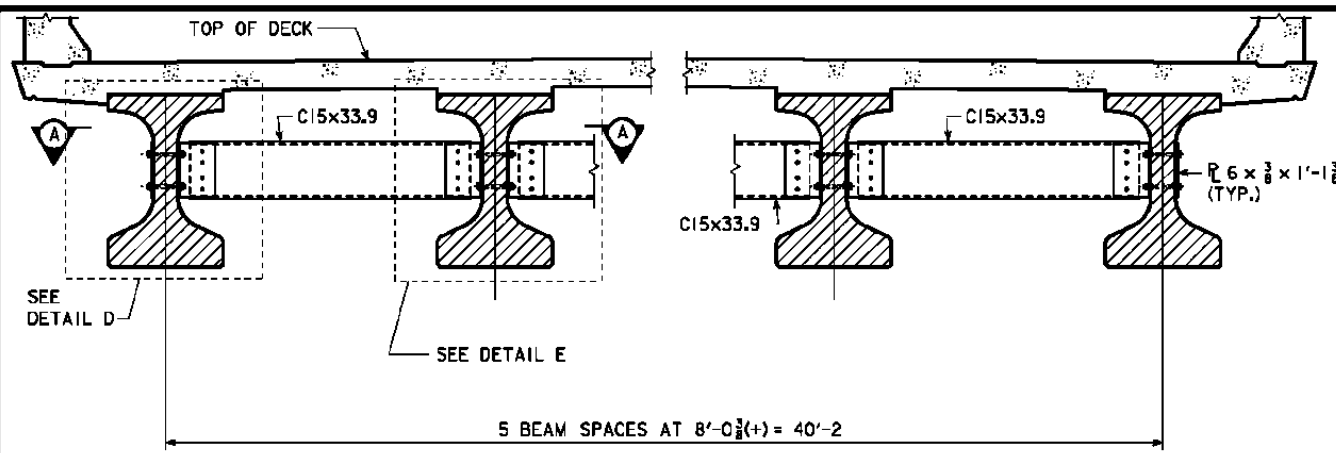

SECTION SHOWING INTERMEDIATE DIAPHRAGM

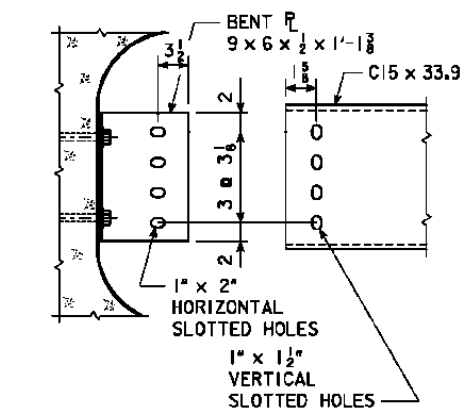

SLOTTED HOLE DETAILS

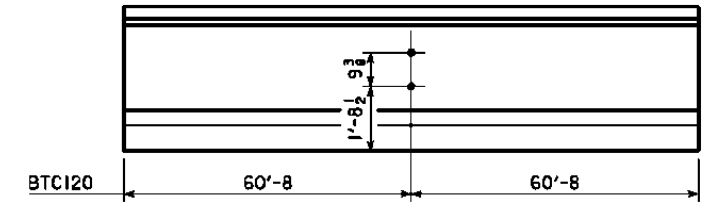

INTERMEDIATE DIAPHRAGM BOLT HOLE LOCATIONS

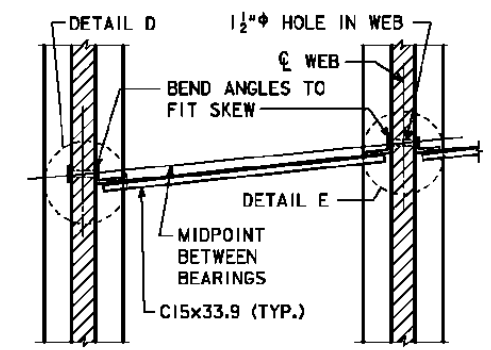

PART SECTION A-A FOR BRIDGES SKEWED LESS THAN OR EQUAL TO 7°30'

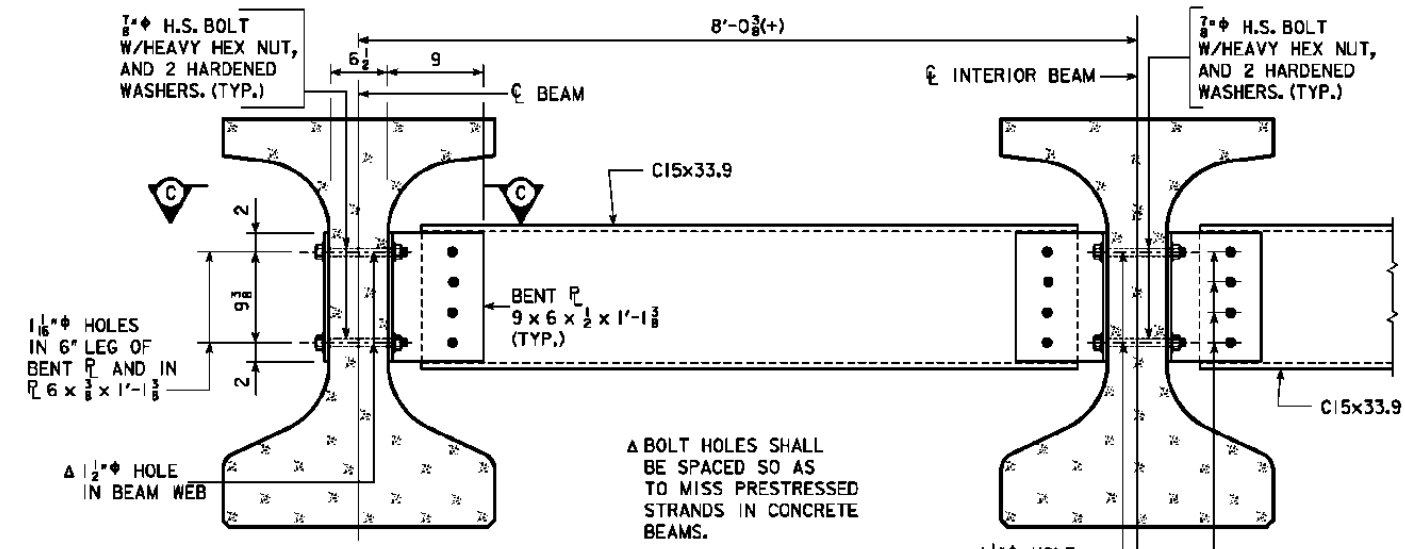

DETAIL D

DETAIL E

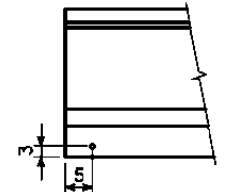

ALL SKEWS
SEMI-INTEGRAL ABUT.
BEAM COIL TIE LOCATION

BULB TEE "C" BEAM INTERMEDIATE DIAPHRAGM STRUCTURAL STEEL

ONE BEAM CONNECTION (DETAIL "D" AND/OR DETAIL "E")		WEIGHT
2 - 7/8" x 9 1/4" H.S. BOLTS WITH NUTS & WASHERS = 4.8 LBS.	NO. OF BEAM CONNECTIONS 6	29
ONE DETAIL "E" 2 - BENT PLATE 9 x 6 x 1/2 x 1'-1 3/8 = 57.0 LBS.	4	228
ONE DETAIL "D" 1 - BACKING PLATE 6 x 3/8 x 1'-1 3/8 = 8.5 LBS.	2	17
1 - BENT PLATE 9 x 6 x 1/2 x 1'-1 3/8 = 28.5 LBS.	2	57
ONE DIAPHRAGM		
8 - 7/8" x 2 3/4" H.S. BOLTS WITH NUTS & WASHERS = 10.3 LBS.	NUMBER OF DIAPHRAGMS 5	52
LENGTH OF MEMBER		
1 - C15 x 33.9 = 33.9 LBS./FT.	6'-10 1/8"	5
INTERMEDIATE DIAPHRAGM STRUCTURAL STEEL - TOTAL (LBS.)		1543

NOTES:

- ALL DIAPHRAGM MATERIALS, INCLUDING BOLTS, NUTS AND WASHERS SHALL BE GALVANIZED.
- SHOP DRAWINGS OF THE STEEL DIAPHRAGMS SHOWING LAYOUT AND DETAILS OF THE DIAPHRAGMS SHALL BE SUBMITTED FOR APPROVAL.
- ALL COSTS FOR FURNISHING AND INSTALLING STEEL INTERMEDIATE DIAPHRAGMS SHALL BE INCLUDED IN THE PRICE BID FOR STRUCTURAL STEEL.
- THE 1 1/2" HOLES FOR THE 7/8" H.S. BOLTS SHALL BE CAST INTO THE WEB. DRILLING IS NOT ALLOWED.
- THE 7/8" H.S. BOLTS THROUGH THE WEB SHALL HAVE A THREAD LENGTH OF 3" MIN. AND 4" MAX. AND SHALL MEET THE REQUIREMENTS OF ASTM A449.
- ALL BOLTS ARE TO BE TIGHTENED PRIOR TO PLACING BRIDGE FLOOR CONCRETE WITH THE FOLLOWING EXCEPTION: BOLTS IN DIAPHRAGMS LOCATED UNDER LONGITUDINAL BRIDGE FLOOR CONSTRUCTION JOINTS SHALL NOT BE TIGHTENED UNTIL STAGE TWO OF THE BRIDGE FLOOR HAS BEEN PLACED.

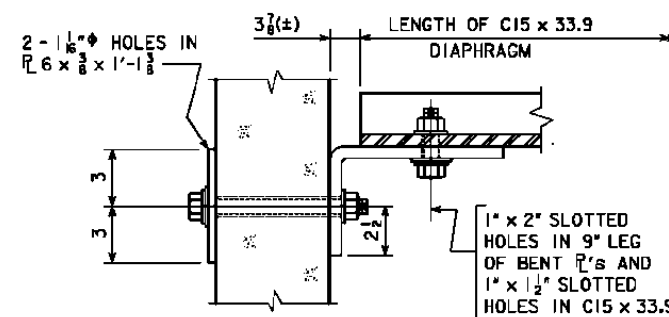

SECTION C-C

DESIGN FOR 0° SKEW
**120'-0" x 44'-0" PRETENSIONED
 PRESTRESSED CONCRETE BEAM BRIDGE**
 120'-0" SINGLE SPAN
INTERMEDIATE DIAPHRAGM DETAILS
 STA. 1134+61.00 (1A 92) FEBRUARY, 2012
CASS COUNTY
 IOWA DEPARTMENT OF TRANSPORTATION - HIGHWAY DIVISION
 DESIGN SHEET NO. 18 OF 25 FILE NO. 30484 DESIGN NO. 113

REVISED 10-07 - 5b2 BAR DELETED. 5b1 BAR LENGTHENED TO EXTEND 5 INCHES ABOVE BEAM TOP. ALTERNATE SECTION A-A ADDED. ENGLISH BEAMS.DGN 4719S2 - THIS SHEET ISSUED 05-04.

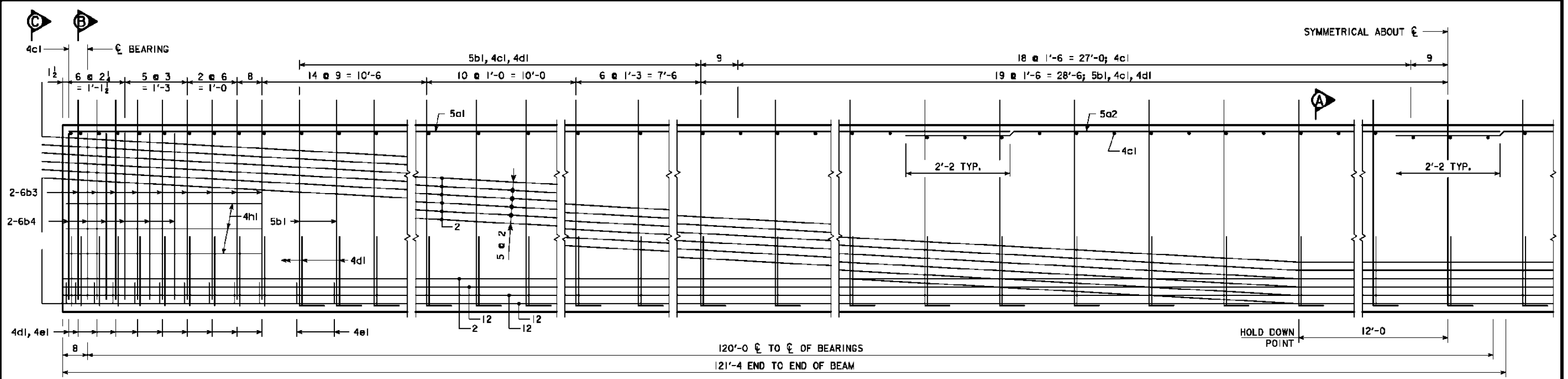

BTC120

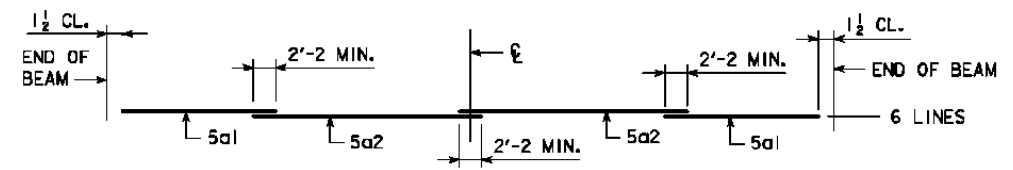

TOP FLANGE LONGITUDINAL BAR LAYOUT

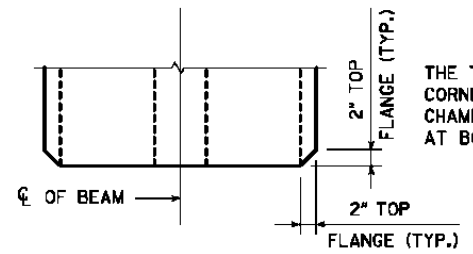

TOP VIEW

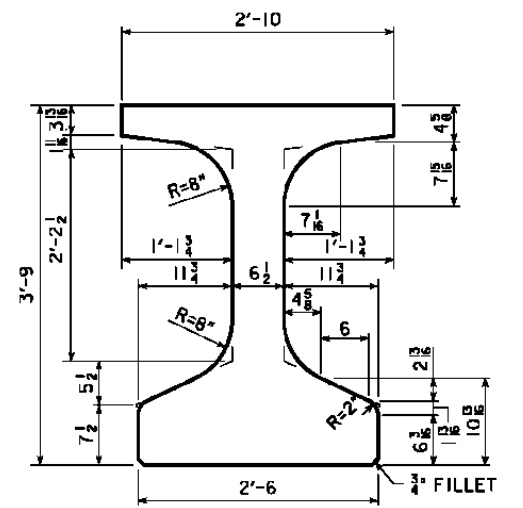

BEAM SECTION PROPERTIES

AREA = 691.8 in²
 $\bar{y}_b = 20.74$ in.
 $I = 178,971$ in⁴

BTC BEAM CROSS SECTION

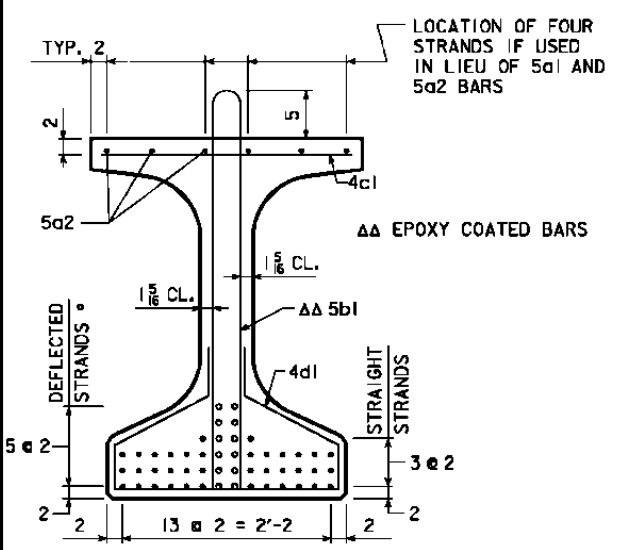

SECTION A-A

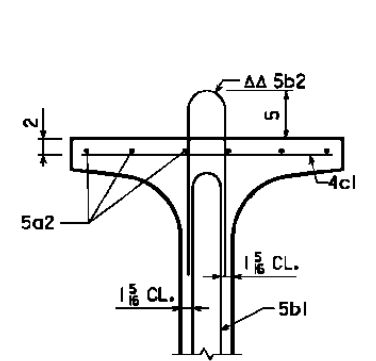

SECTION A-A (ALTERNATE)

SEE ALTERNATE BAR NOTE ON STANDARD SHEET 4719 (SHEET 1).

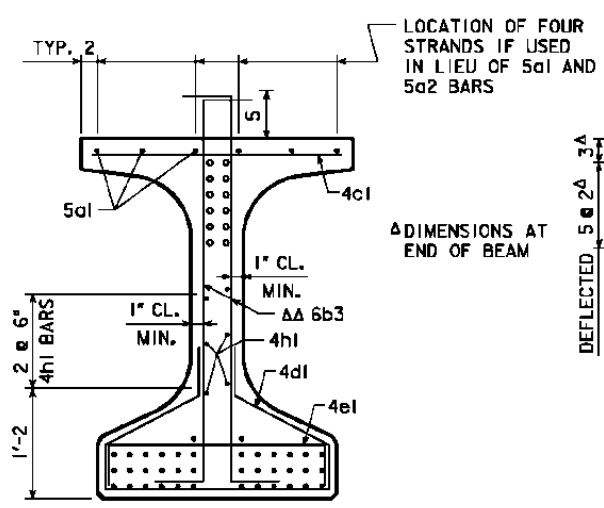

SECTION B-B

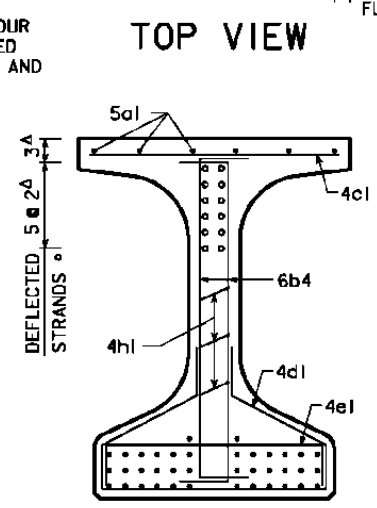

SECTION C-C

DESIGN FOR 0° SKEW
**120'-0" x 44'-0" PRETENSIONED
 PRESTRESSED CONCRETE BEAM BRIDGE**
 120'-0" SINGLE SPAN
BTC120 BEAM DETAILS
 STA. 1134+61.00 (1A 92) FEBRUARY, 2012
CASS COUNTY
 IOWA DEPARTMENT OF TRANSPORTATION - HIGHWAY DIVISION
 DESIGN SHEET NO. 20 OF 25 FILE NO. 30484 DESIGN NO. 113

REVISION 02-08 - REINFORCING STEEL PATTERN & SIZE CHANGED AND WEIGHT ADJUSTED. CONCRETE THICKNESS WAS INCREASED 1/2" AND QUANTITY ADJUSTED. ENGLISH DECK RAIL BRIDGES.DGN 1017 - THIS SHEET ISSUED 09-01

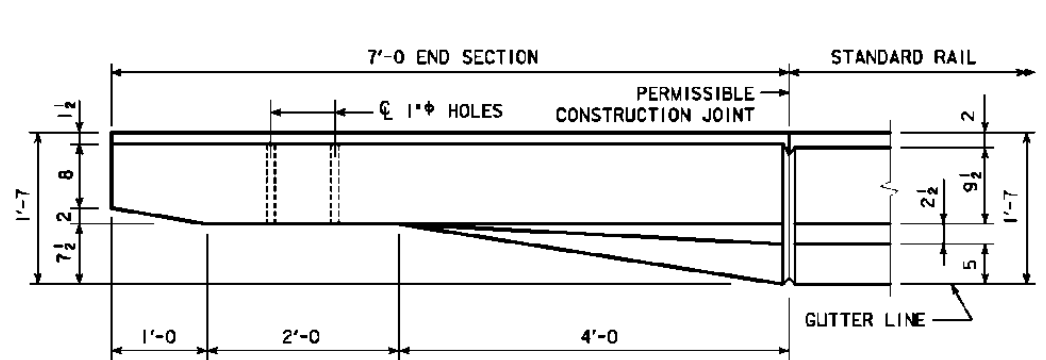

PART PLAN VIEW

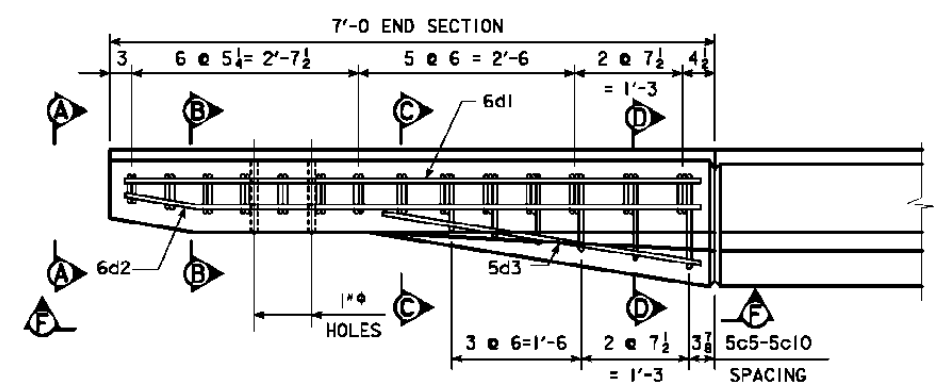

PART VIEW E-E

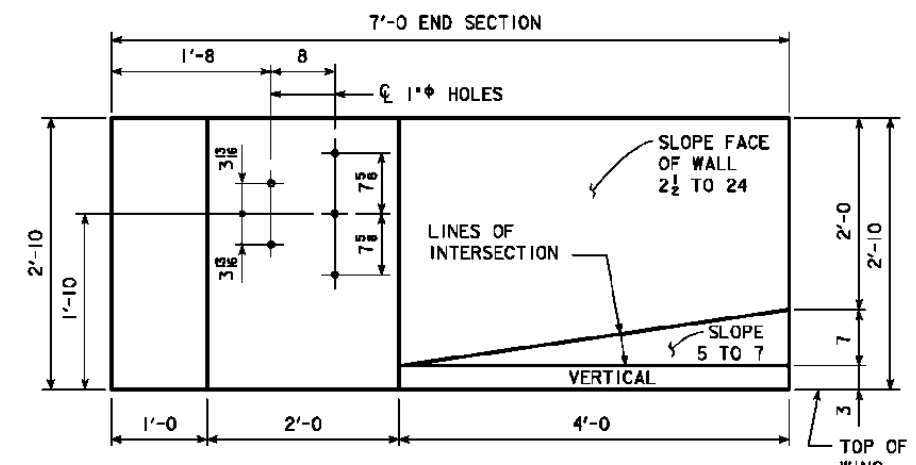

PART ELEVATION VIEW

PROVIDE 5 HOLES FORMED WITH 1" PLASTIC CONDUIT. COST TO BE INCLUDED IN PRICE BID FOR CONCRETE BARRIER RAILING.

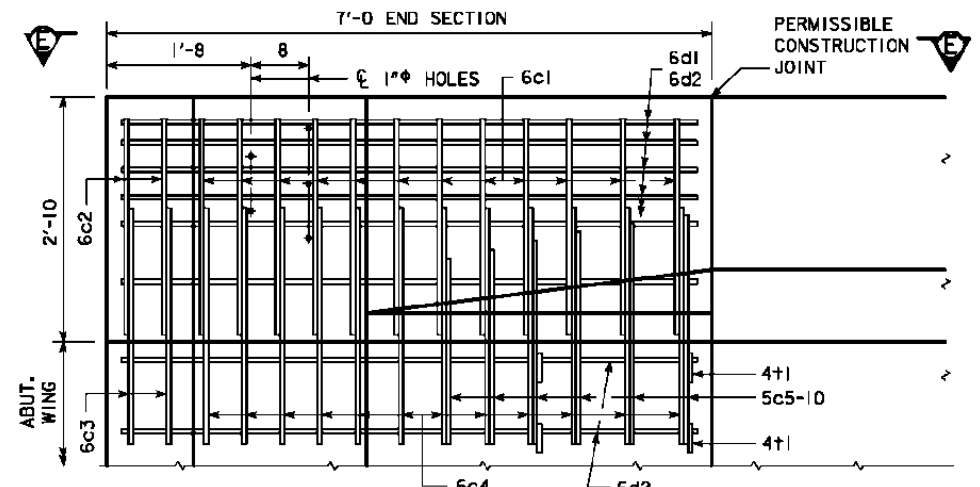

PART VIEW F-F

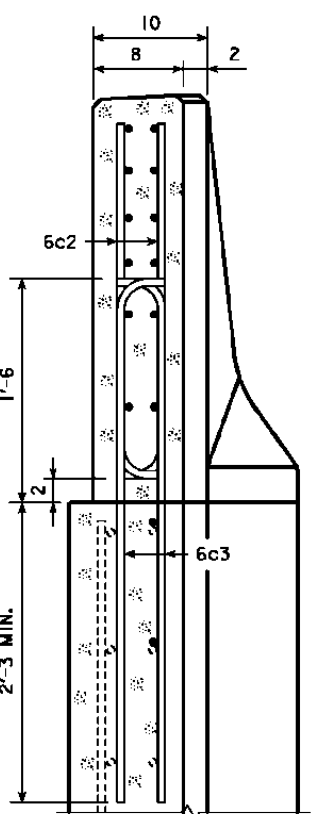

VIEW A-A

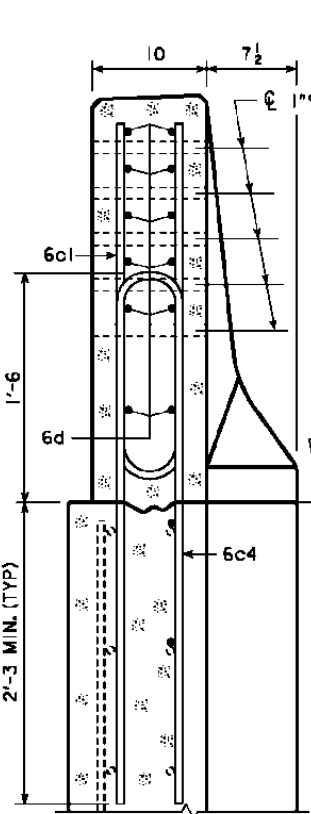

SECTION B-B

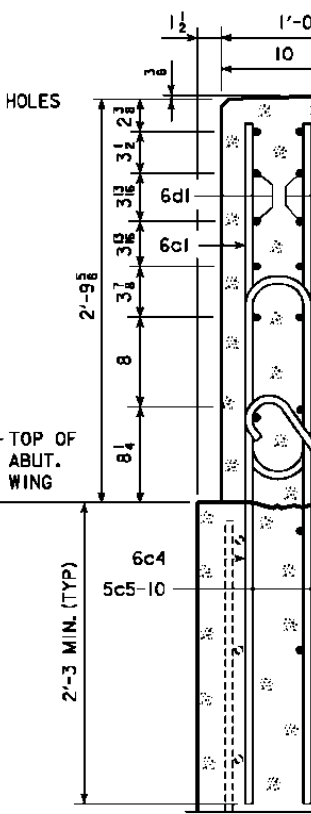

SECTION C-C

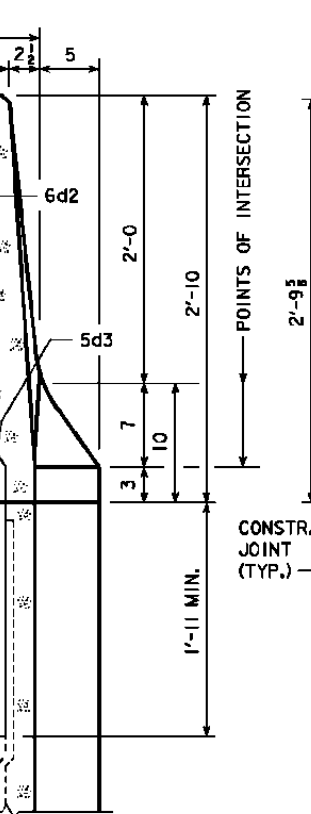

SECTION D-D

POINTS OF INTERSECTION

NOTE: 4+1 PLACEMENT - 2 BARS EACH LEVEL OF 6d2 IN WING FOOTING.

NOTE: CONSTRUCTION JOINT BETWEEN TOP OF WING AND BARRIER RAIL IS ROUGHENED CONCRETE.

NOTE: THE 10" RADIUS AND 1 1/2" RADIUS ARE TYPICAL AND SHALL BE USED WHEN CONSTRUCTING THE CORNERS FOR VIEW A-A, SECTION B-B, SECTION C-C AND SECTION D-D.

NOTE: THE 6c4, 6c3, 5c5-10, 2 - 6d2 AND 4+1 BARS ARE TO BE PLACED WITH THE ABUTMENT WING. THE DETAILS FOR PLACEMENT ARE SHOWN ON THE WING ABUTMENT SHEET.

NOTE: DASHED LINES BELOW THE TOP OF WING ARE THE ABUTMENT WING REINFORCING STEEL. SEE WING ABUTMENT SHEET FOR PLACEMENT.

EPOXY REINFORCING STEEL - ONE END SECTION

BAR	LOCATION	SHAPE	NO.	LENGTH	WEIGHT	
6c1	VERTICAL	U	12	5'-6	99	
6c2	VERTICAL	U	4	2'-10	17	
6c3	VERTICAL	U	4	4'-1	25	
6c4	VERTICAL	U	12	8'-0	144	
5c5-10	VERTICAL	U	6	VARIES	23	
6d1	HORIZONTAL	—	6	6'-8	60	
6d2	HORIZONTAL	—	8	6'-9	81	
5d3	HORIZONTAL	—	1	3'-9	4	
4+1	ABUTMENT WING TIE BARS	U	4	VARIES	5	
(INCLUDE WITH BARRIER RAIL REINFORCING)					TOTAL WEIGHT (LBS.)	458

CONCRETE PLACEMENT SUMMARY

SECTION	TOTAL
BARRIER RAIL ONE END SECTION	0.65 CU. YD.

BENT BAR DETAILS

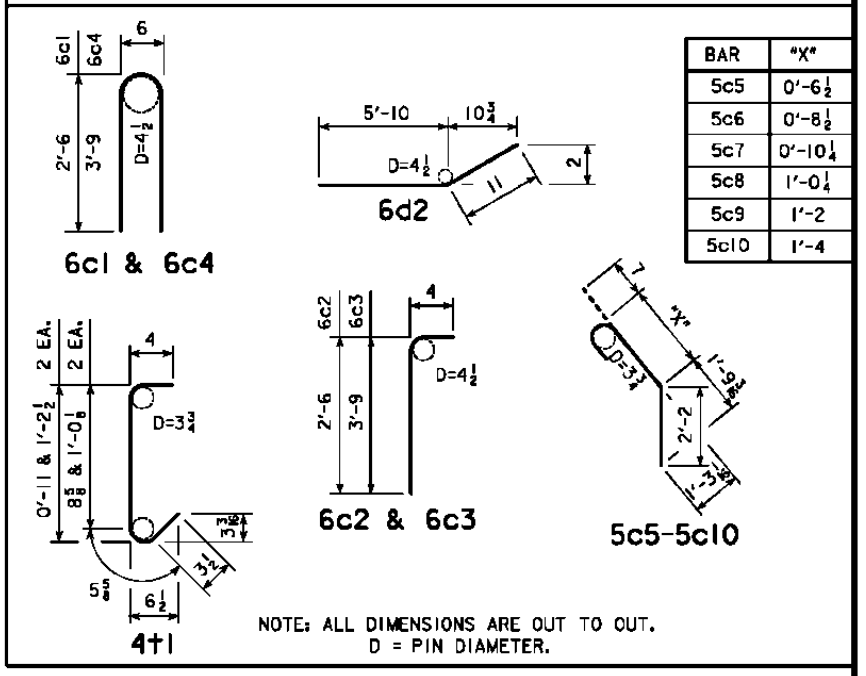

DESIGN FOR 0° SKEW
**120'-0 x 44'-0 PRETENSIONED
 PRESTRESSED CONCRETE BEAM BRIDGE**
 120'-0 SINGLE SPAN
END SECTION DETAILS
 STA. 1134+61.00 (1A 92) FEBRUARY, 2012
CASS COUNTY
 IOWA DEPARTMENT OF TRANSPORTATION - HIGHWAY DIVISION
 DESIGN SHEET NO. 21 OF 25 FILE NO. 30484 DESIGN NO. 113

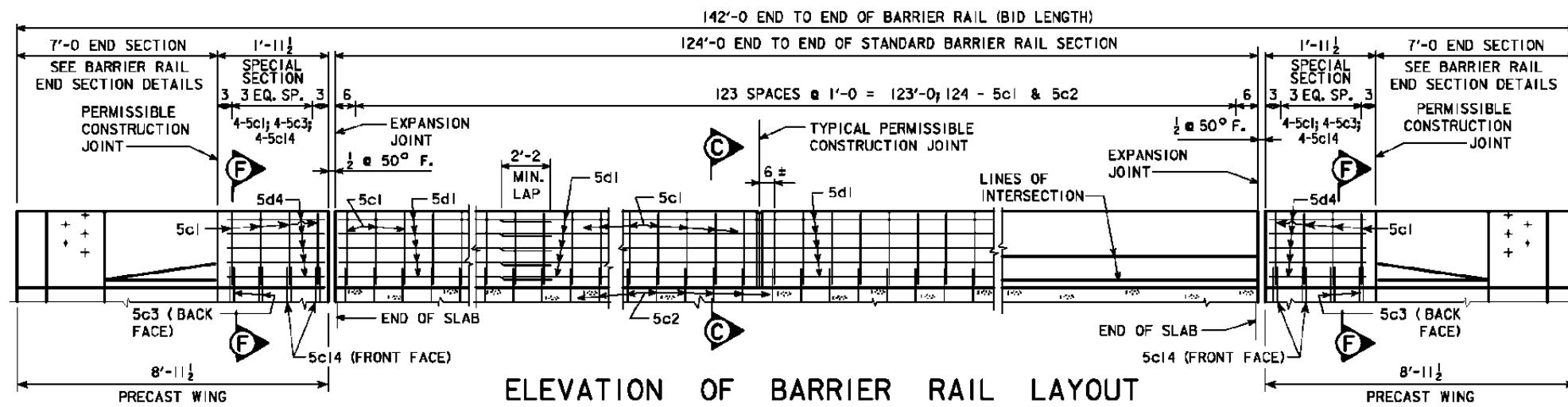

ELEVATION OF BARRIER RAIL LAYOUT

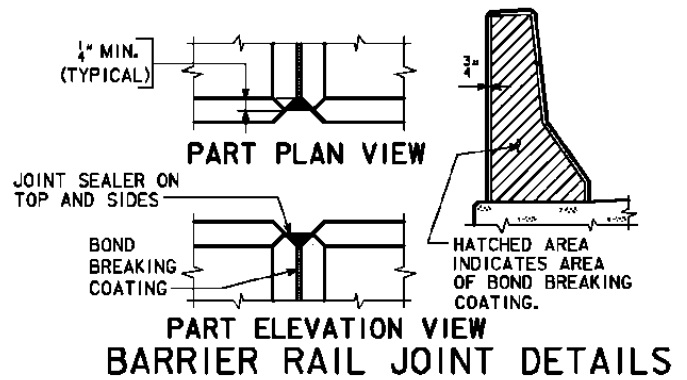

BARRIER RAIL JOINT DETAILS

EPOXY REINF. STEEL-TWO BARRIER RAILS

SECTION	BAR	LOCATION	SHAPE	NO.	LENGTH	WEIGHT
STANDARD SECTION	5c1	VERTICAL	U	248	5'-11	1530
	5c2	VERTICAL	D	248	6'-0	1552
	5d1	LONGITUDINAL	—	72	32'-7	2447
SPECIAL SECTIONS (ALL REINFORCING REQUIRED)	5c1	VERTICAL	U	16	5'-11	99
	5c3	VERTICAL	U	16	3'-3	54
	5c14	VERTICAL	U	16	3'-10	64
	5d4	LONGIT.- SPECIAL SECTIONS	—	36	1'-7	60
BARRIER RAIL END SECTION					4 AT 458 LBS.	1832
(INCLUDE WITH SUPERSTRUCTURE REINFORCING)					TOTAL (LBS.)	7638

BENT BAR DETAILS

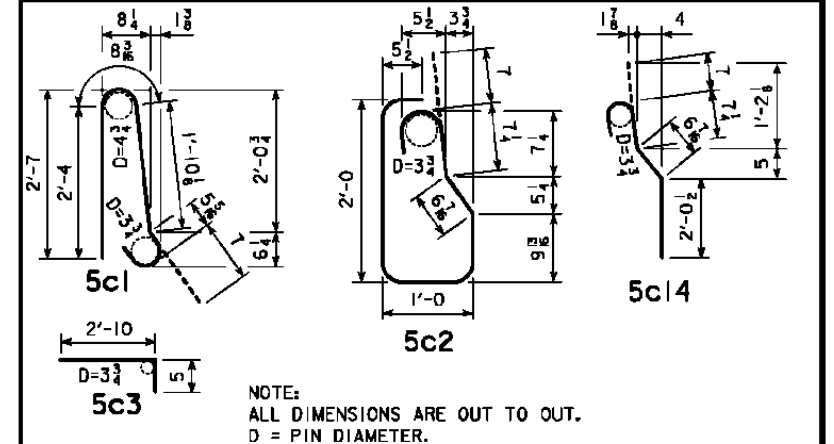

CONCRETE PLACEMENT SUMMARY

SECTION	TOTAL
STANDARD SECTION 2 x 124'-0" @ 0.1052 CU. YD. PER FT.	26.1
SPECIAL SECTION 4 x 1'-11 1/2" @ 0.1052 CU. YD. PER FT.	0.8
BARRIER RAIL END SECTION 4 @ 0.65 CU. YD.	2.6
TOTAL (CU. YD.)	29.5

CONCRETE BARRIER RAIL QUANTITIES

ITEM	UNIT	QUANTITY
CONCRETE BARRIER RAILING	L.F.	284

BARRIER RAIL NOTES:

MINIMUM CLEAR DISTANCE FROM FACE OF CONCRETE TO NEAR REINFORCING BAR IS TO BE 2" UNLESS OTHERWISE NOTED OR SHOWN.
 THE PERMISSIBLE CONSTRUCTION JOINTS ARE TO BE PLACED BETWEEN VERTICAL BARS AT A MINIMUM SPACING OF 20 FEET. CONSTRUCTION JOINT CONTACT SURFACES ARE TO BE COATED WITH AN APPROVED BOND BREAKER. COST OF THE JOINT SEALER AND BOND BREAKER SHALL BE CONSIDERED INCIDENTAL TO OTHER CONSTRUCTION.
 ALL BARRIER RAIL REINFORCING STEEL IS TO BE EPOXY COATED.
 THE CONCRETE BARRIER RAIL IS TO BE BID ON A LINEAL FOOT BASIS. THE NUMBER OF LINEAL FEET OF BARRIER RAIL INSTALLED WILL BE PAID FOR AT THE CONTRACT PRICE PER LINEAL FOOT BASED ON PLAN QUANTITIES. PRICE BID FOR CONCRETE BARRIER RAILING SHALL BE FULL COMPENSATION FOR FURNISHING ALL MATERIAL, EXCLUDING REINFORCING STEEL, AND ALL OF THE EQUIPMENT AND LABOR REQUIRED TO ERECT THE RAIL IN ACCORDANCE WITH THESE PLANS AND CURRENT SPECIFICATIONS. IF CONDUIT IS REQUIRED IN THIS PLAN THE RIGID STEEL CONDUIT, JUNCTION BOXES AND FITTINGS INCLUDING LABOR AND ANY ADDITIONAL WORK TO DO THE INSTALLATION IS CONSIDERED INCIDENTAL TO THE COST OF THE RAILING.
 ALL BARRIER RAIL REINFORCING STEEL IS TO BE INCLUDED WITH THE SUPERSTRUCTURE REINFORCING STEEL.
 THE JOINT SEALER SHALL BE LIGHT GRAY NONSAG LATEX CAULKING SEALER MARKETED FOR OUTDOOR USE. NO TESTING OR CERTIFICATION IS REQUIRED.
 TOP OF THE BARRIER RAIL IS TO BE PARALLEL TO THE THEORETICAL GRADE.
 CROSS SECTIONAL AREA OF THE STANDARD SECTION OF THE BARRIER RAIL = 2.84 SQUARE FEET.

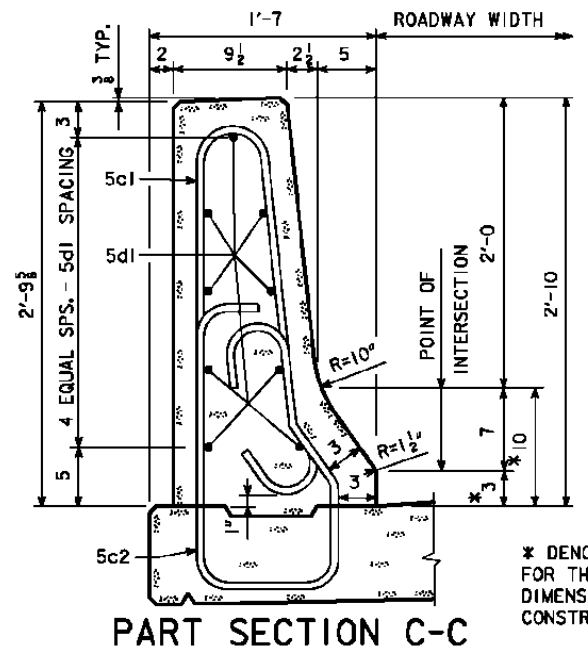

PART SECTION C-C

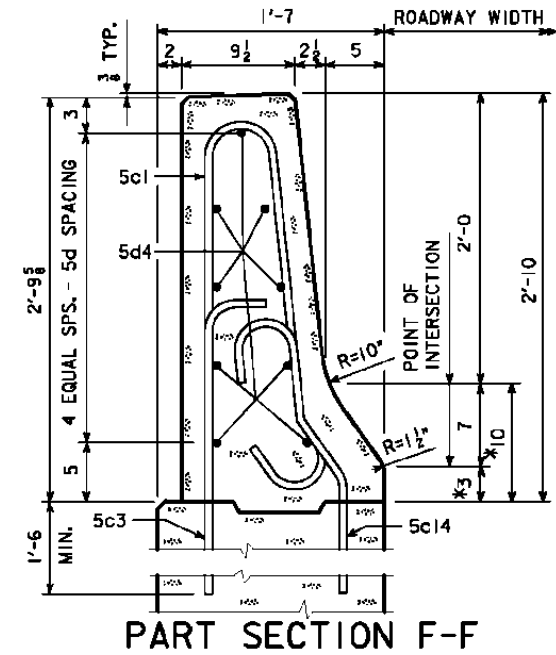

PART SECTION F-F

DESIGN FOR 0° SKEW
**120'-0" x 44'-0" PRETENSIONED
 PRESTRESSED CONCRETE BEAM BRIDGE**
 120'-0" SINGLE SPAN
BARRIER RAIL DETAILS
 STA. 1134+61.00 (1A 92) FEBRUARY, 2012
CASS COUNTY
 IOWA DEPARTMENT OF TRANSPORTATION - HIGHWAY DIVISION
 DESIGN SHEET NO. 22 OF 25 FILE NO. 30484 DESIGN NO. 113

CORRECTION 05-08 - BARRIER RAIL END SECTION QUANTITIES CORRECTED. ENGLISHDECKRAILBRIDGES.DGN 1020B - THIS SHEET ISSUED 02-00

REVISED 07-11 - THE LABELING OF THE BERM SLOPE IS IDENTIFIED AS 'GRADING SURFACE'. MACADAM STONE WAS CHANGED TO EROSION STONE. ENGLISH/SLOPEPROTECTION/BRIDGES.DGN 1005A - THIS SHEET ISSUED 06-02.

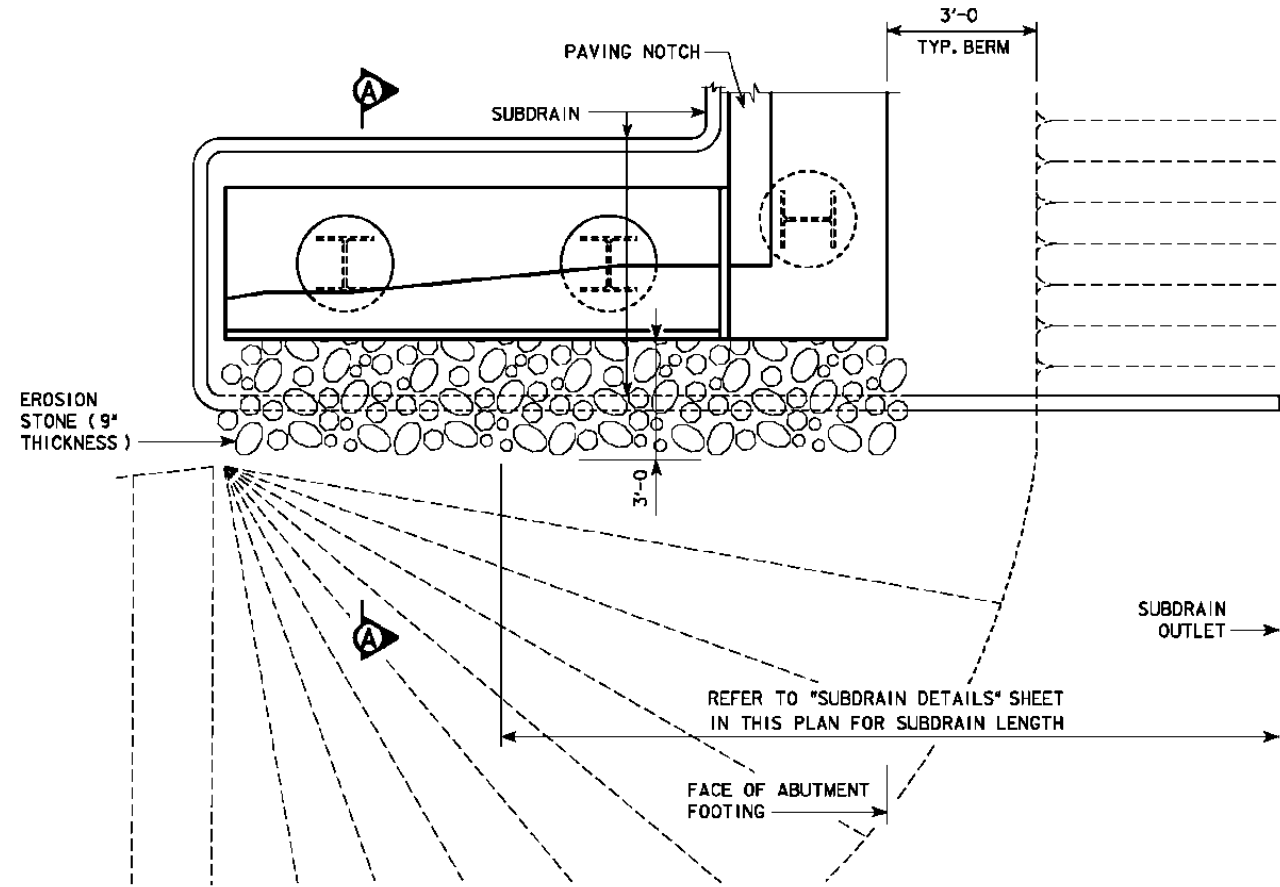

TOP VIEW OF WING ARMORING WITH WING EXTENSION

A CHECK SHALL BE MADE AT THE SUBDRAIN OUTLET TO INSURE THAT IT IS DRAINING PROPERLY DURING THE BACKFILL FLOODING PROCESS.

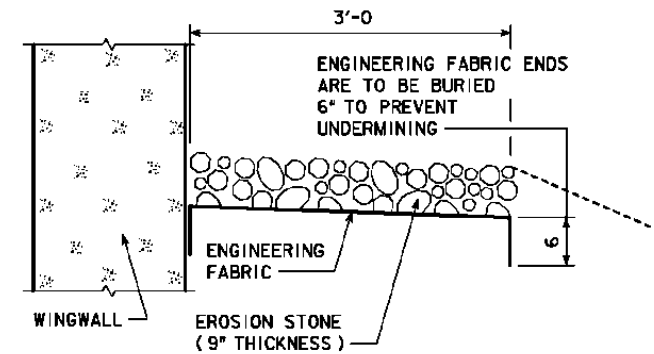

SECTION A-A

GENERAL NOTES:

- EROSION STONE SHALL BE PLACED ALONG THE SIDES OF THE WINGS AND ABUTMENT FOOTING AS SHOWN IN SECTION A-A. THIS IS TYPICAL AT EACH CORNER OF THE BRIDGE UNLESS OTHERWISE NOTED IN THE PLANS. THE EROSION STONE AT THESE LOCATIONS SHALL BE UNDERLAYED WITH ENGINEERING FABRIC IN ACCORDANCE WITH ARTICLE 4196.01, B, 3, OF THE STANDARD SPECIFICATIONS.
- THE EROSION STONE SHALL BE IN ACCORDANCE WITH SECTION 4130, OF THE STANDARD SPECIFICATIONS. MATERIAL PASSING THE 3 INCH SCREEN BUT 100% RETAINED ON A 1 INCH SCREEN MAY BE USED AS CHOKER STONE.
- THE EROSION STONE SHALL BE DEPOSITED, SPREAD, CONSOLIDATED AND SHAPED BY MECHANICAL OR HAND METHODS THAT WILL PROVIDE UNIFORM 9" DEPTH AND DENSITY AND PROVIDE UNIFORM SURFACE APPEARANCE.
- PAYMENT FOR THE BRIDGE WING ARMORING WILL BE BID PER SQUARE YARD. COST WILL INCLUDE ENGINEERING FABRIC, EROSION STONE, EXCAVATION, SHAPING, AND COMPACTION TO DIMENSIONS SHOWN IN THESE PLANS. BID ITEM SHALL BE "BRIDGE WING ARMORING - EROSION STONE".

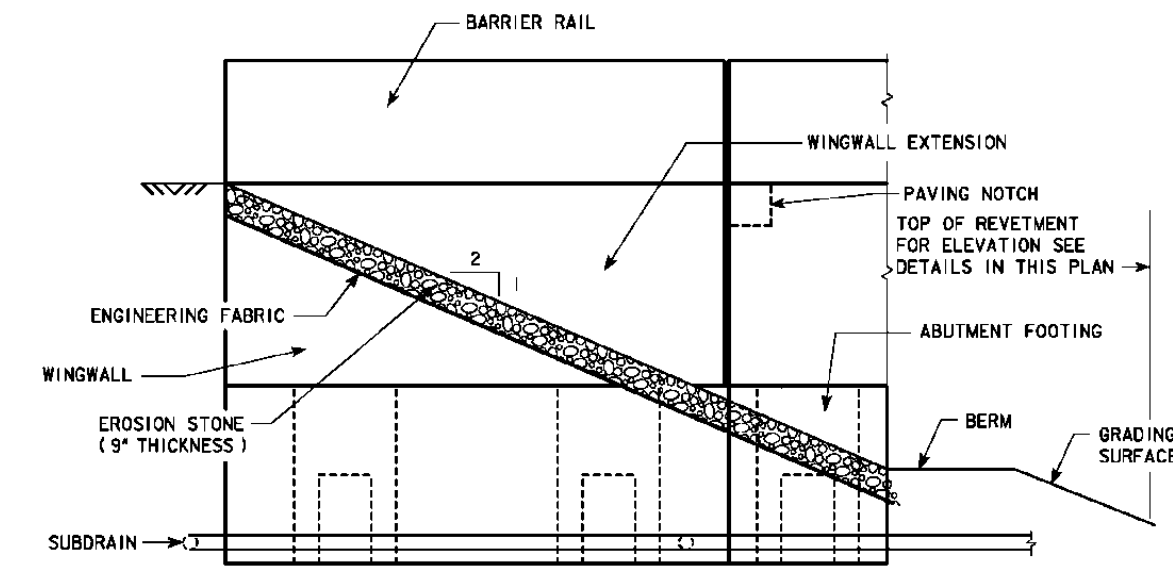

PROFILE VIEW OF WING ARMORING WITH WING EXTENSION

DESIGN FOR 0° SKEW
**120'-0 x 44'-0 PRETENSIONED
 PRESTRESSED CONCRETE BEAM BRIDGE**
 120'-0 SINGLE SPAN
BRIDGE WING ARMORING
 STA. 1134+61.00 (1A 92) FEBRUARY, 2012
CASS COUNTY
 IOWA DEPARTMENT OF TRANSPORTATION - HIGHWAY DIVISION
 DESIGN SHEET NO. 23 OF 25 FILE NO. 30484 DESIGN NO. 113

BENCH MARK 501 SET RR SPIKE IN SOUTH SIDE OF POWER POLE STA 1138+51.59 82.94' LT EL. 1210.986

SUBDRAIN NOTES :

THIS PLAN SHEET SHOWS DETAILS FOR PLACING ALL SUBDRAINS AND SUBDRAIN OUTLETS REQUIRED FOR THIS STRUCTURE.

THE SUBDRAINS SHALL BE 4" IN DIAMETER AND SHALL BE IN ACCORDANCE WITH ARTICLE 4143.01, B, OF THE STANDARD SPECIFICATIONS.

THE SUBDRAIN OUTLET SHALL CONSIST OF A LENGTH OF PIPE WITH A REMOVABLE RODENT GUARD AS DETAILED ON THIS SHEET. THE LENGTH OF THE OUTLET PIPE SHALL BE DETERMINED BY THE REVETMENT AND ITS PLACEMENT LOCATION. THE CONTRACTOR IS TO INSURE THE OUTLET PIPE IS ADEQUATELY STRONG ENOUGH AND WILL NOT BE DAMAGED WHEN REVETMENT IS PLACED. A CHECK WILL BE MADE AT THE SUBDRAIN OUTLET TO INSURE THAT THE SUBDRAIN IS NOT DAMAGED AND IS DRAINING PROPERLY DURING THE BACKFILL FLOODING PROCESS. IF A METAL OUTLET PIPE IS USED, IT SHALL BE 6 INCHES IN DIAMETER AND COUPLED TO THE 4 INCH DIAMETER SUBDRAIN IN ONE OF THE TWO FOLLOWING WAYS.

1. USE AN INSIDE FIT REDUCER COUPLER (COUPLER MUST BE INSERTED A MINIMUM OF 1'-0 INTO THE METAL OUTLET PIPE).
2. INSERT 1'-0 OF THE 4" SUBDRAIN INTO THE 6" METAL OUTLET PIPE, THEN FULLY SEAL THE ENTIRE OPENING WITH GROUT.

THE COST OF FURNISHING AND PLACING SUBDRAIN (INCLUDING EXCAVATION), FLOODABLE BACKFILL, POROUS BACKFILL, AND SUBDRAIN OUTLET IS TO BE INCLUDED IN THE PRICE BID FOR "STRUCTURAL CONCRETE (BRIDGE)". NO EXTRA PAYMENT WILL BE MADE.

THE DIMENSIONS SHOWN FOR THE PROPOSED SUBDRAINS ARE BASED ON THE PROPOSED GRADING LAYOUT OF BRIDGE BERMS. THE DIMENSIONS SHOWN ARE FOR ESTIMATING ONLY. REQUIRED LENGTHS AND GENERAL LOCATIONS OF SUBDRAINS ARE SUBJECT TO CHANGE DUE TO FIELD ADJUSTMENTS OF THE GRADING LAYOUT.

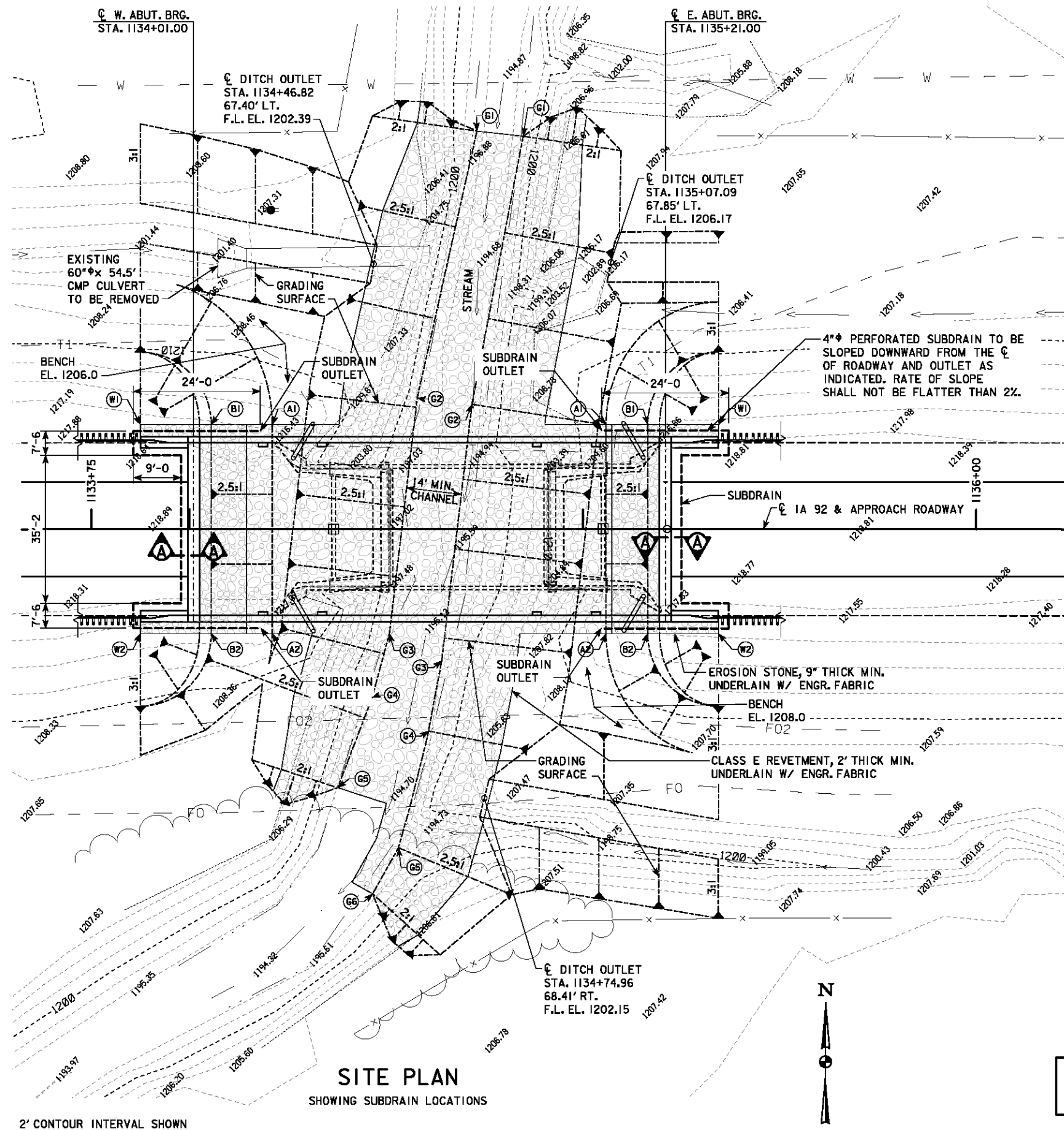

SUBDRAIN OUTLET ELEVATIONS

LOCATION	ELEVATION
EAST ABUTMENT	1209.9
WEST ABUTMENT	1209.8

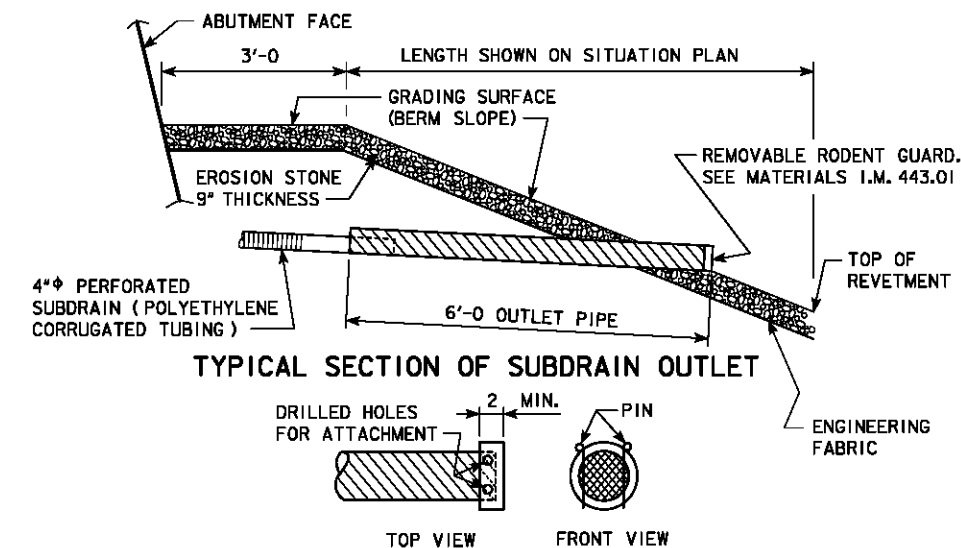

TYPICAL SECTION OF SUBDRAIN OUTLET
 REMOVABLE RODENT GUARD DETAILS
 EROSION STONE (EMBEDDED) OUTLET DETAILS

DESIGN FOR 0° SKEW
**120'-0 x 44'-0 PRETENSIONED
 PRESTRESSED CONCRETE BEAM BRIDGE**
 120'-0 SINGLE SPAN
SUBDRAIN DETAILS
 STA. 1134+61.00 (1A 92) FEBRUARY, 2012
CASS COUNTY
 IOWA DEPARTMENT OF TRANSPORTATION - HIGHWAY DIVISION
 DESIGN SHEET NO. 24 OF 25 FILE NO. 30484 DESIGN NO. 113

NOTE:
 SECTION A-A IS SHOWN ON ABUTMENT
 BACKFILL DETAILS SHEET.

REVISED 02-12 - THE 3'-0 TOP OF THE BERM SLOPE PROTECTION WAS CHANGED TO EROSION STONE FOR ALL SLOPE PROTECTION CONDITIONS. ENGLISH FORESLOPE PROTECTION BRIDGES.DGN 1007C - THIS SHEET ISSUED 06-02 FOR WATER CROSSINGS.

REVISED 04-12 - EXCAVATION LIMIT ON THE FRONT FACE OF THE ABUTMENT WAS CHANGED TO A 3'-0" LIMIT. THE APPROACH FILL WAS IDENTIFIED AS THE GRADING SURFACE. ENGLISHFORPROTECTIONBRIDGES.DGN - 1007E - THIS SHEET ISSUED 08-07.

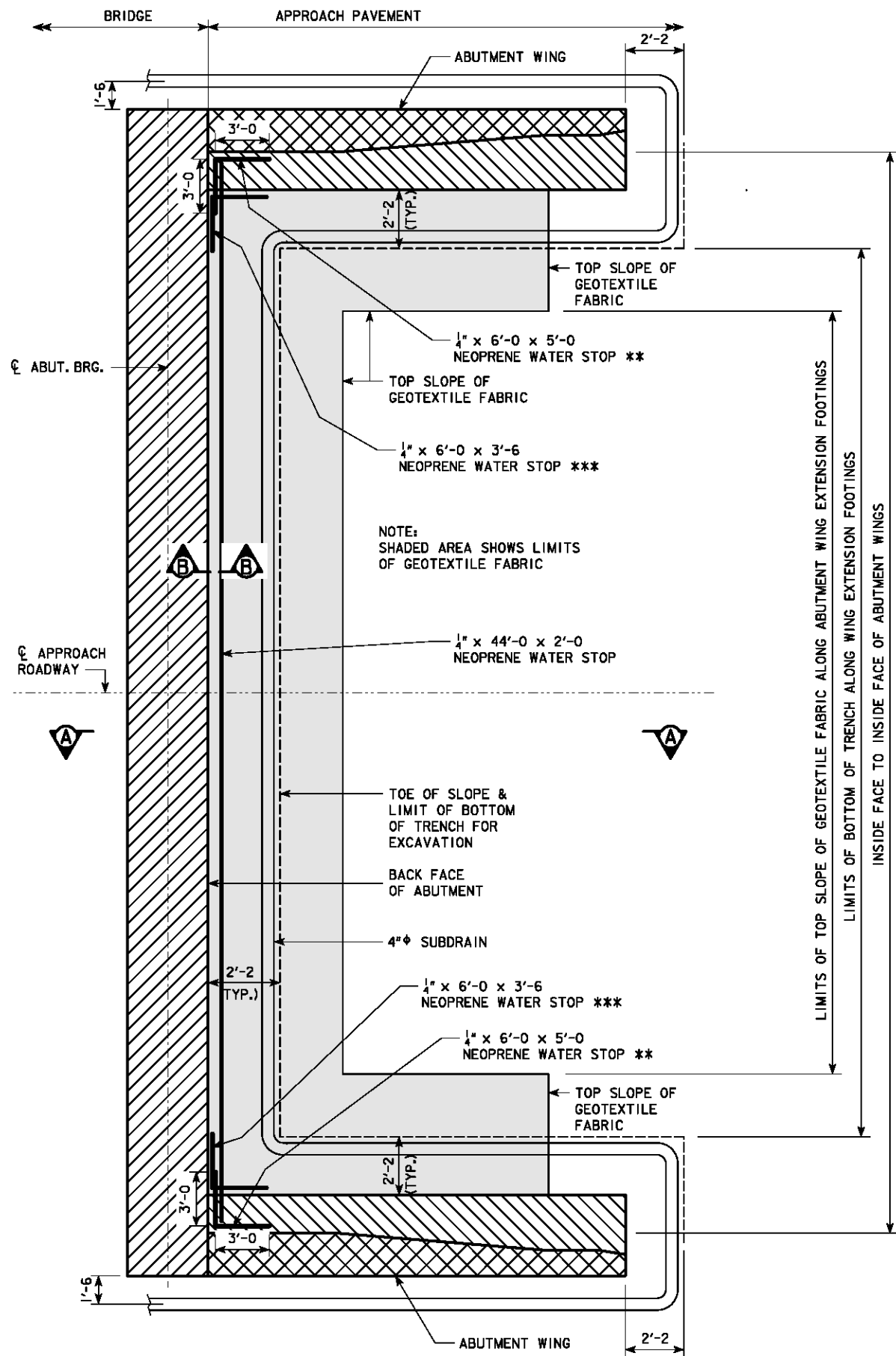

ABUTMENT PLAN WITH WING EXTENSIONS

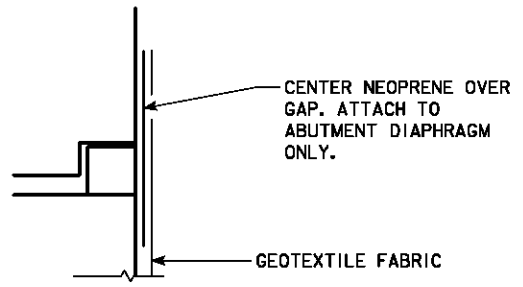

PART SECTION B-B

ABUTMENT BACKFILL PROCESS:

THE BASE OF THE EXCAVATION SUBGRADE BEHIND THE ABUTMENT IS TO BE GRADED WITH A 4% SLOPE AWAY FROM THE ABUTMENT FOOTING AND A 2% CROSS SLOPE IN THE DIRECTION OF THE SUBDRAIN OUTLET. THIS EXCAVATION SHAPING IS TO BE DONE PRIOR TO BEGINNING INSTALLATION OF THE GEOTEXTILE AND BACKFILL MATERIAL.

AFTER THE SUBGRADE HAS BEEN SHAPED, THE GEOTEXTILE FABRIC SHALL BE INSTALLED IN ACCORDANCE WITH THE DETAILS SHOWN. THE FABRIC IS INTENDED TO BE INSTALLED IN THE BASE OF THE EXCAVATION AND EXTENDED VERTICALLY UP THE ABUTMENT BACKWALL, ABUTMENT WING WALLS, AND EXCAVATION FACE TO A HEIGHT THAT WILL BE APPROXIMATELY 3 FEET HIGHER THAN THE HEIGHT OF THE POROUS BACKFILL. PLACEMENT AS SHOWN IN THE "BACKFILL DETAILS" ON THIS SHEET. THE STRIPS OF THE FABRIC PLACED SHALL OVERLAP APPROXIMATELY 1 FOOT AND SHALL BE PINNED IN PLACE. THE FABRIC SHALL BE ATTACHED TO THE ABUTMENT BY USING LATH FOLDED IN THE FABRIC AND SECURED TO THE CONCRETE WITH SHALLOW CONCRETE NAILS. THE FABRIC PLACED AGAINST THE EXCAVATION FACE SHALL BE PINNED.

WHEN THE FABRIC IS IN PLACE, THE SUBDRAIN SHALL BE INSTALLED DIRECTLY ON THE FABRIC AT THE TOE OF THE REAR EXCAVATION SLOPE. A SLOT WILL NEED TO BE CUT IN THE FABRIC AT THE POINT WHERE THE SUBDRAIN EXITS THE FABRIC NEAR THE END OF THE ABUTMENT WING WALL.

POROUS BACKFILL IS THEN PLACED AND LEVELED, NO COMPACTION IS REQUIRED.

THE REMAINING WORK INVOLVES BACKFILLING WITH FLOODABLE BACKFILL, SURFACE FLOODING, AND VIBRATORY COMPACTION. THE FLOODABLE BACKFILL MATERIAL SHALL BE IN ACCORDANCE WITH THE STANDARD SPECIFICATIONS. THE FLOODABLE BACKFILL SHALL BE PLACED IN INDIVIDUAL LIFTS, SURFACE FLOODED, AND COMPACTED WITH VIBRATORY COMPACTION TO ENSURE FULL CONSOLIDATION. LIMIT THE LOOSE LIFTS TO NO MORE THAN 2 FEET OF THICKNESS.

START SURFACE FLOODING FOR EACH FLOODABLE BACKFILL LIFT AT THE HIGH POINT OF THE SUBDRAIN AND PROGRESS TO THE LOW POINT WHERE THE SUBDRAIN EXITS THE FABRIC. TO ENSURE UNIFORM SURFACE FLOODING, WATER RUNNING FULL IN A 2-INCH DIAMETER HOSE SHOULD BE SPRAYED IN SUCCESSIVE 6-FOOT TO 8-FOOT INCREMENTS FOR 3 MINUTES WITHIN EACH INCREMENT.

FLOODABLE BACKFILL LIFT PLACEMENT, FLOODING, AND COMPACTION SHALL PROGRESS UNTIL THE REQUIRED FULL THICKNESS OF THE ABUTMENT BACKFILL HAS BEEN COMPLETED.

WATER REQUIRED FOR FLOODING, SUBDRAINS, POROUS BACKFILL, FLOODABLE BACKFILL, AND GEOTEXTILE FABRIC FURNISHED AT THE BRIDGE ABUTMENTS WILL NOT BE MEASURED SEPARATELY FOR PAYMENT.

THE COST OF WATER REQUIRED FOR FLOODING, SUBDRAINS, POROUS BACKFILL, FLOODABLE BACKFILL, NEOPRENE WATER STOP, AND GEOTEXTILE FABRIC FURNISHED AT THE BRIDGE ABUTMENTS SHALL BE INCLUDED IN THE CONTRACT UNIT PRICE BID FOR STRUCTURAL CONCRETE.

** THE CONTRACTOR SHALL TRIM THE CORNER NEOPRENE WATER STOP TO FIT. USE LATH WITH SHALLOW CONCRETE NAILS TO ATTACH WATER STOP. ATTACH TO ABUTMENT DIAPHRAGM ONLY.

*** THE CONTRACTOR SHALL TRIM THE CORNER NEOPRENE WATER STOP TO FIT. USE LATH WITH SHALLOW CONCRETE NAILS TO ATTACH WATER STOP. ATTACH TO ABUTMENT ONLY.

NOTE: SEE SUBDRAIN DETAILS SHEET FOR DETAILS NOT SHOWN ON THIS SHEET WHICH ARE PERTINENT TO THIS STRUCTURE.

TECHNICAL DATA INFORMATION - GEOTEXTILE FABRIC

MECHANICAL PROPERTIES	TEST METHOD	UNIT	MINIMUM AVERAGE ROLL VALUE	
			MD	CD
TENSILE STRENGTH (AT 5% STRAIN)	ASTM D 4595	kN/m (LBS/FT)	19.8 (1356)	19.8 (1356)
APPARENT OPENING SIZE (AOS)	ASTM D 4751	mm (U.S. SIEVE)	0.43 MAX (#40)	
FLOW RATE	ASTM D 4491	L/MIN/M ² (GAL/MIN/FT ²)	733 (18)	
UV RESISTANCE (AT 500 HOURS)	ASTM D 4355	% STRENGTH RETAINED	70	

NOTE:

SUBDRAIN SHALL SLOPE DOWNWARD 2% FROM C APPROACH ROADWAY WHEN OUTLETTING BOTH SIDES OF THE ABUTMENT.

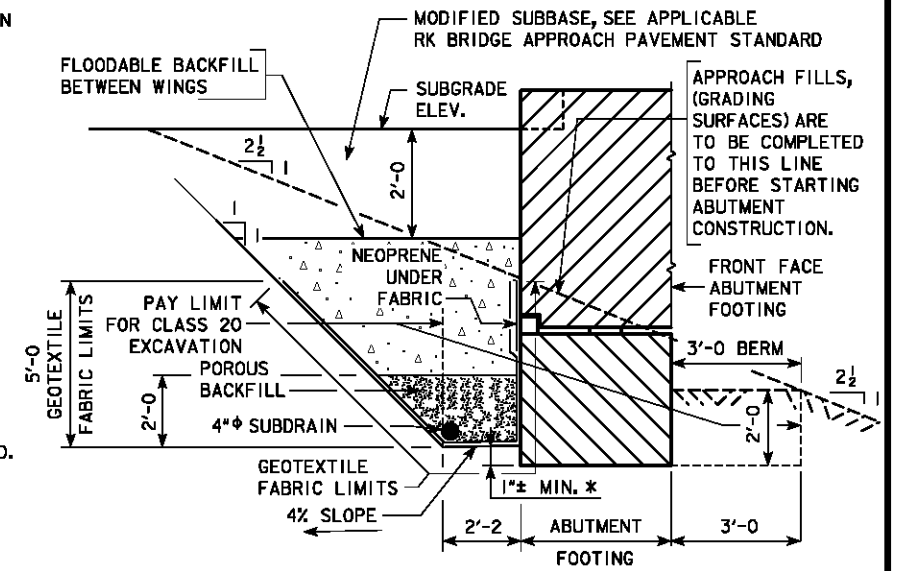

**SECTION A-A
BACKFILL DETAILS**

NOTE: GEOTEXTILE FABRIC WILL BE ATTACHED TO FACE OF ABUTMENT DIAPHRAGM AND WING WALLS.

* DIMENSION VARIES DUE TO 2% SUBDRAIN SLOPE.

DESIGN FOR 0° SKEW
**120'-0" x 44'-0" PRETENSIONED
 PRESTRESSED CONCRETE BEAM BRIDGE**
 120'-0" SINGLE SPAN
ABUTMENT BACKFILL DETAILS
 STA. 1134+61.00 (IA 92) FEBRUARY, 2012
CASS COUNTY
 IOWA DEPARTMENT OF TRANSPORTATION - HIGHWAY DIVISION
 DESIGN SHEET NO. 25 OF 25 FILE NO. 30484 DESIGN NO. 113

THIS SHEET IS INCLUDED TO SHOW SOIL INFORMATION. DETAILS AND NOTES SHOWN ELSEWHERE IN THESE PLANS SHALL BE USED FOR STRUCTURE CONSTRUCTION.

GEOTECHNICAL DESIGN



I hereby certify that this engineering document was prepared by me or under my direct personal supervision and that I am a duly licensed Professional Engineer under the laws of the State of Iowa.
 Signature: *Robert L. Stanley* Date: 9-10-12
 Printed or Typed Name: Robert L. Stanley
 My license renewal date is December 31, 2012.

LOCATION

IA 92 OVER SMALL STREAM
 T-75 N R-34 W
 SECTIONS 28 & 33
 MASSENA TOWNSHIP
 CASS COUNTY
 BRIDGE MAINT. NO. 1563.4S09;
 LATITUDE 41.258376°
 LONGITUDE -94.776114°

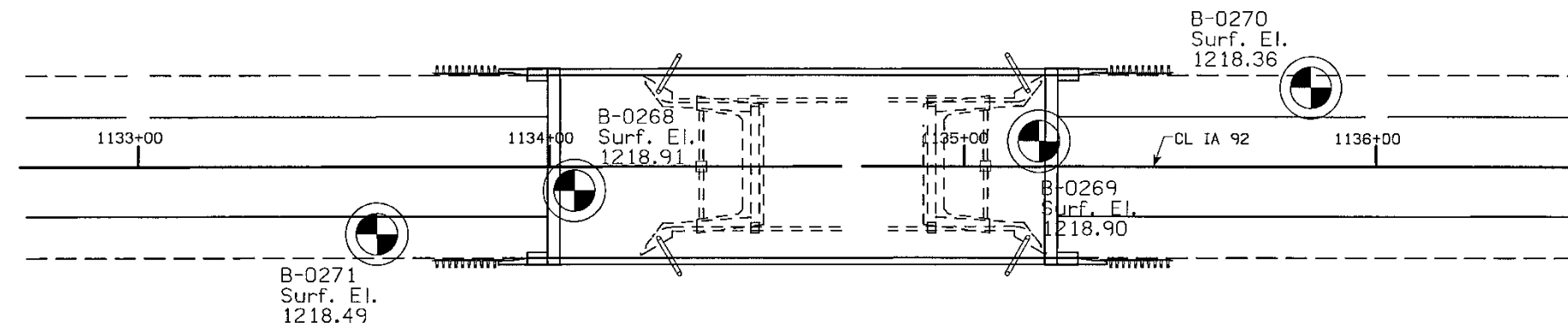
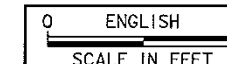

DESIGN FOR 0° SKEW
**120'-0" X 44'-0" PRETENSIONED
 PRESTRESSED CONCRETE BEAM BRIDGE**
 120'-0" SINGLE SPAN
SOIL PROFILE SHEET
 STATION 1134+61.00 AUG 2012
CASS COUNTY
 IOWA DEPARTMENT OF TRANSPORTATION - HIGHWAY DIVISION
 DESIGN SHEET NO. 1 OF 1 FILE NO. 30484 DESIGN NO. 113

Note: [23.0] Indicates Layer Thickness

LEGEND

—H ₂ O—	WATER	BLOW COUNT	SOILS BOOK NO. _____
—DRY—	DRY	LAYER - NO. BLOWS	SOIL REMEDIATION AREA
—P—	PLUGGED	B2 # 5	LIMESTONE (LS.)
M—	MOISTURE		BROKEN & WEATHERED LS.
■	SHELBY		SANDSTONE
■	BLOW COUNT		SHALE
■	DENS. CORE		SANDY SOIL
⊙	SAMPLE		

Boring No.	Date Drilled	GroundWater Level (Ft.)
B-0268	03/01/2012	15.60 WET
B-0269	03/01/2012	13.30 WET
B-0270	03/01/2012	WASH BORE
B-0271	03/01/2012	WASH BORE

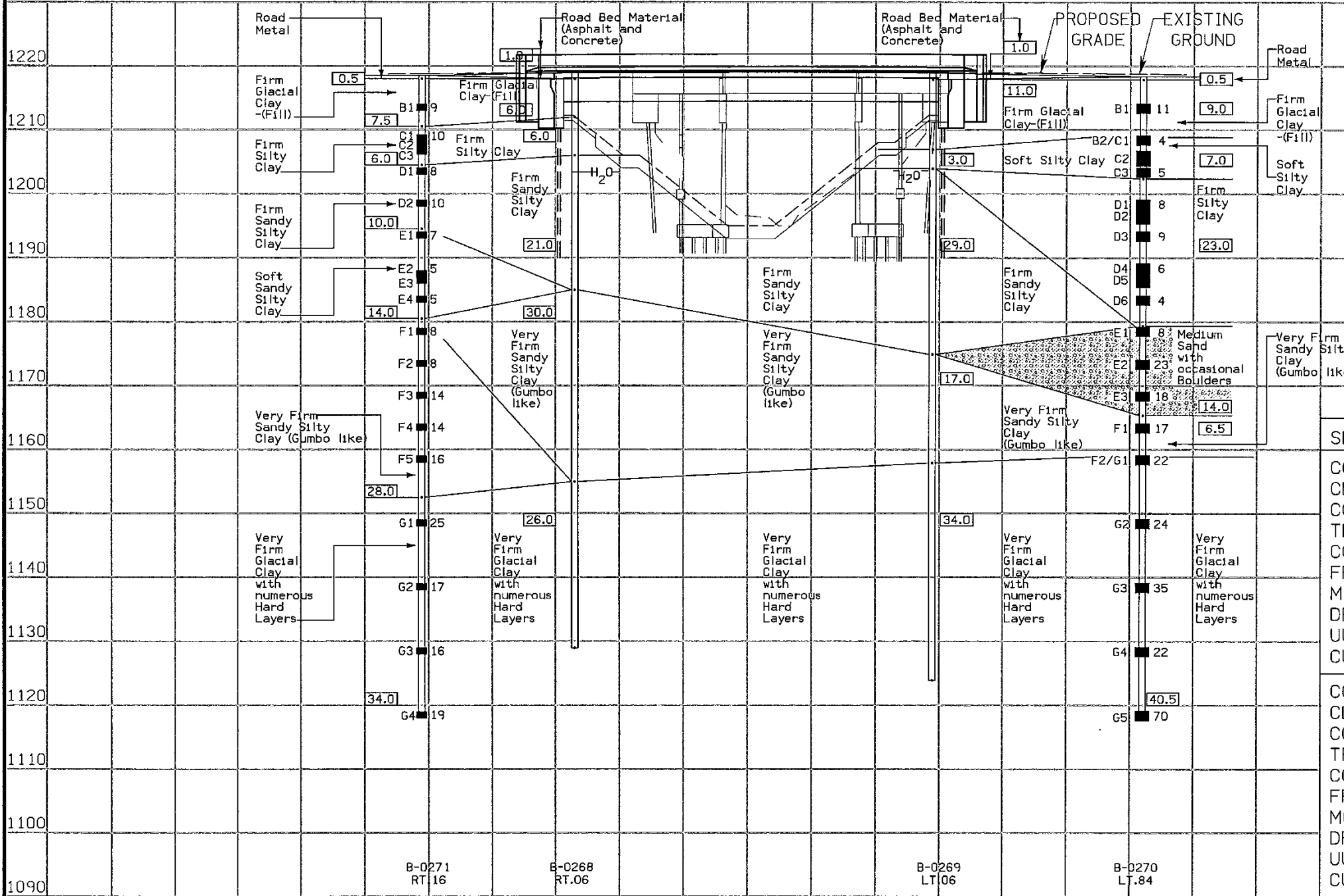

SHELBY TUBE CORE DATA

CORE NO.	B-0270-C1	B-0270-D2	B-0270-D5
CLASSIFICATION [AASHTO]	A-7-6(23)	A-7-6(25)	A-6(16)
COEFF. CONSOL. SQ. FT /DAY	0.277	0.116	0.355
TRIAxIAL COMPRESSION	CU	CU	CU*
COHESION - PSF	274	276	194
FRICITION COEFF.	0.150	0.170	0.150
MOISTURE CONTENT %	37.0	39.2	29.6
DRY DENSITY - PCF	79.4	77.4	93.6
UU-UNCONSOLIDATED & UNDRAINED			
CU-CONSOLIDATED & UNDRAINED			

CORE NO.	B-0271-C2	B-0271-C3	B-0271-E3
CLASSIFICATION [AASHTO]	A-7-6(26)	A-7-6(29)	A-6(26)
COEFF. CONSOL. SQ. FT /DAY	0.243	0.867	0.1
TRIAxIAL COMPRESSION	CU*	CU*	CU*
COHESION - PSF	324	253	205
FRICITION COEFF.	0.142	0.044	0.030
MOISTURE CONTENT %	26.7	31.4	40.8
DRY DENSITY - PCF	82.5	75.5	79.9
UU-UNCONSOLIDATED & UNDRAINED			
CU-CONSOLIDATED & UNDRAINED			

INDEX OF SHEETS

No.	DESCRIPTION
A Sheets	Title Sheets
A.1	Title Sheet
B Sheets	Typical Cross Sections and Details
B.1 - 4	Typical Cross Sections and Details
C Sheets	Quantities and General Information
C.1 - 4	Estimated Project Quantities
CS Sheets	Soils Tabulations
CS.1	Soils Tabulations
D Sheets	Mainline Plan and Profile Sheets
* D.1	Plan & Profile Legend & Symbol Information Sheet
* D.2	ML092
G Sheets	Survey Sheets
G.1	Reference Ties and Bench Marks
G.2	Horizontal Control Tab. & Super for all Alignments
H Sheets	Right-of-Way Sheets
H.1	"Mainline Name"
J Sheets	Traffic Control and Staging Sheets
J.1	Traffic Control Plan
T Sheets	Earthwork Quantity Sheets
T.1	Earthwork Quantity Sheets
W Sheets	Mainline Cross Sections
W.1	Cross Sections Legend & Symbol Information Sheet
W.2 - 10	ML092
X Sheets	Side Road Cross Sections
X.11 - 13	Channel Cross Sections
	* Color Plan Sheets

ROADWAY DESIGN	
	I hereby certify that this engineering document was prepared by me or under my direct personal supervision and that I am a duly licensed Professional Engineer under the laws of the State of Iowa.
	Signature: <u><i>Paul Flattery</i></u> Date: <u>02-05-2013</u>
	Printed or Typed Name: <u>Paul W. Flattery</u>
	My license renewal date is December 31, 2013
Pages or sheets covered by this seal: <u>A.1, B.1-B.4, C.1-C.4, D.1-D.2, G.1-G.2, H.1, J.1, T.1, W.1-W.10, & X.11-X.13.</u>	

Design No. 113
File No. 30484

Paved Shoulder at Guardrail

Shoulder Jointing:
Longitudinal joint: B

2_P_Guard_04-16-13			
STATION TO STATION	(P)	Feet	Remark
1133+31.00	1133+61.00	10.8-9.6	①
1133+61.00	1133+81.00	9.6	
1135+41.00	1135+81.00	9.6	
1135+81.00	1135+91.00	9.6	①

Note: ① See Tab 112-9

Paved Shoulder at Guardrail

Shoulder Jointing:
Longitudinal joint: B

2_P_Guard_04-16-13			
STATION TO STATION	(P)	Feet	Remark
1133+31.00	1133+61.00	12.3-9.6	①
1133+61.00	1133+81.00	9.6	
1135+41.00	1135+61.00	9.6	
1135+61.00	1135+91.00	9.6-10.8	①

Note: ① See Tab 112-9

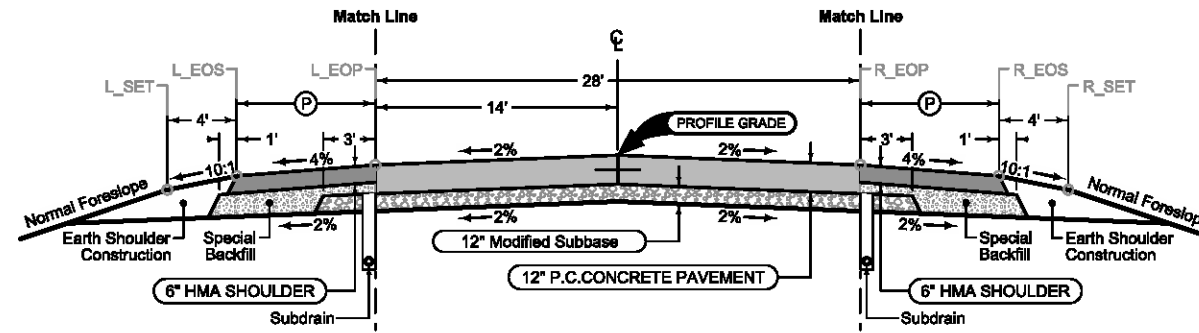

Mainline Jointing:
Transverse joints: CD at 20' spacing
Longitudinal joint: L-2

STATION TO STATION	
1133+31.00	1134+01.00
1135+21.00	1135+91.00

Paved Shoulder at Guardrail

Shoulder Jointing:
Longitudinal joint: B

2_P_Guard_04-16-13			
STATION TO STATION	(P)	Feet	Remark
1132+89.95	1133+31.00	9.0-8.8	①
1135+91.00	1136+12.26	7.4	①
1136+12.36	1136+49.66	7.4-9.3	①
1136+49.66	1136+81.52	9.3	①

Note: ① See Tab 112-9

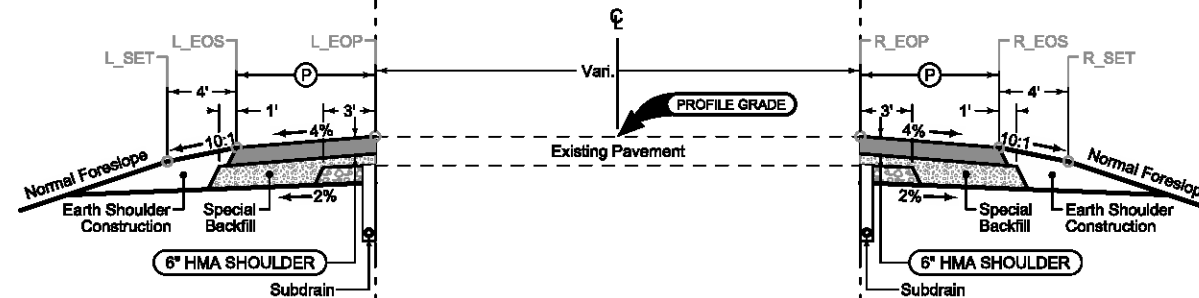

Paved Shoulder at Guardrail

Shoulder Jointing:
Longitudinal joint: B

2_P_Guard_04-16-13			
STATION TO STATION	(P)	Feet	Remark
1132+79.91	1133+04.79	7.0-10.5	①
1133+04.79	1133+31.00	10.5-9.8	①
1135+91.00	1136+32.14	9.4-9.8	①

Note: ① See Tab 112-9

Design No. 113
File No. 30484

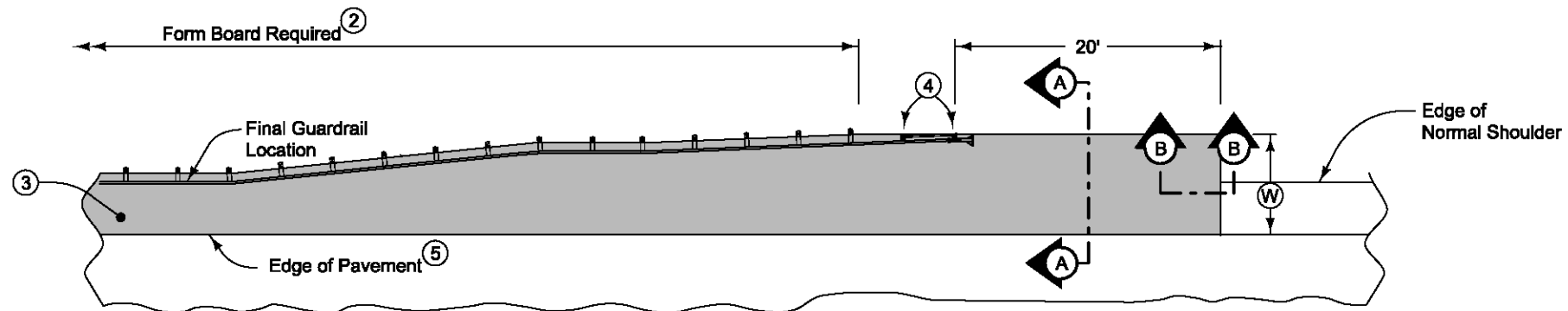

6" HMA Paved Shoulder at guardrail. 7" PCC may be substituted with the following jointing layout:

Match mainline pavement joint spacing. When mainline pavement is 8" or greater in thickness, place additional transverse 'C' joints in shoulder at mid-panel of the mainline pavement. Place longitudinal 'C' joint at W/2 from edge of mainline pavement when W is greater than 10' wide. Terminate longitudinal joint at transverse joint less than 10' in length.

Compaction of HMA is required to face of guardrail post. Hand compaction will be allowed under guardrail. Removal & reinstallation of guardrail will be allowed with no additional payment.

Refer to Shoulder tabulation (112-9) for quantities.

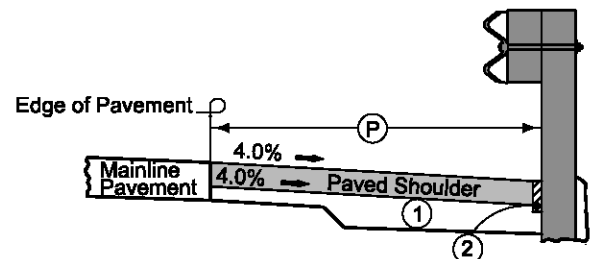

Typical Section with Form Board

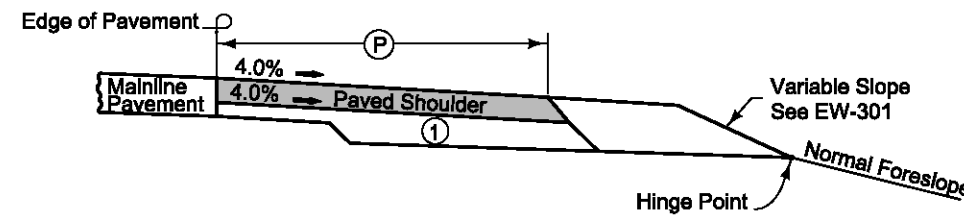

Section A-A

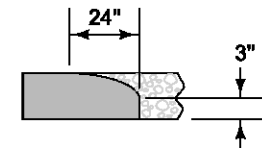

Section B-B
Roll down at granular shoulder or earth.

- ① 6" subgrade treatment.
- ② When guardrail posts are installed prior to construction of paved shoulder, nail 1" x 6" untreated form boards along the face of guardrail posts for the length shown. This board is to prevent shoulder material from contacting the sides of the posts and altering the function of the guardrail. Form board not required for final 2 posts.
- ③ Continue paved shoulder to existing paved shoulder or 20' beyond the end of guardrail.
- ④ Shoulder may be notched for final 2 posts or post sleeves may be installed through pavement.
- ⑤ 'KT-1' joint for PCC shoulder.
'B' joint for HMA shoulder.

PAVED SHOULDER AT GUARDRAIL

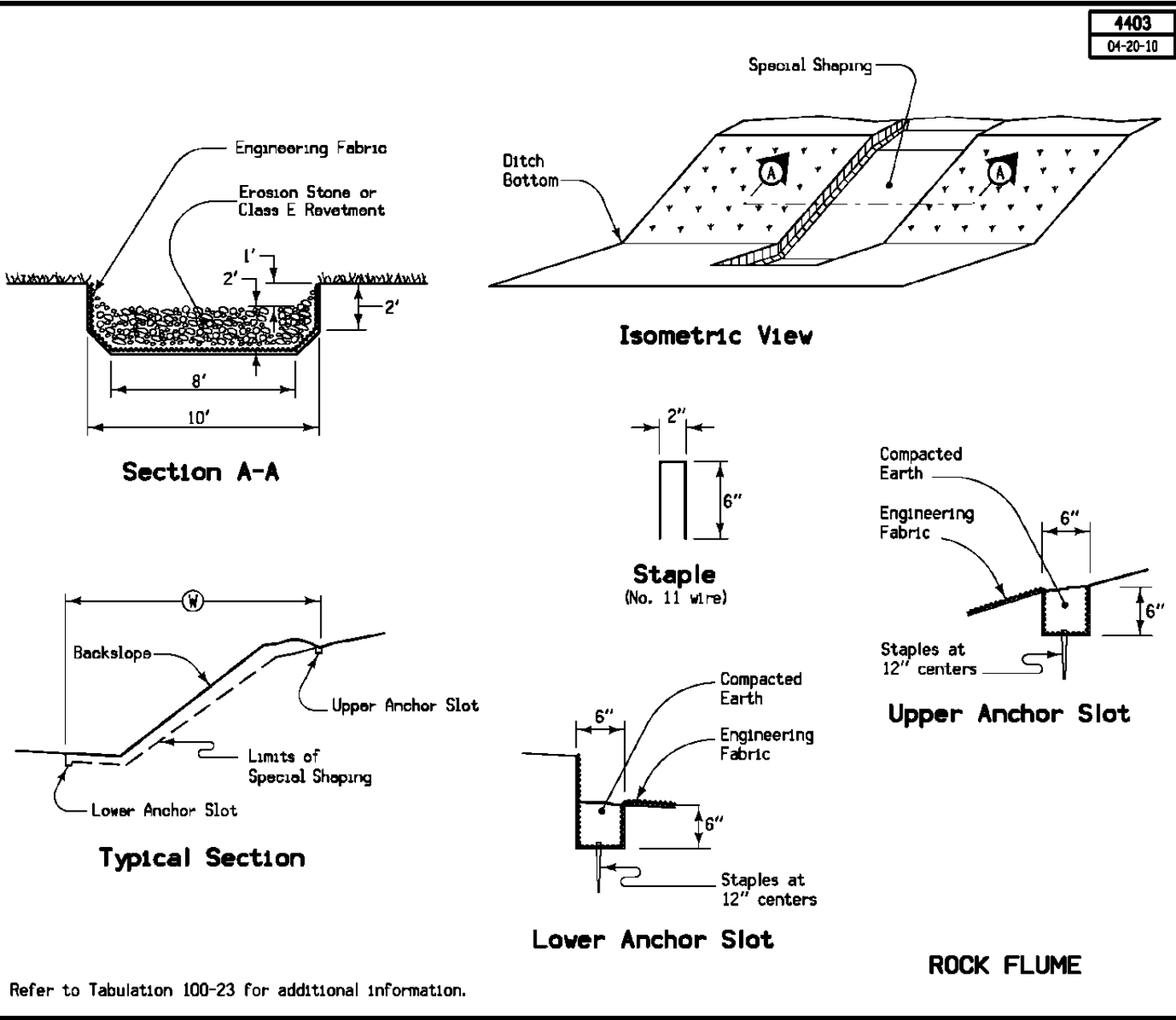
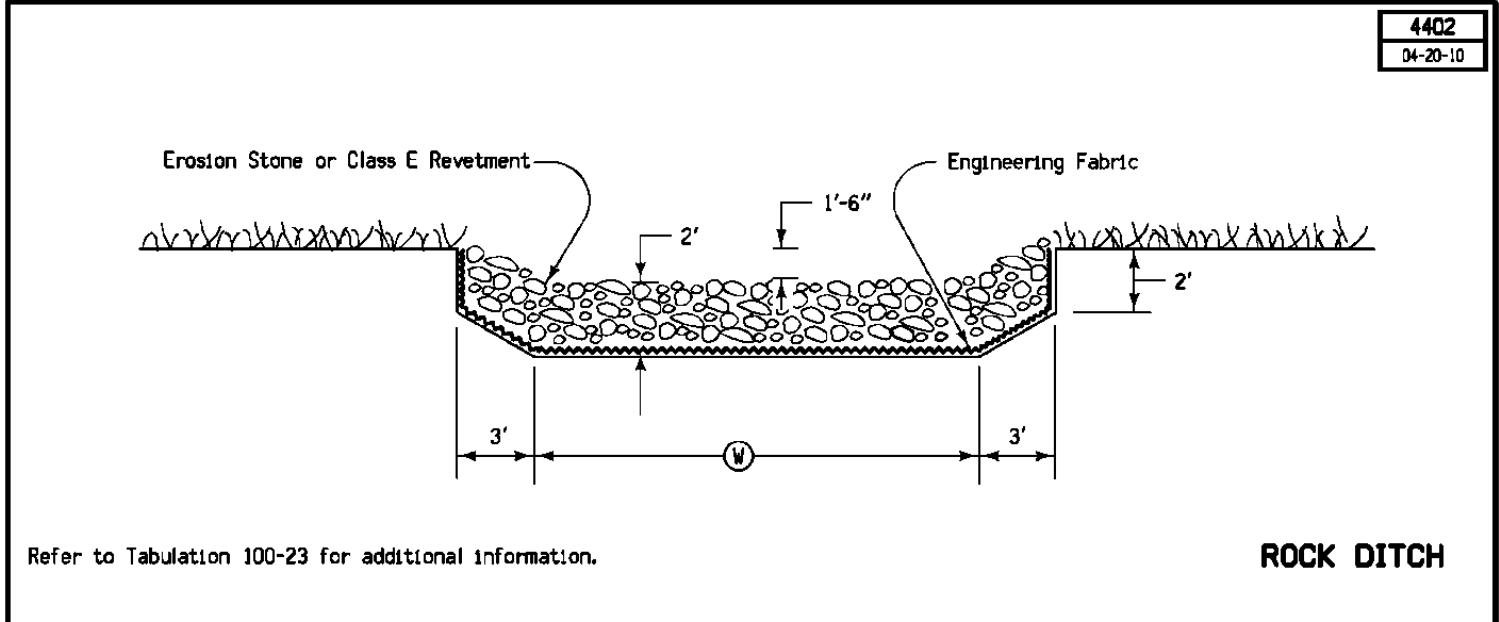
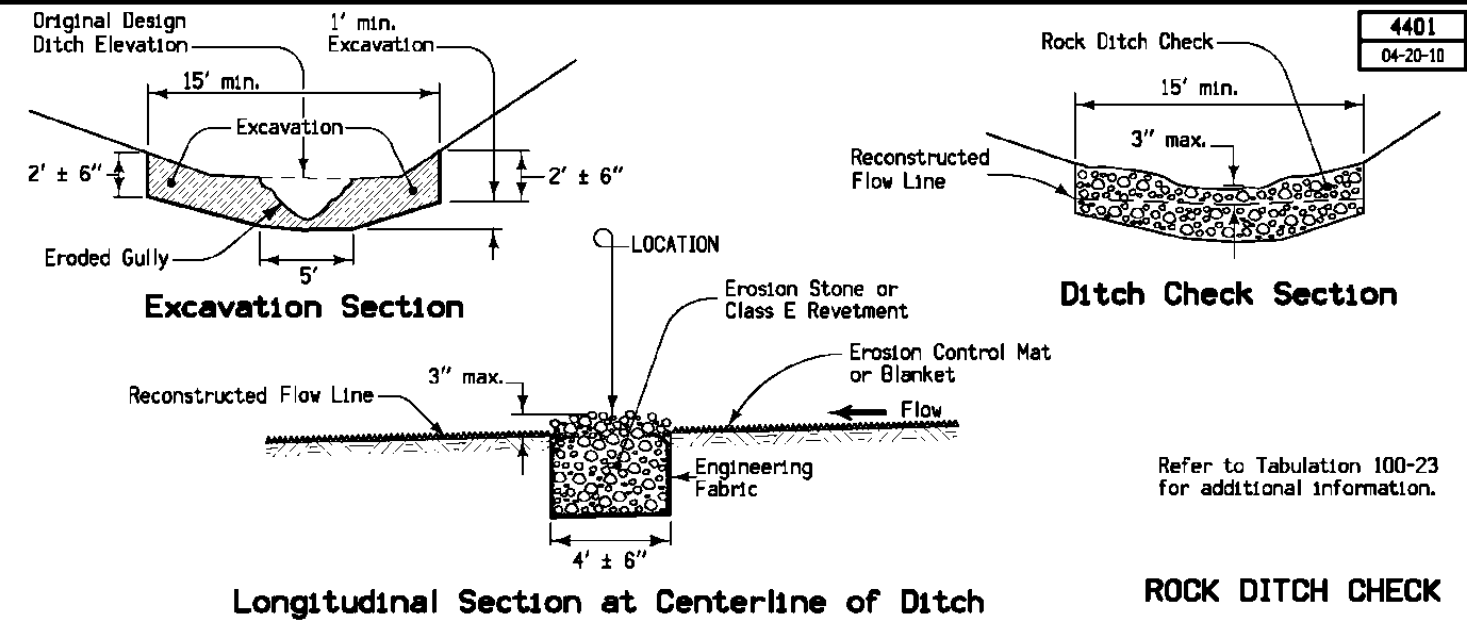

Design No. 113
 File No. 30484

100-1D 10-18-05
PROJECT DESCRIPTION
This project involve bridge replacement in Cass County Ia-092 over small stream 1 mile west of Ia.148.

100-0A 10-28-97					
ESTIMATED ROADWAY QUANTITIES (1 DIVISION PROJECT)					
Item No.	Item Code	Item	Unit	Total	As Built Qty.
1	2101-0850002	CLEARING AND GRUBBING	UNIT	10	
2	2102-0425070	SPECIAL BACKFILL	TON	272.0	
3	2102-2710070	EXCAVATION, CLASS 10, ROADWAY AND BORROW	CY	3,611.0	
4	2102-2712015	EXCAVATION, CLASS 12, BOULDERS OR ROCK FRAGMENTS	CY	10.0	
5	2102-4560000	LOCATING TILE LINES	STA	9.30	
6	2105-8425015	TOPSOIL, STRIP, SALVAGE AND SPREAD	CY	732.0	
7	2122-5190501	PAVED SHOULDER, PORTLAND CEMENT CONCRETE (PAVED SHOULDER PANEL FOR BRIDGE END DRAIN)	SY	107.0	
8	2122-5500060	PAVED SHOULDER, HOT MIX ASPHALT MIXTURE, 6 IN.	SY	340.8	
9	2123-7450000	SHOULDER CONSTRUCTION, EARTH	STA	3.40	
10	2301-0690200	BRIDGE APPROACH, RK-20	SY	512.4	
11	2412-0000100	LONGITUDINAL GROOVING IN CONCRETE	SY	1,062.9	
12	2505-4008120	REMOVAL OF STEEL BEAM GUARDRAIL	LF	300.0	
13	2505-4008300	STEEL BEAM GUARDRAIL	LF	75.0	
14	2505-4008400	STEEL BEAM GUARDRAIL BARRIER TRANSITION SECTION	EACH	4	
15	2505-4021010	STEEL BEAM GUARDRAIL END ANCHOR, BOLTED	EACH	4	
16	2505-4021700	STEEL BEAM GUARDRAIL END TERMINAL	EACH	4	
17	2510-6745850	REMOVAL OF PAVEMENT	SY	588.7	
18	2518-6910000	SAFETY CLOSURE	EACH	4	
19	2520-3350010	FIELD LABORATORY	EACH	1	
20	2527-9263109	PAINTED PAVEMENT MARKING, WATERBORNE OR SOLVENT-BASED	STA	10.40	
21	2528-8445110	TRAFFIC CONTROL	LS	1.00	
22	2528-8445113	FLAGGERS	EACH	See Proposal	
23	2601-2643401	TURF REINFORCEMENT MAT	SQ	16.0	
24	2601-2700010	OUTLET OR CHANNEL SCOUR PROTECTION	SF	128	
25	2602-0000020	SILT FENCE	LF	1,000.0	
26	2602-0000101	MAINTENANCE OF SILT FENCE OR SILT FENCE FOR DITCH CHECK	LF	400.0	

111-25 10-18-11		
INDEX OF TABULATIONS		
Tabulation	Tabulation Title	Sheet No.
100-0A	ESTIMATED ROADWAY QUANTITIES (1 DIVISION PROJECT)	C.1
100-17	TABULATION OF SILT FENCES	C.3
100-4A	ESTIMATE REFERENCE INFORMATION	C.1
102-5	EXISTING PAVEMENT	C.2
104-3	DRAINAGE STRUCTURE BY ROAD CONTRACTOR	C.2
104-8A	SCOUR PROTECTION OR ROCK FLUME FOR BRIDGE END DRAIN	C.3
105-4	STANDARD ROAD PLANS	C.2
108-13A	SAFETY CLOSURES	C.2
108-22	PAVEMENT MARKING LINE TYPES	C.3
108-8A	STEEL BEAM GUARDRAIL AT CONCRETE BARRIER OR BRIDGE END POST	C.2
110-1	REMOVAL OF PAVEMENT	C.2
110-7A	REMOVAL OF STEEL BEAM GUARDRAIL	C.3
111-25	INDEX OF TABULATIONS	C.1
112-6	BRIDGE APPROACH SECTION	C.4
112-9	SHOULDERS	C.4
232-3B	EROSION CONTROL (URBAN SEEDING)	C.3

100-4A 10-29-02		
ESTIMATE REFERENCE INFORMATION		
Item No.	Item Code	Description
1	2101-0850002	CLEARING AND GRUBBING Full description plus location will be furnished by District at pre-construction meeting.
-	-	-
2	2102-0425070	SPECIAL BACKFILL See Tab 112-9 for details and locations.
-	-	-
3	2102-2710070	EXCAVATION, CLASS 10, ROADWAY AND BORROW 2237 cubic yards Class 10 is needed to build this project as shown on Tab 107-27 (Sheet T.1) and 1374 cubic yards of waste. All quantity include 30% for shrinkage. No pavement for overhaul will be allowed.
-	-	-
4	2102-2712015	EXCAVATION, CLASS 12, BOULDERS OR ROCK FRAGMENTS For boulders encountered during excavation. Refer to Tab 103-7.
-	-	-
5	2102-4560000	LOCATING TILE LINES As needed.
-	-	-
6	2105-8425015	TOPSOIL, STRIP, SALVAGE AND SPREAD See Tab 103-4 for details and locations. All areas to receive fill are to have 12 inches of topsoil stripped.
-	-	-
7	2122-5190501	PAVED SHOULDER, PORTLAND CEMENT CONCRETE (PAVED SHOULDER PANEL FOR BRIDGE END DRAIN) See Tab 104-8A for details and locations.
-	-	-
8	2122-5500060	PAVED SHOULDER, HOT MIX ASPHALT MIXTURE, 6 IN. See Tab 112-9 for details and locations.
-	-	-
9	2123-7450000	SHOULDER CONSTRUCTION, EARTH See Tab 112-9 including 40% for shrinkage. No over haul allowed for this material.
-	-	-
10	2301-0690200	BRIDGE APPROACH, RK-20 See Tab 112-6 for details and locations.
-	-	-
11	2412-0000100	LONGITUDINAL GROOVING IN CONCRETE See Tab 100-28 for information and details.
-	-	-
12	2505-4008120	REMOVAL OF STEEL BEAM GUARDRAIL See Tab.110-7A for information and details. Materials to become property of the contractor. Guardrail shall be disposed of per Article 1106.07 of the current Specifications.
-	-	-
13	2505-4008300	STEEL BEAM GUARDRAIL
14	2505-4008400	STEEL BEAM GUARDRAIL BARRIER TRANSITION SECTION
15	2505-4021010	STEEL BEAM GUARDRAIL END ANCHOR, BOLTED
16	2505-4021700	STEEL BEAM GUARDRAIL END TERMINAL See Tab.108-8A for information and details.
-	-	-
17	2510-6745850	REMOVAL OF PAVEMENT See Tab 102-5 and Tab 110-1 for details and locations.
-	-	-
18	2518-6910000	SAFETY CLOSURE See Tab.108-13A for information and details.
-	-	-
19	2520-3350010	FIELD LABORATORY
-	-	-
20	2527-9263109	PAINTED PAVEMENT MARKING, WATERBORNE OR SOLVENT-BASED Refer Tab.108-22 in the C Sheets.
-	-	-
21	2528-8445110	TRAFFIC CONTROL See Tab 108-23A for information's and details.
-	-	-
22	2528-8445113	FLAGGERS
-	-	-
23	2601-2643401	TURF REINFORCEMENT MAT
24	2601-2700010	OUTLET OR CHANNEL SCOUR PROTECTION See Tab 104-8A for details and locations.
-	-	-
25	2602-0000020	SILT FENCE This item includes 25% more silt fence than the Tab 100-17 quantity for field adjustment and replacement. See Tab 100-17 for details and locations.
-	-	-
26	2602-0000101	MAINTENANCE OF SILT FENCE OR SILT FENCE FOR DITCH CHECK This item is included for maintaining the silt fence during the project and is estimated as 50% fo the tab quantity. See Tab 100-17 for details.
-	-	-

Design No. 113
File No. 30484

105-4
10-18-11

STANDARD ROAD PLANS

The following Standard Road Plans apply to construction work on this project.

Number	Date	Title
BA-200	10-18-11	Steel Beam Guardrail Components
BA-201	10-19-10	Steel Beam Guardrail Barrier Transition Section
BA-202	10-18-11	Steel Beam Guardrail Bolted End Anchor
BA-203	10-18-11	Steel Beam Guardrail W-Beam End Anchor
BA-205	10-18-11	Steel Beam Guardrail End Terminal
EC-201	04-20-10	Silt Fence
EW-201	04-17-12	Bridge Berm Grading without Recoverable Slope (Barnroof Section)
EW-301	04-19-11	Guardrail Grading
PM-110	04-16-13	Line Types
PV-101	04-17-12	Joints
RF-39	04-16-13	Scour Protection for Bridge End Drain
RK-20	04-16-13	Double Reinforced 12" Approach
SI-173	04-20-10	Object Markers
SI-211	10-19-10	Object Marker and Delineator Placement with Guardrail
TC-1	04-16-13	Work Not Affecting Traffic (Two-Lane or Multi-Lane)
TC-202	04-16-13	Shoulder Closure (One Lane)
TC-213	04-17-12	Lane Closure with Flaggers
TC-252	04-17-12	Routes Closed to Traffic

110-1
04-16-13

REMOVAL OF PAVEMENT

Refer to Tabulation 102-5

* Not a Bid Item

Begin Station	End Station	Side	Pavement Type	Area		Saw Cut*	Remarks
				SY	LF		
1133+31.00	1134+35.40	Lt.	AAC	324.8		28.0	
1135+06.18	1135+91.00	Rt.	AAC	263.9		28.0	
Totals:				588.7			

102-5
10-16-12

EXISTING PAVEMENT

No.	Location					Year	Type	Project Number	Surface		Base		Subbase		Removal		Coarse Aggregate			Reinforcement	Remarks
	County	Route	Dir. of Travel	Begin Milepost	End Milepost				Type	Depth	Type	Depth	Type	Depth	Type	Depth	Source	Type	Durability Class	Type	
1	Cass	92	EB	52.53	67.36	1988		F-92-2(16)--20-15	AAC	3							CRESCENT	C.LST.			
2						1949		F-464(1)	PC8	8							WEST DES MOINES	GRAVEL	2		

103-4
04-19-11

TABULATION OF SPREADING TOPSOIL

Perform this work according to Section 2105. Prior to placing topsoil on any cohesive soil, scarify the area to be covered to a minimum depth of 3 inches.

Appropriate adjustments have been made in the template quantities to reflect the placement of topsoil on foreslope, backslope and ditch bottom as detailed hereon.

Placement Description							Topsoil Excavation Available From			
Area	Quantity	Location		Side	Slope	(T)	Amount Reserved	Station to Station		Remarks
No.	CY	Station to Station	L. or R.	B. or F.	IN	CY				
	291.0	1132+75.00	1134+00.00	Both	Both	8.0	285.0	1132+75.00	1134+00.00	
	441.0	1135+00.00	1137+25.00	Both	Both	8.0	447.0	1135+00.00	1137+25.00	
	732.0	TOTAL					732.0			

108-13A
08-01-08

SAFETY CLOSURES

Refer to Section 2518 of the Standard Specifications

Station	Closure Type		Remarks
	Road Qty.	Hazard Qty.	
1132+50	1		
1134+00	1		
1135+25	1		
1137+25	1		
Totals:	4		

Design No. 113
File No. 30484

SCOUR PROTECTION OR ROCK FLUME FOR BRIDGE END DRAIN

104-8A
04-20-10
① Not a Bid Item

Refer to Standard Road Plan RF-39 or RF-40

Location			Shoulder				Rock Flume RF-40			Scour Protection RF-39			Remarks	
Bridge Station	Bridge Corner	Distance DI-1 or DI-2	Panels Required				Macadam Stone Base ①	Engineering Fabric ①	Erosion Stone ①	Outlet or Channel Scour Protection	Turf Reinforced Mat (TRM)			
			A	B	C or D	PCC						Polymer Grid ①		Modified Subbase ①
1134+61.00	NW	33.3		B			21.4	21.4	18.900			32.0	4.0	
1134+61.00	SW	33.3		A			21.4	21.4	18.900			32.0	4.0	
1134+61.00	NE	42.6		D			42.8	42.8	33.600			32.0	4.0	
1134+61.00	SE	33.3		B			21.4	21.4	18.900			32.0	4.0	
Totals:						107.0	107.0	90.300				128.0	16.0	

PAVEMENT MARKING LINE TYPES

108-22
04-16-13

See PM-110

*BCY4 - Place on the same side of the roadway to match existing markings near the project.

***MNY4 - Factor of 1.00 as value includes number of 4-inch passes to cover median nose area.

**NPY4 - For estimating purposes only. No Passing Zone Lines will be located in the field.

BCY4: Broken Centerline (Yellow) @ 0.25

DCY4: Double Centerline (Yellow) @ 2.00

NPY4: No Passing Zone Line (Yellow) @ 1.25

BLW4: Broken Lane Line (White) @ 0.25

ELW4: Edge Line Right (White) @ 1.00

ELY4: Edge Line Left (Yellow) @ 1.00

Road ID	Location			Marking Type	Side		Length by Line Type (Unfactored)													Remarks					
	Station to Station	Dir. of Travel			L	C	R	BCY4*	DCY4	NPY4**	BLW4	ELW4	ELY4												
																									STA
IA.92	1133+31.00	1135+91.00	BOTH																						
IA.92	1133+31.00	1135+91.00	EB		x				2.60					2.60											
IA.92	1133+31.00	1135+91.00	WB			x								2.60											
Totals:									5.20				5.20												

REMOVAL OF STEEL BEAM GUARDRAIL

110-7A
04-17-12

- ① Lane(s) to which the installation is adjacent.
- ② Includes length of End Terminals and End Anchors.

No.	Direction of Traffic	Location		Side	Removal of Guardrail ②
		Station to Station			
1	EB	1133+77	1134+52	Lt.	75.0
2	EB	1134+92	1135+67	Lt.	75.0
3	WB	1134+92	1135+67	Rt.	75.0
4	WB	1133+77	1134+52	Rt.	75.0
Totals:					300.0

EROSION CONTROL (URBAN SEEDING)

232-3B
10-16-12

Following the completion of work in a disturbed area, place seed, fertilizer, and mulch on the disturbed area as follows:

SEEDING MIXTURE: Seeding Rate: 4 lbs. per 1000 sq. ft.
Bluegrass, KY 70%
Fescue, Creeping Red 20%
Ryegrass, Perennial (Fineleaf) (Derby, Manhattan or equivalent) 10%

FERTILIZER:
17 lbs. of 13-13-13 (or equivalent) commercial fertilizer per 1000 sq. ft.

MULCH:
70 lbs. of dry cereal straw per 1000 sq. ft. For areas disturbed, but not seeded by September 30th, scarify to a 3 inch depth and mulch. Consolidate all mulch into the soil with a mulch stabilizer.

Use Certified Noxious Weed Seed Free Mulch as determined by the Iowa Crop Improvement Association or adjacent state's Crop Improvement Association.

Preparing the seedbed and furnishing and applying seed, fertilizer, and mulch is incidental to mobilization and will not be paid for separately.

TABULATION OF SILT FENCES

100-17
04-20-10

Refer to EC-201

Location			Length LF	Remarks
Begin Station	End Station	Side		
1132+50.00	1135+00.00	Both	500.0	Rt. & Lt.
1134+25.00	1137+25.00	Both	300.0	Rt. & Lt.
Totals:			800.0	

LONGITUDINAL GROOVING

100-28
10-19-10

Location	Total	Remarks
	SY	
1133+31	256.2	Bridge Approach.
1134+61	550.5	Bridge Deck.
1135+21	256.2	Bridge Approach.

Design No. 113
File No. 30484

BRIDGE APPROACH SECTION

Refer to the RK-Series.

* Not a bid item

Location		Approach Pavement							Subdrain					Remarks		
Bridge Station	End	Skew Ahead		Thickness T	Pay Length	Non-Reinf. Pavement Area	Single-Reinf. Pavement Area	Double-Reinf. Pavement Area	Fixed or Movable Abutment	Perforated Subdrain 4"		Porous Backfill	Class 'A' Crushed Stone Backfill	Modified Subbase	Polymer Grid	Remarks
		LEFT	RIGHT							LF	STA					
		Degrees		Inches	FT	SY	SY	SY	F or M	LF	STA	Side	CY	CY	TON	
1134+61.00		--	--	12.0	70.0	93.3	62.2	100.7	M					267.700	288.2	
1134+61.00	x	--	--	12.0	70.0	93.3	62.2	100.7	M					267.700	288.2	
Totals:						186.7	124.4	201.3						535.400	576.4	

SHOULDERS

- ① Lane(s) to which the shoulder is adjacent.
- ② Bid Item
- ③ Applies only for Paved Shoulders constructed on project with existing granular shoulders.
- ④ Does not include shrink.

Calculations assume a HMA unit weight (lbs/cf) of 0, a Special Backfill unit weight (lbs/cf) of 140, and a Granular Shoulder unit weight (lbs/cf) of 140.

Road Identification	Direction Of Traffic	Location		Side	P Width FT	G Width FT	L Length FT	Quantities												Remarks		
		Station to Station						Class 13 Excavation Widening CY ②	HMA Base Widening ③ TON ② TON/STA		Hot Mix Asphalt TON TON/STA		Paved Shoulder SY ②	Reinforced Paved Shoulder SY ②	Special Backfill TON ② TON/STA		Modified Subbase CY ②	Granular Shoulder TON ② TON/STA			Earth Shoulder Construction STA ② CY ④	
		Start	End						TON	TON/STA	TON	TON/STA			TON	TON/STA		TON	TON/STA		TON	TON/STA
IA.92	EB	1132+79.91	1133+04.79	Rt.	7.0-10.5	0.0	24.9						24.4		18.300						0.2	
IA.92	EB	1133+04.79	1133+31.00	Rt.	10.5-9.8	0.0	26.2						29.6		23.680						0.3	
IA.92	EB	1133+31.00	1133+81.00	Rt.	12.3-9.6	0.0	50.0						36.8		28.340						0.5	
IA.92	EB	1135+61.00	1135+91.00	Rt.	9.6-10.8	0.0	30.0						33.8		27.040						0.3	
IA.92	EB	1135+91.00	1136+32.14	Rt.	9.4-9.8	0.0	41.1						44.4		35.080						0.4	
IA.92	WB	1132+89.95	1133+31.00	Lt.	9.0-8.8	0.0	41.1						41.3		33.870						0.4	
IA.92	WB	1133+31.00	1133+61.00	Lt.	10.8-9.6	0.0	30.0						33.9		27.800						0.3	
IA.92	WB	1135+81.00	1135+91.00	Lt.	9.6	0.0	10.0						10.7		8.560						0.1	
IA.92	WB	1135+91.00	1136+12.26	Lt.	7.4	0.0	21.3						17.7		14.510						0.2	
IA.92	WB	1136+12.36	1136+49.66	Lt.	7.4-9.3	0.0	37.3						35.2		28.160						0.4	
IA.92	WB	1136+49.66	1136+81.52	Lt.	9.3	0.0	31.9						33.0		26.730						0.3	
Totals:													340.8		272.070						3.4	

STEEL BEAM GUARDRAIL AT CONCRETE BARRIER OR BRIDGE END POST

Refer to BA-200, BA-201, BA-202, BA-205, BA-250, SI-172, SI-173 and SI-211.

① See Standards for list of materials.

No.	Station	Offset	Layout Lengths				Delineators and Object Markers				Bid Items ①					Remarks				
			VT1	VF	VT2	ET Terminal	Type	Delineator Type 1	Object Marker		End Anchor Bolted	Barrier Transition Section	Steel Beam Guardrail	End Terminal						
									Type 2	Type 3				Standard	Flared for Cable Connection		Adapter			
			White No.	No.	OM-3L No.	OM-3R No.	BA-202 Type	BA-201 No.	BA-200 LF	BA-205 No.	BA-206 No.	BA-210 No.								
1	1134+01	6	28.125	25.00	--	50.0	3				B	1	25.0	1						
2	1134+01	6	28.125	--	--	50.0	3				B	1	0.0	1						
3	1135+21	6	28.125	50.00	--	50.0	3				B	1	50.0	1						
4	1135+21	6	28.125	--	--	50.0	3				B	1	0.0	1						
Totals:													4	4	75.0	4				

Design No. 113
File No. 30484

SHRINKAGE DATA

Material	%	Remarks
TOPSOIL	40%	
REMAINDER PROJECT CUT	30%	
		BOULDERS 10 Cu. Yds.

SPECIAL ATTENTION-SLIVER FILL

Special Attention should be given to Section 2107.03.C, Standard Specification Series of 2012, on this project.

LONGITUDINAL SUBDRAINS

RECORDS INDICATE THAT LONGITUDINAL SUBDRAINS AND OUTLETS EXIST NEAR THE PROJECT AREA. ANY LONGITUDINAL SUBDRAINS AND THEIR ASSOCIATED OUTLETS SHALL BE REMOVED TO THE OUTER LIMITS OF THE PROJECT AND NEW LONGITUDINAL SUBDRAIN OUTLETS INSTALLED

Design No. 113
File No. 30484

GEOTECHNICAL DESIGN

	I hereby certify that this engineering document was prepared by me or under my direct personal supervision and that I am a duly licensed Professional Engineer under the laws of the State of Iowa.	
	Signature: <i>Robert Stanley</i>	Date: 2-11-13
	Printed or Typed Name: Robert L. Stanley	
	My license renewal date is December 31, 2014	
Pages or sheets covered by this seal: CS.1		

SURVEY SYMBOLS

- BNK Stream Bank
- PIP Pipe Culvert
- Tile --- TIL Tile Line
- SIGN SI Sign
- PR Electric Riser Pole
- #--- FCL Chain Link and Security Fence
- EB EB Electrical Box
- x--- FW Wire Fence
- +--- GDL Guard Rail (Rail and Cable)
- GV GV Gas Valve
- BRG Bridge
- MIS Miscellaneous
- SIGN SL Speed Limit Sign
- TDC Tree Deciduous
- COS Square Bridge Pier Column
- TLNL Tree Line Left
- BLD Building or Foundation
- GP GP Guard Post (Less Than 4 Posts)
- TP TPD Telephone Pedestal
- ▼ VS Valley Section
- > D Centerline Draw or Stream (Down)
- EG Edge of Gravel Road
- ENT Centerline BL of Entrance
- EP Edge of Paved Roads (ML or SR)
- SP Stream Profile
- <--- DU Centerline Draw or Stream (Up)
- CON Concrete or A/C Slab
- GU Gutter In Front of Curb
- RIP Rip-Rap
- EW Edge of Water
- Power Pole
- F0 --- Existing Fiber Optics Telephone Line
- F02 --- Existing Fiber Optics Telephone Line 2
- W --- Existing Water Line
- T1 --- Existing Telephone Line

UTILITY LEGEND

- Alliant Energy
- F0 --- Lightcore
- F02 --- MCI
- Black Hills Energy
- W --- Southern Iowa Rural Water Association
- T1 --- Massena Telephone Company

PLAN VIEW COLOR LEGEND OF PLAN AND PROFILE SHEETS

- | | | |
|--------------|-------|---|
| Green | (2) | Existing Topographic Features and Labels |
| Blue | (1) | Proposed Alignment, Stationing, Tic Marks, and Alignment Annotation |
| Purple | (5) | Existing Utilities |
| Yellow | (4) | Highlight for Critical Notes or Features |
| Red | (3) | Delineates Restricted Areas |
| Lavender | (9) | Temporary Pavement Shading |
| Gray, Light | (48) | Proposed Pavement Shading |
| Gray, Med | (80) | Proposed Granular Shading |
| Gray, Dark | (112) | Proposed Grade and Pave Shading |
| Brown, Light | (237) | Grading Shading |

PROFILE VIEW COLOR LEGEND OF PLAN AND PROFILE SHEETS

- | | | |
|-------------|-------|---------------------------------|
| Green | (2) | Existing Ground Line Profile |
| Blue | (1) | Proposed Profile and Annotation |
| Purple | (5) | Existing Utilities |
| Blue, Light | (230) | Proposed Ditch Grades, Left |
| Black | (0) | Proposed Ditch Grades, Median |
| Rust | (14) | Proposed Ditch Grades, Right |

CONVENTIONAL SIGNS

- Reference Point
- Station
- Survey Line
- Section Corner
- Clearing & Grubbing Area
- Pavement Removal

RIGHT-OF-WAY LEGEND

- ▲ Proposed Right-of-Way
- △ Existing Right-of-Way
- ▲ Existing and Proposed Right-of-Way
- ▲ Easement and Existing Right-of-Way
- Borrow
- Easement (Temporary)
- Easement
- X Excess
- Property Line
- A/C Access Control

Design No. 113
File No. 30484

PLAN AND PROFILE LEGEND AND SYMBOL INFORMATION SHEET

(COVERS SHEET SERIES D, E, F, & K)

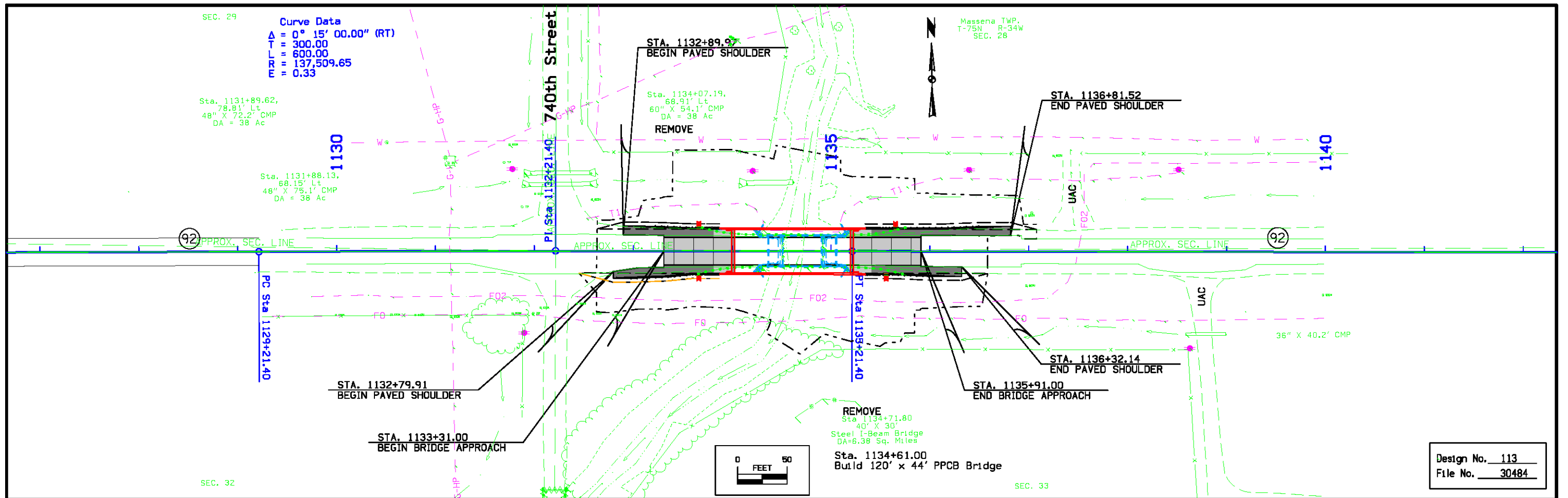

Design No. 113
File No. 30484

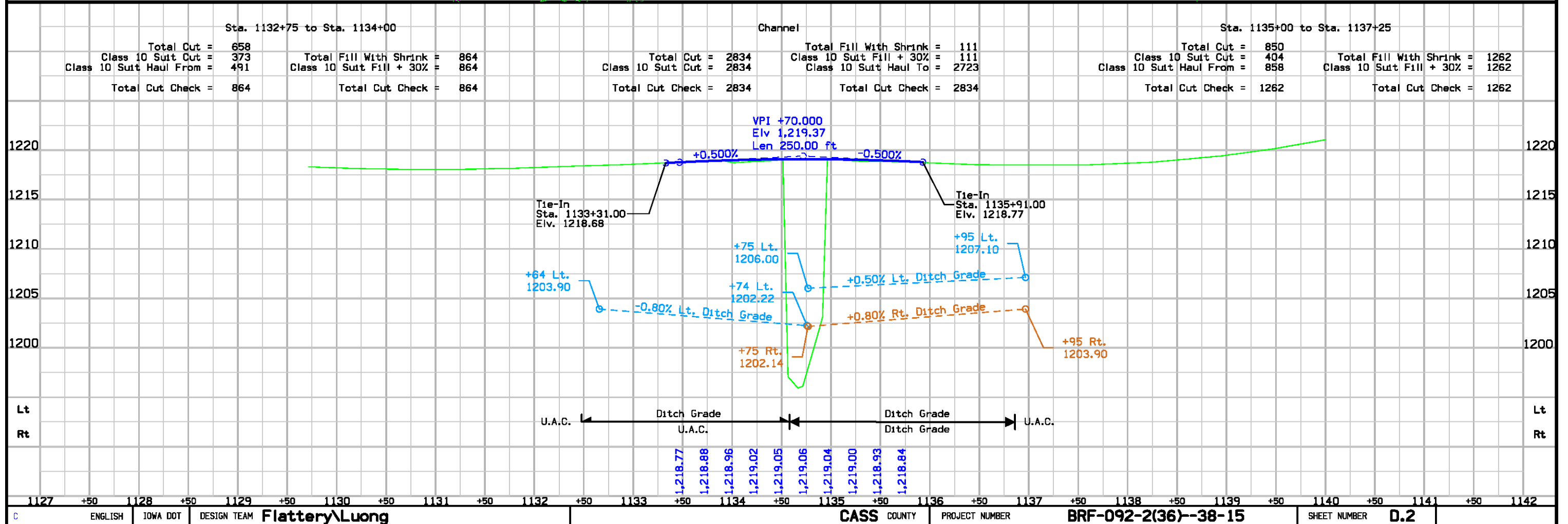

Survey Information

General Information

Measurement units for this survey are US survey feet.

The purpose of this survey is to replace the existing IA 92 Bridge (Maint. No. 1563.4S092) in Cass County over a small natural stream 1 mile west of IA 148.

Vertical Control

Vertical datum for this survey is relative to NAVD88. GEOID09. US survey feet.

This survey control is relative to IARTN reference stations. Multiple Iowa RTN observations were completed on a G001. After review of these observations, the shots were averaged to establish the site BM elevation. A level run was then completed through project control points and benchmarks. The error was allowable and the error was distributed proportionately among the project monuments.

Horizontal Control

Iowa State Plane South Zone coordinates were transformed to project ground coordinates using a 1/combined scale factor broadcast about held point G001 at the east end of project using OPUS in US Feet. The State Plane coordinate and Project Coordinate at:

G001 are: N=460972.55 E=1280032.05

Combined Scale=0.99989548
1/Combined Scale=1.000104531

VERTICAL DATUM = NAVD88 (COMPUTED FROM IARTN observations using GEOID09)
HORIZONTAL DATUM = NAD83 (1996CORS) for Epoch 2002.0000 From OPUS

Alignment Information

The horizontal alignment for this survey is a retrace of the Office Relocate line in Cass & Adair Counties Iowa 92 from U.S. 71 east toward Fontanelle: F. project 464 as identified on sheet No. 29 thru 33. Survey stationing was equated holding section corners referenced in the plan set.

PI Sta. 1068+97.4 This Survey
= PT Sta. 1068+97.4 Cass & Adair Counties F. Proj. No. 464

PI Sta. 1132+21.4 This Survey
= PI Sta. 1132+21.4 Cass & Adair Counties F. Proj. No. 464

PI Sta. 1192+83.69 This Survey
= PC Sta. 1192+83.7 Cass & Adair Counties F. Proj. No. 464

VERTICAL CONTROL

Point	North	East	Elevation	Station	Offset	Feature	Description
500	461123.980	1289091.990	1215.629	1129+76.77	-76.189	BM	SET RR SPIKE IN SOUTH SIDE OF POWER POLE
501	461116.750	1289967.110	1210.986	1138+51.59	-82.939	BM	SET RR SPIKE IN SOUTH SIDE OF POWER POLE

Design No. 113
File No. 30484

STA. 1139+19.00, 60.12 Rt.
 CP G001, SET 1/2" REBAR 3" BELOW SURFACE
 N=4609672.55, E=1290032.05

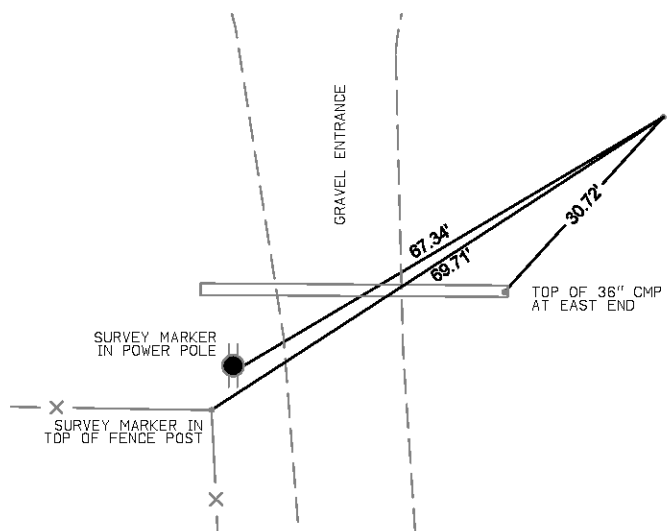

STA. 1132+59.19, 383.29 Rt.
 CP G002, SET 1/2" REBAR 3" BELOW SURFACE
 N=460660.53, E=1289367.51

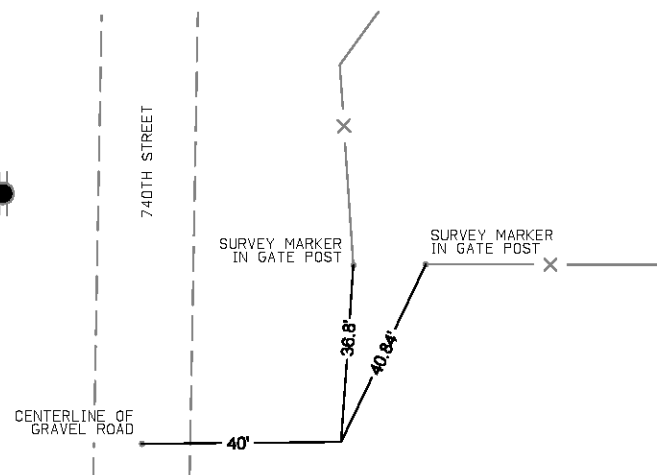

STA. 1127+89.45, 61.31 Lt.
 CP G003, SET 1/2" REBAR 3" BELOW SURFACE
 N=461111.52, E=1288904.47

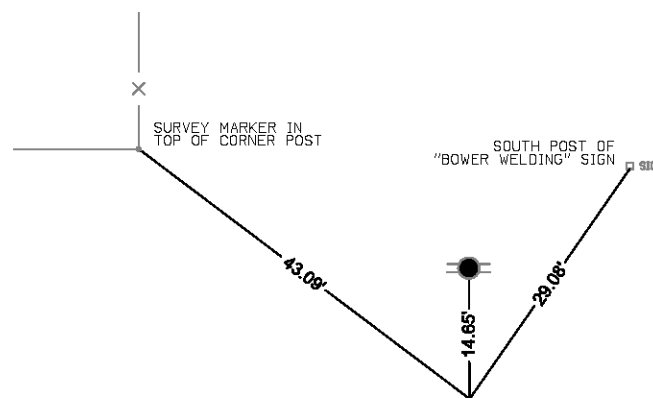

STA. 1128+75.62, 0.38 Lt.
 PHOTO CONTRL POINT 1001
 N=461049.49, E=1288989.85

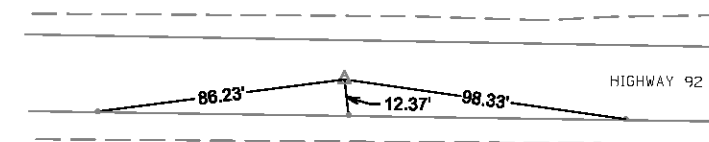

ALL TIES
 MAG NAIL

STA. 1127+89.19, 73.80 Lt.
 PHOTO CONTROL POINT 2001
 N=461124.01, E=1288904.36

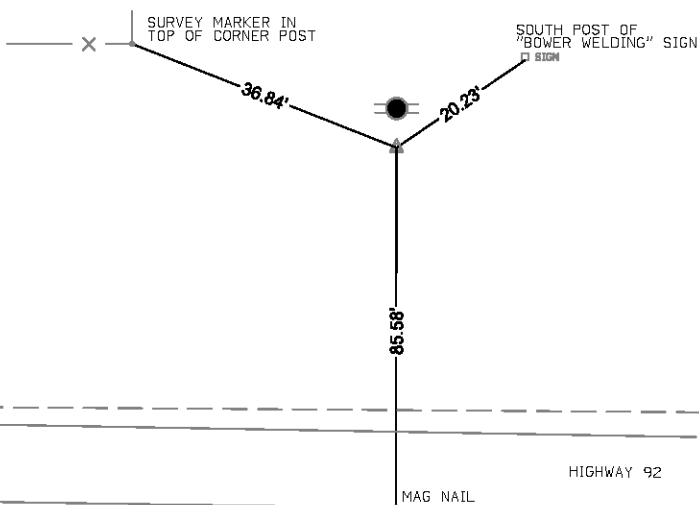

STA. 1132+26.99, 708.10 Lt.
 PHOTO CONTROL POINT 1002
 N=461752.28, E=1289351.84

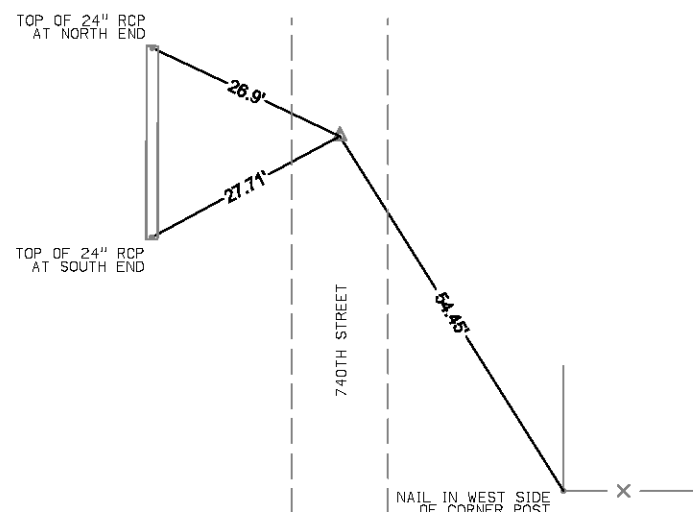

STA. 1131+94.30, 613.12 Lt.
 PHOTO CONTROL POINT 2002
 N=461657.80, E=1289317.584

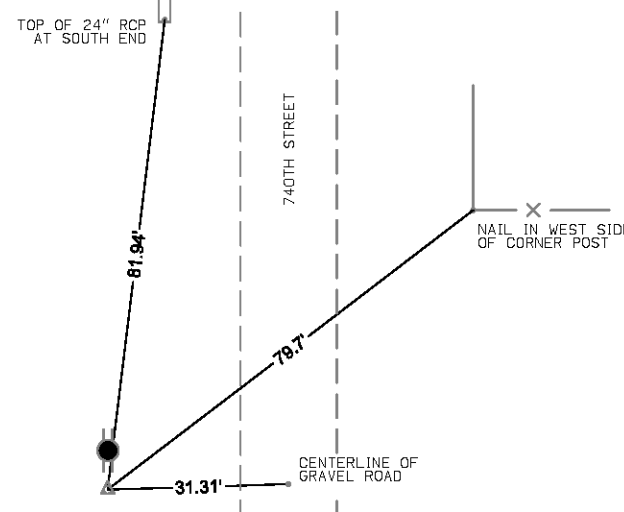

STA. 1132+17.01, 1249.59 Rt.
 PHOTO CONTROL POINT 1003
 N=459794.96, E=1289312.46

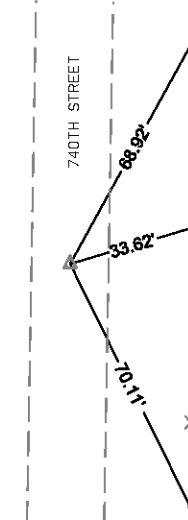

ALL TIES NAIL IN
 TOP OF FENCE POST

STA. 1137+41.33, 1082.87 Rt.
 PHOTO CONTROL POINT 2003
 N=459953.01, E=1289836.81

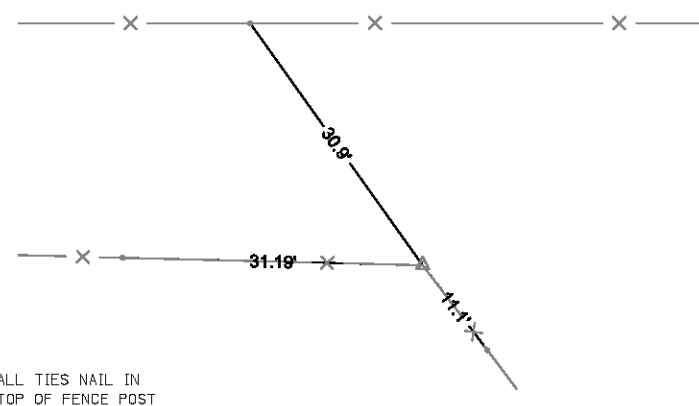

ALL TIES NAIL IN
 TOP OF FENCE POST

STA. 1138+70.47, 0.38 Lt.
 PHOTO CONTROL POINT 1004
 N=461033.88, E=1289984.57

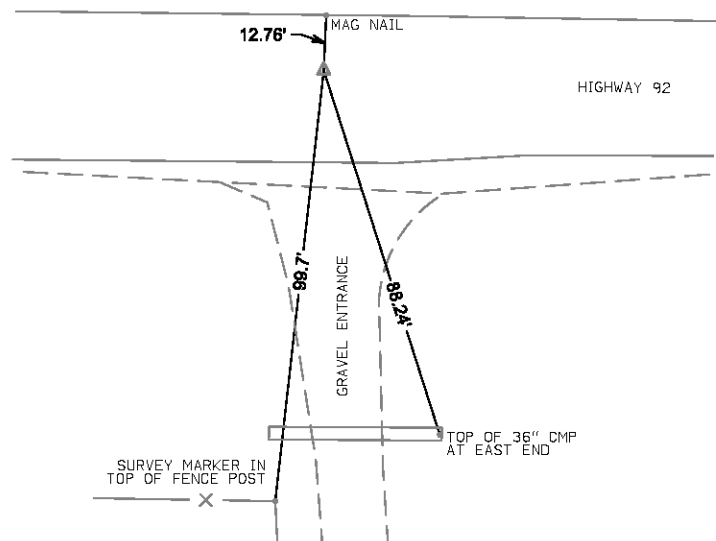

STA. 1138+63.54, 99.26 Rt.
 PHOTO CONTROL POINT 2004
 N=460934.37, E=1289975.93

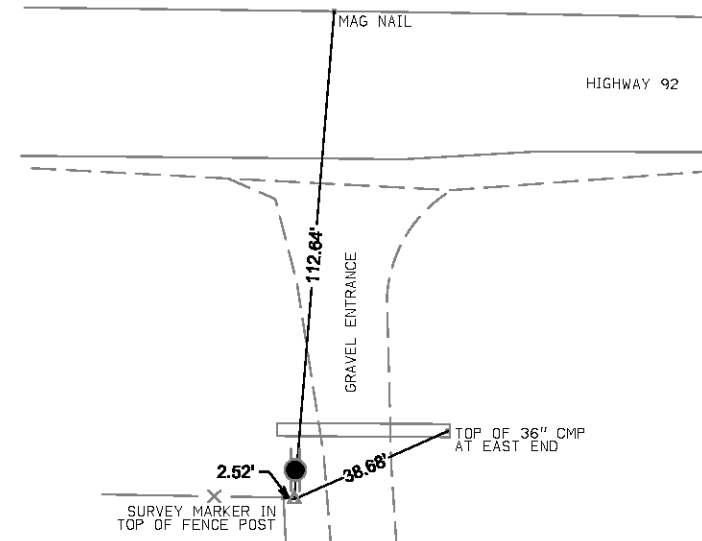

Design No. 113
 File No. 30484

Curve Data
 = 0° 15' 00.00" (RT)
 = 300.00
 = 600.00
 = 137,509.65
 = 0.33

2

1
 DONALD E. SHILLING

BILL & LILA BEHNKEN IRREVOCABLE LIVING TRUST
 TRUSTEES: TERESA M. MEEK AND BLAINE L. BEHNKEN
 Massena TWP.
 T-75N R-34W
 SEC. 28

1132+55
 ±110'±Ex.R/W

1134+34±P
 ±125'

1133+45
 ±125'

Remove Handrail and Guardrail
 Build 120'x44' Prestressed
 Concrete Beam Bridge

1135+95
 ±100'±Ex.R/W

STA. 1136+81.52
 END PAVED SHOULDER

Design No. 113
 File No. 30484

APPROX. SEC. LINE

APPROX. SEC. LINE

APPROX. SEC. LINE

STA. 1132+79.91
 BEGIN PAVED SHOULDER

STA. 1133+31.00
 BEGIN CONSTRUCTION

END CONSTRUCTION
 STA. 1135+91.00

1135+30
 ±135'

1138+15
 ±100'±Ex.R/W

SEC. 33

SEC. 32

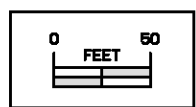

3

1133+50
 ±100'±Ex.R/W

RANDALL K. & NANCY C.
 MCCUNN

Right of Way Design Information	
THIS SHEET INCLUDED FOR INFORMATION ONLY	
ROW Team: GETTINGS/CUVA	
ROW #: STPN-92-2(37)-2J-15	
Plan Date: 4/10/12	
Color Legend:	
	Property Lines
	Temporary Easement
	Permanent Acquisition

102-15
08-01-08

TABULATION OF SPECIAL EVENTS

Event	Location	Date
No special events provided.		

108-23A
08-01-08

TRAFFIC CONTROL PLAN

1. Traffic on IA 92 will be closed and an offsite detour will be utilized. The detour would follow Cass county road N-28 north for 3 miles, then continue east on county road G-43 for 6.5 miles to the junction with IA 148. It would then turn south on IA 148 for 3.5 miles to rejoin IA 92. Traffic will be maintained by offside detour by the Iowa Department of Transportation.
2. Traffic control on this project shall be in accordance with the Standard Road Plans listed in Tabulation 105-4 and the J Sheets in this plan. For additional complimentary information refer to Part 6 of the Manual on Uniform Traffic Control Devices and the current Standard Specifications.

Design No. <u>113</u>
File No. <u>30484</u>

I-80; Wanship Bridge, Utah

I-80 CURVE DATA

$\Delta = 69^{\circ}00'00.00"$ LEFT
 $R = 2292.01'$
 $T = 1575.25'$
 $L = 2760.22'$
 $PI = 638+65.95$

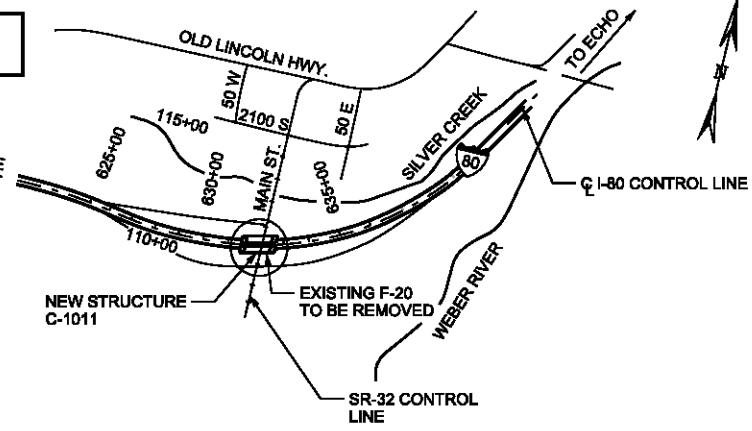

GENERAL NOTES

- USE COATED DEFORMED-CARBON REINFORCING STEEL BARS CONFORMING TO AASHTO M 284 OR M 111 AND M 31 GRADE 60 RESPECTIVELY IN ALL SUBSTRUCTURE ELEMENTS AND PRECAST APPROACH SLAB DRAINS, AND ELEMENTS NOT NOTED OTHERWISE.
- USE DEFORMED STAINLESS STEEL REINFORCING BARS CONFORMING TO ASTM A 955 TYPE XM-28 IN ALL DECK, APPROACH SLABS, SLEEPER SLABS, AND PARAPETS.
- USE STRUCTURAL STEEL CONFORMING TO AASHTO M 270 GRADE 50 EXCEPT WHERE NOTED OTHERWISE.
- CHAMFER ALL EXPOSED CONCRETE CORNERS 3/4" EXCEPT WHERE NOTED OTHERWISE.
- PROVIDE 2" CONCRETE COVER TO REINFORCING STEEL EXCEPT WHERE NOTED OTHERWISE.
- USE CLASS AA(AE) CAST-IN-PLACE CONCRETE EXCEPT WHERE SPECIFIED OTHERWISE. COAT OR GALVANIZE ALL MATERIALS PLACED IN STRUCTURAL CONCRETE UNLESS NOTED OTHERWISE.
- USE LIGHT WEIGHT CLASS AA(AE) (120 pcf) CAST-IN-PLACE CONCRETE PER SPECIAL PROVISION NO. 03314S FOR DECK, PARAPET, AND APPROACH SLABS.
- USE NORMAL WEIGHT CLASS AA(AE) (150 pcf) CAST-IN-PLACE CONCRETE FOR ALL SLEEPER SLABS, END DIAPHRAGMS, ABUTMENTS, FOUNDATIONS, WINGWALLS, AND ELEMENTS NOT NOTED OTHERWISE.
- PROTECT EXISTING UTILITIES IN PLACE UNLESS NOTED OTHERWISE. VERIFY UTILITY LOCATIONS PRIOR TO CONSTRUCTION.
- ALL BRIDGE GEOMETRY IS BASED ON CHORD "A". CHORD "A" IS DEFINED AS A LINE FROM STA. 631+41.40 TO STA. 632+80.49 OF CENTERLINE CONTROL LINE I-80.
- REMOVE EXISTING STRUCTURES A MINIMUM OF 2'-0" BELOW PROPOSED GRADE OR PROPOSED SLEEPER SLAB.
- PAINT ALL STRUCTURAL STEEL AS PER UDOT SPECIFICATION.
- DO NOT SCALE DRAWINGS.

DESIGN DATA

HL-93 IN ACCORDANCE WITH AASHTO LRFD BRIDGE DESIGN SPECIFICATIONS, FIFTH EDITION WITH 2010 INTERIM SPECIFICATIONS. SEISMIC DESIGN IN ACCORDANCE WITH AASHTO GUIDE SPECIFICATION FOR LRFD SEISMIC DESIGN, FIRST EDITION 2009.

CAST-IN-PLACE CONCRETE: $f'_c = 4000$ PSI; f_y (REINF.) = 60,000 PSI;
 CLASS AA (AE) $n = 8$ NORMAL WEIGHT, $n = 11$ LIGHT WEIGHT
 STRUCTURAL STEEL: $F_y = 50,000$ PSI
 WEARING SURFACE: 1/2" CONCRETE; 40 PSF (FUTURE)
 DESIGN SPEED: I-80 70 M.P.H.; SR-32 40 M.P.H.
 PARAPET TEST LEVEL: TL-4
 SEISMIC DESIGN PARAMETERS (1000 YEAR RETURN PERIOD, 7% PE IN 75 YR.)
 $PGA = 0.21$ g
 $SD_s = \text{MAX. CONSIDERED EQ GROUND MOTION AT } 0.2s = 0.50g$
 $SD_1 = \text{MAX. CONSIDERED EQ GROUND MOTION AT } 1.0s = 0.26g$
 SITE CLASS C, SDC B, ESSENTIAL

QUANTITIES

ITEM	ESTIMATED	UNIT	AS CONST.
GRANULAR BACKFILL BORROW (PLAN QUANTITY)	510	CU. YDS.	
REMOVE BRIDGE	1	LUMP	
TEMPORARY RETAINING WALLS	1	LUMP	
REINFORCING STEEL - COATED (PLAN QUANTITY)	227,755	LBS	
REINFORCING STEEL - STAINLESS (PLAN QUANTITY)	129,714	LBS	
STRUCTURAL CONCRETE (EST. LUMP QTY: 1,395 CU. YDS.)	1	LUMP	
STRUCTURAL LIGHTWEIGHT CONCRETE (EST. LUMP QTY: 492 CU. YDS)	1	LUMP	
MOVE PREFABRICATED BRIDGE	1	LUMP	
FLOWABLE FILL	1,140	CU. YDS.	
STRUCTURAL STEEL (EST. LUMP QTY: 213,000 LBS.)	1	LUMP	
ELECTRICAL WORK BRIDGES	1	LUMP	

BRIDGE LOAD RATING

	HL-93	
	RATING	LOCATION
INV.	1.07	43.50' F Str. I
OPER.	1.58	43.50' F SERV IIA

F DENOTES RATING CONTROLLED BY FLEXURE
 S DENOTES RATING CONTROLLED BY SHEAR
 $M_r \text{ AT } 43.50' = 4588 \text{ k-ft}$
 $V_r \text{ AT } 0.00' = 420.50 \text{ k}$

INDEX OF SHEETS

- SITUATION AND LAYOUT I
- SITUATION AND LAYOUT II
- SOIL DATA SHEET I
- SOIL DATA SHEET II
- SOIL DATA SHEET III
- SOIL DATA SHEET IV
- SOIL DATA SHEET V
- FOUNDATION PLAN
- ABUTMENT #1; 1 OF 4
- ABUTMENT #1; 2 OF 4
- ABUTMENT #2; 3 OF 4
- ABUTMENT #2; 4 OF 4
- ABUTMENT SECTIONS
- W.B. ABUTMENT #1 WINGWALL DETAILS
- W.B. ABUTMENT #2 WINGWALL DETAILS
- E.B. ABUTMENT #1 WINGWALL DETAILS
- E.B. ABUTMENT #2 WINGWALL DETAILS
- FRAMING PLAN
- GIRDER DETAILS
- STEEL DETAILS
- DECK DETAILS
- END DIAPHRAGM DETAILS 1 OF 3
- END DIAPHRAGM DETAILS 2 OF 3
- END DIAPHRAGM DETAILS 3 OF 3
- WBL SCREED ELEVATIONS
- EBL SCREED ELEVATIONS
- SLEEPER SLAB DETAILS 1 OF 2
- SLEEPER SLAB DETAILS 2 OF 2
- PARAPET DETAILS
- PARAPET END DETAILS
- WB APPROACH SLAB DRAIN
- EB APPROACH SLAB DRAIN
- ELECTRICAL DETAILS
- MISCELLANEOUS I DETAILS
- MISCELLANEOUS II DETAILS
- STAINLESS STEEL REINFORCING STEEL SCHEDULE
- COATED REINFORCING STEEL SCHEDULE I
- COATED REINFORCING STEEL SCHEDULE II

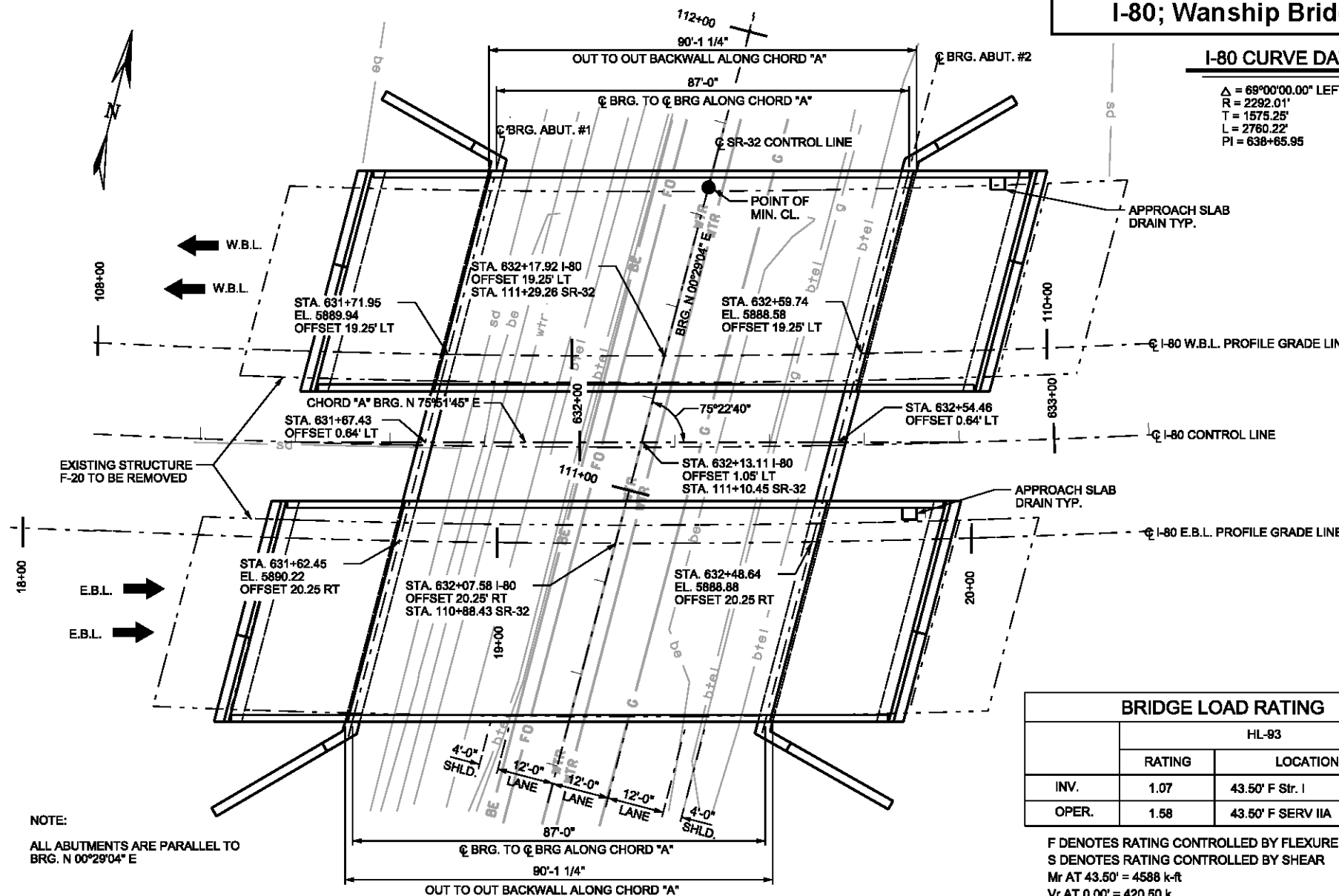
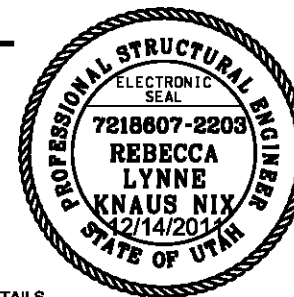

NOTE:
ALL ABUTMENTS ARE PARALLEL TO BRG. N 00°29'04\"/>

PLAN

OUT TO OUT BACKWALL ALONG CHORD "A" 87'-0"

ELEVATION

NORMAL TO SR-32

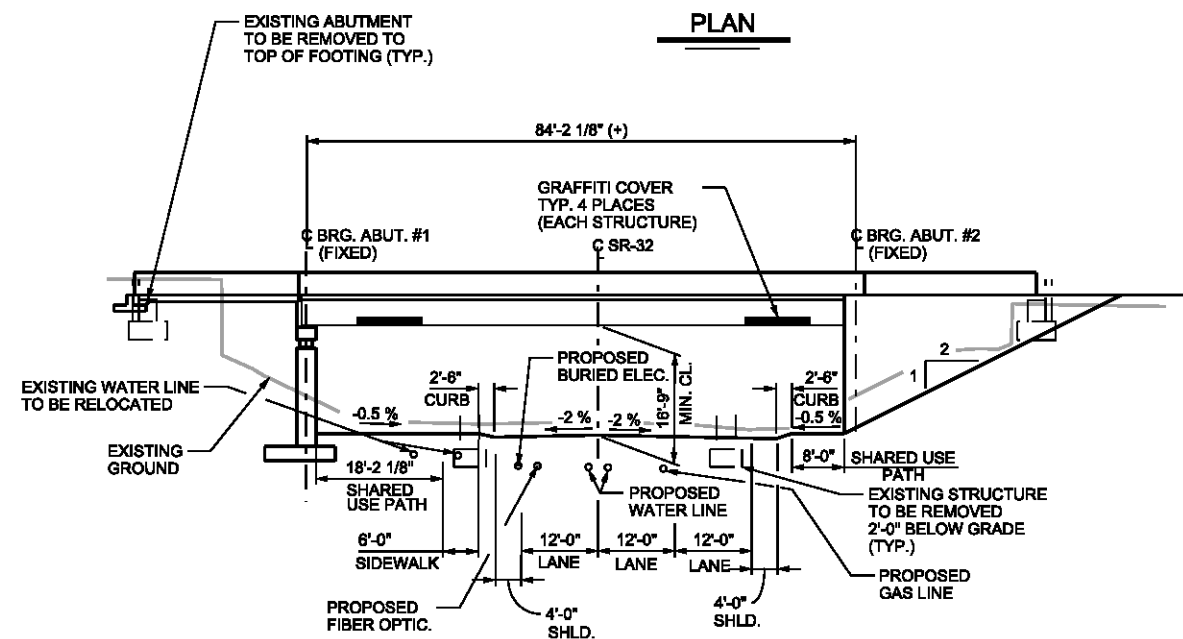

REVISION	DATE	BY	DATE	BY	
DESIGN	RLN	6/11	CHECK	TAH	11/11
DRAWN	MPP	7/11	CHECK	TAH	11/11
QUANT.	RLN	10/11	CHECK	TAH	11/11

UTAH DEPARTMENT OF TRANSPORTATION
 STRUCTURES DIVISION

I-80; WANSHIP TO COALVILLE
 WANSHIP INTERCHANGE: I-80 OVER SR-32
 SITUATION AND LAYOUT I
 PROJECT NUMBER: F-180-4(133)156
 PIN: 8098
 SUMMIT COUNTY
 C-1011
 DRG. NO.

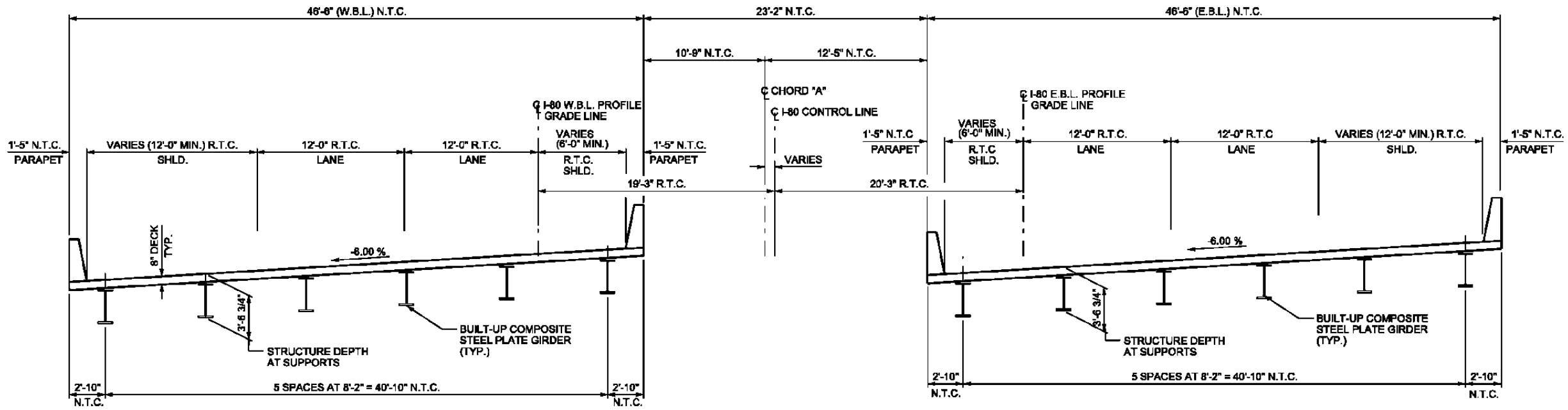

TYPICAL SECTION THROUGH STRUCTURE

LOOKING STATION AHEAD
 N.T.C. = NORMAL TO CHORD 'A'
 R.T.C. = RADIAL TO CURVE

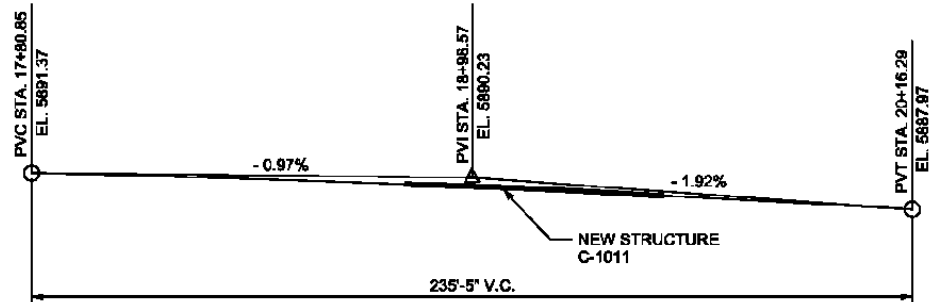

I-80 E.B.L. PROFILE

I-80 CONTROL LINE STA. 623+07.09 = I-80 E.B.L. PROFILE GRADE LINE STA. 10+18.54. STATIONING ALONG I-80 E.B.L. PROFILE GRADE LINE IS OFFSET 20.25' RT FROM I-80 CONTROL LINE.

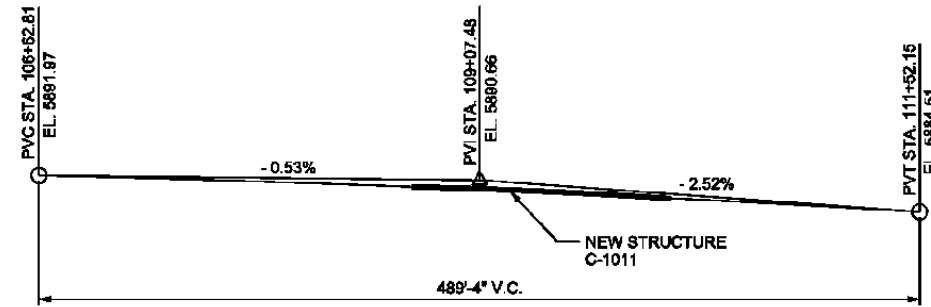

I-80 W.B.L. PROFILE

I-80 CONTROL LINE STA. 629+30.37 = I-80 W.B.L. PROFILE GRADE LINE STA. 106+34.30. STATIONING ALONG I-80 W.B.L. PROFILE GRADE LINE IS OFFSET 19.25' LT FROM I-80 CONTROL LINE.

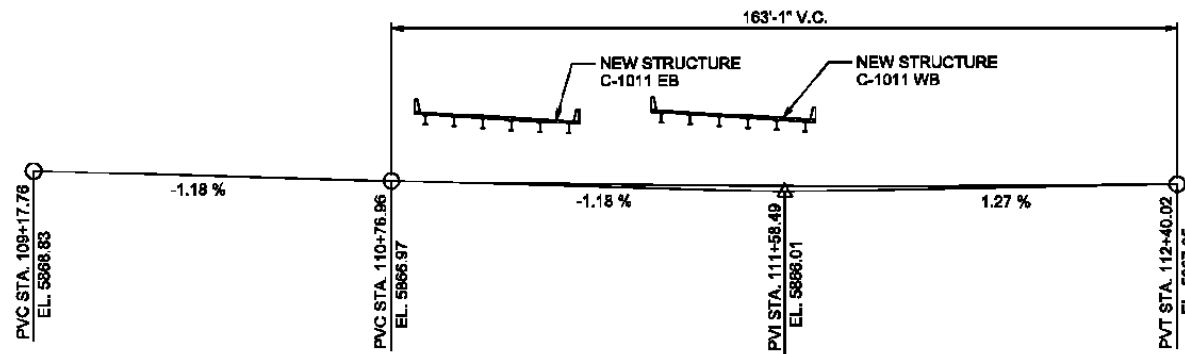

SR-32 PROFILE

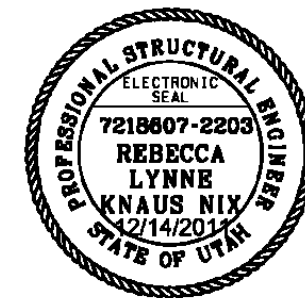

NO.	DATE	BY	REVISION
DESIGN	6/11		CHECK TAH 11/11
DRAWN	MFP	7/11	CHECK TAH 11/11
QUANT.	RLN	10/11	CHECK TAH 11/11

UTAH DEPARTMENT OF TRANSPORTATION
 STRUCTURES DIVISION

I-80; WANSHIP TO COALVILLE
 WANSHIP INTERCHANGE: I-80 OVER SR-32
 SITUATION AND LAYOUT II
 PROJECT NUMBER: F-180-4(133)156
 PIN: 8098

SUMMIT COUNTY
 C-1011
 DRG NO.

I-80 OVER SR-32 WANSHIP INTERCHANGE

DATE BEGAN: 08DEC10
 DATE FINISHED: 09DEC10/0715
 GROUND SURFACE ELEVATION: 5867.5
 GWL DEPTH: 14.0'
 GWL DATE/TIME: 08DEC10

BORING NO: B-1
 NORthing: 454928.860
 EASTING: 666439.735
 DRILLING METHOD: ROTARY WASH
 DRILL EQUIP: CME-850

DRILLER: WORWOOD
 FIELD GEOLOGIST: FADLING
 CONTRACTOR: UDOT
 CHECKED BY: DLS&JEB

ELEV (ft)	DEPTH (ft)	SAMPLE TYPE AND NO.	SPT BLOWS/ 6 in. (N160)	Recovery (in)	Lithology	DESCRIPTION	LAB DATA			REMARKS
							LL (%)	PI (%)	MC (%)	
5865	0	CS-1	1-2-2-3 (9)	15		FILL: CLAYEY SAND (SC), TRACE GRAVEL, WET, GRAY, A-6(3)	28	13	24	
5860	-5	CS-2	8-9-7-6 (15)	16		SILTY SAND WITH GRAVEL: (SM), MOIST, GRAY, GRAVEL IS SUBROUNDED UP TO 1", A-1-b			NP	16
5855	-10	CS-3	39-41-42 (70)	14		POORLY GRADED GRAVEL WITH SILT AND SAND, AND COBBLES (GP-GM), GRAVEL IS SUBANGULAR TO SUBROUNDED, COBBLES UP TO 6" WEBER QUARTZITE, TAN & KEETLEY VOLCANICS, DARK GRAY				20
5850	-15	CS-4	12-35-49-85 (65)	15		DRILL ACTION INDICATES COURSE GRAVEL, COBBLES AND BOULDERS UP TO 16", PRIMARILY BROWN QUARTZITE, A-1-a			NP	7
5845	-20	CS-5	60-52-75 (88)	17		DRILL ACTION INDICATES 6"-12" COBBLES				22
5840	-25	CS-6	23-30-32-40 (43)	18		GRADES WITH SOME ANDESITE & LIMESTONE, PRIMARILY QUARTZITE LITHOLOGY				
5835	-30	CS-7	62-85/5" REF.	9		DRILLING INDICATES PRIMARILY 2" MINUS MATERIAL BETWEEN 25 AND 30 FEET IN DEPTH				
5830	-35	CS-8	85/3" REF.	NR		DRILLING INDICATES COBBLES BELOW 32				

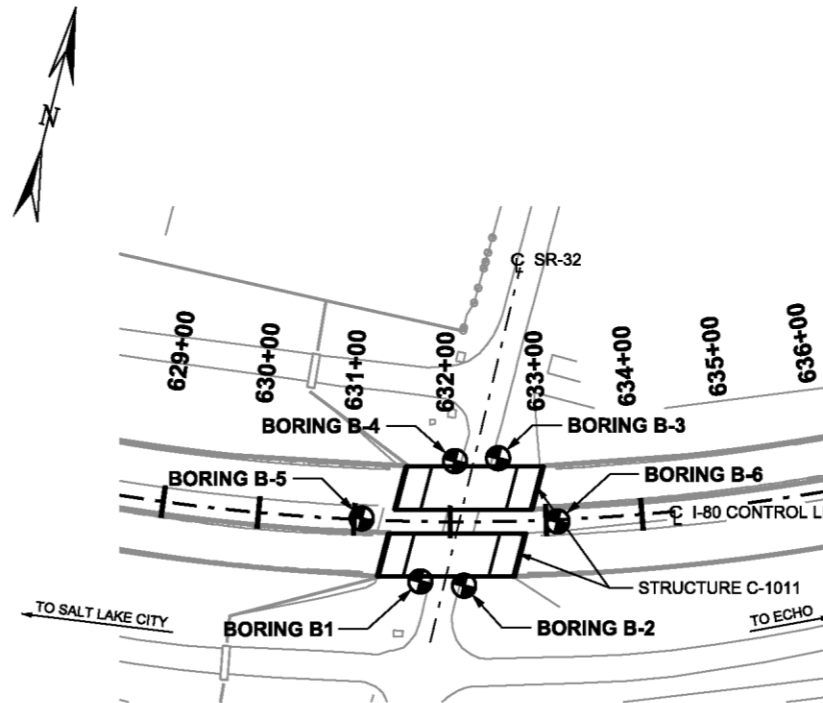
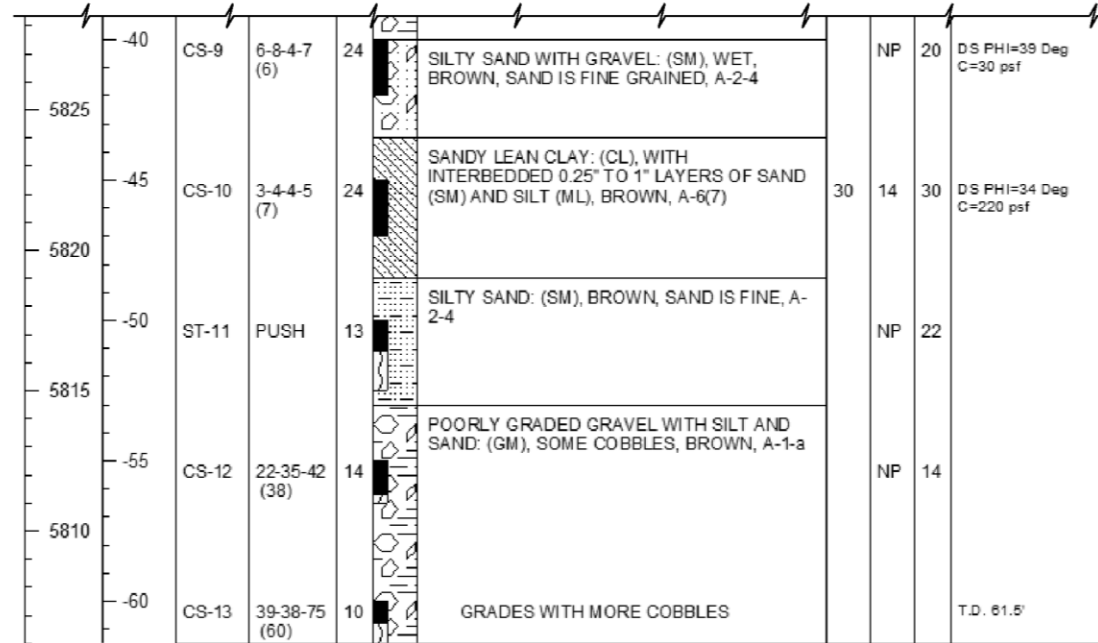

LOCATION PLAN

KEY TO BORING LOG

- SYMBOLS**
- LL - LIQUID LIMIT
 - PI - PLASTICITY INDEX
 - NP - NON-PLASTIC
 - MC - NATURAL MOISTURE CONTENT (%)
 - N - CORRECTED SPT BLOW COUNT (N-160)
 - REF - REFUSAL (> 50 BLOWS PER 6")
 - PEN - SPT SAMPLE
 - CS - CALIFORNIA SAMPLE
 - ▽ - GROUNDWATER TABLE
 - A-2-6(1) - AASHTO CLASSIFICATION
 - CL - USCS CLASSIFICATION
 - NR - NO SAMPLE RECOVERY
 - D.S. - DIRECT SHEAR TEST RESULTS
 - PHI - ANGLE OF INTERNAL FRICTION
 - C - SOIL COHESIVE STRENGTH
 - LV - LAB VEIN SHEAR STRENGTH
 - PP - POCKET PENETROMETER STRENGTH
 - T.D. - TOTAL DEPTH
 - ST - SHELBY TUBE

RELATIVE DENSITY (NON-PLASTIC - SAND & SILT)

- VERY LOOSE N<4;
- LOOSE N 4-10;
- MED DENSE N 10-30;
- DENSE N 30-50;
- VERY DENSE N>50;

CONSISTENCY (PLASTIC - SILT & CLAY)

- VERY SOFT N<2;
- SOFT N 2-4;
- MEDIUM STIFF N 4-8;
- STIFF N 8-15;
- VERY STIFF N 15-30;
- HARD N>30;

GENERAL NOTES

- THE SUBSURFACE EXPLORATIONS SHOWN WERE CONDUCTED BETWEEN DEC. 10, 2010 AND MAY 25, 2011 BY THE GEOTECHNICAL DIVISION OF UDOT.
- THESE BORING LOGS REPRESENT A SYNOPSIS OF THE SOIL DEPOSITS ENCOUNTERED WITHIN EACH BORING AND ARE BASED ON SOUND GEOLOGICAL AND ENGINEERING JUDGMENT. BECAUSE SOIL IS A COMPLEX MEDIUM, THESE BORING LOGS MAY OR MAY NOT REPRESENT THE SOIL CONDITIONS AT THIS SITE. THIS SUBSURFACE INTERPRETATION IS PRESENTED IN GOOD FAITH AND IS NOT INTENDED AS A SUBSTITUTE FOR PERSONAL INVESTIGATION AND JUDGEMENT OF THE CONTRACTOR.
- THE WATER LEVELS AND CONDITIONS INDICATED ON THE BORING LOGS REPRESENT HOLE CONDITIONS ON THE DATE SHOWN, HOWEVER, IT SHOULD BE NOTED, THAT AT LOCATIONS AWAY FROM THE BORINGS OR AT ANOTHER TIME THE WATER LEVELS AND CONDITIONS MAY VARY SIGNIFICANTLY.
- THE STRATIFICATION LINES REPRESENT THE APPROXIMATE BOUNDARIES BETWEEN SOIL TYPES AND THE TRANSITION MAY BE GRADUAL.
- COBBLE - A ROCK WITH AN AVERAGE DIMENSION BETWEEN 3 INCHES AND 12 INCHES
- BOULDER - A ROCK WITH AN AVERAGE DIMENSION OF 12 INCHES OR GREATER

NOTE: DRILL RIG USED - CME 850 HAMMER E=0.80

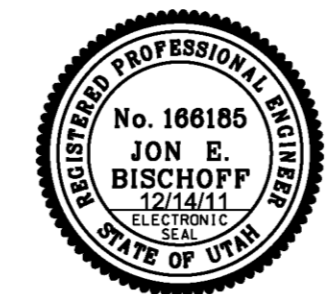

GEOTECHNICAL ENGINEER

UTAH DEPARTMENT OF TRANSPORTATION STRUCTURES DIVISION

I-80; WANSHIP TO COALVILLE
 WANSHIP INTERCHANGE; I-80 OVER SR-32
 SOIL DATA SHEET 1

PROJECT NUMBER: F-180-4(133)156
 PIN: 8098

SUMMIT COUNTY
 C-1011 DRG. NO.

SHT. 3 OF 38

REVISION REMARKS: DESIGN_JEB_10/11, CHECK_DLS_10/11, DRAWN_DEF_10/11, CHECK_JEB_10/11, QUANT., UDOT BRIDGE ENGR., SENIOR DESIGN ENGR., DATE 12/14/11, APPROVED FOR USE BY UDOT, DATE 12/14/11

I-80 OVER SR-32 WANSHIP INTERCHANGE

DATE BEGAN: 11JAN11
 DATE FINISHED: 18JAN11
 GROUND SURFACE ELEVATION: 5867.7
 GWL DEPTH: 20.5'
 GWL DATE/TIME: 18JAN11/0710

BORING NO: B-2
 NORTHING: 454933.891
 EASTING: 868484.931
 DRILLING METHOD: ROTARY WASH
 DRILL EQUIP: CME-850

DRILLER: WORWOOD
 FIELD GEOLOGIST: FADLING
 CONTRACTOR: UDOT
 CHECKED BY: DLS&JEB

ELEV (ft)	DEPTH (ft)	SAMPLE TYPE AND NO.	SPT BLOWS/6 in. (N160)	Recovery (in)	Lithology	DESCRIPTION	LAB DATA			REMARKS
							LL (%)	PI (%)	MC (%)	
5865						FILL: SILTY SAND WITH GRAVEL (SM), DARK BROWN TO DARK GRAY				
						FILL: SILTY GRAVEL (GM), GRAY				
5860	-5	CS-1	3-5-3-4 (7)	21		SANDY LEAN CLAY: (CL), MOIST, GRAY, A-6(3)	27	10	23	
5855	-10	CS-2	25-32-42 (61)	13		POORLY GRADED GRAVEL WITH SILT AND SAND: (GP-GM), WITH QUARTZITE COBBLES, GRAY			34	DS PHI=47 Deg C=120 psf
5850	-15	CS-3	8-26-28-32 (41)	13		WELL GRADED GRAVEL WITH SAND AND COBBLES (GW), GRAY, A-1-a			7	DS PHI=48 Deg C=850 psf
5845	-20	CS-4	85/3' REF.	2		GRAVEL AND QUARTZITE COBBLES UP TO 10" BETWEEN 20 AND 25 FEET IN DEPTH				
5840	-25	CS-5	85/6' REF.	6						
5835	-30	CS-6	48-53-54 (70)	14		POORLY GRADED GRAVEL WITH SAND: (GP), GRAY A-1-a			13	
5830	-35	CS-7	88/6' REF.	6						
						SANDY SILT: TO SILTY SAND WITH GRAVEL				

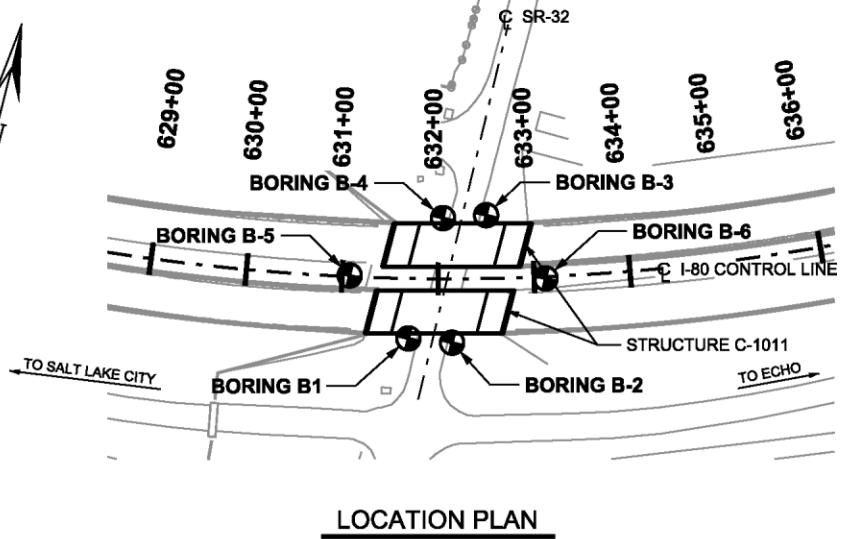
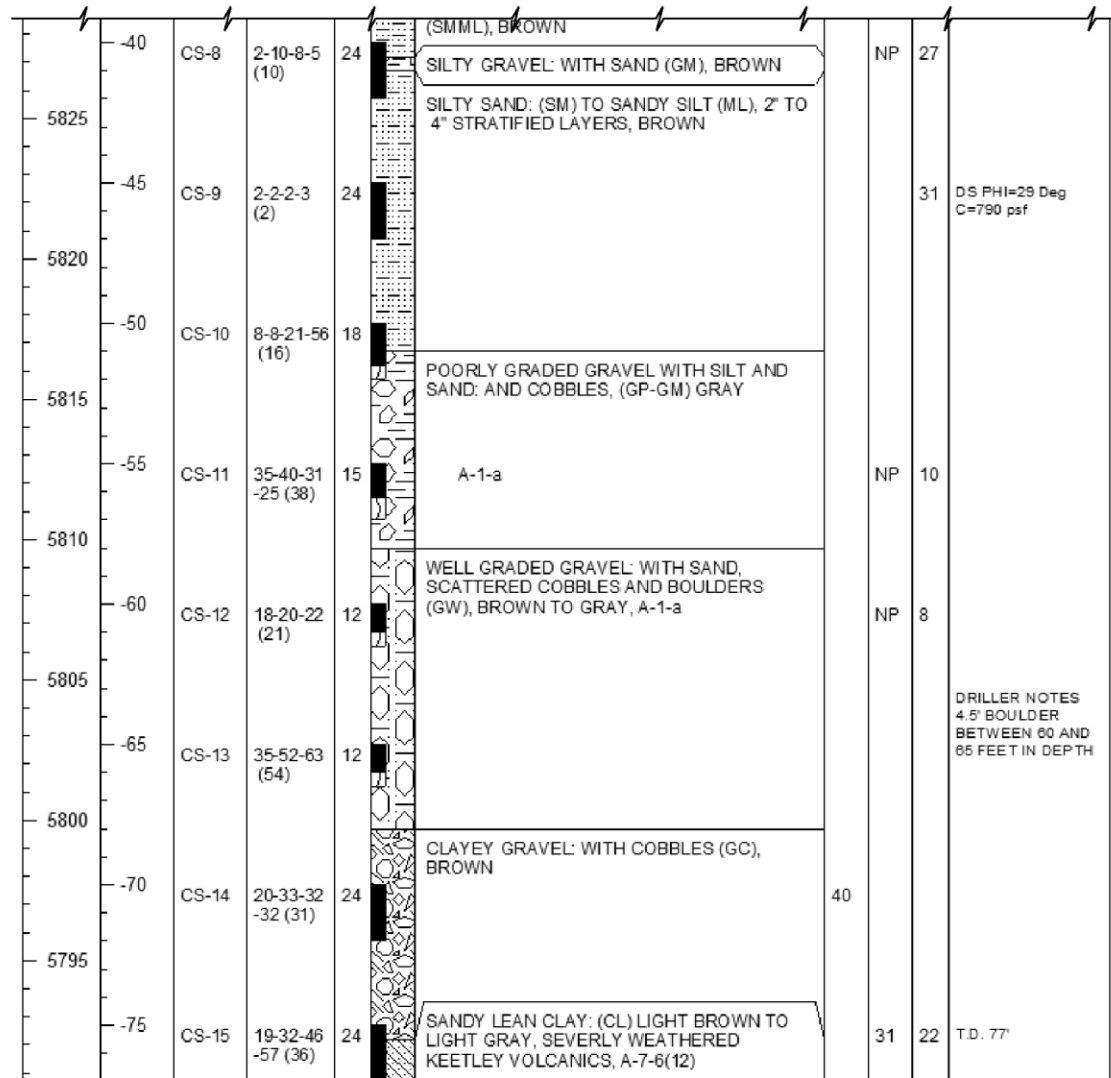

KEY TO BORING LOG

SYMBOLS

LL - LIQUID LIMIT
 PI - PLASTICITY INDEX
 NP - NON-PLASTIC
 MC - NATURAL MOISTURE CONTENT (%)
 N - CORRECTED SPT BLOW COUNT (N-160)
 REF - REFUSAL (> 50 BLOWS PER 6")
 PEN - SPT SAMPLE
 CS - CALIFORNIA SAMPLE
 GWT - GROUNDWATER TABLE
 A-2-6(1) - AASHTO CLASSIFICATION
 CL - USCS CLASSIFICATION
 NR - NO SAMPLE RECOVERY
 D.S. - DIRECT SHEAR TEST RESULTS
 PHI - ANGLE OF INTERNAL FRICTION
 C - SOIL COHESIVE STRENGTH
 LV - LAB VEIN SHEAR STRENGTH
 PP - POCKET PENETROMETER STRENGTH
 T.D. - TOTAL DEPTH
 ST - SHELBY TUBE

RELATIVE DENSITY (NON-PLASTIC - SAND & SILT)

VERY LOOSE N<4;
 LOOSE N 4-10;
 MED DENSE N 10-30;
 DENSE N 30-50;
 VERY DENSE N>50;

CONSISTENCY (PLASTIC - SILT & CLAY)

VERY SOFT N<2;
 SOFT N 2-4;
 MEDIUM STIFF N 4-8;
 STIFF N 8-15;
 VERY STIFF N 15-30;
 HARD N>30;

GENERAL NOTES

- THE SUBSURFACE EXPLORATIONS SHOWN WERE CONDUCTED BETWEEN DEC. 10, 2010 AND MAY 25, 2011 BY THE GEOTECHNICAL DIVISION OF UDOT.
- THESE BORING LOGS REPRESENT A SYNOPSIS OF THE SOIL DEPOSITS ENCOUNTERED WITHIN EACH BORING AND ARE BASED ON SOUND GEOLOGICAL AND ENGINEERING JUDGMENT. BECAUSE SOIL IS A COMPLEX MEDIUM, THESE BORING LOGS MAY OR MAY NOT REPRESENT THE SOIL CONDITIONS AT THIS SITE. THIS SUBSURFACE INTERPRETATION IS PRESENTED IN GOOD FAITH AND IS NOT INTENDED AS A SUBSTITUTE FOR PERSONAL INVESTIGATION AND JUDGEMENT OF THE CONTRACTOR.
- THE WATER LEVELS AND CONDITIONS INDICATED ON THE BORING LOGS REPRESENT HOLE CONDITIONS ON THE DATE SHOWN, HOWEVER, IT SHOULD BE NOTED, THAT AT LOCATIONS AWAY FROM THE BORINGS OR AT ANOTHER TIME THE WATER LEVELS AND CONDITIONS MAY VARY SIGNIFICANTLY.
- THE STRATIFICATION LINES REPRESENT THE APPROXIMATE BOUNDARIES BETWEEN SOIL TYPES AND THE TRANSITION MAY BE GRADUAL.
- COBBLE - A ROCK WITH AN AVERAGE DIMENSION BETWEEN 3 INCHES AND 12 INCHES
- BOULDER - A ROCK WITH AN AVERAGE DIMENSION OF 12 INCHES OR GREATER

NOTE: DRILL RIG USED - CME 850 HAMMER E=0.80

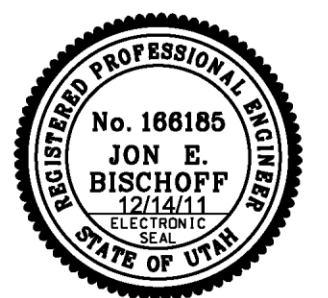

GEOTECHNICAL ENGINEER

REVISION REMARKS	DESIGN JEB 10/11	CHECK DLS 10/11
	DRAWN DEF 10/11	CHECK JEB 10/11
	QUANT.	CHECK
APPROVAL RECORD	DATE	BY
SENIOR DESIGN ENGR.	12/14/11	
APPROVED FOR USE BY UDOT	12/14/11	
UTAH DEPARTMENT OF TRANSPORTATION		
STRUCTURES DIVISION		
I-80; WANSHIP TO COALVILLE	PROJECT NUMBER	
WANSHIP INTERCHANGE: I-80 OVER SR-32	PIN 8098	
SOIL DATA SHEET II	F-180-4(133)156	
SUMMIT COUNTY	DRG. NO. C-1011	
SHT. 4 OF 38		

14-DEC-2011 14:28:51 IP: 209.49.152.255 \0899_C-1011-94.esd.ctb-2.dgn

I-80 OVER SR-32 WANSHIP INTERCHANGE

BORING NO: B-3 DRILLER: WORWOOD
 DATE BEGAN: 18JAN11 NORTHING: 455071.186 FIELD GEOLOGIST: FADLING
 DATE FINISHED: 24JAN11 EASTING: 688486.915 CONTRACTOR: UDOT
 GROUND SURFACE ELEVATION: 5868.8 DRILLING METHOD: ROTARY WASH
 GWL DEPTH: 19.9' DRILL EQUIP: CME-850
 GWL DATE/TIME: 24JAN11/0700 CHECKED BY: DLS&JEB

ELEV (ft)	DEPTH (ft)	SAMPLE TYPE AND NO.	SPT BLOWS/ 6 in. (N160)	Recovery (in)	Lithology	DESCRIPTION	LAB DATA			REMARKS
							LL (%)	PI (%)	MC (%)	
5865	0	CS-1	6-18-17 -18 (78)	24		FILL: SILTY GRAVEL (GM), BROWN, GRAY, REDDISH-BROWN, A-2-4		NP	12	
5860	-5	CS-2	32-23-27 -27 (51)	15						
5855	-10	CS-3	85/5" REF.	4		POORLY GRADED GRAVEL WITH SAND (GP) AND COBBLES, TAN QUARTZITE, A-1-a		NP	11	
5850	-15	CS-4	85/4" REF.	NR						
5845	-20	CS-5	46-56 -85/5" REF.	9						
5840	-25	CS-6	85/5" REF.	1						
5835	-30	CS-7	85/5" REF.	9						
5830	-35	CS-8	45-63-50 (70)	16		SILTY GRAVEL WITH SAND (GM), TAN QUARTZITE, A-1-a		NP	17	

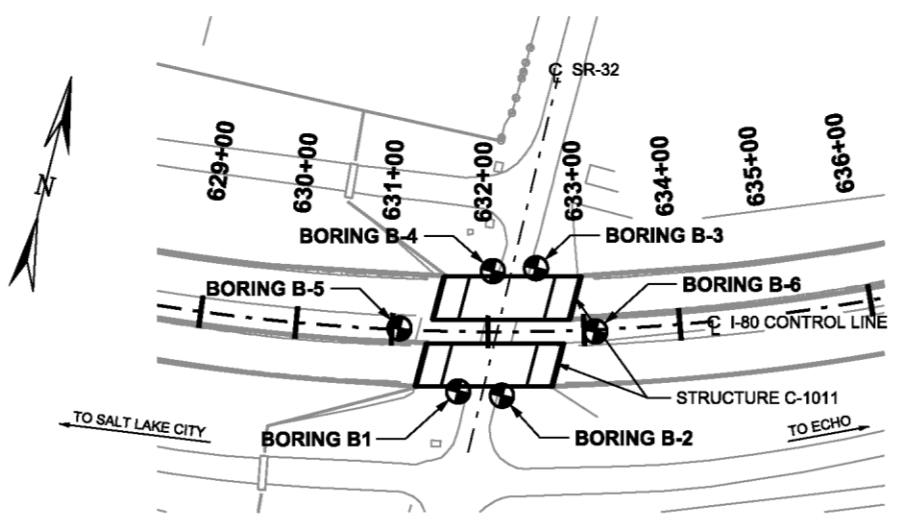
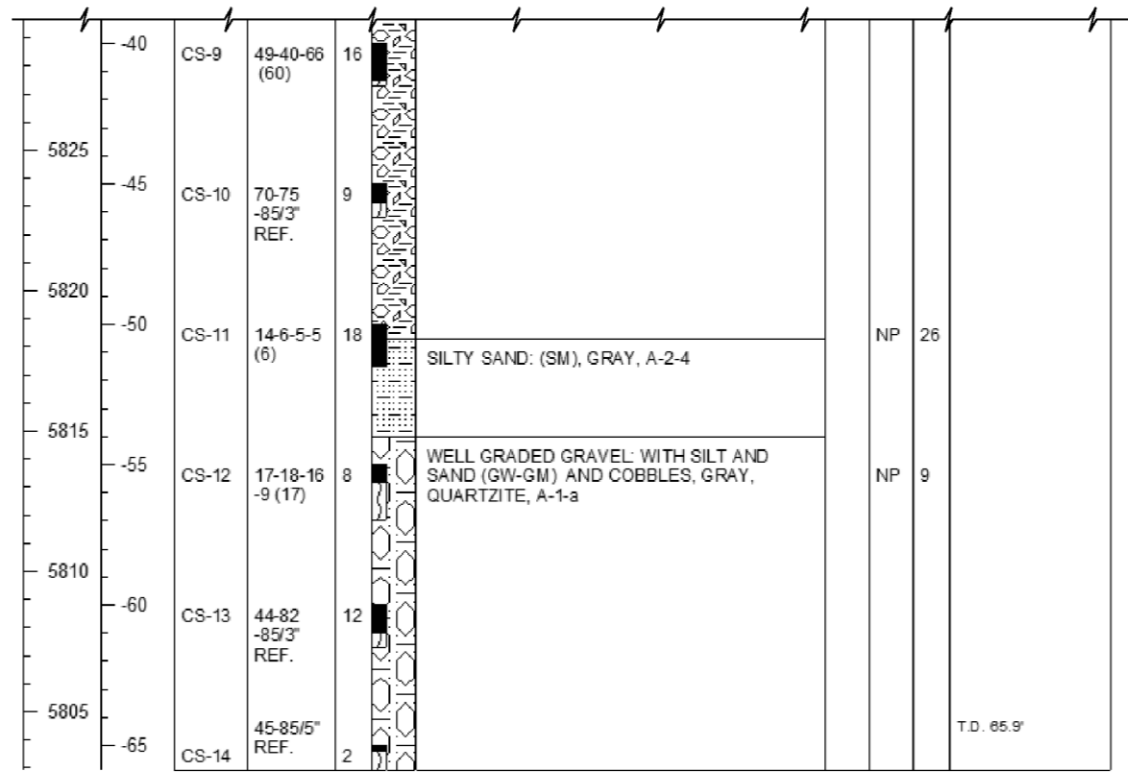

LOCATION PLAN

KEY TO BORING LOG

- ### SYMBOLS
- LL - LIQUID LIMIT
 - PI - PLASTICITY INDEX
 - NP - NON-PLASTIC
 - MC - NATURAL MOISTURE CONTENT (%)
 - N - CORRECTED SPT BLOW COUNT (N-160)
 - REF - REFUSAL (> 50 BLOWS PER 6")
 - PEN - SPT SAMPLE
 - CS - CALIFORNIA SAMPLE
 - ▽ - GROUNDWATER TABLE
 - A-2-6(1) - AASHTO CLASSIFICATION
 - CL - USCS CLASSIFICATION
 - NR - NO SAMPLE RECOVERY
 - D.S. - DIRECT SHEAR TEST RESULTS
 - PHI - ANGLE OF INTERNAL FRICTION
 - C - SOIL COHESIVE STRENGTH
 - LV - LAB VEIN SHEAR STRENGTH
 - PP - POCKET PENETROMETER STRENGTH
 - T.D. - TOTAL DEPTH
 - ST - SHELBY TUBE

RELATIVE DENSITY (NON-PLASTIC - SAND & SILT)

- VERY LOOSE N<4;
- LOOSE N 4-10;
- MED DENSE N 10-30;
- DENSE N 30-50;
- VERY DENSE N>50;

CONSISTENCY (PLASTIC - SILT & CLAY)

- VERY SOFT N<2;
- SOFT N 2-4;
- MEDIUM STIFF N 4-8;
- STIFF N 8-15;
- VERY STIFF N 15-30;
- HARD N>30;

GENERAL NOTES

- THE SUBSURFACE EXPLORATIONS SHOWN WERE CONDUCTED BETWEEN DEC. 10, 2010 AND MAY 25, 2011 BY THE GEOTECHNICAL DIVISION OF UDOT.
- THESE BORING LOGS REPRESENT A SYNOPSIS OF THE SOIL DEPOSITS ENCOUNTERED WITHIN EACH BORING AND ARE BASED ON SOUND GEOLOGICAL AND ENGINEERING JUDGMENT. BECAUSE SOIL IS A COMPLEX MEDIUM, THESE BORING LOGS MAY OR MAY NOT REPRESENT THE SOIL CONDITIONS AT THIS SITE. THIS SUBSURFACE INTERPRETATION IS PRESENTED IN GOOD FAITH AND IS NOT INTENDED AS A SUBSTITUTE FOR PERSONAL INVESTIGATION AND JUDGEMENT OF THE CONTRACTOR.
- THE WATER LEVELS AND CONDITIONS INDICATED ON THE BORING LOGS REPRESENT HOLE CONDITIONS ON THE DATE SHOWN, HOWEVER, IT SHOULD BE NOTED, THAT AT LOCATIONS AWAY FROM THE BORINGS OR AT ANOTHER TIME THE WATER LEVELS AND CONDITIONS MAY VARY SIGNIFICANTLY.
- THE STRATIFICATION LINES REPRESENT THE APPROXIMATE BOUNDARIES BETWEEN SOIL TYPES AND THE TRANSITION MAY BE GRADUAL.
- COBBLE - A ROCK WITH AN AVERAGE DIMENSION BETWEEN 3 INCHES AND 12 INCHES
- BOULDER - A ROCK WITH AN AVERAGE DIMENSION OF 12 INCHES OR GREATER

NOTE: DRILL RIG USED - CME 850 HAMMER E=0.80



GEOTECHNICAL ENGINEER

DESIGN	JEB	10/11	CHECK	DLS	10/11
DRAWN	DEF	10/11	CHECK	JEB	10/11
QUANT.			CHECK		
REVISION	REMARKS				
NO.	DATE	BY			
APPROVAL	12/14/11	DATE	SENIOR DESIGN ENGR.		
APPROVED	12/14/11	DATE	FOR USE		
BY	UDOT	DATE	UDOT BRIDGE ENGR.		
UTAH DEPARTMENT OF TRANSPORTATION					
STRUCTURES DIVISION					
I-80; WANSHIP TO COALVILLE					
WANSHIP INTERCHANGE; I-80 OVER SR-32					
SOIL DATA SHEET III					
PROJECT NUMBER: F-180-4(133)156					
PIN: 8098					
SUMMIT COUNTY					
C-1011					
DRG. NO.					
SHT. 5 OF 38					

D:\n_51\m_12_24\p\ad\520255\0899_C-1011-25.esd\c:\data-3.dwg
 14:25:28

I-80 OVER SR-32 WANSHIP INTERCHANGE

DATE BEGAN: 24JAN11
 DATE FINISHED: 26JAN11
 GROUND SURFACE ELEVATION: 5868.5
 GWL DEPTH: 19.8'
 GWL DATE/TIME: 26JAN11/0700

BORING NO: B-4
 NORTHING: 455057.298
 EASTING: 688444.079
 DRILLING METHOD: ROTARY WASH
 DRILL EQUIP: CME-850

DRILLER: WORWOOD
 FIELD GEOLOGIST: FADLING
 CONTRACTOR: UDOT
 CHECKED BY: DLS&JEB

ELEV (ft)	DEPTH (ft)	SAMPLE TYPE AND NO.	SPT BLOWS/6 in. (N180)	Recovery (in)	Lithology	DESCRIPTION	LAB DATA			REMARKS
							LL (%)	PI (%)	MC (%)	
5865	0	CS-1	18-50-41 -25 (42)	24	FILL: CLAYEY SAND WITH GRAVEL (SC), DARK BROWN, A-6(0)		27	12	16	
5860	-5	CS-2	2-3-4-4 (11)	14	FILL: SANDY LEAN CLAY WITH GRAVEL (CL), GRAY, MOIST, A-6(3)		29	13	22	
5855	-10	CS-3	24-60-47 (86)	13	POORLY GRADED GRAVEL WITH SILT AND SAND: (GP-GM), COBBLES AND BOULDERS, A-1-a		NP	9		DS PHI=50 Deg C=130 psf
5850	-15	CS-4	26-36-55 (68)	10	DRILLING ACTION INDICATES 2 QUARTZITE BOULDER DRILLING ACTION INDICATES LARGE COBBLES (6"-12") AND BOULDERS (12"-24") BETWEEN 15 AND 20 FEET IN DEPTH				26	DRILLER NOTES VERY HARD DRILLING AT 13' DS PHI=43 Deg C=990 psf
5845	-20	CS-5	29-70-75 (99)	13	A-1-a		25	4	11	DS PHI=52 Deg C=1530 psf
5840	-25	CS-6	85/3" REF.	2	SILTY GRAVEL WITH SAND (GM), A-1-a					
5835	-30	CS-7	50-52-58 (69)	12			NP		15	
5830	-35	CS-8	32-20-12 -5 (23)	16	LEAN CLAY: (CL), TRACE OF SAND, BROWN					

ELEV (ft)	DEPTH (ft)	SAMPLE TYPE AND NO.	SPT BLOWS/6 in. (N180)	Recovery (in)	Lithology	DESCRIPTION	LAB DATA	REMARKS		
5825	-40	CS-9	4-2-3-8 (3)	18	SILTY, CLAYEY SAND: (SC-SM), WITH TRACE OF GRAVEL, BROWN, A-4(1)		26	6	28	DS PHI=35 Deg C=720 psf
5820	-45	CS-10	14-40-32 -45 (40)	18	SILTY GRAVEL WITH SAND (GM) AND COBBLES, BROWN					
5815	-50	CS-11	20-16-9-5 (13)	17	WELL GRADED GRAVEL WITH SAND (GW) AND COBBLES, A-1-a					
5810	-55	CS-12	85/6" REF.	0						
5805	-60	CS-13	45-45-30 (40)	11					11	
5800	-65	CS-14	85/2" REF.	0						T.D. 66"

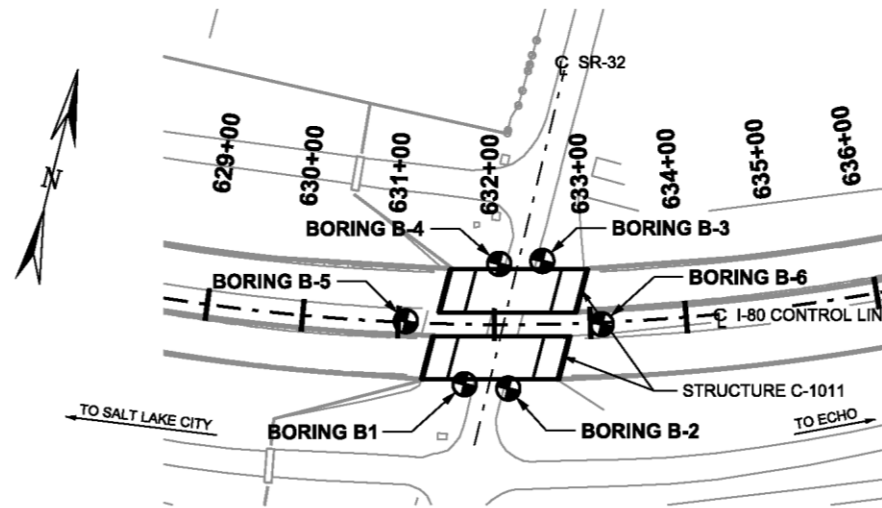

LOCATION PLAN

KEY TO BORING LOG

SYMBOLS

LL - LIQUID LIMIT
 PI - PLASTICITY INDEX
 NP - NON-PLASTIC
 MC - NATURAL MOISTURE CONTENT (%)
 N - CORRECTED SPT BLOW COUNT (N-180)
 REF - REFUSAL (> 50 BLOWS PER 6")
 PEN - SPT SAMPLE
 CS - CALIFORNIA SAMPLE
 GWT - GROUNDWATER TABLE
 A-2-6(1) - AASHTO CLASSIFICATION
 CL - USCS CLASSIFICATION
 NR - NO SAMPLE RECOVERY
 D.S. - DIRECT SHEAR TEST RESULTS
 PHI - ANGLE OF INTERNAL FRICTION
 C - SOIL COHESIVE STRENGTH
 LV - LAB VEIN SHEAR STRENGTH
 PP - POCKET PENETROMETER STRENGTH
 T.D. - TOTAL DEPTH
 ST - SHELBY TUBE

RELATIVE DENSITY (NON-PLASTIC - SAND & SILT)

VERY LOOSE N<4;
 LOOSE N 4-10;
 MED DENSE N 10-30;
 DENSE N 30-50;
 VERY DENSE N>50;

CONSISTENCY (PLASTIC - SILT & CLAY)

VERY SOFT N<2;
 SOFT N 2-4;
 MEDIUM STIFF N 4-8;
 STIFF N 8-15;
 VERY STIFF N 15-30;
 HARD N>30;

GENERAL NOTES

- THE SUBSURFACE EXPLORATIONS SHOWN WERE CONDUCTED BETWEEN DEC. 10, 2010 AND MAY 25, 2011 BY THE GEOTECHNICAL DIVISION OF UDOT.
- THESE BORING LOGS REPRESENT A SYNOPSIS OF THE SOIL DEPOSITS ENCOUNTERED WITHIN EACH BORING AND ARE BASED ON SOUND GEOLOGICAL AND ENGINEERING JUDGMENT. BECAUSE SOIL IS A COMPLEX MEDIUM, THESE BORING LOGS MAY OR MAY NOT REPRESENT THE SOIL CONDITIONS AT THIS SITE. THIS SUBSURFACE INTERPRETATION IS PRESENTED IN GOOD FAITH AND IS NOT INTENDED AS A SUBSTITUTE FOR PERSONAL INVESTIGATION AND JUDGEMENT OF THE CONTRACTOR.
- THE WATER LEVELS AND CONDITIONS INDICATED ON THE BORING LOGS REPRESENT HOLE CONDITIONS ON THE DATE SHOWN, HOWEVER, IT SHOULD BE NOTED, THAT AT LOCATIONS AWAY FROM THE BORINGS OR AT ANOTHER TIME THE WATER LEVELS AND CONDITIONS MAY VARY SIGNIFICANTLY.
- THE STRATIFICATION LINES REPRESENT THE APPROXIMATE BOUNDARIES BETWEEN SOIL TYPES AND THE TRANSITION MAY BE GRADUAL.
- COBBLE - A ROCK WITH AN AVERAGE DIMENSION BETWEEN 3 INCHES AND 12 INCHES
- BOULDER - A ROCK WITH AN AVERAGE DIMENSION OF 12 INCHES OR GREATER

NOTE: DRILL RIG USED - CME 850
 HAMMER E=0.80

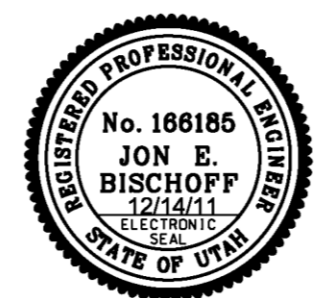

GEOTECHNICAL ENGINEER

DESIGN	JEB	12/14/11	CHECK	DLS	10/11
DRAWN	DEF	10/11	CHECK	JEB	10/11
QUANT.			CHECK		
REVISION REMARKS					
UTAH DEPARTMENT OF TRANSPORTATION STRUCTURES DIVISION					
I-80; WANSHIP TO COALVILLE					
WANSHIP INTERCHANGE: I-80 OVER SR-32					
SOIL DATA SHEET IV					
PROJECT NUMBER: F-180-4(133)156					
PIN: 8098					
SUMMIT COUNTY					
C-1011					
DRG. NO.					
SHT. 6 OF 38					

D:\14-25EC-2811\14-25EC-2811\14-25EC-2811\14-25EC-2811-06-soil-data-s-4.dwg

I-80 OVER SR-32 WANSHIP INTERCHANGE

I-80 OVER SR-32 WANSHIP INTERCHANGE

DATE BEGAN: 23MAY11
 DATE FINISHED: 25MAY11
 GROUND SURFACE ELEVATION: 5889.2
 GWL DEPTH: -
 GWL DATE/TIME: NOT ENCOUNTERED

BORING NO: B-5
 NORTHING: 454975.542
 EASTING: 666384.347
 DRILLING METHOD: ROTARY WASH
 DRILL EQUIP: CME-850

DRILLER: WORWOOD
 FIELD GEOLOGIST: FADLING
 CONTRACTOR: UDOT
 CHECKED BY: DLS&JEB

DATE BEGAN: 25MAY11
 DATE FINISHED: 25MAY11
 GROUND SURFACE ELEVATION: 5886.6
 GWL DEPTH: -
 GWL DATE/TIME: NOT ENCOUNTERED

BORING NO: B-6
 NORTHING: 455022.380
 EASTING: 666583.024
 DRILLING METHOD: ROTARY WASH
 DRILL EQUIP: CME-850

DRILLER: WORWOOD
 FIELD GEOLOGIST: FADLING
 CONTRACTOR: UDOT
 CHECKED BY: DLS&JEB

ELEV (ft)	DEPTH (ft)	SAMPLE TYPE AND NO.	SPT BLOWS/6 in. (N160)	Recovery (in)	Lithology	DESCRIPTION	LAB DATA			REMARKS
							LL (%)	PI (%)	MC (%)	
5885	-5	CS-1 2-8-8-9 (24)	24	24		FILL: CLAYEY SAND WITH GRAVEL (SC), DARK BROWN TO BROWN, 3" ROOT ZONE AT SURFACE, A-2-6(0)	27	12	13	
5880	-10	CS-2 3-6-10-13 (22)	18	18		FILL: SILTY SAND WITH GRAVEL (SM), GRAY, A-1-b	NP	21	DS PHI=54 Deg C=210 psf	
5875	-15	CS-3 2-12-21-19 (28)	19	19		FILL: GRAVELLY LEAN CLAY WITH SAND (CL), BROWN, A-7-6 (11)	40	24	22	
5870	-20	CS-4 6-9-13-26 (15)	21	21		COBBLE AT 17.5 FEET FILL: CLAYEY GRAVEL (GC), GRAY				
5865	-25	CS-5 4-7-9-10 (12)	22	22		SANDY LEAN CLAY WITH GRAVEL (CL), BROWN WITH TAN MOTTLING, A-6(5)	30	14	20	CU TOT. PHI=33 Deg C=160 psf CU EFF PHI=23 Deg C=300 psf
5860	-30	ST-6 PUSH	18	18		WELL GRADED GRAVEL WITH SAND (GW), TAN, COBBLES, WEBER QUARTZITE GRAVEL, A-1-a	NP	11	T.D. 36.5'	
5855	-35	CS-7 29-31-36-34 (37)	16	16						
		CS-8 36-69-46 (55)	14	14						

ELEV (ft)	DEPTH (ft)	SAMPLE TYPE AND NO.	SPT BLOWS/6 in. (N160)	Recovery (in)	Lithology	DESCRIPTION	LAB DATA			REMARKS
							LL (%)	PI (%)	MC (%)	
5885	-5	CS-1 3-7-9-12 (24)	24	24		FILL: SILTY GRAVEL WITH SAND (GM) TO SILTY SAND WITH GRAVEL (SM), ORANGE-BROWN, 3 INCH LAYER OF CHIP SEAL SAND AND GRAVEL AT SURFACE				
5880	-10	CS-2 7-4-4-9 (9)	18	18		FILL: CLAYEY GRAVEL WITH SAND (GC), BROWN A-2-6(0)	29	12	19	DS PHI=49 Deg C=0 psf
5875	-15	CS-3 6-7-13-11 (19)	11	11		A-2-6(1)	33	17	14	
5870	-20	CS-4 10-12-12-12 (17)	17	17						
5865	-25	CS-5 5-6-6-12 (7)	20	20		FILL: SILTY CLAYEY SAND WITH GRAVEL (SC-SM), BROWN A-2-4	23	7	13	
5860	-30	CS-6 7-12-12-11 (14)	13	13		WELL GRADED GRAVEL WITH SILT AND SAND: (GW-GM), GRAY AND TAN A-1-a	NP	10		
5855	-35	CS-7 12-25-135/5" REF.	6	6		GRADES WITH NO SILT, PROBABLY SLUFF				DRILLER NOTES DRILL CUTTINGS FROM 30'-35' CONSIST OF TAN QUARTZITE T.D. 35.0'

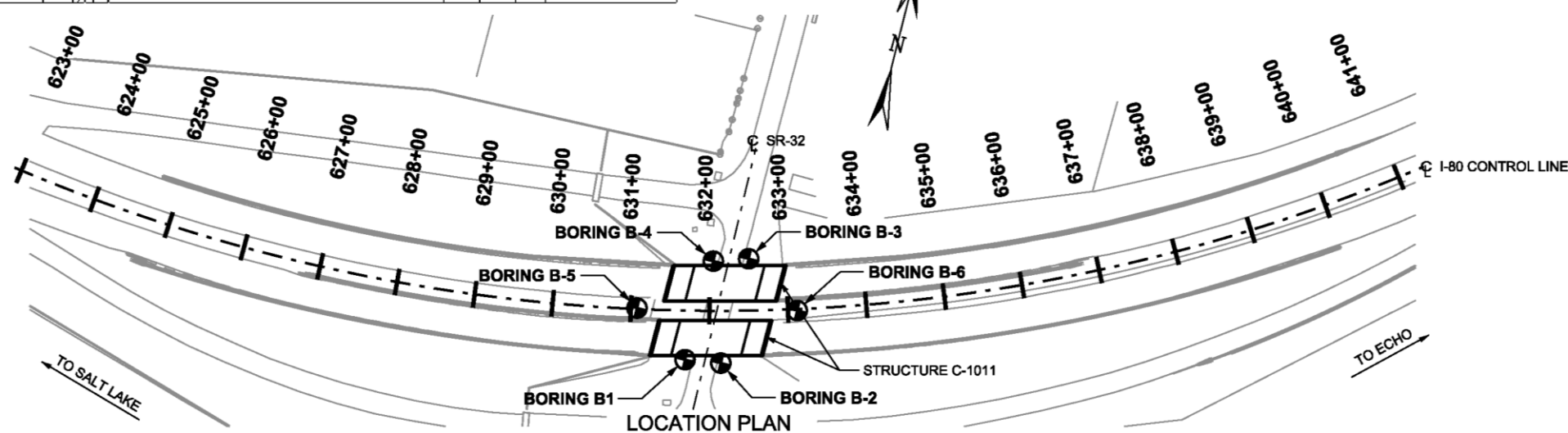

KEY TO BORING LOG

- SYMBOLS**
- LL - LIQUID LIMIT
 - PI - PLASTICITY INDEX
 - NP - NON-PLASTIC
 - MC - NATURAL MOISTURE CONTENT (%)
 - N - CORRECTED SPT BLOW COUNT (N-160)
 - REF - REFUSAL (> 50 BLOWS PER 6")
 - PEN - SPT SAMPLE
 - CS - CALIFORNIA SAMPLE
 - GT - GROUNDWATER TABLE
 - A-2-6(1) - AASHTO CLASSIFICATION
 - CL - USCS CLASSIFICATION
 - NR - NO SAMPLE RECOVERY
 - D.S. - DIRECT SHEAR TEST RESULTS
 - PHI - ANGLE OF INTERNAL FRICTION
 - C - SOIL COHESIVE STRENGTH
 - LV - LAB VEIN SHEAR STRENGTH
 - PP - POCKET PENETROMETER STRENGTH
 - T.D. - TOTAL DEPTH
 - ST - SHELBY TUBE

RELATIVE DENSITY (NON-PLASTIC - SAND & SILT)

- VERY LOOSE N<4;
- LOOSE N 4-10;
- MED DENSE N 10-30;
- DENSE N 30-50;
- VERY DENSE N>50;

CONSISTENCY (PLASTIC - SILT & CLAY)

- VERY SOFT N<2;
- SOFT N 2-4;
- MEDIUM STIFF N 4-8;
- STIFF N 8-15;
- VERY STIFF N 15-30;
- HARD N>30;

GENERAL NOTES

- THE SUBSURFACE EXPLORATIONS SHOWN WERE CONDUCTED BETWEEN DEC. 10, 2010 AND MAY 25, 2011 BY THE GEOTECHNICAL DIVISION OF UDOT.
- THESE BORING LOGS REPRESENT A SYNOPSIS OF THE SOIL DEPOSITS ENCOUNTERED WITHIN EACH BORING AND ARE BASED ON SOUND GEOLOGICAL AND ENGINEERING JUDGMENT. BECAUSE SOIL IS A COMPLEX MEDIUM, THESE BORING LOGS MAY OR MAY NOT REPRESENT THE SOIL CONDITIONS AT THIS SITE. THIS SUBSURFACE INTERPRETATION IS PRESENTED IN GOOD FAITH AND IS NOT INTENDED AS A SUBSTITUTE FOR PERSONAL INVESTIGATION AND JUDGEMENT OF THE CONTRACTOR.
- THE WATER LEVELS AND CONDITIONS INDICATED ON THE BORING LOGS REPRESENT HOLE CONDITIONS ON THE DATE SHOWN, HOWEVER, IT SHOULD BE NOTED, THAT AT LOCATIONS AWAY FROM THE BORINGS OR AT ANOTHER TIME THE WATER LEVELS AND CONDITIONS MAY VARY SIGNIFICANTLY.
- THE STRATIFICATION LINES REPRESENT THE APPROXIMATE BOUNDARIES BETWEEN SOIL TYPES AND THE TRANSITION MAY BE GRADUAL.
- COBBLE - A ROCK WITH AN AVERAGE DIMENSION BETWEEN 3 INCHES AND 12 INCHES
- BOULDER - A ROCK WITH AN AVERAGE DIMENSION OF 12 INCHES OR GREATER

NOTE: DRILL RIG USED - CME 850
HAMMER E=0.80

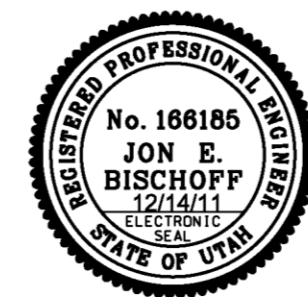

GEOTECHNICAL ENGINEER

UTAH DEPARTMENT OF TRANSPORTATION
 STRUCTURES DIVISION

I-80; WANSHIP TO COALVILLE
 WANSHIP INTERCHANGE; I-80 OVER SR-32
 SOIL DATA SHEET V
 F-180-4(133)156

PROJECT NUMBER: 8098

SUMMIT COUNTY
 C-1011
 DRG. NO.

SHT. 7 OF 38

REVISION REMARKS: DESIGN JEB 10/11, CHECK DLS 10/11, DRAWN DEF 10/11, CHECK JEB 10/11, QUANT. CHECK

APPROVAL RECORD: 12/14/11 DATE, SENIOR DESIGN ENGR., 12/14/11 DATE, APPROVED FOR USE BY UDOT

D:\n_51m_1p_2wp\40152835\8899_C-1011-32.asd\c:\data\505gm
 14-DEC-2011

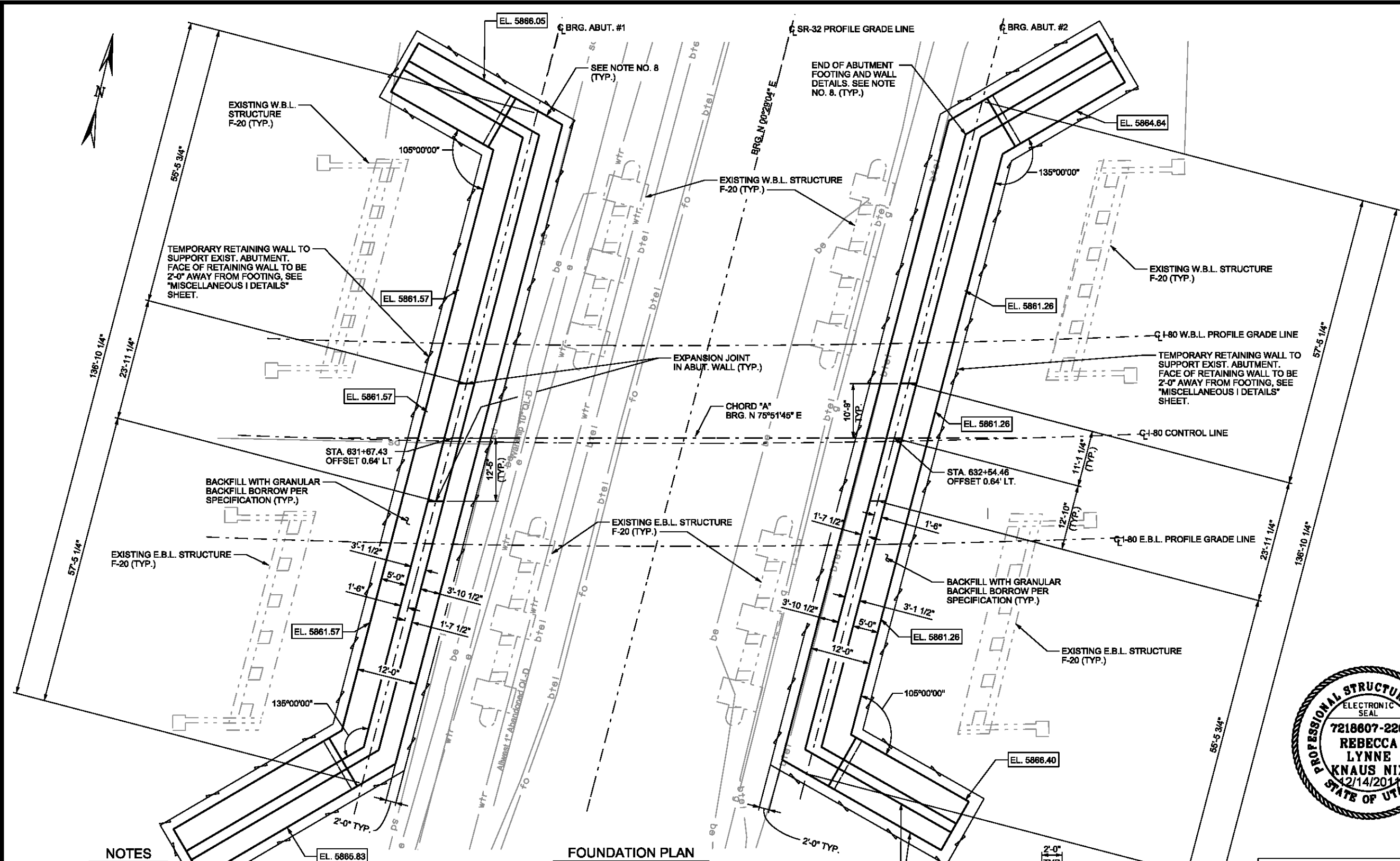

NOTES

1. CONSTRUCT ABUTMENT #1 AND #2 WHILE EXISTING BRIDGE IS IN SERVICE. TEMPORARY RETAINING WALLS (LEFT IN PLACE) ARE REQUIRED TO MAINTAIN STABILITY OF EXISTING STRUCTURE.
2. ELEVATIONS AT THE BOTTOM OF THE FOOTINGS ARE SHOWN ENCLOSED IN RECTANGLES, FOR EXAMPLE: EL. 5861.87
3. LOCATION OF EXISTING STRUCTURES ARE APPROXIMATE AND SHOWN FOR INFORMATION ONLY.
4. SEE NOTE NO. 9 OF GENERAL NOTES ON "SITUATION AND LAYOUT I" SHEET FOR CHORD "A" DEFINITIONS. BEARING OF CHORD "A" N 75°51'45" E
5. AT ABUTMENTS AND WINGWALLS IN REGIONS WHERE FOOTING IS NOT ON BED ROCK, OVER EXCAVATE FROM THE BOTTOM OF FOOTING ELEVATIONS TO THE TOP OF VERY DENSE GRAVEL AT APPROXIMATE EL. 5858 AND REPLACE WITH GRANULAR BACK FILL BORROW 2'-0" WIDER THAN THE FOOTING FOOT PRINT LIMITS AT EACH EDGE. PAYMENT FOR GRANULAR BACKFILL BORROW UNDER FOOTING (MENTIONED ABOVE IN THIS NOTE) INCLUDED IN "STRUCTURAL CONCRETE" PAY ITEM.
6. ALL ABUTMENTS ARE PARALLEL TO BRG. N 00°29'04" E
7. PROVIDE 2'-0" OF GRANULAR BACKFILL BORROW BEHIND ALL ABUTMENTS AND WINGWALLS.
8. SEE "ABUTMENT #1; 1 OF 4" SHEET THROUGH "ABUTMENT #2; 4 OF 4" SHEET FOR DETAILS AND DIMENSIONS NOT SHOWN AT ENDS OF ABUTMENTS.
9. SEE "W.B. ABUTMENT #1 WINGWALL DETAILS" SHEET THROUGH "E.B. ABUTMENT #2 WINGWALL DETAILS" SHEET FOR DETAILS OF WINGWALL AND WINGWALL FOOTINGS.

FOUNDATION PLAN

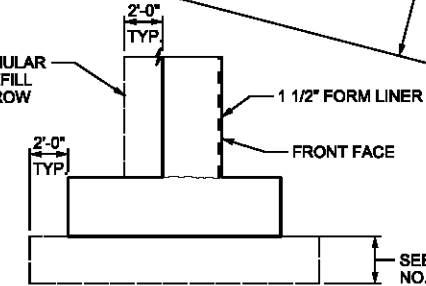

TYPICAL FOOTING SECTION

(SEE FOUNDATION PLAN FOR DIMENSIONS NOT SHOWN)

QUANTITIES	
GRANULAR BACKFILL BORROW	500 C.Y.
FLOWABLE FILL	1140 C.Y.

* GRANULAR BACKFILL BORROW QUANTITIES ONLY INCLUDE THE 2'-0" SECTION BEHIND THE ABUTMENT AND WINGWALLS. ALL OTHER GRANULAR BACKFILL BORROW IS INCIDENTAL TO THE "STRUCTURAL CONCRETE" PAY ITEM.

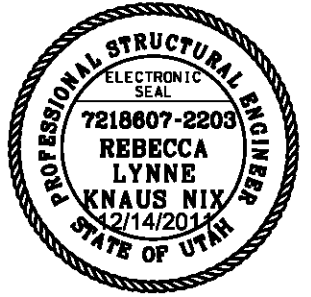

REVISION REMARKS			
NO.	DATE	BY	CHECK
DESIGN	RLN	6/11	CHECK
DRAWN	MPP	7/11	CHECK
QUANT.	MPP	9/11	CHECK

UTAH DEPARTMENT OF TRANSPORTATION
STRUCTURES DIVISION

I-80; WANSHIP TO COALVILLE
WANSHIP INTERCHANGE: I-80 OVER SR-32
FOUNDATION PLAN
PROJECT NUMBER: F-180-4(133)156
PIN: 8098

SUMMIT COUNTY
C-1011
DRG. NO.
SHT. 8 OF 38

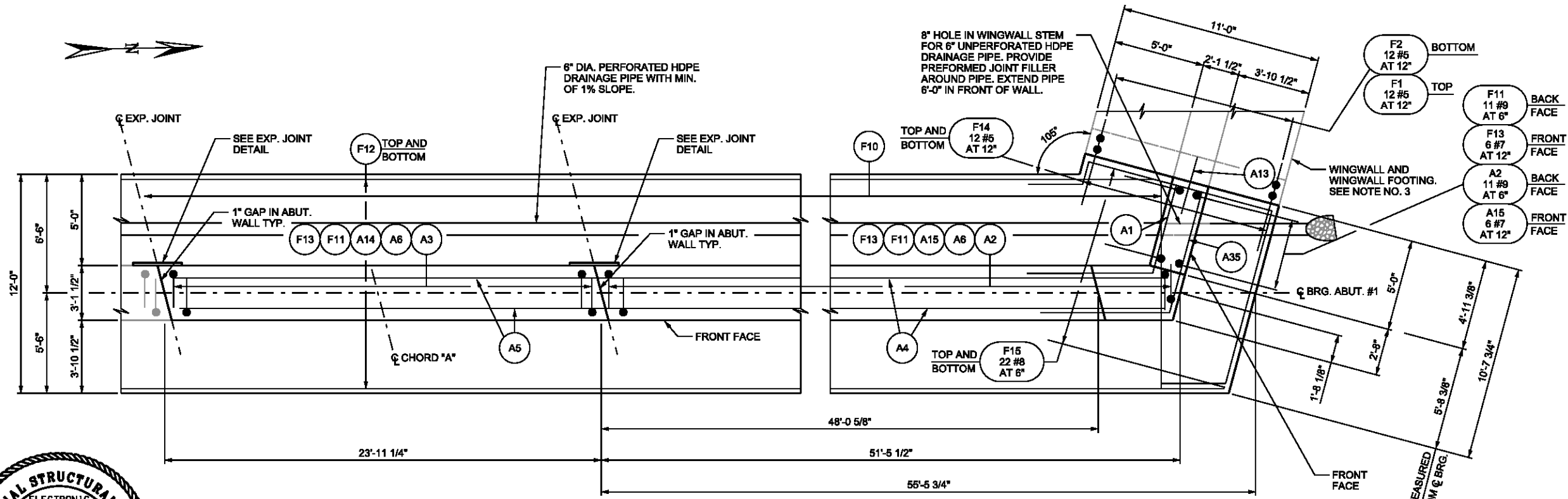
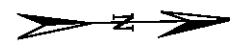

PLAN - ABUTMENT #1 W.B.L AND CENTER WALL

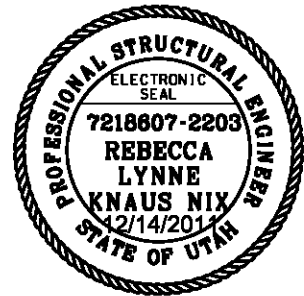

NOTES

1. SEE "ABUTMENT #1; 2 OF 4" SHEET FOR EXPANSION JOINT DETAIL.
2. SEE "ABUTMENT SECTIONS" SHEET FOR ABUTMENT SECTIONS A-A, B-B, AND DRAINAGE PIPE DETAILS.
3. SEE "W.B. ABUTMENT #1 WINGWALL DETAILS" SHEET FOR WINGWALL AND WINGWALL FOOTING DETAILS AND REINFORCING.
4. FINISH TOP OF ABUTMENT HIGH AND RUB OR GRIND LEVEL TO ELEVATIONS SHOWN + OR - 1/8". GROUTING NOT ALLOWED.
5. PAYMENT FOR PREFORMED JOINT FILLER, WATERPROOFING MEMBRANE, DRAIN PIPE, AND RIPRAP AT DRAIN PIPE OUTFALL INCLUDED IN "STRUCTURAL CONCRETE" PAY ITEM.
6. SEE "ABUTMENT #2; 4 OF 4" SHEET FOR ABUT. AND WINGWALL DOWEL DETAIL.

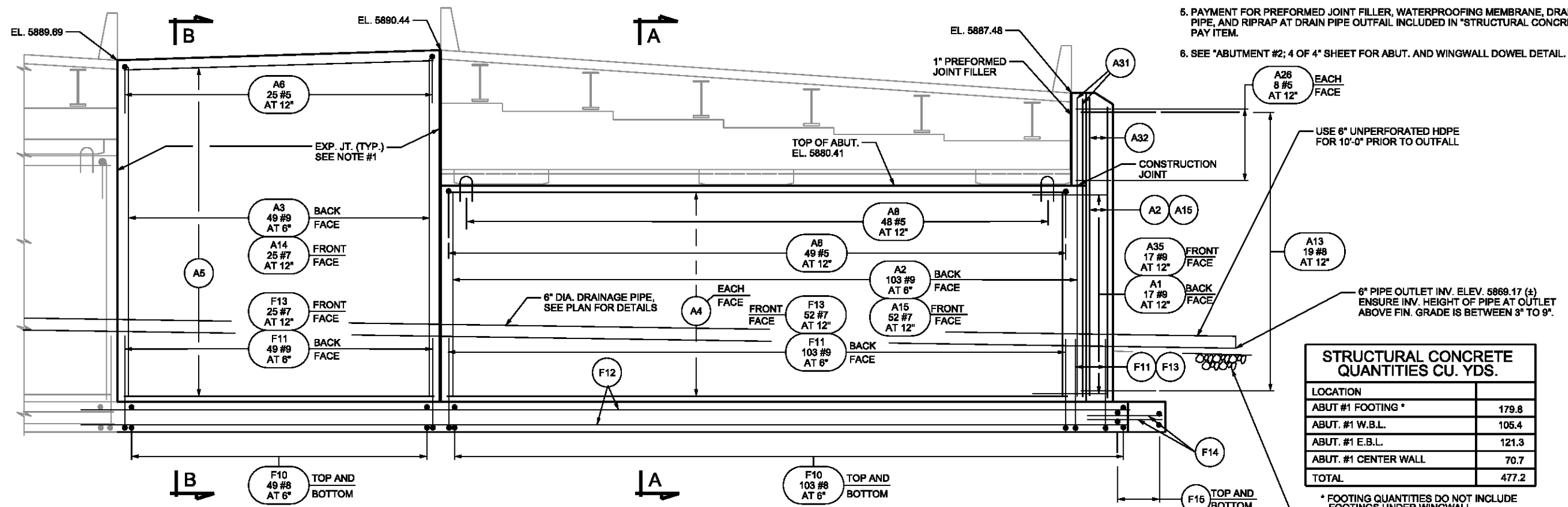

ELEVATION - ABUTMENT #1 W.B.L AND CENTER WALL

LOOKING BACK STATION

STRUCTURAL CONCRETE QUANTITIES CU. YDS.	
LOCATION	
ABUT #1 FOOTING *	179.8
ABUT. #1 W.B.L.	105.4
ABUT. #1 E.B.L.	121.3
ABUT. #1 CENTER WALL	70.7
TOTAL	477.2

* FOOTING QUANTITIES DO NOT INCLUDE FOOTINGS UNDER WINGWALL

LOOSE RIP RAP 1 CU. YD. TO DISPERSE OUTLET FLOW

REVISION	REVISION	REVISION	REVISION
NO.	DATE	BY	QUANT.
1	12/14/2011	SRM/DAVIDSON/ENR.	
2	12/14/2011	SRM/DAVIDSON/ENR.	
3	12/14/2011	SRM/DAVIDSON/ENR.	
4	12/14/2011	SRM/DAVIDSON/ENR.	
5	12/14/2011	SRM/DAVIDSON/ENR.	
6	12/14/2011	SRM/DAVIDSON/ENR.	
7	12/14/2011	SRM/DAVIDSON/ENR.	
8	12/14/2011	SRM/DAVIDSON/ENR.	
9	12/14/2011	SRM/DAVIDSON/ENR.	
10	12/14/2011	SRM/DAVIDSON/ENR.	
11	12/14/2011	SRM/DAVIDSON/ENR.	
12	12/14/2011	SRM/DAVIDSON/ENR.	
13	12/14/2011	SRM/DAVIDSON/ENR.	
14	12/14/2011	SRM/DAVIDSON/ENR.	
15	12/14/2011	SRM/DAVIDSON/ENR.	
16	12/14/2011	SRM/DAVIDSON/ENR.	
17	12/14/2011	SRM/DAVIDSON/ENR.	
18	12/14/2011	SRM/DAVIDSON/ENR.	
19	12/14/2011	SRM/DAVIDSON/ENR.	
20	12/14/2011	SRM/DAVIDSON/ENR.	
21	12/14/2011	SRM/DAVIDSON/ENR.	
22	12/14/2011	SRM/DAVIDSON/ENR.	
23	12/14/2011	SRM/DAVIDSON/ENR.	
24	12/14/2011	SRM/DAVIDSON/ENR.	
25	12/14/2011	SRM/DAVIDSON/ENR.	
26	12/14/2011	SRM/DAVIDSON/ENR.	
27	12/14/2011	SRM/DAVIDSON/ENR.	
28	12/14/2011	SRM/DAVIDSON/ENR.	
29	12/14/2011	SRM/DAVIDSON/ENR.	
30	12/14/2011	SRM/DAVIDSON/ENR.	
31	12/14/2011	SRM/DAVIDSON/ENR.	
32	12/14/2011	SRM/DAVIDSON/ENR.	
33	12/14/2011	SRM/DAVIDSON/ENR.	
34	12/14/2011	SRM/DAVIDSON/ENR.	
35	12/14/2011	SRM/DAVIDSON/ENR.	
36	12/14/2011	SRM/DAVIDSON/ENR.	
37	12/14/2011	SRM/DAVIDSON/ENR.	
38	12/14/2011	SRM/DAVIDSON/ENR.	
39	12/14/2011	SRM/DAVIDSON/ENR.	
40	12/14/2011	SRM/DAVIDSON/ENR.	
41	12/14/2011	SRM/DAVIDSON/ENR.	
42	12/14/2011	SRM/DAVIDSON/ENR.	
43	12/14/2011	SRM/DAVIDSON/ENR.	
44	12/14/2011	SRM/DAVIDSON/ENR.	
45	12/14/2011	SRM/DAVIDSON/ENR.	
46	12/14/2011	SRM/DAVIDSON/ENR.	
47	12/14/2011	SRM/DAVIDSON/ENR.	
48	12/14/2011	SRM/DAVIDSON/ENR.	
49	12/14/2011	SRM/DAVIDSON/ENR.	
50	12/14/2011	SRM/DAVIDSON/ENR.	
51	12/14/2011	SRM/DAVIDSON/ENR.	
52	12/14/2011	SRM/DAVIDSON/ENR.	
53	12/14/2011	SRM/DAVIDSON/ENR.	
54	12/14/2011	SRM/DAVIDSON/ENR.	
55	12/14/2011	SRM/DAVIDSON/ENR.	
56	12/14/2011	SRM/DAVIDSON/ENR.	
57	12/14/2011	SRM/DAVIDSON/ENR.	
58	12/14/2011	SRM/DAVIDSON/ENR.	
59	12/14/2011	SRM/DAVIDSON/ENR.	
60	12/14/2011	SRM/DAVIDSON/ENR.	
61	12/14/2011	SRM/DAVIDSON/ENR.	
62	12/14/2011	SRM/DAVIDSON/ENR.	
63	12/14/2011	SRM/DAVIDSON/ENR.	
64	12/14/2011	SRM/DAVIDSON/ENR.	
65	12/14/2011	SRM/DAVIDSON/ENR.	
66	12/14/2011	SRM/DAVIDSON/ENR.	
67	12/14/2011	SRM/DAVIDSON/ENR.	
68	12/14/2011	SRM/DAVIDSON/ENR.	
69	12/14/2011	SRM/DAVIDSON/ENR.	
70	12/14/2011	SRM/DAVIDSON/ENR.	
71	12/14/2011	SRM/DAVIDSON/ENR.	
72	12/14/2011	SRM/DAVIDSON/ENR.	
73	12/14/2011	SRM/DAVIDSON/ENR.	
74	12/14/2011	SRM/DAVIDSON/ENR.	
75	12/14/2011	SRM/DAVIDSON/ENR.	
76	12/14/2011	SRM/DAVIDSON/ENR.	
77	12/14/2011	SRM/DAVIDSON/ENR.	
78	12/14/2011	SRM/DAVIDSON/ENR.	
79	12/14/2011	SRM/DAVIDSON/ENR.	
80	12/14/2011	SRM/DAVIDSON/ENR.	
81	12/14/2011	SRM/DAVIDSON/ENR.	
82	12/14/2011	SRM/DAVIDSON/ENR.	
83	12/14/2011	SRM/DAVIDSON/ENR.	
84	12/14/2011	SRM/DAVIDSON/ENR.	
85	12/14/2011	SRM/DAVIDSON/ENR.	
86	12/14/2011	SRM/DAVIDSON/ENR.	
87	12/14/2011	SRM/DAVIDSON/ENR.	
88	12/14/2011	SRM/DAVIDSON/ENR.	
89	12/14/2011	SRM/DAVIDSON/ENR.	
90	12/14/2011	SRM/DAVIDSON/ENR.	
91	12/14/2011	SRM/DAVIDSON/ENR.	
92	12/14/2011	SRM/DAVIDSON/ENR.	
93	12/14/2011	SRM/DAVIDSON/ENR.	
94	12/14/2011	SRM/DAVIDSON/ENR.	
95	12/14/2011	SRM/DAVIDSON/ENR.	
96	12/14/2011	SRM/DAVIDSON/ENR.	
97	12/14/2011	SRM/DAVIDSON/ENR.	
98	12/14/2011	SRM/DAVIDSON/ENR.	
99	12/14/2011	SRM/DAVIDSON/ENR.	
100	12/14/2011	SRM/DAVIDSON/ENR.	

UTAH DEPARTMENT OF TRANSPORTATION STRUCTURES DIVISION

I-80; WANSHIP TO COALVILLE
 WANSHIP INTERCHANGE: I-80 OVER SR-32
 ABUTMENT #1; 1 OF 4
 PROJECT NUMBER: F-180-4(133)156
 PIN: 8098

SUMMIT COUNTY
 C-1011
 DRG. NO.
 SHT. 9 OF 38

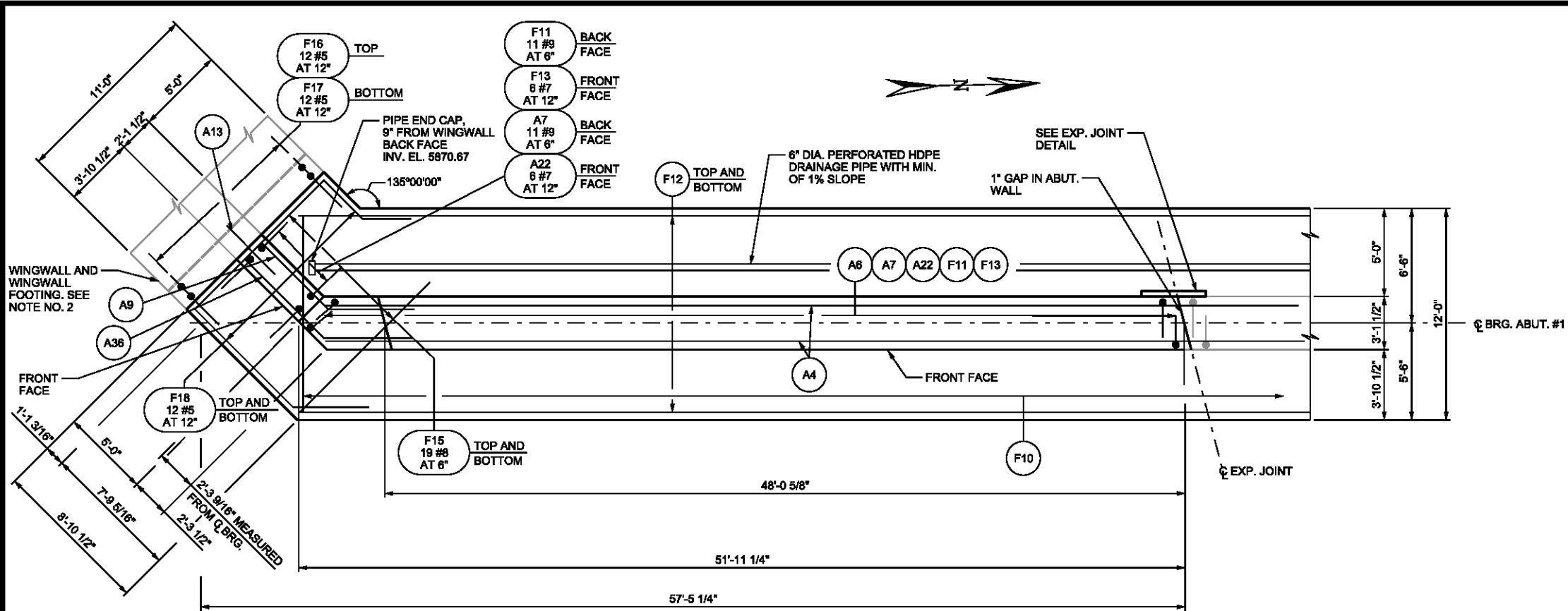

REVISION REMARKS		DESIGN	CHK	DD
1		RLN	9/11	11/11
2		MPP	9/11	11/11
3		MPP	9/11	11/11

UTAH DEPARTMENT OF TRANSPORTATION
STRUCTURES DIVISION

I-80; WANSHIP TO COALVILLE
WANSHIP INTERCHANGE: I-80 OVER SR-32
ABUTMENT #1; 2 OF 4
PROJECT NUMBER: F-180-4(133)156
PIN: 8098

SUMMIT COUNTY
C-1011
DRG. NO.
SHT. 10 OF 38

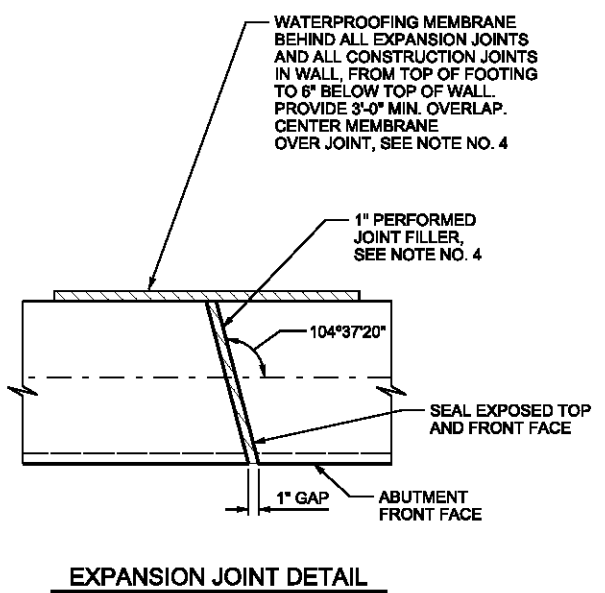

NOTES

1. SEE "ABUTMENT SECTIONS" SHEET FOR SECTIONS C-C.
2. SEE "E.B. ABUTMENT #1 WINGWALL DETAILS" SHEET FOR WINGWALL AND WINGWALL FOOTING DETAILS AND REINFORCING.
3. FINISH TOP OF ABUTMENT HIGH AND RUB OR GRIND LEVEL TO ELEVATIONS SHOWN ± 1/8 INCH. GROUTING NOT ALLOWED.
4. PAYMENT FOR PREFORMED JOINT FILLER, WATERPROOFING MEMBRANE, AND DRAIN PIPE INCLUDED IN "STRUCTURAL CONCRETE" PAY ITEM.
5. SEE "ABUTMENT #2; 4 OF 4" SHEET FOR ABUT. AND WINGWALL DOWEL DETAIL.

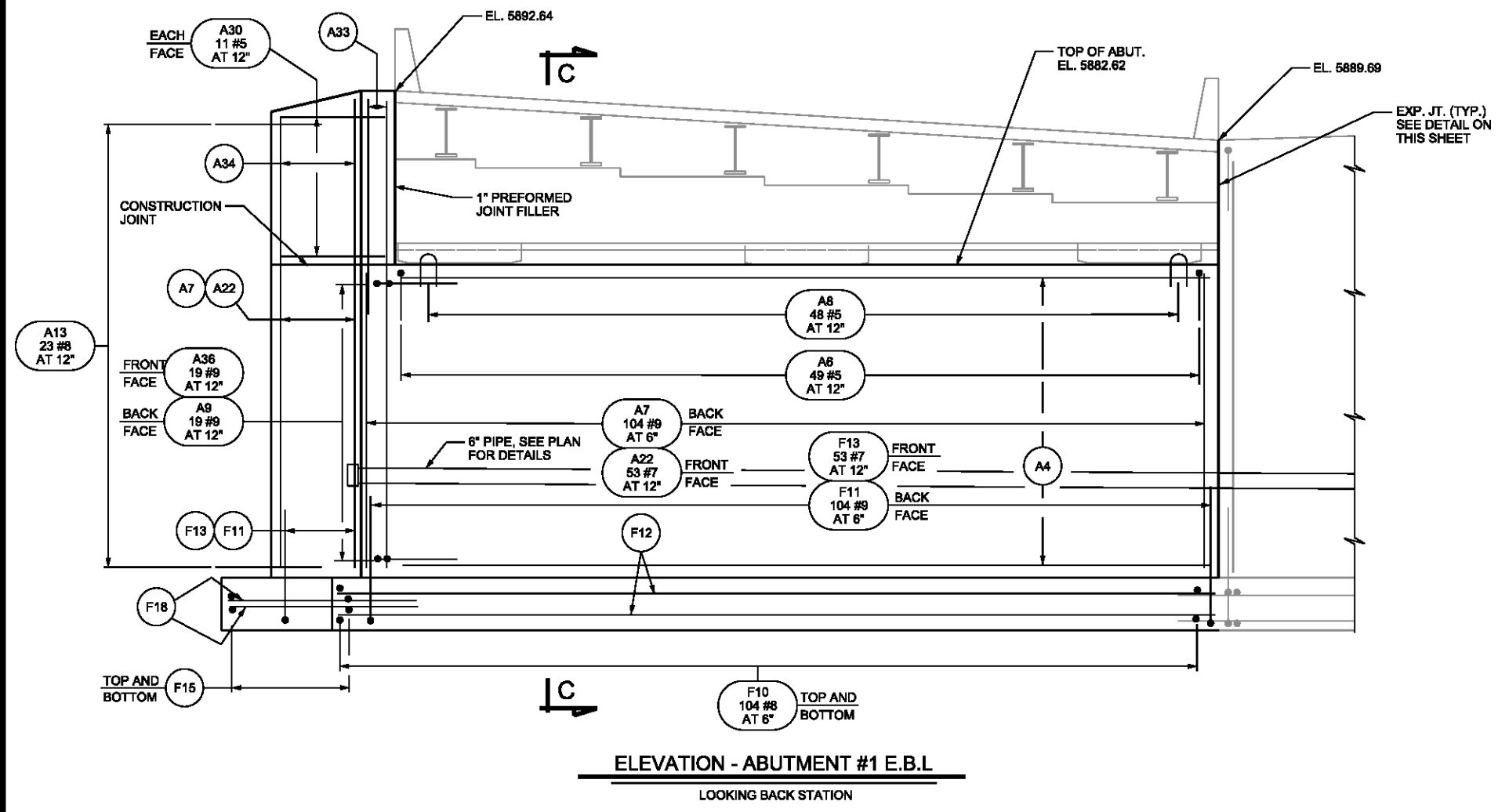

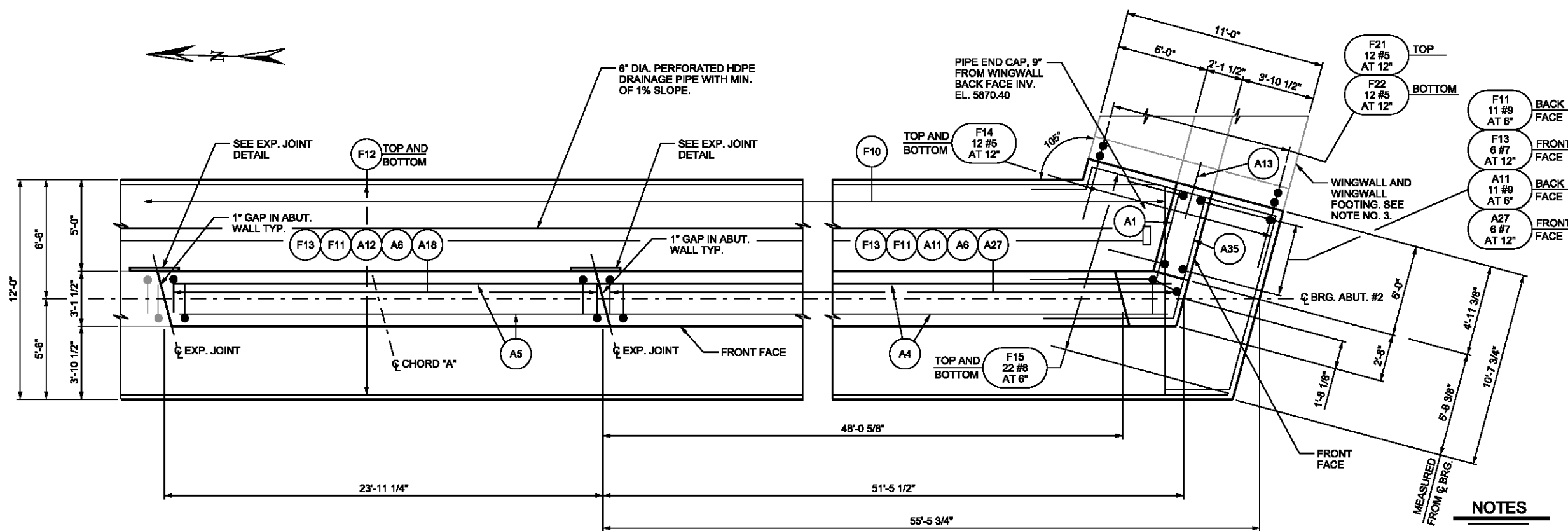

PLAN - ABUTMENT #2 E.B.L AND CENTER WALL

- NOTES**
1. SEE "ABUTMENT #1; 2 OF 4" SHEET FOR EXPANSION JOINT DETAIL.
 2. SEE "ABUTMENT SECTIONS" SHEET FOR ABUTMENT SECTIONS D-D AND E-E.
 3. SEE "E.B. ABUTMENT #2 WINGWALL DETAILS" SHEET FOR WINGWALL AND WINGWALL FOOTING DETAILS AND REINFORCING.
 4. FINISH TOP OF ABUTMENT HIGH AND RUB OR GRIND LEVEL TO ELEVATIONS SHOWN + OR - 1/8". GROUTING NOT ALLOWED.
 5. PAYMENT FOR PREFORMED JOINT FILLER, WATERPROOFING MEMBRANE, AND DRAIN PIPE INCLUDED IN "STRUCTURAL CONCRETE" PAY ITEM.
 6. SEE "ABUTMENT #2; 4 OF 4" SHEET FOR ABUT. AND WINGWALL DOWEL DETAIL.

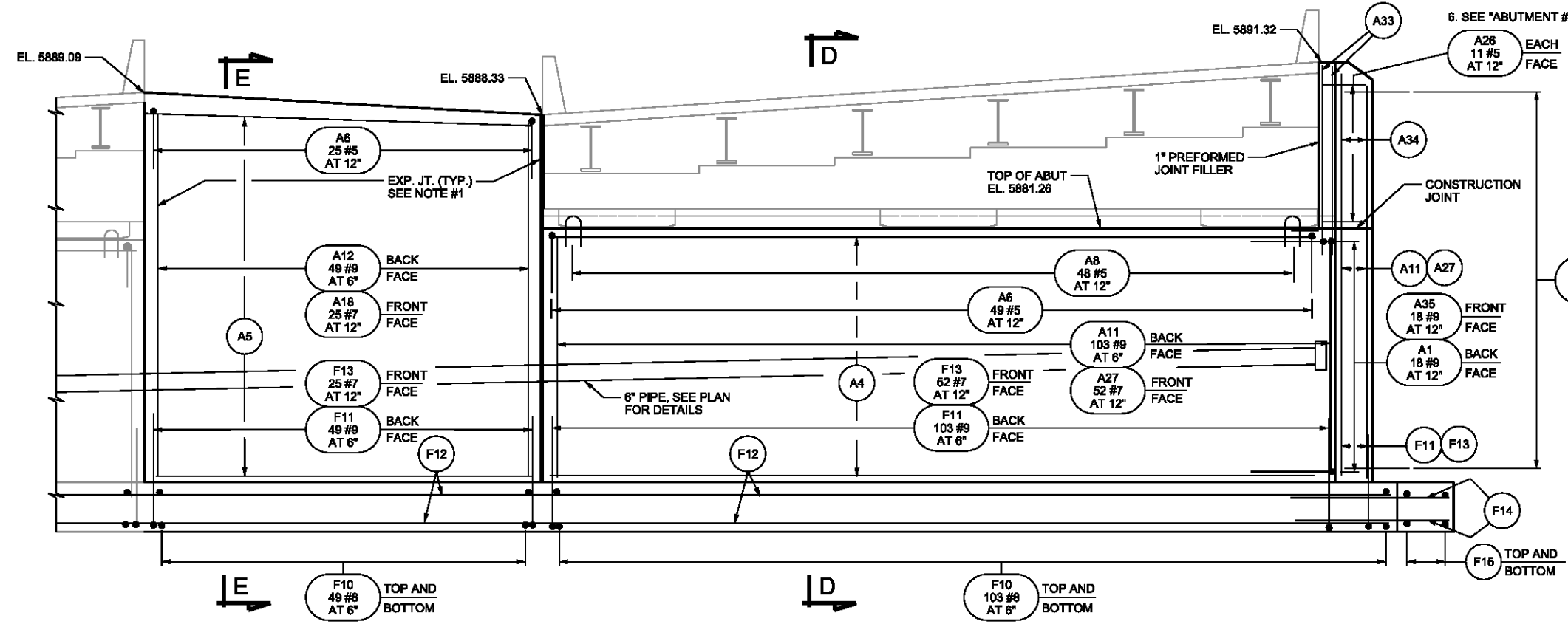

ELEVATION - ABUTMENT #2 E.B.L AND CENTER WALL

STRUCTURAL CONCRETE QUANTITIES CU. YDS.

LOCATION	QUANTITY
ABUT #2 FOOTING *	179.8
ABUT. #2 W.B.L.	98.3
ABUT. #2 E.B.L.	115.0
ABUT. #2 CENTER WALL	67.8
TOTAL	460.9

* FOOTING QUANTITIES DO NOT INCLUDE FOOTINGS UNDER WINGWALLS.



UTAH DEPARTMENT OF TRANSPORTATION		STRUCTURES DIVISION	
I-80; WANSHIP TO COALVILLE		WANSHIP INTERCHANGE: I-80 OVER SR-32	
ABUTMENT #2; 3 OF 4		PROJECT NUMBER: F-180-4(133)156	
SUMMIT COUNTY		C-1011	
DRG. NO.		SHT. 11 OF 38	

REVISION	REMARKS	DATE	BY	DATE	BY
11/11	CHECK	DD	11/11		
9/11	DESIGN	RLN	9/11		
9/11	DRAWN	MPP	9/11		
9/11	QUANT.	MPP	9/11		

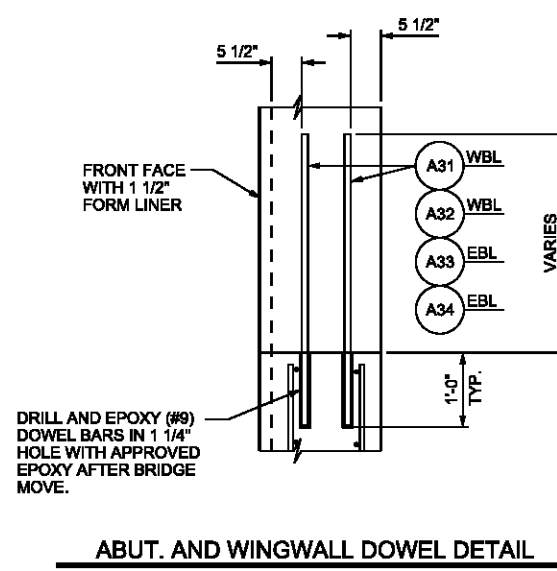
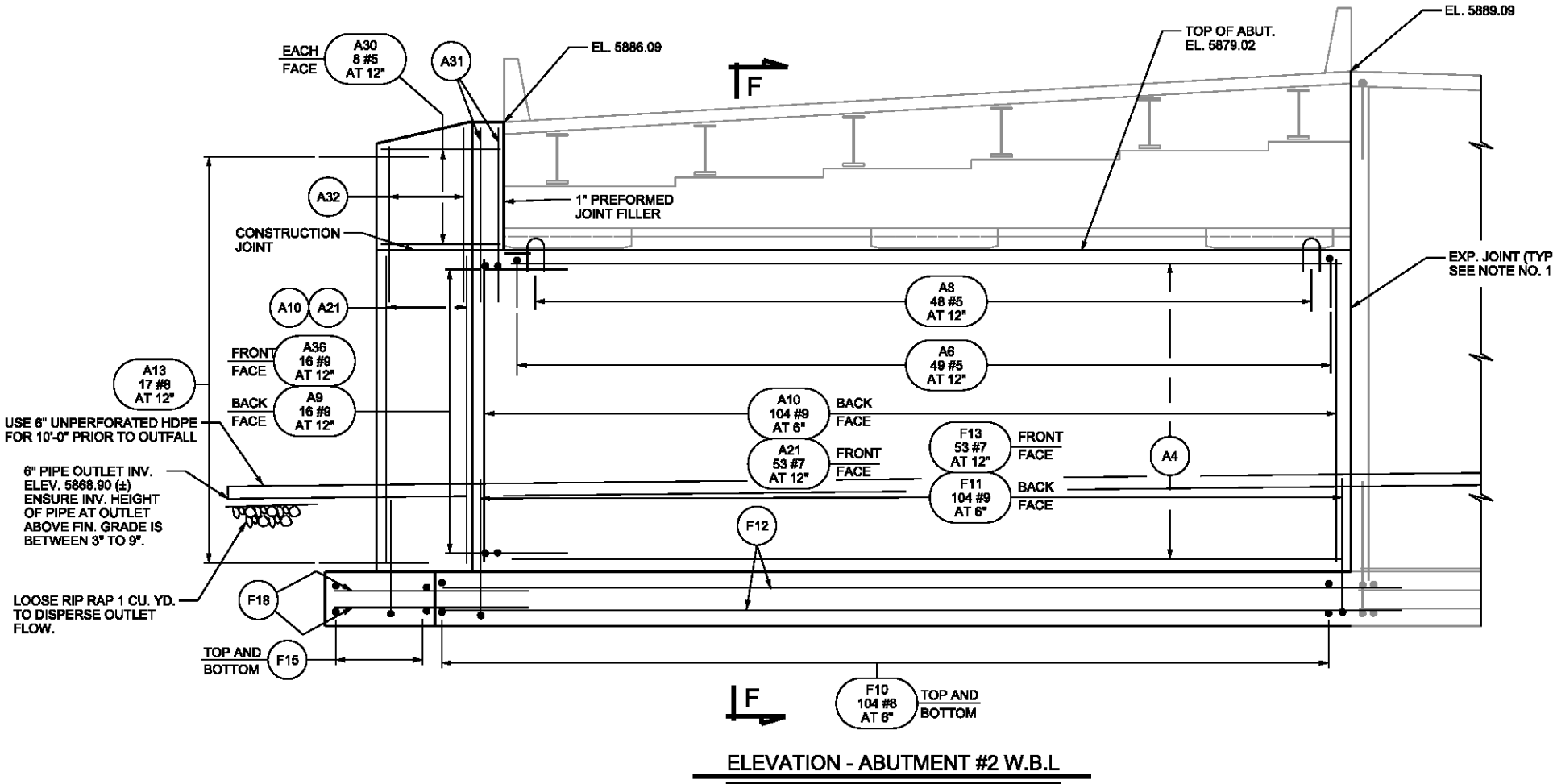
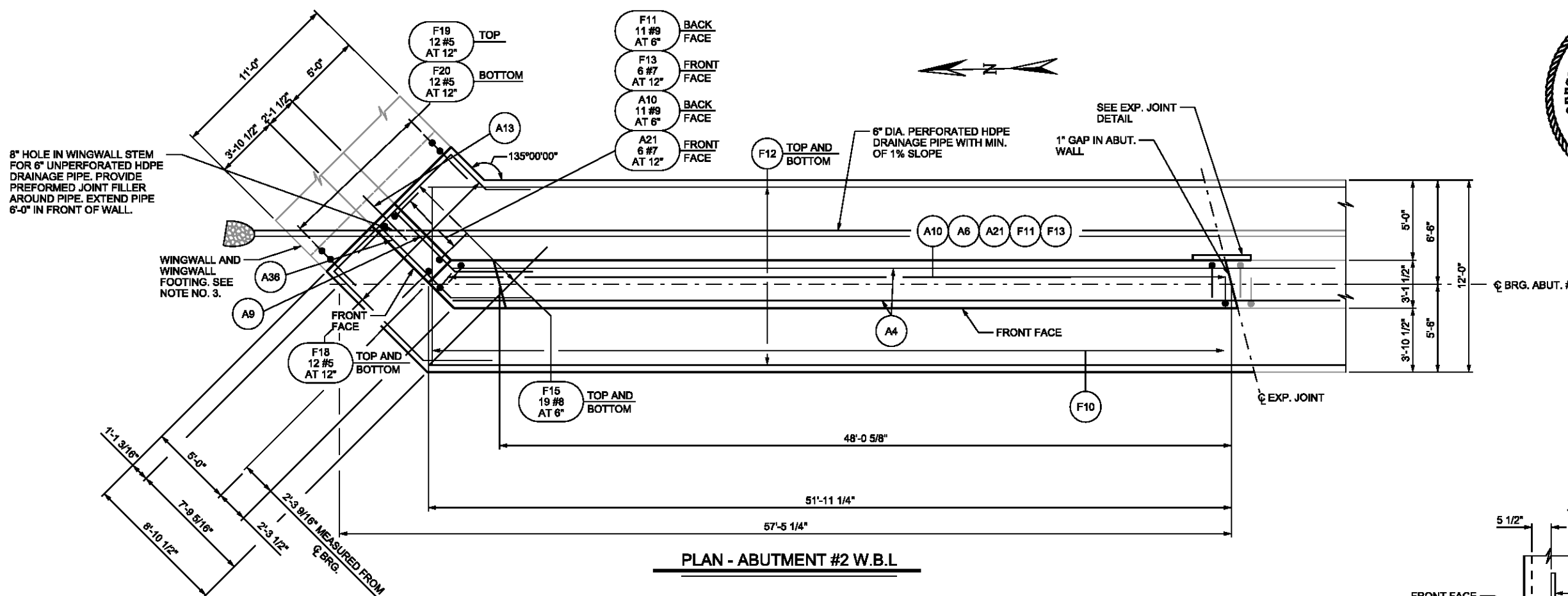
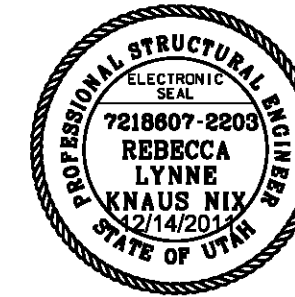

- NOTES**
1. SEE "ABUTMENT #1; 2 OF 4" SHEET FOR EXPANSION JOINT DETAIL.
 2. SEE "ABUTMENT SECTIONS" SHEET FOR SECTION F-F.
 3. SEE "W.B. ABUTMENT #2 WINGWALL DETAILS" SHEET FOR WINGWALL AND WINGWALL FOOTING DETAILS AND REINFORCING.
 4. FINISH TOP OF ABUTMENT HIGH AND RUB OR GRIND LEVEL TO ELEVATIONS SHOWN ± 1/8 INCH. GROUTING NOT ALLOWED.
 5. PAYMENT FOR PREFORMED JOINT FILLER, WATERPROOFING MEMBRANE, DRAIN PIPE, AND RIPRAP AT DRAIN PIPE OUTFALL INCLUDED IN "STRUCTURAL CONCRETE" PAY ITEM.

DESIGN	RLN	9/11	CHECK	DD	11/11
DRAWN	MPP	9/11	CHECK	DD	11/11
QUANT.	MPP	9/11	CHECK	DD	11/11
REVISION	REMARKS				
NO.	DATE	BY			
APPROVAL	12/14/2011	REBECCA LYNNE KNAUS NIX	DESIGNER		
FOR USE	2/14/2011		DATE		
BY			DATE		
UTAH DEPARTMENT OF TRANSPORTATION STRUCTURES DIVISION					
I-80; WANSHIP TO COALVILLE					
WANSHIP INTERCHANGE: I-80 OVER SR-32					
ABUTMENT #2; 4 OF 4					
PROJECT NUMBER: F-180-4(133)156					
PIN: 8098					
SUMMIT COUNTY					
C-1011					
DRG. NO.					
SHT. 12 OF 38					

14-DEC-2011 09:11:11 PM P:\w\p\180\133\156\180-4(133)156-401.dwg

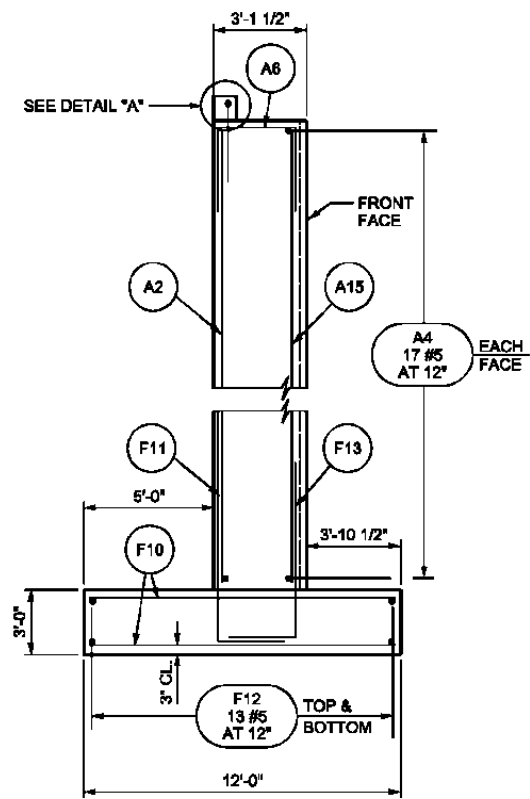

SECTION A-A
ABUTMENT #1 WB WALL

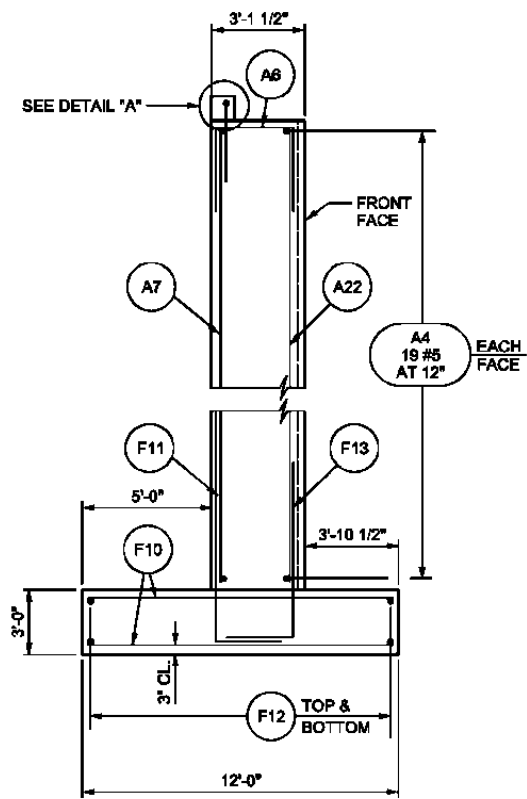

SECTION C-C
ABUTMENT #1 EB WALL

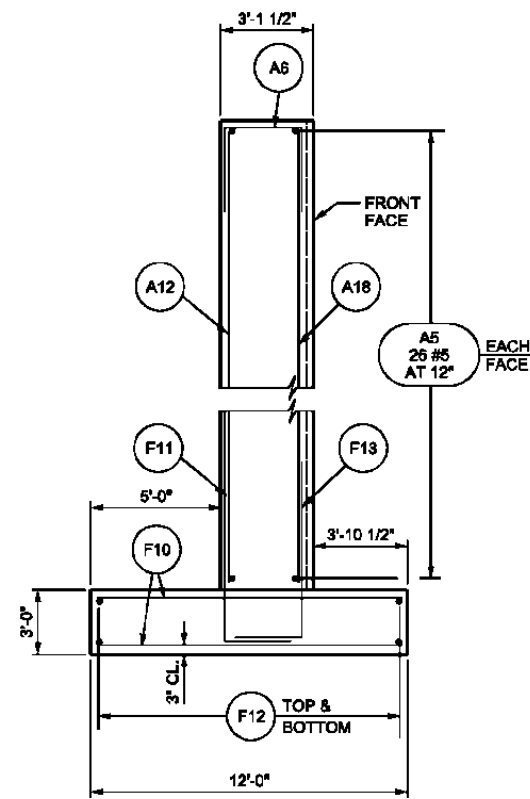

SECTION E-E
ABUTMENT #2 CENTER WALL

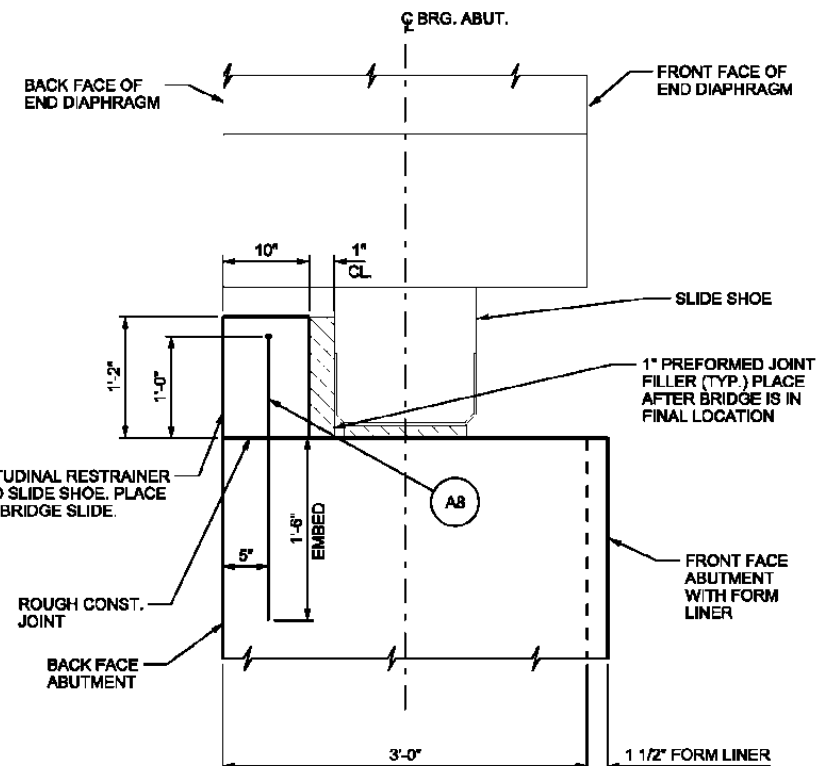

DETAIL "A"

NOTES:

1. SECTIONS ARE TAKEN FROM ABUTMENT SHEETS.
2. CONTRACTOR IS RESPONSIBLE FOR THE DESIGN AND DETAILING OF THE CONNECTION BETWEEN THE TEMPORARY SUPPORTS AND THE ABUTMENTS.

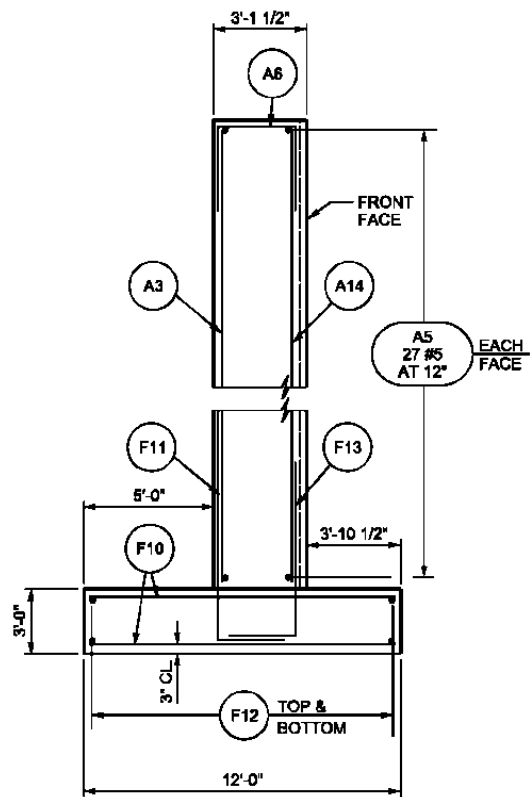

SECTION B-B
ABUTMENT #1 CENTER WALL

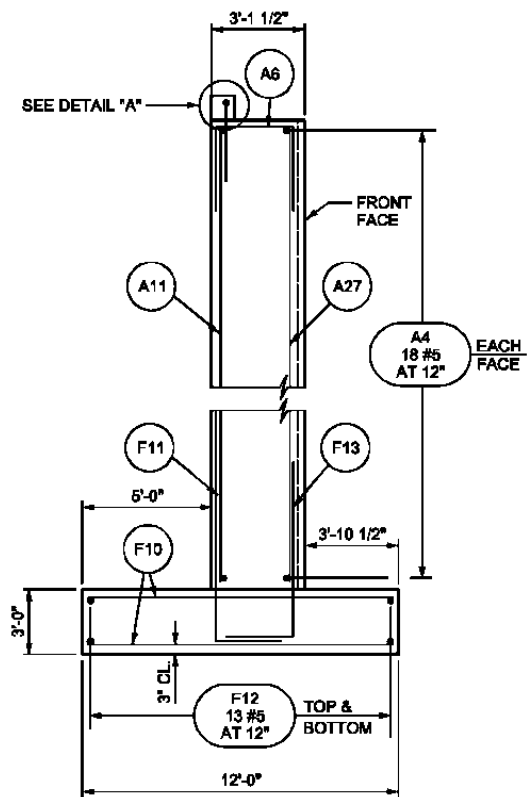

SECTION D-D
ABUTMENT #2 EB WALL

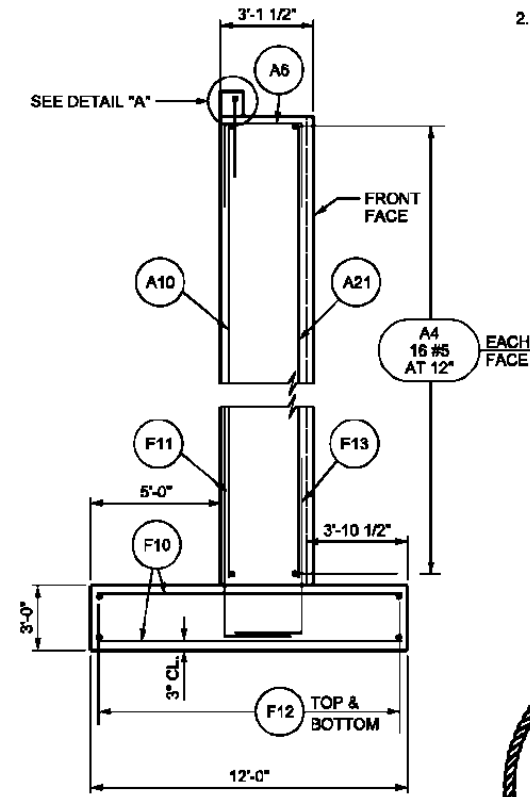

SECTION F-F
ABUTMENT #2 WB WALL

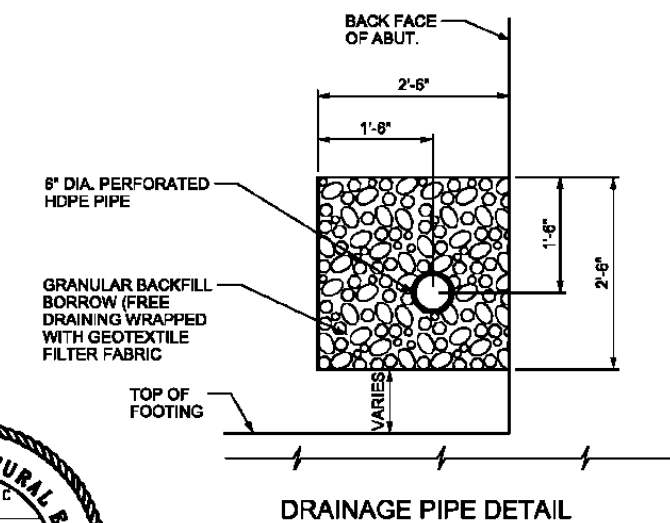

DRAINAGE PIPE DETAIL



UTAH DEPARTMENT OF TRANSPORTATION		STRUCTURES DIVISION
I-80; WANSHIP TO COALVILLE		
WANSHIP INTERCHANGE: I-80 OVER SR-32		
ABUTMENT SECTIONS		
PROJECT NUMBER	F-180-4(133)156	PIN 8098
SUMMIT COUNTY	C-1011	
DRG. NO.		
SHT. 13 OF 38		

REVISION REMARKS		
DESIGN	RLN	9/11
CHECK	DD	11/11
DRAWN	MPP	9/11
CHECK	DD	11/11
QUANT.	MPP	9/11
CHECK	DD	11/11

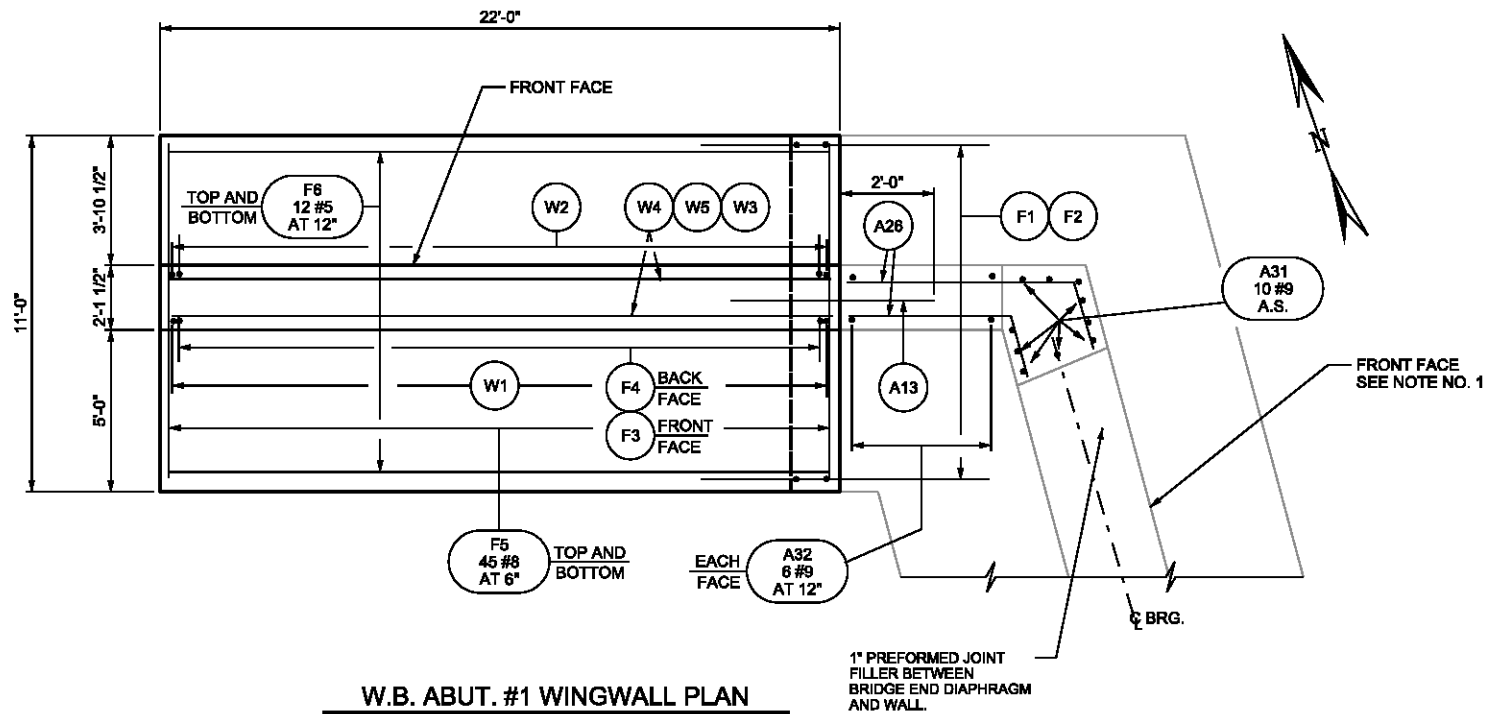

W.B. ABUT. #1 WINGWALL PLAN

1" PREFORMED JOINT FILLER BETWEEN BRIDGE END DIAPHRAGM AND WALL.

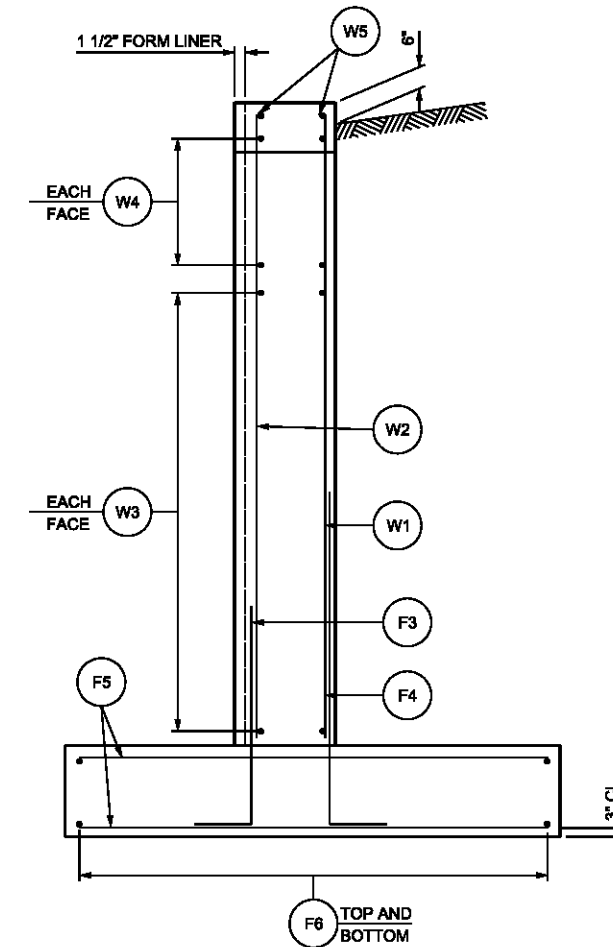

SECTION A-A

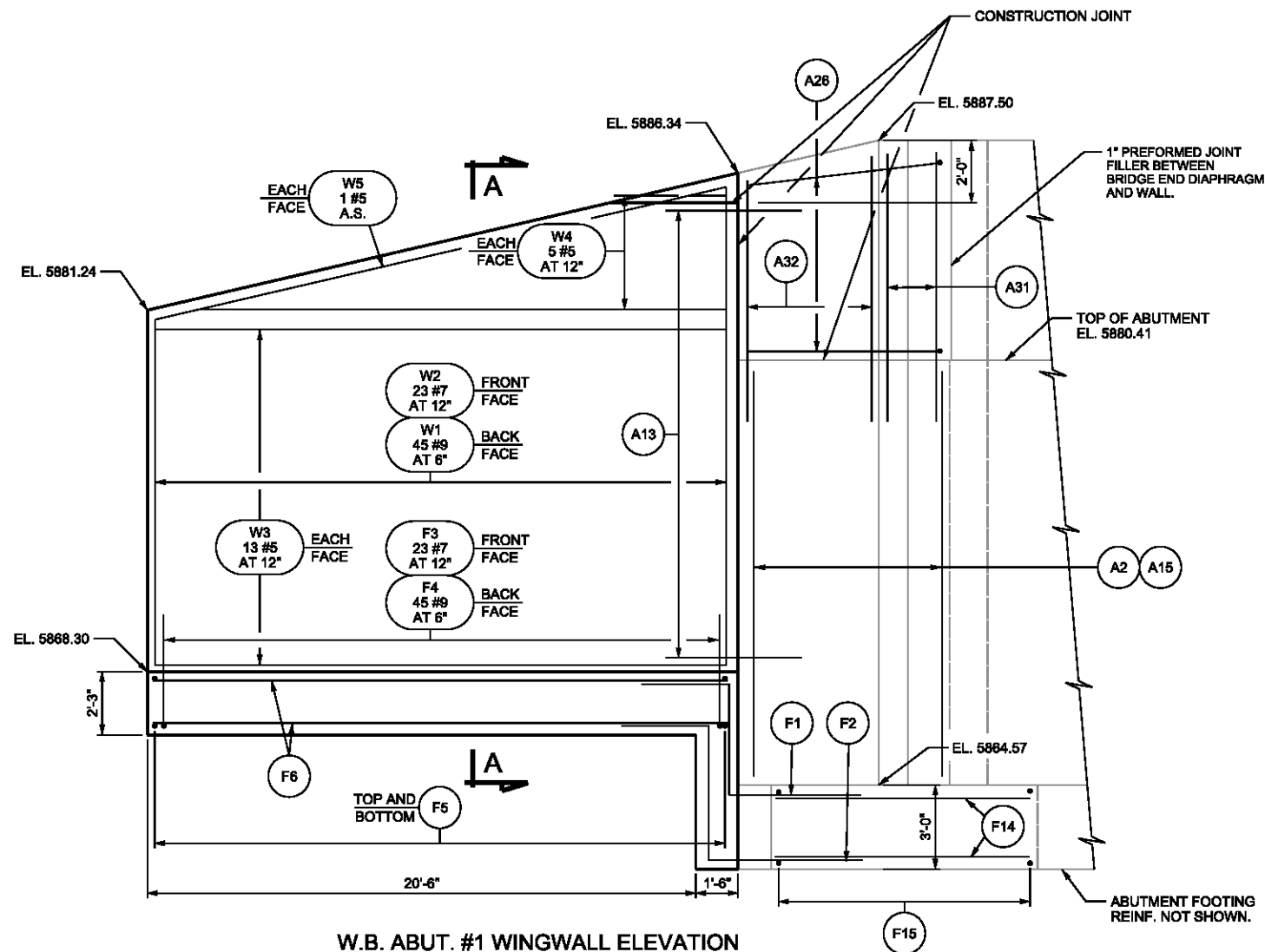

W.B. ABUT. #1 WINGWALL ELEVATION

ABUTMENT FOOTING REINF. NOT SHOWN.

NOTES:

- SEE "ABUTMENT #1; 1 OF 4" SHEET AND "FOUNDATION PLAN" SHEET FOR WINGWALL LOCATION AND ABUTMENT DETAILS.
- FIELD BEND W1 AND W2 BARS TO NOT OBSTRUCT THE BRIDGE MOVE. IF REQUIRED FIELD CUT BARS AND DRILL AND EPOXY DOWELS WITH ENGINEER'S APPROVAL.

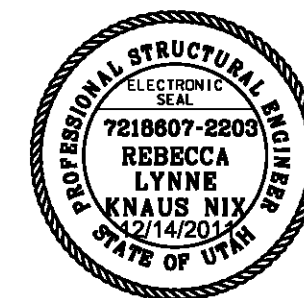

STRUCTURAL CONCRETE QUANTITIES	
LOCATION	CU. YDS.
WB ABUT. #1 WINGWALL	26.9
FOOTING	22.9
TOTAL	49.8

REVISION REMARKS		CHECK DD	11/11
DESIGN	RLN	10/11	
DRAWN	MPP	10/11	
QUANT.	MPP	10/11	

UTAH DEPARTMENT OF TRANSPORTATION
STRUCTURES DIVISION

I-80; WANSHIP TO COALVILLE	PIN	8098
WANSHIP INTERCHANGE: I-80 OVER SR-32	PROJECT NUMBER	F-180-4(133)156
W.B. ABUTMENT #1 WINGWALL DETAILS		

SUMMIT COUNTY
C-1011
DRG. NO.

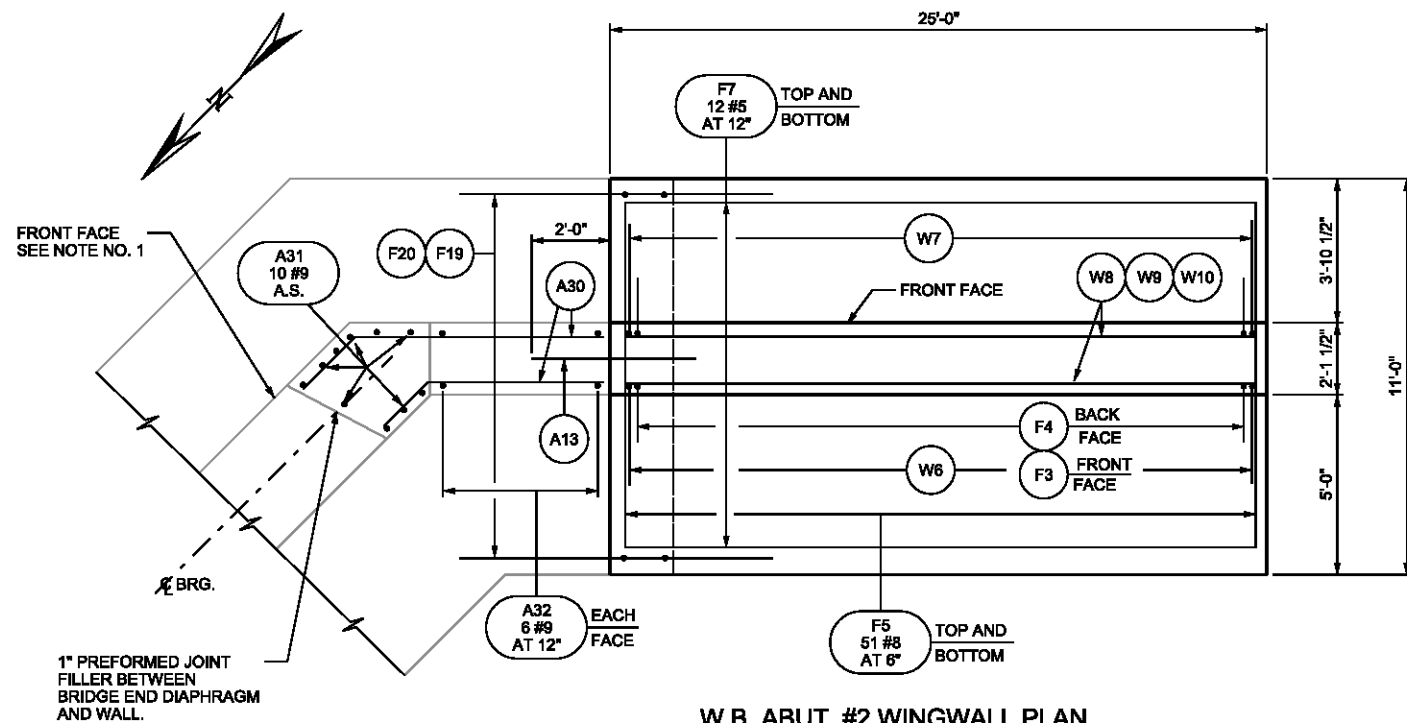

W.B. ABUT. #2 WINGWALL PLAN

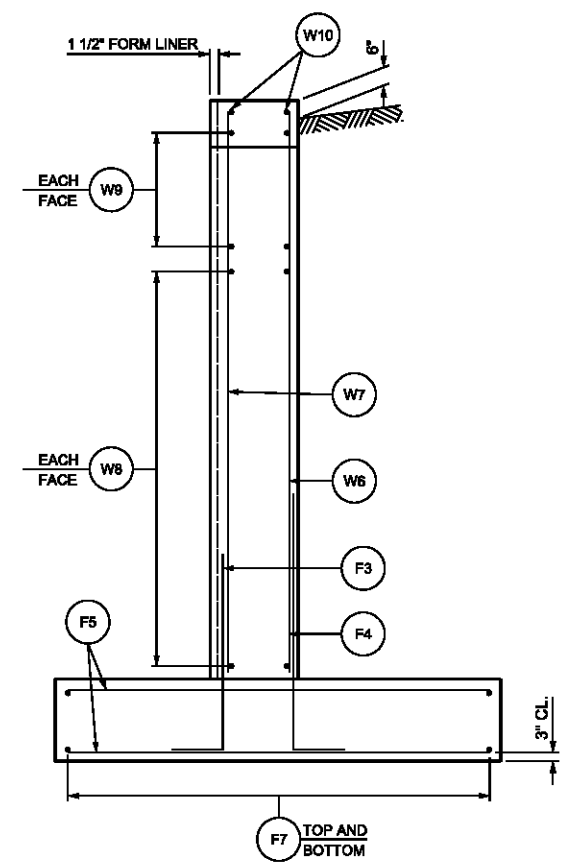

SECTION A-A

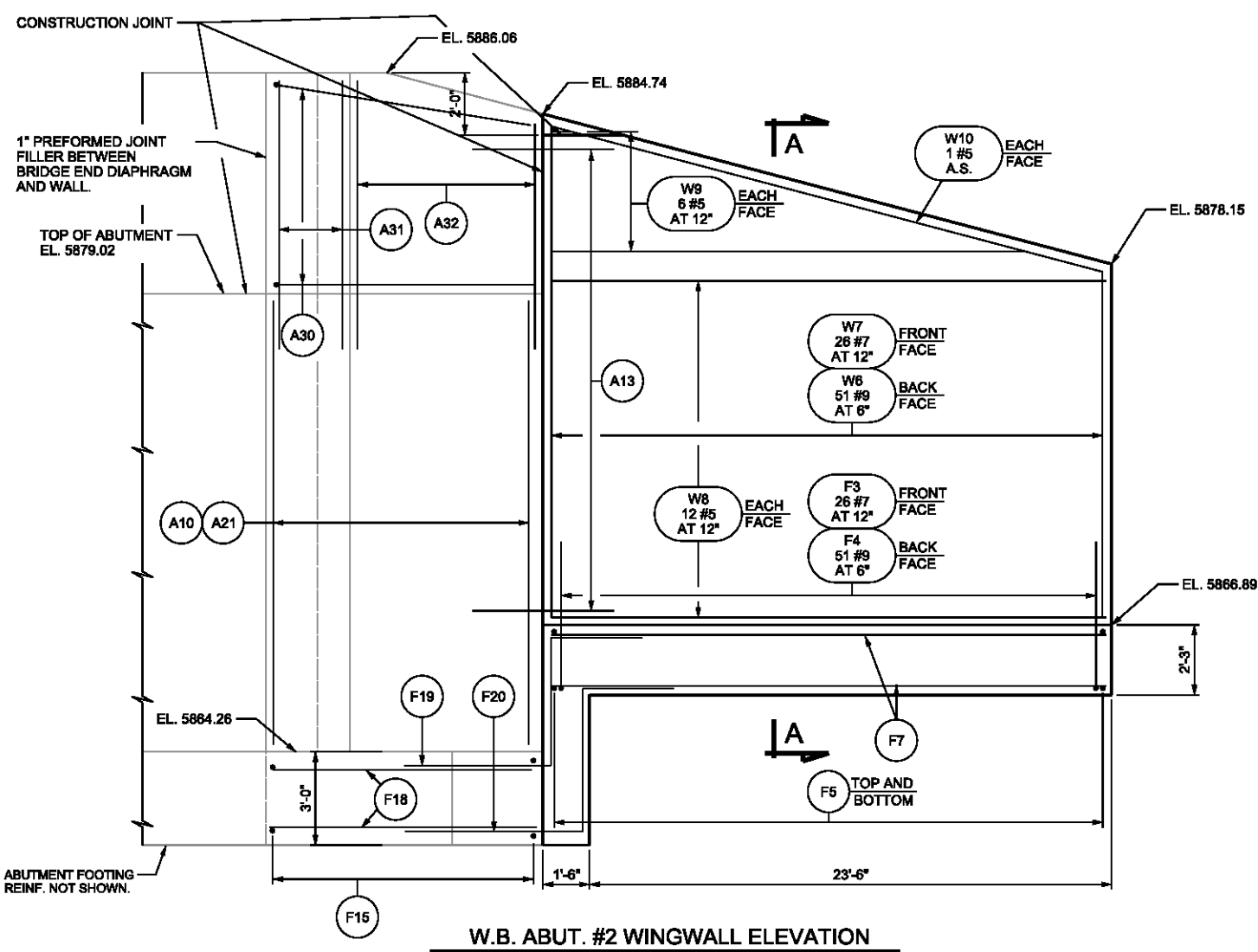

W.B. ABUT. #2 WINGWALL ELEVATION

- NOTES:
- SEE "ABUTMENT #2; 4 OF 4" SHEET AND "FOUNDATION PLAN" SHEET FOR WINGWALL LOCATION AND ABUTMENT DETAILS.
 - FIELD BEND W6 AND W7 BARS TO NOT OBSTRUCT THE BRIDGE MOVE. IF REQUIRED FIELD CUT BARS AND DRILL AND EPOXY DOWELS WITH ENGINEER'S APPROVAL.



STRUCTURAL CONCRETE QUANTITIES	
LOCATION	CU. YDS.
WB ABUT. #2 WINGWALL	28.7
FOOTING	25.0
TOTAL	53.7

UTAH DEPARTMENT OF TRANSPORTATION STRUCTURES DIVISION		I-80; WANSHIP TO COALVILLE	
WANSHIP INTERCHANGE: I-80 OVER SR-32		PROJECT NUMBER: F-180-4(133)156	
W.B. ABUTMENT #2 WINGWALL DETAILS		PIN: 8098	
SUMMIT COUNTY		C-1011	
DRG. NO.		SHT. 15 OF 38	

REVISION REMARK	DESIGN_RLN	CHECK_DD
	10/11	11/11
BY	SENIOR DESIGN ENGR.	CHECK_DD
DATE	12/14/2011	11/11
APPROVED FOR USE	DATE	QUANT.
BY UDOT	12/14/2011	MPP
		10/11
		11/11
		11/11

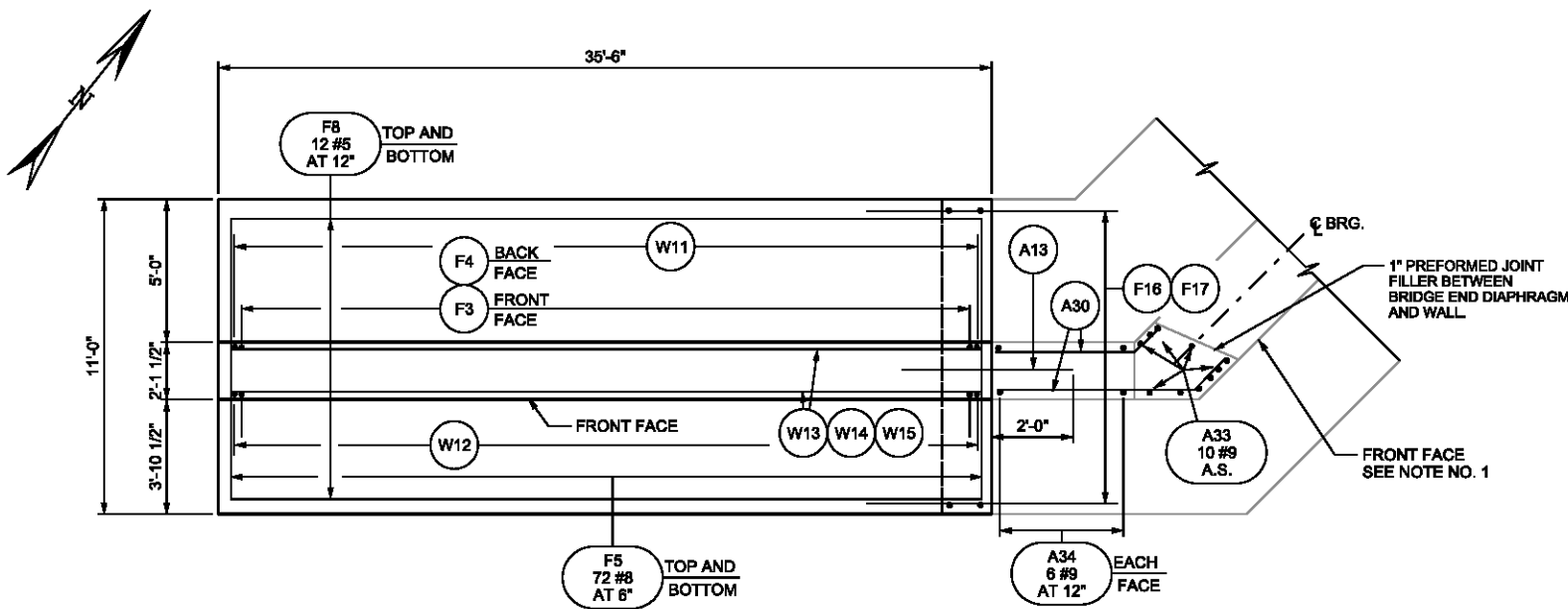

E.B. ABUT. #1 WINGWALL PLAN

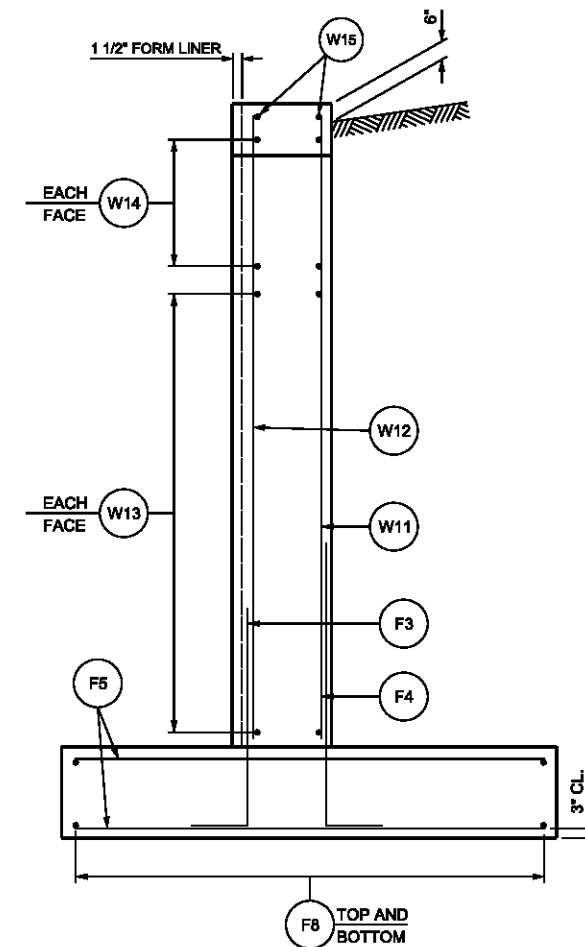

SECTION A-A

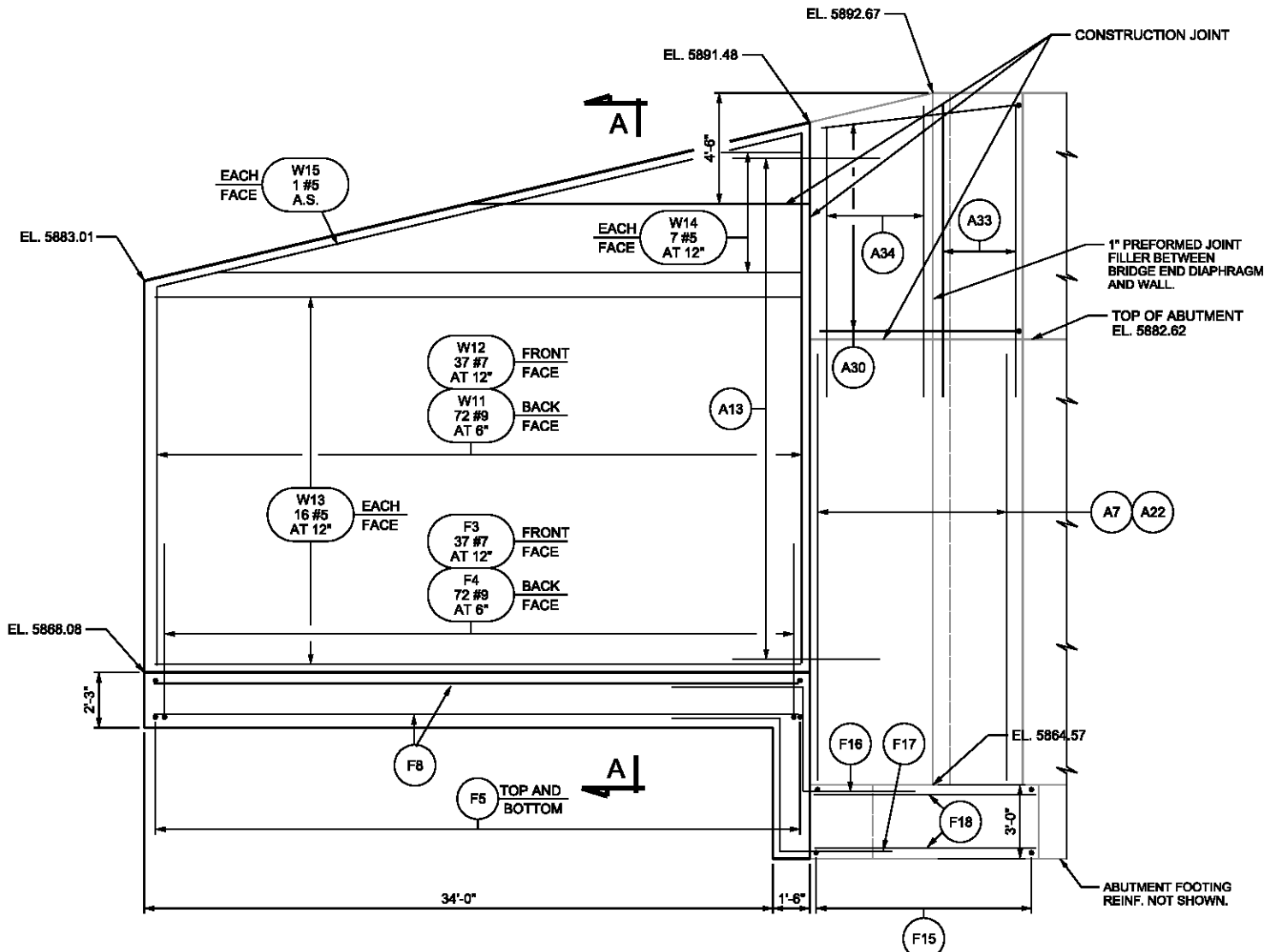

E.B. ABUT. #1 WINGWALL ELEVATION

NOTES:

1. SEE "ABUTMENT #1; 2 OF 4" SHEET AND "FOUNDATION PLAN" SHEET FOR WINGWALL LOCATION AND ABUTMENT DETAILS.
2. FIELD BEND W11 AND W12 BARS TO NOT OBSTRUCT THE BRIDGE MOVE. IF REQUIRED FIELD CUT BARS AND DRILL AND EPOXY DOWELS WITH ENGINEER'S APPROVAL.



STRUCTURAL CONCRETE QUANTITIES	
LOCATION	CU. YDS.
EB ABUT. #1 WINGWALL	53.6
FOOTING	35.2
TOTAL	88.8

UTAH DEPARTMENT OF TRANSPORTATION STRUCTURES DIVISION	
PROJECT NUMBER	F-180-4(133)156
PIN	8098
WANSHIP TO COALVILLE	I-80; WANSHIP TO COALVILLE
WANSHIP INTERCHANGE: I-80 OVER SR-32	
E.B. ABUTMENT #1 WINGWALL DETAILS	
SUMMIT COUNTY	
C-1011	
DRG. NO.	
SHT. 16	OF 38

REVISION REMARKS	NO.	DATE	BY
DESIGN	RLN	10/11	
CHECK	DD	11/11	
DRAWN	MPP	10/11	
CHECK	DD	11/11	
QUANT.	MPP	10/11	
CHECK	RLN	11/11	

APPROVAL FOR USE	DATE	BY
12/14/2011	12/14/2011	UDOT
SENIOR DESIGN ENGR.		
12/14/2011		
UDOT		

14-DEC-2011 1:16 PM F:\WORK\DOT\2011\16-EBABUT#1\WINGWALL.dwg

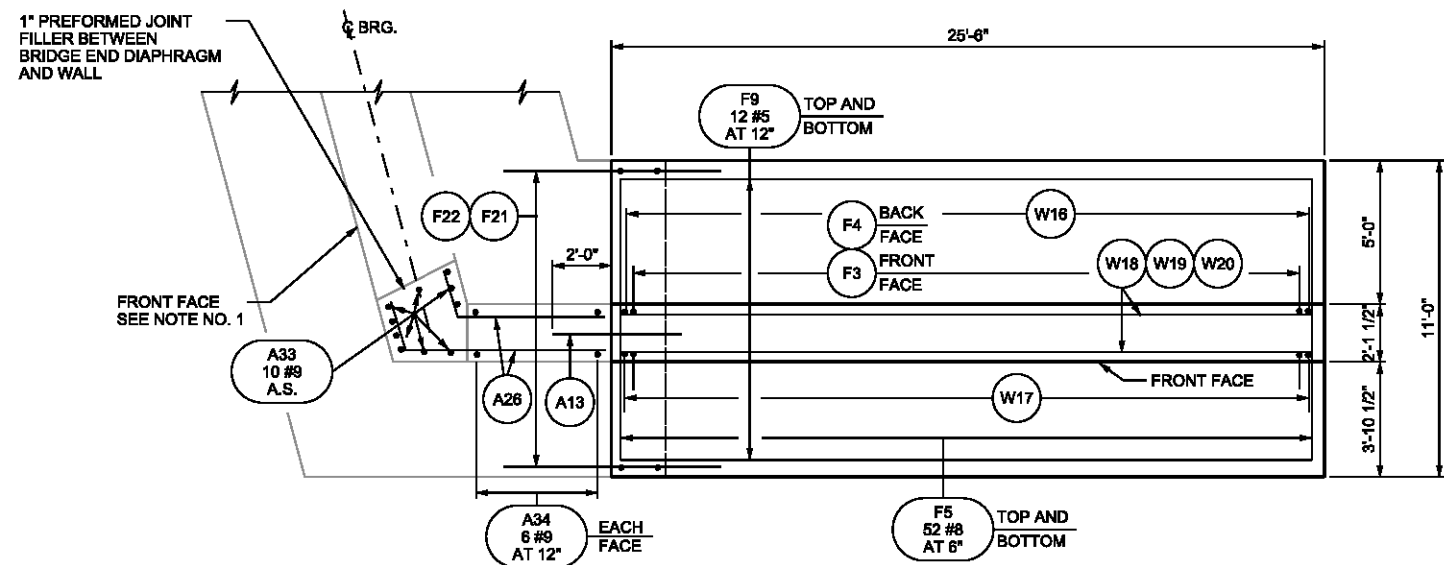

E.B. ABUT. #2 WINGWALL PLAN

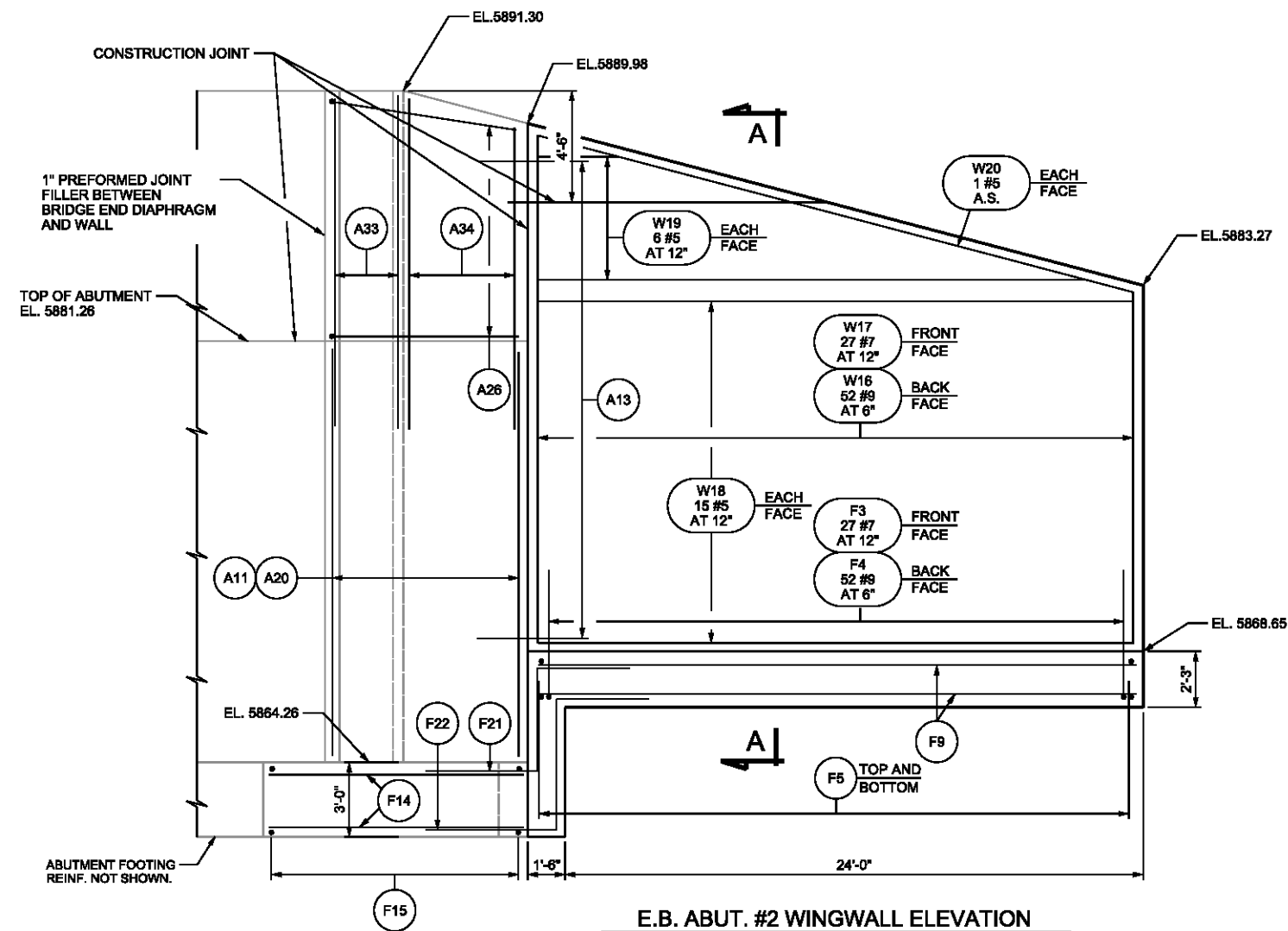

E.B. ABUT. #2 WINGWALL ELEVATION

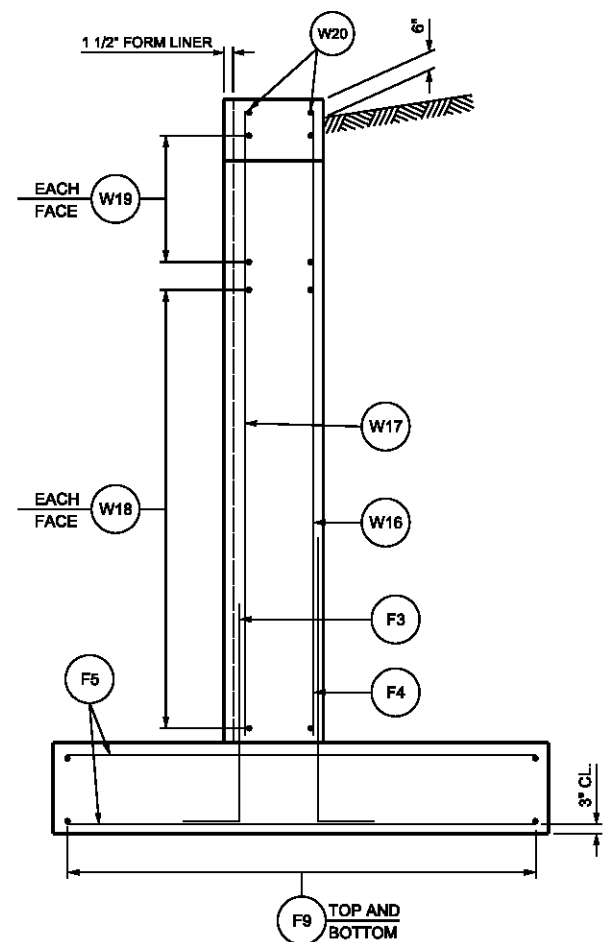

SECTION A-A



STRUCTURAL CONCRETE QUANTITIES	
LOCATION	CU. YDS.
EB ABUT. #2 WINGWALL	36.1
FOOTING	26.6
TOTAL	62.7

- NOTES:
- SEE 'ABUTMENT #2; 3 OF 4' SHEET AND 'FOUNDATION PLAN' SHEET FOR WINGWALL LOCATION AND ABUTMENT DETAILS.
 - FIELD BEND W16 AND W17 BARS TO NOT OBSTRUCT THE BRIDGE MOVE. IF REQUIRED FIELD CUT BARS AND DRILL AND EPOXY DOWELS WITH ENGINEER'S APPROVAL.

UTAH DEPARTMENT OF TRANSPORTATION STRUCTURES DIVISION		I-80; WANSHIP TO COALVILLE	
WANSHP INTERCHANGE: I-80 OVER SR-32		E.B. ABUTMENT #2 WINGWALL DETAILS	
PROJECT NUMBER: F-180-4(133)156		PIN: 8098	
SUMMIT COUNTY		C-1011 DRG. NO.	
SHT. 17		OF 38	

REVISION	REMARKS	DESIGN	CHECK	DATE
1		RLN	DD	11/11
2		MPP	DD	11/11
3		MPP	DD	11/11

14-DEC-2011 D:\F1\m_jp_f\p\01502035\8098\C-1011-17_EBAbut#2WingWall.dgn

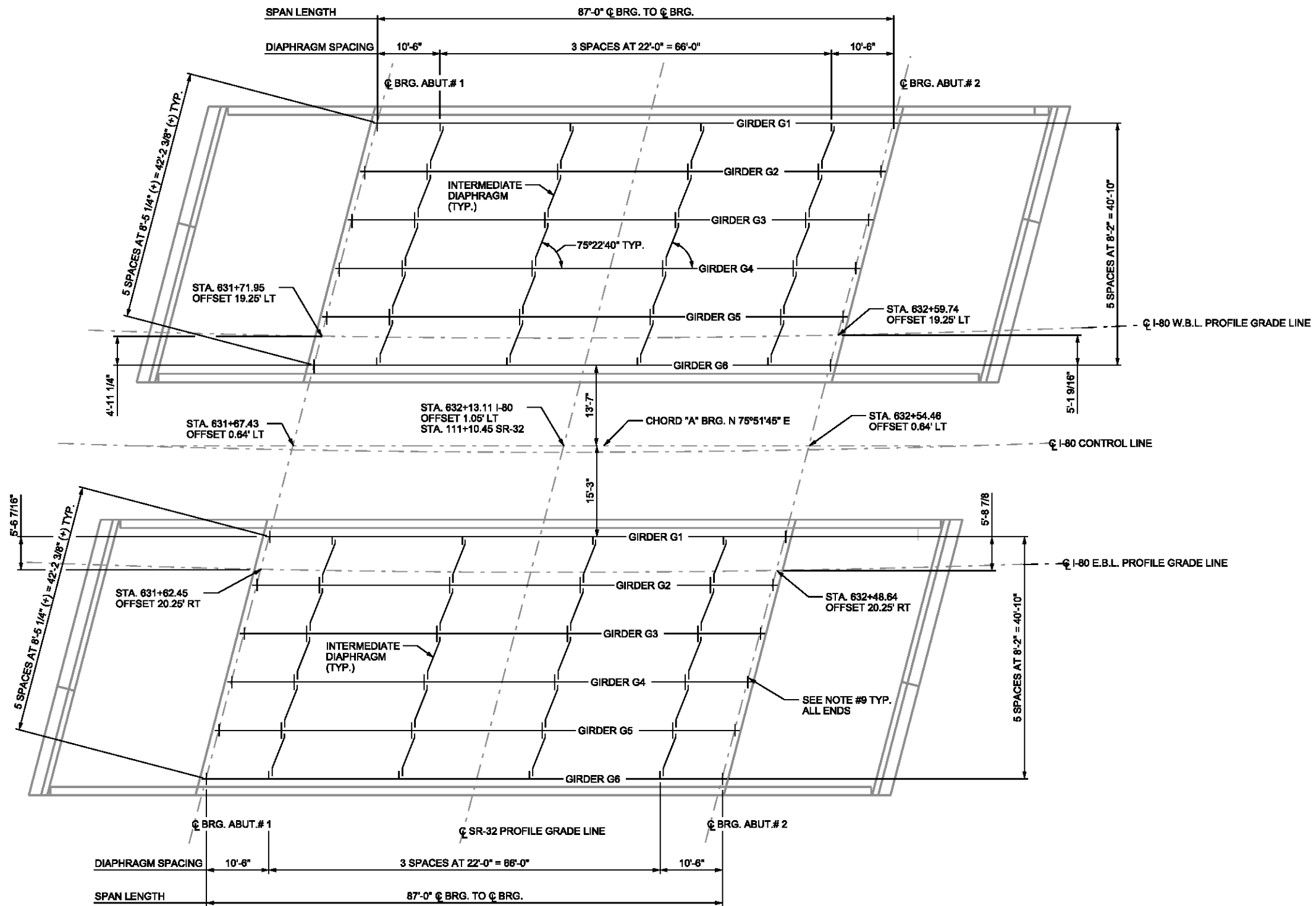

FRAMING PLAN

NOTES

1. CENTERLINE OF BEARING LINES AND INTERMEDIATE DIAPHRAGMS ARE PARALLEL TO BRG. N 00°29'04" E.
2. ALL GIRDERS ARE PARALLEL TO CHORD "A" BRG. N 75°51'45" E.
3. SEE "GIRDER DETAILS" SHEET FOR GIRDER AND DIAPHRAGM DETAILS.
4. ALL BOLTED CONNECTIONS ARE SLIP CRITICAL.
5. BLAST CLEAN (CLASS A) ALL BOLTED CONTACT SURFACES.
6. USE AASHTO M270 GR-36 FOR ALL DIAPHRAGMS.
7. USE 1" DIA. HIGH STRENGTH BOLTS CONFORMING TO ASTM A325 FOR ALL FIELD CONNECTIONS.
8. ALL DIMENSIONS ARE HORIZONTAL.
9. PROVIDE TEMPORARY BRACING TO ENSURE GIRDER ENDS STAY VERTICAL DURING DECK PLACEMENT.

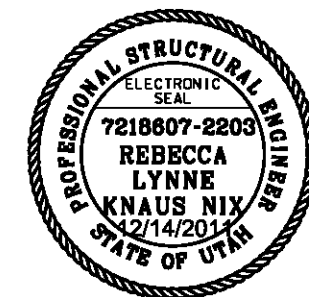

UTAH DEPARTMENT OF TRANSPORTATION		STRUCTURES DIVISION																	
I-80; WANSHIP TO COALVILLE		WANSHIP INTERCHANGE: I-80 OVER SR-32																	
FRAMING PLAN		PROJECT NUMBER: F-180-4(133)156																	
SUMMIT COUNTY		PIN: 8098																	
C-1011		DRG. NO.																	
SHT. 18		OF 38																	
<table border="1"> <tr> <th colspan="4">REVISIONS</th> </tr> <tr> <td>NO.</td> <td>DATE</td> <td>BY</td> <td>REVISION</td> </tr> <tr> <td>APPROVAL</td> <td>12/14/2011</td> <td>DATE</td> <td>SENIOR DESIGN ENGR.</td> </tr> <tr> <td>FOR USE</td> <td>12/14/2011</td> <td>DATE</td> <td>DOT BRIDGE ENGR.</td> </tr> </table>				REVISIONS				NO.	DATE	BY	REVISION	APPROVAL	12/14/2011	DATE	SENIOR DESIGN ENGR.	FOR USE	12/14/2011	DATE	DOT BRIDGE ENGR.
REVISIONS																			
NO.	DATE	BY	REVISION																
APPROVAL	12/14/2011	DATE	SENIOR DESIGN ENGR.																
FOR USE	12/14/2011	DATE	DOT BRIDGE ENGR.																
DESIGN: RLN 6/11		CHECK: TAH 11/11																	
DRAWN: MPP 7/11		CHECK: TAH 11/11																	
QUANT: MPP 9/11		CHECK: TAH 11/11																	

14-DEC-2011 5:10:31 PM F:\P\180\133\156\Framing.dgn

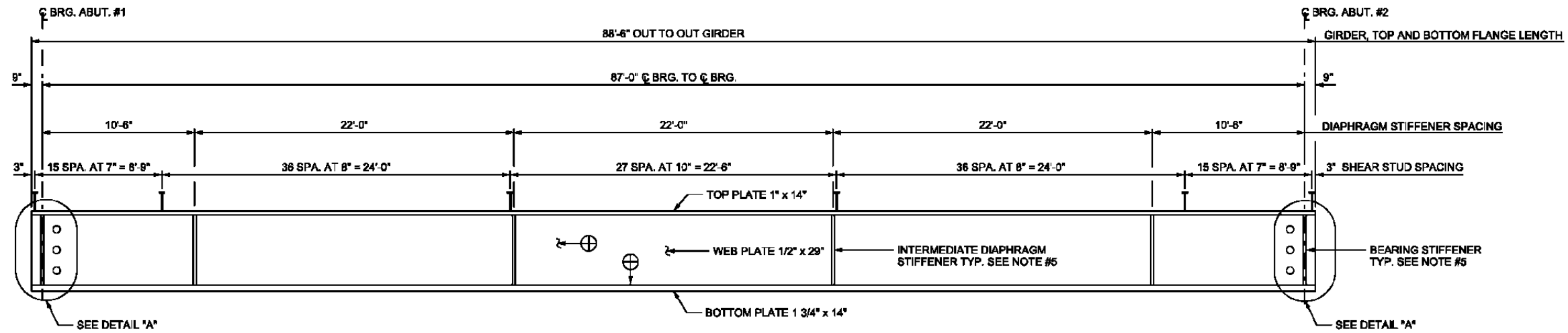

GIRDER ELEVATION

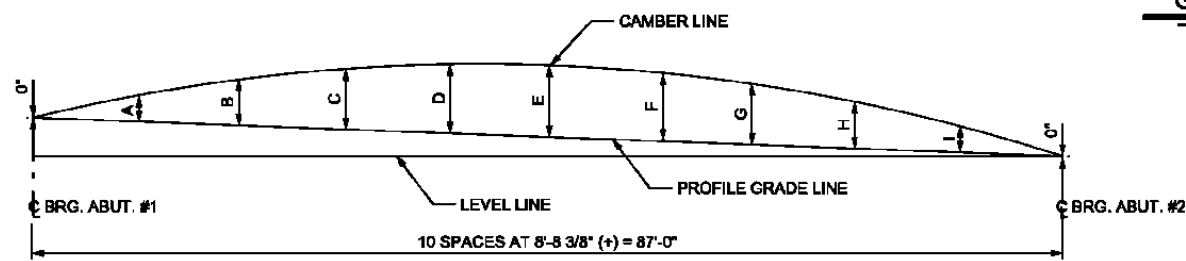

CAMBER DIAGRAM

NOTES

1. USE STRUCTURAL STEEL CONFORMING TO AASHTO M270 GR 50 FOR ALL GIRDER PLATES, CONNECTION PLATES, STIFFENERS AND DIAPHRAGM MEMBERS UNLESS NOTED OTHERWISE.
2. CAMBER ORDINATE IS FOR DEAD LOAD DEFLECTION ONLY. THE FABRICATOR IS RESPONSIBLE FOR CORRECTION TO CAMBER BASED ON GRADE.
3. ALL DIMENSIONS ARE HORIZONTAL. FABRICATOR MUST CORRECT FOR VERTICAL GRADE.
4. PERFORM CHARPY V-NOTCH TOUGHNESS TEST ON ALL MAIN LOAD CARRYING MEMBERS SUBJECT TO TENSION STRESS INDICATED BY ⊕ TEST RESULTS MUST MEET ZONE 2 REQUIREMENTS.
5. ALL BEARING STIFFENERS ARE PLACED 90° TO WEB AND ARE ON BOTH SIDES OF WEB. INTERMEDIATE DIAPHRAGM STIFFENERS ARE PLACED 90° TO WEB AND ARE ON INSIDE FACE OF WEB ON EXTERIOR GIRDERS AND ON BOTH SIDES OF WEB ON INTERIOR GIRDERS AT LOCATION OF INTERMEDIATE DIAPHRAGMS. SEE "FRAMING PLAN" SHEET.
6. BEARING STIFFENERS MUST BE VERTICAL AFTER DEAD LOAD IS APPLIED. INTERMEDIATE STIFFENERS CAN BE NORMAL TO GRADE.
7. BEARING STIFFENERS ARE PLATE 5/8" x 6". INTERMEDIATE DIAPHRAGM STIFFENERS ARE 1/2" x 6".
8. SEE "STEEL DETAILS" SHEET FOR WELDING DETAILS, WELDING SPECIFICATIONS GRAFFITI COVER PLATE, BEARING DETAILS AND ADDITIONAL NOTES.
9. SHEAR STUDS, BOLTS AND STIFFENERS ARE INCLUDED IN THE CONTRACT PRICE FOR STRUCTURAL STEEL.

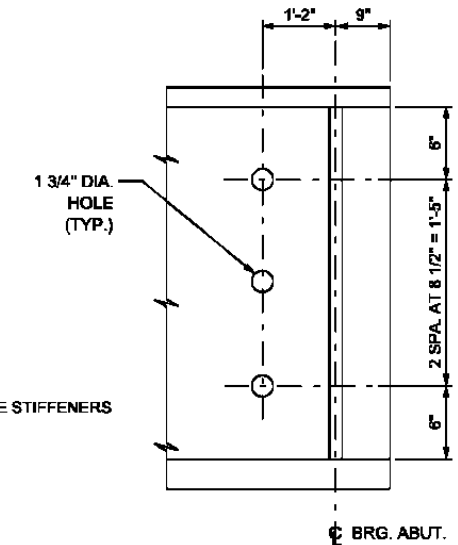

DETAIL "A"
(TYP. EACH END)

GIRDER	A	B	C	D	E	F	G	H	I
GIRDER 1 & 6 SELF WEIGHT	1/4"	1/2"	11/16"	13/16"	7/8"	13/16"	11/16"	1/2"	1/4"
GIRDER 1 & 6 NON-COMPOSITE DEAD LOAD	7/8"	1 11/16"	2 3/8"	2 3/4"	2 7/8"	2 3/4"	2 3/8"	1 11/16"	7/8"
GIRDER 1 & 6 TOTAL	1 3/16"	2 3/16"	3 1/16"	3 8/16"	3 3/4"	3 3/16"	3 1/16"	2 3/16"	1 3/16"
GIRDER 2 - 5 SELF WEIGHT	1/4"	1/2"	11/16"	13/16"	7/8"	13/16"	11/16"	1/2"	1/4"
GIRDER 2 - 5 NON-COMPOSITE DEAD LOAD	1 1/16"	2"	2 3/4"	3 1/4"	3 7/16"	3 1/4"	2 3/4"	2"	1 1/16"
GIRDER 2 - 5 TOTAL	1 5/16"	2 9/16"	3 1/2"	4 1/16"	4 1/4"	4 1/16"	3 1/2"	2 9/16"	1 5/16"

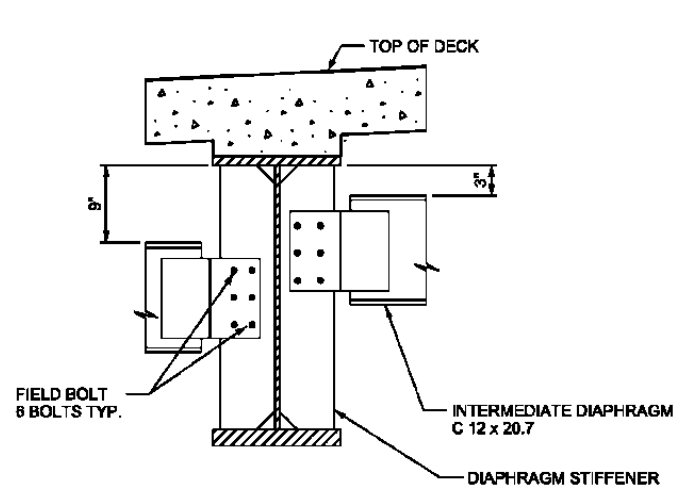

INTERMEDIATE DIAPHRAGM DETAIL

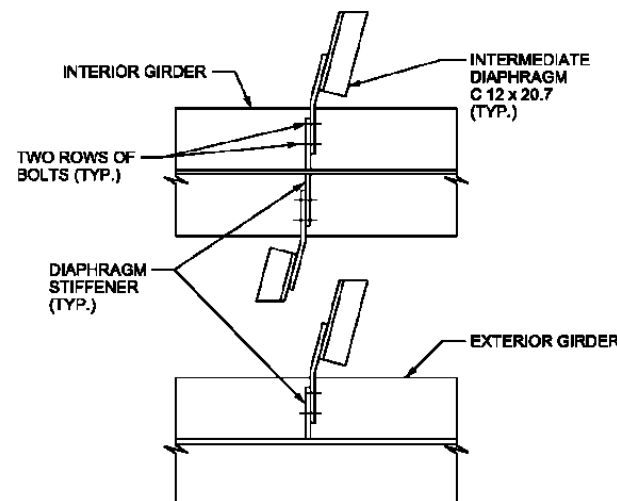

INTERMEDIATE DIAPHRAGM PLAN

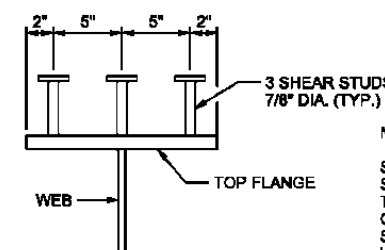

SHEAR STUD DETAIL

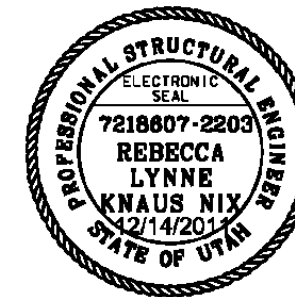

NOTE:

STUD TYPE SHEAR CONNECTORS ARE HEADED ANCHOR STUDS CONFORMING TO THE DIMENSIONS SHOWN ON THE PLANS. THEY WILL BE MANUFACTURED FROM STEEL CONFORMING TO THE REQUIREMENTS OF AASHTO M-189. STUDS ARE AUTOMATICALLY END WELDED IN THE FIELD WITH EQUIPMENT DESIGNED FOR STUD WELDING OPERATIONS. EQUIPMENT CAPACITY WILL BE ADEQUATE FOR THE SIZE OF STUD BEING WELDED.

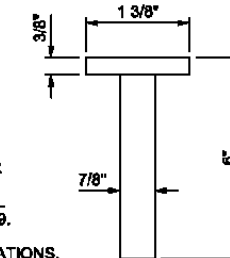

SHEAR STUD DIMENSIONS

NO.	DATE	BY	REVISION
DESIGN	RLN	6/11	CHECK T.A.H. 11/11
DRAWN	MPP	7/11	CHECK T.A.H. 11/11
QUANT.	MPP	9/11	CHECK T.A.H. 11/11

UTAH DEPARTMENT OF TRANSPORTATION
STRUCTURES DIVISION

I-80; WANSHIP TO COALVILLE
WANSHIP INTERCHANGE: I-80 OVER SR-32
GIRDER DETAILS
PIN 8098
PROJECT NUMBER F-180-4(133)156

SUMMIT COUNTY
C-1011
DRG. NO.
SHT. 19 OF 38

NOTES

1. WELDING, WELDER QUALIFICATIONS, PREQUALIFICATION OF WELD DETAILS AND INSPECTION OF WELDS MUST CONFORM TO THE REQUIREMENTS OF THE ANS/AASHTO/AWS BRIDGE WELDING CODE D1.5.
2. THE METHODS OF JOINT PREPARATION FOR WELDING SHOWN ON THE PLANS ARE BASED ON THE USE OF MANUAL SHIELDED METAL-ARC WELDING. THE USE OF THIS OR ANY OTHER WELDING PROCESS WILL BE SATISFACTORY ONLY AFTER THE WELDING PROCEDURE HAS BEEN SUBMITTED BY THE CONTRACTOR AND APPROVED BY THE ENGINEER.
3. ALL STRENGTH FILLET WELDS ARE MINIMUM SIZED WELDS REQUIRED BY ANS/AASHTO/AWS BRIDGE WELDING CODE D1.5 FOR THE THICKNESS OF THE MATERIAL JOINED UNLESS OTHERWISE SPECIFIED.
4. THE MINIMUM WELD SIZE FOR ANY CONNECTION IS 1/4".
5. DIMENSIONS SHOWN ON THE PLANS ASSUME THE AMBIENT TEMPERATURE OF THE GIRDER TO BE 70°F. LENGTH USED IN FABRICATION MUST BE CORRECTED AT THE RATE OF ± 0.078" PER EACH 100'-0" OF LENGTH FOR EVERY 10°F DIFFERENCE IN TEMPERATURE TO ALLOW FOR EXPANSION AND CONTRACTION.
6. FIELD WELDING TO GIRDERS IS NOT PERMITTED, UNLESS OTHERWISE NOTED.
7. SEE "FRAMING PLAN" FOR INTERMEDIATE DIAPHRAGM STIFFENER LOCATIONS.
8. SEE "GIRDER DETAILS" FOR END DIAPHRAGM STIFFENER SIZES AND ADDITIONAL NOTES.
9. USE 1" DIA. HIGH STRENGTH BOLTS CONFORMING TO ASTM A325 FOR ALL FIELD CONNECTIONS, UNLESS NOTED OTHERWISE.
10. USE 1 1/16" DIA. HOLES IN CONNECTING PLATES AND 1 1/8" DIA. HOLES IN CONNECTING MEMBERS, TYPICAL UNLESS NOTED.
11. GALVANIZE NUTS AND WASHERS IN ACCORDANCE WITH AASHTO M232 (ASTM A 153). ALL GALVANIZED STEEL THREADS WILL BE FREE FROM DEFECTS ALLOWING NUTS TO BE FREE RUNNING BY HAND FOR THE ENTIRE LENGTH ON THE THREADS.
12. USE 80 DUROMETER HARDNESS ELASTOMERIC BEARING PADS.
13. THE MAXIMUM ALLOWED SOLE PLATE TEMPERATURE AT THE ELASTOMERIC PAD DURING WELDING IS 250° F.
14. INCLUDE PAYMENT FOR BEARING DEVICES AND GRAFFITI COVERS IN THE CONTRACT PRICE FOR STRUCTURAL STEEL.

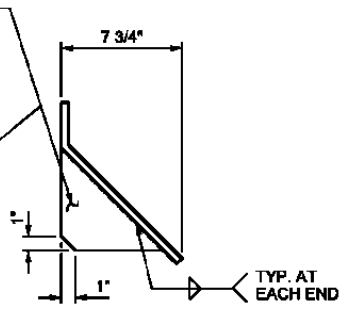
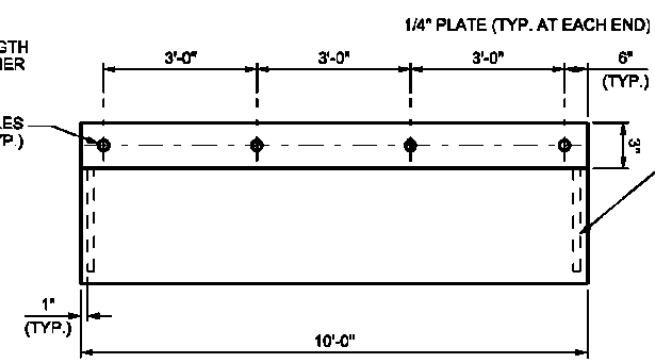
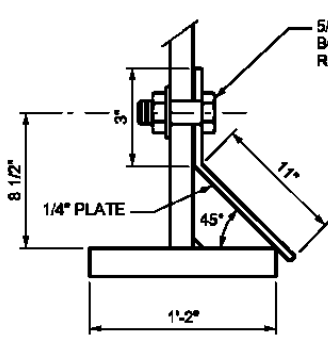
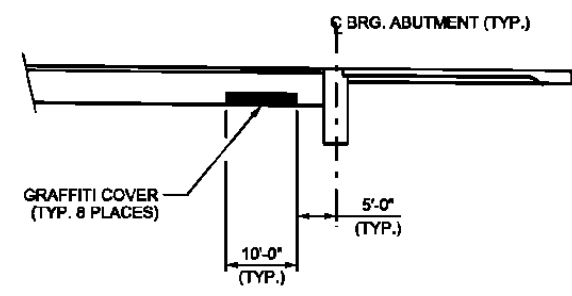
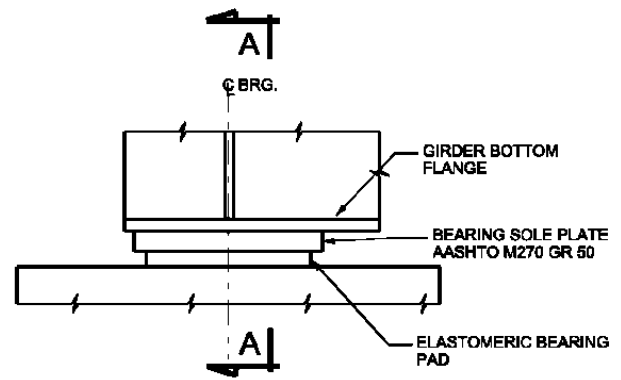
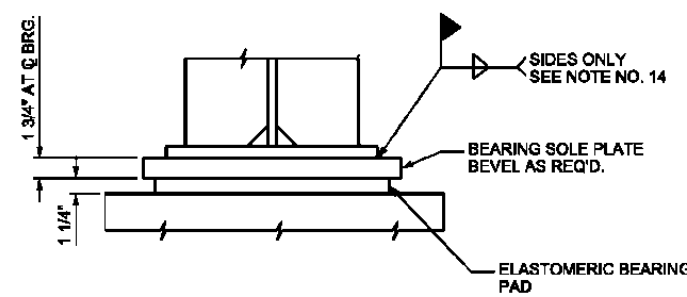
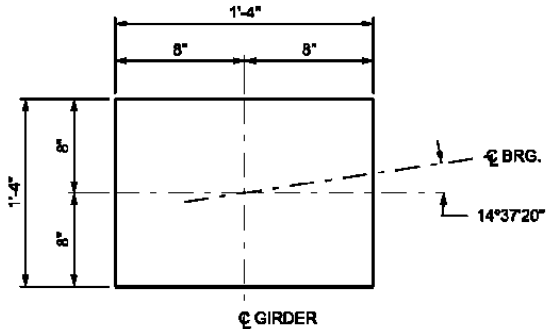
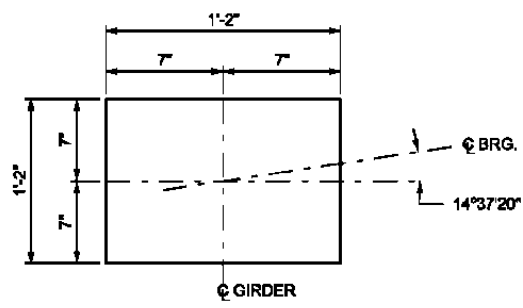
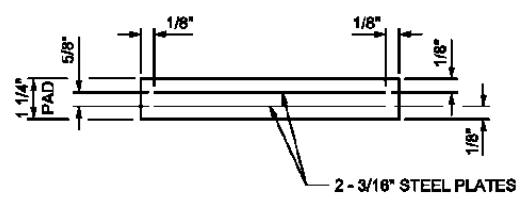
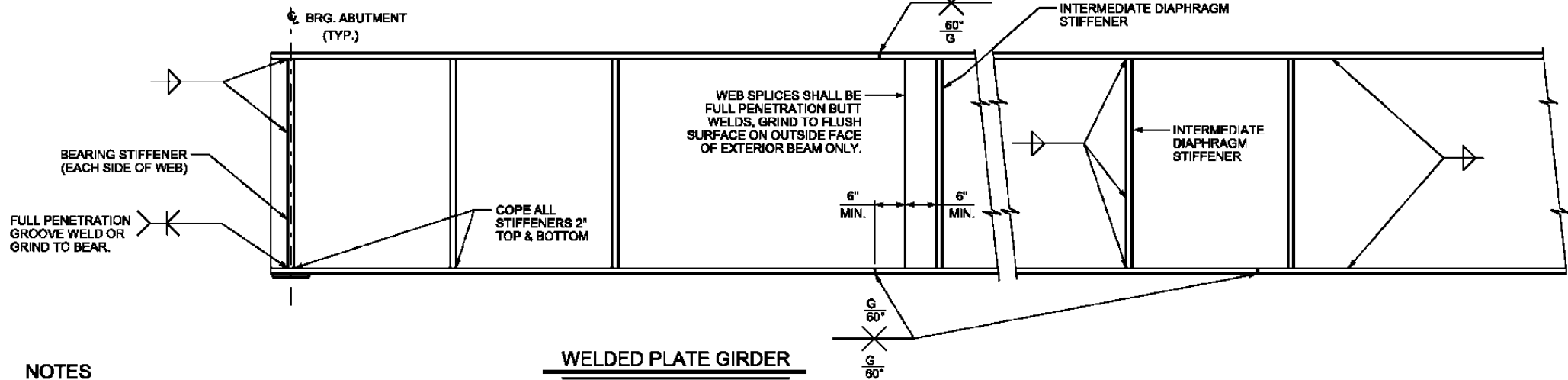

GRAFFITI PROTECTION COVER DETAILS

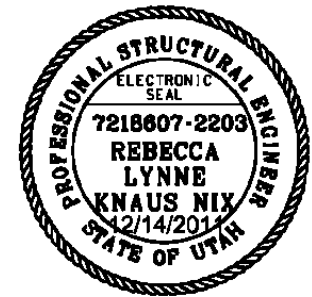

NO.	DATE	BY	REVISION
DESIGN	RLN	6/11	CHECK TAH 11/11
DRAWN	MPP	7/11	CHECK TAH 11/11
QUANT.	MPP	9/11	CHECK TAH 11/11

UTAH DEPARTMENT OF TRANSPORTATION
STRUCTURES DIVISION

I-80; WANSHIP TO COALVILLE
WANSHIP INTERCHANGE: I-80 OVER SR-32
STEEL DETAILS
PIN 8098
PROJECT NUMBER F-180-4(133)156

SUMMIT COUNTY
C-1011
DRG NO.
SHT. 20 OF 38

14-LE-C-2011

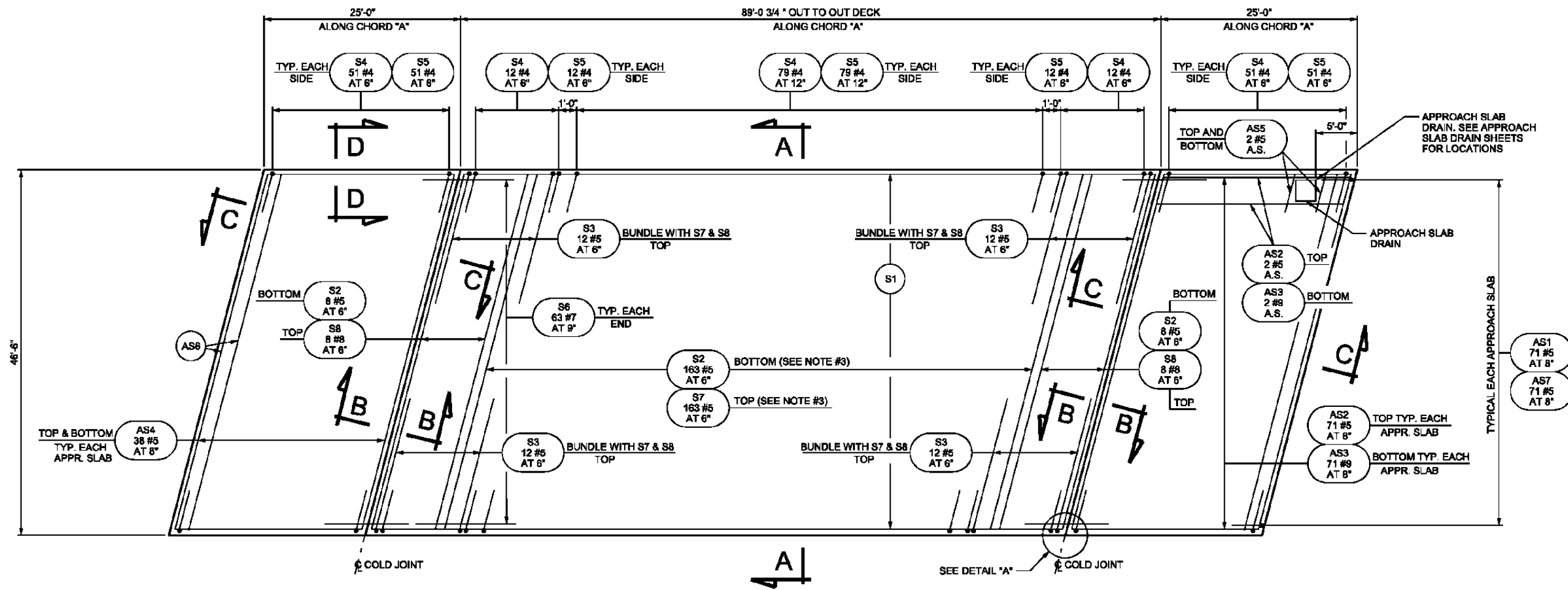

DECK AND APPROACH SLAB PLAN

W.B.L. AS SHOWN, E.B.L. SIMILAR UNLESS NOTED

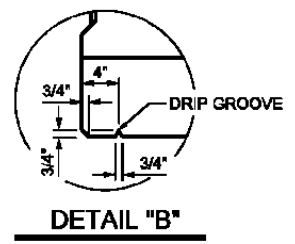

- NOTES:
1. ALL REINFORCING STEEL IN APPROACH SLABS ARE TYPICAL EACH APPROACH SLAB.
 2. SEE "END DIAPHRAGM DETAILS 1 OF 3" AND "END DIAPHRAGM DETAILS 2 OF 3" SHEETS FOR SECTIONS B-B, C-C, AND D-D.
 3. STAGGER TOP S7 WITH BOTTOM S2 TRANSVERSE DECK BARS. PLACE ONE S7 BAR ON TOP AT EACH END.
 4. STAY-IN-PLACE FORMS ARE NOT PERMITTED.

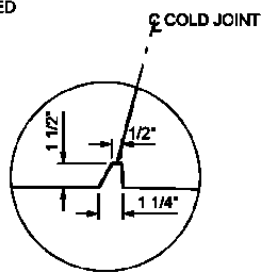
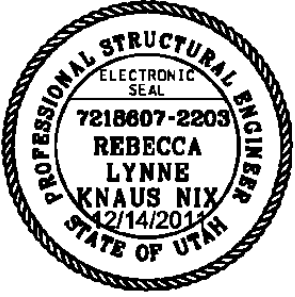

DETAIL "A"
TYPICAL AT ALL 4 CORNERS OF DECK

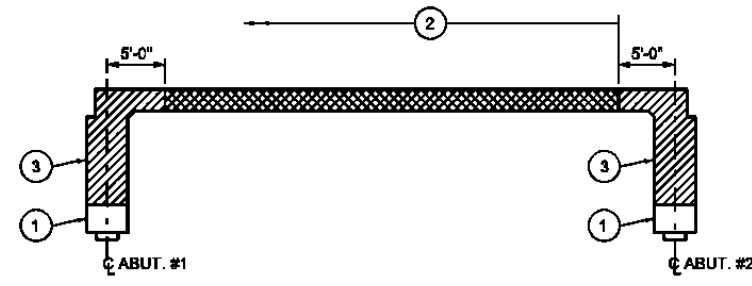

LONGITUDINAL DECK PLACING SEQUENCE

1. ① DESIGNATES PLACING SEQUENCE
2. → ARROWS DESIGNATES DIRECTION OF PLACEMENT.

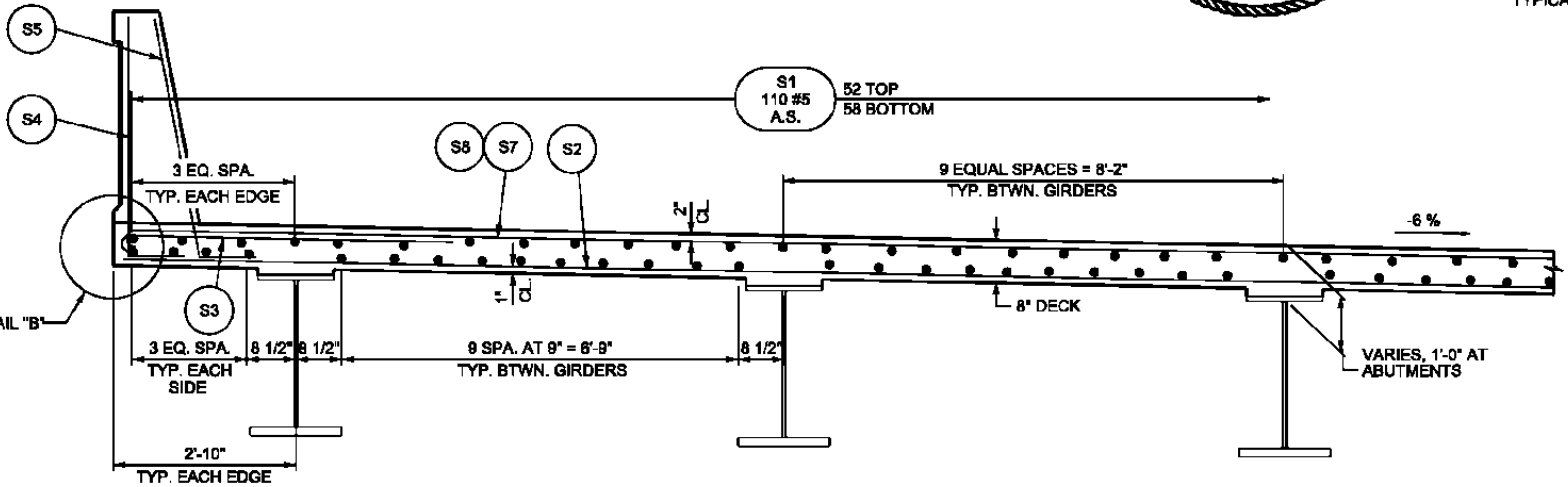

PARTIAL SECTION A-A

(W.B.L. AS SHOWN, E.B.L. SIMILAR UNLESS NOTED)

STRUCTURAL CONCRETE QUANTITIES CU. YDS.		
LOCATION	W.B.L.	E.B.L.
ABUTMENT DIAPHRAGMS	70.1	70.1
TOTAL	140.2	

STRUCTURAL LIGHTWEIGHT CONCRETE QUANTITIES CU. YDS.		
LOCATION	W.B.L.	E.B.L.
DECK	107.8	107.8
APPROACH SLABS	99.3	99.3
TOTAL	414.2	

REVISION NUMBER	DESIGN	APPROVAL	DATE	BY
6/11	RLN	RECORDED	12/14/2011	
7/11	MPP	APPROVED FOR USE	12/14/2011	
9/11	MPP	BY UDOT		
CHECK	TAH	11/11		
CHECK	TAH	11/11		
CHECK	TAH	11/11		

UTAH DEPARTMENT OF TRANSPORTATION STRUCTURES DIVISION

I-80; WANSHIP TO COALVILLE
WANSHIP INTERCHANGE: I-80 OVER SR-32
DECK DETAILS
PROJECT NUMBER: F-180-4(133)156
PIN: 8098

SUMMIT COUNTY
C-1011
DRG NO.

SHT. 21 OF 38

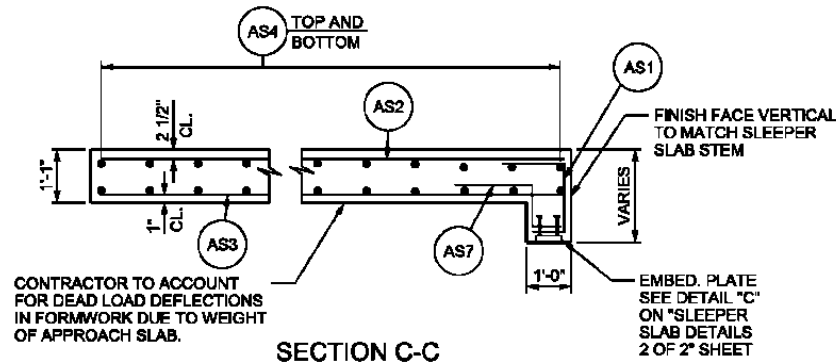

CONTRACTOR TO ACCOUNT FOR DEAD LOAD DEFLECTIONS IN FORMWORK DUE TO WEIGHT OF APPROACH SLAB.

SECTION C-C

NOTE:

SEE SECTION A-A, AND C-C ON "SLEEPER SLAB DETAILS 2 OF 2" FOR REBAR AND EMBED. PLATE DETAILS NOT SHOWN IN HAUNCH.

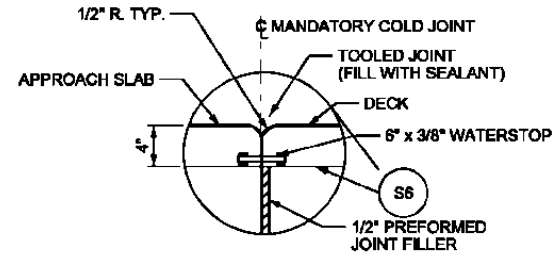

DETAIL "B"

NOTES:

1. SEE "END DIAPHRAGM DETAILS 2 OF 3" SHEET FOR GIRDER SEAT TABLE.
2. SEE "END DIAPHRAGM DETAILS 3 OF 3" FOR REINFORCING IN PUSH BLOCK AND SHOES.
3. SEE "DECK DETAILS" SHEET FOR TYPICAL DECK REINFORCING.
4. BEND OR FIELD CUT FRONT LEG OF D5 - D10 BARS WHERE CONFLICTING WITH GIRDER. FIELD ADJUST LOCATION OF D11 BAR WHERE CONFLICTING WITH GIRDER.
5. SECTION B-B, C-C AND D-D ARE TAKEN FROM "DECK DETAILS" SHEET.
6. SEE "END DIAPHRAGM DETAILS 3 OF 3" SHEET FOR BEARING PAD LOCATIONS AND ADDITIONAL DETAILS.
7. PROVIDE CONTINUOUS BLOCKING BELOW END DIAPHRAGM WHILE PLACING GIRDERS, DECK, AND END DIAPHRAGM.

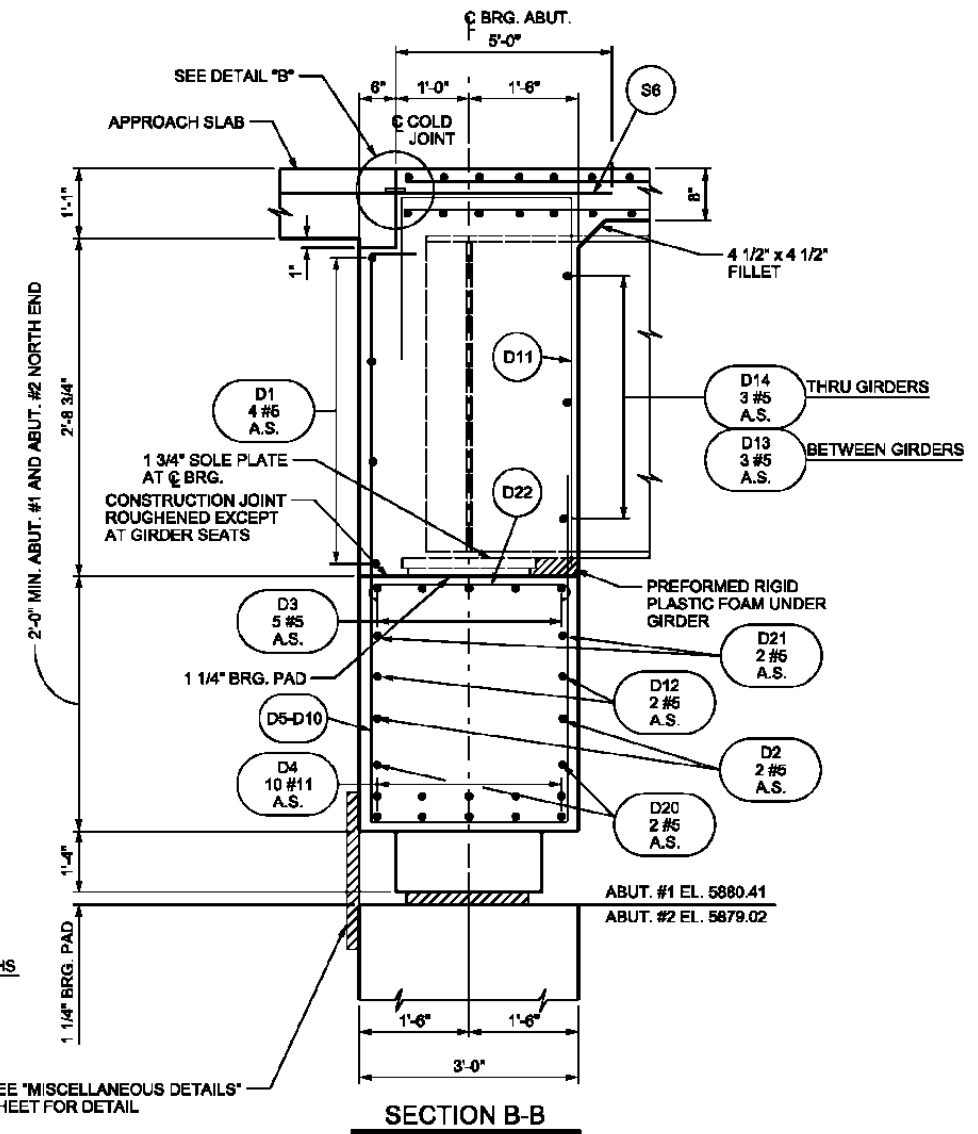

SECTION B-B

WBL ABUT. #1 SHOWN, WBL ABUT. #2 OPPOSITE HAND, SIMILAR AS NOTED

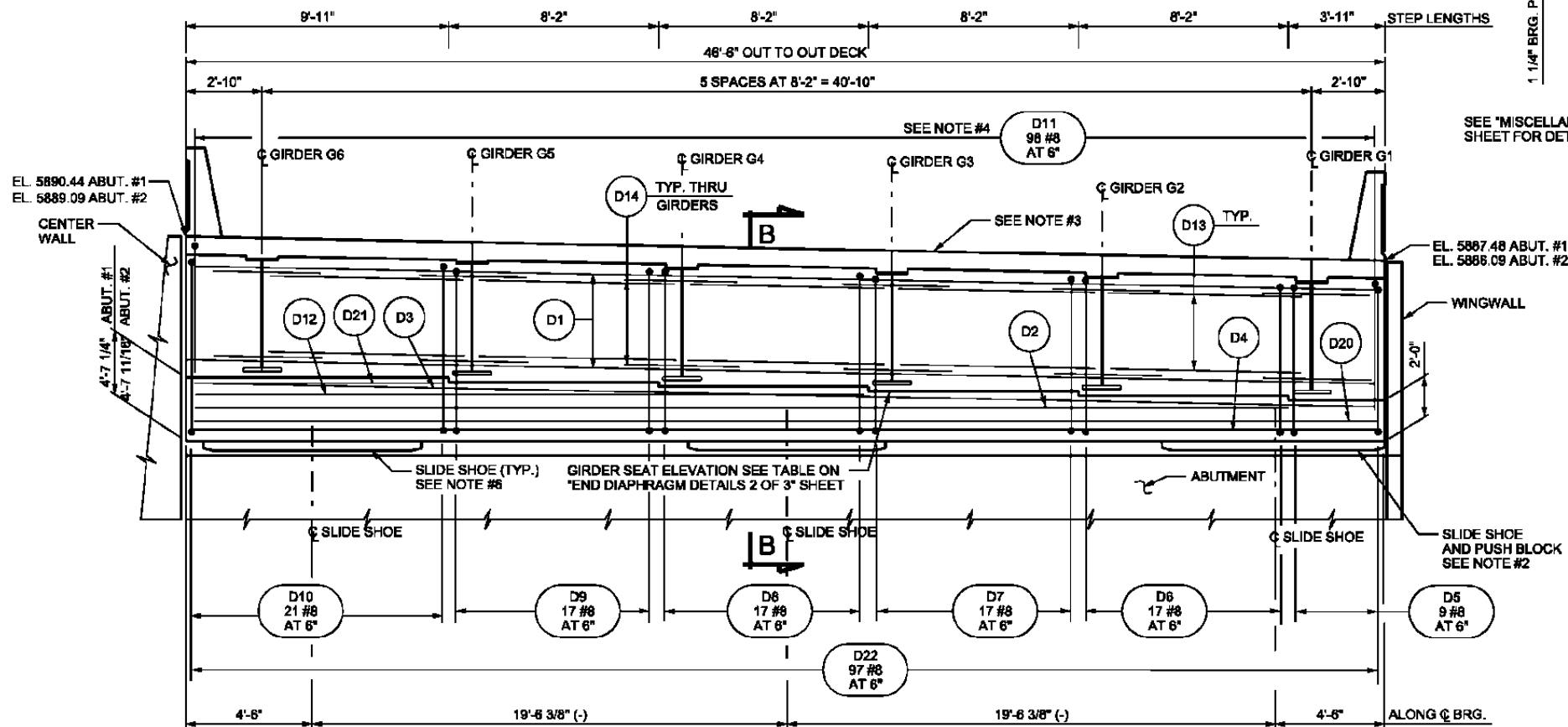

WB ABUT #1 ELEVATION (AS SHOWN)

WB ABUT #2 ELEVATION (SIMILAR AS NOTED)

LOOKING STATION BACK (NORMAL TO STRUCTURE)

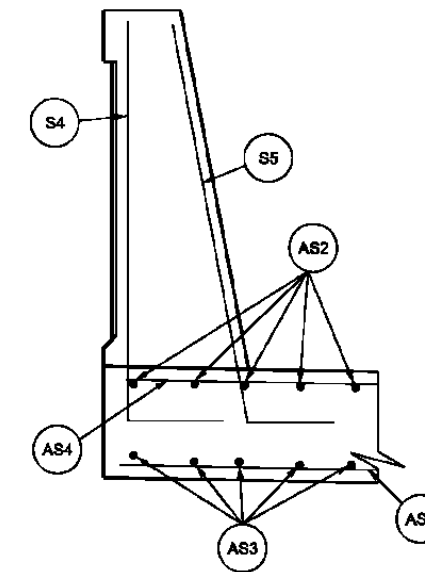

SECTION D-D

REVISION NUMBER	DESIGN	CHECK	DATE
6/11	TAH	11/11	
7/11	TAH	11/11	
9/11	TAH	11/11	
DATE	BY	DATE	BY
12/14/2011	GRAND DESIGN ENGR.	12/14/2011	LOOT BRIDGE ENGR.
APPROVAL	FOR USE	DATE	BY/DOOR
		12/14/2011	
UTAH DEPARTMENT OF TRANSPORTATION			
STRUCTURES DIVISION			
I-80; WANSHIP TO COALVILLE		PIN 8098	
WANSHIP INTERCHANGE: I-80 OVER SR-32		PROJECT NUMBER F-180-4(133)156	
END DIAPHRAGM DETAILS 1 OF 3			
SUMMIT COUNTY			
C-1011			
DRG NO.			
SHT. 22 OF 38			

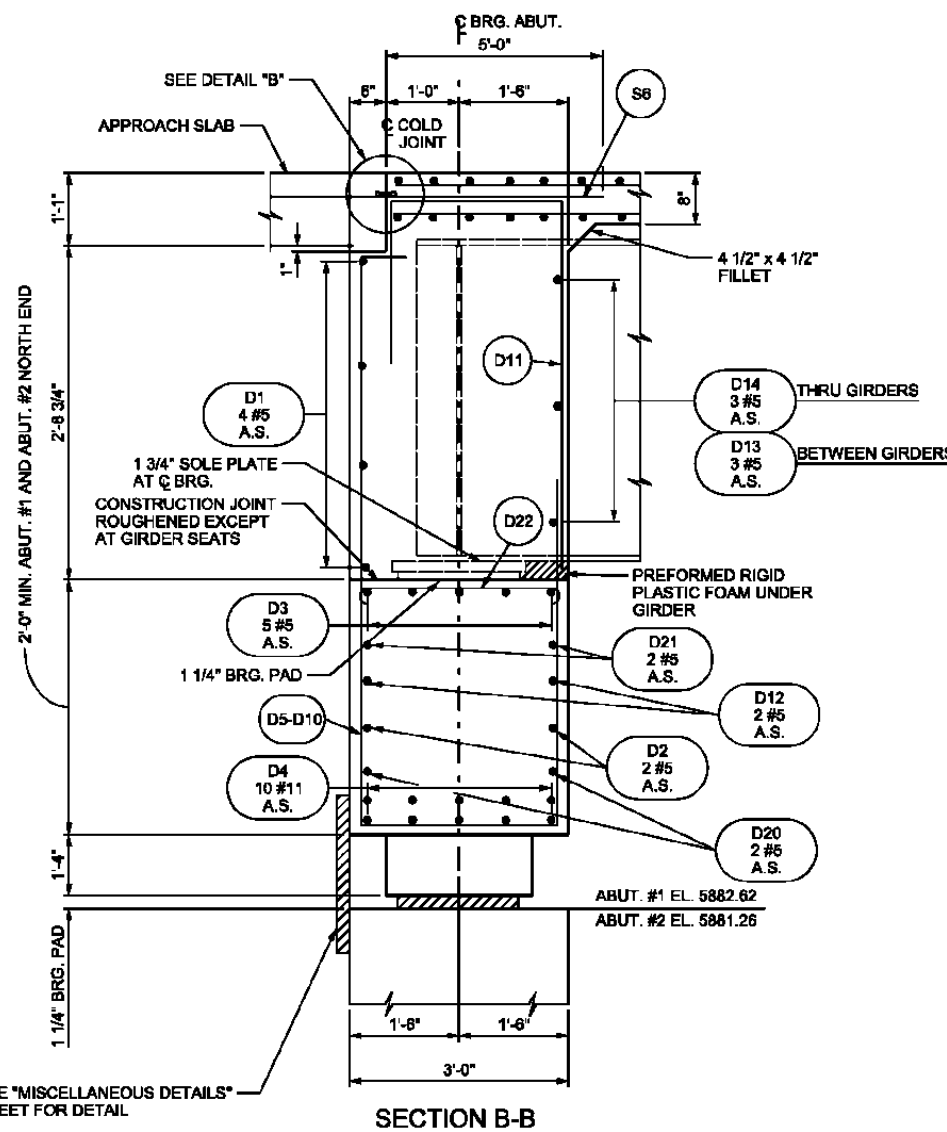

GIRDER SEAT	
LOCATION	ELEV.
GIRDER G1	5883.84
GIRDER G2	5884.36
GIRDER G3	5884.89
GIRDER G4	5885.41
GIRDER G5	5885.93
GIRDER G6	5886.45

GIRDER SEAT	
LOCATION	ELEV.
GIRDER G1	5886.06
GIRDER G2	5886.58
GIRDER G3	5887.10
GIRDER G4	5887.62
GIRDER G5	5888.13
GIRDER G6	5888.65

GIRDER SEAT	
LOCATION	ELEV.
GIRDER G1	5882.46
GIRDER G2	5882.99
GIRDER G3	5883.52
GIRDER G4	5884.04
GIRDER G5	5884.57
GIRDER G6	5885.10

- NOTES:
- SEE "END DIAPHRAGM DETAILS 3 OF 3" SHEET FOR REINFORCING IN PUSH BLOCK AND SHOES.
 - SEE "DECK DETAILS" SHEET FOR TYPICAL DECK REINFORCING.
 - FINISH GIRDER SEATS (2" LARGER THAN BEARING PAD) HIGH AND RUB OR GRIND LEVEL TO REQUIRED ELEVATION ± 0.125 INCH. NO GROUTING ALLOWED.
 - BEND OR FIELD CUT FRONT LEG OF D5-D10 BARS WHERE CONFLICTING WITH GIRDER. FIELD ADJUST LOCATION OF D11 BAR WHERE CONFLICTING WITH GIRDER.
 - SEE "END DIAPHRAGM DETAILS 3 OF 3" SHEET FOR BEARING PAD LOCATION AND ADDITIONAL DETAILS.
 - SEE "END DIAPHRAGM DETAILS 1 OF 3" SHEET FOR DETAIL "B"

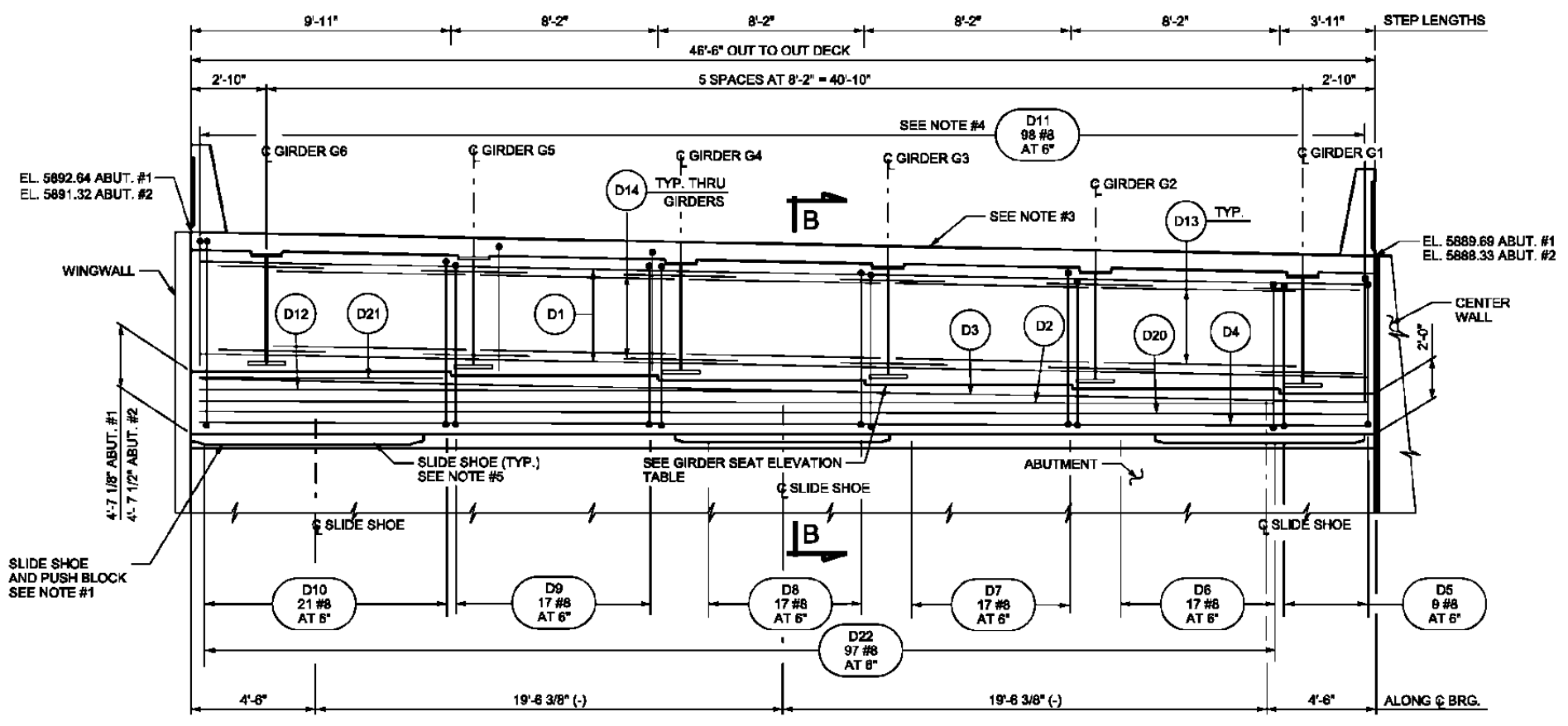

EB ABUT #1 ELEVATION (AS SHOWN)
 EB ABUT #2 ELEVATION (SIMILAR AS NOTED)
 LOOKING STATION BACK (NORMAL TO STRUCTURE)

UTAH DEPARTMENT OF TRANSPORTATION STRUCTURES DIVISION	
I-80; WANSHIP TO COALVILLE	PROJECT NUMBER: F-180-4(133)156
WANSHIP INTERCHANGE: I-80 OVER SR-32	PIN: 8098
END DIAPHRAGM DETAILS 2 OF 3	SUMMIT COUNTY
	C-1011
	DRG NO.
SHT. 23	OF 38

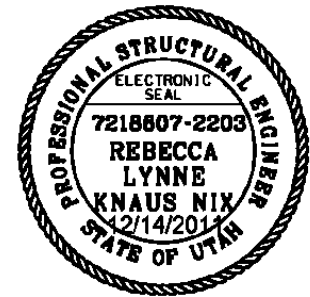

14-111-2011

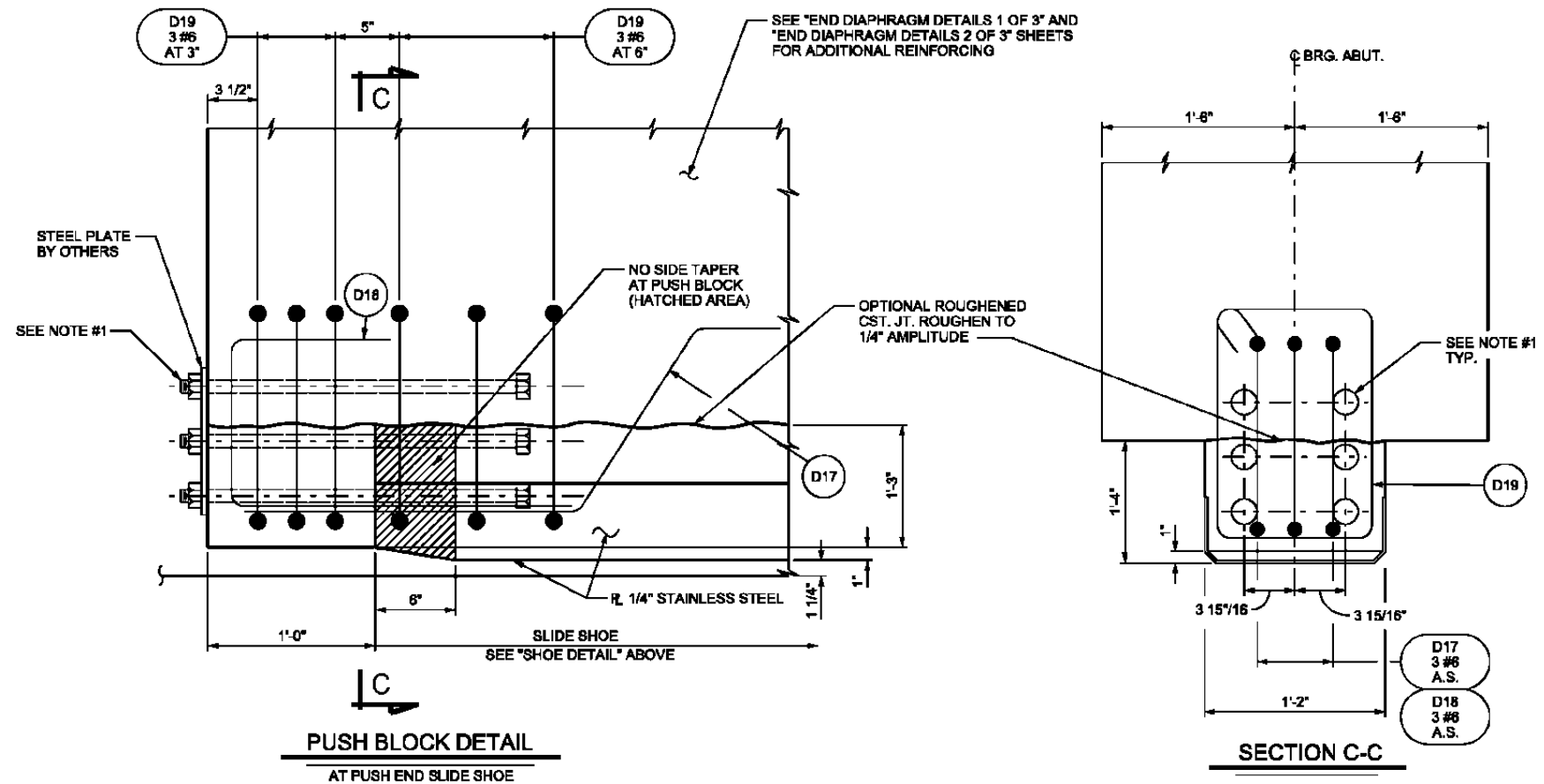
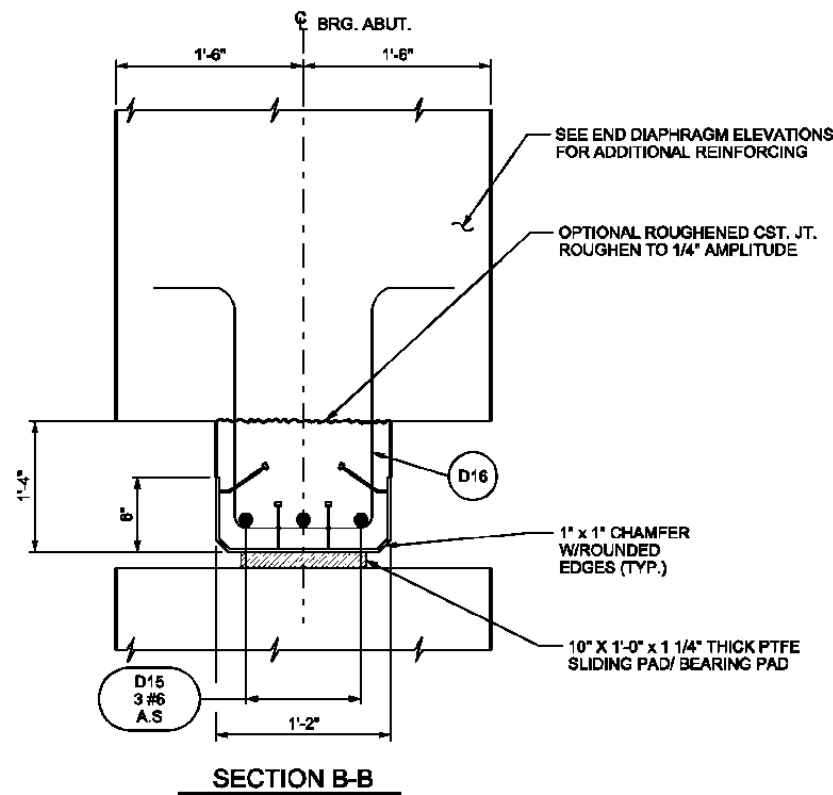
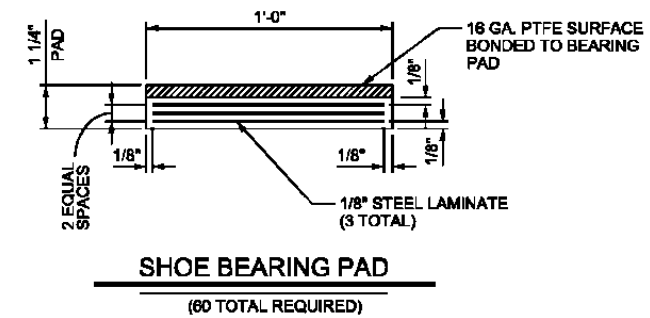
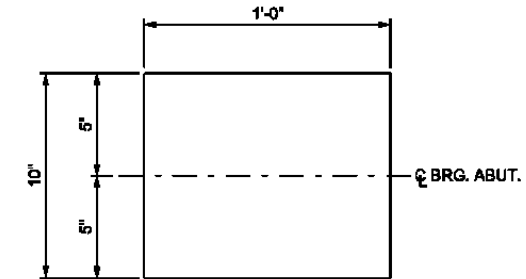
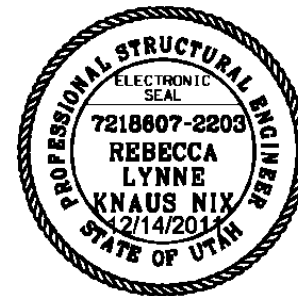
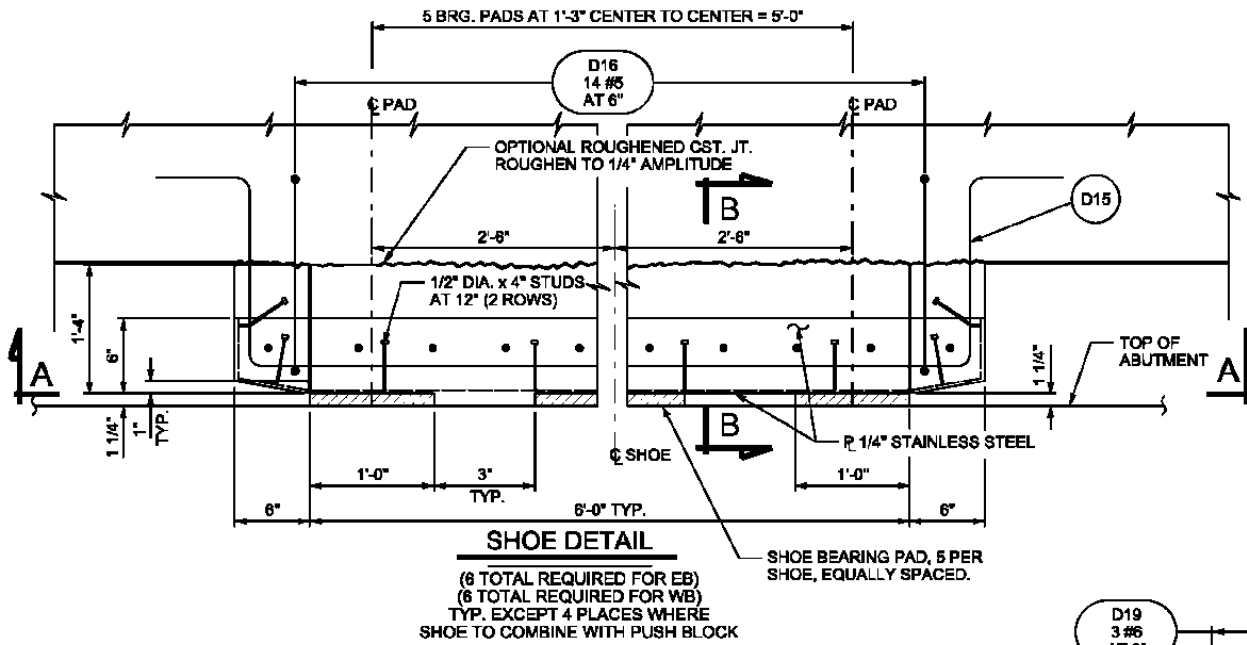
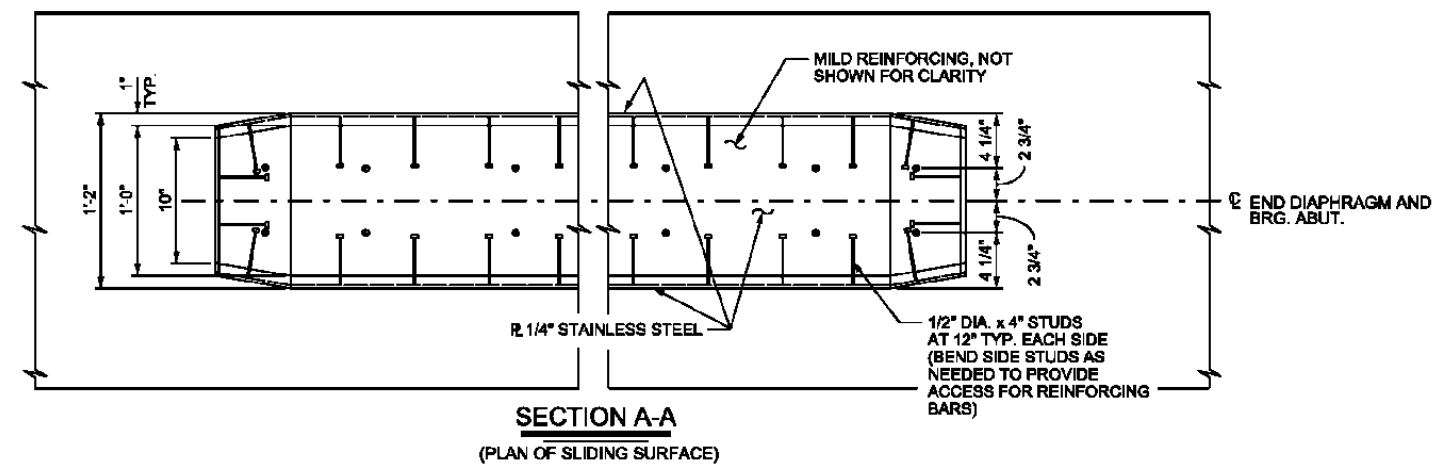

NOTES:

- 1" DIA ASTM F-1554 GR 36 ANCHOR BOLT (2'-0" EMBEDMENT) WITH WASHER AND HEAVY HEX NUT (ALL GALVANIZED). VERIFY DIMENSIONS WITH HEAVY MOVE CONTRACTOR PRIOR TO PLACEMENT. CUT BOLTS FLUSH AND PATCH AFTER SLIDING OPERATION IS COMPLETE. VERIFY PUSH BLOCK CONNECTION FOR ADEQUATE CAPACITY FOR PUSHING OPERATION.
- INCLUDE COST OF STAINLESS STEEL 1/4" PLATE, 1/2" DIA. STUDS AT SHOES, 1" DIA. BOLTS AT PUSH BLOCK AND SHOE BRG. PADS IN THE "STRUCTURAL CONCRETE" PAY ITEM.

REVISION		DATE	BY	DATE	BY
DESIGN	R.L.N.	6/11		CHECK	T.A.H.
DRAWN	M.P.P.	7/11		CHECK	T.A.H.
QUANT.	M.P.P.	9/11		CHECK	T.A.H.

UTAH DEPARTMENT OF TRANSPORTATION
STRUCTURES DIVISION

I-80; WANSHIP TO COALVILLE
WANSHIP INTERCHANGE: I-80 OVER SR-32
END DIAPHRAGM DETAILS 3 OF 3
PROJECT NUMBER: F-180-4(133)156
PIN: 8098

SUMMIT COUNTY
C-1011
DRG. NO.

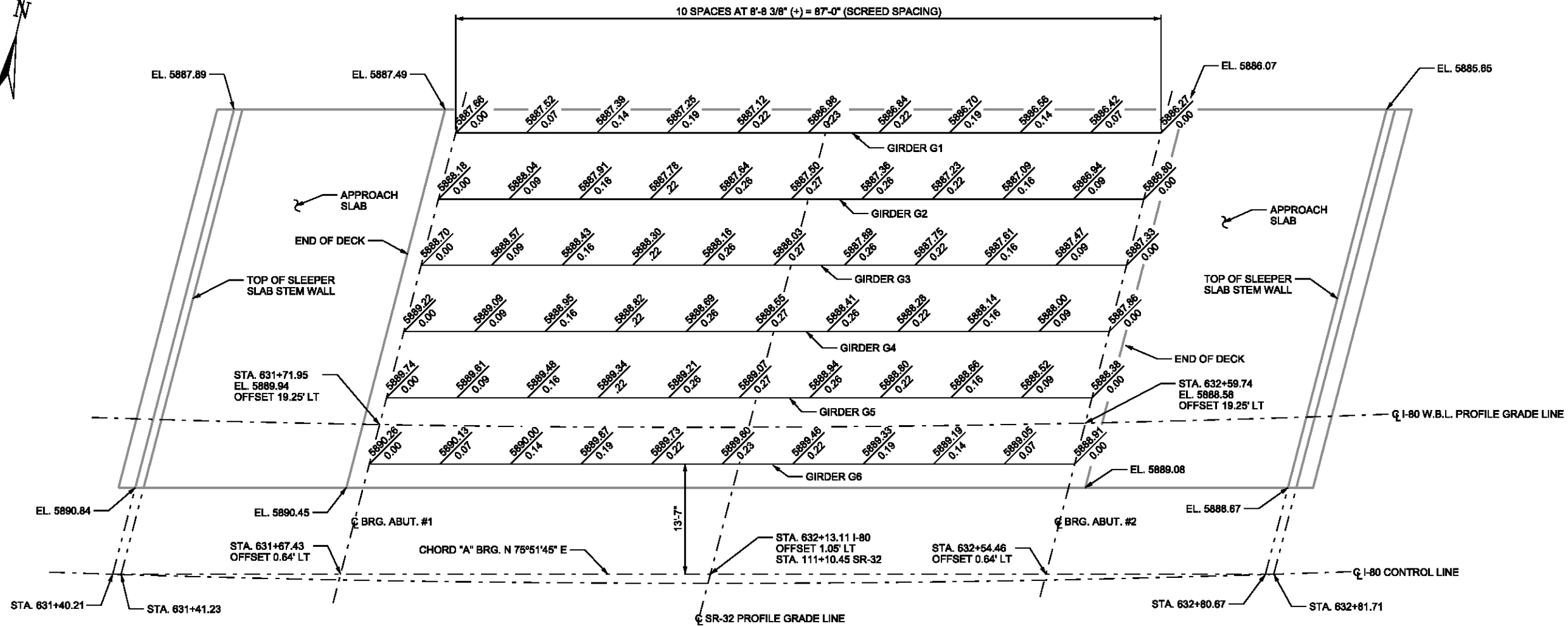
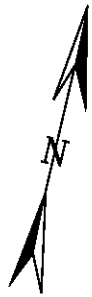

WBL SCREED PLAN

FINAL LOCATION SHOWN, SEE NOTES FOR TEMPORARY LOCATION

NOTES

- FIGURES ABOVE THE LINE ARE TOP OF CONCRETE ELEVATIONS. FIGURES BELOW THE LINE ARE DEAD LOAD DEFLECTIONS OF THE DECK AND WILL BE ADDED TO ELEVATIONS SHOWN TO OBTAIN SCREED ELEVATIONS.
- ALL ELEVATIONS SHOWN ARE INDICATED AT FINISHED GRADE AND IN FINAL LOCATION. ELEVATIONS SHOWN ON SLEEPER SLABS ARE AT TOP OF STEM.
- ALL LONGITUDINAL DIMENSIONS ARE TYPICAL ALONG GIRDER LINES.
- DECK AND APPROACH SLAB ELEVATIONS AT TEMPORARY LOCATION AND FINAL LOCATION ARE THE SAME.

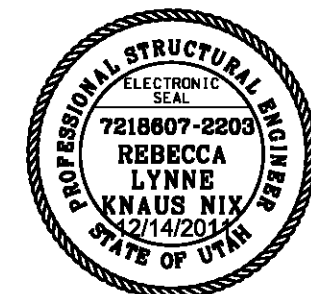

DESIGN	RLN	6/11	CHECK	TAH	11/11
DRAWN	MPP	7/11	CHECK	TAH	11/11
QUANT.	MPP	9/11	CHECK	TAH	11/11

UTAH DEPARTMENT OF TRANSPORTATION
STRUCTURES DIVISION

I-80; WANSHIP TO COALVILLE
WANSHIP INTERCHANGE: I-80 OVER SR-32
WBL SCREED ELEVATIONS
PROJECT NUMBER: F-180-4(133)156
PIN: 8098

SUMMIT COUNTY
C-1011
DRG. NO.

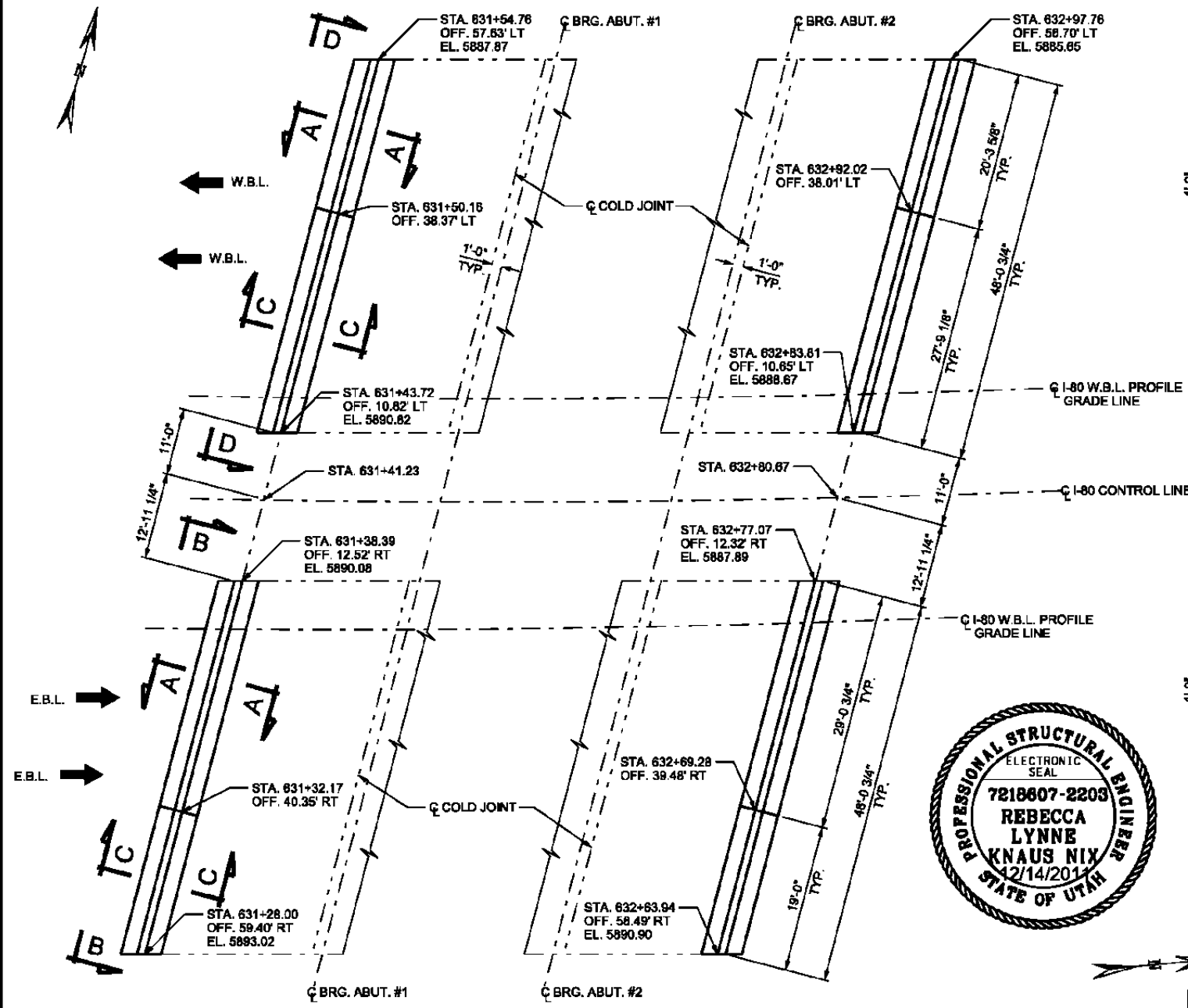

SLEEPER SLAB LOCATION PLAN

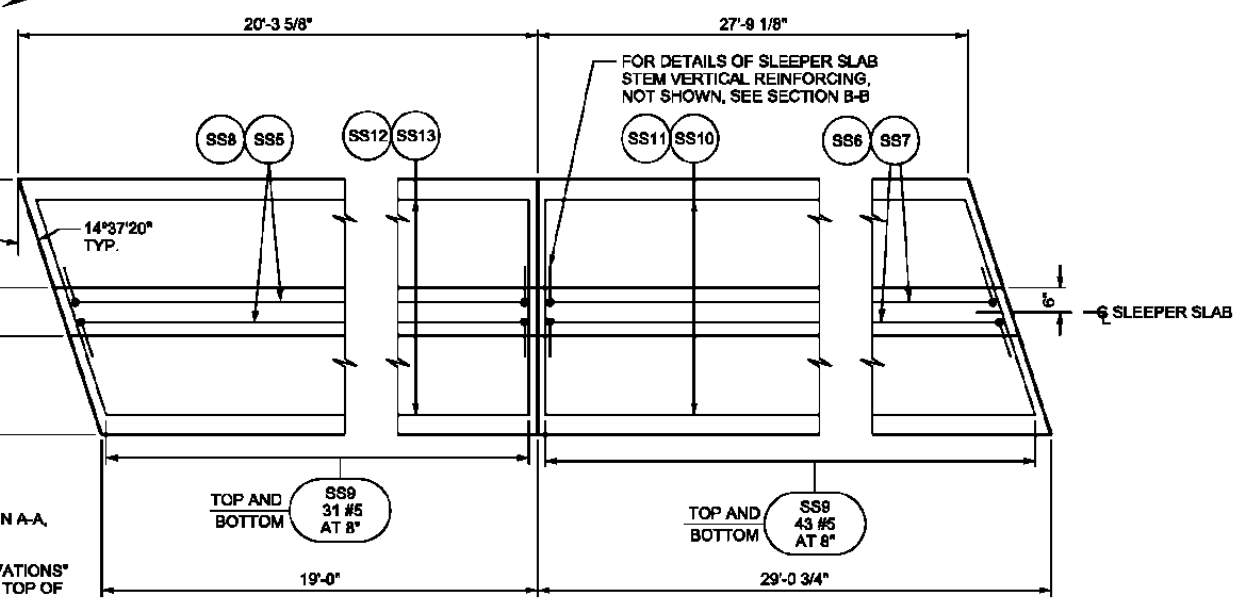
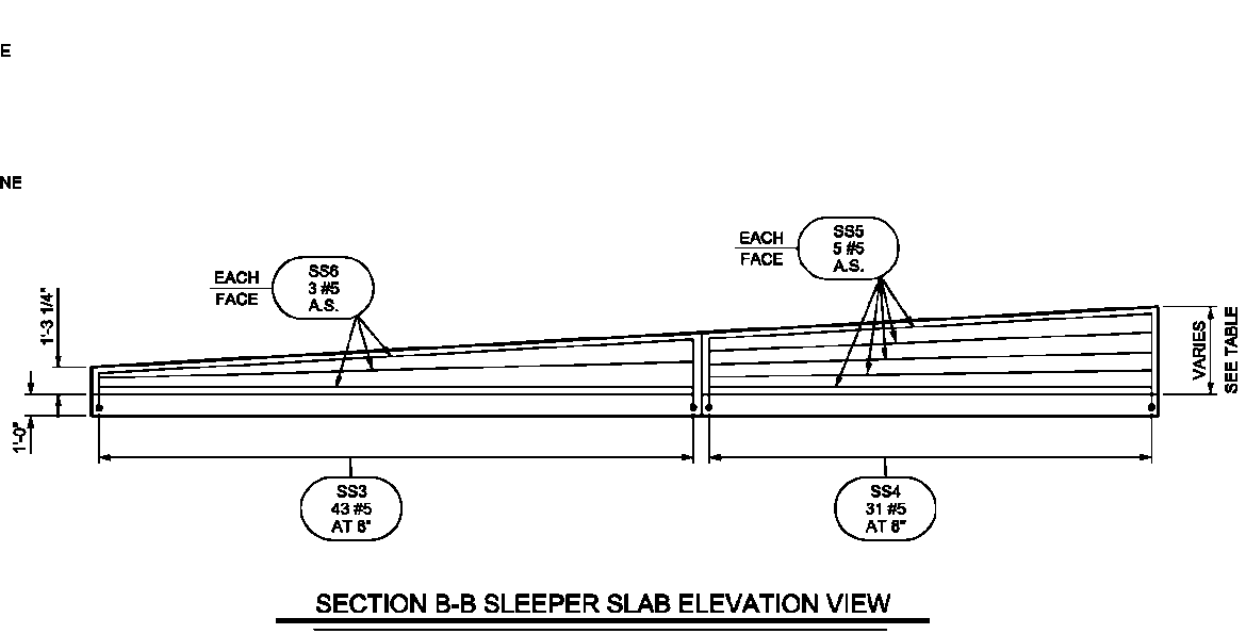
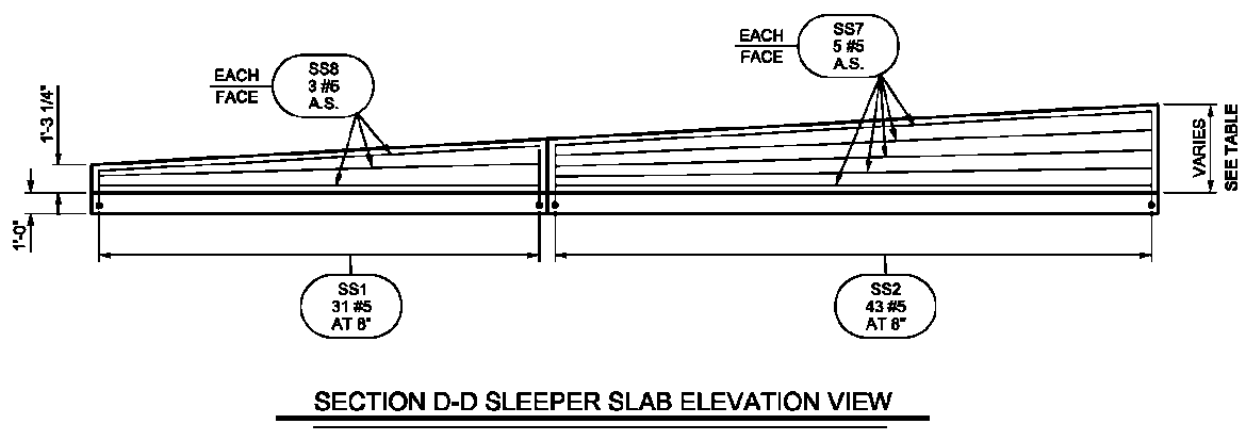
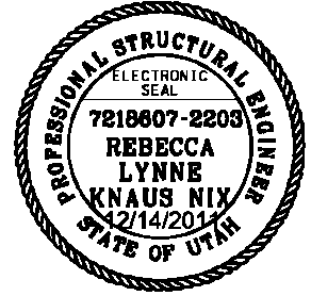

SLEEPER SLAB REBAR PLAN

EBL ABUT. #1 SHOWN, EBL ABUT. #2 SHOWN
OTHERS SIMILAR AS NOTED

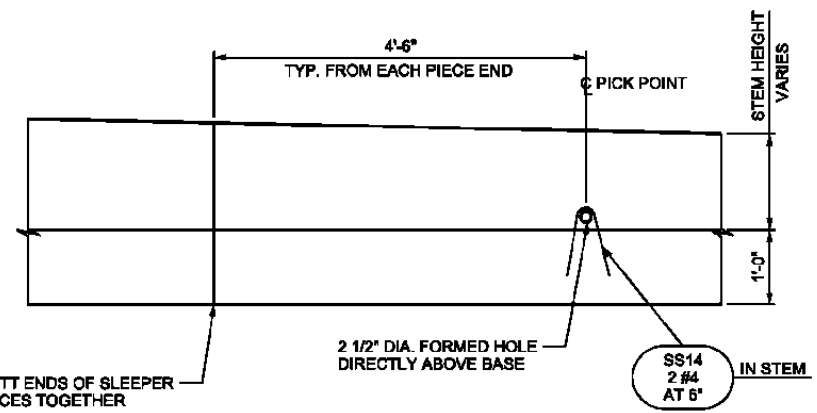

SLEEPER SLAB - LIFTING & CONNECTION DETAIL

SLEEPER SLAB STEM HEIGHTS AT SOUTH END	
ABUT. #1 WBL	4'-2 11/16"
ABUT. #2 WBL	4'-3 1/2"
ABUT. #1 EBL	4'-2 9/16"
ABUT. #2 EBL	4'-3 3/8"

- NOTES:
- SEE "SLEEPER SLAB DETAILS 2 OF 2" SHEET FOR SECTION A-A, C-C AND EST. CONCRETE QUANTITIES.
 - SEE "WBL SCREED ELEVATIONS" AND "EBL SCREED ELEVATIONS" SHEETS FOR TOP OF APPROACH SLAB ELEVATIONS AND TOP OF STEM OF SLEEPER SLAB ELEVATIONS.

NO.	DATE	BY	REVISION
DESIGN	RLN	6/11	CHECK TA/ 11/11
DRAWN	MPP	7/11	CHECK TA/ 11/11
QUANT.	MPP	9/11	CHECK TA/ 11/11
APPROVAL	RECOMM.	12/14/2011	DATE
FOR USE	BY/DOOR	12/14/2011	DATE
UTAH DEPARTMENT OF TRANSPORTATION STRUCTURES DIVISION I-80; WANSHIP TO COALVILLE WANSHIP INTERCHANGE: I-80 OVER SR-32 SLEEPER SLAB DETAILS 1 OF 2 PROJECT NUMBER: F-180-4(133)156 PIN: 8098			
SUMMIT COUNTY C-1011 DRG NO.			
SHT. 27 OF 38			

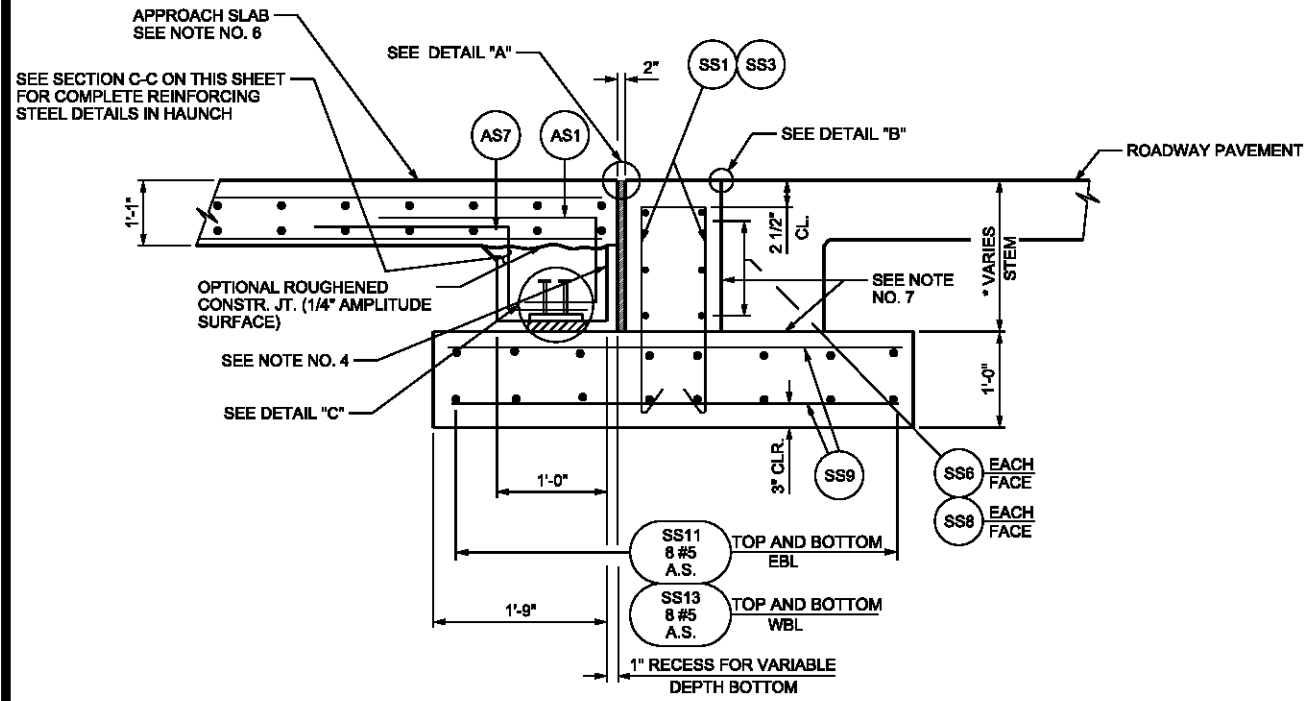

SECTION A-A

* SEE SECTION B-B ON "SLEEPER SLAB DETAILS 1 OF 2" SHEET FOR DIMENSIONS AT EACH END OF SLEEPER SLABS AND REINFORCING DETAILS IN STEM

NOTES:

1. USE CLOSED CELL, RIGID PLASTIC FOAM. CUT RIGID PLASTIC FOAM TO CONFORM TO THE CROSS SECTION OF THE PANEL AND FURNISH IN STRIPS EQUAL TO THE FULL WIDTH OF THE APPROACH SLAB. MAKE THE TOP SURFACE SMOOTH. ENSURE FOAM BACKER ROD IS PLACED AS SHOWN IN DETAIL "A".
2. DO NOT INSTALL JOINT SEALANT ABOVE 90° F. OR BELOW 50° F.
3. DEPTH OF RIGID PLASTIC FOAM IN SLEEPER SLAB JOINT TO BE DETERMINED BY CONTRACTOR BASED ON ACTUAL COMPRESSED BACKER ROD HEIGHT.
4. NO RIGID PLASTIC FORM REQUIRED BETWEEN APPROACH SLAB HAUNCH AND SLEEPER SLAB STEM EXCEPT AT THE ENDS. SEAL EACH END WITH BACKER ROD AND SILICONE JOINT SEALANT AFTER APPROACH SLAB SLID INTO PLACE.
5. SECTION A-A AND C-C ARE TAKEN FROM "SLEEPER SLAB DETAILS 1 OF 2" SHEET.
6. SEE "DECK DETAILS" SHEET FOR REINFORCEMENT IN APPROACH SLAB.
7. SEE "SLEEPER SLAB DETAILS 1 OF 2", SECTION A-A, AND SECTION C-C ON THIS SHEET FOR STEM REINFORCING DETAILS. SEE "SLEEPER SLAB DETAILS 1 OF 2" SHEET FOR FOOTING REBAR DETAILS.
8. INCLUDE COST OF 1/2" PLATE WITH SHEAR STUDS AND 1/4" SLIDING PADS FOR BOTH EBL AND WBL IN THE "STRUCTURAL LIGHT WEIGHT CONCRETE" PAY ITEM.
9. PAYMENT FOR GRANULAR BACKFILL BORROW UNDER SLEEPER SLAB IS INCLUDED IN "STRUCTURAL CONCRETE" PAY ITEM.

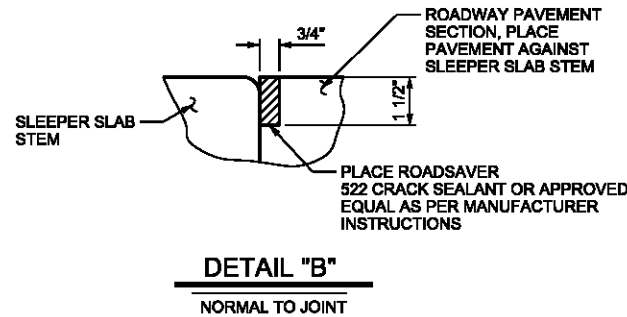

DETAIL "B"

NORMAL TO JOINT

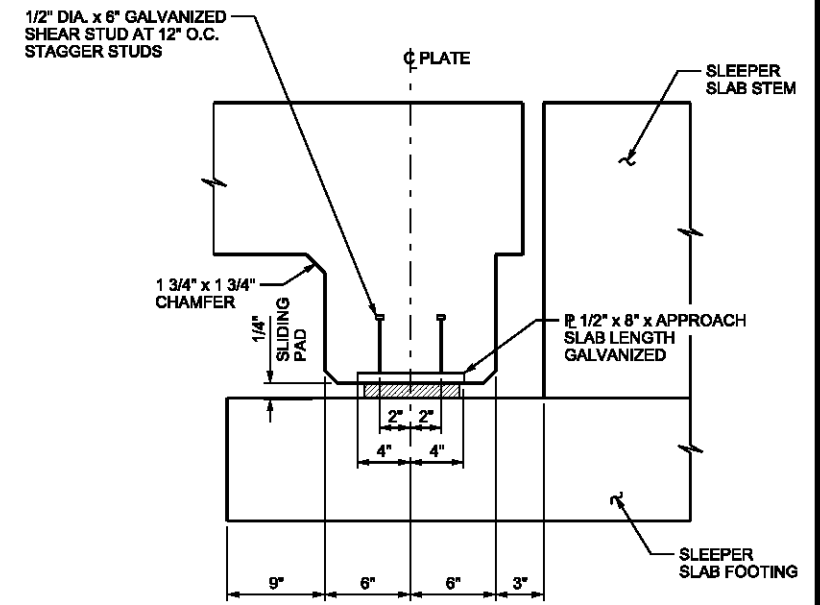

DETAIL "C"

SEE NOTE NO. 8

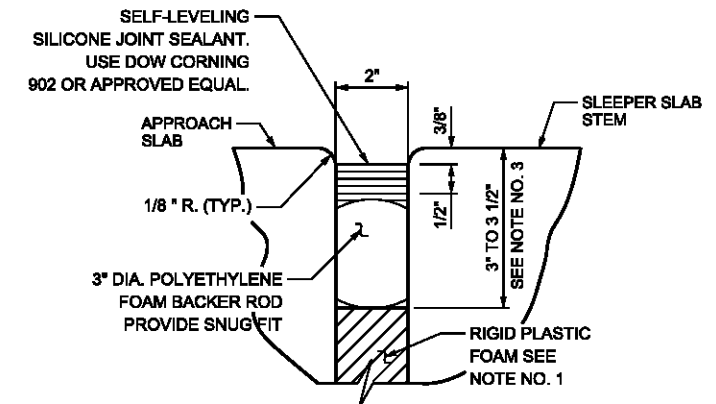

DETAIL "A"

APPROACH SLAB STEM HEIGHTS AT SOUTH END	
ABUT. #1 WBL	3'-1 3/8"
ABUT. #2 WBL	3'-2 1/4"
ABUT. #1 EBL	3'-1 5/16"
ABUT. #2 EBL	3'-2 1/8"

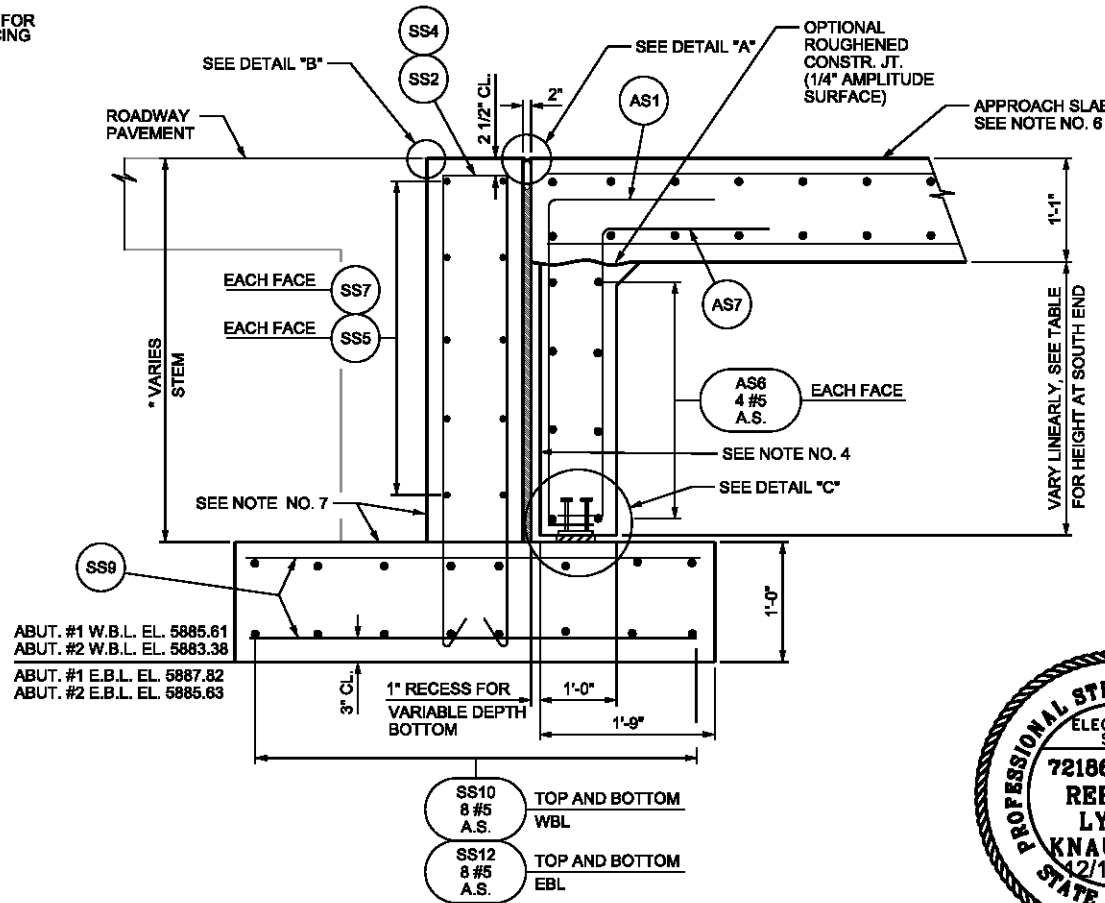

SECTION C-C

* SEE SECTION B-B ON "SLEEPER SLAB DETAILS 1 OF 2" SHEET FOR DIMENSIONS AT EACH END OF SLEEPER SLABS AND REINFORCING DETAILS IN STEM

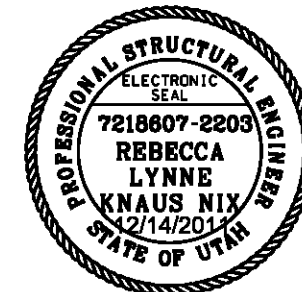

STRUCTURAL CONCRETE QUANTITIES (CU. YDS.)

LOCATION	QUANTITY
WB SLEEPER SLABS	28.6
EB SLEEPER SLABS	28.6
TOTAL	57.2

UTAH DEPARTMENT OF TRANSPORTATION STRUCTURES DIVISION		PROJECT NUMBER: F-180-4(133)156	PIN: 8098
I-80; WANSHIP TO COALVILLE		SUMMIT COUNTY	
WANSHIP INTERCHANGE: I-80 OVER SR-32		C-1011	
SLEEPER SLAB DETAILS 2 OF 2		DRG. NO.	
REVISIONS	DESIGN	CHECK	DATE
6/11	RLN	TAH	11/11
7/11	MPP	TAH	11/11
9/11	MPP	TAH	11/11
APPROVAL FOR USE	DATE	BY	DATE
12/14/2011	12/14/2011	UDOT BRIDGE ENGR.	

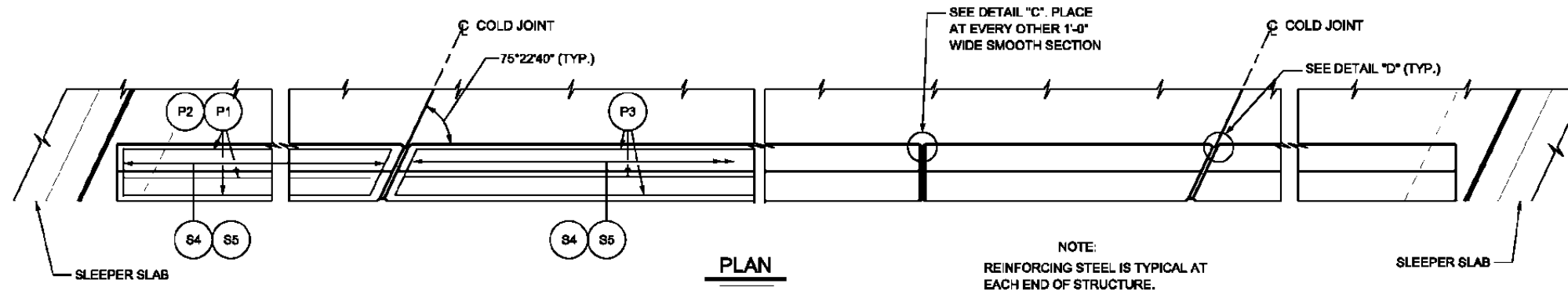

PLAN

NOTE:
REINFORCING STEEL IS TYPICAL AT EACH END OF STRUCTURE.

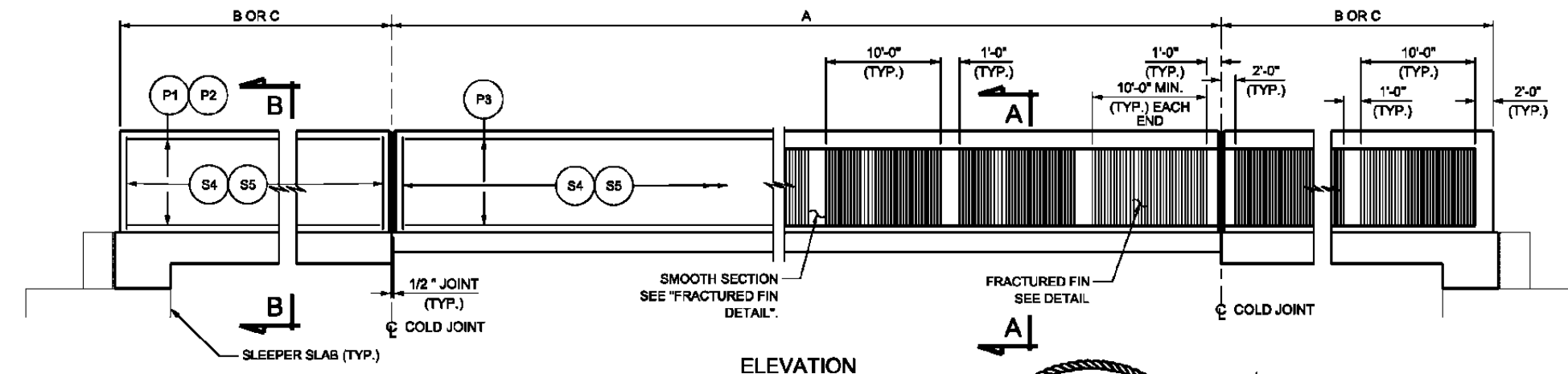

ELEVATION

ALL DIMENSIONS SHOWN ARE ALONG EDGE OF DECK

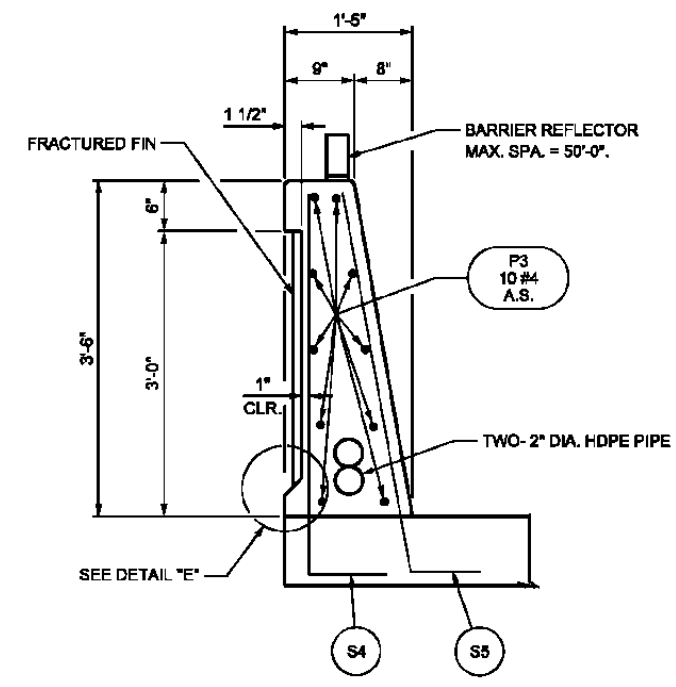

SECTION A-A

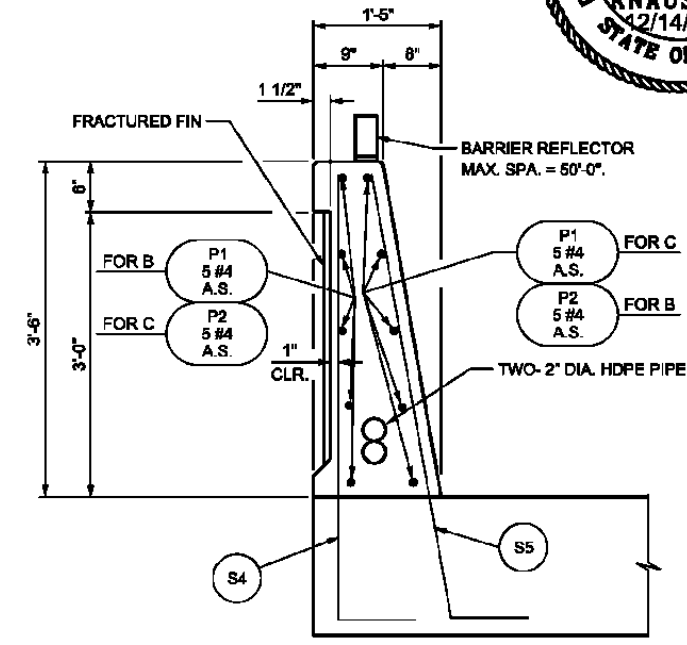

SECTION B-B

- GENERAL NOTES**
1. ALTERNATE ALL REINFORCING STEEL SPLICES.
 2. PROVIDE 2" MIN. COVER TO REINFORCING STEEL UNLESS NOTED OTHERWISE.
 3. PLACE CONTRACTION JOINT ON SIDES AND TOP OF PARAPET.
 4. EXTEND SEALANT AND FOAM BACKER ROD FROM DECK TO TOP OF PARAPET ON THE INSIDE PARAPET FACE AND ACROSS TOP OF PARAPET.
 5. LOCATE STRUCTURE NUMBER ON RIGHT-HAND SIDE OF APPROACH PARAPET.

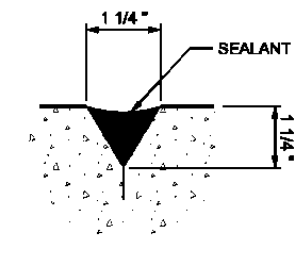

DETAIL "C"

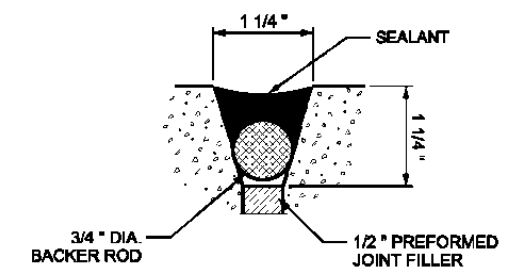

DETAIL "D"

A	B	C
88'-0 3/4"	24'-10"	24'-5 5/8"

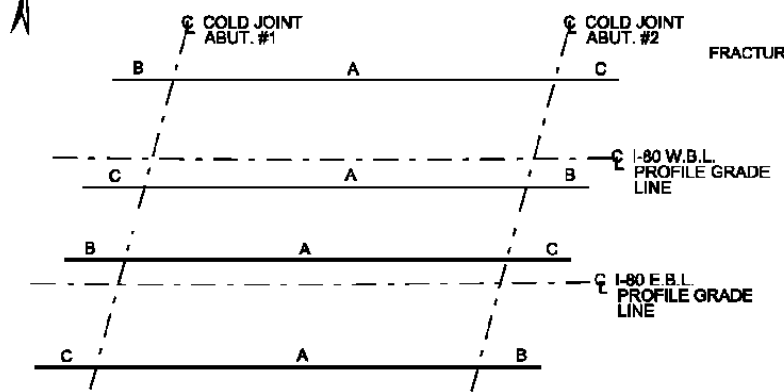

KEY PLAN

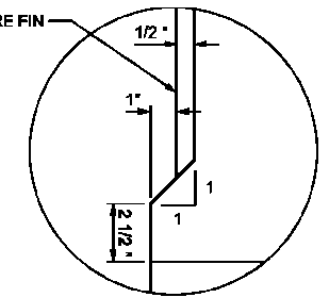

DETAIL "E"

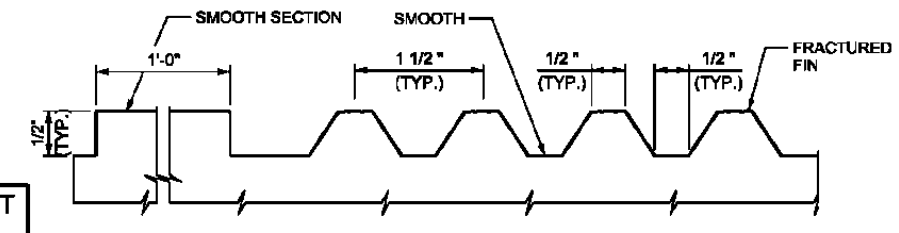

FRACTURED FIN DETAIL

STRUCTURAL LIGHT WEIGHT CONCRETE QUANTITIES

LOCATION	CU. YDS.
WB PARAPETS	38.9
EB PARAPETS	38.9
TOTAL	77.8

REVISION NUMBER	CHECK TA#	11/11
DESIGN R/L N	CHECK TA#	11/11
DRAWN M/P	CHECK TA#	11/11
QUANT. M/P	CHECK TA#	11/11
DATE	BY	
APPROVAL RECORD	DATE	
GRAND DESIGN ENGR.	DATE	
APPROVED FOR USE	DATE	
BY	DATE	
PROJECT NUMBER	F-180-4(133)156	
PIN	8098	
SUMMIT COUNTY	C-1011	
DRG NO.	C-1011	
SHT. 29	OF 38	

UTAH DEPARTMENT OF TRANSPORTATION STRUCTURES DIVISION

I-80; WANSHIP TO COALVILLE
WANSHIP INTERCHANGE: I-80 OVER SR-32
PARAPET DETAILS

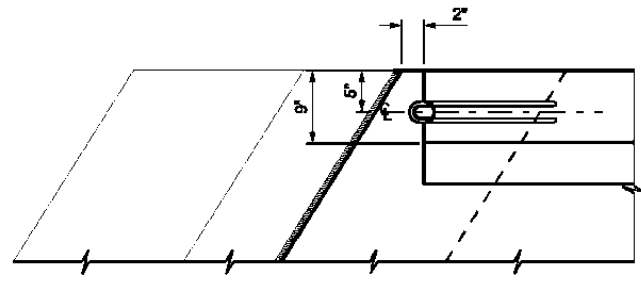

PLAN

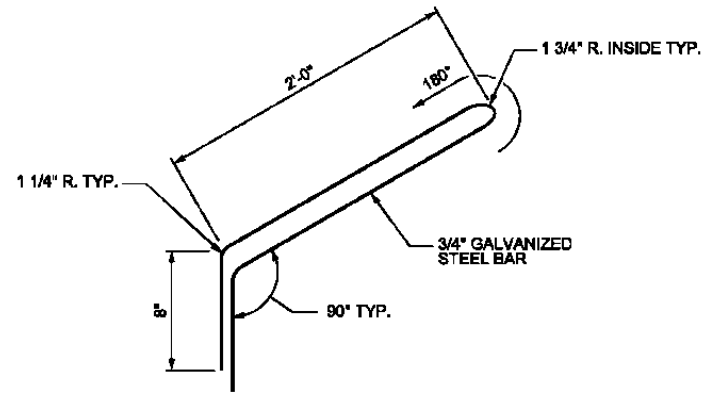

CONNECTION LOOP DETAIL

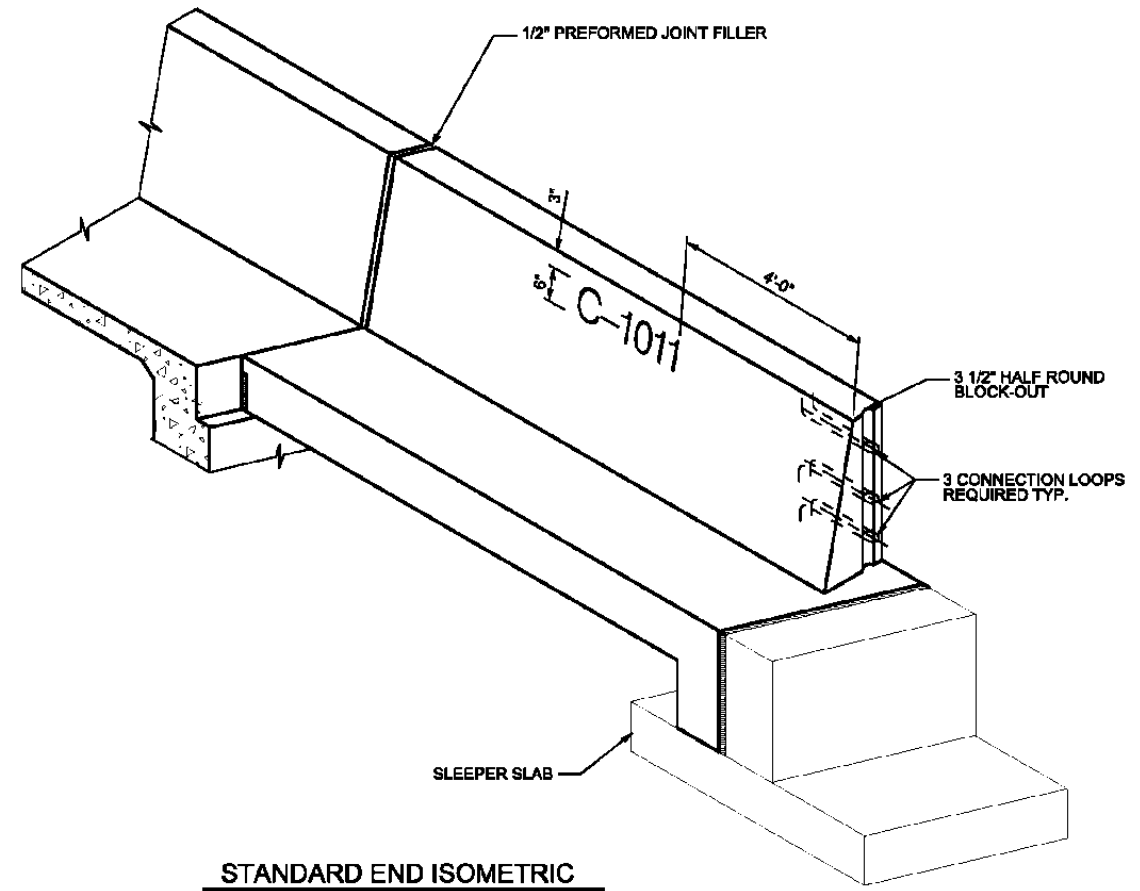

STANDARD END ISOMETRIC

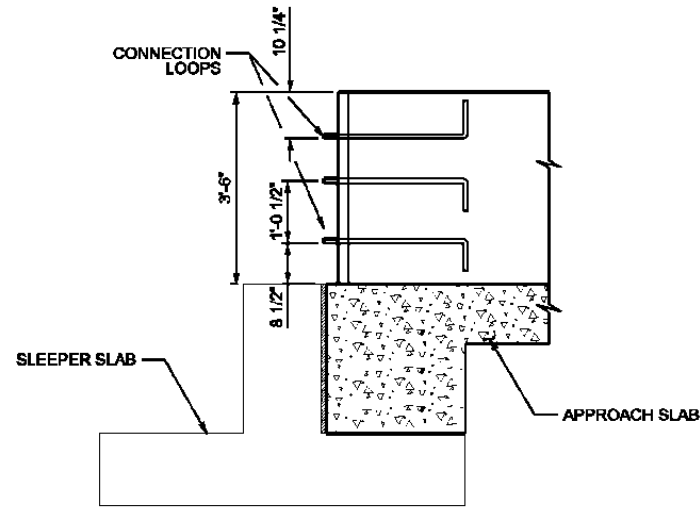

TYPICAL ELEVATION

STANDARD END DETAIL

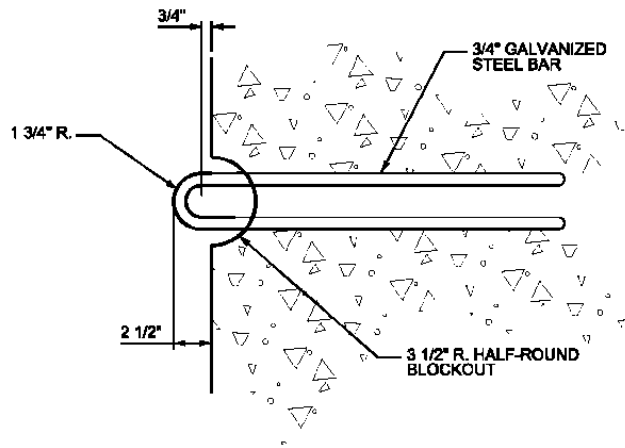
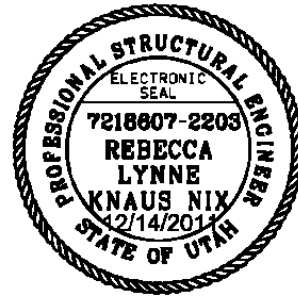

CONNECTION END DETAIL

NO FRACTURED FIN IN THIS AREA, BACKING PLATE. SEE STD. DWG. BA 5C2.

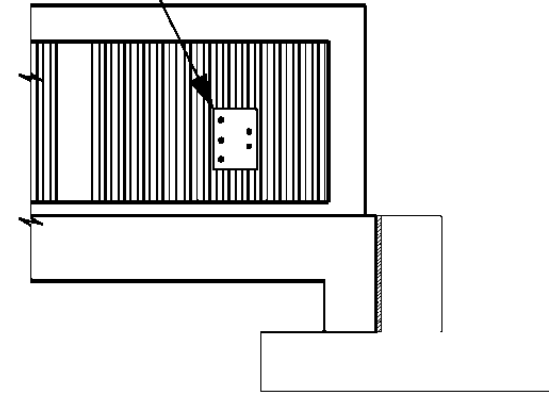

BACKING PLATE DETAIL

AT E.B.L. NORTH EAST CORNER ONLY

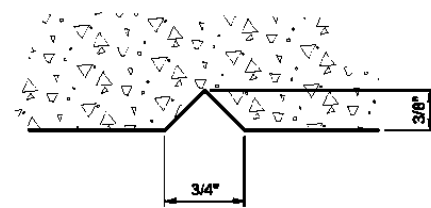

TYPICAL SECTION THRU STRUCTURE NUMBER

NO.	DATE	BY	REVISION	DESIGN	CHECK
1	12/14/2011	GRAND DESIGN ENGR.	DESIGN	R.L.N.	6/11
2	12/14/2011	GRAND DESIGN ENGR.	APPROVAL FOR USE	M.P.P.	7/11
3	12/14/2011	LOOT BRIDGE ENGR.	APPROVAL FOR USE	M.P.P.	9/11
4	12/14/2011	LOOT BRIDGE ENGR.	APPROVAL FOR USE	M.P.P.	11/11

UTAH DEPARTMENT OF TRANSPORTATION
STRUCTURES DIVISION

I-80; WANSHIP TO COALVILLE
WANSHIP INTERCHANGE: I-80 OVER SR-32
PARAPET END DETAILS
PROJECT NUMBER: F-160-4(133)156
PIN: 8098

SUMMIT COUNTY
C-1011
DRG NO.
SHT. 30 OF 38

134112-C-2011 10/24/11 10:45:30 AM P:\Projects\102030\102030_P\102030_P\102030_P\102030_P.dwg

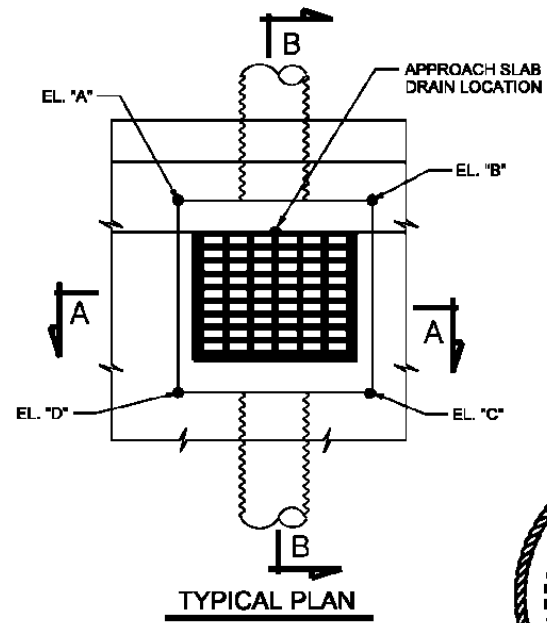

TYPICAL PLAN

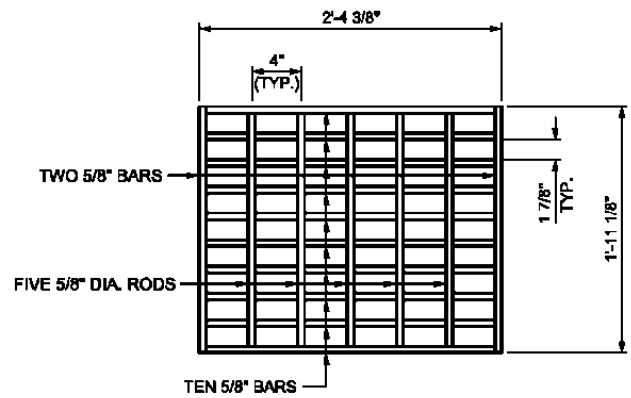
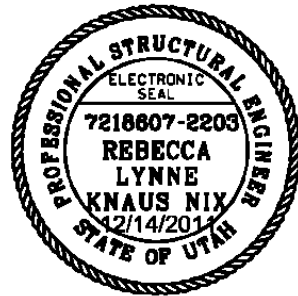

GRATE DETAIL

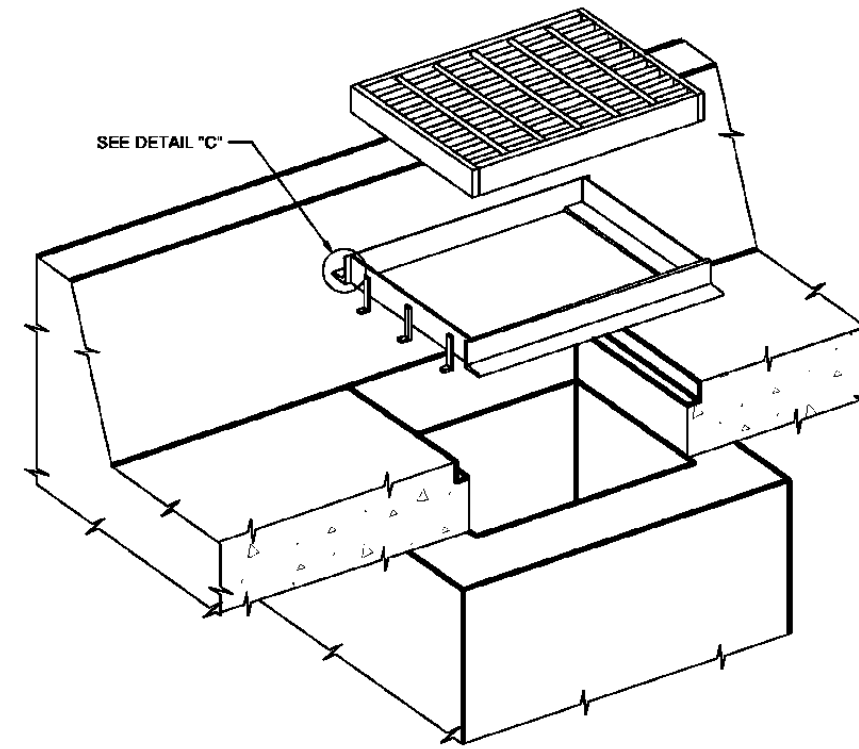
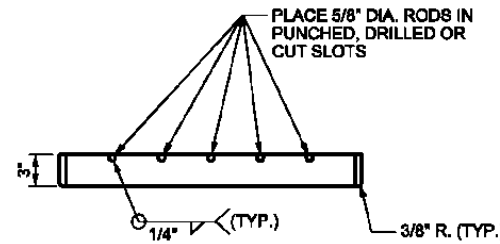

ISOMETRIC

ELEVATIONS & LOCATIONS							
LOCATION	STATION	OFFSET	EL. 'A'	EL. 'B'	EL. 'C'	EL. 'D'	EL. 'E'
W.B.L.	632+90.87	55.53' LT	5885.84	5885.79	5885.97	5886.02	5879.96

NOTE:
ELEVATIONS ARE AT TOP OF APPROACH SLAB.

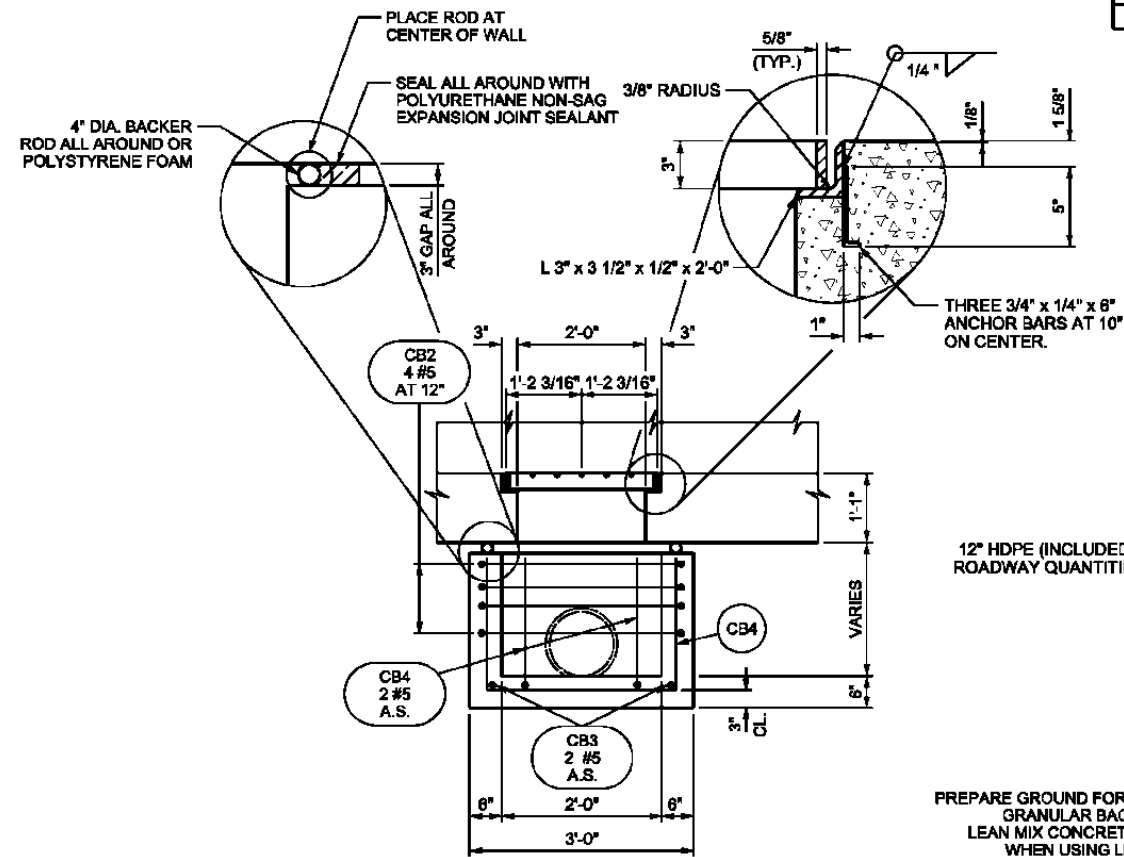

SECTION A-A

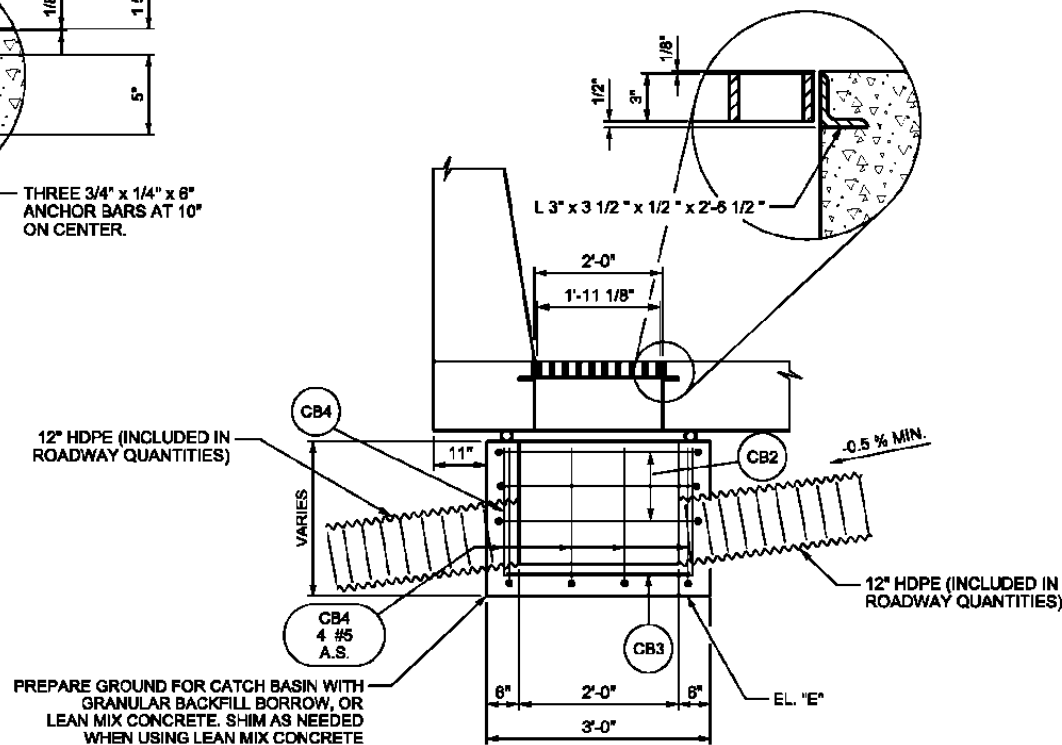

SECTION B-B

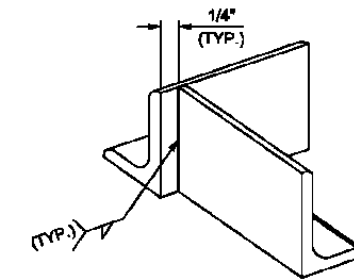

DETAIL "C"

GENERAL NOTES

- FIELD CUT OR BEND APPROACH SLAB REINFORCING TO CLEAR APPROACH SLAB DRAINS.
- USE ASTM A36 OR A572 GRADE 50 FOR GRATE AND FRAME.

QUANTITIES

- STRUCTURAL CONCRETE QUANTITIES
 1. CATCH BASINS AT 1.0 CU. YDS. = 1.0 CU. YDS.
- STRUCTURAL STEEL QUANTITY
 1. GRATES AND FRAMES AT 273 LBS. = 273 LBS.

UTAH DEPARTMENT OF TRANSPORTATION		STRUCTURES DIVISION	
I-80; WANSHIP TO COALVILLE		WANSHIP INTERCHANGE: I-80 OVER SR-32	
WB APPROACH SLAB DRAIN		F-180-4(133)156	
PROJECT NUMBER		PIN 8098	
SUMMIT COUNTY			
C-1011			
DRG NO.			
SHT. 31		OF 38	

NO.	DATE	BY	REVISION
DESIGN	5/11	TAH	11/11
DRAWN	7/11	MPP	11/11
APPROVED FOR USE	12/14/2011	DATE	GRAND DESIGN ENGR.
APPROVED BY USDT	12/14/2011	DATE	USDT BRUCE ENGR.

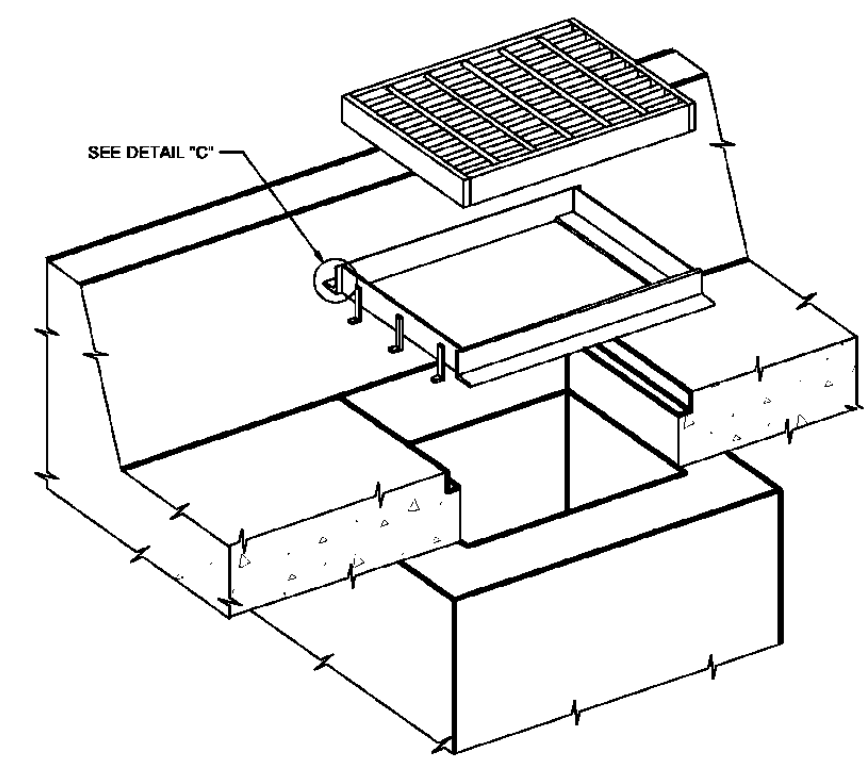
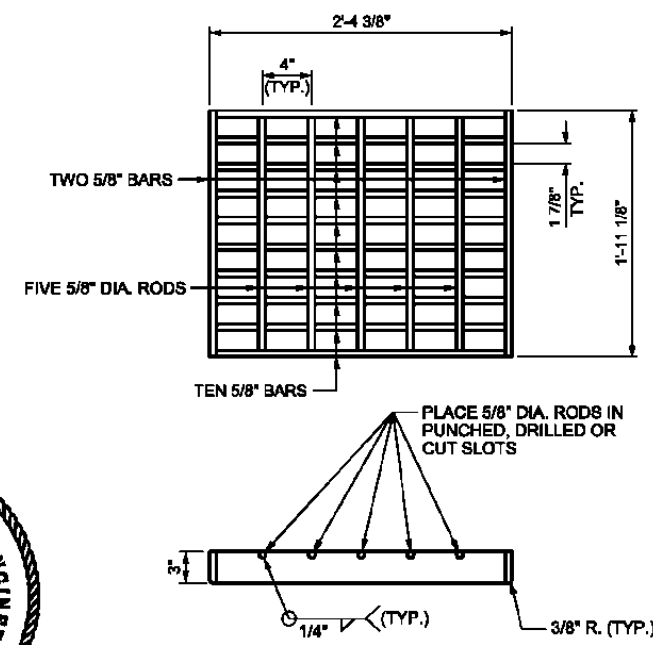
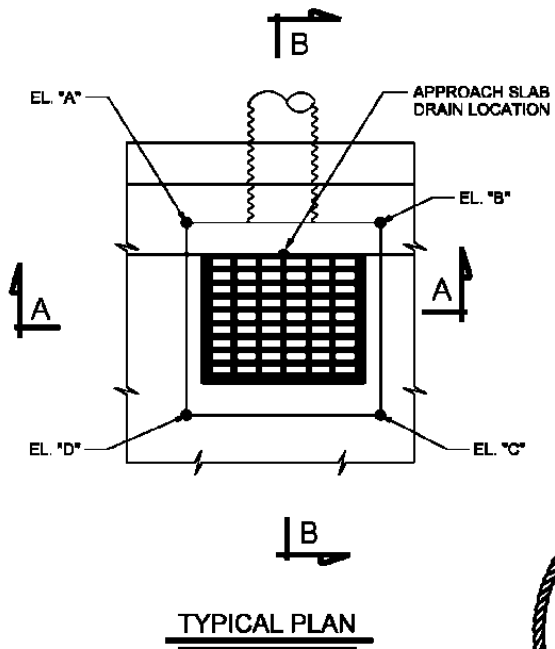

ELEVATIONS & LOCATIONS							
LOCATION	STATION	OFFSET	EL. 'A'	EL. 'B'	EL. 'C'	EL. 'D'	EL. 'E'
E.B.L.	832+70.40	13.55' RT	5888.09	5888.04	5888.22	5888.27	5882.79

NOTE: ELEVATIONS ARE AT TOP OF APPROACH SLAB.

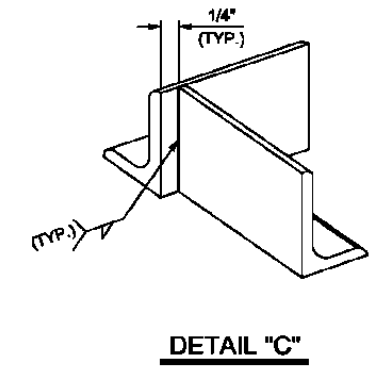
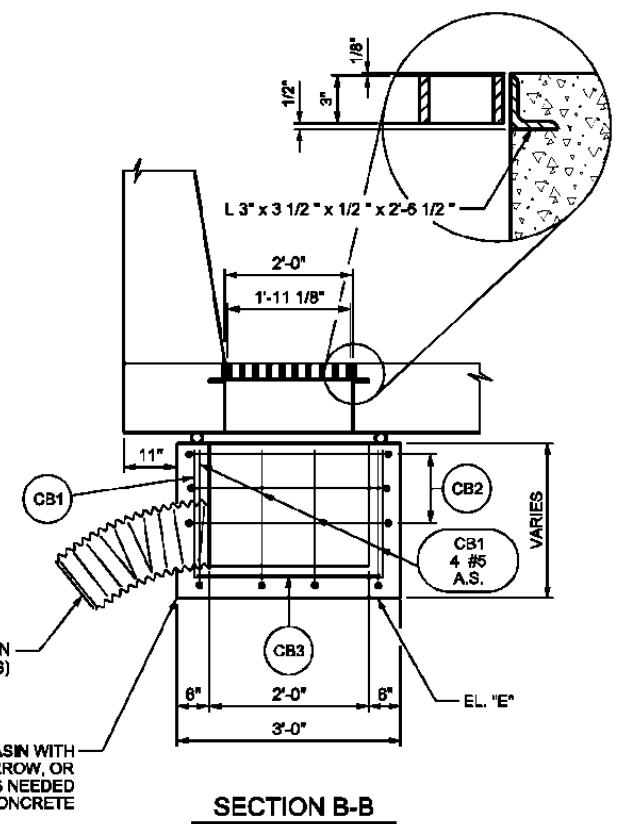
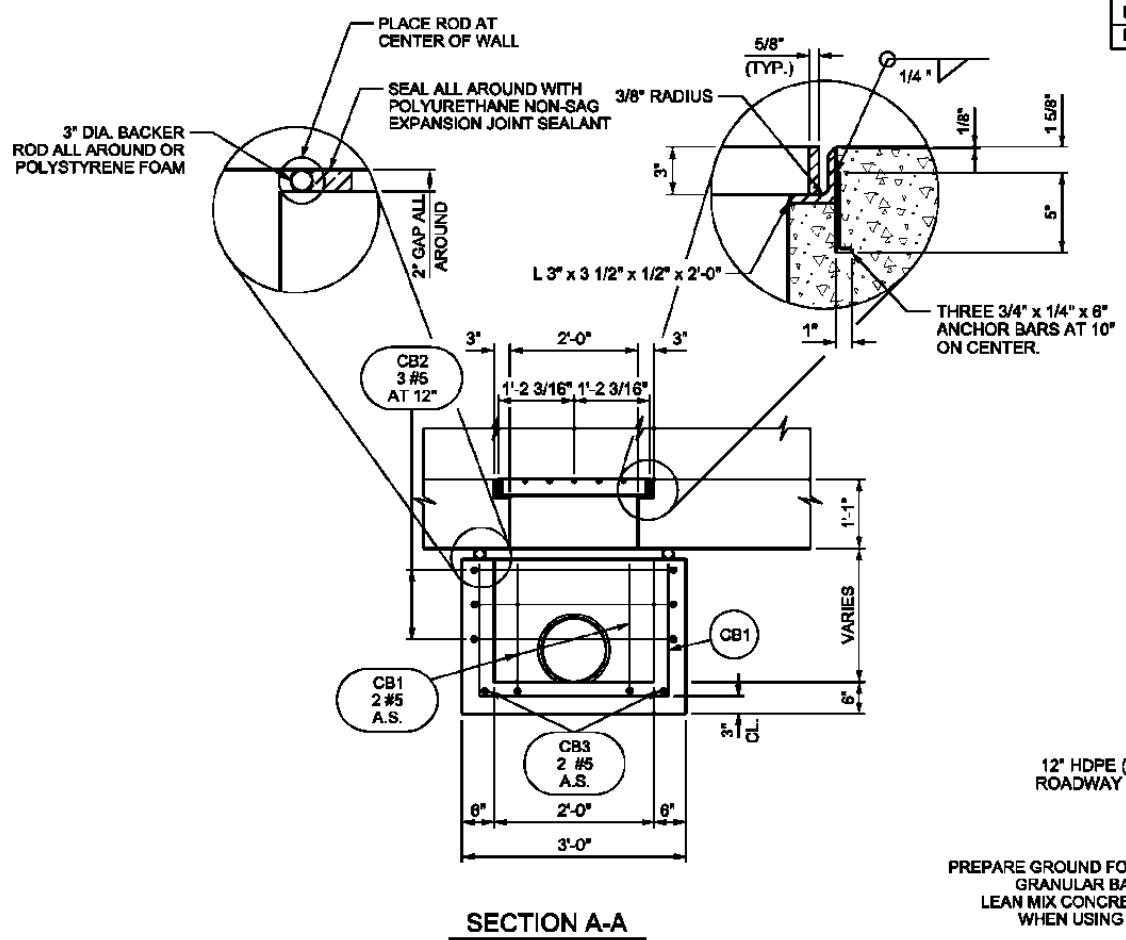

GENERAL NOTES

- FIELD CUT OR BEND APPROACH SLAB REINFORCING TO CLEAR APPROACH SLAB DRAINS.
- USE ASTM A36 OR A572 GRADE 50 FOR GRATE AND FRAME.

QUANTITIES

- STRUCTURAL CONCRETE QUANTITIES
- 1. CATCH BASINS AT 0.9 CU. YDS. = 0.9 CU. YDS.
- STRUCTURAL STEEL QUANTITY
- 1. GRATES AND FRAMES AT 273 LBS. = 273 LBS.

UTAH DEPARTMENT OF TRANSPORTATION		STRUCTURES DIVISION	
I-80; WANSHIP TO COALVILLE		PIN 8098	
WANSHIP INTERCHANGE: I-80 OVER SR-32		PROJECT NUMBER F-180-4(133)156	
EB APPROACH SLAB DRAIN		SUMMIT COUNTY	
C-1011		DRG NO.	
SHT. 32		OF 38	

NO.	DATE	BY	REVISION	DESIGN	CHECK	DATE
1	12/14/2011	REBECCA LYNNE KNAUS NIX	DESIGN	RLN	SL	11/11
2	12/14/2011	REBECCA LYNNE KNAUS NIX	FOR USE	MPP	SL	11/11
3	12/14/2011	REBECCA LYNNE KNAUS NIX	BY USDT	MPP	SL	11/11

14-LEC-2011

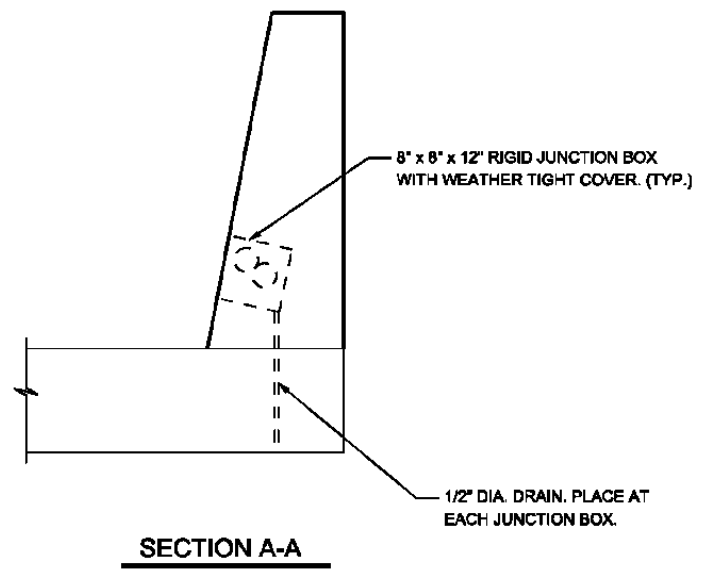

SECTION A-A

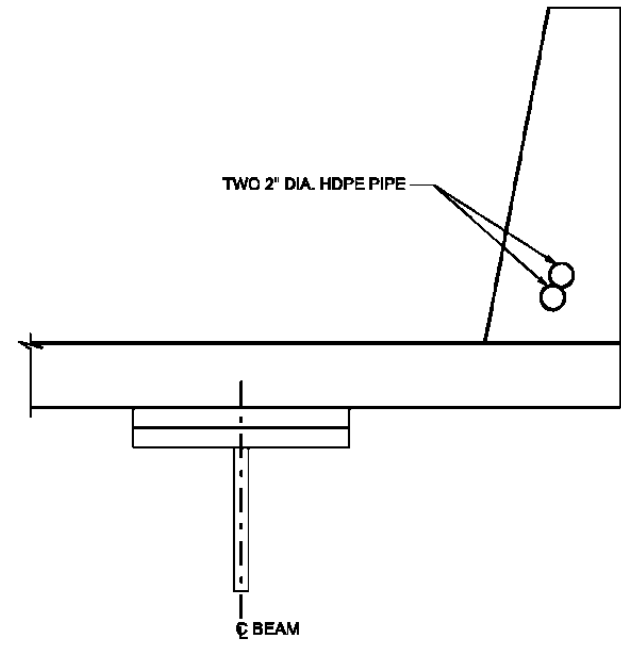
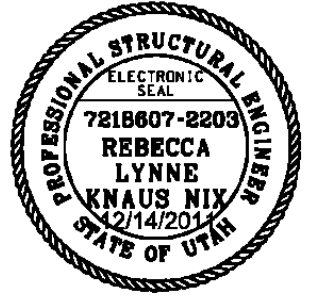

SECTION B-B

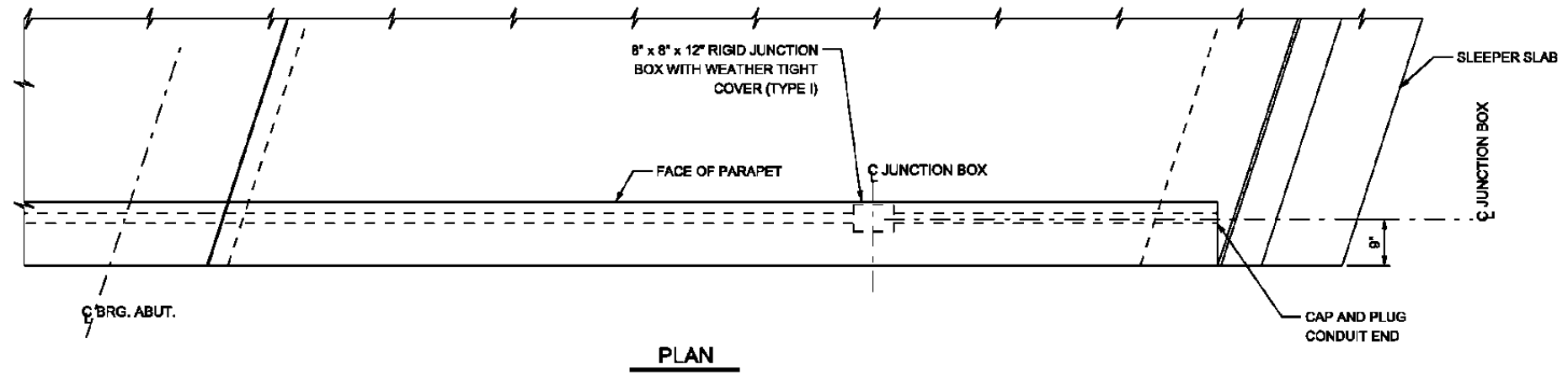

PLAN

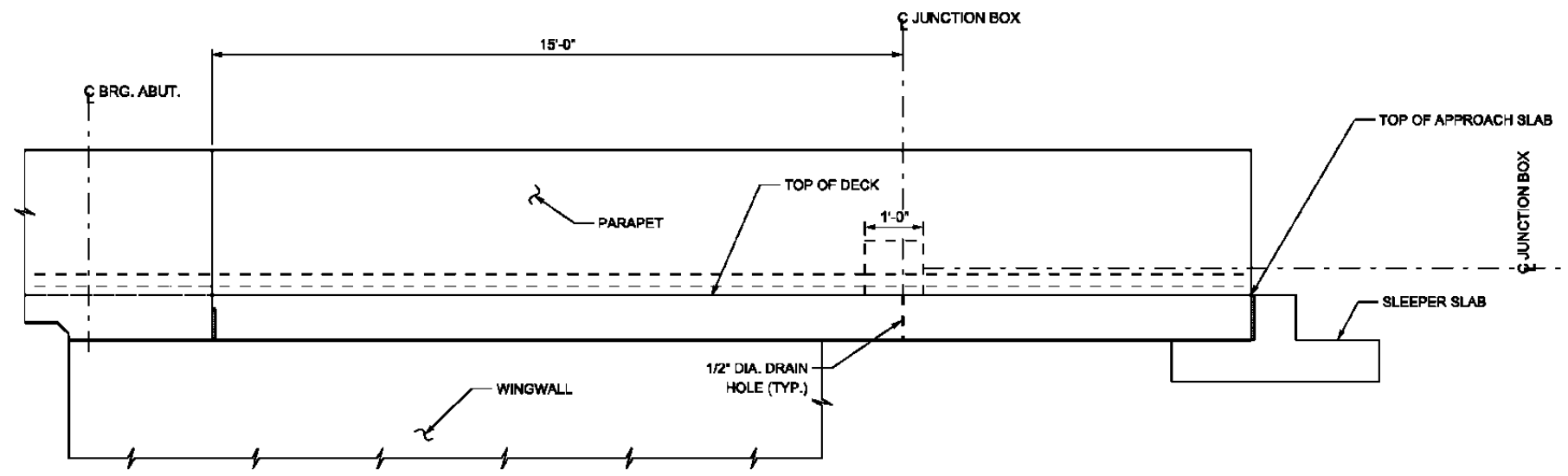

ELEVATION

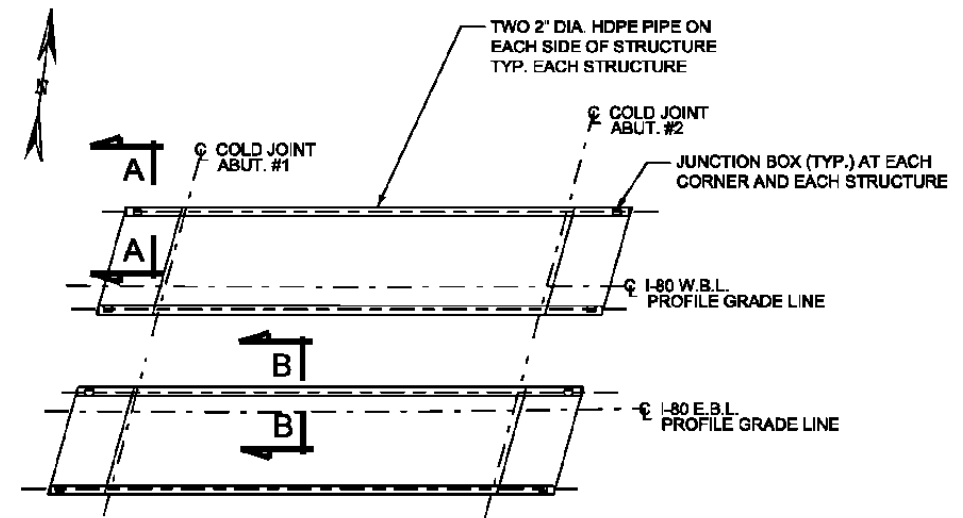

KEY PLAN

GENERAL NOTES

1. USE HDPE PIPE.
2. TERMINATE HDPE PIPE AT JUNCTION BOXES WITH DOUBLE LOCK NUTS.
3. ALL WORK SHALL COMPLY WITH THE LATEST EDITIONS OF THE NATIONAL ELECTRICAL CODE AND UNDERWRITERS LABORATORIES INC. STANDARDS WHERE APPLICABLE.

NO.	DATE	BY	REVISION
DESIGN	5/11		CHECK TAH 11/11
DRAWN	7/11		CHECK TAH 11/11
QUANT.	9/11		CHECK TAH 11/11

UTAH DEPARTMENT OF TRANSPORTATION
STRUCTURES DIVISION

I-80; WANSHIP TO COALVILLE
WANSHIP INTERCHANGE: I-80 OVER SR-32
ELECTRICAL DETAILS
PROJECT NUMBER: **F-180-4(133)156**
PIN: **8098**

SUMMIT COUNTY
C-1011
DRG. NO.
SHT. 33 OF 38

13414-C-2011

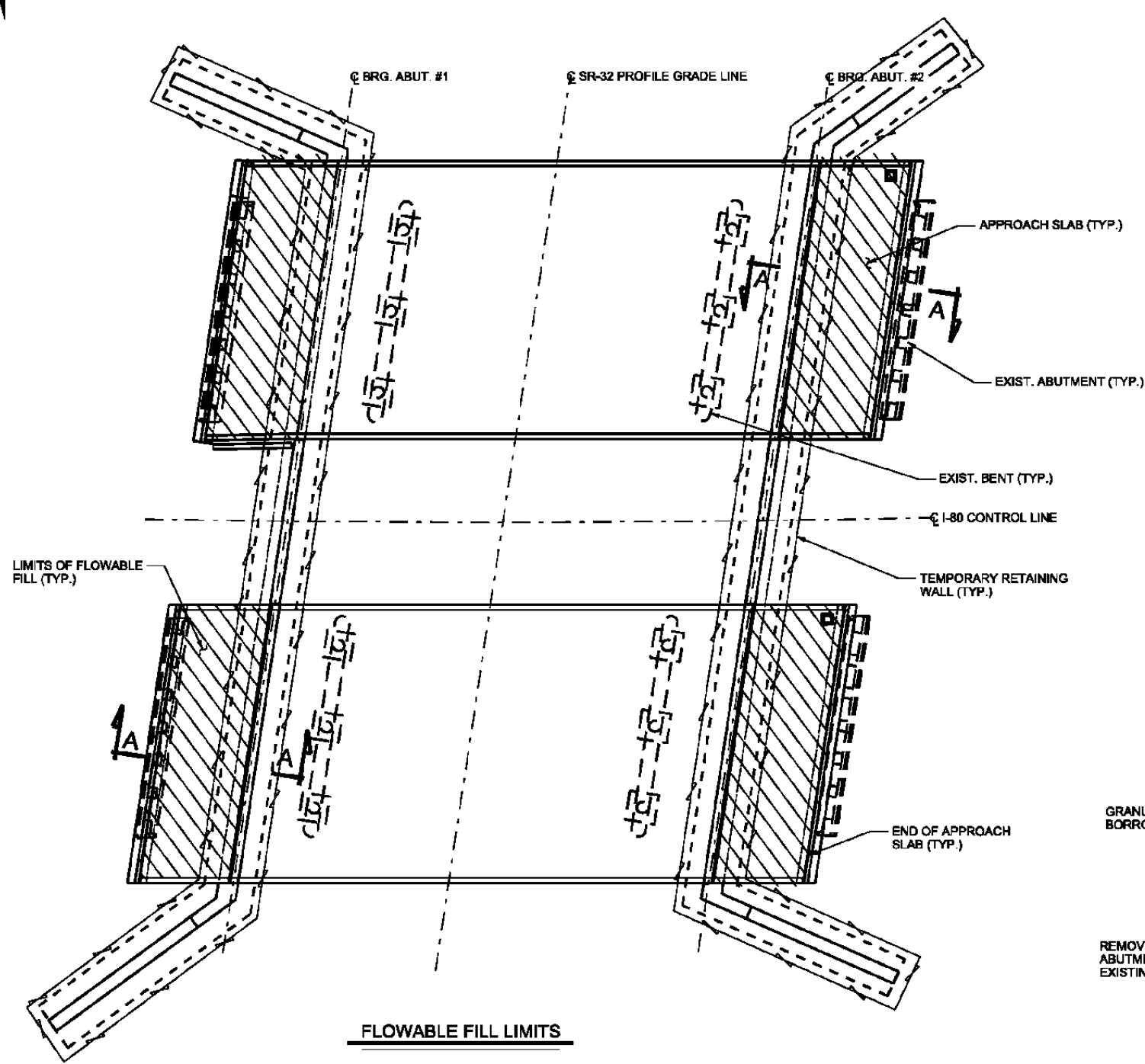

FLOWABLE FILL LIMITS

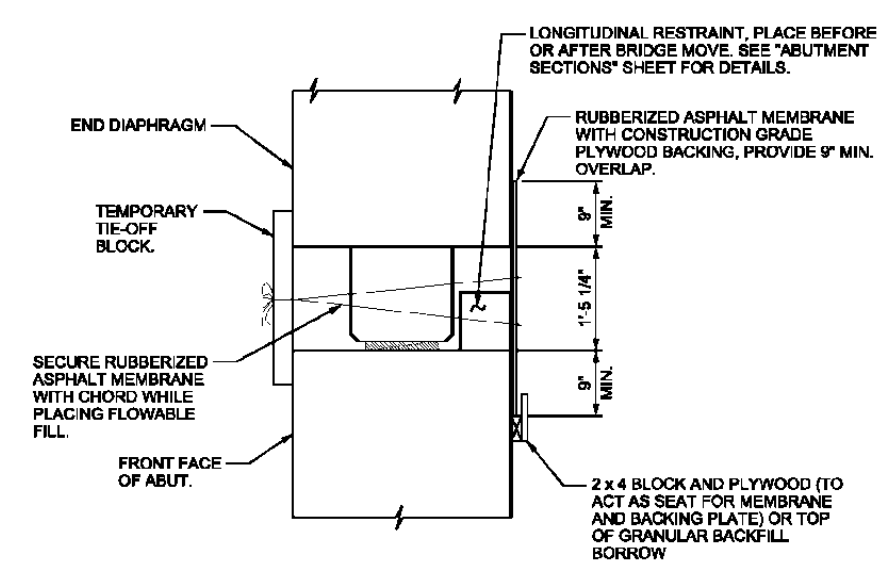

WATERPROOFING DETAIL

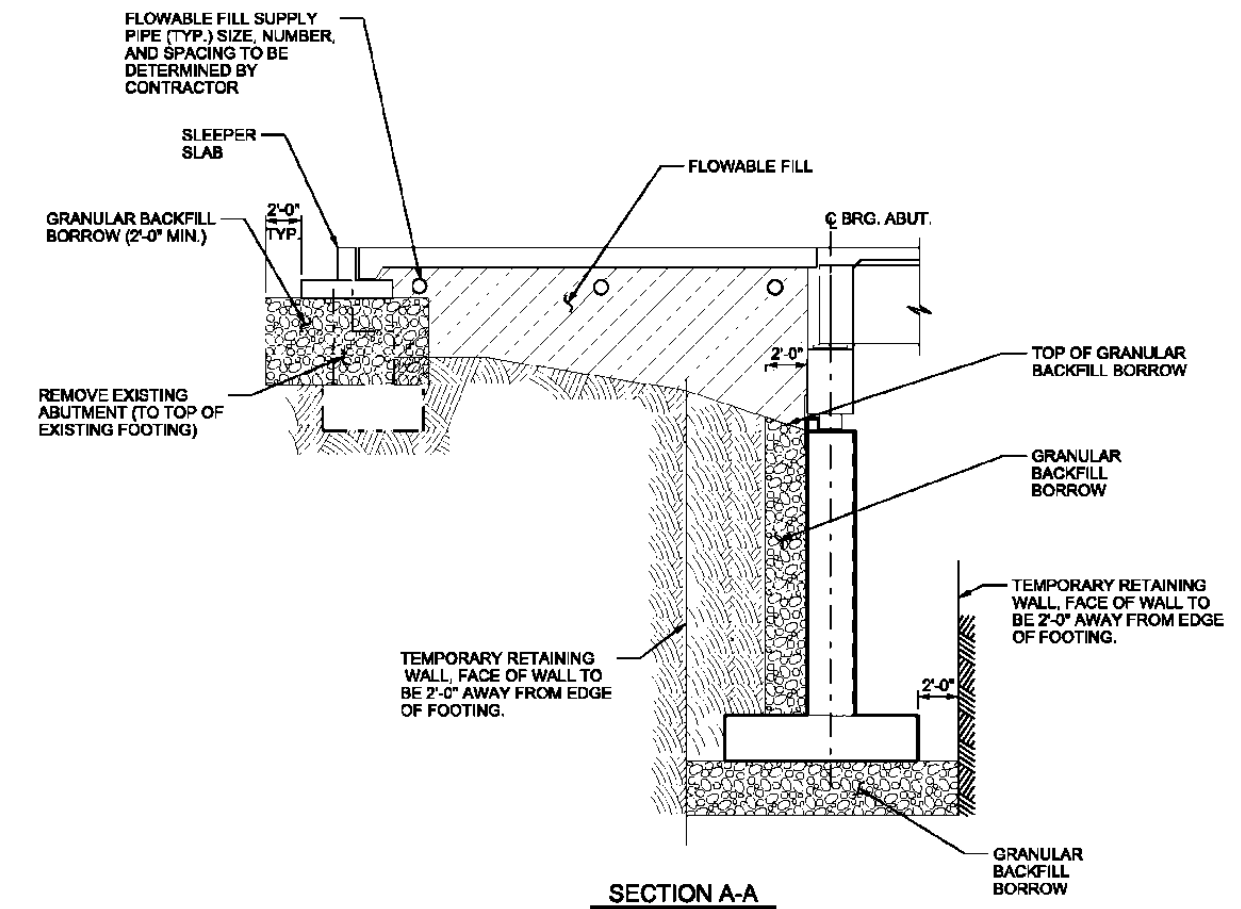

SECTION A-A



NO.	DATE	BY	REVISION
DESIGN	RLN	6/11	CHECK: TAH 11/11
DRAWN	MFP	7/11	CHECK: TAH 11/11
QUANT.	MFP	9/11	CHECK: TAH 11/11
APPROVAL FOR USE	DATE	BY	DATE
12/14/2011	12/14/2011	GRAND DESIGN ENGR.	DOT BRIDGE ENGR.

UTAH DEPARTMENT OF TRANSPORTATION
STRUCTURES DIVISION

I-80; WANSHIP TO COALVILLE
WANSHIP INTERCHANGE: I-80 OVER SR-32
MISCELLANEOUS I DETAILS
PROJECT NUMBER: **F-180-4(133)156** PIN: **8098**

SUMMIT COUNTY
C-1011
DRG. NO.
SHT. 34 OF 38

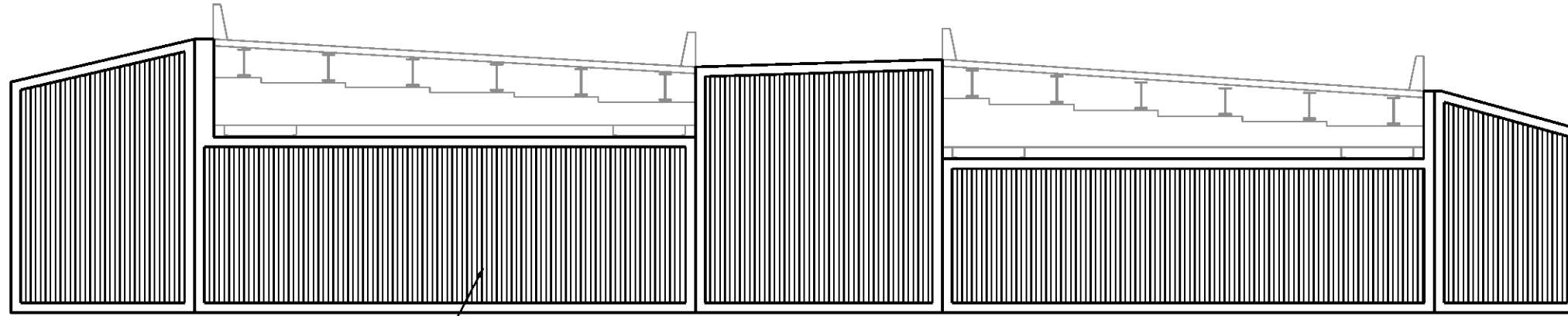

FRACTURED FIN TYPICAL
SEE "FRACTURED FIN DETAIL"

TYPICAL ABUTMENT AND WINGWALL ELEVATION

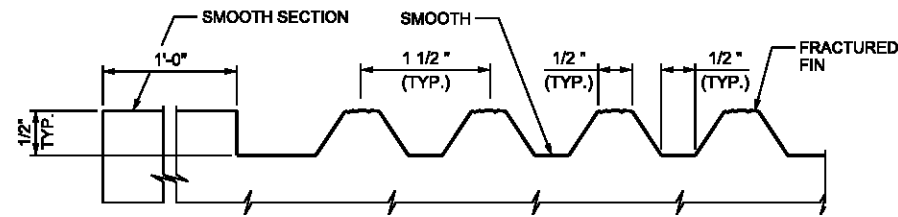

FRACTURED FIN DETAIL

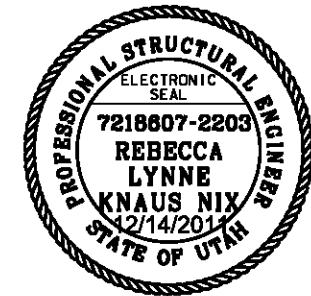

UTAH DEPARTMENT
OF
TRANSPORTATION
STRUCTURES DIVISION

I-80; WANSHIP TO COALVILLE
WANSHIP INTERCHANGE: I-80 OVER SR-32
MISCELLANEOUS II DETAILS
PROJECT NUMBER: F-180-4(133)156
PIN: 8098

SUMMIT COUNTY
C-1011
DRG. NO.

NO.	DATE	BY	REVISION REMARKS
DESIGN: RLN	6/11	CHECK: TAH	11/11
DRAWN: MPP	11/11	CHECK: TAH	11/11
QUANT: MPP	11/11	CHECK: TAH	11/11
APPROVAL FOR USE BY UDOT	DATE	BY	UDOT BRIDGE ENGR.
APPROVAL FOR USE BY UDOT	12/14/2011	REBECCA LYNNE KNAUS NIX	SENIOR DESIGN ENGR.

14-DEC-2011 09:41:10 PM F:\WP\DOT\BID\SR32\I-80\SR32\I-80 OVER SR-32\MISCELLANEOUS II DETAILS.dwg

MARK	LOCATION	SIZE NO.	NO. BARS	TYPE	LENGTH	TOTAL LENGTH	DIMENSIONS				SERIES INC.	REMARKS
							A	B	C	D		
S1	DECK	5	220	STR.	91'-4"	20093'-3"	88'-9"	2'-7"	1			
S2	DECK	5	358	STR.	47'-8"	17064'-8"	47'-8"					
S3	DECK	5	96	8	6'-7"	632'-0"	6'-0"					
S4	DECK	4	820	1	4'-11"	4031'-8"	1'-0"	3'-11"				
S5	DECK	4	820	10	4'-11"	4031'-8"	0'-8"	3'-11"	1'-0"			
S6	DECK	7	252	STR.	10'-0"	2520'-0"	10'-0"					
S7	DECK	5	326	12	48'-10"	15919'-8"	47'-8"					
S8	DECK	8	32	12	49'-10"	1594'-8"	47'-8"					
AS1	APPR. SLAB	5	SER. OF 71	2	TO 6'-6"	1431'-10"	2'-0"	0'-11"	0'-8"	0'-0 1/2"	A	
AS2	APPR. SLAB	5	288	STR.	24'-8"	7104'-0"	24'-8"					
AS3	APPR. SLAB	9	288	STR.	24'-8"	7104'-0"	24'-8"					
AS4	APPR. SLAB	5	304	STR.	47'-8"	14490'-8"	47'-8"					
AS5	APPR. SLAB	9	8	STR.	6'-0"	48'-0"	6'-0"					
AS6	APPR. SLAB	5	32	STR.	47'-8"	1525'-4"	47'-8"					
AS7	APPR. SLAB	5	SER. OF 71	13	TO 6'-1"	1313'-6"	2'-0"	0'-6"	0'-8"	0'-0 1/2"	A	
P1	PARAPET	4	40	STR.	24'-6"	980'-0"	24'-6"					
P2	PARAPET	4	40	STR.	24'-1"	983'-4"	24'-1"					
P3	PARAPET	4	40	STR.	90'-8"	3626'-8"	88'-8"	2'-0"	1			
SS1	SLEEPER SLAB	5	SER. OF 31	16	TO 7'-9"	403'-0"	0'-8"	1'-10"		0'-0 1/2"	A	
SS2	SLEEPER SLAB	5	SER. OF 43	16	TO 11'-3"	817'-0"	0'-8"	3'-1"		0'-0 1/2"	A	
SS3	SLEEPER SLAB	5	SER. OF 43	16	TO 8'-9"	602'-0"	0'-8"	1'-10"		0'-0 1/2"	A	
SS4	SLEEPER SLAB	5	SER. OF 31	16	TO 11'-3"	620'-0"	0'-8"	3'-7"		0'-0 1/2"	A	
SS5	SLEEPER SLAB	5	20	STR.	19'-3"	385'-0"	19'-3"					
SS6	SLEEPER SLAB	5	12	STR.	28'-0"	336'-0"	28'-0"					
SS7	SLEEPER SLAB	5	20	STR.	28'-0"	560'-0"	28'-0"					
SS8	SLEEPER SLAB	5	12	STR.	19'-3"	231'-0"	19'-3"					
SS9	SLEEPER SLAB	5	592	STR.	4'-8"	2762'-8"	4'-8"					
SS10	SLEEPER SLAB	5	SER. OF 8	STR.	TO 28'-8"	897'-4"				0'-2 1/8"		
SS11	SLEEPER SLAB	5	SER. OF 8	STR.	TO 18'-8"	897'-4"				0'-2 1/8"		
SS12	SLEEPER SLAB	5	SER. OF 8	STR.	TO 19'-11"	617'-4"				0'-2 1/8"		
SS13	SLEEPER SLAB	5	SER. OF 8	STR.	TO 19'-11"	617'-4"				0'-2 1/8"		
SS14	SLEEPER SLAB	4	32	6	2'-6"	80'-0"	0'-8"	1'-3"	1'-3"			

SUMMARY OF STAINLESS BARS

13633'-5"	OF	NUMBER 4	BARS	AT	0.668	LBS/FT	=	9108	LBS
83297'-1	OF	NUMBER 5	BARS	AT	1.043	LBS/FT	=	86880	LBS
2520'-0"	OF	NUMBER 7	BARS	AT	2.044	LBS/FT	=	5151	LBS
1594'-8"	OF	NUMBER 8	BARS	AT	2.670	LBS/FT	=	4258	LBS
7152'-0"	OF	NUMBER 9	BARS	AT	3.400	LBS/FT	=	24317	LBS

TOTAL = 129714 LBS

BENDING DIAGRAMS

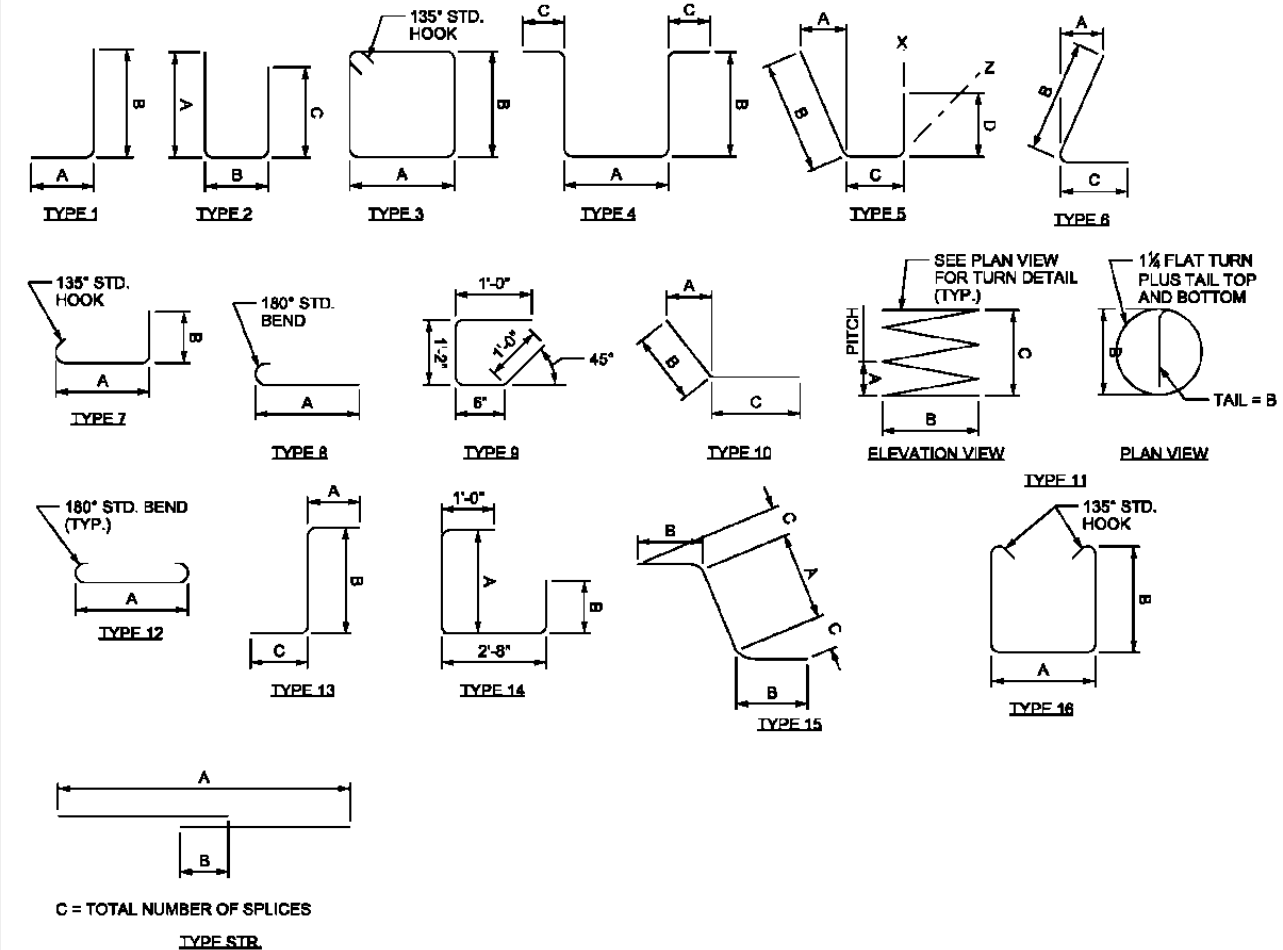

REMARKS CODES

- A - "B" DIMENSION SHOWN IS THE STARTING LENGTH. INCREMENT "B" DIMENSION FOR EACH BAR BY DIMENSION UNDER "SERIES INC."
- B - "C" DIMENSION SHOWN IS THE STARTING LENGTH. INCREMENT "C" DIMENSION FOR EACH BAR BY DIMENSION UNDER "SERIES INC."
- C - "B" AND "C" DIMENSION SHOWN IS THE STARTING LENGTH. INCREMENT "B" AND "C" DIMENSION FOR EACH BAR BY DIMENSION UNDER "SERIES INC."

NOTES:

- ALL BARS DETAILED ON THIS SHEET ARE STAINLESS STEEL.
- BAR SIZES ARE U.S. UNITS.
- REINFORCING STEEL DIMENSIONS ARE OUT TO OUT OF BARS UNLESS OTHERWISE NOTED.
- TYPE 'STR.' INDICATES A STRAIGHT BAR. TYPE 'SER. OF' INDICATES SERIES (CUT SET) BARS AND COLUMN TITLE 'SERIES INC.' IS ABBREVIATED FOR 'SERIES INCREMENT'.
- SERIES BARS - EACH BAR VARIES BY TABULATED AMOUNT.
- SPLICES MAY BE OMITTED AT FABRICATORS OPTION, HOWEVER, IN SUCH CASE, FABRICATOR ASSUMES RESPONSIBILITY FOR FIT.
- USE THE CRSI MANUAL OF PRACTICE, LATEST EDITION FOR ALL HOOKS, BENDS AND FABRICATION OF REINFORCING STEEL UNLESS NOTED OTHERWISE.
- STAGGER MECHANICAL SPLICES IN BUNDLED BARS.



UTAH DEPARTMENT OF TRANSPORTATION STRUCTURES DIVISION

I-80; WANSHIP TO COALVILLE
WANSHIP INTERCHANGE: I-80 OVER SR-32
STAINLESS STEEL REINFORCING STEEL SCHEDULE
PROJECT NUMBER F-180-4(133)156 PIN 8098

SUMMIT COUNTY
C-1011
DRG NO.

MARK	LOCATION	SIZE NO.	NO. BARS	TYPE	LENGTH	TOTAL LENGTH	DIMENSIONS				SERIES INC.	REMARKS
							A	B	C	D		
A1	ABUTMENT	9	35	10	9'-0"	315'-0"	0'-9"	4'-0"	5'-0"			
A2	ABUTMENT	9	103	STR.	15'-6"	1596'-6"	15'-6"					
A3	ABUTMENT	9	SER. OF 49	STR. TO	24'-9"	1231'-2"				0 1/8"		
A4	ABUTMENT	5	140	STR.	47'-8"	8673'-4"	47'-8"					
A5	ABUTMENT	5	108	STR.	23'-7"	2499'-10"	23'-7"					
A6	ABUTMENT	5	248	2	8'-8"	2132'-0"	3'-0"	2'-8"	3'-0"			
A7	ABUTMENT	9	115	STR.	17'-8"	2031'-8"	17'-8"					
A8	ABUTMENT	5	192	6	4'-0"	768'-0"	2'-0"	2'-0"	2'-0"			
A9	ABUTMENT	9	35	10	9'-0"	315'-0"	2'-10"	4'-0"	5'-0"			
A10	ABUTMENT	9	115	STR.	14'-5"	1657'-11"	14'-5"					
A11	ABUTMENT	9	114	STR.	16'-8"	1900'-0"	16'-8"					
A12	ABUTMENT	9	SER. OF 49	STR. TO	23'-9"	1182'-2"				0 1/8"		
A13	ABUTMENT	8	81	STR.	4'-0"	324'-0"	4'-0"					
A14	ABUTMENT	7	SER. OF 25	STR. TO	24'-9"	628'-2"				0'-0 3/8"		
A15	ABUTMENT	7	58	STR.	15'-6"	899'-0"	15'-6"					
A18	ABUTMENT	7	SER. OF 25	STR. TO	23'-9"	603'-2"				0'-0 3/8"		
A21	ABUTMENT	7	59	STR.	14'-5"	850'-7"	14'-5"					
A22	ABUTMENT	7	59	STR.	17'-8"	1042'-4"	17'-8"					
A26	ABUTMENT	5	SER. OF 2	STR. TO	9'-3"	318'-3"	0'-6"	2'-0"	5'-0"	1'-9"	B	
A27	ABUTMENT	7	52	STR.	16'-8"	866'-8"	16'-8"					
A30	ABUTMENT	5	SER. OF 2	STR. TO	8'-5"	356'-3"	1'-5"	2'-0"	5'-0"	1'-11"	B	
A31	ABUTMENT	9	20	STR.	7'-11"	158'-4"	7'-11"					
A32	ABUTMENT	9	SER. OF 6	STR. TO	6'-9"	176'-0"				0'-2 3/4"		
A33	ABUTMENT	9	20	STR.	7'-11"	218'-4"	10'-11"					
A34	ABUTMENT	9	SER. OF 6	STR. TO	9'-9"	248'-0"				0'-2 3/4"		
A35	ABUTMENT	9	35	10	10'-11"	376'-3"	1'-0"	4'-0"	6'-9"			
A36	ABUTMENT	9	35	10	10'-11"	382'-1"	2'-10"	4'-0"	6'-11"			
F1	FOOTING	5	12	13	9'-9"	117'-0"	3'-9"	3'-0"	3'-0"			
F2	FOOTING	5	12	13	10'-6"	126'-0"	4'-6"	3'-0"	3'-0"			
F3	FOOTING	7	113	1	9'-2"	1035'-10"	3'-0"	6'-2"				
F4	FOOTING	9	220	1	11'-0"	2420'-0"	3'-0"	8'-0"				
F5	FOOTING	8	440	STR.	10'-8"	4693'-4"	10'-8"					
F6	FOOTING	5	24	STR.	21'-8"	520'-0"	21'-8"					
F7	FOOTING	5	24	STR.	24'-8"	592'-0"	24'-8"					
F8	FOOTING	5	24	STR.	35'-2"	844'-0"	35'-2"					
F9	FOOTING	5	24	STR.	25'-2"	604'-0"	25'-2"					
F10	FOOTING	8	1024	STR.	11'-8"	11946'-8"	11'-8"					
F11	FOOTING	9	556	1	11'-9"	6533'-0"	3'-0"	8'-9"				
F12	FOOTING	5	52	STR.	136'-6"	7088'-0"	129'-0"	3'-9"	2			
F13	FOOTING	7	284	1	10'-0"	2840'-0"	3'-0"	7'-0"				
F14	FOOTING	5	SER. OF 12	STR. TO	4'-11"	454'-0"	0'-9"	3'-0"	1'-2"	0'-9 7/8"	B	
F15	FOOTING	8	164	STR.	14'-0"	1749'-4"	10'-8"					
F16	FOOTING	5	12	13	9'-6"	114'-0"	3'-6"	3'-0"	3'-0"			
F17	FOOTING	5	12	13	10'-3"	123'-0"	4'-3"	3'-0"	3'-0"			
F18	FOOTING	5	SER. OF 12	STR. TO	8'-1"	516'-0"	2'-1"	3'-0"	3'-0"	0'-5 7/8"	B	
F19	FOOTING	5	12	13	13'-5"	104'-0"	2'-8"	3'-0"	3'-0"			
F20	FOOTING	5	12	13	8'-8"	113'-0"	3'-5"	3'-0"	3'-0"			
F21	FOOTING	5	12	13	9'-5"	125'-0"	4'-5"	3'-0"	3'-0"			
F22	FOOTING	5	12	13	11'-2"	134'-0"	5'-2"	3'-0"	3'-0"			
D1	DIAPHRAGM	5	16	STR.	47'-8"	762'-8"	47'-8"					
D2	DIAPHRAGM	5	8	STR.	43'-9"	350'-0"	43'-9"					
D3	DIAPHRAGM	5	20	STR.	47'-9"	955'-0"	47'-9"					
D4	DIAPHRAGM	11	40	STR.	47'-8"	1906'-8"	47'-8"					
D5	DIAPHRAGM	8	36	14	11'-6"	414'-0"	4'-3"	3'-7"				
D6	DIAPHRAGM	8	68	14	12'-6"	850'-0"	4'-9"	4'-1"				
D7	DIAPHRAGM	8	68	14	13'-6"	918'-0"	5'-3"	4'-7"				
D8	DIAPHRAGM	8	68	14	14'-6"	986'-0"	5'-9"	5'-1"				
D9	DIAPHRAGM	8	68	14	15'-6"	1054'-0"	6'-3"	5'-7"				
D10	DIAPHRAGM	8	84	14	16'-6"	1386'-0"	6'-9"	6'-1"				
D11	DIAPHRAGM	8	392	2	7'-2"	2809'-4"	3'-3"	2'-2"	1'-9"			
D12	DIAPHRAGM	5	8	STR.	25'-11"	207'-4"	25'-11"					
D13	DIAPHRAGM	5	60	STR.	7'-10"	470'-0"	7'-10"					
D14	DIAPHRAGM	5	72	STR.	6'-0"	432'-0"	6'-0"					
D15	DIAPHRAGM	6	36	4	13'-9"	495'-0"	6'-3"	2'-6"	1'-3"			
D16	DIAPHRAGM	5	168	4	7'-6"	1280'-0"	0'-10"	2'-8"	0'-10"			
D17	DIAPHRAGM	6	36	15	6'-3"	225'-0"	1'-9"	2'-3"	1'-8"			
D18	DIAPHRAGM	6	36	2	4'-8"	168'-0"	2'-2"	1'-6"	1'-0"			

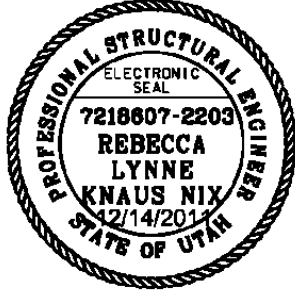
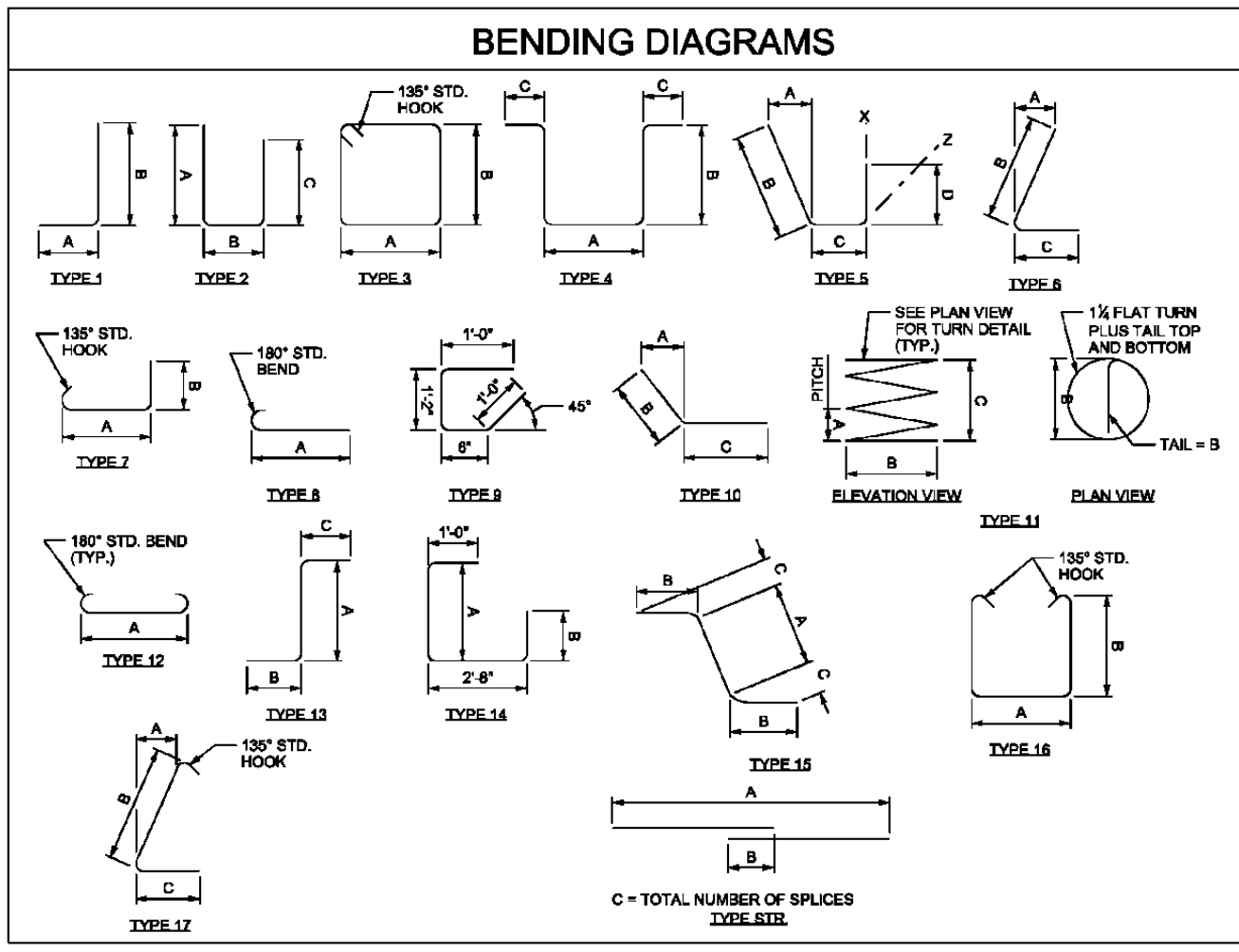

REMARKS CODES

- A - "B" DIMENSION SHOWN IS THE STARTING LENGTH. INCREMENT "B" DIMENSION FOR EACH BAR BY DIMENSION UNDER "SERIES INC."
- B - "C" DIMENSION SHOWN IS THE STARTING LENGTH. INCREMENT "C" DIMENSION FOR EACH BAR BY DIMENSION UNDER "SERIES INC."
- C - "B" AND "C" DIMENSION SHOWN IS THE STARTING LENGTH. INCREMENT "B" AND "C" DIMENSION FOR EACH BAR BY DIMENSION UNDER "SERIES INC."

NOTES:

1. ALL BARS DETAILED ON THIS SHEET ARE COATED.
2. BAR SIZES ARE U.S. UNITS.
3. REINFORCING STEEL DIMENSIONS ARE OUT TO OUT OF BARS UNLESS OTHERWISE NOTED.
4. TYPE 'STR.' INDICATES A STRAIGHT BAR. TYPE 'SER. OF' INDICATES SERIES (CUT SET) BARS AND COLUMN TITLE 'SERIES INC' IS ABBREVIATED FOR 'SERIES INCREMENT'.
5. SERIES BARS - EACH BAR VARIES BY TABULATED AMOUNT.
6. SPLICES MAY BE OMITTED AT FABRICATORS OPTION, HOWEVER, IN SUCH CASE, FABRICATOR ASSUMES RESPONSIBILITY FOR FIT.
7. USE THE CRSI MANUAL OF PRACTICE, LATEST EDITION FOR ALL HOOKS, BENDS AND FABRICATION OF REINFORCING STEEL UNLESS NOTED OTHERWISE.
8. STAGGER MECHANICAL SPLICES IN BUNDLED BARS.

UTAH DEPARTMENT OF TRANSPORTATION STRUCTURES DIVISION

WANSHIP TO COALVILLE
 WANSHIP INTERCHANGE: I-80 OVER SR-32
 COATED REINFORCING STEEL SCHEDULE I

PROJECT NUMBER: F-180-4(133)156
 PIN: 8098

REVISIONS: DESIGNER: RLN, 5/11, CHECK: DD, 11/11; DRAWN: MFP, 7/11, CHECK: DD, 11/11; QUANT: MFP, 9/11, CHECK: DD, 11/11

APPROVAL: RECORDED: 12/14/2011, DATE: 12/14/2011, FOR USE: 12/14/2011, BY: JDOT

SUMMIT COUNTY

C-1011
 DRG NO.

SHT. 37 OF 38

MARK	LOCATION	SIZE NO.	NO. BARS	TYPE	LENGTH	TOTAL LENGTH	DIMENSIONS				SERIES INC.	REMARKS
							A	B	C	D		
D19	DIAPHRAGM	6	24	3	6'-6"	156'-0"	1'-9"	0'-10"				
D20	DIAPHRAGM	5	8	STR.	47'-8"	381'-4"	47'-8"					
D21	DIAPHRAGM	5	8	STR.	9'-7"	78'-8"	9'-7"					
D22	DIAPHRAGM	8	388	12	3'-10"	1487'-4"	2'-8"					
CB1	CATCH BASIN	5	6	2	9'-10"	58'-0"	3'-8"	2'-6"	3'-8"			
CB2	CATCH BASIN	5	7	3	11'-3"	78'-9"	2'-7"	2'-7"				
CB3	CATCH BASIN	5	4	STR.	2'-8"	10'-8"	2'-8"					
CB4	CATCH BASIN	5	6	2	10'-10"	65'-0"	4'-2"	2'-6"	4'-2"			
W1	WINGWALL	9	1 45	SER. OF STR.	12'-8" 17'-9"	684'-5"					0'-13/8"	
W2	WINGWALL	7	1 23	SER. OF STR.	12'-8" 17'-9"	349'-10"					0'-2 3/4"	
W3	WINGWALL	5	26 2	STR.	21'-8" 3'-5"	563'-4"	21'-8"					
W4	WINGWALL	5	5	SER. OF STR.	20'-8"	120'-5"					4'-3 3/4"	
W5	WINGWALL	5	2	STR.	22'-3"	44'-6"	22'-3"					
W6	WINGWALL	9	1 51	SER. OF STR.	10'-11" 17'-6"	724'-8"					0'-15/8"	
W7	WINGWALL	7	1 28	SER. OF STR.	10'-11" 17'-6"	369'-5"					0'-3 1/8"	
W8	WINGWALL	5	24 2	STR.	24'-8" 2'-3"	592'-0"	24'-8"					
W9	WINGWALL	5	6	SER. OF STR.	21'-2"	140'-6"					3'-9 3/8"	
W10	WINGWALL	5	2	STR.	25'-6"	51'-0"	25'-6"					
W11	WINGWALL	9	1 72	SER. OF STR.	14'-7" 23'-2"	1359'-0"					0'-11/2"	
W12	WINGWALL	7	1 37	SER. OF STR.	14'-7" 23'-2"	698'-5"					0'-2 7/8"	
W13	WINGWALL	5	32 2	STR.	35'-2" 4'-10"	1125'-4"	35'-2"					
W14	WINGWALL	5	7	SER. OF STR.	30'-0"	243'-10"					4'-2 3/8"	
W15	WINGWALL	5	2	STR.	36'-2"	72'-4"	36'-2"					
W16	WINGWALL	9	1 52	SER. OF STR.	14'-4" 21'-0"	918'-8"					0'-15/8"	
W17	WINGWALL	7	1 27	SER. OF STR.	14'-4" 21'-0"	477'-0"					0'-3 1/8"	
W18	WINGWALL	5	30 2	STR.	25'-2" 4'-1"	755'-0"	25'-2"					
W19	WINGWALL	5	6	SER. OF STR.	23'-1"	163'-0"					3'-9 5/8"	
W20	WINGWALL	5	2	STR.	26'-0"	52'-0"	26'-0"					

SUMMARY OF COATED BARS

33363'-4"	OF NUMBER 5	BARS AT 1.043	LBS/FT = 34798	LBS
1044'-0"	OF NUMBER 6	BARS AT 1.502	LBS/FT = 1569	LBS
10660'-3"	OF NUMBER 7	BARS AT 2.044	LBS/FT = 21790	LBS
28618'-1"	OF NUMBER 8	BARS AT 2.670	LBS/FT = 76411	LBS
24428'-0"	OF NUMBER 9	BARS AT 3.400	LBS/FT = 83056	LBS
1906'-8"	OF NUMBER 11	BARS AT 5.313	LBS/FT = 10131	LBS
TOTAL =				227755 LBS

NOTE:

SEE "COATED REINFORCING STEEL SCHEDULE I" SHEET FOR BENDING DIAGRAMS, REMARK CODES AND NOTES.

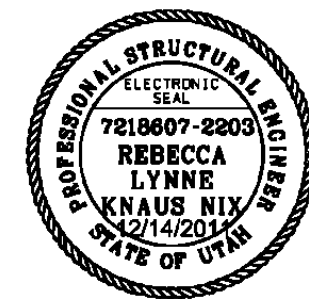

UTAH DEPARTMENT OF TRANSPORTATION STRUCTURES DIVISION		I-80; WANSHIP TO COALVILLE	
WANSHIP INTERCHANGE: I-80 OVER SR-32		COATED REINFORCING STEEL SCHEDULE II	
PROJECT NUMBER F-180-4(133)156		PIN 8098	
SUMMIT COUNTY		C-1011 DRG NO.	
SHT. 38		OF 38	

NO.	DATE	BY	REVISION
1	12/14/2011		DESIGN
2	12/14/2011		DRAWN
3	12/14/2011		CHECKED
4	12/14/2011		APPROVED

14-100-2011

Appendix D: Sample Special Provisions



Massena Bridge, Iowa

**SPECIAL PROVISIONS FOR
PREFABRICATED BRIDGE SUPERSTRUCTURE MOVE**

**Cass County
BRF-092-2(36)--38-15**

**Effective Date
April 16, 2013**

THE STANDARD SPECIFICATIONS, SERIES 2012, ARE AMENDED BY THE FOLLOWING MODIFICATIONS AND ADDITIONS. THESE ARE SPECIAL PROVISIONS AND THEY SHALL PREVAIL OVER THOSE PUBLISHED IN THE STANDARD SPECIFICATIONS.

120041.01 DESCRIPTION.

- A.** Furnish, erect and install a prefabricated bridge superstructure move system including temporary works. Move the prefabricated bridge superstructure constructed off of the existing alignment into its final position.
- B.** Bridge Staging Area (BSA) – a suggested BSA off of the existing alignment and within the Right-of-Way for constructing the prefabricated bridge superstructure is shown in the plans.
- C.** Temporary works (falsework) for supporting and moving the prefabricated bridge superstructure shall be designed in accordance with the AASHTO LRFD Bridge Construction Specifications, 3rd Edition 2010 by a Professional Engineer licensed in the State of Iowa.
- D.** Prefabricated bridge superstructure move system shall be designed by a Professional Engineer licensed in the State of Iowa.
- E.** This specification is written assuming the contractor will use a system to move the prefabricated bridge superstructure such as a slide along the bridge superstructure bearings (permanent or temporary) or as a heavy lift transporting the prefabricated bridge superstructure into its final position.

120041.02 MATERIALS.

Apply the requirements of the Standard Specifications and Project Plans.

120041.03 CONSTRUCTION.

A. Submittals.

1. Temporary Works (Falsework).

- a. Include detailed plans for items such as temporary support structures, falsework, cofferdams, shoring and temporary bridges.
 - 1) Show temporary supports for the superstructure. Include bents or ground beams, foundations and temporary piling.
 - 2) Show elevations and dimensions of temporary bearings, as necessary, to match the relative positions of the final permanent bearings at the bridge site.
 - 3) If attachment of the temporary system to the bridge substructure is required, submit detailed calculations and plans for the proposed attachment.
- b. Include design calculations and supporting data for all temporary works.

2. Prefabricated Bridge Superstructure Move.

Detailed shop and/or working drawings, and/or cut sheets of all equipment and material used for sliding and/or lifting/lowering the prefabricated bridge superstructure are to be submitted. Include the following:

- a. Details of the move system, components, mechanical devices, jacks, temporary blocking, and operational techniques.
 - 1) Include locations of all equipment during the structure move.
 - 2) Include calculated superstructure weight for the move based on actual, known dimensions of components and known densities of materials.
 - 3) Include weight capacities of the move system and limitations necessary for stability during all jacking, raising or lowering, and moving operations.
 - 4) Include QC/QA procedures to be followed during the prefabricated bridge superstructure move.
 - 5) Include a contingency plan in the event of a major equipment breakdown or other major delays.
 - 6) Include operational details for the control of the movement (forward and reverse), braking, lifting and lowering. Include a system of check off items for the Operators and for safety purposes.
- b. Revisions to the concepts and to the detailed descriptions of materials, components, erection methods, and sequencing indicated on the plans. Include changes to locations of permanent support conditions, cross section component sizes and/or connectivity, construction joints in any plane, and splice location, sizes and/or types.
- c. Details of the BSA and travel path.
 - 1) Provide details of the BSA, general layout, surface grading, surface material, drainage, environmental protection, material storage area, concrete delivery methods, shelters, prefabricated superstructure move path, accesses, fences, gates, barriers, offices, and workshops.
 - 2) Include foundations and details of temporary bents or abutment seats to support the span under construction, including piling, spread footings, or other foundations.
 - 3) Include clearances, utilities, details of construction, and intended access under the completed superstructure.
- d. Geotechnical report and calculations for the temporary works, BSA, prefabricated bridge superstructure move system and travel path.
 - 1) Verify that the BSA and travel path have suitable foundations for all proposed construction operations.
 - 2) Include the means for mitigating unacceptably high or concentrated loads.
 - 3) Include calculations for actual and allowable bearing pressures along the travel path, or actual pile loads and design bearing for temporary piling.
- e. A step-by-step sequence of prefabricated bridge superstructure move operations.
- f. Design calculations and supporting data.

3. Geometry Control Plan.

- a. The geometry control plan can be submitted in the form of working drawings or a manual.
- b. Include measuring equipment, procedures and locations of geometry control reference points on the superstructure and in the BSA. Establish longitudinal and lateral location reference points on the prefabricated superstructure that correspond to, or can be referenced to, appropriate longitudinal and lateral reference points at the erection site.
- c. Include locations and values of permanent benchmarks and reference points in the BSA and the bridge site.
- d. Include a geometry control procedure for monitoring deflection change and twist before, during the move and after setting the superstructure in the permanent position.
- e. Establish and maintain records of key vertical elevations along the main longitudinal elements at the ends, proposed lifting supports, and mid-span.
- f. Include a monitoring plan for deflections and twist distortion during the move.

4. Submittal Review Period.

Allow the Engineer 14 calendar days to review submittals.

B. Prefabricated Bridge Superstructure Construction.**1. Temporary Support Structures**

- a. Verify that temporary support structures are built according to the plans for temporary works.
- b. Verify that support surfaces are built to the required elevations and tolerances with sufficient clearances to accommodate the prefabricated bridge superstructure move system.

2. Embedded Items.

- a. Embedded items include scuppers, hand holes, anchor bolts or fixtures for bearings, barriers, and similar appurtenances. Where post-tensioning is used, embedded items also include associated post-tensioning components, whether permanent or for temporary purposes.
- b. Ensure all embedded items are in their correction locations and elevations.

3. Age At Prefabricated Bridge Superstructure Move.

- a. Do not lift or move the prefabricated bridge superstructure until the concrete has attained the concrete design strength specified in the plans and has cured the minimum number of calendar days per Article 2412.03, E of the Standard Specifications.
- b. The concrete design strength shall be verified in accordance with Article 2403.03, N, 2 of the Standard Specifications.

C. Prefabricated Bridge Superstructure Move.**1. General.**

- a. The intent during lifting, transportation and placement is to ensure the structure is delivered to the Contracting Authority, in its final location, with no damage or adverse loss of strength, loss of performance or loss of long term durability. To this end, it is necessary to place certain limitations upon characteristics that can be quantified and observed or checked by careful observations or by using suitable detection methods during these operations.
- b. Exercise care when placing the span into its final location on the bridge bearings and use observations to monitor and record conditions just before and just after setting the span in place.
- c. The Contractor shall schedule a test move of a minimum of 6 inches prior to the actual move day to test their systems and controls.

2. Deflection and Twist Control During Prefabricated Bridge Superstructure Move.

- a. The Contractor is responsible for ensuring the superstructure span does not deflect or twist beyond the allowable tolerances and are responsible for ensuring the superstructure is not damaged during lifting, transporting and setting.
- b. Maintain twist distortion of superstructure within maximum allowable tolerance at all times during movement. The maximum allowable twist distortion is defined in Tolerances.
- c. Immediately prior to setting span down in final bridge location, check that twist distortion of superstructure span is less than that allowed.
- d. Immediately after setting span in final location on permanent bearings, check that elevations and twist distortion of superstructure span are satisfactory. Allowable permanent twist distortion is zero.
- e. In the event of breakdown during transport, perform deflection and twist check as soon as possible after bringing operations to a halt. Perform intermediate checks during the period of the breakdown and again prior to moving.

3. Deflection and Twist Control Monitoring During Prefabricated Bridge Superstructure Move.

- a. Using measurements of elevations, determine the Deflection Change of the ends of the span relative to mid-span as a result of the first lifting of the span. During transport, use elevation measurements or devices to monitor twist distortion (Twist) of the span itself.
- b. Monitor the global rotational attitude of the span itself longitudinally and transversely in a manner independent of any self-leveling devices and monitoring systems of the move system itself.
- c. By means of taking elevation readings or by using other methods approved by the Engineer, take responsibility for taking the above observations or implementing monitoring methods accordingly. As a minimum, observe, report and act upon the following to avoid exceeding these limits and tolerances:
 - 1) Deflection Change:
 - a) For observation purposes, as a minimum, take elevations over the end bearings, the centers of any supplementary supports and at mid-span on the centerlines of the fascia beams and calculate the Deflection Change as the difference between the condition just before to just after the initial lifting of the span (if applicable).
 - b) Take the Deflection Change as the average of the four observations over each end of each fascia beam.
 - 2) Twist.
 - 3) Change in Longitudinal Gradient (along the beams).
 - 4) Change in Transverse Gradient (across the beams of the span).

4. Tolerances.

a. Plan Alignment: Location and Clearances.

For the final condition of the span after placement in the prefabricated bridge superstructure:

- 1) Do not exceed 1/4 inch maximum deviation at each end of the span from overall longitudinal alignment after setting.
- 2) Do not exceed 1/4 inch maximum deviation from overall transverse location (i.e. longitudinal position) at each line of bearings.
- 3) Maximum deviation from alignment in both primary plan directions at each end of the span being set shall not exceed 1/4 inch or that required for the accommodation of manufactured expansion joint components or bearings, whichever is the less.
- 4) In the absence of other constraints, keep individual elements or surfaces within 1/4 inch of location with respect to similar matching surfaces.

b. Bridge Bearings: Elevation and Location.

- 1) Keep the elevation of individual bridge bearings or bearing plinths for prefabricated superstructure within plus or minus 1/8 inch of required elevations, unless tighter tolerances are required according to the bearing manufacturer or as specified on the Plans or Shop Drawings.

- 2) Keep the plan location of bridge bearings within 1/8 inch and the alignment within plus or minus 1/16 inch across the bearing, unless tighter tolerances are required according to the bearing manufacturer or as specified on the Plans or Shop Drawings.
 - 3) If tolerances are not met, submit for approval of Engineer, means to adjust elevations or to correct for or accommodate errors or unintended deviations from required tolerances. Submit proposals and seek approval of the Engineer for the use of shims, injection of high strength grout or other methods to accommodate differences from required tolerance. Do likewise, for the accommodation of anchor bolts or similar restraining devices.
- c. During Lifting, Transportation and Placement (Erection).**
- 1) **Deflection Change.**
Relative to the local tangent to the vertical profile grade at mid-span, keep the anticipated downward deflection of ends of superstructure when lifted at heavy lift support locations within $\pm 20\%$ of that given on the Plans or Shop Drawings.
 - 2) **Twist.**
 - a) For this purpose, twist is defined and measured as the maximum allowable upward or downward deflection of one corner relative to the plane defined concurrently by the elevations of the other three corners.
 - b) Twist is not allowed to exceed the lesser of $W/200$ or 0.25 feet when the four monitored points are over the centerlines of the permanent span support bearings. Twist is not allowed to exceed the lesser of $W/300$ or 0.16 feet when the four monitored points are over the centerlines of the heavy lift supports during the prefabricated bridge superstructure move. W is defined as the perpendicular width in feet between the centerlines of the fascia beams.
 - c) Keep the centers of the heavy lift support points no closer than the lesser of $0.10L$ or 15 feet and no further than $0.15L$ or 25 feet from the centerlines of permanent bearings. L is defined as the span between permanent bearings in feet.
 - d) Twist must remain within the above allowable limits or as otherwise predetermined and provided on the Plans or Shop Drawings in order to incur no damage (i.e. cracks), even if cracks close after setting the bridge span in place.
 - 3) **Change in Longitudinal Gradient (Along the Beams).**
 - a) The heavy lift firm is required to provide the maximum allowable change in longitudinal gradient.
 - b) The change in longitudinal gradient is defined as the change in slope experienced along the fascia beams from conditions just before first lifting to any time during transportation.
 - c) The longitudinal gradient may be calculated from differences in elevations taken just before lifting to elevations taken at any time during transport.
 - 4) **Change in Transverse Gradient (Across the Beams of Span).**
 - a) The heavy lift firm is required to provide the maximum allowable change in transverse gradient.
 - b) The change in transverse gradient is defined as the change in slope experienced along the end diaphragms from conditions just before first lifting to any time during transportation.
 - c) The change in transverse gradient may be calculated from differences in elevations taken just before lifting to elevations taken at any time during transport.

120041.04 METHOD OF MEASUREMENT.

Method of measurement is lump sum.

120041.05 BASIS OF PAYMENT.

Payment for Prefabricated Bridge Superstructure Move will be the Lump Sum contract price. Payment will be full compensation for furnishing a temporary support system, furnishing a bridge moving system, moving the prefabricated bridge superstructure into the final bridge position and removal of temporary works for the support and moving system. All the cost for equipment, labor and materials to complete the Prefabricated Bridge Superstructure Move shall be included in the contract price.

Wanship Bridge, Utah

**SPECIAL PROVISION PROJECT # F-I80-4(133)156
PIN # 8098**

SECTION 03371S

MOVE PREFABRICATED BRIDGE (SUPERSTRUCTURE)

PART 1 GENERAL

1.1 SECTION INCLUDES

- A. Furnish shop drawings and working load capacities of all heavy lift equipment (mechanical devices, jacks and other components).
- B. Execution of bridge movement.
- D. Monitoring of bridge movement.
- E. Post-event inspections and remedial action.

1.2 RELATED SECTIONS

- A. Section 02221M: Remove Structure and Obstruction
- B. Section 02455: Driven Piles
- C. Section 03055: Portland Cement Concrete
- D. Section 03211S: Reinforcing Steel and Welded Wire
- E. Section 03310: Structural Concrete
- F. Section 03314S: Structural Concrete - Lightweight
- G. Section 03390M: Concrete Curing
- H. Section 03392: Penetrating Concrete Sealer
- I. Section 03924: Structural Concrete Repair and Sealing
- J. Section 05120: Structural Steel

1.3 REFERENCES

- A. AASHTO Guide Design Specifications for Bridge Temporary Works
- B. AASHTO LRFD Bridge Construction Specifications
- C. AASHTO LRFD Bridge Design Specifications
- D. UDOT SPMT Process Manual

1.4 DEFINITIONS

- A. Working Drawings: Drawings produced by the Contractor that supplement the contract drawings to provide information not included in the contract documents, but that is required to fabricate, erect, transport or temporarily support the structure or structural elements in the completion of the work.
 - 1. Working drawings do not supersede the contract drawings.
- B. Approval of Working Drawings: Acceptance by the Department for use on the project. The Department will review working drawings for general conformance with the design concept and compliance with the contract documents. Review and approval do not relieve the Contractor from responsibility for errors, correctness of details, conformance to the contract, and the successful completion of the work.
- C. Temporary Works: Facilities that are generally designed by the Contractor and employed by the Contractor in the execution of the work, and whose failure to perform properly could adversely affect the character of the contract work or endanger the safety of adjacent facilities, property, or the public. Such facilities include but are not limited to temporary support structures, falsework, forms and form travelers, cofferdams, shoring, water control systems, and temporary bridges.

1.5 SUBMITTALS

- A. Working Drawings:
 - 1. Detailed shop drawings of all equipment and material used for sliding and/or lowering the bridge superstructure for approval.
 - a. Include the following:
 - 1) Details of the heavy lift system, components, mechanical devices, jacks, temporary blocking, and operational techniques.
 - i. Include locations of all equipment during the structure move.
 - ii. Include calculated superstructure weight for transportation based on actual, known

- iii. Include weight capacities of the heavy lift system and limitations necessary for stability during all jacking, raising or lowering, and moving operations.
 - iv. Include QC/QA procedures to be followed during the structure move.
 - v. Include a contingency plan in the event of a major equipment breakdown or other major delays.
 - vi. Include operational details for the control of the movement, lifting, and transportation. Include a system of check off items for the Operators and for safety purposes.
- 2) Revisions to the concepts and to the detailed descriptions of materials, components, erection methods, and sequencing indicated on the contract plans.
- i. Include changes to locations of permanent support conditions, cross section component sizes and/or connectivity, construction joints in any plane, and splice location, sizes, and/or types.
- 3) Details of the bridge staging area (BSA) and travel path.
- i. Provide details of the BSA and travel path location, general layout surface grading, surfacing material, drainage, environmental protection, material storage area, concrete delivery methods, shelters, heavy lift travel path(s), accesses, fences, gates, barriers, offices, and workshops.
 - ii. Include foundations and details of temporary bents or abutment seats to support the span under construction, including piling, spread footings, or other foundations.
 - iii. Include clearances, utilities, details of construction, and intended access under the completed superstructure.
- 4) Geotechnical report and calculations for the temporary works, bridge staging area, heavy lift system, and bridge travel path.
- i. Verify that the BSA and travel path have suitable foundations for all proposed construction operations.

- ii. Include the means of mitigating unacceptably high or concentrated loads.
 - iii. Include calculations for actual and allowable bearing pressures along the travel path.
 - b. Provide the seal of a Professional Engineer (PE) or Professional Structural Engineer (SE) licensed in the State of Utah.
 - c. Include supporting engineering calculations.
 - d. Design according to the AASHTO LRFD Bridge Design Specifications and the AASHTO Guide Design Specifications for Bridge Temporary Works.
 - e. Do not begin work until receiving approval of the shop drawings. The Department will reject units fabricated before shop drawing approval.
 - f. Costs incurred due to faulty design or detailing are the Contractor's responsibility.
- 2. Drawings for Temporary Works for approval.
 - a. Include detailed plans for items such as temporary support structures, falsework, concrete forms, cofferdams, shoring, and temporary bridges.
 - i. Show temporary supports for the superstructure. Include bents or ground beams and temporary piling.
 - ii. Show elevations and dimensions of temporary bearings, as necessary, to match the relative positions of the final permanent bearings at the bridge site.
 - iii. If attachment of the temporary system to the bridge substructure is required, submit detailed calculations and plans for the proposed attachment.
 - b. Include design calculations and supporting data.
 - c. Design temporary works according to the current edition of the AASHTO LRFD Bridge Construction Specifications, including additions incorporated by the UDOT SPMT Process Manual.
 - d. Provide the seal of a PE or SE licensed in the State of Utah.
 - e. Submit falsework drawings when the height of falsework exceeds 14.0 ft or whenever traffic, other than workers involved in constructing the bridge, will travel under the bridge.
 - f. Do not begin work until receiving approval of the drawings and calculations.
 - g. Costs incurred due to faulty design or detailing are the Contractor's responsibility.
- 3. Prepare drawings according to the following:
 - a. Submit drawings electronically in PDF format, 11 x 17 inch sheets with a 1½ inch blank margin on the left edge. Place

the following information in the title block in the lower right corner of each sheet:

- 1) State Project Designation
 - 2) State Project Name
 - 3) State Structure Number
 - 4) Contractor, Fabricator, or Erector Name
 - 5) Contractor, Fabricator, or Erector Drawing Number
 - 6) Contractor, Fabricator, or Erector Sheet Number
- b. Place basis of design criteria for all assumed loads, including wind and impact effects, limits for stability against overturning, combined stresses, deflection, and buckling on the working drawings.
 - c. Revise and resubmit drawings when directed by the Department.
 - d. Provide the seal of a PE or SE licensed in the State of Utah when required in the contract. Place the seal in the lower right corner of each sheet when required.
4. Prepare engineering calculations according to the following:
- a. Submit calculations electronically in PDF format. Use 8½ x 11 inch sheets with a 1-inch blank margin on the left edge or 11 x 17 inch sheets with a 1½ inch blank margin on the left edge. Title block location is at the top of 8½ x 11 inch sheets or the lower right corner of 11 x 17 inch sheets. Place the following information in the title block:
 - 1) State Project Designation
 - 2) State Project Name
 - 3) State Structure Number
 - 4) Contractor, Fabricator, or Erector Name
 - 5) Contractor, Fabricator, or Erector Drawing Number
 - 6) Contractor, Fabricator, or Erector Sheet Number
 - b. Provide the seal of a PE or SE licensed in the State of Utah on all engineering calculations. Place the seal on the calculation cover sheet.
 - c. Certify that engineering calculations have been checked according to the Department QC/QA Procedures.
5. Allow the Engineer 14 calendar days to review and approve working drawings and supporting calculations.
- a. The Engineer may grant an increase in the number of working days for the project when that time is exceeded.
 - b. This review period applies each time the drawings and calculations are submitted.
6. Do not deviate from the approved drawings unless authorized in writing by the Engineer. Assume the responsibility for costs incurred due to faulty detailing or fabrication.
- B. Other items not covered above to be submitted for approval.

1. Overall schedule of the timing and sequence of superstructure fabrication, erection, and transportation.
 - a. Submit an hour by hour schedule of the bridge move 14 calendar days prior to the scheduled move date for review.
2. Lift, Transport, and Place Superstructure - Step-by-Step Procedures
 - a. Provide a step-by-step sequence of operations for lifting, transporting, and placing the superstructure span.
3. Repair procedures for damage and injecting and sealing cracks.
 - a. Include verification of repair methodology and supporting calculations as necessary.
4. Geometry Control Plan
 - a. The geometry control plan can be submitted in the form of working drawings or a manual.
 - b. Include measuring equipment, procedures and locations of geometry control reference points on the superstructure and in the BSA.
 - i. Establish longitudinal and lateral location reference points on the fabricated superstructure that correspond to, or can be referenced to, appropriate longitudinal and lateral reference points at the erection site.
 - c. Include locations and values of permanent benchmarks and reference points in the BSA and at the bridge site.
 - d. Include a geometry control procedure for monitoring deflection change and twist before, during transportation, and after setting the superstructure span(s) in the permanent position.
 - e. Establish and maintain a record of key vertical elevations along the main longitudinal elements at the ends, proposed lifting supports, and midspan.
 - i. Maintain records in good condition so that they may be used for reference during erection and transportation.
 - f. Include a monitoring plan for deflections and twist distortion during transportation.

PART 2 PRODUCTS

2.1 MATERIALS

- A. Concrete
 1. Refer to Section 03055, Section 03310, and Section 03314S.
- B. Reinforcing Steel
 1. Refer to Section 03211.

- C. Structural Steel
 - 1. Refer to Section 05120.
- D. Temporary Piles
 - 1. Refer to Section 02455.

PART 3 EXECUTION

3.1 GENERAL REQUIREMENTS

- A. Design all temporary works according to the current edition of the AASHTO LRFD Bridge Construction Specifications, Section 3 (Temporary Works).
- B. Use methods and procedures to provide adequate safety to the general public from all construction activities, superstructure delivery, and erection using heavy lift equipment and falsework placed over or adjacent to traveled roadways, navigational or recreational waterways or any existing commercial, industrial or other facilities.

3.2 BRIDGE SUPERSTRUCTURE CONSTRUCTION

- A. Temporary Supports Structures
 - 1. Verify that temporary support structures are built according to approved working drawings.
 - 2. Verify that support surfaces are built to required elevations and tolerances with sufficient clearances to accommodate the heavy lift system and that the latter are independently verified by the heavy lift firm.
- B. Parapets
 - 1. Construct parapets prior to transporting the superstructure from the BSA to the final location.
- C. Embedded Items
 - 1. Embedded items include scuppers, manholes, anchor bolts or fixtures for bearings, barriers, light-poles, signs, utilities, and similar appurtenances. Where post-tensioning is used, embedded items also include associated post-tensioning components, whether permanent or for temporary purposes.
 - 2. Install reinforcing bar couplers and splices at designated construction joints and take measures to protect reinforcing bars when installing and making connections, in accordance with the approved Shop Drawings.
 - 3. Install temporary post-tensioning applied to the superstructure for the purpose of controlling tensile stresses during lifting and transportation using heavy lift systems in accordance with Move Prefabricated Bridge (Superstructure)

approved Shop Drawings. Follow approved details and procedures for restoring areas at temporary attachments for post-tensioning devices.

4. Ensure all embedded items are in their correct locations and elevations in accordance with tolerances required by UDOT Standards and Approved Shop Drawings.

D. Casting Requirements

1. Concrete Placement
 - a. Refer to Section 03310 and Section 03314S.
2. Concrete Curing
 - a. Refer to Section 03390M.
3. Age at Erection, (Lift, Transport, and Place)
 - a. Do not lift or attempt to transport the superstructure until it has attained a minimum age of 21 days since the last casting operation, unless otherwise approved by the Engineer.

E. Corrections and Repairs

1. For classification of crack treatments see Table 1.2. Penetrating Sealer for Cracks in Concrete Structures
 - a. Refer to Section 03392.
3. Epoxy Injection of Cracks in Concrete Structures
 - a. Refer to Section 03924.

Table 1

Crack Width	Location	Treatment
Less than 0.006 inches	Substructure and superstructure	Coat with penetrating sealer
Greater than 0.006 inches and less than 0.012 inches	Substructure and superstructure less than 18 feet above existing ground or high water elevation	Epoxy injection
Greater than 0.006 inches and less than 0.012 inches	Superstructure and substructure more than 18 feet above existing ground or high water elevation	Coat with penetrating sealer
Greater than 0.012 inches and less than 0.025 inches	Substructure and superstructure	Epoxy injection

3.3 PREPARATION FOR TRANSPORT OF SUPERSTRUCTURE

A. Heavy Lift System (Jacking, Cribbing, Raising and Lowering)

1. Carefully jack-up and /or jack-down superstructure in an incremental or differential fashion using the insertion or removal of incremental cribbing, purpose-made steel grillages, blocks, prefabricated falsework sections or similar devices to facilitate raising or lowering of the superstructure span by the amount necessary to move the bridge to the final elevation.
2. Operate heavy lift system with care and within anticipated height change limitations (stroke limits) of the jacking systems. Follow limitations on Shop Drawings or Manuals for all incremental and differential jacking with due regard to corresponding stability conditions for the heavy lift system, super-works and falsework.
3. Implement checking (QC/QA) procedures prior to a transportation operation in order to ensure satisfactory completion.
4. Implement contingency plans in the event of a major breakdown or equipment malfunction.

3.4 LIFT, TRANSPORTATION, AND PLACEMENT OF SUPERSTRUCTURE

A. General

1. The intent during lifting, transportation and placement is to ensure that the structure is delivered to the Owner, in its final location, with no damage or adverse loss of strength, loss of performance or loss of long term durability. To this end, it is necessary to place certain limitations upon characteristics that can be quantified and observed or checked by careful observations or by using suitable detection methods during these operations.
2. Exercise care and precaution when placing the span into its final location on the bridge bearings and use observations to monitor and record conditions just before and just after setting the span in place.

B. Deflection and Twist Control During Transportation

1. The Contractor is responsible for ensuring the superstructure span does not deflect or twist beyond the allowable tolerances and are responsible for ensuring the superstructure is not damaged during lifting, transporting and setting.
2. Maintain twist distortion of superstructure within maximum allowable tolerance at all times during movement. The maximum allowable twist distortion is defined in Section 3.5.
3. Immediately prior to setting span down in final bridge location, check that twist distortion of superstructure span is less than that allowed.
4. Immediately after setting span in final location on permanent bearings, check that elevations and twist distortion of

superstructure span are satisfactory. Allowable permanent twist distortion is zero.

5. In the event of breakdown during transport, perform deflection and twist check as soon as possible after bringing operations to a halt. Perform intermediate checks during the period of the breakdown and again prior to moving.

C. Deflection and Twist Control Monitoring During Transportation

1. Using measurements of elevations, determine the Deflection Change of the ends of the span relative to mid-span as a result of the first lifting of the span. During transport, use elevation measurements or devices to monitor twist distortion (Twist) of the span itself.
2. Monitor the global rotational attitude of the span itself longitudinally and transversely in a manner independent of any self-leveling devices and monitoring systems of the heavy lift system itself.
3. By means of taking elevation readings or by using other methods approved by the Engineer, take responsibility for taking the above observations or implementing monitoring methods accordingly. As a minimum, observe, report and act upon the following to avoid exceeding these limits and tolerances:
 - a. Deflection Change
 - 1) For observation purposes, as a minimum, take elevations over the end bearings, the centers of the HL supports and at mid-span on the centerlines of the edge beams (total of 10 locations) and calculate the Deflection Change as the difference between the condition just before to just after the initial lifting of the span.
 - 2) Take the Deflection Change as the average of the four observations over each end of each edge beam.
 - b. Twist
 - c. Change in Longitudinal Gradient (along the beams)
 - d. Change in Transverse Gradient (across the beams of the span)

3.5 TOLERANCES

A. Plan Alignment: Location and Clearances

1. For the final condition of the span after placement in the bridge:
 - a. Do not exceed $\frac{1}{4}$ inch maximum deviation at each end of span from overall longitudinal alignment of an individual span after setting.

- b. Do not exceed $\frac{1}{4}$ inch maximum deviation from overall transverse location (i.e. longitudinal position) at each line of bearings.
 - c. Maximum deviation from alignment in both primary plan directions at each end of the span or spans being set shall not exceed $\frac{1}{4}$ inch or that required for the accommodation of manufactured expansion joint components or bearings, whichever is the less.
 - d. In the absence of other constraints, keep individual elements or surfaces within $\frac{1}{4}$ inch of location with respect to similar matching surfaces at expansion joints (i.e. plane of web or parapet) of adjacent spans, pier or abutment features.
- B. Bridge Bearings: Elevation and Location
- 1. Keep the elevation of individual bridge bearings or bearing plinths for prefabricated superstructure within plus or minus $\frac{1}{16}$ inch of required elevations, unless tighter tolerances are required according to the bearing manufacturer or as specified on the Plans or approved Shop Drawings.
 - 2. Keep the plan location of bridge bearings within $\frac{1}{8}$ inch and the alignment within plus or minus $\frac{1}{16}$ inch across the bearing, unless tighter tolerances are required according to the bearing manufacturer or as specified on the Plans or approved Shop Drawings.
 - 3. If tolerances are not met, submit for approval of Engineer, means to adjust elevations or to correct for or accommodate errors or unintended deviations from required tolerances.
 - a. Submit proposals and seek approval of the Engineer for the use of shims, injection of high strength grout or other methods to accommodate differences from required tolerance. Do likewise, for the accommodation of anchor bolts or similar restraining devices.
- C. Expansion Joints
- 1. Keep elevations and alignments of surfaces of adjacent spans to accommodate expansion joint devices within plus or minus $\frac{1}{8}$ inch of dimensioned locations, unless tighter tolerances are required according to the expansion joint device manufacturer or as specified on the Plans or approved Shop Drawings.
 - 2. If tolerances are not met submit for approval of Engineer, means to adjust elevations or to correct for or accommodate errors or unintended deviations from required tolerances.
- D. During Lifting, Transportation and Placement (Erection)
- 1. Deflection Change

- a. Relative to the local tangent to the vertical profile grade at mid-span, keep the anticipated downward deflection of ends of superstructure when lifted at heavy lift support locations within plus or minus 20% of that given on the Plans or approved Shop Drawings.
2. Twist
 - a. For this purpose, twist is defined and measured as the maximum allowable upward or downward deflection of one corner relative to the plane defined concurrently by the elevations of the other three corners.
 - b. Twist is not allowed to exceed the lesser of $W/200$ or 0.25 feet when the four monitored points are over the centerlines of the permanent span support bearings. Twist is not allowed to exceed the lesser of $W/300$ or 0.16 feet when the four monitored points are over the centerlines of the heavy lift supports during transportation.
 - 1) W is defined as the perpendicular width in feet between the centerlines of the edge beams.
 - c. Keep the centers of the heavy lift support points no closer than the lesser of $0.10L$ (or 15 feet) and no further than $0.15L$ (or 25feet) from the centerlines of permanent bearings.
 - 1) L is defined as the span between permanent bearings in feet.
 - d. Twist must remain within the above allowable limits or as otherwise predetermined and provided on the Plans or approved Shop Drawings in order to incur no damage (i.e. cracks), even if cracks close after setting the bridge span in place.
3. Change in Longitudinal Gradient (along the beams)
 - a. The heavy lift firm is required to provide the maximum allowable change in longitudinal gradient.
 - b. The change in longitudinal gradient is defined as the change in slope experienced along the edge beams from conditions just before first lifting to any time during transportation.
 - c. The longitudinal gradient may be calculated from differences in elevations taken just before lifting to elevations taken at any time during transport.
4. Change in Transverse Gradient (across the beams of span)
 - a. The heavy lift firm is required to provide the maximum allowable change in transverse gradient.
 - b. The change in transverse gradient is defined as the change in slope experienced along the end diaphragms from conditions just before first lifting to any time during transportation.

- c. The change in transverse gradient may be calculated from differences in elevations taken just before lifting to elevations taken at any time during transport.

END OF SECTION