

FTA RESEARCH

FEDERAL TRANSIT ADMINISTRATION

An Assessment of the Business Case for Communications-Based Train Control

SEPTEMBER 2013

FTA Report No. 0045
Federal Transit Administration

PREPARED BY

Delcan Corporation
New York Rail Technology, PE PC



COVER PHOTO

Photograph by Justin Lane. Purchased from European Pressphoto Agency b.v. (epa) in Frankfurt, Germany; Image #50584103.

DISCLAIMER

This document is disseminated under the sponsorship of the U.S. Department of Transportation in the interest of information exchange. The United States Government assumes no liability for its contents or use thereof. The United States Government does not endorse products or manufacturers. Trade or manufacturers' names appear herein solely because they are considered essential to the objective of this report.

An Assessment of the Business Case for Communications- Based Train Control

SEPTEMBER 2013

FTA Report No. 0045

PREPARED BY

Alan Rumsey
Lori Colangelo
Nigel Astell
Delcan Corporation
8618 Westwood Center Drive, Suite 450
Tysons, VA 22182

Nabil Ghaly
New York Rail Technology, PE PC
PO Box 2687
Huntington Station, NY 11746

SPONSORED BY

Federal Transit Administration
Office of Research, Demonstration and Innovation
U.S. Department of Transportation
1200 New Jersey Avenue, SE
Washington, DC 20590

AVAILABLE ONLINE

<http://www.fta.dot.gov/research>

Metric Conversion Table

SYMBOL	WHEN YOU KNOW	MULTIPLY BY	TO FIND	SYMBOL
LENGTH				
in	inches	25.4	millimeters	mm
ft	feet	0.305	meters	m
yd	yards	0.914	meters	m
mi	miles	1.61	kilometers	km
VOLUME				
fl oz	fluid ounces	29.57	milliliters	mL
gal	gallons	3.785	liters	L
ft³	cubic feet	0.028	cubic meters	m ³
yd³	cubic yards	0.765	cubic meters	m ³
NOTE: volumes greater than 1000 L shall be shown in m ³				
MASS				
oz	ounces	28.35	grams	g
lb	pounds	0.454	kilograms	kg
T	short tons (2000 lb)	0.907	megagrams (or "metric ton")	Mg (or "t")
TEMPERATURE (exact degrees)				
°F	Fahrenheit	$5 (F-32)/9$ or $(F-32)/1.8$	Celsius	°C

REPORT DOCUMENTATION PAGE		Form Approved OMB No. 0704-0188	
Public reporting burden for this collection of information is estimated to average 1 hour per response, including the time for reviewing instructions, searching existing data sources, gathering and maintaining the data needed, and completing and reviewing the collection of information. Send comments regarding this burden estimate or any other aspect of this collection of information, including suggestions for reducing this burden, to Washington Headquarters Services, Directorate for Information Operations and Reports, 1215 Jefferson Davis Highway, Suite 1204, Arlington, VA 22202-4302, and to the Office of Management and Budget, Paperwork Reduction Project (0704-0188), Washington, DC 20503.			
1. AGENCY USE ONLY	2. REPORT DATE September 2013	3. REPORT TYPE AND DATES COVERED	
4. TITLE AND SUBTITLE An Assessment of the Business Case for Communications-Based Train Control		5. FUNDING NUMBERS FTA-2011-006-TRI	
6. AUTHOR(S) Alan Rumsey, Lori Colangelo, Nigel Astell, Delcan Corporation Nabil Ghaly, New York Rail Technology PE, PC			
7. PERFORMING ORGANIZATION NAME(S) AND ADDRESS(ES) Delcan Corporation 8618 Westwood Ctr. Dr. Suite 450 Tysons, VA 22182		8. PERFORMING ORGANIZATION REPORT NUMBER FTA Report No. 0045	
9. SPONSORING/MONITORING AGENCY NAME(S) AND ADDRESS(ES) U.S. Department of Transportation Federal Transit Administration Office of Research, Demonstration and Innovation East Building 1200 New Jersey Avenue, SE		10. SPONSORING/MONITORING AGENCY REPORT NUMBER FTA Report No. 0045	
11. SUPPLEMENTARY NOTES [http://www.fta.dot.gov/research]			
12A. DISTRIBUTION/AVAILABILITY STATEMENT Available from: National Technical Information Service (NTIS), Springfield, VA 22161. Phone 703.605.6000, Fax 703.605.6900, email [orders@ntis.gov]		12B. DISTRIBUTION CODE TRI-20	
13. ABSTRACT This study examines the retrofit of Communications-Based Train Control (CBTC) on two North American transit properties, namely New York City Transit (NYCT) and the Southeastern Pennsylvania Transportation Authority (SEPTA), with the objective of assessing the benefits realized and implementation challenges experienced. The study validates broader industry experience that CBTC offers benefits that cannot be achieved with prior generations of signaling technology. The study also highlights that the challenges in upgrading the signaling/train control systems on an existing high-capacity mass transit system should not be underestimated. To this end, the study recommends that an increased emphasis on a Systems Engineering process be adopted throughout the life-cycle of a CBTC upgrade project. This study provides transit agencies contemplating a CBTC upgrade program with a better understanding of CBTC technology, as well as a tool to assist in the planning, business case development, and management of CBTC projects.			
14. SUBJECT TERMS Communications-based train control, CBTC, signaling technology, train control systems, positive train control		15. NUMBER OF PAGES 195	
16. PRICE CODE			
17. SECURITY CLASSIFICATION OF REPORT Unclassified	18. SECURITY CLASSIFICATION OF THIS PAGE Unclassified	19. SECURITY CLASSIFICATION OF ABSTRACT Unclassified	20. LIMITATION OF ABSTRACT

TABLE OF CONTENTS

1	Executive Summary
4	Section 1: Introduction
7	Section 2: Study Background and Objectives
7	Study Context
15	Study Purpose
15	Study Scope
17	Section 3: Project Reviews
17	Compliance with Industry Standards
18	Assessment of Enabling Technologies
21	Safety Certification Process Review
23	Qualitative Cost/Benefit Assessments
32	Section 4: NYCT Canarsie Line CBTC Pilot Project
34	Pre-CBTC Operations
39	CBTC Solution Selected
54	Implementation Approach
63	Post-CBTC Operations
67	Qualitative Cost/Benefit Assessment
70	Section 5: SEPTA Light Rail Tunnel CBTC Project
71	Pre-CBTC Operations
74	CBTC Solution Selected
88	CBTC Implementation Approach
95	Post-CBTC Operations
98	Qualitative Cost/Benefit Assessment
101	Section 6: Major Findings
102	Compliance with Industry Standards
102	Assessment of Enabling Technologies
104	Safety Certification Process Reviews
105	Qualitative Cost/Benefit Assessments
107	Section 7: Other Analyses
107	Need for Secondary Train Control with CBTC
119	Lessons Learned from Positive Train Control (PTC)
133	Section 8: Conclusions and Recommendations
133	Conclusions
134	Recommendations
139	Opportunities for Further Research
140	Appendix A: IEEE Std 1474.1™ Comparison Assessment – NYCT
152	Appendix B: IEEE Std 1474.1™ Comparison Assessment – SEPTA
163	Appendix C: Assessment of NYCT Safety Certification Process
172	Appendix D: Assessment of SEPTA Safety Certification Process
181	Acronyms and Abbreviations
185	References

LIST OF FIGURES

24	Figure 3-1:	CBTC Benefit Factors
24	Figure 3-2:	CBTC Cost Factors
32	Figure 4-1:	Canarsie Line
35	Figure 4-2:	NYCT Signal Control Line
35	Figure 4-3:	Typical NYCT Mechanical Interlocking Control Machine
45	Figure 4-4:	NYCT Transponder Message Communication
46	Figure 4-5:	NYCT Optical Speed and Position Measurement System (OSMES)
46	Figure 4-6:	OSMES Device Mounted under the Truck
48	Figure 4-7:	NYCT Wayside CBTC Network – General Architecture
49	Figure 4-8:	NYCT WCN Typical Relay Room Configuration
50	Figure 4-9:	Typical Outdoor Antenna Installation
50	Figure 4-10:	NYCT Wayside Radio Architecture
52	Figure 4-11:	NYCT Multiple Unit Radio Configuration
53	Figure 4-12:	Canarsie Zone Controller Configuration
54	Figure 4-13 :	Typical Canarsie Zone Controller Installation
56	Figure 4-14:	Procurement Process to Achieve Interoperability
70	Figure 5-1:	SEPTA Light Rail Tunnel Track Plan
80	Figure 5-2:	SEPTA Vehicle Location Processing
80	Figure 5-3:	SEPTA Onboard CBTC Architecture
81	Figure 5-4:	Location of On-Board CBTC Components
82	Figure 5-5:	Typical SEPTA Transponder Installations
82	Figure 5-6:	Amtech AT5112 Transportation Tag
83	Figure 5-7:	Jaquet Tachometer Assembled in Vehicle Gear Box
83	Figure 5-8:	Signal Outputs of Two-Channel Tachometer
84	Figure 5-9:	Bach-Simpson Doppler Speed Sensor
85	Figure 5-10:	SEPTA Radio Communications System (RCS)
86	Figure 5-11:	SEPTA Distributed Communications System
115	Figure 7-1:	Secondary Train Control Logic
121	Figure 7-2:	ACSES System Diagram
123	Figure 7-3:	Enhanced ACSES Display Unit
124	Figure 7-4:	GE MDS 220 MHz Radio

LIST OF TABLES

20	Table 3-1:	Vehicle-Wayside Communications Technology
26	Table 3-2:	Benefits of Increased GoA
28	Table 3-3:	GoL Benefits of CBTC Upgrades
31	Table 3-4:	CBTC Cost Factors
36	Table 4-1:	NYCT Ridership
36	Table 4-2:	Number of Canarsie Line Trips Scheduled and Ridership
38	Table 4-3:	NYCT Accident Summary
68	Table 4-4:	NYCT Benefits of Increased GoA
68	Table 4-5:	NYCT GoL Benefits from CBTC Upgrade
69	Table 4-6:	NYCT Cost Factors
72	Table 5-1:	SEPTA Passenger Counts
73	Table 5-2:	SEPTA Accident Summary
75	Table 5-3:	SEPTA Signal Technology Evaluations
99	Table 5-4:	SEPTA Benefits of Increased GoA
99	Table 5-5:	SEPTA GoL Benefits from CBTC Upgrade
100	Table 5-6:	SEPTA Cost Factors

FOREWORD

In 2011, the Federal Transit Administration (FTA) entered into a Cooperative Agreement with Delcan Corporation to assess the benefits and challenges of retrofitting Communications-Based Train Control (CBTC) on heavy rail and light rail transit systems. The results of this study are presented in this report, which forms part of FTA's ongoing efforts to promote the research and development of new technologies that will improve the safety and efficiency of rail transit system operation in the United States.

ACKNOWLEDGMENTS

The authors acknowledge FTA for funding this study, and particularly the support and guidance provided by FTA Project Manager Patrick Centolanzi. The authors also wish to acknowledge the many individuals, companies, and organizations that contributed to this study either directly, through the provision of information, data, and advice, or indirectly, through their participation in the signaling upgrade projects referenced in this report. In particular, the authors wish to acknowledge and thank New York City Transit (NYCT) and the Southeastern Pennsylvania Transportation Authority (SEPTA), who have been pioneers within the U.S. in embracing both the benefits and challenges of introducing CBTC technology on an operating transit system and whose cooperation and sharing of information was essential for completing this study. In particular, the authors would like to thank the following individuals for their assistance in developing the case studies documented in this report: Nidhish Patel, Ken Mooney, and Ken Rogers from NYCT and Mike Monastero and the late John LaForce from SEPTA.

ABSTRACT

This study examines the retrofit of CBTC technology on two North American transit properties, namely New York City Transit (NYCT) and the Southeastern Pennsylvania Transportation Authority (SEPTA), with the objective of assessing the benefits realized and implementation challenges experienced.

The study validates broader industry experience that CBTC offers benefits that cannot be achieved with prior generations of signaling technology.

The study also highlights that the challenges in upgrading the signaling/train control systems on an existing high-capacity mass transit system should not be underestimated. To this end, the study recommends that an increased emphasis on a Systems Engineering process be adopted throughout the life-cycle of a CBTC upgrade project.

This study provides transit agencies contemplating a CBTC upgrade program with a better understanding of CBTC technology, as well as a tool to assist in the planning, business case development, and management of CBTC projects.

EXECUTIVE SUMMARY

Communications-Based Train Control (CBTC) is the latest evolution in train control technology and is becoming widely accepted as a *de facto* standard for both “new start” mass transit projects and older transit properties that need to upgrade their earlier generations of signaling/train control systems for safety, state-of-good-repair, or operational/capacity reasons.

The implementation of CBTC on an existing operating transit line does, however, present a number of significant challenges. As such, FTA recognizes the value in documenting the experiences of those transit properties in North America that have already addressed these challenges to realize the benefits offered by CBTC.

A previous FTA study focused on the effectiveness of the retrofit of a CBTC system at the San Francisco Municipal Railway (Muni) by analyzing all cost elements before and after CBTC implementation. That study concluded that the benefits of CBTC offset the capital costs and provided a net benefit to the Muni Metro service area.

This current study similarly examines the retrofit of CBTC on two additional North American transit properties, namely New York City Transit (NYCT) and the Southeastern Pennsylvania Transportation Authority (SEPTA), with the objective of assessing the implementation challenges and the benefits realized in implementing CBTC technology at these transit properties.

This report first provides the context for the study’s purpose and scope by defining the key characteristics and anticipated benefits of CBTC technology and by summarizing typical CBTC system deployments over the past 30 years. The approach to conducting the project reviews is also described, which includes a review of pertinent documentation and the collection of both pre-CBTC and post-CBTC statistics regarding operational performance, safety, and maintenance at the two transit agencies selected for the study. The project reviews include specific consideration of compliance with industry standards, an assessment of enabling technologies, reviews of the agencies’ safety certification processes, and qualitative cost/benefit assessments.

With respect to the cost/benefit assessments, the study recognizes that CBTC can be implemented in many different forms across a range of rail transit modes. The costs and associated benefits of CBTC can, therefore, vary widely, depending on the specific scope and characteristics of the application, and, as such, the business case that applies for one transit agency is unlikely to similarly apply in another agency. The approach adopted in this study, therefore, was to first identify the various factors (benefits and costs) that could contribute to an agency’s business case for CBTC and then to identify those specific factors that actually applied at NYCT and SEPTA. This approach may also be of value to other transit agencies contemplating CBTC technology.

The study reaches two major conclusions. First, the study validates broader industry experience that CBTC offers benefits that cannot be achieved with prior generations of signaling technology. Given the extensive installed-base of CBTC systems around the world today, and with close to 30 years of actual revenue service experience with this technology, the benefits of CBTC are now clearly real and repeatable and the technology is well-established as both “service-proven,” and “safety-proven.” Enhanced safety was the major driver for implementing CBTC for both NYCT and SEPTA. Improved state-of-good-repair and improved service delivery, including increased grade of automation, were also major factors in NYCT’s decision to adopt CBTC.

The study shows that the enabling technologies used in CBTC systems have evolved from designs, equipment, and devices that had been employed in conventional signaling installations for many years. What distinguishes these technologies from prior installations is the way they are applied to achieve the unique functional requirements of CBTC. As such these enabling technologies do not represent a fundamental risk to successful CBTC project implementation.

Second, the study highlights (as was highlighted in the previous FTA study) that the challenges in upgrading the signaling/train control systems on an existing high-capacity mass transit system should not be underestimated, and any shortcomings in project planning and execution can have significant risk, schedule, and cost consequences.

The key challenge facing the rail transit industry in implementing CBTC is, therefore, not the technology but rather the process followed to implement CBTC technology on an operating transit system. To this end, the study recommends that an increased emphasis on a Systems Engineering process be adopted throughout the life-cycle of a CBTC upgrade project. Applying a Systems Engineering process includes:

- Adopting a “Total System” vision
- Integrating all stakeholders into a team effort
- Capturing the user requirements through processes that focus on early definition of agency needs and required functionality with consideration of all relevant factors such as Operations, Performance, Cost & Schedule, Installation, Test & Commissioning, Safety Certification, Training and Support
- Evaluating alternatives and selecting an optimized solution when considering the “Total System” as a whole
- Managing the design process to ensure the system solution is implemented correctly, with traceability of the top level requirements through subsequent levels of design
- Managing the migration to the new signaling system while verifying the system solution, as implemented, satisfies the user requirements and overall program goals

The data generated from this study provide transit operators and local officials contemplating a CBTC upgrade program with a better understanding of all aspects of CBTC technology (including, applicable standards, design issues, procurement methodologies, implementation challenges, safety certification, migration strategies, and project management approaches), as well as a tool to assist in the planning, business case development, and management of CBTC projects.

This report also discusses when, and to what extent, a secondary train control system should be considered in conjunction with the implementation of a CBTC system. In addition, the report includes a brief review of Positive Train Control (PTC) implementation projects that are currently being undertaken at Amtrak and NJ Transit, in recognition of the common issues associated with both PTC and CBTC projects.

Finally, the report identifies opportunities for further research.

Introduction

The New York Subway: Its Construction and Equipment was first published more than 100 years ago, in 1904, by the Interborough Rapid Transit (IRT) Company as a commemorative celebrating the opening of New York City's first subway [1]. This book includes the following quote:

Early in the development of the plans for the subway system ... it was foreseen that the efficiency of operation of a road with so heavy a traffic as is being provided for would depend largely upon the completeness of the block signaling and interlocking systems.... On account of the importance of this consideration, not only for safety of passengers, but also for conducting operation under exacting schedules, it was decided to install the most complete and effective signaling system procurable.... The application of such a system ... involved an elaboration of detail not before attempted....

This quote could equally be applied to every new subway system constructed in North America since that time, with the designers in that particular time period continuing to focus on installing the most “most complete and effective signal system procurable.”

For the earliest subway systems in North America, such as the systems in New York City, Boston, and Chicago, the technology available at that time was wayside signal/trip stop technology. This technology subsequently evolved into speed code-based cab-signaling systems that were introduced in the mid-20th century and were adopted by the newer North American subway systems in Washington DC, Atlanta, and San Francisco. Boston and Chicago also embarked on programs during that time period to upgrade their subway lines with this later technology. The next major signaling evolution was profile-based cab-signaling systems introduced in the late 20th century. The Green Line in Los Angeles was one North American property that adopted this technology, and this technology was also recently selected for the new Honolulu driverless system. This profile-based train control technology evolved into what is now referred to as Communications-Based Train Control (CBTC) technology that uses vehicle-based moving-block train location determination as an alternative to fixed-block train detection using track circuits. CBTC is the current state-of-the-art technology in mass transit train control systems and is being implemented on the majority of “new start” transit systems being implemented around the world. In North America, this included the Vancouver SkyTrain system that entered service in 1986.

While the specific signaling technologies have evolved, the fundamental fail-safe signaling design concepts related to train detection, safe train separation assurance, and interlocking protection, for example, have remained largely unchanged, and each successive signaling evolution has focused on providing enhanced service delivery benefits.

In addition to CBTC becoming widely accepted as a *de facto* standard for “new start” mass transit projects, an increasing number of existing transit properties that need to upgrade their earlier generations of signaling/train control systems—either for safety, state-of-good-repair, or operational/capacity reasons—are also considering CBTC. It is the applicability of CBTC to such upgrade projects that is the primary focus of this report.

The implementation of CBTC on an existing operating transit line presents a number of significant challenges. As such, there is value in documenting the experiences of the transit properties in North America that have already addressed these challenges in order to realize the benefits offered by CBTC.

A previous FTA report (FTA-TX-26-7005.2010.01, “Communications-Based Train Control [CBTC] Before/After Cost Effectiveness Study”), dated March 2011, examined the effectiveness of the retrofit of a CBTC system at the San Francisco Municipal Railway (Muni) and concluded that the benefits of CBTC offset the capital costs and provided a net benefit to the Muni Metro service area.

This report similarly examines the retrofit of CBTC on two additional North American transit properties, namely New York City Transit (NYCT) and the Southeastern Pennsylvania Transportation Authority (SEPTA), with the objective of assessing the implementation challenges and the benefits realized in implementing CBTC technology at these transit properties. The study described in this report is part of FTA’s efforts to promote the research and development of new technologies that will improve the safety and efficiency of rail transit system operation in the United States.

This report is divided into eight sections, starting with this initial Introduction.

Section 2 provides the overall context for the study and defines the study purpose and scope.

Section 3 describes the approach to the project reviews and the specific tasks undertaken to meet the study objectives.

Sections 4 and 5 provide the detailed results of the project reviews for the NYCT Canarsie Line CBTC Pilot Project and the SEPTA Light Rail Tunnel CBTC Project, respectively, focusing first on establishing the pre-CBTC baseline, then describing the CBTC solution selected and the agency’s specific implementation

approach, following by an assessment of the post-CBTC operational experience and benefits realized.

Section 6 summarizes the major findings that emerge from the project reviews.

Section 7 discusses the need for secondary train control systems with CBTC and provides lessons learned from the mainline railroads' PTC initiatives.

Section 8 provides general conclusions, offers recommendations with respect to applicability of the study findings to other North American transit properties, and identifies opportunities for further research.

SECTION
2

Study Background and Objectives

Study Context

CBTC Definition

CBTC is the latest evolution of signaling/train control systems for mass transit railways, using two-way communications between intelligent trains and wayside computers. An intelligent train is defined as a train that can determine its own location and that calculates and enforces safe operating speeds without the use of track circuits or wayside signals. In CBTC systems, the exact position of a train is known more accurately than with track circuit-based signaling systems. CBTC systems also offer opportunities for improved safety and operational performance, in addition to reduced life-cycle cost.

IEEE Std 1474.1™-2004 (R2009) defines CBTC as:

A continuous Automatic Train Control (ATC) system utilizing:

- high-resolution train location determination, independent of track circuits
- continuous, high capacity, bidirectional train-to-wayside data communications
- train-borne and wayside processors capable of implementing vital functions

The four primary components of a CBTC system are:

- CBTC train-borne equipment
- CBTC wayside equipment
- CBTC data communications equipment
- CBTC ATS equipment

CBTC Train-borne Equipment

CBTC train-borne equipment consists of one or more processor-based controllers and associated speed measurement and location determination sensors. It interfaces to the train subsystems (including train operator displays), the CBTC wayside equipment, and the CBTC Automatic Train Supervision (ATS) equipment via the CBTC data communication equipment. It is responsible for CBTC train location determination, the enforcement of permitted speed and movement authority limits, and other allocated train-borne Automatic Train Protection (ATP) and Automatic Train Operation (ATO) functions.

CBTC Wayside Equipment

CBTC wayside equipment consists of a network of processor-based, wayside controllers installed at central and/or wayside locations. Each wayside controller interfaces to the CBTC train-borne equipment and CBTC ATS equipment via the CBTC data communication equipment. CBTC wayside equipment also interfaces to external interlockings, unless interlocking functions are included within the CBTC wayside equipment. The wayside intelligence for CBTC-related ATP functions—such as movement authority setting based on the tracking of both CBTC-equipped and unequipped trains, as well as other allocated wayside ATP, ATO, and ATS functions—resides in the CBTC wayside equipment. Train location determination is a train-borne function for CBTC-equipped trains and a wayside function for unequipped trains. CBTC wayside equipment also includes any track-based equipment necessary to provide a unique absolute positioning reference to the CBTC train-borne equipment.

CBTC Data Communications Equipment

CBTC data communications equipment includes equipment located at central and wayside locations and onboard trains to support wayside-to-wayside and wayside-to-train data communications (as well as intra-train data communications for those applications where the train-borne equipment consists of multiple processor-based controllers). The data links between the major CBTC subsystems support bidirectional data transfer and have sufficient bandwidth and exhibit sufficiently low latency to support all defined ATS, ATP, and ATO functions. The data links include a protocol structure to support timely and secure delivery of train control messages.

CBTC ATS Equipment

CBTC ATS equipment includes equipment installed at central and/or wayside locations responsible for ATS (non-vital) functions such as identifying, tracking, and displaying trains, providing manual and automatic route setting capabilities, regulating train movements to maintain operating schedules, and initiating temporary speed restrictions and work zones.

CBTC Benefits

It is claimed that CBTC can provide the following safety, operational, and life-cycle cost benefits to a typical transit property; this study assessed the extent to which these claimed benefits were actually achieved at the two North American transit properties studied.

Safety

All modern fixed-block and CBTC train control systems are designed to stringent “fail-safe” design principles such that in the event of a failure in a safety-critical element of the train control system, the system will fail into a state known to be

safe. Typically, affected vehicles are brought to a stop in a protected segment of track. However, hazards still remain in this safe state. For example, if a train is stranded between stations for a prolonged period of time as a result of a train control failure, passengers may de-train onto the railroad right-of-way with consequential exposure to tripping, falling, and potential electrocution hazards, as well as exposure to potential hazards from train movements on adjacent tracks. Similarly, recovering from a train control failure and/or maintaining service operation during a train control failure (with associated loss of automatic train protection) can result in a need for train movements protected solely by operating procedures, with exposure to human errors and collision/derailment hazards. Achieving high levels of system availability for the train control system is, therefore, an important hazard mitigation strategy.

If the potential cost of accidents is incorporated into a Life-Cycle Cost Model, a train control system such as CBTC that is specifically designed to eliminate single points of failure and provide the highest levels of system availability should exhibit life-cycle cost advantages through increased probability of accident cost avoidance.

CBTC can also provide enhanced safety functions related to enforcement of temporary speed restrictions and protection of railroad workers. These safety functions can be provided without the constraints imposed by track circuit boundaries. In addition, CBTC can provide positive stop enforcement at discrete points without the need for an emergency brake application, which would present certain hazards to passengers.

When compared to fixed-block systems, CBTC systems require less track-based equipment, and, as a result, track-based equipment access and track maintenance requirements are reduced with associated improvements in track worker safety.

Train control systems using track circuits as the primary means of train detection have been the foundation of train protection systems for 100 years. While the safety performance of track circuit-based train control systems is extremely high, there have nevertheless been occurrences of train detection failures with track circuit-based systems through failures to shunt the track circuit, maintenance errors, and equipment failures. For example, in June 2009, a “wrong-side” failure of an audio frequency track circuit on the Washington Metro caused the automatic train control system to lose detection of a train, resulted in two trains colliding. Nine people were killed and 56 people were injured. Damage to train equipment was estimated to be \$12 million [2]. One of the National Transportation Safety Board (NTSB) recommendations was to enhance the safety redundancy of the train control system by evaluating track occupancy data on a real-time basis in order to detect losses in track occupancy, automatically generate alerts, and take action to prevent collisions. A CBTC-based train detection subsystem is immune to loss of shunt and other hazards inherent in

track circuit equipment. Further, a CBTC system overlaid onto a track circuit-based system can provide the level of safety redundancy required by the NTSB to detect any loss in track occupancy detection by the track circuits.

Capacity

One of the primary operational benefits of CBTC systems, when compared to track circuit-based systems, is that movement authority limits are no longer constrained by physical fixed-block boundaries. Instead, they are established through train position reports that can provide for “virtual block” or “moving block” control philosophies. Such control philosophies allow trains to operate safely at shorter headways and can permit system operations to recover more rapidly in the event of service delays. All of this can offer a more regular and improved passenger service, which can translate into increased line capacity constrained only by the performance of the rolling stock and the limitations of the physical track alignment. While recognizing these constraints, design headways as low as 60 seconds or even less become theoretically achievable with CBTC systems. For example, the SkyTrain system in Vancouver, one of the first applications of CBTC technology, has a line headway design capability of 60 seconds.

As a consequence, an increase in passenger demands over the life of a CBTC system can be accommodated easily through the simple addition of trains to the line and adjusting the operating schedule in the software. In comparison, if a track circuit-based system is designed and implemented to support, say, 180-second headways, it would not be possible to respond to passenger demands that would require shorter headway operations except by removal of the existing blocks and replacement by shorter block lengths with associated loss of service and increased life-cycle cost. In other words, fixed-block systems represent a constraint on future capacity growth opportunities and, hence, a constraint on future farebox revenues. It is for this reason that many of the major rail transit authorities around the world (e.g., NYCT, Port Authority Trans Hudson [PATH], London Underground, Paris Metro, Madrid Metro) are upgrading their track circuit-based signaling/train control systems with CBTC.

The ability of CBTC systems to support shorter headway operations also means that the same capacity demands can be satisfied using shorter trains (which, in turn, would require shorter platforms) operating more frequently, with the attendant elimination of the cost and service disruption of retrofitting longer platforms.

Travel Times

The ability of a CBTC system to accurately determine train location, provide precise profile-based movement authority limits to support a moving-block control philosophy, and precisely control train speed with respect to this

movement authority, as well as the ability of a CBTC system to minimize operational margins through real-time automatic train regulation, can all contribute to a reduced round-trip time. This not only benefits the passengers but can also reduce the required operating fleet size required to deliver the same capacity, when compared to track circuit-based systems.

Operations

Other characteristics of CBTC systems that can improve operational efficiency and encourage ridership growth include:

- Real-time information on the precise location, speed, and operational status of CBTC-equipped trains
- Ability to operate trains with different propulsion and braking characteristics on the same track without any constraint imposed by the design of a wayside fixed-block installation
- Ability to define new interlocking moves and traffic patterns without the constraints imposed by a hard-wired fixed-block installation
- Inherent bidirectional capability for train movements providing maximum operational flexibility both for normal operations and in support of failure and emergency management (bidirectional operations with track circuit-based systems requires a doubling of the number of track circuits equipment with significant additional capital investment)
- Ability to precisely forecast train arrival times at downstream stations for schedule regulation, passenger information purposes, and coordination with other transit service modes
- Ability to coordinate multiple train movements for junction management and energy optimization purposes
- Ability to employ coasting or alternative strategies to conserve energy consumption
- Ability to communicate train health status and other system alarms to a central control location on a frequent basis
- Real-time ability to restrict train movements in response to detected hazards or other conditions
- Accurate, frequent location detection of equipped maintenance vehicles and work trains

Maintenance

CBTC systems can be designed specifically to minimize required maintenance effort (both preventive and corrective) by minimizing the repair time as well as the time to restore service by maintenance personnel. Specifically, the amount of track-based signaling/train control equipment is significantly reduced, thereby minimizing the need for maintenance staff to work on or adjacent to the track.

With CBTC systems, the majority of the signaling/train control equipment is increasingly train-borne or located in readily-accessible wayside or central equipment rooms. CBTC systems also provide for improved maintenance and diagnostic capabilities to detect and react to signaling and train control equipment failures. These diagnostic capabilities include remote diagnostics and local built-in test equipment and other fault displays for troubleshooting and the timely identification of failed components and functions. Data logging capabilities also are provided in wayside and train-borne equipment to permit the recreation of a sequence of events to allow maintenance personnel to identify the cause of any failure and/or mis-operation of equipment that cannot be identified by the in-built diagnostics of the equipment.

Although specific and different skills are required to maintain the computer-based and communications-based equipment as compared to those for a fixed-block, track circuit-based system, the signaling and control system maintenance costs should be no greater for CBTC technology than for any other signaling technology. Indeed, experience would suggest that reductions in maintenance costs can be anticipated once familiarity has been gained with the system operations and after the system has reached its specified reliability/availability targets.

All of the above potential benefits and the associated cost factors are discussed in more detail in Section 3.

CBTC Deployments

The first CBTC system entered revenue service in Toronto, Canada, in 1985 on the Scarborough Rapid Transit line. By 1990, additional CBTC systems had entered service in Vancouver on the fully-automated (driverless) Vancouver SkyTrain system and in Detroit on the fully-automated Downtown People Mover. All of these initial CBTC systems were for “new start” applications.

Over the past 30 years, CBTC has become the technology of choice for the majority of “new start” transit projects around the world, and an increasing number of leading and internationally recognized transit agencies have undertaken extensive studies to investigate and review the applicability of CBTC as part of re-signaling and system upgrade programs aimed at not only addressing state-of-good repair concerns, but also at overcoming the fundamental safety and operational limitations of fixed-block, track circuit-based signaling technologies.

These transit agencies have included, but are not limited to:

- San Francisco Municipal Railway (Muni), U.S.
- New York City Transit (NYCT), U.S.
- Southeastern Pennsylvania Transportation Authority (SEPTA), U.S.

- Port Authority Trans Hudson (PATH), U.S.
- Toronto Transit Commission, Canada
- London Underground (LU), England
- Paris Metro (RATP), France
- Madrid Metro, Spain
- Amsterdam Metro, The Netherlands
- Copenhagen S-Bahn, Denmark
- Beijing Metro, China
- Metro de Santiago, Chile
- São Paulo Metro, Brazil

All of these agencies independently concluded that CBTC was the optimal technology choice for their re-signaling program with respect to offering the best return on investment with the lowest implementation risks. For example, on the London Underground, the Jubilee line has recently been converted from a manually-operated fixed-block wayside signaling systems to semi-automatic train operation using CBTC. It is claimed the new system will enable the London Underground to run more trains, increase capacity by 33 percent, and cut journey times by around 22 percent [3]. Similarly, the PATH CBTC re-signaling project is a major component of that transit agency's \$3.3 billion plan to modernize the entire PATH system. This initiative also includes a new 340-car train fleet and extensions to station platforms that collectively are designed to add up to 20-percent capacity to meet the system's future peak-time demands, in addition to increasing safety and reliability while reducing ongoing maintenance costs [4].

Similar conclusions have also been reached on major "new start" projects around the world. For example, in London, England, the Crossrail project is a massive £15 billion (\$24 billion) cross-London rail link project that includes the construction of a twin-bore tunnel on a west-east alignment under central London and the upgrading of existing National Rail lines to the east and west of central London. CBTC technology has been selected for this project as the least-risk technical solution to achieve the sponsor requirements.

In addition, each agency has published and reported on its rationale for selecting CBTC technology over fixed-block track-circuit-based signaling systems through a variety of industry forums, including papers, industry magazines, and conferences such as:

- MetroRail¹
- CBTC World Congress²
- Railway Age International CBTC Conference³
- Institution of Railway Signal Engineers (IRSE) CBTC Seminar⁴

With respect to the IRSE CBTC seminar held in February 2011 [5]:

- The Engineering Manager at Banedanmark, Copenhagen, provided an update on the re-signaling of the S-bahn as an element of the ambitious nationwide re-signaling of Denmark’s railway. In comparing “moving block” CBTC technology with “fixed-block,” distance-to-go, audio-frequency track circuit technology, Banedanmark had concluded that CBTC offered lower life-cycle costs, was easier to install and commission on a working railway, provided improved capacity, was capable of sustaining Banedanmark’s punctuality and performance requirements, and, when integrated with automatic train operations, enabled less costly migration to Unattended Train Operation (UTO).
- A representative of the RATP in Paris described experiences in operating and maintaining CBTC systems on its transit system, which have shown that CBTC solutions do indeed allow improved operational margins between trains by providing improved headway flexibility and offer minimal impact on wayside and track and improved operating costs significantly when combined with organizational changes such as operating procedures. It was noted that CBTC represented a fundamental element of RATP’s strategy in operating and maintenance cost optimization.
- A representative of the London Docklands Light Railway built on this theme by highlighting business case drivers and operational/maintenance benefits for CBTC which included improved train protection, support to driverless operations, and “moving block” control philosophy providing shorter headways and optimized network capacity, schedule/timetable regulation, coordination of multiple train movements (e.g., junction management), improved passenger service, bi-directional capability, real-time train data, real-time response to hazardous conditions, integration of operating systems (including traction power, tunnel/station ventilation, and passenger information & security systems), redundant/fault tolerant designs, lower maintenance costs, less trackside equipment, and reduced support costs (energy savings). It was stressed that the aim of CBTC was to effectively

¹Publications associated with MetroRail can be found at http://www.terrapinn.com/conference/metrorail/?pk_campaign=Terr-Listing&pk_kwd=Transport+%26+Logistics.

²Publications associated with CBTC World Congress can be found at <http://www.cbtcworldcongress.com/>.

³Publications associated with the Railway Age International CBTC Conference can be found at <http://railwayage.com/>.

⁴Publications associated with the Institution of Railway Signal Engineers (IRSE) CBTC Seminar can be found at www.irse.org.

- remove the signaling system as a constraint on line capacity, with operating performance being constrained only by the capabilities of the rolling stock and the physical track curvatures.

Study Purpose

Given the above context, the purpose of this study was to evaluate CBTC system retrofits at two North American transit properties, document the implementation issues and lessons learned, and provide a comparative evaluation of the specific CBTC functional, performance, and safety requirements against industry standards. The implementation details, including safety certification, were also documented and analyzed, and the actual CBTC benefits achieved at the selected transit properties were identified. The data generated from this research will provide transit operators and local officials contemplating similar upgrade programs with a better understanding of CBTC technology and an awareness of the implementation challenges and the project management issues associated with CBTC projects.

Study Scope

The selection of the NYCT and SEPTA transit properties for this study provided two diverse operating environments for CBTC implementation. This study evaluated and documented the differences in functionality, performance, design complexity, and safety approach and the differences in CBTC implementations between heavy and light rail applications.

NYCT Canarsie Line CBTC Pilot Project

In 2006, NYCT completed a CBTC installation on its Canarsie Line and became the first transit property in the U.S. to implement CBTC technology in a heavy rail environment. The Canarsie Line was NYCT's "pilot project" for CBTC prior to rolling out the technology system-wide. NYCT's goals for CBTC are to increase capacity, enhance safety, and improve the availability and maintainability of the signaling system. The Canarsie Line CBTC system was supplied by Siemens and designed for semi-automatic train operations. While a train operator is retained in the lead cab of the train, train movements between stations are automatic under the control and protection of the CBTC system.

In 2010, NYCT awarded its second CBTC project to Thales to modernize the signaling on the Flushing Line, one of the busiest lines in the NYCT rail network. As part of a progressive systemwide rollout of CBTC, NYCT is currently planning a CBTC installation on the Queens Boulevard Line and for future phases of the Second Avenue Subway Line.

SEPTA Light Rail Tunnel CBTC Project

In 2006, SEPTA successfully implemented a CBTC system on the tunnel portion of its Green Line, becoming one of the first light rail transit (LRT) lines in the U.S. to employ moving-block CBTC. SEPTA installed CBTC on the Green Line primarily to improve safety. SEPTA also has plans to install CBTC technology on its Media-Sharon Hill Line.

SECTION 3

Project Reviews

The general objective of the NYCT and SEPTA project reviews was to obtain and review all pertinent documentation at each of the two transit properties for pre-CBTC and post-CBTC operation. Statistics regarding operational performance, safety, and maintenance were collected and meetings were held with key staff at these transit properties to review documentation and to discuss lessons learned during the CBTC implementation.

The project reviews included a review of the specification and design documentation, provided by both NYCT and SEPTA, that describe the functional and performance requirements for the installed CBTC systems, as well as specific details of the implemented designs as installed. Meetings were held with representatives of the transit properties to clarify and discuss any issues related to the functional requirements of the ATP, ATO, and ATS subsystems. The extent to which the functional requirements for the installed systems, as initially specified by NYCT and SEPTA, were actually achieved was also discussed.

The project reviews included specific consideration of:

- Compliance with industry standards
- Assessment of enabling technologies
- Safety certification process reviews
- Qualitative cost/benefit assessments

Compliance with Industry Standards

As an element of the NYCT and SEPTA project reviews, compliance with industry standards was assessed by first capturing and summarizing in tabular form the specified functional and performance requirements for each of the two selected lines. These requirements were then assessed for compliance with the provisions of IEEE Std 1474.1™-2004 (R2009). This standard was first published in 1999 and updated in 2004 to incorporate driverless/unattended train operations. The standard was reaffirmed in 2009 without revision. This IEEE standard is a performance and functional requirements standard that defines mandatory and optional requirements for a CBTC system. The standard also defines information that the “authority having jurisdiction” must provide to the CBTC supplier. The assessment, therefore, addressed the following questions:

- Were the mandatory requirements of IEEE Std 1474.1™ included in the agency’s CBTC specification?

- How many of the optional requirements of IEEE Std 1474.1™ were included in the agency's CBTC specification?
- Did the agency's CBTC specification provide the information to the supplier recommended by IEEE Std 1474.1™?

The results of the assessment are provided in Appendix A and Appendix B of this report and are also summarized in Sections 4 and 5.

Assessment of Enabling Technologies

CBTC requires unique functionality that distinguishes it from other train control systems and that are critical in providing high levels of safety and operational performance. These unique functions include:

- High-resolution vehicle location determination, independent of track circuits
- Continuous high-capacity, bi-directional vehicle to wayside data communications
- Wayside and car-borne vital (safety-critical) processing that provide ATP functions

As an element of the project reviews, the specific enabling technologies that provided the fundamental building blocks for the NYCT and SEPTA CBTC installations were assessed with specific consideration of the following:

- Attributes and unique characteristics of each technology used
- Decision-making process and rationale for selecting the technologies used
- Lessons learned from the implementation and operations of each technology

As background, a general discussion on enabling technologies for the three CBTC functions defined above is provided in the following subsections.

High-Resolution Train Location Determination

High-resolution train location determination requires a CBTC system to calculate the location of the front and end car of a train at any point in time (subject to communication and processing delays) to a resolution capable of supporting the desired performance and safety requirements.

The CBTC system must take into account the inaccuracies of train location and speed calculations caused by communication latencies, the slipping and sliding of wheels (if a free axle is not available), and variations in distance moved resulting from wheel wear, truing, and replacement.

In a typical CBTC system, the measurements of speed and distance traveled generally rely on tachometers that measure the rotation of a train's axle. There are generally two types of tachometers:

- Hall effect sensor, which uses a rotating target attached to a wheel
- Opto-isolator slotted disk sensor, which requires post processing to calculate speed

Hall effect sensors are considered less reliable as they are prone to dust buildup between the wheel and the sensor. The opto-isolator slotted disk sensors are a closed system requiring less maintenance, yet these sensors require an independent speed measurement system such as an accelerometer or Doppler radar device to monitor for slip-slide conditions, for example.

Transponders or balises are also commonly used for track location validation (absolute position reference), providing the exact location of the train at predefined locations. Transponders are typically used to:

- Initialize train location on the approach to the CBTC Mainline territory
- Reinitialize train location within a CBTC territory
- Determine train direction and orientation
- Reduce and maintain vital position uncertainty close to predefined zones or specific points
- Comply with stopping accuracy requirements in station

High-Capacity Data Communications

There are three communication networks that form part of most train control systems:

- Wayside communications network between central control and interlocking and wayside equipment
- Wayside-to-vehicle communications network between the vehicle and wayside signaling equipment
- In-vehicle communications network between train operator controls, train subsystems, and train-borne signaling equipment

CBTC requires high-capacity, bi-directional, continuous wayside, wayside-to-vehicle, and in-vehicle communications network to deliver a safe and operable train control system.

Wayside communications include a data network linking interlockings and CBTC vital wayside equipment (sometimes referred to as zone controllers) and central control equipment. Dedicated communication links are typically used between interlockings and CBTC wayside equipment, while an existing backbone fiber

network may be used for communication to central control. Redundancy is typically designed into the system so that single point failures will have limited impact on system operation. The data rate requirements and the number of required channels are unique to each supplier's system.

Communication methods between the wayside and vehicle components have seen significant advancements over the last 20 years, taking advantage of radio development and, more recently, Wi-Fi.

Table 3-1

*Vehicle-Wayside
Communications
Technology*

Technology	Description	Service Proven
Inductive Loop	Bi-directional electromagnetic communications requires installation of loops usually in the track-bed, operating in tunnel and open environments.	Multiple CBTC applications. Service proven for three decades.
Leaky Feeder	Coaxial cable functioning as extended antenna for bi-directional communications. Usually mounted on the tunnel wall but also operational in open environments.	Multiple CBTC applications. Service proven for three decades.
Point Radio	Spread spectrum radio communications on dedicated frequencies. Proprietary (COTS) and standard (IEEE Standard 802.11) data radios systems are available, offering cost and performance options.	Proprietary, COTS and standard radio systems proven in CBTC applications. Service proven over last decade.

Most recent CBTC applications have tended towards radio communications, given the ability to mount most equipment at stations (maintenance benefits) and opportunity for more standardized equipment (cost benefits). However, inductive loop and leaky feeder systems remain in operation, offering highly-reliable wayside-vehicle communications.

One challenge for radio communication is allocation of spectrum by the Federal Communications Commission (FCC). Currently, within FCC rules, possible assignments for unlicensed frequencies exist in the Industrial, Scientific, and Medical (ISM) service in the microwave bands, for which rapid transit is eligible:

- L-band, (UHF) 902.0 - 928.0 MHz
- S-band, (UHF) 2400.0 - 2483.5 MHz
- C-band, (SHF) 5725.0 - 5850.0 MHz

In addition to these bands, other bands are becoming available as a result of the frequency reallocation activities of the FCC and other existing licensable bands in FCC rules.

Vital Processing

The vital calculation and determination of movement authority using software-based vital processors is a cornerstone of CBTC systems. Coded processor and

checked-redundant software are among the techniques employed in the design and coding of wayside and train-borne equipment to ensure that safety-critical functions are implemented in a vital, fail-safe fashion. While both approaches have been used successfully on various CBTC projects, the coded processor approach has desirable features such as:

- Enabling the use of formal methods for software fault avoidance
- Ensuring a reliable and exact software design from specifications to runtime code
- Requiring no specific qualification of the compiler
- Demonstrating a Safety Integrity Level with relative ease

Internationally, IEC 61508 and CENELEC 50128 define the processes and requirements necessary to achieve a Safety Integrity Level (SIL) rating for vital, safety-critical software functions, where SIL defines the level of risk associated with a function. Many international signaling systems are specified based on SIL requirements and IEC/CENELEC standards, SIL 4 being the most critical. Similarly, ISO/IEC 12207 standard establishes a process of lifecycle for software, including processes and activities applied during the acquisition and configuration of the services of the system.

The selection of the technique for vital processing is usually driven by the CBTC supplier rather than the transit agency. Most CBTC systems are based on existing projects, and modification of such a critical aspect of the system will introduce significant risk to the development and delivery of the CBTC system.

Safety Certification Process Review

As safety is a high-priority consideration for any agency contemplating a replacement of its existing signaling system, the safety certification processes implemented by NYCT and SEPTA were reviewed in detail.

To provide a framework against which to review the NYCT and SEPTA safety certification and risk assessment processes, in this study, the Federal Railroad Administration (FRA) standard (49 CFR Part 236, Subpart H) was used as a standard for comparison purposes. For reference, however, there are other safety and risk standards specific to CBTC systems, including:

- IEEE Std 1474.1™-2004 (R2009) is a guideline for CBTC systems that seeks to define the overall system requirements. Included in this standard are high-level safety standards, specifically that “the CBTC System Safety Program shall emphasize the prevention of accidents by identifying and resolving hazards in a systematic manner” and “a CBTC System Safety Program Plan (SSPP) shall be developed for each CBTC application.”

- The American Public Transportation Association (APTA) developed a *Manual for System Safety Program Plan Development (for Commuter Rail)* that defines in detail the objective, role, content and specific requirements for a System Safety Program Plan (SSPP). APTA is also updating the *Manual for System Safety Program Plan for Urban Applications* and has just issued a new revision to the *Manual for the Development of an Urban Rail Safety Management System*. These manuals also outline a systematic approach to safety management.
- Internationally, many agencies are using the CENELEC standards to specify the processes required for the delivery of CBTC systems, although these standards have not been typically used in the United States. The specific CENELEC standards typically used include:
 - EN50126: Railway applications – The specification and demonstration of Reliability, Availability, Maintainability, and Safety (RAMS)
 - EN50128: Railway applications – Communication, signaling and processing systems, software for railway control and protection systems
 - EN50129 : Railway applications – Communication, signaling and processing systems, safety-related electronic systems for signaling

Review of the CBTC safety certification processes at NYCT and SEPTA included a review of the safety documents provided by both transit properties, and discussions with NYCT and SEPTA representatives to answer the following questions, as related to the FRA standard:

- Did the CBTC project (transit property and/or supplier) employ a software management control plan to ensure the integrity of the developed software? What process was used to develop safety-critical software?
- Did the transit property employ a Railroad Safety Program Plan (or equivalent)? What were the elements of such plan, and how did they compare to the specific requirements of Subpart H?
- Did the transit property and the supplier employ a Product Safety Plan (or equivalent)? What were the elements of such plan, and how did they compare to the specific requirements of Subpart H?
- Did the transit property establish minimum performance standards for the CBTC system, and what type of risk assessment (if any) was performed on the CBTC system?
- Does the transit property currently operate and maintain the CBTC system in accordance with the Product Safety Plan?
- Did any safety-critical part or component of the CBTC system fail to perform its intended function?

- Did the transit property implement a training program related to the CBTC installation, and how does such a program compare to the requirements of Subpart H?
- What safety assurance criteria, standards and processes were used by the transit property/supplier to ensure the safety of the CBTC system under all operating conditions?
- Did the transit property and/or the supplier employ an independent third party (Independent Safety Assessor) to provide an independent assessment of the CBTC system safety verification and validation?
- Did the transit property/supplier use Human-Machine Interface (HMI) design in the development of the CBTC system?

Qualitative Cost/Benefit Assessments

CBTC can be implemented in many different forms across a range of rail transit modes. CBTC can be implemented on new, “green field” projects or can be retrofit at an existing transit agency (“brown field” application). CBTC can be implemented as a stand-alone re-signaling project or as just one component of an agency’s overall program to upgrade and modernize its operating systems, including interlockings, rolling stock, central control, passenger information, and fare collection systems.

The costs and associated benefits of CBTC can, therefore, vary widely, depending on the specific scope and characteristics of the application, and, as such, the business case that applies in one application is unlikely to similarly apply in another application. Indeed, a review of CBTC project cost data in the public domain revealed a wide range of CBTC contract costs when measured against simple metrics such as costs per route mile.

The approach adopted in this study, therefore, was first to identify the various factors (benefits and costs) that could contribute to an agency’s business case for CBTC, as summarized in this section and then in Sections 4 and 5 to identify those specific factors that actually applied at NYCT and SEPTA. This approach may also be of value to other transit agencies contemplating CBTC technology.

The factors identified are summarized in Figure 3-1 and 3-2, and the specific benefit and cost factors are described in the following subsections.

Figure 3-1
Benefit Factors

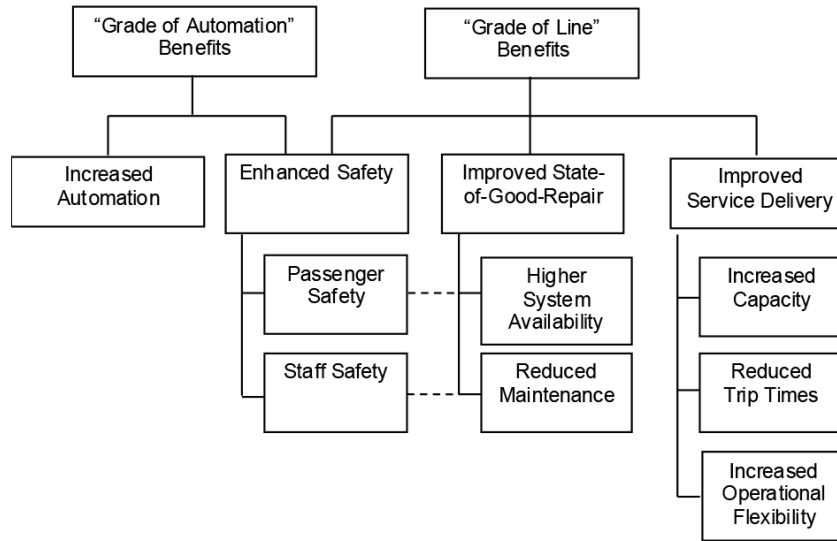
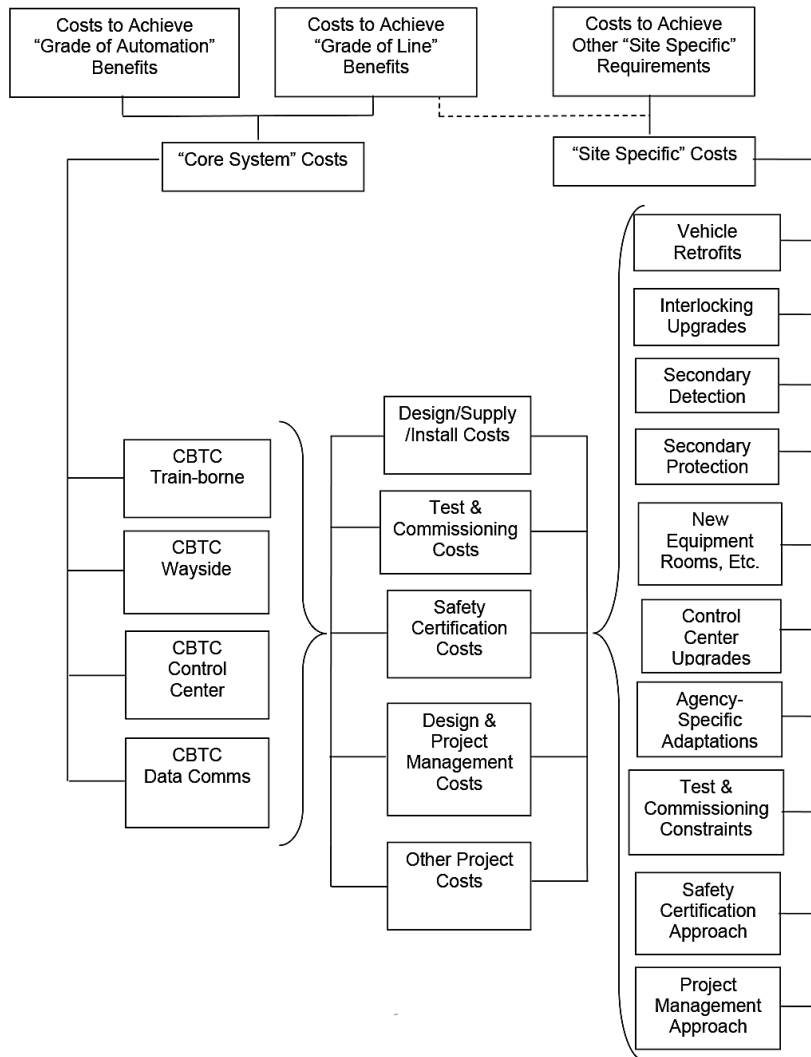

Figure 3-2
CBTC Cost Factors



Benefit Factors

IEC 62290-1:2006 is an international standard that establishes system principles and fundamental concepts for command, control, and management systems used on urban, guided passenger transport lines and networks. This international standard recognizes that the design of any modern signaling/train control system for a specific application will be driven by two fundamental criteria, namely the “Grade of Automation” (GoA) and “Grade of Line” (GoL). These criteria establish mandatory and optional requirements for any signaling/train control system and, in general, the higher the GoA and the higher the GoL, the more complex is the signaling/train control solution, but the greater the benefits provided. These two criteria are discussed in more detail below.

Grade of Automation (GoA)

GoA is a measure of the functional requirements to be satisfied by the signaling/train control system. For example, the system may be required to provide ATP functions only for manually-driven trains, with no ATO functions. Alternatively, the system may be required to provide ATP functions, as well as various levels of ATO and ATS functions, as required for the specific GoA, up to and including fully-automated, driverless/unattended train operations.

The IEC standards define five basic GoA:

- GoA 0: Manual operation with no ATP
- GoA 1: Manual operation with ATP
- GoA 2: Semi-automatic train operation (STO)
- GoA 3: Driverless train operation (DTO)
- GoA 4: Unattended train operation (UTO)

A summary of the benefits that can be realized through increased grades of automation (compared to manual train operations) is provided in Table 3-2. STO has become the de facto minimum industry standard on the vast majority of re-signaling projects with DTO and UTO increasingly becoming an industry trend.

Table 3-2Benefits of
Increased GoA

Benefits of Automation	Manual		Automatic		
	GoA0	GoA1	GoA2 (STO)	GoA3 (DTO)	GoA4 (UTO)
Automatic Train Protection (ATP)		√	√	√	√
More predictable run times between stations			√	√	√
More uniform ride quality			√	√	√
Reduced wear-and-tear of train propulsion/braking systems			√	√	√
Reduction in variations in line operation/improved service regulation			√	√	√
Energy optimization			√	√	√
Automation of turnbacks				√	√
Remove constraint of rostering train crews					√
Flexibility to operate shorter trains more frequently					√
Ability to respond to unexpected increases in passenger demands					√
Potential for reduction in operating costs					√
Automated failure detection/response					√

While, subjectively, the benefits of increased grades of automation may be self-evident, quantifying these benefits to develop a specific business case is very application-specific and dependent upon the particular GoA that is adopted. For any specific re-signaling project, however, this table illustrates the benefits that can be realized in moving from one GoA to a higher GoA.

Even if a transit property remained at the same GoA when upgrading to CBTC (e.g., remain at GoA 2 without moving to DTO or UTO), there are still significant additional benefits that can be realized by improving the overall GoL, as discussed below.

Grade of Line (GoL)

GoL is a measure of the complexity of the line to be equipped with the new signaling/train control system, as well the service levels to be supported by the new system. The typical GoL benefits that can be realized through CBTC upgrades include:

- Enhancing safety and security for passengers and staff on the line
- Achieving improved state-of-good-repair for the line with the associated benefits of:
 - Higher system availability and dependability
 - Reduced preventive and corrective maintenance requirements

- Improving the service levels that can be delivered on the line through:
 - Increased passenger-carrying capacity
 - Reduction in end-to-end trip times through increased average operating speeds and improved dwell-time control
 - Increased operational flexibility of service offered to passengers—for example, full bi-directional capabilities on all mainline track to permit continued operations in the event of a track outage

With respect to safety and security enhancements, maintaining and improving the safety of rail transportation requires a continuous focus on the details of railway signaling designs, installations and maintenance as signaling technologies evolve, new hazard risks are identified, and unexpected component and equipment failure modes are uncovered. Indeed, while any specific signaling design would have been judged acceptable at the time of its original implementation, in the event of a future incident or accident, any determination as to the “reasonableness” of the signal system design will likely be made based on the expectations and prevailing state-of-the-art of signaling systems at the time of the incident.

Maintaining a state-of-good-repair relates to consideration of equipment reliability, system availability, equipment obsolescence, and the level of required preventive and corrective maintenance to keep the signaling system operable. Improved system availability also contributes to improved levels of safety, as there is less need for reliance on operating procedures to manage train movements during signaling system failures. Similarly, a reduction in maintenance—in particular, maintenance of track-based equipment—also contributes to increased levels of safety for track maintenance personnel. Addressing state-of-good-repair issues is a challenge for many transit agencies with limited capital funding at their disposal. It is also a challenge in terms of impact on passenger service during project implementation.

With respect to capacity improvements, given the often prohibitive costs associated with the construction of new metro/subway lines, many transit agencies are embarking on capacity upgrade programs to achieve a step-change increase in the passenger-carrying capacity of their existing rail network infrastructure. The maximum achievable passenger-carrying capacity of any transit line is not only constrained by the signaling/train control technology, however, but also by:

- Track alignment, specifically at terminal stations
- Vehicle design and performance characteristics, including number/width/spacing of vehicle doors, propulsion and door interlocks, door opening/closing times, maximum train speed, acceleration/braking rates, and interfaces to train-borne train control equipment

- Platform lengths and station capacities (passenger circulation constraints)
- Available in-service fleet size (number of trains that can be regularly and reliably made available for revenue service on the line, which, in turn, is constrained by the available storage tracks and train maintenance facilities)
- Traction power capacity (ability of the traction power system to maintain train performance both during normal and abnormal operations)
- Tunnel emergency ventilation system design (which may constrain the maximum number of trains permitted within a tunnel section between stations)
- Operating staff availability (to operate and maintain the line)

As such, optimizing the passenger-carrying capacity of an existing rail transit line is a complex, highly-integrated, multi-disciplinary problem. Capacity improvement programs (and the business case for capacity improvement programs), therefore, have to be viewed not solely in the context of a “re-signaling” project.

The GoL benefits of a CBTC upgrade are summarized in Table 3-3.

Table 3-3
GoL Benefits of CBTC Upgrades

Potential GoL Benefits of CBTC Upgrades	Required by Specific Agency
<i>Enhanced Safety</i>	
Passenger safety	
Staff safety	
<i>Improved State of Good Repair</i>	
Higher system availability	
Reduced maintenance	
<i>Improved Service Delivery</i>	
Increased capacity	
Reduced trip times	
Increased operational flexibility	

Cost Factors

Capital cost factors related to re-signaling with CBTC technology can be broadly classified as:

- “Core system” costs associated with design, supply, installation, test & commissioning, safety certification, and other support services for the “core” CBTC systems required to deliver the specific GoA and GoL benefits identified above

- Additional “site-specific” costs not directly related to the CBTC-specific systems, but that have to be considered in that agency’s site-specific business case to deliver the required benefits

“Core System” Costs

The “core system” capital costs for the CBTC system include:

- Design, supply, and installation of CBTC train-borne equipment, CBTC wayside equipment, CBTC control center equipment, and CBTC data communications equipment
- Test & commissioning of core CBTC system
- Safety certification of core CBTC system elements
- CBTC design management and project management
- Other miscellaneous CBTC-related costs, such as documentation, training, manuals, etc.

These “core system” capital costs will be influenced by the required GoA and GoL benefits to be achieved. For example:

- Increased grades of automation will require more complex vehicle subsystem interfaces and more complex ATO and ATS functionality; however, the core CBTC train-borne, wayside, and data communications equipment responsible for ATP functions can be largely unaffected by the grade of automation, unless higher levels of equipment redundancy are required.
- The complexity of the rail network will influence the application-specific configuration for the data radio network, the number of locations requiring CBTC wayside equipment, and the configuration of the CBTC control center equipment (e.g., number of workstations, etc.).
- System availability requirements will influence the level of equipment redundancy to be incorporated into the CBTC system design.
- Capacity and other operational requirements will influence the number of trains to be equipped with CBTC train-borne equipment.

“Site-specific” Costs

For re-signaling projects, the age of the line being re-signaled, agency-specific standards and regulatory requirements, the procurement and program management approach, installation labor costs, existing/historic operating practices, institutions, and culture can all differ significantly from one transit agency to another and can all have a significant impact on the overall project costs and achievable benefits.

“Site-specific” costs include consideration of the following:

- If CBTC train-borne equipment is to be installed on new, “CBTC-ready” rolling stock, or retrofit on existing rolling stock – The latter would generally not only require modifications to the rolling stock, but also modifications to the CBTC train-borne equipment to accommodate space constraints and trainline limitations, for example, all of which can negatively impact project costs. It is for this reason many transit agencies integrate CBTC re-signaling with new car procurements.
- If CBTC wayside equipment is to interface with existing interlockings or with new “CBTC-ready” interlockings procured under a separate contract or with new interlockings to be procured as an element of the CBTC contract – This consideration not only will affect the costs of the CBTC contract but also will establish which party (the agency or the contractor) has CBTC/interlocking integration responsibility.
- If the agency’s operational requirements and/or other institutional factors will require the installation of a secondary train detection system (track circuits or axle counters) in addition to the CBTC primary train detection (refer to Section 7 for an analysis of situations in which this may be considered).
- If the agency’s operational requirements and/or other institutional factors will require the installation of a secondary train protection system (e.g., wayside signals and trip stops) in addition to the CBTC automatic train protection system (refer to Section 7 for an analysis of situations in which this may be considered).
- If existing equipment rooms, signal power supplies and cable support systems, for example, can be re-used for the new CBTC equipment, or if new facilities are required – A requirement to construct additional equipment rooms, to upgrade power supplies and/or to install new cable ducts, messenger wire, etc., can add significant costs to any re-signaling project, regardless of the specific technology.
- If CBTC control center equipment will be stand-alone, required to integrate with existing control center equipment, or new control center equipment being procured under a separate contract – This consideration affects the scope of the CBTC contract and systems integration responsibilities.
- If the selected supplier’s service-proven CBTC system can be implemented as-is, or if agency-specific adaptations are required to meet the agency’s existing/historic operating practices – This can be a major factor in additional software development costs/risks and as such relates to an agency’s willingness to adapt their operating practices to match the new technology. This can also be an important factor in the supplier-selection process.

- If the need to maintain revenue service operations and minimize passenger service impacts during the installation, test, and commissioning of the new CBTC signaling system will result in severe track access limitations – This can significantly extend the implementation schedule with corresponding project cost increases.
- If the agency will accept product safety certification documentation from other in-service applications or require a new safety assurance process to be followed with agency-specific documentation.

An agency’s procurement and project management approach can also influence the overall project costs. In “green field” applications, there is increasing interest in alternative project delivery methods such as turnkey design-build, design-build-maintain, and even design-build-operate-maintain procurements against high level performance/output specifications. For re-signaling projects, however, an agency may prefer to use a more traditional procurement/project management approach against detailed design specifications with more extensive design submittals and agency oversight, review, and approval.

The above cost factors are summarized in Table 3-4.

Table 3-4
CBTC Cost Factors

Cost Factors	Required for Agency Specific Application
<i>Core System” Cost Factors</i>	
CBTC train-borne equipment	
CBTC wayside equipment	
CBTC control center equipment	
CBTC data communications equipment	
<i>Site Specific” Cost Factors</i>	
Vehicle retrofits	
Interlocking upgrades	
Secondary train detection	
Secondary train protection	
New equipment rooms/etc.	
Control center upgrades	
Agency-specific adaptations	
Test & commissioning constraints	
Safety certification approach	
Project management approach	

SECTION
4

NYCT Canarsie Line CBTC Pilot Project

New York City Transit (NYCT)⁵ operates one of the most extensive and complex public transportation systems in the world; passenger services run 24 hours a day, 7 days a week throughout the 5 boroughs of New York City. New York's first subway line entered service in 1904 and has grown to a network of 23 subway lines on 803 miles of track with 468 stations. The 23 subway lines are interconnected, and many lines feature express trains, across-the-platform transfers to local trains, and "skip-stop" operation. The subway trains run approximately every 2–10 minutes during rush hours, every 10–15 minutes during non-rush hours, and every 20 minutes during late night hours and weekends.

The Canarsie Line is served by the L train, which is shown in gray on the NYC Subway map and on station signs in Figure 4-1. It is essentially a northwest-southeast two track line with the 8th Avenue station in Manhattan at the northwest end and Rockaway Parkway station in Brooklyn at the southeast end. The length of the Canarsie Line is 10 route miles (22 track miles), with 24 passenger stations.

Figure 4-1

Canarsie Line

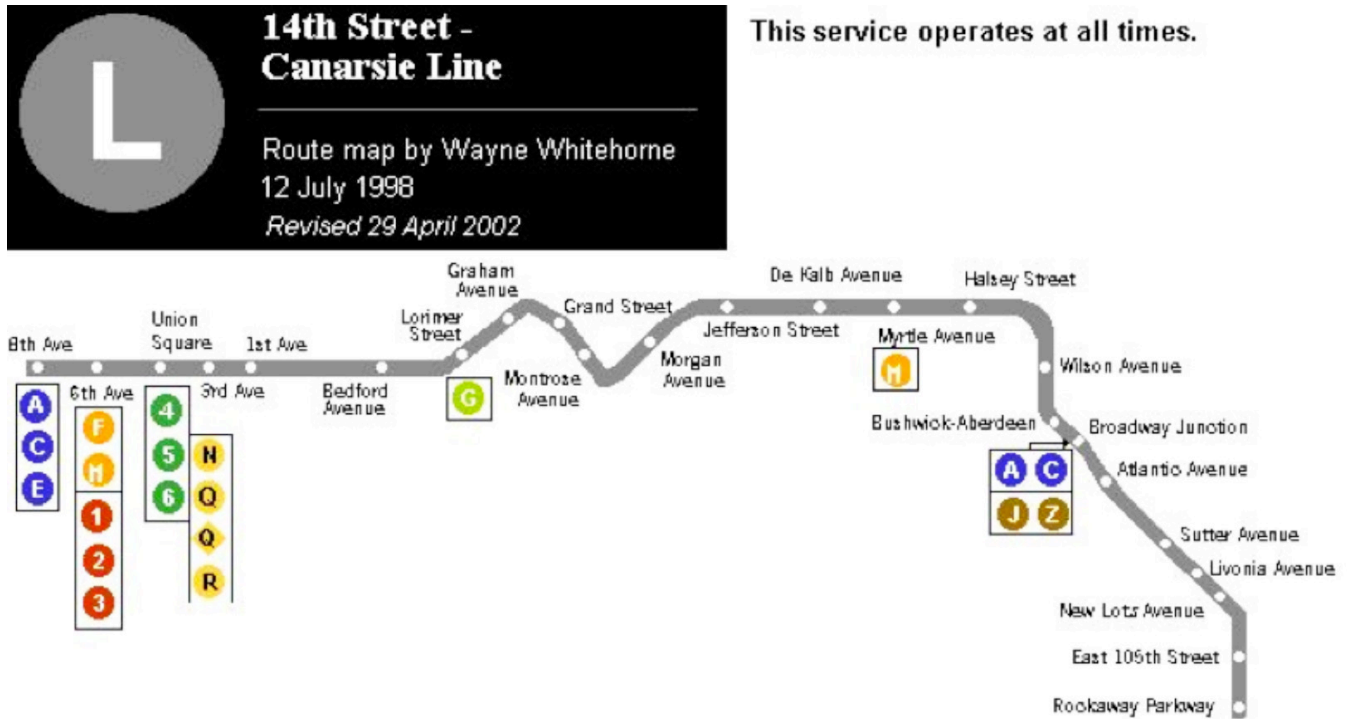

⁵The information presented in this section was obtained during the project reviews during which the project team met with individuals from the NYCT agency.

Canarsie Yard, which is located at the line's southeast end, includes a car washing facility for the Canarsie Line service trains and trains from the Nassau Street lines (J and M). As J and M service trains are not equipped for CBTC operation, it is of fundamental necessity that the system support mixed-fleet operation to enable unequipped trains to reach the washing facility.

The Canarsie Line is one of the oldest lines in the NYCT system, dating back to the beginning of the 20th century when it was operated as a steam railroad between East New York and the area near Canarsie Pier/Canarsie Beach Park. Brooklyn Rapid Transit (BRT) began train service in 1906 between Canarsie and Williamsburg, with the trains using trolley poles for power in the ground-level section. This line ran at grade level from the Canarsie Pier terminus to a point north of the East 105th Street station. In 1924, at what is now the other end of the line, a subway line was opened that ran beneath 14th Street in Manhattan and extended under the East River, through the Williamsburg neighborhood, to Montrose and Bushwick Avenues. Four years later, in 1928, the line was extended further east to a new station at Broadway Junction, above the existing Broadway-Eastern Parkway elevated station. This route was also extended south, connecting to the six-track Atlantic Avenue Brooklyn-Manhattan Transit (BMT) station. In 1931, an additional station was opened at 8th Avenue and 14th Street in Manhattan, connecting the Canarsie Line to the newly-opened Eighth Avenue Independent Subway. At this point, the Canarsie Line's route took the shape that it still has today.

Since 1982, NYCT has been undertaking one of the largest capital programs in U.S. history to maintain its rail cars, tracks, and infrastructure in a state of good repair. The main objectives of this program are to enhance safety of operation, improve customer service, and reduce operating and maintenance costs. As part of its ongoing modernization program, and to achieve a full state of good repair of its aging signal system, NYCT has initiated a program to replace the existing fixed-block, wayside signals/trip stop signal technology with state-of-the-art CBTC technology. The CBTC system will allow trains to be operated at closer distances (increasing capacity) with greatly enhanced safety compared to the current analog signaling/human control system and will allow NYCT to keep track of trains in real time and provide more information to the public regarding train arrivals and delays. The modernization of the entire NYCT signaling system to CBTC operation is currently planned to occur over multiple projects through the year 2044 (subject to budget availability and approval by the Metropolitan Transportation Authority).

The Canarsie Line was chosen for NYCT's CBTC pilot installation because it is a self-contained line that does not operate in conjunction with other subway lines in the New York City subway system. The 10-mile length of the Canarsie Line is also shorter than the majority of other subway lines. It was thought that the initial installation and testing of CBTC on the Canarsie Line would be less

complex than the implementation on subway lines that have junctions and that share trackage with other lines.

Canarsie was not only a pilot for the system itself, but also for the establishment of CBTC design and safety standards, as well as the development of operating rules and procedures. Furthermore, the Canarsie Line project defined the requirements for all the training courses for operations, maintenance, and engineering and for the various processes that the implementation of a software based safety-critical system require in the short, medium and long terms.

The modernization of the Canarsie Line was intended to provide the following benefits:

- Enhanced safety due to continuous over-speed protection and reduced reliance on human factors
- Lower maintenance costs due mainly to less field equipment and to state-of-the-art real time maintenance tools
- Greater operational flexibility
- Smoother and more predictable operation
- Increased throughput
- Shorter runtimes
- Improved reliability and availability

Pre-CBTC Operations

Signaling/Train Control System Configuration

NYCT's pre-CBTC train control system was based on fixed-block technology with wayside signals using mechanical trippers for enforcement of stop signal aspects. Each signal has a "control line" that represents the section of track that must be clear in order for the signal to display a proceed aspect (yellow or green). The control lines of successive signals overlap, so that each "proceed" signal:

- Gives the train permission to proceed to the next signal
- Guarantees that there is a buffer of clear track in advance of the next signal sufficient for the train to stop, if it should overrun that signal and be tripped

The buffer zone is sized for the emergency braking distance of a train proceeding at maximum attainable speed.

Figure 4-2 shows the simplest possible arrangement, where the signal control line includes two track circuits. Actual signal controls may include two or more track circuits in each zone as necessary to satisfy operating requirements and provide adequate train separation.

Figure 4-2

NYCT Signal Control Line

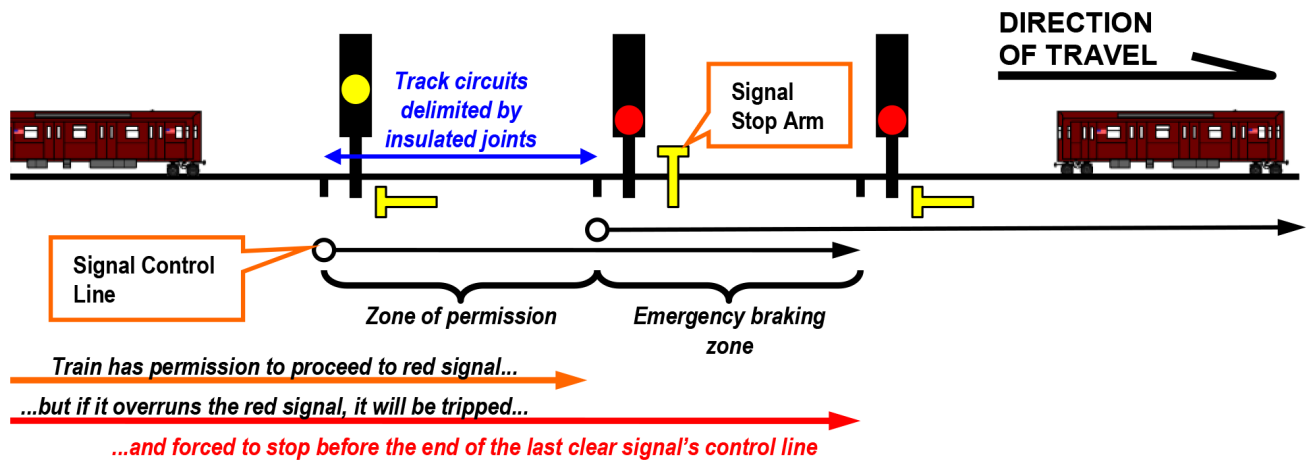

The general principle of trip-stop signaling is unchanged from the original Interborough Rapid Transit (IRT) system, although some refinements have been introduced over the years. For example, grade time signaling was used to control the speed of trains at curves and to enforce civil speed limits. Station time-controlled signals were used at the approach to stations to provide closer headways.

Overall, the signal system was designed for 150-second headway that provided the capability to run 20 trains per hour (an operating headway of 180 seconds).

Mechanical interlockings were used to provide protection to train movements over track switches and have been replaced over the years by all-relay interlockings to enable central control through master towers. A typical mechanical interlocking machine from that era is shown in Figure 4-3.

Figure 4-3

Typical NYCT
Mechanical
Interlocking Control
Machine

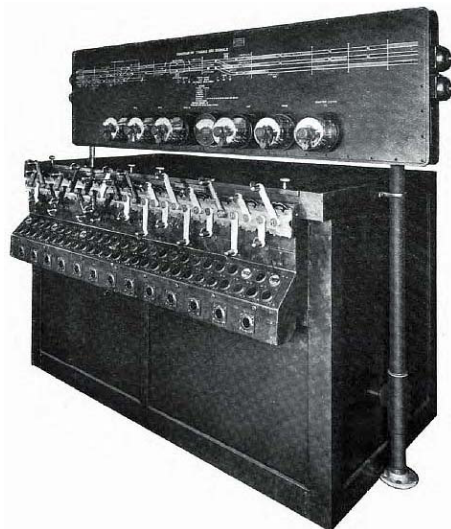

Service Levels

Following a peak in the 1940s, passenger volumes on the New York City subways decreased through the early 1990s, for reasons that had little to do with the train control system; in fact, there was considerable investment in new signal equipment during this period. Except for specific lines where passenger volume remained high, service levels were lowered to meet reduced demand. For most of the lines, the train control system did not present a capacity constraint. However, in the decade prior to the CBTC implementation, ridership almost doubled, as shown in Table 4-1:

Table 4-1
NYCT Ridership

Year	Annual Ridership
1994	16,968,000
1996	18,107,000
1998	21,197,000
2000	26,156,000
2005	30,452,000

Since 1995, and to accommodate the increase in ridership on the Canarsie Line, NYCT gradually increased peak service to the level of 15 trains per hour and expanded the period of peak service to 2 hours. However, during the temporary closure of the Williamsburg Bridge in 1999, NYCT increased service on the Canarsie Line to its maximum practical throughput of 20 trains per hour to compensate for the loss of J, M, and Z service between Brooklyn and Manhattan.

The increase in ridership continued during the implementation phase of the Canarsie CBTC project, which commenced revenue service in 2006. Ridership increased during weekdays and during the weekend, which led NYCT to increase the daily trips, as indicated in Table 4-2. NYCT reported that the increase in ridership has continued to accelerate since 2006.

Table 4-2
Number of Canarsie
Line Trips Scheduled
and Ridership

Year	Number of Trips Scheduled and Ridership						
	Average Weekday			Average Sunday		Average Sunday	
	Daily Trips	Peak TPH*	Ridership	Daily Trips	Ridership	Daily Trips	Ridership
1998	292	12	68,104	244	40,742	212	29,927
1999	292	13	75,552	244	46,772	212	34,011
2000	348	15	83,411	274	51,092	226	38,421
2001	382	15	90,618	350	55,528	258	41,676
2002	384	15	95,317	350	59,186	258	45,079
2003	384	15	94,634	350	50,425	258	38,610
2004	400	15	97,057	350	58,272	258	43,415
2005	400	15	100,852	350	51,675	258	40,471
2006	400	15	103,944	350	51,023	258	39,511
% Change 1998–2006	38%	20%	53%	43%	25%	22%	32%

*Trains per hour

Operations & Maintenance

While the fixed-block, wayside signal technology protects against a train operator's simple carelessness, this protection is not complete. A basic safety limitation of the trip-stop system is that it can do only one thing—trigger an emergency brake application—at a specific location (where a train stop is located). There is no direct way of enforcing, for example, a speed limit on a train. On a curve, for example, a grade-timed signal can be placed in approach to the curve to address the case of an inattentive train operator approaching the curve at an inappropriate speed. Grade-timed signals can be placed along the curve to prevent a gross over-speed condition. But if the intent is to absolutely enforce a designated “safe speed,” the additional signals required would effectively limit operating speeds below optimal values. This is a particular issue for diverging movements over switches, where safe speeds can easily be exceeded. In addition, once a train is stopped at a red signal, the train operator may be directed to pass it at restricted speed. At that point, the train operator is completely responsible for safe operation; there is nothing to stop a train operator from accelerating after passing a red signal and precipitating an accident. As such, the safety of operation is highly dependent on compliance with operating rules and procedures.

Over time, design rules were changed in an effort to make the system safer:

- In stations, historical design rules required that the train reduce its speed when passing through a station. This allowed the clear block buffers (and signal control lines) to be shorter, improving headway at the expense of safety. These design rules were, however, changed to assume that train speeds are not reduced on approaching stations.
- At interlockings, additional signals were added in approaches to trailing point switches so that a train that had passed a red signal would not be able to accelerate to a speed that would enable it to foul a conflicting move in progress over the switch.
- At terminal tracks ending in bumper blocks, grade-time signals were added to limit the speed at which a train could overrun the end of track.

While all of these changes improved safety, they did so at the cost of additional signals and track circuits. And since the signal system was entirely electromechanical, with relay logic and mechanical train stops, more signals meant more preventive maintenance and more potential for failure. In the 1990s, the mean time between failures of the NYCT signal system was calculated at approximately 11 hours. Moreover, furnishing and installing additional signal and track circuit equipment increased the capital cost of the new signal equipment.

In addition to the safety limitations of fixed-block technology, the existing signal installations had limited operational flexibility and were difficult to modify and maintain. The mechanical interlocking became obsolete, and spare parts had to

be handcrafted by maintenance personnel. Furthermore, a mechanical interlocking had to be operated from a local tower and could not be operated remotely.

The above is not meant to imply that the existing wayside signal system is unsafe. On the contrary, over the last 50 years, NYCT has successfully implemented fixed-block technology to provide a high level of operational safety to its passengers. However, the safety of operation in a fixed-block environment is highly dependent on the human element and compliance with operating rules and procedures. To enhance the safety and operational flexibility of the signal system, and to make more effective and efficient use of existing infrastructure while minimizing the capital investment and recurring maintenance costs, new technology had to be considered.

Safety Incidents

Over the years the safety limitations of fixed-block installations has resulted in a number of accidents at NYCT. These accidents were mainly due to the failure of operating personnel to comply with rules and procedures. A summary of the accidents that occurred during the period from 1969–1997 is indicated in Table 4-3.

Table 4-3

NYCT Accident Summary

Date	Accident Summary
Dec 29, 1969	Train derailment near East 180th Street in the Bronx, injuring 48. An inquiry found that the train operator misread a signal and failed to slow his train.
Feb 27, 1970	An IRT train hit a bumper at the Pelham Bay Park Station (Bronx), injuring 7. An inquiry found that the train apparently came into the station too fast.
May 20, 1970	A train collision west of Roosevelt Avenue station killed two passengers and injured 77. The cause of the accident was identified as a human error when a train was operated from the third car with the brake cutout on the first two cars.
Jul 17, 1970	A rear-end collision near Hoyt-Schmerhorn Street station injured 37 passengers. The cause of this accident was attributed to failure by the train operator to comply with operating rules after keying by a red signal.
May 22, 1975	Collision on the middle track of the Astoria Line near Grand Avenue Station.
Nov 24, 1979	Rear end collision at Morris Park, Dyre Avenue Line.
Jul 30, 1981	A motorman was killed and 135 passengers were injured in a rear-end collision in a Brooklyn tunnel.
Jul 26, 1990	36 passengers were injured in a rear-end collision near Brooklyn Park, Brooklyn.
Aug 28, 1991	Five people were killed and more than 200 injured when a southbound No. 4 train derailed going over a switch just north of Union Square Station. The accident was attributed to excessive speed over a diverging route.
Jul 7, 1993	A rear-end train collision on the Canarsie Line injured 45 passengers. The cause of this accident was attributed to failure by the train operator to comply with operating rules after keying by a red signal.

Table 4-3 (cont.)*NYCT Accident Summary*

Date	Accident Summary
Aug 15, 1994	A derailment of a south bound “B” train injured 11 passengers near 9th Avenue, 4th Avenue Line. A track switch operated under the last car of the train.
Sep 28, 1994	Two work trains collided near Graham Avenue in Brooklyn. The accident was attributed to a train operator passing two red signals after working 16 hours straight in violation of NYCT rules.
Feb 9, 1995	A rear-end collision near the 9th Avenue Station in Brooklyn injured 7 people. The cause of this accident was attributed to failure by the train operator to comply with operating rules after intentionally keying by a red signal.
Jun 5, 1995	A rear-end collision on the Williamsburg Bridge killed the train operator and injured 50 passengers. The cause of the collision was attributed to a failure of the train operator to stop at a red signal, combined with insufficient braking distance at the signal and poor performance of the train’s brakes.
Aug 22, 1995	A rear-end collision at Brooklyn Bridge, City Hall Station injured 6 passengers. The cause of this accident was attributed to failure by the train operator to comply with operating rules after keying by a red signal.
Nov 20, 1997	A rear-end collision near the Steinway Street Station in Queens injured 40 passengers. The cause of this accident was attributed to failure by train operator to comply with operating rules after inadvertently keying by a red signal.

The accident that took place on August 28, 1991, noted above, was the catalyst for the decision to implement a new technology signal system, which led to the implementation of CBTC. The train derailment on a crossover at the 14th Street Station on Division A was due to excessive operating speed, and resulted in the death of five passengers; the accident also resulted in severe damage to the train and equipment in the tunnel. While the signal system had tripped the train before it entered the crossover, the emergency brake application was triggered too late to meaningfully reduce the speed of the train.

A common factor in many of the accidents listed above was the failure by operating personnel to comply with operating rules and procedures, especially during failure modes when the safety of operation is highly dependent on such compliance given the lack of a “secondary” train protection system. NYCT identified continuous over-speed protection and improved availability of the signaling system as essential requirements in a new signal technology.

CBTC Solution Selected

Technology Selection Process

In response to the 1991 accident, NYCT assessed the risk associated with over-speed through diverging routes and implemented a program to address the locations with the highest risk. Some locations were addressed through modifications of interlocking rules, so that trains would effectively be required to stop before a diverging route could be established for them. At other locations,

a wheel-detector based system was installed, using pairs of axle counters as detection points to dynamically measure train speeds and release the mechanical trippers if an over-speed was detected.

Shortly afterwards, NYCT conducted a consultant study to identify a more effective approach to train control. The study focused on four alternatives:

1. Existing fixed-block system enhanced with axle-counter-based speed enforcement for diverging routes
2. Fixed-block audio frequency cab signaling
3. New CBTC system
4. Overlay CBTC

These alternatives were analyzed for functionality, operating performance, availability/reliability, ease of migration, safety, and cost. The results of this study are summarized below:

- The **enhanced fixed-block system** generally produced the worst results. It provided the least functionality, the worst performance, the least improvement in safety, and the second-highest cost. However, it presented the fewest migration issues. Ultimately, the wheel detector speed enforcement system proved cumbersome in operation and unreliable and is no longer part of NYCT signal designs.
- **Audio-frequency cab signaling** scored well in functionality, safety, and cost. However, it did not support operation of unequipped trains, except under procedure (i.e., no signal or ATP protection).
- **“Pure” (not overlay) CBTC** scored best in functionality, safety, and cost. However, it did not support protected operation of unequipped trains. Moreover, given that the levels of operational availability that could be achieved in revenue service had not been validated at that time, there was concern that a CBTC failure could lead to widespread operational disruption.
- **Overlay CBTC** had the highest cost, but scored well in other areas. Overlaying CBTC on a non-CBTC signal system addressed concerns of a catastrophic CBTC failure and facilitated migration as well as detection and protection of unequipped trains.

NYCT ultimately selected the overlay CBTC approach. In addition to the advantages noted above, it enabled NYCT to proceed with signal modernization (installing “CBTC-ready” signals and interlockings) in areas where the existing signal system was due for replacement, but there were no immediate plans to implement CBTC. While it was the most expensive approach, it provided the greatest flexibility in implementation when there is an operational need to support mixed-mode operations.

Compliance with Industry Standards

The specifications for NYCT's Canarsie Line CBTC system were developed prior to the publication of IEEE Std 1474.1™ and, indeed, the NYCT specifications were one of many inputs to the development of this standard. As a consequence, there is a strong correlation between the performance and functional requirements developed by NYCT for its CBTC system and the performance and functional requirements established in IEEE Std 1474.1™. Specifically:

- NYCT's CBTC specifications included all of the mandatory ATP functional requirements defined in IEEE Std 1474.1™
- Many of the optional ATO and ATS functional requirements of IEEE Std 1474.1™ were also included in the NYCT CBTC specifications.
- NYCT's CBTC specifications also provide information to the CBTC supplier as recommended by IEEE Std 1474.1™, including performance requirements (headways, travel times, safety criteria, and Reliability, Availability and Maintainability [RAM] requirements), track alignment details, and rolling stock performance characteristics.

During the Preliminary Design Phase, NYCT worked closely with the CBTC supplier to clarify the initially specified requirements, which were then captured in an approved System Functional Specification (SFS) and System Design Document (SDD). Some new functional requirements not included in IEEE Std 1474.1™ were identified in this process, including the addition of functions to provide CBTC protection in yards, a traffic interlock function for Restricted Manual mode operations, and functions to detect and protect against wrong-side failures of track circuits.

The results of the IEEE Std 1474.1™ comparison assessment are provided in Appendix A.

CBTC System Description

NYCT selected the joint venture of Siemens Transportation Systems, Inc., Union Switch & Signal, Inc. (US&S), and RWKS Comstock to be the Lead Contractor for Phase II of the NYCT Canarsie Line CBTC Project. The contract was awarded in December 1999.

Phase II of the Canarsie Line project involved re-signaling the entire Canarsie Line (22 track miles), including the yard, and furnishing CBTC equipment for 212 new R143 cars. Siemens was responsible for the design and supply of the car-borne and wayside CBTC subsystems (including the data communications system), an ATS subsystem, and overall project management and systems integration. US&S was responsible for the design and supply of an Auxiliary Wayside System (AWS) including six relay-based interlockings, track circuits, wayside home and approach signals, and automatic train stops. RWKS Comstock was responsible for equipment installation and associated equipment room construction.

The CBTC system for the Canarsie Line was based on a similar system that had been installed on the RATP Meteor Line in Paris and had entered revenue service in October 1998. Two major changes were required to accommodate NYCT's specific operating environment:

- Adaptations to support automatic train operations with a driver (the Meteor Line is driverless)
- Adaptations to support a radio-based train-to-wayside data communications (Meteor Line uses inductive loop)

The basic principles of operation of the NYCT CBTC system are as follows:

- For CBTC-equipped trains, train location is determined by the CBTC train-borne equipment, independent of track circuits.
- This train location information and other train status data are communicated to CBTC wayside equipment (zone controllers) over the CBTC train-to-wayside radio-based data communications link.
- Zone controllers determine movement authorities for CBTC-equipped trains within their specific area of control, based on CBTC train location information and inputs from the AWS equipment that provides interlocking status and the detection of unequipped trains through a secondary track circuit-based train detection system.
- Movement authority and other vital and non-vital train control data are communicated to the appropriate train over the CBTC wayside-to-train data communications link.
- Based on movement authority data and using an onboard track map, the CBTC train-borne equipment determines and enforces the ATP profile.
- The CBTC wayside equipment (zone controllers) also provides inputs to the interlockings to modify interlocking functions for approaching CBTC trains.

CBTC Train-borne Equipment

As summarized above, the CBTC train-borne equipment is responsible for CBTC train location determination, the enforcement of permitted speed and movement authority limits, and other allocated train-borne ATP and ATO functions.

The CBTC train-borne equipment was installed by NYCT forces on new R143 cars built by Kawasaki. These cars feature AC traction, full-width cabs, and wide use of train networks. The CBTC interfaces to the cars had been carefully coordinated so that the cars were delivered “CBTC ready.” This meant that space, power, and all interface wiring for CBTC equipment was provided by the carbuilder, making equipment installation a relatively simple task. Each four-car unit includes a redundant set of CBTC train-borne equipment.

The CBTC train-borne equipment interfaces to the train subsystems (including train operator displays) and also to the CBTC wayside equipment and CBTC ATS equipment via the CBTC data communications equipment.

In a typical CBTC system, the measurements of speed and distance traveled generally rely on tachometers that measure the rotation of a train's axle. The design, therefore, has to compensate for wheel wear and, unless a free axle is available, it also has to accommodate slip/slide effects. As no free axle was available on the Canarsie Line rolling stock, Siemens elected to use a novel Optical Speed and Position Measurement System (OSMES), which was independent of the wheel-rail interface, as an alternative to tachometers. The use of OSMES enabled Siemens to minimize changes to the onboard vital software. In addition to OSMES, passive transponders are mounted periodically between the rails and are detected by the CBTC train-borne equipment to provide an absolute position reference.

With the availability of a free axle on the Flushing Line rolling stock, a train location determination system based on tachometers is planned for the CBTC implementation on that line. A tachometer-based system does not require a free axle if accelerometers (or other means) are used to detect slip/slide.

CBTC Wayside Equipment

As summarized above, the wayside intelligence for CBTC-related ATP functions, such as movement authority setting based on the tracking of both CBTC-equipped and unequipped trains, as well as other allocated wayside ATP, ATO, and ATS functions, resides in the CBTC wayside equipment.

CBTC wayside equipment consists of a network of vital processor-based, wayside controllers—zone controllers—installed at a number of locations along the wayside. Each zone controller interfaces to the CBTC train-borne equipment via the CBTC data communication equipment and also interfaces to interlockings and to CBTC ATS equipment located at the Rail Control Center.

As supporting mixed-fleet operation was a critical operational requirement on the Canarsie Line, the zone controllers interface to existing wayside signals, train stops, and other equipment, which allows unequipped trains (detected through track circuit occupancies) to move safely under signal protection. The wayside signal control circuits were modified to provide a flashing green indication for approaching CBTC-equipped trains and conventional wayside aspects for unequipped trains.

CBTC Data Communications Equipment

The NYCT CBTC data communications equipment includes equipment located at central and wayside locations, as well as onboard trains, to support wayside-to-wayside and wayside-to-train data communications. Wayside-to-wayside data communications is by means of a dedicated fiber optic network.

An RF data network provides two way continuous data communications between trains and wayside. The data exchanged includes train location reports sent to the wayside and movement authorities sent to the train. The radio subsystem operates on 2.4 GHz Direct Sequence Spread Spectrum transmission in the unlicensed ISM band. Radios and antennas are located primarily at the ends of station platforms and at some locations between distantly spaced stations. In total, 55 bases were installed on the Canarsie Line.

The radio system supplied by Siemens was based on a proprietary, free-propagation radio rather than leaky co-axial cables. The radio system uses a deterministic protocol—Direct Sequence Spread Spectrum modulation, a custom-designed demodulator, and micro-synchronization. Prior to entering revenue service, extensive tests were performed to ensure the robustness of the radio system to interference from Wi-Fi users and to check that the CBTC system would not affect Wi-Fi users. Extensive tests were also performed to demonstrate the robustness of the radio system to jamming and hacking.

CBTC-ATS Equipment

The CBTC ATS equipment includes equipment installed at NYCT's Rail Control Center responsible for ATS (non-vital) functions such as identifying, tracking, and displaying trains; providing manual and automatic route setting capabilities; and regulating train movements to maintain operating schedules.

Assessment of Enabling Technologies

High-Resolution Train Location Determination

The Canarsie Line CBTC train location determination includes three primary components:

- Transponders to provide absolute position reference throughout the system and for entry into the system
- Optical Speed and Position Measurement System (OSMES) to provide train displacement between absolute position reference points
- Switch location and status to update the train position when passing over switches

The Canarsie CBTC system also includes track circuits for detection of unequipped trains. Unequipped train detection is monitored by wayside controllers and is not used as part of the CBTC train location determination.

The Canarsie CBTC system uses the DIGISAFE® passive transponder system, with the transponders mounted periodically between the rails (see Figure 4-5) and the Transponder Interrogator Antenna (TIA) mounted onboard the train.

The DIGISAFE® passive transponders are digital transponders, powered by the trains themselves (passive devices) through a magnetic coupling at a 128 kHz frequency. They are installed on the center of the track in order to be read by all equipped trains, whatever their orientation. When a train goes over a transponder, it energizes the track-mounted transponder and receives a vital digital message, which identifies the transponder and gives a data entry to the track database, specifying the geographical position of the transponder middle point (Figure 4-4).

Figure 4-4

NYCT Transponder Message Communication

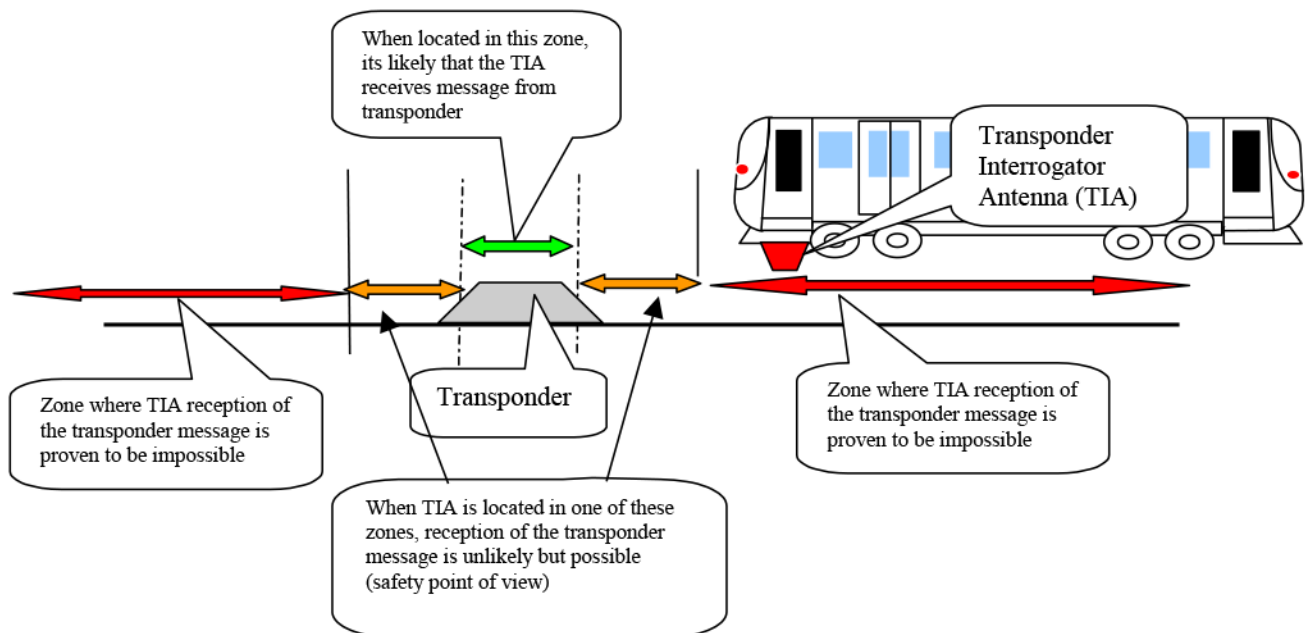

The track database is resident within the Onboard Control Units (OBCUs), including reference to transponder and switch locations. The safety of transponders computing is ensured through coded messages and vital position calculations.

As no free axle is available on the Canarsie Line rolling stock and satellite navigation is not viable due to extensive tunnel operation, a new approach using OSMES was taken for train location determination. OSMES, therefore, is independent of the wheel-rail interface and is based on optical principles using a laser diode source that projects a collimated (parallel) beam of invisible light on the top of the running rail. The reflection of any laser beam produces an interference pattern, typically speckled. Every single image of the speckle pattern taken by a CCD (charge-coupled device) sensor represents a unique signature of the illuminated surface. The principles of OSMES and its vital measurement rely on this unique signature and on the large amount of information contained

in each image. Whenever the train has moved between two time steps, the same image of the speckle pattern appears shifted on the CCD sensor and this shift, measured in pixels, is used to calculate the distance traveled and the speed of the train. Figure 4-5 provides an illustration of the OSMES system.

Figure 4-5

NYCT Optical Speed and Position Measurement System (OSMES)

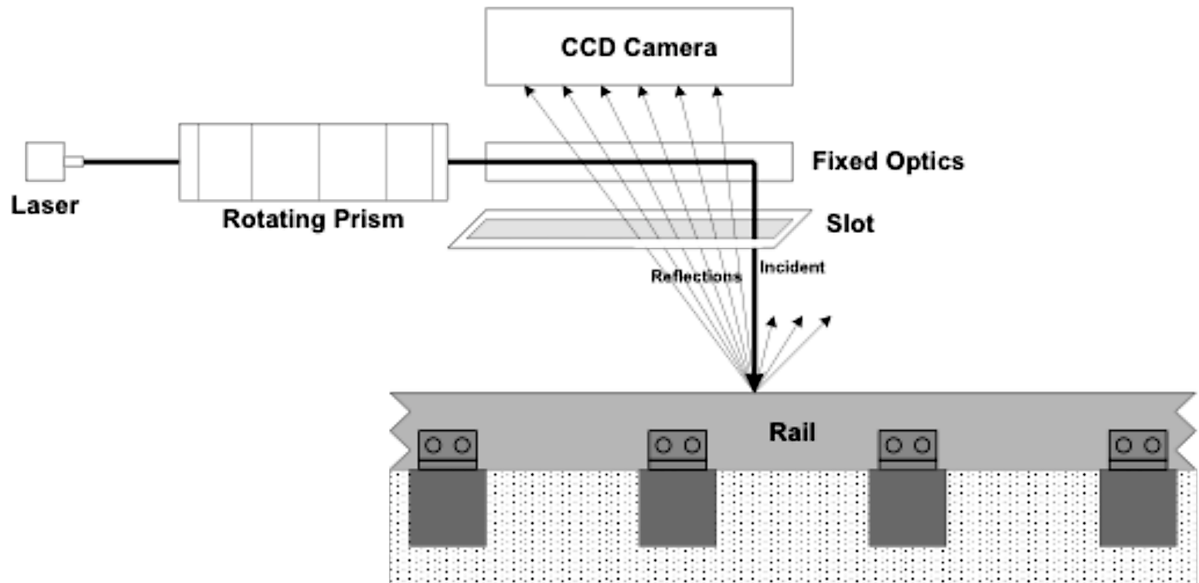

OSMES is mounted under the truck, above the rail (Figure 4-6). The device includes the laser diode aimed at the rail, a laser beam alignment device (rotating deflector prism) and a CCD sensor set parallel to the rail.

Figure 4-6

OSMES Device Mounted under Truck

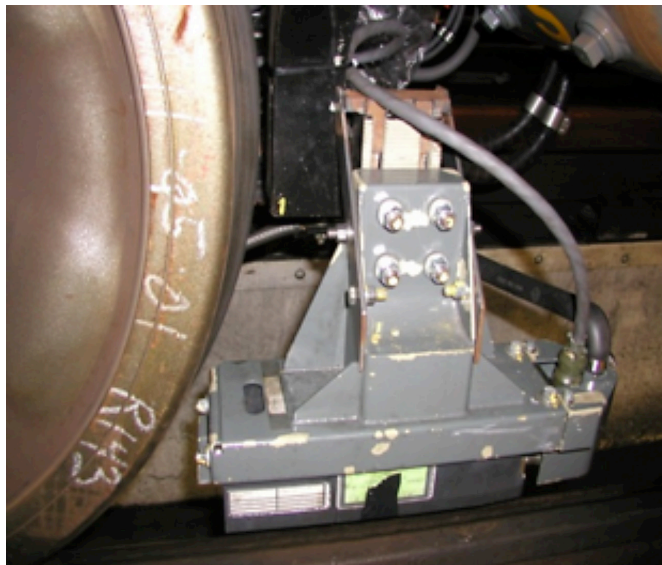

The optical components are isolated from the external environment by means of a protective glass and, under the optical sensor, a chamber is maintained in slight overpressure by a fan to prevent dust sticking to the protection glass. Although OSMES has provided accurate location and speed measurements, it requires extensive maintenance efforts to ensure cleanliness of the protective glass.

High-Capacity Data Communications

The NYCT CBTC data communications equipment includes equipment located at central and wayside locations, as well as onboard trains, to support wayside-to-wayside, wayside-to-train, and in-vehicle data communications.

Wayside Network

The Wayside CBTC Network (WCN) is based on a standard Internet Protocol (IP) data communications network to provide all the communications means between:

- ATS server and its remote consoles (Remote Workstation (RWS) consoles not located in Rail Control Center (RCC))
- ATS server and the AWS Programmable Logic Controllers (PLCs)
- ATS server and Wayside Cell Controller (WCC), and then with trains through the Radio DCS
- ATS server and Zone Controller (ZC)
- ZC and WCC (and then with trains through the Radio DCS)
- Adjacent zone controllers

The WCN is made of 10/100 Mbps COTS IP nodes (Wayside Interface Units, WIU) interconnected together with a fiber optic network. The WIU is a redundant device allowing a multipath link between wayside equipment located in relay rooms and with central ATS in the RCC. CBTC devices are connected to the nodes using Ethernet LAN topology. The WCN is divided in two parts:

- RCC-located equipment that connects the ATS equipment to the NYCT backbone; includes at least a routing function for packets taking into account the three connections between the NYCT backbone and the field part of the WCN
- Field part of the WCN with three access points to NYCT backbone; the network consists of nodes (routing/switching units, WIU) that route/switch data packets:
 - between ATS and wayside equipment via NYCT backbone (WIU is used as access point)
 - between CBTC wayside equipment (WCC, ZC, PLC, remote ATS console) inside a relay a room or between devices located inside separate relay rooms

Figure 4-7 illustrates the general architecture of the WCN for the Canarsie Project.

Figure 4-7

NYCT Wayside CBTC Network – General Architecture

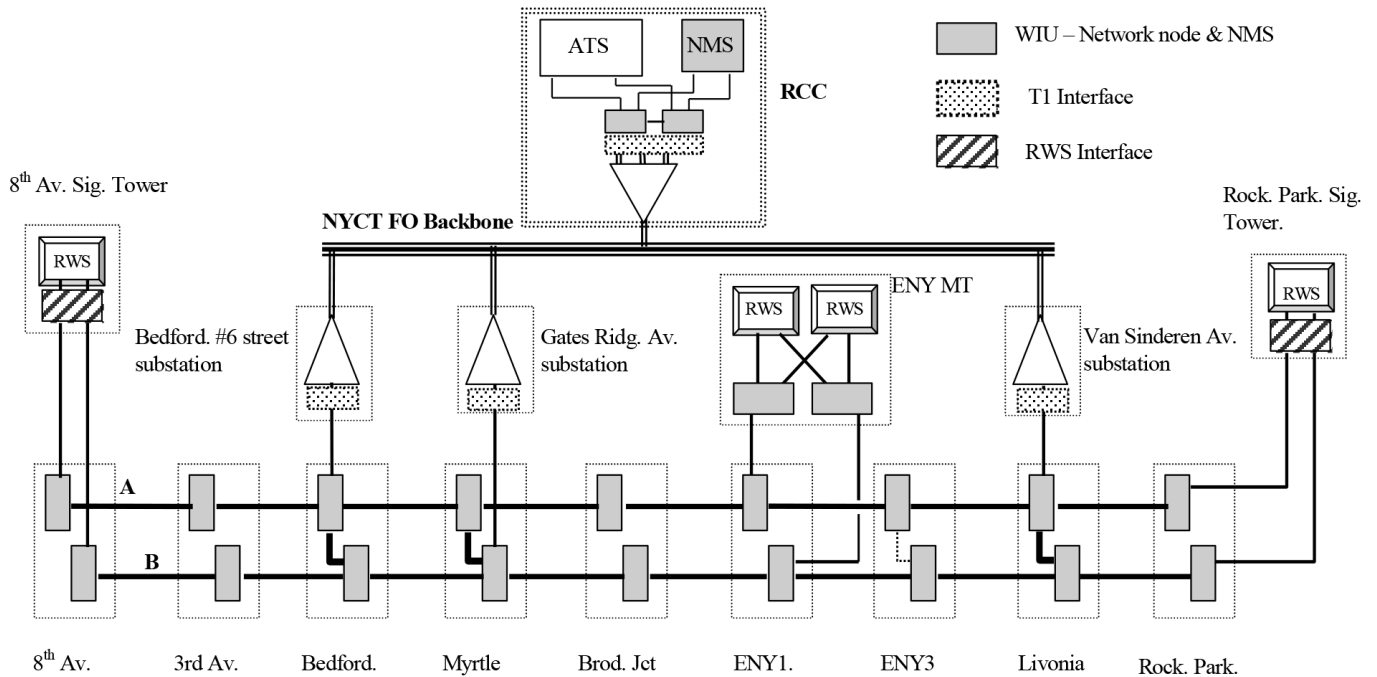

Interfaces between the nodes (WIU) and the different equipment are done through standard IEEE 802.3 100BaseT 100 Mbps Ethernet links. To ensure a high availability level, the Wayside Network is split into two independent physical networks, A and B. Critical equipment such Zone Controller (made of WCUs), Wayside Cell Controller (made of WTUs) and PLCs are linked to the nodes (WIU) as follows:

- ZC connection to network: Each ZC is composed of two units (WCU-A and WCU-B), and each unit is connected separately to each fiber of the Redundant Ethernet nodes WIU located in the relay room.
- WCC and PLC connection to network: WCC and PLC connections to network are similar to ZC connection.

Figure 4-8 shows a typical relay room configuration with a RWS interface. When distance from the relay room to a remote workstation exceeds 300 feet, connection between WIU and RWS is implemented through a fiber optic Ethernet link.

Figure 4-8

NYCT WCN Typical Relay Room Configuration

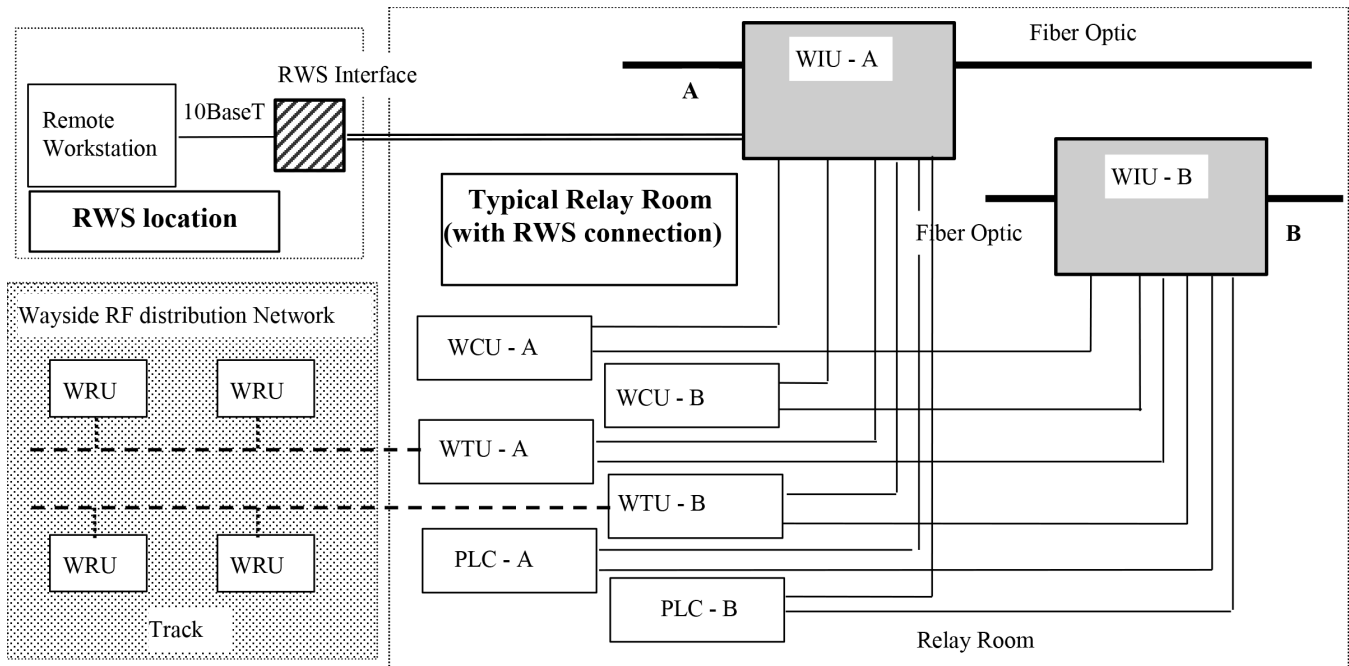

The Wayside Network nodes located at relay rooms at Bedford Avenue, Myrtle Avenue, Livonia Avenue, and the RCC are connected to the NYCT fiber optic network via a high-speed T1 port (1.544 Mbits/s).

The NYCT Fiber Optic network uses Time Division Multiplex (TDM) ring topology and is made up of 7 backbone TDM rings, labeled A through G. In addition, there are 6 spur TDM rings and 11 protected optical extensions. The Canarsie Line is serviced by backbone Ring E as well as optical extension 4(E). Ring E has a 565 Mbps optical transmission system capable of carrying 12 multiplexed DS3 channels and overhead data. Optical extension ring 4(E) has a 150 Mbps capacity capable of transmitting three multiplexed DS3 channels and overhead data.

Network management is controlled via a console based on a personal computer running Windows NT 4.0 operating system. It is located at the RCC and performs the following three main tasks:

- Network administration
- Network configuration
- Monitoring the network and reporting

Any failure of network devices is displayed and easily localized.

RF Data Network

An RF data network provides two-way continuous data communications between wayside subsystems (ZC and ATS), and car-borne subsystems (car-borne controller). The data exchanged includes train location reports sent to the wayside and movement authorities sent to the train. The radio subsystem operates on 2.4 GHz in the unlicensed ISM band. Radios and antennas are located primarily at the ends of station platforms and at some locations between distantly-spaced stations. A typical outdoor antenna installation is shown in Figure 4-9. In total, 55 bases were installed on the Canarsie Line.

Figure 4-9
Typical Outdoor
Antenna Installation



The wayside radio is made up of Wayside Cell Controller (WCC) and Wayside Radio Units (WRUs), configured as illustrated in Figure 4-10.

Figure 4-10
NYCT Wayside
Radio Architecture

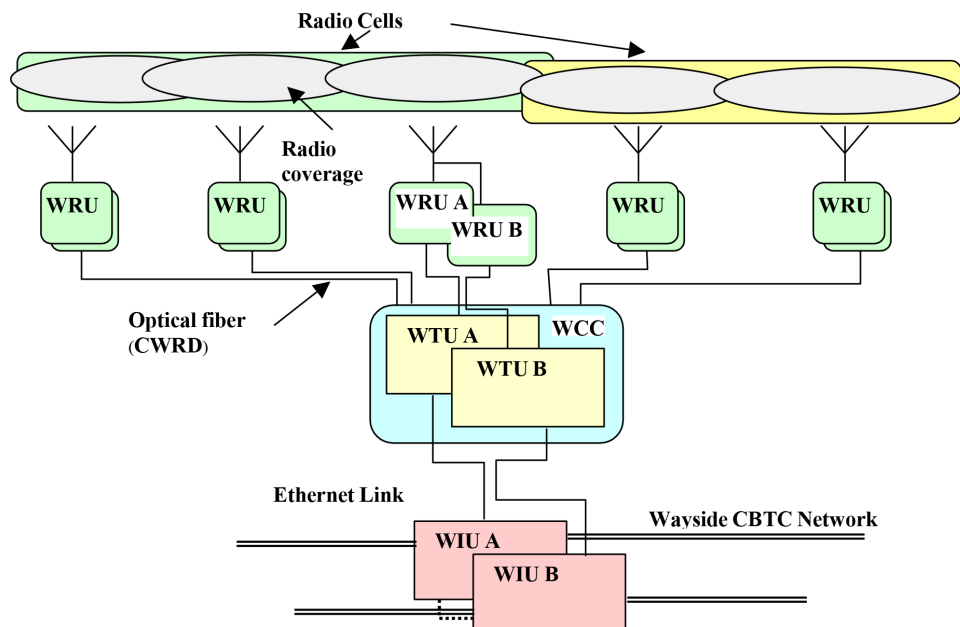

A WCC manages up to four radio cells and is a redundant device made up of two Wayside Transmission Units (WTUs). Each unit is linked to the wayside CBTC network to exchange messages with the ZC and ATS. The wayside radio units are distributed along the track through optical fiber network to exchange messages with the trains. The main tasks of the WCC include:

- Managing the radio link to define the radio cell frequencies and the spread sequence and allocating the radio resources to different services: CBTC, non CBTC, database transmission
- Managing the list of trains that can be reached within a cell using Sign-in/Log out protocol
- Performing messages routing to collect messages from ZC and ATS and to build the wayside radio frame to send to the different radio cells and to route the trains' messages to the relevant equipment (ZCs, ATS).

The WRU is a redundant device (WRU-A and WRU-B). WRUs are arranged along the track to ensure the whole radio coverage of the line according to the radio link budget. Antennas are connected to the WRU in such a way that each track is covered in both directions.

WRUs are organized in radio cells. The radio cell layout is determined according to the radio cycle performances (number of trains that can be polled within a cycle). For the Canarsie project, the radio cells layout is optimized to eight trains per cell with trains running at design headway. In this configuration, trains are polled at least every 0.5 seconds. The WRUs manage the radio link and the low-level radio protocol, transmitting frames to/from the WCC and trains.

The car-borne radio equipment is made up of radio bases called Carborne Radio Unit (CRU) located at each end of each four-car unit. The radio layout is defined so that each train-end may communicate with at least one wayside radio unit. A train is, therefore, linked to the wayside radio through two different radio paths for redundancy. The data exchanged between the carborne controller (OBCUs) and the CRUs is done through dedicated wire network CBTC Carborne Radio Distribution (CCRD), which is fully redundant and able to manage multiple train configurations. The multiple unit configuration is illustrated in Figure 4-11.

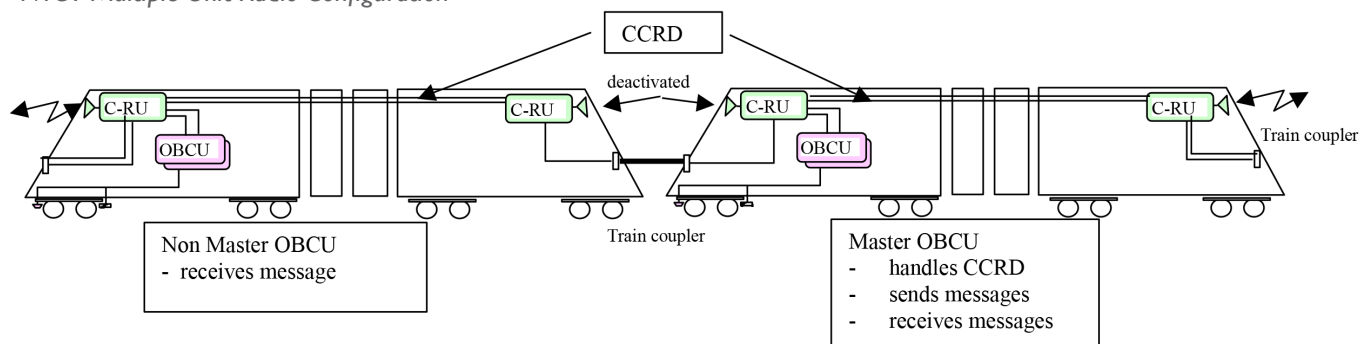
Figure 4-11*NYCT Multiple Unit Radio Configuration*

The CCRD of the two trains are linked together through the train coupler to form one single train CCRD. The intermediate CRUs are deactivated. The Master OBCU manages the CCRD, sending and receiving messages. The Master OBCU also performs polling for all CRUs. The Non-master OBCU is in listen mode receiving messages only. To avoid frames collision, each CRU (A1 car and A2 car) stores the radio frames and transmits them to the OBCU only in answer to active OBCU polling.

In-Car Network

The Canarsie Line RI43 cars were CBTC-ready and used IEEE1473-L (LonWorks) for communication in-vehicle. Discrete unit lines are also used for direct communications between Onboard Control Units and for direct inputs from Transponder Interrogator Antenna, the train location system, and the carborne radio distribution system.

Vital Processing

The wayside intelligence for CBTC-related ATP functions, such as movement authority setting based on the tracking of both CBTC-equipped and unequipped trains, as well as other allocated wayside ATP, ATO, and ATS functions, resides in the CBTC wayside equipment.

CBTC wayside equipment consists of a network of vital processor-based, wayside controllers—“zone controllers”—installed at a number of locations along the wayside. Each zone controller interfaces to the CBTC train-borne equipment via the CBTC data communication equipment and also interfaces to interlockings and to CBTC ATS equipment located at the Rail Control Center. Refer to Figure 4-12.

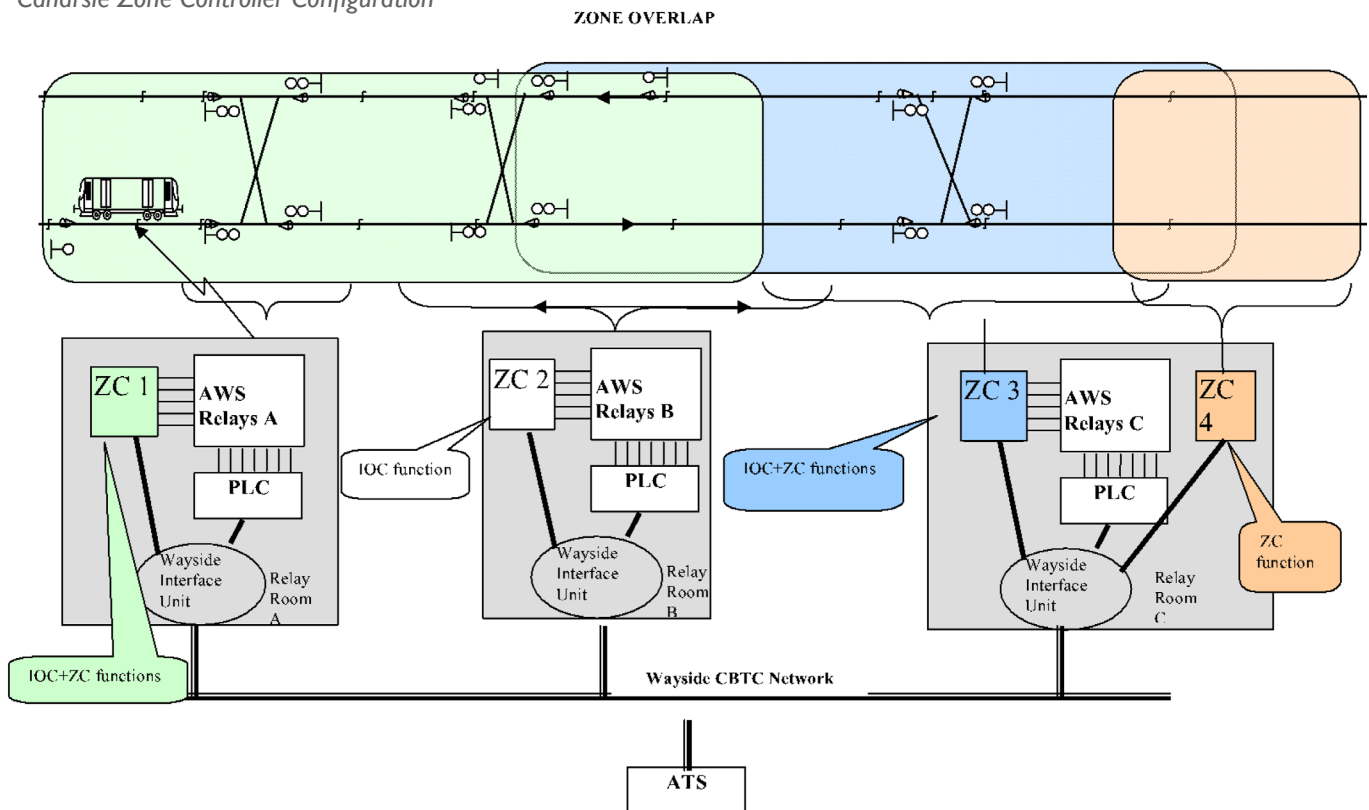
Figure 4-12*Canarsie Zone Controller Configuration*

As supporting mixed-fleet operation was a critical operational requirement on the Canarsie Line, the zone controllers interface to existing wayside signals, train stops, and other equipment, allowing unequipped trains (detected through track circuit occupancies) to move safely under signal protection. The wayside signal control circuits were modified to display a flashing green indication to approaching CBTC-equipped trains and conventional wayside aspects to unequipped trains.

The Canarsie vital systems used “coded processors,” and formal methods of software development are employed in both the CBTC wayside and train-borne equipment to ensure safety-critical functions are implemented in a vital (“fail-safe”) fashion. With a “coded processor” approach, data and programming within the processor are automatically encoded such that run-time errors and hardware failures can be detected and the system forced into a safe state. The “coded processor” approach is an alternative to the “checked-redundant” approach that is also used in CBTC system implementations. A typical zone controller installation is shown in Figure 4-13.

Figure 4-13

*Typical Canarsie
Zone Controller
Installation*



The “B method” was adopted by Siemens to develop and validate its safety-critical software. With B, the software is derived in a number of steps from an abstract mathematical specification and formal proof ensures that each intermediate step is equivalent to the previous one.

Implementation Approach

Procurement Approach

Retaining the flexibility of interoperable service between lines is a fundamental necessity for NYCT. In addition, given that the modernization of the entire NYCT signal system to CBTC operation will occur over a number of years and through multiple contracts, NYCT desires to have multiple sources of supply for CBTC equipment. This translates into a need for interoperability between CBTC equipment provided by different suppliers. Specifically:

- Trains equipped with CBTC equipment provided by one supplier must be capable of operating in CBTC territory equipped with wayside CBTC equipment provided by another supplier.
- Wayside CBTC equipment provided by two separate suppliers must be able to communicate with each other in the overlap area and with a common operations control center.
- A basic operating unit equipped with train-borne CBTC equipment provided by one supplier must be capable of operating within a train with another basic operating unit equipped with train-borne CBTC equipment provided by another supplier.

NYCT, therefore, implemented a unique procurement strategy to select the new signal system and achieve interoperability among two or more signal system suppliers. The procurement strategy included three phases on the Canarsie Line to demonstrate interoperability, and an additional step on the Culver Test Track project to finalize interoperability requirements and ensure safe interoperable subsystems.

In Phase I of the Canarsie project, three selected suppliers—Alcatel (now Thales), Alstom, and Siemens Transportation Systems—demonstrated their CBTC systems on a designated test track on the Culver Line. At the conclusion of the demonstration tests, a lead contractor - Siemens Transportation Systems, in a joint venture with Union Switch & Signal and RWKS Comstock, was selected as the Leader Contractor to provide a pilot installation of CBTC technology on the Canarsie Line. Thales and Alstom were awarded follower contracts. (Alstom has since withdrawn from the project.)

In Phase II of the Canarsie project, the CBTC pilot installation on the Canarsie Line was completed. NYCT's main objective in Phase II was to service prove CBTC technology in NYCT's operating environment. In addition, Phase II included the development of design, operational, and safety standards for the implementation of CBTC on the entire rapid transit system. Further, the Leader Contractor was required to develop Interoperability Interface (I²) specifications to be used by the follower contractors in demonstrating interoperability during Phase III of the Canarsie project. The ultimate objective of the I² specifications is to enable multiple suppliers to competitively compete for subsequent signal modernization contracts, and provide interoperable CBTC systems.

As Alstom withdrew from the program, Thales was left as the sole Follower Contractor to participate in Phase III of Canarsie (Interoperability Demonstration), with support from STS. Phase III was successfully completed when Siemens and Thales demonstrated interoperability between their respective CBTC subsystems.

Although interoperability was demonstrated in Phase III, it was a necessary but not sufficient step to ensure that the I² specifications are complete and provide safe interoperable subsystems. As such, NYCT contracted with both Siemens (Leader Contractor), and Thales (the remaining follower) to finalize the I² specifications using a test track on the Culver Line. This project is currently ongoing. The entire procurement process to demonstrate and ensure interoperability between systems provided by different suppliers is shown in Figure 4-14.

Figure 4-14
Procurement
Process to Achieve
Interoperability

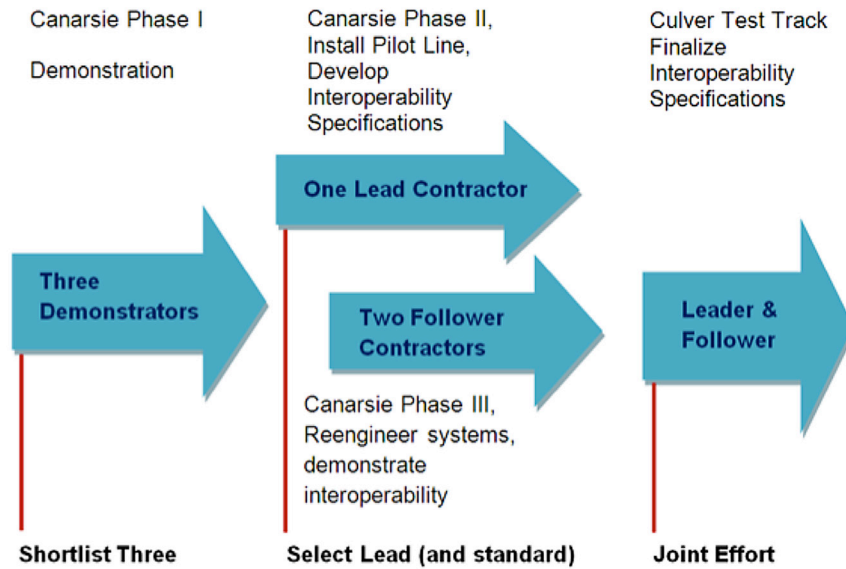

By requesting multi-sourced standardized CBTC solutions, NYCT not only aims to retain operational flexibility but also to foster competition between suppliers.

Safety Certification Process Review

The following subsection compares the safety certification and risk assessment processes used by NYCT with the requirements of FRA standard 49 CFR Part 236, Subpart H.

Software Management Control Plan

NYCT included formal software management requirements throughout the delivery of the Canarsie Line, which was consistent with requirements of the FRA Subpart H. The NYCT safety certification process involved a highly-structured delivery process that was consistent with both U.S. and European Standards (CENELEC). The applicable CENELEC standard is EN50128: “Railway applications – Communication, signaling and processing systems – Software for railway control and protection systems,” and the processes specified in this standard formed the basis for NYCT’s Software Management Plan.

EN50128 specifically relates to software safety and introduces levels of software safety integrity, from Level 0 to Level 4 (Level 4 being the most stringent). All levels require a top-down design method: modularity, verification, and validation at each development stage; clear documentation and traceability of requirements; configuration management/change control; and an appropriate organization to ensure personnel competency. The key sections of EN50128 required the development and execution of the following plans and processes by NYCT and the contractor:

- Software Requirements Specification reflecting the system architecture
- Software Quality Assurance Plan
- Integrated software product, ensured through structured reviews
- Software and System test program to accept and deploy software
- Software Maintenance Plan

One area to note is that the NYCT solution delivered by the contractor was based on a previous system (also see Product Safety Plan below). Initially, there was an assumption that there would be minimal software modifications. However, during project implementation, more software modifications were required as a result of new functional requirements and needed enhancements to control algorithms. Hence, along with the contractor's software management approach based on EN50128, NYCT and an Independent Safety Assessor performed an independent review of the software.

Railroad Safety Program Plan

NYCT was not under federal or other mandated regulations pertaining to the safety certification of systems or equipment, and there were no other U.S. regulations defining a required safety certification process for signal systems in heavy-rail transit applications. Therefore, NYCT made a decision to self-certify the safety of the CBTC system for the Canarsie Line.

NYCT developed a safety certification process consistent with applicable U.S. safety standards and accepted industry practice. The process included 10 components:

1. Siemens Safety Report
2. Independent Safety Assessor (ISA) Report
3. ISA Risk Assessment
4. Hazards Assessment
5. Testing Results
6. Operating Rules & Procedures
7. Training
8. Manuals
9. Working Groups Report
10. System Safety Certification Board certificate

As part of the safety certification process, safety management requirements to be employed by the CBTC contractor were developed by NYCT and its Independent Safety Assessor in accordance with relevant existing standards, including:

- MIL-STD-882C (system safety)
- IEEE 1483 Standard for Safety Verification of Vital Functions in Processor Based Systems Used in Rail Transit Control (safety verification)
- IEEE 1012 Standard for Software Verification and Validation (software V&V)
- MIL-STD-498, Software Development and Documentation (software development)
- CENELEC Standards (EN50126, 50128 and 50129)

In addition, although NYCT was not required to comply with the FRA new Code of Federal Regulation regarding the safety of processor-based systems (49 CFR Subpart H of Part 236), the CBTC safety certification process was developed to be as consistent as possible with that rule. Mainly, the new requirements brought by this code (compared to the requirements traditionally specified in the other safety standards) include the following:

- Development of a Railroad Safety Program Plan
- Performance of a quantitative risk assessment that compares the risk to operation between the existing signaling system being replaced and the new processor-based signaling system (CBTC)

One key element of the safety certification process defined by NYCT was the creation of a System Safety Certification Board (SSCB) consisting of senior management staff from different NYCT departments, including Engineering, Operations, and Maintenance groups. The main role of the SSCB was to review the implementation of the safety certification program and the gathered evidence of safety for the CBTC System. Ultimately, the SSCB was responsible for the final certification of the system.

Product Safety Plan

Agencies often seek to procure a “proven in service” signaling solution to minimize development risk for major re-signaling projects. Even though a system is often selected based on its proven history, the procured system is rarely exactly the same as the one presented by the supplier during the bid phase. The core of procured products is often modified or “re-packaged” between projects in order to meet the ever increasing performance requirements of modern train control (moving block) application, such as NYCT Canarsie Line CBTC.

NYCT required that the re-certification of the vital platform by an independent certifying body. In particular, fundamental safety requirements to which the key algorithms must adhere were identified. These requirements were based on the understanding of the vital functions being performed by the algorithms of interest, and were developed in a different and complementary manner from the contractor’s approach, which is based on a top-down hazard analysis technique:

- Review and identify new performance and functional requirements
- Identify key software algorithms
- Develop a hazard log that describes all safety relevant hazards
- Conduct a risk assessment
- Conduct a hazard mitigation analysis
- Conduct a safety assessment and verification
- Testing and safety evaluation
- Safety incident reporting

New functional requirements from users often lead to modification of key vital algorithms that were already certified for previous applications. The specificities of the NYCT environment and the specific features required to enhance flexibility and performance led, in some cases, to modification of key algorithms. NYCT and its safety consultant intensively reviewed the functional specifications down to the software level to ensure that the modified portion of the design was compared to the baseline product and was implemented safely. Furthermore, NYCT mandated its independent safety consultant to perform regular audits at the contractor's facilities to review the progress of this re-certification.

A complete assessment of compliance with the requirements of Product Safety Plan is included in Appendix C.

Minimum Performance Standards

The System Safety Program followed by NYCT for the delivery of the Canarsie Line included a comprehensive process for development of requirements, achievement of performance standards, structured risk assessment, detailed hazard analysis, and final test and certification of the CBTC installation. Working Groups were used in the development of the requirements to evaluate the technical solution and assess the likelihood of the achievement of the requirements, including performance standards.

NYCT established a centralized hazard log that contained all the hazards identified by the contractor through its safety management, as well as hazards identified through the Working Groups and by NYCT. Key to the hazard log was the identification of the mitigation requirements for NYCT operations and maintenance. A specific mitigation form was used that described the hazard and documented required mitigation actions, supported by appropriate analysis and documentation. This mitigation form ensured open communications among the contractor, design teams, and Operations and Maintenance divisions.

Operations & Maintenance Assessment

The delivery of the NYCT Canarsie System included ongoing engagement with Operations and Maintenance. CBTC systems often significantly change operating

rules and procedures and also impact the skill requirements of a maintenance organization. NYCT managed this by engaging with Operations and Maintenance staff throughout the specification and procurement process and throughout delivery. The Operations and Maintenance divisions were represented on the SSCB and were active participants in the technical Working Groups that were used during the detailed development of the system jointly with the contractor. A dedicated Working Group was established to manage the scoping, drafting, review, and approval of the new and revised operating rules and procedures. The System Design Reviews (SDRs), a key element of the System Safety Plan, involved a safety review and analysis of new rules, procedures, and manuals.

Training and Qualification

Similar to the approach to Operations and Maintenance outlined above, training and qualification programs also formed part of NYCT's structured 10-step approach to safety. A Training Working Group was established and remained active throughout the project to evaluate and develop the training program for all persons who will actively interface with the system. The System Design Review (SDR) evaluated the training and qualification needs.

The NYCT staff involved in the training program included:

- Train operators
- Train dispatchers
- Signal tower operators
- Control center staff
- Maintainers
- Operations and Maintenance managers and supervisors
- Engineering staff

Quantitative Risk Assessment

As part of the contractual requirements, the CBTC contractor assessed the risk for all the hazards identified through the safety analyses. Post-mitigation risk assessment was also performed for those hazards requiring further control. In the final Project Safety Report, the CBTC contractor evaluated the mean time between hazardous events based on a top-down fault tree analysis to demonstrate that the safety contractual quantitative targets were met.

In addition to this conventional risk assessment approach, NYCT followed the new FRA RSAC rule, even though it was not required, and performed pre-CBTC and post-CBTC quantitative risk assessments to demonstrate that the level of safety of the CBTC system is as good or higher than that of the existing signal system that it replaces. NYCT used the Axiomatic Safety-Critical Assessment Process (ASCAP), which is a simulation methodology that generates data for

the quantification of the risk assessment of the NYCT Canarsie Line. Within ASCAP, the Canarsie Line track plan infrastructure and signaling and train control system devices are characterized as objects, and the dispatchers, train crews, and other personnel are characterized as agents. As a given train moves along the track, its interaction with both stationary/mobile objects and the various agents determines the train movement modalities, which are defined by the operating rules and procedures governing the Canarsie Line. Each train within the simulation is an independent “mobile” object, which creates a simulation environment of n train-centric mobile objects moving asynchronously along the track. ASCAP models this continuous train-centric movement using both time- and event-driven simulation techniques. The actual train movement modalities are predicated upon state behavior defined by the object and agent interactions. As the trains move along the track, the sequence of events that dictate the movement are generated within the simulation. Thus, if an incident/accident occurs, the sequence of events that led to the incident/accident event are known.

The results of the ASCAP compared the base case (Canarsie Line prior to CBTC implementation) with the CBTC case. The comparison showed the risks of the CBTC case were substantially better (i.e., the level of safety was substantially higher in the CBTC case) than the base case.

Safety Assurance Criteria & Process

NYCT specified a detailed System Assurance Program for the delivery of the Canarsie Line. These requirements required that the RAMS requirements are met under normal and degraded modes of operation, with specified Mean Time Between Unsafe Failure (MTBUF), Corrective Maintenance Time (CMT), Mean Time to Repair (MTTR), Mean Time Between Functional Failure (MTBFF), and Mean Repair Travel Time (MRTT). The Canarsie Specification required that the CBTC system include all redundancy, reliability, maintainability and safety design characteristics to achieve the required levels of RAMS, and included the following plans and processes:

- Structured Design Process and Requirements Traceability
- Safety Management Program
- Reliability and Maintainability Program
- Hazard Analysis
- Availability Analysis
- Reliability Calculations
- Risk Assessment
- Safety Analysis and Certification
- Availability and Reliability Demonstration
- Maintainability Demonstration
- Overall Proof of Safety

The overall Proof of Safety relied on the successful completion of the processes, programs, and plans above, in addition to a regiment of factory testing, with most safety proof achieved prior to introduction on the track. Many of the processes and plans have been described in earlier sections of this report.

Factory safety validation was performed by an independent safety team and verified that the intended design was safe. By means of safety analysis and critical review of the system specifications, the safety engineers sought to identify unsafe scenarios for the system. These scenarios were analyzed against the CBTC design as a means of validation of the safety of the system.

Field testing consisted of installation and post-installation tests, integration tests, and track database verification. Functional and endurance demonstrations were also performed in the field:

- Installation and post-installation tests verify that the equipment has been installed correctly. No specific safety tests were performed at this time.
- Integration tests included testing primarily the communications links between subsystems. A key, safety-critical link was the interface between the CBTC system and the underlay track circuits and systems. As this test required interfaces with existing railway systems, it was performed in the field, and independent safety engineers verified the tests and results.
- Track database verification ensures that track survey and internal CBTC system track database conform, including the location of track objects such as transponders, point of switch, signals, track-circuit junctions and other physical interfaces such as platform locations. The safe operation of the system is dependent upon the accuracy of the track database. The verification of the database involved a comparison of two track surveys prepared independently, with different survey equipment. The encoding of the track database was verified through automatic and manual checks against track drawings.
- Functional demonstrations consisted of demonstrations of key safety functions, including train tracking, safe train separation and stopping point tests. All functional demonstrations were performed in a controlled, safe manner, ensuring back-up systems are in place in case of the failure of the function.
- Endurance tests focused on reliability, specifically tracking the number of emergency brake applications, loss of redundancy, and loss of communications. No specific safety tests were performed as part of endurance testing.

Independent Review of Validation and Verification Activities

NYCT retained an Independent Safety Assessor (ISA) to perform an independent review of the system during development prior to introduction into revenue service. The scope of the ISA was consistent with subpart H and included:

- Safety case and proof of safety document reviews
- On-site audits of safety processes and procedures
- Test witnessing
- Independent review and analysis of operation and maintenance rules and procedures
- Independent verification of key safety algorithms
- Independent reviews of subsystem safety
- Track database configuration management audit
- Hazard log audit
- OSMES safety analysis

The ISA is required to be fully independent from the design and development of the system and provides NYCT an independent recommendation in the compliance of the system to the safety requirements and the overall certification process. NYCT relied on the recommendations of the ISA, in conjunction with the overall System Assurance Process and System Safety processes, to gain confidence that the system was safe for revenue service operation.

Human-Machine Interface Design

The Human-Machine Interface (HMI) was specified at the bid stage in the form of a detailed specification. This specification includes details of key interfaces (such as “Stop Now” requirements), in addition to the methods and review processes for the HMI interface to be reviewed and approved. HMI was managed as part of the 10-step safety process, engaged with the Working Groups.

Post-CBTC Operations

Service Levels

One of the fundamental changes in the Canarsie Line CBTC operation was the introduction of a centralized and ATS to regulate and supervise the line. Another important change was the introduction of ATO between stations. These two features greatly improved the flexibility of operations and improved service delivery.

In terms of performance, since the beginning of CBTC operations on the first section, NYCT went through a two-year period of lower performance due to various software bugs and car interfaces issues. Today, the system performance meets the contractual reliability and availability targets. NYCT did not see the need to enhance the design of the Auxiliary Wayside System (AWS) that provides fallback operation during CBTC failures. NYCT indicated that major failures of the CBTC system have been rare and the probability of having such failures in the future is very remote. Currently, the AWS installed north of Broadway

junction in Brooklyn and all the way to the 8th Avenue terminal in Manhattan uses wayside signals only at interlockings, and, therefore, in case of a system failure, trains operate in Restricted Manual mode at low speed between two interlockings.

Regarding the capacity performance, while the CBTC system itself is capable of supporting a theoretical throughput of at least 30 trains per hour (TPH), due to the topology of the line, the number of trains available and the throughput capacity at the terminals, the actual headway that can be supported on the Canarsie Line is 26 TPH (an endurance test was performed to demonstrate this). Today, with the number of trains available, a service of 22 TPH is being provided. It is important to note that the NYCT engineering group conducted some simulations and analyses that show that the current traction power substations would need to be upgraded if service on the line were to be increased above 24 TPH.

Another performance indicator is the reduction in run time. NYCT goal was to obtain a 3 percent reduction in travel time from one terminal to the other using CBTC. NYCT confirmed that this goal has been achieved with CBTC.

Operations & Maintenance

Regarding the operating performance metrics, NYCT implemented a tracking system for specific groups of failures (both hardware and software) as well as calculating the On Time Performance (OTP) of the line (percentage of train on-time or delayed for less than 2 min). These failures were regularly reviewed by a special task force involving all the key stakeholders of the project, including the CBTC supplier.

An interesting point raised by NYCT was that the OTP metrics were affected by the existing internal procedure that required the train operator to walk the entire length of the train in case of an emergency brake application. This procedure is in place to verify the causes of mechanical tripping of the train. Despite the fact that the CBTC system provides onboard information to the driver about the cause of the emergency braking, NYCT decided to keep this procedure in place.

For the maintenance metrics, with the introduction of CBTC, the number of regular maintenance interventions for the wayside equipment has decreased with the new system. The reduction of wayside equipment to be maintained is about 75 percent (mainly trip stops and signals). Prior to the introduction of CBTC, there was no train control equipment onboard the trains, so the maintenance effort on the car equipment has increased significantly with CBTC.

NYCT indicates that many maintenance interventions could be avoided if the maintenance tools were further improved. Despite the fact that CBTC provides advanced remote diagnostic functions and greatly improves the maintenance,

there are still a number of cases of “No Defect Found” (a failure is detected remotely by the system but cannot be confirmed on the test bench).

The size of the maintenance team for the wayside and central parts of the new system is about 30 people. It should be noted that this team is also responsible for other new technology systems implemented on the NYCT property. One important note is that this maintenance group has not increased in size since the start of the CBTC implementation and has used only internal staff personnel who have been trained to maintain the new system.

Achieving Organizational Readiness

In general, all the key stakeholders of the NYCT organization have been involved since the beginning of the design phase, allowing them to be fully prepared before the training program started. NYCT took an active part in defining and implementing the training program for the users, both for the maintenance group and the operators.

A dedicated Working Group was created involving the supplier and NYCT staff to jointly define the training program. A “train-the-trainers” concept was implemented: the supplier trained NYCT trainers who, in turn, trained the operating and maintenance staffs.

For maintenance training, NYCT took extra steps to improve the quality of the training material and the maintenance manuals by working closely with the supplier.

NYCT operating groups, including Rapid Transit Operation (RTO), were well prepared and trained before the introduction of the system. The main challenge was to adapt the training program for the large number of train operators to the different software releases.

Safety

With the introduction of CBTC, NYCT achieved significant safety improvements through continuous speed enforcement and the ability to establish temporary speed restrictions and work zone protections.

Lessons Learned

The Canarsie Line CBTC project was a pilot project for NYCT and established the foundation for the future deployment of CBTC on the Flushing Line and the entire subway system. There are a number of lessons learned from this pilot project and all of them have been taken into account for the ongoing Flushing Line CBTC project (now in the construction phase). Some of the key lessons learned are listed below:

- **Procurement** – It is critical to capture all the users’ requirements/needs early in the procurement phase to incorporate them in the functional specification in an unambiguous manner. During this phase or just after contract award, it is essential to ensure that the bidders/contractor understand clearly all the functional requirements in order to avoid any contractual claim in the future.
- **Design** – Deploying CBTC on an existing line and on existing cars (even though the R143 cars were “CBTC-ready”) is a complex task. Among the most critical design issues were:
 - *Interface design* between CBTC and the conventional signal system (i.e., the interlocking logic)—Because CBTC is a moving block system and the safe train separation is based on the train position calculated by the system and no longer based on the track-circuit detection, many interlocking functions had to be modified. The effort concerning this aspect of the design had been underestimated by the supplier and NYCT. It required a deep understanding of the NYCT signaling principles and a deep understanding of how CBTC works. This issue has been resolved by the efforts of various working groups to finalize the new CBTC signaling principles and the interface design. This new design now forms the basis for all future CBTC-ready interlocking contracts.
 - *Car integration*: Even though the rolling stock was designed to be “CBTC-ready,” the car integration was still complex and several interface design issues have been encountered along the way.
 - *Speed measurement system*: Because the rolling stock did not provide a free axle, the supplier decided during the design phase to implement an optical device independent of the wheel – hence not being affected by the slip/slide effects which make the speed calculation algorithm very complex. This system was never used on any property before NYCT. Even though the characteristics and the performance of this system on the paper looked promising, it generated a significant increase in the maintenance as it requires frequent cleaning of the camera lenses and chamber. The performance of the system is also affected when trains are stopped on curves as the device cannot take adequate pictures of the rail. Therefore, due to the poor performance and the significant amount of maintenance generated, it has been decided to replace OSMES with a more conventional speed measurement system for the entire fleet. The supplier is, therefore, replacing OSMES with a technical solution based on redundant tachometers and accelerometers.
- **“Slack protection” function** – The CBTC system introduces a safety distance between the point to protect and a normal stopping point, such as a station stop. In some cases, the point to protect (such as switch points) is located a short distance from the end of a platform, making train berthing at the correct location difficult. The issue has been resolved by relaxing the safe

braking model for these locations without compromising the overall safety level of the system.

- **Test and commissioning** – CBTC systems require a significant amount of track outage to be able to perform tests in the field. The Canarsie Line was also subject to other types of work (track repair, station works, etc.), making the planning for these track outages a complex process. The planning of these track outages had to be carefully planned and each cancellation due to the supplier delay (e.g., software release for testing not ready) had significant consequences on the project schedule. One way to resolve this issue was to reduce the number of software releases to be tested in the field, and increase the amount of tests performed in the factory through the development and use of simulation facilities. The use of a fully-functional test track is also a lesson learned that NYCT has brought into the Flushing CBTC project, as the CBTC test track for the Canarsie project had limited functionality and was mainly used to check the installation of the onboard CBTC equipment.
- **Maintenance** – NYCT emphasized that despite the advanced maintenance and diagnostics features provided by CBTC compared with the current system, there are still opportunities for further improvements in this area. It was felt that, in general, the focus during the project was mainly on the core CBTC system design.

Qualitative Cost/Benefit Assessment

Using the tables provided in Section 3, the benefit and cost factors applicable to the NYCT CBTC are summarized below.

Benefit Factors

GoA Benefits

NYCT's GoA on the Canarsie Line, pre-CBTC, was GoA1 (manual train operations). NYCT's GoA post-CBTC was GoA2 (semi-automatic train operations.) As such, NYCT realized the benefits summarized in Table 4-4.

GoL Benefits

NYCT also realized the safety, state-of-good-repair, and operational benefits as summarized in Table 4-5.

Cost Factors

Cost factors applicable to the NYCT Canarsie Line CBTC implementation costs are summarized in Table 4-6.

The NYCT budget for Phase II and Phase III of the Canarsie Line project – at the time of award of the contract to the Siemens/US&S/Comstock JV - was \$217 million. This included contractor costs, NYCT costs, and contingency. In addition, NYCT's budget for an Independent Safety Assessor was \$5 million.

Table 4-4

NYCT Benefits of Increased GoA

Benefits of Automation – Achieved by NYCT	Manual		Automatic		
	GoA0	GoA1	GoA2 (STO)	GoA3 (DTO)	GoA4 (UTO)
Automatic Train Protection (ATP)		Pre-CBTC	Post- CBTC		
More predictable run times between stations			Post- CBTC		
More uniform ride quality			Post- CBTC		
Reduced wear-and-tear of train propulsion/braking systems			Post- CBTC		
Reduction in variations in line operation/improved service regulation			Post- CBTC		
Energy optimization					
Automation of turnbacks					
Remove constraint of rostering train crews					
Flexibility to operate shorter trains more frequently					
Ability to respond to unexpected increases in passenger demands					
Potential for reduction in operating costs					
Automated failure detection/response					

Table 4-5

NYCT GoL Benefits from CBTC Upgrade

Potential GoL Benefits from CBTC Upgrades	NYCT Benefits Achieved
<i>Enhanced Safety</i>	
Passenger safety	Continuous over-speed protection
Staff safety	Work zone protection
<i>Improved State of Good Repair</i>	
Higher system availability	Higher system availability achieved following initial period of system debugging
Reduced maintenance	Reduction in wayside equipment maintenance was limited, given need to also maintain secondary train control system, and any reduction in wayside equipment was offset by increased train-borne equipment maintenance; however, redundancy coupled with remote diagnostic capabilities led to more proactive and less reactive maintenance activities
<i>Improved Service Delivery</i>	
Increased capacity	Increase in line capacity was achieved up to limits of infrastructure
Reduced trip times	Reduction in trip times achieved
Increased operational flexibility	Increased operational flexibility achieved

Table 4-6

NYCT Cost Factors

Cost Factors	Required for NYCT Specific Application
Core System” Cost Factors	
CBTC train-borne equipment	Costs for redundant train-borne equipment included; additional cars had to be equipped to satisfy capacity demands
CBTC wayside equipment	Costs for redundant CBTC wayside equipment included
CBTC control center equipment	Costs for full, stand-alone, ATS system included
CBTC data communications equipment	Costs for full wayside and wayside-to-train data communications equipment included
Site Specific Cost Factors	
Vehicle retrofits	CBTC installed on new vehicles that had been designed and were delivered “CBTC-ready”
Interlocking upgrades	All interlockings replaced with new relay-based interlockings under CBTC contract
Secondary train detection	Track circuits were retained for secondary train detection to support mixed-mode operations and broken rail detection
Secondary train protection	Wayside signals (with CBTC-specific aspect) and trip stops were retained at certain locations to support mixed-mode operations and to provide degraded modes of operation (with limited headway) during CBTC failure modes
New equipment rooms/etc.	New equipment rooms constructed under CBTC contract, together with upgrades to signaling power supplies, etc.
Control center upgrades	Not required – stand-alone CBTC-ATS was provided (see above)
Agency-specific adaptations	Significant adaptations to supplier’s previous service-proven” system were required to meet NYCT-specific requirements
Test & commissioning constraints	Significant constraints on track access, given NYCT’s 24/7 operations
Safety certification approach	In general, followed new FRA Subpart H requirements; this was a new process for NYCT and supplier
Project management approach	NYCT’s applied its standard approach for managing conventional re-signaling projects, with consultant support

SECTION
5

SEPTA Light Rail Tunnel CBTC Project

SEPTA⁶ is the nation's sixth-largest public transportation system. It is a multimodal transit system, providing a vast network of fixed-route services including 117 bus routes, subway, and subway-elevated lines, 13 regional rail lines, 8 trolley lines, 3 trackless trolley routes, an inter-urban high-speed rail line, and customized community service.

SEPTA's Light Rail Tunnel is 2.5 miles long and contains 2 main tracks, for a total of 5 track miles. Five light rail surface routes converge into the tunnel at two different portals. Ridership in the tunnel is approximately 90,000 passengers per day using a fleet of 112 light rail vehicles.

The objective of the SEPTA CBTC project was to install a state-of-the-art CBTC system in SEPTA's Light Rail Tunnel to improve safety while maintaining efficient rail car movements. The CBTC system provides train separation and civil speed control with continuous over-speed protection and an overlay on the existing wayside indication system with minor modifications. All track circuits are of the single rail type and currently remain in service. The single interlocking was upgraded to a processor based interlocking in 2008. There is no ATO or ATS functionality except a mimic display and the ability to apply slow zones at the central control facility.

The primary objective of the SEPTA CBTC project, therefore, was to upgrade the train control system in the Light Rail Tunnel from GoA Level 0 to GoA Level I.

Figure 5-1

SEPTA Light Rail Tunnel Track Plan

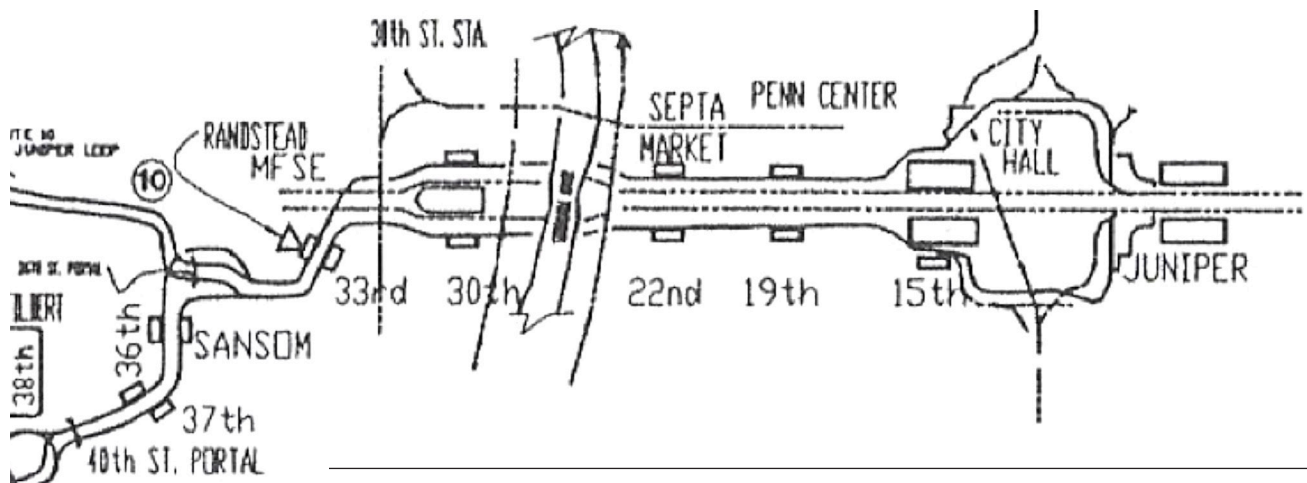

⁶The information presented in this section was obtained during the project reviews during which the project team met with individuals from SEPTA.

Pre-CBTC Operations

Signaling/Train Control System Configuration

SEPTA's light rail pre-CBTC signal installation evolved over a long period of time. Prior to 1955, there were no signals in the tunnel portion of the line except for two locations:

- A curve at 15th Street
- A second curve at the 22nd Street Portal

At that time, trolley operation was based on a line-of-sight principle whereby the operator used his judgment and experience to adjust the car speed. Then, in 1955, the tunnel was extended from 22nd Street to 40th Street and Woodland Avenue. In an effort to improve the level of safety, a complete two-block, three-aspect, automatic block signal system was installed in this section. However, line-of-sight operation continued between Juniper Street and 22nd Street. In 1971 and 1974, additional automatic block signals were installed in the 15th Street area as part of the realignment associated with the 15th Street Rehabilitation Project.

Therefore, the pre-CBTC signal installation was a result of *ad hoc* solutions to meet specific requirements rather than an overall system design to provide a comprehensive technical solution based on operational needs.

This pre-CBTC signal installation included three types of signals, as follows:

1. **Automatic Block Signal** – This type of signal controls the entry into a typical signal block, and was based on conventional two blocks, three-aspects. The three aspect indications are red for stop and proceed, yellow for prepare to stop at next signal, and green for proceed at authorized speed.
2. **Speed Control Signals** – This type of signal is used to restrict the speed over curves or to maintain a reduced speed through several consecutive blocks. Speed control signals are electrically timed and are actuated on the approach block to the signal. They normally display a “red” aspect for stop and proceed. The signal then upgrades to “yellow” or “green” aspect after a predetermined time of 3–9 seconds. The signal requires the car operator to reduce speed until the signal displays a permissive indication. Speed control signals are used to increase safety, but they tend to cause an overall decrease in operating speed.
3. **Call-on Signals** – This type of signal is used for LRV entrance into a station platform to enable more than one vehicle to berth at the platform. This is done by dividing the platform track into two track circuits, front and rear. When the first vehicle clears the rear track circuit, a second vehicle is permitted to enter the platform track at a restricted speed. By increasing the number of track circuits, some stations were designed to permit up to four cars to berth at the same time.

The pre-CBTC signal installation did not have any provisions to enforce the allowable speed limits dictated by the prevailing wayside conditions. As a result, the signals were used solely to provide speed information to the operator, who, in turn, assumed total safety responsibility for the passengers and the vehicle.

Service Levels

Prior to CBTC, the five light rail lines that operated through the tunnel carried just under 80,000 riders daily. During the AM and PM peak periods, as many as 50–60 cars per hour operated through the tunnel. During these peak conditions, the average operating speed was 11.25 MPH. This represents an approximately 50 percent reduction in utilization from the 1950s when more than 125 cars per hour operated through the tunnel. The signal configuration through the tunnel supported a headway of 20–30 seconds.

Although the ridership was relatively stable through the 1980s, passenger demands continued to fall slightly during the early 1990s on the Southwest Philadelphia and North Philadelphia routes. This was mainly due to a general decline in population in the city of Philadelphia, economic recession, and the exodus of employment centers to suburban areas. Prior to CBTC implementation, SEPTA developed a demand forecast based on a population forecast study (1990–2020) by the Delaware Valley Regional Planning Commission (DVRPC). The study predicted a boost in passenger demands in the lines that operate through the tunnel. At the time of that study, the passenger counts on these lines were as shown in Table 5-1.

Figure 5-1

SEPTA Passenger Counts

Route	Daily Passenger Count	Annual Passenger Count
10	14,200	4,200,000
11	12,000	3,500,000
13	21,000	6,200,000
34	15,700	4,650,000
36	14,400	4,250,000

SEPTA also concluded that the introduction of reliable light rail vehicles (LRVs) with climate control features, excellent suspension, and smooth acceleration and braking characteristics would attract more riders. Other studies by SEPTA projected growth of 5-7 percent in Southwest Philadelphia and nearly 10 percent in North Philadelphia routes.

Operations & Maintenance

Four of the five light rail lines that operate through the tunnel are the South Philadelphia routes (11, 13, 34, and 36), which converge at the portal at 40th Street and travel on to City Hall and then back to the 40th Street Portal. The fifth line, Route 10, enters the tunnel from a separate portal at 36th Street. Prior to CBTC operation, each track was signaled for unidirectional movements. One main operational constraint was the lack of passing sidings

and crossovers between the two main tracks. Slowing or stopping of traffic at any point inside the tunnel had a “ripple” effect on operation.

With the pre-CBTC signal installation, there were no signals from 15th Street to 22nd Street except for clusters of short blocks in certain areas. This deficiency reflected the operational needs and philosophy of the 1950s when a heavy concentration of LRVs was needed to carry a high volume of passengers through the tunnel. These cars operated at a slow speed and on a close headway of 20–30 seconds. As a result of a decrease in ridership levels, SEPTA determined that there was no further need for the short headways that existed in the 1950s and concluded that the priorities in a new signal system should be a high level of safety, increased reliability, and shorter travel times.

Safety Incidents

The most serious deficiency of the pre-CBTC signal installation was the lack of speed enforcement. The system acted in an advisory capacity, leaving the control with the car operator. Therefore, the safety of operation was highly dependent on compliance by car operators to the operating rules and procedures. There were no devices onboard the car that would actuate automatically if, for some reason, the car operator ignored a wayside speed indication. The chances of human error in this situation were much higher than in an automatic system.

Following a number of safety incidents such as derailments and rear-end collisions, speed control signals were installed to enhance safety of operation. For example, a series of speed control signals exist on the descending grades under the Schuylkill River that permits close headways but also limits speeds. However, the lack of speed enforcement limited safety improvements, and the addition of speed control signals further reduced operating speeds.

During the period 1982–1996, SEPTA documented six accidents, with an average cost of approximately \$344,000 per accident. A list of these accidents is shown in Table 5-2.

Figure 5-2

*SEPTA Accident
Summary*

Date	Location	Accident Category
Dec 3, 1982	36th West	Derailment
Feb 10, 1987	36th West	Derailment
Apr 10, 1988	36th West	Derailment
Aug 21, 1991	36th West	Collision
Jan 4, 1994	36th West	Derailment
Mar 11, 1996	36th West	Collision

One of the most serious accidents was the derailment that occurred on April 10, 1988. A SEPTA trolley that apparently was traveling too fast derailed and crashed into a wall as it approached the 33d Street Station in West Philadelphia, sending 23 people to area hospitals, including the critically-injured driver. Witnesses indicated that the Route 11 trolley, which was traveling east on the subway-surface line, did not slow down as it approached a curve several hundred feet before the station platform. The trolley derailed, pitching right, left, and then right again before finally slamming into a column in the station beneath Market Street. The crumpled trolley car was sheared at the front portion, where the passenger door is located. The car juttied off the track, with its front hanging over the tracks on the platform side.

The investigators of these accidents, including NTSB and FTA safety experts, raised concerns about the lack of enforcement feature on the signal system. SEPTA planned a number of actions to enhance the safety of operation by the installation of some form of automatic speed enforcement feature. Ultimately, this has led to the installation of a CBTC system within the tunnel.

CBTC Solution Selected

Technology Selection Process

After two accidents in the early 1990s, SEPTA identified the following criteria for a proposed new signal system:

- *Safety* – The prime consideration is the safety of passengers and equipment. The design should have sufficient redundancy to operate safely and efficiently under normal and contingency conditions. In other words, single-point failure should not affect the safety of the system.
- *Proven Technology* – SEPTA required the installation of a proven technology. The system should have been installed and operational on a property with initial problems resolved. The technology should have distinct advantages in terms of operations, control, and maintenance functions.
- *Headways* – To render maximum utilization of operations within the tunnel, headways of less than 60 seconds together with maximum train protection is required, without any compromise to safety of operation.
- *Train Control* – The system should contain all automatic train control features such as Automatic Speed Control (ASC), Automatic Train Protection (ATP) and Automatic Train Stop (ATS). Operator override features and the ability to manually operate the LRV must be inherent in the design.
- *Mixed-Fleet Operation* – Mixed-fleet operation is initially required. The proposed system should have the ability to communicate train locations with respect to positioning of new-to-existing as well as new-to-new LRVs.
- *Existing Operations* – The proposed system should be able to perform all existing functions such as call-on, multiple berthing at stations, civil speed restrictions, and interlocking operation.

SEPTA then used these criteria to evaluate a number of signal technologies. The following alternatives were considered:

- *Conventional Block Signal System* – Install a conventional block signal system with wayside train stops and revise signal spacing to meet the required capacity. This alternative would evaluate the need for additional wayside track circuits and signals to improve speed control and safety.
- *Conventional Cab Signaling System* – Install conventional cab signaling system using standard jointless audio frequency (AF) track circuits. For this system, revised block spacing would be designed to reflect field conditions and scheduling requirements. The design would adjust civil speeds to meet operating requirements.
- *Moving Block System* – Install a moving block signal system that adjusts civil speeds and uses continuous car positioning to control the length of the block. This system employs modern technology to communicate between operating vehicles, omits the use of track circuits, and minimizes the use of other trackside devices.

A summary of SEPTA’s evaluation of the above signal technologies is provided in Table 5-3.

Figure 5-3

*SEPTA Signal
Technology
Evaluations*

Signal Technology	Evaluation Summary
Conventional Block Signal System	<ul style="list-style-type: none"> • Available “off the shelf” from reliable manufacturers • Industry experience with incorporating systems with safety features • Least disruptive to existing operation • Provides positive stop protection • Requires the installation of additional track circuits, signals and train stops • Will increase the overall cost of maintenance on the line
Conventional Cab Signaling System	<ul style="list-style-type: none"> • Available “off the shelf” from reliable manufacturers • Both hardware and the system’s design has been proven reliable on many systems • Possible to achieve required headway of 60 seconds • System similar to many other systems operating within SEPTA; as such, maintenance costs will be low due to familiarity with this type of system • Potential problems with post-shunt and pre-shunt
Moving Block System	<ul style="list-style-type: none"> • System is result of technological developments based on computers, microprocessors, and reliable communications • Does not require track circuits and minimizes wayside equipment • Wayside communications link and antennas/repeaters needed to poll information continuously • Has ability to achieve 60-second headways • Of the three systems considered, is the only system that minimizes reliance on operator for control of train operation • Most economical in terms of maintenance costs

To further advance its signal modernization efforts, SEPTA conducted an industry review, inviting seven signaling suppliers to present their new train control systems. SEPTA analyzed each of these systems by identifying the advantages and disadvantages of each and, based on this Industry Review, selected “moving block” technology to modernize the signal system in the Light Rail Tunnel. SEPTA justified its selection as follows:

- Requires minimal wayside apparatus and offers continuous train control
- Provides reasonable initial investment
- Long-term maintenance costs can be reduced.
- Can be easily enhanced to ATO system
- Can handle close headways of 60 seconds

SEPTA then proceeded with the development of performance based specifications for a Moving Block System that employs communications-based technology with the following elements:

- *Leaky co-axial antenna cable* – Tunnel wall is available for the installation of the cable; this will keep the track area clear.
- *Spread spectrum technology* – This method of communication has a good military history.

Compliance with Industry Standards

The specifications for the SEPTA CBTC system were finalized in May 1998 using a pre-ballot draft of IEEE Std. 1474.1™ as a key input. As the SEPTA CBTC system involves a simple light rail operation that employs manually-driven single-car vehicles and was planned with the main objective of enhancing the safety of operation, there was strong correlation between the performance and functional requirements developed by SEPTA for its CBTC system and the performance and functional requirements established in IEEE Std 1474.1™ for the vital ATP functions. There was little correlation for ATO and ATS functions. Specifically, SEPTA’s CBTC specifications included:

- Most of the mandatory ATP functional requirements defined in IEEE Std 1474.1™. The ATP functional requirements that were not included in SEPTA’s CBTC specifications were not compatible with SEPTA’s operating environment.
- Few of the optional ATO and ATS functional requirements of IEEE Std 1474.1™. This is due to the nature of the SEPTA’s light rail operating environment and its heavy reliance on manual operation.
- Operational and performance requirements as recommended by IEEE Std 1474.1™. More specifically, the specifications included performance requirements (headways, safety criteria, risk assessment, reliability and

maintainability requirements), operating requirements (operating modes, failure modes, and transition between operating modes), track alignment details, and vehicle performance characteristics.

The results of the IEEE Std 1474.1™ comparison assessment are provided in Appendix B.

CBTC System Description

The SEPTA CBTC implementation is based on the FLEXIBLOK™ system (now referred to as CityFlow 650™) from Bombardier (formally Adtranz). This system permits the train operator to manually drive the train within the dynamic speed limits that are automatically enforced by the ATC system.

During the Preliminary Design Phase, SEPTA worked closely with Bombardier to clarify and finalize system requirements. During the Final Design Phase, Bombardier adapted its FLEXIBLOK™ CBTC Platform to SEPTA's operating environment and also focused on the wayside CBTC controller/Ludlow interlocking interfaces, as well as the human machine interfaces for all aspects of CBTC implementation.

The ATC system is divided into wayside ATC and train-borne ATC subsystems. The wayside ATC consists of ATS, Region Automatic Train Operation (RATO), and Region Automatic Train Protection (RATP) subsystems. The train-borne ATC consists of vehicle ATO (VATO) and vehicle ATP (VATP) subsystems. It should be noted that in view of the manual operation required for the SEPTA light rail system, many of the ATO and ATS functions offered by the FLEXIBLOK™ platform are not implemented at SEPTA.

The ATC functional components of the FLEXIBLOK™ system, regardless of physical location, are connected by two types of distributed networks; the radio network and the wayside network. The radio network is supported by equipment in the Train-to-Wayside Communications (TWC) system, linking train and wayside ATCs. Within the TWC is the Radio Communication System (RCS), which provides radio coverage and end-to-end data transmission between train-borne and wayside radio equipment.

The wayside network, supported by the wayside communications system, links entities within the wayside ATC system, such as region ATPs, ATOs, and Zone and Central Control.

The major functions of the train-borne ATC, wayside ATC, data communication, and ATS subsystems are summarized as follows.

CBTC Train-Borne Equipment

The train-borne ATC performs the general functions of location and speed determinations, overspeed protection, and enforcement of a movement authority limit received from the wayside ATC.

The car ATP system enforces safe movement by calculating a velocity-vs.-distance braking profile (over-speed ramp). The over-speed ramp is the maximum safe speed allowed leading up to a conflict point, which is a must-stop position in a route, such as a train ahead. The ATP system permits movement as long as the actual speed of the train is less than the over-speed ramp. If an over-speed condition occurs, the ATP system commands the emergency brakes to be applied to bring the train to a full stop.

CBTC Wayside Equipment

The wayside ATC performs the general functions of generation of conflict points, train tracking, and safe train management.

The wayside region ATP receives the locations of all trains in the region, as well as the status of interlocking signals and track switches. It then determines the closest conflict point for each train and transmits conflict point information to the trains in the region. It continuously updates the conflict points information as it receives updated location information from trains and updated interlocking status information.

The wayside ATP interfaces with a track circuit at each portal to detect the movement of an unequipped train or a failed CBTC train into the CBTC territory (tunnel section). Upon such detection, the wayside ATP causes the next CBTC train entering the territory to perform a “sweep” function to ensure that it is safe to issue a movement authority limit to CBTC-equipped trains.

One important difference between the SEPTA and NYCT CBTC applications is that for the NYCT application, the Canarsie Line was fully CBTC-equipped and, hence, initialization into CBTC-controlled territory occurs only once as a train enters the line. However, for the SEPTA application, as the CBTC territory only forms a part of the line (the tunnel section), initialization into CBTC-controlled territory has to occur during every trip and, hence, is much more frequent. As such, the initialization process needs to be correspondingly more reliable.

CBTC Data Communications Equipment

The Radio Communications System (RCS) provides the data link between train-borne and wayside ATC subsystems. It is designed around the network concept where the base radio at the wayside ATC is the master and the mobile radios are slaves. Data are exchanged between the trains and wayside in a poll-response sequence, and the entire ATC system is divided into regions, defined by the limits of base radio coverage. Spread spectrum radios are used. The RCS equipment consists of three basic components:

- Base data radio (BDR)
- Mobile data radio (MDR)
- Wayside antenna system

The BDRs are located with the wayside ATC equipment and interface with the ATC via a serial communication processor. This processor gathers ATP and ATO data and combines them into a single ATC packet for transmission to the MDRs. On the train is an MDR for each train-borne ATC. The wayside antenna system is designed to efficiently transfer 2400-MHz RF between the base and mobile radios. The design of the wayside antenna system takes into consideration the geographical and structural environment of the CBTC territory through which the SEPTA light rail system operates. In the tunnel section, a combination of radiating coaxial cable (Radiax©) and amplifiers are used to ensure proper propagation of the RF signal.

CBTC ATS Equipment

The CBTC ATS equipment includes equipment installed at SEPTA's Central Control facility, which provides limited ATS (non-vital) functions, including identifying, tracking, and displaying trains (car numbers), providing manual route setting capabilities, and monitoring the status of CBTC equipment (both wayside and onboard). The ATS subsystem also provides the tools to establish and manage temporary speed restrictions and work zones.

Assessment of Enabling Technologies

High-Resolution Train Location Determination

The SEPTA light rail CBTC system is a position-based system, wherein as the vehicle moves along the track, its ATP continuously calculates the vehicle location using onboard odometry equipment. The onboard vehicle location determination (position determination) is performed vitally through a system consisting of two tachometers, Doppler radar, and a norming point (transponder) reader. Norming point passive tags (RF tags) are placed at track level throughout the system to normalize accrued position errors inherent in the tachometer and Doppler devices. In total, 147 transponders are installed on the system. The tags also provide a unique identification code to the vehicle, which is then used to determine absolute position and direction of travel.

To calculate vehicle position, the system processes the outputs from the tachometers and radar unit to produce an accurate representation of distance traveled (displacement), and direction. The outputs from the tachometer and Doppler radar unit are compared to ensure that both are in agreement as to the displacement of the vehicle. During an occurrence of spin/slide, the radar unit, being a true ground speed sensor, provides an accurate displacement reading. By keeping track of the distance and direction traveled from a known location, the onboard CBTC equipment can determine the vehicle's location as it travels along the track. A block diagram of the location determination process is shown in Figure 5-2.

Figure 5-2
SEPTA Vehicle Location Processing

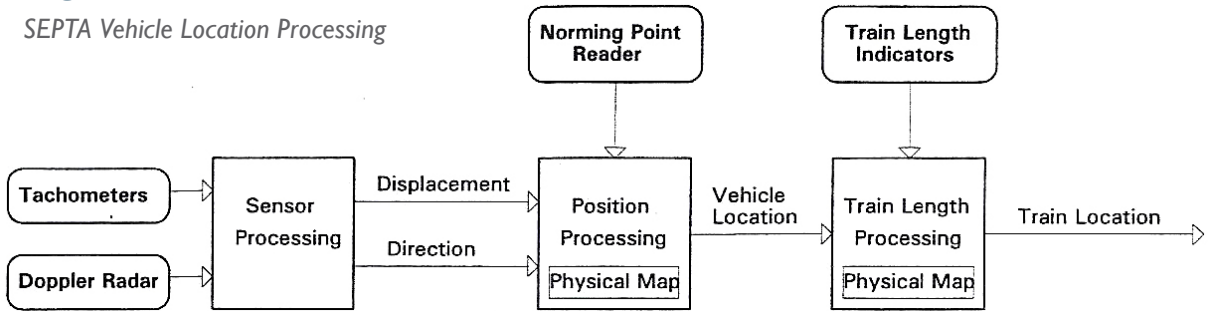

Wheel wear, poor adhesion, and calibration errors result in an inaccurate representation of displacement. To account for these errors, the vehicle borne ATC assumes that a fixed percentage of error in the location processing accumulates over the distance traveled by the vehicle. To prevent a large build-up of this position error, passive devices (norming points) are placed along the track, each having a unique identity. The vehicle is equipped with a reader (norming point reader) which reads the identity of the norming point devices as the vehicle encounters them. The geographical location of the norming points is stored in the vehicle's database (physical map). These norming points along with the physical map allow the ATC to absolutely determine the geographical location of the vehicle and clear (normalize) the position error on a frequent basis.

A block diagram of the vehicle-borne CBTC equipment is illustrated in Figure 5-3 and indicates the equipment used for position determination.

Figure 5-3
SEPTA Onboard CBTC Architecture

TRAINBORNE ATC

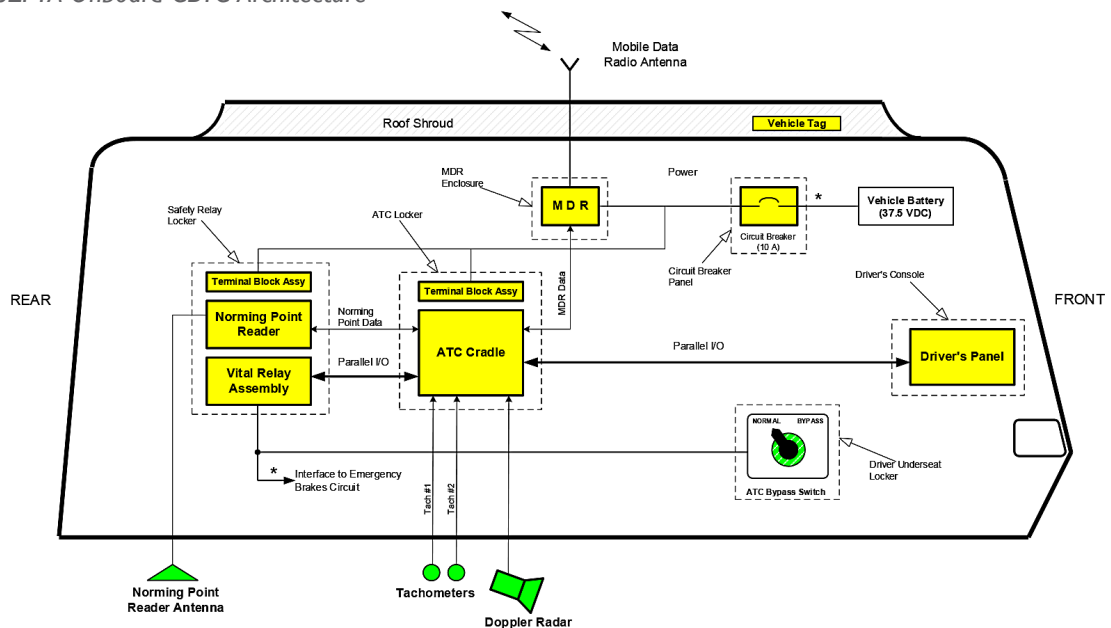

NOTES:
* Denotes Vehicle Interface Wiring

Figure 5-4 illustrates the physical locations of the various CBTC components onboard the SEPTA vehicle. Shown in this figure are the norming point antenna, the Doppler radar, and the tachometers. The vehicle ATP computer repeatedly sends information about the vehicle location to the wayside ATP computers. In turn, the wayside ATP computer detects and tracks all vehicles throughout the system. For a vehicle to be tracked by the wayside ATP computer, it must be initialized by the CBTC system. Upon initialization, the vehicle will be registered on the region's operational roster of initialized trains. Until a vehicle has been properly initialized and is communicating, none of the vehicle location information will be available to the CBTC system.

Figure 5-4

Location of On-board CBTC Components

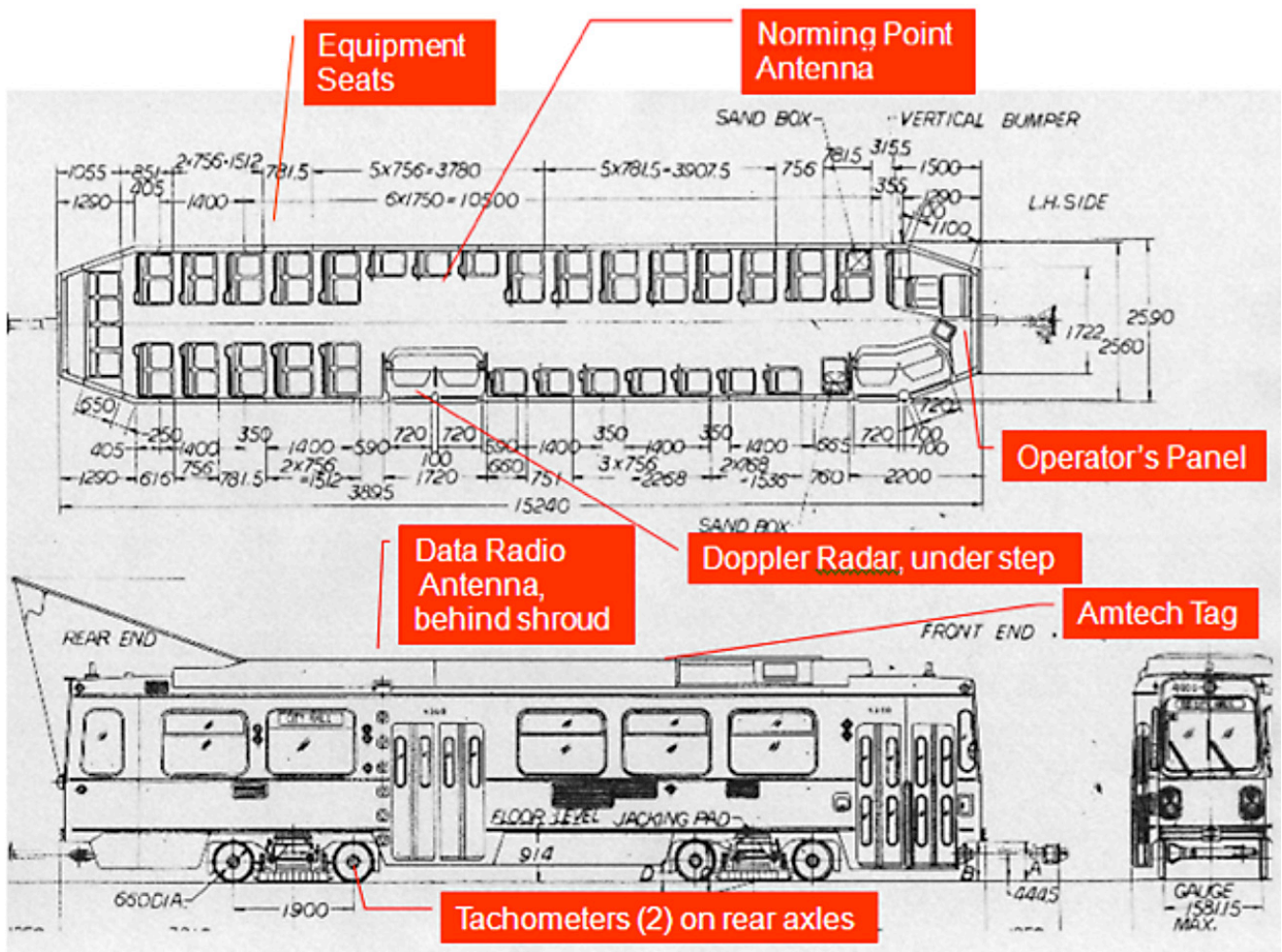

To initialize a vehicle, it is required to operate through an initialization area, which is established as the physical entry point of a vehicle into the CBTC territory. For the SEPTA light rail system, one initialization area is located prior to entering the portal at 40th Street. A second initialization area is located at

the leaving end of the maintenance yard. The initialization areas provide a way of establishing the vehicle to wayside communication link. Also, the vehicle ATC system uses the initialization areas to determine starting location, direction correspondence and position device calibration. At the portal, two transponders are located 50 feet apart and are used to calibrate the system for the vehicle wheel diameter.

When a vehicle encounters a norming point tag along a route, the tag transmits its location data to the vehicle ATC equipment using commercial radio transponder readers operating in the 902 to 928 MHz frequency band. This band provides 100 selectable channels for the norming point system. The vehicle reads the location information embedded within the norming point tag, verifies the tag location, and resets its positioning error to a minimum. Following this, the error accumulates again until its next adjustment at the next norming point. Figure 5-5 illustrates typical tag installations on the light rail tracks.

Figure 5-5

*Typical SEPTA
Transponder
Installations*



The SEPTA system employs the AT5112 Transportation tag manufactured by Amtech (Figure 5-6). The tag can store up to 10 alphanumeric characters (60 data bits) and is factory-programmed or laser-etched. The AT5112 contains electronically programmable circuitry activated by an RF beam that is broadcast by the vehicle reader. The tag has a maximum working range of 14 ft, and its design enhances system discretion within 2 to 10 ft diameter reading areas.

Figure 5-6

*Amtech AT5112
Transportation Tag*



Each vehicle is equipped with two tachometers that are mounted on the rear axles to determine displacement and direction. The output of the tachometers is a pulse that equates to a displacement the wheel has traveled. The specific tachometer used by SEPTA is manufactured by Jaquet AG (typical installation shown in Figure 5-7) and has two phase-shifted channels to enable the sensing

of movement direction. As shown in Figure 5-8, the outputs of the two channels (A & B) provide information whether the wheel is rotating clockwise or counter-clockwise.

Figure 5-7

*Jaquet Tachometer
Assembled in a
Vehicle Gear Box*

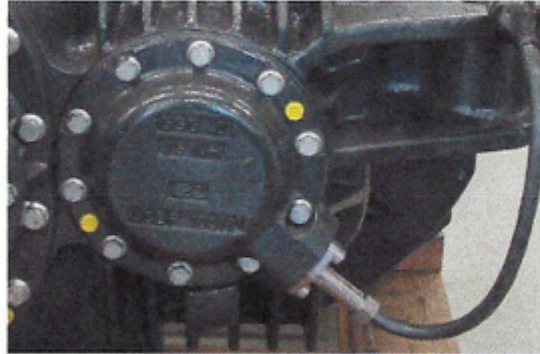
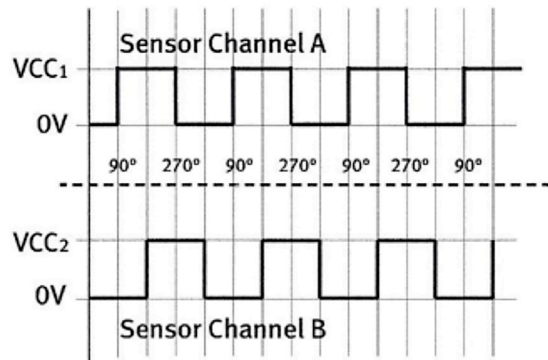

Figure 5-8

*Signal Outputs
of Two-Channel
Tachometer*



Doppler radar is used to minimize the effects of wheel spin/slide in the vehicle's position calculations. The function of the Doppler radar is to monitor the velocity at which the ground is passing underneath the vehicle (True Ground Speed Sensor). The radar produces an output signal that is very similar to the tachometers, where a pulse is equal to a pre-defined displacement that the vehicle has traveled.

The SEPTA CBTC installation employs a Doppler speed sensor manufactured by Bach-Simpson (Figure 5-9). The sensor is mounted and wired independently from the truck to simplify routine truck maintenance tasks. It is located under the vehicle and determines the vehicle speed via a low power microwave signal. The Doppler sensor is designed to operate at speeds from 0–100 MPH with a measuring accuracy of 1 percent of full range.

Figure 5-9

*Bach-Simpson
Doppler Speed
Sensor*



High-Capacity Data Communications

The ATC functional components of the SEPTA CBTC installation, regardless of physical location, are connected by two types of distributed networks:

- Radio network, which is supported by equipment in the train-to-wayside communications (TWC) system, linking train and wayside ATCs. Within the TWC is the radio communication system (RCS), which provides radio coverage and end-to-end data transmission between train borne and wayside radio equipment.
- Wayside network, which is supported by the wayside communications system, links entities within the wayside ATC system, such as region ATPs, ATOs, and Zone and Central Control.

The RCS is the radio data link between train and wayside, which provides one of the main characteristics for a CBTC system. The RCS is designed around the network concept where the base radio at the wayside ATC is the “master” and the mobile radios are “slaves.” Data are exchanged between the trains and wayside in a poll-response sequence and the entire ATC system is divided into regions, defined by the limits of base radio coverage. Spread spectrum radios are used. Two base data radios (BDRs) are located at each wayside ATC, each dedicated to a primary and backup ATC. A synchronizer vital driver (SVD) board drives an enable signal to the RCS-ATC interface, ensuring that a failed ATC does not transmit data to the wayside RCS. The design of the radio communications system is such that it can compensate for the adjacent region's RCS failure. The RCS network has its own set of addressing, error checking, message numbering, and retransmission functions, independent of the TWC system.

The architecture of the RCS depends on whether it is located in a tunnel or free-space environment. In a tunnel location, the signal coverage is accomplished by a combination of radiating cable and amplifiers, known as the distributed

communications system (DCS). Failure recovery of a DCS is accomplished by reconfiguring the distributed communications system's amplifiers to drive the entire length of the system from either base data radio. The station ATOs, which are distributed along the system, control the realignment of the amplifiers. In the free-space scenario, radio coverage from point-source antennas is designed to overlap, or redundant base data radio locations are used.

The architecture of the RCS is illustrated in Figure 5-10 and includes the following elements:

- Base Data Radio (BDR) – usually located with the wayside ATC equipment
- Mobile Data Radio (MDR) – one is provided for each train borne ATC
- Wayside Antenna System – designed to efficiently transfer 2400-MHz radio frequency (RF) between the base and mobile radios

Figure 5-10

SEPTA Radio Communications System (RCS)

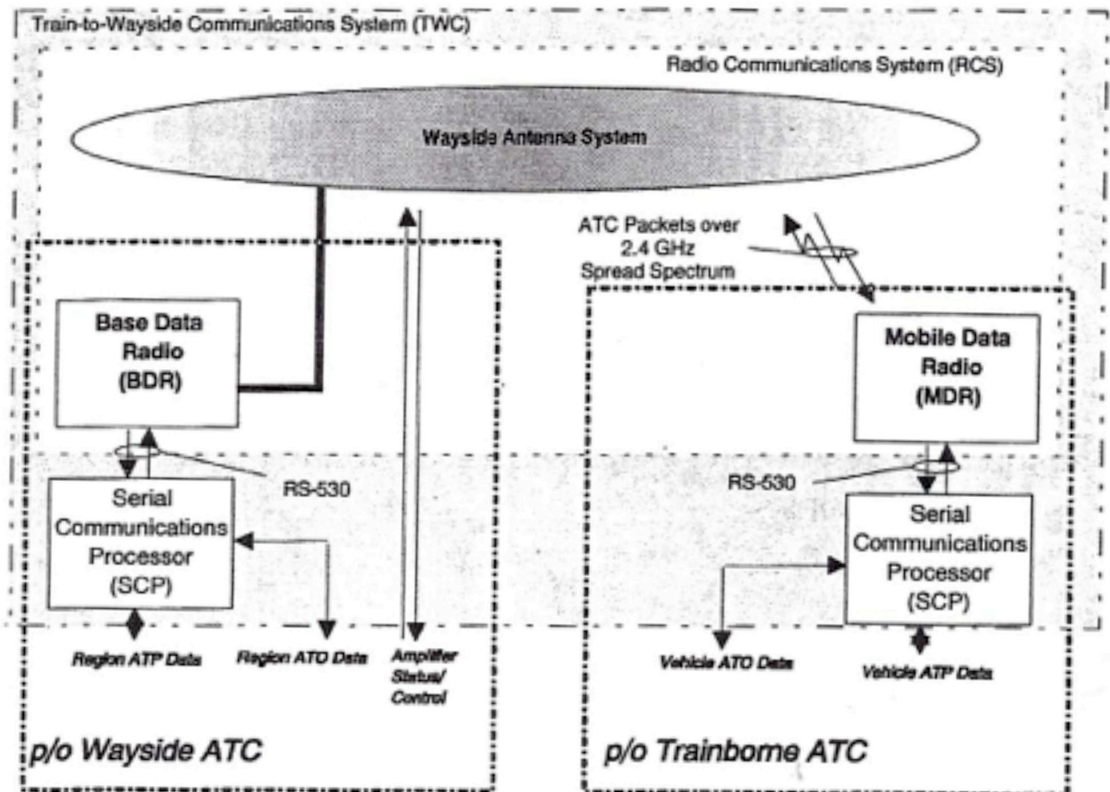

The initial SEPTA installation used the Andrew Corporation model 2400 BDR and MDR, which is a spread spectrum design that operates in one of the FCC-defined instrumentation, scientific, and medical (ISM) bands (2.4 GHz to 2.4835 GHz). FCC regulations limit transmitter output power to 1W. To ensure the security and reliability

of the CBTC system, the spread spectrum radio design approach increases the capability to reject interfering signals and give higher immunity to interferences encountered in mass transit environments. The following features are provided by the design:

- Direct sequence spread spectrum technique
- Wideband system operation
- High processing gain
- Long code length
- Balanced gold codes

The wayside antenna system is a subsystem of the RCS. Its primary purpose is to provide a reliable RF path between the BORs and MORs. In the tunnel section of the SEPTA light rail system, a combination of radiating coaxial cable (also known as lossy line, leaky feeder, or Radiax®), and amplifiers are used.

Figure 5-11 illustrates a typical distributed communications system, wherein bi-directional amplifiers are used for both signal loss compensation and realignment of region RCS coverage in the event of a DCS component failure. This feature also allows multiple BDRs to operate under the control of one region ATC. When more than one BDR is used in a system, a boundary is formed between the coverage areas of each BDR. This overlap area is a location where the signal strength from both coverage areas can provide simultaneous communication.

Figure 5-11

SEPTA Light Rail Tunnel CBTC Project
 SECTION 5: SEPTA LIGHT RAIL TUNNEL CBTC PROJECT

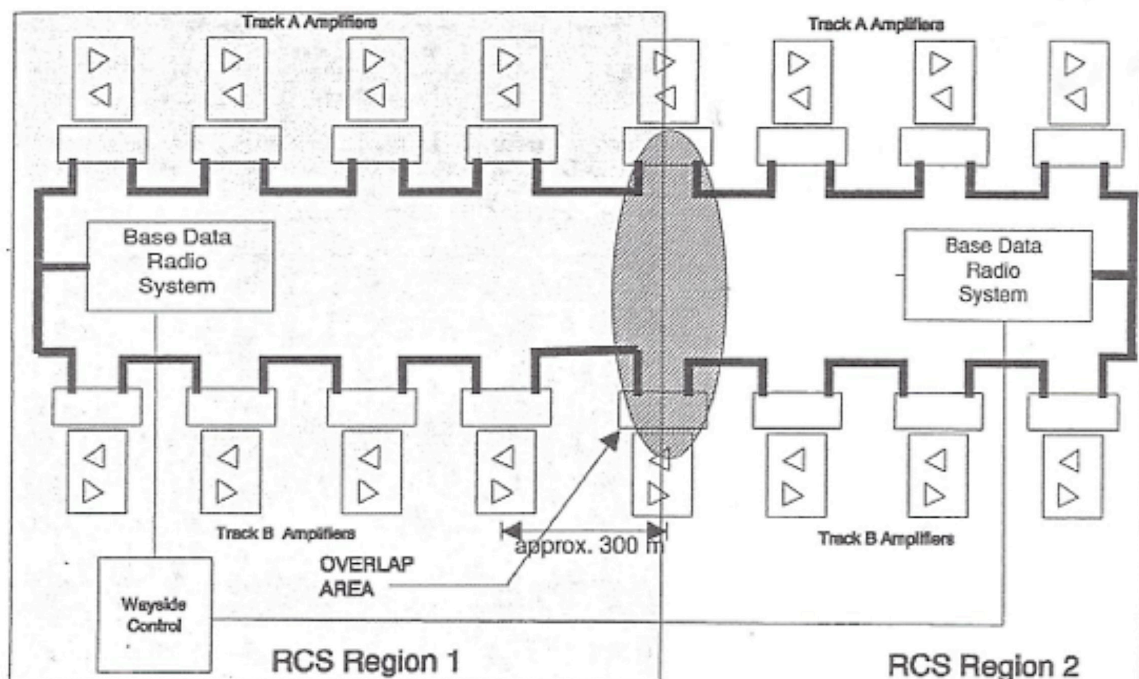

Lossy line cable has two functional characteristics: coaxial or transverse electromagnetic (TEM) and radiating modes of propagation. The SEPTA installation employs the Andrew Corporation Radiax® RCW-5, which was optimized for operation between 900 and 3300 MHz. In the coaxial (TEM) mode, the signal is carried along the 7/8-inch diameter cable, limited by attenuation (2.7dB/100 ft at 2400 MHz).

In the radiation mode of propagation, the signal from the center conductor leaks through openings in the outer shield. This allows the cable to transmit and receive signals along its path. An additional loss factor, called coupling loss, is present due to the air gap between the cable and the mobile antenna. This loss is specified at a distance of twenty feet from the cable and is 72 +/- 5dB, at 2400 MHz operation for the RCW-5 cable.

Amplifiers are installed approximately every 300 meters to provide not only compensation for Radiax® cable losses, but the ability to reconfigure the DCS if a cable, amplifier, or BDR fails. A maximum of 25 amplifiers can be cascaded.

The RCS uses an enhanced spread spectrum technology. Data transmission between the train and wayside makes use of the widely-accepted industry standard high-level data link control (HDLC) protocol and hardware interface (RS-530).

The TWC system function is common to both wayside and train borne ATCs. It processes packets from its respective ATP and ATO and sends it to the RCS to be sent over the Radio Network. To ensure the integrity of the data transmitted over the communication system between the region and vehicles, the following checks are performed:

- *Data Integrity Checks* – The integrity of the data transmitted between the train and the wayside (or vice versa) is protected through the use of Cyclic Redundancy Checks.
- *Authenticity Checks* – To verify the authenticity of the messages transmitted between the train and wayside a header that contains information specific to the message type, vehicle and region is placed at the beginning of each message.
- *Cross Checking of Data* – Messages received by each channel of the ATP are cross-checked with the other channel to ensure that both channels have received the same message and that both channels agree that the message is valid.
- *Loss of Communication* – In the event the region loses communication with a train, the region will block off an area around the last reported location of the train. The region will not permit any other train to enter the blocked off area. Similarly, in the event a vehicle loses communication with the region, this will result in the vehicle ATP forcing the train to a stop until communication with the region is restored.

The SEPTA CBTC system is supported by a fiber optic data distribution interface (FDDI) network, which is a deterministic, high-speed data link that allows each Region ATP, Region ATO, Zone Control Computer, and Central Control Computer to be networked. Redundancy is accomplished by implementing the FDDI counter-rotating ring approach. When a node or link fails, two rings are folded into a single ring to provide full connectivity. FDDI uses token ring protocol over fiber optic cables to provide a transmission rate of 100 Mbytes/second.

Wayside communications includes data transfers between the following entities:

- Region ATPs
- Region ATPs and Region ATOs
- Region ATOs
- Region ATOs and Central Control

Vital Processing

The SEPTA CBTC installation employs a distributed wayside ATC architecture, wherein the line is divided into three wayside ATC regions. Each region is defined by the coverage area of the wayside RCS. Further, each region includes a completely independent ATC installation, which, in turn, includes a redundant Region ATP computer, a redundant Region ATO computer, and a single wayside RCS. The functions of each ATP system are identical. However, the inactive ATP is restricted from exchanging data with the vehicle ATC. This redundant architecture is able to sustain a single channel failure without impacting operation or performance (quantity of vehicles or ability to control/monitor). In the event of a dual ATP failure at the same wayside ATC location, the ATC operation is interrupted, and vehicle movement is then performed under manual mode operation.

The vehicle ATC architecture includes a vehicle ATP, ATO, and mobile data radio (MDR). The vehicle ATC is not redundant, and in the event of a failure, the train comes to a controlled service brake. The vehicle is then operated in cutout mode, which enforces a speed restriction of 20 MPH. Both the wayside and onboard ATC systems employ a Motorola 68K family version of a checked-redundant ATP architecture, based on safety principles certified by TÜV Rheinland for ATC use in Europe. The system also uses versa module Eurocard bus architecture.

CBTC Implementation Approach

Procurement Approach

In late 1997, Adtranz, since acquired by Bombardier, agreed to supply a \$23.6-million CBTC system for the 2.5-mi. (4 km) downtown tunnel at no cost to SEPTA in lieu of payment of liquidated damages associated with an earlier subway

car procurement. To validate the price for the CBTC system, FTA required SEPTA to obtain competitive CBTC proposals from a number of other CBTC system suppliers.

Safety Certification Process Review

The following subsection compares the safety certification and risk assessment processes used by SEPTA with the requirements of the FRA standard 49 CFR Part 236, Subpart H, as summarized in Section 3.

Software Management Control Plan

The internal safety process employed by SEPTA to certify the safety of the CBTC installation does not include a software management control plan. However, the technical specifications required the CBTC supplier to implement a safety process pursuant to the requirements of MIL-STD-882C, including the requirements of Task 204, Subsystem Hazard Analysis (SSHA). In turn, Task 204 requires the system developer to implement a software development process and to evaluate the software contribution to the SSHA.

During discussions, Bombardier indicated that the Software Development Plan (SDP) for the SEPTA CBTC system was based on IEEE 1012 Standards for Software Verification and Validation. Further, it was indicated that the SDP included elements for requirements traceability and configuration management. A review of IEEE 1012 indicates that it does include requirements for an Installation Configuration Audit. The objectives of this audit are to:

- Verify that all software products required to correctly install and operate the software are present in the installation package
- Validate that all site-dependent parameters or conditions to verify supplied values are correct.

The contract documents and discussions with Bombardier further indicate that SEPTA and its consultant did review and audit the SDP and that Bombardier did conduct internal audits to ensure the integrity of the software development process.

Railroad Safety Program Plan

The technical specifications for the SEPTA CBTC project required Bombardier to institute and implement a System Safety Program during the design, installation, testing, and commissioning phases of the CBTC installation, including cut-over into revenue operations. Bombardier was required to submit and implement a System Safety Program Plan (SSPP) that complies with the requirements of MIL-STD-882C, Task 102. The main objectives of the System Safety Program for the Green Line CBTC system were to ensure safety of operation and to resolve hazards in a systematic manner throughout the project life cycle.

During the implementation phase of the project, SEPTA, by its ISA, performed an audit of the SSPP to ensure compliance with the provisions of Task 102 of MIL-STD-882C, Task 102, and to ensure that appropriate emphasis has been given to hazard mitigation and the prevention of accidents.

In performing this audit, the ISA focused on the following factors:

- System Safety Program scope and objectives
- System safety organization
- System safety program milestones
- General system safety requirements and criteria
- Hazard analysis techniques
- System safety data
- Safety verification procedures
- Audit program
- Training
- Incident reporting
- System safety interfaces

The FLEXIBLOK System Safety Program, as well as an independent audit report performed by Parsons, were reviewed and compared the elements of that program to the requirements of Subpart H. The assessment indicates that the main SSPP requirements of Subpart H are included in the FLEXIBLOK System Safety Program.

Product Safety Plan

The requirement for a Product Safety Plan (PSP) was not an industry practice prior to the FRA mandate under the provisions of Subpart H. However, some of the requirements included in the PSP were generally carried out by suppliers to ensure the safety and integrity of their safety-critical systems. For the SEPTA CBTC project, Bombardier employed the traditional approach to product safety. A comparison of the FLEXIBLOCK system safety program, which is based on MIL-STD-882C, with the provisions of Subpart H, indicates that while MIL-STD-882C is focused on Department of Defense applications, the requirements for Subpart H are more specific to a railway environment. As such, a number of PSP requirements, including description of railroad operation, operational concepts, and specific training to railroad personnel are not addressed in MIL-STD-882C. However, certain general safety requirements are common to both standards.

Based on the above and the representation that MIL-STD-882C was followed, it was concluded that the following PSP requirements were adhered to during the implementation of the SEPTA CBTC system:

- Identification of safety requirements and criteria
- Development of a hazard log that describes all safety relevant hazards
- Performing a risk assessment
- Performing a hazard mitigation analysis
- Performing safety assessment and verification
- Testing and evaluation safety
- Safety incident reporting

A complete assessment of compliance with the requirements of Product Safety Plan is included in Appendix D.

Minimum Performance Standards

The Safety Program for the SEPTA CBTC system did not incorporate the Minimum Performance Standards as set forth in Subpart H. However, a traditional approach for product safety was used. This traditional approach was based on assuring a probability of unsafe failure of 10⁻⁹. Also, the supplier indicated that it has followed the provisions of MIL-STD-882C, which requires that system design eliminate hazards and that in the event an identified hazard cannot be eliminated, then the associated risk must be reduced to an acceptable level.

Operations & Maintenance Assessment

The initial safety certification process for the SEPTA CBTC installation did not incorporate a formal approach to assess CBTC operational and maintenance issues. One of the findings of the safety audit performed by the ISA was the lack of evidence that appropriate emphasis had been given in the safety program to the operating and maintenance procedures required to preserve the safety integrity of the CBTC system. In response to the audit finding, the CBTC supplier submitted a document entitled “Operational & Support Hazard Analysis,” which identified the hazards for maintenance and operations personnel and defined mitigation measures to control these hazards. However, based on the ISA observation, the listed hazards were based on past experience in the development of similar systems, previous safety analyses of similar systems, and from the FLEXIBLOK ATP safety analysis.

Further, based on information provided by the CBTC supplier, SEPTA held meetings on a regular basis to discuss maintenance and operational issues, including failure modes and required mitigations. Also, certain aspects of the required safety mitigations are addressed in the maintenance manuals.

Training and Qualification

Based on information provided by SEPTA and Bombardier, the Green Line CBTC project included a training and qualification program to ensure that the SEPTA organization was ready to operate and maintain the new CBTC installation. This

training program included classroom and practical training for train operators, maintenance personnel, and control center dispatchers.

Quantitative Risk Assessment

No quantitative risk assessment was performed as part of the implementation of the SEPTA CBTC system.

Safety Assurance Criteria & Process

The Safety Assurance Criteria and Process used to ensure the safety and integrity of the SEPTA CBTC system included the following elements:

- Analysis of safety design concept
- Analysis of safety critical hardware
- Analysis of safety critical software
- Audit of Preliminary Hazard Analysis and Fault Tree Analysis
- Software verification and validation

Analysis of Safety Design Concept

To protect against unsafe operation of the system, and to detect system failures, the SEPTA CBTC system employs a design concept for both the car-borne and wayside ATP components that is based on the checked-redundant principles.

The safety design concept of checked redundancy uses dual, independent hardware units that execute identical software and perform identical functions. A vital architecture is used to periodically compare vital parameters and results of the independent redundant units and requires agreement of compared parameters to assert or maintain a permissive output. If the units do not agree, safety-critical functions and outputs must default to a known safe state.

The safety analysis and assessment of the checked redundancy concept used at SEPTA focused on the following activities:

- Integrity of the checking process and its ability to provide permissive outputs only, and only if the redundant systems agree, i.e., the vitality of the comparison mechanism
- Degree to which the checking process includes comparison of all vital parameters and of all results of vital functions
- Ability to place and maintain the system in a known safe state under any failure which could affect safety, i.e., fail-safe implementation
- Degree to which the effects of common mode failures have been eliminated, i.e., the degree of independence achieved between redundant hardware units
- Ability to detect all hardware failures affecting safe operation in either redundant unit at point of comparison

- Frequency with which the checking process between redundant units is performed
- Degree to which the software employed by each redundant unit is either error-free or does not contain identical errors

Analysis of Safety Critical Hardware

In addition to the checked-redundant architecture used for the car-borne and wayside CBTC equipment, the SEPTA ATP system employed safety-critical hardware that is based on fail-safe closed loop hardware circuits that are implemented with vital relays. The safety analysis of this safety-critical hardware focused on verifying fail-safe operation under various failure modes. To accomplish this safety analysis, it was necessary to consider, analyze, and document the effect of every relevant failure mode of each component, as well as relevant combinations of component failure modes.

The detailed hardware safety analysis was performed by Bombardier and audited by SEPTA's ISA. The degree of safety achieved through fail-safe closed loop hardware design is dependent upon the following factors:

- Correctness of selected component failure characteristics
- Comprehensive and accurate identification of all component failure modes
- Extent to which all combinations of failure modes have been analyzed
- During the implementation phase of the SEPTA CBTC project, SEPTA through its ISA assessed each of these factors.

Analysis of Safety Critical Software

The safety of the CBTC system is dependent upon the correctness and integrity of the safety-critical software and its ability to detect and respond to hardware failures to ensure that the system reverts to a known safe state. Under the CBTC contract, SEPTA delegated the primary responsibility for the analysis of safety-critical software to Bombardier. However, SEPTA, through its ISA, performed a safety audit on the safety-critical software design to assess the following factors:

- Degree to which continued system operations is dependent upon a software generated "refresh" signal
- Ability of the software design to remove the "refresh" signal and decouple all outputs from the ATC subsystem in response to a detected fault
- Extent of the software checks to detect EPROM and RAM failures

Audit of Preliminary Hazard Analysis and Fault Tree Analysis

During the development of the CBTC system, Bombardier performed a Preliminary Hazard Analysis (PHA) and Fault Tree Analysis (FTA) to identify faults that could lead to a hazardous situation and to establish corrective actions and system requirements to eliminate or control these hazards to an acceptable

level. In turn, SEPTA, through its ISA, performed an audit on the hazard analysis process to assess the following:

- Completeness of the identified hazards, including appropriate consideration of the specific requirements of the SEPTA application, and especially the safety requirements to eliminate train collision and train derailment hazards
- Extent to which safety requirements for the design and development of the CBTC system have been captured in a separate requirements document
- Traceability of these safety requirements throughout the design and development life cycle

Software Verification and Validation (V&V)

One of the critical elements of the Safety Assurance Criteria and Processes is to ensure the correctness and integrity of the vital software for the CBTC system. Further, software V&V artifacts provide evidence of proper application of software process management throughout the project life cycles in order to provide the confidence that vital software has been implemented without errors.

Independent Review of Validation and Verification Activities

As stated above, at the time of implementation of the SEPTA CBTC system, the requirements for Subpart H of 49 CFR Part 236 were still under development. However, industry practices recommended that transit properties perform an independent assessment on safety-critical systems. As such, SEPTA retained Parsons to perform an independent safety audit to assess the extent to which the engineering techniques, processes and system design adopted by the CBTC supplier (Bombardier) for the CBTC system conforms to defined minimum standards. The audit was accomplished by review and analyses of various design documents, plans and manuals provided by the CBTC supplier. Further, Parsons held meetings with the CBTC supplier to obtain clarifications, and discuss preliminary findings of the safety audit. This independent safety audit relied on the following Industry Standards:

- MIL STD 882C “System Safety Program Requirements”
- IEEE 1474.1™-1999 “IEEE Standard for Communications Based Train Control (CBTC) Performance and Functional Requirements”
- IEEE 1483-2000™ “IEEE Standard for Verification of Vital Functions in Processor-Based Systems Used in Rail Transit Control”
- MIL STD 1629 A “Standards for Failure Mode Effects and Criticality Analysis” (specifically, FMECA standard form for component failure analysis tree)

Human-Machine Interface (HMI) Design

During the development phase of the project, SEPTA requested that the Human-Machine Interfaces (HMIs), including the train operator display, to the

extent possible, be transparent to existing procedures employed by the light rail operation. Based on this approach, the CBTC supplier kept the HMI's as simple as possible. The process used to review the HMI design was based on a First Article Inspection, where the proposed HMIs were presented and discussed at meetings. Any comments or requested modifications were reflected in the final version of the HMI design.

SEPTA representatives advised that the HMI design approach used by SEPTA and its CBTC supplier was effective in addressing and meeting SEPTA's operational needs and requirements. However, this approach is not based on the requirements of Appendix E of Subpart H.

Post-CBTC Operations

Service Levels

SEPTA representatives indicated that there was an initial degradation of service when CBTC was first introduced. The system had a number of initial shortcomings, including poor reliability of the data communication subsystem and a high level of emergency brake applications that negatively impacted service. The main focus of CBTC implementation was the need to improve safety, and, as such, the system was rushed into service before the organization was ready to operate and maintain the CBTC equipment. At the time when the CBTC installation was placed in revenue service, the operating personnel did not have a clear understanding of the technology and especially of how to handle a loss of communication and "zero" speed code conditions. In addition, the SEPTA trainers who were trained by the supplier did not have sufficient knowledge on how the CBTC system worked and could not provide effective training to the train operators. Further, there was a need for degraded modes of operation during failure conditions rather than simply stopping service upon equipment failure. Currently, the only degraded mode of operation is "restricted manual," which is used if a train misses a transponder. During other CBTC failures (wayside or carborne), and because "restricted manual" has a detrimental impact on operation, trains are operated in "bypass" mode, with full speed capabilities. During this mode of operation, the safety of the system is dependent on compliance with operating rules and procedures. SEPTA has indicated that under future CBTC projects, it plans to incorporate additional degraded modes of operation to reduce the reliance on the "by-pass" mode.

Recognizing the initial CBTC shortcomings, SEPTA instituted a corrective program to enhance equipment reliability and to provide training to train operators on how to handle emergency brake conditions. As a result, service has improved considerably and is currently at the levels of pre-CBTC installation. SEPTA is confident that as ridership demands increase, the CBTC system will be able to provide a level of service that exceeds prior levels. However, it was pointed out that future enhancements of service delivery are limited due to a

number of factors external to CBTC, including the existing track layout based on a loop configuration.

SEPTA further indicated that the Train Driver Display design was critical for the performance of the system. It was mentioned that the simpler the HMI design is better. Another important aspect mentioned by SEPTA is that the environment of a light rail system is much more stressful for the driver than for a Metro environment. The driver has to check many other parameters in addition to the movement authority information on the display.

Although initial service reliability due to hardware failures and operational issues, a number of initiatives resulted in very reliable and consistent train service. One drawback on the operation after the introduction of the system is that in case a train fails (onboard CBTC failure or radio failure), the train disappears from the tracking at the Control Center.

Operations & Maintenance

SEPTA provided limited information related to its operating and maintenance metrics. As indicated previously, the SEPTA CBTC system has limited degraded modes of operation, and during CBTC failures, trains are operated in bypass with full speed capabilities to lessen the impact on passenger service. The following operating metrics were provided by SEPTA:

- Communication failures are rare. Currently, SEPTA experiences one non-communicating train upon entering CBTC territory every 9–12 months.
- Delocalization failures depend on the weather and are more common during the Fall season. On average, SEPTA experiences one delocalization failure every 4–5 months.
- Emergency brake applications are more common and are mainly due to operator error. On average, there are 5–6 emergency brake applications per week. To recover from this condition, trains are operated in bypass mode.

Overall, the current level of service delivery is at least the same or better than before CBTC implementation.

With respect to maintenance benefits (cost reduction), SEPTA indicated that they cannot be realized yet as the agency is keeping the wayside signal system as a fallback. SEPTA further indicated that as soon as it is more confident about the reliability of the system, the fallback system will be removed. SEPTA anticipates lower maintenance costs due to a reduction in wayside equipment. However, it was noted that this benefit somehow may be offset by the new cost of maintaining the onboard equipment.

SEPTA also indicated that the performance of the system from a maintenance perspective could have been improved greatly if a remote diagnostic feature for the onboard equipment had been provided. This would have allowed detecting cars with failed onboard CBTC equipment before they enter into the CBTC area. This situation greatly affects the performance of the system.

Achieving Organizational Readiness

SEPTA did not implement a structured approach or a formal process to prepare its organization for CBTC operation. The transfer of knowledge, especially for maintenance, was provided by the supplier. The SEPTA maintenance staff learned from attending meetings and hands-on experience working together with the supplier troubleshooting the system.

It should be noted that SEPTA's representatives have recognized that they should have used more time to prepare all the stakeholders for CBTC operation. They pointed out that the system introduction was rushed because of the operational safety concerns on the line.

Safety

The main objective of the CBTC installation is to enhance safety of operations, and, as such, the new system improved greatly the safety of the line by ensuring safe train separation and providing over-speed protection at curves. Further, CBTC provided additional safety for the staff working near the track. It was noted that there has been no safety incident recorded since the introduction of the CBTC system. CBTC also enhanced service delivery in two ways:

- SEPTA is able to operate short headways under signal protection. Track capacity under CBTC protection currently exceeds ridership demands.
- Average operating speed has increased, especially at curves, where CBTC is able to provide consistent and safe operation.

Lessons Learned

SEPTA's representatives indicated that they have captured a number of lessons learned from the implementation of CBTC in the Light Rail Tunnel and that they intend to apply these lessons to the upcoming CBTC project on the Media-Sharon Hill Line. More specifically, SEPTA has identified the following lessons that were learned from their CBTC deployment:

- SEPTA recognized that the implementation was difficult because no set of operating and functional requirements had been set at the beginning of the project; this was due to the particular context of this project (the CBTC system was offered by the supplier as compensation in lieu of paying liquidated damages due on a different contract).

- The design of the CBTC system in the Light Rail Tunnel does not provide for degraded modes of operation. As a result, it is difficult to manage service delivery during failure modes. Future CBTC projects will include requirements for degraded modes of operation that is based on SEPTA's operational needs.
- There was a lack of organizational readiness when CBTC was placed in revenue service. Future CBTC projects will have more focus on providing comprehensive training to operating and maintenance personnel.
- The involvement of the stakeholders is key for a successful implementation of a new system like CBTC.
- No remote diagnostics were provided under this contract, which limit the maintenance philosophy to a reactive approach. SEPTA is considering a more proactive approach for future CBTC project.
- An efficient training program can improve the performance of the system.
- SEPTA indicated that one of the most difficult issues was the initialization into the CBTC area. The Media-Sharon Hill project will have to focus more on this functionality.

Qualitative Cost/Benefit Assessment

Using the tables provided in Section 3, the benefit and cost factors applicable to the SEPTA CBTC are summarized below.

Benefit Factors

GoA Benefits

SEPTA's GoA within the Light Rail Tunnel pre-CBTC was GoA 0 (manual operations with no ATP). Post- CBTC, SEPTA had upgraded to GoA 1 (manual operations with ATP; no automatic driving functions). The benefits realized were, therefore, limited to those summarized in Table 5-4.

GoL Benefits

As improved safety was the primary objective to SEPTA's CBTC upgrade, additional benefits realized were limited to those summarized in Table 5-5.

Cost Factors

Cost factors applicable to SEPTA summarized in Table 5-6.

Table 5-4

SEPTA Benefits of Increased GoA

Benefits of Automation Achieved by SEPTA	Manual		Automatic		
	GoA0	GoA1	GoA2 (STO)	GoA3 (DTO)	GoA4 (UTO)
Automatic Train Protection (ATP)	Pre-CBTC	Post-CBTC			
More predictable run times between stations (more predictable operation in curves only)		Post-CBTC			
More uniform ride quality (more predictable operation in curves only)		Post-CBTC			
Reduced wear-and-tear of train propulsion/braking systems					
Reduction in variations in line operation/improved service regulation					
Energy optimization					
Automation of turnbacks					
Remove constraint of rostering train crews					
Flexibility to operate shorter trains more frequently					
Ability to respond to unexpected increases in passenger demands					
Potential for reduction in operating costs					

Table 5-5

SEPTA GoL Benefits from CBTC Upgrade

Potential GoL Benefits of CBTC Upgrades	SEPTA Benefits Achieved
Enhanced Safety	
Passenger safety	Continuous over-speed protection
Staff safety	
Improved State of Good Repair	
Higher system availability	Not applicable
Reduced maintenance	Reduced maintenance will be achieved upon planned removal of wayside signalling equipment
Improved Service Delivery	
Increased capacity	Current CBTC operation provides same level of capacity as pre-CBTC operation
Reduced trip times	Reduced trip times achieved
Increased operational flexibility	Enhanced operational flexibility was not a design objective

Table 5-6*SEPTA Cost Factors*

Cost Factors	Required for SEPTA Specific Application
<i>Core System” Cost Factors</i>	
CBTC train-borne equipment	Costs of non-redundant train-borne equipment included
CBTC wayside equipment	Costs of redundant wayside equipment included
CBTC control center equipment	Minimal control center equipment included
CBTC data communications equipment	Full wayside and wayside-to-vehicle data communications equipment included
<i>Site Specific Cost Factors</i>	
Vehicle retrofits	CBTC equipment had to be installed on existing vehicles
Interlocking upgrades	Not required under CBTC contract
Secondary train detection	Not required under CBTC contract
Secondary train protection	Not required under CBTC contract
New equipment rooms/etc.	Not required
Control center upgrades	Not required
Agency-specific adaptations	Limited adaptations required
Test & commissioning constraints	Significant
Safety certification approach	Primary responsibility on supplier with oversight by SEPTA and SEPTA's ISA
Project management approach	Consistent with this particular procurement approach

SECTION 6

Major Findings

In both the NYCT and SEPTA case studies, CBTC technology was selected because it offered unique benefits that could not be easily provided with traditional fixed-block technology, and both NYCT and SEPTA confirmed that the operational and safety benefits of implementing CBTC were achieved, specifically:

- Increased safety levels through continuous speed enforcement, ability to setup temporary speed restrictions, and work zones to protect staff working near the track
- Ability to support short headway operations, thereby maximizing line capacity
- Flexibility and consistency of operations using ATO mode (NYCT only)
- Centralized, efficient supervision and regulation of the line (NYCT only)

However, both NYCT and SEPTA went through a rather long period of “de-bugging” or performance improvement phase (1–2 years) before reaching the expected reliability and availability targets and fully obtaining the benefits of the new CBTC system. The primary causes of this protracted transition period were multiple software releases to correct software bugs and vehicle interface issues (NYCT) and unreliable data communications and inadequate organizational readiness (SEPTA).

Regarding organization readiness, it was clear from discussion with both transit properties that the involvement of agency operating and maintenance departments should start early in the implementation phase of the project. NYCT had the opportunity to prepare its stakeholders for the implementation of the new system and had its operating and maintenance staff working with the supplier from the beginning of the project. However, SEPTA did not have this opportunity, and the lack of training was an important factor that contributed to the low level of performance when CBTC was first introduced.

Concerning the need for a fallback system, both NYCT and SEPTA confirmed that they would rather not have a complex back-up system using wayside signals and track-circuits, as they trust the high availability level of CBTC. However, NYCT has a unique requirement to support mixed-fleet operation, which will require the use of an Auxiliary Wayside System (Secondary Train Control System) for a prolonged duration.

One other theme echoed by both agencies is the need for more powerful maintenance and diagnostic tools. Even though CBTC came with many advanced maintenance tools, it was felt by both agencies that the suppliers could and should further enhance these tools.

Compliance with Industry Standards

In both cases, the development of the procurement specifications for the NYCT and SEPTA CBTC systems proceeded in parallel with the development of the original IEEE Std 1474.1™. As such, there is a high degree of correlation and compliance with relevant sections of this standard by both the NYCT and SEPTA systems. As IEEE Std 1474.1™ is a consensus standard developed with the support and input of many of the major signaling suppliers, it can also be reasonably assumed that all of the service-proven CBTC systems available in the market today comply with this standard.

As such, it can be concluded that IEEE Std 1474.1™ and other IEEE standards in the 1474 series represent a useful starting point for other transit properties developing procurement specifications for CBTC, as these standards not only define the capabilities of CBTC systems and typical CBTC system architectures, but also mandatory and optional functions as well as information that needs to be defined by the transit property in developing a CBTC procurement specification.

Assessment of Enabling Technologies

The enabling technologies in the NYCT and SEPTA CBTC designs had evolved from designs, equipment, and devices that had been employed in conventional signaling installations for many years. What distinguished the CBTC-enabling technologies from prior installations was the way they were applied to achieve the unique functional requirements of CBTC. For example:

- Transponders have been used in train control installations for many years to provide vehicle identifications and to transmit the status of wayside signal equipment (signals, switches, etc.) to approaching trains. In a CBTC installation, transponders are used to provide absolute reference location to the onboard CBTC equipment for the purpose of determining the location of a train independent of track circuits. One of the main motivations to use transponders for this application is the fact that these devices are passive (do not require wiring or electrical power to operate) and easy to install and provide a high level of reliability/availability.
- Tachometers and Doppler speed sensors have also been used in cab-signaling systems to measure the actual speed of trains. The Doppler speed sensor provides a true ground speed independent of wheel rotation, which is used to correct errors in tachometer speed measurements caused by wheel slip and slide. In CBTC applications (SEPTA), the combination of tachometer and Doppler is used in a similar manner to the cab-signaling application; however,

these devices provide the added functionality of continuously determining the location of a train as it moves between transponders.

- In the NYCT Canarsie Line CBTC installation, an optical speed measurement device (OSMES) was used for location and speed measurement in lieu of a tachometer/Doppler combination. While the OSMES device is new and unique to Canarsie CBTC, the optical speed measurement technology has been used in the past during brake testing of new rail vehicles. Optical speed measurement has the advantage of precise distant measurement independent of wheel rotation and wheel diameter. The NYCT Canarsie Line CBTC supplier was able to develop a speed and location measurement device based on this technology and which provides a vital input to the onboard CBTC equipment. However, optical speed measurement requires a “clean” environment, which is difficult to achieve in a rail system. The presence of dirt particles, steel dust, and other elements has presented maintenance challenges to NYCT on the Canarsie Line.
- Data communication has been used in cab-signaling systems to communicate signals and safe speeds. CBTC requires continuous bi-directional vital communication throughout the system. Radio is becoming more prevalent and was used by both NYCT and SEPTA, although inductive loop and leaky feeder communications methods are also used in CBTC systems. Inductive loop is installed in the track bed and is subject to wear and tear from maintenance. Experience has shown damage to inductive loops is frequent, but the cost of repair is low when not considering performance disruptions or possession requirements for repairs. Leaky feeder coaxial cable may also be subject to maintenance wear and tear depending on its physical location, but also with fairly low cost of repair (again, not considering the disruptions or possessions).
- Vital processors are used onboard trains and at wayside locations to process the various CBTC functions. The technical approach used to implement vital processors (coded mono processors, checked-redundant processors, etc.) is based on the technologies used in conventional signal installations to achieve vitality. For example, coded mono processors and checked-redundant processors were used to implement vital electronic interlocking and cab-signaling control devices. In CBTC, vital processors are programmed using new algorithms and functions to achieve the defined characteristics of CBTC.

In assessing proprietary vs. open standards technical solutions employed at NYCT and SEPTA, a key finding was that while many of the enabling technologies employ off-the-shelf devices (for example, transponders, tachometers, Doppler speed sensors, radios, etc.), the packaging of these devices into a CBTC subsystem is proprietary. Also, with respect to the data communication subsystem, there are two main approaches:

- Proprietary design approach using communication devices that were specifically designed for CBTC applications
- Open Standard design approach based on IEEE standards 802.11

Each of these approaches could be used to provide a reliable CBTC installation; however, there are a number of advantages and disadvantages to each approach, including:

- A proprietary design can lead to higher performance and operationally consistent CBTC installation (for example, the use of a special algorithm in radio design to affect the transfer from one data communication cell to another based on train location). However, the inclusion of such algorithm makes it more difficult to achieve interoperability between different systems.
- Open standard design benefits from a much larger base of applications in term of lower cost and the availability of a large number of features.
- A proprietary design can potentially provide more immunity against interference and intentional jamming.
- It is easier to control future product evolution in a proprietary design because an open standard design is subject to future changes in the standards, which, in turn, are driven by the needs of different communication applications.
- With a proprietary design, an agency may be locked in to a sole-source supplier.

One of the main driving factors in the selection of a specific enabling technology to provide a particular CBTC function is the desire of both the transit property and supplier to minimize changes to the CBTC platform, especially if the platform was proven in revenue service in a prior application.

In summary, it can be concluded that the CBTC-enabling technologies do not represent a technical risk in successfully implementing CBTC projects.

Safety Certification Process Reviews

NYCT and SEPTA used substantially different approaches to certify the safety of the CBTC installation. NYCT opted to follow the provisions of FRA Subpart H, established an internal safety organization, and engaged an Independent Safety Assessor and a System Safety Certification Board (SSCB) to implement and manage the safety certification process. SEPTA's safety approach relied primarily on the CBTC supplier, but included audits to ensure compliance with the safety requirements of the contract. Both approaches have led to acceptance by the respective property of the CBTC installation and placing the CBTC equipment in revenue service.

The NYCT approach to safety certification was largely consistent with the industry standards and practices, nationally (49 CFR subpart H of Part 236) and internationally (CENELEC). However, because this project was a first-time implementation on an NYCT existing infrastructure, several additional steps were taken to provide better assurance that the safety goals were going to be met. One key aspect of this was the commitment and wide involvement of NYCT staff across the organization, from the signal engineering department, car equipment engineering group, and operations and maintenance groups. All these departments spent much time and effort to successfully certify the CBTC system, engaged through working groups, the System Design Review, and the System Safety Certification Board.

While the SEPTA safety methodology did not closely follow the requirements of FRA Subpart H, it did cover critical safety requirements of the FRA standards. SEPTA also relied on its CBTC supplier to carry on the safety certification process, which was based on MIL and IEEE standards and which followed the industry safety practices that prevailed at the time.

Based on discussions with the CBTC suppliers, it appears that the future trend in the industry is to structure a safety certification process based on CENELEC standards. This will provide transit properties with another option in formulating the requirements for a system safety certification process. It should be noted that what is critical for a successful safety certification process is for the transit property to formulate its safety approach and methodology early in the project life cycle. It is also important to allocate adequate resources to manage the implementation of the safety process. It should also be noted that the specific methodology selected for safety certification depends on a number of factors, including applicable government regulations, system complexity, the operating environment, degree of back-up system, and the maturity of the supplier and agency in vital software delivery.

Qualitative Cost/Benefit Assessments

The potential benefits to a transit property in implementing CBTC relate to:

- Increased grade of automation
- Enhanced safety
- Improved state-of-good-repair
- Improved service delivery

Enhanced safety was the major driver for implementing CBTC for both NYCT and SEPTA. Improved state-of-good-repair and improved service delivery were also major factors in NYCT's decision to adopt CBTC; these benefits were less critical for SEPTA. Increased grade of automation was also not a significant

consideration for SEPTA, which retained manual operations through the Light Rail Tunnel. For NYCT, consistent with the desire to improve service delivery, CBTC supported a transition to semi-automatic train operations. Achieving the potential additional benefits of driverless or unattended train operations was not a consideration for NYCT.

Both case studies highlighted that the capital costs associated with implementing CBTC include many site-specific factors, in addition the core costs of designing, supplying, installing, testing, and commissioning of the CBTC specific equipment. These costs can vary widely, depending on the specific scope and characteristics of the CBTC implementation. As such, the CBTC business case that is applicable in one application is unlikely to similarly apply to another application.

SECTION 7

Other Analyses

In addition to the project reviews, the study scope also included the following additional tasks:

- Need for secondary train control systems
- Lessons learned from PTC projects

Need for Secondary Train Control with CBTC

To date, deployment of CBTC technology within the United States has been limited, due, at least in part, to a perception of higher costs associated with the implementation of this technology. This perception of higher costs is in turn driven, in part, by a perception that CBTC systems require a secondary track circuit-based or axle counter-based “fall-back” system to detect and protect trains in the event of CBTC system failures.

For CBTC to completely replace a conventional track circuit-based signaling system, either all trains operating on the line must be equipped with functioning CBTC equipment, or alternative means have to be provided to detect and protect the movement of unequipped trains within CBTC territory. Depending on the specific operational and safety requirements, these alternative means may require additional (i.e., secondary) wayside and/or train-borne signaling equipment. Alternatively, given the high levels of system availability and the functional capabilities of CBTC systems, it may be possible to achieve an acceptable level of system safety through strict adherence to operating procedures without the need for a secondary train control system.

The intent of this analysis was to establish guidelines to enable any transit agency to establish to what extent track circuits, or other secondary detection equipment, would need to be retained when implementing a CBTC system.

Assumptions and Definitions

Consistent with the capabilities of CBTC systems, this analysis assumes that a CBTC system is designed to provide complete bidirectional running capability and to support short-headway automatic train operations as the normal operating mode.

The CBTC system is also assumed to support a Protected Manual mode of operations in which the vehicle is manually driven by the vehicle operator, with ATP supervision/enforcement.

Other assumed train operating modes include:

- Restricted Manual – Manual operation with no ATP supervision/enforcement, but with a speed restriction imposed by the car equipment (not the CBTC system)
- Bypass – Vehicle driven manually with no restraint on speed by the car or ATP

This analysis also assumes there is some form of dynamic departure test of the CBTC system functionalities prior to train movements from the yard departure track onto the mainline. This departure test would verify that all train-borne equipment is operational and that the database is loaded and confirmed. Train position, train configuration, and operating modes would also be verified to ensure the vehicle is ready for revenue service. It is assumed that a train that fails the departure test would be precluded from entering CBTC mainline territory through appropriate track configurations and interlocks.

Secondary Train Control System

In this analysis a secondary train control system is defined as signaling equipment within CBTC territory that, when integrated with the primary CBTC system, provides a level of ATP functionality for trains either:

- Not equipped with train-borne CBTC equipment, and/or
- Trains operating with partially or totally inoperative train-borne CBTC equipment (including train-borne CBTC data communications equipment), and/or
- Trains operating within an area of track with partially or totally inoperative wayside CBTC equipment (including wayside CBTC data communications equipment).

A secondary train control system is not a complete/stand-alone signaling/train control system, but, rather, auxiliary equipment to provide partial ATP functionality for the movement of non-CBTC-equipped trains and/or the movement of CBTC-equipped trains in the event of certain CBTC system failures.

A secondary train control system may comprise either:

- Secondary train detection systems only, or
- Both secondary train detection and secondary train protection systems

A secondary train detection system could be track circuits or axle counters capable of determining if a fixed-block section of track is occupied by one or more trains, including trains not equipped with CBTC equipment and/or trains with inoperative CBTC equipment. This track occupancy data can be provided to CBTC wayside equipment and CBTC ATS equipment. A secondary train detection system will not necessarily determine the location of non-CBTC-equipped trains, or trains with inoperative CBTC equipment, to the same accuracy as CBTC-equipped trains.

A secondary train protection system could be wayside signals/trip stops, or equivalent, that when interfaced with a secondary train detection system can provide safe train separation assurance, over-speed protection, and interlocking protection for the movement of trains not protected by the CBTC system.

One specific application of a secondary train control system that needs to be considered is at the boundary between CBTC territory and non-CBTC territory (where non-CBTC territory is defined as any territory that is not equipped with wayside CBTC equipment fully compatible with the train-borne CBTC equipment). An example would be the boundary between a maintenance and storage facility equipped with a yard signaling system and mainline track equipped with wayside CBTC equipment. At such locations, some form of secondary train detection/protection/interlocking system is typically required on a “transition track” between the non-CBTC and CBTC territory to preclude a train that would not be detected and protected by the CBTC system from intentionally or inadvertently being routed into CBTC territory, unless such a train would be detected and protected by a secondary train control system within the CBTC territory. (See also Step 2 below). The “transition track” would typically be where the CBTC train would be initialized and accepted for operation within CBTC territory.

Secondary Train Control Design Alternatives

The following levels of secondary train control within CBTC territory are defined for the purposes of this analysis. These levels are intended to represent broad levels of additional functionality only. Variations on these broadly defined levels are possible.

Level 0 Secondary Train Control

Level 0 would include primary CBTC protection only, with no secondary train detection and no secondary train protection. At this level, the safety of any train movements during CBTC system or equipment failures would depend on compliance with operating rules and procedures.

Level 1 Secondary Train Control

Level 1 would provide secondary train detection at interlockings only to provide totally independent switch deadlocking. At this level, similar to Level 0, the safety of any train movements during CBTC system or equipment failures would depend on compliance with operating rules and procedures. The independent switch deadlocking would prevent a switch moving under a train during a CBTC failure; however, during normal (non-CBTC failure) operations, the primary CBTC system would need to address the case of failure of the independent switch deadlocking preventing a desired switch movement from being executed, with associated operational impact.

Level 2 Secondary Train Control

Level 2 would be an extension to Level 1 with secondary train detection extended in approach of the interlocking area together with a trackside indicator to tell a train operator of an approaching non-CBTC/failed train not only the switch position, but also that the switch is locked. In other words, Level 2 would essentially provide a form of approach locking or “route secure” function. Level 2 would provide additional information to the train operator, but would not prevent a train operator of a non-CBTC/failed train entering an unsafe switch area, or entering a switch area at an unsafe speed. Similar to levels 0 and 1, at this level, the safety of any train movements during CBTC system or equipment failures would still depend on compliance with operating rules and procedures. Although additional information would be provided to the train operator during a CBTC failure, during normal (non-CBTC failure) operations, the primary CBTC system would again need to address the case of failures of the Level 2 equipment preventing a desired switch movement/train routing from being executed, with associated operational impact.

Note that Levels 1 and 2 are focused primarily on mitigating the hazard of train derailments at interlockings for trains that are not detected by the CBTC system.

Level 3 Secondary Train Control

Level 3 would further extend the secondary train detection to include all mainline track, providing an indication to the CBTC wayside equipment if a section of track were occupied by a train (or trains) not detected by the primary CBTC system (i.e., unequipped or failed train). The limitations and implications noted above for Levels 1 and 2 apply equally for Level 3. Specifically, under normal (non-CBTC failure) operations, the primary CBTC system would need to address failures in the secondary train detection equipment. In addition, if the secondary train detection system is being used to detect unequipped or failed CBTC trains, then the primary CBTC system has to include additional functionalities to limit the movement authorities for CBTC-equipped trains based on “block occupied” indications from the secondary train detection equipment.

Note that in Levels 1, 2, or 3, the secondary train detection could be by means of track circuits or axle counters. Axle counters have some advantages over track circuits, including the ability to determine the number of vehicles within an occupied block, but may also have more complex failure modes. For example, in the event of a miscount by an axle counter, it may be necessary to “sweep” the axle block with a train in order to confirm the block is indeed unoccupied.

Level 4 Secondary Train Control

Level 4 would add to Level 3 a secondary train protection system (e.g., wayside signals or cab signals with mechanical or electronic train stops) to provide back-up ATP protection for the non-CBTC/failed train. In addition to secondary safe train

separation assurance, a Level 4 secondary train control system could also provide overspeed protection on curves and on approach to terminal stations, as may be required by the specific track alignment. For this level, the safety of any train movements during CBTC system or equipment failures would now be provided by the secondary train protection system. However, during normal (non-CBTC failure) operations, the primary CBTC system would now need to address failures in both the secondary train detection system and the secondary train protection system. The complexity of a Level 4 secondary train control system would depend in part on whether or not the system was required to support full bi-directional operations.

Note that in addition to mitigating derailment hazards, Levels 3 and 4 are also focused on mitigating the hazards of train collisions involving trains that are not detected by the CBTC system.

It is important to note that the implementation of specific levels of secondary train control can vary significantly in terms of technology, complexity, and costs. There is no “standard” secondary train control system for CBTC, and where a level of secondary train control is deployed, the design of the secondary train control system and its interfaces to the CBTC system are typically custom-designed to meet the specific needs of each transit property.

Selecting the Appropriate Level of Secondary Train Control

The following 10 steps define a logical process that could be followed in order to select the appropriate level of secondary train control for a specific CBTC application.

Step 1 – Is “Mixed Mode” an Operational Requirement?

The first and most important step in identifying a need for a secondary train control system should be to determine if, for operational reasons, there is a requirement for the simultaneous operation within CBTC-equipped territory of passenger trains that are protected by the CBTC system and passenger trains that are not protected by the CBTC system (i.e., “unequipped” trains). “Mixed-mode” operations could potentially be required for one or more of the following reasons:

- During the transition period only, in a CBTC re-signaling project, as a new CBTC system is being cut-in while maintaining revenue service operations
- As a regularly-scheduled mode of operation within CBTC territory—for example, when the train fleet required to provide revenue service is not all CBTC-equipped
- As an infrequent/unscheduled mode of operation within CBTC territory—for example, if the CBTC-equipped line is part of a wider rail network with interfaces to lines that are not CBTC-equipped and where non-equipped trains may be routed onto the CBTC-equipped line for service recovery or other reasons

A requirement to support “mixed mode” operations during the transition period in a CBTC re-signaling project is not unusual, and dual equipping the rolling stock and/or the wayside is a typical approach to migrating to the new technology while minimizing the impacts to revenue service operations. This, however, does not justify the continuing need for a secondary train control system once the primary CBTC system has been cut-in and all passenger trains are CBTC-equipped.

“Mixed mode” operations as a regularly scheduled mode of operation would be unusual, particularly for driverless/unattended CBTC system applications. With “mixed mode” operations as a regularly scheduled mode of operation, it would be impossible to fully realize the operational benefits of CBTC technology. A requirement to support “mixed mode” operations on an infrequent and/or unscheduled basis would generally be a consideration only for complex rail networks when only a portion of the rail network is CBTC-equipped. This is the situation that exists at NYCT.

If, following consideration of the above, “mixed-mode” is considered a fundamental operational requirement for the line in question, then a Level 4 secondary train control system would generally be considered mandatory for the detection and protection of the non-equipped trains.

Step 2 – Are Inadvertent “Mixed Mode” Operations a Possibility?

If “mixed-mode,” per Step 1, is not an operational requirement, consideration should also be given to whether or not an “unequipped” train could be inadvertently or intentionally routed into CBTC-equipped territory—for example, from a maintenance yard or from an adjoining non CBTC-equipped line. (This latter scenario could also arise, for example, if CBTC-equipped trains were regularly required to transition between non-equipped and CBTC-equipped territory as an element of their scheduled route.) If this were possible, it would represent a severe hazard that in the first instance should be prevented at source through design, i.e., through interlocks at the entry points into CBTC-equipped territory to prevent the entry of “unequipped” trains.

If this were not practical for whatever reason, then as a minimum a secondary train detection system (Level 3) would likely be required, at least at the entry points into CBTC-equipped territory, to detect the entry of the unequipped train.

Step 3 – Failure Recovery Considerations

The next step is to determine if a level of secondary train control is required to support recovery from total CBTC equipment failures (i.e., total failure of train-borne location determination and/or total failure to issue/enforce movement authorities). Following a total CBTC system failure affecting a particular train operating within any area of control (i.e., CBTC train-borne equipment failure),

the assumed operational requirement is to be able to safely/efficiently re-enter the failed train into CBTC operation and/or to safely/efficiently remove the failed train from CBTC mainline territory. Similarly, following a total CBTC system failure affecting all trains operating within a particular area of control (i.e., CBTC wayside equipment or wayside-to-train data communications failure), the assumed operational requirement is to be able to safely/efficiently repair/restart the failed wayside CBTC equipment. It is assumed there is no operational requirement to be able to provide continued (i.e., sustained) revenue service operation for trains without CBTC protection. If this were a requirement, then this would be equivalent to a requirement to support “mixed mode” operations (i.e., Step 1 above).

Given the fail-safe characteristics of a CBTC system, under CBTC failure scenarios the affected train or trains come to a safe stop within its movement authority. This prevents other CBTC trains from colliding with the failed trains, and all trains remain protected provided the failed train does not move beyond its train protection envelope. CBTC failure scenarios, therefore, do not represent an immediate safety hazard. It is only if a failed train or the following train is subsequently moved in Restricted Manual or Bypass mode, beyond its train protection envelope, that a potential hazard could arise.

The determination of the level of secondary train control required to support CBTC failure management should, therefore, consider the fail-operational characteristics of the CBTC system and CBTC design features that could reduce the reliance on operating procedures when recovering from infrequent CBTC system failures. This determination should be based on a structured hazard analysis considering both hazard severity and hazard probability, such as:

- The likelihood/frequency of a CBTC system failure given the anticipated level of CBTC system availability
- The likely number of vehicles that could be impacted by the CBTC failure scenario
- The likely hazard exposure time following the CBTC failure scenario before full CBTC functionality is restored
- The likelihood of human error (or other CBTC equipment failure) occurring during the time period when full CBTC functionality is not available.

Specifically, under normal (non-failure) operations, the CBTC system will mitigate the following hazards:

- Train derailments, mitigated through overspeed protection and route interlocking protection functions
- Train-to-train collisions (rear-end, sideswipe, head-on; mitigated through train separation assurance, rollback protection, parted consist protection, route interlocking protection, and traffic direction reversal interlock functions
- Train-to-structure collisions (specifically at the end-of-lines), mitigated through end-of-track protection

The structured failure analysis under total CBTC failure conditions should, therefore, consider all other means to mitigate these potential hazards for train movements under CBTC failure scenarios, to include, for example, limiting train speed (e.g., Restricted Manual mode of operations), design provisions within the CBTC system architecture (e.g., an ability to block and protect tracks and switches for manual train movements), and strict adherence to operating procedures, in addition to the various levels of secondary train control. This structured failure analysis should then form the basis for a decision on the appropriate level of secondary train control (0, 1, 2, 3, or 4).

Step 4 – Work Train Considerations

If the Step 1, 2, and 3 determinations establish that there is no requirement for a secondary train control system, then the need to equip work trains with onboard CBTC equipment should be addressed. For example, if there were an operational requirement to dispatch work trains onto the mainline ahead of the last revenue train, then the work train would need to be CBTC-equipped. If work trains were dispatched onto the mainline only during non-revenue hours, then operating procedures may be sufficient to protect work train movements.

If the Step 1, 2, and 3 determinations establish there is a requirement for a Level 3 or 4 secondary train control system for “unequipped” trains, then there should be no requirement to equip work trains with CBTC, as they could be protected by the secondary train control system. In other words, work train considerations should not drive the decision on the level of secondary train control to be provided; rather, the level of secondary train control provided should drive whether or not the work trains need to be CBTC-equipped.

Step 5 – Broken Rail Detection Considerations

If (and only if) the determinations in Steps 1, 2, and 3 establish that there is a requirement for a Level 3 or 4 secondary train control system, and if (and only if) track circuits are selected as the technology for secondary train detection, then the track circuits could also be used as one element of a broken rail detection strategy (with the recognition that track circuits are only capable of detecting a subset of hazardous rail defects). If axle counters were selected as the technology for secondary train detection, or if there is no requirement for a secondary train control system, then alternative strategies to broken rail detection should be employed that does not depend on track circuits (for example, increased use of track condition monitoring equipment). In other words, broken rail detection considerations should not drive the decision on the level of secondary train control to be provided.

These initial Steps are summarized in Figure 7-1.

Figure 7-1

Secondary Train Control Logic

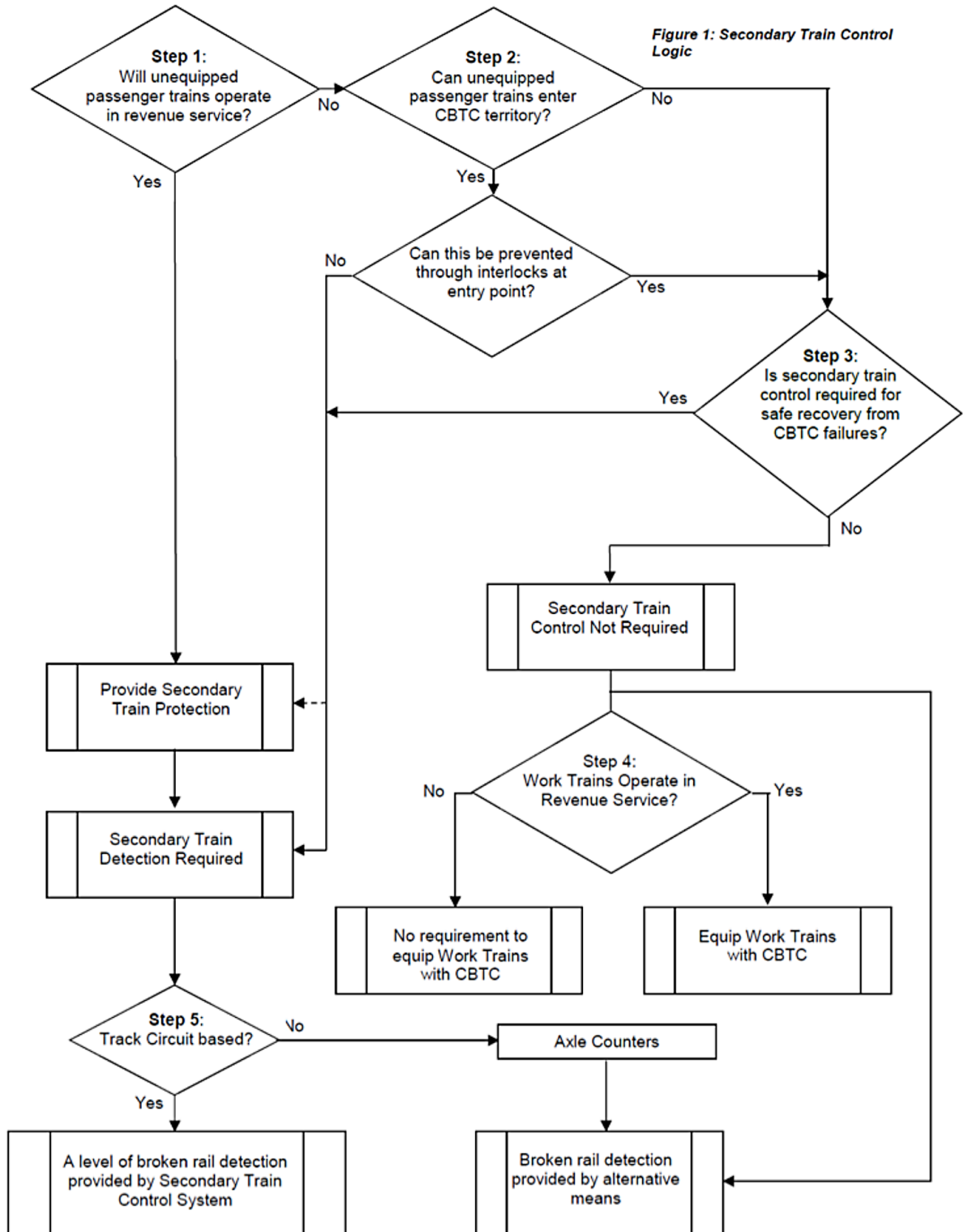

Step 6 – Other Safety Considerations

One of the advantages of CBTC technology is that CBTC systems require less track-based equipment when compared to track circuit-based signaling systems. As a result, with a CBTC system, track-based equipment access and maintenance requirements are reduced with associated improvements in track worker safety. This safety benefit is particularly relevant for transit systems operating in an automatic (driverless/unattended) mode. With the introduction of a secondary train control system, this additional safety benefit of CBTC may not be realized to the same extent as the requirement for track-based equipment and its associated access requirements may be more akin to conventional signaling implementations.

Step 7 – Overall Systems Availability Considerations

CBTC systems have now been in revenue service for more than 25 years and have an impressive safety and availability performance record. All service-proven CBTC systems are designed to stringent “fail-safe” design principles such that in the event of a failure in a safety-critical element of the train control system, the system will fail into a state known to be safe. As hazards can still exist should there be a need to move trains following a CBTC system failure, achieving high levels of system availability for the train control system, to reduce the probability of train movements without CBTC/ATP protection, is therefore an important hazard mitigation strategy.

CBTC systems can be specified and designed to provide the highest levels of system availability (for example through appropriate use of equipment redundancy) and to include fail-operational characteristics. A secondary train control system, on the other hand, typically would not include a high level of equipment redundancy or fail-operational characteristics with many single points of failure, and, as such, the system availability of a secondary train control system could be less than the primary CBTC system.

In addition, a secondary train control system invariably requires complex interfaces to the CBTC system, and the CBTC system itself can require additional complex functionality to not only respond to inputs from the secondary train control system under normal operations, but also to react to secondary train control system failure conditions.

As a consequence, the overall system availability for a signaling system that incorporates both a CBTC system and a secondary train control system can be less than the system availability for a stand-alone CBTC system and revenue-service delays with a secondary train control system could be higher unless careful attention is given to the specification and design of the specific, integrated system architecture. For example, the secondary train control system could be specified such that any failures in the secondary train control system do not

impact the primary CBTC system under normal operations. Nevertheless, given that additional maintenance requirements for secondary train control equipment, some impact on service availability is considered inevitable.

Step 8 – Maintenance Considerations

CBTC systems exploit state-of-the-art computer-based and communications-based technologies using data communications networks that provide high capacity, reliable, and timely communication of control and status information between wayside and train-borne devices using radios as the communications medium. CBTC systems can, therefore, provide improved maintenance and diagnostic capabilities to detect and react to signaling and train control equipment failures, including remote diagnostics capabilities as well as local built-in test equipment and other fault displays for troubleshooting and the timely identification of failed components and functions. Data logging capabilities also permit the recreation of a sequence of events to assist maintenance personnel to identify the cause of any failure and/or mis-operation of equipment that cannot be identified by the in-built diagnostics of the equipment.

From a life cycle cost perspective, this translates into reduced maintenance resource requirements and reduced downtime of equipment when compared to other conventional signaling technologies. With the introduction of a secondary train control system and the associated equipment maintenance requirements, and with the reduction in overall system availability, as discussed above, the life cycle cost benefits of CBTC technology would not be fully realized.

Step 9 – CBTC Technology Evolution Considerations

There is currently no “industry standard” CBTC system design, and the detailed system architecture and functional allocations can vary from one service-proven CBTC system to another. In addition, CBTC system architectures have evolved significantly over the past decade and can be expected to continue to evolve over the next decade as additional operational experience is gained with this technology. As such, it is not unreasonable to assume that the benefits of computer- and communications-based technologies will continue to be exploited to improve the fail-operational characteristics of CBTC systems and to include CBTC design features that will reduce the reliance on operating procedures when recovering from infrequent CBTC system failures. Such CBTC design features could include, for example, automatic system restart, automatic train re-entry, enhanced train positioning determination, etc.

Step 10 – Capital Cost Considerations

The final step is to assess the capital cost implications of providing a secondary train control system. For the purposes of a capital cost comparison, the scope of the primary (stand-alone) CBTC system can be assumed to include:

- Design, supply, and installation of CBTC operations control center equipment, CBTC wayside equipment, interlockings, CBTC train-borne equipment, and CBTC data communications equipment
- Test and commissioning of the primary CBTC system
- Safety certification of the primary CBTC system
- CBTC contractor’s project management
- Other miscellaneous CBTC contractor’s costs, such as documentation, training, manuals, etc.
- Agency costs for project management, training, operations & maintenance transition, etc.

The additional (delta) costs for a Level 4 secondary train control system would include:

- Design, supply, and installation of secondary train detection equipment (track circuits or axle counters) and secondary train protection equipment (wayside signals/trip stops or equivalent), including interfaces to the primary CBTC system/interlockings and vehicles
- Test and commissioning of the additional secondary train control equipment
- Revisions/updates to the primary CBTC safety certification documentation related to the addition of the secondary train control equipment
- Additional CBTC contractor project management related to the secondary train control equipment
- Other miscellaneous CBTC contractor costs, such as documentation, training, manuals, for the secondary train control equipment etc.
- Any potential cost deltas in the fixed facilities and/or vehicles to accommodate the secondary train control equipment
- Agency costs for project management, training, operations & maintenance transition, etc.

Based on available cost data from those CBTC projects that have included a secondary train control system, it is estimated that a Level 4 secondary train control system would increase the capital costs of the signaling system by at least 30 percent.

Summary

The primary conclusion of this analysis is that unless there is an operational requirement to support “mixed mode” operations, per Step 1, or other operational or failure management requirements as indicated in Steps 2 and 3 above, there is no mandatory, overarching technical requirement to include a secondary train control system with CBTC. In particular, track circuits should not be provided solely for the purpose of providing a (limited) broken rail detection capability.

In the absence of a secondary train control system, this analysis also suggests that recovery from infrequent total CBTC system failures can be achieved efficiently and to an acceptable level of safety through design provisions incorporated within the CBTC system and strict adherence to operating procedures. This must, however, be confirmed through a structured, application-specific hazard analysis.

If a decision were made to further mitigate safety risks during CBTC failure recovery through the provision of a full or partial secondary train control system, it should be recognized that one of the track worker safety benefits of CBTC, namely, a reduction in track-based equipment maintenance, may not be realized to the same extent. In addition, the overall system availability for a train control system that incorporates both a CBTC system and a secondary train control system can be less than the system availability for a stand-alone CBTC system, and revenue-service delays with a secondary train control system likely will be higher. Depending on the specific level implemented, secondary train control systems can also significantly increase the capital costs of the train control system with a corresponding increase in operations and maintenance costs given the additional equipment to maintain.

In specifying a CBTC system, and in recognition of continued CBTC technology evolution, it is, therefore, recommended that particular attention should be given to the specification of the system availability requirements, the failure management requirements, and the functionality to be incorporated into the detailed CBTC system design to support failure recovery operations, with minimum reliance on operating procedures. If the evaluation criteria for the CBTC system procurement were also to place an emphasis on life cycle costs, in addition to capital costs, CBTC system suppliers could be given the option to satisfy these performance requirements through features inherent in their proposed CBTC system or through the incorporation of additional secondary train control system equipment.

Lessons Learned from Positive Train Control (PTC)

The various PTC technologies being implemented by the Class I Railroad Industry have some similarities to the CBTC technology in use in a rapid transit environment with respect to train detection independent of track circuits, bi-directional train-to-wayside data communications, and vital train-borne and wayside processors. Further, there are a number of implementation issues that are common to both CBTC and PTC projects.

Because of these similarities, it was considered beneficial to capture the lessons learned during sample PTC implementations, as such lessons learned may provide valuable information to transit operators and to local officials who are contemplating CBTC systems.

Lessons learned from two specific PTC projects were, therefore, obtained from discussions with individuals familiar with the Amtrak and NJ Transit PTC projects, with a focus on the following project areas:

- Requirements definition
- Design and implementation challenges
- Technical solutions to meet PTC system objectives as established by FRA
- Initial assumptions vs. actual performance
- Management of spectrum requirements
- Assessment of PTC implementation impact on capacity and service
- Testing and commissioning strategies
- Organizational readiness
- Training of operating and maintenance personnel
- Proactive measures to maintain schedule and budget within initial targets
- Interoperability with other railroads/operators

Case Study – Amtrak Advanced Civil Speed Enforcement System (ACSES) Project

Project Background and Description

During the early 1990s, Amtrak employed a four-aspect ATC system on its Northeast Corridor (NEC). The ATC system provided continuously-coded cab signal commands for speed control. This cab-signaling system is based on repeating the wayside signal aspects in the cab and enforces the speeds associated with each of these aspects. The four-aspect ATC installation enforced speeds at 20, 30, 45, and 80 MPH. However, the system permitted trains receiving a “stop and proceed” indication to continue to move under a restricted speed, even past an interlocking home signal displaying a “stop” aspect. The lack of enforcement of a positive stop at an interlocking signal presented an operational hazard. When the operating speed on the NEC increased to 120 MPH (and plans were underway to increase it further to 150 MPH), Amtrak adopted a combination of “expanded” ATC and a proven technology from Europe that is based on transponders placed in the center of the track. This technical approach preserved the advantages of cab signaling technology in providing continuous speed control and added the capability of positive stop enforcement at desired locations, including interlocking signals. The expansion of the ATC system was achieved by adding a new 250 Hz carrier frequency and a new speed code of 270 pulses per minute.

Also, in 1992, and in response to Amtrak's plans to increase the maximum operating speed above 125 MPH, FRA mandated Amtrak to add enhanced protection functionality to its signaling system, and specifically required the following functions to be provided:

- Enforce a positive stop at interlocking home signals
- Enforce all permanent civil speed restrictions
- Enforce all temporary speed restrictions (TSR)

Amtrak contracted with Alstom and PHW, Inc., to provide the transponder-based technology that became known as the Advanced Civil Speed Enforcement System (ACSES). A system diagram of the Alstom ACSES system is shown in Figure 7-2.

Figure 7-2

ACSES System Diagram

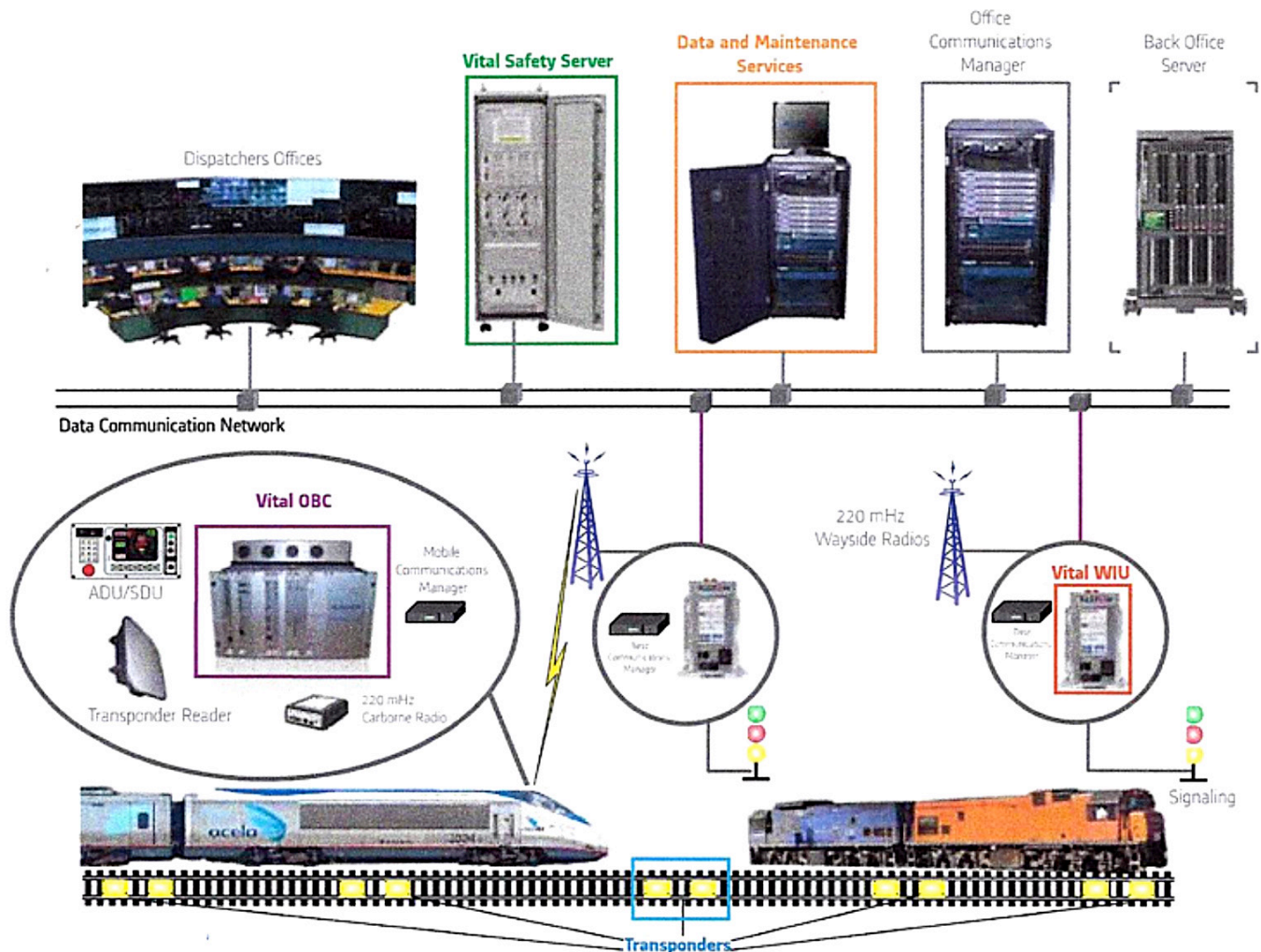

The initial implementation of ACSES was focused on enforcement of civil speed limits and enforcement of a train stop at interlocking home signals displaying a stop aspect. ACSES employs passive transponders mounted in the center of the track. Each transponder contains information related to the civil speed limit that needs to be enforced or the positive stop information for a home signal ahead. An onboard antenna then reads the information from the transponder and feeds it to the onboard computer, which activates the onboard display and enforces civil speed limits and positive stops at home signals. The ACSES system was successfully implemented on the NEC, and currently, Amtrak is in the process of implementing an enhancement version of ACSES (ACSES II) to comply with the provisions of the Rail Safety Improvement Act of 2008.

Design and Implementation Issues

Requirements Definition

As indicated above, during the early 1990s, Amtrak decided to increase the maximum operating speed on the NEC to 150 MPH. Amtrak did not take the initiative to start the planning and preparation for the required signal enhancements to support the higher speed operation. Rather, Amtrak waited until 1992, when FRA put Amtrak “on notice” to introduce a PTC system on the sections of the North East Corridor that were going to implement service above 125 MPH. FRA mandated Amtrak to add enhanced protection functionality to its signaling system, including positive stop at interlocking signals. The FRA directive placed time constraints on system requirements and functional definitions. As a result, Amtrak did not have a comprehensive requirement definition document to guide the design and development of the ACSES system. The following requirements were not addressed in the system design:

- Requirements unique to freight operation, including dropping and pushing of cars
- Requirements for tenant railroads
- HMI requirements and the need to provide more operational information to the train engineer

In the current PTC project (to comply with the mandates of the Rail Safety Improvement Act of 2008), Amtrak has learned from its experience of the initial ACSES installation and has followed a structured approach to define the requirements and functionalities for the new ACSES II system. For example, Amtrak has involved its transportation group early in the contract to ensure that operating requirements are captured and implemented in the initial system design. Further, Amtrak is holding regular meetings with commuter railroads and other tenant railroads to identify the interoperability requirements.

Design Challenges

As indicated above, ACSES, in combination with an expanded cab-signal system, can fulfill the PTC requirements. However, because ACSES was designed to enforce the Maximum Authorized Speed (MAS), the main design implementation challenge was for the Temporary Speed Restriction function. Other challenges included the following:

- The transportation Rule Group was not sufficiently involved during the planning stage for the project, which resulted in requested changes during the deployment phase.
- The interface design between ACSES and existing cab-signal system proved to be difficult.
- Other passenger and freight railroads using the Amtrak infrastructure were not involved in the initial requirement and design phases of the project, but subsequently had to equip their rolling stock with ACSES. This was the case with MBTA, CSX and other commuter and freight railroads.
- Implementation of the stop release function was a challenge.

With respect to the current ACSES II project, Amtrak identified the following issues and challenges:

- One of the lessons learned from the initial ACSES implementation is that the onboard ACSES Display Unit (ADU) did not provide sufficient information to the operator or the engineer. Under ACSES II, the ADU was enhanced to provide additional information (e.g., Countdown to Penalty). A configuration of the enhanced ADU is shown in Figure 7-3.

Figure 7-3
Enhanced ACSES
Display Unit



- ACSES II is using a radio link to transmit the movement authorities to the train (as opposed to a transponder on the track in the original ACSES).
- The system does not provide rear-end protection for following trains. Amtrak indicated that the existing signal system limits the speed of a following train (Stop and Proceed) and that there was never a serious collision at restricted speed.
- Amtrak received a waiver from the implementation of the FRA requirement to provide protection to roadway workers (“Grandfather” Clause).
- The system does not provide protection at major stations (e.g., NY Penn Station). The operating speed is limited to 20 MPH.
- FRA has determined that the ACSES transponders operate reliably at speeds between 135–160 MPH. Under the High Speed Rail (HSR) initiative, some NEC sections in New Jersey will have a maximum operating speed that exceeds 160 MPH. For those sections, a new transponder may be required.
- Due to time constraints, Amtrak has eliminated, for now, the implementation of an onboard vital data map. This design feature could be implemented after 2015.
- Amtrak indicated as part of the safety certification process for the ACSES II that it must apply for a variance approval to FRA any time there is a change or a need for FRA Type Approval.

Management of Spectrum Requirements

Amtrak indicated that the initial ACSES installation employed 900 MHz radios. However, these radios experienced coverage problems, and there was a limited number of suppliers that support the 900 MHz band. In addition, the 900 MHz band cannot support Amtrak and all the commuters on the NEC. For the ACSES II project, the NEC PTC Working Group selected the GE MDS 220 MHz radios (shown in Figure 7-4). The use of the 220 MHz band eliminated the radio coverage problems. However, Amtrak has not been able to acquire the entire required spectrum. This represents a huge effort of coordination with the other railroads. Amtrak further indicated that if it is unable to acquire the needed spectrum, the project will be impacted.

Figure 7-4
GE MDS 220 MHz
Radio



Assessment of PTC Implementation on Service Delivery

Amtrak indicated that the implementation of the initial ACSES system did not have any adverse impact on service delivery or performance. Amtrak further indicated that it does not expect any operational impact from the implementation of ACSES II.

Testing and Commissioning Strategies

Amtrak implemented a testing and commissioning approach that focuses on one section at a time and has used “shadow mode” operation for the testing of its new communications system. The use of “shadow mode” is consistent with the CBTC testing and commissioning approach used for rapid transit applications. Further, Amtrak is currently using a test track for testing the ACSES II functionalities.

Project Management & Organizational Issues

Amtrak indicated that with respect to the initial ACSES project, it was very hard to maintain the project within budget and schedule due to the research and development nature of the ACSES system. It was also indicated that the project team gained a better understanding of the technical aspects of the system as the project progressed. One of the lessons learned by Amtrak is the need to periodically re-evaluate project assumptions and make the necessary adjustments in technical approach, project sequencing, budget, and schedule. Amtrak further indicated that it did accomplish its objectives from the initial ACSES implementation; however, it took longer time to achieve these objectives.

With respect to the ACSES II project, Amtrak indicated that it has adopted a more proactive approach in involving the internal operating groups early in the project. It is also coordinating various aspects of the project with the commuter railroads and freight operators. As a result of the extensive coordination, more dedicated resources are required. Due to shortage of internal resources, Amtrak is relying more on consultants.

Training of Operating & Maintenance Personnel

A re-training program is being implemented by Amtrak, in particular to address the new train operator display of ACSES-2 and the operations at the transition zones between Amtrak and the other railroads (SEPTA and NJ Transit). Amtrak is using a train driving simulator for training purposes.

Interoperability

As indicated above, Amtrak took a proactive approach in the ACSES II project to involve commuter railroads and freight operators to define and implement the interoperability requirements. However, there are a number of remaining interoperability issues that need to be resolved, including:

- Boundary issues between railroads and between different lines within the same railroad
 - Handling of TSR data
 - Train tracking, etc.
- Nested Interlockings
- Commuter train turnbacks
- Enforcement of directives associated with highway crossings

These items will involve software/hardware changes to the onboard system and will have to be approved by FRA before they can be implemented. These changes will be made as the commuters begin to roll out their systems. Amtrak also indicated that one of the critical aspects of interoperability that affect the safety case is to ensure that the TSR servers at various railroads perform identical functions.

Lessons Learned

The following are the lessons learned from the implementation of the Amtrak Advanced Civil Speed Enforcement System:

- It is essential for the successful implementation of a PTC/CBTC project to define the functional, operational, performance, and safety requirements early in the project and before the commencement of design.
- It is essential for the successful implementation of a PTC/CBTC project that all stakeholders be involved in the requirements definition phase of the project.
- The railroad/transit property must focus on HMI during the requirements definition phase of a PTC/CBTC project.
- It is essential for the successful implementation of a PTC/CBTC project to have effective coordination among all the stakeholders throughout all project phases.
- Prior to the selection of a spectrum for a PTC or CBTC system, it is essential for the railroad or transit property to perform a comprehensive investigation of the identified spectrum, including radio propagation studies and availability of sufficient spectrum.
- A transit or rail property has a better chance of obtaining new spectrum for PTC/CBTC application if it coordinates its efforts with other railroads and/or properties.
- “Shadow Mode” operation is an effective way to perform operational testing of PTC/CBTC installations prior to revenue service.
- It is preferable and more cost-effective to use a test track for testing the functionalities of PTC/CBTC system.

- It is useful to periodically evaluate project assumptions and make adjustments in the technical approach, project sequencing, schedule, and/or budget to optimize project implementation.
- It is essential to have timely and effective coordination among different projects that affect the same signaling/ train control installation.

Case Study – NJ Transit Advanced Speed Enforcement System (ASES)

Project Background and Description

On February 9, 1996, NJ Transit experienced a head-on collision between two passenger trains, resulting in three fatalities at a busy interlocking in Secaucus, New Jersey. To prevent similar accidents and improve safety, NJ Transit decided to equip its network with an automatic speed enforcement system that supplements its existing signaling installations. NJ Transit initiated a program that, in the short term, would have equipped all of its territory with some form of enforcement system. Longer term, this program would have equipped all of NJ Transit's territory with a system that provides the core safety functions of PTC, as defined by FRA.

The technical approach for the project was based on adding Positive Train Stop (PTS) to existing or enhanced wayside signal installations. The objective was to integrate these two complementary systems to provide what was identified as the Advanced Speed Enforcement System (ASES). The safety objectives of ASES were to be achieved by enforcing signal indications and permanent and temporary speed limits, and by ensuring positive train stop at Stop or Stop and Proceed signals.

To implement ASES, NJ Transit selected a technology that was originally developed by a Swedish company, AT Signal System (ATSS), a sister company of US&S. In turn, US&S engineers worked closely with NJ Transit and ATSS to upgrade and adapt this technology for applications and use in the North American market.

The PTS system uses transponders that are located along the tracks to provide digital data to trains as they pass over the transponders. At each signal location, fixed transponders are installed and are encoded with the topographical data of the railroad such as milepost location, speed limits, and grades. The transponders are also interfaced with the circuits that control interlocking and automatic signal aspects and dynamically adjust their message to transmit the signal aspect. The fixed transponders are logically linked so that, at any point, the system knows the expected location of at least the next transponder. Portable transponders are used to enforce temporary slow orders and provide protection to work zones. The onboard computer uses information received from the transponders to enforce a target speed limit or a stopping point.

As indicated above, this project started in 1996, after a head-on collision between two passenger trains. The project included three phases. Phase I, a “demo” phase, was completed successfully. Phase II of the project was completed in 2005 and included the Pascack Valley Line. In Phase III, NJ Transit planned to install ASES on the remainder of its network. However, even though all design issues were addressed, the system was experiencing severe quality issues, causing many interruptions to service, and, as a result, the project was terminated. NJ Transit is currently implementing a PTC system on its network in compliance with the mandate of the Rail Safety Improvement Act of 2008.

Design and Implementation Issues

Requirements Definition

Due to the urgency after the February 9, 1996, accident, the development of the technical specifications proceeded without a clear understanding of the concept of operation and without the development of detailed functional and operational requirements. It was indicated that the technical specifications were performance-based and did not include sufficient details of various aspects of the ASES system. As a result, during the project implementation phase, many assumptions needed to be made. Further, it was indicated that the technical specifications were developed without consultation with the Operations Group and other NJ Transit departments. This resulted in many changes during the design and implementation phases of the ASES system.

Design Challenges

The ASES project encountered major technical and implementation difficulties that ultimately led to the termination of the project. The following were the main issues and challenges that impacted the project:

- Although the initial intent was to implement an off-the-shelf system based on a technology that was proven in operating European railroads, it was soon realized that the regulatory environment in Europe is very different from FRA-mandated regulations. Significant system changes had to be made to comply with prescriptive FRA requirements.
- Functional software was modified to be more operation-tolerant.
- Additional changes were needed to adapt the system to a transit operating environment.
- The implementation of new functions required an extensive research and development effort, which had an adverse impact on schedule.
- The original software was not modular and was difficult to modify.
- In an effort to adapt the European system to North America’s application, the supplier attempted to implement the system using a

new hardware platform. This created many timing issues, and a newly-developed transponder reader was not properly tuned to the transponders manufactured in Europe.

- The mass-produced equipment suffered from extremely poor quality control, including bad soldered connections, loose connections, unreliable power supplies, circuit boards coming out of their slots due to vibration, and multiple SDU versions.

With respect to the current PTC project, it is understood that one of the implementation challenges is the lack of a ground base network. Sections of the existing back bone network are based on copper cable, and there is a need for the implementation of a fiber-optic based network in these sections in order to provide the reliable communications required for PTC operation. Various options are currently being explored.

Management of Spectrum Requirements

NJ Transit has faced difficulties in obtaining the spectrum needed for its PTC operation. Despite efforts by NJ Transit, Amtrak and other railroads collaborating to obtain the needed spectrum, there remain a number of challenges in securing the required spectrum. This issue is current, and NJ Transit is working with Amtrak and other railroads to manage spectrum allocation and resolve the remaining challenges.

Assessment of PTC Implementation on Service Delivery

NJ Transit did perform an analysis of the impact PTC implementation will have on service delivery. Overall, NJ Transit has concluded that the current level of scheduled service will not be impacted by the implementation of PTC. However, it was also concluded that train operators will have less flexibility in recovering from service delays/interruptions.

Testing and Commissioning Strategies

During the testing phase of the ASES project, NJ Transit performed many of the tests, including functional tests, using trains. This led to a very large force account and an increase in project budget. Consequently, under the current PTC project, it is understood that NJ Transit has minimized the level of testing using trains on NJ Transit property and is performing approximately 90 percent of the tests in the lab using a simulator.

Project Management & Organizational Issues

With respect to the ASES project, NJ Transit had a well-coordinated team with dedicated resources to support various design and implementation tasks. However, it was indicated that, partly due to the reliability issues and other difficulties faced by the project, there was some lack of support for the project within the organization.

The current PTC project faces a different organizational challenge. It was indicated, for example, that there has been a lack of staff continuity within the contractor and agency organizations, in part as a result of retirement of key project personnel. Also, the current project requires additional resources to comply with and support the safety process and the paper work required by Subpart I of the FRA safety regulation.

One of the lessons learned from the ASES project is to establish a realistic budget for the project. NJ Transit added funds to the budget of the current PTC project as engineering contingencies for undefined tasks. This project is currently one year behind schedule. NJ Transit informed FRA in writing that it will not meet the 2015 deadline for PTC implementation.

Training of Operating & Maintenance Personnel

Training is progressing well. It should be noted that under the current PTC project, NJ Transit must comply with the training provisions in Subpart I of the FRA safety regulation.

Interoperability

The initial ASES system was not interoperable with Amtrak operation. At the time of ASES implementation, the ACSES system was not in service, and NJ Transit anticipated that major design and implementation changes were required in the ASES system in order to make it interoperable with ACSES. However, the ASES project was terminated before the interoperability issues needed to be addressed. Although NJ Transit is taking a more proactive approach with respect to interoperability in the current PTC project, there are complex interoperability challenges that need to be resolved, including:

- Different characteristics of freight and passenger trains
- Host and tenant interoperability issues
- Variable train length

Lessons Learned

The following are the lessons learned from the implementation of the New Jersey Transit Advanced Speed Enforcement System:

- It is essential for the successful implementation of a PTC/CBTC project to define the functional, operational, performance, and safety requirements early in the project and before the commencement of design.
- It is essential for the successful implementation of a PTC/CBTC project that all stakeholders be involved in the requirements definition phase of the project.
- It is essential for the successful implementation of a PTC/CBTC project to have effective coordination among all the stakeholders throughout all project phases.

- Prior to selecting a technology or a platform to implement a PTC/CBTC system, the railroad/transit property must investigate regulatory context and standards used in the development and design of the platform.
- Prior to selecting a technology or a platform to implement a PTC/ CBTC system, the railroad/transit property must investigate and analyze if the technology or platform is suitable to operate in its operating environment.
- It is not recommended for a supplier to develop a new platform (hardware or software) as part of a PTC/CBTC project. This adds a high risk to project schedule.
- It is essential to implement an effective quality assurance/quality control (QA/QC) plan during system design and project implementation to ensure the reliability and availability of the PTC/CBTC system.
- The technical specifications must include strict requirements to comply with American Railway Engineering and Maintenance of Way Association (AREMA) environmental requirements.
- For a successful implementation of a PTC/CBTC system, the railroad/transit property must ensure the availability of an adequate ground based communications network.
- A transit or rail property has a better chance of obtaining new spectrum for PTC/CBTC application if it coordinates its efforts with other railroads and/or properties.
- It is preferable and more cost-effective to perform functional testing in the lab rather than in actual field environment.
- It is essential for the successful implementation of a PTC/CBTC project that all levels of the organization buy into and support the project.

Summary

The case studies of the Amtrak and New Jersey Transit PTC systems demonstrate the similarities in technical issues and implementation challenges between PTC and CBTC projects. Although PTC and CBTC are normally implemented in different operating environments, the fundamentals for a successful implementation are the same. Both the Amtrak and NJ Transit projects were adversely impacted by the lack of a comprehensive requirements document and the lack of involvement by all the stakeholders during the early phases of the project. This made the design and implementation phases of the PTC system more challenging and negatively impacted budget and schedule. During the meetings and discussions with representatives from NYCT and SEPTA, similar comments, observations, and conclusions were heard related to the importance of the requirement definition phase in a CBTC project. Accordingly, one of the main lessons learned from PTC implementation is the necessity of developing a comprehensive system requirement document early in the contract and with participation by and input from all stakeholders.

Another challenge that is common to both PTC and CBTC implementation is the need to define adequate spectrum for radio communications. In the PTC world, although securing the required spectrum is not totally resolved, the railroads have done a good job in coordinating their efforts to define and allocate the needed spectrum. There are a number of advantages to such coordinated effort, including more leverage on the FCC and other government entities, the identification of radio equipment supported by multiple suppliers, and a large user base to facilitate interoperability. Transit operators have not engaged in similar coordination efforts to secure the required spectrum and have relied mostly on the unlicensed ISM band to support CBTC radio communications. There may be benefits for transit operators to follow the lead of Class I railroads and coordinate their efforts to identify and secure spectrum for future CBTC applications.

During the investigation and analysis of the PTC projects at Amtrak and NJ Transit, no concerns were identified related to the safety certification of the PTC installation. It is believed that FRA has provided a structured process and clear road map for certifying the safety of PTC installations (Subparts H & I regulations). However, NJ Transit pointed to the need for additional resources to support the FRA-mandated process, there are clear advantages and benefits to a standardized process for safety certification. As such, one of the lessons learned from PTC implementation is the need for a standardized process to be used by transit operators to certify the safety of CBTC installations.

SECTION
8

Conclusions and Recommendations

Conclusions

Two major conclusions can be drawn from this study. First, the study has validated broader industry experience that CBTC offers benefits that cannot be achieved with prior generations of signaling technology. These benefits relate to:

- Increased grades of automation
- Safety enhancements
- State-of-good-repair considerations to improve system availability and reduce system maintenance
- Improved levels of service with respect to line capacity, trip times, and operational flexibility

This is an important conclusion that is worth stressing. Given the extensive installed base of CBTC systems around the world today, and with close to 30 years of actual revenue service experience with this technology, the benefits of CBTC are now clearly real and repeatable, and the technology is well established as both “service-proven” and “safety-proven.”

Second, the study has highlighted (as was highlighted in the previous FTA study), that the challenges involved in upgrading the signaling/train control systems on an existing high-capacity mass transit system should not be underestimated. Shortcomings in project planning and execution can add significant risk to a project and impact schedule and cost.

Based on these two major conclusions of the study, it can be seen that the challenges facing the rail transit industry in implementing CBTC are less related to “can CBTC deliver the anticipated benefits?” and more related to “what is the process that should be followed to successfully implement CBTC technology on an operating transit system?” Here, the lessons learned from the case studies presented in this study clearly point to the need for an increased emphasis on a Systems Engineering process being adopted throughout the project life cycle, as required by the U.S. Department of Transportation and FTA for federally-funded projects.

A search of the technical literature uncovers many definitions for “systems engineering,” and the International Council of Systems Engineers (INCOSE) proposes the following generic definition that would be applicable to a wide range of industry applications (www.incose.org):

Systems engineering is an interdisciplinary approach and means to enable the realization of successful systems. It focuses on defining customer needs and required functionality early in the development cycle, documenting requirements, then proceeding with design synthesis and system validation while considering the complete problem: Operations, Cost & Schedule, Performance, Training & Support, Test, Manufacturing and Disposal. Systems engineering integrates all the disciplines and specialty groups into a team effort forming a structured development process that proceeds from concept to production to operation. Systems engineering considers both the business and the technical needs of all customers with the goal of providing a quality product that meets the user needs.

A key element of the INCOSE definition is that the fundamental goal of Systems engineering is to contribute to the successful implementation of projects, “Success” being defined as meeting the needs and expectations of the stakeholders within cost, schedule, and risk constraints. In other words, Systems engineering is not to be viewed as a stand-alone, isolated discipline, but rather as an integral component of good design and project management. Specifically, Systems engineering is not solely concerned with meeting user requirements, but also with managing costs, schedule, and risk. Indeed, an important benefit of adopting a Systems engineering process is the early identification and mitigation of project risks.

The INCOSE definition also highlights that Systems Engineering is a team effort bringing together a broad range of resources, with a thorough understanding of the subject matter and with a holistic or “total system” focus on achieving the program vision.

Recommendations

Developing the Business Case

Based on the above conclusions, a primary recommendation arising from this study is for existing transit agencies that are in need of upgrades to their signaling/train control systems for safety, state-of-good-repair, or operational reasons to seriously consider the business case for CBTC. In developing such a business case, they should focus on:

- Exploiting and maximizing the service-proven benefits of CBTC, while
- Developing a complete and detailed design, implementation, and migration strategy that minimizes the various cost factors and that reflects good Systems Engineering principles

This study has identified the various benefit and cost factors that should be addressed in such a business case.

Applying a Systems Engineering Approach

With respect to the applicability of the study findings to other North American transit properties considering major upgrades to their signaling, train control, and other operating system elements, and as highlighted above, the importance of adopting Systems Engineering principles is also stressed as a primary recommendation of this study, to include the following:

- Adopting a holistic (“total system”) vision
- Integrating all stakeholders into a team effort
- Capturing user requirements through processes that focus on early definition of agency needs and required functionality with consideration of all relevant factors such as operations, performance, cost & schedule, installation, test & commissioning, safety certification, training, and support
- Evaluating alternatives and selecting an optimized solution when considering the “total system” as a whole
- Managing the design process to ensure the system solution is implemented correctly, with traceability of the top level requirements through subsequent levels of design
- Managing the migration to the new signaling system while verifying the system solution, as implemented, satisfies the user requirements and overall program goals

Adopting a “Total System” Vision

Rarely are re-signaling projects stand-alone, unless the project is simply a “replacement-in-kind” project to achieve a state-of-good-repair, with no other anticipated benefits. More typically, specifically for CBTC upgrade projects, they are often part of a highly integrated program, comprised of multiple projects, focused on achieving specific long-term business needs for the transit property. Such major system upgrade programs, which include the signaling/train control system as one critical component, will typically provide a step-change improvement in passenger transportation services to the benefit of the local region and the transit agency’s passengers. Other interrelated projects could include new vehicle procurements, control center modernization, upgrades to passenger information systems and traction power supplies, replacement of backbone communications networks, track alignment and special track work changes, installation of platform screen doors, platform extensions, etc. that are invariably also linked to changes in the operational service plans.

The first key step in any major signaling upgrade project therefore is to recognize, at the most senior level within the organization, that the signaling upgrade is just one element of a highly integrated program focused on achieving specific system-level business needs. These system level business needs then become the “vision” for the project. Major signaling upgrade projects are complex, can

involve multiple phases with many interrelated and integrated contracts, can cost hundreds of millions of dollars, and can take many years to implement in order to fully realize the anticipated business case benefits. Care must be taken to ensure that the business objectives and project vision remain in focus during the course of a project implementation and throughout the project delivery organization.

Assembling an Integrated Team

Once the “vision” has been adopted, the next logical step is the formation of a single, focused, multi-disciplined Systems Engineering team led by a “program champion” who can act as a facilitator to ensure the team as a whole embraces the program vision and objectives.

While assembling a multi-disciplined team can be relatively straightforward for a “new start” project, within an existing transit agency this can be more of a challenge as organizational structures for operating transit systems tend to be more “discipline-focused” than “inter-disciplinary-focused.” An integrated team approach is necessary however to ensure that, for example:

- The traction power systems can accommodate the increased power demands resulting from shorter headway operations.
- The performance characteristics of the rolling stock match the safe braking model assumed in the signaling/train control designs.
- Communications backbones have sufficient bandwidth and system availability to support all of the subsystems relying on the backbone.
- The vehicle fleet size is sufficient to take advantage of the increased capacity provided by the new signal system.
- Updates to operating and maintenance procedures and practices, and associated staff training, are completed in a timely fashion in parallel with the signaling equipment upgrades.
- Timely engagement with organized labor unions related to technology and operational changes, in particular when increased levels of automation are being introduced.

Capture the User Requirements

As was stressed by all of the case studies in this report, capturing the user requirements for a new signaling/train control system within a major system upgrade program is critical. While the need to capture user requirements may be considered self-evident, experience would suggest that this is not a trivial activity, and often insufficient effort is applied to this up-front task. In adopting a Systems Engineering approach, capturing user requirements first demands a “big picture,” strategic view of the problems to be solved and the business needs to be met. The process has to be a top-down, and not bottom-up i.e. requirements must first be established at the “Total System” level and then flowed down to the

individual system elements (vehicles, train control, communications, etc.) The process also has to first focus on the desired outputs – what performance and functional benefits the system upgrade is required to achieve – rather than on the design details – how these benefits are to be realized. For example, if secondary train control systems and/or major adaptations to service-proven system designs are being proposed as an element of a CBTC system upgrade, then the top-down Systems Engineering process would have to justify these additional costs on the basis of additional benefits realized in meeting the agency’s business needs.

Any major re-signaling project not only represents an upgrade to the operating systems equipment, but also fundamental modifications to the agencies operating and maintenance policies, practices and procedures. As such, there may also be cultural and institutional constraints within the agency’s existing operations that need to be carefully assessed as to their relevance to the system upgrade.

In addition, when capturing user requirements, there are significant constraints that must be recognized related to interfaces to the existing infrastructure and legacy systems. This includes, for example:

- Interfaces between the CBTC control center equipment and control center equipment provided by others (including legacy system interfaces)
- Interfaces between the CBTC wayside equipment and external interlockings and other wayside equipment
- Allowances for the potential differences in CBTC wayside configurations in the infrastructure designs (equipment rooms, cable runs, transponder mountings, etc.)
- Allowances/constraints in the rolling stock designs to accommodate a range of different CBTC equipment configurations

Given that defining such interfaces can be complex, there is often a tendency to “worry about that later.” However, as the case studies in this report have demonstrated, the failure to fully and unambiguously define the total system requirements up-front can be the dominant cause of cost and schedule overruns on major system upgrade projects.

Evaluate the Alternatives

Developing the business case and selecting the most appropriate technologies for a major signaling upgrade project requires a careful evaluation of the available alternatives against the established system-level requirements, drawing on not only local or domestic experience, but also on experiences from around the world. While CBTC may not always be the appropriate choice for all applications, to not consider this state-of-the-art technology as one of the alternatives would be short-sighted.

When selecting a CBTC system for a specific application, there is a natural tendency to procure a system that is already service proven in a similar application as a means of minimizing project implementation risks. However, in the absence of detailed design and interface standards for CBTC systems, experience would suggest, and as the case studies in this report have demonstrated, that some changes to an existing “service-proven” product are often inevitable to meet the specific operating requirements, failure management requirements and signaling principles of a new application. It is therefore important that all of these required changes be clearly identified up-front so that the adaptation risks can be realistically assessed and managed.

Manage the Design

If a Systems Engineering approach has been adopted up-front, and with an integrated multi-disciplined team focused on achieving the agency’s vision and business needs, then the essential ingredients are in place to successfully manage the detail design phase of the project.

Given that the time has been taken up front to capture the user requirements at the system level, and select the most appropriate system solution to meet these requirements, then the detailed design can be progressed with the support of appropriate project control and requirements management tools and procedures.

Manage the Migration

As this study has highlighted, implementing a CBTC system upgrade on an operating transit system is very complex, and establishing clear requirements for an overall installation, test, commissioning and cut-over strategy is critical – a strategy recognizing that with CBTC technology, the majority of the field testing will require the availability of one or more CBTC-equipped trains and associated track access. For example, conventional test practices for fixed-block, track circuit-based signaling systems may no longer be applicable or practicable, and alternative test procedures become necessary reflecting the specific principles of operation of CBTC systems.

The case studies suggest that insufficient attention is given to the up-front planning for the migration to new technology systems and the migration to new operating and maintenance practices. This can result in unrealistic implementation schedules being established, unexpected and undesirable impacts on passenger service, and down-stream cost overruns.

Any implementation of a new signaling technology on an operating railway will require some level of dual-equipment of train-borne and/or wayside equipment during the migration period. The specific solution adopted can have impacts to the approaches adopted for the system design, installation, testing & commissioning, safety certification, training and support etc.; all of which can have

impacts on the project schedule, project costs, and passenger service disruption risks. This level of migration detail is often only developed well in to the project implementation when project budgets/schedules and stakeholder expectations are already well established. The recommendation here is that migration planning be developed to a more detailed level during the project definition stage, prior to award of contracts.

As signaling systems are safety-critical, certifying that the system is safe for passenger-carrying service is a fundamental component of the migration plan.

As noted in this study, while CBTC systems are “safety-proven” in revenue service, there is no industry standard approach to certifying a CBTC system for a specific application. As different approaches to safety certification can have schedule and cost implications, it is again recommended that the assessment of the most appropriate approach for a given application be undertaken during the project definition and technology selection stage – and not during the project execution.

In this regard, it should be recognizing that different “service proven” CBTC systems may have adopted somewhat different approaches to safety certification. Given that safety assurance is a result of the design and development process, if any of the approaches and/or principles adopted by a specific CBTC system are not considered acceptable then this could drive significant redesign of a service-proven product.

Opportunities for Further Research

To date, no North American transit property has considered CBTC as a foundation to migrate from conventional to driverless or unattended train operations, although other transit agencies around the world are moving to these higher grades of automation given the increased benefits that can be derived. Additional research is therefore recommended to explore the implementation challenges and benefits of CBTC as a foundation for transit systems to migrate to driverless/unattended train operations.

Further research could also be undertaken into the need for and/or benefits of secondary train control systems with CBTC, building on the analysis in Section 7, through a more detailed survey of transit properties that have implemented CBTC systems around the world.

IEEE Std 1474.1™ Comparison Assessment – NYCT

IEEE Std 1474.1™ Assessment Checklist

Agency: New York City Transit – Canarsie Line

IEEE Std 1474.1™ identifies:

- Operating and performance requirements that are to be specified by the Authority having Jurisdiction
- Mandatory and Optional ATP requirements
- Optional ATO requirements (that would be mandatory for driverless train operations)
- Optional ATS requirements

I) Operating and Performance Requirements that are to be Specified by the Authority Having Jurisdiction

IEEE Ref	IEEE Requirement	Assessment
4.1	Characteristics of CBTC systems	The technical specifications for the NYCT CBTC implementation required the CBTC contractor to provide a CBTC system based on the characteristics defined in the IEEE standards. More specifically, the specification included the following requirements: a) A high resolution location determination subsystem, independent of track circuits, b) Continuous, high capacity, bi-directional train-to-wayside data communications, c) On-board and wayside processors that perform vital functions.
4.3 6.4	Extent of required interoperability between equipment provided by multiple vendors.	Interoperability between equipment provided by multiple vendors is a critical element of the NYCT CBTC implementation strategy. As such, the CBTC contractor for the Canarsie Line Pilot Project was required to develop and submit Interoperability Interface Specifications that included all information required for another contractor to be able to independently develop a safe, reliable and interoperable CBTC/AWS system. The Interoperability Interface Specifications included all information required to define the interfaces between vehicles, wayside elements, and the central CBTC-ATS system. The required level of interoperability defined in the Interoperability Interface Specifications will permit trains equipped by one contractor to operate in CBTC territory equipped by the other contractor. In addition, the Interoperability Interface Specifications will permit wayside equipment supplied by two separate contractors to communicate with each other in the overlap area. Interchangeability of individual subsystems on trains, or at the wayside, is not required.
4.4	Capability to support a variety of train configurations	The technical specifications for the NYCT CBTC implementation required the Canarsie CBTC system to support two different train configurations, namely four-car and eight-car trains.

IEEE Ref	IEEE Requirement	Assessment
4.5	Extent to which mixed-mode operation is to be considered a normal operating mode.	In the NYCT CBTC implementation, mixed-mode operation (i.e. operation of both CBTC-equipped and non-equipped trains) is considered a normal operating mode. For example, on the Canarsie Line, empty, unequipped trains from other lines will also operate on the line between Atlantic Avenue and the Canarsie Yard in order to wash the train cars at Canarsie Yard. Other unscheduled, non-revenue (work) trains will operate between Atlantic Avenue and Livonia Yard. The operation of unequipped trains is normally arranged to occur during non-rush periods so as to minimize the impact upon scheduled revenue trains. In addition, during the initial years of operation of CBTC on the Canarsie Line, there were an insufficient number of trains equipped with CBTC to meet service requirements. As such, for an interim period, mixed-mode operation was a normal operating mode during revenue service scheduled operations.
4.5.1.1	Extent to which train is to be capable of being controlled automatically by the CBTC system.	Trains can be operated with either one or two person crews. The Train Operator is stationed in the lead car of the train and is responsible for moving the train from station to station. With a two person crew, and an eight-car train, the Conductor normally operates from a cab near the center of the train and operate the train's doors and makes announcements to the passengers. For a four-car train, the Conductor normally operates from the rear end of the train. The CBTC system is required to support One Person Train Operation (OPTO) by combining the Conductor and Train Operator display information on the Train Operator's Displays. For a two person crew, Conductor display information is required to be provided on separate Conductor Displays. The CBTC system is not required to support operation of trains without crews. CBTC-equipped trains operating in CBTC territory normally operate in one of the following two modes: (a) ATO Mode; The mode of operation when the train operates automatically from station to station under CBTC control, and within ATP limits. ATO mode does not include the automatic opening or closing of doors. (b) Automatic Train Protection Manual (ATPM) Mode; The mode of operation when the Train Operator controls the train within ATP limits prescribed by the CBTC system.
4.5.1.2 4.5.2 4.5.2.1 4.5.2.2 5.3.5.4	Extent to which trains not equipped with train-borne CBTC equipment and/or trains with inoperative train-borne CBTC are to be protected through an auxiliary wayside system and/or operating procedures.	The NYCT CBTC implementation incorporates a full AWS comprised of a track circuit-based secondary train detection system and a wayside signal/trip stop-based secondary train protection system to detect and protect the movement of trains not equipped with train-borne CBTC equipment, and trains with inoperative train-borne CBTC equipment. In the event of CBTC failures, CBTC-equipped trains operating within CBTC territory are capable of operating in either of the following modes, depending on the nature of the failure: (a) AWP Mode; The mode of operation when the train is operating under AWS signal protection due to a CBTC communications failure or the total failure of a wayside zone controller. The carborne CBTC equipment will continue to provide civil speed enforcement, and perform other safety-related functions, when operating in this mode. (b) Restricted Manual Mode; The mode of operation following loss of CBTC train location detection, due to a failure of the carborne CBTC equipment. In this mode of operation, the train will operate under AWS signal protection with the train speed limited by the propulsion system, until the carborne CBTC position system is re-initialized. Selection of Restricted Manual Mode by the Train Operator is governed by operating procedures except that an interlock will prevent the selection of Restricted Manual Mode if a head-to-head train movement were in progress at the time of the failure. (c) CBTC Bypass Mode; The mode of operation when the carborne CBTC equipment cannot be re-initialized. In this mode of operation, the CBTC equipment, and the propulsion system speed limiter, are bypassed to permit manual operation of the train up to full speed under AWS signal protection. Selection of CBTC Bypass Mode by the Train Operator is by the operation of a sealed switch, and governed by operating procedures.

IEEE Ref	IEEE Requirement	Assessment
4.5.3	Extent to which train-borne CBTC equipment is required to perform ATP functions while operating in non-CBTC territory.	CBTC-equipped trains operating in non-CBTC territory normally operate in the Wayside Signal Protection (WSP) Mode under wayside signal/trip stop protection. The carborne CBTC equipment does not perform any train control or supervisory functions, other than to monitor for transitions into CBTC territory. Failure of the carborne CBTC equipment within non-CBTC territory should have no impact upon train operation. The failure is indicated to the Train Operator.
4.5.3	Extent to which train-borne CBTC equipment operating in non-CBTC territory is to interface with wayside equipment that is not fully compatible with the train-borne CBTC equipment.	In the NYCT CBTC implementation, there is no requirement for the train-borne CBTC equipment to interface with wayside equipment that is not fully interface compatible with the train-borne CBTC equipment.
4.7	Range of possible train operating speeds.	The NYCT CBTC implementation enforces a maximum operating speed of 55 MPH for trains on the re-signalled Canarsie Line.
5.1	Required design and operating headways for both normal and reverse directions.	The NYCT CBTC system is required to provide the closest feasible safe operating headways for equipped trains in both the normal and reverse directions, on all CBTC equipped track. In determining the minimum achievable design headway the maximum allowance for all CBTC system latencies and tolerances, including ATS, CBTC, and AWS is specified as 3 seconds. The design headway is calculated based upon normal operation of a preceding train not interfering with the performance of a following train operating in ATO Mode. The target scheduled peak service operating headway on the Canarsie Line is 3 minutes.
5.1	Track alignment, gradients, civil speed limits, station dwell times, and terminal track configurations.	Non-CBTC parameters that impact achievable design and operating headways, such as track alignment, gradients, civil speed limits, station dwell times, and terminal track configurations, were defined by NYCT in the CBTC Technical Specifications.
5.1	Train acceleration and braking rates, and driver reaction times.	Similarly, train performance parameters were also defined by NYCT in the CBTC Technical Specifications.
5.2	Trip time requirements	For the NYCT CBTC implementation on the Canarsie Line, the CBTC system was specified to contribute no more than 2% to the theoretical minimum run time between 8th Avenue and Rockaway Parkway, assuming 30 second dwells at intermediate stations. The CBTC contribution to run time includes, for example: delays in initiating trains start from a station after door closed status is established; ATP profile determination process for safety, headway, and other requirements of the Technical Specifications; the resolution of speed commands; the tolerances required between ATO and ATP profiles to ensure that a train does not normally exceed the ATP profile; passenger comfort constraints; train position resolution constraints; system response times, at central, wayside, and carborne; communication delays in all communications links; and constraints on the station stopping profile to ensure the required stopping accuracy is achieved.

IEEE Ref	IEEE Requirement	Assessment
5.3.1	CBTC System Safety Program requirements.	<p>In the NYCT CBTC implementation on the Canarsie Line, the CBTC Contractor had complete responsibility for the safety of the CBTC/AWS System and was responsible for performing, and documenting, all required safety analyses and tests to verify that the CBTC/AWS System satisfied the safety performance levels established by NYCT.</p> <p>The CBTC/AWS System was required to provide a level of safety such that any single, independent hardware, software or communication failure, or any combination of such failures, with the potential for causing death or severe injury to customers or staff would not occur with a frequency greater than once per 10⁹ system operating hours.</p> <p>The CBTC Contractor was required to implement the following major safety program activities:</p> <ol style="list-style-type: none"> 1. Identification and assessment of hazards. 2. Resolution of actions to mitigate hazards. 3. Identification of system items/elements requiring Safety Certification (compiled into a Certifiable Items List). 4. Identification of safety requirements for each certifiable item/element. 5. Review of compliance with these identified safety requirements. 6. Documentation of the hazards resolution, compliance review and system safety approval process. <p>NYCT completed the Safety Certification for the CBTC/AWS System, prior to revenue use, based on inputs from the CBTC Contractor, and an Independent Safety Consultant.</p>
5.3.2	Hazard Analyses requirements/ criteria	<p>The CBTC Technical Specifications for the NYCT CBTC implementation noted that the NYCT operating environment is unlike other North American transit agencies. Due to the size and complexity of the NYCT system, customer volume and habits, and diversity of operating systems, the Contractor was required to include and analyze in the Hazard Analysis, conditions which might not be considered at other agencies. (For example: the hazard in which a train is stranded between stations for more than fifteen minutes is considered a Critical hazard inasmuch as a likely effect of the hazard is that NYCT customers de-train onto the railroad right-of-way. Any and all CBTC/AWS system contributions to hazards in which an effect may be that a train is stranded between stations for more than fifteen minutes was therefore required to be analyzed.)</p>
5.3.3.	Level to which unacceptable or undesirable hazards are to be controlled.	<p>The CBTC Contractor was required to identify, analyze and classify inherent risks in each type of technology used in the CBTC/AWS System. For the software elements of the System this was to include the risks inherent in each part of the software (for example: operating system, application software and databases), and to the methodologies and tools used for their development. The CBTC Technical Specifications placed emphasis on designing safety into the CBTC/AWS System from the outset, with a clear segregation of vital and non-vital equipment and functions.</p>
5.4.1	On-time performance and fleet availability objectives.	<p>The CBTC/AWS System was specified to be designed such that the failure of any single component, processor, or device would not render the system unavailable or a critical function non-operative. The CBTC/AWS System was specified to be designed for a useful life of at least thirty (30) years for mechanical equipment and electro-mechanical equipment, and twenty-five (25) years for microprocessor equipment.</p>
5.4.2	Quantitative CBTC system availability requirements.	<p>The CBTC/AWS System was specified by NYCT to achieve a total availability of 99.99% in the Canarsie Line configuration.</p>
5.4.2	System availability analysis/modeling requirements to predict CBTC the system availability.	<p>The CBTC Contractor was required to prepare and submit an availability analysis of the CBTC/AWS System during the design review process.</p>

IEEE Ref	IEEE Requirement	Assessment
5.4.2	System availability demonstration test requirements to determine actual CBTC system availability.	A Demonstration Test was required to be performed as part of the Availability and Reliability Test to show compliance with the specified system availability and reliability requirements.
5.4.3	Quantitative CBTC system and subsystem Mean Time Between Failures (MTBF) and Mean Time Between Functional Failures (MTBFF) requirements.	Quantitative MTBF and MTBFF requirements were specified by NYCT for: CBTC Carborne Equipment; CBTC Zone Control Equipment; Interlocking and AWS Equipment; Train to Wayside Data Communications; CBTC/AWS Control Center Equipment; and
5.4.3.1	Requirements with respect to spare part availability.	Under the Canarsie Line contract, the CBTC Contractor was required to provide a spare parts list including the equipment manufacturers, recommended quantity of spare parts of each type based on the quantity of equipment installed under this contract, and the life expectancy of each part.
5.4.4	Scope of logged CBTC events.	Event recording was specified to be provided in both wayside and carborne CBTC equipment with the full scope of recorded CBTC events to be approved by NYCT.
5.4.4	Extent of capabilities to facilitate modifications (by the user) to CBTC system parameters, track databases, and applications software.	Under the Canarsie Line contract, the CBTC Contractor was required to provide full and complete documentation for all aspects of the CBTC/AWS software systems for purposes including operations, maintenance, repair, training, and possible future modifications and enhancements.
6.1.2 6.1.3	Whether penalty brake applications are to be an immediate emergency brake application or a supervised service brake application.	In the NYCT CBTC application, the CBTC system will apply the emergency brakes if service brakes fail to keep the train within safe limits.
6.1.2.1	Requirements with respect to guaranteed emergency brake rate.	The guaranteed emergency brake rate for the NYCT trains was specified by NYCT for use by the CBTC Contractor in the development of the CBTC Safe Braking Model.
6.1.8	Designated station stopping points and required tolerances.	Designated stopping point and required tolerances were specified by NYCT in the CBTC Technical Specifications.

IEEE Ref	IEEE Requirement	Assessment
6.1.10	Criteria for resetting the emergency brakes.	Events resulting in emergency brake applications are alarmed to the Rail Control Center by way of the CBTC-ATS system. The train must come to a stop before the emergency brakes can be reset.
2) Mandatory and Optional ATP Requirements (all functions mandatory except where indicated)		
IEEE Ref	IEEE Requirement	Assessment
6.1	All ATP functions are to be vital functions.	ATP functions were specified to be implemented vitally.
6.1	CBTC system is to be capable of providing bidirectional ATP.	The CBTC system was specified to be capable of providing bi-directional ATP.
6.1.1.1	CBTC train location/ train speed determination requirements.	<p>NYCT's CBTC implementation is compliant with IEEE Std 1474.1™ requirements. Specifically, the CBTC system establishes the position, speed, travel direction and length of each CBTC-equipped train operating in ATO, ATPM, AWP, and wherever possible in Restricted Manual operating modes. In CBTC territory, CBTC train detection established by the CBTC carborne equipment is transmitted to the appropriate CBTC zone controller using the train-to-wayside data communications network. CBTC train detection establishes the position of both the front and the rear of the train and verifies train length.</p> <p>The CBTC train detection function provides sufficient position accuracy to support the specified performance and safety requirements.</p> <p>In the event of failure, including loss of power both at the wayside and on board the train, the train position function is self-initializing. No manual input of data is required.</p> <p>Speed and position is determined in a vital manner through the use of wayside transponders and a train-borne OSMES.</p>
6.1.1.2	Optional: Provision of secondary train location determination to establish if a section of track is occupied by one or more trains, including trains not equipped with train-borne CBTC equipment and/or trains with inoperative train-borne CBTC equipment.	<p>A track circuit-based secondary train location determination system is provided in the NYCT CBTC implementation.</p> <p>The CBTC system is also required to be capable of differentiating between a track circuit occupied by a train and an unexpected track circuit occupancy.</p>
6.1.2	Safe train separation assurance requirements.	NYCT's CBTC implementation is compliant with IEEE Std 1474.1™ requirements. Specifically, the CBTC system provides safe train separation between all trains operating in CBTC territory under CBTC or AWS protection. Unequipped or failed trains are controlled by AWS wayside signals.

IEEE Ref	IEEE Requirement	Assessment
6.1.2	Optional: If secondary train location determination is provided, CBTC system to limit the movement authority to the route entry point of a route occupied by the non-CBTC-equipped train or failed train.	In the NYCT CBTC implementation, equipped trains are capable of closing up to the entrance of an unoccupied track circuit in rear of a track circuit occupied by an unequipped or failed train.
6.1.2 6.1.2.1	Optional: Extent of support for automatic close-up of trains and automatic coupling and uncoupling of trains in designated areas.	The CBTC system is required to support NYCT's existing procedures for cutting and combining of trains and to make the appropriate changes to CBTC parameters such as train length. Combining and cutting train consists results in an automatic update of the consist length within the CBTC system. Coupling and uncoupling of trains can be accomplished in any operating mode except ATO mode. Full automatic coupling and uncoupling of trains is not required in the NYCT CBTC implementation.
6.1.2	Optional: Facilities to bypass the CBTC safe train separation function to allow a train, under the control of a train operator, to travel beyond its movement authority limit.	Facilities exist within the NYCT CBTC implementation to allow a train, under specific failure scenarios and under the control of a train operator, to travel beyond its last movement authority limit.
6.1.2	Optional: Facilities to pull back (i.e., make more restrictive) a movement authority limit previously granted to a train.	The NYCT CBTC implementation includes facilities that enable operating personnel to pull back a movement authority limit previously granted to a train. For example, a provision to cancel a clear interlocking signal is used to pull back the movement authority limit to the signal location.
6.1.2.1	Safe braking model requirements.	The CBTC Contractor was required to determine the safe braking model for the CBTC system, which was submitted to NYCT for approval.
6.1.3	Overspeed protection requirements.	NYCT's CBTC implementation is compliant with IEEE Std 1474.1™ requirements. Specifically, the CBTC system detects and reacts to overspeed conditions.

IEEE Ref	IEEE Requirement	Assessment
6.1.4	Rollback protection requirements.	NYCT's CBTC implementation is compliant with IEEE Std 1474.1™ requirements. Specifically, the CBTC system detects and reacts to roll-back conditions.
6.1.5	End of track protection requirements.	NYCT's CBTC implementation includes end of track protection.
6.1.6	Parted consist protection and requirements for coupling/uncoupling of trains.	The CBTC train detection function is capable of detecting and protecting parted trains.
6.1.6	Optional: CBTC system can assume a fixed, worst-case, maximum train length.	This option was not specified in the NYCT CBTC implementation.
6.1.7	Zero speed detection	The carborne CBTC equipment provides a “zero speed” input for the “train berthed” function.
6.1.8 5.3.2	Door opening control protection interlocks and associated interface requirements between the CBTC system and the train and (optional) platform doors. Interlocks optional for trains with driver/attendant)	The carborne CBTC equipment provides a “train berthed” function in ATO, ATPM and AWP modes and only enables opening of the doors on the platform side when the train is fully stationary within a platform area.
6.1.8	Optional: Locations other than stations at which train doors can be opened.	In the NYCT CBTC implementation, doors of trains in passenger service could only be opened when trains are properly berthed at passenger stations.
6.1.8	Optional: Facilities for a local manual bypass of the door open control protection interlocks.	This option was not specified as a CBTC function in the NYCT CBTC implementation.
6.1.9	Departure interlocks.	The CBTC system monitors the door status and will not enable ATO mode of operation until all doors are reported as closed.

IEEE Ref	IEEE Requirement	Assessment
6.1.9	Optional: Facilities for a local manual bypass of departure interlocks.	This option was not specified as a CBTC function in the NYCT CBTC implementation.
6.1.10	Emergency braking requirements.	Carborne CBTC equipment interfaces to the emergency brake system. An emergency brake application also vitally inhibits the propulsion system. The Train Operator is required to reset the emergency brakes following a CBTC enforced application.
6.1.11	Route interlocking requirements.	In the NYCT CBTC implementation, conventional route interlocking functions are performed by separate, external interlocking equipment.
6.1.11	Optional: Requirements with respect to sectional release of routes behind a train.	The NYCT CBTC implementation did not require the CBTC contractor to provide the function of sectional release of routes behind a train.
6.1.11	Optional: Provision of interlocking functions by separate interlocking equipment.	In the NYCT CBTC implementation, interlocking functions are provided by separate interlocking equipment that interfaces to the CBTC wayside zone controllers. The CBTC system provides outputs to the external interlocking to modify the conventional interlocking functions based on CBTC train location reports, train speeds and movement authorities. These outputs permit early release of approach locking and traffic locking, the display of a unique signal aspect for CBTC trains, and the early release of routes based on CBTC train passage.
6.1.11.1	Optional: Extent to which wayside signals are to be provided.	To support mixed-mode operations, an auxiliary wayside system, with wayside signals, is integral to the NYCT CBTC implementation. For CBTC-equipped trains approaching a wayside signal, the CBTC system can override the conventional signal aspects to permit a CBTC train to enter a block occupied by another CBTC-equipped train,
6.1.12	Traffic direction reversal interlocks.	Traffic direction reversal interlock functionality is included in the design of the interlockings and in the NYCT CBTC implementation. It is not possible to extend the movement authority for a train into a section of track where an opposing traffic direction has already been established.
6.1.13	Work zone protection requirements.	Work zone functionality is included within the NYCT CBTC implementation. The Rail Control Center has the capability to enter details of a work zone into a CBTC-ATS workstation.
6.1.14 5.3.2	Optional: Broken rail detection requirements.	(Partial) broken rail detection capability is provided in the NYCT CBTC implementation through the provision of single-rail track circuits within the AWS. Functionality is included within the CBTC system to react to a detected broken rail condition.
6.1.15 6.1.2	Optional: Highway grade crossing interfaces.	Highway grade crossing interfaces are not required in the NYCT CBTC implementation.

IEEE Ref	IEEE Requirement	Assessment
6.1.16 5.3.2	Optional: Restricted route protection including interface requirements between the CBTC system and intrusion detection devices.	Interfaces between the CBTC system and track intrusion detection devices are not required in the NYCT CBTC implementation.

3) Optional ATO Requirements (mandatory for systems without drivers)

IEEE Ref	IEEE Requirement	Assessment
6.2.1	Automatic speed regulation	In the NYCT CBTC implementation, in ATO Mode, train acceleration, deceleration and station stop are controlled by the carborne CBTC equipment within the established ATP profile. The CBTC system affects this control by providing commands to the train's propulsion and braking systems in real time. The carborne CBTC equipment can enter ATO Mode only if ATO is enabled and the Train Operator presses the "ATO Start" pushbutton. ATO operation is enabled by the carborne CBTC equipment only when the train has a valid movement authority, the doors are closed and the controller handle is in the full service brake position.
6.2.2	Platform berthing control	In the NYCT CBTC implementation, the CBTC system provides for automatic station stopping in ATO Mode. ATO station stops were specified to be accurate within ± 12 inches of the designated stop location at least 99.9% of the time. The CBTC system will prevent the train doors from being opened in the event that the train is not fully "berthed" within the platform area. The berthed function is specified to be enabled within one half second after the train has stopped in a fully berthed position.
6.2.3	Train and platform door control	In the NYCT CBTC implementation, train doors are not opened or closed automatically by the CBTC system. Doors are controlled manually by the train crew to facilitate passenger boarding and discharging. (There are no platform doors in the NYCT CBTC implementation). The CBTC system does monitor the door status and will not enable ATO mode of operation until all doors are reported as closed. In addition, the carborne CBTC equipment does provide a "train berthed" function, which only enables opening of the doors on the platform side when the train is fully stationary within a platform area.

4) Optional ATS Requirements

IEEE Ref	IEEE Requirement	Assessment
6.3.3	CBTC train identification and train tracking.	Train identification and train tracking functionality is included within the NYCT CBTC implementation with train status information displayed on an Overview Screen Display and on individual Workstations at the Rail Control Center.
6.3.4	Train routing.	Functionality at the Rail Control Center to support manual and automatic routing of trains is included within the NYCT CBTC implementation.

IEEE Ref	IEEE Requirement	Assessment
6.3.5.1	Schedule/headway regulation.	Schedule regulation/headway regulation functionality is included within the NYCT CBTC implementation. The CBTC-ATS system at the Rail Control Center has the capability to automatically monitor and regulate the performance of CBTC equipped trains operating in CBTC territory, in relation to schedule and/or headway adherence. Schedule and headway regulation for CBTC-equipped trains is achieved through dwell time variance and through adjustments to train acceleration, service brake rates, and operating speeds within the constraints established by the ATP subsystem. The NYCT CBTC implementation also provides a capability to adjust the train service braking profiles for CBTC-equipped trains in response to wet rail conditions.
6.3.5.2	Junction management.	Junction management functionality is not a requirement of the current NYCT CBTC implementation. However, the ATS subsystem provides the function of automatic routing and dispatching based on an established schedule.
6.3.5.3	Energy optimization.	Energy optimization functionality is not a requirement of the current NYCT CBTC implementation.
6.3.6.1	Stop train at next station.	Functionality to stop a train at the next station is included within the NYCT CBTC implementation. The CBTC-ATS system provides a means for the Rail Control Center to stop equipped trains at the next station.
6.3.6.2	Hold train at station.	Functionality to hold a train at a station is included within the NYCT CBTC implementation. The CBTC-ATS system includes facilities to enable the Rail Control Center to hold a train in a station. The CBTC system does not enforce trains to be held at stations. A Train Operator always retains the ability to move the train out of a station in ATPM Mode, whether a hold indication exists or not. A hold indication from the Rail Control Center will however inhibit a train from leaving the station in ATO Mode.
6.3.6.3	Skip station stop.	Skip station functionality is included within the NYCT CBTC implementation. The CBTC-ATS system includes facilities for the Rail Control Center to direct a train or group of trains to skip stop a station or group of stations.
6.3.6.4	Door controls inhibit.	There is no functionality within the NYCT CBTC implementation to remotely inhibit door control functionality from the Rail Control Center.
6.3.7.1	Stopping a train en route.	Functionality to stop a train en route is included in the NYCT CBTC implementation. The CBTC-ATS system includes facilities for the Rail Control Center to designate trains to be stopped immediately. This command will cause the carborne CBTC equipment on all designated trains to immediately apply the brakes and to notify the Train Operator via the display.
6.3.7.2	Temporary speed restrictions	Slow speed order functionality is included within the NYCT CBTC implementation. The CBTC-ATS system allows the Rail Control Center to enter the limits of a slow speed order area and applicable temporary speed restriction. The temporary speed restrictions are enforced by the CBTC system in a similar manner to civil speeds, for all CBTC-equipped trains.
6.3.7.3	Switch/track blocking.	Switch/track blocking functionality is included within the NYCT CBTC implementation. The CBTC-ATS system includes facilities to allow the Rail Control Center to block and unblock track sections and switches. The CBTC system will not grant movement authorities to trains to operate into or out of out-of-service (blocked) tracks or switches.
6.3.7.4	Work zones.	Work zone functionality is included within the NYCT CBTC implementation. The Rail Control Center has the capability to enter details of a work zone into a CBTC-ATS workstation. The CBTC system processes the request for the work area and notifies all equipped trains. ATO Mode is inhibited by the CBTC system through work zones and the CBTC system enforces a speed restriction through the work area.

IEEE Ref	IEEE Requirement	Assessment
6.3.8	Passenger information system interfaces.	The NYCT CBTC implementation includes interfaces with wayside and train-borne public address/customer information screens to trigger automatic passenger information messages, such as train arrival information, based on CBTC train location reports.
6.3.9.1	CBTC fault reporting.	The NYCT CBTC implementation includes maintenance and diagnostic provisions to detect and react to equipment failures. This includes CBTC fault reporting to the Rail Control Center and the ability to remotely interrogate CBTC wayside and carborne equipment.
6.3.9.2	Train fault reporting.	In the NYCT CBTC implementation, train-borne CBTC equipment interfaces to the train Health Monitor System for the purposes of communicating train health data to the wayside for display on the CBTC-ATS user interface displays.

APPENDIX
B

IEEE Std 1474.1™ Comparison Assessment – SEPTA

IEEE Std 1474.1™ Assessment Checklist

Agency: Southeastern Pennsylvania
Transportation Authority (SEPTA)

IEEE Std 1474.1™ identifies:

- Operating and performance requirements that are to be specified by the Authority having Jurisdiction
- Mandatory and Optional ATP requirements
- Optional ATO requirements (that would be mandatory for driverless train operations)
- Optional ATS requirements

I) Operating and Performance Requirements that are to be Specified by the Authority having Jurisdiction		
IEEE Ref	IEEE Requirement	Assessment
4.1	Characteristics of CBTC systems	The technical specifications for the SEPTA CBTC implementation reflect the characteristics of the CBTC system as defined in the IEEE standards. More specifically, the specification included the following requirements: d) A high resolution location determination subsystem, independent of track circuits e) Continuous, high capacity, bi-directional train-to-wayside data communications f) On-board and wayside processors that perform vital functions
4.3 6.4	Extent of required interoperability between equipment provided by multiple vendors.	SEPTA did not include in its specifications any requirements for interoperability. The SEPTA CBTC installation was provided by a single supplier, Bombardier.
4.4	Capability to support a variety of train configurations	The CBTC technical specifications for the SEPTA implementation reflected a single vehicle configuration.

IEEE Ref	IEEE Requirement	Assessment
4.5	Extent to which mixed-mode operation is to be considered a normal operating mode.	The SEPTA CBTC implementation considered “mixed mode operation” a normal operating mode, and defined it as operation as a result of carborne CBTC equipment failures.
4.5.1.1	Extent to which train is to be capable of being controlled automatically by the CBTC system.	<p>In the SEPTA CBTC implementation, trains are operated manually under CBTC protection. The Train Operator is stationed in the lead cab of the train and is responsible for moving the train from station to station. The train operator is also responsible to operate the train’s doors and makes announcements to the passengers. The CBTC system is not required to support operation of trains without crews. CBTC-equipped trains operating in CBTC territory normally operate in one of the following modes:</p> <ul style="list-style-type: none"> • CABS – normal operating CBTC mode • Restricted Manual – enforces a speed restriction of 20 MPH or less, depending on civil speed limit indicated in the vital data base • CBTC Bypass – requires the breaking of a seal. No speed enforcement, safety is based on compliance with operating rules.
4.5.1.2 4.5.2 4.5.2.1 4.5.2.2 5.3.5.4	Extent to which trains not equipped with train-borne CBTC equipment and/or trains with inoperative train-borne CBTC are to be protected through an auxiliary wayside system and/or operating procedures.	<p>SEPTA has eliminated all existing speed control signals, and intends to remove all remaining signals that are not required for interlocking protection. However, trains not equipped with train-borne CBTC equipment, and/or trains with inoperative train-borne CBTC are protected as follows:</p> <p>A non-equipped train entering the CBTC protected territory is detected by a track circuit at each portal. A following CBTC equipped train must then sweep the CBTC territory before it receives a movement authority.</p>
4.5.3	Extent to which train-borne CBTC equipment is required to perform ATP functions while operating in non-CBTC territory.	The specifications for the SEPTA CBTC implementation did not require train-borne CBTC equipment to perform ATP functions while operating in non-CBTC territory. For example, operation in the yard is governed by the operating rules.
4.5.3	Extent to which train-borne CBTC equipment operating in non-CBTC territory is to interface with wayside equipment that is not fully compatible with the train-borne CBTC equipment.	In the SEPTA CBTC implementation, there is no requirement for the train-borne CBTC equipment to interface with wayside equipment that is not fully interface compatible with the train-borne CBTC equipment.

IEEE Ref	IEEE Requirement	Assessment
4.7	Range of possible train operating speeds.	The SEPTA CBTC implementation provides for a maximum operating speed of 45 mph.
5.1	Required design and operating headways for both normal and reverse directions.	The technical specifications for the SEPTA CBTC implementation require the CBTC system to provide 30 seconds design headway in both normal and reverse directions, and with multiple berthings within stations. SEPTA is currently operating 60–62 trains per hour during peak service.
5.1	Track alignment, gradients, civil speed limits, station dwell times, and terminal track configurations.	Non-CBTC parameters that impact achievable design and operating headways, such as track alignment, gradients, civil speed limits, station dwell times, and track configurations, were defined by SEPTA in the CBTC Technical Specifications.
5.1	Train acceleration and braking rates, and driver reaction times.	The SEPTA CBTC implementation is based on the following operating characteristics: <ul style="list-style-type: none"> • Acceleration Rate: 3 mphps • Deceleration Rate: Track brake rate—9 mphps Emergency brake rate 3-4 mphps • Driver reaction time: 2 seconds
5.2	Trip time requirements	There were no specific trip time requirements set forth by SEPTA for the CBTC implementation on the light rail system. However, in general, the trip time for the SEPTA CBTC installation is affected by the following parameters: <ul style="list-style-type: none"> • Nominal operating speed • Civil speed limits • CBTC reaction time • Driver reaction time • Stations dwell times
5.3.1	CBTC System Safety Program requirements.	In the SEPTA CBTC implementation on the light rail system, the CBTC Contractor had complete responsibility for the safety of the CBTC installation and was responsible for performing, and documenting, all required safety analyses and tests to verify that the CBTC System complies with relevant Industry Standards, and provides safe train operation. SEPTA retained an independent consultant to perform a “Proof of Safety Process Audit.” This safety audit focused on the engineering techniques and processes applied to the CBTC system being implemented, the core safety functions of the proposed CBTC platform, as well as SEPTA specific application design features to ensure that the proposed system functions safely in SEPTA’s operating environment.
5.3.2	Hazard Analyses requirements/ criteria	SEPTA did not establish explicit requirements for the CBTC contractor to perform Hazard Analyses. However, relevant industry standards (such as MIL STD 882C, IEEE Std. 1474.1™-1999 and IEEE Std. 1483-2000) anticipated that a Preliminary Hazard Analysis would be performed early in the project. The contractor for the SEPTA CBTC Light Rail System did perform a PHA, and Fault Tree Analysis (FTA) to identify faults that could lead to hazardous conditions, and to establish corrective actions and system requirements to eliminate or mitigate these hazards in an acceptable manner.
5.3.3.	Level to which unacceptable or undesirable hazards are to be controlled.	SEPTA did not establish explicit levels to which unacceptable or undesirable hazards are to be controlled. However, during the implementation phase of the project, all identified hazards were mitigated to the satisfaction of SEPTA.

IEEE Ref	IEEE Requirement	Assessment
5.4.1	On-time performance and fleet availability objectives.	The SEPTA CBTC installation incorporates redundant design that makes critical systems fault tolerant. For example, the TWC design employs redundant radios, redundant Wayside Radio Network Assemblies, and redundant feed into the leaky coax cable. Further, the ATP system uses a distributed system architecture, and the wayside ATP and car ATP are operationally redundant. In addition, the SEPTA CBTC system employs degraded modes of operation to minimize the operational impacts of equipment failures. The above listed practices are in line with the requirements of this section of the IEEE standards, and are keys in meeting the on-time performance and fleet availability objectives.
5.4.2	Quantitative CBTC system availability requirements.	The technical specifications for the SEPTA CBTC implementation did not include a requirement for a quantitative CBTC system availability. However, a comprehensive set of equipment reliability requirements were included.
5.4.2	System availability analysis/modeling requirements to predict CBTC the system availability.	There was no requirement in the SEPTA CBTC specifications for the contractor to prepare and submit availability analysis of the CBTC system.
5.4.2	System availability demonstration test requirements to determine actual CBTC system availability.	There was no requirement in the SEPTA CBTC specifications for the contractor to conduct system availability demonstration in order to determine actual CBTC system availability.
5.4.3	Quantitative CBTC system and subsystem MTBF and MTBFF requirements.	SEPTA specified that CBTC equipment be designed for maximum reliability. Further, quantitative MTBF and MTBFF requirements were specified by SEPTA for CBTC Carborne Equipment, CBTC Zone Control Equipment, and Train to Wayside Data Communications.
5.4.3.1	Requirements with respect to useful life and spare part availability.	The technical specifications for the SEPTA CBTC implementation required the CBTC equipment to be designed for a useful life of at least 25 years. Under the SEPTA CBTC contract, the CBTC Contractor was required to provide a spare parts list including the equipment manufacturers recommended quantity of spare parts of each type based on the quantity of equipment installed under this contract, and the life expectancy of each part.
5.4.4	Scope of logged CBTC events.	Event recorders were specified by SEPTA for both wayside and carborne CBTC equipment.
5.4.4	Extent of capabilities to facilitate modifications (by the user) to CBTC system parameters, track databases, and applications software.	The technical specifications for the SEPTA CBTC implementation did not require the CBTC contractor to provide documentation and tools that would enable SEPTA to modify CBTC system parameters, track databases, and applications software. SEPTA elected to enter into a contract with the CBTC supplier (Bombardier) to perform these tasks when required.

IEEE Ref	IEEE Requirement	Assessment
6.1.2 6.1.3	Whether penalty brake applications are to be an immediate emergency brake application or a supervised service brake application.	In the SEPTA CBTC implementation, the CBTC system activates the emergency brakes when it detects an operational hazard, or encounters a failure. For example, if the actual speed of the train exceeds the authorized speed, the emergency brakes will be activated. Similarly, if the safe braking distance to the object limiting the movement authority is violated, the system will apply the emergency brakes. In both examples, the emergency brake application is an immediate action.
6.1.2.1	Requirements with respect to guaranteed emergency brake rate.	The technical specifications for the SEPTA CBTC system did not include requirements or values related to “guaranteed emergency brake rate.” However, during the implementation phase of the project, Bombardier conducted a series of brake tests to determine the brake rate to be used in CBTC system design.
6.1.8	Designated station stopping points and required tolerances.	The functional requirements for the SEPTA CBTC implementation did not include a programmed station stop function.
6.1.10	Criteria for resetting the emergency brakes.	Events resulting in emergency brake applications are alarmed at the Central Control by way of the CBTC-ATS system. The train must come to a complete stop before the emergency brakes can be reset.

2) Mandatory and Optional ATP Requirements (all functions mandatory except where indicated)

IEEE Ref	IEEE Requirement	Assessment
6.1	All ATP functions are to be vital functions.	The technical specifications for the SEPTA CBTC implementation required the ATP system to perform all safety functions in a vital manner. In the implemented CBTC system, the wayside ATP and car ATP are operationally redundant, vital, cross-checked, microprocessor-based systems.
6.1	CBTC system is to be capable of providing bidirectional ATP.	The SEPTA CBTC system implementation was specified to provide bi-directional ATP.
6.1.1.1	CBTC train location/ train speed determination requirements.	SEPTA’s CBTC implementation was specified to provide the following functions, as required by IEEE Std 1474.1™: <ul style="list-style-type: none"> • Establish the position, speed, travel direction and length of each CBTC-equipped train • In CBTC territory, transmit CBTC train location established by the CBTC carborne equipment to the appropriate wayside ATP computer using the train-to-wayside data communications network • Establish the position of both the front and the rear of the train and verify train length (protects two car operation to permit removing failed vehicles), • The CBTC train detection function to provide sufficient position accuracy to support the specified performance and safety requirements • In the event of failure, including loss of power both at the wayside and on board the train, the train position function is to be self-initializing. No manual input of data is required • To determine speed and position in a vital manner through the use of wayside “norming points” (passive transponders), four tachometers and a Doppler radar

IEEE Ref	IEEE Requirement	Assessment
6.1.1.2	Optional: Provision of secondary train location determination to establish if a section of track is occupied by one or more trains, including trains not equipped with train-borne CBTC equipment and/or trains with inoperative train-borne CBTC equipment.	The SEPTA CBTC implementation does not employ a means for secondary detection. However, at the entrance from each portal, a track circuit is used to detect unequipped trains and/or trains with inoperative train-borne CBTC equipment. Upon such detection, a following CBTC train is required to sweep the CBTC territory before a movement authority is issued.
6.1.2	Safe train separation assurance requirements.	The SEPTA CBTC implementation provides safe train separation between trains travelling in the same or opposing directions, between trains and switch conflicts, and between trains and end-of-track buffers. This protection is based on the assumption that any detected entity may instantly stop, and the separation envelope includes worst case braking performance distances. In the event of a CBTC train failure, the affected trains operate at restricted speeds, and safe train separation is dependent on compliance with operating rules and procedures.
6.1.2	Optional: If secondary train location determination is provided, CBTC system to limit the movement authority to the route entry point of a route occupied by the non-CBTC-equipped train or failed train.	In the SEPTA CBTC implementation, secondary train location determination was not required in the technical specifications.
6.1.2 6.1.2.1	Optional: Extent of support for automatic close-up of trains and automatic coupling and uncoupling of trains in designated areas.	In the SEPTA CBTC implementation, the functions of automatic close-up of trains, and automatic coupling and uncoupling of trains were not included in the technical specifications.

IEEE Ref	IEEE Requirement	Assessment
6.1.2	Optional: Facilities to bypass the CBTC safe train separation function to allow a train, under the control of a train operator, to travel beyond its movement authority limit.	The SEPTA CBTC implementation has an operational provision to allow a train, under specific failure scenarios and under the control of a train operator, to travel beyond its last movement authority limit. The train operator must break a seal, and switch the control to CBTC Bypass. This action is alarmed at Central Control.
6.1.2	Optional: Facilities to pull back (i.e., make more restrictive) a movement authority limit previously granted to a train.	The technical specifications for the SEPTA CBTC implementation did not require a function to pull back a movement authority limit previously granted to a train. However, a temporary speed restriction could be used to achieve this function. By imposing a temporary civil speed limit of “zero” mph, a previously granted movement authority is pulled back.
6.1.2.1	Safe braking model requirements.	There were no requirements in the technical specifications for the CBTC Contractor to determine the safe braking model for the CBTC system.
6.1.3	Overspeed protection requirements.	SEPTA’s CBTC implementation is compliant with IEEE Std 1474.1™ requirements. More specifically, the CBTC system monitors the actual speed of the train as it approaches a “conflict point” (end of movement authority), and permits movement as long as the actual speed of the train is less than an over-speed profile. If an over-speed condition occurs, the ATP system commands the emergency brakes.
6.1.4	Rollback protection requirements.	SEPTA’s CBTC implementation is compliant with IEEE Std 1474.1™ requirements. The technical specifications require the initiation of an emergency brake application in the event the vehicle moves against the actual traffic direction by more than two feet. The CBTC onboard equipment is designed to initiate the emergency brakes when it detects its speed sensor going reverse.
6.1.5	End of track protection requirements.	Although the SEPTA track configuration is in the form of a loop, SEPTA’s CBTC implementation includes end of track protection at the spur track.
6.1.6	Parted consist protection and requirements for coupling/ uncoupling of trains.	The SEPTA CBTC implementation does not provide for the operation of multi-car trains.
6.1.6	Optional: CBTC system can assume a fixed, worst-case, maximum train length.	The SEPTA CBTC implementation does not provide this function. It is based on a single length vehicle.
6.1.7	Zero speed detection	In the SEPTA CBTC implementation, two independent, phase-related tachometer pairs per car measure the speed and direction of the car. The ATP equipment defines zero speed as 0.3 m/s (one foot per second) or less. Non-zero speed is detected based on this threshold.

IEEE Ref	IEEE Requirement	Assessment
6.1.8 5.3.2	Door opening control protection interlocks and associated interface requirements between the CBTC system and the train and (optional) platform doors. Interlocks optional for trains with driver/ attendant)	The SEPTA CBTC provides door opening control protection interlocks as follows: <ul style="list-style-type: none"> • ATP prevents unscheduled door openings • ATP prevents any train movement if any train door becomes unlocked • The system does not require the train to be located within designated station platform passenger exchange area for the doors to operate The SEPTA CBTC implementation does not use platform doors.
6.1.8	Optional: Locations other than stations at which train doors can be opened.	The SEPTA CBTC implementation does not restrict door operation to station platform locations. Train doors can be opened at any location as long as the train is at a complete stop.
6.1.8	Optional: Facilities for a local manual bypass of the door open control protection interlocks.	The SEPTA CBTC implementation does not employ this function.
6.1.9	Departure interlocks.	In the SEPTA CBTC implementation, before a train departs from the station, the ATC system implements departure interlocks to ensure operational integrity. The ATC system initiates departure of the train from the station only after the following three requirements are satisfied: <ul style="list-style-type: none"> • All train doors are closed and locked • A route has been granted by the wayside ATP system • The wayside ATP system has not issued a stop command
6.1.9	Optional: Facilities for a local manual bypass of departure interlocks.	The SEPTA CBTC implementation does not use this function.
6.1.10	Emergency braking requirements.	Carborne CBTC equipment interfaces to the emergency brake system. An emergency brake application also vitally inhibits the propulsion system. The Train Operator is required to reset the emergency brakes following a CBTC enforced application.
6.1.11	Route interlocking requirements.	In the SEPTA CBTC implementation, conventional route interlocking functions are performed by separate, external interlocking equipment.

IEEE Ref	IEEE Requirement	Assessment
6.1.11	Optional: Requirements with respect to sectional release of routes behind a train.	The technical specifications for the SEPTA CBTC implementation do not include the functional requirement of sectional release of routes behind a CBTC train.
6.1.11	Optional: Provision of interlocking functions by separate interlocking equipment.	In the SEPTA CBTC implementation, interlocking functions are provided by separate interlocking equipment that interfaces to the CBTC wayside zone controllers.
6.1.11.1	Optional: Extent to which wayside signals are to be provided.	In the SEPTA CBTC implementation, wayside signals are only provided at the interlocking leading to the 36th Street Portal.
6.1.12	Traffic direction reversal interlocks.	The SEPTA CBTC implementation provides for direction reversal interlock. The wayside ATP system controls traffic direction and governs reverse operations in any automatically-controlled section of track. Further, it is not possible to extend the movement authority for a train into a section of track where an opposing traffic direction has already been established.
6.1.13	Work zone protection requirements.	In the SEPTA CBTC implementation, the central control facility has tools to define and establish work zones to protect workers on the track. ATP enforcement of restriction zones consists of imposing temporary speed restrictions, applying a work zone and enforcing a mode of operation over a defined section of track. Active work zones are sent to the trains as they pass through the region. A train receives a map of the work zone and can determine when it enters and leaves the work zone. When the train is automatically operated, the onboard CBTC equipment enforces the predefined restricted speed.
6.1.14 5.3.2	Optional: Broken rail detection requirements.	The existing single rail track circuits have not been removed, and are currently providing broken rail detection in a single rail. SEPTA intends to remove these track circuits in the future.
6.1.15 6.1.2	Optional: Highway grade crossing interfaces.	The track configuration for the SEPTA CBTC implementation does not include any grade crossings. Accordingly, highway grade crossing interfaces were not specified in the technical specifications.
6.1.16 5.3.2	Optional: Restricted route protection including interface requirements between the CBTC system and intrusion detection devices.	No intrusion detection devices are installed in the SEPTA CBTC territory. Accordingly, the technical specifications for the CBTC implementation did not require any interfaces to track intrusion detection devices.
3) Optional ATO Requirements (mandatory for systems without drivers)		
IEEE Ref	IEEE Requirement	Assessment
6.2.1	Automatic speed regulation.	The technical specification for the SEPTA CBTC implementation did not require the CBTC contractor to provide automatic speed regulation function.

IEEE Ref	IEEE Requirement	Assessment
6.2.2	Platform berthing control.	The technical specification for the SEPTA CBTC implementation did not require the CBTC contractor to provide a platform berthing control function.
6.2.3	Train and platform door control.	SEPTA does not employ platform doors.
4) Optional ATS Requirements		
6.3.3	CBTC train identification and train tracking.	The SEPTA CBTC implementation provides for train identification and train tracking. The system employs car tags that are scanned by a wayside tag reader. The trains are tracked by the ATP subsystem. Car numbers are displayed at ATS consoles. However, train routes are not provided. Currently, the SEPTA light rail system has five (5) different train routes.
6.3.4	Train routing.	In the SEPTA CBTC implementation, train routing is provided by a separate interlocking installation.
6.3.5.1	Schedule/headway regulation.	The SEPTA CBTC implementation did not require the CBTC contractor to provide schedule/headway regulation functions.
6.3.5.2	Junction management.	In the SEPTA CBTC implementation, junction management is provided by a separate interlocking installation.
6.3.5.3	Energy optimization.	Energy optimization functionality is not a requirement of the current SEPTA CBTC implementation
6.3.6.1	Stop train at next station.	The SEPTA CBTC implementation did not require the CBTC contractor to provide a “stop train at next station” function.
6.3.6.2	Hold train at station.	The SEPTA CBTC implementation did not require the CBTC contractor to provide “hold train at station” function.
6.3.6.3	Skip station stop.	The SEPTA CBTC implementation did not require the CBTC contractor to provide “skip station stop” function.
6.3.6.4	Door controls inhibit.	The SEPTA CBTC implementation provides protection for unscheduled door opening. The ATP system prevents any train movement if any train door becomes unlocked for any reason.
6.3.7.1	Stopping a train en route.	The SEPTA CBTC implementation did not require the CBTC contractor to provide a function to stop a train en route. However, a train could be stopped en route by the imposition of a “zero” MPH temporary speed restriction.
6.3.7.2	Temporary speed restrictions.	In the SEPTA CBTC implementation, the central control facility has tools to impose temporary speed restrictions on a section of the track. When the train is automatically operated, the onboard CBTC equipment enforces the predefined speed restrictions.
6.3.7.3	Switch/track blocking.	The SEPTA CBTC implementation did not require the CBTC contractor to provide switch/track blocking functions.
6.3.7.4	Work zones.	In the SEPTA CBTC implementation, the central control facility has tools to define and establish work zones to protect workers on the track. ATP enforcement of restriction zones consists of imposing temporary speed restrictions, applying a work zone and enforcing a mode of operation over a defined section of track. Active work zones are sent to the trains as they pass through the region. A train receives a map of the work zone and can determine when it enters and leaves the work zone. When the train is automatically operated, the onboard CBTC equipment enforces the predefined restricted speed.
6.3.8	Passenger information system interfaces.	The SEPTA CBTC implementation did not require the CBTC contractor to interface the CBTC system with a passenger information system. However, SEPTA currently has a plan to provide a passenger information system that informs passengers of the route for an approaching CBTC train.

6.3.9.1	CBTC fault reporting.	The SEPTA CBTC implementation provides diagnostic, fault and data logging capability to identify problems within the region ATP and ATO equipment. These failures are reported to the central control facility.
6.3.9.2	Train fault reporting.	In the SEPTA CBTC implementation, the vehicle CBTC equipment provides diagnostic, fault and data logging capability to identify problems within the train-borne ATC equipment and the train consist. These failures are reported to the Region ATO, which in turn, reports the failure to the central control system.

APPENDIX
C

Assessment of NYCT Safety Certification Process

FRA Paragraph	Requirement	Assessment of NYCT Safety Plan
(h)	Did the property use Subpart H as the basis for its safety certification process?	NYCT used Subpart H as a component of their safety certification process, in particular for the comparative hazard risk assessment. The safety certification process was built around the 10 steps detailed in the report.
§ 236.18	Software management control plan.	
(a)	Was a software management control plan adopted for the CBTC system prior to the commencement of operation?	The Contractor submitted a Software Configuration Management Plan (SCMP) to NYCT for approval. The Plan was consistent with the CENELEC safety standard EN-50128. Before each installation of any new software for revenue service or test in the field, NYCT and the ISA verified that agreed process was followed.
(b)	Did the property implement the software management control plan within 30 months of the completion of the plan?	No. However, the CBTC supplier did implement a software configuration management plan (SCMP) that was approved by NYCT.
(c)	Is the plan compliant with the requirements of § 236.18 (c)?	Yes, the SCMP included elements for requirements traceability and configuration management.
§ 236.110	Results of tests.	
(b)	Did the property develop a Railroad Safety Program Plan (RSPP) pursuant to §236.905, and which addresses, at a minimum, the following subject areas:	No. However, NYCT developed a System Safety Certification Plan (SSCP) and required the CBTC supplier to implement a System Safety Plan (SSP) that complies with the requirements of both CENELEC standard EN50126 and MIL-STD-882C, Task 102.
(1)	A description of the preliminary safety analysis, including:	The CBTC supplier SSP included a description of general system safety requirements, and hazard analysis techniques.
(i)	A complete description of methods used to evaluate a system's behavioral characteristics;	Was not included in the SSCP nor the SSP.
(ii)	A complete description of risk assessment procedures;	Both the NYCT SSCP and the CBTC supplier SSP included hazard analysis techniques.
(iii)	The system safety precedence followed; and	Was not included in the SSPP.
(iv)	The identification of the safety assessment process.	The SSCP included detailed steps (10) for the safety certification process.
(2)	Design for verification and validation.	The SSP included safety verification procedures.
(3)	Design for human factors.	Was not included in the SSP.
(4)	Configuration management control plan.	Both the SSCP and the SSP included requirements for configuration management of the hardware and software elements of the NYCT CBTC system.

FRA Paragraph	Requirement	Assessment of NYCT Safety Plan
§ 236.907	Product Safety Plan (PSP).	
(a)	Did the property develop a Product Safety Plan (PSP) pursuant to the requirements of §236.907, and which include the following:	No. But the CBTC system supplier developed a System Safety Plan (SSP) which included safety requirements for the products.
(1)	A complete description of the product, including a list of all product components and their physical relationship in the subsystem or system;	This was included in the System Design Document (SDD) provided by the CBTC system supplier.
(2)	A description of the railroad operation on which the product is designed to be used, including train movement density, railroad operating rules, and operating speeds;	<p>The System Requirements Specification (SRS) provided by the CBTC system supplier included information related to the railroad operation on which the product was designed to be used.</p> <p>Train movement density was addressed by the System Performance Simulation files. The operating rules were described in specific operating rules and procedures document.</p>
(3)	An operational concepts document, including a complete description of the product functionality and information flows;	This was included in both the SDD and the SRS provided by the CBTC system supplier.
(4)	A safety requirements document, including a list with complete descriptions of all functions which the product performs to enhance or preserve safety;	This was included in the SRS provided by the CBTC system supplier. Every safety related functions were identified in the document.
(5)	A document describing the manner in which product architecture satisfies safety requirements;	This was included in the SDD.
(6)	A hazard log consisting of a comprehensive description of all safety-relevant hazards to be addressed during the life cycle of the product, including maximum threshold limits for each hazard (for unidentified hazards, the threshold shall be exceeded at one occurrence);	NYCT created and managed a central Hazard Log for the project with inputs from the CBTC system supplier hazard log as well as the NYCT safety certification activities.
(7)	A risk assessment,	As part of the system safety certification process NYCT performed a comparative risk assessment between the existing signaling system and CBTC. The CBTC system supplier also performed hazard risk assessment for their scope of the work.
(8)	A hazard mitigation analysis, including a complete and comprehensive description of all hazards to be addressed in the system design and development, mitigation techniques used, and system safety precedence followed, as prescribed by the applicable RSPP;	A hazard mitigation analysis was performed.
(9)	A complete description of the safety assessment and verification and validation processes applied to the product and the results of these processes, describing how subject areas covered in Appendix C of Subpart H are either: addressed directly, addressed using other safety criteria, or not applicable;	Safety assessment and verification were performed. However, there was no mapping of the results to subject areas covered in Appendix C of Subpart H.
(10)	A complete description of the safety assurance concepts used in the product design, including an explanation of the design principles and assumptions;	This was included in the Safety Concepts document provided by the CBTC system supplier.

FRA Paragraph	Requirement	Assessment of NYCT Safety Plan
(11)	A human factors analysis, including a complete description of all human-machine interfaces, a complete description of all functions performed by humans in connection with the product to enhance or preserve safety, and an analysis in accordance with Appendix E of Subpart H;	The CBTC system supplier included human factors analysis as part of all the safety analyses provided.
(12)	A complete description of the specific training of railroad and contractor employees and supervisors necessary to ensure the safe and proper installation, implementation, operation, maintenance, repair, inspection, testing, and modification of the product;	This was included in the training program documents. One step of the safety certification process was to verify the readiness of the organization for each new release of the system to be placed in revenue service.
(13)	A complete description of the specific procedures and test equipment necessary to ensure the safe and proper installation, implementation, operation, maintenance, repair, inspection, testing, and modification of the product. These procedures, including calibration requirements, shall be consistent with or explain deviations from the equipment manufacturer's recommendations;	Testing requirements were included in the test procedures. Testing requirements and reports were reviewed as part of the safety certification process. Requirements related to test equipment and calibration requirements were only addressed when applicable (note that this requirement is almost not applicable for a CBTC system as most of the test equipment are software driven simulator tools).
(15)	A complete description of the necessary security measures for the product over its life-cycle;	Was not included in the SSCP.
(16)	A complete description of each warning to be placed in the Operations and Maintenance Manual identified in § 236.919, and of all warning labels required to be placed on equipment as necessary to ensure safety;	This was included in relevant Operations and Maintenance manuals.
(17)	A complete description of all initial implementation testing procedures necessary to establish that safety-functional requirements are met and safety-critical hazards are appropriately mitigated;	This was included in the test program documentation.
(18)	A complete description of:	
(i)	All post-implementation testing (validation) and monitoring procedures, including the intervals necessary to establish that safety-functional requirements, safety-critical hazard mitigation processes, and safety-critical tolerances are not compromised over time, through use, or after maintenance (repair, replacement, adjustment) is performed; and	Was not included in the FSSP.
(ii)	Each record necessary to ensure the safety of the system that is associated with periodic maintenance, inspections, tests, repairs, replacements, adjustments, and the system's resulting conditions, including records of component failures resulting in safety-relevant hazards;	Was not included in the SSCP.
(19)	A complete description of any safety-critical assumptions regarding availability of the product, and a complete description of all backup methods of operation; and	Was not included in the SSCP.
(20)	A complete description of all incremental and predefined changes.	Was not included in the SSCP.

FRA Paragraph	Requirement	Assessment of NYCT Safety Plan
(1)	All contractual arrangements with hardware and software suppliers for immediate notification of any and all safety critical software upgrades, patches, or revisions for their processor-based system, sub-system, or component, and the reasons for such changes from the suppliers, whether or not the railroad has experienced a failure of that safety-critical system, sub-system, or component.	Was not included in the SSCP.
(2)	The railroad’s procedures for action upon notification of a safety-critical upgrade, patch, or revision for this processor-based system, sub-system, or component, and until the upgrade, patch, or revision has been installed;	Was not included in the SSCP.
(3)	Identify configuration/revision control measures designed to ensure that safety-functional requirements and safety-critical hazard mitigation processes are not compromised as a result of any such change, and that any such change can be audited.	Was not included in the SSCP.
(4)	Did the CBTC supplier report any safety relevant failure to the property? Did the CBTC supplier report any previously unidentified hazards to the property?	No. No.
§ 236.909	Minimum performance standard.	
(a)	Did the property establish a minimum performance standard for the CBTC system as defined by § 236.909?	No. However, a traditional approach for product safety was used, and was based on assuring a probability of unsafe failure of 10-9.
(c)	Did the property perform a full risk assessment on the CBTC system as defined by § 236.909? Did the property perform an abbreviated risk assessment on the CBTC system as defined by § 236.909?	NYCT performed a comparative risk assessment between the existing signaling system and the new CBTC system.
(e)	If the property employed full risk assessment: 1. How did the property measure the safety and risk to operation? 2. Does the methodology used to measure the safety and risk to operation comply with the requirements of § 236.909?	Mean Time Between Unsafe Failures Yes
(c)	Does the office subsystem of the CBTC installation perform a safety function? If yes, then how did the property handle the safety assessment of the Office subsystem?	The ATS subsystem is involved in safety related functions such as programming Temporary Speed Restriction or Work Zones. The overall safety level of these functions was assessed. The Office subsystem (ATS) is not required to be fail-safe or SIL4 (vital equipment). Hazards have been mitigated by double entry and in different format of these safety critical commands. The safety integrity of the message is ensured by encoding process handled by the Zone Controller (wayside CBTC computer) which is vital equipment.

FRA Paragraph	Requirement	Assessment of NYCT Safety Plan
(h)	How did the property determine if a third party assessment is required? Who performed the third party assessment? Does the selected third party assessor comply with the definition and requirements of §236.911(h)(2) & (3)?	NYCT retained Battelle as the Independent Safety Assessor (ISA).
§ 236.915	Implementation and operation.	
(b)	Did the property operate the CBTC system in accordance with its PSP?	Yes
(c)	Does the property employ an operation that interferes with the normal functioning of the CBTC system? If yes, What precautions and measures are implemented by the property to ensure safe movements of trains and the safety of railway workers and track equipment?	Yes (fixed block wayside signals for failed trains and unequipped trains). The fallback system is fully integrated with the CBTC system. The safety was assessed for the whole system (CBTC + fallback).
(d)	Did any safety critical part or component of the CBTC system fail to perform its intended function? What action was taken by the property in response to such failure?	No
§ 236.917	Retention of records.	
(a)	Does the property have a record retention policy for the CBTC safety documents? Does this policy comply with the provisions of § 236.917?	No
(b)	Did a safety related hazard occur in the CBTC installation after it was placed in revenue service? Did the property maintain a data base for such hazards? What action did the property take to address these hazards?	No Yes (hazard log)
§ 236.919	Operations and Maintenance Manual.	
(c)	Hardware, software, and firmware revisions must be documented in the Operations and Maintenance Manual according to the railroad’s configuration management control plan and any additional configuration/revision control measures specified in the PSP.	According to the configuration management plans (software and hardware).
(d)	Safety-critical components, including spare equipment, must be positively identified, handled, replaced, and repaired in accordance with the procedures specified in the PSP.	According to the configuration management plans (software and hardware).
§ 236.921	Training and qualification program, general.	
(a)	Did the property implement a training program related to the CBTC installation? Does the training program comply with the requirements of §236.921?	Yes – The training was not based on the requirements of § 236.921
§ 236.925	Did the property provide training specific to control office personnel related to CBTC? Did the training conform to the requirements of § 236.925?	Yes – The training was not based on the requirements of § 236.925
§ 236.927	Did the property provide training specific to train operators related to CBTC? Did the training conform to the requirements of § 236.927?	Yes – The training was not based on the requirements of § 236.927

FRA Paragraph	Requirement	Assessment of NYCT Safety Plan
§ 236.929	Did the property provide training specific to roadway workers related to CBTC? Did the training conform to the requirements of § 236.929?	Yes – The training was not based on the requirements of § 236.929
	Did the property perform a risk assessment related to the CBTC installation?	Yes (comparative risk assessment between the existing and the new systems)
Appendix B to Part 236	Does the risk assessment comply with the following requirements of Appendix B to Part 236?	Yes
(a)	The risk metric for the CBTC system must describe with a high degree of confidence the accumulated risk of a train system that operates over a life-cycle of 25 years or greater.	Yes
(b)	The safety-critical assessment of the CBTC system must include all of its interconnected subsystems and components and, where applicable, the interaction between such subsystems.	Yes
(c)	Each subsystem or component of the previous condition must be analyzed with a Mean Time To Hazardous Event (MTTHE) as specified subject to a high degree of confidence.	Yes
(d)	Each risk calculation must consider the total signaling and train control system and method of operation, as subjected to a list of hazard to be mitigated by the signaling and train control system.	Yes
(e)	The failure modes of each subsystem or component, or both, must be determined for the integrated hardware/software (where applicable) as a function of the Mean Time To Failure (MTTF) failure restoration rates, and the integrated hardware/software coverage of all processor-based subsystems or components, or both. Train operating and movement rules, along with components that are layered in order to enhance safety-critical behavior, must also be considered.	Yes
(f)		
(l)	An MTTHE value must be calculated for each processor-based subsystem or component, or both, indicating the safety-critical behavior of the integrated hardware/software subsystem or component, or both. The human factor impact must be included in the assessment, whenever applicable, to provide an integrated MTTHE value. The MTTHE calculation must consider the rates of failures caused by permanent, transient, and intermittent faults accounting for the fault coverage of the integrated hardware/software subsystem or component, phased-interval maintenance, and restoration of the detected failures.	Yes

FRA Paragraph	Requirement	Assessment of NYCT Safety Plan
(2)	MTTHE compliance verification and validation must be based on the assessment of the design for verification and validation process, historical performance data, analytical methods and experimental safety-critical performance testing performed on the subsystem or component. The compliance process must be demonstrated to be compliant and consistent with the MTTHE metric and demonstrated to have a high degree of confidence.	Yes
(g)		
(1)	The safety-critical behavior of all non-processor-based components, which are part of a processor-based system or subsystem, must be quantified with an MTTHE metric. The MTTHE assessment methodology must consider failures caused by permanent, transient, and intermittent faults, phase-interval maintenance and restoration of failures and the effect of fault coverage of each non-processor-based subsystem or component.	Yes
(2)	MTTHE compliance verification and validation must be based on the assessment of the design for verification and validation process, historical performance data, analytical methods and experimental safety-critical performance testing performed on the subsystem or component. The non-processor-based quantification compliance must be demonstrated to have a high degree of confidence.	Yes
(h)	Did the property document the following assumptions related to the risk assessment performed on the CBTC system?	Yes
(1)	Assumptions regarding the reliability or availability of mechanical, electric, or electronic components.	Yes
(2)	Assumptions regarding human performance.	Yes
(3)	Assumptions regarding software defects.	Yes
(4)	All of the identified safety-critical fault paths.	Yes
Appendix C to Part 236	Safety Assurance Criteria and Processes	
(a)	Did the safety assurance criteria and processes used by the property address the following provisions of Appendix C to Part 236?	
(1)	Normal operation.	The safety design concepts, as well as the safety analyses performed for hardware and software focused on normal operation, as well as to place and maintain the system in a known safe state under any failure that could affect safety.
(2)	Systematic failure.	Systematic failures were addressed as part of the analysis of safety design concepts.
(3)	Random failure.	Random failures were addressed as part of the analysis of safety design concepts.
(4)	Common Mode failure.	Common failure mode analysis was performed as part of the analysis of safety critical hardware.

FRA Paragraph	Requirement	Assessment of NYCT Safety Plan
(5)	External influences.	External influences (e.g., EMI) were addressed as part of the analysis of safety design concepts.
(6)	Modifications.	Modifications were addressed as part of the analysis of safety design concepts.
(7)	Software.	The CBTC supplier (Siemens) performed an analysis of safety critical software, as well as verification and validation of the vital software.
(8)	Closed Loop Principle.	Yes, the NYCT CBTC system employed safety critical hardware that is based on fail-safe closed loop hardware circuits that are implemented with vital relays.
(9)	Human Factors Engineering:	This was assessed in the safety analysis documents.
(c)	What are the standards that were used by the property in its safety assurance process to verify and validate the safety of the CBTC system? Are the standards recognized as acceptable by the provisions of Appendix C of Subpart H?	The safety assurance of the NYCT CBTC system was based the CENELEC standards (EN50126,50128,50129).
Appendix D to Part 236	Independent Review of Verification and Validation	
(a)	Did the property employ the services of a third party to provide an independent assessment of the CBTC system safety verification and validation pursuant to the requirements of Subpart H?	Yes, NYCT retained Battelle as their ISA to perform safety audits, and an independent safety assessment of the CBTC system.
(b)	Did the third party assessment comply with the requirements of Appendix D to Part 236?	Yes
Appendix E to Part 236	Human-Machine Interface (HMI) Design	
(a)	Did the property use a Human-Machine Interface (HMI) Design in the development of the CBTC system as required by Appendix E to Part 236? Did the HMI design comply with the following requirements of Appendix E?	No. However, NYCT used a process that included first article inspection, and a series of meetings with the CBTC supplier to finalize HMI design.
(i)	HMI design must give an operator active functions to perform, feedback on the results of the operator’s actions, and information on the automatic functions of the system as well as its performance. The operator must be “in-the-loop.” Designers shall consider at minimum the following methods of maintaining an active role for human operators:	The HMI design, even if it is a critical part of the system, is not safety critical, as the CBTC (ATP part) is continuously monitoring and enforcing the safety of the system.
(ii)	The system must provide timely feedback to an operator regarding the system’s automated actions, the reasons for such actions, and the effects of the operator’s manual actions on the system;	Yes
(iii)	The system must warn operators in advance when they require an operator to take action; and	Yes
(iv)	HMI design must equalize an operator’s workload.	This requirement was not implemented.

FRA Paragraph	Requirement	Assessment of NYCT Safety Plan
(2)	Expectation of predictability and consistency in product behavior and communications. HMI design must accommodate an operator’s expectation of logical and consistent relationships between actions and results. Similar objects must behave consistently when an operator performs the same action upon them.	This requirement was not implemented.
(3)		
(i)	HMI design must minimize an operator’s information processing load.	This requirement was not implemented.
(ii)	HMI design must minimize the load on an operator’s memory.	This requirement was not implemented.
(4)		
(i)	Anticipate possible user errors and include capabilities to catch errors before they propagate through the system;	This requirement was not implemented.
(ii)	Conduct cognitive task analyses prior to designing the system;	This requirement was not implemented.
(iii)	Present information that accurately represents or predicts system states.	This requirement was not implemented.
(d)	Did the property employ an HMI design for the on board train displays and controls that complies with the requirements of Section (d) of Appendix E?	This requirement was not implemented.
(e)	Did the property employ an HMI design, which provides operational information to enhance the operator’s situation awareness as defined in Section (e) of Appendix E?	This requirement was not implemented.

Notes:

1. Subpart H requirements that are related to FRA audits, approvals, record retention, and other administrative provisions were deleted from this matrix.
2. Subpart H requirements that are related to Class A train operation, and which are not applicable to transit operating environment were deleted from this matrix.

APPENDIX
D

Assessment of SEPTA Safety Certification Process

FRA Paragraph	Requirement	Assessment of SEPTA Safety Plan
(h)	Did the property use Subpart H as the basis for its safety certification process?	At the time when the contract documents for the SEPTA CBTC project were being drafted, Subpart H was still under development by the FRA.
§ 236.18	Software management control plan.	
(a)	Was a software management control plan adopted for the CBTC system prior to the commencement of operation?	SEPTA did not implement a software management control plan as required by the provisions of Subpart H. However, SEPTA required the CBTC supplier to follow the provisions of MIL-STD-882C, which in turn required the implementation of a software development process.
(b)	Did the property implement the software management control plan within 30 months of the completion of the plan?	No. However, the CBTC supplier did implement a software development plan (SDP) that was audited by SEPTA.
(c)	Is the plan compliant with the requirements of § 236.18 (c)?	Yes, the SDP included elements for requirements traceability and configuration management.
§ 236.110	Results of tests.	
(b)	Did the property develop a Railroad Safety Program Plan (RSPP) pursuant to §236.905, and which addresses, at a minimum, the following subject areas:	No. However, SEPTA required the CBTC supplier to implement a System Safety Program Plan (SSPP) that complies with the requirements of MIL-STD-882C, Task 102.
(l)	A description of the preliminary safety analysis, including:	The SSPP included a description of general system safety requirements, and hazard analysis techniques.
(i)	A complete description of methods used to evaluate a system's behavioral characteristics;	Was not included in the SSPP.
(ii)	A complete description of risk assessment procedures;	The SSPP included hazard analysis techniques.
(iii)	The system safety precedence followed; and	Was not included in the SSPP.
(iv)	The identification of the safety assessment process.	The SSPP included general system safety requirements and criteria.
(2)	Design for verification and validation.	The SSPP included safety verification procedures.
(3)	Design for human factors.	Was not included in the SSPP.
(4)	Configuration management control plan.	Was not included in the SSPP. However, the CBTC supplier did implement a configuration management plan for the hardware and software elements of the SEPTA CBTC system.
§ 236.907	Product Safety Plan (PSP).	
(a)	Did the property develop a Product Safety Plan (PSP) pursuant to the requirements of §236.907, and which include the following:	A Product Safety Plan was not developed for the SEPTA CBTC project. This project preceded Subpart H, and requirement for a PSP. However, the FLEXIBLOCK system safety program (FSSP), which is based on MIL-STD-882C, included some of the PSP requirements.

FRA Paragraph	Requirement	Assessment of SEPTA Safety Plan
(1)	A complete description of the product, including a list of all product components and their physical relationship in the subsystem or system;	Was not included in the FSSP.
(2)	A description of the railroad operation on which the product is designed to be used, including train movement density, railroad operating rules, and operating speeds;	Was not included in the FSSP.
(3)	An operational concepts document, including a complete description of the product functionality and information flows;	Was not included in the FSSP.
(4)	A safety requirements document, including a list with complete descriptions of all functions which the product performs to enhance or preserve safety;	The FSSP included the safety requirements for the CBTC system, as well as the required safety criteria.
(5)	A document describing the manner in which product architecture satisfies safety requirements;	Was not included in the FSSP.
(6)	A hazard log consisting of a comprehensive description of all safety-relevant hazards to be addressed during the life cycle of the product, including maximum threshold limits for each hazard (for unidentified hazards, the threshold shall be exceeded at one occurrence);	A hazard log was included in the FSSP.
(7)	A risk assessment,	A risk assessment was included in the FSSP.
(8)	A hazard mitigation analysis, including a complete and comprehensive description of all hazards to be addressed in the system design and development, mitigation techniques used, and system safety precedence followed, as prescribed by the applicable RSPP;	A hazard mitigation analysis was performed.
(9)	A complete description of the safety assessment and verification and validation processes applied to the product and the results of these processes, describing how subject areas covered in Appendix C of Subpart H are either: addressed directly, addressed using other safety criteria, or not applicable;	Safety assessment and verification were performed. However, there was no mapping of the results to subject areas covered in Appendix C of Subpart H.
(10)	A complete description of the safety assurance concepts used in the product design, including an explanation of the design principles and assumptions;	Was not included in the FSSP.
(11)	A human factors analysis, including a complete description of all human-machine interfaces, a complete description of all functions performed by humans in connection with the product to enhance or preserve safety, and an analysis in accordance with Appendix E of Subpart H;	Was not included in the FSSP.
(12)	A complete description of the specific training of railroad and contractor employees and supervisors necessary to ensure the safe and proper installation, implementation, operation, maintenance, repair, inspection, testing, and modification of the product;	Was not included in the FSSP.

FRA Paragraph	Requirement	Assessment of SEPTA Safety Plan
(13)	A complete description of the specific procedures and test equipment necessary to ensure the safe and proper installation, implementation, operation, maintenance, repair, inspection, testing, and modification of the product. These procedures, including calibration requirements, shall be consistent with or explain deviations from the equipment manufacturer’s recommendations;	Testing requirements were included in the FSSP. However, requirements related to test equipment and calibration requirements were not addressed.
(15)	A complete description of the necessary security measures for the product over its life-cycle;	Was not included in the FSSP.
(16)	A complete description of each warning to be placed in the Operations and Maintenance Manual identified in § 236.919, and of all warning labels required to be placed on equipment as necessary to ensure safety;	Was not included in the FSSP.
(17)	A complete description of all initial implementation testing procedures necessary to establish that safety-functional requirements are met and safety-critical hazards are appropriately mitigated;	Was not included in the FSSP.
(18)	A complete description of:	
(i)	All post-implementation testing (validation) and monitoring procedures, including the intervals necessary to establish that safety-functional requirements, safety-critical hazard mitigation processes, and safety-critical tolerances are not compromised over time, through use, or after maintenance (repair, replacement, adjustment) is performed; and	Was not included in the FSSP.
(ii)	Each record necessary to ensure the safety of the system that is associated with periodic maintenance, inspections, tests, repairs, replacements, adjustments, and the system’s resulting conditions, including records of component failures resulting in safety-relevant hazards;	Was not included in the FSSP.
(19)	A complete description of any safety-critical assumptions regarding availability of the product, and a complete description of all backup methods of operation; and	Was not included in the FSSP.
(20)	A complete description of all incremental and predefined changes.	Was not included in the FSSP.
(1)	All contractual arrangements with hardware and software suppliers for immediate notification of any and all safety-critical software upgrades, patches, or revisions for their processor-based system, sub-system, or component, and the reasons for such changes from the suppliers, whether or not the railroad has experienced a failure of that safety-critical system, sub-system, or component.	Was not included in the FSSP.
(2)	The railroad’s procedures for action upon notification of a safety-critical upgrade, patch, or revision for this processor-based system, sub-system, or component, and until the upgrade, patch, or revision has been installed;	Was not included in the FSSP.

FRA Paragraph	Requirement	Assessment of SEPTA Safety Plan
(3)	Identify configuration/revision control measures designed to ensure that safety-functional requirements and safety-critical hazard mitigation processes are not compromised as a result of any such change, and that any such change can be audited.	Was not included in the FSSP.
(4)	Did the CBTC supplier report any safety relevant failure to the property? Did the CBTC supplier report any previously unidentified hazards to the property?	The FSSP included provisions for safety incident reporting.
§ 236.909	Minimum performance standard.	
(a)	Did the property establish a minimum performance standard for the CBTC system as defined by § 236.909?	No. However, a traditional approach for product safety was used, and was based on assuring a probability of unsafe failure of 10 ⁻⁹ .
(c)	Did the property perform a full risk assessment on the CBTC system as defined by § 236.909? Did the property perform an abbreviated risk assessment on the CBTC system as defined by § 236.909?	No.
(e)	If the property employed full risk assessment: • How did the property measure the safety and risk to operation? • Does the methodology used to measure the safety and risk to operation comply with the requirements of § 236.909?	N/A
(c)	Does the office subsystem of the CBTC installation perform a safety function? If yes, then how did the property handle the safety assessment of the Office subsystem?	SEPTA did not perform a safety assessment on the office subsystem. However, new operating rules were created to address operational risks, including any risks associated with the office subsystem.
(h)	How did the property determine if a third party assessment is required? Who performed the third party assessment? Does the selected third party assessor complies with the definition and requirements of §236.911(h)(2) & (3)?	SEPTA retained Parsons Transportation Group to perform a safety audit and an independent safety assessment of the CBTC system. However, this assessment was not based on the requirements of §236.911(h)(2) & (3).
§ 236.915	Implementation and operation.	
(b)	Did the property operate the CBTC system in accordance with its PSP?	N/A – SEPTA did not develop a PSP document.
(c)	Does the property employ an operation that interferes with the normal functioning of the CBTC system? If yes, What precautions and measures are implemented by the property to ensure safe movements of trains and the safety of railway workers and track equipment?	No
(d)	Did any safety-critical part or component of the CBTC system fail to perform its intended function? What action was taken by the property in response to such failure?	No

FRA Paragraph	Requirement	Assessment of SEPTA Safety Plan
§ 236.917	Retention of records.	
(a)	<p>Does the property have a record retention policy for the CBTC safety documents?</p> <p>Does this policy comply with the provisions of § 236.917?</p>	<p>SEPTA has not implemented a record retention policy based on the provisions of § 236.917. However, SEPTA does rely on its general record retention procedures for various types of documents. Further, SEPTA indicated that it has a policy to maintain all records associated with CBTC alarms.</p>
(b)	<p>Did a safety related hazard occur in the CBTC installation after it was placed in revenue service? Did the property maintain a data base for such hazards? What action did the property take to address these hazards?</p>	<p>No. However, SEPTA recognizes that when a train operates in “bypass” mode, it represents risks to operation. An alarm is generated at the Control Center.</p>
§ 236.919	Operations and Maintenance Manual.	
(c)	<p>Hardware, software, and firmware revisions must be documented in the Operations and Maintenance Manual according to the railroad’s configuration management control plan and any additional configuration/revision control measures specified in the PSP.</p>	<p>SEPTA has delegated this requirement to the CBTC supplier.</p>
(d)	<p>Safety-critical components, including spare equipment, must be positively identified, handled, replaced, and repaired in accordance with the procedures specified in the PSP.</p>	<p>Yes, vital and safety-critical components are tagged and handled differently from non-vital components.</p>
§ 236.921	Training and qualification program, general.	
(a)	<p>Did the property implement a training program related to the CBTC installation?</p> <p>Does the training program comply with the requirements of §236.921?</p>	<p>Yes</p> <p>The training was not based on the requirements of § 236.921</p>
§ 236.925	<p>Did the property provide training specific to control office personnel related to CBTC?</p> <p>Did the training conform to the requirements of § 236.925?</p>	<p>Yes</p> <p>The training was not based on the requirements of § 236.925</p>
§ 236.927	<p>Did the property provide training specific to train operators related to CBTC?</p> <p>Did the training conform to the requirements of § 236.927?</p>	<p>Yes</p> <p>The training was not based on the requirements of § 236.927</p>
§ 236.929	<p>Did the property provide training specific to roadway workers related to CBTC?</p> <p>Did the training conform to the requirements of § 236.929?</p>	<p>Yes</p> <p>The training was not based on the requirements of § 236.929</p>
	<p>Did the property perform a risk assessment related to the CBTC installation?</p>	<p>No</p>
Appendix B to Part 236	<p>Does the risk assessment comply with the following requirements of Appendix B to Part 236?</p>	<p>SEPTA did not perform risk assessment pursuant to the requirements of Appendix B to Part 236.</p>
(a)	<p>The risk metric for the CBTC system must describe with a high degree of confidence the accumulated risk of a train system that operates over a life-cycle of 25 years or greater.</p>	<p>This requirement was not implemented.</p>

FRA Paragraph	Requirement	Assessment of SEPTA Safety Plan
(b)	The safety-critical assessment of the CBTC system must include all of its interconnected subsystems and components and, where applicable, the interaction between such subsystems.	This requirement was not implemented.
(c)	Each subsystem or component of the previous condition must be analyzed with a Mean Time To Hazardous Event (MTTHE) as specified subject to a high degree of confidence.	This requirement was not implemented.
(d)	Each risk calculation must consider the total signaling and train control system and method of operation, as subjected to a list of hazard to be mitigated by the signaling and train control system.	This requirement was not implemented.
(e)	The failure modes of each subsystem or component, or both, must be determined for the integrated hardware/software (where applicable) as a function of the Mean Time To Failure (MTTF) failure restoration rates, and the integrated hardware/software coverage of all processor-based subsystems or components, or both. Train operating and movement rules, along with components that are layered in order to enhance safety-critical behavior, must also be considered.	This requirement was not implemented.
(f)		
(1)	An MTTHE value must be calculated for each processor-based subsystem or component, or both, indicating the safety-critical behavior of the integrated hardware/software subsystem or component, or both. The human factor impact must be included in the assessment, whenever applicable, to provide an integrated MTTHE value. The MTTHE calculation must consider the rates of failures caused by permanent, transient, and intermittent faults accounting for the fault coverage of the integrated hardware/software subsystem or component, phased-interval maintenance, and restoration of the detected failures.	This requirement was not implemented.
(2)	MTTHE compliance verification and validation must be based on the assessment of the design for verification and validation process, historical performance data, analytical methods and experimental safety-critical performance testing performed on the subsystem or component. The compliance process must be demonstrated to be compliant and consistent with the MTTHE metric and demonstrated to have a high degree of confidence.	This requirement was not implemented.
(g)		
(1)	The safety-critical behavior of all non-processor-based components, which are part of a processor-based system or subsystem, must be quantified with an MTTHE metric. The MTTHE assessment methodology must consider failures caused by permanent, transient, and intermittent faults, phase-interval maintenance and restoration of failures and the effect of fault coverage of each non-processor-based subsystem or component.	This requirement was not implemented.

FRA Paragraph	Requirement	Assessment of SEPTA Safety Plan
(2)	MTTHE compliance verification and validation must be based on the assessment of the design for verification and validation process, historical performance data, analytical methods and experimental safety-critical performance testing performed on the subsystem or component. The non-processor-based quantification compliance must be demonstrated to have a high degree of confidence.	This requirement was not implemented.
(h)	Did the property document the following assumptions related to the risk assessment performed on the CBTC system?	This requirement was not implemented.
(l)	Assumptions regarding the reliability or availability of mechanical, electric, or electronic components.	This requirement was not implemented.
(2)	Assumptions regarding human performance.	This requirement was not implemented.
(3)	Assumptions regarding software defects.	This requirement was not implemented.
(4)	All of the identified safety-critical fault paths.	This requirement was not implemented.
Appendix C to Part 236	Safety Assurance Criteria and Processes	
(a)	Did the safety assurance criteria and processes used by the property address the following provisions of Appendix C to Part 236?	
(1)	Normal operation.	The safety design concepts, as well as the safety analyses performed for hardware and software focused on normal operation, as well as to place and maintain the system in a known safe state under any failure that could affect safety.
(2)	Systematic failure.	Systematic failures were addressed as part of the analysis of safety design concepts.
(3)	Random failure.	While random failures were not specifically addressed under a separate heading in the safety analysis, it is implied that this type of failure was assessed during the analysis of safety-critical hardware.
(4)	Common Mode failure.	Common failure mode analysis was performed as part of the analysis of safety-critical hardware.
(5)	External influences.	This was not assessed in the safety analysis documents.
(6)	Modifications.	This was not addressed in the safety analysis documents
(7)	Software.	The CBTC supplier (Bombardier) performed an analysis of safety-critical software, as well as verification and validation of the vital software.
(8)	Closed Loop Principle.	Yes, the SEPTA ATP system employed safety-critical hardware that is based on fail-safe closed loop hardware circuits that are implemented with vital relays.
(9)	Human Factors Engineering:	This was not assessed in the safety analysis documents.
(c)	<p>What are the standards that were used by the property in its safety assurance process to verify and validate the safety of the CBTC system?</p> <p>Are the standards recognized as acceptable by the provisions of Appendix C of Subpart H?</p>	<p>he safety assurance of the SEPTA CBTC system was based on a number MIL-STD-882C. This standard is recognized as acceptable in Appendix C of Subpart H.</p>

FRA Paragraph	Requirement	Assessment of SEPTA Safety Plan
Appendix D to Part 236	Independent Review of Verification and Validation	
(a)	Did the property employ the services of a third party to provide an independent assessment of the CBTC system safety verification and validation pursuant to the requirements of Subpart H?	Yes, SEPTA retained Parsons Transportation Group to perform a safety audit, and an independent safety assessment of the CBTC system.
(b)	Did the third party assessment comply with the requirements of Appendix D to Part 236?	No. Subpart H was still under development when the SEPTA CBTC specification was being drafted.
Appendix E to Part 236	Human-Machine Interface (HMI) Design	
(a)	Did the property use a Human-Machine Interface (HMI) Design in the development of the CBTC system as required by Appendix E to Part 236? Did the HMI design comply with the following requirements of Appendix E?	No. However, SEPTA used a process that included first article inspection, and a series of meetings with the CBTC supplier to finalize HMI design.
(1)	HMI design must give an operator active functions to perform, feedback on the results of the operator’s actions, and information on the automatic functions of the system as well as its performance. The operator must be “in-the-loop.” Designers shall consider at minimum the following methods of maintaining an active role for human operators:	To the extent possible, the HMI for train operator was made to be transparent to existing operation and procedures. However, this approach is not based on the requirements of Appendix E. As such, the specific requirements of Appendix E were not implemented.
(ii)	The system must provide timely feedback to an operator regarding the system’s automated actions, the reasons for such actions, and the effects of the operator’s manual actions on the system;	This requirement was not implemented.
(iii)	The system must warn operators in advance when they require an operator to take action; and	This requirement was not implemented.
(iv)	HMI design must equalize an operator’s workload.	This requirement was not implemented.
(2)	Expectation of predictability and consistency in product behavior and communications. HMI design must accommodate an operator’s expectation of logical and consistent relationships between actions and results. Similar objects must behave consistently when an operator performs the same action upon them.	This requirement was not implemented.
(3)		
(i)	HMI design must minimize an operator’s information processing load.	This requirement was not implemented.
(ii)	HMI design must minimize the load on an operator’s memory.	This requirement was not implemented.
(4)		

FRA Paragraph	Requirement	Assessment of SEPTA Safety Plan
(i)	Anticipate possible user errors and include capabilities to catch errors before they propagate through the system;	This requirement was not implemented.
(ii)	Conduct cognitive task analyses prior to designing the system;	This requirement was not implemented.
(iii)	Present information that accurately represents or predicts system states.	This requirement was not implemented.
(d)	Did the property employ an HMI design for the on board train displays and controls that complies with the requirements of Section (d) of Appendix E?	This requirement was not implemented.
(e)	Did the property employ an HMI design, which provides operational information to enhance the operator’s situation awareness as defined in Section (e) of Appendix E?	This requirement was not implemented.

Notes:

1. Subpart H requirements that are related to FRA audits, approvals, record retention, and other administrative provisions were deleted from this matrix.
2. Subpart H requirements that are related to Class A train operation, and which are not applicable to transit operating environment were deleted from this matrix.

ACRONYMS AND ABBREVIATIONS

AC	Alternating Current
ACSES	Advanced Civil Speed Enforcement System
ADU	ACSES Display Unit
AF	Audio Frequency
APTA	American Public Transit Association
ASC	Automatic Speed Control
ASCAP	Axiomatic Safety-Critical Assessment Process
ASES	Advanced Speed Enforcement System
ATC	Automatic Train Control
ATO	Automatic Train Operation
ATP	Automatic Train Protection
ATPM	Automatic Train Protection Manual Mode
ATS	Automatic Train Stop or Automatic Train Supervision
ATSS	AT Signal System
AWS	Auxiliary Wayside System
BDR	Base Data Radio
BMT	Brooklyn Manhattan Transit
BRT	Brooklyn Rapid Transit
CBTC	Communications-Based Train Control
CCD	Charge Coupled Device
CCRD	CBTC Carborne Radio Distribution
CENELEC	Commission Européenne de Normalisation Électrique
CMT	Corrective Maintenance Time
COTS	Commercial off-the-Shelf
CPU	Central Processing Unit
CRU	Carborne Radio Unit
DCS	Data Communication System
ERTMS	European Rail Traffic Management System
FCC	Federal Communications Commission
FDDI	Fiber Data Distribution interface
FRA	Federal Railroad Administration
FTA	Federal Transit Administration
HMI	Human-Machine Interface
I/O	Input/Output

I2	Interoperability Interface
IEC	International Electrotechnical Commission
IEEE	Institute of Electrical and Electronics Engineers
IRSE	Institution of Railway Signal Engineers
IRT	Interborough Rapid Transit
ISA	Independent Safety Assessor
ISM	Industrial, Scientific, & Medical (service)
ISO	International Organization for Standardization
LRT	Light Rail Transit
LRV	Light Rail Vehicle
LU	London Underground
MAS	Maximum Authorized Speed
MDR	Mobile Data Radio
MPH	Miles per Hour
MRTT	Mean Repair Travel Time
MTBF	Mean Time Between Failures
MTBFF	Mean Time Between Functional Failures
MTBUF	Mean Time Between Unsafe Failure
MTTR	Mean Time to Repair
Muni	San Francisco Municipal Railway
NEC	Northeast Corridor
NJ Transit	New Jersey Transit
NTSB	National Transportation Safety Board
NVATC	Region Non-vital Automatic Train Control
NYC	New York City
NYCT	New York City Transit
OBCU	Onboard Control Unit/Carborne Controller
OPTO	One Person Train Operation
OSMES	Optical Speed and Position Measurement System
OTP	On Time Performance
PATH	Port Authority Trans Hudson
PLC	Programmable Logic Controller
PSP	Product Safety Plan
PTC	Positive Train Control

PTG	Parsons Transportation Group
PTS	Positive Train Separation
RAM	Reliability, Availability and Maintainability
RAMS	Reliability, Availability, Maintainability, & Safety
RATO	Region Automatic Train Operation
RATP	Régie Autonome des Transports Parisiens
RCC	Rail Control Center
RCS	Radio Communication System
RF	Radio-Frequency
RSPP	Railroad Safety Program Plan
RTO	New York City Transit, Rapid Transit Operation
RTVI	Rail Transit Vehicle Interface
RWS	Remote Workstation
SDD	System Design Document
SDP	Software Development Plan
SDR	System Design Review
SEPTA	Southeastern Pennsylvania Transportation Authority
SFS	System Functional Specification
SIL	Safety Integrity Level
SSCB	System Safety Certification Board
SSHA	Subsystem Hazard Analysis
SSPP	System Safety Program Plan
STO	Semi-automatic Train Operation
STS	Siemens Transportation Systems
TDM	Time Division Multiplex
TPH	Train-Per-Hour
TSR	Temporary Speed Restrictions
TWC	Train-to-Wayside Communications
US	United States
US&S	Union Switch & Signals
UTO	Unattended Train Operation
V&V	Verification & Validation
VATO	Vehicle Automatic Train Operation
VATP	Vehicle Automatic Train Protection

VPI	Vital Processor Interlocking
WCC	Wayside Cell Controller
WCN	Wayside CBTC Network
WCU	Wayside Control Unit
WIU	Wayside Interface Unit
WRU	Wayside Radio Unit
WSP	Wayside Signal Protection
WTU	Wayside Transmission Unit
ZC	Zone Controller

REFERENCES

1. Interborough Rapid Transit Company. 1904. The New York Subway: Its construction and equipment. Accessed July 17, 2013, http://www.nycsubway.org/wiki/The_New_York_Subway:_Chapter_09,_Signal_System.
2. National Transportation Safety Board. 2009. Collision of two Washington Metropolitan Area Transit Authority Metrorail trains near Fort Totten Station: Railroad accident report. NTSB/RAR 10-02, PB2010-916302, Washington, DC, June 22. Accessed on July 17, 2013, <http://www.nts.gov/doclib/reports/2010/RAR1002.pdf>.
3. Transport for London. 2013. Tube Improvement Plan. Accessed July 17, 2013, <http://www.tfl.gov.uk/corporate/projectsandschemes/18090.aspx>.
4. Siemens lands PATH CBTC contract. 2013. *Railway Age*. Accessed July 17, 2013, <http://www.railjournal.com/this-month/are-operators-making-the-best-use-of-technology.html>.
5. Rumsey, Alan. 2011. Communications Based Train Control. *IRSE News* 166, April.



U.S. Department of Transportation
Federal Transit Administration

East Building
1200 New Jersey Avenue, SE
Washington, DC 20590
<http://www.fta.dot.gov/research>