

Automated Track Video Inspection Pilot Project

SEPTEMBER 2013

FTA Report No. 0049
Federal Transit Administration

PREPARED BY
MTA-NYCT



COVER PHOTO

Courtesy of New York City Transit

DISCLAIMER

This document is disseminated under the sponsorship of the U.S. Department of Transportation in the interest of information exchange. The United States Government assumes no liability for its contents or use thereof. The United States Government does not endorse products or manufacturers. Trade or manufacturers' names appear herein solely because they are considered essential to the objective of this report.

Automated Track Video Inspection Pilot Project

SEPTEMBER 2013

FTA Report No. 0049

PREPARED BY

MTA-NYCT
130 Livingston Street
Brooklyn, NY 11201

SPONSORED BY

Federal Transit Administration
Office of Research, Demonstration and Innovation
U.S. Department of Transportation
1200 New Jersey Avenue, SE
Washington, DC 20590

AVAILABLE ONLINE

<http://www.fta.dot.gov/research>

Metric Conversion Table

SYMBOL	WHEN YOU KNOW	MULTIPLY BY	TO FIND	SYMBOL
LENGTH				
in	inches	25.4	millimeters	mm
ft	feet	0.305	meters	m
yd	yards	0.914	meters	m
mi	miles	1.61	kilometers	km
VOLUME				
fl oz	fluid ounces	29.57	milliliters	mL
gal	gallons	3.785	liters	L
ft³	cubic feet	0.028	cubic meters	m ³
yd³	cubic yards	0.765	cubic meters	m ³
NOTE: volumes greater than 1000 L shall be shown in m ³				
MASS				
oz	ounces	28.35	grams	g
lb	pounds	0.454	kilograms	kg
T	short tons (2000 lb)	0.907	megagrams (or "metric ton")	Mg (or "t")
TEMPERATURE (exact degrees)				
°F	Fahrenheit	5 (F-32)/9 or (F-32)/1.8	Celsius	°C

REPORT DOCUMENTATION PAGE		Form Approved OMB No. 0704-0188	
Public reporting burden for this collection of information is estimated to average 1 hour per response, including the time for reviewing instructions, searching existing data sources, gathering and maintaining the data needed, and completing and reviewing the collection of information. Send comments regarding this burden estimate or any other aspect of this collection of information, including suggestions for reducing this burden, to Washington Headquarters Services, Directorate for Information Operations and Reports, 1215 Jefferson Davis Highway, Suite 1204, Arlington, VA 22202-4302, and to the Office of Management and Budget, Paperwork Reduction Project (0704-0188), Washington, DC 20503.			
1. AGENCY USE ONLY	2. REPORT DATE September 2013	3. REPORT TYPE AND DATES COVERED May 2012–September 2013	
4. TITLE AND SUBTITLE Automated Track Video Inspection Pilot Project		5. FUNDING NUMBERS NY-26-7112-00	
6. AUTHOR(S) Antonio Cabrera, P.E., Assistant Chief Officer, Track Engineering, Division of MOW Engineering, Department of Subways Marcelo Vargas, P.E., Senior Director of Automated Track Inspections			
7. PERFORMING ORGANIZATION NAME(S) AND ADDRESS(ES) MTA-NYCT 130 Livingston Street Brooklyn NY 11201		8. PERFORMING ORGANIZATION REPORT NUMBER FTA Report No. 0049	
9. SPONSORING/MONITORING AGENCY NAME(S) AND ADDRESS(ES) U.S. Department of Transportation Federal Transit Administration Office of Research, Demonstration and Innovation East Building 1200 New Jersey Avenue, SE Washington, DC 20590		10. SPONSORING/MONITORING AGENCY REPORT NUMBER FTA Report No. 0049	
11. SUPPLEMENTARY NOTES [http://www.fta.dot.gov/research]			
12A. DISTRIBUTION/AVAILABILITY STATEMENT Available from: National Technical Information Service (NTIS), Springfield, VA 22161. Phone 703.605.6000, Fax 703.605.6900, email [orders@ntis.gov]		12B. DISTRIBUTION CODE TRI-20	
13. ABSTRACT This project had two main objectives. The first was to improve the safety of transit workers, specifically right-of-way safety for rail transit workers through demonstration of advanced track inspection techniques that limit the inspector's exposure to rail right-of-way by visually inspecting the condition of the tracks from a safe location. The second objective was to enhance the quality of inspection by the use of objective, high-quality video systems capable of recording detailed images of the track and its main components at train speeds, coupled and synchronized with the use of multiple measuring systems installed onboard a Track Inspection Car. This report describes the use of those systems under a Pilot Project performed by MTA-NYCT using its TGC4 car on a segment of the Flushing Line (#7 Train) in New York City and includes a discussion of the results and benefits found by the use of the video and measuring systems together.			
14. SUBJECT TERMS Train worker safety, rail transit worker safety, advanced track inspection, track condition, safety video systems, train measuring systems, MTA-NYCT, TCG4		15. NUMBER OF PAGES 84	
16. PRICE CODE			
17. SECURITY CLASSIFICATION OF REPORT Unclassified	18. SECURITY CLASSIFICATION OF THIS PAGE Unclassified	19. SECURITY CLASSIFICATION OF ABSTRACT Unclassified	20. LIMITATION OF ABSTRACT

TABLE OF CONTENTS

1	Executive Summary
5	Section 1: Phase 1: Engineering and Feasibility Study of Installation of Power Rail View and Field Side Rail View Video Systems
14	Section 2: Phase 2: Manufacturing of Mounting Platforms, Installation and Mounting of Power Rail View and Field Side Rail View Video Cameras
19	Section 3: Phase 3: Improvements and Additions to Existing TGC4 Video System Software
27	Section 4: Phase 4: Vehicle-Based Visual Track Inspection Pilot Project, Using TGC4 Equipped with Power Rail View and Field Side Rail View Video Cameras
68	Section 5: Final Comments
71	Section 6: Proposal for Further Research

LIST OF FIGURES

3	Figure ES-1:	Summary of defects reported by Track Walker visual inspections vs. TGC4 video inspections
6	Figure 1-1:	Field Side and Power Rail video components conflict with existing Rail View video equipment
7	Figure 1-2:	Existing Gauge Side Rail View cameras and equipment installed on TGC4
7	Figure 1-3:	Power Rail View clearance study in tight curve
8	Figure 1-4:	Field Side Rail View clearance study in tight curve
8	Figure 1-5:	Field Side Rail View and Power Rail View video equipment installed
9	Figure 1-6:	Field Side Rail View mounting hardware with mock-up equipment attached
9	Figure 1-7:	Power Rail View mounting hardware with mock-up equipment attached
10	Figure 1-8:	Power Rail View mounting hardware with mock-up equipment attached
10	Figure 1-9:	Field Side Rail View mounting hardware with mock-up equipment attached
11	Figure 1-10:	Field Side Rail View mounting hardware with mock-up equipment installed on TGC4
11	Figure 1-11:	Mechanical drawing of modified Field Side Rail View video system mounting hardware
12	Figure 1-12:	Modified Field Side Rail View video system mounting hardware with mock-up equipment installed on TGC4
15	Figure 2-1:	Power Rail (Third Rail) View video system installed at axle #2 of TGC4
15	Figure 2-2:	Power Rail View video system illuminating third rail equipment
15	Figure 2-3:	Field Side Rail View video system camera installed at axle #2 of TGC4
16	Figure 2-4:	Field Side Rail View video system illumination lights installed at axle #2 of TGC4
16	Figure 2-5:	Field Side Rail View video system illuminating Field Side of running rail
16	Figure 2-6:	TDK Lambda power supply for halogen spotlights used for illumination
17	Figure 2-7:	Video image recorded with Power Rail View video system
17	Figure 2-8:	Video image recorded with Field Side Rail View video system
20	Figure 3-1:	Image from Rail Side View video AVI movie
20	Figure 3-2:	Image from Rail View video AVI movie
20	Figure 3-3:	Example of user-inserted long comment

- 21 Figure 3-4: Pop-up label added to allow user to see complete comment inserted
- 21 Figure 3-5: Example of border width 1
- 21 Figure 3-6: Example of border width 5
- 22 Figure 3-7: Example with pop-up window to select desired track section
- 23 Figure 3-8: Rail View video image with flangeway gap measurements added to display
- 23 Figure 3-9: Previous runs imported via dialog, allowing selections by track information
- 24 Figure 3-10: Imported marking boxes (events) shown with date of previous run
- 24 Figure 3-11: Imported marking boxes (events) can be moved to compensate for location offsets
- 24 Figure 3-12: Compare Viewer showing two inspection runs side by side
- 25 Figure 3-13: EMGraph with synch line
- 30 Figure 4-1: Track geometry chart of track C2 S/O Hunters Point
- 31 Figure 4-2: Tunnel crosscut of track C2 S/O Hunters
- 32 Figure 4-3: Rail wear measured on track C1
- 33 Figure 4-4: Hot third rail insulator N/O Hunters Point on track C2
- 34 Figure 4-5: B-scan of detected UT defect on track C1 at station #158+28
- 34 Figure 4-6: Rail View video image of UT defect location on track C1 at station #158+28
- 35 Figure 4-7: Image from video of track C2 S/O Hunters Point
- 35 Figure 4-8: Rail View video image of track C2 at station #212+92
- 36 Figure 4-9: Field Side Rail View and Power Rail View video of track C1 at station #211+17
- 37 Figure 4-10: Power Rail View camera and lights pointing to third rail and cover board mock-up model
- 37 Figure 4-11: Field Side Rail View camera and light pointing to field Side of one running rail
- 38 Figure 4-12: Comparison of quality of lighting during various tests in December 2012
- 38 Figure 4-13: Comparison of quality of lighting during various tests in January 2013
- 39 Figure 4-14: Reflector tag (ALD) placed in center of track
- 41 Figure 4-15: Video file in AVI format – Right-of-Way View, run of 1/30/2013
- 42 Figure 4-16: Video file in AVI format – Rail View, run of 1/30/2013
- 42 Figure 4-17: Video file in AVI format – Field Side Rail View and Power Rail View, run of 1/30/2013

- 43 Figure 4-18: Marquee showing condition detected with Power Rail View
video system on track C2, run of 1/30/2013
- 44 Figure 4-19: All defects of the TGC4's measuring systems in one Excel file,
run of 1/30/13
- 46 Figure 4-20: Track geometry Excel databases for 1/30/13 and
2/13/13 inspection runs
- 47 Figure 4-21: Compare Viewer transferring defects between Rail View video
inspection runs of 1/30/13 and 2/13/2013
- 48 Figure 4-22: Compare Viewer transferring marked defects between Field
Side Rail View video inspection runs of 1/30/13 and 2/13/2013
- 49 Figure 4-23: Marquee showing a condition detected with Power Rail View
video system on track C2, run of 2/13/2013
- 50 Figure 4-24: All defects of TGC4's measuring systems in one file, run of
2/13/2013
- 53 Figure 4-25: Track geometry Excel databases for 2/13/2013 and 3/14/2013
inspection runs on track C2
- 54 Figure 4-26: Compare Viewer transferring defects between 2/13/2013 and
3/14/2013 video inspection runs
- 55 Figure 4-27: Marquee showing condition detected with Power Rail View
video system on 3/14/2013 inspection run
- 56 Figure 4-28: Final Excel database for inspection performed on 3/14/2013
on track C2
- 57 Figure 4-29: Picture link of defect on final database
- 59 Figure 4-30: Underside of cover board rubbed by third rail shoe of passenger
cars (field supervisor picture)
- 60 Figure 4-31: Cover board viewed in TGC4 Power Rail View video system of
1/30/2013 inspection run
- 60 Figure 4-32: Cover board viewed in TGC4 Power Rail View video system of
2/13/2013 inspection run
- 60 Figure 4-33: Cover board viewed in TGC4 Power Rail View video system of
3/14/2013 inspection run
- 62 Figure 4-34: Summary of track geometry defects found in the inspections of
1/30/2013, 2/13/2013, and 3/14/2013
- 63 Figure 4-35: Rail View defect detected and marked in 1/30/2013
inspection run
- 63 Figure 4-36: Same Rail View defect detected and marked in 2/13/2013
inspection run
- 64 Figure 4-37: Same Rail View defect detected and marked in 3/14/2013
inspection run
- 66 Figure 4-38: Summary of defects reported by Track Walker visual
inspections vs. TGC4 video inspections

LIST OF TABLES

40	Table 4-1:	Reference ALDs Highlighted
45	Table 4-2:	Tabulation of Defects and Conditions, Tracks C1 and C2, Run of 1/30/2013
51	Table 4-3:	Tabulation of Defects and Conditions, Tracks C1 and C2, Run of 2/13/2013
58	Table 4-4:	Tabulation of Defects and Conditions, Tracks C1 and C2, Run of 3/14/2013

FOREWORD

This project had two main objectives:

- To improve the safety of transit workers, specifically right-of-way safety for rail transit workers through demonstration of advanced track inspection techniques that limits the inspector's exposure to rail right-of-way by visually inspecting the condition of the tracks from a safe location
- To enhance the quality of inspection by increasing the inspection frequency and reporting of defects.

Automated/autonomous track inspection using state-of-the-art techniques (high-resolution track and right-of-way imaging, contactless, and other type of inspection technology) coupled with a data management system enables transit agencies to enhance and strengthen their track inspection and safety program. Automated/autonomous track inspection technologies could minimize the inherent dangers faced by traditional walking inspectors by allowing the survey of tracks from a safe area (for example, placing them on the inspection vehicle or in front of computer screens) as opposed to on the right-of-way. In addition, automated/autonomous inspection methodologies increase the operational frequency of inspection and cover significantly greater distances while decreasing the adverse operational impacts to the system that walking inspection teams create.

Automated/autonomous track inspection technologies are not entirely new to the intercity passenger rail and railroad industry, but transit agencies have not fully leveraged the existing or state-of-the-art track inspection technologies and incorporated their capabilities into their rail operations. Such system (automated/autonomous track inspection technologies coupled with a data management component) would minimize the exposure of track inspectors to the right-of-way and provide warnings of sudden changes in the infrastructure, allowing agency to monitor the rate of deterioration at any location, thus enabling a more accurate prediction of when track components need to be repair or replaced.

ACKNOWLEDGMENTS

Antonio Cabrera, P.E., Assistant Chief Officer, Track Engineering, and Marcelo Vargas, P.E., Senior Director of Automated Track Inspections, of MTA-NYCT were the primary authors of this report. Additional contributors were Gunther Oberlechner, Ph.D., and Bernhard Metzger of Plasser American Corporation. Plasser American's cooperation and involvement were crucial to the success of this work and includes the provision of CADD drawings, photographs, and the hardware and software modifications described in the report. The contribution of Arndt-Christian Voß of bvSys GmbH related to enhancements and additions to the video software was also critical to the success of the project.

Photos in Section 1, Section 2, and Section 3 are courtesy of Plasser American Corp. Photos in Section 4 are courtesy of New York City Transit.

ABSTRACT

This project had two main objectives: 1) to improve the safety of transit workers, specifically right-of-way safety for rail transit workers through demonstration of advanced track inspection techniques that limits the inspector's exposure to rail right-of-way by visually inspecting the condition of the tracks from a safe location and 2) to enhance the quality of inspection by the use of objective, high-quality video systems capable of recording detailed images of the track and its main components at train speeds, coupled and synchronized with the use of multiple measuring systems installed on board of a Track Inspection Car. This report describes the use of those systems under a Pilot Project performed by MTA-NYCT using its TGC4 car on a segment of the Flushing Line (#7 Train) in New York City and includes a discussion of the results and benefits found by the use of the video and measuring systems together.

EXECUTIVE SUMMARY

The Metropolitan Transportation Authority (MTA), through MTA-New York City Transit (NYCT), in partnership with Plasser American Corp. (PAC) of Chesapeake, Virginia, the manufacturer of highly-sophisticated track maintenance and inspection machinery, including MTA-NYCT's Track Inspection Cars, has used its TGC4 Track Inspection Car, already equipped with track geometry and other measuring systems and Right-of-Way, Rail View, and Gauge Side Rail View video systems, to achieve the objectives of this project by installing new Field Side Rail View (of the running rail) and Power Rail (Third Rail) View video systems to complete the spectrum of measurements and video inspection of major track components that can be performed by the TGC4. The project also enhanced and modified the existing video software to provide for proper identification, reporting, and comparison tools for defects found by any onboard video systems. This software enhancement was a critical part of the research study, aimed at improving the efficiency of the video review process.

MTA-NYCT's work under this project consisted of the following phases:

1. With funding from the Federal Transit Administration (FTA), Plasser American Corporation (PAC), in partnership with MTA-NYCT, performed a research study of the feasibility of the installation of a Power Rail (Third Rail) View and a Field Side View video inspection system on MTA-NYCT's TGC4 track inspection car. The potential addition of these two systems would complete the set of track measurement and video inspection systems already present onboard the TGC4 and allow it to perform complete track measurements and video inspections of all main track and third rail components. After the feasibility study confirmed that the installation could be performed, PAC modified and repositioned the two existing Gauge Side Rail View video cameras installed on the TGC4 to capture and record digital video images of the Power Rail (Third Rail) on one side of the track (with one of the cameras) and images of the Field Side Rail View of the running rail on the other side of the track (with the other camera). The feasibility study was performed by PAC at significantly reduced cost as part of this partnership.
2. Concurrent with the above, PAC performed a series of improvements and additions to the existing basic TGC4 video system playback software to allow the effective use of the newly-modified and repositioned video cameras on the TGC4; the coordination of these video systems with the other existing geometry, running rail, and power rail measuring systems on the TGC4; and the efficient reporting of defects found by any video or measuring system, creation of a database of visual defects found, comparison between subsequent test runs of the same track, etc.
3. After modifying and repositioning each of the existing Gauge Side Rail View cameras as the new Power Rail View video camera and the Field Side Rail View video camera, and once the improvements and additions to the existing basic video system software were successfully performed and their

functionality tested, MTA-NYCT performed a Vehicle-Based Visual Track Inspection Pilot Project using the TGC4 on a portion of MTA-NYCT's Flushing Line (#7 train service), in which the TGC4 performed three test runs of both mainline tracks of the section of the line to record images of the gauge side of the power rail on one side of the vehicle, the field side of one running rail, fasteners, top of running rails, and the right-of-way, as well as using the rest of the measuring systems on the TGC4 to perform a complete, objective, and accurate vehicle-based inspection of the tracks.

The concept of employing MTA-NYCT's TGC4 Track Inspection Car, upgraded with the latest state-of-the-art machine vision, allowed for the evaluation of such technology to address or mitigate a number of needs that NYCT and others in the rail transit community have related to track inspections, such as:

- Improve track worker safety by reducing the probability of incidents/accidents and enhancing the safety of the track inspectors and the quality of their inspections.
- Establish an optimum frequency of track and infrastructure inspection adequate to maintain the state of good repair of track's and infrastructure's assets.
- Provide the Division of Track Supervisors, managers, and MTA-NYCT's executives with superior objective and detailed inspection tools for the identification, prioritization, planning, and execution of maintenance, repairs, and reconstruction of track systems.
- Maximize asset (Track Geometry Car) functionality, performing full track system inspections with the TGC4 car inclusive of the power rail system and the field side of the running rails.

Phase 4 Conclusions

Following are the conclusions that can be obtained after the analysis and review of the three Flushing Line inspection runs performed under Phase 4 of this project:

- Defects or conditions detected by the TGC4's Rail View and Field Side Rail View video systems or the Power Rail View video system remained fairly constant for a period of at least 43 days in tracks C1 and C2 of the Flushing Line between Times Square and Queensboro Plaza Stations.
- The TGC4's video systems detected more detailed, accurate, and objective defects or conditions than Track Walkers observed in the same track areas during a two-week period (the time required to complete the 1st inspection run). The TGC4's video systems detected 90 defects or conditions on track C1 and 96 on track C2 in the 1/30/2013 inspection alone.

- The video systems on the TGC4 can serve as a very useful complement to the measurements acquired with the other measuring systems, providing images of the defect location to maintenance crews. In addition, they make the reports detailed, accurate, and informative of all track conditions and measurements.
- Track video inspection systems could greatly improve Track Walker safety because no personnel are needed to be on the tracks to perform track inspections, and maintenance crews are, in advance of their field work, aware of the areas where repairs need to be performed—in effect, “zeroing” in on the defects that really need attention.

Performing automated track video inspections in conjunction with other loaded dynamic measurements that the TGC4 can perform on a monthly basis seems to be more than adequate to provide an accurate assessment of track conditions and to provide an objective way to visualize conditions to infrastructure personnel in this segment of MTA-NYCT’s Flushing Line.

COMPARISON OF TGC4 VIDEO DEFECTS WITH THE TRACK WALKER INSPECTION DEFECTS									
FLUSHING LINE - TRACK C1 - TIMES SQUARE TO QUEENSBORO PLAZA									
TGC VIDEO ANALYSIS					TRACKWALKER INSPECTIONS				POSSIBLE SAME CONDITIONS
Defects Found	Defects Found		Defects Found		TOTAL TRACK WALKER DEFECTS	TRACK WALKER DEFECTS DATED	TRACK WALKER DEFECTS DATED	TRACK WALKER DEFECTS DATED	TGC VIDEO/ TRACK WALKER COMMON TRACK CONDITIONS
1/30/2013	2/13/2013	Number Fixed	3/14/2013	Number Fixed	2011 - 2013	2011	2012	2013	
90	89	1	88	1	98	85	8	5	36
COMPARISON OF TGC4 VIDEO DEFECTS WITH THE TRACK WALKER INSPECTION DEFECTS									
FLUSHING LINE - TRACK C2 - TIMES SQUARE TO QUEENSBORO PLAZA									
TGC VIDEO ANALYSIS					TRACKWALKER INSPECTIONS				POSSIBLE SAME CONDITIONS
Defects Found	Defects Found		Defects Found		TOTAL TRACK WALKER DEFECTS	TRACK WALKER DEFECTS DATED	TRACK WALKER DEFECTS DATED	TRACK WALKER DEFECTS DATED	TGC VIDEO/ TRACK WALKER COMMON TRACK CONDITIONS
1/30/2013	2/13/2013	Number Fixed	3/14/2013	Number Fixed	2011 - 2013	2011	2012	2013	
96	96	0	95	1	128	103	11	14	41

NOTE: MOST OF TRACK WALKER DEFECTS ARE REPETITIVE, STARTING THE FIRST YEAR THE DATA WAS OBTAINED (2011).

Figure ES-1

Summary of defects reported by Track Walker visual inspections vs. TGC4 video inspections

- The identification of critical defects, the prioritization of corrective repairs, the deployment of maintenance personnel for defect repairs, and the execution of maintenance, repairs, and reconstruction could be optimized by the use of the TGC4's video systems by supervisors and superintendents.
- Visual track inspection reports produced by MTA-NYCT's Track Walkers and the TGC4's video system defect reports cannot be compared easily, because the Track Walker visual inspection reports suffer from lack of clarity and objectivity, as there is no objective visual record that can be contrasted to assess the validity of the Track Walker's observations in detail.
- TGC4's video systems provide the means to analyze defects at any time by different reviewers, confirming defects almost instantly, providing a more objective and accurate report to maintenance personnel, eliminating any subjectivity.
- Once the files on the TGC4's Rail View, Field Side Rail View or Power Rail View video systems have been analyzed and marked with the defects or conditions found, these can be transferred easily and accurately to future video inspection files, as it was performed successfully during the analysis of the second and third (final) inspection runs of February 13 and 3/14/2013.
- The Power Rail View video system camera and illumination should ideally be placed in a lower position to allow viewing of conditions under the power rail's cover board. The Power Rail View video system, as it was installed in the TGC4, was not able to detect rubbing marks on the underside of the cover board because of the camera position and the lack of optimal illumination.
- Consistent and periodic use of the TGC4's Video Inspection Systems would avoid the interruptions of revenue service due to the required General Orders that walking inspections unavoidably cause in the Steinway Tunnel. The time required to perform the inspection of both tracks between Times Square and Queensboro Plaza was equal to 25 minutes using the TGC4, while Track Walkers spend several hours to walk each track.

Phase 1: Engineering and Feasibility Study of Installation of Power Rail View and Field Side Rail View Video Systems

Phase 1 Scope and Work Performed

The scope of work of Phase I of this project consisted of performing an engineering and feasibility study to evaluate the possibility of installing a Power Rail (Third Rail) View video system and a Field Side Rail View (of the running rail) video system, using MTA-NYCT'S TGC4 Track Inspection Car and the components of the TGC4-installed Gauge Side Rail View video system as the research platform.

Due to MTA-NYCT's tight clearance profile, only limited installation space was available on the TGC4 for the installation of a new Field Side Rail View and a Power Rail View video system. Before proceeding with the modifications to the existing cameras, the feasibility of their installation and repositioning needed to be evaluated and confirmed. In addition, an engineering study had to be performed to ensure that clearances were not compromised even in the worst-curve configuration and to define the levels of illumination and the optimum field of view for the repositioned cameras.

Plasser American Corporation (PAC) gathered all information required to be able to engineer the mounting hardware for the cameras and illumination equipment, compatible with NYCT's clearance envelope. PAC then designed hardware that allows mounting one each of the currently-used gauge side view cameras and, if feasible, the currently-used illumination equipment in the following two positions:

- a position to optimally see the gauge side of the power rail (third rail), cover board, insulators, anchoring devices, and other appurtenances
- a position to optimally see the field side of the running rail

At the same time, PAC checked to determine if the currently-used illumination equipment could be reused or if it was necessary to replace the light sources with different equipment. With the knowledge of the new mounting positions, PAC also checked to determine if modifications to the camera optics were required.

The first step of the project was to identify the possible mounting locations for the Power Rail View and Field Side Rail View video systems (“location” defines where the system is installed, i.e., which truck or axle; “position” defines how the system is installed in respect to the object observed, i.e., the power rail).

Taking the existing TGC4’s Gauge Side Rail View video system installation into account, it was determined that the preferred mounting location for the repositioned video systems was at truck #5, axle #9, because the Gauge Side Rail View video system was already installed there and, thus, cabling could be easily reused.

After selecting the mounting locations for both systems, PAC researched the optimum positions for the video camera equipment, taking into account:

- the optimum field of view
- the tight NYCT’s clearance requirements (minimum radius curve of 100 ft.)
- being able to reuse the existing video system equipment, including cameras, lenses, and illumination equipment

After establishing the mounting positions, PAC designed the mounting hardware for the cameras.

In the next step, PAC created a 3D CADD model of the truck, the mounting hardware, and the video cameras, including the existing rail view video system. The 3D model showed that the Field Side View and Gauge Side View video systems would conflict with the existing Rail View video system, as can be seen in Figures 1-1 and 1-2. The mounting location was, therefore, changed to axle #10 of the same truck.

Figure 1-1

Field Side and Power Rail video components (grey and light blue) conflict with existing Rail View video equipment (red and olive green)

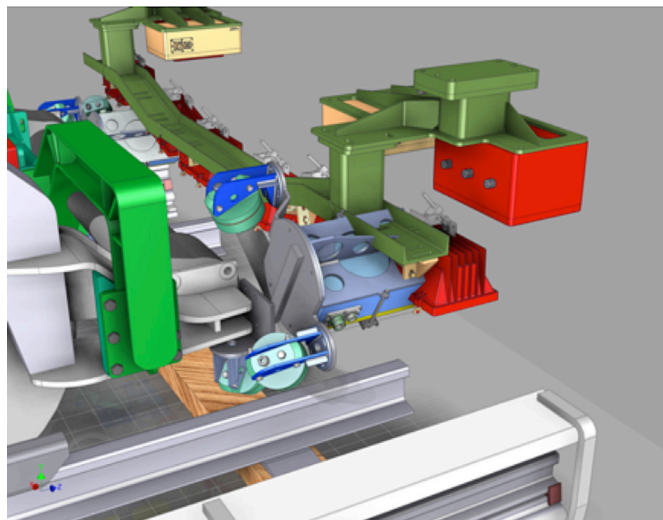

Figure 1-2

Existing Gauge Side Rail View cameras and equipment installed on TGC4



In the next step, it was determined that, due to the tight clearances, it will not be possible to reuse the existing illumination equipment. Therefore, PAC researched which illumination equipment could be used as an alternative. After performing the necessary research, PAC decided to use halogen spotlights (after it was determined that LED lights would not be powerful enough for the application). The selected halogen spotlights would be sufficient to illuminate the area of interest and small enough to fit within the clearance envelope. Three 12V/100W halogen spotlights were used per application. As a power supply, PAC selected the TDK-produced GEN20-165-1P230 device.

After selecting the halogen spotlights, PAC added the lights to the designed camera mounts at positions guaranteeing the optimum illumination of the area observed by the cameras, taking MTA-NYCT's clearance requirements into account. Figures 1-3 through 1-7 show the selected arrangement and the clearances with respect to MTA-NYCT's envelope.

Figure 1-3

Power Rail View clearance study in tight curve

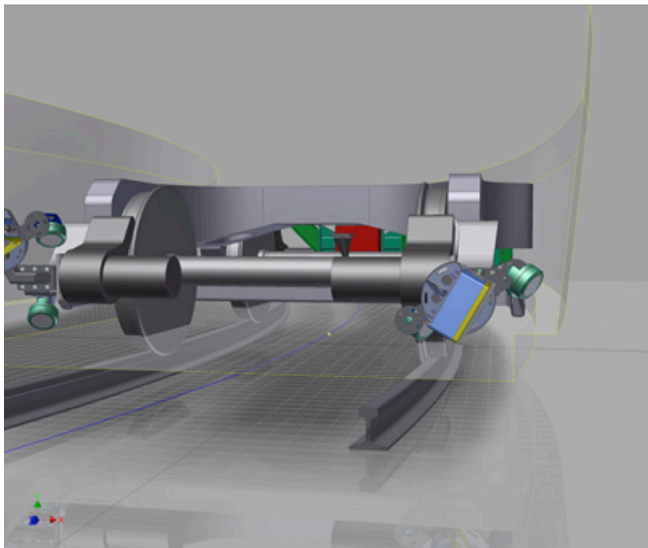

Figure 1-4

*Field Side Rail View
clearance study in
tight curve*

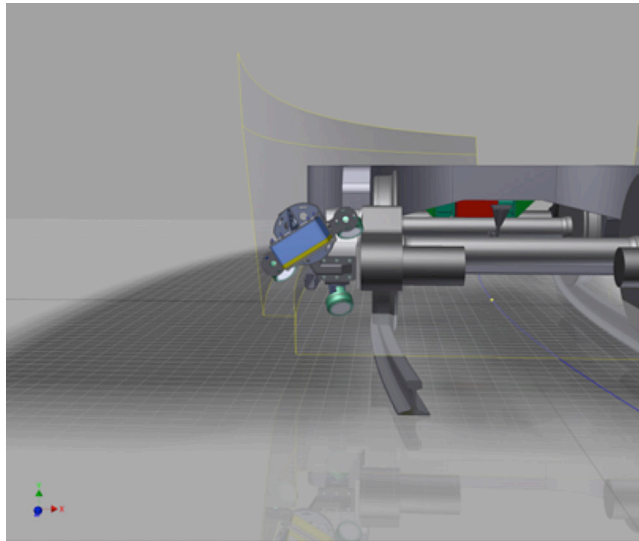
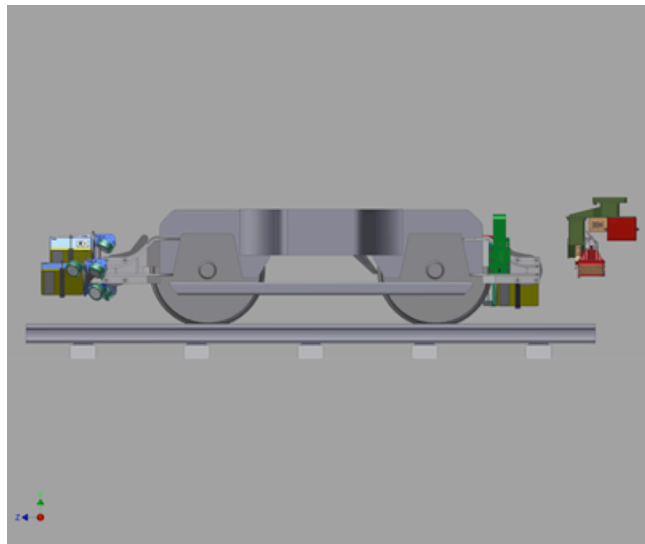

Figure 1-5

*Field Side Rail View
and Power Rail View
video equipment
installed at axle #10
(left side)*



Next, after verifying that the clearance requirements were met, PAC produced the mounting brackets and mock-up cameras and lights, and shipped the brackets, with the mock-up equipment attached, to MTA-NYCT for installation on the TGC4 (see Figures I-6 and I-7). A photo of the mounting brackets is shown in Figures I-8 and I-9.

SECTION 1: PHASE 1: ENGINEERING AND FEASIBILITY STUDY OF INSTALLATION OF POWER RAIL VIEW AND FIELD SIDE RAIL VIEW VIDEO SYSTEMS

Figure 1-6
 Field Side Rail View
 mounting hardware
 with mock-up
 equipment attached

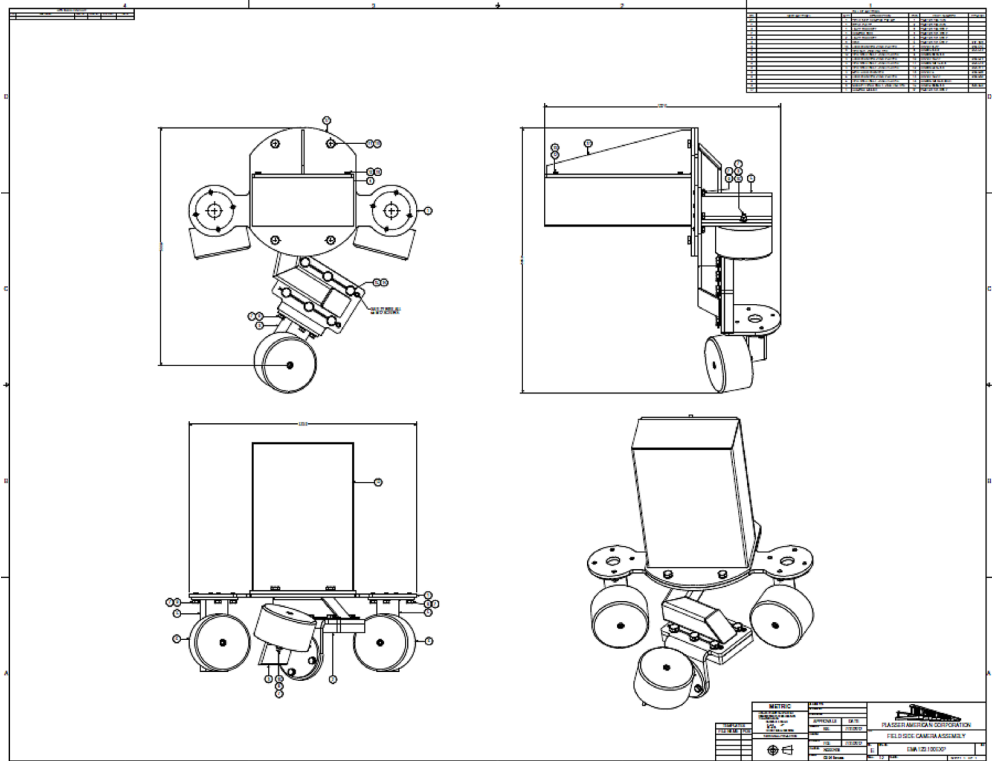

Figure 1-7
 Power Rail View
 mounting hardware
 with mock-up
 equipment attached

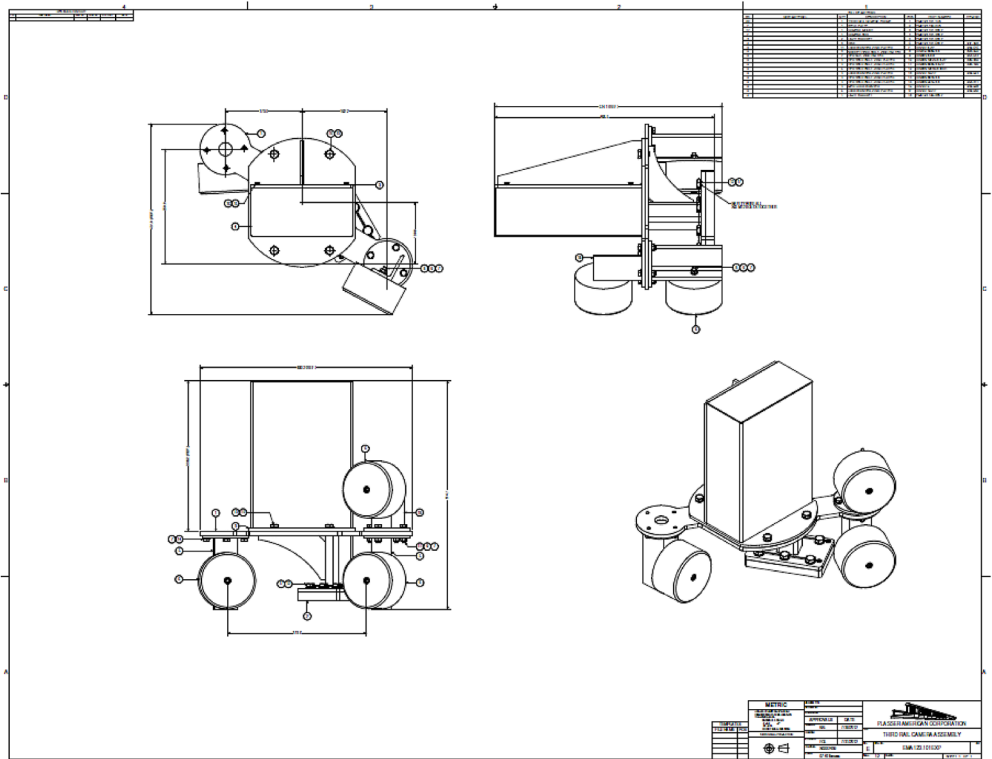

Figure 1-8

Power Rail View mounting hardware with mock-up equipment attached

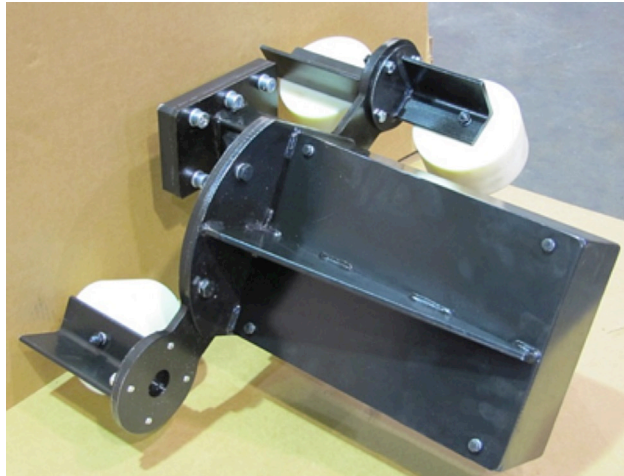

Figure 1-9

Field Side Rail View mounting hardware with mock-up equipment attached



At MTA-NYCT's Coney Island shop, MTA-NYCT and PAC teamed up to install the mounts with the mock-up equipment at axle #10 of TGC4.

MTA-NYCT and PAC then realized that installation at axle #10 was not possible because of potential infringement with the car-body-mounted equipment in tight curves. Therefore, MTA-NYCT and PAC searched the TGC4 for an alternative mounting location and found one at truck #1, axle #2. PAC and MTA-NYCT then installed the equipment at axle #2 (truck #1 and truck #5 are identical, with the exception of a 200 mm bigger axle spacing; therefore, it was possible to install the mounting hardware on truck #1 instead of on truck #5). With the 200 mm bigger axle spacing of truck #1, the maximum possible lateral movement in a 100-ft. radius curve increased by less than 4 mm, which kept the camera and illumination equipment of both systems still within the required clearance limits.

Figure 1-10

Field Side Rail View mounting hardware with mock-up equipment installed on TGC4

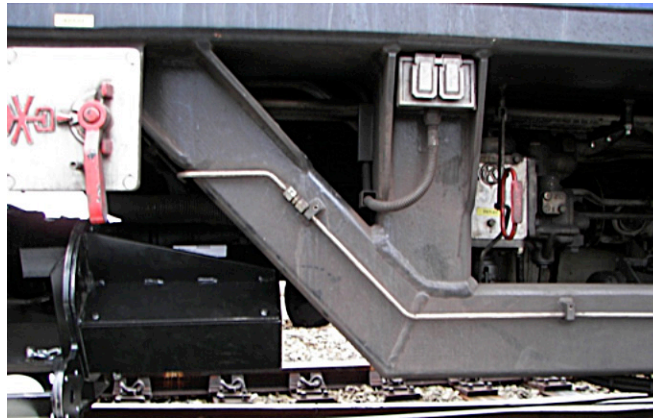

With the equipment installed, the TGC4 was driven through tight curves around MTA-NYCT's Coney Island Yard. The test drive did not show any clearance infringements, but did expose a possible interference of the Field Side Rail View camera equipment with the car body chassis in tight horizontal curves having an additional vertical curvature. PAC evaluated the situation and redesigned the mounting bracket for the Field Side Rail View video system slightly to accommodate the fact. The redesigned bracket was produced and sent to MTA-NYCT for installation on the TGC4. MTA-NYCT installed the new mount and attached the mock-up equipment. (See Figures I-11 and I-12.) With the modified bracket and equipment installed, the TGC4 was driven around the tightest mainline curves in MTA-NYCT's system without any problems.

Figure 1-11

Mechanical drawing of modified Field Side Rail View video system mounting hardware

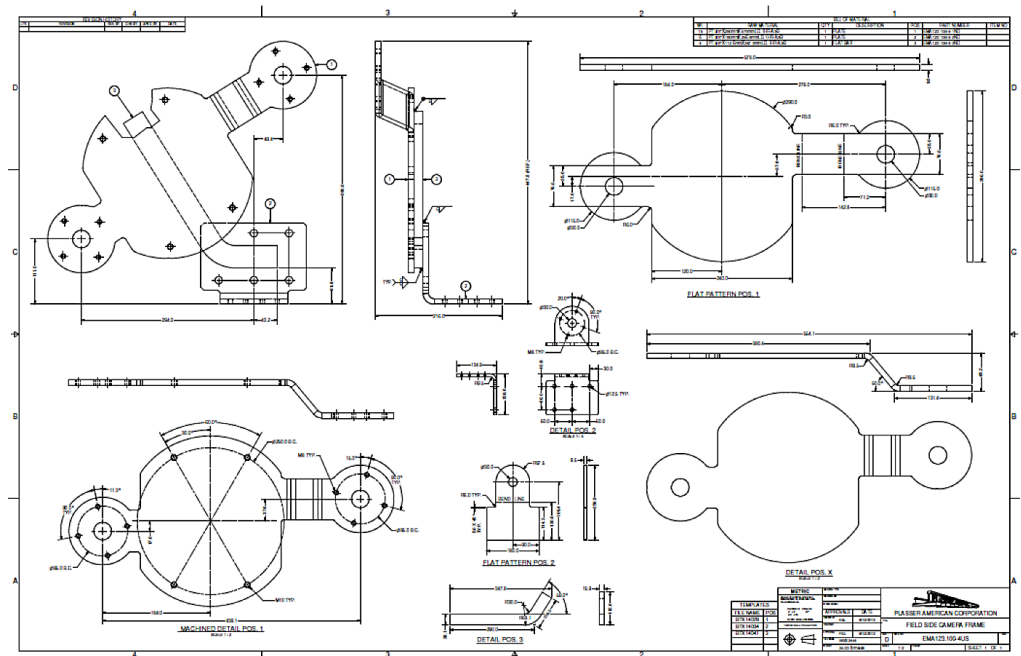

Figure 1-12

Modified Field Side Rail View video system mounting hardware with mock-up equipment installed on TGC4



PAC also performed load calculations to estimate whether the mounting hardware was able to withstand the forces expected at the mounting location. The calculations suggest that forces of 20 g could be tolerated without harmful consequences.

Since the existing camera and illumination equipment signal and power cables could not be used, PAC provided longer camera cables as needed and new cables for the illumination equipment as needed. These cables were fed through holes available in the vicinity of axle #2 of the TGC4.

Phase 1 Conclusion

The feasibility study performed by PAC with the support of MTA-NYCT confirmed that the installation of a Power Rail (Third Rail) View and Field Side Rail View of the running rail video systems on MTA-NYCT's TGC4 were feasible, and that the systems would be able to produce sharp images with the desired content at the selected mounting locations/positions.

It should be noted that, regarding the installation of a Full Field Side Rail View of both running rails and both sides' Power Rail (Third Rail) View video systems on TGC4, the study showed that both systems together cannot be installed as full systems (where each system records images for both the left and right track sides) for the following reasons:

- The field side of the running rail view system must be installed on the same truck as the Gauge Side View video system, which presently in the TGC4 is not possible to achieve due to infringement with car body mounted equipment at axle #9 and axle #10
- Axle #2 is the only position on the existing TGC4 that allows the installation of an additional video system, which, thus, can be only the Power Rail (Third Rail) View video system

In the future, to install a full Field Side Rail View of the running rail video system on the TGC4 (capable of recording both sides of the track at once), it is recommended to add a new center car (unit) to the TGC4 train consist, which can accommodate both the Field Side Rail View and the Gauge Side Rail View video systems on the same truck, or other similar alternative, such as the acquisition of a new state-of-the-art video and track measuring car equipped with the required devices and computer and electrical systems in the proper positions and locations.

SECTION
2

Phase 2: Manufacturing of Mounting Platforms and Installation, Mounting of Power Rail View and Field Side Rail View Video Cameras

Phase 2 Scope and Work Performed

The scope of work of Phase 2 of the project was to produce the mounting hardware and to install the cameras and lights at the locations selected during Phase 1 of the project.

The work comprised the manufacturing and purchasing of the items necessary to install the cameras and the illumination equipment at the locations identified during Phase 1 of the project. The items produced and purchased for the installation included:

- Mounting hardware for cameras and lights
- Camera cables in sufficient length
- Six halogen spotlights
- Power supply for the halogen spotlights
- Cables to power the spotlights
- Circuit breakers for the lights
- Miscellaneous material such as screws, cable ties, connectors, etc.

These items were successfully installed and tested at different MTA-NYCT's locations.

Figures 2-1 through 2-8 are photos of the installed items and of actual video recorded images.

Figure 2-1

Power Rail (Third Rail) View Video System installed at axle #2 of TGC4



Figure 2-2

Power Rail View video system illuminating third rail equipment



Figure 2-3

Field Side Rail View video system camera installed at axle #2 of TGC4



Figure 2-4

*Field Side Rail
View video system
illumination lights
installed at axle #2
of TGC4*



Figure 2-5

*Field Side Rail
View video system
illuminating field side
of running rail*



Figure 2-6

*TDK Lambda power
supply for halogen
spotlights used for
illumination*



Figure 2-7

*Video image recorded
with Power Rail View
video system*



Figure 2-8

*Video image recorded
with Field Side Rail
View video system*

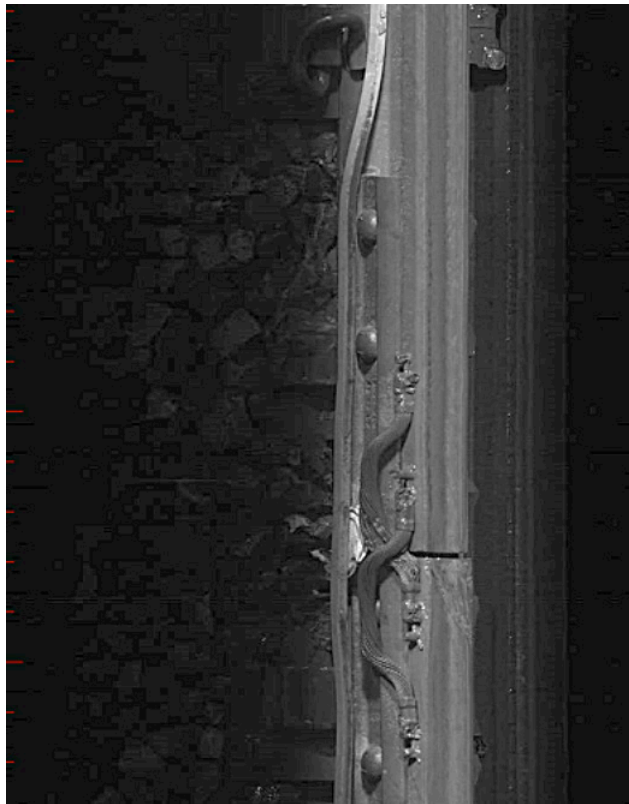

Phase 2 Conclusion

The installation of the cameras and lights was completed within the time frame specified. The clearance requirements complied with MTA-NYCT's clearance envelopes. The image data recorded during the test runs met and exceeded the expectations.

SECTION
3

Phase 3: Improvements and Additions to Existing TGC4 Video System Software

Phase 3 Scope and Work Performed

The scope of work of Phase 3 of the project was to add functionality to the existing onboard and offboard data analysis and video system software.

The work comprised the implementation of the following additions to the existing video software:

- Video image file to AVI conversion
- Increase field size for user inserted comments
- Anomaly (event) marking box border width
- “Go To Location” feature
- Flangeway measurements display
- Historical anomaly (event) marking box import feature
- Playback of two runs simultaneously
- Moving reference line

A manual explaining how to use the new software features was also provided to MTA-NYCT.

The above functionality was needed to be able to properly and accurately mark any defects detected by the reviewer of the video files, convert the video files to AVI movie files capable of being played back by any user, compare two different video runs of the same track, and add a reference line that links the track geometry data graph with the video images at the same exact track location. These features are explained below.

Video Image File to AVI Conversion

The option of converting the Rail Side View video images into AVI movie files was added. Examples are shown in Figures 3-1 and 3-2.

Figure 3-1

Image from Rail Side View video AVI movie

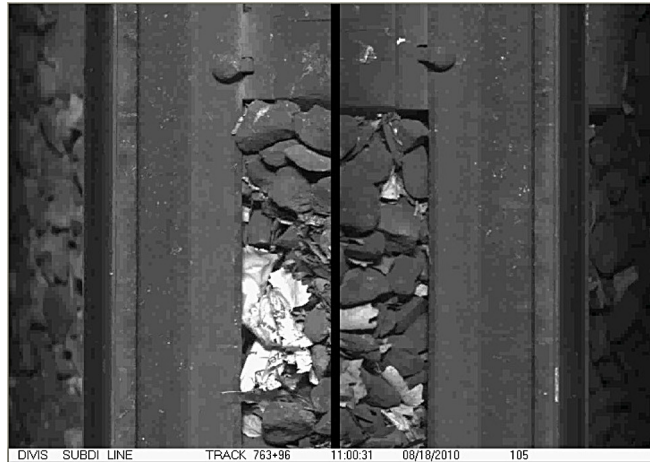

Figure 3-2

Image from Rail View video AVI movie

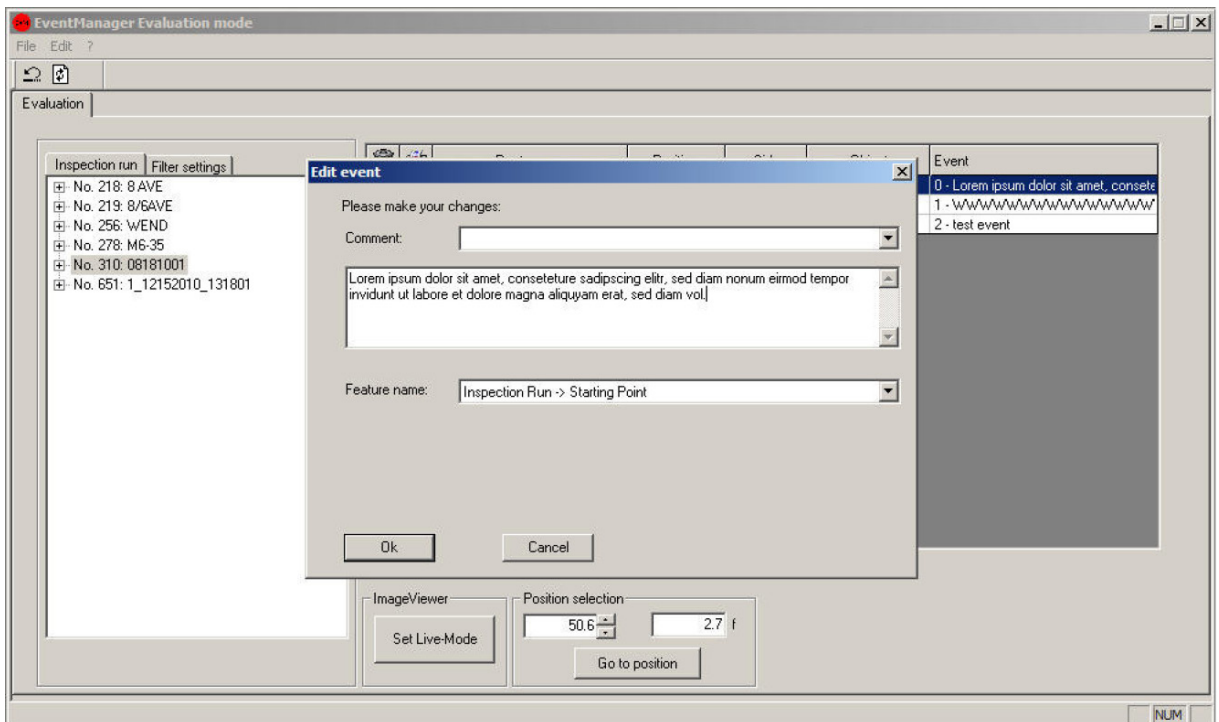

Figure 3-3

Example of user-inserted long comment

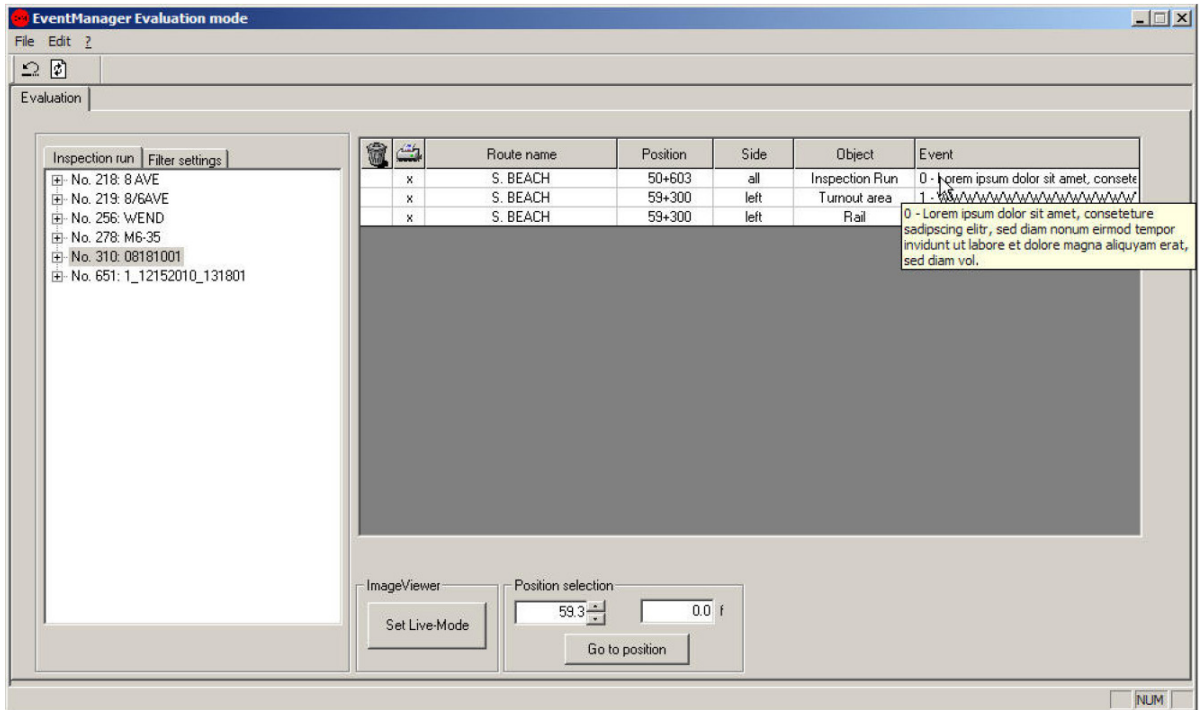

Figure 3-4

Pop-up label added to allow user to see complete comment inserted

Anomaly (Event) Marking Box Border Width

The feature of setting the marking box line width was added. The line width can be adjusted by changing the value “463, int32 Event Marker Box Border Line Width” in the Image Viewer configuration files.

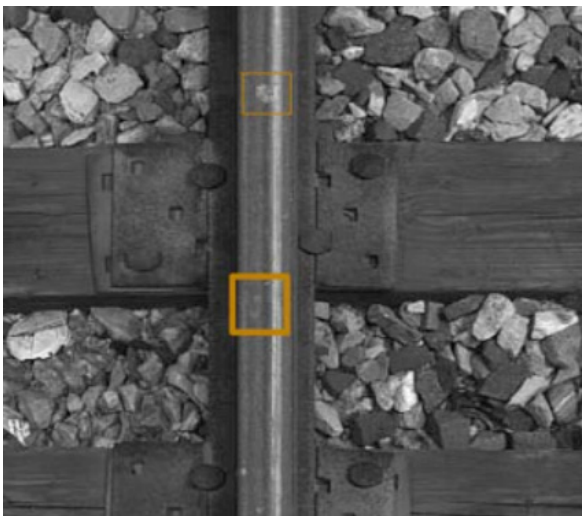

Figure 3-5

Example of border width 1

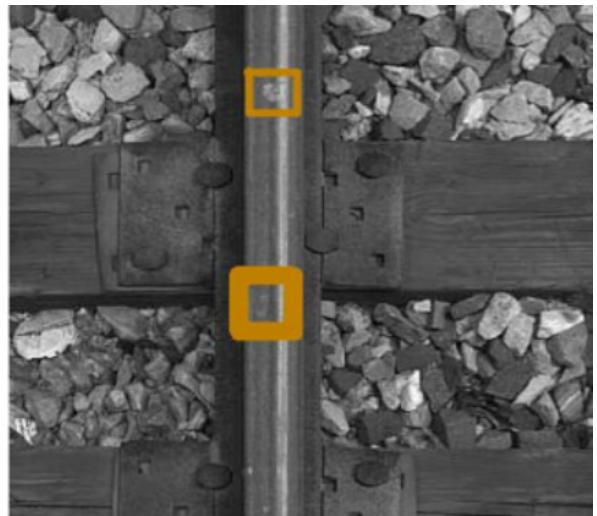

Figure 3-6

Example of border width 5

Go To Location” Feature

If the video data contain ambiguous location information for a user-selected location (same station and footage available in data multiple times), a dialog will ask the user to select the desired location taking additional track information such as line/code/track into account. An example is shown in Figure 3-7.

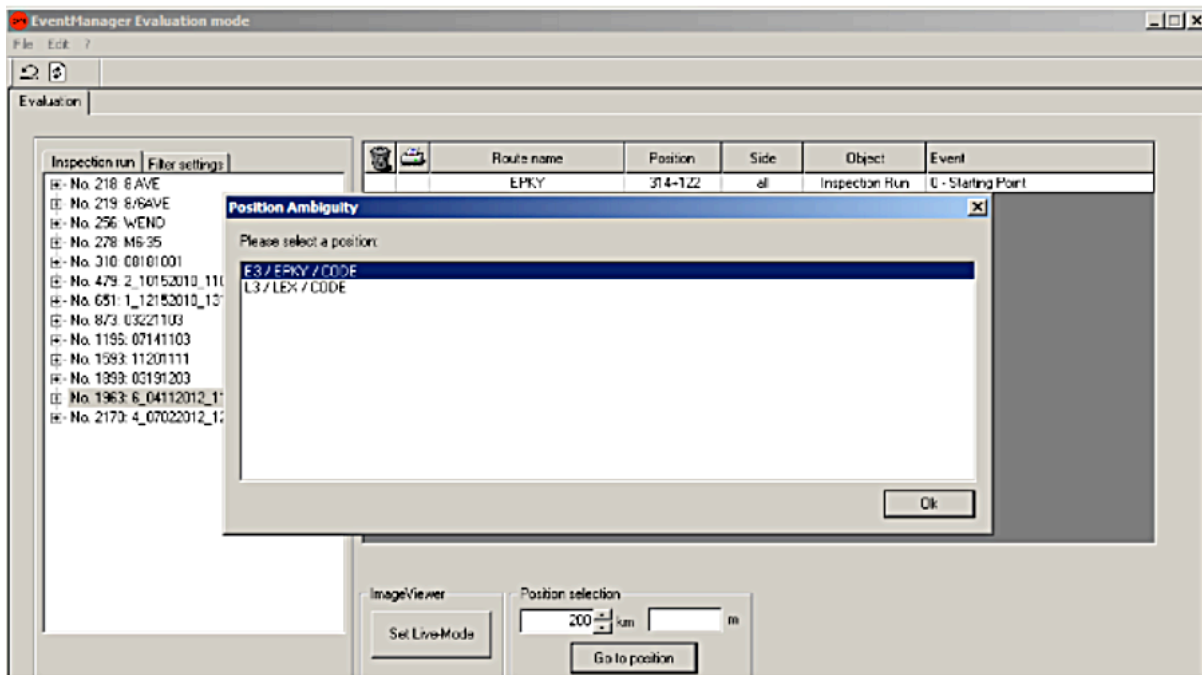

Figure 3-7

Example with pop-up window to select desired track section

Flangeway Measurements Display

This feature was implemented in both the onboard and offboard software. The TGC4’s EMI server onboard computer receives the flangeway (gap) measurements from the flangeway measuring system and forwards the measured values to the video system central computer. Four values are transmitted:

- Flangeway gap left
- Flangeway gap right
- Guard rail gap gage left (referenced to nominal guard rail gap gauge)
- Guard rail gap gage right (referenced to nominal guard rail gap gauge)

If no measurement is available for a parameter or if measurements are invalid, the system reports the value “-128.00in.”

Figure 3-8
Rail View video image with flangeway gap measurements added to display



Historical Anomaly (Event) Marking Box Import Feature

The Historical Anomaly (Event) Marking Box Import feature allows transferring event marking boxes from previously-marked runs. During development, it showed that the most efficient way of using this feature was in combination with the Compare Viewer feature. The latest software release allows showing the originally-placed marking boxes in the Compare Viewer windows. By using the adjustment slider, the software will move the video images of the “new” recording run until the marking box matches the track feature. (See Figures 3-9, 3-10, and 3-11.) Once imported, events can be accepted (stored) or deleted (if no longer present).

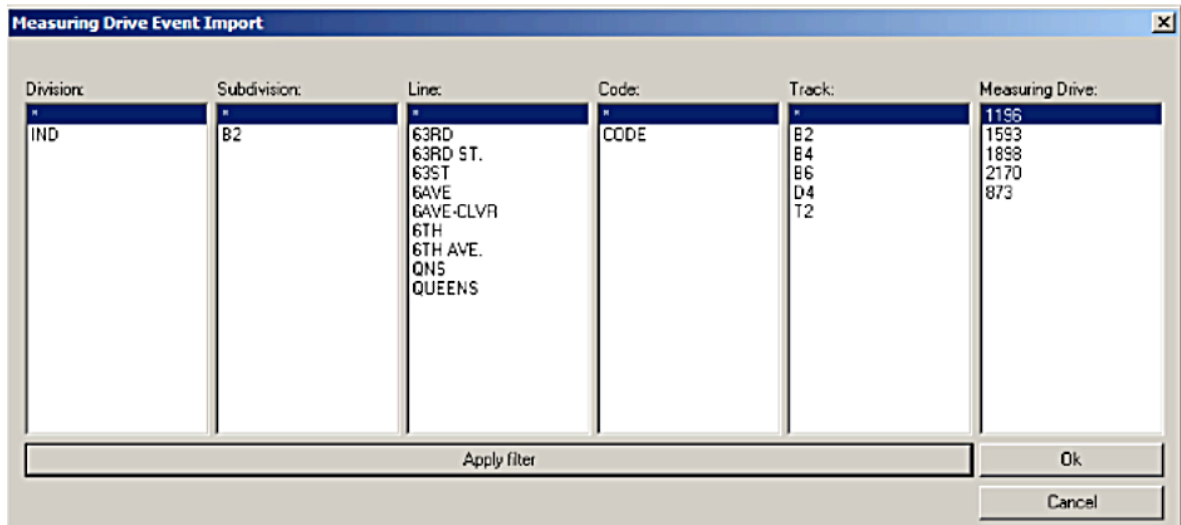

Figure 3-9

Previous runs are imported via a dialog, allowing selections by track information

Figure 3-10

Imported marking boxes (events) shown with date of previous run

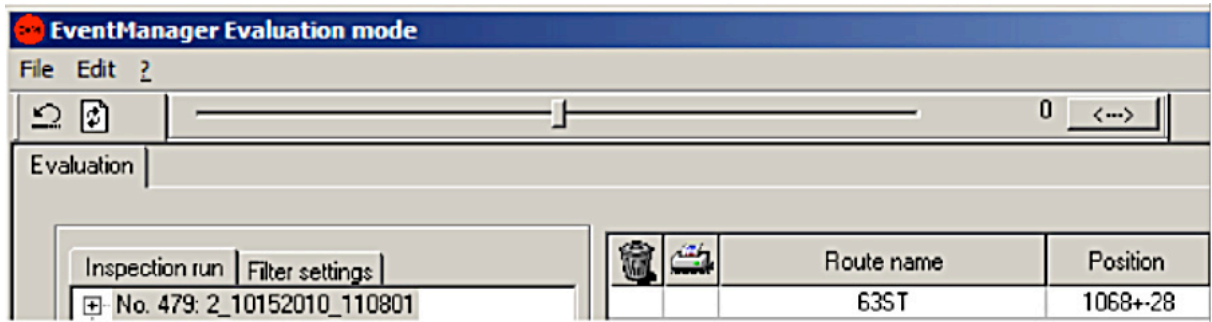

Figure 3-11

Imported marking boxes (events) can be moved to compensate for location offsets

Playback of Two Runs Simultaneously

The Compare Viewer enables playback of two inspection runs side by side.

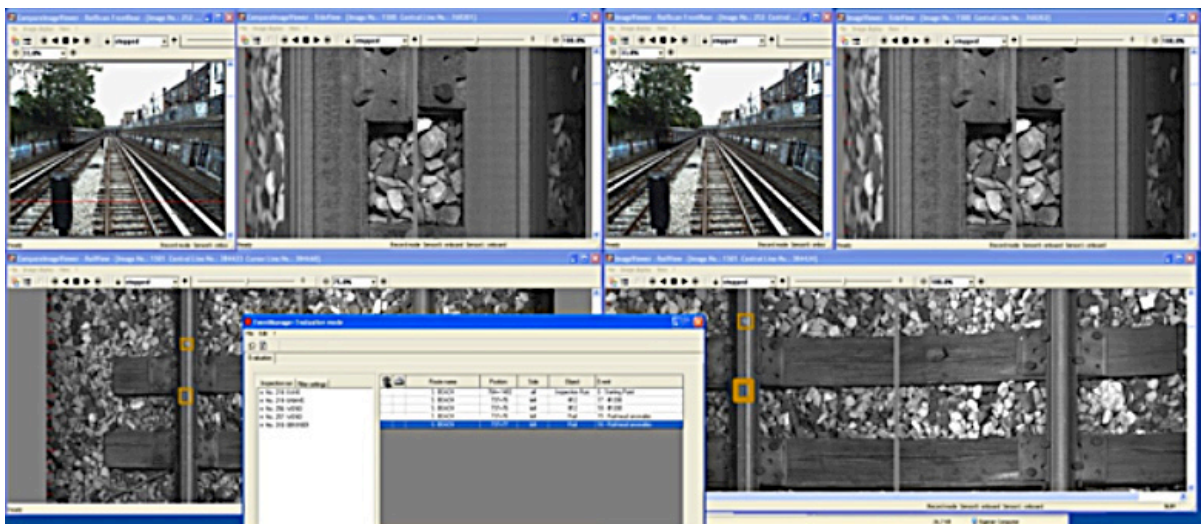

Figure 3-12

Compare Viewer showing two inspection runs side by side

Moving Reference Line

The Moving Reference Line feature synchronizes the display of measuring and video data. Plasser implemented the function as follows: the EMGraph software program, used by MTA-NYCT to display and analyze track data (i.e., track geometry, third rail position, rail profile, rail gap, etc.) shows a red reference line as part of its graphic display.

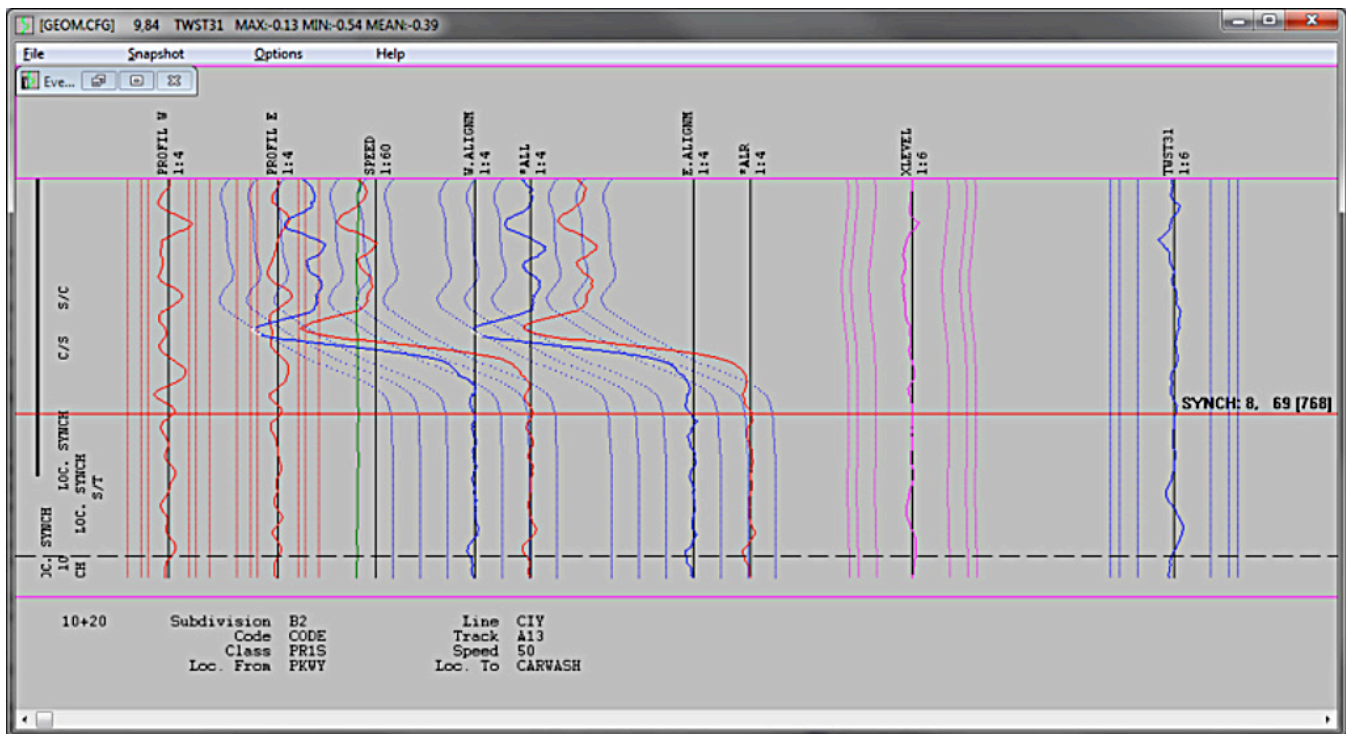

Figure 3-13
EMGraph with synch line

The EMGraph sends the track information data (recording run information, stationing, etc.) for the data displayed at the synch line to the video offboard system and, thus, has the video system display the Rail View, Side View, and Right-of-Way View images recorded exactly at the location of the synch line. The Right-of-Way view video image also shows a synch line. The synch line moves to accommodate the fact that the Right-of-Way View images are recorded only in 6 ft. intervals. The video offboard system selects the video data matching the geometry data automatically.

In addition to Remote Control and Moving Reference Line, PAC also implemented the feature of displaying the rail profiles and tunnel clearance profiles for the location of the EMGraph synch line. This feature allows MTA-NYCT to display the tunnel clearance profiles synchronous with the Right-of-Way View video images and the rail profiles with the Rail View and Side View video images.

Phase 3 Conclusion

The software improvements and additions were completed within the timeframe specified. The new features worked properly as specified. The Moving Reference Line feature, in particular, opened a whole new way of effectively analyzing the track by being able to visually evaluate, for example, the cause of a wide gauge exception shown in the track geometry printout generated by the EMGraph track geometry graphing software.

Phase 4: Vehicle-Based Visual Track Inspection Pilot Project Using TGC4 Equipped with Power Rail View and Field Side Rail View Video Cameras

In Phase 4, MTA-NYCT's TGC4 Inspection Car, already equipped with the Field Side Rail View and Power Rail View video systems installed under Phase 2, including the software modifications and additions performed under Phase 3, performed three inspection runs of mainline tracks C1 and C2 of the segment of the Flushing Line between Times Square and Queensboro Plaza stations. This included two mainline tracks with a combined track length of approximately 34,000 trk.-ft. (6.4 trk.-miles), of which 940 trk.-ft. are in open cut (ballasted track) construction, 9,000 trk.-ft. are on open-deck elevated track structure, and 24,000 trk.-ft. are in subway construction (concreted type track), including the 8,800 trk.-ft. of the Steinway Tunnel, one of the oldest and most physically-constrained under-river tubes of the MTA-NYCT system.

The Flushing Line (#7 train Line) is one of the busiest lines in MTA-NYCT's rapid transit system. During rush hours, the train headways are as short as 90 seconds. The typical traffic levels are equal to 46 MGT per track per year. The Line is also characterized by tight clearances and sharp curves, especially between Times Square (the present westernmost terminus) and Queensboro Plaza (the elevated station in Queens where the "N" train service connects to the "7" train). The Flushing Line is in the midst of conversion to Computer-Based Train Control (CBTC).

In addition, the Steinway Tunnel between 1st Avenue in Manhattan and Vernon-Jackson Avenue in Queens is the oldest under-river tube of the MTA-NYCT system, with less-than-standard clearances and having a type of obsolete power rail that has been recently replaced with the new standard composite aluminum power rail (by MTA-NYCT's Third Rail Operations' forces). It was estimated that the use of the new, improved video inspection systems for the inspection of the Steinway Tunnel potentially could lead to significant improvements regarding the productivity, quality, and safety of the inspection of the track and power rail systems, which currently can be performed only during a shutdown of the tracks

because of the restricted personnel clearances and the limited space allowable to clear up safely.

Phase 4 Scope and Work Performed

The goal of Phase 4 was to capture detailed video images of the track and power rail elements and integrate them with the existing measuring systems installed on the TGC4. In addition, a comparison of the defects found with those found during the visual working inspection process by Track Walkers would be performed. Prior to the start of Phase 4, several test (“debugging”) runs were performed to collect, analyze, and evaluate the data and to obtain the best results in terms of measurements, quality of videos, levels of illumination, etc. At the end of this first stage, the best optimum position in terms of measurements, lighting, and quality of video was achieved under the conditions reported previously in Phases 1, 2, and 3 for the Field Side Rail View and the Power Rail (Third Rail) View video systems.

MTA-NYCT’s Track Engineering personnel started collecting and analyzing video and measurement data in preparation for Phase 4 starting in December 2012, after the effects of Hurricane Sandy flooding were sufficiently mitigated to allow for resumption of normal TGC operations. These tests were dedicated to debug, check, and confirm the accuracy of all measuring systems, especially the newly-added Power Rail View and Field Side Rail View video systems. These “debugging” runs helped to assure that there were no issues with any of the systems or their integration with the rest of the other measuring systems. Results of these debugging runs were compared with the results of the data obtained in the inspections made in December 2012, which helped to evaluate the new software improvements and additions to the onboard and offboard computer systems performed during Phase 3. The data collected consisted of tests performed on sharp curves and tight clearance areas on various yard and mainline tracks. As a result of these tests, small modifications to the position of the Power Rail and Field Side View lights, cameras, and levels of illumination were performed. At the end of the first stage of runs, the TGC4 was ready to perform the final three inspections under Phase 4.

The next stage consisted of the performance of three full inspection and measuring runs of tracks C1 and C2 of the Flushing Line between Times Square and Queensboro Plaza. These inspection runs recorded detailed images and measurements of the tracks using all the video and measuring equipment installed onboard the TGC4, inspecting the tracks and power rail components, and measuring track geometry, tunnel clearances, thermal imaging, rail wear, and ultrasonic rail flaw inspection under dynamic loads at speeds up to 20 MPH (the limit for the proper operation of the ultrasonic rail flaw inspection system).

The final three inspection runs were performed successfully, with all measuring and video systems working as designed. These inspections runs were performed as follows.

The first inspection run was performed on 1/30/2013, to establish a “baseline” of the conditions and measurements recorded by the TGC4 using the repositioned video cameras, as well as the other existing measuring systems. The analysis of the inspection data proceeded as planned, and it was satisfactorily completed in the timeframe specified. Excel databases were created for tabulation and recording of defects obtained from the analysis of the data collected by the measuring systems, including defects detected by manual analysis of the video files collected. Both the video system and the existing measuring systems were used concurrently to visualize and confirm track geometry defects. All defects were tabulated to include the description and location of the defect, track and stationing information, size and characteristics of the defect, reported date, etc. The analysis of the data collected during this inspection run was completed in two working weeks.

The second inspection run was performed two weeks later on 2/13/2013, as soon as the evaluation of the first run was completed and the defects were tabulated and entered into Excel spreadsheets. The Excel databases were completed for defects analyzed with each TGC4 measuring system and for the defects identified by manual review of the video files. The analysis of this run was satisfactorily completed, and the results were compared with the defects identified in the previous inspection run performed on 1/30/2013. Defects found during this test run were logged and tabulated to indicate the total number of defects analyzed, new defects found, existing (repeat) defects, and defects that could not be observed due to the location of the video camera for the Power Rail View (looking at only one side) and the video camera for the Field Side Rail View (looking at only the opposite side of the track). The defects or conditions found included the description and location of the defect, track and stationing information, size and characteristics of the defect, repeat date, etc. The time required for the completion of this review and analysis lasted four working weeks, including transfer of the video defects identified during the first inspection run to the new inspection run’s files.

The third (and final) inspection run was performed on 3/14/2013, after the results for the second inspection run were successfully tabulated and recorded. The lapse of time between the second and third final inspections was planned to allow for some defects to be corrected and for new ones to possibly appear. This lapse in time was also necessary to review and analyze the data obtained during the second inspection run. This last inspection run was completed successfully, with all measuring systems working properly. The data obtained were reviewed and analyzed, and the results were tabulated for each measuring system, including the defects identified with the video systems, TGC4’s other measuring systems, and

using both the video systems and the other measuring systems to visualize and confirm the defects. Results of the previous two test runs were also tabulated, arranged, confirmed, and compared in one final database to include pictures of the defect location. All defects were tabulated to include description and location of the defect, track and stationing information, size and characteristics of the defect, repeat date, etc.

The TGC4 car measured the following parameters with its current existing measuring and video systems, as well as with the newly-added Field Side Rail View and Power Rail View video systems:

- **Track Geometry**, which includes longitudinal profile or surface of both running rails, alignment of both running rails, curvature, track gauge, superelevation and twist (Figure 4-1)

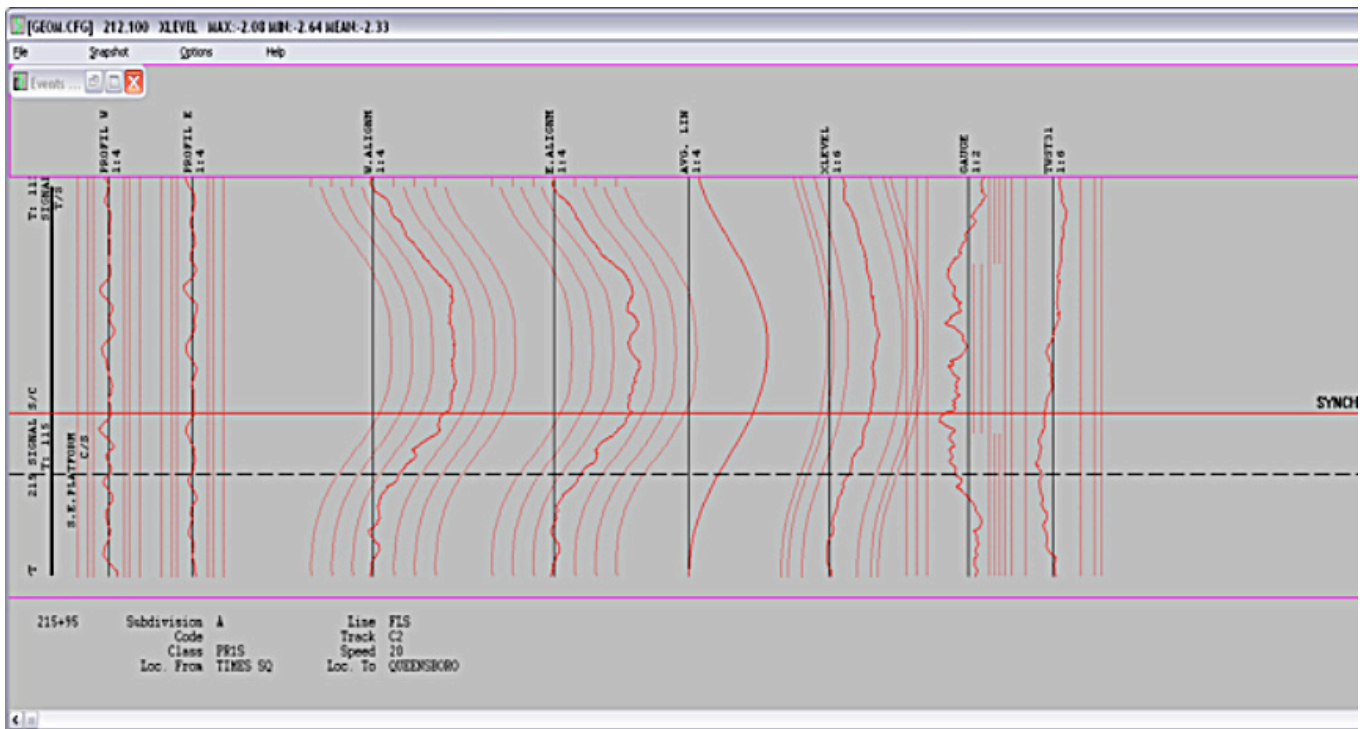

Figure 4-1

Track geometry chart of track C2 S/O Hunters Point

Red line is moving reference line synchronized with video and tunnel crosscut images seen in Figures 4-2 and 4-3

- Tunnel Clearances using the Z+ F tunnel clearance laser scanner (Figure 4-2)

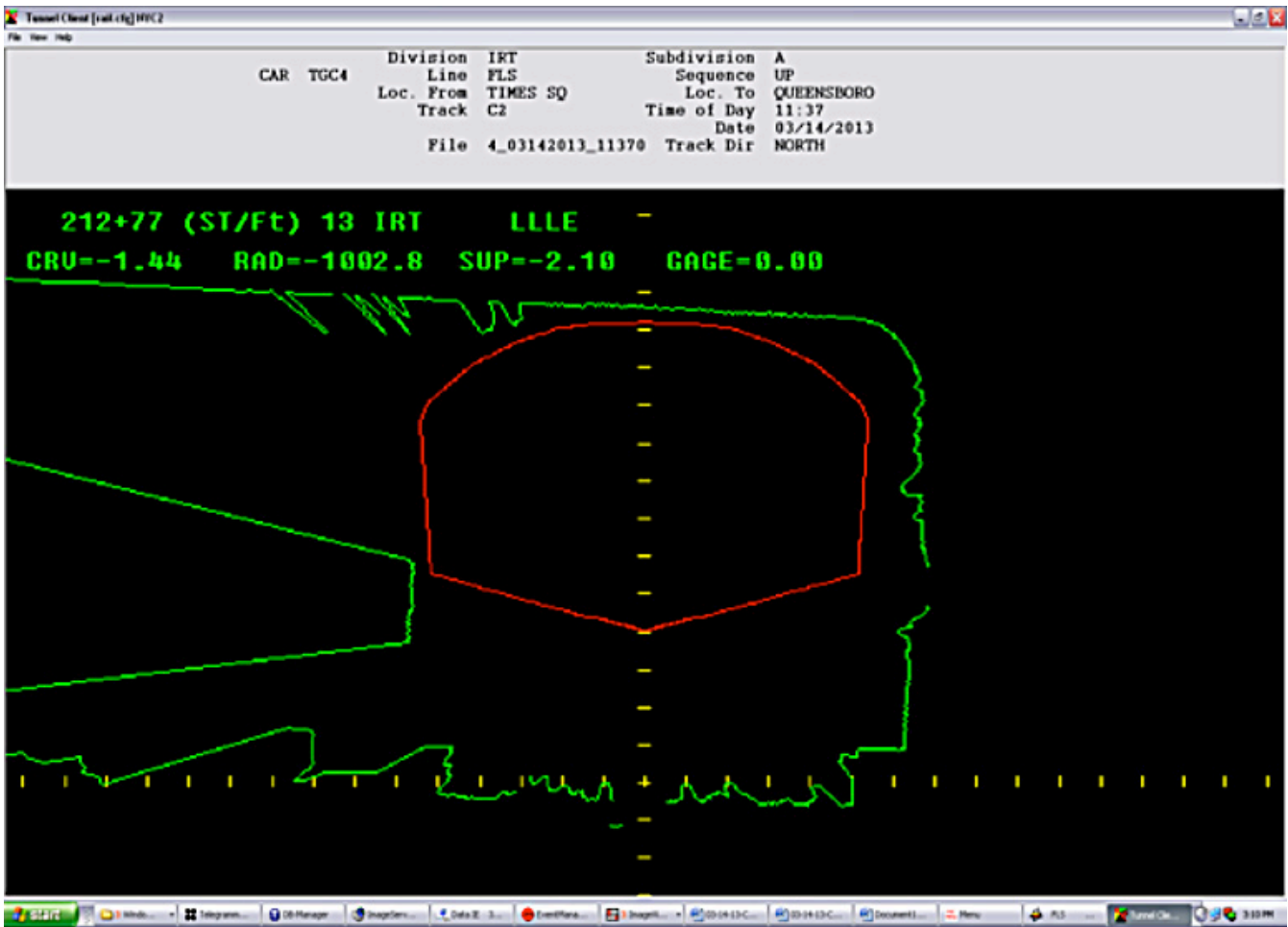

Figure 4-2

Tunnel crosscut of track C2 S/O Hunters Point

Synchronized with red line moving reference line shown in Figures 4-1 and 4-3

- Rail Wear (using the KLD Labs Optical Measuring and Evaluation system; see Figure 4-3)

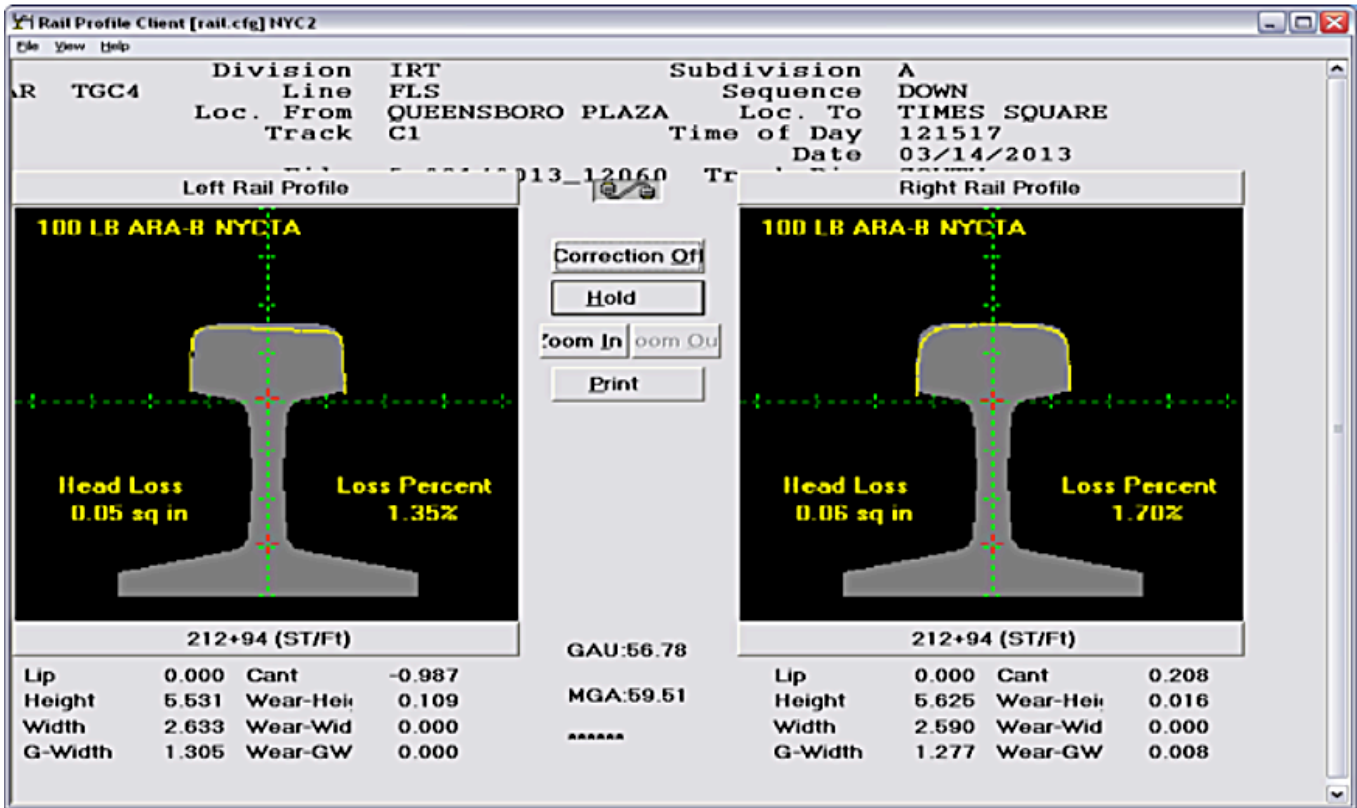

Figure 4-3
Rail wear measured on track C1

- Thermal Imaging of the Power Rail and its components using the FLIR camera (Figure 4-4)



Figure 4-4

Hot third rail insulator N/O Hunters Point on track C2

- Ultrasonic Rail Flaw Detection (UT rail flaw detection system) (Figure 4-5)

Figure 4-5
B-Scan of detected UT defect on track C1 at station # 158+28



Figure 4-6
Rail View Video picture of UT defect location on track C1 at station # 158+28



In addition, the following video systems were used to supplement and augment the above measurements systems on the TGC4:

- Right-of-Way View Video System

Figure 4-7

Image from video of track C2 S/O Hunters Point
 Screen capture of right-of-way video system (red line is moving reference line that synchronizes video picture with track geometry chart shown in Figure 4-1)

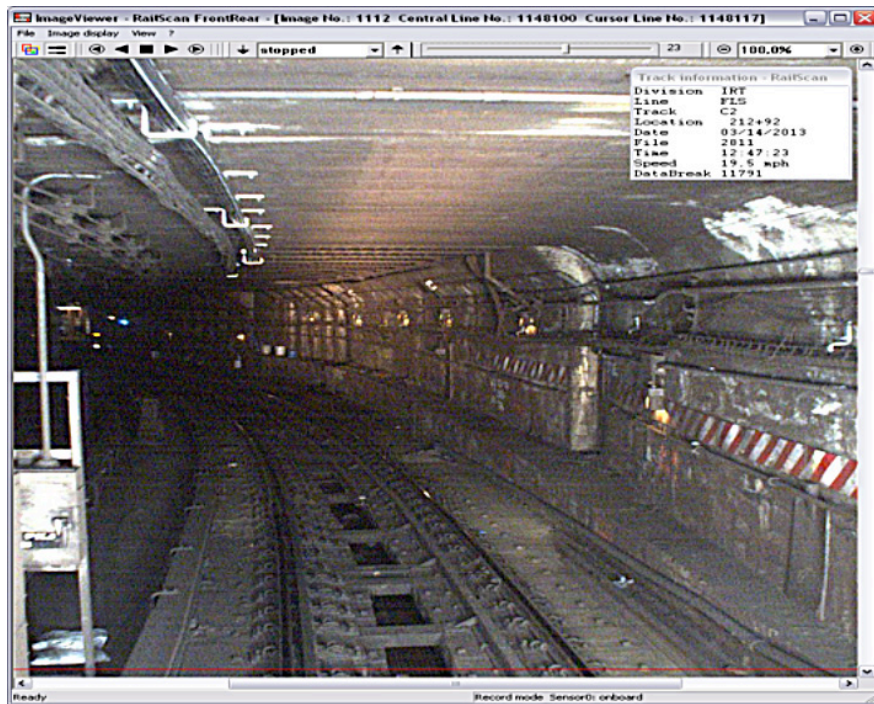

- Rail View Video System

Figure 4-8

Rail View video image of track C2 at station # 212+92 (seen in Figure 4-3)

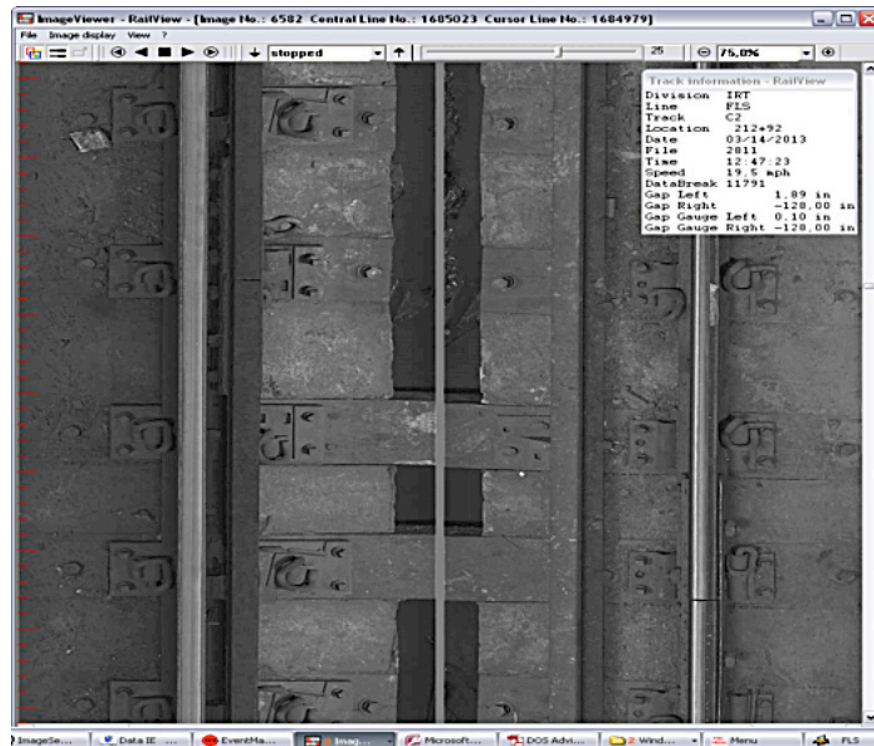

- Field Side Rail view video system of one running rail, installed for this project (Figure 4-9, left) and Power Rail View Video System (one side only), installed for this project (Figure 4-9, right)

Figure 4-9
Field Side Rail View (left) and Power Rail View (right) video of track CI at station # 211+17

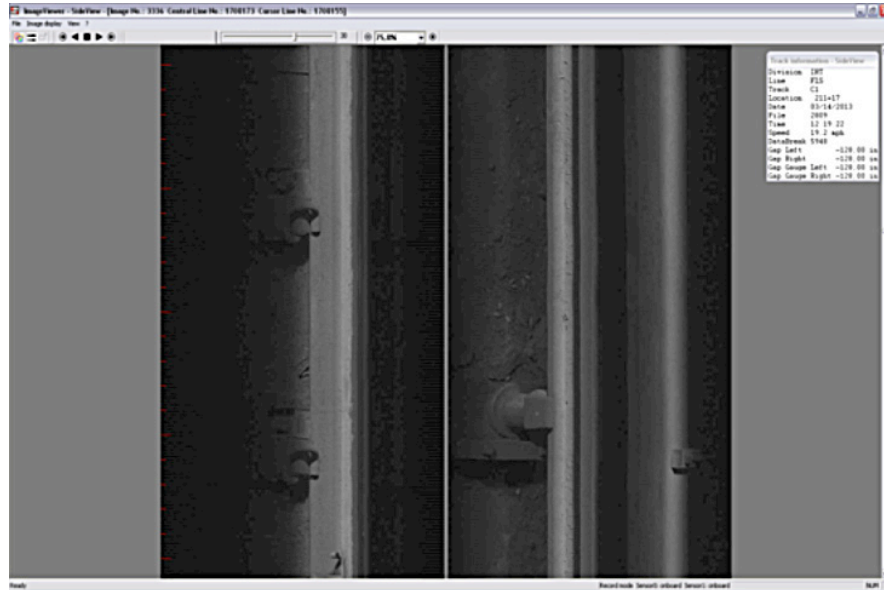

All defects or conditions recorded by the TGC4's measuring systems were analyzed, tabulated, and reported as per standards specified in MTA-NYCT's Track Standards Manual (MW-1).

Work Performed under Phase 4

The first stage of the TGC4 inspection test runs performed under Phase 4 consisted of performing tests on different tracks, including the area of the Flushing Line to be inspected, dedicated to debugging, checking, and confirming the accuracy of all systems. These inspections were classified as “debugging” runs and helped to assure the accuracy of the collected data with all systems in terms of location. All video systems must display the same location in the track within 1–2 ft. Comparison of acquired data was labor intensive but necessary to ensure that there were no issues with any of the systems or the integration of the additional video systems. The tests used in these runs were performed in early December 2012 and were completed in early January 2013. These runs were needed for the evaluation of the new software and the improvements that were incorporated into the onboard and offboard video software under Phase 3. These debugging runs also helped to perform final adjustments to the angle and positioning of lights and cameras on the Power Rail View and Field Side Rail View video systems.

Figure 4-10

Power Rail View camera and lights pointing to third rail and cover board mock-up model



The Power Rail View camera and lights were arranged to cover the maximum angle range from the position of the upper part of the cover board, since this was the best position for the system under the present configuration and also to avoid any potential clearance encroachments. Similar arrangement and issues were faced by the Field Side Rail View video lights and camera. It should be noted that the Field Side Rail View and the Power Rail View video cameras and lights used for the Pilot Test Inspection runs in this project were the existing Gauge Side Rail View video cameras, which were repositioned and rearranged within the confines of the existing dynamic envelope of the TGC4. This constraint somehow limited the space available to optimize the view and illumination for each, as the TGC4 was not originally designed to house these new video systems.

Figure 4-11

Field Side Rail View camera and light pointing to field side a running rail



Figure 4-12

Comparison of quality of lighting during various tests in December 2012



Figure 4-13

Comparison of quality of lighting during various tests in January 2013



The TGC4 inspections were performed and completed after the video systems' software was updated, including the software for the new Field Side Rail View and Power Rail View video systems, with the improvements already implemented under Phase 3.

TGC Stationing and Corrected Stationing

To tabulate and compare defects accurately and to continue to use the same stationing system that the TGC4 used to map the Flushing Line under Contract S-32723 for the installation of the CBTC on the Flushing Line, the TGC4 used an

automatic location detector (ALD) system, consisting of a reflective tag that was placed at the 0+00 (origin) stationing at the Times Square Station of the Flushing line on both tracks C1 and C2. The TGC4 automatically detected the ALD tag using a special light sensor installed at the reference point of all measuring systems in the car.

Figure 4-14
Reflector tag (ALD)
placed in center of
track

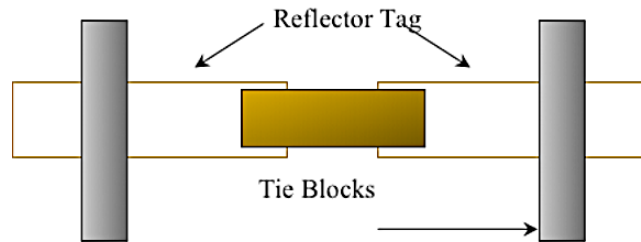

During the inspection runs, the TGC4 traveled over this reference tag (station 0+00) at the Times Square Station and automatically detected the ALD tag as an “external automatic event” that is part of the measurement files and, thus, can be used to calculate the corrected stationing numbers used by MTA-NYCT’s Track Maintenance forces.

The inspection files for these test runs, therefore, have two set of stationing numbers that can be correlated to the correct 0+00 stationing at Times Square station on tracks C1 and C2 by means of the ALD reference tag “external event” location; the first is the TGC stationing numbers that all TGC4’s measuring systems use and store as part of the measurements recorded, and the second is the corrected stationing number that Track Maintenance forces use to report defects or conditions along the tracks. These two sets of stationing numbers are displayed in each file, and the footage of any event or defect on the track is the same with respect to the reference ALD tag (0+00 point). The two sets of stationing numbers were used to detect, analyze, and visualize defects or conditions and to correlate them with the Track Walker Inspection System defects.

The ALD reference tag was also essential to check offsets on the video systems and to confirm that all video systems were pointing to the same spot in the track. In addition, the video inspections were compared for the quality of lighting necessary at specific locations on the third rail, cover board, and field side of the rail.

Once all measurements were confirmed as being accurate and correctly positioned, the three inspection runs were performed as follows.

First Inspection Run – January 30, 2013

The first of three inspection runs on the Flushing Line was performed on 1/30/2013. All systems performed as designed. Table 4-1 shows a typical partial list of the events recorded by the TGC4 during the run.

Table 4-1

Reference ALDs Highlighted

Line	Track	TGC Station*	Corrected Stationing**	Events	ALD # - Signal # - Switch #	Name
FLS	CI	270+19	171+41	N.E. Platform		Queensboro Plaza
FLS	CI	268+01	169+23	Signal	1692-C1	
FLS	CI	264+49	165+71	S.E. Platform		Queensboro Plaza
...
FLS	CI	100+07	1+29	N.E. Platform		Times Square
FLS	CI	98+78	0+00	ALD	CI-4	Reference ALD
FLS	CI	97+39	-1+70			
FLS	CI	95+79	-3+05	Signal	22-C1	
FLS	C2	97+64	-1+14	Signal	11-CC2	
FLS	C2	98+78	0+00	ALD	C2-4	Reference ALD
FLS	C2	100+06	1+28	N.E. Platform		Times Square
...
FLS	C2	263+36	164+58	S.E. Platform		Queensboro Plaza
FLS	C2	265+37	166+59	Signal	1661-C2	
FLS	C2	267+77	168+99	Signal	1681-C2	
FLS	C2	268+97	170+19	N.E. Platform		Queensboro Plaza

*Station numbers used by TGC4 inspection

**Calculated station numbers using reference ALD

The specific parameters and measuring systems analyzed for defects during this inspection were tabulated on their respective Excel databases:

- Track geometry, including longitudinal profile (surface) of both running rails, alignment of both running rails, curvature, track gauge, superelevation and twist (Priority 1–3 defects)
- Rail wear, measured with the KLD Labs Optical Measuring and Evaluation system (Priority 2 defects)
- Tunnel clearances measured with the Z+F tunnel clearance laser scanner (intrusions of objects on the Limiting Line of Line Equipment [LLLE] clearance line)
- Thermal imaging of the power rail and its components, measured with FLIR infrared camera system
- Ultrasonic rail flaw detection measured with DAPCO/NORDCO ultrasonic rail flaw detection system (Priority 1 and 2 defects)
- Video analysis of track geometry and of third rail and cover board obtained with video inspections systems installed with modifications performed in Phases 1, 2, and 3. Video systems were used to confirm or visualize defects found by systems listed above (MW-1 Priority 1–3 defects). The following video systems were used:

- Right-of-Way View video system (Rail Scan)
- Rail View video system
- Field Side Rail View video system of one running rail, installed under this research project
- Power Rail (Third Rail) View video system (on one side only), installed for this project

Excel databases were prepared to store the defects or conditions obtained with each one of the above-mentioned measuring systems, including defects analyzed with the video systems only, the measuring systems only, and the video in conjunction with the additional measuring systems. The video systems helped to visualize and confirm defects or conditions detected with the additional measuring systems of the TGC4. All defects were tabulated to include description and location of the defect, track and stationing information, size and characteristics of the defect, found date, repeat date, etc. Once all the detected defects were analyzed and reported to the respective Track Maintenance group for corrective action, all conditions were recorded in one Excel datasheet for comparison with future inspections.

Figure 4-15

Video file in AVI format – Right-of-Way View, run of 1/30/2013

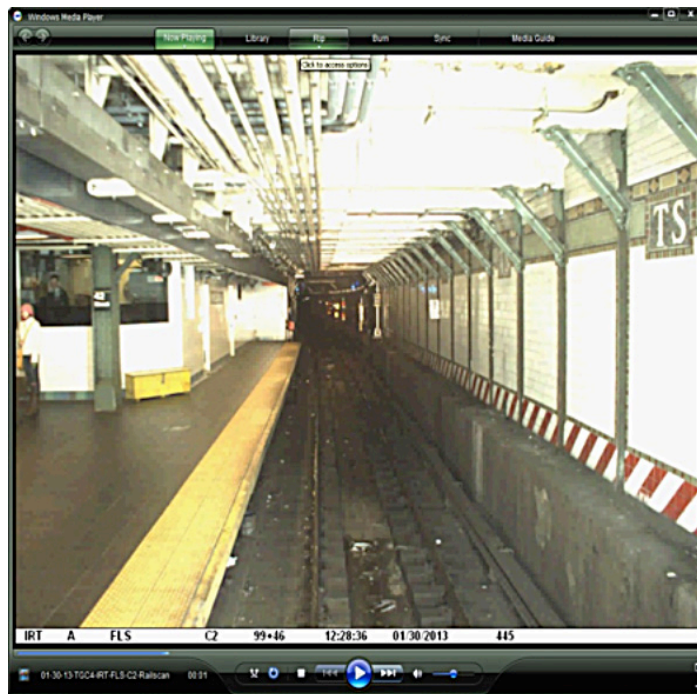

Figure 4-16

Video file in AVI format – Rail View, run of 1/30/2013



Figure 4-17

Video file in AVI format – Field Side Rail View (left) and Power Rail View (right), run of 1/30/2013

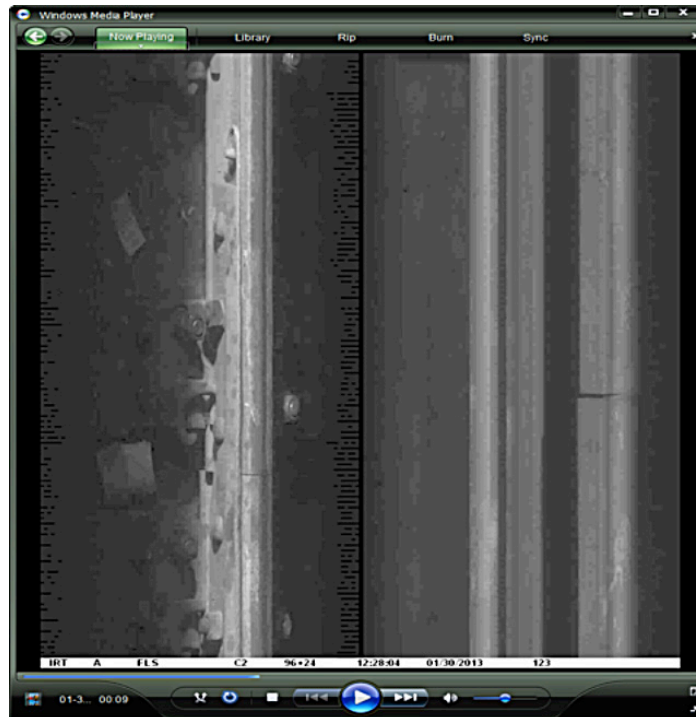

Each video file obtained with the video systems, including the Power Rail View video system, had a corresponding video file conversion in AVI format that can be played back for review by anyone using Windows Media Player in any Windows-based computer.

Excel database files for defects found using the track geometry, rail wear and flangeway, third rail geometry, thermal imaging, tunnel clearances, and UT rail flaw inspection, and the Rail View, Field Side Rail View, and Power Rail View video systems were stored in MTA-NYCT's Track Engineering server. Charts also were prepared showing the total number of defects, new defects or conditions, repeat defects or conditions, and the number of defects that could not be observed using either the Field Side View or Power Rail View Video systems because the specific video camera was installed on one side of the TGC4 only.

Figure 4-18

Marquee (right image) showing condition detected with Power Rail View video system on track C2, run of 1/30/2013



No third rail or cover board defects were observed with the new Power Rail View video system. Defects detected with the Third Rail KLD system that were further analyzed with the Power Rail View video system appeared to be distinguished most of the time. Only one condition was detected with the Power Rail View video system on the third rail, and it was classified as Power Rail View Video defect #TRVideo01, consisting of a slight gouge on the contact rail surface, as determined by the reviewer.

No rail wear defects were detected on the first inspection on 1/30/2013, on either tracks C1 or C2.

Every defect or condition was analyzed and marked in the Track Geometry and Power Rail video files of 1/30/2013 by each reviewer, as can be observed in the marking of one defect in Figure 4-18. These video files had to be completed and marked to use them with the Compare Viewer to play back and transfer marked defects to future inspection run files.

SECTION 4: PHASE 4: VEHICLE-BASED VISUAL TRACK INSPECTION PILOT PROJECT USING TGC4 EQUIPPED WITH POWER RAIL VIEW AND FIELD SIDE RAIL VIEW VIDEO CAMERAS

In addition, one summary file (Figure 4-19) was prepared to place all defects and conditions in one Excel database showing the line, track, TCG stationing, corrected stationing, events “punched” by the TGC operator, ALD/signal/ switches, station name, defect number or ID, marker, length of defect, defect description, date found, date fixed, and comments for each measuring system. The analysis and tabulation of the events, conditions and defects found on this inspection was completed in two working weeks.

The screenshot displays a Microsoft Excel spreadsheet titled "01301301_C1_entire_data_base_all_defects_final". The spreadsheet contains a large table with multiple columns and rows of data. The table is organized into several distinct sections:

- TUNNEL REPORT**: Located at the top left, containing a sub-section for "Ceiling & wall Clearances (Limiting Line of Line Equipment)".
- Virtual track defects report**: A large central table with columns for Defect, Date Found, Date Fixed, and other tracking information.
- Flangeway defects Report**: A table to the right of the virtual track defects report, also with columns for Defect, Date Found, and Date Fixed.
- Third Rail d**: A final column on the right side of the spreadsheet.

The data rows include various identifiers, stationing numbers (e.g., 101-10, 101-11), and descriptions of defects or conditions. The spreadsheet interface shows standard Excel menus (File, Edit, View, Insert, Format, Tools, Data, Window, Help) and a status bar at the bottom.

Figure 4-19
All defects of TGC4’s measuring systems in one Excel file, run of 1/30/13

The tabulation of defects or conditions found in the 1/30/2013 inspection run is shown in Table 4-2.

Table 4-2

Tabulation of Defects and Conditions, Tracks C1 and C2, Run of 01/30/13

Rail View and Field Side Rail View Video Inspection, Track C1										
Date of Run	Total Video Defects	New Video Defects			Repeat Video Defects			Fixed Video Defects		
1/30/2013	90	90			0			0		
Third Rail Geometry Defects Verification Using the Power Rail View Video, Track C1										
Date of Run	Total Third Rail Geometry Defects Verified	New/Repeat Third Rail Geometry Defects Seen			Defects Not Seen (camera on one side)			Fixed Third Rail Geometry Defects		
1/30/2013	22	15			0			0		
Defects Detected by Track Geometry and Other Measuring Systems, Track C1										
Defects Type	Total Defects	Priority 3 Defects			Priority 2 Defects			Priority 1 Defects		
		P3	New	Repeat	P2	New	Repeat	PI	New	Repeat
Profile	14	12	12	0	2	2	0	0	0	0
Alignment	9	9	9	0	0	0	0	0	0	0
Gauge	10	8	8	0	2	2	0	0	0	0
Crosslevel	0	0	0	0	0	0	0	0	0	0
Rail Wear	0	0	0	0	0	0	0	0	0	0
Flangeway	7	0	0	0	7	7	0	0	0	0
Thermal	1	0	0	0	1	1	0	0	0	0
Ultrasonic	2	0	0	0	0	0	0	2	2	0
Rail View and Field Side Rail View Video Inspection, Track C2										
Date of Run	Total Video Defects	New Video Defects			Repeat Video Defects			Fixed Video Defects		
1/30/2013	96	96			0			0		
Third Rail Geometry Defects Verification Using Power Rail View Video, Track C2										
Date of Run	Total Third Rail Geometry Defects Verified	New/Repeat Third Rail Geometry Defects Seen			Defects not seen (camera on one Side)			Fixed Third Rail Geometry Defects		
1/30/2013	21	16/0			5			0		
Defects Detected by Track Geometry and Other Measuring Systems, Track C2										
Defect Type	Total Defects	Priority 3 Defects			Priority 2 Defects			Priority 1 Defects		
		P3	New	Repeat	P2	New	Repeat	PI	New	Repeat
Profile	15	14	14	0	1	1	0	0	0	0
Alignment	5	5	5	0	0	0	0	0	0	0
Gauge	12	11	11	0	1	1	0	0	0	0
Crosslevel	0	0	0	0	0	0	0	0	0	0
Rail Wear	0	0	0	0	0	0	0	0	0	0
Flangeway	5	0	0	0	5	5	0	0	0	0
Thermal	2	0	0	0	2	2	0	0	0	0
Ultrasonic	1	0	0	0	0	0	0	1	1	0

Second Inspection Run – February 13, 2013

The second inspection run was performed on 2/13/2013 (two weeks after the first run) after the defects and conditions on the first inspection run were analyzed and tabulated. All the measuring systems in the TGC4 worked well, including the Field Side Rail View video system, the Power Rail View video system, and all additional measuring and video systems. The TGC4 detected the ALD reference tag at the Times Square Station automatically, and its position was used to calculate the corrected stationing numbers used in the field by Track Maintenance personnel. The TGC stationing numbers used by the TGC4 in this inspection differed slightly from the stationing numbers used in the first inspection run (an approximately 20-ft offset, due to the start of the measuring run at a slightly different location than that of the first run), but the corrected stationing numbers matched within ± 1 ft.

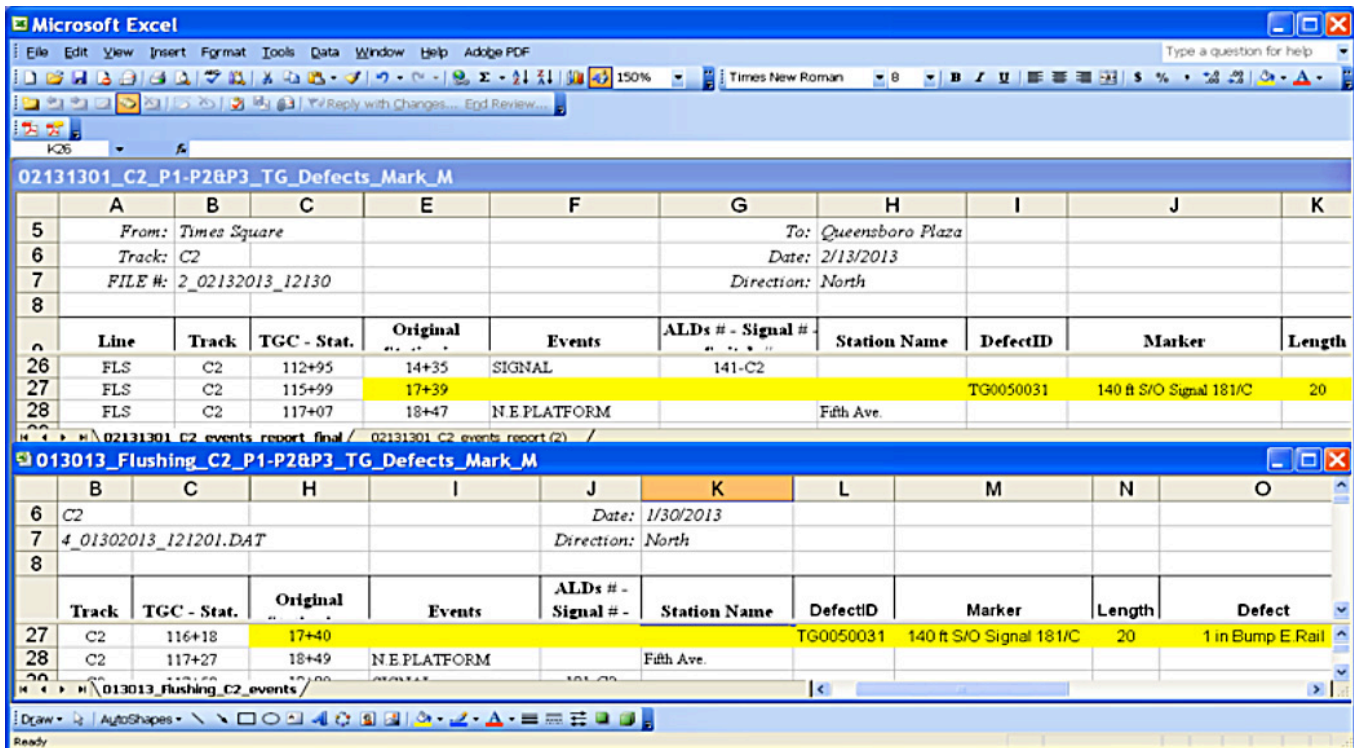

Figure 4-20

Track geometry Excel databases for the 1/30/13 and 2/13/13 inspection runs

The reference ALD (0+00 Station) tag placed at Times Square Station, detected automatically by the TGC4, assured that the corrected stationing numbers could be computed relative to this reference point, therefore allowing for the correlation of the defects' locations between the two inspection runs. All repeated defects or conditions could be observed at exactly the same location in both inspection runs. The calculated corrected stationing numbers correlated between the second and first inspection runs within 1 ft. accuracy. Figure 4-20 shows that defect TG0050031 can be found at the TGC stationing number 116+18 in the 1/30/2013

inspection, corresponding to a calculated corrected stationing number of 17+40, and the same defect TG0050031 can be found at the TGC stationing number 115+99 corresponding to a calculated corrected stationing number of 17+39 in the 2/13/2013 inspection. Defects on all databases follow the same pattern, and the repeated conditions could be observed at the same locations, especially when the calculated corrected stationing numbers were used.

The same number of Excel databases was prepared and populated with the defect data obtained from the second inspection run performed on 2/13/2013. The databases contain the defects or conditions found by each of the measuring systems as described above, including the additional video systems installed under this project. Databases tabulate the defects found with video systems only, with the TGC4's measuring systems, and with both in conjunction. The video systems, including the Field Side Rail View and Rail Scan and Rail View video systems were used to visualize and confirm the measuring defects found. All defects were tabulated to include description and location of the defect, track and stationing information, size and characteristics of the defect, repeat date, etc.

Every defect or condition that was found and marked in the Rail View, Field Side Rail View, and Power Rail View video files of 1/30/2013 were transferred to the new Rail View, Field Side Rail View, and the Power Rail View video files recorded during the 2/13/2013 run. The Compare Viewer software, provided in Phase 3, was used for the task of playing back and transferring the previously-marked defects, as shown in Figures 4-21 and 4-22.

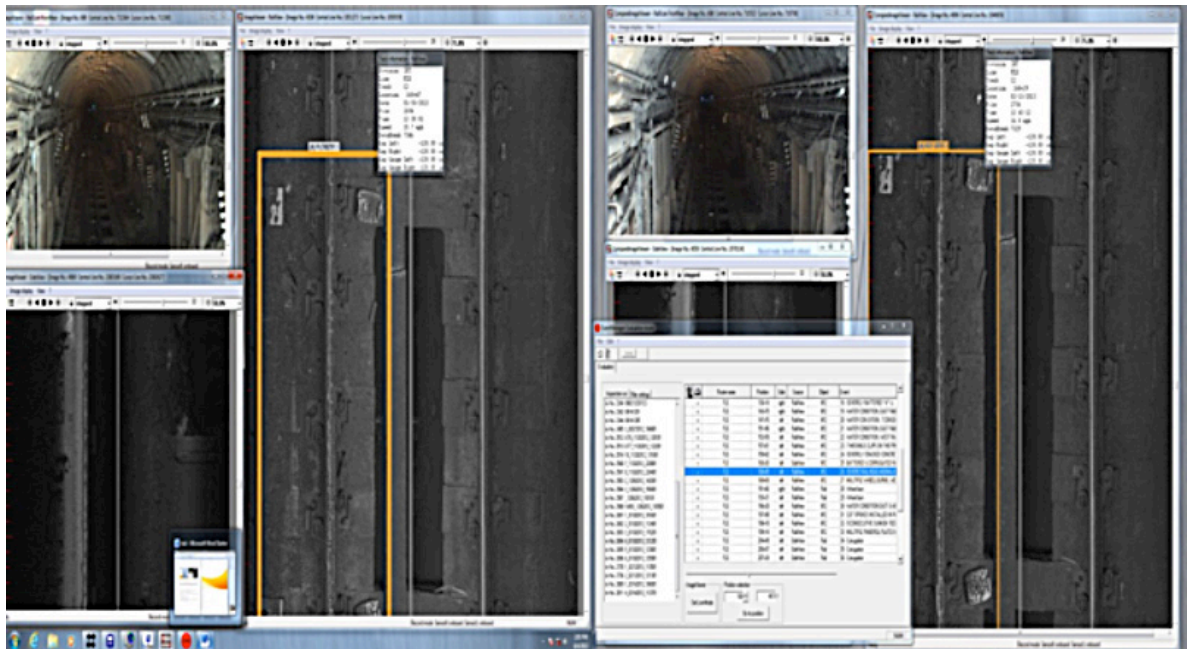

Figure 4-21

Compare Viewer transferring defects between Rail View video inspection runs of 1/30/13 (left) and 2/13/2013 (right)



Figure 4-22

Compare Viewer transferring marked defects between Field Side Rail View video inspection runs of 1/30/13 (left) and 2/13/2013 (right)

Once all previously marked defects (from the 1/30/2013 inspection run) were transferred using the Compare Viewer to the Rail View, Field Side Rail View, and Power Rail View video files recorded during the run of 2/13/2013, the information of each defect or condition was extracted, including the corresponding stationing numbers for this inspection. After reporting the defects found to the respective Track Maintenance groups for corrective action, the defects or conditions were tabulated in one Excel database for further analysis and comparison with previous and future inspections.

Each video file recorded with the Rail View, Field Side Rail View, and Power Rail View video systems had a corresponding video file conversion in AVI format that can be played back by anyone having Windows Media Player in any Windows based computer.

The Excel database of the defects detected using the third rail measuring system (KLD) was used to further review and confirm the conditions found using the video of the Power Rail View video system. The video location of each defect was reviewed to confirm repeated defects or conditions and to observe conditions creating new defects.

Only one video condition was detected on the contact rail with the Power Rail View video system alone; this condition was classified as a “slight gouge.” The Compare Viewer software was used to play back and transfer the above marked condition detected with the Power Rail View video files of the 1/30/2013 inspection run.

Figure 4-23
Marquee (right image) showing condition detected with Power Rail View Video System on Track C2 – run of 2/13/2013



No rail wear defects on tracks C1 or C2 were detected on the inspection performed on 2/13/2013.

The review and analysis of the Rail View and Field Side Rail View video systems’ files detected the same number of conditions and defects found on the previous inspection run of 1/30/2013. The video files of the first inspection (January) were, in fact, reviewed a couple of times to assure that all conditions or defects were marked.

One summary Excel database for tracks C1 and C2 was then prepared to place all the defects and conditions from each measuring and video systems, showing the line, track, TGC stationing number, corrected stationing number (calculated), events (north end or south end of platforms), ALD/signal/switches, station name, defect number or ID, marker, length of defect, defect description, date found, date fixed, and special comments for each system (Figure 4-24). The analysis and tabulation for the defects and conditions found during this second inspection run was completed in four working weeks.

SECTION 4: PHASE 4: VEHICLE-BASED VISUAL TRACK INSPECTION PILOT PROJECT USING TGC4 EQUIPPED WITH POWER RAIL VIEW AND FIELD SIDE RAIL VIEW VIDEO CAMERAS

The screenshot shows a Microsoft Excel spreadsheet titled "02131301_C2_All_defects_report". The spreadsheet is divided into several sections. The top section is a "TUNNEL REPORT" with a sub-section for "Ceiling & wall Clearances (Limiting Line of Line Equipment)". Below this, there are columns for "Visual track defects report" and "Flangeway defects Report". The spreadsheet contains a large table with columns for "Defect", "Defn Found", "Platform", "Defn Found", "Platform", "Length", "Defect", "Defn Found", "Platform", "Length". The table lists numerous defects with details such as location, date, and description. The spreadsheet is displayed in a window titled "Microsoft Excel - 02131301_C2_All_defects_report".

Figure 4-24

All defects of TGC4's measuring systems in one file – run of 2/13/2013

The tabulation of defects or conditions found during the inspection run performed on 2/13/2013 is shown in Table 4-3 (figures in *italics* correspond to those found during the first inspection run of 1/30/2013 as a comparison).

Table 4-3

Tabulation of Defects and Conditions, Tracks C1 and C2, Run of 02/13/2013

Rail View and Field Side Rail View Video Inspection, Track C1										
Date of Run	Total Video Defects	New Video Defects	Repeat Video Defects	Fixed Video Defects						
1/30/2013	90	90	0	0						
2/13/2013	90	0	89	1						
Third Rail Geometry Defects Verification Using the Power Rail View Video, Track C1										
Date of Run	Total Third Rail Geometry Defects Verified	New/Repeat Third Rail Geometry Defects Seen	Defects Not Seen (camera on one side)	Fixed Third Rail Geometry Defects						
1/30/2013	22	15	0	0						
2/13/2013	23	1/15	7	0						
Defects Detected by Track Geometry and Other Measuring Systems, Track C1										
Defects Type	Total Defects	Priority 3 Defects			Priority 2 Defects			Priority 1 Defects		
		P3	New	Repeat	P2	New	Repeat	P1	New	Repeat
Profile	14	12	1	11	2	0	2	0	0	0
Alignment	9	9	0	9	0	0	0	0	0	0
Gauge	10	9	1	8	1	1	0	0	0	0
Crosslevel	0	0	0	0	0	0	0	0	0	0
Rail Wear	0	0	0	0	0	0	0	0	0	0
Flangeway	7	0	0	0	7	0	7	0	0	0
Thermal	1	0	0	0	1	1	0	0	0	0
Ultrasonic	4	0	0	0	3	3	0	1	1	0
Rail View and Field Side Rail View Video Inspection, Track C2										
Date of Run	Total Video Defects	New Video Defects	Repeat Video Defects	Fixed Video Defects						
1/30/2013	96	96	0	0						
2/13/2013	96	0	96	0						
Third Rail Geometry Defects Verification Using Power Rail View Video, Track C2										
Date of Run	Total Third Rail Geometry Defects Verified	New/Repeat Third Rail Geometry Defects Seen	Defects not seen (camera on one Side)	Fixed Third Rail Geometry Defects						
1/30/2013	21	16/0	5	0						
2/13/2013	21	0/16	5	0						
Defects Detected by Track Geometry and Other Measuring Systems, Track C2										
Defect Type	Total Defects	Priority 3 Defects			Priority 2 Defects			Priority 1 Defects		
		P3	New/Fixed	Repeat	P2	New/Fixed	Repeat	P1	New/Fixed	Repeat
Profile	14	14	0	14	0	0	0	0	0	0
Alignment	5	5	0	5	0	0	0	0	0	0
Gauge	17	14	4	10	2	1	1	1	1	0
Crosslevel	0	0	0	0	0	0	0	0	0	0
Rail Wear	0	0	0	0	0	0	0	0	0	0
Flangeway	4	0	0	0	4	0	4	0	0	0
Thermal	0	0	0	0	0	0	0	0	0	0
Ultrasonic	1	0	0	0	1	1	0	0	0	0

A comparison of the defects found between the first and second inspection runs shows that, on both tracks C1 and C2, the video and measuring systems detected all of the existing defects or conditions. The Rail View and Field Side View video systems were able to identify all the prior 90 defects detected in the 1/30/2013 inspection, including the 1 fixed defect on track C1, and all the prior 96 defects on track C2 in both inspections.

The Power Rail View video system files were reviewed carefully to detect all possible conditions, but only one condition was identified on the third rail on track C2, and no conditions were detected on the cover board of either track C1 or C2. This one condition was classified as a “slight gouge” on the contact rail (defect ID TRVideo01), which was the same condition identified during the inspection performed on 1/30/2013. Profile, alignment, gauge, crosslevel, rail wear, flangeway, and thermal defects were basically unchanged in number and magnitude between these two inspection runs on tracks C1 and C2.

Third (and Final) Inspection Run – March 14, 2013

The third (and final) inspection run was performed with the TGC4 on 3/14/2013, four weeks after the second inspection run, after the defects and conditions found on the second inspection run were analyzed and tabulated. The existing measuring systems and all the video systems, including the Power Rail View and the Field Side Rail View video systems installed as part of this project, worked well, and the TGC4 data collection under this inspection was successfully completed. The ALD reference tags at Times Square Station were detected automatically in this inspection, and their positions were used to calculate the corrected stationing numbers used to correlate defects. The TGC stationing number used by the TGC4 in this inspection differed slightly from the stationing numbers used in the first and second inspection runs; there was a \pm 20-ft. difference when comparing the TGC stationing numbers of the third and second inspection runs, due to different starting points of the measuring run on each date. The calculated corrected stationing numbers, however, correlated with each other from run to run within 2 ft. of each other.

031413_C2_P1-P28P3_TG_Defects_M

Line	Track	TGC - Stat.	Original Stationing	Events	ALDs # - Signal # - Switch #	Station Name	DefectID	Marker	Length	Defect
FLS	C2	112+99	14+29	SIGNAL	141-C2					
FLS	C2	116+11	17+41				TG0050031	140 ft S/O Signal 181/C	20	1 in Bump E Rail

02131301_C2_P1-P28P3_TG_Defects_Mark_M

Line	Track	TGC - Stat.	Original Stationing	Events	ALDs # - Signal # - Switch #	Station Name	DefectID	Marker	Length	Defect
FLS	C2	112+95	14+35	SIGNAL	141-C2					
FLS	C2	115+99	17+39				TG0050031	140 ft S/O Signal 181/C	20	1 in Bump E Rail

Figure 4-25

Track geometry Excel databases for 2/13/2013 and 3/14/2013 inspection runs on track C2

The reference ALD tag (0+00 Station) placed at the Times Square Station was also automatically detected by the TGC4 in this inspection, assuring that the calculated corrected stationing numbers be computed relative to the ALD location and also assuring the correlation of the corrected stationing numbers between all the inspection runs. For example, defect # TG0050031 was detected at TGC station number 116+11 with a computed corrected stationing number of 17+41 in the March inspection, and the same defect # TG0050031 was detected at TGC stationing number 115+99 and computed corrected stationing number of 17+39 in the February inspection (see Figure 58 above). Using the computed corrected stationing numbers referenced to the ALD tag 0+00 station at the Times Square Station allowed for all the defects to be precisely located from one inspection run to the next.

The same Excel databases were prepared and completed to tabulate the defects or conditions obtained in the inspection performed on 3/14/2013. These databases show the defects or conditions obtained with each of the measuring

systems on this inspection run, including the additional Field Side Rail View and Power Rail View video systems. Databases tabulate the defects analyzed and found with the video systems only, with the TGC4's measuring systems only, and with both in conjunction. The video systems, including the Field Side Rail View and the Power Rail View video systems, were used to visualize and confirm the defects detected by the TGC4's measuring systems. All defects were tabulated to include description and location of the defect, track and stationing information, size and characteristics of the defect, repeat date, and other information.

Every defect or condition that was marked in the Rail View, Field Side Rail View, and the Power Rail View video files of 2/13/2013, including the already-marked and transferred defects from the video files of the 1/30/2013 inspection, was transferred to the Rail View, Field Side Rail View, and Power Rail View video files recorded during the 3/14/2013 inspection run. The Compare Viewer software was used for the task of playing back and transferring the previously-marked defects.

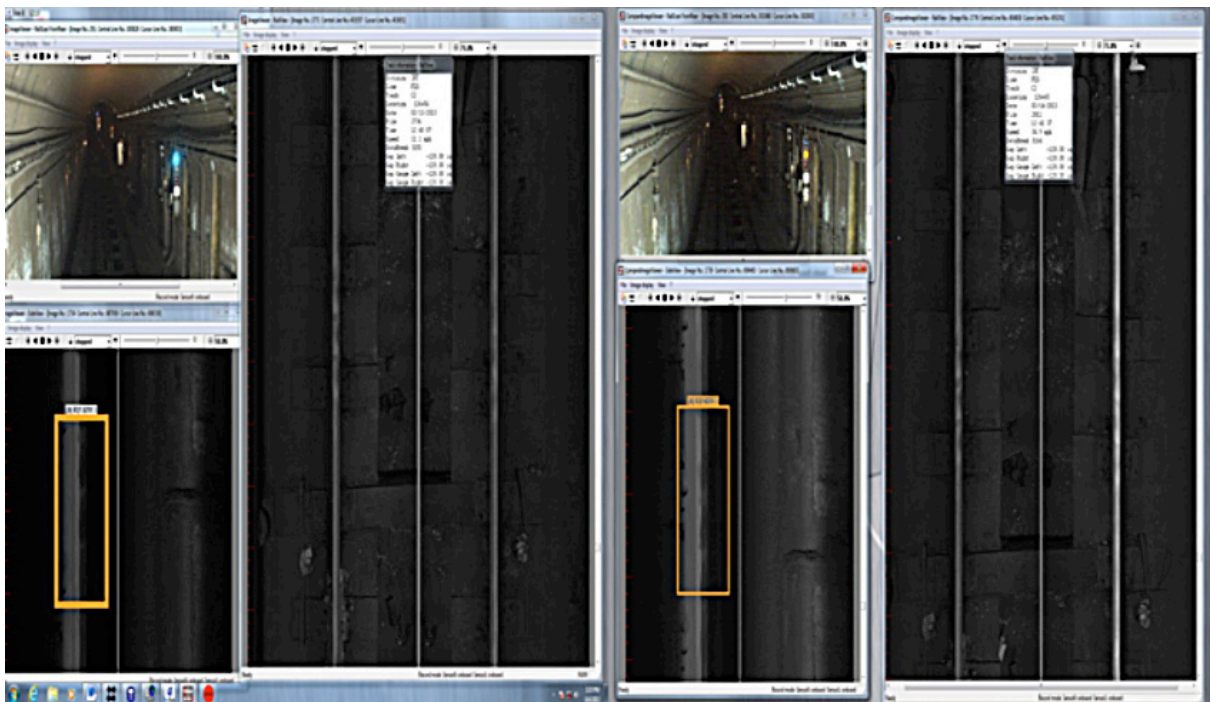

Figure 4-26

Compare Viewer transferring defects between 2/13/2013 (left side) and 3/14/2013 (right side) video inspection runs

During the 3/14/2013 inspection run, the Rail View and the Field Side Rail View video systems detected the same number of conditions or defects found on the previous inspections performed on 1/30/2013 and 2/13/2013.

Figure 4-27

Marquee (right image) showing condition detected with Power Rail View video system on 3/14/2013 inspection run

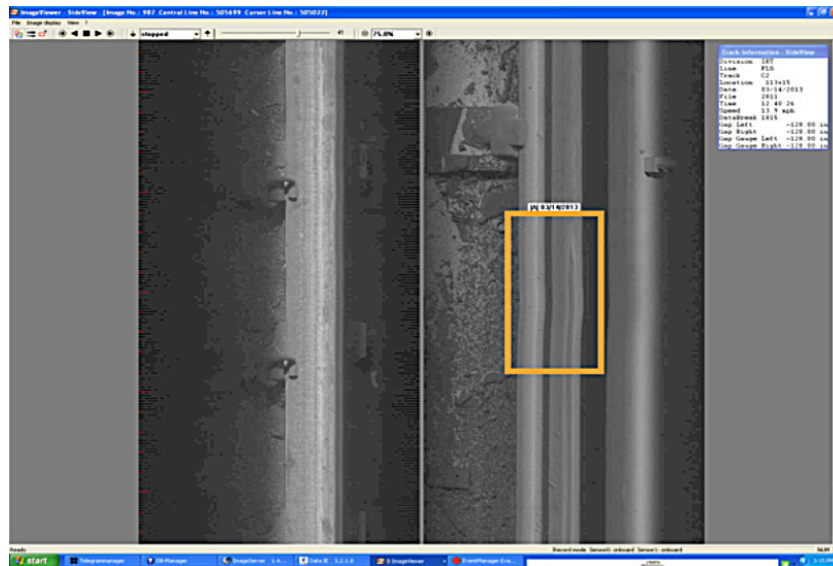

No new third rail or cover board defects were detected in the video files analyzed and reviewed with the Power Rail View video system, except for the one condition detected in previous inspections and classified as a “slight gouge” on the contact rail (defect ID TRVideo01).

No rail wear defects were detected on tracks C1 or C2 during the inspection performed on 3/14/2013.

One final Excel file (Figure 4-28) was prepared to place all defects and conditions found by each measuring and video system to facilitate the comparison of defects and conditions found on tracks C1 and C2. This file was prepared to show the line, track, TGC stationing number, corrected stationing number, events (north end or south end), ALD/signal/switches, station name, defect number or ID, marker, length of defect, defect description, date found, date fixed, and special comments for each system. In addition, this final database includes a column containing a linked picture to the location where the defect can be found. This final file tabulates all the defects or conditions found using the Track Geometry, Rail Wear and Flangeway, Third Rail Geometry, Thermal Image, Ultrasonic Rail Flaw, Rail View, and Field Side Rail View video systems and the Power Rail View video system for tracks C1 and C2.

SECTION 4: PHASE 4: VEHICLE-BASED VISUAL TRACK INSPECTION PILOT PROJECT USING TGC4 EQUIPPED WITH POWER RAIL VIEW AND FIELD SIDE RAIL VIEW VIDEO CAMERAS

TUNNEL REPORT
Ceiling & Wall Clearances
(Limiting Line of Line Equipment)

Division: IRT
Line: FLS
From: Times Square
Track: C2
FILE #: 4_04142013_11370

Defect Type	Line	Track	TGC-From	Mark-From	DefectID	Marker	Length	Defect	Date Found	Date Fixed	Picture Link	Special Comments	
VD	FLS	C2	97+42	-128	-1+28								
TR	FLS	C2	98+34	-36	-0+36								
FLS	FLS	C2	98+70	0	0+00								
UT	FLS	C2	98+05.8	64	0+64							UT3	
FLS	FLS	C2	97+55	115	11+5								
FLS	FLS	C2	100+02	132	1+32								
TG	FLS	C2	97+30	140	14+0	TG0050063	25 ft S/O Signal 11/C	20	55.87 in. TIGHT GAUGE	2/13/2013	C2_track_geom	P3 Defect Upgrade P2	
TG	FLS	C2	100+34	164	1+64	TG0030286	30 ft S/O Signal 21/C	25	57.75 in. WIDE GAUGE	11/20/2012	1/20/2013	metry_pics\031	
VD	FLS	C2	100+58	188	1+88								
FLS	FLS	C2	100+64	194	1+94								
VD	FLS	C2	100+80	210	2+10								
TR	FLS	C2	101+19	249	2+49								
VD	FLS	C2	101+23	253	2+53								
FLS	FLS	C2	101+93	323	3+23								
UT	FLS	C2	102+04.6	335	3+35							UT3	
FLS	FLS	C2	102+55	385	3+85								
FLS	FLS	C2	102+96	426	4+26								
FLS	FLS	C2	103+63	493	4+93								
VD	FLS	C2	103+71	501	5+01								
VD	FLS	C2	105+17	647	6+47								
TR	FLS	C2	106+77	807	8+07								
FLS	FLS	C2	106+87	817	8+17								
FW	FLS	C2	107+07	837	8+37								
VD	FLS	C2	107+11	841	8+41								
TG	FLS	C2	107+12	852	8+52	TG0036909	25 ft S/O Signal 81/C	20	56 in. TIGHT GAUGE	2/13/2013	3/14/2013	C2_track_geometry_pics\031413_C2	

Figure 4-28

Final Excel database for inspection performed on 3/14/2013 on track C2

As an example, clicking on the first defect in the Picture Link column of the Final Excel database above (Figure 4-28) opens the picture with the location of the defect (see Figure 4-29).

Figure 4-29
*Picture link of defect
on final database*

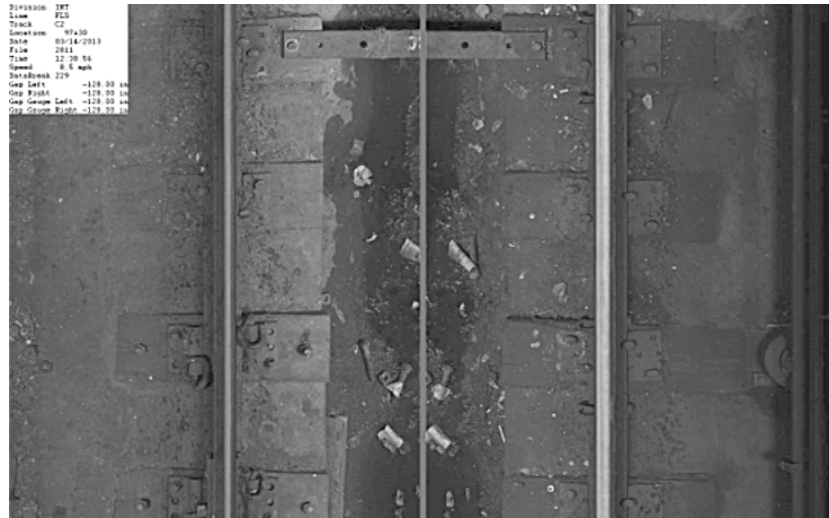

The tabulation of defects or conditions found on the 3/14/2013 inspection run is as shown in Tables 4-4.

Table 4-4

Tabulation of Defects and Conditions – Tracks C1 and C2

Rail View and Field Side Rail View Video Inspection - Test Run of 3/14/2013										
Date of Run	Total Video Defects	New Video Defects			Repeat Video Defects			Fixed Video Defects		
1/30/2013	90	90			0			0		
2/13/2013	90	0			89			1		
3/14/2013	89	0			88			1		
Third Rail Geometry Defects Verification Using the Power Rail View Video Test Run of 3/14/2013										
Date of Run	Total Third Rail Geometry Defects Verified	New/Repeat Third Rail Geometry Defects Seen			Defects Not Seen (camera on one side)			Fixed Third Rail Geometry Defects		
1/30/2013	22	15			0			0		
2/13/2013	23	1/15			7			0		
3/14/2013	21	0/14			7			0		
Defects Detected by Track Geometry and Other Measuring Systems - Test Run of 3/14/2013										
Defects Type	Total Defects	Priority 3 Defects			Priority 2 Defects			Priority 1 Defects		
		P3	New	Repeat	P2	New	Repeat	P1	New	Repeat
Profile	11	11	0	11	0	0	0	0	0	0
Alignment	9	9	0	9	0	0	0	0	0	0
Gauge	10	9	0	9	1	0	1	0	0	0
Crosslevel	0	0	0	0	0	0	0	0	0	0
Rail Wear	0	0	0	0	0	0	0	0	0	0
Flangeway	4	0	0	0	4	0	4	0	0	0
Thermal	1	0	0	0	1	0	1	0	0	0
Ultrasonic	2	0	0	0	1	1	0	1	1	0
Rail View and Field Side Rail View Video Inspection - Test Run of 3/14/2013										
Date of Run	Total Video Defects	New Video Defects			Repeat Video Defects			Fixed Video Defects		
1/30/2013	96	96			0			0		
2/13/2013	96	0			96			0		
3/14/2013	96	0			95			1		
Third Rail Geometry Defects Verification Using Power Rail View Video Test Run of 3/14/2013										
Date of Run	Total Third Rail Geometry Defects Verified	New/Repeat Third Rail Geometry Defects Seen			Defects not seen (camera on one Side)			Fixed Third Rail Geometry Defects		
1/30/2013	21	16/NA			5			0		
2/13/2013	21	0/16			5			0		
3/14/2013	20	0/15			5			2		
Defects Detected by Track Geometry and Other Measuring Systems - Test Run of 3/14/2013										
Defect Type	Total Defects	Priority 3 Defects			Priority 2 Defects			Priority 1 Defects		
		P3	New	Repeat	P2	New	Repeat	P1	New	Repeat
Profile	15	13	0	13	2	1	1	0	0	0
Alignment	5	5	0	5	0	0	0	0	0	0
Gauge	16	12	0	12	4	1	3	0	0	0
Crosslevel	0	0	0	0	0	0	0	0	0	0
Rail Wear	0	0	0	0	0	0	0	0	0	0
Flangeway	3	0	0	0	3	3	3	0	0	0
Thermal	2	0	0	0	2	2	2	0	0	0
Ultrasonic	2	0	0	0	1	0	0	1	1	0

A comparison of defects or conditions found among the first, second, and third (final) inspection runs show that the Rail View and Field Side Rail View video systems detected all defects or conditions that were present on tracks C1 and C2, including a video confirmation of defects that were no longer visible because these were repaired. The result is that a 100% defect detection rate was achieved from one inspection run to the next. It has to be noted that, at this stage, the defect detection rate greatly depends on the accuracy, consistency, and dedication of the reviewer that marks and identifies the defects during the first video inspection, as this is not an automatic process. The reviewer has to be proficient and experienced to be able to detect and properly mark all defects on the initial inspection run; otherwise, defects or conditions detected on subsequent runs would be wrongly classified as “new” conditions or defects rather than being in reality “repeat” defects. Another item of note is that using the Rail View and Field Side Rail View video systems to review the location of the defects detected with the additional measuring systems on the TGC4 can possibly reveal conditions in the track that might not have been easily seen by the reviewer initially; therefore, the use of the video systems in this manner tends to enhance the detection of defects.

The Power Rail View video system alone did not detect as many defects as was expected on any of the three inspection runs. However, it could be said that a 100% defect detection rate was achieved, since the outcome was the same on each of the three inspection runs. The “slight gouge” on the contact rail V was detected in the 3/14/2013 inspection run, as well as in the previous two. However, in late March 2013, a report was received from field personnel regarding an issue of a passenger car’s third rail shoe rubbing against the lower bottom of the third rail’s cover board (see Figure 4-30). The Power Rail View video system did not display clearly the rubbing on the cover board because of the lighting, angle, and position of the camera (see Figures 4-30, 4-31, and 4-32).

Figure 4-30

Underside of cover board rubbed by third rail shoe of passenger cars (field supervisor picture)



SECTION 4: PHASE 4: VEHICLE-BASED VISUAL TRACK INSPECTION PILOT PROJECT USING TGC4 EQUIPPED WITH POWER RAIL VIEW AND FIELD SIDE RAIL VIEW VIDEO CAMERAS

Figure 4-31
Cover board viewed
in TGC4 Power
Rail View video
system of 1/30/2013
inspection run

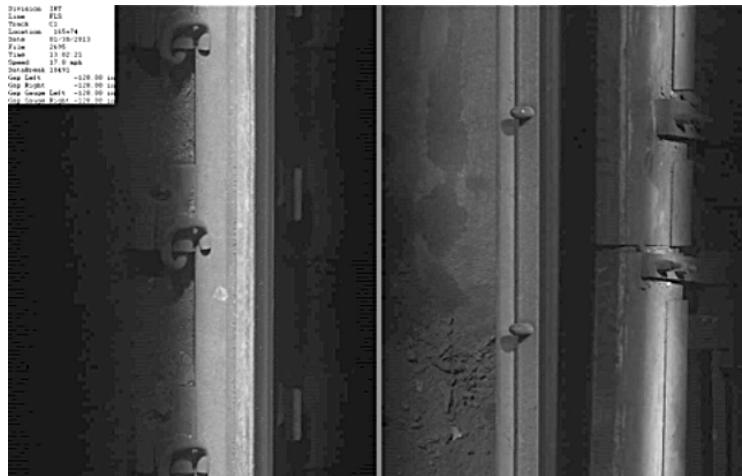

Figure 4-32
Cover board viewed
in TGC4 Power
Rail View video
system of 2/13/2013
inspection run

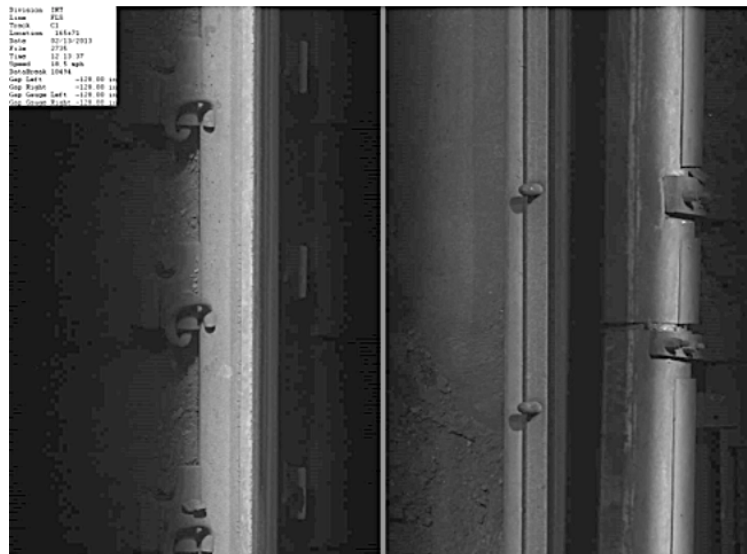
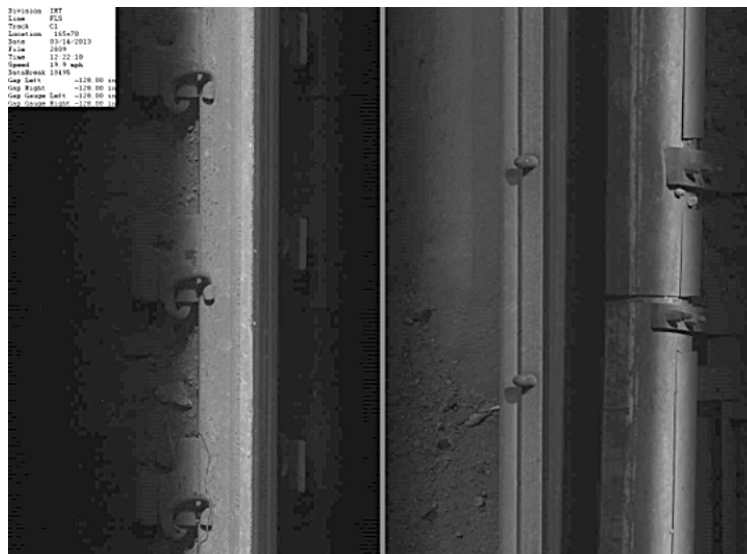

Figure 4-33
Cover board viewed
in TGC4 Power
Rail View video
system of 3/14/2013
inspection run



The limitations regarding the angle of the Power Rail View video camera, the levels of illumination, the position of the lights, and the lack of color in the images did not allow the reviewer to realize that there were rubbing marks on the underside of the cover board.

The profile, alignment, crosslevel, rail wear, and flangeway defects detected on the third (final) inspection run were basically the same as those detected in the previous inspection runs. There were small increases in the number of gauge, thermal image, and ultrasonic defects from run to run.

Defect Summaries

Charts were produced for each Excel file to identify the total number of defects or conditions detected and analyzed (including fixed defects), new defects or conditions, repeated defects or conditions, fixed defects that were no longer detected or viewed, and the defects or conditions detected with TGC4's measuring systems that were not seen in the video files. The charts for video system defects, including the Rail View and Field Side Rail View video systems or the Power Rail View video system, contain a column to identify the defects or conditions that could not be seen because the Field Side Rail View or the Power Rail View cameras were installed each on only one side of the TGC4.

There are charts for track geometry, railwear and flangeway, third rail geometry, thermal image, ultrasonic, video track geometry, and video third rail listing the defects found on tracks C1 and C2.

A defect summary table for track geometry (profile, alignment, gauge, crosslevel), rail wear (RW), flangeway, thermal, and ultrasonic defects of the three inspection runs for tracks C1 and C2 of the Flushing line between Times Square and Queensboro Plaza Stations is presented in Figure 4-34 for the runs performed on 1/30/2013, 2/13/2013, and 3/14/2013. It can be observed from this summary that the defects or conditions found by the TGC4 and all its measuring systems during the first inspection remained basically the same, with very small fluctuations, during the 43-day period between 1/30/2013 and 3/14/2013, except for gauge and ultrasonic rail flaw defects, which experienced a small increase. The Rail View and the Field Side Rail View video systems, including the Power Rail View video system, did not detect as many new defects as was expected during the second and third inspection runs, and the initial marked defects detected remained constant, or slightly decreased, during the second and third (final) inspection runs. For this busy segment of the Flushing Line, it can be concluded, therefore, that a monthly video Inspection, complemented with the use of the TGC4's other measuring systems, could be sufficient to detect all pertinent track defects and assure the safety and integrity of these tracks.

Defect Summary of Track Geometry Parameters for Track C1 - Flushing Line (Queensboro- PlazaTimes Square)																														
Defect Type	Inspection Run of 1/30/2013									Inspection Run of 2/13/2013									Inspection Run of 3/14/2013											
	Total Defects	P3 Defects			P2 Defects			P1 Defects			Total Defects	P3 Defects			P2 Defects			P1 Defects			Total Defects	P3 Defects			P2 Defects			P1 Defects		
		P3	New	Rep.	P3	New	Rep.	P1	New	Rep.		P3	New	Rep.	P2	New	Rep.	P1	New	Rep.		P3	New	Rep.	P2	New	Rep.	P1	New	Rep.
Profile	14	12	12	0	2	2	0	0	0	0	14	12	1	11	2	0	2	0	0	0	11	11	0	11	0	0	0	0	0	0
Alignment	9	9	9	0	0	0	0	0	0	9	9	0	9	0	0	0	0	0	0	9	9	0	9	0	0	0	0	0	0	0
Gauge	10	8	8	0	2	2	0	0	0	10	9	1	8	1	1	0	0	0	0	10	9	0	9	1	0	1	0	0	0	0
X-Level	0	0	0	0	0	0	0	0	0	0	0	0	0	0	0	0	0	0	0	0	0	0	0	0	0	0	0	0	0	0
Rail Wear	0	0	0	0	0	0	0	0	0	0	0	0	0	0	0	0	0	0	0	0	0	0	0	0	0	0	0	0	0	0
Flangeway	7	0	0	0	7	7	0	0	0	7	0	0	0	7	0	7	0	0	0	4	0	0	0	4	0	4	0	0	0	0
Thermal	1	0	0	0	1	1	0	0	0	1	0	0	0	1	0	0	0	0	0	1	0	0	1	0	1	0	0	0	0	0
Ultrasonic	2	0	0	0	0	0	0	2	2	0	4	0	0	0	3	3	0	1	1	0	2	0	0	0	1	1	0	1	1	0

Defect Summary of Track Geometry Parameters for Track C2 - Flushing Line (Queensboro Plaza-Times Square)																														
Defect Type	Inspection Run of 1/30/2013									Inspection Run of 2/13/2013									Inspection Run of 3/14/2013											
	Total Defects	P3 Defects			P2 Defects			P1 Defects			Total Defects	P3 Defects			P2 Defects			P1 Defects			Total Defects	P3 Defects			P2 Defects			P1 Defects		
		P3	New	Rep.	P2	New	Rep.	P1	New	Rep.		P3	New	Rep.	P2	New	Rep.	P1	New	Rep.		P3	New	Rep.	P2	New	Rep.	P1	New	Rep.
Profile	15	14	14	0	1	1	0	0	0	0	15	14	0	14	0	0	0	0	0	15	13	0	13	2	1	1	0	0	0	0
Alignment	5	5	5	0	0	0	0	0	0	5	5	0	5	0	0	0	0	0	5	5	0	5	0	0	0	0	0	0	0	0
Gauge	12	11	11	0	1	1	0	0	0	17	14	4	10	2	1	1	1	1	0	16	12	0	12	4	1	3	0	0	0	0
X-Level	0	0	0	0	0	0	0	0	0	0	0	0	0	0	0	0	0	0	0	0	0	0	0	0	0	0	0	0	0	0
Rail Wear	0	0	0	0	0	0	0	0	0	0	0	0	0	0	0	0	0	0	0	0	0	0	0	0	0	0	0	0	0	0
Flangeway	5	0	0	0	5	5	0	0	0	4	0	0	0	4	0	4	0	0	0	3	0	0	0	3	0	3	0	0	0	0
Thermal	2	0	0	0	2	2	0	0	0	0	0	0	0	0	0	0	0	0	2	0	0	0	2	0	2	0	0	0	0	0
Ultrasonic	1	0	0	0	0	0	0	1	1	0	1	0	0	0	1	1	0	0	0	2	0	0	0	1	1	0	1	1	0	0

Figure 4-34

Summary of track geometry defects found in inspections of 1/30/2013, 2/13/2013, and 3/14/2013

SECTION 4: PHASE 4: VEHICLE-BASED VISUAL TRACK INSPECTION PILOT PROJECT USING TGC4 EQUIPPED WITH POWER RAIL VIEW AND FIELD SIDE RAIL VIEW VIDEO CAMERAS

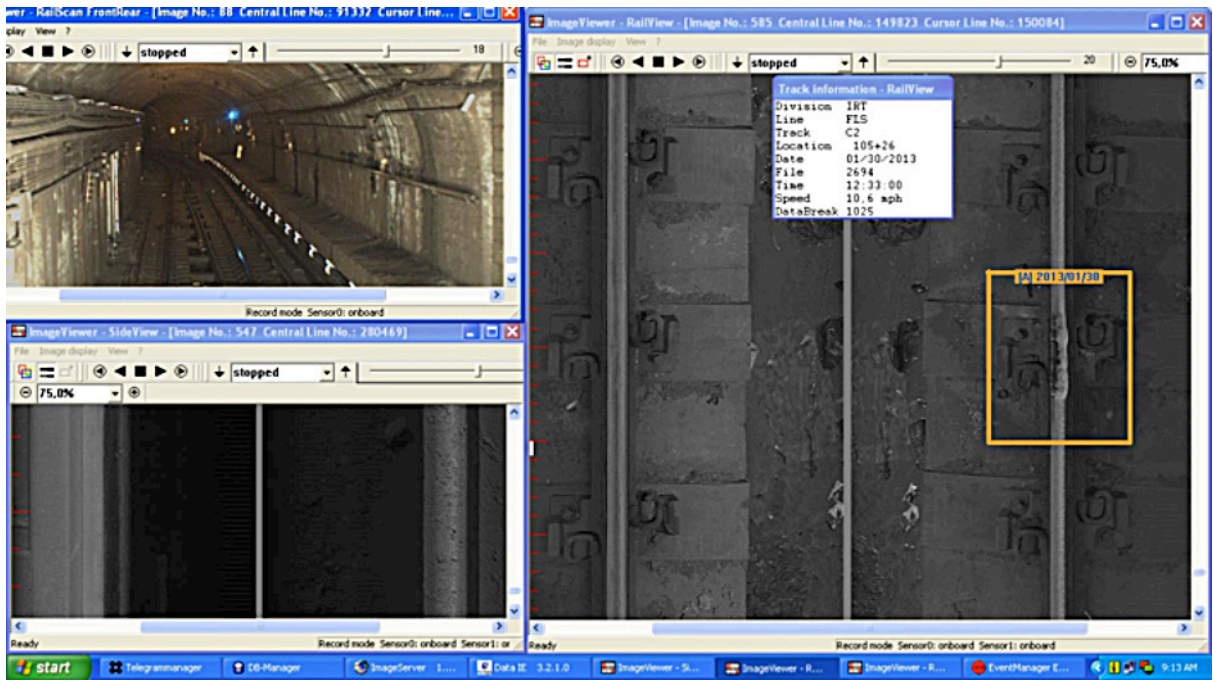

Figure 4-35
Rail View defect detected and marked in 1/30/2013 inspection run



Figure 4-36
Same Rail View defect detected and marked in 2/13/2013 inspection run



Figure 4-37

Same Rail View defect detected and marked in 3/14/2013 inspection run

Comparison Between Defects and Conditions Detected by TGC4 Video Systems and Track Walker Visual Inspection

The visual track defects—or, more accurately, the conditions—reported by Track Walkers during their visual inspections of the sections of tracks C1 and C2 of the Flushing Line between Times Square and Queensboro Plaza could not be easily compared with the defects or conditions found with the TGC4 video systems during the three inspection runs performed under this project. This is due to several factors:

- The defects or conditions obtained with the TGC4 video systems were obtained almost exclusively during the first inspection run performed on 1/30/2013; in contrast, the Track Walker Inspection defects stored in the Visual Inspection Database encompassed a period of more than three years (mid-2010 to early 2013).
- It was impossible to separate old reported Track Walker Inspection defects from recently reported ones.
- Some of the reported Track Walker Inspection defects stored on the Visual Inspection Database could not be seen at all during close scrutiny of the Rail View and Field Side View video files obtained during the three TGC4 inspection runs performed as part of this project. It was unclear if those visual defects—or track conditions—were corrected or not, or at what time were they reported first.

- The Track Walker Visual Inspection Database contains a significant number of observations that could not be identified as true “defects” from a MW-I Standards Manual point of view regarding their Priority severity (P1, P2 and P3 defects).

The Rail View and Field Side View video systems on the TGC4 detected 90 defects or conditions on track C1 and 96 on track C2 during its inspection run of 1/30/2013 alone. Of the visual defects reported by Track Walkers and stored in the Track Walker Visual Inspection Database, only 36 defect or conditions on track C1 and 41 defects or conditions on track C2 were judged by Track Engineering Supervision to be fairly equivalent or almost identical to the defects or conditions found with the TGC4 video systems during the three inspection runs performed in early 2013. Other defects stored in the Track Walker Visual Inspection Database could not be found or were judged not to be defects, but rather “observations” or conditions that had not reached a Priority 3 defect level as per MW-I Standards.

Therefore, taking in consideration these facts, the detection rate of the TGC4’s video systems can be stated as being about 250% for track C1 (90 TGC4 video system defects vs. 36 Track Walker defects) and 234% for track C2 (96 tgc4 video system defects vs. 48 Track Walker defects) when compared to the reported Track Walker visual inspections defects.

Phase 4 Conclusions

Following are the conclusions that can be obtained after the analysis and review of the three Flushing Line inspection runs performed under Phase 4 of this project:

- Defects or conditions detected by the TGC4’s Rail View and Field Side Rail View video systems or the Power Rail View video system remained fairly constant for a period of at least 43 days in tracks C1 and C2 of the Flushing Line between Times Square and Queensboro Plaza Stations.
- The TGC4’s video systems detected more detailed, accurate, and objective defects or conditions than Track Walkers observed in the same track areas during a two-week period (the time required to complete the 1st inspection run). The TGC4’s video systems detected 90 defects or conditions on track C1 and 96 on track C2 in the 1/30/2013 inspection alone.
- The video systems on the TGC4 can serve as a very useful complement to the measurements acquired with the other measuring systems, providing images of the defect location to maintenance crews. In addition, they make the reports detailed, accurate, and informative of all track conditions and measurements.

- Track video inspection systems could greatly improve Track Walker safety because no personnel are needed to be on the tracks to perform track inspections, and maintenance crews are, in advance of their field work, aware of the areas where repairs need to be performed—in effect, “zeroing” in on the defects that really need attention.
- Performing automated track video inspections in conjunction with other loaded dynamic measurements that the TGC4 can perform on a monthly basis seems to be more than adequate to provide an accurate assessment of track conditions and to provide an objective way to visualize conditions to infrastructure personnel in this segment of MTA-NYCT’s Flushing Line.

COMPARISON OF TGC4 VIDEO DEFECTS WITH THE TRACK WALKER INSPECTION DEFECTS									
FLUSHING LINE - TRACK C1 - TIMES SQUARE TO QUEENSBORO PLAZA									
TGC VIDEO ANALYSIS					TRACKWALKER INSPECTIONS				POSSIBLE SAME CONDITIONS
Defects Found	Defects Found		Defects Found		TOTAL TRACK WALKER DEFECTS	TRACK WALKER DEFECTS DATED	TRACK WALKER DEFECTS DATED	TRACK WALKER DEFECTS DATED	TGC VIDEO/ TRACK WALKER COMMON TRACK CONDITIONS
1/30/2013	2/13/2013	Number Fixed	3/14/2013	Number Fixed	2011 - 2013	2011	2012	2013	
90	89	1	88	1	98	85	8	5	36

COMPARISON OF TGC4 VIDEO DEFECTS WITH THE TRACK WALKER INSPECTION DEFECTS									
FLUSHING LINE - TRACK C2 - TIMES SQUARE TO QUEENSBORO PLAZA									
TGC VIDEO ANALYSIS					TRACKWALKER INSPECTIONS				POSSIBLE SAME CONDITIONS
Defects Found	Defects Found		Defects Found		TOTAL TRACK WALKER DEFECTS	TRACK WALKER DEFECTS DATED	TRACK WALKER DEFECTS DATED	TRACK WALKER DEFECTS DATED	TGC VIDEO/ TRACK WALKER COMMON TRACK CONDITIONS
1/30/2013	2/13/2013	Number Fixed	3/14/2013	Number Fixed	2011 - 2013	2011	2012	2013	
96	96	0	95	1	128	103	11	14	41

NOTE: MOST OF TRACK WALKER DEFECTS ARE REPETITIVE, STARTING THE FIRST YEAR THE DATA WAS OBTAINED (2011).

Figure 4-38

Summary of defects reported by Track Walker visual inspections vs. TGC4 video inspections

- The identification of critical defects, the prioritization of corrective repairs, the deployment of maintenance personnel for defect repairs, and the execution of maintenance, repairs, and reconstruction could be optimized by the use of the TGC4’s video systems by supervisors and superintendents.

- Visual track inspection reports produced by MTA-NYCT's Track Walkers and the TGC4's video system defect reports cannot be compared easily, because the Track Walker visual inspection reports suffer from lack of clarity and objectivity, as there is no objective visual record that can be contrasted to assess the validity of the Track Walker's observations in detail.
- TGC4's video systems provide the means to analyze defects at any time by different reviewers, confirming defects almost instantly, providing a more objective and accurate report to maintenance personnel, eliminating any subjectivity.
- Once the files on the TGC4's Rail View, Field Side Rail View or Power Rail View video systems have been analyzed and marked with the defects or conditions found, these can be transferred easily and accurately to future video inspection files, as it was performed successfully during the analysis of the second and third (final) inspection runs of February 13 and 3/14/2013.
- The Power Rail View video system camera and illumination should ideally be placed in a lower position to allow viewing of conditions under the power rail's cover board. The Power Rail View video system, as it was installed in the TGC4, was not able to detect rubbing marks on the underside of the cover board because of the camera position and the lack of optimal illumination.
- Consistent and periodic use of the TGC4's Video Inspection Systems would avoid the interruptions of revenue service due to the required General Orders that walking inspections unavoidably cause in the Steinway Tunnel. The time required to perform the inspection of both tracks between Times Square and Queensboro Plaza was equal to 25 minutes using the TGC4, while Track Walkers spend several hours to walk each track.

SECTION
5

Final Comments

Vehicle-based video automated track inspection systems, as envisioned in this project, are indeed successful in augmenting the capabilities of detecting and confirming defects found by the TGC4's measuring systems. These video systems have the potential to provide a more detailed and comprehensive picture of the actual location where the defect can be found.

The TGC4's video systems did not detect as many new defects as was expected at the beginning of this project. In fact, the second and third (final) video systems found the same amount of track defects or conditions that were found on the first inspection run of 1/30/2013. On the second and third (final) inspection runs, it was observed that the conditions detected tended to deteriorate slowly, since no new defects were detected, and only one defect was corrected, as it was detected on the February 13 inspection, and another one corrected during the March 30 inspection. These observations and the data collected and analyzed by the Automated Track Inspections group of Track Engineering lead to the conclusion that a once-a-month automated video inspection, complemented by the analysis of all the other measuring systems on board the TGC4, has the potential to detect most of the pertinent defects or conditions on this segment of the Flushing Line between Times Square and Queensboro Plaza.

It should be noted that a key factor at the present time for any successful, accurate, and quality video inspection is the experience, dedication, accuracy, and track knowledge of the personnel performing the video review; the reviewer assigned to analyze, review, and mark the defects and log them into a database must be willing to dedicate long hours to review the video files with accuracy and keen attention. Marking of video defects on the initial or base inspection run is essential to save reviewing time and provide the necessary accuracy for the identification of the defects in future video inspection runs.

The track defects or conditions reported by Track Walkers could not be easily or properly compared with the defects or conditions obtained with the TGC4's video systems because the defects or conditions stored in the Track Walker's Visual Inspection Database suffer from ambiguity regarding the description and magnitude of the defects, and they are not updated and purged from the database as they are corrected or reinspected. The result is that many of the Track Walker's visual defects could not be verified using the TGC4's video systems or other measuring systems.

One of the advantages of the use of the TGC4 video systems is the transfer of marked defects from the base or original video file to future video inspection files. The Compare Viewer software plays back and transfers marked defects from one video inspection run to the next without the need for a lengthy review process. One of the disadvantages is that the current software is not able to detect defects automatically without human intervention—although such software does exist (see Section 8). The steps to load the video inspection files into the Compare Viewer software to compare and play back the files have to be simplified or redesigned to make them more logical, simple, and foolproof. Perhaps the introduction of help menus in each of the software steps to advise the reviewer of the next possible choices would avoid confusion in the loading of files and the comparing of marked defects.

Several of the shortcomings observed with the Field Side Rail View and Power Rail View video systems were due to the fact that the existing TGC4 cameras and illumination lights needed to be modified in situ, and, due to clearance constraints and lack of available space, they could not be installed close to the same truck (the TGC4 was initially built without provision for the installation of such equipment). These factors affected slightly the quality and/or clarity of the Power Rail View and Field Side View video systems.

Regarding the quality of the image and the illumination, it was initially thought that it was good enough at the start of Phase 4, but it was later realized that better lighting for the Power Rail View video system may be required. The illumination and quality of the Power Rail View video system needs to be improved to detect certain cover board conditions such as shoe-rubbing marks.

Regarding the productivity and personnel safety enhancements offered by the use of vehicle-based video automated track inspection systems, the following facts are noted:

- Track Walker visual inspection of the Flushing Line sections between Times Square and Queensboro Plaza Stations is currently performed twice weekly for each track. The subway portion, between the Times Square and Hunters Point stations, is inspected by a team of one Flagger and one Track Walker, except for the Steinway Tube portion, which requires a General Order and an additional two track workers to set up trips and lights. The team inspects track C1 on Wednesdays and Fridays and track C2 on Tuesdays and Thursdays. Thus, four persons are able to inspect 12,000 ft. of track per night in a six-hour time period.
- On the elevated portion of the Line between Hunters Point and Queensboro Plaza Stations, a team of a Flagger and a Track Walker are able to inspect each track, approximately 5,000 ft. long, twice a week during a 2–3-hour time period.

- In comparison, the TGC4 was able to fully inspect each track and take the relevant track measurements under dynamic loads in less than 12 minutes without exposing personnel to safety hazards, without requiring the tracks to be taken out of service, and providing for a more accurate, complete, and objective inspection.

SECTION
6

Proposal for Further Research

One of the shortcomings of the video systems installed on the TGC4 car is that the existing software is not capable of detecting rail and fastener defects automatically. This requires that the personnel performing the review of the initial video inspection file pay close attention and scrutinize the video files painstakingly to assure that all pertinent conditions and defects have been identified and properly marked, so as to serve as the reference for future inspection runs of the same track. This can take a long time.

The issue regarding automatic defect identification being performed by the video software is that MTA-NYCT has a large variety of fasteners, track types, and track conditions, including rail conditions and environmental conditions, that make the task of automatically detecting potential defects a complicated one, given the amount of “false positives” that such software may initially detect. Examples of such “false positive” indications could be a piece of garbage lying over the rail or a soda can on top of a fastener or a newspaper lying on top of a crosstie or tie block.

Nevertheless, such automatic detection video inspection software does exist, and it would be very beneficial, and complementary to this project, to procure and install such video software to test it along with the other software already installed on the TGC4 under Phase 3 of this project. The automatic detection video software could then be used in conjunction with the Rail View and Gauge Side Rail View video systems that the TGC4 already has to investigate if the software can automatically detect cracks in the side of the web or base of the rail, as well as base corrosion and wheel burns or squats on the top of the rail. These defects are critical to assure the safety and integrity of the rail system, and their early and accurate detection could potentially save a derailment or similar incident due to a broken rail condition. Although the video reviewer still would have to “weed out” the “false positives,” the research could indicate to what extent the task of finding these types of defects has been simplified and accelerated, and how well it could perform that detection.



U.S. Department of Transportation
Federal Transit Administration
East Building
1200 New Jersey Avenue, SE
Washington, DC 20590
<http://www.fta.dot.gov/research>

U.S. Department of Transportation
Federal Transit Administration
East Building
1200 New Jersey Avenue, SE
Washington, DC 20590
<http://www.fta.dot.gov/research>