



U.S. Department
of Transportation
**Federal Highway
Administration**

1200 New Jersey Ave., SE
Washington, D.C. 20590

June 5, 2013

In Reply Refer To:
HSST/B-241

Mr. Michael Elle
Office of Project Management and Technical Support
Minnesota Department of Transportation
395 John Ireland Blvd, MS 696
St. Paul MN-55155-180

Dear Mr. Elle:

This letter is in response to your request for the Federal Highway Administration (FHWA) to review a roadside safety system for eligibility for reimbursement under the Federal-aid highway program.

Name of system: 31-inch high W-Beam Guardrail on a Low-Fill Box Culvert
Type of system: Bridge Rail
Test Level: MASH Test Level 3
Testing conducted by: Texas Transportation Institute
Task Force 13 Designator: SBW09c
Date of request: November 14, 2012
Date initially acknowledged: November 14, 2012
Date of completed package: May 14, 2013

Decision:

The following device is eligible, with details provided in the form which is attached as an integral part of this letter:

- 31-inch high W-Beam Guardrail on a Low-Fill Box Culvert

Based on a review of crash test results submitted by the manufacturer certifying the device described herein meets the crash test and evaluation criteria of the American Association of State Highway and Transportation Officials' Manual for Assessing Safety Hardware (MASH), the device is eligible for reimbursement under the Federal-aid highway program. Eligibility for reimbursement under the Federal-aid highway program does not establish approval or endorsement by the FHWA for any particular purpose or use.

The FHWA, the Department of Transportation, and the United States Government do not endorse products or services and the issuance of a reimbursement eligibility letter is not an

FHWA: HSST: WLongstreet: sf.x60087: WLongstreet: 5/31/13: **Updated 6/4/13**

File: h://directory folder/HSST/ B241_MnDOT wbeam post barrier for lowfill box culverts.docx

cc: HSST Will Longstreet

endorsement of any product or service.

Requirements

To be found eligible for Federal-aid funding, roadside safety devices should meet the crash test and evaluation criteria contained in the American Association of State Highway and Transportation Officials' Manual for Assessing Safety Hardware (MASH).

Description

The device and supporting documentation are described in the attached form.

Summary and Standard Provisions

Therefore, the system described and detailed in the attached form is eligible for reimbursement and may be installed under the range of conditions tested.

Please note the following standard provisions that apply to FHWA eligibility letters:

- This letter provides a AASHTO/ARTBA/AGC Task Force 13 designator that should be used for the purpose of the creation of a new and/or the update of existing Task Force 13 drawing for posting on the on-line 'Guide to Standardized Highway Barrier Hardware' currently referenced in AASHTO Roadside Design Guide.
- This finding of eligibility does not cover other structural features of the systems, nor conformity with the Manual on Uniform Traffic Control Devices.
- Any changes that may influence system conformance with MASH will require a new reimbursement eligibility letter.
- Should the FHWA discover that the qualification testing was flawed, that in-service performance reveals safety problems, or that the system is significantly different from the version that was crash tested, we reserve the right to modify or revoke this letter.
- You are expected to supply potential users with sufficient information on design and installation requirements to ensure proper performance.
- You are expected to certify to potential users that the hardware furnished has the same chemistry, mechanical properties, and geometry as that submitted for review, and that it will meet the test and evaluation criteria of the MASH.
- To prevent misunderstanding by others, this letter of eligibility is designated as number B-241 and shall not be reproduced except in full. This letter and the test documentation upon which it is based are public information. All such letters and documentation may be reviewed at our office upon request.

- This letter shall not be construed as authorization or consent by the FHWA to use, manufacture, or sell any patented system for which the applicant is not the patent holder. The FHWA does not become involved in issues concerning patent law. Patent issues, if any, are to be resolved by the applicant.

Sincerely yours,

A handwritten signature in blue ink that reads "Michael S. Griffith". The signature is written in a cursive style with a large initial "M" and "G".

Michael S. Griffith
Director, Office of Safety Technologies
Office of Safety

Enclosures

Request for Federal Aid Reimbursement Eligibility Of Highway Safety Hardware

Submitter	Date of Request:	November 14, 2012	<input type="radio"/> New <input checked="" type="radio"/> Resubmission
	Name:	Michael J. Elle P.E. <i>Michael J- Elle</i>	
	Company:	Minnesota Department of Transportation	
	Address:	395 John Ireland Blvd, MS 696 St. Paul, MN 55155-1800	
	Country:	U.S.	
	To:	Michael S. Griffith, Director FHWA, Office of Safety Technologies	

I request the following devices be considered eligible for reimbursement under the Federal-aid highway program.

[Help](#)

System Type	Submission Type	Device Name / Variant	Testing Criterion	Test Level
'B': Barriers (Roadside, Media	<input checked="" type="radio"/> Physical Crash Testing <input type="radio"/> FEA & V&V Analysis	31-inch high W-Beam Guardrail on a Low-Fill Box Culvert	AASHTO MASH	TL3

By submitting this request for review and evaluation by the Federal Highway Administration, I certify that the product(s) was (were) tested in conformity with the AASHTO Manual for Assessing Safety Hardware and that the evaluation results meet the appropriate evaluation criteria in the MASH.

Identification of the individual or organization responsible for the product:

Contact Name:	Dave Olson, Chair	Same as Submitter <input type="checkbox"/>
Company Name:	Roadside Safety Research Program, Pooled Fund Study No. TPF-5(Same as Submitter <input type="checkbox"/>
Address:	Washington State Department of Transportation, Transportation B	Same as Submitter <input type="checkbox"/>
Country:	U.S.	Same as Submitter <input type="checkbox"/>

PRODUCT DESCRIPTION

New Hardware
<p>For this project, a new W-beam guardrail system with posts spaced on 6'-3" on center with a new post anchorage design utilizing adhesive anchors was developed and full-scale crash tested with respect to MASH specifications.</p> <p>The design tested for this project consists of a W6x9 guardrail post anchored to the top of a simulated box culvert with approximately 9-inches of soil on top of the box culvert. The W-beam rail splices were located between the posts. The height of the W-beam guardrail installation was 31 inches.</p>

CRASH TESTING

A brief description of each crash test and its result:

Request for Federal Aid Reimbursement Eligibility Of Highway Safety Hardware

Submitter	Date of Request:	November 14, 2012	<input type="radio"/> New <input checked="" type="radio"/> Resubmission
	Name:	Michael J. Elle P.E.	
	Company:	Minnesota Department of Transportation	
	Address:	395 John Ireland Blvd, MS 696 St. Paul, MN 55155-1800	
	Country:	U.S.	
	To:	Michael S. Griffith, Director FHWA, Office of Safety Technologies	

I request the following devices be considered eligible for reimbursement under the Federal-aid highway program.

[Help](#)

System Type	Submission Type	Device Name / Variant	Testing Criterion	Test Level
'B': Barriers (Roadside, Media	<input checked="" type="radio"/> Physical Crash Testing <input type="radio"/> FEA & V&V Analysis	31-inch high W-Beam Guardrail on a Low- Fill Box Culvert	AASHTO MASH	TL3

By submitting this request for review and evaluation by the Federal Highway Administration, I certify that the product(s) was (were) tested in conformity with the AASHTO Manual for Assessing Safety Hardware and that the evaluation results meet the appropriate evaluation criteria in the MASH.

Identification of the individual or organization responsible for the product:

Contact Name:	Dave Olson, Chair	Same as Submitter <input type="checkbox"/>
Company Name:	Roadside Safety Research Program, Pooled Fund Study No. TPF-5(Same as Submitter <input type="checkbox"/>
Address:	Washington State Department of Transportation, Transportation B	Same as Submitter <input type="checkbox"/>
Country:	U.S.	Same as Submitter <input type="checkbox"/>

PRODUCT DESCRIPTION

New Hardware
<p>For this project, a new W-beam guardrail system with posts spaced on 6'-3" on center with a new post anchorage design utilizing adhesive anchors was developed and full-scale crash tested with respect to MASH specifications.</p> <p>The design tested for this project consists of a W6x9 guardrail post anchored to the top of a simulated box culvert with approximately 9-inches of soil on top of the box culvert. The W-beam rail splices were located between the posts. The height of the W-beam guardrail installation was 31 inches.</p>

CRASH TESTING

A brief description of each crash test and its result:

Required Test Number	Narrative Description	Evaluation Results
3-10 (1100C)	(Revised/added 11/14/2012) Test 3-10 was not performed due to review of previous crash testing on 31-inch high guardrail that was successful with respect to MASH performance Criteria. Midwest Roadside Safety Facility performed MASH Test 3-10 on a Non-Blocked MGS Guardrail System (31-inches high) in June 2011 (Research Report MGSNB-2 and dated 2011). Midwest also performed MASH Test 3-10 on a Blocked MGS Guardrail System (31-inches high with 12-inch Blocks) in 2006 (research Report 2214MG-3 dated October 2006). The results of these crash tests were successful with respect to MASH 3-10 Specifications (PASS). The use of 8-inch blocks as used for our box culvert guardrail crash test installation would improve the performance of the MASH small car. Based on previous successful testing, MASH Test 3-10 was not performed on this test installation."	WAIVER REQUES
3-11 (2270P)	The guardrail system contained and redirected the vehicle without penetrating, underriding, or overriding the installation. The occupant risk values recorded for this test were acceptable with respect to MASH criteria. Based on the review of all available test data, the W-beam Guardrail on Low-Fill Box Culvert met the required criteria for TL-3 according to the specifications for MASH. The W6x9 post and anchorage details developed under this project demonstrated satisfactory performance. No damage to the deck or failure of the adhesive anchors was observed in the full-scale crash testing. The W6x9 post and anchorage details tested for this project can be used in lieu of the conventional through-bolt design, provided sufficient anchorage depth as tested for this project is provided.	PASS
3-20 (1100C)		
3-21 (2270P)		

Full Scale Crash Testing was done in compliance with MASH by the following accredited crash test laboratory (cite the laboratory's accreditation status as noted in the crash test reports.):

Laboratory Name:	Texas Transportation Institute	
Laboratory Contact:	William Williams, P.E.	Same as Submitter <input type="checkbox"/>
Address:	Texas Transportation Institute 3135 TAMUS Texas A&M University System College Station, Texas 77843-3135	Same as Submitter <input type="checkbox"/>
Country:	U.S.	Same as Submitter <input type="checkbox"/>
Accreditation Certificate Number and Date:	Certificate No.: 2821.01 Expiration Date: 4/30/2013	

ATTACHMENTS

Attach to this form:

- 1) A copy of the full test report, video, and a Test Data Summary Sheet for each test conducted in support of this request.
- 2) A drawing or drawings of the device(s) that conform to the Task Force-13 Drawing Specifications [[Hardware Guide Drawing Standards](#)]. For proprietary products, a single isometric line drawing is

usually acceptable to illustrate the product, with detailed specifications, intended use, and contact information provided on the reverse. Additional drawings (not in TF-13 format) showing details that are key to understanding the performance of the device should also be submitted to facilitate our review.

FHWA Official Business Only:

Eligibility Letter		AASHTO TF13	
Number	Date	Designator	Key Words
B241	May 30, 2013	SBW09c	W-beam guardrail, Low-Fill Box Culvert, W6x9 guardrail post, 31 inches high



General Information

Test Agency Texas Transportation Institute (TTI)
 Test Standard Test No MASH Test 3-11
 TTI Test No 405160-23-2
 Date November 11, 2011

Test Article

Type Longitudinal Barrier
 Name W-Beam Guardrail on Low-Fill Box Culvert
 Installation Length 105 ft
 Material or Key Elements 12 gage W-beam guardrail system on
 W6x9 steel posts anchored to simulated
 concrete box culvert
 Soil Type and Condition Concrete box culvert, dry

Test Vehicle

Type/Designation 2270P
 Make and Model 2003 Dodge Ram 1500
 Curb 4900 lb
 Test Inertial 5005 lb
 Dummy No dummy
 Gross Static 5005 lb

Impact Conditions

Speed 62.9 mi/h
 Angle 26.1 degrees
 Location/Orientation 5.5 ft upstream
 of the post 12

Impact Severity

Exit Conditions
 Speed 32.2 mi/h
 Angle 10.9 degrees

Occupant Risk Values

Impact Velocity
 Longitudinal 15.4 ft/s
 Lateral 14.4 ft/s
 Ridedown Accelerations
 Longitudinal 5.3 G
 Lateral 6.4 G
 THIV 22.1 km/h
 PHD 6.7 G
 ASI 0.58
 Max. 0.050-s Average
 Longitudinal -4.7 G
 Lateral -4.3 G
 Vertical 2.0 G

Post-Impact Trajectory

Stopping Distance 123 ft downstream
 37 ft twds field side

Vehicle Stability

Maximum Yaw Angle 37 degrees
 Maximum Pitch Angle 11 degrees
 Maximum Roll Angle 9 degrees
 Vehicle Snagging No
 Vehicle Pocketing No

Test Article Deflections

Dynamic 3.8 ft
 Permanent Terminal detached
 Working Width 4.1 ft

Vehicle Damage

VDS 01RFQ4
 CDC 01FREW3
 Max. Exterior Deformation 14.0 inches
 OCCDI RF000000
 Max. Occupant Compartment
 Deformation Nil

Figure 5.7. Summary of results for MASH test 3-11 on the W-Beam Guardrail on Low-Fill Box Culvert.

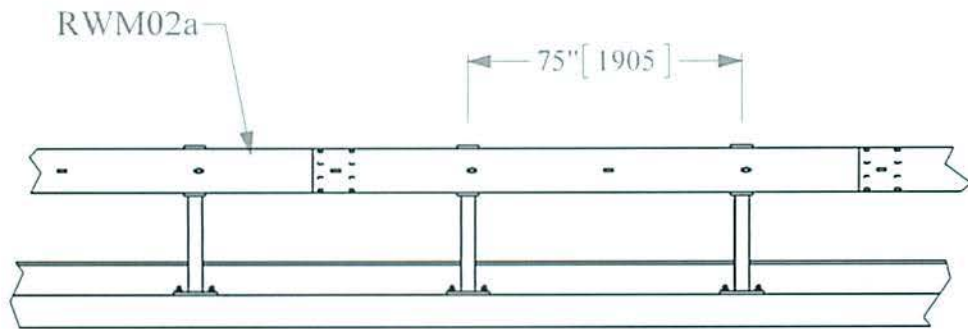

ELEVATION VIEW

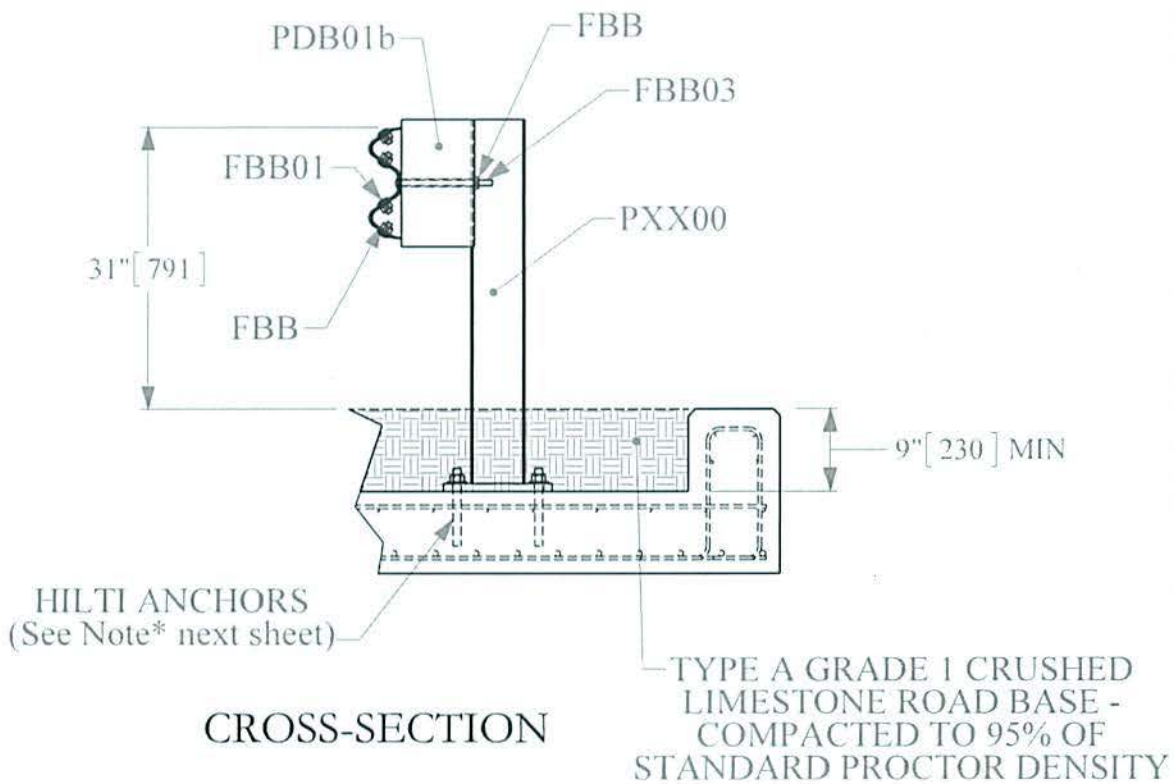

2012

W-Beam Guardrail on Box Culvert



SXX00

SHEET NO.

DATE

1 of 2

06/05/2012

INTENDED USE

This guardrail system is intended for use over a concrete culvert. This drawing and specification address only the bridge railing and not the design or detailing of the concrete and rebar components of the culvert, but this system is not to be used if concrete strength of the box culvert is less than 5000 psi (34.5 MPa).

COMPONENTS			
Unit Length = 105' [32m]			
#	PART NUMBER	QTY.	ARTBA
1	Box Culvert Post	17	PXX00
2	12' 6" W-Beam, 4- space 12 gauge	9	RWM02a
3	Blockout, 8-inch W-beam Routered	17	PDB01b
4	Bolt, Button-head 10 inch	17	FBB03
5	Nut, Recessed Guardrail	89	FBB
6	Bolt, Button-head 1-1/4"	72	FBB01
7	Hilti Anchor *	68	

* Hilti HAS-E Ø7/8 Anchor (cut off to 8-1/2" [215] long) with washer and nut. Installed with Hilti RE500 epoxy according to label directions with minimum 6" [150] embedment.

REFERENCES

MASH Test 3-11 of the W-beam Guardrail on low-fill Culvert, Roadside Safety Research Program, Pool Fund Study No. TPF-5 (119) Test No. 405160-23 (1 and 2), November, 2011.

2012

W-Beam Guardrail on Box Culvert



SXX00

SHEET NO.	DATE
2 of 2	06/05/2012