

PAVEMENT MAINTENANCE EFFECTIVENESS PREVENTIVE MAINTENANCE TREATMENTS

Participant's

Handbook



U.S. Department
of Transportation

**Federal Highway
Administration**



Innovation Through
Partnership

NOTICE

This document is disseminated under the sponsorship of the Department of Transportation in the interest of information exchange. The United States Government assumes no liability for its contents or use thereof.

The contents of this report reflect the views of the contractor who is responsible for the accuracy of the data presented herein. The contents do not necessarily reflect the official policy of the Department of Transportation.

This report does not constitute a standard, specification, or regulation.

The United States Government does not endorse products or manufacturers. Trade or manufacturer's names appear herein only because they are considered essential to the object of this document.

1. Report No. FHWA-SA-96-027		2. Government Accession No.		3. Recipient's Catalog No.	
4. Title and Subtitle Preventive Maintenance Effectiveness - Preventive Maintenance Treatments Participant's Handbook			5. Report Date February, 1996		
			6. Performing Organization Code		
7. Author(s) John P. Zaniewski and Michael S. Mamlouk			8. Performing Organization Report No.		
9. Performing Organization Name and Address Center for Advanced Transportation Systems Research Mail Code 6306 Arizona State University Tempe, AZ 85287			10. Work Unit No. (TRAIS)		
			11. Contract or Grant No. DTFH-61-94-C-00032		
12. Sponsoring Agency Name and Address Federal Highway Administration Office of Engineering/Office of Technology Applications 400 Seventh Street S.W. Washington, DC 20590			13. Type of Report and Period Covered June 1994 - February 1996		
			14. Sponsoring Agency Code		
15. Supplementary Notes Contracting Officer's Technical Representative - Michael R. Smith, Pavement Division, HNG-40, Phone: 202-366-4057					
16. Abstract Pavement preventive maintenance is an important tool for extending the service life of pavements in a cost effective manner. Many of the available treatments are currently used by state highway agencies for pavement preservation. However, to be effective as a preventive maintenance practice, these treatments must be placed on the pavement much earlier in the pavement service life than is currently the practice. The purpose of this document is to describe the need for and benefits of preventive maintenance, discuss the engineering applications of these treatments, review the materials used for preventive maintenance, and describe the application process for these treatments. The treatments described in this document include: fog seals, slurry seals, micro-surfacing, chip seals, thin hot-mix overlays, and crack sealing of flexible pavements; crack and joint sealing, subsealing, and retrofit of dowel bars of rigid pavements. This Participant's Handbook was developed to support a one day workshop on Pavement Maintenance Effectiveness - Preventive Maintenance Treatments.					
17. Key Words Pavement preventive maintenance, flexible pavements, rigid pavements, preventive maintenance treatments			18. Distribution Statement No restrictions. This document is available to the public from the National Technical Information Service, Springfield, Virginia 22161		
19. Security Classif. (of this report) Unclassified		20. Security Classif. (of this page) Unclassified		21. No. of Pages 190	

METRIC (SI*) CONVERSION FACTORS

APPROXIMATE CONVERSIONS TO SI UNITS					APPROXIMATE CONVERSIONS TO SI UNITS				
Symbol	When You Know	Multiply By	To Find	Symbol	Symbol	When You Know	Multiply By	To Find	Symbol
LENGTH					LENGTH				
in	inches	2.54	centimeters	cm	mm	millimeters	0.039	inches	in
ft	feet	0.3048	meters	m	m	meters	3.28	feet	ft
yd	yards	0.914	meters	m	yd	meters	1.09	yards	yd
mi	miles	1.61	kilometers	km	km	kilometers	0.621	miles	mi
AREA					AREA				
in ²	square inches	6.452	centimeters squared	cm ²	mm ²	millimeters squared	0.0016	square inches	in ²
ft ²	square feet	0.0929	meters squared	m ²	m ²	meters squared	10.764	square feet	ft ²
yd ²	square yards	0.836	meters squared	m ²	yd ²	kilometers squared	0.39	square miles	mi ²
mi ²	square miles	2.59	kilometers squared	km ²	ha	hectares (10,000 m ²)	2.53	acres	ac
ac	acres	0.395	hectares	ha					
MASS (weight)					MASS (weight)				
oz	ounces	28.35	grams	g	g	grams	0.0353	ounces	oz
lb	pounds	0.454	kilograms	kg	kg	kilograms	2.205	pounds	lb
T	short tons (2000 lb)	0.907	megagrams	Mg	Mg	megagrams (1000 kg)	1.103	short tons	T
VOLUME					VOLUME				
fl oz	fluid ounces	29.57	milliliters	mL	mL	milliliters	0.034	fluid ounces	fl oz
gal	gallons	3.785	liters	L	L	liters	0.264	gallons	gal
ft ³	cubic feet	0.0328	meters cubed	m ³	m ³	meters cubed	35.315	cubic feet	ft ³
yd ³	cubic yards	0.765	meters cubed	m ³	m ³	meters cubed	1.308	cubic yards	yd ³
Note: Volumes greater than 1000 L shall be shown in m ³ .									
TEMPERATURE (exact)					TEMPERATURE (exact)				
°F	Fahrenheit temperature	5/9 (after subtracting 32)	Celsius temperature	°C	°C	Celsius temperature	9/5 (then add 32)	Fahrenheit temperature	°F
These factors conform to the requirement of FHWA Order 5190.1A									
*SI is the symbol for the International System of Measurements									

PAVEMENT MAINTENANCE EFFECTIVENESS PREVENTIVE MAINTENANCE TREATMENTS

Participant's

Handbook

**PREPARED FOR
U.S. DEPARTMENT OF TRANSPORTATION
FEDERAL HIGHWAY ADMINISTRATION**

**PREPARED BY
CENTER FOR ADVANCED
TRANSPORTATION SYSTEMS RESEARCH
ARIZONA STATE UNIVERSITY**

FEBRUARY 1996

PUBLICATION No. FHWA-SA-96-027



U.S. Department
of Transportation
**Federal Highway
Administration**



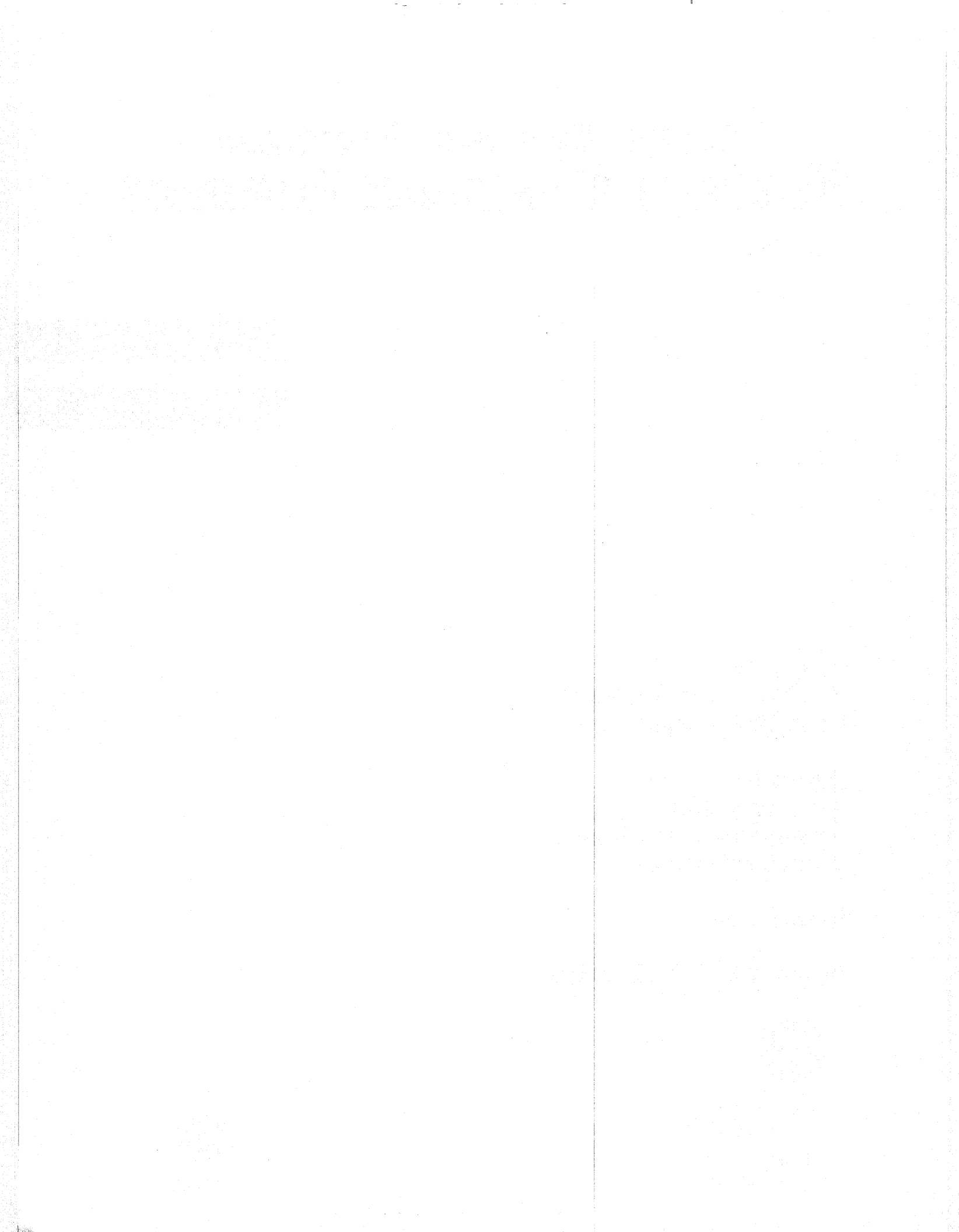

CONTENTS

CHAPTER 1 THE CASE FOR PREVENTIVE MAINTENANCE	1
INTRODUCTION	1
DEFINITION OF PAVEMENT PREVENTIVE MAINTENANCE	4
PAVEMENT PREVENTIVE MAINTENANCE TREATMENTS	7
PAVEMENT CONDITIONS AND PREVENTIVE MAINTENANCE	9
PREVENTIVE MAINTENANCE AND PAVEMENT MANAGEMENT	12
IMPROVING PAVEMENT PERFORMANCE	12
IMPACT OF PREVENTIVE MAINTENANCE	19
SHRP MAINTENANCE EFFECTIVENESS RESEARCH	23
SUMMARY	26
CHAPTER 2. ENGINEERING A PREVENTIVE MAINTENANCE PROGRAM	28
INTRODUCTION	28
SELECTION OF PREVENTIVE MAINTENANCE TREATMENTS	28
Existing Pavement Condition	29
Traffic	35
Environment	36
Other Considerations	37
DESIGN OF PREVENTIVE MAINTENANCE TREATMENTS	38
DESIGN OF A PREVENTIVE MAINTENANCE PROGRAM	39
QUALITY CONTROL OF PREVENTIVE MAINTENANCE	39
Method Specifications	40
End-result Specifications	41
Performance Specifications	41

MONITORING THE PERFORMANCE OF PREVENTIVE MAINTENANCE TREATMENTS	42
CHAPTER 3. MATERIALS FOR PREVENTIVE MAINTENANCE	44
INTRODUCTION	44
BINDERS FOR PREVENTIVE MAINTENANCE	44
Asphalt Cement	44
Asphalt Emulsions	49
BINDER MODIFICATION	53
AGGREGATES FOR PAVEMENT MAINTENANCE TREATMENTS	54
CHAPTER 4. FOG SEALS AND REJUVENATORS	57
INTRODUCTION	57
PAVEMENT CONDITIONS FOR FOG SEALING	57
DESIGN CONSIDERATIONS	58
Materials	58
Application Rate	58
CONSTRUCTION CONSIDERATIONS	59
Pavement Preparation	59
Weather Conditions	59
Equipment	59
Construction Process	59
Inspection and Acceptance	60
Specifications	61
PERFORMANCE	61
LIMITATIONS	61
VARIATIONS	62
Rejuvenators	62
CHAPTER 5. CHIP SEALS	63
INTRODUCTION	63

SHRP EXPERIENCE	64
PAVEMENT CONDITION FOR SUCCESSFUL APPLICATION	66
DESIGN OF CHIP SEALS	67
Binder Selection	67
Aggregate Selection	67
Application Rate	67
CONSTRUCTION CONSIDERATIONS	70
Pavement Preparation	70
Weather Conditions	70
Construction Process Methodology	70
Inspection and Acceptance	76
Specifications	79
PERFORMANCE	81
LIMITATIONS	81
VARIATIONS ON CHIP SEALS	81
Alternative Binders	82
Double and Triple Chip Seals	82
Precoated Chips	83
Sand Seal	84
Sandwich Seal	85
Cape Seal	86
CHAPTER 6. COLD THIN SEALS	87
INTRODUCTION	87
SLURRY SEALS	87
SHRP Experience	88
Pavement Conditions for Successful Application of Slurry Seals	90
Design Considerations for Slurry Seals	91
Construction Considerations	93
Performance	99
Limitations	99
MICRO-SURFACING	100
Introduction	100
Pavement Condition for Successful Application of Micro-surfacing	101
Design Considerations for Micro-surfacing	101

Construction Considerations	104
Performance	112
Limitations	112
CHAPTER 7. THIN HOT MIX ASPHALT OVERLAYS	113
INTRODUCTION	113
SHRP EXPERIENCE	114
DESIGN CONSIDERATIONS FOR THIN OVERLAYS	114
Binder Selection	114
Aggregate Selection	115
PAVEMENT CONDITION FOR SUCCESSFUL APPLICATION	120
CONSTRUCTION PROCEDURES	121
INSPECTION AND ACCEPTANCE	122
PERFORMANCE	123
LIMITATIONS	124
VARIATIONS ON GAP-GRADED THIN HOT MIX OVERLAYS	125
Alternative Binders	125
Stone Matrix Asphalt	125
Other Thin Gap-Graded Overlays	130
CHAPTER 8. CRACK TREATMENT OF FLEXIBLE PAVEMENTS	133
INTRODUCTION	133
SHRP EXPERIENCE	133
PAVEMENT CONDITIONS FOR SUCCESSFUL APPLICATION	
OF CRACK SEALING	134
CRACK TREATMENT DESIGN	134
Materials	139
Sealing Configurations	140
CONSTRUCTION CONSIDERATIONS	141
Pavement Preparation	141
Weather Conditions	142

Equipment	142
Construction Process	142
Inspection and Acceptance	145
COST	145
PERFORMANCE	145
LIMITATIONS	146
CHAPTER 9. PREVENTIVE MAINTENANCE OF CONCRETE PAVEMENTS	147
INTRODUCTION	147
SHRP EXPERIENCE	147
CRACK AND JOINT SEALING	148
Pavement Conditions Warranting Crack and Joint Sealing	148
Materials	150
Equipment	151
Construction Process	151
Specifications	153
Performance	154
Limitations	154
SUBSEALING	154
Pavement Conditions Warranting Subsealing	155
Design Consideration for Undersealing	159
Construction Consideration	159
Performance	164
Limitations	164
RETROFIT OF DOWEL BARS	164
APPENDIX REVIEW OF SHRP PREVENTIVE MAINTENANCE RESEARCH	169
EXPERIMENTAL DESIGN	170
SHRP Flexible Pavement Sections	171
SHRP Rigid Sections	176
State Supplemental Sections	178
SHRP H-101 RESEARCH RESULTS AND PRODUCTS	178
Evaluation of Preventive Maintenance Treatments	178
Method to Rate the Application of Pavement Maintenance Treatments	180
Making Pavement Maintenance More Effective - Training Supplement	181

Proposed Test Method - Detection of Voids Under Rigid Pavements	182
Benefits of the H-101 Research	182
CONTINUING FHWA ACTIVITIES	183
REFERENCES	186

LIST OF FIGURES

<u>FIGURES</u>	<u>Page</u>
1. Trends in Federal obligations by construction category.	1
2. Percentage of kilometerage of capital improvements by construction category.	2
3. Distribution of pavement condition based on functional classification.	3
4. Definition of categories of maintenance.	6
5. Conceptual performance of preventive maintenance treatments.	10
6. Definition of pavement effectiveness.	15
7. Effectiveness of placing a single preventive maintenance treatment.	15
8. Effectiveness of treatments placed at periodic times.	16
9. Cost-effectiveness of preventive maintenance treatments placed at different times.	18
10. Average pavement condition for preventive maintenance, rehabilitation, and reconstruction.	21
11. Remaining life estimate for preventive maintenance, rehabilitation, and reconstruction options.	22
12. Comparison of different pavement preservation strategies.	23
13. Severe fatigue cracking.	32
14. An example of rutting.	33
15. Types of aggregate gradations.	56
16. Spraying fog seal material with an asphalt distributor.	60
17. A schematic of asphalt distributor components.	72
18. Asphalt distributor, chip spreader and rollers.	72
19. Spreading chips with a chip spreader.	73
20. Compacting chip seals using rubber wheel rollers.	73
21. Proper angle setting of nozzles.	77
22. Overlapping spray fans.	77
23. Brooming excess chips using a rotary broom.	80

24. Applying slurry seal using a slurry machine.	95
25. Schematic diagram of a typical slurry mixing machine.	95
26. Aggregate gradations for micro-surfacing recommended by ISSA. ⁽³¹⁾	102
27. Micro-surfacing self-propelled machine.	106
28. Micro-surfacing truck mounted machine.	106
29. Spreader box of the micro-surfacing machine.	107
30. Special rut box for filling wheel ruts.	108
31. Typical gradations specifications for thin hot-mix overlays.	117
32. Schematic of the structure of dense mix.	117
33. Schematic of the gap-graded mix structure.	118
34. Schematic of the structure of open-graded mix.	118
35. The Novachip paver.	132
36. Pavement candidate for surface treatment: high density cracking.	136
37. Pavement candidate for crack repair.	137
38. Pavement candidate for transverse crack sealing.	138
39. Pavement candidate for longitudinal crack filling.	138
40. Crack sealing configurations.	141
41. Router for shaping cracks.	143
42. Diamond bladed saw for shaping cracks.	143
43. An asphalt kettle with pressure applicator.	144
44. Finishing and shaping the sealant using hand squeegee.	144
45. Preformed compression seals.	151
46. Schematic of backer rod.	152
47. Pumping of concrete pavement.	155
48. Concept of joint load transfer efficiency.	158
49. Typical hole pattern for jointed concrete pavements. ⁽⁴⁶⁾	161
50. Typical hole pattern for continuously reinforced concrete pavements. ⁽⁴⁶⁾	162
51. Location of retrofit dowel bars. ⁽⁵²⁾	165
52. Dimensions of slot for retrofit dowel bars. ⁽⁵²⁾	166

53. Side view of slot for retrofit dowel bars. ⁽⁵²⁾	167
54. Environmental zones for SHRP LTPP studies. ⁽¹⁵⁾	172
55. Distribution of flexible pavement preventive maintenance studies. ⁽¹⁵⁾	175
56. Typical layout of test sections for flexible pavements. ⁽¹⁵⁾	175
57. Distribution of rigid pavement test sections. ⁽¹⁵⁾	177
58. Typical layout of test sections for rigid pavements ⁽¹⁵⁾	177

LIST OF TABLES

Table	Page
1. Observations of preventive maintenance performance.	14
2. Relative costs used for example analysis.	18
3. Distribution of pavement conditions used in example analysis.	20
4. Strategies used for the example analysis.	21
5. Flexible pavement distresses and candidate preventive maintenance treatments.	30
6. Penetration graded asphalt cement specifications (AASHTO M 20-70).	47
7. Viscosity grading system unconditioned asphalt (AASHTO M226-80).	48
8. Viscosity grading specifications unconditioned asphalt (AASHTO M226-80).	48
9. Aged residue grading system (AASHTO M226-80).	49
10. Emulsion types defined by ASTM.	51
11. CALTRANS Specifications for quick set emulsions.	52
12. Specifications for aggregate used for chip seals.	68
13. Typical quantities of aggregate and emulsion for single chip seal applications.	69
14. Recommended binder application temperatures for chip sealing.	74
15. New York DOT application rates for double chip seal.	83
16. Slurry mixture characteristics. ⁽³⁰⁾	92
17. Aggregate gradation for micro-surfacing recommended by ISSA.	102
18. Typical gradation specifications for hot mix asphalt concrete. ⁽²⁹⁾⁽³⁴⁾	116
19. Comparison of United States and European SMA Mixes.	127
20. SMA aggregate requirements.	128
21. Guidelines for determining the type of maintenance.	136
22. Corner deflection (mm) and joint efficiency values used to determine location of slabs that need undersealing. ⁽⁴⁹⁾	157
23. Subgrade soil descriptions.	172
24. Definition of condition categories based on cracking amount and severity for flexible pavements.	174

CHAPTER 1

THE CASE FOR PREVENTIVE MAINTENANCE

INTRODUCTION

Highway agencies throughout the United States face increasing demands on the highway network and decreasing resources to maintain and preserve it. The demand to “do more with less” has become an operating slogan for many highway agencies. Historically, emphasis of highway agencies focused on new facility construction. However, with the completion of the Interstate Highway system, the highway infrastructure is largely in place. As the National Highway System, (NHS) is identified restoration, rehabilitation and reconstruction, (the 3R program) along with preventive maintenance, is now required. As shown on figure 1, the percent allocation of funds to new route construction fell from 24 percent

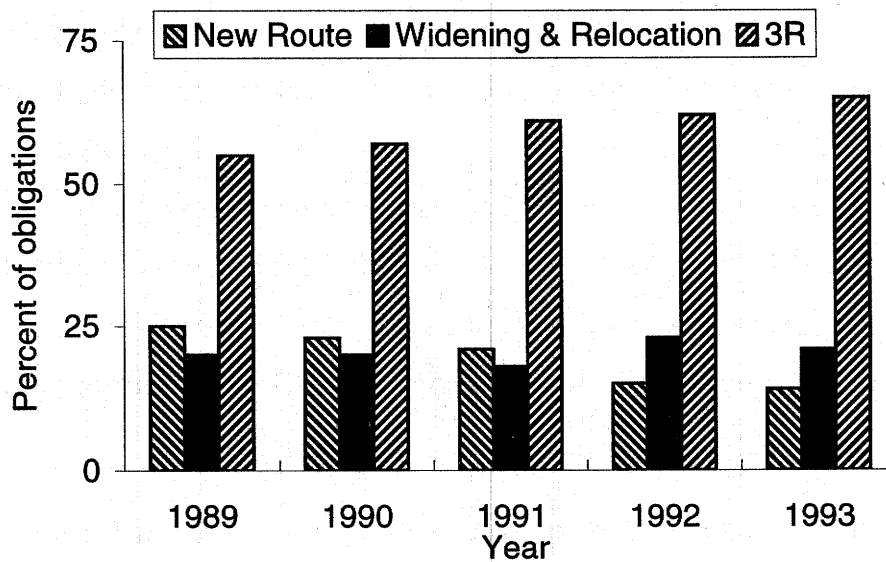

Figure 1. Trends in Federal obligations by construction category.

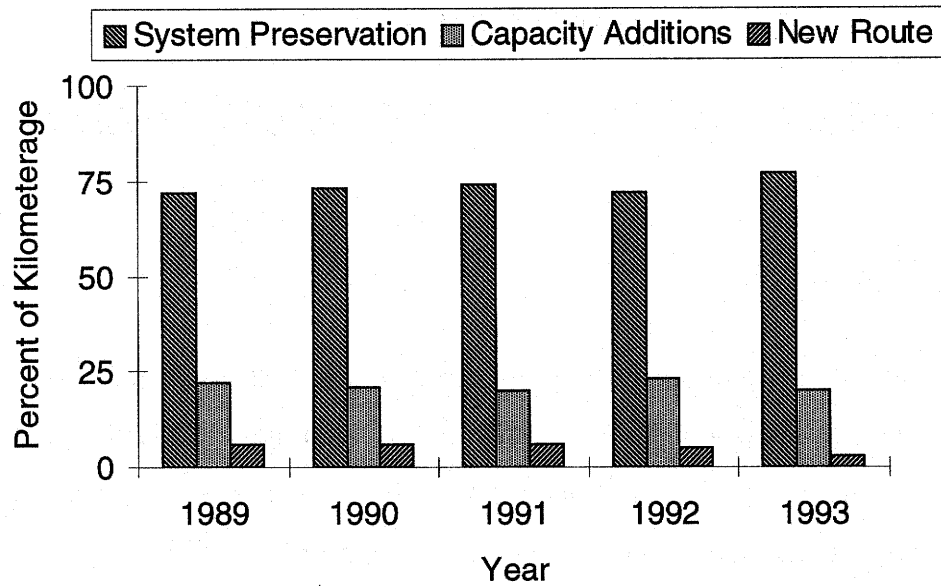

Figure 2. Percentage of kilometerage of capital improvements by construction category.

in 1989 to 14 percent in 1993.⁽¹⁾ Concurrently, allocations for restoration, rehabilitation, and resurfacing (3R treatments) increased from 53 percent in 1989 to 66 percent in 1993. In 1993, approximately \$5.5 billion was obligated to the 3R treatments. Figure 2 demonstrates that of kilometers of pavements receiving capital improvements, approximately 75 percent is for system preservation, a little over 20 percent for capacity additions, and 3 percent for new construction.⁽¹⁾ This distribution was practically constant from 1989 to 1993. Figures 1 and 2 demonstrate that highway agencies are currently in a maintenance and preservation mode of operation. This trend can be expected to continue into the foreseeable future.

Figure 3 shows the distribution of pavement conditions in the United States in 1993.⁽²⁾ The Federal Highway Administration (FHWA) estimated

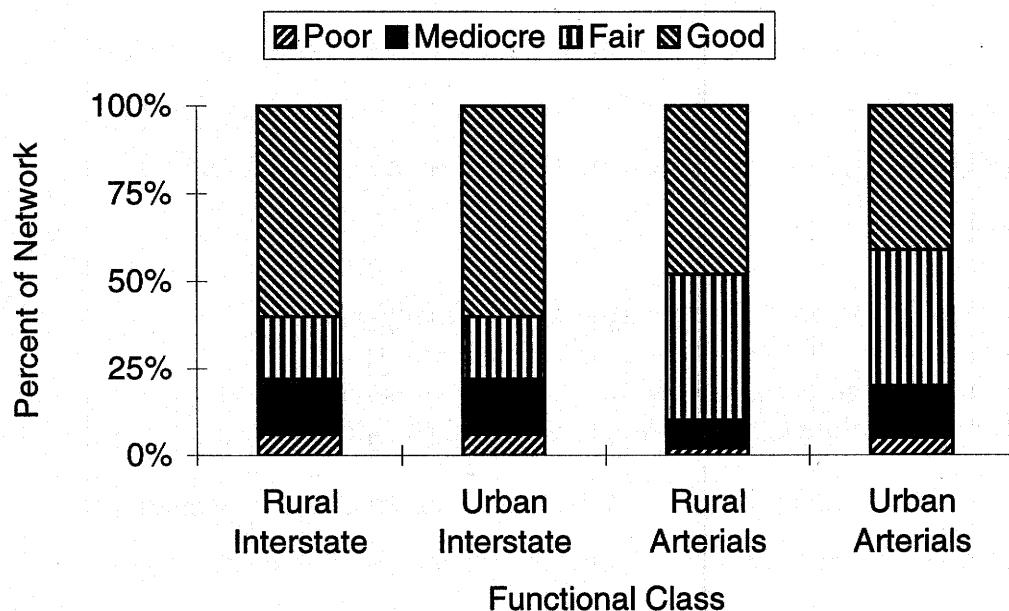

Figure 3. Distribution of pavement condition based on functional classification.

maintaining this level of pavement condition requires \$50 billion annually; eliminating the backlog of pavement deficiencies would require \$210 to 220 billion. However, the budget for highway operations, including traffic services and maintenance, is only \$27 billion annually.⁽²⁾

Clearly, under current policies and funding levels, we can expect further deterioration in the quality of the nation's pavements. Since funding levels are not likely to significantly increase, highway agencies must seek more cost effective methods of pavement preservation.

Pavement preventive maintenance is a tool that has the potential to both improve quality and reduce expenditures for pavement network. Preventive maintenance is based on the concept that periodic inexpensive treatments are more economical than infrequent high cost treatments. As popularized in the oil filter commercial, "you can pay me now, or pay me

later.” The potential for preventive maintenance to improve the cost effectiveness of pavement preservation was recognized in the Intermodal Transportation Efficiency Act (ISTEA). This was strengthened under the National Highway System bill (Public Law 104-59-Nov. 28, 1995) which states in Section 309:

A preventive maintenance activity shall be eligible for Federal assistance under this title if the State demonstrates to the satisfaction of the Secretary that the activity is a cost-effective means of extending the useful life of a Federal-aid highway

Several efforts have recently been undertaken to increase the awareness of pavement preventive maintenance in the United States. These include the Strategic Highway Research Program (SHRP) studies Pavement Maintenance Effectiveness (H-101) and Innovative Material Development (H-106) contracts, the FHWA Test and Evaluation projects Surface Rehabilitation Techniques (TE 9) and Innovative Contracting Procedures (TE 14), the National Cooperative Highway Research Program (NCHRP) syntheses, and efforts by several State highway agencies.

DEFINITION OF PAVEMENT PREVENTIVE MAINTENANCE

Pavement maintenance is broadly identified as work accomplished to preserve or extend the pavement’s service life until major rehabilitation or complete reconstruction is performed. Pavement maintenance is classified by function as either routine or preventive. Pavement preventive treatments are surface rehabilitation and operations applied to improve or extend the functional life of a pavement. O’Brien defines pavement preventive maintenance as a program strategy intended to arrest light deterioration, retard progressive failures, and reduce the need for routine

maintenance and service activities.⁽³⁾ This definition includes treatments that correct distress (such as crack sealing) if they also reduce the rate of distress development.

Pavement preventive maintenance treatments preserve, rather than improve, the structural capacity of the pavement structure. Thus, preventive maintenance treatments are limited to pavements in sound structural condition. In addition, in order to be effective, preventive maintenance should be applied before pavements displays significant amounts of environmental distress such as raveling, oxidation, and block cracking. To be cost-effective, pavement preventive maintenance treatments should be applied before most engineers, or project decision makers would normally consider their use. Timely treatments prove to be most cost effective.

One of the difficulties in describing and developing a preventive maintenance program is that the same pavement treatments can be used for preventive, corrective, or emergency maintenance. As shown on figure 4, the differences between preventive, corrective, and emergency repair is the condition of the pavement when the treatment is applied, rather than the type of treatment. For example, if a surface treatment is applied to a pavement in good condition, the function of the treatment is to extent the service life of the pavement by sealing the surface and protecting it from oxidation. The same type of treatment may be applied to correct minor-to-moderate distresses and seal the surface. Finally, under some conditions, surface treatments are applied to highly distressed pavements as an emergency measure to hold the surface together until a rehabilitation or reconstruction treatment can be programmed. The shaded areas between the different classifications of treatments indicate

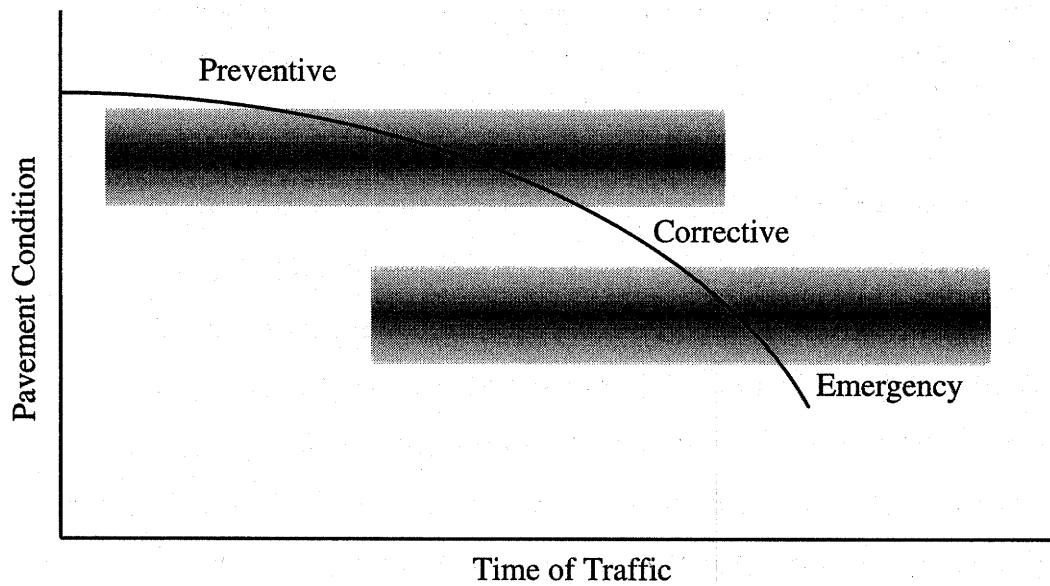

Figure 4. Definition of categories of maintenance.

that there are no clear boundaries between when a treatment is preventive versus corrective or corrective versus emergency.

Many agencies in the United States have more aggressive preventive maintenance programs for low-volume roads than for high-volume primary and interstate highways. For example, the Virginia Department of Transportation (VDOT) predominantly uses 40-mm overlays on primary and interstate highways when they reach a level of distress that VDOT associates with failure. However, chip seals are programmed on the secondary roads on a time based schedule established to delay or prevent the distress development. A variety of reasons explain this difference in the treatment of high-volume and low-volume roads, including:

1. Traditionally, many of the available preventive maintenance treatments were considered unsuitable for high-volume roads because of chip damage to vehicles, slurry seals lack durability, etc.

2. In the past, lack of Federal aid for maintenance, , encouraged highway agencies to allow pavements to deteriorate sufficiently to qualify for rehabilitation funded by Federal aid.
3. Lack of information on the performance and cost effectiveness of preventive maintenance practices on high-volume roads.
4. Desire of the highway agencies to minimize driver exposure to roadway operations and lane closures.

Another hindrance to the development of effective pavement preventive maintenance programs in the United States is the result of the budgeting process for many State highway agencies. Legislative allocations frequently specify fixed budgets for capital improvement and operation. Operations generally include all of the activities required to keep a highway functional, such as signing and restriping, snow removal, mowing, etc., in addition to maintaining the pavement. When circumstances require responsive activities (for example snow removal) in excess of the anticipated levels, pavement maintenance budgets are compromised. Since the consequences of deferring preventive maintenance do not immediately affect pavement quality or the traveling public, preventive maintenance is often the first activity cut when budgets are tight. This budgeting process has been a major deterrent to the development of effective pavement preventive maintenance programs.

PAVEMENT PREVENTIVE MAINTENANCE TREATMENTS

Several types of treatments can be used for preventive maintenance.

Examples for flexible pavements include:

- Conventional treatments crack treatment, fog seal, chip seal, thin hot-mix overlay (both dense- and open-graded), thin cold-mix treatment,
- Emerging treatments stone matrix asphalt, Novachip, very thin and ultra thin overlays, micro-surfacing.

Except for crack treatments, each of the treatments for flexible pavements provides a new wearing surface.

There is a lack of consistency in the terminology used to describe pavement maintenance techniques. For clarity, the following brief definitions describe the terms as used in this workbook:

- **Crack treatment** an application of a sealing material directly into the cracks in the pavement surface. For flexible pavements, the crack should be routed or prepared to ensure that sufficient sealer can be applied to the crack and that proper depth of sealing is achieved.
- **Fog seal** an application of bitumen sprayed directly on the surface of the existing pavement. This treatment provides new bituminous materials to enrich the surface of the pavement.
- **Chip seal** treatments constructed with a spray application of binder immediately covered by a single layer of one-sized aggregates. Chip seals can be placed in either single or multiple layers.
- **Thin hot-mix overlays** similar to conventional overlays except the thickness is 40 mm or less. Conventional construction methods are used. Generally thin hot-mix overlays can correct surface irregularities which cannot be corrected with most other types of preventive maintenance. Thin hot-mix overlays are generally categorized by the type of aggregate gradation used in the mix such as dense, open or gap-graded. Stone matrix asphalt is an example of a gap-graded hot-mix overlay with relatively thick asphalt films and stone-to-stone contact.
- **Thin cold seals** treatments composed of emulsion and aggregates, mixed at the job site in specially designed trucks, and placed on the existing surface. Slurry seals and micro-surfacing are examples of thin cold seals.

Fewer preventive maintenance options are available for rigid pavements.

The first option is to maintain the joint seals in the pavement and seal other cracks as they develop. Voids under the pavement can be filled with

a grout material. There have been some applications of retrofitting jointed reinforced pavements with dowel bars at mid slab when there is an excessively wide transverse crack. Some engineers include grinding and partial depth patching as preventive maintenance treatments. Thin, cold applied materials such as slurry seals and micro-surfacing are gaining acceptance for maintenance on rigid pavements.

An effective pavement preventive maintenance program must include the periodic application of the preventive maintenance treatments, as demonstrated in figure 5. This program can be a mixture of various preventive maintenance treatments. For example, Mesa, Arizona's preventive maintenance program uses a fog seal 3 and 6 years after construction or rehabilitation. In the eighth year a rubber-asphalt crack sealer is applied to all cracks. In the ninth year, either a chip seal or slurry seal is placed on the pavement. This sequence of treatments generally proves to be the most cost-effective for Mesa's hot-mix asphalt pavements, given their hot-dry climate and traffic levels.

PAVEMENT CONDITIONS AND PREVENTIVE MAINTENANCE

The need for preventive maintenance of equipment is well understood. State highway agencies routinely maintain their fleet of vehicles and equipment using a preventive maintenance schedule to identify when a planned maintenance activity to each vehicle is due. Oil changes, lubrication, and filter changes are done in advance of any problem with the vehicle all with the intention of prolonging the service life of the vehicle. Inspections identify needed repairs before they contribute to a serious problem. Generally, it is understood and accepted that maintaining the vehicle is more cost-effective than waiting for serious

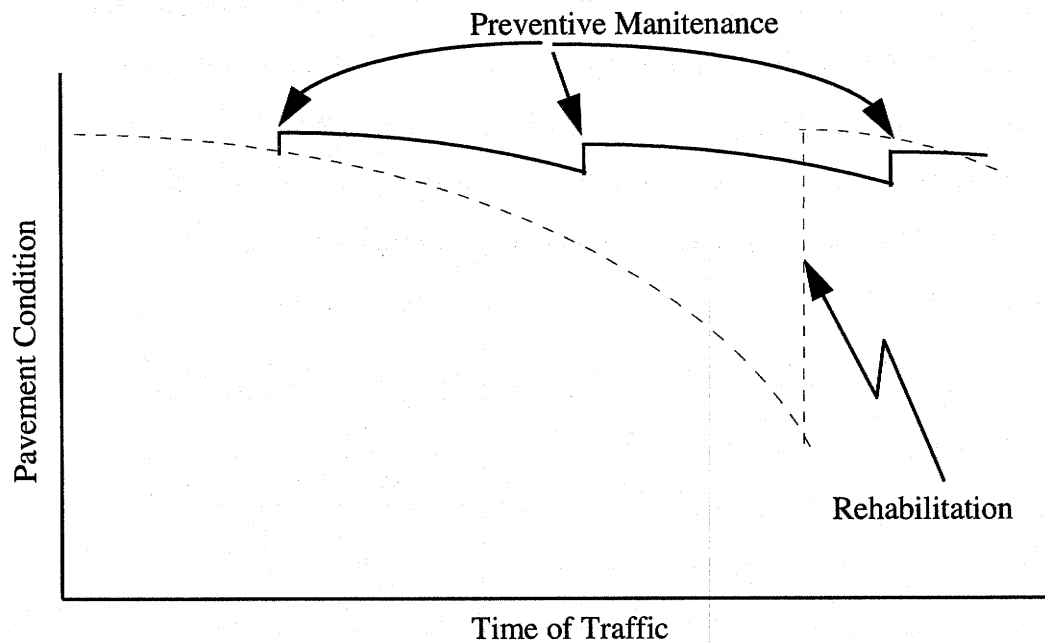

Figure 5. Conceptual performance of preventive maintenance treatments.

failures and major repairs. This program has proven to maximize the cost-effective use of fleet equipment.

Pavement preventive maintenance is designed to maximize the cost-effectiveness of pavement preservation. One of the questions raised by highway agencies evaluating the development of a pavement preventive maintenance program is, "At what level of distress should a preventive maintenance treatment be applied?" There is no single answer to this question, and research is still being performed to better answer the question. Peterson states, "Timing is crucial in preventive maintenance: it should be performed before a failure occurs."⁽⁴⁾ Waiting to maintain a pavement until after a failure occurs is analogous to scheduling oil changes based on the amount of oil a car burns.

There are several types of pavement distresses that contribute in different ways to *pavement failure*. Some distresses can be corrected with treatments used for preventive maintenance treatments, while in other cases the treatment would serve as a corrective or emergency treatment. Flexible pavements with structural distress such as fatigue cracking are not good candidates for preventive maintenance. Other distresses such as weathering and raveling can be completely corrected with a preventive maintenance treatment. General statements about the applicability of pavement preventive maintenance treatments to other distress types are problematical. In some cases the treatments may be effective, while in other cases little or no benefit may be realized from the treatment. For example, if ruts are the result of an initial densification of the pavement following construction, then a preventive maintenance treatment that fills the ruts with a stable material may be effective. On the other hand, if the ruts result from an unstable asphalt mix, then topical treatments will not be effective. The key point is that in order to be effective, an engineering approach is necessary for the selection, design, and construction of the treatment. There are even situations where sealing the pavement surface can accelerate the development of pavement distress.

The goal of a pavement preventive maintenance program is to provide smooth high quality facility users expect. This is done by applying engineering criteria for determining when, where, and what treatments are cost-effective under different conditions. This requires understanding the mechanisms that deteriorate the pavements. Preventive maintenance treatments should then be selected and designed to counteract the effect of these deterioration mechanisms.

A program of periodically maintaining a pavement surface mitigates many of the environmental distress mechanisms. However, this

intervention must take place before excessive deterioration of the pavement occurs. Thus, the greatest benefit of preventive maintenance is achieved by placing the treatments on sound pavements that have little or no distress.

PREVENTIVE MAINTENANCE AND PAVEMENT MANAGEMENT

The ISTEA legislation permits the use of Federal funding for preventive maintenance treatments on the Federal Aid Interstate System. This is a major change in Federal policy and indicates congressional recognition of pavement preventive maintenance for preservation of the transportation infrastructure. However, to qualify for funding, State highway agencies must demonstrate, through a pavement management system, the cost-effectiveness of the pavement preventive maintenance treatments. This requires developing engineering knowledge that preventive maintenance both extends the life of the pavement, provides better performance, and is more economical than other strategies for maintaining pavements. Pavement management systems provide a structure for the collection of the required information.

IMPROVING PAVEMENT PERFORMANCE

The majority of treatments for flexible pavements involves sealing the existing surface and providing a new wearing surface for traffic. This is a logical approach to preventive maintenance of flexible pavements, as weathering and other environmental damage are primary factors leading to premature failure of flexible pavements. Periodic renewing of the surface preserves the pavement structure.

There is generally a lack of information that *quantifies* the improvement in pavement performance achieved with preventive maintenance programs. There have been several studies of the cost-effectiveness of preventive maintenance. Peterson evaluated the effectiveness of pavement maintenance strategies for a NCHRP synthesis in 1981.⁽⁶⁾ Darter et al. reported on the cost-effectiveness of maintenance and rehabilitation procedures.⁽⁷⁾ Sinha reported on the effectiveness of maintenance treatments based on experience in Indiana.⁽⁸⁾⁽⁹⁾ O'Brien completed a NCHRP synthesis of "Evolution and Benefits of Preventive Maintenance Strategies" in 1989.⁽³⁾ Geoffroy is currently surveying the practices of State highway agencies for NCHRP Project 20-5, Topic 25-10, "Cost-effectiveness of Preventive Pavement Maintenance".⁽¹⁰⁾ Chong and Phang reported that routing and sealing of transverse cracks may extend pavement life by four years in Ontario, Canada.⁽¹¹⁾ Sharaf and Sinha reported Indiana pavements that were crack sealed in the fall require less patching after the winter.⁽¹²⁾

Geoffroy conducted a survey of 60 highway agencies on the benefits of preventive maintenance.⁽¹⁰⁾ Table 1 presents the mode (most frequent observation) of observed increase in pavement life for different treatments reported by Geoffroy. The results of this survey were based primarily on observed performance of the pavements rather than from data from a pavement management system. As noted in table 1, the frequency of application for treatments other than crack sealing and thin hot-mix asphalt concrete overlays is 5 to 6 years, with a corresponding extension of effective pavement life. Geoffroy did not request information on the condition of the pavement either when the preventive maintenance treatments were placed or when the treatments were taken out of service.

Table 1. Observations of preventive maintenance performance.

Treatment	Pavement age at time of first application (yr.)	Frequency of application (yr.)	Observed increase in pavement life (yr.)
Crack filling	5 to 6	2 to 4	2 to 4
Single chip seal	7 to 8	5 to 6	5 to 6
Multiple chip seal	7 to 8	5 to 6	5 to 6
Slurry seal	5 to 10	5 to 6	5 to 6
Micro-surfacing	9 to 10	5 to 6	5 to 6
Thin hot-mix overlay	9 to 10	9 to 10	7 to 8

The cost-effectiveness of preventive maintenance is demonstrated through a hypothetical example. This example evaluates the application of different preventive maintenance programs using assumed performance curves and improvements in pavement quality resulting from the application of a preventive maintenance strategy.

Effectiveness, the area under a pavement condition versus time curve (figure 6), is a measure of benefits resulting from different pavement treatment strategies. Figure 7 shows the relative effectiveness of placing, at different times, a single preventive maintenance during the life of the pavement. For example, the effectiveness of placing a treatment at year 5 is about 1,700. Figure 7 shows the most effective time to place a *single treatment* is in year 11.

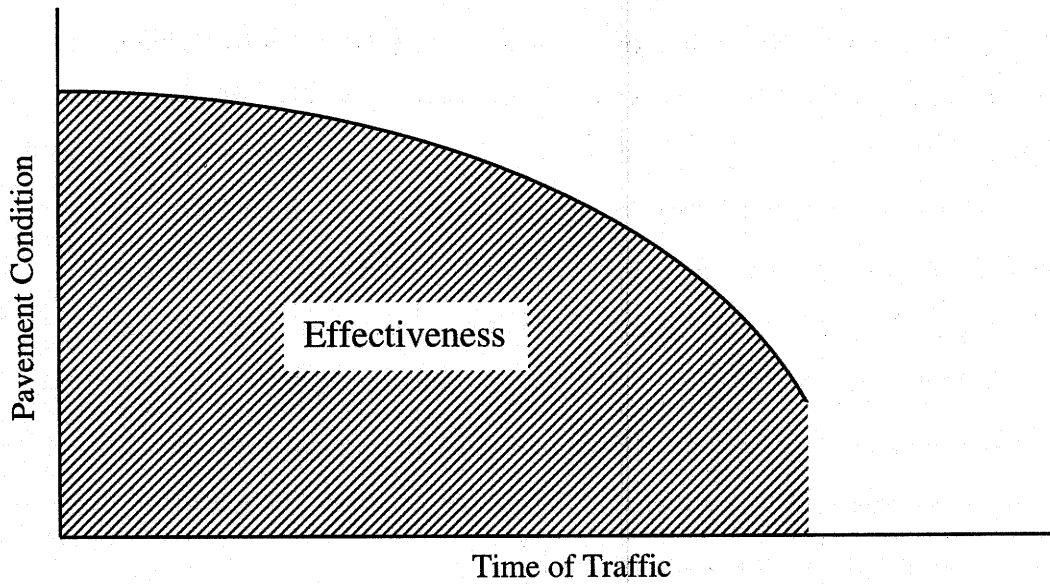

Figure 6. Definition of pavement effectiveness.

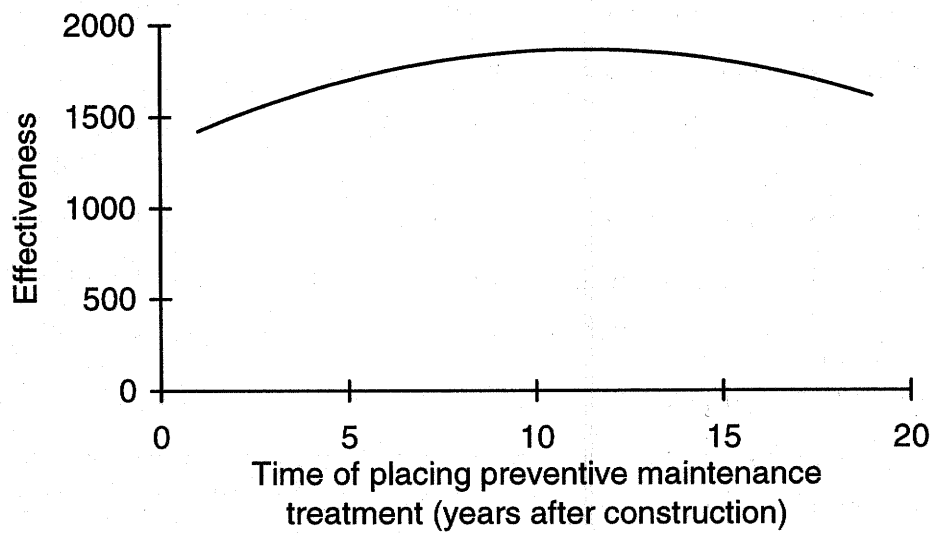

Figure 7. Effectiveness of placing a single preventive maintenance treatment.

Figure 7 represents a single application of a preservation treatment. Preventive maintenance treatments should be repeatedly applied. Figure 8 demonstrates the effectiveness for repeated periodic applications of preventive maintenance treatments. The X axis on figure 8 is the frequency of the application of the pavement preventive maintenance treatment, e.g., the effectiveness of placing a treatment every 4 years is about 2000. Increasing the interval between treatments reduces the area under the pavement condition curve, as can be seen on figure 5. An analysis of treatment applications based on pavement condition rather than time demonstrates similar results.

Although the curves in figure 8 appear relatively flat, there is a significant improvement in the effectiveness of the pavements when compared to a "do nothing" strategy, i.e., a period of 20 years between treatments. Applying preventive maintenance every five years produces an effectiveness of 1960, compared to an effectiveness of 1550 for the

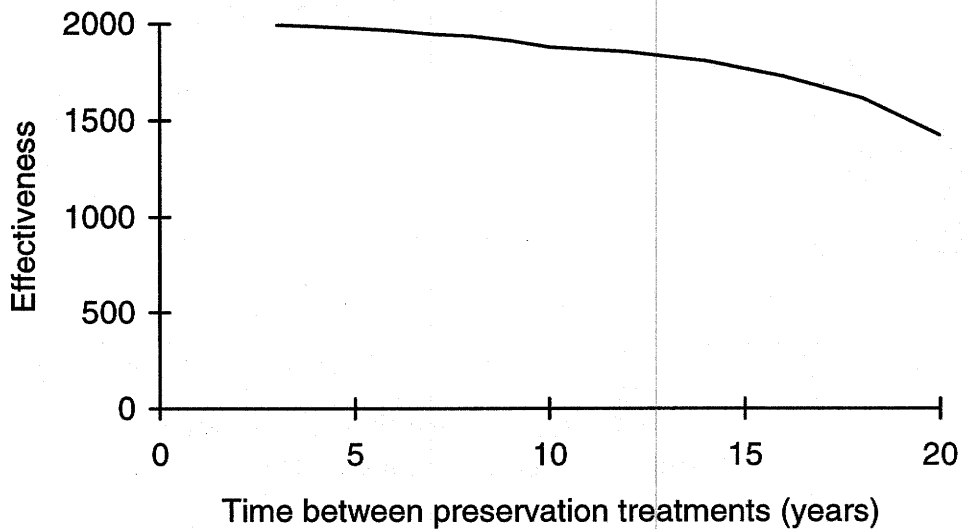

Figure 8. Effectiveness of treatments placed at periodic times.

conventional strategy, and indicates an improvement of 26 percent. Applying the preventive maintenance treatments whenever the PCI reaches 85 is also 26 percent more effective than a single rehabilitation strategy.

Effectiveness is only half of the consideration for a preventive maintenance program; cost must also be considered. Generally the cost-to-effectiveness ratio is used to determine the advantages of one option over another. Since the preventive maintenance programs are periodically performed, the life-cycle cost of the treatments must be estimated and discounted to their present value. In addition, treatment cost depends on the pavement condition at the time of treatment. For example, the relative costs in table 2 were used to estimate the cost-effectiveness of alternative treatments.

Figure 9 shows the cost-effectiveness ratio of treatments placed at different time intervals. Since cost-effectiveness is a measure of the cost per unit of effectiveness, a low value is desirable. Figure 9 demonstrates that the placing treatments at frequencies of 5 to 10 years is four to five times more cost-effective than reconstructing the pavement. The cost-effectiveness analysis for the road with a higher traffic growth rate is less than the cost-effectiveness for the road with the low traffic growth rate. This is due to the fact that the high traffic growth road serves more traffic for a fixed cost of treatment and thus the effectiveness is greater, thereby decreasing the cost-to-effectiveness ratio.

Table 2. Relative costs used for example analysis.

Pavement age when treatment is placed	Relative cost for placing each treatment	Total Relative Cost to Maintain
4, 7, 10, 13, 16, 19	0.75	4.50
5, 9, 13, 17	0.85	3.40
6, 11, 16	0.95	2.85
7, 13, 19	1.10	3.30
8, 15	1.20	2.40
9, 17	1.50	3.00
10, 19	2.00	4.00
11	2.50	2.50
13	3.00	3.00
15	5.00	5.00
17	7.00	7.00
19	12.00	12.00

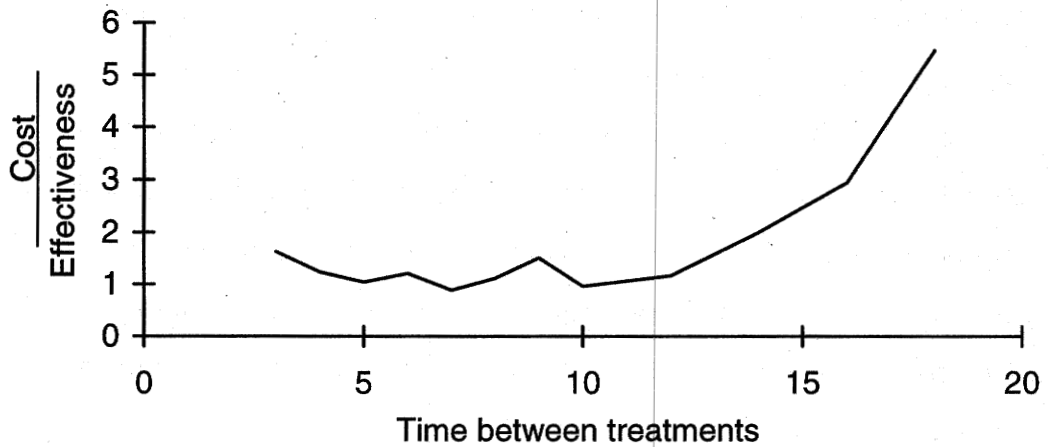

Figure 9. Cost-effectiveness of preventive maintenance treatments placed at different times.

In this example, the cost-effectiveness of the preventive maintenance program is 3 to 6 times better than the cost-effectiveness of reconstruction. While the pavement performance model and the costs used in this example were hypothetical, information in the literature supports the resulting numbers and conclusions. The New York DOT reported a cost-effectiveness ratio of 3.65 for preventive maintenance as compared to a "do-nothing" strategy.⁽¹³⁾ In this study, a preventive maintenance strategy of sealing cracks every four years and placing a 40-mm overlay at years 12 and 24 was compared to a do-nothing approach and reconstructing the pavement after 24 years. Sharaf et al. reported in a study of the United States Army Corps of Engineers that placing chip seals at the proper time was 4 times more cost-effective than repairing a deteriorated pavement.⁽¹²⁾

IMPACT OF PREVENTIVE MAINTENANCE

Given proper engineering analysis and material mix design, preventive maintenance treatments are cost-effective and provide a more uniform riding surface with good skid resistance for the traveling public.

Currently, pavements are treated with corrective maintenance until they deteriorate to the point of requiring either a structural overlay or reconstruction. Due to funding pressures, the overlays are often not thick enough to fully compensate for the structural damage caused to the pavement prior to the overlay. Consequently, optimum life of the overlay may not be attained.

The benefit of a preventive maintenance program to a highway agency is that it can maximize the performance of the structural section by effectively deferring the need for more expensive reconstruction and rehabilitation. Extending the previous example, assume a highway

agency has pavements with the distribution of pavement conditions given in table 3.

For these pavements, a performance model was used to compute the deterioration of the pavements and three preservation strategies were analyzed as shown in table 4.

Figure 10 shows the average condition of the network over time for each of the strategies. Strategy A uses preventive maintenance and provides the best overall condition. The dip in the condition at year 10 is the result of not considering a uniform budget distribution over time in the analysis. Using a pavement performance model, the average remaining service life for each strategy was computed annually based on the condition of the pavement and assuming no further work over the life of the pavement. The analysis demonstrates the preventive maintenance program increased

Table 3. Distribution of pavement conditions used in example analysis.

Pavement Condition Index	Percent of Network
100 to 90	10
89 to 80	10
79 to 70	15
69 to 60	15
59 to 50	15
49 to 40	15
39 to 30	10
29 to 0	10

Table 4. Strategies used for the example analysis.

Strategy	Program
A	Preventive maintenance when the pavement reached 80 PCI, rehabilitation of pavements when PCI was 40, and reconstruction of pavement when the PCI was less than 20.
B	Rehabilitation of pavement when PCI was 40, and reconstruction of pavement when the PCI was less than 20.
C	Reconstruction when the PCI reaches 20.

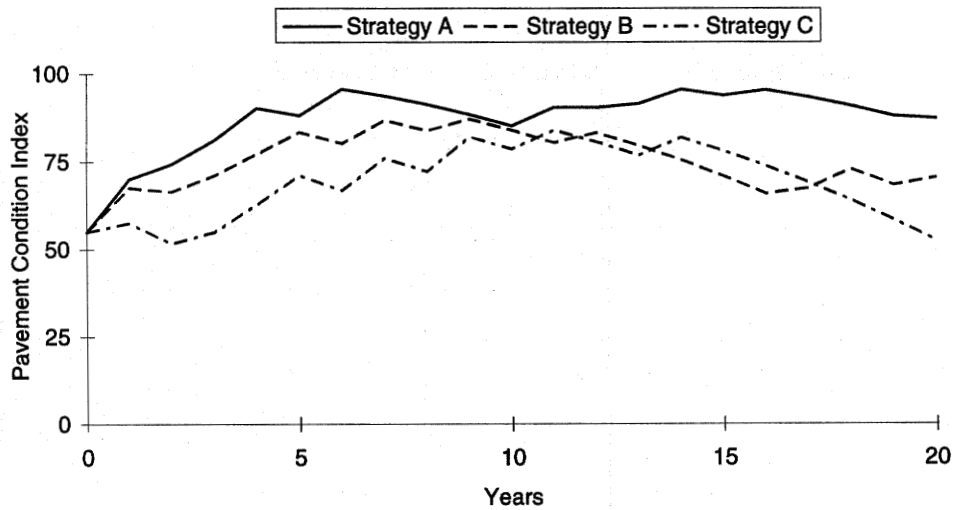

Figure 10. Average pavement condition for preventive maintenance, rehabilitation, and reconstruction.

the remaining life relative to the other strategies, as shown on figure 11. At the start of the analysis, the remaining life of the pavements in the network (based on their initial condition) is 6 years. With the preventive maintenance program, the remaining life increases to 14 years after about 4 years. There is a decrease in the remaining life of the network after 6 years due to the rules used for the selection of treatments. In reality, the highway agency would spread the work out and a steady-state condition would develop.

Figure 12 shows the cumulative costs of the three strategies. Initially, the costs for the preventive maintenance strategy are higher than the other two options. However, as the network quality improves, the cost of the preventive maintenance program decreases. Preventive maintenance keeps pavements in good condition, deferring the need for rehabilitation and reconstruction.

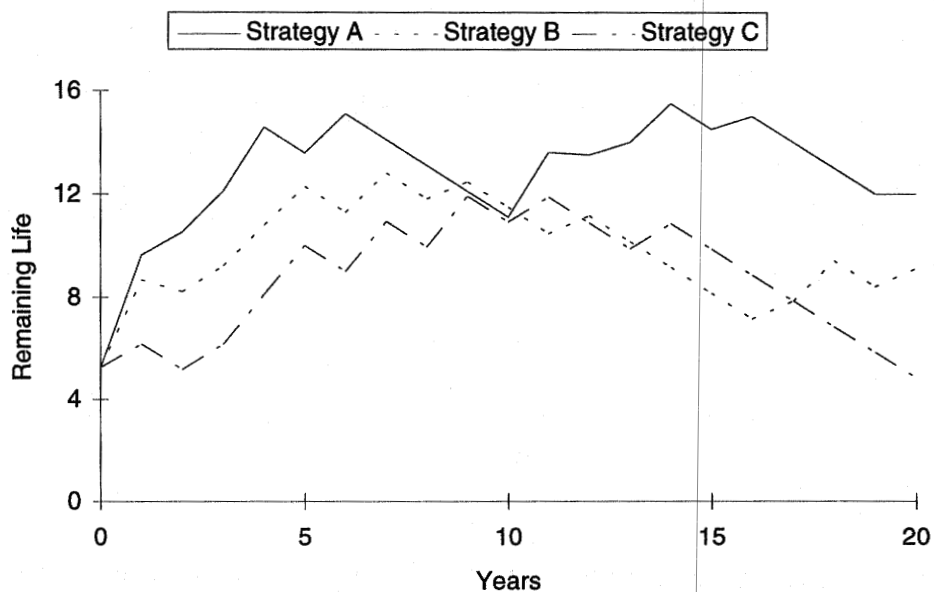

Figure 11. Remaining life estimate for preventive maintenance, rehabilitation, and reconstruction options.

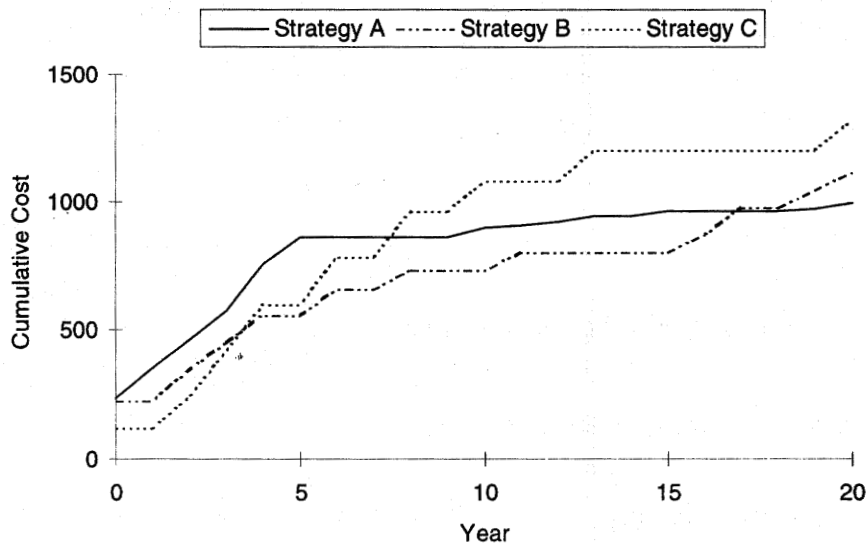

Figure 12. Comparison of different pavement preservation strategies.

These figures demonstrate that preventive maintenance treatments are effective at both improving the quality of the pavements and reducing the costs of pavement preservation. For this analysis, the preventive maintenance program was 30 percent and 60 percent more cost-effective over the 20-year analysis period than strategies B and C, respectively. These ratios are lower than computed for the previous example due to the need to perform rehabilitation and reconstruction projects on deteriorated pavements. This example simulates what a highway agency could expect from implementing a preventive maintenance program.

SHRP MAINTENANCE EFFECTIVENESS RESEARCH

The effectiveness of preventive maintenance treatments was studied in the Strategic Highway Research Program Project H-101 Experiments SPS-3 and SPS-4 for flexible and rigid pavements respectively.⁽¹⁵⁾ During the SPS-3 experiments, test sections were constructed with:

- Chip seals,
- Crack seals,
- Slurry seals,
- Thin hot-mix asphalt overlays, and
- State supplemental sections using
 - micro-surfacing,
 - plant mix seals,
 - open-graded friction courses, and
 - chip seals constructed to State specifications.

During the SPS-4 experiments, crack sealing, joint sealing, and undersealing of rigid pavements were studied. Retrofit of dowel bars was included as a State supplemental section. The details of these experiments are summarized in the appendix.

Sections were selected to represent a range of traffic, environment, and pavement conditions. Three levels of pavement conditions were included in the experiment: good, fair and poor. Because of time limitations, the performance of the test sections has not been fully evaluated. The FHWA is continuing the evaluation of the test sections. The FHWA established technical work groups (TWGs) to assist with the assessment and implementation of the SHRP products. In addition, the TWGs are supported by expert task groups (ETGs) who provide hands-on expertise at the field level. The ETGs have performed field evaluations in each of

the four regions to gather information on the early performance of the test sections and treatments.

Field reviews of the sections by the ETG have identified several key observations. Some general performance-related findings were:⁽¹⁴⁾

- *The pavement sections on which preventive maintenance treatments have been applied have generally out-performed the associated control sections (i.e., sections that received no treatment).*
- *A specific treatment's performance is generally related to the condition of the pavement at the time the treatment was applied. Treatments applied to pavements in good condition have good results... The treatments themselves are performing well. They appear to have bonded to the pavement and to have improved the pavement's functional condition.*
- *State supplemental treatments, such as micro-surfacing and polymer-modified chip seals, appeared to be performing well.*
- *Sections treated with slurry seals perform better when the treatment had been applied to a pavement with few cracks. In cases where the pavement was already cracked, the cracks reflected through the thin slurry seal.*
- *Cracked pavement sections treated with chip seals are performing better than sections treated with other treatments.*
- *Thin asphalt overlays performed better than the other treatments on pavements in relatively poor condition.*
- *Joint and crack seals applied to portland cement concrete pavements are performing well. Long-term pavement performance data may not be available for several years.*
- *No significant information is available on undersealing applications of portland cement concrete pavements.*

The essence of the early message from the SHRP preventive maintenance research indicates that preventive maintenance treatments can be effectively applied to high-volume roads. Success depends on:

- Proper selection of pavements to receive the treatment, based on the amount and type of distress.
- Proper material mixture design and specifications for the treatments.
- Good construction practices.

Objective data on the test sections have been collected since the time of construction, and the FHWA is continuing this effort. A data analysis contractor will continue the objective evaluation of these test sections under a FHWA contract. The challenge now is to extend this concept to the practices of State highway agencies and promote pavement preventive maintenance.

SUMMARY

Current funding for highway preservation is not adequate for preserving the quality of the pavements. Unless there is a change in the way pavements are maintained, the condition of pavements in the United States will continue to deteriorate. Pavement preventive maintenance is a tool that can extend the pavement life in a cost-effective manner.

Evidence is accumulating that the concept of "pay me now or pay me later" is applicable to pavement preventive maintenance, and the highway industry needs to adopt this strategy for the preservation of pavements. Several studies have shown that pavement preventive maintenance is three to five times more cost effective than a "do nothing" strategy.

The objectives of this document, and the workshop it supports, are to:

- Describe the need for pavement preventive maintenance,
- Increase the awareness of the importance of pavement preventive maintenance and the need to properly evaluate pavements for preventive maintenance treatments,

- Present information on the materials and techniques used for preventive maintenance, and
- Present a summary of the different treatments used for pavement preventive maintenance.

In support of States' interest in applying and evaluating pavement preventive maintenance treatments to NHS pavements, the FHWA can provide technical assistance to State highway agencies under projects Pavement Maintenance Materials and Treatments (TE-27) and Surface Rehabilitation Techniques (TE 9). For further information, contact the Office of Technology Application (HTA-21), Washington D.C., through the local FHWA division office.

CHAPTER 2. ENGINEERING A PREVENTIVE MAINTENANCE PROGRAM

INTRODUCTION

This chapter presents preventive maintenance as a significant activity of the highway agency and one that deserves attention in the engineering and design process. The elements of engineering a preventive maintenance program are:

1. Selection of pavement sections that will benefit from preventive maintenance treatments,
2. Design of the preventive maintenance treatments,
3. Quality control of the preventive maintenance construction, and
4. Monitoring the performance of the preventive maintenance treatments.

Each of these steps is discussed in detail for the various preventive maintenance treatments described in this workbook. The purpose of this chapter is to present an overview of the factors and considerations that should go into engineering a preventive maintenance program.

SELECTION OF PREVENTIVE MAINTENANCE TREATMENTS

The preventive maintenance treatment selected for a section of pavement should consider the condition of the existing pavement, the traffic volumes using the pavement, and the environmental conditions. Other factors managers must consider include experience with treatments, budget constraints, political reality, etc. But the initial key engineering,

traffic, and environmental conditions should be considered and documented. Research to date has not produced detailed rules for selecting one treatment over another for high-volume, high-speed highways. However, some general guidelines can be presented.

Existing Pavement Condition

Pavement condition should be evaluated with respect to distress, structural capacity, roughness, and skid resistance. *Pavement distresses* are flaws in the surface condition of the pavement. *Structural capacity* refers to the ability of the pavement to carry the anticipated traffic loads.

Roughness is defined as variations in the longitudinal profile of the pavement surface that affect ride quality. *Skid resistance* is an interaction between the vehicle tire and the pavement surface. The pavement's contribution to skid resistance is a function of surface texture and is particularly important in reducing wet weather accidents.

The number one rule for selecting a preventive maintenance treatment based on pavement condition is that **only pavements in reasonably good structural condition are candidates for preventive maintenance.**

Preventive maintenance treatments can be used to improve non-load-associated distresses, roughness, and skid resistance. The structural condition of a pavement can be assessed by surface distress evaluation and analysis of deflection data.

The surface of the pavement can be evaluated with a standard distress evaluation method such as that developed as a part of SHRP or local SHA distress condition manuals.⁽¹⁶⁾ The types of distresses defined in the SHRP Distress Identification Manual for the Long Term Pavement Performance Project are identified in table 5, along with potential actions.

Table 5. Flexible pavement distresses and candidate preventive maintenance treatments.

Category of distress	Type of distress	Potential actions
Cracking	Fatigue cracking	Not a candidate for preventive maintenance
	Block cracking (low to moderate)	Thin cold treatment, chip seal, thin hot mix overlay
	Edge cracking	Crack treatment
	Longitudinal cracking	Crack treatment
	Reflection cracking at joints	Crack treatment
	Transverse cracking	Crack treatment
Patching and Potholes	Patch/Patch Deterioration	Extensively patched pavements are not good candidates for preventive maintenance
	Pot holes	Pot hole pavements are not good candidates for preventive maintenance
Surface Defects	Rutting - Densification of pavement - Unstable asphalt concrete	Fill ruts with micro-surfacing or strip chip seal, then thin cold treatment or chip seal Preventive maintenance cannot repair problem
	Shoving	Unstable pavement, not a candidate for preventive maintenance
	Bleeding	Sand seal, chip seal, micro-surfacing
	Polished aggregate	Thin cold treatment, chip seal, thin hot mix overlay
	Raveling	Fog seal, thin cold treatment, chip seal, thin hot mix overlay

Load-associated fatigue cracking of flexible pavements indicates a lack of structural capacity. Fatigue cracking develops in the wheel path in progressive stages.

Figure 13 shows severe fatigue cracking. The distinction of the cracking occurring in the wheel path is important, as other non-load associated longitudinal cracks such as ones at the original construction joint can occur. Early stages of fatigue cracking propagate as longitudinal cracks in the wheel path. At the low-severity level, fatigue cracks have no or few connecting cracks. If there are any signs of spalling or sealing of the cracks, they should not be rated as low-severity. Moderate fatigue cracks are areas of interconnected cracks forming a complete pattern; cracks may be slightly spalled; pumping is not evident. High-severity cracking has moderately or severely spalled interconnected cracks forming a complete pattern; pieces may move when subjected to traffic; pumping may be evident. Sealing of a high-density crack does not change the rating of the crack. Since preventive maintenance treatments cannot correct a structural deficiency, pavements with fatigue cracking are not good candidates. However, a limited area of the fatigue cracking can be repaired with a full-depth patch and a preventive maintenance applied to renew the pavement surface. For example, a local drainage problem that has weakened the pavement in a small area can promote fatigue cracking in the area. If the drainage problem is repaired, the fatigue crack can be repaired, and a preventive maintenance treatment can be applied over the entire area of the section.

Block cracking is the result of volatilization of the asphalt cement in the pavement surface. As the lighter hydrocarbons evaporate from the asphalt, the volume of binder reduces and the asphalt becomes stiff and brittle. Block cracking is a pattern of cracks that divides the pavement into approximately rectangular pieces ranging in size from 0.1 to 10 m². Low-to-moderate-severity block cracking can be treated with actions that renew the pavement surface, such as thin cold mix treatments, chip seals,

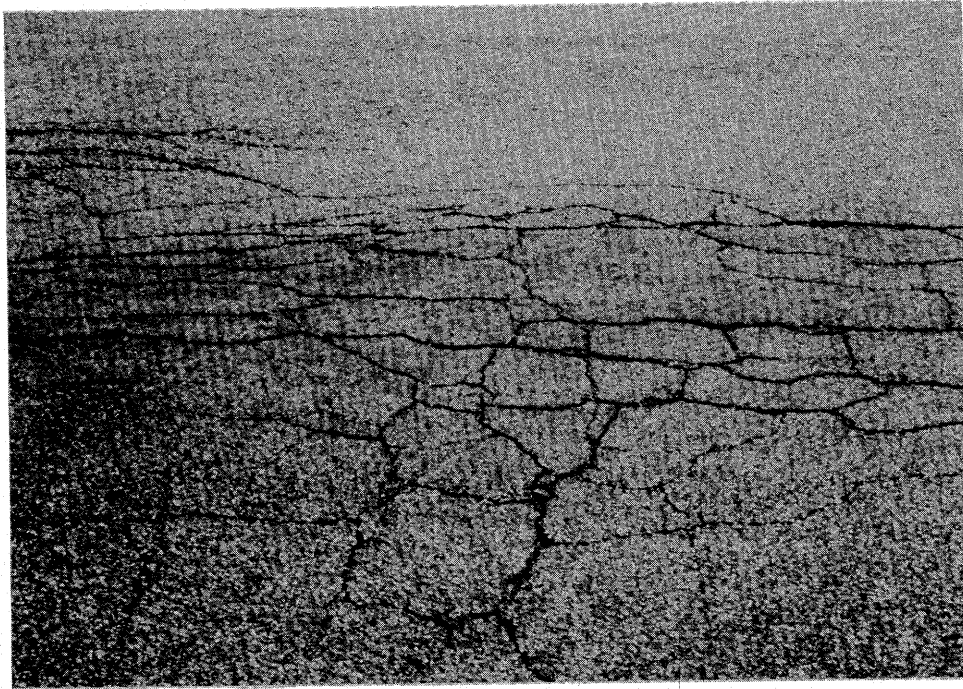

Figure 13. Severe fatigue cracking.

and thin hot mix overlays. Low-severity block cracking has cracks less than 5 mm wide. Pavements with medium to high-severity block cracking are not candidates for preventive maintenance.

The other forms of cracking do not occur in aerial patterns; they are isolated and random in nature. Due to the nature of edge, longitudinal, transverse, and reflection cracks at joints, crack sealing can be an effective treatment for sealing and filling these cracks.

Pavements with extensive patches and potholes are not good candidates for preventive maintenance. As with fatigue cracking, limited deteriorated patches and potholes can be repaired prior to applying a preventive maintenance treatment.

Rutting is permanent deformation in the wheel path as shown in figure 14. There are several mechanisms that can contribute to rutting. However, the primary causes are either densification of the pavement structure under traffic action or instability of a layer material. If rutting is the result of densification, then the depth of the ruts will stabilize after a period of time. This type of rutting can be filled. The surface of the pavement can be renewed with a surface seal such as a thin cold mix treatment, chip seal, or thin hot mix overlay. On the other hand, if the rutting is the result of an unstable layer, then preventive maintenance is not suitable for repairing the distress. The lack of stability of the layer can be the result of an improper mix design or stripping of the asphalt binder from the aggregates. The unstable layer should be removed and replaced.



Figure 14. An example of rutting.

Shoving is a longitudinal displacement of a localized area of the pavement surface. It should be removed and replaced with a full-depth patch.

Bleeding is the migration of asphalt cement to the surface of the pavement. Insufficient voids or excess binder in the asphalt-bound layers contributes to bleeding. Stripping can also lead to bleeding as the asphalt that debonds from the aggregates is free to come to the pavement surface; this is frequently accompanied by rutting or shoving. If stripping is suspected as one of the mechanisms contributing to a bleeding problem, the pavement should be cored and the samples inspected or tested for stripping. A surface seal will not repair a stripping problem. Frequently, bleeding occurs in the wheel paths. Micro-surfacing and sand or chip seals can be placed on pavements with low-to-moderate-severity bleeding. In all cases, care must be taken in selecting the amount of binder used in the treatment, as there is already excess asphalt on the surface of the pavement. Other treatments can be applied, as well. However, there may be a tendency for them to peel off the surface as the film of bleeding asphalt may prevent good bonding with the existing surface. High-severity bleeding should be milled off prior to placing a preventive maintenance treatment.

The SHRP distress identification manual identifies polished aggregate as the result of wearing away of the surface binder to expose coarse aggregate. Other manuals define polished aggregate as a reduction in the surface texture of the aggregate due to traffic action. In either case, any of the preventive maintenance treatments that renew the pavement surface are good candidates. Since the polished aggregate surface generally has low skid resistance, a fog seal should not be applied.

Raveling is caused by dislodging of aggregate particles and loss of asphalt binder. This is generally associated with oxidation of the pavement

surface. Low severity raveling can be treated with a fog seal. Moderate-to-severe raveling can be treated by renewing the pavement surface or the combination of a fog seal and one of the other treatments. When a fog seal is applied to a dense-graded asphalt concrete surface, a light application of sand should be applied to provide skid resistance.

If structural capacity is a concern, and the pavement is not displaying fatigue cracking, an engineering evaluation of the pavement needs to be performed. Procedures for performing a structural evaluation of an existing pavement are described in various pavement design publications, such as the AASHTO Guide for the Design of Pavement Structures or by contacting the State pavement design engineer.⁽¹⁷⁾

Roughness of the pavement surface can be corrected with either thin cold mix treatments or thin hot mix overlays. An analysis of the ADOT pavement management data base demonstrated that thin open-graded friction courses could improve roughness to levels that are usually associated with construction of a structural overlay.⁽¹⁸⁾

Traffic

As described in chapter 1, traditionally preventive maintenance treatments have not been applied to high-volume, high-speed roads in the United States. Many State highway agencies even limit application of chip seals to pavements carrying less than 1000 to 5000 ADT. Tradition notwithstanding, there is evidence now that preventive maintenance treatments can be applied to high-volume, high-speed highways.

However, care must be taken in the choice of pavements to receive the treatments and in their design and construction. For example, if a chip seal is applied to a high-volume, high-speed road, care must be taken to determine the proper amount of chips, calibrate the chip spreader to place

the design amount, and control traffic speeds during the initial curing period. Without these precautions, chips can be dislodged from the pavement surface, reducing the effectiveness of the treatment and potentially causing vehicle damage.

In traditional pavement design, the pavement materials and layer thicknesses are selected to provide sufficient structural capacity to carry the anticipated traffic. Since preventive maintenance treatments are not structural elements, the thickness of the layer is not designed in the traditional sense. However, the ability of the surface to resist wear abrasion of the traffic must be considered. Generally, the abrasion resistance is related to the mix design of the treatment. In order for a preventive maintenance treatment to be effective on a high-volume, high-speed highway, materials must be properly selected and mix design must be carefully performed and implemented in the construction process. This is equally valid for commonly used chip seals. The equivalent of the mix design process for chip seals is the determination of the binder application rates and the aggregate size, properties, and application rate.

Traffic volumes are also important during the construction of the treatment. Most preventive maintenance treatments need a curing period. The construction plans and specifications need to identify the type and duration of the traffic control, both during the construction and the curing period. The traffic control plans should conform to the requirements set forth in the Manual on Uniform Traffic Control Devices or similar requirements of the SHA.

Environment

To a large extent, preventive maintenance treatments are designed to mitigate the damage that results from environmental conditions. Periodic

renewal of the pavement surface provides several benefits. The two most important with respect to pavement performance are that it:

- Seals the pavement surface, preventing water from penetrating into the pavement structure, and
- Provides a new pavement surface controlling the effects of oxidation, raveling and surface cracking.

Environmental conditions remain fairly consistent over time. Hence, the *maximum* time between preventive maintenance treatments should be based on time rather than on the amount of traffic the pavement carries. For example, a chip-sealing program may specify placing treatments every 7 years unless the pavement conditions indicate at an earlier time treatment is required.

Other Considerations

Construction is one of the most important considerations in determining the quality and life of a preventive maintenance treatment. The treatments described in this report can be broadly classified as either conventional or emerging treatments. Highway agencies are familiar with the construction of the conventional treatments. However, since these treatments were traditionally limited to low-volume roads, there may be a tendency to not be as precise in the construction of the treatments as will be required for high-speed, high-volume roads. For example, one of the major problems that has limited the use of chip seals to high-volume roads is the possibility of vehicle damage due to loose chips. Loose chips can result from several factors that can be controlled in the design and construction process. During design, the exact quantity of aggregate required to cover the pavement without excess can be determined. For construction the design chip application rate is frequently increased to allow for waste and inaccurate distribution of the chips. Hence, the

probability of loose chips is increased. The quality of the chip sealing job can be improved by accurately calibrating the chip distributor and constructing the treatment with a minimum of wastage. This not only increases the quality of the treatment, but also decreases the probability of vehicle damage by loose chips.

DESIGN OF PREVENTIVE MAINTENANCE TREATMENTS

The steps in the design of a preventive maintenance treatment are:

- Selecting the type of treatment based on
 - condition of existing pavement
 - traffic loading
 - environmental conditions

- Determining the mix design for the selected treatment:
 - type of binder
 - aggregate characteristics
 - quantities of binder and aggregates

- Developing construction specifications.

Mix design refers to the selection of the binder, aggregates, and their relative proportions for durability and economy. For example, for hot mix asphalt concrete, there are several well established mix design methods such as the Hveem and Marshall methods. The SHRP SUPERPAVE procedure may become a standard in the future.⁽¹⁹⁾⁽²⁰⁾ For other treatments, such as chip seals, the mix design procedures are in various states of development and acceptance. For other methods, such as fog seals, published guidelines and rules of thumb provide a starting point for estimating the quantity of asphalt. Guides for the design of surface treatments are published by several trade organizations such as the Asphalt Institute, International Slurry Seal Association, and the Asphalt Emulsion Manufacturers Association.

Once the preventive maintenance treatment is designed, the quality of the treatment depends on the ability to the agency to communicate the design to the contractor and enforce the requirements through specifications and acceptance evaluation. This topic is discussed below.

DESIGN OF A PREVENTIVE MAINTENANCE PROGRAM

As defined in chapter 1, a preventive maintenance program consists of a series of preventive maintenance treatments that are applied to the pavement over time. A single preventive maintenance treatment will improve the quality of the pavement surface and extend the pavement life. However, the true benefits of pavement preventive maintenance are realized when there is a consistent schedule for performing the preventive maintenance. The preventive maintenance program can include a variety of preventive maintenance treatments. For example, crack sealing may be performed biannually, with renewal of the pavement surface performed every 5 to 6 years.

QUALITY CONTROL OF PREVENTIVE MAINTENANCE

Regardless of the effort put into the design of a preventive maintenance treatment, the eventual performance of the treatment is greatly dependent on the quality of construction. Under quality management concepts, the quality of the treatment can only be controlled by the constructor. The highway agency can monitor the quality and adjust pay factors, but it is up to the personnel placing the treatment to “build in” the quality. The agency develops specifications that define the rules that the contractor must comply with during construction. There are three distinct types of specifications:

- Method,

- End-result, and
- Performance.

Method Specifications

Historically, specifications were instructions from the design engineer to the field personnel on the steps, materials, and equipment required for the successful completion of a project. These are sometimes referred to as means and methods specifications. These specifications are reasonable when both the designer and construction personnel were employees of the highway agencies. However, when the designer and construction personnel are employed by different organizations, as is the common practice for capital improvements work, means, and methods specifications have severe limitations. The primary problem with means and methods specifications occurs when the contractor follows the instructions in the specifications but does not achieve the desired product. For example, a contractor may follow all the specifications with respect to compaction equipment, time of rolling, etc., but may not achieve the required densities. With means and methods specifications, the highway agency must continuously monitor the construction quality and make recommendations to the contractor on adjustments to the construction process. Means and methods specifications split the responsibility for quality between the contractor and the highway agency. Recognition of the limitations of means and methods specifications has led to the development of end-result specifications. However, the transition to end-result specifications is in the early stages and a great deal of highway construction is still accomplished under means and methods specifications.

End-result Specifications

As indicated by the name, end-result specifications identify the properties of the desired product. The means and methods of achieving the desired product are left to the discretion and expertise of the contractor. For example, end-result specifications for a hot mix overlay may define the required density, air void percentage, aggregate distribution, and asphalt content. It is then left up to the contractor to develop and implement a scheme that can achieve the required quality. Therefore, the contractor must take responsibility for quality control testing. The agency's responsibility is limited to quality assurance testing to verify the reliability of the contractor's quality control test.

Implementation of end-result specifications is a major step forward since the contractor is clearly assigned the responsibility for quality. However, the ability of end product specifications to ensure good quality pavement is limited by the highway agency's ability to identify properties that will ensure long pavement life. In other words, the highway agency is still accepting the responsibility for the performance of the pavement.

Performance Specifications

The next step in the development of specifications is to assign the contractor responsibility for the pavement performance. In other words, the contractor would warranty the quality of the pavement for a specified time period following construction. This is analogous to product warranties provided by manufactures. For example, an automobile purchaser may be concerned with ride quality and acceleration. The manufacturer designs the suspension and engine to deliver the desired performance. Then to ensure the automobile will perform at the desired

level for a certain period of time, the manufacture offers a warranty that limits the consumers' maintenance cost liability.

With respect to pavements, a performance specification would place the responsibility for the design, construction, and performance of the pavement on the contractor. The highway agency specifies a performance period, quality levels, and limits on the time the pavement may be closed for maintenance. In other words, the highway agency has switched from purchasing pavements with certain physical properties to purchasing a pavement that provides a specified level of quality over a period of time.

MONITORING THE PERFORMANCE OF PREVENTIVE MAINTENANCE TREATMENTS

Since preventive maintenance programs have not been extensively used for high-volume, high-speed roads, it is important to monitor the performance of different treatments. Usually these data can be collected within the scope of a pavement management system. Data that should be collected for evaluating the effectiveness of a preventive maintenance program include:

- As-built data for the existing pavement, thickness, and material type of each layer.
- Traffic data, both historical and loads applied to the treatment, including the number of 80 kN equivalent single axle loads.
- Condition of the pavement prior to the preventive maintenance treatment and periodically afterward.
- Design features of the preventive maintenance treatment such as the material type and thickness of the layer or application rates.
- As-built construction data.

Many preventive maintenance treatments involve new or emerging technologies. When these treatments are applied, there should be a program of more intensive evaluation of the performance of the treatments over time. This should include a detailed survey of pavement distresses prior to application of the treatment as well as subsequent periodic evaluations. The SHRP pavement distress evaluation procedure should be used for these treatments.⁽¹⁶⁾ When a new type of treatment is used, extra care should be taken to document the quality of the construction. For example, during the construction of one of the SHRP test sections, the slurry machine ran out of binder and deposited loose sand on the pavement surface. Even though the contractor cleaned up the construction site before correctly placing the treatment, the section failed prematurely. The researchers believed that this failure was related to the error in the construction process rather than a systemic problem with slurry seals. If a highway agency had such an experience, it could incorrectly lead to the rejection of slurry seals since the "experiment" failed.

CHAPTER 3. MATERIALS FOR PREVENTIVE MAINTENANCE

INTRODUCTION

Selection of materials for a preventive maintenance treatment is critical to the success of the treatment. This chapter presents background information on the materials used for asphalt treatments. Much of this information is compiled from industry literature.⁽²¹⁾

BINDERS FOR PREVENTIVE MAINTENANCE

Asphalt residue (cement) is the primary binder used for preventive maintenance treatments. Asphalt cement is used directly for hot mixed treatments. To facilitate application, asphalt cements are made into emulsions or dissolved in solvents to produce cutbacks. Emulsions have wide applications in preventive maintenance treatments. Cutbacks are equally effective; however, environmental restrictions limit their use. Cutbacks are not considered further in this chapter.

Asphalt Cement

Asphalt cement is a high-molecular-weight hydrocarbon. Asphalt cement exists in nature, such as the Trinidad Lake Asphalt. However, asphalt cement used for highway construction is predominately produced by refining crude oil. The refining process removes lighter-molecular-weight hydrocarbons from the oil by distillation. Depending on the characteristics of the crude oil, the asphalt cement may be the direct product of distillation, "straight run" asphalt. In some cases, it may be

necessary to use solvent extraction to remove low-volatility components to produce the final asphalt cement.

Asphalt is a viscoelastic-thermoplastic material. Increasing temperature changes asphalt from a solid to a liquid. Asphalt cements are characterized by their consistency or their ability to flow at different temperatures. Consistency describes the viscosity of asphalt at a specific temperature. The sensitivity of asphalt cement to temperature requires use of standard temperatures for all tests of asphalt cement properties.

Asphalt cements are graded based on consistency, which can be evaluated with either penetration or viscosity. The standard penetration test is conducted at 25°C and absolute viscosity measured at 60°C for determining the grade of asphalt. There are two viscosity grading methods for asphalt cement; the sample can either be tested before conditioning for the AC grading method or it may be conditioned in the thin-film-oven for AR grading.

Penetration tests are performed on unconditioned asphalt cement. The grades used for pavement construction are 40-50, 60-70, 85-100, 120-150, and 200-300. The grade designation gives the acceptable range of penetration test results.

AC grading is based on the viscosity of the unconditioned asphalt cement.⁽²¹⁾ The grades are AC-2.5, AC-5, AC-10, AC-20, AC-40, and sometimes AC-30. The numerical values indicate the midpoint of the required absolute viscosity range in hundreds of poises. The allowable tolerance is plus or minus 20 percent of the midpoint, e.g., an AC-20 must have a viscosity in the range of 1600 to 2400 poises.

Since heating the asphalt cement for blending in a hot mix plant can significantly alter the asphalt cement characteristics, the other grading method uses a conditioning method to simulate mix plant hardening. For asphalt residue (AR) grading, the rolling thin film oven procedure conditions, or ages, the asphalt cement before measuring the viscosity. The grades are AR-10, AR-20, AR-40, AR-80 and AR-160. The numerical value indicates the midpoint of the required viscosity range in hundreds of poise. The allowable tolerance is plus or minus 25 percent, e.g., an AR-40 must have a viscosity in the range of 3000 to 5000 poises.

In addition to meeting the consistency requirements for a particular grade, the asphalt cement must meet other specifications as shown in tables 6, 7, 8 and 9.⁽²²⁾ Tables 7 and 8 are for AC grades. For a given grade of asphalt, table 8 requires higher kinematic viscosity and penetration than table 7. ASTM provides no guidance on which table should be selected. The AC grades specify a maximum allowable viscosity for samples conditioned with the thin film oven (TFO) procedure. In addition to these specifications, all asphalt cements must be at least 99 percent soluble in trichloroethylene.

The SHRP asphalt research developed a new method for performance grading of asphalt cement. The performance grading method was developed for hot mix asphalt concrete design. Its only application for preventive maintenance is for mix design for thin hot mix overlays.

Table 6. Penetration graded asphalt cement specifications (AASHTO M 20-70).

Test	Penetration Grade									
	40-50		60-70		85-100		120-150		200-300	
	Min.	Max.	Min.	Max.	Min.	Max.	Min.	Max.	Min.	Max.
Penetration at 25° C (0.1 mm)	40	50	60	70	85	100	120	150	200	300
Flash point (C)	232		232		232		218		177	
Ductility, 25° C, 5 cm/min (cm)	100		100		100		100		100	
TFO Samples										
Loss on heating (%)		0.8		0.8		1.0		1.3		1.5
Penetration of residue	58		54		50		46		40	

**Table 7. Viscosity grading system unconditioned
asphalt (AASHTO M226-80).**

Grade	Viscosity		Penetration*	Flash Point*	Tests on TFO Samples	
	Absolute (poises)	Kinematic* (cSt)			Absolute Viscosity (poise)	Ductility (cm)
AC-2.5	250±50	80	200	163	1000	100
AC-5	500±100	110	120	177	2000	100
AC-10	1000±200	150	70	219	4000	50
AC-20	2000±400	210	40	232	8000	20
AC-40	4000±800	300	20	232	16000	10

* Specification is for the minimum acceptable values.

**Table 8. Viscosity grading specifications unconditioned
asphalt (AASHTO M226-80).**

Grade	Viscosity		Penetration*	Flash Point*	Tests on TFO Samples	
	Absolute (poises)	Kinematic* (cSt)			Absolute Viscosity (poise)	Ductility (cm)*
AC-2.5	250±50	125	220	163	1000	100
AC-5	500±100	175	140	177	2000	100
AC-10	1000±200	250	80	219	4000	75
AC-20	2000±400	300	60	232	8000	50
AC-30	3000±600	350	50	232	1200	40
AC-40	4000±800	400	40	232	16000	25

* Specification is for the minimum acceptable values.

Table 9. Aged residue grading system (AASHTO M226-80).

Grades	Viscosity		Penetration*	Flash Point* [®] °C	Percent Original Penetration*	Ductility*
	Absolute (poises)	Kinematic* (cSt)				
AR-10	1000±250	140	65	205	-	100
AR-20	2000±500	200	40	219	40	100
AR-40	4000±1000	275	25	227	45	75
AR-80	8000±2000	400	20	232	50	75
AR-160	16000±4000	550	20	238	52	75

* Specification is for the minimum acceptable values

@ Specification is for the asphalt cement before rolling thin film oven conditioning for the AR grade asphalt cements. All other specifications are for conditioned samples.

SHRP binder specifications relate fundamental binder properties to pavement performance. Note that the SHRP specifications use the term asphalt *binder* referring to asphalt cement with or without the addition of a non-particulate organic modifier. Performance grading of asphalt binders requires more complex testing than the traditional grading procedures. Since these specifications are still in an implementation phase, they are not presented here.

Asphalt Emulsions

Asphalt emulsions are manufactured by physically breaking asphalt cement down into micron size globules and mixing them into water containing an emulsifying agent. Emulsified asphalt typically consist of about 60 percent to 70 percent asphalt residue, water and a fraction of a percent of emulsifying agent. Mixing the emulsion with aggregates or spraying it onto pavement causes the asphalt globs to come together forming the binder. The separation the asphalt cement from the water is referred to as breaking or setting.

Asphalt emulsion types reflect the charge of the emulsifying agent, the rate of setting, the viscosity of the emulsion, and the viscosity of the base asphalt. The charge of the emulsifying agent can be either cationic (positive) or anionic (negative). Emulsions are produced with rapid, medium, and slow set times. Two viscosity grades of emulsions are produced. Viscosity describes the ability of the emulsion to flow; a low-viscosity asphalt flows more readily than a high-viscosity asphalt. The viscosity of emulsions is measured with the Saybolt-Furol test, which determines the amount of time required for an emulsion to flow through a standard orifice. Finally, high-float emulsions are produced that are chemically modified to permit a thicker asphalt film on the aggregate particles with a minimum probability of drainage.

There are several possible combinations of emulsion types. However, not all possible combinations of emulsions are produced. AASHTO M140 and M208 specifications cover the emulsion types shown in table 10.

Asphalt emulsion names are coded to describe the type of emulsion. For example type **CSS-2h** is a **Cationic Slow Setting high viscosity, -2, emulsion with a hard base asphalt.**

In addition to the emulsion types defined by ASTM, there are a variety of State and manufacture specifications. Frequently, these have variations on the standard coded names. For example QS-1 is used for most slurry seal and micro-surfacing applications. Since there is no ASTM or AASHTO specification for these materials, the CALTRANS requirements are presented in table 11 as an example. Polymer modified emulsions are usually identified by a "p" at the end of the code name.

Table 10. Emulsion types defined by ASTM.

Type	Charge	Setting Rate	Viscosity Saybolt-Furol Range	Asphalt Grade Penn. Range
RS-1	Anionic	Rapid	20 to 100	100 - 200
RS-2	Anionic	Rapid	-	100 - 200
MS-1	Anionic	Medium	20 to 100	100 - 200
MS-2	Anionic	Medium	100+	100 - 200
MS-2h	Anionic	Medium	100+	40 - 90
HFMS-1	Anionic	Medium	20 to 100	100 - 200
HFMS-2	Anionic	Medium	100+	100 - 200
HFMS-2h	Anionic	Medium	100+	40 - 90
HFMS-2s	Anionic	Medium	50+	200+
SS-1	Anionic	Slow	20 to 100	100 - 200
SS-1h	Anionic	Slow	20 to 100	40 - 90
CRS-1	Cationic	Rapid	20 to 100*	100 - 250
CRS-2	Cationic	Rapid	100 to 400*	100 - 250
CMS-2	Cationic	Medium	50 to 450*	100 - 250
CMS-2h	Cationic	Medium	50 to 450*	40 - 90
CSS-1	Cationic	Slow	20 to 100	100 - 250
CSS-1h	Cationic	Slow	20 to 100	40 - 90

Table 11. CALTRANS Specifications for quick set emulsions.

Type	Anionic				Cationic			
Grade	QS1		QS1h		CQS1		CQS1h	
Properties	min.	max.	min.	max.	min.	max.	min	max
Test on Emulsion								
Viscosity SF @ 50° C, (sec)	15	90	15	90	15	90	15	90
Sieve Test (%)		0.30		0.30		0.30		0.30
Storage Stability, 1 day (%)		1		1		1		1
Residue by Distillation, (%)	57		57		57		57	
Particle Charge	Negative		Negative		Positive		Positive	
Tests on Residue from Distillation Test								
Penetration, 25° C (0.1 mm)	100	200	40	90	100	200	40	90
Ductility, 25° C (cm)	40		40		40		40	
Solubility (%)	97		97		97		97	

As the names indicate, the breaking time of emulsions depend on the type of emulsion (rapid, medium, or slow). However, there are no specifications on the setting times due to the influence of environmental factors on the setting rate. In general, factors that promote rapid evaporation reduce the setting time of an emulsion, i.e., high temperature, low humidity, and windy conditions reduce set time. Under favorable conditions, rapid set emulsions may set in several minutes while slow setting emulsions may take 4 to 6 minutes. The set rate can also be altered with admixtures. For example, portland cement is frequently used with anionic emulsions to speed the setting time.

The amount of emulsions used for a particular application can be specified in terms of the residual asphalt, the amount of emulsion, or the dilute asphalt. The residual asphalt is the actual asphalt content of the emulsion. Frequently, for ease of construction, emulsions are diluted with an equal amount of water. In this case, the contractor measures the quantity of dilute emulsion placed during the construction. This quantity must take into account the asphalt content of the emulsion and the amount of water used for dilution to achieve the desired residual asphalt content.

Since most aggregates have either positive surface charges (such as limestone) or negative charges (such as siliceous aggregates), they tend to be compatible with anionic or cationic emulsions, respectively.

BINDER MODIFICATION

Many types of asphalt additives (modifiers) are available to improve the properties of asphalt or add special properties to the asphalt concrete mixtures. Laboratory tests are usually performed and field performance is observed in order to evaluate the effect of the additives and justify their cost. The effects of using additives should be carefully evaluated for their cost effectiveness.

Rubber has been used in asphalt concrete mixture in the form of natural rubber, SBR, SBS, or recycled rubber. Rubber increases elasticity and stiffness of the mix and increases bond between asphalt and aggregates. Ground tire rubber can be added to the asphalt cement (wet method) or added as crumb rubber to the aggregates (dry method). In the wet method, the rubber is mixed with the asphalt at high temperatures to chemically and physically bond the rubber particles with the asphalt cement. The asphalt binder is then used for spray applications, such as chip seals, or as the binder in a hot-mix asphalt concrete.

Plastics have been used to improve certain properties of asphalt. Plastics used include polyethylene, polypropylene, EVA, and PVC. They increase the stiffness of the mix, thus reducing the rutting potential. Plastics also may reduce the

the stiffness of the mix, thus reducing the rutting potential. Plastics also may reduce the temperature susceptibility of asphalt and improve its performance at low temperatures.

Antistripping agents improve the bond between asphalt cement and aggregates, especially for water susceptible mixtures. Lime and portland cement are the most commonly used antistripping agents.

AGGREGATES FOR PAVEMENT MAINTENANCE TREATMENTS

The performance of pavement maintenance treatments is very dependent on the quality of the aggregates. There are standard specifications and tests to evaluate and define the required characteristics for the aggregates. The quality of aggregates is a function of their shape, texture, toughness, gradation, absorption, and affinity for asphalt.

Particle shape is important for determining how the material will pack into a dense configuration. There are two considerations in the shape of the aggregate - angularity and flakiness. Crushing rocks produces angular particles with sharp edges and corners and a rough texture. Pit or bank-run aggregates may have subangular or rounded shapes with little texture. Angular aggregates with a rough texture are best for preventive maintenance. Many specifications require a minimum percentage of aggregates with crushed faces as a surrogate shape and texture requirement. For example, micro-surfacing specifications call for 100 percent crushed aggregate from the parent rock. Flakiness refers to the relationship between the largest and smallest dimensions of the aggregate particle. Flakey and elongated aggregates are undesirable since they are difficult to compact.

Gradation describes the particle size distribution of the aggregates. Gradation is evaluated by passing the aggregates through a series of sieves and determining the percentage passing each sieve. Aggregate distributions are described as dense, gap, one-sized, and open, as shown on figure 15. Dense-graded aggregates have a distribution that maximizes the unit weight of the aggregate mixture. On standard semilog gradation paper, dense-graded aggregates have an "S" shape. Gap-graded aggregates are missing one or more of the aggregate sizes. Some treatments require gap-graded aggregates to provide room in the mixture for the binder. One-sized aggregates are predominantly single size. Their distribution is nearly vertical as most of the aggregates pass one sieve but are retained on the next sieve. One-sized aggregates are required for chip seals. Open-graded aggregates have a high void content; they do not have fines (material passing a 0.075 mm sieve) that would fill the voids.

For asphalt concrete, the size of the aggregates used in the mix are frequently specified by the size of the largest aggregate in the mix. Two terms are used to describe the size of the largest aggregate: the maximum aggregate size or the nominal maximum aggregate size. The maximum aggregate size is the size of the smallest sieve that passes 100 percent of the aggregate. The nominal maximum aggregate size is the largest sieve that retains any of the aggregate, but generally not more than 10 percent. For example, a 12.5-mm maximum aggregate would completely pass through the 12.5 mm sieve. On the other hand, a 12.5-mm nominal maximum aggregate would have 5 percent of the material retained on the 12.5 mm sieve.

Porous aggregates absorb asphalt, resulting in a dry mix with poor cohesion unless the amount of asphalt is increased to compensate for absorption. Because increasing the asphalt content increases the cost of the mix, highly porous aggregates are not normally used unless they possess other qualities that compensate for the increased cost.

Stripping, separation of the asphalt film from the aggregates through the action of water, is a major problem with pavement performance in the United States. An aggregate's affinity for asphalt should be evaluated as part of the mix design process. Several test methods are available for evaluating stripping potential. These include the immersion compression (AASHTO 165) and the Lottman procedure (AASHTO 283).

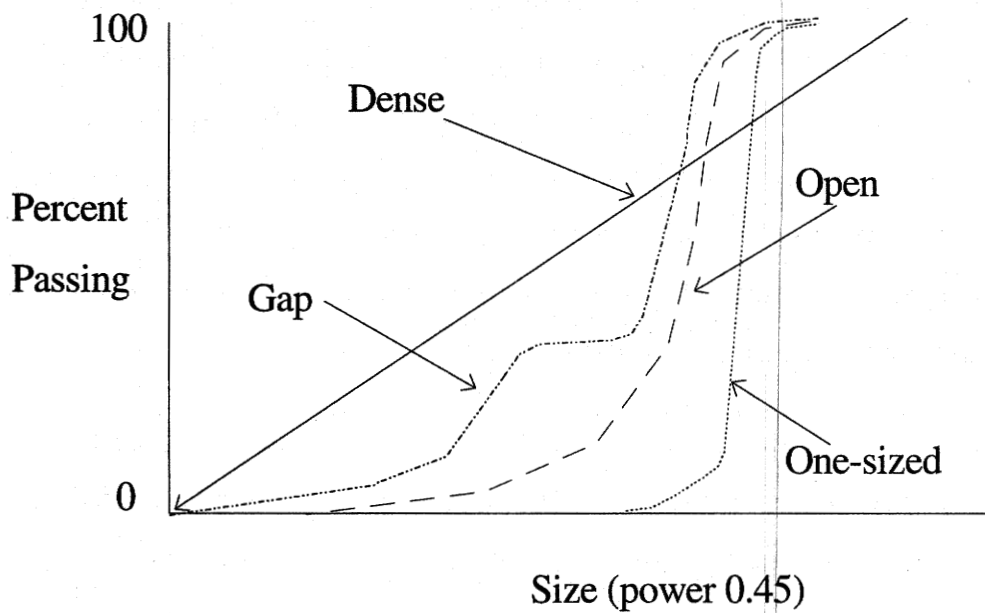

Figure 15. Types of aggregate gradations.

CHAPTER 4. FOG SEALS

INTRODUCTION

This chapter presents the proper techniques for fog sealing with respect to material selection, design, and construction. Variations of fog seals, such as the use of rejuvenators, will also be discussed. A fog seal is a light application of diluted asphalt emulsion without an aggregate cover. Fog seals are used to:

- Renew old asphalt surfaces,
- Seal small cracks and surface voids,
- Address raveling of chip seals, and open-graded surfaces on high-volume roads, and
- Maintain and delineate shoulders in high-volume roads.

On high-volume roads, fog seal is used mostly to address raveling of open-graded friction courses and to provide delineation between the traveled way and shoulder. The use of fog seal on high-volume roads with dense-graded asphalt concrete surfaces is potentially hazardous because friction may be initially reduced until traffic wears some of the asphalt off the surface. During this time it is desirable to reduce traffic speed and be prepared to apply a light sand coat.

PAVEMENT CONDITIONS FOR FOG SEALING

Fog seal is used only where the existing surface is sufficiently porous to absorb a substantial amount of the emulsion. Fog seals are generally

applied to pavements displaying low to moderate weathering or raveling. Fog seals are used on both low- and high-volume roads. Fog seals should never be applied to a pavement that has low skid resistance or an unstable asphalt concrete as indicated by rutting or shoving.

DESIGN CONSIDERATIONS

Materials

The material used for fog seal is an anionic or cationic slow or medium setting emulsion diluted with water. The water is added to the emulsion to reduce the viscosity of the material, allowing better control of application rate and penetration of the emulsion into fine cracks and small voids. When the fog seal is used to seal the shoulder, some States have found it desirable to use a sterilent with the emulsion to control weed growth.

A sand cover may also be used to improve surface friction. The sand may be spread over the entire surface, or it may be used to treat local areas, such as near intersections, where skid resistance or tracking of the emulsion is a concern. If the fog seal is placed on an open-graded friction course, the sand coating should not be required.

Application Rate

The application of the binder is usually 0.45 to 0.7 liters/m² of dilute emulsion. Heavier applications can adversely affect skid resistance. The high end of the application range is used for severely weathered pavements. A spray temperature of the emulsion between 20 to 60°C is recommended.⁽²³⁾

CONSTRUCTION CONSIDERATIONS

Pavement Preparation

The pavement surface needs to be thoroughly cleaned before applying the fog seal. This is best accomplished with a power broom. The pavement surface should also be dry before the fog seal is applied.

Weather Conditions

The fog seal should be applied when the temperature of the pavement surface is above 16°C and there is no threat of rain. Under adverse weather conditions, such as low temperature and high humidity, the road may need to be closed to traffic for several hours after applying the fog seal.⁽²¹⁾

Equipment

The main piece of equipment used for fog sealing is the asphalt distributor, as shown in figure 16. Miscellaneous equipment is also needed such as power brooms to clean the surface before applying the fog seal.

Construction Process

The construction of fog seals is rather simple. After cleaning the surface of the existing pavement, the diluted emulsion is sprayed using the asphalt distributor. The distributor should be calibrated prior to each project. The proper application rate should be used. Over-application must be avoided to prevent asphalt pickup by vehicles and slippery surface. If an excess emulsion is applied, a light dusting of the affected area with a fine sand may remedy the problem.

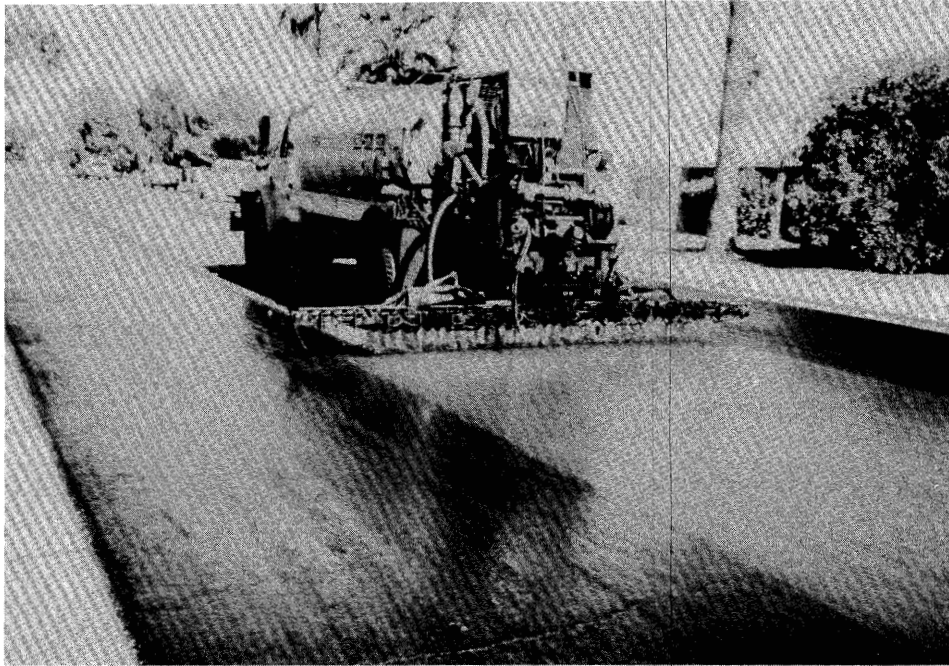

Figure 16. Spraying fog seal material with an asphalt distributor.

Traffic should be rerouted until the emulsion has cured significantly. Under favorable conditions, 2 to 3 hours are usually sufficient.

Inspection and Acceptance

Proper materials and construction procedure should be used in order to obtain good performance. Before work begins equipment should be checked to make sure it is in good working condition. Nozzles should be clean and at the correct angle, the spray bar should be at the correct height, and the pump should be set at proper pressure. The application rate of the spray bar should be calibrated prior to each use. Calibration is performed using pre-weighed metal trays or sheets of heavy paper to determine the amount of emulsion per unit area. To ensure uniform application, this process is repeated in both longitudinal and transverse

directions. The asphalt distributor should be driven at the appropriate speed determined to apply the correct amount of emulsion.

Specifications

Typical State specifications include description, materials, application rates, construction requirements, weather conditions, method of measurement, and basis of payment. For example, the Arizona Department of Transportation requires that when the types and grade of bituminous material are not specified, the contractor should furnish emulsified recycling agent with certain designation. The material shall be diluted with one part water to two parts emulsified recycling agent. Blotter material should be applied to the treated surface at a time specified by the engineer and before opening to the traffic.

PERFORMANCE

Fog seals are intended to reduce the oxidation of the pavement surface and seal minor surface cracks. The life of the treatment depends on the condition of the pavement when the treatment was placed, the amount applied, and the environmental conditions.

LIMITATIONS

Fog seals must not be applied to pavements with large cracks, low skid resistance, rutting, shoving, or structural deficiency.

VARIATIONS

Rejuvenators

Rejuvenators are generally materials applied to the surface of aged asphalt pavements. They rejuvenate the surface, reduce raveling, coat stripped surfaces, and may reduce crack development.

Rejuvenating materials can be classified in two groups. The first group is proprietary materials that are sold by their trade names. The second group fits within general specification limits such as those proposed for recycling agents by the Pacific Coast Conference on Asphalt Specifications or materials that have been defined as "a fine-particle-size, cationic, oil in water emulsion of a selected blend of four principle fractions of maltenes."⁽²⁴⁾⁽²⁵⁾

Similar to fog seals, rejuvenating agents may cause skid hazard if applied excessively. They should not be used if the pavement: contains excess asphalt, is distorted, corrugated or shows signs of instability, or is structurally deficient as may be indicated by alligator cracking.

CHAPTER 5. CHIP SEALS

INTRODUCTION

The objective of this chapter is to present the proper techniques for chip seals (also called surface treatments, seal coat, or armor coating) with respect to material selection, design, and construction. Variations of chip seals are also described. These include modified binders, single, double and triple chip seals, precoated aggregates, sand seal, sandwich seal, and cape seal.

A chip seal is a sprayed application of asphalt binder immediately covered by a layer of one-sized aggregate. The chip seal course provides a new wearing surface. Chip seals provide several benefits, such as:

- Waterproofing the surface,
- Sealing small cracks,
- Protecting the original surface from solar radiation, and
- Improving the surface friction.

Chip sealing has been used for many years on low-volume roads. Recently, chip seals have been used by many States on roads with traffic volume greater than 5,000 vehicles/lane/day. However, in spite of its benefits, chip sealing has not been widely used for high-volume highways in the United States. Reasons limiting the use of chip seals on high-volume roads include:

- The possibility of loosing chips and damaging vehicles,
- Lack of performance data,
- Relatively short performance life, and
- Variable life expectancy.

If chip seal is not properly designed and constructed, several problems can develop. Windshield damage may occur if the chips are not adequately embedded in the asphalt, or if excess stones are not swept, or if traffic speeds are not controlled during the initial curing period. Other problems include increased tire noise, prolonged traffic control during construction, flushing, streaking due to non-uniform binder application, and potential for premature failure. It is also difficult or expensive to obtain one-sized aggregate needed for long lasting chip seals.

The use of chip sealing on high-volume roads has increased in recent years. A recent study showed that 10 States use chip seal on high-traffic facilities.⁽²⁶⁾

SHRP EXPERIENCE

Chip sealing was one of the treatments applied in the SPS-3 experiment of SHRP. Preliminary observations of these sections indicate that, when properly constructed, chip seals can effectively improve the condition of the existing pavement and extend pavement life. However, the performance of the chip seal treatments in the SHRP research was highly variable. About 1/4 of the sections failed prematurely, particularly in the western States. The premature failure of these sections may have been the results of the low binder rates used in the construction of the sections.

The H-101 researchers recorded several observations about the design and construction of chip seals such as:

1. *No uniform design is used for chip seals, and no best procedure has been identified by research. However, factors that should be a part of this design have been identified. They are listed below.*
2. *Embedment of aggregate should be included in chip seal design to help determine the size of aggregate to be used.*
3. *Applying too much aggregate, or asphalt, is as bad or worse as not applying enough.*
4. *Upper, as well as lower, (ambient) temperature limits should be included in the specifications.*
5. *Slightly damp chips seemed to work better than dry or wet chips. (Applies only to emulsion binders.)*
6. *Asphalt distributors are not being calibrated for transverse application rate, and should be. The current ASTM procedure for asphalt distributor calibration is laborious and needs to be simplified.*
7. *Many pavements would have benefited if we were able to apply a different asphalt application rate in the wheel paths than between the wheel paths. This is possible through the use of different size nozzles.*
8. *Chip spreaders that kick the aggregate backward reduce aggregate rollover and reduces pickup of the aggregate on tires. The chip spreader in one region was a variable width type machine. One half of the width had a plate that kicked the aggregate forward, while the other half had a plate that kicked the aggregate backward. The aggregate that was kicked backwards would fall vertically with little or no horizontal velocity and were therefore not susceptible to rolling. The half width that was kicked backwards generally looked better than the side that was kicked off of the forward facing plate and experienced less pickup on tires.*
9. *Chip spreaders are not being calibrated for longitudinal and transverse application rate. The chip spreader calibration procedure developed at the University of Reno is simple and*

effective for both longitudinal and transverse rates. (Chip spreaders should be calibrated both longitudinally and transversely.)

10. *Many different rolling patterns, from one pass only, to five or seven passes, are used.*
11. *The amount of time after rolling, but before opening the surface to traffic seemed important in hot weather.*
12. *Requiring reduced speed for at least one hour, either by posting speed limits or through the use of pilot vehicles, seemed to reduce loss of chips.*

PAVEMENT CONDITION FOR SUCCESSFUL APPLICATION

Since chip seal does not add to the structural capability of pavement, the existing pavement has to be structurally sound in order to obtain a long performance life. If needed, the existing pavement has to be repaired, patched, and allowed to cure before applying the chip seal. The existing surface has to be clean.

Since chip seals follow the original profile of the pavement, they do not correct surface irregularities. Chip seals cannot be used on pavements with more than 10 to 15 mm of rutting. Aggregates in the ruts cannot be fully compacted, and cleaning loose aggregate from the rut with a power broom will dislodge the aggregates from the non-rutted area. If the surface has light-to-moderate bleeding, the binder application rate should be reduced. Pavements with high severity bleeding are not good candidates for chip seals.

DESIGN OF CHIP SEALS

Binder Selection

The binder used for chip seals is usually rapid setting emulsion, although medium setting emulsion could be used with fine aggregates. Asphalt cutback or asphalt cement can also be used. Asphalt emulsion is preferred over asphalt cement since it can be used with damp aggregates. Emulsion is also preferred over cutback because of environmental requirements and the slight saving in cost.

Aggregate Selection

The aggregates used for chip seals should be one size of about 9.5 to 12.5 mm in order to provide good stability and maximum contact with tires. Cubical particle shape is preferred for the same reasons. Also, aggregates should have good resistance to abrasion, polishing, and degradation in order to resist traffic wear and impact and provide maximum friction resistance.

Table 12 presents the ASTM D1139 requirements for aggregates used for chip seals.

Application Rate

Before construction, the chip seal has to be designed in order to find the target application rates for both asphalt binder and aggregates. Both mathematical and laboratory procedures are available for designing chip seals. Application rates are controlled to produce a pavement surface one stone thick with enough asphalt to hold the aggregate in place, but not so much that it will bleed. It is desirable to fill the voids between aggregate particles about two-thirds to three-fourths with asphalt. After rolling, an

Table 12. Specifications for aggregate used for chip seals.

LA abrasion	40 percent maximum
Two crushed faces	60 percent minimum
Sodium sulfate soundness	12 percent maximum
Magnesium sulfate soundness	18 percent maximum
Clay lumps and friable particles	3 percent maximum
Flat or elongated pieces (for AASHTO sizes No. 5, 6 and 7)	10 percent maximum

embedment depth of aggregate into the asphalt film of 50 to 70 percent is typical.⁽²¹⁾

Table 13 shows typical application rates for aggregate and asphalt emulsion as a binder.⁽²¹⁾⁽²⁷⁾ Similar rates are recommended by ASTM D1369. Note that when the aggregate nominal size decreases, both aggregate and binder quantities decrease. The material quantities shown in table 13 should be adjusted based on local experience, road condition, specific gravity of aggregate, and aggregate precoating. The table also assumes an aggregate bulk specific gravity of 2.65. If the specific gravity is outside of the range of 2.55 and 2.75, the amounts of aggregate shown in the table should be multiplied by the ratio of actual bulk specific gravity to 2.65. In addition, the table shows ranges of aggregate gradation and rates of materials. If the aggregate has a gradation on the fine side of the specified range, a binder rate closer to the lower limit of the quantity range should be used. If the existing surface is flushed, the quantities shown in the table should be reduced by 0.04 to 0.27 liters/m². For absorbent surfaces the quantities should be increased by 0.14 to 0.40 liters/m².⁽²¹⁾

**Table 13. Typical quantities of aggregate and emulsion for
single chip seal applications.**

Nominal Size of Aggregate	AASHTO Size No.	Quantity of Aggregate, kg/m ²	Quantity of Asphalt, liters/m ²	Type and Grade of Asphalt
19 to 9.5 mm	6	22 to 27	1.6 to 2.0	Asphalt Cement
			1.8 to 2.3	RS-2, CRS-2
12.5 to 4.75 mm	7	14 to 16	0.9 to 1.4	Asphalt Cement
			1.4 to 2.0	RS-1, RS-2, CRS-1, CRS-2
9.5 to 2.36 mm	8	11 to 14	0.7 to 1.1	Asphalt Cement
			0.9 to 1.6	RS-1, RS-2, CRS-1, CRS-2
4.75 to 1.18 mm	9	8 to 11	0.5 to 0.7	RS-1, MS-1, CRS-1, HFMS-1
			0.5 to 0.7	RS-1, CRS-1, MS-1, HFMS-1
Sand	AASHTO M-6	5 to 8	0.5 to 0.7	RS-1, CRS-1, MS-1, HFMS-1

The values in table 13 are general estimates of the quantity of materials required. A rather simple laboratory procedure can directly estimate the required amount of aggregate and asphalt. The aggregate is spread over an area of 1 m².⁽²¹⁾ A 1 m x 1 m x 25 mm pan can be used for this purpose. Aggregate is placed in the densest condition anticipated to exist in the field. The weight of the aggregate needed to cover the pan with a single layer of aggregates equals the required weight of the aggregate to be used in the field in kg/m². The pan is then carefully filled with water until the surface of the water comes just to the top of the aggregate. The volume of water is determined and approximately two-thirds of that volume is the quantity of asphalt residue required in the field.

CONSTRUCTION CONSIDERATIONS

Pavement Preparation

Before applying the chip seal, the condition of the existing pavement has to be surveyed. Most old pavements need some patching and removal of excess asphalt before chip sealing. Damaged areas must be patched and wide cracks sealed. The chip seal should not be placed until all of the asphalt used in the repair of the section has thoroughly cured.

Immediately prior to construction of the chip seal, the pavement must be cleaned with a power broom.

Weather Conditions

Many specifications require the air temperature be at least 10° C before chip sealing begins. Some require the road surface temperature to be above 20° C before work starts.⁽²¹⁾ Air temperatures of 40° C or higher may reduce the bonding of the aggregates due to rapid breaking of the emulsion. Chip sealing should never be started when the surface is wet or when it is threatening to rain.

Construction Process Methodology

The construction sequence for a chip seal is:

- Clean surface with a power broom.
- Apply binder with a calibrated distributor truck.
- Apply cover aggregate when the binder is tacky.
- Roll the aggregate to embed in the binder.

- Allow binder to set.
- Clean excess aggregate with a power broom.

Equipment consists of trucks, asphalt distributor, chip spreader, pneumatic (rubber tired) rollers, steel-wheel rollers, and power brooms. Sufficient trucks must be available in order to ensure continuous operation. There must be enough rollers to immediately roll the aggregates behind the spreader without delaying the operation.

The asphalt distributor consists of an insulated tank, asphalt pump, spray bar and nozzles, bitumeter wheel, and controls as illustrated in figure 17.⁽²¹⁾ Most distributors are equipped with a heating system that will maintain the asphalt at the proper spray temperature. The asphalt distributor is equipped with a control system which includes a valve system which governs the flow of material, a pump tachometer or a pressure gauge that registers the pump output, and a bitumeter. The bitumeter is a rubber-tired wheel mounted on a retractable frame with a cable leading to a dial in the cab of the vehicle. The dial registers the rate of travel in distance per minute and the traveled distance. The bitumeter should be kept clean and checked for accuracy at regular intervals. The typical capacity of the truck varies from 3,000 to 20,000 liters. The spray bar can cover a width of 3 to 9 m in a single pass, depending on the pump capacity.⁽²¹⁾

Figure 18 shows the asphalt distributor, chip spreader and pneumatic rollers prior to start of the chip sealing job. Figures 19 and 20 show the chip spreader and the rollers, respectively.

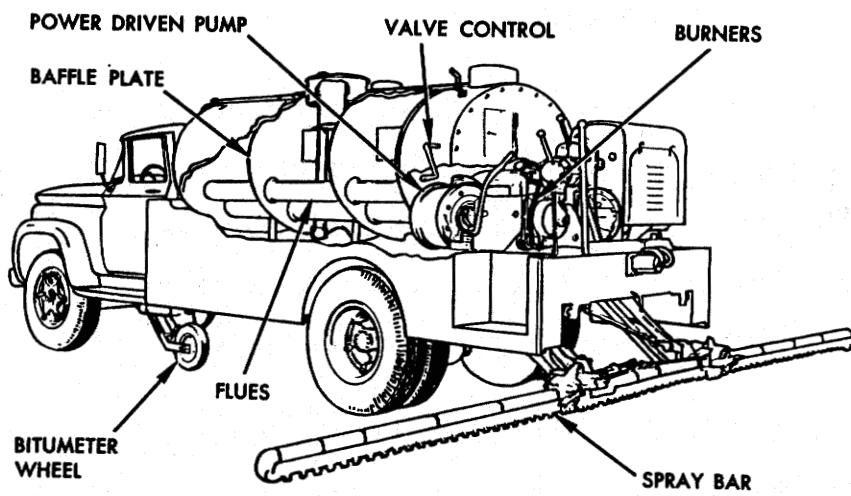

Figure 17. A schematic of asphalt distributor components.



Figure 18. Asphalt distributor, chip spreader and rollers.

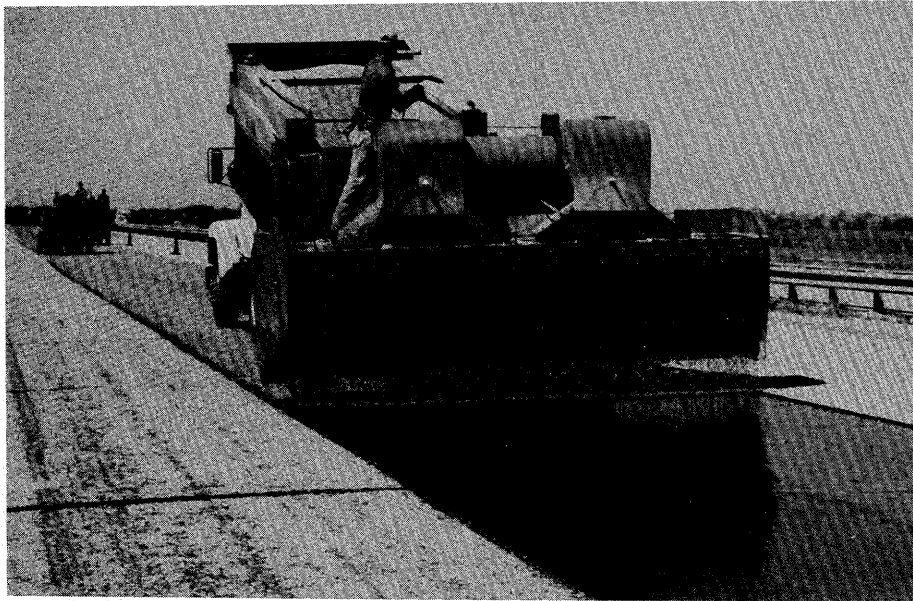

Figure 19. Spreading chips with a chip spreader.



Figure 20. Compacting chip seals using rubber wheel rollers.

The temperature of the binder is adjusted to achieve a viscosity that permits proper spraying without fogging. The recommended application temperatures are given in table 14:⁽²¹⁾

Table 14. Recommended binder application temperatures for chip sealing.

Type and Grade	Spraying Temperature °C
CRS-1	50 to 85
CRS-2	50 to 85
RS-1	20 to 60
RS-2	50 to 85
MS-1	20 to 70
HFMS-1	20 to 70
Asphalt Cement	130+

It is important to note that the chip spreader should follow the asphalt distributor immediately before emulsion breaks. The time between the application of binder and aggregate generally should not exceed 1 to 2 minutes. This time may be increased (up to a maximum of 3 minutes), depending on field conditions such as temperature and humidity.

Applying the chips too early permits the chips to roll over when they hit the binder, putting a coating on the top side of the chip. This can lead to traffic raveling the aggregate off the surface. Applying the aggregate too late reduces the ability of the aggregate to bond with the asphalt.

In case of wide roads, when two passes are used, it is a good practice to spread the aggregate on the first half of the roadway so that a 100 to

150 mm strip of asphalt is left exposed along the center line. This will form a lap for the second pass.

Rolling should be done immediately after spreading the chips to embed and orient them on their flat side. Rubber-tired rollers should be used since they kneed the chips firmly into the binder and small depressions without crushing. Light-weight, steel-wheel rollers can be used at the end for finishing, if crushing is not a problem. Rollers weighing 6 to 8 metric tons are suitable. It is important to adjust the tire pressure of rubber-tired rollers according to the manufacturer's recommendation. The speed of the roller should not exceed 10 km/h to avoid displacing the chips.

The use of several rollers is preferred to provide full coverage in one pass. A minimum of three rollers is recommended. The required number of passes varies from one to five. Usually two to four passes are needed to produce good embedment of the chips. The last pass should be in the direction of traffic to properly orient the aggregate and reduce dislodging of aggregate by traffic.

The final construction step is to clean any excess aggregate with a power broom.

After the construction, the road may be opened to traffic. Traffic speed should be limited to about 25 to 40 km/h for about 2 hours on newly placed chip seals. This time may be increased in humid weather or reduced if modifiers or asphalt cements are used. A pilot car can be used to control the traffic speed. Using a pilot car is important not only to reduce the problem of breaking windshields, but also to keep the traffic from dislodging the aggregate from the surface.

Inspection and Acceptance

Before work begins, equipment should be checked to make sure it is in good working condition and properly calibrated. Be certain that nozzles are clear and at the correct angle, the spray bar is at the correct height, and the pump is set at proper pressure. Verify the calibration of the spray bar.

All nozzles have to be clean and unplugged. Otherwise a non-uniform application of binder or uncovered longitudinal streaks will develop. Nozzles have to be set at an angle so that the spray fans do not interfere with each other. The nozzle angle varies according to the make of the distributor but is typically between 15 and 30 degrees as shown on figure 21. It is important that all nozzles be set at the proper angle within close tolerances in order to obtain a uniform application rate.

The height of the spray bar must be properly set and maintained to obtain a uniform spray and avoid longitudinal streaking. Improper spray bar height causes streaks of over and under binder application. The height of the spray bar should be adjusted to produce a single, double, or triple coverage in order to obtain a uniform binder distribution as shown in figure 22. During construction, it may be necessary to adjust the spray bar height to compensate for a change in the truck height as the emulsion load on the truck is reduced. A double coverage is more suitable for a 100 mm nozzle spacing, but triple coverage can also be used. Note that triple coverage requires a greater height between the spray bar and the pavement surface. This may permit wind distortion of the spray fans.

Adjusting the height of the spray bar is done manually. The height to produce a single coverage is determined first by visual observation. To obtain a double coverage, every other nozzle is turned off and the spray bar is raised in increments of 10 mm until a single coverage is obtained.

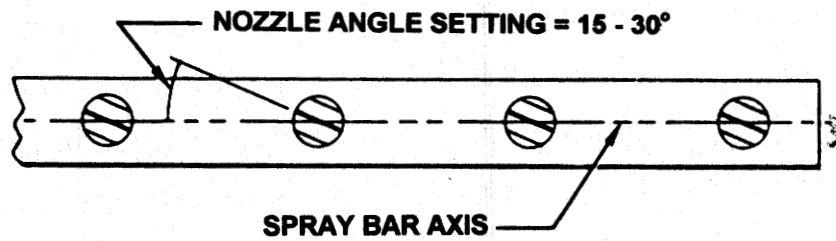

Figure 21. Proper angle setting of nozzles.

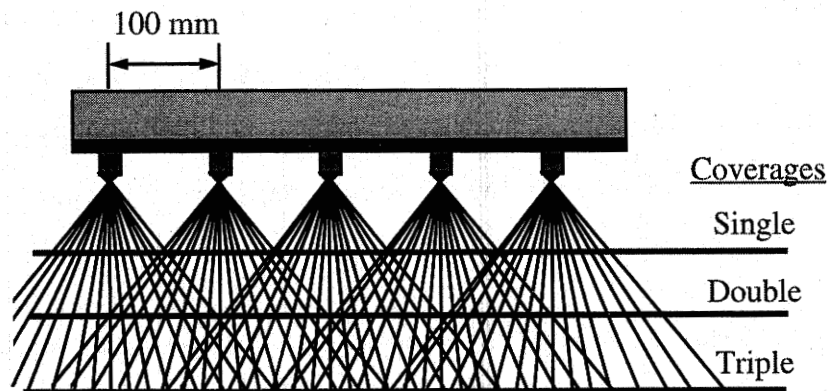

Figure 22. Overlapping spray fans.

This height will produce a double coverage when all nozzles are unplugged. Triple coverage can be obtained using similar procedure, except that two out of every three nozzles are closed. Note that the height needed for a double coverage is double that of a single coverage, and that of a triple coverage is 1.5 times that of a double coverage.

The application rate of the spray bar should be verified prior to use. Calibration is performed using pre-weighed metal trays or sheets of heavy paper to determine the amount of binder per unit area. To ensure uniform binder application, this process is repeated in both longitudinal and transverse directions. During construction, the application rate can be monitored by measuring the amount of emulsion used over a fixed-length section of pavement.

The asphalt distributor should be driven at the appropriate speed. Asphalt should be at the proper temperature before spraying. The asphalt binder should not be too hot or too cold. A typical range of binder temperature between 55 and 80° C is common when rapid setting emulsions are used. If asphalt cement is used, it is normally sprayed at temperatures of 130° C or higher. Air temperatures of 40° C or higher may reduce the bonding of the aggregates due to rapid setting of the emulsion. Overheating could break the emulsion prematurely, which reduces the bond with aggregate.

The aggregate spreader should be checked to ensure proper working condition. The aggregate spread rate should be adjusted to form a single layer. The rate of chip spreading and the consistency of spreading in both transverse and longitudinal directions should be checked prior to each application. Chip spreaders can be calibrated by placing mats of known surface area (approximately 1 m²) in the path of the spreader. Chip quantities on each mat are weighed. Spreader gates are adjusted to the desired quantity of chips. Calibration should be performed using the same aggregate as that used in the chip sealing. Chip spreaders that kick the aggregate backward or drop the aggregate straight down reduce aggregate rollover.

Aggregate should be spread immediately after spraying asphalt to embed and orient them on their flat side. Longitudinal joints can be eliminated by using full-width applications. Also, rough and unsightly transverse joints can be avoided by starting and stopping the asphalt and aggregate spread on building paper.

Rolling should be done using pneumatic-tired rollers immediately after the aggregate is spread and continue until the aggregate is properly seated in the asphalt membrane. Rollers should be as close as possible to the chip spreader.

Loose aggregate should be swept by lightly brooming with a power broom (figure 23) after the asphalt has set and a good bond has developed. The time required before brooming varies and ranges from 1 day to a few weeks. In any case, a good bond between the binder and the chips is a prerequisite. Brooming should be performed during the cooler morning weather. If the embedment is low and there are signs of chip loss after brooming, a fog seal can be considered.

Specifications

State specifications usually include description of work, materials, construction details, weather limitations, method of measurement, and basis of payment. For example, New York requires that asphalt and aggregate need to meet State specification requirements. Crushed stone, crushed gravel, or crushed slag can be used. Aggregate shall not contain more than 5 percent chert. Aggregate sizes for single and double chip seals are specified. The bituminous material should not be applied on a wet surface when the air temperature is below 10° C or above 35° C, or when weather conditions would prevent the proper construction of the surface treatment. The required equipment is a bituminous material

distributor, an aggregate spreader, a pneumatic rubber tire roller, and a power broom. The pavement surface needs to be free from irregularities to provide a reasonably smooth and uniform surface to receive the treatment. The bituminous material should be applied at a rate of 1.1 to 1.8 liters/m² unless otherwise directed by the engineer. Aggregate is to be spread immediately following the application of asphalt at a rate of 8 to 14 kg/m² unless otherwise directed by the engineer. Traffic should be detoured until the final layer is applied and rolled, after which controlled traffic may be permitted. Traffic shall be maintained at a speed not to exceed 25 km/h for 2 to 4 hours after rolling. The time and the method of traffic control are determined by the engineer.

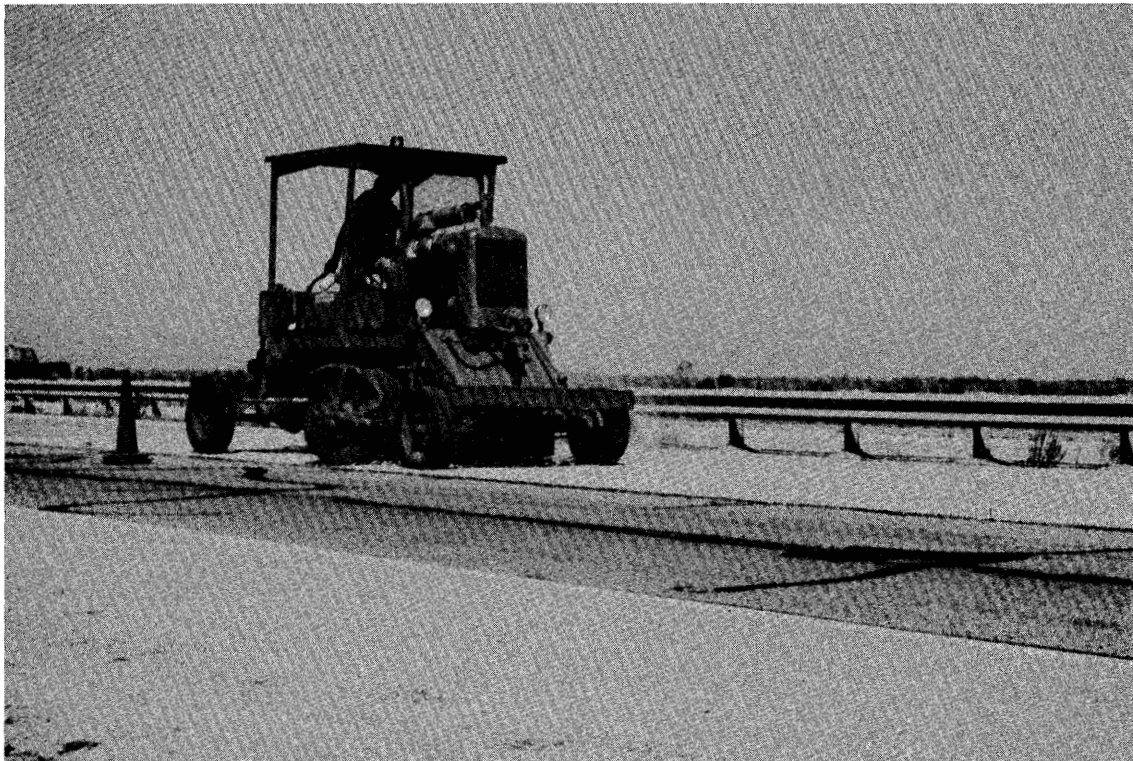

Figure 23. Brooming excess chips using a rotary broom.

PERFORMANCE

Chip seals typically provide good performance on highways with as much as 5,000 vpd for 4 to 7 years.⁽²³⁾ Several chip seal projects were constructed under the SHRP SPS-3 project. Preliminary indications show that timing of chip seal applications relative to existing pavement condition is critical to its performance and cost-effectiveness.

By and large, chip seals in Europe and other countries are similar to those in the United States. However, polymer modified binders are commonly used in Europe. In other countries such as Australia, New Zealand, and South Africa, large stone aggregate is used to obtain long service life.⁽²³⁾

LIMITATIONS

Some of the limitations of chip seal applications include the difficulty and expense of obtaining one-sized aggregates needed for long lasting chip sealing. Also, windshield damage may occur if aggregates larger than 12.5 mm are used, especially if the chips are not adequately embedded in the asphalt or excessive stones are not swept. Other problems include increased tire noise, prolonged traffic control, flushed pavements, and potential for premature failure if not properly designed or constructed.

VARIATIONS ON CHIP SEALS

Several variations can be used with the chip seal to address some of the previously noted problems. These variations include using modified binders; single, double, or triple chip seal; asphalt cement; precoated chips; sand seal; sandwich seal; and cape seal.

Alternative Binders

Some States such as Arizona, California, Texas, and Washington use polymer-modified chip seal on their high-volume roads. The use of modified emulsion reduces temperature susceptibility, provides better adhesion to the existing surface, and allows the road to be opened to traffic earlier. Both recycled rubber and synthetic polymers have been used as modifiers. The cost of crumb rubber modified (CRM) chip seals has been about twice the cost of conventional seals. Wet processed asphalt-rubber has a higher viscosity than asphalt cement at higher temperatures. This permits increasing the binder application rate, and better chip retention, without resulting in a bleeding problem.

Asphalt cement is sometimes used as a binder to allow opening the roadway traffic earlier. However, it increases the cost and is more sensitive to dirty aggregates than emulsion binders. When asphalt cement is used, the chips must be placed and rolled while the asphalt cement is hot enough to allow embedment of the aggregates. Depending on ambient conditions, this can be limited to just a few minutes of effective rolling time.

Double and Triple Chip Seals

A double or triple chip seal consists of two or three alternate applications of asphalt and aggregate, respectively. The nominal top size of the cover aggregate for each successive course should not be more than one-half that of the preceding one. When using multiple chip seal applications, the first layer should be cured before the application of the second layer.

The aggregate size of the first course determines the surface layer thickness, while the aggregate in the following layers fills voids in the preceding layers. The use of multiple chip seals fill the voids between

aggregate particles and increase the service life. The use of double and triple chip seals is not as common as single chip seals. Double chip seals can cost about 1 1/2 times single chip seals; however, double chip seals usually give more than twice the service life of single chip seals.

The New York specifications for double surface treatment require the application rates given in table 15.

Table 15. New York DOT application rates for double chip seal.

	Bituminous Material, liters/m ²	Aggregate, kg/m ²
1st Course (base)	1.1 to 2.3	11 to 16
2nd Course (surface)	1.1 to 1.8	8 to 14

Precoated Chips

Precoated aggregate is used by a small number of States such as Illinois, Oregon, Pennsylvania, Texas, Utah, and Virginia for high-volume roads.⁽²⁸⁾ Precoating eliminates dust and improves adhesion between aggregate and binder. Asphalt cement is used for coating with a content of about 0.75 to 1 percent by weight of chips. A 90 percent or more coating is desired. A mixing temperature of about 140° C is recommended. Correctly coated aggregate particles should separate from each other easily and flow readily through spreaders.⁽²⁹⁾

The use of precoated chips is not as common as the use of uncoated chips due to the difficulty in coating and spreading the chips and the extra expense. Also, it is reported that coated aggregates delay the break of the cationic emulsions.⁽²³⁾

Sand Seal

Sand seal is an application of asphalt followed by a sand cover aggregate. The sand or stone screenings should be 6.35 mm sieve size or smaller. The binder used for sand seals is usually a rapid setting (anionic or cationic) or a medium setting (anionic or high float) emulsion. Therefore, sand seal is essentially the same as chip seal except finer aggregates are used as cover.

Sand seals are used to:

- Improve microtexture and provide better surface friction,
- Renew old asphalt surfaces,
- Seal small cracks and surface voids,
- Address raveling of chip seals and open-graded surfaces in high-volume roads, and
- Maintain and delineate shoulders in high-volume roads.

Sand seals are not routinely used by many agencies. They have mostly been applied to low-volume roads. Some agencies have applied sand seals on moderate-to-high-volume roads and reported good performance.⁽²³⁾ The use of sand seals on high-volume roads is limited due to the excessive traffic control requirements and the difficulty in determining the appropriate binder rate.

The rate of emulsion application varies from 0.5 to 0.7 liters/ m² depending on the texture of the existing surface, local conditions, and traffic. Sand is applied at a rate of about 5 to 8 kg/m².

Sand seal should not be applied unless the surface temperature is at least 15° C. Pneumatic tire rollers are recommended. Two hours of lane closure is generally required under normal conditions. The performance life

varies between 3 and 6 years. Variables include traffic, construction quality, materials, and environmental conditions.

Among the limitations of sand seals is that it is not effective for long-term crack sealing, it may take several hours for the emulsion to cure and may not provide the distinct delineation depending on the aggregate color.

Sandwich Seal

Sandwich seal is an application of binder sandwiched between two layers of aggregate. In this process, one-sized aggregates (either 4.75 or 9.5 mm) are spread on a clean and dry pavement at a rate of about 80 percent of the amount needed to provide coverage at one stone thickness.

Aggregates are compacted and asphalt emulsion is applied at a rate of 1.2 to 1.5 times the amount for a conventional single chip seal. A second course of one-sized 2.36 to 4.75 mm is applied and rolled.⁽²³⁾

Before applying the sandwich seal the existing pavement has to be clean and dry. All aggregates used in the sandwich seal application have to be clean. A light-weight steel roller may be used to seat the first layer of aggregate. A slow-moving pneumatic roller is used to compact the top aggregate layer.

Sandwich seal is used for sealing high traffic pavements and flushed pavements. It also improves skid resistance. Sandwich seal has approximately the same service life as the double chip seal.

Sandwich seal is generally more economical than the double chip seal since only one application of binder is used.

Cape Seal

A cape seal is chip seal topped with a seal coat such as slurry seal. The name is derived from the Cape Province of South Africa where it was originally developed. The cape seal provides a dense surface with good skid resistance and a relatively long service life. The slurry cover over the chip seal eliminates the problem with loose aggregates and reduces traffic noise. These properties of cape seal make it very suitable for high-traffic-volume roads.

In this treatment, a single course of chip seal is applied in the conventional manner. The chip seal cures for 4 to 10 days; the slurry seal is then applied. The surface has to be broomed before applying the slurry in order to provide better adhesion of the slurry. After the chip seal has been cured, the slurry seal is applied to fill the texture of the chip seal.

For a 15 mm thick layer, the emulsion is applied at a rate of about 1.4 to 2.0 l/m², the chip at a rate of 14 to 16 kg/m², and the slurry mixture (usually type I) at a rate of 3 to 5.5 kg/m².

After applying the slurry seal, traffic should be detoured for about 2 hours in warm weather and 6 to 12 hours or more in cool weather. One of the limitations of the cape seal is the need to establish traffic control twice in a relatively short time period.

CHAPTER 6. COLD THIN SEALS

INTRODUCTION

This chapter discusses the types and proper techniques for cold thin seals with respect to material selection, design, and construction. Thin cold seals are mixtures of asphalt emulsion and aggregates blended at the job site in specially designed mixing units. Slurry seals are the predominate type of thin cold seal used in the United States. Micro-surfacing modification of the slurry seal process, was developed in Europe and is widely used in the United States. At least 25 States routinely use micro-surfacing.

SLURRY SEALS

Slurry seal is a mixture of asphalt emulsion, well-graded fine aggregate (sand) and mineral filler (in most cases) mixed with water to produce slurry consistency. Additives such as portland cement, hydrated lime, or aluminum sulfate liquids are often used to aide setting the slurry. Either a quick or slow set emulsion is used for the binder. Slurry seals are used for the following purposes:

- Sealing minor surface cracks and voids,
- Retarding surface raveling,
- Improving surface friction characteristics, and
- Delineation of different pavement surface areas.

Slurry seals are routinely applied on city and county streets. Only a few States have used slurry seals on moderate- and high-volume roads. At

least one State has used slurry seal to cover open-graded friction courses on interstates and other high-volume roads.⁽²³⁾

A curing period is necessary before allowing traffic on the slurried surface. Under warm conditions slurry seals require 1 to 2 hours or more to cure depending on the type of emulsion used. Thus, slurry seals may not be appropriate for situations where early use of the facility is required.

SHRP Experience

Slurry seals were applied on moderate to high-volume roads under the SHRP SPS-3 experiment. Single application slurry seals were applied to 81 SHRP test sections throughout the United States and Canada. These sections are now being evaluated under the SHRP's Long Term Pavement Performance (LTPP) program. They generally confirm the expected performance and sections with these treatments are demonstrating a better performance than the control sections. The SHRP sections in good condition have benefited the most from the slurry treatment. Reflection cracking has developed in the slurry seals on sections in poorer condition.

Lessons learned on slurry seal design and construction covered five topics: general, specifications, mix design, calibration, and construction.

There were four general observations:

1. *A successful slurry (seal) depends on the skill and experience of the operator (and crew).*
2. *It may be possible to determine when a slurry can be opened to traffic by using a non-contact thermometer. When the temperature of the surface of the recently placed slurry approached the temperature of the untreated lane or of a lane that was treated much earlier, the lane may be ready to open. The surface temperature of the treated and untreated lanes was one factor used in one region to determine when to open the lane to traffic.*

3. *Roads with superelevation made it difficult to manage the spreader box to keep the slurry flowing well. On roads with no shoulders, the slurry box had to be kept up on the pavement. Otherwise, the slurry would flow out from under the box onto the shoulder.*
4. *Rutted areas take longer to cure. (The depth of the slurry application affects the cure time.)*

The H-101 researchers recorded five observations on slurry seal specifications:

1. *Upper as well as lower air and pavement temperature limits should be included in the specifications. When it is too cold, the slurry sets much too slowly. When it is too hot, the slurry tends to set too fast. To counteract this fast set, the operator will add extra water which may affect the final product.*
2. *When soliciting bids for slurry seal work, it should be considered appropriate to require a certain minimum level of experience for the slurry machine operator (and crew), thereby avoiding many of the problems associated with placing and fine tuning a slurry mix.*
3. *Any oversized aggregate or large clumps get hung up under the strike-off bar. This leaves streaks in the fresh treatment. These streaks do seem to close up by themselves somewhat but also usually fill up with the water coming out of the mix. This may leave a weak area. An on-site final screening eliminates oversize aggregates and clump.*
4. *One region found that hard water may have contributed to set problems on a couple of sites. It was also found that cement purchased in Canada was different than cement from the United States. Using the Canadian type 10 cement, the slurry seal set up almost as soon as it hit the spreader box and the operator had to increase water to the pug mill as well as to add water by spraying water into the spreader box. Observations later seemed to indicate that was an acceptable application, but the site deserves extra concern due to this cement problem. Canadian type 2 is equivalent to United States type I.*
5. *The time to opening of the slurry seal to traffic is highly dependent on the temperature of the pavement prior to placing the slurry and the ambient conditions.*

Three observations were made about the slurry mix design process:

1. *Slurry mix design is normally left to the contractor.*
2. *The operator should be allowed to change the amounts of slurry seal additives as the environmental conditions change.*
3. *The moisture content of the slurry seal aggregate is not important to the operator because the (on-site) changes made to the mix are (based on operator observation and experience).*

One observation was made on the calibration of the equipment used for a slurry seal.

Slurry seal contractors typically calibrate their equipment once per year, but it is not required by most agencies. Slurry seal equipment calibration procedures are available, and the calibration is relatively simple. The calibration could be performed before every large job.

The current practice of the industry is to calibrate slurry equipment once per year. The above observation by the SHRP researchers indicates this may not be adequate to ensure the material proportions and application rates are correct.

There was also one observation of the slurry seal construction process.

In one region, the 2 hour set time for slurry seal was seldom observed. The time was generally longer. Also the slurry seal machine used in the North Central region had no means to monitor the amount of water added to the slurry seal mix. It would be helpful if we could determine the amount of water used in a mix and monitor success of an application with knowledge of this variable and other environmental factors.

Pavement Conditions for Successful Application of Slurry Seals

The SHRP experience demonstrated that slurry seals are not effective treatments for cracked pavements. For a successful slurry seal application, the existing pavement should not have large cracks that displace under traffic. Pavement has to be stable with no excessive rutting

or shoving. If the pavement has high severity weathering or raveling, a tack coat may be used to promote bonding of the slurry to the surface.

Design Considerations for Slurry Seals

The International Slurry Surfacing Association defines three types of slurry seal based on aggregate size and percent asphalt residue. Type I is generally used for fine crack sealing in low traffic areas. Type II is used to correct raveling oxidation in moderate to heavy traffic areas. Type III is used to fill minor surface irregularities and restore friction. It is also used as the first course in multi-course applications for heavy traffic areas.

Table 16 shows the mixture characteristics of the three types of slurry seal.⁽²¹⁾ Note that Type I slurry has the finest aggregate gradation, highest asphalt residue content, and lowest application rate, while Type III has the coarsest gradation, lowest asphalt residue content and highest application rate. Therefore, Type III produces the maximum improved friction and improved wearing surface as compared with other types.

Binder Selection

Quick set emulsions are widely used even though they are not defined by an ASTM or AASHTO specification. The Asphalt Institute recommends the use of slow set emulsions for normal slurry seal construction.⁽²¹⁾

Aggregate Selection

Well-graded crushed fine aggregate (sand) is used together with a mineral filler in most slurry applications. Table 16 defines the required aggregate distribution for each of the slurry seal types. The aggregates must be clean, angular, durable, and well graded.⁽³⁰⁾ Quality aggregates are essential for durable performance of micro-surfacing.

Table 16. Slurry mixture characteristics.⁽³⁰⁾

	Type of Slurry		
	I	II	III
Sieve Size	% Passing		
9.5 mm	100	100	100
4.75 mm	100	90 to 100	70 to 90
2.36 mm	90 to 100	65 to 90	45 to 70
1.18 mm	65 to 90	45 to 70	28 to 50
0.600 mm	40 to 65	30 to 50	19 to 34
0.300 mm	25 to 42	18 to 30	12 to 25
0.150 mm	15 to 30	10 to 21	7 to 18
0.075 mm	10 to 20	5 to 15	5 to 15
Percent Asphalt Residue (by Aggregate Dry Weight)	10 to 16	7.5 to 13.5	6.5 to 12
Application Rate, kg/m ²	3 to 5.5	5.5 to 8	8 or more
General Usage	Fine crack sealing (low traffic areas)	Correct raveling, oxidation (moderate to heavy traffic)	Fills minor surface irregularities, restores surface friction, first course in multi-course applications for heavy traffic

Mix Design

Currently, the design of slurry seal mixture is performed using a trial-and-error procedure. This empirical process usually results in an acceptable slurry mixture. The process consists of the following three steps:⁽³⁰⁾

1. Selection and testing of the mixture components mainly aggregate and emulsion,
2. Testing of the slurry mixture to determine compatibility of the mixture components, and
3. Determination of the optimum asphalt content.

Detailed information on slurry seal design can be found in industry literature. A useful reference is "Recommended Reference Guidelines for Emulsified Slurry Seal - A105," which is published by the International Slurry Surfacing Association (ISSA).⁽³⁰⁾ Also, ASTM D3910 provides guidelines for designing, testing and construction of slurry seals. The ISSA procedure uses the wet track abrasion test to determine the optimum asphalt residue for a durable mixture.

The amounts of blend water and admixture are estimated in the design process. However, the final quantities of water and additives depend on field conditions. The slurry machine operator adjusts the amounts of water and admixture based on the flowability and setting times observed on the site.

Application Rate

The application rates recommended by ISSA for the three types of slurry are shown in table 16. The thickness of a single coat of slurry seal is approximately 5 mm. The thickness should not exceed the largest size aggregate in the mix.

Construction Considerations

Pavement Preparation

Crack sealing and patching of the existing surface must be completed prior to the application of a slurry seal. These repairs must be performed

sufficiently in advance of the slurry treatment to allow complete curing of the asphalt. Since the slurry seal is very thin, crack sealing should be flush with, or just below, the pavement surface. Band-aid and overfilled joint seal are not recommended. Immediately prior to construction of the slurry seal, the pavement surface should be cleaned with a power broom. If the existing pavement is dry or raveled, a tack coat is used before the slurry seal application. During hot weather, if a tack coat is not used, the surface of the pavement should be dampened before the slurry seal application. Most slurry trucks are equipped with a spray bar for this purpose.

Weather Conditions

To obtain best performance, both air and pavement temperatures should be at least 10° C and there is no chance of freezing within 24 hours after placement. Slurry seal should not be applied during rain or if rain is expected before the slurry is set.

Equipment Considerations

The equipment used for slurry seal construction includes:

- Power broom,
- Slurry mixing machine (figure 24), and
- Rubber-tired roller (if required to achieve a dense layer).

The performance of the slurry mixing machine is critical to obtaining a good quality mix. Slurry machines can be either self-propelled or truck mounted. Self-propelled machines are generally preferred for high-volume roads since they can place more material without reloading. This allows the seal to be placed with fewer transverse joints. Figure 25 shows

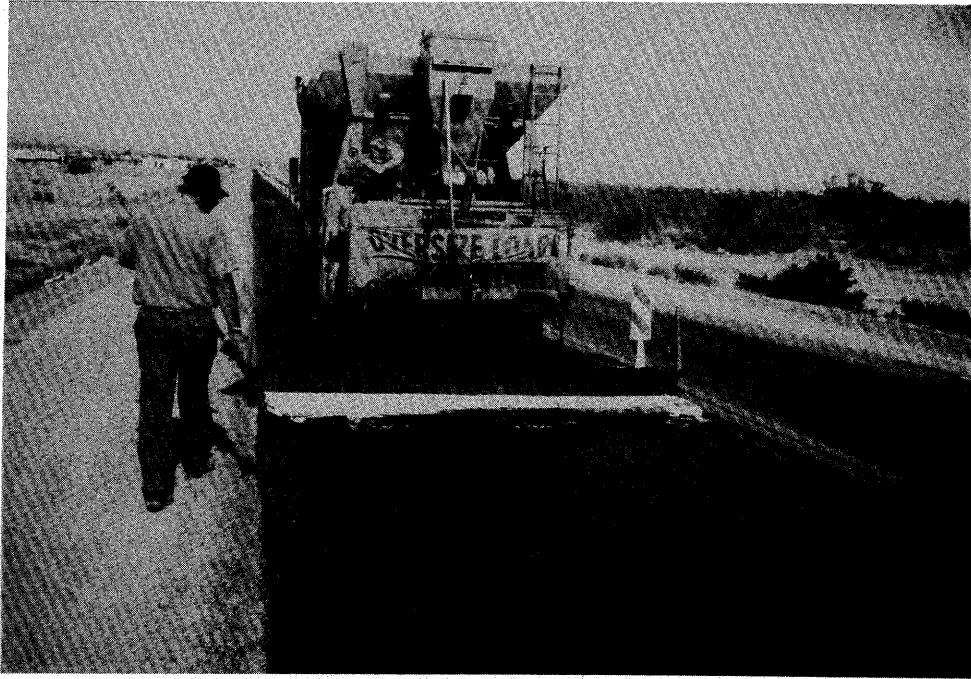

Figure 24. Applying slurry seal using a slurry machine.

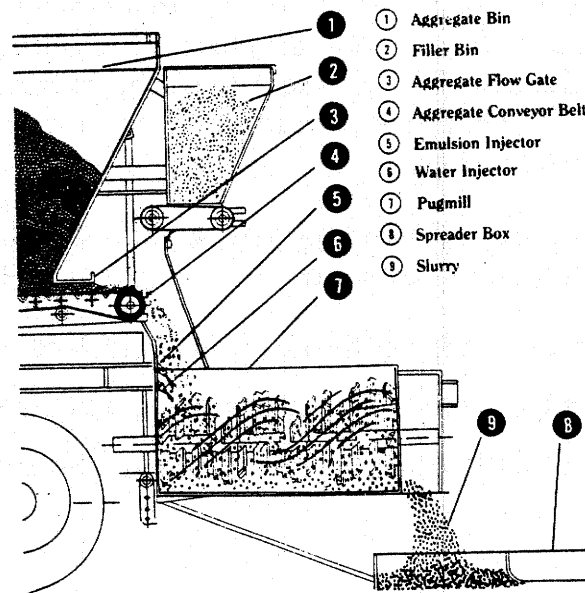

Figure 25. Schematic diagram of a typical slurry mixing machine.

a schematic diagram of a typical slurry mixing machine.⁽²¹⁾ The machine consists of:

- A water spray bar attached to the rear of the truck is used to wet the pavement surface ahead of the mixture placement.
- Separate tanks for water, emulsion, additives, mineral filler, and aggregate.
- A mixing chamber with a multi-bladed single shaft used for blending the materials. Aggregate and mineral filler are introduced into the mixer. Emulsion is introduced at about the one-third point of the mixer.
- A chute is used to discharge the mixture into the spreader box. Some chutes are fitted with a divider in order to distribute the material evenly. This is particularly important when placing slurry in areas of high crown or on superelevated curves. In such cases the slurry should be diverted to the high side of the spreader box since gravity will keep the lower side filled.
- Spreader box for applying the slurry to the pavement surface. Newer type spreader boxes fitted with augers are recommended to achieve uniform distribution of material particularly when quick set type slurry is used. Boxes are fitted with neoprene seals on all sides to hold the material within the box while ensuring a uniform depth are maintained. The spreader box can be fitted with flow gates to better distribute the mixture when working on high crowns or superelevations.
- A drag mop (burlap) is commonly used with the spreader box to provide a uniform surface texture.

Accurate mixing and application of the slurry is dependent on the calibration of the slurry machine. The current practice is to calibrate every 12 months. However, SHRP recommends calibrating before every large job.

Construction Process

Construction of a slurry seal essentially consists of:

- Preparing the pavement surface,
- Tacking or wetting the surface just in advance of placing the slurry
- Applying the slurry,
- Rolling (if required), and
- Allowing the slurry to set.

The mixture is applied at a speed of 1.5 to 2 km/h. The slurry should be produced and spread at the optimum consistency and stability. If it is too fluid, the slurry may run into channels and segregate resulting in poor skid resistance. If it is too stiff, it may prematurely set in the spreader box or may tend to drag behind the burlap. Because of its fluid nature, many operators prefer to place the slurry while going uphill. This application should be placed as continuous as possible. Each start and stop requires hand work and can be a potential blemish.

Rolling is generally not required for a normal thickness of slurry seal. However, in locations subjected to abrasion caused by severe steering, braking, or acceleration, rolling with a 4.5 Mg pneumatic tire roller can densify the mat and improve toughness. Rolling can start as soon as clear water can be pressed out of the slurry mixture with a piece of paper without discoloring the paper.

Traffic should be detoured for about 2 hours in warm weather and 6 to 12 hours or more in cool weather to allow curing of the slurry. SHRP found that when the temperature of the slurry, measured with a non contact thermometer, equals the temperature of an untreated pavement area, the slurry is ready for traffic. Also, it was found that ambient conditions may affect the slurry set time. For example, the slurry set time increases in shadowed areas such as underpasses and under tree branches.

Inspection and Acceptance

Proper materials, mix design and construction procedure should be used in order to obtain good performance. Before work begins equipment should be checked to make sure it is in good working condition.

Specifications

State specifications for slurry seal usually include description of work, materials, mix design, proportioning, construction requirements, method of measurement, and basis of payment. Features from the California Department of Transportation (CalTrans) specification are presented as an example of the requirements in State highway agency specifications:

- Binder must be QS1h anionic or grade CQS1h cationic emulsion.
- Aggregate shall consist of rock dust and plaster sand or other sands of similar nature; 100 percent of the aggregate larger than 0.3 mm must be crushed.
- The sand equivalency test is used to control clay content. CalTrans requires a minimum SE of 45, 55, and 60 for Type I, II, and III slurries respectively.
- Aggregate shall be free from vegetable matter and other deleterious substances.
- The contractor is required to furnish an aggregate moisture determination for every 2 hours of operation or maintain the moisture content to within a maximum daily variation of ± 0.5 percent.
- Emulsion should not break before the slurry seal is applied.
- The slurry seal is required to be mixed in continuous pugmill mixers of adequate size and power for the type of slurry seal to be placed.
- The slurry mixture should be uniformly spread by means of a controlled spreader box.

- Flexible drags attached to the rear of the spreader box shall be provided as directed by the engineer.
- Before applying the slurry seal, the pavement surface shall be cleaned by sweeping, flushing, or other means.
- Slurry seal shall not be placed when the atmospheric temperature is below 10°C or during unsuitable weather.

Specifications can vary between agencies or trade organizations. For example, the ISSA places the following requirement on aggregates for slurry seals.

The aggregate shall be manufactured crushed stone such as granite, slag, limestone or other high quality aggregate, or combination thereof. To assure the material is totally crushed, 100 percent of the parent aggregate will be larger than the largest stone in the gradation to be used.

Performance

The nominal life of slurry seals is 3 to 5 years on roads with moderate to heavy traffic (ADT of 5000 vehicles/lane/day). The slurry seal performance is affected by several factors such as, existing pavement condition, quality of materials and design, construction quality traffic loading, and environmental conditions.

Limitations

Slurry seals do not perform well if the underlying pavement surface is cracked and moves under traffic. Debonding and delamination can occur when the slurry does not fully bond to the existing surface. Also, slurry seals typically require longer curing time than chip seals.

MICRO-SURFACING

Introduction

Micro-surfacing can be viewed as a polymer-modified cold paving slurry seal system. This is basically a variation on slurry seal technology that uses a polymer modified emulsion and 100 percent crushed aggregates with at least one crushed face. Micro-surfacing cures and develops strength faster and can be placed in a thicker layer than the slurry seal.⁽²³⁾⁽³¹⁾⁽³²⁾

Micro-surfacing was developed in Europe in the 1970s. It was first introduced in the United States in 1980 in Kansas. Since then, many other States and local agencies have used this treatment to address certain pavement conditions on moderate- to-heavy volume roads. At present, major user States are Kansas, Ohio, Oklahoma, Pennsylvania, Tennessee, Texas, and Virginia. Over 20 states routinely use micro-surfacing. Micro-surfacing was also used as SHRP State supplemental sections in North Central, South Eastern, and North Atlantic regions.

Micro-surfacing has been used on both asphalt and portland concrete pavements. For asphalt pavements, it has been mostly used for texturing, sealing, and rut filling. Micro-surfacing can provide long-term solution for ruts if the pavement is stable. If the underlying surface is unstable, micro-surfacing only provides a short-term solution. For concrete pavements, it has been used mostly for texturing. Other uses of micro-surfacing include:

1. Applications on oxidized, raveled and flushed surfaces,
2. Crack and void filing,
3. Minor leveling,

4. As an interlayer, and
5. Bridge decks.

Pavement Condition for Successful Application of Micro-surfacing

For a successful micro-surfacing application, the existing pavement should have no large cracks that displace under traffic. Pavement has to be stable with no excessive irregularities or shoving. With a special attachment, micro-surfacing can be used to fill stable ruts.

Design Considerations for Micro-surfacing

Binder Selection

The binder used in micro-surfacing is typically a polymer modified CSS-1h emulsion conforming to the requirements of AASHTO M208 and ASTM D2397 in addition to other requirements.

Aggregate Selection

The durability of micro-surfacing is achieved to a large extent by strict aggregate specifications. The aggregate should be manufactured crushed stone such as granite, slag, limestone, or other high quality aggregate or combination thereof.

Two types of micro-surfacing (Types II and III) are recommended by the International Slurry Surfacing Association with different aggregate gradations, binder contents, and application rates. The maximum aggregate size of both types is 9.5 mm. Type III has coarser gradation than Type II. Type III is usually used for rut filling and texturing on high-volume roads. Table 17 shows the aggregate gradations for micro-surfacing recommended by ISSA.⁽³¹⁾ Figure 26 shows the same gradations on a 0.45 power chart.

Table 17. Aggregate gradation for micro-surfacing recommended by ISSA.

Sieve Size	Type II % Passing	Type III % Passing	Stockpile Tolerance
9.5 mm	100	100	
4.75 mm	90 to 100	70 to 90	±5%
2.36 mm	65 to 90	45 to 70	±5%
1.18 mm	45 to 70	28 to 50	±5%
600 μm	30 to 50	19 to 34	±5%
300 μm	18 to 30	12 to 25	±4%
150 μm	10 to 21	7 to 18	±3%
75 μm	5 to 15	5 to 15	±2%

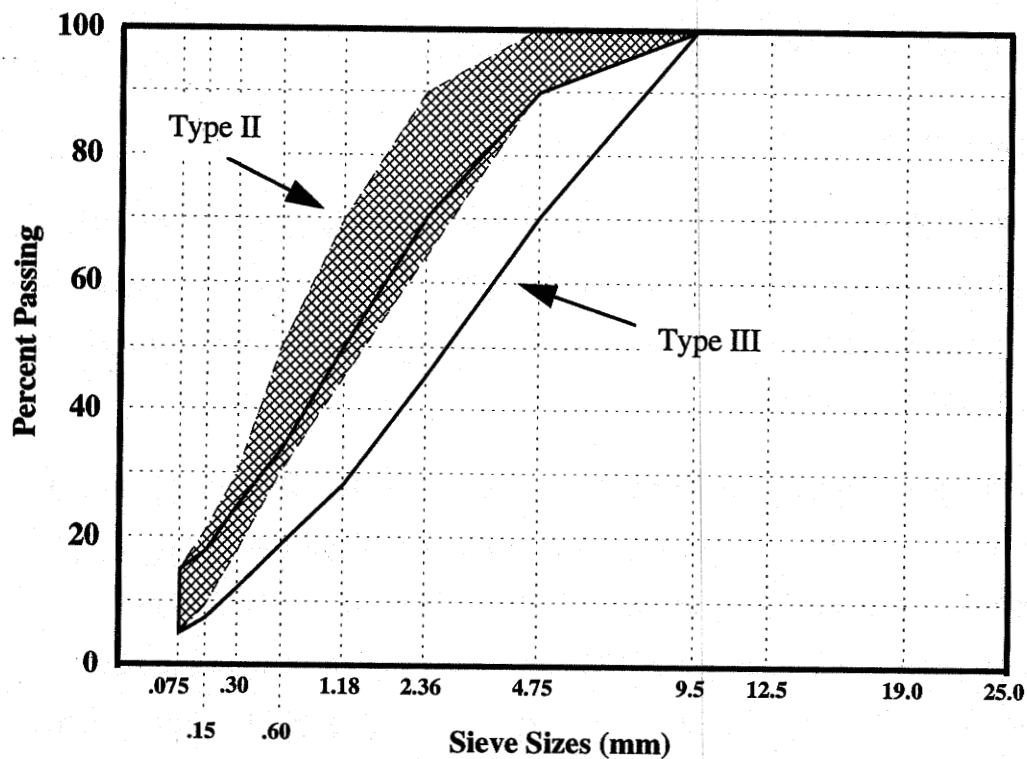

Figure 26. Aggregate gradations for micro-surfacing recommended by ISSA.⁽³¹⁾

Mineral fillers such as portland cement and hydrated lime are often used as stabilizers. Mineral fillers also shorten the break time. An additive may also be used as needed to control the break time. Most States require the following: 1) 82 to 90 percent aggregate, 2) 2 to 4 percent latex polymer by weight of asphalt, 3) 1.5 to 3 percent portland cement as a mineral filler, and 4) 5.5 to 9.5 percent asphalt residue. Detailed information on micro-surfacing can be found in FHWA publication "State of the Practice-Design, Construction, and Performance of Micro-surfacing".⁽³³⁾

European countries use aggregate gradations close to that recommended by ISSA. The mineral filler, if required, is a portland cement or hydrated lime in some cases. A minimum of 3 percent polymer solids, based on asphalt weight, is generally used. The latest European innovation includes the incorporation of fibers and the use of gap-graded mixtures. The incorporation of fibers increases viscosity, improves skid resistance, and retards cracking. The gap grading provides space in the aggregate matrix for the mastic of binder, fine aggregate, and fibers.

Mix Design

The micro-surfacing mixture design process consists of the following steps:⁽³³⁾

1. Component selection and testing,
2. Mixture testing to determine
 - a) mixing and application characteristics of emulsion and aggregate
 - b) effect of water content
 - c) effect of filler and additives
 - d) optimum asphalt content, and
3. Performance related tests on mixture samples.

The main purpose of the design tests at this time is to determine the compatibility of the materials. The design process of micro-surfacing is

still evolving. Sample preparation procedure has not been perfected or adopted by AASHTO or ASTM. Therefore, repeatability of tests is not ensured. The industry is currently trying to improve the design procedures and adjust standards to reflect the effect of various material combinations. There is a need to standardize the test procedure used to design micro-surfacing. Also, design procedures need to be validated by field performance.

Application Rate

The application rate for retexturing seals on high-volume roads range from 8 to 19 kg/m² depending upon the desired surfacing thickness. In general, 8 to 16 kg/m² is used for layer thicknesses of 5 to 15 mm for a single application. For wheel ruts, the application rate varies according to the rut depth.⁽³³⁾ If the ruts are greater than 40 mm the micro-surfacing should be placed in two lifts to avoid curing problems. Traffic can be allowed on the pavement between placing the lifts.

Construction Considerations

Pavement Preparation

The existing surface needs to be prepared before micro-surfacing. Potholes as well as joints and cracks that are 6 mm or wider should be repaired and sealed before the application of micro-surfacing. Crack/joint sealants should have sufficient time to cure and should not be allowed to build on the surface, otherwise the sealant could be torn by screeds during the application of micro-surfacing leaving drags or tear marks. A tack coat is not required unless the pavement surface is extremely dry, raveled, or made of concrete. During hot weather, the pavement is usually prewetted to control premature breaking of the emulsion and to improve bonding with the existing surface.

Weather Conditions

Micro-surfacing should not be placed when the pavement or air temperature is below 10° C, it is raining, or there is a forecast of ambient temperature below 0° C within 24 hours of placement. If placed in a very hot, dry weather, the surface can break too fast, causing water retention within the micro-surfacing, and slow interior curing. High temperatures require a formulation change for longer mixing times to enable the micro-surfacing to be properly applied.

Equipment Consideration, Calibration, and Scheduling

Micro-surfacing is placed with either a self propelled (figure 27) or truck-mounted mixers (figure 28). The self propelled machine is more efficient and generally used for major highway projects. It can place up to 500 metric tons of material a day at an operating speed of 2 to 4 km/h. The truck-mounted unit is used for smaller projects. A fully loaded truck can place 1400 to 1800 m² of finished product depending on the truck capacity. The truck mounted unit can be modified with an aggregate conveyor to allow continuous operation.

The self propelled machine provides synchronized and continuous loading and mixing of the micro-surfacing. The major components of the machine are the proportioning controls, material storage, front feed for continuous aggregate loading, proportioning controls, mixer drum, and spreader box.

The aggregate is received by a front hopper, delivered to the storage area, and then fed to the mixer on a conveyor belt. The micro-surfacing

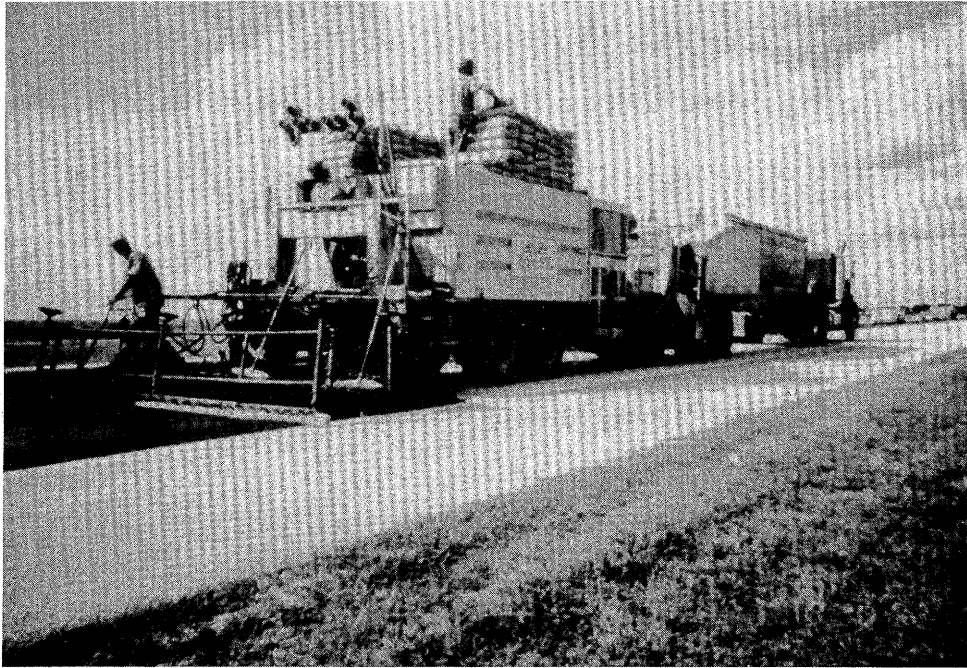

Figure 27. Micro-surfacing self-propelled machine.



Figure 28. Micro-surfacing truck mounted machine.

mixture has a higher viscosity than a slurry seal. This requires a more robust mixing chamber than used in a conventional slurry machine. The mixing chamber is about 1 to 1.3 m long and is fitted with multibladed twin shafts to allow thorough mixing of the materials. Controls and meters are used for proportioning and monitoring the quantity of all components. These controls should be periodically checked and calibrated at least once every construction season. The spreader box (figure 29) distributes and textures the micro-surfacing. Augers are used to distribute the mixture uniformly. The rear seal of the strike-off box strikes off the material at the desired level. For level up or scratch courses, a steel strike-off is preferred by some agencies. For final surfacing work, the strike-off is usually a flexible material.

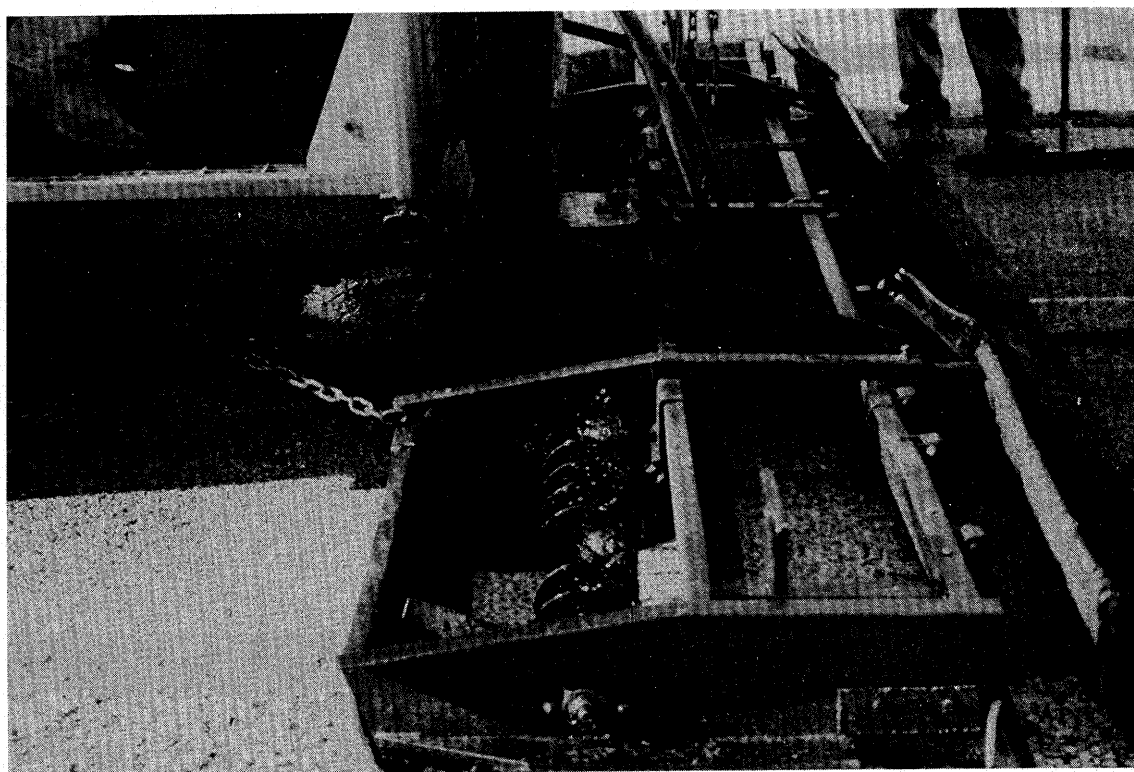

Figure 29. Spreader box of the micro-surfacing machine.

During application of the scratch course, the screed is set to make contact with pavement high points. This causes filling of the low points. A scratch course, followed by the final surface, is applied when the surface is uneven or ruts are less than 15 mm.

For pavements with rutting greater than 15 mm, a special rut box is used to fill wheel ruts and depressions as illustrated in figure 30. The rut box is either 1.5 m or 1.8 m wide and has two V-shaped chambers with the point of the V toward the rear of box. Continuous agitation of the material is achieved by means of two shafts with multiple blades. The box is designed to push the larger size aggregate to the deeper parts of the rut. The box is capable of filling up to 40 mm ruts in one pass. To fill deeper ruts multiple passes should be used as thicker layers may not cure properly. It was found that micro-surfacing will undergo an initial

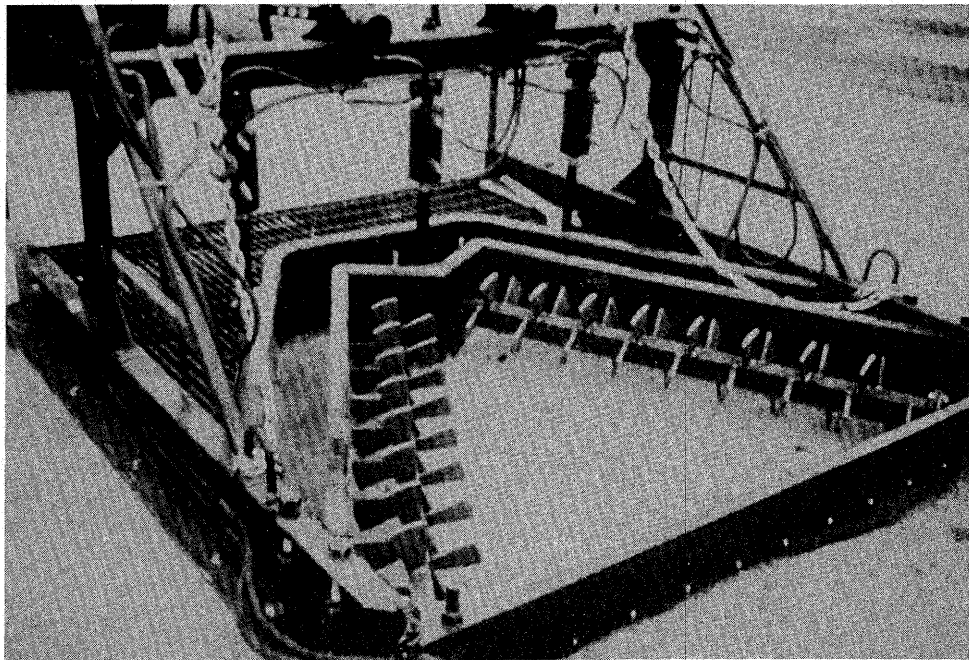

Figure 30. Special rut box for filling wheel ruts.

compaction when first placed under traffic. Therefore, rut boxes may be adjusted to leave a slight crown in the surface to compensate for compaction by traffic. Generally the crown is 3 mm of crown for every 25 mm of rut. No more than 6 mm of crown should be provided to avoid possible drainage problems.

Construction Process

After preparing the existing pavement surface, a tack coat should be applied on all PCC pavements as well as dry and raveled asphalt pavements. During hot weather, the pavement is usually prewetted to prevent premature breaking of the emulsion and to improve bonding with the existing surface. A spray bar attached to the micro-surfacing machine is used for this purpose. The micro-surfacing mixture is then applied using the equipment discussed earlier.

Micro-surfacing is designed so that the system can sustain rolling traffic after one hour of application.

Inspection and Acceptance

Micro-surfacing should produce a smooth, skid resistant surface. To achieve this, the finished surface should be free from rippling and drag marks. In addition, the surface should have uniform texture and good-quality joints and neat edge lines.

Two types of ripples - transverse and longitudinal - have been observed in the field. Transverse ripples are alternate valleys and crests at regular intervals in the surface of the pavement in the transverse direction. Thin and fast applications could cause this type of rippling. Other contributing factors are aggregate gradation, dirty and worn screeds, and drag mops if used.

A secondary strike-off can be used to reduce transverse rippling and improve texture. A drag mop has been used by some contractors for texturing. However, the use of the drag mop is not recommended since the micro-surfacing mix is heavy and dry. The use of a drag mop can result in longitudinal streaking. Specifications should include construction criteria for both transverse and longitudinal rippling and streaking.

The following may cause tear and drag marks:

1. Buildup of sealant or other surface imperfections,
2. Worn screeds or buildup of materials on the screed,
3. Insufficient materials due to improper speed or inconsistency of the mix,
4. Premature breaking of the emulsion, and
5. Oversized aggregate.

Aggregate should be screened just prior to use in micro-surfacing projects to avoid clotting, oversized materials and the drag marks they cause. Most State specifications require that the aggregate be passed over a scalping screen prior to the use in the mixing machine to remove oversize material.

To obtain uniform texture, the mixture must have the proper consistency. If the mixture is too dry, it could break or set early and may not bond well with the existing surface. On the other hand, if the mixture is too wet, an inconsistent texture may occur. The condition of the spreader box also may have an affect on the uniformity of the texture. The spreader box should be capable of distributing the material evenly across its full width.

Good-quality joints and neat edge lines are important to provide ride quality and overall project appearance. Current State specifications prohibit excessive overlap, uncovered areas, and unsightly appearance for either transverse or longitudinal joints. However, these parameters are not always well defined or enforced.⁽³²⁾ To facilitate straight and uniform longitudinal joints a string line or a chain mounted at the front of the machine can be used.

Since micro-surfacing is a quick-set system, it is quite possible that a mixture designed under laboratory conditions may not work the same under field conditions. To ensure proper proportioning and placement of micro-surfacing in the field, it is highly desirable to construct a test strip prior to actual placement. The water content and admixtures can be adjusted to a small in the field to achieve the required consistency. However, the mix design formulas must be designed and adjusted to permit smooth, continuous, and trouble free operations.

Raveling, debonding, and rutting immediately after the construction could be caused by inadequate design and poor construction quality control.

Specifications

The International Slurry Surfacing Association has developed guidelines for selecting the micro-surfacing materials. Also, several States have developed their own micro-surfacing specifications. The FHWA through project TE-14 has developed a set of warranty specifications for the application of micro-surfacing.

Performance

The performance of micro-surfacing is affected by several factors such as climatic conditions, traffic loading, existing pavement condition, quality of materials, mixture design, and construction quality. When properly designed and constructed and used on structurally sound pavements, micro-surfacing has generally performed well and resisted wheel rutting for 4 to 7 years under various climatic and traffic conditions. With respect to skid resistance, micro-surfacing has proved to be efficient. Micro-surfacing has been used to address raveling by a number of States with good results. Micro-surfacing, like other thin treatments and overlays, offers no long-term resistance to reflective cracks. Most of the cracks will reappear within a year. Some States use micro-surfacing to address flushing on asphalt pavements. Pennsylvania and Oklahoma have used micro-surfacing as an interlayer, and both have obtained good performance. Many successful micro-surfacing projects have been constructed throughout the United States.⁽²⁹⁾ Micro-surfacing has been used to repair open-graded friction courses and raveled surfaces with considerable success.⁽³²⁾

Limitations

Micro-surfacing requires special application equipment with a more powerful and faster mixer than for slurry seals. The contractor has to have good experience in similar applications. The lack of equipment and experienced contractors may inhibit the wide-spread application of this treatment. Also, because of the fast-setting characteristics of micro-surfacing, mixes are more sensitive to aggregate characteristics than normal slurry seals. Micro-surfacing also may increase tire noise level relative to hot mix asphalt due to the surface texture.

CHAPTER 7. THIN HOT MIX ASPHALT OVERLAYS

INTRODUCTION

This chapter presents information on preventive maintenance using hot mix asphalt concrete (HMAC) overlays. HMAC is a mixture of asphalt cement and aggregate blended together and laid and compacted at a high temperature. Thin HMAC overlays with thicknesses from 15 to 40 mm have been used in the United States and other countries to improve functional conditions of pavements. Thin HMAC overlays can be classified according to aggregate gradation as dense-graded, gap-grade (such as stone matrix asphalt and Novachip), and open-graded friction course (OGFC) overlays.⁽³⁴⁾ Dense- and open-graded mixes have been used for many years in the United States. Most State highway agencies have specifications for these types of mixtures. Gap-graded mixtures are an emerging technology that has been developed primarily in Europe. Several types of gap-graded mixes can be used for preventive maintenance, including stone matrix asphalt (SMA), Novachip, hot rolled mix (sand asphalt), GussAsphalt and very-thin and ultra-thin overlays.

Dense- and gap-graded mixes are used to seal the pavement surface, improve ride quality and skid resistance. The main advantage of open-graded mixes is the ability of water to drain through the mix. This reduces the chance of splash, spray, and hydroplaning. Open-graded friction courses also reduce tire pavement noise levels.

Thin HMAC overlays have many benefits. Compared to chip seals, there is minimal generation of dust during construction. Thin dense-graded

hot-mix overlay can be designed to resist rutting due to heavy traffic and high shear stresses. There is no stone loss that might cause windshield damage and no binder run-off causing discoloration of concrete gutters. Since HMAC does not require curing, it can be immediately opened to traffic. It also has high salvage value since it can be reclaimed and reused in recycled asphalt pavement. Similar to other preventive maintenance treatments, however, it does not appreciably correct structural weaknesses in the existing pavement surface.

SHRP EXPERIENCE

Eighty-one dense-graded HMAC overlays test sections were constructed under the SHRP SPS-3 experiment throughout the United States. These test sections were constructed using the State's standard thin hot mix overlay specifications. Thicknesses of these overlays varied from 20 to 40 mm. The performance of these sections is currently being evaluated. Evaluation by the ETG indicated that thin HMAC overlays have performed better when compared to the other treatments, when the original surface has a moderate amount of roughness.

In addition, the State supplemental sections included construction of several HMAC types. Several gap-graded sections were constructed as part of this experiment.

DESIGN CONSIDERATIONS FOR THIN OVERLAYS

Binder Selection

Since conventional asphalt concrete is used for dense-graded thin overlays, the asphalt binder used should meet all the requirements for conventional asphalt concrete. Frequently a modified binder is used for

gap and open-graded mixes to increase the viscosity of the mix and prevent drainage during construction.. In some cases, fibers are used in gap-graded mixes to reduce the tendency of the asphalt to drain away from the aggregates.⁽²⁵⁾⁽³⁴⁾⁽³⁵⁾⁽³⁶⁾⁽³⁷⁾⁽³⁸⁾⁽³⁹⁾⁽⁴⁰⁾⁽⁴¹⁾

In addition to the previous mix design criteria, a drain-down requirement is typically specified for gap-graded mixtures. Several drain-down tests are available.⁽³⁷⁾ In general, a specified amount of loose mix is prepared and allowed to drain at a high temperature for a specified period of time. The amount of asphalt that drains off the mix is measured.

Aggregate Selection

Aggregates used for HMAC thin overlays should meet all the requirements for conventional asphalt concrete surface courses, as a minimum. The maximum aggregate particle size is generally 9.5 to 19.0 mm depending on the thickness of the overlay. The bulk of the aggregate material should be crushed to provide good stability. Dense-graded aggregate contains appropriate amounts of various particle sizes to form a high density with a small amount of air voids between aggregate particles. Gap-graded aggregates are missing one or more sizes, resulting in high voids between particles. Open-graded aggregate contains very small amounts of fine aggregate, and has high voids between particles. Typical gradation specifications are given in table 18. Figure 31 shows the same specifications plotted on a 0.45 power chart.

The differences in these aggregate gradations are highlighted in figures 32, 33, and 34. In dense-graded aggregates (figure 32) the distribution of aggregate sizes is selected such that the voids between the largest aggregates are filled with aggregates of smaller sizes, leaving room for the binder and air voids needed for a quality mix. Thus, aggregates are

Table 18. Typical gradation specifications for hot mix asphalt concrete.⁽²⁹⁾⁽³⁴⁾

	Dense	Gap (SMA)	Open
Sieve-size, mm	percent passing		
19	100	100	
12.5	90 to 100	85 to 95	100
9.5	70 to 85	60 to 75	95 to 100
4.75		25 to 34	30 to 50
2.36	44 to 52	18 to 24	5 to 15
0.45	13 to 21		
0.300		12 to 15	
0.075	3 to 6.5	8 to 12	2 to 5
Asphalt (% of Mix)	5 to 6	6 to 7	5.5 to 7.5
Void Content (%)	4	3 to 4	15+

bearing directly on the different size aggregates. This provides stability in the mix, with a minimum need for binder. In the gap-graded mixes (figure 33) the larger size aggregates bear directly on each other and the voids are filled with a mastic of small aggregate and binder. This permits a greater binder content than for dense-graded mixes. Filling the voids with the mastic produces a highly stable mix that resists plastic deformation and abrasion due to studded tire wear. The thicker film coating on the aggregates reduces aging and raveling of the surface. Open-graded mixes (figure 34) are designed to have a very open structure with a high void content to promote drainage through the mix. The open gradation is inherently unstable, thus open-graded mixes are limited to very thin layers.

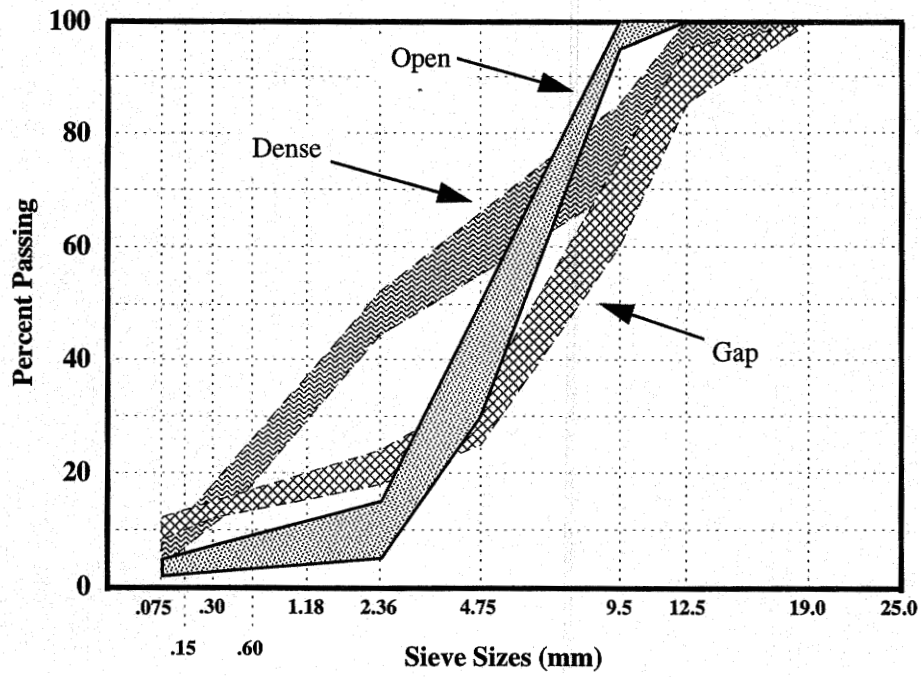

Figure 31. Typical gradations specifications for thin hot-mix overlays.

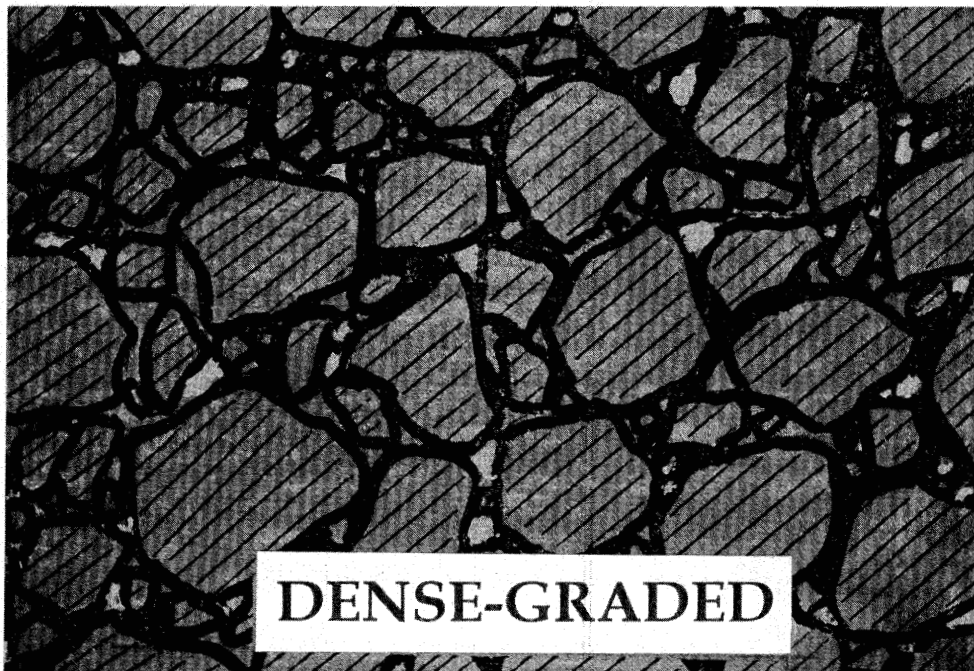

Figure 32. Schematic of the structure of dense mix.

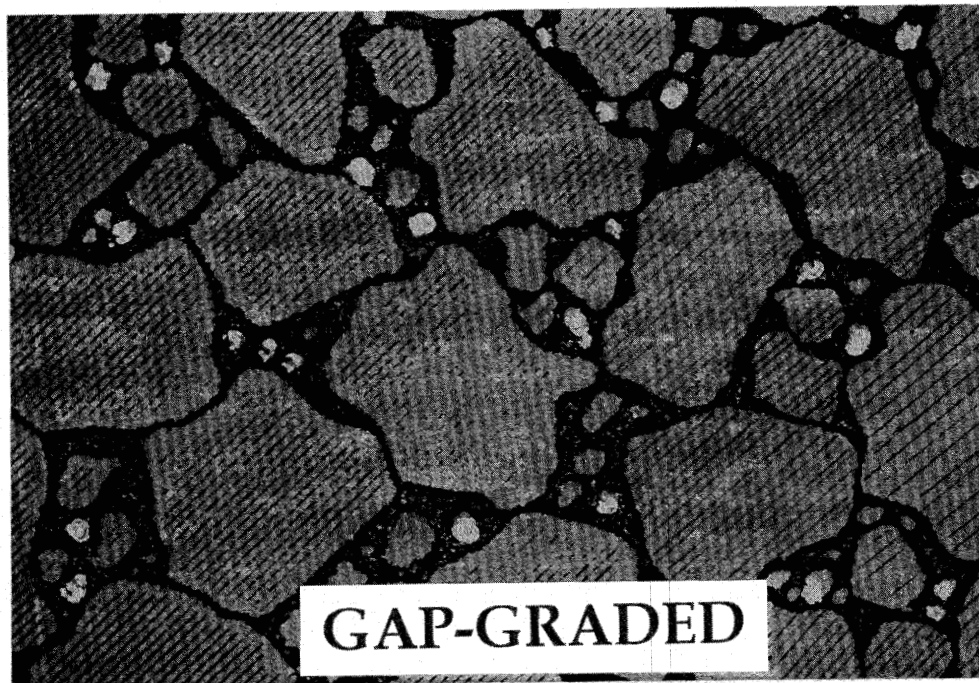

Figure 33. Schematic of the gap-graded mix structure.

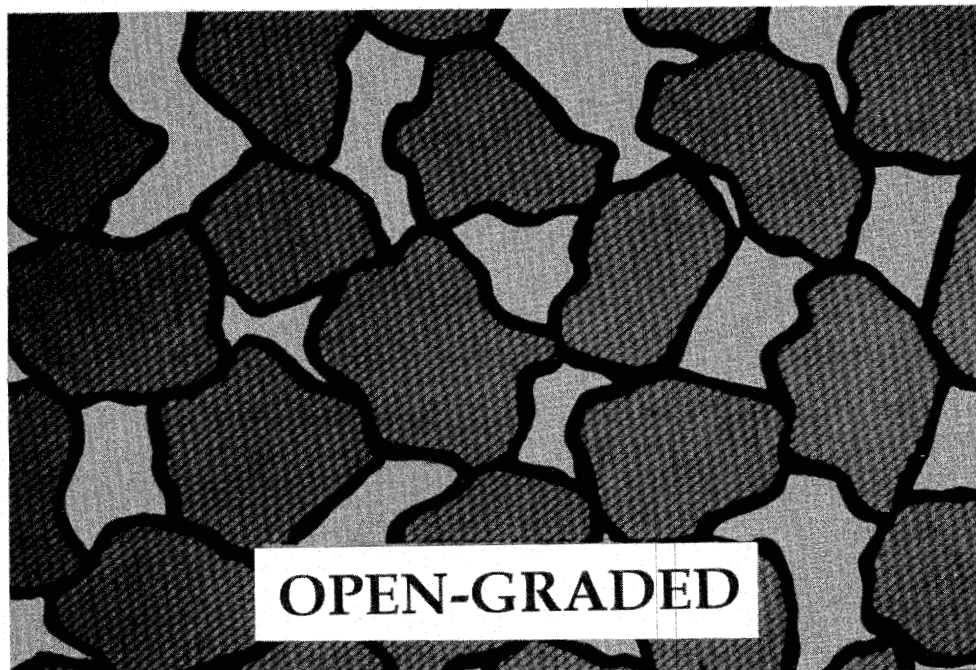

Figure 34. Schematic of the structure of open-graded mix.

The gap-graded mixes developed in Europe generally have stricter aggregate requirements than conventional HMAC used in the United States. For example, ADOT requires a minimum of 30 percent crushed faces in asphalt concrete, whereas the typical European specification for SMA requires 100 percent of the particles larger than 4.75 mm have one crushed face and 90 percent must have two crushed faces.

Mix Design

Conventional mix design methods such as Marshall or Hveem procedure are used to design thin dense hot-mix overlays. The SUPERPAVE procedure developed by SHRP can also be used to design dense-graded mixes. Level I mix design is essentially volumetric mix design.⁽⁴²⁾

The mix design method of OGFCs is different than dense hot mixes.⁽⁴⁰⁾ The basic steps in mix design include determination of asphalt content, void analysis, moisture susceptibility testing, and determination of mixing temperature. The optimum asphalt content of OGFC is a balance between the requirement of thick films to hold the aggregates together and the need to prevent binder runoff. The asphalt content of OGFCs is determined from the surface capacity (K_c) of the aggregate retained on a 4.75 mm sieve. The K_c value is determined using SEA No. 10 oil and is related to the surface area, absorption, and roughness of aggregate. The percent asphalt content (%AC) by weight of aggregate can be obtained from the FHWA equation:⁽⁴⁰⁾

$$\%AC = 2 K_c + 4$$

A correction factor is needed if the apparent specific gravity of coarse aggregate (G_{ca}) is outside of the range of 2.6 to 2.7. In this case, %AC is multiplied by $2.65/G_{ca}$.

The asphalt content of open-graded HMAC generally ranges from 5.5 to 6.5 percent. The typical air voids is 15 percent or more. The minimum retained coating (AASHTO T182) is 95 percent, while the minimum retained stability (AASHTO T 165) is 50 percent. The mixing temperature normally ranges between 107 and 121° C. Initial and intermediate compaction should be completed while the temperature of the mix is above 95° C and final compaction should be completed before the temperature drops below 85° C.

PAVEMENT CONDITION FOR SUCCESSFUL APPLICATION

Thin hot-mix overlay can be placed over either new or old pavement surface. Since a thin overlay does not add to the structural capability of the existing pavement, the pavement must be structurally sound. If the existing pavement is rough, milling or adding a leveling course is recommended. For open-graded mixes, any ruts in the surface should be milled or leveled out with a leveling course. Otherwise, water can pond in the ruts, retaining moisture in the overlay and encouraging stripping through hydrogenesis. In addition, cracks and other pavement distresses should be repaired before placing thin hot-mix overlay. All crack sealing in advance of the overlay should be flush with the pavement surface to prevent high spots in the overlay over the repaired cracks. Areas with excessive joint seal material often reflect as fat spots or surface bumps. All repairs should have sufficient time to cure prior to placing the overlay.

Since all of the treatments provide a new wearing surface, they are suitable for restoring skid resistance and treatment of weathered or raveled surfaces. It should be noted that dense- and gap-graded overlays of greater thickness can be applied to the pavement to restore or improve

structural capacity. However, the design of these treatments is outside the scope of this report since the thicker sections would not normally be considered a preventive maintenance treatment.

Prior to placing the overlay, the pavement should be cleaned of all debris with a power broom. A tack coat is usually required to bond the overlay to the existing surface. In addition, the tack coat can seal minor cracks in the pavement surface.

CONSTRUCTION PROCEDURES

The construction processes for the different types of hot mix asphalt concrete are very similar. In general the process consists of preparing the hot mix in a central plant, transporting the mix to the job site, placing it with a paver, and compaction. Either batch or drum plants can be used to prepare the HMAC. Depending on the haul distance and ambient conditions, the mixtures should be covered with tarps to help retain the temperature of the mix.

Conventional pavers are used to lay dense- and open-graded HMAC. Due to the coarse nature of gap-graded mixtures, they are more difficult to place than the other types. Some types of gap-graded mixtures require special paving machines that can handle the harsher mix.

The thin nature of these paving mixes means the surface will cool very quickly, limiting the time available for compaction. Depending on the ambient conditions, it may be necessary to complete the compaction within 3 to 5 minutes of placing the mix. Arizona DOT requires a minimum temperature behind the paver of 120° C. Steel wheeled or vibratory rollers in static mode, with a minimum weight of 7.3 Mg are used for initial or breakdown compaction. Intermediate compaction

requires 4 passes with a rubber tire roller or 2 to 4 passes with a vibratory steel roller. Intermediate compaction must be completed before the pavement temperature reaches 95° C. Static steel rollers finish the pavement with 1 to 3 passes. Care must be taken not to crush the aggregates when rolling with a vibratory roller. If the overlay is 25 mm or less, rollers are not operated in the vibratory mode. Frequently the rolling pattern is specified based on the number of passes, as determined from a test strip to achieve the required density.

To obtain proper compaction of gap-graded mixtures, the mix is delivered at a temperature not less than 145° C. Rolling should begin immediately after placement before the mix temperature decreases significantly. Compaction is done by use of 9 to 10.8 Mg steel-wheeled roller. Vibratory rollers may be used. Pavement should be compacted to at least 94 percent of maximum theoretical density, with no more than 6 percent air voids.

Open-graded mixes are relatively easy to compact. Steel wheel static rollers with a minimum weight of 7.3 Mg make 2 to 3 passes over the hot mix to seat the aggregate. The initial compaction should be completed while the pavement temperature is above 95° C.

Traffic can be allowed on the sections as soon as the surfaces have cooled, typically to 60° C.

INSPECTION AND ACCEPTANCE

Correct construction procedures should be followed in order to obtain a long-lasting thin overlay application. Before work begins equipment should be checked to make sure it is in good working condition. Special attention should be given to the condition of the screed and the adjustments to the paver. Appropriate materials should be used and

proper mixture design and construction procedure should be followed. Weather conditions, mixture temperature, compaction density, layer thickness, and smoothness should be checked and satisfied.

Thin dense-graded hot mix overlay seals the underlying surface and protects the lower courses of the pavement from the environment. It extends the life of structurally sound pavements by sealing the surface and providing a new wearing course. Thin dense-graded hot mix overlays improve skid resistance and surface drainage. In addition, it enhances appearance and reduces road-tire noise.⁽²⁸⁾

PERFORMANCE

The performance of dense-graded thin overlays on high-volume roads has been mixed. A recent NCHRP survey of thin (30 mm or less) HMAC applications indicated a mixed performance varying from 5 to 8 years with some States reporting as low as 2 to 4 years and some States reporting as high as 9 to 10 years.⁽²³⁾ Several factors could contribute to this variance in performance, such as the condition of the existing pavement, traffic levels, design and construction parameters, etc.

Based on European experience, the expected service life of gap-graded thin overlays is typically higher than conventional dense asphalt concrete. There is not a sufficient number of thin gap-graded overlays in the United States to quantify its long term performance.

The typical performance life of OGFC's is about 8 to 12 years depending on traffic, environment, and the existing pavement condition. Properly designed and constructed OGFC surfaces have performed satisfactorily for periods in excess of 12 years. Some agencies indicated they have

received expressions of approval from the public due to the reduced road noise and the elimination of splash and spray.

LIMITATIONS

If an overlay is needed for strengthening the existing pavement, thin overlays are seldom cost effective. Thin overlays are more susceptible to reflection cracking than thick overlays..

Potential problems with gap-graded mixtures are (1) drain-down of the binder and mineral filler during storage, hauling, and placement, (2) bleeding, and (3) poor initial skid resistance due to the high asphalt content. Further research is still needed to study gap-graded mixes with respect to the use of SUPERPAVE procedure, selection of the appropriate asphalt grade, use of stabilizers, and evaluation of performance under various traffic and environmental conditions.

Open-graded mixes have several maintenance concerns. Since these mixes are designed to allow water to drain through the material, maintenance, in particular crack sealing and patching is a problem. Sealed cracks and patches at the edge of the pavement can create a dam in the surface that inhibits the flow of water. As a result the surface can become saturated, which can lead to stripping. Winter conditions also create special considerations for open-graded mixtures. Deicing salt requirements are increased because the salt penetrates into the pavement surface. Freezing of moisture in the pavement surface can develop excessive stresses and promote fracture. Over time, the drainage ability may decrease due to the clogging of the voids with dust and the application of winter deicing chemicals and abrasives. For high-volumes, high-speed roads, some self-cleaning action is evident due to the hydrodynamic sucking action of the tires on the road surface.

VARIATIONS ON GAP-GRADED THIN HOT MIX OVERLAYS

Several alternatives can be used with gap-graded thin hot mix overlays. Among these alternatives are the use of modified binders, different binder contents, different aggregate gradations, and different layer thicknesses. Specific types of thin gap-graded HMAC overlays are available and have been used in Europe. These systems compete with other preventive maintenance treatments. These mixes are usually less than 40 mm thick. The combined market share for these mixes is more than 10 percent of the overall hot mix production in Europe. Among these systems are stone matrix asphalt (SMA), very thin HMAC, ultra thin HMAC, hot rolled mix (sand asphalt), GussAsphalt, and Novachip.

Alternative Binders

Stabilizing agents such as fibers, rubbers, polymers, Lake Trinidad Asphalt, carbon black, artificial silica, or combination of these materials are added to stiffen the mastic and to reduce problems with binder drainage or separation and bleeding.

Stone Matrix Asphalt

Stone Matrix Asphalt (SMA) can be viewed as an OGFC with voids filled with mastic of asphalt cement, a stabilizer, and finer aggregate. The SMA mix was developed by the German and Swedish contractors in the 1970s.⁽³⁵⁾ It is used as a surface course on both new construction and surface renewal to provide a rut resistant wearing course and restore surface friction. It also provides resistance to abrasive action of studded tires, provides slow aging, and good low-temperature performance.

The aggregate plays an important role in the SMA mix. Both the coarse and fine aggregates in SMA mixtures are generally 100 percent crushed materials. Rounded natural sand is not recommended and can only be used in limited amounts, generally less than or equal to 10 percent by total aggregate weight.

SMA usually have 70 to 75 percent coarse aggregate (greater than 4.75 mm), and approximately 10 percent filler (passing 0.075 mm). The amount of sand is about half as much as that used in dense HMA. Also, SMA requires two or three times the mineral dust (passing 0.075 mm) of the dense mixes. Table 19 compares the composition of United States and European SMA mixes.⁽²³⁾

The aggregates must have (1) a highly cubic shape and rough texture to resist rutting, (2) a hardness that can resist fracturing under heavy traffic loads, (3) a high resistance to polishing, and (4) a high resistance to abrasion. Aggregates used in SMA mixtures, like many other types of mixtures, cannot have excessive flat and/or elongated particles. SMA aggregate should satisfy the requirements in table 20.

Marshall procedure is currently used to design SMA mixes. Specimens are prepared using 50 blows on each side. Typical SMA mixes have 6 to 7 percent asphalt cement and 0.3 to 0.4 percent fibers by weight of mix. Polymers (5 to 7 percent by weight of binder) have also been used in SMA mixes, either alone or with fibers as additives/modifiers. The fibers and modifiers allow a thicker asphalt film while controlling drain-down. Voids in total mix are normally kept between 3 and 4 percent. The minimum Marshall stability is 6.23 kN and the flow is between 200 and 400 mm.

Table 19. Comparison of United States and European SMA Mixes.

Country	United States	Germany	Sweden	Denmark	Norway
Sieve size, mm	% passing				
19					
12.5	85 to 95				
11		90 to 100	95	93	80 to 100
9.5	60 to 75				
8		50 to 75	38 to 50	53	47 to 64
5	25 to 34	30 to 50			
4			30	28	30 to 45
2.36	18 to 24				
2.00		20 to 30	20 to 26	18 to 28	20 to 32
0.300	12 to 15				
0.09		8 to 13		4 min.	
0.075	8 to 12		10		9 to 14
Asphalt (% of Mix)	6 to 7	6.5 to 6.8	6.5 to 6.8	6.5 to 6.9	6.3
Fibers (% of Mix)	Cellulose (0.3) mineral (0.4)	Cellulose (0.3)	Cellulose (0.3) mineral (0.5)	Cellulose (0.25)	

Table 20. SMA aggregate requirements.

LA abrasion	30 percent maximum
Sodium sulfate soundness	15 percent maximum
Particles > 4.75 mm	
One fractured face	100 percent minimum
Two fractured faces	90 percent minimum
Absorption	2 percent maximum
Durability index	40 percent minimum

In addition to the previous mix design criteria, a drain-down requirement is typically specified. Several drain-down tests are available. In general, a specified amount of loose mix is prepared and allowed to drain at a high temperature. A maximum of 0.3 percent drain-down after one hour is required.

Either a batch or drum mix plant can be used for the production of SMAs. A high mixing temperature of about 155 to 165° C is usually necessary because of coarser aggregate, additives, and relative high-viscosity asphalts in SMA mixes.

The fiber is introduced and mixed inside the drum with hot aggregate and asphalt cement using a special blower system.

To obtain proper compaction, the mix is delivered at a temperature not less than 145° C. Rolling should begin immediately after placement before the mix temperature decreases significantly. Compaction is done by use of 9 to 10.8 Mg steel-wheeled roller. Roller speed should not exceed 5 km/h. Pneumatic tire rollers should not be used on SMA. Vibratory

rollers may be used as long as the aggregates are not fractured. Pavement should be compacted to at least 94 percent of maximum theoretical density, with no more than 6 percent air voids.

A material transfer device can be used to store and transfer the mix to the paver. This device can store up to 45 Mg of mix which helps in the continuity of the paving operation and reduce segregation.

Traffic should not be placed on the newly compacted surface until the mat has cooled to 60° C or lower.

The cost of SMA mixes in the United States is estimated to be 20 to 40 percent higher than conventional hot-mix asphalt concrete, based on the initial experimental projects. Reports from Sweden indicate a 10 to 12 percent higher first cost for SMA over typical dense-graded asphalt hot mixes. Reports from Germany indicate a 20 to 30 percent higher initial cost. Prices may vary depending on size of the project, material cost and availability, layer thickness, location, and other project items.

The expected service life of SMA in Europe has been reported to be around 10 to 12 years, which is about 20 to 40 percent higher compared with dense-graded asphalt concrete. In the United States, 80 SMA demonstration projects have been constructed in different climatic zones as part of the FHWA Test and Evaluation project No. 18. Some of these projects were built within the SHRP SPS-3 State supplemental sections. Future evaluation of these experimental projects will provide information on the effectiveness of these mixes in the United States.

The Germans report that SMA is very resistant to plastic deformation. They also rank SMA much better than normal dense mix with respect to

its resistance to shear, abrasion, cracking, and skid. SMA has about equal noise generation compared to dense-graded HMAC.

Other Thin Gap-Graded Overlays

In addition to SMA, other types of thin gap-graded HMAC overlay have been used such as very thin and ultra thin overlays, hot rolled mix (sand asphalt, GussAsphalt and Novachip).

Very thin HMAC is used in Europe, particularly in France. It is spread in layers of 20 to 25 mm. It contains gap-graded aggregate and 5.8 to 6.0 percent binder. An emulsion tack coat is typically used with a rate of 0.4 to 0.7 liters/ m². The tack coat plays a dual role of waterproofing the existing surface and tacking the wearing coarse. Conventional equipment is used to spread the mix. An application rate of 50 to 65 kg/m² is used.

Ultra thin HMAC is also used in Europe, particularly in France. It is spread in layers of 10 to 15 mm. It contains gap-graded aggregate and 5.2 to 5.6 percent binder. An emulsion tack coat is typically used with a rate of 0.8 to 1.0 liters/ m². Similar to very thin mixes, the tack coat plays a dual role of waterproofing the existing surface and tacking the wearing coarse. Special equipment is used to spread the mix. An application rate of 25 to 35 kg/m² is used.

The hot rolled mix is mostly used in the United Kingdom. It is also called sand asphalt. The aggregate used in this mix is either manufactured sand, natural sand, or slag screening. The mix may include mineral filler.

GussAsphalt is a mastic asphalt mix that is essentially voidless and lacks a coarse aggregate structure. The stability of this mix is provided by a stiff asphalt cement. The mix requires no rolling. It is primarily used in the UK and Switzerland. However, its use has been decreasing.

The Novachip thickness ranges from 10 to 20 mm, depending on the aggregate size.⁽³⁵⁾ The material is a hot mix asphalt with an open-graded aggregate and a maximum size of 9.5 mm. The Novachip mix contains 5.1 to 5.5 percent conventional asphalt cement. Conventional equipment and practices are used in mixing and transporting Novachip. The mixing temperature varies from 160 to 165° C.

The Novachip layer is spread over a polymer modified RS emulsion tack coat. The tack coat application rate is usually 0.70 to 1.00 liters/m². The Novachip paver is a proprietary machine, designed specifically for the application of this treatment (figure 35). This paver has an emulsion spray bar placed about 0.25 m ahead of the front of the spreader box. Hence, the hot Novachip mix is placed on the emulsion before it breaks. The open gradation of the mix allows water from the emulsion to evaporate. The hopper of the Novachip paving machine receives the mix and transfers it to the rear. The paver augers in this machine are 2.4 m wide with 0.6-m extensions on each side.

Nurse trucks are used to periodically fill the emulsion tank on the machine. The capacity of the emulsion tank on the Novachip machine is about 8,300 liters, adequate for nearly 3 hours of operation. Emulsion is applied at a temperature of 60° C. The Novachip mix is rolled immediately after placing. Two 9 Mg rollers are typically used for a total of four passes.

Novachip has a coarse, rich, open texture, and longitudinal joints are nearly invisible. Demonstration projects were placed in Alabama, Mississippi, Texas, and Pennsylvania in 1992 and 1993.⁽³³⁾



Figure 35. The Novachip paver.

CHAPTER 8. CRACK TREATMENT OF FLEXIBLE PAVEMENTS

INTRODUCTION

Crack treatment of flexible pavements is a routine maintenance activity that basically involves cleaning and filling cracks with a sealant. Crack treatment prevents or reduces intrusion of water and incompressible materials.⁽²⁵⁾⁽⁴³⁾

SHRP EXPERIENCE

Crack sealing was placed on 81 test sections for the H-101 research (SPS-3 sections). The ETG found the crack sealants were performing well, but there was concern that the States were not maintaining the seals and not filling new cracks as they developed. The H-101 researchers made the following observations about the placement of the crack treatments. The general observations of crack sealing were:

1. *The hot-air lance seemed to be an effective tool in crack sealing.*
2. *The lance is easy to use and requires little training.*
3. *Surface cracks associated with alligator cracking are not good candidates for crack sealing. (This cracking indicates a structural problem.)*

There were two observations of crack sealing construction:

1. *Two passes with the lance were often required. One pass without heat was required to blow out the crack and a second pass with heat was used to prepare the crack for sealant. Another procedure that was used in another region was to rout all of the cracks, broom the surface with a power broom, blow out the cracks with the air compressor only, then use the hot-air lance.*

2. *When sealing cracks routed to 1½ inches wide in one region, a layer of single-ply toilet paper kept debris out of the cracks, helped in forming a skin over the sealant, and reduced the time to opening the section to traffic without increasing tire pickup.*

PAVEMENT CONDITIONS FOR SUCCESSFUL APPLICATION OF CRACK SEALING

The appropriate type of maintenance for cracked asphalt pavements depends on the type, density, and general condition of the cracks. If cracks are abundant (i.e., high in density) and do not exhibit high degree of edge deterioration, they may best be treated through chip seals, slurry seals, or a similar treatment. If cracks are low to moderate in density and have typically progressed to a point of high edge deterioration, then crack repair strategies such as partial-depth patching or spot patching may be warranted. Finally, if cracks are moderate in density and show moderate-to-no deterioration at the edges, they may be treated effectively through sealing or filling operations.

CRACK TREATMENT DESIGN

Although little distinction has been made in the past between crack sealing and crack filling, it is important to understand the objective of crack treatment so that the most cost-effective and long-lasting treatment is applied. *Crack sealing* is defined as the placement of specialized materials either above or into *working* cracks using unique configuration to **prevent** the intrusion of water and incompressible materials into the crack. *Crack filling* is the placement of materials into *nonworking* cracks to substantially **reduce** infiltration of water and to preserve the pavement.⁽⁴³⁾

Working refers to horizontal and/or vertical crack movements greater than or equal to 3 mm, while *nonworking* refers to movements less than 3 mm.

Generally, crack sealing is more difficult to accomplish than crack filling. Sealing requires considerably more forethought, greater costs, and the use of specially formulated materials and more sophisticated equipment.

Normally, working cracks with limited edge deterioration should be sealed, while nonworking cracks with moderate-to-no edge deterioration should be filled. Table 21 presents SHRP H-106 guidelines for selecting the type of treatment.⁽⁴³⁾ The selection of a treatment depends on the density and condition of the cracks. Crack condition is evaluated in terms of the degree of edge deterioration of the cracks. High density cracking with a low-to-moderate amount of edge deterioration requires a surface treatment such as a chip seal or slurry seal. It should be noted that these recommendations are for maintenance treatments of deteriorated pavements. With respect to preventive maintenance, the surface treatment should be applied prior to the development of high-density cracking, especially if the condition of the cracks is moderate. If both the density and edge deterioration are high, rehabilitation is required. Low-to-moderate crack densities with high edge deterioration require a repair treatment such as a partial-depth or spot patch. Moderate density cracking with low-to-moderate edge deterioration needs a crack treatment. Low-density cracks with moderate-severity edge condition may benefit from a crack treatment. Low-density cracks with low-severity edge condition do not require a crack treatment. These guidelines are subjective because "experienced personnel can usually make reasonable assessments of density."⁽⁴³⁾ Figures 36 through 39 demonstrate typical crack situations and remedies.

Table 21. Guidelines for determining the type of maintenance.

Crack Density	Average Level of Edge Deterioration (percent of crack length)		
	Low (0 to 25)	Moderate (26 to 50)	High (51 to 100)
Low	None	Crack treatment??	Crack repair
Moderate	Crack treatment	Crack treatment	Crack repair
High	Surface treatment	Surface treatment	Rehabilitation

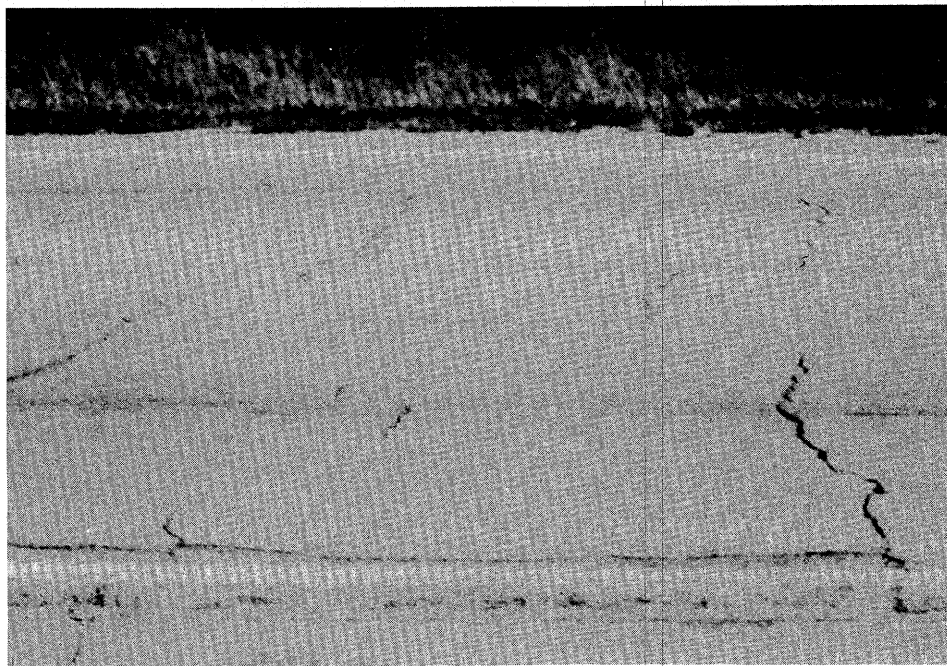

Figure 36. Pavement candidate for surface treatment: high density cracking.

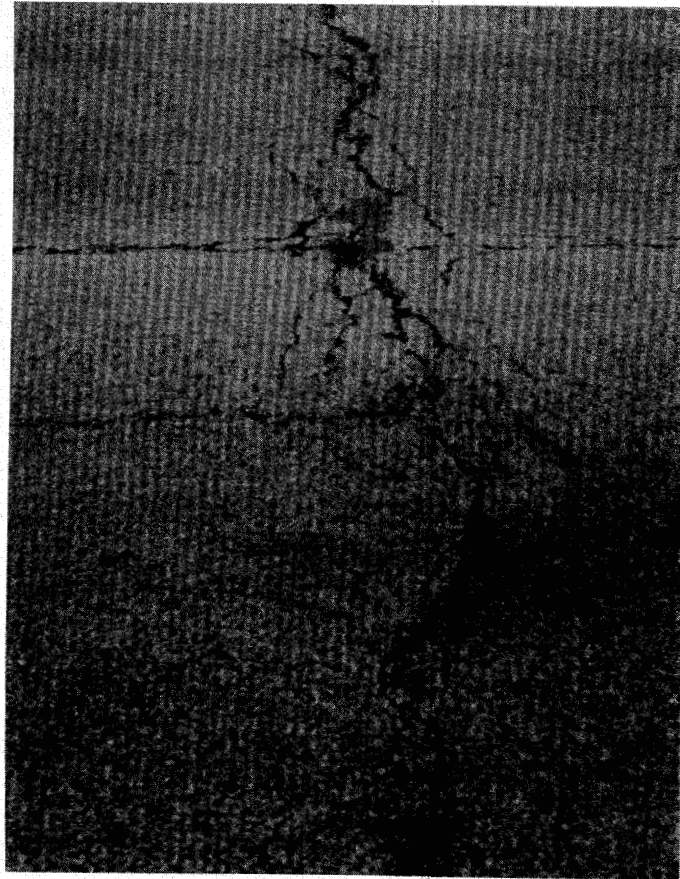

Figure 37. Pavement candidate for crack repair.

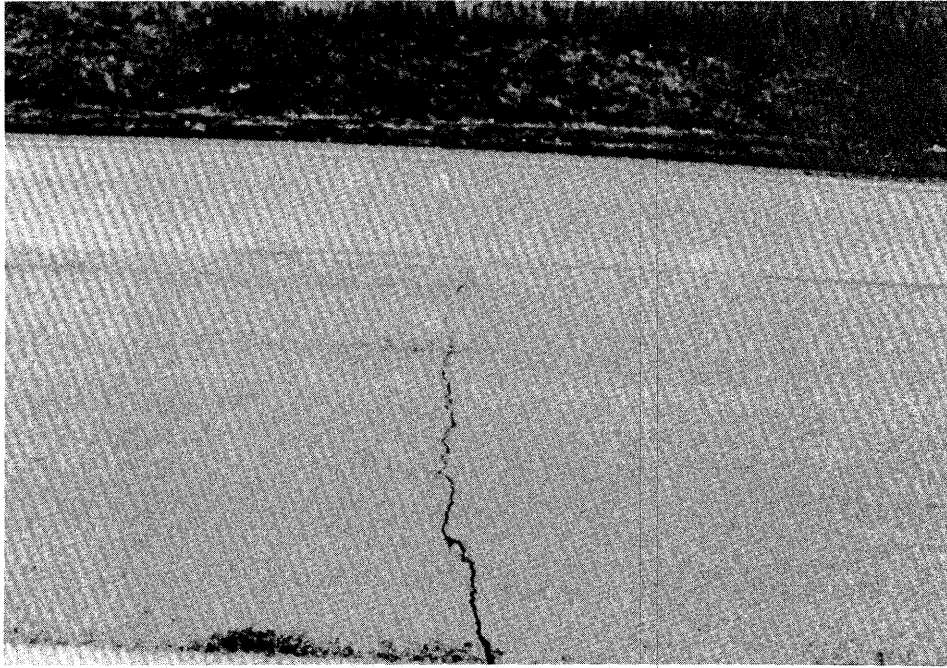

Figure 38. Pavement candidate for transverse crack sealing.

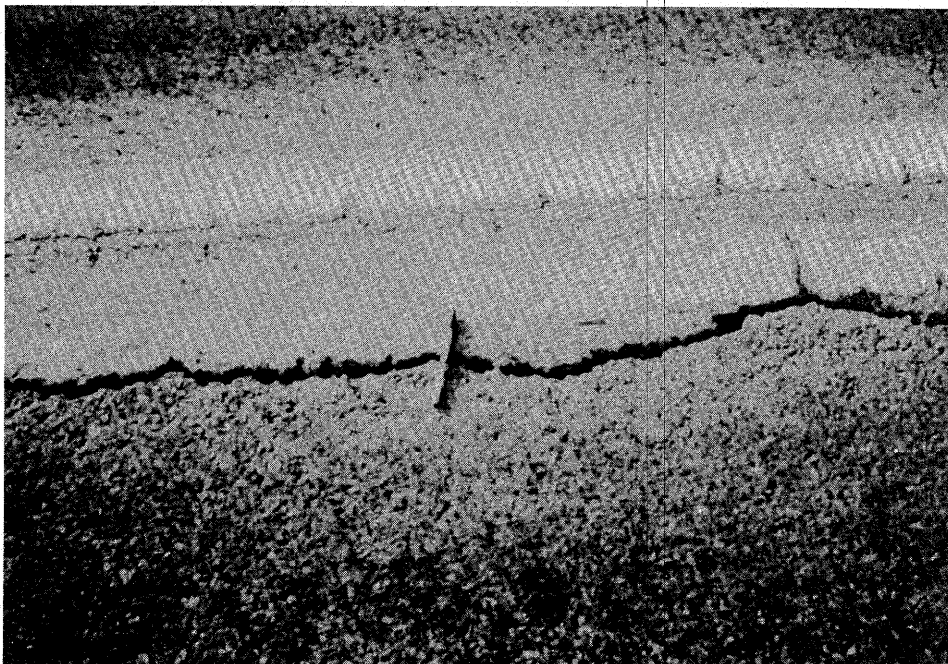

Figure 39. Pavement candidate for longitudinal crack filling.

Materials

Materials for sealing/filling asphalt pavement cracks may be divided into three categories:⁽⁴³⁾

1. Cold applied thermoplastic materials such as: a) liquid asphalt (emulsion or cutback), and b) polymer-modified liquid asphalt.
2. Hot applied thermoplastic materials such as: a) asphalt cement, b) mineral-filled asphalt cement, c) fiberized asphalt, d) asphalt rubber, e) rubberized asphalt, and e) low-modulus rubberized asphalt.
3. Chemically cured thermosetting materials

Asphalt cement, liquid asphalt, mineral-filled asphalt cement, and fiberized asphalt possess little flexibility and are very temperature susceptible. Therefore, their use as fillers for nonworking cracks is limited.

The addition of rubber polymer improves the flexibility of the asphalt. The degree of flexibility depends on the type and nature of the asphalt, percentage of vulcanized rubber used, and how the rubber is incorporated into the asphalt (i.e., mixed or melted in). Other additives are often incorporated into the asphalt, either exclusively or along with rubber, to increase resilience. In general, the performance increases in the order of: polymer-modified liquid asphalt, asphalt rubber, rubberized asphalt, and low-modulus rubberized asphalt.

Chemically cured thermosetting materials are cured by chemical reaction from liquid state to solid state. Self-leveling silicone is one of these sealant materials that is cold-applied and does not require tooling since it is self leveling.

Sealing Configurations

Sealant and filler materials can be placed in cracks in numerous configurations, figure 40. These configurations are grouped into four categories:⁽⁴³⁾

1. Flush-fill,
2. Reservoir,
3. Overband, and
4. Combinations.

In the flush-fill configuration, material is simply dispensed into the existing, **uncut** crack, and the excess material is struck off. In the reservoir configuration, material is placed only within the confines of a **cut** crack (i.e., crack reservoir). In the overband configuration, the material is placed into and over an **uncut** crack. In this case, the material over the crack can be left unshaped (creating capped shape) or shaped using squeegee (creating simple band-aid shape). The flush-fill configuration is recommended for cracks less than 15 mm wide, while the reservoir type is suitable for wider cracks. Overband and excessive joint seal material are not recommended since they create surface bumps and may cause the sealant to be picked up by snow plows.

Occasionally, a bond-breaker material such as a polyethylene foam backer rod is placed at the reservoir bottom of a working crack prior to applying the sealant. The backer rod prevents the sealant material from running down into the crack during application and also from forming a three-sided bond with the reservoir perimeter. As a result, the sealant's potential performance is enhanced.

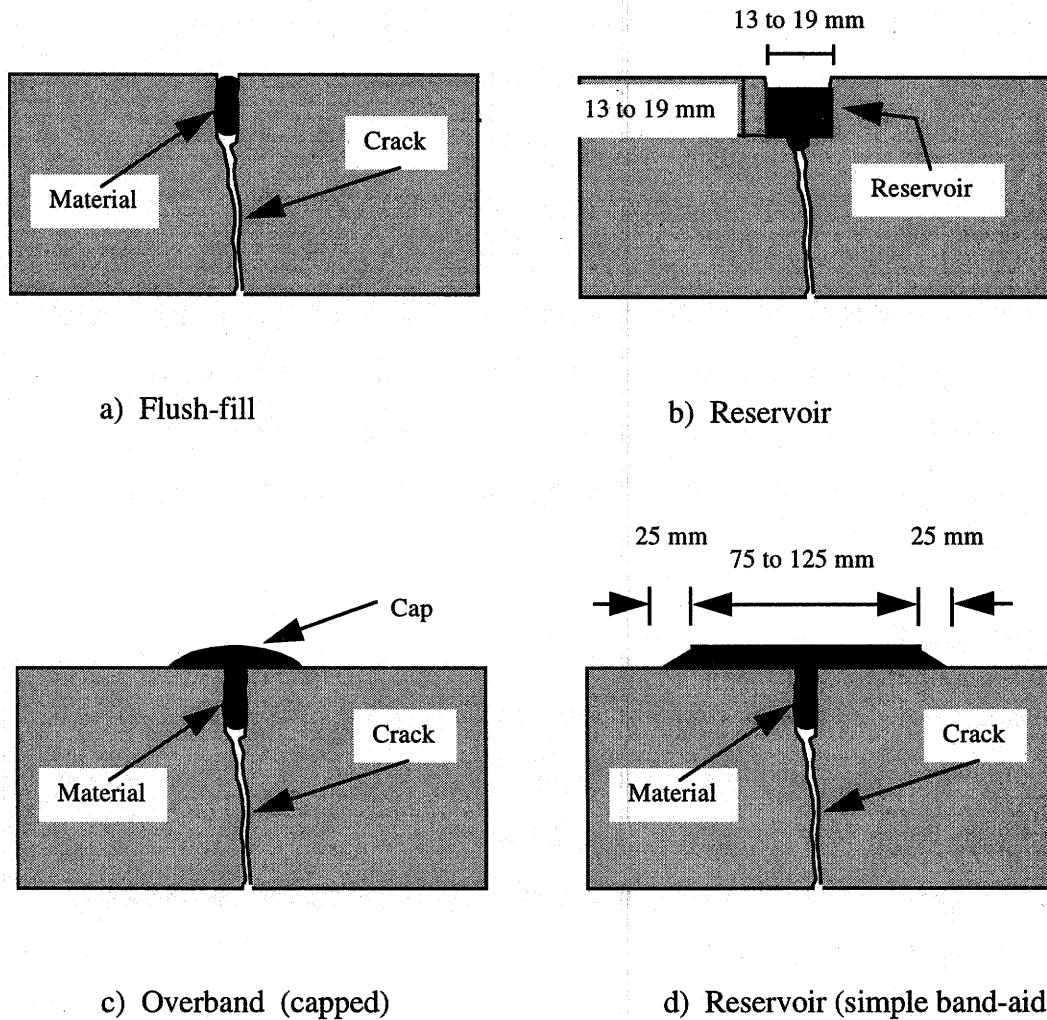

Figure 40. Crack sealing configurations.

Backer-rod applications should be considered only if the crack is relatively straight and its use is expected to be cost-effective.

CONSTRUCTION CONSIDERATIONS

Pavement Preparation

Open cracks should be routed to a width of 10 mm and a depth of 20 mm using either a rotary-impact router or diamond-blade crack saw. For best

results, the crack should be cleaned with a stiff-bristled broom, compressed air, hot air blasting using a heat lance, or sandblasting. Some agencies consider routing of cracks as optional.

Weather Conditions

Ideally, crack sealing should be conducted shortly after working cracks have developed to an adequate extent and at a time of year when temperatures are moderately cool (7 to 18°C), such as in the spring or fall.⁽⁴³⁾ Cracks are open in cool weather allowing better penetration of the sealant into the crack.

Equipment

Either a rotary-impact router (figure 41) or diamond-blade crack saw (figure 42) is needed for crack routing. An asphalt kettle with pressure applicator is usually used to apply the sealant as shown in figure 43. A hand squeegee can be used to finish and shape the sealant as shown in figure 44.

Construction Process

Crack treatment consists of at least two and up to five steps, depending on the type of treatment (sealing or filling), treatment policy, and available equipment. These steps are: 1) crack cutting (routing or sawing), 2) crack cleaning and drying, 3) material preparation and application, 4) material finishing/shaping, and 5) blotting.

The surface of the crack after sealing can be sprinkled with dry sand to prevent pick-up by traffic. Traffic should be diverted until the sealant material cures. If the pavement is to be opened to traffic immediately after sealing, the material must be protected against pick-up by tires by dusting the sealant with fine sand, mineral dust, or a similar material.



Figure 41. Router for shaping cracks.

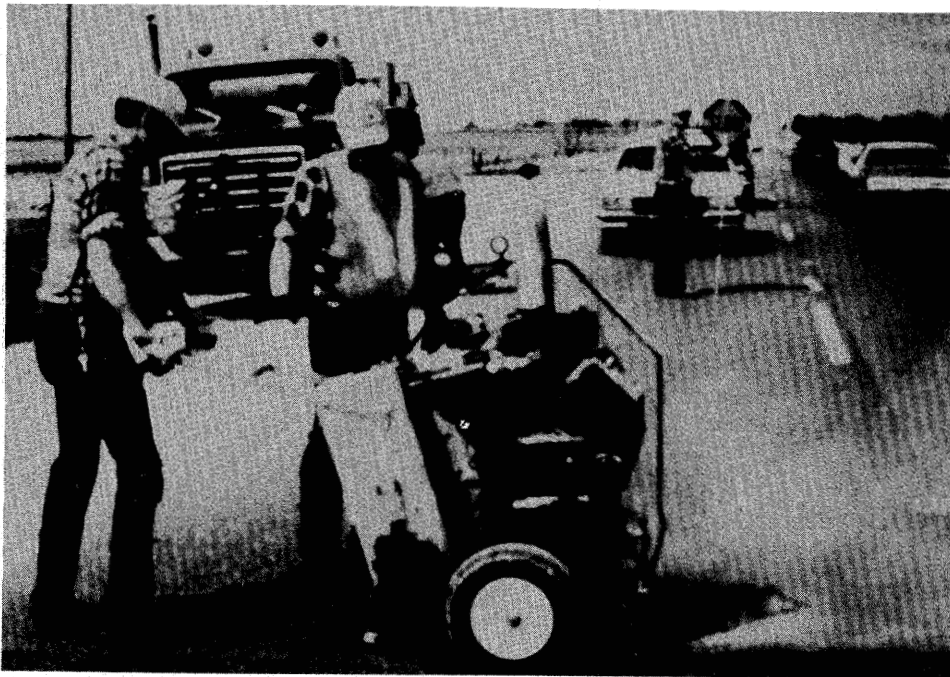

Figure 42. Diamond bladed saw for shaping cracks.



Figure 43. An asphalt kettle with pressure applicator.



Figure 44. Finishing and shaping the sealant using hand squeegee.

It is a good practice for workmen to begin filling operations at the centerline and back towards the edge of the pavement in order to avoid backing into the stream of traffic.

Inspection and Acceptance

Correct construction procedure should be followed in order to obtain long-lasting sealing. Before work begins, equipment should be checked to make sure it is in good working condition. Appropriate materials should be used and proper construction procedures should be followed.

Specifications

State specifications usually include description of work, materials, construction details, weather limitations, method of measurement, and basis of payment.

COST

The cost of crack treatment varies depending on the sealant material, method of application, and equipment used. Sealant costs are highly variable as many of the products are proprietary. A material truck costs \$20/day. A spray injection device costs \$750/day including crew and material.⁽⁴³⁾

PERFORMANCE

Crack sealing effectively retards internal and external deterioration and slows down the progress of cupping deformation (depression of pavement profile at the transverse crack). A study in Toronto found rout-and-seal treatment of transverse cracks can extend pavement life by at least 4 years.⁽¹¹⁾

LIMITATIONS

As discussed, crack treatments are limited with respect to the types of cracks. High-density and high-severity cracking cannot be cost-effectively treated. Crack treatments also have a limited service life and new cracks develop. Thus, crack treatments must be repeatedly applied to pavements in order to maintain the seal.

CHAPTER 9. PREVENTIVE MAINTENANCE OF CONCRETE PAVEMENT

INTRODUCTION

The objective of this chapter is to discuss the techniques for preventive maintenance of portland cement concrete pavements. The primary types of treatments are crack and joint sealing, undersealing, and retrofit of dowel bars. Other treatments, such as partial depth patching are discussed in the FHWA workshop "Pavement Maintenance Effectiveness - Innovative Materials." Further information is available in the National Highway Institute short course on "Portland Cement Concrete Pavement Construction and Concrete Pavement Restoration."

SHRP EXPERIENCE

Crack treatments of concrete pavement were conducted under SHRP projects H-105 and H-106. In project H-105, Innovative Materials and Equipment for Surface Repair, the researchers conducted a massive literature review and a nationwide survey of highway agencies to identify potentially cost-effective repair and treatment options. The information and findings from this study were then used in the subsequent field experiments conducted under project H-106, Innovative Materials Development and Testing. In the H-106 project, test sections were installed at 22 sites throughout the United States and Canada between March 1991 and February 1992 under the supervision of SHRP representatives. South Dakota and Kansas installed retrofit dowel bars as State supplemental sections. Initial performance data were collected by

SHRP and is currently being evaluated through the long-term pavement performance (LTPP) program of the FHWA.

In addition, crack and joint sealing was performed on 35 sections for the SHRP H-101 research. The ETG observed the treatments are performing well. However, it may be several years before performance trends can be established from the LTPP data.

CRACK AND JOINT SEALING

Sealing cracks and joints in concrete pavements is a maintenance operation considered for joints and cracks that are open enough to permit the entry of joint sealant or mechanical routing tools. Cracks and joints are sealed to inhibit the intrusion of surface water and incompressible materials.⁽⁴⁵⁾⁽⁴⁶⁾

Pavement Conditions Warranting Crack and Joint Sealing

Excessive delay in replacing a failing sealant system in concrete pavement joints can result in rapid deterioration of the pavement. Also, replacing the sealant too early results in wasting limited maintenance funds. Therefore, the optimum time for resealing should be determined.

Some States specify that joints be resealed when a specified amount of sealant material (25 to 50 percent) has failed, allowing moisture and/or incompressible materials to progress past the sealant to the underlying layers. Other agencies base their decision on pavement type, pavement and sealant condition, and available funding. A more complete method is to calculate rating numbers based on the sealant and pavement condition, traffic levels, and climatic conditions.

Cracks in concrete pavement may be longitudinal, transverse, or diagonal.

Before resealing joints, it is important to determine the objective of resealing. Possible objectives include:

1. Temporarily sealing joints for 1 to 2 years until the pavement is overlaid or replaced.
2. Sealing and maintaining watertight joints for 3 to 5 years.
3. Sealing and maintaining watertight joints for more than 5 years.

The selection depends on pavement condition and traffic level and affects the type of sealant and installation method.

If cracks and joints are not sealed routinely, water will infiltrate under the slab and contribute to pumping. Pumping is the ejection of water together with fine materials from underneath the slab through open joints and cracks when wheel loads are applied. Pumping results in voids under the slab, leading to loss of support. Water infiltration may also cause corrosion of dowel and tie bars. Infiltration of water may also lead to slab deterioration resulting from freezing and thawing.

The intrusion of incompressible materials in the joints may contribute to blowup, joint deterioration, or spalling. These conditions typically result from high compressive stresses developed at the joint when the incompressible material restrains the change in slab length due to temperature increases.

The condition of the pavement when it is resealed can greatly affect the performance of the seal. It is important to consider the following tasks before resealing:

1. Repair corner breaks and spalls,
2. Repair large spalls at the face of the joint,
3. Improve subdrainage and/or roadside drainage,

4. Restore load transfer at joints and cracks where poor load transfer exists,
5. Underseal the pavement where voids exist, and
6. Grind the pavement surface to restore ride quality or improve skid resistance.

Materials

Sealant materials have to be durable, ductile, resilient, adhesive, and cohesive. There are a wide variety of sealants currently on the market. The general categories used by the American Concrete Institute (ACI) to differentiate among sealing materials are:

1. Thermoplastic materials,
2. Thermosetting materials, and
3. Preformed compression seals.

The thermoplastic sealants are bitumen-based materials that typically soften upon heating and harden upon cooling. These sealants vary in their elastic and thermal properties and are affected by weathering to some degree. They include asphalt cement, asphalt emulsion, polymer-modified asphalt emulsion, asphalt rubber, fiberized-asphalt, PVC coal tar, rubberized asphalt, and low-modulus rubberized asphalt.

Thermosetting sealants are typically one- or two-component materials that set by the release of solvents or cure through a chemical reaction. Some of these sealants have shown potential for good performance, but they are also 4 to 10 times more expensive (material cost) than standard rubberized asphalt. However, thermosetting sealants often are placed thinner and may have lower labor and equipment costs. They include polysulfide, polyurethane, and silicon.

Preformed compression seals (figure 45) are premolded strips of styrene, urethane, neoprene, or other synthetic materials that are designed to be placed in PCC pavement joints under compression. They are designed to be compressed 20 to 50 percent of their uncompressed width.

Equipment

Crack cleaning can be done manually, using compressed air, heat lance, or by sandblasting. If necessary, the crack can be dried with a heat lance. The sealant can be applied with an applicator.

Construction Process

Sealing joints and cracks in PCC pavement include removal of old sealant, routing joint sidewalls, cleaning the joint, installation of backer rod, and installation of new sealant.

Before placing a new sealant, the old sealant has to be removed. Also, at the time of sealing the crack must be completely free of dirt, dust, and other materials that might prevent bonding of the sealant.

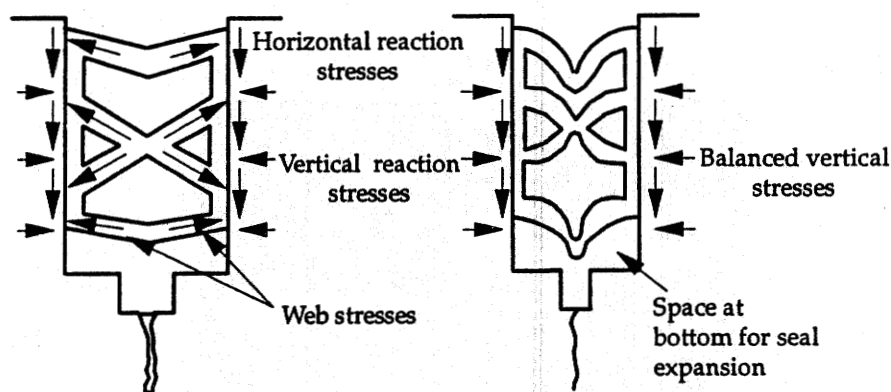

Figure 45. Preformed compression seals.

In cases where cracks are open, a groove about 10 mm wide and 20 mm deep should be made along the crack using diamond-blade; random-cut saws; random crack grinders, or vertical-bit routers. The sawing or grooving tool must be capable of closely following the path of the crack and of widening the top to the required section without causing excessive spalling or other damage to the concrete.

Backer rod (figure 46) is typically inserted in PCC joints and cracks prior to resealing to keep the sealant from sinking into the reservoir. It also keeps the sealant from bonding to the bottom of the reservoir and, if properly selected and installed, it helps maintain the proper sealant thickness. The rod must be flexible, compressible, non-shrinking, non-reactive, and non-absorptive. Materials for backer rods include extruded closed-cell polyethylene foam, cross-linked extruded closed-cell polyethylene foam, and extruded polyolefine foam.

The depth of the backer rod needs to be set to achieve the optimum shape factor for the sealant. The shape factor is the ratio of the depth of sealant to the in-service width of the joint. Sealant manufacturers generally recommend a shape factor for their materials, for example 3:2.⁽⁴⁷⁾

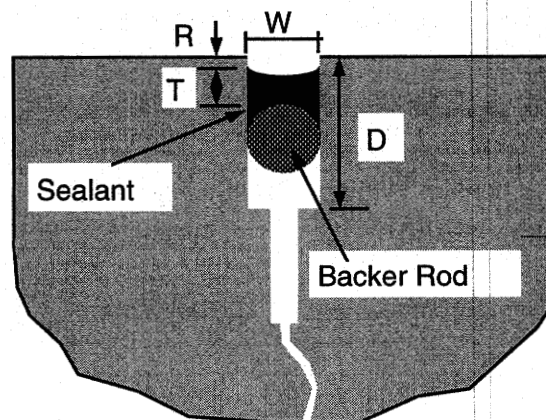

Figure 46. Schematic of backer rod.

Traffic should be detoured until the sealant material cures. If the pavement is to be opened to traffic immediately after sealing, the material must be protected against pick up by tires by dusting the cracks or joints with fine sand, mineral dust, or a similar material.

It is a good practice for workmen to begin filling operations at the centerline and back towards the edge of the pavement in order to avoid backing into the stream of traffic. Newly applied seals can be dusted with fine sand to prevent pick up by tires.

Specifications

State specifications usually include: a description of work, materials, construction requirements, method of measurement, and basis of payment. For example, Colorado requires that hot poured material for filling joints and cracks conforms to the requirements of ASTM D3405 or D1190. ASTM D1191 mortar blocks shall be used for concrete bond test. ASTM D1190 material must pass an asphalt compatibility test, Section 9, ASTM D3407. Using a mixture of different manufacturers' brands or different types of sealant is prohibited. Immediately before applying the sealant, the cracks should be cleaned of loose and foreign matter to a depth approximately twice the crack width. Cleaning shall be performed using a hot compressed air lance. Cracks shall be filled with hot poured joint and crack sealant flush with the pavement surface. Any excess sealant shall be leveled off at the wearing surface by squeegee, a shoe attached to the applicator wand, or other suitable means approved by the engineer. The squeegeed material shall be centered on the cracks and shall not exceed 75 mm in width or 2 mm in depth. The sealant material shall be heated and applied according to the manufacturer's recommendations. Sealant material picked up or pulled out after being placed shall be replaced at the contractor's expense. The sealant is

measured and paid for by quantity of material used. This payment includes the cost of material, equipment, and preparation of surface prior to sealant application.

Performance

It is believed that crack and joint sealing typically preserves pavement condition and extends the serviceability of the pavement. However, the literature lacks conclusive evidence on performance and cost effectiveness. Studies are on-going in Kentucky, Iowa, Michigan, North Dakota, and Wisconsin.⁽⁴⁷⁾

Limitations

If the existing pavement is badly deteriorated, sealing cracks and joints may not be effective. In such cases, the slab may continue to crack and spall. It is also possible that routing actually contributes to further spalling by stressing the already weakened surface or areas that have "micro-cracks" that were not visible during original routing.

SUBSEALING

Subsealing of concrete pavements is filling the voids under the concrete pavement slab with a material such as cement grout or bituminous materials under pressure through holes drilled in the slab.⁽⁴⁸⁾ A survey of State practices found 16 states that use subsealing and 17 states that do not subseal; the remaining states did not respond to the survey.⁽⁴⁹⁾ Only six States participated in the construction of test sections. The ETG recorded no observations on the performance of these sections.

Pavement Conditions Warranting Subsealing

With the continuous applications of heavy traffic loads in the presence of water, concrete pavement slabs tend to lose the uniform support of the underlying subbase or subgrade. The presence of water and fine materials may result in pumping and migration of fine-grained materials from beneath the slab through joints and cracks that lead to erosion of granular and stabilized subbases (figure 47).

The void space gradually increases and eventually the slab loses the support leading to faulting and cracking of the slab. Faulting occurs due to differential settlement of the two slabs that could happen due to pumping. The mechanisms that are associated with pumping and faulting were identified in 1948 as:⁽⁵⁰⁾

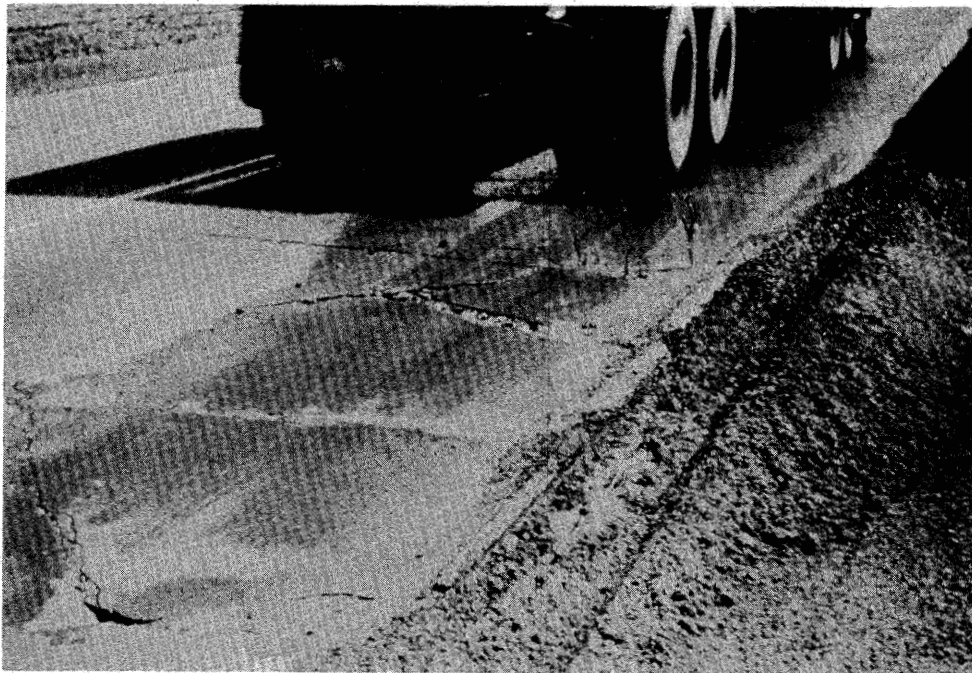

Figure 47. Pumping of concrete pavement.

1. Free water under the slabs,
2. Frequent heavy axle loads,
3. Cracks or joints in the pavement, and
4. Unstabilized or erodible material under or adjacent to the slabs.

The key to preventing pumping and faulting is to interrupt these mechanisms.

It is important to detect voids under the concrete pavement early since traffic induced stresses in an unsupported slab are much greater than allowed for by the pavement design process. Several methods are available to detect voids such as:

1. Visual inspection of pavement to locate areas of distress such as the presence of holes or depressions in the adjacent asphalt shoulder edge, excessive vertical movement of the slab at joints or cracks, or faulting of joints. Pumping can be identified by staining of the concrete surface.
2. Use of a loaded truck and two Benkelman beams to measure the deflection on the approach and leave slabs.
3. Use of deflection nondestructive testing devices such as the Falling Weight Deflectometer (FWD), Dynaflect, or Road Rater to detect the possible weak areas and the extent of voids.
4. Use of non-contact ground-penetrating radar equipment or infrared thermology to detect the location and extent of voids.
5. Use of the epoxy core test method developed by the SHRP H-101 researchers.

Table 22 presents deflection criteria used by 16 States for determining the location of slabs that need under sealing.

Table 22. Corner deflection (mm) and joint efficiency values used to determine location of slabs that need undersealing.⁽⁴⁹⁾

State	>0.25	>0.38	>0.51	>0.64	>0.76	>0.89	LTE<65
California ^b							
Florida		x					
Georgia					x		
Kansas ^c							
Illinois ^b							
Indiana ^d							
Iowa ^b							
Missouri ^e							x
Oklahoma ^b							
Oregon ^f				x			
Pennsylvania			x				x
Puerto Rico					x		
South Dakota	x						
Texas		x					
Tennessee				x			
Washington					x		

a: LTE = Load transfer efficiency.

b: Not specified

c: If corner deflections are greater than a base value established from the interior of slab deflection.

d: Judgement plus modified Majidzadeh criteria.

e: Corner deflection greater than 0.45 mm is also used.

f: Darter/Crovetti slope intercept method is also used (based on a deflection of 0.25 mm).

Figure 48 demonstrates the measurement of load transfer efficiency. Two equations have been used for determining load transfer efficiency:

$$LTE = \frac{\Delta_u}{\Delta_l} 100$$

or

$$LTE = \frac{2\Delta_u}{(\Delta_l + \Delta_u)} 100$$

Where:

LTE = load transfer efficiency

Δ_u = deflection of the unloaded or leave slab

Δ_l = deflection of the loaded or approach slab.

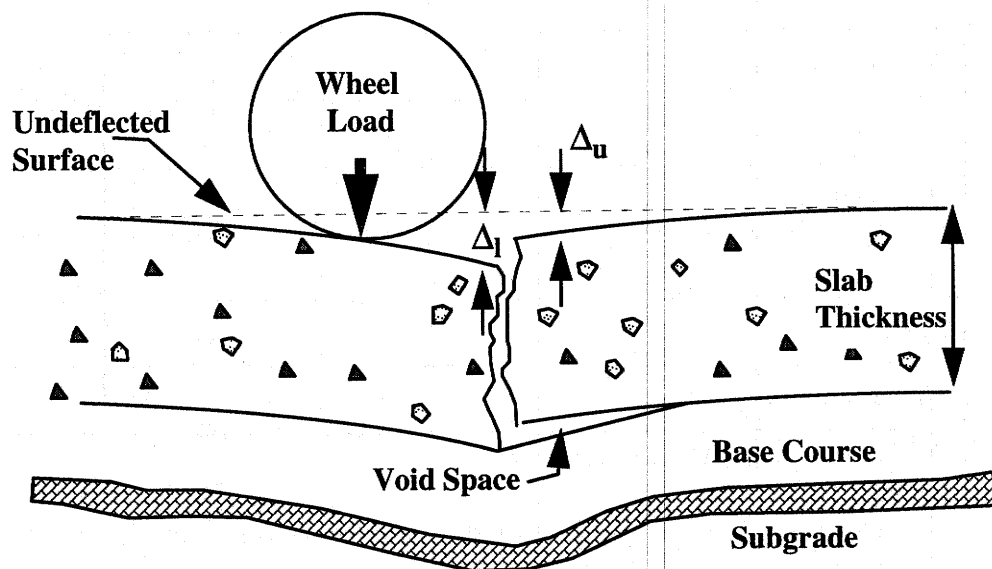

Figure 48. Concept of joint load transfer efficiency.

Design Consideration for Undersealing

Materials

Grouting materials must be very flowable (low internal friction) during pumping to move through small openings and follow water channels to fill existing voids. The grout material must also have sufficient density to displace free water from under the slab. After pumping and hardening, the material must be durable, insoluble, incompressible, and nonerodable.

Several materials can be used, including, portland cement and water with or without sand, lime-dust, pozzolan and other admixtures. Hot asphalt cement can also be used.

Application Rate

The amount of grout used depends on the size of voids to be filled. The grout material is pumped until it appears along the shoulder line or joints, denoting that sufficient material has been pumped. The elevation of the edge of the slab should be monitored to ensure that the grouting operation is not raising the elevation of the slab.

Construction Consideration

Equipment

Required equipment varies with the type of grout used. Equipment for portland cement type grouts includes a hole drilling device, grout mixer, pump, and consistency tester. Other miscellaneous items such as hoses, valves, pressure gages, dial gages to monitor slab movement, plugs for plugging holes, proper safety clothes, and traffic control devices are also needed. Equipment for asphalt cement grout includes drilling device,

insulated pressure distributor or tank truck, booster heater, and asphalt applicators (nozzles).

Construction Process

The undersealing process involves void detection, material selection, and use of efficient grout distribution pattern, depending on the location and size of the voids under the slab. If a large percentage of the slabs require stabilizing, blanket coverage may seem feasible. However, if grout is forced under slabs that do not have voids, will likely result in unstable support, high corner deflections, and eventual slab cracking. Therefore, care must be takes to ensure the crew uses proper injection techniques. Proper injection techniques should indicate that slabs that do not have voids will not accept grout.⁽⁴⁸⁾ Georgia attempts to pour water into drill holes. If the hole does not take water, they do not subseal; they just patch the hole.

The grout material is pumped until it appears along the shoulder line or joints denoting that sufficient material has been pumped. Since high pressure is required to force the grout into the voids, extreme care must be used when removing the nozzle from the grout hole. The elevation of the pavement should be monitored when sealing to avoid lifting the slab. Lifting the slab can create voids under the pavement. After completing grout subsealing or slabjacking, the holes should be plugged immediately with temporary wood plugs. The holes are later backfilled with a stiff cement grout or concrete mixture and finished to match the pavement texture.

Figure 49 shows typical hole pattern used in the outer lane of jointed PCC pavement. However, the hole pattern may need to be adjusted during construction, depending upon the results obtained. A typical hole spacing

for CRCP is shown in figure 50. It is recommended that this pattern be adjusted after initial field trials are completed to provide the best coverage.

The maintenance crew should be properly dressed and furnished with appropriate safety equipment such as hard hats, goggles, insulated shoes and any other safety apparel that will reduce the possibility of injury.

Traffic can be allowed back on newly grouted slabs after 1 to 3 hours.

Inspection and Acceptance

Correct construction procedures should be followed in order to obtain long-lasting subsealing. Before work begins, equipment should be checked to make sure it is in good working condition. Appropriate

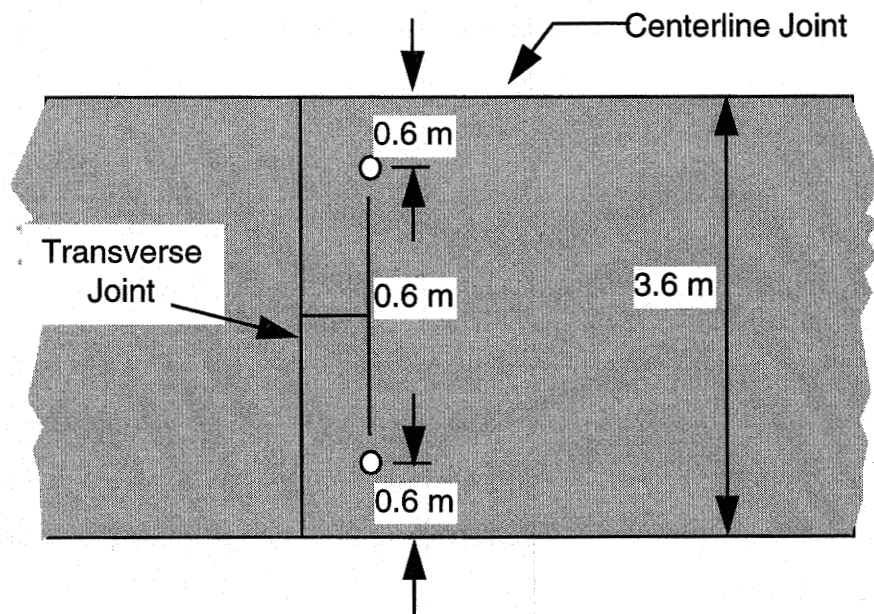

Figure 49. Typical hole pattern for jointed concrete pavements. ⁽⁴⁶⁾

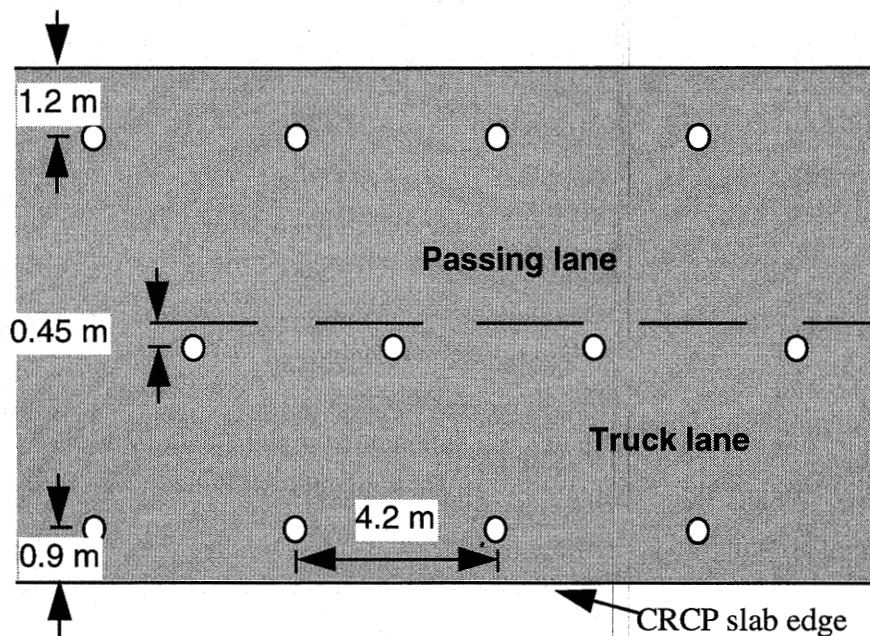

Figure 50. Typical hole pattern for continuously reinforced concrete pavements.⁽⁴⁶⁾

materials should be used and proper construction procedures should be followed.

Specifications

State specifications usually include description of work, materials used for subsealing and slab jacking, construction procedures and conditions, measurement of number of drill holes, quantity of grout material, and method of payment.

For example, CalTrans requires that the material for pavement subsealing to be composed of portland cement, fly ash, and water. A modified Type II portland cement is used. Fly ash can be either Class C or F satisfying ASTM C618 requirements except that the loss on ignition shall not exceed

4 percent. Portland cement and fly ash are proportioned at a rate of 43 kg of portland cement to 102 to 116 kg of fly ash. Water is to be added in an amount to provide a grout efflux time of 10 to 16 seconds. Chemical admixtures and calcium chloride may be used in the grout mixture, subject to the engineer's approval. The contractor is required to submit a proposal for the materials indicating the initial set time and the 1 day, 3 day, and 7 day compressive strengths of the grout at 10-, 12-, and 14-second efflux times following ASTM C109 procedure. Grouts having a seven day compressive strength of less than 5.17 MPa at a 12-second efflux time are not accepted. Mortar for filling the holes in the concrete pavement is composed of one part portland cement to three parts fine aggregate, by volume, and only enough water to permit placing and packing of the mortar in the hole. A commercial quality premix rapid set mortar or concrete may also be used.

Payment is made at the contract unit price for drill hole and per ton for grout. Prices and payments include full compensation for furnishing all labor, materials, tools, equipment, and incidentals, and for doing all the work shown on the plans.

Indiana uses asphalt to underseal concrete pavements⁽⁴⁹⁾. The specifications require drilling holes 40 mm in diameter on the centerline of the lane to be treated. Prior to pumping, the pavement surface around the hole is sprinkled with water to prevent the undersealing material from adhering to the pavement surface. Asphalt is pumped through the holes and under the pavement with an approved type of self-propelled pressure distributor. Upon completion of the pumping operation, wood plugs are driven into the holes. When the asphalt is hardened, the wood plugs are replaced with grout flush with the pavement surface and traffic may be permitted to use the road. The asphalt temperature shall not exceed

260°C at any time, and shall not be less than 177°C during pumping. Pumping is not allowed when the subgrade is frozen or when the atmospheric temperature is 4°C or lower. If needed, up to 5 percent of the original number of holes, may be undersealed a second time. Payment is made at the contract unit price for drilled hole and per ton for asphalt material for underseal.

Performance

Subsealing provides continuous support under the slab which in turn increases the structural integrity of the pavement section and extends its performance life. Since subsealing does not restore ride quality or joint transfer efficiency, subsealing is usually done as part of a restoration process that can include grinding and retrofit of dowel bars. South Dakota has estimated that such restoration projects can extend the life of pavements by 10 years.⁽⁵¹⁾

Limitations

Subsealing requires considerable expertise, trained personnel, and special equipment. The work is particularly suited to specialty contractors in order to correct unsatisfactory conditions without damaging the pavement. Subsealing is quite often ineffective when used alone as faulting quickly returns. This should be used with load transfer restoration and diamond grinding to restore ride quality.

RETROFIT OF DOWEL BARS

Retrofitting dowels reestablishes load transfer across joints and cracks. Load transfer refers to the ability of a joint or crack to transfer a portion of the load applied on one slab to an adjacent slab. This improves pavement performance by reducing faulting, pumping corner breaks, and

spalling.⁽⁵²⁾⁽⁵³⁾ As shown in figure 51, generally three dowels are placed in each wheel path. Depending on the traffic loads, the retrofit of dowel bars can be placed in only the outside lane or in all travel lanes.

Construction consists of:

- Cutting the slots,
- Cleaning and preparing the slots,
- Placing the dowel bars, and
- Backfilling the slots.

The dimensions of the slots are shown in figure 52. Each slot should be cut to a width about 20 mm wider than the dowel bar. The slots should be slightly deeper than one half the slab depth to permit the dowel to be placed at the mid depth of the slab. The slot should be long

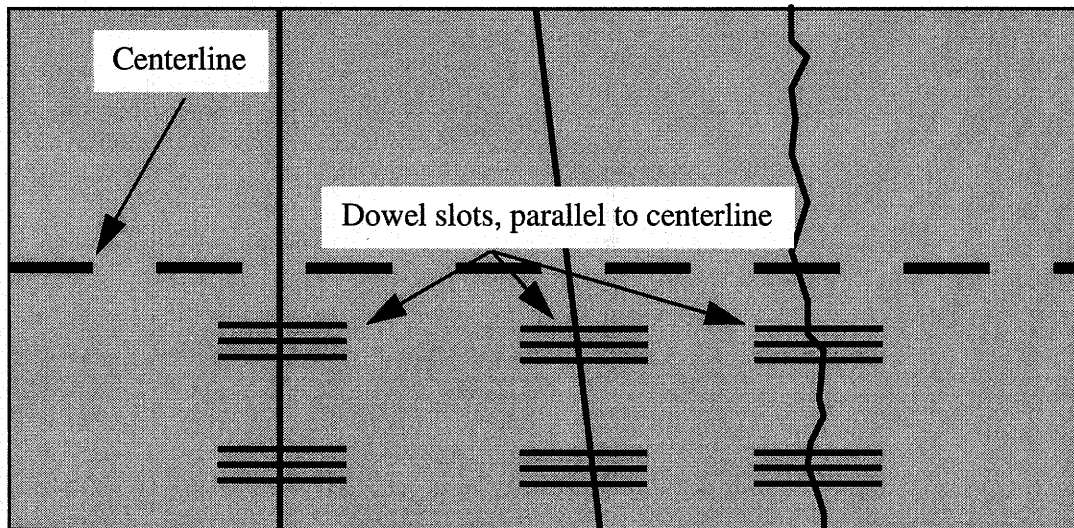

Figure 51. Location of retrofit dowel bars.⁽⁵²⁾

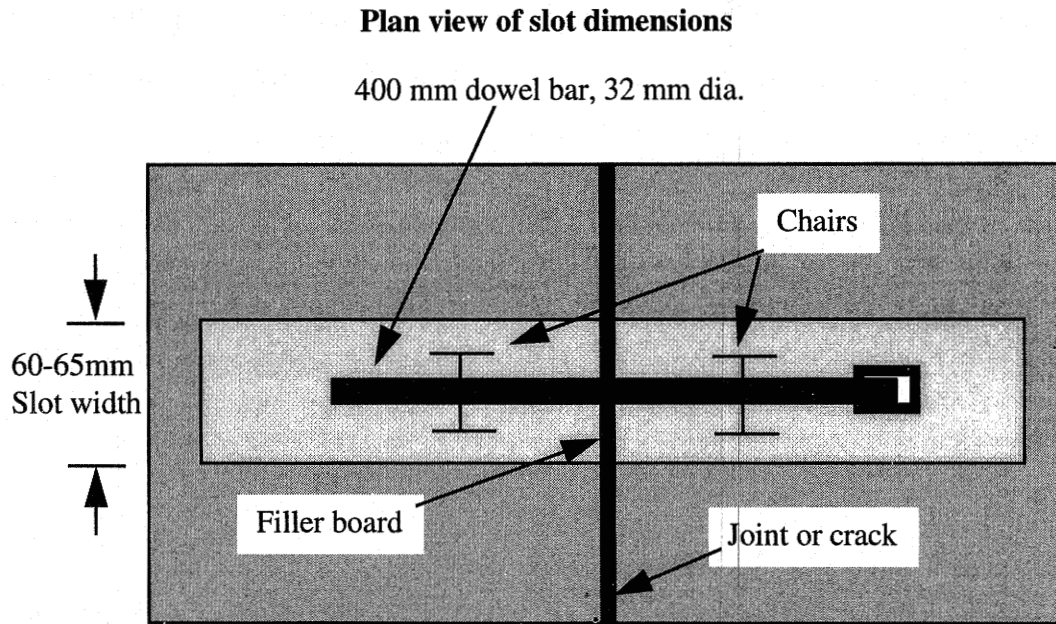

Figure 52. Dimensions of slot for retrofit dowel bars. ⁽⁵²⁾

enough to fit the dowel without touching the curved ends of the slot, as shown in figure 53. Most installations use standard dowel bars that are 400 mm long, requiring a slot 800 mm long.

Within the past few years, several contractors have developed machines that can simultaneously cut three or six slots. These machines make two saw cuts for each slot. The material between the slots is removed with a jack-hammer. Small burrs and rocks are smoothed out with a small hammerhead. This flattens the slot bottom so the dowel can sit level.

The slots are cleaned with sand blasting followed by air blowing to produce a clean, dry, and roughened surface free of loose particles.

Before the dowel is placed, caulk is placed along the sides and bottom of the joint or crack. The caulk will prevent the patch material from working into the crevice or the joint. If the patch material enters the crevice, it may

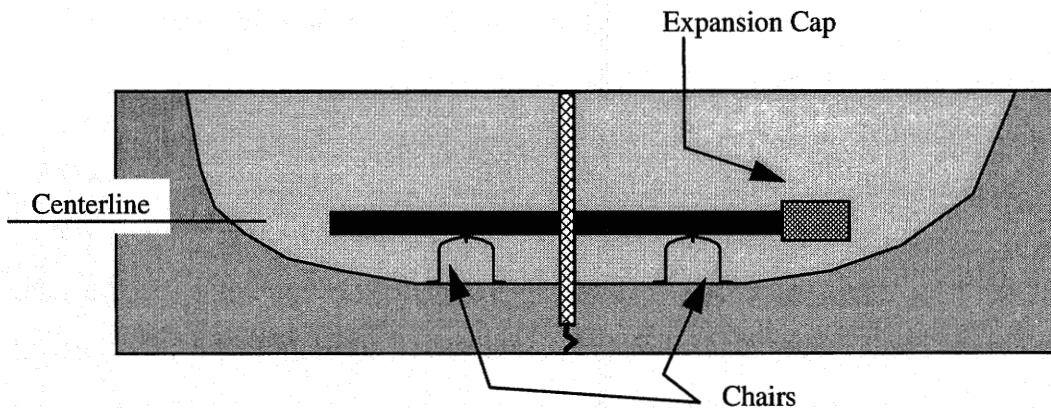

Figure 53. Side view of slot for retrofit dowel bars. ⁽⁵²⁾

prevent the joint from closing during warm weather causing blowups and corner breaks.

The dowels are similar to those used for new construction. They should be epoxy coated to prevent corrosion. A non metallic expansion cap is placed on one end of end of the bar. A thin bond-breaker is also required to allow the dowles to move freely.

Styrofoam or filler-board joint reformer is placed at the center of the bar. The bars are lubricated to prevent bonding with the concrete. Non metallic chairs are used to support the bar off the bottom of the slot.

The dowels are placed in the slot. The dowel alignment should be parallel to the pavement center line and true to the surface of the pavement.

The concrete backfill material should have a maximum aggregate size of 10 mm so the material can completely encase the dowel. Usually an accelerator is used in the concrete to reduce the time that traffic must be diverted. An aluminum powder is used to reduce shrinkage. The backfill

material is mixed on site in a small mobile drum or paddle mixer.

Proprietary patching materials are also available.

The slot is slightly overfilled to compensate for consolidation around the dowel. Vibrate the fresh concrete to eliminate any voids and ensure the dowel is completely encased. Small spud vibrators (diameter less than 25 mm) are used to consolidate the concrete. Care must be taken to avoid hitting the dowel bar. A curing compound should be placed on the concrete, especially in hot and windy weather.

After placing the dowel bars, the entire pavement surface is usually reprofiled with diamond grinding. Joints and crack seals should be placed as needed.

APPENDIX REVIEW OF SHRP PREVENTIVE MAINTENANCE RESEARCH

Hypothetical “what if” analyses, using pavement management systems, are useful for gaining insight into the potential cost-effectiveness of pavement preventive maintenance programs. However, implementation of preventive maintenance programs requires altering conventional practices of highway agencies. Implementing a preventive maintenance program requires diverting funds from existing activities, a decision that cannot be made lightly. The design, performance, and cost-effectiveness of preventive maintenance needs to be established and verified through research. Toward this end, there have been several recent and ongoing research projects for evaluating preventive maintenance treatments. The largest of these was the H-101 Project of the Strategic Highway Research Program. Other studies have been sponsored by the FHWA, NCHRP, and various State highway agencies. The purpose of this chapter is to summarize the SHRP H-101 research and the FHWA’s program for evaluating and implementing the findings and products of the SHRP research.

The purpose and objectives of the SHRP preventive maintenance studies are to:⁽¹⁵⁾

... develop a data base that will permit increased understanding of selected maintenance treatments in extending pavement service life or reducing the development of pavement distress. This includes an evaluation of the effectiveness of the pavement maintenance treatments and establishment of a study methodology that can be followed by highway agencies to evaluate other maintenance treatments. Specific objectives include:

- 1. design and coordination of the experimental design, implementation and analysis plans for a controlled experiment to evaluate performance, preserve and extend pavement service life;*
- 2. develop technology transfer materials for highway agencies to assist in implementing the study; and*

- 3. identify and quantify the effectiveness of specific pavement maintenance.*

Since the SHRP research time frame was 5 years, it was not possible to completely achieve these objectives of the project. The focus of the H-101 researchers was on the development of the experiment, location of the test sections, construction, and initial monitoring of their performance. The time between the end of the construction of the sections and the end of the SHRP H-101 research was not sufficient to observe and document the full service life of the test sections and develop models of the effectiveness of preventive maintenance treatments. This work has been continued by the FHWA under the LTPP Program.

EXPERIMENTAL DESIGN

The effectiveness of pavement preventive maintenance treatments for extending the pavement service life was studied in the SHRP experiments SPS-3 and SPS-4, for flexible and rigid pavements, respectively. Both experiments required construction of several experimental treatments that could be compared to the performance of control (untreated) pavement sections. In addition, several States constructed treatments of local interest adjacent to the SHRP sections.

A common set of primary variables and levels were used of both the flexible and rigid pavement experiments:

<u>Factor</u>	<u>Levels</u>
Moisture	Wet, dry
Temperature	Freeze, no-freeze
Subgrade type	Fine grain, coarse grain
Traffic loading	Low, high

The temperature and moisture condition of the sections were determined based on the location of the section. Figure 54 shows the map used to assign sections to an environmental area.

Subgrade type was based on the geological classification of the soil as shown in table 23.

Traffic levels were defined as low and high using a division point of 85,000 equivalent single axle loads per year.

SHRP Flexible Pavement Sections

In addition to the primary variables, a second level of variables were defined to control the type of test sections in the flexible pavements experiment:

<u>Factor</u>	<u>Levels</u>
Pavement condition	Good, fair, poor
Pavement structural adequacy	High, low



Figure 54. Environmental zones for SHRP LTPP studies.⁽¹⁵⁾

Table 23. Subgrade soil descriptions.

Fine-Grained Subgrade Soils	Coarse-Grained Subgrade Soils
Clay (liquid limit > 50)	Sand
Sandy Clay	Poorly Graded Sand
Silty Clay	Silty Sand
Silt	Clayey Sand
Sandy Silt	Gravel
Clayey Silt	Poorly Graded Gravel
	Clayey Gravel
	Shale
	Rock

The condition of the pavement was evaluated according to the procedures developed for the SHRP research. Limits for classifying the pavement according to the condition of the pavement are shown in table 24. These limits are for pavement sections 152 m by 4 m. In addition, potential sections were eliminated from the experiment if they exhibited:

1. Extensive medium or any appreciable high-severity structural distresses, or potholes of any severity,
2. More than 5 percent of the surface was patched,
3. Bleeding over more than 10 percent of the surface,
4. Rutting greater than 25 mm, and
5. Roughness that could not be corrected with a thin overlay.

The structural capacity of the pavement was rated based on the ratio of the in-place structural number versus the required structural number. The in-place

structural number was determined using the actual materials and thicknesses of the pavement layers. The required structural number was determined based on a new pavement design for the conditions and traffic at the test section. The AASHTO "Guide for the Design of Pavement Structures" was used to determine both the in-place and required structural numbers.⁽²¹⁾

The treatments included in the flexible pavement experiments were:

- Crack seal,
- Slurry seal,
- Chip seal, and
- Hot-mix thin overlay.

In addition, the designed experiment was supplemented with the construction of State supplemental sections.

Table 24. Definition of condition categories based on cracking amount and severity for flexible pavements.

Condition Category	Longitudinal and Transverse Cracking Severity			Alligator Cracking	Rutting
	Low	Moderate	High		
Excellent	<7 m	0	0	None	< 6 mm
Good	0 to 18 m	<7m	0	None	< 6 mm
Fair	0 to 36 m	4 to 18 m	< 7 m	Low Severity ≤ 5% Medium Severity ≤ 2%	6 to 13 mm
Poor		≥ 18 m	≥ 7 m	Low Severity ≥ 5% Medium Severity ≥ 2%	> 13 mm

Figure 55 shows the distribution of flexible pavement sections throughout the United States and Canada. Treatment designs and specifications were developed for each of the SHRP regions:

<u>Region</u>	<u>Participating States and Provinces</u>
Southern	Alabama, Arkansas, Florida, Mississippi, Oklahoma, Tennessee, Texas
North Atlantic	Maryland, New York, Ontario, Pennsylvania, Quebec, Virginia
North Central	Illinois, Indiana, Iowa, Kansas, Kentucky, Manitoba, Michigan, Minnesota, Missouri, Nebraska, Saskatchewan
Western	Arizona, California, Colorado, Idaho, Montana, Nevada, Utah, Washington, Wyoming

A typical layout of the test sections is shown on figure 56. Where possible, sections were located adjacent to the General Pavement Study (GPS) sections of

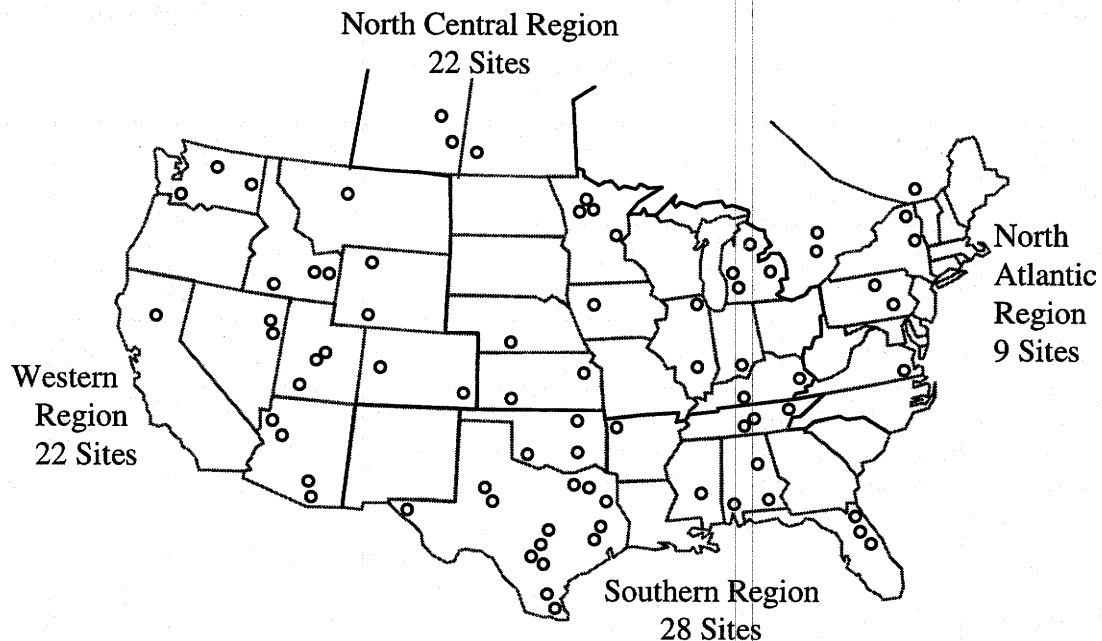

Figure 55. Distribution of flexible pavement preventive maintenance studies.⁽¹⁵⁾

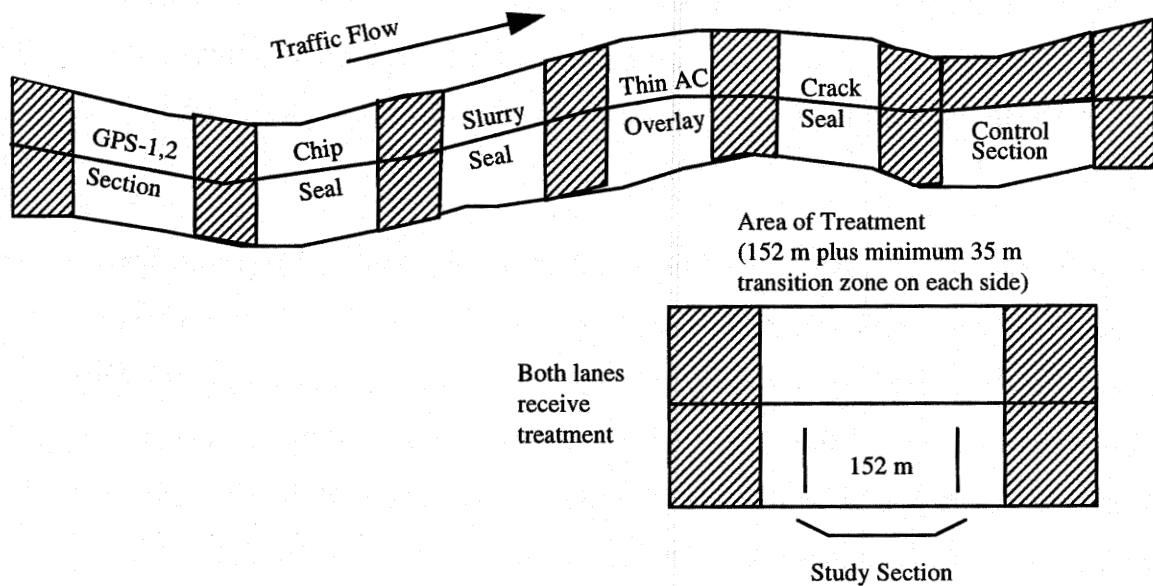

Figure 56. Typical layout of test sections for flexible pavements.⁽¹⁵⁾

the SHRP experiments to economize on travel time for the test equipment and staff.

SHRP Rigid Sections

The original design of the rigid pavement preventive maintenance experiment was the same as for the flexible pavement sections. However, there was considerable difficulty in locating the required sections. After compromises between the desired experiment and the available sections, the following factors and levels were included in the rigid pavement experiment:

<u>Factor</u>	<u>Levels</u>
Moisture	Wet, dry
Temperature	Freeze, dry
Subgrade type	Fine grained, coarse grade
Subbase type	Granular, stabilized

This combination of factors and levels was applied to plain concrete pavements. Reinforced pavements were only included for the wet region since these pavements are generally not constructed by agencies in the dry environmental areas.

The study was to include joint sealing and slab undersealing. However, several of the States were not willing to underseal their pavements. Since it was not possible to attract States to perform both treatments for all environmental areas, the researchers allowed States to participate if they were willing to construct either joint seal alone, or joint seal and undersealing together. Several States added supplemental sections to evaluate retrofit load transfer devices. The States participating in the rigid pavement study are shown on figure 57, and a typical layout of the sections is shown on figure 58.

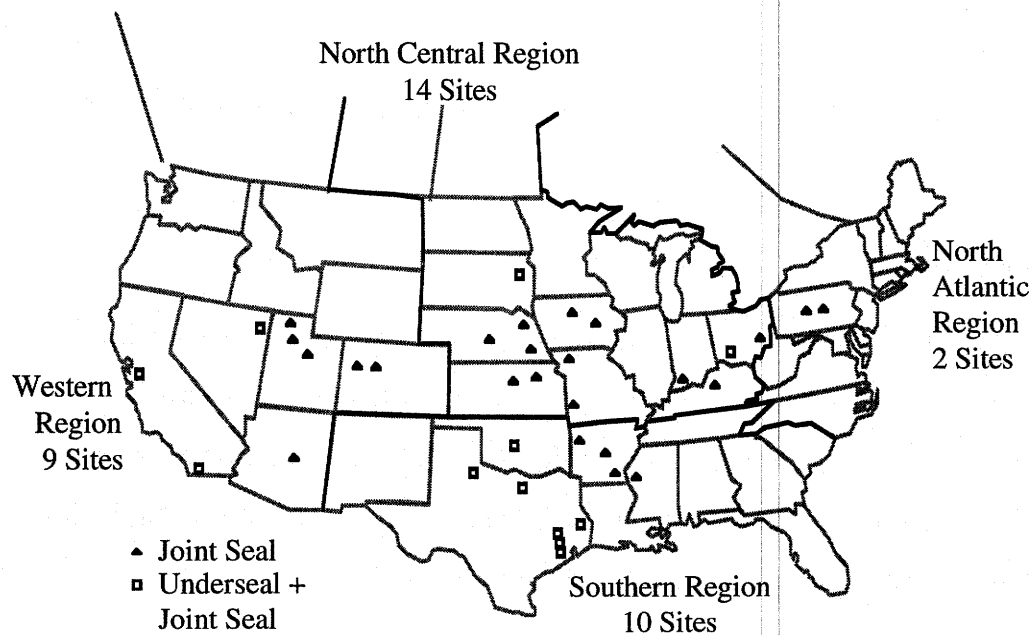

Figure 57. Distribution of rigid pavement test sections.⁽¹⁵⁾

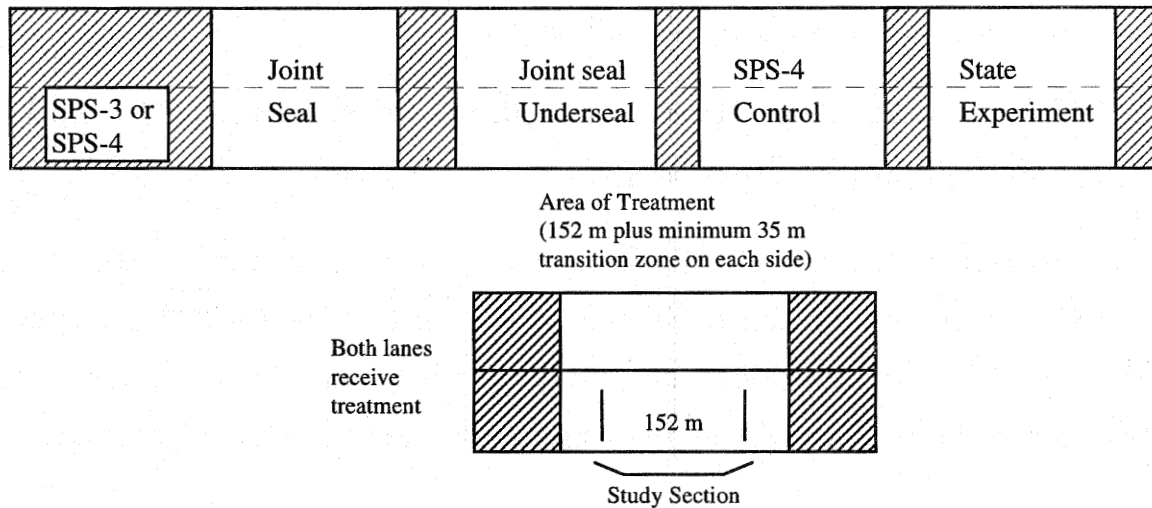

Figure 58. Typical layout of test sections for rigid pavements ⁽¹⁵⁾

State Supplemental Sections

As previously mentioned, in addition to the treatments constructed as part of the SHRP experimental design, States were encouraged to construct supplemental sections that had a particular design feature that the State wanted to investigate. For example, several States constructed chip seals to their local specification, micro-surfacing, and ultra thin hot-mix overlays with polymer modified asphalt.

SHRP H-101 RESEARCH RESULTS AND PRODUCTS

The H-101 contract developed several reports and a slide presentation:

1. Report SHRP-H-358 "Pavement Maintenance Effectiveness". ⁽¹⁵⁾
2. Report SHRP-M/FR-92-102 "Development of a Procedure to Rate the Application of Pavement Maintenance Treatments". ⁽⁵⁴⁾
3. Proposed Test Method - "Detection of Voids Under Rigid Pavements". ⁽⁵⁵⁾
4. Making Pavement Maintenance More Effective, Training Supplement. ⁽⁵⁶⁾
5. Making Pavement Maintenance More Effective, Slide Presentation. ⁽⁵⁷⁾

Evaluation of Preventive Maintenance Treatments

The Pavement Maintenance Effectiveness H-101 research successfully developed the experimental design, located test sections for construction

of the experimental treatments, and initiated the pavement performance data base. Continued evaluation of the test sections under the FHWA-LTPP Program should provide valuable information on the cost-effectiveness of the various treatments and more information on the appropriate timing of the treatment.

Even though the H-101 research provides a very valuable resource for understanding the performance and cost-effectiveness of preventive maintenance, there were some limitations to the research. For example, the construction of the chip seals had a 24 percent failure rate in terms of chip loss during, or shortly after, construction. This problem could be a result of the specifications and construction constraints of the research project; the asphalt, aggregate, and application were not uniquely designed for each site.

The H-101 researchers developed a sophisticated methodology for modeling the performance of preventive maintenance treatments (15). This methodology assumes pavement deterioration follows an exponential curve. The proposed equations allow for both a change in the condition of the pavement at the time of the treatment and for a change in the rate of deterioration. The researchers define treatment effectiveness as how long it takes a treated section to reach the maximum acceptable level of the distress, compared with how long it takes an untreated section to reach the same level when both sections started at the same initial condition.

It was recognized at the start of the H-101 research that there would be treatments and design conditions that could not be covered within the SHRP experiment. Thus, the researchers were charged with specifying a methodology that can be followed by highway agencies for evaluating other preventive

maintenance treatments. Such a methodology is not presented in the project documents. However, the H-101 methodology provides a model for other studies of preventive maintenance effectiveness. This model includes the following elements:

- Defining the variables that are addressed in the experiment.
- Defining methods for measuring variables.
- Using the SHRP pavement distress identification manual (16) for evaluating pavement condition before and after construction.
- Recording detailed information on the construction process, e.g., variances between design and construction, weather conditions, application rates, etc.
- Constructing a trial section before constructing the test section to ensure the experimental treatments construction will proceed smoothly.
- Specifying the analysis methodology that will be used for testing for the significance of the trends in the data from the experiment.
- Establishing communication procedures within the agency to maintain the integrity of the test sections, e.g., maintenance personnel should not place treatments on the test section without notifying the researchers.
- Defining data that will be collected throughout the experiment and at the end of the test section's service life.

The SHRP researchers performed tremendous tasks in designing the experiment and designing an analysis methodology. Time constraints were too tight to permit the collection of a sufficient number of data points to quantify the effectiveness of the selected treatment strategies. However, through the continuing LTPP efforts of the FHWA, more data points may be available in the future to quantify the performance and cost-effectiveness of the preventive maintenance treatments constructed during the H-101 contract. Some subjective

results have been developed through evaluation of the sections by the ETG, as described in chapter 1.

Method to Rate the Application of Pavement Maintenance Treatments

The H-101 researchers developed a methodology for rating the application of pavement maintenance treatments.⁽⁵⁴⁾ The methodology computes a summary statistic that combines the multitude of factors that can affect the performance of a preventive maintenance treatment into a single rating number. While conceptually, this is a worthwhile goal, it was evident from a review of the method that there are several areas needing further refinement. Therefore, this document is not considered further herein.

Making Pavement Maintenance More Effective - Training Supplement

This a summary report addressing the lessons learned during the construction of the SPS treatments.⁽⁵⁶⁾ It is a compilation of observations about the various pavement treatment mixture designs and their construction process and contains important results of the research and the general observations about the construction process quoted in the following. Other observations on the design, construction, and performance of specific of the treatment types are presented in chapters on each of the treatments.

Some general observations about the research construction process are:⁽⁵⁶⁾

1. *Federal and State agencies can work together in a complex construction oriented research project and complete it in a relatively short time period.*
2. *The practice run of all applications at the demonstration site was very helpful for the contractor to check his equipment and procedures. It was also helpful for the Project Engineer to get acquainted with the operations, sequence of construction, and personnel (SHRP representatives, interested parties, and contractor personnel) involved. This response was echoed in the other regions.*

3. *It was also noted that the weather, both temperature and humidity, had a significant impact on set times for the chip and slurry seal applications. Generally, conditions favorable for one were unfavorable to the other. Higher air and pavement surface temperatures would help the slurry seal lose water and set but would keep the chip seal too tacky to allow traffic. Cooler temperatures seemed to quicken the set for the chip seal, but would delay evaporation and setting of the slurry seal. High humidity did not seem to slow setting of the chip seal, but definitely retarded the setting of the slurry seal.*
4. *It was the intent of the specifications, and of the Project Engineer, to complete each test site in it's entirety during one day. In most cases, this may not have been in the best interest of good research efforts. As noted above, ideal conditions for one application did not necessarily suit the requirements of another application. It would have preferred to place the chip seal applications and then allow controlled, low speed traffic to work this application prior to brooming. This would have resulted in a much better setting of the chips and less chip displacement would be experienced than that caused by early brooming.*

Proposed Test Method - Detection of Voids Under Rigid Pavements

The H-101 researchers developed a proposed test method for detection of voids under rigid pavements. The purpose of the method is to verify the presence and thickness of voids under portland cement concrete pavements. The researchers suggest the method can be used to verify nondestructive test procedures used to identify voids under concrete pavements and to determine how well the undersealing was placed. The premise of the procedure is that if a suspected void lens can be filled with a low viscosity liquid that subsequently solidifies, then a core of the pavement and the supporting foundation would reveal any void that existed at the interface of the subbase and the pavement.

The test protocol is relatively simple and, although time consuming and costly, there do not appear to be any technical difficulties with the method. The viscosity of the liquid epoxy used to fill the void could vary and is not controlled in the protocol. No information was presented in any of the reports relative to the success of the method in field trials. The test method at this time is probably

a research tool rather than application in a field construction situation. AASHTO is evaluating the method to determine if it should be developed into a standard test method.

Benefits of the H-101 Research

Even though further work is needed before the benefits of the H-101 research can be fully realized, there were several important findings from the research. There has been a reluctance to place preventive maintenance treatments on high-volume, high-speed roads in the United States. Chip seals cause concern that chip loss will result in vehicle damage and slurry seals are thought to lack the durability to withstand heavy traffic. While several of the SHRP chip seal treatments failed more than 75 percent of the sections are still in service after 5 years. The sections that failed lost chips immediately after construction, indicating a problem with either the design, materials or construction quality on these sites. Several chip seal sections constructed to State specifications are performing better than the sections constructed to SHRP specifications, indicating the problem is probably with the design of the treatments. The successful construction of sections on high-speed roads indicate the feasibility of applying chip seals and slurry seals to high-volume, high-speed roads.

One of the objectives of the H-101 research was to determine the optimal timing of preventive maintenance treatments. This question cannot be fully resolved from the current experiment at this time, however, the lower bound of conditions where pavement preventive maintenance treatments are effective was verified. Preventive maintenance treatments are not successful when placed on deteriorated pavements. Depending on the condition of the pavement, sealing the surface can, in some cases, be detrimental to the performance of the pavement. For example, sealing a cracked pavement while there is moisture in the pavement structure can promote stripping. On the other hand, treatments placed on pavements in good condition are performing well.

CONTINUING FHWA ACTIVITIES

The interest in pavement preventive maintenance supported by the maintenance provisions of the ISTEA legislation has generated increased interest and research into the performance of preventive maintenance treatments. The National Highway Systems Bill further supports the implementation of pavement preventive maintenance practices by the States. The Federal Highway Administration is continuing the investigation of the SHRP H-101 research with ongoing data collection and analysis efforts under its LTPP activities. In addition, the ETG has performed subjective evaluations of the test sections. These reviews have been carried out in the Western SHRP region during 1991 and 1992, and were performed nationwide in 1993. These reviews indicate that a majority of the H-101 sections were performing satisfactorily 3 years after placement.⁽¹⁴⁾ It was generally noted that the treated sections are performing better than the untreated sections. In addition, treatments placed on pavements in good condition are performing better than treatments placed on pavements in marginal condition. The PCC treatments are performing well, but it will be several years before conclusions on the effectiveness of these treatments can be evaluated. Another nationwide review is scheduled for the Fall of 1995.

The FHWA's H-101 implementation contract will assist the State highway agencies with the implementation of preventive maintenance programs by providing recommendations about preventive maintenance treatments, through workshops, and by assisting State highway agencies in developing test and evaluation plans. This contract can also assist State highway agencies with design and evaluation of projects to evaluate preventive maintenance treatments.

In addition, the FHWA is performing Test and Evaluation Project Number 9 (TE-9). The purpose of this project is to gather and share information on conventional and emerging surface rehabilitation techniques, especially for high-

volume roads. Data and information was collected from the literature, by discussion with user agencies and from evaluation of field construction and performance of treatments placed by the States. Products developed under the TE-9 project include:

1. An Overview of Surface Rehabilitation Techniques for Asphalt Pavements, (FHWA-PD-92-008) and an instructor guide (FHWA-SA-94-074)
2. State of the Practice - Design, Construction, and Performance of Micro-surfacing (FHWA-SA-94-051), and an instructor guide (FHWA-SA-94-072).

The National Cooperative Highway Research Program has four current projects on preventive maintenance:

1. Pavement Management Methodologies to Select Projects and Recommend Preservation Treatments (Topic 24-05),
2. Asphalt Surface Treatments and Thin Overlays (Project, Topic 24-10),
3. Cost Effective Preventive Maintenance (Topic 25-10), and
4. Chip Seals for High-volume Roads (Topic 14-8A).

REFERENCES

1. Teets, M.K., "1993 Highway Statistics", Federal Highway Administration, Office of Information Management, Report No. FHWA-PL-94-023, Washington DC, October 1994.
2. "The Status of the Nation's Highways, Bridges, and Transit: Conditions and Performance", U.S.D.O.T., Federal Highway Administration, Report No. FHWA-PL-93-017, Washington, DC, 1993.
3. O'Brien, L.G., "Evolution and Benefits of Preventive Maintenance Strategies", NCHRP Synthesis of Highway Practices 153, Transportation Research Board, National Research Council, Washington, DC, 1989.
4. Peterson, D. E., "Life Cycle Cost Analysis of Pavements," NCHRP Synthesis 122, Transportation Research Board, National Research Council, Washington D.C., 1985.
5. Haas, R.C.G., Hudson, W.R., and J.P. Zaniewski, *Modern Pavement Management*, Kreiger Publishing, Malabar, FL., 1994.
6. Peterson, D.E., "Evaluation of Pavement Maintenance Strategies," NCHRP Synthesis 77, Transportation Research Board, National Research Council, Washington D.C., 1981.
7. Darter, M.I., Smith, R.E., and Shahin, M.Y., "Use of Life Cycle Analysis as the Basis for Determining the Cost-Effectiveness of Maintenance and Rehabilitation Treatments for Developing a Network Level Assignment Procedure," Proc., North American Pavement Management Conference, Toronto Canada, 1985.
8. Mouaket, I.M., Al-Mansour, a., and Sinha, K.C., "Evaluation of the Cost Effectiveness of Pavement Surface Maintenance Activities," Report No. FHWA/IN/JHRP-90-12, Joint Highway Research Project, Purdue University, West Lafayette, IN, 1991.
9. Al-Mansour, A.I., and Sinha, K.C., "Economic Analysis of Pavement Preventive Maintenance," Transportation Research Record 1442, Transportation Research Board, National Research Council, Washington D.C., 1994.

10. Geoffroy, D.N., "Cost Effective Preventive Maintenance", (Second Draft) NCHRP Project 20-5, Topic 25-10, Transportation Research Board, National Research Council, Washington, DC, 1994.
11. Chong, G.J., and W.A. Phang, "Improved Preventive Maintenance: Sealing Cracks in Flexible Pavements in Cold Regions", Transportation Research Record 1205, Pavement Maintenance, Transportation Research Board, National Research Council, Washington, DC, 1988.
12. Sharaf, E.A., Shahin, M.Y., and K.C. Sinha, "Analysis of the Effect of Deferring Pavement Maintenance", Transportation Research Record 1205, Pavement Maintenance, Transportation Research Board, National Research Council, Washington, DC, 1988.
13. "Comprehensive Report on Preventive Maintenance", New York State Department of Transportation, Albany NY, April 1992.
14. Raza, H., "Summary Report - 1993 Field Evaluations of SPS-3 and SPS-4 Test Sites", Federal Highway Administration, Office of Engineering/Office of Technical Applications, Report No. FHWA-SA-94-078, Washington DC, October 1994.
15. Smith, R., Freeman, T., and O. Pendleton, "Pavement Maintenance Effectiveness", Report SHRP-H-358, National Research Council, Washington, DC, 1993.
16. "Distress Identification Manual for the Long-Term Pavement Performance Project", Strategic Highway Research Program Report SHRP-P-338, National Research Council, Washington, DC, 1993.
17. "Guide for the Design of Pavement Structures," American Society of Highway and Transportation Officials, Washington, D.C., 1993.
18. Mamlouk, M., Zaniewski, J.P., Houston, S., and W. Houston, "Rational Characterization of Pavement Structures Using Deflection Analysis", Volume 1 Final Report, Arizona Department of Transportation, Phoenix, Arizona, December, 1988.
19. Hot Mix Asphalt Paving, UN-13 (CEMP-ET), Corps of Engineers, 1991.
20. Kennedy, T.W., Moulthrop, J.S., and G.A. Huber, "Development of SHRP Mixture Specifications and Design and Analysis System", Vol., 62, Journal of Association of Asphalt Paving Technologists, Association of Asphalt Paving Technologist, St. Paul,, MN, 1993.
21. "The Asphalt Handbook," Manual Series No. 4, Asphalt Institute, 1989.

22. Standard Specifications for Transportation Materials and Methods of Sampling and Testing, Part I, Specifications, American Association of State Highway and Transportation Officials, Washington DC, 1986.
23. Raza, H., "An Overview of Surface Rehabilitation Techniques for Asphalt Pavement," Instructor's Guide, Publication No. FHWA-SA-94-074, Federal Highway Administration, Washington, DC, 1994.
24. "Techniques For Pavement Maintenance and Rehabilitation Using Asphalt," A 1984-85 Workshop series, The Asphalt Institute, 1984.
25. Roberts, F.L. et al., "Hot Mix Asphalt Materials, Mixture Design, and Construction," 1st edition, NAPA Education Foundation, Lanham, M.D., 1991.
26. Schuller, S., "Chip Seals For High Traffic Pavements," Transportation Research Board, Washington, DC, 1990.
27. "A Basic Asphalt Emulsion Manual," 2nd ed., Asphalt Emulsion Manufacturers Association, Washington, D.C, 1986.
28. Kandhal, P.S. and Motter, J.B., "Criteria For Accepting Precoated Aggregates For Seal Coats and Surface Treatments," Transportation Research Record 1300, Washington, DC, 1991.
29. "An Overview of Surface Rehabilitation Techniques for Asphalt Pavements," Federal Highway Administration, Washington, DC, 1992.
30. International Slurry Surfacing Association, "Recommended Reference Guidelines for Emulsified Slurry Seal," Leaflet A143, Jan. 1991.
31. International Slurry Surfacing Association, "Recommended Performance Guidelines for Micro-Surfacing," Leaflet A105, Jan. 1991.
32. Raza, H., "Design, Construction, and Performance of Micro-surfacing," Instructor's Guide, Publication No. FHWA-SA-94-072, Federal Highway Administration, Washington, DC, 1994.
33. "State of the Practice- Design, Construction, and Performance of Micro-surfacing," Publication No. FHWA-SA-94-051, Federal Highway Administration, Washington, DC, 1994.
34. Acott, M., "Thin Hot Mix Asphalt Surfacing," Information Series 110, National Asphalt Pavement Association, Lanham, Maryland, 1991.

35. Stuart, K.D., "Stone Mastic Asphalt (SMA) Mixture Design," Report No. FHWA-RD-92-006, Federal Highway Administration, Washington, DC, March 1992.
36. Stuart, K.D., and Mogawer, W.S., "Effect of Coarse Aggregate Content on Stone Matrix Asphalt (SMA) Durability and Low Temperature Cracking," Preprint 950301, Transportation Research Board, Washington, DC, 1994.
37. Stuart, K.D., and Mogawer, W.S., "Effect of The Coarse Aggregate Content on Stone Matrix Asphalt (SMA) Rutting And Draindown," Preprint 950193.
38. SMA Technical Working Group (Sponsored by the FHWA Office of Technology Applications), "SMA Materials and Construction Model Guidelines," January 1994.
39. "Novachip, A New Type of Pavement Surfacing" Screg routes, France.
40. "Open-Graded Friction Courses for Highways," NCHRP Synthesis of Highway Practice 49, Transportation Research Board, Washington, DC, 1978.
41. AASHTO "Draft Report on The AASHTO Survey of Current Use of OGFC," May 1989, (Not Published).
42. McGennis, R.B., et al., "Background of SUPERPAVE Asphalt Mixture Design and Analysis," Publication No. FHWA-SA-95-003, Federal Highway Administration, Feb. 1995.
43. "Asphalt Pavement Repair Manuals of Practice," Report No. SHRP-H-348, Federal Highway Administration, August 1993.
44. "Automated Crack Sealing Machine," TR News, No 176 Transportation Research Board, Jan.-Feb. 1995.
45. "Concrete Pavement Repair Manuals of Practice," Report No. SHRP-H-349, Federal Highway Administration, August 1993.
46. "Techniques for Pavement Rehabilitation," A Training Course, 5th ed., National Highway Institute, Federal Highway Administration, March 1993.
47. NCHRP Synthesis of Highway Practice 211: Design, Construction, and Maintenance of PCC Pavement Joints, Transportation Research Board, National Research Council, Washington, DC, 1995.

48. "Slab Stabilization Guidelines for Concrete Pavements", American Concrete Pavement Association, Washington D.C., 1994
49. Taha, R., Selim. A., Hasan, S., and B. Lunde, "Evaluation of Highway Undersealing Practices of Portland Cement Concrete Pavements", Transportation Research Record 1449, Transportation Research Board, Washington D.C., 1994
50. Allen, H., "Final Report of Committee on Maintenance of Concrete Pavements as Related to the Pumping Action of Slabs", HRB Proc. Vol. 28, Highway Research Board, Washington D.C., 1948
51. Taha, R., Selim. A., Schaefer, V., and S. Hasan, "Evaluation of Undoweled Plain Jointed PCC Pavements in South Dakota", Report No. SD92-01-F, South Dakota Department of Transportation, Pierre, SD, 1994
52. "AASHTO/FHWA Industry Joint Training, Construction of Portland Cement Concrete Pavements", Draft, American Concrete Pavement Association, Arlington Heights, Il, 1995
53. Pierce, L., "Portland Cement Concrete Pavement Rehabilitation in Washington State: A Case Study", Transportation Research Record 1449, Transportation Research Board, Washington D.C., 1994
54. Bullard, D.J., Smith, R.E., and T.J. Freeman, "Development of a Procedure to Rate the Application of Pavement Maintenance Treatments", Strategic Highway Research Program Report SHRP-M/FR-92-102, National Research Council, Washington, DC, 1992.
55. Proposed Test Method - "Detection of Voids Under Rigid Pavements", Strategic Highway Research Program, National Research Council, Washington, DC, 1992.
56. Making Pavement Maintenance More Effective, Training Supplement, SHRP H-380, 1994.
57. "Making Pavement Maintenance More Effective, A Slide Presentation," Texas Transportation Institute, Texas A&M University College Station, SHRP, National Research Council, Washington, DC.

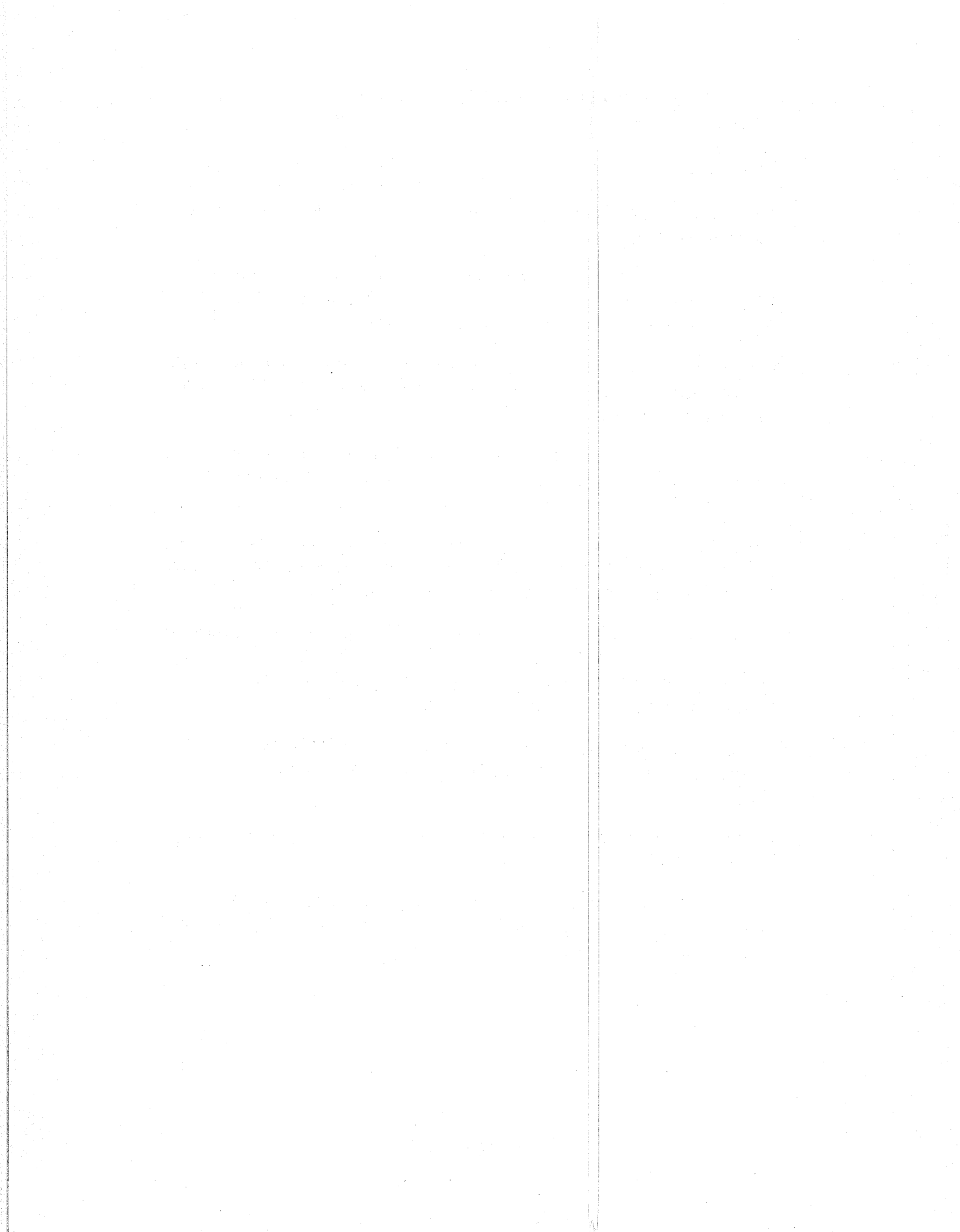

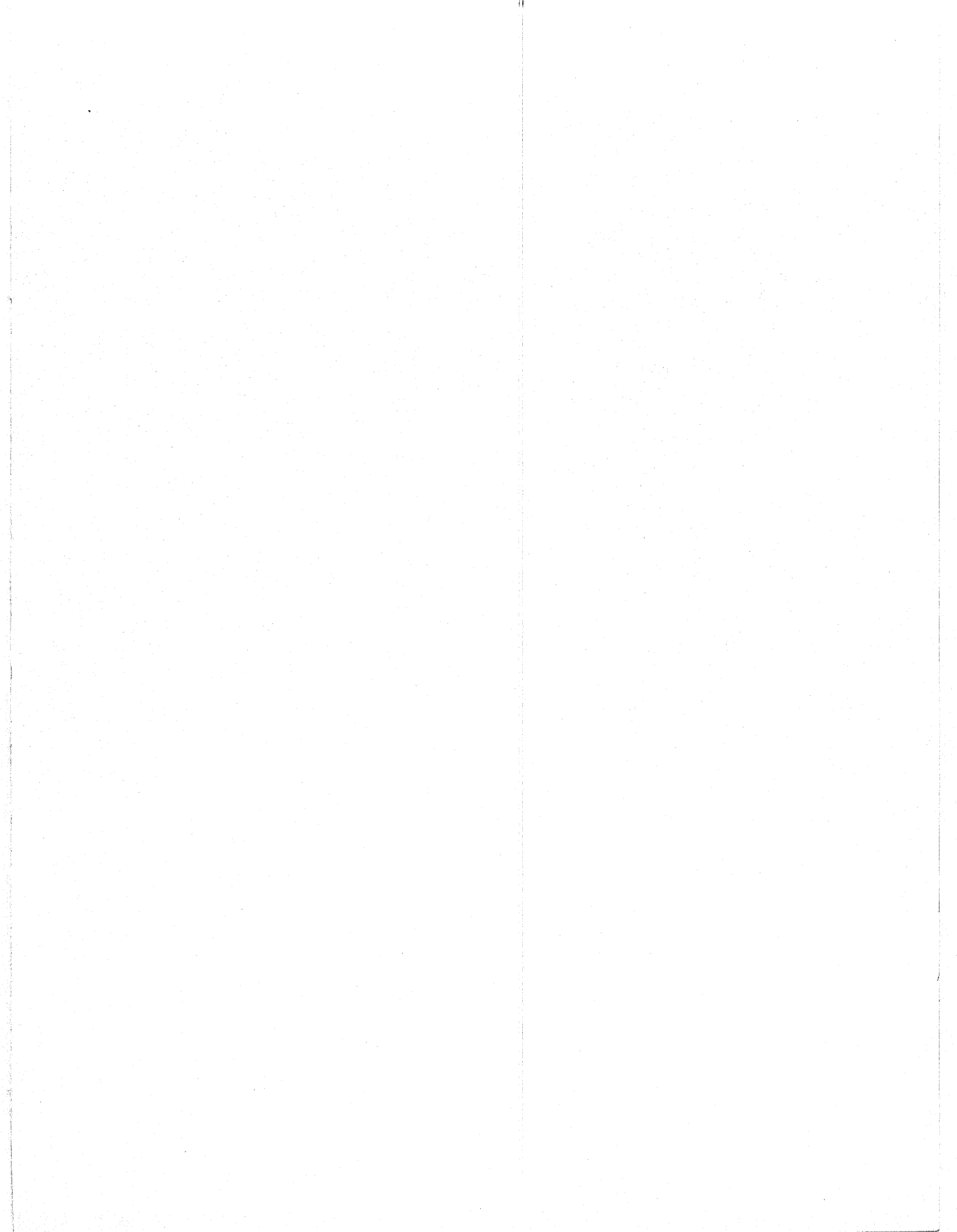

Federal Highway Administration
U.S. Department of Transportation
400 Seventh Street, SW
Washington, D.C. 20590

Publication No. FHWA-SA-96-027
HNG-40/2-96(3M)P