

# PAVEMENT MAINTENANCE EFFECTIVENESS / INNOVATIVE MATERIALS WORKSHOP

Participant's

Handbook

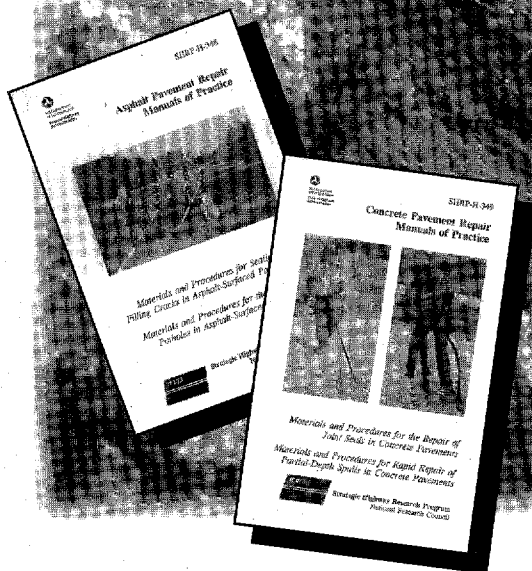

U.S. Department  
of Transportation  
**Federal Highway  
Administration**

## NOTICE

This document is disseminated under the sponsorship of the Department of Transportation in the interest of information exchange. This publication does not constitute a standard, specification, or regulation.

The United States Government does not endorse products or manufacturers. Trademarks or manufacturers' names appear herein only because they are considered essential to the object of this document.



U.S. Department  
of Transportation

**Federal Highway  
Administration**

OCTOBER 1995

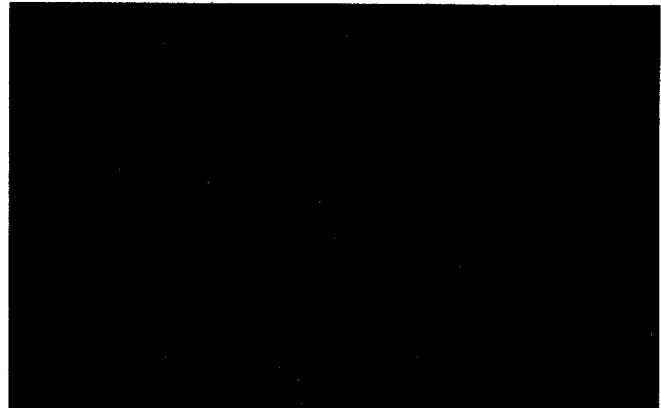

Participants Workbook



**Pavement  
Maintenance  
Effectiveness  
Innovative  
Materials  
Workshop**



*Innovation Through Partnerships*



# PAVEMENT MAINTENANCE EFFECTIVENESS INNOVATIVE MATERIALS WORKSHOP

Page

## SESSION 1. PAVEMENT MAINTENANCE EFFECTIVENESS

|  |     |
|--|-----|
| INTRODUCTION .....                     | 1-1 |
| EFFECTIVE PAVEMENT MAINTENANCE .....   | 1-3 |
| Why Maintain Pavements? .....          | 1-5 |
| OBJECTIVES AND SCOPE OF WORKSHOP ..... | 1-5 |
| WORKSHOP OUTLINE .....                 | 1-7 |
| SUMMARY .....                          | 1-7 |

## SESSION 2. CURRENT RESEARCH TRENDS

|   |      |
|---|------|
| INTRODUCTION .....                            | 2-1  |
| PAVEMENT MAINTENANCE AND PAVEMENT LIFE .....  | 2-2  |
| TIMING PAVEMENT MAINTENANCE .....             | 2-7  |
| NEW MAINTENANCE TECHNOLOGIES .....            | 2-8  |
| Pavement Survey and Evaluation .....          | 2-8  |
| Repair and Treatment Equipment .....          | 2-10 |
| Pavement Maintenance Management Systems ..... | 2-11 |
| EFFECT OF MAINTENANCE ON THE PUBLIC .....     | 2-12 |
| CASE STUDIES .....                            | 2-12 |
| Ontario .....                                 | 2-12 |
| France .....                                  | 2-13 |
| Texas .....                                   | 2-13 |
| SUMMARY .....                                 | 2-15 |

## SESSION 3. PCC JOINT RESEALING

|                                      |     |
|--------------------------------------|-----|
| SESSION OBJECTIVES .....             | 3-1 |
| SHRP RESEARCH FINDINGS TO DATE ..... | 3-1 |
| RESEALING OBJECTIVES .....           | 3-5 |
| PROJECT PLANNING AND DESIGN .....    | 3-7 |

# PAVEMENT MAINTENANCE EFFECTIVENESS INNOVATIVE MATERIALS WORKSHOP

|  | <u>Page</u> |
|--|-------------|
| <b>Selecting a Sealant Material</b> .....              | 3-7         |
| <u>Laboratory Testing</u> .....                        | 3-8         |
| <u>Selecting a Backer Material</u> .....               | 3-9         |
| <u>Selecting a Primer Material</u> .....               | 3-10        |
| <b>Selecting a Material Design Configuration</b> ..... | 3-10        |
| <b>Selecting an Installation Procedure</b> .....       | 3-13        |
| <b>Determining Resource Requirements</b> .....         | 3-15        |
| <u>Materials</u> .....                                 | 3-15        |
| <u>Equipment</u> .....                                 | 3-15        |
| <u>Labor</u> .....                                     | 3-16        |
| <b>Cost Effectiveness</b> .....                        | 3-16        |
| <b>INSTALLATION</b> .....                              | 3-19        |
| <b>Traffic Control</b> .....                           | 3-19        |
| <b>Safety</b> .....                                    | 3-19        |
| <b>Joint Preparation</b> .....                         | 3-20        |
| <u>Removing Old Sealant</u> .....                      | 3-20        |
| <u>Refacing the Joints</u> .....                       | 3-22        |
| <u>Sandblasting</u> .....                              | 3-24        |
| <u>Airblasting</u> .....                               | 3-26        |
| <u>Applying Primer Material</u> .....                  | 3-28        |
| <b>Material Preparation and Application</b> .....      | 3-28        |
| <u>Installing Backer Rod</u> .....                     | 3-28        |
| <u>Sealant Installation</u> .....                      | 3-30        |
| <i>Hot-Applied Sealants</i> .....                      | 3-31        |
| Heating the Sealant .....                              | 3-32        |
| Applying the Sealant .....                             | 3-33        |
| Cleanup Requirements .....                             | 3-34        |
| <i>Cold-Applied Sealants</i> .....                     | 3-36        |

# PAVEMENT MAINTENANCE EFFECTIVENESS INNOVATIVE MATERIALS WORKSHOP

|  | <u>Page</u> |
|--|-------------|
| Loading Sealant into the Pumping Apparatus ..... | 3-36        |
| Applying the Sealant .....                       | 3-37        |
| Cleanup Requirements .....                       | 3-38        |
| <b>EVALUATING RESEAL EFFECTIVENESS .....</b>     | <b>3-39</b> |
| <b>Reseal Performance .....</b>                  | <b>3-39</b> |
| <u>IA-VAC Joint Seal Tester</u> .....            | 3-41        |
| <b>Pavement Performance .....</b>                | <b>3-42</b> |

## SESSION 4. PCC PARTIAL-DEPTH SPALL REPAIR

|   |             |
|---|-------------|
| <b>SESSION OBJECTIVES .....</b>             | <b>4-1</b>  |
| <b>SHRP RESEARCH FINDINGS TO DATE .....</b> | <b>4-1</b>  |
| <b>REPAIR OBJECTIVES .....</b>              | <b>4-5</b>  |
| <b>PROJECT PLANNING AND DESIGN .....</b>    | <b>4-5</b>  |
| <b>Selecting a Material .....</b>           | <b>4-7</b>  |
| <b>Cementitious Concretes .....</b>         | <b>4-10</b> |
| <u>Portland Cement Concrete</u> .....       | 4-10        |
| <u>Gypsum-Based Concrete</u> .....          | 4-10        |
| <u>Magnesium Phosphate Concrete</u> .....   | 4-10        |
| <u>High-Alumina Concrete</u> .....          | 4-11        |
| <u>Hydraulic Cement Concrete</u> .....      | 4-11        |
| <b>Polymer Concretes .....</b>              | <b>4-11</b> |
| <u>Epoxy Concrete</u> .....                 | 4-11        |
| <u>Methyl Methacrylate Concrete</u> .....   | 4-11        |
| <u>Polyurethane Concrete</u> .....          | 4-12        |
| <b>Bituminous Materials .....</b>           | <b>4-12</b> |
| <u>Cost Effectiveness</u> .....             | 4-12        |

# PAVEMENT MAINTENANCE EFFECTIVENESS INNOVATIVE MATERIALS WORKSHOP

|  | <u>Page</u> |
|--|-------------|
| <b>Laboratory Testing</b> .....                      | 4-12        |
| <b>Selecting a Patch Preparation Procedure</b> ..... | 4-13        |
| <b>Saw-and-Patch</b> .....                           | 4-14        |
| <b>Chip-and-Patch</b> .....                          | 4-16        |
| <b>Mill-and-Patch</b> .....                          | 4-18        |
| <b>Waterblast-and-Patch</b> .....                    | 4-19        |
| <b>Clean-and-Patch</b> .....                         | 4-20        |
| <b>Determining Resource Requirements</b> .....       | 4-21        |
| <u>Material</u> .....                                | 4-21        |
| <u>Equipment</u> .....                               | 4-21        |
| <u>Labor</u> .....                                   | 4-21        |
| <b>INSTALLATION</b> .....                            | 4-26        |
| <b>Traffic Control</b> .....                         | 4-26        |
| <b>Safety</b> .....                                  | 4-26        |
| <b>Joint Preparation</b> .....                       | 4-27        |
| <b>Material Removal</b> .....                        | 4-30        |
| <b>Cleaning the Repair Area</b> .....                | 4-31        |
| <u>Inspection of the Repair Area</u> .....           | 4-32        |
| <b>Material Preparation and Application</b> .....    | 4-32        |
| <u>Bonding Agents</u> .....                          | 4-32        |
| <u>Material Mixing</u> .....                         | 4-33        |
| <u>Material Placement</u> .....                      | 4-33        |
| <b>Material Finishing and Curing</b> .....           | 4-34        |
| <u>Consolidation and Compaction</u> .....            | 4-34        |
| <u>Screeding and Finishing</u> .....                 | 4-35        |
| <u>Curing</u> .....                                  | 4-35        |
| <b>Joint Sealing</b> .....                           | 4-36        |
| <b>EVALUATING REPAIR EFFECTIVENESS</b> .....         | 4-36        |
| <b>Repair Performance</b> .....                      | 4-36        |



# PAVEMENT MAINTENANCE EFFECTIVENESS INNOVATIVE MATERIALS WORKSHOP

|   | <u>Page</u> |
|---|-------------|
| <b>Material Preparation and Application</b> ..... | 5-28        |
| <u>Bond-Breaker Installation</u> .....            | 5-28        |
| <u>Material Preparation</u> .....                 | 5-28        |
| <u>Material Application</u> .....                 | 5-30        |
| <u>Kettle Cleanup</u> .....                       | 5-32        |
| <b>Material Finishing</b> .....                   | 5-32        |
| <b>Material Blotting</b> .....                    | 5-33        |
| <b>EVALUATING TREATMENT EFFECTIVENESS</b> .....   | 5-33        |
| <b>Treatment Performance</b> .....                | 5-34        |
| <b>Pavement Performance</b> .....                 | 5-35        |

## SESSION 6. AC POTHOLE REPAIR

|  |      |
|--|------|
| <b>SESSION OBJECTIVES</b> .....                      | 6-1  |
| <b>SHRP RESEARCH FINDINGS TO DATE</b> .....          | 6-1  |
| <b>REPAIR OBJECTIVES</b> .....                       | 6-4  |
| <b>PROJECT PLANNING AND DESIGN</b> .....             | 6-5  |
| <br>   |      |
| <b>Selecting a Material</b> .....                    | 6-6  |
| <u>Cost Effectiveness</u> .....                      | 6-6  |
| <u>Laboratory Testing</u> .....                      | 6-6  |
| <br>   |      |
| <b>Selecting a Patch Preparation Procedure</b> ..... | 6-7  |
| <u>Throw-and-Roll</u> .....                          | 6-8  |
| <u>Edge Seal</u> .....                               | 6-9  |
| <u>Semi-Permanent</u> .....                          | 6-10 |
| <u>Spray Injection</u> .....                         | 6-11 |
| <u>Surface Seal</u> .....                            | 6-12 |
| <u>Heat-and-Tack</u> .....                           | 6-14 |

# PAVEMENT MAINTENANCE EFFECTIVENESS INNOVATIVE MATERIALS WORKSHOP

|                            | <u>Page</u> |
|----------------------------|-------------|
| Pavement Performance ..... | 4-37        |

## SESSION 5. AC CRACK TREATMENT

|  |      |
|--|------|
| SESSION OBJECTIVES .....                               | 5-1  |
| SHRP RESEARCH FINDINGS TO DATE .....                   | 5-1  |
| TREATMENT OBJECTIVES .....                             | 5-5  |
| PROJECT PLANNING AND DESIGN .....                      | 5-8  |
| <b>Selecting a Material</b> .....                      | 5-8  |
| <u>Laboratory Testing</u> .....                        | 5-10 |
| <b>Selecting a Material Design Configuration</b> ..... | 5-12 |
| <b>Determining Resource Requirements</b> .....         | 5-16 |
| <u>Material</u> .....                                  | 5-16 |
| <u>Equipment</u> .....                                 | 5-16 |
| <u>Labor</u> .....                                     | 5-16 |
| <b>Cost Effectiveness</b> .....                        | 5-18 |
| <b>INSTALLATION</b> .....                              | 5-20 |
| <b>Traffic Control</b> .....                           | 5-21 |
| <b>Safety</b> .....                                    | 5-21 |
| <b>Crack Cutting</b> .....                             | 5-22 |
| <b>Crack Cleaning and Drying</b> .....                 | 5-24 |
| <u>Airblasting</u> .....                               | 5-24 |
| <u>Hot Airblasting</u> .....                           | 5-25 |
| <u>Sandblasting (Followed by Airblasting)</u> .....    | 5-27 |
| <u>Wirebrushing (and Airblasting)</u> .....            | 5-27 |

# PAVEMENT MAINTENANCE EFFECTIVENESS INNOVATIVE MATERIALS WORKSHOP

|   | <u>Page</u> |
|---|-------------|
| <b>Determining Resource Requirements</b> .....    | 6-15        |
| <u>Materials</u> .....                            | 6-15        |
| <u>Equipment</u> .....                            | 6-16        |
| <u>Labor</u> .....                                | 6-16        |
| <b>INSTALLATION</b> .....                         | 6-16        |
| <b>Traffic Control</b> .....                      | 6-16        |
| <b>Safety</b> .....                               | 6-17        |
| <b>Pothole Preparation</b> .....                  | 6-17        |
| <b>Material Preparation and Application</b> ..... | 6-17        |
| <b>Material Finishing and Curing</b> .....        | 6-18        |
| <b>EVALUATING REPAIR EFFECTIVENESS</b> .....      | 6-18        |
| <b>Repair Performance</b> .....                   | 6-18        |
| <b>Pavement Performance</b> .....                 | 6-19        |
| <b>REFERENCES</b> .....                           |             |
| <b>GLOSSARY</b> .....                             |             |

## LIST OF FIGURES

|  | <u>Page</u> |
|--|-------------|
| Figure 1-1. Typical pavement life cycle. . . . .   | 1-4         |
| Figure 1-2. Relationship between pavement performance and routine maintenance . . . . .  | 1-4         |
| Figure 2-1. Relationship between pavement performance and routine maintenance . . . . .  | 2-3         |
| Figure 2-2. Subjective performance rating of SHRP SPS-3 and SPS-4 maintenance test sections after 3 years. . . . .               | 2-5         |
| Figure 2-2. Subjective performance rating of SHRP SPS-3 and SPS-4 maintenance test sections after 3 years. (continued) . . . . . | 2-6         |
| Figure 2-3. Performance curves of sealed and unsealed pavement sections in Ontario(Highway 21) . . . . .                         | 2-14        |
| Figure 2-4. Performance curves of sealed and unsealed pavement sections in Ontario(Highway 11) . . . . .                         | 2-14        |
| Figure 3-1. Material placement configurations for SHRP H-106 joint reseal treatments . . . . .                                   | 3-4         |
| Figure 3-2. Pumping of fines from subsurface layers. . . . .   | 3-6         |
| Figure 3-3. Collection of stones and sand in joint. . . . .  | 3-6         |
| Figure 3-4. Typical joint cross section . . . . .  | 3-10        |
| Figure 3-5. Rear-mounted joint plow. . . . .   | 3-20        |
| Figure 3-6. Sandblasting operation . . . . .   | 3-24        |
| Figure 3-7. Adjustable backer rod insertion tool. . . . .  | 3-29        |
| Figure 3-8. Hot-applied sealant application. . . . .   | 3-34        |
| Figure 3-9. Silicone sealant installation . . . . .  | 3-37        |
| Figure 3-10. Example joint seal deterioration chart . . . . .  | 3-40        |
| Figure 3-11. IA-VAC joint seal tester . . . . .  | 3-41        |
| Figure 4-1. Development of partial-depth spalls at PCC joints. . . . .   | 4-6         |
| Figure 4-2. Proper use of jackhammers for removal of spalled PCC material. . . . .   | 4-14        |
| Figure 4-3. Saw overcuts for rectangular repair areas. . . . .   | 4-15        |
| Figure 4-4. Scalloped edges resulting from chip and patch procedure. . . . .   | 4-17        |
| Figure 4-5. Vertical sides for chip and patch repair areas. . . . .  | 4-17        |
| Figure 4-6. Milling machine edges in need of straightening. . . . .  | 4-18        |
| Figure 4-7. Water blasting equipment with remote-controlled robot device. . . . .  | 4-19        |
| Figure 4-8. Dimensions of joint bond breaker for rigid repairs. . . . .  | 4-27        |
| Figure 4-9. Bond breaker with scored top for renewal. . . . .  | 4-28        |
| Figure 4-10. Use of latex could for joining multiple pieces of bond breaker. . . . .   | 4-29        |
| Figure 4-11. Joint placement in flexible repairs bridging existing joint. . . . .  | 4-30        |
| Figure 4-12. Sawing pattern for large repair areas. . . . .  | 4-31        |
| Figure 4-13. Use of internal vibrator for cementitious repairs. . . . .  | 4-34        |
| Figure 5-1. Material placement configurations for SHRP H-106 crack treatments . . . . .  | 5-4         |
| Figure 5-2. Basic material placement configurations . . . . .  | 5-13        |
| Figure 5-3. Example problem for determining material requirements . . . . .  | 5-17        |
| Figure 5-4. Example of treatment cost-effectiveness analysis . . . . .   | 5-19        |
| Figure 5-5. Routing with a rotary-impact router . . . . .  | 5-22        |
| Figure 5-6. Crack segment missed by cutting equipment . . . . .  | 5-23        |

## LIST OF FIGURES (Continued)

|   | <u>Page</u> |
|---|-------------|
| Figure 5-7. Hot airblasting using HCA (heat) lance .....                | 5-26        |
| Figure 5-8. Treatment material application. ....                        | 5-31        |
| Figure 5-9. Example graph of treatment effectiveness versus time .....  | 5-35        |
| Figure 6-1. Edge seal pothole repair. ....                              | 6-10        |
| Figure 6-2. Pavement saw cutting semi-permanent repair boundaries. .... | 6-11        |
| Figure 6-3. Single-vehicle spray injection device. ....                 | 6-13        |
| Figure 6-4. Truck-trailer spray injection device. ....                  | 6-13        |
| Figure 6-5. Propane torch being used to heat cold-mix. ....             | 6-14        |

## LIST OF TABLES

|             |   | <u>Page</u> |
|-------------|---|-------------|
| Table 2-1.  | Preliminary analysis of SMERP sites. ....   | 2-15        |
| Table 3-1.  | Summary of material-procedure combinations used in SHRP-H-106 joint resealing experiment. ....            | 3-3         |
| Table 3-2.  | Summary of PCC joint resealing materials. ....  | 3-8         |
| Table 3-3.  | Backer-rod materials. ....  | 3-9         |
| Table 3-4.  | Typical joint design dimensions. ....   | 3-12        |
| Table 3-5.  | Common joint preparation and sealant installation methods. ....   | 3-13        |
| Table 3-6.  | Production rates for various resealing activities. ....   | 3-16        |
| Table 3-7.  | Summary of resealing option costs. ....   | 3-18        |
| Table 3-8.  | Troubleshooting procedures for plowing operations. ....   | 3-22        |
| Table 3-9.  | Troubleshooting procedures for resawing operations. ....  | 3-23        |
| Table 3-10. | Troubleshooting procedures for sandblasting operations. ....  | 3-26        |
| Table 3-11. | Troubleshooting procedures for airblasting operations. ....   | 3-27        |
| Table 3-12. | Troubleshooting procedures for backer-rod installation. ....  | 3-30        |
| Table 3-13. | Troubleshooting procedures for hot-applied sealant application. ....                                      | 3-35        |
| Table 3-14. | Troubleshooting procedures for cold-applied sealant application. ....                                     | 3-39        |
| Table 4-1.  | Summary of material-procedure combinations used in SHRP H-106 partial-depth spall repair experiment. .... | 4-3         |
| Table 4-2.  | Descriptions of SHRP H-106 partial-depth spall repair procedures. ....                                    | 4-4         |
| Table 4-3.  | SHRP H-106 partial-depth spall repair materials. ....   | 4-8         |
| Table 4-4.  | Initial materials selection criteria for some rapid-setting materials. ....                               | 4-9         |
| Table 4-5.  | Present worth costs for two partial-depth spall repair alternatives. ....                                 | 4-13        |
| Table 4-6.  | Typical equipment used for the five patch preparation procedures. ....                                    | 4-22        |
| Table 4-7.  | Typical mixing and placement equipment and supplies. ....   | 4-23        |
| Table 4-8.  | Typical personnel used for spall repair procedures. ....  | 4-24        |
| Table 4-9.  | Typical personnel used for mixing and placing. ....   | 4-25        |
| Table 4-10. | Worksheet for calculating patch survival rate. ....   | 4-38        |
| Table 5-1.  | Summary of material-method combinations used in SHRP H-106 crack treatment experiment. ....               | 5-3         |
| Table 5-2.  | Guidelines for determining the type of crack maintenance to perform. ....                                 | 5-6         |
| Table 5-3.  | Recommended criteria for determining whether to seal or fill. ....  | 5-7         |
| Table 5-4.  | Summary of AC crack treatment materials. ....   | 5-10        |
| Table 5-5.  | Properties associated with various material types. ....   | 5-11        |
| Table 5-6.  | Placement configuration considerations. ....  | 5-17        |
| Table 5-7.  | Typical labor requirements and production rates for crack treatment operations. ....                      | 5-18        |
| Table 6-1.  | Summary of material-procedures combinations used in SHRP H-106 pothole repair experiment. ....            | 6-3         |
| Table 6-2.  | Descriptions of SHRP H-106 pothole patching procedures. ....  | 6-3         |
| Table 6-3.  | Present-worth costs for two pothole repair materials. ....  | 6-7         |
| Table 6-4.  | Worksheet for calculating patch survival rate. ....   | 6-20        |

## WORKSHOP SCHEDULE

| <u>SESSION</u> | <u>TITLE</u>                       | <u>TIME</u> |
|----------------|------------------------------------|-------------|
| 1              | PAVEMENT MAINTENANCE EFFECTIVENESS | 8:00—8:30   |
| 2              | CURRENT RESEARCH TRENDS            | 8:30—9:00   |
|                | BREAK                              | 9:00—9:15   |
| 3              | PCC JOINT RESEALING                | 9:15—10:45  |
| 4              | PCC SPALL REPAIR                   | 10:45—12:30 |
|                | LUNCH                              | 12:30—1:15  |
| 5              | AC CRACK TREATMENT                 | 1:15—2:45   |
|                | BREAK                              | 2:45—3:00   |
| 6              | AC POTHOLE REPAIR                  | 3:00—4:30   |
|                | DISCUSSION AND CLOSURE             | 4:30—5:00   |

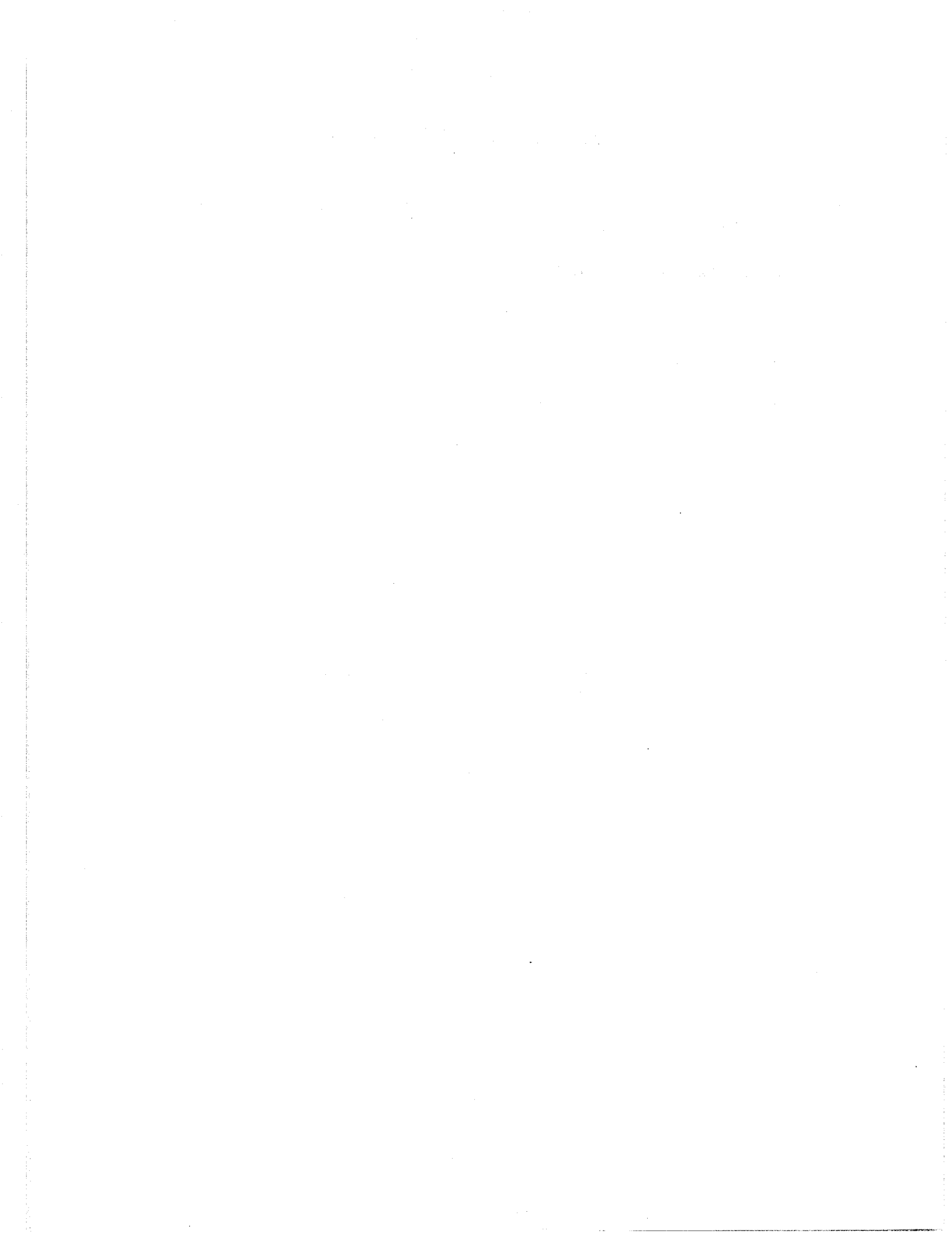



## Acknowledgment of Instructors

The following is the list of instructors for the 1-day workshop entitled “Pavement Maintenance Effectiveness/Innovative Materials.”

- ☞ A. Russell Romine, Principal Instructor
- ☞ Marshall L. Stivers, Co-Principal Instructor
- ☞ Thomas P. Wilson
- ☞ Lynn D. Evans
- ☞ Kelly L. Smith



## **SESSION 1. PAVEMENT MAINTENANCE EFFECTIVENESS**

**Time—0:30**

Notes

### **SESSION OBJECTIVES**

This session provides participants with an introduction to the concepts of effective and timely pavement maintenance. It also presents the overall objectives and scope of the workshop.

Upon successful conclusion of this session, the participant will be able to accomplish the following:

1. Understand why pavement maintenance is necessary and why careful consideration must be given to how and when it's performed.
2. List the major course objectives.
3. List the technical subjects that are included in the workshop.

### **INTRODUCTION**

Few would challenge the general concept that timely and properly performed maintenance on any product that deteriorates will improve the long-term performance of that product. This is a concept that we embrace routinely in our own lives; for example, every time we change the oil in our cars or repaint our houses, we demonstrate our belief in the principle that a well-maintained item will at least have a chance of providing the years of service expected of it. However, when it comes to pavements, observation suggests that we doubt the concept of the positive role of maintenance. Although a 1989 National Cooperative Highway Research Program (NCHRP) synthesis stated that most (78 percent) State highway agency chief executive officers strongly supported pavement maintenance as a cost-effective measure,<sup>1</sup> the actions of many highway agencies suggest a sharp contradiction: The level and quality of maintenance performed on our roads does not always reflect the relative importance of pavement maintenance.

How does this contradiction look? To begin with, inferior repairs are accepted far too often simply for the sake of expediency. For example, a widely used means of repairing potholes is the throw-and-go procedure in which cold mix patch material is shoveled from a maintenance truck into a pothole even as the truck is moving on to the next repair. A mound of cold mix is then left to be compacted and leveled off by traffic. This practice continues despite the fact that

## Notes

most maintenance practitioners of this repair method acknowledge that the patch may not last for more than a few hours.

Another common practice is to postpone pavement maintenance until its condition is too deteriorated to benefit from the action. Examples of procedures whose application are time-sensitive include surface treatments and crack sealing—by the time the need for these treatments is obvious, the pavement may be beyond salvage by these maintenance activities. Most skilled maintenance crews can look at a pavement and know whether or not crack sealing will be worthwhile. Yet the marginal pavements are often the ones that receive maintenance because there is a reluctance to apply maintenance treatments to pavements that appear to the casual observer to be in fine condition.

There is overwhelming evidence available about the positive contributions of timely and appropriate maintenance to the long-term performance of pavements of all types. In recent years, a concerted effort has been made to gather this evidence, reassess it objectively, fill in gaps where necessary, and widely disseminate the useful and implementable findings to practitioners who can apply this information. This workshop is one such effort. It has at its foundation the following four beliefs:

1. There is an appropriate way to maintain pavements, a “do it right” approach that can help to ensure the success of any maintenance procedure.
2. The right procedure, which may combine materials and construction methods, is often only marginally more time-consuming than the incorrect methods.
3. Although the initial costs of the do-it-right procedure may be higher than conventional approaches, the improved long-term performance of such procedures usually more than justifies the higher initial expense.
4. Appropriate pavement maintenance procedures applied in a timely manner improve the performance and safety of a pavement and thus also reduces user costs. Conversely, the right maintenance procedure applied too late may add little or no benefit to the pavement.

Examples of other similar workshops can be found in the training programs of the National Highway Institute (NHI), seminars and workshops conducted by State Technology Transfer (T<sup>2</sup>) centers around the country, and the efforts of organizations such as the American Public Works Association (APWA) and the National Association of County Engineers (NACE).

## EFFECTIVE PAVEMENT MAINTENANCE

What is pavement maintenance? Why perform pavement maintenance? Is it even necessary? What happens if less-effective pavement maintenance treatments are applied? These questions are at the heart of the debate over pavement maintenance effectiveness and are addressed throughout this workshop. Concepts central to this discussion are defined as:

- **Routine pavement maintenance** is a program in which minor distresses in a pavement are repaired as they develop. Routine maintenance includes reactive or corrective maintenance activities, such as pothole repair and spall repair.
- **Preventive pavement maintenance** is a program strategy intended to arrest light deterioration, retard progressive failures, and reduce the need for routine maintenance and service activities.<sup>1</sup> Preventive maintenance, which includes activities such as crack sealing, joint resealing, and surface treatments, extends the useful life of a pavement and improves its level of service.
- **Cost-effectiveness** achieves an objective (such as a design life or a level of service) for the least cost or receives the most benefit from a fixed investment.

Although by these definitions, routine maintenance is more reactive than preventive maintenance, often no distinction is made between the two. What is important is the effect of these actions on a pavement. Routine maintenance could be thought of as those activities that allow an agency to maintain the performance desired from its pavements. The impact of this view of maintenance is shown in the graph of pavement deterioration in figure 1-1; routine maintenance is those corrective activities performed as the pavement follows its typical life cycle.

Pavement maintenance activities, such as joint repair, crack sealing, and pavement patching, represent activities that are capable of "extending the pavement life to at least achieve the design life of the facility."<sup>2</sup> This is more like preventive maintenance, and the effects of these actions are represented in the shaded curves in the upper right-hand side of figure 1-1, which show how maintenance might improve the overall condition of the pavement by shifting a portion of the performance curve to the right. This view is also reflected in the pavement deterioration curves shown in figure 1-2, where reactive maintenance is performed to reach the lower line.

When the two concepts of cost-effectiveness and pavement maintenance are joined, cost-effective pavement maintenance suggests maintenance strategies are selected that consider the life and the long-term benefits of the procedure rather than only its initial costs. Cost-effective maintenance, by its definition, provides a positive, measurable, and lasting benefit.

Notes

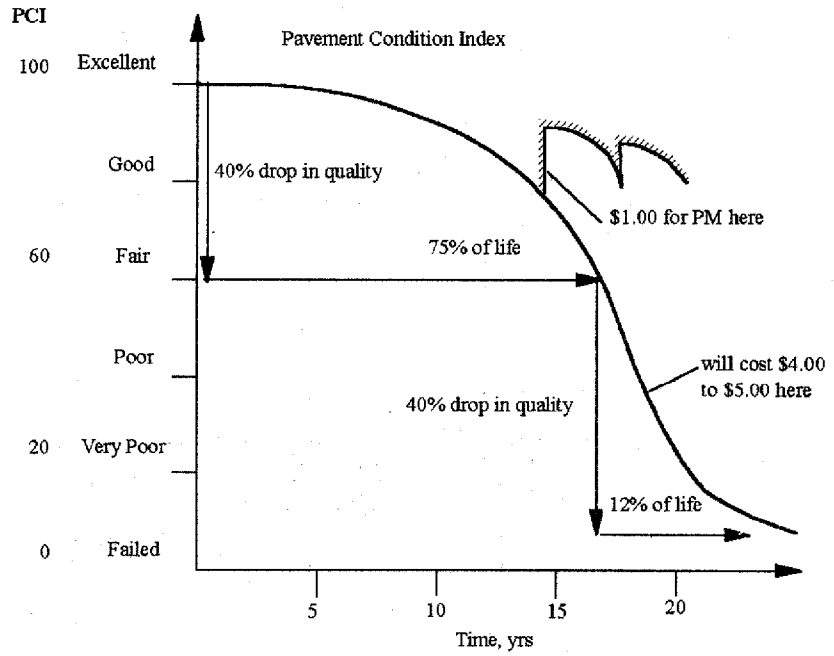

Figure 1-1. Typical pavement life cycle.<sup>1</sup>

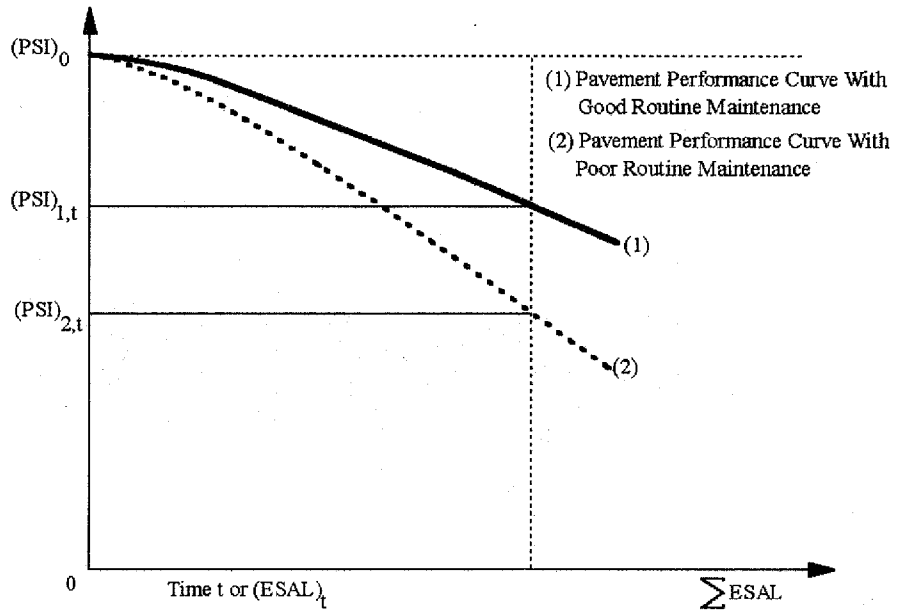

Figure 1-2. Relationship between pavement performance and routine maintenance.<sup>3</sup>

## Why maintain pavements?

From the above discussion, it should be clear that pavement maintenance is an essential part of an agency's efforts to protect its investment in pavements. Whether maintenance actually extends the life of the pavement or simply allows the pavement to reach its intended life, pavement maintenance helps to ensure that a pavement achieves the desired level of service. As a pavement ages and is exposed to more and more loads, maintenance activities allow the pavement to continue to perform at acceptable levels.

If maintenance contributes to a pavement's ability to provide the intended level of service over its design life, another reason to perform routine and preventive maintenance is it postpones the need for more costly pavement rehabilitation and reconstruction. For example, sealing joints in concrete pavements should delay the need for spall repair, as the collection of incompressible materials (i.e., rocks, sand) in the joints is largely reduced. Similarly, sealing cracks in asphalt pavements should delay the need for pothole repair, as the rate of pavement deterioration because of moisture infiltration is reduced. Failure to perform pavement maintenance results in a pavement that deteriorates faster.

Proper pavement maintenance also helps to provide a higher level of service to the traveling public. Well-maintained pavements will have a higher serviceability rating than pavements that are not as well maintained. Well-maintained pavements are safer to operate traffic on, as they will have fewer distresses. Well-maintained pavements will also have better skid resistance, further contributing to their better performance. These benefits may be difficult to measure, but they are not ignored by the traveling public.

The benefits of performing cost-effective pavement maintenance can be summarized as:

- Making a positive contribution to pavement life.
- Postponing more expensive pavement rehabilitation and reconstruction.
- Contributing to an improved ride and enhanced safety.
- Cost-effective way of protecting a pavement investment.

## OBJECTIVES AND SCOPE OF WORKSHOP

Applying the previously mentioned benefits of pavement maintenance, the objective of effective pavement maintenance should be to use the most appropriate combination of materials and maintenance procedures, applied in a timely manner, to provide the maximum benefit to the traveling public. That benefit might be realized in a number of different ways, including better pavement

## Notes

performance, longer lasting pavement repairs, and shorter and less frequent delays to users. Over time, this should also translate into an economic benefit—lower maintenance expenditures and lower user costs.

This workshop presents information on materials and procedures that can improve the performance of routine and preventive maintenance repairs and treatments. It focuses on four primary maintenance areas:

1. Pothole repair (AC pavements).
2. Crack sealing and filling (AC pavements).
3. Spall repair (PCC pavements).
4. Joint resealing (PCC pavements).

Much of the material presented in this workshop is based on the results of an ongoing nationwide study of pavement maintenance activities. This study was started in 1988 under the Strategic Highway Research Program (SHRP) and has as its primary objective to identify the best materials and procedures to use in routine and preventive maintenance activities.

The study began with a worldwide survey of what highway agencies were using to maintain their pavements and how their materials and procedures performed for them. Following a comprehensive review of the performance of many maintenance applications, 22 test sites were constructed around the United States and Canada to try out the most promising materials and installation methods. Sites were selected for their ability to represent different climatic conditions and pavement types. An effort was also made to identify sites that would be available for long-term monitoring.

This study represents the most comprehensive research effort in pavement maintenance ever performed in this country. A wide variety of repairs has been constructed under carefully monitored and controlled conditions using identical materials and consistent construction practices. Because of this study's high degree of control and monitoring, results can be compared within sites as well as from site to site.

Since the completion of these test sites in 1992—more than 2,850 pothole and spall repairs were accomplished, and approximately 12,200 m of cracks and joints were sealed—regular monitoring of the performance of the experimental repairs/treatments has been conducted. This monitoring, initiated under SHRP, continues as part of the FHWA's long-term commitment to improve pavement performance. Test sites are thoroughly surveyed on an annual basis (or, in the case of pothole repair sites, a semi-annual basis). The deterioration of the repairs, failures, and specific distresses are noted as part of those surveys. The results are then analyzed to update the performance results of the various material and construction procedure combinations.



The knowledge gained from this study can be used by highway agencies interested in becoming familiar with new, effective maintenance technologies. Participants will develop an appreciation for how to select repair methods and procedures, as well as how to carry out their own evaluations.

## WORKSHOP OUTLINE

This workshop has been divided into six sessions. The first two sessions introduce information on the importance of pavement maintenance and current research in the pavement maintenance field. The target audience of these two sessions is both decision makers and the maintenance crews in the field who make decisions that affect pavement maintenance performance.

The next four sessions cover each of the pavement maintenance areas. Each of these sessions is designed to present a means of assessing a potential maintenance project, how to select the repair/treatment materials, how to place those materials, and how to evaluate the effectiveness of the repairs/treatments. The target audience for these sessions is primarily the agency personnel who specify, purchase, or select for purchase maintenance materials, procedures, or contractors for pavement maintenance. These sessions may either be presented together as an 8-hour workshop or in shorter sessions that address specific interests.

## SUMMARY

Cost-effective pavement maintenance is the application of the right procedures and materials, using appropriate construction practices, at the right time. As noted in reference 1, it has several components, including the timing of the activity and its quality level:

*Cost-effective preventive maintenance is largely dependent on the timing of the activity and the quality of the work performed. For a preventive maintenance strategy to be successful, it must be recognized that it is cyclic and requires scheduling. It must be properly funded over a period of years to be effective. Deferring preventive maintenance only increases reactive (or routine) maintenance and accelerates deterioration ... "Do it right" performance on routine and preventive maintenance activities is a key element in the durability of the repairs and their cost-effectiveness.<sup>1</sup>*

This workshop has been developed to provide the latest information on successful routine and preventive maintenance strategies for AC pavements (pothole repair and crack sealing/filling) and PCC pavements (spall repair and joint resealing). Agencies that are able to apply the information in this workshop

## Notes

to maintain their pavements will see an improvement in the long-term performance of their pavements.

## **SESSION 2. CURRENT RESEARCH TRENDS IN PAVEMENT MAINTENANCE**

**Time—0:30**

Notes

### **SESSION OBJECTIVES**

This session presents an overview of current research and new insights or philosophies in the field of pavement maintenance. The focus is in the area of the effectiveness of pavement maintenance and the importance of its timing. Some current maintenance technologies are also highlighted, and a discussion of the impact of maintenance on the traveling public is provided.

Upon completion of this session, the participant will be familiar with the following:

1. The status of recent studies that have been conducted regarding the effectiveness of various pavement maintenance activities.
2. The newest technologies in maintenance.
3. The effect of preventive maintenance on the traveling public.

### **INTRODUCTION**

Over time, pavements wear out. This statement of fact applies to all pavements regardless of type, cost, quality or any other intrinsic or extrinsic factors: The deterioration of pavements is an inevitable process that occurs as a result of the combined action of the environment and loadings. The ideal of “zero maintenance pavements,” explored during the 1970's and 1980's as an objective that could be reached through the selection of appropriate designs and materials, remains a distant dream that lies well beyond the current capabilities of materials and engineers.

Nonetheless, the idea that pavements are immune to the forces of man and nature is persistent. Camomilla sums up the prevailing attitude perfectly: “In the sector of civil engineering in general, and that of highway engineering in particular, the ordinary man, and also the distracted expert, clings to the idea of durability over time, without limit.”<sup>4</sup> Although it is not surprising that pavements wear out, the ability of certain activities, such as pavement maintenance, to change the rate or the severity of such deterioration has been given a fresh look, based on both a renewed interest in cost-effective strategies for pavements and

new evidence that pavement maintenance can forestall the inevitable process of deterioration.

The obstacles to a broader acceptance of the benefits of maintenance are great. Funding for proper and timely pavement maintenance has almost always taken a back seat to other activities, such as new construction and rehabilitation. While there have been some recent improvements in this area, maintenance expenditures have not readily kept pace with the increase in traffic. Maintenance activities, beyond those that are performed to make the road passable, are often seen as an undesirable diversion of funds that can be used for other, more urgent activities. Symbolic perhaps of the low esteem in which maintenance is held is the treatment accorded the prototypical pavement maintenance treatment—pothole repair. Typically, the only interest shown in this activity by the general public is to ridicule or complain about it when it becomes an inconvenience, but it receives nearly the same treatment from most highway agencies as well.

Maintenance plays an essential part in obtaining the desired life and level of service from a pavement. Pavement maintenance should not only be a routine act that is carried out on high volume roads or roads that demand attention to the defects (e.g., potholes), it should be performed on all roads from which agencies wish to obtain good performance. Although the importance of timely pavement maintenance and the benefits of many maintenance activities has been written about for many years, there has been a major resurgence in interest in this topic in the past decade. Such an interest is vital if spending is to be increased to the point where the benefits of maintenance may be realized. There is a great deal of new, comprehensive, and convincing information regarding pavement maintenance, maintenance materials, and maintenance equipment that helps to document the benefits of maintenance and addresses some of the concerns regarding maintenance efficacy that have been brought up over the years. This section introduces some of this research.

### **PAVEMENT MAINTENANCE AND PAVEMENT LIFE**

Many agencies and researchers have reported on the relationship between pavement maintenance and pavement life. The expectation of those who advocate timely pavement maintenance is that a properly maintained pavement will perform better than an identical pavement exposed to the same conditions that does not receive maintenance. This is explicit from examining curves of pavement performance over time, with and without maintenance, as is shown in figure 2-1. A curve such as this illustrates the contribution of pavement maintenance to pavement performance by either improving the serviceability of the pavement over its life or, for a given change in serviceability, allowing the pavement to carry more traffic or last longer. This is also a fundamental tenet of pavement management: Treatments that are applied to a pavement that have an economic

cost are acknowledged to provide some measurable benefit. Many agencies have started to shift the emphasis of their maintenance activities away from corrective or reactive repairs to those proactive or preventive treatments that allow them to more nearly reach the desired life of their facilities.

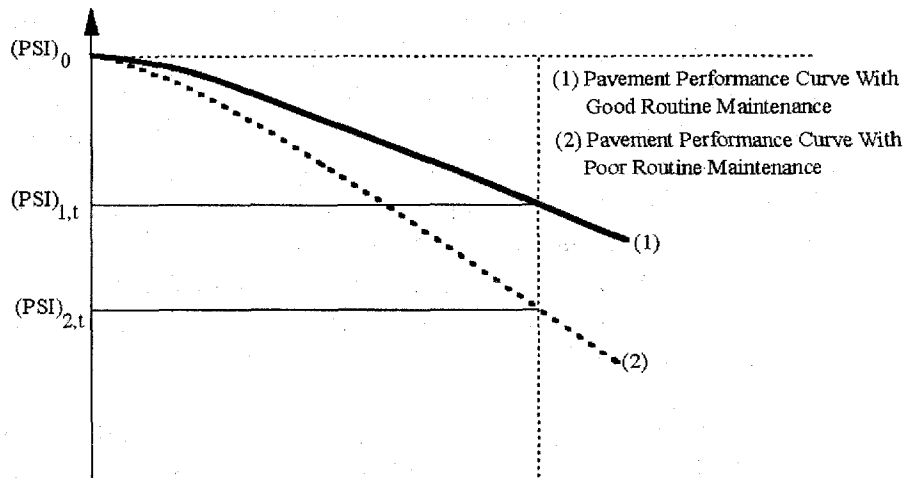

Figure 2-1. Relationship between pavement performance and routine maintenance.<sup>3</sup>

Testing the hypothesis that pavement maintenance contributes to better pavement performance is the basis for the pavement maintenance effectiveness studies that were initiated as part of SHRP (SPS-3 for flexible pavements and SPS-4 for rigid pavements). In those studies, numerous test sites were constructed in each climatic region in which the following treatments were applied to test sections:

- Slurry seals.
- Chip seals.
- Thin hot-mix overlays.
- Joint and crack sealing in PCC pavements.
- Crack sealing in AC pavements.
- Undersealing PCC pavements.
- State supplemental treatments.

As part of the study (with the exception of the thin hot-mix overlay treatments and State supplemental treatments), a single material and contractor was generally used for each technique, and the treatment was applied under controlled conditions so that the results from site to site could be more reasonably compared. A control section (no treatment) was also established at each location.

## Notes

Since these sites were constructed, annual data collection has included distress surveys, deflection testing, and roughness. Long-term performance data, the type that would enable calculations of cost-effectiveness to be made, are not yet available, but the results of these intensive data collection efforts are now being analyzed. However, in order to speed up the availability of results in this important area, a team of highway engineers has undertaken an effort to subjectively evaluate these treatments and provide preliminary results now.<sup>5</sup> Two general findings of this work are summarized here:

1. The sections that received maintenance treatments are generally outperforming the control sections. This is shown in the graphs in figure 2-2, where the differences in ratings between the treated sections and the control sections are illustrated. Positive differences mean that the treated sections are performing better than the control sections, whereas negative differences indicate the control sections are performing better than the treated sections.
2. The performance of the treatment is generally linked to the condition of the pavement on which it is applied. That is, treatments applied to pavements in better condition tend to perform better than treatments applied to pavements in worse condition.

There are also a number of observations made regarding the specific treatments and their efficacy in relation to the field conditions that are of interest:

1. Slurry seals perform better when the treatment is applied to a pavement that has little cracking.
2. Cracked pavements treated with chip seals are performing better than similar sections treated with other methods.
3. Thin hot-mix overlays performed better than other treatments on pavements with higher roughness or rutting.

The findings from this study suggest that there are a number of extrinsic factors that affect whether or not maintenance will be beneficial. One major factor is the condition of the pavement when maintenance is applied. This is discussed in greater detail in the next section. Another extrinsic factor is the region in which the treatments are applied; some treatments appear to perform better in certain environments than others. A third factor affecting these results may be the experiment itself. The experimental design required the use of the same aggregates, materials, and treatments at all sites, notwithstanding pavement condition, traffic loads, and environment.

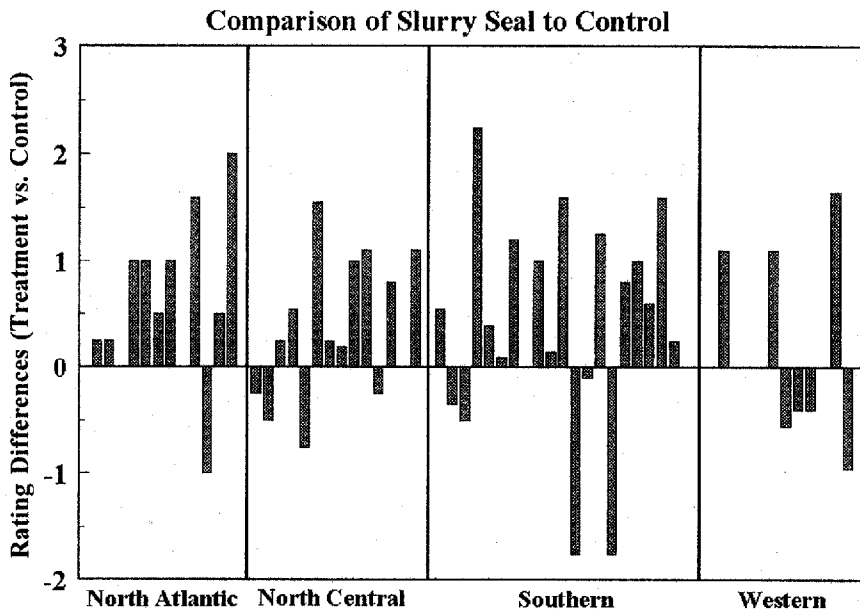
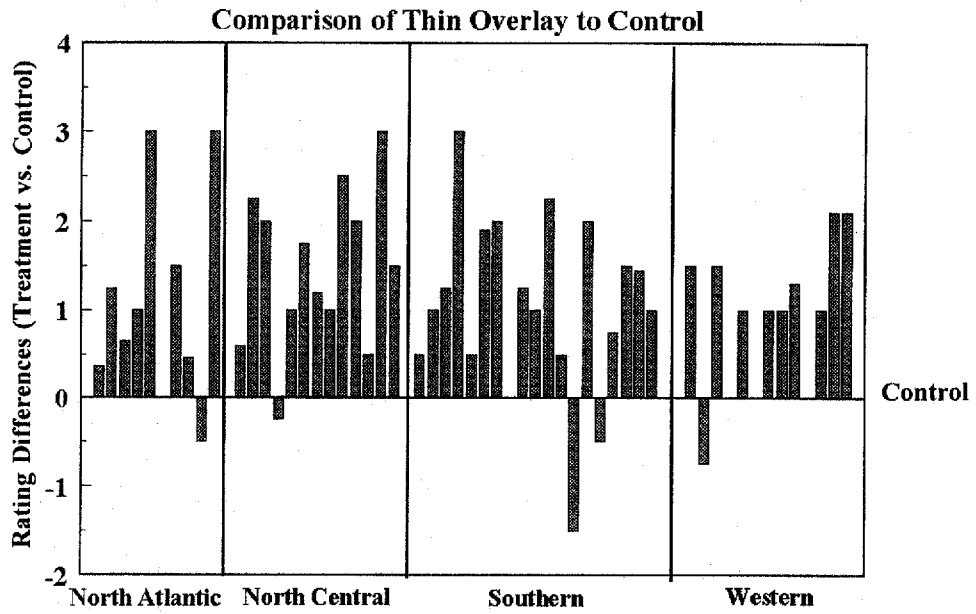

Figure 2-2. Subjective performance ratings of SHRP SPS-3 and SPS-4 maintenance test sections after 3 years.<sup>5</sup>

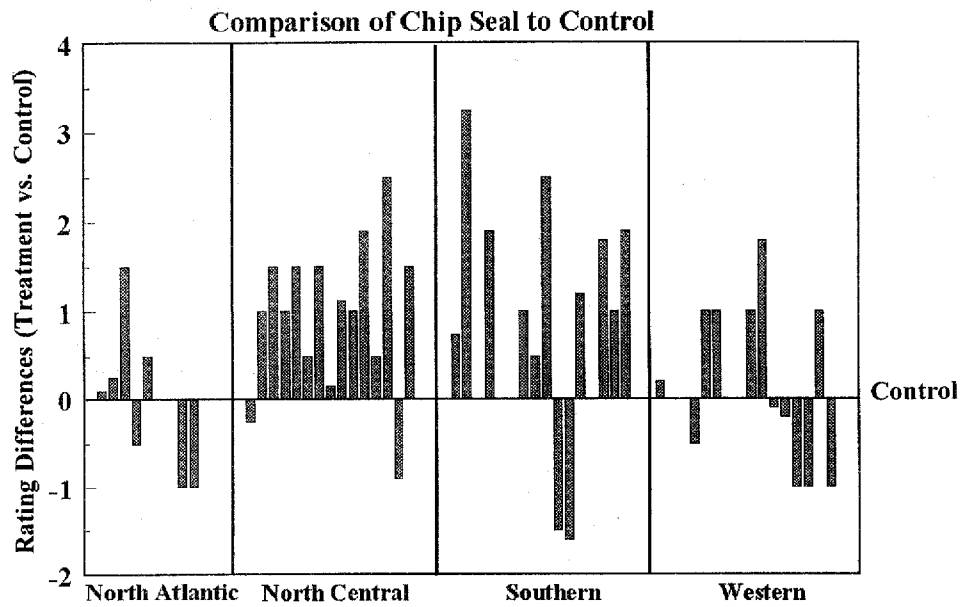
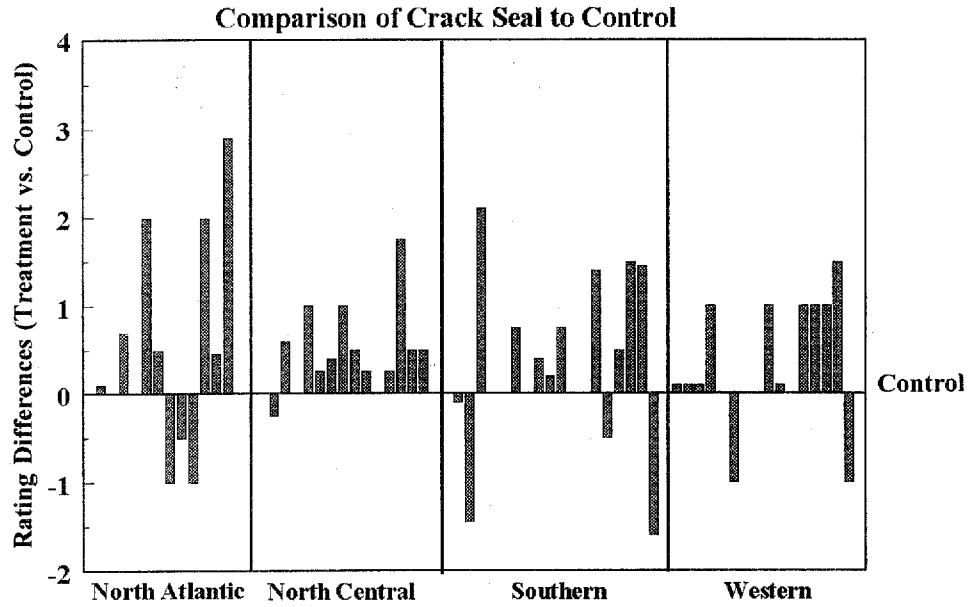

Figure 2-2. Subjective performance ratings of SHRP SPS-3 and SPS-4 maintenance test sections after 3 years (continued).<sup>5</sup>



## TIMING PAVEMENT MAINTENANCE

A 1981 NCHRP Synthesis on pavement maintenance stated that the most common trigger for pavement maintenance was to correct deficiencies.<sup>6</sup> Another common trigger was complaints from users. These approaches are representative of the philosophy that pavement maintenance is a reactive activity that is not initiated until something goes wrong: “if it ain’t broke, don’t fix it.” At the same time, however, it was observed that many agencies saw their responsibility being to preserve the highway investment. This is a classic example of how an objective—preserving the investment—can be fundamentally incompatible with the means of achieving the objective—reactive or routine maintenance.

What steps can an agency take to actually preserve its highway investment? The timing of a maintenance treatment has a large effect on the subsequent performance of that treatment. “It is now an accepted fact in many organizations and countries that properly timed and executed preventive maintenance activities will extend the useful service life of a highway facility and delay higher-cost major rehabilitation or reconstruction projects beyond the original design life.”<sup>1</sup> This concept is repeated over and over in the literature, although again the proof of this fact is somewhat elusive. However, the research in maintenance effectiveness that was initiated under SHRP and is being followed through on by FHWA again may be the key to obtaining definitive proof of this fact.

Maintenance intervention that is applied too late will not provide any benefit. The importance of timing has already been suggested from the early analyses of the SPS-3 test sites, where it was found that good treatments applied to poor pavements did not perform as well as good treatments applied to good pavements. This is especially true of the thin resurfacings that form the core of a preventive maintenance strategy. These treatments are effective when they maintain the impervious nature of the pavement surface, and that is easier to do before the pavement has begun to deteriorate. For instance, one test site was lost immediately after placing the SPS-3 treatment. Investigations by the State Highway Agency (SHA) revealed that both the slurry seal and chip seal applied to a severely aged and open pavement accelerated vapor action and stripping. This process, called hydrogenesis, caused pavement sections to fail.<sup>7</sup>

Not only is preventive maintenance gaining national attention through studies such as the LTPP program, but other countries worldwide are seeing the benefits of timely maintenance. For instance, in a study of the performance of slurry seals in Malaysia, Sabri reports that thin surfacings do not perform well if placed on pavements with more than one crack if the crack is not repaired prior to placement of the slurry.<sup>8</sup> Findings such as this should help to support the application of treatments to pavements that are in good “visible” condition.

Another, albeit indirect, example of the importance of timing is the shift of the Public Works Department of Singapore from an emphasis on reactive to preventive maintenance. Narayanan et al. describe the new approach being followed by the agency to maintain a high level of service on their highways.<sup>9</sup> This change has taken place by increasing preventive maintenance expenditures (primarily thin surface treatments) to 90 percent of the total maintenance budget. This change is based on the conviction that “deferring pavement maintenance only increases reactive maintenance and accelerates deterioration” and that a proactive strategy actually has lower costs over the life of the facility. Another benefit of this skew toward preventive maintenance and away from reactive maintenance is the enhanced ability to more accurately plan budgets, as most of the funds are going to activities that can be planned.

### **NEW MAINTENANCE TECHNOLOGIES**

The possibilities for the application of new technologies in pavement maintenance are wide open. New ideas and innovative ideas are continually being evaluated and tested at every level, from small agencies to the Federal government, in both the public and private sector. These ideas encompass the broad range of pavement maintenance activities, from pavement evaluation to maintenance application to maintenance management. The following sections discuss a range of technologies currently being developed by research organizations and industry alike.

#### **Pavement Survey and Evaluation**

As has been noted previously, it is believed that preventive or proactive maintenance is more effective and less expensive than damage repair, and that the treatments that constitute a proactive approach must be applied earlier in a pavement's life in order to be effective. The problem that must be addressed, however, is how to identify that time in a pavement's life when preventive maintenance should be applied? While the extra costs associated with late treatments are well-documented, there are also extra costs that are associated with applying a preventive treatment too early: both treatments are “sub-optimal.”

As preventive maintenance is applied when the pavement is in good condition and before it starts to deteriorate, the problem becomes one of identifying the factors that indicate that accelerated deterioration is imminent. Conventional survey methods concentrate on conditions visible at the pavement surface; however, surface distresses are usually indicative of the need for reactive or routine maintenance, or even rehabilitation. This highlights the importance of SHRP-funded research into identifying technologies that could be used for the early detection of pavement problems.

A number of technologies that could be applicable for evaluating a pavement's need for maintenance before distress is visible are reported by Maser and Markow.<sup>10</sup> A partial listing of the technologies that they consider in their survey of the state of the art, and which are generally still in the development stage, includes the following:

- Radar.
- Infrared thermography.
- Mechanical surface waves.
- Spectral analysis of surface waves (SASW).
- Dynamic deflection.
- Direct compression and shear waves.
- Ultrasound.
- Nuclear magnetic resonance.
- Moisture meters.

The application of these technologies to pavement maintenance lies in their ability to examine sub-surface conditions that would provide information about the pavement. In particular, these technologies might be used to identify the presence of saturated layers, the onset of sub-surface cracking, or the initial development of small voids between layers that could be corrected by a maintenance treatment without waiting until the distress is visible.

One particular technology recently reported on is the Seismic Pavement Analyzer (SPA), which grew out of the SHRP project H-104B and is undergoing continued development at the University of Texas–El Paso.<sup>11</sup> This device is similar in size and concept to a falling weight deflectometer (FWD), as it is towed behind a vehicle and positioned at various locations along a pavement for spot tests.

The testing process involves lowering a set of geophones and accelerometers to the pavement surface to digitally record the surface deformations created by low- and high-frequency pneumatic hammer sources. The measured responses are then analyzed using various technologies, such as the impulse-response analysis or SASW, to determine the shear moduli of the paving layers, the damping ratio (the degree of resistance to movement) of a slab, and subsurface voids. Although the device shows promise, it is not available on the commercial market.

A pavement testing device considered to have more practical application at this time than many of the technologies above is the Iowa Vacuum (IA-VAC) Joint Seal Tester. This system, developed in the early 1990s by the Iowa Department of Transportation (DOT), consists of a 50 × 150 × 1,220 mm suction chamber connected to a vacuum pump that is powered by a portable, gasoline-powered generator. The chamber is placed lengthwise over a solution-treated PCC joint seal, and upon application of the vacuum force, any leaks in the joint

seal test segment are identified through the appearance of bubbles. The IA-VAC joint seal tester has been used substantially by the Iowa DOT and is being made available for use by selected SHA's by the FHWA. More detailed information on this system is provided in session 3 of this handbook.

### **Repair and Treatment Equipment**

In two SHRP projects, H-107A and H-107B, support was provided to researchers for the development of two automated pavement surface maintenance devices—a pothole repair machine and a crack sealing machine. These projects were intended to test the feasibility of several concepts related to the actual performance of maintenance work:

- Could the work be performed more efficiently, with reduced labor and greater consistency?
- Could maintenance tasks be automated to the point that the safety of both workers and the traveling public was improved?
- Could automated equipment be more productive than maintenance crews?

In the automated pothole repair project, the objective was to develop a device that could locate and repair a pothole without exposing any crew to traffic. Although the idea of automated pothole repair machines is not new—there are several equipment manufacturers that have had commercial units available in recent years—the machine developed under SHRP aimed at a higher level of automation and integration among functions.

The prototype device contains separate storage bins for the various patch mix components and computerized metering systems for blending the components. The unit was designed to be capable of cutting the edges of a pothole, removing (by vacuum) the loose material, drying and heating the repair area, and blowing the hot-mix material into the hole with enough velocity such that additional compaction is not required.

At the August 1994 FHWA Highway Operations Technical Working Group (TWG) Meeting, the automated pothole patcher was reported as mechanically complete, but lacking full installation and integration of computer control systems. It is still under development by Northwestern University's Basic Industrial Research Laboratory (BIRL).

The objectives in the automated crack sealing project were to develop a machine that could locate sealable cracks and then seal them without human intervention. Again, the goal was to create a device that could seal cracks on a busy road without having to expose a maintenance crew to traffic.

The prototype device was to use a computer-interpreted video image to locate cracks and a robotic arm to apply sealant to the cracks. Separate components were developed that would be capable of sealing both longitudinal and transverse cracks using as few as two persons. The vision sensors "map" the cracks, which then can be widened (if desired) using a newly designed router, cleaned and dried with a hot compressed air attachment, and sealed with asphalt-based sealant material.

Although at the August 1994 TWG Meeting the machine's vision sensing system had not been developed, it was reported that the longitudinal crack sealing system is functional. The automated crack sealing device is still under development by the University of California-Davis and the California DOT (CALTRANS).

Both of these developments have proven that certain maintenance activities can be successfully automated. Although after roughly 4 yrs of development and testing neither of these automated devices are ready to be commercially marketed, the demand for such approaches is being driven by overcrowded urban highways in desperate need of repair.

### **Pavement Maintenance Management Systems**

Pavement maintenance management systems can be thought of as the subset of pavement management systems (PMS) dedicated to maintenance and perhaps minor rehabilitation activities. As such, their focus is more directed toward supporting decision-making for both routine and preventive maintenance efforts than for triggering larger projects, such as rehabilitation or reconstruction.

In general, these systems focus on a shorter-term horizon that stretches to the point where a pavement's rate of deterioration increases significantly. To monitor the performance and assist in effective decision-making, these systems incorporate systematic methods for collecting, storing, and retrieving information, such as pavement condition data, maintenance cost data, and as-built construction information.

The properly functioning pavement maintenance management system provides the ability "to do the right thing at the right time." The innovations related to pavement maintenance management systems lie less in their technology than in the very fact that their use is becoming increasingly widespread and that this "feedback" mechanism is assisting in more cost-effective decision making.

## **EFFECT OF MAINTENANCE ON THE PUBLIC**

In general, the objective in performing pavement maintenance activities should be to render pavement condition a "non-issue to the highway user." Pavement distresses, such as potholes, delaminated surface treatments, spalls, and badly cracked surfaces, are usually a signal to drivers that highway agencies are not doing their jobs. Lack of properly maintained roads are a major source of public dissatisfaction with highway agencies, although this does not need to be the case.

Properly timed and applied maintenance provides a number of benefits to road users. Some of these benefits are largely intangible and because they are difficult to quantify, they tend to be avoided in the decision-making process. The result of this is that at times there is an over-representation of the benefits of less cost-effective strategies. A pavement that is maintained properly after its construction will be closed less frequently for repairs. The repairs will be less intrusive and they will usually be constructable over a shorter period of time at less cost. Thus, increased costs related to delays, accidents, and rerouting are minimized.

When preventive maintenance is applied, the need for rehabilitation is postponed and the severity of the rehabilitation may be reduced. This can be translated into quicker repairs (and again, shorter delays and less cost). The overall life of the pavement is increased and the benefit to the public is in a more economical pavement structure, less vehicle wear (and its associated costs), and a smoother ride.

## **CASE STUDIES**

Several research efforts have been undertaken in the past 15 years to examine the effectiveness of various types of pavement maintenance. Summaries of several prominent studies are provided in the following sections.

### **Ontario**

Throughout the 1980's, the Ministry of Transportation of Ontario (MTO) performed extensive research on the effectiveness of routing and sealing cracks in flexible pavements.<sup>12</sup> With sealed and nonsealed sections, researchers found that while there was not a discernible difference in crack development among the sections, the cracks on the nonsealed sections were more deteriorated and thus contributed to a poorer ride. Based on their research, the MTO developed guidelines for sealing methods and materials, with the emphasis being placed on the use of high quality materials and more time-intensive preparation and placement methods.

A subsequent study by the MTO initiated in 1986 was intended to document the cost-effectiveness of the high quality sealant approach.<sup>13</sup> In this study, treated and control sections were constructed and monitored. Results were analyzed to identify the most cost-effective approach. Performance curves for treated and control sections are shown in figures 2-3 and 2-4. These curves clearly show the superior performance of the treated sections, both as observed and projected. The study showed that routing and sealing cracks could minimize the development of additional cracks, thereby increasing pavement service life by at least 2 years. The life-cycle cost analysis of these results showed that this was a cost-effective procedure, but it was emphasized that the treatment must be applied according to the guidelines that the agency had developed.

### France

In France, a strategy of preventive maintenance was undertaken for older pavements in need of rehabilitation.<sup>14</sup> The approach that was taken to take care of these pavements was to carry out rehabilitation using high quality procedures and then apply seal coats and thin AC layers as preventive maintenance. It was found that although the initial costs of the maintenance were much higher than alternatives, following such an approach eliminated the need for a second, more costly rehabilitation. The needs that were identified also led to extensive research into better performing surface treatments, with the result of longer performing and better riding surfaces.

Because of the success of this strategy, extensive research has been made into the development of improved surface treatments. Bellanger et al. report on the increasing application of "very thin" (20 to 25 mm) and "ultrathin" (10 to 15 mm) surface treatments that are being constructed on "pavements that need neither structural strengthening nor major correction of evenness."<sup>15</sup> The ultrathin surfacings are even being used in new construction as a wearing course because of their excellent performance. These treatments provide good skid resistance, are relatively impermeable, and may even correct some surface profile deficiencies. Thus represent a step forward in the development of preventive maintenance strategies that can be applied quickly and economically.

### Texas

The Texas DOT has initiated a study of maintenance effectiveness through the construction of their own SPS-3 test sites.<sup>16</sup> The study is titled Supplemental Maintenance Effectiveness Research Program (SMERP) and it involves the evaluation of the following maintenance techniques:

- Microsurfacing (modified slurry seals).
- Asphalt rubber chip seal.
- Polymer-modified emulsion chip seal.

Control vs treated (40 x 10 mm rout & seal) sections - Highway 21

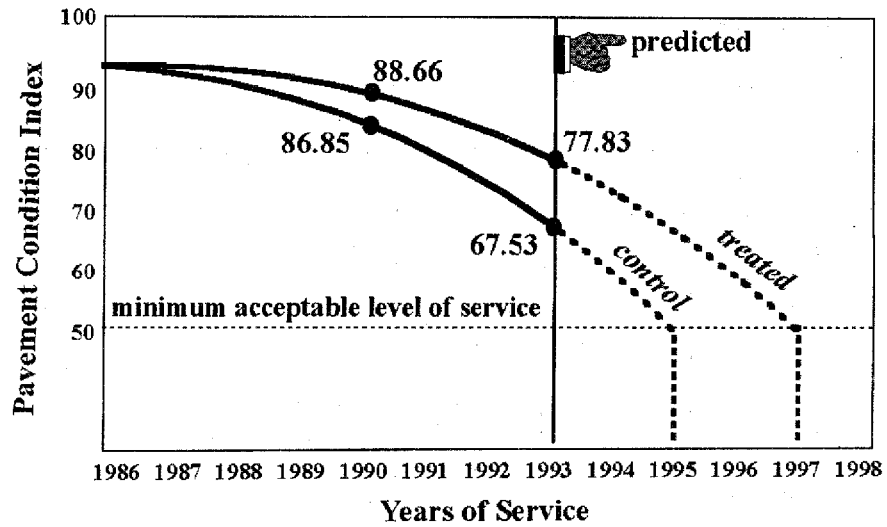

Figure 2-3. Performance curves of sealed and unsealed pavement sections in Ontario (Highway 21).<sup>13</sup>

Control vs treated (40 x 10 mm rout & seal) sections - Highway 11

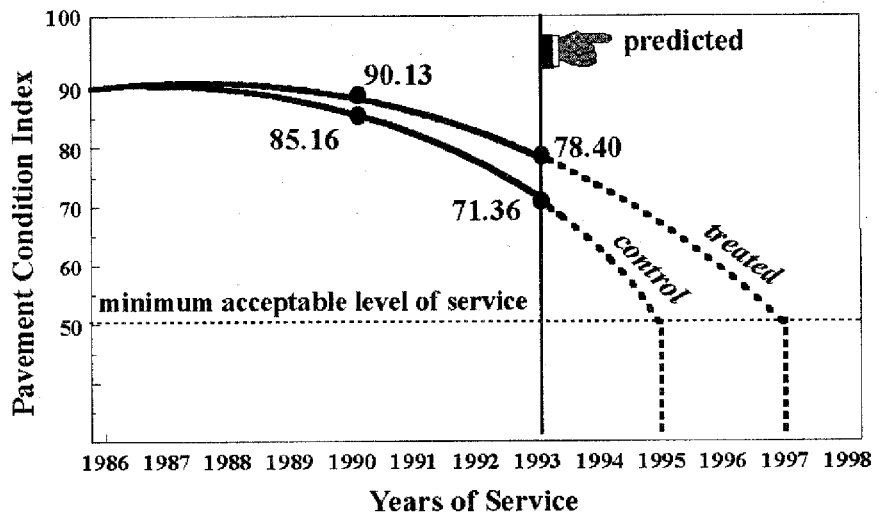

Figure 2-4. Performance curves of sealed and unsealed pavement sections in Ontario (Highway 11).<sup>13</sup>



Table 2-1. Preliminary analysis of SMERP sites.<sup>17</sup>

|          | Alligator Cracking | Bleeding  | (*) Block Cracking | Long and Trans Cracking | Long Wheelpath Cracking | (*) Raveling |
|----------|--------------------|-----------|--------------------|-------------------------|-------------------------|--------------|
| Rubber   | Reduced            | Increased | Reduced            | Reduced                 | Reduced                 | Increased    |
| Micro    | Reduced            | Reduced   | Reduced            | Mixed                   | Increased               | Reduced      |
| Emulsion | Reduced            | Reduced   | Reduced            | Reduced                 | Reduced                 | Reduced      |
| Latex    | Reduced            | Increased | Reduced            | Reduced                 | Reduced                 | Mixed        |
| AC       | Mixed              | Increased | Reduced            | Reduced                 | Reduced                 | Mixed        |
| Fog      | Reduced            | Increased | Increased          | Reduced                 | Mixed                   | Increased    |
| Control  | Mixed              | Increased | Increased          | Reduced                 | Increased               | Increased    |

(\*) - Few sites affected, trends questionable

- Latex-modified asphalt chip seal.
- Asphalt chip seal.
- Fog seal.

Control sections having no applied treatments are also included. The goal of the study is "to determine optimum preventive maintenance strategies that prolong pavement life and to demonstrate positive rates of return on preventive maintenance funds."

The construction of the SMERP sections was completed during 1993. Since that time, 6- and 12-month inspections have been performed. Preliminary analyses using the 12-month inspection data generally show a positive impact on distress occurrence by all treated sections, as shown in table 2-1.<sup>17</sup> The untreated sections, on the other hand, have in most instances exhibited increased distress occurrence. A 2-yr inspection of the experimental sections was slated for the summer of 1995, with data analyses and reporting occurring shortly thereafter.

## SUMMARY

Pavement maintenance may be effective in extending pavement life, but this benefit cannot be expected from any maintenance treatment applied to a pavement in any condition at any time in its life. Effective maintenance interventions are typically applied early in the life of the pavement, when the pavement is still in

## Notes

good condition. Although this philosophy may run counter to the public's perception of which pavements should be treated first, it is entirely consistent with the concepts of preventive maintenance to obtain a longer-lasting product.

In a recent NCHRP Synthesis, *Evolution and Benefits of Preventive Maintenance Strategies* (reference 1), this concept was highlighted from the results of a survey of SHA's:

*Cost-effective preventive maintenance [PM] is largely dependent on the timing of the activity and the quality of the work performed. For a PM strategy to be successful, it must be recognized that it is cyclic and requires scheduling. It must be properly funded over a period of years to be effective. Deferring PM only increases reactive (or routine) maintenance and accelerates deterioration.*

In order to improve the performance of maintenance activities, research is underway on the development of automated technologies to improve maintenance. The most promising technologies lie in the areas of surface and sub-surface detection and automated repair. The increasingly widespread use of maintenance management systems is also a positive sign.

A final key to the successful application of new technologies and philosophies lies in obtaining irrefutable proof of the success of proper pavement maintenance. Work is underway across North America to document which maintenance strategies are effective and under what conditions. This work should also serve to shed further light on the important issue of timing of preventive maintenance treatments. Many agencies have already demonstrated these benefits in their own studies.

good condition. Although this philosophy may run counter to the public's perception of which pavements should be treated first, it is entirely consistent with the concepts of preventive maintenance to obtain a longer-lasting product.

In a recent NCHRP Synthesis, *Evolution and Benefits of Preventive Maintenance Strategies* (reference 1), this concept was highlighted from the results of a survey of SHA's:

*Cost-effective preventive maintenance [PM] is largely dependent on the timing of the activity and the quality of the work performed. For a PM strategy to be successful, it must be recognized that it is cyclic and requires scheduling. It must be properly funded over a period of years to be effective. Deferring PM only increases reactive (or routine) maintenance and accelerates deterioration.*

In order to improve the performance of maintenance activities, research is underway on the development of automated technologies to improve maintenance. The most promising technologies lie in the areas of surface and sub-surface detection and automated repair. The increasingly widespread use of maintenance management systems is also a positive sign.

A final key to the successful application of new technologies and philosophies lies in obtaining irrefutable proof of the success of proper pavement maintenance. Work is underway across North America to document which maintenance strategies are effective and under what conditions. This work should also serve to shed further light on the important issue of timing of preventive maintenance treatments. Many agencies have already demonstrated these benefits in their own studies.



**SESSION OBJECTIVES**

This session discusses the proper methods for planning, conducting, and monitoring a PCC joint resealing project. It presents the latest findings on the performance of materials and methods tested under the SHRP H-106 joint resealing experiment and contains detailed information on the processes of performing effective joint sealing operations.

Upon successful conclusion of this session, the participant shall be able to accomplish the following:

1. Recall which joint resealing materials and methods are performing best in the SHRP H-106 experiment.
2. State the primary objectives of joint resealing.
3. Select the most appropriate and cost-effective materials and procedures for a specific project, given various constraints and limitations.
4. List the various steps in a joint resealing operation and describe the recommended procedures and equipment associated with each step.
5. Evaluate the effectiveness of a joint resealing project.

**SHRP RESEARCH FINDINGS TO DATE**

Between April and July 1991, approximately 5,860 m of transverse joints were resealed at test sites throughout the United States as part of the SHRP H-106 project (*Innovative Materials Development and Testing*). The primary objective of the experiment was to determine the most cost-effective joint resealing materials and procedures under various climatic conditions and traffic. The materials and procedures used in the H-106 study were identified in a predecessor project (SHRP H-105, *Innovative Materials and Equipment for Pavement Surface Repairs*) as having the most potential to improve the state of the practice in joint resealing.

Five joint reseat test sites were constructed in four climatic regions as part of the H-106 experiment. These sites consisted of the following:

## Notes

- |                                 |               |                |
|---------------------------------|---------------|----------------|
| • I-17—Phoenix, Arizona         | Dry/nonfreeze | April 1991     |
| • I-77—Columbia, South Carolina | Wet/nonfreeze | April 1991     |
| • I-25—Ft. Collins, Colorado    | Dry/freeze    | April/May 1991 |
| • I-80—Grinnell, Iowa           | Wet/freeze    | May/June 1991  |
| • US 127—Frankfort, Kentucky    | Wet/freeze    | June/July 1991 |

The last two sites were installed on short- and long-jointed concrete pavements, respectively, to examine the effect of joint spacing on sealant performance.

A total of 12 different proprietary materials and 4 different installation methods were included in the experiment, resulting in 31 unique types of joint reseal treatments (a treatment being the combination of a material and installation method). Table 3-1 shows the combinations of material and installation method that were used at each of the five sites, and figure 3-1 illustrates the material placement configurations associated with each installation method. Further details about materials and installation methods are provided in the section titled "Project Planning and Design."

At a given site, each reseal treatment type was represented by a test section containing 10 transverse joints. All of the test sections planned at each site were placed in random order along the test site pavement. For greater statistical validity, the randomly arranged block of sections was then repeated at the end to form a replicate block of sections.

Since installation, sealant performance at each site has been evaluated several times through detailed visual inspections conducted under both the H-106 project and the FHWA follow-up study, *Long-Term Monitoring (LTM) of Pavement Maintenance Materials Test Sites*. In these inspections, sealant system distresses and failures (i.e., segments of seal allowing water to penetrate the joint), such as joint spalls, adhesion loss, and cohesion loss, were identified along each experimental joint of a given reseal treatment. Each type of distress and failure observed was then recorded in units of length, which later enabled calculation of the average percentages of each distress and failure type, as well as the average overall percentage of effectiveness (see section titled "Evaluating Reseal Effectiveness").

Under the *LTM* study, annual field inspections are scheduled for every fall from 1993 through 1997. Thus far, all five sites have remained free of rehabilitation work, thus allowing for more long-term performance assessments.

Table 3-1. Summary of material-procedure combinations used in SHRP H-106 joint resealing experiment.

| Sealant Material  | Installation Method | State Installed |    |    |    |    |
|---|---------------------|-----------------|----|----|----|----|
|   |                     | AZ              | SC | CO | IA | KY |
| Crafco RS 221<br><i>Rubberized Asphalt</i>                | 1                   | ✓               |    |    |    |    |
|   | 2                   | ✓               |    |    |    |    |
|   | 4                   | ✓               |    |    |    |    |
| Crafco RS 231<br><i>Low-Modulus Rubberized Asphalt</i>    | 1                   | ✓               | ✓  | ✓  | ✓  | ✓  |
|   | 2                   | ✓               | ✓  | ✓  | ✓  | ✓  |
|   | 3                   |                 | ✓  |    | ✓  | ✓  |
|   | 4                   | ✓               |    | ✓  |    |    |
| Koch 9005<br><i>Rubberized Asphalt</i>                    | 1                   | ✓               | ✓  | ✓  | ✓  | ✓  |
|   | 2                   | ✓               | ✓  | ✓  | ✓  | ✓  |
|   | 3                   |                 | ✓  |    | ✓  | ✓  |
|   | 4                   | ✓               |    | ✓  |    |    |
| Koch 9030<br><i>Low-Modulus Rubberized Asphalt</i>        | 1                   |                 | ✓  | ✓  | ✓  | ✓  |
|   | 2                   |                 | ✓  | ✓  | ✓  | ✓  |
|   | 3                   |                 | ✓  |    | ✓  | ✓  |
|   | 4                   |                 |    | ✓  |    |    |
| Meadows Hi-Spec<br><i>Rubberized Asphalt</i>              | 1                   | ✓               |    |    |    |    |
|   | 2                   | ✓               |    |    |    |    |
|   | 4                   | ✓               |    |    |    |    |
| Meadows Sof-Seal<br><i>Low-Modulus Rubberized Asphalt</i> | 1                   |                 | ✓  | ✓  | ✓  | ✓  |
|   | 2                   |                 | ✓  | ✓  | ✓  | ✓  |
|   | 3                   |                 | ✓  |    | ✓  | ✓  |
|   | 4                   |                 |    | ✓  |    |    |
| Dow 888<br><i>Nonsag Silicone</i>                         | 1                   | ✓               | ✓  | ✓  | ✓  | ✓  |
| Dow 888-SL<br><i>Self-Leveling Silicone</i>               | 1                   | ✓               | ✓  | ✓  | ✓  | ✓  |
| Mobay 960-SL<br><i>Self-Leveling Silicone</i>             | 1                   | ✓               | ✓  | ✓  | ✓  | ✓  |
| Mobay 960<br><i>Nonsag Silicone</i>                       | 1                   | ✓               |    |    | ✓  |    |
| Crafco 903-SL<br><i>Self-Leveling Silicone</i>            | 1                   | ✓               |    |    |    |    |
| Koch 9050<br><i>Polysulfide</i>                           | 1                   |                 |    | ✓  |    | ✓  |
| Dow 888 w/ primer   | 1                   |                 |    |    | ✓  |    |
| Dow 888-SL w/ primer                                      | 1                   |                 |    |    | ✓  |    |
| Koch 9005 w/ primer                                       | 1                   |                 |    |    |    | ✓  |

#### Installation Method

1. Saw-and-Recess—Joint reservoir sawed, sandblasted, and airblasted; backer rod inserted at bottom of reservoir; sealant placed into joint reservoir and recessed from pavement surface.
2. Saw-and-Overband—Joint reservoir sawed, sandblasted, and airblasted; backer rod inserted at bottom of reservoir; sealant placed into and over joint, and then struck-off to form overband on pavement surface.
3. Plow-and-Overband—Joint reservoir removed of existing sealant using joint plow, and then airblasted; backer rod inserted at bottom of reservoir; sealant placed into and over joint, and then struck-off to form overband on pavement surface.
4. Saw-and-Flush—Saw-and-Recess—Joint reservoir sawed, sandblasted, and airblasted; backer rod inserted at bottom of reservoir; sealant placed into and over joint, and then struck-off flush with pavement surface.

## Notes

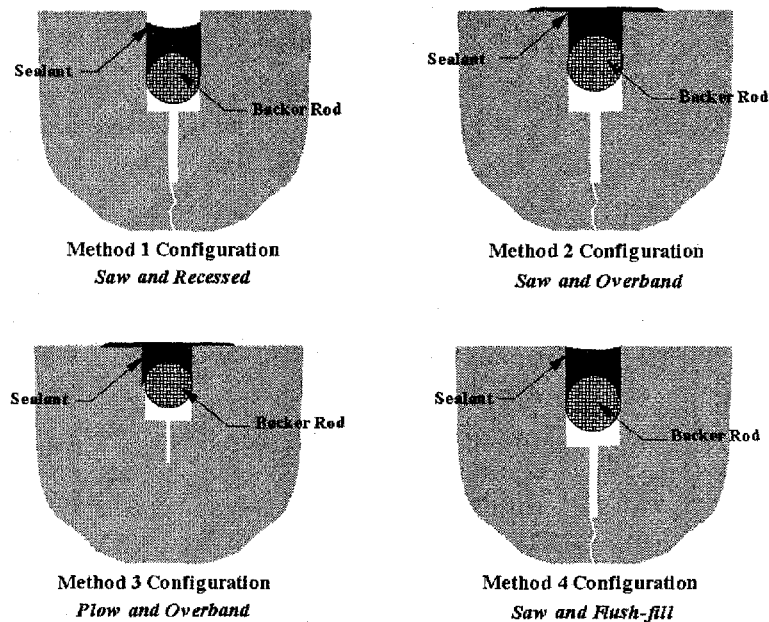

Figure 3-1. Material placement configurations for SHRP H-106 joint reseal treatments.

Major observations and performance data analysis results from the most recent inspection—fall 1994—are summarized below.

- The average overall effectiveness of the experimental joint seals has decreased from 96 to 86 percent between the fall of 1993 and the fall of 1994. Of 83 total joint reseal treatments, 32 have dropped below 80 percent overall effectiveness, with 3 of those treatments having dropped below 50 percent overall effectiveness.
- The average overall effectiveness of all hot-applied rubberized asphalt sealants in all configurations is 85 percent, with adhesion loss being the primary failure mode. In contrast, the average overall effectiveness of all cold-applied silicone sealants is greater than 96 percent, with spall distress serving as the primary mode of failure.
- The average overall effectiveness of Hi-Spec, Sof-Seal, 9030, and 9050 in all configurations is less than 70 percent. The only other material with less than 90 percent average overall effectiveness is RS 221, with 88 percent effectiveness. The overall effectiveness levels of RS 231 and 9005 are not statistically different from those of the silicone sealants at all five sites.
- Hot-applied sealants placed using the saw-and-overband method are showing better or equal performance when compared with hot-applied sealant materials



placed using the saw-and-recess, plow-and-overband, and saw-and-flush methods, with the exception of the Kentucky site.

- At the Colorado site, significantly more full-depth spalls have occurred in the Sof-Seal, 960-SL, 888, 888-SL, and 9030 sealants than in the 9005 sealant. At the Iowa site, significantly more full-depth spalls have developed in the Sof-Seal product than in 9005.
- At Arizona, Colorado, Iowa, and Kentucky, hot-applied sealants installed using the saw-and-recess method have performed significantly worse than the same sealants placed using other methods. At South Carolina, hot-applied sealants placed using the plow-and-overband method have developed significantly more failure than the same sealants placed using other methods.
- Based on actual and estimated service lives corresponding to 90 percent effectiveness, the average annual cost of cold-applied, silicone sealants placed using the saw-and-recess method is approximately one-half the average annual cost of hot-applied, rubberized asphalt sealants placed using the same method. Moreover, among the hot-applied, rubberized asphalt sealants, the average annual cost is least for the saw-and-overband method and greatest for the saw-and-recess and plow-and-overband methods.

## RESEALING OBJECTIVES

The two primary objectives of joint resealing in PCC pavements are to prevent the passage of water through the joint and to prevent the intrusion of incompressible materials, such as rocks, sand, and dirt, into the joint.

In the case of the first objective, water that is allowed through the joint enters into the underlying pavement structure where it can potentially cause a number of pavement distresses. Among these distresses are pumping (figure 3-2), base/subbase erosion, loss of support, and faulting.

In the case of the second objective, incompressible materials (figure 3-3) that penetrate the joint reservoir can interfere with the routine thermal expansions and contractions of the concrete slabs. Such interference can cause the development of spalls along the joint and, in more extreme cases, pavement blowups.

Along with these objectives, it is important to establish the approximate length of service desired from resealed joints. Current sealing materials and procedures can be combined to provide adequate performance for a range of years. For the maintenance planner, performance goals can be viewed according to three general levels:

Notes

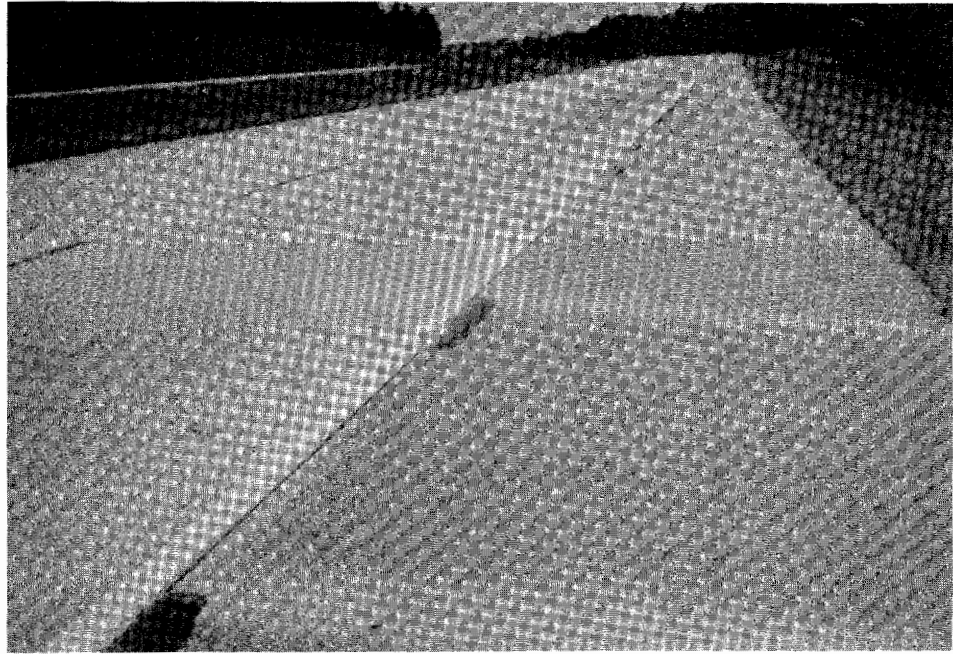

Figure 3-2. Pumping of fines from subsurface layers.

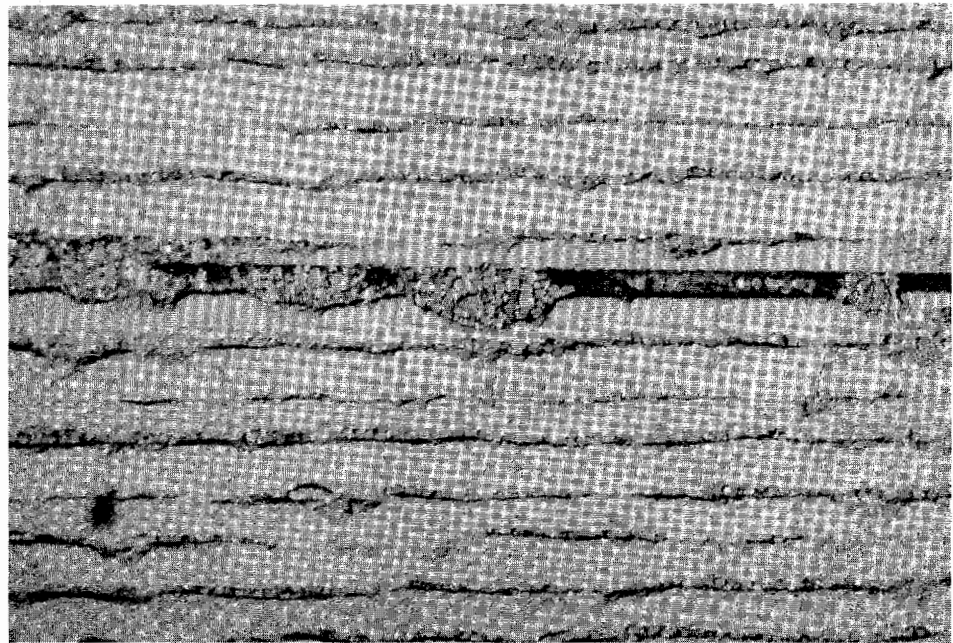

Figure 3-3. Collection of stones and sand in joint.

- Short-term performance—temporarily sealing joints for 1 to 3 years until the pavement is overlaid or replaced.
- Mid-term performance—sealing and maintaining watertight joints for 3 to 5 years.
- Long-term performance—sealing and maintaining watertight joints for a period extending more than 5 years.

Once a general performance level is established, it is possible to develop more detailed plans and objectives that consider the resources available and the characteristics (pavement condition, traffic, climate) of the resealing project.

## **PROJECT PLANNING AND DESIGN**

### **Selecting a Sealant Material**

Sealant materials are undoubtedly subjected to very harsh conditions. The selected sealant must have the capability to:

- Withstand horizontal movement and vertical shear at all temperatures and conditions to which they are exposed.
- Withstand environmental effects, such as weathering, extreme temperatures, and excess moisture.
- Resist stone and sand penetration at all temperatures.
- Maintain complete adhesion to concrete joint sidewalls at all temperatures.

There is a variety of sealant materials on the market today, each with its own inherent set of characteristics. Unfortunately, there is no one sealant that meets the demands of every resealing project. As such, sealant selection must be based on the objectives of the resealing project.

Table 3-2 contains a listing of sealant materials commonly used in resealing PCC joints. Example products for each sealant type are included, along with applicable specifications. The allowable extension and cost ranges are shown to help the maintenance planner choose a sealant material. Actual costs may vary considerably depending on project size and material availability. The allowable extension is the maximum in-place sealant extension, as recommended by the manufacturer.

Table 3-2. Summary of PCC joint resealing materials.

| Sealant Material                    | Example Products                                 | Applicable Specification(s)                            | Design Expansion   | Cost Range (\$/L) <sup>b</sup> |
|-------------------------------------|--|--|--------------------|--------------------------------|
| PVC coal tar                        | Crafco Superseal 444                             | ASTM D3406   | 10 to 20%          | \$2.10 to \$3.20               |
| Rubberized asphalt                  | Koch 9005, Crafco RoadSaver 221, Meadows Hi-Spec | ASTM D1190, D3405, AASHTO M173, M301-851, Fed SS-S-164 | 15 to 30%          | \$0.85 to \$1.10               |
| Low-modulus rubberized asphalt      | Crafco 231, Meadows Sof-Seal, Koch 9030          | Modified ASTM D3405                                    | 30 to 50%          | \$1.20 to \$1.40               |
| Polyurethane                        | Mameco Vulkem 300 SSL, Sikaflex, Burke U-Seal    | Fed SS-S-200E  | 10 to 50%          | \$6.30 to \$8.40               |
| Silicone (nonself-leveling)         | Dow 888, Bayer Baysilone 960, Crafco 902         | State specifications                                   | 30 to 50%          | \$7.10 to \$10.30              |
| Silicone (self-leveling)            | Dow 890-SL, Crafco 903                           | State specifications                                   | 30 to 50%          | \$7.65 to \$10.55              |
| Preformed neoprene compression seal | DS Brown Delastic, Watson-Bowman WB series       | ASTM D2628, AASHTO M220                                | Compress 45 to 85% |                                |

<sup>a</sup> Consult manufacturers for specific design extensions.

<sup>b</sup> Based on 1995 costs.

When the pavement joints are spalled, resealing with compression seals is not typically done because the seals tend to twist or move up or down in the joint at locations where the joint edge is not vertical and completely smooth.

### Laboratory Testing

Thorough laboratory and field testing is highly recommended before any sealant is used on a large-scale project. Testing can be quite useful in precluding the placement of obviously deficient materials. To a certain extent, it can indicate the large-scale performance potential of various materials under local conditions.

Various material testing specifications have been developed at both the national and local levels. Organizations, such as the American Society for Testing and Materials (ASTM), the American Association of State Highway and Transportation Officials (AASHTO), and the General Services Administration (Federal Specifications), have issued standard specifications for rubberized asphalt materials. A few States (e.g., Iowa, Minnesota, Michigan) have developed modified specifications for the low-modulus rubberized asphalt sealants and silicone sealant manufacturers have recommended specifications for their silicone products. Summaries of test criteria for these types of materials are available in appendix A of the SHRP *Manual of Practice* on Repair of Joint Seals in Concrete Pavements.<sup>18</sup>

Table 3-3. Backer-rod materials.

| Backer Material Type                                    | Example Products                  | Properties <sup>a</sup> | Compatibility                        |
|---|-----------------------------------|-------------------------|--------------------------------------|
| Extruded closed-cell polyethylene foam rod              | Nomaco HBR, ITP SBR               | NMA, ECI, NS            | Most cold-applied sealants.          |
| Cross-linked extruded closed-cell polyethylene foam rod | Nomaco HBR-XL, ITP Hot Rod-XL     | HR, NMA, ECI, NS        | Most hot- and cold-applied sealants. |
| Extruded polyolefin foam rod                            | Nomaco Sof-Rod, ITP Soft-Type Rod | NMA, NS, NG, CI, IJ     | Most cold-applied sealants.          |

- |     |   |                              |    |   |                |
|-----|---|------------------------------|----|---|----------------|
| CI  | - | Chemically inert             | NG | - | Nongassing     |
| ECI | - | Essentially chemically inert | NS | - | Nonstaining    |
| IJ  | - | Fills irregular joints well  | HR | - | Heat resistant |
| NMA | - | Nonmoisture-absorbing        |    |   |                |

Conduct laboratory testing in full accordance with the test methods specified for the material. If the material does not meet all applicable specifications, reject it. On the other hand, good performance is not guaranteed by compliance with material specifications.

#### Selecting a Backer Material

Backer rod is typically inserted in PCC joints before resealing to keep the sealant from sinking into the reservoir. It also keeps the sealant from bonding to the bottom of the reservoir and, if properly selected and installed, helps maintain the proper sealant thickness.

The ideal rod is flexible, compressible, nonshrinking, nonreactive, and nonabsorptive. Shrinking rod may allow sealant to flow past the rod before the sealant sets. Backer rod that reacts with certain sealants may produce bubbles in or staining of the sealant. Finally, a backer rod that absorbs water may shorten the life of the sealant material.

Several currently available types of backer rod are listed in table 3-3. As can be seen, each type has specific properties and intended uses. For example, several backer-rod types are designed to withstand the extreme temperatures of hot-applied sealants, while others are intended only for cold-applied sealants.

## Notes

Since sealant and backer rod must be compatible, follow the manufacturers' recommendations when selecting the type of backer rod. Typically, the cross-linked, extruded foam rods are used with hot-applied sealants, while extruded closed-cell polyethylene foam or extruded polyolefin foam rods are used with cold-applied sealants.

Finally, to achieve a snug fit, backer-rod diameter should be approximately 25 percent larger than the joint width. Backer rod is available in diameters ranging from 10 to 100 mm or more. Since joint widths may vary within a rehabilitation project, a sufficient range of rod sizes should be on hand to obtain a tight seal in all joints.

### Selecting a Primer Material

The purpose of a primer is to bond to the concrete joint surface and to provide a surface to which the new sealant can bond well. In areas where high humidity and moisture or other factors make it difficult to obtain a good bond between the sealant and the concrete, use of a primer material may be entirely appropriate. Currently, primers are used in only a small percentage of major PCC resealing operations, with most of the use in wet or cold climates.

### **Selecting a Material Design Configuration**

The width of a joint and the thickness of the sealant in that joint can significantly affect the performance of the seal.<sup>19</sup> If a joint is too narrow and temperature changes cause the joint to widen significantly, the sealant may be stretched beyond its breaking point or pulled away from the concrete. In addition, if a thick sealant is stretched, it may either tear or debond from the concrete.

Determine two major items in designing the dimensions of a joint sealant and the sealant reservoir—the shape factor and the expected joint movement. Figure 3-4 shows the dimensions of a typical joint reservoir containing sealant material

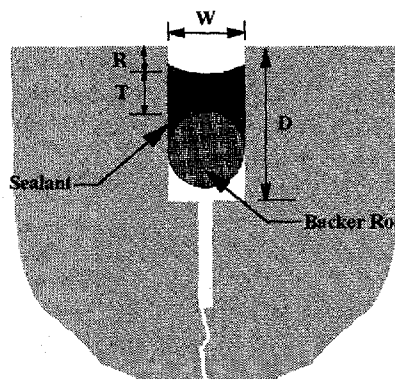

Figure 3-4. Typical joint cross section.

and backer rod. The shape factor is the ratio of the sealant width (W) to the sealant thickness (T). The sealant recess is designated R, and the joint channel depth is D.

To the extent possible, follow manufacturers' recommendations when choosing a shape factor. Below are typical recommended shape factors for five types of sealants.

| <u>Sealant Type</u> | <u>Typical Shape Factor (W/T)</u> |
|---------------------|-----------------------------------|
| Rubberized asphalt  | 1:1                               |
| Silicone            | 2:1                               |
| PVC coal tar        | 1:2                               |
| Polysulfide         | 1:1                               |
| Polyurethane        | 1:1                               |

To estimate the maximum opening movement in a joint, use the following equation:

$$M = (1000 \text{ mm/m}) \times C \times L \times \alpha \times T$$

- where:
- M = Joint opening movement caused by temperature change of PCC, mm.
  - C = Subbase/slab friction resistance adjustment factor (0.65 for stabilized subbase, 0.80 for granular subbase).
  - L = Joint spacing, m.
  - $\alpha$  = Thermal coefficient of contraction for PCC (9.0 to  $10.8 \times 10^{-6}/^{\circ}\text{C}$ ).
  - T = Temperature range: temperature at placement minus lowest mean monthly temperature,  $^{\circ}\text{C}$ .

Based on this equation, the percent elongation for which the new sealant must allow is:

$$\%E_{\max} = 100 \times (M_{\max}/W_{\text{init}})$$

- where:
- $\%E_{\max}$  = Estimated elongation, percent.
  - $M_{\max}$  = Joint opening movement caused by change of PCC temperature, mm.
  - $W_{\text{init}}$  = Joint width at the time of sealant placement, mm.

Hence, for a concrete pavement with 9-m joint spacing, 10-mm joint width at time of sealant placement, a granular subbase, and an estimated temperature range

**Notes**

of 30°C, the joint opening movement and required elongation characteristics of the sealant are computed as follows:

Joint Opening Movement

$$M = 1000 \times C \times L \times \alpha \times T$$

$$M = 1000 \times 0.8 \times 9 \times (9.0 \times 10^{-6}) \times 30$$

$$M = 2 \text{ mm}$$

Required Elongation

$$\%E_{\max} = 100 \times (M_{\max} / W_{\text{init}})$$

$$\%E_{\max} = 100 \times (2/10)$$

$$\%E_{\max} = 20\%$$

Some planners prefer to determine  $M_{\max}$  using the safer assumption that a joint between two slabs may be called upon to take the total movement of both slabs. In this assumption:

$$M_{\max} = 2 \times M$$

The initial joint width,  $W_{\text{init}}$ , should be wide enough to keep the sealant from being stretched in cold weather more than the design amount, typically 20 percent. However, joints typically should not be wider than 20 mm.<sup>19,21</sup>

Table 3-4 lists suggested sealant thicknesses and minimum joint widths for various joint spacings as a check for more detailed joint design. This table is based on limiting the sealant stress to less than 20 percent.

The joint reservoir depth,  $D$ , should be the sum of the selected sealant thickness, the compressed backer-rod thickness, and the depth that the sealant surface is to be recessed. Some manufacturers recommend that an extra 5 mm be added to prevent water and material beneath the sealant from pushing the sealant up and out of the joint.

Table 3-4. Typical joint design dimensions.

| Maximum Joint Spacing, m | Minimum Joint Width, mm <sup>a</sup> |                            |
|--------------------------|--------------------------------------|----------------------------|
|                          | Nonfreeze Region <sup>b</sup>        | Freeze Region <sup>c</sup> |
| ≤ 5                      | 6                                    | 10                         |
| 5-8                      | 6-10                                 | 10-13                      |
| 8-12                     | 10-13                                | 13-19                      |
| 12-18                    | 13-19                                | 19-29                      |

<sup>a</sup> Installation temperature is 27°C, base is stabilized,  $\%E_{\max} \leq 20\%$ .

<sup>b</sup> Minimum nonfreeze region temperature is -7°C.

<sup>c</sup> Minimum freeze region temperature is -26°C.



## Selecting an Installation Procedure

The type of joint cleaning procedures and the final cleanliness of the concrete joint walls prior to sealant installation can significantly affect the performance of sealant materials. As a rule, the cleaner and dryer the joint surfaces, the better a sealant will adhere and the more effective it will be. Therefore, choose preparation and installation procedures as carefully as you choose sealant materials.

Base the selection of which combination of preparation and installation procedures to use on the condition and requirements of each individual resealing project. Table 3-5 shows some of the more common joint preparation and sealant installation combinations, including the four methods used in the SHRP H-106 experiment. Each option, if selected properly and followed completely, should result in clean joint surfaces and increase the chances for good performance.

Method 1, saw-and-recess, includes sawing, sandblasting, and airblasting the joint, followed by backer rod insertion and recessed sealant placement. This and other methods that don't include water washing should only be used when it can be demonstrated that adequate joint surface cleanliness can be achieved without water washing.

Method 2, saw-and-overband, differs slightly from method 1 in that the adjacent pavement surface is sandblasted and the joint is overfilled with hot-applied sealant material, which is then struck-off with a squeegee to form an overband on the pavement surface. In general, overbanding appears to provide similar or better performance than the recessed configuration, and is most suitable for use on lower trafficked roads.

Table 3-5. Common joint preparation and sealant installation methods.

| Method | Plow | Saw | Water Wash | Initial Airblast | Sandblast | Final Airblast | Backer Rod | Recessed Sealant | Flush Sealant | Overband Sealant |
|--------|------|-----|------------|------------------|-----------|----------------|------------|------------------|---------------|------------------|
| 1*     |      | ✓   |            | ✓                | ✓         | ✓              | ✓          | ✓                |               |                  |
| 2*     |      | ✓   |            | ✓                | ✓         | ✓              | ✓          |                  |               | ✓                |
| 3*     | ✓    |     |            |                  |           | ✓              | ✓          |                  |               | ✓                |
| 4*     |      | ✓   |            | ✓                | ✓         | ✓              | ✓          |                  | ✓             |                  |
| 5      |      | ✓   | ✓          | ✓                | ✓         | ✓              | ✓          | ✓                |               |                  |
| 6      | ✓    | ✓   |            | ✓                | ✓         | ✓              | ✓          | ✓                |               |                  |
| 7      | ✓    |     |            |                  | ✓         | ✓              | ✓          | ✓                |               |                  |

\* SHRP H-106 installation methods.<sup>20</sup>

## Notes

In method 3, plow-and-overband, the sawing operation in method 2 is replaced by plowing, and sandblasting is not performed. This method has reduced preparation time and, because it is a dry operation, it allows for immediate cleaning and resealing. Method 3 may be used if:

- The joint dimensions are adequate.
- The plowing equipment removes more than 95 percent of the sealant from the joint faces, leaving fresh, unspalled concrete.
- Adequate joint cleanliness can be achieved via high-pressure air only.

Method 4, saw-and-flush, differs slightly from methods 1 and 2 in that the joint is filled with sealant material flush with the pavement surface. The flush configuration also appears to provide similar or better performance than the recessed configuration.

Method 5, which is simply method 1 with the addition of water washing, should be considered when:

- The resealing project carries a high volume of traffic.
- A high-quality sealant is being used.
- Joint widths or depths do not meet the minimum design requirements.
- The existing sealant is hardened and will not melt and gum up the saw blades.

Method 6 adds a plowing operation to method 1 and should be used in the following situations:

- The saw blade is melting the existing sealant and sawing cannot remove the sealant efficiently by itself.
- The joint dimensions are not adequate.

Finally, method 7 includes sandblasting in the plowed joint preparation phase of method 3, and substitutes the overband with a recessed configuration. Again, in comparison with method 1, preparation time is significantly reduced and cleaning and resealing can be done immediately after joint preparation, since it is a dry operation. It may only be used if:

- The joint dimensions are adequate.
- The plowing equipment removes more than 95 percent of the sealant from the joint faces, leaving fresh, unspalled concrete.
- The sandblaster can efficiently remove any remaining sealant.

If compression seals are being replaced with formed-in-place sealant, sawing is not required when sandblasting can completely remove the old lubricant from the joint walls,<sup>21</sup> unless the joint width is too narrow.

## Determining Resource Requirements

### Materials

Quite often, an estimate of the quantity of material required for a project is needed. Such a task is not overly difficult, but does require a brief inspection of the project site, as well as knowledge of the material design configuration.

The field inspection provides an estimate of the total length of joints to be resealed. Only a small portion (3 to 5 percent) of the project needs to be inspected, or sampled, as long as it is fairly representative of the entire project with respect to the type and condition of joints targeted for resealing.

The total length of joints to be resealed is determined simply by dividing the total project length by the total length of the sample segment, and then multiplying by the length of joints observed in the sample segment. The resulting value is then divided by the sealant coverage rate, which is estimated using the following equation:

$$CR = (1000 \text{ L/m}^3) \times (10^{-6} \text{ m}^2/\text{mm}^2) \times WF \times ST \times W \times T$$

where:

- CR = Sealant coverage rate, L/m.
- WF = Waste factor (WF = 1.20 for 20 percent waste).
- ST = Surface type constant (for tooled surface, ST = 1.1; for nontooled surface, ST = 1.0).
- W = Joint width, mm.
- T = Thickness of sealant, mm.

Thus, for a concrete pavement with 15-mm wide joints that will be sealed with nonsag silicone (i.e., tooling required) to a thickness of 10 mm, the coverage rate using 20 percent wastage is determined as follows:

$$\begin{aligned} CR &= (1000) \times (10^{-6}) \times WF \times ST \times W \times T \\ CR &= (1000) \times (10^{-6}) \times 1.20 \times 1.1 \times 15 \times 10 \\ CR &= 0.2 \text{ L/m} \end{aligned}$$

### Equipment

Major problems for many maintenance groups are the availability of adequate equipment and the need for equipment rental. As such, some options for joint preparation and material installation may risk being eliminated from consideration.

Considering only the equipment available for use, base the equipment selection process on proven effectiveness and efficiency. Although the relative

## Notes

tradeoff between these two criteria will certainly vary from agency to agency, effectiveness should be the more dominant criterion.

Many types and brands of equipment are available for joint resealing operations. These equipment are best categorized according to the specific task for which they're used (e.g., joint plowing, sandblasting). A comprehensive list of characteristics and recommendations about joint resealing equipment is found in table 11 of reference 18.

### Labor

Another major planning consideration is the amount of labor required to perform the resealing operation. Each task in the resealing process requires a certain number of workers to complete the task efficiently. Because production rates among the individual activities can vary considerably, adjustments should be made to the labor afforded each activity so that the overall operation is well-synchronized and worker productivity is increased. Table 3-6 provides additional information about the work crew requirements and typical production rates associated with each task.

### **Cost-Effectiveness**

Although sealant performance is important, the preferred basis for determining which materials and procedures to use is cost effectiveness. Obviously, a sealant with an in-place cost of \$600/km (of highway) and that performs adequately for 5 years is more desirable than a sealant with an in-place cost of \$1,000/km and that performs for the same amount of time.

Table 3-6. Production rates for various resealing activities.

|                         | Number of Workers | Average Rate, hrs/300 m |
|-------------------------|-------------------|-------------------------|
| Joint plowing           | 2                 | 2.0 - 3.0               |
| Sawing                  | 1                 | 3.5 - 7.5               |
| Sandblasting            | 2                 | 1.5 - 4.0               |
| Airblasting             | 2                 | 1.5 - 4.0               |
| Backer rod installation | 2                 | 1.0 - 3.0               |
| Sealant installation    | 2                 | 1.5 - 2.5               |

To determine the cost-effectiveness of various joint resealing options, use the following steps:

1. Determine the amounts and costs of materials needed.
2. Estimate the labor needs and costs.
3. Determine the equipment requirements and costs.
4. Estimate the effective lifetime of each resealing option.
5. Calculate the average annual cost for each option under consideration using the following equation:

$$AAC = TRC \left[ \frac{(i)[(1+i)^{ESL}]}{(1+i)^{ESL} - 1} \right]$$

where: AAC = Average annual cost of resealing option, \$  
 TRC = Total resealing cost, \$  
 ESL = Estimated service life, years  
 i = Interest rate

Determine the most cost-effective resealing option by comparing the average annual cost of the various material-procedure combinations. Table 3-7 provides sample cost-effectiveness comparisons. In the exercise, two different joint resealing options are being considered by a maintenance agency for a 4.0-km project, with approximately 6,710 m of joint.

#### Reseal Option 1

Rubberized asphalt, coverage rate = 0.18 L/m

Backer rod, coverage rate = 1.05 m/m

Blasting sand, coverage rate = 0.3 kg/m

Sealant cost: \$0.80/L

Backer rod cost: \$0.33/m

Blasting sand: \$0.11/kg

Estimated service life: 5 years

Total labor cost: \$9,000

Equipment cost: \$12,000

User delay cost: \$2,200

#### Reseal Option 2

Silicone sealant, coverage rate = 0.09 L/m

Backer rod, coverage rate = 1.05 m/m

Blasting sand, coverage rate = 0.3 kg/m

Notes

Table 3-7. Summary of resealing option costs.

|                        | Reseal Option 1  | Reseal Option 2   |
|------------------------|--|---|
| Total Material Cost    | $(\$0.8/L) \times (0.18 \text{ L/m}) \times (6,710 \text{ m})$<br>$+ (\$0.33/\text{m}) \times (1.05 \text{ m/m}) \times (6,710 \text{ m})$<br>$+ (\$0.11/\text{kg}) \times (0.3 \text{ kg/m}) \times (6,710)$<br>= \$3,512 | $(\$7.39/L) \times (0.09 \text{ L/m}) \times (6,710 \text{ m})$<br>$+ (\$0.30/\text{m}) \times (1.05 \text{ m/m}) \times (6,710 \text{ m})$<br>$+ (\$0.11/\text{kg}) \times (0.3 \text{ kg/m}) \times (6,710 \text{ m})$<br>= \$6,798 |
| Total Labor Cost       | \$9,000  | \$11,000  |
| Total Equipment Cost   | \$12,000   | \$14,000  |
| User Delay Cost        | \$2,200  | \$2,500   |
| Total Resealing Cost   | \$26,712   | \$34,298  |
| Estimated Service Life | 5 years  | 10 years  |
| Interest Rate          | 0.05   | 0.05  |
| Average Annual Cost    | \$6,170  | \$4,442   |

Reseal Option 2 (continued)

- Sealant cost: \$7.39/L
- Backer rod cost: \$0.30/m
- Blasting sand: \$0.11/kg
- Estimated service life: 10 years
- Total labor cost: \$11,000
- Equipment cost: \$14,000
- User delay cost: \$2,500

As can be seen in table 3-7, even though the material cost associated with option 2 is many times greater than the material cost associated with option 1, the added service life makes the second option more cost-effective.

## INSTALLATION

Joint resealing operations consist of two fundamental steps, each involving multiple tasks:

1. Joint preparation.
  - removal of old sealant.
  - refacing of joint sidewalls.
  - abrasive blasting.
  - airblasting.
  - primer installation.
2. Material preparation and application.
  - installation of backer rod.
  - sealant preparation (e.g., loading, heating)
  - sealant application and finishing.
  - cleanup.

This section provides general guidance on how each task should be performed in order to create as long-lasting seals as possible. For work quality monitoring by field supervisors/inspectors, detailed operational checklists are available in appendix D of reference 18. Additional guidance on installing joint seals is provided in the FHWA Technical Advisory on Concrete Pavement Joints.<sup>40</sup>

### Traffic Control

Whenever a joint resealing operation is performed, it is critical that adequate traffic control be in place to provide a safe working environment for the installation crew and a safe travel lane for vehicles. The operation should also cause the least possible disturbance to the flow of traffic.

Besides normal signs, arrow boards, cones, and attenuators, flaggers may be required to accompany the sawing and/or plowing operations if the plow or saw must extend into the lane carrying traffic.

### Safety

The equipment and materials used in a joint resealing operation can present safety hazards to workers if appropriate precautions are not taken. All guards must be in place, operational worker protection devices must be used, and appropriate clothing should be worn. Obtain material safety data sheets (MSDS) for each sealant material to be installed, and take proper care to protect workers from any potentially harmful materials. A more detailed explanation of material and equipment safety is provided in appendix C of reference 18.

## Notes

### Joint Preparation

The objective of the joint preparation task is to provide clean, dry, and properly dimensioned joints that are free from sawing dust, old sealant, or other contaminants, and to which sealant material can adequately bond. Careful and thorough joint preparation is essential to good sealant performance. Regardless of the sealant material quality, if the joint faces are not clean and dry, the sealant will pull away from the joint walls prematurely.

Depending on the project, joint preparation may involve any number of subtasks, including removing old sealant, refacing joint sidewall, abrasive-blasting (i.e., sandblasting), airblasting, and applying primer material. The following sections discuss the equipment and procedures recommended to achieve these subtasks.

#### Removing Old Sealant

Joint plows, such as the one shown in figure 3-5, can be used to remove old sealant from concrete joints prior to or in place of sawing. Remove preformed compression seals by hand or by pulling out longer sections with a tractor. Plowing involves pulling a thin blade through a joint to remove old sealant and backer material from the reservoir and to clean sealant from the sides of the joint.

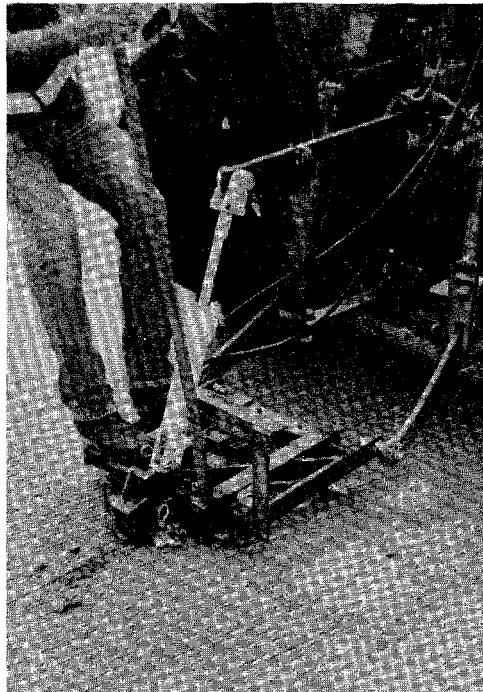

Figure 3-5. Rear-mounted joint plow.



To effectively remove sealant before sawing, the plowing operation must achieve two results:

- Sufficient sealant and debris must be removed so that saw blades are not "gummed up" during sawing.
- Joint walls must not be spalled by the plow.

If sawing will not follow the plowing operation, the following additional results must be achieved:

- At least 95 percent of old sealant must be removed from the joint sidewalls.
- All sealant remaining on joint sidewalls must be easily removable by sandblasting.

Several types of plows have been used, and a few have functioned successfully. Two particular types of tractor-mounted plows are the rear-mounted, mechanically controlled plow and the belly-mounted, hydraulically controlled plow. The first plow is generally effective at removing most of the old sealant, while the second plow is capable of complete sealant removal.

Successful use of a joint plow typically requires the following equipment and procedures:

- Multiple passes of a blade that is narrower than the joint, cleaning each channel face individually.
- Carbide-tipped, straight-sided blades instead of tapered blades to significantly reduce the risk of joint spalling.
- Effective vertical and horizontal control of the plow blade to scrape sealant from the joint sidewalls.
- Sufficient tractor weight and power to maintain blade depth and remove old sealant.
- Effective traffic control and equipment guards to protect workers from flying debris and moving traffic.

Joint plow operators must use special care or an alternative procedure, to overcome difficulties with spalling or improper cleaning. Table 3-8 lists several common plowing problems and possible solutions.

## Notes

Table 3-8. Troubleshooting procedures for plowing operations.

| Problems Encountered   | Possible Solutions  |
|--|---|
| Plow is spalling joint edges.                                | Use an untapered plow bit or a narrower blade.  |
| Plow is not completely removing sealant.                     | Increase pressure on the joint sidewall.<br>Check or replace blade.<br>Use hand tools.          |
| Belly-mounted plow places tractor in traffic.                | Use rear- or front-mounted blades, hand tools, or a router.                                     |
| Guardrail or curb keeps plow from reaching the entire joint. | Use rear/front-mounted blades.<br>Reverse the plowing direction.<br>Use hand tools or a router. |
| Lining up the plow with a joint is difficult.                | Use a belly-mounted plow.<br>Use an assistant.  |
| Original saw cuts are offset.                                | Use additional care in plowing.<br>Use hand tools or a router.                                  |

Removing old joint material and other debris should be a continual process during joint preparation. The following concurrent work is recommended with the plowing operation:

- Blow sealant and debris from the plowed joints.
- Vacuum, blow away, or pick up debris from the plowing operation.
- Remove the old sealant and properly dispose of it. (Some materials may require hazardous or specialized waste disposal methods.)

### Refacing the Joints

Joints in concrete pavements are resawed either to increase the joint width and depth to the design requirements or to expose clean, fresh concrete to which new sealant can adhere. The following results of sawing must be achieved for the entire project:

- Uniform width and depth of joint in compliance with the design dimensions.
- No spalls resulting from resawing.

Table 3-9. Troubleshooting procedures for resawing operations.

| Problems Encountered                                   | Possible Solutions  |
|--|---|
| Blade is pulling to one side.                          | Change the rate of sawing.<br>Check for rear wheel alignment.   |
| Blade is not cleaning both sides.                      | Use wider blades.<br>Use smaller diameter blades.<br>Use a more skilled operator.                                 |
| Sealant is "gumming up" blade.                         | Remove (plow) sealant before sawing.  |
| One side of the ganged blades is worn.                 | Switch the inside and outside blades.   |
| The saw cut does not begin in the center of the joint. | Have the saw operator take more care.<br>Replace the saw operator.<br>Provide an assistant to the operator.       |
| Sawing is slow.  | Use a more powerful saw.<br>Use a more appropriate blade.<br>Adjust the water feed.<br>Increase the cutting rate. |

- Sealant completely removed and concrete freshly exposed on both sides of each joint.

A properly completed resawing operation greatly simplifies the remainder of the preparation tasks. Therefore, take care to ensure accurate and complete sawing, and if poor results are noticed they should be corrected promptly. Table 3-9 highlights several common problems encountered in resawing and their recommended solutions.

Although self-propelled, dry saws are available and have been used successfully in joint refacing operations, water-cooled diamond-blade saws are the current norm. The blades on these devices are often ganged side-by-side on the blade arbor with a solid metal spacer to allow the saw to reface the joint to a proper, uniform width in one pass.<sup>22</sup> The spacer diameter must be sized to prevent sealant from building up between the blades. Ganged blades can be exchanged on the arbor to provide more even wear, more uniform sawing widths, and longer blade life. Single, full-width blades are also used to resaw joints for resealing.

Since smaller blades are less expensive and make the saw easier to maneuver, blades should be no larger than necessary to achieve the required depth. Use blades specifically designed for resawing hardened concrete, and ensure that the body of these blades is thick enough to resist warping.

## Notes

Wet-sawing leaves behind old sealant and a slurry of water and concrete dust in the joint. It is very difficult to remove this slurry if it dries on the joint walls. It will keep new sealant from bonding to the concrete. Therefore, remove the sealant and slurry immediately after sawing by one of the following three slurry removal methods:

- Flush joints with low-pressure water, simultaneously blowing the slurry out with high-pressure air until all sawing waste is removed.<sup>22</sup>
- Flush joints with high-pressure water until all sawing waste is removed.
- Clean joints with high-pressure air until all sawing waste is removed.

The first two methods are considered to be more effective at removing concrete dust slurry than the last method.

### Sandblasting

A sandblasting apparatus, like the one shown in figure 3-6, directs a mixture of clean, dry air and abrasive material (typically sand) onto the walls of concrete joints. Desired results of sandblasting include removal of sawing dust, old sealant, and other foreign material from the concrete joint surfaces, as well as the roughening of the concrete surface, which creates a better bonding surface.

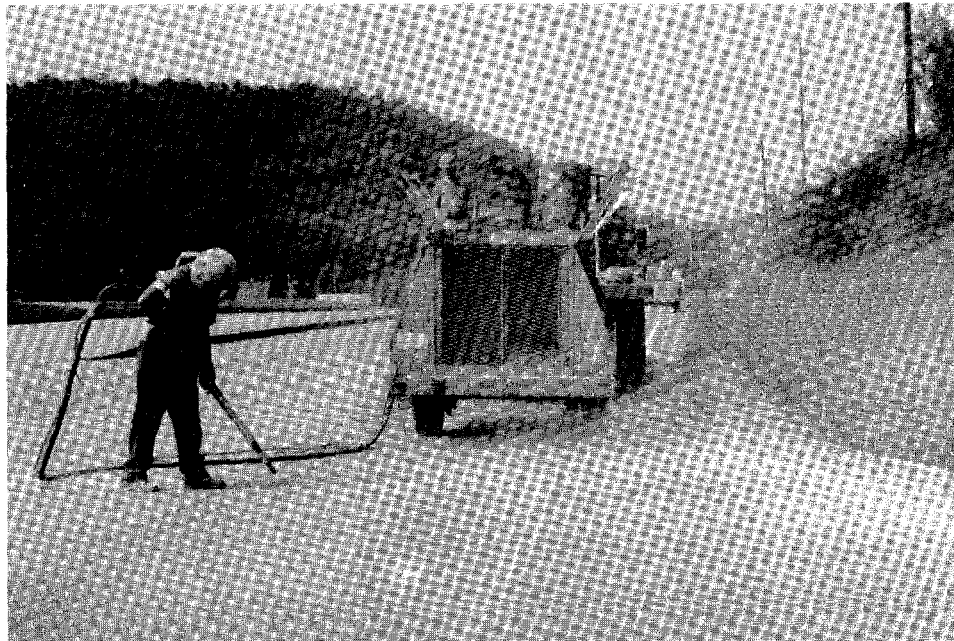

Figure 3-6. Sandblasting operation.

Sandblasting equipment typically consists of a compressed-air unit, a sandblast machine, hoses, and a wand with a proper size nozzle. As a minimum, the complete unit should maintain a nozzle pressure of 620 kPa at 70 L/sec and should provide a supply of air that is clean, dry, and free from oil. In some instances, the latter requirement may require the installation of an oil and moisture filter on the air compressor.

Use tungsten carbide nozzles for larger projects, and ceramic nozzles are more useful for 3- to 4-hr projects. Tungsten carbide and ceramic nozzles are available in several diameters, lengths, and shapes. A 5- to 6-mm diameter venturi nozzle has been used successfully for sandblasting joints. The manufacturer should be consulted for proper nozzle sizing.

A sandblast chamber that allows continuous loading increases production rates. Furthermore, attaching an adjustable guide to the nozzle to keep it 25 to 50 mm from the pavement surface promotes consistent results and reduces operator fatigue.

The following procedures can provide successful sandblast cleaning results:

1. Use approved sandblast units, safety equipment, and safety procedures.
2. Hold the sandblast nozzle no more than 50 mm from the pavement surface. A long handle attached to the hose and extending slightly past the nozzle will allow this to be done from an upright position.
3. Make one complete pass for each joint wall at an angle from the pavement that directs the blast onto the surface to which sealant must bond.
4. Angle the sandblast nozzle to push sand and debris in the direction of nozzle travel.
5. Remove any old sealant with repeat passes or with a knife and repeat passes.
6. Protect traffic in nearby lanes from sand and dust by using a portable shield and low-dust abrasive.
7. Use airblasting and/or vacuuming equipment to remove sand and dust from the joint and nearby pavement to prevent recontamination.

Problems encountered in sandblasting must be solved quickly. Several common sandblasting problems and possible solutions are provided in table 3-10.

## Notes

Table 3-10. Troubleshooting procedures for sandblasting operations.

| Problems Encountered                              | Possible Solutions  |
|---|---|
| Sandblasting is not removing sealant.             | Ensure that sandblaster is functioning.<br>Cut away old sealant and reblast.<br>Use a different blaster or abrasive or larger hoses.<br>Improve the accuracy of sawing. |
| Sandblast quality is not consistent.              | Ensure that sandblaster is functioning.<br>Keep the nozzle height and alignment consistent.<br>Use a nozzle guide attachment.   |
| Sandblast progress is too slow.                   | Ensure that sandblaster is functioning.<br>Use a different blaster or abrasive or a larger hose.  |
| There is oil or moisture in the sandblast stream. | Install a functional oil/moisture filter.<br>Use another compressor that doesn't add oil or moisture.<br>Use drier sand.  |
| The operator is quickly fatigued.                 | Use a guide and handle for upright sandblasting.<br>Alternate operators.  |

The sand and dust must be removed from the joints and pavement surfaces before sealing can begin, otherwise sand and dust can be blown back into the joints, reducing sealant performance. Use self-propelled vacuums and portable blowers for debris removal.

### Airblasting

After the joints have been sandblasted, and immediately before sealant installation, use a compressed-air stream to blow the dust, dirt, and sand from the joints and pavement surface. The following results of airblasting are desired over the entire project:

- Sand, dust, and dirt must be completely removed from the joint reservoir.
- Any sand, dust, and dirt that may recontaminate the joints must be removed from the surrounding pavement surface.

Several models of air compressors are currently available for use. From the standpoint of cleaning effectiveness, these units should have a minimum blast pressure of 620 kPa and a blast flow of 0.07 m<sup>3</sup>/s. Compressors that introduce contaminants, such as moisture and oil, into the air stream must be corrected before use on a resealing project. This can be done by disconnecting the lubricant system and installing an effective oil- and moisture-filtering system.

Table 3-11. Troubleshooting procedures for airblasting operations.

| Problems Encountered                   | Possible Solutions   |
|--|--|
| Oil in airstream.                      | Ensure oil/moisture filter is functional.<br>Clean or replace the hose.                        |
| Moisture in airstream.                 | Ensure oil/moisture filter is functional.  |
| Air not removing dust, dirt, and sand. | Use a larger compressor.<br>Use a larger diameter hose.<br>Reduce the nozzle opening diameter. |

In general, airblast joints immediately before installing backer rod. The airblasting, rod placement, and sealant installation operations must occur on the same day. If rain or dew recontaminate the joints, they must be sandblasted and airblasted again after drying. Airblasting methods for successfully accomplishing these results include:

1. Use approved air compressors, safety equipment, and safety procedures.
2. Hold the nozzle no more than 50 mm from the pavement surface.
3. Blow debris in front of the nozzle. Do not walk backwards.
4. Make slower or repeated passes until the joint reservoir is completely clean.
5. Elevate and fan the nozzle across the pavement on the last pass to remove debris from the joint area to a place where it cannot recontaminate the joints.

The most common problems encountered in airblasting are related to contamination of the air stream or lack of air volume and pressure. Table 3-11 describes methods for addressing these and other problems.

If the joints are slightly damp, a hot compressed air (HCA) lance may be used to dry the joints before installing backer rod.<sup>23</sup> Several heat lance options are available with varying blast velocities and temperatures, ignition methods, and support types (e.g., wheels, balancing straps).

The extreme temperatures that a heat lance can produce (820° to 1,650°C) can severely spall concrete pavement that is exposed to the heat for more than a very short time. Thus, take care to keep the heat lance from remaining in one location for an extended time, typically 2 or more seconds.

## Notes

### Applying Primer Material

If the application of primer to joint surfaces is necessary, it must be applied as follows for effective and economical results:

- Primer must very thinly and uniformly coat all joint surfaces to which the sealant must bond.
- Primer should not be wasted by applying thick coats or covering nonessential concrete surfaces.

Primer can be installed using a brush or spray equipment. Spray equipment is much more efficient, generally resulting in a thinner coat, and spray nozzles can be designed to coat only the upper joint wall surface. It is critical that the primer be allowed to dry, because as it dries it gives off gas.<sup>24</sup> If hot-applied sealant is installed before the primer has dried, bubbles will form in the sealant as the gas tries to escape. It is important to use all required operator safety equipment. This may include goggles, gloves, protective clothing, and respirators.

### **Material Preparation and Application**

The objective of this task is to properly install backer rod in clean joint channels and to adequately prepare, install, and shape the selected sealant material. The following sections discuss the equipment and procedures recommended to achieve these subtasks.

### Installing Backer Rod

Install backer rod immediately after airblasting and immediately before placing the sealant. Naturally, joint reservoirs and pavement surfaces must be completely clean before the backer rod is inserted.

To perform properly and reduce sealant stress, the backer rod must be placed with the following results:

- Backer rod must be at the depth required in the plans.
- No gaps should be evident between the backer rod and joint walls.
- The rod must be compressed in the joint enough that the weight of uncured sealant or the tooling operation does not force it down into the reservoir before the sealant cures.
- The rod must be dry and clean.



- The surface of the rod must not be damaged during installation (i.e., avoid twisting and stretching).
- No gaps should form between backer rod that is butted together in a joint or at a joint intersection.

Many devices have been used to insert backer rod into joints. The ideal installation device is one that pushes the backer rod into the joint to the specified depth without tearing, stretching, or damaging the rod. Using a screwdriver or similar tool is not recommended as they may damage the surface of the rod and result in bubbles forming in the sealant. Roller-type devices generally provide a more efficient and careful means of inserting the backer material. Automated equipment is most effective for continuous joints where only one size of backer rod is generally needed.

The steps to the most commonly used and successful method of installing backer rod are:

1. Have enough rod sizes available to fit all of the joint widths at the project.
2. Use a long-handled installation tool with a large-diameter central disk (125 to 250 mm) that fits into all joints and does not cut or damage the backer rod, such as the one shown in figure 3-7.

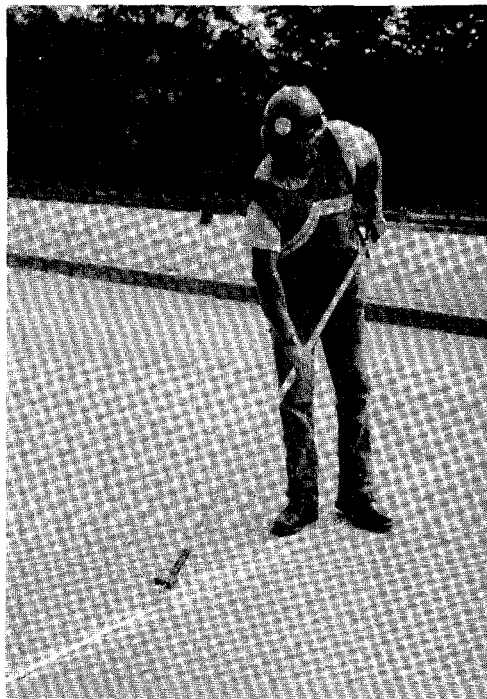

Figure 3-7. Adjustable backer rod insertion tool.

## Notes

Table 3-12. Troubleshooting procedures for backer-rod installation.

| Problems Encountered   | Possible Solutions  |
|--|---|
| Rod is tearing when installed.   | Use a smaller diameter backer rod.<br>Ensure that installation tool is smooth.      |
| Side gaps are evident or rod is slipping or is easily pushed down in joints. | Use a larger diameter rod.  |
| Rod depth is inconsistent.   | Check the installation tool for depth.<br>Repeat passes with the installation tool. |
| Rod is shrinking in the joint.<br>Gaps are formed between the rod ends.      | Do not stretch the rod when installing.<br>Use a larger diameter roller.            |

3. Insert one end of the proper size of rod into the end of a joint.
4. Tuck the rod loosely into the joint and push the remainder of the rod into the joint to the required depth by rolling the installation tool along the joint.
5. Roll over the rod a second time (from the other direction, if necessary) with the installation tool to ensure proper depth.
6. Cut the rod to the proper length, making sure no gaps exist between segments of backer rod.
7. Install larger diameter backer rod in sections where the rod does not fit tightly to the joint walls.

The depth of the installation tool must be slightly greater than the required depth of backer rod.<sup>25</sup> This is because the rod compresses slightly when installed. Certain rod materials are more compressible and require additional tool depth. Stretching and twisting of backer rod must be minimized during installation, because gaps may form at joint intersections and result in sealant failure as the material relaxes.

When transverse and longitudinal joints are being sealed in one operation, better results are obtained if rod is installed in the entire length of the transverse joints. That rod is then cut at the intersection with longitudinal joints and rod is installed in the longitudinal joints. Table 3-12 describes possible solutions to common problems encountered when installing backer rod.

### Sealant Installation

Sealant installation can begin once the joints have been cleaned, backer rod has been installed, and the weather conditions are appropriate (most sealant

manufacturers recommend installing sealant when the pavement is dry and the air temperature is 5°C and rising). Allow only minimal time—typically 5 to 10 min—to pass between backer rod installation and sealant placement; longer periods can result in significant collections of dirt and other debris blown into the joints.

In the event that rain interrupts the resealing operation, the open joints must be recleaned before installing sealant. Moreover, remove any backer rod dampened by the rain from the joints and subsequently replace it.

The sealing operation should progress quickly and result in a seal with the following characteristics:

- Prevents infiltration of water through the joints.
- Remains resilient and capable of rejecting incompressible materials at all pavement temperatures.
- Maintains a tight bond with the sidewalls of the joint.
- Has no bubbles or blisters.
- Is not cracked or split.
- Cannot be picked up or spread on adjacent pavement surfaces by traffic.
- Provides a finished, exposed joint surface that is nontacky and will not permit adherence or embedment of dust, dirt, small stones, and similar contaminants.

#### *Hot-Applied Sealants*

Use proper heating and installation methods to install hot-applied sealant that successfully meets the above requirements. In addition, follow suitable cleanup and safety procedures to ensure worker protection and properly functioning equipment.

Many companies manufacture mobile equipment designed to heat, mix, pump, and dispense sealant into pavement joints. Several such companies are listed in appendix E of reference 18.

The recommended characteristics of asphalt kettle equipment for use in joint resealing operations include:

- A double-walled heating chamber with heating oil between the walls as the heat transfer medium.

## Notes

- A mechanical agitator.
- Accurate thermostats to monitor both the sealant and the heating oil temperatures (these thermostats should control the operation of the burners).
- A reversible pump that can feed sealant to the applicator wand or recirculate the sealant into the melter vat.
- A nozzle with an outside diameter small enough to allow it to be pulled through the narrowest joint without binding yet large enough to maintain a suitable application rate.

Other useful options include electronic ignition, diesel heating fuel, wand nozzles that maintain the sealant at a certain depth,<sup>26</sup> and insulated and/or heated hoses and wands.

### Heating the Sealant

Hot-applied sealant performance can be significantly affected by the procedures used to heat and maintain its temperature during installation. Prior to heating sealant, check the melter/applicator for carbon buildup and accurately calibrated temperature gauges.

Schedule heating so that the sealant will be at the recommended temperature when sealing is to begin. During initial heating, adhere to the following guidelines:

1. Keep the heating oil temperature no more than 24°C above the safe sealant heating temperature stated on the sealant packaging.
2. Keep sealant temperatures between the recommended pouring temperature and the safe heating temperature printed on the sealant packaging.
3. Start the agitator as soon as possible.
4. Do not hold the sealant at application temperatures for a long period before using it.

Two temperatures are important to monitor while preparing hot-applied materials:

- **Recommended pouring temperature** is the temperature of the material at the nozzle that is recommended for optimum performance.

- **Safe heating temperature** is the maximum temperature that a material can be heated to before its formulation begins to quickly breakdown.

These temperatures vary between sealant manufacturers and sealant types. Therefore, obtain the pouring and safe heating temperatures of the sealant in use from the sealant packaging, and ensure that all sealant operators are aware of it.

Some of the critical checks that the operator of the asphalt kettle must make during the installation process are:

- Check to ensure that the pavement temperature is above the minimum recommended installation temperature and above the dew point.
- Check the temperature of the sealant at the nozzle and adjust the melter controls to achieve the recommended pouring temperature at the nozzle.
- Regularly check the sealant temperatures and adjust as necessary.
- Watch for carbon buildup on the sidewalls of the heating chamber. This is a sign of overheating.
- Do not use sealant that has been overheated or heated for an extended time, or sealant that remains tacky and shows signs of breakdown.

#### Applying the Sealant

Begin applying hot-applied sealant once the material has reached the recommended pouring temperature and the first few joints have been properly prepared and equipped with backer rod. Observe the following recommended practices to achieve proper application:

1. Pour the sealant with the nozzle in the joint so that the joint is filled from the bottom and air is not trapped beneath the sealant.
2. Apply the sealant in one continuous motion while moving the wand in a way that the sealant flows out behind the wand,<sup>22</sup> as shown in figure 3-8.
3. Apply sealant in one pass, filling the reservoir to the recommended level. If additional sealant is required in low sections, it should be added as soon as possible.
4. Recirculate sealant through the wand into the melting chamber when not applying sealant.

## Notes

5. Watch for bubbles, areas of sunken sealant, sealant that remains tacky, and sealant that has not bonded to the joint walls.



Figure 3-8. Hot-applied sealant application.

6. Use equipment and installation practices that result in consistent sealant thickness, little waste, and low operator fatigue.
7. Do not allow traffic onto the pavement until the sealant has set and there is no danger of tracking or stone intrusion.

Table 3-13 provides possible solutions to common problems encountered during the hot-applied sealant application process.

### Cleanup Requirements

At the end of each day's work, the applicator system lines on the asphalt kettle should be purged of sealant material. In addition, if nonreheatable materials are being used, remove material left in the melting vat. In any case, the amount of material in the melting vat should be closely monitored so that as little material as possible remains when work is finished for the day.

Table 3-13. Troubleshooting procedures for hot-applied sealant application.

| Problem Encountered                       | Possible Causes  | Possible Solutions  |
|---|--|---|
| Bubbles in sealant.                       | Reaction with backer rod.  | Use nonreactive rod.  |
|   | Damaged backer rod.  | Change rod installation method or rod diameter.   |
|   | Moisture in joint.   | Allow joint to dry.<br>Install above dew point.   |
|   | Bubbles in melter.   | Add sealant material.<br>Reduce agitator speed.   |
|   | Air trapped by sealant.  | Fill joint from bottom.   |
| Sealant is deeply sunken in joint.        | Gaps remain between rod and joint wall.<br>Rod is slipping into joint.   | Use proper rod diameter.  |
|   | Gaps remain between backer rod ends.   | Do not stretch rod.<br>Install rod carefully.   |
| Sealant recess is not consistent.         | Operator control is poor.<br>Operator movement is uneven.<br>Joint width is variable.<br>Hoses are unmanageable. | Use a nozzle with a depth-control plate.<br>Use a wand with a shutoff at the nozzle.<br>Use an experienced operator.<br>Provide a hose support. |
| Sealant is not sticking to joint walls.   | Joint walls are not clean.   | Remove all old sealant, oil, dust, dirt, sawing slurry, and other contaminants.   |
|   | There is moisture on the joint walls from rain, dew, or condensate.  | Wait for concrete to dry.<br>Use an HCA lance, if slightly damp.<br>Install above dew point.  |
|   | Sealant temperature is too low.  | Maintain recommended sealant temperature.<br>Insulate and heat hoses.   |
|   | Pavement temperature is too low.   | Maintain recommended sealant temperature.<br>Insulate and heat hoses.<br>Wait for pavement to warm.   |
| Sealant remains tacky after installation. | Kettle is contaminated with asphalt, heat transfer oil, solvent, or other sealant.                               | Remove sealant.<br>Clean and flush kettle.<br>Replace with uncontaminated sealant.  |
|   | Sealant has been overheated or heated too long.  | Remove and replace with fresh sealant.<br>Check melter temperatures.  |

## Notes

When using reheatable materials, purge the applicator lines of material using either reverse flow or air clean out procedures. Thorough cleaning can be accomplished using reverse flow procedures followed by solvent flushing procedures.

When using nonreheatable materials, place as much material as possible in cracks at the project site. Discharge any leftover material into containers for subsequent disposal. Solvent may then be added and circulated through the system to flush it of any excess material.

If flushing solvents are used in cleanout, the kettle operator must ensure that they do not contaminate the sealant material. Step-by-step instructions on how to clean kettles and applicator lines are generally found in the kettle manufacturer's operation manual.

### *Cold-Applied Sealants*

Several types of sealant are installed without heating. They include polysulfides, polyurethanes, and silicones. Because one-part sealants are the predominant cold-applied sealant, the discussion in this handbook will focus only these material types.

Silicone pumps and applicators should provide sealant to the joint at a rate that does not slow the operator. The applicator equipment should:

- Not introduce bubbles into the sealant.
- Not allow air to reach the sealant before it enters the joint, to prevent premature curing.
- Maintain a feed rate of at least 1.5 L/min.
- Have a nozzle designed to fill the joint from the bottom up.

Applicators that have Teflon-lined hoses and Teflon seals are less likely to allow the sealant to cure in the pump or hose than those that use neoprene seals and standard hose.

### Loading Sealant into the Pumping Apparatus

Typically, silicone sealant is pumped from storage containers through compressed-air-powered pumping equipment to a wand with an application nozzle. The sealant is pumped from 19-L buckets or 208-L drums. It is important to observe two important precautions when loading silicone into an approved pumping apparatus.



- Load the sealant into the apparatus so that bubbles don't become trapped in the sealant.
- Limit the exposure of the sealant to air and moisture because premature curing can result from such exposure.

### Applying the Sealant

The following practices have been successfully used and are generally recommended for installing silicone sealants.

1. Pour the sealant with the nozzle in the joint, so that the joint is filled from the bottom and air is not trapped beneath the sealant.
2. Use a nozzle that applies sealant at a 45° angle and push the bead along the joint rather than draw it with the gun leading. An applicator, like the one shown in figure 3-9, can provide good results.
3. Apply the sealant in one continuous motion, moving steadily along the joint so that a uniform bead is applied without dragging, tearing, or leaving unfilled joint space.<sup>19</sup>
4. Adjust the pump rate, nozzle type, and nozzle diameter to control the application speed.

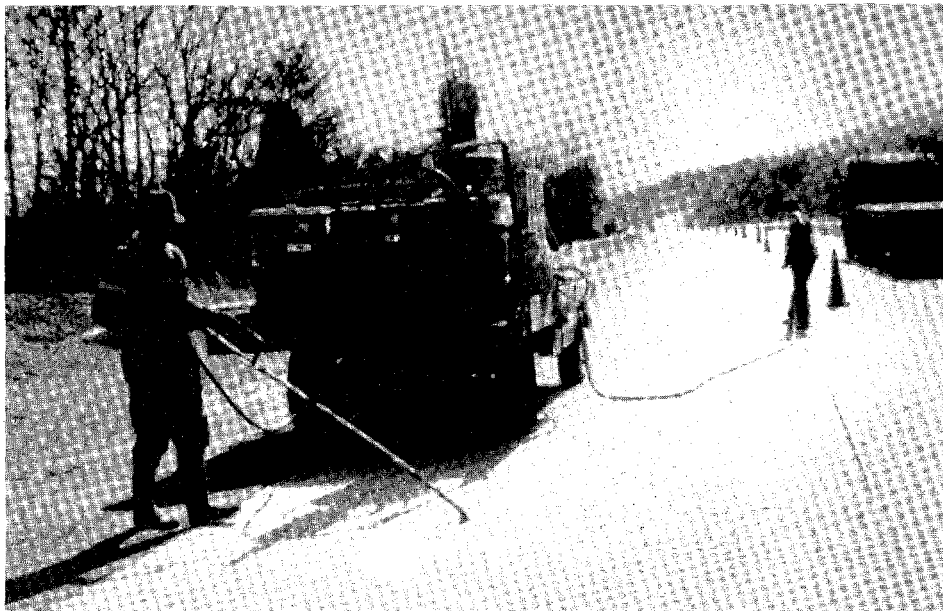

Figure 3-9. Silicone sealant installation.

## Notes

5. Form a concave surface in nonself-leveling sealant using a piece of oversized backer rod, a dowel, or other suitable instrument.
6. When tooling is required, press the sealant around the backer rod to form a uniform concave surface with no wasted sealant on the pavement surface. The bottom of the concave surface should be 5 mm below the pavement surface.
7. The surface of any silicone sealant must be recessed 5 mm below the pavement surface and must never be exposed to traffic wear.
8. Watch for bubbles, sunken sealant, a nonuniform surface, or other installation deficiencies, and solve these problems as soon as they are identified.
9. Allow nonself-leveling sealant to become tack free and self-leveling sealant to skin over before opening the pavement to traffic. Allow a longer cure time if large pavement deflections are expected.

Table 3-14 provides possible solutions to common problems encountered during the cold-applied sealant application process.

### Cleanup Requirements

Cleaning the applicator equipment apparatus will be required if the sealant begins to cure in the pump or hose. Follow the sealant pump manufacturer's instructions as to cleaning frequency and required solvents.

## EVALUATING RESEAL EFFECTIVENESS

To determine the full effect of a joint resealing operation, two basic questions should be answered:

1. Is the joint reseal performing its intended function?
2. Is the joint reseal extending the life of the pavement to the point where the cost benefit of added pavement life equals or exceeds the cost of performing the resealing operation?

Although many agencies are fairly convinced that joint resealing extends pavement life, some agencies are unsure of the overall cost benefit or believe there is no overall benefit.

Table 3-14. Troubleshooting procedures for cold-applied sealant application.

| Problem Encountered                     | Possible Sources  | Possible Solutions  |
|---|---|---|
| Sealant is not sticking to joint walls. | Joint walls are not clean.  | Remove all old sealant, oil, dust, dirt, sawing slurry, and other contaminants.                                     |
|   | Moisture remains on the joint walls from rain, dew, or condensate.                    | Wait for concrete to dry. Carefully use an HCA lance, if the pavement surface is slightly damp.                     |
|   | Tooling was inadequate.   | Use more tooling care. Use another striking tool.   |
| Sealant is deeply sunken in the joint.  | Gaps remain between rod and joint wall.<br>Rod slipping into joint.                   | Use a larger diameter backer rod.   |
|   | Gaps remain between backer rod ends.  | Do not stretch rod. Install rod carefully.  |
| Installed sealant contains bubbles.     | Reaction with backer rod.   | Use nonreactive backer rod.   |
|   | Damaged backer rod.   | Change rod installation method or rod diameter.   |
|   | Bubbles in pump lines.  | Set the pump diaphragm into sealant better.   |
|   | Air was trapped by sealant.   | Fill the joint from bottom.   |
| Sealant recess is not consistent.       | Operator control is poor.<br>Operator movement is uneven.<br>Joint width is variable. | Use a "dog-leg" applicator.<br>Use an experienced operator.   |
|   | Surface tooling is poor.  | Use more tooling care. Use another striking tool (large backer rod, plastic, or rubber tubing on a flexible handle) |

Answering these questions requires some additional time and effort in field monitoring. However, the findings can help justify the use of certain materials and procedures over others and can help determine the importance of a joint resealing program relative to other aspects of maintenance.

### Reseal Performance

It is good practice to monitor the performance of joint reseal treatments and it can be done rather quickly (in 1 or 2 hrs) with fairly good accuracy. At least one visual inspection should be made each year to chart the overall rate of failure and to plan for subsequent maintenance. An evaluation between November and March is highly recommended because during that time, joints are near their maximum opening and, as a result, it is easier to observe the condition of the sealant system.

## Notes

The field inspection primarily entails the identification of sealant failures, which are defined as segments of seal that allow the entrance of water into the pavement structure. Specific modes of failure include the following:

- Full-depth adhesion loss.
- Full-depth cohesion loss.
- Full-depth joint spalls.

Other items that can be noted during the inspection are sealant distresses, such as partial-depth adhesion and cohesion loss, partial-depth joint spalls, stone intrusion, and overband wear (if applicable).

For the inspection, select a small representative sample of the resealed pavement. Measure and sum the lengths of all failed segments, divide this value by the total length of resealed joints inspected, and multiply by 100 percent to yield the percentage of sealant failure. The joint seal effectiveness can then be calculated using the following equation:

$$\%Eff = 100 - \%Fail$$

where:    %Eff = Percentage of joint seal effectiveness.  
          %Fail = Percentage of joint seal failure.

After a few inspections, construct a graph of joint seal effectiveness versus time, such as the one in figure 3-10. A minimum allowable effectiveness level—commonly 50 percent—can be used to forecast the need for additional seal repair.

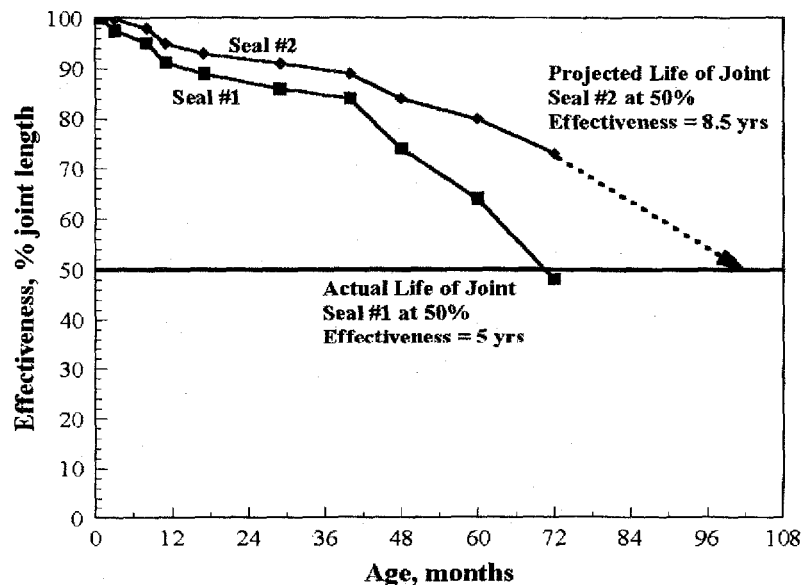

Figure 3-10. Example joint seal deterioration chart.

### IA-VAC Joint Seal Tester

An alternate method of evaluating joint seal performance is the innovative leak test performed using the IA-VAC joint seal tester (figure 3-11), previously discussed in session 2. This non-destructive testing device consists of a 50 × 150 × 1,220 mm suction chamber, a 246-W vacuum pump, hoses and couplings, a 14-L vacuum reserve tank, and a portable generator.<sup>27</sup> The suction chamber is a metal frame with a clear acrylic top and a flanged open bottom, affixed with a molded silicone seal for achieving air-tight vacuums.

The complete IA-VAC system is transportable in a small van or pickup truck. Testing is typically performed by three persons—two persons can conduct testing at a lower production rate—with one test of a 1.2-m joint seal segment requiring about 1 min or less, depending on the desired level of analysis. The test sequence is as follows:

1. Spray the joint seal test area with a foaming water solution.
2. Place the suction chamber over the joint seal test area.
3. Insert stopgap filler pieces at each end of the suction chamber–joint seal interface.
4. While standing on top of suction chamber, apply vacuum (nominally -10 kPa) to the joint seal test area.

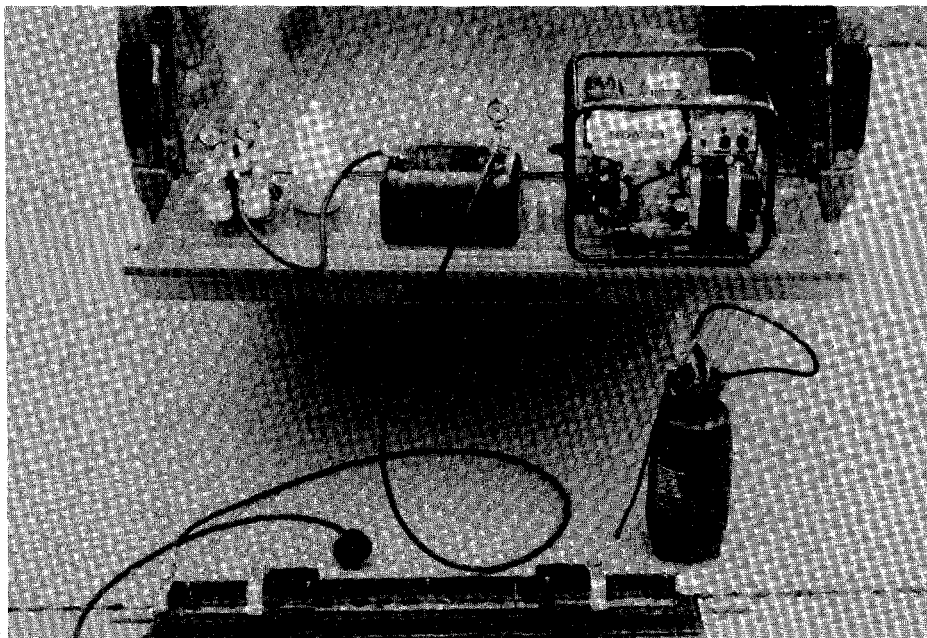

Figure 3-11. IA-VAC joint seal tester.

## Notes

5. Observe, mark, and document locations of bubbles (i.e., leakages) generated by vacuum.
6. Remove suction chamber and record the type of failure (e.g., full-depth adhesion, cohesion, or spall failure) noted at each leakage location.

The Iowa DOT's experience with the IA-VAC system has been quite good. They continue to use the device for researching joint seal performance and for identifying problems of poor material or installation practices that lead to undesirable performance. In addition, they intend to establish a specification for sealant performance that uses the IA-VAC system for construction inspection.<sup>27</sup>

From their preliminary work, Iowa identified some causes of joint seal leakage for various sealant types that were not generally expected. These causes were:<sup>27</sup>

- Preformed neoprene seals.
  - variable amount of lubricant adhesive used.
  - irregular sawed joint width.
- Self-leveling silicone seals.
  - joint spalls made from sawing.
- Hot-applied rubberized asphalt seals.
  - poor joint cleaning or no adhesion.
  - improper installation of backer rod as a result of bad sawing.

Under the FHWA *Pavement Maintenance Effectiveness/Innovative Materials* project, several IA-VAC joint seal testers are being made available to SHA's interested in evaluating the usefulness of this device. The devices will be provided on a loan basis under the Test and Evaluation portion of this project.

### **Pavement Performance**

The overall performance of a pavement is characterized by the results of a condition survey and, if available, by nondestructive deflection tests and ride quality tests. The results of these tests can be affected considerably by the performance of the joint seals. Joint faulting, pumping, joint spall development, and loss of support are signs that the seals may not be performing their intended function.

To determine whether joint resealing is a cost-effective method of extending the life of a pavement, do performance comparisons between treated and untreated segments of a particular pavement section. In general, this entails charting the decreases in serviceability of each segment, estimating the projected differences in pavement life, and comparing the cost benefit of added pavement life to the cost of performing the resealing operation.

## **SESSION 4. PCC PARTIAL-DEPTH SPALL REPAIR**

**Time—1:30**

Notes

### **SESSION OBJECTIVES**

This session discusses the proper methods for planning, conducting, and monitoring a PCC partial-depth spall repair project. It presents the latest findings on the performance of materials and methods tested under the SHRP H-106 spall repair experiment and contains detailed information on the processes of performing effective spall repair operations.

Upon successful conclusion of this session, the participant will be able to accomplish the following:

1. Recall which repair materials and procedures are performing best in the SHRP H-106 experiment.
2. State the objective of spall repair operations.
3. Select the most appropriate and cost-effective materials and procedures for a specific project, given various constraints and limitations.
4. List the various steps in a partial-depth spall repair operation and describe the recommended procedures and equipment associated with each step.
5. Evaluate the effectiveness of a partial-depth spall repair project.

### **SHRP RESEARCH FINDINGS TO DATE**

Between March and July 1991, a total of 1,607 partial-depth spall repairs were made at test sites throughout the United States as part of the SHRP H-106 project. The primary objective of the experiment was to determine the most cost-effective spall repair materials and procedures under various climatic conditions and traffic. The materials and procedures used in the H-106 study were identified in the predecessor project, SHRP H-105, as having the most potential to improve the state of the practice in PCC partial-depth spall repair.

Four spall repair test sites were constructed in four climatic regions as part of the H-106 experiment. These sites consisted of the following:

## Notes

- |                                  |               |                      |
|----------------------------------|---------------|----------------------|
| • PA 28—Kittanning, Pennsylvania | Wet/freeze    | March/June/July 1991 |
| • I-15—Ogden, Utah               | Dry/freeze    | April/May 1991       |
| • I-20—Columbia, South Carolina  | Wet/nonfreeze | May 1991             |
| • I-17—Phoenix, Arizona          | Dry/nonfreeze | May/June 1991        |

A total of 10 different materials and 5 different repair procedures were included in the experiment, resulting in 30 unique types of repairs (a repair being the combination of a material and procedure). Table 4-1 shows the combinations of material and procedure that were used at the four test sites, and table 4-2 describes the steps associated with each repair procedure. Further details about materials and procedures are provided in the section titled "Project Planning and Design."

At a given site, each repair type was represented by a test section containing 10 partial-depth patches. All of the test sections planned at each site were placed in random order along the test site pavement. For greater statistical validity, the randomly arranged block of sections was then repeated to form a replicate block of sections.

Since installation, repair performance at each site has been evaluated several times through detailed visual inspections conducted under both the H-106 project and the FHWA *LTM* follow-up study. In these inspections, each experimental repair type was primarily examined for failures (i.e., patches that require repatching or have been repatched due to breakup and/or loss of patch material), which were then documented. In addition, for cementitious and polymeric repairs, distresses such as cracking, edge fraying, spalling, and debonding were measured and recorded. And, for bituminous repairs, distresses such as raveling, shoving, dishing, and edge disintegration were measured and recorded. Using the recorded patch failure data, calculations of average survival rates for each repair type were subsequently made.

Under the *LTM* study, annual field inspections were scheduled for every fall from 1993 through 1997. Thus far, three of the four sites have remained free of rehabilitation work; the Arizona site was overlaid in October, 1995.

Major observations and performance data analysis results from the most recent inspection—fall 1994—are summarized below.

- Pavement condition continues to be a factor in the performance of the spall repairs, with the best overall pavement condition (Utah test site) having the highest performance of repairs. Continued spall development along that test site will undoubtedly impact the condition of the pavement and could quite likely impact the performance of the experimental repairs.



Table 4-1. Summary of material-procedure combinations used in SHRP H-106 partial-depth spall repair experiment.

| Repair Material                                       | Installation Procedure | State Installed |    |    |    |
|---|------------------------|-----------------|----|----|----|
|   |                        | PA              | UT | SC | AZ |
| Type III PCC<br><i>Cementitious Concrete</i>          | 1                      | ✓               | ✓  | ✓  | ✓  |
|   | 2                      | ✓               | ✓  | ✓  | ✓  |
|   | 3                      | ✓               |    |    |    |
|   | 4                      |                 | ✓  |    |    |
| Duracal<br><i>Cementitious Concrete</i>               | 1                      |                 | ✓  | ✓  | ✓  |
|   | 2                      | ✓               | ✓  | ✓  | ✓  |
| Set-45<br><i>Cementitious Concrete</i>                | 1                      | ✓               | ✓  | ✓  | ✓  |
|   | 2                      | ✓               | ✓  | ✓  | ✓  |
|   | 3                      | ✓               |    |    |    |
| Five Star HP<br><i>Cementitious Concrete</i>          | 1                      | ✓               | ✓  | ✓  | ✓  |
|   | 2                      | ✓               | ✓  | ✓  | ✓  |
|   | 3                      | ✓               |    |    |    |
| MC-64<br><i>Polymeric Concrete</i>                    | 1                      | ✓               | ✓  | ✓  | ✓  |
|   | 2                      | ✓               | ✓  | ✓  | ✓  |
|   | 3                      |                 |    |    | ✓  |
| SikaPronto 11<br><i>Polymeric Concrete</i>            | 1                      | ✓               | ✓  | ✓  | ✓  |
|   | 2                      | ✓               | ✓  | ✓  | ✓  |
| Percol FL<br><i>Polymeric Concrete</i>                | 1                      | ✓               | ✓  | ✓  | ✓  |
|   | 2                      | ✓               | ✓  | ✓  | ✓  |
|   | 3                      | ✓               |    |    | ✓  |
|   | 5                      | ✓               |    |    |    |
| Pyrament 505<br><i>Polymeric Concrete</i>             | 1                      | ✓               |    |    |    |
|   | 2                      | ✓               |    |    |    |
|   | 3                      |                 |    |    | ✓  |
|   | 5                      | ✓               |    |    |    |
| UPM High-Performance<br>Cold-Mix<br><i>Bituminous</i> | 2                      | ✓               | ✓  | ✓  | ✓  |
|   | 5                      | ✓               |    |    |    |
| Penatron R/M-3003<br><i>Polymeric Concrete</i>        | 1                      |                 |    |    | ✓  |
| Spray-Injection (AMZ)<br><i>Bituminous</i>            | 2                      |                 |    | ✓  |    |
| Spray-Injection (Rosco)<br><i>Bituminous</i>          | 2                      | ✓               |    |    |    |

**Notes**

Table 4-2. Descriptions of SHRP H-106 partial-depth spall repair procedures.

| Procedure | Procedure Name       | Description   |
|-----------|----------------------|---|
| 1         | Saw-and-patch        | <p>Boundaries of spalled area sawed with diamond-blade saw and deteriorated concrete within those boundaries removed with jackhammer and hand-tools.</p> <p>Repair area surfaces sandblasted and then airblasted.</p> <p>Bond-breaker placed full-depth along adjacent joints (non-flexible repair materials only).</p> <p>Repair materials and any accessories installed.</p> <p>Patch finished or compacted.</p> <p>Joint sealant applied upon curing of patch.</p>                   |
| 2         | Chip-and-patch       | <p>Loose and unsound concrete within repair area removed with jackhammer, hand tools, and broom.</p> <p>Repair area surfaces sandblasted and then airblasted.</p> <p>Bond-breaker placed full-depth along adjacent joints (non-flexible repair materials only).</p> <p>Repair materials and any accessories installed.</p> <p>Patch finished or compacted.</p> <p>Joint sealant applied upon curing of patch.</p>   |
| 3         | Mill-and-patch       | <p>Loose and unsound concrete within repair area removed using a carbide-tipped cold-milling machine.</p> <p>Edges of repair area made vertical with light jackhammer.</p> <p>Repair area surfaces sandblasted and then airblasted.</p> <p>Bond-breaker placed full-depth along adjacent joints (non-flexible repair materials only).</p> <p>Repair materials and any accessories installed.</p> <p>Patch finished or compacted.</p> <p>Joint sealant applied upon curing of patch.</p> |
| 4         | Waterblast-and-patch | <p>Loose and unsound concrete within repair area removed using a high-pressure waterblasting machine.</p> <p>Repair area surfaces sandblasted and then airblasted.</p> <p>Bond-breaker placed full-depth along adjacent joints (non-flexible repair materials only).</p> <p>Repair materials and any accessories installed.</p> <p>Patch finished or compacted.</p> <p>Joint sealant applied upon curing of patch.</p>  |
| 5         | Clean-and-patch      | <p>Loose and unsound concrete within repair area removed using hand tools.</p> <p>Repair materials installed.</p> <p>Patch finished or compacted</p> <p>No joint sealant application.</p>   |

- The bituminous repairs—UPM High Performance Cold-Mix and spray-injection—have begun to perform at a lower level than the majority of the other repair types. Given the material cost and placement productivity advantages of these two options, they are still recommended in situations where repairs are only needed to last 2 to 3 years.
- Type III PCC repairs have performed as well as the other repair types at all test sites.
- The performance of the Percol has been somewhat inconsistent, with very good performance and poor performance exhibited between different sets of materials at a given test site.
- No clear trends have become apparent in comparing the various repair procedures. However, the adverse-condition repairs placed at the Pennsylvania test site have performed better than expected.

## REPAIR OBJECTIVES

The objective of partial-depth spall repair operations is to place the longest lasting patch possible in each spalled area. The primary concern of each spall repair crew should be to fill each spall only one time. Placing repairs more than once at a given location results in increased crew exposure to traffic, additional cost for the agency, and additional user delay.

There are many different ways to effectively repair partial-depth spalls in PCC pavement. The materials used can range from very expensive two-part epoxy compounds to asphalt cold-mix, depending on the type of pavement, the resources of the agency, and the time remaining until the pavement is to be rehabilitated or overlaid. The methods to prepare these repair areas range from sawing and chipping the repair area to the use of hydro-blasting equipment. For most agencies, there is an optimum combination of materials and preparation procedures for their particular situation. Determining that optimum combination can help agencies charged with the repair of partial-depth spalls ensure that they are making the most cost-effective repairs.

## PROJECT PLANNING AND DESIGN

Partial-depth spall repair of PCC pavement is recommended only for the top one-third of the pavement depth. Such repairs should not be made in areas of high steel, along joints with misaligned dowels, or where D-cracking or reactive aggregate are a problem. In these instances, the partial-depth spall repair

## Notes

operation will not address the cause of the spalling, and a reduction in performance of the repairs will generally result.

The most common situation where partial-depth spall repair is appropriate is along joints that become filled with incompressibles during colder portions of the year (maximum joint opening) and that experience very high point stresses as the slabs expand and the joints attempt to close, as shown in figure 4-1. Other factors contributing to the development of partial-depth spalls include freeze-thaw cycles and the corrosion of reinforcing steel caused by de-icing salts, high steel, or inadequate concrete cover over the steel.

Performing partial-depth spall repairs is partially a function of the repair design. To avoid design-related causes of partial-depth patch failure:

- Include all deteriorated concrete within the repair boundaries.
- Anticipate the climatic conditions during the time that the repair is made when selecting the repair material and the installation procedure.
- Select a repair material that has thermal compatibility with the pavement.
- Anticipate the climatic conditions that the repair material will experience throughout its lifetime.
- Consider the expected time of opening to traffic when selecting the repair material.

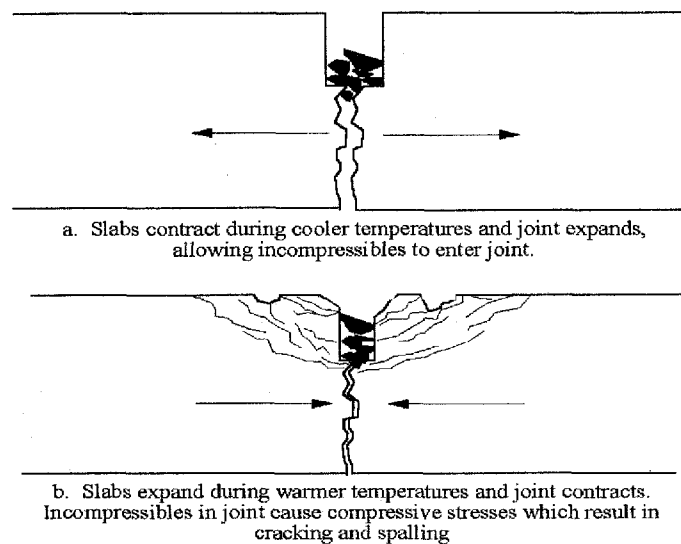

Figure 4-1. Development of partial-depth spalls at PCC joints.

- Select the type of aggregate that will be used when selecting the repair material.
- Choose a joint bond breaker compatible with the selected joint sealant.

The following sections discuss how to determine the optimum material and preparation combination for placing partial-depth spall repairs.

### Selecting a Material

Each agency must determine potential materials for performing partial-depth spall repair in its area. Some material characteristics that must be considered include working time, installation temperature range, time required before opening, aggregate moisture conditions, repair area moisture conditions, and whether special equipment or bonding agents are required.

A number of patching materials are available for use. Most fall into one of three primary material categories:

- Cementitious concretes.
- Polymer concretes.
- Bituminous materials.

Table 4-3 lists the spall repair materials included in the SHRP H-106 partial-depth spall repair experiment, along with information concerning each material characteristic listed above.

Because the cost of materials for partial-depth spall repair vary so dramatically, always consider the length of time before overlay when choosing a material. If an overlay or rehabilitation project will cover a partial-depth repair in 6 to 12 months, then a more expensive epoxy material is not justified and a lower cost alternative such as Type III PCC or asphalt cold-mix may be appropriate.

Other considerations when choosing a material are the number of repairs to be made and the relative distance between repairs. For materials with short working times, it may be inappropriate to mix up large quantities if the repair locations are far apart. For areas with a lot of distress in a concentrated area, more expensive materials may be more cost-effective since larger batches can be prepared. Table 4-4 gives information on the H-106 materials and some material selection criteria.

Table 4-3. SHRP H-106 partial-depth spall repair materials.

| Material Product        | Material Category                  | Working Time, min | Installation Temp. Range <sup>a</sup> | Time-to-Traffic, hr (21°C) | Moisture Conditions <sup>b</sup> |                | Cost Factor <sup>c</sup> |
|-------------------------|------------------------------------|-------------------|---------------------------------------|----------------------------|----------------------------------|----------------|--------------------------|
|                         |                                    |                   |                                       |                            | Repair Surface                   | Aggregate      |                          |
| Type III PCC            | Cementitious (PCC)                 | 20                | 0° to 43°C                            | 4 to 6                     | SSD to dry                       | 1 to 3% to dry | 1.0                      |
| Duracal                 | Cementitious (gypsum-based)        | 20                | 0° to 43°C                            | 1.5                        | SSD to dry                       | 1 to 3% to dry | 0.7 <sup>d</sup>         |
| Set-45                  | Cementitious (magnesium phosphate) | 10                | 0° to 32°C                            | 1.5                        | dry                              | 1 to 3% to dry | 3.5 <sup>d</sup>         |
| Five Star HP            | Cementitious (high alumina)        | 20                | 0° to 32°C                            | 1.5                        | SSD to dry                       | 1 to 3% to dry | 3.0                      |
| Pyrament 505            | Hydraulic cement                   | 30                | 4° to 43°C                            | 2 to 3                     | SSD to dry                       | 1 to 3% to dry | 2.0                      |
| Sika Pronto 11          | Polymer (modified methacrylate)    | 30                | 2° to 32°C                            | 1.5                        | SSD to dry <sup>e</sup>          | dry            | 16.0                     |
| Penatron R/M-3003       | Polymer (epoxy-urethane)           | 7 to 10           | -23° to 65°C                          | 0.5                        | dry                              | dry            | 17.0                     |
| MC-64                   | Polymer (epoxy)                    | 10                | 4° to 32°C                            | 2                          | dry                              | dry            | 23.0                     |
| Percol FL               | Polymer (polyurethane)             | 1                 | -17°C                                 | 0.2 to 0.4                 | dry                              | dry            | 9.0                      |
| UPM High Perf. Cold-Mix | Bituminous                         | NA <sup>f</sup>   | 0° to 38°C                            | Immediately                | SSD to dry                       | 1 to 3% to dry | 0.5 to 0.6               |
| Spray-injection mix     | Bituminous                         | NA                | -23° to 38°C                          | Immediately                | SSD to dry                       | 1 to 3% to dry | 0.2 to 0.4 <sup>g</sup>  |

<sup>a</sup> The installation temperature range shown is the temperature range at which the material manufacturer claims it can be installed. However, patching is generally not recommended when the temperature is below 4°C or above 32°C. At cold or hot temperatures, special precautions may be needed, such as the use of warmed or iced water during mixing, or insulating blankets during curing.

<sup>b</sup> SSD = saturated, surface-dry; dry aggregate = oven-dried; 1 to 3% = 1 to 3% moisture allowed in the aggregate.

<sup>c</sup> The cost factor is the ratio of the cost of the given material to the cost of a typical rapid-setting Type III PCC material. It includes the cost of bagged aggregate, bonding agent if required, and admixtures if required.

<sup>d</sup> Does not include the cost of the bonding agent. Bonding agent recommended if used in shallow patches.<sup>28</sup>

<sup>e</sup> The manufacturer states a SSD pavement surface is acceptable; however, lab tests indicate bonding needs a dry surface.

<sup>f</sup> NA = not available.

<sup>g</sup> The cost of spray-injection bituminous patching material represents averages provided by the manufacturers. These costs include the cost of purchasing the equipment (amortized over the life expectancy of the equipment), maintenance, binder, aggregate, and other variable costs.

Table 4-4. Initial material selection criteria for some rapid-setting materials.

| Criteria                                    | Materials |         |        |              |              |                |                   |       |           |                               |                     |
|---|-----------|---------|--------|--------------|--------------|----------------|-------------------|-------|-----------|-------------------------------|---------------------|
|   | Type III  | Duracal | Set-45 | Five Star HP | Pyrament 505 | SikaPronto 11  | Penetron R/M-3003 | MC-64 | Percol FL | UPM High Performance Cold-Mix | Spray-injection Mix |
| <b>Installation temperature<sup>a</sup></b> |           |         |        |              |              |                |                   |       |           |                               |                     |
| -23°C < T < 0°C                             |           |         |        |              |              |                | ✓                 |       | ✓         | ✓                             | ✓                   |
| 0°C ≤ T < 4°C                               | ✓         | ✓       | ✓      | ✓            | ✓            |                | ✓                 |       | ✓         | ✓                             | ✓                   |
| 4°C < T ≤ 32°C                              | ✓         | ✓       | ✓      | ✓            | ✓            | ✓              | ✓                 | ✓     | ✓         | ✓                             | ✓                   |
| T > 32°C                                    | ✓         | ✓       |        |              |              |                | ✓                 |       | ✓         | ✓                             | ✓                   |
| <b>Time-to-traffic at 21°C</b>              |           |         |        |              |              |                |                   |       |           |                               |                     |
| 5 min                                       |           |         |        |              |              |                |                   |       |           | ✓                             | ✓                   |
| 30 min                                      |           |         |        |              |              |                | ✓                 |       | ✓         | ✓                             | ✓                   |
| 2 hr  |           | ✓       | ✓      | ✓            | ✓            | ✓              | ✓                 | ✓     | ✓         | ✓                             | ✓                   |
| 4 hr  | ✓         | ✓       | ✓      | ✓            | ✓            | ✓              | ✓                 | ✓     | ✓         | ✓                             | ✓                   |
| <b>Aggregate moisture</b>                   |           |         |        |              |              |                |                   |       |           |                               |                     |
| 1-3% moisture allowed                       | ✓         | ✓       | ✓      | ✓            |              |                |                   |       |           | ✓                             | ✓                   |
| Oven-dried <sup>b</sup>                     | ✓         | ✓       | ✓      | ✓            | ✓            | ✓              | ✓                 | ✓     | ✓         | ✓                             | ✓                   |
| <b>Pavement surface moisture</b>            |           |         |        |              |              |                |                   |       |           |                               |                     |
| Saturated, surface-dry                      | ✓         | ✓       |        | ✓            | ✓            | ✓ <sup>c</sup> |                   |       |           | ✓                             | ✓                   |
| Dry <sup>d</sup>                            | ✓         | ✓       | ✓      | ✓            | ✓            | ✓              | ✓                 | ✓     | ✓         | ✓                             | ✓                   |
| <b>Working time<sup>e</sup></b>             |           |         |        |              |              |                |                   |       |           |                               |                     |
| < 5 min                                     |           |         |        |              |              |                | ✓                 |       | ✓         |                               |                     |
| 5 to 10 min                                 |           | ✓       | ✓      | ✓            | ✓            |                |                   | ✓     |           |                               |                     |
| 10 to 30 min                                | ✓         |         |        |              |              | ✓              |                   |       |           |                               |                     |
| > 30 min                                    |           |         |        |              |              |                |                   |       |           | ✓                             | ✓                   |

<sup>a</sup> Patching is generally not recommended when the temperature is below 4°C or above 32°C. At cold or hot temperatures, special precautions may be needed, such as the use of warmed or iced water during mixing, or insulating blankets during curing.

<sup>b</sup> Water content should be adjusted as needed.

<sup>c</sup> The manufacturer states a saturated, surface-dry pavement surface is acceptable; however, lab tests indicate bonding needs a dry surface.

<sup>d</sup> Wet surface before placing material if required by manufacturer.

<sup>e</sup> At 25°C air temperature.

## **Cementitious Concretes**

Cementitious materials include PCC-based, gypsum-based, magnesium phosphate, and high alumina concretes. Regular PCC is the most common material used for spall repair. However, if the road must be opened to traffic relatively quickly, rapid-setting or high, early-strength materials must be used.

### Portland Cement Concrete

Typical PCC mixes combine Type I, II, or III portland cement with coarse aggregate. Type III portland cement, or Type I portland cement with the addition of a set-accelerator, may be used when the concrete repair must be opened to traffic quickly. The main difference between Type I and Type III portland cement is that Type III is ground more finely than Type I. When cement is ground more finely, more cement surface area comes into contact with the water in the mix. This speeds the hydration rate, which speeds strength development and heat release during the first 7 days of curing. Type II portland cement, even though it is ground to the same fineness as Type I, gains strength too slowly to be used for rapid repair.

Type III portland cement, with or without admixtures, has been used for fast, permanent repairs more predominantly than most other materials because of its relatively low cost, availability, compatibility with existing pavements, and ease of use. Rich mixtures (420 to 540 kg/m<sup>3</sup>) gain strength quickly in warm weather (4 to 12 hr). However, the rate of strength gain may be too slow to permit quick opening to traffic in cool weather. Insulating layers can be used to retain the heat of hydration and reduce curing time.

### Gypsum-Based Concrete

Gypsum-based (calcium sulfate) patching materials, such as Duracal and Rockite, gain strength rapidly and can be used in temperatures above freezing (up to 43°C, for example, in the case of Duracal). However, gypsum concrete does not appear to perform well when exposed to moisture or freezing weather.<sup>29</sup> Additionally, the presence of free sulfates in the typical gypsum mixture may promote steel corrosion in reinforced pavements.<sup>28</sup>

### Magnesium Phosphate Concrete

Magnesium phosphate concretes, such as Set-45, Eucospeed MP, and Propatch MP, set quickly and make high early-strength, impermeable patches that bond to clean and dry surfaces. However, these materials are sensitive to water on the pavement, and even very small amounts of extra water in the mix severely decrease strength. They also cannot be used with limestone aggregates.<sup>28</sup> These limitations have led to variable field performance.<sup>29,30</sup>



### High-Alumina Concrete

Calcium aluminate concretes, such as Five Star HP, gain strength fast, bond well (best to a dry surface), and shrink very little during curing. However, they may lose strength over time because of a chemical conversion that occurs particularly at high curing temperatures.<sup>28,29,31</sup>

### Hydraulic Cement Concrete

Hydraulic cement patching materials (e.g. Pyrament) behave much like regular concrete under normal conditions (air temperature above 4°C, dry repair area). Mixing times are longer than for other cementitious materials (except Type III PCC) and the materials appear dry until the very end of the mix cycle. When using hydraulic cement at low temperatures (less than 4°C) hot water and insulating blankets are needed to achieve expected set times.

### **Polymer Concretes**

Polymer concretes are a combination of polymer resin, aggregate, and a set initiator. The aggregate makes the polymer concrete more economical, provides thermal compatibility with the pavement, and affords a wearing surface. The polymer concretes described in this manual are epoxy, methyl methacrylate, and polyurethane concretes.

### Epoxy Concrete

Epoxy concretes, such as MC-64, Burke 88/LPL and Mark 103 Carbo-Poxy, are impermeable and are excellent adhesives. They have a wide range of setting times, application temperatures, strengths, and bonding conditions. The epoxy concrete mix design must be thermally compatible with the pavement, otherwise the patch may fail. Deep epoxy repairs often must be placed in lifts to control heat development. Epoxy concrete should not be used to patch spalls caused by reinforcing steel corrosion, as it may accelerate the rate of deterioration of adjacent sound pavement.<sup>32</sup>

### Methyl Methacrylate Concrete

Methyl methacrylate concretes and high molecular weight methacrylate concretes, such as SikaPronto 11 and Degadur 510, are polymer-modified concretes that could also be classified as cementitious materials. They have relatively long working times, high compressive strengths, and good adhesion. Many methyl methacrylates are volatile and may pose a health hazard from prolonged exposure to the fumes.<sup>33</sup> As with all materials, obtain MSDS' from the manufacturer and follow instructions to ensure the safe use of these materials.

### Polyurethane Concrete

Polyurethane concretes, such as Percol FL and Penatron R/M-3003, generally consist of a two-part polyurethane resin mixed with aggregate. Polyurethanes usually set very quickly (90 sec) and some manufacturers claim their materials are moisture-tolerant (i.e., can be placed on a wet surface with no adverse effects). This material type has been used for several years with variable results.<sup>33,34</sup>

### **Bituminous Materials**

Bituminous patches are used almost everywhere in all climates. Although often considered temporary, they are sometimes left in place for many years. They are fairly inexpensive, widely available, and easy to place with small crews. They usually need little, if any, cure time. The most effective bituminous materials are the hot-mix asphalt concretes (HMAC). A few States have successfully used bituminous spray-injection mixes, such as AMZ and Rosco. Many proprietary cold-mixes (e.g., UPM High-Performance Cold-Mix) also perform well, although they may become sticky and hard to work with at the upper end of their placement temperature range.

### Cost-Effectiveness

The most important aspect of any partial-depth spall repair material is its impact on cost-effectiveness of the overall patching operation. Inexpensive materials with a short service life will drastically increase the patching operation cost by requiring additional effort to re-patch failed repairs. For example, a typical type III PCC material may cost approximately \$200/m<sup>3</sup>, whereas some epoxy repair materials may cost as much as \$4,000/m<sup>3</sup>, as seen in table 4-5.

### **Laboratory Testing**

Test partial-depth spall repair materials in a laboratory before field use to determine if the product is suitable for local conditions. Some suggested tests for cementitious materials include:

- Compressive strength.
- Modulus of elasticity.
- Flexural strength.
- Bond strength.
- Freeze-thaw resistance.
- Surface abrasion resistance.
- Thermal compatibility.
- Coefficient of thermal expansion.

For guidance on testing bituminous materials, please refer to session 6.

Table 4-5. Present-worth costs for two partial-depth spall repair alternatives.

|                          |        | Type III PCC          | Epoxy Material          |
|--------------------------|--------|-----------------------|-------------------------|
| Material Cost            |        | \$ 200/m <sup>3</sup> | \$ 1,000/m <sup>3</sup> |
| Labor Cost               |        | \$ 1,000/day          | \$ 1,000/day            |
| Productivity             |        | 2 m <sup>3</sup> /day | 2 m <sup>3</sup> /day   |
| Initial Daily Cost       |        | \$ 1,400/day          | \$ 9,000/day            |
| Expected Service Life    |        | 1 yr                  | 10 yrs                  |
| Discount Rate            |        | 4%                    | 4%                      |
| Present<br>Worth<br>Cost | Year 0 | \$ 1,400/day          | \$ 9,000/day            |
|                          | Year 1 | \$ 1,346              | 0                       |
|                          | Year 2 | \$ 1,294              | 0                       |
|                          | Year 3 | \$ 1,245              | 0                       |
|                          | Year 4 | \$ 1,197              | 0                       |
|                          | Year 5 | \$ 1,151              | 0                       |
|                          | Year 6 | \$ 1,106              | 0                       |
|                          | Year 7 | \$ 1,064              | 0                       |
|                          | Year 8 | \$ 1,023              | 0                       |
|                          | Year 9 | \$ 984                | 0                       |
| Total Present Worth Cost |        | \$ 11,810/day         | \$ 9,000/day            |

### Selecting a Patch Preparation Procedure

There are several different techniques available for repairing partial-depth spalls in PCC pavements. As discussed earlier, the techniques being studied as part of the SHRP H-106 project include:

- Saw-and-patch.
- Chip-and-patch.
- Mill-and-patch.
- Waterblast-and-patch.
- Clean-and-patch (adverse climatic conditions).

When selecting a procedure, the highway agency should consider equipment availability and cost, the availability of a crew trained in the procedure, the available construction time, and the cost effectiveness of the procedure. The basic

## Notes

steps associated with each repair procedure were outlined in table 4-2. More complete descriptions are given in the following sections.

### Saw-and-Patch

The first step in the saw-and-patch procedure is to saw the patch boundaries with a diamond blade saw. The deteriorated concrete in the center of the patch is then removed using a light jackhammer with a maximum weight of 7 kg; if damage to sound pavement is avoided, a jackhammer with a maximum weight of 14 kg may be allowed. Finally, the deteriorated concrete near the patch borders is removed using a light jackhammer with a maximum weight of 7 kg and hand tools. The work should progress from the inside of the patch toward the edges, and the chisel point should be directed toward the inside of the patch as seen in figure 4-2.

The advantages of the saw-and-patch procedure are:

- The saw leaves vertical edge faces.
- The forces experienced by the pavement during chipping are isolated within the sawed boundaries.
- Very little spalling of the remaining pavement occurs.

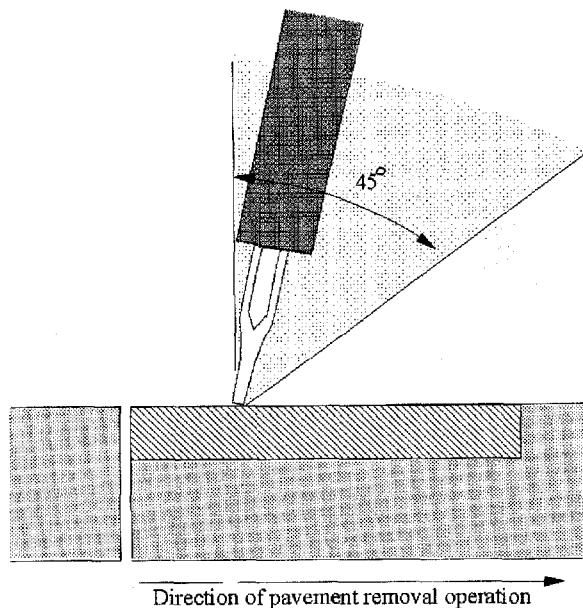

Figure 4-2. Proper use of jackhammers for removal of spalled PCC material.

- It is usually easier and faster to remove deteriorated concrete within the boundaries when the boundaries are sawed than when they are not sawed.
- Most crews are familiar with the method.

The disadvantages of the saw-and-patch procedure include the following:

- More workers are required than with the other procedures.
- Because water is used when sawing, the repair area is saturated for some time, possibly delaying the repair.
- Saw overcuts weaken the repair area and must be cleaned and sealed as shown in figure 4-3.
- The saw may encroach into the open lane of traffic.
- The polished, vertical patch boundary faces may lead to poor bonding.

Delay placement if the patching material is moisture sensitive and will not bond to a wet surface. This can be avoided by sawing joints and boundaries 1 to 2 days before removing and replacing the material. (Sawed edges do not spall when traffic is allowed onto repair areas that have been cut 1 to 2 days in advance.)

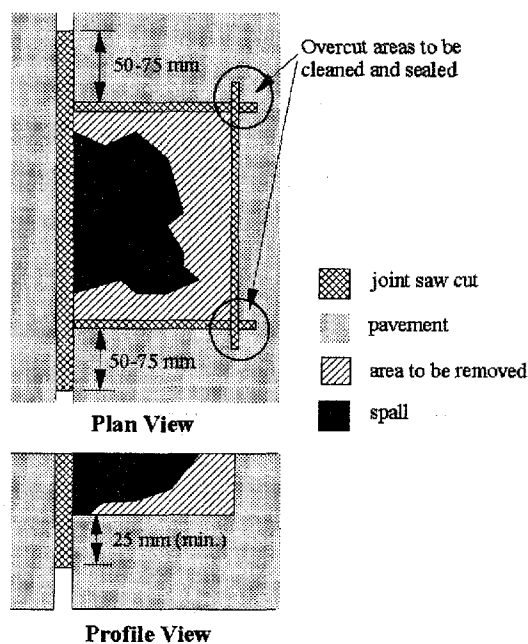

Figure 4-3. Saw overcuts for rectangular repair areas.

## Notes

However, if more unsound concrete is later found beyond the sawed boundaries, the saw must be brought back to cut new boundaries, possibly causing further delay. Also, the saw may encroach into the open lane of traffic if the spall is near the open lane, creating a hazardous situation.

Saw overcuts occur because the boundaries must be overcut 50 to 75 mm in each direction to achieve the needed depth of cut. These overcuts create weak areas that may deteriorate unless cleaned and sealed

### **Chip-and-Patch**

The chip-and-patch procedure is the same as the saw-and-patch procedure except the patch boundaries are not sawed. The deteriorated concrete in the center of the patch is removed using a light jackhammer with a maximum weight of 7 kg; however, a jackhammer with a maximum weight of 14 kg may be allowed if damage to sound pavement is avoided. The deteriorated concrete near the patch borders is then removed using hand tools and a light jackhammer with a maximum weight of 7 kg. The work should progress from the inside of the patch toward the edges, and the chisel point should be directed toward the inside of the patch.

The advantages of the chip-and-patch procedure include:

- The rough vertical edge produced promotes bonding.
- There are no saw overcuts.
- It has fewer steps than the saw-and-patch method.
- Spalling is controlled by using light hammers at the edges.
- Generally quicker than the saw-and-patch method.

There are no saw overcuts to be cleaned and sealed. Once joint sawing is completed, the saw is not needed again, even if more unsound concrete is later found beyond the boundaries.

The disadvantages of the chip-and-patch procedure include:

- Sound concrete may be damaged by heavy hammers.
- Jackhammers can cause feathered patch edges as shown in figure 4-4.
- Vertical sides are difficult to achieve.

The transmission of destructive forces may be reduced by using a heavy hammer only at the center of the repair area and a light hammer around the edges. If the selected repair material should not be feathered (e.g., some cementitious materials), a minimum 25-mm vertical face on all sides must be specified; that is, the top portion of the patch boundaries must be vertical for at least 25 mm, as shown in figure 4-5.

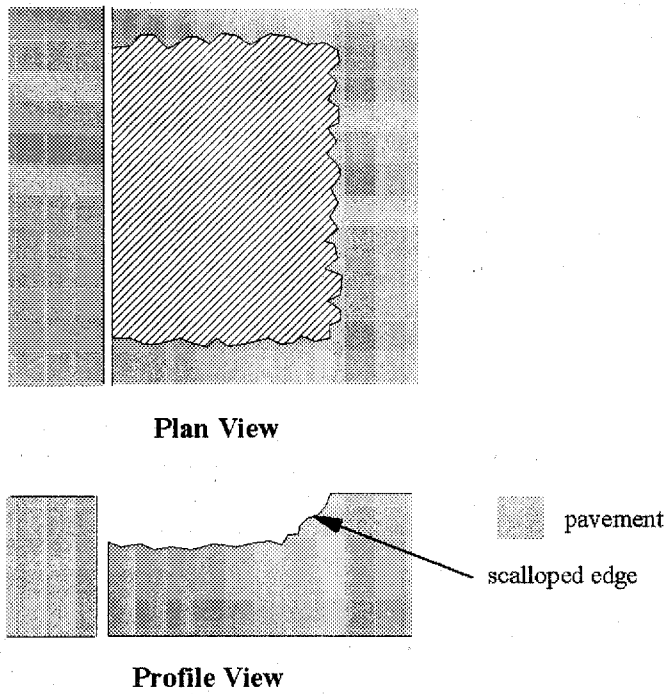

Figure 4-4. Scalloped edges resulting from chip-and-patch procedure.

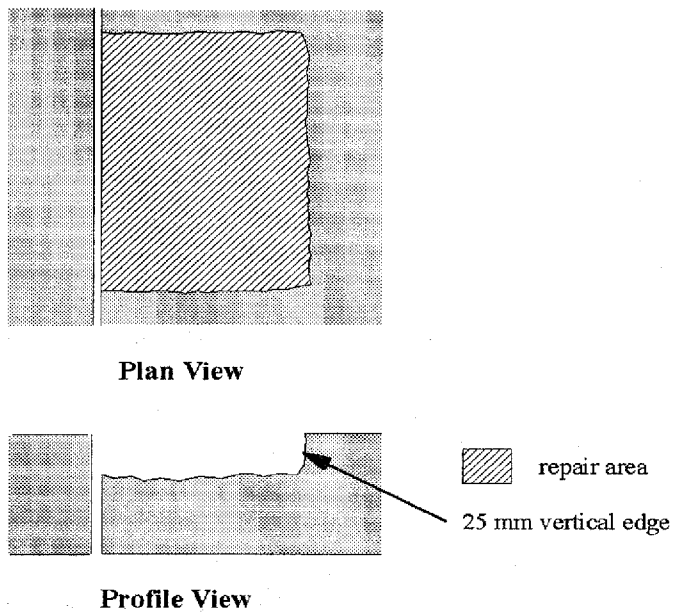

Figure 4-5. Vertical sides for chip-and-patch repair areas.

## Notes

### Mill-and-Patch

Some States have successfully used carbide-tipped milling machines for spall repair. Standard milling machines with 300- to 450-mm wide cutting heads have proven efficient and economical, particularly when used for large areas (e.g., for full lane-width repairs). The milling operation leaves a rounded cavity that may be made vertical by hammering or sawing. The milling machine should have a drum diameter of 900 mm or less and make a 300-mm wide cut or narrower.

The advantages of the mill-and-patch procedure include:

- It is efficient and economical when repairing large areas.
- It leaves a rough, irregular surface that promotes bonding.

The disadvantages of the mill-and-patch procedure include:

- If the spall is less than 0.1 m<sup>2</sup>, the patch may be larger than needed, because the smallest milling head currently available provides a 0.1 m<sup>2</sup> cut.
- The milling operation may cause spalling on the adjacent pavement edges.
- The milling machine makes a hole with two rounded edges (perpendicular to the direction of milling). If they are perpendicular to the direction of traffic, they should be made vertical by chiseling as shown in figure 4-6.

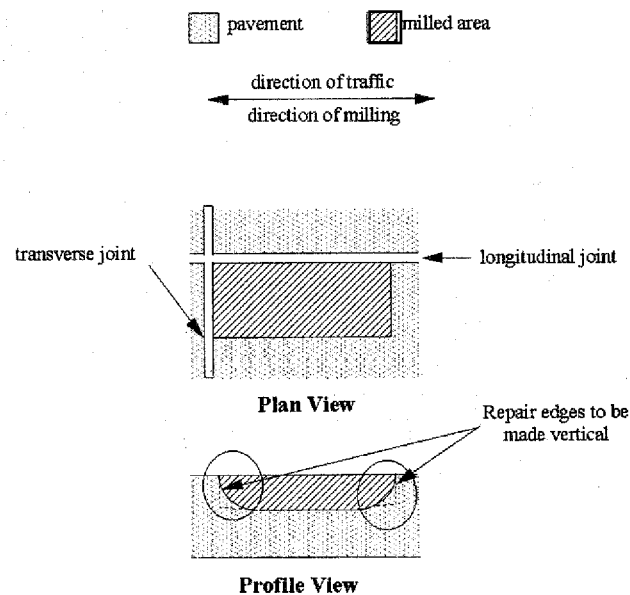

Figure 4-6. Milling machine edges in need of straightening.



Some milling machines are better suited for milling asphalt than for milling concrete. More powerful equipment may increase concrete milling efficiency and reduce spalling of the adjacent pavement.

Whenever possible, the orientation of the rounded edges should be parallel to the direction of traffic. However, because of traffic in the adjacent lane, the equipment may not always be able to maneuver into such an orientation. The larger the repair areas and the further they are from the adjacent lane of traffic, the higher the efficiency of the milling operation. Milling efficiency is also affected by the number of milling teeth that must be replaced each day.

Milling machines are readily available in many regions of the United States. However, a suitable machine at a reasonable cost may not be available at a specific project site.

### **Waterblast-and-Patch**

The waterblast-and-patch procedure uses a high-pressure water jet to remove the deteriorated concrete. Several States are testing this method for repairing pavements. The waterblasting machine should be capable of producing a stream of water at 100,000 to 200,000 kPa and should be controlled by a mobile robot. The waterblasting equipment must be capable of removing deteriorated concrete at an acceptable production rate, be under continuous automatic control, and have filtering and pumping units operating with a remote-controlled robotic device similar to that shown in figure 4-7. The noise level must be less than 90 db a distance of 15 m from either the power pack unit or the remote robot.

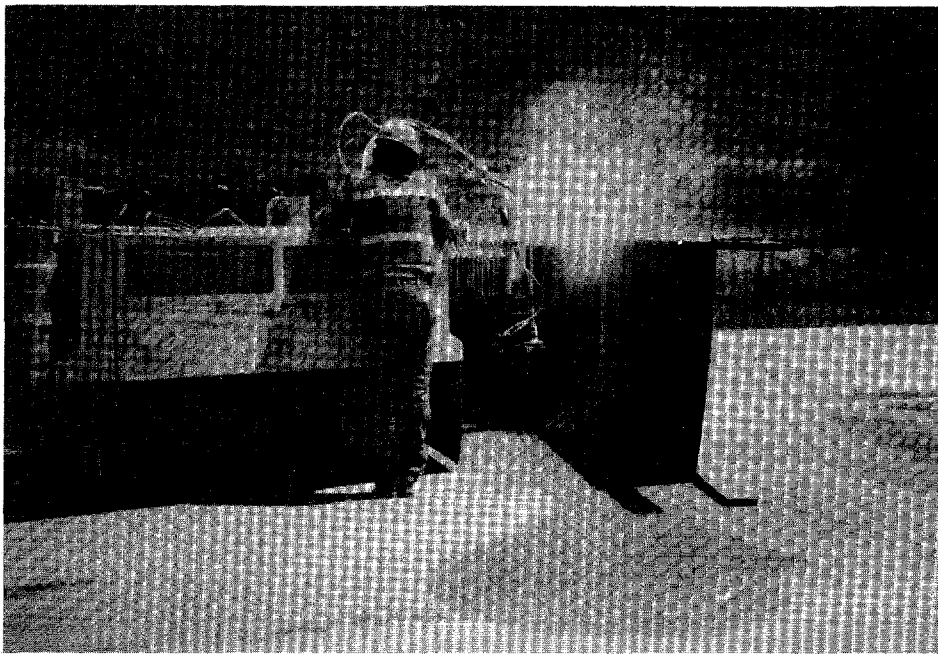

Figure 4-7. Water blasting equipment with remote-controlled robot device.

## Notes

The advantages of waterblasting include:

- It requires fewer workers than the other procedures.
- Once an experienced operator adjusts the operating parameters, only weak concrete is removed.
- The patch surfaces produced are vertical, rough, irregular, and enhance bonding.
- No hauling is required.

The disadvantages of waterblasting are:

- The finished surfaces are saturated. Placement must be delayed until the area dries unless the repair material is not moisture-sensitive.
- The fine slurry laitance remaining after the procedure requires careful attention during cleaning.
- A shield must be built around the repair area to protect traffic if the patch is next to a lane carrying traffic.
- It can be difficult to control the depth of removal.
- Equipment rental is expensive.
- It can be difficult to obtain a good production rate; performance of waterblasting equipment has been variable, and waterblasting had to be abandoned in several recent projects.

Some manufacturers expect a concrete removal rate of close to 6 m<sup>2</sup>/hr from their waterblasting equipment. But problems with equipment or very tough aggregate (such as granite) can quickly drop the production rate to as low as 1 to 1.5 m<sup>2</sup>/hr. The waterblasting equipment must function properly, and the operator must be very skilled to achieve high production rates.

### **Clean-and-Patch**

Adverse patching conditions consist of an air temperature below 4°C and a repair area saturated with surface moisture. Under these conditions, highway agencies often use the clean-and-patch procedure to perform emergency repairs. Deteriorated and loose concrete is removed with hand tools and swept away using stiff brooms. Occasionally, a light jackhammer may be used if the spalled area is large or if the cracked concrete is held tightly in place. Use the clean-and-patch

procedure only if a spall is hazardous to highway users and the climate is so adverse that no other procedure can be used.

### **Determining Resource Requirements**

Because of differences in the availability of various materials, equipment, crew size, and contractors, each agency will have a different set of resources available for performing partial-depth spall repair. Determining what resources are available is the first step toward developing the optimum repair procedure for a particular agency.

#### Material

Estimates of the amount of materials needed will depend on the size and number of spalls as well as the type of repair material selected. Many repair materials have a range within which they may be extended with aggregate (e.g., Type III PCC, Duracal, Set-45, Five Star HP, Pyrament 505). Other materials such as Percol FL and Penatron R/M-3003 require that the aggregate be placed in the repair hole before the material itself is applied. Volume yields of these two types of materials will depend on the size and amount of the aggregate used to extend the material. Extending a material with aggregate (up to the manufacturer's approved limit) will make the mix more thermally compatible with the existing pavement and reduce its overall cost. Estimate the total volume needed to fill all the patches and consult material manufacturers to determine the necessary amount of materials.

#### Equipment

Once a repair material has been chosen, consult the manufacturer's material specifications for equipment requirements. The types of equipment typically used for the five spall preparation procedures discussed to this point are shown in table 4-6. Table 4-7 shows the mixing and placement equipment and supplies typically used with some rapid-setting spall repair materials.

#### Labor

Table 4-8 shows the personnel typically used with the five spall preparation procedures. Table 4-9 shows the personnel typically used for the mixing and placement of some rapid-setting partial-depth spall repair materials. In certain cases, for example the pre-placement of the aggregate with Percol FL or Penatron R/M-3003 and the insertion of the joint bond breaker, one worker can be used for two activities that do not occur at the same time. A supervisor may be needed to oversee the crews and their operations. Additional personnel may be needed for inspection and traffic control.

Notes

Table 4-6. Typical equipment used for the five patch preparation procedures.

| Equipment  | Preparation Procedure |                |                |                      |                                   |
|--|-----------------------|----------------|----------------|----------------------|-----------------------------------|
|  | Saw-and-Patch         | Chip-and-Patch | Mill-and-Patch | Waterblast-and-Patch | Adverse-Condition Clean-and-Patch |
| Sounding equipment: rod, chain, or ball-peen hammer                            | ✓                     | ✓              | ✓              | ✓                    | ✓ <sup>a</sup>                    |
| Double-bladed concrete saw for joint sawing                                    | ✓                     | ✓              | ✓              | ✓                    |                                   |
| Single-bladed concrete saw for sawing patch boundaries                         | ✓                     |                |                |                      |                                   |
| 7-kg jackhammer with air compressor  | ✓                     | ✓              | ✓ <sup>b</sup> |                      | ✓ <sup>c</sup>                    |
| 14-kg jackhammer with air compressor   | ✓ <sup>d</sup>        | ✓ <sup>d</sup> |                |                      |                                   |
| Stiff brooms for debris removal  | ✓                     | ✓              | ✓              | ✓                    | ✓                                 |
| Hand tools (pick axe, etc.)  | ✓                     | ✓              |                |                      | ✓                                 |
| Truck for hauling removed material   | ✓                     | ✓              | ✓              |                      | ✓                                 |
| Waterblasting machine  |                       |                |                | ✓                    |                                   |
| Milling machine  |                       |                | ✓              |                      |                                   |
| Sandblasting equipment with directional nozzle, sand, air compressor           | ✓                     | ✓              | ✓              | ✓                    | ✓ <sup>c</sup>                    |
| Air blasting equipment with oil and water filtering capability, air compressor | ✓                     | ✓              | ✓              | ✓                    | ✓ <sup>c</sup>                    |

- <sup>a</sup> Sounding, sandblasting, and airblasting may not be practical under adverse conditions.
- <sup>b</sup> To remove rounded edges.
- <sup>c</sup> Jackhammering may be used for large areas, or when the deteriorated concrete cannot be removed using hand tools.
- <sup>d</sup> 7-kg jackhammers are preferred. Never use 14-kg hammers at patch boundaries.

Table 4-7. Typical mixing and placement equipment and supplies.

| Typical Equipment and Supplies                              | Type III PCC | Duraca | Set-45 | Five Star HP | Pyrament | MC-64          | SikaPronto 11  | Percol FL | Penatron | Spray-Injection Mix | UPM High-Performance Cold-Mix |
|---|--------------|--------|--------|--------------|----------|----------------|----------------|-----------|----------|---------------------|-------------------------------|
| Potable water/hose/pump                                     | ✓            | ✓      | ✓      | ✓            | ✓        |                | ✓              |           |          |                     |                               |
| Drum mixer (2 to 2.5 m)                                     | ✓            | ✓      |        |              | ✓        |                |                |           |          |                     |                               |
| Mortar mixer (1 to 1.5 m)                                   |              |        | ✓      | ✓            |          |                | ✓              |           |          |                     |                               |
| 20-mm electric drills & 530-mm stainless steel Jiffy mixers |              |        |        |              |          | ✓ <sup>b</sup> | ✓ <sup>b</sup> |           | ✓        |                     |                               |
| Bonding agent brush/roller                                  | ✓            |        |        |              |          |                | ✓              |           |          |                     |                               |
| Vibrators and/or screeds                                    | ✓            | ✓      | ✓      |              | ✓        |                | ✓              |           |          |                     |                               |
| Trowels   | ✓            | ✓      | ✓      | ✓            | ✓        | ✓              | ✓              |           |          |                     |                               |
| Shovels   | ✓            | ✓      | ✓      | ✓            | ✓        |                | ✓              |           |          |                     | ✓                             |
| Curing compound, applicator, burlap, or plastic sheeting    | ✓            | ✓      | ✓      |              | ✓        |                |                |           |          |                     |                               |
| Insulating blankets   | ✓            |        |        |              | ✓        |                |                |           |          |                     |                               |
| Vibratory roller or plate                                   |              |        |        |              |          |                |                |           |          |                     | ✓                             |
| Electric generator  | ✓            | ✓      | ✓      | ✓            | ✓        | ✓              | ✓              | ✓         | ✓        |                     |                               |
| Grayco Percat 500   |              |        |        |              |          |                |                | ✓         |          |                     |                               |
| Spray-injection machine                                     |              |        |        |              |          |                |                |           |          | ✓                   |                               |
| Nonwater cleaning solvent                                   |              |        |        |              |          | ✓              | ✓              | ✓         | ✓        |                     | ✓                             |
| Compression cylinders/rod                                   | ✓            | ✓      | ✓      | ✓            | ✓        |                |                |           |          |                     |                               |
| Slump cone  | ✓            | ✓      | ✓      | ✓            | ✓        |                |                |           |          |                     |                               |
| Air meter, rod, water bulb                                  | ✓            |        |        |              |          |                |                |           |          |                     |                               |

- <sup>a</sup> Mixer should have twice the volume of the amount of material to be mixed.
- <sup>b</sup> Capable of 400 to 600 rpm.
- <sup>c</sup> May be used in hot (°C) windy (> 40 km/hr) weather.
- <sup>d</sup> In weather below 7°C.
- <sup>e</sup> As needed; sufficient for demand.
- <sup>f</sup> Air-driven, automatic, ration-metering pump.
- <sup>g</sup> Capable of delivering chip-sized aggregate and asphalt emulsion (e.g., AMZ, Rosco).

Notes

Table 4-8. Typical personnel used for spall repair procedures.

| Procedure                    | Typical personnel <sup>a</sup>   | Total  |
|------------------------------|--|--------|
| Joint sawing                 | 1 worker operating saw<br>1 worker directing saw   | 2      |
| Saw-and-patch                | 1 worker operating saw<br>0 to 1 worker directing saw<br>1 to 2 workers operating jackhammers<br>1 to 2 workers cleaning repair hole<br>0 to 1 worker removing debris                    | 4 to 7 |
| Chip-and-patch               | 1 to 2 workers operating jackhammers<br>1 to 2 workers cleaning repair hole<br>0 to 1 worker removing debris   | 2 to 5 |
| Mill-and-patch               | 1 worker operating milling machine<br>1 worker directing milling machine<br>1 to 2 workers operating jackhammers<br>1 to 2 workers cleaning repair hole<br>0 to 1 worker removing debris | 5 to 7 |
| Waterblast-and-patch         | 1 worker operating waterblaster<br>1 worker operating water truck<br>1 worker cleaning repair hole   | 3      |
| Clean-and-patch              | 1 worker using hand tools (or jackhammer if necessary)<br>1 worker cleaning repair hole  | 2      |
| Inserting joint bond breaker | 1 worker installing bond breaker (otherwise available for other activities)  | 1      |

<sup>a</sup> Does not include traffic control personnel.

Table 4-9. Typical personnel used for mixing and placing.

| Material                | Typical personnel   | Total No. Workers |
|-------------------------|---|-------------------|
| Type III PCC            | 1 to 2 workers mixing and applying epoxy<br>1 worker proportioning and mixing Type III mix<br>2 workers placing, compacting, and finishing                                | 4 to 5            |
| Duracal                 | 1 worker proportioning and mixing Duracal<br>1 to 2 workers placing, compacting and finishing   | 2 to 3            |
| Five Star HP            | 1 worker proportioning and mixing Five Star HP<br>1 to 2 workers placing, compacting, and finishing<br>1 worker spraying curing compound                                  | 3 to 4            |
| Set to 45               | 1 worker proportioning and mixing Set-45<br>2 workers placing, compacting and finishing   | 3                 |
| Pyrament 505            | 1 worker proportioning and mixing Pyrament 505<br>2 workers placing, compacting, and finishing  | 3                 |
| MC-64                   | 1 to 4 workers mixing MC-64<br>1 to 2 workers placing and finishing   | 2 to 6            |
| Sika Pronto 11          | 2 workers mixing and applying SikaPronto 11<br>1 worker proportioning and mixing SikaPronto 11<br>2 workers placing, compacting, and finishing                            | 5                 |
| Percol FL               | 1 worker placing rock into prepared hole<br>0 to 1 worker driving truck with pumps and tanks<br>1 worker applying Percol FL<br>0 to 1 worker applying broadcast aggregate | 2 to 4            |
| Penatron R/M-3003       | 1 worker placing rock into prepared hole<br>1 to 2 workers mixing Penatron R/M-3003<br>1 to 3 workers placing and finishing   | 3 to 6            |
| Spray-Injection Mix     | 1 worker driving truck<br>1 worker operating binder/aggregate sprayer   | 2                 |
| UPM High Perf. Cold-Mix | 1 to 2 workers shoveling and placing mix<br>1 worker operating vibratory roller or plate  | 2 to 3            |

## **INSTALLATION**

In general, partial-depth spall repair operations consist of the following six steps:

1. Joint preparation.
2. Material removal.
3. Cleaning the repair area.
4. Material preparation and application.
5. Material finishing and curing.
6. Joint sealing.

For expedient repairs using flexible materials, steps 1, 2, and 6 are typically precluded. Such repairs do not require joint restoration and the repair area is only cleaned so as to allow for adequate bonding.

This section provides general guidance on how each operational step should be performed in order to create as long-lasting patches as possible. For work quality monitoring by field supervisors/inspectors, detailed operational checklists are available in appendix D of reference 35. Additional guidance on proper placement procedures is available in the FHWA Pavement Rehabilitation Manual.<sup>7</sup>

### **Traffic Control**

It is very important to provide adequate traffic control whenever any partial-depth patching operation is performed. This ensures a safe working environment for the maintenance crew and safe travel for vehicles in the construction area. Traffic control should cause the least possible disturbance to the flow of traffic. While traffic control requirements for each construction site will vary, every maintenance agency is responsible for ensuring that all necessary steps are taken to maintain safety.

### **Safety**

Many rapid-setting materials require special safety precautions to protect the maintenance workers using them and to protect the environment. It is extremely important that highway agencies follow all instructions regarding worker protection and repair material disposal. These instructions are available from the manufacturer on the material safety data sheets.

In addition, the agency should follow safety instructions for worker protection and material disposal for any other accessory material or substance used (e.g., solvents, bonding agents, joint bond breakers, admixtures, curing compounds, etc.), as well as for all equipment used in the partial-depth spall repair process.



## Joint Preparation

High compressive stress is the most frequent cause of failure of partial-depth spall repairs. Nonflexible partial-depth patches placed directly against transverse joints and cracks will be crushed by the compressive forces created when there is not enough room for thermal expansion of the slabs. Patches may also fail if, during placement, the repair material is allowed to flow into the joint or crack opening below the bottom of the patch. When cured, the material will prevent the crack or joint from working and will keep the slabs from moving. These failures must be prevented by using proper joint preparation methods.

If a nonflexible patching material is used, the old sealant in the adjacent joint and 75 to 100 mm beyond the patch must be removed for placement of a joint bond breaker as shown in figure 4-8. If a flexible polymer material is used, still remove the old sealant, and clean the area adjacent to the patch thoroughly. Bituminous materials do not need any special cleaning.

Most spall repair materials are nonflexible. However, some materials, such as some polymers, cold-mixes, and spray-injection mixes, are flexible and do not need a joint sealant or a joint bond breaker. Consult the material manufacturer to determine if joint sealant or bond breakers are necessary.

When a joint bond breaker is needed, the existing transverse and longitudinal joints next to the repair should be resawn using a double-bladed concrete saw. The depth of the cut should be at least 25 mm deeper than the depth of the repair as shown in figure 4-8. The saw cut should extend 50 to 75 mm beyond the repair

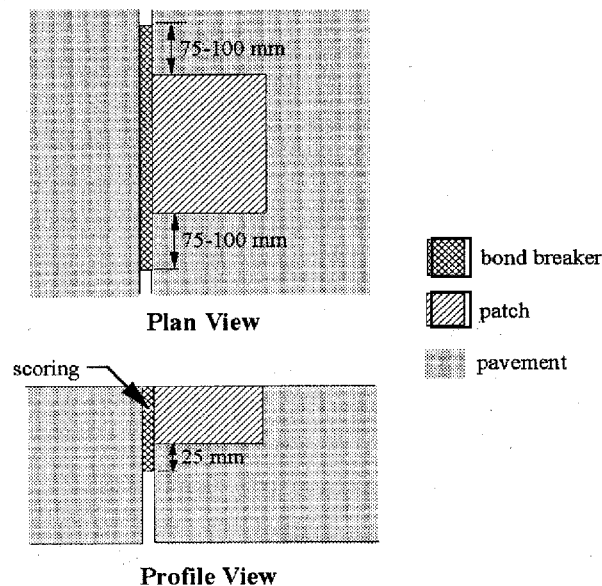

Figure 4-8. Dimensions of joint bond breaker for rigid repairs.

## Notes

area in each direction as shown earlier in figure 4-3. This sawing is usually done before deteriorated concrete is removed and must be done before the repair area is cleaned. Use water-wash equipment to remove all sawing slurry from the repair area before it dries. Joint sawing may not be needed if flexible polymer materials (e.g., Percol FL, Penatron R/M-3003) are used, and is not typically done as part of the clean-and-patch procedure or when bituminous materials are used.

Spalls caused by metal or plastic joint inserts usually start at the bottom fin of the insert, about 60 mm below the surface. When repairing this type of spall, saw the joint insert along its entire length to prevent further deterioration. The joint can then be repaired and resealed. This is normally done using a double-bladed concrete saw before the deteriorated concrete is removed.

If a nonflexible repair material is used, install a compressible joint bond breaker as the last step of joint preparation. The type of joint (i.e., transverse, centerline, or lane-shoulder) will determine the type of bond breaker to use. Some flexible materials may not need a bond breaker.

Place polystyrene or polyethylene joint bond breakers flush with the pavement surface, between the new (nonflexible) concrete and the adjacent slab to reduce the risk of compression-related failure. They also protect the patch from damage caused by deflection under traffic.

The bond breaker should have a scored top strip as shown in figure 4-9 and should extend 25 mm below and 75 mm beyond the repair boundaries. The

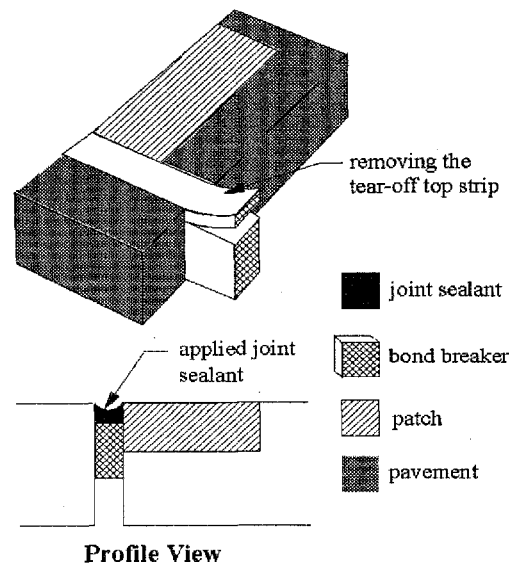

Figure 4-9. Bond breaker with scored top for renewal.

extension will prevent the repair material from flowing into the joint during placement. The bond breaker should be slightly wider than the joint so that it is slightly compressed when installed. The scored top strip must be torn off later and the resulting joint reservoir filled with an appropriate joint sealant. Refer to session 3 for additional information on selecting appropriate dimensions for the joint reservoir and other joint details.

Maintain a straight joint line during bond breaker placement at transverse joints. This may be difficult with back-to-back patches. Bond breakers of different heights may be installed in patches of different depths. Alternatively, the bond breaker may be stacked to the needed depth, which may be difficult. Latex caulking may be used to seal any gaps between layers of bond breaker or between the bond breaker and the joint opening. This will prevent the repair material from flowing into the joint or a crack opening below the bottom of the patch. This is illustrated in figure 4-10.

Partial-depth patches placed at the centerline joint often spall because of curling stresses. To prevent this, place a polyethylene strip (or other thin bond-breaker material) along the centerline joint to prevent the patch from contacting the adjacent lane, as described previously.

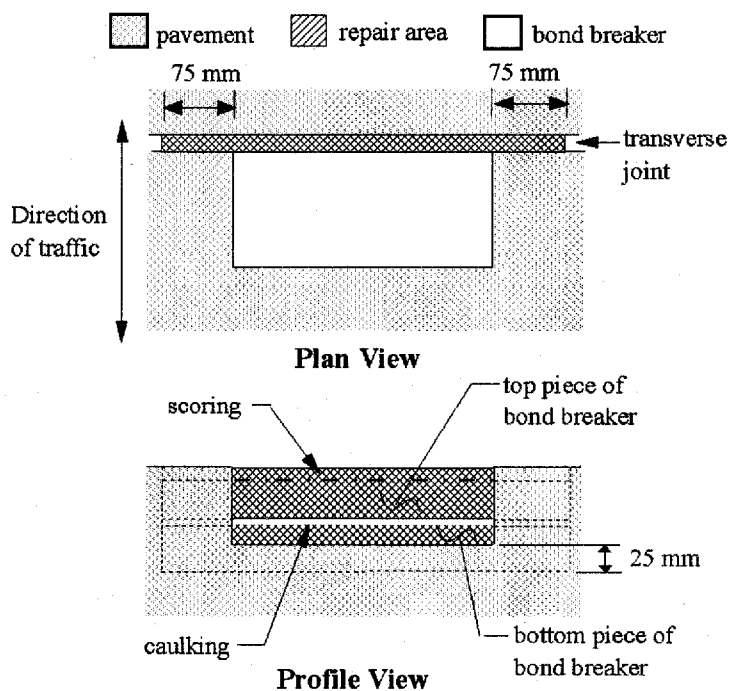

Figure 4-10. Use of latex caulk for joining multiple pieces of bond breaker.

## Notes

The joint must be formed using a piece of fiberboard if the repair is at the lane-shoulder joint. Fiberboard is stiffer than a polyethylene or polystyrene joint bond breaker, and it provides the support needed at the lane-shoulder joint when placing the repair material. Like more flexible bond breakers, fiberboard will prevent the repair material from flowing into the shoulder during material placement. If the repair material flows into the lane-shoulder joint, it will restrict longitudinal movement of the slab and damage the repair. Place fiberboard to the same dimensions as the more flexible bond breaker.

Bituminous materials, in general, and some proprietary flexible repair materials, such as Percol FL and Penatron R/M-3003, may have enough compressibility to allow joints to move without needing a joint bond breaker. Consult the manufacturer for the appropriate joint treatment when using a flexible spall repair material. In cases where the repair area spans a joint, a joint should be formed in the flexible materials, even when the manufacturer does not feel it is necessary. This is illustrated in figure 4-11.

### Material Removal

In many cases, a single-bladed concrete saw is used to cut the boundaries of the patch and to make removing the deteriorated concrete easier. The saw cut should be 25 to 50 mm deep and usually extends 50 to 75 mm beyond the patch boundaries to obtain that depth for the entire length and width of the patch. The cut boundary should have straight, vertical faces and square corners. Vertical boundaries reduce the spalling associated with thin or feathered concrete along the repair perimeter. For large areas of repair saw the area to be removed in a shallow

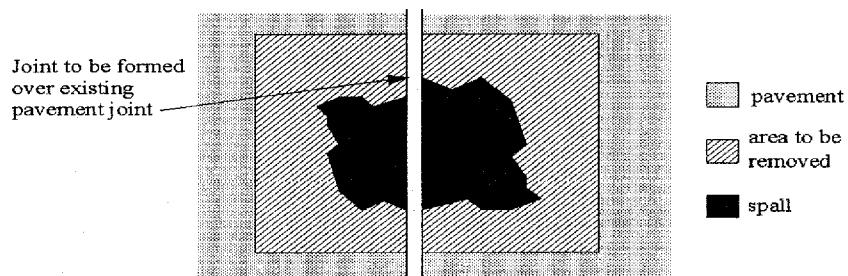

Figure 4-11. Joint placement in flexible repairs bridging existing joint.

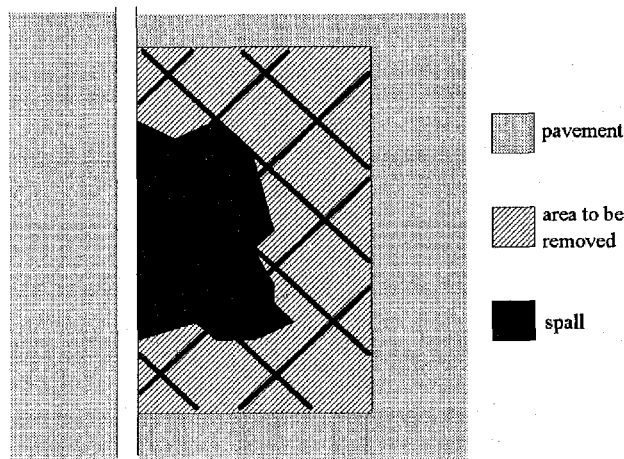

Figure 4-12. Sawing pattern for large repair areas.

crisscross or waffle pattern to facilitate concrete removal. Use water-wash equipment to remove sawing slurry from the repair area before it dries. This is illustrated in figure 4-12.

Complete removal near the repair boundaries with 5- to 7-kg hammers fitted with spade bits, as gouge bits can damage sound concrete. Operate jackhammers and mechanical chipping tools at an angle less than  $45^\circ$  from the vertical, as illustrated earlier in figure 4-2.

### Cleaning the Repair Area

After all unsound concrete has been removed, clean the surface of the repair area. Sandblasting, airblasting, and sweeping normally provide a clean, rough surface for the development of a good bond between the patch and the pavement. High-pressure water may also be used to remove dirt, dust, and other contaminants, but sandblasting usually produces better results.

Sandblasting is recommended highly for cleaning the surface. It removes dirt, oil, thin layers of unsound concrete, and laitance. Sandblasting equipment consists of a compressed-air unit, a sand dispenser, hoses, and a wand with a venturi-type nozzle. The compressed air must be free of oil and water, because a contaminated surface will prevent bonding. Check the air quality by placing a cloth over the air compressor nozzle and visually inspecting for oil. Sandblasting is generally not used under adverse conditions.

## Notes

After sandblasting, use high-pressure airblasting to remove any remaining dust, debris, and loosened concrete fragments. Debris must be blown out and away from the patch so that wind or passing traffic cannot carry it back into the patch. Use a black glove or cloth to check the cleanliness of the repair area. If the glove or cloth picks up material (dust, asphalt, slurry) when rubbed across the prepared surface, clean the surface again or poor bonding will result. If there is a delay between cleaning and patch placement, the surface may have to be cleaned again. Airblasting is generally not used with the clean-and-patch procedure under adverse conditions.

Use either trailer-mounted air compressors or portable backpack blowers. Backpack blowers need only one laborer and are very mobile. However, trailer-mounted air compressors are recommended because they provide a higher pressure (greater than 670 kPa). The compressed air unit should have oil and moisture filters, otherwise, it may blow oil or moisture into the repair area and prevent the patch from bonding. When patching with a spray-injection machine, the hole can be cleaned with air from the aggregate delivery system.

The debris and slurry that result from the waterblasting operation must be removed using a low-pressure water stream before the slurry dries and hardens on the surface of the hole. If this is not done, the repair area may have to be refaced. Once dried, sandblasting may or may not be able to remove the dried slurry residue. Some moisture-sensitive materials may require the repair area be completely dry before placing the material.

Sweeping is the most common way to clean the repair area when patching under adverse conditions. Under better conditions, use sandblasting and airblasting.

### Inspection of the Repair Area

After cleaning, inspect the repair area to determine if there is any more unsound concrete. If there is, it should be removed, and the repair area should be cleaned again. Never use sandblasting to remove unsound material.

If the repair area is sound, inspect it for clean, dry, freshly exposed concrete. Remove any dust remaining on the pavement surface around the repair area by sweeping or vacuuming, especially on windy days or when traffic passes alongside the repair. If there is a delay between cleaning and placing the material, the repair area must be inspected again at the time of placement and must be cleaned again by airblowing if dirt has blown into it.

### **Material Preparation and Application**

#### Bonding Agents

Some partial-depth patching materials require epoxy or proprietary bonding agents. Mix epoxy bonding agents carefully according to the manufacturer's instructions. An electric drill with a Jiffy mixer may be used to mix the two epoxy components for the required time.

Some spall repair materials, such as SikaPronto 11, specify a proprietary bonding agent. Follow the manufacturer's mixing instructions exactly to ensure good patch performance.

Apply a bonding agent after cleaning the repair area and just before placing PCC repair materials. The manufacturer's directions must be closely followed when using epoxies or other manufactured grouts. Thoroughly coat the bottom and sides of the repair area by brushing the grout or epoxy onto the concrete. Spraying may be appropriate for large repair areas. Do not allow excess bonding agent to collect in pockets. Time the placement of the bonding agent so that it is tacky when the repair material is placed.

### Material Mixing

The volume of material required for a partial-depth repair is usually small—0.01 to 0.05 m<sup>3</sup>. Ready-mix trucks and other large equipment cannot efficiently produce small quantities. Small drum or paddle-type mixers with capacities of 0.15 to 0.25 m<sup>3</sup> and Jiffy mixers are often used. Based on trial batches, repair materials may be weighed and bagged in advance to make the batching process easier. Prebagged cement may also be used; aggregate may be weighed using a precalibrated volume method (i.e., a bucket can be marked by volume for the appropriate weight). Continuous-feed mixers are also widely used.

Mixing times and water content must be carefully observed for prepackaged rapid-setting materials. Mixing for a longer time than needed for good blending reduces the already short time available for placing and finishing rapid-setting materials. Additional water may significantly reduce the strength of the patch.

Also, give careful consideration to the working times of the repair materials when determining the appropriate mixing batch size. Mixing a larger quantity of material than can be placed in the corresponding working time will only increase the material waste of the overall operation.

### Material Placement

For materials that will be consolidated or compacted, the placement procedure begins by slightly overfilling the repair hole to allow for the reduction in volume. Materials that contain aggregate must be placed with a shovel. Segregation will occur if these materials are dumped from a bucket or wheelbarrow.

## Notes

### Material Finishing and Curing

#### Consolidation and Compaction

Consolidate cementitious repair materials by vibration during placement to release trapped air from the fresh mix. Failure to do so may result in poor durability, spalling, and rapid deterioration. Voids between the repair material and pavement can cause total debonding and loss of repair material. Percol FL, MC-64, Penatron R/M-3003, bituminous cold mixes, and spray-injection materials do not need vibration.

Three common methods of consolidation are to:

- Use internal vibrators with small heads (less than 25 mm in diameter).
- Use vibrating screeds.
- Rod or tamp and cut with a trowel or other hand tools.

The internal vibrator and the vibrating screed give the best results. However, partial-depth patches are usually too small to use a vibrating screed. Internal pencil vibrators are recommended. Very small repairs may be consolidated using hand tools. Cutting with a trowel seems to give better results than rodding or tamping. The tools used should be small enough to work easily in the repair area.

Hold the vibrator at 15 to 30° from the vertical and move through the patch until the entire repair has been vibrated as shown in figure 4-13. It should be lifted

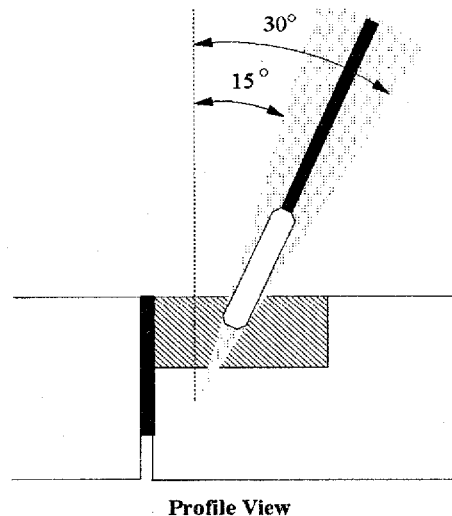

Figure 4-13. Use of internal vibrator for cementitious repairs.



up and down but not moved horizontally in the patch. Do not use the vibrator to relocate material within the repair as this may cause segregation. The mix is consolidated adequately when it stops settling, air bubbles no longer emerge, and a smooth layer of mortar appears at the surface.

Bituminous patching materials such as UPM High Performance Cold Mix are generally compacted using a vibratory roller or plate until level with the pavement. The patches should be compacted with three to eight passes. The roller or plate must not bridge the patch. Repairs that settle below the surrounding pavement should have additional material added, to allow for 3 to 5 mm of crown once compaction is completed. This crown is necessary to allow the finished surface to be flush once it is compacted by traffic.

### Screeding and Finishing

The surface of the patch should be troweled flush with the pavement surface. Vibration may be needed to make the work finishable if the mix is too stiff. Partial-depth repairs are usually small enough that a stiff board resting on the adjacent pavement can be used as a screed. The material should be worked toward the edges of the patch to establish contact and enhance bonding to the pavement. Make at least two passes to ensure a smooth surface.

The repair surface must be hand-troweled to remove any remaining minor irregularities. Tool the edge of a repair located next to a transverse joint to provide a good reservoir for joint sealing. Use extra mortar from troweling to fill any saw overcuts at the patch corners. Extra epoxy may also be used, or the saw overcuts may be filled with joint sealant during the joint sealing process.

Partial-depth repairs typically cover only a small portion of the pavement surface and have little effect on skid resistance. However, the finished surface of the repair should match that of the pavement as closely as possible.

### Curing

Curing is as important for partial-depth repairs as it is for full-depth repairs. Since partial-depth repairs often have large surface areas in relation to their volumes, moisture can be lost quickly. Improper curing can result in shrinkage cracks that may cause the repair to fail prematurely.

The most effective curing method when patching with PCC materials in hot weather is to apply a white-pigmented curing compound as soon as water has evaporated from the repair surface. The compound will reflect radiant heat while allowing the heat of hydration to escape and will provide protection for several days. Moist burlap and polyethylene sheeting can also be used, but they must be removed when the roadway is opened to traffic. In cold weather, use insulating

## Notes

blankets or tarps to provide more rapid curing and to allow an earlier opening to traffic. The required curing time should be stated in the project plans and specifications.

Some proprietary materials (e.g., Five Star HP) may require moist curing after the mix has stiffened. Others (e.g., Pyrament 505) require the application of a curing compound. Some proprietary repair materials (e.g., SikaPronto 11) may be air-cured. Epoxy and proprietary repair materials should be cured as recommended by their manufacturers.

### **Joint Sealing**

The final step in partial-depth spall repair is to restore the joints. When the recommended scored bond breaker has been used, remove the tear off top strip and apply the selected sealant. If a scored bond breaker has not been used, restore the joint by resawing the joint to a new shape factor, sandblasting and airblasting both faces of the joint, inserting a closed-cell backer rod, and applying the sealer. Allow a minimum 1-week cure time before joint sealing. Refer to session 3 for more information on proper joint sealing practices.

## **EVALUATING REPAIR EFFECTIVENESS**

As stated initially, the goal of all partial-depth spall repair operations should be to place the longest lasting patch possible in each distress area. In many cases, each repair crew must make the determination of what is the longest-lasting repair for the particular conditions and available materials. This section provides some general guidelines for repair crews to make such determinations.

### **Repair Performance**

The most frequent construction-related causes of partial-depth patch failure include:

- Failure to square the hole.
- Failure to remove all deteriorated material.
- Inadequate cleaning.
- Lack of bond.
- Failure to re-establish the joint (compression failure).
- Variability of the repair material.
- Insufficient consolidation.

It is important to remember that every partial-depth spall repair patch is necessary because of a localized failure to the original pavement. In some instances, the conditions which led to the initial failure may cause partial-depth

spall repairs to fail repeatedly. Do not confuse this type of repeat patching with situations where the material is placed and does not perform because of inferior quality.

Another consideration in evaluating repair performance is that repairs placed during adverse weather conditions will generally not last as long as repairs placed during good weather, especially when there is moisture present either at the time of patching or within several days after the repair is placed.

To monitor the performance of partial-depth spall repairs, it is necessary to document when repairs were placed, what materials and procedures were used, the conditions under which the repairs were placed, and how long the repairs survived, or remained unfailed. In general, survival time is defined as the amount of time until an area needs to be repaired again. It is not necessary to document all repairs placed, simply take a single day's or week's worth of patching (between 10 and 30 repairs is recommended) and track those as a sample of the material-procedure-condition combination. To compare differences in performance, take another sampling of repairs whenever the material, procedure, or conditions change.

Use the procedure outlined in table 4-10 to calculate the percent survival rate for any given material-procedure-condition combination. Even though the survival rate is independent of the time since the repairs were placed, it is recommended that different repair types be compared with similar placement dates whenever possible.

### **Pavement Performance**

In many cases, the development of partial-depth joint spalls can signal the end of the service life for a pavement. If the quantity of spalls exceeds more than 100/km, examine the overall condition of the pavement and consider rehabilitation options. In situations where spalls are not indicative of a severely deteriorated pavement, expect the repairs to perform quite well and in some cases will survive as long as the surrounding pavement. Determining the remaining life of the pavement will be crucial to ensuring that the most cost-effective repair option is chosen.

Notes

Table 4-10. Worksheet for calculating patch survival rate.

| Observe. No. (I) | Time, weeks (T) | Surviving/ Total Patches | Perc. Surv. ( $P_{surv}$ ) | Avg. Perc. Surv. ( $P_{avg}$ ) | Time Interval ( $T_{int}$ ) | Partial Area ( $A_{part}$ ) | Total Possible Area ( $A_{tot}$ ) |
|------------------|-----------------|--------------------------|----------------------------|--------------------------------|-----------------------------|-----------------------------|-----------------------------------|
| 0                | 0               | 10/10                    | 100                        |                                |                             |                             |                                   |
|                  |                 |                          |                            | 95                             | 3                           | 285                         | 300                               |
| 1                | 3               | 9/10                     | 90                         |                                |                             |                             |                                   |
|                  |                 |                          |                            | 85                             | 2                           | 170                         | 200                               |
| 2                | 5               | 8/10                     | 80                         |                                |                             |                             |                                   |
|                  |                 |                          |                            | 70                             | 3                           | 210                         | 300                               |
| 3                | 8               | 6/10                     | 60                         |                                |                             |                             |                                   |
|                  |                 |                          |                            | 55                             | 3                           | 165                         | 300                               |
| 4                | 11              | 5/10                     | 50                         |                                |                             |                             |                                   |
|                  |                 |                          |                            | 45                             | 4                           | 180                         | 400                               |
| 5                | 15              | 4/10                     | 40                         |                                |                             |                             |                                   |
|                  |                 |                          |                            | 30                             | 5                           | 150                         | 500                               |
| 6                | 20              | 2/10                     | 20                         |                                |                             |                             |                                   |
|                  |                 |                          |                            |                                |                             |                             |                                   |
|                  |                 |                          |                            |                                |                             |                             |                                   |
|                  |                 |                          |                            |                                |                             |                             |                                   |
|                  |                 |                          |                            |                                |                             |                             |                                   |
|                  |                 |                          |                            |                                |                             |                             |                                   |
|                  |                 |                          |                            |                                |                             |                             |                                   |
|                  |                 |                          |                            |                                |                             |                             |                                   |
|                  |                 |                          |                            |                                |                             |                             |                                   |
|                  |                 |                          |                            |                                |                             |                             |                                   |
|                  |                 |                          |                            |                                |                             |                             |                                   |
|                  |                 |                          |                            |                                |                             |                             |                                   |
|                  |                 |                          |                            |                                |                             |                             |                                   |
|                  |                 |                          |                            | Total                          |                             | 1,160                       | 2,000                             |

Patch Survival Rate

55.3

$$P_{avg} = (P_{surv(i)} + P_{surv(i+1)}) / 2$$

$$T_{int} = T_{int(i+1)} - T_{int(i)}$$

$$A_{part} = P_{avg} \times T_{int}$$

$$A_{tot} = T_{int} \times 100$$

**SESSION OBJECTIVES**

This session discusses the proper methods for planning, installing, and monitoring an AC crack-treatment project. It presents the latest findings on the performance of materials and methods tested under the SHRP H-106 crack treatment experiment and contains detailed information on the processes of performing effective crack-sealing and -filling operations.

Upon successful conclusion of this session, the participant shall be able to accomplish the following:

1. Recall which crack-treatment materials and methods are performing best in the SHRP H-106 experiment.
2. Differentiate between sealing and filling, in terms of both objectives and operations.
3. Select the most appropriate and cost-effective materials and procedures for a specific project, given various constraints and limitations.
4. List the various steps in a crack-treatment operation and describe the recommended procedures and equipment associated with each step.
5. Evaluate the effectiveness of a crack treatment project.

**SHRP RESEARCH FINDINGS TO DATE**

Between March and August 1991, over 6,700 m of cracking in asphalt pavement was treated (sealed or filled) at test sites located throughout the U.S. and Canada as part of the SHRP H-106 project. The primary objective of the experiment was to determine the most cost-effective crack treatment materials and procedures under various climatic conditions and traffic. The materials and procedures used in the H-106 study were identified in the predecessor project, SHRP H-105, as having the most potential to improve the state of the practice in both crack sealing and crack filling.

Five crack treatment test sites were constructed in four climatic regions as part of the H-106 experiment. These sites consisted of the following:

## Notes

|                            |               |                |
|----------------------------|---------------|----------------|
| • I-20—Abilene, Texas      | Dry/nonfreeze | March, 1991    |
| • KS 254—Wichita, Kansas   | Dry/freeze    | April/May 1991 |
| • WA 8—Elma, Washington    | Wet/nonfreeze | April 1991     |
| • I-35—Des Moines, Iowa    | Wet/freeze    | June 1991      |
| • ON 401—Prescott, Ontario | Wet/freeze    | August 1991    |

The first four sites were transverse crack seal sites, whereas the Ontario site was a longitudinal crack fill site. To examine the effect of weather conditions at the time of sealing, the Kansas site included sections installed in ideal (dry and warm) and adverse (moderately wet and cold) conditions.

A total of 14 different proprietary materials and one asphalt cement material were included in the experiment. Moreover, 8 different material placement configurations and seven different crack preparation procedures were used to install the materials, resulting in 31 unique treatment combinations or types. Table 5-1 shows the combinations of material and installation method that were used at each of the five test sites, and figure 5-1 illustrates the eight material placement configurations used. Further details about materials and installation methods are provided in the section titled "Project Planning and Design."

At a given site, each treatment type was represented by a test section containing 10 transverse cracks (crack seal) or 12 longitudinal crack segments (crack fill). All of the test sections planned at each site were placed in random order along the test site pavement. For greater statistical validity, the randomly arranged block of sections was then repeated at the end to form a replicate block of sections.

Since installation, treatment performance at each site has been evaluated several times through detailed visual inspections conducted under both the H-106 project and the FHWA *LTM* follow-up study. In these inspections, treatment distresses and failures (i.e., segments of treatment allowing water to penetrate the crack), such as edge deterioration, adhesion loss, and cohesion loss, were identified along each experimental crack of a given treatment. Each type of distress and failure observed was then recorded in units of length, which later enabled calculation of the average percentages of each distress and failure type, as well as the average overall percentage of effectiveness (see section titled "Evaluating Treatment Effectiveness").

Under the *LTM* study, annual field inspections are scheduled for every fall from 1993 through 1997. Thus far, four of the five sites have remained free of rehabilitation work; the Washington crack seal site was overlaid in summer, 1995.

Table 5-1. Summary of material-method combinations used in SHRP H-106 crack treatment experiment.

| Material   | Installation Method<br>(material configuration–<br>crack preparation procedure) | State/Province Installed |    |    |    |                       |
|--|---|--------------------------|----|----|----|-----------------------|
|  |   | TX                       | KS | WA | IA | ON<br>(crack filling) |
| Meadows Hi-Spec<br>Rubberized Asphalt            | A-2   |                          |    |    | ✓  |                       |
|  | A-3   | ✓                        | ✓  | ✓  | ✓  |                       |
|  | B-3   | ✓                        | ✓  | ✓  | ✓  |                       |
|  | C-3   |                          | ✓  |    | ✓  |                       |
|  | D-3   | ✓                        | ✓  | ✓  | ✓  |                       |
|  | D-4   | ✓                        | ✓  | ✓  | ✓  |                       |
| Crafco RS 515<br>Rubberized Asphalt              | B-3   | ✓                        |    | ✓  | ✓  |                       |
|  | C-3   |                          | ✓  |    | ✓  |                       |
|  | D-3   | ✓                        | ✓  | ✓  | ✓  |                       |
| Koch 9030<br>Low-Modulus<br>Rubberized Asphalt   | B-3   | ✓                        |    | ✓  | ✓  |                       |
|  | C-3   |                          | ✓  |    | ✓  |                       |
|  | D-3   | ✓                        | ✓  | ✓  | ✓  |                       |
| Meadows XLM<br>Low-Modulus<br>Rubberized Asphalt | B-3   | ✓                        |    | ✓  | ✓  |                       |
|  | C-3   |                          | ✓  |    | ✓  |                       |
|  | D-3   | ✓                        | ✓  | ✓  | ✓  |                       |
| Kapejo BoniFiber + AC<br>Fiberized Asphalt       | D-3   | ✓                        | ✓  | ✓  | ✓  |                       |
| Dow 890-SL<br>Self-Leveling Silicone             | E-5   | ✓                        | ✓  | ✓  | ✓  |                       |
|  | E-6   |                          | ✓  |    |    |                       |
|  | F-7   |                          | ✓  |    |    |                       |
| Crafco AR+<br>Rubberized Asphalt                 | B-3   |                          | ✓  |    |    |                       |
| Koch 9000-S<br>Asphalt Rubber                    | B-3   |                          | ✓  |    |    |                       |
| Elf CRS-2P<br>Modified Emulsion                  | G-4   |                          |    |    | ✓  |                       |
| Crafco RS 211<br>Rubberized Asphalt              | B-3   |                          |    | ✓  |    |                       |
|  | D-4   |                          |    |    |    | ✓                     |
| AC   | G-1   |                          |    |    |    | ✓                     |
|  | G-4   |                          |    |    |    | ✓                     |
| Crafco AR2<br>Asphalt Rubber                     | D-4   |                          |    |    |    | ✓                     |
|  | G-4   |                          |    |    |    | ✓                     |
| Hercules FiberPave + AC<br>Fiberized Asphalt     | D-4   |                          |    |    |    | ✓                     |
| Witco CRF<br>Modified Emulsion                   | G-4   |                          |    |    |    | ✓                     |
| Hy-Grade Kold Flo<br>Rubberized Emulsion         | G-4   |                          |    |    |    | ✓                     |

Configuration

- A. Standard Reservoir-and-Flush
- B. Standard Recessed Band-Aid
- C. Shallow Recessed Band-Aid
- D. Simple Band-Aid
- E. Deep Reservoir-and-Recess
- F. Standard Reservoir-and-Recess
- G. Simple Flush-Fill
- H. Capped

Crack Preparation Procedure

- 1. None
- 2. Wire Brush and Compressed Air
- 3. Hot Compressed-Air Lance
- 4. Compressed Air
- 5. Light Sandblast, Compressed Air, and Backer Rod
- 6. Compressed Air and Backer Rod
- 7. Light Sandblast, Compressed Air, and Backer Tape

Notes

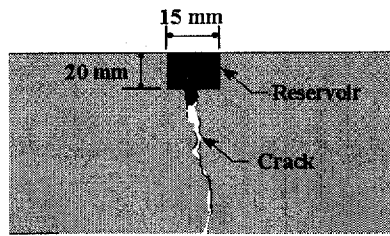

**Configuration A**  
*Standard Reservoir-and-Flush*

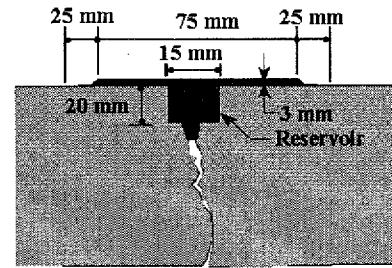

**Configuration B**  
*Standard Recessed Band-Aid*

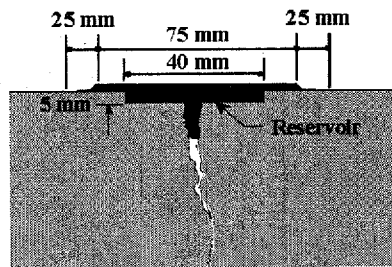

**Configuration C**  
*Shallow Recessed Band-Aid*

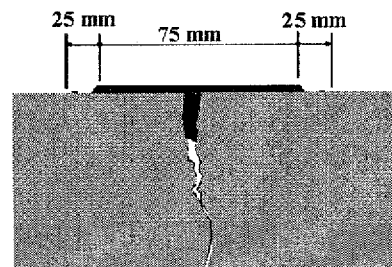

**Configuration D**  
*Simple Band-Aid*

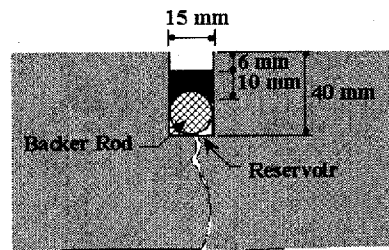

**Configuration E**  
*Deep Reservoir-and-Recess*

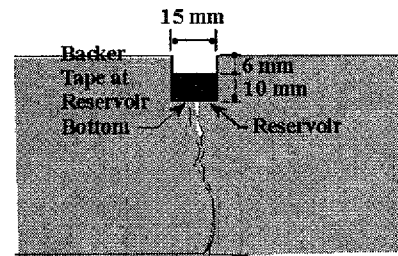

**Configuration F**  
*Standard Reservoir-and-Recess*

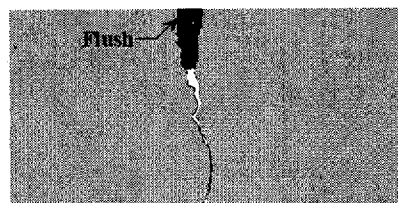

**Configuration G**  
*Simple Flush-Fill*

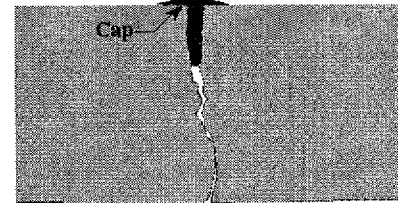

**Configuration H**  
*Capped*

Figure 5-1. Material placement configurations for SHRP H-106 crack treatments.



Major observations and performance data analysis results from the most recent inspection—fall 1994—are summarized below.

- Most of the crack treatments are performing favorably after approximately 3.5 years of service. Of 74 distinct crack seal treatments, 44 show greater than 90 percent overall effectiveness, 12 show between 80 and 90 percent effectiveness, 10 show between 66 and 80 percent effectiveness, 3 show between 51 and 65 percent effectiveness, and 5 have dropped below 50 percent effectiveness. Of 8 distinct crack fill treatments, 5 show greater than 90 percent effectiveness, 2 show between 80 and 90 percent effectiveness, and 1 shows 68 percent effectiveness.
- Good mid-term performance is being achieved by both standard and low-modulus rubberized asphalt sealants (Hi-Spec, RS 515, 9030, and XLM) placed in the reservoir-and-flush and recessed band-aid configurations. Slightly lower mid-term performance is being achieved with self-leveling silicone (890-SL) placed in the reservoir-and-recess configuration, partly because of spalling and secondary cracking created during crack-cutting operations. Boni-fiberized asphalt placed in a simple band-aid configuration has failed at the Texas, Iowa, and Kansas sites, but showed good mid-term performance at the Washington site, where recorded annual crack movements were quite low in comparison with other sites. Other rubber-modified asphalt products (9000-S, AR+, RS 211, and AR2) have shown good mid-term performance as both crack sealants and crack fillers. Emulsified asphalts can perform satisfactorily as fillers for cracks that undergo little movement, but are generally inadequate as sealants for working cracks.
- The standard reservoir-and-flush configuration and the two recessed band-aid configurations are providing better mid-term performance than the simple band-aid configuration. The three former configurations are showing more than 94 percent effectiveness, whereas the latter configuration is showing 87 percent effectiveness.
- Based on actual and estimated service lives corresponding to 90 percent effectiveness, emulsion and fiberized asphalt sealants were found to be much less cost-effective than rubberized asphalt sealants. In addition, some of the self-leveling seals were less cost-effective than rubberized asphalt sealants.

## TREATMENT OBJECTIVES

Crack treatment is a general term that refers to the application of sealant or filler materials to pavement cracks to significantly slow crack deterioration. Although once considered to be a routine maintenance operation, today it is

Notes

largely a preventive maintenance strategy, performed early in a pavement's life so as to more effectively extend its life.

Table 5-2. Guidelines for determining the type of crack maintenance to perform.

| Crack Density | Average Level of Edge Deterioration<br>(percent of crack length) |                               |                     |
|---------------|--|-------------------------------|---------------------|
|               | Low<br>(0 to 25)   | Medium<br>(26 to 50)          | High<br>(51 to 100) |
| Low           | Nothing  | Crack Treatment<br>(possibly) | Crack Repair        |
| Moderate      | Crack Treatment  | Crack Treatment               | Crack Repair        |
| High          | Surface Treatment  | Surface Treatment             | Rehabilitation      |

Crack treatment differs from similar maintenance activities, such as surface treatments (fog seals, slurry seals, etc.) and crack repair (patching, milling, etc.), primarily in objective and application criteria. Although preventive in nature, surface treatments generally serve to seal the entire pavement surface and are most appropriate on pavements with minor or hairline cracks having little or no associated edge deterioration (i.e, cupping, lipping, spalling). Crack repair, on the other hand, is a corrective maintenance action and is most suitable for pavements having a moderate or small amount of highly deteriorated cracks. And, as seen in table 5-2, crack treatment is generally preferred where cracks are moderate in density and show moderate to no deterioration.

Sealing and filling are the two types of crack treatment. Although little distinction has been made in the past between these activities, the purposes and functions of each must be clearly understood so that the most cost-effective and long-lasting treatment is applied.

- **Crack sealing** is the placement of specialized materials either above or into working cracks using unique configurations to prevent the intrusion of water and incompressibles into the crack.
- **Crack filling** is the placement of materials into nonworking cracks to substantially reduce infiltration of water and to reinforce the adjacent pavement.

Table 5-3. Recommended criteria for determining whether to seal or fill.

| Crack Characteristics                                  | Crack Treatment Activity   |   |
|--|--|---|
|  | Crack Sealing  | Crack Filling   |
| Width, mm  | 5 to 20  | 5 to 25   |
| Edge Deterioration<br>(i.e., spalls, secondary cracks) | Minimal to None<br>( $< 25\%$ of crack length)   | Moderate to None<br>( $\leq 50\%$ of crack length)  |
| Annual Horizontal<br>Movement, mm                      | $\geq 2$   | $< 2$   |
| Type of Crack  | Transverse thermal cracks<br>Transverse reflective cracks<br>Diagonal cracks<br>Longitudinal cracks? | Longitudinal reflective cracks<br>Longitudinal cold-joint cracks<br>Longitudinal edge cracks<br>Distantly spaced blocked cracks |

Working cracks are those cracks that move horizontally greater than or equal to 2 mm. Conversely, nonworking cracks are cracks that move less than 2 mm.

Whether a crack is working or nonworking can generally be judged by its orientation or type. For example, transverse or diagonal cracks are usually found to be working cracks, because of the sizeable spacing between adjacent cracks (often greater than 8 m). Longitudinal and block cracks, on the other hand, are normally found to be nonworking cracks, due to the short crack spacing or close proximity to a free edge of the pavement.

Crack sealing is a preventive maintenance activity. Ideally, it is conducted shortly after working cracks have developed to an adequate extent and at a time of year when temperatures are moderately cool ( $7^{\circ}$  to  $18^{\circ}\text{C}$ ), such as in the spring and fall. Cracks are partly opened during such times, which, in the case of uncut cracks, allows the treatment material to better penetrate the crack channel. Also, partly opened crack channels—whether cut or uncut—are nearly at the middle of the working range, which means that the treatment material placed in them will not have to undergo excessive extension or contraction during its performance period.

Crack filling has historically been a routine maintenance activity. However, in recent years, it has been given more regard as a preventive maintenance activity. This is largely because agencies have recognized that repeat applications, on an annual or bi-annual basis, are not cost effective and that they significantly increase the risk of safety problems. Although moderately cool temperatures are also preferred when performing filling operations, temperature is not nearly as critical to filler performance as it is to sealant performance, since the cracks are nonworking. Hence, filling operations can be effectively conducted year-round.

Table 5-3 provides recommended criteria for determining which cracks to seal and which to fill, given various crack characteristics. In comparison with crack filling, crack sealing involves much more planning and uses specially formulated materials and more sophisticated equipment. As a direct result, the overall costs associated with this operation are considerably higher than crack-filling operations.

## PROJECT PLANNING AND DESIGN

### Selecting a Material

There are many different crack-treatment material products on the market today, each with distinct characteristics. The products essentially comprise three material families and are often grouped by material type, according to their composition and manufactured process. The principal material families and types are as follows:

- Cold-applied thermoplastic materials.
  - Liquid asphalt (emulsion, cutback).
  - Polymer-modified liquid asphalt.
- Hot-applied thermoplastic materials.
  - Asphalt cement.
  - Mineral-filled asphalt cement.
  - Fiberized asphalt.
  - Asphalt rubber.
  - Rubberized asphalt.
  - Low-modulus rubberized asphalt.
- Chemically cured thermosetting materials.
  - Self-leveling silicone.

Asphalt cement and liquid asphalt possess little if any flexibility and are very temperature susceptible. Thus, they are limited to use as fillers for nonworking cracks. Similarly, since additives such as mineral fillers and fibers provide minimal elasticity to asphalt and do not significantly affect temperature susceptibility, mineral-filled and fiberized asphalts are most appropriate in crack-filling operations.

The addition of rubber polymer to liquid or heated asphalt generally improves field performance because it gives flexibility to the asphalt. The degree of flexibility basically depends on the type and nature of the asphalt, the percentage of vulcanized rubber used, and how the rubber is incorporated into the asphalt (i.e., mixed or melted in). Other polymers are often incorporated into asphalt

either exclusively or along with rubber to increase resilience. The following is the general increasing trend in performance characteristics of polymer-modified asphalts:

Polymer-Modified Liquid Asphalt  $\Rightarrow$  Asphalt Rubber  $\Rightarrow$   
Rubberized Asphalt  $\Rightarrow$  Low-Modulus Rubberized Asphalt

Chemically cured thermosetting materials are one- or two-component materials that cure by chemical reaction from a liquid state to a solid state. This type of material has been used in asphalt concrete pavement only in recent years. Self-leveling silicone is a one-component, cold-applied sealant that requires no tooling since it is self-leveling.

Table 5-4 provides general information about each material type, including examples of products, applicable specifications, and cost ranges. It should be noted that asphalt cutback is not listed in this table. This material is rarely used today because it presents environmental hazards; therefore, it is not discussed in this workshop.

The first step in selecting a material is to identify the key properties that a material must possess for it to be placed efficiently and to perform successfully in the conditions provided and for the desired time. Several of the more desirable properties include:

- Short preparation time.
- Quick and easy to place (good workability).
- Short cure time.
- Adhesiveness.
- Cohesiveness.
- Resistance to softening and flow.
- Flexibility.
- Elasticity.
- Resistance to aging and weathering.
- Abrasion resistance.

Table 5-5 illustrates the material types that possess most of the above properties. As can be seen, the rubberlike properties associated with the materials on the right make them good choices for sealing working cracks, whereas the preparation and installation attributes of emulsion and asphalt cement make them desirable for crack filling.

## Laboratory Testing

Laboratory testing of the selected treatment material is highly recommended, especially for elastomeric material products (e.g., rubber-modified asphalt, silicone). Testing ensures that the material acquired for a project exhibits the properties for which it was selected.

Table 5-4. Summary of AC crack treatment materials.

| Material Type                  | Example Product(s)   | Applicable Specification(s)   | Recommended Application    | Cost Range, \$/kg <sup>a</sup> |
|--------------------------------|--|---|----------------------------|--------------------------------|
| Asphalt Emulsion               | CRS-2, CMS-2, HFMS-1   | ASTM <sup>b</sup> D977 & AASHTO <sup>c</sup> M140, ASTM D2397 & AASHTO M208 | Filling                    | 0.20 to 0.35                   |
| Polymer-Modified Emulsion      | Elf CRS-2P, Hy-Grade Kold Flo  | ASTM D977 & AASHTO M140, ASTM D2397 & AASHTO M208                           | Filling (possibly sealing) | 0.90 to 1.30                   |
| Asphalt Cement                 | AC-10, AC-20   | ASTM D3381, AASHTO M20, AASHTO M226   | Filling                    | 0.20 to 0.35                   |
| Mineral-Filled Asphalt Cement  |  | Various state specs   | Filling                    | 0.35 to 0.60                   |
| Fiberized Asphalt              | Hercules Fiber Pave <sup>®</sup> + AC, Kapejo BoniFibers <sup>®</sup> + AC | Manufacturer's recommended specs  | Filling                    | 0.35 to 0.60                   |
| Asphalt Rubber                 | Koch 9000, Crafcro AR2   | Various state specs, ASTM D 5078  | Sealing (possibly filling) | 0.50 to 0.70                   |
| Rubberized Asphalt             | Meadows #164, Koch 9001, Crafcro RoadSaver <sup>®</sup> (RS) 211           | ASTM D1190 & AASHTO M173 & Fed SS-S-164                                     | Sealing                    | 0.60 to 0.95                   |
|                                | Meadows Hi-Spec, <sup>®</sup> Koch 9005, Crafcro RS 221                    | ASTM D3405 & AASHTO M301 & Fed SS-S-1401                                    | Sealing                    | 0.95 to 1.25                   |
| Low-Modulus Rubberized Asphalt | Meadows XLM, Koch 9030, Crafcro RS 231                                     | Various state-modified ASTM D 3405 specs                                    | Sealing                    | 1.30 to 1.60                   |
| Silicone                       | Dow Corning <sup>®</sup> 890-SL, Crafcro 903-SL                            | Manufacturer's recommended specs  | Sealing                    | 8.50 to 11.80                  |

<sup>a</sup> Based on 1995 costs

<sup>b</sup> ASTM - American Society for Testing and Materials

<sup>c</sup> AASHTO - The American Association of State Highway and Transportation Officials

Table 5-5. Properties associated with various material types.

| Property                                       | Material Type <sup>a</sup> |                           |                |                   |                |                    |                                |                        |  |  |
|--|----------------------------|---------------------------|----------------|-------------------|----------------|--------------------|--------------------------------|------------------------|--|--|
|  | Asphalt Emulsion           | Polymer-Modified Emulsion | Asphalt Cement | Fiberized Asphalt | Asphalt Rubber | Rubberized Asphalt | Low-Modulus Rubberized Asphalt | Self-Leveling Silicone |  |  |
| Short Preparation                              | ✓                          | ✓                         |                |                   |                |                    |                                | ✓✓                     |  |  |
| Quick & Easy to Place                          | ✓                          | ✓                         | ✓✓             | ✓✓                | ✓✓             | ✓✓                 | ✓✓                             |                        |  |  |
| Short Cure Time                                |                            |                           | ✓✓             | ✓✓                | ✓✓             | ✓✓                 | ✓✓                             | ✓                      |  |  |
| Adhesiveness                                   | ✓✓                         | ✓                         | ✓✓             | ✓                 | ✓              | ✓                  | ✓                              | ✓                      |  |  |
| Cohesiveness                                   |                            |                           |                |                   | ✓              | ✓                  | ✓✓                             | ✓                      |  |  |
| Resistance to Softening and Flow (cured state) |                            | ✓                         |                |                   | ✓              | ✓                  | ✓✓                             | ✓✓                     |  |  |
| Flexibility                                    |                            | ✓                         |                |                   | ✓              | ✓                  | ✓✓                             | ✓✓                     |  |  |
| Elasticity                                     |                            | ✓                         |                |                   | ✓              | ✓                  | ✓                              | ✓✓                     |  |  |
| Resistance to Aging and Weathering             |                            |                           |                |                   |                | ✓                  | ✓                              | ✓✓                     |  |  |
| Resistance to Tracking and Abrasion            |                            |                           |                |                   | ✓              | ✓✓                 | ✓                              |                        |  |  |

<sup>a</sup> ✓ Applicable; ✓✓ Very Applicable

## Notes

Like joint resealing, various material testing specifications have been developed at both the national and local levels. ASTM, AASHTO, and Federal specifications are available for asphalt rubber and rubberized asphalt materials, a few States have developed low-modulus rubberized asphalt sealant specifications, and material manufacturers generally have recommended specifications for their products. Summaries of test criteria for these types of materials are available in appendix A of the SHRP *Manual of Practice on Sealing and Filling Cracks in Asphalt-Surfaced Pavements*.<sup>36</sup>

Laboratory testing should be done in full accordance with the test methods specified for the material. A material should be rejected if it does not meet all applicable specifications, but the user must recognize that full compliance does not guarantee good performance in the field.

### Selecting a Material Design Configuration

As demonstrated by the H-106 crack treatment project, sealant and filler materials can be placed in numerous configurations in crack channels. These configurations can be grouped into four basic categories,<sup>37</sup> as listed below and shown in figure 5-2:

- Flush-fill.
- Reservoir.
- Overband.
- Combination (reservoir and overband).

In the flush-fill configuration, material is simply dispensed into the existing crack and excess material is struck off. An example of this configuration is configuration G (figure 5-1) used in the H-106 study.

In a reservoir configuration, material is placed in the confines of the crack reservoir (i.e., the channel made by cutting operations), such that it is either flush with or recessed slightly below the pavement surface. Examples of this configuration are configurations A and E (figure 5-1) used in the H-106 study.

In an overband configuration, the material is placed into and over the existing crack channel. If the material over the crack is shaped into a band using a squeegee or similar strike-off tool, the configuration is referred to as a simple band-aid configuration (configuration D in figure 5-1). If the material over the crack is left unshaped, the configuration is referred to as a capped configuration (configuration H in figure 5-1).

A combination configuration (configurations B and C in figure 5-1) consists of a material placed into and over a crack reservoir. A squeegee is then used to shape the material into a band that is centered over the crack reservoir.



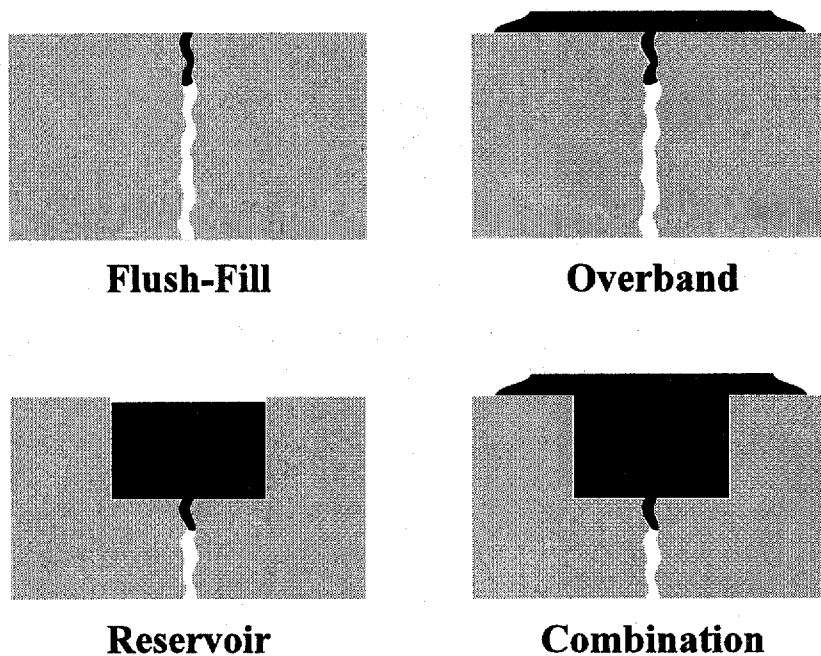

Figure 5-2. Basic material placement configurations.

Individual material design configurations are based on four controlling variables.

1. Type of application.
  - a. Direct—material applied directly to crack channel.
  - b. Bond-breaker—backer material placed at bottom of crack reservoir before installing material to prevent three-sided adhesion.
2. Type of crack channel.
  - a. Uncut.
  - b. Cut—router or saw used to create uniform crack reservoir.
3. Strike-off or finishing characteristics.
  - a. Recessed.
  - b. Flush.
  - c. Capped.
  - d. Band-aid.
4. Dimensions of crack reservoir and/or overband.

Nearly all sealing and filling operations have the material applied directly to the crack channel. Occasionally, however, a bond-breaker material such as a

## Notes

polyethylene foam backer rod is placed at the reservoir bottom of a working crack before applying sealant. The backer rod prevents sealant material from running down into the crack during application and also from forming a three-sided bond with the reservoir walls and bottom. As a result, the sealant's potential performance is enhanced.

Sealant shape, particularly for reservoir configurations, also influences performance. It is the primary design consideration and is often dealt with in terms of shape factor. The shape factor is defined as the ratio between the width and depth of the sealant.<sup>38</sup> In direct applications, shape factor is controlled solely by the crack-cutting operation (i.e., cutting width and depth). In backer rod applications, shape factor is controlled by the cutting operation and the depth to which the backer rod is placed.

Current recommendations for both direct and bond-breaker applications are that rubber-modified asphalt sealants be given a shape factor of 1 and silicone sealants a shape factor of 2. Generally, seals with smaller shape factors risk adhesion loss, while those with larger shape factors have increased resistance to adhesion loss.

Bond-breaker application should be considered only when the following two factors apply.

1. The costs of installing backer rod are anticipated to be lower than the cost-benefits of improved performance.
2. Working cracks are relatively straight (as with joint reflection cracks) and are accompanied by very little edge deterioration.

Most hot-applied, rubber-modified sealants are recommended for direct application; the increased cost of using backer rod with these materials is not justified. Silicone is perhaps the only material recommended for placement with backer rod.

A jagged or meandering crack is often difficult to follow accurately with cutting equipment. Portions of the crack may occasionally be missed, resulting in two adjacent channels. This presents the dilemma of whether to seal both the cut and uncut crack segments, or to cut the missed segment too and seal both reservoirs. Secondary cracks along a primary crack present a similar dilemma.

Routers and saws are usually equipped with controls for varying the depth of cut and the width setting can normally be adjusted manually. Backer rod can be placed in deep reservoirs (25 to 40 mm) to a depth that allows for the desired shape factor. This depth normally varies between 10 and 20 mm. The backer rod

should be about 25 percent wider than the width of the crack reservoir for it to maintain its vertical position and provide proper shape for the material.

The decision of whether or not to overband a sealant or filler material depends primarily on the material used. Some materials such as silicone and emulsion simply must not come in contact with traffic. Also, some materials wear away more easily under traffic than others.

If overbanding of hot-applied, rubber-modified asphalt is desired, it also must be decided if the material will be shaped into a band-aid or left as a capped configuration. The latter process generally requires one less laborer but possibly at the sacrifice of treatment effectiveness. This is because shaping with a squeegee or dish attachment helps in establishing a "hot bond" for the entire band. In capped configurations, the material may continue to flow and level out after application. Bonds occurring as a result of this self-leveling are likely to be weaker because the material will have decreased in temperature.

The dimensions of the band-aid are typically 75 to 125 mm wide and 3 to 5 mm thick. The simple band-aid configuration evolved out of a desire to make application quick and easy by eliminating crack-cutting operations. The recessed band-aid configuration was devised to improve the performance of reservoir-type configurations through the addition of the band as a wearing surface.

Because available resources and project circumstances tend to vary, selecting a material design configuration can be an involved process. Table 5-6 offers a few basic considerations when planning a crack treatment project.

Table 5-6. Placement configuration considerations.

| Consideration                | Applicability  |
|------------------------------|--|
| Type and Extent of Operation | Most filling operations and some sealing operations omit crack-cutting operation.<br>Many northern States find crack cutting necessary and/or desirable.   |
| Traffic                      | Overband configurations experience wear and subsequent high tensile stresses directly above the crack edges, leading to internal rupture.  |
| Crack Characteristics        | Overband configurations may be more appropriate for cracks with a considerable, but not excessive, amount of edge deterioration (10 to 50% of crack length) because the overband simultaneously fills and covers the deteriorated segments in the same pass. |
| Material Type                | Materials such as emulsion, asphalt cement, and silicone must not be exposed to traffic because of serious tracking or abrasion problems.  |
| Desired Performance          | For long-term sealant performance, flush or reservoir configurations and recessed band-aid configurations should be considered.  |
| Aesthetics                   | Overband and combination configurations detract from the appearance of the pavement.   |
| Cost                         | Omission of crack-cutting operation reduces equipment and labor costs. Combination configurations cost more than reservoir configurations because they use significantly more material.  |

## **Determining Resource Requirements**

### Material

Whether treatment materials are purchased on a project-by-project basis or on a time-supply basis, an estimate of the quantity of material required for a project or set of projects is usually necessary. Such a task is not overly difficult, but it does require a quick inspection of the project(s) at-hand as well as knowledge of the type of material configuration(s) to be used.

The field inspection provides an estimate of the total length of cracks to be treated in a given project. Only a small portion (3 to 5 percent) of the project needs to be inspected as long as it is fairly representative of the entire project with respect to the type and density of cracks targeted for treatment.

The worksheet in figure 5-3 is an example of how to calculate the amount of sealant or filler material needed for a project. In this example, a 6.5-km long project is to be treated for transverse cracking. A 150-m segment was inspected and approximately 92 m of transverse cracks observed. A rubberized asphalt product with a unit weight of 1.18 kg/L will be placed in the shallow reservoir-and-flush configuration (configuration h). Using a 20 percent waste factor, the estimated quantity of sealant material for the project is about 1,300 kg.

### Equipment

The plans for a crack treatment project are occasionally influenced by the availability of suitable equipment. Maintenance units that are poorly equipped usually must either do without the desired equipment or make arrangements to borrow or rent it.

If the desired equipment can be accessed, it is almost as important to ensure that the equipment is suitable for use. A deficient piece of equipment can easily offset an otherwise effective crack treatment operation.

Many types and brands of equipment are available for crack treatment operations. These equipment are best categorized according to the specific task for which they're used (e.g., crack cleaning, material application). A comprehensive list of characteristics and recommendations pertaining to crack treatment equipment can be found in table 7 of reference 36.

### Labor

Another major planning consideration is the amount of labor required to perform the treatment operation. Each task in the treatment process requires a certain number of workers in order to complete the task efficiently. Because

| <b>Determining Material Quantity Requirements</b>   |                                       |   |
|---|---------------------------------------|---|
| a. Length of section to be treated  |                                       | <u>6,500 m</u>                            |
| b. Length of sample segment inspected   |                                       | <u>150 m</u>                              |
| c. Amount (length) of targeted crack in sample segment inspected  |                                       | <u>92 lin m</u>                           |
| d. Amount (length) of targeted crack in section ( $D = C \times [A/B]$ )  | $92 \times (6500/150) =$              | <u>3,990 lin m</u>                        |
| e. Average estimated width of targeted crack  |                                       | <u>6 mm</u>                               |
| f. Type of material configuration planned   |                                       | <u>Shallow Reservoir-and-Flush</u>        |
| g. Cross-sectional area of planned configuration  |                                       | $6 \times 38 =$ <u>228 mm<sup>2</sup></u> |
| h. Total volume in m <sup>3</sup> of design crack to be treated ( $H = [G \times 10^{-6} \text{ m}^2/\text{mm}^2] \times D$ ) | $(228 \times 10^{-6}) \times 3,990 =$ | <u>0.91 m<sup>3</sup></u>                 |
| i. Total volume in liters of design crack to be treated ( $I = H \times 1000 \text{ L/m}^3$ )                                 |                                       | $0.91 \times 1000 =$ <u>910 L</u>         |
| j. Unit weight of planned treatment material in kg/L  |                                       | <u>1.18 kg/L</u>                          |
| k. Theoretical amount of material needed in kg [ $K = I \times J$ ]   | $910 \times 1.18 =$                   | <u>1,074 kg</u>                           |
| l. Total amount of material recommended with 20 percent overage [ $L = 1.20 \times K$ ]                                       | $1.20 \times 1,074 =$                 | <u>1,289 kg</u>                           |

Figure 5-3. Example problem for determining material requirements.

production rates among the individual activities can vary considerably, further consideration of the labor afforded each activity may be necessary so that the overall operation is well-synchronized and worker productivity is maximized.

Table 5-7 provides additional information about the labor requirements and typical production rates associated with each task.

### Cost-Effectiveness

Although treatment performance is important, cost-effectiveness is the preferred basis for determining which materials and procedures to use. Obviously, a treatment that costs \$16.40/m in-place and performs adequately for 5 years is more desirable than a treatment that costs \$32.80/m in-place and performs for the same amount of time.

The steps in determining cost-effectiveness of various treatment options are:

1. Determine the cost of purchasing and shipping material.
2. Determine the material application rate.

Table 5-7. Typical labor requirements and production rates for crack treatment operations.

| Operation                 | Equipment                                  | Manpower  |        | Approximate Productivity, m/min |
|---------------------------|--|-----------|--------|---------------------------------|
|                           |  | Equipment | Driver |                                 |
| Crack Cutting             | Routing (vertical-spindle router)          | 1         | —      | 0.5 to 0.8                      |
|                           | Routing (rotary-impact router)             | 1         | —      | 3.6 to 4.5                      |
|                           | Sawing (diamond-blade crack saw)           | 1 to 2    | —      | 1.2 to 2.1                      |
| Crack Cleaning and Drying | Airblasting (blowers)                      | 1         | —      | 3.6 to 5.5                      |
|                           | Airblasting (compressed air)               | 1         | 1      | 3.0 to 4.6                      |
|                           | Hot airblasting (hot compressed-air lance) | 1         | 1      | 1.5 to 3.0                      |
|                           | Sandblasting (sandblaster)                 | 2 to 3    | 1      | 0.9 to 1.2<br>(2 passes)        |
|                           | Wirebrushing (wirebrush)                   | 1         | —      | 2.7 to 3.6                      |
| Material Installation     | Drums and pour-pots                        | 2 to 3    | 1      | 1.5 to 3.0                      |
|                           | Asphalt distributor with wand and hose     | 2         | 1      | 4.6 to 7.6                      |
|                           | Melter-applicator                          | 2         | 1      | 4.6 to 7.6                      |
|                           | Backer rod                                 | 2         | —      | 2.7 to 4.6                      |
|                           | Silicone pump and applicator               | 2         | 1      | 1.8 to 3.6                      |
| Material Finishing        | U- or V-shaped squeegee                    | 1         | —      | 7.6 to 10.7                     |
| Material Blotting         | Sand                                       | 1 to 2    | 0 to 1 | 3.7 to 5.5                      |
|                           | Toilet paper                               | 1         | —      | 9.2 to 13.7                     |

3. Estimate the daily cost of equipment and labor required to apply the treatment.
4. Estimate the daily production rate.
5. Estimate the daily user-delay cost.

6. Calculate the total installation cost.
7. Estimate the expected service life of the treatment.
8. Calculate the average annual cost using an assumed interest rate.

Figure 5-4 provides an example illustration of how to compute material cost-effectiveness. In the exercise, two different treatment options considered by a maintenance agency for an AC transverse crack-sealing project.

| <b>Treatment Cost-Effectiveness</b>   |  |  |
|---|--|--|
|   | <b>Option #1</b>   | <b>Option #2</b>   |
| A. Cost of purchasing and shipping material   | \$ 1.40/kg   | \$ 1.90/kg   |
| B. Net application rate   | 1.06 kg/lin m  | 0.79 kg/lin m  |
| C. Placement cost (labor and equipment)   | \$ 1900/day  | \$ 1900/day  |
| D. Production rate  | 750 lin m/day  | 1000 lin m/day   |
| E. User delay cost  | \$ 2000/day  | \$ 2000/day  |
| F. Total installation cost<br>$F = (A \times B) + (C/D) + (E/D)$                    | $(1.40 \times 1.06) +$<br>$(1900/750) +$<br>$(2000/750) =$ \$ 6.68/lin m               | $(1.90 \times 0.79) +$<br>$(1900/1000) +$<br>$(2000/1000) =$ \$ 5.40/lin m             |
| G. Interest rate  | 5.0 percent  | 5.0 percent  |
| H. Estimated service life   | 3 years  | 5 years  |
| I. Average annual cost<br>$I = \frac{F \times [G \times (1 + G)^H]}{(1 + G)^H - 1}$ | $\frac{6.68 \times [0.05 \times (1 + 0.05)^3]}{[(1 + 0.05)^3 - 1]}$<br>= \$ 2.45/lin m | $\frac{5.40 \times [0.05 \times (1 + 0.05)^5]}{[(1 + 0.05)^5 - 1]}$<br>= \$ 1.25/lin m |

Figure 5-4. Example of treatment cost-effectiveness analysis.

## Notes

### Option 1

Rubberized asphalt, unit weight: 1.15 kg/L

Standard recessed band-aid configuration,

cross-sectional area: 761 mm<sup>2</sup>

volume per 1 m of crack:  $(761 \text{ mm}^2 \times 1000 \text{ mm}) / (10^6 \text{ mm}^3/\text{L}) = 0.761 \text{ L}$

gross application rate:  $(1.15 \text{ kg/L}) \times (0.761 \text{ L/m}) = 0.88 \text{ kg/m}$

Material and shipping cost: \$ 1.40/kg

Estimated production rate: 1,000 lin m of crack per day

Net application rate (20% waste):  $(1.20 \times 0.88 \text{ kg/m}) = 1.06 \text{ kg/m}$

Estimated service life: 3 years

### Option 2

Low-modulus rubberized asphalt, unit weight: 1.10 kg/L

Shallow recessed band-aid configuration,

cross-sectional area: 600 mm<sup>2</sup>

volume per 1 m of crack:  $(600 \text{ mm}^2 \times 1000 \text{ mm}) / (10^6 \text{ mm}^3/\text{L})$   
 $= 0.600 \text{ L}$

gross application rate:  $(1.10 \text{ kg/L}) \times (0.600 \text{ L/m}) = 0.66 \text{ kg/m}$

Material and shipping cost: \$ 1.90/kg

Estimated production rate: 750 lin m of crack per day

Net application rate (20% waste):  $(1.20 \times 0.66 \text{ kg/m}) = 0.79 \text{ kg/m}$

Estimated service life: 5 years

Both options contain the following assumptions:

- Labor cost (10 laborers, each @ \$120/day and 1 supervisor @ \$200/day): \$1400/day
- Equipment cost: \$500/day
- User delay cost: \$2000/day

As can be seen, option 2, with an average annual cost of \$1.25/m, is more cost-effective than option 1, with an average annual cost of \$2.45/m.

## INSTALLATION

Crack treatment consists of at least two and as many as five individual tasks, depending on the type of treatment (sealing or filling) planned, the agency's current treatment policy, and available equipment. These tasks are:



1. Crack cutting (i.e., routing or sawing).
2. Crack cleaning and drying.
3. Material preparation and application.
4. Material finishing/shaping.
5. Blotting.

Tasks 2 and 3 are essential, whereas tasks 1, 4, and 5 are considered optional but are generally desirable.

The first task, crack cutting, is much more common in sealing operations than in filling operations. In regions with significant annual temperature variations, crack cutting is often used to achieve material shape factors that can provide added flexibility for withstanding high crack movements.

Material finishing/shaping is commonly performed in crack treatment operations. Typically, squeegees of different sizes and shapes are used to help form the material into the desired configuration. Configurations that require no finishing include the capped and recess configurations.

The fifth task, blotting, consists of placing a temporary covering such as sand or toilet paper on top of the treatment material to prevent tracking. Prime candidates for blotting are asphalt emulsions and hot-applied materials placed in overband configurations and prematurely subjected to traffic.

### **Traffic Control**

Traffic control is a vital part of crack treatment operations. Whether it's provided as a moving operation or a stationary work zone, good traffic control is necessary to provide a safe working environment for the installation crew and a safe, minimally disruptive path for traffic.

Department policies usually stipulate the appropriate traffic control setups. However, a quick survey of the roadway to be treated can help identify special precautions and the need for additional safety equipment during the installation. Flaggers are often needed on operations that encroach into adjacent lanes, particularly on moderately and highly trafficked highways. Such operations often include crack cutting, crack cleaning, and squeegeeing.

### **Safety**

Another aspect of safety is worker protection from material and equipment hazards. Mandated highway safety attire (e.g., vests and hard hats) and other accessories, such as masks and gloves, should always be worn by crews and foremen while equipment are in operation. In addition, crews should be made

## Notes

aware of all safety precautions associated with the particular materials with which they are working. MSDSs should be available to workers when possible.

A more detailed explanation of material and equipment safety is provided in appendix E of reference 36.

### Crack Cutting

The objective of crack cutting is to create a uniform, rectangular reservoir, centered as closely as possible over a particular crack, while inflicting as little damage as possible to the surrounding pavement. This activity is accomplished using either a pavement router or crack saw. Because the operation can inflict additional damage on the pavement and is often the slowest activity in sealing operations, it is desirable to use a high-production machine that follows cracks well and produces minimal spalls or fractures.

The vertical-spindle router is perhaps the least damaging and most maneuverable cutting machine; however, its production rate is quite low. Rotary-impact routers, like the one shown in figure 5-5, are much more productive than vertical-spindle routers but, depending on the type of cutting bit used, can cause considerably more damage. For both types of routers, carbide router bits are recommended highly over steel router bits.



Figure 5-5. Routing with a rotary-impact router.

A random-crack saw with 150- to 200-mm diameter diamond blades can follow meandering cracks moderately well. While its cutting rate is not nearly as high as the rotary-impact router, it provides a more rectangular reservoir with smoother walls and a higher percentage of aggregate surface area.

If crack cutting is to be performed, check saw blades or router-bits for sharpness and size or space them to produce the desired cutting width. Most cutting equipment have mechanical or electric-actuator cutting-depth controls and depth gauges for quick depth resetting. Establish the desired cutting depth and corresponding gauge setting before formal cutting of cracks.

Regardless of the type of cutting equipment used, make every effort to follow the crack accurately while cutting. Even though production may be considerably compromised on jagged cracks, missed crack segments can be minimized, and high performance potential can be maintained. Centering the cut over the crack as much as possible provides added leeway when cutting.

If a secondary crack is encountered along a primary crack, such as that shown in figure 5-6, a decision must be made as to whether or not to cut it. Two closely spaced channel cuts can significantly weaken the integrity of the AC along that particular segment. A general rule is to cut only secondary cracks spaced farther than 300 mm from a primary crack. Secondary cracks closer than 300 mm should be cleaned and sealed only.



Figure 5-6. Crack segment missed by cutting equipment.

## Notes

Finally, the cutting operator should periodically inspect newly created reservoirs for shape and size. Cold temperatures, coarse AC mixes, or dull cutting elements can lead to spalled crack edges and/or highly distorted rectangular channels. These have an adverse effect on material performance.

### **Crack Cleaning and Drying**

The objective of this task is to provide a clean, dry crack channel, free of loosened AC fragments, in which the crack treatment material and any accessory materials can be placed. Currently, four general procedures are used to clean and dry crack channels. These procedures, which are individually discussed in the following sections, include:

1. Airblasting.
2. Hot airblasting.
3. Sandblasting (followed by airblasting).
4. Wirebrushing (followed by airblasting).

Crack cleaning and drying is perhaps the most important aspect of sealing and filling operations. This is because a significant percentage of treatment failures can be attributed to the presence of particle matter such as dirt, dust, grit and/or moisture in the crack channels. These materials can effectively reduce or prevent the bond between the treatment material and the crack channel walls.

Crack-cleaning operators are likely to encounter some loosened AC fragments while cleaning, particularly if cracks are cut. Operators should remove these fragments because they will be detrimental to sealant or filler performance. If the cleaning equipment is unable to remove these fragments, remove them manually with hand tools.

### Airblasting

Airblasting, perhaps the most common method of cleaning, airblasting, is accomplished using one of two types of equipment:

- Portable backpack or power-driven blowers.
- High-pressure air compressors with hoses and wands.

Backpack and power-driven blowers generally are used to clean pavement surfaces before sealcoating. However, they have also been used to clean cracks. These blowers deliver high volumes of air but at low pressures. As a result, blast velocity is generally limited to between 75 and 105 m/s. Although blowers require only one laborer and provide better mobility, the high-pressure (> 620 kPa) capabilities of compressed-air units make them more desirable than blowers for crack cleaning.

High-pressure airblasting is fairly effective in removing dust, debris, and some loosened AC fragments. However, it is not nearly as effective in removing laitance or in drying the crack channel.

Compressed-air units should have a minimum blast pressure of 620 kPa and a blast flow of 0.07 m<sup>3</sup>/s. In addition, compressed-air units equipped with oil- and moisture-filtering systems are highly recommended, as the introduction of oil or moisture to the crack channel can seriously inhibit the sealant bonding to the sidewall.

Because high-pressure airblasting provides no heat and very little drying, it should be performed only when the pavement and crack channels are completely dry and when ambient temperatures are above 4°C and rising. Furthermore, since many modern air compressors introduce water and oil into the air supply, compressors should be equipped with moisture and oil filters that effectively remove these contaminants.

Operators should make at least two passes of high-pressure airblasting along each crack or crack segment. The first pass dislodges loose and partially loose dirt and debris from the crack channel. Hold the wand no less than 50 mm away from the crack. The second pass completely removes all the dislodged crack particles from the roadway and shoulder. In this pass, the wand can be held further away from the pavement surface to make use of a larger blast area.

High-pressure airblasting should be conducted just ahead of the sealing or filling operation. The greater the time interval between these two operations, the more likely dust and debris will resettle in the crack channel.

### Hot Airblasting

Hot airblasting is performed with an HCA lance, or heat lance, connected to a compressed-air unit, as illustrated in figure 5-7. This form of crack preparation is quite effective at removing dirt, debris, and grit. Moreover, the extreme heat it delivers to a crack provides two unique benefits. First, crack moisture is quickly dissipated, thereby improving the potential for bonding of the sealant or filler material. Second, assuming the material installation operation follows closely behind the hot airblasting operation, the heated crack surface can enhance the bonding of hot-applied sealant or filler materials.

There are a number of HCA lance models on the market today, each with its own heat and blast capacities and operational control features, including push-button ignition, wheels, and balancing straps. Minimum requirements for these units are a 1370°C heat capacity and a 610 m/s blast velocity. Heat lances with high heat and blast velocity (1650°C and 915 m/s) are preferred for production

## Notes



Figure 5-7. Hot airblasting using HCA (heat) lance.

operations. However, exercise caution with these units to avoid burning the asphalt concrete. Finally, direct-flame torches should never be used, and air compressors used in hot airblasting operations should be equipped with oil- and moisture-filter systems.

Unlike high-pressure airblasting, hot airblasting can be used in both ideal and partly adverse conditions to clean, dry, and warm cracks. Its most practical applications are drying damp cracks resulting from overnight dew or a short sprinkle and warming pavement cracks below 10°C to promote bonding with hot-applied materials. However, a heat lance should not be used as part of a crack treatment operation conducted during rainshowers or in saturated pavement conditions.

Conduct hot airblasting in two steps. The first pass, made along the crack in a steady fashion, should clean and heat, but not burn, the crack sidewalls (and surrounding pavement if material is to be overbanded). The heat lance should be held approximately 50 mm above the crack channel. Proper heating is manifested by a slightly darkened color; burning is apparent by a black color and a very gritty texture. The second pass completely removes all the dislodged crack particles from the roadway and shoulder.

Conduct hot airblasting immediately ahead of the sealing or filling operation. This will not only limit the amount of dust and debris blown into the cleaned crack channel, but it will also increase crack warmth and lessen the potential for the formulation of moisture condensation in the crack channel. The less time

between the two operations, the greater the bonding potential of the sealant/filler material.

#### Sandblasting (Followed by Airblasting)

Sandblasting is a labor-intensive operation that is quite effective at removing debris, laitance, and loosened AC fragments from the sidewalls of sawn cracks. This cleaning procedure leaves a clean, textured surface that is ideal for bonding.

Sandblasting equipment consists of a compressed-air unit, a sandblast machine, hoses, and a wand with a venturi-type nozzle. A second air compressor is often necessary for follow-up cleaning after the sandblasting operation.

The compressed-air supply is the most critical part of a sandblasting operation. At least 620 kPa of pressure and 0.07 m<sup>3</sup>/s of oil- and moisture-free air volume should be provided. Use large air supply and sandblast hoses to reduce friction losses and resulting pressure drops. A minimum of 25-mm inside diameter lines and a 6-mm diameter nozzle orifice size are recommended.

Sandblasting operations should be conducted in dry weather and should be followed up by airblasting to remove abrasive sand from the crack reservoir and roadway. The sandblasting equipment must be capable of removing dirt, debris, and sawing residue with a correctly metered mixture of air and abrasive sand.

Make one pass of the sandblaster along each side of the crack reservoir. The flow of air and sand should be directed toward the surfaces (generally crack sidewalls) that will form bonds with the treatment material. In general, the wand should be kept 100 to 150 mm from the crack reservoir to provide optimal cleaning without damaging the integrity of the crack reservoir. An adjustable guide can be attached quickly to the nozzle to provide consistent, desired results and reduce operator fatigue.

#### Wirebrushing (and Airblasting)

Occasionally, sawed or routed cracks are cleaned using mechanical, power-driven wirebrushes in conjunction with some form of compressed air. Depending on the brush and bristle characteristics, this combination is effective at removing debris lodged in the crack reservoir, but it is not as effective at removing laitance and loosened AC fragments from the crack sidewalls.

Wirebrushes are available commercially, with and without built-in airblowers. Some agencies have had success modifying pavement saws by removing the sawblades and attaching wirebrush fittings to the rotor of the machine.

## Notes

Use power-driven, mechanical wirebrushes only for cleaning dry crack channels that have very little laitance. They must be able to follow the crack closely and should be supplemented with some form of airblasting. In addition, brush attachments should contain bristles flexible enough to allow penetration into the crack channel yet rigid enough to remove dirt and debris.

As with saws and routers, most mechanical wirebrushes have actuator-type depth-control switches. The absence of depth gauges, however, requires careful setting for each new crack to be cleaned.

### **Material Preparation and Application**

The objective of this activity is to install any accessory materials into the crack channel, prepare the crack treatment material for recommended application, and place the proper amount of material into and over the crack to be treated.

#### Bond-Breaker Installation

If a particular project calls for the use of backer rod with the treatment material, the backer material may be installed after the cleaning activity using one of a variety of insertion devices. The selected device should allow for quick and accurate placement of the rod into the reservoir without severely twisting, puncturing, or otherwise damaging it in the process. Furnish segments of crack reservoir that are wider than the backer rod with additional pieces of backer rod or larger-sized backer rod.

#### Material Preparation

Every crack treatment material requires some form of preparation, whether it's loading the material into the applicator, heating it to the appropriate temperature, or mixing it for proper consistency and uniform heating. Although this workbook presents some basic guidelines for the preparation and installation of materials, the specific recommendations provided by the manufacturer of the material to be placed should be followed closely. Such recommendations generally pertain to items such as minimum placement temperature, material heating temperatures, prolonged heating, and allowable pavement temperature and moisture conditions.

The best placement conditions for most materials are dry pavement and an air temperature that is at least 4°C and rising. However, the use of a heat lance will usually permit many hot-applied materials to be placed in cold or damp conditions, as discussed earlier. Some emulsion materials can be placed in temperatures below 4°C, but the threat of rain generally precludes their placement because they are susceptible to being washed away by water.



It is important to monitor two temperatures while preparing hot-applied materials:

- **Recommended application temperature** is the temperature of the material at the nozzle that is recommended for optimum performance.
- **Safe heating temperature** is the maximum temperature that a material can be heated to before experiencing a breakdown in its formulation.

Recommended application temperatures for hot-applied asphalt materials generally range from 190° to 200°C. Notable exceptions to this are some fiberized asphalt materials that must be applied at temperatures in the range of 140° to 160°C. Emulsions may be applied at ambient temperature or may be partially heated to between 50° to 65°C.

Before heating a material, kettle operators should know its safe heating temperature and the effects of overheating or extended heating. Safe heating temperatures for hot-applied materials are typically 11° to 17°C higher than recommended application temperatures. The effects of overheating or extended heating depend on the specific material. Some materials exhibit a thickened, gel-like consistency, while others thin out or soften considerably. In either case, discard the material and prepare new material.

Other preparation-related concerns for hot-applied materials include prolonged heating and reheating that result from work delays. Most hot-applied materials have prolonged heating periods between 6 and 12 hrs, and they may be reheated once. In both instances, add more material, if available, to extend application life.

Substantial carbon buildup should be cleaned off the melting vat walls before an asphalt kettle is used. In addition, calibrate all temperature gauges on the unit to display exact temperatures. An ASTM 11F or equivalent thermometer should be available for verifying material temperatures in the kettle and measuring material temperatures at the nozzle.

Four guidelines for initial heating of hot-applied materials are:

1. Begin heating so that the material is ready by the time normal work operations begin.
2. Keep heating oil temperature no more than 28° to 42°C above the safe heating temperature of the material, depending on the material manufacturer's recommendation.
3. Maintain material temperatures below the recommended pouring temperature.

## Notes

4. Start the agitator as soon as possible.

An emulsion material applied cold from the original container may need to be mixed if asphalt particles have settled during storage. Simple stirring at the bottom of the container will bring the material to a uniform consistency.

### Material Application

Begin the hot-pour application once the material has reached the recommended application temperature and the first few cracks have been prepared. From this point, the focus is on three items:

1. Ensure material remains at or near the recommended application temperature without overheating.
2. Maintain a sufficient supply of heated material in the kettle.
3. Properly dispense the right amount of material into the crack channels.

The kettle operator must be fully aware of the recommended application temperature and the safe heating temperature of the material being installed. These temperatures are generally marked on the material containers for quick and easy reference.

Maintaining a consistent material temperature can be difficult, especially in cold weather. Underheated material may produce a poor bond and/or freeze the application line, which causes a work delay. However, overheating will lead to either poor treatment performance or a suspended operation.

Guidelines for maintaining hot-applied material in a sufficient quantity and at the proper temperature during application are:

1. Check the temperature of the material at the nozzle and in the melting vat.
2. Adjust the heating controls to reach the recommended application temperature (or as near to as possible without exceeding the safe heating temperature).
3. Check the sealant temperatures regularly and adjust as necessary.
4. Watch for carbon buildup on the sidewalls of the heating chamber and visually inspect material for changes in consistency.
5. Check the level of material in the melting vat periodically. Add material as needed.

The application procedure for all crack treatment materials is basically the same, regardless of what application device is used. Pressure applicators are almost always used; however, pour-pots are occasionally used for applying cold-applied emulsion materials. In all cases, a relatively free-flowing material must be poured into and possibly over the crack channel.

General guidelines for material application include:

1. Apply the material with the nozzle in the crack channel so that the channel is filled from the bottom up and air is not trapped beneath the material (see figure 5-8).
2. Apply the material in a continuous motion, making sure to fill the channel to the proper level for recessed configurations or provide a sufficient amount of material for flush, capped, or overbanded configurations.
3. Reapply material to crack segments where material has sunk into the crack or an insufficient amount was furnished in the previous pass.
4. Recirculate material through the wand into the melting vat during idle periods.

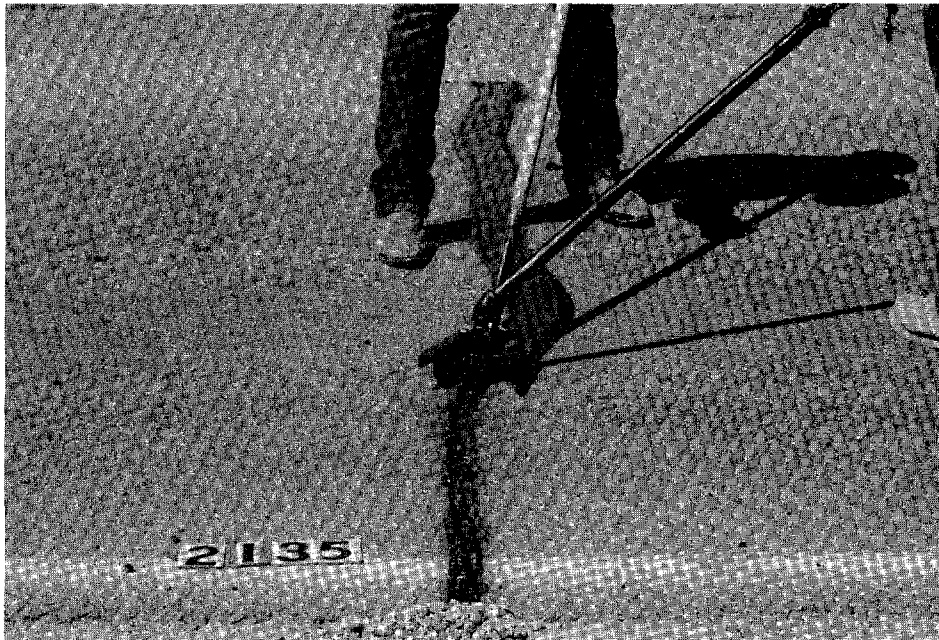

Figure 5-8. Treatment material application.

## Notes

### Kettle Cleanup

At the end of each day's work, purge hot-pour material from the applicator system lines on the asphalt kettle. In addition, if nonreheatable materials are being used, remove material left in the melting vat. In any case, closely monitor the amount of material in the melting vat so that as little material as possible remains when work is finished for the day.

When using reheatable materials, the applicator lines can be purged of material using either reverse flow or air cleanout procedures. Thorough cleaning can be accomplished using reverse flow procedures followed by solvent flushing procedures.

When using nonreheatable materials, place as much material as possible in cracks at the project site. Any leftover material will have to be discharged into containers for subsequent disposal. Solvent may then be added and circulated through the system to flush it of any excess material.

If flushing solvents are used in cleanout, the kettle operator must ensure that they do not contaminate the sealant or filler material. Step-by-step instructions on how to clean kettles and applicator lines are generally found in the kettle manufacturer's operation manual.

The material installation operation must follow closely behind the crack cleaning and drying operation to ensure the cleanest possible crack channel.

### **Material Finishing**

The objective of material finishing is to shape or mold the dispensed material into the desired configuration. This can be accomplished in two ways. First, various sizes of dish-shaped attachments are available that can be connected to the end of the application wand for one-step application and finishing. Second, industrial rubber squeegees can be used behind the material applicator to provide the desired shape.

The one-step method requires one less worker but often does not provide as much control in finishing as the squeegee method, especially for overband configurations.

Before installation, test the finishing tool to ensure that the desired configuration is achieved. If a dish attachment is to be used on the applicator wand, it should be the proper size and aligned to facilitate application.

Squeegees should be properly molded into a "U" or "V" shape so that the material can be concentrated over the crack. If strike-off is to be flush, the rubber

insert should be flat. If a band-aid configuration is required, cut the rubber insert to the desired dimensions. The depth of the cut should be a little larger than the desired thickness of the band because some thickness will be lost as a result of the squeegee being pushed forward and slightly downward. A few recommendations for material finishing are:

1. Operate the squeegee closely behind the wand. If the material is runny enough to sink into the crack or flows from the mold provided by the squeegee, maintain a little distance to allow for reapplication and material cooling.
2. Concentrate on centering the application dish or band-aid squeegee over the crack channel.
3. Keep the squeegee free from material buildup by regularly scraping it on the pavement. It may be necessary periodically to remove buildup material with a propane torch.

### **Material Blotting**

The objective of blotting is to provide sufficient cover or protection of the uncured treatment material so that it does not track under traffic. The equipment necessary for this activity depends on the type of blotter material to be used. For instance, sand, which is used primarily with emulsion materials, generally requires a truck or trailer on which it can be stored, in addition to shovels for spreading.

Toilet paper, talcum powder, and limestone dust are often used when rubber-modified asphalt materials must be blotted to prevent tracking. Apply these blotters immediately after finishing so that they stick to the material and serve as temporary covers.

Toilet paper rolls can usually be loaded on the same truck with the prepackaged sealant blocks. For easy application, individual rolls can be placed on a modified paint roller (equipped with a long handle). As for powders and dusts, they can be stored and applied in ways similar to sand, taking care not to overapply them to the treatment material.

### **EVALUATING TREATMENT EFFECTIVENESS**

To determine the full effect of a crack treatment operation, two basic questions should be answered:

1. Is the crack treatment performing its intended function?

## Notes

2. Is the crack treatment extending the life of the pavement to the point where the cost benefit of added pavement life equals or exceeds the cost of performing the treatment operation?

Although many agencies are largely convinced that crack treatment extends pavement life (and have documented results to back it up), the value of the additional life, in relation to the price paid to achieve it, remains less clear.

Answering these questions undoubtedly requires some additional time and effort in the way of field monitoring. However, the findings can help justify the use of certain materials and procedures over others and can help determine the importance of a crack treatment program relative to other aspects of maintenance.

### **Treatment Performance**

Monitoring the performance of crack treatments is good practice, and it can be done rather quickly (1 or 2 hours) with fairly good accuracy. Conduct at least one inspection each year to chart the rate of failure and plan for subsequent maintenance. An evaluation between November and March is highly recommended because during that time, cracks are near their maximum opening and, as a result, it is easier to observe the condition of the treatment system.

To evaluate the performance inspection, select a small representative sample of the pavement section—about 150 m. Visually examine the sealant or filler material in each crack within the sample section to determine how well the material is performing its function of keeping out water.

Items signifying treatment failures include the following:

- Full-depth adhesion loss.
- Full-depth cohesion loss.
- Complete pull-out of material.
- Full-depth spalls or secondary cracks.
- Potholes.

A good estimate of the percentage of treatment failure can be calculated by measuring and summing the lengths of failed segments, dividing the value by the total length of treated cracks inspected, and multiplying by 100 percent. The crack treatment effectiveness can then be determined using the following equation:

$$\%Eff = 100 - \%Fail$$

where:    %Eff = Percentage of crack treatment effectiveness.  
          %Fail = Percentage of crack treatment failure.

After a few inspections, construct a graph of effectiveness versus time, such as the ones shown in figure 5-9. A minimum allowable effectiveness level—commonly 50 percent—will help indicate when future maintenance should be performed.

### Pavement Performance

The overall performance of a pavement is characterized by the results of a condition survey and, if available, by nondestructive deflection tests and ride quality tests. The results of these tests can be affected considerably by the performance of the crack treatments. Signs that the treatment may not be performing its intended function include lipping or cupping of the crack edges, the development of crack spalls, secondary cracks, or potholes, and the presence of base/subbase fines located at the surface of the cracks.

To determine whether crack treatment is a cost-effective method of extending the life of a pavement, compare performance between treated and untreated segments of a particular pavement section. In general, this entails charting the decreases in serviceability of each segment, estimating the projected differences in pavement life, and comparing the cost benefit of added pavement life to the cost of performing the treatment operation.

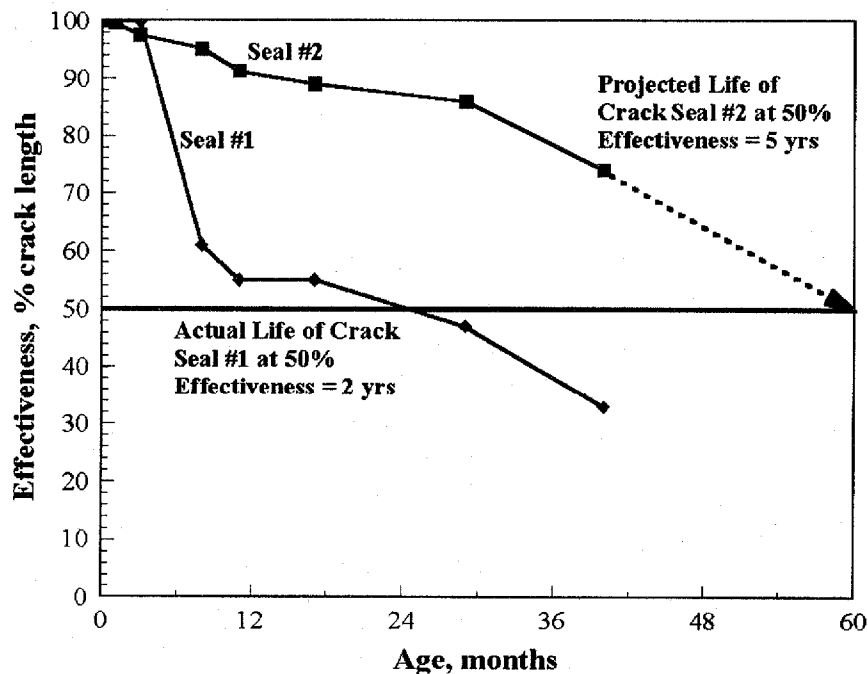

Figure 5-9. Example graph of treatment effectiveness versus time.





**SESSION OBJECTIVES**

This session discusses the proper methods for planning and conducting AC pothole repair operations and monitoring the performance of the installed patches. It presents the latest findings on the performance of materials and methods tested under the SHRP H-106 pothole repair experiment and contains detailed information on the processes of performing effective pothole repair operations.

Upon successful conclusion of this session, the participant will be able to accomplish the following:

1. Recall which pothole repair materials and methods are performing best in the SHRP H-106 experiment.
2. State the objective of pothole repair operations.
3. Select the most appropriate and cost-effective materials and procedures for patching potholes, given various constraints and limitations.
4. List the various steps in a pothole repair operation and describe the recommended procedures and equipment associated with each step.
5. Evaluate the effectiveness of pothole repair operations.

**SHRP RESEARCH FINDINGS TO DATE**

Between March 1991 and February 1992, 1,250 experimental pothole patches were placed at test sites throughout the U.S. and Canada as part of the SHRP H-106 project. The primary objective of the experiment was to determine the most cost-effective pothole repair materials and procedures under various climatic conditions and traffic. The materials and procedures used in the H-106 study were identified in the predecessor project, SHRP H-105, as having the most potential to improve the state of the practice in pothole patching.

As seen below, eight pothole repair test sites were constructed in four climatic regions as part of the H-106 experiment. The installations were completed in two phases; phase I, which took place in spring 1991, and phase II, which occurred in winter 1992.

## Notes

### Phase I

|  |               |            |
|--|---------------|------------|
| • <i>FM 1570—Greenville, Texas</i>       | Wet/nonfreeze | March 1991 |
| • <i>I-70—Vandalia, Illinois</i>         | Wet/freeze    | April 1991 |
| • <i>NM 518—Las Vegas, New Mexico</i>    | Dry/nonfreeze | April 1991 |
| • <i>I-15—Frontage Road Draper, Utah</i> | Dry/freeze    | April 1991 |
| • <i>US 395—Alturas, California</i>      | Dry/freeze    | May 1991   |
| • <i>VT 28—Bradford, Vermont</i>         | Wet/freeze    | May 1991   |

### Phase II

|                                    |            |               |
|------------------------------------|------------|---------------|
| • <i>ON 2—Prescott, Ontario</i>    | Wet/freeze | January 1992  |
| • <i>US 97—Modoc Point, Oregon</i> | Dry/freeze | February 1992 |

A total of three different proprietary materials, three State-specified materials, and eight local materials included by the participating SHA's were placed in the experiment. Moreover, six different repair procedures were used to install the materials, resulting in 23 unique repair types (i.e., material-procedure combinations). Table 6-1 shows the repair types that were used at each of the eight test sites, and table 6-2 describes the steps associated with each repair procedure. Further details about materials and procedures are provided in the section titled "Project Planning and Design."

At each site, a control repair type (UPM throw-and-roll) was alternately placed with two other repair types, until 10 of each (30 total) had been placed. The control repairs were repeated with additional sets of two experimental repair types until all repair types planned for the site were installed.

Since installation, repair performance at each site has been evaluated several times through detailed visual inspections conducted under both the H-106 project and the FHWA *LTM* follow-up study. In these inspections, each experimental repair type was examined for failures (i.e., patches that require repatching or have been repatched due to breakup and/or loss of patch material), which were then recorded. In addition, distresses such as dishing, raveling, edge disintegration, and cracking were rated on a scale of 0 to 10, with 0 representing the worst case of distress and 10 representing no distress. Using the recorded failure data, calculations of average survival rates for each repair type were subsequently made.

Under the *LTM* study, semi-annual field inspections were scheduled for every spring and fall from 1993 through 1995. After the fall 1993 inspection, however, only two of the eight sites—Ontario and Texas—remained available for additional inspections; the other six sites were overlaid between the spring and fall of 1993.

Major observations and performance data analysis results from the most recent inspection—fall 1994—are summarized below.

Table 6-1. Summary of material-procedure combinations used in SHRP H-106 pothole repair experiment.

| Material                      | Installation Procedure      | State/Province Installed |    |    |    |    |    |    |    |
|-------------------------------|-----------------------------|--------------------------|----|----|----|----|----|----|----|
|                               |                             | CA                       | IL | NM | ON | OR | TX | UT | VT |
| UPM High-Performance Cold-Mix | Throw-and-Roll <sup>a</sup> | ✓                        | ✓  | ✓  | ✓  | ✓  | ✓  | ✓  | ✓  |
|                               | Edge Seal                   | ✓                        | ✓  | ✓  |    | ✓  | ✓  | ✓  | ✓  |
|                               | Semipermanent               | ✓                        | ✓  | ✓  | ✓  | ✓  | ✓  | ✓  | ✓  |
| PennDOT 485                   | Throw-and-Roll              | ✓                        | ✓  | ✓  | ✓  | ✓  | ✓  | ✓  | ✓  |
|                               | Edge Seal                   |                          |    |    |    | ✓  |    |    |    |
|                               | Semipermanent               |                          |    |    | ✓  | ✓  |    |    |    |
| PennDOT 486                   | Throw-and-Roll              | ✓                        | ✓  | ✓  |    | ✓  | ✓  | ✓  | ✓  |
| HFMS-2 with Styrelf           | Throw-and-Roll              | ✓                        | ✓  | ✓  | ✓  | ✓  | ✓  | ✓  | ✓  |
| Perma-Patch                   | Throw-and-Roll              | ✓                        | ✓  | ✓  | ✓  | ✓  | ✓  | ✓  | ✓  |
| QPR 2000                      | Throw-and-Roll              | ✓                        | ✓  | ✓  | ✓  | ✓  | ✓  | ✓  | ✓  |
|                               | Edge Seal                   |                          |    |    |    | ✓  |    |    |    |
|                               | Semipermanent               |                          |    |    | ✓  | ✓  |    |    |    |
| Spray-Injection               | Spray-Injection             | ✓                        | ✓  | ✓  | ✓  |    | ✓  | ✓  | ✓  |
| Local Material                | Throw-and-Roll              | ✓                        | ✓  | ✓  | ✓  | ✓  | ✓  | ✓  | ✓  |
|                               | Surface Seal                |                          | ✓  |    |    |    |    |    |    |
|                               | Heat-and-Tack               |                          |    |    |    | ✓  |    |    |    |

<sup>a</sup> Control patch type for all sites.

Table 6-2. Descriptions of SHRP H-106 pothole patching procedures.

| Procedure       | Description   |
|-----------------|---|
| Throw-and-Roll  | Material placed in unprepared pothole and then compacted with truck tire.   |
| Edge Seal       | The throw-and-roll procedure followed by an asphalt seal application along the patch-pavement interface.  |
| Semipermanent   | Pothole prepared by moving water and debris and by straightening the sides; material placed in the pothole and compacted with a compaction device other than the truck tires. |
| Spray Injection | Use of an automated patching machine that shoots heated emulsion and virgin aggregate into an unprepared pothole.   |
| Surface Seal    | The throw-and-roll procedure followed by an asphalt seal application over the entire patch area.  |
| Heat-and-Tack   | The semipermanent procedure with the inclusion of tacking the prepared pothole with asphalt emulsion and using a heat torch to break the emulsion.                            |

## Notes

- The repair survival rates at the three wet-freeze test sites—Illinois, Ontario, and Vermont—are significantly lower than those for the three dry-freeze sites—California, Oregon, and Utah.
- Although performance comparisons between semipermanent and control (UPM throw-and-roll) repair types usually showed no significant difference, cost-effectiveness comparisons between the two showed significant life-cycle cost differences due to the increase labor and equipment needs of the semipermanent and the reduced productivity.
- The survival rates of patches placed at the two remaining test sites—Texas and Ontario—have leveled out considerably in the past year and a half. The overall survival rates at these sites have become essentially the same, with approximately 60 percent of the total repairs still in place after 4 years for the Texas site and 3 years for the Ontario site.
- The PennDOT 485 throw-and-roll combination was found to be the most cost-effective (on a  $\$/m^3$  basis) combination at 6 of the 8 test sites. The cost-effectiveness calculations took into account the cost of the material, the productivity at which it can be placed, the procedure used, and the performance of the repairs (measured in average weeks of repair life).
- The proprietary materials—UPM High Performance Cold-Mix, QPR 200, and Perma-Patch—continue to perform well, especially when they are compared to the local materials being used by many agencies.
- The success of materials such as the PennDOT 485, UPM High Performance Cold-Mix, QPR 2000, Perma-Patch, and spray-injection indicates that most agencies can obtain materials which will effectively repair potholes, even under adverse conditions.
- The production rates for the spray injection devices were comparable or slightly higher than the throw-and-roll procedure. Performance of the spray injection repairs has been equivalent to the the throw-and-roll control patches at seven of the eight sites.

### REPAIR OBJECTIVES

The objective of all pothole repair operations is to fill each pothole with the longest-lasting patch possible. The primary concern of each pothole repair crew should be to fill each pothole only one time. Placing repairs more than once at a given location increases crew exposure to traffic and adds costs for the agency.

There are many different ways to repair potholes effectively. These methods range from manual placement of hot-mix asphalt concrete (HMAC) and cold-mix asphalt materials (made with asphalt emulsions and cutback asphalts) to using spray-injection devices. While all of these are effective methods, certain conditions will dictate that one or another of these procedures is the most effective—such as when HMAC materials and spray-injection machines are not available, leaving cold-mix as the only practical alternative.

In general, make pothole repairs with hot-mix materials whenever possible. The repair procedure for hot mix should include four steps:

1. Remove debris from the pothole.
2. Create straight, sound sides for the repair area.
3. Place the material in lifts and compact each as it is placed.
4. Place all repairs during warm, dry weather.

In practice, pothole repairs are placed as a temporary means of repairing a local distress that poses a hazard to traffic. In many instances, there is not time to obtain hot-mix, assuming it is available, and it would not be practical to purchase the small amounts needed for patching. The other major drawback to using hot-mix is the short time during which it remains hot enough to be workable.

So, although HMAC materials may be preferable for repairing potholes, they are not always the most practical. For that reason, this session concentrates on the use of cold-mix materials and spray-injection machines for making emergency, temporary repairs to potholes. Recent research efforts sponsored by the SHRP and continued by the FHWA have collected data on several different pothole repair materials and procedures.

## **PROJECT PLANNING AND DESIGN**

The two main ingredients to any pothole patching operation are the materials and methods used to make the repairs. There will be specific conditions for each agency that dictate which combination of material and method is the most effective for making long-lasting pothole repairs. In some instances, the most effective combination actually may change from year to year, depending on the circumstances.

The criterion that should be used for judging the optimum material-method combination is the cost effectiveness of the overall repair operation. The costs of repairing potholes include the cost of purchasing the material, the labor cost, the equipment cost, and the cost in delays experienced by the user. The service life of the repairs is another crucial factor in determining cost-effectiveness of a pothole repair operation. In comparison to the costs of the patching operation, this is the

## Notes

most difficult value to accurately determine when calculating the overall cost-effectiveness. In section 5 of this session, a method is provided to help agencies monitor pothole repairs and to estimate the corresponding service life.

### **Selecting a Material**

Most agencies have three types of cold-mixes available to them. The first is cold-mix produced by a local asphalt plant using the available aggregate and binder, generally without the benefit of any mix design process.

The second type is cold-mix produced according to the agency's specifications for aggregate and asphalt. The agency generally performs acceptance testing to ensure that the final product meets some minimum performance level. The use of spray-injection devices by agency personnel usually falls into this category.

The third type is proprietary cold-mix produced by a local asphalt plant in conjunction with a firm that performs the mix design using local aggregate and specially blended binders. The quality of the final product is generally monitored by the proprietary firm since its name is associated with the material. As with most cold-mixes, these materials can be purchased in bulk to be stockpiled, in 208-L drums, in buckets, or in bags. Spray-injection patching performed by a contractor, who also supplies the aggregate and binder, falls into this third category.

### Cost-Effectiveness

The most important aspect of any pothole patching material is its impact on the cost-effectiveness of the overall pothole patching operation. Materials that are inexpensive to purchase but have a short service life will drastically increase the cost of the patching operation by requiring additional effort to re-patch failed repairs. For example, a typical inexpensive cold-mix may cost \$20/Mton, whereas some proprietary materials cost as much as \$100/Mton. If the expected service lives of the two material types are 1 and 2 yrs, respectively, the actual life-cycle cost over a 2-yr period is calculated as shown in table 6-3.

### Laboratory Testing

Three primary types of testing are performed on cold-mix patching materials: compatibility testing, mix design testing, and acceptance testing. Compatibility testing is intended to identify combinations of aggregate and asphalt that will not work well together—before a large quantity of cold mix is produced. Compatibility testing should only be used to identify potentially poor performing combinations and never superior combinations of aggregate and asphalt.

Table 6-3. Present-worth costs for two pothole repair materials

|                          |        | Local Cold Mix | Proprietary Cold Mix |
|--------------------------|--------|----------------|----------------------|
| Material Cost            |        | \$20/Mton      | \$100/Mton           |
| Labor/ Equipment Cost    |        | \$500/day      | \$500/day            |
| Productivity             |        | 4 Mtons/day    | 4 Mtons/day          |
| Initial Daily Cost       |        | \$580/day      | \$900/day            |
| Expected Service Life    |        | 1 yr           | 2 yrs                |
| Discount rate            |        | 4%             | 4%                   |
| Present-Worth Cost       | Year 0 | \$580/day      | \$900/day            |
|                          | Year 1 | \$558/day      | \$0/day              |
| TOTAL Present-Worth Cost |        | \$1,138/day    | \$900/day            |

1 Mton = 1.10 ton

Mix design testing is conducted once a particular combination of aggregate and asphalt has passed the compatibility testing. Mix design testing is intended to determine the optimum residual asphalt content for a particular aggregate-binder combination. Any changes in the aggregate source or binder formulation will require that compatibility and mix design testing be repeated.

Acceptance testing is the final type of testing performed on cold-mix materials. This testing ensures that the material purchased by an agency meets some minimum level of quality as specified by the agency. Although acceptance testing does not guarantee a successful patching material, it should be able to identify materials likely to fail in the field.

A collection of test procedures for compatibility, mix design, and acceptance testing are provided in appendix A of the *Manual of Practice on Repair of Potholes in Asphalt-Surfaced Pavements*.<sup>39</sup> These tests can be used by an agency to develop its own cold-mix specification, or can be used to test potential proprietary cold mixes before agency acceptance.

### Selecting a Patch Preparation Procedure

There are several different techniques for repairing potholes in asphalt pavements. These range from the throw-and-go or dump-and-run to the placement of full-depth repairs including base removal and replacement. As

## Notes

presented earlier, the techniques evaluated in the SHRP H-106 pothole repair experiment included:

- Throw-and-roll.
- Edge seal.
- Semipermanent.
- Spray-injection.
- Surface seal.
- Heat-and-tack.

The selection of the optimum repair technique will be influenced by the time available for making the repairs, the traffic level along the road, the types of material and equipment available, and the experience of the repair crew. The following section describes each of the procedures listed above, as well as the productivity, equipment needs, and labor needs for each. For all of the procedures, the traffic control requirements are based on the traffic, geometric, and other site-specific data for a particular repair area. Take every precaution to ensure the safety of the crew and motorists in the repair area.

### Throw-and-Roll

The throw-and-roll technique consists of five steps:

1. Place cold mix into pothole (no removal of water or debris is necessary).
2. Compact the patch using the tires of the truck transporting the material (generally between four and eight passes).
3. Verify that the patch has maintained some crown at the center of the patch (between 3 and 5 mm). If the patch has any depressions, place additional material and recompact it with the truck.
4. Move on to the next pothole location.
5. Open repairs to traffic as soon as the crew and equipment are out of the way.

To perform the throw-and-roll procedure effectively, use a good-quality cold-mix. Data collected during the H-106 pothole repair experiment indicated that two laborers can handle this procedure effectively—one to drive the truck and one to place material into the pothole. The productivity of this operation ranged from 0.8 to 2.9 Mton/hr, with a mean value of 1.8 Mton/hr.

Equipment needed for this procedure includes a truck to haul the material to the repair site and hand tools to place the cold-mix into the pothole.



### Edge Seal

The edge seal procedure consists of seven steps:

1. Place cold mix into pothole (no removal of water or debris is necessary).
2. Compact the patch using the tires of the truck transporting the material (generally between 4 and 8 passes).
3. Verify that the patch has maintained some crown at the center of the patch (between 3 and 5 mm). If the patch has any depressions, place additional material and recompact the patch with the truck.
4. Move on to the next pothole location.
5. Return to the patch location the following day (assuming the pavement surface is dry) and place a band of asphaltic tack material on top of the patch-pavement interface.
6. Cover the tack material with a layer of sand to prevent tracking by passing vehicles.
7. Open repairs to traffic as soon as the crew and equipment are out of the way.

Figure 6-1 shows a typical edge seal repair. The same type of cold mix used for the edge seal is used for the throw-and-roll. In some cases, the process of sealing the patch perimeter can prevent water intrusion and improve the performance of the patch material. This is especially true when patching on older pavements where the pavement surrounding the patch may not be able to provide solid support for the patch materials.

Data collected during the H-106 pothole repair experiment indicated that the placement of the repair materials for the edge seal operation was roughly equivalent to the throw-and-roll procedure, using the same two-person crew. However, the overall productivity was roughly 50 to 60 percent of the 1.8 Mton/hr because of the two traffic control setups and the second pass through the repairs to place the edge seal.

Equipment needed for this procedure is a truck to haul the cold-mix, tack material, and sand to the repair site; hand tools to place the cold-mix into the pothole and the sand on the edge seal; and a broom or brush for applying the tack material.

## Notes

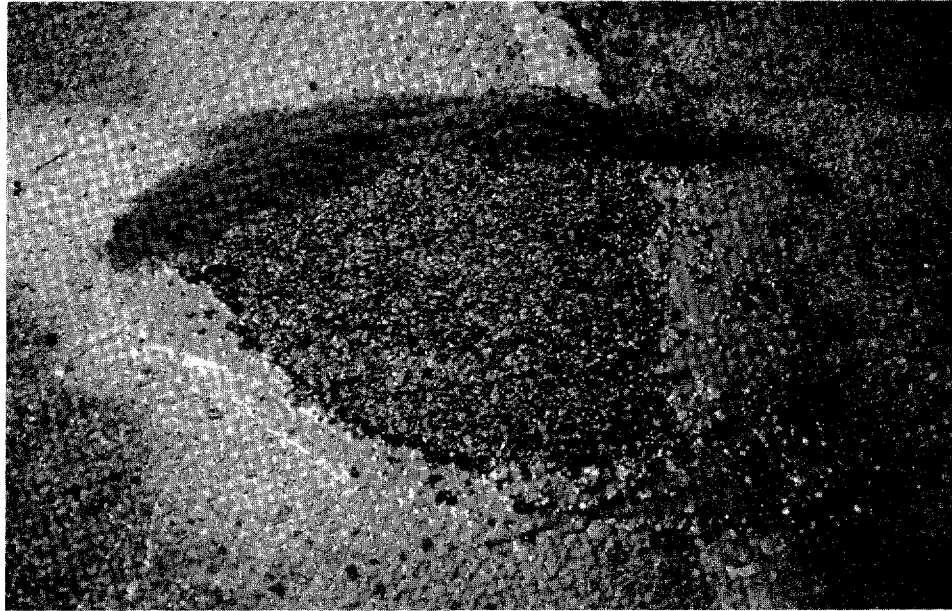

Figure 6-1. Edge seal pothole repair.

### Semipermanent

The semipermanent technique consists of five steps:

1. Remove water and debris from the pothole.
2. Square the sides of the patch area until vertical sides exist in reasonably sound pavement. The corners of the squared-up area should be greater than or equal to 90°.
3. Place the cold mix into the pothole.
4. Compact the patch with a portable compaction device such as a vibratory plate compactor or a single-drum vibratory roller.
5. Open repairs to traffic as soon as the crew and equipment are out of the way.

This repair technique should be used with good quality cold mixes, though the added benefits of the water removal and sound edges can improve the performance of lesser-quality cold-mixes. Because of the additional activities associated with this procedure, the recommended crew size is four laborers—two for the pothole preparation and two for the placement of the patches. The average productivity for this operation during the H-106 project was approximately 0.33 Mton/hr.

Equipment needed for this procedure includes the truck to transport the material, a truck to remove debris taken from the pothole (optional), hand tools for placing the material, compaction device (either vibratory plate or single-drum vibratory roller), air compressor, and an edge-straightening device (either a jack hammer with spade bit attachment, pavement saw, or cold milling machine). Figure 6-2 shows a hand-held pavement saw cutting the boundaries of a semi-permanent repair.

### Spray-injection

The spray-injection technique consists of five steps:

1. Blow water and debris from the pothole using air from aggregate delivery system.
2. Spray a layer of asphaltic tack coat on the bottom and sides of the cleaned-out pothole.
3. Blow a combination of asphalt and aggregate into the pothole until it is filled.



Figure 6-2. Pavement saw cutting semi-permanent repair boundaries.

## Notes

4. Cover the patched area with a layer of aggregate only.
5. Open repairs to traffic as soon as the crew and equipment are out of the way.

The only equipment needed for this procedure is the spray-injection device, which can consist of a single vehicle system (all aggregate and heated asphalt tank carried on a single vehicle along with hoses and delivery system) or a trailer system (aggregate carried by a truck towing the spray-injection device that has a heated asphalt tank, hoses, and delivery system). The choice of aggregate and asphalt are dependent on what is available and some compatibility testing is recommended before committing to a specific combination. Figures 6-3 and 6-4 show the single vehicle and trailer spray-injection systems, respectively.

The productivity of the spray-injection devices during the H-106 project averaged 1.9 Mton/hr, with a single operator needed for the single vehicle system and a two-person crew needed for the trailer system—one worker to drive the tow vehicle and one to operate the hose for placing the patch material. In general, no additional equipment is needed for the spray-injection operations, other than the device itself.

### Surface Seal

The surface seal technique consists of seven steps:

1. Place cold mix into pothole (no removal of water or debris is necessary).
2. Compact the patch using the tires of the truck transporting the material (generally between four and eight passes).
3. Verify that the patch has maintained some crown at the center of the patch (between 3 and 5 mm). If the patch has any depressions, place additional material and recompact the patch with the truck.
4. Move on to the next pothole location.
5. Return to the patch location the following day (assuming the pavement surface is dry) and place a layer of asphaltic tack material over the entire patch and extending on to the adjacent pavement.
6. Cover the tack material with a layer of sand to prevent tracking by passing vehicles.
7. Open repairs to traffic as soon as the crew and equipment are out of the way.



Figure 6-3. Single-vehicle spray injection device.

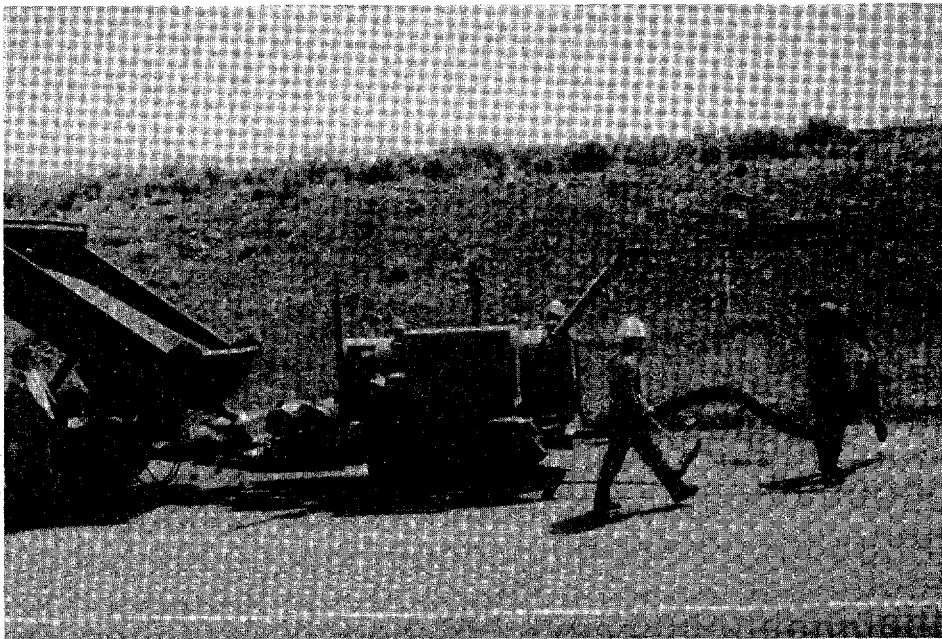

Figure 6-4. Truck-trailer spray injection device.

## Notes

This procedure is very similar to the edge seal procedure in that crew size (two laborers), equipment needed (truck, hand tools, and broom), and recommended material (best available cold mix) are the same. The productivity of the surface seal also is similar to the edge seal, at about 1 Mton/hr when considering the two traffic control set ups and two passes through the repairs.

### Heat-and-Tack

The heat-and-tack technique consists of eight steps:

1. Remove water and debris from the pothole.
2. Place asphaltic emulsion along sides and bottom of cleaned out pothole.
3. Heat emulsion using a propane torch to accelerate the break of the material.
4. Place cold mix into pothole, and heat with propane torch to improve workability and compactability of the material (as shown in figure 6-5).
5. Compact the patch using the tires of the truck transporting the material (generally between four and eight passes).

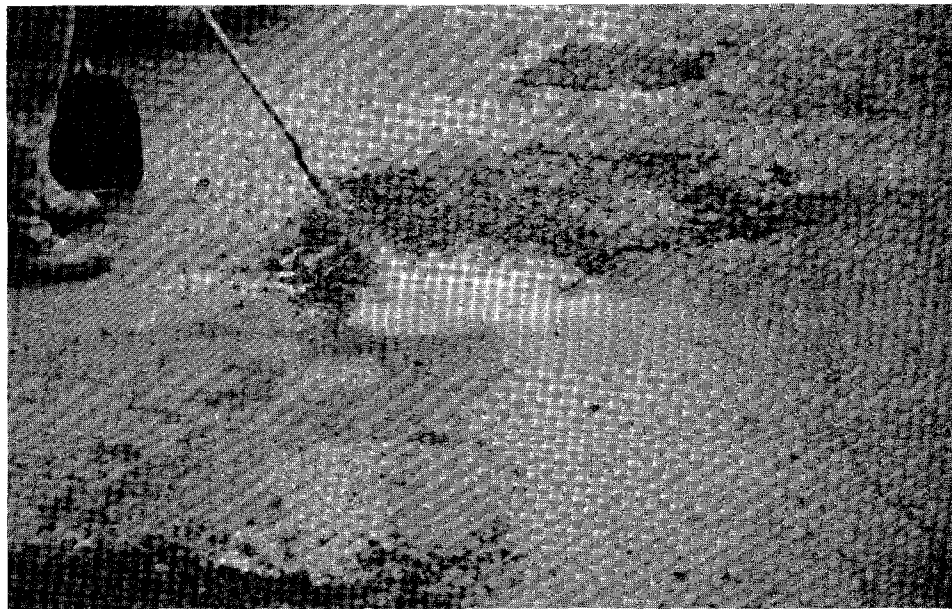

Figure 6-5. Propane torch being used to heat cold-mix.

6. Verify that the patch has maintained some crown at the center of the patch (between 3 and 5 mm). If the patch has any depressions, place additional material and recompact the patch with the truck.
7. Move on to the next pothole location.
8. Open repairs to traffic as soon as the crew and equipment are out of the way.

For this procedure, the best available cold-mix is recommended as it is for the other procedures. The added benefits of cleaning the pothole, placing the tack coat, and heating the cold-mix can improve the performance of lesser-quality cold mixes if necessary. A crew of two laborers is recommended for this procedure, with an average productivity of 0.44 Mton/hr observed during the H-106 project.

The equipment needed for this technique includes a truck to transport the cold-mix to the repair site, a truck to remove debris taken from the pothole (optional), hand tools for placing the material, propane tank and torch, and an applicator for the asphalt emulsion.

The last two procedures, surface seal and heat and tack, were used by agencies having very poor performing cold mixes. While the procedures did improve the performance of the poor cold-mixes, the overall operation did not produce repairs as quickly as the throw-and-roll and spray-injection procedures. Also, the improvements in performance still did not match the results obtained with the better-quality cold-mixes. Although these repair procedures did improve poor performing cold-mix performance, it is still recommended to use high-quality cold mixes whenever possible.

### **Determining Resource Requirements**

Because of differences in the availability of various materials, equipment, crew size, and contractors, each agency will have a different set of resources available for repairing potholes. Determining what resources are available is the first step toward developing the optimum pothole repair method for a particular agency.

### **Materials**

Each agency responsible for repairing potholes should be using the best cold-mix available, when hot mix is not a repair option. Make the determination of which material is best strictly on the basis of what material will stay in the potholes the longest. Differences in purchasing cost for a metric ton become irrelevant if the less expensive material will last only a short time and require additional patching.

## Notes

### Equipment

For most cold-mix materials, the equipment needed for performing the throw-and-roll will include mostly the truck to transport the material and crew and the hand tools needed to place the material. Additional pieces of equipment are required for spray-injection and semi-permanent procedures; these are described in the previous sections.

### Labor

The recommended labor for each of the repair procedures discussed in this session are as follows:

- Throw-and-roll (two laborers).
- Semi-permanent (four laborers).
- Spray-injection (one or two laborers depending on equipment type).
- Edge seal (two laborers).
- Surface seal (two laborers).
- Heat-and-tack (two laborers).

## **INSTALLATION**

The two types of pothole patching operations are winter and spring repairs. Winter repairs are defined as patching operations performed to address emergency situations where adverse weather conditions increase the hazard to repair crews and motorists. Spring repairs are defined as patching operations performed during good weather when many potholes may be repaired at the same time. In both instances, the immediate goal of the patching operation is to restore rideability by repairing the pothole as quickly and as effectively as possible.

### **Traffic Control**

The objective of traffic control during pothole patching is to provide a safe area for the repair crew to work while causing minimal disruptions to passing vehicles. Because of the variety of conditions under which potholes are patched, traffic control arrangements need to be flexible. Although the traffic control requirements for each agency and each patching operation will vary, every maintenance agency has a responsibility to provide a safe work area for the repair crew and safe travel lanes for motorists. Every agency should take all necessary steps to maintain safety each time pothole patching is performed.



## **Safety**

In addition to traffic control, there are other safety concerns for the pothole repair crew. For all cold mixes, material safety data sheets should be available and all workers should be familiar with the materials they are using. While the majority of cold-mix materials do not require special handling, manufacturer's instructions should always be followed when applicable.

Operators of jackhammers and other compressed-air equipment should exercise caution with the equipment and use proper eye protection and other safety gear at all times when operating such equipment. Spray-injection operators should also exercise caution as the aggregate sprayed into the pothole can rebound and present a hazard, as can the heated emulsion being sprayed into the pothole. Vehicle operators must be cautious when moving in reverse, especially when other workers are in the area.

## **Pothole Preparation**

For the throw-and-roll, edge seal, and surface seal procedures, no preparation of the pothole is necessary. If the semipermanent repair procedure is used, then steps should be taken to remove moisture and debris from the pothole and square the sides of the repair area prior to material placement. For the spray-injection procedure, blow the pothole clean before blowing an asphaltic tack layer into the bottom and onto the sides of the pothole.

## **Material Preparation and Application**

No special preparation is required for the majority of cold-mixes. When patching in cold weather (less than 2°C), it may be necessary to heat the cold mix to improve the workability and increase the productivity of the operation. In many cases, simply loading the transport truck the night before the patching operation and parking it in a heated garage will be sufficient. There are also a wide variety of commercial and homemade "hot boxes" that apply heat to the material as it is being transported to the repair area. Any type of hot box should still provide easy access to the material.

For spray-injection devices, it is important to use clean, dry aggregate whenever possible. Any moisture present in the aggregate can cause severe problems if it freezes and disrupts the aggregate flow system.

For cold mixes, the placement for all procedures will simply consist of shoveling the material from the truck into the pothole until the pothole is filled. The loose material should be mounded slightly in the center in anticipation of compaction. For the spray-injection procedure, placement simply consists of blowing heated asphalt emulsion and aggregate into the pothole. Since most

## Notes

spray-injection devices have no automatic flow controls, the amount of aggregate and asphalt are controlled by operators as they watch the potholes fill. For new operators or new combinations of asphalt and aggregate, it is better to err on the side of too much asphalt, because too little asphalt has been observed to cause premature raveling of the patches. Too much asphalt may cause problems with bleeding of the patches or asphalt running out of the patch as traffic compacts it, but generally the patches do remain in place.

### **Material Finishing and Curing**

For all cold-mixes, finishing pothole patches should consist of compacting repairs with truck tires before opening the repair to traffic. This provides an opportunity to make sure that there is enough material in the pothole, and also helps close the surface and prevent moisture from getting into the patch. While most cold-mixes take anywhere from several days to several weeks to cure, all can generally be opened to traffic as soon as the repair crew has completed the repair and is clear of the area.

In most cases, compaction of the spray-injection repairs is not necessary. However, roll the layer of aggregate placed on the top of the repair to seat as much of the aggregate as possible. Before the repair is opened to traffic, sweep the patch surface to move any loose gravel to the shoulder where it is less likely to be thrown up by passing tires.

## **EVALUATING REPAIR EFFECTIVENESS**

As stated initially, the goal of all pothole repair operations should be to place the longest lasting patch possible in each pothole. In many cases, the determination of what is the longest lasting repair must be made by each repair crew for the particular conditions and available materials. This section provides some guidelines for repair crews to make those determinations for themselves and also provides some information on the findings of the H-106 project to date.

### **Repair Performance**

It is important to remember that every pothole patch placed is only intended to be a temporary repair that is necessary because of a local failure of the original pavement. In some instances, the conditions that led to the initial failure may cause the repairs to fail repeatedly. This type of repeat patching should not be confused with situations where the material is placed in a pothole and does not perform because of inferior quality.

Another consideration in evaluating repair performance is that winter repairs generally will not last as long as spring repairs, especially when there is moisture present at the time of patching or within several days after the repair is placed.

To monitor the performance of pothole repairs, it is necessary to document when repairs were placed, the materials and procedures that were used, the conditions under which the patches were placed, and how long they survived. In general, survival time is defined as the amount of time until an area needs to be repaired again. It is not necessary to document all patches placed, simply take a single day's or week's worth of patching (between 10 and 30 repairs is recommended) and track those as a sample of the material-procedure-condition combination. To compare differences in performance, take another sampling of repairs whenever the material, procedure, or conditions change.

Use the procedure outlined in table 6-4 to calculate the percent survival rate for any given material-procedure-condition combination. Even though the survival rate is independent of the time since the repairs were placed, it is recommended that different repair types with similar placement dates be compared whenever possible.

### **Pavement Performance**

In many cases, the development of potholes can signal the end of the service life for a pavement. If the quantity of potholes exceeds more than 100/km then examine the overall condition of the pavement and consider rehabilitation options. In situations where potholes do not indicate a severely deteriorated pavement, cold-mix patches should be expected to perform quite well and, in some cases, will survive as long as the surrounding pavement.

Notes

Table 6-4. Worksheet for calculating patch survival rate.

| Observe. No. (i) | Time, weeks (T) | Surviving/ Total patches | Perc. Surv. (P <sub>surv</sub> ) | Avg. Perc. Surv. (P <sub>avg</sub> ) | Time Interval (T <sub>int</sub> ) | Partial Area (A <sub>part</sub> ) | Total Possible Area (A <sub>tot</sub> ) |
|------------------|-----------------|--------------------------|----------------------------------|--------------------------------------|-----------------------------------|-----------------------------------|---|
| 0                | 0               | 10/10                    | 100                              |                                      |                                   |                                   |   |
| 1                | 3               | 9/10                     | 90                               | 95                                   | 3                                 | 285                               | 300                                     |
| 2                | 5               | 8/10                     | 80                               | 85                                   | 2                                 | 170                               | 200                                     |
| 3                | 8               | 6/10                     | 60                               | 70                                   | 3                                 | 210                               | 300                                     |
| 4                | 11              | 5/10                     | 50                               | 55                                   | 3                                 | 165                               | 300                                     |
| 5                | 15              | 4/10                     | 40                               | 45                                   | 4                                 | 180                               | 400                                     |
| 6                | 20              | 2/10                     | 20                               | 30                                   | 5                                 | 150                               | 500                                     |
|                  |                 |                          |                                  |                                      |                                   |                                   |   |
|                  |                 |                          |                                  |                                      |                                   |                                   |   |
|                  |                 |                          |                                  |                                      |                                   |                                   |   |
|                  |                 |                          |                                  |                                      |                                   |                                   |   |
|                  |                 |                          |                                  |                                      |                                   |                                   |   |
|                  |                 |                          |                                  |                                      |                                   |                                   |   |
|                  |                 |                          |                                  |                                      |                                   |                                   |   |
|                  |                 |                          |                                  | Total                                |                                   | 1,160                             | 2,000                                   |

Patch Survival Rate

55.3

---

$$P_{avg} = (P_{surv(i)} + P_{surv(i+1)}) / 2$$

$$T_{int} = T_{int(i+1)} - T_{int(i)}$$

$$A_{part} = P_{avg} \times T_{int}$$

$$A_{tot} = T_{int} \times 100$$

## REFERENCES

1. O'Brien, L.G. (1989). *Evolution and Benefits of Preventive Maintenance Strategies*, National Cooperative Highway Research Program, Synthesis of Highway Practice 153, Transportation Research Board, National Research Council, Washington, D.C.
2. FHWA Preventive Maintenance Memo, July 27, 1992.
3. Fwa, T.F., and K.C. Sinha. (1986). *A Study of the Effects of Routine Pavement Maintenance*, Transportation Research Record 1102, Transportation Research Board, National Research Council, Washington, D.C.
4. Gillespie, H.M. (1988). *Maintenance Worldwide Priority*, Roads and Bridges. November issue.
5. Raza, H. (1994). *Summary Report—1993 Field Evaluation of SPS-3 and SPS-4 Test Sites*, FHWA-SA-94-078, Federal Highway Administration, Washington, D.C.
6. Peterson, D.E. (1981). *Evaluation of Pavement Maintenance Strategies*, National Cooperative Highway Research Program, Synthesis of Highway Practice 77, Transportation Research Board, Washington, D.C.
7. ERES Consultants, Inc. (1993). "Techniques for Pavement Rehabilitation: Training Course." Federal Highway Administration, U.S. Department of Transportation, Washington, D.C.
8. Sabri, M.H. (1994). "Performance of Slurry Seals in Routine Maintenance and Pavement Rehabilitation." in *Proceedings of the International Workshop on HDM-4: Volume 2*. Kuala Lumpur, Malaysia.
9. Narayanan, N., et al. (1995). *Proactive Highway Maintenance Management in Singapore*, Proceedings, 8th Road Engineering Association of Asia and Australia, Volume 1.
10. Maser, K. R., and M. J. Markow. (1991). *Measuring Systems and Instrumentation for Evaluating the Effectiveness of Pavement Maintenance*, Strategic Highway Research Program, Report SHRP-M/UWP-91-513, National Research Council, Washington, D.C.
11. Nazarian, S., M. Baker, and K. Crain. (1995). *Use of Seismic Pavement Analyzer in Pavement Evaluation*, paper presented at the 74th Annual Meeting of the Transportation Research Board, Washington, D.C.
12. Chong, G.J. (1990). *Rout and Seal Cracks in Flexible Pavement—A Cost-Effective Preventive Maintenance Procedure*, Transportation Research Record 1268, Transportation Research Board, Washington, D.C.

13. Ponniah, J., and G. Kennepohl. (1995). *Crack Sealing in Flexible Pavements: a Life-Cycle Cost Analysis*, paper presented at the 74th Annual Meeting of the Transportation Research Board, Washington, D.C.
14. TR News. (1988). *Preventive Maintenance Strategy Adopted in France*.
15. Bellanger, J., Y. Brosseaud and J. Gourdon. (1992). *Thinner and Thinner Asphalt Layers for Maintenance of French Roads*, Transportation Research Record 1334, Transportation Research Board, Washington, D.C.
16. Freeman, T. J., and E. Rmeili. (1995). *Development and Construction of the Texas Supplemental Maintenance Effectiveness Research Program (SMERP) Experiment*, paper presented at the 74th Annual Meeting of the Transportation Research Board, Washington, D.C.
17. Freeman, T.J. (1994). *Results of 6- and 12-Month Evaluations of the Texas Supplemental Maintenance Effectiveness Research Program (SMERP) Sites, TX-94/2908-1F*. Texas Transportation Institute.
18. Evans, L.D., and A.R. Romine. (1993). *Materials and Procedures for Repair of Joint Seals in Concrete Pavements: Manual of Practice*. In *Concrete Pavement Repair Manuals of Practice*. Report No. SHRP-H-349. SHRP, National Research Council, Washington, D.C.
19. "Rigid Pavement Design for Airports-Chapter 7-Standard Practices for Sealing Joints and Cracks in Airfield Pavements," (1983). *Air Force Manual 88-6*.
20. Evans, L.D., et al. (1993). *Innovative Materials Development and Testing-Final Report*. Volumes I-V. SHRP, National Research Council, Washington, D.C.
21. Collins, A.M., et al. (1986). *Improved Methods for Sealing Joints in Portland Cement Concrete Pavements*. Research Report 385-1, FHWA/TX-87-385-1. Center for Transportation Research, University of Texas at Austin.
22. Darter, M.I., E.J. Barenberg, and W.A. Yrandson. (1971). *NCHRP Research Report 1-21: Joint Repair Methods for Portland Cement Concrete Pavements*. TRB, National Research Council, Washington, D.C.
23. Mildenhall, H.S., and G.D.S. Northcott. *A Manual for Maintenance and Repair of Concrete Roads*. Department of Transportation, Cement and Concrete Association.
24. *Guide to Sealing Joints in Concrete Structures*. (1990). Report ACI 504R-90. American Concrete Institute.
25. Blais, E.J. (1984). *Value Engineering Study of Crack and Joint Sealing*. Report no. FHWA-TS-84-221. Federal Highway Administration, U.S. Department of Transportation,

Washington, D.C.

26. Bugler, J.W. (1983). "Problems and Solutions in Rigid Pavement Joint Sealing," *Public Works*.
27. Steffes, R.F. (1993). "Innovative Leak Test for Pavement Joint Seals," Iowa Department of Transportation, Paper Presented at 72nd Annual Meeting of the Transportation Research Board.
28. Smith, K.D., et al. (1991). *Innovative Materials and Equipment for Pavement Surface Repairs. Volume I: Summary of Material Performance and Experimental Plans*. Report no. SHRP-M/UFR-91-504. SHRP, National Research Council, Washington, D.C.
29. NCHRP. (1977). *Synthesis of Highway Practice 45: Rapid Setting Materials for Patching of Concrete*. TRB, National Research Council, Washington, D.C.
30. Tyson, S. (1977). *Partial Depth Repairs of Jointed PCC Pavements: Cast-in-Place and Precast Procedures*. Virginia Highway and Transportation Research Council, Charlottesville.
31. Snyder, M.B., et al. (1989). *Rehabilitation of Concrete Pavements, Volume I-Repair Rehabilitation Techniques*. Contract no. FHWA-RD-88-071. Federal Highway Administration, U.S. Department of Transportation, Washington, D.C.
32. Furr, H. (1984). NCHRP *Synthesis of Highway Practice 109: Highway Uses of Epoxy with Concrete*. TRB, National Research Council, Washington, D.C.
33. Krauss, P. (1985). *New Materials and Techniques for the Rehabilitation of Portland Cement Concrete*. California Department of Transportation, Sacramento.
34. Mueller, P., J. Zaniewski, and S. Tritsch. (1988). "Concrete Pavement Spall Repair." Prepared for the 67th Annual Meeting of the Transportation Research Board, Washington, D.C.
35. Patel, A.J., C.A. Good Mojab, and A.R. Romine (1993). Materials and Procedures for Rapid Repair of Partial-Depth Spalls in Concrete Pavements: *Manual of Practice*. In *Concrete Pavement Repair Manuals of Practice*. No. SHRP-H-349. SHRP, National Research Council, Washington, D.C.
36. Smith, K.L., and A.R. Romine (1993). Materials and Procedures for Sealing and Filling Cracks in Asphalt Surfaced Pavements: *Manual of Practice*. In *Asphalt Pavement Repair Manuals of Practice*. Report No. SHRP-H-348. SHRP, National Research Council, Washington, D.C.
37. Cook, J.P., F.E. Weisgerber, and I.A. Minkarah. (1991). Development of a Rational Approach to the Evaluation of Pavement Joint and Crack Sealing Materials-Final Report.

University of Cincinnati.

38. Peterson, D.E. (1982). *NCHRP Synthesis of Highway Practice No. 98: Resealing Joints and Cracks in Rigid and Flexible Pavements*. TRB, National Research Council, Washington, D.C.
39. Wilson, T.P., et al. (1993). *Materials and Procedures for Repair of Potholes in Asphalt Pavements: Manual of Practice*. In *Asphalt Pavement Repair Manuals of Practice*. Report no. SHRP-H-348. SHRP, National Research Council, Washington, D.C.
40. FHWA (1990). *Technical Advisory on Concrete Pavement Joints*. Advisory Code 5040.30.



## GLOSSARY

### AC Crack Treatment

- Abrasion*—The wearing away of treatment material by tire friction or snowplow scraping.
- Adhesiveness*—The ability of a material to remain bonded to crack sidewalls and /or pavement surface.
- Bandaid*—An overband configuration where material is shaped/finished to desired dimensions.
- Capped*—An overband configuration where material is not shaped/finished. The material is allowed to level over the crack channel by itself.
- Cohesiveness*—The ability of a material to resist internal rupture.
- Cost Effectiveness*—The degree to which a treatment is both useful and economical.
- Crack channel*—The crack cavity as defined by either the original (uncut) crack or cut crack.
- Crack repair*—Maintenance in which badly deteriorated cracks are repaired through patching operations.
- Crack reservoir*—A uniform crack channel resulting from cutting operations. Generally rectangular in shape.
- Crack treatment*—Maintenance in which cracks are directly treated through sealing or filling operations.
- Cupping*—A depression in the pavement profile along crack edges caused by damaged or weakened sublayers.
- Edge deterioration*—Secondary cracks and spalls that occur within a few millimeters of the edges of a primary crack.
- Effectiveness*—See *Treatment effectiveness*
- Elasticity*—The ability of a material to recover from deformation and resist intrusion of foreign materials.
- Faulting*—A difference in elevation between opposing sides of a crack caused by weak or moisture-sensitive foundation material.

*Flexibility*—The ability of a material to extend to accommodate crack movement.

*Incompressible*—Material, such as sand, stone, and dirt, that resists the compression of a closing crack channel.

*Lipping*—An upheaval in the pavement profile along crack edges. Lipping may be the result of bulging in underlying PCC base or the infiltration and buildup of material in the crack.

*Longitudinal*—Parallel to the centerline of the pavement or laydown direction.

*Nonworking (cracks)*—Cracks that experience relatively little horizontal and/or vertical movement as a result of temperature change or traffic loading. As a general rule, movement less than 3 mm.

*Overband*—A type of finish in which material is allowed to completely cover crack channel by extending onto pavement surface. Overbands consist of band-aid capped configurations.

*Secondary crack*—A crack extending parallel to and/or radially from a primary crack. A form of edge deterioration.

*Serviceability*—The ability, at time of observation, of a pavement to serve traffic that use the facility.

*Spall*—A chipped segment of asphalt concrete occurring along a primary crack edge. A form of edge deterioration.

*Thermoplastic (material)*—A material that becomes soft when heated and hard when cooled.

*Thermosetting (material)*—A material that hardens permanently when heated.

*Transverse*—Perpendicular to the pavement centerline or direction of laydown.

*Treatment failure*—The degree to which a treatment is not performing its function.

*Treatment effectiveness*—The degree to which a treatment is performing its function.

*Working (cracks)*—Cracks with or exhibiting considerable horizontal and/or vertical movement as a result of temperature change or traffic loading. In general, movement greater than or equal to 3 mm.

## **AC Pothole Repair**

*Pothole*—Localized distress in an asphalt-surfaced pavement resulting from the breakup of the asphalt surface and possibly the asphalt base course. Pieces of asphalt pavement created by the action of climate and traffic on the weakened pavement are then removed under the action of traffic, leaving a pothole.

*Pothole patching*—The repair of severe, localized distress in asphalt-surfaced pavements. This maintenance activity is generally performed by the agency responsible for the roadway and is intended to be a temporary repair at best. Pothole patching is not intended to be a permanent repair. Full-depth reconstruction of the distressed areas is necessary for a permanent repair in most instances.

*Semipermanent*—Repair technique for potholes in asphalt-surfaced pavements that includes removing water and debris from the pothole before placing repair material. Once the pothole has been cleaned, the edges of the distress are straightened using a pavement saw, jack hammer, milling machine, or similar equipment. After the edges have been straightened and are in sound pavement, the cold mix is placed. The patch is compacted using a single-drum vibratory roller or a vibratory-plate compactor.

*Spray injection*—Repair technique for potholes in asphalt-surfaced pavements and spalls in PCC-surfaced pavements that uses a spray-injection device. Spray-injection devices are capable of spraying heated emulsion, virgin aggregate, or both into a distress location.

*Throw-and-go*—Repair technique for cold-mix patching materials in which material is shoveled into the pothole, with no prior preparation of the pothole, until it is filled; compaction of the patch is left to passing traffic, while the maintenance crew moves on to the next distress location.

*Throw-and-roll*—Repair technique for cold-mix patching materials in which material is shoveled into the pothole, with no prior preparation of the pothole, until it is filled; the material truck tires are used to compact the patch before the crew moves on to the next distress location.

## **PCC Joint Resealing**

*Adhesion failure*—Complete loss of bond between a sealant material and the concrete joint wall.

*Allowable extension*—The amount of stretching of a sealant material under which performance is estimated to be adequate.

*Average daily traffic (ADT)*—The total traffic volume carried by a pavement during a given period (in whole days), greater than 1 day and less than 1 year, divided by the number of days in that period.

*Blowups*—The result of localized upward movement or shattering of a slab along a transverse joint or crack.

*Channel face*—The vertical concrete sidewall of a sawed joint sealant reservoir.

*Compression seals*—Preformed seals, generally made from neoprene, that can be compressed and inserted into concrete joints for sealing purposes.

*Corner break*—A diagonal crack forming between transverse and longitudinal joints that extends through the slab, allowing the corner to move independently from the rest of the slab.

*D cracking*—The breakup of concrete because of freeze-thaw expansive pressures within certain susceptible aggregates (also called durability cracking).

*Embedment*—To become fixed firmly in a surrounding mass, as stones sink into and become fixed in soft sealant material.

*Extruded*—Forced through a die to give the material a certain shape.

*Flow*—The sinking of unstable sealant into a sealant reservoir.

*Horizontal movement*—Opening and closing of joints resulting from pavement expansion and contraction.

*Incompressible*—Material that resists compression, such as stones, sand, and dirt in a crack or joint reservoir that is closing.

*Joint growth*—The gradual increase in joint width resulting from the filling of joints with incompressible materials during cold cycles.

*Joint sidewalls*—The vertical concrete edges of a sawed joint reservoir.

*Life-cycle cost analysis*—An investigation of the present and future costs of each repair alternative, taking into account the effects of both inflation and interest rates on expenses over the life of the project.

*Load transfer*—The transfer of load across a joint or crack in concrete pavement resulting from aggregate interlock, dowels, or other load-carrying devices.

*Overbanding*—Spreading a thin layer of sealant (about 1.5 in [38 mm] wide) onto a pavement surface centered over a joint or crack at the same time that the sealant reservoir is filled.

*Pumping*—The ejection of water and fine materials from beneath a concrete pavement through cracks or joints under pressure from moving loads.

*Refacing*—Removing about 1/16 in (1.6 mm) of concrete from each wall of a sealant reservoir using diamond saw blades.

*Plowing*—Removing existing joint sealant by forcing a metal blade (plow) against the joint sidewalls.

*Resealing*—Replacing sealant in joints or cracks, preferably using good-quality methods and materials.

*Sealant/channel interface*—The vertical edge of a sealed joint where sealant material and concrete joint face meet.

*Sealant reservoir*—The channel along a joint or crack that has been widened by sawing to allow sealant to be placed in it.

*Sealant system*—All components that function to seal joints, such as sealant material, surrounding concrete, and sealant/concrete interface.

*Shape factor*—The ratio of the width to depth of a sealant.

*Slurry*—The mixture of water, concrete dust, old sealant, and dirt that results from resawing a joint in concrete pavement.

*Subdrainage*—Moisture drainage from beneath a pavement by means of a porous subbase material connected to outlet drain lines.

*Track*—The spreading of unstable sealant material along the pavement surface by traffic tires.

*Undersealing*—Filling voids beneath a concrete pavement using a pressurized slurry or hot asphalt material.

*Vertical shear*—Vertical stress along the sealant/concrete interface resulting from traffic loading, curling, and pavement faulting.

*Weathering*—Breakdown of sealant material caused by moisture, ultraviolet rays, and time.

## **PCC Partial-Depth Spall Repair**

*Admixture*—A substance added to a mixture during mixing.

*Adverse patching conditions*—Climatic conditions in which the air temperature is below 4°C and the repair area is saturated with surface moisture.

*Bonding agent*—A substance that promotes good bonding between the pavement surface and a repair material placed on the surface.

*Breaking and seating*—The breaking and compaction of a continuously reinforced concrete pavement, reducing the amount of reflective cracking in the overlay.

*Calcium aluminate concrete*—A high alumina ( $Al_2O_3$ ) cementitious concrete.

*Chemical conversion*—A chemical process that results in a change in the nature, structure, or properties of a substance.

*Compact*—To release trapped air and reduce volume using compression.

*Compression failure*—The crushing of a repair caused by the expansion of the surrounding pavement during freeze-thaw cycles.

*Compression recovery*—The property of being able to regain original shape and volume after being compressed.

*Compressive strength*—The maximum compressive stress a material can withstand before failure.

*Compressive stress*—A stress that causes an elastic body to shorten in the direction of the applied force and that causes an inelastic body to rupture.

*Consolidate*—To release trapped air from fresh concrete mix by using vibration.

*Cracking and seating*—The breaking and compacting of a plain concrete pavement, reducing the amount of reflective cracking in the overlay.

*D Cracking*—Durability cracking; a pattern of cracks running parallel and close to a joint or linear crack caused by freeze-thaw expansion of large, nondurable aggregate.

*Debonding*—The partial or complete loss of bond between two materials, such as between a patch and a slab.

*Diamond grinding*—A surface restoration to correct surface distresses in which patterns are cut into hardened concrete with closely spaced diamond saw blades.

*Epoxy concrete*—A polymer concrete containing epoxy resin, a flexible, thermosetting resin made by polymerization of an epoxy compound.

*Feathering*—The thin placement of patching materials because of curved or angled patch edges that do not allow adequate depth of placement.

*Free sulfate*—A chemical group containing sulfur and oxygen ( $-\text{SO}_4$ ) that is free to react chemically with other chemical groups.

*Full-depth spall repair*—The removal of an area of deteriorated concrete the entire depth of a pavement slab and its replacement with a repair material along with the restoration of load transfer devices.

*Full lane-width patch*—A patch that extends the entire width of a lane.

*Gouge bit*—A curved chisel tip used in jackhammering that is not recommended for partial-depth spall repair.

*Gypsum-based concrete*—A cementitious concrete that contains gypsum, a common sulfate mineral.

*Heat of Hydration*—The heat given off when molecular water is incorporated into a complex molecule with molecules such as those found in cementitious mixes.

*High alumina concrete*—A cementitious concrete that contains a higher amount of alumina, the native form of aluminum oxide, than regular concrete.

*High early-strength materials*—Patching materials that gain high strength levels early in their curing period.

*High molecular weight methacrylate concrete*—A cementitious concrete containing high molecular weight methacrylate, an acrylic resin or plastic made from a derivative of methacrylic acid ( $\text{C}_4\text{H}_6\text{O}_2$ ).

*Hydration rate*—The rate at which molecular water is incorporated into a complex molecule with molecules such as those found in cementitious mixes.

*Incompressible*—A material that resists compression, such as stones, sand, or dirt, in a crack or joint reservoir that is closing.

*Joint bond breaker*—A strip of polyurethane, polyethylene, or fiberboard that is placed in a joint to prevent a patch placed at that joint from bonding to that adjacent slab.

*Joint insert*—A metal or plastic strip inserted into fresh concrete to form a weakened plane and induce cracking at a desired location.

*Joint sealant system*—All components that function to seal joints, including the sealant material, surrounding concrete, and the sealant-concrete interface.

*Laitance*—A residue left on a surface, such as the dried residue left on pavement after a wet-sawing operation.

*Lateral confinement*—Being held in place from the sides.

*Latex caulking*—The filling and water sealing of a space with a latex material.

*Load transfer devices*—Devices such as dowel bars that transfer the traffic load from one slab across a joint to the adjacent slab and that reduce the relative deflection across that joint.

*Magnesium phosphate concrete*—A cementitious concrete that contains magnesium phosphate, a metallic element (Mg) bound to a phosphate group ( $-\text{PO}_4$ ).

*Methyl methacrylate concrete*—Cementitious concrete containing methyl methacrylate ( $\text{C}_5\text{H}_8\text{O}_2$ ), a volatile, flammable liquid that readily polymerizes.

*Opaque*—Not transparent to light rays.

*Operating parameters*—Equipment settings, such as speed, pressure, and number of overlapping passes.

*Partial-depth spall*—An area of deteriorated concrete that is limited to the top third of a concrete pavement slab.

*Polymer*—A chemical compound or mixture of compounds formed by polymerization and consisting of repeating structural units; a substance made of giant molecules formed by the union of simple molecules.

*Polymer resin*—A resin that is a polymer; see polymer and resin.

*Polyurethane concrete*—A concrete consisting of aggregate mixed with a two-part polyurethane resin a resin of repeating structural units of urethane ( $\text{C}_3\text{H}_7\text{NO}_2$ ).



*Preformed compression seal*—A preformed seal, generally made from neoprene, that can be compressed and inserted into concrete joints for sealing purposes.

*Proprietary*—Something that is used, produced, or marketed under exclusive legal right of the inventor or makes.

*Radiant heat*—Heat that radiates from the sun.

*Rapid-setting materials*—In the context of this manual, patching materials that set within 30 minutes of mixing.

*Resin*—Any of a class of solid or semisolid organic products of natural or synthetic origin with no definite melting point, generally of high molecular weight. Most resins are polymers.

*Retarding agent*—A substance added to a cementitious material mixture that initially slows down the rate of hydration, allowing a longer period of workability.

*Rubblization*—The breaking of a concrete pavement into pieces smaller than 300 mm in diameter and its compaction, reducing the amount of reflective cracking in the overlay.

*Saturated*—Full of moisture; having voids filled with water.

*Scalloped*—Having a series of curves in its edges.

*Segregation*—The separation of cement and aggregate.

*Set initiator*—An admixture that triggers the setting of a material.

*Shrinkage cracks*—Fine hairline cracks that develop as a result of water loss and volume reduction during curing.

*Skid resistance*—The resistance of a pavement to tires sliding over its surface; generally a function of the macro- and micro-texture of the pavement surface.

*Slab jacking*—The lifting of a slab at a low point to restore it to its original elevation and rideability.

*Slurry*—The mixture of water, concrete dust, old sealant, and dirt that results from resawing a joint in concrete pavement.

*Spade bit*—A flat, spade-shaped chisel tip used in jackhammering that is recommended for partial-depth spall repair.

*Spalling*—The cracking, breaking, or chipping away of concrete fragments in a pavement.

*Spall*—A small broken or chipped segment of concrete normally occurring along a joint or crack.

*Substrate*—A base layer, such as the repair surface, upon which a material is applied or placed.

*Thermal compatibility*—Compatibility between the thermal properties of two materials, such as similar amounts of thermal expansion resulting from a given temperature increase in the two materials.

*Undersealing*—Filling voids beneath a concrete pavement using a pressurized slurry or hot asphalt material.

*Vibrating screed*—A leveling device drawn over freshly poured concrete that is vibrated to allow consolidation of the material.

*Waterblasting machine*—A machine controlled by a mobile robot that produces a high-pressure water jet capable of removing deteriorated concrete.

*Weight and volume stability*—Structural strength because of sufficient patch weight and volume.



Federal Highway Administration  
U.S. Department of Transportation  
400 Seventh Street, SW  
Washington, D.C. 20590

Publication No. FHWA-SA-96-002  
HNG-42/11-95(2M)EW



U.S. Department  
of Transportation

**Federal Highway  
Administration**

Publication No. FHWA-SA-94-068

July 1994

---

# **SUPERPAVE ASPHALT BINDER TEST METHODS**

## **AN ILLUSTRATED OVERVIEW**

**NATIONAL ASPHALT TRAINING CENTER  
DEMONSTRATION PROJECT 101**



**Asphalt Institute**



**Innovation Through Partnerships**

#### NOTICE

This document is disseminated under the sponsorship of the Department of Transportation in the interest of information exchange. This publication does not constitute a standard, specification, or regulation.

The United States Government does not endorse products or manufacturers. Trademarks or manufacturers' names appear herein only because they are considered essential to the object of this document.

|   |  |  |  |   |           |
|---|--|--|--|---|-----------|
| 1. Report No.<br>FHWA-SA-94-068   |  | 2. Government Accession No.                          |  | 3. Recipient's Catalog No.  |           |
| 4. Title and Subtitle<br>SUPERPAVE Asphalt Binder Test Methods<br>An Illustrated Overview   |  |  |  | 5. Report Date<br>January 1994  |           |
|   |  |  |  | 6. Performing Organization Code   |           |
| 7. Author(s)<br>R.S. Warren, R. B. McGennis, H.U. Bahia   |  |  |  | 8. Performing Organization Report No.   |           |
| 9. Performing Organization Name and Address<br>Asphalt Institute<br>P.O. Box 14052<br>Lexington, KY 40512-4052  |  |  |  | 10. Work Unit No. (TRIS)  |           |
|   |  |  |  | 11. Contract or Grant No.<br>DTFH61-92-C-00098                                      |           |
| 12. Sponsoring Agency Name and Address<br>Federal Highway Administration<br>Office of Technology Applications<br>400 Seventh St., SW<br>Washington, DC 20590  |  |  |  | 13. Type of Report and Period Covered<br>Final Report<br>December 1992-January 1993 |           |
|   |  |  |  | 14. Sponsoring Agency Code<br>HTA-21  |           |
| 15. Supplementary Notes<br>FHWA Technical Representative - J.R. Bukowski  |  |  |  |   |           |
| 16. Abstract<br><br>This manual provides sequential, illustrated steps for performing the SUPERPAVE test procedures on asphalt cements. It also serves as a self-contained laboratory reference document on those procedures. These tests and procedures represent the results of the SHRP 5-year research effort to investigate and improve asphalt cement technology. This manual was developed under the FHWA's National Asphalt Training Center |  |  |  |   |           |
| 17. Key Words<br>Asphalt cement, binder, dynamic shear rheometer, bending beam rheometer, pressure aging vessel, direct tension devices, PG grading system  |  |  | 18. Distribution Statement<br>No restrictions. This document is available to the public from the National Technical Information Service, Springfield, Virginia 22161 |   |           |
| 19. Security Classif. (of this report)<br>Unclassified  |  | 20. Security Classif. (of this page)<br>Unclassified |  | 21. No. of Pages<br>140   | 22. Price |

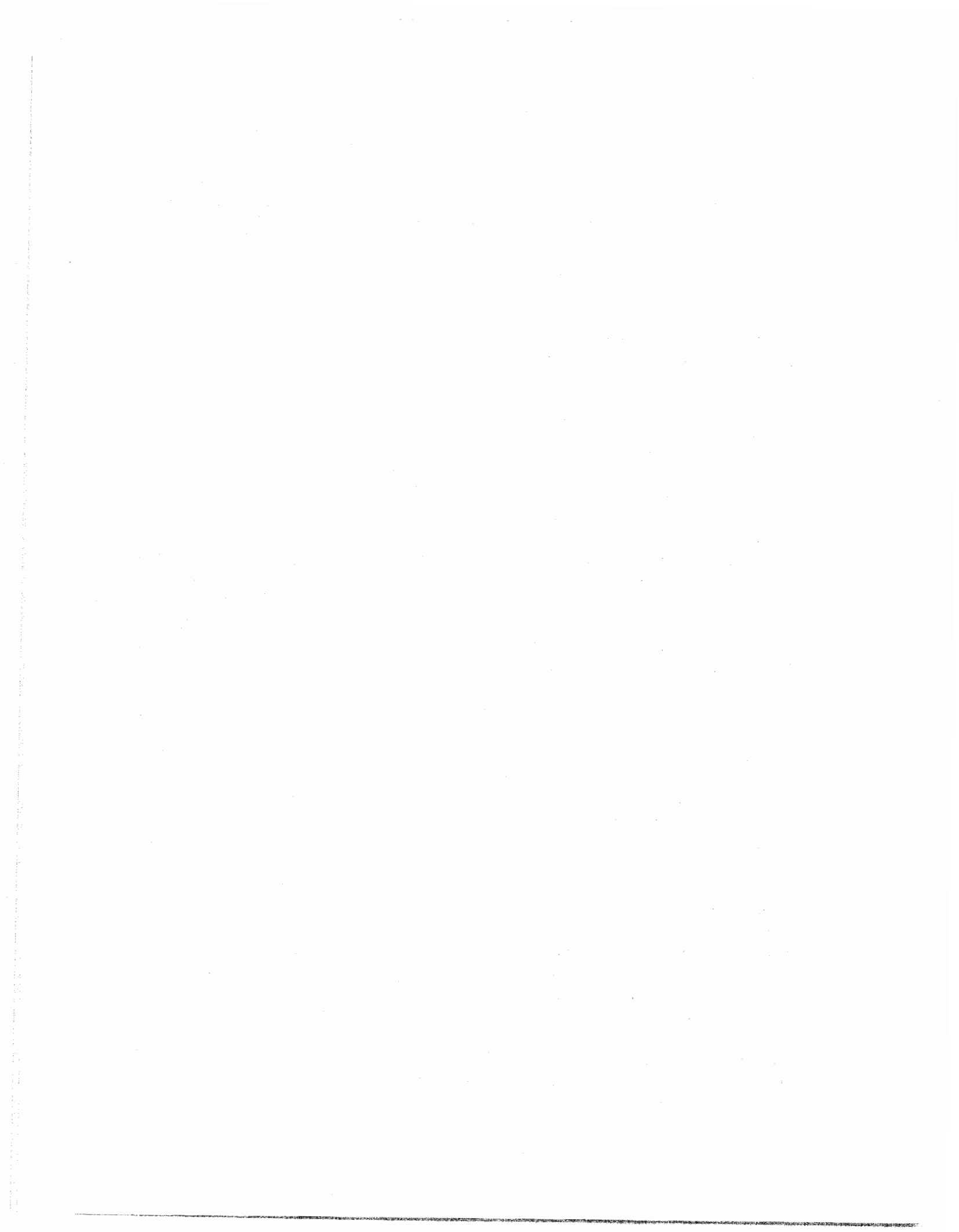



## FOREWORD

From October 1987 through March 1993, the Strategic Highway Research Program (SHRP) conducted a \$50 million research effort to develop new ways to test and specify asphalt binders. Near the end of SHRP, the Federal Highway Administration assumed a leadership role in the implementation of SHRP research. An integral part of FHWA's implementation strategy was a project to develop a nationally accessible training center aimed at educating both agency and industry personnel in the proper use and application of the final SHRP asphalt products referred to as SUPERPAVE™. This project was administered by the FHWA's Office of Technology Applications and designated Demonstration Project 101, the National Asphalt Training Center (NATC).

The NATC resides at the Asphalt Institute's Research Center in Lexington, Kentucky. While the day-to-day affairs of the NATC are directed by Institute personnel, course development and technical direction were duties shared by a team of engineers and technologists from the Asphalt Institute, the Pennsylvania State University, the University of Texas at Austin, the National Center for Asphalt Technology, Marathon Oil Company, and FHWA.

The principal objective of the educational program is to train students in the proper use of the new SUPERPAVE binder test methods and equipment. Another key objective is to teach students how to interpret and apply the new SUPERPAVE binder specification. The training program consists of 40 hours of instruction. Of this 40 hours, students receive eight hours of classroom instruction, 28 hours of laboratory instruction, and four hours of classroom discussion of actual test results. By the end of the course, students will be familiar with binder test procedures and equipment and will know how to use binder test results to classify binders according to the SUPERPAVE binder specification.

The purpose of this manual is to provide a laboratory instructional reference that will be used by students at the Center as they are instructed in asphalt binder test procedures. This instruction occurs principally in the NATC laboratories. The manual is written for technicians and engineers with no previous training in SUPERPAVE products, but with some knowledge in asphalt technology. Other instructional aids at the Center include a student text that is used in the classroom portion of training.

Included in Appendix A of this manual is a set of AASHTO Provisional Standards (September 1993) for Asphalt Binders and other current AASHTO procedures. This manual provides an illustrated overview of these test methods but it is not intended to replace them. The AASHTO Provisional Standards provide detailed information pertaining to all aspects of the tests and form the most important tool in properly performing binder testing.

The illustrated procedures contained in this manual should be used with great caution. It was developed during the last stages of SHRP and in the first few months following SHRP's completion. While the test procedures were largely complete by this time,

specific details of the procedures were (and still are) changing. During preparation of this illustrated overview, no fewer than four drafts of the test methods were available. The steps outlined in this manual follow, as closely as possible, the procedures outlined in the standards contained in Appendix A. *Users of the manual are strongly encouraged obtain the latest versions of the AASHTO test procedures as the most up-to-date reference.*

One of the principal benefits of many of the new SUPERPAVE binder test procedures is their reliance on computer control and data acquisition. The dynamic shear rheometer, bending beam rheometer, direct tension tester, and some rotational viscometers use computers to control testing and capture test results. Because this manual was prepared for use at the National Asphalt Training Center, it is written around the testing equipment and related computer software used for training at the Center. Users should be aware that future developments in binder test equipment and software may conflict with information in this manual. In such cases, users should implicitly follow operational guides and software instructions from the equipment manufacturers along with the most current AASHTO standards.

This manual was co-authored by:

*Mr. Raymond S. Warren  
Asphalt Binder Technologist  
Asphalt Institute*

*Mr. Robert B. McGennis  
Director of Research & Engineering Services  
Asphalt Institute*

*Dr. Hussain U. Bahia  
Research Associate and Assistant Professor of Civil Engineering  
The Pennsylvania State University*

January 1994  
Lexington, KY

***SUPERPAVE™ is a registered trademark of the Strategic Highway Research Program***

## TABLE OF CONTENTS

|   |     |
|---|-----|
| Foreword.....   | i   |
| Table of Contents.....  | iii |
| Test Method for Complex Modulus ( $G^*$ ) and Phase Angle ( $\delta$ ) of Asphalt Binders<br>Using a Dynamic Shear Rheometer.....   | 1   |
| Test Method for Measuring Viscosity of Asphalt Binders Using a Rotational<br>Coaxial Cylinder Viscometer.....   | 16  |
| Test Method for Aging Asphalt Binders Using a Rolling Thin Film Oven.....   | 23  |
| Test Method for Aging Asphalt Binders Using a Pressure Aging Vessel.....  | 27  |
| Test Method for Measuring Creep Stiffness ( $S$ ) and Slope ( $m$ ) of the Log Stiffness<br>versus Log Time Curve of Asphalt Binders at Low Temperatures Using the<br>Bending Beam Apparatus..... | 37  |
| Test Method for Measuring Tensile Strain at Failure of Asphalt Binders at Low<br>Temperatures Using a Direct Tension Apparatus.....   | 54  |
| Appendix A - AASHTO Provisional Standards for Asphalt Binders.....  | A1  |
| Appendix B - AASHTO Standards T 240 and T 48.....   | B1  |
| Appendix C - Forms for Recording Binder Test Results.....   | D1  |



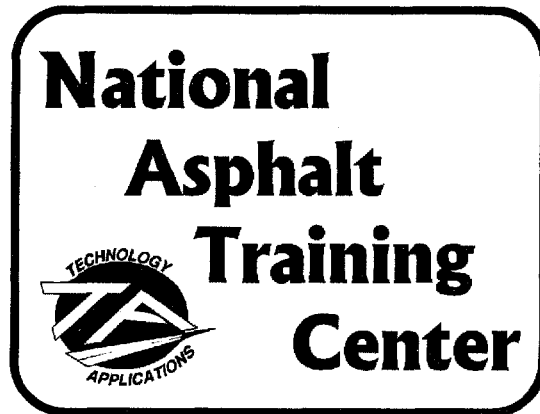

## **Dynamic Shear Rheometer**



## Test Method for Complex Modulus ( $G^*$ ) and Phase Angle ( $\delta$ ) of Asphalt Binders Using a Dynamic Shear Rheometer

This document outlines the basic steps in measuring the complex shear modulus ( $G^*$ ) and the phase angle ( $\delta$ ) of asphalt binders according to AASHTO Provisional Method TP5. It provides an illustrated overview, but it is not intended to replace the standard test method which contains detailed information pertaining to all aspects of the test.

1. This procedure outlines determination of complex shear modulus and phase angle of asphalt binders. The apparatus consists of a dynamic shear rheometer (DSR), a temperature controller, and a computer that is used to control the rheometer and acquire data. The test is performed on unaged binders and binders that have been aged in a rolling thin film oven and pressure aging vessel. One apparatus is shown in Figure 1.
2. At the beginning of the procedure, a 10 g sample is usually in a small container such as a "3 ounce tin." To prepare for testing heat the sample until it is sufficiently fluid to pour. The consistency should be less than 0.5 Pa-sec which is the approximate consistency of motor oil. The sample should never be heated above 150° C.

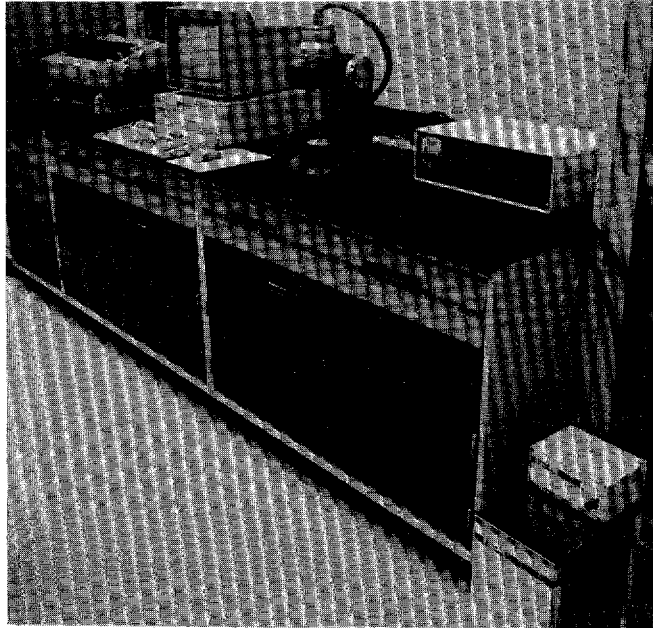

Figure 1. DSR Apparatus

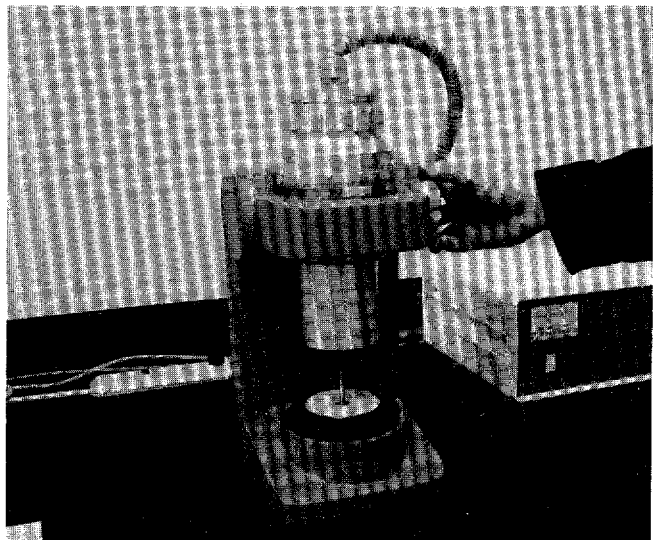

Figure 2. Dynamic Shear Rheometer

3. Two acceptable techniques can be used to procure a specimen for testing. One technique uses a small silicone rubber mold to fabricate a test specimen. The other technique simply requires the operator to pour close to the required amount of asphalt directly onto the upper or lower plate (Figure 3). This method is fast and simple but requires experience in pouring the precise amount needed for testing. The silicone rubber mold procedure is slightly more time consuming, but since it results in a more precise sample size, requires less trimming.

4. To use the silicone rubber mold procedure, pour a thin stream into the mold center (Figure 4) and allowing it to cool at room temperature for about 10 minutes. While most samples can be demolded (Figure 5) at room temperature, some soft samples require slight chilling in a freezer for 5 minutes or less prior to demolding. The sample would be applied directly to the plate before testing and not handled.

5. While the sample is being prepared, the operator should prepare the rheometer for testing.

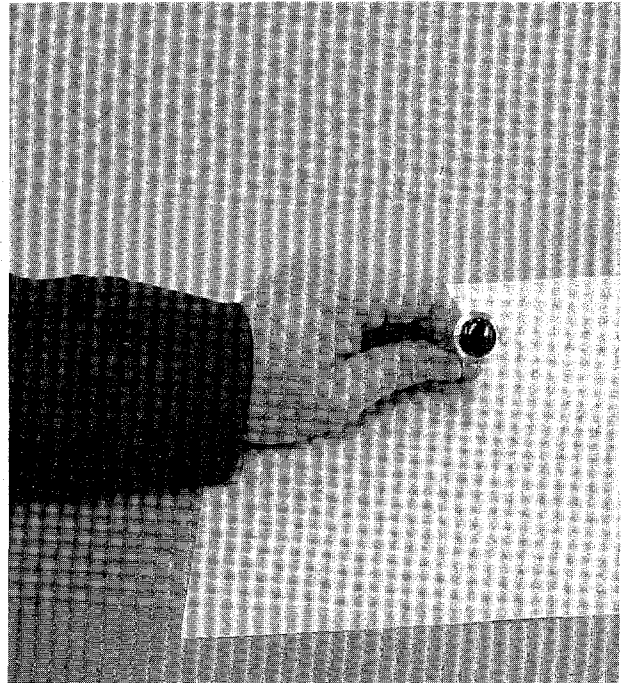

Figure 3. Asphalt Applied to Upper Plate

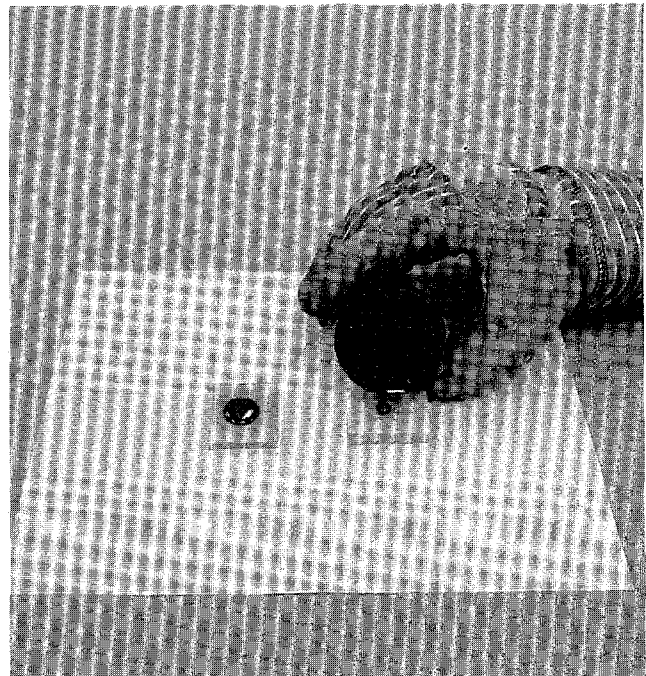

Figure 4. Pouring Hot Asphalt Into Mold



6. Turn on the rheometer air system by opening the supply regulator. The regulator is a valve affixed to the central laboratory air system and is normally located close to the rheometer. In many cases, the valve is part of a combination regulator/water filter system and is not part of the rheometer itself. It is important that the rheometer air system be on prior to manipulation of the rheometer to prevent damage to any components. Turn on personal computer system and temperature control system. Figure 6 is one type of temperature control system that circulates water.

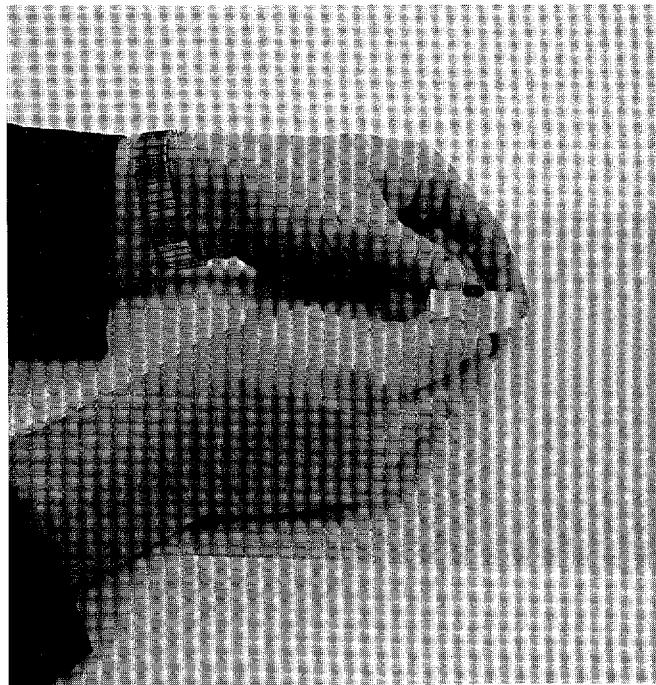

Figure 5. Flexing Mold to Remove Specimen (specimen would be applied directly to plate)

7. Turn on rheometer. Refer to the operator's manual for detailed instructions, such as location of the on/off switch, etc.
8. Initialize rheometer software program. The main menu will appear on computer screen. If rheometer is equipped with a calibration or equipment check routine, perform this step now. Different brands of rheometers require varying degrees of such checks. Consult the operator's manual for details.
9. From the main menu, select or verify that the rheometer is in the oscillatory load mode.

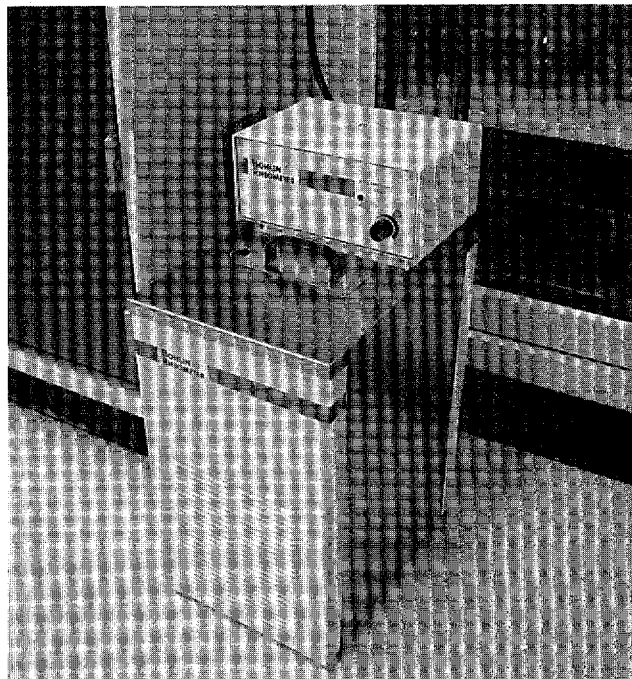

Figure 6. Temperature Control System

10. Use the rheometer software to set the proper base plate test temperature. If only one test temperature is to be used, set the rheometer accordingly. If using a range of temperatures, set the base plate temperature in the middle of this range.

11. When the computer screen indicates the desired temperature has been reached the operator can set the gap between the upper plate and base plate. This is accomplished in two distinct steps: establishing the zero gap position and the desired gap position.

12. Attach the upper plate to the rheometer spindle. Two plate sizes are used. A small plate, 8 mm in diameter, is used to perform tests at moderate temperatures of about 40° C or below. A large plate, 25 mm in diameter, is used to perform tests at higher temperatures greater than 46° C. Figure 7 shows various sizes of plates.

13. Depending on the type of rheometer, either lower the upper plate or raise the base plate (Figure 8) so that they are in close proximity (approximately 3 mm). These large adjustments are made using a variety of techniques, which are rheometer dependent. In some cases, the upper plate is lowered with a coarse adjustment knob similar to a drill press (Figure 2). In other cases, the lower plate is raised by means of a hydraulic ram (Figure 9). The operator should consult the rheometer instruction manual to determine how to adjust the gap.

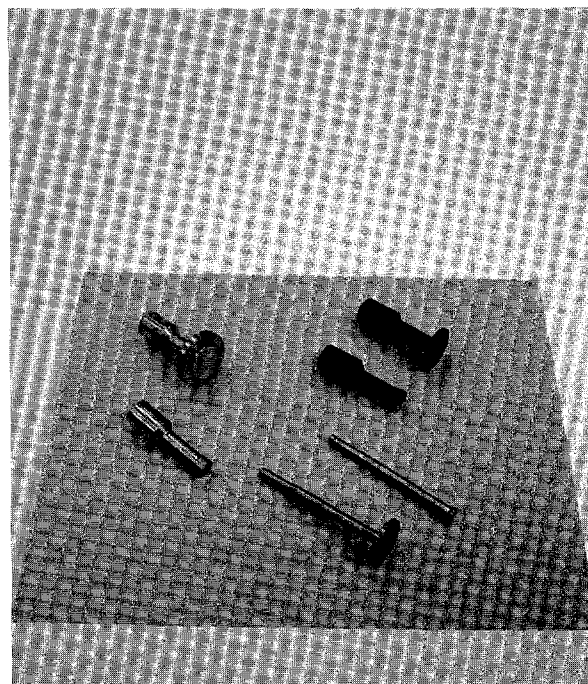

Figure 7. Various DSR Plates

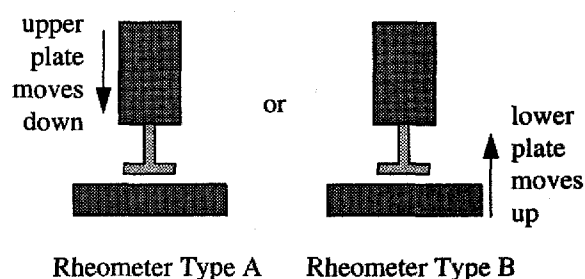

Figure 8. Methods of Adjusting Gap Between Upper and Lower Plates

14. Gently spin the spindle and upper plate. The point where the upper plate contacts the base plate and just stops spinning is considered a zero gap condition. After zero gap position has been established, the operator should read and record the number off the micrometer wheel. The micrometer wheel indicator is usually located above the upper plate or below the base plate and functions as a vertical position indicator to establish the position of the base plate and upper plate relative to each other. In Figure 9, the micrometer wheel is in the small oval window in front of the ram. Figure 10 shows the micrometer wheel on another rheometer. Graduations on the micrometer wheel are normally in 5 micron increments; the operator should consult the operator's manual if questions arise over this scale. This procedure of spinning the upper plate followed by gentle contacting with the base plate to establish zero gap should be performed several times to firmly establish that a zero gap has been achieved. When two successive micrometer wheel readings are 2 microns or less apart, the operator can be assured that a zero gap condition has been achieved. It should be noted that the zero gap condition assumes that the upper plate and base plate are barely in contact, and hence, the upper plate is no longer free to spin. On some rheometers, the micrometer wheel indicator can be reset to read "zero" when the zero gap position has been achieved. For other rheometers without this capability, it is sufficient to simply record the observed number on the micrometer wheel when the rheometer is in the zero gap position to establish the base or "zero" reading.



Figure 9. Hydraulically Activated Lower Plate (Note specimen being trimmed)

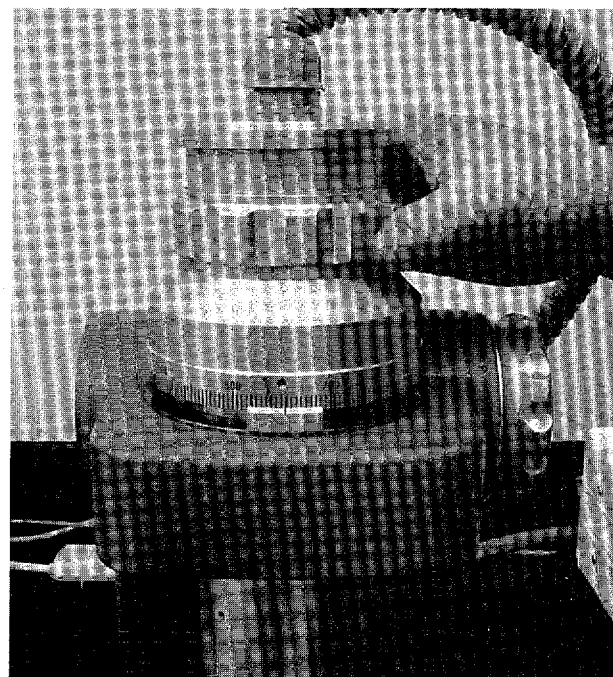

Figure 10. Micrometer Wheel

15. Once the operator sets the zero gap condition, the testing gap can be set. For the larger plate used at high test temperatures of 46° C or more, the gap between the upper plate and base plate should be set at 1 mm. The smaller plate used at intermediate test temperatures of 40° C and below require a gap of 2 mm.

16. When initially setting the gap between the upper plate and base plate, the operator sets a gap equal to the desired gap plus an extra 50 microns (Figure 11). The extra 50 microns will be dialed-out prior to testing but is included to achieve the proper sample shape during testing.

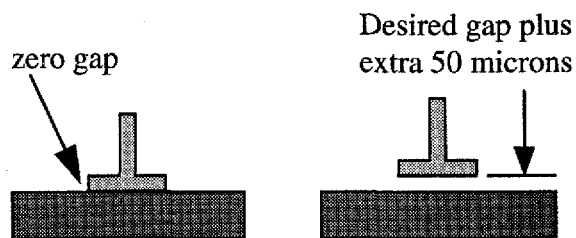

Figure 11. Extra Gap Set by Operator

17. Set the desired gap (including the extra 50 microns) by dialing the micrometer wheel to 1 mm plus 50 microns (high test temperature gap) or 2 mm plus 50 microns (low test temperature gap). Normally, one full revolution of the micrometer wheel results in a 1 mm (1000 microns) change in vertical position.

18. A skilled operator should be able to prepare the rheometer for testing, including all gap settings in 5 minutes or less.

19. The operator should clean and dry the upper and lower plates before testing. Acetone is a suitable fluid for cleaning and drying.

20. The exact steps in installing the binder sample are rheometer dependent. The two most common procedures are as follows.
  
21. For rheometers that have an activated base plate such as shown in Figure 12, lower the base plate to its lowest vertical position. This is normally accomplished by using the rheometer control software. Pour the heated sample onto the base plate. Pour the sample in a single, thin stream so that it spreads to form a disc that has a diameter within about 2 mm of the upper plate. If a molded sample is used, flex the silicone mold (Figure 5) and apply the molded sample directly to the base plate. The operator should not use fingers to handle or position the molded sample. A clean tool may be used for this purpose. Use the rheometer software to raise the base plate back up to its previous position, at which the preliminary gap had been set. This gap setting should not have changed. The sample should now be squeezed between the upper and base plates, ready for trimming (Figure 12).

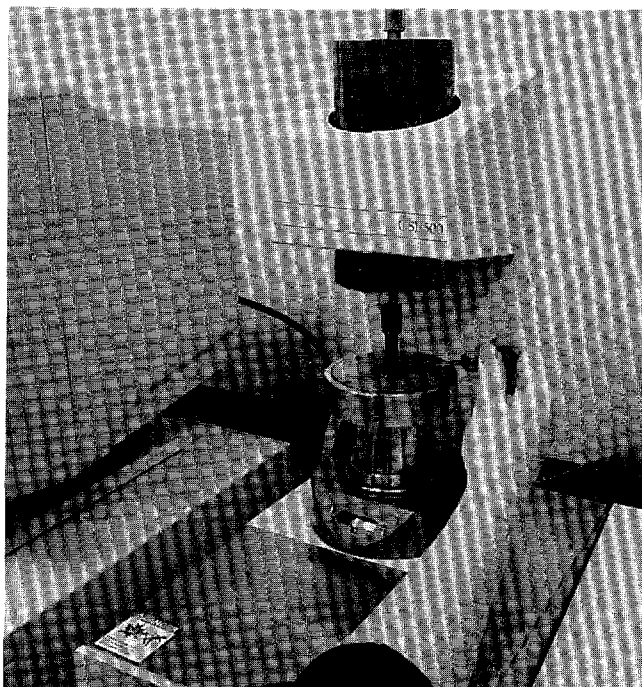

Figure 12. Base Plate Raised Squeezing Sample in Gap; Sample Being Trimmed

22. For rheometers with an activated upper plate, the sample is installed on the upper plate. Thus, the first step is to raise the upper plate (Figure 13) and remove it from the rheometer. Invert the plate and pour the sample in a single, thin stream (Figure 14) so that it spreads to form a disc shape that has a diameter within about 2 mm of the upper plate. If a molded sample is used, flex the silicone mold and apply the molded sample directly to the upper plate (Figure 5). The operator should not use fingers to handle or position the molded sample. A clean tool may be used for this purpose. Reinstall the upper plate. It now has the cooled sample stuck to its surface. Lower the upper plate back down to its previous position, at which the preliminary gap had been set. This gap setting should not have changed. The sample should now be squeezed between the upper and base plates, ready for trimming.

23. Trim the sample using an appropriate, heated tool. Such a tool should be in the shape of a small slotted screwdriver with a slot width greater than 4 mm. Trimming should result in a specimen that has vertical sides, flush with the edge of the upper plate.

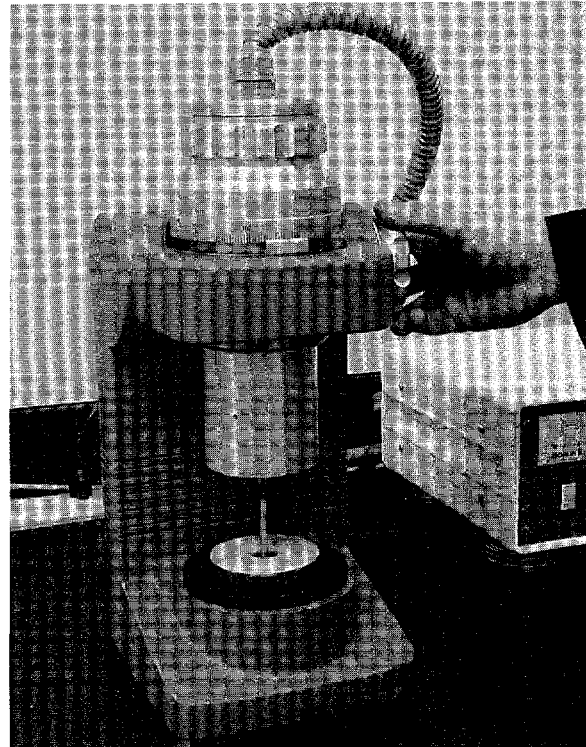

Figure 13. Adjusting Position of Upper Plate



Figure 14. Applying Specimen to Upper Plate

24. Next, the operator should dial out the extra 50 microns by adjusting the micrometer wheel. At this point, the gap should be exactly the desired testing gap, either 1 or 2 mm, and the sides of the specimen should bulge slightly (Figure 15). The specimen is now ready for thermal conditioning.

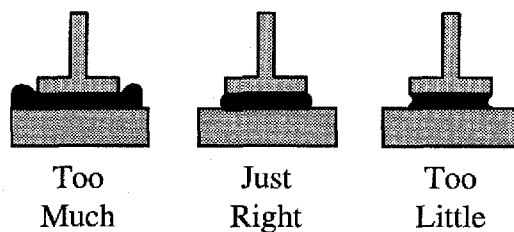

Figure 15. Proper and Improper Sample Shapes

25. Because the properties of asphalt binders are extremely sensitive to temperature, it is necessary to precisely control the temperature of the specimen during the test. The temperature of the sample must be within  $\pm 0.1^\circ \text{C}$  of the desired test temperature. Sample temperature is controlled by surrounding it with a circulating water bath (Figure 16) or air oven (Figure 17) that is precisely maintained at the testing temperature. Typically, it takes 10 minutes for the sample to achieve the desired test temperature when an air oven is used. Water baths normally take less time, usually about 5 minutes. The actual amount of time can be determined using a dummy specimen described in step 26.

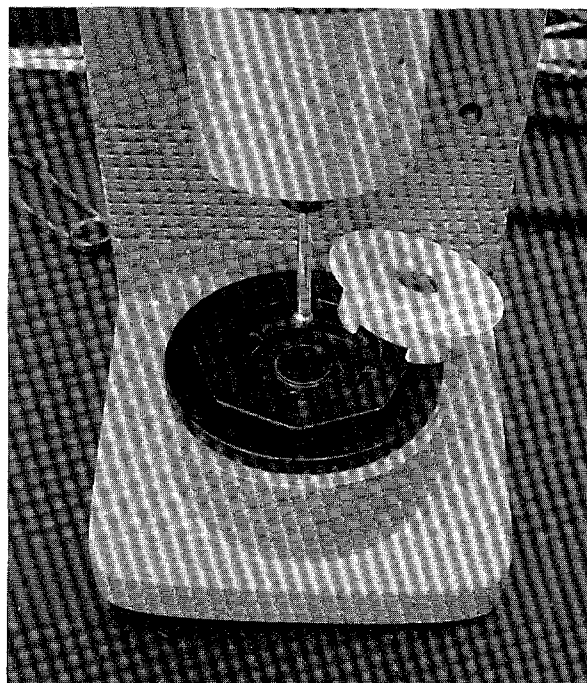

Figure 16. Water Bath for Controlling Specimen Temperature During Testing

26. To ascertain the temperature control characteristics of rheometers, a dummy specimen may be used. One example is the thermistor unit shown in Figure 18. The thermistor unit consists of a resistor embedded between two sheets of silicone rubber. The resistance of the resistor is highly temperature dependent. A calibration is used to convert a change in resistance to a corresponding change in temperature. The unit is placed between the upper and lower rheometer plates and connected to an ohmmeter. Thus, a highly accurate determination of temperature between the plates can be made. By using this approach, the operator can learn the proper amount of time for binder specimens to reach the desired test temperatures. This step need not be performed before each test but rather, on a periodic basis to calibrate the rheometer temperature control system and determine equilibration time (step 27).

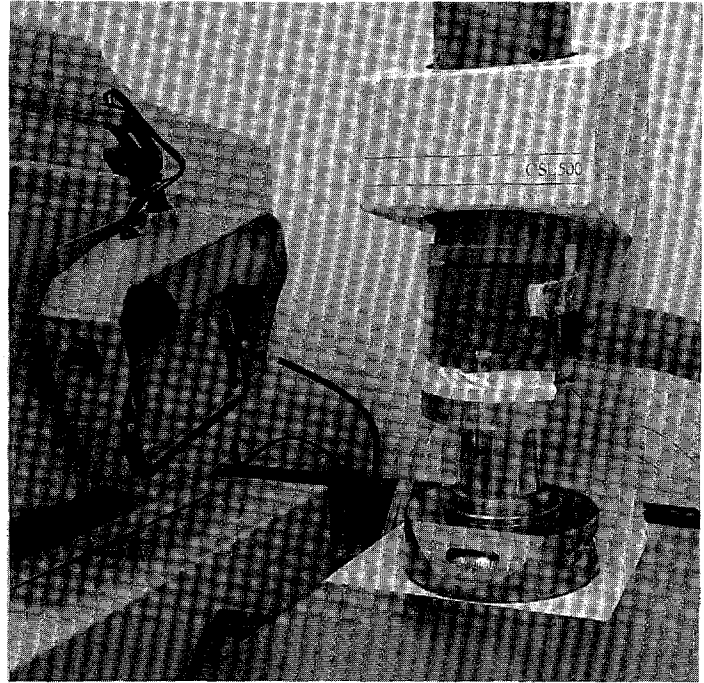

Figure 17. Air Oven for Controlling Specimen Temperature During Test

27. After the temperature reading has reached the desired value, allow the temperature to equilibrate. The equilibration time will be different for different rheometers, temperature control systems, and starting temperature. The equilibration time can be determined using the dummy specimen procedure outlined in step 26. After the temperature has equilibrated, anneal the specimen for 5 minutes (water bath) or 10 minutes (air oven).

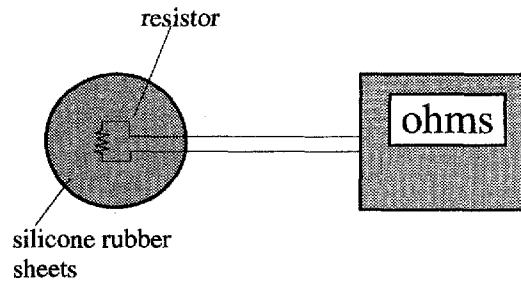

Figure 18. Thermistor Unit Used to Measure Temperature Between Plates



28. At this point the sample is ready to be tested and the operator should use the rheometer software to set the desired test inputs and conduct the test (Figure 19). Once again, the operator should consult the rheometer manual if questions arise concerning the exact steps necessary to perform testing. In most cases, system software is sufficiently self explanatory and often prompts the operator for needed items. Software often contains default values for items such as gap, frequency, etc. and the operator need not worry about setting these values. In other cases, the operator sets inputs the first time and the software "remembers" these values for subsequent tests. The following testing procedure consists of steps that are generic to most rheometers.

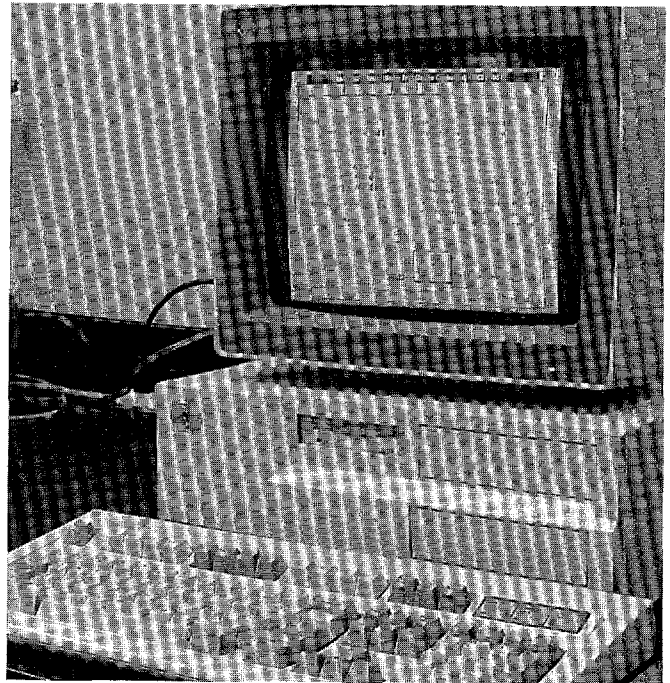

Figure 19. Computer for Controlling Test

29. Using the system software set the desired inputs or verify that the software has selected the proper values. The following items are of interest.
30. Most control software requires the operator to input items like sample identification number, sample age condition, and operator name.
31. The frequency always should be set at 10 radians per second (1.59 Hz).
32. Verify that the gap displayed on the computer screen is the proper value. By so doing, the operator is not resetting the gap between the upper and base plates. This displayed value is simply that which is used by the software to perform subsequent calculations.

33. The displayed plate size should be set or verified by the operator. This value will be either 8 or 25 mm, depending on test conditions.

34. The shear strain or shear stress should be set by the operator. The proper testing values depend on the value of the complex modulus ( $G^*$ ), but the operator can use the values shown in the table (right) as a starting point. After setting a value, the rheometer software will automatically control the shear strain or shear stress during the test.

| Material Tested | Shear Strain, % | Shear Stress, kPa |
|-----------------|-----------------|-------------------|
| Orig Binder     | 12              | 0.12              |
| RTFO Residue    | 10              | 0.22              |
| PAV Residue     | 1               | 50                |

35. Initiation of the test may occur in several different ways. Some rheometers will automatically begin testing after the specified temperature equilibration time has been reached. Other rheometers require a manual initiation by the operator. In any case, the operator should follow the directions given by the control software and /or the operator's manual.

36. A test consists of two phases, load conditioning and data acquisition. The conditioning phase consists of a complete run time application of load cycles. During this phase, the sample is subjected to the same shear loads but no tests results are captured. In the data acquisition phase, the sample is similarly loaded and system software captures the response of the sample to the load application and computes test results. During testing, the operator may watch the computer screen and observe the acquisition of test results.

37. Condition the specimen by applying the required shear strain (or stress) for 10 cycles at the required rate of 10 radians per second. Obtain test measurements by loading the specimen for an additional 10 cycles. Test results are automatically acquired by the rheometer software.

38. At the end of the testing sequence, the operator should manipulate the software to get a printed copy of test results (Figure 20) and if necessary, store results on the computer's hard disk drive.

39. All of the required reporting items are printed by the rheometer software. These are:

- test plate size, nearest 0.1 mm,
- test gap, nearest  $\mu\text{m}$ ,
- test temperature, nearest  $0.1^\circ\text{C}$ ,
- test frequency, nearest 0.1 rad/sec,
- strain amplitude, nearest 0.01%, or torque, nearest mN-m,
- complex modulus ( $G^*$ ) for the second 10 cycles, kPa to three significant figures, and,
- the phase angle ( $\delta$ ), nearest  $0.1^\circ$ .

Additional reporting items include a complete identification and description of the material tested, including name code, source, and type of sample container. The instrument used for the test should also be described, including whether it is a constant strain or stress device, the type of environmental chamber, and any other information to describe the rheometer.

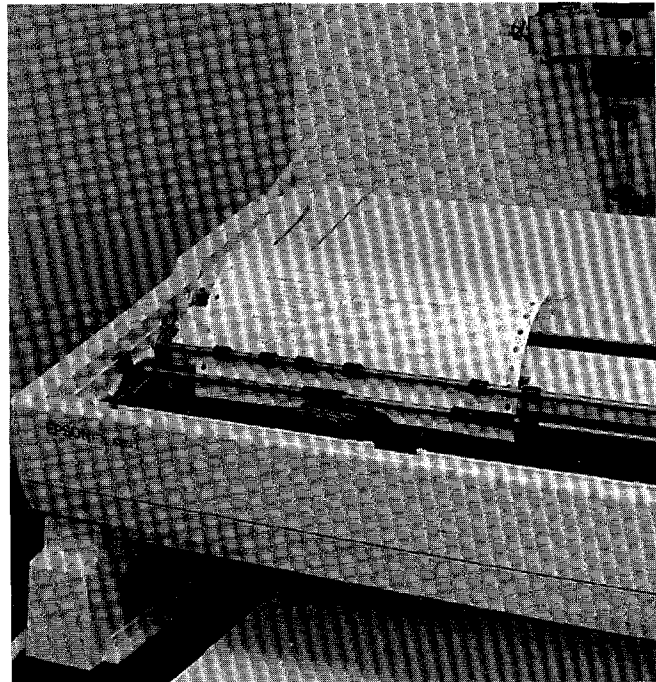

Figure 20. Printer for Printing Test Results

40. The operator may wish to run additional tests on the same sample, but at a different temperature. In these cases, all that need be done is to reset the temperature control to the desired temperature and allow sufficient time for the specimen to reach the desired temperature followed by temperature equilibration and annealing. The test is performed as before. When multiple temperatures are to be used, the operator should start at a midrange temperature and proceed to next desired temperature.
  
41. Total time, including sample and equipment preparation, to perform this procedure should be about 1 hour for a skilled operator. This time will increase if test results at different temperatures are required. Each additional testing temperature will normally add about 20 minutes to total test time. When testing one sample at multiple temperatures, the entire testing must be completed within 4 hours from the time the sample was heated to pouring temperature.
  
42. The operator should clean the upper plate by heating it (if necessary) and wiping with mineral spirits or other suitable solvent. The warm base plate should be wiped with a paper towel to remove excessive binder. The remaining residue should be removed by wiping the base plate with a paper towel moistened with solvent. Always use acetone to clean the plates to remove solvent residue.

43. Rheometer calibration and verification should be performed periodically. This includes calibration of the resistance thermal detector (RTD), load transducer, and strain transducer. A confidence check on the rheometer can be performed using suitable reference fluids or a dummy specimen with known properties. Calibration procedures are provided in the test method.

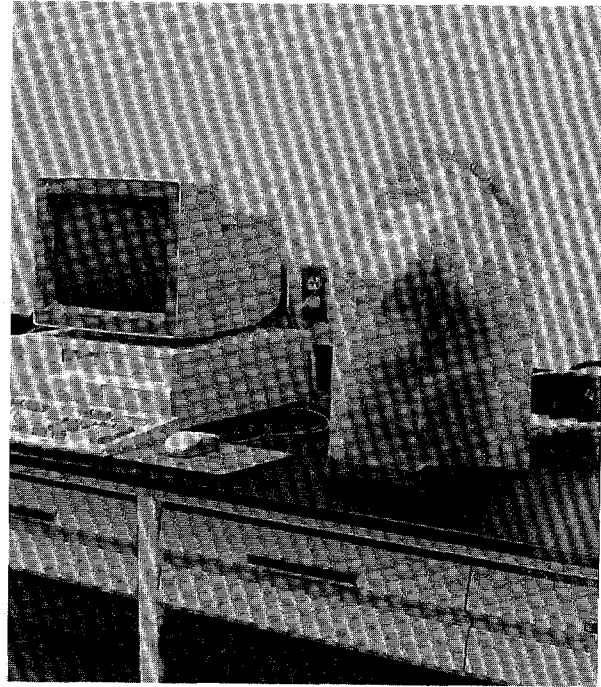
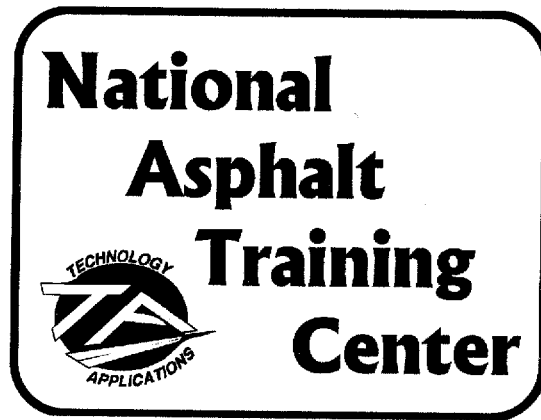

Figure 21. Dynamic Shear Rheometer





## **Rotational Viscometer**

## Test Method for Measuring Viscosity of Asphalt Binders Using a Rotational Coaxial Cylinder Viscometer

This document outlines the basic steps in measuring the viscosity of asphalt binders using a rotational coaxial cylinder viscometer according to procedures outlined by ASTM D 4402. It provides an illustrated overview, but it is not intended to replace the standard test method which contains detailed information pertaining to all aspects of the test. This procedure assumes that the operator is using a Brookfield (or similar) Viscometer (DV-II+) with a Thermosel™ temperature control system.

1. This procedure outlines determination of high temperature viscosity of asphalt binders. The apparatus consists of a rotational coaxial cylinder viscometer (Figure 1) and a unit to control temperature (Figure 2). The test is performed on unaged binders.

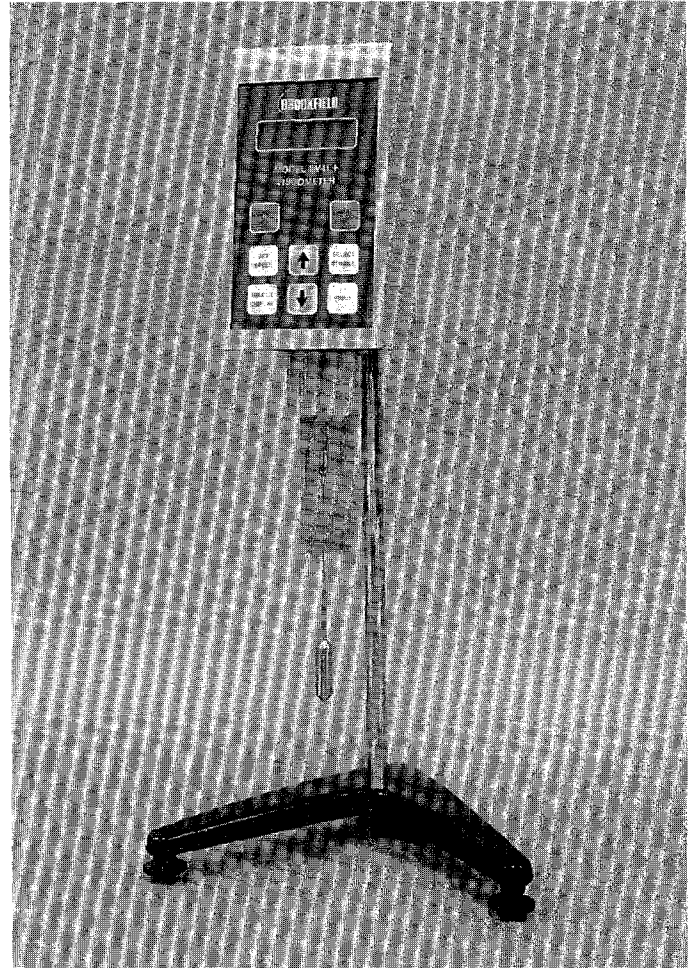

Figure 1. Rotational Viscometer with Spindle Attached



2. Turn on the Thermosel™ (Figure 2). Set the desired test temperature, usually 135 ° C, on the Thermosel controller by holding the set button and turning the set point knob until the digital display reads the proper temperature.

3. Place the sample chamber into the sample chamber holder and then both into an oven at 135° C. In the same oven, place a "3-ounce" container containing the asphalt sample. Also place the spindle in the oven.

4. Turn on the viscometer and remove spindle if necessary. Level the viscometer and thermo container using the bubble indicators on each device.

5. By using the keypad on the front of the viscometer (Figure 3), push the "Select Spindle" button and press arrow keys until the proper spindle number is displayed. For most unmodified asphalts, spindle nos. 21 and 27 are used. For soft asphalts or modified asphalts, consult the Thermosel system operator's manual for the proper spindle. The spindle used is determined by the anticipated viscosity of the fluid being tested.

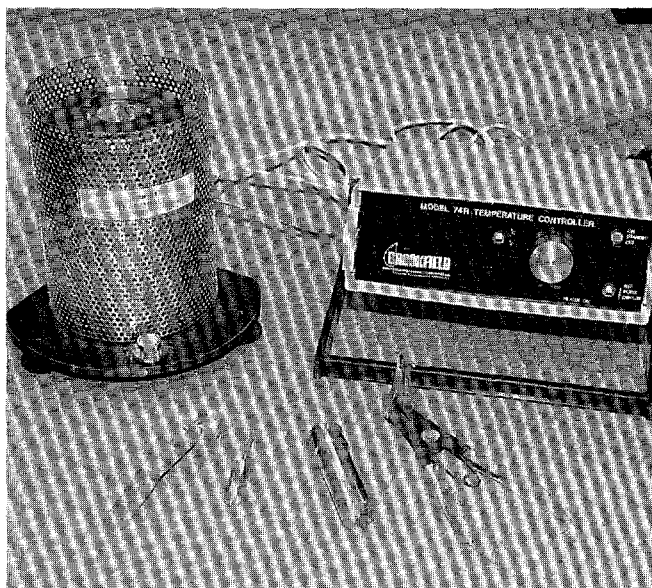

Figure 2. Temperature Control System (background is thermo-container and controller; foreground is insulating cap, spindle, sample chamber, and extraction tool)



Figure 3. Viscometer Keypad

- When the digital display on the thermoset indicates the desired temperature has been reached, remove the sample chamber still in its holder from the oven and place both on a scale accurate to the nearest 0.1 g. Tare the scale.

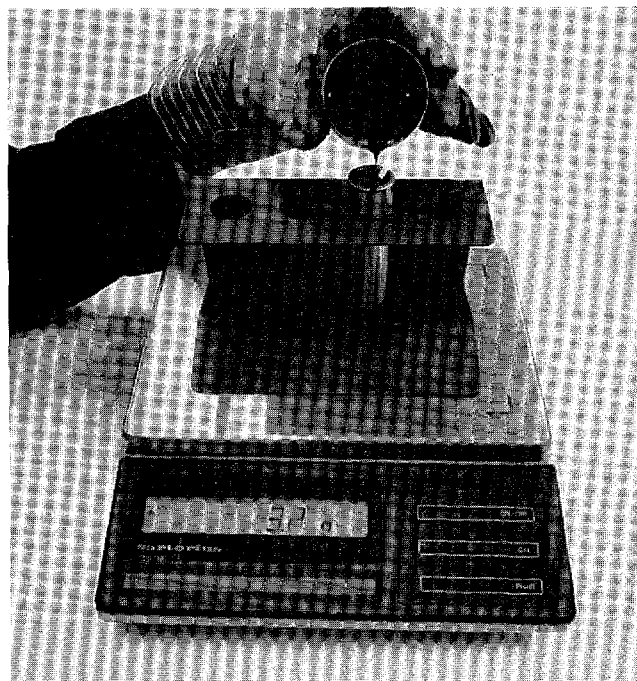

Figure 4. Pouring Sample Into Chamber

- Pour the required amount of asphalt binder in to the sample chamber (Figure 4). The amount of asphalt used depends on the spindle size. For spindle no. 27, 10.5 ml of asphalt is the correct amount to be loaded into the sample chamber. Consult the operator's manual for the proper sample size for other spindles.

- Using the extraction tool, remove the sample chamber containing the hot sample from the chamber holder and place it in the thermo-container (Figure 5).

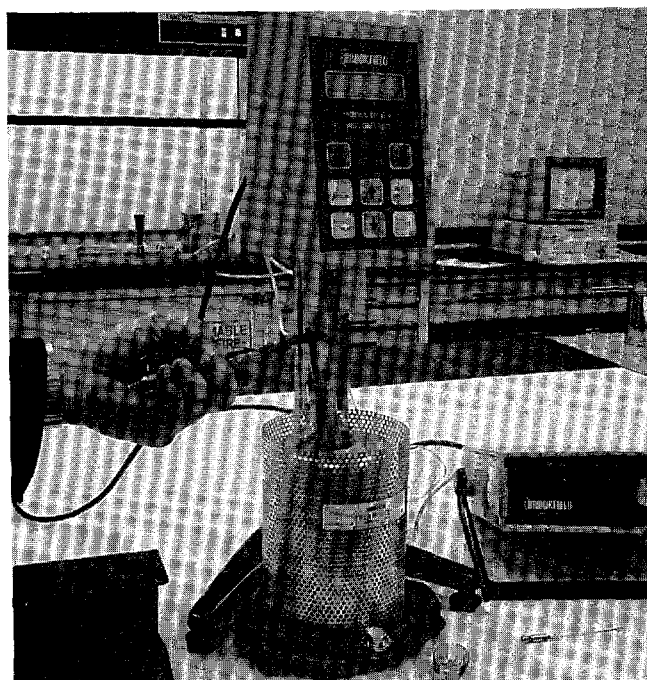

Figure 5. Placing Sample Chamber in Thermo-Container

- Align the thermo container with the viscometer. To accomplish this, lower the viscometer by turning the height adjustment knob until the alignment bracket makes contact with the rear vertical face and horizontal face of the locating ring on the thermo-container (Figure 6). From this position, raise the viscometer approximately 1.5 mm. Since this is such a critical measurement, a reference point should be marked on the rear vertical face of locating ring to facilitate precise vertical positioning.

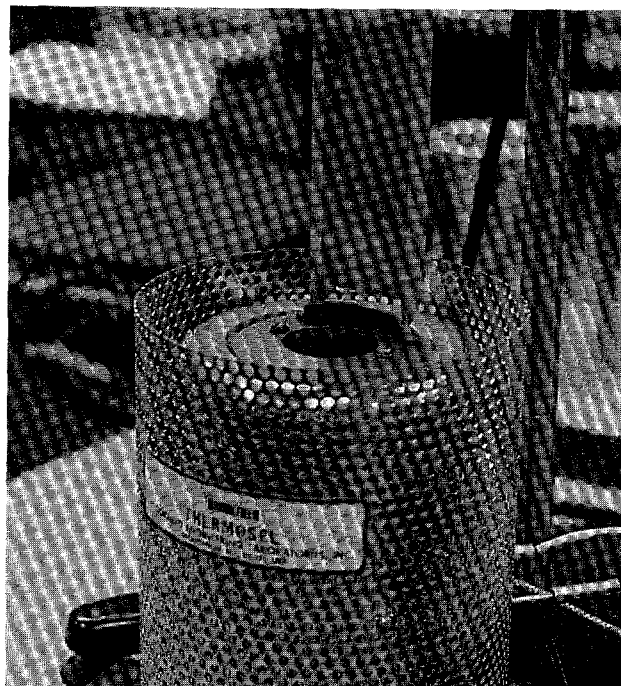

Figure 6. Alignment Bracket and Locating Ring

- Remove the spindle from the oven and attach it to the spindle extension (Figure 7). The spindle extension is a stiff wire with a loop on one end and a female coupling on the other. To attach the spindle, simply insert the loop through the small hole in the top of the spindle.

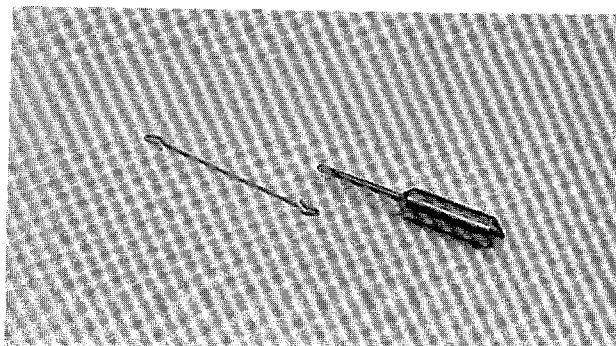
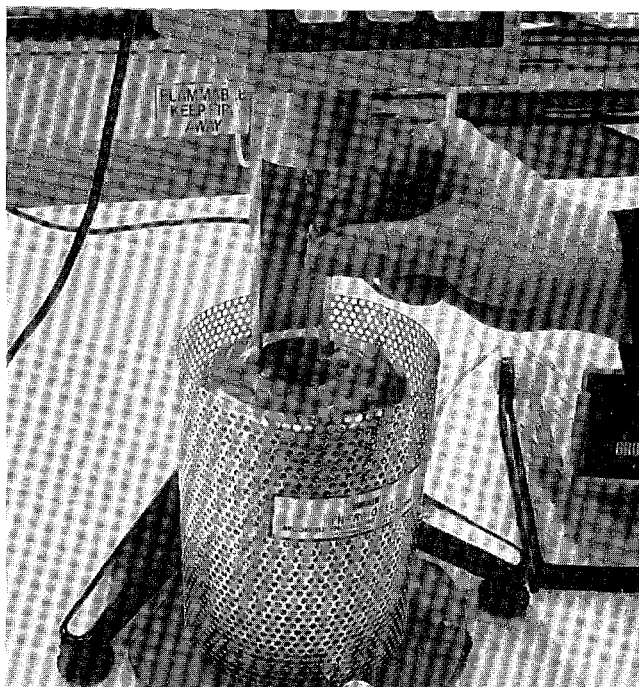

Figure 7. Spindle and Extension

11. Gently lower the spindle into the sample chamber containing the hot sample. Lower it enough so that the female coupling on the end of the spindle extension can be screwed onto the male viscometer coupling nut (Figure 8).



12. Place the insulating cap over the opening in the thermo container (Figure 9). Equilibrate the sample temperature for a period of approximately 30 minutes. During this period, occasionally observe the digital temperature display on the controller to verify that the temperature is rising toward the test temperature.

Figure 8. Attaching Spindle Extension with Viscometer Coupling Nut

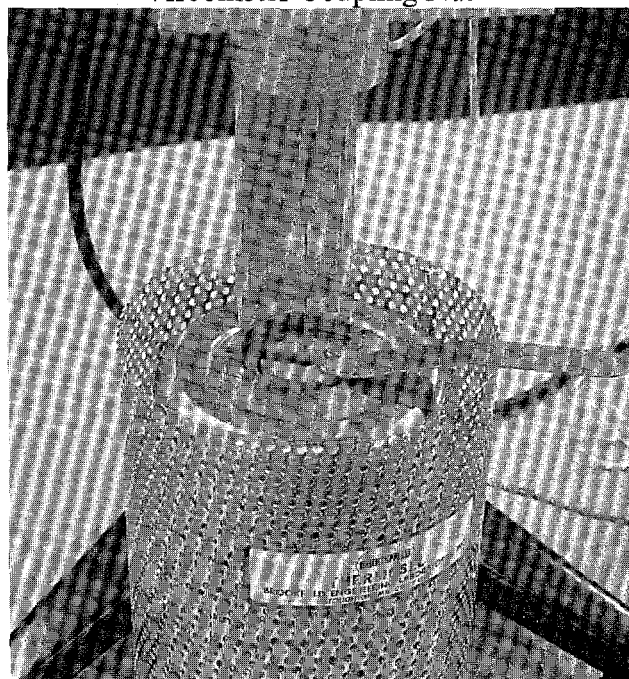

Figure 9. Insulating Cap on Thermo-Container

13. Set the viscometer motor speed by pressing the "Speed" key on the viscometer keypad (Figure 10). Use the arrow keys to set the desired testing speed, 20 rpm. For relatively soft binders, the speed may need to be increased in order to increase the viscometer torque value so that it is within the acceptable range of 2 to 98 percent torque.

14. Set the display to read viscosity by pressing the "Set Display" key until viscosity in centipoises (cP) is shown in the upper left corner of the display. During the equilibration period, observe the viscosity. The viscosity will normally decrease as the temperature of the sample rises. When the viscosity reading remains constant, the temperature is considered equilibrated.

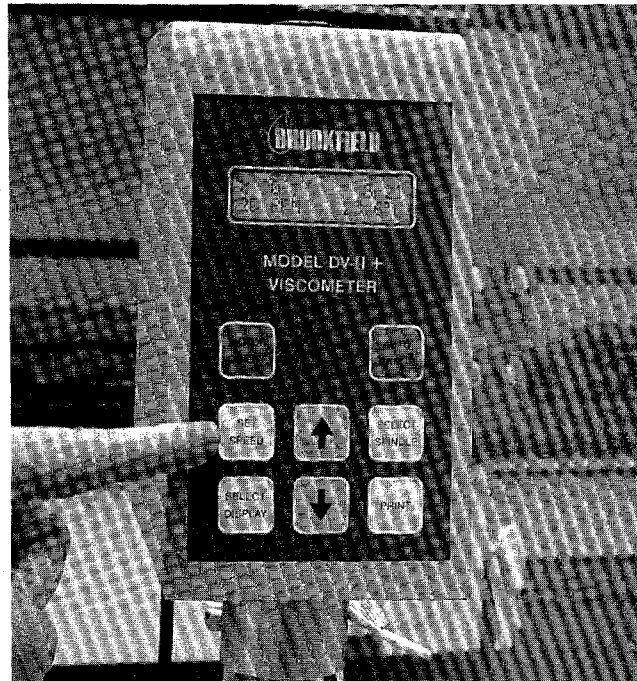

Figure 10. Viscometer Keypad

15. Read and record a viscosity value at one-minute intervals for a total of three readings. The viscosity measurements are in units of centipoises (cP). Convert cP to Pascal·seconds (Pa·s) by dividing cP by 1000.

16. The following items should be reported:

- test temperature,
- spindle number,
- spindle speed, rpm, and
- viscosity, Pa·s, nearest 0.1 Pa·s.

17. Total time, including sample and equipment preparation, to perform this procedure should be less than an hour for a skilled operator.

18. To clean the sample chamber, remove it from the thermo-container using the extraction tool and discard the sample. Allow the hot sample chamber to cool about 5 minutes. Clean the sample chamber using mineral spirits or other suitable solvent. The sample chamber should be wiped with a clean cloth so that no solvent residue remains. Acetone is effective in removing solvent residue.

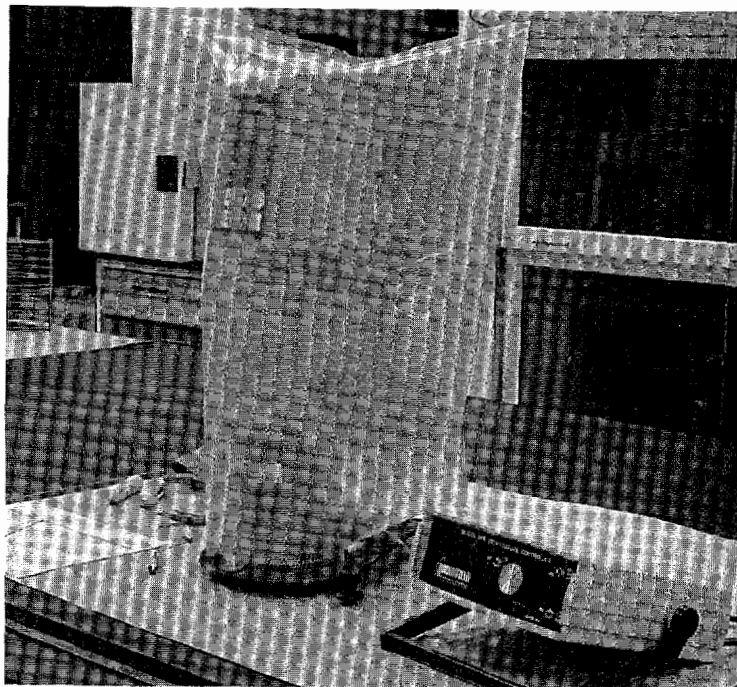
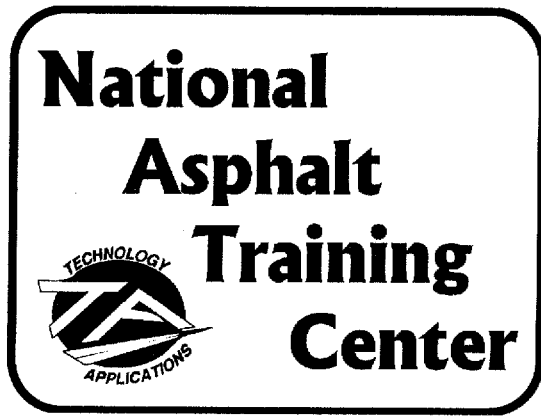

Figure 11. Rotational Viscometer



## **Rolling Thin Film Oven**





## Test Method for Aging Asphalt Binders Using a Rolling Thin Film Oven

This document outlines the basic steps in aging asphalt binders using a rolling thin film oven (RTFO) according to AASHTO T 240. It provides an illustrated overview, but it is not intended to replace the standard test method which contains detailed information pertaining to all aspects of the test.

1. The rolling thin film oven (RTFO) aging procedure is a conditioning step that simulates construction aging of asphalt binders. Additional tests are performed on the residue from the test. The rolling thin film oven (Figure 1) consists of an oven chamber with a vertical circular carriage. Sample bottles rest in the carriage and the assembly rotates about the carriage center. A fan circulates air in the chamber. At the bottom of the rotation, an air jet blows hot air into the sample bottle.

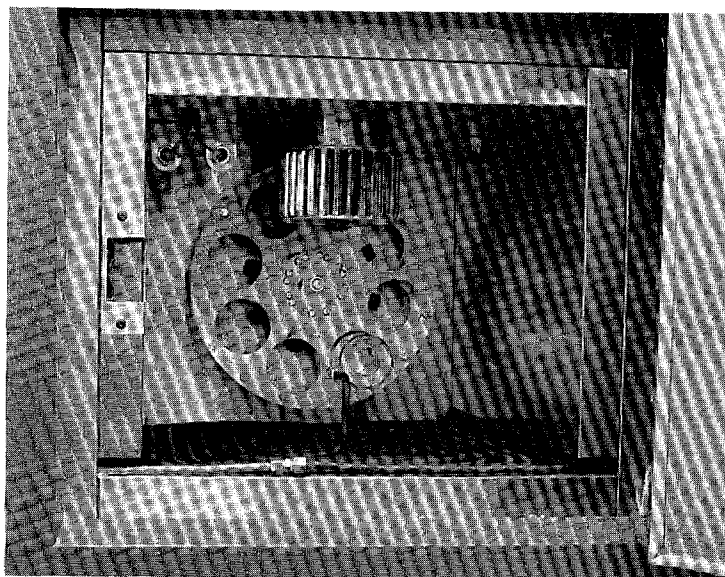

Figure 1. Inside of Rolling Thin Film Oven

2. Turn on the oven and all associated devices (e.g., carriage, fan, etc.) at least 16 hours prior to testing.
3. Heat at least 350 g of asphalt binder sample in a suitable container until the sample is sufficiently fluid to pour. Occasionally stir the sample to ensure homogeneity.
4. While sample is heating, weigh two bottles on a scale accurate to the nearest 0.001 g. These will be used for mass change determination (Figure 2).

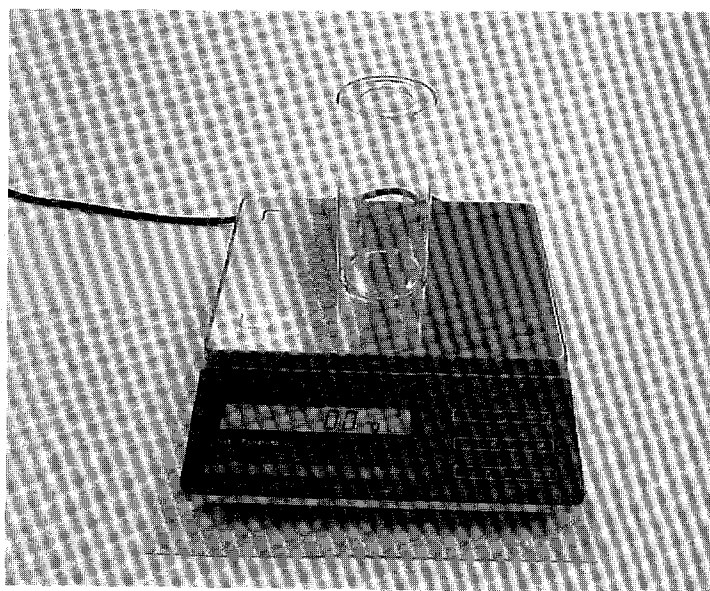

Figure 2. Bottle Prior to Loading Specimen

5. Pour into each bottle  $35 \pm 0.5\text{g}$  of binder (Figure 3). Cool to room temperature.
6. Weigh to the nearest 0.001 g the mass loss samples and bottles.

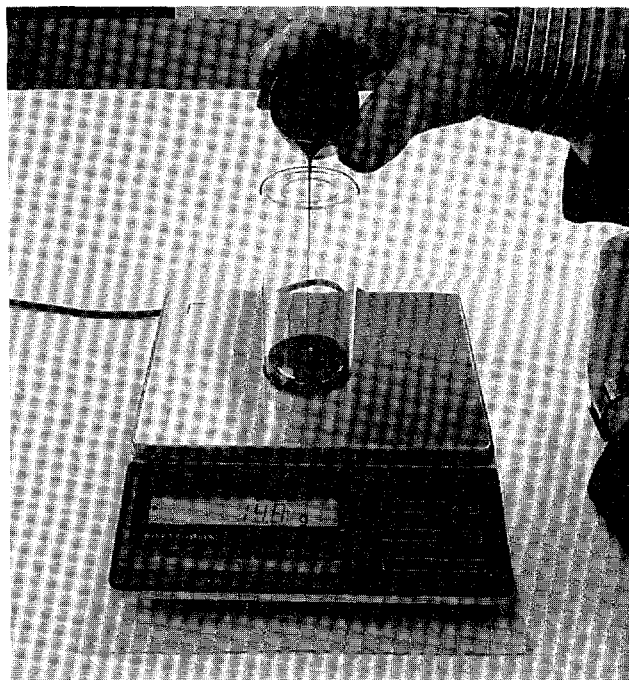

Figure 3. Weighing Specimen Into Bottle

7. With the oven at operating temperature,  $163^{\circ} \pm 0.5^{\circ} \text{C}$ , place bottles containing asphalt into the circular carriage Figure 4). Fill any unused spaces with an empty bottle. Oven temperature is displayed by a thermometer suspended in the oven and will drop during placement of the bottles.

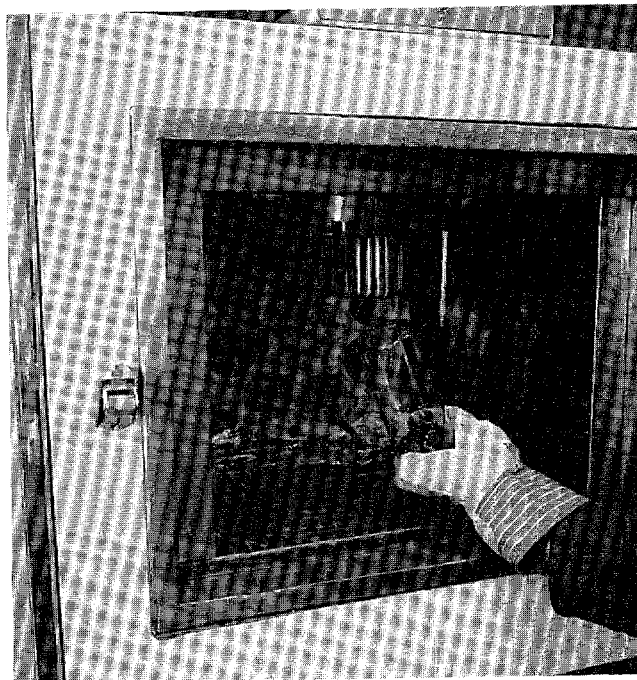

Figure 4. Placing Bottle in Oven

8. Close the door and begin rotation of carriage assembly at a rate of  $15 \pm 0.2$  rpm. Start the air flow at a rate of  $4000 \pm 200$  ml/min.