

January 24, 2002

HSA-10/B-84

Mr. Richard Smutzer
Chief Engineer
Indiana Department of Transportation
100 North Senate Avenue – Room N755
Indianapolis, Indiana 46204-2217

Dear Mr. Smutzer:

In response to your September 19 letter to Mr. Frederick G. Wright, I am pleased to provide formal acceptance of the Indiana Department of Transportation's (INDOT) temporary concrete barrier. A corrected edition of the test report was delivered to Mr. Richard Powers of my staff during the last week of December. The INDOT design was tested at the Transportation Research Center's (TRC) facility in East Liberty, Ohio and shown to meet the performance evaluation criteria contained in the National Cooperative Highway Research Program (NCHRP) Report 350 for a test level 3 (TL-3) traffic barrier. This barrier is shown on INDOT Standard Drawings E602-TCCB-01 and E602-TCCB-02, which are enclosed.

The tested barrier was a 3.0-m (10-ft) long F-shape design, 790-mm tall, with a base width of 600 mm and a top width of 250 mm. The vertical reveal at the base of the barrier was only 50-mm high, rather than the standard 75-mm height. Reinforcing consisted of four 19M bars which also formed the loops at the ends of each segment. Adjacent segments were connected with a 30-mm diameter hex head bolt 660-mm long with a hex nut at the bottom. Two tubular spacers were used, a 250-mm long TS 100 x 50 x 8 under the bolt head, and a 400-mm long TS 100 x 50 x 8 above the nut. These spacers were intended to fill the gap between barrier segments to limit deflection upon vehicular impact.

Twenty-six barrier segments, each approximately 3.0-m long comprised the 79-m long test installation. It was impacted with a 2000-kg pickup truck approximately 11 m from the upstream end of the test installation at a speed of 102.9 km/h and at an angle of 23.8 degrees. Occupant impact velocity was reported to be 6.1 m/sec and the subsequent ridedown acceleration was 10.4 g's. Maximum barrier deflection was reported as 1.6 m. Although not included in the test report, the roll angle of the truck after impact was later estimated to be no more than 5 degrees and its pitch was estimated to be approximately 20 degrees.

Based on staff review and evaluation of the test results, I concur that the INDOT barrier, as tested, meets all evaluation requirements for an NCHRP Report 350 TL-3 traffic barrier. It may be used on the National Highway System when such use is deemed appropriate by the contracting authority. INDOT's design is unique in that it uses only a 50-mm (2-in) vertical reveal in lieu of the standard 75-mm (3-in) reveal. A standard F-shape with a 75-mm (3-in) vertical reveal and an overall height of 810 mm (32 inches) with your tested connection can also be considered a crashworthy design.

Sincerely yours,

(original signed by Michael L. Halladay)

Michael L. Halladay
Acting Program Manager, Safety

Enclosure

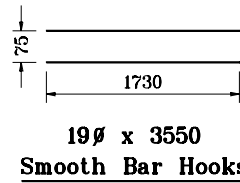
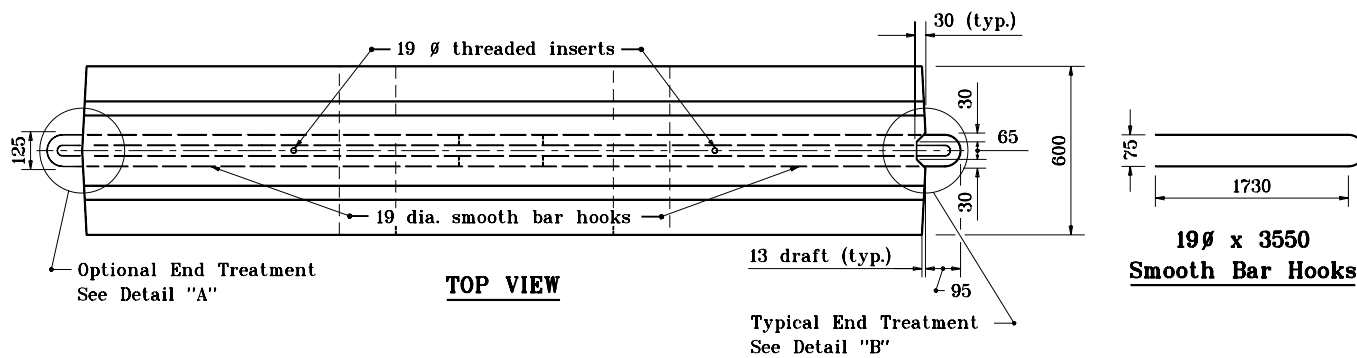

NOTES :

1. The dimensions of the lifting slots are subject to adjustment as necessary to accommodate handling equipment.
2. Maximum barrier taper rate flares for lane closures for legal posted speed are shown in Table No.2.
3. For additional connection details, see Standard Drawing 602-TCCB-02.

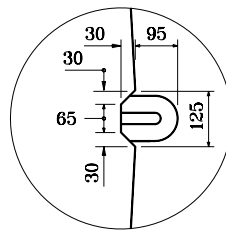
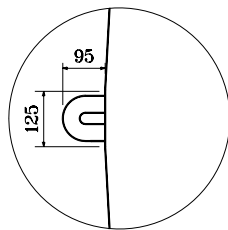
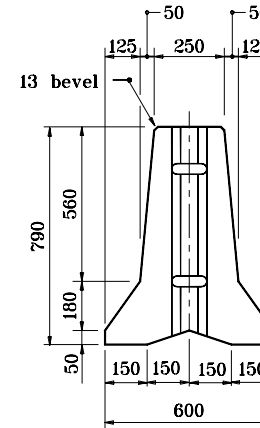
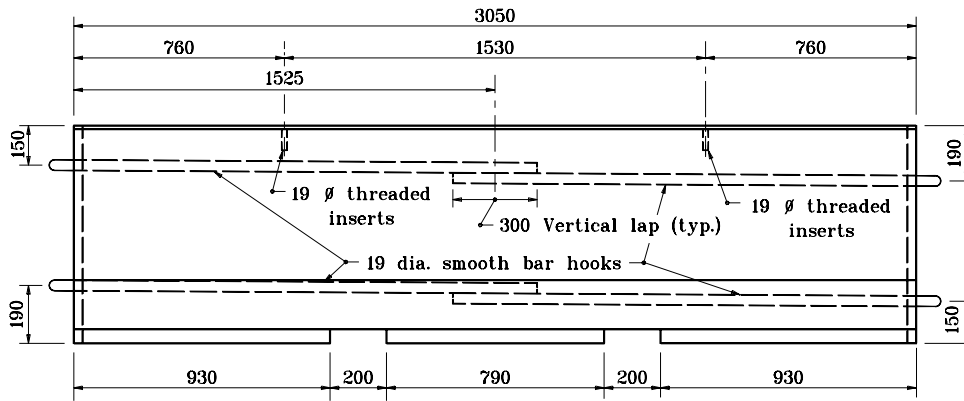

CONSTRUCTION ZONE SPEED	TAPER FLARE RATE
55 mph	16 : 1
50 mph	14 : 1
45 mph	13 : 1
40 mph	11 : 1

All dimensions are in mm unless otherwise specified.

INDIANA DEPARTMENT OF TRANSPORTATION
TEMPORARY CONCRETE BARRIER
DIMENSIONS
 MARCH 2002
 STANDARD DRAWING NO. **602-TCCB-01**

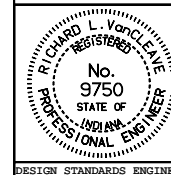

/s/ Richard L. VanCleave 3-01-02
 DESIGN STANDARDS ENGINEER DATE

/s/ Richard K. Smutzer 3-01-02
 CHIEF HIGHWAY ENGINEER DATE

DESIGN STANDARDS ENGINEER

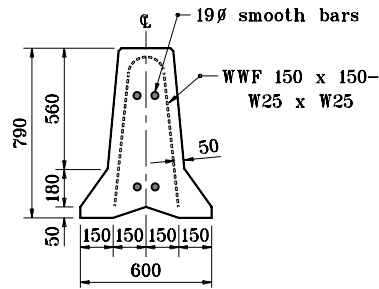
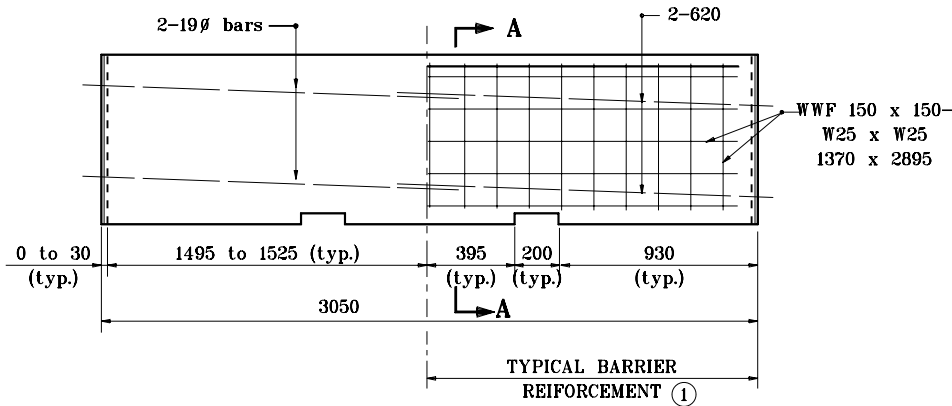

SECTION A-A ①

REINFORCEMENT DETAILS

NOTES :

- ① Section A-A shows reinforcement with welded wire fabric.
- ② Hex nut may be tack welded to bottom spacer to facilitate installation and removal. Bolts shall be torqued only to tight condition. Clearance between the spacer and the ends of the barrier shall permit angular deflection at the joints to permit flare rate 11 : 1 or flatter.
- ③ Top spacer TS 100 x 50 x 8 x 250 long
- ④ Bottom spacer TS 100 x 50 x 8 x 400 long
- ⑤ Where necessary to meet short radius curving alignment, the shorter top spacer (250) may be substituted for the standard bottom spacer (400).
- ⑥ For additional connection details see Standard Drawing 602-TCCB-01.

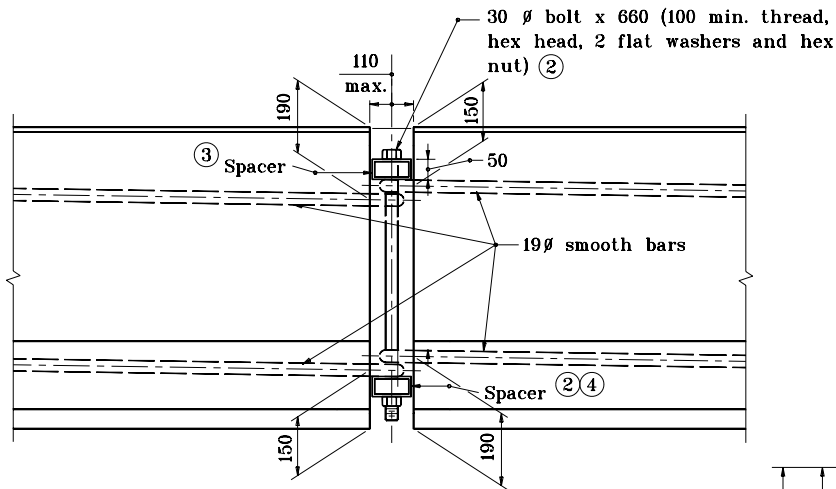

**FRONT VIEW
CONNECTION DETAIL**

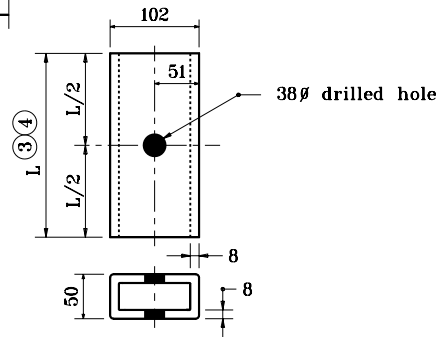

SPACER DETAIL

**REINFORCEMENT AND CONNECTION
DETAILS**

All dimensions are in mm unless otherwise specified.

INDIANA DEPARTMENT OF TRANSPORTATION

TEMPORARY CONCRETE BARRIER

DETAILS

MARCH 2002

STANDARD DRAWING NO. **602-TCCB-02**

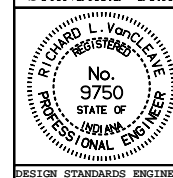

/s/ Richard L. VanCleave 3-01-02
DESIGN STANDARDS ENGINEER DATE

/s/ Richard K. Smutzer 3-01-02
CHIEF HIGHWAY ENGINEER DATE

DESIGN STANDARDS ENGINEER