



U.S. Department
of Transportation
**Federal Highway
Administration**

1200 New Jersey Avenue, SE
Washington, D.C. 20590

February 2, 2010

In Reply Refer To:
HSSD/B-25A

Mr. Barry D. Stephens, P.E.
Sr. Vice President Engineering
Energy Absorption Systems, Inc.
3617 Cincinnati Avenue
Rocklin, CA 95765

Dear Mr. Stephens:

This letter is in response to your request for the Federal Highway Administration (FHWA) acceptance of a roadside safety system for use on the National Highway System (NHS).

Name of system:	BarrierGate at Test Level 4
Type of system:	Positive longitudinal barrier/gate
Test Level:	NCHRP Report 350 TL-4
Testing conducted by:	E-Tech Testing Services, Inc. and L.I.E.R. (France)
Task Force 13 Designator:	SGM20
Date of request:	June 13, 2008
Date of completed package:	February 27, 2009
Request initially acknowledged:	February 3, 2009

You requested that we find this system acceptable for use on the NHS under the provisions of the National Cooperative Highway Research Program (NCHRP) Report 350 "Recommended Procedures for the Safety Performance Evaluation of Highway Features."

Requirements

Roadside safety devices should meet the guidelines contained in the NCHRP Report 350 or the American Association of State Highway and Transportation Officials' Manual for Assessing Safety Hardware. The FHWA Memorandum "Identifying Acceptable Highway Safety Features" of July 25, 1997, provides further guidance on crash testing requirements of longitudinal barriers.



Description

The BarrierGate has been tested and was accepted as a Test Level 3 (TL-3) product via FHWA letter B-25 on April 19, 1993. You provided the following in support of your request that the BarrierGate be considered a TL-4 barrier system:

1. Per NCHRP Report 350 page 31, Table 3.6, the impact capacity of a TL-3 barrier with the pickup truck is equal to the impact capacity of a TL-4 barrier:
 - a. NCHRP 350 Test 3-11 calls for a 2000kg/100kph/25 degree impact into the side of the barrier. Using the formula to calculate impact severity ($I.S. = \frac{1}{2} m (V \sin\theta)^2$), the impact severity for this test is 138 kJ. The BarrierGate passed this test.
 - b. NCHRP 350 Test 4-11 also calls for a 2000kg/100kph/25 degree impact into the side of the barrier. The impact severity of this impact is 138 kJoules, the same as TL-3.
 - c. The BarrierGate's TL-4 capacity with the 2000 kg pickup truck should not be in question because the unit has already passed Test 3-11.

2. TL-4 also requires an 8000kg/80kph/15 degree impact into the side of the barrier (NCHRP Report 350 Test 4-12). The Impact Severity of this test is 132.5 kJ, which is less than the pickup truck test. The 4-12 test is principally conducted to evaluate vehicle stability and trajectory. The 8000s box truck has a higher center of gravity than the 2000p pickup so it has a greater tendency to roll over rigid barriers. The argument supporting Energy's position that the BarrierGate will work well during a TL-4 test is tied to the known impact performance of a very similar Energy product called the Vulcan (*steel*) Barrier:
 - a. Like the BarrierGate, the Vulcan was accepted as a TL-3 product in FHWA Acceptance Letter B-134 on February 14, 2005.
 - b. Both the BarrierGate and the Vulcan Barrier have very similar thrie-beam side profiles with the exception that the Vulcan Barrier is wider at the top than at the base, and the BarrierGate is narrower at the top than at the base.
 - c. The BarrierGate profile is 2 inches taller than the Vulcan Barrier (34 inches for the BarrierGate vs. 32 inches for the Vulcan). This extra 2 inches will help improve the stability of the high center of gravity 8000s trucks used in the TL-4 test.
 - d. Even at the shorter height of 32 inches, the Vulcan Barrier successfully passed a full-scale city bus test (European test EN-1317 Test H2 = 13,000kg (bus)/70kph/20 degrees) at the LIER facility in France. The impact severity for this test was 287 kJ, twice the impact severity of a TL-4 test. Like the 8000s vehicle required for the TL-4 test, the city bus used in this H2 test had a high center of gravity. Very little bus roll, pitch or yaw was noted during the impact. The bus was very smoothly redirected. The FHWA accepted the Vulcan Barrier at TL-4 in Acceptance Letter B-134D dated August 29, 2008.
 - e. The positive slope of the upper portion of the BarrierGate (vs. negative slope of the Vulcan) is not a concern relative to passing the TL-4 test. This conclusion is reached after considering that the positive side slope of the BarrierGate is 6 degrees. We know that standard New Jersey wall is smooth, has the same slope of 6 degrees, and its height is 2 inches shorter (only 32 inches tall). We also know that the New Jersey wall has successfully passed NCHRP Report 350 TL-4 testing. The BarrierGate's thrie-beam side ribs will help keep the 8000p from climbing the

barrier, the shallow 6-degree side slope will induce no greater upward ramping (vs. the New Jersey wall), and the extra 2 inches of height will further help stabilize the high center of gravity 8000s box truck and keep it from climbing over the BarrierGate.

In summary we concur that the BarrierGate may be classified as a TL-4 barrier because:

- a) the BarrierGate has shown that it can handle 138 kJ of impact energy (TL-4 capacity),
- b) the BarrierGate has a similar side profile as the Vulcan which has successfully redirected a large/high-CG city bus as described above, c) New Jersey concrete barriers that are shorter and have a greater side slope than the BarrierGate pass at NCHRP Report 350 under TL-4 conditions and d) because the BarrierGate is 2 inches taller than the Vulcan.

Findings

The system described above and detailed in the enclosed drawings is acceptable for use on the NHS under the NCHRP Report 350 TL-4 conditions, when such use is acceptable to a highway agency.

Please note the following standard provisions that apply to FHWA letters of acceptance:

- This acceptance is limited to the crashworthiness characteristics of the systems and does not cover their structural features, nor conformity with the Manual on Uniform Traffic Control Devices.
- Any changes that may adversely influence the crashworthiness of the system will require a new acceptance letter.
- Should the FHWA discover that the qualification testing was flawed, that in-service performance reveals unacceptable safety problems, or that the system being marketed is significantly different from the version that was crash tested, we reserve the right to modify or revoke our acceptance.
- You will be expected to supply potential users with sufficient information on design and installation requirements to ensure proper performance.
- You will be expected to certify to potential users that the hardware furnished has essentially the same chemistry, mechanical properties, and geometry as that submitted for acceptance, and that it will meet the crashworthiness requirements of the FHWA and the NCHRP Report 350.
- To prevent misunderstanding by others, this letter of acceptance is designated as number B-25A and shall not be reproduced except in full. This letter and the test documentation upon which it is based are public information. All such letters and documentation may be reviewed at our office upon request.
- The BarrierGate is a patented product and considered proprietary. If proprietary systems are specified by a highway agency for use on Federal-aid projects, except exempt, non-NHS projects, a) they must be supplied through competitive bidding with equally suitable unpatented items; b) the highway agency must certify that they are essential for synchronization with the existing highway facilities or that no equally suitable alternative exists; or c) they must be used for research or for a distinctive type of construction on relatively short sections of road for experimental purposes. Our regulations concerning proprietary products are contained in Title 23, Code of Federal Regulations, Section 635.411.

- This acceptance letter shall not be construed as authorization or consent by the FHWA to use, manufacture, or sell any patented system for which the applicant is not the patent holder. The acceptance letter is limited to the crashworthiness characteristics of the candidate system, and the FHWA is neither prepared nor required to become involved in issues concerning patent law. Patent issues, if any, are to be resolved by the applicant.

Sincerely yours,

David A. Nicol, P.E.
Director, Office of Safety Design
Office of Safety

Enclosures

FHWA:HSSD:NArtimovich:tb:x61331:1/21/10

File: s://directory folder/nartimovich/B25A_BarrierGateTL4.doc

cc: HSSD (Reader, HSA; Chron File, HSSD; N.Artimovich, HSSD; MMcDonough, HSSD;
DNicol, HSSD)



U.S. Department
of Transportation
**Federal Highway
Administration**

1200 New Jersey Avenue, SE
Washington, D.C. 20590

February 2, 2010

In Reply Refer To:
HSSD/B-25A

Mr. Barry D. Stephens, P.E.
Sr. Vice President Engineering
Energy Absorption Systems, Inc.
3617 Cincinnati Avenue
Rocklin, CA 95765

Dear Mr. Stephens:

This letter is in response to your request for the Federal Highway Administration (FHWA) acceptance of a roadside safety system for use on the National Highway System (NHS).

Name of system:	BarrierGate at Test Level 4
Type of system:	Positive longitudinal barrier/gate
Test Level:	NCHRP Report 350 TL-4
Testing conducted by:	E-Tech Testing Services, Inc. and L.I.E.R. (France)
Task Force 13 Designator:	SGM20
Date of request:	June 13, 2008
Date of completed package:	February 27, 2009
Request initially acknowledged:	February 3, 2009

You requested that we find this system acceptable for use on the NHS under the provisions of the National Cooperative Highway Research Program (NCHRP) Report 350 "Recommended Procedures for the Safety Performance Evaluation of Highway Features."

Requirements

Roadside safety devices should meet the guidelines contained in the NCHRP Report 350 or the American Association of State Highway and Transportation Officials' Manual for Assessing Safety Hardware. The FHWA Memorandum "Identifying Acceptable Highway Safety Features" of July 25, 1997, provides further guidance on crash testing requirements of longitudinal barriers.



Description

The BarrierGate has been tested and was accepted as a Test Level 3 (TL-3) product via FHWA letter B-25 on April 19, 1993. You provided the following in support of your request that the BarrierGate be considered a TL-4 barrier system:

1. Per NCHRP Report 350 page 31, Table 3.6, the impact capacity of a TL-3 barrier with the pickup truck is equal to the impact capacity of a TL-4 barrier:
 - a. NCHRP 350 Test 3-11 calls for a 2000kg/100kph/25 degree impact into the side of the barrier. Using the formula to calculate impact severity ($I.S. = \frac{1}{2} m (V \sin\theta)^2$), the impact severity for this test is 138 kJ. The BarrierGate passed this test.
 - b. NCHRP 350 Test 4-11 also calls for a 2000kg/100kph/25 degree impact into the side of the barrier. The impact severity of this impact is 138 kJoules, the same as TL-3.
 - c. The BarrierGate's TL-4 capacity with the 2000 kg pickup truck should not be in question because the unit has already passed Test 3-11.

2. TL-4 also requires an 8000kg/80kph/15 degree impact into the side of the barrier (NCHRP Report 350 Test 4-12). The Impact Severity of this test is 132.5 kJ, which is less than the pickup truck test. The 4-12 test is principally conducted to evaluate vehicle stability and trajectory. The 8000s box truck has a higher center of gravity than the 2000p pickup so it has a greater tendency to roll over rigid barriers. The argument supporting Energy's position that the BarrierGate will work well during a TL-4 test is tied to the known impact performance of a very similar Energy product called the Vulcan (*steel*) Barrier:
 - a. Like the BarrierGate, the Vulcan was accepted as a TL-3 product in FHWA Acceptance Letter B-134 on February 14, 2005.
 - b. Both the BarrierGate and the Vulcan Barrier have very similar thrie-beam side profiles with the exception that the Vulcan Barrier is wider at the top than at the base, and the BarrierGate is narrower at the top than at the base.
 - c. The BarrierGate profile is 2 inches taller than the Vulcan Barrier (34 inches for the BarrierGate vs. 32 inches for the Vulcan). This extra 2 inches will help improve the stability of the high center of gravity 8000s trucks used in the TL-4 test.
 - d. Even at the shorter height of 32 inches, the Vulcan Barrier successfully passed a full-scale city bus test (European test EN-1317 Test H2 = 13,000kg (bus)/70kph/20 degrees) at the LIER facility in France. The impact severity for this test was 287 kJ, twice the impact severity of a TL-4 test. Like the 8000s vehicle required for the TL-4 test, the city bus used in this H2 test had a high center of gravity. Very little bus roll, pitch or yaw was noted during the impact. The bus was very smoothly redirected. The FHWA accepted the Vulcan Barrier at TL-4 in Acceptance Letter B-134D dated August 29, 2008.
 - e. The positive slope of the upper portion of the BarrierGate (vs. negative slope of the Vulcan) is not a concern relative to passing the TL-4 test. This conclusion is reached after considering that the positive side slope of the BarrierGate is 6 degrees. We know that standard New Jersey wall is smooth, has the same slope of 6 degrees, and its height is 2 inches shorter (only 32 inches tall). We also know that the New Jersey wall has successfully passed NCHRP Report 350 TL-4 testing. The BarrierGate's thrie-beam side ribs will help keep the 8000p from climbing the

barrier, the shallow 6-degree side slope will induce no greater upward ramping (vs. the New Jersey wall), and the extra 2 inches of height will further help stabilize the high center of gravity 8000s box truck and keep it from climbing over the BarrierGate.

In summary we concur that the BarrierGate may be classified as a TL-4 barrier because:

- a) the BarrierGate has shown that it can handle 138 kJ of impact energy (TL-4 capacity),
- b) the BarrierGate has a similar side profile as the Vulcan which has successfully redirected a large/high-CG city bus as described above,
- c) New Jersey concrete barriers that are shorter and have a greater side slope than the BarrierGate pass at NCHRP Report 350 under TL-4 conditions and
- d) because the BarrierGate is 2 inches taller than the Vulcan.

Findings

The system described above and detailed in the enclosed drawings is acceptable for use on the NHS under the NCHRP Report 350 TL-4 conditions, when such use is acceptable to a highway agency.

Please note the following standard provisions that apply to FHWA letters of acceptance:

- This acceptance is limited to the crashworthiness characteristics of the systems and does not cover their structural features, nor conformity with the Manual on Uniform Traffic Control Devices.
- Any changes that may adversely influence the crashworthiness of the system will require a new acceptance letter.
- Should the FHWA discover that the qualification testing was flawed, that in-service performance reveals unacceptable safety problems, or that the system being marketed is significantly different from the version that was crash tested, we reserve the right to modify or revoke our acceptance.
- You will be expected to supply potential users with sufficient information on design and installation requirements to ensure proper performance.
- You will be expected to certify to potential users that the hardware furnished has essentially the same chemistry, mechanical properties, and geometry as that submitted for acceptance, and that it will meet the crashworthiness requirements of the FHWA and the NCHRP Report 350.
- To prevent misunderstanding by others, this letter of acceptance is designated as number B-25A and shall not be reproduced except in full. This letter and the test documentation upon which it is based are public information. All such letters and documentation may be reviewed at our office upon request.
- The BarrierGate is a patented product and considered proprietary. If proprietary systems are specified by a highway agency for use on Federal-aid projects, except exempt, non-NHS projects, a) they must be supplied through competitive bidding with equally suitable unpatented items; b) the highway agency must certify that they are essential for synchronization with the existing highway facilities or that no equally suitable alternative exists; or c) they must be used for research or for a distinctive type of construction on relatively short sections of road for experimental purposes. Our regulations concerning proprietary products are contained in Title 23, Code of Federal Regulations, Section 635.411.

- This acceptance letter shall not be construed as authorization or consent by the FHWA to use, manufacture, or sell any patented system for which the applicant is not the patent holder. The acceptance letter is limited to the crashworthiness characteristics of the candidate system, and the FHWA is neither prepared nor required to become involved in issues concerning patent law. Patent issues, if any, are to be resolved by the applicant.

Sincerely yours,

A handwritten signature in black ink, appearing to read "David A. Nicol". The signature is written in a cursive style with a large, sweeping initial "D".

David A. Nicol, P.E.
Director, Office of Safety Design
Office of Safety

Enclosures

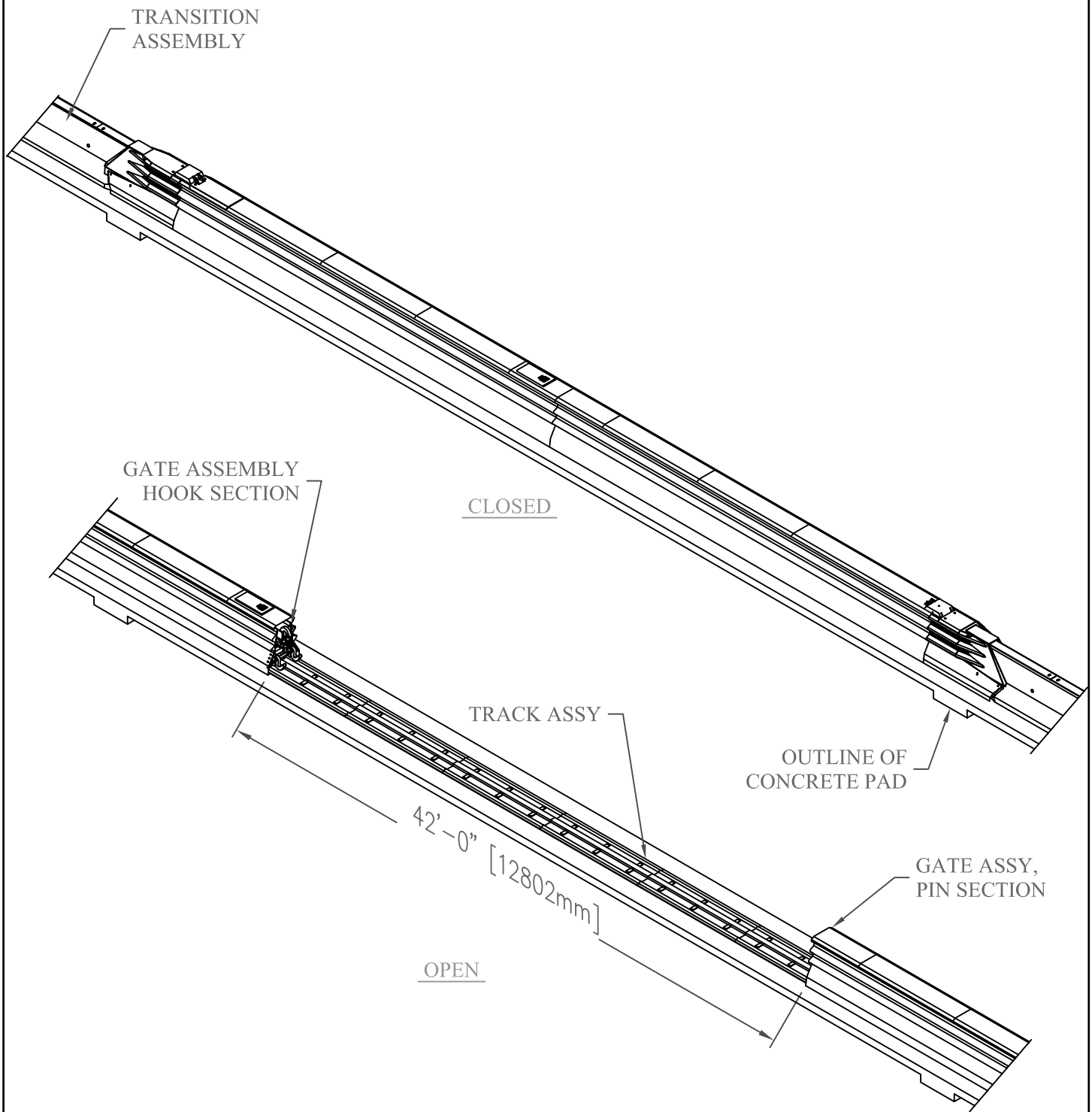

BARRIERGATE[®]

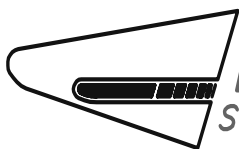

**ENERGY ABSORPTION
SYSTEMS, INC.**

SGM20

SHEET NO.

DATE:

1 of 2

4/18/05

INTENDED USE

The BarrierGate[®] is a longitudinal barrier and gate in one System. When closed, the BarrierGate[®] is a positive, crashworthy longitudinal barrier. The BarrierGate[®] opens to provide a nominal 42 ft [12.8 m] opening in concrete median barrier (CMB).

The BarrierGate[®] meets NCHRP 350 test level 3 criteria for longitudinal barriers.

The BarrierGate[®] provides several unique advantages over traditional median barrier openings:

- * Eliminates exposed barrier ends that threaten motorist safety
- * Provides positive and crashworthy protection for errant vehicles
- * Prevents dangerous and illegal U-turns
- * Mitigates traffic congestion and air pollution caused by delayed traffic
- * Offers the opportunity for an alternative traffic flow pattern
- * Allows more efficient highway maintenance operations
- * Improves emergency response times

APPROVALS: http://safety.fhwa.dot.gov/roadway_dept/road_hardware/barriers/pdf/b-25.pdf

Contact Information

Corporate Offices:
35 East Wacker Dr., 11th Floor
Chicago, IL 60601-2076
Telephone: (312) 467-6750
FAX: (312) 467-1356
<http://www.energyabsorption.com/>

BARRIERGATE[®]

#SGM20

SHEET NO.	DATE
2 of 2	4/18/05

