



U.S. Department
of Transportation
**Federal Highway
Administration**

1200 New Jersey Ave., SE
Washington, D.C. 20590

May 3, 2011

In Reply Refer To:
HSST/B-220

Mr. John Addy
Hill & Smith. Inc.
Springvale Business and Industrial Park
Bilston, Wolverhampton, West Midlands, UK, WV14 OQL

Dear Mr. Addy:

This letter is in response to your request for Federal Highway Administration (FHWA) acceptance of a roadside safety system for use on the National Highway System (NHS).

Name of system: Zoneguard™, Portable Steel Barrier Expansion Joint Units
Type of system: portable longitudinal steel barrier
Test Level: NCHRP Report 350 (Report 350) Test Level 3 (TL-3)
Testing conducted by: TRL Limited
Date of request: December 7, 2010
Date of follow-up: December 8, 2010
Task Force 13 Designation: SWM10

You requested that we find this system acceptable for use on the NHS under the provisions of National Cooperative Highway Research Program (NCHRP) Report 350 "Recommended Procedures for the Safety Performance Evaluation of Highway Features" for both the standard and minimum deflection arrangements of Zoneguard™.

Requirements

Roadside safety systems should meet the guidelines contained in the NCHRP Report 350, "Recommended Procedures for the Safety Performance Evaluation of Highway Features". FHWA Memorandum "ACTION: Identifying Acceptable Highway Safety Features" of July 25, 1997 provides further guidance on crash testing requirements of longitudinal barriers.

Decision

The following devices are found acceptable, with details provided below:

- Zoneguard™, Expansion Unit for the Zoneguard Portable Steel Barrier



FHWA: HSST: WLongstreet: ms: x60087:3/31/11

Updated by ms: 5/3/11

File: h://directory folder/HSST/ B-220 HS Expansion

Description

The Zoneguard™, Portable Steel Barrier Expansion Joint Unit is an appurtenance to the previously accepted Zoneguard™ portable longitudinal barrier system as per FHWA acceptance letter HSSD/B-176 (as per Report 350). The test article description is as follows and in addition to the originally tested barrier as per HSSD/B-176.

The as tested barrier consisted of eight 12 meter (39.37 feet) 'speed joint' barriers. Each 12 meter (39.37 feet) length of barrier consisted of three 4 meter (13.12 feet) sections that were bolted together. The 4 meter (13.12 feet) section at impact point was a three part expansion joint with longitudinal expansion provided by eight sleeved tubes. Each of the expansion joint inner tubes measured 694 millimeters (27.32 inches) x 70 millimeters (2.75 inches) and passed through an outer sleeve (276 millimeters (10.86 inches) x 80 millimeters (3.15 inches)). Each inner tube was fitted with an end cap.

The approach side of the expansion joint was pinned on the traffic side at 29 meters (95.14 feet) and on the rear at 30 meters (98.42 feet), to the running surface using two 30 millimeter (1.18 inches) diameter 500 millimeter (19.68 inches) long pins. The base of each 12 meter (39.37 feet) barrier section had twelve rubber feet fitted that were fixed using contact adhesive. Some of these rubber feet were displaced from their original location. Due to variations in test site levels, not all of the feet were in contact with the ground; the foot at impact point was lifted off the running surface by 5 millimeters (0.197 inches) and barrier section number 4 was lifted off of the test surface by a nominal 20 millimeters (0.79 inches). The complete barrier installation was nominally 0.815 meters (2.67 feet) high, 0.7 meters (2.3 feet) wide and 96 meters (315 feet) long. The approach terminal was pinned using four 30 millimeter (1.18 inches) diameter 450 millimeter (17.72 inches) long terminal pins located at 0.45 meters (1.47 feet) and 4.45 meters (14.6 feet) measured from the start of the barrier. The departure terminal was pinned using four 30 millimeter (1.18 inches) diameter 500 millimeter (19.68 inches) long terminal pins located at 0.45 meters (17.72 inches) and 4.45 meters (14.6 feet) measured from the end of the barrier. The barrier was installed so that the vehicles center line intersected the barrier at a point 32.67 meters (107.19 feet) from the start of the barrier, with the point of first contact being 31.08 meters (102 feet) (0.92 meter (3 feet) before the end of the expansion joint barrier). To aid post test analysis two lines were painted behind the barrier at 1.7 meters (5.6 feet) and 2.7 meters (8.86 feet) measured from the front edge of the impact side of the barrier.

Details of this system are provided as enclosures to this correspondence.

Crash Testing

The barrier was crash tested at the test facilities at TRL Limited, United Kingdom according to the following testing criteria for the evaluation of temporary longitudinal barriers used in work and construction zones. This report describes the dynamic impact test of a Zoneguard™, Portable Steel Barrier fitted with Zoneguard™, Portable Steel Barrier Expansion Joint Unit to test designation level 3-11 as per NCHRP Report 350. The impact conditions of this test are met with a total test mass of 2,000 kg (4.4 kips) at a speed of 100 (± 4 %) km/h (62.13 mph) and at an angle of 25 (± 1.5) degrees to the line of the barrier traffic face. The impact speed was 100.6 km/h (62.5 mph) and the impact angle was 24.9 degrees and therefore satisfactory. However the vehicle's actual total test mass was 2,139 kg (4.715 kips), which is outside the recommended

value specified in Report 350 and therefore this test was not fully compliant with the requirements of Report 350. However this non compliance represents a worst case test in terms of test item performance. The dynamic deflection was 0.97 meter (3.18 feet) and the working width was 1.64 meters (5.38 feet). The permanent deflection was 0.82 meter (2.69 feet).

Analysis of the high speed footage, together with witness marks on the barrier, show that the right hand side of the vehicle remained in contact until the end of barrier number 4. After this point only the vehicle's right-hand side wheel track remained in contact with the toe of the barrier. The vehicle continued on this path, travelling parallel to, and on the toe of the barrier. Once past the end of the departure terminal, the vehicle's remotely operated brakes were applied and the vehicle came to a rest 34 meters (111.5 feet) beyond the end of, and 3 meters (9.84 feet) behind the barrier.

Findings

The analysis of the Report 350 TL3 testing showed there were no detached elements from the impacting vehicle or system that penetrated the occupant compartment of the impacting vehicle or presented hazards to others in the area. There was no significant deformation of the roof, windshield or occupant compartment. The occupant impact velocities and ridedown accelerations were within the recommended limits for the impacting vehicle.

Therefore, the system described in the request above and detailed in the enclosed drawings is acceptable for use on the NHS under the range of conditions tested, when such use is acceptable to a highway agency.

The Crash Test Summary details of this system are provided as enclosures to this correspondence.

Please note the following standard provisions that apply to FHWA letters of acceptance:

- This acceptance provides a AASHTO/ARTBA/AGC Task Force 13 designator that should be used for the purpose of the creation of a new and/or the update of an existing Task Force 13 drawing.
- This acceptance is limited to the crashworthiness characteristics of the systems and does not cover its structural features, nor conformity with the Manual on Uniform Traffic Control Devices.
- Any changes that may adversely influence the crashworthiness of the system will require a new acceptance letter.
- Should the FHWA discover that the qualification testing was flawed, that in-service performance reveals unacceptable safety problems, or that the system being marketed is significantly different from the version that was crash tested, we reserve the right to modify or revoke our acceptance.
- You will be expected to supply potential users with sufficient information on design and installation requirements to ensure proper performance.
- You will be expected to certify to potential users that the hardware furnished has essentially the same chemistry, mechanical properties, and geometry as that submitted for acceptance, and that it will meet the crashworthiness requirements of the FHWA and the NCHRP Report 350.

- To prevent misunderstanding by others, this letter of acceptance is designated as number B-220 and shall not be reproduced except in full. This letter and the test documentation upon which it is based are public information. All such letters and documentation may be reviewed at our office upon request.
- The Zoneguard™, Portable Steel Barrier Expansion Joint Units Steel Barrier system is a patented product and considered proprietary. If proprietary systems are specified by a highway agency for use on Federal-aid projects, except exempt, non-NHS projects, (a) they must be supplied through competitive bidding with equally suitable unpatented items; (b) the highway agency must certify that they are essential for synchronization with the existing highway facilities or that no equally suitable alternative exists; or (c) they must be used for research or for a distinctive type of construction on relatively short sections of road for experimental purposes. Our regulations concerning proprietary products are contained in Title 23, Code of Federal Regulations, Section 635.411.
- This acceptance letter shall not be construed as authorization or consent by the FHWA to use, manufacture, or sell any patented system for which the applicant is not the patent holder. The acceptance letter is limited to the crashworthiness characteristics of the candidate system, and the FHWA is neither prepared nor required to become involved in issues concerning patent law. Patent issues, if any, are to be resolved by the applicant.

Sincerely yours,

Michael S. Griffith
Director, Office of Safety Technologies
Office of Safety



U.S. Department
of Transportation
**Federal Highway
Administration**

1200 New Jersey Ave., SE
Washington, D.C. 20590

May 3, 2011

In Reply Refer To:
HSST/B-220

Mr. John Addy
Hill & Smith. Inc.
Springvale Business and Industrial Park
Bilston, Wolverhampton, West Midlands, UK, WV14 OQL

Dear Mr. Addy:

This letter is in response to your request for Federal Highway Administration (FHWA) acceptance of a roadside safety system for use on the National Highway System (NHS).

Name of system: Zoneguard™, Portable Steel Barrier Expansion Joint Units
Type of system: portable longitudinal steel barrier
Test Level: NCHRP Report 350 (Report 350) Test Level 3 (TL-3)
Testing conducted by: TRL Limited
Date of request: December 7, 2010
Date of follow-up: December 8, 2010
Task Force 13 Designation: SWM10

You requested that we find this system acceptable for use on the NHS under the provisions of National Cooperative Highway Research Program (NCHRP) Report 350 "Recommended Procedures for the Safety Performance Evaluation of Highway Features" for both the standard and minimum deflection arrangements of Zoneguard™.

Requirements

Roadside safety systems should meet the guidelines contained in the NCHRP Report 350, "Recommended Procedures for the Safety Performance Evaluation of Highway Features". FHWA Memorandum "ACTION: Identifying Acceptable Highway Safety Features" of July 25, 1997 provides further guidance on crash testing requirements of longitudinal barriers.

Decision

The following devices are found acceptable, with details provided below:

- Zoneguard™, Expansion Unit for the Zoneguard Portable Steel Barrier



FHWA: HSST: WLongstreet: ms: x60087:3/31/11

Updated by ms: 5/3/11

File: h://directory folder/HSST/ B-220 HS Expansion

Description

The Zoneguard™, Portable Steel Barrier Expansion Joint Unit is an appurtenance to the previously accepted Zoneguard™ portable longitudinal barrier system as per FHWA acceptance letter HSSD/B-176 (as per Report 350). The test article description is as follows and in addition to the originally tested barrier as per HSSD/B-176.

The as tested barrier consisted of eight 12 meter (39.37 feet) 'speed joint' barriers. Each 12 meter (39.37 feet) length of barrier consisted of three 4 meter (13.12 feet) sections that were bolted together. The 4 meter (13.12 feet) section at impact point was a three part expansion joint with longitudinal expansion provided by eight sleeved tubes. Each of the expansion joint inner tubes measured 694 millimeters (27.32 inches) x 70 millimeters (2.75 inches) and passed through an outer sleeve (276 millimeters (10.86 inches) x 80 millimeters (3.15 inches)). Each inner tube was fitted with an end cap.

The approach side of the expansion joint was pinned on the traffic side at 29 meters (95.14 feet) and on the rear at 30 meters (98.42 feet), to the running surface using two 30 millimeter (1.18 inches) diameter 500 millimeter (19.68 inches) long pins. The base of each 12 meter (39.37 feet) barrier section had twelve rubber feet fitted that were fixed using contact adhesive. Some of these rubber feet were displaced from their original location. Due to variations in test site levels, not all of the feet were in contact with the ground; the foot at impact point was lifted off the running surface by 5 millimeters (0.197 inches) and barrier section number 4 was lifted off of the test surface by a nominal 20 millimeters (0.79 inches). The complete barrier installation was nominally 0.815 meters (2.67 feet) high, 0.7 meters (2.3 feet) wide and 96 meters (315 feet) long. The approach terminal was pinned using four 30 millimeter (1.18 inches) diameter 450 millimeter (17.72 inches) long terminal pins located at 0.45 meters (1.47 feet) and 4.45 meters (14.6 feet) measured from the start of the barrier. The departure terminal was pinned using four 30 millimeter (1.18 inches) diameter 500 millimeter (19.68 inches) long terminal pins located at 0.45 meters (17.72 inches) and 4.45 meters (14.6 feet) measured from the end of the barrier. The barrier was installed so that the vehicles center line intersected the barrier at a point 32.67 meters (107.19 feet) from the start of the barrier, with the point of first contact being 31.08 meters (102 feet) (0.92 meter (3 feet) before the end of the expansion joint barrier). To aid post test analysis two lines were painted behind the barrier at 1.7 meters (5.6 feet) and 2.7 meters (8.86 feet) measured from the front edge of the impact side of the barrier.

Details of this system are provided as enclosures to this correspondence.

Crash Testing

The barrier was crash tested at the test facilities at TRL Limited, United Kingdom according to the following testing criteria for the evaluation of temporary longitudinal barriers used in work and construction zones. This report describes the dynamic impact test of a Zoneguard™, Portable Steel Barrier fitted with Zoneguard™, Portable Steel Barrier Expansion Joint Unit to test designation level 3-11 as per NCHRP Report 350. The impact conditions of this test are met with a total test mass of 2,000 kg (4.4 kips) at a speed of 100 (± 4 %) km/h (62.13 mph) and at an angle of 25 (± 1.5) degrees to the line of the barrier traffic face. The impact speed was 100.6 km/h (62.5 mph) and the impact angle was 24.9 degrees and therefore satisfactory. However the vehicle's actual total test mass was 2,139 kg (4.715 kips), which is outside the recommended

value specified in Report 350 and therefore this test was not fully compliant with the requirements of Report 350. However this non compliance represents a worst case test in terms of test item performance. The dynamic deflection was 0.97 meter (3.18 feet) and the working width was 1.64 meters (5.38 feet). The permanent deflection was 0.82 meter (2.69 feet).

Analysis of the high speed footage, together with witness marks on the barrier, show that the right hand side of the vehicle remained in contact until the end of barrier number 4. After this point only the vehicle's right-hand side wheel track remained in contact with the toe of the barrier. The vehicle continued on this path, travelling parallel to, and on the toe of the barrier. Once past the end of the departure terminal, the vehicle's remotely operated brakes were applied and the vehicle came to a rest 34 meters (111.5 feet) beyond the end of, and 3 meters (9.84 feet) behind the barrier.

Findings

The analysis of the Report 350 TL3 testing showed there were no detached elements from the impacting vehicle or system that penetrated the occupant compartment of the impacting vehicle or presented hazards to others in the area. There was no significant deformation of the roof, windshield or occupant compartment. The occupant impact velocities and ridedown accelerations were within the recommended limits for the impacting vehicle.

Therefore, the system described in the request above and detailed in the enclosed drawings is acceptable for use on the NHS under the range of conditions tested, when such use is acceptable to a highway agency.

The Crash Test Summary details of this system are provided as enclosures to this correspondence.

Please note the following standard provisions that apply to FHWA letters of acceptance:

- This acceptance provides a AASHTO/ARTBA/AGC Task Force 13 designator that should be used for the purpose of the creation of a new and/or the update of an existing Task Force 13 drawing.
- This acceptance is limited to the crashworthiness characteristics of the systems and does not cover its structural features, nor conformity with the Manual on Uniform Traffic Control Devices.
- Any changes that may adversely influence the crashworthiness of the system will require a new acceptance letter.
- Should the FHWA discover that the qualification testing was flawed, that in-service performance reveals unacceptable safety problems, or that the system being marketed is significantly different from the version that was crash tested, we reserve the right to modify or revoke our acceptance.
- You will be expected to supply potential users with sufficient information on design and installation requirements to ensure proper performance.
- You will be expected to certify to potential users that the hardware furnished has essentially the same chemistry, mechanical properties, and geometry as that submitted for acceptance, and that it will meet the crashworthiness requirements of the FHWA and the NCHRP Report 350.

- To prevent misunderstanding by others, this letter of acceptance is designated as number B-220 and shall not be reproduced except in full. This letter and the test documentation upon which it is based are public information. All such letters and documentation may be reviewed at our office upon request.
- The Zoneguard™, Portable Steel Barrier Expansion Joint Units Steel Barrier system is a patented product and considered proprietary. If proprietary systems are specified by a highway agency for use on Federal-aid projects, except exempt, non-NHS projects, (a) they must be supplied through competitive bidding with equally suitable unpatented items; (b) the highway agency must certify that they are essential for synchronization with the existing highway facilities or that no equally suitable alternative exists; or (c) they must be used for research or for a distinctive type of construction on relatively short sections of road for experimental purposes. Our regulations concerning proprietary products are contained in Title 23, Code of Federal Regulations, Section 635.411.
- This acceptance letter shall not be construed as authorization or consent by the FHWA to use, manufacture, or sell any patented system for which the applicant is not the patent holder. The acceptance letter is limited to the crashworthiness characteristics of the candidate system, and the FHWA is neither prepared nor required to become involved in issues concerning patent law. Patent issues, if any, are to be resolved by the applicant.

Sincerely yours,



Michael S. Griffith
Director, Office of Safety Technologies
Office of Safety

10 DRAWINGS AND INSTALLATION OF THE TEST ITEM

The drawings have been supplied by the Client. The test house has checked main dimensions only.

10.1 Drawing 1

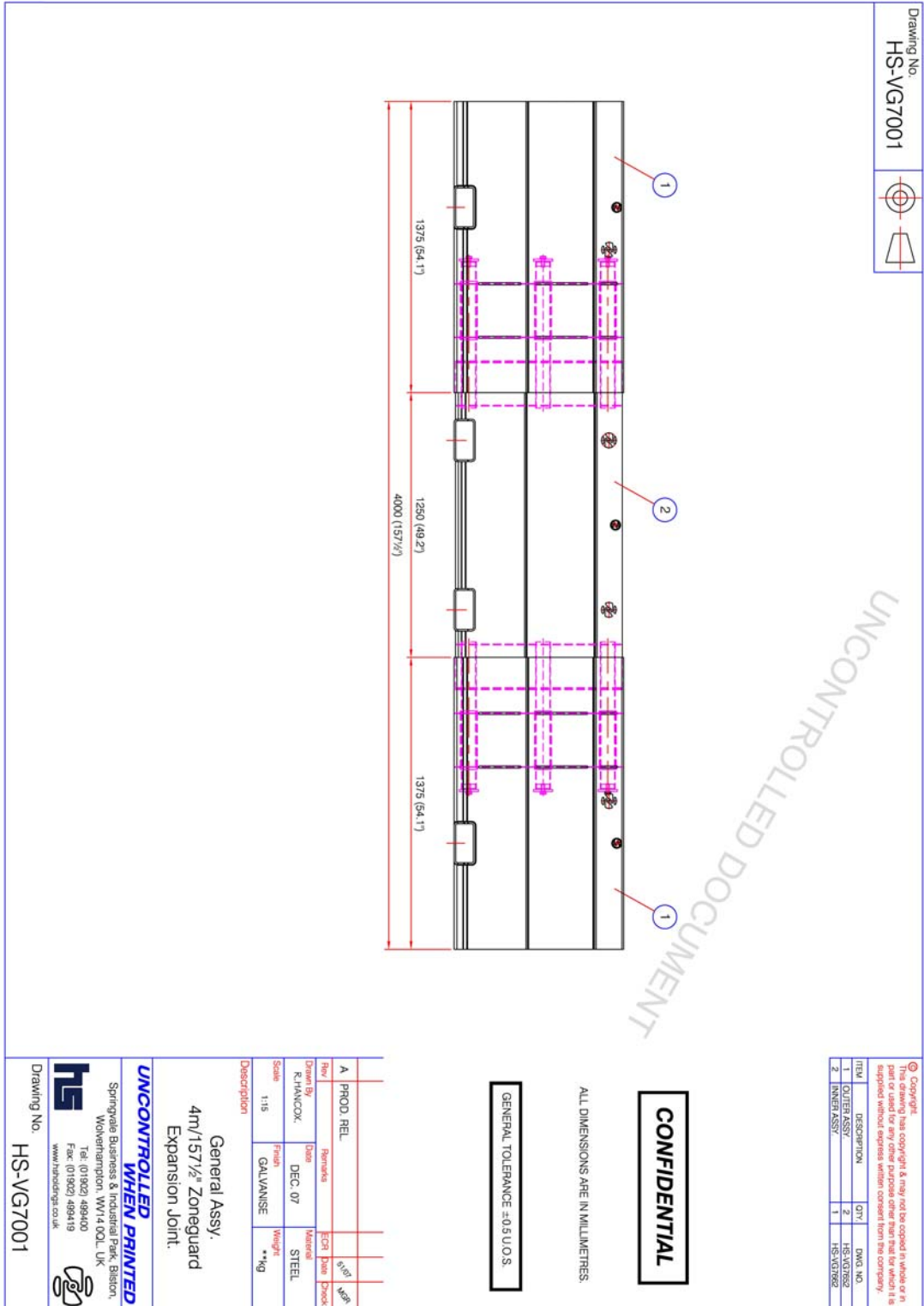

10.2 Drawing 2

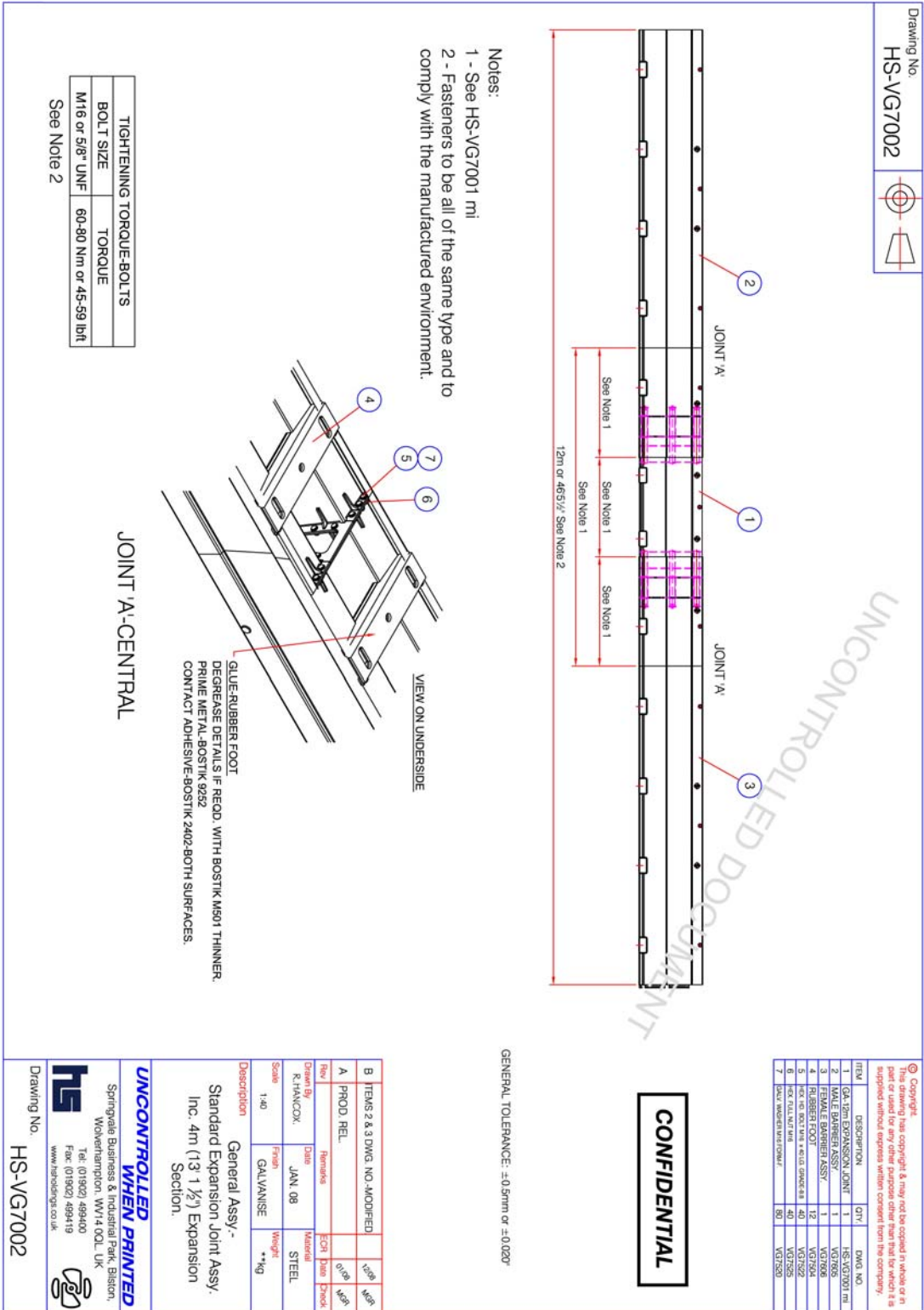

This test was to evaluate the 4 m expansion joint assembly. The length of the tested assembly was 12m (39'4 1/2"). Another configuration of this assembly is to use the expansion joint and two 5.08 m (16'8") barriers to give an assembly length of 46'5 1/2" (14.16m).

10.3 Drawing 3

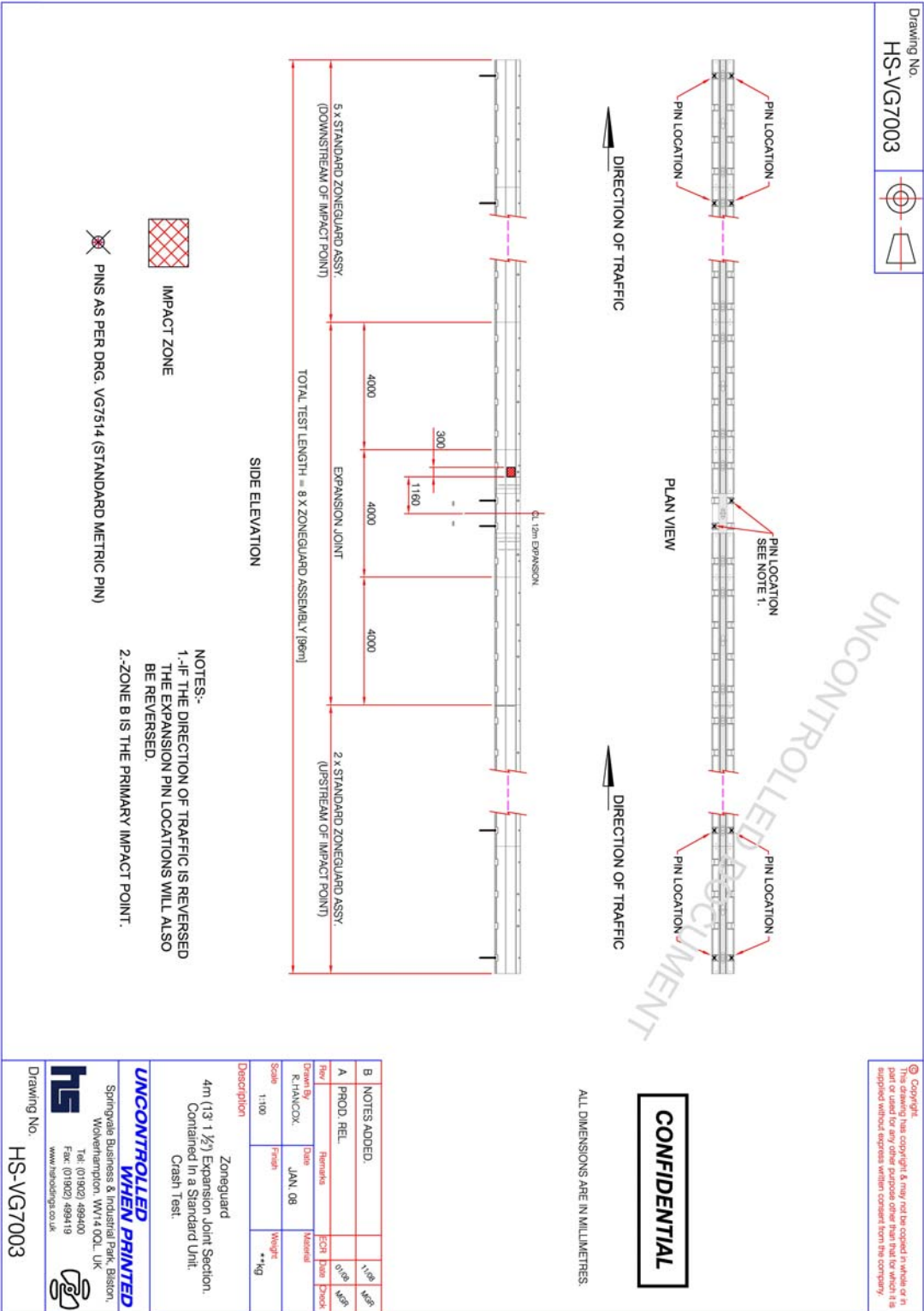

10.4 Drawing 4

Drawing No.
HS-VG7502

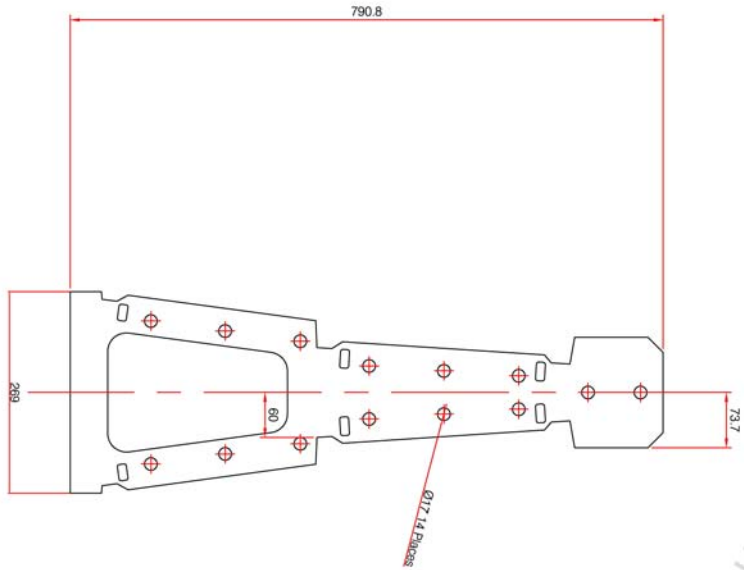

UNCONTROLLED DOCUMENT

CONFIDENTIAL

ALL DIMENSIONS ARE IN MILLIMETRES.

GENERAL TOLERANCE ±0.5 U.O.S.

© Copyright
This drawing has copyright & may not be copied in whole or in part or used for any other purpose other than that for which it is supplied without express written consent from the company.

- NOTES:
1. MATERIAL THICKNESS RADI PERMISSABLE TO ALL SQUARE CORNERS TO SUIT MANUFACTURING REQUIREMENTS
 2. DIMENSIONS TYPICAL EACH SIDE.

Rev	Remarks	ECN	Issue	Check	Appr
A	PROD. REL.				
Drawn By	Date	Material			
R. HANCOX	NOV. 07	S275JR			
Scale	Finish	Weight			
1:5	SELF COLOUR	**Kg			

Description
Central Joint Plate.
4m Zoneguard Expansion
Joint.

UNCONTROLLED WHEN PRINTED

Springvale Business & Industrial Park, Bilston.
Wolverhampton, WV14 0DL, UK
Tel: (01902) 499400
Fax: (01902) 499419
www.hsindustrial.co.uk



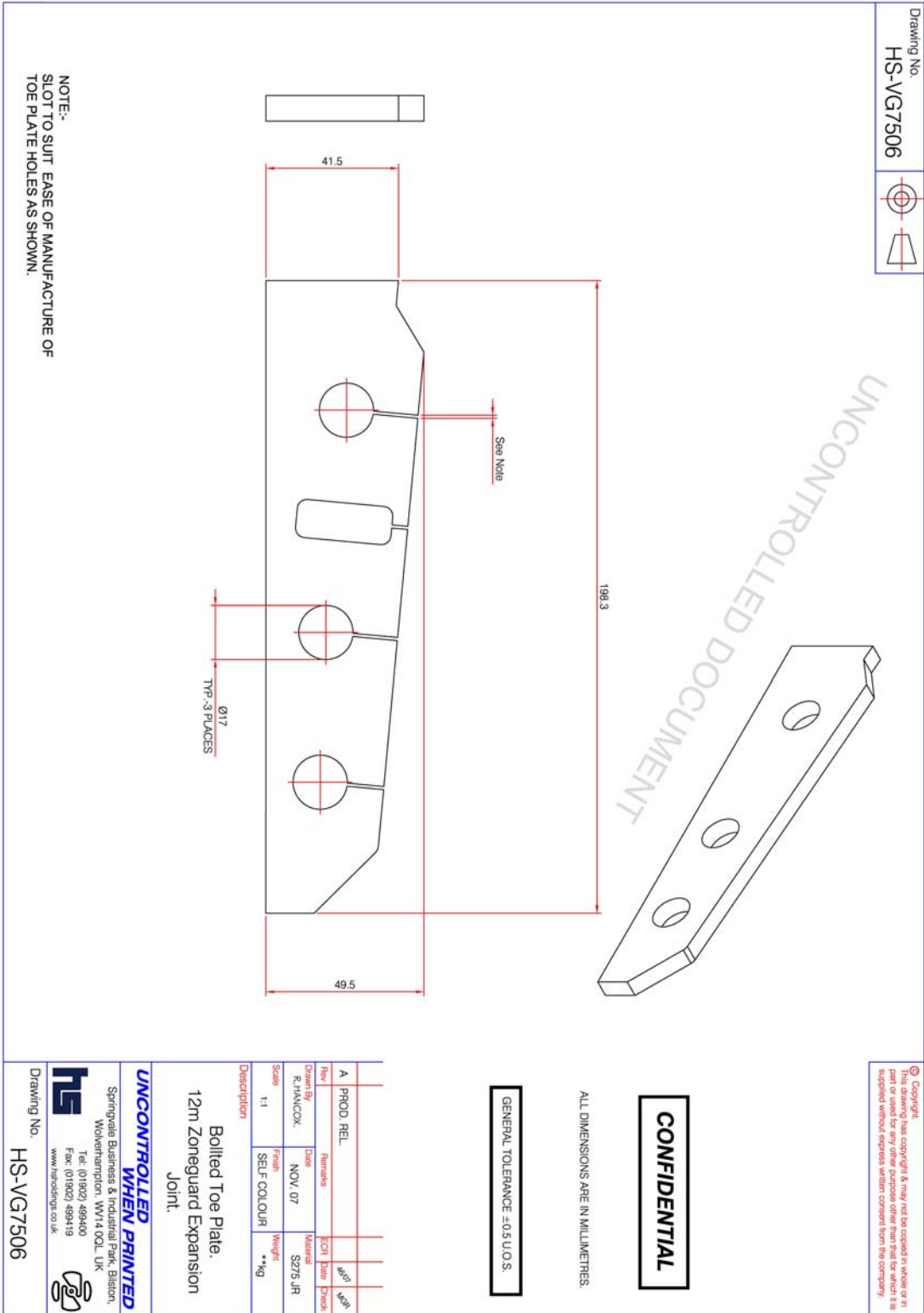

Drawing No.
HS-VG7502

10.5 Drawing 5

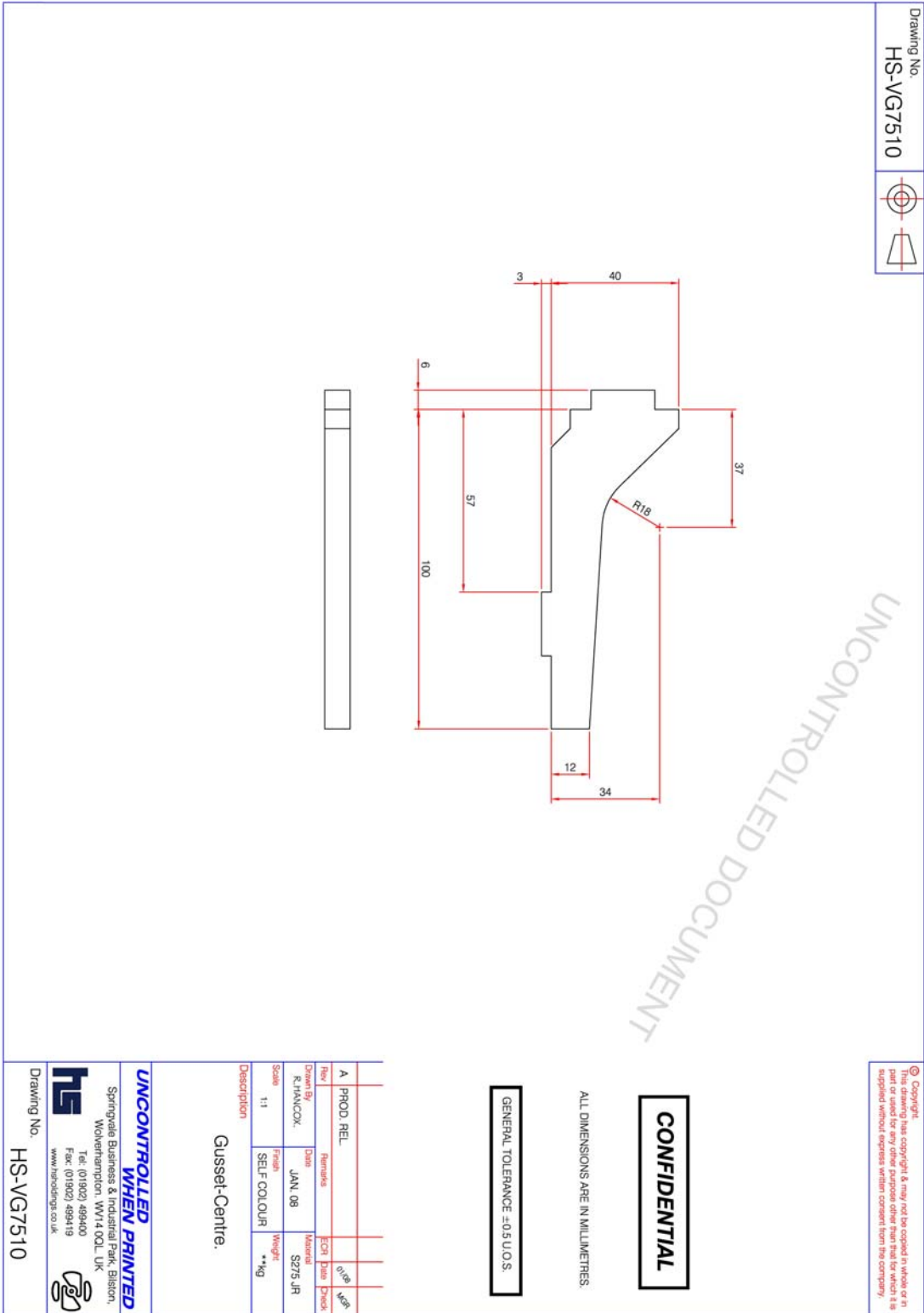

NOTE:-
SLOT TO SUIT EASE OF MANUFACTURE OF
TOE PLATE HOLES AS SHOWN.

10.6 Drawing 6



10.7 Drawing 7

Drawing No.
HS-VG7550 SHEET 2

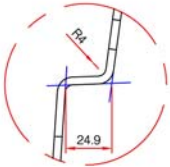
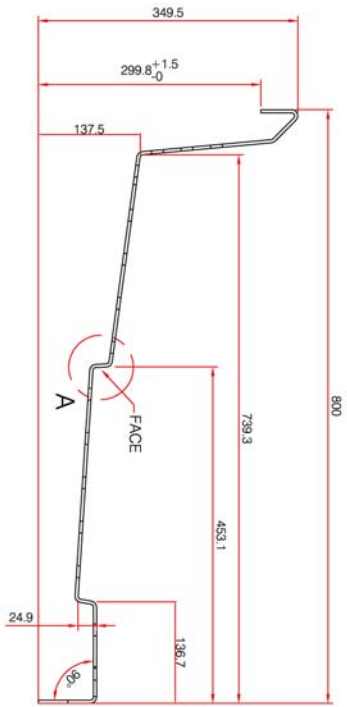

DETAIL A
SCALE:-1:2
TYP. 2-PLACES

- NOTES:
1. DWG:-HS-VG7551 OUTER EXPANSION RIGHT SKIN-SYMMETRICALLY OPPOSITE.
 2. ALL BEND RADII TO BE 4mm UNLESS OTHERWISE SPECIFIED.
 3. ALL ANGULAR TOLERANCES ±1°

© Copyright
This drawing has copyright & may not be copied in whole or in part or used for any other purpose other than that for which it is supplied without express written consent from the company.
NOTE:-DRAWING TO BE READ IN CONJUNCTION WITH:-HS-VG7550 SHEET 1.

CONFIDENTIAL

ALL DIMENSIONS ARE IN MILLIMETRES.

GENERAL TOLERANCE ±0.5 U.O.S

A	PROD. REL.				
Rev	Remarks	ECN	Date	Drawn By	Material
				KJH/MCOX	SZ75-JH
Scale	Finish	Weight	SELF COLOUR	1:5 & 1:2	**Kg
Description					
Outer Expansion Left Skin.					
4m Zoneguard Expansion Joint.					
UNCONTROLLED WHEN PRINTED					
Springvale Business & Industrial Park, Biston, Wolverhampton, WV14 0DL, UK					
Tel: 01902 489400					
Fax: 01902 489419					
www.hsindeng.co.uk					
Drawing No. HS-VG7550 SHEET 2					

10.8 Drawing 8

Drawing No.
HS-VG7553

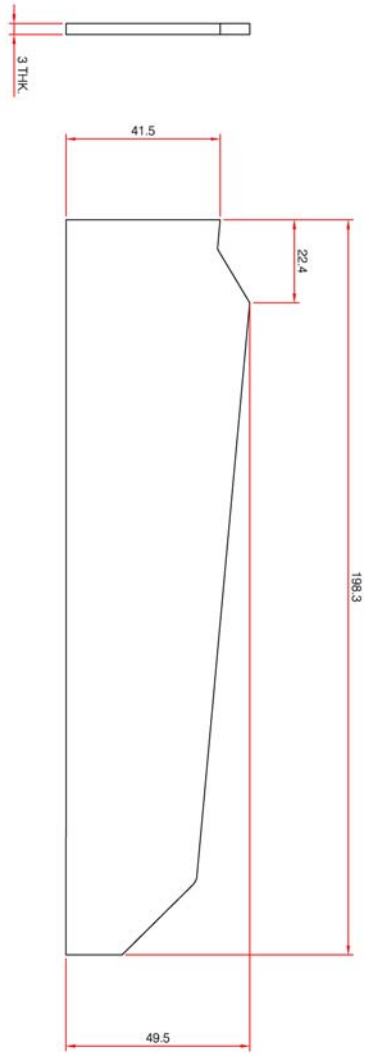
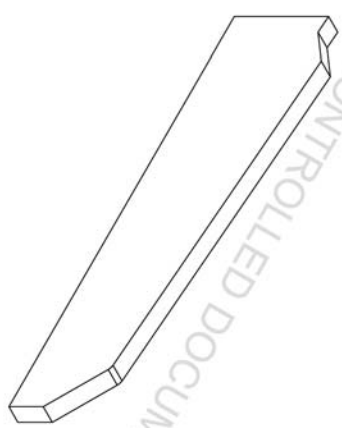

UNCONTROLLED DOCUMENT

CONFIDENTIAL

ALL DIMENSIONS ARE IN MILLIMETRES.

GENERAL TOLERANCE ±0.5 U.O.S.

© Copyright
This drawing has copyright & may not be copied in whole or in part or used for any other purpose other than that for which it is supplied without express written consent from the company.

Row	A	PROD. REL.	ECN	Rev	App
Drawn By	KIRKCOX		Date	DEC. 07	
Scale	1:1	Finish	SELF COLOUR	Material	S275 JH
Description	Outer Tube Plate Toe, 4m Zoneguard Expansion Joint.				
Weight	**Kg				

UNCONTROLLED WHEN PRINTED
Springvale Business & Industrial Park, Biston,
Wolverhampton, WV14 0DL, UK
Tel: 01902 489400
Fax: 01902 489419
www.hsindeng.co.uk

Drawing No. HS-VG7553

10.9 Drawing 9

Drawing No.
HS-VG7560 SHEET 2

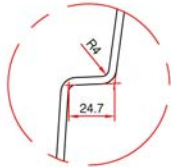
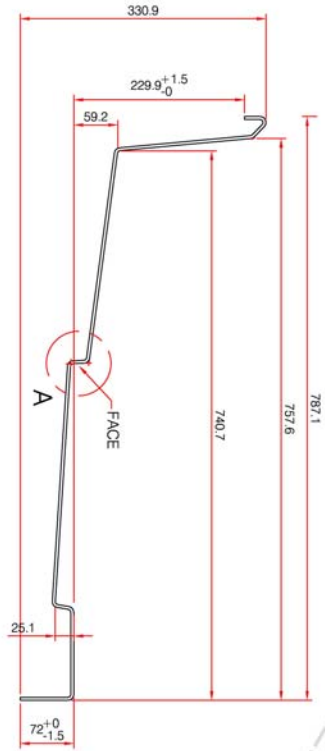

- NOTES:
1. ALL BEND RADII TO BE 4mm UNLESS OTHERWISE SPECIFIED.
 2. ALL ANGULAR TOLERANCES ±1°

DETAIL A
SCALE:-1:2
TYP. 2-PLACES

UNCONTROLLED DOCUMENT

CONFIDENTIAL

ALL DIMENSIONS ARE IN MILLIMETRES.

GENERAL TOLERANCE ±0.5 U.O.S.

© Copyright
This drawing has copyright & may not be copied in whole or in part or used for any other purpose other than that for which it is supplied without express written consent from the company.

Rev	A	PROD. REL.	ECN	Rev	Check
Drawn By	KJH/ACOX		Date	DEC. 07	
Scale	1:5 & 1:2	Finish	SELF COLOUR	Weight	**Kg
Description	Inner Expansion Skin. 4m Zoneguard Expansion Joint.				

UNCONTROLLED WHEN PRINTED

Springvale Business & Industrial Park, Biston,
Wolverhampton, WV14 0DL, UK
Tel: 01902 489400
Fax: 01902 489419
www.hsindeng.co.uk

Drawing No. HS-VG7560 SHEET 2



10.10 Drawing 10

Drawing No.
HS-VG7600

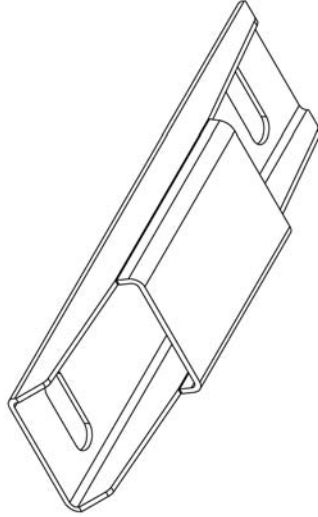
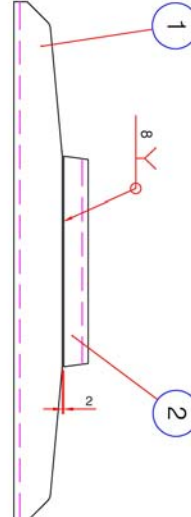

© Copyright
This drawing has copyright & may not be copied in whole or in part or used for any other purpose other than that for which it is supplied without express written consent from the company.

ITEM	DESCRIPTION	QTY	UNIT NO.
1	FOOT LOWER	1	HS-VG7600-2
2	FOOT UPPER	1	HS-VG7600-3

CONFIDENTIAL

ALL DIMENSIONS ARE IN MILLIMETRES.

GENERAL TOLERANCE ±0.5 U.O.S.

Rev	Remarks	ECN	Part	Check
A	PROD. REL.			
Drawn By	Date	Material		
KIRKCOX	JAN. 08	STEEL		
Scale	Finish	Weight		
1:5	SELF COLOUR	**Kg		

Description
Fabricated Foot Assy.
4m Zoneguard Expansion Joint.

UNCONTROLLED WHEN PRINTED

Springvale Business & Industrial Park, Biston,
Wolverhampton, WV14 0DL, UK
Tel: 01902 489400
Fax: 01902 489419
www.hsindings.co.uk

HS

Drawing No. **HS-VG7600**

NOTE:-
ALL WELDS - MINIMUM 30% PENETRATION.

UNCONTROLLED DOCUMENT

10.11 Drawing 11

Drawing No.
HS-VG7650



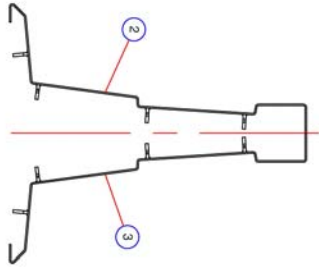

END ELEVATION

© Copyright
This drawing has copyright & may not be copied in whole or in part or used for any other purpose other than that for which it is supplied without express written consent from the company.

ITEM	DESCRIPTION	QTY	DMT NO.
1	GUSSET CENTRE	8	HS-VG7650
2	OUTER EXPANSION LEFT SKIN	1	HS-VG7650
3	OUTER EXPANSION RIGHT SKIN	1	HS-VG7650

UNCONTROLLED DOCUMENT

CONFIDENTIAL

ALL DIMENSIONS ARE IN MILLIMETRES.

GENERAL TOLERANCE ±0.5 U.O.S.

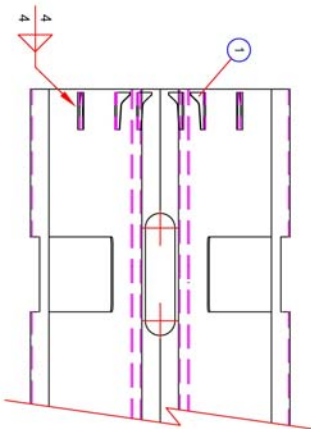

VIEW ON UNDERSIDE OF SECTION

A	PROD. REL.	ECON	MATERIAL	DRAWN BY	REMARKS
		REL	STEEL	KIRKACOX	DEC. 07
				Scale	1:10
				Finish	SELF COLOUR
				Weight	**kg

Description

Outer Skin with Gussets.
4m Zoneguard Expansion Joint.

UNCONTROLLED WHEN PRINTED

Springvale Business & Industrial Park, Biston,
Wolverhampton, WV14 0DL, UK
Tel: 01902 489400
Fax: 01902 489419
www.hsinddrg.co.uk

HS

Drawing No. **HS-VG7650**

NOTES:-
1. ALL GUSSETS TO BE PERPENDICULAR TO SKIN.

10.12 Drawing 12

Drawing No.
HS-VG7651



NOTES:

1. FINISH ALL WELDS TO LEAVE FLUSH MATING FACE.
2. ALL WELDS-MINIMUM 30% PENETRATION.

© Copyright
This drawing has copyright & may not be copied in whole or in part or used for any other purpose other than that for which it is supplied without express written consent from the company.

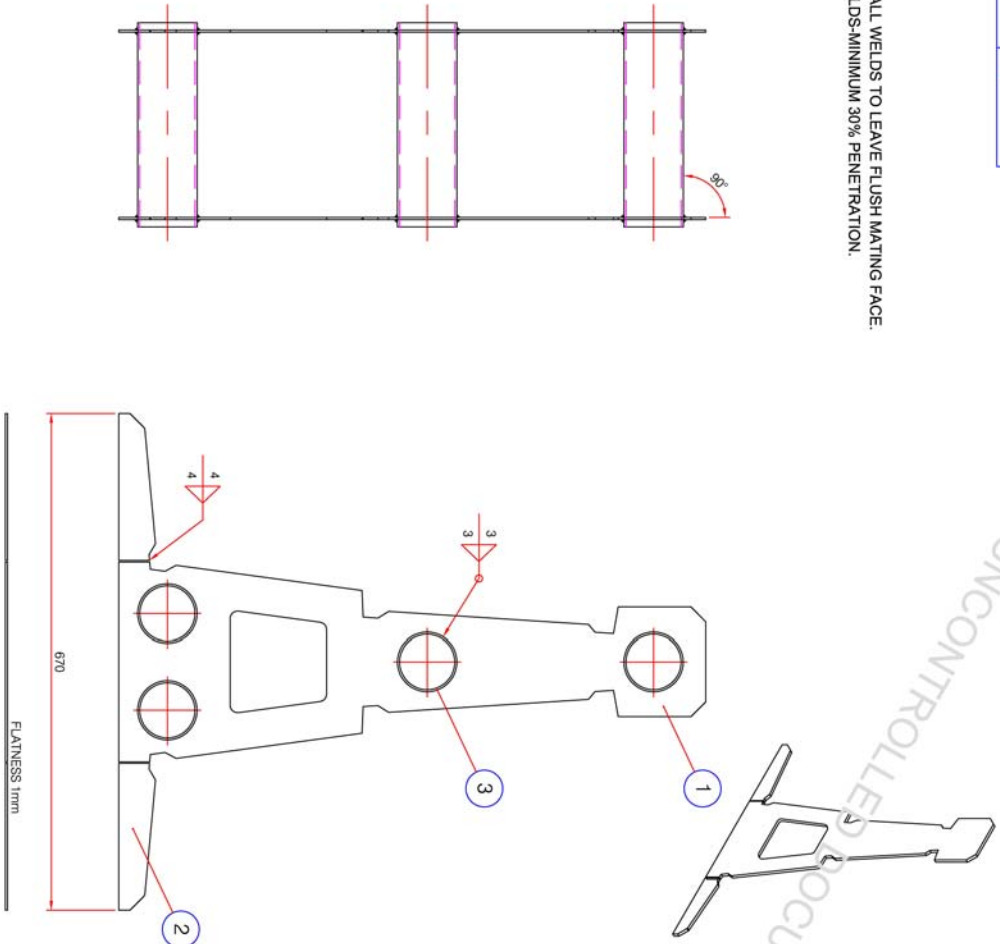

CONFIDENTIAL

ALL DIMENSIONS ARE IN MILLIMETRES.

GENERAL TOLERANCE ±0.5 U.O.S.

ITEM	DESCRIPTION	QTY	DMT. NO.
1	OUTER TUBE PLATE CENTRE	1	HS-VG7652
2	OUTER TUBE PLATE TOE	2	HS-VG7653
3	TUBE COLLAR	4	HS-VG7654



Rev	A	PROD. REL.	ECN	None	Checked
Drawn By	KIRKCOX		Date	DEC. 07	
Scale	1:5	Finish	SELF COLOUR	Weight	**Kg

Description

Outer Tube Plate Assy.
4m Zoneguard Expansion Joint.

UNCONTROLLED WHEN PRINTED

Springvale Business & Industrial Park, Biston,
Wolverhampton, WV14 0DL, UK
Tel: 01902 489400
Fax: 01902 489419
www.hsindings.co.uk





Drawing No. **HS-VG7651**

10.14 Drawing 14

Drawing No.
HS-VG7661

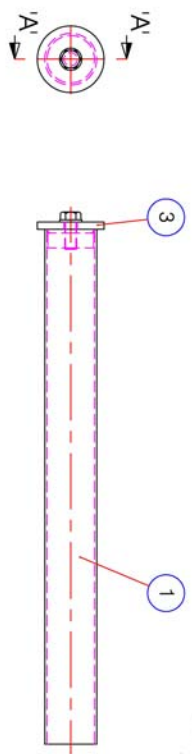



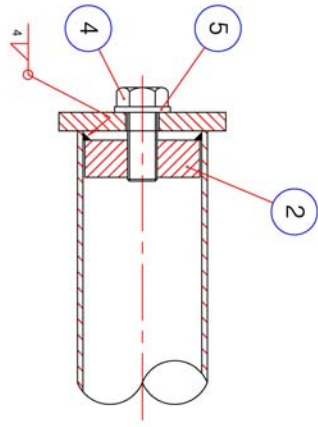

ENLARGED PART SECTION 'A-A'

CONFIDENTIAL

ALL DIMENSIONS ARE IN MILLIMETRES.

GENERAL TOLERANCE ±0.5 U.O.S.

UNCONTROLLED DOCUMENT

ITEM	DESCRIPTION	QTY	UNIT NO.
1	EXPANSION TUBE	1	HS-VG7661
2	TUBED END TUBE INSERT	1	HS-VG7662
3	TUBE END CAP	1	HS-VG7663
4	HEX HD BOLT M16 x 40 LG	1	HS-VG7664
5	FLAT WASHER M16	1	HS-VG7665

© Copyright
This drawing has copyright & may not be copied in whole or in part or used for any other purpose other than that for which it is supplied without express written consent from the company.

Rev	Remarks	ECN	Rev	Check
A	PROD. REL.			

Drawn By	DATE	MATERIAL
KIRKCOX	DEC. 07	STEEL
Scale	Finish	Weight
1:5 & 1:2	SELF COLOUR	**Kg

Description

Expansion Tube Assy.
4m Zoneguard Expansion Joint.



Springvale Business & Industrial Park, Biston,
Wolverhampton, WV14 0DL, UK
Tel: 01902 489400
Fax: 01902 489419
www.hsindeng.co.uk



Drawing No. **HS-VG7661**

10.15 Drawing 15

Drawing No.
HS-VG7662



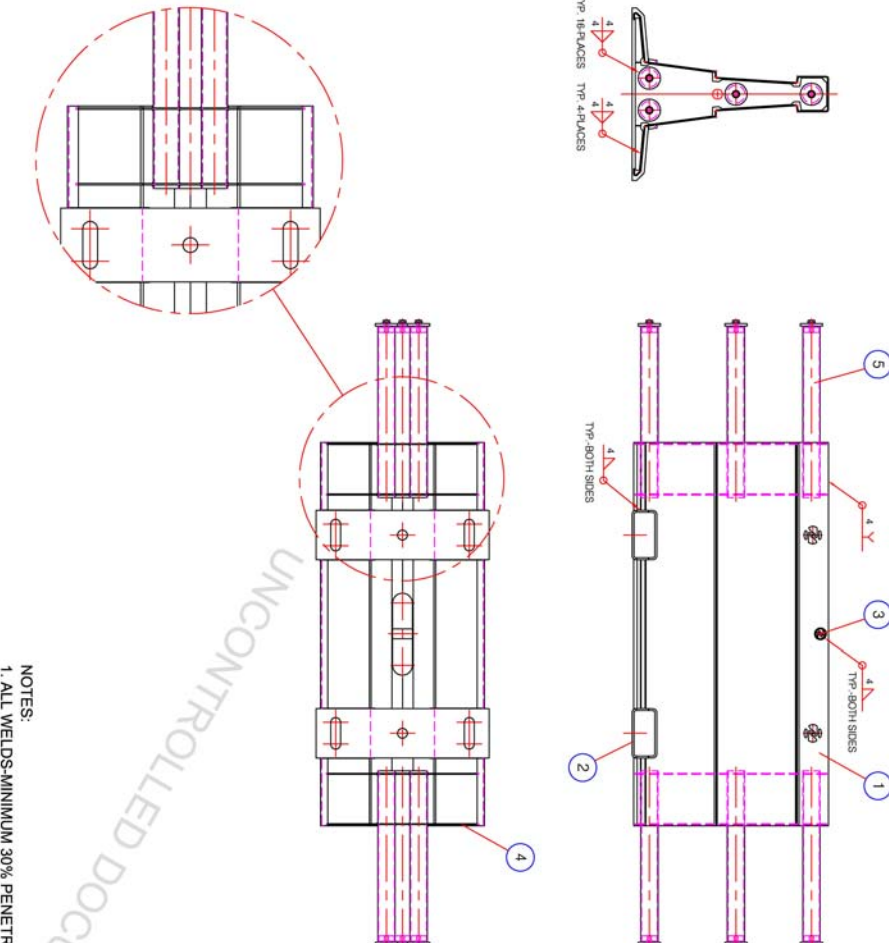

NOTES:
1. ALL WELDS-MINIMUM 30% PENETRATION.

UNCONTROLLED DOCUMENT

CONFIDENTIAL

ALL DIMENSIONS ARE IN MILLIMETRES.

GENERAL TOLERANCE ±0.5 U.O.S.



ITEM	DESCRIPTION	QTY	DMT NO.
1	INNER EXPANSION SKIN	2	HS-VG7660
2	FABRICATED FOOT ASSY	2	HS-VG7660
3	LIFTING BAR	1	HS-VG7611
4	INNER TUBE PLATE ASSY	4	HS-VG7660
5	EXPANSION TUBE ASSY	8	HS-VG7661

A	PROD. REL.	ECON	MATERIAL	DATE	CHECK
Drawn By	DATE	Scale	Finish	Weight	**Kg
KIRKACOX	DEC. 07	1:15 & 1:10	GALVANISE		

Description
Inner Assy.
4m Zoneguard Expansion Joint.

UNCONTROLLED WHEN PRINTED

Springvale Business & Industrial Park, Bliston,
Wolverhampton, WV14 0DL, UK
Tel: 01902 499400
Fax: 01902 499419
www.hsindings.co.uk

Drawing No. **HS-VG7662**