



U.S. Department
of Transportation
**Federal Highway
Administration**

1200 New Jersey Avenue, SE
Washington, D.C. 20590

March 18, 2010

In Reply Refer To:
HSSD/B-191

Ronald K. Faller, Ph.D., P.E.
Research Assistant Professor
UNL - Midwest Roadside Safety Facility
527 Nebraska Hall
P.O. Box 880529
Lincoln, Nebraska 68588-0529

Dear Dr. Faller:

This letter is in response to your request for the Federal Highway Administration (FHWA) acceptance of a roadside safety system and end anchors for use on the National Highway System (NHS).

Name of system: Low Tension, Three-Cable Guardrail System placed adjacent to a steep slope (1.5H:1V) and Alternative End Anchor Systems
Type of system: Cable Barrier with 4-foot post spacing
Test Level: NCHRP Report 350 Test Level 3
Testing conducted by: Midwest Roadside Safety Facility
Date of request: October 24, 2008
Date of Completed Package: May 12, 2009

You requested that we find this system and anchors acceptable for use on the NHS under the provisions of the National Cooperative Highway Research Program (NCHRP) Report 350 "Recommended Procedures for the Safety Performance Evaluation of Highway Features."

Requirements

Roadside safety systems should meet the guidelines contained in the NCHRP Report 350 or the AASHTO Manual for Assessing Safety Hardware. The FHWA Memorandum "Identifying Acceptable Highway Safety Features" of July 25, 1997, provides further guidance on crash testing requirements of longitudinal barriers.



Cable Barrier Description

The system's overall length was 150.57-m (494-ft) and consisted of four major structural components: (1) wire rope; (2) posts; (3) cable compensator end assemblies, and (4) tangent anchor assemblies. Design details are shown in the enclosure for reference. Three 19-mm (3/4-in) diameter cables comprised of 3x7 wire rope were used for the rail elements. The cable rails were supported by ninety-two guardrail posts with an uppermost mounting height of 762 mm (30 in) and with 76-mm (3-in) incremental spacing for the two lower cables. The cables were tightened with the use of cable compensators. The ends of the cables were threaded rods that terminated in the cable anchor. The threaded rods were attached to the cable anchor with three 51-mm (2-in) diameter washers and two 19-mm (3/4-in) diameter Grade 5 nuts.

The line posts consisted of 1,600-mm (63-in) long S76x8.5 (S3x5.7) rolled steel sections with a 203-mm x 610-mm x 6-mm (8-in. x 24-in x 1/4-in) soil plate welded along the back flange of the post. The line posts were spaced 1,219 mm (48 in) on center with a soil embedment depth of 762 mm (30 in). The line posts were set 1,219 mm (48 in) back from the slope breakpoint.

Post numbers 1 through 7 and 86 through 92 were part of the tangent cable end anchor system as developed as part of a previous study. The anchor bracket post, post numbers 1 and 92, were W152x37.2 (W6x25) steel sections with a 610-mm x 610-mm x 13-mm (24-in x 24 in x 1/2-in) soil plate. The anchor post was embedded to a depth of 2,438 mm (96 in). A 368-mm x 229 mm x 13 mm (14 1/2 in x 9 in x 1/2 in) plate welded to the top of the anchor post to which the cable anchor bracket was bolted with four 19-mm diameter x 64-mm long (3/4-in. x 2.5-in.) Grade 5 hex head bolts.

Post numbers 2 and 91 were configured with S76x8.5 (S3x5.7) sections measuring 838 mm (33 in) long for the slip posts with W152x13.4 (W6x9) sections measuring 1,829-mm (72-in) long for the foundation posts. The foundation post was embedded to a depth 1,778 mm (70 in). A slip base plate was welded to the bottom of the slip post and the top of the foundation post. Four 13-mm diameter x 51-mm (1/2-in x 2-in) long ASTM A307 bolts with nuts and washers to form the slip base configuration. Post numbers 3 through 7 and 86 through 90 were also slip posts that were configured with S76x8.5 (S3x5.7) sections and W152x13.4 (W6x9) sections. These posts were identical to post numbers 2 and 91, except the cable bracket was replaced with three cable hooks as shown in Figures 16 and 17. The top cable hook was located 90 mm (3 1/2 in) down from the top of the post with the middle and lower cable 166 mm and 242 mm (6 1/2 in and 9 1/2 in) from the top of the post, respectively.

A 48.7-m long x 6.1-m wide (160-ft x 20-ft) pit was excavated behind the cable system. In order to develop a 1.5H:1V slope, the pit's profile was identified by horizontal and vertical components of 6.1 m (240 in.) and 4.1 m (160 in.), respectively.

Cable End Anchor Alternatives Descriptions

Three anchor design options were considered to simplify construction of the three-cable guardrail system. These include a reinforced concrete block, a reinforced concrete shaft, and a driven steel post. The concrete block option mimics that of the existing design, but utilizes a

smaller concrete block that can be lifted with existing equipment. The reinforced concrete shaft provides a simplified concrete design alternative, but still relies on the use of cast-in-place concrete. The steel post design incorporates a large steel beam that is driven into the ground.

Concrete Block

The revised concrete block design is 1,524 mm long x 1,015 mm deep x 610 mm wide (60-in x 40 in x 24 in) and weighs approximately 2,268 kg (5,000 lbs). The block fabricated with 27.58-MPa (4,000-psi) minimum compressive strength concrete contains Grade 60 Number 4 reinforcement bars.

Reinforced Concrete Shaft

The drilled shaft concrete anchor is 457 mm (18 in) in diameter and is 1,829 mm (72 in) deep. The anchor is reinforced with a spiral rebar cage fabricated with Grade 60 steel. The spiral reinforcement was designed with a 38-mm (1.5-in) clear cover over Number 3 rebar and ten Number 4 vertical bars equally spaced around the interior circumference. A concrete mix with compressive strength of 27.58 MPa (4,000-psi) was also specified. Anchor rods embedded 305 mm (12 in) into the structure were used to secure the cable anchor bracket.

Steel Post

A W152x37.2 (W6x25) steel section with a 248-MPa (36-ksi) yield strength and a 2,438-mm (96-in) overall length was selected for the design. The addition of a 610-mm x 610-mm x 13-mm (24-in x 24-in x 1/2-in.) soil bearing plate provides further resistance against lateral forces. In this case, the anchor bracket is bolted to a steel plate welded to the top of the post.

Crash Testing

Longitudinal barriers are typically subjected to testing with both a small car and a pickup truck. The higher impact energy associated with the pickup truck test produces larger barrier deflections and greatly increases the likelihood of vehicle rollover as compared to the small car test. The impact of the reduced post spacing on the small car was considered and judged to have no adverse affect on the barrier performance. Therefore, the 2,000-kg (4,409-lb) pickup truck test was selected as sufficient to evaluate the performance of the cable guardrail adjacent to steep slopes, and the 820-kg (1,808-lb) small car test was considered unnecessary for this project.

Developmental Test

A developmental test of low tension 3-cable barrier was conducted with the posts spaced at 4.88-m (16-ft) and set back 12-in from the slope break point. This test failed when the test vehicle rolled over the barrier and down the ditch slope. It was concluded that the barrier stiffness and the offset from the hinge point both needed to increase in order for the system to pass NCHRP Report 350 criteria.

Test on Final Design

A subsequent crash test was conducted on the final barrier design as discussed in the section above titled "Cable Barrier Description." The line posts were spaced 1,219 mm (48 in) on center with a soil embedment depth of 762 mm (30 in). The line posts were set 1,219 mm (48 in) back from the slope breakpoint. The 2,032-kg (4,481-lb) pickup truck impacted this three cable guardrail system at a speed of 99.1 km/h (61.6 mph) and at an angle of 23.6 degrees.

The vehicle was contained and redirected by the barrier. The longitudinal and lateral occupant impact velocities were determined to be -4.16 m/s (-13.64 ft/s) and 3.42 m/s (11.22 ft/s), respectively. The maximum 0.010-sec average occupant ridedown deceleration in the longitudinal and lateral directions were -5.73 g's and 6.96 g's, respectively. Both the occupant impact velocities (OIVs) and occupant ridedown decelerations (ORDs) were within the suggested limits provided in NCHRP Report 350. The maximum lateral permanent set post deflection was 578 mm (22.75 in) at the centerline of post number 36 as measured in the field. The maximum lateral dynamic cable deflection was 3,163 mm (124.5 in), as determined from high-speed digital video analysis. The working width of the system was found to be 3,318 mm (130.6 in).

Anchor Testing

A 2,223-kg (4,900-lb) wheeled bogie was attached to each anchor and accelerated to provide a dynamic load of 178-kN (40,000-lbs). The reinforced concrete block option represented the strongest design with a 254-kN (57,000-lbs) peak resisting force. The drilled shaft produced a resisting force of 205 kN (46,000 lbs) and the driven steel post sustained 187 kN (42,000 lbs.) Although the driven steel post anchor is considered a viable anchor design and performed satisfactorily under full scale test, its structural performance was slightly out of the acceptable performance range. This makes the reuse of this anchor undesirable with the strong likelihood it would have to be replaced after each impact event.

Findings

Therefore, the low-tension 3-cable barrier system with posts spaced 1,219-mm (48 in) on center set 1,219 mm (48 in) back from the slope breakpoint of the steep slope described above and detailed in the enclosed drawings is acceptable for use on the NHS under the range of conditions tested, when such use is acceptable to a highway agency. The three alternative cable anchor systems are similarly acceptable as long as they are designed to work properly with local soil conditions.

Please note the following standard provisions that apply to FHWA letters of acceptance:

- This acceptance is limited to the crashworthiness characteristics of the systems and does not cover their structural features, nor conformity with the Manual on Uniform Traffic Control Devices.
- Any changes that may adversely influence the crashworthiness of the system will require a new acceptance letter.
- Should the FHWA discover that the qualification testing was flawed, that in-service performance reveals unacceptable safety problems, or that the system being marketed is significantly different from the version that was crash tested, we reserve the right to modify or revoke our acceptance.
- You will be expected to supply potential users with sufficient information on design and installation requirements to ensure proper performance.
- You will be expected to certify to potential users that the hardware furnished has essentially the same chemistry, mechanical properties, and geometry as that submitted for acceptance, and that it will meet the crashworthiness requirements of the FHWA and the NCHRP Report 350.

- To prevent misunderstanding by others, this letter of acceptance is designated as number B-191 and shall not be reproduced except in full. This letter and the test documentation upon which it is based are public information. All such letters and documentation may be reviewed at our office upon request.
- This acceptance letter shall not be construed as authorization or consent by the FHWA to use, manufacture, or sell any patented system for which the applicant is not the patent holder. The acceptance letter is limited to the crashworthiness characteristics of the candidate system, and the FHWA is neither prepared nor required to become involved in issues concerning patent law. Patent issues, if any, are to be resolved by the applicant.

Sincerely yours,

David A. Nicol, P.E.
Director, Office of Safety Design
Office of Safety

Enclosure

FHWA:HSSD:NArtimovich:tb:x61331:3/11/10

File: s://directory folder/nartimovich/B191-MWRSF3CAbleSteepSlopePreFinal.doc

cc: HSSD (Reader, HSA; Chron File, HSSD; N.Artimovich, HSSD; MMcDonough, HSSD;
WLongstreet, HSSD; DNicol, HSSD)



U.S. Department
of Transportation
**Federal Highway
Administration**

1200 New Jersey Avenue, SE
Washington, D.C. 20590

March 18, 2010

In Reply Refer To:
HSSD/B-191

Ronald K. Faller, Ph.D., P.E.
Research Assistant Professor
UNL - Midwest Roadside Safety Facility
527 Nebraska Hall
P.O. Box 880529
Lincoln, Nebraska 68588-0529

Dear Dr. Faller:

This letter is in response to your request for the Federal Highway Administration (FHWA) acceptance of a roadside safety system and end anchors for use on the National Highway System (NHS).

Name of system: Low Tension, Three-Cable Guardrail System placed adjacent to a steep slope (1.5H:1V) and Alternative End Anchor Systems
Type of system: Cable Barrier with 4-foot post spacing
Test Level: NCHRP Report 350 Test Level 3
Testing conducted by: Midwest Roadside Safety Facility
Date of request: October 24, 2008
Date of Completed Package: May 12, 2009

You requested that we find this system and anchors acceptable for use on the NHS under the provisions of the National Cooperative Highway Research Program (NCHRP) Report 350 "Recommended Procedures for the Safety Performance Evaluation of Highway Features."

Requirements

Roadside safety systems should meet the guidelines contained in the NCHRP Report 350 or the AASHTO Manual for Assessing Safety Hardware. The FHWA Memorandum "Identifying Acceptable Highway Safety Features" of July 25, 1997, provides further guidance on crash testing requirements of longitudinal barriers.



Cable Barrier Description

The system's overall length was 150.57-m (494-ft) and consisted of four major structural components: (1) wire rope; (2) posts; (3) cable compensator end assemblies, and (4) tangent anchor assemblies. Design details are shown in the enclosure for reference. Three 19-mm (3/4-in) diameter cables comprised of 3x7 wire rope were used for the rail elements. The cable rails were supported by ninety-two guardrail posts with an uppermost mounting height of 762 mm (30 in) and with 76-mm (3-in) incremental spacing for the two lower cables. The cables were tightened with the use of cable compensators. The ends of the cables were threaded rods that terminated in the cable anchor. The threaded rods were attached to the cable anchor with three 51-mm (2-in) diameter washers and two 19-mm (3/4-in) diameter Grade 5 nuts.

The line posts consisted of 1,600-mm (63-in) long S76x8.5 (S3x5.7) rolled steel sections with a 203-mm x 610-mm x 6-mm (8-in. x 24-in x 1/4-in) soil plate welded along the back flange of the post. The line posts were spaced 1,219 mm (48 in) on center with a soil embedment depth of 762 mm (30 in). The line posts were set 1,219 mm (48 in) back from the slope breakpoint.

Post numbers 1 through 7 and 86 through 92 were part of the tangent cable end anchor system as developed as part of a previous study. The anchor bracket post, post numbers 1 and 92, were W152x37.2 (W6x25) steel sections with a 610-mm x 610-mm x 13-mm (24-in x 24 in x 1/2-in) soil plate. The anchor post was embedded to a depth of 2,438 mm (96 in). A 368-mm x 229 mm x 13 mm (14 1/2 in x 9 in x 1/2 in) plate welded to the top of the anchor post to which the cable anchor bracket was bolted with four 19-mm diameter x 64-mm long (3/4-in. x 2.5-in.) Grade 5 hex head bolts.

Post numbers 2 and 91 were configured with S76x8.5 (S3x5.7) sections measuring 838 mm (33 in) long for the slip posts with W152x13.4 (W6x9) sections measuring 1,829-mm (72-in) long for the foundation posts. The foundation post was embedded to a depth 1,778 mm (70 in). A slip base plate was welded to the bottom of the slip post and the top of the foundation post. Four 13-mm diameter x 51-mm (1/2-in x 2-in) long ASTM A307 bolts with nuts and washers to form the slip base configuration. Post numbers 3 through 7 and 86 through 90 were also slip posts that were configured with S76x8.5 (S3x5.7) sections and W152x13.4 (W6x9) sections. These posts were identical to post numbers 2 and 91, except the cable bracket was replaced with three cable hooks as shown in Figures 16 and 17. The top cable hook was located 90 mm (3 1/2 in) down from the top of the post with the middle and lower cable 166 mm and 242 mm (6 1/2 in and 9 1/2 in) from the top of the post, respectively.

A 48.7-m long x 6.1-m wide (160-ft x 20-ft) pit was excavated behind the cable system. In order to develop a 1.5H:1V slope, the pit's profile was identified by horizontal and vertical components of 6.1 m (240 in.) and 4.1 m (160 in.), respectively.

Cable End Anchor Alternatives Descriptions

Three anchor design options were considered to simplify construction of the three-cable guardrail system. These include a reinforced concrete block, a reinforced concrete shaft, and a driven steel post. The concrete block option mimics that of the existing design, but utilizes a

smaller concrete block that can be lifted with existing equipment. The reinforced concrete shaft provides a simplified concrete design alternative, but still relies on the use of cast-in-place concrete. The steel post design incorporates a large steel beam that is driven into the ground.

Concrete Block

The revised concrete block design is 1,524 mm long x 1,015 mm deep x 610 mm wide (60-in x 40 in x 24 in) and weighs approximately 2,268 kg (5,000 lbs). The block fabricated with 27.58-MPa (4,000-psi) minimum compressive strength concrete contains Grade 60 Number 4 reinforcement bars.

Reinforced Concrete Shaft

The drilled shaft concrete anchor is 457 mm (18 in) in diameter and is 1,829 mm (72 in) deep. The anchor is reinforced with a spiral rebar cage fabricated with Grade 60 steel. The spiral reinforcement was designed with a 38-mm (1.5-in) clear cover over Number 3 rebar and ten Number 4 vertical bars equally spaced around the interior circumference. A concrete mix with compressive strength of 27.58 MPa (4,000-psi) was also specified. Anchor rods embedded 305 mm (12 in) into the structure were used to secure the cable anchor bracket.

Steel Post

A W152x37.2 (W6x25) steel section with a 248-MPa (36-ksi) yield strength and a 2,438-mm (96-in) overall length was selected for the design. The addition of a 610-mm x 610-mm x 13-mm (24-in x 24-in x 1/2-in.) soil bearing plate provides further resistance against lateral forces. In this case, the anchor bracket is bolted to a steel plate welded to the top of the post.

Crash Testing

Longitudinal barriers are typically subjected to testing with both a small car and a pickup truck. The higher impact energy associated with the pickup truck test produces larger barrier deflections and greatly increases the likelihood of vehicle rollover as compared to the small car test. The impact of the reduced post spacing on the small car was considered and judged to have no adverse affect on the barrier performance. Therefore, the 2,000-kg (4,409-lb) pickup truck test was selected as sufficient to evaluate the performance of the cable guardrail adjacent to steep slopes, and the 820-kg (1,808-lb) small car test was considered unnecessary for this project.

Developmental Test

A developmental test of low tension 3-cable barrier was conducted with the posts spaced at 4.88-m (16-ft) and set back 12-in from the slope break point. This test failed when the test vehicle rolled over the barrier and down the ditch slope. It was concluded that the barrier stiffness and the offset from the hinge point both needed to increase in order for the system to pass NCHRP Report 350 criteria.

Test on Final Design

A subsequent crash test was conducted on the final barrier design as discussed in the section above titled "Cable Barrier Description." The line posts were spaced 1,219 mm (48 in) on center with a soil embedment depth of 762 mm (30 in). The line posts were set 1,219 mm (48 in) back from the slope breakpoint. The 2,032-kg (4,481-lb) pickup truck impacted this three cable guardrail system at a speed of 99.1 km/h (61.6 mph) and at an angle of 23.6 degrees.

The vehicle was contained and redirected by the barrier. The longitudinal and lateral occupant impact velocities were determined to be -4.16 m/s (-13.64 ft/s) and 3.42 m/s (11.22 ft/s), respectively. The maximum 0.010-sec average occupant ridedown deceleration in the longitudinal and lateral directions were -5.73 g's and 6.96 g's, respectively. Both the occupant impact velocities (OIVs) and occupant ridedown decelerations (ORDs) were within the suggested limits provided in NCHRP Report 350. The maximum lateral permanent set post deflection was 578 mm (22.75 in) at the centerline of post number 36 as measured in the field. The maximum lateral dynamic cable deflection was 3,163 mm (124.5 in), as determined from high-speed digital video analysis. The working width of the system was found to be 3,318 mm (130.6 in).

Anchor Testing

A 2,223-kg (4,900-lb) wheeled bogie was attached to each anchor and accelerated to provide a dynamic load of 178-kN (40,000-lbs). The reinforced concrete block option represented the strongest design with a 254-kN (57,000-lbs) peak resisting force. The drilled shaft produced a resisting force of 205 kN (46,000 lbs) and the driven steel post sustained 187 kN (42,000 lbs.) Although the driven steel post anchor is considered a viable anchor design and performed satisfactorily under full scale test, its structural performance was slightly out of the acceptable performance range. This makes the reuse of this anchor undesirable with the strong likelihood it would have to be replaced after each impact event.

Findings

Therefore, the low-tension 3-cable barrier system with posts spaced 1,219-mm (48 in) on center set 1,219 mm (48 in) back from the slope breakpoint of the steep slope described above and detailed in the enclosed drawings is acceptable for use on the NHS under the range of conditions tested, when such use is acceptable to a highway agency. The three alternative cable anchor systems are similarly acceptable as long as they are designed to work properly with local soil conditions.

Please note the following standard provisions that apply to FHWA letters of acceptance:

- This acceptance is limited to the crashworthiness characteristics of the systems and does not cover their structural features, nor conformity with the Manual on Uniform Traffic Control Devices.
- Any changes that may adversely influence the crashworthiness of the system will require a new acceptance letter.
- Should the FHWA discover that the qualification testing was flawed, that in-service performance reveals unacceptable safety problems, or that the system being marketed is significantly different from the version that was crash tested, we reserve the right to modify or revoke our acceptance.
- You will be expected to supply potential users with sufficient information on design and installation requirements to ensure proper performance.
- You will be expected to certify to potential users that the hardware furnished has essentially the same chemistry, mechanical properties, and geometry as that submitted for acceptance, and that it will meet the crashworthiness requirements of the FHWA and the NCHRP Report 350.

- To prevent misunderstanding by others, this letter of acceptance is designated as number B-191 and shall not be reproduced except in full. This letter and the test documentation upon which it is based are public information. All such letters and documentation may be reviewed at our office upon request.
- This acceptance letter shall not be construed as authorization or consent by the FHWA to use, manufacture, or sell any patented system for which the applicant is not the patent holder. The acceptance letter is limited to the crashworthiness characteristics of the candidate system, and the FHWA is neither prepared nor required to become involved in issues concerning patent law. Patent issues, if any, are to be resolved by the applicant.

Sincerely yours,

A handwritten signature in cursive script, appearing to read "David A. Nicol".

David A. Nicol, P.E.
Director, Office of Safety Design
Office of Safety

Enclosure

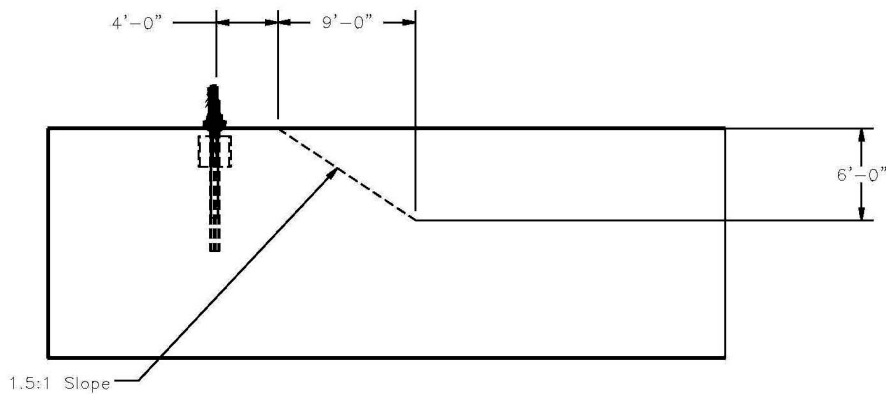
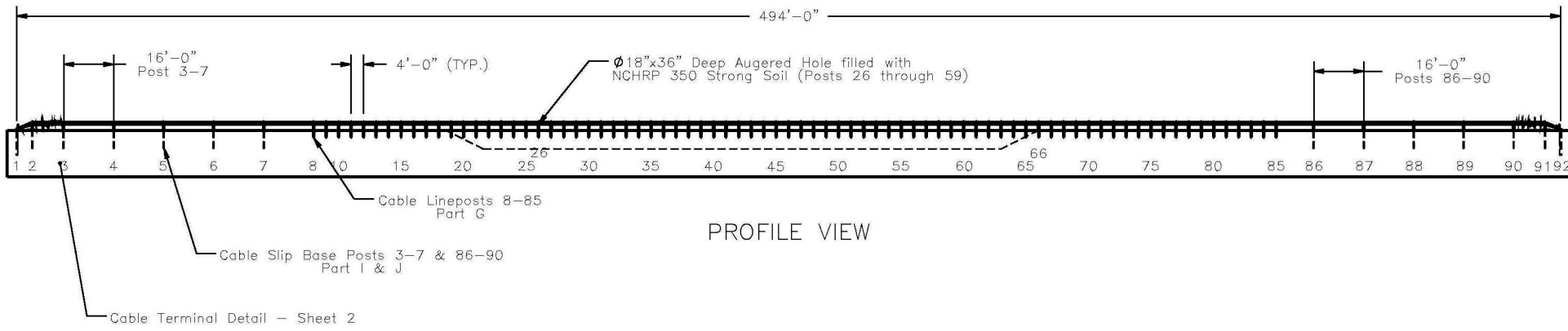
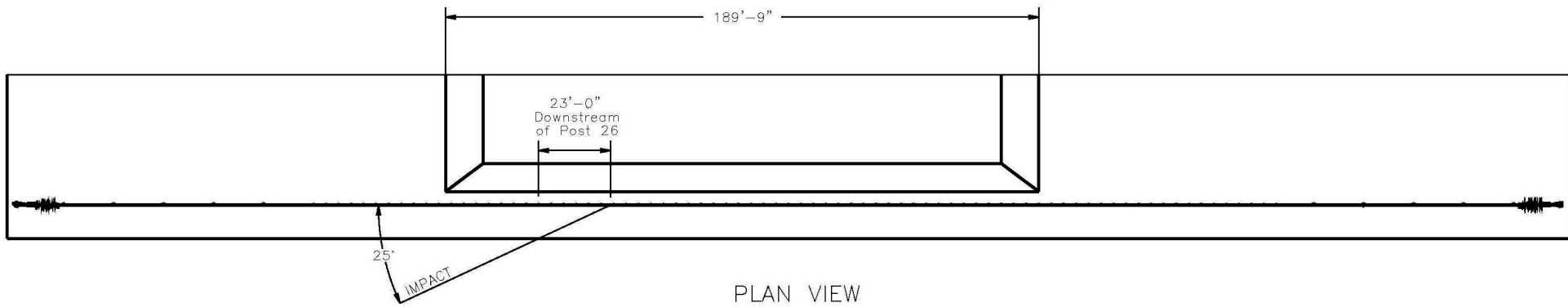

Midwest Roadside Safety Facility

Cable on Slope System Layout		SHEET: 1 of 12
		DATE: 11/1/2006
DWG. NAME: CS-2		DRAWN BY: GEP/CSS
		SCALE: None UNITS: Inches
		REV. BY: CME

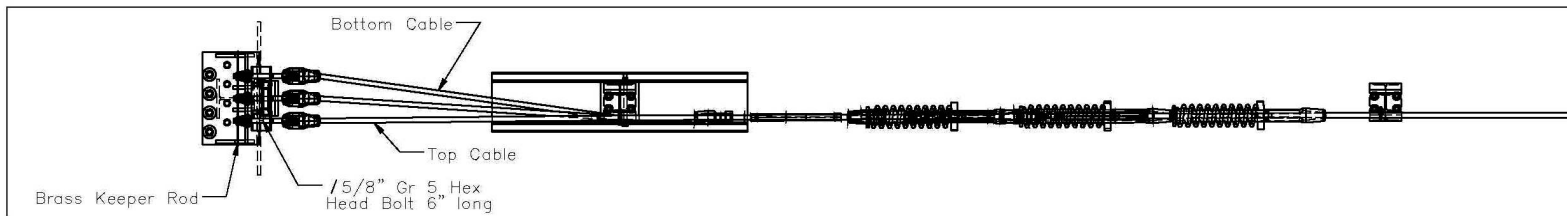

NOTE:

All cables run over the foot of the cable release lever. The middle cable runs through the Lever uprights.

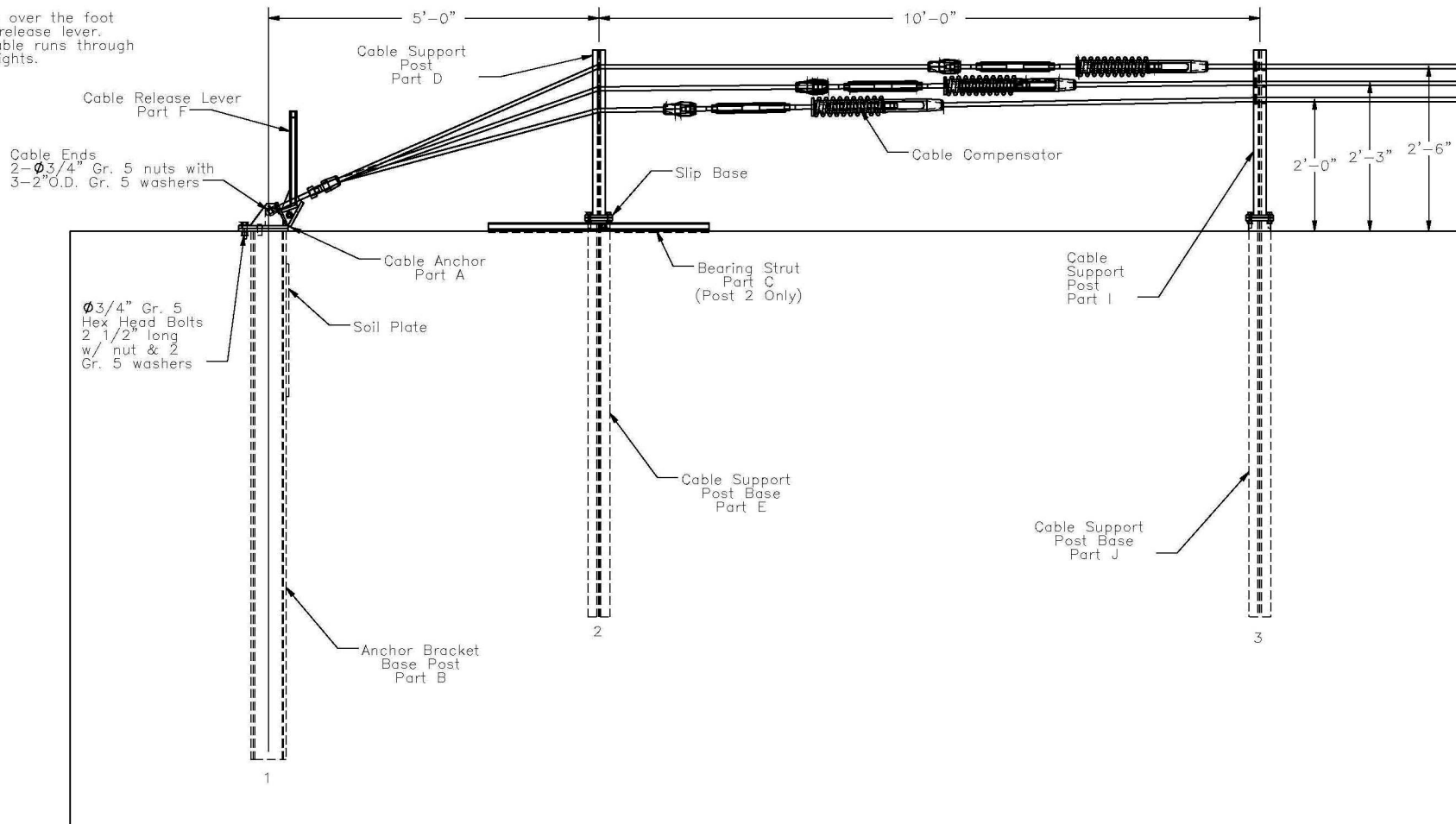

NOTE:

- 1) Use Grade 2 bolts, nuts, and washers
- 2) A36 Steel components (plate, angles, etc)



Midwest Roadside
Safety Facility

Cable on Slope

Cable Terminal Detail

DWG. NAME.
CS-2

SCALE: None
UNITS: Inches

SHEET:
2 of 12
DATE:
11/1/2006
DRAWN BY:
GEP/CSS
REV. BY:
CME

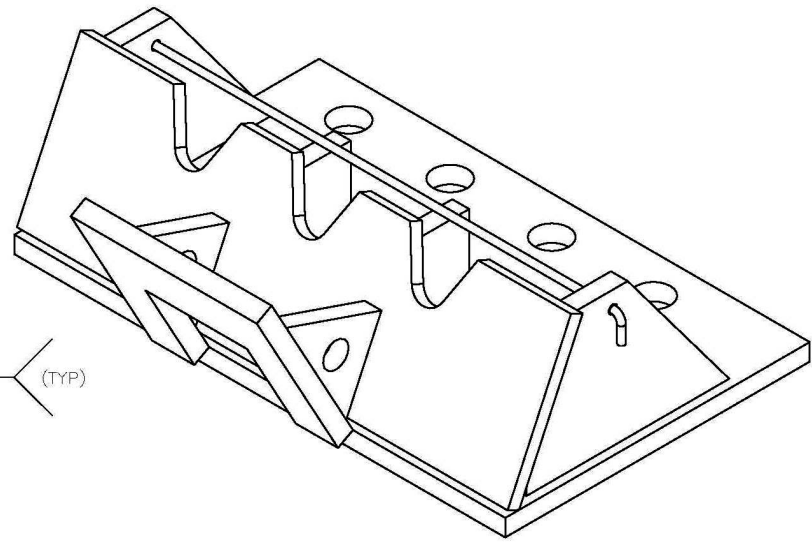
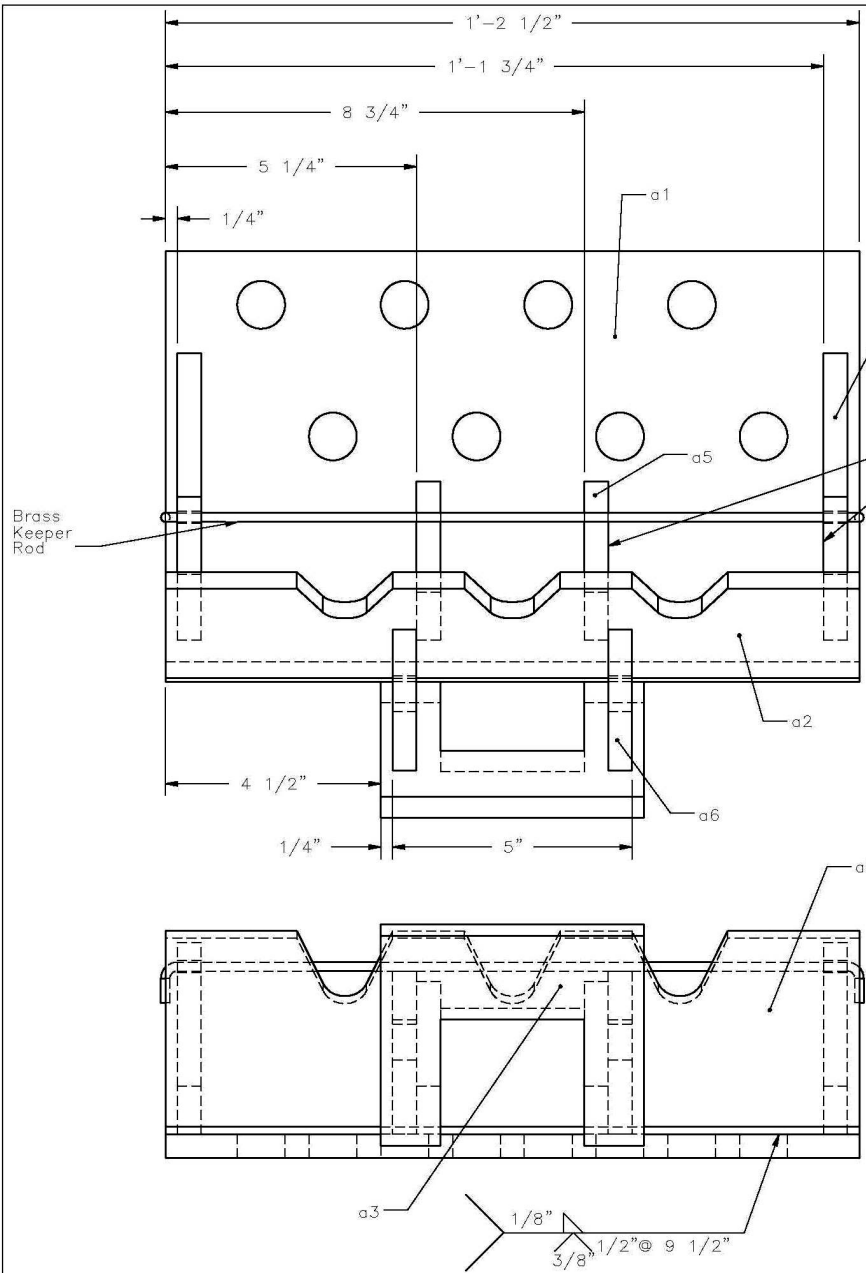

NOTE:
The lever retaining cable is a 1/4",
7x19 galvanized aircraft cable, 36" long
with 3 1/2" long loops and 1" clips.

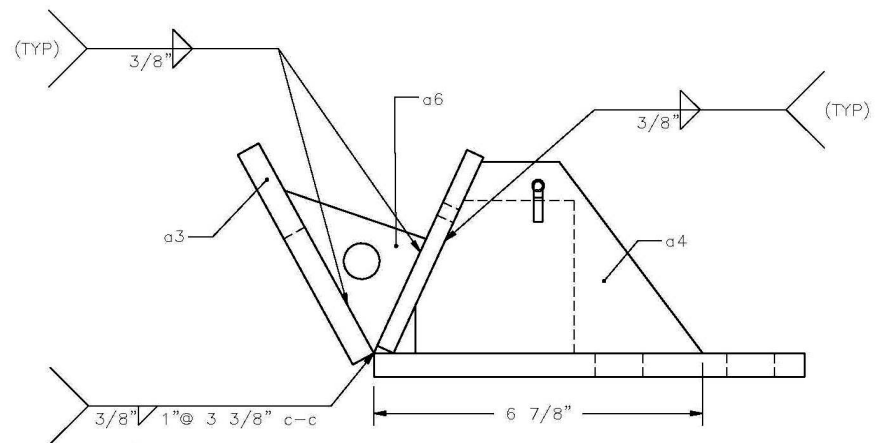

Midwest Roadside
Safety Facility

Cable on Slope

Cable Anchor Bracket
Part A

DWG. NAME:
CS-2

SCALE: None
UNITS: Inches

SHEET:
3 of 12
DATE:
11/1/2006
DRAWN BY:
GEP/CSS
REV. BY:
CME

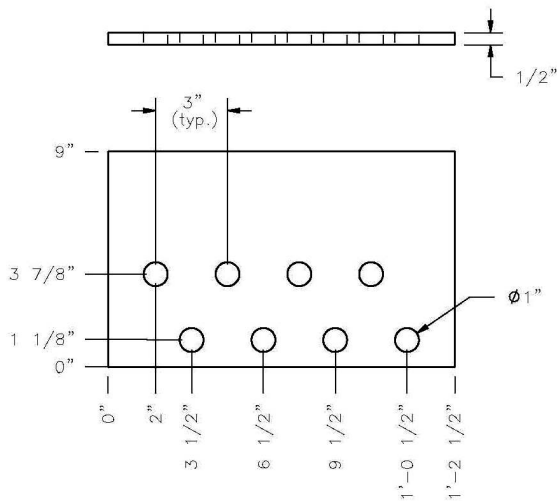

Anchor Bracket Plate
Part a1

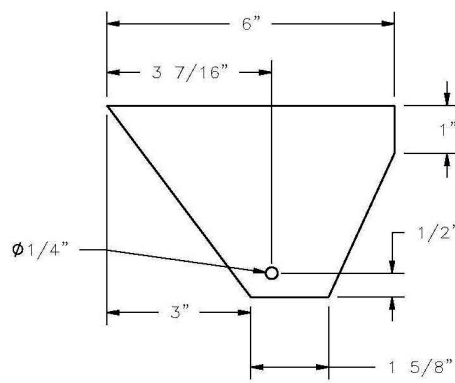

Exterior Cable Gusset
Part a4

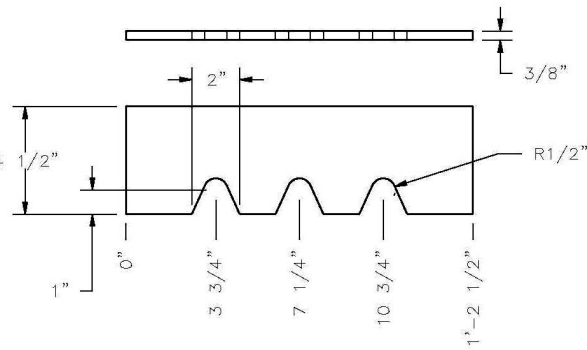
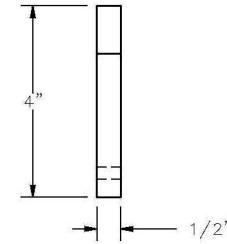

Cable Plate
Part a2

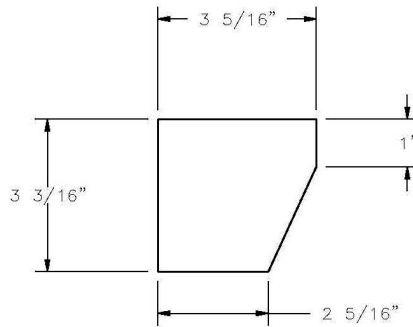

Interior Cable Gusset
Part a5

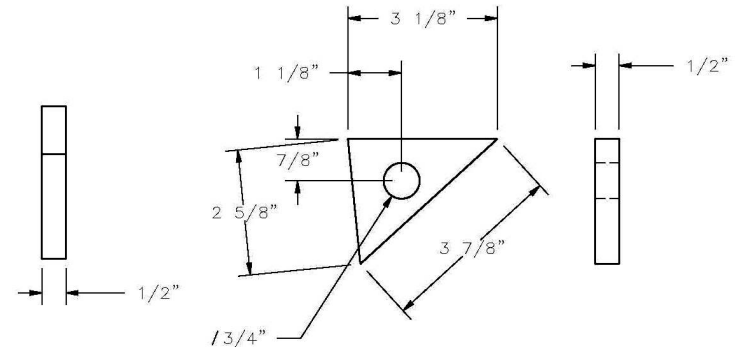

Release Lever Plate Gusset
Part a6

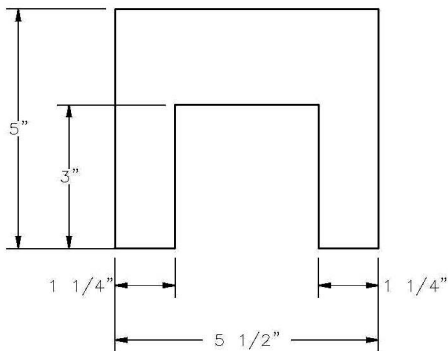

Release Lever Plate
Part a3

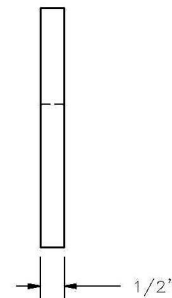

Midwest Roadside
Safety Facility

Cable on Slope

Cable Anchor Bracket
Part A Details

DWG. NAME.
CS-2

SCALE: None
UNITS: Inches

SHEET:
4 of 12
DATE:
11/1/2006
DRAWN BY:
GEP/CSS
REV. BY:
CME

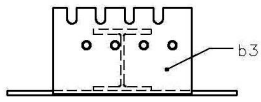

3/4" Rod, weld
in place from
beneath, 1/4" min.
fillet all-around.

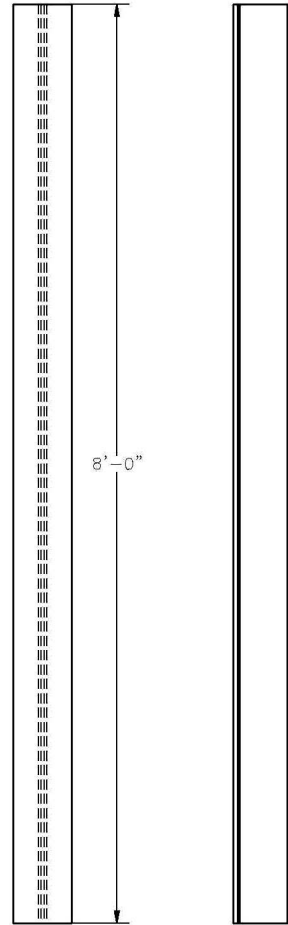

W6x25 Post
Part b1

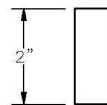

∅3/4" Rod
Part b4

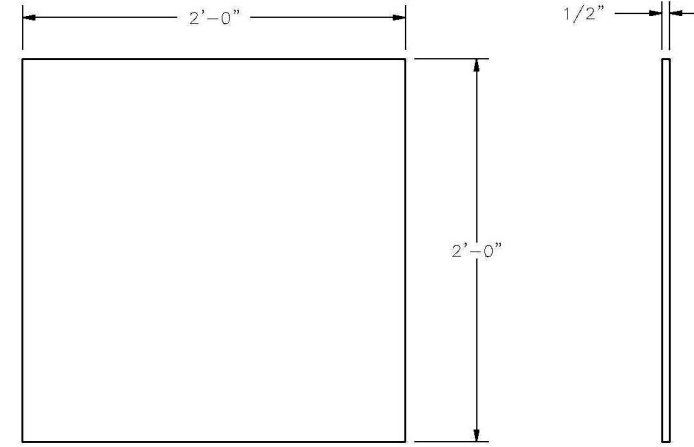

Soil Plate
Part b2

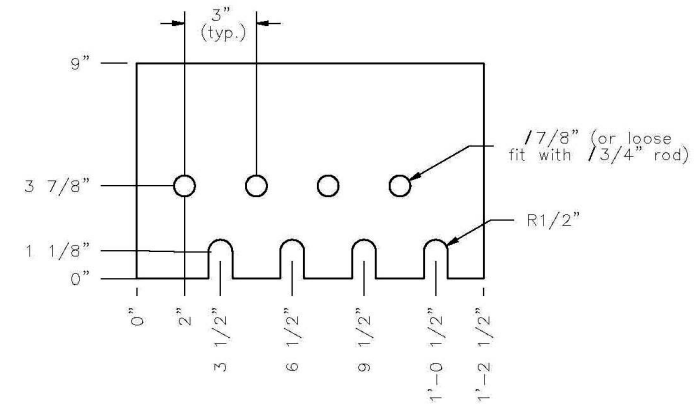
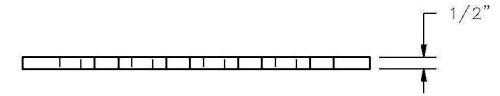

Anchor Base Plate
Part b3

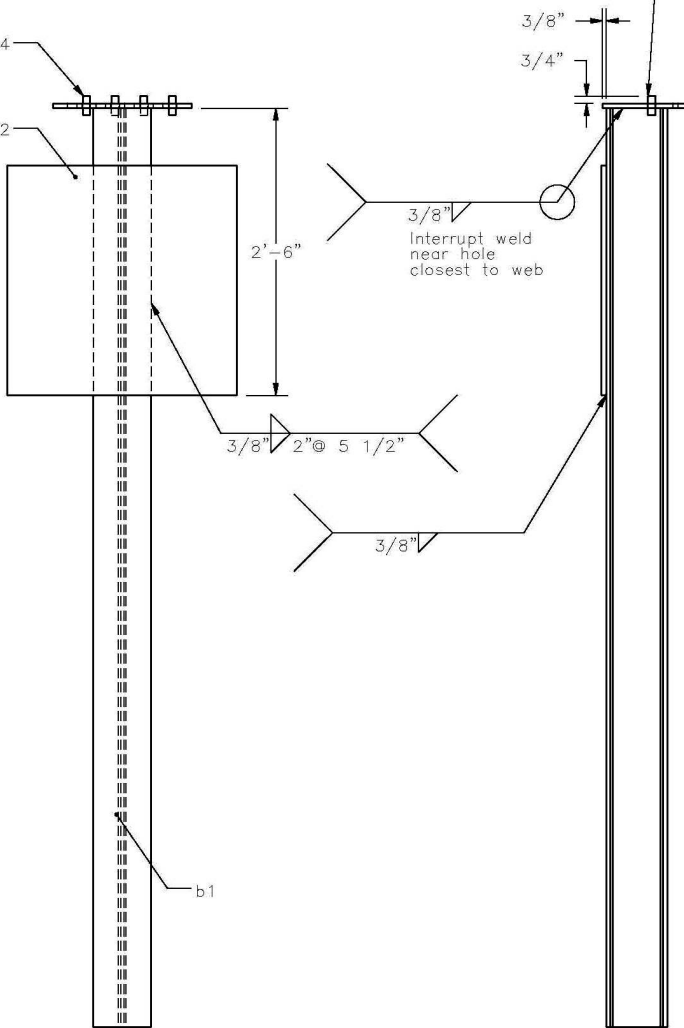

Anchor Bracket Base
Part B



Midwest Roadside
Safety Facility

Cable on Slope

Anchor Bracket Base
Part B

DWG. NAME:
CS-2

SCALE: None
UNITS: Inches

SHEET:
5 of 12
DATE:
11/1/2006
DRAWN BY:
GEP/CSS
REV. BY:
CME

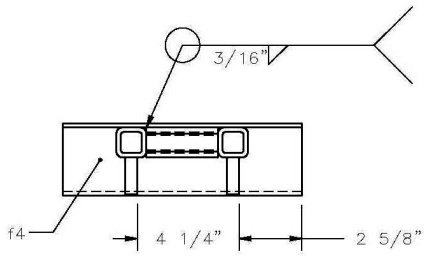

NOTE: The kicker lever should be flush with the top of the kicker plate, and the $3\ 1/4"$ leg of the kicker plate gusset should line up with the kicker lever, and the bottom of the kicker plate gusset should align with the bottom of the kicker plate.

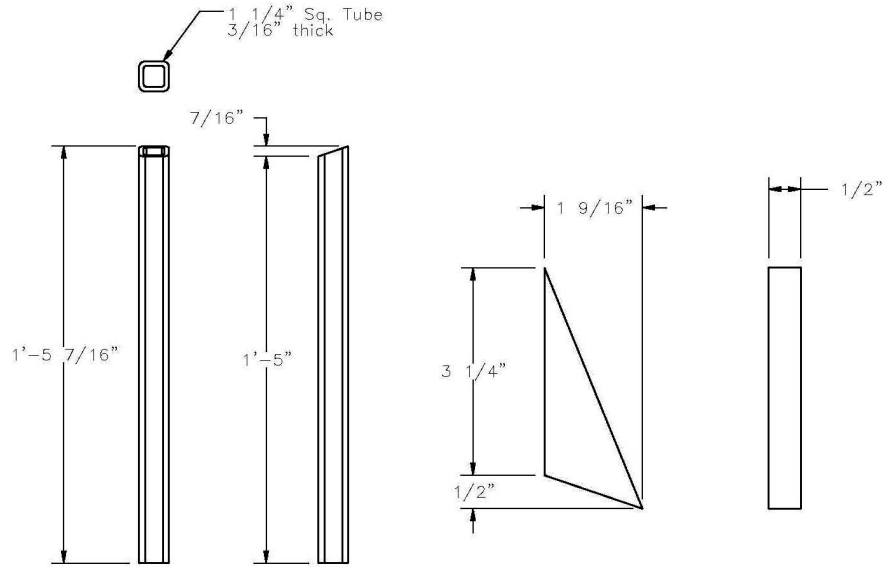
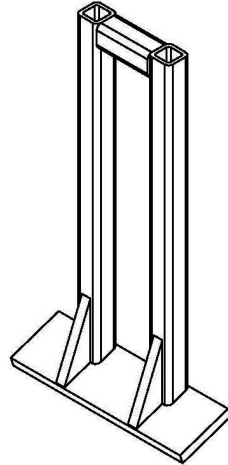

Kicker Lever Part f1

Kicker Plate Gusset Part f3

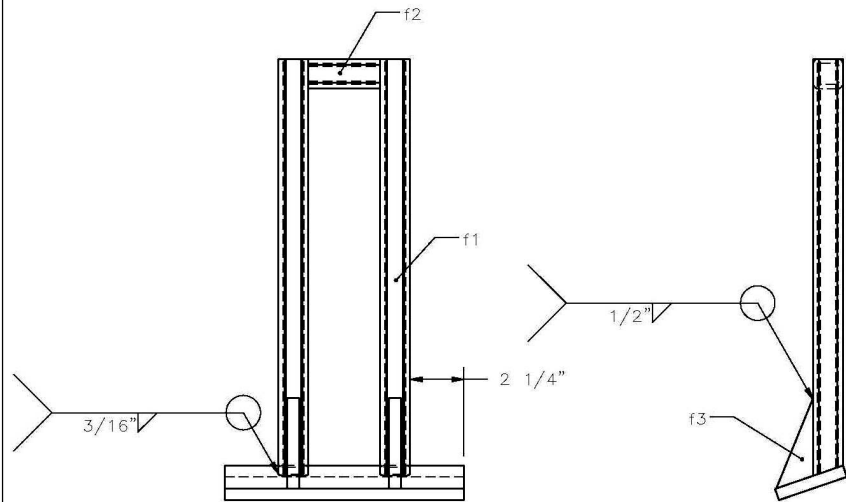

Cable Release Lever Part F

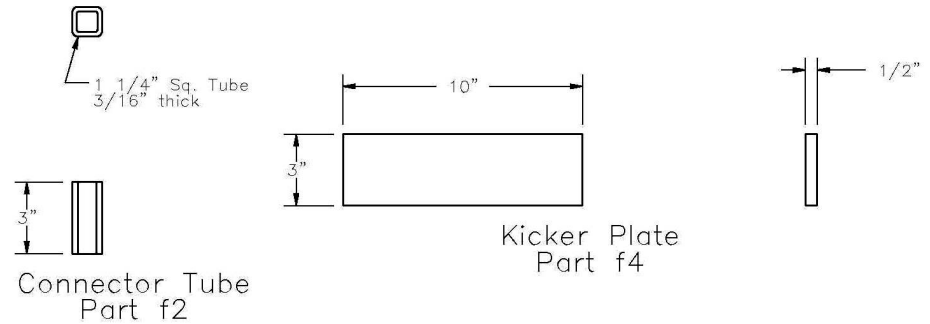

Connector Tube Part f2

Kicker Plate Part f4



Midwest Roadside Safety Facility

Cable on Slope

Cable Release Lever Part F Details

DWG. NAME:
CS-2

SCALE: None
UNITS: Inches

SHEET:
6 of 12
DATE:
11/1/2006
DRAWN BY:
GEP/CSS
REV. BY:
CME



Part C
Post 2 & 91 Only

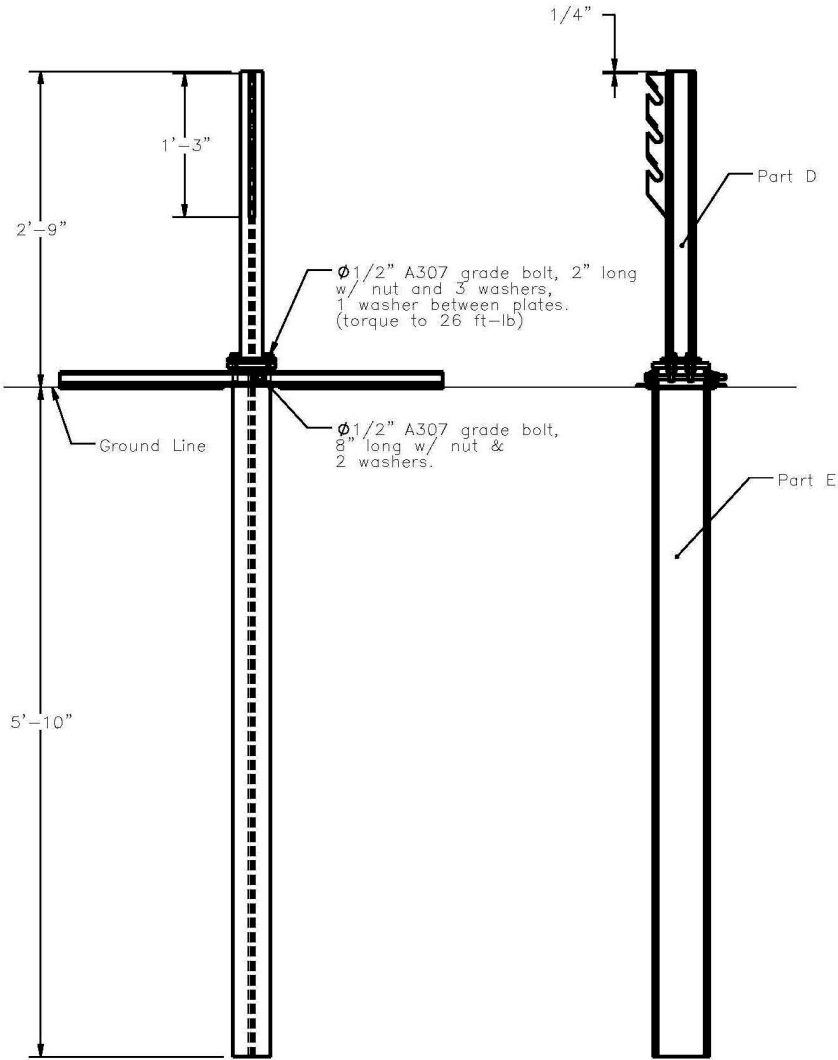

Cable Support Post
Post 2 & 91 Only

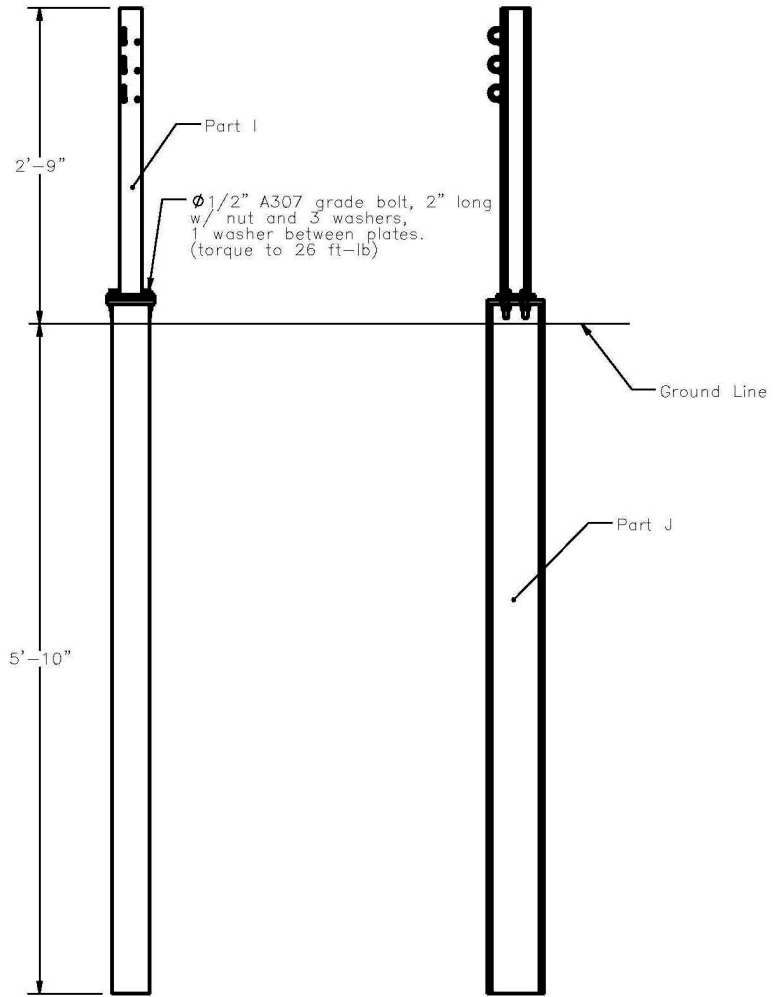

Cable Support Post
Post 3-7 & 86-90



Midwest Roadside
Safety Facility

Cable on Slope

Cable Support Post
Post 2 & 91
Post 3-7 & 86-90

DWG. NAME:
CS-2

SCALE: None
UNITS: Inches

SHEET:
7 of 12
DATE:
11/1/2006
DRAWN BY:
GEP/CSS
REV. BY:
CME

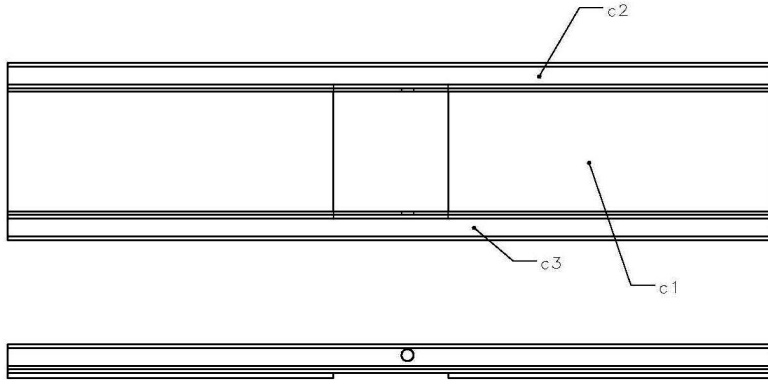

Bearing Strut
Part C (Post 2 & 90 Only)

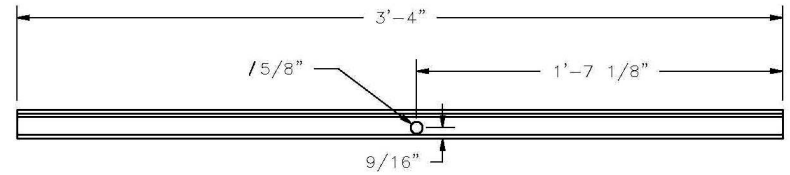
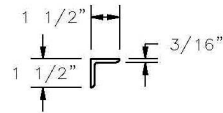
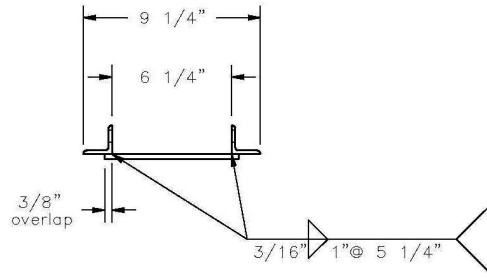

Bearing Plate Brace
Part c2

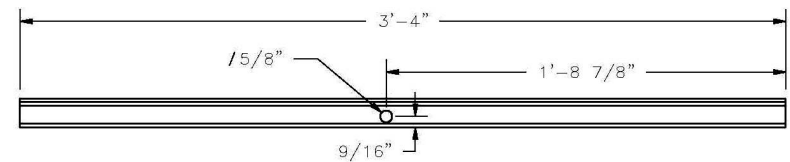
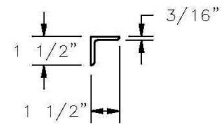

Bearing Plate Brace
Part c3

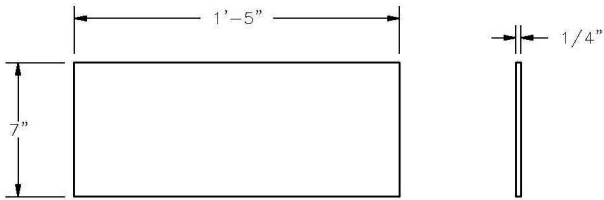

Bearing Plate
Part c1



Midwest Roadside
Safety Facility

Cable on Slope

Bearing Strut
Part C Details

DWG. NAME:
CS-2

SCALE: None
UNITS: Inches

SHEET:
8 of 12
DATE:
11/1/2006
DRAWN BY:
GEP/CSS
REV. BY:
CME

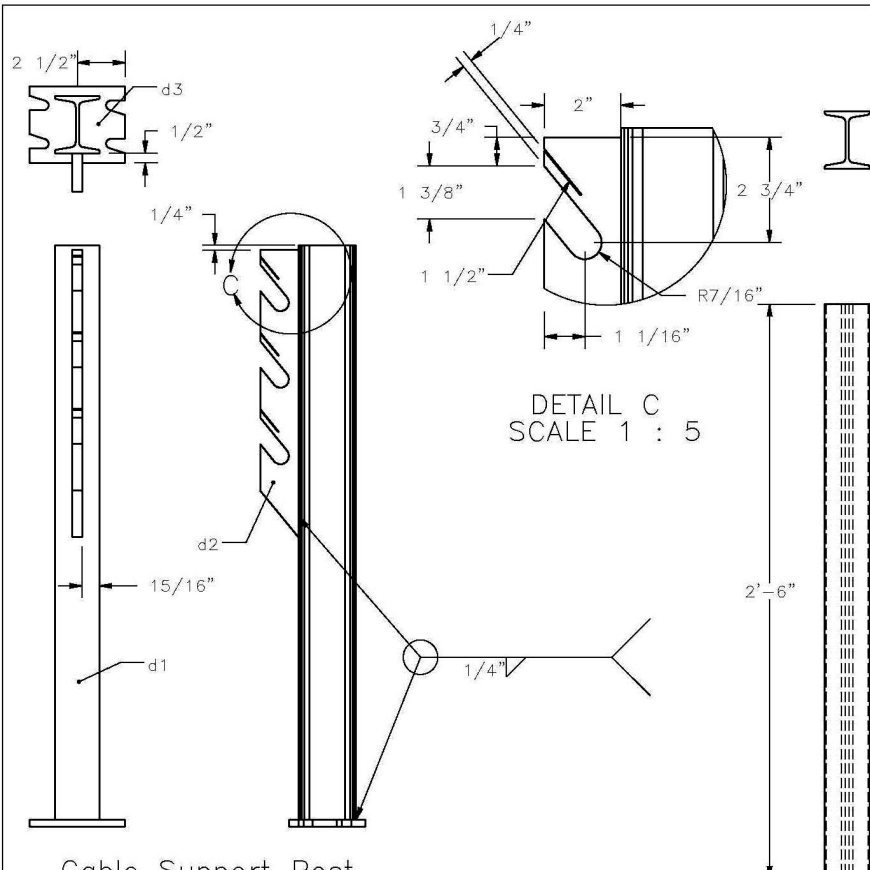

Cable Support Post Part D

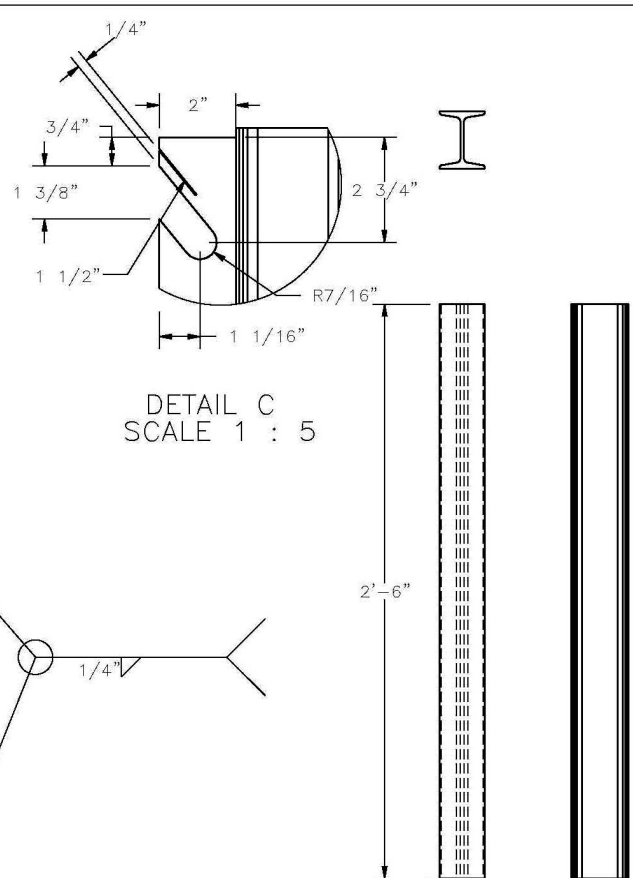

S3x5.7 Post Part d1

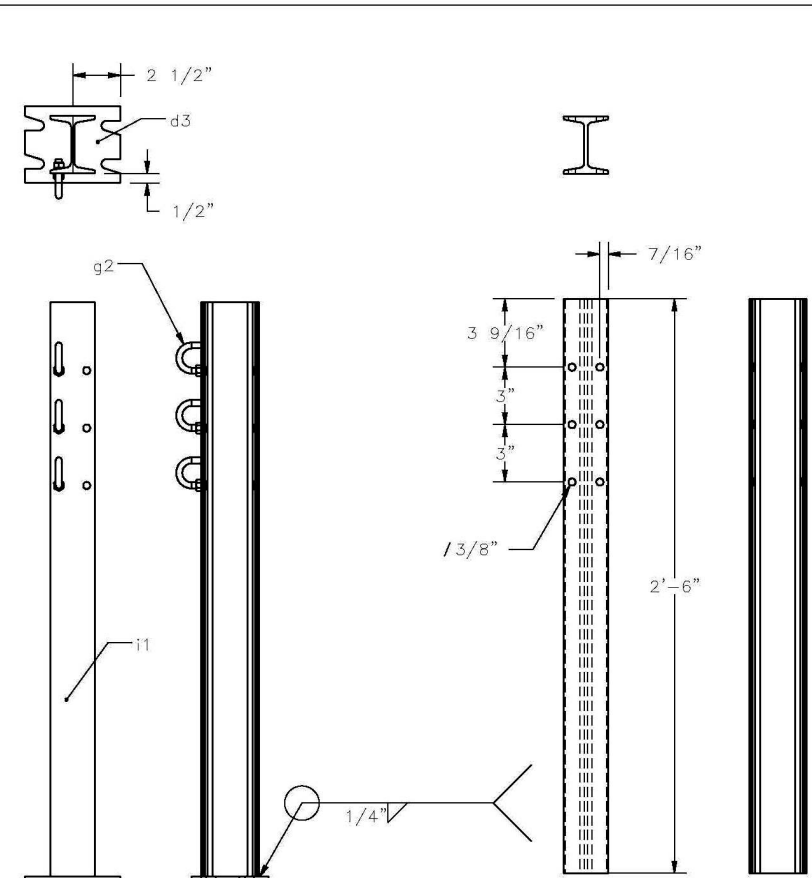

Cable Support Post Part I

S3x5.7 Post Part i1

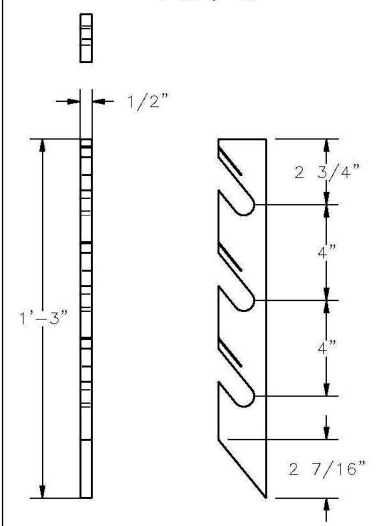

Cable Bracket Part d2

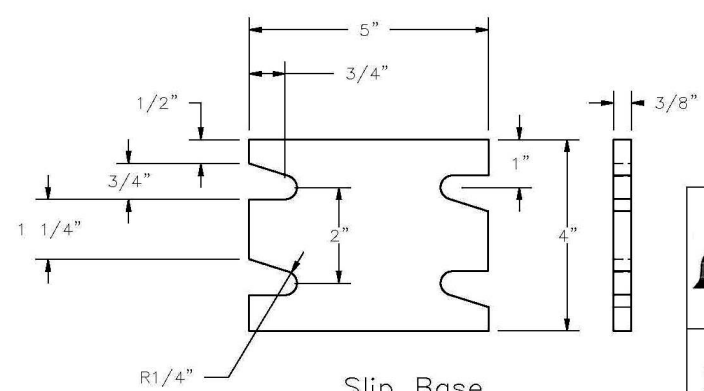

Slip Base Part d3

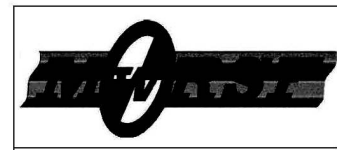

Midwest Roadside Safety Facility

Cable on Slope
Cable Support Post Top Details
Part D & I Details

DWG. NAME: CS-2	SCALE: None UNITS: Inches	REV. BY: CME
--------------------	------------------------------	-----------------

SHEET: 9 of 12
DATE: 11/1/2006
DRAWN BY: GEP/CSS

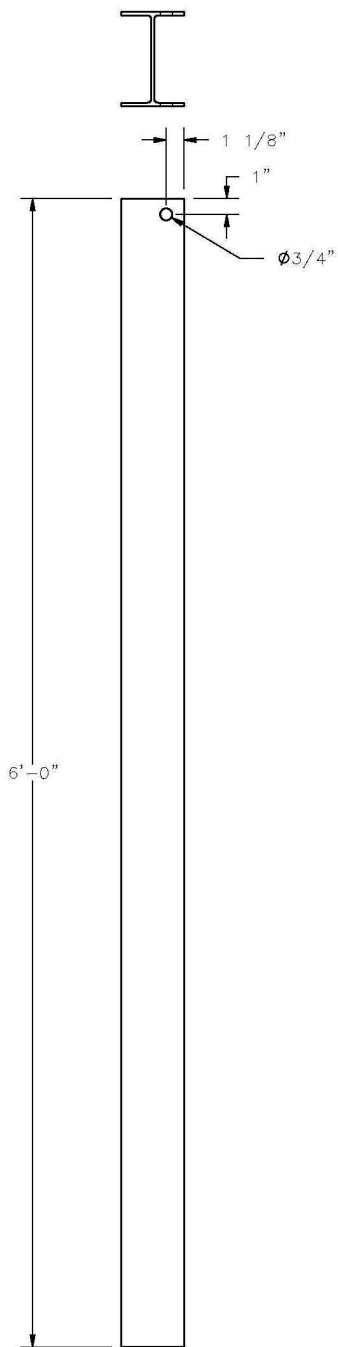

W6x9
Part e1

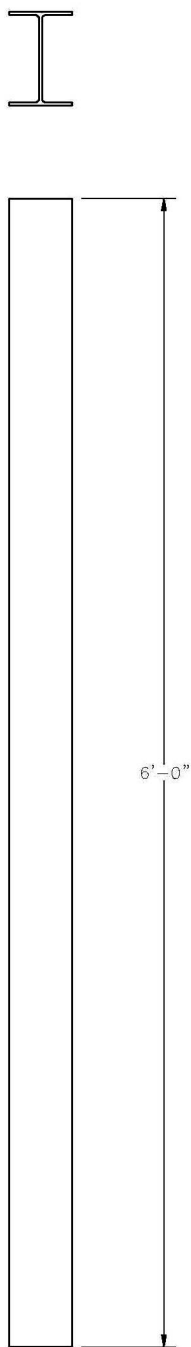

W6x9
Part j1

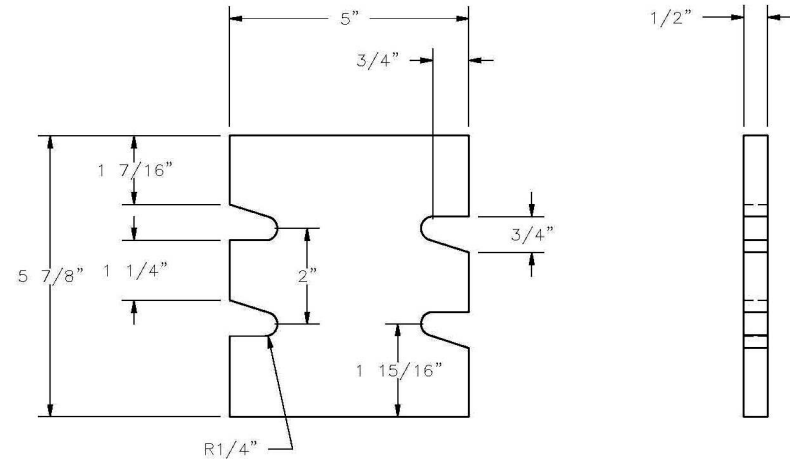

Slip Base
Part e2



Midwest Roadside
Safety Facility

Cable on Slope

Cable Support Post
Base Details
Part E & J Details

DWG. NAME.
CS-2

SCALE: None
UNITS: Inches

SHEET:
10 of 12

DATE:
11/1/2006

DRAWN BY:
GEP/CSS

REV. BY:
CME

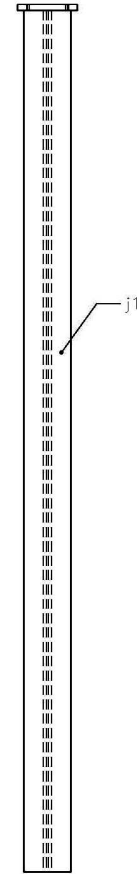
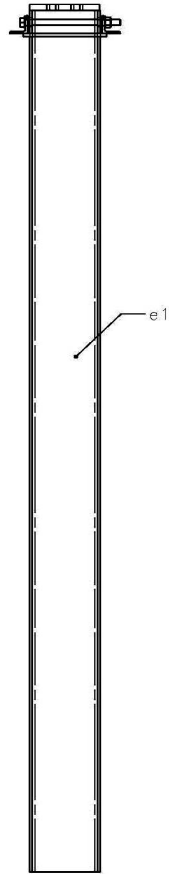
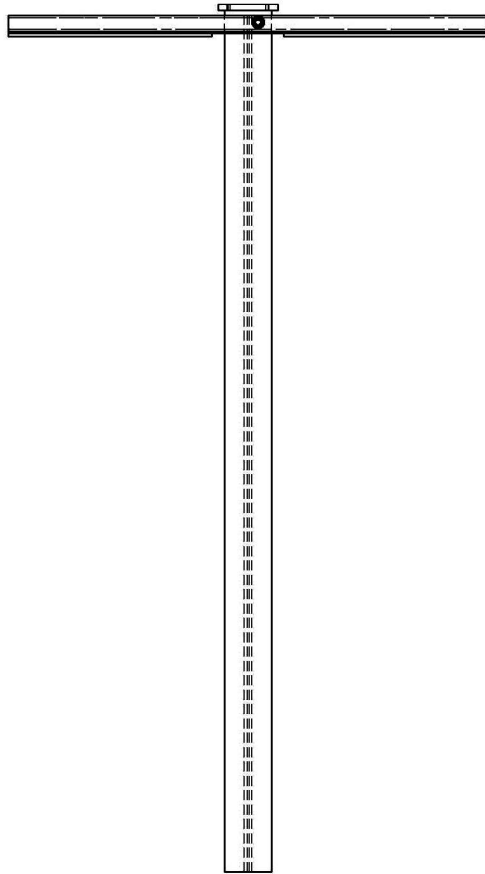
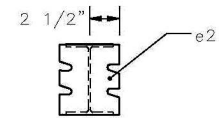
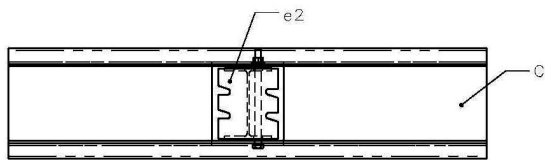

Cable Support Post
Part E

Cable Support Post
Part J



Midwest Roadside
Safety Facility

Cable on Slope

Cable Support Post
Base Assembly
Part E and J Details

DWG. NAME:
CS-2

SCALE: 1:16
UNITS: Inches

SHEET:
11 of 12
DATE:
11/1/2006
DRAWN BY:
GEP/CSS
REV. BY:
CME

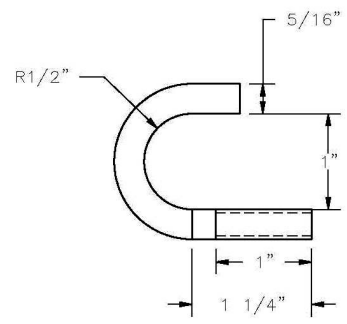
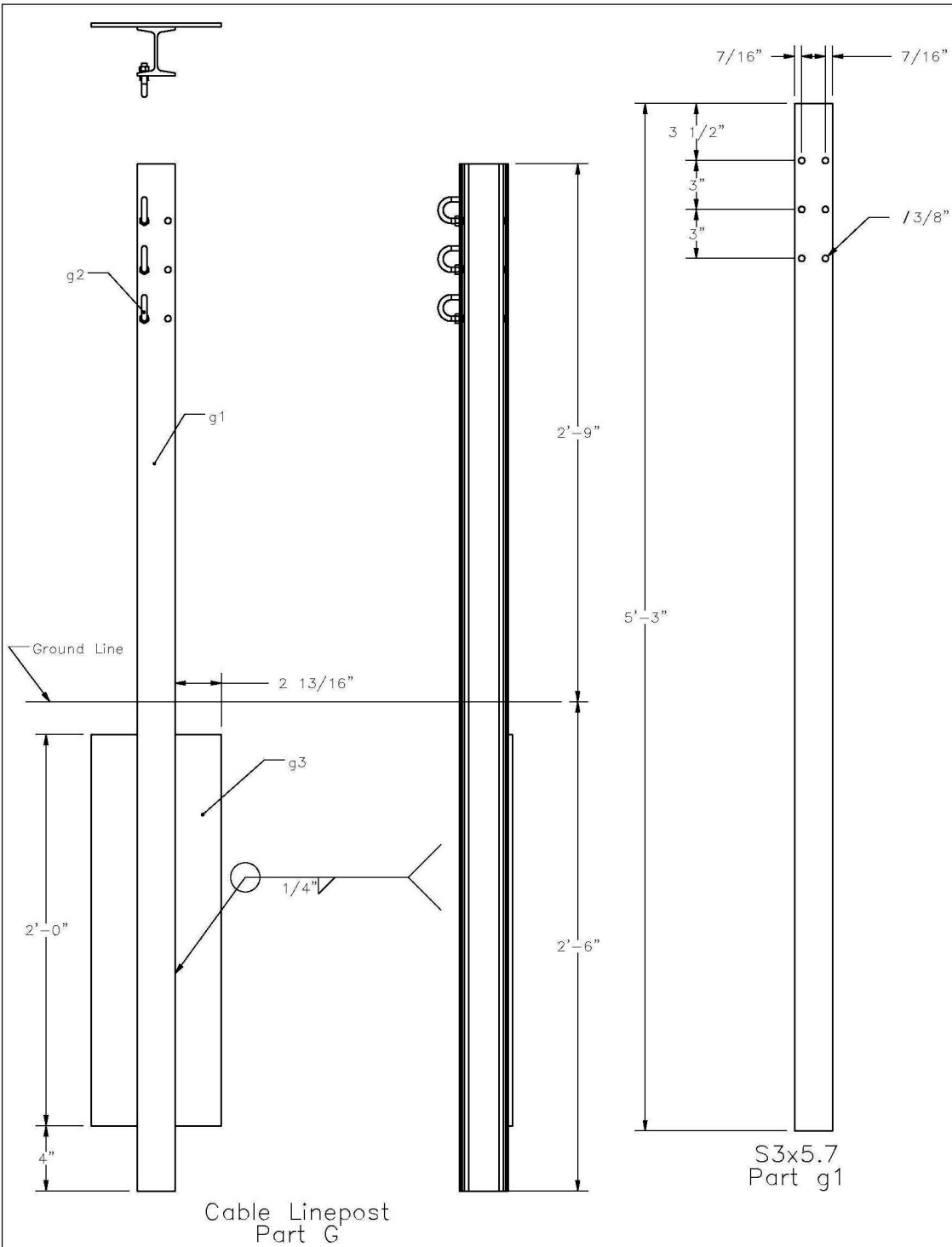

Cable Hook Bolt
Part g2 Option 1

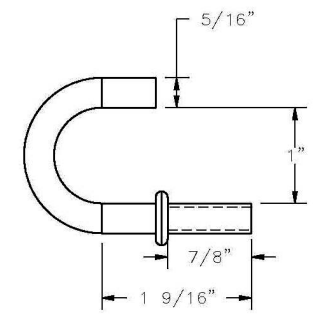

Cable Hook Bolt
Part g2 Option 2

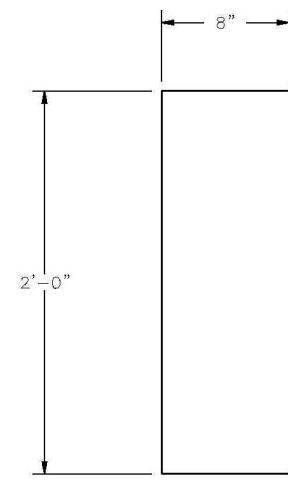

Soil Plate
Part g3

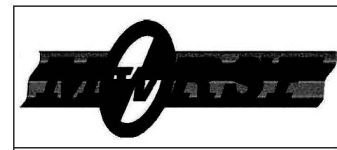
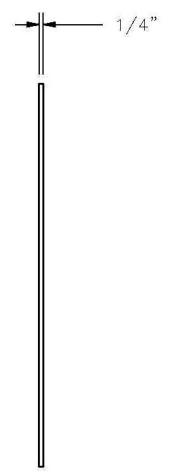

Midwest Roadside
Safety Facility

Cable on Slope		SHEET: 12 of 12
		DATE: 11/1/2006
Cable Linepost Part G Details		DRAWN BY: GEP/CSS
		REV. BY: CME
DWG. NAME: CS-2	SCALE: None UNITS: Inches	