



U.S. Department
of Transportation
**Federal Highway
Administration**

July 11, 2008

1200 New Jersey Avenue, SE.
Washington, DC 20590

In Reply Refer To: HSSD/B-179

Mr. Barry D. Stephens, P.E.
Sr. Vice President Engineering
Energy Absorption Systems, Inc.
3617 Cincinnati Avenue
Rocklin, CA 95678

Dear Mr. Stephens,

This letter is in response to your request for Federal Highway Administration (FHWA) acceptance of a roadside safety system for use on the National Highway System (NHS).

Name of system: TRITON BARRIER® Test Level 1 (TL-1)
Type of system: Water Filled Barrier
Test Level: National Cooperative Highway Research Program (NCHRP) Report 350
TL-1
Testing conducted by: E-TECH Testing Services, Inc.
Date of request: January 11, 2008

You requested that we find this system acceptable for use on the NHS under the provisions of National Cooperative Highway Research Program Report 350 "Recommended Procedures for the Safety Performance Evaluation of Highway Features."

Requirements

Roadside safety systems should meet the guidelines contained in the NCHRP Report 350, "Recommended Procedures for the Safety Performance Evaluation of Highway Features". FHWA Memorandum "ACTION: Identifying Acceptable Highway Safety Features" of July 25, 1997 provides further guidance on crash testing requirements of longitudinal barriers.

Description

The new system is a portable, water-filled plastic longitudinal barrier intended for use as a temporary barrier in highway construction zones. Energy developed the TRITON BARRIER® TL-1 to prevent vehicle penetration at impact speeds up to 50 km/h (31 mph) and impact angles up to 25 degrees.



The test installation was 29.7 m (97.45 feet) long, consisting of 15 TRITON units. The dimensions of the individual Triton units are as follows:

Height -	813 mm (32 in)
Width -	533 mm (21 in)
Length* -	1981 mm (78 in) [*Length measured pin to pin]
Weight (empty) -	45 kg (99 lbs)
Weight (full) -	595 kg (1312 lbs)
Water ballast -	550 L (145 gal)
Color(s) -	Orange and White

The TRITON BARRIER® TL-1 barrier consists of multiple barrier sections pinned together using a 48 mm (1-½ in Schedule 40) diameter steel pipe connecting pin to optimize impacting vehicle redirection. Each individual section will incorporate a 12.7 mm (½ in) diameter steel cable towards the top of the unit to maximize the tension capacity of the system during impacts. The plastic mold design allows for the stacking of the empty sections (up to three high) during storage and transport. The TRITON BARRIER® TL-1 sections are identical to the TRITON BARRIER® TL-2 unit previously accepted by the FHWA except the internal steel framework inherent to these existing units was removed for this TRITON BARRIER® TL-1 test. A decal will be affixed to the exterior of each TRITON BARRIER® TL-1 section to prevent these units from being mistakenly being used with the TRITON BARRIER® TL-2 and the TRITON BARRIER® TL-3 products.

Crash Testing

Full-scale crash testing was conducted on the TL-1 barrier. We concur that conducting one full-scale “capacity” NCHRP 350 test was adequate to validate the performance of this system. The test you completed was NCHRP 350 Test 1-11 (2000P/50KPH/25 deg). Your test verified that the impact performance for heavier vehicles (2000kg) was acceptable and successfully prevented vehicle penetration into the work zone behind the product. We noted that the nearly 30-meter (100-ft) long system was not anchored during the test, resulting in lateral barrier deflection of 2.7 meters (8.9 ft).

The test data sheet summarizing the results of the impact is enclosed for reference. Based upon the successful completion of the aforementioned NCHRP 350 test you provided, we agree that your TRITON BARRIER® TL-1 system is acceptable for use as a TL-1 longitudinal barrier. The system, as described above, may be used on the NHS when such use is acceptable to the contracting authority.

Findings

Therefore, the system described above and detailed in the enclosed drawing is acceptable for use on the NHS under the range of conditions tested, when acceptable to a highway agency.

Please note the following standard provisions that apply to FHWA letters of acceptance:

- This acceptance is limited to the crashworthiness characteristics of the systems and does not cover their structural features, nor conformity with the Manual on Uniform Traffic Control Devices.

- Any changes that may adversely influence the crashworthiness of the system will require a new acceptance letter.
- Should the FHWA discover that the qualification testing was flawed, that in-service performance reveals unacceptable safety problems, or that the system being marketed is significantly different from the version that was crash tested, we reserve the right to modify or revoke our acceptance.
- You will be expected to supply potential users with sufficient information on design and installation requirements to ensure proper performance.
- You will be expected to certify to potential users that the hardware furnished has essentially the same chemistry, mechanical properties, and geometry as that submitted for acceptance, and that it will meet the crashworthiness requirements of the FHWA and the NCHRP Report 350.
- To prevent misunderstanding by others, this letter of acceptance is designated as number B-179 and shall not be reproduced except in full. This letter and the test documentation upon which it is based are public information. All such letters and documentation may be reviewed at our office upon request.
- Triton Barriers are patented products and considered proprietary. If proprietary systems are specified by a highway agency for use on Federal-aid projects, except exempt, non-NHS projects, they: (a) must be supplied through competitive bidding with equally suitable unpatented items; (b) the highway agency must certify that they are essential for synchronization with the existing highway facilities or that no equally suitable alternative exists; or (c) they must be used for research or for a distinctive type of construction on relatively short sections of road for experimental purposes. Our regulations concerning proprietary products are contained in Title 23, Code of Federal Regulations, Section 635.411.
- This acceptance letter shall not be construed as authorization or consent by the FHWA to use, manufacture, or sell any patented system for which the applicant is not the patent holder. The acceptance letter is limited to the crashworthiness characteristics of the candidate system, and the FHWA is neither prepared nor required to become involved in issues concerning patent law. Patent issues, if any, are to be resolved by the applicant.

Sincerely yours,



David A. Nicol, P.E.
Director, Office of Safety Design
Office of Safety

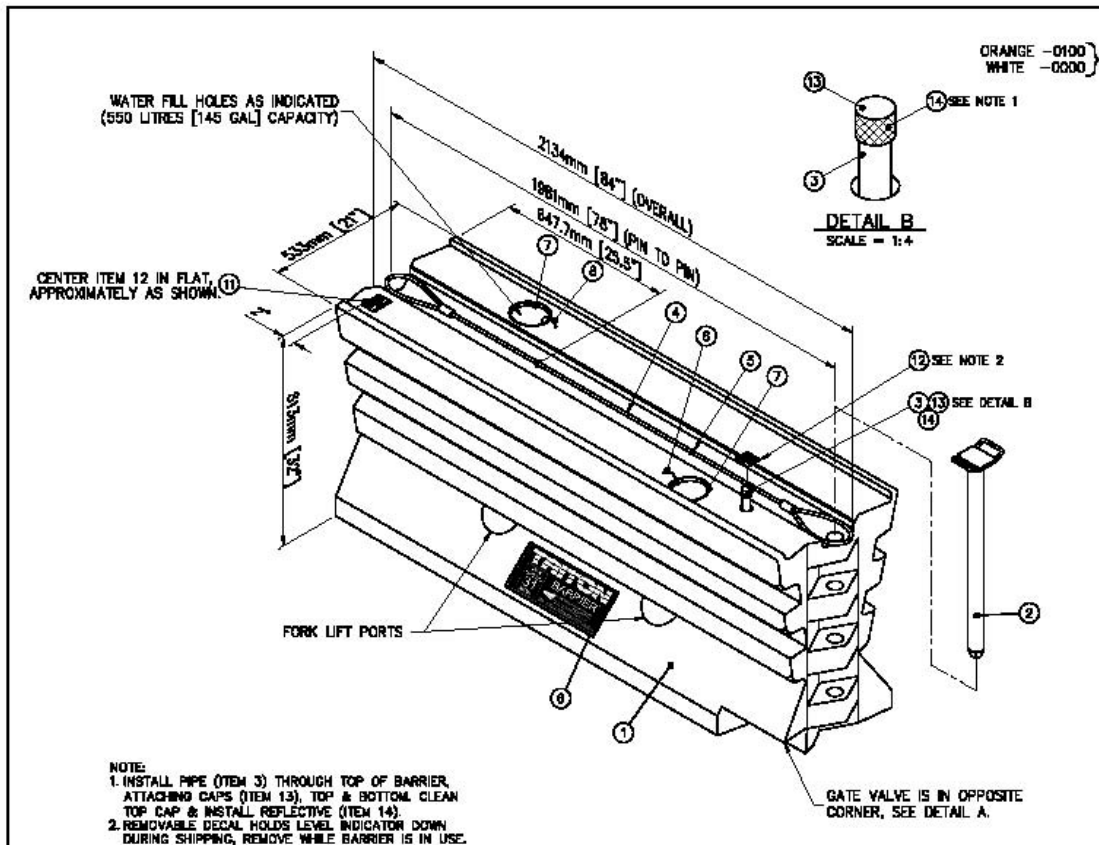

WATER FILL HOLES AS INDICATED
(550 LITRES [145 GAL] CAPACITY)

CENTER ITEM 12 IN FLAT,
APPROXIMATELY AS SHOWN

FORK LIFT PORTS

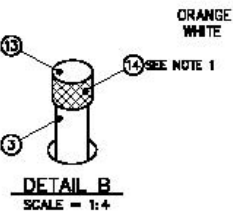

DETAIL B
SCALE = 1:4

12 SEE NOTE 2
13 SEE DETAIL B
14

GATE VALVE IS IN OPPOSITE
CORNER, SEE DETAIL A.

NOTE:
1. INSTALL PIPE (ITEM 3) THROUGH TOP OF BARRIER,
ATTACHING CAPS (ITEM 13), TOP & BOTTOM. CLEAN
TOP CAP & INSTALL REFLECTIVE (ITEM 14).
2. REMOVABLE DECAL HOLDS LEVEL INDICATOR DOWN
DURING SHIPPING, REMOVE WHILE BARRIER IS IN USE.

PARTS LIST			
ITEM	STOCK NO.	DESCRIPTION	QTY
1	2795010-0000	BARRIER SECTION, TRI, TL, (O OR W)	1.00
2	2795481-0000	PIN, CONNECTING, TRI, PT	1.00
3	2021390-0000	PIP, PVC 3/4 SDR21X7	1.00
4	2795071-0000	CABLE, TENSION, 1/2", TRITON	1.00
5	2701742-0000	BOLT, U, 3/8X1 1/2X1/2X1, G	2.00
6	2750068-0000	DECAL, TRITON, TL-1	2.00
7	2021402-0000	PLUG, PLASTIC, 5 W/HOLE	2.00
8	2795281-0000	TIE, NYLON, 3/16XB	2.00
9	FLOOR STOCK	PLASTIC STRAPPING, WIDTH 1/4	A/R
10	2704011-0000	NUT, HX, 1/2, G	4.00
11	2750083-0000	DECAL, TRITON BARRIER, AVOID PINCHING	1.00
12	2750352-0000	DECAL, WATER LEVEL, TRITON	1.00
13	2021342-0000	CAP, PVC, 3/4, SCH 40	2.00
14	2712212-0000	TAPE, REFLECTIVE, 1, ORANGE *	0.33
15	2708044-0000	WASHER, BAR, 1/8X2X3, G	2.00

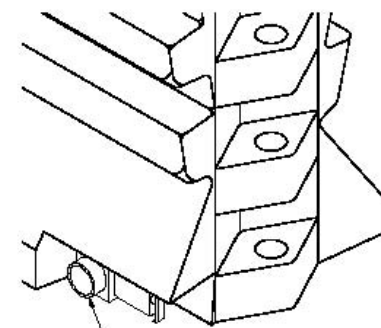

DETAIL A
SCALE = 1:5

Assembly No. 3595010-0000 (White)
Assembly No. 3595010-0100 (Orange)

Revisions	Date	Rev.	By	Clk.	App.

REFERENCES	

DATE	BY
10/3/07	D. Standridge
9/28/07	K. Looney
10/12/07	KRM
10/12/07	K. Looney

PRO FILE: 3595010-0000
NEXT APPROVAL:

ENERGY ABSORPTION SYSTEMS, INC.
ENGINEERING AND RESEARCH DEPARTMENT

TRITON BARRIER® TL-1
SECTION, TRI
WHITE OR ORANGE

REV: 1-18 P/N: 3595010-0000 REV: 1 of 2 REV:

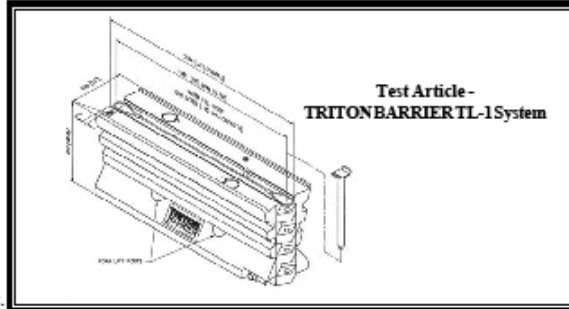
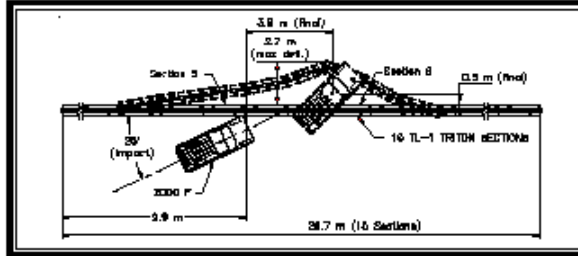
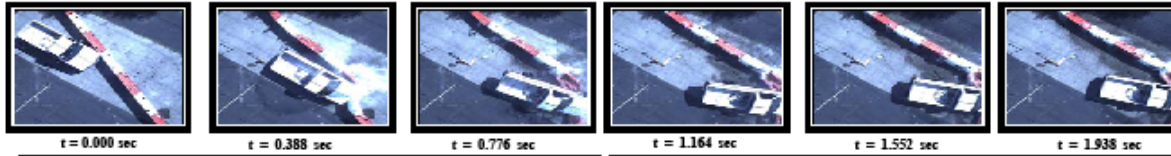

E-TECH
 E-TECH Testing Services, Inc.
 3817 B. Chatham Avenue
 Modesto, CA 95205
 Phone: (209) 542-1111
 Fax: (209) 542-5323

TRITON BARRIER TL-1 Crash Test Results - 9 of 32

General Information

Test Agency	E-TECH Testing Services, Inc.
Test Designation	NCHRP 350 Test 1-11
Test No.	01-4318-001
Date	8/28/07
Test Article	
Type	Energy Absorption Systems, Inc.
Installation Length	TRITON BARRIER TL-1 System
Size and/or dimension and material of key elements	29.7 m - (15) sections total, pinned and freestanding
.....	Polyethylene Plastic section
.....	Length - 1981 mm
.....	Width - 533 mm
.....	Height - 813 mm
.....	Mass - 45 kg (empty) / 595 kg (full)
.....	
Foundation and Anchoring	
.....	Portland Cement Concrete, clean and dry, unanchored
Test Vehicle	
Type	Production Model
Designation	2000P
Model	1988 Chevrolet C2500 Pickup
Mass (kg)	
Curb	1939
Test inertial	1994
Dummy	N/A
Gross Static	1994
Impact Conditions	
Speed (km/h)	51.6
Angle (deg)	25
Impact Severity (kJ)	36.6

Exit conditions	
Speed (km/h)	N/A
Angle (deg)	N/A
Occupant Risk Values	
Impact Velocity (m/s)	
x-direction	5.0
y-direction	0.7
Ridedown Acceleration (g's)	
x-direction	-3.9
y-direction	-2.6
European Committee for Normalization (CEN) Values	
THIV (km/h)	18.4
PHD (g's)	4.5
ASI	0.3
Post-Impact Vehicular Behavior (deg - rate gyro)	
Maximum Roll Angle	32.4
Maximum Pitch Angle	-11.8
Maximum Yaw Angle	-25.4
Test Article Deflections (m)	
Dynamic	2.7
Permanent	2.7
Vehicle Damage (Primary Impact)	
Exterior	
VDS	LFQ-2
CDC	11FLEW2
Interior	
VCDI	AS0000000
Maximum Deformation (mm)	N/A

Figure 1. Summary of Results - TRITON BARRIER TL-1 Test 01-4318-001