

# Memorandum

Subject: INFORMATION: Cable Barrier Transitions to W-Beam  
Guardrail

Date: May 8, 2006

From: **/original signed by/**  
John R. Baxter  
Director, Office of Safety Design

Reply to  
Attn. of: HSA-10/B147

To: Director of Field Services  
Resource Center Managers  
Division Administrators  
Safety Field

In the late 1980's, the Southwest Research Institute conducted successful crash tests on a cable barrier transition to a strong-post W-beam guardrail using a passenger sedan. In 1998, the Midwest Roadside Safety Facility (MwRSF) tested this transition design using NCHRP Report 350 test vehicles and concluded that it met all appropriate evaluation criteria at test level 3 (TL-3). The non-proprietary design tested in both cases was one developed by the South Dakota Department of Transportation. This design transitioned the generic 3-strand cable barrier over and under the W-beam using special steel straps and connected each cable to a standard concrete anchor block located behind the W-beam. A reduced post spacing was used as the cable barrier approached the W-beam installation, which was itself anchored with a Breakaway Cable Terminal (BCT) offset 4 feet from the cable barrier. In 2002, the MwRSF again tested this design successfully with the 2000-kg pickup truck, but with a FLEAT guardrail terminal anchoring the W-beam installation in lieu of a BCT. Although the South Dakota design remains an acceptable TL-3 transition, the 6-foot or more dynamic deflection of the cable barrier in each of the Report 350 crash tests allowed direct vehicular contact with the W-beam terminals, resulting in considerable pitch, yaw, and roll to the pickup trucks. This design also requires installation of a downstream anchor for the cable barrier.

Recently, the manufacturers of several of the high-tensioned proprietary cable barrier systems have requested acceptance of unique transition designs for connecting their barriers to strong-post W-beam and/or Thrie-beam guardrail. Each of these eliminates the need for a separate downstream cable anchor by attaching each cable directly to the metal beam rail element. Like the South Dakota design, the cable rail post spacing is also reduced to further limit deflection of the cable in the transition area. Reduced dynamic deflection can also be expected with the greater cable tension specified for all of the proprietary designs.

Each of these designs has been previously accepted as a TL-3 transition based on our review of the designs themselves and the crash testing done on the South Dakota design. Copies of the letters sent to each manufacturer are attached for ready reference. Note that for each specific design, the W-beam terminal itself should be offset at least 4 feet. Because the cable will prevent virtually all head-on impacts into the W-beam terminal, a light-weight, non-energy absorbing terminal would be the preferred method of anchoring the W-beam barrier. The MELT, which has been accepted as a TL-2 design, could be used to anchor the W-beam if a generic terminal is desired.

Attachments



U.S. Department  
of Transportation  
**Federal Highway  
Administration**

June 8, 2004

400 Seventh St., S.W.  
Washington, D.C. 20590

In Reply Refer To: HSA-10

Mr. Rodney A. Boyd  
Trinity Highway Safety Products Division  
P.O. Box 568887  
Dallas, Texas 75356-8887

Dear Mr. Boyd:

In his May 12 letter to Mr. Richard Powers of my staff, Mr. Brian Smith requested formal Federal Highway Administration acceptance of a design by which your CASS cable barrier is transitioned to a strong-post W-beam or Thrie-beam guardrail.

The CASS to W-Beam Transition and CASS to Thrie Beam Transition were submitted for acceptance for use in front of standard W-beam terminals having a 4'0" minimum offset behind the 3-cable prestretched and tensioned CASS system. The transition includes 10-gauge W-beam (either two 12'6"-long or one 25'-long element) or 10-gauge Thrie beam rail elements (one 12'6"-long element and one 6'3"-long transition element) with one-inch wide by 12-inch long slots in the valley of the rail elements. The cables are threaded through the front of the rail and connected to standard cable anchor brackets bolted to the backside of the rail elements. The first CASS post is placed 12'0" from the point where the cables first meet the W-beam or Thrie beam. The transition then consists of 14 CASS posts spaced at 5'0" on center, and then 5 posts spaced on 10'0" centers. The 3 cables, starting at the second post or 17'0" from the tangent W-beam or Thrie beam, taper together to nest into the valley(s) of the W-beam or Thrie beam. Design and layout details are shown in the enclosed drawings.

Previous full-scale crash testing has shown that the high tension and pre-stretched cables of the CASS system result in lower deflections than those seen in the non-tensioned cable barrier. In earlier cable-to-W-beam transition testing with the lower-tensioned generic cable rail, the cable deflection allowed the W-beam terminals to be impacted, resulting in some vehicle instability. With the CASS Transition, it is less likely that the nose of the terminal will be impacted in a typical design impact.

Based on the specific design details noted above, the CASS to W-Beam or Thrie Beam Transitions may be considered acceptable for use on the National Highway System at National Cooperative Highway Research Program Report 350 test level 3 when used in conjunction with



any crashworthy terminal having a minimum 4-foot offset from the cables. Since this design has not been physically tested, field installations should be monitored to verify both its ease of construction and its presumed crashworthiness.

Sincerely yours,

*/Original Signed by Richard D. Powers/  
~for~*

John R. Baxter, P.E.  
Director, Office of Safety Design  
Office of Safety

Enclosures

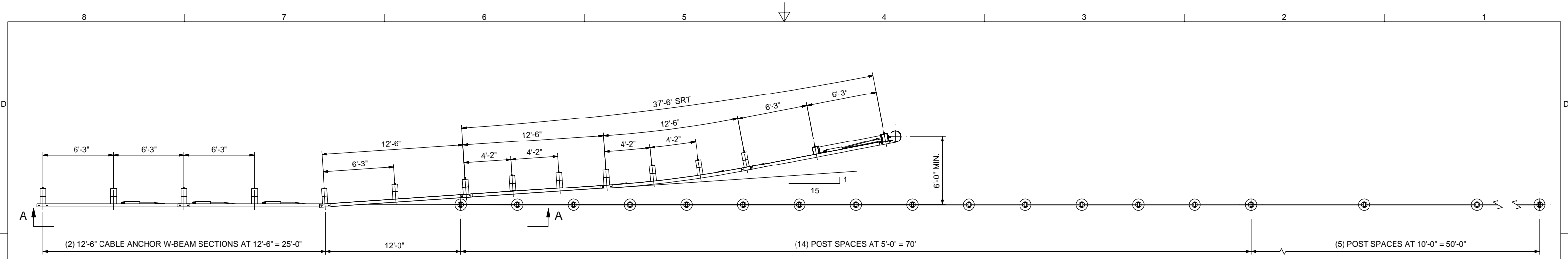

**PLAN VIEW ~ CASS - SRT CONNECTION**  
(W-BEAM GUARDRAIL WITH 8-POST SRT)

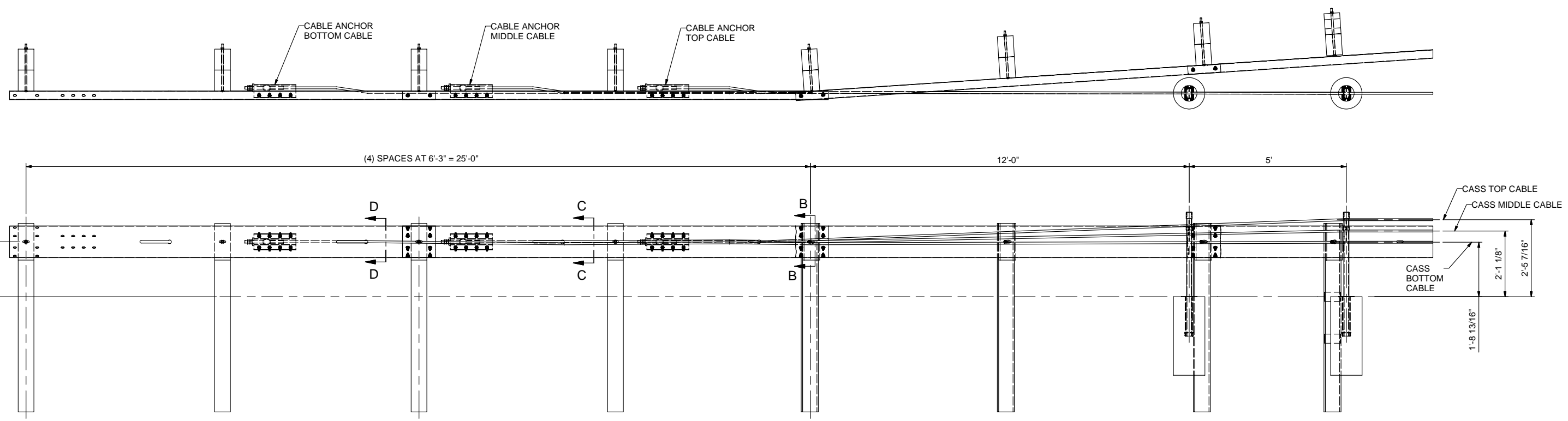

**VIEW A-A**

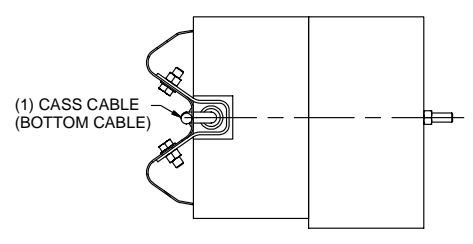

**SECTION D-D**

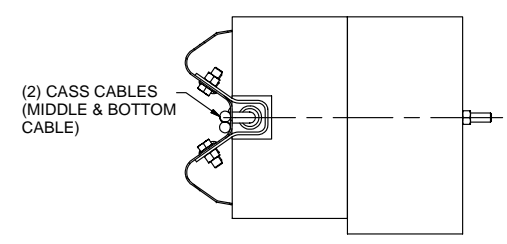

**SECTION C-C**

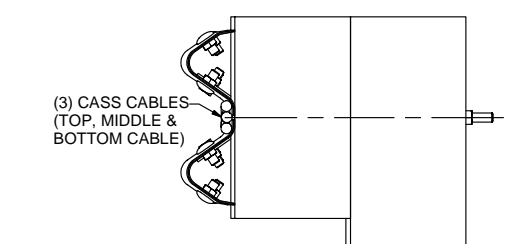

**SECTION B-B**

<p><b>CASS - W-BEAM GUARDRAIL WITH 8-POST SLOTTED RAIL TERMINAL</b></p> <p><b>TRINITY INDUSTRIES, INC.</b> HIGHWAY SAFETY DIVISION</p>		GALV SPEC:	
		SHIPPING WT:	
		DRW: E.A.S.	3/21/2004
		CHK: D.G.	3/21/2004
<p>PROJ: CASS - WB - SRT (8)</p>		DWG NO:	CASS-WB
		REV:	0

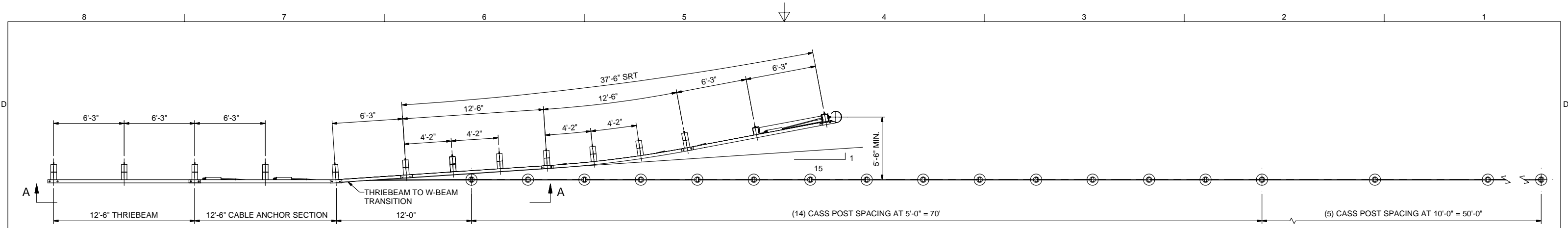

**PLAN VIEW ~ CASS - SRT CONNECTION**  
 (THRIEBEAM GUARDRAIL WITH 8-POST SRT)

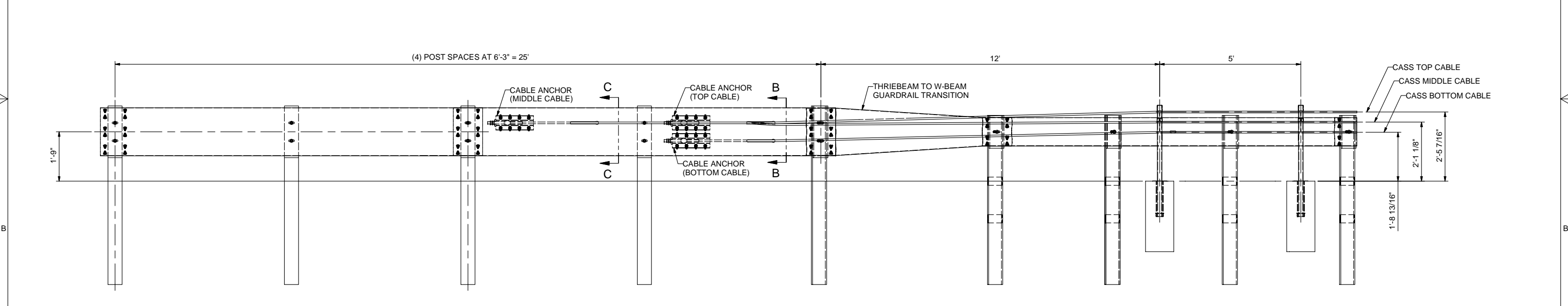
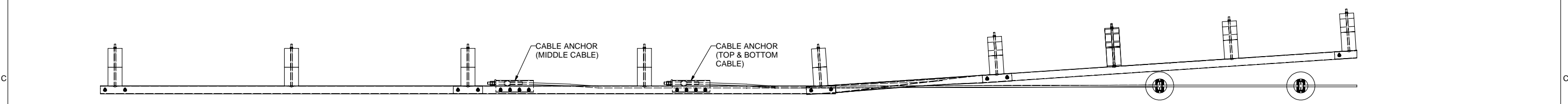

**VIEW A-A**

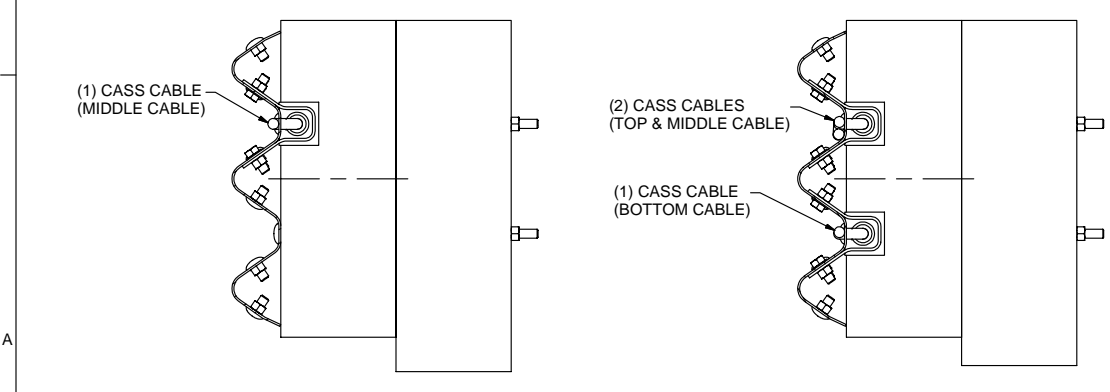

**SECTION C-C**

**SECTION B-B**

<p><b>CASS - THRIEBEAM GUARDRAIL WITH 8-POST SLOTTED RAIL TERMINAL</b></p> <p><b>TRINITY INDUSTRIES, INC.</b> HIGHWAY SAFETY DIVISION</p>		GALV SPEC:	
		SHIPPING WT:	
		DRW: E.A.S.	4/21/2004
		CHK: D.G.	4/19/2004
SHT: 1 OF 1		SIZE: D	
DWG NO:		CASS-TB	REV: 0

PROJ: CASS - TB - SRT (8)

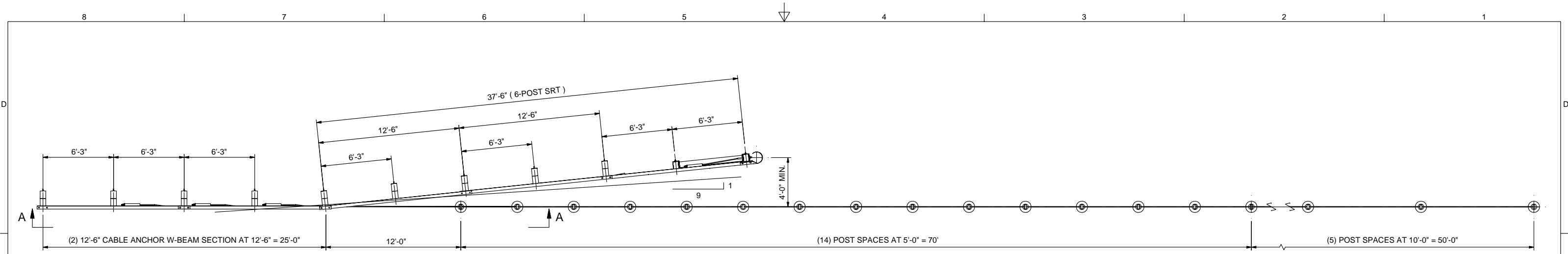

**PLAN VIEW ~ CASS - SRT CONNECTION**  
(W-BEAM GUARDRAIL WITH 6-POST SRT)

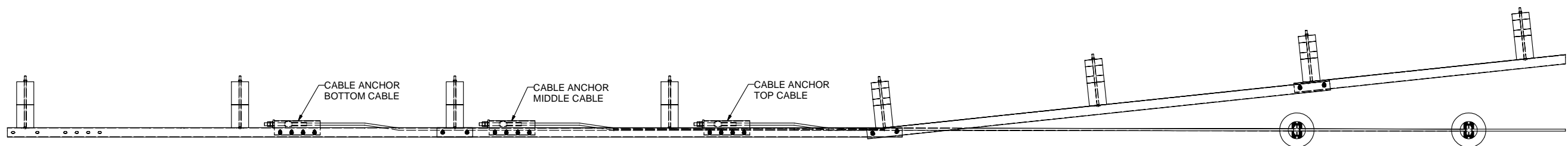

(4) POST SPACES AT 6'-3" = 25'

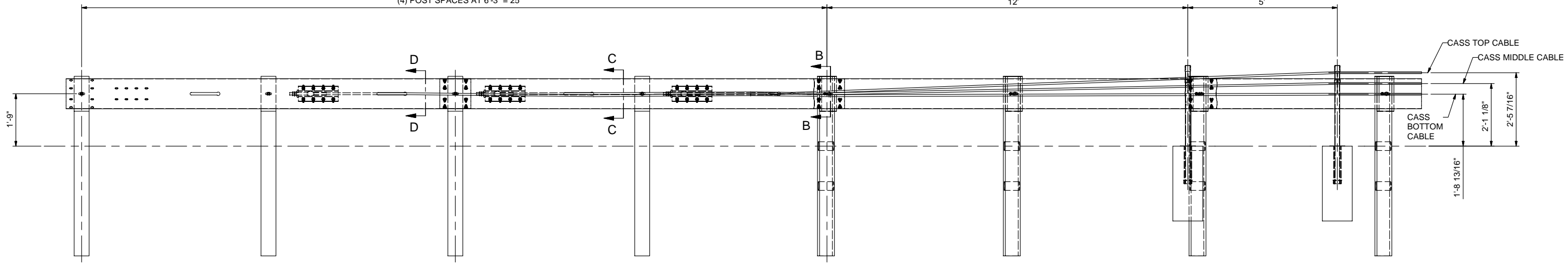

**VIEW A-A**

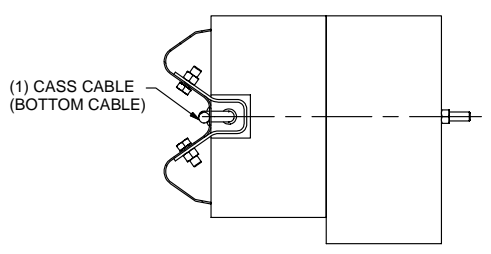

**SECTION D-D**

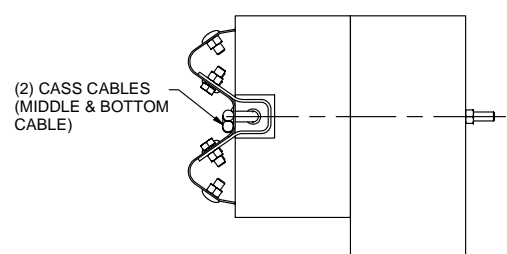

**SECTION C-C**

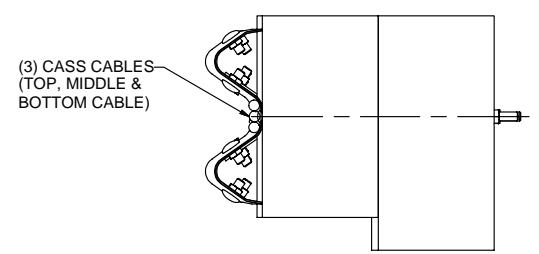

**SECTION B-B**

<p><b>CASS - W-BEAM GUARDRAIL WITH 6-POST SLOTTED RAIL TERMINAL</b></p> <p><b>TRINITY INDUSTRIES, INC.</b> HIGHWAY SAFETY DIVISION</p>		GALV SPEC:	
		SHIPPING WT:	
		DRW: E.A.S.	5/7/2004
		CHK: D.G.	5/7/2004
<p>PROJ: CASS - WB - SRT (6)</p>		DWG NO:	CASS-6P
		REV:	0

BILL OF MATERIAL					
QTY	ITEM	DESCRIPTION	LENGTH	Lbs / Each	MATERIAL
1	1	10 GA W-BEAM	12'-6"	115.18	M180

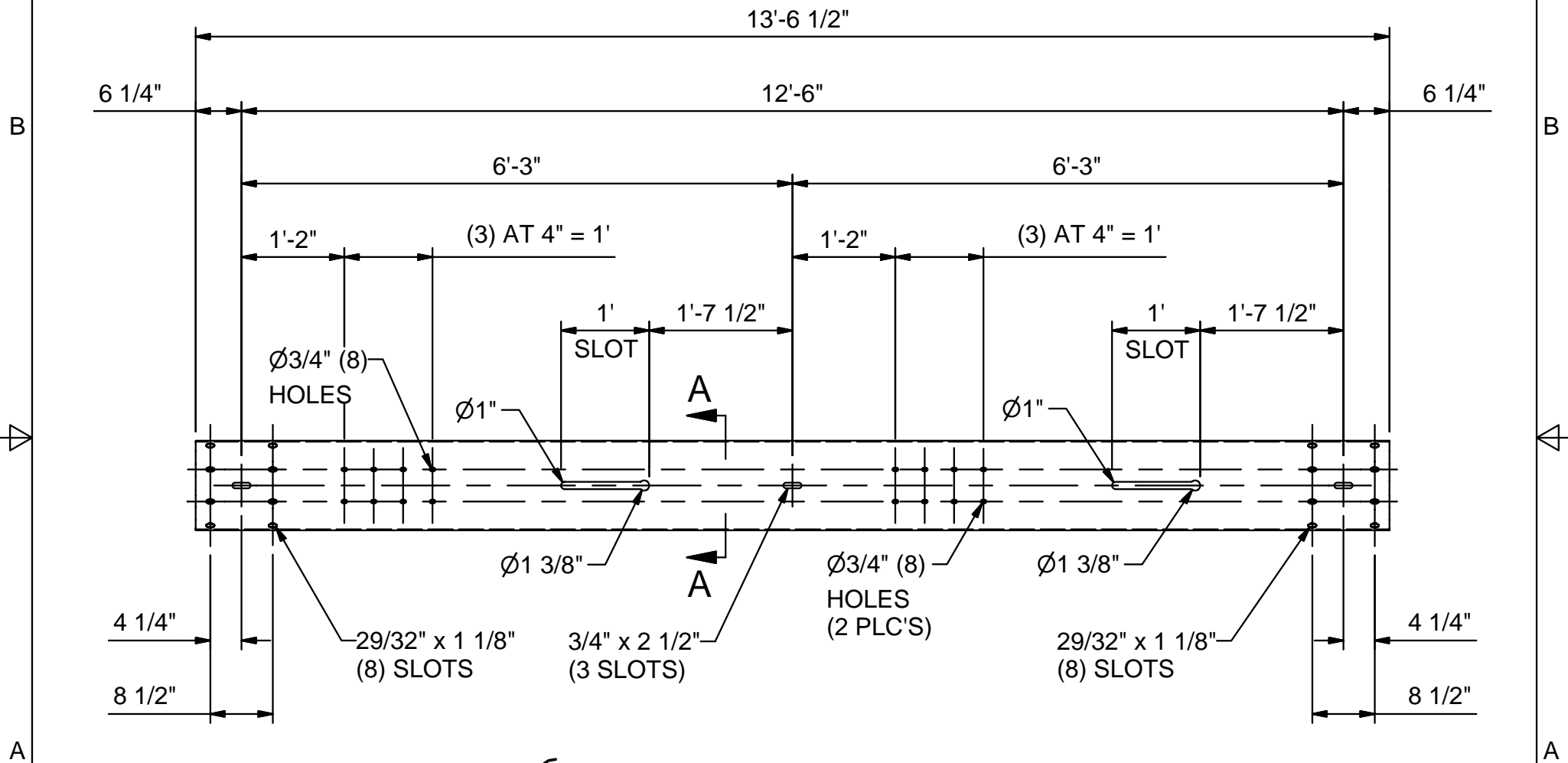

**SECTION A-A**

<p align="center"><b>CASS TO W-BEAM GUARD RAIL CONNECTION</b></p> <p align="center">10/12'6/6'3/CASS-CA/S</p>		GALV SPEC: A123	
		SHIPPING WT: 122.1 lb	
DRW: E.A.S.		5/24/2004	
CHK: R.M.H.		5/25/2004	
DWG NO:		REV	
033920		0	



**TRINITY INDUSTRIES, INC.**  
HIGHWAY SAFETY DIVISION

PROJ. CASS - WBEAM

2

1

2

1



4

3

2

1

BILL OF MATERIAL						
QTY	ITEM	PC NO.	DESCRIPTION	LENGTH	Lbs / Each	MATERIAL
1	1	033922	10 GA THRIEBEAM	12'-6"	182.92	M180

B

B

A

A

A

A

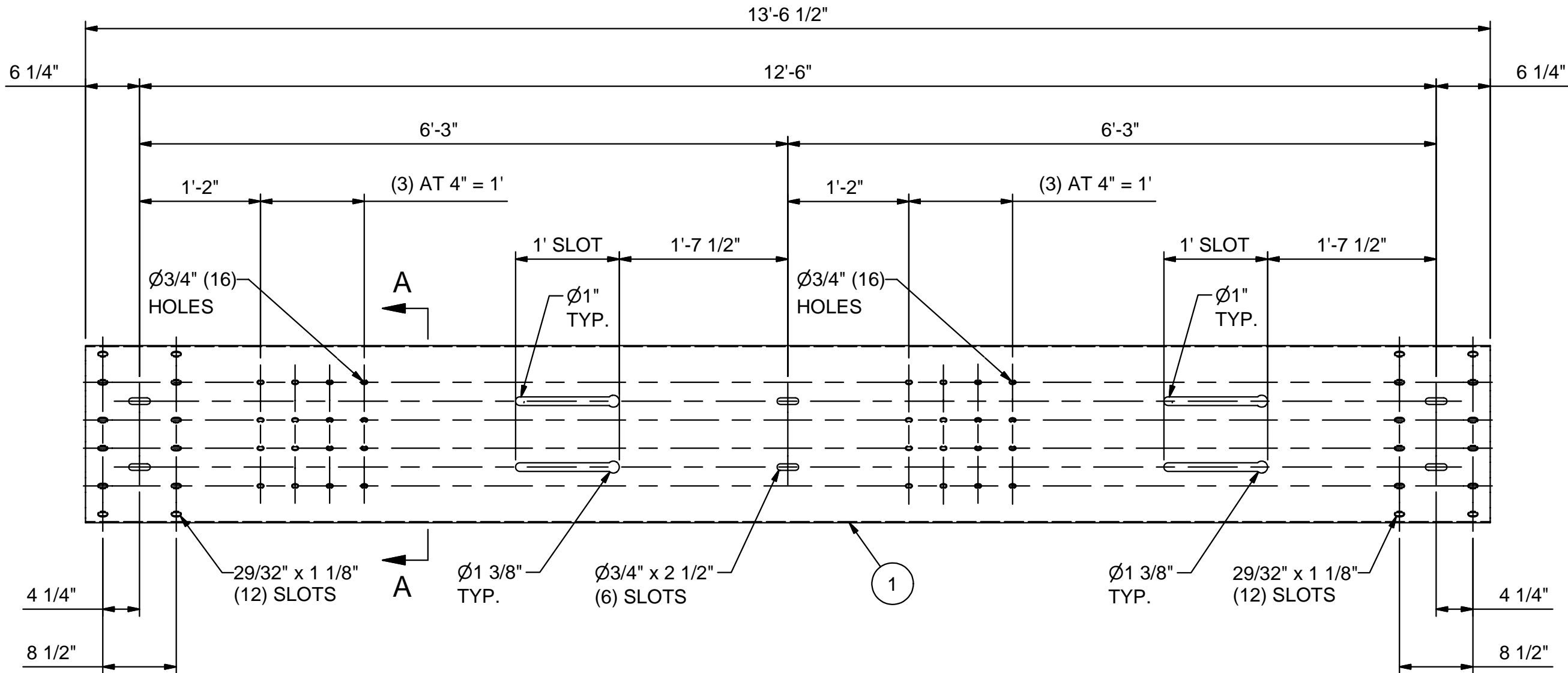

**SECTION A-A**



<b>CASS TO THRIEBEAM GUARD RAIL CONNECTION T10/12'6/6'3/CASS-CA/S</b>		GALV SPEC: A123	
		SHIPPING WT: 193.9 lb	
DRW: E.A.S. 5/24/2004		CHK: R.M.H. 5/25/2004	
DWG NO: 033922		REV: 0	



**TRINITY INDUSTRIES, INC.**  
HIGHWAY SAFETY DIVISION

PROJ. CASS - THRIEBEAM

4

3

2

1



U.S. Department  
of Transportation  
**Federal Highway  
Administration**

400 Seventh St., S.W.  
Washington, D.C. 20590

October 4, 2005

In Reply Refer To: HSA-10

Mr. Jerry Emerson, P.E.  
BrifenUSA, Inc.  
P.O. Box 94220  
Oklahoma City, Oklahoma 73143

Dear Mr. Emerson:

In your September 2 letter to Mr. Richard Powers of my staff, you requested formal Federal Highway Administration acceptance of a design concept by which your Brifen Wire Rope Safety Fence (WRSF) could be transitioned and connected to a strong-post W-beam or Thrie-beam guardrail.

The Brifen WRSF to W-Beam Transition was submitted for acceptance for use in front of standard W-beam terminals having a 4'-0" minimum offset behind the 4-cable pre-stretched and tensioned Brifen system. The 4-cable transition requires four 12-gauge W-beam rail elements 12'-6" long, beginning at the first standard line post in the barrier installation. A unique Brifen attachment bracket is bolted to the rail at each of the first four W-beam rail splice locations and one cable is anchored at each of these brackets. For your 3-cable WRSF, three 12.5' W-beam rail elements and attachment brackets are used. The first WRSF post is placed 10.5' upstream from the first standard guardrail line post at which the lowest cable is connected to the W-beam. The upstream WRSF transition then consists of 16 additional line posts set on 5.25' centers, at which point the standard WRSF post spacing (10.5' or other) begins. Details for the 4-cable, 10.5' post spacing WRSF transition are shown in the enclosed drawing.

Attachment to Thrie-beam guardrail is similar to that shown for W-beam except that, for your 4-cable system, two attachment brackets are located at the first splice and two are located at the second splice. The top and second cables are connected to the brackets in the upper valley (top cable at second splice) and the third and bottom cables are attached to the brackets in the lower valley (bottom cable at first splice). For your 3-cable WRSF the top two cables are attached to the two upper valley brackets (top cable at second splice) and the bottom cable is attached in the lower valley at the first splice location. As with W-beam, all attachments must be at a splice.



Previous full-scale crash testing has shown that the high tension and pre-stretched cables of the Brifen WRSF result in lower deflections than those seen in the lesser-tensioned generic cable barrier. In earlier cable-to-W-beam transition testing with the lower-tensioned generic cable rail, the cable deflection allowed the W-beam terminals to be impacted, resulting in significant vehicle instability. With the Brifen WRSF design, it is less likely that the nose of the terminal will be impacted in a typical design impact. Even so, the use of a lightweight, non-energy absorbing W-beam terminal is suggested to minimize vehicle instability if the terminal is hit.

Based on the specific design details noted above, the Brifen WRSF to W-Beam or Thrie Beam Transitions may be considered acceptable for use on the National Highway System at National Cooperative Highway Research Program Report 350 test level 3 when used in conjunction with a crashworthy terminal having a minimum 4-foot offset from the cables. The design may also be used to connect the WRSF to a weak post W-beam installation when the W-beam is adequately anchored with a crashworthy terminal. Since these transition designs have not been physically tested, field installations should be monitored to verify their presumed crashworthiness.

Sincerely yours,

*/original signed by/*

John R. Baxter, P.E.  
Director, Office of Safety Design  
Office of Safety

Enclosure





U.S. Department  
of Transportation  
**Federal Highway  
Administration**

400 Seventh St., S.W.  
Washington, D.C. 20590

October 19, 2005

In Reply Refer To: HSA-10

Mr. Rick Mauer  
Outside Sales National Representative  
Nucor Steel Marion, Inc.  
912 Chaney Avenue  
Marion, Ohio 43302

Dear Mr. Mauer:

In your September 2 letter to Mr. Richard Powers of my staff, you requested formal Federal Highway Administration acceptance of a design concept by which your high-tension cable rail could be transitioned and connected to a strong-post W-beam guardrail.

Your transition design is intended for use in conjunction with a W-beam installation that has a standard, crashworthy terminal with a minimum 4'-0" offset from the cable. A unique gusset plate is nested behind and bolted to the back of a special 6 foot-3 inch W-beam panel at the splice located at the first line post. Each cable is threaded through 1-in by 2-in slots in the W-beam panel and connected to the bracket. The first U-channel cable post is placed in line with the barrier proper and 6.5 feet upstream from the first W-beam line post. The transition then consists of 11 additional line posts also set on 6.5 foot centers, at which point your standard post spacing begins. Details for the transition design are shown in the enclosed drawings.

Previous full-scale crash testing has shown that high-tension cable barriers result in lower deflections than those seen in the lesser-tensioned generic cable barrier. In earlier cable-to-W-beam transition testing with the lower-tensioned generic cable rail, the cable deflection allowed the W-beam terminals to be impacted, resulting in significant vehicle instability. With your high-tension design, it is less likely that the nose of the terminal will be impacted in a typical impact. Even so, the use of a lightweight, non-energy absorbing W-beam terminal is suggested to minimize vehicle instability if the terminal is hit.

Based on the specific design details noted above, your proposed transition design is acceptable for use on the National Highway System at National Cooperative Highway Research Program Report 350 test level 3 when used in conjunction with a crashworthy terminal having a



minimum 4-foot offset from the cables. Since this transition design has not been physically tested, field installations should be monitored to verify their presumed crashworthiness.

Sincerely yours,

*/original signed by George Ed Rice, Jr./*

*~for~*

John R. Baxter, P.E.  
Director, Office of Safety Design  
Office of Safety

Enclosure

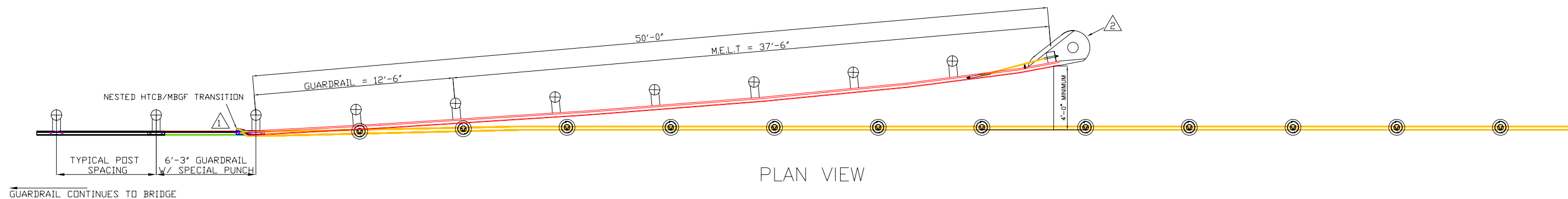

PLAN VIEW

GUARDRAIL CONTINUES TO BRIDGE

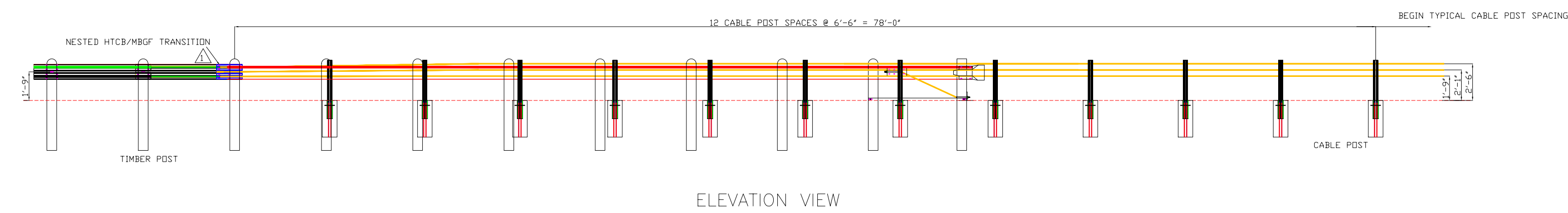

ELEVATION VIEW

- NOTES:
1. CABLE TERMINATES INTO ADJUSTABLE CABLE END FITTINGS BEHIND GUARDRAIL.
  2. M.E.L.T. OR OTHER END-SECTION AS NEEDED PARTICULAR TO TRAFFIC REQUIREMENTS.

<b>G.S.I. HIGH TENSION CABLE, LP</b>		
720 W. WINTERGREEN RD., HUTCHINS, TEXAS 75141 (972) 225-1660		
CONTRACTOR:		
SCALE: VARIES	GSI#:	DATE: 10/05/05
REVISED:	CHECKED:	DRAWN: DPD
<b>NESTED PLATE DETAIL FOR HTCB TO MBGF TRANSITION</b>		
TYPE MBGF/HTCB TRANSITION	LAYOUT	1 / 3

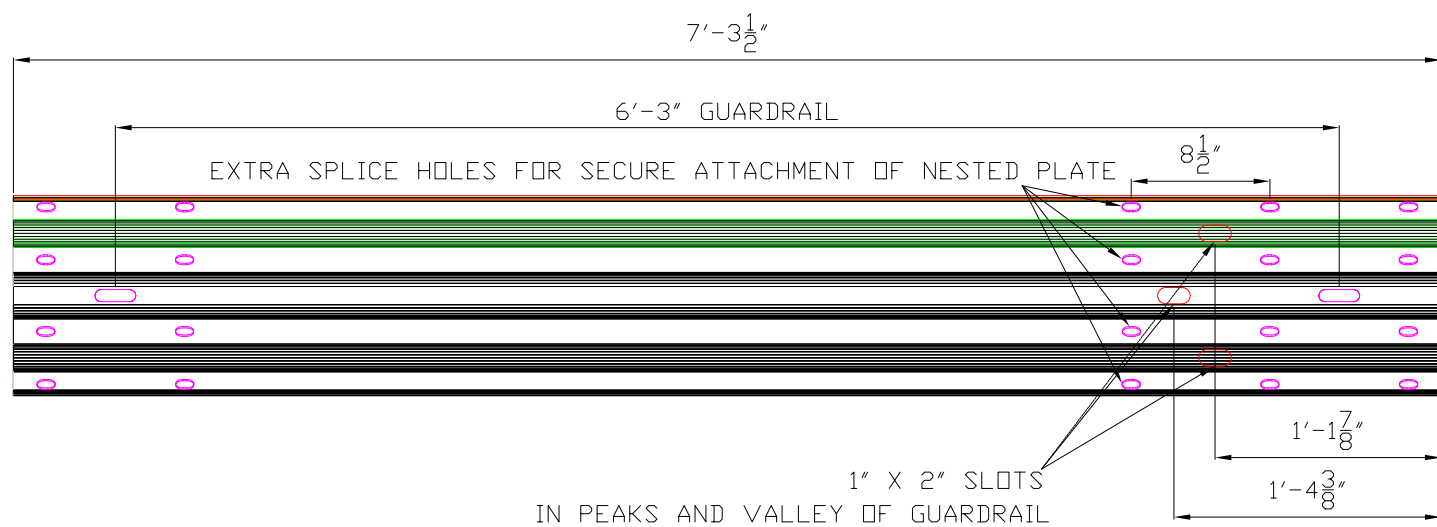

SPECIAL 6'-3" GUARDRAIL FOR NESTED PLATE

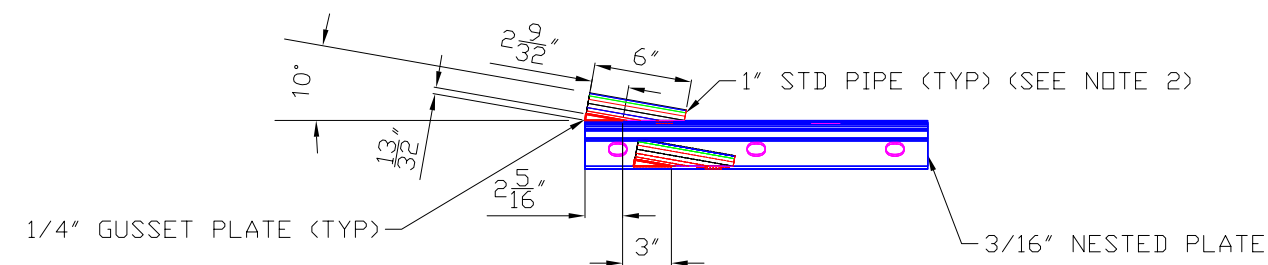

PLAN VIEW  
SHOWING GUSSET PLATE, 1" PIPE DETAIL

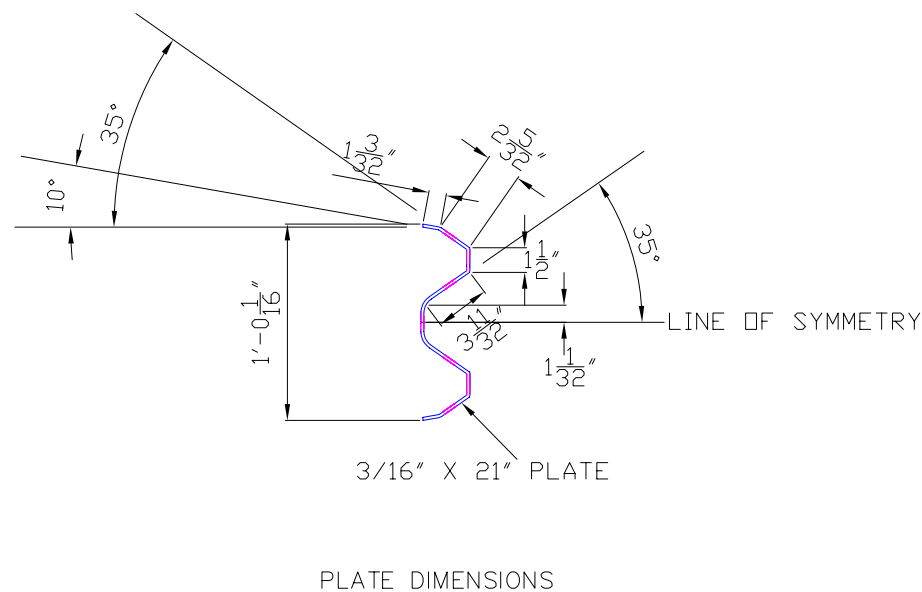
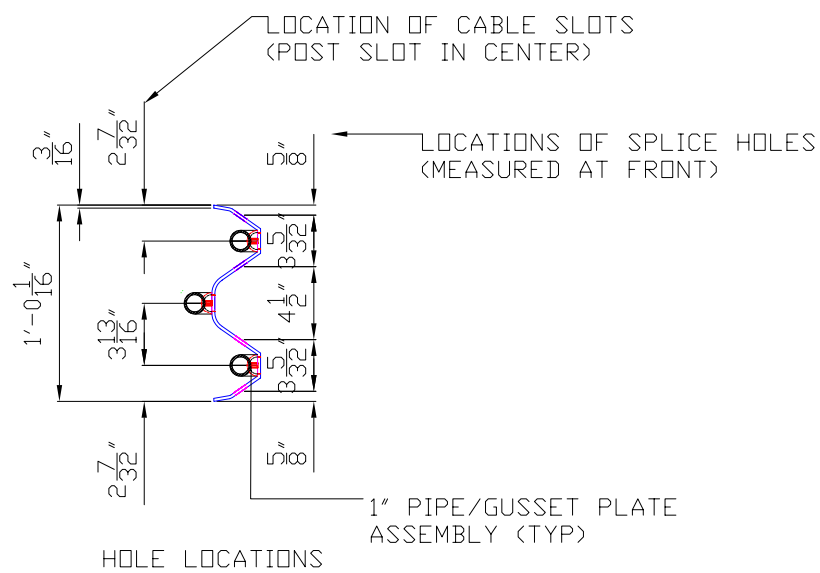
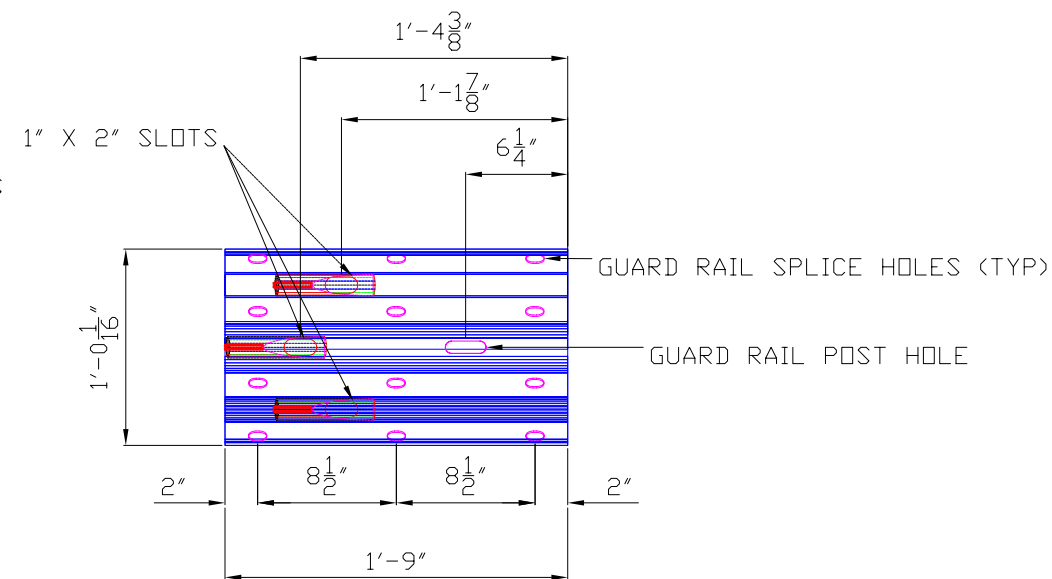

PLATE DIMENSIONS



HOLE LOCATIONS

SECTION VIEW



ELEVATION VIEW  
SHOWING FRONT HOLE PATTERN

NOTES: 1. FILLET WELD ALL CONNECTIONS  
2. CUT 1" PIPE FROM CL TO EDGE AT 10° ANGLE.

G.S.I. HIGH TENSION CABLE, LP		
720 W. WINTERGREEN RD., HUTCHINS, TEXAS 75141 (972) 225-1660		
CONTRACTOR:		
SCALE: NONE	GSI#:	DATE: 10/05/05
REVISED:	CHECKED:	DRAWN: DPD
<b>NESTED PLATE DETAIL FOR HTCB TO MBGF TRANSITION</b>		
MBGF/HTCB TRANSITION	FABRICATION	2 / 3



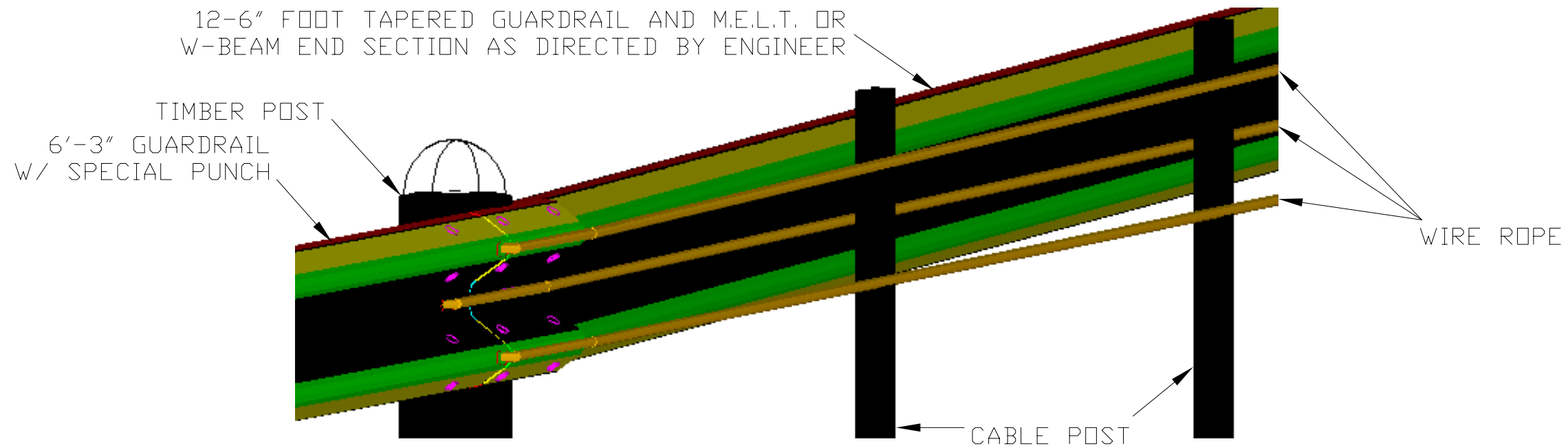

ISOMETRIC OF HTCB/MBGF TRANSITION

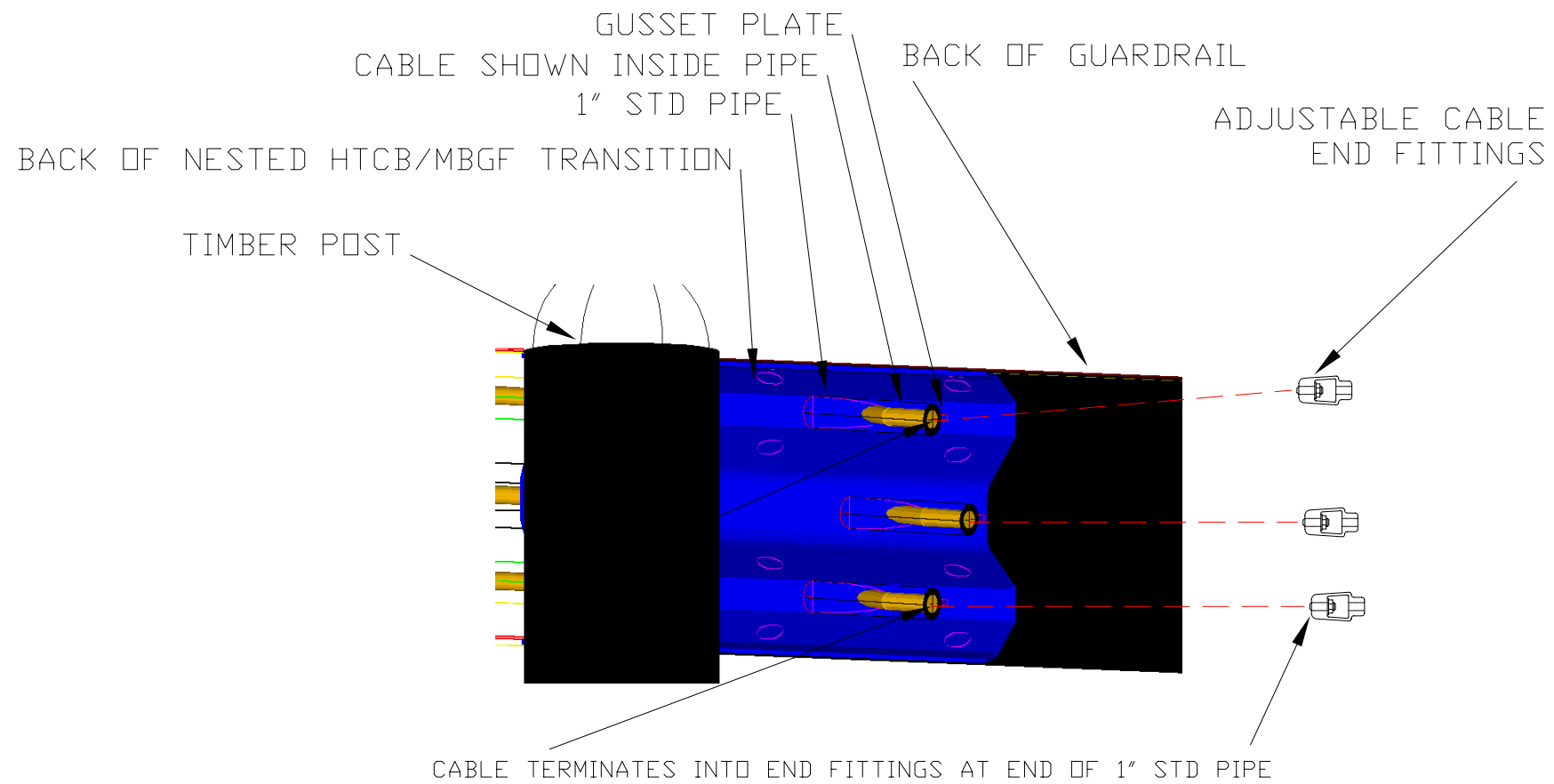

BACK OF HTCB/MBGF TRANSITION SHOWING CABLE END DETAILS

G.S.I. HIGH TENSION CABLE, LP		
720 W. WINTERGREEN RD., HUTCHINS, TEXAS 75141 (972) 225-1660		
CONTRACTOR:		
SCALE: NONE	GSI#:	DATE: 10/05/05
REVISED:	CHECKED:	DRAWN: DUGAN
<b>NESTED PLATE DETAIL FOR HTCB TO MBGF TRANSITION</b>		
MBGF/HTCB TRANSITION	CABLE END DETAILS	3 / 3