



U.S. Department
of Transportation
**Federal Highway
Administration**

400 Seventh St., S.W.
Washington, D.C. 20590

August 4, 2005

In Reply Refer To: HSA-10/B-138

Ronald K. Faller, Ph.D., P.E.
Research Assistant Professor
Midwest Roadside Safety Facility
University of Nebraska-Lincoln
527 Nebraska Hall
Lincoln, Nebraska 68588-0529

Dear Dr. Faller:

On August 19, 2004, you sent Mr. A. George Ostensen, former Associate Administrator of Federal Highway Administration's (FHWA) Office of Safety, copies of two Midwest Roadside Safety Facility (MwRSF) test reports which detailed the design and testing of four bridge railings and their respective transitions for use on transverse, glue-laminated timber bridge decks. You included videotapes and digitized videos of the tests you conducted and requested FHWA acceptance of the designs for use on the National Highway System.

Staff members have belatedly reviewed the information you submitted and agree that the bridge rail designs shown as Enclosures 1 and 2 meet all evaluation criteria for a test level 2 (TL-2) bridge railing and those shown as Enclosures 3 and 4 meet TL-4 criteria. I understand that detailed test results and design drawings for these railings and their respective transitions can be obtained directly from you through the MwRSF.

Although the cargo bed separated from the single-unit truck frame in the TL-4 transition test with the wood post system, film analysis revealed that this separation was the result of inadequate connections between the cargo box and the truck frame and was not attributable to any contact with the transition elements. In the test on the bridge railing itself, the single-unit truck was contained and redirected with no separation of the cargo box from its frame. Nonetheless, designers should be cautioned against using a relatively low bridge railing at locations where failure to retain a cargo box could have severe consequences.

Sincerely yours,

/original signed by/

John R. Baxter, P.E.
Director, Office of Safety Design
Office of Safety

4 Enclosures



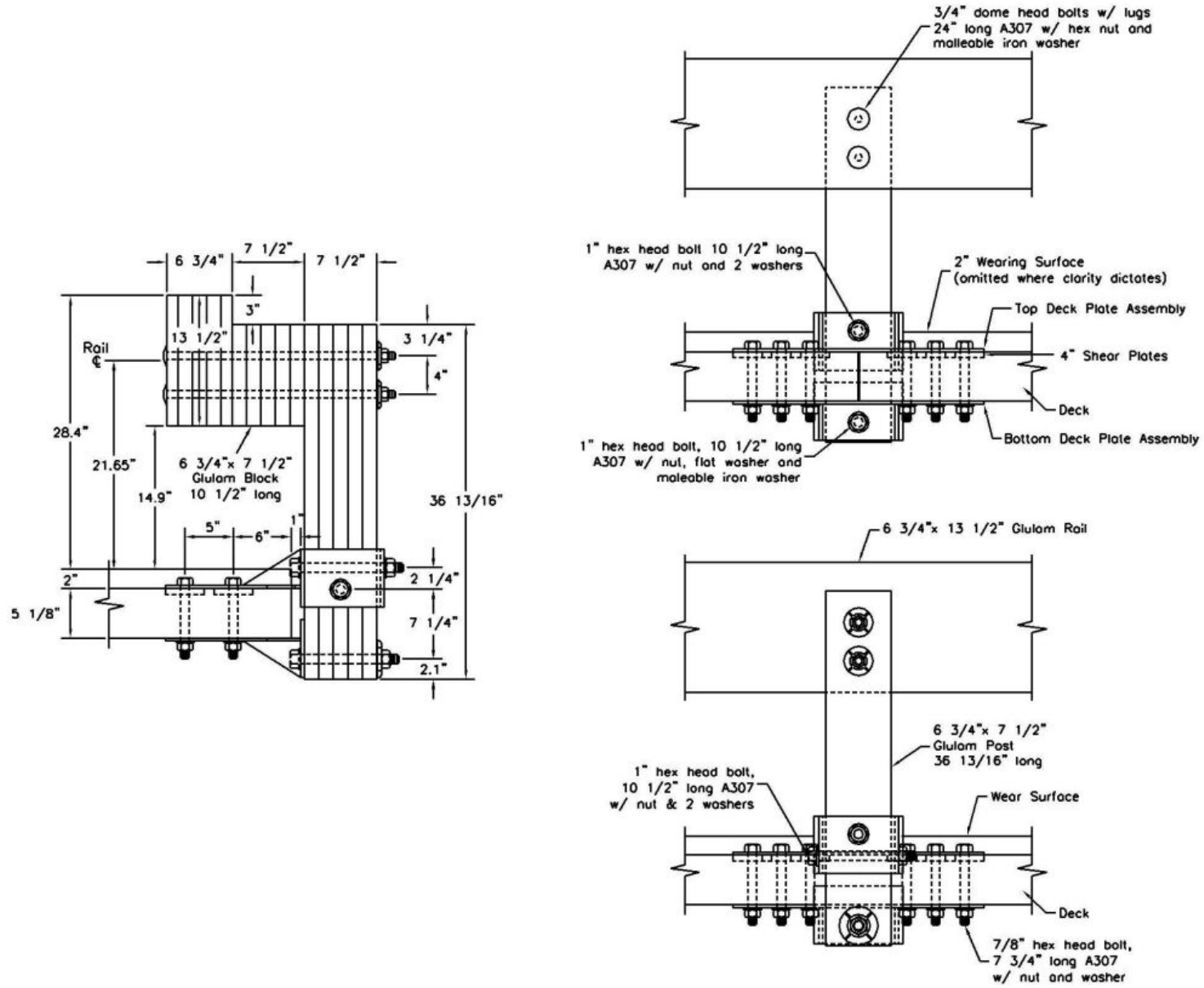

Figure 91. Bridge Railing Design Details - Wood System

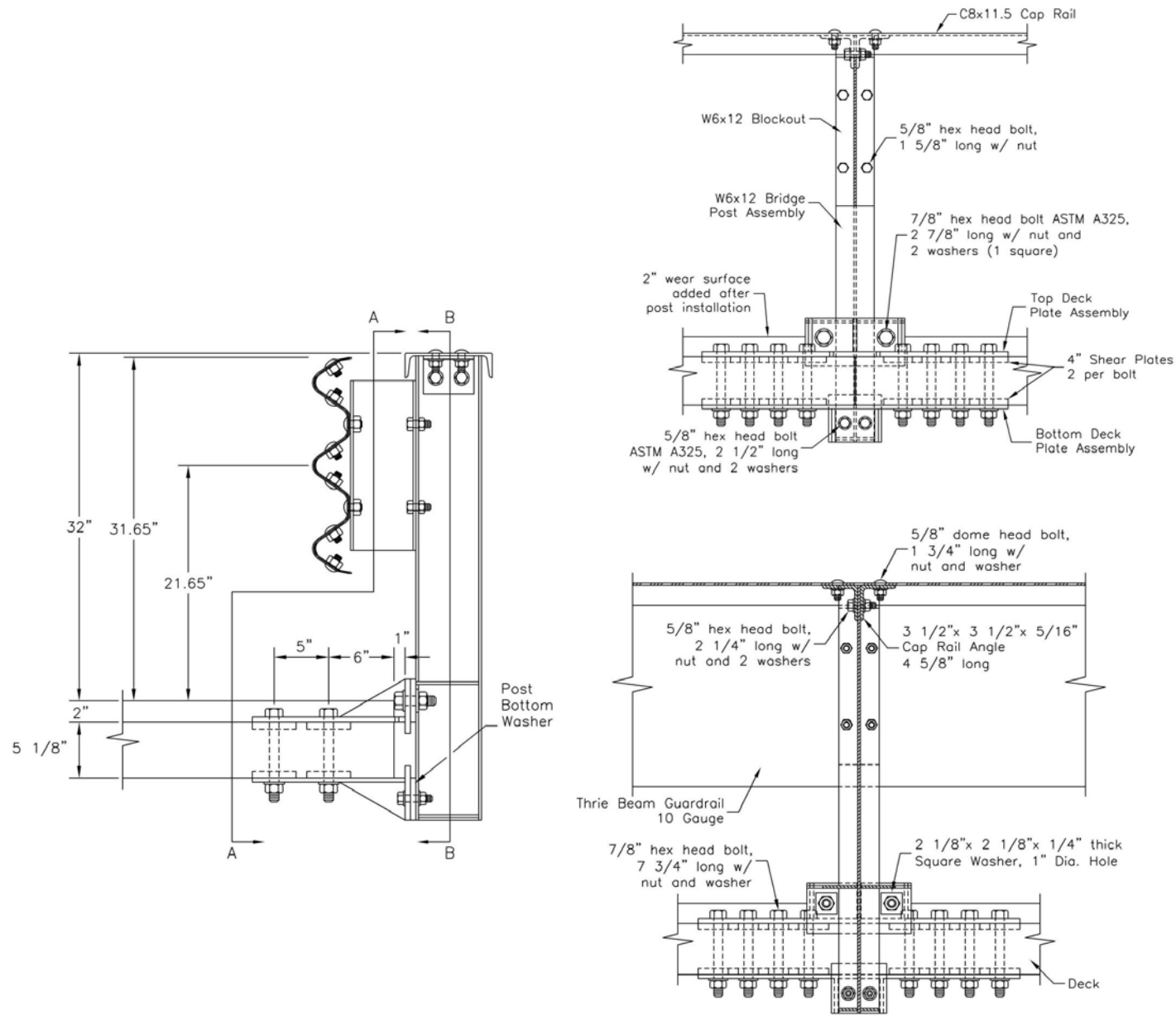

Figure 33. Bridge Railing Design Details - Steel System

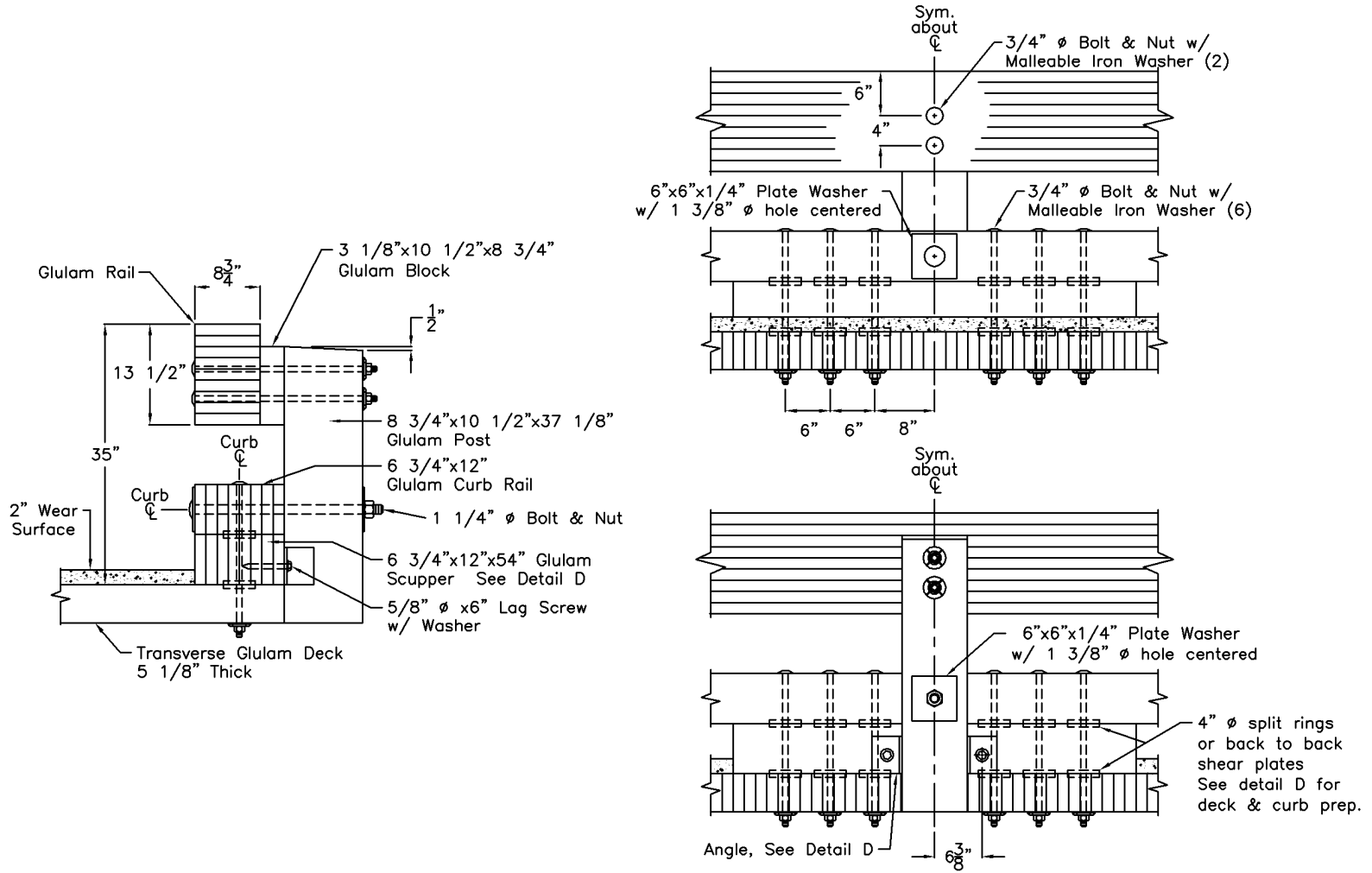

Figure 52. Bridge Railing Design Details - Wood System

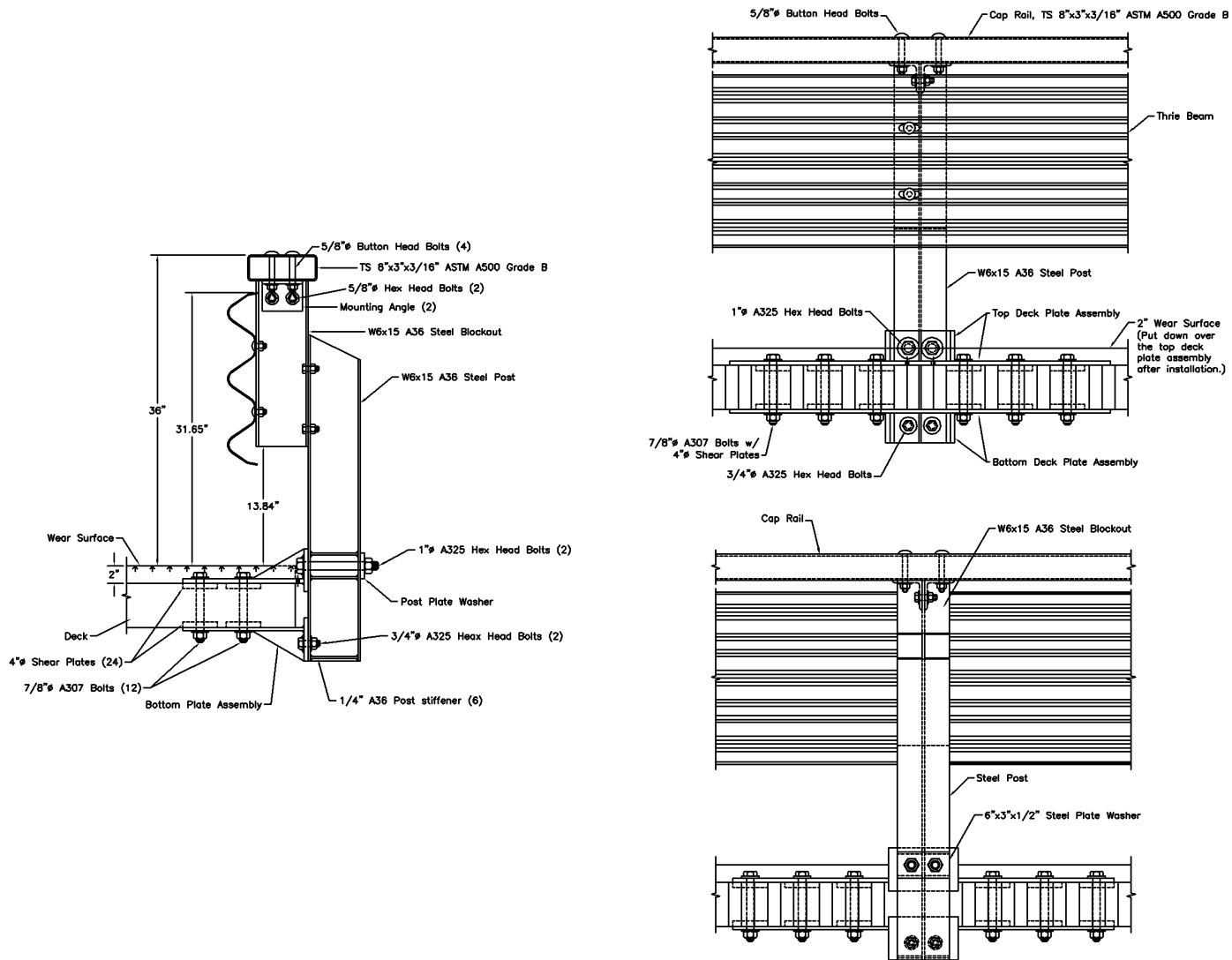

Figure 121. Bridge Railing Design Details - Steel System