

Rev. 09/19/12

September 2012

U.S. DEPARTMENT OF TRANSPORTATION

NATIONAL HIGHWAY TRAFFIC SAFETY ADMINISTRATION

LABORATORY TEST PROCEDURE FOR THE NEW CAR ASSESSMENT PROGRAM SIDE IMPACT RIGID POLE TEST



U.S. Department of Transportation
National Highway Traffic Safety Administration
Office of Crashworthiness Standards
Mail Code: NVS-111
1200 New Jersey Ave. S.E., Room W43-410
Washington, DC 20590

This publication is distributed by the U.S. Department of Transportation, National Highway Traffic Safety Administration, in the interest of information exchange. The opinion, findings, and conclusion expressed in this publication are those of the author(s) and not necessarily those of the Department of Transportation or the National Highway Traffic Safety Administration. The United States Government assumes no liability for its contents or use thereof. If trade or manufacturer's name or products are mentioned, it is because they are considered essential to the object of the publication and shall not be construed as an endorsement. The United States Government does not endorse products or manufacturers.

LABORATORY TEST PROCEDURE FOR NCAP SIDE IMPACT RIDGID POLE TEST**TABLE OF CONTENTS**

	PAGE
1. PURPOSE AND APPLICATION	1
2. GENERAL REQUIREMENTS.	1
3. SECURITY	3
4. GOOD HOUSEKEEPING	4
5. TEST SCHEDULING AND MONITORING.....	4
6. PRE-TEST REQUIREMENTS.	4
6.1 PROJECT PLAN.....	4
6.2 FACILITY AND EQUIPMENT	5
7. GOVERNMENT FURNISHED PROPERTY (GFP).	8
7.1 TEST VEHICLES	8
7.2 ANTHROPOMORPHIC TESTING DEVICES	9
8. CALIBRATION AND TEST INSTRUMENTATION.	9
8.1 GENERAL REQUIREMENTS.....	9
8.2 ANTHROPOMORPHIC TESTING DEVICES	11
9. PHOTOGRAPHIC DOCUMENTATION.....	11
9.1 CAMERAS	11
9.2 COLORING REQUIREMENTS FOR PHOTOGRAPHIC PURPOSES.....	14
9.3 IMPACT EVENT MARKERS.....	15
9.4 PHOTOGRAPHIC TARGETS, TAPE, AND VEHICLE ALIGNMENT WITH POLE	15
9.5 TARGET VEHICLE INFORMATION PLACARDS	19
9.6 CRASH VIDEO TITLE HEADING AND SEQUENCE	19
9.7 REAL-TIME DOCUMENTATION VIDEO EDITING	20
9.8 STILL PHOTOGRAPHS	21
10. DEFINITIONS	24
11. TEST EXECUTION.....	25
11.1 TEST VEHICLE PREPARATION.....	25
11.2 DUMMY PREPARATION, POSITIONING, AND PLACEMENT	40
11.3 VEHICLE MEASUREMENTS	43
11.4 SIDE POLE TEST CONDITION.....	45
12. POST-TEST MEASUREMENTS AND OBSERVATIONS.	46
12.1 TEST SPEED.....	46
12.2 TEMPERATURE AND HUMIDITY STABILIZATION	46
12.3 DUMMY CONTACT POINTS.....	46
12.4 IMPACT POINT.....	46
12.5 VEHICLE DOORS, SEAT MOVEMENT, RESTRAINT SYSTEMS, AND PROFILE MEASUREMENTS	47
12.6 REMOVAL OF ANTHROPOMORPHIC TEST DEVICE	47
12.7 FMVSS NO. 301/305 STATIC ROLLOVER.....	48
12.8 POST-TEST VEHICLE EXTERIOR CRUSH MEASUREMENTS.....	48
12.9 REMOVAL OF TEST INSTRUMENTATION AND EVENT DATA RECORDER.....	48

TABLE OF CONTENTS....Continued

12.10 PREPARATION FOR STORAGE..... 48

13. TEST DATA DISPOSITION..... 49

13.1 TEST DATA LOSS..... 49

13.2 DATA PROCESSING..... 51

13.3 REQUIRED DATA TRACE ORDER..... 53

13.4 NOTIFICATION OF APPARENT TEST FAILURE..... 54

13.5 DELIVERABLES 54

13.6 DATA AND VEHICLE RETENTION BY CONTRACTOR 59

13.7 DATA AVAILABILITY TO THE PUBLIC..... 59

APPENDICES

- A. SID-IIS CALIBRATION TEST PROCEDURE
- B. POSITIONING 5TH PERCENTILE SID-IIS DUMMY IN DRIVER POSITION IN THE TEST VEHICLE
- C. DELIVERABLE GUIDELINES FOR NEW CAR ASSESSMENT PROGRAM SIDE IMPACT POLE TESTING

**REVISION CONTROL LOG
FOR NCAP LABORATORY
TEST PROCEDURES**

SIDE NCAP RIGID POLE TEST

TEST PROCEDURE		Side NCAP Pole		DESCRIPTION
REV. No.	DATE	AMENDMENT	EFFECTIVE DATE	
00	06/23/2010			Seating procedure revision. APPENDIX C revision to correct errors, add information to Form No. 1. As Delivered Weight condition revision.
01	08/30/2011			Minor revisions/clarifications.
02	05/17/2012			Revisions/clarifications to main procedure. Appendix C revised. Added Appendix D.
03	07/11/2012			Revisions to Appendix C.
04	07/23/2012			Revisions to Appendix C.
05	08/09/2012			Revisions to main procedure and Appendix C.
06	09/19/2012			Revisions to main procedure and Appendix C.
07				
08				

1. PURPOSE AND APPLICATION

The New Car Assessment Program (NCAP) side impact rigid pole test procedure is based on Section 9 of Federal Motor Vehicle Safety Standard (FMVSS) No. 214. Whereas the primary objective of FMVSS No. 214 is to reduce the risk of serious and fatal injury to occupants of passenger vehicles in side impact crashes, the primary purpose of the NCAP side impact program is to provide comparative vehicle side protection information to assist consumers in making vehicle purchase decisions, thereby providing an incentive for vehicle manufacturers to design safer vehicles.

The Office of Crashworthiness Standards (OCWS) provides contracted laboratories with Laboratory Test Procedures which serve as guidelines for obtaining test data. The data are used to support the OCWS consumer information program in providing consumers with comparative crash test information. The purpose of the OCWS Laboratory Test Procedures is to present a uniform testing and data recording format, and provide suggestions for the use of specific equipment and procedures. Any Contractor interpreting any part of an OCWS Laboratory Test Procedure to be in conflict with any referenced materials or observing any deficiencies in a Laboratory Test Procedure is required to advise the Contracting Officer's Technical Representative (COTR) and resolve the discrepancy prior to the start of testing.

The OCWS Laboratory Test Procedures are not intended to limit or restrain a Contractor from developing or utilizing any testing techniques or equipment which will assist in procuring the required test data. These Laboratory Test Procedures do not constitute an endorsement or recommendation for use of any product or method. However, the application of any such testing technique or equipment is subject to prior approval by the COTR.

NOTE: *The OCWS Laboratory Test Procedures, prepared for the limited purpose of use by independent laboratories under contract to conduct tests for the OCWS, are not rules, regulations or NHTSA interpretations regarding the meaning of an associated FMVSS. The Laboratory Test Procedures are not intended to limit the requirements of the applicable FMVSS(s).*

In addition, the Laboratory Test Procedures may be modified by the OCWS at any time without notice, and the COTR may direct or authorize contractors to deviate from these procedures, as long as the tests remain within the scope of the contract and are performed in a manner consistent with the Side NCAP test protocol and the applicable parts of S9 of FMVSS No. 214, "Vehicle to pole requirements."

2. GENERAL REQUIREMENTS

For all tests conducted using this NCAP Side Impact Rigid Pole Laboratory Test Procedure, the contract laboratories are directed to use an impact speed of 32.20 km/h. This speed, which is the upper test speed limit required by FMVSS No. 214, is specified in order that the NHTSA can obtain new car assessment and research data. Additionally, the Part 572, Subpart V (SID-IIIs) dummy will be the only acceptable anthropomorphic testing device used in the Side NCAP pole test. The 32.20 km/h pole crash tests conducted by NCAP will be viewed as "indicant tests" to the requirements of the FMVSS No. 214.

Each vehicle subjected to a crash test in accords with this Laboratory Test Procedure shall be tested by impacting it into a fixed, rigid pole 254 mm \pm 3 mm (10 inches) in diameter, at a speed of 32.20 km/h.

2. GENERAL REQUIREMENTS....Continued

When tested according to the test conditions outlined in this test procedure, each vehicle shall comply with the following criteria:

A. DUMMY INJURY CRITERIA – SID-IIS FEMALE DUMMY

- (1) **HEAD** - The Head Injury Criterion (HIC) (36) may not exceed **1000**. HIC 36 is the maximum HIC value when calculated in accordance with the following formula:

$$\text{HIC} = \left[\frac{1}{t_2 - t_1} \int_{t_1}^{t_2} A_r dt \right]^{2.5} (t_2 - t_1)$$

where $A_R = [A_x^2 + A_y^2 + A_z^2]^{1/2}$ is the resultant acceleration magnitude in g units at the dummy head center of gravity (CG), and t_1 and t_2 are any two points in time during the impact event which are separated by not more than a 36 millisecond time interval.

- (2) **LOWER SPINE** - The resultant lower spine acceleration may not exceed **82 g**.
 (3) **PELVIS** - The sum of the acetabular and iliac pelvic forces may not exceed **5,525 N (1,242 lb)**.

B. DOOR OPENING CRITERIA

- (1) Any side door that is struck by the pole shall not separate totally from the vehicle.
 (2) Any door (including a rear hatchback or tailgate) that is not struck by the pole must meet the following requirements:
- i. The door shall not disengage from the latched position.
 - ii. The latch shall not separate from the striker, and the hinge components shall not separate from each other or from their attachment to the vehicle.
 - iii. Neither the latch nor the hinge systems of the door shall pull out of their anchorages.

NOTE: *All examination results must be recorded in the Final Test Report.*

C. FMVSS NO. 301 – STODDARD SPILLAGE

- (1) **DUE TO POLE BARRIER CRUSH** – Stoddard spillage shall not exceed 28 g from impact until motion of the vehicle has ceased, and shall not exceed a total of 142 g in the 5-minute period following cessation of motion. For the subsequent period of time that elapses prior to the static rollover, fuel spillage during any 1 minute interval shall not exceed 28 g.
 (2) **DUE TO STATIC ROLLOVER** – Stoddard spillage in any rollover test, from the onset of rotational motion, shall not exceed a total of 142 g for the first 5 minutes of testing at each successive 90° increment. For the remaining test period, at each increment of 90°, Stoddard spillage during any 1 minute interval shall not exceed 28 g.

NOTE: *All results must be recorded in the Final Test Report.*

2. GENERAL REQUIREMENTS....Continued

D. FMVSS NO. 305 (IF APPLICABLE) – ELECTROLYTE SPILLAGE, ELECTRICAL ISOLATION, AND BATTERY RETENTION

The test vehicle must meet the requirements outlined in CFR §571.305 S5.1, S5.2, and S5.3.

NOTE: *All results must be recorded in a supplemental test report to be submitted along with the Final Test Report for this side NCAP pole test.*

3. SECURITY

The Contractor must provide appropriate security measures to protect the OCWS test vehicles, dummies, and other government-furnished property (GFP) from unauthorized personnel during the entire testing program. The Contractor is financially responsible for any acts of theft and/or vandalism which occur during the storage of test vehicles and GFP. Any security problems which arise shall be reported by telephone to the Industrial Property Manager (IPM), Office of Contracts and Procurement, within two working days after the incident. A letter containing specific details of the security problem will be sent to the IPM (with copy to the COTR) within 48 hours.

The Contractor shall protect and segregate the data that evolves from testing before and after each vehicle test. No information concerning the vehicle testing program shall be released to anyone except the COTR, unless specifically authorized by the COTR, or the COTR's Branch or Division Chief.

NO INDIVIDUALS, OTHER THAN CONTRACTOR PERSONNEL DIRECTLY INVOLVED IN THE TESTING PROGRAM, SHALL BE ALLOWED TO WITNESS ANY OCWS VEHICLE TEST UNLESS SPECIFICALLY AUTHORIZED BY THE COTR. IT IS THE CONTRACTOR'S RESPONSIBILITY TO SECURE THE TEST SITE AREA DURING A TEST AND TO SHIELD THE IMPACT AREA FROM THE PUBLIC VIEW BY THE USE OF CANVAS OR OTHER BLOCKING DEVICES.

RULES FOR CONTRACTORS

- A. No vehicle manufacturer's representative(s) or anyone other than the Contractor's personnel working on the OCWS Contracts and NHTSA personnel shall be allowed to inspect OCWS vehicles or witness vehicle preparations without prior permission from the OCWS. Such permission can never be assumed.
- B. All communications with vehicle manufacturers shall be referred to the OCWS. The Contractor shall not release crash test results or data without the permission of the OCWS. The Contractor may, however, provide the QuickLook (not including data plots) to the vehicle manufacturer post-test. Only this one-page QuickLook (see Form No. 5 in Section 3 of **APPENDIX C**) may be provided to the vehicle manufacturer without permission from the OCWS.
- C. Unless otherwise specified, the vehicle manufacturer's representative(s) shall only be authorized to visit the Contractor's test facility on the day that the test is scheduled, and the representative(s) must be escorted by OCWS and/or Contractor personnel.
- D. Test vehicle inspection by the vehicle manufacturer's representative(s) shall be limited to 30 minutes prior to the start of vehicle impact. Post-test inspection shall be limited to one hour after the Contractor's personnel have completed their test tasks. No parts shall be removed from the vehicle during the post-test inspection without the approval of the COTR.

3. SECURITY....Continued

- E. Photographs and videos of the test vehicle, associated test equipment, and test event shall be allowed. However, test personnel shall not be included in any photographic coverage, and videotaping of vehicle preparation must be approved by the OCWS. The Contractor's personnel shall not respond to any questions from the manufacturer's representatives regarding the OCWS test. All questions shall be referred to the COTR, an OCWS representative present at the test site, or to the OCWS.
- F. The Contractor shall permit public access to and inspection of the test vehicles and related data during the times specified by the OCWS COTR. The OCWS shall advise interested parties that such access and inspection shall be limited to a specified day and specified hours and require prior approval from the OCWS. The Contractor shall refer all visit requests from vehicle manufacturer's representatives to the OCWS. This service shall be included as an incidental part of the crash test program and will not result in any additional cost to the OCWS. The Contractor shall make his own arrangements with interested parties for expenses incurred beyond providing access and inspection services.

4. GOOD HOUSEKEEPING

Contractors shall maintain the entire vehicle testing area, dummy calibration area, test fixtures and instrumentation in a neat, clean and painted condition with test instruments arranged in an orderly manner consistent with good test laboratory housekeeping practices.

5. TEST SCHEDULING AND MONITORING

The Contractor shall submit a test schedule to the COTR prior to testing. Tests shall be completed as required in the contract. The COTR will make adjustments to the crash test schedule in cases of unusual circumstances such as inclement weather or difficulty experienced by the Agency in the procurement of a particular vehicle make and model.

Scheduling shall be adjusted to permit other vehicles to be tested to other FMVSS as may be required by the NHTSA. All testing shall be coordinated with the COTR to allow monitoring by the COTR and/or other Agency personnel if desired.

6. PRE-TEST REQUIREMENTS

6.1 PROJECT PLAN

Every contractor is required to submit a detailed project plan to the COTR before initiating the test program. The project plan must include a step-by-step description of the methodology to be used. The Contractor's project plan shall contain check-off sheets and a complete listing of test equipment and instrumentation used to conduct the side impact pole test. The list of test equipment shall include make, model, instrument accuracy, and calibration dates. All equipment shall be calibrated in accordance with the manufacturer's instructions. There shall be no contradictions between the OCWS Laboratory Test Procedure and the Contractor's project plan. Written approval of the Contractor's project plan shall be obtained from the COTR before initiating the Side NCAP Pole test program.

6. PRE-TEST REQUIREMENTS....Continued

6.2 FACILITY AND EQUIPMENT

A. TEST SURFACE

The test surface on which the vehicle rests prior to impact, shall be level, smooth, of uniform construction, and shall remain in the same plane during the impact. The surface must be large enough to support the test vehicle throughout the event. Additionally, the coefficient of friction of the test surface shall be such that the test vehicle remains in the same plane throughout the main event, and does not roll (angular movement about the vehicle's x-axis) into the pole. The COTR may approve the Contractor to take certain steps to reduce the friction of the test surface.

B. TOW ROAD

The tow road surface shall be straight, level, smooth and of uniform construction. The tow road must have sufficient length to allow the vehicle velocity to stabilize (zero acceleration) prior to impacting the pole.

C. TEST VEHICLE PREPARATION BUILDING/STRUCTURE

A test vehicle preparation building/structure must be constructed (if the test surface is located outdoors) to enclose the area where the test vehicle is prepared immediately prior to the impact test. This building or structure shall be temperature-controlled and large enough to house the test vehicle, test equipment and instrumentation while allowing room for personnel to move freely about the test vehicle. The temperature inside the test vehicle must be maintained between 20.6° C and 22.2° C (69° F and 72° F) for a minimum of four (4) hours prior to the side impact event.

D. TOW AND GUIDANCE SYSTEMS

The tow system must be capable of ensuring that the test vehicle impacts the rigid pole laterally at a speed of 32.20 km/h \pm 0.80 km/h. The system must operate smoothly and permit minimal movement of the dummy's head and/or torso during vehicle acceleration and towing such that the dummy's head remains level at impact. It will be at the COTR's discretion to deem **any** movement of the dummy's head and/or torso as acceptable. Accordingly, if approved by the COTR, the Contractor may take additional steps to eliminate or reduce head movement during towing.

The tow cable attachment device must release from the tow cable before impact.

A guidance system is required to assure that the test vehicle is propelled sideways so that its line of forward motion forms an angle of 75 degrees (\pm 3 degrees) with the vehicle's longitudinal centerline and the pole, and within \pm 38 mm (\pm 1.5 in) horizontally of the vehicle's vertical impact reference line, as specified in the standard from which this test was derived, FMVSS No. 214.

NOTE: *Modification of the test vehicle to allow for towing is not permitted.*

6. PRE-TEST REQUIREMENTS....Continued

E. RIGID POLE

The impact face of the rigid pole shall be a vertically oriented metal structure with a diameter of 254 mm ± 3 mm (10 inches) and beginning no more than 102 mm above the lowest point of the tires on the struck side of the fully loaded test vehicle and extending at least 150 mm above the highest point of the roof of the test vehicle. It shall consist of four solid half-circle steel impact faces mounted to two load cells via two high-strength connecting rods per face (for a total of eight load cells). The load cells shall be mounted at the heights specified in **Figure 1**. The pole face shall be offset from its mounting and support such that the vehicle will not contact the mounting and support structures within 100 ms from the initial vehicle-to-pole contact. The pole illustrated in the following figures (**Figure 1** and **Figure 2**) is from the Federal Highway Administration's Turner-Fairbank Highway Research Center and is provided for illustrative purposes only.

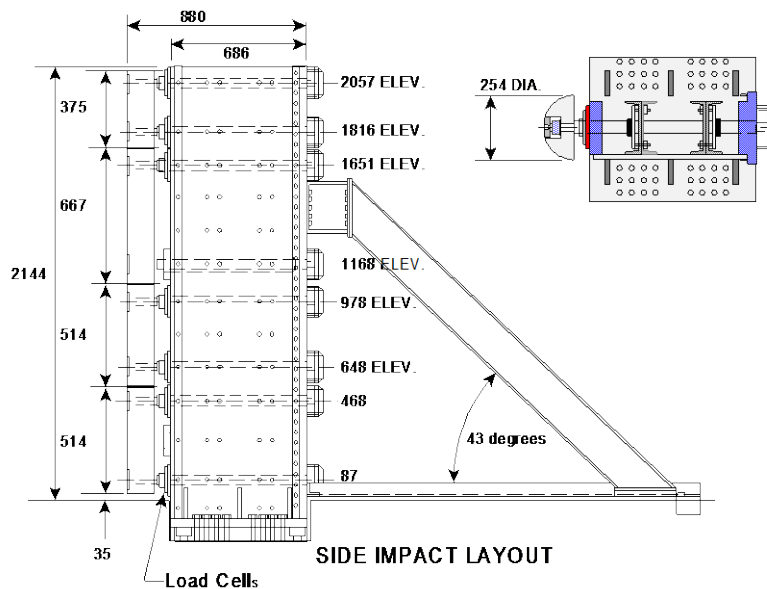

Figure 1 – FOIL 300K Rigid Pole – Side View
(All measurements in mm)

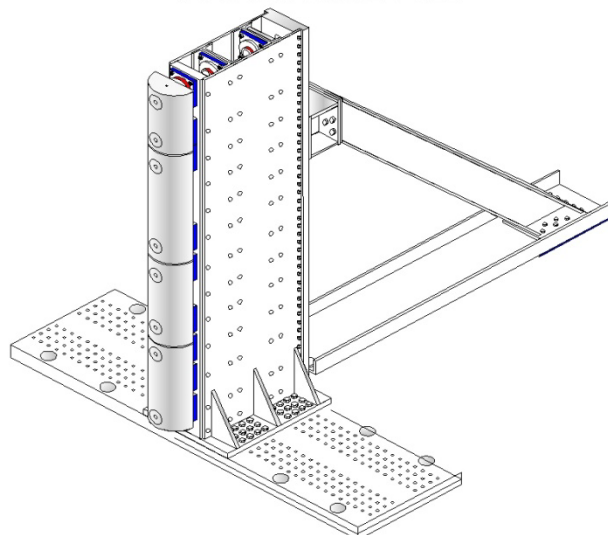

Figure 2 – FOIL 300K Rigid Pole – 3/4 View

6. PRE-TEST REQUIREMENTS....Continued

F. TEST VEHICLE VELOCITY MEASUREMENT

The test vehicle's velocity shall be constant (essentially having zero acceleration or deceleration) for a minimum of the last 1.5 meters of travel before impact. The final impact velocity is measured after the tow system releases, when the test vehicle is within $305 \text{ mm} \pm 10 \text{ mm}$ of the initial contact surface of the pole. Final impact velocity is measured by no less than two sets of independent timing devices accurate to within $\pm 0.08 \text{ km/h}$ and calibrated by an instrument traceable to the National Institute of Standards and Technology (NIST). The impact velocity measurement recorded closest to the point of impact should be regarded as the primary measurement. The physical locations of the recorded primary and redundant impact velocity readouts should remain the same from test to test; for example, the laboratory may always choose to display the primary speed on the left-hand side, etc. If the display location of the primary and redundant speeds will change, the COTR should be notified prior to the test. Recorded values in these timing devices, displayed to the hundredths, shall be permanently documented in a video or photograph. They should also both be reported on the applicable Data Sheet in **APPENDIX E**. The reported final impact velocity shall take into consideration all of the response characteristics of the entire velocity measurement system utilized in its determination.

NOTE: *For test vehicle conveyance systems that utilize a platform upon which the test vehicle rests during towing, the final velocity of the platform must also be measured by no less than two sets of independent timing devices that meets the specifications listed above. The final velocity of the platform shall be taken within $600 \text{ mm} \pm 60 \text{ mm}$ of vehicle impact.*

G. TEST BRAKE ABORT SYSTEM

The vehicle conveyance system shall be equipped with a brake abort system that, when triggered, is capable of preventing the vehicle from impacting the pole. Abort criteria consists of vehicle velocity, data acquisition and instrumentation system readiness, and stability of the vehicle conveyance system on the tow road. The first two criteria are to be automatically monitored by the test brake abort system. The third criteria shall be monitored manually by test personnel.

H. STATIC ROLLOVER DEVICE

A static rollover device, provided by the laboratory and used to conduct an FMVSS No. 301 and/or FMVSS No. 305 test, must be capable of rotating the impacted test vehicle about its longitudinal axis, with the axis kept horizontal, to each successive increment of 90° , 180° , and 270° at a uniform rate. Ninety degrees (90°) of rotation must take place within 1 to 3 minutes.

I. DATA ACQUISITION SYSTEM

The contractor-furnished data acquisition system shall have a sufficient number of channels available for recording and processing signals from the test dummy and vehicle sensors starting 30 ms prior to impact. The system must record time histories of the instrumentation specified for each test dummy used in the test. Each data channel shall be comprised of a sensor, signal conditioner, data acquisition device, and all interconnecting cables, and must conform to the appropriate section of SAE Recommended Practice SAE J211/1 MAR95. The schematic in **Figure 3** depicts a typical configuration for a vehicle and occupant impact test data acquisition system.

6. PRE-TEST REQUIREMENTS....Continued

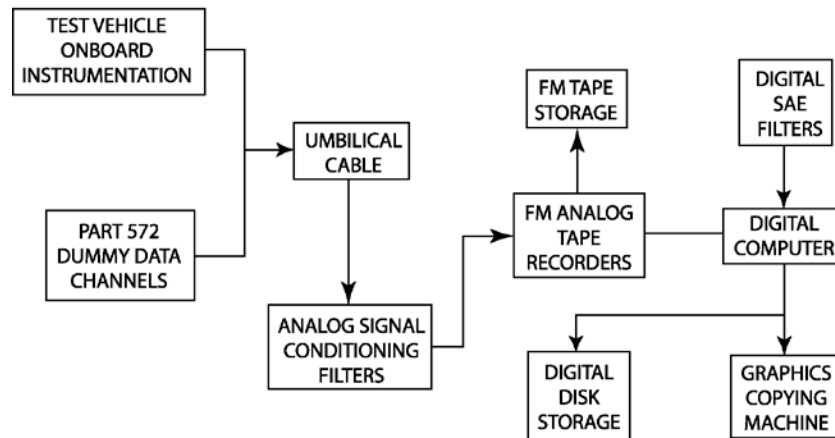

Figure 3 – Typical Vehicle and Occupant Impact Test Data Acquisition System

7. GOVERNMENT FURNISHED PROPERTY (GFP)

The Government will furnish the Contractor with test vehicles and an adequate number of Part 572, Subpart V 5th percentile small female side impact (SID-IIs) test dummies. The test dummies will be instrumented with potentiometers and load cells; accelerometers must be supplied by the contract laboratory. Contractors are required to supply all other equipment and instrumentation necessary to properly conduct vehicle side impact testing according to this test procedure. This will include, but is not limited to, the vehicle conveyance system, the rigid pole, and all other instrumentation (including accelerometers) necessary to collect data from the test dummies, the pole, and the test vehicle.

7.1 TEST VEHICLES

The Contractor has the responsibility of accepting test vehicles. The Contractor acts on the OCWS's behalf when signing an acceptance of test vehicles. If a vehicle is delivered by a dealer, the Contractor must check to verify the following:

- A. All options listed on the 'window sticker' are present on the test vehicle.
- B. Tires and wheel rims are the same as listed.
- C. There are no dents or other interior or exterior flaws.
- D. The vehicle has been properly prepared and is in running condition.
- E. The glove box contains an owner's manual, warranty document, consumer information, and extra set of keys.
- F. Proper fuel filler cap is supplied on the test vehicle.
- G. Spare tire, jack, lug wrench and tool kit (if applicable) is located in the vehicle cargo area.
- H. The odometer reflects that the vehicle has been driven \leq 200 miles.
- I. The VIN (vehicle identification number) on the "Report of Vehicle Condition" form matches the VIN on the vehicle.
- J. The vehicle is equipped as specified by the COTR.

The Contractor shall check for damage that may have occurred during transit. The COTR is to be notified of any damage prior to preparation of the vehicle for testing.

A "Report of Vehicle Condition" form (see Form No. 2 in **APPENDIX C**) shall be completed by the Contractor and submitted to the COTR as part of the QCPackage.zip file. The upper half of the form is used to describe the vehicle as initially accepted. The lower half of the form provides space for a detailed description of the post-test condition of the vehicle.

7. GOVERNMENT FURNISHED PROPERTY (GFP)....Continued

If the test vehicle is delivered by a government-contracted transporter, the Contractor should check for damage that may have occurred during transit. If any discrepancy or damage is found at the time of delivery, the COTR should be contacted via telephone immediately. A GFP vehicle shall not be driven by the Contractor on public roadways unless authorized by the COTR.

7.2 ANTHROPOMORPHIC TESTING DEVICES

An adequate number of fully-instrumented Part 572 Subpart V, 5th percentile female small side impact anthropomorphic testing devices (ATDs) (e.g., 5th female SID-IIs dummies) will be furnished to the contract laboratory by the NHTSA. The dummies shall be stored in an upright-seated position with the weight supported by the internal structure of the pelvis. The eye-bolt in the top of the dummy's head shall not be used to support the dummy during storage between tests. These dummies shall be allowed to soak for 24 hours in an environment that is maintained between 18.9° C and 25.5° C and at a relative humidity from 10% to 70% prior to placement in the test vehicle. **The test dummy shall be positioned in the test vehicle the morning of the test. The test dummy should not be placed in the test vehicle the day before the test.** The Contractor will check the dummy components for damage when performing the calibrations and complete a dummy damage checklist.

The Contractor shall report to the COTR the condition of the dummies in order that replacement parts can be provided or refurbishment can be scheduled.

The Contractor shall keep a detailed record for each dummy, describing parts replaced and the results of calibration tests.

8. CALIBRATION AND TEST INSTRUMENTATION

8.1 GENERAL REQUIREMENTS

Before the Contractor initiates the OCWS test program, a test instrumentation calibration system must be implemented and maintained in accordance with established calibration practices.

The calibration system shall include the following at a minimum:

- A. Standards for calibrating the measuring and test equipment will be stored and used under appropriate environmental conditions to assure their accuracy and stability.
- B. All measuring instruments and standards shall be calibrated by the Contractor, or a commercial facility, against a higher order standard at periodic intervals not exceeding **6 months for accelerometers and 12 months for load cells (dummy qualification shall be performed after every test)**. Records, showing the calibration traceability to the National Institute of Standards and Technology (NIST), shall be maintained for all measuring and test equipment.

Accelerometers must be calibrated prior to 6 months if a vehicle fails to meet the FMVSS 214 pole test performance requirements or after any indication from calibration checks that there may be a problem with a particular accelerometer. In such cases, only those accelerometers directly related to channels that exceeded the 214 pole test requirements, or those indicating problems during calibration checks, must be recalibrated prior to 6 months.

8. CALIBRATION AND TEST INSTRUMENTATION...Continued

- C. All measuring and test equipment and measuring standards will be labeled with the following information:
- (1) Date of calibration
 - (2) Date of next scheduled calibration
 - (3) Name of the technician who calibrated the equipment
- D. A written calibration procedure shall be provided by the Contractor, which includes, at a minimum, the following information for all measurement and test equipment:
- (1) Type of equipment, manufacturer, model number, etc.
 - (2) Measurement range
 - (3) Accuracy
 - (4) Calibration interval
 - (5) Type of standard used to calibrate the equipment (calibration traceability of the standard must be evident)
 - (6) The actual procedures and forms used to perform the calibrations.
- E. Records of calibration for all test instrumentation shall be kept by the Contractor in a manner that assures the maintenance of established calibration schedules.
- F. All such records shall be readily available for inspection when requested by the COTR. The calibration system will need the approval of the COTR before testing commences.
- G. The contractor-furnished data acquisition and processing system for recording signals from test dummies and vehicle sensors in vehicle tests shall be qualified prior to each test. Furthermore, a polarity check should be conducted for all ATD and vehicle sensors immediately prior to the test to ensure that all data is accurately recorded and reported. All checks shall be recorded by the test technician(s).
- H. Test equipment shall receive a system functional check using a known test input immediately before and after the test. This check shall be recorded by the test technician(s).
- I. Anthropomorphic test devices shall be calibrated before and after each crash test. The post-test calibration data obtained after a side pole test can be used as the pre-test calibration data for a subsequent side pole test as long as the dummy is used in a side pole test within 8 weeks of the post-test calibration.
- The calibration data for the test device shall be submitted as part of the Quality Control Package, the Draft Test Report, and the Final Test Report (see Section 13.5, Deliverables). Calibration data must also be available electronically (in UDS format with a .EV5 header) if requested by the COTR. Electronic data collected for all dummy calibrations must be saved and retained by the Contractor for at least five years from the test date.
- J. The Contractor may be directed by NHTSA to evaluate its data acquisition system.

NOTE: *In the event of a test failure (i.e. failure to meet FMVSS No. 214 pole test performance requirements) or data anomaly, that region on the anthropomorphic test device must be recalibrated. Additional calibration checks of some critically sensitive test equipment and instrumentation may be required for verification of accuracy. The necessity for the calibration will be at the COTR's discretion and will be performed without additional cost.*

8. CALIBRATION AND TEST INSTRUMENTATION...Continued

Further guidance is provided in the International Standard ISO 10012-1, "Quality Assurance Requirements for Measuring Equipment" and American National Standard ANSI/NCSS Z540-1, "Calibration Laboratories and Measuring and Test Equipment General Requirements."

8.2 ANTHROPOMORPHIC TESTING DEVICES

The full-vehicle test concept requires the use of human surrogates to determine the injury levels listed previously in Section 2.1. The Part 572 V (SID-IIs) has been chosen as the appropriate Anthropomorphic Testing Device for the Side NCAP pole test.

- A. For the purposes of rating and research purposes, test dummies shall be instrumented with the following:

- (1) Primary and redundant tri-axial head accelerometers
- (2) Thorax upper rib, middle rib, and lower rib y-axis displacement potentiometers
- (3) Abdomen upper rib and lower rib y-axis displacement potentiometers
- (4) Lower spine (T12) tri-axial accelerometers
- (5) Acetabulum and iliac wing y-axis load cells

Record the number of actual number of channels used for the driver dummy on Data Sheet No. 5. Also record the serial numbers, manufacturer, and calibration date of each accelerometer, potentiometer, and load cell for incorporation into Appendix D of the Final Report (See **APPENDIX C**, Section 1.9).

- B. The Part 572 V (SID-IIs) dummy shall be calibrated (pre- and post-test) by the Contractor ON-SITE. **APPENDIX A** contains calibration procedures for GFE Part 572 V (SID-IIs) ATDs. All calibration data shall be recorded and submitted as part of the Quality Control Package, the Draft Test Report, and the Final Test Report (see Section 13.5, Deliverables).
- C. The Part 572 V (SID-IIs) dummy shall be clothed in a short-sleeved form-fitting 100% cotton stretch top and knee-length pants during the calibration tests and also during the Side NCAP test. Additionally, each foot shall have a size 7.5W shoe that meets the configuration and size specification of MIL-S-21711E or its equivalent. All articles of clothing must be clean prior to testing and should not exhibit evidence of extreme wear. Shoes should not show separation(s) at the seams, and clothing should not be ripped or torn.
- D. Prior to positioning, the dummy's limb joints shall be set at between 1 and 2 g. Adjust the leg joints with the torso in the supine position.
- E. SID -IIs dummies shall be fitted with pelvis plugs. A new, unstruck pelvis plus shall be placed in the dummy on the struck side. Once used, the struck pelvis plus shall be removed to the non-struck side.

9. PHOTOGRAPHIC DOCUMENTATION

9.1 CAMERAS

- A. *HIGH-SPEED DIGITAL CAMERAS*

The Contractor shall document the crash event in color with high-speed digital cameras that operate at a minimum speed of 1000 frames per second (fps) for at least 50 ms before the vehicle contacts the pole and for at least 300 ms after the vehicle contacts the

9. PHOTOGRAPHIC DOCUMENTATION....Continued

pole. The cameras shall be positioned as indicated in **Figure 4** and should have a minimum resolution of 1024 x 1024 pixels.

The Contractor shall record the frame speed and lens length for all cameras on Data Sheet No. 5. Camera lens locations shall be referenced to the test vehicle's struck side

and the centerline of the pole. X, Y, and Z coordinates of the lens shall be recorded for cameras 2,3,4,8,9, and 10. Specifically, the X and Y coordinates shall reference the designated impact point on the target vehicle's struck side and the Z coordinate shall reference the ground (+X = forward of impact, +Y = right of impact, +Z = Down). The coordinate system shall be aligned with the test vehicle's struck side.

A time zero (T(0)) impact event marker to indicate when the test vehicle contacts the pole must be present in each high speed video camera view. This may be accomplished by placing strobe lights or flash bulbs that illuminate at t(0) in each field-of-view. The strobes are wired to contact switch plates tapes to the test vehicle or pole impact face.

Each video frame shall contain the camera speed and the frame number beginning with the time zero frame labeled as "Frame 0." The frame numbers prior to time zero shall be negative numbers.

The impact area must be equipped with sufficient lighting to provide the proper exposure without producing excess glare or shadows. The vehicle interior may require auxiliary onboard lighting to facilitate video analysis. Any action taken by the Contractor to reduce the friction of the test surface shall not interfere with the quality or clarity of the test video views.

Post-test, the Contractor shall verify that all high-speed cameras operated at or above 1000 fps and produced video at or above the minimum resolution specification of 1024 x 1024 pixels. The Contractor shall also verify that the real-time cameras operated within specification. If any camera view was not captured, or if a camera did not operate within specifications, the camera number and the reason why it did not operate as intended should be indicated on Data Sheet No. 5.

A digital file for each camera shall be uploaded to the established FTP site and transferred in .avi, .mpeg, or .wmv format with a standard or generally available 'codec' (see Section 13.5,A). Other types of files can be used if prior approval is granted by the COTR. The standard resolution of the digital video files is 1024 x 1024 pixels. However, a duplicate impact video for the NHTSA website shall also be included. This duplicate video file shall have a resolution of 300-400 kb and shall be in .wmv format. Any other resolution level for these test videos must be approved by the COTR.

NOTE: *The test laboratory's name or logo shall not appear in any high-speed videos.*

B. REAL TIME CAMERA

The Contractor shall use a "real time" color digital video camera that operates at 24-30 frames per second. It shall be used to document the views indicated below for Camera 1. The video footage shall also be uploaded to the established FTP site as part of the QCPackage.zip file and transferred as .avi, .mpeg, or .wmv files with a standard or generally available 'codec' (see Section 13.5,D).

NOTE: *The test laboratory's name shall only appear in the documentary real-time video as part of the title frame.*

9. PHOTOGRAPHIC DOCUMENTATION....Continued

C. CAMERA LOCATIONS

Figure 4 provides a schematic that should be referenced when determining camera locations

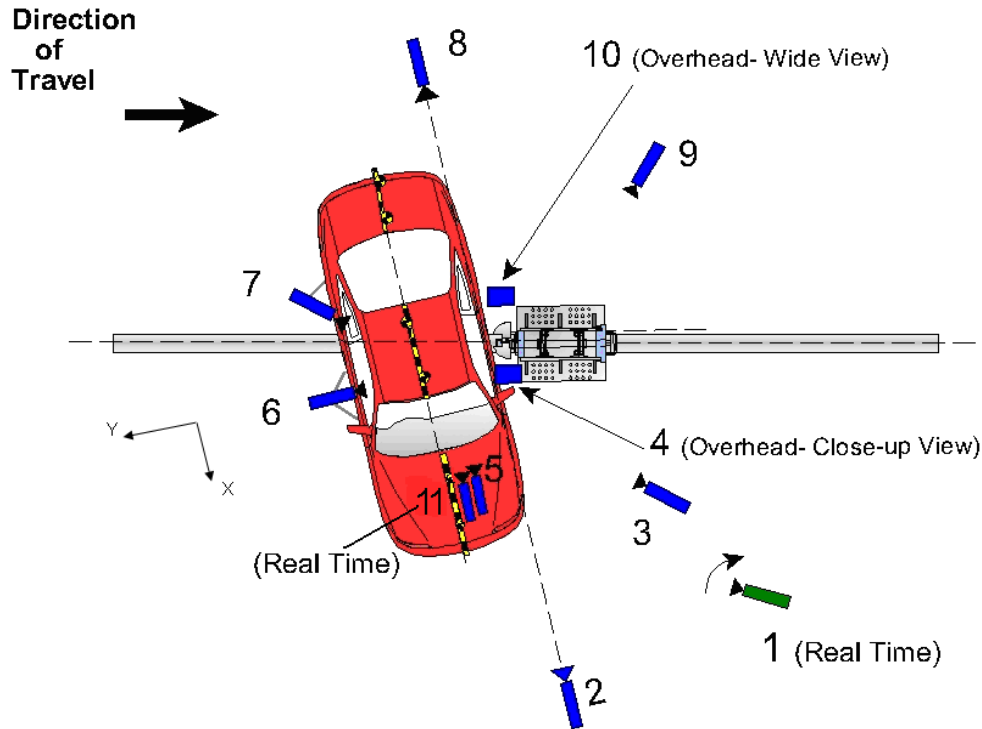

Figure 4 – Camera Locations

Camera 1 Real-time (24-30 fps) camera to provide the following pre-test, test, and post-test coverage:

- (1) side panned view of the test vehicle traveling down the track and impacting the pole
- (2) impact side, front, non-impact side and rear of the test vehicle, and condition of the pole prior to impact
- (3) pre-test dummy position (including, but not limited to the placement of lap and shoulder belt on the dummy)
- (4) cycling of air bag indicator light
- (5) door closings (including any rear hatchback or tailgate)
- (6) lab technician installing fuel filler cap onto the filler neck and the rotation of the cap to the installed position
- (7) speed traps, post-test
- (8) front, front $\frac{3}{4}$ view of impact side, impact side, rear $\frac{3}{4}$ view of impact side, rear, and non-impact side of test vehicle, and condition of the pole after impact
- (9) post-test dummy position
- (10) chalk markings on air bag(s)
- (11) static rollover
- (12) other vehicle failures or anomalies, including door openings and any fluid spillage (along with its collection after impact)

9. PHOTOGRAPHIC DOCUMENTATION....Continued

- Camera 2 A high-speed digital camera positioned at the front of the test vehicle, in-line with (or parallel to) the vertical plane of impact.
- Camera 3 A high-speed digital camera positioned approximately 45° to the impacted side of the vehicle viewing the impact area forward of the pole.
- Camera 4 A high-speed digital camera, positioned directly overhead, to provide a view of the top of the rigid pole and a close-up view of impact. (The cement tack (or other marker) required in Section 9.4,A(5) of this laboratory test procedure should be visible, as should the top of the pole and the impact reference line required in Section 9.4,B(2).
- Camera 5 A high-speed digital camera, positioned on the hood structure and placed to the left side of the vehicle, to provide a frontal view of dummy kinematics and side air bag deployment. (Should be sufficiently raised above the hood structure and positioned such that it shows not only curtain air bag deployment in relation to the dummy's head, but also torso air bag deployment in relation to the dummy's chest, if applicable.)
- Camera 6 A high-speed digital camera, mounted to the non-struck side front door structure, to provide a side view of dummy kinematics through the vehicle's front side door window.
- Camera 7 A high-speed digital camera, mounted to the non-struck side rear door structure or rear window opening, to provide an oblique view of the dummy kinematics.
- Camera 8 A high-speed digital camera, positioned at the rear of the test vehicle, in-line with (or parallel to), the vertical plane of impact.
- Camera 9 A high-speed digital camera, positioned approximately 45° to the impacted side of the vehicle viewing the impact area rearward of the pole.
- Camera 10 A high-speed digital camera, positioned directly overhead to provide a wide view of impact. (Should show entire roof of vehicle and the three angle at impact reference lines described in 9.4D. Ensure the vehicle will not cast a shadow over these lines such that they will not be visible immediately prior to impact.)
- Camera 11 A real-time (24 fps) camera, positioned on the hood structure and placed to the left side of the vehicle, to provide a frontal view of dummy kinematics from onset of towing until the vehicle comes to rest.

The exact camera coordinates and specifications shall be noted as requested on Data Sheet No. 5. (See Section 2 of **APPENDIX C.**)

9.2 COLORING REQUIREMENTS FOR PHOTOGRAPHIC PURPOSES

- A. Vehicle interior surfaces such as the A, B, C-pillars and trim panels, interior door trim panels, etc., on the impact side of the vehicle shall be painted with flat white paint unless otherwise noted in the manufacturer's submission of test setup information (Form 1). The air bag indicator light on the dash shall **NOT** be painted so as to be visible prior to testing. The area around surfaces where an air bag or dynamic system deploys shall **NOT** be painted. In addition, the air bag or dynamic system indicator light on the instrument panel shall **NOT** be painted so as to be visible prior to testing.
- B. Parts of the anthropomorphic test device shall be coated with colored face paint solutions to show contact points with the vehicle's door and interior components. The paint shall

9. PHOTOGRAPHIC DOCUMENTATION....Continued

be applied after final dummy positioning. In the event that the paint is partially covered by a latched seat belt, the coloring shall be applied to the seat belt as well to ensure any interior contact is evident post-test. If necessary, a colored chalk/water solution may be used, but face paint is preferred.

PAINT COLORS TO BE USED ON TEST DUMMIES

DUMMY PART	COLOR
Face	Blue
Top of Head (<i>stop painting at skull cap</i>)	Yellow
Left Side of Head	Green
Back of Head (<i>skull cap</i>)	Red
Left Shoulder	Orange
Upper Torso	Blue
Lower Torso	Yellow
Left Hip	Red
Left Knee	Green

9.3 IMPACT EVENT MARKERS

Time zero indicated on the side impact high-speed video must be synchronized to the event time zero point. Additionally, strobes or flash bulbs with diffused light shall be placed in the field-of-view of all nine high-speed cameras to mark the time zero point. The Contractor shall use pressure switches attached to the test vehicle or pole impact face in order to trigger the time zero indicators.

9.4 PHOTOGRAPHIC TARGETS, TAPE, AND VEHICLE ALIGNMENT WITH POLE

A. VERTICAL IMPACT REFERENCE LINE

- (1) Position the vehicle on the test pad area so that its longitudinal centerline is approximately at 75° relative to its intended line of forward motion.
- (2) Position the dummy in accordance with the seating procedure in **APPENDIX B**.
- (3) Adjust the vehicle (or pole) for proper alignment. A vertical plane passing through the 3-dimensional center of gravity of the head of the dummy shall be coincident to the intended forward line of motion.
- (4) Affix 25 mm (1 inch) wide yellow/black checkerboard tape vertically along the exterior front door panel to mark where the plane determined in step 3 intersects the door. See **Figure 5**. This is the vertical impact reference line. At impact, the test vehicle's vertical impact reference line is aligned with the centerline of the pole ± 38 mm (1.5 in).
- (5) Measure the distance from the front axle to the edge of the tape used to denote the vertical impact reference line and record the measurement on Data Sheet No. 8.
- (6) Place 25 mm (1 inch) wide yellow/black checkerboard tape laterally across the vehicle's roof along the vertical transverse plane that passes through the vertical impact reference line, coincident with the intended line of forward motion (after final positioning of the dummy). See **Figure 7**. Extend this tape line vertically onto the vehicle's non-struck side along the vertical transverse plane to the lower sill.

9. PHOTOGRAPHIC DOCUMENTATION....Continued

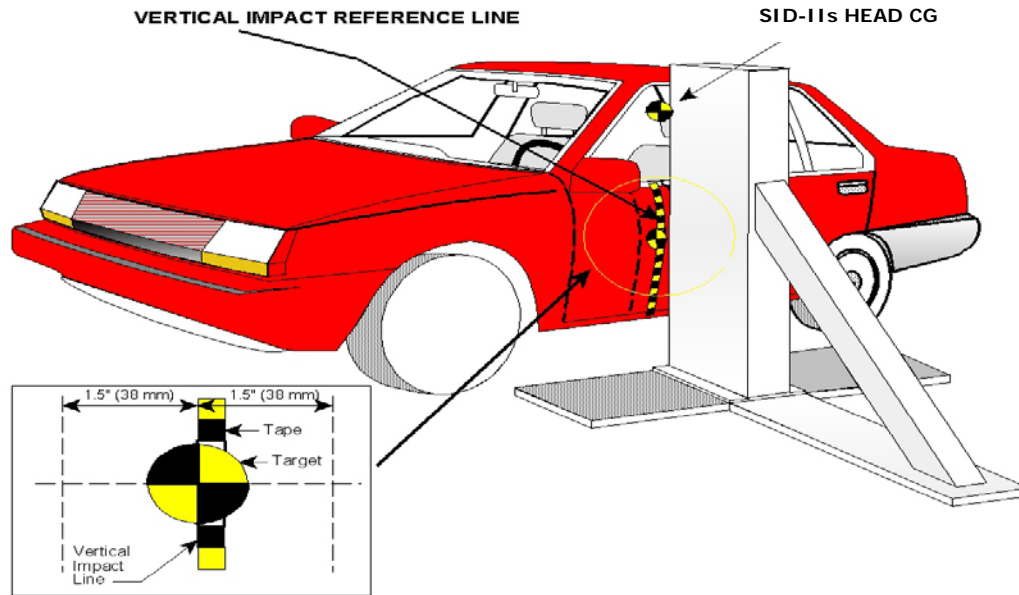

Figure 5 – Vertical Impact Reference Line

B. HORIZONTAL IMPACT REFERENCE LINES

As shown in **Figure 6**, affix 25 mm (1 inch) wide yellow/black checkerboard tape horizontally along the struck side of the test vehicle at the five levels indicated below. Measure and record (on Data Sheet No. 10) the vertical distance from ground to each level (top edge of the tapeline) along the vertical impact reference line.

- LEVEL 1 – Top of side sill: Affix tape along the door sill from the front to the rear wheel-wells.
- LEVEL 2 – Occupant Hip Point: Project the location of the driver dummy's hip point laterally through the door to its exterior panel. Affix tape to the side body panels so that the tape intersects the hip point.
- LEVEL 3 – Mid-door: Measure the height of the front door body panel at two different locations that are at least 600 mm apart. Take the average of the two measurements. Mark this point on the exterior door panel. Affix tape to the side body panels so that the tape intersects this point.
- LEVEL 4 – Window sill: Affix tape just below the front door window sill.
- LEVEL 5 – Top of window: Affix tape just above the top of the front door window.

9. PHOTOGRAPHIC DOCUMENTATION....Continued

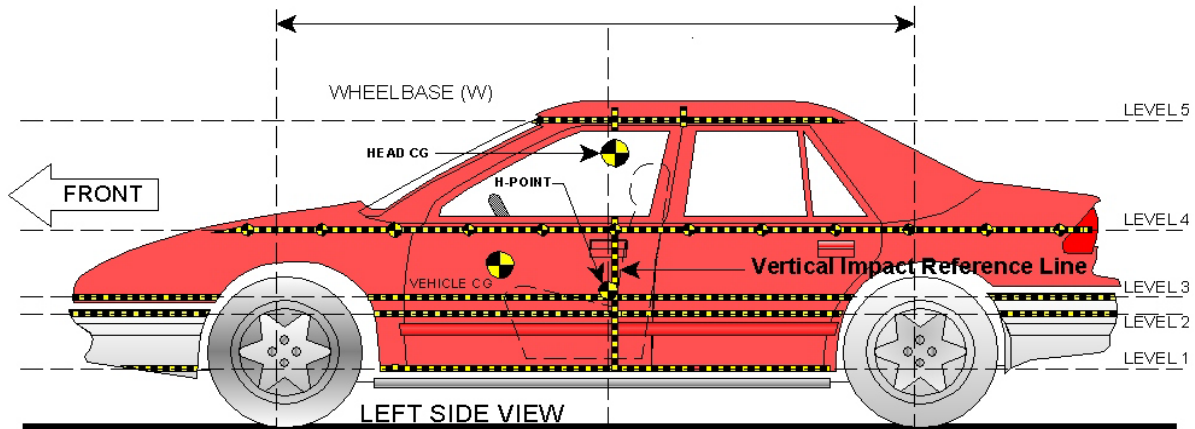

Figure 6 – Horizontal and Vertical Impact Reference Lines

C. VEHICLE LONGITUDINAL CENTERLINE

Place 25 mm (1 inch) wide yellow/black checkerboard tape on the hood and roof along the longitudinal centerline of the entire vehicle (excluding glazing surfaces) as shown in **Figure 7** to provide a reference line for the overhead film coverage.

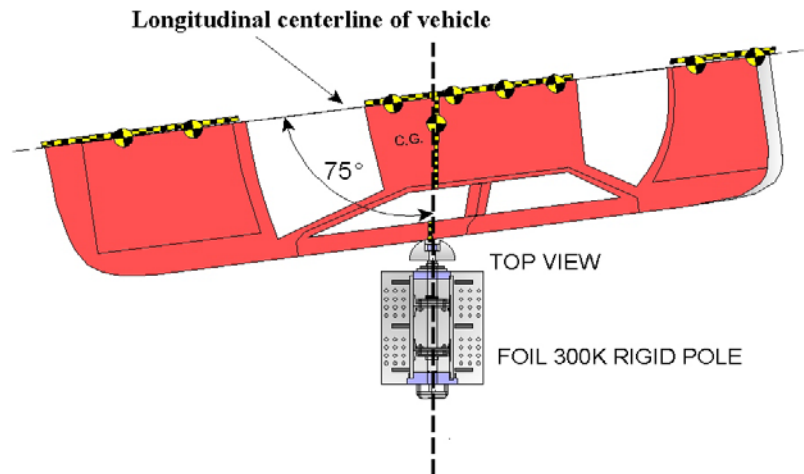

Figure 7 – Vehicle Longitudinal Centerline

D. ANGLE AT IMPACT REFERENCE LINES

When the vehicle is properly positioned such that it is contacting the pole at the initial point of contact along the vertical impact reference line (in accord with Section 9.4,A(3)), strike a plane perpendicular to the ground that passes through the initial point of contact and is parallel to the vehicle's longitudinal centerline. Accordingly, this plane should form an angle of 75 degrees (± 3 degrees) with a plane perpendicular to the ground along the centerline of the pole (as determined in Section 9.4,A(3)). Place 25 mm (1 inch) wide yellow/black checkerboard tape on the test surface directly in front of the pole along the line determined by the plane passing through the initial point of contact. This line should extend past the front and rear of the vehicle when it is properly positioned. Use the 25 mm (1 inch) wide yellow/black checkerboard tape to place two additional lines on the test surface that are parallel to the first. All lines should be spaced 1 foot apart.

9. PHOTOGRAPHIC DOCUMENTATION....Continued

E. VEHICLE HEIGHT REFERENCE ON POLE

Place 25 mm (1 inch) wide yellow/black checkerboard tape horizontally around the pole in line with the height of the top of window level (LEVEL 5) illustrated in **Figure 5**.

F. VEHICLE AND POLE TARGETS

Affix targets, labeled appropriately (if applicable), on the vehicle as follows:

- (1) along LEVEL 4, window sill tape line, at every 300 mm (see **Figure 6**). Use 50 mm (2 inch) diameter targets.
- (2) the front door or side panel to denote the hip pivot center of the test dummy (See **Figure 6**). Use a 100 mm (4 inch) diameter target and label with "HP".
- (2) the front door to denote the vehicle CG location (See **Figure 6**). Use a 100 mm (4 inch) diameter target and label with "CG".
- (3) the roof to mark the test dummy's head CG location (See **Figure 7**). Use a 100 mm (4 inch) diameter target and label with "CG".
- (4) Over the vertical impact reference line at the outermost contour of the front door panel (See **Figure 5**) at the point where the properly positioned vehicle (as determined in Section 9.4,A(3)) makes contact with the pole. If the properly positioned vehicle contacts the pole at more than one point along the vertical impact reference line, place the target at the location that is closest to the mid-door level. If the driver's side mirror prohibits the vehicle from contacting the pole along the vertical impact reference line, the mirror should be removed. For vehicles with running boards installed as optional equipment, if the only point of contact along the vertical impact reference line is the running boards, they should be removed. Affix a cement tack (or other marker) to the pole at this same level such that it will transfer into the vehicle's door skin at the target located on the vehicle's impact reference line upon initial contact.
- (5) along the roof aligned with the longitudinal centerline of the test vehicle, at every 300 mm (See **Figure 7**). Use 100 mm (4 inch) diameter targets.
- (6) the windshield of the vehicle at the intersection formed by two planes passing parallel and perpendicular through the target placed on the face of the anthropomorphic test device at the head CG location. Use a 25 mm (1 inch diameter target).
- (7) the top center of the steering wheel, such that it is visible when looking through the windshield at the dummy. Use a 25 mm (1 inch diameter target).
- (8) Centered on the centerline of the top of the pole. Use a 100 mm (4 inch) diameter target. If the pole is hollow, affix 25 mm (1 inch) wide yellow/black checkerboard tape coincident with the line of forward motion to the top of the pole through its centerline.

G. DUMMY TARGETS

Place a 100 mm (4 inch) diameter target on the head of the anthropomorphic test device at the CG location on the struck side.

Place 25 mm (1 inch) diameter targets on the anthropomorphic test device as follows:

- (1) on the front of the dummy's head/face at the head CG location
- (2) on the dummy's chest, at the positions determined when taking the CS and CD measurements in Section 11.2 of this laboratory test procedure.

9. PHOTOGRAPHIC DOCUMENTATION....Continued

9.5 TARGET VEHICLE INFORMATION PLACARDS

Test vehicle identification placards shall be positioned so that at least one placard will be visible and legible in each of the cameras' field of view. The following information shall be shown:

- A. Target vehicle's NHTSA number
- B. The words "75° Oblique Rigid Pole Side NCAP Impact"
- C. Date of the side impact test
- D. Vehicle year, make, and model

NOTE: *The test laboratory's name and logo shall not appear on vehicle information placards.*

9.6 CRASH VIDEO TITLE HEADING AND SEQUENCE

The Contractor shall upload the color videos for each crash test to the established FTP website as part of the QCPackage.zip file (see Section 13.5,D) within **five (5)** days after completion of the test. These videos shall also be provided as part of the final test deliverables in the FinalDeliverables.zip file. The master copy for each of the crash test videos shall be retained by the Contractor and will be made available to the OCWS upon request.

A separate video shall be created from the footage recorded by each high-speed camera, for a total of ten high-speed videos. A video should also be created from the footage recorded by the real-time camera that is positioned on the vehicle (Camera # 11). These videos should appear in numerical order in both the QCPackage.zip file and the FinalDeliverables.zip file and should be labeled as follows:

- Camera No. 1 – Real-Time Pan View of Impact
- Camera No. 2 – Front Impact View
- Camera No. 3 – 45° Front Impact View
- Camera No. 4 – Overhead Close-Up View
- Camera No. 5 – Dummy Front View (On-board)
- Camera No. 6 – Dummy Side View (On-board)
- Camera No. 7 – Dummy Rear Oblique View (On-board)
- Camera No. 8 – Rear Impact View
- Camera No. 9 – 45° Rear Impact View
- Camera No. 10 – Overhead Wide View
- Camera No. 11 – Real-Time View of Dummy Movement

The test laboratory shall also make a separate movie of the impact event that is acceptable for inclusion on the NHTSA's website. This movie file shall be labeled as "<Model Year><Make & Model><Number of Doors><Body> Pole IMPACT FOR WEB", have an approximate size of 300-400 kb, and shall be in .wmv format.

9. PHOTOGRAPHIC DOCUMENTATION....Continued

9.7 REAL-TIME DOCUMENTATION VIDEO EDITING

A test documentation video file shall also be made to include all real-time video footage and must only be submitted as part of the FinalDeliverables.zip file. The real-time video shall be edited in the following sequence:

- A. Title, to include the following title frames:
 - (1) The following Side NCAP Pole Test was conducted under contract with the National Highway Traffic Safety Administration by (laboratory name, city, and state).
 - (2) 75° OBLIQUE RIGID POLE SIDE IMPACT NCAP
Test Vehicle Model Year, Make, and Model
NHTSA No. MXXXXX
Test Laboratory
Date of Impact Event
Contract No.: DTNH22-0X-X-XXXXX
- B. Pre-Test Coverage (real-time)
 - (1) Vehicle
 - i. View of front of vehicle
 - ii. Front $\frac{3}{4}$ view of struck-side of vehicle
 - iii. View of struck-side of vehicle
 - iv. Rear $\frac{3}{4}$ view of struck-side of vehicle
 - v. View of rear of vehicle
 - vi. View of non-struck-side of vehicle
 - (2) Test Dummy
 - i. Left side view of SID-IIs in front seat (struck-side door open)
 - ii. Left side view of SID-IIs in front seat (struck-side door closed)
 - iii. Right side view of SID-IIs in front seat (non-struck-side door open)
 - iv. Right side view of SID-IIs in front seat (non-struck-side door closed)
 - (3) Pole
 - (4) Gas cap being attached to filler pipe
 - (5) Cycling of air bag indicator light (to include full view of instrument panel)
 - (6) Door closings (including all passenger doors, trunk or rear hatch (if applicable))
- C. Real-Time Pan Coverage of Impact Event

9. PHOTOGRAPHIC DOCUMENTATION....Continued

- D. Post-Test Coverage (real-time)
- (1) Test Speed
 - i. View of primary and redundant speed traps (include NHTSA No. placard)
 - (2) Vehicle
 - i. View of front of vehicle
 - ii. Front $\frac{3}{4}$ view of struck-side of vehicle
 - iii. View of struck-side of vehicle
 - iv. View of impact point – close-up
 - v. Rear $\frac{3}{4}$ view of struck-side of vehicle
 - vi. View of rear of vehicle
 - vii. View of non-struck-side of vehicle
 - (3) Test Dummy
 - i. View of SID-IIs – parallel to impact door (door closed)
 - ii. View of SID-IIs – through opposite window (door closed)
 - (4) Air bags
 - i. View of struck-side of vehicle (dummy removed)
 - ii. View of inside front door showing chalk marks on air bag(s) (dummy removed)
 - iii. View of inside rear door (dummy removed)
 - (5) Pole
 - (6) Static Rollover
 - i. View of static rollover – 0 degrees
 - ii. View of static rollover – 90 degrees
 - iii. View of static rollover – 180 degrees
 - iv. View of static rollover – 270 degrees
 - v. View of static rollover – 360 degrees
- E. Any Vehicle Failures or Anomalies (show tape measure from latch to door if door opening)
- F. The final frame shall state “The End”

NOTE: *The test laboratory’s name and logo shall not appear in any videos.*

9.8 STILL PHOTOGRAPHS

Clear and properly focused digital, color still photographs shall be taken to document the test. Information placards for the target vehicle and/or pole, which identify the test vehicle model as well as the pole, NHTSA number, and test date, along with an indication of whether the photo was taken pre-test or post-test, shall appear in each photograph and be legible. Glare or light from any illuminated or reflective surface shall be minimized while taking photographs. **All pre-test photos should be taken immediately prior to impact (i.e. within the hour preceding impact after the manufacturer has been given a chance to review the test set-up) and all post-test photos should be taken immediately after impact (within the hour following impact before the manufacturer has been given a chance to examine the crashed vehicle).**

Photographs that are approximately 4 in. x 6 in. (at a minimum) shall be included in **APPENDIX A** of the Final Test Report. Two photographs shall be provided on each page and each photograph shall be labeled as to subject matter in accordance with the list below. See also Section 1.6 of **APPENDIX C**. All digital still photographs shall also be properly labeled, should include a time/date stamp, and should be posted to the established FTP site in the order specified below as part of the QCPackage.zip and FinalDeliverables.zip files (See Sections 13.5,D and F). At a minimum, the following photographs, numbered as follows, shall be included as part of the QCPackage.zip file (**only these photos (which must be both numbered and labeled) should be included in the FinalDeliverables.zip file, unless the OCWS requests additional photos be included**):

9. PHOTOGRAPHIC DOCUMENTATION....Continued

- No. 001 – As Delivered Right Front 3-4 View of Test Vehicle
- No. 002 – As Delivered Left Rear 3-4 View of Test Vehicle
- No. 003 – Pre-Test Frontal View of Test Vehicle
- No. 004 – Post-test Frontal View of Test Vehicle
- No. 005 – Pre-Test Left Front 3-4 View of Test Vehicle
- No. 006 – Post-Test Left Front 3-4 View of Test Vehicle
- No. 007 – Pre-Test Left Side View of Test Vehicle
- No. 008 – Post-Test Left Side View of Test Vehicle
- No. 009 – Pre-Test Left Rear 3-4 View of Test Vehicle
- No. 010 – Post-Test Left Rear 3-4 View of Test Vehicle
- No. 011 – Pre-Test Rear View of Test Vehicle
- No. 012 – Post-Test Rear View of Test Vehicle
- No. 013 – Pre-Test Right Side View of Test Vehicle
- No. 014 – Post-Test Right Side View of Test Vehicle
- No. 015 – Pre-Test Overhead View of Test Area *(to include pole and vehicle, if possible)*
- No. 016 – Post-Test Overhead View of Test Area *(to include pole and vehicle, if possible)*
- No. 017 – Pre-Test Left Side View of Pole Positioned Against Side of Vehicle *(should be positioned at Ideal Impact Point, if possible)*
- No. 018 – Pre-Test Right Side View of Pole Positioned Against Side of Vehicle *(should be positioned at Ideal Impact Point, if possible)*
- No. 019 – Pre-Test Close-Up View of Impact Point Target *(impact reference line should be clearly indicated)*
- No. 020 – Post-Test Close-Up View of Impact Point Target Showing Impact Location *(impact reference line and impact point should be clearly indicated)*
- No. 021 – Pre-Test Front Close-Up View of Dummy Head and Chest *(through front window to show position of seat belt across dummy's chest, including inch tape intended to show pretensioner firing)*
- No. 022 – Post-Test Front Close-Up View of Dummy *(through front window)*
- No. 023 – Pre-Test Left Side View of Dummy Showing Belt and Chalking *(door open)*
- No. 024 – Pre-Test Left Side View of Dummy Shoulder and Door Top View
- No. 025 – Post-Test Left Side View of Dummy Shoulder and Door Top View
- No. 026 – Pre-Test Frontal View of Seat Back Prior to Dummy Positioning *(should show head restraint and seat centerline)*
- No. 027 – Pre-Test Frontal Close-Up View of Dummy Head and Shoulders in Relation to Head Restraint *(through front window) (should only show head and shoulders, not chest, and level should be included in photo, as should seat centerline)*
- No. 028 – Pre-Test Frontal View of Seat Pan Prior to Dummy Positioning *(should show seat centerline)*
- No. 029 – Pre-Test Overhead View of Dummy Thighs on Seat Pan *(should be taken through the steering wheel, if possible)*
- No. 030 – Pre-Test Left Side View of Dummy's Neck Showing Position of Adjustable Neck Bracket
- No. 031 – Pre-Test Left Side View of Dummy's Head Showing Dummy's Head is Level *(level should be shown in photo)*
- No. 032 – Pre-Test Placement of Dummy's Feet
- No. 033 – Pre-Test View of Belt Anchorage for Dummy *(should show the test position and include detent or millimeter markings, if applicable)*
- No. 034 – Pre-Test Left Side View of Steering Wheel *(should show the test position and include detent or millimeter markings, if applicable)*
- No. 035 – Pre-Test View of Disengaged Parking Brake *(taken at the same time as As-Delivered photos)*
- No. 036 – Pre-Test View of Parking Brake *(should be taken at the same angle as previous photo)*
- No. 037 – Pre-Test Close-Up Left Side View of Driver Seat Track *(should show the test position and include detent or millimeter markings)*
- No. 038 – Pre-Test Close-Up Left Side View of Driver Seat Back *(should show test position and include detent or degree markings)*

9. PHOTOGRAPHIC DOCUMENTATION....Continued

- No. 039 – Pre-Test Close-Up View of Driver Seat Back or Head Restraint *(should show test position and include level, placed at manufacturer's designated location, as indicated on Form No. 1, to show angle at test position)*
- No. 040 – Pre-Test Dummy and Door Clearance View
- No. 041 – Post-Test Dummy and Door Clearance View
- No. 042 – Pre-Test Right Side View of Dummy and Front Seat of Occupant Compartment *(through vehicle with door open)*
- No. 043 – Post-Test Right Side View of Dummy and Front Seat of Occupant Compartment *(through vehicle with door open)*
- No. 044 – Pre-Test Inner Door Panel View
- No. 045 – Post-Test Inner Door Panel View Showing Dummy Contact Locations *(with dummy removed and air bags untouched)*
- No. 046 – Post-Test Dummy Close-Up Head Contact with Vehicle Interior View *(if applicable, with dummy removed)*
- No. 047 – Post-Test Dummy Close-Up Head Contact with Side Air bag View *(if applicable, with dummy removed and air bag arranged to show contact marks)*
- No. 048 – Post-Test Dummy Close-Up Torso Contact with Vehicle Interior View *(if applicable, with dummy removed)*
- No. 049 – Post-Test Dummy Close-Up Torso Contact with Side Air bag View *(if applicable, with dummy removed and air bag arranged to show contact marks)*
- No. 050 – Post-Test Dummy Close-Up Pelvis Contact with Vehicle Interior View *(if applicable, with dummy removed)*
- No. 051 – Post-Test Dummy Close-Up Pelvis Contact with Side Air bag View *(if applicable, with dummy removed and air bag arranged to show contact marks)*
- No. 052 – Post-Test Dummy Close-Up Knee Contact with Vehicle Interior View *(if applicable)*
- No. 053 – Pre-Test View of Fuel Filler Cap or Fuel Filler Neck
- No. 054 – Post-Test View of Fuel Filler Cap or Fuel Filler Neck
- No. 055 – Close-Up View of Vehicle's Certification Label (photograph of certification label, include a photograph of the reduced load carrying capacity as No. 055a, if applicable)
- No. 056 – Close-Up View of Vehicle's Tire Information Placard or Label
- No. 057 – Pre-Test Pole Barrier Front View
- No. 058 – Post-Test Pole Barrier Front View
- No. 059 – Pre-Test Pole Barrier Side View
- No. 060 – Post-Test Pole Barrier Side View
- No. 061 – Pre-Test Ballast View
- No. 062 – Post-Test Primary and Redundant Speed Trap Read-Out *(primary and redundant speeds should be labeled and photo should include placard that displays NHTSA No.)*
- No. 063 – FMVSS No. 301 Static Rollover 0 Degrees
- No. 064 – FMVSS No. 301 Static Rollover 90 Degrees
- No. 065 – FMVSS No. 301 Static Rollover 180 Degrees
- No. 066 – FMVSS No. 301 Static Rollover 270 Degrees
- No. 067 – FMVSS No. 301 Static Rollover 360 Degrees
- No. 068 – Impact Event *(impact side)*
- No. 069 – Monroney Label
- No. 070 – Head Restraint Use and Adjustment Information from Vehicle Owner's Manual
- No. 071 – Post-Test View of Shattered Vehicle Inner Door Panel *(if applicable)*

NOTE: *The numbering convention shown above must be maintained. It is deliberate and intended to keep the photographs in a specific order when sorting photographs electronically. For the QCPackage.zip file, photographs should be labeled with a minimum of the numbering convention shown here. When the FinalDeliverables.zip file is submitted, however, the photographs should also be labeled with the text descriptions provided. Italicized information provided in parentheses is intended for clarity only and is should not be considered part of the text descriptions.*

NOTE: *The test laboratory's name or logo shall not appear in any photographs.*

9. PHOTOGRAPHIC DOCUMENTATION....Continued

Additional photographs which further describe what is visible in Photograph Nos. 1 – 70 should be labeled with the most relevant photograph number followed by a, b, c, etc. Any additional photographs taken for documentation of vehicle anomalies, safety concerns, test details, etc. which do not fit under the photograph descriptions above should be appropriately labeled and shall follow the list of preceding required photographs in numerical order.

Photograph No. 067 shall be additionally formatted to be 222 x 127 pixels in size and be approximately 100 kb in size. This formatted photograph shall be appropriately labeled as “<Model Year><Make & Model><Number of Doors><Body> Pole Impact FOR WEB”, and should be included separately as part of the QCPackage.zip and FinalDeliverables.zip files on the FTP site.

10. DEFINITIONS**DESIGNATED SEATING CAPACITY (DSC)**

The number of designated seating positions provided as found on the tire information placard (required by FMVSS No. 110). This number must be consistent with the number of restraints in the vehicle.

DESIGNATED SEATING POSITION (DSP)

Any plain view location capable of accommodating a person at least as large as a 5th percentile adult female, if the overall seat configuration and design and vehicle design is such that the position is likely to be used as a seating position while the vehicle is in motion, except for auxiliary seating accommodations such as temporary or folding jump seats. Any bench or split-bench seat in a passenger car, truck or multipurpose passenger vehicle with a GVWR less than 10,000 pounds, having greater than 1,270 mm of hip room (measured in accordance with SAE Standard J 1100(a)) shall not have less than three designated seating positions, unless the seat design or vehicle design is such that the center position cannot be used for seating.

DOUBLE SIDE DOORS

A pair of hinged doors with the lock and latch mechanisms located where the door lips overlap.

FOOT

The foot, including the ankle.

LEG

The lower part of the entire leg, including the knee.

THIGH

The femur between, but not including, the knee and pelvis.

HIP POINT

The actual pivot center of the dummy's torso and thigh.

TRANSVERSE INSTRUMENTATION PLATFORM

The surface inside the dummy's skull casting to which the neck load cell mounts. This surface is perpendicular to the skull cap's machined surfaced inferior-superior mounting surface.

10. DEFINITIONS....Continued

MIDSAGITTAL PLANE

The vertical plane that separates the dummy into equal left and right halves.

LONGITUDINAL OR LONGITUDINALLY

Parallel to the vehicle's longitudinal centerline.

VERTICAL LONGITUDINAL PLANE

A vertical plane parallel to the vehicle's longitudinal centerline.

VERTICAL PLANE

A vertical plane, not necessarily parallel to the vehicle's longitudinal centerline.

SEAT CUSHION REFERENCE POINT (SCRCP)

A point placed on the outboard side of the seat cushion at a horizontal distance between 150 mm (5.9 in.) and 250 mm (9.8 in.) from the front edge of the seat, which is used as a guide in positioning the seat.

SEAT CUSHION REFERENCE LINE (SCRL)

A line on the side of the seat cushion, passing through the seat cushion reference point, whose projection in the vehicle vertical longitudinal plane is straight and has a known angle with respect to the horizontal.

UNLOADED VEHICLE WEIGHT (UVW)

The weight of a vehicle with maximum capacity of all fluids necessary for operation of the vehicle, **WITHOUT** cargo or occupants.

11. TEST EXECUTION

11.1 TEST VEHICLE PREPARATION

A. TEST VEHICLE INFORMATION AND OPTIONS

Using the owner's manual, information provided by the COTR, and any other data available, determine the following vehicle information and record it on Data Sheet No. 1:

- (1) NHTSA No. (supplied by COTR)
- (2) Vehicle model year, make, model, and body style
- (3) Body color
- (4) VIN
- (5) Current odometer reading (in km and mi)
- (6) Engine data, to include displacement (CID, liters or cc), type and number of cylinders, and placement (longitudinal or lateral)
- (7) Transmission data, to include type (manual or automatic), number of speeds, and whether the vehicle is equipped with overdrive
- (8) Final drive (rear, front, or four-wheel-drive)
- (9) All major options (indicate "Yes" if the vehicle is equipped with an option and "No" if it is not)

11. TEST EXECUTION....Continued

- (10) All available occupant safety restraints (indicate "Yes" if the vehicle is equipped with a safety restraint and "No" if it is not)
- (11) Instructions to turn off ADLs

B. DATA FROM CERTIFICATION LABEL

Record the following vehicle information from the vehicle's certification label on Data Sheet No. 1:

- (1) Manufacturer
- (2) Build date (or month and year of manufacture)
- (3) Vehicle type
- (4) Gross Vehicle Weight Rating (GVWR)
- (5) Gross Axle Weight Rating (GAWR) for the front and rear of the vehicle

C. TIRE DATA RECORDED FROM FMVSS NO. 110 VEHICLE TIRE PLACARD OR OPTIONAL TIRE INFLATION PRESSURE LABEL

Record the following information in the appropriate tables included in Data Sheet No. 1:

- (1) Designated Seating Capacity (DSC)
- (2) Vehicle Capacity Weight (VCW)
- (3) Rated Cargo and Luggage Weight (RCLW)

NOTE: Account for reduced load capacity if applicable.

D. VEHICLE SEAT TYPE

Record the following information from the manufacturer's submitted Form No. 1 (see sample of Form No. 1 in Section 3 of **APPENDIX C**) data onto Data Sheet No. 1. Visually inspect the seat to verify seat type:

- (1) Type of front seat pan (bucket, bench, or split bench)
- (2) Type of front seat back (fixed or adjustable w/lever or knob)
- (3) Type of rear or second row seat pan (bucket, bench, split bench, or contoured)
- (4) Type of rear or second row seat back (fixed or adjustable w/lever or knob)
- (5) Type of third row seat pan (bucket, bench, split bench, or contoured)
- (6) Type of third row seat back (fixed or adjustable w/lever or knob)

E. DATA RECORDED FROM TIRE PLACARD AND SIDEWALLS

Record the following additional information onto Data Sheet No. 1:

- (1) Recommended cold tire pressure for both the front and rear tires
- (2) Recommended tire size for both the front and rear tires
- (3) Tire Pressure for maximum load carrying capacity (Verify that this pressure exceeds or is equal to the recommended cold tire pressure listed on the vehicle placard.)
- (4) Size of tires (Verify that the tire size(s) meet the manufacturer's specifications as listed on the vehicle placard or optional tire label.)
- (5) Tire manufacturer
- (6) Tire name
- (7) Tire type and width
- (8) Aspect ratio, radial, and wheel diameter
- (9) Load index and speed symbol
- (10) Treadwear, traction grade, and temperature grade
- (11) Tire Material

11. TEST EXECUTION....Continued

F. AS DELIVERED VEHICLE WEIGHT CONDITION

- (1) Fill the transmission with transmission fluid to full capacity.
- (2) Drain the fuel from the fuel tank. Run the engine until all fuel remaining in the fuel delivery system is used and the engine stops. Describe the fuel pump type, details about how it operates, and the location of the fuel filler neck on Data Sheet No. 2.
- (3) Record the usable fuel tank capacity of both standard and optional (if applicable) fuel tanks as supplied by the COTR on Data Sheet No. 2.
- (4) Record the fuel tank capacity of both standard and optional (if applicable) fuel tanks as supplied in the owner's manual on Data Sheet No. 2.
- (5) Calculate 1/3 of the usable capacity of the fuel tank(s) (as supplied on Form 1) and record the calculated value on Data Sheet No. 2. Also calculate 93% of the usable capacity of the fuel tank(s) and record the calculated value on Data Sheet No. 2.
- (6) Using purple dyed Stoddard solvent having the physical and chemical properties of Type 1 solvent or cleaning fluid, Table 1, ASTM Standard D484-71, "Standard Specifications for Hydrocarbon Dry-cleaning Solvents," fill the fuel tank to 100% of the usable capacity as supplied on Form 1. Record the amount of solvent added for the "As Delivered" weight condition on Data Sheet No. 2.

NOTE: *Stoddard solvent shall be free of debris. It is considered debris-free only if, upon filtering with a 10 micron filter, no solid debris is retained on the filter media or in any conduit, container or vessel upstream from the filter paper (e.g. debris is not allowed to be present in the funnel, pump, or container.). The solvent used for NHTSA testing must be designated for NHTSA testing only.*

- (7) Crank the engine to fill the fuel delivery system with Stoddard solvent.
- (8) Fill the coolant system to capacity.
- (9) Fill the engine with motor oil to the maximum mark on the dip stick.
- (10) Fill the brake reservoir with brake fluid to its normal level
- (11) Fill the windshield washer reservoir to capacity.
- (12) Record the As Delivered tire pressure for each tire on Data Sheet No. 1. Inflate the tires to the cold tire pressure indicated on the tire placard. If no tire placard is available, inflate the tires to the recommended pressure in the owner's manual and record the As Tested pressure for each tire on Data Sheet No. 1.
- (13) Weigh the vehicle at each wheel and add the weights together to determine the "As Delivered" (or "Unloaded Vehicle") weight. Record the weight measurements on Data Sheet No. 1.

G. VEHICLE ATTITUDE AND CG MEASUREMENTS – AS DELIVERED WEIGHT CONDITION

- (1) With the vehicle in the "As Delivered" weight condition, place it on a flat, level surface.
- (2) Place the transmission in neutral.
- (3) If the vehicle has an Auto-Leveling System, the ignition must be set to the "on" position. If the vehicle is equipped with a self-adjusting hydraulic system, contact the COTR for further guidance on attitude measurements.
- (4) Exercise the suspension by rolling the vehicle forward and rearward approximately 4 to 6 feet. Repeat this step three to four additional times.
- (5) Pitch Angle Measurement – Mark a reference point on the driver's and front passenger's door sills. Measure and record the rear-to-front (pitch) angle of the door sills at that point on Data Sheet No. 1. Indicate rear-to-front (pitch) angles (or nose up) as positive.

11. TEST EXECUTION....Continued

- (6) Roll Angle Measurement – Mark a reference point at the front and rear of the vehicle along a vertical plane that passes through the longitudinal centerline of the vehicle. Mark reference planes that are perpendicular to the vertical plane that passes through the longitudinal centerline of the vehicle and coincide with the reference points. Measure and record the left-to-right (roll) angles at the front and rear of the vehicle on Data Sheet No. 1. Indicate left-to-front (roll) angles (or left up) as positive.
- (7) Measure and record the vehicle CG aft of the front axle and left(+)/right(-) from the longitudinal centerline on Data Sheet No. 1.

H. CALCULATION OF VEHICLE TARGET TEST WEIGHT

- (1) Calculate the Rated Cargo and Luggage Weight (RCLW) as follows and record on Data Sheet No. 1:

$$\text{RCLW} = \text{VCW} - (68.04 \text{ kg} \times \text{DSC})$$

VCW = the Vehicle Capacity Weight from the vehicle placard also taking into account any reduction in load capacity.

DSC = the designated seated capacity as indicated on the vehicle placard.

FOR TRUCKS, MPV's or BUSES - If the RCLW calculated above is greater than 136 kg, use 136 kg as the RCLW.

- (2) Weigh the fully instrumented SID-IIs test dummy to be used in the test.
- (3) Calculate the Test Vehicle Target Weight by adding the "As Delivered" weight, the RCLW, and the weight of the fully instrumented SID-IIs dummy.

$$\text{TVTW} = \text{As Delivered Weight (UVW)} + \text{RCLW} + \text{SID-IIs weight}$$

Record the TVTW on Data Sheet No. 1.

I. FULLY LOADED VEHICLE WEIGHT CONDITION

- (1) With the vehicle in the "As Delivered" weight condition, load the vehicle with the ballast equal to the RCLW placed in the luggage or load carrying/cargo area. Center the load over the longitudinal centerline of the vehicle.
- (2) Place the weight of the fully instrumented test dummy (with clothes and shoes) into the driver seating position.
- (3) Weigh the vehicle at each wheel and add the weights together to determine the "Fully Loaded" weight. Record the weight measurements on Data Sheet No. 1.

J. VEHICLE ATTITUDE AND CG MEASUREMENTS – FULLY LOADED WEIGHT CONDITION

- (1) With the vehicle in the "Fully Loaded" weight condition, place it on a flat, level surface.
- (2) If the vehicle has an Auto-Leveling System, the ignition must be set to the "on" position. If the vehicle is equipped with a self-adjusting hydraulic system, contact the COTR for further guidance on attitude measurements.
- (3) Pitch Angle Measurement – Measure and record (on Data Sheet No. 1) the rear-to-front (pitch) angle of the door sills using the same reference points on the driver's and front passenger's door sills as were used to determine the pitch angles for the "As Delivered" weight condition. Indicate rear-to-front (pitch) angles (or nose up) as positive.

11. TEST EXECUTION....Continued

- (4) Roll Angle Measurement – Measure and record (on Data Sheet No. 1) the left-to-right (roll) angles at the front and rear of the vehicle using the same reference point and reference planes as were used to determine the roll angles for the “As Delivered” weight condition. Indicate left-to-right (roll) angles (or left up) as positive.
- (5) Measure and record the vehicle CG aft of the front axle and left(+)/right(-) from the longitudinal centerline on Data Sheet No. 1.

K. AS TESTED VEHICLE WEIGHT CONDITION

- (1) With the test vehicle in the “Fully Loaded” weight condition, drain the fuel tank.
- (2) Using purple dyed Stoddard solvent having the physical and chemical properties of Type 1 solvent or cleaning fluid, Table 1, ASTM Standard D484-71, “Standard Specifications for Hydrocarbon Dry-cleaning Solvents.”, fill the tank to 93 % (± 1%) of the usable capacity as supplied on Form 1.
- (3) Drain transmission fluid, engine coolant, motor oil, and windshield washer fluid from the vehicle.
- (4) Remove the ballast (RCLW) from the cargo area.
- (5) Load the vehicle with the necessary onboard test equipment (including all instrumentation boxes, onboard cameras, lighting equipment, etc.) Secure the equipment in the load carrying area and distribute it, as nearly possible, to obtain the proportion of axle weight indicated by the gross axle weight ratings. Center it over the longitudinal centerline of the vehicle.
- (4) Load the 5th female dummy (with umbilical cord) into the driver seating position.
- (5) Calculate the actual test weight range as follows and record on Data Sheet No.1:

$$(\text{Test Vehicle Target Weight} - 4.5 \text{ kg.}) \geq \text{As Tested Weight} \geq (\text{Test Vehicle Target Weight} - 9 \text{ kg.})$$

- (6) Weigh the vehicle at each wheel and add the weights together to determine the “As Tested” weight. Record the weight measurements on Data Sheet No. 1.
- (7) Verify that the “As Tested” weight is within the range specified in (5). If necessary, to achieve an “As Tested” weight that falls within the required weight range, adjust the weight of the test vehicle by either adding ballast or removing vehicle components in accordance with the manufacturer’s data provided by the COTR on Form No. 1. Record the weight of any added ballast on Data Sheet No. 1. Alternatively, on Data Sheet No. 1, list any vehicle components that were removed, and the associated total weight of each removed component. Also, list the removed vehicle components.

NOTE: *If the calculated Test Vehicle Target Weight is exceeded, the Contractor must notify the COTR to discuss the possible removal of additional vehicle components, instrumentation, or Stoddard (not to exceed 2/3 of the useable capacity) to decrease the weight. Under no circumstances shall the “As Tested” weight be greater than the Test Vehicle Target Weight.*

11. TEST EXECUTION....Continued**L. VEHICLE ATTITUDE AND CG MEASUREMENTS – AS TESTED WEIGHT CONDITION**

- (1) With the vehicle in the “As Tested” weight condition, place it on a flat, level surface.
- (2) If the vehicle has an Auto-Leveling System, the ignition must be set to the “on” position. If the vehicle is equipped with a self-adjusting hydraulic system, contact the COTR for further guidance on attitude measurements.
- (3) Pitch Angle Measurement – Measure and record (on Data Sheet No. 1) the rear-to-front (pitch) angle of the door sills using the same reference points on the driver’s and front passenger’s door sills as were used to determine the pitch angles for the “As Delivered” and “Fully Loaded” weight conditions. Indicate rear-to-front (pitch) angles (or nose up) as positive.
- (4) Roll Angle Measurement – Measure and record (on Data Sheet No. 1) the left-to-right (roll) angles at the front and rear of the vehicle using the same reference point and reference planes as were used to determine the roll angles for the “As Delivered” and “Fully Loaded” weight conditions. Indicate left-to-right (roll) angles (or left up) as positive.
- (5) Measure and record the vehicle CG aft of the front axle and left(+)/right(-) from the longitudinal centerline on Data Sheet No. 1.
- (6) Verify that the “As Tested” vehicle attitude measurements are equal to or between the “As Delivered” and “Fully Loaded” vehicle attitude measurements. If any “As Tested” attitude measurements do not meet this requirement, adjust the load by shifting ballast, instrumentation, and/or cameras. Repeat steps (1) through (6) of this section. If, after repeating these steps, any of the “As Tested” attitude measurements do not meet the requirement, contact the COTR. Indicate whether this requirement is met for each of the measurements on Data Sheet No. 1.

NOTE: *The “As Tested” vehicle attitude measurements shall be taken within an hour of impact to ensure the proper attitude is met.*

M. VEHICLE INSTRUMENTATION

Mount accelerometers to the test vehicle at the locations indicated below. (See **Figure 8** as a guide.) Use an attachment method that is considered acceptable by the COTR. It is typically acceptable to use self-tapping screws to affix the accelerometers to a test vehicle except for those required on the A-pillar, B-pillar, and roof. An appropriate adhesive (such as MBond200 glue) can be used to affix all other accelerometers to the test vehicle.

Record the actual number of channels used for the vehicle structure on Data Sheet No. 5. Record the accelerometer coordinates on Data Sheet No. 6. Also record the serial numbers, manufacturer, and calibration date of each accelerometer for incorporation into Appendix D of the Final Report (See **APPENDIX C**, Section 1.9).

- 1 *Vehicle CG* – One triaxial accelerometer mounted to the floorpan at the longitudinal and lateral location of the vehicle CG to measure accelerations in the x, y, and z directions.
- 2 *Left Floor Sill* – Uniaxial accelerometer mounted on the struck side sill forward of the vertical impact reference line, but rearward of the A-pillar to measure acceleration in the y direction.
- 3 *A-Pillar Sill* – Uniaxial accelerometer mounted on the struck side A-pillar at the lower sill level to measure acceleration in the y direction.
- 4 *A-Pillar Low* – Uniaxial accelerometer mounted on the struck side A-pillar approximately 1/3 the distance from the floorpan to the bottom of the front door’s window opening to measure acceleration in the y direction.

11. TEST EXECUTION....Continued

- 5 *A-Pillar Mid* – Uniaxial accelerometer mounted on the struck side A-pillar approximately 2/3 the distance from the floorpan to the bottom of the front door's window opening to measure acceleration in the y direction.

NOTE: Do not install if disassembly of the dash is required for installation.

- 6 *B-Pillar Sill* – Uniaxial accelerometer mounted on the struck side B-pillar at the lower sill level to measure acceleration in the y direction.
- 7 *B-Pillar Low* – Uniaxial accelerometer mounted on the struck side B-pillar approximately 1/3 the distance from the floorpan to the bottom of the front door's window opening to measure acceleration in the y direction.
- 8 *B-Pillar Mid* – Uniaxial accelerometer mounted on the struck side B-pillar approximately 2/3 the distance from the floorpan to the bottom of the front door's window opening to measure acceleration in the y direction.
- 9 *Driver Seat Track at Dummy Hip Point* – Uniaxial accelerometer mounted on the floorpan at the seat track in a vertical longitudinal plane that intersects the dummy's hip pivot bolt center (± 20 mm) to measure acceleration in the y direction.
- 10 *Engine Top* – Biaxial accelerometer mounted on the top of the engine to measure accelerations in the x and y directions.
- 11 *Firewall* – Uniaxial accelerometer mounted near the center of the firewall to measure acceleration in the y direction.
- 12 *Right Roof* – Uniaxial accelerometer mounted on the non-struck side roof rail at the B-pillar to measure acceleration in the y-direction.
- 13 *Right Floor Sill* – Uniaxial accelerometer mounted on the non-struck side floor sill opposite location (2).
- 14 *Rear Floorpan* – Biaxial accelerometer mounted on the rear floorpan behind the rear axle as close as possible to the longitudinal centerline of the vehicle to measure accelerations in the x and y directions.

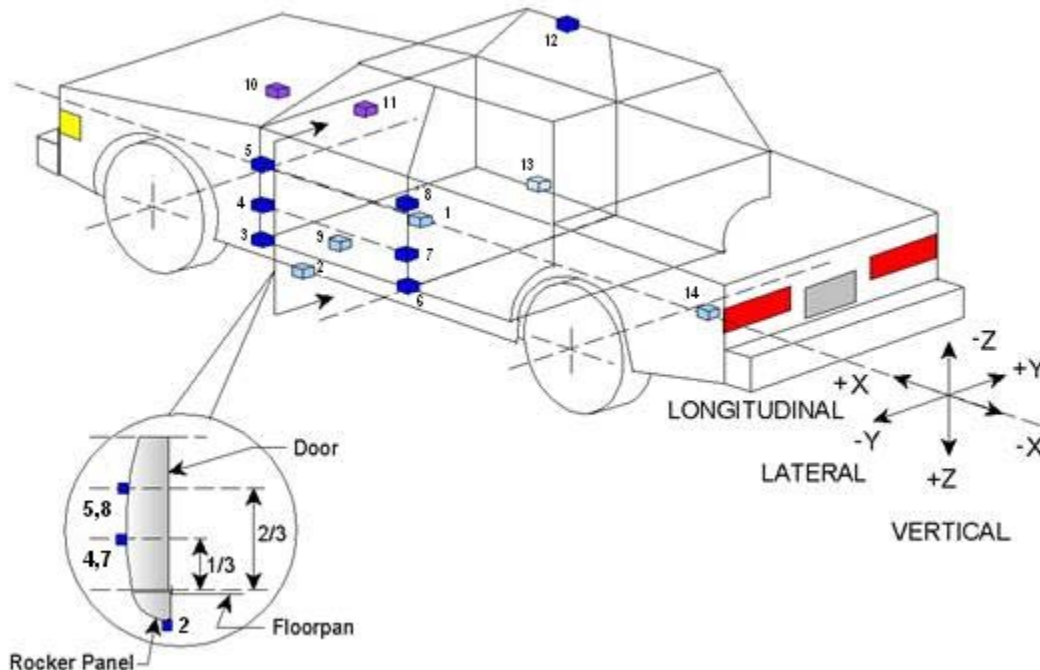

Figure 8 – Vehicle Accelerometer Locations

11. TEST EXECUTION....Continued

N. POLE LOAD CELLS

Record the actual number of channels used for the pole load cells on Data Sheet No. 5. Record the height of the pole load cells (1 through 8) from the ground to the center of each load cell on Data Sheet No. 7 (See **Figure 9** as a guide). Also record the serial numbers, manufacturer, and calibration date of each load cell for incorporation into Appendix D of the Final Report (See **APPENDIX C**, Section 1.9).

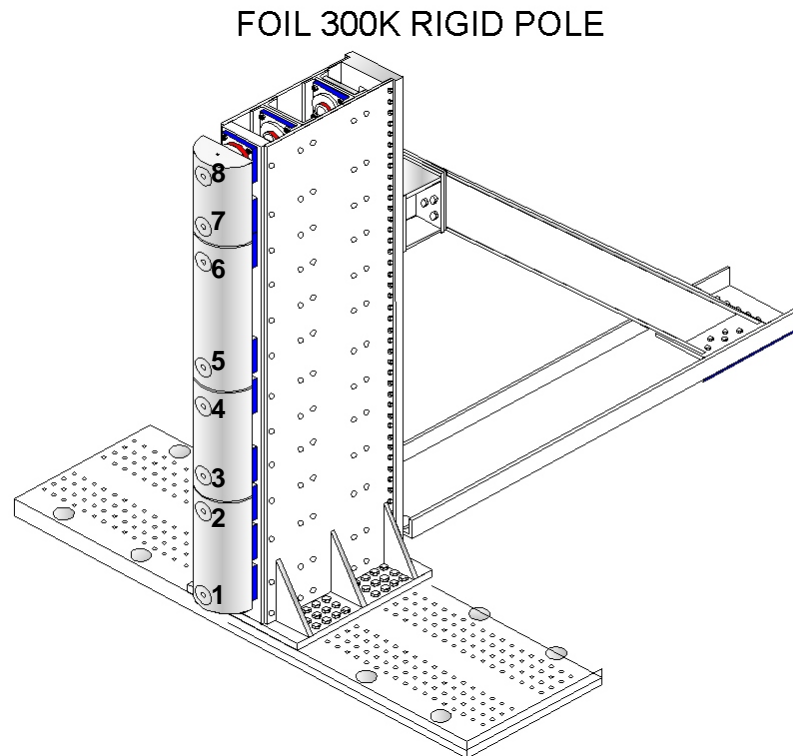

Figure 9 – Pole Load Cell Locations

O. SIDE AIR BAGS

All side air bags on the non-struck side of the vehicle shall be disabled by the vehicle manufacturer prior to the test.

P. ADJUSTABLE SUPPORTS

Position the seat's adjustable lumbar supports so that they are in the lowest, retracted or deflated adjustment positions. Position any adjustable parts of the seat that provide additional support so that they are in the lowest or most open adjustment position. Place any adjustable leg support system in its rearmost position.

11. TEST EXECUTION....Continued

Q. ADJUSTABLE HEAD RESTRAINTS

Use any adjustment of the head restraint to position it at its lowest and most full forward in-use position. If it is possible to achieve a position lower than the effective detent range, the head restraint shall be set to its lowest possible position. Only positions intended for occupant use as defined by FMVSS No. 202a shall be considered. Any non-use position is excluded from being considered as the lowest possible position. This information should also be included in the manufacturer-supplied data found in Form 1. If the head restraint rotates, rotate it such that the head restraint extends as far forward as possible. Mark the head restraint at its fully retracted and fully full forward positions to demonstrate range of motion. Measure the lowest position of the bottom edge of the head restraint from a fixed point on the seat back along a vertical plane perpendicular to the longitudinal centerline of the test vehicle. Mark the point on the seat back where the measurement was taken for future reference. Note the position of the driver's head restraint on Data Sheet No. 2.

R. VEHICLE SEAT CENTERLINES

If adjustable, place the seat back in its most vertical (upright) position. For bucket seats, draw a line along the intersection of a vertical longitudinal plane that passes through the SgRP and the seat cushion upper surface, seat back, and head restraint. For bench seats, draw a line along the intersection of a vertical longitudinal plane that passes through the centerline of the steering wheel and the seat cushion upper surface, seat back, and head restraint. Seat centerlines should be visible in video footage from Camera No. 5 and Camera No. 11.

S. SEAT ADJUSTMENT REFERENCE MARKS

NOTE: *Before marking, move each seat through its full range of motion using all available controls. Separately, operate each control to determine whether it moves the seat and/or seat cushion primarily in the fore-aft or up-down directions. Draw arrows on these controls to demonstrate how each one operates.*

Driver, Front Center, and Front Passenger Seats

Prior to placing the dummy in the driver position, mark for reference the seat adjustment as follows:

- (1) With the seat's adjustable lumbar supports in the lowest, retracted or deflated adjustment positions, and any adjustable parts of the seat that provide additional support in the lowest or most open adjustment position, **mark** a point (seat cushion reference point - **SCRCP**) on the side of the seat cushion that is between 150 mm and 250 mm from the front outermost edge of the seat cushion. For seat cushions that move up and down independently from the seat housing, **mark** the point on the side of the cushion in an area that will not be obscured by the seat housing when the seat cushion is at its lowest height position.
- (2) Draw a horizontal line (seat cushion reference line - **SCRL**) through the **SCRCP**.
- (3) Using only the controls that primarily move the seat in the fore-aft direction, move the **SCRCP** to the rearmost position.
- (4) If the seat cushion adjusts fore-aft, independent of the seat back, use only the controls that primarily move the seat cushion in the fore-aft direction to move the **SCRCP** to the rearmost position.
- (5) Using any part of any control, other than the parts just used for fore-aft positioning, determine and record the range of angles of the **SCRL** and set the

11. TEST EXECUTION....Continued

- SCRL** at the mid-angle. Record the maximum, minimum, and mid-angles on Data Sheet No. 2.
- (6) If the seat and/or seat cushion height is adjustable, use any part of any control other than those which primarily move the seat or seat cushion fore-aft, to put the **SCR**P in its lowest position with the **SCRL** line angle at the mid-angle found in step (5).
 - (7) Using only the controls that primarily move the seat in the fore-aft direction, verify the seat is in the rearmost position.
 - (8) Using only the controls that primarily move the seat in the fore-aft direction, **mark** for future reference the fore-aft seat positions. **Mark** each position so that there is a visual indication when the seat is at a particular position. For manual seats, move the seat forward one detent at a time and **mark** each detent. For power seats (no detents), move the seat forward 10 mm at a time and mark each increment. Then label the rearmost, middle, and foremost positions as: F for foremost, M for mid-position (if there is no mid-position, label the closest adjustment position to the rear of the mid-point), and R for rearmost. Record the total fore-aft seat movement in millimeters and detents, if applicable, on Data Sheet No. 2.
 - (9) Use only the controls that primarily move the **SCR**P to the fore-aft direction to place the seat in the rearmost position.
 - (10) Using any part of any control, other than the parts which primarily move the seat or seat cushion fore-aft, find and visually mark for future reference the maximum, minimum, and middle heights of the **SCR**P with the **SCRL** at the mid-angle determined in step (5) by measuring from the **SCR**P to a reference point on the floor pan or sill. Record the maximum, minimum, and middle heights on Data Sheet No. 2.
 - (11) Using only the controls that primarily move the seat and/or seat cushion in the fore-aft direction, place the **SCR**P at the mid-fore-aft position.
 - (12) Using any part of any control, other than the parts which primarily move the seat or seat cushion fore-aft, find and visually **mark** for future reference the maximum, minimum, and middle heights of the **SCR**P with the **SCRL** at the mid-angle determined in step (5) by measuring from the **SCR**P to a reference point on the floor pan or sill. Record the maximum, minimum, and middle heights on Data Sheet No. 2.
 - (13) Using only the controls that primarily move the seat in the fore-aft direction, place the **SCR**P in the foremost position.
 - (14) Using any part of any control, other than the parts which primarily move the seat or seat cushion fore-aft, find and visually mark for future reference the maximum, minimum, and middle height of the **SCR**P with the **SCRL** at the mid-angle determined in step (5) by measuring from the **SCR**P to a reference point on the floor pan or sill. Record the maximum, minimum, and middle heights on Data Sheet No. 2.
 - (15) For adjustable seat backs, position the seat back at the foremost stop. **Mark** each position of adjustment from the foremost to rearmost stops so that there is a visual indication when the seat back is at a particular position. For manually adjustable seat backs (with detents), move the seat back rearward one detent at a time and **mark** each detent. Label the rearmost, middle, and foremost positions with the measured detent. If no middle detent exists, label the next most-rearward detent to the middle position. For power seat backs (no detents), move the seat back rearward one degree at a time and **mark** each angle. Angles should be measured at the location on the seat (head restraint, seat back, plastic trim, etc.) as indicated by the manufacturer on Form No. 1 (see sample of Form No. 1 in Section 3 of **APPENDIX C**). Label the rearmost, middle, and foremost positions with the measured angle. Record the range of angles in degrees and detents on Data Sheet No. 2. Visually **mark** and label for future reference the front seat back angle, if adjustable, as provided by the

11. TEST EXECUTION....Continued

manufacturer on Form No. 1 for the 5th percentile female dummy in a Side NCAP pole test.

Repeat steps (1) through (15) of this section to determine the reference marks for the front outboard passenger seat as well unless the front outboard passenger seat **does not** adjust independently of the driver's seat. Also, repeat (1) through (15) of this section to determine the reference marks for the front center seat if the front center seat adjusts independently of the front passenger seat.

NOTE: *If the front outboard passenger seat **does not** adjust independently of the driver's seat, the driver's seat shall control the final position of the passenger seat and there is no need to repeat steps (1) through (15) of this section for the front outboard passenger seat. If the front center seat does not adjust independently of the front passenger's seat, the front passenger's seat shall control the final position of the front center seat and there is no need to repeat (1) through (15) of this section for the front center seat.*

Rear Center and Rear Outboard Passenger Seats

The position of the rear center and rear outboard passenger seats will be dictated by the information provided by the manufacturer on Form No. 1 (see sample of Form No. 1 in Section 3 of **APPENDIX C**) for the 5th percentile female dummy in the rear seat of the Side NCAP MDB test. Mark for reference the seat adjustment for second and third row rear seats on the struck side of the vehicle as follows:

- (1) With the seat's adjustable lumbar supports in the lowest, retracted or deflated adjustment positions, and any adjustable parts of the seat that provide additional support in the lowest or most open adjustment position, **mark** a point (seat cushion reference point - **SCR**P) on the side of the seat cushion that is between 150 mm and 250 mm from the front outermost edge of the seat cushion. For seat cushions that move up and down independently from the seat housing, **mark** the point on the side of the cushion in an area that will not be obscured by the seat housing when the seat cushion is at its lowest height position.
- (2) Draw a horizontal line (seat cushion reference line - **SCR**L) through the seat **SCR**P.
- (3) If possible, using only the controls that primarily move the seat in the fore-aft direction, move the **SCR**P to the rearmost position.
- (4) If the seat cushion adjusts fore-aft, independent of the seat back, use only the controls that primarily move the seat cushion in the fore-aft direction to move the **SCR**P to the rearmost position.
- (5) Using any part of any control, other than the parts just used for fore-aft positioning, determine and record the range of angles of the **SCR**L and set the **SCR**L at the mid-angle. Record the maximum, minimum, and mid-angles on Data Sheet No. 2.
- (6) If the seat and/or seat cushion height is adjustable, use any part of any control other than those which primarily move the seat or seat cushion fore-aft, to put the **SCR**P in its lowest position with the **SCR**L line angle at the mid-angle found in step (5).
- (7) Using only the controls that primarily move the seat in the fore-aft direction, verify the seat is in the rearmost position.

11. TEST EXECUTION....Continued

- (8) Using only the controls that primarily move the seat in the fore-aft direction, **mark** for future reference the fore-aft seat positions. **Mark** each position so that there is a visual indication when the seat is at a particular position. For manual seats, move the seat forward one detent at a time and **mark** each detent. For power seats (no detents), move the seat forward 10 mm at a time and mark each increment. Then label the rearmost, middle, and foremost positions as: F for foremost, M for mid-position (if there is no mid-position, label the closest adjustment position to the rear of the mid-point), and R for rearmost. Record the total fore-aft seat movement in millimeters and detents, if applicable, on Data Sheet No. 2.
- (9) Use only the controls that primarily move the **SCRIP** to the fore-aft direction to place the seat in the rearmost position.
- (10) Using any part of any control, other than the parts which primarily move the seat or seat cushion fore-aft, find and visually mark for future reference the maximum, minimum, and middle height of the **SCRIP** with the **SCRL** at the mid-angle determined in step (5) by measuring from the **SCRIP** to a reference point on the floor pan or sill. Record the maximum, minimum, and middle heights on Data Sheet No. 2.
- (11) For adjustable seat backs, position the seat back at the foremost stop. **Mark** each position of adjustment from the foremost to rearmost stops so that there is a visual indication when the seat back is at a particular position. For manually adjustable seat backs (with detents), move the seat back rearward one detent at a time and **mark** each detent. Label the rearmost, middle, and foremost positions with the measured detent. If no middle detent exists, label the next most-rearward detent to the middle position. For power seat backs (no detents), move the seat back rearward one degree at a time and **mark** each angle. Angles should be measured at the location on the seat (head restraint, seat back, plastic trim, etc.) as indicated by the manufacturer on Form No. 1 (see sample of Form No. 1 in Section 3 of **APPENDIX C**). Label the rearmost, middle, and foremost positions with the measured angle. Record the range of angles in degrees and detents on Data Sheet No. 2. Visually **mark** and label for future reference the rear seat back angle, if adjustable, as provided by the manufacturer on Form No. 1 for the 5th percentile female dummy in a Side NCAP MDB test.

Repeat steps (1) through (11) of this section to determine the reference marks for the non-struck side rear outboard passenger seat as well unless the rear outboard non-struck side passenger seat **does not** adjust independently of the struck side rear passenger seat. Also, repeat steps (1) through (11) of this section to determine the reference marks for the rear center seat if the rear center seat adjusts independently of the rear outboard non-struck side passenger seat.

NOTE: *If the rear passenger seat on the non-struck side of the vehicle **does not** adjust independently of the struck side rear passenger seat, the struck side rear passenger seat shall control the final position of the rear non-struck side passenger seat and there is no need to repeat steps (1) through (11) of this section for the rear passenger seat on the non-struck side. If the rear center seat does not adjust independently of the rear non-struck side passenger's seat, the rear non-struck side passenger's seat shall control the final position of the rear center seat and there is no need to repeat steps (1) through (11) of this section for the rear center seat.*

11. TEST EXECUTION....Continued

T. SETTING THE SEATS

Driver, Front Center, and Front Passenger Seats

Using the reference marks determined in Section 11.1,S, Driver, Front Center, and Front Passenger Seats, set the driver, front center (if applicable), and front passenger seats accordingly:

- (1) Using only the controls that primarily move the seat and seat cushion independent of the seat back in the fore and aft directions, move the **SCR**P to the rearmost position. Using any part of any control, other than those just used, determine the full range of angles of the **SCRL** and set the **SCRL** to the middle of the range. Using any part of any control other than those that primarily move the seat or seat cushion fore and aft, while maintaining the **SCRL**, place the **SCR**P to its lowest position.
- (2) Using only the control that primarily moves the seat fore and aft, move the **SCR**P to the most forward position.
- (3) If the seat or seat cushion height is adjustable, other than by the controls that primarily move the seat or seat cushion fore and aft, set the **SCR**P to the midpoint height, to the extent the **SCRL** mid-angle determined in Section 11.1,S(5), Driver, Center, and Front Passenger Seats, can be maintained. **Mark** this position for future reference. It is the pre-determined test position. Record the "As-Tested" **SCRL** angle and **SCR**P height on Data Sheet No. 2. Also, record the test detent and/or fore-aft position of the seat at the test position on Data Sheet No. 2.

NOTE: *If the front outboard passenger seat **does not** adjust independently of the driver's seat, the driver's seat shall control the final position of the front passenger's seat. If the non-struck-side passenger's seat **does** adjust independently of the driver's seat, repeat steps 1 and 2 of this section to set the non-struck-side seat. If the front center seat **does not** adjust independently of the front passenger's seat, the front passenger's seat shall control the final position of the front center seat. The seat back angle for the driver's seat shall control the seat back angle for the front passenger seat. If the front center seat **does** adjust independently of the front passenger's seat, repeat steps 1 and 2 of this section to set the front center seat. The seat back angle for the driver's seat shall control the seat back angle for the front center seat.*

Rear Center and Rear Outboard Passenger Seats

Using the reference marks determined in Section 11.1,S, Rear Center and Rear Outboard Passenger Seats, set the second and third row rear center and rear outboard seats accordingly:

- (1) Using only the control that primarily moves the seat fore and aft, move the **SCR**P to the full rearward position.
- (2) If the seat or seat cushion height is adjustable, other than by the controls that primarily move the seat or seat cushion fore and aft, set the height of the **SCR**P to the minimum height, with the **SCRL** set as closely as possible to the mid-angle determined in Section 11.1,S(5), Rear Center and Rear Outboard Passenger Seats, can be maintained. Record the "As-Tested" **SCRL** angle and **SCR**P height on Data Sheet No. 2. Also, record the total fore/aft travel and test detent and/or fore/aft position of the seat at the test position on Data Sheet No. 2.

11. TEST EXECUTION....Continued

- (3) If adjustable, set the seat back angle in accordance with the rear seat back angle provided by the manufacturer on Form No. 1 (see sample of Form No. 1 in Section 3 of **APPENDIX C**) for the 5th percentile female dummy in a Side NCAP MDB test. Record the seat back angle in degrees and detents, if applicable, for the test configuration on Data Sheet No. 2.

NOTE: *If the rear passenger seat on the non-struck side **does not** adjust independently of the struck side rear passenger seat, the struck side rear passenger seat shall control the final position of the non-struck side rear passenger seat. If the non-struck-side seat **does** adjust independently of the struck side seat, repeat steps 1 and 2 of this section to set the non-struck-side seat. If the rear center seat **does not** adjust independently of the rear passenger's seat on the non-struck side, the rear passenger's seat on the non-struck side shall control the final position of the rear center seat. The seat back angle for the struck side rear passenger's seat shall control the seat back angle for the non-struck side rear passenger seat. If the rear center seat **does** adjust independently of the non-struck side rear passenger's seat, repeat steps 1 and 2 of this section to set the rear center seat. The seat back angle for the struck side rear passenger's seat shall control the seat back angle for the rear center seat.*

U. STEERING WHEEL ADJUSTMENT

If the steering wheel is adjustable up and down and/or in and out complete the following steps to set the final steering wheel location:

- (1) Determine each up and down position. **Mark** and label three of the positions with the following: H for highest, M for mid-position (if there is no mid-position, label the next lowest adjustment position), and L for lowest. Record the tilt angle of each position on Data Sheet No. 2.
- (2) Determine each in and out position. **Mark** and label three of the positions with the following: F for foremost, M for mid-position (if there is no mid-position, label the next rearmost adjustment position), and R for rearmost. Record the fore/aft measurement of each position on Data Sheet No. 2.
- (3) Place the steering wheel in the mid up/down and mid in/out position. If no up-and-down mid-position exists, place the steering wheel in the next lowest adjustment position to the mid-position. If no in-and-out mid-position exists, place the steering wheel in the next rearmost adjustment position to the mid position. Record the fore/aft measurement and tilt angle of the test position on Data Sheet No. 2.

V. ADJUSTABLE SEAT BELT ANCHORAGES

Place adjustable seat belt anchorages in the nominal adjustment position in accordance with the manufacturer's data on Form No. 1 for a 5th percentile female adult occupant. **Mark** and label each position with the following: H for highest, M"X" for mid-positions (where "X" stands for 1, 2, 3, etc. and 1 is used for the highest mid-position), and L for lowest. Note the position of the seat belt anchorages on Data Sheet No. 2.

W. SEAT BELT GUIDES

Usage of seat belt guides should be in accords with instructions included in the vehicle owner's manual or in Form No. 1 (see sample of Form No. 1 in Section 3 of **APPENDIX C**).

11. TEST EXECUTION....Continued

X. *ADJUSTABLE ARMRESTS AND CONSOLES*

Place any adjustable armrest and/or console in the retracted position.

Y. *ACCELERATOR PEDAL*

If the vehicle has an adjustable accelerator pedal, adjust it to the full forward position.

Z. *DOORS*

Place all doors (including a hatchback or tailgate) in the fully closed and latched position. Check instrument panel telltales just prior to the test to ensure that all doors and hatches are closed. If the test vehicle comes equipped with standard Automatic Door Locks (ADLs) and the vehicle owner's manual does not provide instructions on how to disable this feature (and only the dealer can deactivate the door locks), the struck-side doors shall be locked pre-test. If the vehicle owner's manual provides instructions on how to disable this feature, the struck-side doors should NOT be locked pre-test. If the test vehicle is not equipped with ADLs or if ADLs are considered optional equipment, the struck-side doors should NOT be locked pre-test. In all instances, non-struck-side doors should be unlocked pre-test.

AA. *TRANSMISSION ENGAGEMENT*

Manual Transmission – Place manual transmissions in 2nd gear.

Automatic Transmission – Place automatic transmissions in neutral.

AB. *PARKING BRAKE ENGAGEMENT*

Engage the parking brake.

AC. *IGNITION SWITCH*

The key shall be in the ignition and switched to the “**ON**” position. If the ignition switch operates without entry of a key, assure the ignition is in the “power on” position.

AD. *WINDOWS*

Place any movable windows and vents located on the struck side of the vehicle in the fully closed position.

AE. *SUNROOF*

Place sunroof(s) in the fully closed position.

AF. *CONVERTIBLE TOPS*

Place convertible tops in the closed passenger compartment configuration (i.e. top-up).

AG *FLOOR MATS*

If the vehicle was received with floor mats, place them in their proper locations prior to testing.

11. TEST EXECUTION....Continued**11.2 DUMMY PREPARATION, POSITIONING, AND PLACEMENT**

Place a properly clothed and calibrated 5th percentile female (in accordance with **APPENDIX A**) in the driver's seat in accordance with **APPENDIX B** – Positioning Dummies in the Test Vehicle.

PLACE TEST DUMMIES IN THE TEST VEHICLE ON THE DAY OF THE TEST. DO NOT PLACE THE DUMMIES IN THE VEHICLE THE DAY BEFORE THE TESTING FOR OVERNIGHT STORAGE. TEST DUMMIES SHALL REMAIN IN THE TEST VEHICLE FOR A TIME NOT TO EXCEED TWELVE (12) HOURS.

Ensure that all cables from the dummy are routed in accords with Section 7.0 of the *Procedures for Assembly, Disassembly, and Inspection of the SID-IIsD Side Impact Crash Test Dummy, September 2006* (PADI) document and all required strain relief is used. Cables from the upper and lower torso should be combined as shown in PADI Figure 190. This combined cable bundle should be routed exterior to the dummy from the dummy's pelvis. The laboratory should take precaution to ensure that this cable bundle is routed over the front seat armrest/console such that it allows sufficient slack and does not preclude or restrict dummy movement during impact. Duct tape may be used to secure the cable bundle to the front seat armrest/console to prevent cable damage, and to permanently set the necessary amount of slack.

Once the dummy is properly positioned, and the seat belt has been fastened over the dummy's chest, align a 150 mm (6-inch) segment of yellow/red checkerboard tape with the outboard edge of the shoulder belt portion of the seat belt such that it will be visible in Camera View No. 11. Place a second 150 mm (6-inch) segment of yellow/red checkerboard tape on the dummy's chest such that it is aligned with the first segment that was placed along the outboard edge of the shoulder belt. Do not allow tape segments to overlap the each other. The two checkerboard tape segments should be cut and positioned such that the colors for each square-inch section alternate on either side of the edge of the shoulder belt. Alternatively, align a 150 mm (6-inch) segment of yellow/red checkerboard tape near the buckle of the shoulder belt portion of the seat belt such that is will be visible in Camera View No. 6. Place a second 150 mm (6-inch) segment of yellow/red checkerboard tape on the dummy's torso such that it is aligned with the first segment that was placed along the shoulder belt near the buckle.

Document the final positions of the dummy after it is seated in the test vehicle by taking the following measurements shown in **Figure 10** and **Figure 11** (accurate to ± 3 mm). Record measurements on Data Sheet No. 3 and Data Sheet No. 4, respectively. (See Section 2 of **APPENDIX C**.)

NOTE: *When a level is to be used, it is to ensure that the line containing the two points described is either parallel or perpendicular to the ground. If a measurement to be made is less than 250 mm, ignore the directions to use a level and approximate a level measurement. Also, when a measurement is to be taken to or from the center of a bolt on the dummy, take the measurement from the center of the bolt hole if the bolt is recessed.*

* **Measurement** used in Data Tape Reference Guide

11. TEST EXECUTION....Continued

A. DUMMY LONGITUDINAL CLEARANCE DIMENSIONS

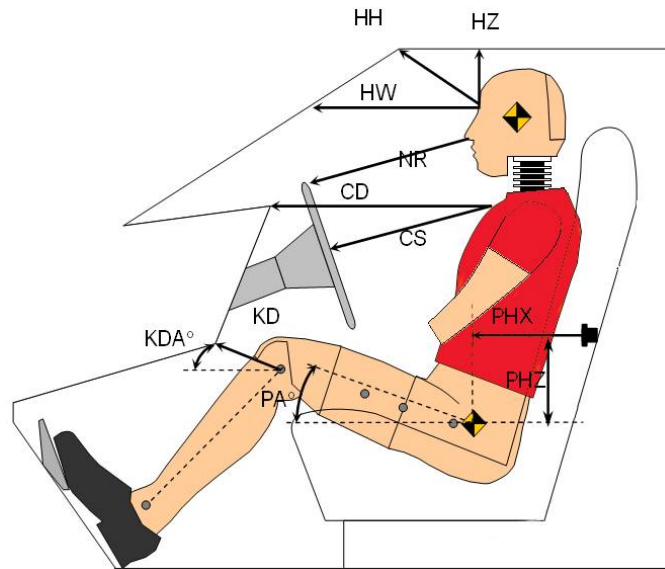

Figure 10 – Dummy Longitudinal Clearance Dimensions

- *HH HEAD TO HEADER – Measure the distance from the point where the dummy's nose meets his forehead (between the eyes) to the furthest point forward on the header.
- *HW HEAD TO WINDSHIELD – Measure the distance from the point where the dummy's nose meets his forehead (between the eyes) to a point on the windshield directly in front of it. Use a level or plumb-bob.
- HZ HEAD TO ROOF LINER – Measure the distance from the point where the dummy's nose meets his forehead (between the eyes) to the point on the roof directly above it. Use a level or plumb-bob.
- NR NOSE TO RIM – Measure the distance from the tip of the dummy's nose to the closest point on the top of the steering wheel rim.
- *CD CHEST TO DASHBOARD – Place a tape measure on the tip of the dummy's chin and rotate 125 mm of it downward toward the dummy to the point of contact on the transverse center of the dummy's chest. Mark this point with a 25 mm (1 inch) diameter target. Measure the distance from this point to the closest point on the dashboard either between the upper part of the steering wheel between the hub and the rim, or measure to the dashboard placing the tape measure above the rim, whichever is a shorter measurement.
- *CS CHEST TO STEERING WHEEL – Measure the distance from the center of the steering wheel hub to the dummy's chest. Use a level. Mark this location on the dummy's chest with a 25 mm (1 inch) diameter target.
- KDL/KDR LEFT AND RIGHT KNEES TO DASHBOARD – Measure the distance from the center of the knee pivot bolt's outer surface to the closest point forward acquired by swinging the tape measure in continually larger arcs until it contacts the dashboard.

11. TEST EXECUTION....Continued

KDAL/KDAR KNEE TO DASHBOARD ANGLE – Using the line representing the length measurement of the knee to the dashboard above, measure the angle between that line and the horizontal.

PAX PELVIC TILT ANGLE (X) – Measure by inserting the pelvic angle gauge into the Hip Point gauging hole (actual pivot center of the dummy's torso and thighs) on the dummy and taking this angle with respect to the horizontal. Alternatively, record the pelvic tilt angle X measured by tilt sensors installed in the test dummy.

PAY PELVIC TILT ANGLE (Y) – Measure by inserting the pelvic angle gauge into the Hip Point gauging hole (actual pivot center of the dummy's torso and thighs) on the dummy and taking this angle with respect to the vertical. Alternatively, record the pelvic tilt angle Y measured by tilt sensors installed in the test dummy.

PHX HIP POINT TO STRIKER (X) – Locate a point on the front door striker and project this point (with a level) vertically downward. Measure the distance horizontally from the pivot center of the dummy's torso and thigh to the point it intersects with the level.

PHZ HIP POINT TO STRIKER (Z) – Locate a point on the front door striker and project this point (preferably, with a level) horizontally toward the pivot center of the dummy's torso and thigh. Measure the distance vertically from the pivot center of the dummy's torso and thigh to the point it intersects with the level.

NOTE: *The B-pillar striker will be used as the reference point for PHX & PHZ measurements.*

B. DUMMY LATERAL CLEARANCE DIMENSIONS

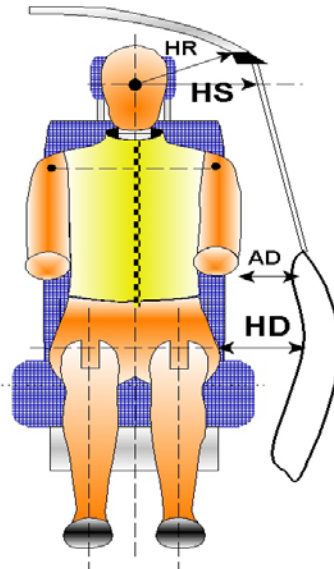

Figure 11 – Dummy Lateral Clearance Dimensions

***HR HEAD TO SIDE HEADER** – Measure the shortest distance from the point where the dummy's nose meets his forehead (between the eyes) to the side edge of the header just *above* the window frame, directly adjacent to the dummy.

***HS HEAD TO SIDE WINDOW** – Measure the distance horizontally from the point where the dummy's nose meets his forehead (between the eyes) to the outside of the side window. In order to take this measurement, roll the window down to the exact height that allows a level measurement. Use a level.

11. TEST EXECUTION....Continued

- *AD ARM TO DOOR – Measure the distance from the center of the bottom of the outboard arm segment where it meets the driver or passenger dummy’s torso to the closest point on the door.
- *HD HIP POINT TO DOOR – Project a point horizontally from the pivot center of the dummy’s torso and thigh, outward to the edge of the pelvis plug. Measure the distance horizontally from this point to the closest point on the door panel. Use a level.

11.3 VEHICLE MEASUREMENTS

A. VEHICLE PROFILE MEASUREMENTS (IMPACT SIDE ONLY)

Using **Figure 12** as a guide, take the following measurements listed below prior to impact with the vehicle in the “As Tested” condition resting on a level surface and post-test, at the same points, with the vehicle’s tires inflated and resting on a level surface. Compute the difference between the pre-test and post-test measurements and record all measurements on Data Sheet No. 9.

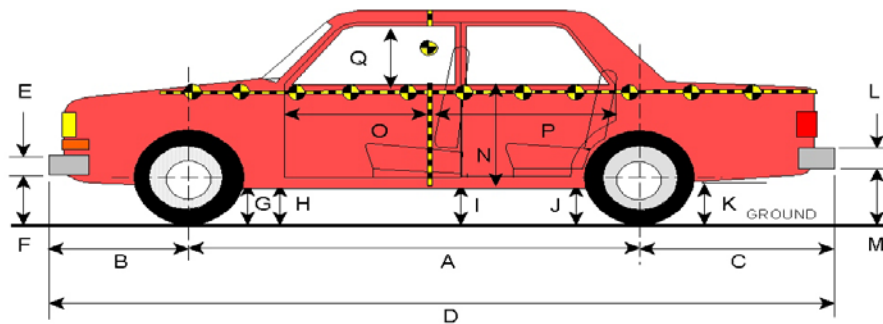

Figure 12 – Vehicle Profile Measurements (Impact Side)

- A *Wheelbase* – Front axle centerline to rear axle centerline
- B *Front Axle to FSOV* – The longitudinal distance between the front axle centerline and the most forward surface of the vehicle
- C *Rear Axle to RSOV* – The longitudinal distance between the rear axle centerline and the most rearward surface of the vehicle
- D *Total Length at Centerline* – Overall length of the vehicle measured at its longitudinal centerline
- E *Front Bumper Thickness* – The vertical height of the front bumper fascia
- F *Front Bumper Bottom to Ground* – Vertical distance from ground to the bottom of the front bumper fascia
- G *Sill Height at Front Wheel Well* – Vertical distance from ground to the sill at the front wheel well opening
- H *Sill Height at Front Door Leading Edge* – Vertical distance from ground to the sill at the front door seam
- I *Sill Height at B-Pillar* – Vertical distance from ground to the sill in line with the front door striker or B-pillar if no striker exists
- J1 *Sill Height at Rear Wheel Well* – Vertical distance from ground to the sill at the rear wheel well opening
- J2 *Pinch Weld Height at Rear Wheel Well* – Vertical distance from ground to the pinch weld at the rear wheel well opening

11. TEST EXECUTION....Continued

K	<i>Sill Height Aft of Rear Wheel Well</i> – Vertical distance from ground to the vehicle sheet body at the rear of the rear tire’s wheel well
L	<i>Rear Bumper Thickness</i> – Vertical height of the rear bumper fascia
M	<i>Rear Bumper Bottom to Ground</i> – Vertical distance from the ground to the rear bumper
N	<i>Sill Height to Bottom of Front Window Sill</i> – Vertical distance from the bottom of door to the bottom of the front windowsill
O	<i>Front Door Leading Edge to Impact CL</i> – Longitudinal distance from the vertical impact reference line to the front door seam
P	<i>Rear Door Trailing Edge to Impact CL</i> – Longitudinal distance from the vertical impact reference line to the rear door seam
Q	<i>Front Window Opening</i> – Vertical distance that measures the front window opening on the impact side
R	<i>Right Side Length</i> – Longitudinal distance of the right side of the vehicle measured along a plane parallel to its longitudinal centerline
S	<i>Left Side Length</i> – Longitudinal distance of the left side of the vehicle measured along a plane parallel to its longitudinal centerline
T	<i>Maximum Vehicle Width</i> – Width of the vehicle measured laterally across the vehicle at the location of maximum width

B. VEHICLE EXTERIOR CRUSH MEASUREMENTS

- (1) Pre-test, with the vehicle resting on a flat level surface in the “As Tested” configuration, establish a fixed reference plane that is parallel to the vehicle’s longitudinal centerline.
- (2) Measure from the fixed reference plane to the exterior vehicle body across the entire length of the impact side at all five levels (as determined in Section 9.4,B). See **Figure 13**. Take measurements at 150 mm intervals forward and rearward of the vertical impact reference line and record all measurements on Data Sheet No. 10. Mark the location where each measurement is taken for future reference.
- (3) Post-test, place the test vehicle on a flat, level surface. Inflate the test vehicle’s tires to the maximum cold pressure.
- (4) Using the same reference locations established in step (2) above, begin taking static crush measurements at the first 150 mm interval forward of the forward-most point of the induced body damage and end at the first 150 mm interval past the rearward-most point of induced body damage. See **Figure 13**. Record all measurements on Data Sheet No. 10.
- (5) Compute the difference between the pre-test and post-test measurements (static crush) at each interval and record all calculations on Data Sheet No. 10.
- (6) For each level, 1 through 5, (on Data Sheet No. 10) record the vertical height above ground. Compute the maximum static crush at each level. Record the maximum static crush and the distance from the impact line (i.e., a vertical line that intersects the actual impact point) on Data Sheet No. 10.
- (7) For each level, 1 through 5, plot the distance from impact in 150 mm intervals (X-axis) versus the static crush measurement (Y-axis), and include the plot on Data Sheet No. 10.

11. TEST EXECUTION....Continued

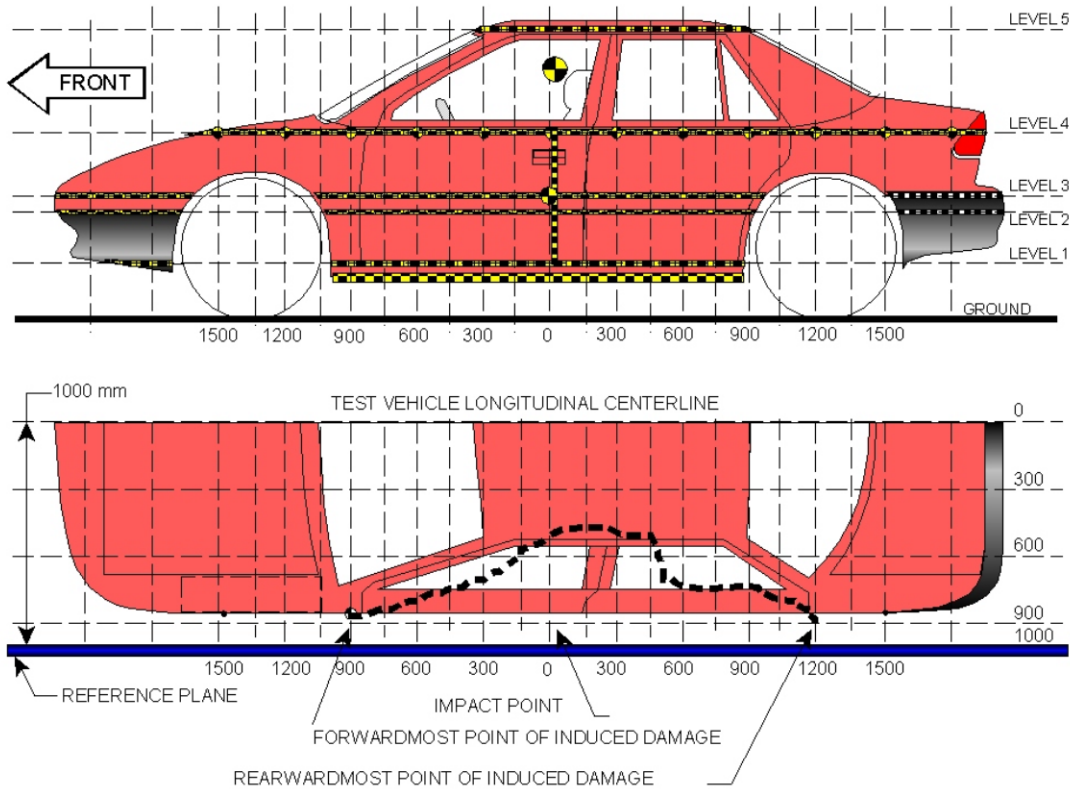

NOTE: All measurements are in millimeters (mm)

Figure 13 – Vehicle Exterior Crush Measurements

11.4 SIDE POLE TEST CONDITION

The test vehicle and the pole are shown in the impact configuration at $t = 0$ in **Figure 14** below. During towing and at impact, the following conditions must be met:

- A. The pole shall remain stationary at impact and shall have a diameter of $254 \text{ mm} \pm 3 \text{ mm}$ (10 inches).
- B. The vehicle (or pole) shall be adjusted for proper alignment (see **Figure 14**) such that a vertical plane passing through the three-dimensional center of gravity of the head of the dummy forms an angle of 75° with the vehicle's longitudinal centerline.
- C. The test vehicle shall be towed sideways, at the specified test speed, toward the stationary pole so that its line of forward motion forms an angle of $75^\circ \pm 3^\circ$ (for left side impact) with the vehicle's longitudinal centerline.
- D. The test vehicle's velocity shall be constant (essentially having zero acceleration or deceleration) for a minimum of the last 1.5 meters of travel before impact.
- E. The vehicle's impact speed shall be $32.20 \text{ km/h} \pm 0.80 \text{ km/h}$.
- F. At impact, the test vehicle's vertical impact reference line shall be aligned with the centerline of the pole $\pm 38 \text{ mm}$ ($\pm 1.5 \text{ in}$) horizontally.

11. TEST EXECUTION....Continued

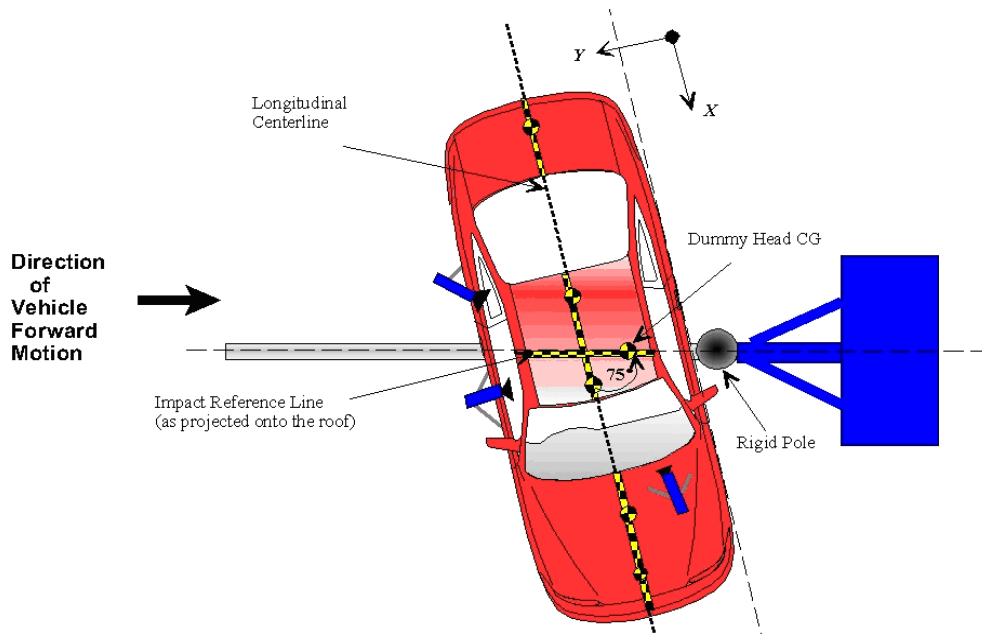

Figure 14 – Pole Impact Configuration

12. POST-TEST MEASUREMENTS AND OBSERVATIONS

After the test, the information specified in the following sections shall be recorded on the applicable Data Sheets (see **APPENDIX C**).

12.1 TEST SPEED

Record the test speed (km/h) recorded by the primary and redundant speed traps on Data Sheet No. 8.

12.2 TEMPERATURE AND HUMIDITY STABILIZATION

Record the dummy/vehicle temperature and humidity stabilization data on Data Sheet No. 12.

12.3 DUMMY CONTACT POINTS

Prior to removing the test dummy from the vehicle, observe where dummy body parts made contact with the vehicle's door, interior components, other body parts, the rigid pole, and air bags, as indicated by chalk markings transferred to the contacted surfaces. Where applicable, confirm contact locations by using high speed video analysis. Record observations on Data Sheet No. 8. If no contact occurred for a particular body region, indicate as "No contact".

12.4 IMPACT POINT

Measure the horizontal distance from the center of the impact point (caused by the cement tack or other marker that was affixed to the pole pre-test) to the center of the target that was placed along the vertical impact reference line in Section 9.4,A(5) of this test procedure to denote the point of initial contact. Record these distances on Data Sheet No. 8. Also, measure the distance of the actual impact point aft of the front axle, calculate the horizontal offset, and record on Data Sheet No. 8.

12. POST-TEST MEASUREMENTS AND OBSERVATIONS...Continued**12.5 VEHICLE DOORS, SEAT MOVEMENT, RESTRAINT SYSTEMS, AND PROFILE MEASUREMENTS****A. DOORS**

The Contractor shall note the status of all doors post-test. In particular, for each door, it should be noted whether: the door remained closed and operational, the door totally separated from the vehicle at the hinges or latches, the door disengaged from the latched position, the latch separate from the striker, the hinge components separated from each other, the latch or hinge systems pulled out of their anchorages, or the door was jammed shut. All applicable conditions should be noted on Data Sheet No. 8. Video analysis should also be used to verify whether any door, including the rear hatch, opened during the impact event. If the door is open at the striker post-test, the Contractor should take a measurement (mm) of the door opening at this location. Record this information on Data Sheet No. 8. Indicate any door or door component failure, or door opening, on the QuickLook Report (see Section 13.5,B).

B. SEAT MOVEMENT AND STRUCTURAL OBSERVATIONS

Note any seat or seat back movement or disengagement on Data Sheet No. 8. Also, note any structural observations pertaining to the pillars, sill, window, and windshield on Data Sheet No. 8. In particular, the Contractor should describe the amount of deformation to the struck-side pillars and struck side sill. The Contractor should also note whether there was damage to the front windshield area and if so, where the damage occurred. A similar assessment should be made for the side windows. Any other notable effects from the impact should also be indicated.

C. SUPPLEMENTAL RESTRAINT SYSTEMS

Note whether the vehicle was equipped with the supplemental restraint systems listed in Data Sheet No. 8. Also indicate the deployment status of each restraint system. The Contractor should also verify that the restraint systems for the driver occupant deployed within 20 ms of impact using high speed video analysis, and should provide descriptive comments for any air bag that failed to deploy, deployed late, or appeared not to have inflated to full volume during impact.

D. PROFILE MEASUREMENTS

After photos have been taken to document the position of the test dummy and condition of the vehicle post-test, and post-test observations related to dummy contact have been recorded on Data Sheet No. 8, collect the post-test vehicle profile measurements and record them on Data Sheet No. 9.

12.6 REMOVAL OF ANTHROPOMORPHIC TEST DEVICE

Once all post-test vehicle profile measurements have been taken, remove the anthropomorphic test device from the test vehicle and take the remaining post-test photographs of the vehicle interior. Vehicle doors should not be removed to facilitate the removal of the dummy unless all other available options have been exercised (i.e. removal of the dummy's legs, removal of the shift knob, front passenger seat movement, steering wheel movement, etc.). The test dummy should incur no additional damage during removal from the test vehicle. Record any additional post-test observations related to dummy contact on Data Sheet No. 8.

12. POST-TEST MEASUREMENTS AND OBSERVATIONS...Continued**12.7 FMVSS NO. 301/305 STATIC ROLLOVER**

After removal of the anthropomorphic test device, and within 2 hours after impact (unless otherwise instructed by the COTR), perform an FMVSS No. 301 static rollover fuel system integrity test and/or an FMVSS No. 305 propulsion battery integrity test (electrolyte spillage and electrical isolation), if applicable, on the test vehicle.

NOTE: *The Contractor must keep the test vehicle under constant observation for Stoddard or propulsion battery electrolyte leakage during the transition between impact and static rollover testing.*

NOTE: *The static rollover test WILL NOT BE CONDUCTED unless instructed by the COTR if any of the following occur: There is an indication of a test anomaly or door opening; If the vehicle exceeds any of the injury criteria stipulated by FMVSS No. 214 during the side impact pole test; If the vehicle exceeds maximum allowable solvent requirements in accord with FMVSS No. 301 post-impact; If the vehicle exceeds electrolyte spillage requirements in accord with FMVSS No. 305 post-impact; If the vehicle does not meet battery retention or electrical isolation requirements in accord with FMVSS No. 305 immediately post-impact.*

To avoid damage to the underbody of the test vehicle when moving the vehicle to the static rollover device, ensure that the forklift is only permitted to make contact with the body sills of the vehicle. Accordingly, it may be necessary to place a stabilizer block made of rubber, wood, or polypropylene between the body sills and the forks of the forklift. This is particularly important for electric vehicles in order to avoid electric shock. Record the details from the FMVSS No. 301 test on Data Sheet No. 11. Details of the FMVSS No. 305 test, if conducted, should be recorded in a supplemental test report to be submitted along with the test report for this side NCAP pole test.

12.8 POST-TEST VEHICLE EXTERIOR CRUSH MEASUREMENTS

After the FMVSS No. 301/305 static rollover test is completed and properly documented, collect the post-test vehicle exterior crush measurements and record them on Data Sheet No. 10.

12.9 REMOVAL OF TEST INSTRUMENTATION AND EVENT DATA RECORDER

Immediately following the collection of the post-test crush measurements, the Contractor shall remove all test-related instrumentation from the test vehicle and shall also remove the vehicle's Event Data Recorder (EDR) using the information supplied on Form No. 1 (see sample of Form No. 1 in Section 3 of **APPENDIX C**) by the vehicle manufacturer. The EDR shall be handled with care and labeled. It shall also be protected from the elements and retained by the test contractor until requested by the COTR.

12.10 PREPARATION FOR STORAGE

After removal of all test instrumentation and the vehicle's EDR, the test vehicle should be prepared for storage. Raise all windows on the test vehicle, if possible, close any hatches, if applicable, and close and latch all doors to the extent permitted by the vehicle crush. Exposed window openings should be covered with a covering that will protect the test vehicle from the elements for a period of one year (example: self-adhesive polyethylene plastic film).

13. TEST DATA DISPOSITION

The Contractor shall provide a QuickLook Report, which includes Form No. 5 (see Section 3 of **APPENDIX C**) and a copy of preliminary test data/computer-generated plots (see Section 13.5,B), to the NHTSA representative within two hours after the test. If there is no NHTSA representative at the test, the Contractor shall send this preliminary information to the COTR via e-mail or fax within one (1) day of the test. Additionally, the Contractor shall analyze the preliminary test results as directed by the COTR. The test data tape (see Section 13.5,C of this laboratory procedure) shall also be submitted within three (3) days of the test via e-mail.

13.1 TEST DATA LOSS

A. *INVALID TEST DESCRIPTION*

The Part 572V (SID-IIs) test dummies and the test vehicle and instrumented in order to obtain data needed for the New Car Assessment Program (NCAP). The dummy data from 75° 32.20 km/h oblique pole side impact tests for evaluation against FMVSS No. 214 injury criteria and the visual record of dummy kinematics are essential to NCAP. An invalid NCAP test is one which does not conform precisely to all requirements/specifications of the NCAP Laboratory Test Procedure and Statement of Work applicable to the test.

B. *INVALID TEST NOTIFICATION*

The Contractor shall notify NHTSA of any test not meeting all requirements/specifications of the Side NCAP Pole Laboratory Test Procedure and Statement of Work applicable to the test, by telephone, within 24 hours of the test. Additionally, written notice shall be sent to the COTR within 48 hours of the test completion.

C. *RETEST NOTIFICATION*

The contracting Officer of the NHTSA is the only NHTSA official authorized to notify the Contractor that a retest is required. The retest shall be completed within 2 weeks after receipt of notification by the Contracting Officer that a retest is required.

D. *WAIVER OF RETEST*

NHTSA, in its sole discretion, reserves the right to waive the retest requirement. This provision shall not constitute a basis for dispute over the NHTSA's waiving or not waiving any requirement.

E. *TEST VEHICLE*

The NHTSA shall furnish only one vehicle for each test ordered. The Contractor shall furnish the test vehicle required for a retest, should a retest be required. The retest vehicle shall be equipped as the original vehicle. The original vehicle used in the invalid test shall remain the property of the NHTSA, and the retest vehicle shall remain the property of the Contractor. The Contractor shall retain the retest vehicle for a period not exceeding 180 days if there is a test anomaly or door opening, if the vehicle exceeds any of the injury criteria stipulated by FMVSS No. 214, if the vehicle exceeds maximum allowable solvent requirements in accords with FMVSS No. 301 or does not comply with electrolyte spillage, battery retention, or electrical isolation requirements in accords with FMVSS No. 305 (where applicable), or if the test results are deemed questionable. If the retest is deemed valid, the vehicle does not exceed any of the injury criteria, the vehicle does not exceed maximum allowable solvent spillage requirements, and no test anomalies occur, the Contractor may dispose of the retest vehicle upon notification from the COTR that the Final Test Report has been accepted, unless otherwise directed.

13. TEST DATA DISPOSITION....Continued

RETEST CONDITIONS

FAILURE OF THE CONTRACTOR TO OBTAIN THE SPECIFIED DATA AND TO MAINTAIN ACCEPTABLE LIMITS OF TEST PARAMETERS IN THE MANNER OUTLINED IN THIS TEST PROCEDURE SHALL REQUIRE A RETEST AT THE EXPENSE OF THE CONTRACTOR AND WILL INCLUDE THE COST OF THE VEHICLE REPLACEMENT AND RETEST AT THE CONTRACTOR'S EXPENSE. THE PROVISIONS OF THIS PARAGRAPH APPLY, BUT ARE NOT LIMITED TO THE CONTRACTOR MAINTAINING PROPER IMPACT ANGLE, VEHICLE SEAT CUSHION AND BACK POSITIONING, DUMMY POSITIONING, CORRECT LAP AND SHOULDER BELT POSITIONING, AND TEST DATA ACQUISITION, REDUCTION, AND PROCESSING.

THE PROPER SPEED TOLERANCE SHALL BE ATTAINED; ONLY SPEEDS MEASURED IN KILOMETERS PER HOUR (KM/HR), DISPLAYED TO THE HUNDREDTHS, WILL BE ACCEPTED. THE REDUNDANT SPEED WILL ONLY BE ACCEPTED IF THE PRIMARY SPEED IS LOST. ALTERNATIVE METHODS SUCH AS FILM ANALYSIS OR AVERAGING OF THE PRIMARY AND REDUNDANT TEST SPEEDS WILL NOT BE ACCEPTED.

THE CONTRACTOR SHALL ALSO BE RESPONSIBLE FOR OBTAINING ACCEPTABLE DATA FROM ALL PRIMARY CHANNELS FROM THE PART 572 SUBPART V TEST DUMMY PLACED IN THE DRIVER'S SEATING POSITION (DSP). FAILURE TO PRODUCE SUCH DATA SHALL ALSO BE AT THE EXPENSE OF THE CONTRACTOR AND SHALL INCLUDE VEHICLE REPLACEMENT AND RETEST UNLESS THE OFFICE OF CRASHWORTHINESS STANDARDS DETERMINES THAT THE DUMMY DATA LOSS OCCURRED THROUGH CONDITIONS BEYOND REASONABLE AND FORESEEABLE CONTROL OF THE CONTRACTOR. SHOULD IT BECOME NECESSARY FOR THE CONTRACTOR TO PROCURE ANOTHER TEST VEHICLE, IT MUST HAVE IDENTICAL EQUIPMENT AND OPTIONS AS THE ORIGINAL TEST VEHICLE. THE ORIGINAL VEHICLE REMAINS THE PROPERTY OF THE NHTSA. THE RETESTED VEHICLE BECOMES THE PROPERTY OF THE CONTRACTOR. THE RETESTED VEHICLE SHALL BE RETAINED WITHOUT FEE BY THE TESTING FACILITY UNTIL ITS DISPOSAL IS AUTHORIZED BY THE COTR.

F. TEST REPORT

No test report is required for any test that is determined to be invalid unless NHTSA specifically decides, in writing, to require the Contractor to submit such report. The test data from the invalid test must be safeguarded until the data from the retest has been accepted by the COTR. The Final Test Report and other required deliverables for the retest vehicle are required to be submitted to the COTR within 3 weeks after completion of the retest.

G. DEFAULT

The Contractor is subject to the default and subsequent re-procurement costs for non-delivery of valid or conforming tests (pursuant to the *Termination For Default* clause in the contract).

H. CONDITIONS FOR PARTIAL PAYMENT

The Contractor shall exercise reasonable and foreseeable control to insure that no data is lost or rendered useless. If some non-critical data (such as camera failure) and critical data (acceleration and load data) are not obtained for the crash test and the test is accepted by the NHTSA, the NHTSA will not pay for missing or lost data.

13. TEST DATA DISPOSITION....Continued**I. NHTSA'S RIGHTS**

None of the requirements herein stated shall diminish or modify the rights of NHTSA to determine that any test submitted by the Contractor does not conform precisely to all requirements/specifications in the OCWS Laboratory Test Procedure and Statement of Work applicable to the test.

13.2 DATA PROCESSING

NOTE: *Parts of the following may not apply to onboard data acquisition systems.*

- A. Prior to the vehicle crash test, a null reference and a shunt calibration adjustment are performed to set all analog and direct digitized data devices (including FM magnetic tape recorders, if applicable). Immediately following the crash test, a post impact null reference and shunt calibration check will be performed. The pre- and post-test zero and shunt calibration check will be recorded and the data submitted with the report as shown below:

CHANNEL DESCRIPTION	S/N	DLR	UNITS	PRE-ZERO	PRE-CAL	POST-ZERO	POST-CAL
Head x	123abc	106.1	G's	0.045	2.202	0.045	2.203
Head y							

- B. As a secondary instrumentation check, it is suggested that just prior to vehicle testing, accelerometers and on-board signal conditioning equipment be lightly tapped with a rubber mallet to ensure that sensors are recording, and that instrumentation connections are secure.
- C. Prior to initiation of the testing program and periodically thereafter, onboard equipment shall be drop-tested and performance checked at G levels expected in the NCAP testing. The equipment shall be sufficiently shock-hardened to function in the adverse environment. In addition, it is recommended that on a periodic basis, the instrumentation be energized with the sensors removed from the system. The system shall then be subjected to a shock equivalent to that in the crash test event. The output voltages shall remain stable confirming system integrity.
- D. A precision time system compatible with the test equipment shall be used to provide a time reference for all recorded data. A system that identifies the precise instant of pole contact will be incorporated with the time reference signal. An instrumentation self-checking system that simultaneously monitors all data channels and displays, on a single indicator, will provide the GO/NO-GO status of the sensor system.
- E. Test data should NOT be prefiltered, should be submitted (as part of the data tape (see Section 13.5,C)) at a Class that is higher than Class 1000, and should be digitized at a minimum rate of 10,000 samples per second. Additionally, the data should be truncated at 300 ms. The data is then placed into permanent storage after the application of appropriate calibration scale factors.
- F. As the data is recalled for integration or plotting, the appropriate filter is applied. These filters are in accordance with SAE Recommended Practice J211 "Instrumentation for Impact Tests." Vehicle acceleration data and pole load cell data shall be plotted after the application of an SAE Class 60 filter (and cut-off frequency of 100). Vehicle velocity and displacement data shall be plotted after the application of an SAE Class 180 filter. The filtering requirements for the test dummy are as follows:

13. TEST DATA DISPOSITION....Continued

SID-IIS FILTERING REQUIREMENTS

	Filter Class	Cut-off Frequency
Head Acceleration	1000	1650
Thorax Rib Deflection	600	1000
Lower Spine T12 Acceleration	180	300
Abdomen Rib Deflection	600	1000
Acetabulum Force	600	1000
Iliac Force	600	1000

- G. Before plotting, the Contractor shall determine the “time zero”, which is verified with the trigger signal. When a velocity or displacement trace is to be plotted, integration for the appropriate acceleration signal is performed digitally.
- H. Time zero bias shall be removed prior to submission of the data tape disk to NHTSA.
- I. Reported injury measures in test report shall be rounded to one significant decimal place according to accepted rounding practices.
- J. As stated previously, the minimum sampling rate requirement is 10,000 samples per second per channel. The Contractor must have the ability to produce deliverables that conform to the latest version of the NHTSA “Data Tape Reference Guide”. This guide can be obtained from:

U.S. Department of Transportation
National Highway Traffic Safety Administration
Office of Crashworthiness
1200 New Jersey Ave SE
Washington, DC 20590

For online access to the most recent version of the Data Tape Reference Guide, visit <http://www-nrd.nhtsa.dot.gov/> and click on “R&D Software.” Under “NVS Software Applications,” click “NHTSA Test Reference Guides” and select the latest version of Volume I: Vehicle Tests.

- K. A file containing the most recent versions of the algorithms used to calculate various injury parameters, such as HIC, can be obtained from the agency. Any questions pertaining to the algorithms or requests for the algorithms shall be directed to the following organization:

U.S. Department of Transportation
National Highway Traffic Safety Administration
Office of Vehicle Safety Research
Crashworthiness Research Division
1200 New Jersey Ave, SE
Room W46-312
Washington, DC 20590

Telephone No.: 202-366-4712 Steve Summers

13. TEST DATA DISPOSITION....Continued**13.3 REQUIRED DATA TRACE ORDER**

To increase uniformity in data tape formatting, the following curve order is required:

DRIVER TRACES
Head Acceleration (X) Primary
Head Acceleration (Y) Primary
Head Acceleration (Z) Primary
Head Acceleration (X) Redundant
Head Acceleration (Y) Redundant
Head Acceleration (Z) Redundant
Upper Thorax Rib Deflection (Y)
Middle Thorax Rib Deflection (Y)
Lower Thorax Rib Deflection (Y)
Abdomen Upper Rib Deflection (Y)
Abdomen Lower Rib Deflection (Y)
Lower Spine T12 Acceleration (X)
Lower Spine T12 Acceleration (Y)
Lower Spine T12 Acceleration (Z)
Iliac Wing Force on Impact Side (Y)
Acetabulum Force on Impact Side (Y)

VEHICLE TRACES
Vehicle Center of Gravity Acceleration (X)
Vehicle Center of Gravity Acceleration (Y)
Vehicle Center of Gravity Acceleration (Z)
Left Floor Sill Acceleration (Y)
Left A-Pillar Sill Acceleration (Y)
Left Lower A-Pillar Acceleration (Y)
Left Mid A-Pillar Acceleration (Y)
Left B-Pillar Sill Acceleration (Y)
Left Lower B-Pillar Acceleration (Y)
Left Mid B-Pillar Acceleration (Y)
Driver Seat Track at Dummy Hip Point Acceleration (Y)
Engine Top Acceleration (X)
Engine Top Acceleration (Y)
Firewall Center Acceleration (Y)
Right Roof at Vertical Impact Reference Line Acceleration (Y)
Right Sill at Vertical Impact Reference Line Acceleration (Y)
Rear Floorpan Behind Rear Axle at Centerline Acceleration (X)
Rear Floorpan Behind Rear Axle at Centerline Acceleration (Y)

RIGID POLE TRACES
Load Cell Pole Barrier #1 Force (Y)
Load Cell Pole Barrier #2 Force (Y)
Load Cell Pole Barrier #3 Force (Y)
Load Cell Pole Barrier #4 Force (Y)
Load Cell Pole Barrier #5 Force (Y)
Load Cell Pole Barrier #6 Force (Y)
Load Cell Pole Barrier #7 Force (Y)
Load Cell Pole Barrier #8 Force (Y)

13. TEST DATA DISPOSITION....Continued

13.4 NOTIFICATION OF APPARENT TEST FAILURE

The performance requirements are found in Section 2, General Requirements, of this test procedure. If the test results indicate that the test vehicle has exceeded any of the injury criteria or has not met a requirement, the Contractor shall notify the COTR.

13.5 DELIVERABLES

Required deliverables for each test are discussed in this section. A Schedule of Deliverables is also provided at the end of this section.

A. FTP WEBSITE

To expedite data transfer between the Contractor and NHTSA, a File Transfer Protocol (FTP) website will be made available to Contractors through an FTP coordinator.

(1) Accessing the FTP Site

The Point of Contact at each test facility will receive an e-mail with the FTP site address and a unique username and password to access the website. A new password will be issued on the 1st of each month. Any FTP client can be used to access and upload data.

(2) Uploading Test Data

Associated test documentation (test data, photos, videos, reports, etc.) required for each relevant deliverable must be placed in organized and labeled folders such that each folder's contents are easily recognizable. Once the data is organized, the Contractor shall place all folders into **ONE (1)** .zip file per test via the FTP website. The .zip file should then be uploaded using an FTP client.

To ensure successful transfers, please contact your network administrator and confirm that FTP transfers are permitted. Set your FTP client program to upload in passive (PASV) mode and set the "file exists" action to "skip". For FTP assistance, please contact the COTR.

NOTE: *If the Contractor is experiencing difficulty uploading the test data to the FTP site, it is the Contractor's responsibility to alert NHTSA in order to arrange for them to download the data instead.*

13. TEST DATA DISPOSITION....Continued

B. QUICKLOOK REPORT

The QuickLook Report is a preliminary summary of the test that shall be **e-mailed** to the OCWS **within 24 hours of the impact event**. The Report shall detail all relevant injury criteria, vehicle information, air bag deployment, and evidence of compliance with Section 9 of FMVSS No. 214, FMVSS No. 301, and FMVSS No. 305, if applicable (see Form No. 5 located in Section 3 of **APPENDIX C**), and shall include data traces relevant to the injury criteria it contains. The QuickLook Report should not include preliminary star ratings. Also, anything of interest or out of the ordinary shall be included in the QuickLook Report in the comments section.

Form No. 5 of the QuickLook Report should be supplied to the vehicle manufacturer at the conclusion of a test. However, no other test information, including data plots and/or star ratings, should be provided.

The filename for the QuickLook Report file should be formatted as follows:

<NHTSANO><Model Year><Make & Model><Body><SPNCAP>-Quicklook.pdf

C. DATA TAPE

Within three (3) business days of the test, the Contractor shall **e-mail** NHTSA the test data (data tape) as a .zip file, formatted as specified in the Office of Crashworthiness Research Data Reference Guide – Volume I: Vehicle Tests. Visit <http://www-nrd.nhtsa.dot.gov/> and click on “Databases and Software”. Under “NVS Software Applications”, click “NHTSA Test Reference Guides” and select the latest version of “Volume I: Vehicle Tests”.

Data entry software (ENTRÉE) may also be downloaded from the website and used to generate the specification data files as defined in the guides. Visit <http://www-nrd.nhtsa.dot.gov/> and click on “Databases and Software”. Under “NVS Software Applications”, click “ENTRÉE for Windows” and select the latest version of the program.

The filename for the DataTape file should be formatted as follows:

<NHTSANO><Model Year><Make & Model><Body><SPNCAP>-DataTape.zip

D. QUALITY CONTROL PACKAGE

The Quality Control Package is a .zip file that includes all of the information necessary for quality control review. It serves as a summary of the test and includes the data tape, all photographs, and all videos (both high-speed and real-time, with the exception of the documentary video, which must only be submitted with the final deliverables), pre- and post-test dummy calibration data (formatted in accordance with the deliverable guidelines outlined in Section 1.8 of **APPENDIX C** of this laboratory test procedure), as well as a QuickLook Report (including data traces) (refer to 13.5, B) previously e-mailed to the OCWS, and Report of Vehicle Condition form (see Form No. 2 in Section 3 of **APPENDIX C**). It shall be **uploaded to the FTP site within five (5) business days of the test** for review by the OCWS. Providing this data in a timely manner will ensure that the Contractor and the COTR will be able to discuss the details of both test conduct and report content soon after the test is conducted.

The filename for the Quality Control Package should be formatted as follows:

<NHTSANO><Model Year><Make & Model><Body><SPNCAP>-QCPackage.zip

13. TEST DATA DISPOSITION....Continued

Photographs included as part of the Quality Control Package should be numbered, at a minimum, and preferably also labeled, and should be arranged such that they are in the same order as they appear in the draft version of the Test Report. See Section 9.8 to determine proper photo order and labeling requirements. Additional photographs, which may be taken to document a test concern, anomaly, etc, may be included as part of the Quality Control Package, but should appear in order after all required photos.

Videos should be numbered, appropriately labeled, and ordered as specified in Section 9.6 of this laboratory procedure.

The Contractor will also provide website-related material with this data. The Contractor shall provide a .jpg image of the vehicle impact, which shall be approximately 222 pixels x 127 pixels. The web photo shall be approximately 100 kb in file size and appropriately labeled as outlined in Section 9 of this test procedure. The Contractor shall also include an appropriately labeled real-time video of the impact itself in .wmv format for the web, which should be between 300-400 kb in size.

E. DRAFT TEST REPORT

Contractors are required to submit, via e-mail to the OCWS, the **draft** version of the Final Test Report (.pdf) to the OCWS **within two (2) weeks of the test**. If the electronic file is larger than 10 MB, it is requested that the Contractor upload the file to the FTP site instead.

The filename for the Draft Test Report should be formatted as follows:

<NHTSANO><Model Year><Make & Model><Body><SPNCAP>-DraftReport.pdf

The Contractor shall use **detailed** descriptions of all test events. Any events that are associated with the pass/fail of FMVSS No. 214 or FMVSS No. 301, or that are of technical interest, shall also be included. Events associated with the pass/fail of FMVSS No. 305 (if applicable) should be included in a supplemental test report to be submitted along with the draft test report for a side NCAP pole test.

Contractors are required to review and proofread all test reports before submittal to the COTR. The OCWS will not act as a report quality control office for Contractors. Reports containing a significant number of errors will be returned to the Contractor for correction. The OCWS will alert the Contractor to minimal corrections that should be made prior to submission of the Final Test Report.

F. FINAL TEST REPORT AND DELIVERABLES

The Final Test Report and associated documentation, including test data, **properly labeled and numbered photographs and videos** (both high-speed and real-time, and including those for the web), are relied upon as the chronicle of the NCAP test. For these reasons, each Final Test Report must be a complete document capable of standing by itself. The Contractor should use DETAILED descriptions of all test events. Any events that are not directly associated with the side NCAP pole test, but that are of technical interest, should also be included. The Contractor should include as much DETAIL as possible in the report.

13. TEST DATA DISPOSITION....Continued

The Final Test Report and associated deliverables will be released to the public domain after review and acceptance by the COTR. For these reasons, all deliverables must be complete and error-free. Final Test Reports containing errors will be returned to the Contractor for correction and a hold will be placed on invoice payment for the particular test.

Only those photos required in the Final Test Report, as set forth in this procedure, shall be included unless the OCWS requests the inclusion of additional photos to document specific test events or anomalies.

The Final Test Report and associated deliverables shall be uploaded to the FTP website **within two (2) weeks of receiving data tape and Draft Test Report corrections** from the OCWS.

The filename for the Final Test Report and deliverables should be formatted as follows:

<NHTSANO><Model Year><Make & Model><Body><SPNCAP>-FinalDeliverables.zip

G. OTHER REPORTS**(1) Monthly Vehicle Status Report**

The Contractor shall submit a Monthly Vehicle Status Report (see Form No. 4 in Section 3 of **APPENDIX C**) to the COTR on the first Friday of every month. The Monthly Vehicle Status Report form shall be submitted until all vehicles or items of equipment are disposed of.

(2) Laboratory Notice of Test Failure Report

An apparent test failure (i.e., a test vehicle exceeds injured criteria outlined by the applicable FMVSS, No. 214, or fails to meet all other requirements stipulated by that Standard) shall be communicated by telephone to the COTR within 24 hours. Written notification shall be mailed within 48 hours (Saturdays and Sundays excluded). A Laboratory Notice of Test Failure (see Form No. 3 in Section 3 of **APPENDIX C**) with a copy of the related NCAP test data sheet(s) and preliminary data plot(s) shall be included. In the event a body region of the anthropomorphic test device exceeds injury performance standards required by FMVSS No. 214, that region of the test device must be recalibrated. Additionally, in such an event, a post-test calibration check of some of the critically sensitive test equipment and instrumentation may be required for verification of accuracy. The necessity of calibration shall be at the COTR's discretion and shall be performed without additional costs to the OCWS.

(3) Report of Vehicle Condition

As noted in Section 7.1, a Report of Vehicle Condition form (see Form No. 2 in Section 3 of **APPENDIX C**) shall be completed by the Contractor and submitted to the COTR as part of the QCPackage.zip file.

13. TEST DATA DISPOSITION....Continued

(4) Dummy Inspection Report

The Contractor shall submit a Dummy Inspection Report to include the following on the first Friday of every month to the COTR: a list of all NCAP-furnished test dummies available for side pole NCAP testing along with date(s) tested; a list of all dummy parts (including serial numbers); a list of parts inspected post-test (including serial numbers) and any associated comments; a list of parts replaced post-test (including serial numbers) and any associated comments; any other dummy information requested by the COTR.

H. SCHEDULE FOR DELIVERABLES

The following is a summary of all NCAP test deliverable requirements:

Test Deliverable	Procedure Section	File Format & Naming Convention	Time Requirement	Submit Via	Submit To
QuickLook Report	13.5, B	.pdf with filename format: <NHTSANO><Model Year><Make & Model><Body><SPNCAP>-Quicklook.pdf	One (1) day from test	E-mail	OCWS
Data Tape	13.5, C	.zip with filename format: <NHTSANO><Model Year><Make & Model><Body><SPNCAP>-DataTape.zip	Three (3) business days from test	E-mail	OCWS
Quality Control Package (QuickLook Report, Report of Vehicle Condition form, data tape, web photo and video, high speed and real time videos, all pre- and post-test photographs, and dummy calibration data)	13.5, D	.zip with filename format: <NHTSANO><Model Year><Make & Model><Body><SPNCAP>-QCPackage.zip	Five (5) business days from test	FTP	FTP
Draft Test Report	13.5, E	.pdf with filename format: <NHTSANO><Model Year><Make & Model><Body><SPNCAP>-DraftReport.pdf	Two (2) weeks from test date	E-mail/FTP depending on file size	OCWS/FTP
Final Test Report, photos, and high speed and real time videos	13.5, F	.zip with filename format: <NHTSANO><Model Year><Make & Model><Body><SPNCAP>-FinalDeliverables.zip	Two (2) weeks after receiving corrections to preliminary test report	FTP	FTP

13. TEST DATA DISPOSITION....Continued

13.6 DATA AND VEHICLE RETENTION BY CONTRACTOR

The Contractor shall retain reproducible copies of all data tapes (analog and digital), high-speed and real-time digital videos, digital photograph files, electronic data collected for all dummy calibrations, and Form No. 1 manufacturer information for at least 5 years from the test date at no extra cost to the NHTSA.

The tested vehicle, protected from the elements, shall be retained by the test Contractor for a minimum of 60 days so that OCWS and vehicle manufacturer personnel can be given an inspection opportunity.

13.7 DATA AVAILABILITY TO THE PUBLIC

The Contractor shall provide interested parties with copies of the Final Test Reports, test data tapes, test videos, and test digital photographs, at a reasonable cost to the purchaser, but only after an Office of Crashworthiness Standards representative has advised the Contractor that the results of that particular New Car Assessment Program test have been released by the Agency to the public.

APPENDIX A

SID-IIs Calibration Procedure

In addition to the following document, **49 CFR 572 Subpart V** may be referenced.

U.S. DEPARTMENT OF TRANSPORTATION
NATIONAL HIGHWAY TRAFFIC SAFETY ADMINISTRATION
LABORATORY TEST PROCEDURE
FOR
Part 572, SUBPART V
PERFORMANCE CALIBRATION REQUIREMENTS



ENFORCEMENT
Office of Vehicle Safety Compliance
Mail Code: NVS-220
1200 New Jersey Ave. SE
Washington, DC 20590

TABLE OF CONTENTS

- 1. PURPOSE AND APPLICATION1
- 2. GENERAL REQUIREMENTS1
- 3. SECURITY1
- 4. GOOD HOUSEKEEPING.....2
- 5. TEST SCHEDULING AND MONITORING2
- 6. TEST DATA DISPOSITION2
- 7. GOVERNMENT FURNISHED PROPERTY.....2
- 8. CALIBRATION AND TEST INSTRUMENTATION.....3
- 9. PHOTOGRAPHIC DOCUMENTATION4
- 10. PRETEST REQUIREMENTTS4
- 11. CALIBRATION TEST EXECUTION7
- 12. POST TEST REQUIREMENTS7
- 13. REPORTS7
- 14. CHECK SHEETS8
 - V1 EXTERNAL MEASUREMENTS.....8
 - V2 HEAD DROP TEST11
 - V3 NECK FLEXION TEST17
 - V4 SHOULDER IMPACT TEST.....39
 - V5 THORAX – W/ARM IMPACT TEST46
 - V6 THORAX – W/O ARM IMPACT TEST51
 - V7 ABDOMEN IMPACT TEST.....55
 - V8 PELVIS PLUG QUASI-STATIC TESTS59
 - V9 PELVIS ACETABULUM IMPACT TEST61
 - V10 PELVIS ILIAC IMPACT TEST.....66
- List of Figures iii
- List of Tables v

ATTACHMENT 1-Attachment of Thoracic and Abdominal Pads
ATTACHMENT 2-Iliac Probe Face
ATTACHMENT 3-Iliac Alignment Tool

List of Figures

Figure 1. Seated Position of SID-IIIsD for taking external dimensions	8
Figure 2. Threaded cylindrical tool for SID-IIIsD	9
Figure 3. Threaded cylindrical tool installed at the acetabulum	9
Figure 4. Installing head accelerometers to mount	11
Figure 5. Installing accelerometers in head	11
Figure 6. Head reassembly with hex rod installed for routing suspension cable.....	12
Figure 7. Securing the suspension cable to the top of the head	12
Figure 8. Routing the suspension cables for head drop tests	13
Figure 9. Adjusting the D-plane to 35°	14
Figure 10. Leveling the head in the fore-aft direction	14
Figure 11. Raising head to proper drop height	15
Figure 12a. Center bracket, front and rear disks of head form	18
Figure 12b. Head potentiometer	18
Figure 13. Attaching the pot shaft collar to the head pot.....	19
Figure 14. Assembling front head form disk to rear disk	19
Figure 15. Attaching the pot extension shaft to the pot shaft collar	20
Figure 16. Attaching the retaining collar to the pot extension shaft.....	20
Figure 17. Removing the nodding joint assembly	22
Figure 18. Install bib simulator	23
Figure 19. Assemble molded neck to neck mounting plate	23
Figure 20. Install lower neck bushing, washer, and hex nut unto neck cable	23
Figure 21. Torque hex nut on neck cable to 10-12 in-lbs	24
Figure 22. Reinstall neck nodding joint assembly.....	24
Figure 23. Install potentiometer brackets (left side neck test illustrated	25
Figure 24. Install brass nodding joint washers.....	26
Figure 25. Install the upper neck load cell.....	26
Figure 26. Align brass nodding joint washers with holes	27
Figure 27. Insert and install neck pivot pin.....	27
Figure 28. Install upper neck load cell to head form	28
Figure 29. Install the inner potentiometer rod assembly.....	29
Figure 30. Install the outer potentiometer rod assembly.....	29
Figure 31. Assembling chest rotary potentiometer and potentiometer housing assembly	30
Figure 32. Install potentiometer on inner pot rod onto inner potentiometer pivot bracket.....	31
Figure 33. Tighten set screws for inner potentiometer pivot bracket	31
Figure 34. Final configuration of head form attached to neck with dummy head.....	32
Figure 35. Pendulum configuration for a left side neck test	33
Figure 36. Attachment of inner and outer pot rod assemblies to neck mounting plate	34
Figure 37. Pendulum configuration for a right side neck test.....	35
Figure 38. Correct outer and inner pot/rod assembly locations for a right-side test.....	36
Figure 39. Angle measurements with the head form setup.....	37

ist of Figures (cont'd)

Figure 40. Certification bench seat specifications	39
Figure 41. Shoulder impact test configuration for SID-IIIsD	40
Figure 42. Impact probe and dummy seating position.....	41
Figure 43. SID-IIIsD leg positioning	42
Figure 44. SID-IIIsD feet positioning	42
Figure 45. Adjusting the SID-IIIsD dummy in the lateral direction	43
Figure 46. Adjusting the SID-IIIsD in the fore/aft plane	44
Figure 47. Aligning the upper and lower neck brackets flush for testing.....	46
Figure 48. Thorax with arm impact test configuration for SID-IIIsD.....	47
Figure 49. Impact probe position for the SID-IIIsD thorax with arm qualification test	48
Figure 50. Thorax without arm impact test configuration for SID-IIIsD.....	52
Figure 51. Impact probe position for the SID-IIIsD thorax w/o arm test.....	53
Figure 52. Abdomen impact test configuration for SID-IIIsD.....	56
Figure 53. Impact probe position for the SID-IIIsD abdomen test	57
Figure 54. Pelvis plug quasi static test.....	59
Figure 55. Corridors for pelvis plug certification test t	60
Figure 56. Maximum force and displacement corridors for pelvis plug certification test.....	60
Figure 57. Acetabulum test for SID-IIIsD	61
Figure 58. Impact probe position for the SID-IIIsD pelvis certification test	62
Figure 59. SID-IIIsD leg and back positioning for pelvis certification test.....	63
Figure 60. Adjusting the SID-IIIsD in the fore/aft plane for pelvis certification test.....	64
Figure 61. Setup of the dummy for the iliac test.....	67
Figure 62. Using masking tape to seat the dummy upright	68
Figure 63. Adjusting the SID-IIIsD in the fore/aft plane for the iliac certification test.....	68
Figure 64. Adjusting the SID-IIIsD in the lateral direction for the iliac certification test	69
Figure 65. Iliac alignment tool.....	69
Figure 66. Iliac probe with alignment tool inserted.....	70
Figure 67. Iliac alignment tool inserted into iliac load cell	70
Figure 68. Adjusting the pelvic position for inserting the alignment tool.....	71
Figure 69. Assuring smooth motion of the alignment tool shaft within the probe	71

List of Tables

Table V1. External Measurements.....	10
Table V2. Head Drop Test	16
Table V3. Neck Flexion Test	38
Table V4. Shoulder Impact Test	45
Table V5. Thorax with Arm Impact Test.....	50
Table V6. Thorax without Arm Impact Test	54
Table V7. Abdomen Impact Test.....	58
Table V8. Pelvis Plug Quasi-Static Test.....	60
Table V9. Pelvis Acetabulum Impact Test	65
Table V10. Pelvis Iliac Impact Test.....	72

1. PURPOSE AND APPLICATION

The purpose of this laboratory procedure is to provide dummy users (independent testing laboratories under contract with the Office of Vehicle Safety Compliance) with standard test procedures for performing receiving-inspection and performance calibration tests on the Part 572, Subpart V dummy so that repetitive and correlative test results can be obtained. The following tests have been developed to establish a uniform calibration procedure for all users as the means of verifying the performance of the dummy.

- A. EXTERNAL MEASUREMENTS
- B. HEAD DROP TEST (572.192)
- C. NECK FLEXION TEST (572.193)
- D. SHOULDER IMPACT TEST (572.194)
- E. THORAX w/ARM IMPACT TEST (572.195)
- F. THORAX w/o ARM IMPACT TESTS (572.196)
- G. ABDOMEN IMPACT TEST (572.197)
- H. PELVIS PLUG QUASI-STATIC TEST
- I. PELVIS ACETABULUM IMPACT TEST (572.198)
- J. PELVIS ILIAC IMPACT TEST (572.199)

2. GENERAL REQUIREMENTS

A properly configured Part 572, Subpart V SIDIIIs-D, 5th percentile female side impact dummy must be tested to the calibration requirements stated herein prior to and after being used in a compliance crash test. Contractors may use "passing" post test calibration data to indicate the pre-test condition of a test dummy used in consecutive crash tests occurring less than 90 days apart. Otherwise, a full pretest calibration must be performed.

3. SECURITY

All NHTSA test dummies delivered to the contract laboratory as Government Furnished Property (GFP) will be stored in a safe and secure area such as the dummy calibration laboratory. The contractor is financially responsible for any acts of theft and/or vandalism which occur during the storage of GFP. Any security problems shall be reported by telephone to the Industrial Property Manager (IPM), Office of Contracts and Procurement, within two working days after the incident. A letter containing specific details of the security problem will be sent to the IPM (with copy to the COTR) within 48 hours.

3. SECURITY....Continued

The contractor is responsible for maintaining the NHTSA test dummies in good working order, and shall protect and segregate the data that evolves from conducting dummy calibration tests before and after each vehicle crash usage.

No information concerning the dummy calibration data shall be released to anyone except the COTR, unless specifically authorized by the COTR or the COTR's Branch or Division Chief.

NOTE: No individuals, other than contractor personnel directly involved in the dummy calibration test program, shall be allowed to witness dummy calibration tests unless specifically authorized by the COTR.

4. GOOD HOUSEKEEPING

Contractors shall maintain the entire dummy calibration laboratory, test fixtures, and instrumentation in a neat, clean, and painted condition with test instruments arranged in an orderly manner consistent with good test laboratory housekeeping practices.

5. TEST SCHEDULING AND MONITORING

The Part 572, Subpart V dummies are being calibrated as test tools to be used in a vehicle test to determine compliance with the requirements of FMVSS 214. The schedule for these performance calibration tests must be correlated with that of the vehicle tests. Upon request, all testing shall be coordinated to allow monitoring by the COTR.

6. TEST DATA DISPOSITION

The contractor shall make all dummy calibration data available to the COTR for review and analysis as required. Calibration test data for each dummy will be sent to the COTR with each test report in the format indicated in this test procedure.

All backup data sheets, strip charts, recordings, plots, technician's notes, etc. shall be either sent to the COTR or destroyed at the conclusion of each delivery order, purchase order, etc.

7. GOVERNMENT FURNISHED PROPERTY (GFP)

Part 572 test dummies will be furnished to the contract laboratory by the OVSC. The dummies shall be stored in an upright sitting position with the weight supported by the internal structure of the pelvis. The dummies head shall be held upright without supporting the weight of the dummy by using an eyebolt that can be secured in the top of the head. These dummies shall be stored in a secured room that is kept between 55°F and 85°F. The contractor will check dummy components for damage after each crash test and complete a dummy damage checklist that will be included with the posttest dummy calibration. The COTR will be kept informed of the dummies condition in order that replacement parts can be provided. The contractor shall calibrate the dummies before and verify the calibration after every crash test.

8. CALIBRATION AND TEST INSTRUMENTATION

Before the contractor initiates the dummy performance calibration test program, a test instrumentation calibration system must be implemented and maintained in accordance with established calibration practices. The calibration system shall be set up and maintained as follows:

- A. Standards for calibrating the measuring and test equipment shall be stored and used under appropriate environmental conditions to assure their accuracy and stability.
- B. All measuring instruments and standards shall be calibrated by the contractor, or a commercial facility, against a higher order standard at periodic intervals not exceeding 12 months for instruments and 12 months for calibration standards. Records, showing the calibration traceability to the National Institute of Standards and Technology (NIST), shall be maintained for all measuring and test equipment.
- C. All measuring and test equipment and measuring standards shall be labeled with the following information:
 - (1) Date of calibration
 - (2) Date of next scheduled calibration
 - (3) Name of the technician who calibrated the equipment
- D. The contractor shall provide a written calibration procedure that includes, as a minimum, the following information for all measurement and test equipment.
 - (1) Type of equipment, manufacturer, model number, etc.
 - (2) Measurement range
 - (3) Accuracy
 - (4) Calibration interval
 - (5) Type of standard used to calibrate the equipment (calibration traceability of the standard must be evident)
 - (6) The actual procedures and forms used to perform calibrations.
- E. The contractor shall keep records of calibrations for all test instrumentation in a manner that assures the maintenance of established calibration schedules. All such records shall be readily available for inspection when requested by the COTR. The calibration system will need the written acceptance of the COTR before testing begins.
- F. Test equipment shall receive a calibration check immediately prior to and after each test. This check shall be recorded by the test technician(s) and submitted with the final report.
- G. Anthropomorphic test devices shall be calibrated before and after each test. These calibrations shall be submitted with the final report.

9. PHOTOGRAPHIC DOCUMENTATION

Provide digital still photographs showing any damage that occurred to the test dummy as a result of the crash test. Provide copies of the photographs in the draft test report.

10. PRETEST REQUIREMENTS

10.1 HEAD DROP TEST FIXTURE (572.192(a) & 572.112(a))

A test fixture configured in accordance with the specifications contained in the figure below shall be used to conduct the head drop tests.

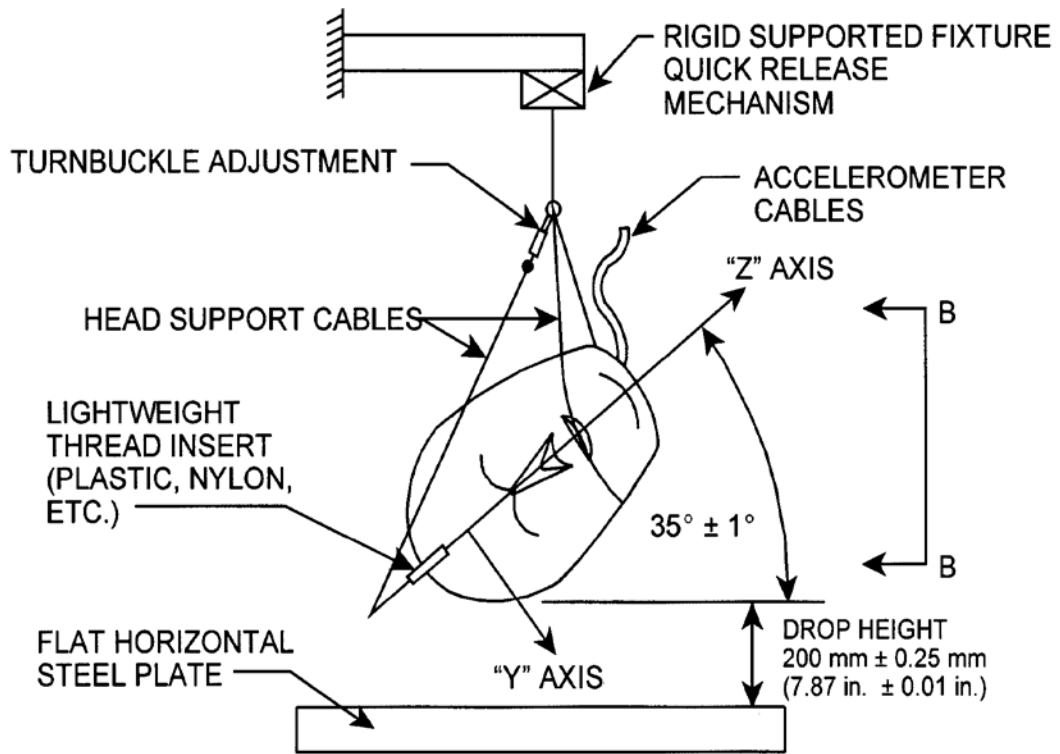
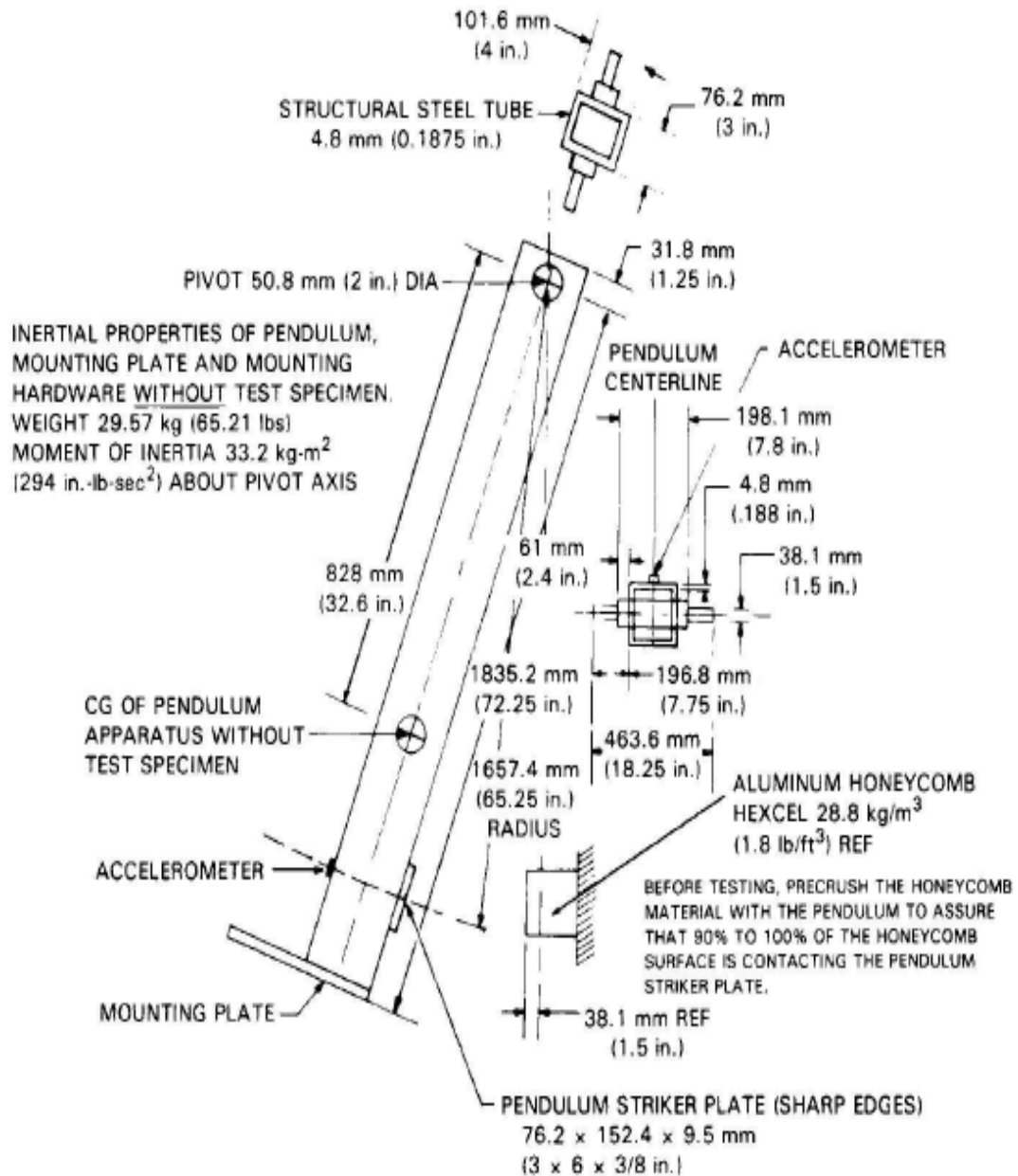

Plate is 51 mm x 610 mm x 610 mm (2 x 24 x 24 in.) with SURFACE FINISH 0.2 microns (8 microinches) to 2.0 microns (80 microinches). IMPACT SURFACE to be clean and dry.

10. PRETEST REQUIREMENTS...Continued

10.2 PART 572 PENDULUM TEST FIXTURE (572.193(b)(2), 572.33)

A pendulum configured in accordance with the specifications contained in the figure below shall be used to conduct the neck and lumbar flexion tests.



10. PRETEST REQUIREMENTS...Continued**10.3 TEST PROBES (572.200(a), 572.137(a))**

- A. All hardware attached directly to the impactor and one-third (1/3) of the mass of the suspension cables must be included in the calculations of the total impactor mass. The sum mass of the attachments and 1/3 cable mass must not exceed 5 percent of the total pendulum mass. No suspension hardware, suspension cables, or any other attachments to the test probe, including velocity vane, shall make contact with the dummy during the test (572.189(a)).
- B. The test probe for shoulder, lateral thorax, and pelvis-acetabulum impact tests is the same as that specified in 49 CFR 572.137(a) except that its impact face diameter is 120.70 ± 0.25 mm and it has a minimum mass moment of inertia of 3646 kg-cm^2 .
- C. The test probe for the lateral abdomen impact test is the same as that specified in 572.137(a) except that its impact face diameter is 76.20 ± 0.25 mm and it has a minimum mass moment of inertia of 3646 kg-cm^2 .
- D. The test probe for the pelvis-iliac impact tests is the same as that specified in 572.137(a) except that it has a rectangular flat impact surface 50.8×88.9 mm for a depth of at least 76 mm and a minimum mass moment of inertia of 5000 kg-cm^2 .

10.4 TRANSDUCER REQUIREMENTS

The contractor shall provide and install the following instrumentation;

- A. **ACCELEROMETERS**
Accelerometers for the head, the thoracic spine, and the pelvis that conform to specifications of SA572-S4.(572.200(d))
- B. **ROTARY POTENTIOMETER**
Rotary potentiometers for the neck-headform assembly that conform to SA572-51.(572.200(e))

10.5 OTHER TRANSDUCER CONDITIONS

- A. **TRANSDUCER MOUNTS**
The mountings for sensing devices shall have no resonance frequency within range of 3 times the frequency range of the applicable channel class. (572.200(h)).
- B. **TRANSDUCER SIGN CONVENTION**
Coordinate signs for instrumentation polarity shall conform to the Sign Convention For Vehicle Crash Testing, Surface Vehicle Information Report, SAE J1733, 1994-12 (refer to §572.191(a)(5)).

10. PRETEST REQUIREMENTS....Continued**C. TRANSDUCER OUTPUT FILTERING**

The outputs of acceleration and force-sensing devices installed in the dummy and in the test apparatus specified by this part are recorded with individual data channels. Each data channel is comprised of a sensor, signal conditioner, data acquisition device and all interconnecting cables. Instrumentation and sensors conform to the Recommended Practice SAE J-211 (Mar. 1995)—Instrumentation for Impact Test unless noted otherwise.

All instrumented response signal measurements shall be treated to the following specifications:

- (1) Head acceleration—Digitally filtered CFC 1000;
- (2) Neck headform assembly translation rotation – Digitally filtered at CFC 60;
- (3) Neck pendulum, T1 and T12 thoracic spine and pelvis accelerations—digitally filtered CFC 180;
- (4) Neck forces (for the purpose of occipital condyle calculation) and moments—digitally filtered at CFC 600;
- (5) Pelvis, shoulder, thorax and abdomen impactor accelerations—digitally filtered CFC 180;
- (6) Acetabulum and iliac wings forces—digitally filtered at CFC 600;
- (7) Shoulder, thorax, and abdomen deflection—digitally filtered CFC 600;

11. CALIBRATION TEST EXECUTION

See Check Sheets in Section 14.

12. POST TEST REQUIREMENTS

The contractor shall verify all required data has been collected and recorded on the tables provided in Section 14. The contractor shall perform instrumentation checks necessary to validate data results.

13. REPORTS**13.1 APPARENT NONCONFORMANCE**

During the post test calibration, any indication of apparent nonconformance to the requirements of Regulation P572 shall be communicated by telephone to the COTR within 24 hours with written notification mailed within 48 hours (Saturdays and Sundays excluded). Written notification shall be submitted with a copy of the particular test data sheet(s) and preliminary data plot(s).

In the event of an apparent nonconformance, a post test calibration check of some critically sensitive test equipment and instrumentation may be required for verification of accuracy. The necessity for the calibration shall be at the COTR's discretion and shall be performed without additional costs to the OVSC.

13.2 FINAL PERFORMANCE CALIBRATION REPORTS

The pre-test calibration and post test calibration verification data for each Part 572, Subpart V dummy used in the vehicle compliance test shall be submitted with the FMVSS 214 final test report for the vehicle tested.

14. CHECK SHEETS

CHECK SHEET NO. V1
EXTERNAL MEASUREMENTS

Dummy Serial No. _____
Technician _____

Test Date _____

- ___1 With the dummy's jacket in place, seat the dummy on a flat, rigid, smooth, clean, dry, horizontal surface. The seating surface must be at least 406 mm (16-in) wide and 406-mm (16-in) deep, with a vertical section at least 406 mm (16 in) wide and 914-mm (36 in) high attached to the rear of the seating fixture. The dummy's midsagittal plane is vertical and centered on the test surface.
- ___2 Seat the dummy in the test fixture so that the torso is against the vertical surface of the fixture (Figure 1).

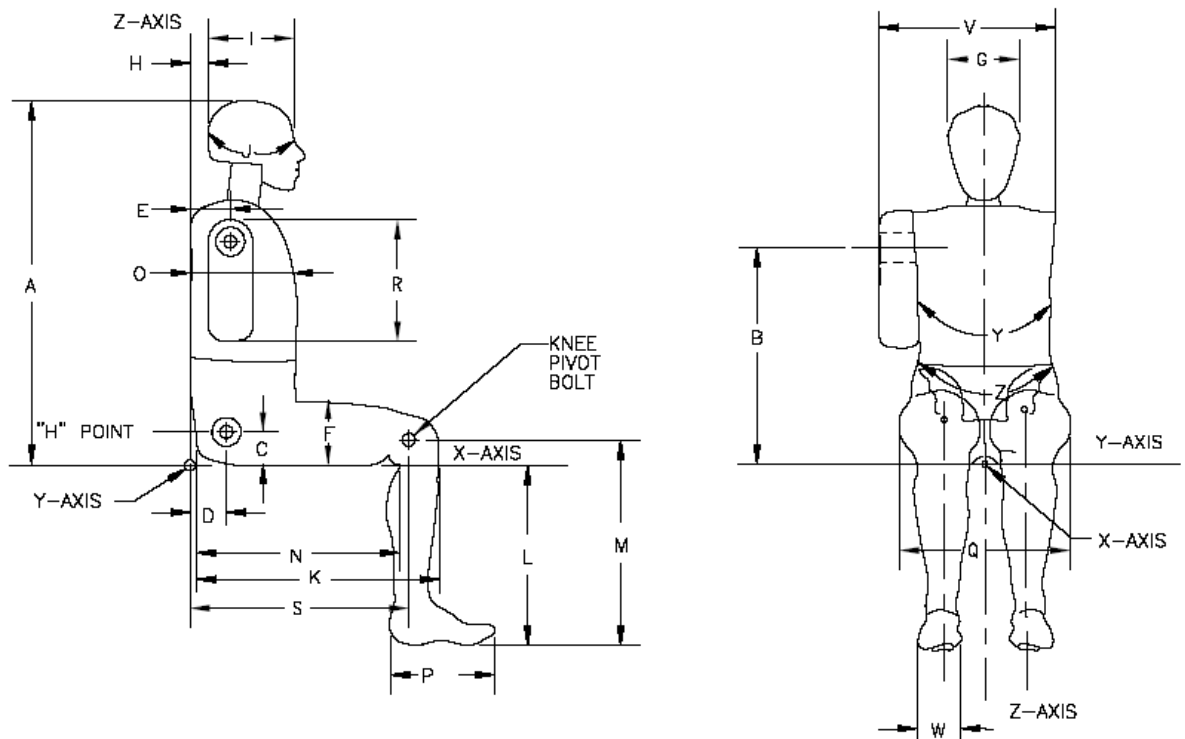

Figure 1. Seated Position of SID-IIsD for taking external measurements
(Dummy configured for right-side impact)

- ___3 Take the following measurements and record on Table V1. Verify that each measurement meets the specification by indicating "Pass" or "Fail" in the far right column.
- ___4 **Chest Circumference (Y):** With the jacket on, using a tape measure positioned 114 mm (4.5") below the top surface of the non-struck side shoulder, measure the chest circumference.
- ___5 Remove the chest jacket. Position the dummy against the vertical back plate so that dummy is in contact with the surface. Level the top surface of the top rib guide laterally. Extend the dummy's neck so that the base of the skull is level side-to-side, within 0.5 degrees. The rear surface of the skull cap should be 43 +/- 3 mm (1.70 +/- 0.10 in) from the vertical surface of the test fixture (parameter H). A 43-mm wide block mounted to the vertical surface of the seat behind the head will aid in this process. In addition, a strap or bungee cord may be placed around the forehead of the dummy to stabilize the head in this position.

CHECK SHEET NO. V1 (Continued)
EXTERNAL MEASUREMENTS

- __6 Position the dummy's H-point (both left and right sides) so it is 84 +/- 5 mm (3.30 +/- 0.20 in) above the horizontal seating surface and 146 +/- 5 mm (5.75 +/- 0.20 in) forward of the rear vertical surface of the fixture (parameters **C** and **D**, respectively). A threaded cylindrical tool, as illustrated in Figure 2, which can be screwed into the acetabulum load cell replacement (Figure 3) in place of the 1/4-20 x 5/8" FHCS, will aid this process.

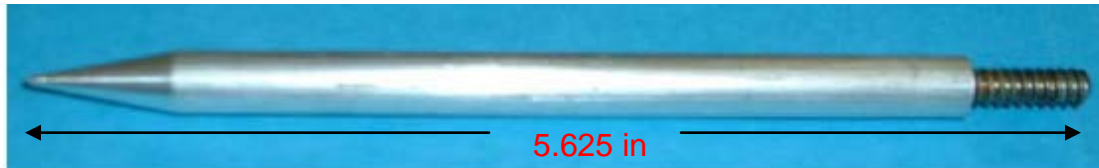

Figure 2. Threaded cylindrical tool



Figure 3. Threaded cylindrical tool installed at acetabulum

- __7 **Sitting Height (A):** With the head positioned as indicated in step 6, measure the distance from the seat horizontal surface to a level placed on top of the head.
- __8 **Shoulder Pivot Height (B):** Level the shoulder load cell structural replacement. Measure from the centerline of the shoulder yoke assembly to the seat horizontal surface. For ease of measurement, it is recommended to measure from the top of the load cell replacement to the horizontal seat surface and adjust this value by 1/2 the height of the structural load cell replacement.
- __9 **Shoulder Pivot From Backline (E):** Level the shoulder load cell structural replacement. Measure from the centerline of the shoulder yoke assembly to the seat vertical surface (seatback). For ease of measurement, it is recommended to measure from the front of the load cell replacement to the seat back and adjust this value by 1/2 the width of the structural load cell replacement.
- __10 **Thigh Clearance (F):** Measure from the horizontal seat surface to the highest point on the thigh flesh. A level placed laterally across both thighs at the highest point will aid in this process
- __11 **Head Breadth (G)** Measure the widest part of the head.
- __12 **Head Depth (I)** Measure from the back of the head to the forehead.
- __13. **Head Circumference (J)** Measure at the point used for dimension "I".
- __14 **Buttock to Knee Length (K):** Measure from the rear surface of the buttock to the front edge of the knee in line with the knee pivot and hip pivot. Use of a vertically positioned level will aid in this measurement.
- __15 **Popliteal Height (L):** Position the front edge of the lower leg vertically. Level the bottom of the feet. Measure from the bottom of the feet to the seat horizontal surface.

CHECK SHEET NO. V1 (Continued)
EXTERNAL MEASUREMENTS

- __16 **Knee Pivot to Floor Height (M):** Position the front edge of the lower leg vertically. Level the bottom of the feet. Measure from the bottom of the feet to the knee pivot.
- __17 **Buttock Popliteal Length (N):** Place a ½" diameter rod behind the knee and pull it forward against the back of the knee joint. Measure from the (anterior) edge of the rod nearest the knee joint to the rear surface of buttock.
- __18 **Foot Length (P):** Measure the maximum foot length from heel to toe.
- __19 **Hip Breadth (Q)** Measure the widest part of the hip with both pelvic plugs installed.
- __20 **Arm Length (R)** Measure from the top of the shoulder to the bottom of the elbow.
- __21 **Knee Joint to Seat Back (S)** Measure from the center of the knee joint to the seat back. Use of a horizontally positioned level will aid in this measurement.
- __22 **Foot Width (W):** Measure the maximum foot width from left to right.
- __23 **Chest Depth (O):** Push the thorax against the seat back. At a distance of 381 mm (15") above the seat surface (on the rib guide between the first and second ribs), measure the horizontal distance from this point to the seatback.
- __24 **Shoulder Width (V):** With only one arm installed (left or right), measure the distance between the outside surface of the shoulder plug and the rib mounting bracket on the non-struck side.
- __25 **Waist Circumference (Z):** Use a tape measure to measure the circumference of the waist within 6 mm (0.25") of the topmost portion of the pelvis flesh, avoiding the zipper closure.

Table V1. External Measurements

No.	Name	Spec. (mm)	Result	Pass/Fail
A	Sitting Height	772 – 788		
B	Shoulder Pivot Height	437 – 453		
C	H-point Height	79 – 89		
D	H-point from seatback	141 – 151		
E	Shoulder Pivot from Backline	97 – 107		
F	Thigh Clearance	119 – 135		
G	Head Breadth	140 – 148		
H	Head Back from Backline	40 – 46		
I	Head Depth	178 – 188		
J	Head Circumference	541 – 551		
K	Buttock to Knee Length	514 – 540		
L	Popliteal Height	343 – 369		
M	Knee Pivot to floor height	392 – 409		
N	Buttock Popliteal Length	416 – 442		
O	Chest Depth w/o jacket	195 – 211		
P	Foot Length	216 – 232		
Q	Hip Breadth (w/pelvic plugs)	313 – 323		
R	Arm Length	249 – 259		
S	Knee Joint to seatback	477 – 493		
V	Shoulder Width	341 – 357		
W	Foot Width	78 – 94		
Y	Chest Circumference w/jacket	851 – 881		
Z	Waist Circumference	761 - 791		

Signature

Completion Date

CHECK SHEET NO. V2 HEAD DROP TEST (S572.192)

Dummy Serial No. _____
Technician _____

Test Date _____

Pretest Preparation

- __1 Inspect the head skin for cracks, tears or other damage. Replace the skin if necessary.
- __2 Remove the skullcap from the head assembly (Part No. 180-1000) and inspect for defects. If defects are present, repair or replace.

Note: If the damage results from the vehicle crash test in which the dummy was an occupant, the damaged area is to be documented with photography and the post test calibration verification testing completed before any replacement or repairs are made.

- __3 Soak the head assembly in a controlled environment at a temperature and relative humidity indicated in Table V2 for at least four hours prior to a test. Record the length of time for the soak and the maximum and minimum temperature and humidity in Table V2. Verify that each measurement meets specification by indicating "Pass" or "Fail" in the far right column.
- __4 Install the 3 accelerometers onto the mount (Figure 4) assuring that all axes are oriented properly.
- __5 Install the accelerometer mount into the head (Figure 5) and tighten all screws.

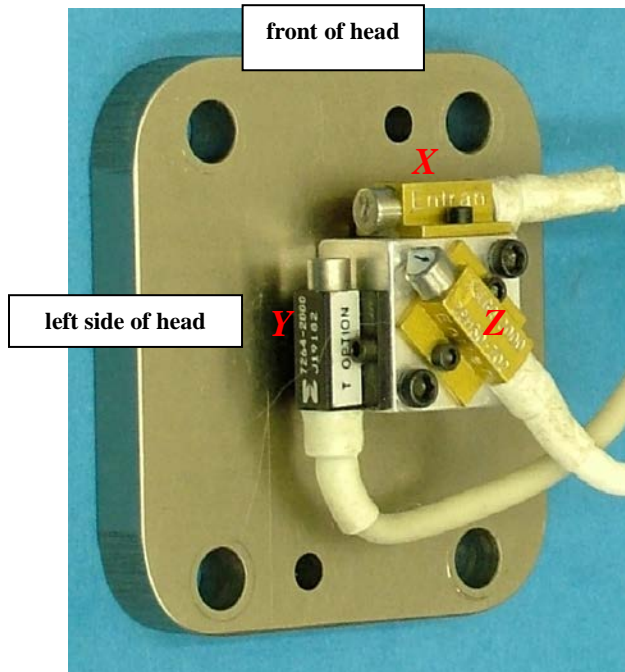

Figure 4. Installing head accelerometers to mount

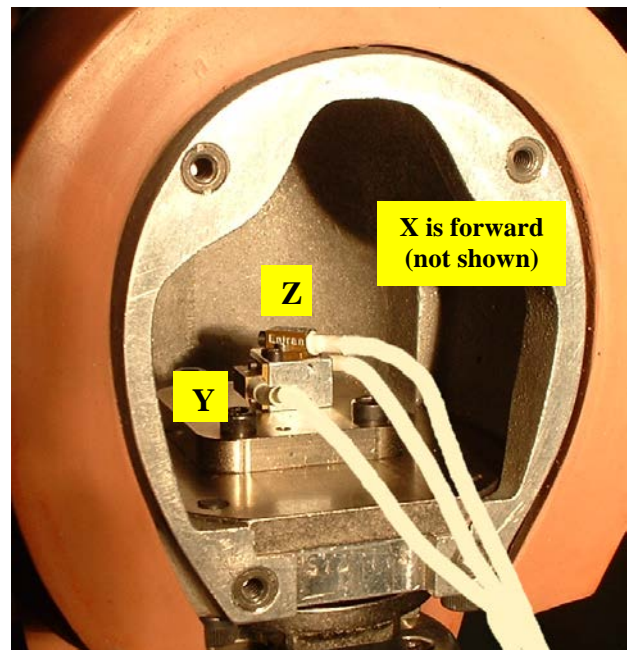

Figure 5. Installing accelerometers in head

CHECK SHEET NO. V2 HEAD DROP TEST (S572.192)

- __6 Replace the skullcap, taking care not to damage accelerometer wiring protruding from the head (Figure 6).
- __7 When replacing the skullcap, use the standard skullcap bolts for all but the bottom left (for left side impacts) or bottom right (for right side impacts) bolts. Instead, insert a threaded 4.2 cm long (1.3 cm of the 4.2 cm is threaded) hex rod so that it protrudes from the skullcap. Tighten the rod into the threaded hole with a wrench. This rod will be used to route the cabling which holds the head assembly for test.
- __8 Install the upper neck structural replacement to the base of the head.
- __9 Clean the headskin with isopropyl alcohol and allow it to dry thoroughly.

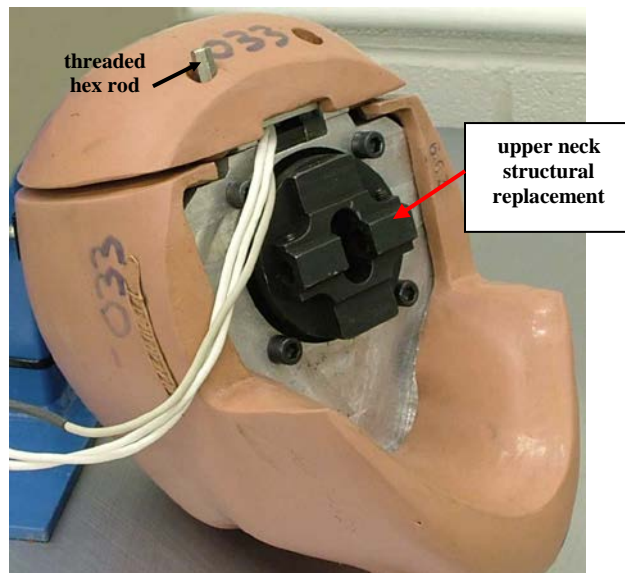

Figure 6. Head reassembly with hex rod installed for routing suspension cable

- __10 Install the threaded Teflon® cylinder with suspension cable attached into the top of the head (Figure 7).

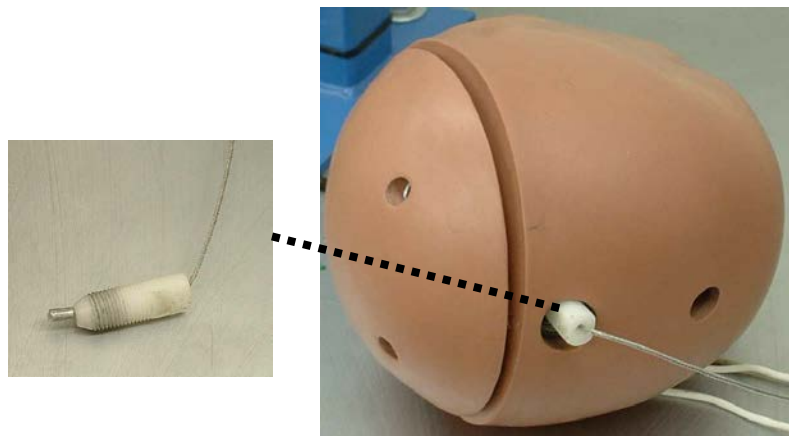

Figure 7. Securing the suspension cable to the top of the head

CHECK SHEET NO. V2 (Continued)
HEAD DROP TEST (S572.192)

- __11 Suspend the head assembly using the head suspension cables (Figure 8). Route the suspension cable around the protruding hex bolt, and between the lips.

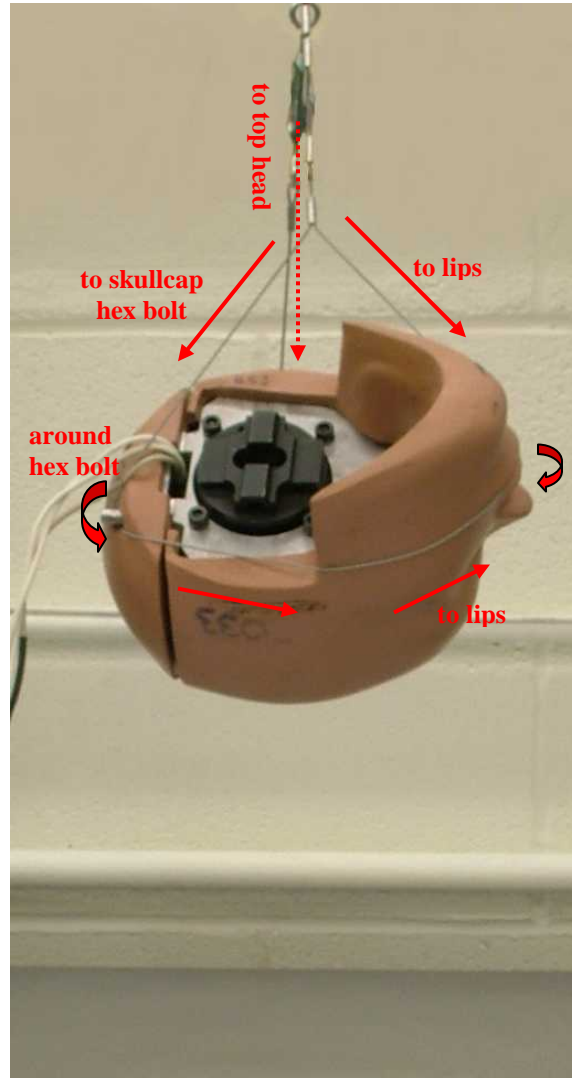

Figure 8. Routing the suspension cables for head drop tests (left-side impact)

CHECK SHEET NO. V2 (Continued)
HEAD DROP TEST (S572.192)

- __12 Adjust the head so that the skull base/D-plane is $35^\circ \pm 1^\circ$ from the vertical (Figure 9).

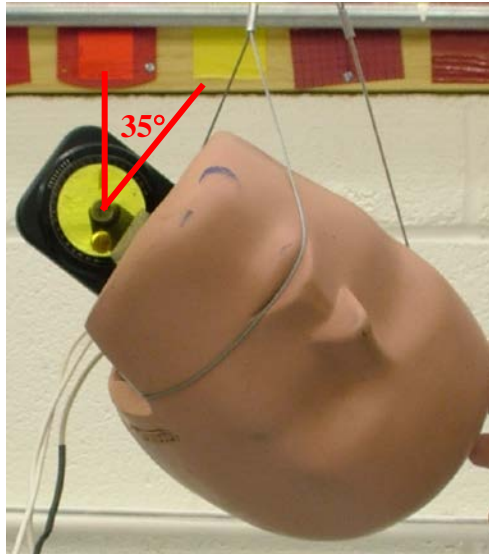

Figure 9. Adjusting the D-plane to 35°
(left side impact shown)

- __13 Level the head so that it is horizontal in the fore-aft direction (Figure 10).

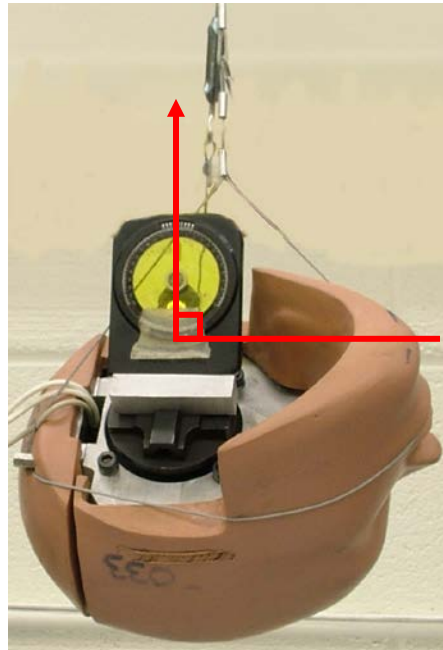

Figure 10. Leveling the head in
the fore-aft direction

CHECK SHEET NO. V2 (Continued)
HEAD DROP TEST (S572.192)

- __14 Raise the head assembly so that it is 200mm ± 1 (7.87in. ± 0.04) from the impact point to the lowest point on the head (Figure 10).
- __15 Clean the impact surface with isopropyl alcohol.

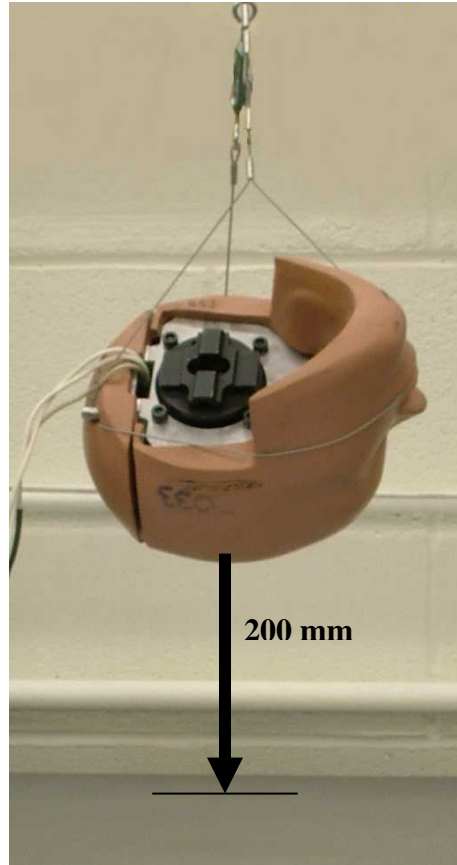

Figure 11. Raising head to proper drop height

Conduct the Test, Collect Data and Verify Performance

- __16 Record the room temperature and humidity in Table V2. Verify that the temperature and relative humidity meets specification by indicating “Pass” or “Fail” in the far right column.
- __17 Release the head assembly so that it falls freely to the impact surface.
- __18 Record head accelerations and filter using a Channel Class 1000 phaseless filter.
- __19 Time zero is defined as the time of contact between the head and the impact surface. All channels should be at a zero level at this point.
- __20 Plot the Head X acceleration and resultant acceleration data traces.
- __21 Calculate the resultant head acceleration using the formula:

$$\mathbf{a}_{res} = [(\mathbf{a}_x)^2 + (\mathbf{a}_y)^2 + (\mathbf{a}_z)^2]^{1/2}$$
- __22 Record the peak head resultant acceleration and peak head X acceleration in Table V2. Verify that each measurement meets specification by indicating “Pass” or “Fail” in the far right column.
- __23 If the test results are not within specification, wait at least 2 hours, conduct another head drop test.
- __24 Record and report the results of each additional test in a separate table.

CHECK SHEET NO. V2 (Continued)
HEAD DROP TEST (S572.192)

Table V2. Head Drop Test

Tested Parameter		Units	Specification	Result	Pass/ Fail
Head Assembly Soak Time		Minutes	240		
Temperature - During Soak	Max	°C	18.9 to 25.6		
	Min	°C			
Humidity - During Soak	Max	%	10.0 to 70.0		
	Min	%			
Temperature – During test		°C	18.9 to 25.6		
Humidity – During test		%	10.0 to 70.0		
Peak Head Resultant Acceleration		g's	115 to137		
Peak Head X Acceleration		g's	<15		
Unimodal (Oscillation)		Yes/No	<15%		

Signature

Completion Date

CHECK SHEET NO. V3

NECK FLEXION TEST (S572.193)

Dummy Serial No. _____

Test Date _____

Technician _____

Prepare the Head Form

- __1 The head form is designed to simulate the SID-ILsD head. To assemble the head form, gather the parts listed below in Table I.

Table I. Head Form Parts

Item Number	Quantity	Part Number	Description
1	1	SA572-S11	6 axis upper neck load cell (Ref)
2	4	9000115	Screw, SHCS ¼-28 x ½
3	1	180-1005	Pivot Pin, Neck
4	2	180-1007	Washer, Nodding Joint
5	1	180-9062	Head Form Rear Disk
6	6	9000151	Screw, SHCS #10-32 x ¾
7	1	SA572-S51	Chest Rotary Potentiometer
8	1	180-9011	Head Form Center Bracket
9	1	9000033	Roll Pin, 1/16 x 5/32 long
10	1	180-9051	Pot Shaft Collar
11	1	180-9050	Pot Extension Shaft
12	1	9002317	Ball Bearing
13	1	180-9052	Retaining Collar
14	4	9002360	Screw, SSCP #6-32 x 1/8
15	1	180-9061	Head Form Front Disk
16	2	9000452	Screw, SSCP #8-32 x ¼

- __2 When assembling the head form, it is critical that the parts are installed correctly. The head form consists of a center bracket and a front and a rear disk (Figure 12a). The front disk represents the front of the dummy head (stamped "front head") and the rear disk represents the rear of the dummy head (stamped "rear head").

Note - The front and rear disks appear identical, but are different and should not be interchanged.

- __3 The first step in assembling the head form is to install a rotary potentiometer (often referred to as a "pot") on the rear disk as shown in Figure 12b. As this pot is assembled to the head form, it is referred to as the "head potentiometer". When assembling the head potentiometer to the head form rear disk (Items 7 and 5, Figure 12b), it is important to position the roll pin (Item 9, Figure 12b), which is press fit into a hole in the potentiometer, within the locator hole in the rear head form disk. Inserting the roll pin into the locator hole of the head form disk ensures that the housing of the potentiometer will not slip within the assembly during testing. The potentiometer is secured to the head form disk with an internal tooth lock washer and threaded hex nut.

CHECK SHEET NO. V3 (Continued)
NECK FLEXION TEST (S572.193)

Dummy Serial No. _____

Test Date _____

Technician _____

Figure 12a. Center bracket, front and rear disks of head form

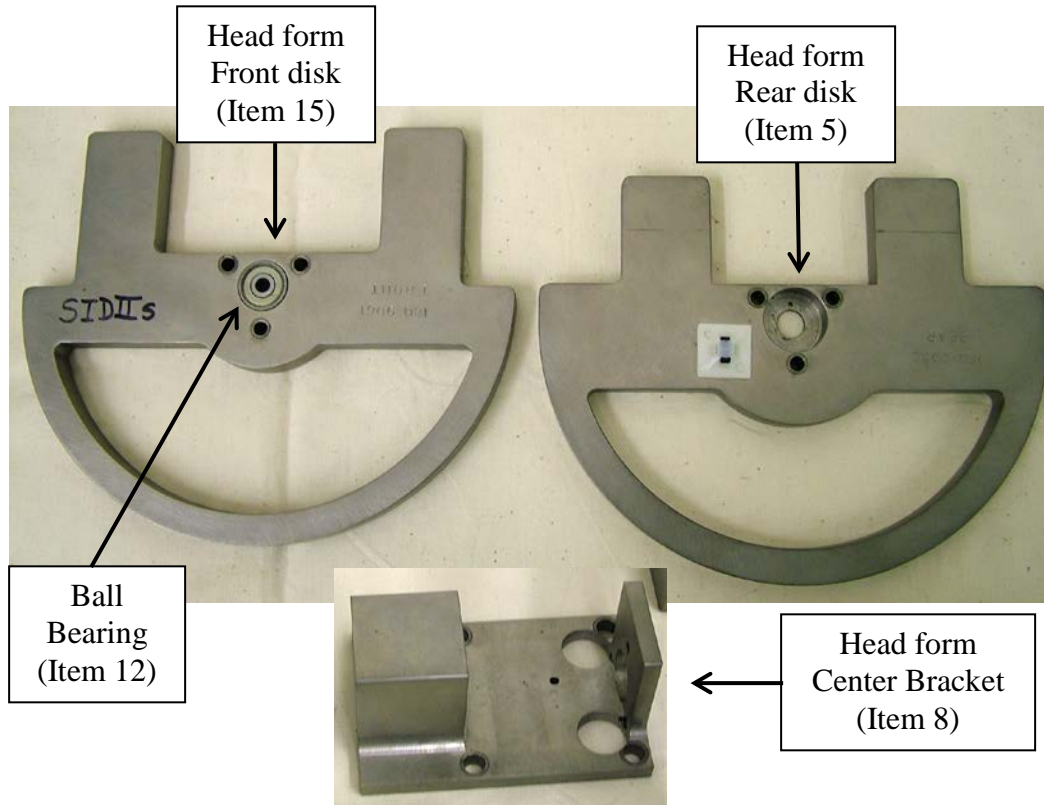
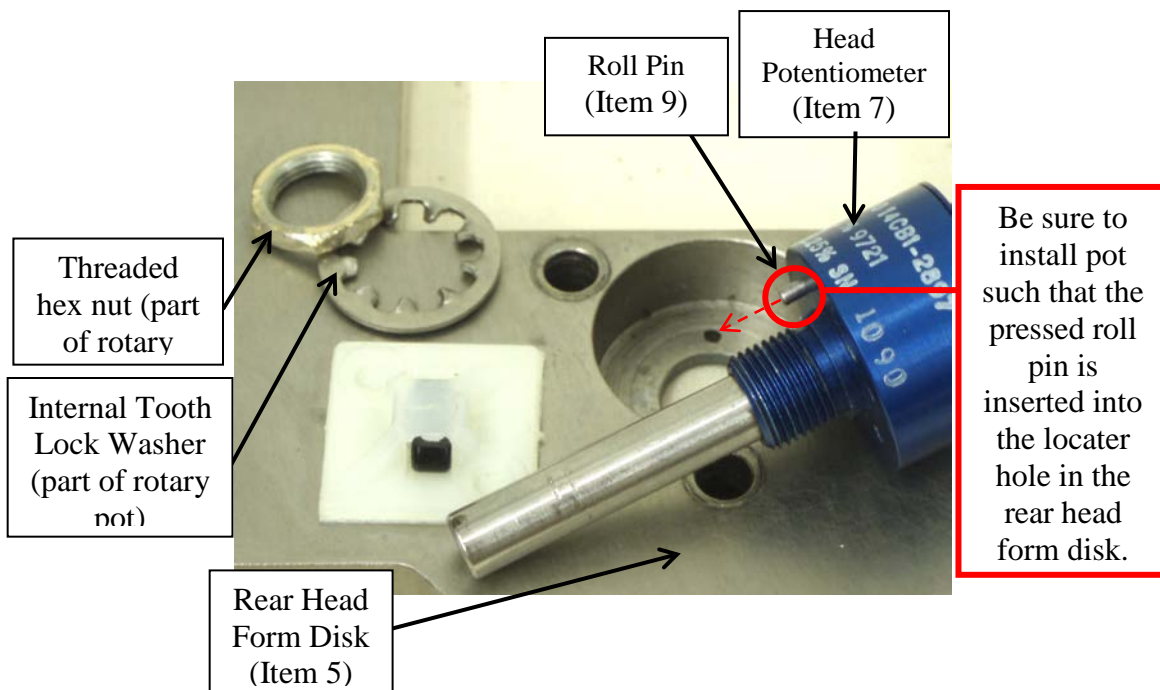

Figure 12b. Head Potentiometer



CHECK SHEET NO. V3 (Continued)
NECK FLEXION TEST (S572.193)

Dummy Serial No. _____

Test Date _____

Technician _____

- ___4 After the head pot is installed, the pot shaft collar is attached to the shaft of the head pot via one #6-32 x 1/8 SSCP (Figure 13). The center bracket and head form front disk are assembled to the rear disk using three #10-32 x 3/4 SHCS for each of the front and rear disks (Figure 14).

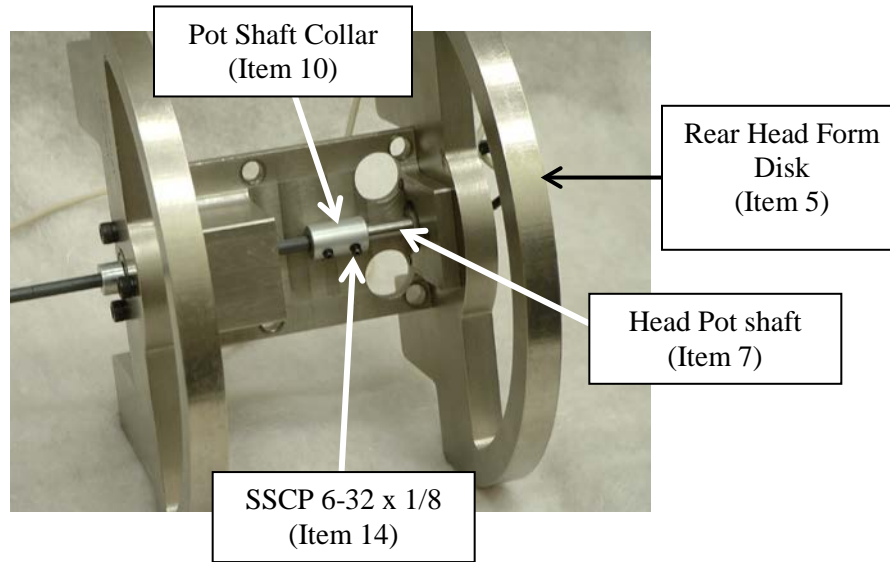

Figure 13. Attaching the pot shaft collar to the head pot

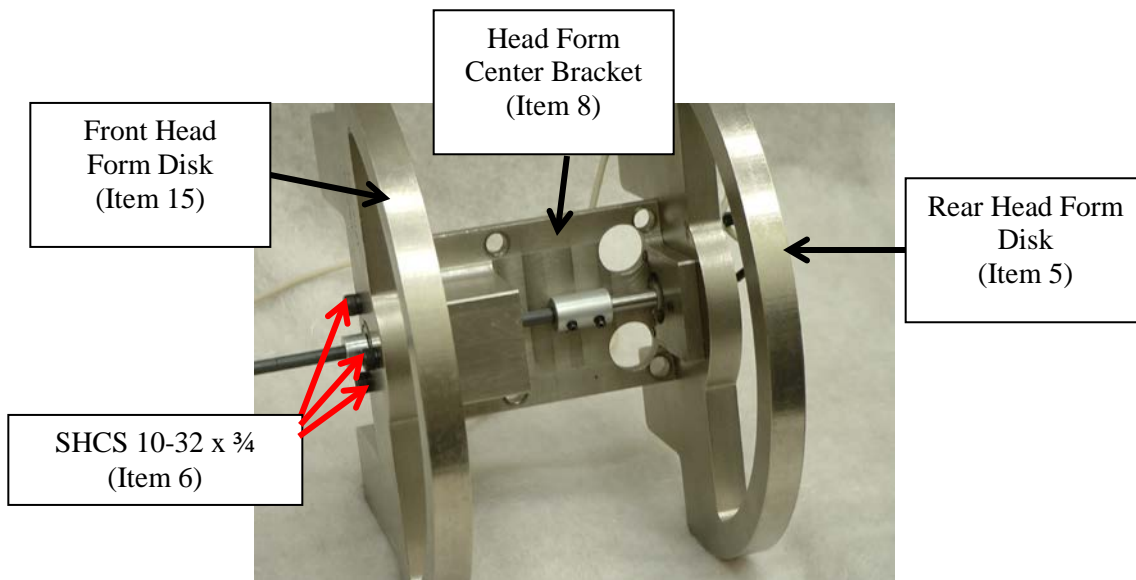

Figure 14. Assembling front head form disk to rear disk

CHECK SHEET NO. V3 (Continued)
NECK FLEXION TEST (S572.193)

Dummy Serial No. _____
 Technician _____

Test Date _____

- 5 The pot extension shaft is attached to the pot shaft collar via two (perpendicular) #6-32 x 1/8 SSCP (Figure 15). The retaining collar is secured to the extension shaft on the outside of the front head form disk with one #6-32 x 1/8 SSCP (Figure 16).

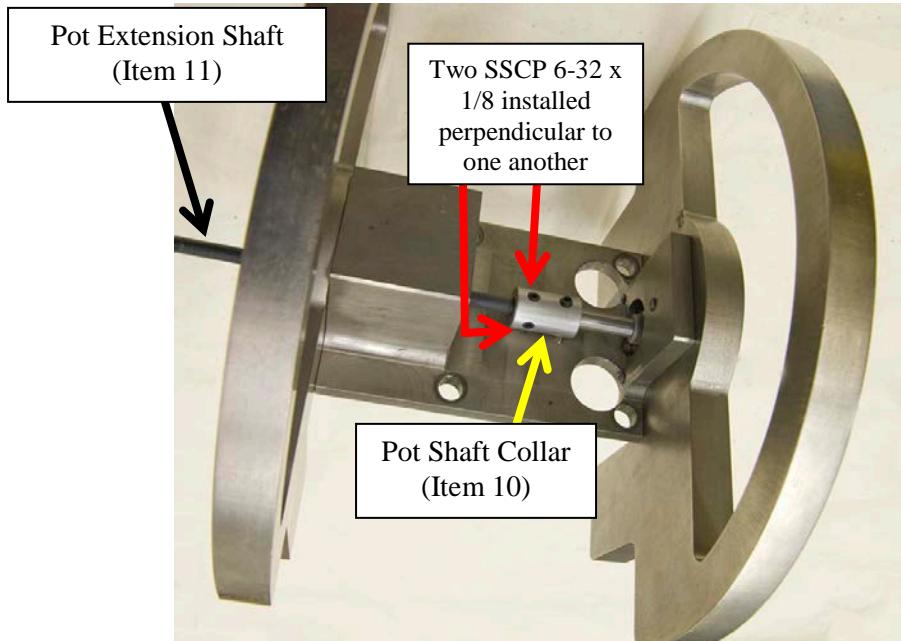

Figure 15. Attaching the pot extension shaft to the pot shaft collar

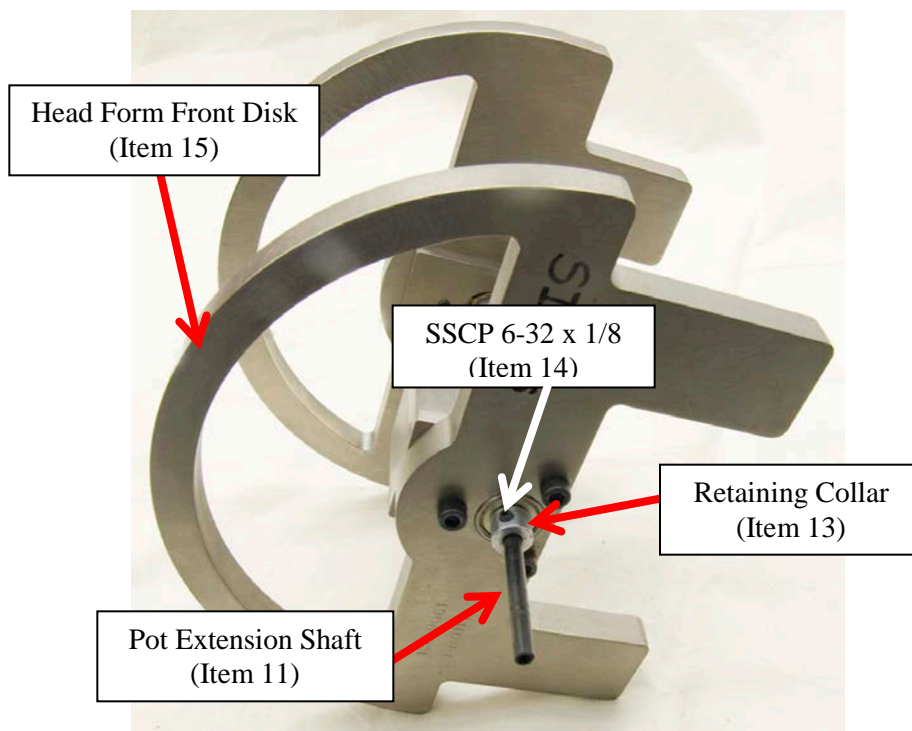

Figure 16. Attaching the retaining collar to the pot extension shaft

CHECK SHEET NO. V3 (Continued)
NECK FLEXION TEST (S572.193)

Dummy Serial No. _____
 Technician _____

Test Date _____

- ___6 Table II lists the parts that make up the head form assembly. The base of the neck is mounted on the neck mounting plate with four 10-24 x 5/8 SHCS and four flat washers (Figure 16), with the bib simulator located between the base of the neck and the neck mounting plate. Four 1/4 -20 SHCS are used to mount the neck and head form assembly to the Part 572 neck pendulum.

Table II. Head Form Assembly Parts

Item Number	Quantity	Part Number	Description
1	1	180-9002	Head Form
2	1	180-9060	Spacer
3	1	180-9040	Potentiometer Inner-Rod Assembly
4	1	180-9030	Potentiometer Outer-Rod Assembly
5	1	180-2000	Neck Assembly (Ref.)
6	1	180-9058	Neck Mounting Plate
7	2	9001021	Screw, SHSS 5/16 x 5/8 Shoulder w/ 1/4-20 x 7/16 Thread
8	2	180-9021	Bracket, Potentiometer Pivot
9	4	9000155	Screw, SSCP #6-40 x 1/4
10	2	SA572-S51	Chest Rotary Potentiometer
11	2	180-9010	Potentiometer Housing Assembly
12	1	180-3006	Simulator, Bib
13	4	9000224	Screw, SHCS #10-24 x 5/8
The Upper Neck Bracket (180-2006) of the Neck Assembly is not utilized for Neck Qualification Tests.			

- ___7 Soak the neck assembly in a controlled environment at a temperature and relative humidity indicated in Table V3 for at least four hours prior to a test. Record the length of time for the soak and the maximum and minimum temperature and humidity in Table V3. Verify that each measurement meets specification by indicating "Pass" or "Fail" in the far right column.
- ___8 Inspect the neck for deformation, tears or breaks in the rubber. Replace the neck if deformation or damage is observed.
- ___9 Inspect the two nodding blocks for deformation or damage. Deformed nodding blocks can cause the head to rattle and allow improper loading of the nodding joint and should be replaced.
- ___10 Remove the hex jam nut (9000018), 1.06 OD x .53 ID x .06 washer (9001260), and lower neck bushing (180-2005) from the end of the neck cable.
- ___11 Uninstall the four #10-24 x 5/8 FHCS to detach the nodding joint assembly (with nodding blocks) from the neck (Figure 17). Remove the neck cable (180-2013) from the neck assembly (180-2000). The upper neck bushing should be present, but need not be removed.

CHECK SHEET NO. V3 (Continued)
NECK FLEXION TEST (S572.193)

Dummy Serial No. _____
Technician _____

Test Date _____



Figure 17. Removing the nodding joint assembly

- ___12 Inspect the neck cable by observing the condition of the strands. If they are not tightly wound, if frays are visible, or the cable appears larger in diameter on one end, replace the cable. If the cable is permanently bent, replace the cable.
- ___13 With the upper neck bushing installed, insert the neck cable through the top of the neck.

CHECK SHEET NO. V3 (Continued)
NECK FLEXION TEST (S572.193)

- __14 Insert the bib simulator over the threaded end of the neck cable taking care to align the holes in the bib simulator with those in the neck (Figure 18).
- __15 Orient the molded neck so that the front of the neck (which has slits) faces the front of the neck mounting plate. Assemble the molded neck to the neck mounting plate with four #10-24 x 5/8 SHCS and four flat washers (Figure 19). *(Note: the upper neck bracket (180-2006) of the neck assembly is not used in the neck qualification test.)*



Figure 18. Install bib simulator



Figure 19. Assemble molded neck to neck mounting plate

CHECK SHEET NO. V3 (Continued)
NECK FLEXION TEST (S572.193)

- __16 Insert the lower neck bushing into the neck mounting plate over the neck cable, then the 1.06 OD x .53 ID x .06 washer and finally the hex jam nut (Figure 20). Torque the nut to 10-12 in-lbs (Figure 21). If the proper torque cannot be achieved, replace the neck cable.



Figure 20. Install lower neck bushing, washer, and hex nut onto neck cable



Figure 21. Torque hex nut on neck cable to 10-12 in-lbs

CHECK SHEET NO. V3 (Continued)
NECK FLEXION TEST (S572.193)

- __17 Reinstall the nodding joint assembly with nodding blocks using the four #10-24 x 5/8 FHCS (Figure 22).
- __18 Install the potentiometer pivot brackets to the neck mounting plate using one SHSS 5/16 x 5/8 shoulder screw with 1/4-20 x 7/16 thread for each bracket (Figure 23).

Note - For a left side test (shown) the pivot bracket is placed in the innermost threaded hole on the right side of the neck, and on the outermost threaded hole on the left side of the neck.



Figure 22. Reinstall neck nodding joint assembly

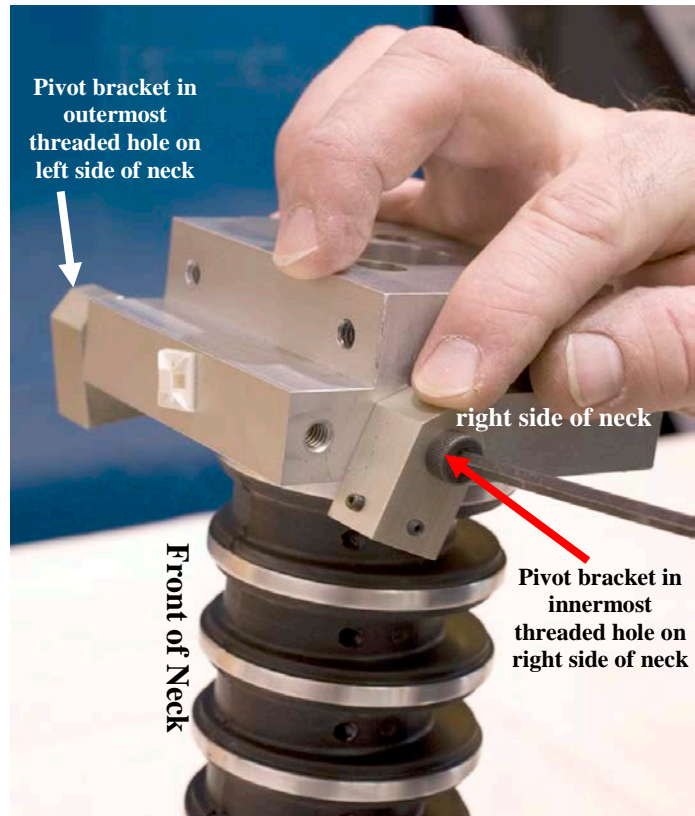

Figure 23. Install potentiometer brackets (left side neck test illustrated)

CHECK SHEET NO. V3 (Continued)
NECK FLEXION TEST (S572.193)

- __19 Prior to installing the neck to the six axis upper neck load cell, install the brass nodding joint washers by holding them on either side of the pivot hole on the neck cap (Figure 24); orient the upper neck load cell so that the straight edge of the load cell is towards the back of the neck, and press the upper neck load cell onto the pivot while maintaining the positioning of the brass washers (Figure 25).



Figure 24. Install brass nodding joint washers

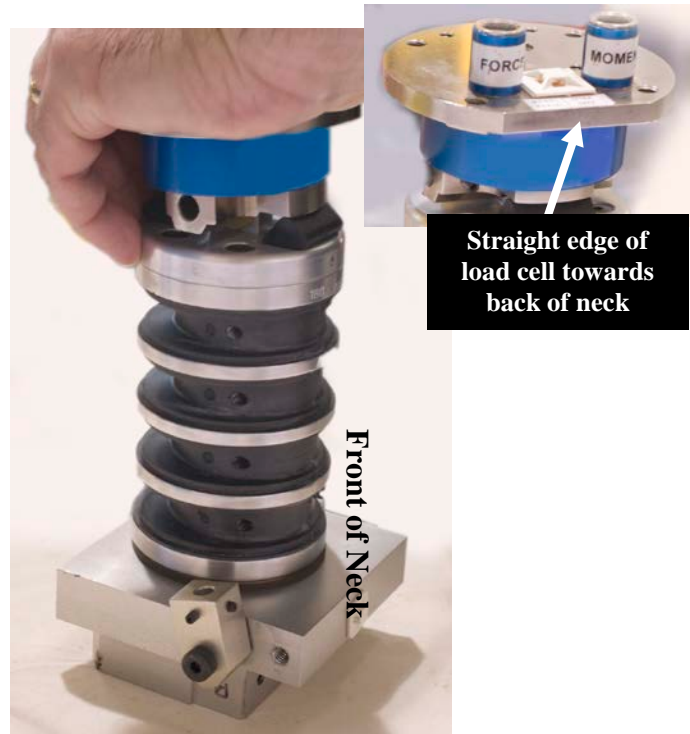

Figure 25. Install the upper neck load cell

CHECK SHEET NO. V3 (Continued)
NECK FLEXION TEST (S572.193)

- __20 In order to insert the pivot pin through the neck, the brass nodding joint washers must be aligned properly with the holes. A punch tool or other appropriate tool, may aid in this alignment (Figure 26).
- __21 Uninstall the two #8-32 x 1/4 set screws located on the back underside of the load cell. Insert the neck pivot pin so that the “flat” sections of the pin face the rear of the load cell. Using a nylon or similar “soft” mallet so that the load cell will not be damaged (Figure 27), drive the neck pivot pin into the nodding joint. When the flat portions of the pivot pin are visible through the set screw holes, the pin is properly located. Reinstall and tighten the set screws.



Figure 26. Align brass nodding joint washers with holes

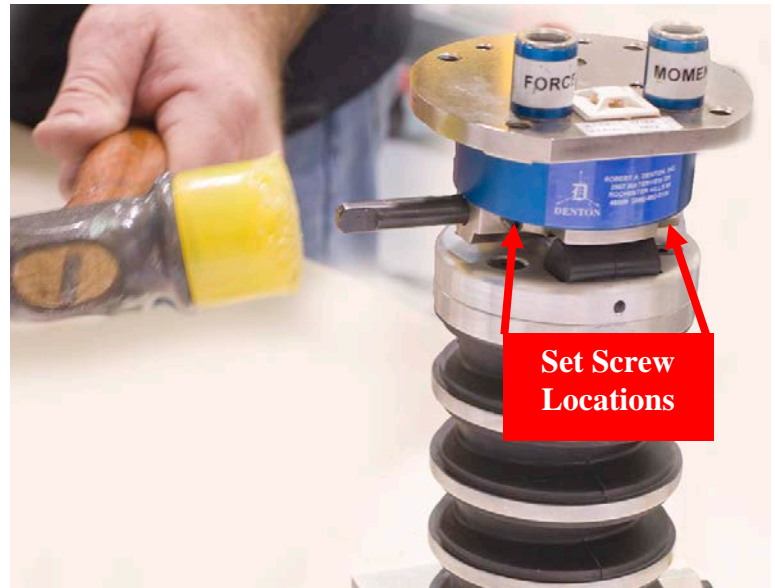

Figure 27. Insert and install neck pivot pin

CHECK SHEET NO. V3 (Continued)
NECK FLEXION TEST (S572.193)

- __22 Install the upper neck load cell to the head form using four $\frac{1}{4}$ - 28 x $\frac{1}{2}$ SHCS (Figure 28). Be sure to orient the neck appropriately with the Rear Head Form Disk at the rear of the neck and the Front Head Form Disk at the front of the neck. Recall that the straight edge of the load cell corresponds to the back of the neck and the front of the neck has slits.

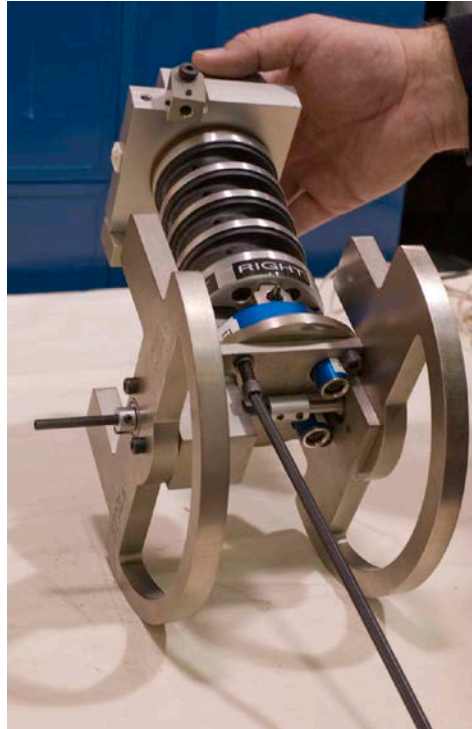

Figure 28. Install upper neck load cell to head form

CHECK SHEET NO. V3 (Continued)
NECK FLEXION TEST (S572.193)

- __23 Carefully slide the potentiometer inner rod assembly (which has a bearing in the clevis) onto the head potentiometer extension shaft (Figure 29). The pot/rod assemblies are referred to as the inner and outer pot rod assemblies due to their relative positions on the head pot extension shaft.

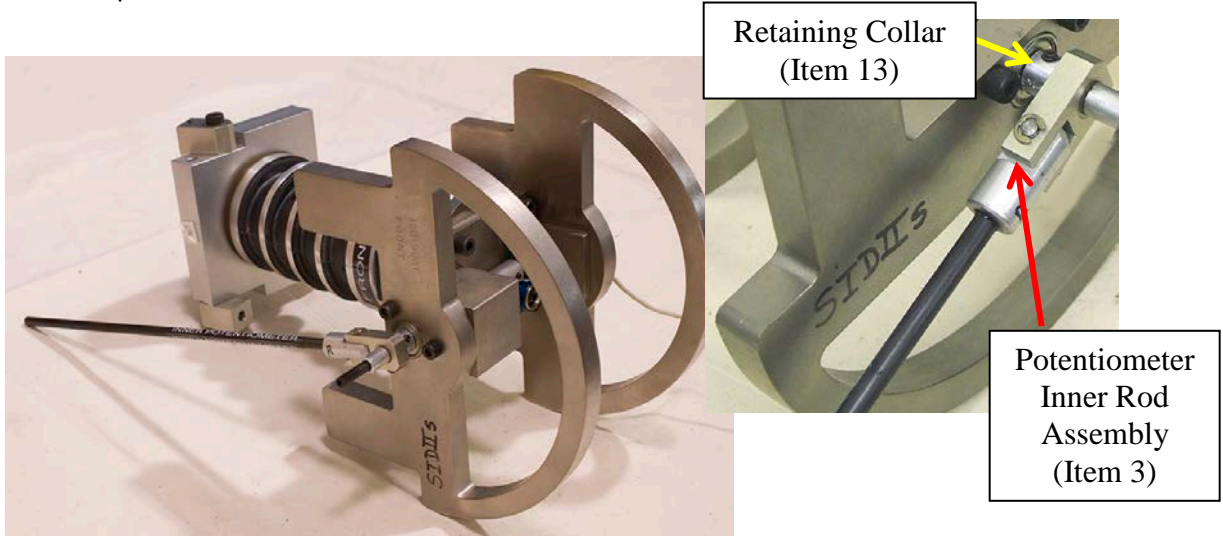

Figure 29. Install the inner potentiometer rod assembly

- __24 Place the spacer onto the head pot extension shaft, followed by the potentiometer outer rod assembly (which has holes for set screws in the clevis) (Figure 30). Lightly tighten the two set screws in the outer rod assembly clevis to clamp it to the head pot extension shaft, being careful not to damage the shaft.

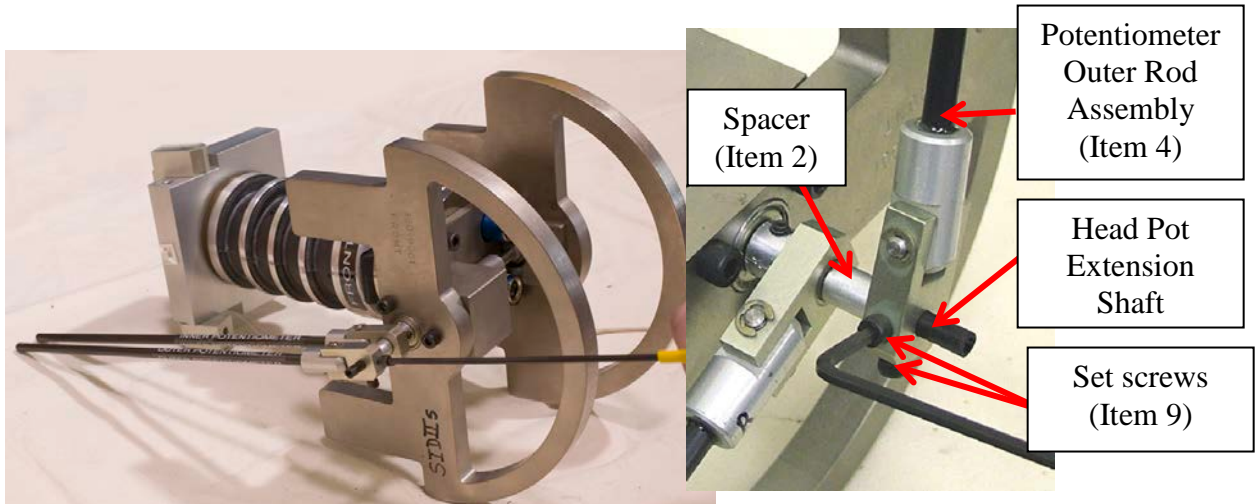

Figure 30. Install the outer potentiometer rod assembly

CHECK SHEET NO.V3 (Continued)
NECK FLEXION TEST (S572.193)

- __25 Install the chest rotary potentiometers into the potentiometer housing assemblies (Figure 31). During installation, it is important to insert the roll pin, which is press fit into the potentiometer housing assembly, into one of the locator holes of the potentiometer. **Inserting the roll pin of the potentiometer housing assembly into the locator hole of the potentiometer ensures that the potentiometer will not slip within the assembly during testing.** The potentiometer is secured to the assembly with an internal tooth lock washer and threaded hex nut.

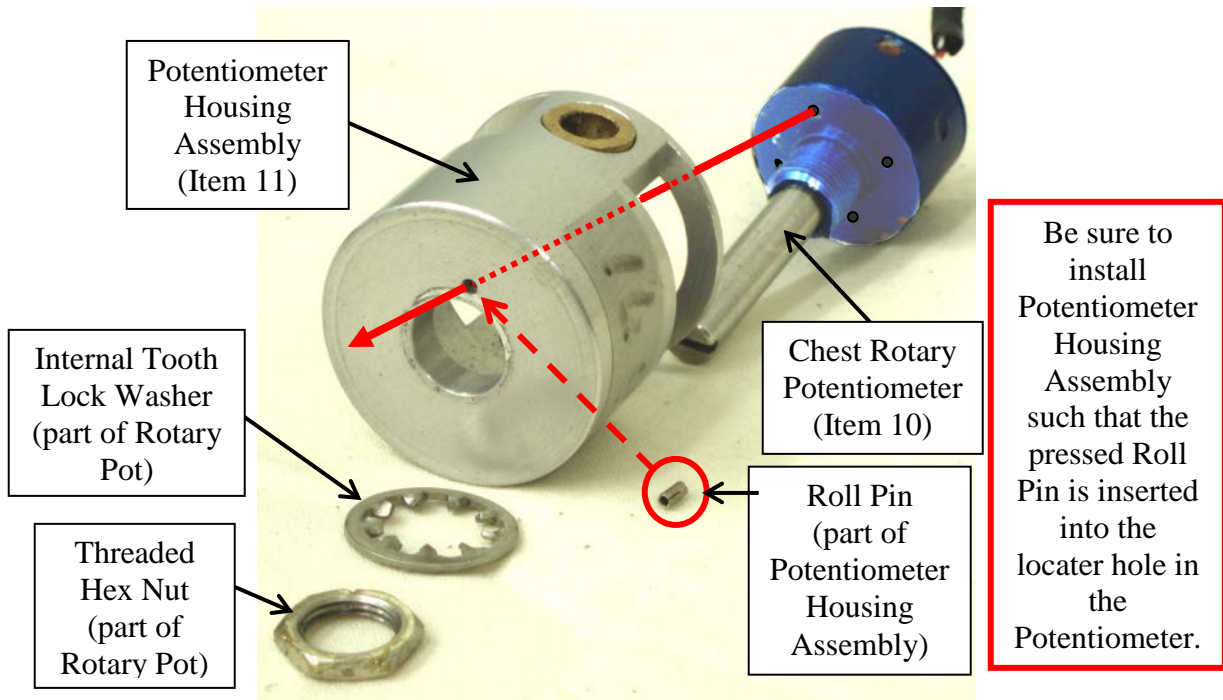

Figure 31. Assembling chest rotary potentiometer and potentiometer housing assembly

- __26 Slide a potentiometer housing assembly onto each potentiometer rod.
 __27 Install the shaft of the potentiometer on the inner pot rod onto the inner potentiometer pivot bracket (Figure 32). Note that the pivot bracket is bolted to the innermost bolt location for this pot (Figures 23 and 32). Tighten the two #6-40 x ¼ SSCP set screws into the pot shaft (Figures 32 and 33).

NOTE -These potentiometers are referred to as “forward” and “rearward” or “fore” and “aft” to describe their position on the neck mounting plate relative to the honeycomb. Regardless of which side of the neck is tested (left or right), the inner pot rod should **always** be attached to the pot housing assembly that is farthest from the honeycomb, referred to as the Aft/Inner Pot; the outer pot rod should **always** be attached to the pot housing assembly that is nearest to the honeycomb, referred to as the Fore/Outer Pot. It is important to assure that the potentiometers are in the correct locations in order to obtain the appropriate rotation measurements

CHECK SHEET NO. V3 (Continued)
NECK FLEXION TEST (S572.193)

- __28 Repeat the same installation procedure for the potentiometer on the outer pot rod using the outer potentiometer pivot bracket. For the outer rod, be sure the pot bracket is installed in the outermost position (Figure 23).

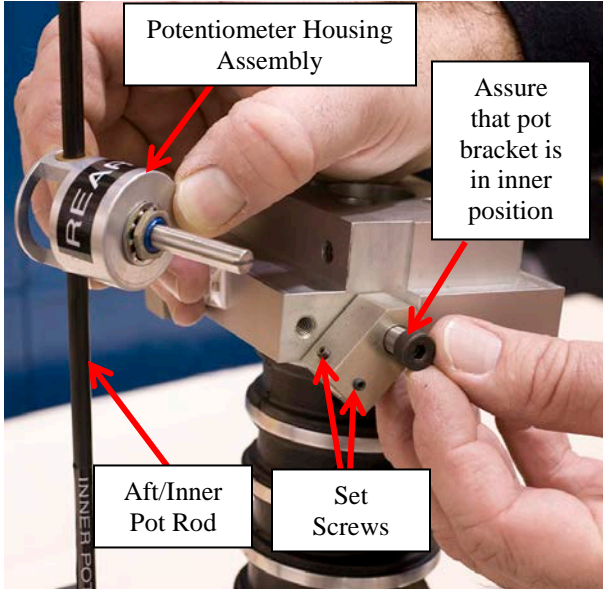

Figure 32. Install potentiometer on inner pot rod onto inner potentiometer pivot bracket



Figure 33. Tighten set screws for inner potentiometer pivot bracket

CHECK SHEET NO. V3 (Continued)
NECK FLEXION TEST (S572.193)

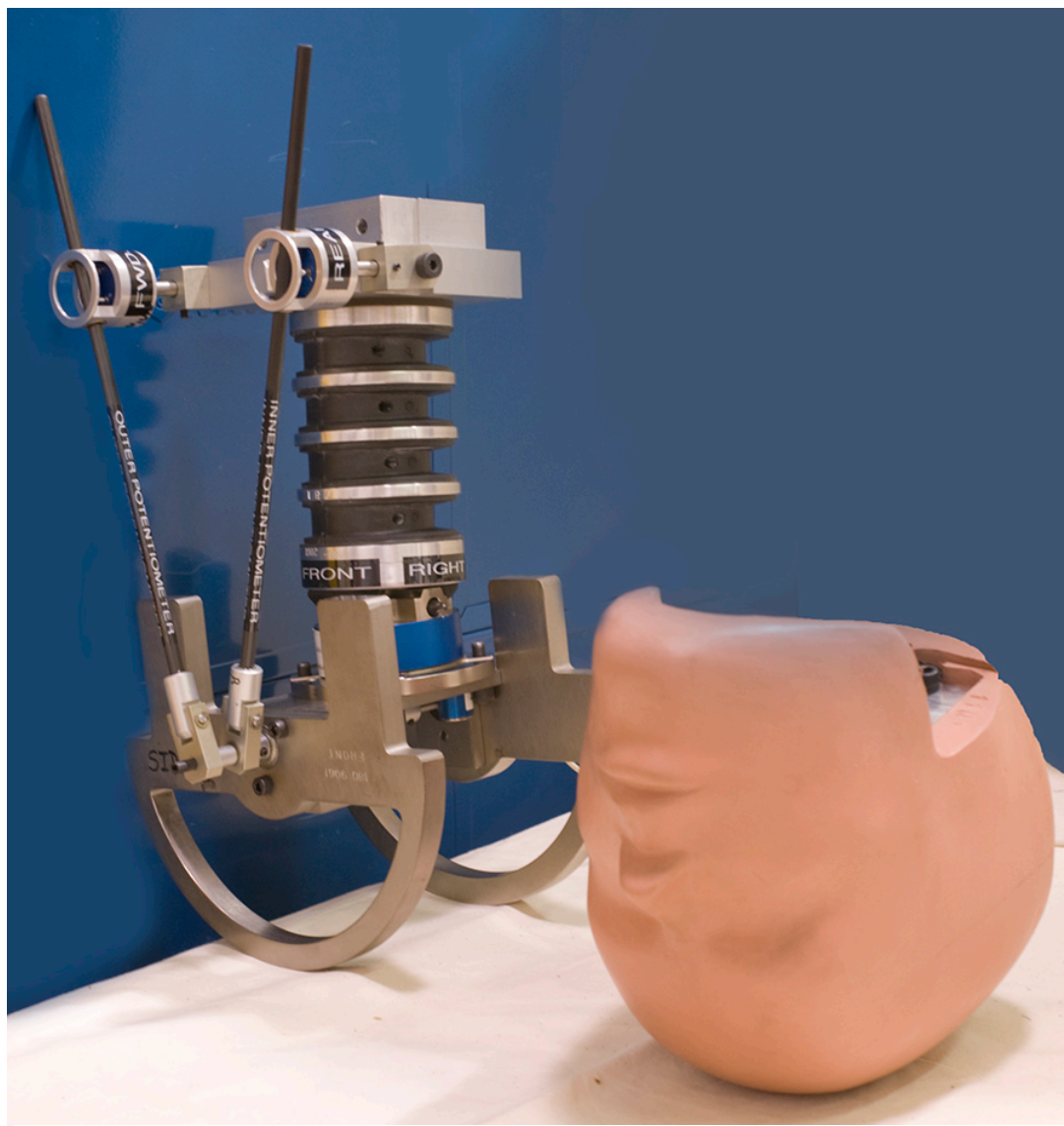

Figure 34. Final configuration of head form attached to neck with dummy head shown for orientation (head form is configured for left side impact)

CHECK SHEET NO. V3 (Continued)
NECK FLEXION TEST (S572.193)

- __29 Insert the neck mounting plate into the pendulum such that the impact side of the neck is closest to the honeycomb, screw and tighten with four ¼-20 x 5/8 SHCS. Note that the CG of the head form is not in line with the centerline of the neck, causing the head form to “sag.” Figure 35 shows a neck and head form installed for a left side impact. Figure 36 shows a schematic for the configuration viewed from above.

Note -The outermost pot, which is closest to the honeycomb, is used for obtaining $\Delta\Theta_{Outer}$ (Figure 39).

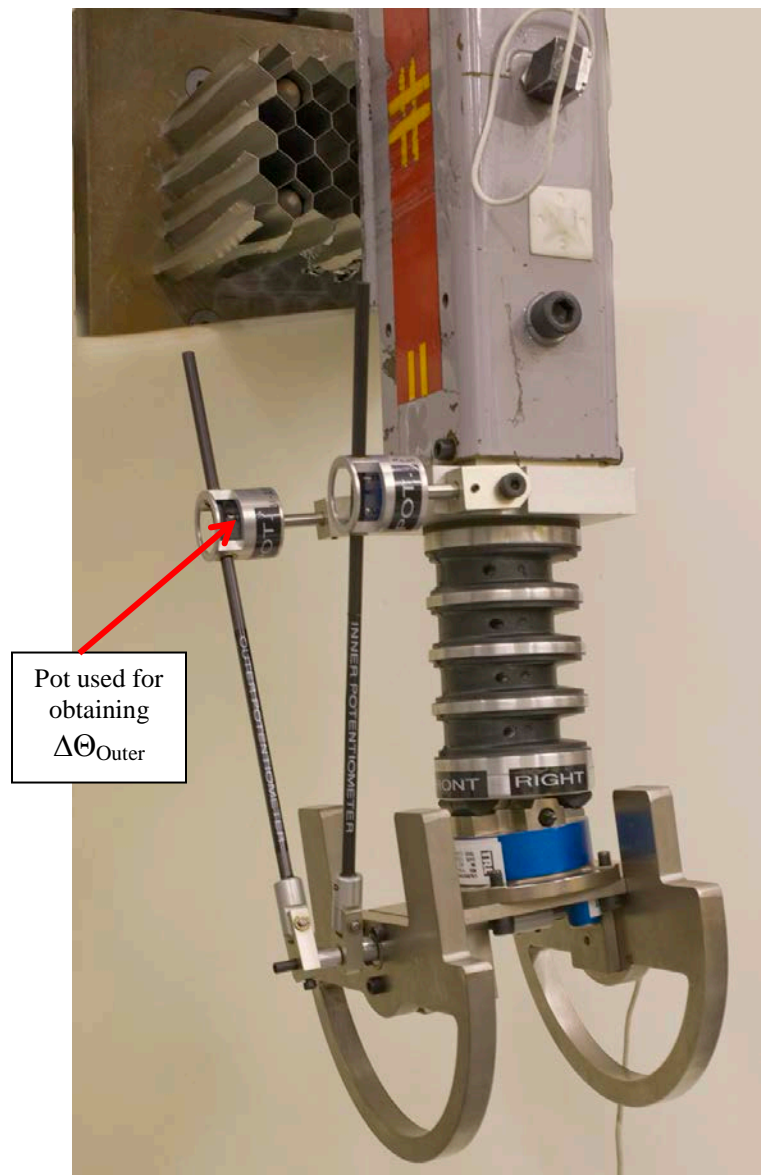

Figure 35. Pendulum configuration for a left side neck test

CHECK SHEET NO. V3 (Continued)
NECK FLEXION TEST (S572.193)

HONEYCOMB

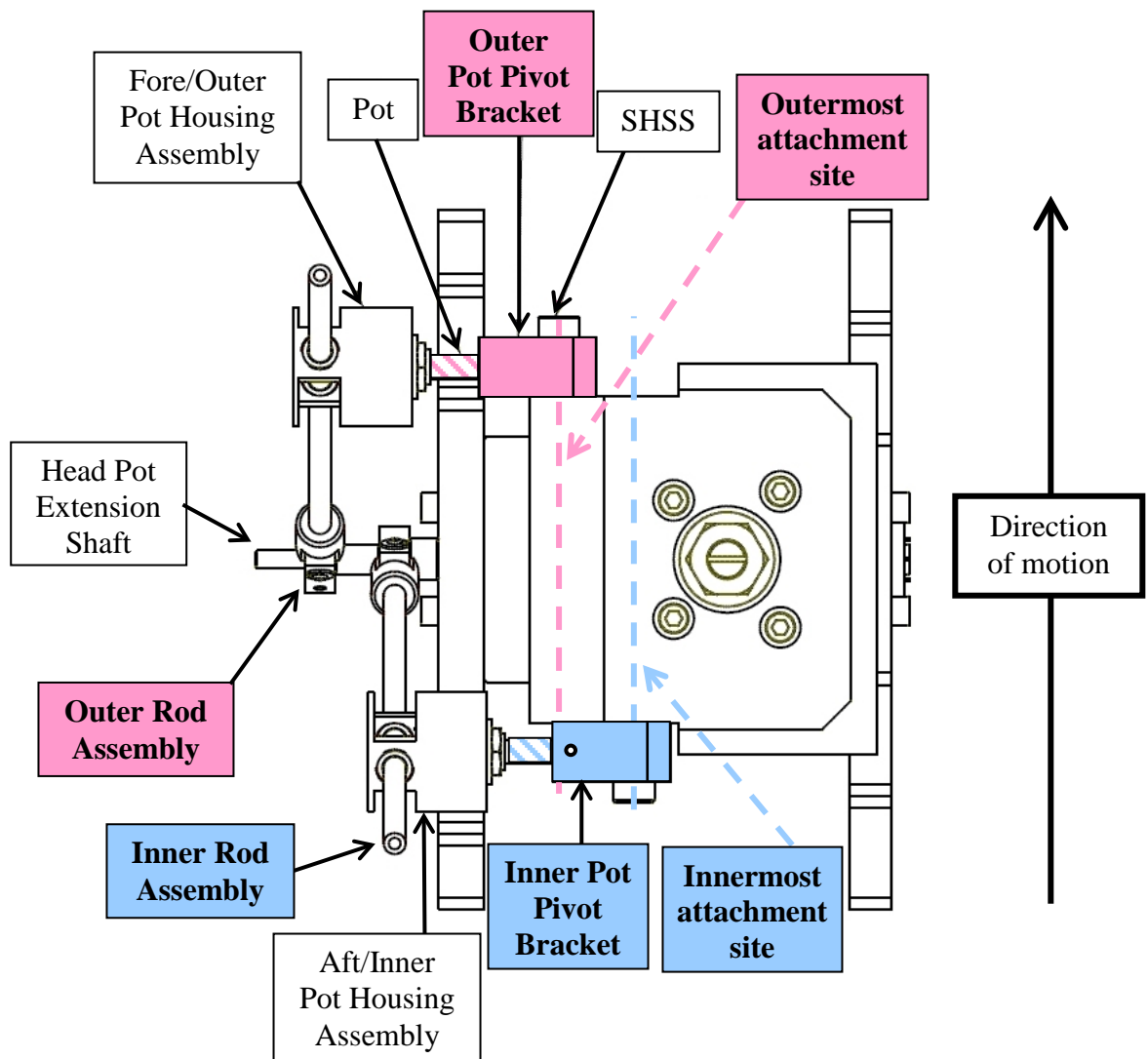

Figure 36. Attachment of inner and outer pot rod assemblies to neck mounting plate for left side impact (view from above)

CHECK SHEET NO. V3 (Continued)
NECK FLEXION TEST (S572.193)

Opposite Side Test Preparation - To test the opposite side of the neck, follow these steps:

- ___1 Remove the entire assembly from the pendulum, rotate it 180 degrees and reassemble the neck mounting plate to the pendulum.
- ___2 Switch the position of the two potentiometer rod assemblies by removing the potentiometer pivot brackets at the neck mounting plate and securing the outer rod/pot pivot bracket to the outermost attachment site closest to the honeycomb (i.e., in the fore position) and the inner rod/pot pivot bracket to the innermost attachment site furthest from the honeycomb (i.e., in the aft position) (Figures 37 and 38). **When calculating the D-plane rotation, be sure that the potentiometers being used are in the appropriate locations during the test.**

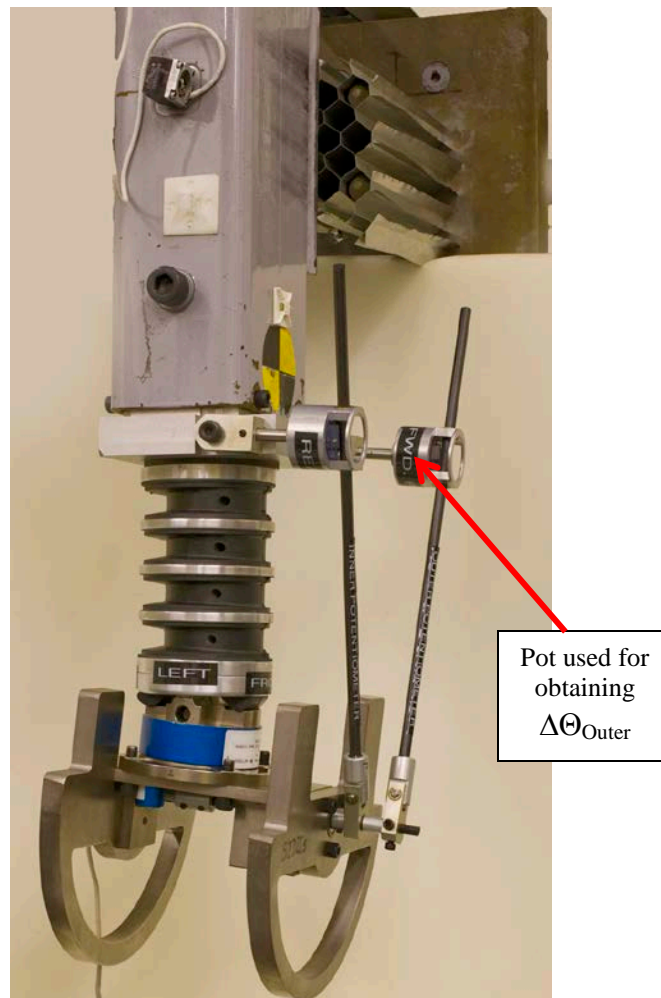

Figure 37 Pendulum configuration for a right side neck test

CHECK SHEET NO. V3 (Continued)
NECK FLEXION TEST (S572.193)

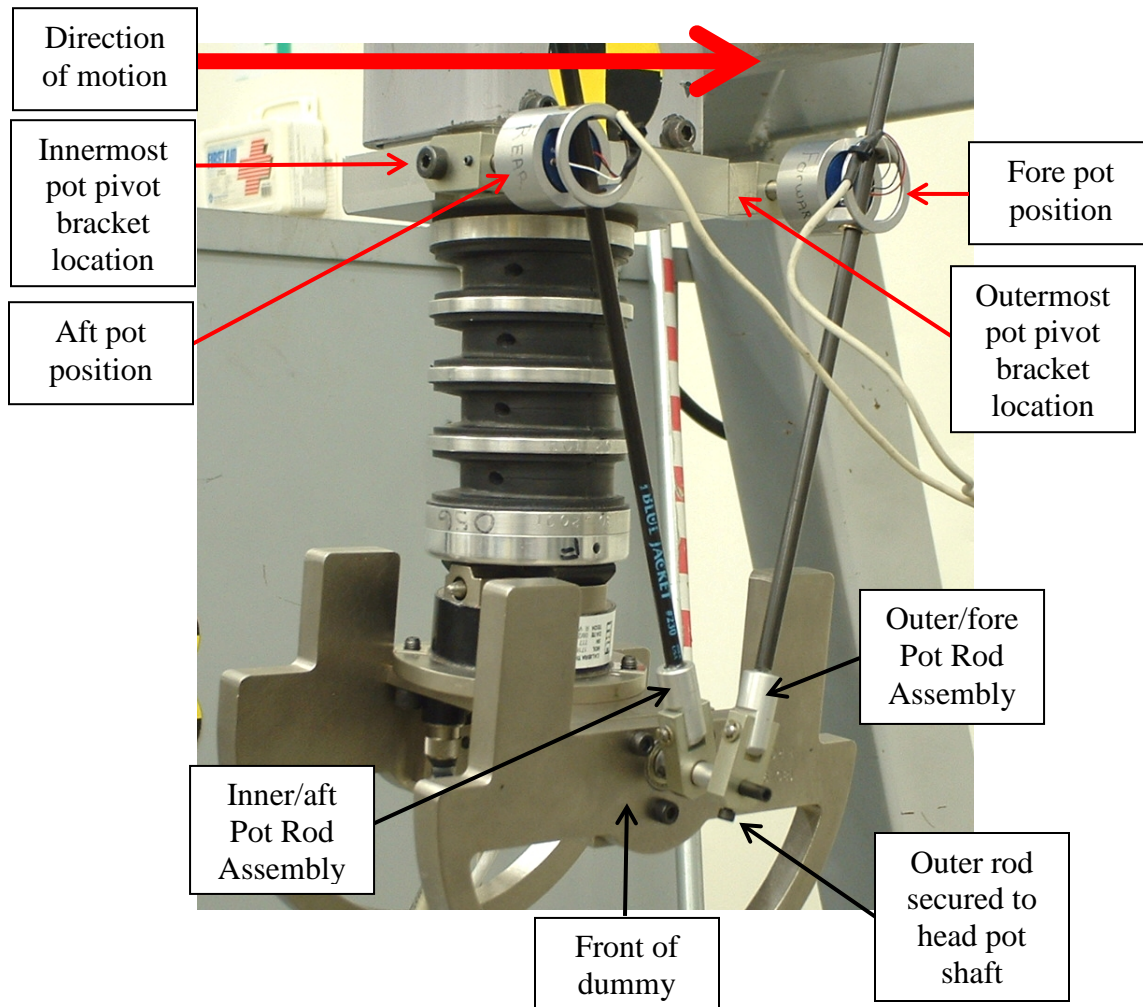

Figure 38. Correct outer and inner pot/rod assembly locations for a right-side test

Conduct the Test, Collect Data and Verify Performance

- ___1 Record the room temperature and relative humidity on the table. Verify that each measurement meets specifications by indicating "Pass" or "Fail" in the far right column.
- ___2 The neck pendulum should have a mass as specified in Figure 22, 49 CFR 572.33.
- ___3 Mount an accelerometer on the pendulum with its sensitive axis on the side of the pendulum that impacts the honeycomb at the location specified in Figure 22, 49 CFR 572.33.
- ___4 Raise the pendulum and allow it to fall freely such that it achieves an impact velocity of 5.51-5.63 m/s at the time of contact with the arresting block.
- ___5 The pendulum acceleration is filtered using a Channel Class 180 phaseless filter.
- ___6 The potentiometers are filtered using a Channel Class 60 phaseless filter.
- ___7 The neck lateral shear force is filtered using Channel Class 600 phaseless filter for the purpose of occipital condyle calculation.
- ___8 The neck moment about the x-axis is filtered using Channel Class 600 phaseless filter.
- ___9 Time zero is defined as the time of contact between the pendulum and the honeycomb. All channels should be at the zero level at this point.

CHECK SHEET NO. V3 (Continued)
NECK FLEXION TEST (S572.193)

__10 Calculate the moment about the occipital condyle for lateral flexion using the formula:
 $M_{x_{oc}} = M_x + (0.01778 * F_y)$

where $M_{x_{oc}}$ is the moment about the occipital condyle for lateral flexion in Newton-meters,
 M_x is the moment about the x axis measured by the upper neck load cell in Newton-meters
 and F_y is the lateral shear force measured by the upper neck load cell in Newtons.

__11 Calculate the D-plane rotation using the formula: (see Figure 39)

$$\beta_{D\text{-plane}} = \Delta\Theta_{\text{Head}} + \Delta\Theta_{\text{Outer}}$$

where $\Delta\Theta_{\text{Head}}$ and $\Delta\Theta_{\text{Outer}}$ are the deviations of the angles Θ_{Head} and Θ_{Outer}

__12 Determine the change in pendulum deceleration by integrating the pendulum acceleration beginning at time zero.

__13 Record the test parameters indicated in Table V3. Verify that the parameters meet specification by indicating "Pass" or "Fail" in the far right column.

__14 If the test results are not within specification, wait at least 30 minutes, conduct another test.

__15 Record and report the results of each additional test in a separate table.

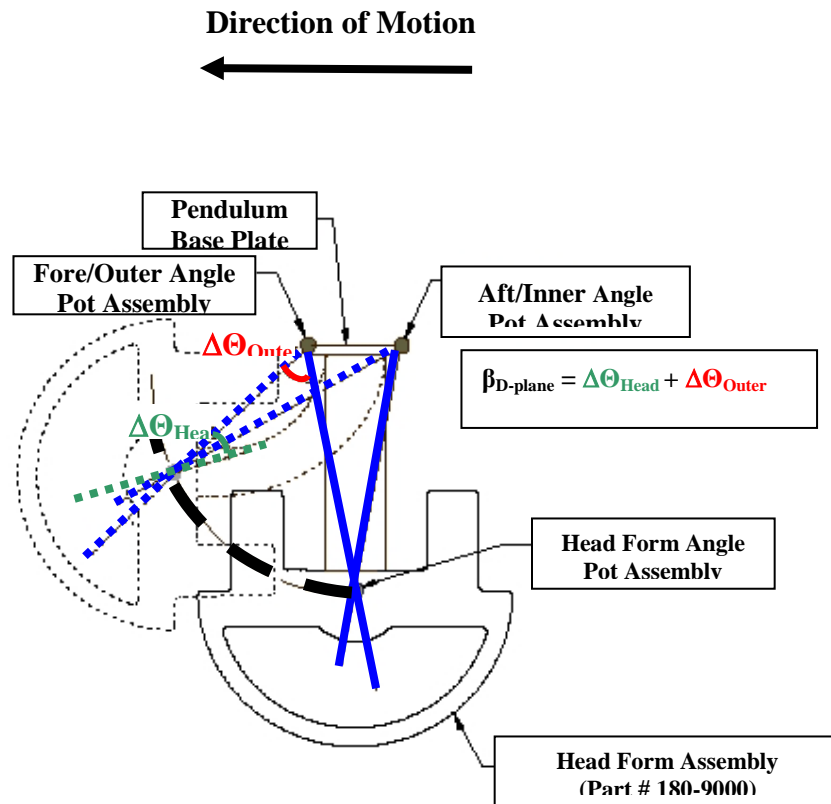

Figure 39. Angle measurements with the head form setup

CHECK SHEET NO. V3 (Continued)
NECK FLEXION TEST (S572.193)

Table V3. Neck Flexion Test

Tested Parameter		Units	Spec.	Result	Pass/ Fail
Neck Assembly Soak Time		Minutes	≥240		
Temperature – During Soak	Max	C°	20.6 to 22.2		
	Min				
Humidity – During Soak	Max	%	10.0 to 70.0		
	Min				
Temperature – During test		C°	20.6 to 22.2		
Humidity – During test		%	10.0 to 70.0		
Pendulum Velocity		m/s	5.51 to 5.63		
Pendulum Deceleration	10 ms	G's	2.20 to 2.80		
	15 ms	G's	3.30 to 4.10		
	20 ms	G's	4.40 to 5.40		
	25 ms	G's	5.40 to 6.10		
	25-100 ms	G's	5.50 to 6.20		
Maximum D-plane rotation		deg	71 to 81		
Time of Maximum D-plane rotation		ms	50 to 70		
Peak Occ. Condyle Moment		Nm	-44 to -36		
Time of Moment Decay		ms	102 to 126		

Signature

Completion Date

CHECK SHEET NO. V4 SHOULDER IMPACT TEST (S572.194)

Dummy Serial No. _____

Test Date _____

Technician _____

Pretest Preparation

- ___1 Soak the dummy in a controlled environment at a temperature and relative humidity indicated in Table V4 for at least four hours prior to a test. Record the length of time for the soak and the maximum and minimum temperature and humidity in Table V4. Verify that each measurement meets specification by indicating "Pass" or "Fail" in the far right column.
- ___2 Install the thoracic and abdominal pads using cable ties.
- ___3 Place the chest jacket on the dummy.
- ___4 Clothe the dummy with cotton underwear pants, cut off just above the knees, but no shirt or shoes.
- ___5 Ground the dummy using a cable between a metal component of the dummy and the ground.
- ___7 Align the upper and lower neck brackets of the neck load cell replacement so that the top edges are flush with one another.
- ___8 Place the bench (Figure 40) in the probe's impact area so that the dummy can be impacted in the shoulder.

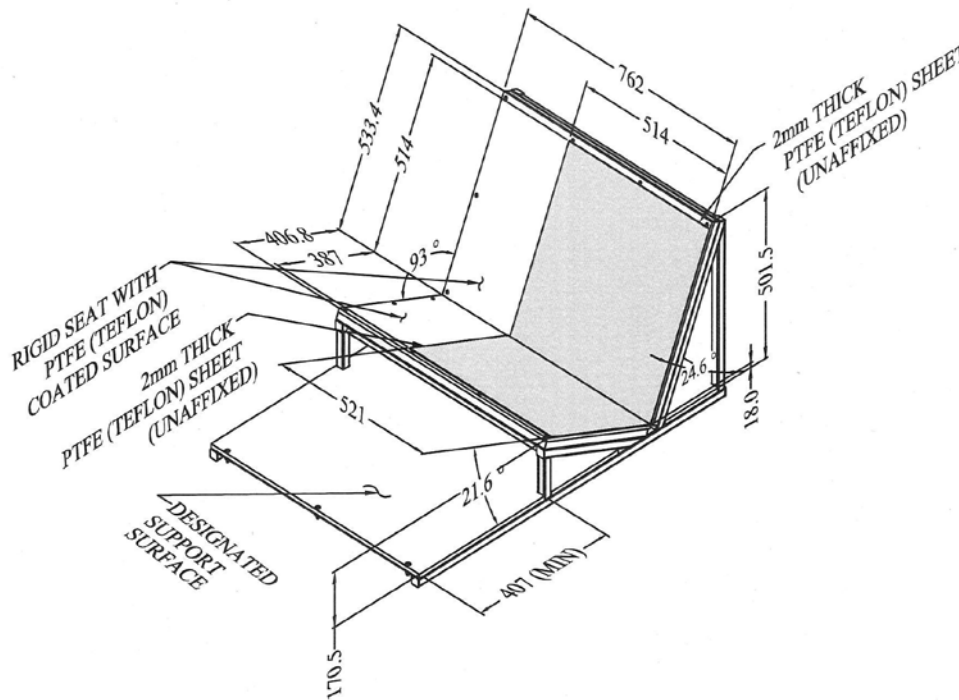

Figure 40. Certification bench seat specifications

- ___9 Seat the dummy on a sheet of 387 x 521 mm PTFE (Teflon®) (2-mm thick) on the bench. Position the dummy so that the outermost pelvic flesh is within 10 mm of the edge of the Teflon® sheet; the edge of the sheet must be along the impact side of the bench's seat pan (Figure 41).
- ___10 Place a sheet of 514 x 514 mm PTFE (Teflon®) (2-mm thick) between the seatback and the dummy's posterior thorax; the edge of the sheet must be along the impact side of the bench's seatback.

CHECK SHEET NO. V4 (Continued)
SHOULDER IMPACT TEST (S572.194)

- __11 Be sure that the molded arm assembly plug (drawing 180-6019) is completely inserted into the arm and secured to the arm bone with screws.
- __12 Position the arm so that it points forward at $90^\circ \pm 2^\circ$ relative to the inferior-superior orientation of the upper torso (spine box).

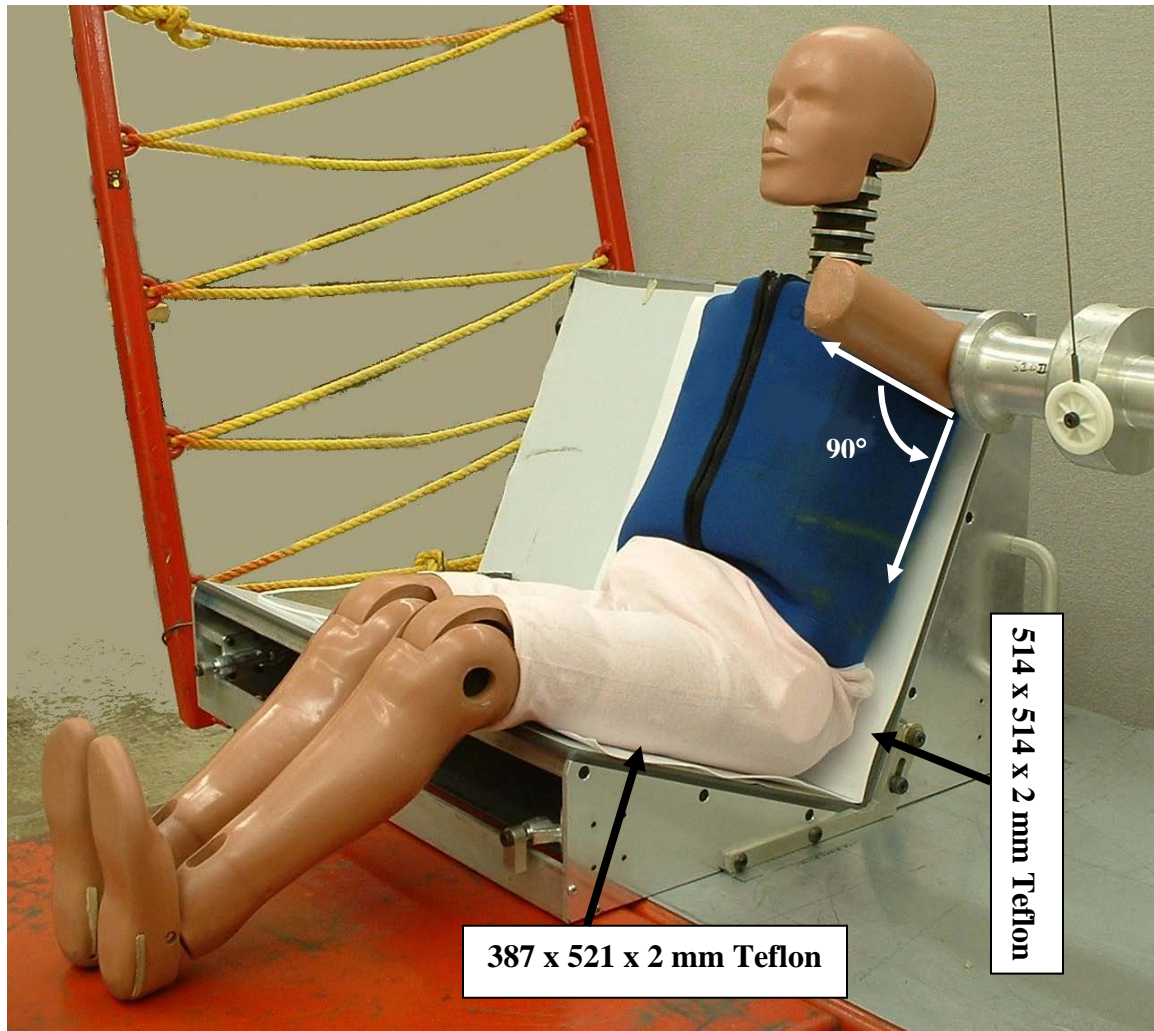

Figure 41. Shoulder impact test configuration for SID-IIIsD

- __13 Position the dummy so that the centerline of the arm bolt (ref. item 23 in drawing 180-3000) is centered on the centerline of the impact probe within 2 mm. The face of the impactor should be parallel to, and just touching, the surface of the molded arm assembly plug when the pendulum is at its lowest position during travel.
- __14 Push the dummy's chest towards the seatback, so that the back of the thorax is touching the seatback (Figure 42).

CHECK SHEET NO. V4 (Continued)
SHOULDER IMPACT TEST (S572.194)

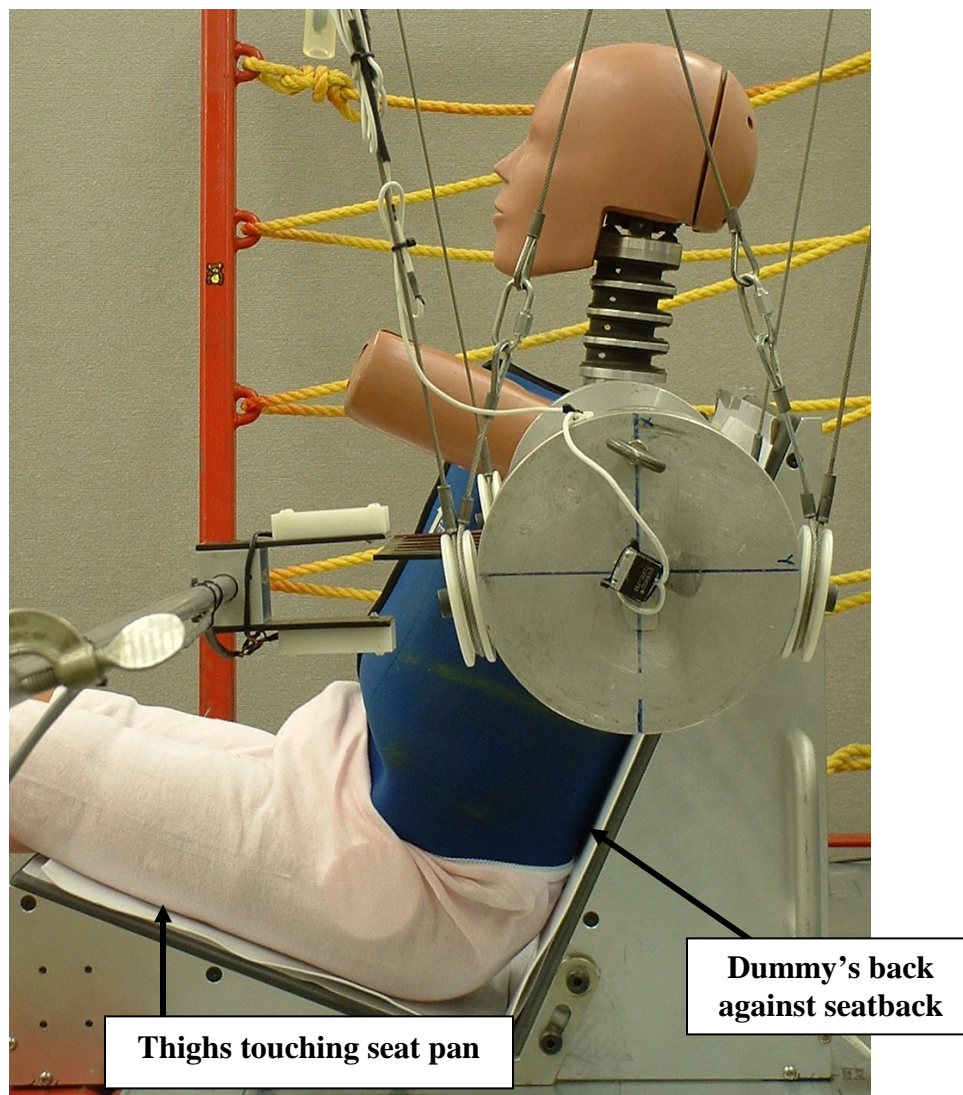

Figure 42. Impact probe and dummy seating position

CHECK SHEET NO. V4 (Continued)
SHOULDER IMPACT TEST (S572.194)

- __15 Push the femurs towards the seat pan so that the thighs are in contact with the seat.
- __16 Move the legs together so that the knees are as close together as possible (Figure 43).

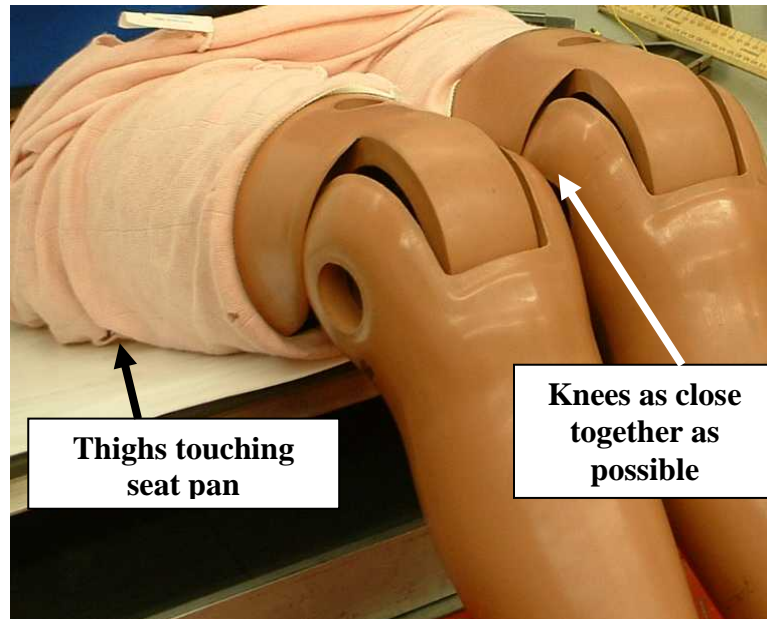

Figure 43. SID-IIIsD leg positioning

- __17 Position the feet so that they are vertical and as close together as possible, with the heels touching the surface of the support table (Figure 44).

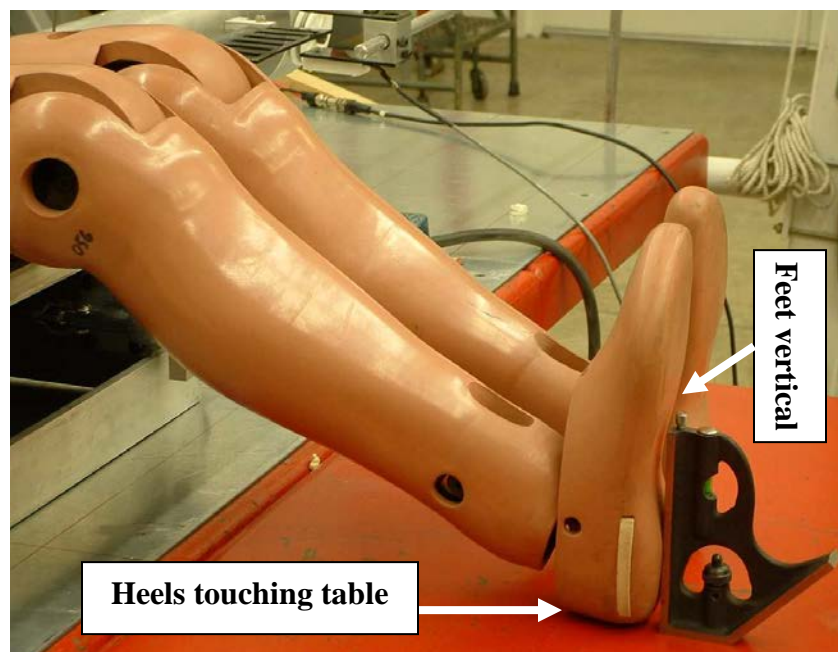

Figure 44. SID-IIIsD feet positioning

CHECK SHEET NO. V4 (Continued)
SHOULDER IMPACT TEST (S572.194)

- __18 Adjust the dummy so that the thoracic lateral plane is $0^\circ \pm 1$ relative to horizontal as referenced at the top surface of the lower neck bracket (Figure 45).



Figure 45. Adjusting the SID-IIIsD dummy in the lateral direction

CHECK SHEET NO. V4 (Continued)
SHOULDER IMPACT TEST (S572.194)

- __19 Adjust the dummy so that the thoracic fore/aft plane measures $24.6 \pm 2^\circ$ relative to horizontal. This measurement can be taken at the top of the shoulder rib mount (Figure 46).



Figure 46. Adjusting the SID-IIsD in the fore/aft plane

Conduct the Test, Collect Data and Verify Performance

- __20 Record the room temperature and humidity in Table V4. Verify that the temperature and relative humidity meets specification by indicating “Pass” or “Fail” in the far right column.
- __21 The impactor should have a mass of $13.97 \pm 0.23 \text{ kg}^1$ with a $120.7 \pm 0.25 \text{ mm}$ face diameter, and a 12.7 mm radius.
- __22 Mount an accelerometer on the impactor with its sensitive axis in line with the longitudinal centerline of the test probe.
- __23 Release the impactor so that it achieves a velocity between 4.2 – 4.4 m/s at the instant of contact with the dummy.
- __24 At the instant of contact, the impactor should be horizontal $\pm 1^\circ$ with its centerline within 2 mm of the dummy’s arm rotation centerline (ref. item 23 in drawing 180-3000).

¹ Mass includes probe mass and all rigidly attached hardware, plus 1/3 of supporting cable weight.

CHECK SHEET NO. V4 (Continued)
SHOULDER IMPACT TEST (S572.194)

- __25 The impactor and spine accelerations are collected and filtered using a Channel Class 180 phaseless filter.
- __26 The shoulder deflection is collected and filtered using a Channel Class 600 phaseless filter.
- __27 Time zero is defined as the time of contact between the impactor probe and the shoulder. All channels should be at a zero level at this point.
- __28 Record impactor velocity, peak impactor acceleration, peak shoulder deflection and peak lateral spine acceleration in Table V4. Verify that each measurement meets specification by indicating "Pass" or "Fail" in the far right column.
- __29 If test results do not meet specifications, wait at least 30 minutes, conduct another test.
- __30 Record and report the results of each additional test in a separate table.

Table V4. Shoulder Impact Test

Tested Parameter		Units	Spec.	Result	Pass/ Fail
Dummy Soak Time		Minutes	≥180		
Temperature – During Soak	Max	C°	20.6 to 22.2		
	Min				
Relative Humidity – During Soak	Max	%	10.0 to 70.0		
	Min				
Temperature – During test		C°	20.6 to 22.2		
Relative Humidity - During test		%	10.0 to 70.0		
Impactor Velocity		m/s	4.2 to 4.4		
Peak Shoulder Deflection		mm	28 to 37		
Peak Lateral Spine (T1) Acceleration (Y)		G's	17 to 22		
Peak Impactor Acceleration		G's	13 to 18		

Signature

Completion Date

CHECK SHEET NO. V5 THORAX WITH ARM IMPACT TEST (S572.195)

Dummy Serial No. _____

Test Date _____

Technician _____

Pretest Preparation

- ___1 Soak the dummy in a controlled environment at a temperature and relative humidity indicated in Table V5 for at least four hours prior to a test. Record the length of time for the soak and the maximum and minimum temperature and humidity in Table V5. Verify that each measurement meets specification by indicating "Pass" or "Fail" in the far right column
- ___2 Install the thoracic and abdominal pads using cable ties².
- ___3 Place the chest jacket on the dummy.
- ___4 Place on the dummy's lower torso cotton underwear pants, cut off just above the knees, but no shirt or shoes.
- ___5 Ground the dummy using a cable between a metal component of the dummy and the ground.
- ___6 Align the upper and lower neck brackets of the load cell replacement so that the top edges are flush with one another. **DO NOT USE THE LOWER NECK LOAD CELL.** (Figure 47)

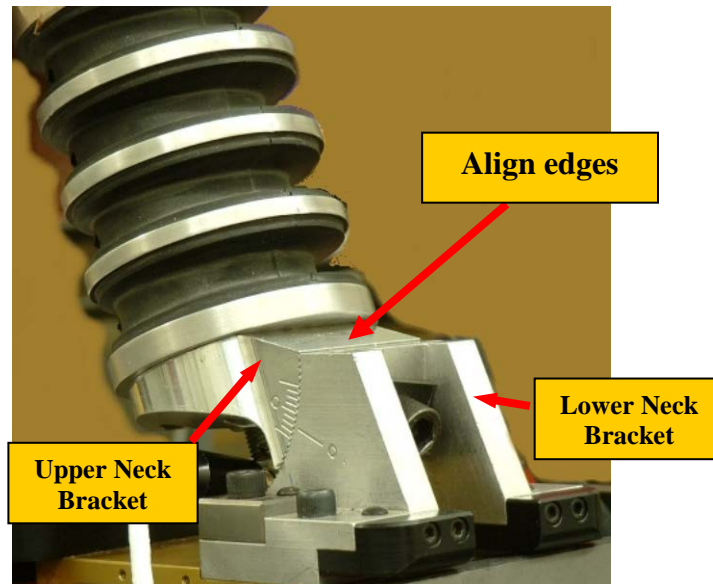

Figure 47. Aligning the upper and lower neck brackets flush for testing.

- ___7 Place the bench seat in the probe's impact area.
- ___8 Seat the dummy on a sheet of 387 x 521 mm PTFE (Teflon®) (2 mm thick) on the bench. Position the dummy within 25mm of the edge of the Teflon® sheet; the edge of the sheet should be along the impact side of the bench's seat pan.
- ___9 Place a sheet of 514 x 514 mm PTFE (Teflon®) (2 mm thick) between the seatback and the dummy's posterior thorax; the edge of the sheet should be along the impact side of the bench's seatback.
- ___10 Position the impact arm to its lowest detent, so that it points downward, parallel to the seatback.

² See Attachment of Thoracic and Abdominal Pads in the SID-IIsD.

CHECK SHEET NO. V5 (Continued)
THORAX WITH ARM IMPACT TEST (S572.195)

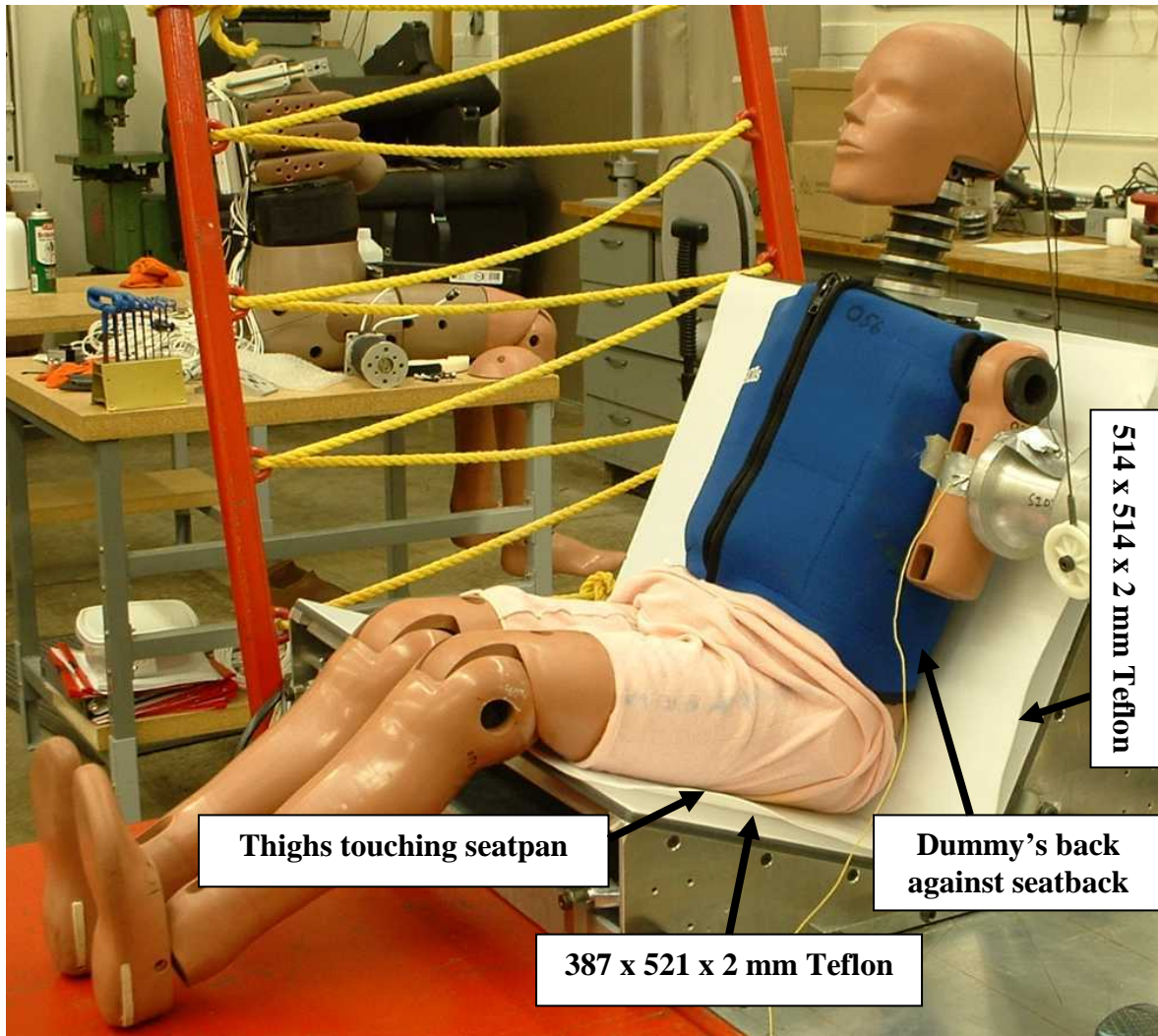

Figure 48. Thorax with arm impact test configuration for SID-II_sD

CHECK SHEET NO. V5 (Continued)
THORAX WITH ARM IMPACT TEST (S572.195)

- __11 Position the dummy so that the centerline of impact probe is centered on the centerline of the middle rib within 2 mm. This corresponds to a reference measurement of 93 ± 2 mm below the centerline of the shoulder yoke assembly arm pivot when measured along the length of the arm. The face of the pendulum should be parallel to ($\pm 1^\circ$), and just touching, the surface of the arm, when the pendulum probe is at its lowest position during travel (Figure 49). (Once the dummy is adjusted in the lateral and fore/aft directions, the probe positioning with respect to the surface of the arm jacket will be complete).
- __12 Push the dummy's chest towards the seatback, so that the back of the thorax is touching the seat.

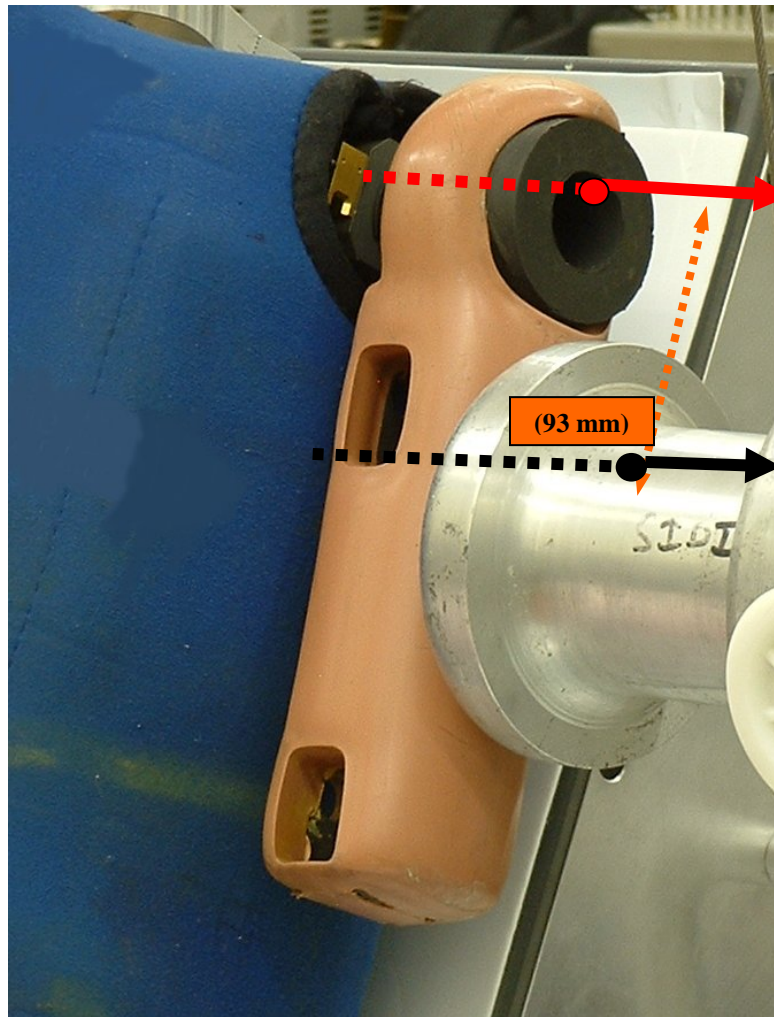

Figure 49. Impact probe position for the SID-IIIsD thorax with arm test

- __13 Push the femurs towards the seat pan so that the thighs make full contact with the seat.
- __14 Move the legs together so that the knees are touching (see Figure 43).
- __15 Position the feet so that they are vertical within 2° , with the heels touching the surface of the support table (see Figure 44).
- __16 Adjust the dummy so that the thoracic lateral plane is $0^\circ \pm 1$ relative to horizontal as referenced at the top surface of the lower neck bracket (see Figure 45).

CHECK SHEET NO. V5 (Continued)
THORAX WITH ARM IMPACT TEST (S572.195)

- __17 Adjust the dummy so that the thoracic fore/aft plane measures $24.6 \pm 2^\circ$ relative to horizontal. This measurement can be taken at the top of the shoulder rib mount (Figure 46).

Conduct the Test, Collect Data and Verify Performance

- __18 Record the room temperature and humidity in Table V5. Verify that the temperature and relative humidity meets specification by indicating "Pass" or "Fail" in the far right column
- __19 The impactor shall have a mass of $13.97 \pm 0.23 \text{ kg}^3$ with a $120.7 \pm 0.25 \text{ mm}$ face diameter, and a 12.7 mm radius.
- __20 Mount an accelerometer on the impactor with its sensitive axis in line with the longitudinal centerline of the impactor.
- __21 Release the impactor so that it achieves a velocity 6.6 – 6.8 m/s at the instant of contact with the dummy.
- __22 At the instant of contact, the impactor should be horizontal $\pm 1^\circ$, and the centerline of the probe should be within 2 mm of the centerline of the middle rib.
- __23 The data acquisition system conforms to SAE Recommended Practice J211.
- __24 Collect the impactor and spine accelerations and filter data using a Channel Class 180 phaseless filter.
- __25 Collect shoulder and thoracic deflections and filter using a Channel Class 600 phaseless filter.
- __26 Time zero is defined as the time of contact between the impactor and the arm. All channels should be at a zero level at this point.
- __27 Record the peak impactor acceleration, peak rib deflections and peak spine accelerations in Table V5. Verify that each measurement meets specification by indicating "Pass" or "Fail" in the far right column.
- __28 If test results do not meet specifications, wait at least 30 minutes, conduct another test.
- __29 Record and report the results of each additional test in a separate table.

³ Mass includes impactor mass and all rigidly attached hardware, plus 1/3 of supporting cable weight.

CHECK SHEET NO. V5 (Continued)
THORAX WITH ARM IMPACT TEST (S572.195)

Table V5. Thorax with Arm Impact Test

Tested Parameter		Units	Specification	Result	Pass/ Fail
Dummy Soak Time		Minutes	≥180		
Temperature - During Soak	Max	°C	20.6 to 22.2		
	Min	°C			
Relative Humidity - During Soak	Max	%	10.0 to 70.0		
	Min	%			
Temperature – During test		°C	20.6 to 22.2		
Relative Humidity – During test		%	10.0 to 70.0		
Impactor Velocity		m/s	6.6 to 6.8		
Peak Shoulder Deflection		Mm	31 to 40		
Peak Upper Rib Deflection		Mm	25 to 32		
Peak Middle Rib Deflection		Mm	30 to 36		
Peak Lower Rib Deflection		Mm	32 to 38		
Peak Upr Spine (T1) Acceleration (Y)		G's	34 to 43		
Peak Lower Spine (T12) Accel (Y)		G's	29 to 37		
Peak Impactor Acceleration		G's	30 to 36		

Signature

Completion Date

CHECK SHEET NO. V6
THORAX WITHOUT ARM IMPACT TEST (S572.196)

Pretest Preparation

- ___1 Soak the dummy in a controlled environment at a temperature and relative humidity indicated in Table V6 for at least four hours prior to a test. Record the length of time for the soak and the maximum and minimum temperature and humidity in Table V6. Verify that each measurement meets specification by indicating "Pass" or "Fail" in the far right column.
- ___2 Remove the arm on the impact side.
- ___3 Install the thoracic and abdominal pads using cable ties⁴.
- ___4 Place the chest jacket on the dummy.
- ___5 The dummy should wear cotton underwear pants, cut off just above the knees, but no shirt or shoes.
- ___6 Ground the dummy using a cable between a metal component of the dummy and the ground.
- ___7 Align the upper and lower neck brackets so that the top edges are flush.
- ___8 Place the bench in the pendulum's impact area so that the dummy can be impacted in the thorax.
- ___9 Seat the dummy on a sheet of 387 x 521 mm PTFE (Teflon®) (2 mm thick) on the bench. Position the dummy within 25mm of the edge of the Teflon® sheet; the edge of the sheet should be along the impact side of the bench's seat pan (Figure 50).
- ___10 Place a sheet of 514 x 514 mm PTFE (Teflon®) (2 mm thick) between the seatback and the dummy's posterior thorax; the edge of the sheet should be along the impact side of the bench's seatback.
- ___11 Position the dummy so that the centerline of impact probe is vertically centered on the centerline of the middle thoracic rib within 2 mm. This corresponds to a reference measurement of 93 ± 2 mm below the centerline of the shoulder yoke assembly arm pivot when measured along a line parallel to the seatback (Figure 51). The center point of the impactor face is aligned horizontally with a line parallel to the seatback incline passing through the center of the shoulder yoke assembly arm pivot. The face of the impactor should be approximately parallel to, and just touching, the surface of the thorax, when the pendulum is at its lowest position during travel. Once the dummy is adjusted in the lateral and fore/aft directions, the impactor positioning with respect to the surface of the thorax jacket will be complete.

⁴ See Attachment of Thoracic and Abdominal Pads in the SID-IIsD.

CHECK SHEET NO. V6 (Continued)
THORAX WITHOUT ARM IMPACT TEST (S572.196)

- __12 Push the dummy's chest towards the seatback, so that the back of the thorax is touching the seat.

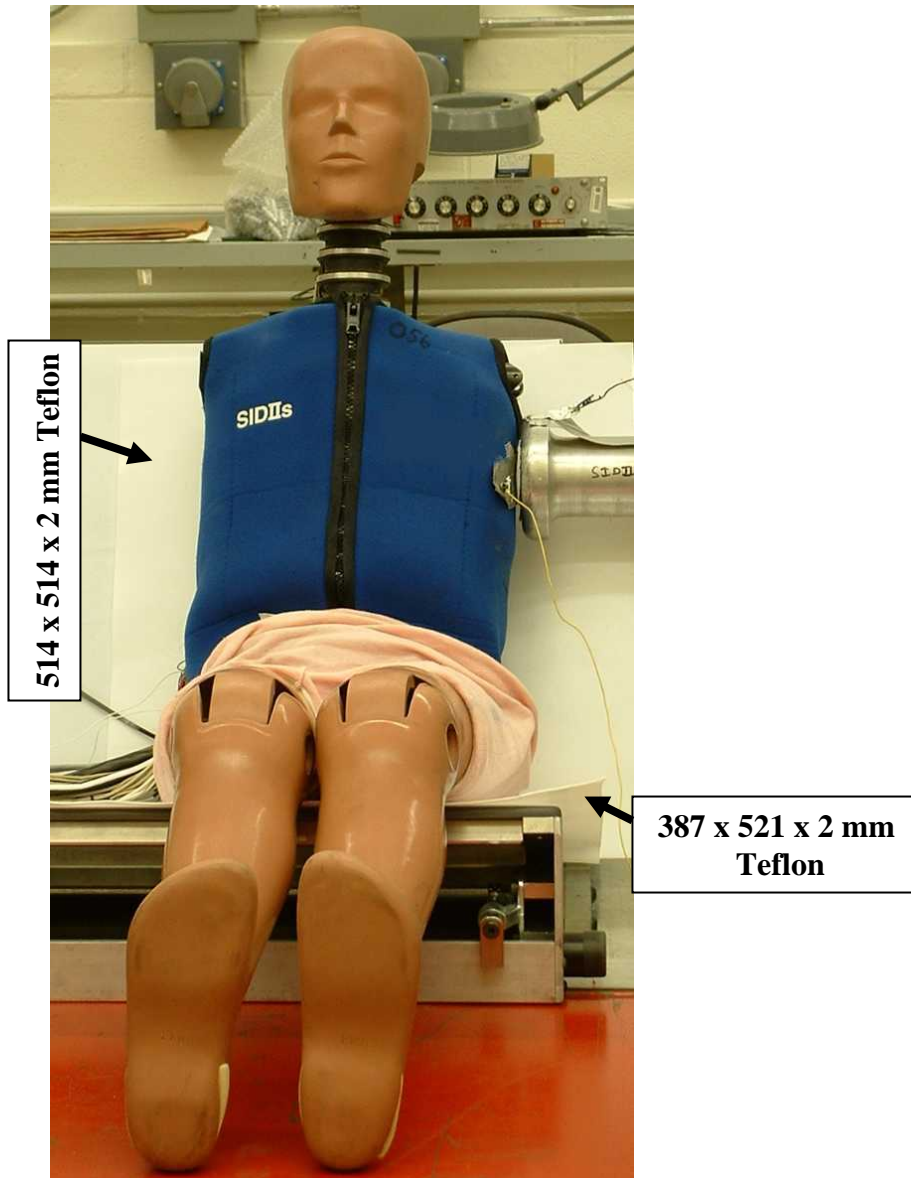

Figure 50. Thorax without arm impact test configuration for SID-II'sD

CHECK SHEET NO. V6 (Continued)
THORAX WITHOUT ARM IMPACT TEST (S572.196)

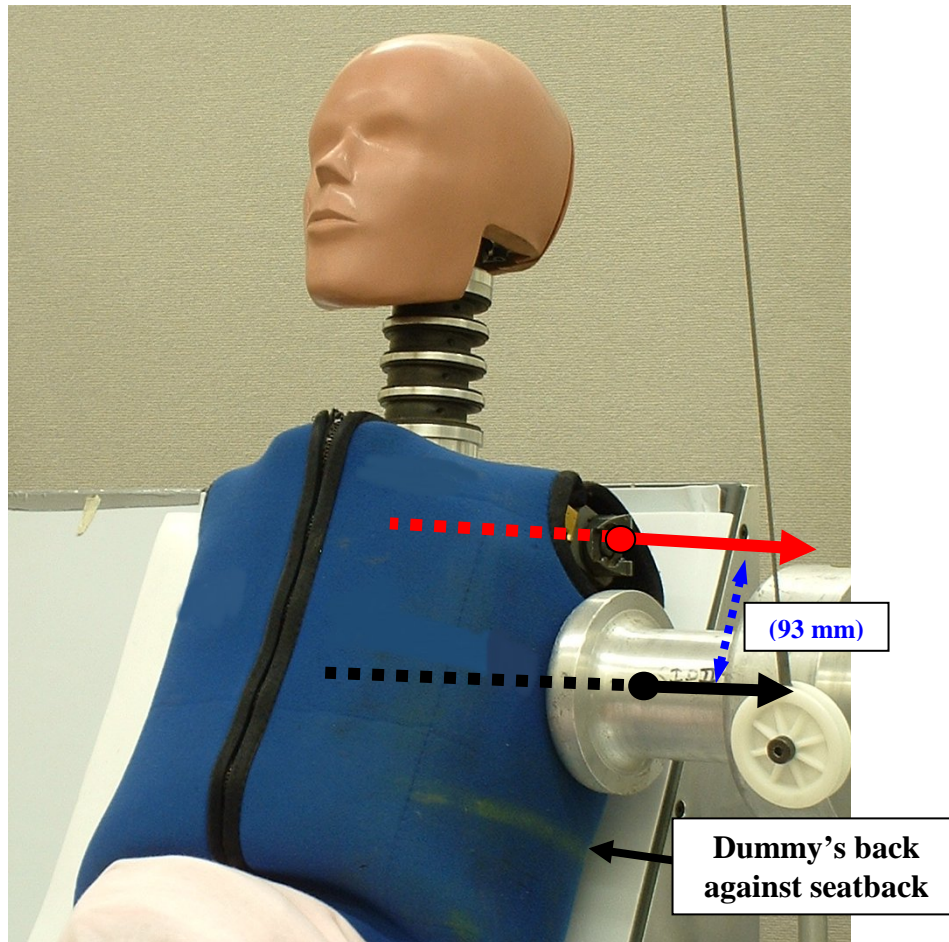

Figure 51. Impactor position for the SID-IIIsD thorax without arm test

- __13 Move the legs together so that the knees are touching (see Figure 43).
- __14 Position the feet so that they are vertical and as close together as possible, with the heels touching the surface of the support table (see Figure 44).
- __15 Adjust the dummy so that the thoracic lateral plane is $0^\circ \pm 1^\circ$ relative to horizontal (see Figure 45).
- __16 Adjust the dummy so that the thoracic fore/aft plane measures $24.6 \pm 2^\circ$ relative to horizontal. This measurement can be taken at the top of the shoulder rib mount (see Figure 46). Once this positioning is complete, the face of the impactor should be approximately parallel to ($\pm 1^\circ$), and just touching, the surface of the thorax, when the pendulum is at its lowest position during travel.

Conduct the Test, Collect Data and Verify Performance

- __17 Record the room temperature and humidity in Table V6. Verify that the temperature and relative humidity meets specification by indicating "Pass" or "Fail" in the far right column
- __18 The impactor shall have a mass of 13.97 ± 0.23 kg with a 120.7 mm face diameter, and a 12.7 mm radius.
- __19 Mount an accelerometer on the impactor with its sensitive axis in line with the longitudinal centerline of the test probe.
- __20 Release the impactor at an impact speed between 4.2 - 4.4 m/s at the instant of contact with the dummy.
- __21 The data acquisition system should conform to SAE Recommended Practice J211.

CHECK SHEET NO. V6 (Continued)
THORAX WITHOUT ARM IMPACT TEST (S572.196)

- __22 The impactor and spine accelerations are collected and filtered using a Channel lass 180 phaseless filter.
- __23 The rib deflections are collected and filtered using a Channel Class 600 phaseless filter.
- __24 Time zero is defined as the time of contact between the impactor and the thorax. All channels should be at a zero level at this point.
- __25 Record the peak impactor acceleration, peak rib deflections and peak spine accelerations in Table V6. Verify that each measurement meets specification by indicating "Pass" or "Fail" in the far right column.
- __26 If test results do not meet specifications, wait at least 30 minutes, conduct another test.
- __27 Record and report the results of each additional test in a separate table.

Table V6. Thorax without Arm Impact Test

Tested Parameter		Units	Specification	Result	Pass/ Fail
Dummy Soak Time		Minutes	≥180		
Temperature - During Soak	Max	°C	20.6 to 22.2		
	Min	°C			
Relative Humidity - During Soak	Max	%	10.0 to 70.0		
	Min	%			
Temperature – During test		°C	20.6 to 22.2		
Relative Humidity – During test		%	10.0 to 70.0		
Impactor Velocity		m/s	4.2 to 4.4		
Peak Upper Rib Deflection		mm	32 to 40		
Peak Middle Rib Deflection		mm	39 to 45		
Peak Lower Rib Deflection		mm	35 to 43		
Peak Upr Spine (T1) Acceleration (Y)		G's	13 to 17		
Peak Lower Spine (T12) Accel (Y)		G's	7 to 11		
Peak Impactor Acceleration		G's	14 to 18		

Signature

Completion Date

CHECK SHEET NO. V7
ABDOMEN IMPACT TEST (S572.197)

Pretest Preparation

- ___1 Soak the dummy in a controlled environment at a temperature and relative humidity indicated in Table V7 for at least four hours prior to a test. Record the length of time for the soak and the maximum and minimum temperature and humidity in Table V7. Verify that each measurement meets specification by indicating "Pass" or "Fail" in the far right column.
- ___2 Remove the arm on the impact side.
- ___3 Install the thoracic and abdominal pads using cable ties⁵.
- ___4 Place the chest jacket on the dummy.
- ___5 The dummy should wear cotton underwear pants, cut off just above the knees, for this procedure. No shirt or shoes should be worn.
- ___6 Ground the dummy using a cable between a metal component of the dummy and the ground.
- ___7 Align the upper and lower neck brackets so that the top edges are flush.
- ___8 Place the bench in the pendulum's impact area so that the dummy can be impacted in the abdomen.
- ___9 Seat the dummy on a sheet of 387 x 521 mm PTFE (Teflon®) (2 mm thick) on the bench. Position the dummy within 25mm of the edge of the Teflon® sheet; the edge of the sheet should be along the impact side of the bench's seat pan.
- ___10 Place a sheet of 514 x 514 mm PTFE (Teflon®) (2 mm thick) between the seatback and the dummy's posterior thorax; the edge of the sheet should be along the impact side of the bench's seatback

⁵ See Attachment of Thoracic and Abdominal Pads in the SID-IIsD.

CHECK SHEET NO. V7 (Continued)
ABDOMEN IMPACT TEST (S572.197)

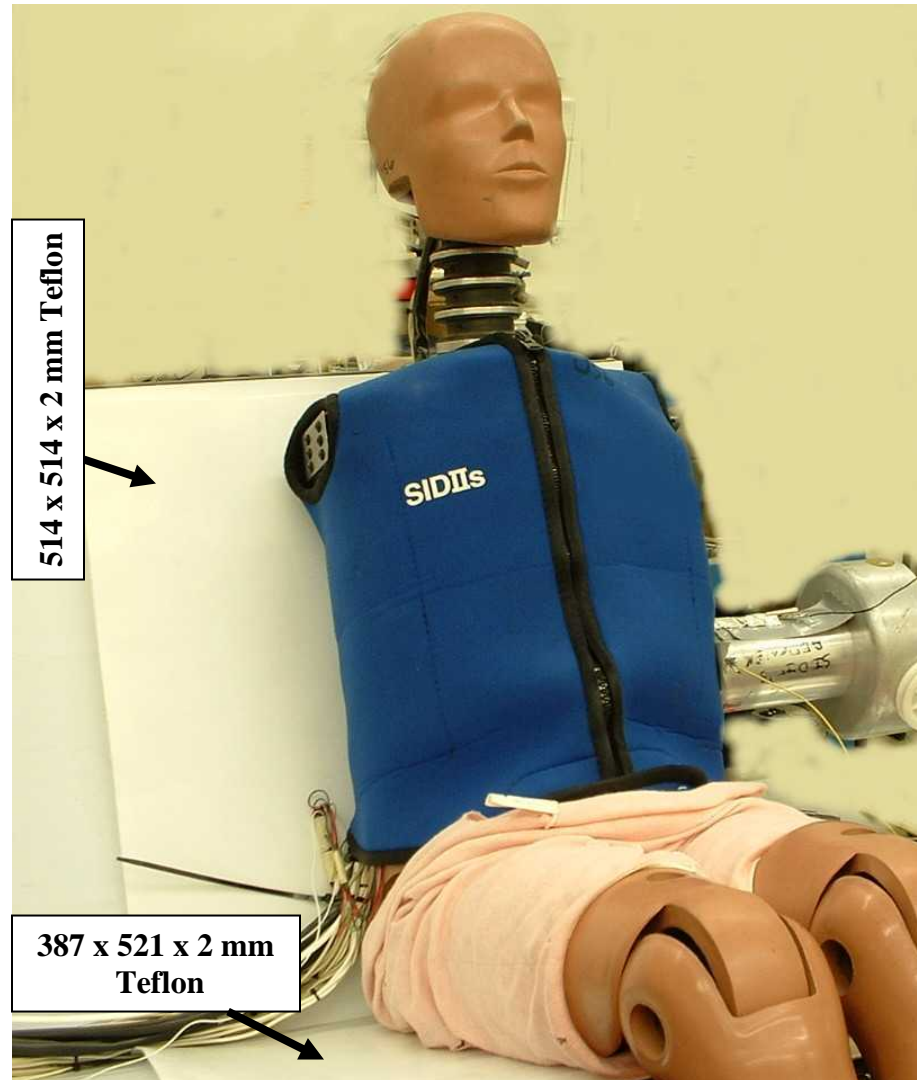

Figure 52. Abdomen impact test configuration for SID-IIIsD

- __11 Position the dummy so that the centerline of impact probe is centered vertically on the midpoint between the two abdominal ribs within 2 mm. This corresponds to a reference measurement of 208 ± 2 mm below the centerline of the shoulder yoke assembly arm pivot when measured along a line parallel to the seatback (Figure 52). The center point of the impactor face is aligned horizontally with a line parallel to the seatback incline passing through the center of the shoulder yoke assembly arm rotation pivot. The face of the probe should be approximately parallel to, and just touching, the surface of the abdomen, when the pendulum probe is at its lowest position during travel. (Once the dummy is adjusted in the lateral and fore/aft directions, the probe positioning with respect to the surface of the jacket at the abdomen will be complete).

CHECK SHEET NO. V7 (Continued)
ABDOMEN IMPACT TEST (S572.197)

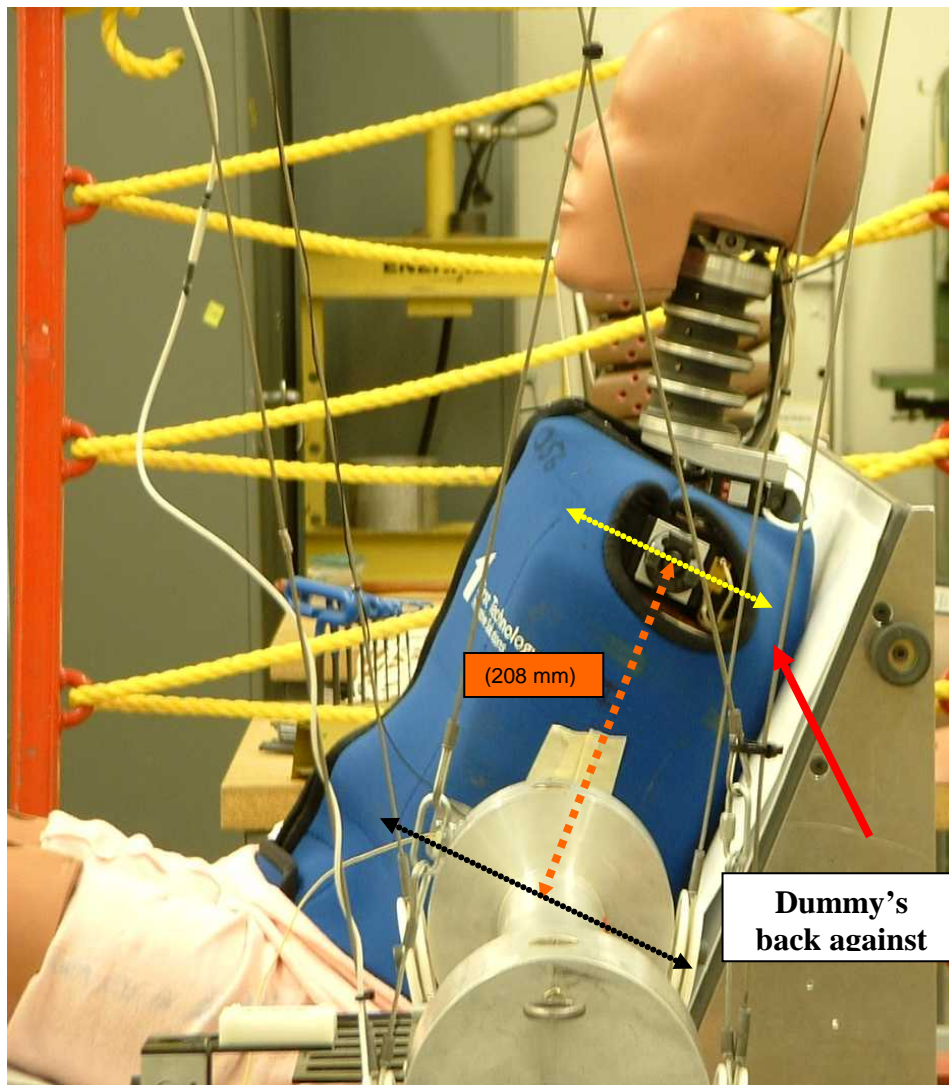

Figure 53. Impact probe position for the SID-II sD abdomen

- __12 Push the dummy's chest towards the seatback, so that the back of the thorax is touching the seat (Figure 53).
- __13 Push the femurs towards the seat pan so that the thighs are in contact with the seat.
- __14 Move the legs together so that the knees are touching (see Figure 43).
- __15 Position the feet so that they are vertical within 2° , with the heels touching the surface of the support table (see Figure 44).
- __16 Adjust the dummy so that the thoracic lateral plane is $0^\circ \pm 1$ relative to horizontal (see Figure 45).
- __17 Adjust the dummy so that the thoracic fore/aft plane measures $24.6 \pm 2^\circ$ relative to horizontal. This measurement can be taken at the top of the shoulder rib mount (see Figure 46).

CHECK SHEET NO. V7 (Continued)
ABDOMEN IMPACT TEST (S572.196)

Conduct Test, Collect Data and Verify Performance

- __1 Record the room temperature and humidity in Table V7. Verify that the temperature and relative humidity meets specification by indicating "Pass" or "Fail" in the far right column
- __2 The impactor shall have a mass of 13.97 ± 0.23 kg⁶ with a 76.2 mm face⁷ and a 12.7 mm radius.
- __3 Mount an accelerometer on the impactor with its sensitive axis in line with the longitudinal centerline of the impactor.
- __4 Release the impactor at an impact speed between 4.2 - 4.4 m/s.
- __5 At the instant of contact, the impactor shall be horizontal $\pm 1^\circ$ and the centerline of the impactor shall be within 2 mm of the centerline of the abdominal ribs.
- __6 The data acquisition system should conform to SAE Recommended Practice J211.
- __7 The impactor and spine accelerations are collected and filtered using a Channel Class 180 phaseless filter.
- __8 The abdominal rib deflections are collected and filtered using a Channel Class 600 phaseless filter.
- __9 Time zero is defined as the time of contact between the impact probe and the abdomen. All channels should be at a zero level at this point.
- __10 Record the peak impactor acceleration, peak abdominal rib deflections and peak lower spine acceleration in Table V7. Verify that each measurement meets specification by indicating "Pass" or "Fail" in the far right column.
- __11 If test results do not meet specification, wait at least 30 minutes, conduct another test.
- __12 Record and report the test results of each additional test in a separate table.

Table V7. Abdomen Impact Test

Tested Parameter		Units	Specification	Result	Pass/ Fail
Dummy Soak Time		Minutes	≥ 180		
Temperature - During Soak	Max	°C	20.6 to 22.2		
	Min	°C			
Relative Humidity - During Soak	Max	%	10.0 to 70.0		
	Min	%			
Temperature – During test		°C	20.6 to 22.2		
Relative Humidity – During test		%	10.0 to 70.0		
Impactor Velocity		m/s	4.2 to 4.4		
Peak Upr Abdominal Rib Deflection		mm	36 to 47		
Peak Lwr Abdominal Rib Deflection		mm	33 to 44		
Peak Lower Spine (T12) Accel (Y)		G's	9 to 14		
Peak Impactor Acceleration		G's	12 to 16		

 Signature

 Completion Date

⁶ Mass includes impactor mass and all rigidly attached hardware, plus 1/3 of supporting cable weight.

⁷ Note that this impactor face differs from impactor faces used in the other certification tests.

CHECK SHEET NO. V8 PELVIS PLUG QUASI-STATIC TEST

Dummy Serial No. _____

Test Date _____

Technician _____

- __1 Clean the contact surfaces of the compression device.
- __2 Assure that the compression head surface and support surfaces are parallel.
- __3 Place the pelvis plug on the support surface and center it under the compression head surface, assuring that the top and bottom of the plug are in full contact with the surfaces.
- __4 Select a maximum displacement value within the corridors indicated in Figures 55 & 56 as a halting point for the compression head.
- __5 Configure the compression system to halt (and return) at the specified displacement.

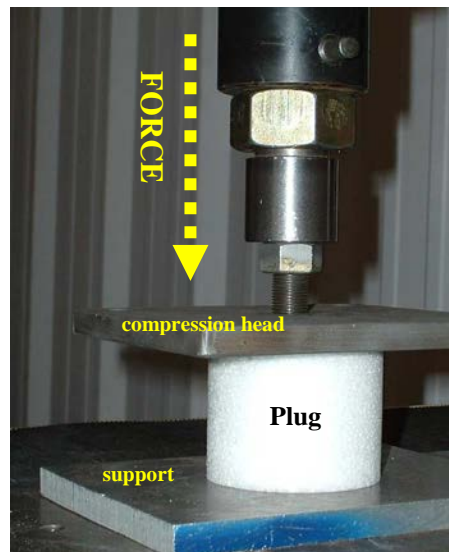

Figure 54. Pelvis plug quasi-static test

- __6 Record the room temperature and humidity in Table V8. Verify that the temperature and relative humidity meets specification by indicating "Pass" or "Fail" in the far right column.
- __7 Record the serial number of the plug in Table V8.
- __8 The force and displacement measurements are collected at a minimum sample rate of 20Hz.
- __9 Pre-load the pelvis plug to 2.27kg (5lb) and zero both the force and displacement measurement channels. Time zero is defined at this point and all channels should be at a zero level.
- __10 With the channels at zero level, compress the plug at a quasi-static rate, nominally 12.7mm/min (0.5"/min), but no greater than 50.8mm/min (2"/min).
- __11 Stop and reverse the compression head when the displacement reaches the preselected value (see pretest setup – step 6).
- __12 Plot force (N) versus displacement (mm). Plot displacement (mm) versus time (ms).
- __13 Record the maximum force achieved at maximum displacement in Table V8. Verify that the measurements meet specification by indicating "Pass" or "Fail" in the far right column.
- __14 Wait at least 4 hours before utilizing the pelvis plug in any certification test or full-scale dummy test.

CHECK SHEET NO. V8 (Continued)
PELVIS PLUG QUASI-STATIC TEST

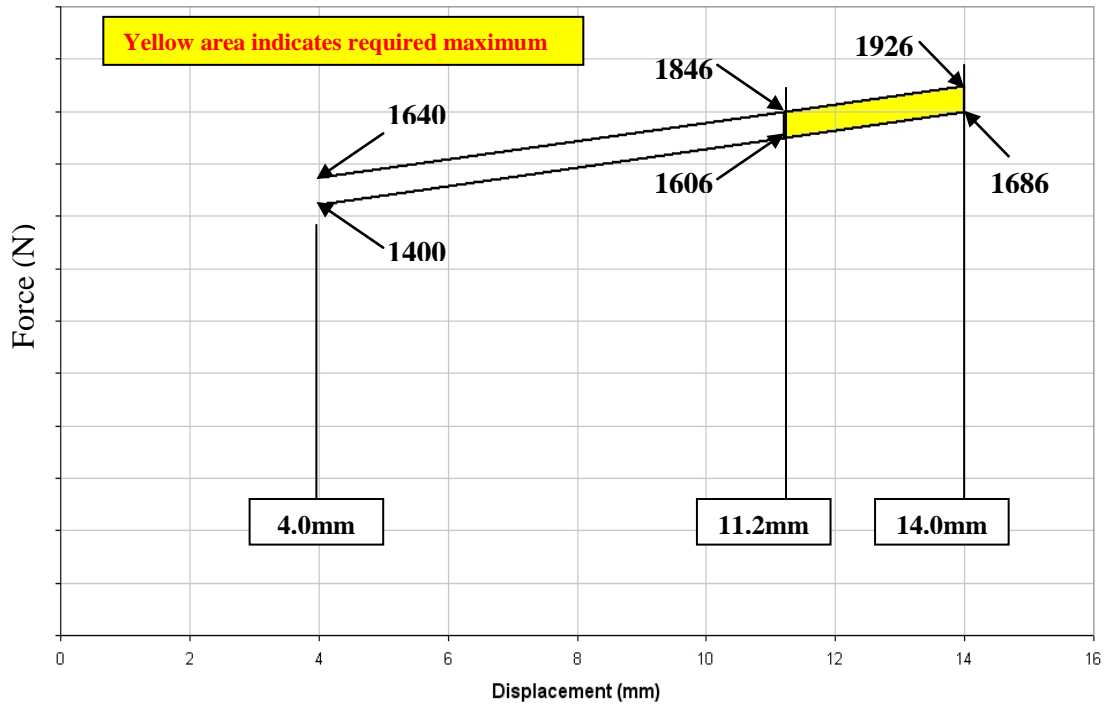

Figure 55. Corridor for pelvis plug certification test

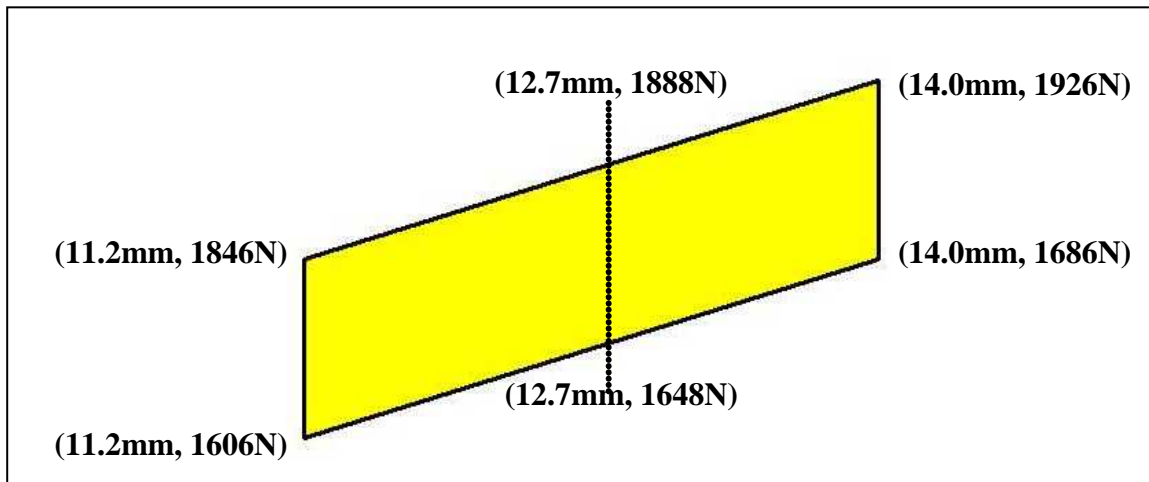

Figure 56. Maximum force and displacement corridors for pelvis plug certification test

Table V8. Pelvis Plug Quasi-Static Test

Tested Parameter	Units	Spec.	Result	Pass/ Fail
Laboratory Temperature	C°	20.6 to 22.2		
Laboratory Relative Humidity	%	10.0 to 70.0		
Maximum Displacement	mm	11.2 to 14.0		
Maximum Force	N	1606 to 1926		
Pelvis Plug Serial No. _____				

CHECK SHEET NO. V9
PELVIS ACETABULUM IMPACT TEST (572.198)

Pretest Preparation

- __1 Soak the dummy in a controlled environment at a temperature and relative humidity indicated in Table V9 for at least four hours prior to a test. Record the length of time for the soak and the maximum and minimum temperature and humidity in Table V2. Verify that each measurement meets specification by indicating "Pass" or "Fail" in the far right column.
- __2 Remove the chest jacket from the dummy.
- __3 Be sure the thoracic and abdominal pads are installed using cable ties⁸.
- __4 Install a certified pelvis plug (see ***Pelvis Plug Quasi-Static Test***)
- __5 Position the arm on the impact side downwards (lowest detent) and parallel to the seatback.
- __6 The dummy should not wear clothing or shoes for this procedure.
- __7 Ground the dummy using a cable between a metal component of the dummy and the ground.
- __8 Align the upper and lower neck brackets so that the top edges are flush.
- __9 Place the bench in the pendulum's impact area so that the dummy can be impacted in the pelvis.
- __10 Seat the dummy on a sheet of 387 x 521 mm PTFE (Teflon®) (2 mm thick) on the bench. Position the dummy within 25mm of the edge of the Teflon® sheet; the edge of the sheet should be along the impact side of the bench's seat pan.
- __11 Place a sheet of 514 x 514 mm PTFE (Teflon®) (2 mm thick) between the seatback and the dummy's posterior thorax; the edge of the sheet should be along the impact side of the bench's seatback (Figure 57).

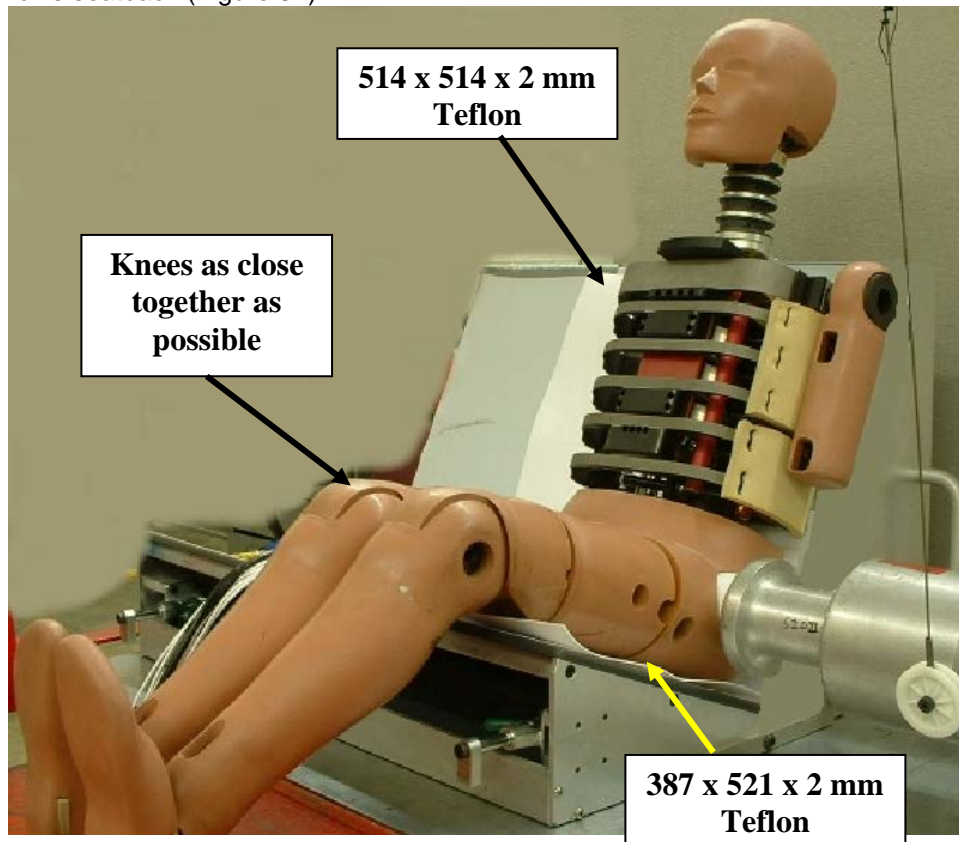

Figure 57. Acetabulum test for SID-IIIsD

⁸ See Attachment of Thoracic and Abdominal Pads in the SID-IIIsD

PELVIS ACETABULUM IMPACT TEST (572.198)

- _11 Position the dummy so that the centerline of impact probe is centered on the centerline of the pelvis plug within 2 mm. The face of the pendulum should be parallel to ($\pm 1^\circ$), and just touching, the surface of the pelvis plug, when the pendulum probe is at its lowest position during travel (Figure 58).

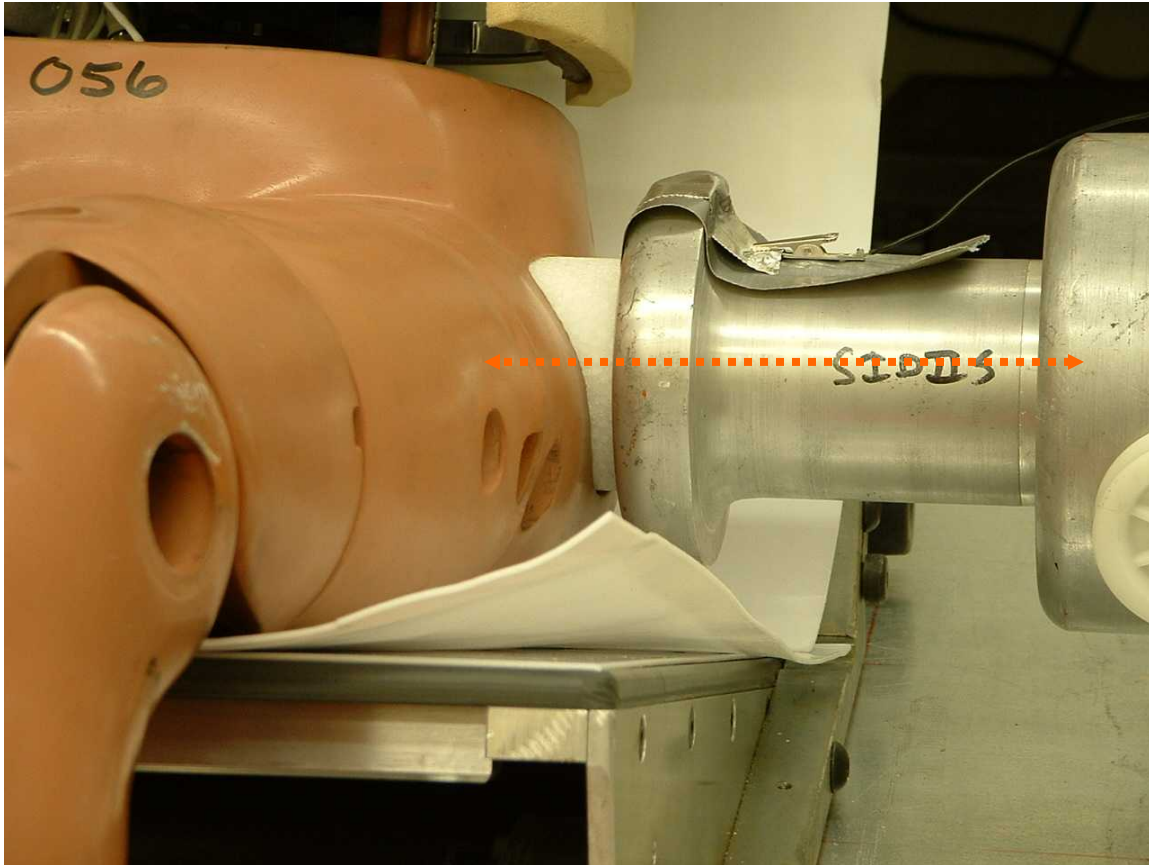

Figure 58. Impact probe position for the SID-IIIsD pelvis certification test

CHECK SHEET NO. V9 (Continued)
PELVIS ACETABULUM IMPACT TEST (572.198)

- __12 Push the dummy's chest towards the seatback, so that the back of the thorax is touching the seat (Figure 59).

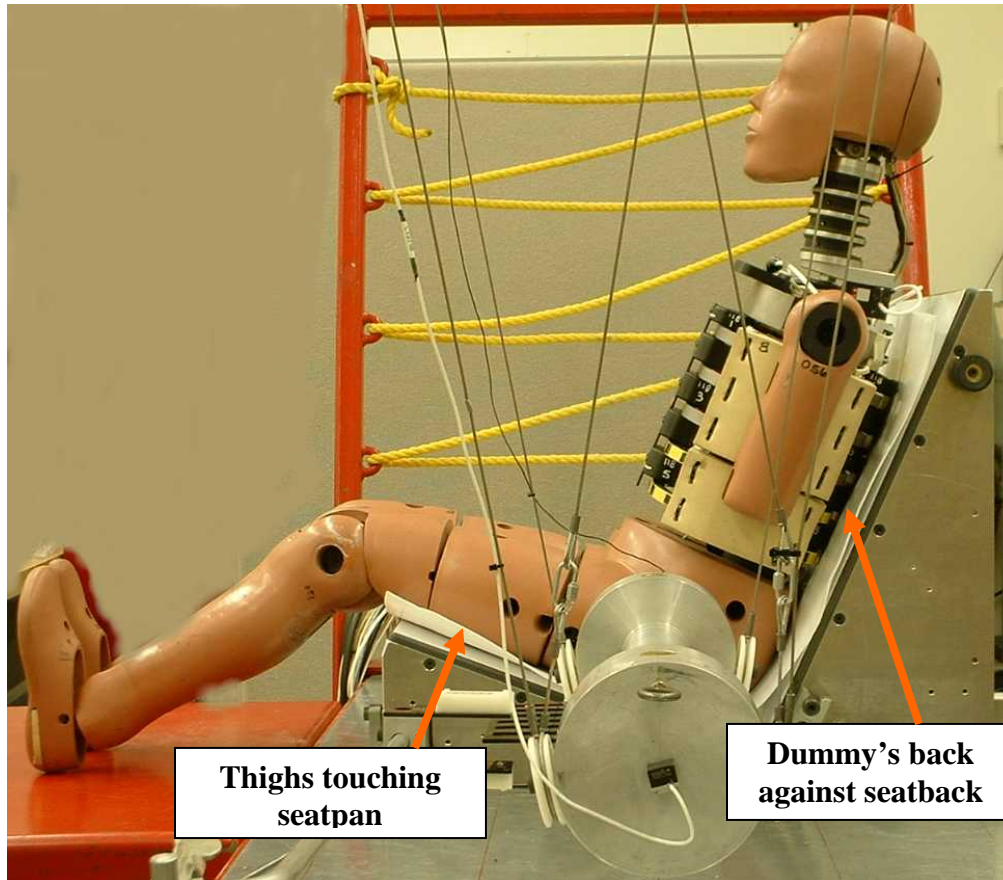

Figure 59. SID-IIIsD leg and back positioning for pelvis certification tests

- __13 Push the femurs towards the seat pan so that the thighs are in contact with the seat.
 __14 Move the legs together so that the knees are touching (see Figure 43).
 __15 Position the feet so that they are vertical within 2° , with the heels touching the surface of the support table (see Figure 44).
 __16 Adjust the dummy so that the thoracic lateral plane is $0 \pm 1^\circ$ relative to horizontal (see Figure 45).
 __17 Adjust the dummy so that the thoracic fore/aft plane measures $24.6 \pm 2^\circ$ relative to horizontal. This measurement can be taken at the top of the shoulder rib mount (see Figure 60).

CHECK SHEET NO. V9 (Continued)
PELVIS ACETABULUM IMPACT TEST (572.198)



Figure 60. Adjusting the SID-IIsD in the fore/aft plane for pelvis certification tests

Conduct Test, Collect Data and Verify Performance

- __18 Record the room temperature and humidity in Table V9. Verify that the temperature and relative humidity meets specification by indicating “Pass” or “Fail” in the far right column.
- __19 Record the serial number of the pelvis plug in Table V9.
- __20 The impactor shall have a mass of 13.97 ± 0.23 kg⁹ with a 120.7 mm face diameter and a 12.7 mm radius.
- __21 Mount an accelerometer on the impactor with its sensitive axis in line with the longitudinal centerline of the impactor.
- __22 Release the impactor at an impact speed between 6.6 – 6.8 m/s.
- __23 At the instant of contact, the probe shall be horizontal $\pm 1^\circ$ and the centerline of the impactor shall be within 2 mm of the centerline of the acetabulum load cell.
- __24 The data acquisition system conforms to SAE Recommended Practice J211.
- __25 The impactor and pelvis accelerations are collected and filtered using a Channel Class 180 phaseless filter.
- __26 The acetabulum force is collected and filtered using a Channel Class 600 phaseless filter.
- __27 Time zero is defined as the time of contact between the impact probe and the pelvis. All channels should be at a zero level at this point.

⁹ Mass includes probe mass and all rigidly attached hardware, plus 1/3 of supporting cable weight.

CHECK SHEET NO. V9 (Continued)
PELVIS ACETABULUM IMPACT TEST (572.198)

- __28 Record the peak impactor acceleration, peak pelvic acceleration (after 6 ms) and peak acetabulum force in Table V9. Verify that the measurements meet specifications by indicating "Pass" or "Fail" in the far right column.
- __29 If the test results do not meet specification, wait at least 2 hours, conduct another test. Record test results in a separate table.
- __30 Discard the impacted pelvis plug and replace it with another certified plug after each test.

Table V9. Pelvis Acetabulum Impact Test

Tested Parameter		Units	Specification	Result	Pass/ Fail
Dummy Soak Time		Minutes	≥180		
Temperature - During Soak	Max	°C	20.6 to 22.2		
	Min	°C			
Humidity - During Soak	Max	%	10.0 to 70.0		
	Min	%			
Temperature – During test		°C	20.6 to 22.2		
Humidity – During test		%	10.0 to 70.0		
Impactor Velocity		m/s	6.6 to 6.8		
Peak Impactor Acceleration		G's	38 to 47		
Pelvis Acceleration (Y) after 6 ms		G's	34 to 42		
Peak Acetabulum Force (Y)		kN	3.60 to 4.30		
Pelvis Plug Serial No. _____					

Signature

Completion Date

CHECK SHEET NO. V10
PELVIS ILIAC IMPACT TEST (572.199)

Pretest Preparation

- ___1 Soak the dummy in a controlled environment at a temperature and relative humidity indicated in Table V10 for at least four hours prior to a test. Record the length of time for the soak and the maximum and minimum temperature and humidity in Table V10. Verify that each measurement meets specification by indicating "Pass" or "Fail" in the far right column.
- ___2 Remove the chest jacket from the dummy.
- ___3 Be sure the thoracic and abdominal pads are installed using cable ties¹⁰.
- ___4 Install a certified pelvis plug (see ***Pelvis Plug Quasi-Static Test***). Be certain that the plug is fully seated in the cavity by pushing on the end of the plug until it fully contacts the acetabulum load cell surface.
- ___5 Position the arm on the impact side downwards (lowest detent) and perpendicular to the seating surface. No bench is used in this procedure.
- ___6 The dummy wears no clothing or shoes for this procedure.
- ___7 The dummy is electrically grounded using a cable between a metal component of the dummy and the ground.
- ___8 Align the upper and lower neck brackets of the neck load cell replacement so that the top edges are flush with one another¹¹ (Figure 47).
- ___9 Place two sheets of 2-mm thick Teflon® on top of one another on the seating surface. The sheets should be large enough to fit completely under the dummy's pelvis, legs, and feet.
- ___10 Position the dummy on the Teflon® (Figure 61) in the probe's impact area so that the dummy can be impacted in the iliac area, with the centerline of the probe aligned with the centerline of the iliac load cell access hole in the pelvis flesh.
- ___11 The probe tip has a 50.8 mm x 88.9 mm face, with an alignment tool access hole in the center. Appendix B includes dimensions for a possible iliac probe face. Care should be taken to adjust probe depth dimensions as needed to maintain the proper 13.97 ± 0.23 kg weight of the probe assembly according to the needs of each test lab.
- ___12 The probe tip should be positioned vertically ($0 \pm 1^\circ$).
- ___13 Position the dummy so that the centerline of impact probe is centered on the centerline of the iliac load cell access hole. When the pendulum probe is at its lowest position during travel, it should be just touching the pelvis. Push the femurs downward so that the thighs make full contact with the test surface.

¹⁰ See *Attachment of Thoracic and Abdominal Pads in the SID-IIsD*.

¹¹ The lower neck load cell should not be used since its fixed setting creates a neck angle (of $\sim 14^\circ$) which is less than the neck angle (of $\sim 19^\circ$) when the upper and lower neck brackets are set flush.

CHECK SHEET NO. V10 (Continued)
PELVIS ILIAC IMPACT TEST (572.199)

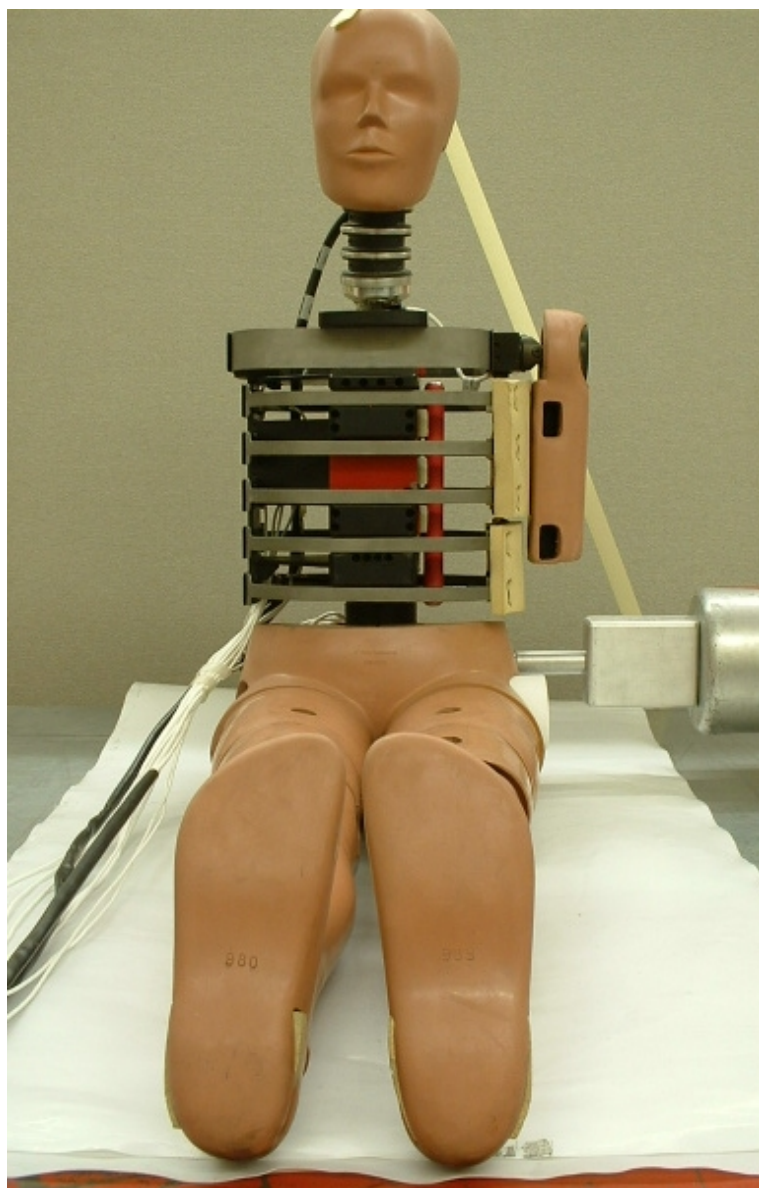

Figure 61. Setup of the dummy for iliac

CHECK SHEET NO. V10 (Continued)
PELVIS ILIAC IMPACT TEST (572.199)

- __14 Move the legs together so that the knees are as close together as possible (Figure 40).
- __15 Position the feet so that they are in dorsiflexion with toes angled towards the dummy's head.
- __16 Using approximately 3 feet of standard 1-inch wide masking tape¹² from the top of the dummy's head to the seating surface (Figure 62), level the shoulder rib so that the fore/aft plane is $0^{\circ} \pm 1^{\circ}$ relative to horizontal. This measurement can be taken at the top of the shoulder rib mount. Adjust the masking tape as necessary to achieve these results (Figure 63).

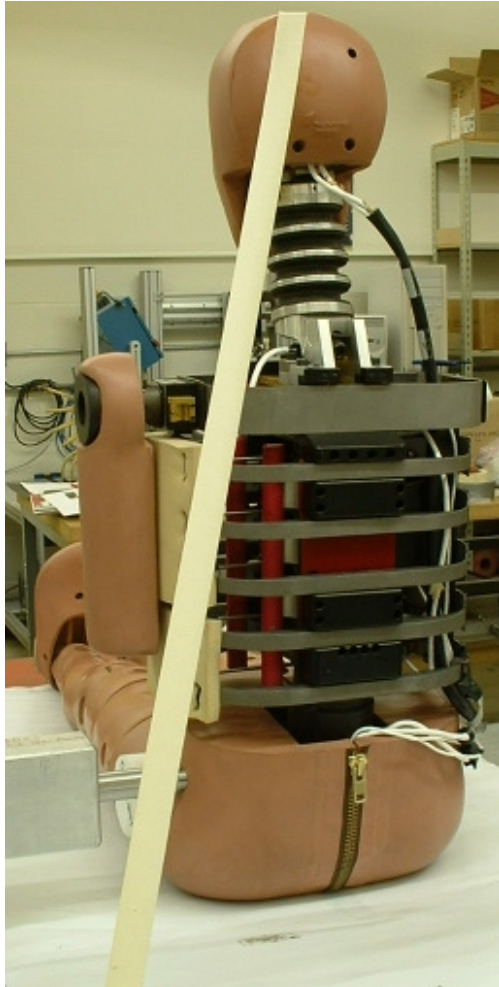

Figure 62. Using masking tape to seat the dummy upright

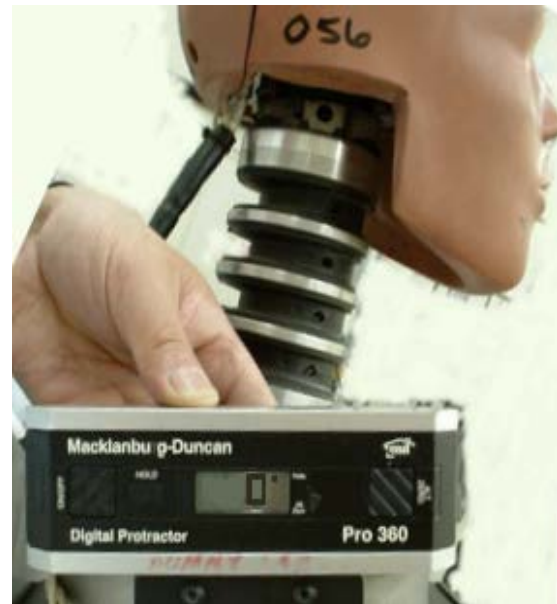

Figure 63. Adjusting the SID-IIIsD in the fore/aft plane for iliac certification test

- __17 Adjust the dummy so that the thoracic lateral plane is $0^{\circ} \pm 1^{\circ}$ relative to horizontal as referenced at the top surface of the lower neck bracket (Figure 63).
- __18 Adjust the masking tape as necessary to achieve these results, taking care to maintain level in the fore/aft direction as well.

¹² Alternatively, a material with a maximum static breaking strength of 311 N (70 lb) may be used to support the dummy in position.

CHECK SHEET NO. V10 (Continued)
PELVIS ILIAC IMPACT TEST (572.199)



Figure 64. Adjusting the SID-IIsD in the lateral direction for iliac certification test

- __19 To correctly position the probe face to the iliac, use the iliac alignment tool shown in Figure 65 (see Attachment 3 for dimensions).

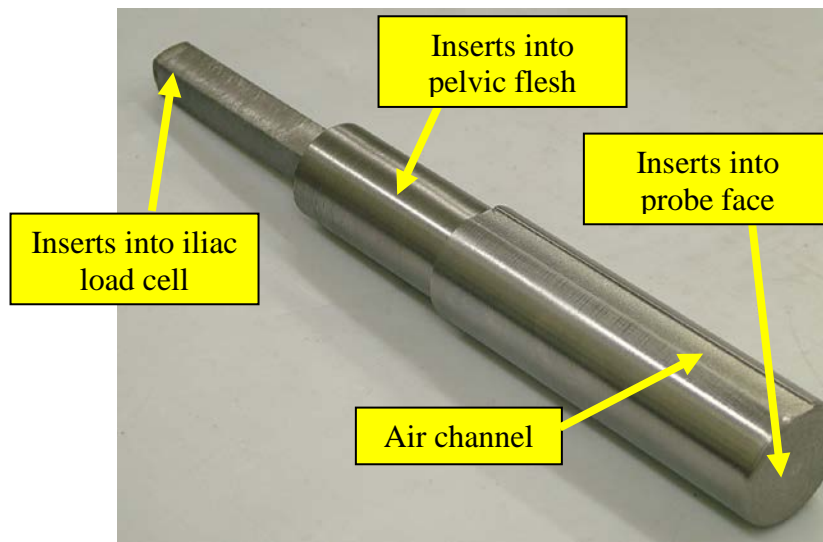

Figure 65. Iliac alignment tool

CHECK SHEET NO. V10 (Continued)
PELVIS ILIAC IMPACT TEST (572.199)

- __20 The access hole in the center of the probe face should mate with the iliac alignment tool such that there is a good fit (with minimal play) when the shaft of the tool is inserted into the probe access hole (Figure 66).

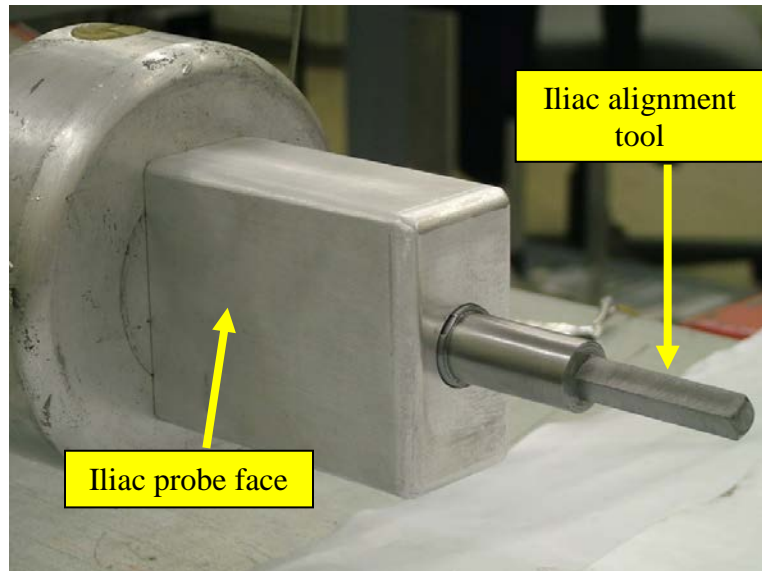

Figure 66. Iliac probe with alignment tool inserted

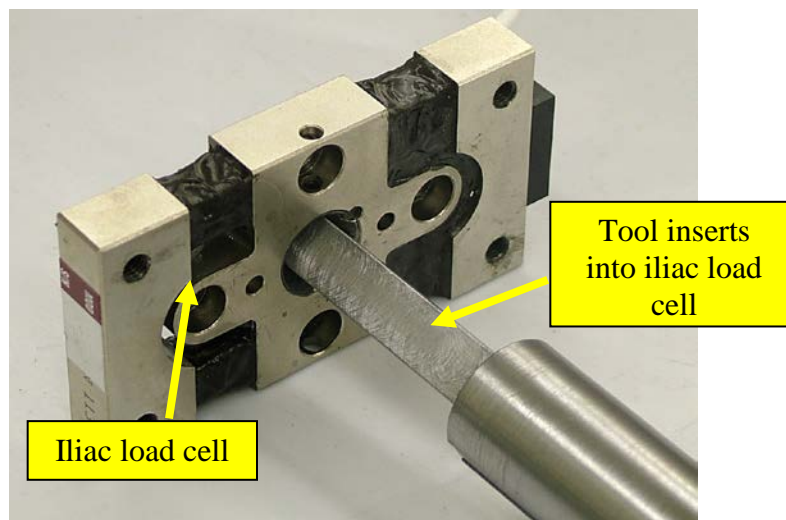

Figure 67. Iliac alignment tool inserted into iliac load cell (shown outside of dummy for clarity)

- __21 To properly align the impact probe for an iliac impact, the square end of the alignment tool is inserted into the center of the iliac load cell through the iliac load cell access hole in the pelvis flesh (Figure 67).
- __22 The dummy's position is then adjusted so that moving the pendulum towards contact with the iliac allows for smooth motion (minimal resistance) of the alignment tool within the probe face (Figures 68 and 69).

CHECK SHEET NO. V10 (Continued)
PELVIS ILIAC IMPACT TEST (572.199)

- __23 Once this position has been achieved, a check of the fore/aft level and right/left level should be conducted and adjusted as necessary.

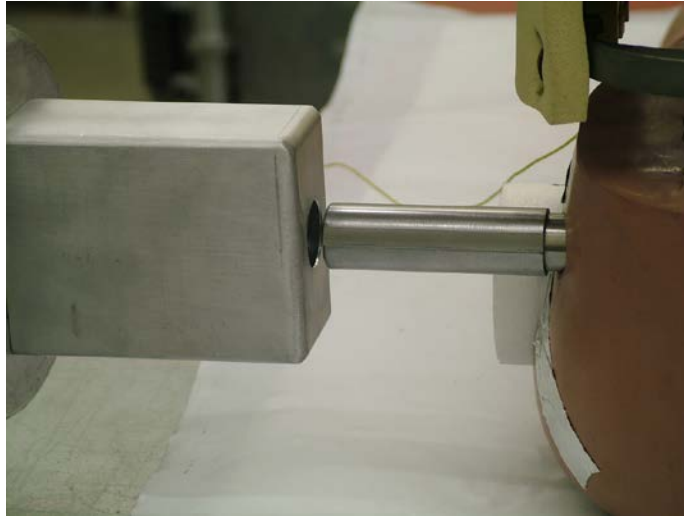

Figure 68. Adjusting the pelvic position for inserting the alignment tool

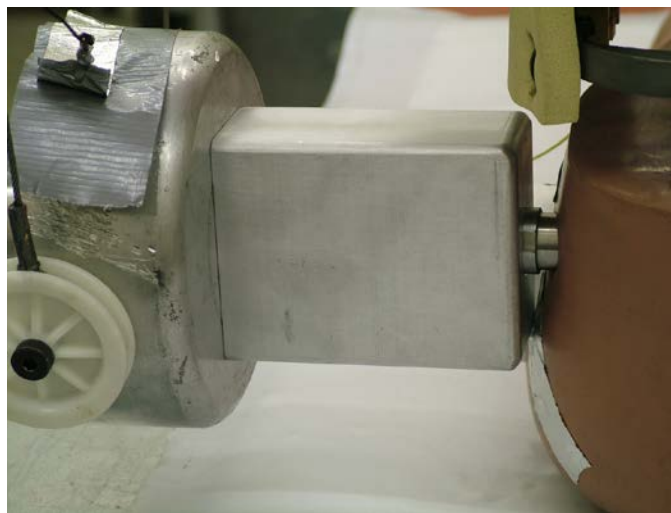

Figure 69. Assuring smooth motion of the alignment tool shaft within the probe.

- __24 Once probe alignment has been achieved, and assuring that the dummy is level, pull back the pendulum probe and carefully remove the alignment tool while maintaining dummy position.

CHECK SHEET NO. V10 (Continued)
PELVIS ILIAC IMPACT TEST (572.199)

Conduct the Test, Collect Data and Verify Performance

- ___25 Record the room temperature and humidity in Table V10. Verify that the temperature and relative humidity meets specification by indicating "Pass" or "Fail" in the far right column.
- ___26 Install a certified pelvis plug. (NOTE - The pelvis plug must be installed in the dummy during this test. However, since it is not impacted, it remains certified and usable after the iliac impact test).
- ___27 The impactor has a mass of $13.97 \pm 0.23 \text{ kg}^{13}$ with a 50.8 mm x 88.9 mm face, (with a minimum depth of 76 mm) and a 6.4 mm edge radius. In addition, the impactor face shall contain an access hole such that an alignment tool can be inserted for proper impact positioning.
- ___28 Mount an accelerometer on the impactor with its sensitive axis in line with the longitudinal centerline of the impactor.
- ___29 Release the impactor 4.2 – 4.4 m/s at the instant of contact with the dummy.
- ___30 At the instant of contact, the probe should be horizontal $\pm 1^\circ$, and the centerline of the probe should be within 2 mm of the centerline of the iliac load cell access hole.
- ___31 The data acquisition system conforms to SAE Recommended Practice J211.
- ___32 The probe and pelvis accelerations are collected and filtered using a Channel Class 180 phaseless filter.
- ___33 The iliac force is collected and filtered using a Channel Class 600 phaseless filter.
- ___34 Time zero is defined as the time of contact between the impactor and the pelvis. All channels are at a zero level at this point.
- ___35 Record the peak impactor acceleration, peak pelvic acceleration, and peak iliac force in Table V10. Verify that the measurements meet specification by indicating "Pass" or "Fail" in the far right column.
- ___36 If the test results do not meet specification, wait at least 2 hours, conduct another test.
- ___37 Record and report the results of each additional test in a separate table.

Table V10. Pelvis Iliac Impact Test

Tested Parameter		Units	Specification	Result	Pass/ Fail
Dummy Soak Time		Minutes	≥ 180		
Temperature - During Soak	Max	$^\circ\text{C}$	20.6 to 22.2		
	Min	$^\circ\text{C}$			
Humidity - During Soak	Max	%	10.0 to 70.0		
	Min	%			
Temperature – During test		$^\circ\text{C}$	20.6 to 22.2		
Humidity – During test		%	10.0 to 70.0		
Peak Impactor Acceleration		G's	36 to 45		
Pelvis Acceleration (Y)		G's	28 to 39		
Peak Iliac Force (Y)		kN	4.10 to 5.10		
Pelvis Plug Serial No. _____					

Signature

Completion Date

¹³ Mass includes probe mass and all rigidly attached hardware, plus 1/3 of supporting cable weight.

ATTACHMENT 1

ATTACHMENT OF THORACIC AND ABDOMINAL PADS IN THE SID-IISD

ATTACHMENT OF THORACIC AND ABDOMINAL PADS IN THE SID-II_sD

Use approximately 185mm (7.31”) long, 4.67mm (0.184”) wide, 1.33mm thick cable ties to attach the pads to the ribs. The cable ties should be used at each rib on both the left and right edges of the pad. Route the cable ties through the holes punched into the pad and around the rib making certain that the cable tie locking apparatus is at the back side of the rib. Be sure not to wrap over rib damping material or over the larger flared out portion of the ribs near the red urethane. Tighten the cable tie so that pad is pulled against the rib and the pad becomes compressed by the cable tie. Once the cable tie is tightened, the cable “tail” (excess which was pulled through the locking mechanism) should be approximately 125mm long. About 55 mm of the tie will be utilized on the loop around the ribs (*Note: about 5 mm of the tie remains inside the locking mechanism*). An indication of the proper “tightness” can be identified in Figure A1 below. After tightening the cable tie the proper amount, cut off the excess “tail” so that no further tightening will occur as well as to reduce interference.



Figure A1. Cable tie attachment to hold the pads for the SID-II_sD

ATTACHMENT 2

ILIAC PROBE FACE

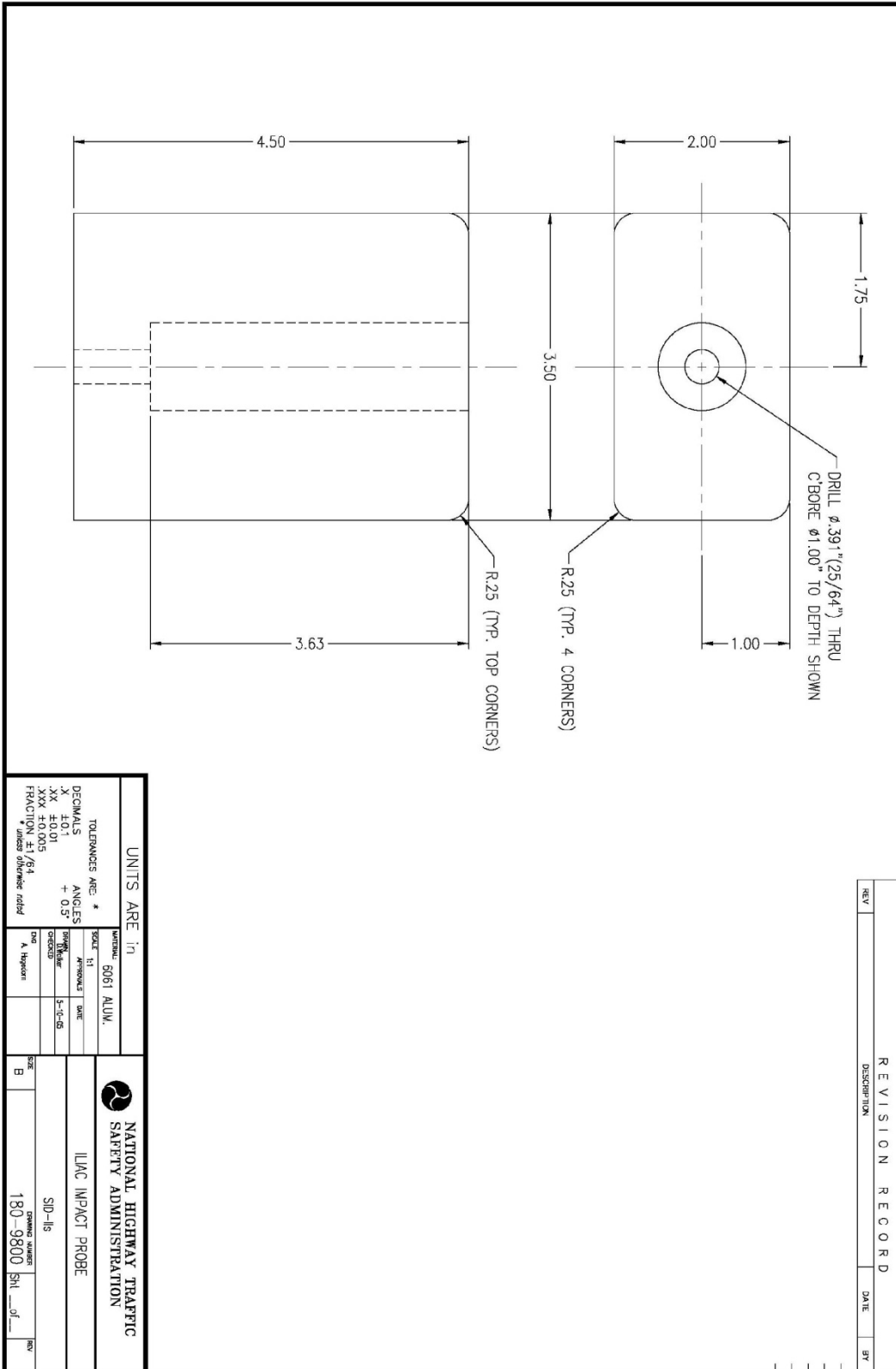

REVISION RECORD		
REV	DESCRIPTION	DATE

UNITS ARE in		NATIONAL HIGHWAY TRAFFIC SAFETY ADMINISTRATION	
TOLERANCES ARE: *		ILMC IMPACT PROBE	
DECIMALS	ANGLES	SCALE	FORMING NUMBER
.X ±0.1	+ 0.5°	1:1	SID-116
.XX ±0.01		DATE	180-9800 SH of
.XXX ±0.005		APPROVAL	REV
FRACTIONS	FRACTIONS	DATE	
1/16 ±0.015	1/16 ±0.015	5-11-80	
1/32 ±0.005	1/32 ±0.005	DATE	
1/64 ±0.002	1/64 ±0.002	DATE	
FRACTIONS	FRACTIONS	DATE	
1/8 ±0.015	1/8 ±0.015	DATE	
1/16 ±0.010	1/16 ±0.010	DATE	
1/32 ±0.005	1/32 ±0.005	DATE	
1/64 ±0.002	1/64 ±0.002	DATE	

ATTACHMENT 3

ILIAC ALIGNMENT TOOL

REVISION RECORD			
REV	DESCRIPTION	DATE	BY
A	CHANGED DIM. .03 TO .06 & .594 to .980	11/22/05	TJR

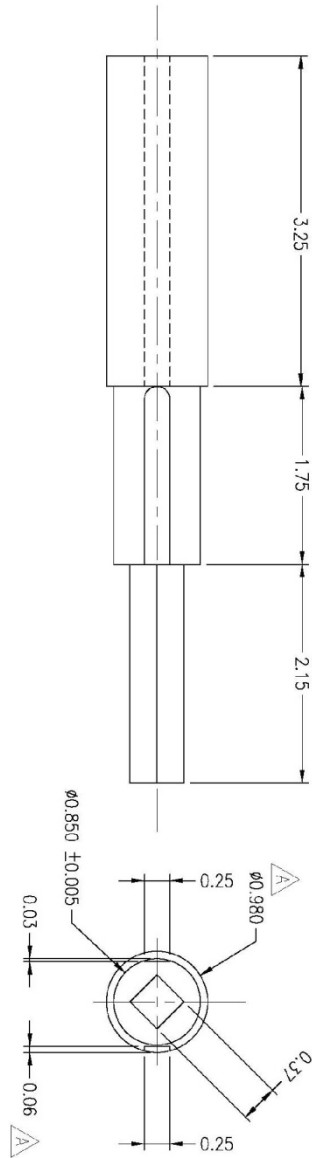

UNITS ARE in		UNITS ARE in	
TOLERANCES ARE: #	UNIFORM: 1045 CRS	NATIONAL HIGHWAY TRAFFIC SAFETY ADMINISTRATION	
DECIMALS	SOCKET #1	 NATIONAL HIGHWAY TRAFFIC SAFETY ADMINISTRATION LMC IMPACT PROBE ALIGNMENT TOOL	
ANGLES	APPROXIMATE DATE		
.XX ± 0.01	REVISED		
.XXX ± 0.005	DATE		
FRACTION ± 1/64	DRW A, Hoppers	SIZE B	REV A
* unless otherwise noted		DRAWING NUMBER	180-9801
		SN	of

APPENDIX B

POSITIONING 5TH PERCENTILE SID-IIS DUMMY IN DRIVER POSITION IN THE TEST VEHICLE

- A. With the seat in the position determined in Section 11.1,T(3) of the Laboratory Test Procedure for the New Car Assessment Program Side Impact Rigid Pole test (full-forward, mid-height, mid-angle), use only the control that moves the seat fore and aft to place the seat in the rearmost, mid-height position. If the seat cushion reference line (SCRL) angle automatically changes as the seat is moved from the full forward position, maintain, as closely as possible, the SCRL angle determined in Section 11.1,T(3) of the Laboratory Test Procedure for the New Car Assessment Program Side Impact Rigid Pole test, for the final forward position when measuring the pelvic angle as specified in step L below. The SCRL angle position may be achieved through the use of any seat or seat cushion adjustments other than that which primarily moves the seat or seat cushion fore-aft.
- B. Verify that the fixed lower neck load cell is not installed. Adjust the dummy's upper and lower neck brackets to align the zero degree index marks.
- C. Fully recline the seat back, if adjustable. Place the dummy in the driver's seat, such that when the legs are positioned 120 degrees to the thighs, the calves of the legs are not touching the seat cushion. If necessary, use a fixed gauge, inserted into the hip, knee, and ankle joints, to maintain the 120 degree angle.
- D. On bucket or contoured seats, center the dummy on the seat cushion so that its mid-sagittal plane is vertical and passes within ± 10 mm (± 0.4 in) of the longitudinal centerline markings on the seat cushion upper surface, seat back, and head restraint that lie in the same vertical longitudinal plane as the SgRP.
- On bench seats, position the midsagittal plane of the dummy vertical and parallel to the vehicle's longitudinal centerline and is aligned within ± 10 mm (± 0.4 in) of the longitudinal centerline markings on the seat cushion upper surface, seat back, and head restraint that lie in the same vertical longitudinal plane as the center of the steering wheel rim.
- E. Hold the dummy's thighs down and push rearward on the upper torso to maximize the dummy's pelvic angle.
- F. While maintaining a leg-thigh angle of 120 degrees, set the initial transverse distance between the longitudinal centerlines at the front of the dummy's knees at 160 to 170 mm (6.3 to 6.7 in), with the thighs and legs of the dummy in vertical planes. Center the knee separation with respect to the longitudinal centerline markings of the seat cushion.
- G. Without allowing the angle between the thighs and lower legs to change, push rearward on the dummy's knees to force the pelvis into the seat so there is no gap between the pelvis and the seat back or until contact occurs between the back of the dummy's calves and the front of the seat cushion. If friction is

prohibiting the dummy from moving rearward as the knees are being pushed rearward such that a gap still exists between the pelvis and the seat back after this step has been performed, and the back of the dummy's calves have not yet contacted the front of the seat cushion, perform one of the following steps until there is no gap between the pelvis and the seat back, or until contact occurs between the back of the dummy's calves and the front of the seat cushion, whichever occurs first:

- (1) Pull forward slightly on the dummy's upper torso while holding the dummy at the base of the back of the neck, and rock the torso from side-to-side while pushing back on the dummy's knees.
- (2) Lift the dummy from beneath the buttocks and slide the pelvis rearward into the seat.

NOTE: *In vehicles with long seat pans, the dummy's pelvis may not contact the seat back even when the back of the calves are touching the front of the seat cushion.*

- H. Gently rock the upper torso relative to the lower torso laterally in a side to side motion three times through a ± 5 degree arc (approximately 51 mm (2 in) side to side) three times to reduce friction between the dummy and the seat. Return the dummy's upper torso to the seat back.
- I. If needed, extend the legs slightly so that the feet are not in contact with the floor pan. Let the thighs rest on the seat cushion to the extent permitted by the foot movement. Keeping the leg and the thigh in a vertical plane, place the right foot in the vertical longitudinal plane that passes through the centerline of the accelerator pedal. Rotate the left leg and thigh outboard (laterally) about the hip until the center of the left knee is the same distance from the longitudinal centerline markings on the seat cushion as the right knee ± 5 mm (± 0.2 in).

Using only the control that moves the seat fore and aft, attempt to return the seat to the full forward, mid-height position with the seat cushion set to the mid-angle, as determined in Section 11.1,T(3) of the Laboratory Test Procedure for the New Car Assessment Program Side Impact Rigid Pole Test. (The right foot may contact and depress the accelerator and/or change the angle of the foot with respect to the leg during seat movement.) If the seat can be set to the full-forward, mid-height position with the seat cushion set to the mid-angle, proceed to step J.

If either of the dummy's legs first contacts the steering wheel, move the steering wheel upward (if adjustable) the minimum amount required to avoid contact. If the steering wheel is not adjustable, separate the knees the minimum distance required to avoid contact.

If the left foot interferes or contacts the vehicle's brake or clutch pedal(s), rotate the test dummy's left foot about the leg to provide clearance. If there is still

interference, rotate the left thigh outboard about the hip the minimum distance necessary to avoid pedal interference.

Proceed with moving the seat forward until either a leg contacts the vehicle interior or the seat reaches the full forward position. Use seat controls to line up the seat markings determined in Section 11.1,T(3) of the Laboratory Test Procedure for the New Car Assessment Program Side Impact Rigid Pole Test to set the full-forward, mid-height position with the seat cushion set to the mid-angle. If a dummy leg contacts the vehicle interior before the full-forward position is attained, move the seat rearward until the seat is in the closest detent position that does not cause dummy contact. If the seat is a power seat, move the seat rearward to avoid contact while assuring that there is a maximum of 5 mm (0.2 in) distance between the vehicle interior and the point on the dummy that would first contact the vehicle interior.

If the steering wheel was moved, return it to the test position specified in 11.1,U(3) of the Laboratory Test Procedure for the New Car Assessment Program Side Impact Rigid Pole Test. If the steering wheel contacts the dummy prior to attaining this position, adjust the steering wheel to the next higher detent that does not cause dummy contact, or if it is infinitely adjustable, position the wheel until there is a maximum clearance of 5 mm (0.2 in) between the wheel and the dummy.

J. Head leveling.

When leveling the head, the dummy's torso should be resting on the seat back and/or the dummy's head should be resting on the head restraint.

- (1) *Vehicles with fixed seat backs.* Adjust the lower neck bracket to level the transverse instrumentation platform angle of the head to within ± 0.5 degrees. If it is not possible to level the transverse instrumentation platform to within ± 0.5 degrees, select the neck bracket adjustment position that minimizes the difference between the transverse instrumentation platform angle and level.
- (2) *Vehicles with adjustable seat backs.* While holding the thighs in place, rotate the seat back forward until the transverse instrumentation platform angle of the head is level to within ± 0.5 degrees, making sure that the pelvis does not interfere with the seat bight and the head does not get pinched under the head restraint. If the pelvis interferes with the seat bight, shift the pelvis forward on the slightly on the seat cushion and complete steps to level the head. If the head gets pinched under the head restraint, it may be necessary to pull the dummy's torso forward slightly as the seat back is raised and then return the torso to the seat back. If the torso contacts the steering wheel, follow step M before proceeding with the remaining portion of this paragraph. If it is not possible to level the transverse instrumentation platform to within ± 0.5 degrees, select the seat back adjustment position that minimizes the difference between the

transverse instrumentation platform angle and level, then adjust the neck bracket to level the transverse instrumentation platform angle to within ± 0.5 degrees, if possible. If it is still not possible to level the transverse instrumentation platform to within ± 0.5 degrees, select the neck bracket angle position that minimizes the difference between the transverse instrumentation platform angle and level.

- K. If the torso contacts the steering wheel while performing step J(1), reposition the steering wheel in the following order until there is no contact: adjust telescoping mechanism, adjust tilt mechanism to lower steering wheel, adjust tilt mechanism to raise steering wheel. If the vehicle has no adjustments or contact with the steering wheel cannot be eliminated by adjustment, position the seat at the next detent rearward where there is no contact with the steering wheel when adjusted per 11.1,U(3) of the Laboratory Test Procedure for the New Car Assessment Program Side Impact Rigid Pole Test. If the seat is a power seat, position the seat to avoid contact while assuring that there is a maximum of 5 mm (0.2 in) distance between the steering wheel when adjusted per 11.1,U(3) of the Laboratory Test Procedure for the New Car Assessment Program Side Impact Rigid Pole Test and the point of contact on the dummy.
- L. Measure and set the dummy's pelvic angle to 20.0 degrees ± 2.5 degrees using the pelvic angle gage. If the dummy's pelvic angle is within the specified range at the head angle determined in step J, continue to step M. If the dummy's pelvic angle is outside of the specified range at the head angle determined in step J, adjust the pelvic angle as close to 20.0 degrees as possible by performing the applicable step listed below while keeping the transverse instrumentation platform of the head as level as possible, as specified in step J. **If it is not possible to achieve both the head level and the specified pelvic angle, priority goes to leveling the head.**
- (1) If the pelvic angle is above the specified range, decrease the pelvic angle by rotating the torso forward and then holding the dummy's thighs down and slowly rotating the torso rearward until it is supported by the seat back and/or the head is supported by the head restraint. Record the pelvic angle and head angle, making sure the transverse instrumentation platform angle of the head can still be leveled to within ± 0.5 degrees or, at most, to the angle determined in step J. Adjustment of the neck bracket is permitted to level the transverse instrumentation platform of angle of the head to within ± 0.5 degrees. Proceed to step M.
 - (2) If the pelvic angle is below the specified range, increase the pelvic angle by holding the dummy's thighs down and pushing rearward on the upper torso. Record the pelvic angle and head angle, making sure the transverse instrumentation platform angle of the head can still be leveled to within ± 0.5 degrees or, at most, to the angle determined in step J. Adjustment of the neck bracket is permitted to level the transverse

instrumentation platform of angle of the head to within ± 0.5 degrees.
Proceed to step M.

- M. If the dummy is contacting the vehicle interior after these adjustments, move the seat rearward until there is a maximum of 5 mm (0.2 in) between the contact point of the dummy and the interior of the vehicle or if it has a manual seat adjustment, to the next rearward detent position. If after these adjustments, the dummy contact point is more than 5 mm (0.2 in) from the vehicle interior and the seat is still not in its forwardmost position, move the seat forward until the contact point is 5 mm (0.2 in) or less from the vehicle interior, or if it has a manual seat adjustment, move the seat to the closest detent position without making contact, or until the seat reaches its forwardmost position, whichever occurs first.
- N. Driver foot positioning.

If the vehicle has an adjustable accelerator pedal, make sure that it has been adjusted to the full forward position.

(1) Driver right foot

Place the right foot perpendicular to the leg and determine if the heel contacts the floor pan at any leg position. If the heel of the right foot can contact the floor pan, proceed to step (a). If it cannot contact the floor pan, proceed to step (b).

- (a) Perform the following steps until either all steps are completed, or until the foot contacts the accelerator pedal. Once the foot contacts the accelerator pedal, stop and record the final foot position.
- i. Rest the right foot of the test dummy on the un-depressed accelerator pedal with the rearmost point of the heel on the floor pan in the plane of the pedal. If the foot cannot be placed on the accelerator pedal, set it initially perpendicular to the leg and then place it as far forward as possible in the direction of the pedal centerline with the rearmost point of the heel resting on the floor pan. If the vehicle has an adjustable accelerator pedal and the right foot is not touching the accelerator pedal when positioned as above, move the pedal rearward until it touches the right foot. If the accelerator pedal in the full rearward position still does not touch the foot, leave the pedal in that position.
 - ii. Extend the foot and lower leg, allowing the heel to lose contact with the floor until the foot contacts the pedal. Do not raise the toe of the foot higher than the top of the accelerator pedal. If the foot does not contact the pedal, proceed to the

- next step. If pedal contact does occur, place a tapered foam block under the heel. Note that the surface of the block in contact with the heel has an inclination of 30 degrees, measured from the horizontal, with the highest surface towards the rear of the vehicle.
- iii. Angle the foot to achieve contact between the foot and the pedal. If the foot does not contact the pedal, return the foot to the perpendicular orientation. If pedal contact does occur, place a tapered foam block under the heel. Note that the surface of the block in contact with the heel has an inclination of 30 degrees, measured from the horizontal, with the highest surface towards the rear of the vehicle.
 - iv. Align the centerline of the foot with the vertical-longitudinal plane passing through the center of the accelerator pedal. Place a tapered foam block under the heel. Note that the surface of the block in contact with the heel has an inclination of 30 degrees, measured from the horizontal, with the highest surface towards the rear of the vehicle.
- (b) Perform the following steps until either all steps are completed, or the foot contacts the accelerator pedal. Once the foot contacts the accelerator pedal, stop and record the final foot position.
- i. Extend the leg until the foot contacts the pedal. Do not raise the toe of the foot higher than the top of the accelerator pedal. If the foot does not contact the pedal, proceed to the next step. If pedal contact does occur, place a tapered foam block under the heel. Note that the surface of the block in contact with the heel has an inclination of 30 degrees, measured from the horizontal, with the highest surface towards the rear of the vehicle.
 - ii. If the vehicle has an adjustable pedal, move the pedal rearward until pedal contact occurs or the pedal reaches the full rearward position. If pedal contact does occur, place a tapered foam block under the heel. Note that the surface of the block in contact with the heel has an inclination of 30 degrees, measured from the horizontal, with the highest surface towards the rear of the vehicle.
 - iii. Angle the foot to achieve contact between the foot and the pedal. If the foot does not contact the pedal, return the foot to the perpendicular orientation. If pedal contact does occur, place a tapered foam block under the heel. Note that the

surface of the block in contact with the heel has an inclination of 30 degrees, measured from the horizontal, with the highest surface towards the rear of the vehicle.

- iv. Align the centerline of the foot in the same horizontal plane as the centerline of the accelerator pedal. Place a tapered foam block under the heel. Note that the surface of the block in contact with the heel has an inclination of 30 degrees, measured from the horizontal, with the highest surface towards the rear of the vehicle.

(2) Driver left foot

Place the right foot perpendicular to the leg and determine if the heel contacts the floor pan at any leg position. If the heel contacts the floor pan, proceed to step (a). If the left foot does not contact the floor pan, place the leg as perpendicular to the thigh as possible with the foot parallel to the floor pan, even if this causes the dummy's calf to contact the front of the seat cushion and record the final foot position.

- (a) Place the left foot on the toe-board with the rearmost point of the heel resting on the floor pan as close to the intersection of the planes described by the toe-board and floor pan as possible. Adjust the angle of the foot, if necessary, to contact the toe-board.
- (b) If the left foot will not contact the toe board, place the foot perpendicular to the lower leg centerline, and set the heel on the floorpan as far forward as possible. Avoid contact with the vehicle's brake pedal, clutch pedal, wheel-well projection or foot rest. To avoid this contact, use the following three manipulations in the order listed below. The adjustment options are listed in priority order, with each subsequent option incorporating the previous until contact is avoided. In making each adjustment, movement should be the minimum amount necessary to avoid contact. If it is not possible to avoid all prohibited foot contact, priority is given to avoiding brake or clutch pedal contact:
 - i. Rotate (abduction/adduction) the test dummy's left foot about the lower leg;
 - ii. Planar flex the foot;
 - iii. Rotate the left leg outboard about the hip.

Record the final foot position.

- G. Place the seat belt around the dummy and fasten the latch. Ensure that the seat belt is routed through the shoulder belt guide, if equipped, unless manufacturer directions state

otherwise. Check again the alignment of the dummy and verify that the head is level. If everything is in position, set the arm. If not, repeat the steps to get the head as level as possible. The head angle should not be larger than the angle determined in Step J.

H. Driver arm/hand positioning.

Place the dummy's upper arm such that the angle between the projection of the arm centerline on the midsagittal plane of the dummy and the torso reference line is 45 ± 5 degrees. The torso reference line is defined as the thoracic spine centerline. The shoulder-arm joint allows for discrete arm positions at $0, \pm 40, \pm 90, \pm 140$, and 180 degree settings where positive is forward of the spine.

APPENDIX C.

DELIVERABLE GUIDELINES FOR NEW CAR ASSESSMENT PROGRAM SIDE IMPACT POLE TESTING

TABLE OF CONTENTS

1.	FINAL TEST REPORT	2
1.1	FIRST THREE PAGES	2
1.2	TABLE OF CONTENTS	6
1.3	SECTION 1 – TEST PURPOSE AND PROCEDURE	7
1.4	SECTION 2 – SUMMARY OF TEST RESULTS	7
1.5	SECTION 3 – OCCUPANT AND VEHICLE INFORMATION	8
1.6	APPENDIX A – PHOTOGRAPHS	9
1.7	APPENDIX B – VEHICLE AND DUMMY RESPONSE DATA PLOTS	12
1.8	APPENDIX C – DUMMY CONFIGURATION AND PERFORMANCE VERIFICATION DATA	13
1.9	APPENDIX D – TEST EQUIPMENT AND INSTRUMENTATION CALIBRATION DATA	15
2.	DATA SHEETS	16
	DATA SHEET NO. 1 – GENERAL TEST AND VEHICLE PARAMETER DATA	17
	DATA SHEET NO. 2 – SEAT, SEAT BELT, STEERING WHEEL ADJUSTMENT AND FUEL SYSTEMS DATA	20
	DATA SHEET NO. 3 – DUMMY LONGITUDINAL CLEARANCE DIMENSIONS	23
	DATA SHEET NO. 4 – DUMMY LATERAL CLEARANCE DIMENSIONS	24
	DATA SHEET NO. 5 – CAMERA AND INSTRUMENTATION DATA	25
	DATA SHEET NO. 6 – VEHICLE ACCELEROMETER DATA	26
	DATA SHEET NO. 7 – RIGID POLE LOAD CELL DATA	27
	DATA SHEET NO. 8 – POST-TEST OBSERVATIONS	28
	DATA SHEET NO. 9 – VEHICLE PROFILE MEASUREMENTS	30
	DATA SHEET NO. 10 – VEHICLE EXTERIOR CRUSH MEASUREMENTS	31
	DATA SHEET NO. 11 – FMVSS NO. 301 STATIC ROLLOVER RESULTS	34
	DATA SHEET NO. 12 – DUMMY/VEHICLE TEMPERATURE STABILIZATION	35
3.	FORMS	36
	FORM NO. 1 – TEST VEHICLE INFORMATION	37
	FORM NO. 2 – REPORT OF VEHICLE CONDITION	55
	FORM NO. 3 – LABORATORY NOTICE OF TEST FAILURE	58
	FORM NO. 4 – MONTHLY VEHICLE STATUS REPORT	59
	FORM NO. 5 – QUICKLOOK REPORT	60

1. FINAL TEST REPORT

Instructions for the preparation of the Draft Test Report Final Test Report are provided in this section. To maintain standardization of test reports, the format outlined below must be adhered to.

1.1 FIRST THREE PAGES

Instructions for the preparation of the first three pages of the Draft Test Report and Final Test Report are provided on the following pages for standardization purposes.

A. COVER PAGE

The cover page for the test report shall contain the following information:

- (1) Final Report Number, such as SPNCAP-ABC-XX-001 where

SPNCAP	denotes a Side Pole NCAP Test
ABC	are the initials for the laboratory
XX	is the last two numbers of the Fiscal Year of the test program
001	is the Group Number (001 for the 1st test, 002 for the 2nd test, etc.)

- (2) Final Report Title and Subtitle such as:

NEW CAR ASSESSMENT PROGRAM (NCAP)
 Side Impact Pole Test

 World Motors Corporation
 20XX SaferRider 4-door sedan
 NHTSA No. MXXXXX

- (3) Contractor's Name and Address such as:

ABC Laboratories, Inc.
 4335 West Main Street
 Detroit, MI 48070-1234

NOTE: DOT symbol should be place between items (3) AND (4).

- (4) Date of Final Report completion
- (5) The words "FINAL REPORT"
- (6) The sponsoring agency's name and address as follows:

U. S. DEPARTMENT OF TRANSPORTATION
 National Highway Traffic Safety Administration
 Office of Crashworthiness Standards
 Mail Code: NVS-111
 1200 New Jersey Ave, SE
 Room W43-410
 Washington, DC 20590

1. **FINAL TEST REPORT....Continued**

B. *FIRST PAGE AFTER COVER PAGE*

A disclaimer statement and an acceptance signature block for the COTR shall be provided as follows:

This publication is distributed by the U.S. Department of Transportation, National Highway Traffic Safety Administration, in the interest of information exchange. The opinions, findings and conclusions expressed in this publication are those of the author(s) and not necessarily those of the Department of Transportation or the National Highway Traffic Safety Administration. The United States Government assumes no liability for its contents or use thereof.

If trade or manufacturers' names or products are mentioned, it is only because they are considered essential to the object of the publication and should not be construed as an endorsement.

Prepared By: _____

Approved By: _____

Approval Date: _____

FINAL REPORT ACCEPTANCE BY OCWS:

 Division Chief, New Car Assessment Program
 NHTSA, Office of Crashworthiness Standards

Date: _____

 COTR, New Car Assessment Program
 NHTSA, Office of Crashworthiness Standards

Date: _____

1. FINAL TEST REPORT....Continued**C. SECOND PAGE AFTER COVER PAGE**

A completed Technical Report Documentation Page (Form DOT F1700.7) shall be completed for those items that are applicable with the other spaces left blank. Sample data for the applicable block numbers of the title page follows.

Block No. 1--REPORT NO.

SPNCAP-ABC-XX-001

Block No. 2--GOVERNMENT ACCESSION NO.

Please leave blank.

Block No. 3--RECIPIENT'S CATALOG NO.

Please leave blank.

Block No. 4--TITLE AND SUBTITLE

Final Report of New Car Assessment Program
Side Impact Pole Testing of 20XX SaferRider 4-Door Sedan,
NHTSA No. MX0000

Block No. 5--REPORT DATE

Month Day, 20XX

Block No. 6--PERFORMING ORGANIZATION CODE

ABC

Block No. 7--AUTHOR(S)

John Smith, Project Manager
Bill Doe, Project Engineer

Block No. 8--PERFORMING ORGANIZATION REPORT NO.

ABC-DOT-20XX-001

Block No. 9--PERFORMING ORGANIZATION NAME AND ADDRESS

ABC Laboratories, Inc.
4335 West Main Street
Detroit, MI 48070-1234

Block No. 10--WORK UNIT NO.

Please leave blank.

Block No. 11--CONTRACT OR GRANT NO.

DTNH22-XX-D-12345

1. FINAL TEST REPORT....Continued

Block No. 12--SPONSORING AGENCY NAME AND ADDRESS

United States Department of Transportation
National Highway Traffic Safety Administration
Office of Crashworthiness Standards
Mail Code: NVS-111
1200 New Jersey Ave., SE, Room W43-410
Washington, DC 20590

Block No. 13--TYPE OF REPORT AND PERIOD COVERED

Final Test Report
Month Day to Month Day, 20XX

Block No. 14--SPONSORING AGENCY CODE

NVS -111

Block No. 15--SUPPLEMENTARY NOTES

Please leave blank.

Block No. 16--ABSTRACT

A 32.20 km/h, 75° oblique impact Side NCAP Test was conducted on the subject 20XX SaferRider 4-door Sedan in accordance with the specifications of the Office of Crashworthiness Standards Side NCAP Pole Laboratory Test Procedure for the generation of consumer information on vehicle side pole crash protection. The test was conducted at the ABC Laboratories, Inc. in Detroit, Michigan, on November 15, 20XX.

The impact velocity was 31.9 km/h, and the ambient temperature at the struck (driver's) side of the target vehicle at the time of impact was 28°C. The test vehicle post-test maximum crush was 250 mm at level 3. The test vehicle's performance was as follows:

Measurement Description	Driver ATD (SID-IIs)		
	Units	Threshold	Result
Head Injury Criteria (HIC ₃₆)	N/A	1000	
Resultant Lower Spine Acceleration	Gs	82	
Total Pelvic Force (sum of acetabular and iliac forces)	N	5525	
Maximum Thoracic Rib Deflection	mm	38*	
Maximum Abdomen Rib Deflection	mm	45*	

* Proposed IARV

The two doors on the struck side of the vehicle did not separate from the body at the hinges or latches and the opposite doors did not open during the side impact event.

1. FINAL TEST REPORT....Continued

Block No. 17--KEY WORDS

New Car Assessment Program (NCAP)
 Side Impact
 Pole
 Part 572V
 SID-IIs

Block No. 18--DISTRIBUTION STATEMENT

Copies of this report are available from:

National Highway Traffic Safety Administration
 Technical Information Services Division, NPO-411
 1200 New Jersey Ave, SE
 Washington, DC 20590

e-mail: tis@nhtsa.dot.gov
 FAX: 202-493-2833

Block No. 19--SECURITY CLASSIFICATION OF REPORT

Unclassified

Block No. 20--SECURITY CLASSIFICATION OF PAGE

Unclassified

Block No. 21--NO. OF PAGES

Add appropriate number

Block No. 22--PRICE

Please leave blank

1.2. TABLE OF CONTENTS

The Final Test Report Table of Contents shall include the following:

<u>Section</u>	
1	Test Purpose and Procedure
2	Summary of Test Results
3	Occupant and Vehicle Information
<u>Appendix</u>	
A	Photographs
B	Vehicle and Dummy Response Data Plots
C	Dummy Configuration and Performance Verification Data
D	Test Equipment and Instrumentation Calibration Data

1. FINAL TEST REPORT....Continued

1.3 SECTION 1 – TEST PURPOSE AND PROCEDURE

This section briefly outlines the purpose for conducting the side impact test and states the appropriate test procedure followed during the test. The following is provided as an example:

This side impact test is part of the MY__ New Car Assessment Program Side Impact Test Program, sponsored by the National Highway Traffic Safety Administration (NHTSA), under contract No. _____. The purpose of this test is to generate comparative side impact performance in a 20__ SaferRider 4-door Sedan. The side impact test was conducted in accordance with the Office of Crashworthiness Standard's Side NCAP Pole Laboratory Test Procedure, dated _____.

NOTE: This section should be double-spaced and requires an entire separate page.

1.4 SECTION 2 – SUMMARY OF TEST RESULTS

This section gives a summary of the side impact event. The following is an example of the content needed in this section:

A rigid pole side impact test was conducted on a 20XX SaferRider 4-door Sedan. The subject vehicle was towed into the rigid pole at an angle of 75° and a velocity of 31.9 km/h. The test was conducted by the ABC Laboratories, Inc. in Detroit, Michigan, on Month Day, 20XX. Pre-test and post test photographs of the test vehicle and side impact dummy (SID-IIs) are included in APPENDIX A of this report.

One Part 572V (SID-IIs) dummy was placed in the driver designated seating position according to instructions specified in the OCWS Side NCAP Pole Laboratory Test Procedure, dated _____, 20__. Camera locations and other pertinent camera information are included in this report.

The Part 572V (SID-IIs) Dummy was instrumented accordingly:

- Primary and Redundant Head CG Triaxial Accelerometers
- Thorax Upper, Middle, and Lower Rib Displacement Potentiometers
- Abdomen Upper and Lower Rib Displacement Potentiometers
- Lower Spine (T12) Triaxial Accelerometers
- Iliac Load Cell
- Acetabulum Load Cell

APPENDIX B contains the vehicle and dummy response data. Dummy configuration and performance verification data can be found in APPENDIX C of this report. APPENDIX D contains the test equipment and instrumentation calibration data.

1. FINAL TEST REPORT....Continued

Injury readings for the SID-IIs dummy were recorded as follows:

Measurement Description	Driver ATD (SID-IIs)		
	Units	IARV	Result
Head Injury Criteria (HIC ₃₆)	N/A	1000	
Lower Spine Acceleration	G	82	
Total Pelvic Force (sum of acetabular and iliac forces)	N	5525	
Maximum Thoracic Rib Deflection	mm	38*	
Maximum Abdominal Rib Deflection	mm	45*	

* Proposed IARV

Supplemental restraint information is given below:

Restraint Type	Left Front (Driver) Occupant Location 1		Left Rear (Passenger) Occupant Location 4	
	Mounted	Deployed	Mounted	Deployed
Frontal Airbag				
Knee Airbag				
Side Airbag 1 (Indicate Type)				
Side Airbag 2 (Indicate Type, if App.)				
Side Airbag 3 (Indicate Type, if App.)				
Seat Belt Pretensioner				
Seat Belt Load Limiter				
Other				

GENERAL COMMENTS

EXAMPLE: The driver door became unlatched and opened during impact. The width of the opening at the latch was 6.5 inches. The fuel line was broken upon impact and fuel leaked at a rate of 30 oz. per minute. The side curtain airbag failed to deploy. The driver's side torso air bag deployed late, and thus failed to provide adequate protection to the occupant. The HIC values for the driver exceeded the threshold.

1.5 SECTION 3 – OCCUPANT AND VEHICLE INFORMATION

This section requires the reporting of all information found in the following data sheets. Data sheets can be found in Section 2 of these Deliverable Guidelines. The Contractor may expand upon the data sheets if desired; however, the data must be presented in the order listed below.

- Data Sheet No. 1 – General Test and Vehicle Parameter Data
- Data Sheet No. 2 – Seat, Seat Belt, Steering Wheel Adjustment, and Fuel Systems Data
- Data Sheet No. 3 – Dummy Longitudinal Clearance Dimensions
- Data Sheet No. 4 – Dummy Lateral Clearance Dimensions
- Data Sheet No. 5 – Camera and Instrumentation Data
- Data Sheet No. 6 – Vehicle Accelerometer Data
- Data Sheet No. 7 – Rigid Pole Load Cell Data
- Data Sheet No. 8 – Post-test Observations
- Data Sheet No. 9 – Vehicle Profile Measurements
- Data Sheet No. 10 – Vehicle Exterior Crush Measurements
- Data Sheet No. 11 – FMVSS No. 301 Static Rollover Results
- Data Sheet No. 12 – Dummy/Vehicle Temperature and Humidity Stabilization Data

1. FINAL TEST REPORT....Continued

1.6 APPENDIX A - PHOTOGRAPHS

The following table and respective photographs shall be included in this Appendix in the following order. All additional photographs taken for clarification should be added after Photograph 69. The Contractor should present two photographs per page.

TABLE OF PHOTOGRAPHS

No.	Description	Page
1	As Delivered Right Front $\frac{3}{4}$ View of Test Vehicle	A-1
2	As Delivered Left Rear $\frac{3}{4}$ View of Test Vehicle	A-1
3	Pre-Test Frontal View of Test Vehicle	A-2
4	Post-Test Frontal View of Test Vehicle	A-2
5	Pre-Test Left Front $\frac{3}{4}$ View of Test Vehicle	A-3
6	Post-Test Left Front $\frac{3}{4}$ View of Test Vehicle	A-3
7	Pre-Test Left Side View of Test Vehicle	A-4
8	Post-Test Left Side View of Test Vehicle	A-4
9	Pre-Test Left Rear $\frac{3}{4}$ View of Test Vehicle	A-5
10	Post-Test Left Rear $\frac{3}{4}$ View of Test Vehicle	A-5
11	Pre-Test Rear View of Test Vehicle	A-6
12	Post-Test Rear View of Test Vehicle	A-6
13	Pre-Test Right Side View of Test Vehicle	A-7
14	Post-Test Right Side View of Test Vehicle	A-7
15	Pre-Test Overhead View of Test Area <i>(to include pole and vehicle, if possible)</i>	A-8
16	Post-Test Overhead View of Test Area <i>(to include pole and vehicle, if possible)</i>	A-8
17	Pre-Test Left Side View of Pole Positioned Against Side of Vehicle <i>(should be positioned at Ideal Impact Point if possible)</i>	A-9
18	Pre-Test Right Side View of Pole Positioned Against Side of Vehicle <i>(should be positioned at Ideal Impact Point if possible)</i>	A-9
19	Pre-Test Close-Up View of Impact Point Target <i>(impact reference line should be clearly indicated)</i>	A-10
20	Post-Test Close-Up View of Impact Point Target Showing Impact Location <i>(impact reference line and impact point should be clearly indicated)</i>	A-10
21	Pre-Test Front Close-Up View of Dummy Head and Chest <i>(through front window to show position of seat belt across dummy's chest, including inch tape intended to show pretensioner firing)</i>	A-11
22	Post-Test Front Close-Up View of Dummy <i>(through front window)</i>	A-11

1. FINAL TEST REPORT....Continued

23	Pre-Test Left Side View of Dummy Showing Belt and Chalking (<i>door open</i>)	A-12
24	Pre-Test Left Side View of Dummy Shoulder and Door Top View	A-12
25	Post-Test Left Side View of Dummy Shoulder and Door Top View	A-13
26	Pre-Test Front View of Seat Back Prior to Dummy Positioning (<i>should include head restraint and show centerline</i>)	A-13
27	Pre-Test Front Close-Up View of Dummy Head and Shoulders in Relation to Head Restraint (<i>through front window</i>) (<i>should only show head and shoulders, not chest, and level should be included in photo, as should seat centerline</i>)	A-14
28	Pre-Test Front View of Seat Pan Prior to Dummy Positioning (<i>should show seat centerline</i>)	A-14
29	Pre-Test Overhead View of Dummy Thighs on Seat Pan (<i>should be taken through the steering wheel, if possible</i>)	A-15
30	Pre-Test Left Side View of Dummy's Neck Showing Position of Adjustable Neck Bracket	A-15
31	Pre-Test Left Side View of Dummy's Head Showing Dummy's Head is Level (<i>level should be shown in photo</i>)	A-16
32	Pre-Test Placement of Dummy's Feet	A-16
33	Pre-Test View of Belt Anchorage for Dummy (<i>should show test position and include detent or millimeter markings, if applicable</i>)	A-17
34	Pre-Test Left Side View of Steering Wheel (<i>should show test position and include detent or millimeter markings, if applicable</i>)	A-17
35	Pre-Test View of Disengaged Parking Brake (<i>taken at the same time as As-Delivered photos</i>)	A-18
36	Pre-Test View of Parking Brake(<i>should be taken at the same angle as previous photo</i>)	A-18
37	Pre-Test Close-Up Left Side View of Driver Seat Track (<i>should show test position and include detent or millimeter markings</i>)	A-19
38	Pre-Test Close-Up Left Side View of Driver Seat Back (<i>should show test position and include detent or degree markings</i>)	A-19
39	Pre-Test Close-Up View of Driver Seat Back or Head Restraint (<i>should show test position and include level, placed at manufacturer's designated location, as indicated on Form 1, to show angle at test position</i>)	A-20
40	Pre-Test Dummy and Door Clearance View	A-20
41	Post-Test Dummy and Door Clearance View	A-21
42	Pre-Test Right Side View of Dummy and Front Seat of Occupant Compartment (<i>through vehicle with door open</i>)	A-21
43	Post-Test Right Side View of Dummy and Front Seat of Occupant Compartment (<i>through vehicle with door open</i>)	A-22
44	Pre-Test Inner Door Panel View	A-22
45	Post-Test Inner Door Panel View Showing Dummy Contact Location (<i>with dummy removed and airbags untouched</i>)	A-23
46	Post-Test Dummy Close-Up Head Contact with Vehicle Interior View (<i>if applicable, with dummy removed</i>)	A-23
47	Post-Test Dummy Close-Up Head Contact with Side Airbag View (<i>if applicable, with dummy removed and airbag arranged to show contact marks</i>)	A-24

1. FINAL TEST REPORT....Continued

48	Post-Test Dummy Close-Up Torso Contact with Vehicle Interior View <i>(if applicable, with dummy removed)</i>	A-24
49	Post-Test Dummy Close-Up Torso Contact with Side Airbag View <i>(if applicable, with dummy removed and airbag arranged to show contact marks)</i>	A-25
50	Post-Test Dummy Close-Up Pelvis Contact with Vehicle Interior View <i>(if applicable, with dummy removed)</i>	A-25
51	Post-Test Dummy Close-Up Pelvis Contact with Side Airbag View <i>(if applicable, with dummy removed and airbag arranged to show contact marks)</i>	A-26
52	Post-Test Dummy Close-Up Knee Contact with Vehicle Interior View <i>(if applicable)</i>	A-26
53	Pre-Test View of Fuel Filler Car or Fuel Filler Neck	A-27
54	Post-Test View of Fuel Filler Cap or Fuel Filler Neck	A-27
55	Close-Up View of Vehicle's Certification Label (photograph of certification label, include a photograph of the reduced load carrying capacity as No. 055a, if applicable)	A-28
56	Close-Up View of Vehicle's Tire Information Placard or Label	A-28
57	Pre-Test Pole Barrier Front View	A-29
58	Post-Test Pole Barrier Front View	A-29
59	Pre-Test Pole Barrier Side View	A-30
60	Post-Test Pole Barrier Side View	A-30
61	Pre-Test Ballast View	A-31
62	Post-Test Primary and Redundant Speed Trap Read-Out <i>(primary and redundant speeds should be labeled and photo should include a placard that displays the NHTSA No.)</i>	A-31
63	FMVSS No. 301 Static Rollover 0 Degrees	A-32
64	FMVSS No. 301 Static Rollover 90 Degrees	A-32
65	FMVSS No. 301 Static Rollover 180 Degrees	A-33
66	FMVSS No. 301 Static Rollover 270 Degrees	A-33
67	FMVSS No. 301 Static Rollover 360 Degrees	A-34
68	Impact Event <i>(impact side)</i>	A-34
69	Monroney Label	A-35
70	Head Restraint Use and Adjustment Information from Vehicle Owner's Manual	A-35
71	Post-Test View of Shattered Vehicle Inner Door Panel <i>(if applicable)</i>	A-36

1. FINAL TEST REPORT....Continued

1.7 APPENDIX B – VEHICLE AND DUMMY RESPONSE DATA PLOTS

The following table and respective vehicle and dummy (filtered) data plots should be included in APPENDIX B:

TABLE OF DATA PLOTS
Driver Dummy Instrumentation Plots

No.	Description	Page
1	Driver Head Acceleration (X) Primary vs. Time	B-1
2	Driver Head Acceleration (Y) Primary vs. Time	B-1
3	Driver Head Acceleration(Z) Primary vs. Time	B-1
4	Driver Head Resultant Primary vs. Time	B-1
5	Driver Lower Spine T12 Acceleration (X) vs. Time	B-2
6	Driver Lower Spine T12 Acceleration (Y) vs. Time	B-2
7	Driver Lower Spine T12 Acceleration (Z) vs. Time	B-2
8	Driver Lower Spine T12 Resultant Acceleration vs. Time	B-2
9	Driver Iliac Wing Force on Impact Side (Y) vs. Time	B-3
10	Driver Acetabulum Force on Impact Side (Y) vs. Time	B-3
11	Driver Total Pelvis Force on Impact Side (Y) vs. Time	B-3

The following information should also be provided:

The following additional data for this test can be obtained from the Research and Development section of the NHTSA website. The website can be found at www.NHTSA.dot.gov.

Additional Driver Dummy Instrumentation Data

Driver Head Acceleration (X) Redundant
Driver Head Acceleration (Y) Redundant
Driver Head Acceleration (Z) Redundant
Driver Upper Thorax Rib Deflection (Y)
Driver Middle Thorax Rib Deflection (Y)
Driver Lower Thorax Rib Deflection (Y)
Driver Upper Abdomen Rib Deflection (Y)
Driver Lower Abdomen Rib Deflection (Y)

1. FINAL TEST REPORT....Continued

Vehicle Instrumentation Data

Vehicle Center of Gravity Acceleration (X)
 Vehicle Center of Gravity Acceleration (Y)
 Vehicle Center of Gravity Acceleration (Z)
 Left Floor Sill Acceleration (Y)
 Left A-Pillar Sill Acceleration (Y)
 Left Lower A-Pillar Acceleration (Y)
 Left Mid A-Pillar Acceleration (Y)
 Left B-Pillar Sill Acceleration (Y)
 Left Lower B-Pillar Acceleration (Y)
 Left Mid B-Pillar Acceleration (Y)
 Driver Seat Track at Dummy Hip Point Acceleration (Y)
 Engine Top Acceleration (X)
 Engine Top Acceleration (Y)
 Firewall Center Acceleration (Y)
 Right Roof at Vertical Impact Reference Line Acceleration (Y)
 Right Sill at Vertical Impact Reference Line Acceleration (Y)
 Rear Floorpan Behind Rear Axle at Centerline Acceleration (X)
 Rear Floorpan Behind Rear Axle at Centerline Acceleration (Y)

Pole Instrumentation Data

Load Cell Pole Barrier #1 Force (Y)
 Load Cell Pole Barrier #2 Force (Y)
 Load Cell Pole Barrier #3 Force (Y)
 Load Cell Pole Barrier #4 Force (Y)
 Load Cell Pole Barrier #5 Force (Y)
 Load Cell Pole Barrier #6 Force (Y)
 Load Cell Pole Barrier #7 Force (Y)
 Load Cell Pole Barrier #8 Force (Y)

1.8 APPENDIX C – DUMMY CONFIGURATION AND PERFORMANCE VERIFICATION DATA

APPENDIX C includes the pre- and post-test calibration data for the test dummy. The following data tables and plots shall be included in the order indicated below (See calibration test procedure or 49 CFR §572, Subpart V).

1. FINAL TEST REPORT....Continued

TABLE OF CALIBRATION MEASUREMENTS AND PLOTS

SID-IIs (Driver) Dummy

Description

Table 1. External Measurements**Table 2.** Head Drop Test

Resultant Head Acceleration (G's) vs. Time (ms)

Head (X) Acceleration (G's) vs. Time (ms)

Head (Y) Acceleration (G's) vs. Time (ms)

Head (Z) Acceleration (G's) vs. Time (ms)

Table 3. Lateral Neck Pendulum Test

Pendulum Acceleration (G's) vs. Time (ms)

Pendulum Velocity (m/s) vs. Time (ms)

Neck (X) Force (N) vs. Time (ms)

Neck (X) Moment (Nm) vs. Time (ms)

Flexion Angle (°) vs. Time (ms)

Moment About Occipital Condyle (Nm) vs. Time (ms)

D-Plane Rotation (°) vs. Time (ms)

Table 4. Shoulder Impact Test

Impactor Acceleration (G's) vs. Time (ms)

Shoulder Displacement (mm) vs. Time (ms)

Upper Spine Acceleration (G's) vs. Time (ms)

Table 5. Thorax (With Arm) Impact Test

Impactor Acceleration (G's) vs. Time (ms)

Shoulder Displacement (mm) vs. Time (ms)

Upper Rib Displacement (mm) vs. Time (ms)

Middle Rib Displacement (mm) vs. Time (ms)

Lower Rib Displacement (mm) vs. Time (ms)

Upper Spine Acceleration (G's) vs. Time (ms)

Lower Spine Acceleration (G's) vs. Time (ms)

Table 6. Thorax (Without Arm) Impact Test

Impactor Acceleration (G's) vs. Time (ms)

Upper Rib Displacement (mm) vs. Time (ms)

Middle Rib Displacement (mm) vs. Time (ms)

Lower Rib Displacement (mm) vs. Time (ms)

Upper Spine Acceleration (G's) vs. Time (ms)

Lower Spine Acceleration (G's) vs. Time (ms)

Table 7. Abdomen Impact Test

Impactor Acceleration (G's) vs. Time (ms)

Upper Abdominal Rib Displacement (mm) vs. Time (ms)

Lower Abdominal Rib Displacement (mm) vs. Time (ms)

Lower Spine Acceleration (G's) vs. Time (ms)

Table 8. Pelvis Plug Quasi-Static Test (Optional*)**Table 9.** Pelvis Acetabulum Impact Test

Impactor Acceleration (G's) vs. Time (ms)

Pelvis (Y) Acceleration (G's) vs. Time (ms)

Acetabulum Force (N) vs. Time (ms)

Table 10. Pelvis Iliac Impact Test

Impactor Acceleration (G's) vs. Time (ms)

Pelvis (Y) Acceleration (G's) vs. Time (ms)

Iliac Force (N) vs. Time (ms)

1. FINAL TEST REPORT....Continued

** - If pre-certified pelvis plugs are used during the calibration tests, include a copy of the certification data provided by the supplier.*

1.9 APPENDIX D – TEST EQUIPMENT AND INSTRUMENTATION CALIBRATION DATA

APPENDIX D should identify all test equipment, dummy sensors, potentiometers, and load cells used to collect data during the test. Calibration dates for each should be provided for each, as indicated in the sample tables below. Comments should also be included, if appropriate.

TABLE 1 – Dummy Instrumentation (SID-IIs)

				SID-IIs S/N		
				Serial Number	Manufacturer	Calibration Date
Head Accelerometers		Primary	X			
			Y			
			Z			
		Redundant	X			
			Y			
			Z			
Displacement Potentiometer	Thoracic Rib	Upper	Y			
		Middle	Y			
		Lower	Y			
	Abdominal Rib	Upper	Y			
		Lower	Y			
Lower Spine Accelerometers (T12)			X			
			Y			
			Z			
Acetabulum Load Cell			Y			
Iliac Wing Load Cell			Y			
Pelvis Plug (struck side)						
Pelvis Plug (non-struck side)						

1. FINAL TEST REPORT....Continued

TABLE 2 – Vehicle Instrumentation

Vehicle Instrumentation		Serial Number	Manufacturer	Calibration Date
Vehicle Center of Gravity	X			
Vehicle Center of Gravity	Y			
Vehicle Center of Gravity	Z			
Left Floor Sill	Y			
A-Pillar Sill	Y			
A-Pillar Low	Y			
A-Pillar Mid	Y			
B-Pillar Sill	Y			
B-Pillar Low	Y			
B-Pillar Mid	Y			
Driver Seat	Y			
Engine Top	X			
Engine Top	Y			
Firewall	Y			
Right Roof	Y			
Right Floor Sill	Y			
Rear Floorpan	X			
Rear Floorpan	Y			

TABLE 3 – Pole Instrumentation

Pole Instrumentation	Serial Number	Manufacturer	Calibration Date
Load Cell 1			
Load Cell 2			
Load Cell 3			
Load Cell 4			
Load Cell 5			
Load Cell 6			
Load Cell 7			
Load Cell 8			

2. DATA SHEETS

Data sheets are provided as templates to document test data in the Final Test Report format outlined in the previous section. The Contractor is not restricted from using other data sheets or expanding the data sheets provided herein. Nevertheless, for consistency and uniformity in reporting data, the Contractor must present, at a minimum, all information included in the following data sheets in the Draft Test Report and in the Final Test Report, and this data must be presented in the order outlined in Section 1 of this Appendix.

2. DATASHEETS....Continued

DATA SHEET NO.1
GENERAL TEST AND VEHICLE PARAMETER DATA

Test Vehicle: _____
 Test Program: _____

NHTSA No.: _____
 Test Date: _____

TEST VEHICLE INFORMATION AND OPTIONS

NHTSA No.	
Model Year	
Make	
Model	
Body Style	
VIN	
Body Color	
Odometer Reading (km/mi)	
Engine Displacement (L)	
Type/No. Cylinders	
Engine Placement	
Transmission Type	
Transmission Speeds	
Overdrive	
Final Drive	
Roof Rack	
Sunroof/T-Top	
Running Boards	
Tilt Steering Wheel	
Power Seats	
Anti-Lock Brakes (ABS)	

Traction Control System (TCS)	
Auto-Leveling System	
Automatic Door Locks (ADL)	
Power Window Auto-Reverse	
Other Optional Feature	
Driver Front Airbag	
Driver Curtain Airbag	
Driver Head/Torso Airbag	
Driver Torso Airbag	
Driver Torso/Pelvis Airbag	
Driver Pelvis Airbag	
Driver Knee Airbag	
Rear Pass. Curtain Airbag	
Rear Pass. Head/Torso Airbag	
Rear Pass. Torso Airbag	
Rear Pass. Torso/Pelvis Airbag	
Rear Pass. Pelvis Airbag	
Driver Seat Belt Pretensioner	
Rear Pass. Seat Belt Pretensioner	
Driver Load Limiter	
Rear Pass. Load Limiter	
Other Safety Restraint	

Does owner's manual provide instructions to turn off automatic door locks?

DATA FROM CERTIFICATION LABEL

Manufactured By		GVWR (kg)	
Date of Manufacturer		GAWR Front (kg)	
Vehicle Type		GAWR Rear (kg)	

VEHICLE SEATING AND WEIGHT CAPACITY DATA

	Front	Rear	Third	Total
Designated Seating Capacity (DSC)				
Vehicle Capacity Weight (VCW) (kg)				
DSC X 68.04 kg				
Rated Cargo and Luggage Weight (RCLW) (kg)				

(A)
 (B)
 (A-B)

VEHICLE SEAT TYPE

Seating Location	Type of Seat Pan				Type of Seat Back		
	Bucket	Bench	Split Bench	Contoured	Fixed	Adjustable	
						W/ Lever	W/ Knob
Front Seat							
Rear or Second Row Seat							
Third row seat							

2. DATA SHEETS....Continued

**DATA SHEET NO. 1 (CONTINUED)
GENERAL TEST AND VEHICLE PARAMETER DATA**

Test Vehicle: _____ NHTSA No.: _____
 Test Program: _____ Test Date: _____

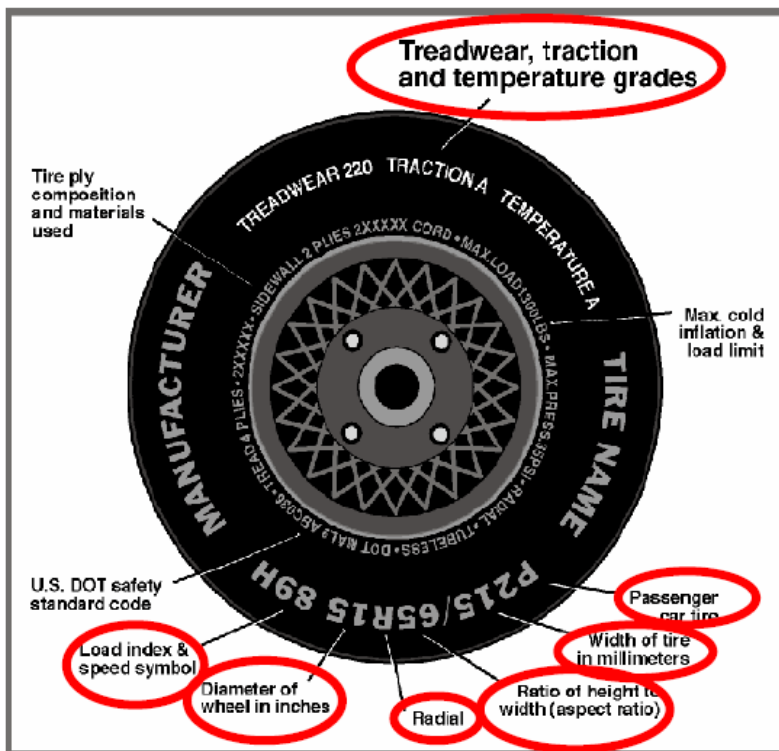

Measured Parameter	Front	Rear
Maximum Tire Pressure (kPa)		
Cold Pressure (kPa)		
Recommended Tire Size		
Tire Size on Vehicle		
Tire Manufacturer		
Tire Model		
Treadwear		
Traction		
Temperature Grades		
Tire Plies Sidewall		
Tire Plies Body		
Load Index/Speed Symbol		
Tire Material		
DOT Safety Code Left		
DOT Safety Code Right		

2. DATA SHEETS....Continued

DATA SHEET NO. 1 (CONTINUED)
GENERAL TEST AND VEHICLE PARAMETER DATA

Test Vehicle: _____
 Test Program: _____

NHTSA No.: _____
 Test Date: _____

TIRE PRESSURES

	Units	LF	RF	LR	RR
As Delivered	kpa				
Tire Placard	kpa				
Owner's Manual	kpa				
As Tested	kpa				

TEST VEHICLE WEIGHTS

	Units	As Delivered (UVW)			As Tested (ATW)			Fully Loaded		
		Front Axle	Rear Axle	Total	Front Axle	Rear Axle	Total	Front Axle	Rear Axle	Total
Left	kg									
Right	kg									
Ratio	%									
Totals	kg									

TARGET TEST WEIGHT CALCULATION

Measured Parameter	Units	Value	
Total As Delivered Weight (UVW)	kg		(A)
Actual Weight of 1 P572V ATD (SID-IIs) Dummy Used	kg		(B)
Rated Cargo/Luggage Weight (RCLW)	kg		(C)
Calculated Vehicle Target Weight (TVTW)	kg		(A+B+C)

Does the measured As Tested Vehicle Weight lie within the required weight range (i.e. Calculated Test Vehicle Target Weight – 4.5 kg to 9 kg)? YES NO

TEST VEHICLE ATTITUDES AND CG

	Units	As Delivered	As Tested	Fully Loaded	Meets Requirement***
Driver Door Sill Angle (front-to-rear)*	Deg.				
Front Passenger Sill Angle (front-to-rear)*	Deg.				
Front Bumper-Line Angle (left-to-right)**	Deg.				
Rear Bumper-Line Angle (left-to-right)**	Deg.				
Vehicle CG (Aft of Front Axle)	mm				
Vehicle CG (Left(+)/Right(-) from Longitudinal Centerline)	mm				

* ND=Nose Down (-), NU=Nose Up (+) ** LD=Left Down (-), LU=Left Up (+)

***The "As Tested" vehicle attitude measurements must be equal to or between the "As Delivered" and "Fully Loaded" vehicle attitude measurements. Indicate "Yes" or "No" for "Meets Requirement".

WEIGHT OF BALLAST AND VEHICLE COMPONENTS REMOVED TO MEET TVTW

Component Description	Weight (kg)
Ballast (if any)	

2. DATA SHEETS....Continued

DATA SHEET NO. 2
SEAT, SEAT BELT, STEERING WHEEL ADJUSTMENT AND FUEL SYSTEMS DATA

Test Vehicle: _____
 Test Program: _____

NHTSA No.: _____
 Test Date: _____

SEAT POSITIONING

The driver's seat, front center seat (if applicable), and right front passenger's seat should be set to the forward-most, mid-height, mid-angle position. The struck-side rear passenger's seat, rear center seat, and non-struck side rear passenger's seats should be set to the rear-most, lowest, mid-angle position.

SCRL ANGLE RANGE

Seat	SCRL (°)		
	Max	Min	Mid
Driver Seat			
Front Passenger Seat			
Front Center Seat*			
Struck Side Rear Seat			
Non-Struck Side Rear Seat			
Rear Center Seat*			

*If applicable

SEAT HEIGHT AND ANGLE

Seat	As Tested SCRL Angle (Mid) (°)	As Tested SCR Height (mm)	SCR Height Position	SCR Height (mm)		
				Rearmost	Mid- Fore/Aft	Forward- Most
Driver Seat			Max			
			Mid			
			Min			
Front Passenger Seat			Max			
			Mid			
			Min			
Front Center Seat*			Max			
			Mid			
			Min			
Struck Side Rear Seat			Max			
			Mid			
			Min			
Non-Struck Side Rear Seat			Max			
			Mid			
			Min			
Rear Center Seat*			Max			
			Mid			
			Min			

*If applicable

2. DATA SHEETS....Continued

DATA SHEET NO. 2 (CONTINUED)
SEAT, SEAT BELT, STEERING WHEEL ADJUSTMENT AND FUEL SYSTEMS DATA

Test Vehicle: _____
 Test Program: _____

NHTSA No.: _____
 Test Date: _____

SEAT FORE/AFT POSITION

Seat	Total Fore/Aft Travel		Test Position from Forwardmost Position	
	mm	Detents*	mm	Detent*
Driver Seat				
Front Passenger Seat				
Front Center Seat*				
Struck Side Rear Seat				
Non-Struck Side Rear Seat				
Rear Center Seat*				

*If applicable

SEAT BACK ANGLE ADJUSTMENT

The driver's seat back is positioned such that the dummy's head is level. The front center and front passenger's seat backs are positioned in a similar manner as the driver's seat back. The struck-side rear passenger seat back is positioned in accordance with the information provided by the manufacturer on Form No. 1 for the 5th percentile female dummy in a Side NCAP MDB test. The rear center and non-struck side rear passenger's seat back is set to match the struck-side rear seat back.

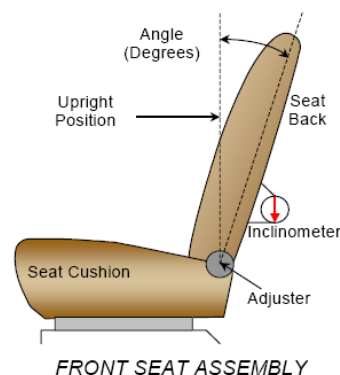

Seat	Total Seat Back Angle Range		Test Position from Most Upright	
	Degrees	Detents*	Degree	Detent*
Driver Seat w/ Seated Dummy				
Front Passenger Seat				
Front Center Seat*				
Struck Side Rear Seat				
Non-Struck Side Rear Seat				
Rear Center Seat*				

*If applicable

SEAT BELT ANCHORAGE ADJUSTMENT

Seat belt anchorages are adjusted in accordance with the information provided by the manufacturer on Form No. 1.

	Total # of Positions	Placed in Position #
Driver Seat		

HEAD RESTRAINT ADJUSTMENT

Head restraints are adjusted to the lowest and most full forward in-use position.

	Total # of Positions	Placed in Position #
Driver Seat		

2. DATA SHEETS....Continued

DATA SHEET NO. 2 (CONTINUED)
SEAT, SEAT BELT, STEERING WHEEL ADJUSTMENT AND FUEL SYSTEMS DATA

Test Vehicle: _____
 Test Program: _____

NHTSA No.: _____
 Test Date: _____

STEERING COLUMN ADJUSTMENT

Steering wheel and column adjustments are made so that the steering wheel geometric locus it describes when it moves through its full range of motion.

	Degrees	Fore/Aft Position (mm)
Lowermost, Position No. 1		
Geometric Center, Position No. 2		
Uppermost, Position No. 3		
Telescoping Steering Wheel Travel		
Test Position		

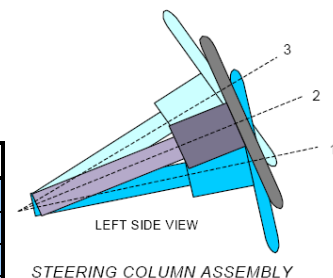

FUEL PUMP

Describe the fuel pump type, details about how it operates, and the location of the fuel filler neck.

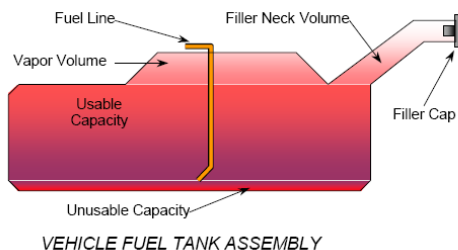

FUEL TANK CAPACITY DATA

	Liters
Usable Capacity of "Standard Tank" (see Form No. 1)	
Usable Capacity of "Optional Tank" (see Form No. 1)	
Usable Capacity of Standard Tank (see Owner's Manual)	
Usable Capacity of Optional Tank (see Owner's Manual)	
93% of Usable Capacity	
Actual Amount of Solvent Used in Test	
1/3 of Usable Capacity	

Is the Actual Amount of Solvent Used in the test equal to 93% ± 1% of the Usable Capacity stated in on Form No. 1? YES NO

2. DATA SHEETS....Continued

DATA SHEET NO. 3
DUMMY LONGITUDINAL CLEARANCE DIMENSIONS

Test Vehicle: _____
 Test Program: _____

NHTSA No.: _____
 Test Date: _____

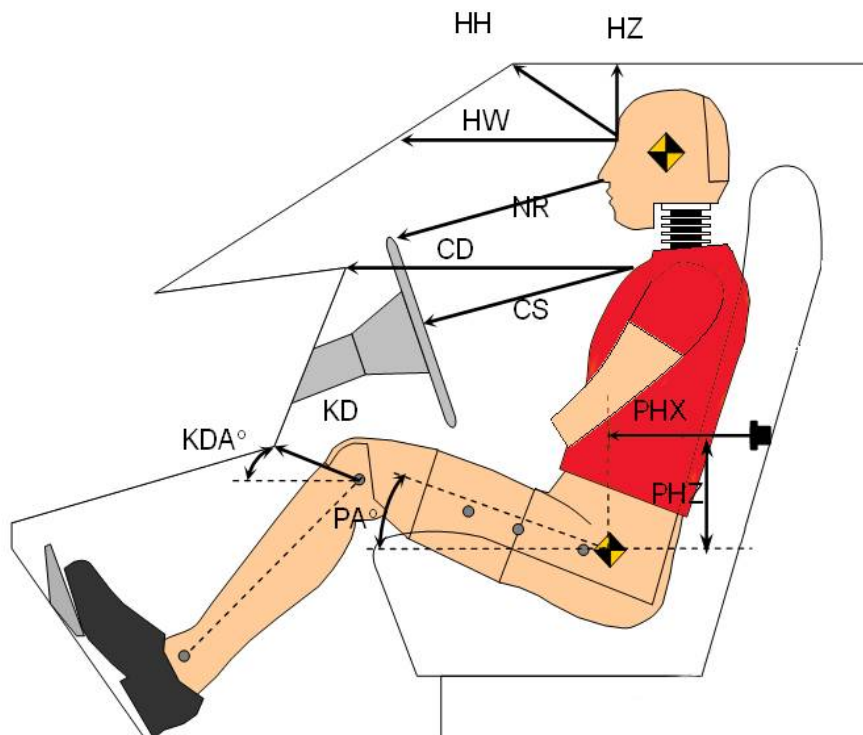

Code	Measurement Description	Driver	
		Length (mm)	Angle (°)
HH	Head to Header		
HW	Head to Windshield		
HZ	Head to Roof Liner		
NR	Nose to Rim		
CD	Chest to Dashboard		
CS	Chest to Steering Wheel		
KDL/KDAL°	Left Knee to Dash		
KDR/KDAR°	Right Knee to Dash		
PAX°	Pelvic Tilt Angle (X-Axis)		
PAY°	Pelvic Tilt Angle (Y-Axis)		
PHX	Hip Point to Striker (X-Axis)		
PHZ	Hip Point to Striker (Z-Axis)		

2. DATA SHEETS....Continued

DATA SHEET NO. 4
DUMMY LATERAL CLEARANCE DIMENSIONS

Test Vehicle: _____
 Test Program: _____

NHTSA No.: _____
 Test Date: _____

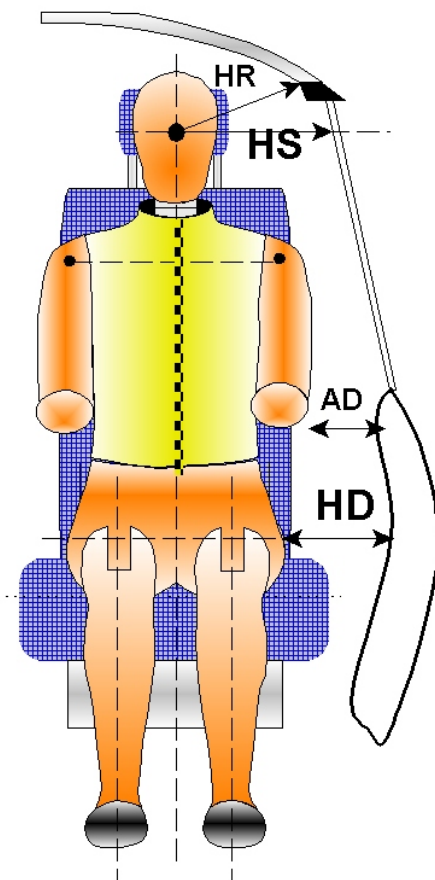

Code	Measurement Description	Length (mm)
HR	Head to Side Header	
HS	Head to Side Window	
AD	Arm to Door	
HD	Hip Point to Door	

2. DATA SHEETS....Continued

**DATA SHEET NO. 5
CAMERA AND INSTRUMENTATION DATA**

Test Vehicle: _____
Test Program: _____

NHTSA No.: _____
Test Date: _____

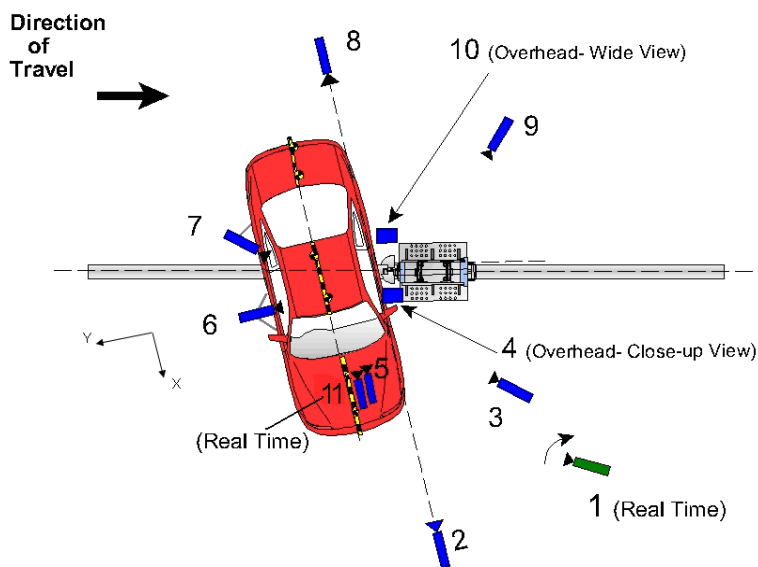

REFERENCE (from Point of Impact for X and Y; from Ground for Z):
+ X = Forward of vehicle, + Y = Right of vehicle, + Z = Down

Camera No.	View	Coordinates (mm)			Lens Length (mm)	Operating Frame Rate (fps)
		X	Y	Z		
1	Real time (24-30 fps) pan view of impact					
2	Front ground level - impact view					
3	Impact side 45° - forward pole view					
4	Overhead Close-up view of impact					
5	Onboard – dummy front view					
6	Onboard – dummy side view					
7	Onboard – dummy rear oblique view					
8	Rear ground level – impact view					
9	Impact side 45° - rearward pole view					
10	Overhead wide-view of impact					
11	Real-time (24-30 fps) – dummy front view					

* All measurements accurate to ± 6 mm.

NOTE: Vehicle is at a 75° angle to the rigid pole.

If applicable, explain why camera(s) did not operate as intended: _____

INSTRUMENTATION

	Number of Channels
Driver Dummy	
Vehicle Structure	
Pole Load Cells	
TOTAL	

2. DATA SHEETS....Continued

**DATA SHEET NO. 6
VEHICLE ACCELEROMETER DATA**

Test Vehicle: _____
Test Program: _____

NHTSA No.: _____
Test Date: _____

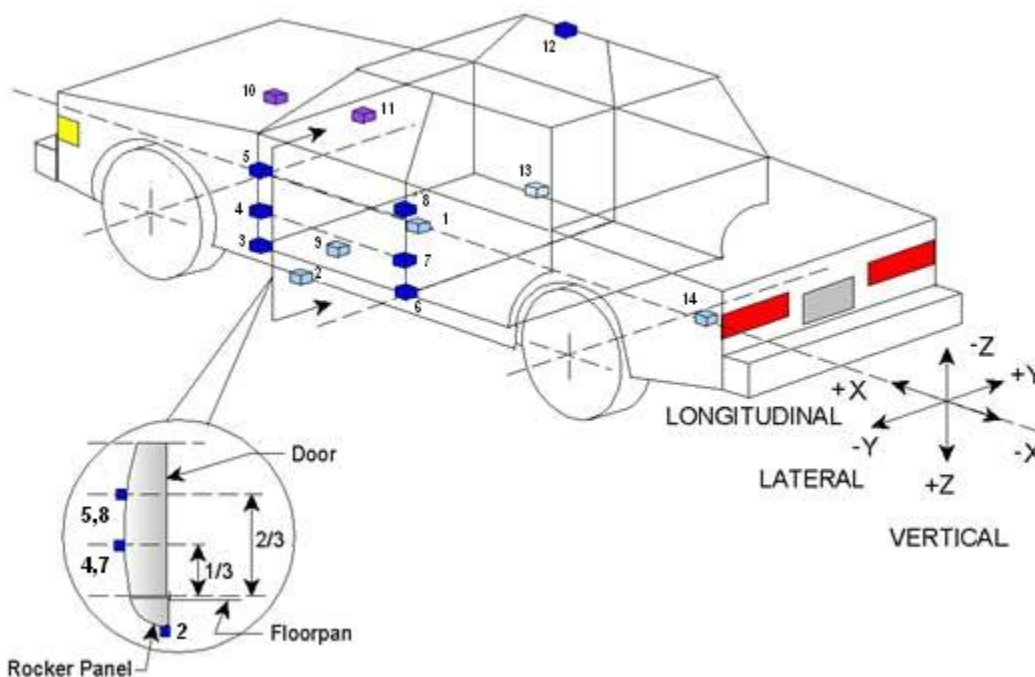

	Accelerometer/Sensor Location			
	ID	Coordinates (mm)		
		X	Y	Z
1	Vehicle CG			
2	Left Floor Sill			
3	A-Pillar Sill			
4	A-Pillar Low			
5	A-Pillar Mid			
6	B-Pillar Sill			
7	B-Pillar Low			
8	B-Pillar Mid			
9	Driver Seat Track			
10	Engine Top			
11	Firewall			
12	Right Roof			
13	Right Floor Sill			
14	Rear Floorpan			

Reference: X – Test Vehicle Rear Bumper (+ forward)
Y – Test Vehicle Centerline (+ to right)

Z – Ground Plane (+ down)

DATA SHEETS....Continued

**DATA SHEET NO. 7
RIGID POLE LOAD CELL DATA**

Test Vehicle: _____
Test Program: _____

NHTSA No.: _____
Test Date: _____

FOIL 300K RIGID POLE

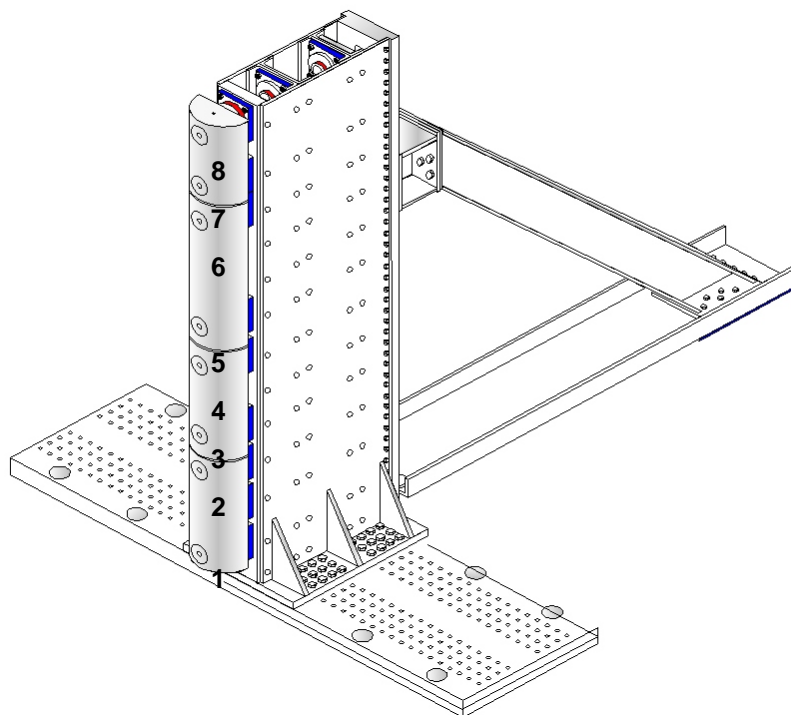

Load Cell Locations	
ID	Height From Ground (mm)
1	
2	
3	
4	
5	
6	
7	
8	

2. DATA SHEETS....Continued

**DATA SHEET NO. 8
POST-TEST OBSERVATIONS**

Test Vehicle: _____

NHTSA No.: _____

Test Program: _____

Test Date: _____

TEST DUMMY INFORMATION AND CONTACT POINTS

Dummy Body Part	Driver SID-IIs Dummy
Face	
Top of Head	
Left Side of Head	
Back of head	
Left Shoulder	
Upper Torso	
Lower Torso	
Left Hip	
Left Knee	

POST-TEST DOOR PERFORMANCE

Description	Struck Side		Non-Struck Side		Rear Hatch/ Other Door
	Front	Rear	Front	Rear	
Remained Closed and Operational					
Total Separation from Vehicle at Hinges or Latches					
Latch or Hinge Systems Pulled Out of Their Anchorages					
Disengaged from Latched Position					
Latch Separated from Striker					
Jammed Shut					
If Door Opened at Striker, Record Width of Opening at Striker (mm)					

* Indicate "Yes", "No", or "N/A".

POST-TEST SEAT PERFORMANCE

Description	Struck Side		Non-Struck Side	
	Front	Rear	Front	Rear
Seat Movement Along Seat Track				
Seat Disengagement from Floor pan				
Seat Back Movement from Initial Position				
Seat Back Collapse				

* Indicate "Yes", "No", or "N/A".

POST TEST STRUCTURAL OBSERVATIONS

Critical Areas of Performance	Observations and Conclusions
Pillar Performance	
Sill Separation	
Windshield Damage	
Side Window Damage	
Other Notable Effects	

2. DATA SHEETS....Continued

DATA SHEET NO. 8 (CONTINUED)
POST-TEST OBSERVATIONS

Test Vehicle: _____
 Test Program: _____

NHTSA No.: _____
 Test Date: _____

SUPPLEMENTAL RESTRAINT SYSTEM INFORMATION

Restraint Type	Struck Side Driver		Struck Side Rear Passenger	
	Mounted	Deployed	Mounted	Deployed
Frontal Airbag				
Knee Airbag				
Side Airbag 1 (Indicate Type)				
Side Airbag 2 (Indicate Type, if App.)				
Side Airbag 3 (Indicate Type, if App.)				
Seat Belt Pretensioner				
Seat Belt Load Limiter				
Other				

VEHICLE SPEED, VEHICLE ANGLE AT IMPACT, AND IMPACT POINT LOCATION DATA

Measured Parameter	Units	Tolerance	Value
Vertical Impact Reference Line (Aft of Front Axle) (Intended Impact Point)	mm		
Actual Impact Point (Aft of Front Axle)	mm		
Horizontal Offset (+ forward / - rearward)	mm	+/- 38 of Intended Impact Point	
Angle Between Vehicle's Longitudinal Centerline and Line of Forward Motion	degrees	75 +/- 3	
Trap No. 1 Velocity (Primary)	km/h	31.4 to 33.0	
Trap No. 2 Velocity (Redundant)	km/h	31.4 to 33.0	

2. DATA SHEETS....Continued

DATA SHEET NO. 9
VEHICLE PROFILE MEASUREMENTS

Test Vehicle: _____
Test Program: _____

NHTSA No.: _____
Test Date: _____

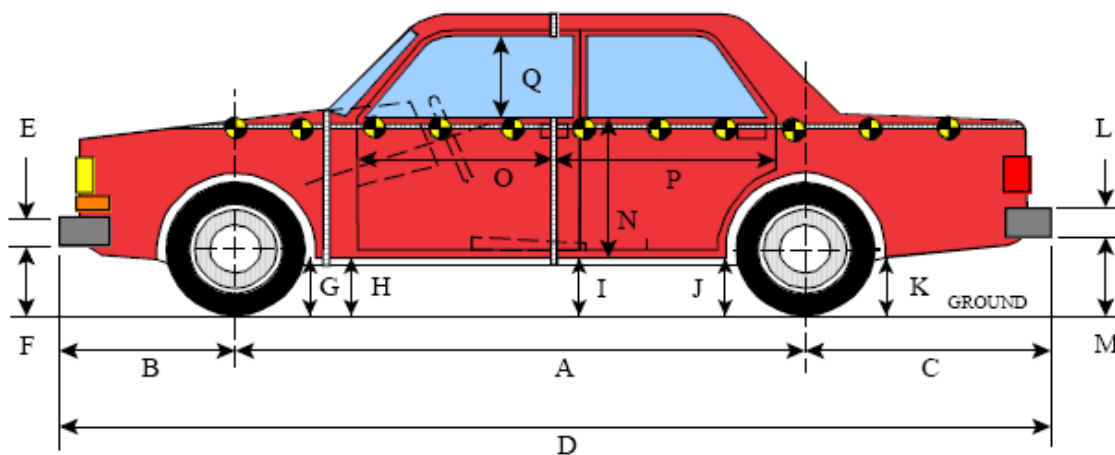

LEFT SIDE VIEW

All MEASUREMENTS IN (mm) WITH TOLERANCE OF ± 3 mm

VEHICLE PRE- AND POST-TEST MEASUREMENT INFORMATION

Code	Description	Pre-Test	Post-Test	Difference
A	Wheelbase			
B	Front Axle to FSOV			
C	Rear Axle to RSOV			
D	Total Length at Centerline			
E	Front Bumper Thickness			
F	Front Bumper Bottom to Ground			
G	Sill Height at Front Wheel Well			
H	Sill Height at Front Door Leading Edge			
I	Sill Height at B-Pillar			
J1	Sill Height at Rear Wheel Well			
J2	Pinch Weld Height at Rear Wheel Well			
K	Sill Height Aft of Rear Wheel Well			
L	Rear Bumper Thickness			
M	Rear Bumper Bottom to Ground			
N	Sill Height to Bottom of Front Window Sill			
O	Front Door Leading Edge to Impact CL			
P	Rear Door Trailing Edge to Impact CL			
Q	Front Window Opening			
R	Right Side Length			
S	Left Side Length			
T	Vehicle Width at B-Pillars			

2. DATA SHEETS....Continued

**DATA SHEET NO. 10
VEHICLE EXTERIOR CRUSH MEASUREMENTS**

Test Vehicle: _____
Test Program: _____

NHTSA No.: _____
Test Date: _____

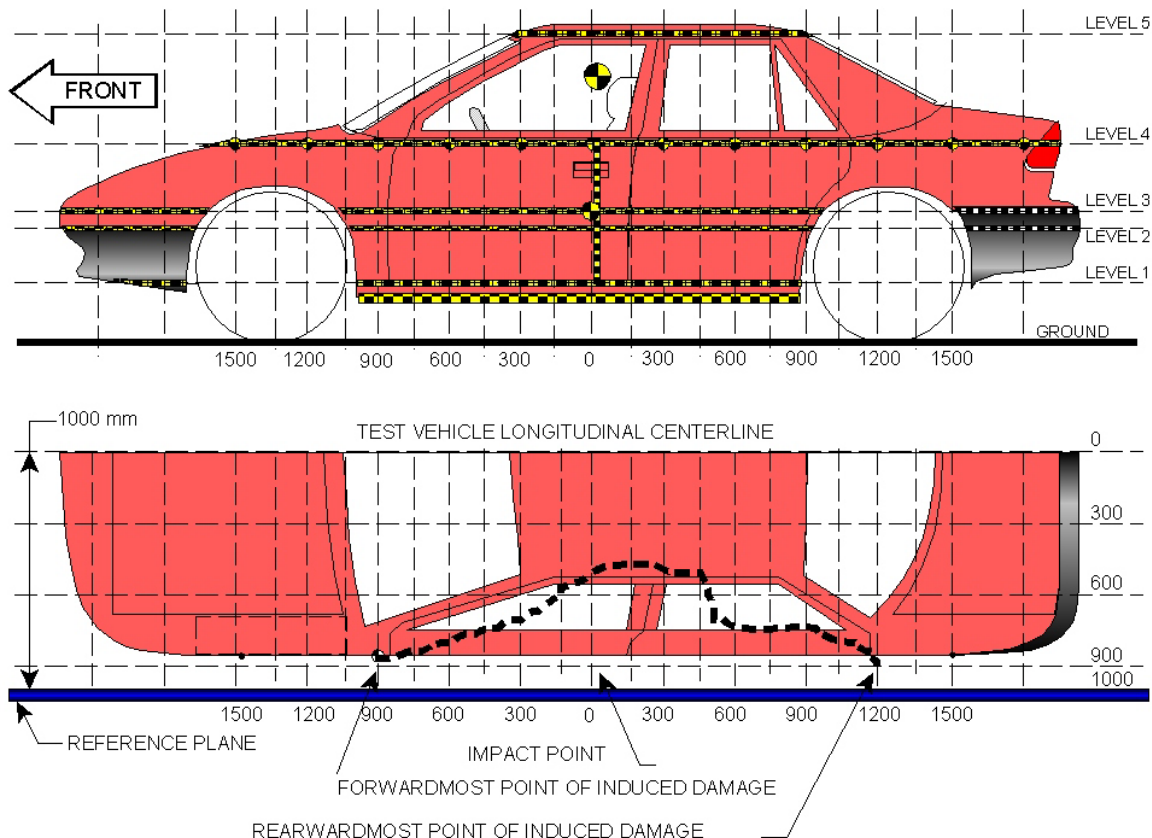

NOTE: All measurements are in millimeters (mm)

MAXIMUM EXTERIOR CRUSH MEASUREMENTS

Level	Measurement Description	Height Above Ground	Maximum Exterior Static Crush	Distance from Impact
1	Sill Top			
2	Occupant Hip Point			
3	Mid-Door			
4	Window Sill			
5	Window Top			

NOTE: The above measurements should be taken along the vertical impact reference line. Vehicle measurements forward of the vertical impact reference line are negative.

2. DATA SHEETS....Continued

DATA SHEET NO. 10 (CONTINUED)
VEHICLE EXTERIOR CRUSH MEASUREMENTS

Test Vehicle: _____
 Test Program: _____

NHTSA No.: _____
 Test Date: _____

	Pre-Test					Post-Test					Difference				
	1	2	3	4	5	1	2	3	4	5	1	2	3	4	5
-900															
-750															
-600															
-450															
-300															
-150															
0															
150															
300															
450															
600															
750															
900															
1050															
1200															
1350															
1500															
1650															
1800															
1950															
2100															
2250															
2400															
2550															
2700															
2850															

NOTE: Pre-test measurements are taken when the vehicle is in the "As Tested" weight condition. Vehicle measurements forward of the vertical impact reference line are negative. The crush profile grid is established prior to the test based on an estimated impact point. The final distance from impact is determined after the final dummy positioning and the pole is aligned with the center of gravity of the dummy's head.

2. DATA SHEETS....Continued

**DATA SHEET NO. 10 (CONTINUED)
VEHICLE EXTERIOR CRUSH MEASUREMENTS**

Test Vehicle: _____
Test Program: _____

NHTSA No.: _____
Test Date: _____

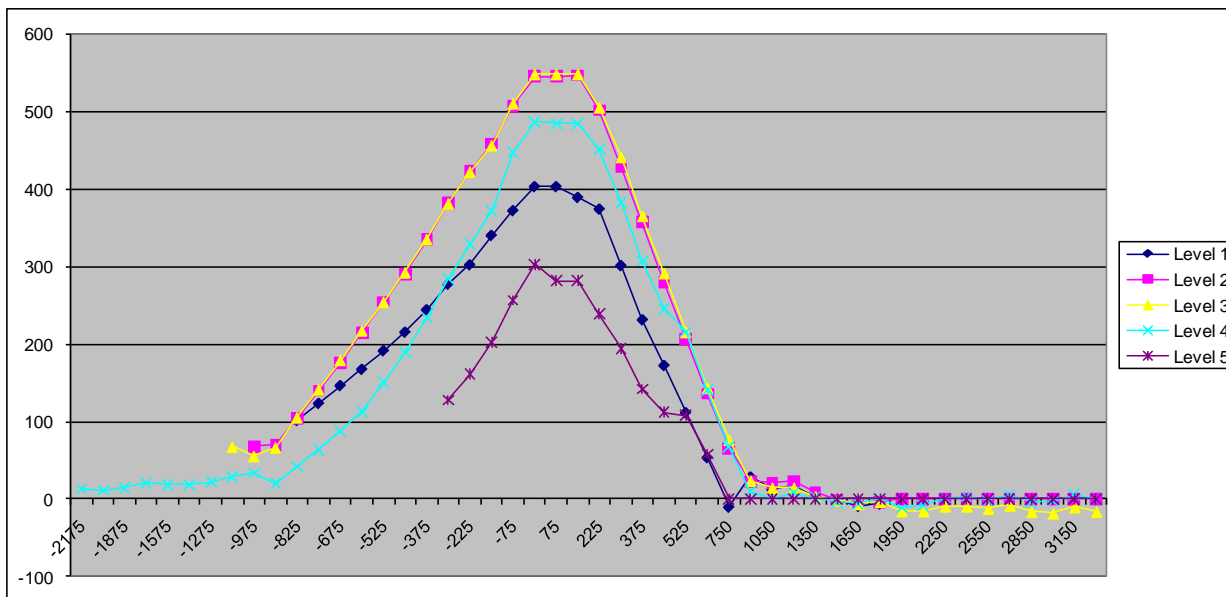

A visual representation of the vehicle exterior crush measurements, such as the one above, should be placed in this space.

2. DATA SHEETS....Continued

**DATA SHEET NO. 11
FMVSS NO. 301 STATIC ROLLOVER RESULTS**

Test Vehicle: _____ NHTSA No.: _____
 Test Program: _____ Test Date: _____

Test Time: _____ Temperature: _____

- A. From impact until vehicle motion ceases: _____ oz.
 (Maximum allowable is 1 oz.)
- B. For the 5-minute period after motion ceases: _____ oz.
 (Maximum allowable is 5 oz.)
- C. For the following 25 minutes: _____ oz.
 (Maximum allowable is 1 oz./minute)
- D. Spillage Details: _____

FMVSS 301 STATIC ROLLOVER DATA

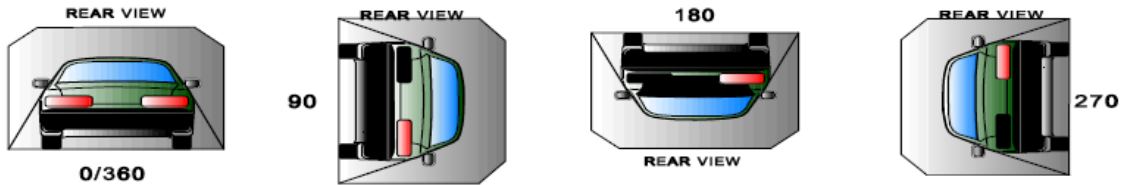

ROLLOVER SOLVENT COLLECTION TIME TABLE IN SECONDS

Test Phase	Rotation Time	Hold Time	Total Time
0 to 90			
90 to 180			
180 to 270			
270 to 360			

FMVSS NO. 301 ROLLOVER SPILLAGE TABLE

Test Phase	First 5 Minutes	Sixth Minute	Seventh Minute	Eighth Minute
0 to 90				
90 to 180				
180 to 270				
270 to 360				

ROLLOVER SOLVENT SPILLAGE LOCATION TABLE

Test Phase	Spillage Location
0 to 90	
90 to 180	
180 to 270	
270 to 360	

2. DATA SHEETS....Continued

**DATA SHEET NO. 12
DUMMY/VEHICLE TEMPERATURE AND HUMIDITY STABILIZATION DATA**

Test Vehicle: _____
Test Program: _____

NHTSA No.: _____
Test Date: _____

Please place the temperature and humidity stabilization chart/data for both dummies and test vehicle in this space.

3. FORMS

Forms, like Data Sheets, are provided as **tools** to use in the exchange of data between the COTR and the Contractor. Forms, unlike Data Sheets, **are not part** of the Final Test Report. The Contractor is not restricted from using other tools or expanding the forms outlined in this section.

FORM NO. 1 – TEST VEHICLE INFORMATION

A “Test Vehicle Information” form will be supplied by the COTR to the Contractor before testing preparation. Information on this form is supplied by the automobile manufacturer to aid in the initial test setup and shall be considered as **reference material**. After vehicle preparation is complete, the Test Vehicle Information shall be retained by the Contractor for at least 5 years. (See Section 12.7 of the Side NCAP Pole Laboratory Test Procedure.)

FORM NO. 2 – REPORT OF VEHICLE CONDITION

A “Vehicle Condition Report” form must be submitted to the COTR with the copies of the Final Test Report. The first page of the form shall be completed when the test vehicle arrives at the testing laboratory. The second page of the form is completed after the test. The forms shall be **legible** (hand written forms are unacceptable) and **complete** (all information requested is filled out).

FORM NO. 3 – LABORATORY NOTICE OF TEST FAILURE

A “Laboratory Notice of Test Failure” form will be submitted to the NHTSA COTR to report a test failure. Performance requirements can be found in Section 2, General Requirements, of the Side NCAP Pole Laboratory Test Procedure. Any failure shall be described **thoroughly** in the space provided.

FORM NO. 4 – MONTHLY VEHICLE STATUS REPORT

A “Monthly Vehicle Status Report” form shall be submitted to the COTR each month until all vehicles have been discarded.

FORM NO. 5 – QUICKLOOK REPORT

The QuickLook Report is a preliminary summary of the test. It should be filled out in its entirety. A completed QuickLook Report includes data traces. Anything interesting or out of the ordinary should be noted in the “Comments” field of the form.

3. FORMS...Continued

TEST VEHICLE INFORMATION
(FORM 1)

NCAP Frontal, Side MDB, and Side Pole Tests

Vehicle Model Year and Make: _____

Vehicle Model and Body Style: _____

1. SEAT FORE-AFT POSITION, CUSHION ANGLE, AND HEIGHT

Provide instructions for positioning the driver, front outboard passenger, and rear left passenger seat(s) in their testing positions. Since seat positioning procedures differ between the Frontal NCAP 50th male and the Side NCAP 50th male, two diagrams are provided below to assist in positioning the seat. These diagrams assume that the seat will move forward if the seat cushion is moved upward in height.

SEAT POSITIONING FOR FRONTAL
ALL
NCAP 50TH PERCENTILE MALE

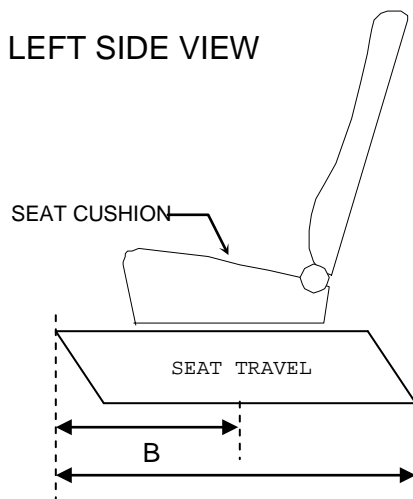

SEAT POSITIONING FOR
OTHER NCAP DUMMIES

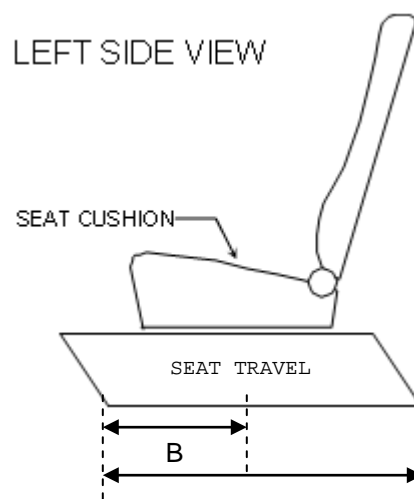

A = Total range of seat travel; B = Mid-track position

For more clarification regarding foremost and rearmost seat positions, please refer to FMVSS 208 S8.1.2 (50th Male Driver), FMVSS 208 S16.2.10.3 (5th Female Front Passenger), FMVSS 214 S8.3.1.3 (50th Male Driver), FMVSS 214 S10.3.2.3 (5th Female Driver), and FMVSS 214 S8.3.3.3 (5th Female Rear Passenger).

1.1 Driver's Seat

1.1A Seat Fore-Aft Positioning

Depending on the seat track adjuster type, complete one of the tables below.

<i>Manual Seat Track Adjuster</i>	
Total number of detents:	
Frontal impact test detent* (50 th percentile male):	
Side impact test detent* (50 th percentile male):	
Side impact test detent* (5 th percentile female):	

* For manual seat track adjustments, test detent is measured from foremost detent, which is defined as 0.

<i>Power Seat Track Adjuster</i>	
Complete range of travel as determined for Frontal NCAP (mm):	
Frontal impact test distance from the foremost position (50 th percentile male):	
Complete range of travel as determined for Side NCAP (mm):	
Side impact test distance from the foremost position (50 th percentile male):	
Side impact test distance from the foremost position (5 th percentile female):	

1.1B Seat Cushion Angle

If the seat cushion angle is adjustable while maintaining the test fore-aft seat track position, describe the angle used during certification testing and how to measure it. Include any reference points and photographs.

Dummy	Angle Used	Additional Description
Frontal Impact - 50 th Male		
Side Impact – 50 th Male		
Side Impact – 5 th Female		

1.1C Seat Cushion Height

If the seat and/or seat cushion height is adjustable at the test fore-aft seat track position and can be adjusted so that the seat cushion angle can be at the angle used in the certification test, describe the height used during certification testing and how to measure it. Include any reference points and photographs.

Dummy	Height Used	Additional Description
Frontal Impact - 50 th Male		
Side Impact – 50 th Male		
Side Impact – 5 th Female		

1.1D Provide any other instructions for positioning the driver’s seat at the required test position(s):

Frontal: _____

Side MDB: _____

Side Pole: _____

1.2 Front Outboard Passenger Seat (5th percentile dummy in frontal impact only)

1.2A *Seat Fore-Aft Positioning*

Depending on the seat track adjuster type, complete one of the tables below.

<i>Manual Seat Track Adjuster</i>	
Total number of detents:	
Frontal impact test detent* (5 th percentile female):	

* For manual seat track adjustments, test detent is measured from foremost detent, which is defined as 0.

<i>Power Seat Track Adjuster</i>	
Complete range of travel (mm):	
Frontal impact test distance from the foremost position (5 th percentile female):	

1.2B *Seat Cushion Angle*

If the seat cushion angle is adjustable while maintaining the test fore-aft seat track position, describe the angle used during certification testing and how to measure it. Include any reference points and photographs.

Dummy	Angle Used	Additional Description
Frontal Impact - 5 th Female		

1.2C *Seat Cushion Height*

If the seat and/or seat cushion height is adjustable at the test fore-aft seat track position and can be adjusted so that the seat cushion angle can be at the angle used in the certification test, describe the height used during certification testing and how to measure it. Include any reference points and photographs.

Dummy	Angle Used	Additional Description
Frontal Impact - 5 th Female		

1.2D Provide any other instructions for positioning the front passenger seat at the required test position:

Frontal: _____

In addition, please indicate the manufacturer of the 5th percentile dummy used for FMVSS 208 crash test certification: _____

1.3 Rear Seats (5th percentile dummy in MDB side impact only)

1.3A Seat Fore-Aft Positioning

Depending on the seat track adjuster type, complete one of the tables below.

<i>Manual Seat Track Adjuster</i>	
Total number of detents:	
Side impact test detent* (5 th percentile female):	

* For manual seat track adjustments, test detent is measured from foremost detent, which is defined as 0.

<i>Power Seat Track Adjuster</i>	
Complete range of travel (mm):	
Side impact test distance from the foremost position (5 th percentile female):	

1.3B Seat Cushion Angle

If the seat cushion angle is adjustable while maintaining the test fore-aft seat track position, describe the angle used during certification testing and how to measure it. Include any reference points and photographs.

Dummy	Angle Used	Additional Description
Side Impact - 5 th Female		

1.3C Seat Cushion Height

If the seat and/or seat cushion height is adjustable at the test fore-aft seat track position and can be adjusted so that the seat cushion angle can be at the angle used in the certification test, describe the height used during certification testing and how to measure it. Include any reference points and photographs.

Dummy	Angle Used	Additional Description
Side Impact - 5 th Female		

1.3D Provide any other instructions for positioning the rear seat at the required test position:

Side MDB: _____

2. SEAT BACK ANGLE

2.1 Driver's Seat

With the seat in the test fore-aft seat track position, what is the angle of the seat back when it is in the forward-most locked position?

Dummy	Angle
Frontal Impact – 50 th Male	
Side Impact – 50 th Male	
Side Impact – 5 th Female	

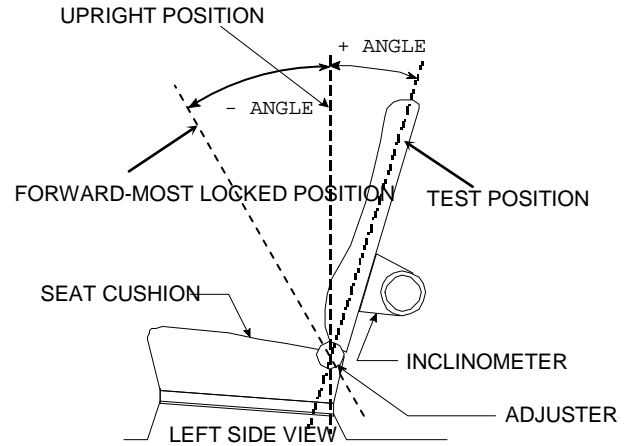

With the seat in the test fore-aft seat track position, what is the angle of the seat back when it is set to the **test** position? (Note: For the frontal impact test and the side impact test with the 50th male dummy, the seat back angle will be set to the Nominal Design Position. For the side impact test with the 5th female dummy, the seat back angle will be determined by the related dummy seating procedure.)

Dummy	Angle
Frontal Impact – 50 th Male	
Side Impact – 50 th Male	
Side Impact – 5 th Female	

For the 50th percentile male, is the seat back angle measured with the dummy in the seat?

Frontal: YES NO
 Side: YES NO

Describe any references used for measuring the seat back angle, e.g., door sill. (Include photograph(s).) *If possible, include measurement from bottom front of head rest post to outboard sun visor anchor, or from bottom back of head rest post to middle of rear door striker.*

Frontal: _____

Side MDB: _____

Side Pole: _____

2.2 Front Outboard Passenger Seat (5th percentile female in frontal impact only)

With the seat in the test seat track position, what is the angle of the seat back when it is in the forward-most locked position?

Dummy	Angle
Frontal Impact – 5 th Female	

With the seat in the test seat track position, what is the angle of the seat back when it is set to the **test** position? (Note: The seat back angle will be determined by the related dummy seating procedure for the frontal impact test.)

Dummy	Angle
Frontal Impact – 5 th Female	

Describe any references used for measuring the seat back angle, e.g., door sill. (Include photograph(s).) *If possible, include measurement from bottom front of head rest post to outboard sun visor anchor, or from bottom back of head rest post to middle of rear door striker.*

Frontal: _____

Side MDB: _____

Side Pole: _____

2.3 2nd Row Seat (5th percentile female in side impact only)

With the seat in the test seat track position, what is the angle of the seat back when it is in the forward-most locked position?

Dummy	Angle
Side Impact – 5 th Female	

With the seat in the test seat track position, what is the angle of the seat back when it is set to the **test** position? (Note: The seat back angle will be determined by the related dummy seating procedure for the side impact barrier test.)

Dummy	Angle
Side Impact – 5 th Female	

Describe any references used for measuring the seat back angle, e.g., door sill. (Include photograph(s).)

2.4 3rd Row Seat (side impact only)

The seat should be set to accommodate a 5th percentile female dummy; however this dummy will not be part of the test(s).

With the seat in the test seat track position, what is the angle of the seat back when it is

in the forward-most locked position?

Dummy	Angle
Side Impact – 5 th Female	

With the seat in the test seat track position, what is the angle of the seat back when it is set to the **test** position? (Note: The seat back angle will be determined by the related dummy seating procedure for the side impact barrier test.)

Dummy	Angle
Side Impact – 5 th Female	

Describe any references used for measuring the seat back angle, e.g., door sill. (Include photograph(s).)

3. ADJUSTABLE D-RING SEAT BELT ANCHORAGE POSITION

Nominal Design Position (NDP)

Please complete the following table for adjustable seat belt anchorages.

Dummy	Total Range of Travel (mm)	Dist. from Upper-most Position to NDP (mm)	Total No. of Detents (if applicable)	Detent No. of NDP*
Driver/Front Passenger - 50 th Male				
Driver/Front Passenger – 5 th Female				
Rear Passenger - 5 th Female				

* The detent number of the Nominal Design Position is counted with respect to the upper-most detent, which is defined as 0.

4. SEAT BELT GUIDES

Is this vehicle equipped with a seat belt guide for any of the following seating positions?

Driver: YES NO
 Right Front Passenger: YES NO
 Left Rear Passenger: YES NO

If YES for any position, please provide instructions for use:

5. STEERING COLUMN AND WHEEL ADJUSTMENTS

STEERING COLUMN ASSEMBLY

If the steering wheel and /or steering column adjustments are available, provide any specific procedures used to determine the geometric center of the locus the steering wheel hub describes when it is moved through its full range of driving positions.

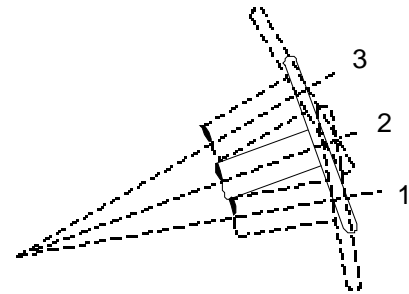

LEFT SIDE VIEW

Angle of the steering wheel with respect to vertical when the steering wheel hub is positioned at the geometric center of the locus it describes when it is moved through its full range of positions:	
Total number of detents:	
Test detent* when the wheel hub is positioned at the geometric center of the locus it describes when it is moved through its full range of positions:	

* Test detent is taken with respect to the upper-most detent, which is defined as 0.

6. SEATING REFERENCE POINT (SgRP)

Please give the location of the Seating Reference Point (SgRP) for each vehicle seating position.

Seating Position	Coordinates (mm)		
	X(+ forward)	Y(+ right)	Z (+ down)
Left Front (Driver)			
Right Front (Front Passenger)			
Left Second Row (Rear Passenger)			

Describe any references used for measuring the SgRP, e.g., center of the front door striker. (Include photograph(s).)

7. DUMMY MEASUREMENTS FOR THE 50TH MALE AND 5TH FEMALE

See the attached instructions and diagram and provide measurements for the following seat configurations:

	HH	NR	CS	KDL/KDR	SH	SHY	HS
Driver (Manual Seat)							
Driver (Power Seat)							
Passenger (Manual Seat)							
Passenger (Power Seat)							
2nd Row Occupant (Side only)							

8. FUEL TANK CAPACITY DATA

"Usable capacity" of standard equipment fuel tank (gal):	
"Usable capacity" of optional equipment fuel tank (gal):	
Capacity used when certification testing to requirements of FMVSS No. 301 (gal):	

Operational instructions:

Suggested methods for draining:

Is the vehicle equipped with an electric fuel pump?

YES NO

If YES, does the pump normally operate when the vehicle's electrical system is activated?

YES NO

If YES, explain the vehicle operating conditions under which the fuel pump will pump fuel:

Provide a drawing (or description) that shows the undercarriage view and/or location of the fuel tank.

VEHICLE FUEL TANK ASSEMBLY

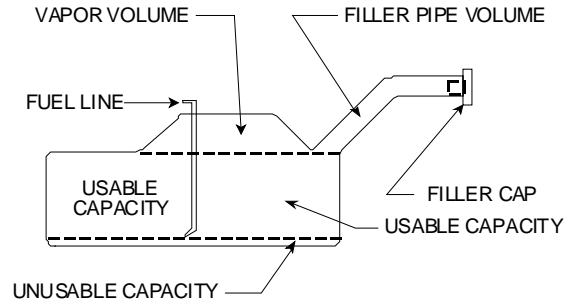

9. DEACTIVATION OF SIDE AIRBAGS

If this vehicle has side airbags, will they deploy in a Frontal NCAP test?

YES NO

IF YES, please be prepared to disable the side airbags on test day in the event that NCAP requests they be deactivated for the Frontal test. If a representative will not be present, be sure to provide the laboratory with detailed instructions prior to test day.

If this vehicle has side airbags, will the side airbags on the non-struck side deploy in a Side MDB test?

YES NO

IF YES, please be prepared to disable the non-struck side airbags on test day. If a representative will not be present, be sure to provide the laboratory with detailed instructions prior to test day.

If this vehicle has side airbags, will the side airbags on the non-struck side deploy in a Side Pole test?

YES NO

IF YES, please be prepared to disable the side airbags on the non-struck side on test day. If a representative will not be present, be sure to provide the laboratory with detailed instructions prior to test day.

10. OCCUPANT CLASSIFICATION SYSTEMS

Are all related airbags activated when a 5th percentile female or 50th percentile male dummy is in the seat? (Please choose YES or NO for each.)

Frontal: YES NO
 Side MDB: YES NO
 Side Pole: YES NO

If NO, please provide system bypass information.

Frontal:

Side MDB:

Side Pole:

11. SHOULDER BELT LOAD CELL POSITIONING (Frontal NCAP)

Can a shoulder belt load cell be mounted on the seat belts?

YES NO

If YES, please provide the following:

Distance from the Driver's side D-ring to the load cell centerline (mm):	
Distance from the Passenger's side D-ring to the load cell centerline (mm):	

12. HEIGHT ADJUSTABLE SUSPENSION

Does this vehicle have a height adjustable suspension? (Off-road modes that must be manually activated are not applicable.)

YES NO

If YES, and the suspension does not automatically adjust to a default ride mode (comfort-ride, sport-ride, etc.) when the ignition is set to "on" (but, the engine is not running), please list and describe the ride mode options available on the vehicle, and discuss when and how they are activated.

If YES above, designate ONE ride mode to be used for all three crash tests (frontal, side MDB, and side pole tests) and provide instructions for adjusting the test vehicle to that designated ride mode.

13. HEAD RESTRAINTS

Do any of the head restraints in this vehicle have a “non-use” position? Please note that “use” positions are defined in FMVSS No. 202a.

YES NO

If YES, please indicate seating positions that apply and how to properly put the applicable head restraint(s) in the lowest “use” position.

14. EVENT DATA RECORDER (EDR) LOCATION

Please specify where the EDR is located and provide brief instructions for its removal. If available, please include a diagram.

15. LIST OF REMOVABLE PARTS

NCAP will remove the following parts if the target test weight cannot be achieved:

Frontal NCAP test: spare tire, rear door windows, rear radio speakers, interior door trim on the rear doors, rear seat cushions, outboard mirrors, taillights, rear bumper

Side NCAP test: spare tire, rear radio speakers, interior door trim and windows on non-struck side, outboard mirrors on non-struck side, taillights, rear bumper

Please prioritize the items in this list in order of removal preference for each NCAP test. Please make a note of any parts that should not be removed because they serve as load bearing or structural components and therefore, will likely affect NCAP test performance. Also, please feel free to add additional items which are not listed if their removal is deemed acceptable.

Frontal NCAP test:

Side MDB NCAP test:

Side Pole NCAP test

16. SPECIAL INSTRUCTIONS

Please make note of any special instructions that you would like NHTSA to consider or be made aware of for the tested vehicle (ex. towing setup, refrain from using seat belt load cells, etc.):

Frontal NCAP test:

Side MDB NCAP test:

Side Pole NCAP test:

DESCRIPTIONS OF DUMMY MEASUREMENTS

When a level is to be used, it is to ensure that the line containing the two points described is either parallel or perpendicular to the ground. If a measurement to be made is less than 10 inches ignore the directions to use a level and approximate a level measurement. Also, when a measurement is to be taken to or from the center of a bolt on the dummy, take the measurement from the center of the bolt hole if the bolt is recessed.

The following measurements are to be made within a vertical longitudinal plane.

HH - Head to Header, taken from the point where the dummy's nose meets his forehead (between his eyes) to the furthest point forward on the header.

CS - Steering Wheel to Chest, taken from the center of the steering wheel hub to the dummy's chest. Use a level.

NR - Nose to Rim, taken from the tip of the dummy's nose to the closest point on the top of the steering wheel rim. Also indicate the angle this line makes with respect to the horizontal (NA).

KDL, KDR - Left and Right Knees to Dashboard, taken from the center of the knee pivot bolt's outer surface to the closest point forward acquired by swinging the tape measure in continually larger arcs until it contacts the dashboard. Also reference the angle of this measurement with respect to the horizontal for the outboard knee (KDA).

SH - Striker to Hip, this measurement is to be taken in the X-Z plane measured from the forward most center point on the striker to the center of the H-point. When taking this measurement a firm device that can be rigidly connected to the striker should be used. The measurement in the Y (transverse) direction from the striker to the H-point should also be taken (SHY).

The following measurements are to be made within a vertical transverse plane.

HS - Head to Side Window, taken from the point where the dummy's nose meets his forehead (between his eyes) to the outside of the side window. In order to make this measurement, roll the window down to the exact height which allows a level measurement. Use a level.

SHY - Striker to H-point, taken from a rod rigidly connected to the forward most center point on the striker to the H-point. Use a level.

DUMMY MEASUREMENTS FOR FRONT SEAT PASSENGERS

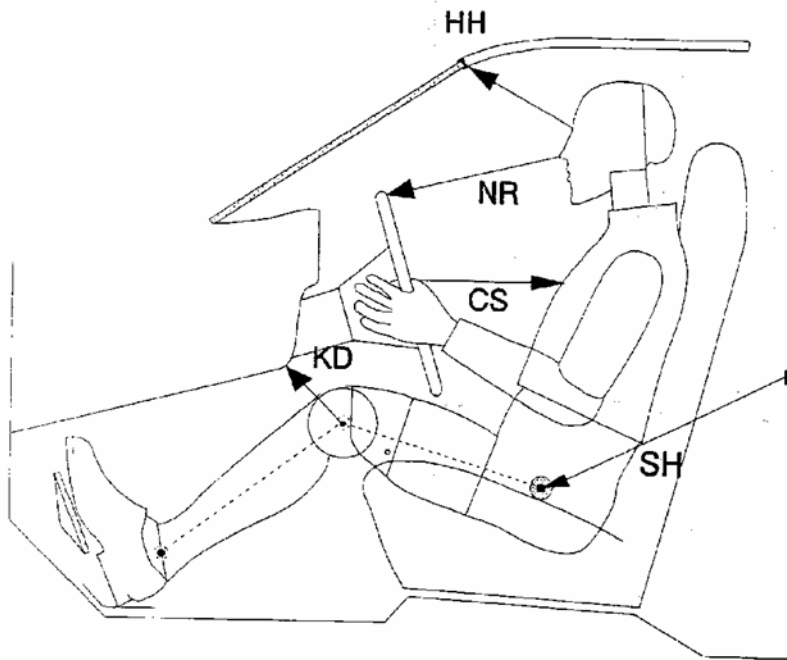

HH - Head to Header
 NR - Nose to Rim
 CS - Steering Wheel to Chest
 KDL/KDR - Knee to Dash
 SH - Striker to H-Point

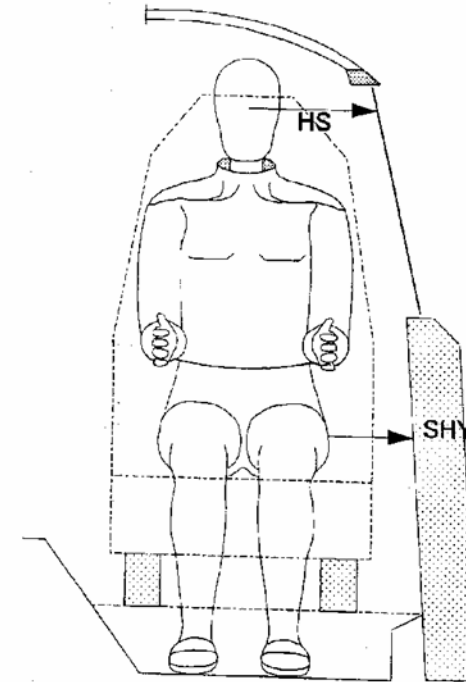

SHY - Striker to H-Point (Y Dir.)
 HS - Head to Side Window

July 10, 1992

Rev. 08/19/11

3. FORMS...Continued

**FORM NO. 2
REPORT OF VEHICLE CONDITION
PRE-TEST**

Contract Number: _____ Date: _____
 From: _____
 To: _____

The vehicle was inspected upon arrival at the laboratory for the test and found to contain all the equipment listed below. All variances have been reported within 2 working days of the vehicle arrival, by letter, to the NHTSA Industrial Property Manager with a copy to the COTR. The vehicle is again inspected after the above test has been conducted, and all changes are noted below. The final condition of the vehicle is also noted in detail on the second page of this form.

NHTSA No.	
Make	
Model	
Body Style	
VIN	
Color	
Delivery Date	
Odometer (mi)	
Dealer	
Transmission	
Type/No. Cyl	
Engine Disp (L)	
Engine Placement	
Roof Rack	
Sunroof/T-Top	
Tinted Glass	
Traction Control	
Power Brakes	
Front Disc	
Rear Disc	

Anti-Lock Brakes	
All-Wheel Drive	
Power Steering	
Driver Front Airbag	
Driver Side Torso Airbag	
Driver Side Head Airbag	
Driver Curtain Airbag	
Rear Pass. Airbag	
Rear Pass. Side Torso Airbag	
Rear Pass. Side Head Airbag	
Rear Pass. Curtain Airbag	
Pretensioners	
Load Limiters	
Bucket Seats	
Air Conditioning	
AM/FM CD	
Tilt Steering	
Automatic Door Locks	
Power Windows	
Power Seats	
Other	

PLEASE LIST OTHER PERTINENT OPTIONAL EQUIPMENT BELOW:

3. FORMS...Continued

**FORM NO. 2 (CONTINUED)
REPORT OF VEHICLE CONDITION
POST-TEST**

Remarks:

Equipment that is no longer on the test vehicle as noted on the previous page:

Explanation for equipment removal:

Test vehicle condition:

RECORDED BY: _____
APPROVED BY: _____

DATE: _____

3. FORMS...Continued

**FORM NO. 2 (CONTINUED)
REPORT OF VEHICLE CONDITION
POST-TEST**

Remarks:

Equipment that is no longer on the test vehicle as noted on the previous page:

Explanation for equipment removal:

Test vehicle condition:

	1		2		3	4	5
	Is Seat Track Movable?		Is Adjacent Window in Good Condition?		Adjacent Door Works Properly/In Good Condition?	Is Seat Airbag Deployed?	Is Curtain Airbag Deployed?
Position	Yes/No/NA	Power or Manual	Yes/No	Power or Manual	Yes/No/NA	Yes/No/NA	Yes/No/NA
Left Front (Driver)							
Right Front Passenger							
Right Rear Passenger							
Left Rear Passenger							

If "No" to Items 1-3 in table above, please describe the nature of the damage and if the damage is repairable/replaceable:

RECORDED BY: _____
APPROVED BY: _____

DATE: _____

3. FORMS...Continued

**FORM NO. 3
LABORATORY NOTICE OF TEST FAILURE**

TEST DATE: _____

TEST PROGRAM: _____

LABORATORY: _____

CONTRACT NO.: _____ DELIV. ORDER NO.: _____

LABORATORY PROJECT ENGINEER'S NAME: _____

VEHICLE MY/MAKE/MODEL: _____

VEHICLE NHTSA NO.: _____ VIN: _____

APPARENT TEST FAILURE DESCRIPTION: _____

NOTIFICATION TO NHTSA (COTR): _____

DATE: _____ BY: _____

REMARKS:

3. FORMS...Continued

FORM NO. 4
MONTHLY VEHICLE STATUS REPORT

Test Program: _____ Contract Number: _____ Fiscal Year: _____
 Laboratory: _____
 Report Date: _____

No.	NHTSA No.	Date Of Delivery	Initial Odometer Reading	Test Date	Date of Final Report	Vehicle Condition Report Date	Invoice No.	Invoice Date	Final Odometer Reading	Date Vehicle Is Disposed
1										
2										
3										
4										
5										
6										
7										
8										
9										
10										

3. FORMS...Continued

**FORM NO. 5
QUICKLOOK REPORT**

<div style="border: 1px solid black; height: 40px; margin-bottom: 5px;"></div> <p style="margin: 0;">Laboratory Name and Logo</p>	<p>QUICKLOOK REPORT</p> <p>32 km/h (20 mph) Side Impact NCAP 75° Rigid Pole Test</p> <p>Model Year/Make/Model/Trimline/Body Style/NHTSA No. MXXXXX</p> <p>Test Date (Month, Day, Year)</p>																																																																																		
<table border="1" style="width:100%; border-collapse: collapse;"> <thead> <tr> <th colspan="7">Position 1 - SID-IIs</th> </tr> <tr> <th></th> <th>Class</th> <th>Units</th> <th>Limit</th> <th>Value</th> <th>t1</th> <th>t2</th> </tr> </thead> <tbody> <tr> <td>HIC 36</td> <td>1000</td> <td></td> <td>1000</td> <td></td> <td></td> <td></td> </tr> <tr> <td>Lower Spine (T12) Resultant</td> <td>180</td> <td>G</td> <td>82</td> <td></td> <td></td> <td></td> </tr> <tr> <td>Combined Pelvic Force</td> <td>600</td> <td>N</td> <td>5525</td> <td></td> <td></td> <td></td> </tr> <tr> <td>Max. Thorax Rib Deflection</td> <td>600</td> <td>mm</td> <td>38</td> <td></td> <td></td> <td></td> </tr> <tr> <td>Max. Abdomen Rib Deflection</td> <td>600</td> <td>mm</td> <td>45</td> <td></td> <td></td> <td></td> </tr> </tbody> </table>	Position 1 - SID-IIs								Class	Units	Limit	Value	t1	t2	HIC 36	1000		1000				Lower Spine (T12) Resultant	180	G	82				Combined Pelvic Force	600	N	5525				Max. Thorax Rib Deflection	600	mm	38				Max. Abdomen Rib Deflection	600	mm	45				<table border="1" style="width:100%; border-collapse: collapse;"> <thead> <tr> <th colspan="2">Vehicle Safety Features</th> </tr> </thead> <tbody> <tr> <td>Pretensioners</td> <td>Yes/No</td> </tr> <tr> <td>Load Limiters</td> <td>Yes/No</td> </tr> <tr> <td>Adjustable Belt Anchors</td> <td>Yes/No</td> </tr> <tr> <td>ABS</td> <td>Yes/No</td> </tr> <tr> <td>ADLs</td> <td>Yes/No</td> </tr> </tbody> </table>	Vehicle Safety Features		Pretensioners	Yes/No	Load Limiters	Yes/No	Adjustable Belt Anchors	Yes/No	ABS	Yes/No	ADLs	Yes/No																					
Position 1 - SID-IIs																																																																																			
	Class	Units	Limit	Value	t1	t2																																																																													
HIC 36	1000		1000																																																																																
Lower Spine (T12) Resultant	180	G	82																																																																																
Combined Pelvic Force	600	N	5525																																																																																
Max. Thorax Rib Deflection	600	mm	38																																																																																
Max. Abdomen Rib Deflection	600	mm	45																																																																																
Vehicle Safety Features																																																																																			
Pretensioners	Yes/No																																																																																		
Load Limiters	Yes/No																																																																																		
Adjustable Belt Anchors	Yes/No																																																																																		
ABS	Yes/No																																																																																		
ADLs	Yes/No																																																																																		
<table border="1" style="width:100%; border-collapse: collapse;"> <thead> <tr> <th colspan="7">SID-IIs Filtered Data</th> </tr> <tr> <th></th> <th>Class</th> <th>Units</th> <th>Max</th> <th>Time</th> <th>Min</th> <th>Time</th> </tr> </thead> <tbody> <tr> <td>Upper Thorax Rib Deflection</td> <td>600</td> <td>mm</td> <td></td> <td></td> <td></td> <td></td> </tr> <tr> <td>Middle Thorax Rib Deflection</td> <td>600</td> <td>mm</td> <td></td> <td></td> <td></td> <td></td> </tr> <tr> <td>Lower Thorax Rib Deflection</td> <td>600</td> <td>mm</td> <td></td> <td></td> <td></td> <td></td> </tr> <tr> <td>Upper Abdomen Rib Deflection</td> <td>600</td> <td>mm</td> <td></td> <td></td> <td></td> <td></td> </tr> <tr> <td>Lower Abdomen Rib Deflection</td> <td>600</td> <td>mm</td> <td></td> <td></td> <td></td> <td></td> </tr> <tr> <td>Lower Spine (T12) Result. Accel.</td> <td>180</td> <td>G</td> <td></td> <td></td> <td></td> <td></td> </tr> <tr> <td>Iliac Force</td> <td>600</td> <td>N</td> <td></td> <td></td> <td></td> <td></td> </tr> <tr> <td>Acetabulum Force</td> <td>600</td> <td>N</td> <td></td> <td></td> <td></td> <td></td> </tr> </tbody> </table>	SID-IIs Filtered Data								Class	Units	Max	Time	Min	Time	Upper Thorax Rib Deflection	600	mm					Middle Thorax Rib Deflection	600	mm					Lower Thorax Rib Deflection	600	mm					Upper Abdomen Rib Deflection	600	mm					Lower Abdomen Rib Deflection	600	mm					Lower Spine (T12) Result. Accel.	180	G					Iliac Force	600	N					Acetabulum Force	600	N					<table border="1" style="width:100%; border-collapse: collapse;"> <thead> <tr> <th colspan="3">Test Vehicle Doors</th> </tr> </thead> <tbody> <tr> <td>Can Disable ADLs Using Owner's</td> <td colspan="2">Yes/No/NA</td> </tr> <tr> <td>Doors Locked (Pre-Test)</td> <td colspan="2">Yes/No/NA</td> </tr> <tr> <td>Doors Latched (Post-Test)</td> <td>Driver Yes/No</td> <td>Rear Pass. Yes/No</td> </tr> </tbody> </table>	Test Vehicle Doors			Can Disable ADLs Using Owner's	Yes/No/NA		Doors Locked (Pre-Test)	Yes/No/NA		Doors Latched (Post-Test)	Driver Yes/No	Rear Pass. Yes/No
SID-IIs Filtered Data																																																																																			
	Class	Units	Max	Time	Min	Time																																																																													
Upper Thorax Rib Deflection	600	mm																																																																																	
Middle Thorax Rib Deflection	600	mm																																																																																	
Lower Thorax Rib Deflection	600	mm																																																																																	
Upper Abdomen Rib Deflection	600	mm																																																																																	
Lower Abdomen Rib Deflection	600	mm																																																																																	
Lower Spine (T12) Result. Accel.	180	G																																																																																	
Iliac Force	600	N																																																																																	
Acetabulum Force	600	N																																																																																	
Test Vehicle Doors																																																																																			
Can Disable ADLs Using Owner's	Yes/No/NA																																																																																		
Doors Locked (Pre-Test)	Yes/No/NA																																																																																		
Doors Latched (Post-Test)	Driver Yes/No	Rear Pass. Yes/No																																																																																	
<table border="1" style="width:100%; border-collapse: collapse;"> <thead> <tr> <th colspan="5">Test Particulars</th> </tr> <tr> <th rowspan="2"></th> <th colspan="2">Metric Units</th> <th colspan="2">English Units</th> </tr> <tr> <th>Units</th> <th>Value</th> <th>Units</th> <th>Value</th> </tr> </thead> <tbody> <tr> <td>Vehicle Velocity</td> <td>km/h</td> <td></td> <td>mph</td> <td></td> </tr> <tr> <td>Vehicle As Delivered Weight</td> <td>kg</td> <td></td> <td>lbs</td> <td></td> </tr> <tr> <td>Vehicle Test Weight</td> <td>kg</td> <td></td> <td>lbs</td> <td></td> </tr> <tr> <td>Vehicle Width</td> <td>mm</td> <td></td> <td>Inches</td> <td></td> </tr> <tr> <td>Vehicle Wheelbase</td> <td>mm</td> <td></td> <td>Inches</td> <td></td> </tr> <tr> <td>Vehicle Length</td> <td>mm</td> <td></td> <td>Inches</td> <td></td> </tr> </tbody> </table>	Test Particulars						Metric Units		English Units		Units	Value	Units	Value	Vehicle Velocity	km/h		mph		Vehicle As Delivered Weight	kg		lbs		Vehicle Test Weight	kg		lbs		Vehicle Width	mm		Inches		Vehicle Wheelbase	mm		Inches		Vehicle Length	mm		Inches		<table border="1" style="width:100%; border-collapse: collapse;"> <thead> <tr> <th colspan="2">Standards Passed Post-Test</th> </tr> </thead> <tbody> <tr> <td>301- Fuel System Integrity</td> <td>Yes/No/NA</td> </tr> <tr> <td>If No, Amount in oz.</td> <td></td> </tr> <tr> <td>305 - Electrolyte Spillage</td> <td>Yes/No/NA</td> </tr> <tr> <td>If No, Amount in oz.</td> <td></td> </tr> <tr> <td>305 - Electrical Isolation</td> <td>Yes/No/NA</td> </tr> <tr> <td>If No, Ohms/Volt</td> <td></td> </tr> <tr> <td>305 - Battery Retention</td> <td>Yes/No/NA</td> </tr> <tr> <td>If No, Location of Failure</td> <td></td> </tr> </tbody> </table>	Standards Passed Post-Test		301- Fuel System Integrity	Yes/No/NA	If No, Amount in oz.		305 - Electrolyte Spillage	Yes/No/NA	If No, Amount in oz.		305 - Electrical Isolation	Yes/No/NA	If No, Ohms/Volt		305 - Battery Retention	Yes/No/NA	If No, Location of Failure																					
Test Particulars																																																																																			
	Metric Units		English Units																																																																																
	Units	Value	Units	Value																																																																															
Vehicle Velocity	km/h		mph																																																																																
Vehicle As Delivered Weight	kg		lbs																																																																																
Vehicle Test Weight	kg		lbs																																																																																
Vehicle Width	mm		Inches																																																																																
Vehicle Wheelbase	mm		Inches																																																																																
Vehicle Length	mm		Inches																																																																																
Standards Passed Post-Test																																																																																			
301- Fuel System Integrity	Yes/No/NA																																																																																		
If No, Amount in oz.																																																																																			
305 - Electrolyte Spillage	Yes/No/NA																																																																																		
If No, Amount in oz.																																																																																			
305 - Electrical Isolation	Yes/No/NA																																																																																		
If No, Ohms/Volt																																																																																			
305 - Battery Retention	Yes/No/NA																																																																																		
If No, Location of Failure																																																																																			
<table border="1" style="width:100%; border-collapse: collapse;"> <thead> <tr> <th colspan="5">Airbag Deployment</th> </tr> <tr> <th rowspan="2"></th> <th colspan="2">Driver (P1)</th> <th colspan="2">Left Rear Passenger (P4)</th> </tr> <tr> <th>Deployment</th> <th>Mount</th> <th>Deployment</th> <th>Mount</th> </tr> </thead> <tbody> <tr> <td>Head Bag</td> <td>Yes/No/NA</td> <td>Curtain</td> <td>Yes/No/NA</td> <td>Curtain</td> </tr> <tr> <td>Torso or Torso/Pelvis Bag</td> <td>Yes/No/NA</td> <td>Door/Seatback</td> <td>Yes/No/NA</td> <td>Door/Seatback</td> </tr> <tr> <td>Combination Bag</td> <td>Yes/No/NA</td> <td>Door/Seatback</td> <td>Yes/No/NA</td> <td>Door/Seatback</td> </tr> <tr> <td>Frontal Bag</td> <td>Yes/No/NA</td> <td>Steering Whl</td> <td></td> <td></td> </tr> </tbody> </table>	Airbag Deployment						Driver (P1)		Left Rear Passenger (P4)		Deployment	Mount	Deployment	Mount	Head Bag	Yes/No/NA	Curtain	Yes/No/NA	Curtain	Torso or Torso/Pelvis Bag	Yes/No/NA	Door/Seatback	Yes/No/NA	Door/Seatback	Combination Bag	Yes/No/NA	Door/Seatback	Yes/No/NA	Door/Seatback	Frontal Bag	Yes/No/NA	Steering Whl			<p>Comments:</p> <hr/> <hr/> <hr/> <hr/> <hr/>																																																
Airbag Deployment																																																																																			
	Driver (P1)		Left Rear Passenger (P4)																																																																																
	Deployment	Mount	Deployment	Mount																																																																															
Head Bag	Yes/No/NA	Curtain	Yes/No/NA	Curtain																																																																															
Torso or Torso/Pelvis Bag	Yes/No/NA	Door/Seatback	Yes/No/NA	Door/Seatback																																																																															
Combination Bag	Yes/No/NA	Door/Seatback	Yes/No/NA	Door/Seatback																																																																															
Frontal Bag	Yes/No/NA	Steering Whl																																																																																	

PROCEDURE FOR CHECKING AND RECORDING DUMMY ACCELEROMETER POLARITY FOR THE HIII 50TH AND 5TH PERCENTILE NINE ACCELEROMETER ARRAY HEAD WITH REDUNDANT C.G. ACCELEROMETERS

Purpose:

The purpose of this procedure is to provide a practical methodology for checking and documenting the recorded polarity of the data channel for each dummy mounted accelerometer relative to the NHTSA sign convention. Documenting the polarity of channels will serve to increase the confidence that polarities have been correctly determined. The polarities in this document are the same as those of the SAE J211 and J1733.

Background:

Standardized coordinate systems and recorded polarities for various transducer outputs defined relative to positive directions of those coordinate systems are defined for crash test dummies, vehicle structures, and laboratory fixtures in the SAE J211 standard. The standardized coordinate system and polarities for data permits comparison of data from different crash test facilities.

There are many ways to influence the polarity of a data channel. NHTSA has required the polarity of any given manufacturer's instrumentation be compatible with and recordable in a J211 channel. The channel by definition includes all the instrumentation from the transducer to the data acquisition system output. The channels therefore include the accelerometers mounted in the dummy connected to a data acquisition system using connectors, wiring, data acquisition software and hardware. The polarity of a data channel for any given dummy may therefore be affected by changing the manufacturer of the accelerometer, positive and negative pins from the accelerometer to the wiring in a connector, the polarity assigned in software, and by changing the way it is mounted in the dummy.

Since there are many ways to influence the polarity of a data channel it is appropriate to document the polarity of the assembled channel just before testing to assure the accelerometer is not exchanged with that of another manufacturer's, and that no changes are made to the way it is mounted in the dummy, the connector pin arrangement, and polarity assigned in software before testing.

When a test dummy is delivered for a test and connected to the data acquisition system the polarity of the internal accelerometers can be established using the following approach. The procedure requires the user to think of the data channel as a black box. The procedure requires manipulating the dummy head to determine the polarity of the black box with respect to the sign convention. If the polarity is wrong, than steps must be taken to correct it prior to submitting data to NHTSA, so that data is in accordance with the sign convention. However, it is recommended to correct and document the channel polarity at the test site so no further modification to the data are required. If difficulty is experienced in determining the polarity when these procedures are being properly followed it may indicate that the accelerometer has not been

mounted in accordance with the dummy instrumentation assembly drawings contained in the appropriate Nine Array Head with Redundant C.G. Accelerometers User's Manual.

SAE J211 Procedure :

The body coordinate system used for reference is attached to the dummy and is x positive pointing forward, y positive pointing to the right, and z positive pointing down. For NHTSA tests the accelerometers referred to are those meeting NHTSA SA572-S4 specifications.

The SAE J1733 explains that for any dummy component oriented in its standard standing position blows to the back side, left side, and top will produce positive accelerations relative to its +x, +y, and +z directions, respectively. As an example to document the polarity of the dummy's head x axis accelerometer data channel in a plot similar to Figure 1, apply a blow to the back of the head with a rubber mallet and record the data channel output. The polarity of the Figure 1 dummy channel is positive and no changes are needed to conform to the sign convention. Similarly to document the polarity of the dummy's head y and z axis accelerometer data channels apply a blow to the left side, and top of the head with a rubber mallet (never apply the blow directly to an accelerometer mount) and record the data channel output as shown for the y axis in Figure 2.

Analysis of Figure 2 for the y axis shows that the polarity of the y axis accelerometer data channel in the dummy head in this example is negative. Change the polarity to be positive (perhaps the simplest way is to change the sign in the software) to agree with the sign convention and make a new plot to document the change. Following this approach it is possible to document the polarity of each accelerometer data channel in the dummy head.

Alternate Procedure :

An alternate approach to determine the polarity of the accelerometers mounted in the dummy head uses the constant force of gravity as the input. This procedure will yield the same polarity as the previous procedure. Since the sign convention is fixed with respect to the dummy, this procedure can be conducted outside the test vehicle on the laboratory floor or table, but the dummy must be attached to the data acquisition system.

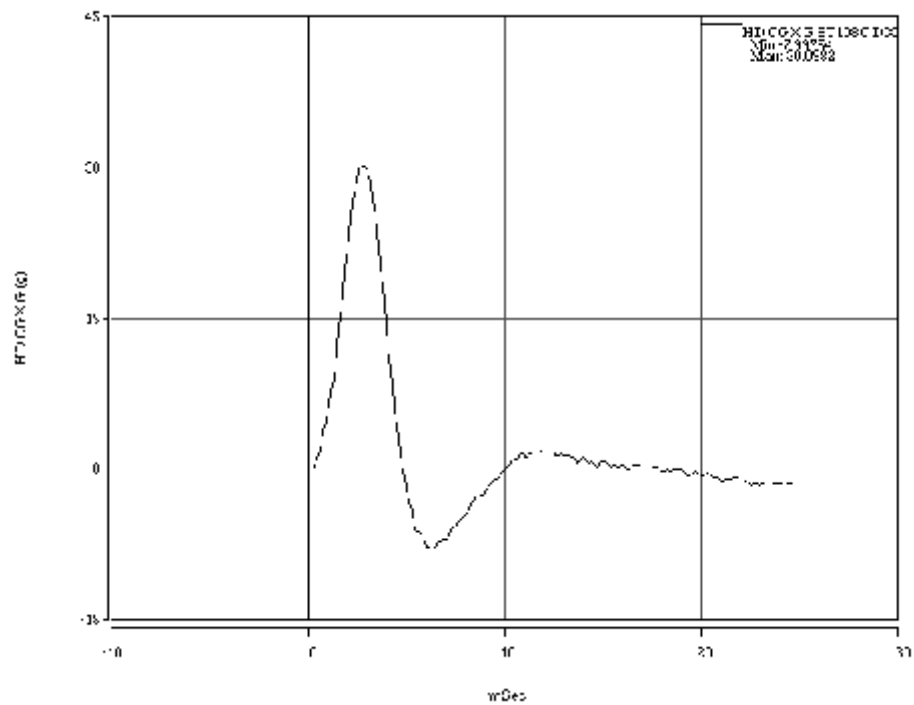

Figure 1 – Response of X Axis Accelerometer Data Channel from blow to rear of head showing desired positive polarity

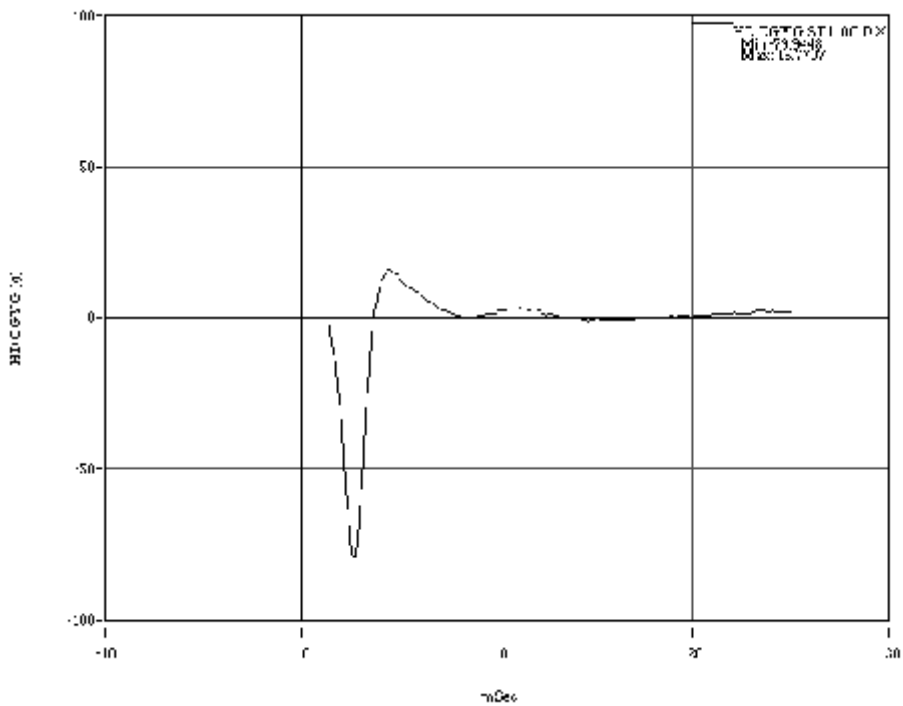

Figure 2 – Response of Y Axis Accelerometer Data Channel from blow to left side of head showing incorrect (negative) polarity

The procedure for each channel requires placing the accelerometers to be checked perpendicular to the axis of gravity in two orientations each 180 degrees apart and recording the sign and value of the acceleration channel due to the earth's gravity for a short period of time. The SA572-S4 accelerometer is defined as perpendicular to the axis of gravity when the plane containing both mounting screw holes is perpendicular to the force of gravity. See Figure 3.

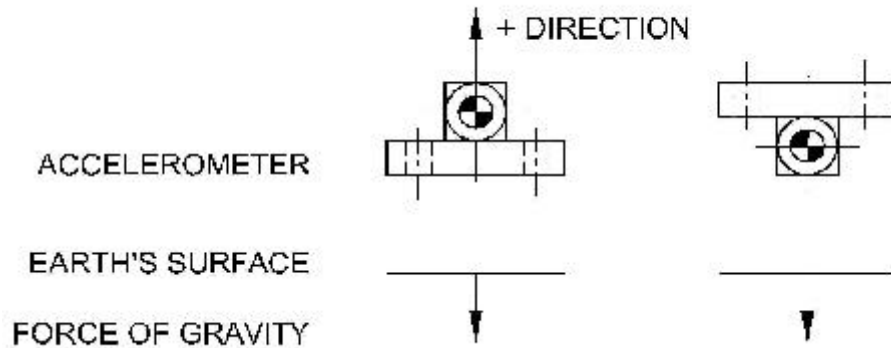

Figure 3 – SA572-S4 Accelerometer Perpendicular to the Force of Gravity in Two Orientations 180 Degrees Apart

When the SA572-S4 accelerometer is mounted in a plane perpendicular to the force of gravity the orientation of the dummy head having the most positive output for that accelerometer channel defines positive polarity when moved away from the earth center. The polarity must agree with the SAE J211 sign convention.

The data collected should be recorded in the Polarity Check Data Sheet respectively for the x, y, and z accelerometers. Samples of these are provided in this Document. As an example, refer to the Polarity Check Data Sheet for documenting the x axis polarity. To determine the polarity of the head x-accelerometer, lay the dummy face down (FD) and record the x-accelerometer's output in g's in the appropriate column. Now place the dummy face up (FU) and record the channel output in g's in the appropriate column. List the orientation of the most positive value in the next column, either FD or FU, paying attention to the sign from the data acquisition system (-1 is more positive than -2 g's). Next, compare the orientation of the most positive value with the J211 orientation for positive sign convention. If the dummy's orientation of the most positive value is consistent with that of the J211 sign convention, then the channel output will be in accordance with the sign convention. If, however, the dummy's orientation of the most positive value is different than that of the J211 sign convention, then the channel's output will have to be reversed by the data acquisition software in order to be in accordance with the sign convention. Place a check in the column titled "Negative Channels To Be Reversed In Data Acquisition System" for those channels that will require reversal by the data acquisition software.

The channel outputs for the x-axis accelerometers can be recorded simultaneously for each orientation. For example, when the dummy is turned face down, the channel outputs for the head can all be recorded at the same time. Then the dummy can be oriented face up and the corresponding channel outputs can be recorded again.

The procedure for the y-axis accelerometers is very similar to that used for the x-axis and can be accomplished on a floor or bench surface. In this instance, the dummy is placed on its side in two different orientations - one where the right shoulder is down (RSD) and one where the right shoulder is up (RSU). Once again, all of the channels can be recorded at one time. Then flip the dummy onto its other side and record the values again. At this point, the procedure is similar to that used for the x-axis channels. List the orientation of the most positive value and compare that with that J211 orientation for positive sign convention. Indicate those channels to be reversed if any.

For the z-axis turning the dummy over and standing it on its head is quite difficult for the larger adult dummies. Thus for the z-axis check it is recommended to secure the dummy in a chair, seat it upright and then rotate the dummy in the chair forward or backward about 60 degrees. The force on the accelerometer varies with the cosine of the angle it makes with respect to tangent to the earth's surface. With the dummy sitting upright (U) in the chair, record the z-axis accelerometer channel outputs in the appropriate column on the Polarity Check Data Sheet. Next, lean the dummy forward or backward approximately 60 degrees and record the z-axis accelerometer outputs in the column labeled "Lean Down." (Note that the symbol "D" for down has been associated with this orientation.) Again, follow the procedure outlined for the x-axis and y-axis accelerometers to complete the z-axis Polarity Check Data Sheet.

Polarity Check Data Sheet For X - Axis Accelerometers

Dummy Type: _____ **Serial No.** _____ **Date:** _____

Component	Channel Output (g)		Orientation of Most Positive Value (FU or FD)	J211 Orientation for Positive Polarity	Negative Channels to be Reversed In Data Acquisition System
	Orientation				
	Face Down (FD)	Face Up (FU)			
Head C.G.				FU	
Head C.G. Redundant NAAH*				FU	
Head Top NAAH*				FU	
Head Left NAAH*				FU	

* NAAH - Indicates Nine Accelerometer Array Head

Polarity Check Data Sheet For Y - Axis Accelerometers

Dummy Type: _____ **Serial No.** _____ **Date:** _____

Component	Channel Output (g)		Orientation of Most Positive Value (RSU or RSD)	J211 Orientation for Positive Polarity	Negative Channels to be Reversed In Data Acquisition System
	Orientation				
	Right Shoulder Down (RSD)	Right Shoulder Up (RSU)			
Head C.G.				RSU	
Head C.G. Redundant NAAH*				RSU	
Head Top NAAH*				RSU	
Head Front NAAH*				RSU	

* NAAH - Indicates Nine Accelerometer Array Head

Polarity Check Data Sheet For Z - Axis Accelerometers					
Dummy Type: _____		Serial No. _____		Date: _____	
Component	Channel Output (g)		Orientation of Most Positive Value (U or D)	J211 Orientation for Positive Polarity	Negative Channels to be Reversed In Data Acquisition System
	Orientation				
	Upright (U)	Lean Down (D)			
Head C.G.				D	
Head C.G. Redundant NAAH*				D	
Head Left NAAH*				D	
Head Front NAAH*				D	

* NAAH - Indicates Nine Accelerometer Array Head