

TYPICAL CONCRETE RAIL SECTION
REINFORCING

Figure 1. Drawings for concrete baluster bridge railing.

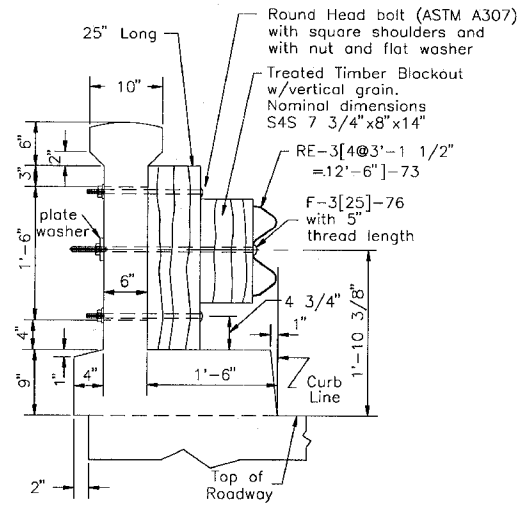

TYPICAL CONCRETE RAIL SECTION
WITH W-BEAM RETROFIT
WHEN \varnothing 5/8" BOLT
CAN NOT GO THROUGH CONCRETE RAILING VOID

Figure 2. Drawings for W-beam retrofit for concrete baluster bridge railing.

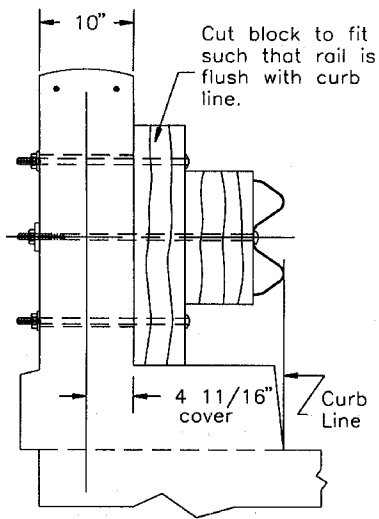

SECTION AT
END OF RAILING

Figure 2. Drawings for W-beam retrofit for concrete baluster bridge railing (continued).

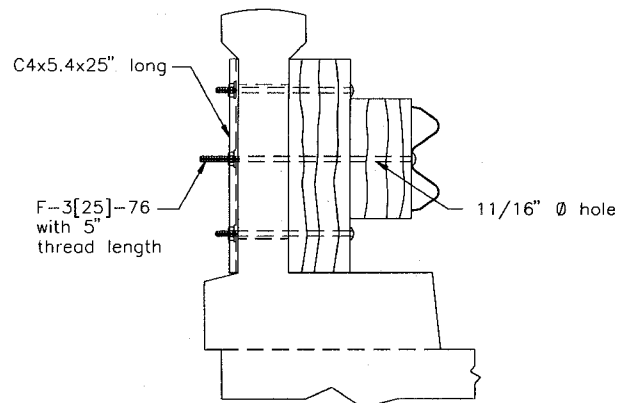

1 ft = 0.305 m
1 in = 25.4 mm

TYPICAL CONCRETE RAIL SECTION
WITH W-BEAM RETROFIT
WHEN \varnothing 5/8" BOLT
CAN GO THROUGH CONCRETE RAILING VOID

Figure 2. Drawings for W-beam retrofit for concrete baluster bridge railing (continued).

Figure B7.2. West Virginia W-Beam Retrofit for Concrete Baluster Designs, Curb Mounted (4).