

TALUGA (AO-62)

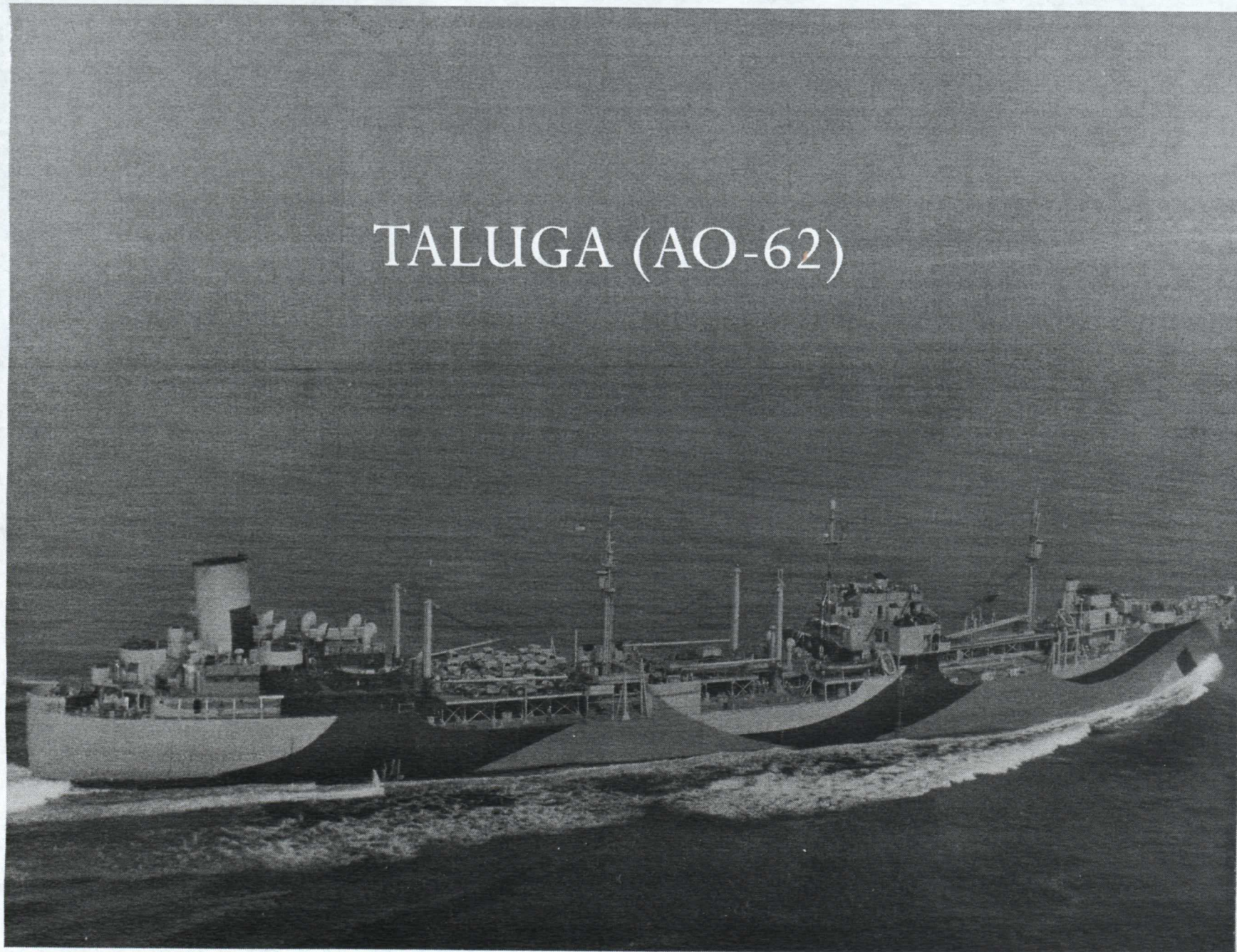

TALUGA
(AO-62)
Suisun Bay Reserve Fleet
Benicia vicinity
Solano County
California

HAER CA-336
HAER CA-336

PHOTOGRAPHS

WRITTEN HISTORICAL AND DESCRIPTIVE DATA

REDUCED COPIES OF MEASURED DRAWINGS

HISTORIC AMERICAN ENGINEERING RECORD
National Park Service
U.S. Department of the Interior
1849 C Street NW
Washington, DC 20240-0001

HISTORIC AMERICAN ENGINEERING RECORD

Taluga (AO-62)

HAER No. CA-336

Location: Suisun Bay Reserve Fleet, Benicia vicinity, Solano County, California

Type of Craft: T3-S2-A1/Auxiliary

Trade: Fleet oiler

Class: *Ashtabula*

Principal Dimensions: Length (oa): 553'
Beam (molded): 75'
Draft: 32'-4"
Displacement: 23,235 long tons
Deadweight: 18,300 long tons
Gross registered tonnage: 11,335 tons
Maximum continuous shaft horsepower: 13,500
Service speed: 18.3 knots
(The listed dimensions are as built, but it should be noted that draft, displacement, and tonnages were subject to alteration over time as well as variations in measurement.)

Dates of Construction: Keel laying: 23 December 1943
Launching: 10 July 1944
Commissioning: 25 August 1944

Designer: U.S. Maritime Commission

Builder: Bethlehem Steel Company, Sparrows Point, Maryland

Present Owner: U.S. Maritime Administration

Disposition: Inactive—National Defense Reserve Fleet

Significance: The *Taluga* is significant as an example of the T3-type tankers, which were developed with steam propulsion rather than turbo-electric drives. The ship is also significant as the first civilian-crewed oiler in the Military Sealift Command. The crew of this ship, known as the “Taluga Tigers,” set the standard for all civilian-manned naval auxiliaries to the present.

Historian: Brian Clayton, spring 2006

**Project
Information:**

This project is part of the Historic American Engineering Record (HAER), a long-range program to document historically significant engineering and industrial works in the United States. The Heritage Documentation Programs of the National Park Service, U.S. Department of the Interior, administers the HAER program.

The project was prepared under the direction of Todd Croteau (HAER Maritime Program Coordinator). Crystal Olin, (HAER Intern), generated the drawings. Jet Lowe (HAER Photographer) produced the large-format photographs. Special thanks to Erhard Koehler (U.S. Maritime Administration), whose help and assistance greatly benefited the project.

BACKGROUND

One of the first priorities of the United States upon entering World War II was the construction of ships. The global experience and ferocity of World War I taught the United States that World War II would be on a grander scale, in more places, involve more people, and require more equipment—total war.¹ During World War II, the U.S. Maritime Commission became a pivotal force in the development and construction of ships, much like the U.S. Shipping Board had been in World War I. Created in 1936, the Maritime Commission succeeded the Shipping Board, but it generally followed the same directive: the promotion of U.S. shipping interests. After the United States entered World War II, the Maritime Commission established the Emergency Program, a massive ship construction plan that utilized new and existing shipyards across the United States.²

The need for the Emergency Program stemmed from the decline of the maritime industry in the inter-war years. Most of the ships in the Merchant Marine originated from the mobilization endeavor authorized by the U.S. Shipping Board to support American troops in World War I. The board had approved the construction of 470 ships to support the war effort. Between 1918 and 1922, however, the board added 1,300 ships to the Merchant Marine, giving the United States a more robust presence in international shipping than it had had in seventy years. The U.S. stock market crash in 1929 and the Great Depression were major setbacks to the maritime industry. Many steamship companies were unable to replace or update aging ships—over 90 percent of the fleet was over twenty years old and had an average speed of between 10 and 11 knots.³

In the mid-1930s, the U.S. government intervened with new legislation to aid the beleaguered maritime industry. President Franklin D. Roosevelt's New Deal economic policies eventually helped revive the Merchant Marine when Congress passed the Merchant Marine Act of 1936. The act created the U.S. Maritime Commission, superseding the U.S. Shipping Board, and it infused new capital and ideas for rebuilding the fleet. In 1937, the U.S. Maritime Commission developed a long-range program for building 500 ships that were both contemporary and economical over a ten-year period. In 1939, the Maritime Commission determined that the production quota of fifty ships per year was too low and doubled it.⁴ There were mounting concerns about the war in Europe and the success of the German U-boat campaign against English shipping, particularly since U.S. steamship companies traded with England and France. The U.S. also feared that Germany might next turn its attention to U.S. ships or U.S. trade routes.

¹ Russell F. Weigley, *The American Way of War: A History of United States Military Strategy and Policy* (New York, NY: MacMillan Publishing Co., Inc., 1973), pp. xxi-xxiii.

² René De La Pedraja, *A Historical Dictionary of the U.S. Merchant Marine and Shipping Industry since the Introduction of Steam* (Westport, CT: Greenwood Press, 1994), pp. 563-566, 629-631. The Maritime Commission issued contracts for 5,601 vessels during World War II. Private firms built an additional 111 ships while foreign firms built sixty-five for a total of 5,777.

³ Brian J. Cudahy, *Box Boats: How Container Ships Changed the World* (New York, NY: Fordham University Press, 2006), pp. 2-3; L.A. Sawyer and W.H. Mitchell, *Victory Ships and Tankers: The History of the 'Victory' Type Cargo Ships and of the Tankers Built in the United States of America during World War II* (Cambridge, MD: Cornell Maritime Press, Inc., 1974), p. 15.

⁴ Cudahy, *Box Boats*, p. 3; Sawyer and Mitchell, *Victory Ships and Tankers*, p. 15.

In response, the Maritime Commission raised its shipping quota once again in August 1940 to 200 ships per year.⁵

FLEET OILERS

Shortly after the signing of the Merchant Marine Act in 1936, U.S. oil companies became interested in constructing high-speed tankers, as did the U.S. Navy. Commissioner Emory S. Land, chairman of the U.S. Maritime Commission, proposed that the commission subsidize the construction of these vessels by paying for upgraded engines. On 3 January 1938, the Maritime Commission signed a contract with the Standard Oil Company of New Jersey to subsidize twelve oilers, designated T3-S2-A1. That same day, Standard commissioned four shipyards, including Sun, Federal, Bethlehem-Sparrows Point, and Newport News, to each construct three tankers.⁶

These new fleet oilers were similar to an earlier design used when Land was Chief of the Bureau of Construction and Repair with the U.S. Navy. The bureau's Central Drafting Office had developed lines for a fleet oiler in 1936 that corresponded to those of the oilers being built two years later. Although the naval architect for Sun Shipbuilding, E.L. Stewart, is credited with laying out the design and specifications, the final lines appear to be a combination of those from Sun's engineering staff and the Maritime Commission's technical team since there is a clear difference between the final version and the early designs of the U.S. Navy for a twin-screw fleet oiler.⁷

The USS *Cimarron*, the first in its class of T3s, was launched on 7 January 1939 and entered naval service as a fleet oiler. This was the navy's first fleet oiler since the *Kanawha*, dating to 1915, and had the distinction of being one of the largest and fastest to date. The addition of T3s to the navy's fleet coincided with the success of U.S. Navy operations in the Pacific. During this time, the navy shifted its campaign from an offensive-defensive posture to a more open offensive drive. The acquisition of the T3-S2-A1s corresponded to the needs of the navy. As military operations increased in the Pacific in 1943, the navy required more oilers to continue operations. The second round of T3-S2-A1s to be built was the *Ashtabula* class, comprised of eighteen ships, including the *Taluga*. Bethlehem Steel in Sparrows Point, Maryland, constructed the entire class from 1943 to 1946.⁸

CONSTRUCTION

Bethlehem Steel in Sparrows Point, Maryland, laid the keel of the *Taluga* (AO-62) under a Maritime Commission contract (Hull No. 728), on 23 December 1943. Bethlehem Steel was an established firm in steel manufacturing, ship building, and ship repairing. The Maryland Steel Company originally built the Sparrows Point Shipyard in 1889 and delivered its first ship in

⁵ Sawyer and Mitchell, *Victory Ships and Tankers*, p. 16; Thomas Wildenberg, "The Origins and Development of the T2 Tanker," *American Neptune* (Summer 1992), pp. 158-159.

⁶ Wildenberg, "Origins and Development," pp. 158-159.

⁷ Wildenberg, "Origins and Development," pp. 159-160.

⁸ Sawyer and Mitchell, *Victory Ships and Tankers*, p. 182; James L. George, *History of Warships: From Ancient Times to the Twenty-First Century* (Annapolis, MD: Naval Institute Press, 1998), p. 219.

1891. In 1917, Bethlehem Steel purchased the shipyard, which by that point had produced 176 ships, almost all of which were commercial, aside from three destroyers and six naval colliers. In the period from 1939 to 1946, the Bethlehem-Fairfield yard built 116 ships, including sixty-eight tankers, twenty-six general cargo ships, ten refrigerated cargo ships, six ore carriers, and six passenger/cargo ships. The yard employed over 20,000 people during the height of production in World War II.⁹

DESCRIPTION

The *Taluga* was 553' in overall length with a 75' beam and draft of 32'-4". The American Bureau of Shipping rated the vessel at 11,335 gross tons and 18,300 deadweight tons. The ship displaced 23,235 tons. The twin-screw propulsion plant created 13,500 shaft horsepower for a top speed of 18.3 knots, with an average cruising distance of around 15,300 miles. The ship maintained a "raked bow, cruiser stern, and the three islands."¹⁰

The machinery space contained four steam turbines built by Bethlehem, as well as two Westinghouse generators on an intermediate deck that generated 400-kilowatts to produce a 230-volt alternating current. Foster and Wheeler supplied the four boilers, which provided steam for the main turbines, auxiliaries, and pumps. The working steam pressure was 450 pounds per square inch at 750 degrees Fahrenheit. Todd oil burners and Hagen controls provided combustion. Two Falk double helical reduction gears stepped the shaft power down. The aft steering compartment housed the quadrant steering gear manufactured by Hyde.¹¹

The T3-S2-A1 design incorporated nine corrugated tanks. Tanks 2 through 9 were centered in the ship with side tanks on the port and starboard sides and cofferdams fore and aft. Tank 1 only had side tanks. The total cargo capacity was 123,700 barrels of oil and 788,000 gallons of gasoline. The upper deck held twenty-six cylindrical hatches with stairwells for access inside the tanks.

Three pump rooms located aft, amidships, and forward were used to move the cargo. The main pump room was located aft and contained four pumps. There were three main Ingersoll-Rand centrifugal pumps, rated at 2,000 gallons-per-minute (gpm). The electric motors to actuate the pumps were in separate compartments to prevent accidental ignition of the cargo fuel. The other pump was a Worthington 1,100-gpm vertical steam reciprocating pump used for stripping. The amidships pump room contained three pumps, including two centrifugal steam cargo pumps, rated at 3,000-gpm and manufactured by Pacific. The remaining pump was vertical steam-reciprocating and manufactured by Worthington Pump. It was rated at 1,400 gpm and primarily used for stripping. The forward pump room contained one vertical steam-reciprocating pump manufactured by Worthington and rated at 1,400 gpm. This pump was used solely for the

⁹ Sawyer and Mitchell, *Victory Ships and Tankers*, p. 28; "Fairfield Shipyard," at <http://www.globalsecurity.org/military/facility/fairfield.htm>, accessed 13 March 2006.

¹⁰ U.S. Navy, *Ships' Data U.S. Navy Vessels: Auxiliary, District Craft, and Unclassified Vessels* (Washington, DC: Government Printing Office, 1946), pp. 176-178.

¹¹ The description is based on the U.S. Navy, *Ships' Data*, pp. 176-180, and *Booklet of General Plans (AO-62)* in Record Group 19, National Archives and Records Administration—College Park, Maryland.

transfer of cargo fuel. All the pump rooms were accessed through small pump houses on the upper deck that contained stairwells.

The cargo deck held a variety of equipment. On the after deck were two kingposts located in the after well that handled the fuel and steam lines through 10-ton and 30' booms. There was also a boom located off the mainmast, like the kingposts. In addition, two more kingposts were located just aft of the bridge that supported two booms for fueling and launching two 40' utility craft. Winches serviced the booms during refueling operations and launches. There were six fueling stations located on this deck, three per side. To help prevent accidents on the ship and to carry miscellaneous equipment, a wooden spar deck was built above the piping equipment. The foredeck included one 10-ton boom located off the foremast for handling fueling lines. Two winches serviced the boom. There were two fueling stations located on the port and starboard sides, just aft of the forecastle deck. An elevated catwalk connected the bridge deck to the forecastle deck so personnel could avoid the piping.

The storerooms and ballast compartments were beneath the foredeck, along with spaces for repair and parts, paint, electrical equipment, and clothing. The forepeak stored fresh water for the crew. Aft of the forepeak were two dual-purpose tanks that could store either ballast or fuel oil.

The T3-S2-A1 was equipped with armament. One 5"/38-caliber dual-purpose gun was located on the stern, while four 40-mm, twin-mounted guns were atop the boat deck just forward of the stack. Lastly, four 3"/50-caliber twin-mounted guns were on the bow. Two ammunition lockers supplied the guns. The forward ammunition storeroom was below the chain locker and under the waterline for protection. The rear ammunition locker was aft of the after peak and also under the waterline. The locker supplied the 5" gun on the poop deck. Elevators transported the ammunition while integrated flash protection prevented an internal explosion during an attack.

Accommodations for the forty-four-person crew consisted of two berthing areas and a galley. The middle island contained accommodations for the officers while the aft island held the majority of the berths for the enlisted crew. The crew's mess for enlisted and officers was in the aft island.

Navigation and communication equipment were located in the middle island. Standard navigation equipment on the bridge consisted of a steering station, binnacle, gyro repeater, gyro pilot, engine telegraph, charts, and a fathometer. Radar and Loran became standard after World War II. The upper bridge deck housed the radio room and the cryptographic equipment. The pilothouse contained a second steering station, binnacle, and gyro repeater.

Lifesaving equipment onboard consisted of small boats on either side of the tanker. There was enough space for the entire crew on each side because a sinking ship tended to list, and the elevated side prevented the crew from deploying the life-saving craft. The lifeboats (twenty-five-man-capacity) contained quick-release tackle on special skids. There were two additional life rafts suspended from inclined troughs. Emergency kick-out panels on divisional bulkheads

in the living quarters and chain ladders in the ventilation ducts provided egress from ship compartments.

UNDERWAY REPLENISHMENT

By 1944, the U.S. Navy began using underway support missions since warships were at sea for longer periods of time and using more ammunition. The U.S. Navy formed the Logistic Support Group, with ammunition and store ships utilizing underway replenishment techniques. Navy oilers, like the *Taluga*, supplied vessels-at-sea using underway replenishment, which involved two or more vessels reaching similar speed and course. With the ships on a parallel course and at a close distance, the oiler's crew would pass a line to the receiving ship. These high-strength lines allowed cargo and fuel lines to be pulled across to the receiving ship. The oiler's boom held the fuel hose through a saddle, and the receiving vessel attached the hose to the bunker for refueling. Underway replenishment became standard procedure for replenishing the battle fleet in World War II.¹²

OPERATIONAL HISTORY

The *Taluga*, named after a river in Florida, was launched on 10 July 1944 with Mrs. Harvey Klemmer as sponsor. The ship arrived in Norfolk on 25 August 1944 under Commander Hans M. Mikkelsen and was commissioned that day. Mikkelsen sailed for the Pacific via the Panama Canal with a stop in Aruba. In December, the *Taluga* reached Ulithi, which became the center of its operations until the end of the war.¹³

The *Taluga*'s mission consisted of taking oil and aviation gas to the ships in the Carrier Task Force. The ship provisioned the task force for eleven months while strikes and landings were conducted against the Japanese on Luzon, Okinawa, Formosa, and the last attack on Japan's home islands. In April and July 1945, the ship maintained station in and around Kerama Retto, the southwestern part of Okinawa. In this area on 16 April, the Japanese launched a kamikaze attack on the formation. Ten Japanese aircraft struck, and one plane peppered the *Taluga*'s decks before aiming for the bridge. The aircraft bounced off the side of the bridge and exploded on the deck into an adjacent compartment beside a tank carrying aviation gas. Twelve men suffered injuries, none fatal, and the ship resumed operations shortly thereafter.

After the Japanese surrender in August 1945, the *Taluga* became a station oiler in Japan. The ship's primary base was on Yokosuka, but it did make runs to Tsingtao and Jinsen to support the occupation of China and Korea. At the end of January, the ship was put to sea and returned to the United States for an overhaul in San Pedro, California.

From July 1946 to June 1949, the *Taluga* transported oil and gasoline to various bases around the globe. In 1949 after the establishment of the Military Sea Transportation Service, the *Taluga*

¹² George, *History of Warships*, p. 220; A.S. Bussey, "Skillful Technique Developed in Replenishment at Sea," *Bureau of Ships Journal* 7 (July 1952): pp. 30-31.

¹³ The operational history is compiled from the U.S. Navy, *Dictionary of American Naval Fighting Ships*, Vol. VII (Washington, DC: Naval Historical Center, 1991), pp. 25-27.

was assigned to the unit. The ship carried oil to the East Coast for several months before sailing to its homeport of Long Beach, California.

With the onset of the Korean War, the *Taluga* headed for the combat zone in summer 1950. The ship operated out of Sasebo, Japan, supplying vessels around the blockade and siege of Wonsan and Songjin. After the Korean settlement, the *Taluga* supplied the Seventh Fleet until the outbreak of hostilities in Vietnam.

In 1965, the *Taluga* began resupplying ships directly participating in operations against the North Vietnamese. Most of the ship's deployments were in or around the combat sectors. During the six deployments, the ship spent a majority of time with the Seventh Fleet, providing replenishment for the larger ships within the carrier task force and the smaller ships associated with Operation "Market Time"—an operation directed against North Vietnamese infiltration and logistics. Shortly after, the ship returned to the United States for decommissioning.

In May 1972, the *Taluga* joined the Military Sealift Command (MSC) and was renamed the USNS *Taluga* (T-AO-62). The U.S. Navy began testing the viability of civilian-crewed oilers within the fleet. The *Taluga* participated in the pilot program, Operation "Charter Log II," and the navy hailed it a total success. The small crew, made up of 105 civil service mariners, proved that a civilian crew could perform the same tasks more efficiently and with less capital. The select and highly-trained crew was known as the "Taluga Tigers." Ship operating costs were reduced from \$6.6 million/year to \$3.6 million/year. Additionally, the success of Operation Charger led the navy to transfer additional oilers to MSC for operations in support of the fleet.

In 1976, the *Taluga* underwent an overhaul that enhanced fueling equipment. New kingposts with hose outriggers were added, along with ram tensioners. Electric-hydraulic winches supplanted old steam winches. The fueling points on the starboard side were fitted with 7" hoses and port side stations received dual probe fueling systems. After the overhaul, the ship began servicing the Third Fleet in the eastern Pacific until October 1982. Shortly after that date, the ship was decommissioned.

CONCLUSION

During its service from 1944 to 1982, the *Taluga* received four battle stars during World War II, four battle stars during the Korean War, and twelve during the Vietnam War. The *Taluga* remains noteworthy as an example of a T3-S2-A1 fleet oiler as well as for its transitional role as a civilian oiler that helped promote more civilian-run ships within Military Sealift Command.

APPENDIX A: HISTORIC PHOTOGRAPHS



Figure 1: Aerial photograph of the USS *Taluga* (AO-62), 6 October 1944. Negative #281859, Box 960, Record Group 80, National Archives and Records Administration-College Park, Maryland.



Figure 2: Aerial photograph of the USS *Taluga* (AO-62) off Norfolk, VA, 2 September 1944. Negative #248483 (AO-62), Box 778, Record Group 80, National Archives and Records Administration-College Park, Maryland.



Figure 3: Aerial photograph of the USS *Taluga* (AO-62) refueling the aircraft carrier USS *Hancock* (CVA-19) and the destroyer USS *Ingersoll* (DD-652), 15 May 1962. Negative #1065060, Box 14, 428-GX-AO 62, Record Group 80, National Archives and Records Administration-College Park, Maryland.



Figure 4: The USS *Taluga* (AO-62) refuels the USS *Galveston* (CGL-3), 8 December 1963. Negative #1100763, Box 14, 428-GX-AO 62, Record Group 80, National Archives and Records Administration-College Park, Maryland.



Figure 5: The USS *Taluga* (T-AO-62) refuels the aircraft carrier USS *Kitty Hawk* (CV-63), July 1980. Negative #1179398, Box 14, 428-GX-AO 62, Record Group 80, National Archives and Records Administration-College Park, Maryland.

APPENDIX B: LIST OF T3-S2-A1 OILERS CONSTRUCTED AND THEIR DISPOSITIONS

Yard	Hull #	MC #	Original Name	Delivered	Disposition
Bethlehem	4329	8	<i>Platte</i>	1-Dec-39	To USN 1940 as Platte (AO-24), converted to CVE 27 1942, scrapped 1962
Bethlehem	4330	9	<i>Esso Annapolis</i>	26-Jan-40	To USN 1941 as Chemung (AO- 30), scrapped 1971
Bethlehem	4331	10	<i>Esso Albany</i>	15-Sep-40	To USN 1940 as Sabine (AO- 25), NDRF 1983
Bethlehem	4397	717	<i>Ashtabula</i>	7-Aug-43	To USN as AO-51, sunk as target 2000
Bethlehem	4398	718	<i>Cacapon</i>	21-Sep-43	To USN as AO-52, disposition unknown
Bethlehem	4399	719	<i>Caliente</i>	22-Oct-43	To USN as AO-53, NDRF 1974
Bethlehem	4400	720	<i>Chikaskia</i>	10-Nov-43	To USN as AO-54, NDRF 1982
Bethlehem	4401	721	<i>Elokomina</i>	30-Nov-43	To USN as AO-55, scrapped 1970
Bethlehem	4402	722	<i>Aucilla</i>	22-Dec-43	To USN as AO-56, NDRF 1992
Bethlehem	4403	723	<i>Marias</i>	12-Feb-44	To USN as AO-57, scrapped 1995
Bethlehem	4404	724	<i>Manatee</i>	6-Apr-44	To USN as AO-58, disposition unknown
Bethlehem	4405	725	<i>Mississinewa</i>	18-May-44	To USN as AO-59, torpedoed and lost at Ulithi Island 1944
Bethlehem	4406	726	<i>Nantahala</i>	19-Jun-44	To USN as AO-60, NDRF 1975
Bethlehem	4407	727	<i>Severn</i>	19-Jul-44	To USN as AO-61, NDRF 1975
Bethlehem	4408	728	<i>Taluga</i>	25-Aug-44	To USN as AO-62, NDRF 1999
Bethlehem	4409	729	<i>Chipola</i>	30-Nov-44	To USN as AO-63, NDRF 1974
Bethlehem	4410	730	<i>Tolovana</i>	24-Feb-45	To USN as AO-64, NDRF 1975

Federal	151	5	<i>Markay</i>	Jun-39	To USN 1940 as Suwanee (AO-33), converted to CVE 27 1942, scrapped 1962
Federal	152	6	<i>Neosho</i>	Aug-39	To USN 1939 as Neosho (AO-23), bombed and scuttled off New Guinea 1942
Federal	153	7	<i>Esso Trenton</i>	Dec-39	To USN 1940 as Sangamon (AO-28), converted to CVE 26 1942, scrapped 1960
Newport	370	11	<i>Esso Richmond</i>	4/20/40	To USN 1940 as Kaskasia (AO-27), scrapped 1970
Newport	371	12	<i>Esso Raleigh</i>	6/21/40	To USN 1940 as Guadelupe (AO- 32), scrapped 1975
Newport	372	13	<i>Esso Columbia</i>	4/28/41	To USN 1940 as Salamonie (AO- 26), scrapped 1971
Sun D&D	172	2	<i>Cimarron</i>	3/20/1939	To USN 1939 as Cimarron (AO-22), scrapped 1969
Sun D&D	173	3	<i>Seakay</i>	3/23/1939	To USN 1939 as Santee (AO-29), converted to CVE 29 1942, scrapped 1960
Sun D&D	174	4	<i>Esso New Orleans</i>	4/14/1939	To USN 1938 as Chenango (AO- 31), converted to CVE 28 1942, scrapped 1962
Bethlehem	4436	2559	<i>Allagash</i>	21-Aug-45	To USN as AO-97, NDRF 1976
Bethlehem	4437	2560	<i>Caloosahatchee</i>	10-Oct-45	To USN as AO-98, jumboized 1966, NDRF 1998, scrapped 2003
Bethlehem	4438	2561	<i>Canisteo</i>	3-Dec-45	To USN as AO-99, jumboized 1966, NDRF 1998, scrapped 2003
Bethlehem	4439	2562	<i>Chukawan</i>	22-Jan-46	To USN as AO-100, scrapped 1973

BIBLIOGRAPHY

Books

Cudahy, Brian J. *Box Boats: How Container Ships Changed the World*. New York, NY: Fordham University Press, 2006.

De La Pedraja, René. *A Historical Dictionary of the U.S. Merchant Marine and Shipping Industry since the Introduction of Steam*. Westport, CT: Greenwood Press, 1994.

George, James L. *History of Warships: From Ancient Times to the Twenty-First Century*. Annapolis, MD: Naval Institute Press, 1998.

Lane, Frederic C. *Ships for Victory: A History of Shipbuilding under the U.S. Maritime Commission in World War II*. Baltimore, MD: The Johns Hopkins Press, 1951.

Sawyer, L.A. and W.H. Mitchell. *From America to the United States: The History of the Merchant Ship Types Built in the United States of America under the Long-Range Programme of the Maritime Commission*. Kendal, UK: World Shipping Society, 1979.

_____. *Victory Ships and Tankers: The History of the 'Victory' Type Cargo Ships and of the Tankers Built in the United States of America during World War II*. Cambridge, MD: Cornell Maritime Press, Inc., 1974.

U.S. Navy. *Dictionary of American Naval Fighting Ships*. Vol. VII. Washington, DC: Naval Historical Center, 1991.

_____. *Ships' Data, U.S. Naval Vessels: Vol. III Auxiliary, District Craft and Unclassified Vessels*. Washington, DC: Government Printing Office, 1946.

Articles

Bussey, A.S. "Skillful Techniques Developed in Replenishment at Sea." *Bureau of Ships Journal* 7 (July 1952): pp. 30-32.

Wildenberg, Thomas. "The Origins and Development of the T2 Tanker." *American Neptune* (Summer 1992), pp. 155-166.

Public Documents

Booklet of General Plans (AO-62). Record Group 19, National Archives and Records Administration-College Park, Maryland.

HISTORIC AMERICAN ENGINEERING RECORD

INDEX TO PHOTOGRAPHS

TALUGA
(AO-62)
Suisun Bay Reserve Fleet
Benicia vicinity
Solano County
California

View aft of stack from port side
UNREP station, looking forward.
Weather deck, looking forward
View of bow with helipad.
Forward midsection deck.
Detail of midsection deck.

HAER CA-336

INDEX TO BLACK AND WHITE PHOTOGRAPHS

Jet Lowe, photographer, January 2006

CA-336-1 Bow with steam-powered anchor windlass.
CA-336-2 Windlass and bow, looking straight forward.
CA-336-3 Forward cargo deck and helipad from above pilothouse. Mast is missing its boom.
CA-336-4 Forward cargo deck and pilothouse.
CA-336-5 Starboard cargo deck with tank hatches and distribution system.
CA-336-6 Underside of helipad with forward cargo deck in background. Note two cargo hatches at center. Looking aft.
CA-336-7 View aft across midship cargo deck from above pilothouse. Signal box in foreground.
CA-336-8 Looking aft across midship cargo deck. Underway replenishment (UNREP) tower in foreground with tensioning ram.
CA-336-9 Detail of kingpost with ram tensioner for UNREP system. The ram tensioner operates with compressed air.
CA-336-10 View forward of midship cargo deck from atop engine room on starboard side. Base for the newer kingpost is in foreground and winches are on the right side.

TALUGA
HAER CA-336
INDEX TO PHOTOGRAPHS

CA-336-11	View aft of stack from port side.
CA-336-12	UNREP station, looking forward.
CA-336-13	Weather deck, looking forward.
CA-336-14	View of bow with helipad.
CA-336-15	Forward midsection deck.
CA-336-16	Detail of midsection deck.
CA-336-17	Midship deck. Forms a sequential panorama with HAER Nos. CA-336-18 and CA-336-19.
CA-336-18	Mid-section deck. Forms a sequential panorama with HAER Nos. CA-336-17 and CA-336-19.
CA-336-19	Aft section. Forms a sequential panorama with HAER Nos. CA-336-17 and CA-336-18.
CA-336-20	Aft section.
CA-336-21	Upper midsection.
CA-336-22	Upper right.
CA-336-23	Bridge.
CA-336-24	Stern view.
CA-336-25	Bridge interior, looking aft.
CA-336-26	Cargo officers room. Note analog computer on wall for allocating cargo loads.
CA-336-27	Detail of stress computer in cargo officers room.
CA-336-28	Steering gear, looking to port.
CA-336-29	Galley, looking to port.
CA-336-30	Yeoman's berth.
CA-336-31	Cargo tank, hatch detail.
CA-336-32	Cargo hatch, pipes forward of bridge.
CA-336-33	View aft and starboard of tank hatch and distribution valves, main line in background.
CA-336-34	Piping for oil transfer and loading on weather deck.

TALUGA
HAER CA-336
INDEX TO PHOTOGRAPHS

- CA-336-35 Winches on mid-section.
- CA-336-36 Stern.
- CA-336-37 Port stern.
- CA-336-38 Bow profile.
- CA-336-39 3/4 view of bow from port.
- CA-336-40 Bow 7/8 starboard.

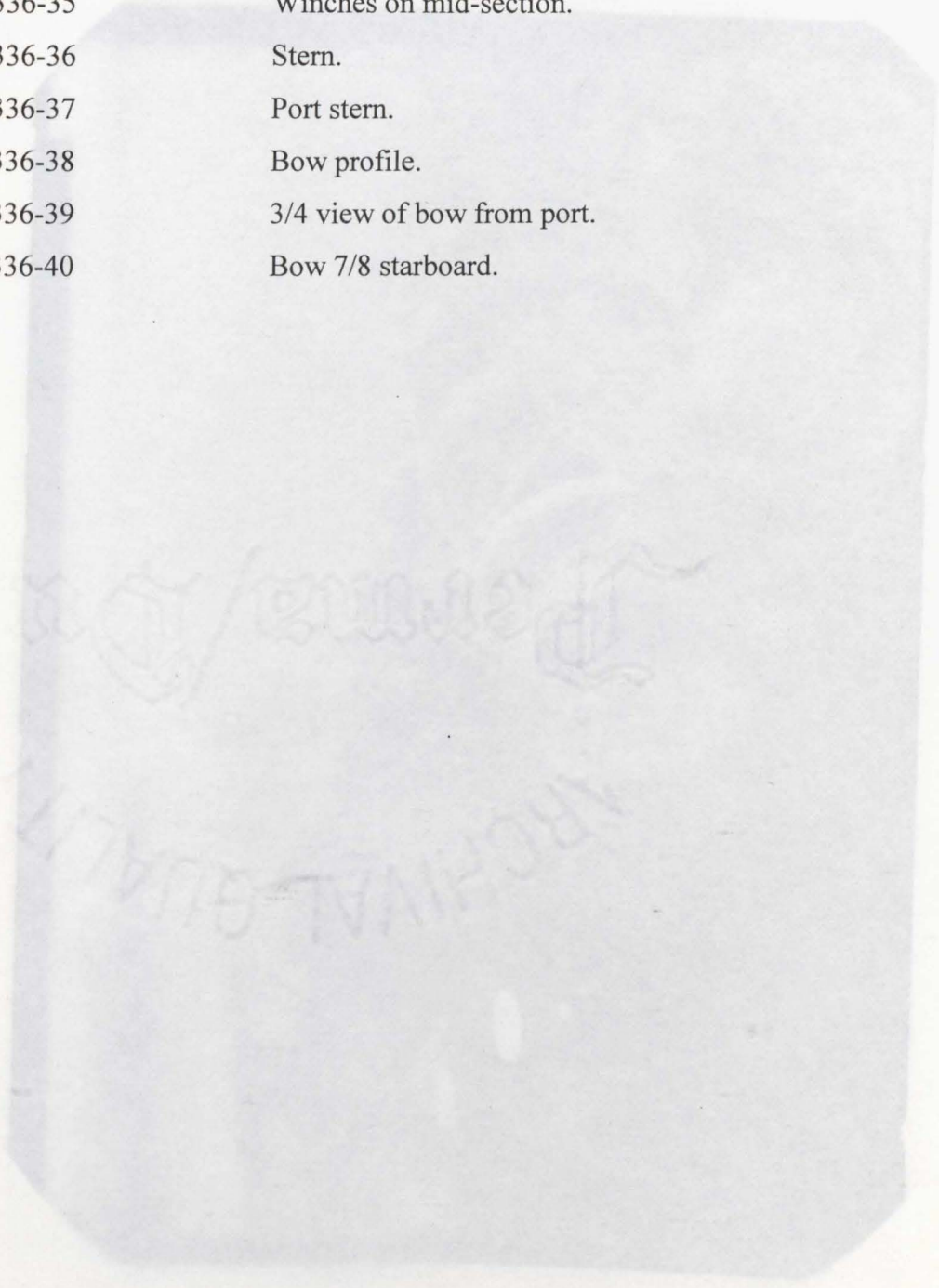

HISTORIC AMERICAN ENGINEERING RECORD
SEE INDEX TO PHOTOGRAPHS FOR CAPTION

HAER No. CA-336-1

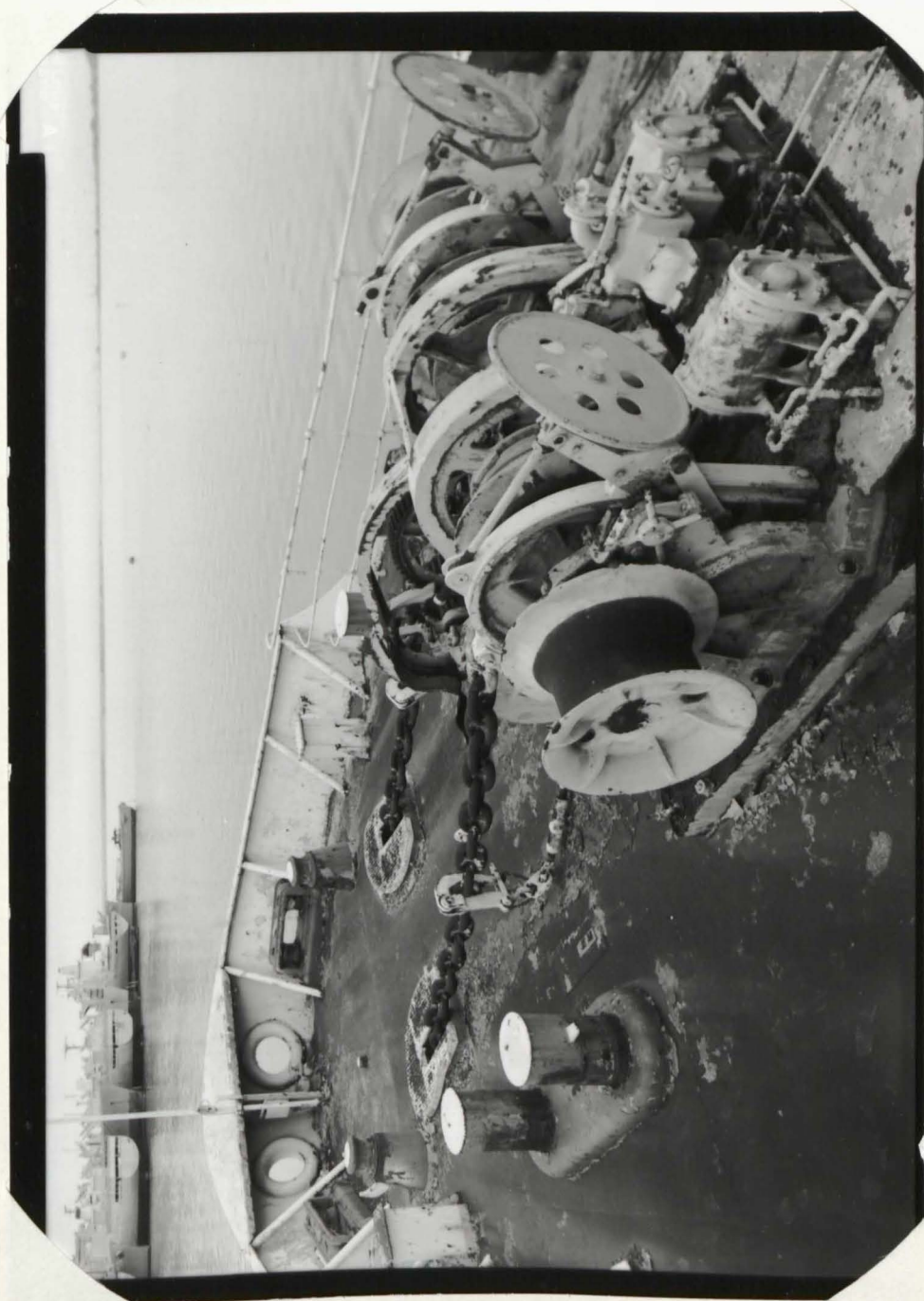

HISTORIC AMERICAN ENGINEERING RECORD
SEE INDEX TO PHOTOGRAPHS FOR CAPTION

HAER No. CA-336-2

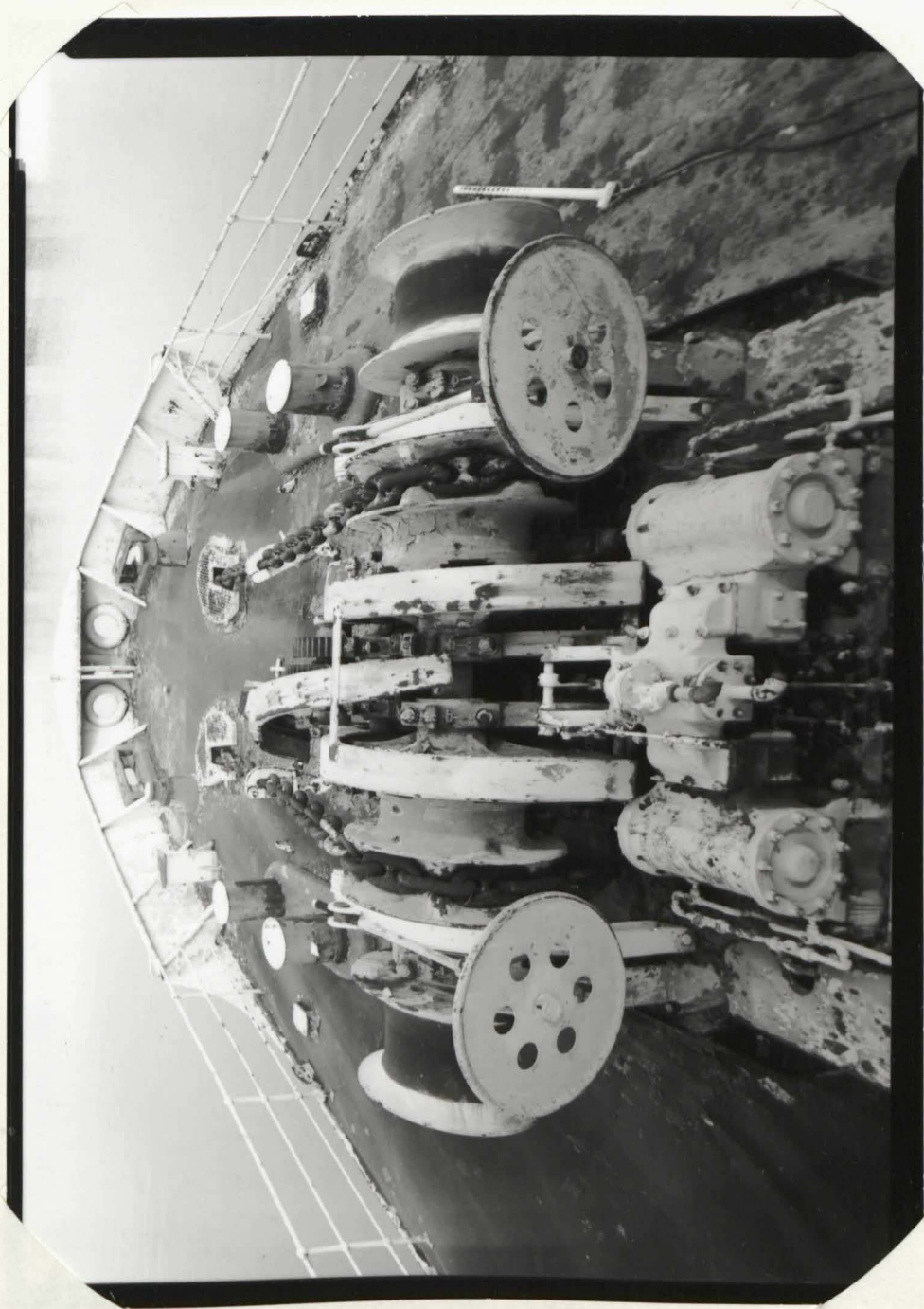

HISTORIC AMERICAN ENGINEERING RECORD
SEE INDEX TO PHOTOGRAPHS FOR CAPTION

HAER No. CA-336-3



HISTORIC AMERICAN ENGINEERING RECORD
SEE INDEX TO PHOTOGRAPHS FOR CAPTION

HAER No. CA-336-4



HISTORIC AMERICAN ENGINEERING RECORD
SEE INDEX TO PHOTOGRAPHS FOR CAPTION

HAER No. CA-336-5



HISTORIC AMERICAN ENGINEERING RECORD
SEE INDEX TO PHOTOGRAPHS FOR CAPTION

HAER No. CA-336-6



HISTORIC AMERICAN ENGINEERING RECORD
SEE INDEX TO PHOTOGRAPHS FOR CAPTION

HAER No. *CA-336-7*

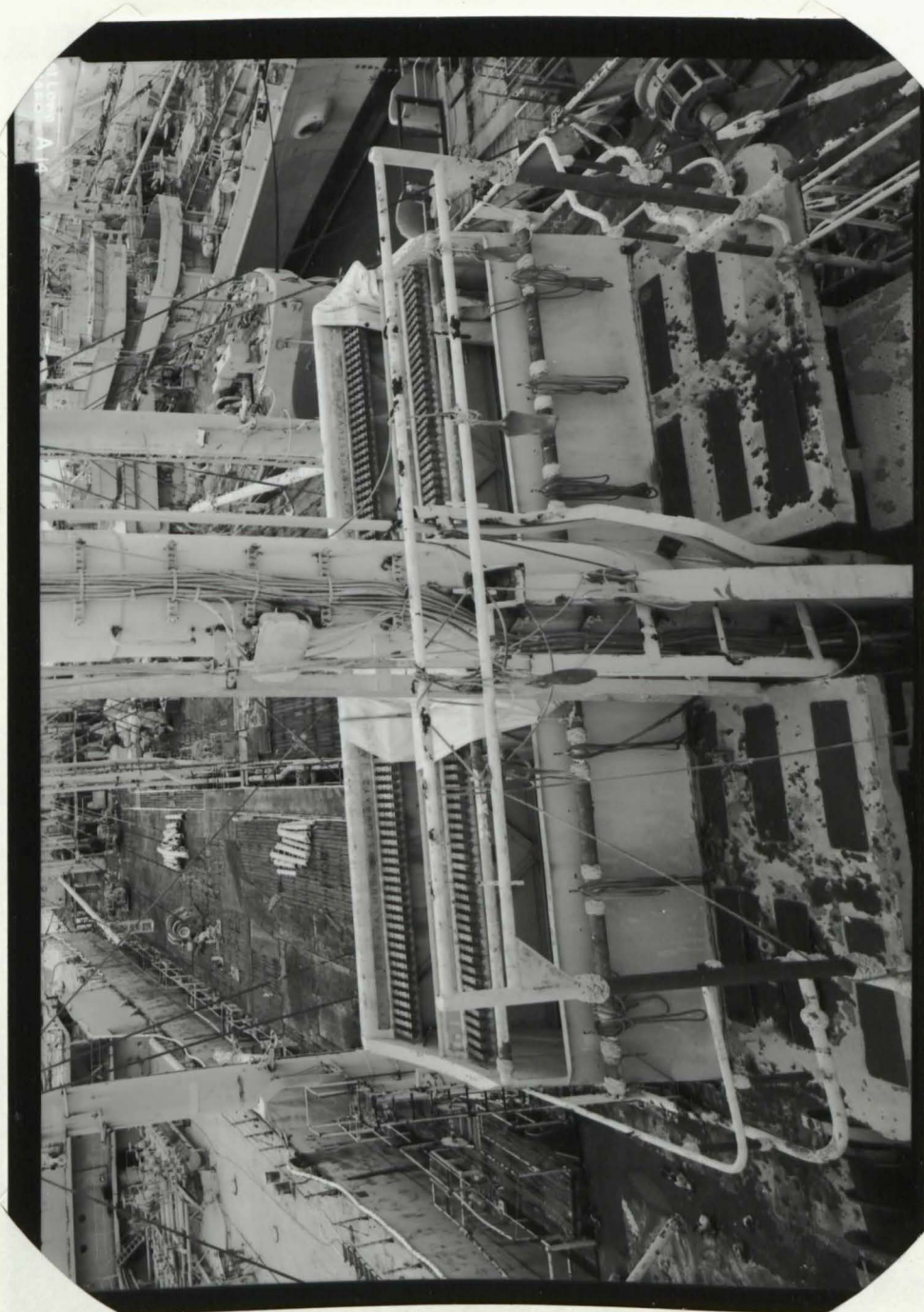

HISTORIC AMERICAN ENGINEERING RECORD
SEE INDEX TO PHOTOGRAPHS FOR CAPTION

HAER No. CA-336-8



HISTORIC AMERICAN ENGINEERING RECORD
SEE INDEX TO PHOTOGRAPHS FOR CAPTION

HAER No. CA-336-9



HISTORIC AMERICAN ENGINEERING RECORD
SEE INDEX TO PHOTOGRAPHS FOR CAPTION

HAER No. CA-336-10

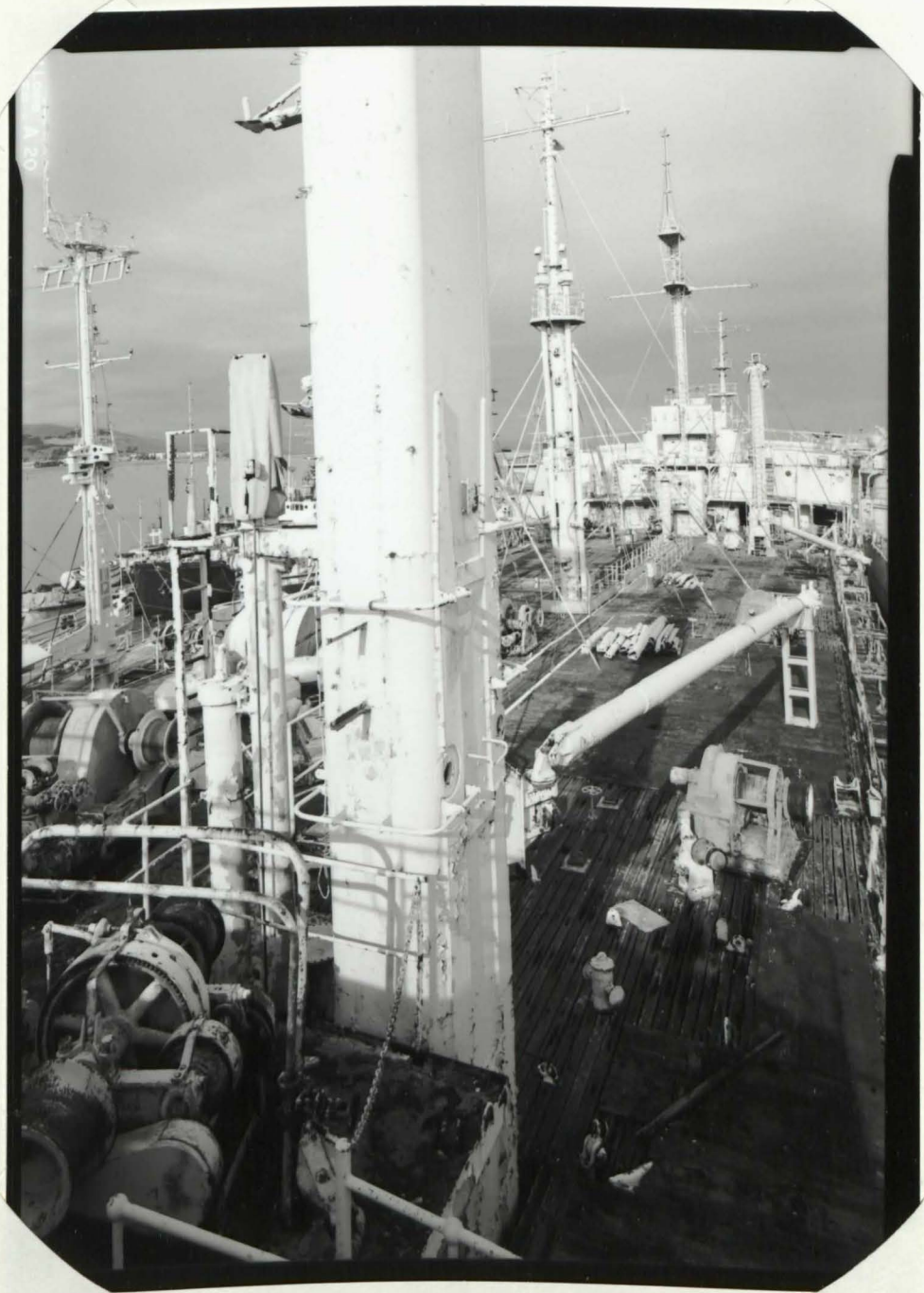

HISTORIC AMERICAN ENGINEERING RECORD
SEE INDEX TO PHOTOGRAPHS FOR CAPTION

HAER No. CA-336-11



HISTORIC AMERICAN ENGINEERING RECORD
SEE INDEX TO PHOTOGRAPHS FOR CAPTION

HAER No. CA-336-12



ALLOTT
NUMBER A 23

HISTORIC AMERICAN ENGINEERING RECORD
SEE INDEX TO PHOTOGRAPHS FOR CAPTION

HAER No. CA-336-13



1000 A 206

HISTORIC AMERICAN ENGINEERING RECORD
SEE INDEX TO PHOTOGRAPHS FOR CAPTION

HAER No. CA-336-14



HISTORIC AMERICAN ENGINEERING RECORD
SEE INDEX TO PHOTOGRAPHS FOR CAPTION

HAER No. CA-336-15



HISTORIC AMERICAN ENGINEERING RECORD
SEE INDEX TO PHOTOGRAPHS FOR CAPTION

HAER No. CA-336-16

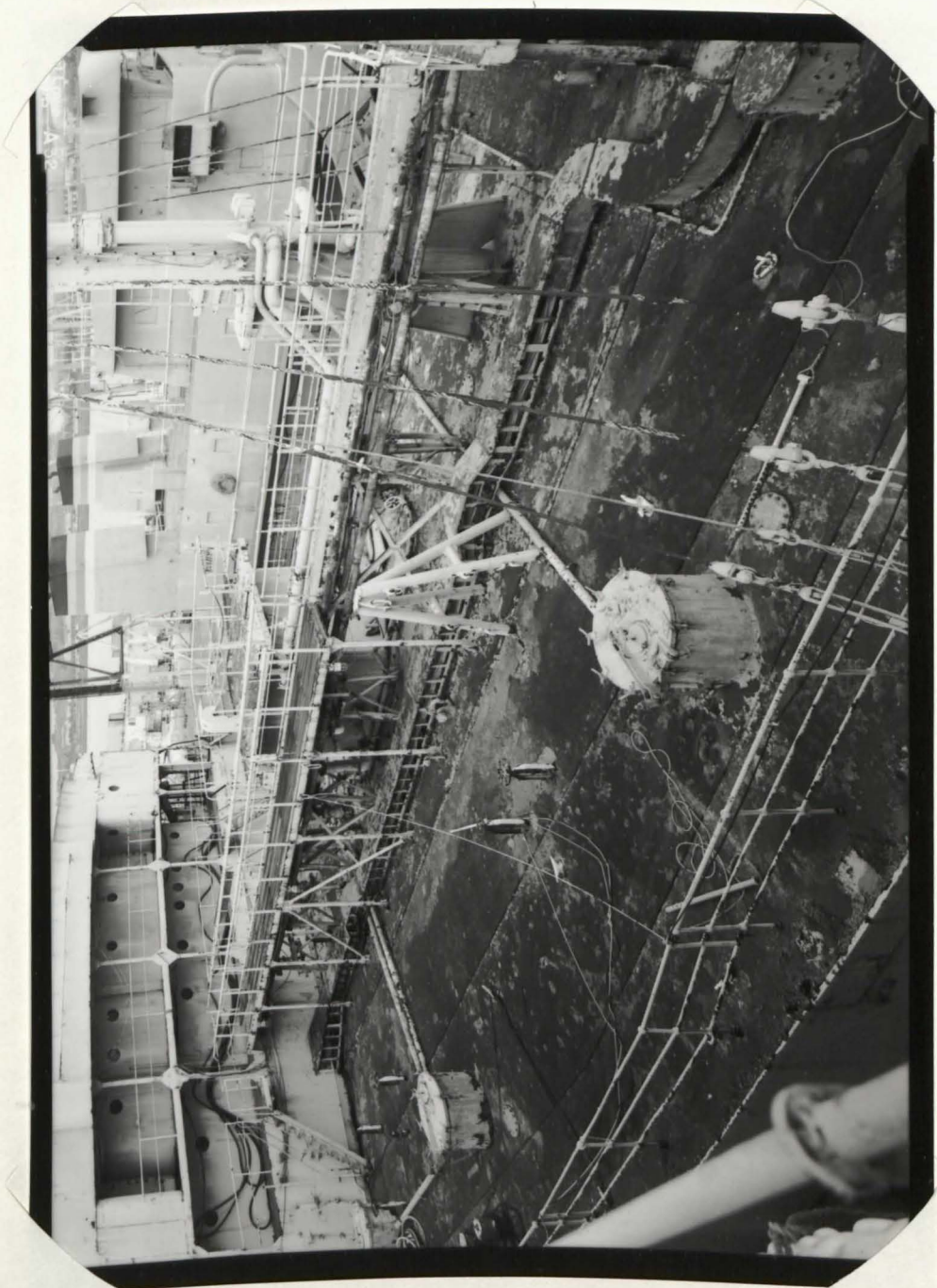

HISTORIC AMERICAN ENGINEERING RECORD
SEE INDEX TO PHOTOGRAPHS FOR CAPTION

HAER No. CA-336-17



HISTORIC AMERICAN ENGINEERING RECORD
SEE INDEX TO PHOTOGRAPHS FOR CAPTION

HAER No. CA-336-18

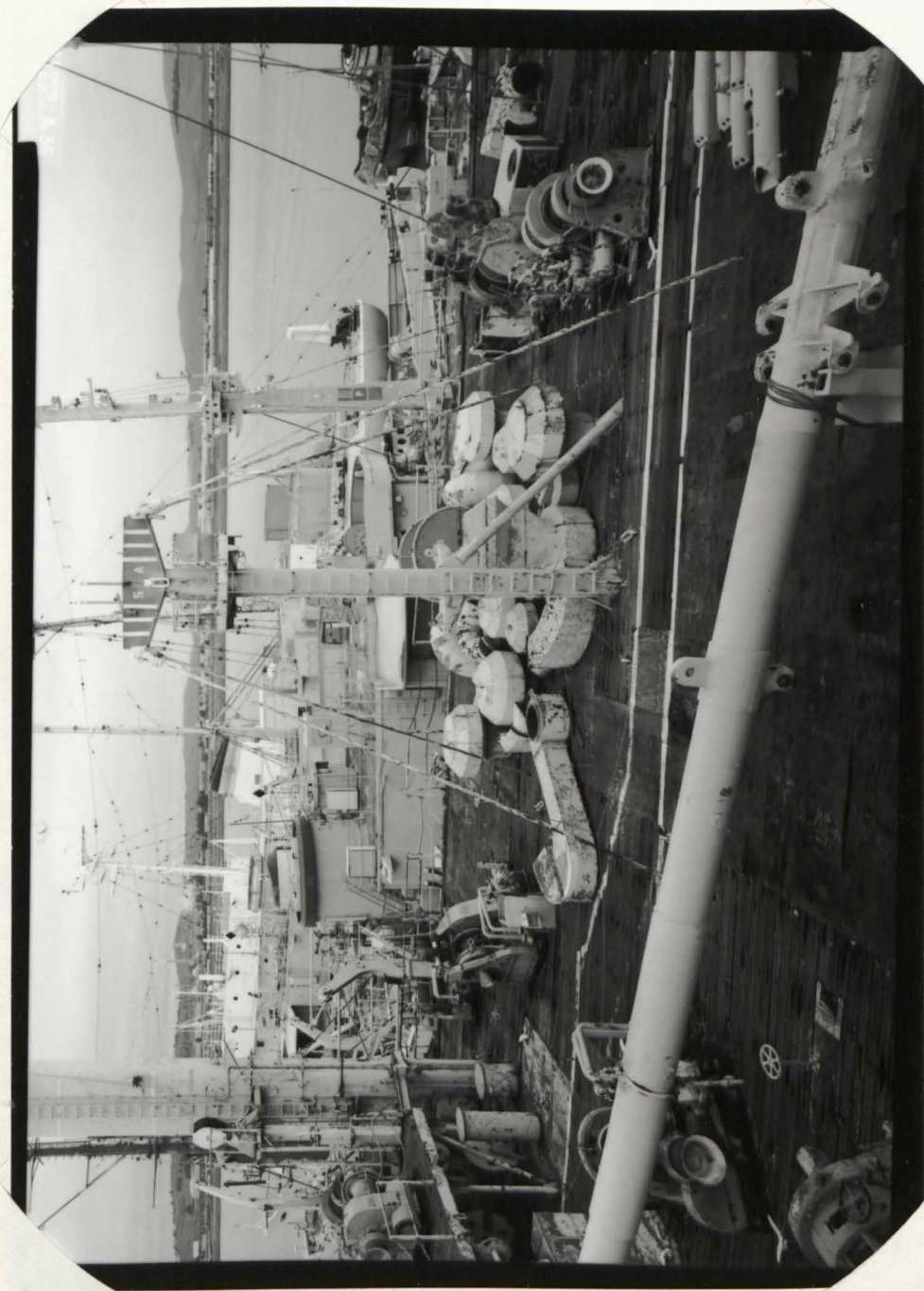

HISTORIC AMERICAN ENGINEERING RECORD
SEE INDEX TO PHOTOGRAPHS FOR CAPTION

HAER No. CA-336-19

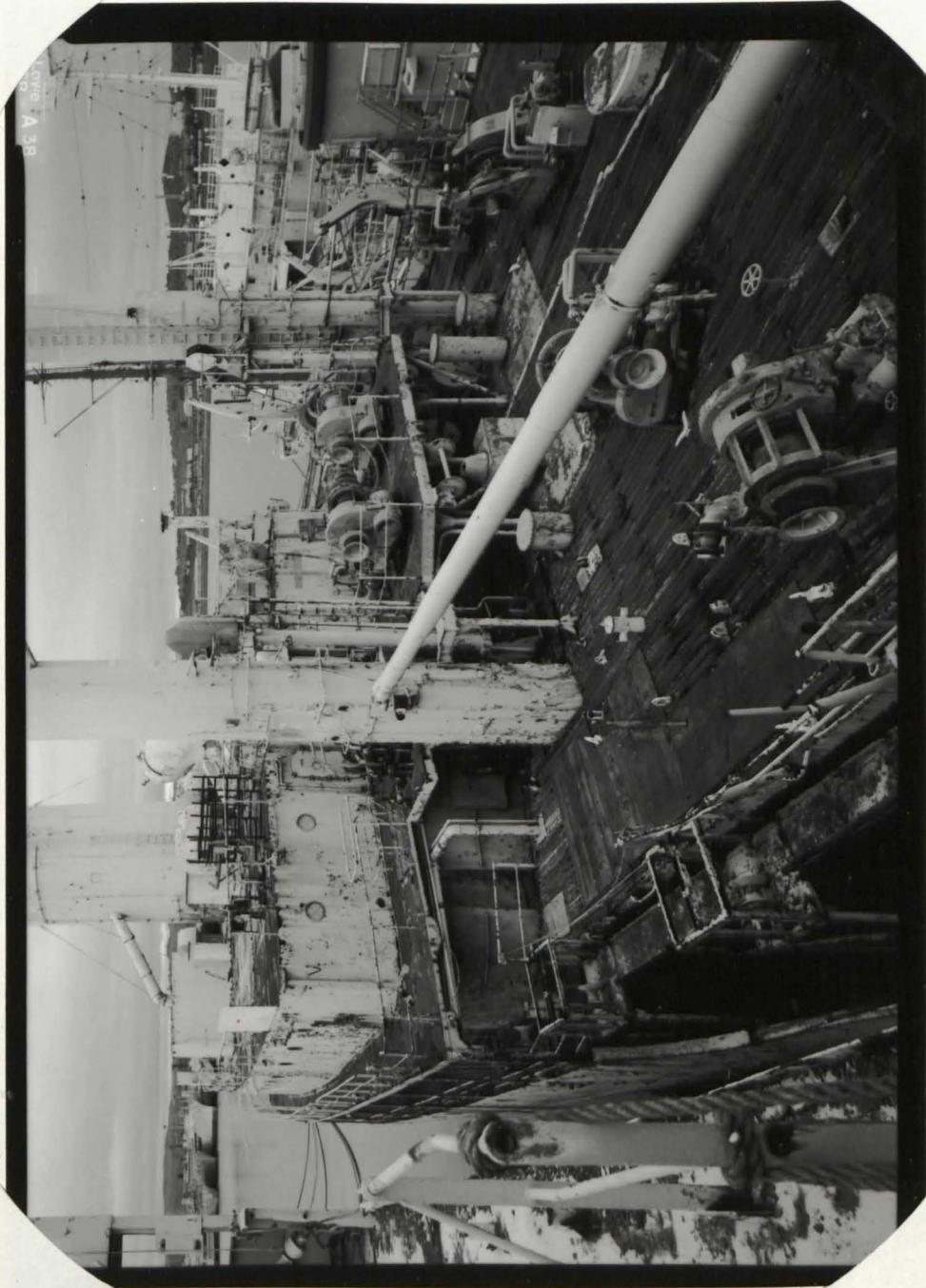

HISTORIC AMERICAN ENGINEERING RECORD
SEE INDEX TO PHOTOGRAPHS FOR CAPTION

HAER No. CA-336-20

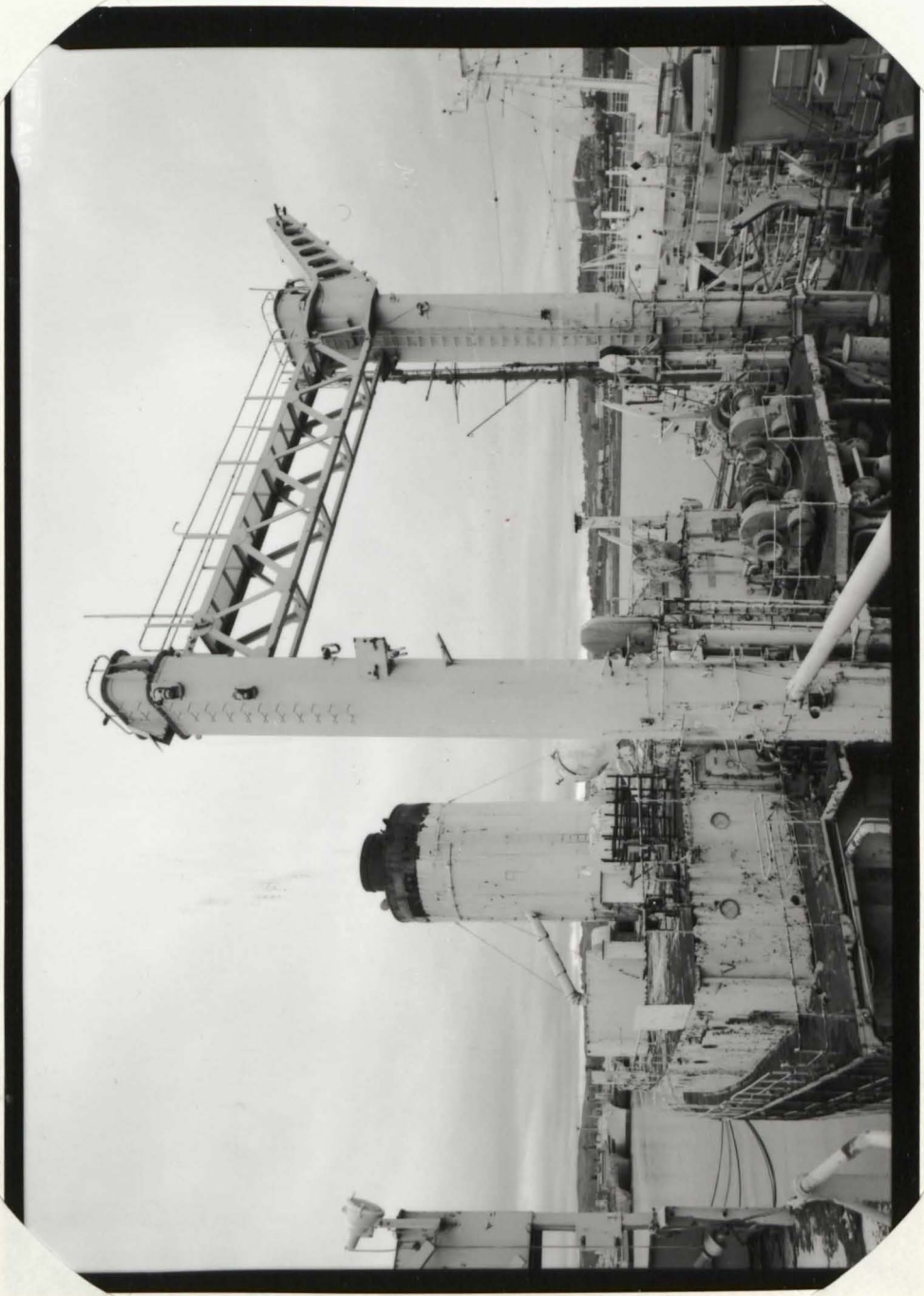

HISTORIC AMERICAN ENGINEERING RECORD
SEE INDEX TO PHOTOGRAPHS FOR CAPTION

HAER No. CA-336-21



15
A 41

HISTORIC AMERICAN ENGINEERING RECORD
SEE INDEX TO PHOTOGRAPHS FOR CAPTION

HAER No. CA-336-22

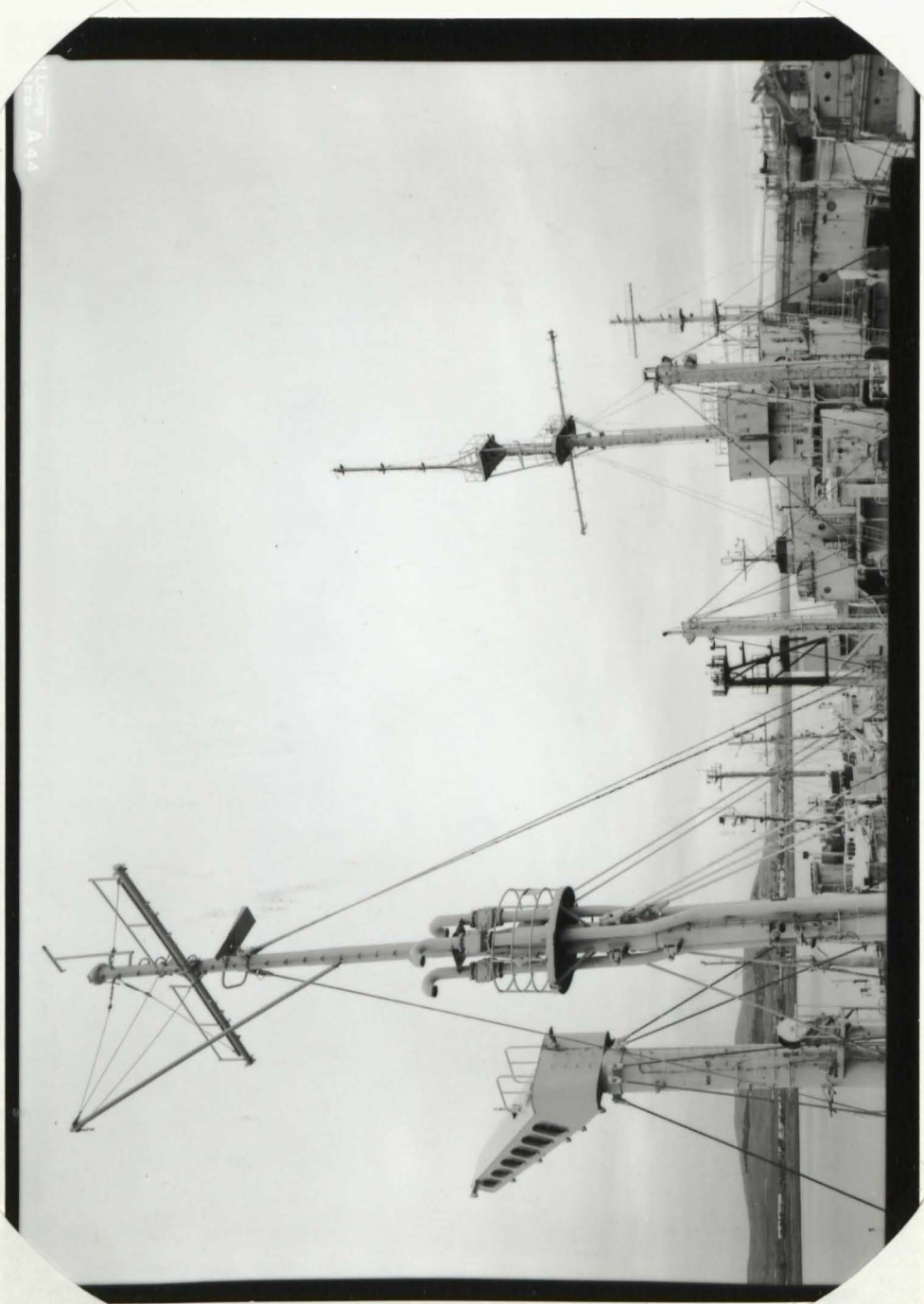

HISTORIC AMERICAN ENGINEERING RECORD
SEE INDEX TO PHOTOGRAPHS FOR CAPTION

HAER No. CA-336-23

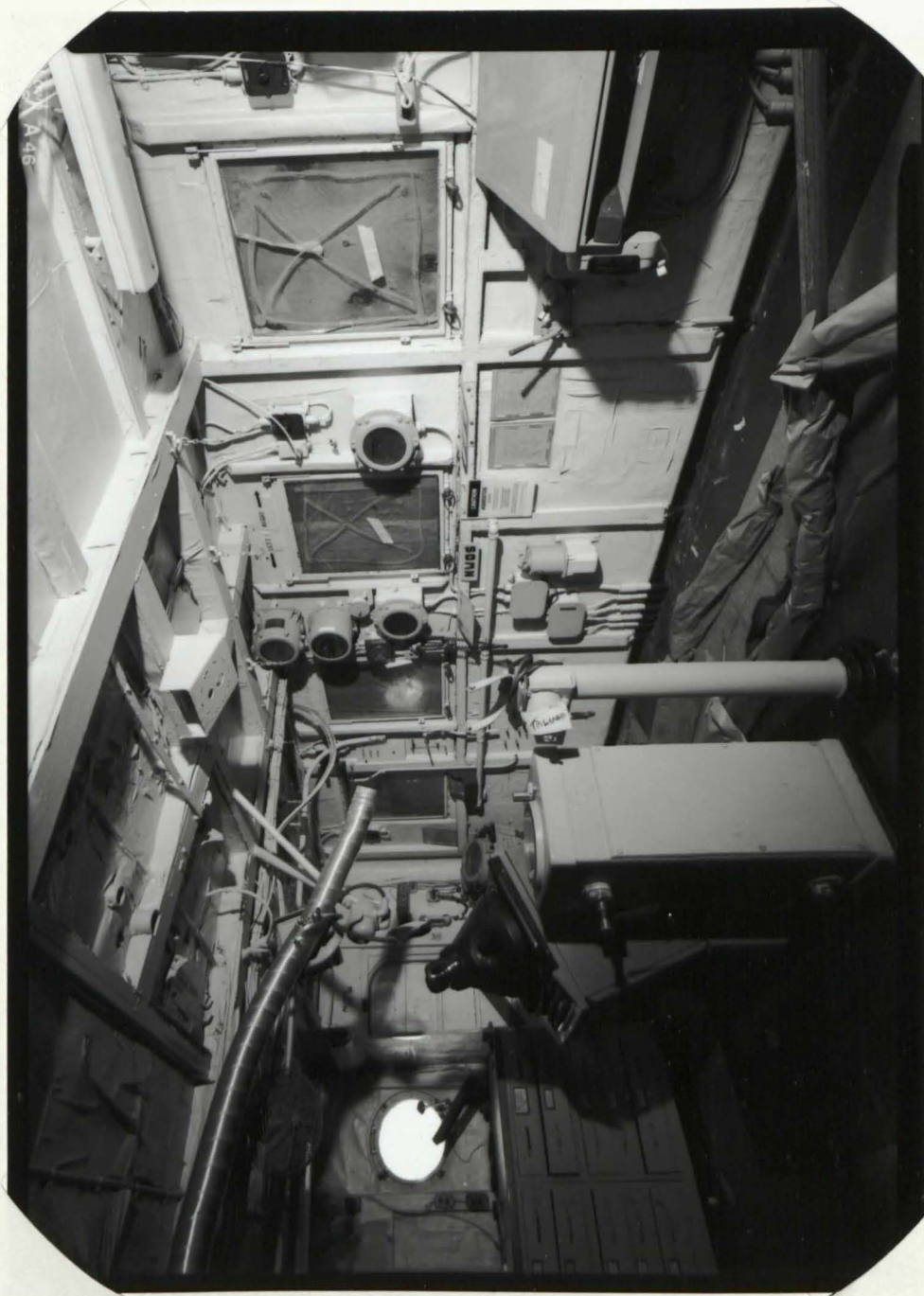

HISTORIC AMERICAN ENGINEERING RECORD
SEE INDEX TO PHOTOGRAPHS FOR CAPTION

HAER No. CA-336-24



HISTORIC AMERICAN ENGINEERING RECORD
SEE INDEX TO PHOTOGRAPHS FOR CAPTION

HAER No. CA-336-25

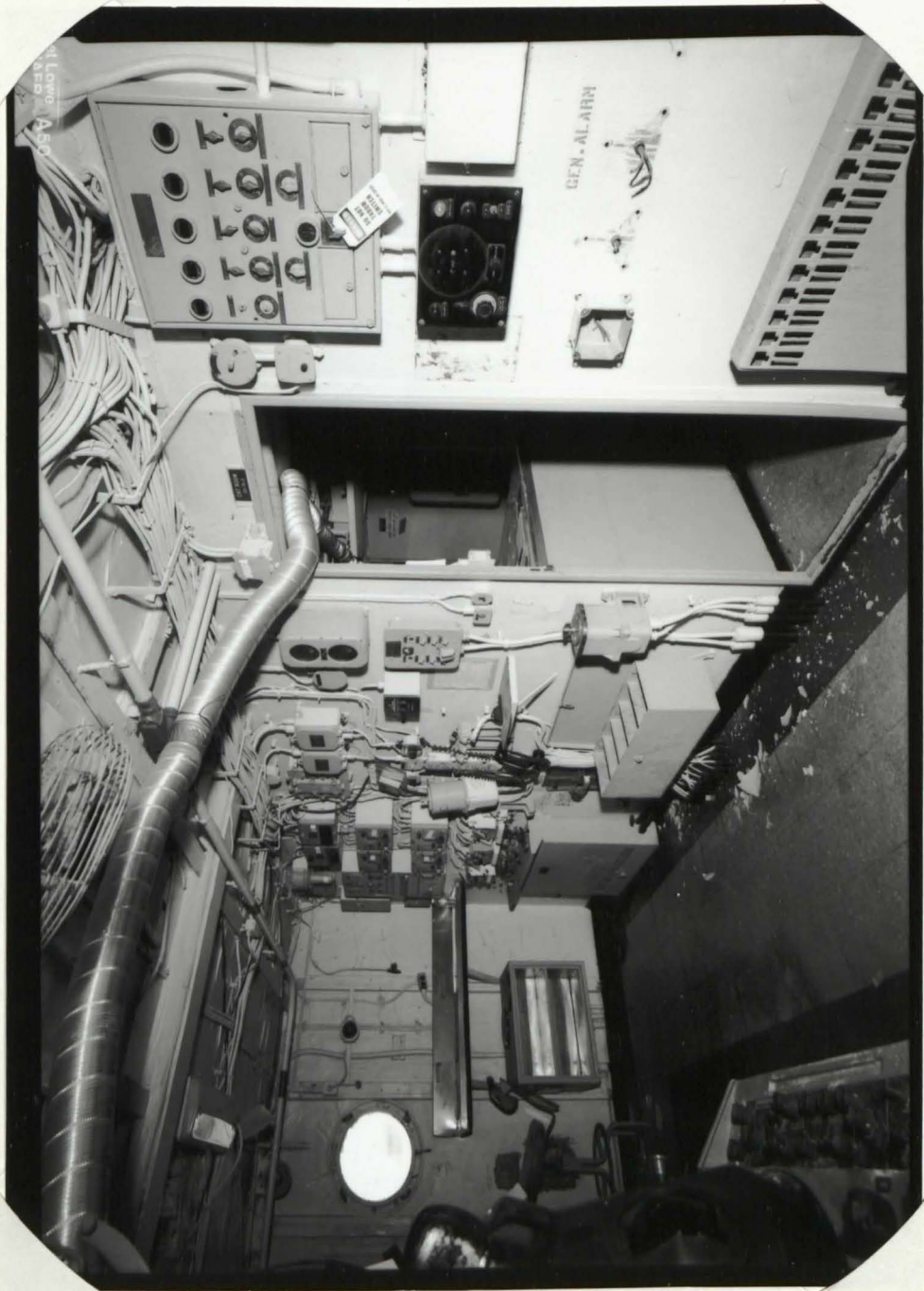

HISTORIC AMERICAN ENGINEERING RECORD
SEE INDEX TO PHOTOGRAPHS FOR CAPTION

HAER No. CA-336-26



HISTORIC AMERICAN ENGINEERING RECORD
SEE INDEX TO PHOTOGRAPHS FOR CAPTION

HAER No. *CA-336-27*

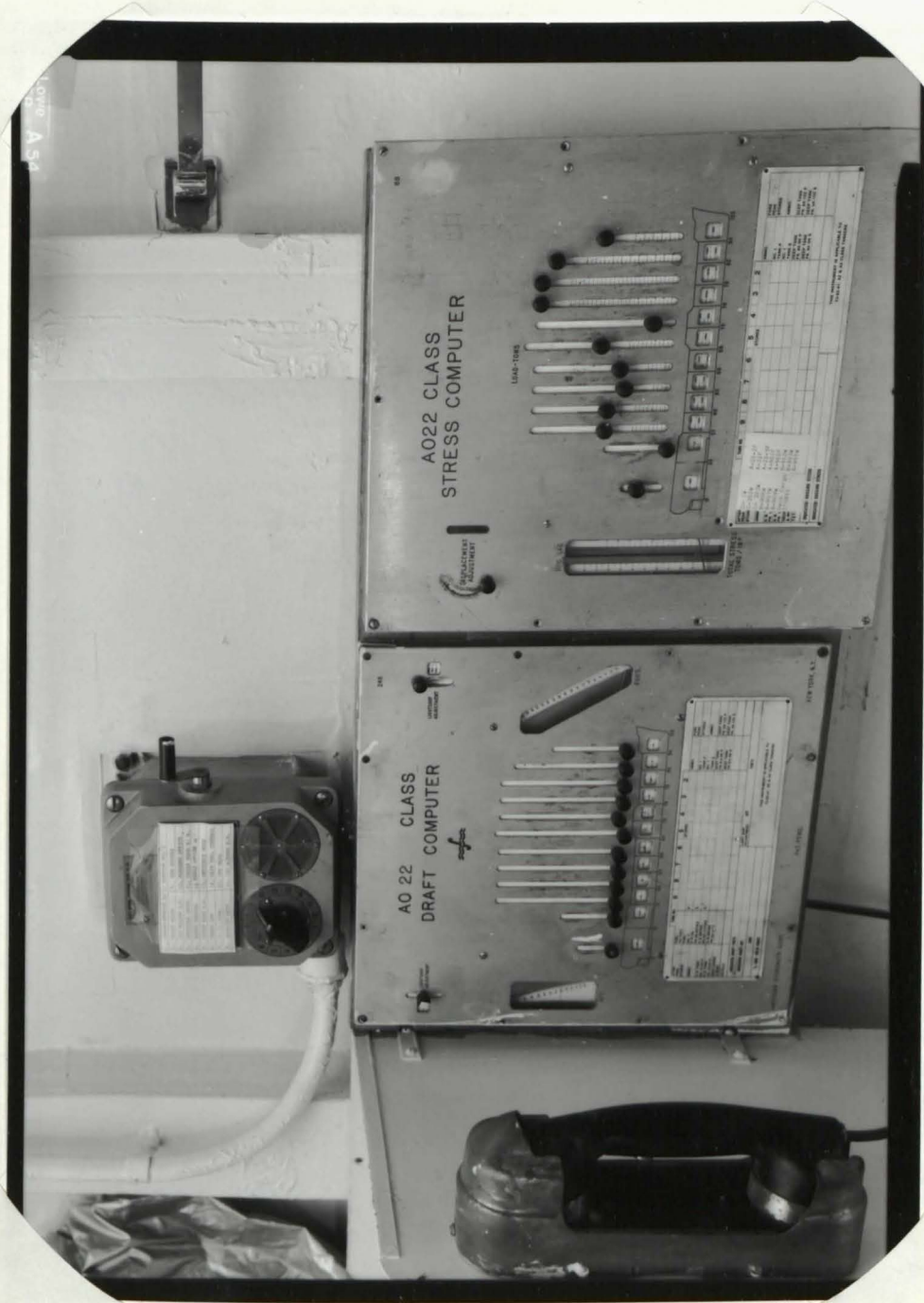

HISTORIC AMERICAN ENGINEERING RECORD
SEE INDEX TO PHOTOGRAPHS FOR CAPTION

HAER No. CA-33628

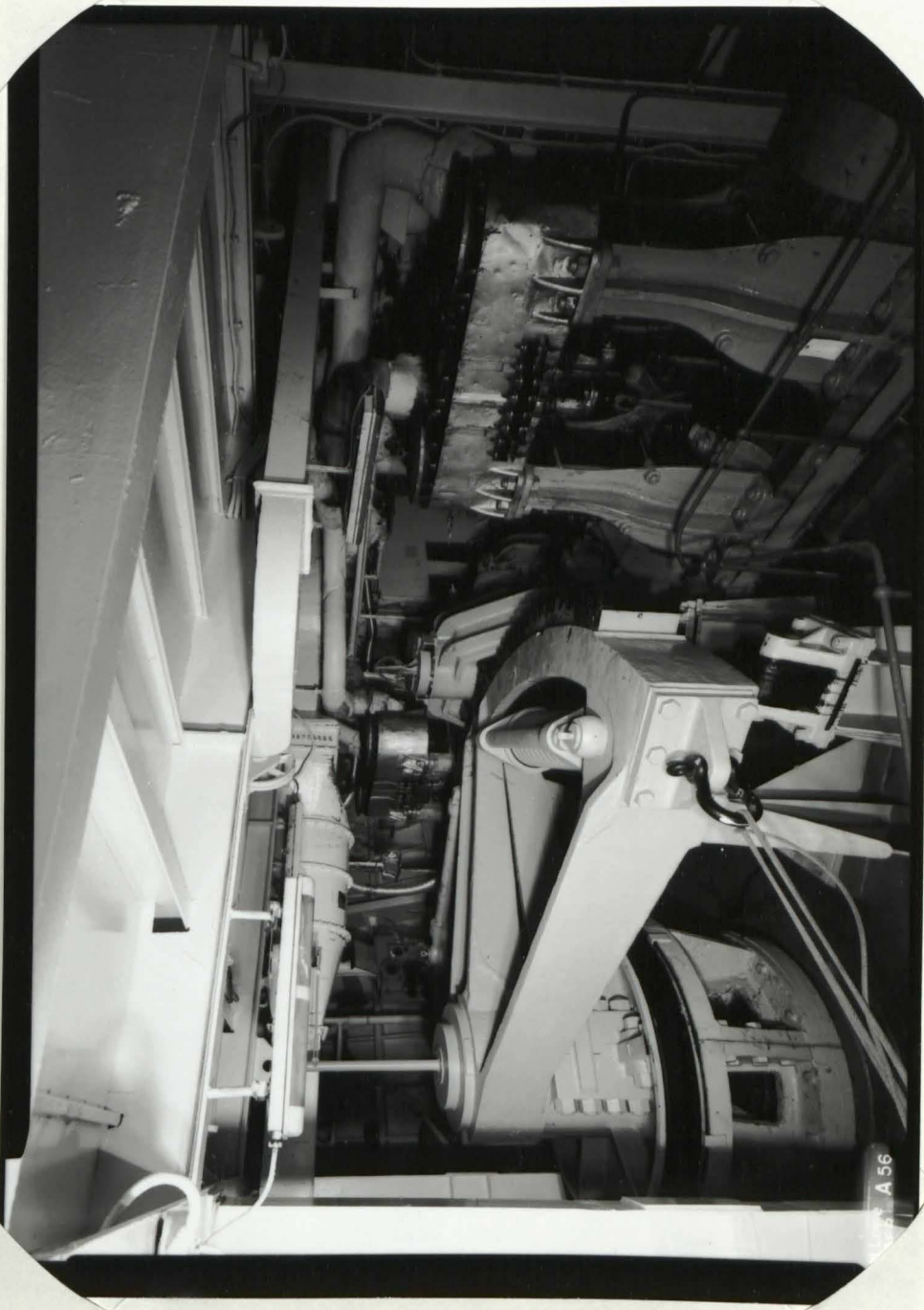

100 A 56

HISTORIC AMERICAN ENGINEERING RECORD
SEE INDEX TO PHOTOGRAPHS FOR CAPTION

HAER No. CA-336-29



HISTORIC AMERICAN ENGINEERING RECORD
SEE INDEX TO PHOTOGRAPHS FOR CAPTION

HAER No. CA-336-30

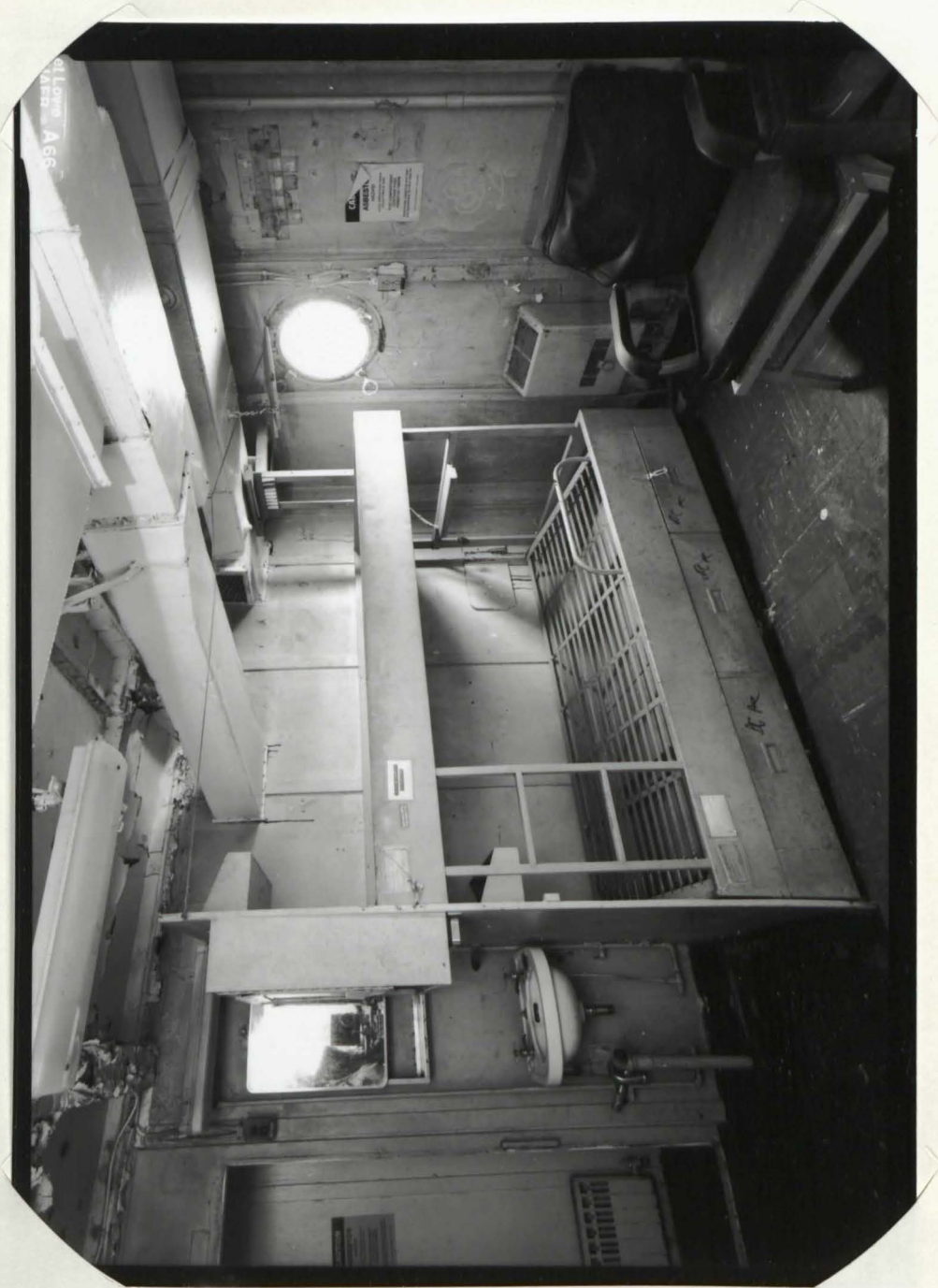

HISTORIC AMERICAN ENGINEERING RECORD
SEE INDEX TO PHOTOGRAPHS FOR CAPTION

HAER No. CA-336-31



HISTORIC AMERICAN ENGINEERING RECORD
SEE INDEX TO PHOTOGRAPHS FOR CAPTION

HAER No. 40-62-32



HISTORIC AMERICAN ENGINEERING RECORD
SEE INDEX TO PHOTOGRAPHS FOR CAPTION

HAER No. CA-336-33

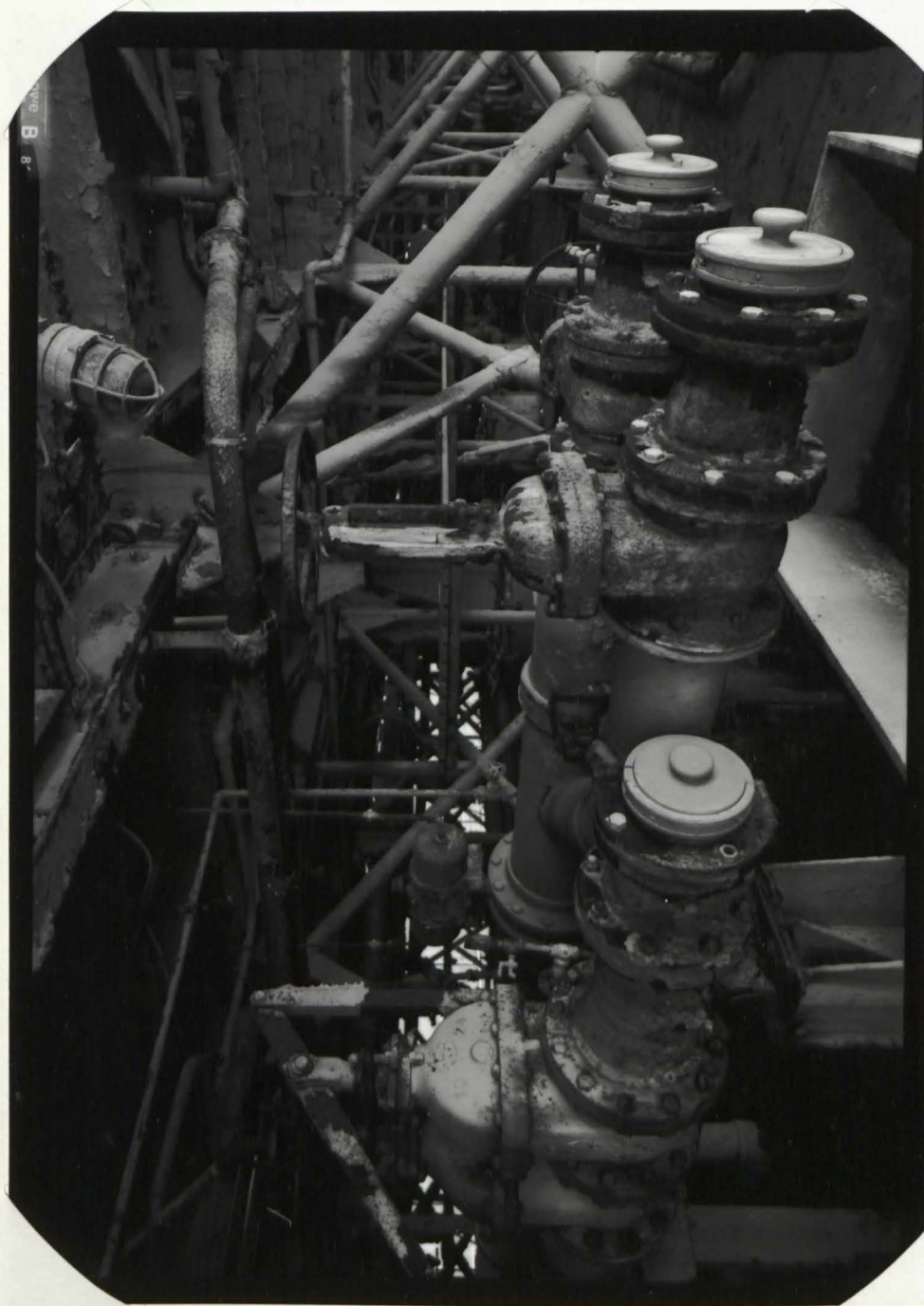

HISTORIC AMERICAN ENGINEERING RECORD
SEE INDEX TO PHOTOGRAPHS FOR CAPTION

HAER No. CA-336-34

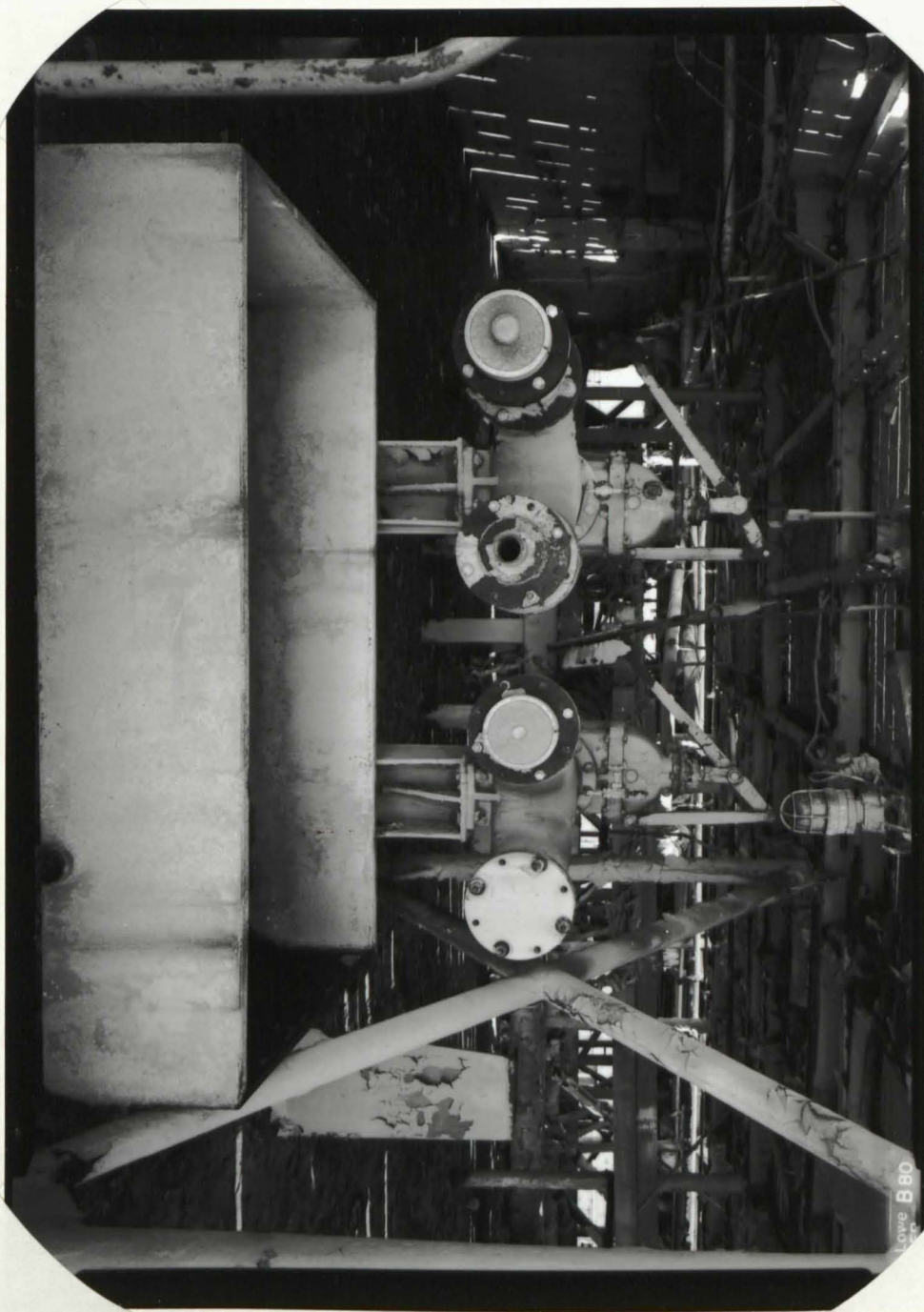

Lowe B 80

HISTORIC AMERICAN ENGINEERING RECORD
SEE INDEX TO PHOTOGRAPHS FOR CAPTION

HAER No. CA-336-35



HISTORIC AMERICAN ENGINEERING RECORD
SEE INDEX TO PHOTOGRAPHS FOR CAPTION

HAER No. CA-336-36

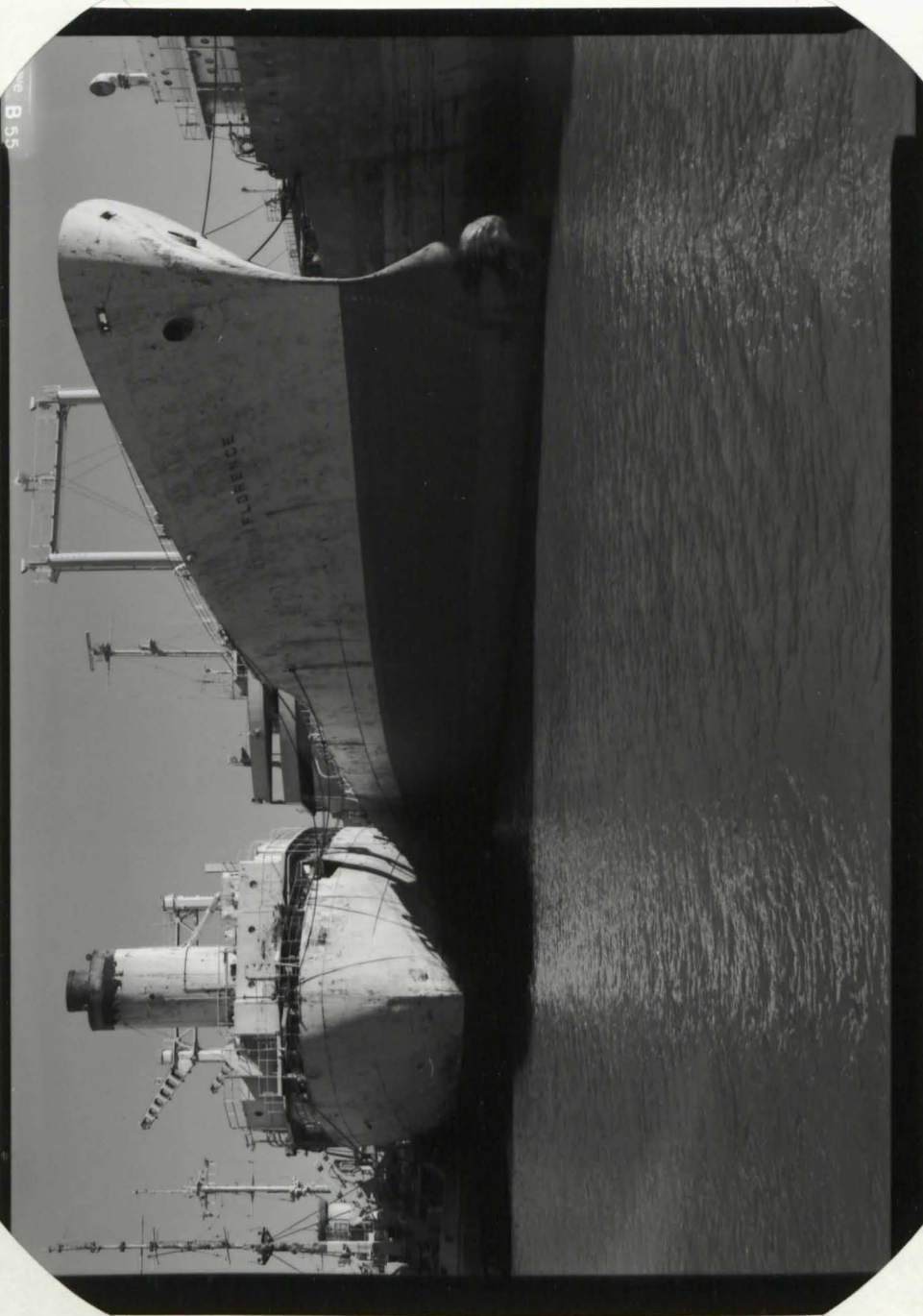

HISTORIC AMERICAN ENGINEERING RECORD
SEE INDEX TO PHOTOGRAPHS FOR CAPTION

HAER No. CA-336-37



15
8
51

HISTORIC AMERICAN ENGINEERING RECORD
SEE INDEX TO PHOTOGRAPHS FOR CAPTION

HAER No. *CA-336-38*



HISTORIC AMERICAN ENGINEERING RECORD
SEE INDEX TO PHOTOGRAPHS FOR CAPTION

HAER No. CA-336-40



Saugatuck

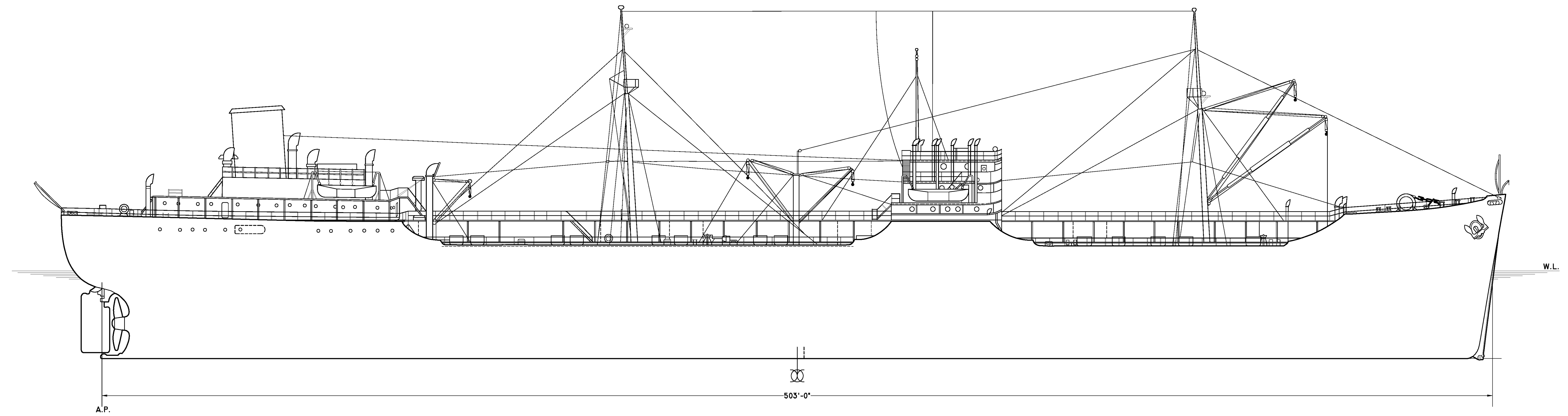

OUTBOARD PROFILE

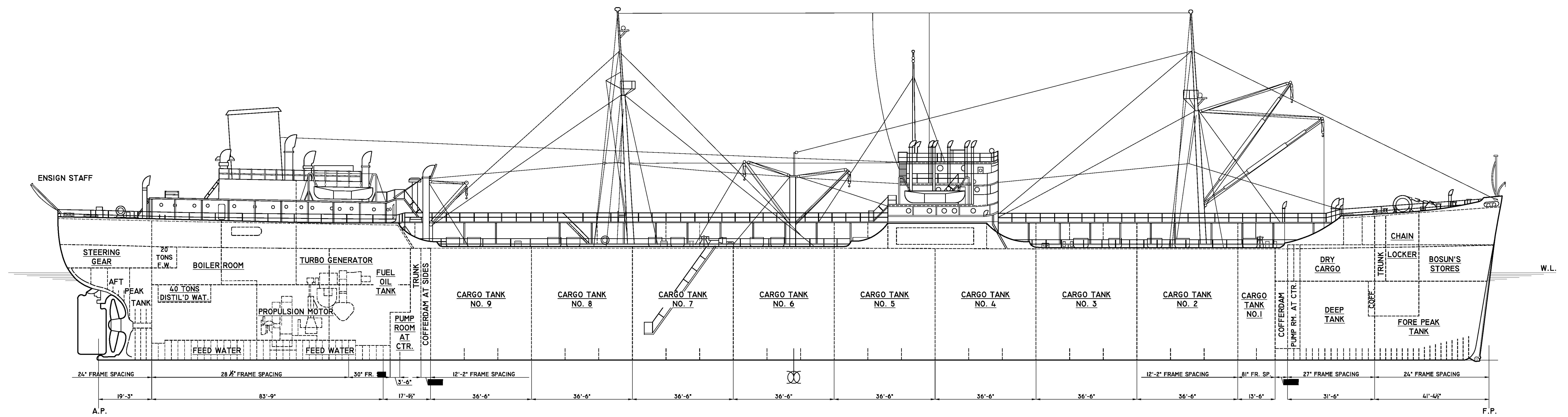

INBOARD PROFILE

NOTE: DRAWINGS TRACED FROM SCANS PROVIDE BY THE MARITIME ADMINISTRATION NATIONAL MUSEUM

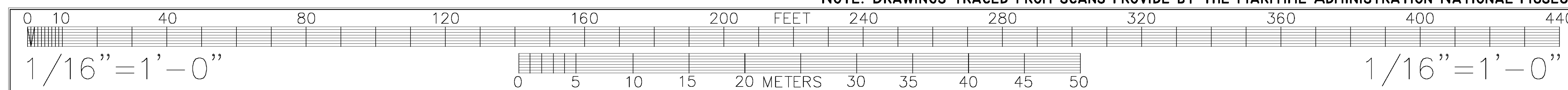

Saugatuck

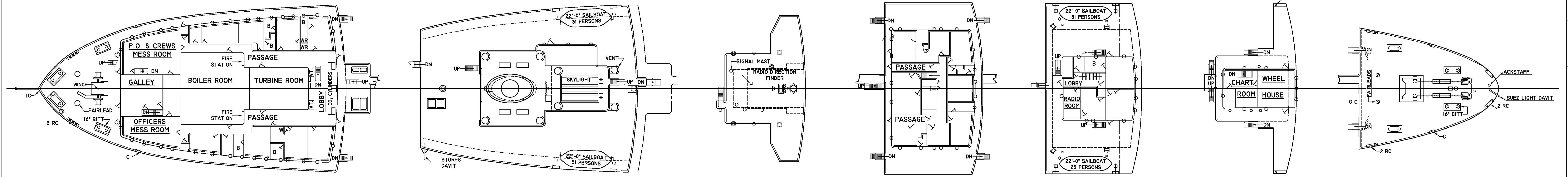

POOP DECK

BOAT DECK

HOUSETOP

BRIDGE DECK

UPPER BRIDGE DECK

NAVIGATING BRIDGE

FORECASTLE DECK

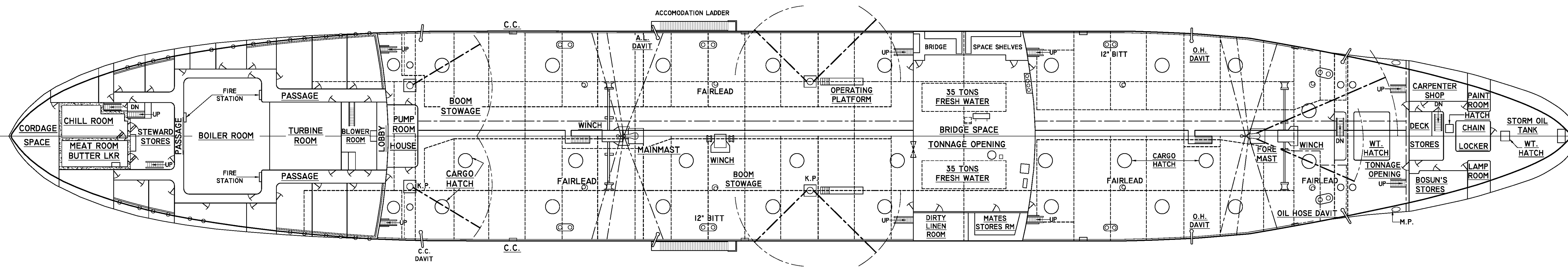

UPPER DECK

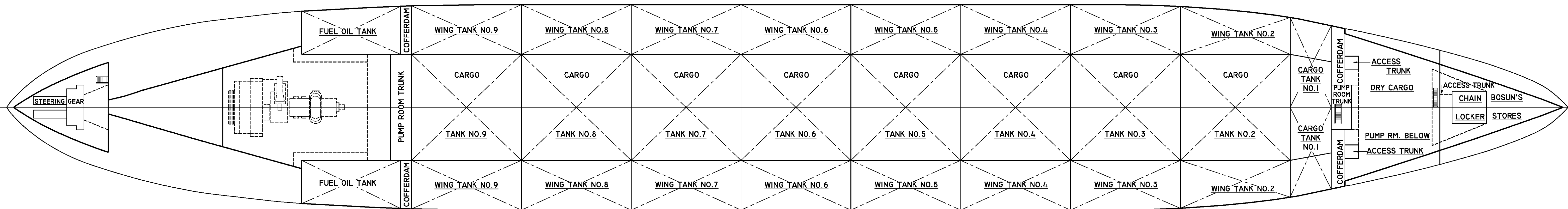

SECOND DECK AND HOLD PLAN

NOTE: DRAWINGS TRACED FROM SCANS PROVIDED BY THE MARITIME ADMINISTRATION NATIONAL MUSEUM

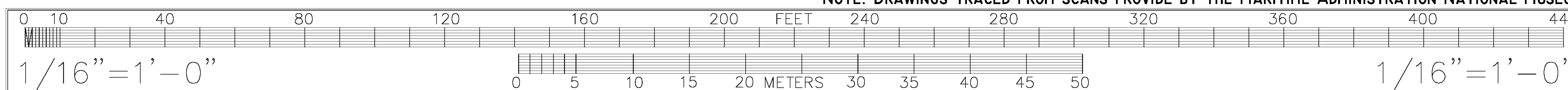

Saugatuck

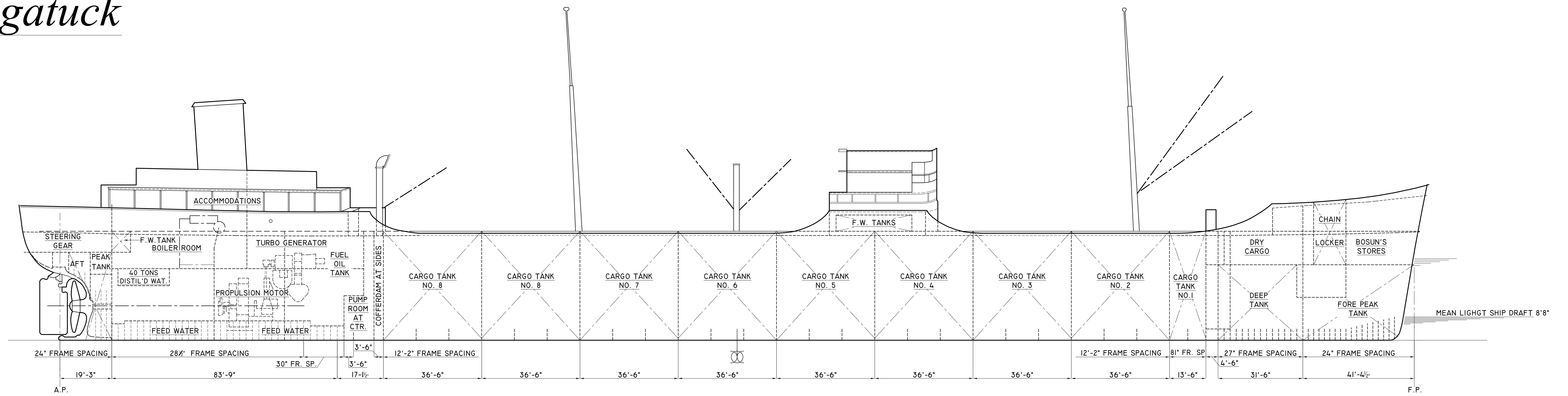

CAPACITY PLAN PROFILE

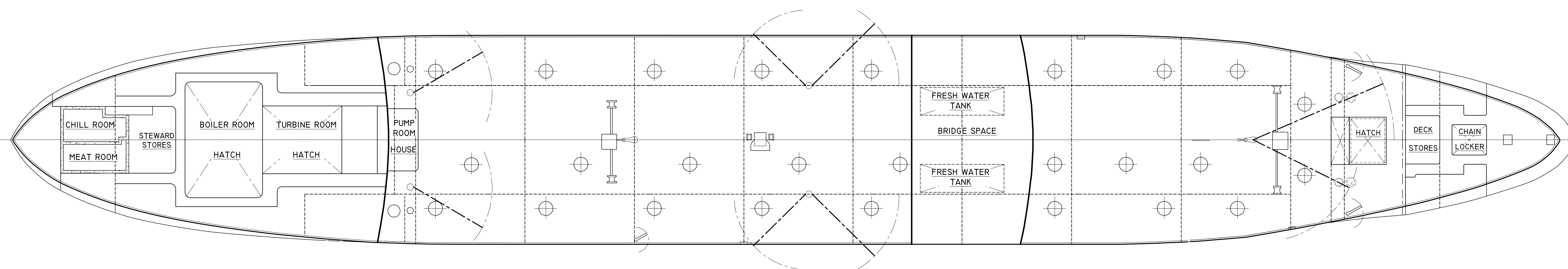

UPPER DECK CAPACITY PLAN

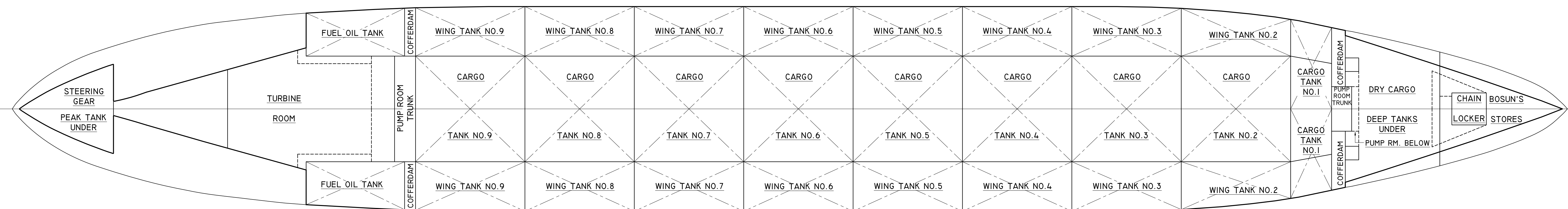

SECOND DECK AND HOLD CAPACITY PLAN

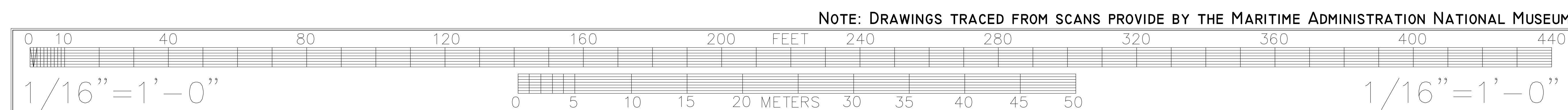

USS Taluga

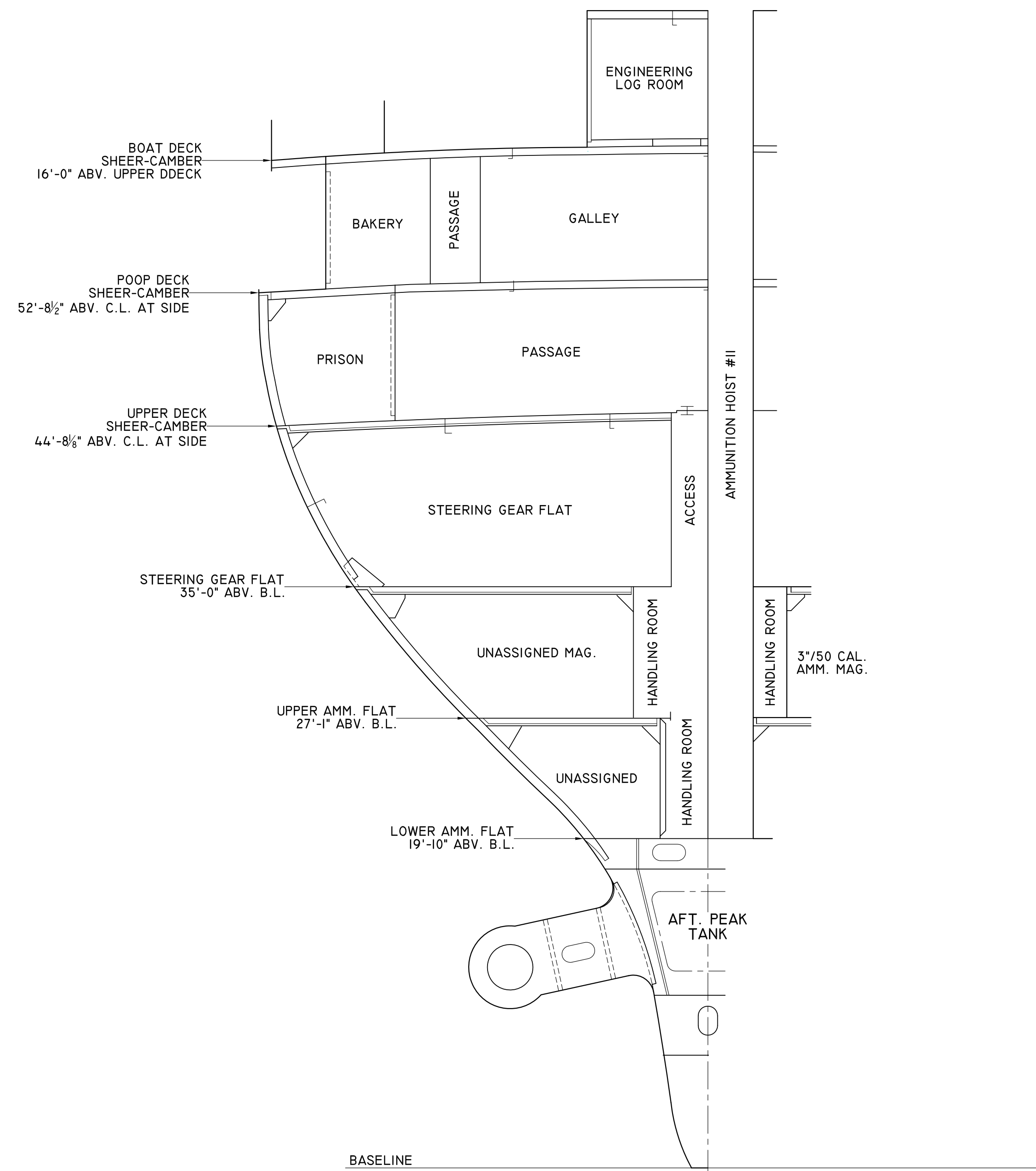

SECTION - FR.12
LOOKING AFT.

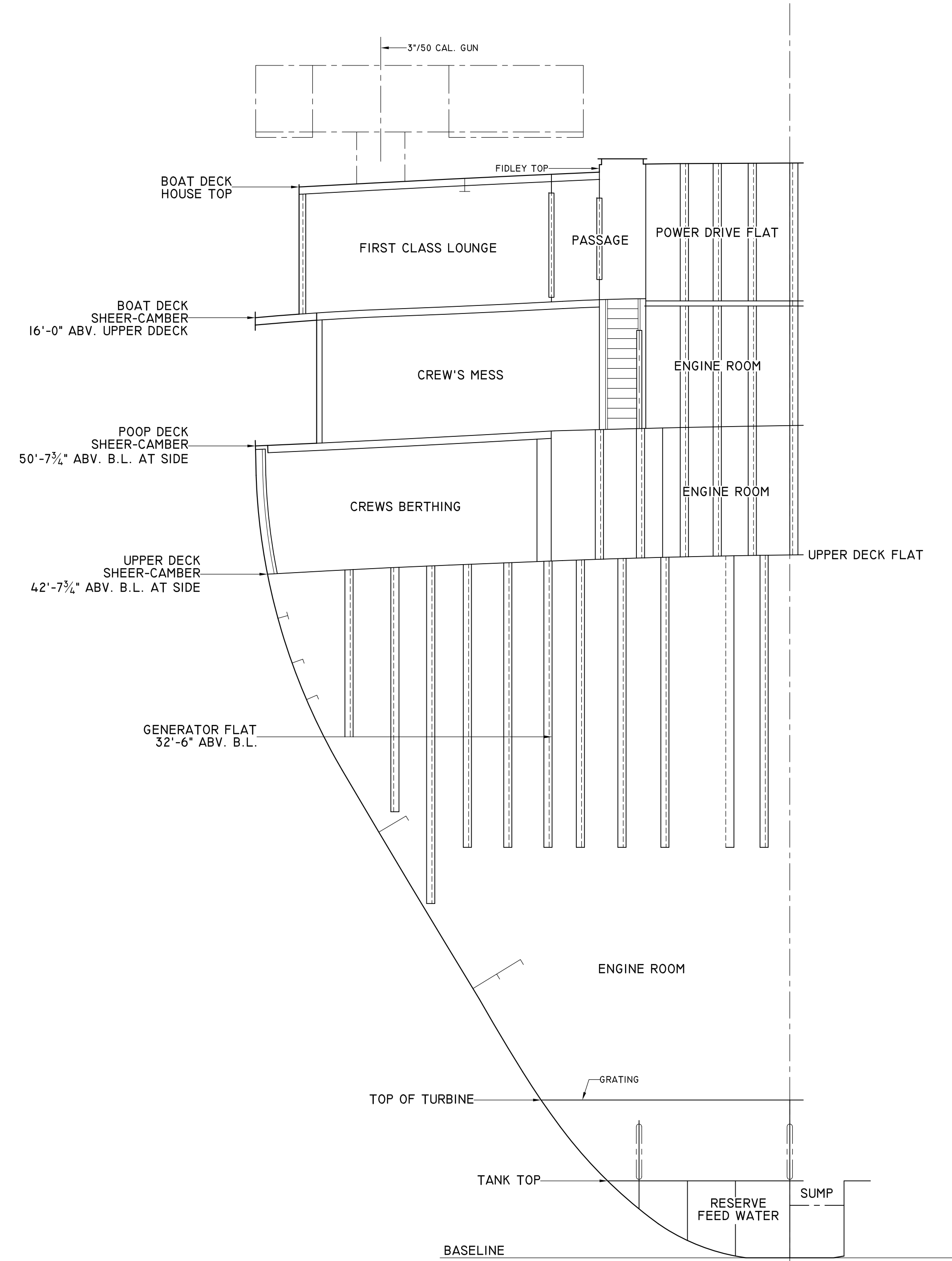

SECTION - FR.33
LOOKING AFT.

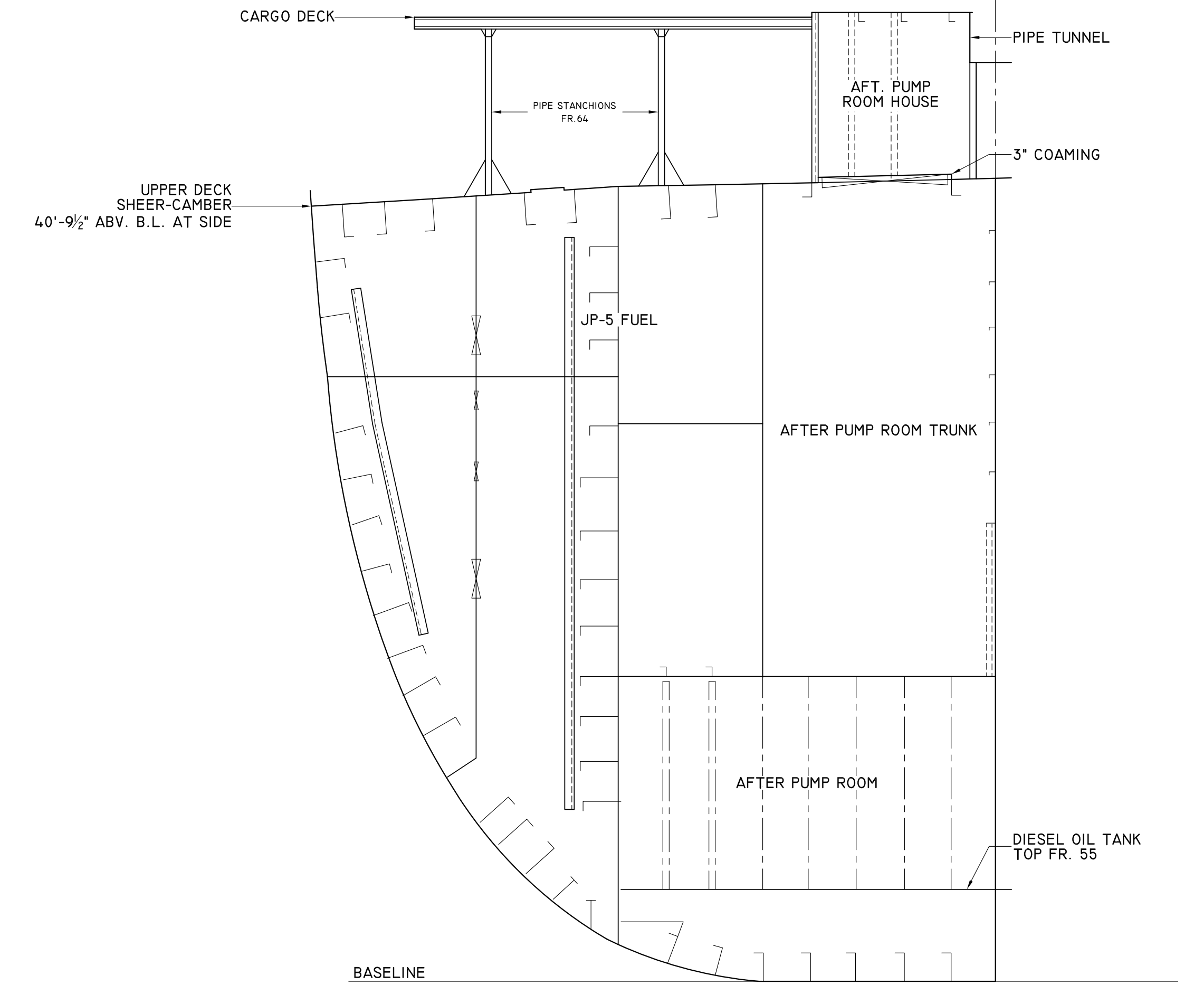

SECTION - FR.56
LOOKING AFT.

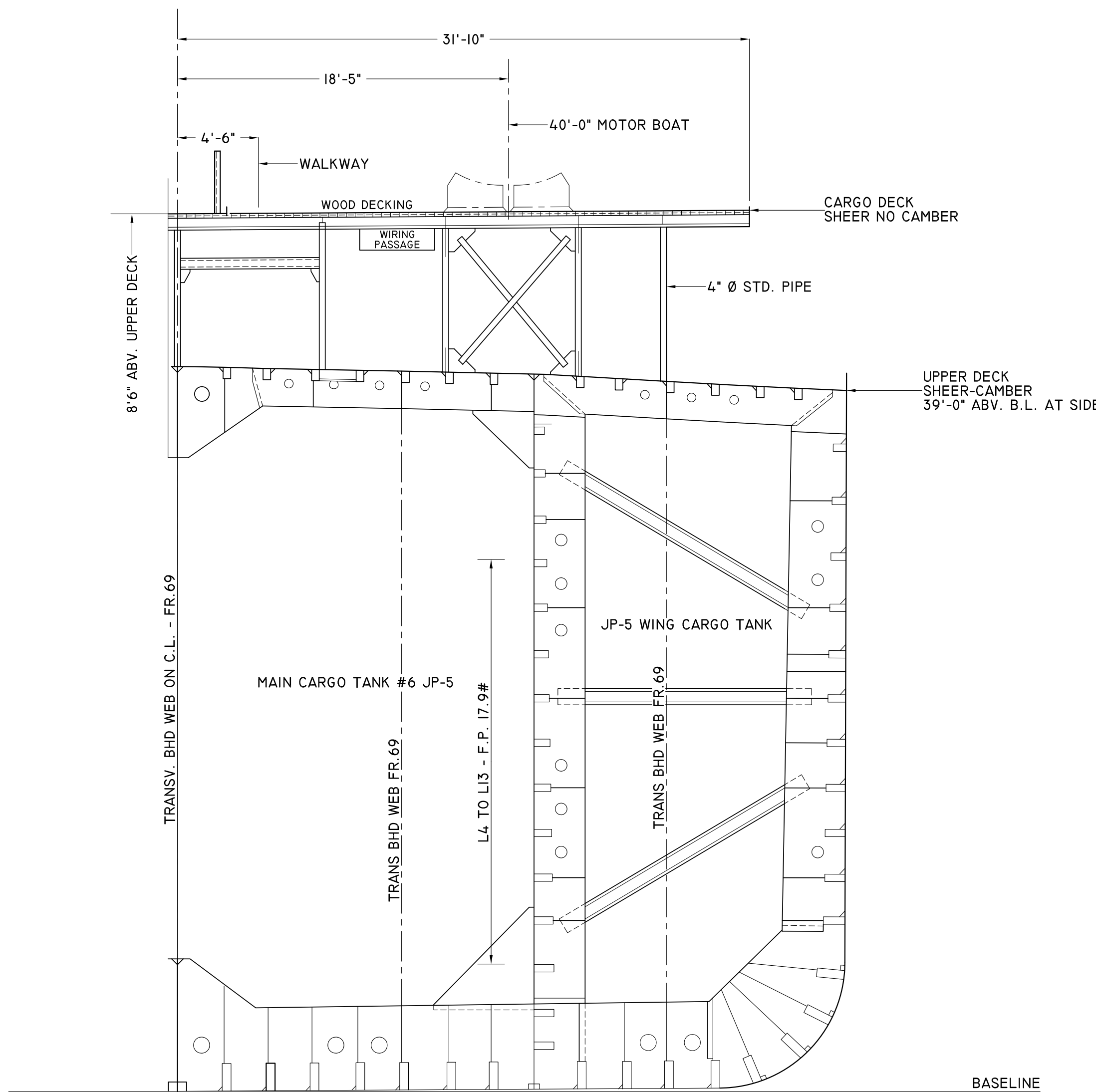

MIDSHIP SECTION
10" AFT. OF FR.68 - LOOKING FWD.

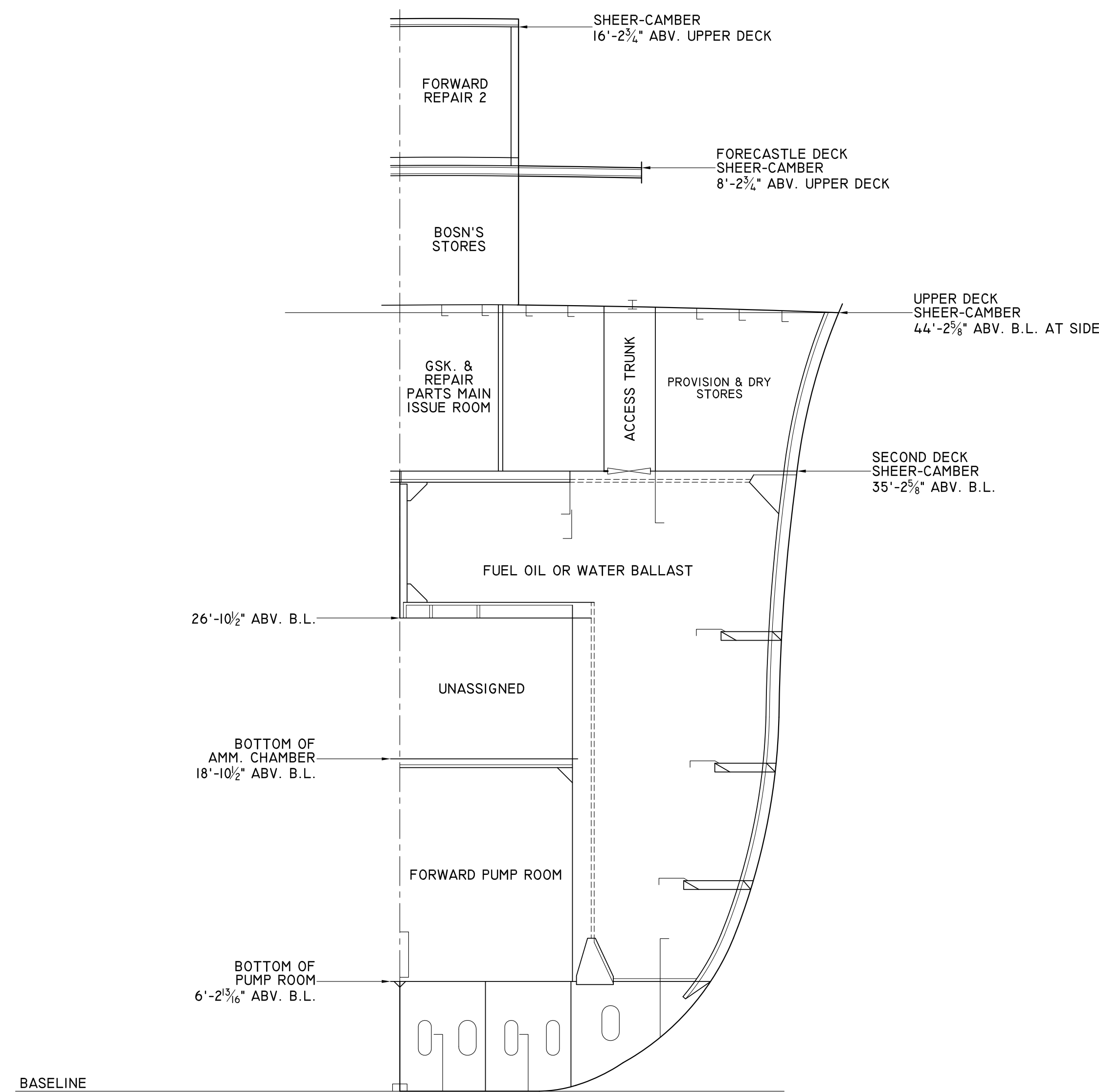

SECTION - FR.85
LOOKING FWD.

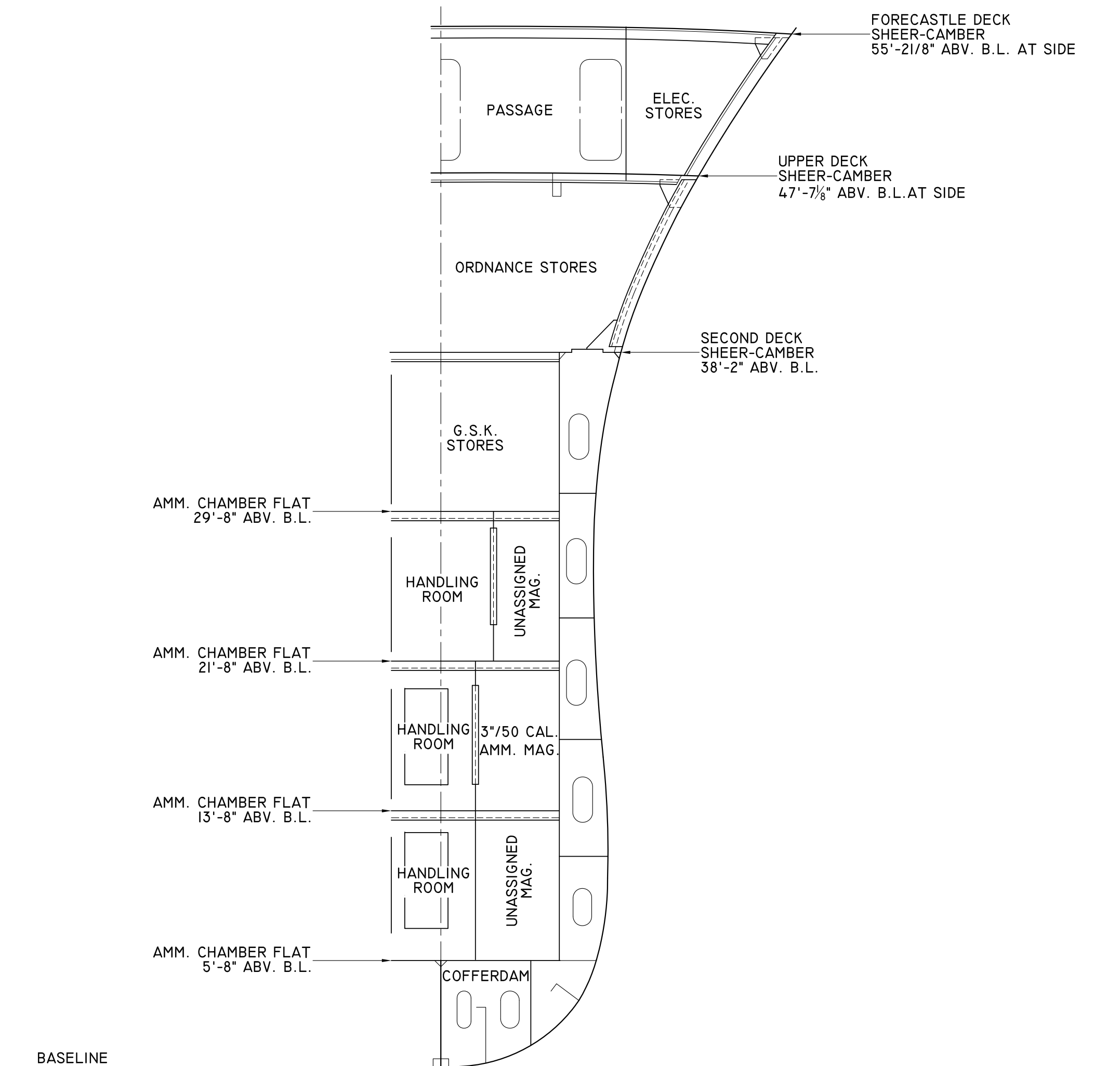

SECTION - FR.105
LOOKING FWD.

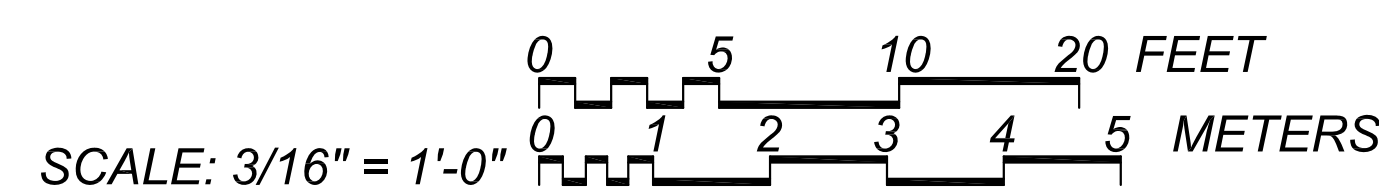

USS Taluga - schematic diagram

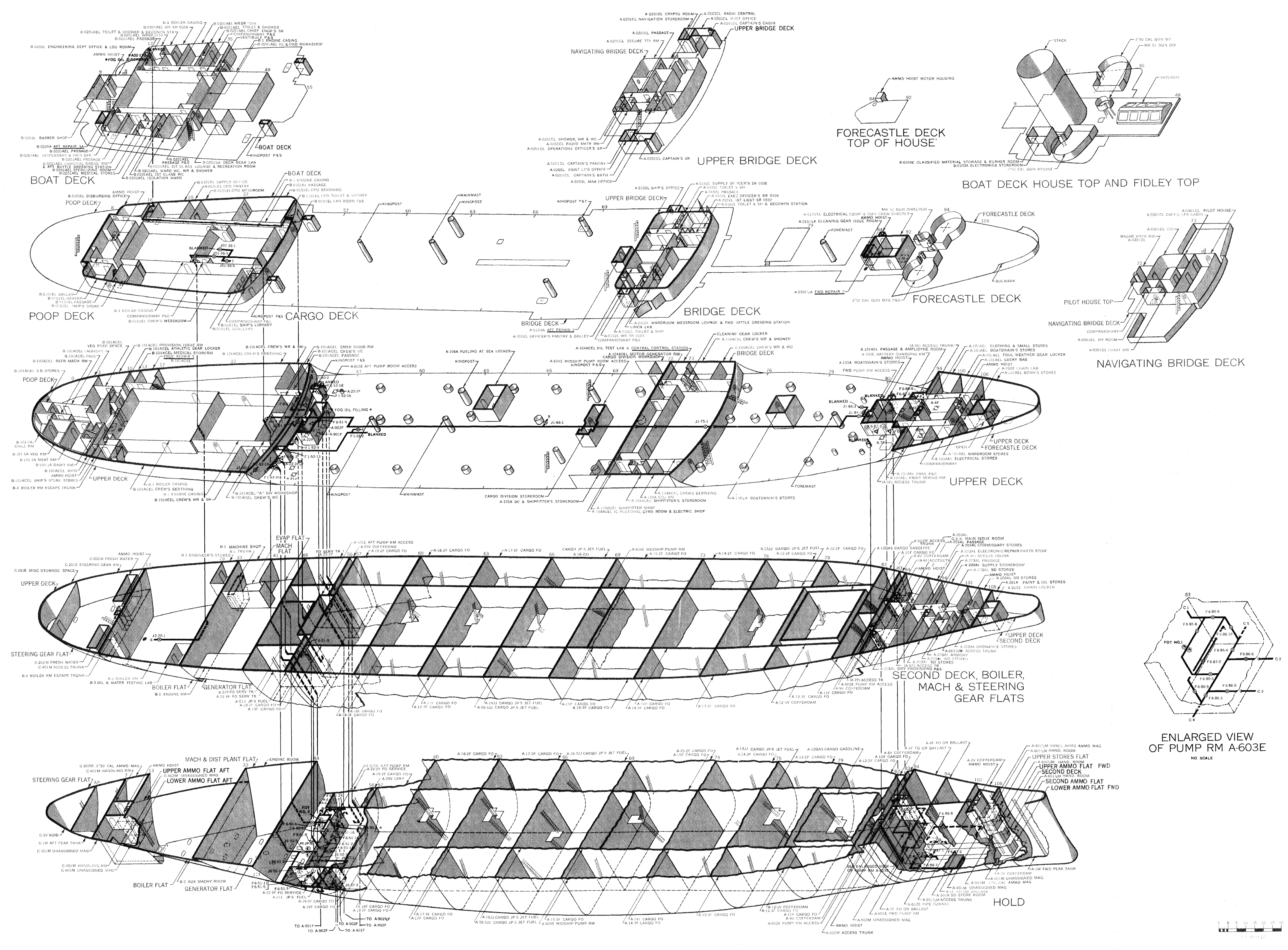

AO 62
DAMAGE CONTROL DIAGRAM
6
FUEL OIL AND JP-5 FUEL
FILLING, TRANSFER, AND
* FOG OIL FILLING SYSTEMS

- KEY
- ▲ FOG OIL FILLING
 - JP-5 FUEL FILLING & TRANSFER
 - FUEL OIL FILLING & TRANSFER
 - ⊕ VALVE (SEE TEXT FOR SIZE AND TYPE)
 - ⊖ VALVE-REMOTELY OPERATED
 - ⊗ VALVE AND CHANGE OF SYSTEM
 - ⊘ HOSE VALVE
 - ⊙ VALVE MANIFOLD
 - ⊚ PRESSURE RELIEF VALVE OR SPRING LOADED CHECK VALVE
 - ⊛ SOUNDING TUBE WITH CAP OR SOUNDING TUBE DECK PLATE—FIGURE INDICATES COMPARTMENT SOUNDED
 - ⊜ REMOTE CONTROL STATION—FIG. INDICATES VALVE OPERATED (SEE TEXT FOR TYPE OF OPERATION)
 - ⊝ SPRING FLANGE
 - ⊞ 180° RETURN BEND
 - ⊟ 90° RETURN BEND
 - ⊠ 90° RETURN BEND
 - ⊡ FUEL OIL FILLING & TRANSFER
 - ⊢ FOG OIL FILLING & TRANSFER
 - ⊣ FOG OIL FILLING & TRANSFER
 - ⊤ FOG OIL FILLING & TRANSFER
 - ⊥ FOG OIL FILLING & TRANSFER
 - ⊦ FOG OIL FILLING & TRANSFER
 - ⊧ FOG OIL FILLING & TRANSFER
 - ⊨ FOG OIL FILLING & TRANSFER
 - ⊩ FOG OIL FILLING & TRANSFER
 - ⊪ FOG OIL FILLING & TRANSFER
 - ⊫ FOG OIL FILLING & TRANSFER
 - ⊬ FOG OIL FILLING & TRANSFER
 - ⊭ FOG OIL FILLING & TRANSFER
 - ⊮ FOG OIL FILLING & TRANSFER
 - ⊯ FOG OIL FILLING & TRANSFER
 - ⊰ FOG OIL FILLING & TRANSFER
 - ⊱ FOG OIL FILLING & TRANSFER
 - ⊲ FOG OIL FILLING & TRANSFER
 - ⊳ FOG OIL FILLING & TRANSFER
 - ⊴ FOG OIL FILLING & TRANSFER
 - ⊵ FOG OIL FILLING & TRANSFER
 - ⊶ FOG OIL FILLING & TRANSFER
 - ⊷ FOG OIL FILLING & TRANSFER
 - ⊸ FOG OIL FILLING & TRANSFER
 - ⊹ FOG OIL FILLING & TRANSFER
 - ⊺ FOG OIL FILLING & TRANSFER
 - ⊻ FOG OIL FILLING & TRANSFER
 - ⊼ FOG OIL FILLING & TRANSFER
 - ⊽ FOG OIL FILLING & TRANSFER
 - ⊾ FOG OIL FILLING & TRANSFER
 - ⊿ FOG OIL FILLING & TRANSFER
 - ⊠ FOG OIL FILLING & TRANSFER
 - ⊡ FOG OIL FILLING & TRANSFER
 - ⊢ FOG OIL FILLING & TRANSFER
 - ⊣ FOG OIL FILLING & TRANSFER
 - ⊤ FOG OIL FILLING & TRANSFER
 - ⊥ FOG OIL FILLING & TRANSFER
 - ⊦ FOG OIL FILLING & TRANSFER
 - ⊧ FOG OIL FILLING & TRANSFER
 - ⊨ FOG OIL FILLING & TRANSFER
 - ⊩ FOG OIL FILLING & TRANSFER
 - ⊪ FOG OIL FILLING & TRANSFER
 - ⊫ FOG OIL FILLING & TRANSFER
 - ⊬ FOG OIL FILLING & TRANSFER
 - ⊭ FOG OIL FILLING & TRANSFER
 - ⊮ FOG OIL FILLING & TRANSFER
 - ⊯ FOG OIL FILLING & TRANSFER
 - ⊰ FOG OIL FILLING & TRANSFER
 - ⊱ FOG OIL FILLING & TRANSFER
 - ⊲ FOG OIL FILLING & TRANSFER
 - ⊳ FOG OIL FILLING & TRANSFER
 - ⊴ FOG OIL FILLING & TRANSFER
 - ⊵ FOG OIL FILLING & TRANSFER
 - ⊶ FOG OIL FILLING & TRANSFER
 - ⊷ FOG OIL FILLING & TRANSFER
 - ⊸ FOG OIL FILLING & TRANSFER
 - ⊹ FOG OIL FILLING & TRANSFER
 - ⊺ FOG OIL FILLING & TRANSFER
 - ⊻ FOG OIL FILLING & TRANSFER
 - ⊼ FOG OIL FILLING & TRANSFER
 - ⊽ FOG OIL FILLING & TRANSFER
 - ⊾ FOG OIL FILLING & TRANSFER
 - ⊿ FOG OIL FILLING & TRANSFER

NOTES

- 1. DOTTED LINES AND CROSS-HATCHING INDICATES BOUNDARIES, PIPING AND FITTINGS HIDDEN FROM VIEW
- 2. DASH LINE INDICATES INTERSECTION OF HORIZONTAL LEVEL WITH VERTICAL BULKHEAD
- 3. HEAVY DOTTED LINE INDICATES WATERTIGHT OR OILTIGHT BOUNDARIES
- 4. THIN GREY LINE INDICATES AIRTIGHT, FIRE-RESISTANT, OR NON-FIRE-RESISTANT BOUNDARIES
- 5. THE LETTERS PRECEDING THE VALVE OR FITTING NUMBER REFERS TO THE SYSTEM AND IS NOT ACTUALLY PART OF THE VALVE OR FITTING NUMBER

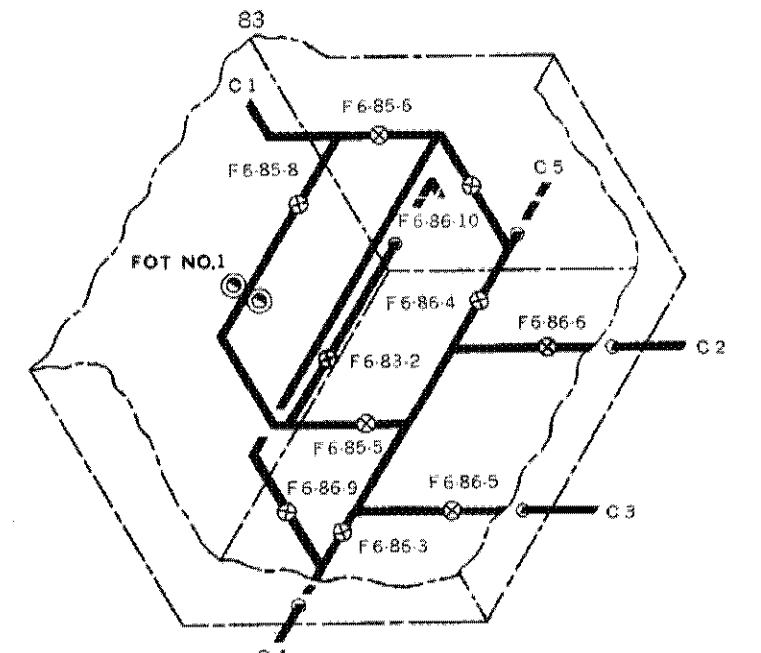

PREPARED BY
MATERIAL LABORATORY
NEW YORK NAVAL SHIPYARD
FOR
BUREAU OF SHIPS
DECEMBER 1960
OVERHAUL ACTIVITY CORRECT MASTER PLASTICS

DRAWINGS WERE ARE SCANS OF HISTORIC DRAWINGS LOCATED ON THE SHIP. DIMENSIONS WERE NOT VERIFIED IN THE FIELD.