



USS Bolster

(1983 Configuration)

Design type: Auxiliary
 Official Number: ARS-38



PRINCIPLE CHARACTERISTICS

BUILDER: BASALT ROCK COMPANY
BUILT: 1945
LOA: 213'-6"
BEAM: 43'-0"
DRAFT: 13'-9"
SPEED: 16 KNOTS
PROPULSION: DIESEL ELECTRIC PLANT
 TWIN SCREW,
 3,000 SHAFT-
 HORSEPOWER
DISPLACEMENT: 1,497 TONS
 (LIGHTWEIGHT)
 2,048 TONS (FULL LOAD)
COMPLEMENT: 7 OFFICERS
 113 ENLISTED
ARMAMENT: 40MM GUN
 2 20MM GUNS
 2 50 CALIBER
 MACHINE GUNS



THE USS BOLSTER, CIRCA 1945 (NARA).

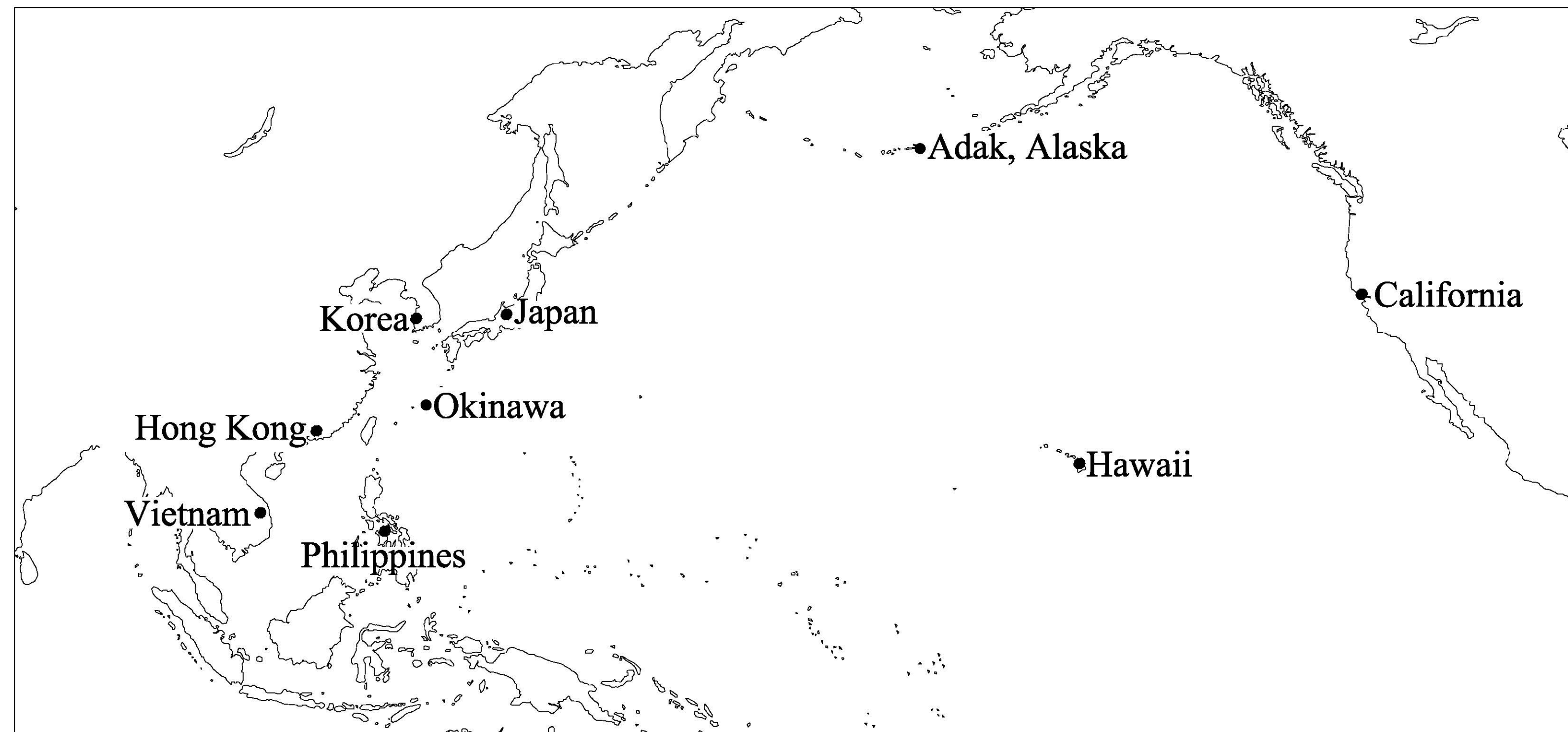

NOTE: SELECTED PORTS OF CALL

THE USS BOLSTER WAS THE FIRST SHIP IN A CLASS OF SIX SALVAGE VESSELS BUILT FOR THE U.S. NAVY DURING WORLD WAR II. THE BOLSTER SERVED DILIGENTLY FOR FORTY-NINE YEARS AND PERFORMED NUMEROUS SALVAGE OPERATIONS THAT SAVED MANY SHIPS WITHIN THE NAVY AND MERCHANT MARINE. THE SHIP REMAINS NOTABLE AS THE LAST SURVIVING AMERICAN VESSEL AFLOAT IN ITS CLASS.

THIS RECORDING PROJECT WAS COSPONSORED BY THE HISTORIC AMERICAN ENGINEERING RECORD (HAER) AND THE U.S. MARITIME ADMINISTRATION (MARAD). THE VESSEL WAS DOCUMENTED UNDER THE DIRECTION OF TODD CROTEAU, HAER MARITIME PROGRAM CO-ORDINATOR AND ERHARD KOEHLER, MARAD SHIPS DISPOSAL CO-ORDINATOR ROBERT D. JAMIESON CREATED DRAWINGS WHICH WERE REFORMATTED INTO HAER SHEETS. TEAM MEMBERS INCLUDED ASHLEY T. WALKER (CONTRACT ARCHITECT), PHOTOGRAPHER DAVID HAAS AND HISTORIAN BRIAN CLAYTON.

USS BOLSTER (ARS-38)
 SUISUN BAY RESERVE FLEET
 SOLANO COUNTY

BENICIA VICINITY

DELINEATED BY: ASHLEY T. WALKER, 2010
 HAER MARITIME
 RECORDING PROGRAM
 NATIONAL PARK SERVICE
 UNITED STATES DEPARTMENT OF THE INTERIOR

SHEET 1 OF 9
 HISTORIC AMERICAN
 ENGINEERING RECORD
 CA-355

IF REPRODUCED, PLEASE CREDIT THE HISTORIC AMERICAN ENGINEERING RECORD, NATIONAL PARK SERVICE, NAME OF DELINEATOR, DATE OF DRAWING

HISTORIC AMERICAN ENGINEERING RECORD

Bolster (ARS-38)

HAER No. CA-355

Location: Suisun Bay Reserve Fleet, Benicia vicinity, Solano County, California

Rig/Type of Craft: Auxiliary

Number: ARS-38

Trade: Salvage rescue

Principal Dimensions: Length (oa): 213'-6"
Length (wl): 207'
Beam: 43'
Draft: 13'-9"
Displacement: 1,897 long tons
Maximum continuous shaft horsepower: 3,000
Service speed: 16 knots
(The listed dimensions are as built, but it should be noted that draft, displacement, and tonnages were subject to alteration over time as well as variations in measurement.)

Propulsion: Diesel-electric plant, twin screw

Dates of Construction: Keel laying: 20 July 1944
Launching: 23 December 1944
Commissioning: 1 May 1945

Builder: Basalt Rock Company, Napa, California

Present Owner: U.S. Maritime Administration

Disposition: Inactive—National Defense Reserve Fleet

Significance: The *Bolster* was the first ship in a class of six salvage vessels built for the U.S. Navy during World War II. The *Bolster* performed numerous salvage operations during its career and remains notable for being the last surviving American vessel afloat in its class.

Historian: Brian Clayton, fall 2008

**Project
Information:**

This project is part of the Historic American Engineering Record (HAER), a long-range program to document historically significant engineering and industrial works in the United States. The Heritage Documentation Programs of the National Park Service, U.S. Department of the Interior, administers the HAER program.

The project was prepared under the direction of Todd Croteau (HAER Maritime Program Coordinator). Ashley T. Walker (HAER Contract Architect) generated vessel drawings. Jet Lowe (HAER Photographer) produced the large-format photographs. Special thanks to Erhard Koehler (U.S. Maritime Administration) whose help and assistance greatly benefited this project.

BACKGROUND

One of the first priorities of the United States upon entering World War II was the construction of ships. The global experience and ferocity of World War I taught the United States that World War II would be on a grander scale, in more places, involve more people, and require more equipment—total war.¹ During World War II, the U.S. Maritime Commission became a pivotal force in the development and construction of ships, much like the U.S. Shipping Board had been in World War I. Created in 1936, the Maritime Commission succeeded the Shipping Board, but it generally followed the same directive: the promotion of U.S. shipping interests. After the United States entered World War II, the Maritime Commission established the Emergency Program, a massive ship construction plan that utilized new and existing shipyards across the United States.²

The need for the Emergency Program stemmed from the decline of the maritime industry in the inter-war years. A majority of the ships in the Merchant Marine originated from the mobilization endeavor authorized by the U.S. Shipping Board to support American troops in World War I. Although the board approved the construction of 470 ships to support the war effort, the United States' participation in the war was brief. Between 1918 and 1922, however, the board added another 1,300 ships to the Merchant Marine, giving the United States a more robust presence in international shipping than it had had in seventy years. The U.S. stock market crash in 1929 and the Great Depression were major setbacks to the maritime industry. Many steamship companies were unable to replace or update aging ships—over 90 percent of the fleet was over twenty years old and had an average speed of between 10 and 11 knots.³

In the mid-1930s, the U.S. government intervened with new legislation to aid the beleaguered maritime industry. President Franklin D. Roosevelt's New Deal economic policies eventually helped revive the Merchant Marine when Congress passed the Merchant Marine Act of 1936. The act created the U.S. Maritime Commission, superseding the U.S. Shipping Board, and it infused new capital and ideas for rebuilding the fleet. In 1937, the U.S. Maritime Commission developed a long-range program for building 500 ships that were both contemporary and economical over a ten-year period. In 1939, the Maritime Commission determined that the production quota of fifty ships per year was too low and doubled it.⁴

There were mounting concerns about the war in Europe and the success of the German U-boat campaign against English shipping, particularly since U.S. steamship companies traded with England and France. The United States also feared that Germany might next turn its attention to

¹ Russell F. Weigley, *The American Way of War: A History of United States Military Strategy and Policy* (New York, NY: MacMillan Publishing Co., Inc., 1973), pp. xxi-xxiii.

² René De La Pedraja, *A Historical Dictionary of the U.S. Merchant Marine and Shipping Industry since the Introduction of Steam* (Westport, CT: Greenwood Press, 1994), pp. 563-566, 629-631. During World War II, the Maritime Commission issued contracts for 5,601 vessels. Private firms built an additional 111 ships while foreign firms built sixty-five for a total of 5,777.

³ Brian J. Cudahy, *Box Boats: How Container Ships Changed the World* (New York: Fordham University Press, 2006), pp. 2-3; L.A. Sawyer and W.H. Mitchell, *Victory Ships and Tankers: The History of the 'Victory' Type Cargo Ships and of the Tankers Built in the United States of America during World War II* (Cambridge, MD: Cornell Maritime Press, Inc., 1974), p. 15.

⁴ Cudahy, *Box Boats*, p. 3; Sawyer and Mitchell, *Victory Ships and Tankers*, p. 15.

U.S. ships or U.S. trade routes. In response, the Maritime Commission raised its shipping quota once again in August 1940 to 200 ships per year.⁵

BOLSTER CLASS

The U.S. Congress passed legislation on 24 October 1941 establishing the Naval Salvage Service. After the attack on Pearl Harbor, the legislation allowed the navy to begin salvage operations through a contract with Merritt-Chapman and Scott on 11 December 1941. In addition, it allowed the U.S. Navy to have Merritt-Chapman and Scott train future naval salvage operators.⁶ A salvage crew's main job was to augment damage control beyond the capacity of the ship's crew. This could include fire fighting, towing ships to repair facilities, and clearing harbors of scuttled ships and vessels targeted in combat. The U.S. Navy quickly learned that it was far faster to repair a damaged vessel than to construct a new one. During the island-hopping campaigns of the Pacific in World War II, for example, salvage crews cleared the beaches of landing craft while also retaining many of the damaged ones for repair. The craft and their cargoes could then be used in future operations, but, more importantly, the beaches were cleared for additional assault waves as the beach heads became staging areas.⁷

The U.S. Navy designed and ordered the *Bolster* class, which was a group of salvage ships. The navy's own Bureau of Construction, along with naval officers and the salvage industry, developed this new class during World War II. The salvage ships were sturdy, oceangoing tugs equipped with diesel-electric propulsion units and strong, auto-tensioned towing winches. The U.S. Navy modeled the *Bolster* class on the *Diver* salvage-ship design. The key difference between the two types of salvage ships was that the *Bolster* class had 5' longer beam, which made it more stable and allowed it to carry more equipment. Otherwise, the *Bolster* and *Diver* classes were identical.⁸

CONSTRUCTION

The Basalt Rock Company's Steel Division built all six of the vessels in the *Bolster* class. The company was located south of Napa, California, on the Napa River. As the name suggests, the company had originally started in 1920 as a rock quarry operation, but by 1938, it had begun constructing its own barges. In addition to the *Bolster* class, the shipyard built sixteen *Diver*-class vessels, 115 barges, and various other vessels for the U.S. Navy from 1940 until 1945. The *Bolster*'s keel was laid on 20 July 1944.⁹

⁵ Sawyer and Mitchell, *Victory Ships and Tankers*, p. 16; Thomas Wildenberg, "The Origins and Development of the T2 Tanker," *American Neptune* (Summer 1992), pp. 158-159.

⁶ C.A. Bartholomew, *Mud, Muscle, and Miracles: Marine Salvage in the United States Navy* (Washington, DC: Department of the Navy, 1990), pp. 55, 69.

⁷ Bartholomew, *Mud, Muscles, and Miracles*, pp. 51-52.

⁸ Bartholomew, *Mud, Muscles, and Miracles*, pp. 54, 444.

⁹ "Basalt Rock Company, Napa, CA," available at <http://shipbuildinghistory.com/history/shipyards/4emergencysmall/basalt.htm>, accessed 17 August 2009.

DESCRIPTION

The *Bolster* measured 213'-6" in overall length with a 43' beam and a limiting draft of 13'-9". The steel-hulled ship displaced 1,441 tons of water when fully loaded. The twin-screw, diesel-electric propulsion plant created 3,000 shaft horsepower per motor for a top speed of 16 knots. Flank speed resulted in a radius of 10,000 nautical miles while cruising speed extended the radius to 13,700 nautical miles. At 95 percent capacity, the fuel tanks held 2,150 barrels of diesel fuel for the main engines and auxiliary generators. There were also tanks that could carry a total of 2,560 barrels of gasoline for use in portable generators and pumps and for the two small boats carried onboard.¹⁰

The machinery spaces contained a wide assortment of equipment dedicated both to operating the ship and to the salvage operations. The engine room on the first platform contained four 8-cylinder Cooper-Bessemer diesel engines. Connected to the engines were four Westinghouse generators that produced 610 kilowatts to create a 500-volt DC current. The generators powered four Westinghouse motors rated at 765 horsepower that drove two shafts at 200 rpm. A single Farrel-Birmingham reduction gear stepped the power down on each shaft to turn a 9'-3" four-blade propeller. The aft steering compartment housed two quadrant steering gears that turned the rudders. In the early 1970s, the *Bolster* underwent a service life extension plan (SLEP) that resulted in the replacement of the engines with four new 399 Caterpillar diesel engines. The 16-cylinder engines increased the shaft horsepower from 3,000 to 3,500.¹¹

Originally, auxiliary power for the ship came from two service generators and one emergency generator. The two primary generators were located in the hold between the main and reduction gears. Two 6-cylinder Cooper-Bessemer diesel generators produced 200 kilowatts creating 120 volts of AC power apiece. The emergency generator was on the first platform and only generated 60 kilowatts as opposed to the main ones.¹²

The forecastle deck had one mast with an 8-ton boom and various salvage gear. An anchor windlass for two Bower-Dunn anchors weighing 7,000 pounds apiece was located near the bow. Behind the anchor windlass was another windlass for the foremast boom; this windlass could also be used for picking up salvage through two forward lifting rollers built into the hull on the port and starboard sides. The windlass was rated for 20 tons. At the front of the stern was a mast and beneath that was the Almon-Johnson towing winch (series 250). The towing winch drum held 2,100' of 2"-steel cable, and the maximum pull rating was 40,000 pounds. Aft of the bulkhead were two capstans on the port and starboard sides. A towing bit was located between the capstans while a towing hawser containing 900' of 5 ½"-nylon line was in a hold beneath the deck.¹³

¹⁰ U.S. Navy, *Ships' Data: U.S. Naval Vessels*, Vol. III (Washington, DC: Government Printing Office, 1946), pp. 350-353.

¹¹ U.S. Navy, *Ships' Data*, pp. 352-353; "Bolster ARS-38 Naval Cruise Book, Class of 1980," available at <http://www.e-yearbook.com/sp/eybb?school=5082&year=1980>, accessed 23 July 2009.

¹² U.S. Navy, *Ships' Data*, p. 353; *Booklet of General Plans USS Bolster (ARS-38)*, Plates 3, 9, in Record Group 19, National Archives and Records Administration-College Park.

¹³ *Booklet of General Plans*, Plates 3, 6.

The ship held an assortment of compressors and pumps. Four compressors were located on the first platform. Two Davy Industrial 100-psi compressors and two Worthington 600-psi compressors pumped air to the divers and to the hyperbaric chamber available to divers suffering from the “bends” (decompression sickness). Four large pumps in the hold level could be used for pumping out the bilge, pumping water to the fire-fighting monitors, pumping air into salvage vessels, or pumping water out of laden ships.¹⁴

The ship’s crew also had the ability to make minor repairs to the *Bolster* itself while underway. A small DC electric shop complete with a welder was located on the main deck, while a larger machine-and-electrical shop that could replicate parts and conduct repairs was on the second deck. The crew could fabricate minor parts using onboard machines, including a drill press, grinder, and lathe. Crewmembers also had access to onboard equipment to patch salvage vessels, but shipyards generally performed the larger and more complex repairs that superseded the crew’s ability.¹⁵

Crew accommodations for the 120 men (seven officers and 113 enlisted personnel) consisted of the executive officers and captain’s living quarters on the forecastle deck. The officer’s wardroom was on the forecastle deck beneath the navigation bridge. The enlisted personnel berths were on the main deck and the first platform. A sick bay was also located on the main deck. The chief petty officer’s mess was on the main deck forward of the galley, while the mess for the enlisted crew was on the port side of the galley. Food storage spaces were on the first platform, fore of the berths.¹⁶

Navigation of the ship took place on the bridge, and the electronics were updated throughout the vessels’ service life. The bridge contained a compass, engine-order telegraph, gyro repeater, and helm. Behind the bridge on the starboard side was the chartroom while the radar room with a fathometer was on the port side. In the aft section of the bridge deck were communications rooms that received and sent communiqués. The gyro room was on the first platform beneath the navigation bridge.¹⁷

During World War II, the U.S. Navy equipped the *Bolster* with defensive armament and safety equipment. The ship’s 40-millimeter gun was primarily used as a defensive weapon against aircraft and small ships. After the war, the navy switched the ship’s armament to two 20-millimeter guns and two 50-caliber machine guns. Eventually, the *Bolster* only carried the 50-caliber guns. In case of sinking, there were two 35’ craft in cradles and seven rubber lifeboats available off the navigation bridge.¹⁸

¹⁴ *Booklet of General Plans*, Plate 9.

¹⁵ *Booklet of General Plans*, Plate 7.

¹⁶ *Booklet of General Plans*, Plates 6, 7.

¹⁷ *Booklet of General Plans*, Plates 4-5.

¹⁸ *Booklet of General Plans*, Plate 5; “*Bolster* ARS-38 Naval Cruise Book, Class of 1994,” available at <http://www.e-yearbook.com/sp/eybb?school=5082&year=1994>, accessed 23 July 2009.

OPERATIONAL HISTORY

On 23 December 1944, Mrs. A.C. Mayo, Jr. christened the *Bolster* as it slid down the ways. The U.S Navy commissioned the *Bolster* on 1 May 1945, and Lt. W.F. Lewis took command of the ship. The *Bolster* conducted repair duties along the California coast in July before setting sail for Pearl Harbor, Hawaii. While the ship was stationed in Pearl Harbor, Japan surrendered, and the war in the Pacific ended on 15 August 1945. The *Bolster* left Pearl Harbor the same day and headed for Yokosuka, Japan, to conduct salvage operations. After the crew completed their duties in Japan, the *Bolster* sailed to Subic Bay, Philippines, on 10 October 1946 and remained there for six months carrying out salvage work.¹⁹

The *Bolster* returned to the United States in April 1947 and spent the next three years working between Adak, Alaska, and Pearl Harbor, Hawaii, doing salvage and towing jobs. In August 1950, the *Bolster* was needed to pull two barges to Sasebo, Japan. The ship continued working in the Central Pacific and assisted troops during the Korean War. The crew took part in the Inchon Landing on 15 September 1950 and the Hungnam Evacuation from 9 December to 25 December 1950, returning to Pearl Harbor on 6 July 1951. During the following year, the *Bolster* periodically traveled to the Far East, performing salvage work and making ports-of-call in Hong Kong, Japan, Korea, Okinawa, and the Philippines.²⁰

After the Korean War, the *Bolster* continued salvage operations out of Pearl Harbor. In May 1955, the ship participated in Operation Wigwam, a nuclear test conducted 500 miles southwest of San Diego, California. The *Bolster* continued salvage operations in the Central Pacific, and in 1964 assisted the *Ajah Soliman*, a Philippine ship, after it was grounded. That same year, the *Bolster* recovered the destroyer *Frank Knox* (DD-742) and towed it back to port for repairs.²¹

From the mid-1960s through the early 1990s, the *Bolster* performed various salvage operations in support of the U.S. Navy. During the Vietnam War, the *Bolster* was stationed off the coast of Da Nang, South Vietnam. In 1965, the *Bolster* rescued the *Sea Raven* and salvaged the *Excellency* the following year. Afterward the *Bolster* participated in the recovery of the Air Force's Skylab 4 mission in 1973. Two years later, the *Bolster* saved the merchant vessel *Lindenbery*. In 1977, the ship came to the aid of the USNS *Ute* off the coast of China, and the following year, the *Bolster* towed the guided-missile destroyer USS *Preble* (DDG-46) back to Pearl Harbor for repairs. Another notable salvage effort took place in 1982 when the *Bolster* retrieved a Marine Corps F-4S jet that had crashed near Subic Bay, Philippines. The navy changed the *Bolster*'s homeport the following year to Long Beach, California, and the ship operated there until its decommissioning.²²

¹⁹ U.S Navy, *Dictionary of American Naval Fighting Ships*, Vol. II (Washington, DC: Naval Historical Center, 1991), pp. 138-39.

²⁰ U.S. Navy, *Dictionary*, p. 139.

²¹ "Bolster ARS-38 Naval Cruise Book, Class of 1994," p. 7.

²² "Bolster ARS-38 Naval Cruise Book, Class of 1994," p. 7.

CONCLUSION

On 24 September 1994, the U.S. Navy decommissioned the *Bolster*, and it was struck from the naval list the same day. On 1 February 1999, the U.S. Maritime Administration acquired the *Bolster* and put the vessel in its mothball fleet in Suisun Bay, California. The *Bolster*'s forty-nine-year career illustrates how important the ship was to the U.S. Navy. Even though the ship was built during World War II, the *Bolster* continued to provide valuable salvage services to the U.S. Navy. The conclusion of the Cold War and budgetary cuts signaled the end of the *Bolster*'s service in the early 1990s. Currently, a non-profit group is interested in turning the *Bolster* into a floating museum exhibit, and the U.S. Maritime Administration has consequently placed the ship on donation hold.

APPENDIX A: *Bolster* Class, List of Ships

<i>Bolster</i> (ARS-38)	Decommissioned 24 September 1994, National Defense Reserve Fleet, Suisun Bay, California
<i>Conserver</i> (ARS-39)	Decommissioned 1 April 1994, disposed of through U.S. Navy ship sinking exercises (SINKEX)
<i>Hoist</i> (ARS-40)	Decommissioned 30 September 1994, scrapped 1 December 2007
<i>Opportune</i> (ARS-41)	Decommissioned 30 April 1993, scrapped 5 December 2003
<i>Reclaimer</i> (ARS-42)	Decommissioned 16 September 1994, SINKEX
<i>Recovery</i> (ARS-43)	Decommissioned 30 September 1994, transferred to Taiwan
<i>Retriever</i> (ARS-44)	Cancelled
<i>Skillful</i> (ARS-45)	Cancelled
<i>Support</i> (ARS-46)	Cancelled
<i>Toiler</i> (ARS-47)	Cancelled
<i>Urgent</i> (ARS-48)	Cancelled
<i>Willing</i> (ARS-49)	Cancelled

BIBLIOGRAPHY

Government Documents

General Booklet of Plans USS Bolster (ARS-38). Record Group 19. National Archives and Records Administration-College Park.

Books

Bartholomew, C.A. *Mud, Muscle, and Miracles: Marine Salvage in the United States Navy*. Washington, DC: Department of the Navy, 1990.

Cudahy, Brian J. *Box Boats: How Container Ships Changed the World*. New York: Fordham University Press, 2006.

De La Pedraja, René. *A Historical Dictionary of the U.S. Merchant Marine and Shipping Industry since the Introduction of Steam*. Westport, CT: Greenwood Press, 1994.

Lane, Frederick C. *Ships for Victory: A History of Shipbuilding under the U.S. Maritime Commission in World War II*. Baltimore: Johns Hopkins Press, 1951.

Sawyer, L.A. and W.H. Mitchell. *Victory Ships and Tankers: The History of the 'Victory' Type Cargo Ships and of the Tankers Built in the United States of America during World War II*. Cambridge, MD: Cornell Maritime Press, Inc., 1974.

U.S. Navy. *Dictionary of American Naval Fighting Ships*. Vol. VI. Washington, DC: Naval Historical Center, 1991.

_____. *Ships' Data U.S. Naval Vessels: Auxiliary, District Craft, and Unclassified Vessels*. Washington, DC: Government Printing Office, 1946.

Internet Material

"Basalt Rock Company, Napa CA." Available at <http://shipbuildinghistory.com/history/shipyards/4emergencysmall/basalt.htm>, accessed 17 August 2009.

"Bolster ARS-38 Naval Cruise Book, Class of 1980." Available at <http://www.e-yearbook.com/sp/eybb?school=5082&year=1980>, accessed 23 July 2009.

"Bolster ARS-38 Naval Cruise Book, Class of 1994." Available at <http://www.e-yearbook.com/sp/eybb?school=5082&year=1994>, accessed 23 July 2009.

HISTORIC AMERICAN ENGINEERING RECORD

INDEX TO PHOTOGRAPHS

BOLSTER
(ARS-38)
Suisun Bay Reserve Fleet
Benicia vicinity
Solano County
California

HAER CA-355

INDEX TO BLACK AND WHITE PHOTOGRAPHS

Jet Lowe, photographer, July 2007

- | | |
|----------|--|
| CA-355-1 | Bow with salvage equipment and bridge. |
| CA-355-2 | Aft fantail with capstan, boom, winch, and jack hatches. |
| CA-355-3 | Top of bridge with mast and salvage equipment. |
| CA-355-4 | Interior of decompression chamber. |
| CA-355-5 | Interior of bridge. |
| CA-355-6 | Port stern quarter. The <i>Bolster</i> is in the middle. |

HISTORIC AMERICAN ENGINEERING RECORD
SEE INDEX TO PHOTOGRAPHS FOR CAPTION

HAER No. CA-355-1



HISTORIC AMERICAN ENGINEERING RECORD
SEE INDEX TO PHOTOGRAPHS FOR CAPTION

HAER No. CA-355-2



HISTORIC AMERICAN ENGINEERING RECORD
SEE INDEX TO PHOTOGRAPHS FOR CAPTION

HAER No. CA-355-3



HISTORIC AMERICAN ENGINEERING RECORD
SEE INDEX TO PHOTOGRAPHS FOR CAPTION

HAER No. CA-355-4

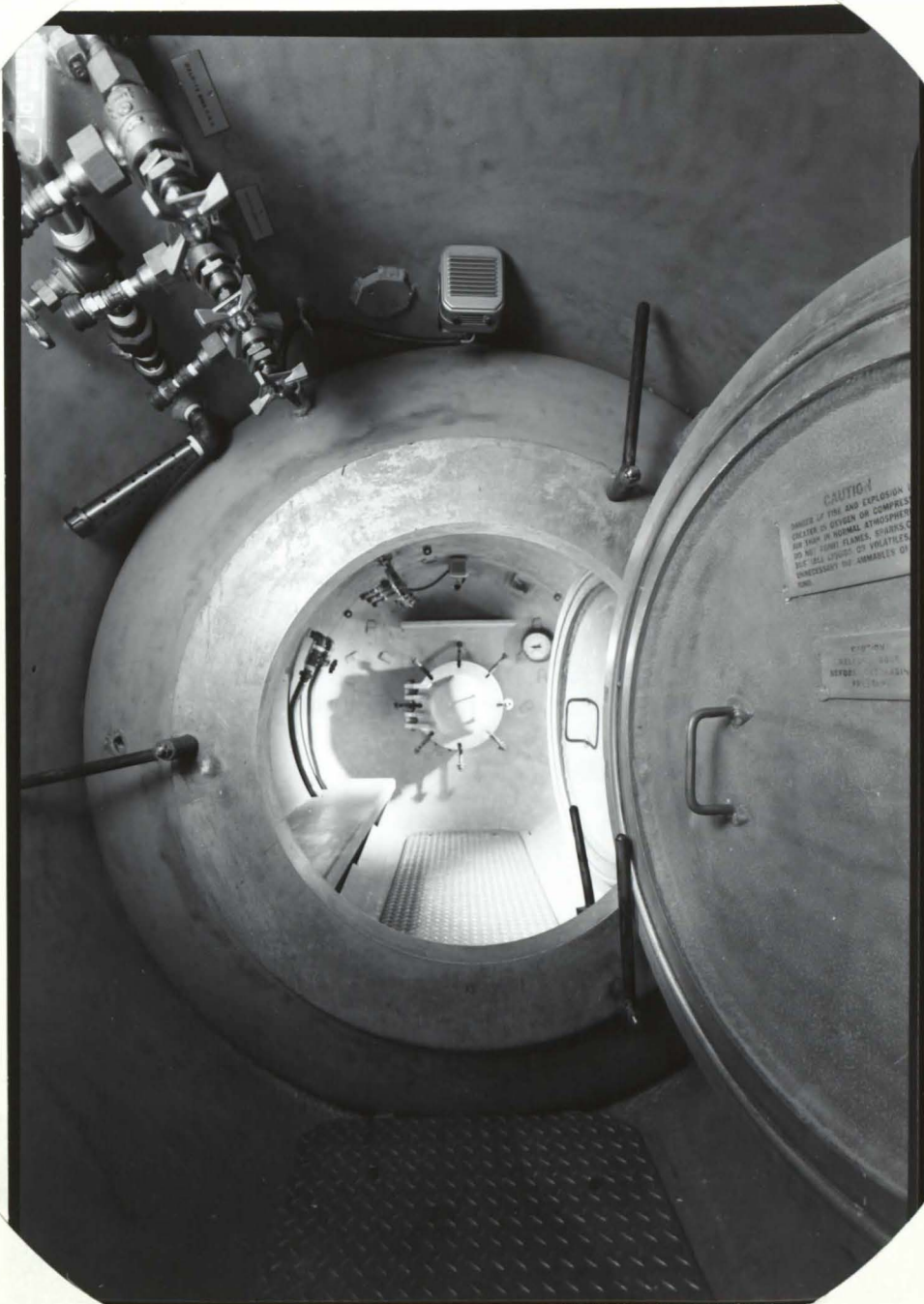

HISTORIC AMERICAN ENGINEERING RECORD
SEE INDEX TO PHOTOGRAPHS FOR CAPTION

HAER No. CA-355-5

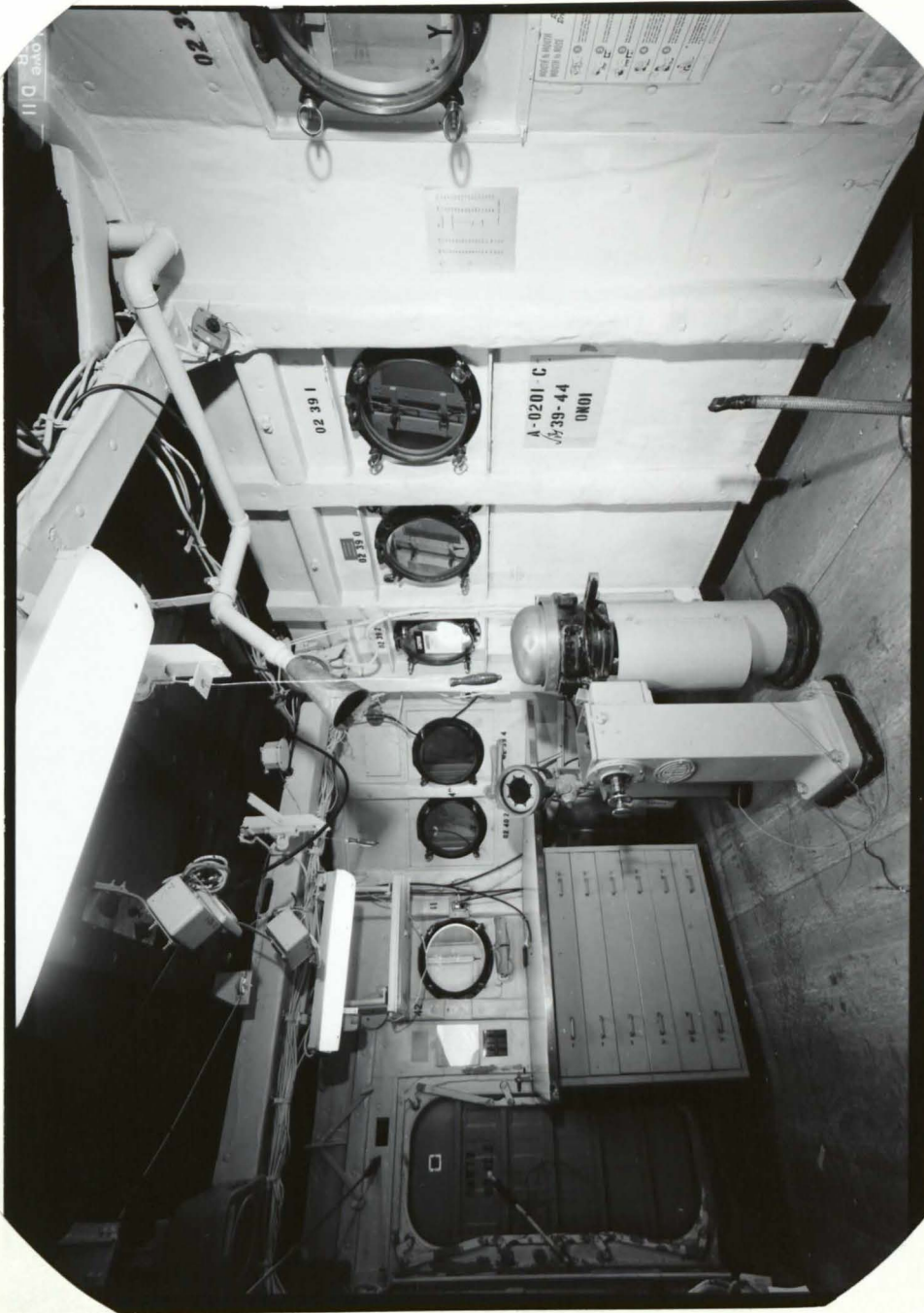

HISTORIC AMERICAN ENGINEERING RECORD
SEE INDEX TO PHOTOGRAPHS FOR CAPTION

HAER No. CA-355-6



USS Bolster (ARS-38) (1983 Configuration)

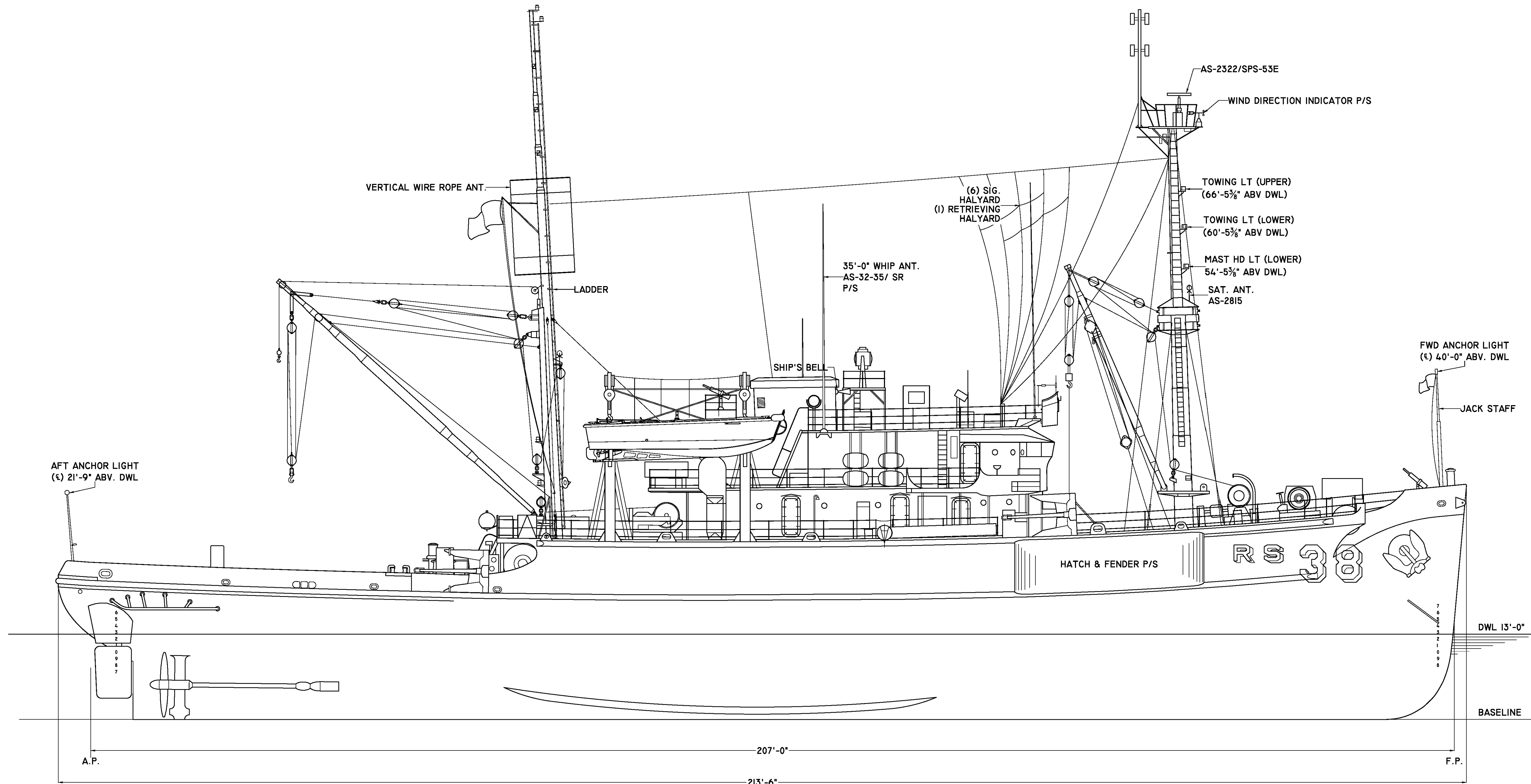

OUTBOARD PROFILE

NOTE: DRAWINGS OF 1983 CONFIGURATION WERE DONATED BY ROBERT D. JAMIESON. MODEL PLANS: 430 W. ALLENS LANE, PHILADELPHIA, PA 19119-2804

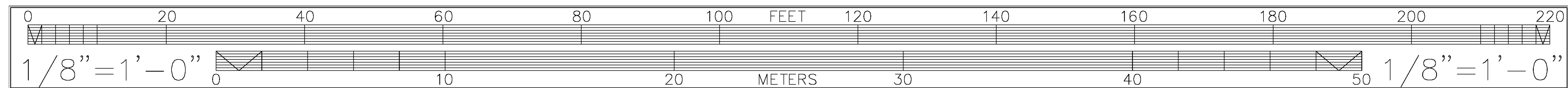

LIBRARY OF CONGRESS
INDEX NUMBER

HISTORIC AMERICAN
ENGINEERING RECORD
CA-355

SHEET 2 OF 9

CALIFORNIA

USS BOLSTER (ARS-38)
SUISUN BAY RESERVE FLEET
SOLANO COUNTY

BENICIA VICINITY

REFORMATTED BY: ASHLEY T. WALKER, 2010
HAER MARITIME
RECORDING PROGRAM
NATIONAL PARK SERVICE
UNITED STATES DEPARTMENT OF THE INTERIOR

IF REPRODUCED, PLEASE CREDIT THE HISTORIC AMERICAN ENGINEERING RECORD, NATIONAL PARK SERVICE, NAME OF DELINEATOR, DATE OF DRAWING

USS Bolster (ARS-38) (1983 Configuration)

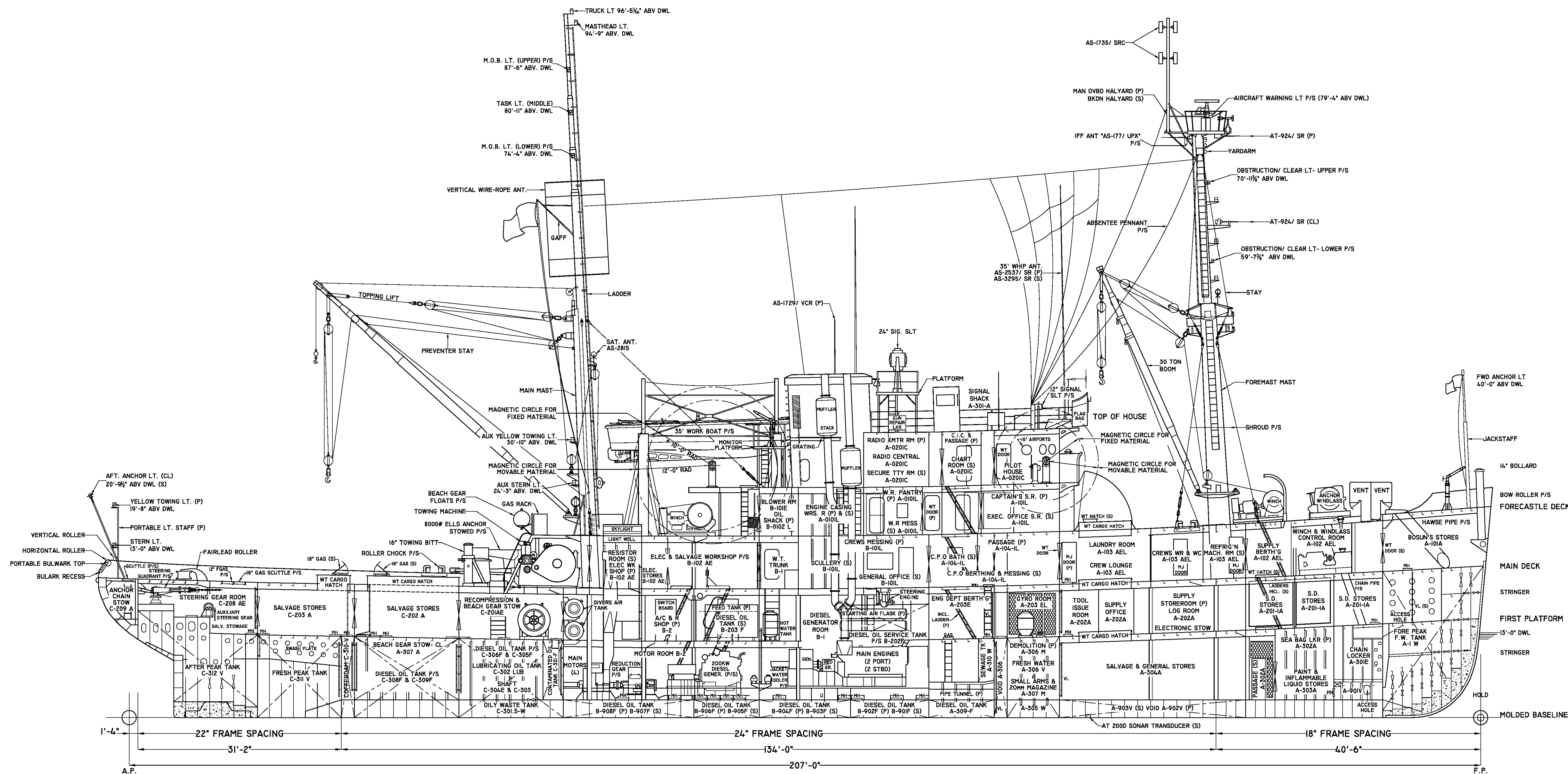

INBOARD PROFILE

NOTE: DRAWINGS OF 1983 CONFIGURATION WERE DONATED BY ROBERT D. JAMIESON. MODEL PLANS: 430 W. ALLENS LANE, PHILADELPHIA, PA 19119-2804

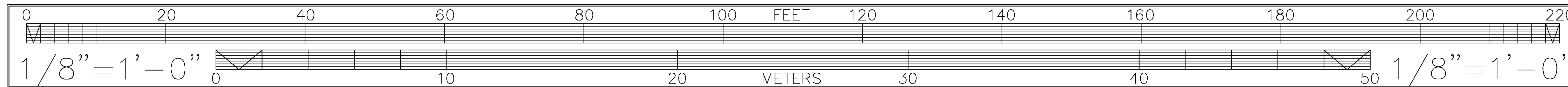

USS Bolster (ARS-38) (1983 Configuration)

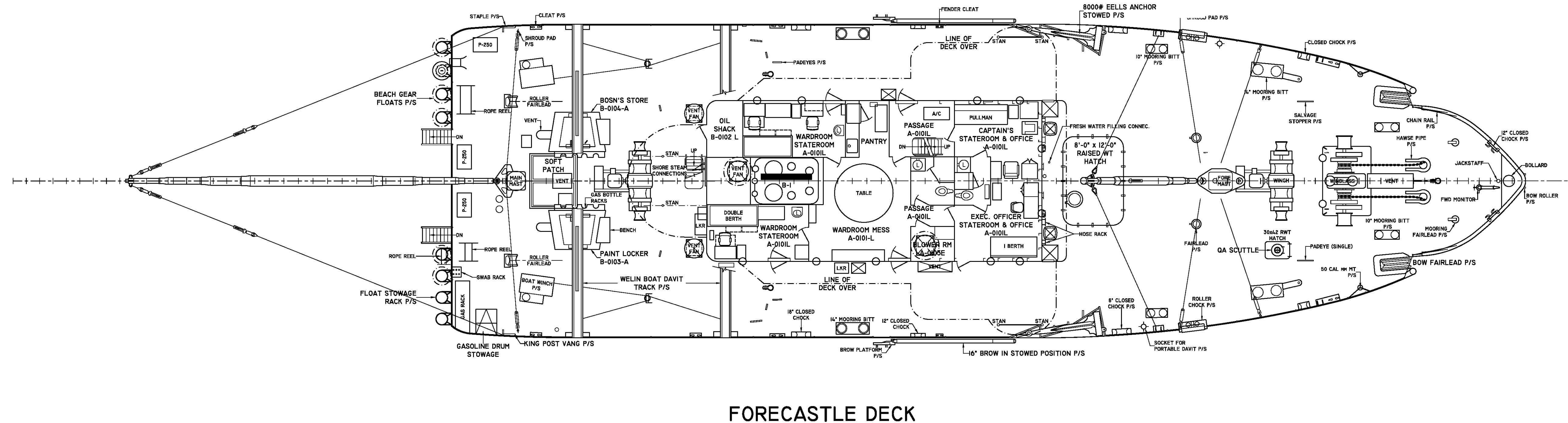
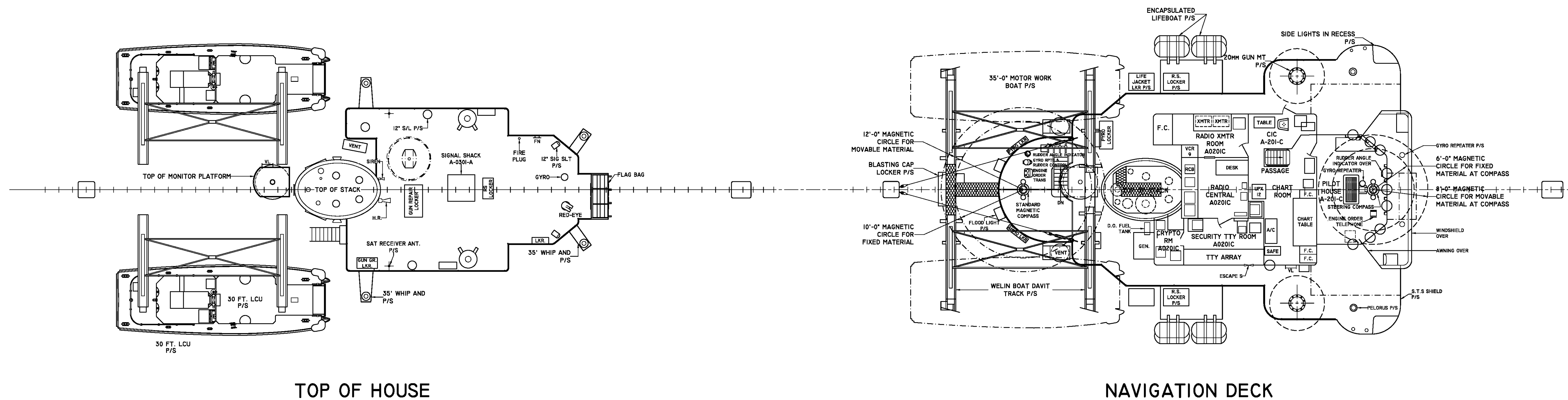

NOTE: DRAWINGS OF 1983 CONFIGURATION WERE DONATED BY ROBERT D. JAMIESON. MODEL PLANS: 430 W. ALLENS LANE, PHILADELPHIA, PA 19119-2804

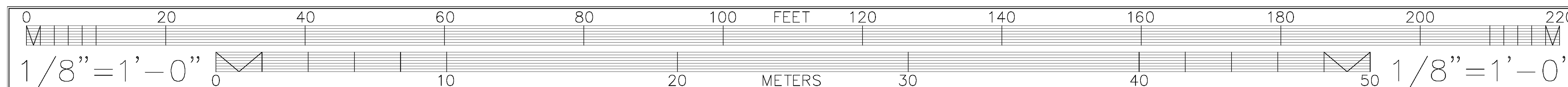

USS Bolster (ARS-38)

(1983 Configuration)

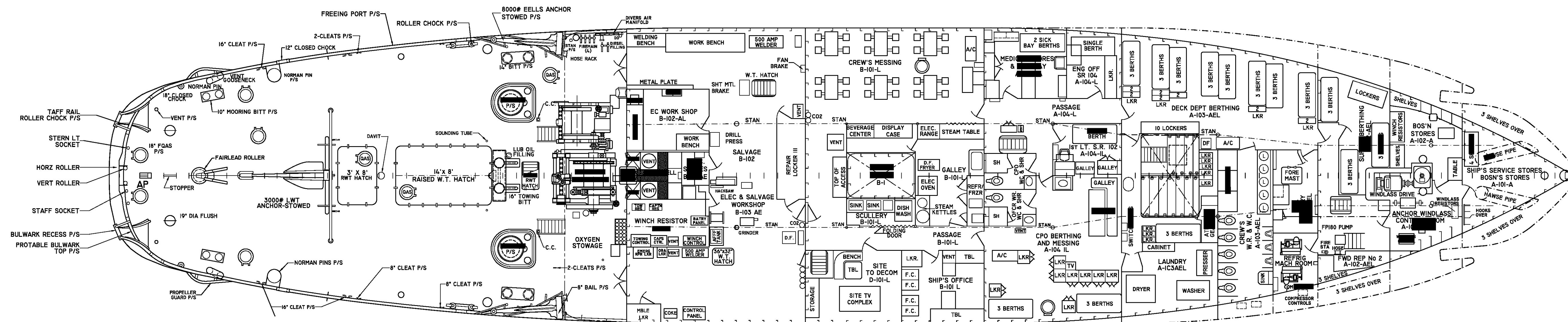

MAIN DECK

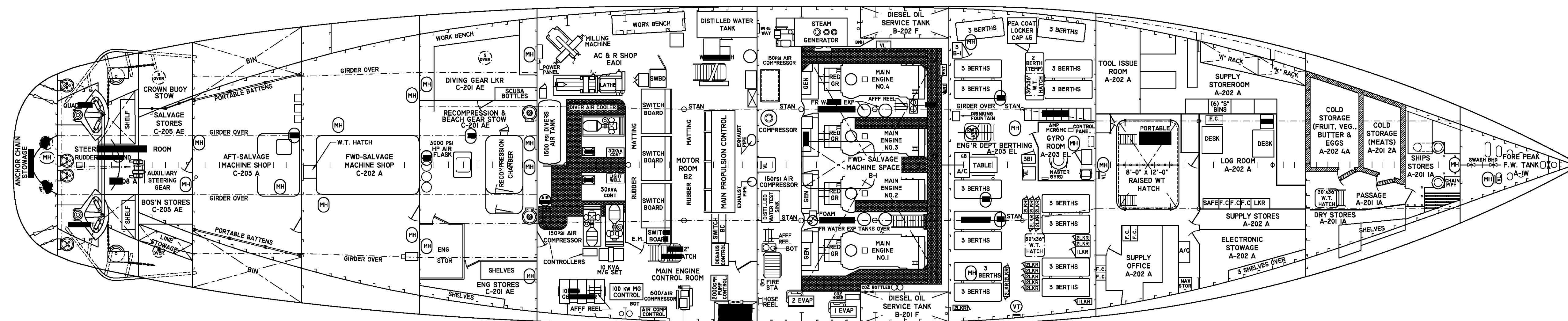

FIRST PLATFORM

NOTE: DRAWINGS OF 1983 CONFIGURATION WERE DONATED BY ROBERT D. JAMIESON. MODEL PLANS: 430 W. ALLENS LANE, PHILADELPHIA, PA 19119-2804

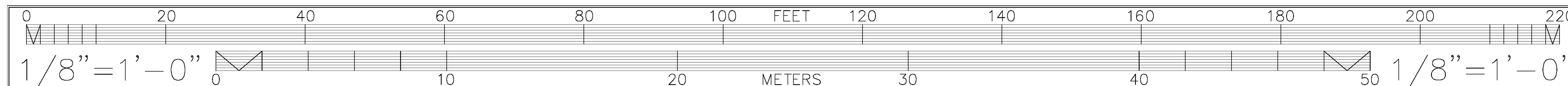

USS Bolster (ARS-38)

(1983 Configuration)

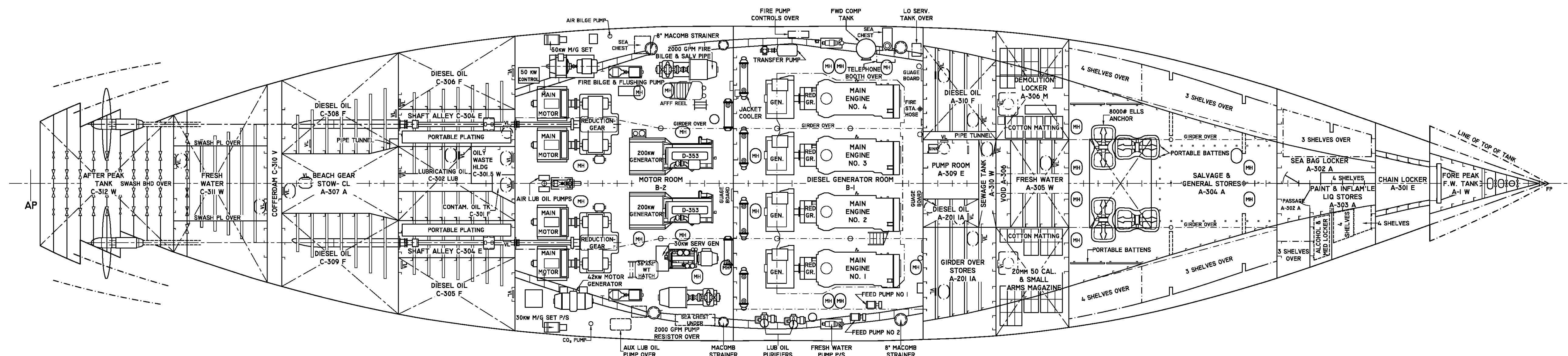

HOLD

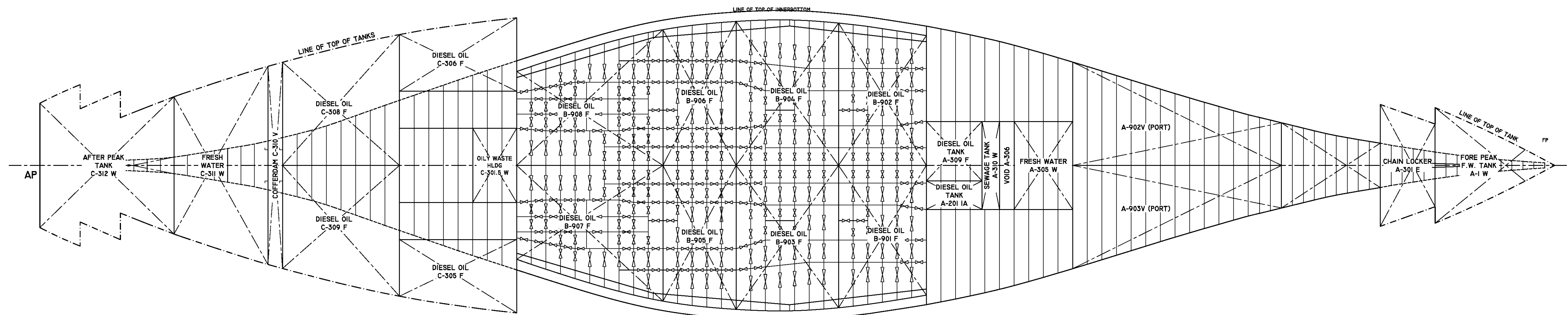

INNERBOTTOM

NOTE: DRAWINGS OF 1983 CONFIGURATION WERE DONATED BY ROBERT D. JAMIESON. MODEL PLANS: 430 W. ALLENS LANE, PHILADELPHIA, PA 19119-2804

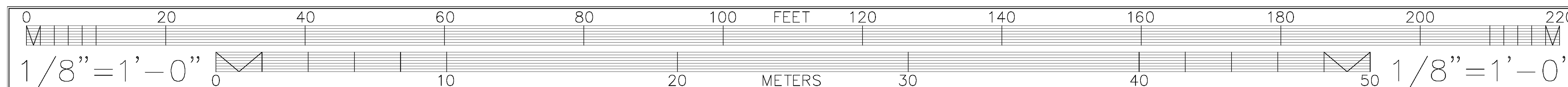

USS Bolster (ARS-38)

(1983 Configuration)

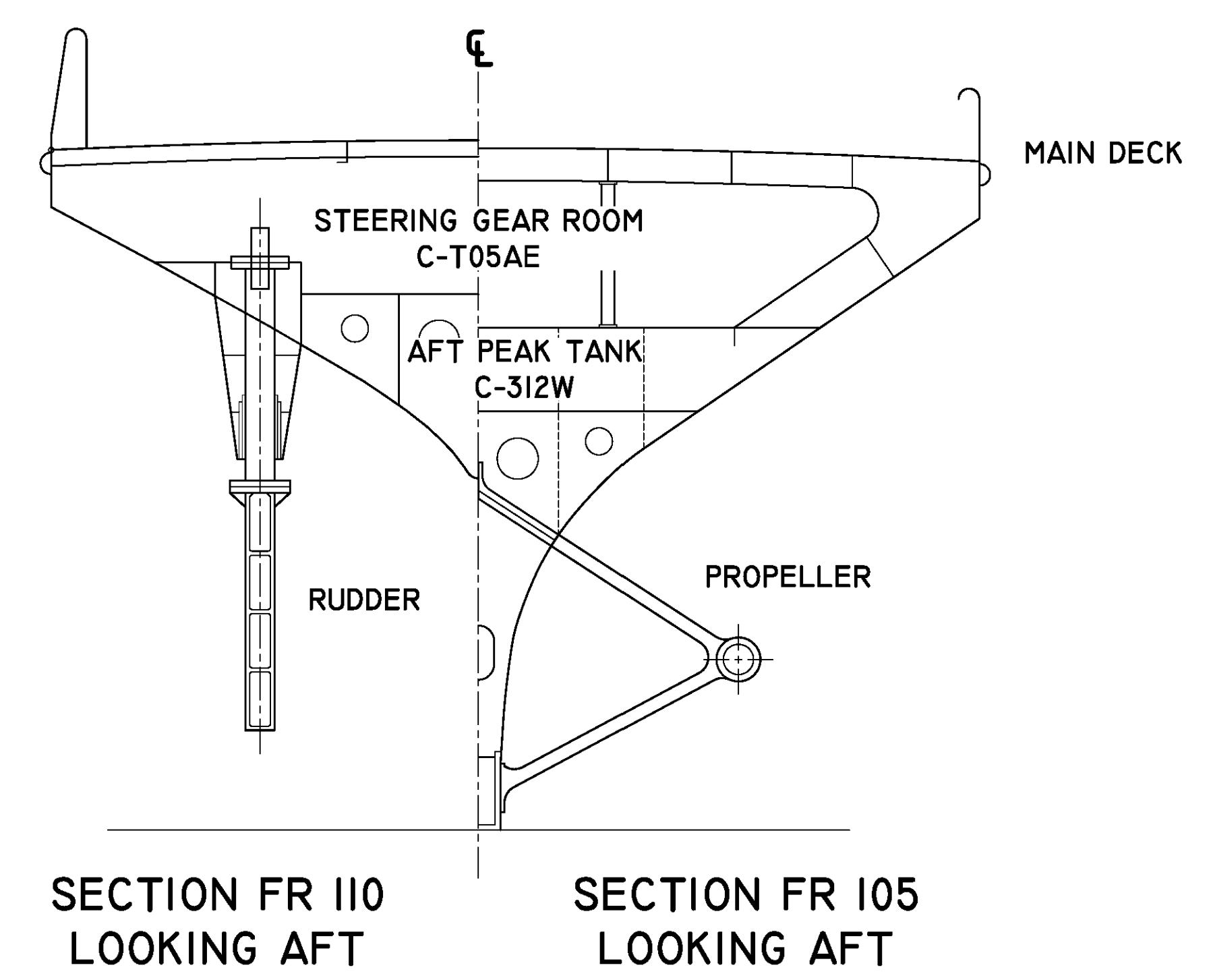
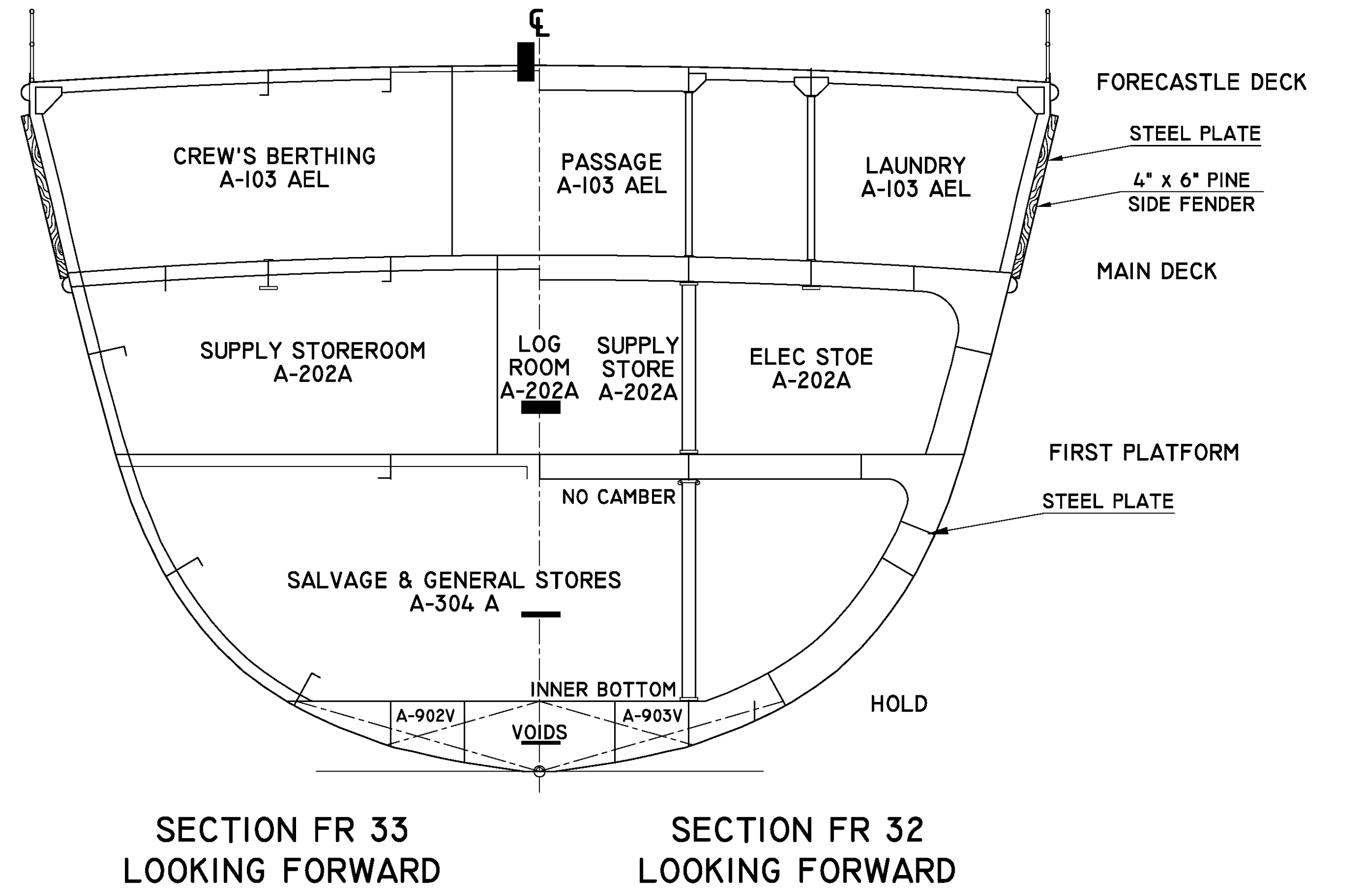
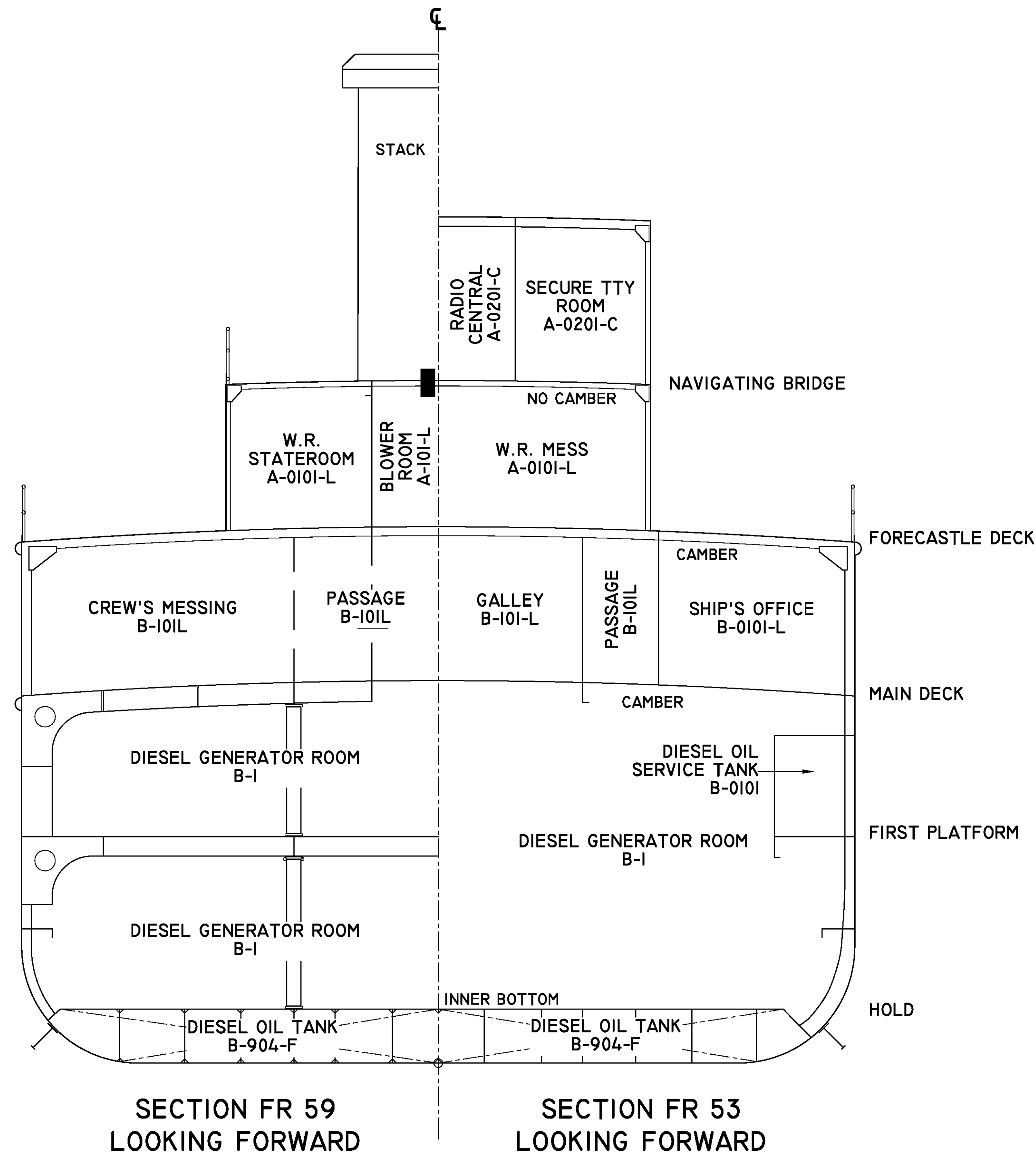

NOTE: DRAWINGS OF 1983 CONFIGURATION WERE DONATED BY ROBERT D. JAMIESON. MODEL PLANS: 430 W. ALLENS LANE, PHILADELPHIA, PA 19119-2804

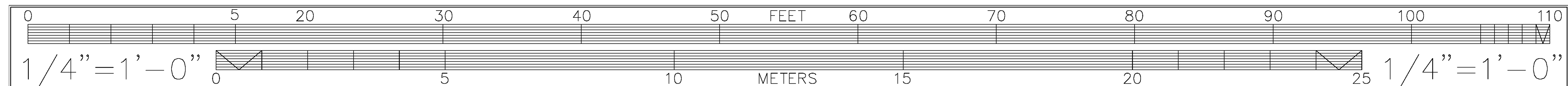

USS Bolster (ARS-38)

(1983 Configuration)

Details

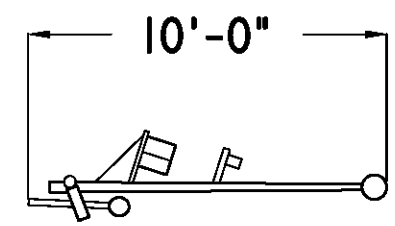

AFTER FLAGSTAFF

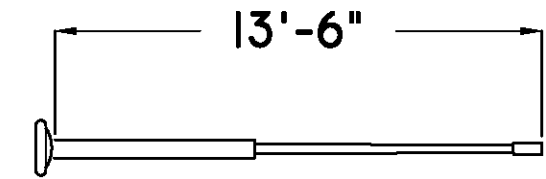

FORWARD FLAGSTAFF

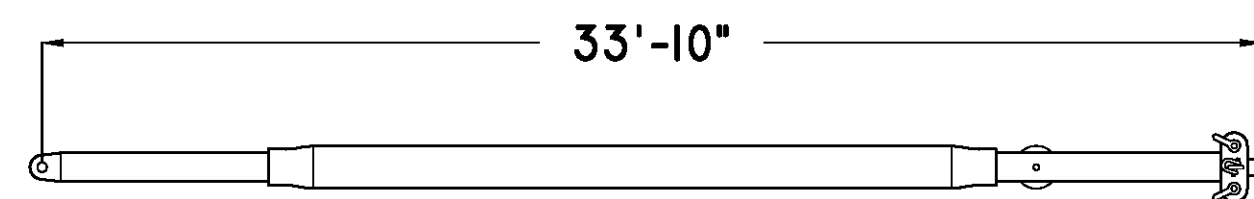

10 TON DERRICK

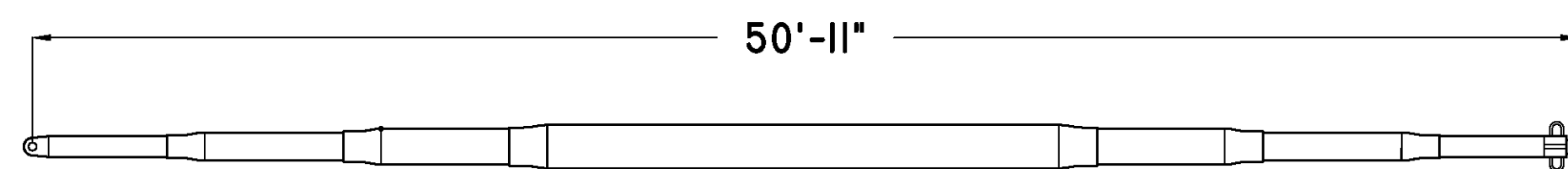

10 TON DERRICK

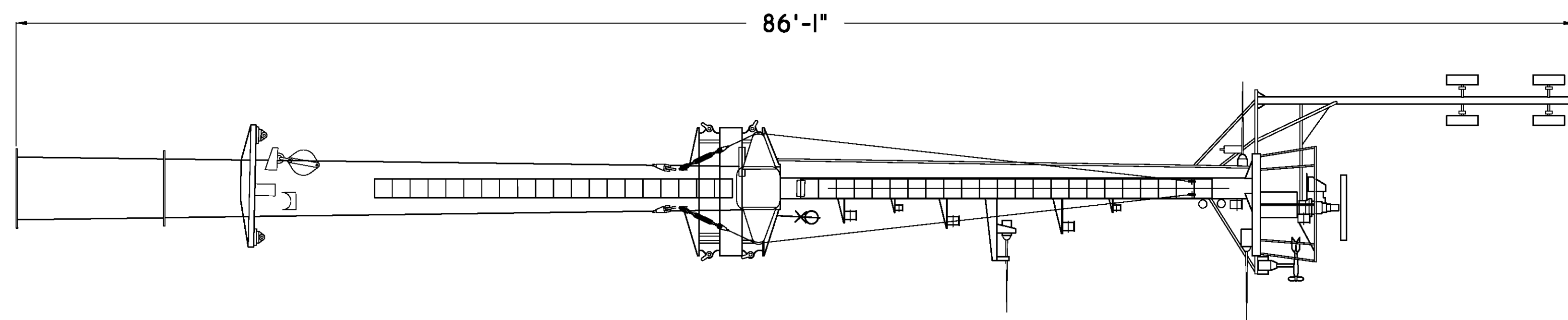

FORE MAST

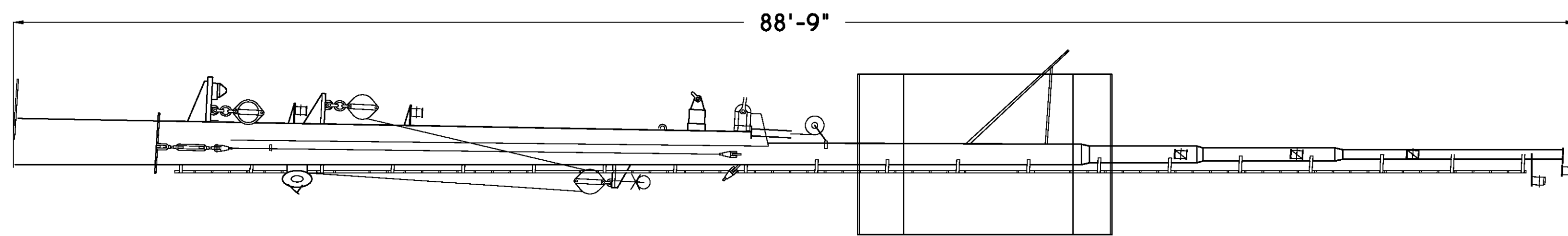

MAIN MAST

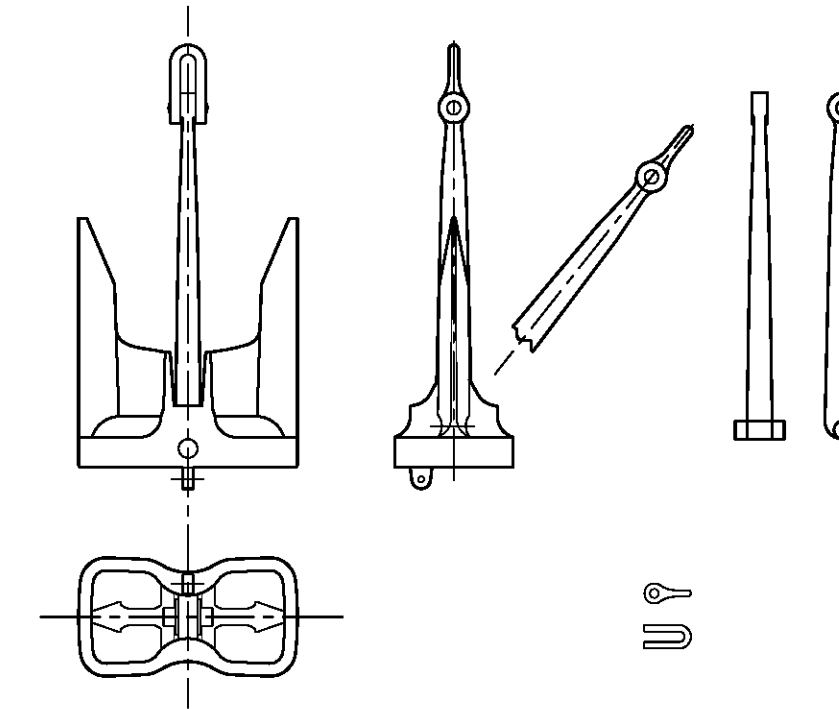

EELLS ANCHOR 8,000 LBS

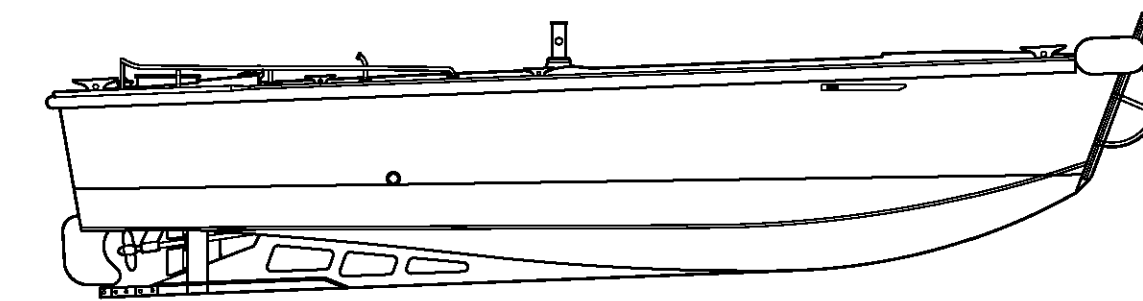

ALMON JOHNSON
AUTOMATIC TOWING
MACHINE

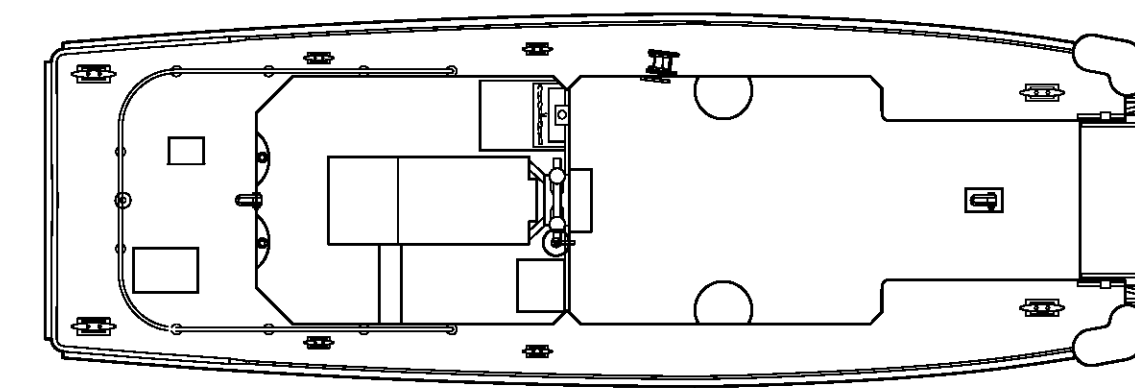

36FT. LCU
(LANDING CRAFT UTILITY)

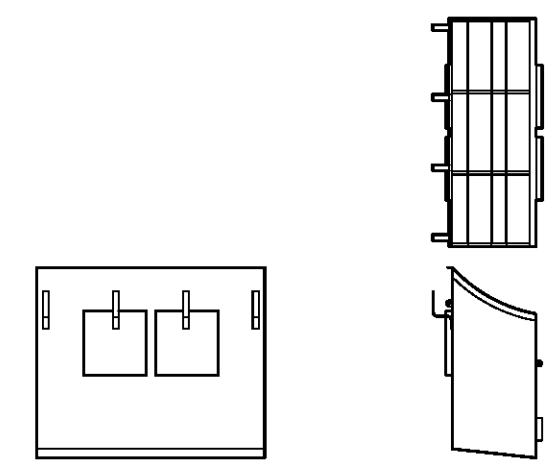

FLAGBAG

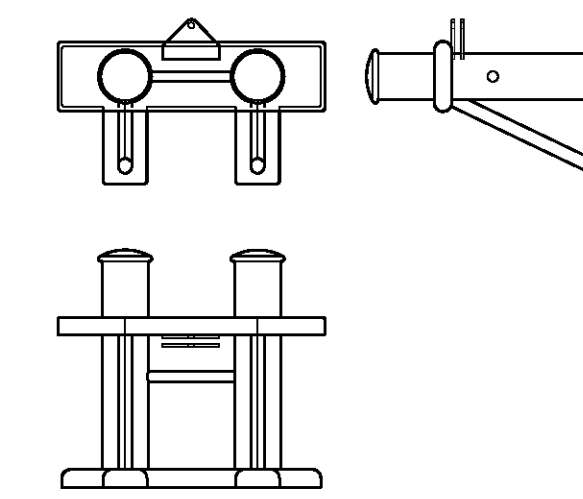

"H" BITT

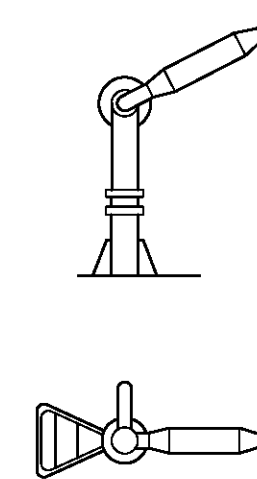

FIRE MONITOR

NOTE: DRAWINGS OF 1983 CONFIGURATION WERE DONATED BY ROBERT D. JAMIESON. MODEL PLANS: 430 W. ALLENS LANE, PHILADELPHIA, PA 19119-2804

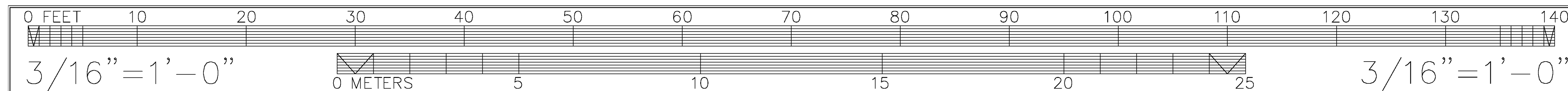

REFORMATTED BY: ASHLEY T. WALKER, 2010
 NAVAL MARITIME RECORDING PROGRAM
 NATIONAL PARK SERVICE
 UNITED STATES DEPARTMENT OF THE INTERIOR
 BENICIA VICINITY
 USS BOLSTER (ARS-38)
 SUISUN BAY RESERVE FLEET
 SOLANO COUNTY
 CALIFORNIA 8 OF 9
 SHEET
 HISTORIC AMERICAN ENGINEERING RECORD
 CA-355
 LIBRARY OF CONGRESS
 INDEX NUMBER

