

New York Integrated Incident Management System Evaluation Project Final Report



Prepared For:
U.S. Department of Transportation
ITS Joint Program Office
Federal Highway Administration

March 23, 2007

NOTICE

This document is disseminated under the sponsorship of the U.S. Department of Transportation in the interest of information exchange. The U.S. Government assumes no liability for the use of the information contained in this document. This report does not constitute a standard, specification, or regulation.

The U.S. Government does not endorse products or manufacturers. Trademarks or manufacturers' names appear in this report only because they are considered essential to the objective of the document.

FOREWORD

This national evaluation final report presents the case study and lessons learned resulting from the examination of the events, challenges, and factors that affected the deployment of the Integrated Incident Management System (IIMS) in New York State. The IIMS system deployment occurred within a five-borough area of New York including: Manhattan, the Bronx, Brooklyn, Queens, and Staten Island. Initially planned as a two-phase deployment (beginning with Phase 1 on the highways of Brooklyn, patrolled by New York Police Department Highway Patrols and expanding to Phase 2 in the remaining four boroughs) the post 9/11 deployment was refined to include both phases. The system has been operating across all five boroughs of New York City since March 2003, with additional IIMS units being deployed continuously since that time.

The initial IIMS deployment focused on incident management, including the deployment of new technologies that improve emergency response capabilities. In particular, emphasis is placed on information exchange and data sharing, and facilitating the coordination of incident response management activities. In the second phase, independent evaluations were conducted to document lessons learned; collect and analyze field data on a “before” and “after” project basis; and to identify benefits realized during the field operational tests.

This Final Report presents the findings of the independent evaluation of the IIMS project. This report encompasses the IIMS evaluation initiated under IPAS I Contract Number DTFH61-96-C-00098, Task 9818, completed in April 2004 and continued under IPAS II DTFH61-02-C-00061, Task 61016. The reason for the extended evaluation period was to enable the IIMS system to be assessed as a mature system. While IIMS is not yet a production system, the system is being used on a regular basis in multiple uses by various agencies. Several system enhancements are nearing deployment, and when deployed, will enable IIMS to move to a production-level system. The IIMS system has matured to the point where the lessons learned and benefits realized are sufficient to successfully complete the evaluation.

The purpose of this document is to report a combined evaluation and case study analysis of the events associated with the IIMS deployment efforts and to present lessons learned that are based on the IIMS Evaluation and IIMS Deployment Teams’ experiences. It is anticipated that reporting on the events and lessons learned may be useful to other public/private sector individuals, Metropolitan Planning Organizations, and jurisdictions who may be considering a similar deployment effort.

This document supersedes an earlier report on the subject.

1. Report No.	2. Government Accession No.	3. Recipient's Catalog No.	
4. Title and Subtitle New York Integrated Incident Management System Evaluation Project Final Report		5. Report Date March 2007	
		6. Performing Organization Code	
7. Authors: Diane Newton (SAIC), Nick Owens (SAIC), Mark Carter (SAIC), and Carol Mitchell (SAIC)		8. Performing Organization Report	
9. Performing Organization Name and Address Science Applications International Corporation (SAIC) 1710 SAIC Drive, M/S T1-12-3 McLean, VA 22102		10. Work Unit No. (TRAIS)	
		11. Contract or Grant No. DTFH61-02-C-00061; Task 61016	
12. Sponsoring Agency Name and Address United States Department of Transportation ITS Joint Program Office, Room 3416 400 7 th Street, SW Washington, DC 20590		13. Type of Report and Period Covered Final Report	
		14. Sponsoring Agency Code HOIT-1	
15. Supplementary Notes Ms. Linda Dodge (COTM) Dr. Joseph I. Peters (COTR)			
16. Abstract The Integrated Incident Management System (IIMS) enables incident response personnel to transmit data about an incident to other responders and dispatchers on a real-time basis. When an incident is entered into IIMS, the system uses GPS to identify the exact location of the incident and also enables response personnel to take and transmit pictures of an incident using a digital camera. The system also enables responders to exchange data about the incident and creates an incident log, including time stamps on incident duration. IIMS is deployed in each of the New York City boroughs and is used by both New York State and New York City transportation, enforcement and emergency response personnel. IIMS is operated by the NY Department of Transportation. IIMS has helped to reduce incident response time by enabling responders to verify incidents and identify what response assets are required through using IIMS data exchange capabilities. Previously, a supervisor was dispatched to an incident scene to make these types of decisions. IIMS will eventually be deployed using Web services, thus enabling users to access the system through a Web browser.			
Key Words Intelligent Transportation Systems, Incident and Emergency Response, Incident Management, Wireless Communications, Interoperable Communications, Real-Time Data Exchange		18. Distribution Statement No restrictions. This document is available to the public from: The National Technical Information Service, Springfield, VA 22161.	
19. Security Classif. (of this report) Unclassified	20. Security Classif. (of this page) Unclassified	21.No of Pages 82	22. Price N/A

Form DOT F 1700.7 Reproduction of completed page authorized.

TABLE OF CONTENTS

EXECUTIVE SUMMARY	1
1. INTRODUCTION.....	7
2. IIMS PROGRAM OVERVIEW.....	8
2.1 IIMS Project Background.....	8
2.1.1 IIMS System Description.....	9
2.1.2 Creating an IIMS Incident Record.....	12
2.1.3 Recent Upgrades	18
2.2 Lessons Learned.....	20
2.2.1 IIMS User Group and System Enhancements	20
2.2.2 Software Testing	21
2.2.3 Resource Allocation.....	21
2.2.4 Interagency Collaboration.....	22
3. USAGE ANALYSIS.....	23
3.1 IIMS Units by Agency	23
3.2 IIMS Usage Information	25
3.2.1 Incident Record Creation	25
3.2.2 Improved Usage and Data Accuracy	26
3.2.3 Future Report Generation Using Archived Data	30
3.3 Innovative Uses of IIMS	31
4. CASE STUDIES.....	32
4.1 Development of Initial Case Studies.....	32
4.1.1 Selection of Incident Types	33
4.1.2 Description of Specific Incidents.....	34
4.2 Initial Case Study Analysis	38
4.2.1 Case I: Incident 4886	39
4.2.2 Case II: Incident 1593.....	41
4.2.3 Case III: Incident 2431.....	44
4.3 Analysis of Additional Incident Types	47
4.3.1 Review of Additional Incident Types	48
4.3.2 Analysis of Additional Individual Incidents	53
5. EVALUATION FINDINGS	55

5.1 Findings..... 55

5.1.1 Finding #1: The Integrated Incident Management System can be Considered a Successful Deployment..... 55

5.1.2 Finding #2: The Integrated Incident Management System is Designed to Deploy New Technologies in a Cost-Effective Manner..... 55

5.1.3 Finding #3: The IIMS Case Studies Successfully Identify Situations Where the Use of IIMS has the Potential to Improve Incident Response Operations..... 56

5.1.4 Finding #4: The Case Studies Identify How the Use of IIMS has the Potential to Substantially Improve Mobility 57

5.1.5 Finding #5: IIMS Has the Potential to Improve Traveler and Responder Safety..... 58

5.1.6 Finding #6: IIMS Has the Potential to Provide Energy and Environmental Benefits 60

5.1.7 Finding #7: The Use of IIMS Has Resulted in Better Incident Management Documentation..... 61

5.1.8 Finding #8: IIMS Improves Post-Incident Assessment/Evaluation Process 62

5.2 Evaluation MOEs..... 65

5.3 Evaluation Lessons Learned 65

6. CONCLUSIONS, RECOMMENDATIONS, AND FUTURE CHALLENGES 67

6.1 Conclusions and Recommendations..... 67

6.1.1 Conclusions..... 67

6.1.2 Recommendations..... 68

6.2 Remaining Challenges 68

6.2.1 System Limitations 68

6.2.2 Impacts 69

REFERENCES..... 70

LIST OF FIGURES

Figure 1. IIMS Deployment Areas.....	9
Figure 2. Overview of the IIMS Operations and Partner Agency Inter-Relationships.....	10
Figure 3. IIMS In-Vehicle Equipment.	11
Figure 4. Local Unit Incident Creation Wizard.	12
Figure 5. “Quick Tab” Incident Type Selection Screen.	13
Figure 6. IIMS In-Vehicle Screen Reporting Incident Type and Location.	14
Figure 7. IIMS Storage Log Containing Digital Images.....	15
Figure 8. IIMS In-Vehicle Screen Providing Incident Details.	15
Figure 9. IIMS Center Screen with a Quad View of Relevant Information Including Digital Images and Captions from the Scene.....	16
Figure 10. IIMS Screen Showing Access/Evacuation Routes and a Staging Area.	17
Figure 11. IIMS Center Screen Showing Lane Status.	17
Figure 12. IIMS System Architecture.....	19
Figure 13. Cumulative Number of IIMS Units by Year.	25
Figure 14. The Trend in IIMS Incident Record Creation Over the First 120 Days.....	25
Figure 15. Trends in IIMS Incident Record Creation from 2004 to 2006.	26
Figure 16. Incidents Created by Type from 2004 to 2006.....	27
Figure 17. Distribution of Incident Durations for all Roadway Damage Incidents.....	33
Figure 18. Distribution of the Roadway Damage Incidents with a Duration of 10 Minutes or Greater.....	34
Figure 19. Unsecured Overhanging Sign in Incident 4886.....	35
Figure 20. GIS Location System Showing Satellite Image.	36
Figure 21. Roadway Damage Next to a Drainage Grate.	37
Figure 22. Temporary Repair to Restore the Right Lane.....	37
Figure 23. Pre-IIMS Activity Network Diagram Incident 4886.....	40
Figure 24. IIMS Activity Network Diagram Incident 4886.	40
Figure 25. Pre-IIMS Activity Network Diagram Incident 1593.....	42
Figure 26. IIMS Activity Network Diagram Incident 1593.	42
Figure 27. Existing IIMS Deployment Activity Network Diagram Incident 2431.	45
Figure 28. Full IIMS Deployment Activity Network Diagram Incident 2431.	46

Figure 29. Roadway Damage Incident Duration Descriptors.....49

Figure 30. Debris Spill and Fuel Spill Incident Duration Descriptors.....50

Figure 31. Fuel Spill Incident Duration Descriptors.....50

Figure 32. Tractor Trailer Incident Duration Descriptors.....51

Figure 33. Sample Archived Picture in IIMS.64

Figure 34. Sample Archived Map in IIMS.64

Cover Photo Credits:

- Upper left: Science Applications International Corporation (SAIC) under contract to the U.S. Department of Transportation
- Upper right, lower left and lower right: Integrated Incident Management System (IIMS) software screen captures

Figure Photo Credits: Science Applications International Corporation (SAIC) under contract to the U.S. Department of Transportation, unless otherwise noted

LIST OF TABLES

Table 1. Evaluation Hypotheses and Findings.....	3
Table 2. Total Units by Agency and Year	24
Table 3. Incidents with Lane Closure	27
Table 4. Lane Closure by Incident Type.....	28
Table 5. Lane Closure Durations in Minutes	28
Table 6. Incident Durations in Hours.....	29
Table 7. Incident 4886 Performance Measures.....	41
Table 8. Incident 1593 Performance Measures.....	43
Table 9. Incident 2431 Performance Measures.....	46
Table 10. Outlier Duration Examples	52
Table 11. Quantitative Improvements in Incident Response	56
Table 12. Quantitative Improvements in Incident Management Communications	57
Table 13. Typical Queue Lengths due to Roadway Damage Incidents	58
Table 14. Results of Various Secondary Crash Search Strategies.....	59
Table 15. Reduction in Exposure to Hazardous Conditions	60
Table 16. Quarterly Review Data for Roadway Damage Incident Management	63
Table 17. Evaluation Hypotheses and Findings.....	65

LIST OF ABBREVIATIONS

CAD	Computer-Aided Dispatch
CORBA	Common Object Request Broker Architecture
CPM	Critical Path Method
DMS	Dynamic Message Sign
DoITT	Department of Information Technology & Telecommunications
DSNY	Department of Sanitation of New York
EMS	Emergency Management Services
FHWA	Federal Highway Administration
FOT	Field Operational Test
GIS	Geographic Information Systems
GPS	Global Positioning Systems
Hazmat	Hazardous Materials
HTTP / HTTPS	HyperText Transfer Protocol / HyperText Transfer Protocol over Secure Sockets Layer
IEEE	Institute of Electrical and Electronics Engineers
IIMS	Integrated Incident Management System
IPAS	ITS Program Assessment Support
IT	Information Technology
ITS	Intelligent Transportation Systems
JPO	Joint Program Office
JTOC	Joint Traffic Operations Center
LOS	Level of Service
MOU	Memorandum of Understanding
mph	miles per hour
MTA	Metropolitan Transit Authority
NY	New York
NYCDOS	New York City Department of Sanitation
NYCDOT	New York City Department of Transportation
NYPD HP	New York Police Department Highway Patrol
NYSDOT	New York State Department of Transportation
NYSP	New York State Police

OER	Office of Emergency Response
OIS	Office of Information Services
PIC	Person in Charge
R&D	Research and Development
SAIC	Science Applications International Corporation (Evaluation Team)
SSL	Secure Sockets Layer
STEAM	Surface Transportation Efficiency Analysis Model
TMC	Traffic Management Center
TTI	Texas Transportation Institute
USDOT	United States Department of Transportation
vph	vehicles per hour
vpm	vehicles per mile
VPN	Virtual Private Network

EXECUTIVE SUMMARY

Introduction

The Integrated Incident Management System (IIMS) in New York State is a real-time incident management system that enhances the incident management process through improved communications among the participating agencies. The IIMS project is under the overall direction of the New York State Department of Transportation (NYSDOT) Research and Development (R&D) Bureau, with direct oversight through NYSDOT's Region 11 Office. The NYSDOT's Office of Information Services (OIS) is providing technical support at the State level, and the New York City Department of Information Technology & Telecommunications (DoITT) is doing so at the city level.

Current IIMS users represent many of the City's response and highway community. At the State level, NYSDOT headquarters and Region 11 office has units in New York City (NYC), and NYC's DOT, Police Department, Office of Emergency Management, Fire Department, Emergency Management Services, Department of Sanitation, Department of Environmental Protection and the Metropolitan Transportation Authority Police all participate and have mobile and local units.

The IIMS deployment area includes the freeways in the five boroughs of New York City.

Approach

Initially, the expectation was that the information exchange facilitated by IIMS would lead to faster incident clearance times, reduced secondary crash risk, and operational savings for the incident responders. Therefore, the initial evaluation methodology focused on identifying the general benefits of the IIMS deployment through a general, comparative "before" and "after" comparison of incident management metrics such as incident duration, mobility, response time, on-scene time, and incident verification time. The evaluation team immediately noted it would be difficult to assess these metrics in the "before" scenario; hence, they focused on developing case studies using existing metrics from IIMS and then conducted focus groups to assess how the system had affected the incident response and management process. Time savings were then identified for the "before" and "after" cases.

After the initial focus groups had been conducted for roadway damage incidents and the draft Final Report produced, the Statement of Work for the evaluation was revised so that the focus became identifying specific benefits by incident type. At this stage in the evaluation however, it was truly difficult to ascertain the "before" and "after" effects of IIMS, especially for particular incident types because the complexity of the focus group/Delphi panel process precluded its use in the later stages of the evaluation. In this way, it was difficult to expand the evaluation to additional incident types.

As the evaluation concluded and the IIMS system developers began the deployment of the Web services version of IIMS, though, the general benefits seemed stronger as they related to the

increased inter-agency collaboration and the potential and existing use of archived data, as opposed to shortening the duration of a particular type of incident. The lesson learned the Evaluation Team took away from this experience was to move forward with the promising conclusions offered by the stakeholder and user groups, as they are also powerful in expressing how the system is actually being used and the value that the stakeholders currently see in IIMS.

Therefore, this evaluation report presents the quantitative results from the initial roadway damage case studies, as well as other quantitative results on IIMS system usage, incident durations, and lane closure durations. In an effort to expand the evaluation to include additional incident types, the team did evaluate a segment of incident records for tractor trailer, debris spill, and fuel spill incidents to investigate certain incident management metrics such as incident duration and lane closure duration. Lastly, the evaluation also includes anecdotal and qualitative results on innovative system usage and the qualitative benefits that local system stakeholders have recognized.

Findings

While the Evaluation Team initially focused on quantitative conclusions, the recent system upgrades have highlighted a number of key qualitative findings. The Evaluation Team considered these findings to be of equal or greater importance than the quantitative analysis results. Therefore, this report provides a mix of both quantitative and qualitative findings. At a high level, there were eight key findings (more detail on these can be found in section 5 of this report):

1. IIMS Stakeholders consider the deployment to be a success. They have concluded this success by measuring a consistently large creation of records among agencies. In addition, IIMS is “mainstreamed” as an operational system by the NYSDOT OIS and the NYC DoITT.
2. The Web services IIMS system has been designed with cost savings in mind. The Web services version has resulted in server consolidation, which resulted in significant cost savings. In addition, report creation will be supported by archived incident data.
3. The evaluation case studies have identified situations where IIMS can improve incident response operations:
 - a. Reduction in roadway damage incident duration.
 - b. Reduction in incident verification and communications times.
4. The evaluation case studies have shown the potential for IIMS to improve mobility.
5. IIMS has the potential to improve traveler and responder safety:
 - a. Reduction in exposure times for responding personnel.
6. IIMS has the potential to provide energy and environmental benefits.
7. IIMS has improved the incident management documentation process, especially in three areas:

- a. Unit activities.
 - b. Record-keeping activities.
 - c. Monitoring activities.
8. IIMS has improved the post-incident analysis process through the provision of a centralized database of incident records and through the maintenance of archived records (under the Web-services version), which allow for individual agency and State-level report creation.

These findings are mapped to the original evaluation hypotheses presented in Table 1.

Table 1. Evaluation Hypotheses and Findings

Goal	Hypothesis	Finding
Evaluate the incident management effects of the IIMS	IIMS will result in improved incident response.	Finding 3: The IIMS case studies successfully identify situations where the use of IIMS has the potential to improve incident response operations.
	IIMS will result in improved communications.	Finding 8: IIMS improves the post-incident assessment/evaluation process.
	IIMS will result in improved coordination of resources.	
Evaluate the transportation system performance effects of the IIMS	IIMS will result in improved mobility.	Finding 4: The case studies identify how the use of IIMS has the potential to substantially improve mobility.
Evaluate the energy and environmental effects of IIMS	IIMS will result in energy and environmental benefits.	Finding 6: IIMS has the potential to provide Energy and Environmental Benefits.
Evaluate the safety effects of IIMS.	IIMS will result in increased traveler safety.	Finding 5: IIMS has the potential to improve traveler and responder safety.
	IIMS will result in increased worker safety.	
Assess the process improvements and institutional impacts of the IIMS.	IIMS will result in better incident management documentation.	Finding 7: The use of IIMS has resulted in better Incident management documentation.
	IIMS will improve evaluation and assessment of the process and its performance.	Finding 1: IIMS has been considered a successful deployment (by stakeholders). Finding 2: IIMS was deployed in a cost-effective manner.

Lessons Learned

The deployment of IIMS has been ongoing for several years. During this time, system stakeholders noted several deployment lessons learned. Although the IIMS deployment is considered successful, some of these lessons learned illustrate how the ITS deployment process can be painstaking, detailed, and lengthy. The lessons learned also illustrate some key aspects that have led IIMS to become a system that is integrated into normal operations and one that has maintained consistent usage for several years.

- First, it was important that the system was developed using standard agency system development processes. This ensures that the system will meet agency standards and operating requirements, and that the system will be mainstreamed into agency Information Technology (IT) services and programs, thus ensuring ongoing operations and maintenance support.
- Second, it was critical that high-level management support be obtained for system development. This would ensure that system development was supported by and integrated into existing IT resources and programs within an agency. This action also would provide an incentive to other user agencies to promote system deployment and integration to a priority level.
 - It also was important to involve users in discussing system requirements and enhancements, and to ensure that this is ongoing throughout the system development process. As an added benefit, user feedback collected on a periodic basis once the system is operational eventually warranted a new, more usable version of the application. This type of involvement provided a venue for users to take ownership of the system, and ensured that the system would be developed to meet user needs, thus ensuring that over time, a consistent or increasing level of usage is realized.
 - System developers have realized that the system will operate more effectively if the list of users is maintained and frequently updated. This should help maintain the system units, ensure that all users have the most current training, and ensure that usage remains consistent within all agencies.
- Third, the IIMS deployment benefited immensely from inter-agency collaboration. Through discussions on IIMS, agencies were brought together and further improved communications and relationships through project activities such as table top exercises to identify requirements and needs.
- Last, IIMS stakeholders recognized that the development of the initial system could have been delayed by trying to implement a formal organizational structure too soon in the process. The establishment and execution of Memorandums of Understanding (MOUs) will likely be significantly easier for the IIMS stakeholders to achieve now, as all stakeholders are aware of the fact that IIMS is now deployed and successfully operational.
 - Stakeholders now feel that establishing a formal structure such as MOUs will likely make further system enhancements easier to “sell” to stakeholders who are aware that their implementation will significantly improve access to IIMS. This demonstrates the

importance of showing the benefits of system use to potential users, which in turn, obtains further stakeholder buy-in and support.

In general, IIMS benefited from its “grass roots” beginning and initial positive attitude by all involved. The IIMS users also determined that achieving longevity through more formal organizational structure/roles may be needed to ensure continued and expanded use of IIMS.

Conclusions

The following conclusions were reached as the evaluation was completed. Many of them reflect the positive nature of the deployment and the system’s success.

- **Conclusion #1: IIMS provides Interoperable Real-Time Communications.** This interoperability will continue to expand with the deployment of the new Web Services version of IIMS. Without question, the key potential benefit offered by IIMS is the deployment of an interoperable communications system with real-time exchange of data. IIMS has addressed what has been a significant issue for the responder community—the lack of interoperable communications. With IIMS, responder agencies at both the State and New York City (or in other regions municipal, county, other local government agencies) are able to communicate directly and use the system to coordinate incident response activities.
- **Conclusion #2: The Integrated Incident Management System can be considered a successful deployment.** IIMS is being used by multiple users from multiple agencies, as summarized in section 3 of the report. These users are continuing to create thousands of IIMS incidents on an annual basis and have also expanded the use of IIMS to support highway maintenance activities in the New York City region. Responders routinely take pictures of and create incidents related to maintenance activities such as damage to roadside infrastructure such as guard rails and signs, and also the identification of potholes and other roadway required roadway repairs.
- **Conclusion #3: IIMS has been “mainstreamed” as an operational system as technical and operations support for IIMS is being provided by the NYSDOT OIS and the NYC DoITT.** What this means is that funds needed for operations and maintenance support are included as part of DoITT’s and OIS’s overall IT program support activities and technical support is being provided by staff from both organizations. This incorporation of IIMS support into OIS and DoITT operations addresses what is consistently a major issue for ITS deployments—identifying and securing the dedicated sources of funding and technical support needed to keep deployments operational.

Recommendations

Based on the positive nature of the preceding conclusions, the Evaluation Team provided several key recommendations for the Joint Program Office’s (JPO) consideration as they relate to the continued monitoring of IIMS as future enhancements are made.

Also, due to the system's continued use and success, it may be prudent to provide some outreach on the system's success and lessons learned.

Following are the recommendations offered:

- **Recommendation #1:** It is recommended that the project partners continue to provide the JPO with information on overall use of IIMS by agency and number of responders, and that this information include appropriate trend analyses. In addition, as the use of IIMS expands, the data available for analysis will be much richer and the possibility of quantifying direct IIMS impacts more feasible. The JPO may wish to provide support for further quantitative analyses when the JPO and project partners agree that IIMS use is at a point and data availability is such that a system-impact assessment may be feasible.
- **Recommendation #2:** It is therefore recommended that the JPO continue to monitor IIMS deployment to determine if further evaluation or assessment would be of benefit to the Public Safety Program. The JPO should consider providing other states and regions with information about the IIMS deployment. As noted previously, IIMS has the potential to provide an interoperable, real-time communication system for incident and emergency management and addresses a major need of the responder community.
- **Recommendation #3:** It is therefore recommended that the JPO develop outreach materials summarizing the IIMS deployment and develop a plan for making these available to other jurisdictions.

1. INTRODUCTION

The Intelligent Transportation Systems (ITS) Public Safety Program was initiated in 2000 to “develop and demonstrate innovative procedures and technologies for more coordinated public safety and transportation operations.”¹ The Federal Highway Administration (FHWA) recognized that ITS technologies were deployed largely without input from the public safety and law enforcement agencies. To remedy this, FHWA initiated the program to establish working relationships between transportation agencies, public safety, and law enforcement at the Federal, State, and local government levels. The goal of this effort is to improve coordination of operations and facilitate the deployment of new technologies that could improve public safety.

The initial program focused on incident management, including the deployment of new technologies that improve emergency response capabilities. In particular, emphasis is placed on information exchange and data sharing, and facilitating the coordination of incident response management activities. To help meet these program goals through the ITS Public Safety Program, FHWA is funding a series of national Field Operations Tests (FOTs) in different regions of the country, which are designed to:

- Develop interagency working relationships between the public safety and law enforcement agencies and departments of transportation to improve the coordination of incident response and management activities.
- Develop and test new technologies to enhance the real-time exchange of communications and data between agencies, and between field and dispatch operations.

A key component of the FOTs was to conduct independent evaluations to document lessons learned; collect and analyze field data on a “before” and “after” project basis; and identify FOT benefits. The New York City Integrated Incident Management System (NY IIMS) FOT, one of the first such tests to be funded through the ITS Public Safety Program, also was selected for independent evaluation through the Joint Program Office’s (JPO) ITS Program Assessment Support (IPAS) program. Science Applications International Corporation (SAIC) was selected as the independent evaluator (Evaluation Team) for this project.

This Final Report presents the findings of the independent evaluation of the IIMS project. This report encompasses the IIMS evaluation initiated under IPAS I Contract Number DTFH61-96-C-00098, Task 9818, completed in April 2004 and continued under IPAS II DTFH61-02-C-00061, Task 61016. The reason for the extended evaluation period was to enable the IIMS system to be assessed as a mature system. While IIMS is not yet a production system, the system is being used on a regular basis in multiple uses by various agencies. Several system enhancements are nearing deployment, and when deployed, will enable IIMS to move to a production-level system. However, the IIMS system has matured to the point where the lessons learned and benefits realized are sufficient to successfully complete the evaluation.

¹ ITS Public Safety Program Website, last accessed March 13 2007:
<http://www.itsdocs.fhwa.dot.gov/pubsafety/what_is_itspub.htm>.

2. IIMS PROGRAM OVERVIEW

The IIMS is designed to allow real-time transmission of accurate data about the location, severity, and impact of an incident to secondary responders with the New York City Department of Transportation (NYCDOT). The intent of this real-time information exchange function is to enable the NYCDOT to dispatch appropriate equipment needed to respond to an incident without also dispatching field Supervisors to the incident site to verify what the secondary response should be. Initially, the expectation was that this information exchange would lead to faster incident clearance times, reduced secondary crash risk, and operational savings for the incident responders.

Funding for the project was provided in part by the U.S. Department of Transportation (USDOT). This funding was used to equip the New York City Police Department's (NYPD) first response (NYPD) and NYCDOT's Office of Emergency Response (OER) "second-response" vehicles and to augment existing dispatch facilities. The USDOT's participation enabled the FOT to expand to the NYC Department of Sanitation (NYCDOS). The NYCDOS assumes responsibility for incident cleanup and deployment of repair crews during evenings, weekends, and holidays, when the NYCDOT OER is off duty.

2.1 IIMS Project Background

The IIMS project is under the overall direction of the New York State Department of Transportation (NYSDOT). The project is under the overall direction of the NYSDOT Research and Development (R&D) Bureau, with direct oversight through NYSDOT's Region 11 Office. The NYSDOT's Office of Information Services (OIS) is providing technical support at the State level, and the Department of Information Technology is providing the same for New York City Department of Information Technology & Telecommunications (DoITT). Current IIMS users include:

- NYSDOT:
 - Region 11 Traffic Management Center (TMC).
 - Region 11 Office.
 - Albany.
- NYC Department of Transportation.
- NYC Police Department.
- NYC Office of Emergency Management.
- NYC Fire Department / Emergency Management Services (EMS).
- NYPD Emergency Operations Center.
- Metropolitan Transportation Authority Police.
- NYC Department of Sanitation.

- NYC Department of Environmental Protection.

The IIMS deployment area includes the freeways in the following five boroughs: Manhattan, the Bronx, Brooklyn, Queens, and Staten Island. Initially planned as a two-phase deployment (beginning with Phase 1 on the highways of Brooklyn, patrolled by NYPD Highway Patrol (HP) Unit 2 and expanding to Phase 2 in the remaining four boroughs) the post 9/11 deployment was refined to include both phases. The system has been operating across all five boroughs of New York City since March 2003, with additional IIMS units being deployed continuously since that time; as an example, over 10 units were put into service during 2006 alone. The total IIMS coverage is shown in Figure 1.



Source: IIMS User Training Manual

Figure 1. IIMS Deployment Areas.

2.1.1 IIMS System Description

IIMS is a real-time incident management system that enhances the incident management process through improved communications among the participating agencies. Real-time, rich communications increases situational awareness as information is passed in text and image form from the personnel on the scene, to dispatch facilities, to a regional operations center, to key emergency response leaders. The system is collaborative, allowing the participants to leverage information in the development of incident-specific operational strategies.

Communications are facilitated by the deployment of wireless, mobile computers in incident responder vehicles equipped with Global Positioning System (GPS) transponders as shown in Figure 2. The computers in the field include interface systems that complement the operational environment using push button screen displays to make the IIMS easy to use for operators, while ensuring the flexibility to adapt to new and unusual circumstances.

IIMS is organized around one or incident management centers, or one or more stationary workstations or “centers”, also known as “local units,” and to the NYPD’s TMC. A local unit is comprised of a workstation computer, display, keyboard, and mouse. Each center can also have a remote unit, which is a workstation located within a partner agency location outside of an incident management center and can be a virtual local unit. All IIMS units require authorized users to log in with a unique user name and pass code. An overview of the IIMS operation and how the partner agencies are involved is shown in Figure 2.²

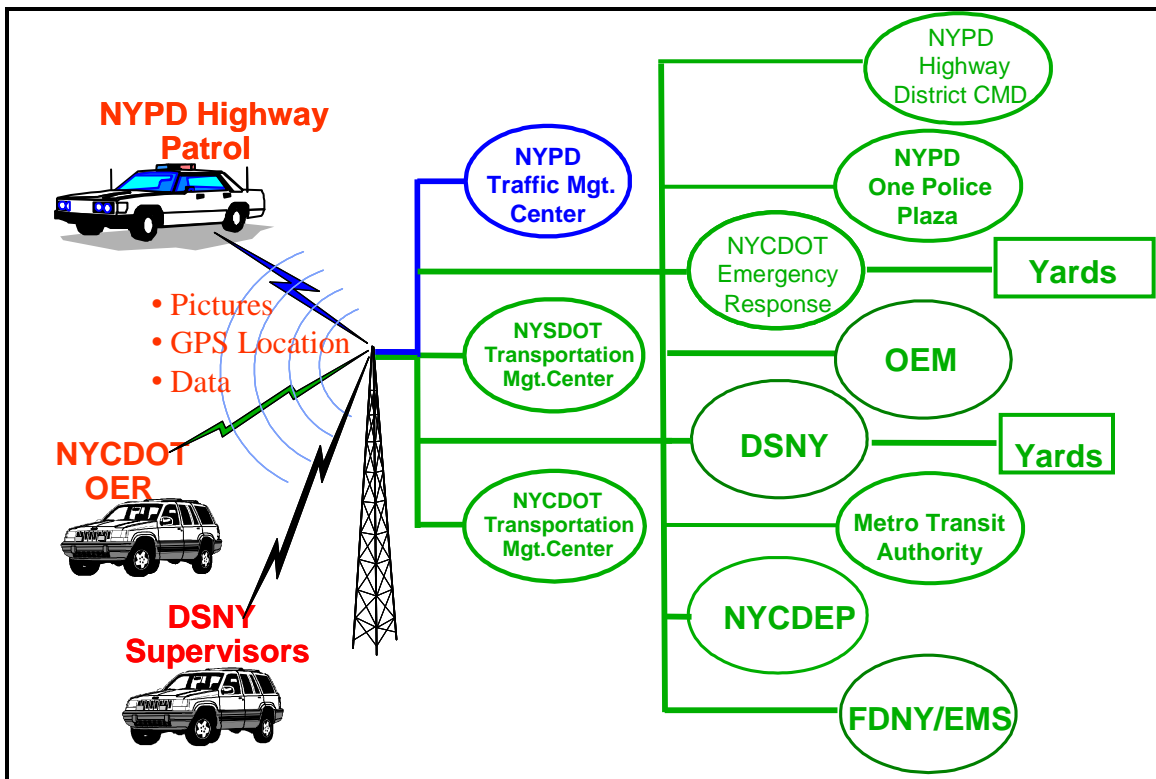

Source: IIMS User Training Manual

Figure 2. Overview of the IIMS Operations and Partner Agency Inter-Relationships.

The field units, known as “mobile units,” consist of a computer with a touch screen display, keyboard, and digital camera (see Figure 3). The mobile units are integrated with digital imaging systems that allow the on-scene responder to transmit the actual on-site conditions to dispatch centers (who assign and allocate resources), and to the operations centers and senior leaders (who formulate and implement incident management strategies to mitigate negative impacts).

Computers in the incident management centers operate on a network to provide access to stored information for facilitating the command and control process. Geographic Information Systems (GIS) and satellite imagery provide instant access to the location of key points of interest. These items may include: utility and rail lines; locations for staging areas; proximity to schools and

² IIMS Local Unit Training Manual, Calspan – University at Buffalo Research Center, Inc., January 2004, page 2.

neighborhoods and associated evacuation routes; and routes that can be used by incident responders.



Figure 3. IIMS In-Vehicle Equipment.

A breakdown of the number of units is presented in section 3, IIMS Usage.

Data communicated from the on-scene (mobile units) includes:

- Incident location.
- Incident type and information needed to dispatch the proper equipment.
- Photographs of the incident scene.

Data from the center or local/unit is typically pertinent incident response information such as which equipment was dispatched and expected time of arrival. Both the local and mobile units can provide and enter pertinent traffic information, such as which lanes are closed when the incident is cleared.

2.1.2 Creating an IIMS Incident Record

A typical IIMS incident management sequence can be illustrated using the following mobile unit example, which is a composite of actual IIMS incidents and the associated data. The screen views are similar for a local unit creating an incident or adding data to an existing incident; however instead of a “Quick Data” tab to begin immediate incident data entry, a local unit would either open an existing incident (to add data) or follow an Incident Creation “wizard,” which is shown in Figure 4. The remaining tabs to enter information are generally the same.

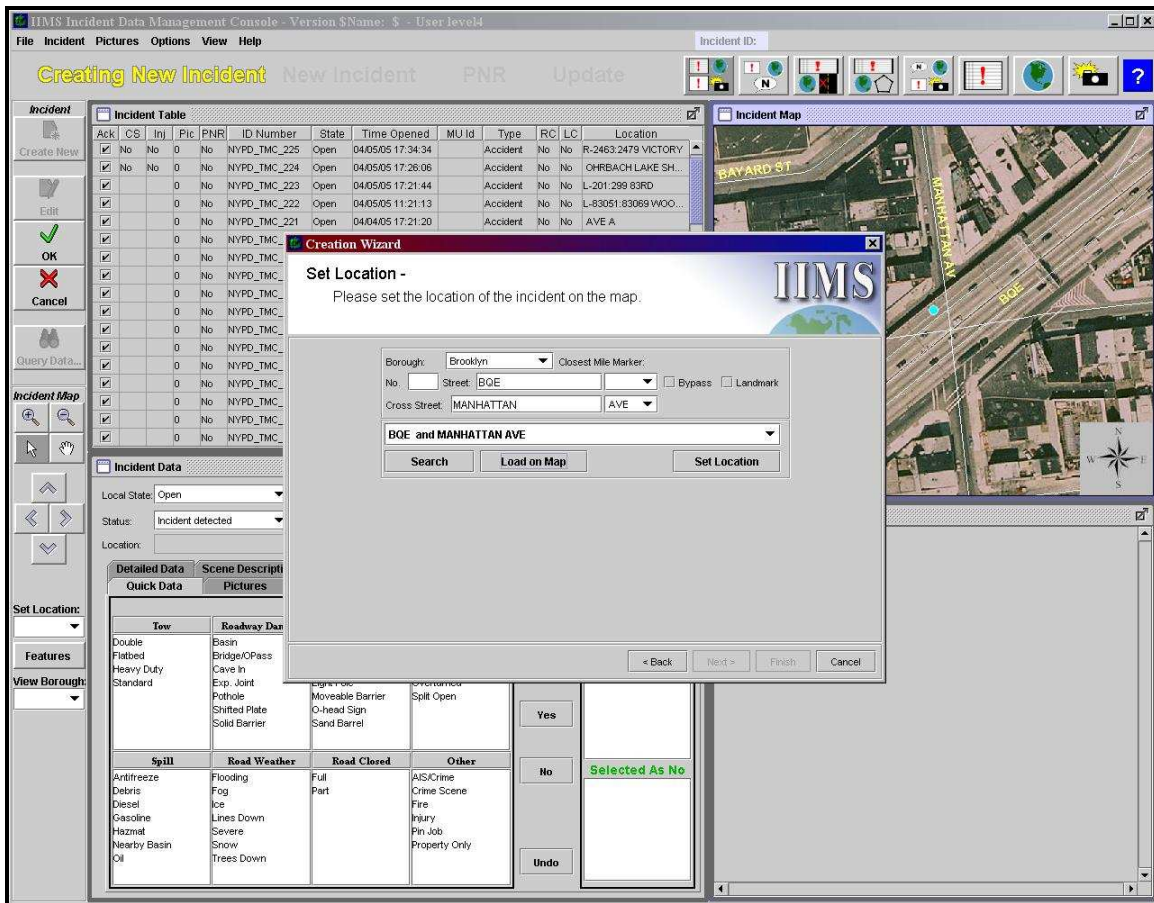

Source: IIMS Software Screen Capture

Figure 4. Local Unit Incident Creation Wizard.

Incident Description

A tractor trailer overturns on one of the IIMS covered freeways and spills hazardous material (Hazmat) onto the freeway. In the crash, there are injuries and there is roadway damage in the form of guardrail damage. The first IIMS-equipped responder (an NYPD HP Officer) on the scene immediately calls for backup for traffic management. Once the patrol vehicle is parked, the Officer logs into the system and generates the screen shown in Figure 5 that enables the selection of incident type. This “Quick Data” tab allows the initial selection of the incident type.

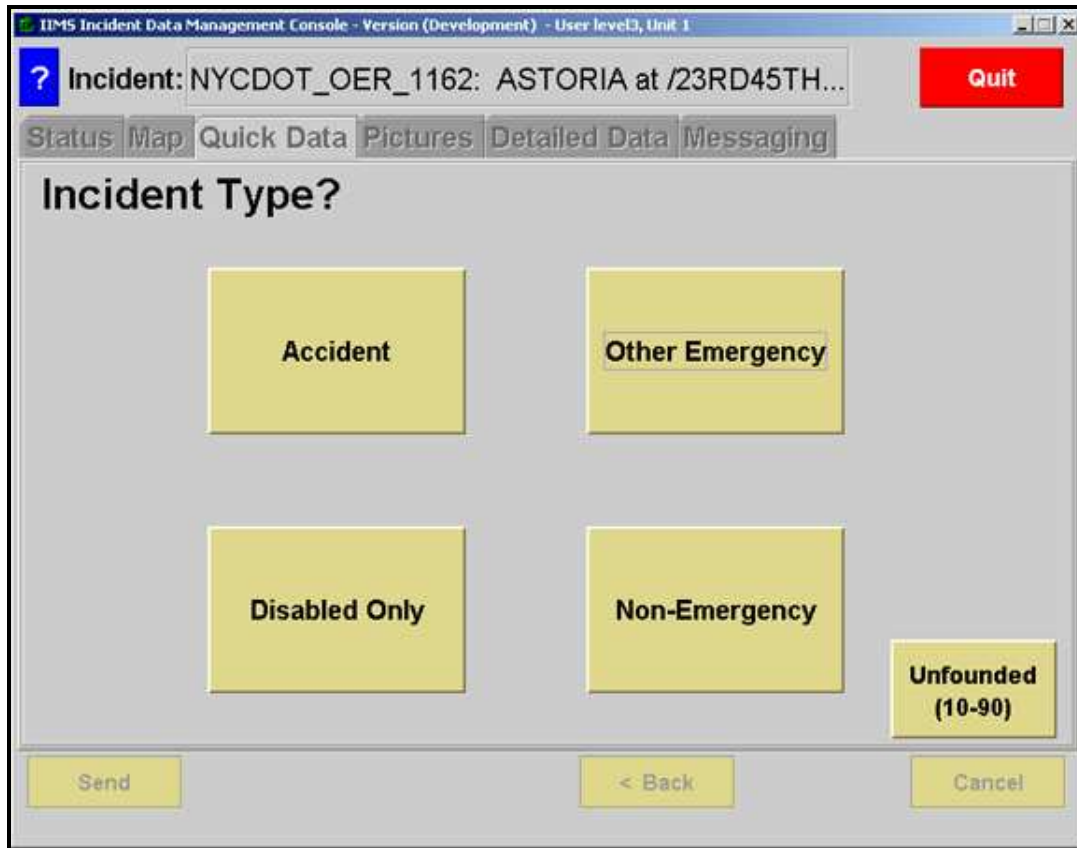

Source: IIMS Software Screen Capture

Figure 5. “Quick Tab” Incident Type Selection Screen.

Once the incident type is selected, the system automatically creates a GPS record of the responder’s location (the blue circle highlighted in Figure 6). Since the satellite image is a file image, the incident will not be seen in this frame.

With the immediate situation under control, the responder can annotate the location of the incident scene on the GIS system using the satellite imagery (the red triangle highlighted in Figure 6). This enables the responder to identify critical information such as which side of the roadway is impacted and location of the incident on the roadway, such as shoulder, on the road, and which lane or lanes are affected.



Source: IIMS Software Screen Capture

Figure 6. IIMS In-Vehicle Screen Reporting Incident Type and Location.

The Officer is then able to leave the vehicle and approach the scene to enable Fire and EMS vehicles and personnel access to the injured. With the digital camera, the Officer is able to photograph the extent of the spill (as shown in Figure 7) and to document the type of material using the push button incident display screen presented in Figure 8. The Officer is also able use the mobile unit to store and view all pictures to ensure complete coverage of the incident and maintain an incident photographic log.

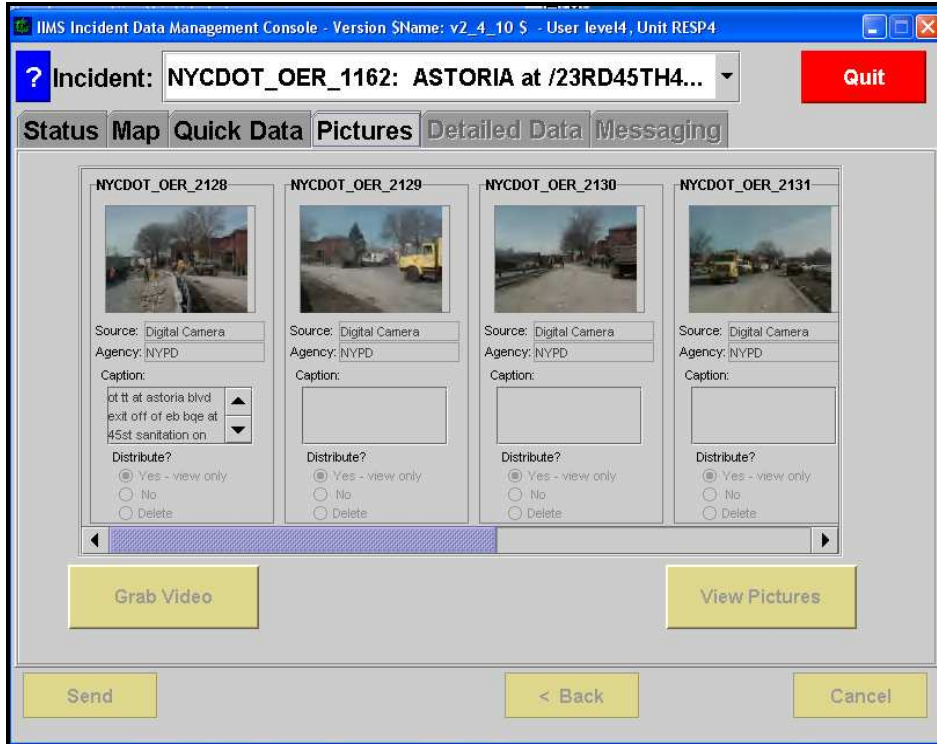

Source: IIMS Software Screen Capture

Figure 7. IIMS Storage Log Containing Digital Images.

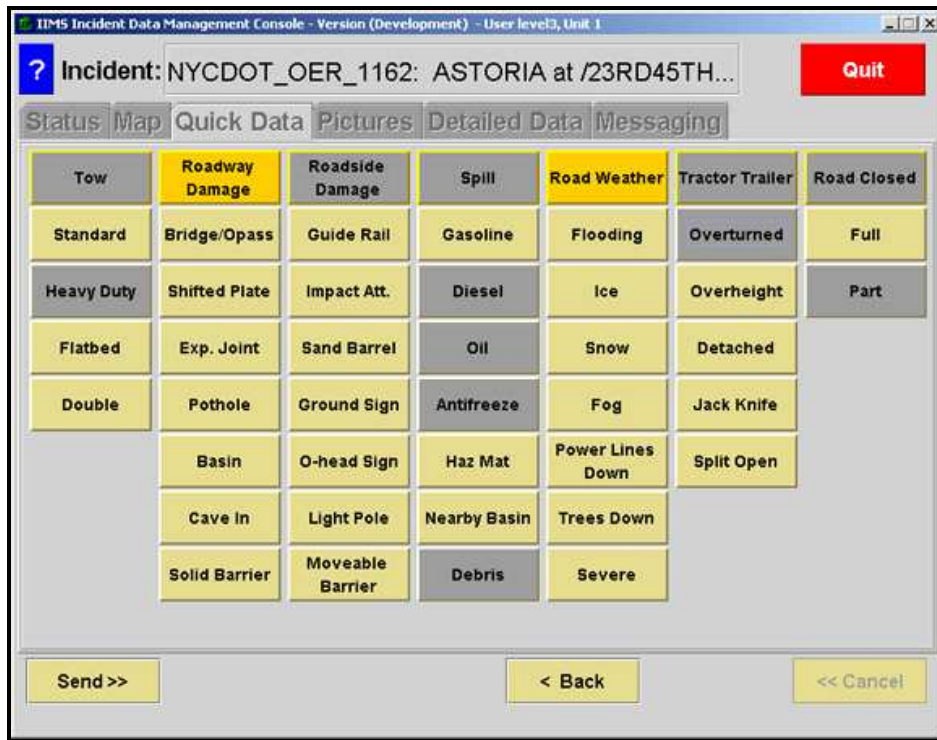

Source: IIMS Software Screen Capture

Figure 8. IIMS In-Vehicle Screen Providing Incident Details.

Once backup traffic management support arrives, the Officer is able to download the images and label them with text captions that describe the situation. The Officer submits the images instantly, making them available to the operations and dispatch centers (i.e., local units) as shown in Figure 9. Subsequently, environmental responders are able to dispatch the proper equipment quickly, and the emergency management center is able to quickly scan the area for neighborhoods, schools, and hospitals.

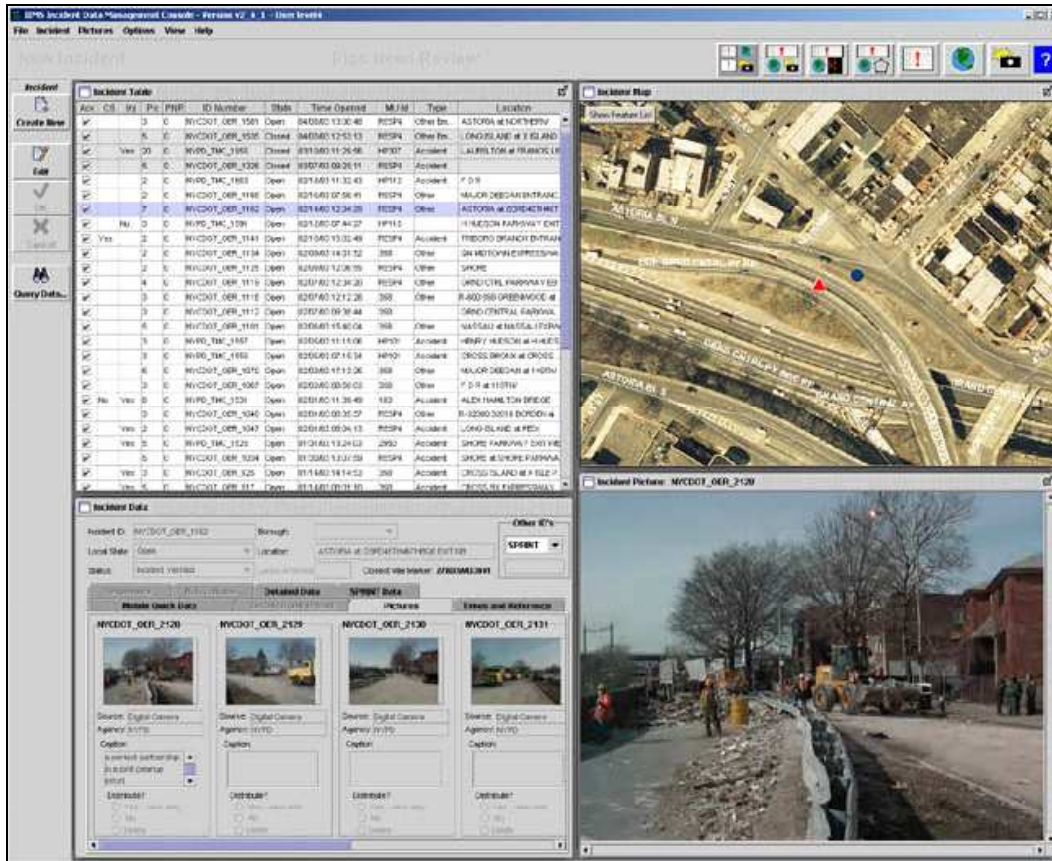

Source: IIMS Software Screen Capture

Figure 9. IIMS Center Screen with a Quad View of Relevant Information Including Digital Images and Captions from the Scene.

Evacuation routes are planned and forwarded to NYPD. Staging areas are designated, and an evacuation corridor is prepared as indicated in Figure 10 (blue and green polygons drawn on the satellite image). NYPD escorts are dispatched to lead emergency responders to the site using the opposing lanes.

The NYPD TMC is able to post messages on the Dynamic Message Signs (DMS) indicating the lane closures and contacts neighboring states to advise motorists in advance, allowing them to make alternate route or mode selections as depicted in Figure 11. As the individual activities on scene are completed, Fire and EMS personnel depart; environmental cleanup is completed on the affected roadway section; tow and recovery operations are completed, thus allowing one or more travel lanes to be reopened. A new report on lane status is transmitted throughout the IIMS

network allowing updates to traffic management plans and plans to restore normal operations, including the return of evacuees.

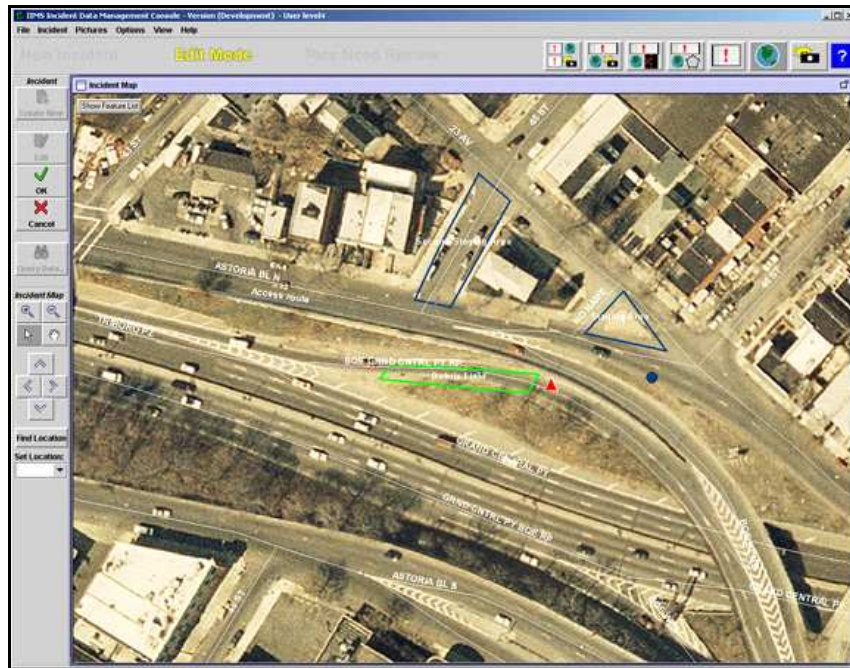

Source: IIMS Software Screen Capture

Figure 10. IIMS Screen Showing Access/Evacuation Routes and a Staging Area.

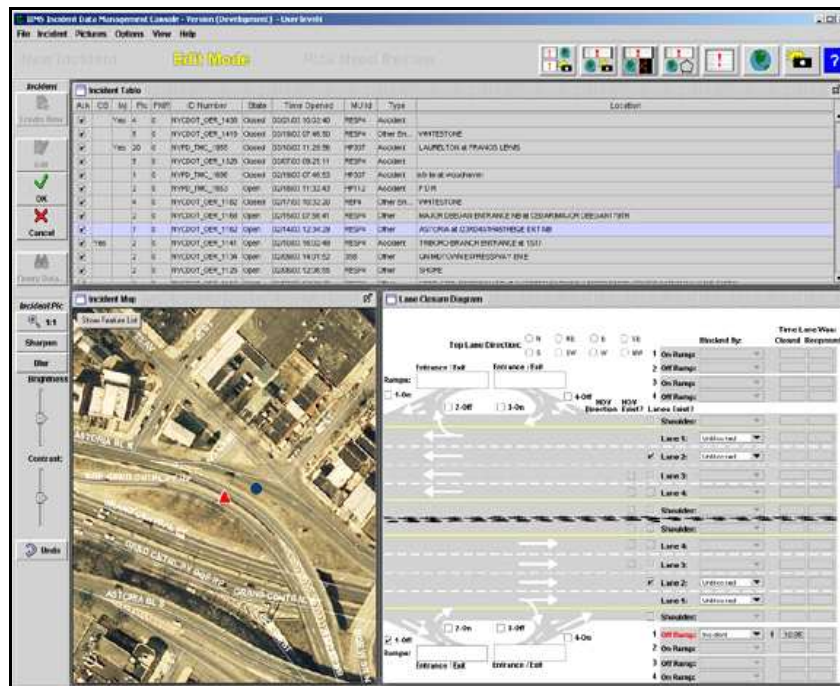

Source: IIMS Software Screen Capture

Figure 11. IIMS Center Screen Showing Lane Status.

2.1.3 Recent Upgrades

IIMS was initially deployed using a Common Object Request Broker Architecture (CORBA), an openly distributed object computing infrastructure, with each agency having its own IIMS server. A total of eight servers were deployed to support IIMS. In 2004, the NYSDOT OIS began to integrate ITS into the Department's overall IT platform. At this time, a study of IIMS was conducted, resulting in a June 2005 decision to deploy IIMS as a regional system, with NYSDOT operating one server in Albany and NYC DoITT operating one server in New York City.

In addition to consolidating the number of servers, IIMS also was transitioned to regional databases. Since Oracle had been the NYSDOT's database of choice for many years, its use was mandated. This required transitioning IIMS so that it conformed to New York State database standards for naming configurations.

Moving to the regional server-centralized database concept has several benefits. In the previous model, each server required an Oracle database license, at a cost of \$40,000, to enable data sharing within IIMS. By changing to a regional system using two servers, a total of eight Oracle database licenses were no longer needed, resulting in a cost savings of \$320,000. In addition, since there are only two servers to maintain, there are lower maintenance costs. These operating and maintenance costs have been mainstreamed into the NYC DoITT budget, freeing up more time and budget for training and other commitments. As the system grows, it also will be easier to expand the cluster in New York City as IIMS usage increases. Using Oracle as the backbone of the regional databases also will provide a report generation capability for each agency in a format to which they are accustomed. Although this capability is not yet fully operational, it is planned for full deployment in mid-2007.

With these new changes, IIMS now operates a distributed model using client-server architecture, as shown in Figure 12, which illustrates the concept of regional servers using regional databases. In converting IIMS to a centralized system, system developers had begun to move IIMS from CORBA to HyperText Transfer Protocol over Secure sockets (HTTPS) to pass the data using the totally open Institute of Electrical and Electronics Engineers (IEEE) 1512 protocol. This allows IIMS data to pass from client to server using HTTPS connections to provide security. This upgrade was planned then re-deployed to coincide with the centralized servers and database; together, these upgrades to IIMS are known as the "Web services" version of IIMS. This version's capability increases access to the system and makes it easier to link IIMS with other systems used by the local agencies.

To access the Web services version of IIMS, a user will need a Web browser as opposed to having the IIMS application loaded and installed on the user's individual hardware. The Web services version requires a Web browser, authorized user name, and password for registered users to gain access. Therefore, users could potentially access via wireless handheld device, permitting the entry of additional field data. This flexibility in connectivity would also allow mobile users to enter incident data directly from the scene, without returning to their vehicle.

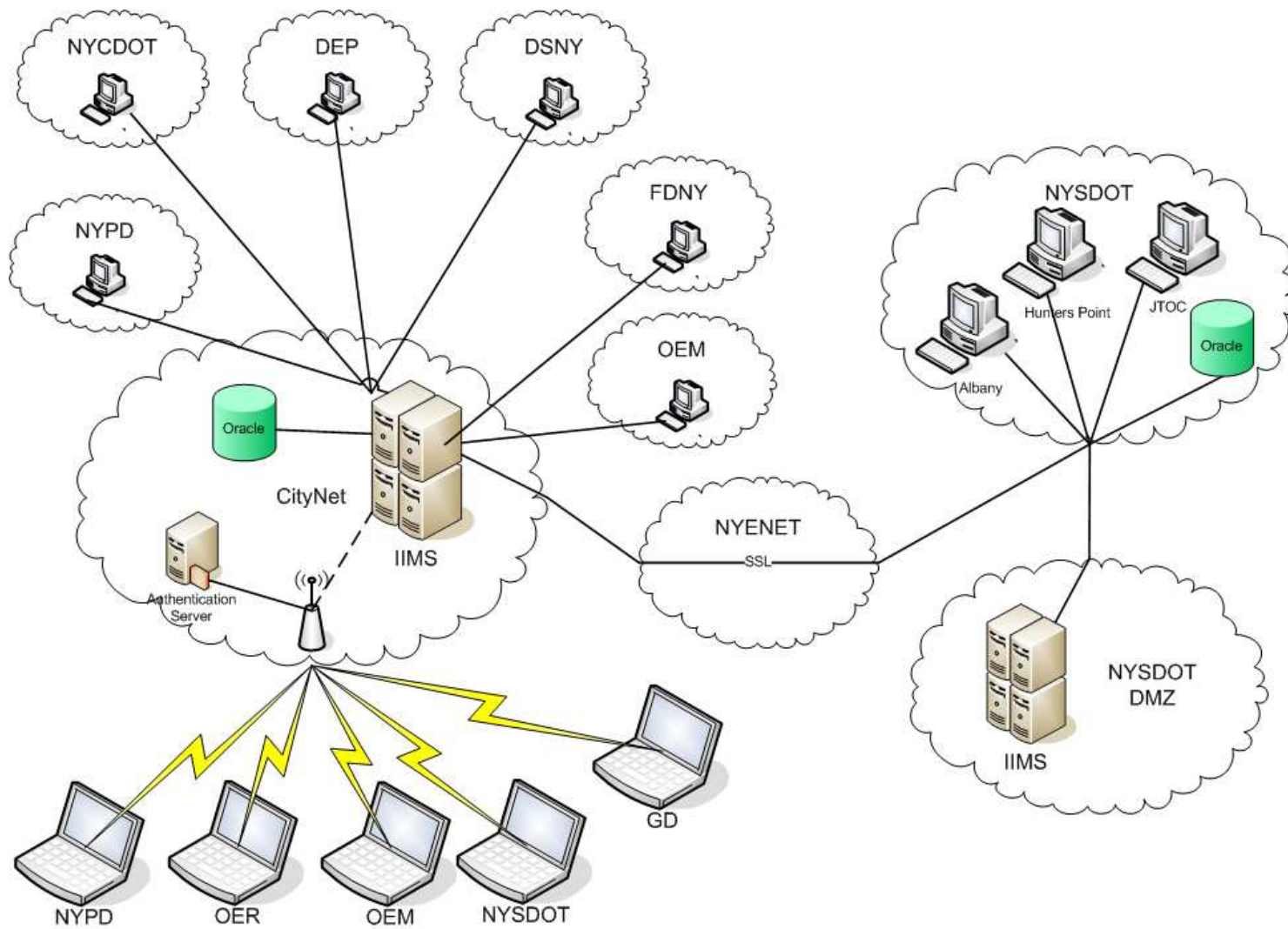

Source: IIMS Software Screen Capture

Figure 12. IIMS System Architecture.

The initial deployment of Web services will provide “read only” functionality for the Web browser in addition to current users who are entering data using the IIMS application installed in existing hardware. The functionality enabling data entry using the Web browser will be a future enhancement.

Operating the Web services version of IIMS with the Oracle backbone provides robust data management and backup capabilities, along with the report generation capability previously discussed. In addition, the SSL virtual private network (VPN) client architecture has increased the IIMS session time-out period to 8 hours, whereas previous versions would time out several times during the course of a shift.

The Web services version of IIMS is expected to be completely operational during the current calendar year. The network connection to the system is currently being tested and the installation of the client software is being completed at NYSDOT. Both the production server and database are already in place.

Another upgrade that may occur in the future is the use of a NYC-planned wide area network. This network is being set up by NYC DoITT and is intended to act as a redundant wireless network covering all of New York City. This network does not require a VPN log in, and will be set up over NYC DoITT’s private network. The only log in that will be required is the standard log in that users are required to use to access the NYC DoITT’s private network. This network will operate at a higher speed, which may allow for the addition of slow scan video, more data, and more effective transmission. The increased redundancy of such a network improves the consistency of system operation. This upgrade is currently being tested by NYC DoITT in lower Manhattan using the previous version of IIMS.

Lastly, two agencies—NYC Office of Emergency Management (OEM) and the New York Fire Department (NYFD)—are planning improvements to their stovepipe systems so that they may interact with IIMS and benefit from the data and information it provides. Although these improvements are currently paused due to staff changes, these improvements will resume with the redeployment of Web services in mid-2007.

2.2 Lessons Learned

2.2.1 IIMS User Group and System Enhancements

As part of the process in planning for the deployment of Web services, IIMS users were interviewed to identify additional features that would enhance the IIMS system. As a result of this consultation, a number of additional system enhancements also were identified and are being added to the system’s functionality. A good example of this type of user input included the added capability for the saving and adding pictures to IIMS storage log, and in creating a Help Desk, which is available to users 24-hours per day, 7 days per week.

Lesson Learned

It is important to involve users in discussing system requirements and enhancements, and to ensure that this is ongoing throughout the system development process. As an added benefit, user feedback collected on a periodic basis once the system is operational may eventually warrant a new version of the application. This type of involvement provides a venue for users to take

ownership of the system, and ensures that the system will be developed to meet user needs, thus ensuring that a consistent or increasing level of usage is realized.

2.2.2 Software Testing

NYSDOT OIS uses a two-tiered process for testing software releases: testing and production. This process involves deploying the system in different stages, with additional capabilities being tested during the testing stage, and the final version being deployed during the production stage. In the future, a three-tiered system involving testing, staging, and production system will be used for the development and deployment of Web services. The test stage will be used for final customer acceptance and approval. The staging stage will be used to test the system under load to simulate operation as a production system. The final stage will be actual deployment as a production system.

This process is supplemented by an independent verification process. The process utilized for the deployment of IIMS followed this model.

Lesson Learned

It is important that the system be developed using standard agency system development processes. This ensures that the system will meet agency standards and operating requirements and that the system will be mainstreamed into agency Information Technology (IT) services and programs, thus ensuring ongoing operations and maintenance support.

2.2.3 Resource Allocation

During the initial phases of IIMS development, NYSDOT OIS system deployment and upgrades were delayed due to other commitments and IT work. This made it difficult for user agency points of contact to obtain approval and support from higher management. The decision by OIS to take ownership of IIMS and conduct the study on how best to deploy IIMS helped the project become a priority deployment. This in turn ensured that IIMS was provided technical and operations support by NYSDOT, as well as other user agencies. In addition, it was difficult for system developers to track the “human” side of IIMS. Staff turnover in certain organizations sometimes resulted in malfunctioning units remaining in the field and or not being repaired in a timely fashion. In addition, staff changes sometimes caused users to not be immediately trained on the system’s use or staff changes at the management level resulted in units not being used at all.

Lesson Learned

It is critical that high-level management support be obtained for system development. This ensures that system development will be supported by and integrated into existing IT resources and programs within an agency. This action will, in turn, provide an incentive to other user agencies to promote system deployment and integration to a priority level. In addition, the system will operate more effectively if the list of users is maintained and frequently updated. This should help maintain the system units, ensure that all users have the most current training, and ensure that usage remains consistent within all agencies.

2.2.4 Interagency Collaboration

The IIMS project benefited enormously from inter-agency collaboration. This collaboration involved New York City agencies as well as NYSDOT, other State agencies, FHWA and its regional office. This collaboration was done without establishing any formal Memorandums of Understanding (MOUs) between agencies, and instead relied on existing working relationships and shared needs. The participating agencies did acknowledge that as IIMS becomes more structured, especially with the deployment of Web services, the next level of structure may require the establishment of inter-agency MOUs to ensure continued operations. In addition, a more formal program structure may make it easier to continue operations if a “champion” is lost within an agency.

IIMS has also benefited from the regional FHWA relationship with the City and State. Through discussions on IIMS, agencies were brought together and further improved communications and relationships through project activities such as table top exercises to identify requirements and needs. In general, IIMS benefited from its “grass roots” beginning and initial positive attitude by all involved. The IIMS users also determined that achieving longevity through more formal organizational structure/roles may be needed to ensure continued and expanded use of IIMS.

Lesson Learned

Establishing collaborative inter-agency relationships is critical to obtaining buy-in and support for the development of a system such as IIMS. While a single agency may take the lead on developing the system, as NYSDOT did, involving all user agencies in the process ensures that agency needs are addressed. This involvement also provides a forum for identifying and resolving interagency differences or issues.

In addition, development of the initial system may be delayed by trying to implement a formal organizational structure too soon in the process, just as IIMS was not delayed by the process of developing MOUs. The establishment and execution of MOUs will likely be significantly easier for the IIMS stakeholders to achieve now, as all stakeholders are aware of the fact that IIMS is now deployed and successfully operational. This formal structure will likely make further system enhancements easier to “sell” to stakeholders who are aware that their implementation will significantly improve access to IIMS. This demonstrates the importance of showing the benefits of system use to potential users, which in turn, obtains further stakeholder buy-in and support.

3. USAGE ANALYSIS

This section discusses the following three key topics:

1. The deployment of the physical IIMS mobile and local units and system servers used by various agencies.
2. An overview of the usage of the IIMS in the 6 years since it was deployed.
3. Specific examples of innovative IIMS usage by the participating agencies.

3.1 IIMS Units by Agency

When the IIMS project began in 2000, the USDOT funding was used to equip NYPD first response and NYCDOT OER second response vehicles, and to augment dispatch facilities with local units. After September 11, 2001, the project was redefined slightly to reflect the operational need for fielded capability. As of 2003, IIMS had been deployed in five operations centers:

- NYPD Highway District Command.
- NYPD TMC.
- NYCDOT OER Operations Center.
- Department of Sanitation of New York Public Works (DSNY).
- NYSDOT Joint Traffic Operations Center (JTOC).

Additional units had been deployed in NYCDOT OER support yards and in vehicles operated by NYPD HP and OER Supervisor vehicles. Since 2003, IIMS has been expanded to include additional operational components (as planned). In conjunction with the system upgrades discussed in section 1, additional mobile and local units and system servers have been deployed. In addition to the expanding the number of IIMS units to other transportation operations within the City, and the upgrade of the system's software and hardware backbone, recent years have seen the development of a 24-hour per day, 7-day per week Help Desk and the provision of additional training to users.

Table 2 summarizes the deployment of units for each year by agency and location. Figure 13 summarizes the cumulative deployment of both mobile and local units from the system's initial deployment in 2000 through the redefinition of the system's scope in 2001 through to 2006, the last full year of data. In 2000, the system began with just 4 mobile units being deployed; currently, there are over 108 total units in operation: 56 mobile units and 52 local units.

Table 2. Total Units by Agency and Year

Agency	Location	2000	2001	2002	2003	2004	2005	2006	Total Local Units	Total Mobile Units
NYCDOT	Agency HQ						3		3	0
	DOT Mobile							9	0	9
	Harper St.						1		1	0
	Mobile		4 ³						0	4
	NYSDOT				1				0	1
	Other				6				6	0
	TMC				5				5	0
NYSDOT	Agency HQ					8			7	1
	Other					1			1	0
	TMC					1			1	0
NYPD	Agency HQ							8	4	4
	Hwy 1			5					0	5
	Hwy 2	4							0	4
	Hwy 3			6	2				2	6
	Hwy 5			3					0	3
	Other						1	1	1	1
	TMC				6				5	1
OEM	Agency HQ					12			12	0
DSNY ⁴	Agency HQ						1		1	0
	Other						1		1	0
FDNY	Agency HQ					1			1	0
MTA PD	Agency HQ							1 ⁵	1	0
Total Units									52	56

³ There were four NYCDOT mobile units deployed between 2001 and 2003. No information was available to determine how many units were deployed for each of these years; therefore, the table shows them all being deployed in 2001.

⁴ "DSNY" is the City of New York Department of Sanitation.

⁵ The local unit within the Metropolitan Transit Authority (MTA) PD is expected to become active in 2007 with the deployment of the Web services version. This unit is currently on line but with limited access to IIMS due to firewall issues.

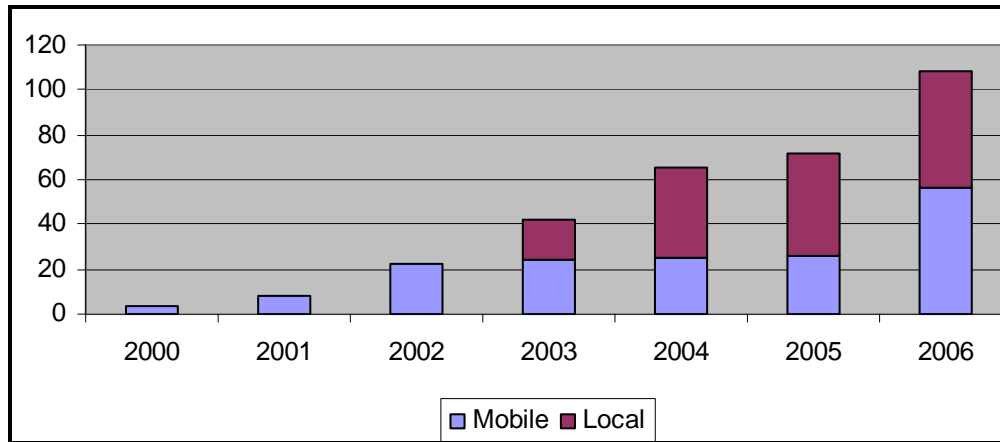

Figure 13. Cumulative Number of IIMS Units by Year.

In addition to these mobile units, there are a total of eight servers deployed with the IIMS. Each agency has one server housed at its headquarters location, with the exception of NYCDOT, which houses two servers at its TMC. Once the Web services version of IIMS is deployed, these servers will be consolidated to two, with one each being located at NYSDOT and NYCDOT.

3.2 IIMS Usage Information

3.2.1 Incident Record Creation

During the expanded IIMS deployment, which began in 2003, user feedback reporting on the system’s ease of usage became apparent. Within just the first 5 months of deployment, the incident record creation steadily grew, as evidenced in Figure 14.

IIMS Incident Record Creation

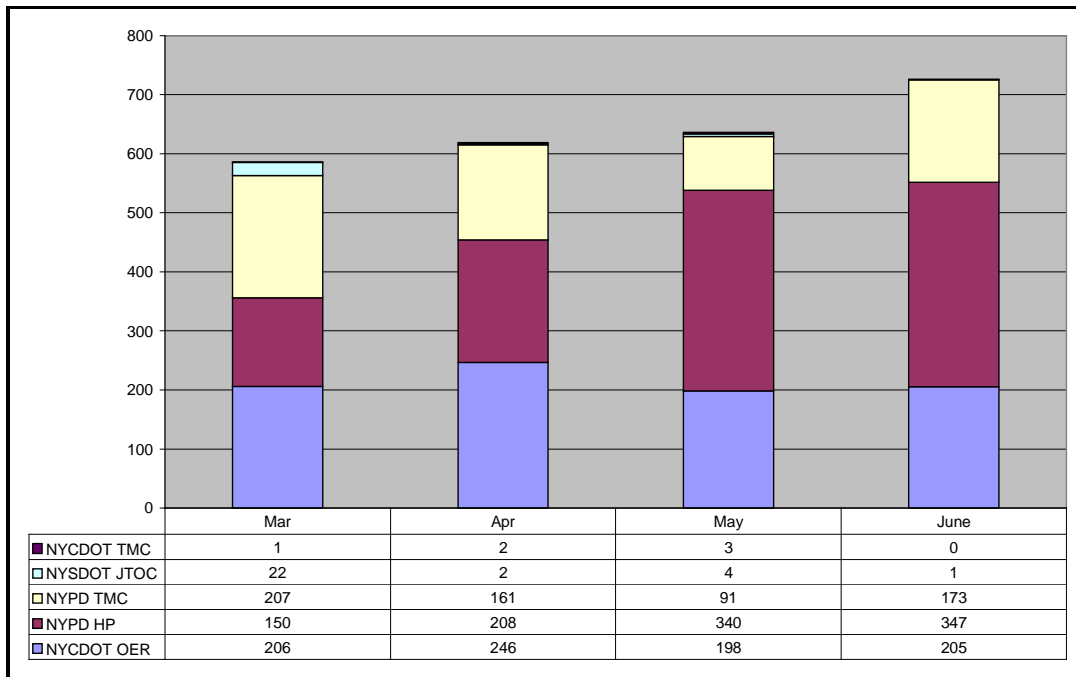

Figure 14. The Trend in IIMS Incident Record Creation Over the First 120 Days

During these first few years of operation from 2000 to 2003, the system matured and the users became more comfortable with the system. In addition to the field inputs which dominated the first 2 years of the system's operation, TMC personnel began to use the system to record and distribute key information from non-IIMS sources. This expanded the number of records generated by mobile versus local IIMS units.

Since 2003, additional units have been deployed among the five key agencies and to new agencies as well. Since 2003, the five key agencies have continued to lead as the primary creators of IIMS records. While IIMS usage has leveled off in the past 3 years (as seen in Figure 15), it is important to note that the usage has not dropped off; rather, it has remained consistent in direct relation to the number of incidents. In addition, if one agency or department has created fewer records, the trends indicate that the agency's mobile or TMC unit has increased in the number of records created. As an example, during 2004 the NYPD's HP unit and TMC created approximately the same number of records. During the 2005-2006 time period, the number of records created by the NYPD HP unit decreased, while the number of records created by the NYPD TMC increased proportionately.

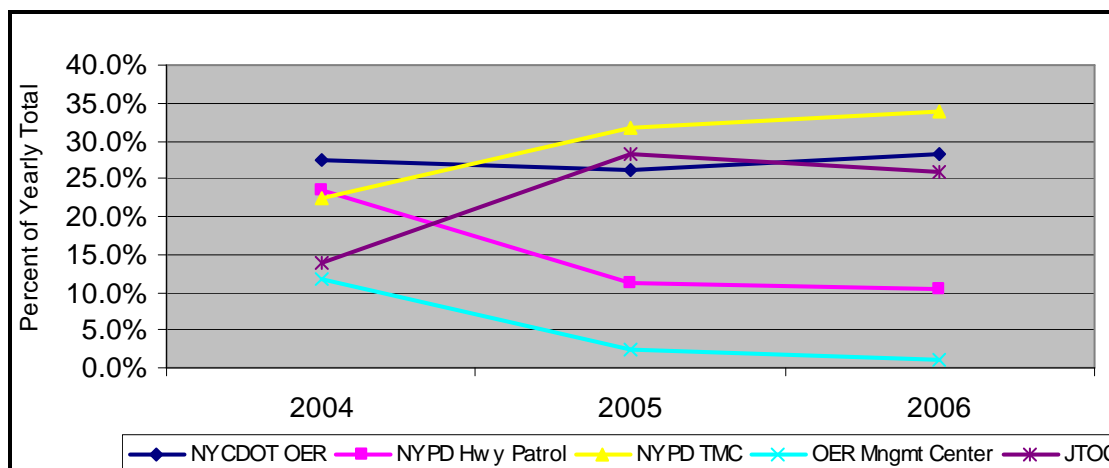

Figure 15. Trends in IIMS Incident Record Creation from 2004 to 2006.

3.2.2 Improved Usage and Data Accuracy

In addition with achieving consistent usage of the IIMS, the quality of the records has continually increased. During the initial deployment of units, the quality of the IIMS reports was low, which showed a lack of familiarity with the system. One notable example of improved data quality is shown by reviewing the number of incidents created by type of incident, as presented in Figure 16. In particular, the incident type "Unfounded" indicates a false entry, or an entry where an incident has not really taken place. During the 2004-2006 time period of increased deployment of both mobile and local units, the increased familiarity with the system's operation and increased training practices showed a notable decrease of nearly 3 percent per year in the number of incidents classified in IIMS as "Unfounded." In addition, there was a 3 percent decrease overall during the same time period in the number of incidents identified as "Type not specified."

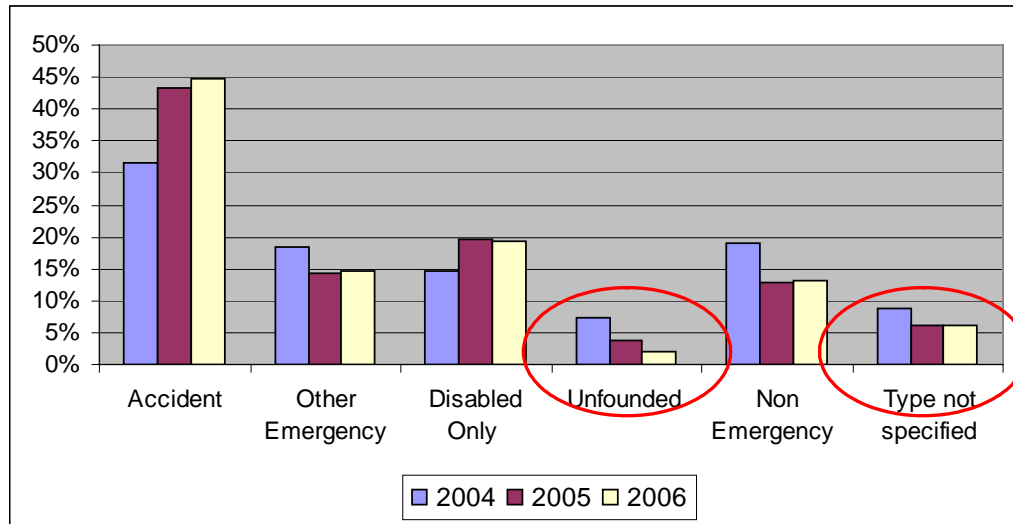

Figure 16. Incidents Created by Type from 2004 to 2006.

Lane Closure Data Improvements

In addition to improved classification of incident type, another significant improvement of the IIMS system came in 2005, when IIMS users became able to enter lane closure information. While lane closure information could be entered prior to this point, the 2005 improvements in the lane closure software led the capture of more accurate information about the time of closure, time of lane clear, and closing agency could be entered. In addition, IIMS usage facilitates the improved exchange of information, which appears to indicate the more efficient closure of lanes.

Since this improved lane closure data has only been available since 2005, it was not possible to assess the efficiency of prior year lane closure activities. Table 3 summarizes the lane closure activity by the number of lanes closed. From this table, it does appear that from 2005 to 2006, IIMS contributed to a reduction in the percent of incidents with three or more lanes closed from 60 percent to 3 percent; conversely, there was an increase in the percentage of incidents with one lane closed from 21 percent to nearly 60 percent. From a traffic management perspective, however, the impact on mobility with one lane closed is far less than with three lanes closed.

Table 3. Incidents with Lane Closure

Year/ % Total	1 Lane Closed	2 Lanes Closed	3 Lanes Closed	>3 Lanes Closed	Total Incidents w/ Closure	Total Incidents
2005	813	421	268	2,251	3,753	4,885
% Total	21.7	11.2	7.1%	60.0	76.8	
2006	2,251	844	562	112	3,769	4,379
% Total	59.7	22.4	14.9%	3.0	86.1	

Similarly, when looking at lane closure by incident type, the improved efficiency in the lane

closure software is particularly evident with incidents classified as an “Accident” or “Disabled Only.” Given that these are two of the more common incident types which occur, the benefits offered by IIMS can help to reduce the number of lanes and to improve the data captured with respect to their closure. Table 4 summarizes the lane closure information with respect to the various incident types in IIMS. As noted, within the “Accident” incident type, the percent of incidents with one lane closed increased from nearly 10 percent to 26 percent, while the percent of incidents with greater than three or more lanes closed decreased from 30 percent to nearly 2 percent. For “Disabled Only” incident types, the percent of incidents with one lane closed increased from 6.5 percent to 16.5 percent, while the percent of accidents with three or more lanes decreased from about 12 percent to less than 1 percent.

Table 4. Lane Closure by Incident Type

Number of Lanes Closed	Year	Accident	Other Emergency		Disabled Only	Construction	Maintenance	Total Incidents w/ Closure	Total Incidents
1 Lane Closed	2005	9.6%	2.5%	2.5%	6.5%	0.5%	0.2%	3753	4885
	2006	26.1%	6.7%	7.8%	16.5%	2.0%	0.6%	3769	4379
2 Lanes Closed	2005	4.9%	1.8%	1.8%	1.9%	0.7%	0.1%	3753	4885
	2006	11.0%	3.9%	3.6%	1.6%	1.9%	0.3%	3769	4379
3 Lanes Closed	2005	3.3%	1.3%	1.1%	1.2%	0.1%	0.0%	3753	4885
	2006	8.0%	3.0%	1.7%	1.5%	0.7%	0.1%	3769	4379
> 3 Lanes Closed	2005	30.3%	9.3%	6.4%	12.2%	1.5%	0.3%	3753	4885
	2006	1.6%	0.6%	0.3%	0.2%	0.3%	0.0%	3769	4379

Recent IIMS data reflects a reduction in the percent of lane closures lasting less than 120 minutes, as shown in Table 5. As with the reduction in incidents with multiple lanes closed, this indicates that the execution of lanes closures is becoming more efficient. Short duration lane closures, especially those less than 30 minutes, may represent incidents where a lane closure was not entirely necessary. Also, a reduction in short-duration lane closures indicates an improvement in data recorded for lane closures.

Table 5. Lane Closure Durations in Minutes

Years/ % Totals	<=10	10-30	30-60	60-120	120-180	180-240	240-300	>300	Total Lanes Closed
2005	1,382	961	1,034	830	357	270	140	1,275	1,382
% Total	22.1	15.4	16.5	13.3	5.7	4.3	2.2	20.4	22.1
2006	881	654	791	572	363	279	195	1,703	881
% Total	16.2	12.0	14.5	10.5	6.7	5.1	3.6	31.3	16.2

Software improvements specifically related to the recording of lane closure data were implemented in 2005; their success is also evident in the corresponding data. It should be noted that incidents with lane closures lasting longer than 2 hours actually increased; again, this may be because the software improvements improved the accuracy of the data being recorded. Also, the use of IIMS cannot reduce the severity of incidents or the likelihood of them occurring.

The past 3 years of IIMS usage also has shown a reduction in the number of incidents lasting less than 10 minutes. When looking at incident data in the first few months of operation, the Evaluation Team members noticed an extremely high occurrence rate in incidents lasting less than 10 minutes. In one incident class, "Roadway Damage," 40 out of 65 records fell into this category. When the Evaluation Team members researched the cause of this observation, and determined that a major contributing factor was due to operator error.

When reviewing data from the past 3 years, incidents lasting less than 10 minutes have decreased steadily, as shown in Table 6. It should be noted that the reason for the number of incidents being significantly less in 2004 is due to a new IIMS version being deployed in August, which significantly changed the IIMS data model. Therefore, while it is possible to obtain data for January to August of 2004, it is extremely labor intensive to do so. Therefore, only data from August to December 2004 is reflected in the table.

Table 6. Incident Durations in Hours

Min/Hrs	2004		2005		2006	
	Total	% Total	Total	% Total	Total	% Total
<= 10 min	468	32.8	1,528	24.6	1,017	23.2
10-60 min	422	29.6	2,380	38.3	1,438	32.8
1-2 (hour)	139	9.8	857	13.8	510	11.6
2-3	45	3.2	307	4.9	256	5.8
3-4	43	3.0	202	3.2	175	4.0
4-5	34	2.4	125	2.0	136	3.1
5-6	31	2.2	88	1.4	103	2.4
6-7	26	1.8	74	1.2	88	2.0
7-8	24	1.7	50	0.8	79	1.8
8-9	10	0.7	58	0.9	59	1.3
9-10	14	1.0	39	0.6	45	1.0
10-15	85	6.0	144	2.3	185	4.2
15-20	24	1.7	84	1.4	64	1.5
20-24	12	0.8	35	0.6	48	1.1
>24 hrs	48	3.4	249	4.0	176	4.0
Total:	1,425		6,220		4,379	

3.2.3 Future Report Generation Using Archived Data

With the deployment of the Web services version of IIMS in 2007, each agency will have the capability to produce their own reports using archived data. There already has been some experimentation with reports being developed by General Dynamics (IIMS Deployment Team). Using basic Microsoft Access query structure, the Development Team has been able to build reports showing a multitude of information from incident type-specific durations to agency-specific responder information. Currently, the Development Team can create reports on the following topics with relative ease:

- Responding Agency Report, which contains tables of information on:
 - Summary of incident response count by agency:
 - Number of incident acknowledged in IIMS.
 - Number of incidents which the agency was the first to arrive.
 - Number of incidents updated in IIMS.
 - Number of incidents closed in IIMS.
 - Incident acknowledgement times by agency displayed in minutes (time of acknowledgement minus incident creation time in IIMS).
 - Incident responder on-scene times by agency displayed in minutes (time of first arrival minus the incident creation time in IIMS). Using this table, the IIMS Deployment Team also has been able to calculate the duration the responder is on scene.
 - Incident last update time by agency displayed in minutes (last update time minus incident creation time in IIMS).
 - Incident closed time by agency displayed in minutes (incident close time minus incident creation time in IIMS).
- Incident Duration Report:
 - Number of incidents by Duration.
 - Number of incidents by Type.
 - Number of incidents with blocking, Quick Data lane closure, Local Unit lane closure.
 - Number of incidents by Borough location.
 - Number of incidents by type and duration range.
 - Number of incidents with lane closures.
 - Number of incidents with tractor trailer involvement, including the specific number of disabled vehicle incidents involving a tractor trailer.
- Lane Closure Report:
 - Number of lane closures by duration and closing agency.
 - Incidents with lane closure, by agency and number of lanes closed.

- Lanes closed by mobile or local unit or by agency.
- Lane closures by lane designation.
- Comparison of local unit lane closure and Quick Data (mobile unit) lane closure usage.
- Comparison of local unit lane closure and blocking usage.
- Lane closure durations.
- Quick Data (Mobile Unit) Report:
 - Incident counts by category/descriptor set.

3.3 Innovative Uses of IIMS

As IIMS system usage grows, certain agencies have begun to utilize the system in innovative means to assist in their incident management processes. One agency in particular, OER, has used the recently added photo-saving capability to create its own internal reports. In addition, as early as 2003, the Evaluation Team noted that OER had used IIMS mobile units to capture roadway maintenance projects as a means of tracking open maintenance activities. In this way, the IIMS has assisted OER in its maintenance management process.

IIMS stakeholders feel that the deployment of the Web services version of IIMS will facilitate the system's use as a lessons learned tool for incident response. In particular, the Web services version will help the NYSDOT at the State level understand the incident response process in New York City; likewise, the archived system data can provide all IIMS stakeholders with a lessons learned tool for each agency's (and their partner agencies) incident management activities. Should IIMS provide a greater understanding of each agency's incident management processes, this may increase the interoperability that the system already offers its stakeholders.

4. CASE STUDIES

In the initial evaluation, cases studies were planned for the top three incident classes: Roadway Damage, Debris Spill and Fuel Spill, and Tractor Trailer. Three Roadway Damage incident case studies were expanded and executed using the detailed Critical Path Method (CPM) and focus group approach. These case studies were completed during the initial 2003 evaluation phase using data from the first 5 months of IIMS operation.

The three case studies are described in section 4.2. Using these studies, the Evaluation Team then re-assessed Debris Spill and Fuel Spill and Tractor Trailer incident information using 2006 data to evaluate whether similar benefits could be seen. This evaluation is discussed in section 4.3.

4.1 Development of Initial Case Studies

Initial case study development relied heavily on the use of the CPM, which depicts and analyzes systems of task activity requests, such as IIMS. The CPM method defines the “critical path” as a set of dependent tasks which take the longest time to complete. Tasks that fall on the critical path are typically called out in activity diagrams. The advantage of the CPM approach is that it reveals the system level impact of incremental improvements within the individual activities that lie on the critical path.

Focus groups were convened to develop the data required to support the initial CPM-based analysis methodology. In the case study focus groups, a post-IIMS incident record was pulled and the CPM-based methodology was used to develop an activity network diagram to support development of the performance measures of interest. This provided the “after” data. To obtain the “before” data, the participants in the actual incident were gathered in focus groups to build the activity network diagram of the same incident as if it had occurred in a pre-IIMS environment. Where estimates of activity duration had to be made in the construction of the pre-IIMS case, the groups used the Delphi method⁶ to generate activity duration values for use in the activity network diagram.

To ensure the highest degree of accuracy, the groups using the Delphi method operated under a set of pre-defined rules. These rules were used to limit the scope of the estimating process only to those activities that were identified as the primary leveraging factors within the IIMS-based incident management process, and included the following:

- Changes in the requirement for secondary response Supervisors to travel to the scene

⁶The Delphi method is a technique used to arrive at a common group position or consensus regarding an issue under investigation. This method consists of a series of repeated interrogations, usually by means of questionnaires, of a group of individuals with expertise in a related area, whose opinions or judgments are of interest. After the initial interrogation of each individual, each subsequent interrogation is accompanied by information regarding the preceding round of replies, usually presented anonymously. Each individual is encouraged to reconsider, and if appropriate, to change a previous reply in the next round in light of the replies of other group members from the previous round. After two or three rounds, the group position is determined by averaging. The Delphi method was originally developed at the RAND Corporation by Olaf Helmer and Norman Dalkey.

prior to dispatch of secondary response teams.

- Conversion of the secondary dispatch communication process from a serial, telephone-based process to a parallel, data-based process.
- Increased accuracy in the information available to identify the required resources.
- Increased ability to get decision quality information to leadership quickly.

4.1.1 Selection of Incident Types

The Evaluation and IIMS Deployment Teams selected the Roadway Damage incident class for use in the evaluation, as it appeared to be an incident type which may realize a myriad of IIMS benefits. After this selection, the Teams proceeded with a search method to identify the individual incidents the focus groups would use to derive representative “before” incident duration data. The method included analysis of the frequency distribution of the Roadway Damage incidents according to the total incident durations as reported in the IIMS archived incident reports. Figure 17 shows the distribution and the descriptive statistics.

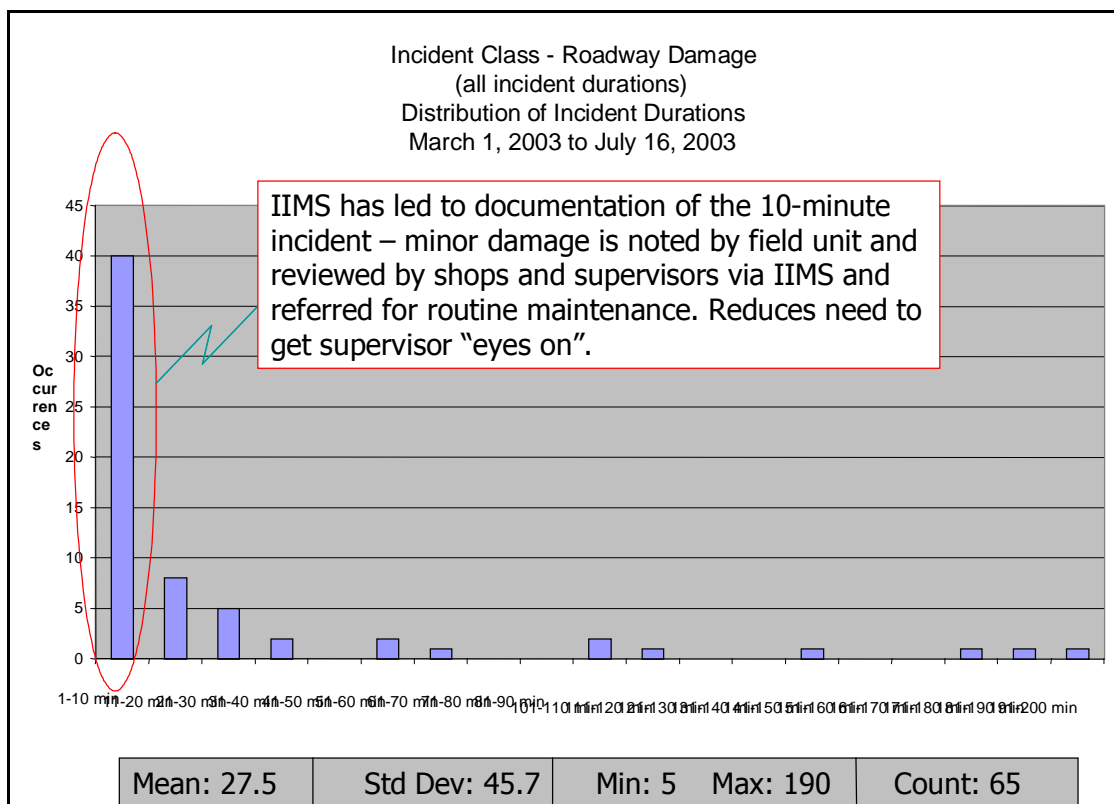

Figure 17. Distribution of Incident Durations for all Roadway Damage Incidents.

One of the first things that became apparent regarding this distribution is the high number of incidents with durations of 10 minutes or less compared to what was expected based on experience. The Team members were concerned that this data may indicate a problem with the IIMS incident logging system or that there was an inordinately high number of operator errors taking place in the field. The Team members looked into this observation by interviewing those involved in OER operations, resulting in an interesting conclusion: operator error. Those

questioned felt there were some cases of operator error in using the system (i.e., not initiating an IIMS event until the incident was almost over or inadvertently reporting the incident as over when, in fact, it was not). The Team members attributed the large number of errors to the ease and utility of reporting and recording all incidents in IIMS.

Pre-IIMS, an OER responder may have simply noticed something that deserved a quick-fix attention, and normally would have fixed it without generating a report. Using IIMS essentially provided a means to document roadway damage incidents that were fixed on the spot or that did not require emergency repair. OER field Supervisors reported that they had, in some cases, used the system as a tool to record an image of the damage developing an accountability trail to ensure that non-emergency work orders were generated and that the repairs were made.

Based on this information, the Evaluation and IIMS Deployment Teams identified the “10-Minute Incident” as a special sub-class and removed the incidents in the sub-class from the case study search database. Figure 18 shows the impact on the incident duration distribution and the revised descriptive statistics.

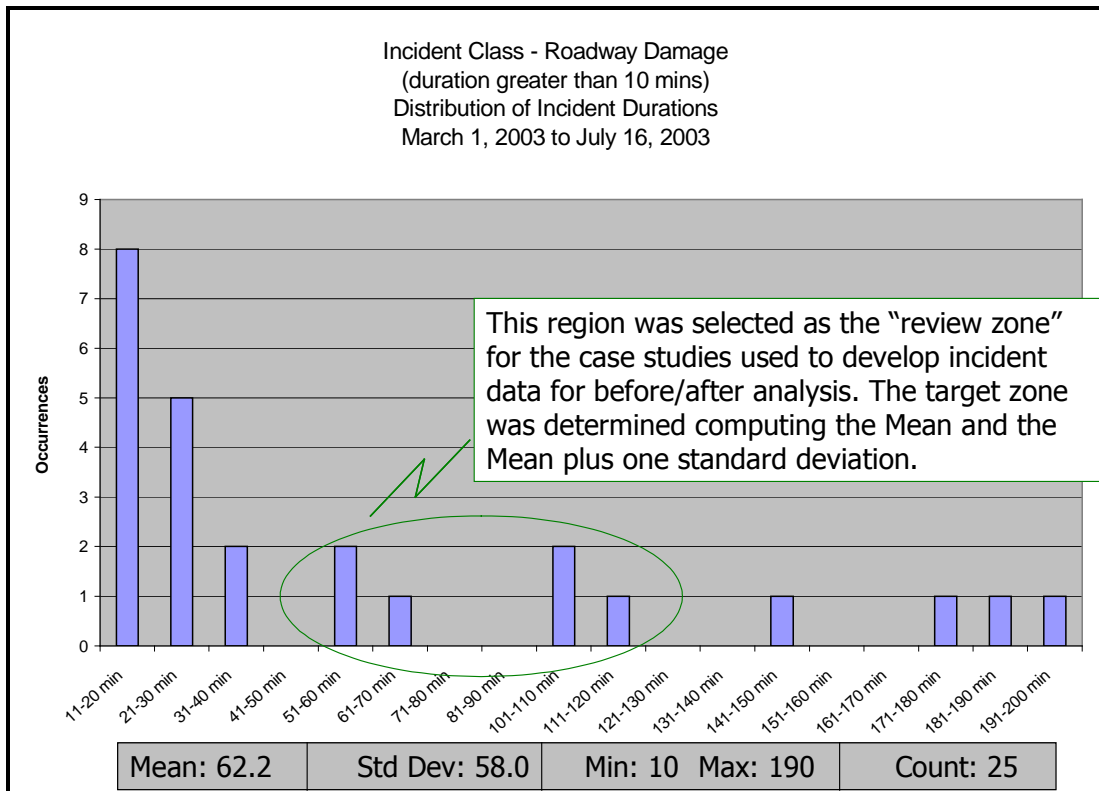

Figure 18. Distribution of the Roadway Damage Incidents with a Duration of 10 Minutes or Greater.

4.1.2 Description of Specific Incidents

The next step in selecting the case study incidents was a line-by-line review of the incidents that were close to the class mean in duration. The objective of this review was to identify three incidents within the Roadway Damage incident class (duration greater than 10 minutes), which

could be used to generate the pre-IIMS activity network diagrams. Two incidents were selected to represent those with durations between the mean and the mean plus one standard deviation. These were used to generate an understanding of a “typical” incident within this class. The third was selected from the extreme high end of the available data to generate an understanding of a “worst case” incident within this class. The three incidents, identified as IIMS Incident Numbers NYPD_TMC_4886, 1593, and 2431, respectively, are briefly described as follows.

Case I: IIMS Incident Number 4886

This incident involved a damaged overhanging sign (Figure 19) on the Long Island Expressway. The damage was discovered by an NYPD HP Officer on patrol. The NYPD vehicle was IIMS-equipped. The Officer set up a temporary traffic control plan by closing the right lane in the vicinity of the sign. The Officer created an IIMS incident record that reported the NYPD vehicle’s location and the location of the sign through the IIMS system. The OER mobile at a location approximately 30 minutes away, was able to assess the damage from the photos and dispatch a repair crew without traveling to the scene. Once on scene, the sign repair crew spent 12 minutes effecting the appropriate repairs and reopening the lanes.



Source: IIMS Software Screen Capture

Figure 19. Unsecured Overhanging Sign in Incident 4886.

Case II: IIMS Incident Number 1593

This incident took place during the evening rush hour on the Long Island Expressway. A large pothole had opened up on the right edge of the right lane of the 3-lane facility. Near a catch basin drainage grate, the pothole had caused flat tires on a New York State Police (NYSP) vehicle and

a civilian vehicle. The NYSP Officer notified New York City officials based on his estimate of the responsible jurisdiction. OER dispatched a Supervisor to the scene. Upon arrival, the Supervisor noticed that the damaged roadway was outside of the city limits and was, in fact, in the Nassau County area of responsibility.

Realizing the delay and the associated negative traffic flow impacts that would be caused by shifting the repair responsibility to the county, the OER Supervisor engaged the IIMS system to generate an incident record that could be used to get real-time approval from the New York City OER Assistant Commissioner for the out-of-jurisdiction repair.

Using GPS coordinates on a GIS satellite photo overlay, the IIMS allowed the damage location to be plotted (Figure 20). This provided OER leadership with the exact location of the damage. The on-scene Supervisor also was able to transmit digital images of the damage (Figure 21) and articulate an estimate of the repair requirements. With the high fidelity information, the OER Assistant Commissioner was able to authorize the repair within minutes after the OER Supervisor had arrived on the scene. The OER Supervisor completed an emergency repair using cold-patch and documented the repair using IIMS digital imaging (Figure 22). NYSDOT was advised of the repair and notified of the need for permanent repair, which could be accomplished outside the peak travel period.

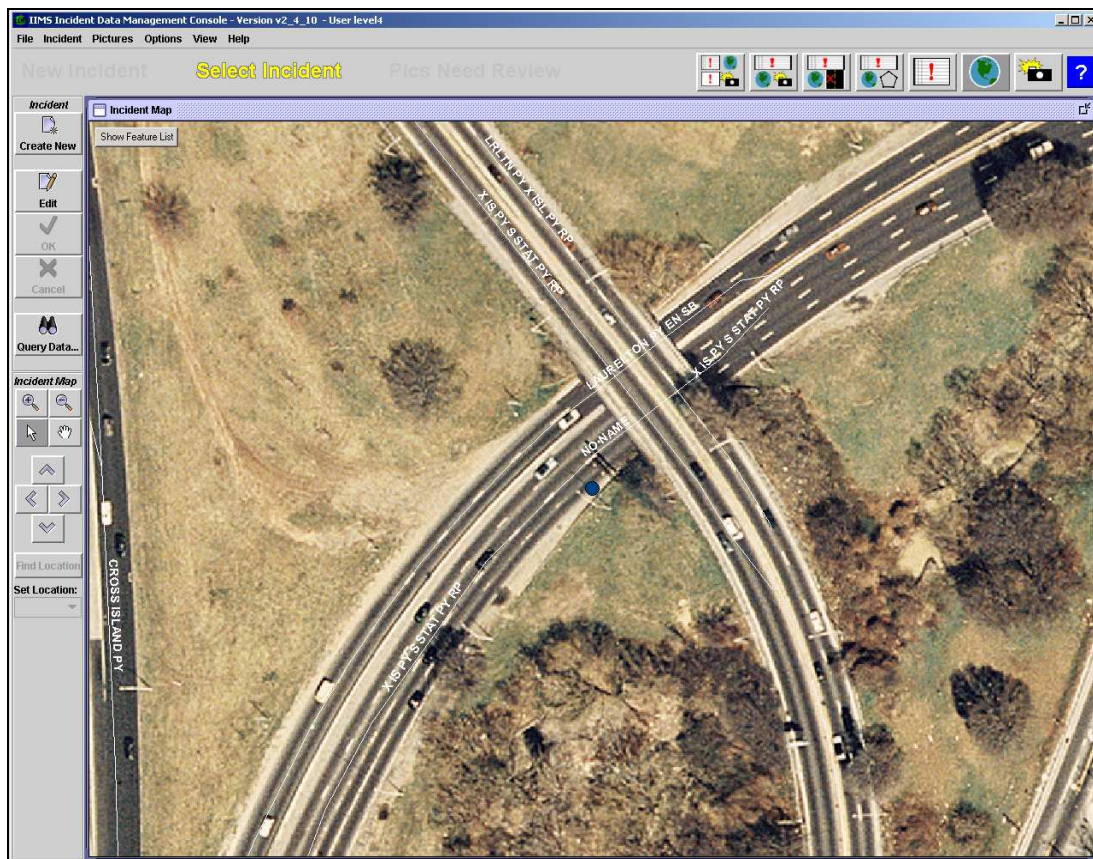

Source: IIMS Software Screen Capture

Figure 20. GIS Location System Showing Satellite Image.

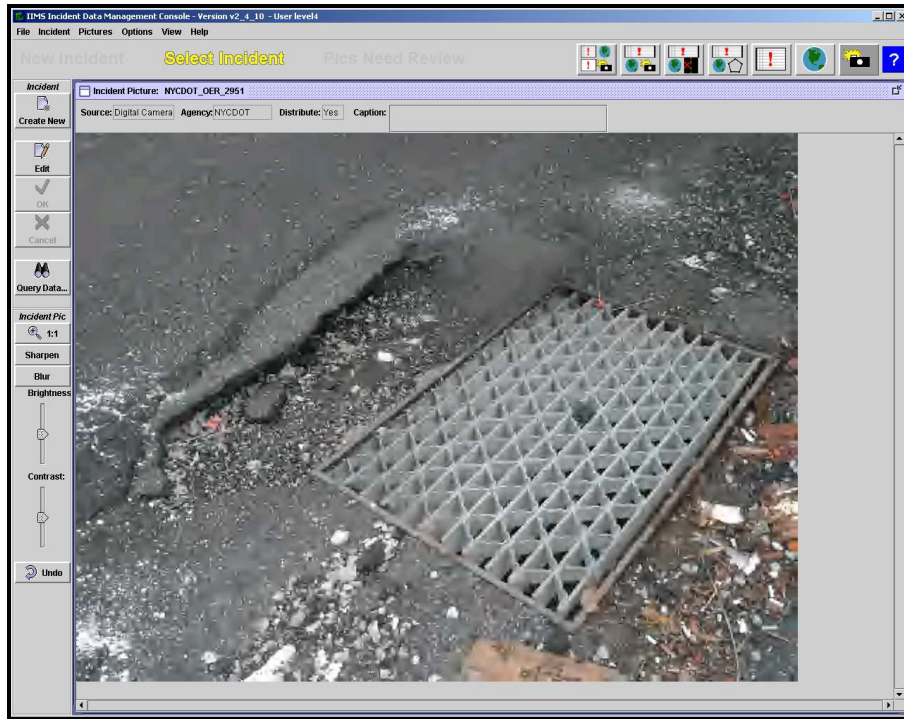

Source: IIMS Software Screen Capture

Figure 21. Roadway Damage Next to a Drainage Grate.

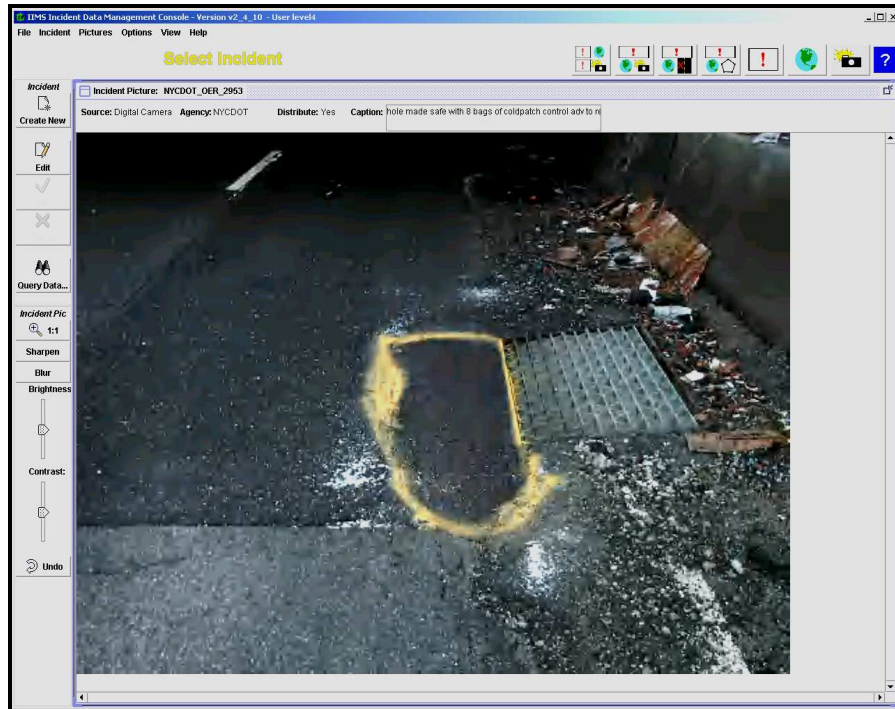

Source: IIMS Software Screen Capture

Figure 22. Temporary Repair to Restore the Right Lane.

Case III: IIMS Incident Number 2431

This incident took place during the morning rush hour on the FDR Drive into Lower Manhattan. At 7:11 a.m., the Computer-Aided Dispatch (CAD) system alerted the TMC of a missing manhole cover in the roadway. The first responder was a non-IIMS NYPD Officer. Upon arrival, the Officer noticed what appeared to be major infrastructure damage in the form of roadway buckling. This level of damage prompted closure of all lanes in both directions at 7:30 a.m. OER responded to the scene with a Supervisor in an IIMS-equipped vehicle and made an initial confirmatory report of roadway buckling. After leaving the vehicle, the OER Supervisor approached the damaged area and began to document the damage using the IIMS digital imaging system to provide the engineering shops and senior leadership with an accurate understanding of the damage level.

Because of concern over the impact of a buckling roadway, the OER Director contacted the NYCDOT Commissioner for an information briefing. Concurrently, the news media was notified of the full roadway closure, and began to report the incident and its impact on mobility.

Once the IIMS images were received, the OER Director conferred with the appropriate specialties. The on-scene OER Supervisor attempted to focus in on the precise nature of the damage and to develop the appropriate response plan. During this process, the images, other information available on IIMS (such as the location of power and other utility lines), and inputs from key advisors allowed the OER Director to determine that the roadway was not buckling and he retracted the buckling report. This reclassification changed the incident management plan, thereby allowing the immediate opening of all three southbound lanes and one northbound lane. OER notified Connecticut-Edison Power personnel and provided them a detailed description of the damage. OER and NYPD personnel maintained on-scene traffic control responsibilities until the power company repair crews arrived.

4.2 Initial Case Study Analysis

Activity network diagrams were produced for each of the three cases using CPM. Once these diagrams were constructed, each case was analyzed according to the following performance measures, resulting in reductions in certain incident elements. The incident elements and how changes in their durations were calculated are summarized as follows:

- Overall incident duration: the delta between the “before” and “after” total incident duration as defined by the incident management critical path.
- Incident verification times: the delta between the “before” and “after” Supervisor verification time.
- Dispatch times for participating agencies: the delta between the “before” and “after” time when the repair crew was dispatched.
- On-scene times for incident response personnel: the delta between the “before” and “after” calculation of time an agency departs minus the time the agency first arrived on scene.
- Non-value added time for personnel from each agency involved (i.e., wait time): “before”

and “after” time spent waiting for the completion of a task by another agency before the initiation of incident management activities by the agency of interest.

- Exposure time for incident response personnel: comparison of “before” and “after” time spent performing incident-related traffic management activities. These times were determined using the following methods, and assume that a certain period of time (10 minutes) will be dedicated to reporting the situation to the TMC and/or the agency control center:
 - For police personnel: exposure time = (on-scene time – 10 minutes) x 0.75.⁷
 - OER Supervision and repair crews: exposure time = (on-scene time – 10 minutes) x 0.6.⁸
 - The duration of lane closures: comparison of “before” and “after” calculation of time between time lane blockage was detected and the time the scene is clear/all lanes reopened.

4.2.1 Case I: Incident 4886

The Pre-IIMS and IIMS activity network diagrams for Incident 4886 are shown in Figure 23 and Figure 24, followed by Table 7, which summarizes the analysis results. In the activity network diagrams, there are three distinct paths. The center pathway primarily depicts, from left to right, the physical activities that take place through the incident management process. The upper pathway depicts the law enforcement activities associated with the incident management process. The lower pathway depicts supervisory activities that take place as the incident management process progresses.

Incident 4886 presents a case in which there is a significant portion of the critical path in the pre-IIMS case time is made up of supervisory activity. In the pre-IIMS case, 30 minutes are dedicated to Supervisor travel time to verify the nature of the damage and to determine the required resources for dispatch. The digital imaging component of the IIMS system allows the Supervisor to make the required assessments from his off-site location reducing the supervisory time on the critical path to 3 minutes.

⁷ The factor 0.75 represents the fact that some time on scene will be devoted to duties other than traffic management. For Police Officers, the assumption is that no more than 75 percent of the time on scene will be devoted to traffic management.

⁸ The factor 0.6 represents that some time on scene will be devoted to duties other than traffic management. For repair crews, the assumption is that no more than 60 percent of the time on scene will be devoted to traffic management.

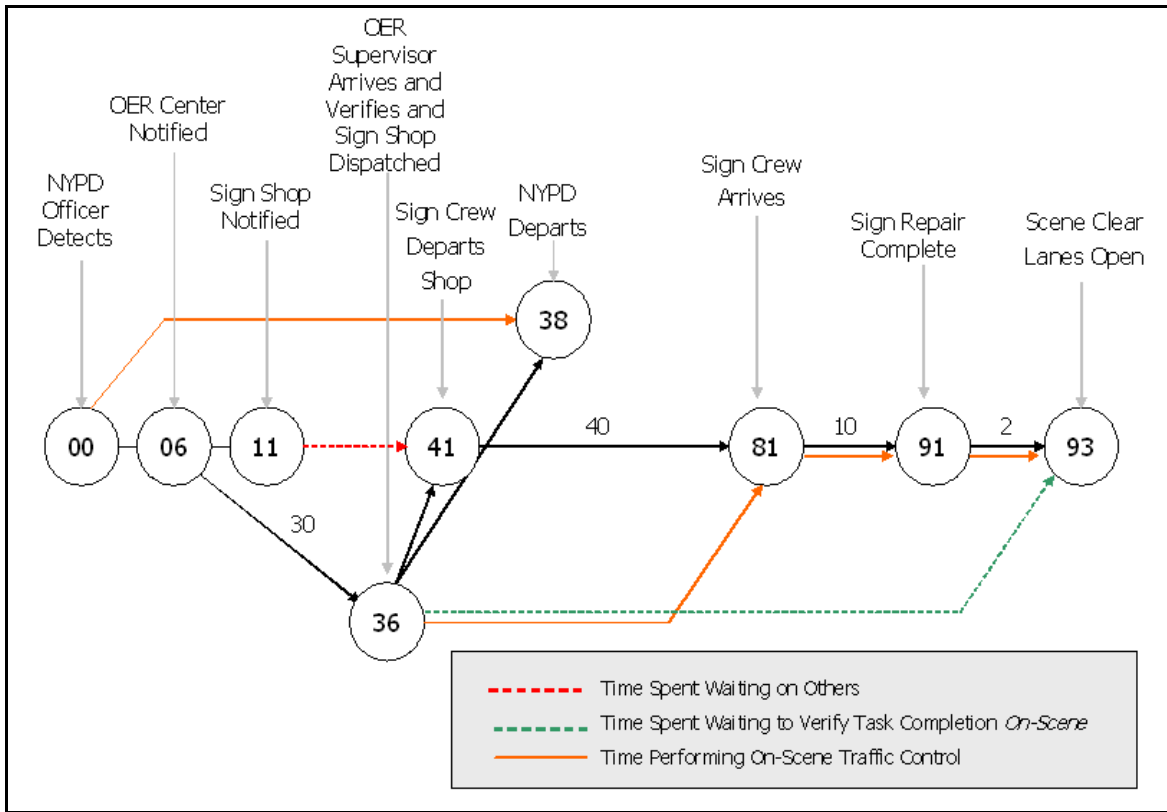

Figure 23. Pre-IIMS Activity Network Diagram Incident 4886.

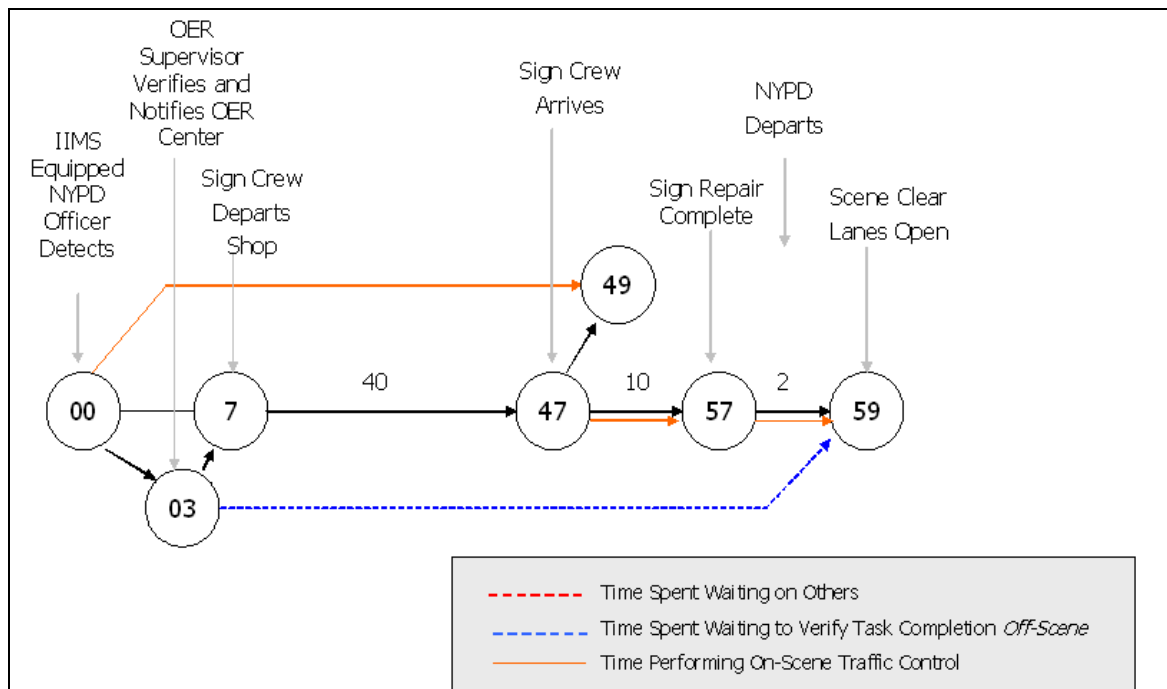

Figure 24. IIMS Activity Network Diagram Incident 4886.

The CPM analysis of the “before” and “after” data for Incident 4886 indicated reduction in several time spans, which are summarized in Table 7.

Table 7. Incident 4886 Performance Measures

Category	“Before” Duration	“After” Duration	Reason
Overall Incident Duration	93 minutes	93 minutes	Elimination of the OER Supervisor traveling to the scene to verify the resources to dispatch.
Incident Verification Time	36 minutes	3 minutes	Elimination of need for OER Supervisor to travel to the scene to verify the nature of the incident
Dispatch Time for Secondary Responders	36 minutes	3 minutes	Elimination of the OER Supervisor traveling to the scene to verify the resources to dispatch.
On-Scene Times for Incident Response Personnel	OER Supervisor:		OER Supervisor did not travel to the scene.
	57 minutes	0 minutes	
	NYPD Officer:		NYPD Officer stayed on scene during the repair to supervise OER Crew because OER Supervisor did not travel to the scene.
	37 minutes	49 minutes	
	OER Crew:		No change – repair time was consistent.
	10 minutes	10 minutes	
Wait Time for Each Agency’s Personnel	OER Supervisor:		OER Supervisor did not travel to the scene.
	57 minutes	0 minutes	
	NYPD Officer:		NYPD Officer waited for the OER Crew to arrive because OER Supervisor did not travel to the scene.
	37 minutes	49 minutes	
	OER Crew:		Attributed to the reduction of the incident verification time.
	30 minutes	0 minutes	
Exposure Time for Incident Response Personnel	OER Supervisor:		Attributed to the reduction of the total incident duration.
	39 minutes	0 minutes	
	NYPD Officer:		
	22 minutes	30 minutes	
	OER Crew:		
	2 minutes	2 minutes	
Duration of Lane Closure	1 Lane:		Attributed to the reduction of the total incident duration.
	93 minutes	59 minutes	

4.2.2 Case II: Incident 1593

The Pre-IIMS and IIMS activity network diagrams for Incident 1593 are shown in Figure 25 and Figure 26, followed by Table 8, which summarized the analysis results. In the activity network diagrams, there are three distinct paths. The center pathway primarily depicts, from left to right, the physical activities that take place through the incident management process. The upper

pathway depicts the law enforcement activities associated with the incident management process, and the lower pathway depicts supervisory activities that take place.

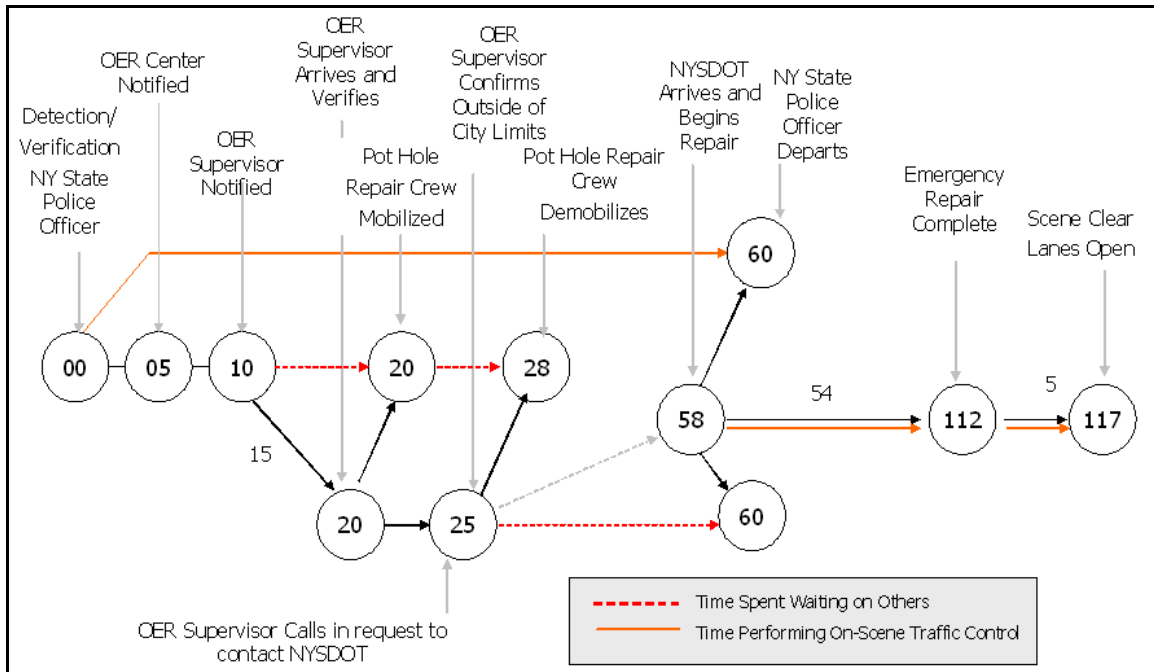

Figure 25. Pre-IIMS Activity Network Diagram Incident 1593.

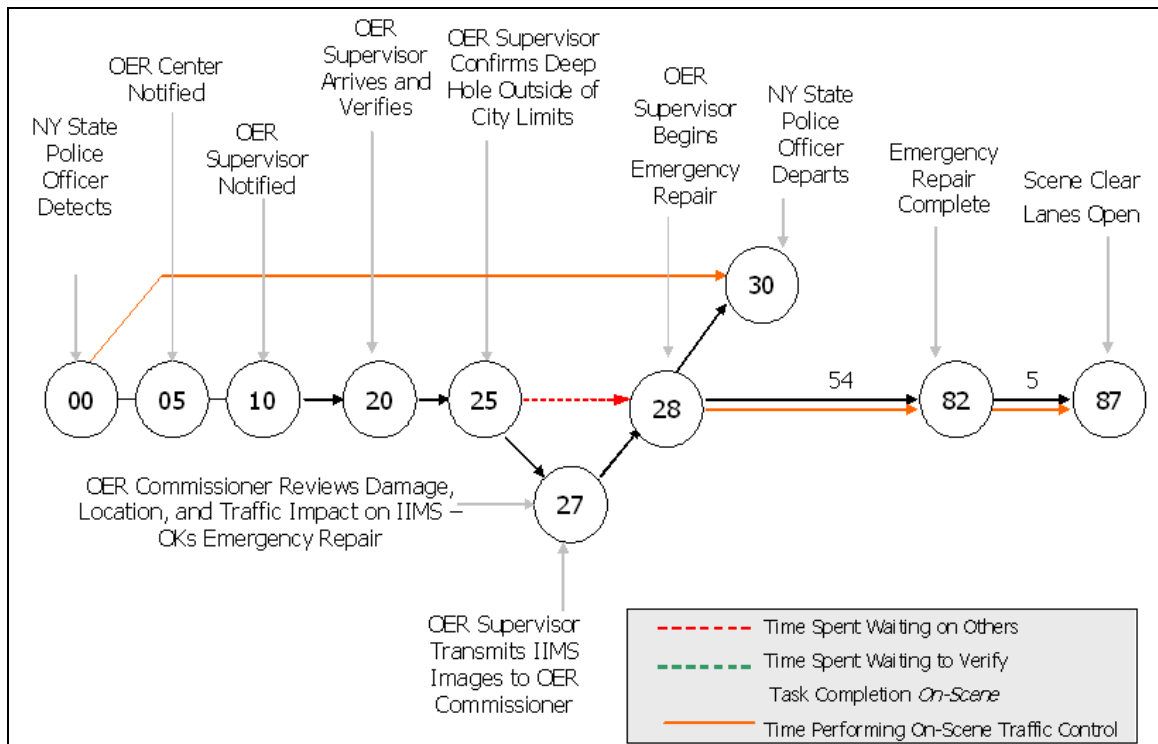

Figure 26. IIMS Activity Network Diagram Incident 1593.

Incident 1593 presents a case in which there is significant supervisory activity, which requires coordination between personnel: in the field; in the operations centers; in positions of senior leadership within the agencies and the city; and in other external agencies.

In the pre-IIMS depiction of Incident 1593, these supervisory activities make up a significant portion of the critical path requiring 48 minutes from the time the OER Supervisor becomes engaged and the time that responsibility for the incident scene is turned over to the NYSDOT crews. The activities taking place to effect this hand-off are voice-intensive communications that occur among a network of participants. These communication patterns are guided by protocol in the initial notification effort, and they tend to develop into ad hoc patterns as each participant seeks to gain a higher level of understanding by communicating with others. The communication patterns introduce significant opportunities for misinterpretation, and the potential to extend the incident duration because they take place on phone networks primarily in a one-to-one mode.

In the IIMS case, Incident 1593 is not only shortened in duration, but is also changed in its complexity as illustrated by the significant change in the supervisory time that is on the critical path. This time was reduced from 48 minutes to 18 minutes. Further, the communications are shifted from the voice network and are made on the data network using images, annotation, and text messaging. Data communications, particularly the digital imaging component, reduce the chance of misinterpretation and provide the members of the decision network a common basis for discussion using messaging capabilities and/or voice communications.

The CPM analysis of the “before” and “after” data for Incident 1593 indicated reduction in several time spans, which are summarized in Table 8.

Table 8. Incident 1593 Performance Measures

Category	“Before” Duration	“After” Duration	Reason
Overall Incident Duration	117 minutes	87 Minutes	Improvement in supervisory communications and coordination.
Incident Verification Time	20 minutes	20 minutes	No change: OER Supervisor had to travel to the scene in both scenarios because the primary responder was not IIMS-equipped.
Dispatch Time for Secondary Responders	33 minutes	0 minutes	The requirement to dispatch secondary responders (i.e., NYSDOT) was eliminated since the OER Supervisor made use of emergency repair materials to complete the emergency patch.
On-Scene Times for Incident Response Personnel	OER Supervisor:		OER Supervisor spent more time on scene because he was able to do the required repair eliminating the need to dispatch a repair crew.
	60 minutes	78 minutes	
	NYSP Officer:		NYSP Officer spent less time on scene as a function of a shorter time from incident detection to the beginning of the emergency repair.
	60 minutes	30 minutes	

Category	“Before” Duration	“After” Duration	Reason
Wait Time for Each Agency’s Personnel	OER Supervisor:		OER Supervisor did not have to wait for the State repair crew to arrive and begin patching.
	35 minutes	3 minutes	
	NYSP Officer:		NYSP Officer spent less time on scene as a function of a shorter time from incident detection to the beginning of the emergency repair.
	60 minutes	30 minutes	
Exposure Time for Incident Response Personnel	OER Supervisor:		Attributed to the reduction of the total incident duration.
	0 minutes	40 minutes	
	NYSP Officer:		OER Supervisor had to maintain control of the scene during the repair process instead of handing the scene off to the NYSDOT Repair Crew.
	38 minutes	15 minutes	
Duration of Lane Closure	1 Lane:		Attributed to the reduction of the total incident duration.
	117 minutes	87 minutes	

4.2.3 Case III: Incident 2431

The analysis of Incident 2431 follows a different pattern. In the previous two cases, the comparison was made between a pre-IIMS incident management process and an IIMS-supported process. For Incident 2431, the Evaluation and IIMS Deployment Teams developed the activity network diagram for the incident as it actually occurred, with the existing level of IIMS deployment, where the primary responder was not IIMS-equipped, with results in Figure 27. An activity network diagram also was developed to show the case in which IIMS is fully deployed the primary responder would be IIMS-equipped, with results in Figure 28. Comparison is made between the two cases using the same performance criteria used in the other two case studies. The focus group felt that had this incident taken place in a pre-IIMS environment, the overall 5-hour duration would easily have been extended to 8 hours or more.

Incident 2431 is a case in which the initial damage assessment is of a severity that dictates roadway closure for an extended period of time. This level of impact brings higher echelons of NYCDOT into the incident management process and requires that the NYPD TMC initiate a regional response to coordinate with TMCs in neighboring states. A freeway closure for an indeterminate period represented a significant transportation event. As a result, this incident involved supervisory activity across the spectrum from shop chiefs to the NYSDOT Commissioner. In the processes that supported these activities, accurate and timely information proved to be the key components of a successful incident management process.

This incident is an example of one in which the primary responder was not IIMS-equipped. The IIMS event was not created in the field, but by a participating operations center, the NYPD TMC, who created an incident record to support the incident management process. Using GIS, the IIMS facilitated the process as the TMC and participating field units and operations centers identified the location of utility lines in the area of the incident; planned access routes for responding personnel; and planned diversion strategies and associated messages for posting on the DMS on local and regional freeways, and for media broadcast.

As with the other case studies, the incident activity network diagrams present three distinct activity paths. The center pathway primarily depicts, from left to right, the physical activities that take place through the incident management process. The upper pathway depicts the law enforcement activities associated with the incident management process, and the lower pathway depicts supervisory activities that take place. These supervisory activities make up a significant portion of the critical path in the existing IIMS deployment case requiring 36 minutes from the first reports of “buckling” until the “buckling” report was retracted. In a case where IIMS was fully deployed, this time could be reduced to 21 minutes. Like the previous case study of Incident 1593, there is a positive impact of the improved communications associated with IIMS in both time and situation understanding by all parties.

In Incident 2431, the importance of these two positive impacts is magnified—unlike the single lane closure in Incident 1593, this incident involved closure of all three travel lanes in both directions. This incident demonstrates that the earlier an IIMS-equipped vehicle can get on scene, the quicker the coordination and decision activities can take place, thereby minimizing the potential for decisions that have large negative impacts on regional mobility.

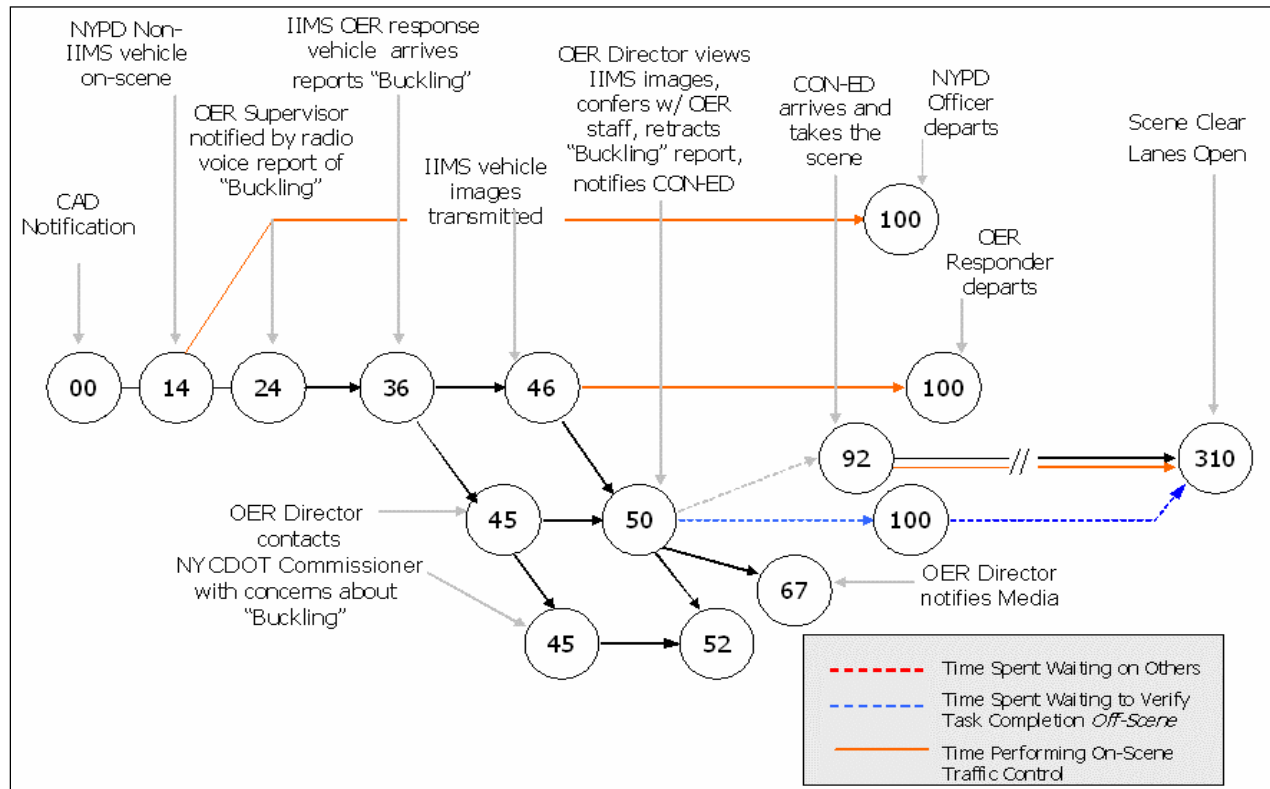

Figure 27. Existing IIMS Deployment Activity Network Diagram Incident 2431.

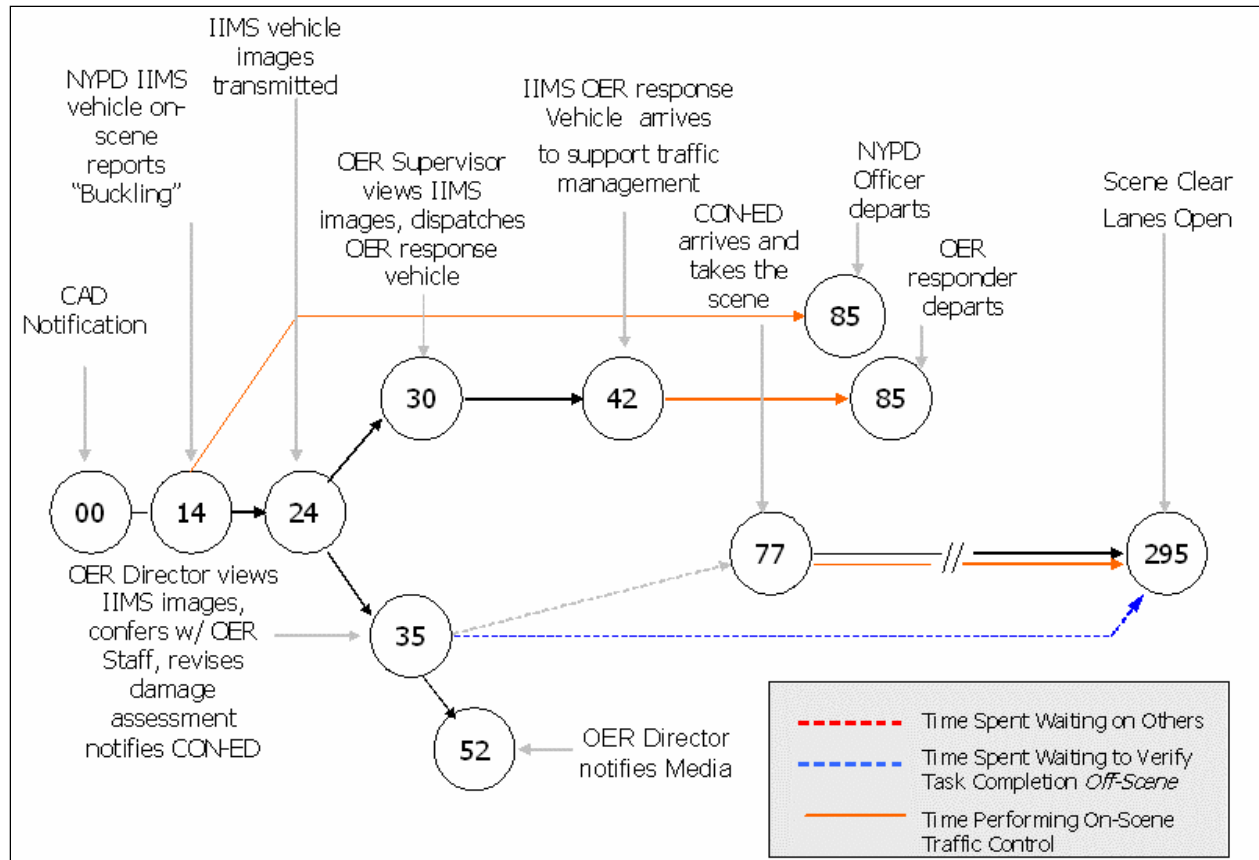

Figure 28. Full IIMS Deployment Activity Network Diagram Incident 2431.

The CPM analysis of the “before” and “after” data for Incident 2431 indicated reduction in several time spans, which are summarized in Table 9.

Table 9. Incident 2431 Performance Measures

Category	“Before” Duration	“After” Duration	Reason
Overall Incident Duration	310 minutes	295 minutes	Early development of decision-level information.
Incident Verification Time	50 minutes	35 minutes	Early development and distribution of decision-level information allows OER director to provide earlier notification to Consolidated Edison, Inc.
Dispatch Time for Secondary Responders	92 minutes	77 minutes	IIMS allowed the person in charge (PIC) to determine exactly which agencies needed to be dispatched. The reduction can be attributed to the overall reduction in incident duration.

Category	“Before” Duration	“After” Duration	Reason
On-Scene Times for Incident Response Personnel	OER Responder:		In full IIMS deployment, the OER responder's role is traffic management only; in addition, this reduction is a function of the overall incident duration being shorter.
	54 minutes	43 minutes	
	NYPD Officer:		This reduction is a function of the overall incident duration being shorter.
	86 minutes	71 minutes	
Wait Time for Each Agency's Personnel	OER Responder:		IIMS allowed the PIC to determine exactly which agencies needed to be dispatched. Thus, the correct unit (Consolidated Edison, Inc.) arrived earlier in the incident management process.
	56 minutes	35 minutes	
	NYPD Officer:		
	78 minutes	63 minutes	
Exposure Time for Incident Response Personnel	OER Responder:		Attributed to the reduction of the total incident duration.
	35 minutes	20 minutes	
	NYPD Officer:		
	56 minutes	42 minutes	
Duration of Lane Closure	1 st Lane – Same Direction:		Due to the nature of the incident, the time that one lane (same direction) would be closed would remain the same.
	285	285	
	2 nd Lane – Same Direction:		The primary impact of the full IIMS deployment would be a reduction in the time required to extent of the roadway damage in the other lanes, and thus reduce the total facility/roadway closure time.
	85	70	
	3 rd Lane – Same Direction:		
	70	50	
All 3 Lanes – Opposite Direction:			
45	25		

4.3 Analysis of Additional Incident Types

Midway through the Evaluation Team's work, a revision to the Statement of Work was made, which specified that the quantitative analysis include an assessment of IIMS performance with respect to the following incident types:

- Roadway Damage.
- Commercial Vehicle Incidents.
- Injury/Fatality Crashes.

This section of the report is meant to discuss these types of incidents in detail, with the exception of Injury/Fatal crashes. The reason these types of crashes were not analyzed in detail was because incidents in the IIMS are not specifically categorized in this manner. The primary method of classifying an incident is in accordance with the following initial “Quick Data” categories that are available on the initial incident creation screen:

- Accident.
- Disabled [Vehicle] Only.
- Construction.
- Maintenance.
- Non-Emergency.
- Other Emergency.
- Unfounded [False Alarm].
- Type Not Specified.

In addition to these main “Quick Data” categories, incidents can be further classified by one or more “category descriptors.” This is typically the second screen the responder sees when creating an incident. The different category descriptors are:

- Roadway Damage.
- Roadside Damage.
- Road Weather.
- Tractor Trailer.
- Spill.
- Tow.
- Road closure.
- Other.

The notion of an injury or fatality occurring in an incident is a “yes” or “no” box that is checked as part of the detailed incident data entry, which the responder may or may not enter. Therefore, it is not possible at this time to understand specifically how many injury or fatal incidents occur each year, as the system cannot accept a blank entry as an assumption of no injury.

Data from 2006 on the remaining incident types of interest was examined, and is discussed in the section 4.3.1.

4.3.1 Review of Additional Incident Types

The Evaluation Team received 6 months’ worth of complete IIMS data for January through June 2006. In keeping with the approach taken during the selection of the initial case studies in 2003,

the Team first conducted a statistical analysis of each incident type and its corresponding incident duration. As with the 2003 data, the Team noted that for each incident type there was a spike in incidents with durations of less than 10 minutes. For each incident type, between 16 and 30 percent of incidents were less than 10 minutes in duration. The Team omitted these incidents from the calculation of the statistical descriptors, as they were likely reflective of either data entry error or a case where IIMS was used to document other damage, especially in Roadway Damage incidents.

When reviewing each incident type of the 2006 data, the Team noticed a few outlier incidents with durations of more than 1,000 minutes (about 16 hours). These durations also were excluded from the calculation of the statistical descriptors, as they were representative of the extreme high end of the duration range.

The distribution and descriptive description for Roadway Damage, Debris Spill and Fuel Spill (which is a combination of oil, diesel, and gasoline spills, as classified by detailed descriptors in IIMS), and Tractor Trailer incidents are shown for incidents of 10 minutes and greater in Figures 29 through 32. Note, if a 10-minute range is not depicted on a figure’s graph, this indicates that no incidents occurred within that duration range.

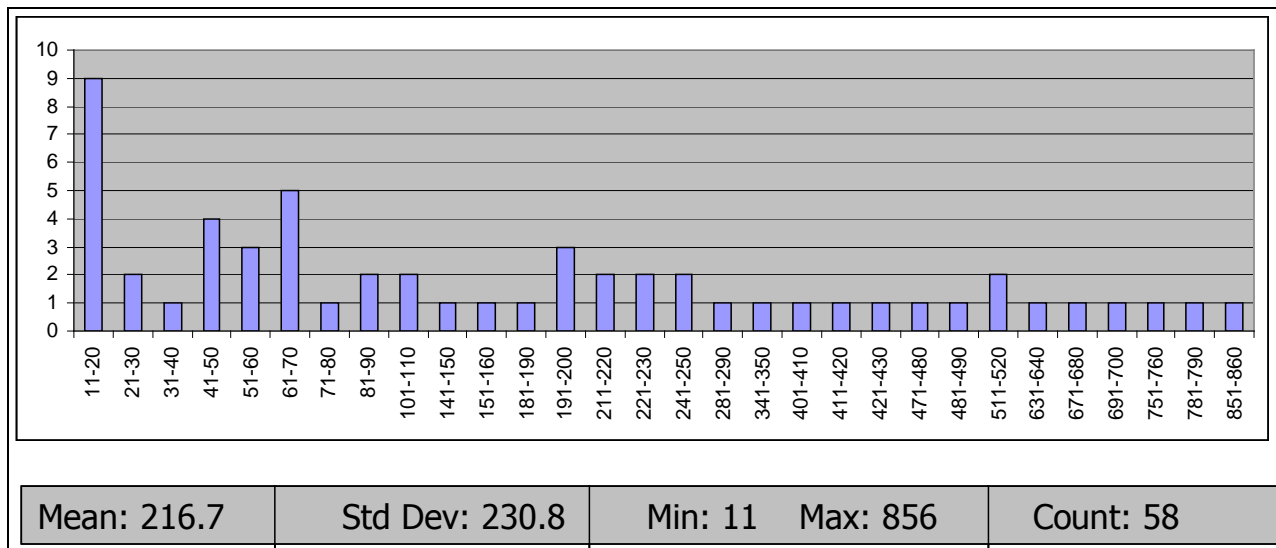

Figure 29. Roadway Damage Incident Duration Descriptors.

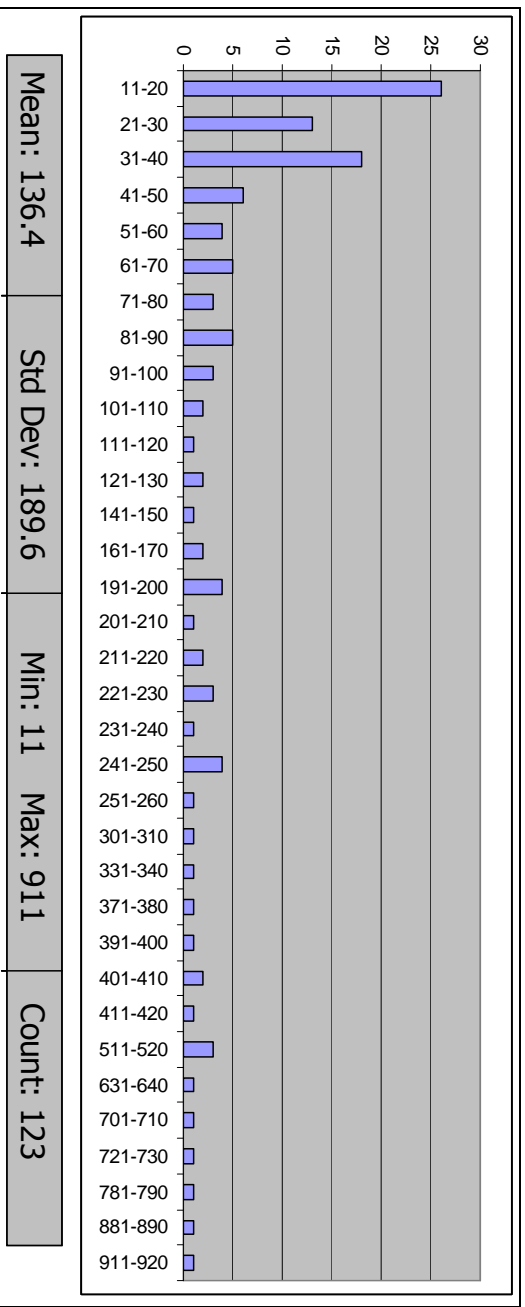

Figure 30. Debris Spill and Fuel Spill Incident Duration Descriptors.

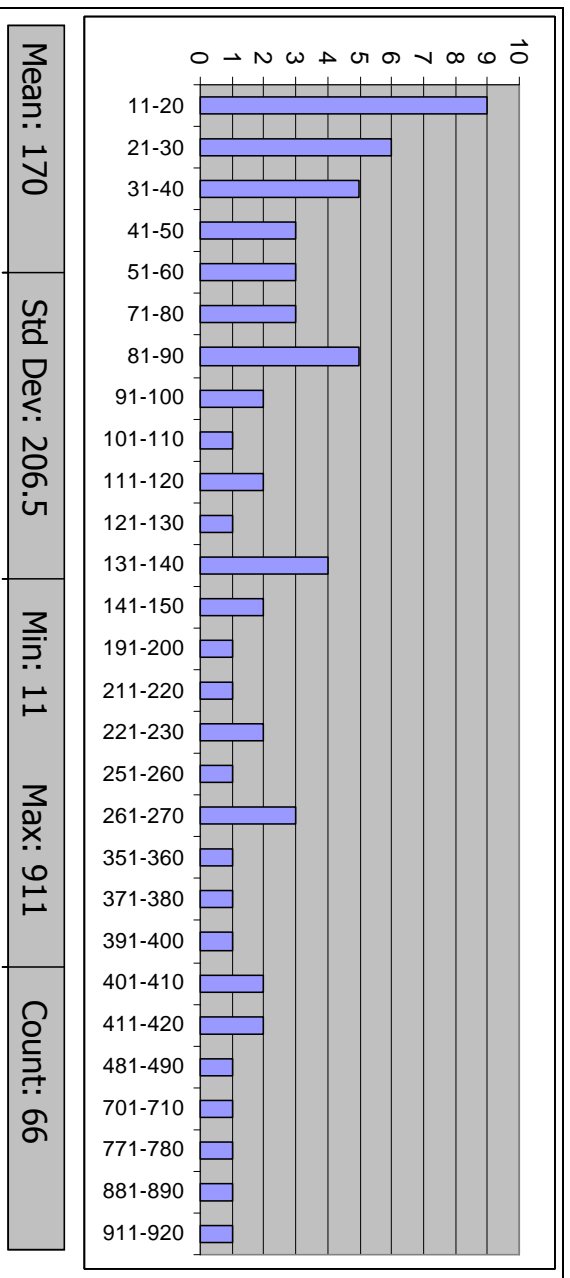

Figure 31. Fuel Spill Incident Duration Descriptors.

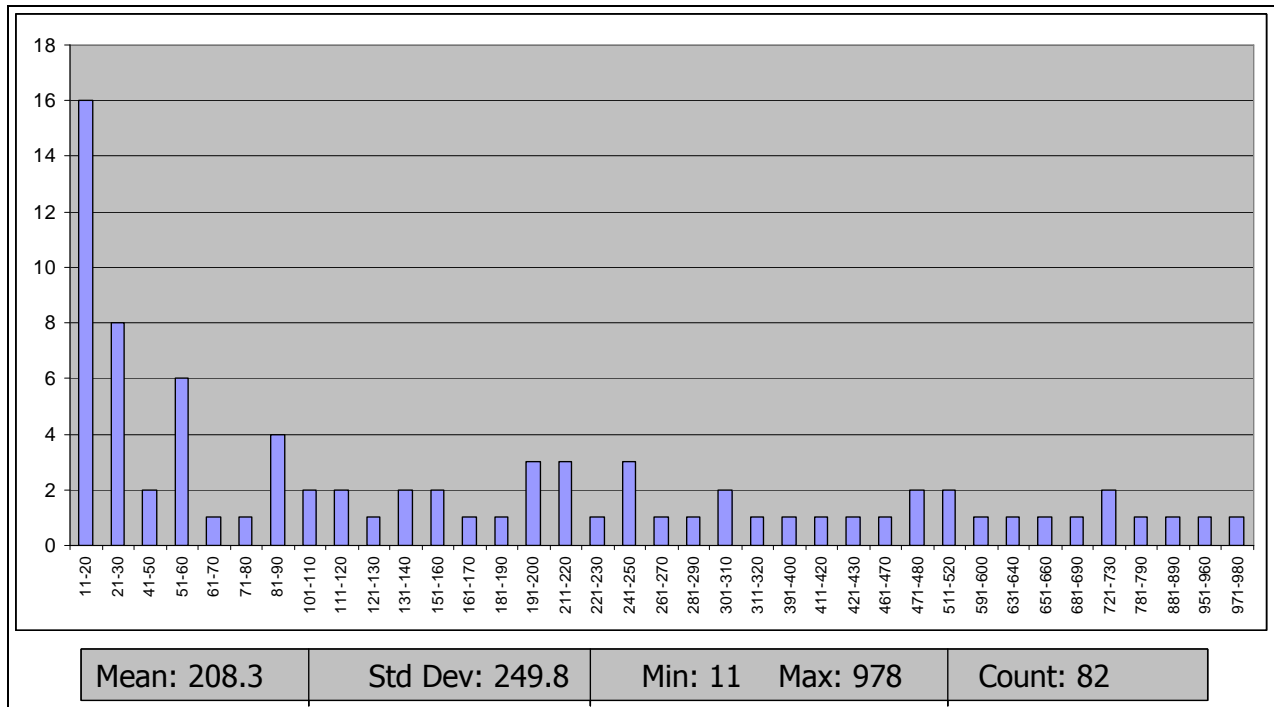

Figure 32. Tractor Trailer Incident Duration Descriptors.

Given that the 2003 statistical descriptors were only calculated for the Roadway Damage incidents, the Evaluation Team was only able to compare the 2006 data for that category. For the 6 months in 2006 during which data was collected, there were twice as many roadway damage crashes as for the 4-month period of 2003 data collection. There were 58 Roadway Damage incidents from January to June 2006 of longer than 11 minutes in duration, while there were only 25 Roadway Damage incidents over 11 minutes from March to June 2003.

In addition to the greater number of incidents, there were great differences in the statistical analysis results for the 2003 and 2006 data. Both the mean and standard deviation for the 2006 Roadway Damage incident durations were significantly higher than for the 2003 data: in 2006, the mean roadway damage incident duration was 216.7 minutes, while in 2003 it was 62.2 minutes. Likewise, the standard deviation for Roadway Damage incident durations was 230.8 minutes, while in 2003 it was just 58 minutes. This indicates that while there were more incidents in 2006, there was more variation in the duration. There were more incidents with durations longer than the mean in 2006 than in 2003, and the maximum duration was significantly longer than in 2003.

While 2003 statistical data was not available for the other incident types (as the desire to focus on these types was not requested until after that time), the Evaluation Team felt that the conclusions for the 2006 Roadway Damage statistical descriptors holds true for the other incident types examined. From this observation, the Team can deduce that while incidents with durations of less than 10 minutes may indicate data entry error, incidents with extremely long durations may indicate the same types of errors, such as a responder forgetting to close out an incident within IIMS. Aside from data entry errors, the Evaluation Team does feel that the added incident types (Tractor Trailer, Debris Spill and Fuel Spills) may represent the type of incident which would be severe enough to last several hours.

Explanation of Outliers

As mentioned, the calculation of the statistical descriptors excluded incidents longer than 1,000 minutes. In addition, when sorting the incident records by incident or lane closure duration, the Evaluation Team noted several other unusual occurrences:

- Incidents with negative lane closure or incident durations.
- Incidents with extremely high (5- or 6- digit) durations, in minutes.
- Incidents with large, negative (i.e., a combination of the first two bullets) lane closure or incident duration.
- Incidents where the lane closure duration was greater than the incident duration.
- Incident durations of zero with a lane closure duration within the normal range.

The Evaluation Team noted multiple occurrences of these outlier durations. In each incident type, approximately 2-5 percent of records had one or more of these types of outlier incident durations in their incident. While it was too time-intensive to review all records related to lane closure for each incident type in detail, a quick scan of the records indicated that a larger percentage of incident may have outlier lane closure durations. To a large extent, the outlier incident duration errors were caused by a software problem that has since been corrected. While there may still be user-related errors that can cause outlier incident duration errors, the system has been corrected.

The Evaluation Team selected a specific incident for each type of outlier occurrence and investigated the reasons for these durations. In each case, the contributing factors were identified as being either a data entry or operational error when using IIMS. Table 10 summarizes the reasons for these types of outlier durations.

Table 10. Outlier Duration Examples

Outlier Description	Reason
Lane closure duration greater than incident duration.	Incident was re-opened after it had been closed in IIMS to enter specific lane closure times. The lane closure values were then entered incorrectly.
Large negative incident and lane closure duration.	Entry was incorrect due to a mobile unit GPS time synchronization issue that occurred during the incident; this resulted in times being recorded as occurring 12 hours earlier than the incident itself.
Zero incident duration with normal lane closure duration.	An IIMS-equipped vehicle was not on scene; hence, the incident was created from local unit based on data called in from the field. The local unit user incorrectly entered this data, so the incident creation time and all lanes clear time were equal.

Outlier Description	Reason
Large (5-digit) lane closure and incident duration.	The incident was created by NYCDOT OER, but OEM EOC reviewed the incident data in IIMS and entered a second "all lanes clear" time during their review that was significantly later than the original "all lanes clear" time entered by NYPD Officer.
4-digit incident duration (1200 minutes) and 5-digit lane closure duration.	Two issues: First, a mobile unit GPS time synchronization error on incident creation time. Second, OEM again updated the lane closure "all lanes clear" time with a significantly later time than NYPD Officer had entered.
Incident duration at high end of duration range included for statistical analysis (835 minutes).	Mobile unit GPS time synchronization issue.

The most common reasons for outlier durations appear to be mobile unit GPS time synchronization issues (where the time will be 12 hours off of the correct time) or incorrect editing of an incident's data after the incident is over. In either case, these types of errors occur in a relatively large portion of incidents. As mentioned earlier, the software error that created a large majority of these has been corrected but the Evaluation Team recommends additional testing to ensure accuracy and reducing future errors by working with IIMS users to ensure accurate data entry.

The GPS time synchronization issue in the mobile units is more of a software issue that would need to be dealt with during normal system maintenance. This error would need to be noted and the specific mobile unit examined. In terms of the incorrect entry of data after an incident is over, this could be addressed in future training sessions or in the user's manual.

4.3.2 Analysis of Additional Individual Incidents

Initially the Evaluation Team planned to select individual Tractor Trailer, and Debris Spill and Fuel Spill incidents to analyze the effect of IIMS. Unfortunately, as the Evaluation Team found initially when completing the case studies in 2003, it is difficult to measure the "before" and "after" impacts of IIMS without "before" incident data. In 2003, a Delphi panel was assembled and the detailed incident records examined. Resource allocation prevented the Evaluation Team from re-creating that elaborate process.

Essentially what the Evaluation Team found was that it is difficult to ascertain the improvements in communications that can be attributed to IIMS simply by reviewing the incident record from the system. What the Evaluation Team did note in reviewing specific incident records for tractor trailer and spill incidents was that the records clearly described the duration, severity and response resources required for each incident. One particular reason for this may be the "Quick Data" screens used by mobile unit responders, which guide the user through the initial incident classification and response resources.

For example, one Fuel Spill incident record that was reviewed showed specific details about the incident itself and the response resources required. In this particular case, the incident was a severe Tractor Trailer and Fuel Spill incident involving an overturned tractor trailer with

multiple substance spill (antifreeze, oil, and diesel were involved). In this case, the initial incident description calls for both a double and heavy duty tow to remove the tractor trailer as well as NYDOS support to clean the spill. In addition, this incident record captures the need for a full road closure to complete the incident removal.

In this case, the Evaluation Team feels that the utility and benefit of IIMS are apparent in that these key pieces of information are captured within the first few screens of data entry. In addition, all information can be entered from the mobile unit. In looking at additional records for Tractor Trailer and Debris Spill incidents, the Evaluation Team noted that in each case, multiple agencies—often the key agencies (NYCDOT OER, TMC, NYPD, NYPD TMC, and NYSDOT JTOC)—are reviewing and acknowledging the records from their local units. In this respect, it is apparent that all agencies are actively using the system.

Certain items could be better highlighted in the archived records like the Evaluation Team reviewed. One particular item is the agency that declares “all lanes clear,” as this entry typically signifies the end of the incident’s duration. While the record creation usually has an agency identified, the “all lanes clear” entry does not. This would help in reviewing how the agencies work together during an incident: for example, if NYCDOT OER is the first agency on scene, does this agency also typically work the scene until all lanes clear or does NYPD assume traffic management responsibilities and declare “all lanes clear?” The system could better indicate which agency is assuming particular incident management activities, especially if the agencies decide to use archived IIMS data to review their incident management practices once the reporting capability is available in the IIMS Web services version.

5. EVALUATION FINDINGS

The Statement of Work issued for the expanded evaluation of the IIMS project requires that the Evaluation Team quantitatively describe IIMS performance and qualitatively describe the impacts that IIMS has had on congestion, safety, and incident management operations. This section of the evaluation report presents the findings for these evaluation metrics, and also presents additional findings that were identified during stakeholder interviews.

5.1 Findings

While the Evaluation Team initially focused on quantitative conclusions, the recent system upgrades have highlighted a number of key qualitative findings. The Evaluation Team considered these findings to be of equal or greater importance than the quantitative analysis results. Therefore, this section provides a mix of both quantitative and qualitative findings.

5.1.1 Finding #1: The Integrated Incident Management System can be Considered a Successful Deployment

IIMS is being used by multiple users from multiple agencies, as summarized in section 3 of this final report. These users are continuing to create thousands of IIMS incidents on an annual basis and also have expanded the use of IIMS to support highway maintenance activities in the New York City region. Responders routinely take pictures of incidents while on scene and create incidents related to maintenance activities, such as damage to roadside infrastructure, including such items as guard rails and signs, and the identification of potholes and other elements requiring roadway repairs.

IIMS has been “mainstreamed” as an operational system as technical and operations support for IIMS is being provided by the NYSDOT Office of Information Systems (OIS). What this means is that funds needed for operations and maintenance support are included as part of OIS’s overall IT program support activities and technical support is being provided by OIS staff. This incorporation of IIMS support into OIS operations addresses what is consistently a major issue for ITS deployments—identifying and securing the dedicated sources of funding and technical support needed to keep deployments operational.

5.1.2 Finding #2: The Integrated Incident Management System is Designed to Deploy New Technologies in a Cost-Effective Manner

The NYSDOT OIS is transitioning to move IIMS to a Web services technology system based on open IEEE 1512 protocols. Currently, a user needs to have IIMS software installed on the user’s machine to access the system. The application uses Remote Procedure Call (RPC) and CORBA software to access an IIMS server. With the pending deployment of Web services, users will be provided with “read only” functionality for the Web browser in addition to current users who are entering data using the IIMS application installed in existing hardware. The functionality enabling data entry using the Web browser will be a future enhancement.

The Web services capability will make use of standard internet security technologies and all transmissions will be encrypted through the use of https technology. In addition, system access

will be user name and password protected. This move to Web services will substantially enhance IIMS accessibility, and offers a significant opportunity to increase the number of agencies and responders using IIMS.

The change in the system architecture from the initial non-distributed system where each project agency required its own server to support IIMS to the regional server deployment has generated substantial cost-savings. The use of two regional servers as compared to eight agency-specific servers has resulted in an immediate cost savings of \$320,000 in Oracle database licenses given the per-server license fee of \$40,000. In addition, overall operations and maintenance costs for IIMS users have been reduced.

An additional benefit of the integration of IIMS with other NYDOT OIT systems is that IIMS data can be archived using existing Oracle databases. This reduces data archiving costs and also makes data available to a wide range of users from other agencies. An additional benefit here is that reports can be generated from IIMS data in the formats used by other agencies.

5.1.3 Finding #3: The IIMS Case Studies Successfully Identify Situations Where the Use of IIMS has the Potential to Improve Incident Response Operations

In all three case studies examined within the Roadway Damage incident class, the overall incident duration was reduced. IIMS has the greatest impact on those incidents in which ratio of decision-making time to repair time is high. The improvements are the result of the ability to give the members of the decision group an image of the damage without having to take the time to travel to the scene in order to verify the actual damage and determine what the appropriate response should be. The results of analysis of the three case studies are shown in Table 11.

Table 11. Quantitative Improvements in Incident Response

Measure	Incident 4886	Incident 1593	Incident 2431
Reduction in Overall Incident Duration	-37%	-26%	-5%

In two of three cases examined within the Roadway Damage incident class, improvements in communications facilitated the reduction in time required to verify the incident. One of the three incidents demonstrated a measurable change in secondary responder dispatch time that corresponded with the change in incident verification time. In the second incident, the requirement for secondary response was eliminated as the on-scene OER personnel were able to make an on-the-spot repair due to the aggressive policies OER has adopted towards equipping response vehicles. In the third incident, no change was measurable because secondary response was made by an out of network agency. The results of this analysis are shown in Table 12.

Table 12. Quantitative Improvements in Incident Management Communications

Measure	Incident 4886	Incident 1593	Incident 2431
Reduction in Incident Verification Time	-92%	No Change	-30%
Reduction in Dispatch Time for Secondary Responders	-92%	Requirement Eliminated	Not Measured

5.1.4 Finding #4: The Case Studies Identify How the Use of IIMS has the Potential to Substantially Improve Mobility

Assessment of this finding includes two levels of analysis: the impact on the regional delay due to non-recurring congestion and the localized impact of incident reduction on the length of freeway queues caused by incident-related bottlenecks.

At the regional level, the Texas Transportation Institute (TTI) indicated that incident management programs that employ service patrols and surveillance cameras can reduce the annual incident related delay by 5 percent for very large metropolitan areas.⁹ The Institute also reported that New York City and San Francisco-Oakland regions are estimated to derive the most benefit from incident management. New York City area-specific non-recurring delay reductions due to incident management strategies involving both cameras and service patrols are estimated to be 37,880,000 vehicle-hours. If the effect of a fully deployed IIMS is considered to leverage these benefits by 20 percent,¹⁰ a fully deployed IIMS system has the potential to further reduce delay by 7,576,000 vehicle-hours.

At the localized level, incidents take lanes out of service for which cause bottlenecks at incident locations, causing queues to build on the highway as the freeway capacity is reduced. Incidents during congested periods will cause these backups to extend upstream a significant distance depending on the number of lanes that are closed and the duration of the closure.

Table 13 provides quantitative examples of the impact on the formation based on the impact of IIMS on incident duration for the two representative Roadway Damage incident class incidents analyzed in section 4. Assumptions used in computing the length of the queues are:

- Upstream traffic approximates mid-day traffic loads flowing at Level of Service (LOS) C at an approximate density of 24 vehicles per mile (vpm) (11 car lengths between vehicles) at the speed limit.

⁹ Texas Transportation Institute, *2003 Urban Mobility Study*, accessed October 24, 2003 from TTI Website available at: <<http://mobility.tamu.edu/ums/>>.

¹⁰ The fact that IIMS leverages the existing incident management strategies as revealed through IIMS case studies suggests some improvement factor between 0.00 and 1.00. The value selected, .20, is a conservative estimate based on the IIMS impact on incident verification and secondary responder dispatch.

- Incident freeway section traffic is flowing at LOS F at an approximate density of 100 vpm (one car length between vehicles) at an average speed of 15 mph through the bottleneck area.
- Drivers will not execute route choice options and or diversion options.

Table 13. Typical Queue Lengths due to Roadway Damage Incidents

Evaluation Incident Number	Upstream Lanes Available	Upstream Traffic Flow per Lane (vph)	Upstream Density (vpm)	Incident Section Lanes Available	Incident Traffic Flow per Lane (vph) ¹¹	Incident Section Density (vpm)	Approximate Incident Duration	Length of Queue ¹²
Pre-IIMS 4886	3	1,600	24 (LOS C)	2	800	100 (LOS F)	90 min	16 miles
IIMS 4886	3	1,600	24 (LOS C)	2	800	100 (LOS F)	60 min	11 miles
Pre-IIMS 1593	3	1,600	24 (LOS C)	2	800	100 (LOS F)	120 min	21 miles
IIMS 1593	3	1,600	24 (LOS C)	2	800	100 (LOS F)	90 min	16 miles

The result of the computations, indicate a significant reduction in the localized mobility impact, indicating that for the conditions assumed, for every 30-minute reduction in the lane closure, there is a 5-mile reduction the upstream impact. Unlike the table results, which assume no route choice and no diversion options are exercised, in the real world, drivers will make “bail-out” decisions and the actual queue length will likely not equal the theoretical queue length. In the real world, driver choices spread the impact of the incident onto the arterial streets decreasing mobility across a portion of the transportation network.

5.1.5 Finding #5: IIMS Has the Potential to Improve Traveler and Responder Safety

It has been widely accepted that secondary crashes due to incidents are related to incident duration but, a 2000 study of approximately 1,000 crashes in Maryland found that a linear

¹¹ Vehicles per hour (vph) information computed using the capacity reduction factors provided by FHWA in The Traffic Incident Management Handbook, November 2000. Information accessed on October 24, 2003 from the FHWA Website available at: <<http://www.itsdocs.fhwa.dot.gov/index.htm>>.

¹² Computed using the equation for the movement of a shockwave due to a bottleneck presented by Nicholas Garber and Lester Hoel *Traffic and Highway Engineering*, 2nd Edition, Books/Cole Publishing Co., Pacific Grove, California, 1999.

relationship exists between the occurrence of secondary crashes and incident duration.¹³ The Maryland freeways examined experienced secondary crash rate between 5 and 15 percent for the years 1992-1994 with an average of 5.7 percent. For the 3-year period, 563 crashes per year were considered to be secondary crashes. This corresponds with analysis of the year 2001 New York City freeway crash data conducted by the Evaluation Team. During 2001, there were 16,337 crashes of which 1046, or 6.4 percent, were found to meet a secondary crash definition of occurrence within 4 miles and 2 hours of a primary crash. Table 14 shows the results of various secondary crash search strategies performed during the analysis of the 2001 crash data.

This analysis only addressed secondary crashes as the result of a primary crash thus, the total secondary crash estimates should be considered low. If secondary crashes were linked to all incidents, the total number of secondary crashes would likely increase by a factor of 2.0 or 3.0 to a range of 13-20 percent based on the proportion of incidents that are crashes.¹⁴

Table 14. Results of Various Secondary Crash Search Strategies

Number Crashes Per Event	Number of Events				
	2 Hours 0.2 Miles	2 Hours 0.5 Miles	2 Hours 1.0 Miles	2 Hours 2.0 Miles	2 Hours 4.0 Miles
1	16,028	15,903	15,763	15,658	15,296
2	287	398	511	654	850
3	22	34	57	101	157
4	2	2	6	21	27
5				1	9
6				2	1
7					2
Total	16,337	16,337	16,337	16,337	16,337

Using the method developed by the University of Maryland, a reduction in Roadway Damage incident duration of between 15 and 25 percent would have a measurable effect on secondary crashes associated with Roadway Damage incidents. The reduction in secondary crashes could be estimated as illustrated below based on the 2001 crash data:

- Percentage of non-crash incidents classified as Roadway Damage: 30 percent.
- Number of crash related secondary incidents: 1,046.
- Total number of secondary crashes (2.0 factor): 2,092.
- Total number of secondary crashes (3.0 factor): 3,138.

¹³ Chang, Gsang-Len, "Performance Evaluation of CHART – The Real-Time Incident Management System – Year 2000," prepared for the Maryland State Highway Administration by the University of Maryland Department of Civil Engineering, March 2002.

¹⁴ Based on the proportions recorded in the first months of IIMS operation (the first comprehensive historical New York City freeway incident database), the proportion of crashes to incidents ranges between 33 and 38 percent.

- Number of non-crash related secondary crashes (total secondary crashes – crash-related secondary crashes) – 2.0 factor: 1,046.
 - Number of non-crash-related secondary crashes (total secondary crashes – crash-related secondary crashes) – 3.0 factor: 2,092.
 - Percent reduction in Roadway Damage incident duration (low): 15 percent.
 - Percent reduction in Roadway Damage incident duration (high): 30 percent.
- Conservative estimate: 1,046 (.30) x .15 = 47 secondary crashes per year.
- Aggressive Estimate: 2,092 (.30) x .30 = 188 secondary crashes per year.

The use of IIMS also appears to have the potential to improve responder safety. Anecdotal information obtained during interviews confirmed that responders are at greater risk of injury the greater the time spent on site at an incident, be it managing traffic, removing debris, or removing an incident from the roadway. In all three cases examined within the Roadway Damage incident class, the overall time dedicated to traffic management was reduced. IIMS appears to have the greatest impact on those incidents in which ratio of decision making time to repair time is high. The improvements are the result of reducing the time personnel are on the roadway managing traffic while verification, damage assessment, and repair crew dispatch processes take place. The results of analysis of the case studies are shown in Table 15. This reduction in exposure time at roadside implies that responder safety is enhanced.

Table 15. Reduction in Exposure to Hazardous Conditions

Measure	Incident 4886	Incident 1593	Incident 2431
Reduction in Exposure Time for Incident Response Personnel	-45%	-19%	-5%

5.1.6 Finding #6: IIMS Has the Potential to Provide Energy and Environmental Benefits

Assessment of this hypothesis is based on the qualitative comparison of speed profiles across the freeway section affected by the incident. As indicated in section 5.1.4, the moving shockwave reduces traffic flow upstream of the incident to LOS F. In LOS F conditions speed profiles are choppy as the close proximity of vehicle causes drivers with varying car following skills to allow gaps to build prior to accelerating then perceive closure and begin to decelerate. The more drivers involved and the wider the car following skill range of the driver population, the more pronounced the wave effect becomes. It is under these conditions where speeds vary around a low average speed, that energy emissions efficiency breaks down and emissions per mile increase dramatically as compared to steady state speeds of 45 mph or higher.¹⁵

¹⁵ Based on the assumptions and typical values employed in FHWA’s Surface Transportation Efficiency Analysis Model (STEAM). The STEAM methods are described in the software documentation available at the FHWA Website accessed on October 20, 2003, available at: <<http://www.fhwa.dot.gov/steam/20manual.htm>>.

In the case of the two incidents used to define the incident duration response to IIMS for the Roadway Damage incident class, a reduction in incident duration leads to a reduction in the number of vehicle that must travel through the section operating at LOS F. At upstream flow rates of 1,800 vehicles per hour on the 3-lane freeway, approximately 5,400 vehicles enter the congested state in each hour. Every 30-minute decrement to the time the freeway is encumbered reduces the number of vehicles that are forced into low fuel efficiency and high emissions speed profiles by approximately 2,700 vehicles. Those that do arrive during the incident-caused congestion state will have their exposure time reduced as incident duration reductions further reduce the length of the queue and the time required to traverse the congested area.

5.1.7 Finding #7: The Use of IIMS Has Resulted in Better Incident Management Documentation

Assessment of this hypothesis is based on the comparison of the pre-IIMS incident records system with the IIMS incident records system and examining the improvement in use rates of the IIMS record system over the initial operational period.

In the pre-IIMS environment, there was no centralized incident management record-keeping function. Each agency in the process used paper logs to make notes of incident management activities. These records are retained by each individual agency according to individual agency archiving policies. The only automated incident management activity in the pre-IIMS environment was the CAD system, which is not designed with an archiving feature.

Prior to IIMS, incident records were fragmented and detailed records were not available. The “history” of an incident resided primarily with the individuals who participated. Generating a coherent picture of what happened and what was the impact was extremely difficult and subject to human error as accounts were generated for high interest level incidents in arrears. Since the IIMS implementation, the system has provided a means to capture important information. The information captured can be broken down into three categories:

- **Individual Unit Activities:** This category includes the automated notation of the activity of an IIMS-equipped response unit. Push button screens on the in-vehicle computer simplify on-scene record entries. This function records typical events from assignment to an incident to arrival on-scene through departure from the scene.
- **Incident Record-Keeping Activities:** This category includes the record building system, which uses a combination of push button screens to correctly classify the incident. The first entry concerns incident classification. Determining whether the incident is a traffic accident, a disabled vehicle, other emergency, or non-emergency. The next entry will include sub-classification such as “Roadway Damage/Spill/Fuel or Oil”. This classification function will create the appropriate record type and will provide the appropriate fields to the participating members for fill-in as the incident progresses. As each participant in the distributed record generation function makes an entry, it is recorded and displayed to all other members of the incident-specific response team. Key parameters that are captured include incident initiation, verification, secondary dispatch, secondary arrival, and on-scene time for equipped units.

- **Incident Impact Monitoring Activities:** This category includes the record of the lane closures and re-opening activities associated with incident management. These activities are recorded by any participant in the system (usually the TMC). These records can be supplemented by photos and notes posted as photo captions by any participant. The center-level IIMS systems provide access to the GIS database and the development of Incident Impact Mitigation plans by referencing access routes, utility locations, school and neighborhood data, etc. The center-level systems also have a “notes” feature, which allows then entry of descriptive and ancillary information.

The records functions of the IIMS system were the critical element in generating this evaluation report. Within just the first 5 months of operation, the number of IIMS incident records created rose each month. Since that initial deployment (and as discussed in section 3), IIMS usage and report generation has remained consistent each year. In addition, the deployment of both mobile and local units has continually grown each year.

The case studies and the development of the performance measurement data act as an example of the data contained in IIMS records. During the evaluation process, the Evaluation and IIMS Deployment Teams identified numerous improvements to record keeping. These improvements have been key to implementing upcoming software and hardware updates. Examples of the improvements include a more intuitive way to record lane closure activities and more intuitive push buttons in the field units.

5.1.8 Finding #8: IIMS Improves Post-Incident Assessment/Evaluation Process

As indicated in section 4.1.7, there was no centralized incident records system to enable an active system-level approach to process improvement. In fact, the incident management process itself was more a collection of independent but related activities centered in space and time around an incident. One of the significant impacts of IIMS was on the culture of New York City incident management process in that incident management is now seen as a process that can be measured in its entirety and in its elements. Over the first several months of IIMS operations, individual Evaluation and IIMS Deployment Team members began to see the value of the system as a leveraging function. As the successes increased in number and the active participation of individuals increased, the Evaluation and IIMS Deployment Teams realized that the benefits had moved beyond individual incidents and had demonstrated improvement across a range of incident types and incident complexities.

This realization resulted in a dedicated effort to produce a system of performance measures for IIMS. The results of this effort are the performance measures used to conduct the analysis in this evaluation report. At the highest level, the principal measures include the incident duration frequency distribution and descriptive statistics for each defined incident class for any defined time period of interest (month, quarter, and/or annual). These performance measures can be generated through automated records queries to support management level review of the incident management process. An example of a quarterly review for the Roadway Damage incident class is shown in Table 16.

Table 16. Quarterly Review Data for Roadway Damage Incident Management

Incident Classification	March 2003 (Mean/ Std Dev) (Minutes)	April 2003 (Mean/ Std Dev) (Minutes)	May 2003 (Mean/ Std Dev) Minutes)	2nd Quarter 2003 (Mean/ Std Dev) (Minutes)
Roadway Damage	62/44	90/69	64/76	72/61

The information presented in Table 16 can now be reviewed by the New York City Freeway Incident Management Team, formed under the direction of the NYCDOT Commissioner as a product of the visibility provided by IIMS. From the top-level information, reviewers can “drill-down” to levels of detail that will reveal opportunities for process improvement or resource distribution.

At a more detailed level, the evaluation has resulted in methods to generate key incident management performance reports which can address, at the incident class level down to the incident level, key measures of interest including:

- Incident duration (minutes).
- Verification times (minutes).
- Dispatch times for participating agencies (minutes).
- On-scene times for incident response personnel (minutes).
- Exposure time for incident response personnel (minutes).
- Lane closure histories (minutes of 3, 2, and 1 lane closure and percent of incident duration in which the 3, 2, and 1 lanes were closed).

These same measures can be used to track performance over time revealing patterns and opportunities for process improvement.

Lastly, as indicated previously in this report, certain agencies have discovered IIMS benefits their post-incident and maintenance activities. For example, pre-IIMS, an OER responder may have simply noticed something that deserved a quick-fix attention, and normally would have fixed it without generating a report. Using IIMS essentially provided a means to document roadway damage incidents that were fixed on the spot or that did not require emergency repair. OER Field Supervisors reported that they had, in some cases, used the system as a tool to record an image of the damage developing an accountability trail to ensure that non-emergency work orders were generated and that the repairs were made.

In addition, OER has been using IIMS’ new photo archiving capability to input additional incident information. OER also has used the new IIMS save and print capability to archive

pictures, maps, and archived data to create and distribute reports. An example of archived pictures and maps are presented in Figure 33 and Figure 34. These pictures provide a better “story” as agencies gather their lessons learned for their incident management and response practices.



Source: IIMS Software Archive

Figure 33. Sample Archived Picture in IIMS.

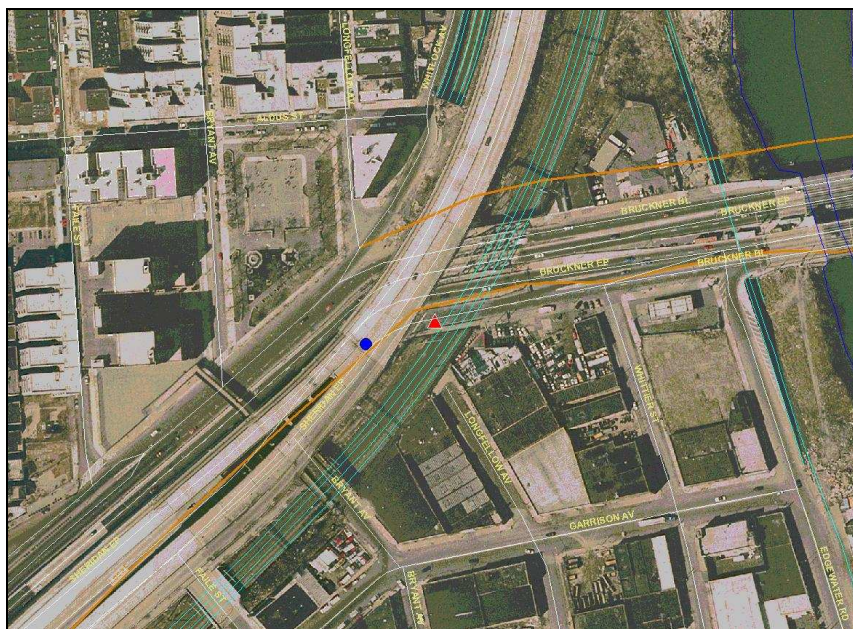

Source: IIMS Software Archive

Figure 34. Sample Archived Map in IIMS.

5.2 Evaluation MOEs

Table 17 maps the original evaluation hypotheses and goal areas to the final evaluation findings.

Table 17. Evaluation Hypotheses and Findings

Goal	Hypothesis	Finding
Evaluate the incident management effects of the IIMS	IIMS will result in improved incident response.	Finding 3: The IIMS case studies successfully identify situations where the use of IIMS has the potential to improve incident response operations.
	IIMS will result in improved communications.	Finding 8: IIMS improves the post-incident assessment/evaluation process.
	IIMS will result in improved coordination of resources.	
Evaluate the transportation system performance effects of the IIMS	IIMS will result in improved mobility.	Finding 4: The case studies identify how the use of IIMS has the potential to substantially improve mobility.
Evaluate the energy and environmental effects of IIMS	IIMS will result in energy and environmental benefits.	Finding 6: IIMS has the potential to provide Energy and Environmental Benefits.
Evaluate the safety effects of IIMS.	IIMS will result in increased traveler safety.	Finding 5: IIMS has the potential to improve traveler and responder safety.
	IIMS will result in increased worker safety.	
Assess the process improvements and institutional impacts of the IIMS.	IIMS will result in better incident management documentation.	Finding 7: The use of IIMS has resulted in better Incident management documentation.
	IIMS will improve evaluation and assessment of the process and its performance.	Finding 1: IIMS has been considered a successful deployment (by stakeholders). Finding 2: IIMS was deployed in a cost-effective manner.

5.3 Evaluation Lessons Learned

With respect to conducting the quantitative assessment of the impact of IIMS, the Evaluation Team notes that straight “before and after” analysis was difficult using:

- Data collection and accuracy improved substantially through the use of IIMS to generate incidents. However, corresponding “before IIMS” data against which direct IIMS impacts can be measured is not as robust or as available.

- While the use of IIMS helped to standardize data formats and structure, these are somewhat different from the same used by agencies before the deployment of IIMS. In addition, incident classification codes were revised through IIMS. The result of this is that it is difficult to map the before and after data to obtain an accurate comparison of incident response times.
- The Evaluation Team was not able to isolate the impacts of IIMS from such external variables such as weather, time of day, level of congestion, etc., and therefore, was not able to develop a quantitative assessment of impacts.

In addition, there was a shift in focus mid-way through the evaluation process from identifying the general benefits of the IIMS deployment to trying to identify specific benefits by incident type. As the evaluation concluded and the IIMS system developers began the deployment of the Web services version of IIMS, though, the general benefits seemed stronger as they related to the increased inter-agency collaboration, and the potential and existing use of archived data, as opposed to shortening the duration of a particular type of incident.

In addition, it was truly difficult to ascertain the “before” and “after” effects of IIMS, especially for particular incident types. The complexity of the focus group/Delphi panel process precluded its use in the later stages of the evaluation. In this way, it was difficult to expand the evaluation to additional incident types. The lesson learned the Evaluation Team took away from this experience was to move forward with the promising conclusions offered by the stakeholder and user groups, as they are also powerful in expressing how the system is actually being used and the value that the stakeholders currently see in IIMS.

6. CONCLUSIONS, RECOMMENDATIONS, AND FUTURE CHALLENGES

6.1 Conclusions and Recommendations

The results of the evaluation indicate benefits already realized through the deployment of IIMS, as well as the potential future benefits that can be realized as IIMS deployment is expanded to include additional agencies and users. The move to deploy IIMS through Web services technology also offers a significant incentive for expanding the number of agencies and responders who use IIMS.

6.1.1 Conclusions

The following conclusions were reached at the conclusion of this evaluation:

- **Conclusion #1: IIMS offers Interoperable Real-Time Communications.** Without question, the key potential benefit offered by IIMS is the deployment of an interoperable communications system with real-time exchange of data. IIMS has the potential to address what has been a significant issue for the responder community—the lack of interoperable communications. This lack of interoperability and the difficulties this causes in responding to major events has been well documented, with the tragic events of 9/11 being the most significant example of how lack of interoperable communications impacts. With IIMS, responder agencies at both the State and New York City (or in other regions municipal, county, other local government agencies) are able to communicate directly and use the system to coordinate incident response activities. This will be significantly enhanced when Web services are deployed, as potential users will need only an internet browser and password to access the system.
- **Conclusion #2: The Integrated Incident Management System can be considered a successful deployment.** IIMS is being used by multiple users from multiple agencies, as summarized in section 3 of this final report. These users are continuing to create thousands of IIMS incidents on an annual basis and have also expanded the use of IIMS to support highway maintenance activities in the New York City region. Responders routinely take pictures of and create incidents related to maintenance activities such as damage to roadside infrastructure such as guard rails and signs, and also the identification of potholes and other roadway required roadway repairs.
- **Conclusion #3: IIMS has been “mainstreamed” as an operational system as technical and operations support for IIMS is being provided by the NYSDOT OIS and NYC DoITT.** What this means is that funds needed for operations and maintenance support are included as part of DoITT’s and OIS’s overall IT program support activities and technical support is being provided by DoITT and OIS staff. This incorporation of IIMS support into DoITT and OIS operations addresses what is consistently a major issue for ITS deployments—identifying and securing the dedicated sources of funding and technical support needed to keep deployments operational.

6.1.2 Recommendations

As the use and deployment of IIMS mature, the Joint Program Office (JPO) may wish to consider periodic updates on trends in IIMS use both by agency and by number of responders and any studies or analyses that are generated by IIMS agencies. These updates should include analyses of trends in the use of IIMS to determine if stakeholder commitment remains strong and if any remedial measures are required to improve stakeholder acceptance. Following are the recommendations offered:

- **Recommendation #1:** It is recommended that the project partners continue to provide the JPO with information on overall use of IIMS by agency and number of responders, and that this information include appropriate trend analyses. In addition, as the use of IIMS expands, the data available for analysis will be much richer and the possibility of quantifying direct IIMS impacts more feasible. The JPO may wish to provide support for further quantitative analyses when the JPO and project partners agree that IIMS use is at a point and data availability is such that a system-impact assessment may be feasible.
- **Recommendation #2:** It is therefore recommended that the JPO continue to monitor IIMS deployment to determine if further evaluation or assessment would be of benefit to the Public Safety Program. Finally, the JPO should consider providing other states and regions with information about the IIMS deployment. As noted previously, IIMS has the potential to provide an interoperable, real-time communication system for incident and emergency management and addresses a major need of the responder community.
- **Recommendation #3:** It is therefore recommended that the JPO develop outreach materials summarizing the IIMS deployment and develop a plan for making these available to other jurisdictions.

6.2 Remaining Challenges

6.2.1 System Limitations

While the system error that was causing incorrect GPS timestamps has been resolved, system stakeholders should maintain awareness of similar errors in the future so as to reduce the number of incidents with outlier incident and lane closure durations. This may affect the accuracy of future reports which each agency can create using the new archived data feature of the Web services version of IIMS.

Another item the Evaluation Team noticed while reviewing archived records was that the system does not track which agencies are responsible for particular incident management activities. For example, while the record creation usually has an agency identified, the “all lanes clear” entry does not. This would help in reviewing how the agencies work together during an incident: for example, if NYCDOT OER is the first agency on scene, does the agency also typically work the scene until all lanes clear or does NYPD assume traffic management responsibilities and declare “all lanes clear?” The system could better indicate which agency is assuming particular incident management activities, especially if the agencies decide to use archived IIMS data to review their incident management.

Lastly, given the transition to the new Web services version of IIMS, system stakeholders recognized that they must be aware of version incompatibility. System developers have already encountered one instance of incorrect data entry on a local unit caused by version incompatibility, as opposed to human error. This is an issue which should be monitored to make sure there are no other similar instances.

6.2.2 Impacts

It appears that the issues causing outlier duration times could be remedied through regular mobile unit testing and maintenance and user training. It will be key for these errors to be addressed should the stakeholders decide it is important to create reports on incident and lane closure durations using archived data. In addition, the user's manual for both the local unit and mobile unit could call out these particular problems. This would encourage mobile unit users to double check the automatic GPS time stamp and encourage local unit users to double check their inputs before closing out the incident in IIMS.

REFERENCES

1. 2003 Urban Mobility Study, published by the Texas Transportation Institute, accessed October 24, 2003, available at: <<http://mobility.tamu.edu/ums/>>.
2. IIMS Local Unit Training Manual, Calspan – University at Buffalo Research Center, Inc., January 2004, page 2.
3. ITS Public Safety Program Website, last accessed March 13 2007: <http://www.itsdocs.fhwa.dot.gov/pubsafety/what_is_itspub.htm>.
4. Gsang-Len Chang, “Performance Evaluation of CHART-The Real-Time Incident Management – Year 2000,” prepared for the Maryland State Highway Administration by the University of Maryland Department of Civil Engineering, March 2002.
5. Nicholas Garber and Lester Hoel, Traffic and Highway Engineering, 2nd Edition, Books/Cole Publishing Co., Pacific Grove, California, 1999.
6. Surface Transportation Efficiency Analysis Model (STEAM) accessed from the FHWA Website October 20, 2003, available at: <<http://www.fhwa.dot.gov/steam/20manual.htm>>.
7. The Traffic Incident Management Handbook, November 2000, accessed from the FHWA Website October 24, 2003, available at: <<http://www.itsdocs.fhwa.dot.gov/index.htm>>.