

# Cooperative Intersection Collision Avoidance System Limited to Stop Sign and Traffic Signal Violations (CICAS-V)

## Subtask 3.4 Interim Report

## Human Factors Pilot Test of the CICAS-V

## (Appendix A-4)

**September 30, 2008**



Crash Avoidance Metrics Partnership (CAMP) Produced  
In conjunction with Virginia Tech Transportation Institute for  
ITS Joint Program Office  
Research and Innovative Technology Administration  
U.S. Department of Transportation

CAMP Members:

Mercedes-Benz  
General Motors (GM)  
Toyota  
Honda  
Ford

## **Notice**

This document is disseminated under the sponsorship of the U.S. Department of Transportation in the interest of information exchange. The U.S. Government assumes no liability for the use of the information contained in this document. This report does not constitute a standard, specification, or regulation.

The U.S. Government does not endorse products or manufacturers. Trademarks or manufacturers' names appear in this report only because they are considered essential to the objective of the document.

## TECHNICAL REPORT DOCUMENTATION PAGE

1. Report No.	2. Government Accession No.	3. Recipient's Catalog No.	
4. Title and Subtitle Cooperative Intersection Collision Avoidance System Limited to Stop Sign and Traffic Signal Violations: Subtask 3.4 Interim Report		5. Report Date September 30, 2008	
		6. Performing Organization Code:	
7. Author(s) Vicki L. Neale, Zachary R. Doerzaph, Derek Viita, Jodi Bowman, Travis Terry, Rajaram Bhagavathula, and Michael A. Maile		8. Performing Organization Report No.	
9. Performing Organization Name and Address Virginia Tech Transportation Institute 3500 Transportation Research Plaza (0536) Blacksburg, VA 24061 <i>In conjunction with:</i> Crash Avoidance Metrics Partnership on behalf of the Vehicle Safety Communications 2 Consortium 39255 Country Club Drive Suite B-40 Farmington Hills, MI 48331		10. Work Unit No.	
		11. Contract or Grant No. <b>DTFH61-01-X-00014</b>	
12. Sponsoring Agency Name and Address United States Department of Transportation, Federal Highway Administration 1200 New Jersey Ave, S.E. Washington, DC 20590		13. Type of Report and Period Covered Subtask Report October 2007 to September 2008	
		14. Sponsoring Agency Code	
15. Supplementary Notes			
16. Abstract <p>The following report documents the work performed in Subtask 3.4 of the Cooperative Intersection Collision Avoidance System for Violations (CICAS-V) project. The basic design objective of the CICAS-V is to create a system that presents a timely and salient in-vehicle warning to those drivers who are predicted, by means of an algorithm, to violate a stop light or a stop sign. The purpose of Subtask 3.4 was to evaluate the CICAS-V and Data Acquisition Systems (DASs) using naive participants in on-road and test-track environments to assess and ensure that all systems are mature enough for a Field Operational Test (FOT).</p> <p>Data were evaluated from 87 naive drivers who were placed into CICAS-V equipped vehicles to navigate a two-hour prescribed route through equipped intersections in the New River Valley region of Virginia. During the prescribed route, each driver was instructed to cross ten stop-controlled and three signal-controlled intersections making a variety of turn maneuvers through each for a total of 52 intersection crossings (the maximum number of crossings per driver). To ensure sufficient data were obtained to understand drivers' impressions of the warning, 18 drivers followed the on-road study with a test-track study. The test-track study used a ruse that required drivers to perform a variety of in-vehicle tasks while driving. A distraction task was delivered at a carefully controlled point near a signalized intersection so that drivers were not looking at the traffic signal during the phase change. A CICAS-V warning was presented and the drivers' responses to the warning were recorded. The outcome of on-road and test-track driver performance and system data indicate that the CICAS-V and the DASs are ready for an FOT.</p>			
17. Key Words Cooperative intersection collision avoidance, crash avoidance, intelligent transportation systems		18. Distribution Statement No restrictions. This document is available to the public through the National Technical Information Service, Springfield, VA 22161.	
19. Security Classif. (of this report) Unclassified	20. Security Classif. (of this page) Unclassified	21. No. of Pages 183	22. Price

Form DOT F 1700.7 (8-72)

Reproduction of completed page authorized



## **Photos Credits**

**Photos and Illustration's courtesy of CAMP**

## Acronyms

CAN: Controller Area Network

CICAS-V: Cooperative Intersection Collision Avoidance System for Violations

DAS: Data Acquisition System

DART: Data Analysis and Reduction Tool

DSRC: Dedicated Short-wave Radio Communication

DII: Driver Infrastructure Interface

DVI: Driver Vehicle Interface

EPIC: Embedded Platform for Industrial Computing

FOT: Field Operational Test

FV: Following Vehicle

FSE: Front Seat Experimenter

GID: Geometric Intersection Description

GPS: Global Positioning System

OBD: On Board Diagnostic

OBE: Onboard Equipment

OEM: Original Equipment Manufacturer

PI: Principal Investigator

POV: Principal Other Vehicle

RDP: Required Deceleration Parameter

RSE: Roadside Equipment

SPaT: Signal Phase and Timing

SRS: Smart Road Study

TTI: Time to Intersection

VTTI: Virginia Tech Transportation Institute

WAAS: Wide Area Augmentation System

WSU: Wireless Safety Unit

# Metric Conversions

<b>SI* (MODERN METRIC) CONVERSION FACTORS</b>				
<b>APPROXIMATE CONVERSIONS TO SI UNITS</b>				
<b>Symbol</b>	<b>When You Know</b>	<b>Multiply By</b>	<b>To Find</b>	<b>Symbol</b>
<b>LENGTH</b>				
in	inches	25.4	millimeters	mm
ft	feet	0.305	meters	m
yd	yards	0.914	meters	m
mi	miles	1.61	kilometers	km
<b>AREA</b>				
in <sup>2</sup>	square inches	645.2	square millimeters	mm <sup>2</sup>
ft <sup>2</sup>	square feet	0.093	square meters	m <sup>2</sup>
yd <sup>2</sup>	square yard	0.836	square meters	m <sup>2</sup>
ac	acres	0.405	hectares	ha
mi <sup>2</sup>	square miles	2.59	square kilometers	km <sup>2</sup>
<b>VOLUME</b>				
fl oz	fluid ounces	29.57	milliliters	mL
gal	gallons	3.785	liters	L
ft <sup>3</sup>	cubic feet	0.028	cubic meters	m <sup>3</sup>
yd <sup>3</sup>	cubic yards	0.765	cubic meters	m <sup>3</sup>
NOTE: volumes greater than 1000 L shall be shown in m <sup>3</sup>				
<b>MASS</b>				
oz	ounces	28.35	grams	g
lb	pounds	0.454	kilograms	kg
T	short tons (2000 lb)	0.907	megagrams (or "metric ton")	Mg (or "t")
<b>TEMPERATURE (exact degrees)</b>				
°F	Fahrenheit	5 (F-32)/9 or (F-32)/1.8	Celsius	°C
<b>ILLUMINATION</b>				
fc	foot-candles	10.76	lux	lx
fl	foot-Lamberts	3.426	candela/m <sup>2</sup>	cd/m <sup>2</sup>
<b>FORCE and PRESSURE or STRESS</b>				
lbf	poundforce	4.45	newtons	N
lbf/in <sup>2</sup>	poundforce per square inch	6.89	kilopascals	kPa
<b>APPROXIMATE CONVERSIONS FROM SI UNITS</b>				
<b>Symbol</b>	<b>When You Know</b>	<b>Multiply By</b>	<b>To Find</b>	<b>Symbol</b>
<b>LENGTH</b>				
mm	millimeters	0.039	inches	in
m	meters	3.28	feet	ft
m	meters	1.09	yards	yd
km	kilometers	0.621	miles	mi
<b>AREA</b>				
mm <sup>2</sup>	square millimeters	0.0016	square inches	in <sup>2</sup>
m <sup>2</sup>	square meters	10.764	square feet	ft <sup>2</sup>
m <sup>2</sup>	square meters	1.195	square yards	yd <sup>2</sup>
ha	hectares	2.47	acres	ac
km <sup>2</sup>	square kilometers	0.386	square miles	mi <sup>2</sup>
<b>VOLUME</b>				
mL	milliliters	0.034	fluid ounces	fl oz
L	liters	0.264	gallons	gal
m <sup>3</sup>	cubic meters	35.314	cubic feet	ft <sup>3</sup>
m <sup>3</sup>	cubic meters	1.307	cubic yards	yd <sup>3</sup>
<b>MASS</b>				
g	grams	0.035	ounces	oz
kg	kilograms	2.202	pounds	lb
Mg (or "t")	megagrams (or "metric ton")	1.103	short tons (2000 lb)	T
<b>TEMPERATURE (exact degrees)</b>				
°C	Celsius	1.8C+32	Fahrenheit	°F
<b>ILLUMINATION</b>				
lx	lux	0.0929	foot-candles	fc
cd/m <sup>2</sup>	candela/m <sup>2</sup>	0.2919	foot-Lamberts	fl
<b>FORCE and PRESSURE or STRESS</b>				
N	newtons	0.225	poundforce	lbf
kPa	kilopascals	0.145	poundforce per square inch	lbf/in <sup>2</sup>

\*SI is the symbol for the International System of Units. Appropriate rounding should be made to comply with Section 4 of ASTM E380.  
(Revised March 2003)

# Executive Summary

## Background

The objective of a Cooperative Intersection Collision Avoidance System for Violations (CICAS-V) is to assist drivers in avoiding intersection crashes by warning those who may be at risk from violating a stop-controlled or red-phased signalized intersection. The basic design objective of the CICAS-V is to create a system that presents a timely and salient in-vehicle warning to those drivers who are predicted, by means of an algorithm, to violate a stop light or a stop sign. The warning is intended to elicit a behavior from the driver that will motivate him or her to respond appropriately to avoid a potential violation, thereby helping them avoid an intersection crash should cross traffic be present.

The CICAS-V project consists of fourteen tasks that involve the complete design, development, and testing of the CICAS-V. Task 3 is primarily concerned with the human-machine aspects of the CICAS-V. This report documents Subtask 3.4, the objective of which is to perform a pilot test of the CICAS-V to:

- Perform the first on-road naive-driver system-level test
- Iteratively refine the CICAS-V warning algorithm
- Closely monitor data from the vehicle and intersection data acquisition systems (DASs) during testing to ensure equipment readiness for a field operational test (FOT)
- Conduct pseudo-naturalistic and test track evaluations of the driver-vehicle interface (DVI) motivated by previous CICAS-V research
- Recommend refinement of the CICAS-V in preparation for the final FOT release

## Recommendations

Subtask 3.4 was a pilot test to perform the first on-road naive-driver system-level test of the CICAS-V. Drivers were placed into CICAS-V equipped vehicles to navigate a two-hour prescribed route through equipped intersections. To ensure that sufficient data were obtained to understand drivers' impressions of the warning, a subset of the drivers followed the on-road study with a test-track study. Based on the results presented, the following conclusions may be drawn.

### 1. The CICAS-V System is FOT Ready

The on-road and test-track portions of data collection, as well as evaluations provided in other reports (e.g., the Task 11 report by Maile et al., in print-a), indicate that the CICAS-V system functions reliably, and as intended, for the purpose of conducting an FOT. The issues noted during data collection have already been addressed with CICAS-V application software upgrades. The problem that occurs when an emergency vehicle preempts the signal, which causes the roadside equipment (RSE) to report incorrect phase information, is being investigated by a signal controller company whose solution has a very high probability of success. The occasional failure of the Netway box, used to translate OEM-specific Controller Area Network (CAN) messages, during data collection is not an issue of the CICAS-V per se; however, it is an issue that would need to be addressed in order to minimize data loss during an FOT.



Approximately 5 percent of data was lost due to this deficiency. One option would be to integrate the functionality of the Netway box into the Wireless Safety Unit (WSU) for the FOT.

## **2. CICAS-V Algorithms are FOT Ready**

The study successfully tested two algorithms for stop-controlled intersections and one algorithm for signalized intersections. Stop-Controlled Algorithm 2 successfully warned three different drivers of an occluded intersection. Signalized Intersection Algorithm 1 provided a valid and timely warning to a driver approaching a light that is going through a phase change.

## **3. The Vehicle DAS is FOT Ready**

The Vehicle DAS performed well during the on-road and test-track portions of the study. Although there was one malfunction in the hard drive during the course of the study, very little data was lost (2 hours out of 191 hours total) due to Vehicle DAS equipment failures. It is recommended that variables that were not useful for the pilot be eliminated from collection to save storage space and simplify the resulting database.

## **4. The Infrastructure DAS is FOT Ready**

The Infrastructure DAS also performed well during the study and is ready for an FOT. The bigger issue for an operational test in the field is if the benefit of collecting infrastructure DAS data is worth the cost to collect, store, reduce, and analyze it. The benefit can be measured in terms of the probability that a warning violation would occur at an equipped intersection, and that there would be information that could only be gleaned from an infrastructure DAS. In addition, the Vehicle DAS may be capable of being upgraded to provide sufficient information (e.g., for the purpose of measuring and characterizing cross traffic).

## **5. Pilot Study Protocols are FOT Ready**

The protocols, pre-drive questionnaires, and post-drive questionnaires worked well for the pilot study and can be implemented during an FOT.

## **6. The CICAS-V Appears to Provide a Benefit to the Driver**

The driver successfully stopped prior to entering the collision zone for every instance in which the driver was provided a valid violation warning. The valid violation warnings from the best performing algorithms, Stop-Controlled Algorithm 2 and the Signalized Intersection Algorithm, are of particular interest since these scenarios mimic those for which the CICAS-V was designed: an occluded stop-controlled intersection that drivers had trouble detecting and a signalized intersection with lead traffic going into a phase change. Of course, the results from this study alone cannot provide an accurate cost/benefit trade off, but the results from this study indicate a potential benefit of the system.

## **7. Drivers like the CICAS-V**

Subjective data on post-test questionnaires indicate that drivers generally like the CICAS-V. A common critique of the system was the conspicuousness of the visual display. Nonetheless, this is a minor critique, considering that 1) the visual display was not designed into the original dash configuration and was added later; 2) drivers had little time with the vehicle (two to three hours) to become accustomed to the display; 3) the speech and brake pulse modalities are very effective; and 4) for the purposes of conducting an FOT, the visual display can be viewed as a

secondary indicator to the speech and brake pulse warning modes and could be modified to improve conspicuity.

## The CICAS-V Pilot Studies

Two studies were conducted as part of the Subtask 3.4 CICAS-V pilot. A Pseudo-Naturalistic on-road study was conducted. Eighty-seven naive drivers were placed into CICAS-V equipped vehicles to navigate a two-hour prescribed route through equipped intersections without an experimenter in the vehicle. To ensure that sufficient data were obtained to understand drivers' impressions during appropriate warning conditions, a Smart Road test-track study was conducted with 18 drivers following the on-road study.

## CICAS-V Equipment and Data Acquisition

The drivers who participated in the study drove vehicles equipped with a CICAS-V and data acquisition system (DAS). The CICAS-V contained several components working together to predict a stop-sign or red-phased signal violation, and provided the driver with a warning when appropriate. The CICAS-V included on-board equipment (OBE) and roadside equipment (RSE).

The WSU, developed by DENSO, is the central processing component of the OBE. It collects data from the vehicle and sensors, and then computes an algorithm to predict when a violation may occur. Based on that prediction, it issues a warning to the driver through the Driver Vehicle Interface (DVI). The DVI presents a violation warning to the driver using three modalities: auditory, visual, and haptic. The DVI has three states: 1) an inactive state when the vehicle is not approaching an equipped intersection; 2) a visual-only indication when approaching an equipped intersection; and 3) a full "single stage" warning mode that encompasses the visual, auditory, and haptic alerts.

The auditory warning consisted of a female voice stating "Stop Light" or "Stop-Sign", presented at 72.6 dBA via the front speakers, measured at the location of the driver's head. The visual warning (Figure 1) displayed a traffic signal and stop-sign icon from a high "head down" display located on top, center of the dashboard near the windshield. Finally, the haptic brake pulse warning consisted of a single 600 millisecond brake pulse (or vehicle jerk) presented in conjunction with the visual icon and an auditory warning.



Figure 1 The visual display is located on the dash of the experimental vehicle.

To activate the DVI, the WSU required the vehicle kinematic data from which the threat assessment was performed. The original equipment manufacturer (OEM) vehicle network provided data such as brake status and velocity to the Netway box. The Netway box, exclusively programmed by each of the OEMs, was used to translate OEM-specific CAN messages to a standard CAN format compatible with the WSU.

A Global Positioning System (GPS) provided longitude/latitude positioning data to the WSU. This allowed the WSU to place the vehicle on a digital representation of the intersection called the Geometric Intersection Description (GID). GIDs were obtained from one of the three Roadside Equipment installations (RSEs) located at the signalized intersections. These RSEs provided GIDS for both stop-controlled and signalized intersections. Each GID was retained on the WSU, unless a newer version was available from the RSE.

In addition to the GIDs, the RSEs also sent differential GPS corrections that allowed the vehicle to accurately place itself on the GID, and signal phase and timing (SPaT) information. The SPaT message was supplied to the RSE by custom firmware installed on the traffic signal controllers, while a GPS base station provided the differential corrections.

The vehicle Data Acquisition System (DAS) was used to record digital video and kinematic data from multiple sources, and was composed of hardware, software, and data storage components. It collected variables representing the information necessary to reconstruct a vehicle’s intersection approach and the driver’s interaction with the CICAS-V. A detailed discussion of the DAS is available in the Task 12 report (Stone et al., in print).

The infrastructure DAS was installed at one of the equipped signalized intersections used in order to determine the utility of having an infrastructure DAS in the planned Field Operational Test. For a detail description of the infrastructure DAS, please refer to the Subtask 3.2 and Task 12 reports (Doerzaph et al., in print; Stone et al., in print).

## Pseudo-Naturalistic Study

The Pseudo-Naturalistic Study was conducted on a predetermined route in Blacksburg and Christiansburg, Virginia. The route was approximately 36 miles long, and contained 13 intersections that were part of the CICAS-V. Three signalized intersections, previously instrumented for Subtask 3.2, and ten stop-controlled intersections were chosen for evaluation.

The route led drivers through each equipped intersection multiple times and was designed with three goals in mind. First, to ensure the driving participants comfort and minimize driving fatigue, the route had to be less than two hours in duration. Second, the route had to maximize the number of intersection crossings while retaining a feasible number of intersections (time constraints did not allow for a large number of intersections to be integrated into the CICAS-V). Finally, a variety of turn maneuvers was desirable in order to fully test the CICAS-V. The turn maneuver summary table for the 13 intersections can be seen in Table 1.

**Table 1 Summary of turn maneuvers for Pseudo-Naturalistic Study experimental method.**

3 Signalized Intersections				10 Stop-Controlled Intersections			Total
Permissive Left	Protected Left	Straight	Right	Left	Straight	Right	
2	5	11	2	12	6	14	52

## Smart Road Study

A subset of the drivers from the Pseudo-Naturalistic Study also participated in the Smart Road test-track study. The primary purpose of this study was to ensure that a group of drivers would experience the CICAS-V warning under identical intersection approach conditions. CICAS-V warnings are generally rare on the open roadway and the test-track study was essential to validate the full CICAS-V system against the Subtask 3.3 results. The protocol for the Smart Road Study was the same as that used for the Subtask 3.3 studies (Perez et al., in print). The study used a ruse that distracted drivers during a signal phase change, which resulted in the presentation of the CICAS-V warning. This surprise phase change was designed to represent a scenario in which the driver needed to make a split-second decision about the potential consequences of a rear-end collision (since following traffic was present) versus the consequences of an intersection collision if cross-traffic was present.

## Stop-Controlled Algorithm 1 Results

The initial stop-controlled intersection warning algorithm incorporated into the CICAS-V was derived directly from the results of Subtask 3.2 (Doerzaph et al., in print). Of the 15 drivers who experienced Stop-Controlled Algorithm 1 (Table 2), 14 received at least one warning. A total of 50 CICAS-V stop-controlled warnings were issued over the course of their drives.

**Table 2 Distribution of drivers by age and gender who experienced Stop-Controlled Algorithm 1.\***

Age Group	Gender		Total
	Male	Female	
18-30	2	1	3
35-50	1	4	5
55+	4	3	7
<b>Total</b>	7	8	15

\*Note: These drivers are a portion of the total number of drivers who participated in the Pseudo-Naturalistic Study.

A review of the warnings indicated that all of the drivers who experienced alerts with Stop-Controlled Algorithm 1 received them at a few particular stop-controlled intersections. After reviewing the intersections' geometry, it was noted that the warnings were occurring on those approaches that had a 3.8 to 7 percent uphill grade. Stop-Controlled Algorithm 1 considered brake status when determining whether drivers should receive a violation alert. If a driver was pressing the brake, it was assumed the driver was attentive to the intersection and the alert was suppressed. On uphill grades, drivers tended to press the brake later in their approach, using gravity to slow the vehicle. Since the algorithms were developed on flat intersection approaches, the later braking caused the warning to activate more often than was expected. Based on these results, the decision was made to change the warning algorithm for stop-controlled intersections to one that did not rely on brake status to suppress the warning. After reviewing the possible algorithms created in Subtask 3.2, a new stop-controlled algorithm (Stop-Controlled Algorithm 2) was selected and integrated into the CICAS-V.

## Stop-Controlled Algorithm 2 Results

A total of 72 drivers completed the Pseudo-Naturalistic Study protocol; they drove the vehicle equipped with Stop-Controlled Algorithm 2 (Table 3). Three violation warnings occurred at the same intersection while drivers were making the same straight-crossing maneuver. The intersection was in the middle of a straight road with a stop sign that was partially occluded at longer distances. The violation warnings were provided to three different drivers: a younger male, a middle-aged male, and an older male. In all three cases, the drivers did not show any indication of intending to stop prior to the warning and completed a safe stop after the warning was issued.

**Table 3 Distribution of drivers by age and gender who experienced Stop-Controlled Algorithm 2.\***

Age Group	Gender		Total
	Male	Female	
18-30	15	14	29
35-50	9	10	19
55+	11	13	24
<b>Total</b>	35	37	72

\*Note: These drivers are a portion of the total number of drivers who participated in the Pseudo-Naturalistic Study.

## Signalized Intersection Algorithm Results

The signal-controlled intersection warning algorithm incorporated into the CICAS-V was also developed in Subtask 3.2 (Doerzaph et al., in print). The warning was deemed successful throughout data collection and was not changed. Therefore, the CICAS-V utilized the same signalized warning timing for all drivers who participated in the Pseudo-Naturalistic Study. A total of 87 drivers completed the Pseudo-Naturalistic Study protocol, as summarized in Table 4.

**Table 4 Distribution of drivers by age and gender who experienced Signalized-Warning Algorithm during the Pseudo-Naturalistic Study.\***

Age Group	Gender		Total
	Male	Female	
18-30	17	15	32
35-50	10	14	24
55+	15	16	31
<b>Total</b>	42	45	87

\*Note that these are all drivers who participated in the Pseudo-Naturalistic Study since the algorithm did not change.

A total of seven violation warnings occurred at signalized intersections: one valid warning, two invalid warnings due to an emergency vehicle signal preemption, and four invalid warnings due to an incorrect GID for the intersection. For the valid warning, a middle-aged male approached the signalized intersection to make a straight-crossing maneuver. The driver braked safely to a stop before crossing the stop bar. If the driver had not stopped, it appears a violation would have occurred, based on the location of the lead vehicle, which crossed over the stop bar as the signal turned red.

Two similar invalid warnings occurred when an emergency vehicle preempted the traffic signal. In both cases, the drivers were approaching a signalized intersection within a couple minutes of the emergency vehicle. When it approached an intersection, the traffic controller switched to a priority mode which guarantees a green phase for the emergency vehicle. Unfortunately, the specialized firmware installed in the traffic controllers did not update the RSE with the correct SPaT messages when the signal was in the priority mode. As a result, the CICAS-V interpreted the signal phase as red, when in actuality the preemption had caused the signal to turn green. This resulted in CICAS-V warnings issued on a green phase.

Four invalid warnings occurred due to an incorrect GID for one of the signalized intersections. The faulty GID incorrectly labeled the left-most through lane as the left turn lane and associated the through lane with the dedicated left-turn signal head. The problem occurred when the drivers were making a straight-crossing maneuver in the left-most through lane, which had a green-phased light. The adjacent left-turn lane had a red-phased light. The CICAS-V would note the red-phase for the left-turn lane and warn the driver who was actually in the through lane with a green-phase. The problem of the incorrect GID was noted the first time that a false alert was issued; however, since the first driver responded calmly to the false alert and proceeded through the intersection, the incorrect GID was left in place in order to learn more about how drivers respond when receiving a false alert during a green phase. The second and third time this occurred, those drivers also responded in a calm manner, assessed the situation quickly, and proceeded through the intersection. The final driver, however, was very startled by the warning on a green phase and responded with abrupt braking, which, under some conditions, could have led to a rear-end crash with the following driver. After this event the GID was corrected and no additional false alerts were observed at this intersection.

## Smart Road Study Results

As stated previously, a Smart Road test-track study was conducted using the same protocol used in Subtask 3.3. Data were evaluated for 18 drivers. The distribution of the 18 drivers by age and gender is shown in Table 5.

**Table 5 Distribution of drivers by age and gender with date analyzed for the Subtask 3.4 Smart Road Study.**

Age Group	Gender		Total
	Male	Female	
18-30	3	3	6
35-50	2	4	6
55+	3	3	6
<b>Total</b>	8	10	18

To lend context to the results of the Smart Road Study, a comparison will be made between these results and those of the Subtask 3.3 Study 6 (S6). Subtask 3.3 S6 tested the same Driver Vehicle Interface (DVI)--the flashing red visual display, an auditory speech warning, and a brake pulse – but with a CICAS-V emulator and preliminary warning algorithm. As such, one goal of the Subtask 3.4 Smart Road Study was to compare compliance rates to Subtask 3.3 S6 to validate the Subtask 3.3 results using the full CICAS-V.

The number of drivers for whom data was usable was 18, which was the same for both Subtask 3.4 and Subtask 3.3 S6. Both the Subtask 3.4 and Subtask 3.3 S6 resulted in 17 of 18 drivers making a compliant stop prior to the collision zone (94 percent compliance rate). In each study, one driver was non-compliant when he/she failed to stop and continued through the intersection. The distribution of compliant drivers by age and gender is presented in Table 6.

**Table 6 Comparing demographics of compliant drivers for Subtask 3.2 SRS and Subtask 3.3 Study 6.**

Subtask 3.4 SR Study	Male	Female	Total	Subtask 3.3 Study 6	Male	Female	Total
Young	3	3	6	Young	3	3	6
Middle	2	4	6	Middle	3	2	5
Old	2	3	5	Old	3	3	6
<b>Total</b>	7	10	17	<b>Total</b>	9	8	17

The parametric data between the two studies is compared in Table 7. The average warning onset Time to Intersection (TTI) in Subtask 3.4 is 2.57s, which is 0.13 s earlier than the preset TTI value in Subtask 3.3 S6. This translated to an average distance to stop bar of 132.17 ft for the Subtask 3.4 Smart Road warnings, compared to 123.2 ft for Subtask 3.3 S6 warnings.

**Table 7 Parametric measures of Subtask 3.4 Smart Road Study and Subtask 3.3 S6.**

Parameter	Subtask 3.4 Smart Road Study		Subtask 3.3 S6	
	Mean	Standard Deviation	Mean	Standard Deviation
Warning TTI	2.57 s	0.11 s	2.44 s	0.02s
Distance to Stop Bar	40.26 m/132.17 ft	3.29 m/10.48 ft	37.55 m/123.2 ft	1.80 m/5.93 ft
Peak Deceleration	0.58 g	0.08 g	0.60 g	0.07 g
Reaction Time	1.01 s	0.36 s	0.74 s	0.14 s

The difference in warning timing resulted in drivers exhibiting slightly lower peak deceleration in Subtask 3.4 (0.58g) compared to Subtask 3.3 (0.60g). The reaction time of the drivers in the Subtask 3.4 Smart Road Study was also longer than the reaction times (time to brake) in the Subtask 3.3 S6. This may be the result of drivers having more time to respond to the warning with the increased TTI, and safely stop the vehicle. In any case, the Smart Road experiment demonstrated that the full CICAS-V system performed similar to the system tested in Subtask 3.3.

## Post-Drive Questionnaire Results

After participating in the driving portion of the study, drivers completed one of three post-drive questionnaires. The questionnaire completed depended on whether or not they received a violation warning while participating in the study, and whether it occurred during the Pseudo-Naturalistic Study or only during the Smart Road Study.

General trends in the data show that drivers who experienced the CICAS-V with Stop-Controlled Algorithm 2 (3 drivers each received one warning) were more satisfied with the system than drivers who experienced Stop-Controlled Algorithm 1 (14 drivers received 50 warnings). This is

an expected outcome. Drivers who experienced the CICAS-V in the manner it was intended to operate (rare warnings issued only when there is a high probability the driver will violate a traffic control device) would find the system more agreeable than drivers who received warnings when they were not necessary. Overall, drivers were satisfied with the system and recognized that they were in danger of violating the stop sign when they received the warning.

It is interesting to note that both aspects of the visual DVI, the blue “intersection ahead” icon and red flashing visual alert, were viewed less favorably than the speech alert and brake pulse warning. Several drivers did not notice the visual icon. Suggested potential improvement to the visual DVI included a more conspicuous visual display that was a little larger and placed closer to the driver.

## **Evaluation of the Study Systems**

One goal of Subtask 3.4 was to evaluate the CICAS-V and DAS hardware and software performance on live roads, and thereby demonstrate FOT readiness. It should be noted that the CICAS-V software tested during Subtask 3.4 was not the final Phase I release. Version 1.11 of the software was implemented for Subtask 3.4 at the time of testing; however, at the writing of this report, the final Phase I is Version 1.15. There were several improvements to the software during the releases after 1.11 that would have likely improved the results presented in this report. In addition, the analyses completed in this section relied on the data provided by the WSU. The DAS was not equipped with an independent set of sensors to verify that data. As a result, these analyses are somewhat limited, in that they assume the data provided by the WSU is accurate.

On average, 96 percent of the time, the CICAS-V appeared to be enabled at either stop-controlled or signalized intersections. The disabled period ranged from 100 msec up to almost 5 sec. Ninety-nine percent of the time over which the DVI was disabled at stop-controlled intersections was due to GID map-matching. Interestingly, at signalized intersections, almost none of the disabled periods were due to the GID map-matching. This is likely explained by the improved skyline and differential GPS available at these intersections. Most of the outages (99%) at signalized intersections were due to the SPaT messages not being received. There were no false alerts or missed warnings due to positioning or SPaT errors detected during data analysis.

It is important to note that instances in which the DVI is only disabled for brief periods (i.e., a few hundred milliseconds) will not have a large impact on system performance. For time periods when the DVI is disabled for several seconds, the impact on the CICAS-V effectiveness is problematic. It was determined that half of the disabled periods at both signalized and stop-controlled intersections were longer than one second. Although there were fewer disabled periods at signalized intersections, they typically lasted longer than at stop-controlled intersections. From these results, it appears that some of these periods have the potential to result in a late warning if the system is momentarily disabled when driver happens to violate. In this instance, the warning would be activated when the system becomes enabled.

A system log that tracked hardware problems that occurred during data collection indicated minor deficiencies that were addressed quickly. The only outstanding issue not being addressed at the time of this writing is with the Netway box during data collection. The OEM vehicle network provided data such as brake status and velocity to the Netway box. The box, exclusively programmed by each of the OEM, was used to translate OEM-specific CAN



messages into a standard CAN format compatible with the WSU. When the box failed, data was not received by the DAS. Deficiencies with the Netway are not an issue of the CICAS-V per se; however, approximately 5 percent of data was lost. It is an issue that will need to be addressed in order to minimize data loss during an FOT.

The vehicle DAS collected the specified measures throughout the Subtask 3.4 studies. There was one malfunction recorded on the DAS issues log that was maintained by experimenters throughout Subtask 3.4. The hard drive malfunction caused the video file to be lost for one driver in the Pseudo-Naturalistic Study. This equates to two hours of data lost out of 191 hours, or just over 1 percent data loss.

The intersection DAS collected the specified measures during the Subtask 3.4 Pseudo-Naturalistic Study. There was one malfunction that occurred during the data collection, as indicated by the issues log maintained by the Subtask 3.4 experimenters. The system overheated when the DAS was initially installed in a weather-tight, non-vented enclosure, which caused the video board to overheat. A redesign of the enclosure to include venting and a fan solved the problem.

### **Limitations of the Study**

One shortcoming of the research is that data collection concluded without benefit of testing the final version of the CICAS-V application. As stated, the Subtask 3.4 studies were conducted using Version 1.11 of the software. By the time data collection had ended and the experimenters had given feedback to the CICAS-V developers, Version 1.15 had been developed, reflecting four software upgrades and several incorporated system refinements. Therefore, it is recommended that a small study be conducted prior to an FOT to test the upgraded software.

Also, this study was conducted in the small metropolitan region of Blacksburg, Virginia. In this area, the GPS coverage was adequate for testing the system, the state DOT was very supportive, and the proximity to data collectors was ideal. Alternative locations are likely to provide different and likely additional, challenges relative to those that were met by the research staff. As such, the trade-offs of alternative locations would need to be carefully considered prior to selecting the final FOT site.

## Table of Contents

### Executive Summary viii

Background.....	viii
Recommendations.....	viii
1. The CICAS-V System is FOT Ready .....	viii
2. CICAS-V Algorithms are FOT Ready .....	ix
3. The Vehicle DAS is FOT Ready.....	ix
4. The Infrastructure DAS is FOT Ready .....	ix
5. Pilot Study Protocols are FOT Ready .....	ix
6. The CICAS-V Appears to Provide a Benefit to the Driver.....	ix
7. Drivers like the CICAS-V .....	ix
The CICAS-V Pilot Studies.....	X
CICAS-V Equipment and Data Acquisition.....	X
Pseudo-Naturalistic Study .....	xi
Smart Road Study.....	xii
Stop-Controlled Algorithm 1 Results .....	xii
Stop-Controlled Algorithm 2 Results .....	xiii
Signalized Intersection Algorithm Results.....	xiii
Smart Road Study Results .....	xiv
Post-Drive Questionnaire Results.....	xv
Evaluation of the Study Systems .....	xvi
Limitations of the Study .....	xvii

### 1 Introduction 1

### 2 Method 2

2.1	Drivers .....	2
2.2	CICAS-V Equipment and Data Acquisition .....	2
2.2.1	CICAS-V Description .....	3
2.2.2	Vehicle DAS .....	5
2.2.2.1	Custom-built Navigation System (Pseudo-Naturalistic Study) 6	
2.2.2.2	Experimental Control Interface for the Smart Road Study 7	
2.2.3	Infrastructure DAS .....	8
2.3	Pseudo-Naturalistic Study Protocol .....	11
2.4	Smart Road Study Protocol.....	15

2.5	Validation and Analysis Techniques.....	18
-----	---	----

### 3 Results and Discussion 21

3.1	Pseudo-Naturalistic Study Results .....	22
3.1.1	Stop-Controlled Algorithm 1 Results .....	22
3.1.2	Stop-Controlled Algorithm 2 Results .....	23
3.1.3	Signalized Intersection Algorithm Results .....	24
3.2	Smart Road Study Results.....	26
3.3	Post-Drive Questionnaire Results .....	28
3.3.1	Results for Drivers Who Received a Violation Warning During the Pseudo-Naturalistic Study and, if Participated, the Smart Road Study .....	28
3.3.1.1	Post-drive questionnaire results for drivers who experienced only valid violation warnings while driving with Stop-Controlled Algorithm 1	29
3.3.1.2	Post-drive questionnaire results for drivers who experienced only valid violation warnings while driving with Stop-Controlled Algorithm 2	29
3.3.1.3	Post-drive questionnaire results for drivers who experienced an invalid violation warning while driving	30
3.3.2	Results from Drivers Who Received a Violation Warning During the Smart Road Study Only.....	30
3.3.3	Results from Drivers Who Did Not Experience a Violation Warning .....	30
3.4	Evaluation of the Study Systems.....	31
3.4.1	Evaluate CICAS-V hardware and software.....	31
3.4.2	Evaluate Vehicle DAS Hardware and Software .....	36
3.4.3	Evaluate Intersection DAS Hardware and Software .....	36

### 4 Recommendations and Study Limitations 37

4.1	The CICAS-V System is FOT Ready .....	37
4.2	CICAS-V Algorithms are FOT Ready .....	38
4.3	The Vehicle DAS is FOT Ready.....	38
4.4	The Infrastructure DAS is FOT Ready .....	38
4.5	Pilot Study Protocols are FOT Ready .....	38
4.6	The CICAS-V Appears to Provide a Benefit to the Driver.....	39
4.7	Drivers like the CICAS-V .....	39
4.8	Limitations of the Study .....	39

### 5 References 40

### 6 Appendices 42

Appendix A: Driver Screening Questionnaire .....	42
Appendix B: Informed Consent – Pseudo-Naturalistic.....	48
Appendix C: Health Screening Questionnaire .....	55
Appendix D: Pre-Drive Questionnaire .....	58
Appendix E: Pseudo-Naturalistic Field Test Route Intersections- Aerial and Ground Images.....	60
Appendix F: Route Directions and Mileage.....	74
Appendix G: Post-Drive Questionnaire – Post-Drive Questionnaire for Drivers Who Received a Violation Warning During the Pseudo-Naturalistic Study and, if Participated, Smart Road Study .....	76
Appendix H: Post-Drive Questionnaire for Drivers Who Did Not Experience a Violation Warning.....	86
Appendix I: Informed Consent – Smart Road.....	89
Appendix J: Smart Road Debriefing Form.....	94
Appendix K: Post-Drive Questionnaire – Drivers Experienced a Violation Warning the Smart Road Study Only .....	96
Appendix L: Subtask 3.4 Algorithms.....	103
Appendix M: Alerts for Each Driver in the 3.4 Studies.....	104
Appendix N: Post-Drive Questionnaire Results for Drivers Who Experienced a Violation Warning While Driving with Stop-Controlled Algorithm 1 .....	106
Appendix O: Post-Drive Questionnaire Results for Drivers Who Experienced a Violation Warning While Driving with Stop-Controlled Algorithm 2 .....	121
Appendix P: Post-Drive Questionnaire Results for Drivers Who Received an Invalid Violation Warning .....	135
Appendix Q: Post-Drive Questionnaire Results for Drivers Who Experienced a Violation Warning on the Smart Road Only .....	144

Appendix R: Post-Drive Questionnaire Results for Drivers Who Did Not Experience a Violation Warning ..... 154

## List of Figures

Figure 1 The visual display is located on the dash of the experimental vehicle.....	x
Figure 2 CICAS-V OBE schematic. ....	3
Figure 3 The visual display is located on the dash of the experimental vehicle.....	4
Figure 4 CICAS-V RSE schematic.....	5
Figure 5 DAS, installed in the vehicle trunk underneath the rear shelf.....	6
Figure 6 GPS interface.....	7
Figure 7 Experimenter interface for Smart Road Study. ....	8
Figure 8 Diagram of the DAS infrastructure components.....	9
Figure 9 Video quadrants from camera units mounted on intersection mast arms.....	10
Figure 10 Camera and radar unit mounted on a single intersection arm mast, along with instrumentation inside traffic signal controller cabinet. ....	11
Figure 11 Map of Pseudo-Naturalistic Study route with intersection ID labels.....	12
Figure 12 Experimental vehicle, 2006 Cadillac STS.....	14
Figure 13 Data collection interface for Pseudo-Naturalistic Study. ....	15
Figure 14 Smart Road intersection diagram. ....	16
Figure 15 Illustration of the four stopping zones on the Smart Road.....	20
Figure 16 Data analysis and reduction software developed at VTTI.....	21
Figure 17 Empirical cumulative probability distribution of the length of a disabled DVI period at stop-controlled intersections. ....	34
Figure 18 Aerial view of Depot & Franklin intersection.....	60
Figure 19 Ground images from Depot & Franklin intersection.....	60
Figure 20 Aerial view Franklin, Elm & Independence intersection. ....	61
Figure 21 Ground images from Franklin, Elm & Independence intersection.....	61
Figure 22 Aerial view of Peppers Ferry (VA-114) & Franklin (Bus460) intersection.....	62
Figure 23 Ground images from Peppers Ferry (VA-114) & Franklin (Bus460) intersection. ....	62
Figure 24 Aerial view of Hickok and First Street intersection. ....	63
Figure 25 Ground images of Tranquility Via & Independence intersection .....	63
Figure 26 Aerial view of Sheltman & College intersection.....	64
Figure 27 Ground images of Sheltman & College intersection.....	65
Figure 28 Aerial view of Magna Carta Via and Constitution Via.....	65
Figure 29 Ground images of Magna Carta Via and Constitution Via. ....	66
Figure 30 Aerial view of Constitution Via & Tranquility Via intersection.....	67

Figure 31 Ground images of Constitution Via & Tranquility Via intersection. ....	67
Figure 32 Aerial view of Tranquility Via & Independence intersection. ....	68
Figure 33 Ground images of Tranquility Via & Independence intersection. ....	68
Figure 34 Aerial view of Independence & Sapphire intersection. ....	69
Figure 35 Ground images of Independence & Sapphire intersection. ....	69
Figure 36 Aerial view of Sapphire & Diamond intersection. ....	70
Figure 37 Ground images of Sapphire & Diamond intersection. ....	70
Figure 38 Aerial view of Windmill Ridge & Cambria intersection. ....	71
Figure 39 Ground images of Windmill Ridge & Cambria intersection. ....	71
Figure 40 Aerial view of Juniper & Morning Star intersection. ....	72
Figure 41 Ground images of Juniper & Morning Star intersection. ....	72
Figure 42 Aerial view of Market & Arbor intersection. ....	73
Figure 43 Ground images of Market & Arbor intersection. ....	73
Figure 44 Graphical representation of the Subtask 3.4 algorithms. ....	103
Figure 45 The “running stop sign” alert that me know that I may be about to run a stop sign was useful. ....	106
Figure 46 The “running stop sign” alert was effect at communicating that I may be about to run a stop sign. ....	107
Figure 47 The “running stop sign” alert was effective at getting my attention quickly. ....	107
Figure 48 What do you think of the timing of the “running stop sign” alert? ....	108
Figure 49 When I received the “running stop sign” alert, I braked without checking for traffic behind me. ....	108
Figure 50 The “running stop sign” alert was annoying when the alert was unnecessary. ....	109
Figure 51 I feel the “running stop sign” alert will increase my driving safety. ....	109
Figure 52 If I was told that I was allowed to turn the “running stop sign” alert system off, I would turned it off the rest of my driving experience. ....	110
Figure 53 Did you ever intentionally activate the “running stop sign” alert? ....	110
Figure 54 Overall, how satisfied were you with the “running stop sign” alert? ....	111
Figure 55 How many times did you run a stop sign or come to close to running at stop sign while driving the test vehicle? ....	111
Figure 56 How many times did you get a “running stop sign” alert you felt was appropriate?. ....	112
Figure 57 How many times did you get a “running stop sign” alert that you felt was not necessary? ....	112
Figure 58 How many times did you NOT get a “running stop sign” alert when you felt one was appropriate? ....	113

Figure 59 How many times did you get a “running stop sign” alert where you could not identify the source of the alert? .....	113
Figure 60 Effectiveness of the DVI in communicating intended information.....	114
Figure 61 Ease of detecting the DVI.....	114
Figure 62 Location of the visual DVI. ....	115
Figure 63 The size of the “blue intersection ahead” display was appropriate .....	115
Figure 64 Annoyance of the DVI.....	116
Figure 65 Distractibility of the DVI.....	116
Figure 66 Effectiveness of the DVI in obtaining driver’s attention.....	117
Figure 67 Startle response to the DVI.....	117
Figure 68 Likelihood of purchasing the intersection warning system. ....	118
Figure 69 Price at which the intersection warning system is considered to be too expensive. ..	118
Figure 70 The “running stop sign” alert was useful. ....	121
Figure 71 The “running stop sign” alert was effective in communicating to the driver that he/she may be about to run a stop sign. ....	122
Figure 72 The “running stop sign” alert was effective at getting my attention quickly. ....	122
Figure 73 What do you think of the timing of the “running stop sign” alert? .....	123
Figure 74 When I received the “running stop sign” alert, I braked without checking for traffic behind me.....	123
Figure 75 The “running stop sign” alert was annoying when the alert was unnecessary.....	124
Figure 76 I feel the “running stop sign” alert will increase my driving safety.....	124
Figure 77 If I was told I was allowed to turn the “running stop sign” alert system off, I would have turned it off for the rest of my driving experience. ....	125
Figure 78 Did you ever intentionally activate the “running stop sign” alert? .....	125
Figure 79 Overall, how satisfied were you with the “running stop sign” alert?.....	126
Figure 80 How many times did you run a stop sign or come close to running a stop sign while driving the test vehicle? .....	126
Figure 81 How many times did you get a “running stop sign” alert that you felt was appropriate?.....	127
Figure 82 How many time did you get a “running stop sign” alert that you felt was not necessary? .....	127
Figure 83 How many times did you NOT get a “running stop sign” alert when you felt one was appropriate?.....	128
Figure 84 How many times did you get a “running stop sign” alert where you could not identify the source of the alert? .....	128



Figure 85 Effectiveness of the DVI in communicating intended information.....	129
Figure 86 Ease of detecting the DVI.....	129
Figure 87 Location of the visual DVI.....	130
Figure 88 The “blue intersection ahead” display was an appropriate size. ....	130
Figure 89 Annoyance of the DVI.....	131
Figure 90 Distractibility of the DVI.....	131
Figure 91 Effectiveness of the DVI in obtaining the driver’s attention.....	132
Figure 92 Startle response of the DVI. ....	132
Figure 93 Likelihood of purchasing the intersection warning system. ....	133
Figure 94 Price at which the intersection warning system is considered to be too expensive. ..	133
Figure 95 How many times did you run a red light or come close to running a red light while driving the test vehicle? .....	135
Figure 96 How many times did you get a “running red light” alert while approaching a traffic light that you felt was appropriate?.....	136
Figure 97 How many times did you get a “running red light” alert that you felt was not necessary? .....	136
Figure 98 How many time did you NOT get a “running red light” alert when you felt one was appropriate?.....	137
Figure 99 How many times did you get a “running red light” alert when you could not identify the source of the alert? .....	137
Figure 100 Effectiveness of DVI in communicating intended information. ....	138
Figure 101 Ease of detecting the DVI.....	138
Figure 102 Location of the visual DVI.....	139
Figure 103 The “blue intersection ahead” display was an appropriate size. ....	139
Figure 104 Annoyance of the DVI.....	140
Figure 105 Distractibility of the DVI.....	140
Figure 106 Effectiveness of DVI in obtaining driver’s attention. ....	141
Figure 107 Startle response of DVI. ....	141
Figure 108 Likelihood of purchasing the intersection warning system. ....	142
Figure 109 Price at which the intersection warning system is considered to be too expensive. ....	142
Figure 110 The “running red light” alert that let me know that I may be about to run a right light would be useful in my everyday driving.....	144
Figure 111 The “running red light” alert was effective at communicating that I may be about to run a red light. ....	145
Figure 112 The “running red light” alert was effective at getting my attention quickly. ....	145

Figure 113 What do you think of the timing of the “running red light” alert?.....	146
Figure 114 I feel the “running red light” alert will increase my driving safety.....	146
Figure 115 Overall, how satisfied were you with the “running red light” alert?.....	147
Figure 116 Almost ran a stop sign or traffic signal. ....	147
Figure 117 Effectiveness of DVI in communicating intended information. ....	148
Figure 118 Ease of detecting the DVI.....	148
Figure 119 Location of the visual DVI. ....	149
Figure 120 The size of the blue “intersection ahead” display was appropriate. ....	149
Figure 121 Annoyance of the DVI.....	150
Figure 122 Distractibility of the DVI.....	150
Figure 123 Effectiveness of the DVI in obtaining driver’s attention.....	151
Figure 124 Startle response of the DVI. ....	151
Figure 125 Likelihood of purchasing the intersection warning system. ....	152
Figure 126 Price at which the intersection warning system is considered to be too expensive. ....	152
Figure 127 The DVI was effective at communicating to me the intended information. ....	154
Figure 128 Ease of detecting the DVI.....	155
Figure 129 Location of the visual DVI. ....	155
Figure 130 Size of the DVI display. ....	156
Figure 131 Annoyance of the DVI.....	156
Figure 132 Distractibility of the DVI.....	157
Figure 133 Likelihood of purchasing the intersection warning system. ....	157
Figure 134 Price at which the intersection warning system is considered to be too expensive. ....	158

## List of Tables

Table 1 Summary of turn maneuvers for Pseudo-Naturalistic Study experimental method. ....	xi
Table 2 Distribution of drivers by age and gender who experienced Stop-Controlled Algorithm 1. ....	xii
Table 3 Distribution of drivers by age and gender who experienced Stop-Controlled Algorithm 2. ....	xiii
Table 4 Distribution of drivers by age and gender who experienced Signalized-Warning Algorithm during the Pseudo-Naturalistic Study.* ....	xiii
Table 5 Distribution of drivers by age and gender with date analyzed for the Subtask 3.4 Smart Road Study. ....	xiv
Table 6 Comparing demographics of compliant drivers for Subtask 3.2 SRS and Subtask 3.3 Study 6. ....	xv
Table 7 Parametric measures of Subtask 3.4 Smart Road Study and Subtask 3.3 S6. ....	xv
Table 8 Summary of turn maneuvers for Pseudo-Naturalistic Study experimental method. ....	13
Table 9 Distribution of drivers by age and gender who had data analyzed in the Pseudo-Naturalistic Study analyses. ....	22
Table 10 Distribution of drivers by age and gender who experienced Stop-Controlled Algorithm 1. ....	22
Table 11 Distribution of drivers by age and gender who experienced Stop-Controlled Algorithm 2. ....	24
Table 12 Distribution of drivers by age and gender who experienced Signalized-Warning Algorithm during the Pseudo-Naturalistic Study.* ....	24
Table 13 Distribution of drivers by age and gender with date analyzed for the Subtask 3.4 Smart Road Study. ....	27
Table 14 Comparing demographics of compliant drivers for Subtask 3.2 SRS and Subtask 3.3 Study 6. ....	27
Table 15 Parametric measures of Subtask 3.4 Smart Road Study and Subtask 3.3 S6. ....	27
Table 16 Percent of working time of the CICAS-V within the warning region. ....	33
Table 17 CICAS-V issues log maintained during the 3.4 study. ....	35
Table 18 Vehicle DAS issues log maintained during the Subtask 3.4 studies. ....	36
Table 19 Infrastructure DAS issues log maintained during the Subtask 3.4 Pseudo-Naturalistic Study ....	36
Table 20 The number of valid and invalid alerts by algorithm and driver in the 3.4 studies (Note: A hyphen in a cell means the driver did not experience that option). ....	104

## Introduction

Intersection crashes account for thousands of injuries and fatalities in the United States every year (National Highway Traffic Safety Administration, 2005). Drivers running stop-controlled and red-phased signalized intersections cost over \$7.9 billion in economic loss each year (Najm et al., 2007). The Cooperative Intersection Collision Avoidance System for Violations (CICAS-V) aims to develop and field test a comprehensive system to reduce the number and severity of crashes at intersections due to violations of traffic control devices (TCD; i.e., traffic lights and stop signs). The basic design objective of the CICAS-V is to create a system that presents a timely and salient in-vehicle warning. The warning is sent to those drivers who are predicted, by means of an algorithm, to violate a stop light or a stop sign. The warning is intended to elicit a behavior from the driver that will motivate him or her to respond appropriately to avoid the potential violation; by doing this, the driver will avoid a potential intersection crash should cross traffic be present.

The CICAS-V project consists of fourteen tasks that involve the complete design, development, and testing of the CICAS-V. Task 3 is primarily concerned with the human-machine aspects of the CICAS-V. Within Task 3, four Subtasks were conducted to assist in the design, development, and testing of the human-machine interface:

- Subtask 3.1 – Mine the 100-Car database to
  - Determine which drivers should receive a warning.
  - Determine preliminary driver vehicle interface (DVI) arrangement.
- Subtask 3.2 – Collect and analyze a large sample of intersection approaches to
  - Determine appropriate warning timing to maximize system effectiveness while minimizing false warnings.
  - Develop and evaluate warning algorithms.
  - Recommend a set of algorithms for system-level testing in Subtask 3.4.
- Subtask 3.3 – Conduct test-track experiments to
  - Provide appropriate warning timing for drivers receiving a warning.
  - Determine and recommend a DVI for system-level testing in Subtask 3.4
- Subtask 3.4 – Perform a pilot test of the CICAS-V to
  - Perform the first on-road naive-driver system-level test
  - Iteratively refine the CICAS-V warning algorithm
  - Closely monitor data from the vehicle and intersection data acquisition systems (DASs) during testing to ensure equipment readiness for a field operational test (FOT).
  - Conduct pseudo-naturalistic and test track evaluations of the preferred DVI motivated by CICAS-V Subtask 3.3 research
  - Suggest refinement of the CICAS-V in preparation for the final FOT release.

This report documents Subtask 3.4. To meet the Subtask 3.4 goals, naive drivers were placed into CICAS-V equipped vehicles to navigate a two-hour prescribed route through designated intersections. A subset of the drivers followed the on-road study with a test-

track study to ensure that sufficient data were obtained to understand drivers' impressions of the warning. The following sections report the method for this task.

## **1 Method**

The Subtask 3.4 experiment consisted of two complimentary studies: a Pseudo-Naturalistic Study (a pre-determined route on open roadways without an experimenter in the vehicle) investigating the CICAS-V in live traffic, and a test-track study validating the CICAS-V against previous test-track data collected in Subtask 3.3. The methods and equipment used for each of these studies will be described in the subsequent sections.

### **1.1 Drivers**

Drivers were recruited through the newspaper, posted flyers, word of mouth, and the Virginia Tech Transportation Institute (VTTI) database of people who had expressed an interest in participating in studies. On initial contact (usually over the phone), individuals were screened to ensure their eligibility for the study (Appendix A). Eligibility criteria included restrictions to: 1) individuals with health conditions or medication intake that may interfere with their ability to operate a motor vehicle and 2) more than two moving violations or any at-fault accidents within the previous three years. The criteria also included the requirement that drivers had to possess a valid driver's license. Additionally, drivers were excluded from the Smart Road subset if they had previously participated in a surprise-scenario experiment at VTTI.

Upon arriving at the Institute, participants were met by the greeter and asked to read an informed consent form (Appendix B). The form provided specific information about the study, including the procedures, risks involved, and measures for confidentiality. After agreeing to the study and signing the informed consent, a health screening questionnaire (Appendix C) was administered to ensure that participants did not have any conditions that would impair their ability to safely operate the test vehicle. A Snellen vision test was conducted to ensure the participants' visual abilities were within Virginia-legal limits of corrected to 20/40 or better. A color vision test was conducted using the Ishihara Test for Color Blindness, and a contrast sensitivity test was performed. The color vision test and the contrast sensitivity tests were recorded for possible future analyses but were not used for screening purposes, although four drivers showed a significant level of red/green color vision deficiency. If it was found that participants were not in good health, or if vision results fell outside the acceptable limits, they would be excused from the study and paid for their participation time. Eligible participants were issued a short pre-drive questionnaire focusing on their driving experiences and habits (Appendix D).

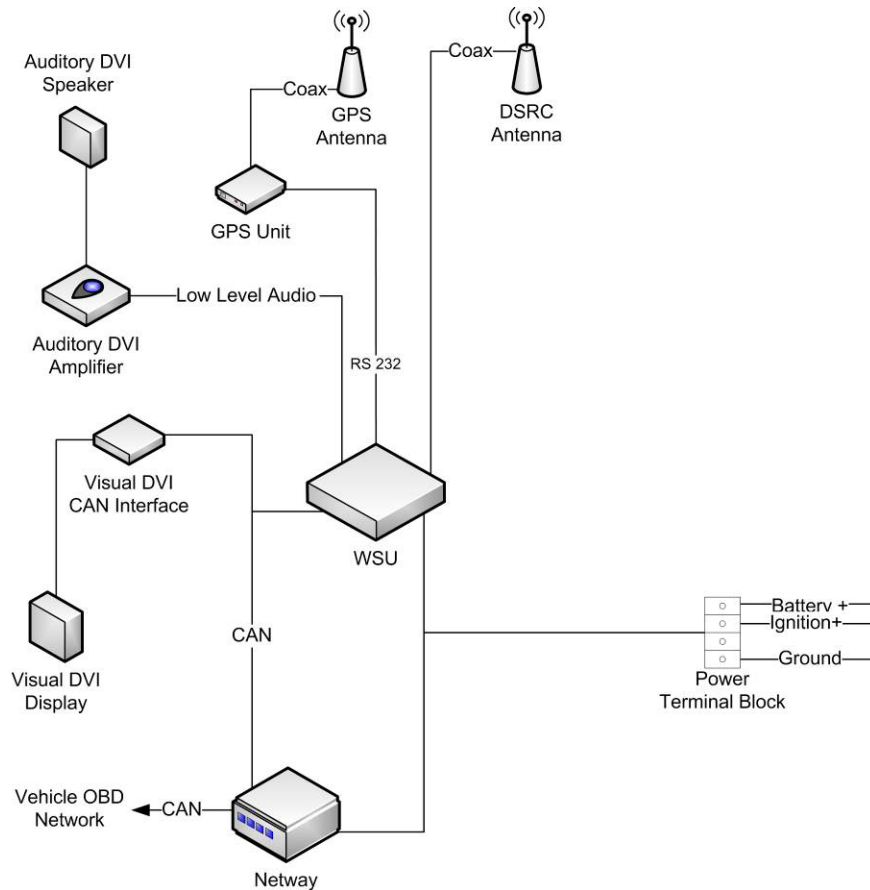
### **1.2 CICAS-V Equipment and Data Acquisition**

The following sections describe the hardware and software used during Subtask 3.4. This includes the CICAS-V designed and developed during Task 8 and Task 10, the DAS developed during Task 12, and the experimental equipment constructed to directly support Subtask 3.4.

### 1.2.1 CICAS-V Description

The CICAS-V contains several components working together to predict a stop-sign or red-phased signal violation, and give the driver a warning when appropriate. To provide context, an overview of the CICAS-V is included. The interested reader should refer to the Task 10 report (Maile et al., in print-b) for a more detailed description of the CICAS-V.

The CICAS-V is comprised of on-board equipment (OBE) and roadside equipment (RSE). Figure 2 provides a schematic illustration of the OBE components and communication pathways of the CICAS-V subsystems.



**Figure 2** CICAS-V OBE schematic.

The Wireless Safety Unit (WSU), developed by DENSO, is the central processing component of the CICAS-V network. It is responsible for collecting data from the vehicle and sensors from which it computes an algorithm to predict when a violation may occur; and, based on that prediction issues a warning to the driver through the DVI. The WSU receives data from the vehicle Controller Area Network (CAN), the global positioning system (GPS), and dedicated short range communication messages (DSRC). These data are pre-processed and then evaluated in parallel by the warning algorithm. If

the algorithm predicts a violation, the WSU will activate the driver vehicle interface (DVI).

The WSU controls the three DVI modalities – auditory, visual, and haptic. The DVI has three states: 1) an inactive state when the vehicle is not approaching an equipped intersection; 2) a visual-only indication when approaching an equipped intersection; and 3) a full warning mode that encompasses a “single stage” activation of the visual, auditory, and haptic alerts.

The auditory warning is sent through the on-board line-out jack to an amplified speaker. The auditory warning consisted of a female voice stating “Stop Light” or “Stop-Sign”, presented at 72.6 dBA out of the front speakers, measured at the location of the driver’s head.

The visual warning is displayed by a dash-mounted icon (Figure 3) positioned at the vehicle centerline near the cowl of the windshield. As implemented in the vehicle, the visual icon was 11.6 mm (0.46 inches) high and 11.6 mm (0.46 inches) wide. It was illuminated as either steady, continuous blue (advisory) or flashing red (warning).



**Figure 3** The visual display is located on the dash of the experimental vehicle.

The haptic brake pulse warning was sent over the CAN through the Netway box to the Original Equipment Manufacturer (OEM) brake controller. When the warning was activated, a single 600 millisecond brake pulse was presented in conjunction with the visual icon and an auditory warning. The Brake Pulse was triggered immediately before the onset of the visual and auditory warnings, so that deceleration would reach ~0.10 g at approximately the same time as the visual and auditory warning onset.

To appropriately activate the DVI, the WSU required vehicle kinematic data from which the threat assessment was performed. The original equipment manufacturer (OEM) vehicle network provided data such as brake status and velocity to the Netway box. The Netway box, exclusively programmed by each of the OEMs, was used to translate OEM-specific CAN messages to a standard CAN format compatible with the WSU.

A GPS system provided longitude/latitude positioning data to the WSU. This allowed the WSU to place the vehicle on a digital representation of the intersection called the

Geometric Intersection Description (GID). GIDs were obtained from one of the three RSEs (Figure 4) located at the signalized intersections. The RSEs provided GIDs for both stop-controlled and signalized intersections. Each GID was retained on the WSU unless a newer version was provided by the RSE.

In addition to the GIDs, the RSEs also sent differential GPS corrections (allowing the vehicle to accurately place itself on the GID) and signal phase and timing (SPaT) information. The messages were sent by a second WSU within the RSE. The SPaT message was supplied to the RSE by custom firmware installed on the traffic signal controllers, while a GPS base station provided the differential corrections.

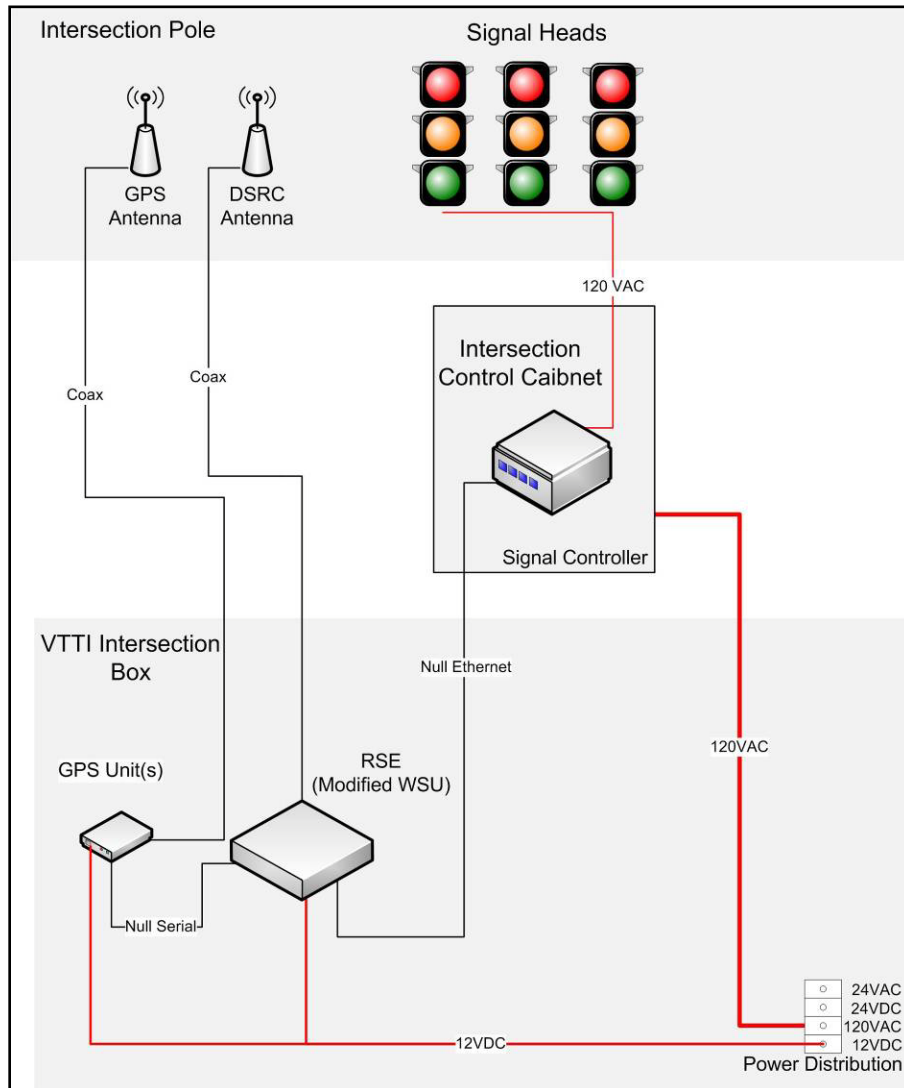


Figure 4 CICAS-V RSE schematic.

## 1.2.2 Vehicle DAS

The vehicle DAS (Figure 5) was used to record digital video and kinematic data from multiple sources, and was composed of hardware, software, and data storage components.



The DAS collected variables representing the information necessary to reconstruct a vehicle's intersection approach and the drivers' interaction with the CICAS-V. A detailed discussion of the DAS is available in the Task 12 report (Stone et al., in print). A short overview of the DAS is provided in this section with an accompanying list of variables provided in section 2.5.



**Figure 5 DAS, installed in the vehicle trunk underneath the rear shelf.**

The vehicle DAS hardware consisted of a main unit, a video system, front and rear radar, and a GPS unit. The main unit contained an Embedded Platform for Industrial Computing (EPIC) single-board computer, hard drive, CAN communication, battery backup system, and several VTTI-developed sensor modules. Four unobtrusive cameras installed in the passenger compartment captured the scene in and around the vehicle.

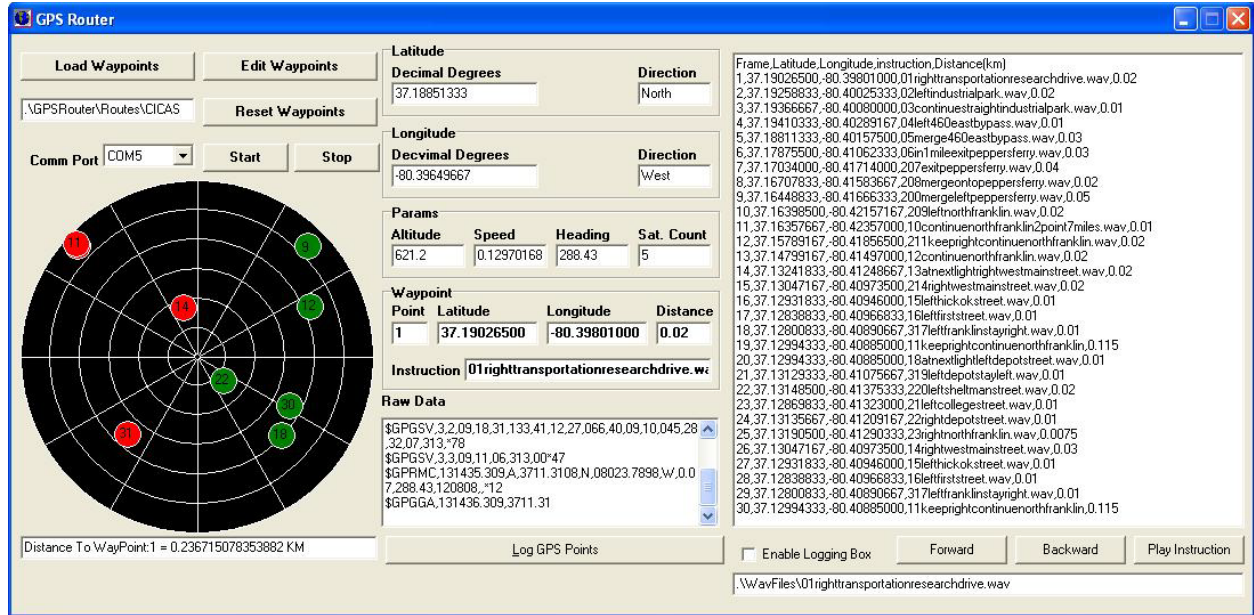
The DAS was attached directly to the OBE CAN which provided all of the CICAS-V variables (see Task 10 [Maile, et al., in print-b] report for additional detail). The DAS recorded all the CICAS-V variables for use in system validation and driver performance analyses. The variables pertinent to Subtask 3.4 included the velocity, distance to the stop bar, DVI status, signal phase and signal timing. Additional variables were also collected by the DAS from a network of sensors installed on the vehicle. Front and rear radar units provided the range and velocity of lead and following vehicles. A Crossbow™ inertial measurement unit provided three axis acceleration and angular rate information.

Data was stored on a 120GB removable hard drive within the main unit. It was accessed and downloaded to a laptop over an Ethernet interface. The download interface included a system health-check component that ensured data integrity was maintained between drivers. This allowed quick transfer of data and indication of whether the participant received a warning without shutting down the system.

#### *1.2.2.1 Custom-built Navigation System (Pseudo-Naturalistic Study)*

In order to ensure drivers could easily and reliably navigate the prescribed route, VTTI built a custom navigation system. The custom navigation system consisted of a laptop computer and a low cost Wide Area Augmentation System (WAAS) enabled GPS

antenna. The navigation system interface is pictured in Figure 6. The system played auditory instructions over a speaker in the front of the vehicle based on the current position of the subject along the route. The custom software solution allowed the researchers to record the instructions to play and to guarantee the timing of the instructions so as to not distract the driver while approaching an equipped intersection.



**Figure 6** GPS interface.

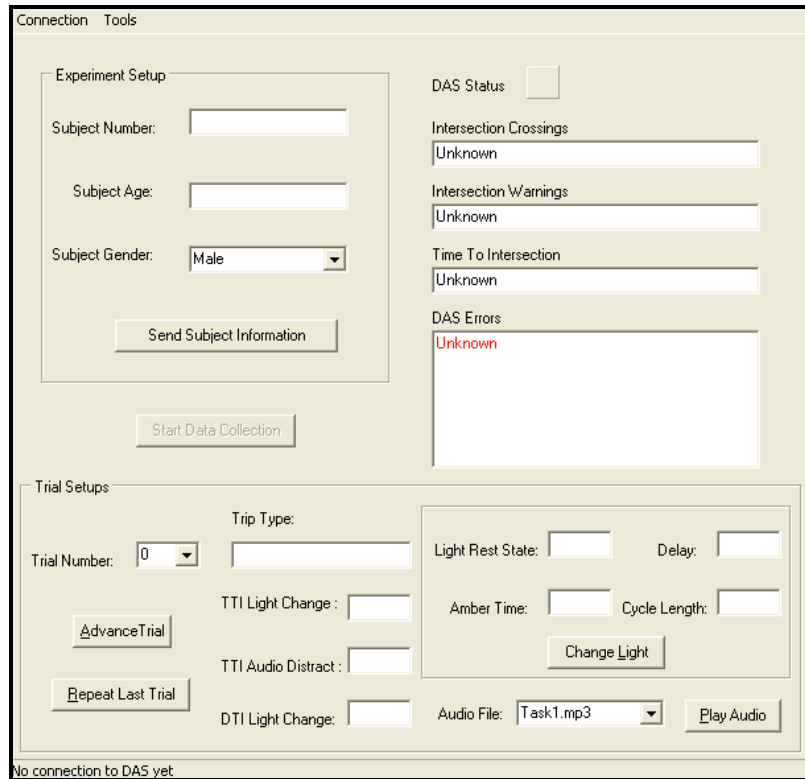
### 1.2.2.2 Experimental Control Interface for the Smart Road Study

To accommodate the subject testing on the Smart Road, a custom DAS software package was developed. The DAS software was modified to replicate the Subtask 3.3 testing protocol, allowing: 1) audio instruction files to be played at specified locations on the Smart Road or by experimenter control; 2) automatically triggering light changes based on time from stop bar; and 3) the ability to control and monitor the data collection and tasks (utilizing a laptop connected to the DAS through the Ethernet port).

The audio instruction files were stored locally on the DAS and could be played back at any time, based on the trial scripts stored on the laptop. The researcher interface would send a command to the DAS to play back the appropriate audio file, either based on a researcher request or on a specific time or distance from the intersection.

Additionally, certain approaches to the intersection required a light change to replicate the previous testing protocols. In order to accomplish this task, the DAS was configured to automatically send messages to the intersection controller to activate a light change. The timings for these changes were stored on the researcher laptop and activated based on a pre-set script. The DAS calculated the time to intersection based on the OBE data provided through the CAN interface. This allowed the light to be triggered at the same timings as the Subtask 3.3 experiments.

The experimenter interface, shown in Figure 7, controlled most aspects of the Smart Road Study. The front seat experimenter (FSE) was able to start and stop data collection, download data, and monitor and trigger events as the study was being run. All commands and necessary information to complete the testing protocol were contained within editable scripts on the laptop. The tasks could be replayed or reset, as needed, so that the participant was always able to complete the tasks or rerun particular trials if deemed necessary.



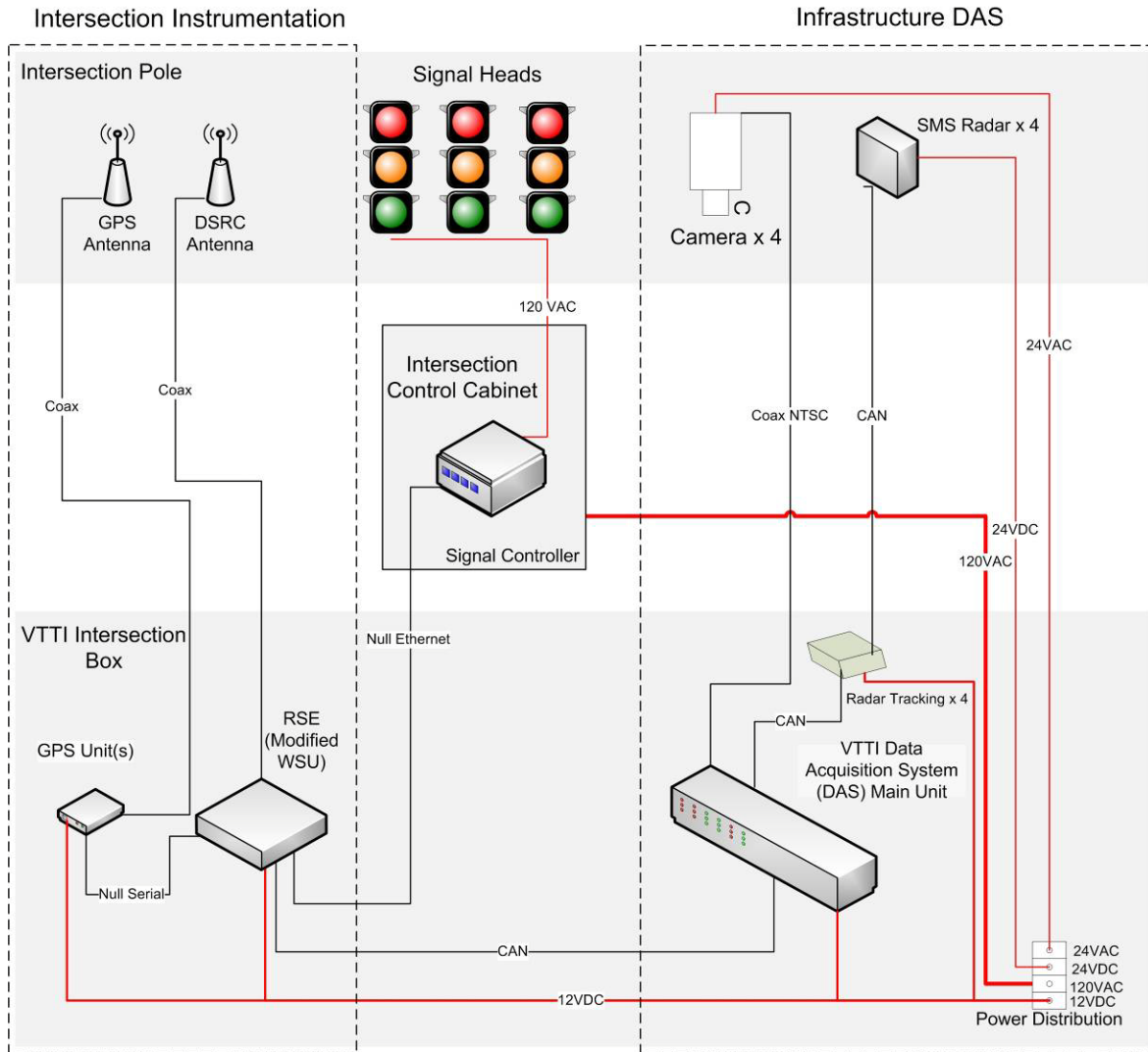
**Figure 7** Experimenter interface for Smart Road Study.

Because the 3.4 Smart Road studies were conducted using the FOT prototype CICAS-V system, the Smart Road pseudo-signal-controller used during Subtask 3.3 was also modified. The main modification required adding the appropriate Ethernet SPaT message structure for connection to the RSE. The code was modified to produce the appropriate message content to signal the light change and time left in phase, for transmission from the RSE to the vehicle OBE.

### 1.2.3 Infrastructure DAS

The infrastructure DAS was installed at one of the equipped signalized intersections in order to determine the utility of having an infrastructure DAS in the planned FOT. The DAS employed a suite of hardware and software to record information about vehicles that approached the test site. A brief summary of infrastructure DAS components is provided in this section, and illustrated in Figure 8. For a detail description of the

infrastructure DAS, the reader is referred to the Subtask 3.2 and Task 12 reports (Doerzaph et al., in print; Stone et al., in print).



**Figure 8 Diagram of the DAS infrastructure components.**

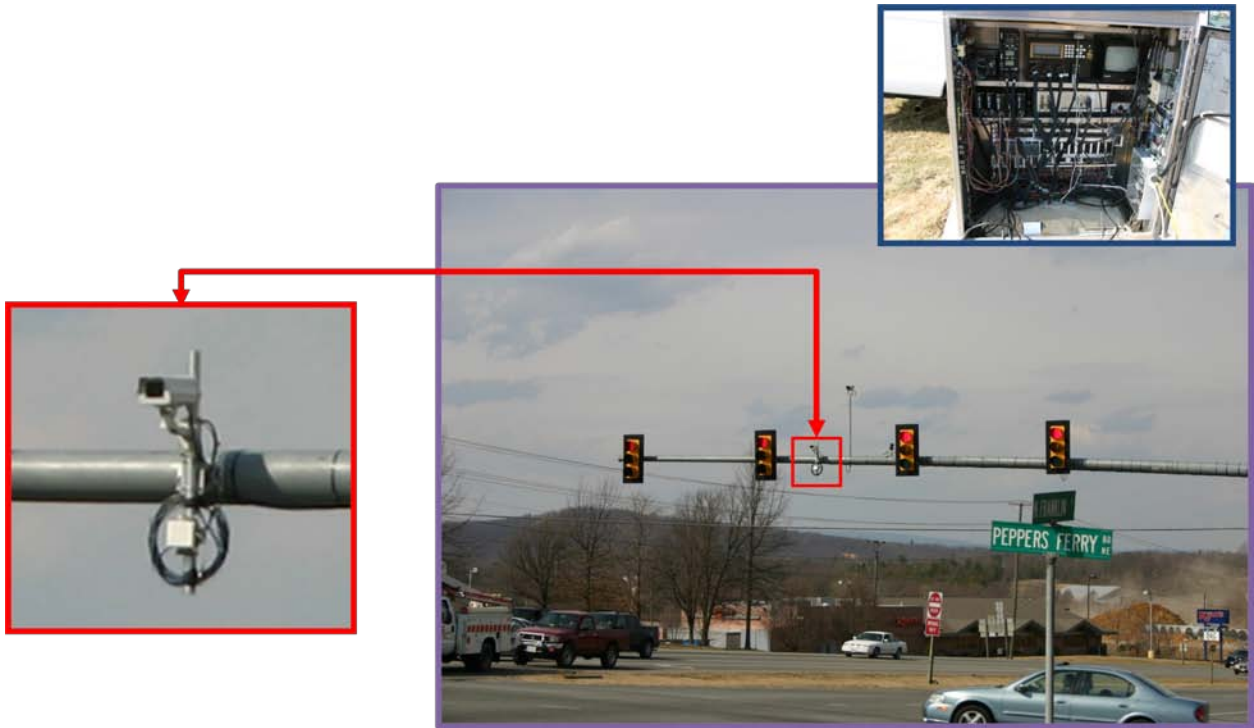
The infrastructure DAS consisted of processing stack, radar, cameras, and a CAN data bus to the RSE. Data from the radar, cameras, and RSE was passed to the processing stack at a rate of 10 Hz. The processing stack pre-processed these inputs and assembled the data set in real time while archiving to binary data files. This system was completely contained at the intersection site and virtually invisible to drivers.

As discussed in section 2.2.1, the RSE used a second WSU to perform the CICAS-V roadside tasks. The DAS was attached to the RSE via a CAN bus and received data packets containing the SPaT. A video camera was installed on each of the four traffic signal mast arms to provide an image of the entire intersection environment (Figure 9).



**Figure 9 Video quadrants from camera units mounted on intersection mast arms.**

Finally, the high-performance radar designed and developed for the CICAS-V team during Subtask 3.2 was placed on each mast-arm below the camera and aimed directly at the approaching traffic (Figure 10). The radar provided range, velocity, and derived acceleration for up to 32 simultaneous vehicles on each approach (128 total vehicles).



**Figure 10** Camera and radar unit mounted on a single intersection arm mast, along with instrumentation inside traffic signal controller cabinet.

Members of the research team retrieved the stored data from the infrastructure DAS on Monday and Thursday of every week. The data was transported to VTTI, where it was uploaded to the database with the vehicle data.

### **1.3 Pseudo-Naturalistic Study Protocol**

The pseudo-naturalistic field test was conducted on a predetermined route in Blacksburg and Christiansburg, Virginia. The route was crafted to pass through many stop-controlled and signalized intersections while performing a variety of maneuvers (i.e., straight, left, and right turns). The route was approximately 36 miles long, and contained 17 intersections that were integrated into the CICAS-V. The signalized intersections included the three that were previously instrumented for Subtask 3.2 and upgraded to support the CICAS-V. Fourteen stop-controlled intersections were also included; 10 of these were finally chosen for evaluation and will be discussed later in this report. The 13 final selected intersections and their associated identification numbers are highlighted in Figure 11. Photos and additional information on the intersections are provided in Appendix E.

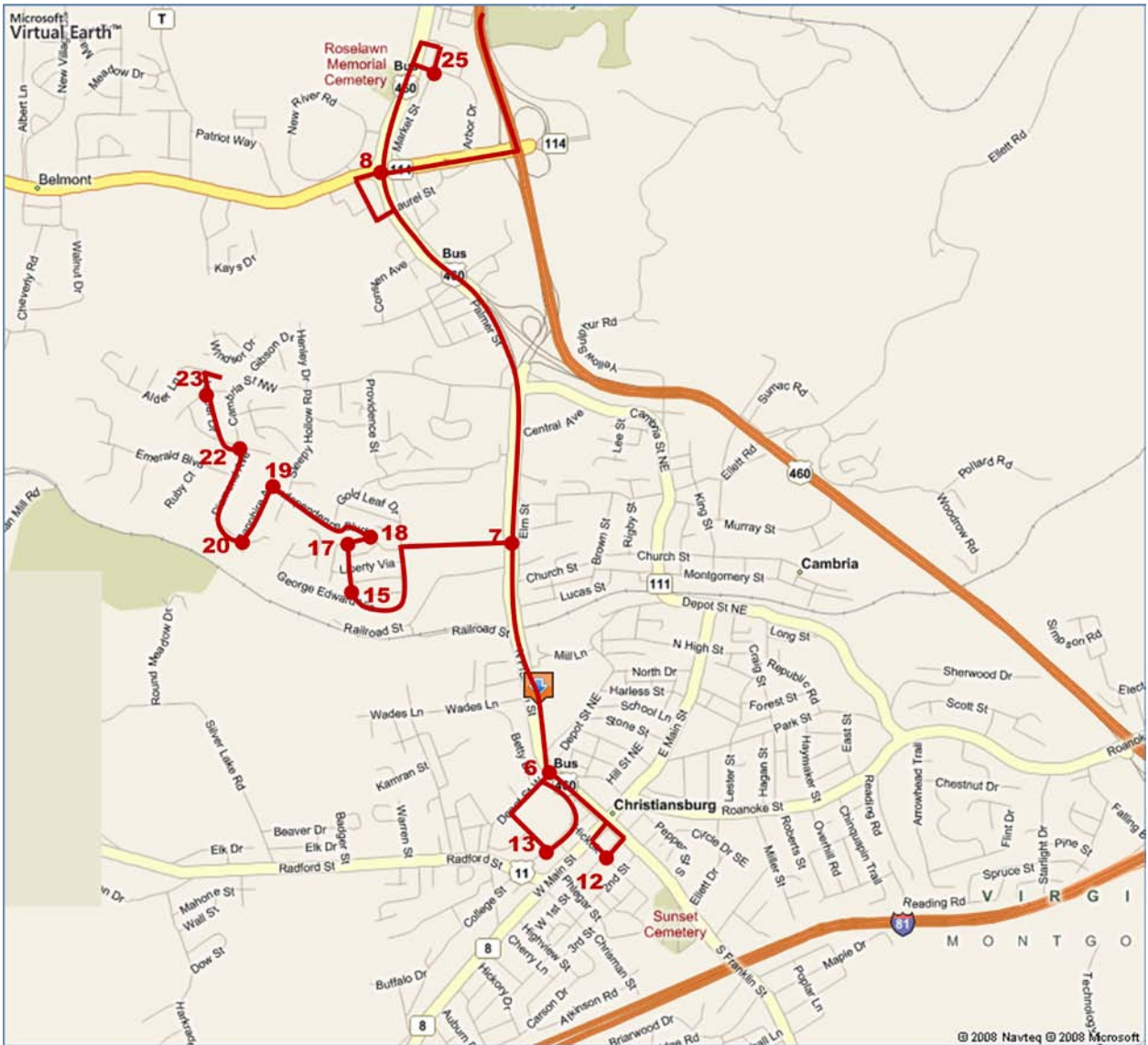


Image is the copyrighted work of Microsoft® and subject to the terms and conditions of the Microsoft® license agreement.

**Figure 11 Map of Pseudo-Naturalistic Study route with intersection ID labels.**

The route led drivers through each equipped intersection multiple times and was designed with three goals in mind. First, to ensure the driving participants comfort and minimize driving fatigue, the route had to be less than two hours in duration. Second, the route had to maximize the number of intersection crossings while retaining a feasible number of intersections (time constraints did not allow for a large number of intersections to be integrated into the CICAS-V). Finally, a variety of turn maneuvers were desirable in order to fully test the CICAS-V. For example, correct operation of the CICAS-V at signalized intersections often depends upon lane position information; therefore, various turn maneuvers at signalized intersections would indicate if the system was correctly mapping the lane to its signal indication. Also, a driver's intersection approach often has different trajectory characteristics if the driver is turning left, right, or straight through the

intersection; accommodating these approach variations directly relate to algorithm evaluation. The turn maneuver summary table for the 13 intersections can be seen in Table 8. There were a total of 20 signal-controlled intersection crossings and 32 stop-controlled intersection crossings along the route. A list of turn-by-turn directions comprising the Pseudo-Naturalistic Study test route is included in Appendix F.

**Table 8 Summary of turn maneuvers for Pseudo-Naturalistic Study experimental method.**

3 Signalized Intersections				10 Stop-Controlled Intersections			Total
Permissive Left	Protected Left	Straight	Right	Left	Straight	Right	
2	5	11	2	12	6	14	52

The staff supporting the daily operations of the Pseudo-Naturalistic Study was conducted by a staff of three. They were responsible for preparing the experiment, interacting with participants, and managing the data. This staff consisted of:

- A greeter who scheduled and screened participants, administered consent forms and questionnaires (provided in Appendix A through Appendix D), and entered all pertinent forms into the database.
- An in-vehicle experimenter who prepared the vehicle and DAS, instructed the participant on proper vehicle use and emergency procedures, and who remained on-call during the Pseudo-Naturalistic Study to address any unforeseen issues.
- A data downloader who retrieved data from the vehicle DAS after the Pseudo-Naturalistic Study was complete and uploaded the data to the database.

After undergoing the initial paper work process, participants were led outside where the experimenter introduced them to the test vehicle (Figure 12). Participants were given a brief tutorial on basic vehicle functions, including ignition procedures, seat movement, and the HVAC system. During the static pre-drive vehicle orientation, the different safety systems available in the experimental vehicle were briefly reviewed. The systems reviewed with the participants included the forward collision warning, backing aid, and the CICAS-V such that drivers were led to believe that various safety systems were being evaluated. The goal was to make the driver aware of the CICAS-V but not to emphasize it over the other available vehicle safety technologies. These additional safety systems were enabled in the vehicle; however, it is unknown as to whether any of the drivers received alerts during the study.





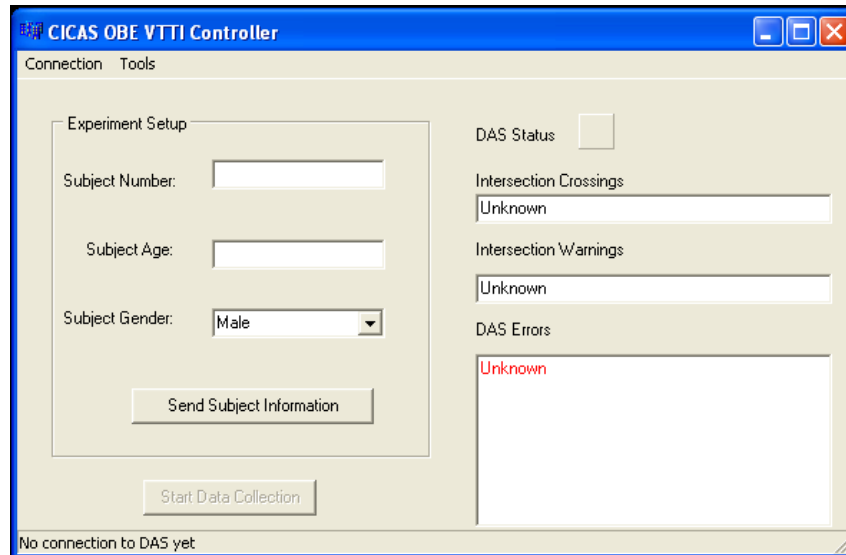
**Figure 12 Experimental vehicle, 2006 Cadillac STS**

During the route, participants received turn-by-turn directions from the GPS-based navigation system, which was developed and customized by VTTI for the purpose of the study. The navigation system was audio-based and not an integrated vehicle system; therefore, in order to alleviate additional distractions, participants were instructed not to use the radio or CD player for the duration of the test drive. Emergency procedures were reviewed, including the location and proper use of a cellular telephone provided by VTTI. Participants were encouraged to call the experimenter at VTTI, from a stopped location, using a number taped to the phone if they encountered any problems (e.g., getting lost, failure of the navigation system, or mechanical problems with the vehicle). Because the participants were asked to drive along the route without an experimenter present, they were given an opportunity to ask questions to help familiarize themselves with the vehicle and navigation system. Once participants stated they were comfortable with the vehicle and study procedures, they were asked to begin driving the route.

When participants returned, a laptop running specialized software was attached to the trunk-mounted DAS. At the same time, the greeter met the participants and led them indoors to a private office space. Most drivers then completed one of two post-drive questionnaires. Which post-drive questionnaire was completed by the participant depended on whether they did receive a warning (Appendix G) or did not (Appendix H) receive a warning. If the driver was scheduled to participate in the Smart Road Study, no questionnaire was administered at that time. Rather, the participant was asked to take a break and offered a small snack while the vehicle was prepared for the Smart Road Study.

While the experimenter downloaded the data, the interface (Figure 13) indicated the number of warnings that were issued and the number of intersections that were crossed. This interface was used to determine which of the questionnaires was administered, based on whether a warning was issued. In addition, the number of equipped intersection crossings was used to determine the extent to which the driver experienced the entire test route. Since an experimenter was not present in the vehicle, it was foreseeable that some drivers might not follow the prescribed route or would not correctly understand the

navigation instructions. Therefore, to motivate drivers to stay on route, they were told a bonus would be provided for drivers who completed the route. The \$25.00 bonus was paid to participants who crossed more than 40 equipped intersections (maximum number of crossings per driver is 52).



**Figure 13 Data collection interface for Pseudo-Naturalistic Study.**

Upon completion of the post-drive questionnaire, participants were paid, thanked for their time, and dismissed. The route took approximately 2 hours to complete, and with pre- and post-drive procedures, total participation time was 2 hours 45 minutes.

An important note for the Pseudo-Naturalistic Study protocol is that not every participant in the study experienced the same warning algorithms. As stated previously, one of the goals of Subtask 3.4 was to iteratively refine the warning algorithm. In other words, researchers conducted initial data reviews to determine the success of the warning algorithms, and made changes based on the driving outcomes. This aspect of the Subtask 3.4 study, including the breakdown of subjects receiving each algorithm, is discussed in detail in the Results and Discussion section.

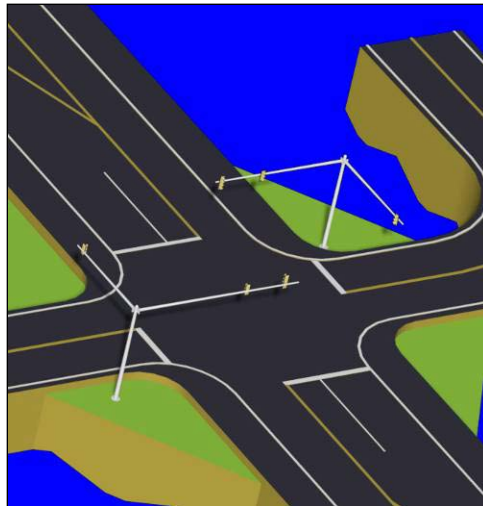
## **1.4 Smart Road Study Protocol**

A subset of the drivers from the Pseudo-Naturalistic Study also participated in the Smart Road test-track study. Drivers were selected to participate in the Smart Road study based upon their ability to spend time participating further, corresponding Smart Road time availability, and the age and gender of the driver to fill experimental cells. The primary purpose of the Smart Road Study was to ensure that a group of drivers would experience the CICAS-V warning under identical intersection approach conditions (these warnings are generally rare on the open roadway) and to validate the full CICAS-V against the Subtask 3.3 results where the research to identify the DVI was conducted. The protocol used for the Smart Road Study was the same as used for the Subtask 3.3 studies (Perez et al., in print). The surprise scenario was designed to represent a scenario in which the driver needed to make a split-second decision about the potential consequences of a rear-

end collision (i.e., being struck by the following vehicle) versus the potential consequences of an intersection collision if cross-traffic was present (as they had experienced during earlier test runs).

Drivers selected for the Smart Road Study did not complete a post-drive questionnaire immediately following the Pseudo-Naturalistic Study portion of their time. Rather, upon arriving at the Institute following the Pseudo-Naturalistic Study, they were asked to read an additional informed consent form (Appendix I). This form indicated that the Smart Road portion of the study was aimed at evaluating comfort level with in-vehicle devices. The participants were initially not told the true purpose of the study in order to gain information on how naive drivers react to an intersection warning.

Drivers were then led to the test vehicle where they were given time to make the necessary adjustments to the seat, mirrors, and climate control. They were instructed to drive towards the Smart Road, a 2.2 mile controlled-access research facility. Drivers drove loops on the roadway which included crossing through the CICAS-V equipped signalized intersection (Figure 14) a total of 10 times.



**Figure 14 Smart Road intersection diagram.**

The Smart Road experiment took approximately 45 minutes per participant and required the following staff to administer:

- A front seat experimenter (FSE), who instructed the participant, started/stopped and monitor data collection, issued distraction tasks, and signaled the confederate vehicles as appropriate.
- A confederate vehicle driver, who drove both confederate vehicles in an elaborate choreography involving precise timing and the ability to keep the confederate vehicle hidden as needed. This driver crossed the intersection during early runs and later served as the following driver.
- An in-building experimenter, who screened and scheduled drivers, prepared paperwork, and entered questionnaire and demographic data into the database

Once on the Smart Road, drivers were asked to stop for further instructions concerning the purpose of the study. Drivers were then told that the experiment concerned comfort level with in-vehicle devices. The different safety systems available in the experimental vehicle were briefly reviewed; they included forward collision warning, backing aid, and the CICAS-V. Drivers were told to follow all the normal traffic rules and that maintenance vehicles would be entering and leaving the road at the intersection. Unbeknownst to the participant, these maintenance vehicles were staged confederate vehicles driven by VTTI on-road crew personnel as part of the study. Drivers were told that speed maintenance and lane position accuracy information would be recorded. They were asked to place the car in third gear (to aid in speed maintenance in graded road sections) and to maintain 35 mph throughout the study.

The protocol used pre-recorded in-vehicle tasks to distract drivers at pre-specified intervals as they were driving on the Smart Road. The distraction tasks included changing the radio station, changing tracks on a CD, changing properties of the heating, ventilation, and air conditioning system, and turning on the vehicle's hazard lights. Drivers were given a brief in-vehicle tutorial of these systems prior to beginning the experiment.

During the experiment, at predetermined landmarks on the Smart Road, the FSE triggered pre-recorded messages instructing the participant to complete certain tasks. Each message ended with the word "Now." Drivers were also instructed to keep both hands on the steering wheel prior to hearing the word "Now." Upon hearing the word "Now," drivers were to complete the task as quickly and as accurately as possible. Once the participant finished the task, they were to say "Done," as an indication to the FSE that they had completed the task.

The study was scripted to build the expectation of possible cross traffic at the intersection in hopes of creating a more realistic driving experience when the warning was present. This protocol was successfully used to compare different DVIs and Driver-Infrastructure Interfaces (DIIs) during the Intersection Collision Avoidance – Violation (ICAV) and Intersection Decision Support (IDS) studies (Lee et al., 2005; Neale et al., 2006), as well as during Subtask 3.3 (Perez et al., in print).

Each 2-3 minute drive (trial) up or down the Smart Road included from two to four tasks. On the first trial down the Smart Road, there was a "maintenance" vehicle (Principal Other Vehicle - POV) parked on a road parallel to the Smart Road. The POV driver appeared to be performing maintenance activities on the road. After the Subject Vehicle (SV) circled through the lower turn-around and approached the intersection for the second trial, the POV drove to the adjacent stop bar at the intersection. The signal, though triggered by the on-board computer in the SV, appeared to be triggered by the waiting POV. The participant then received a common yellow-red light sequence, during which the POV crossed and exited the road.

On the sixth intersection approach, the POV re-entered the road and crossed through the intersection after receiving a green light. Again, the light sequence was triggered by the on-board computer in the SV, though appearing to change because of the presence of the POV. When the SV continued to the lower turn-around during the seventh trial and was no longer in view of the POV, the POV inconspicuously exited the road. At the start of

the SV's tenth intersection approach, a second confederate vehicle (Following Vehicle-FV) followed with approximately 1.5 to 2 s headway behind the SV up the road.

Upon approaching the intersection, a recorded set of instructions was automatically triggered by the on-board computer at a specific time to intersection. This consistent timing of events helped to maximize the probability that drivers would be engaged in the task and looking down as the signal cycled from green to yellow. If the driver was successfully distracted, the CICAS-V initiated a warning when the assessment algorithm detected the driver's lack of response to the traffic signal. Five of the 23 drivers tested who were not fully engaged in the distraction task at the time of the light change (i.e., eyes were on the roadway) were removed from analysis. These five drivers looked directly at the forward roadway at the time of the warning or the yellow light onset. As discussed in Perez et al. (in print), the data loss is an artifact of the protocol; however, distraction protocol provides for high external validity over other methods. This will be discussed further in the Results and Discussion section.

After the surprise trial was completed, drivers were asked to read and sign a debriefing form (Appendix J) that explained the true purpose of the study. The experiment was then concluded and drivers returned to the VTTI main building to complete the post-drive questionnaire (Appendix K). Afterwards, drivers were thanked and paid for their time.

## 1.5 Validation and Analysis Techniques

Recall that the primary purpose of Subtask 3.4 was to determine how well the CICAS-V operated in order to determine if the system was mature enough for a FOT. The vehicle and infrastructure DASs collected dozens of variables from the CICAS-V and other sensors. The lists of variables are defined in detail in the CICAS-V Task 12 report (Stone et al., in print).

To determine the validity of a violation warning during for the Pseudo-Naturalistic Study, several variables in addition to the video were viewed by the data reduction staff. These were:

- **DVI Status:** The DVI was disabled because the vehicle was not within range of an intersection, it was within range of an intersection and providing the blue "intersection ahead" icon, or it was within range of an intersection and providing a violation warning.
- **Current Approach Phase:** Red, Yellow, or Green
- **Brake Status:** The driver was either pressing the brake or not pressing the brake.
- **Distance to Stop Bar (m):** Distance from the front of the vehicle to the stop bar. This was used together with "vehicle speed" to determine if the algorithm was warning correctly.
- **Improved Distance to Stop Bar (m):** Distance to stop bar with missing points filled in using GPS. The raw Distance to Stop Bar provided by the WSU would

drop-out whenever the vehicle was not placed on the GID. The Enhanced Distance to Stop Bar continued to provide data during those drop outs.

- **Intersection ID:** The identification number that was assigned to each CICAS-V intersection and incorporated into the GID.
- **Longitudinal Acceleration (g):** Used to determine whether or not the brake pulse activated.
- **On GID:** A binary indication of whether the vehicle is map-matched to the GID. It was used to determine when the vehicle was not map-matched within the warning region.
- **Present Lane:** As labeled and identified in the GID. Associated with the signal phase and video to assure that the system was identifying the correct lane position and warning accordingly.
- **SPaT Counter:** A counter that increments when the OBE is receiving messages from the RSE. It was used to determine when SPaT messages were not received within the warning region.
- **Vehicle Speed (m/s):** Used with “distance to stop bar” to determine if the algorithm was warning correctly.

One purpose of the Smart Road Study was to compare driver response to the violation warning with the full CICAS-V system with those drivers who participated in the Subtask 3.3 study. The following variables were selected or derived from the raw data available from the vehicle DAS for the Smart Road study:

- **Compliance:** Whether the trial resulted in a participant stopping before the collision zone (which was defined as compliance) or not (either because the vehicle stopped in the collision zone or did not stop at all). Figure 15 shows the area before the collision zone that would be considered compliant and the collision zone (and beyond) that would be considered a non-compliant response.

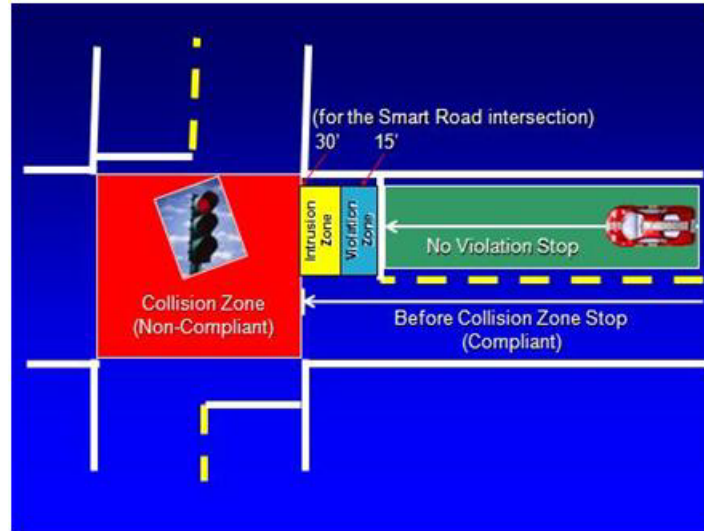


Figure 15 Illustration of the four stopping zones on the Smart Road.

- **Distance to Stop Bar (m):** Distance from the front bumper of the vehicle to the stop bar.
- **Peak Deceleration (g):** Maximum deceleration during the intersection stop.
- **Required Deceleration Parameter (g):** Required constant deceleration to come to a stop at the stop bar based on the observed warning onset distance, as calculated in Equation 1:

$$a = \frac{V^2}{2 \times g \times D_j} \quad (\text{Eq. 1})$$

Where:

a = constant deceleration (g)

V = vehicle speed at the point when driver initiated braking (m/s)

g = Conversion Constant (1g = 9.81 m/s<sup>2</sup>)

D<sub>j</sub> = Distance to intersection at warning onset (m)

- **Vehicle Speed (m/s):** Speed of the vehicle.
- **Time to Brake (s):** Time from the onset of the stimulus to the onset of brake application.
- **Warning Time to Intersection (s):** Once the warning had been issued, the time remaining until the driver would cross the stop bar assuming no change in velocity.

The primary goal of data reduction was to validate CICAS-V warnings that were automatically identified in the parametric data. For the Pseudo-Naturalistic Study, data reductionists determined if the CICAS-V warning was appropriate by reviewing the

video. For the signalized intersections, data reductionists examined the intersection signal phase and timing relative to the vehicle proximity to the stop bar. If the signal phase was red and the vehicle was over the stop bar, the warning was deemed appropriate. For the stop-controlled intersections, data reductionists verified that the warning was provided at a stop-controlled intersection and prior to the vehicle crossing the stop bar.

For the Smart Road Study, the reductionists verified that the driver was distracted (eyes off forward roadway) at the time of the signal phase change. In addition, invalid data points due to drivers who looked directly at the forward roadway at the time of the warning or the yellow light onset were removed from the dataset.

The Data Analysis and Reduction Tool (DART) was used to validate events. DART is a software package developed at VTTI that provides a user interface for the viewing and reducing of digital data (Figure 16). It contains user-configurable video and graphical interfaces, and allows users to simultaneously view synchronized video and graphical data streams frame by frame.

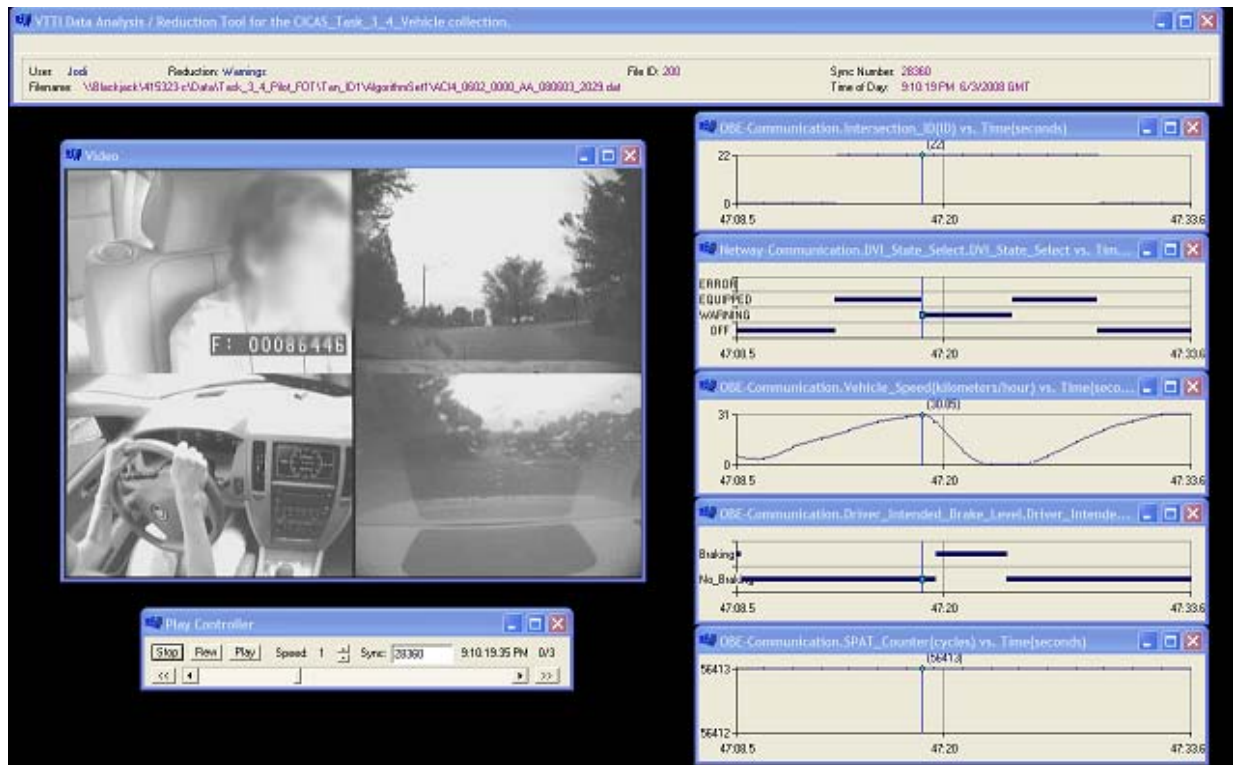


Figure 16 Data analysis and reduction software developed at VTTI (driver face blurred to protect identity).

## 2 Results and Discussion

The following sections describe the results of the Pseudo-Naturalistic and Smart Road studies. The Pseudo-Naturalistic Study results are discussed overall, followed by the results of each of the algorithms evaluated in the pilot FOT. The Smart-Road Study results are then discussed, followed by the CICAS-V and DAS evaluations.



## 2.1 Pseudo-Naturalistic Study Results

Ninety-three drivers participated in the Pseudo-Naturalistic Study. System failures (that will be discussed later in the report) caused data to be retained for 87 drivers; this data was utilized to complete the analyses for the Pseudo-Naturalistic Study, as summarized in Table 9.

**Table 9 Distribution of drivers by age and gender who had data analyzed in the Pseudo-Naturalistic Study analyses.**

Age Group	Gender		Total
	Male	Female	
18-30	17	15	32
35-50	10	14	24
55+	15	16	31
<b>Total</b>	42	45	87

Recall that one of the goals of Subtask 3.4 was to iteratively refine the warning algorithm. In other words, researchers conducted initial data reviews to determine the success of the warning algorithms and made changes based on the driving outcomes. Because drivers approach stop-controlled intersections differently than they approach signalized intersections, two algorithms were used. The algorithms (depicted graphically in Appendix L), the process for evaluation, and the criteria for determining success are discussed in the following sections. The number of valid and invalid alerts for each algorithm by driver is shown in Appendix M.

### 2.1.1 Stop-Controlled Algorithm 1 Results

The initial stop-controlled intersection warning algorithm incorporated into the CICAS-V was derived directly from the results of Subtask 3.2 (Doerzaph et al., in print). Over 160 algorithms were analyzed during the course of the Subtask 3.2 effort. The performance of each potential algorithm was based on its effectiveness in predicting a pending violation while minimizing false detections based on naturalistic intersection approach data. In addition, other measures, such as the location at which a violation warning would be provided, likelihood of annoyance, algorithm complexity, and data requirements, were also considered.

Fifteen drivers experienced Stop-Controlled Algorithm 1, resulting in a total of 493 stop-controlled intersection crossings with 50 CICAS-V warnings being initiated. (Note that there were 32 stop-controlled intersection crossings. When multiplied by the 15 drivers experiencing Stop-Controlled Algorithm 1, one would expect a total of 480 crossings. However, a few drivers made wrong turns along the route and actually crossed the intersections more often than was planned.) Table 10 illustrates the distribution of drivers, by age and gender, which experienced Stop-Controlled Algorithm 1.

**Table 10 Distribution of drivers by age and gender who experienced Stop-Controlled Algorithm 1.\***

Age Group	Gender		Total
	Male	Female	
18-30	2	1	3
35-50	1	4	5
55+	4	3	7
<b>Total</b>	7	8	15

\*Note: These drivers are a portion of the total number of drivers who participated in the Pseudo-Naturalistic Study.

Since the data was downloaded after each drive, the number of warnings was immediately displayed on the vehicle DAS, which provided quick general feedback about alert frequency. When the driver received at least one warning, researchers reviewed the parametric and video data in detail to determine the prevalent conditions of each warning. A review of the warnings indicated that the subset of drivers who experienced alerts received them at five stop-controlled intersections. After reviewing the intersections' geometry, it was noted that the alerts were occurring on intersection approaches that had a 3.8 to 7 percent uphill grade. The intersection identification numbers for those intersections are 12, 15, 17, 22 and 23 (refer to Figure 11 for intersection location on the route and Appendix E).

Note that Stop-Controlled Algorithm 1 considered brake status when determining whether drivers should receive a violation alert. That is, if a driver was pressing the brake, it was assumed the driver was attentive to the intersection and the alert was suppressed. On uphill grades, drivers tended to press the brake later in their approach, using gravity to slow the vehicle. Since the algorithms were developed on flat intersection approaches, the later braking caused the warning to activate more often than was expected.

A review of the video and questionnaire data (discussed later) indicated that, although the drivers always came to a safe stop, they tended to become either annoyed or, possibly, entertained, by repeated warnings. Based on these results, the decision was made to change the warning algorithm for stop-controlled intersections to one that did not rely on brake status to determine when a warning should be initiated. After reviewing the possible algorithms created in Subtask 3.2, a new algorithm (Stop-Controlled Algorithm 2) was selected and integrated into the OBE.

### 2.1.2 Stop-Controlled Algorithm 2 Results

Subtask 3.2 predicted Stop-Controlled Algorithm 2 (coded as 741-9 in the Subtask 3.2 report) would correctly warn 60 percent of the violators and incorrectly warn less than five percent of the compliant drivers. A total of 72 drivers completed the Pseudo-Naturalistic Study protocol using the revised warning algorithm (Table 11). This resulted in a total of 2,125 valid intersection crossings at stop-controlled intersections with a total of three warnings issued. (Again, recall that there were 32 stop-controlled intersection crossings. When multiplied by the 72 drivers, one would expect a total of 2,304 crossings. However, as will be discussed in the Evaluation of the Study Systems section, data was sometimes lost due to system deficiencies.)

**Table 11 Distribution of drivers by age and gender who experienced Stop-Controlled Algorithm 2.\***

Age Group	Gender		Total
	Male	Female	
18-30	15	14	29
35-50	9	10	19
55+	11	13	24
<b>Total</b>	35	37	72

\*Note: These drivers are a portion of the total number of drivers who participated in the Pseudo-Naturalistic Study.

All three warnings occurred at the same intersection while making the same straight-crossing maneuver: traveling west on Windmill Ridge Road through the stop-controlled intersection of Windmill Ridge Road and Cambria Street (intersection identification number 23; refer to Figure 11 for intersection location on the route and to Appendix E for a description of the intersections). The intersection is in the middle of a straight road with a stop sign that is partially occluded at longer distances. The violation warnings were provided to three different drivers: a younger male, a middle-aged male, and an older male. In all three cases, they did not show indications of intending to stop prior to the warning, yet stopped before entering the intersection box after the warning was issued. The drivers' peak decelerations ranged from 0.46 g to 0.6 g and the average decelerations ranged from 0.33 g to 0.41 g.

### 2.1.3 Signalized Intersection Algorithm Results

The signal-controlled intersection warning algorithm incorporated into the CICAS-V was also developed in Subtask 3.2 (Doerzaph et al., in print). The Signalized Intersection Algorithm was predicted to correctly warn 83 percent of the violators and incorrectly warn less than 5 percent of the compliant drivers. As will be discussed, the warning was deemed successful throughout data collection and was not changed. Therefore, the CICAS-V utilized the same signalized warning timing for all drivers who participated in the Pseudo-Naturalistic Study. A total of 87 drivers completed the pseudo-naturalistic protocol, as summarized in Table 12. This resulted in a total of 1,455 valid intersection crossings at signalized intersections.

Recall that there were 20 signal-controlled intersection crossings that occurred through the three instrumented signalized intersections. When multiplied by the 87 drivers, one would expect a total of 1,740 crossings. However, as will be discussed in the Evaluation of the Study Systems section, data was sometimes lost due to system deficiencies.

**Table 12 Distribution of drivers by age and gender who experienced Signalized-Warning Algorithm during the Pseudo-Naturalistic Study.\***

Age Group	Gender		Total
	Male	Female	
18-30	17	15	32
35-50	10	14	24
55+	15	16	31

<b>Total</b>	42	45	87
--------------	----	----	----

\*Note that these are all drivers who participated in the Pseudo-Naturalistic Study since the algorithm did not change.

A total of seven violation warnings occurred at signalized intersections: one valid warning, two invalid warnings due to an emergency vehicle signal preemption, and four invalid warnings due to an incorrect GID for the intersection.

For the valid warning, a middle-aged male approached the Independence by Franklin signalized intersection to make a straight-crossing maneuver (see Appendix E, Figure 20). He was in the right-most straight-through-lane following a vehicle with about a one-second headway. The signal became visible in the video at 53m (173 ft) and is in the yellow state. The driver does not show any indication of intending to brake until after the pre-warning process (a 500 ms process to initialize the warning) has started. Three-hundred ms later, the driver begins to brake. The pre-warning process finished and a warning is issued 200 ms after the braking began. The driver brakes safely to a stop before crossing the stop bar. Although it cannot be determined with certainty, the driver's braking prior to the warning likely indicates intent to stop. The driver did not show any visible expression in response to the warning. If the driver had not stopped, it appears a violation would have occurred, based on the location of the lead vehicle, which crosses over the stop bar as the signal turned red.

Two similar invalid warnings occurred when an emergency vehicle preempted the traffic signal. In both cases, the drivers were approaching a signalized intersection within a couple minutes of the emergency vehicle. When it approached an intersection, the traffic controller switched to a priority mode, which guarantees a green phase for the emergency vehicle. Unfortunately, the specialized firmware installed in the traffic controllers did not update the RSE with the correct SPaT messages when the signal was in the priority mode. As a result, the CICAS-V interpreted the signal phase as red, when, in actuality, the preemption had caused the signal to turn green. This resulted in CICAS-V warnings issued on a green phase. One of the drivers handled the false warning in a calm manner without making any abrupt driving maneuvers. The second driver appeared startled and initially slowed the vehicle in response to the alert. The driver then made a quick assessment of the situation and chose to proceed through the intersection. Notably, a following vehicle did have to slow in response to the test vehicle. The signal priority addressable system issue is discussed further in the Evaluation of the Study Systems section.

Finally, four invalid warnings occurred due to an incorrect GID for one of the signalized intersections. The faulty GID incorrectly labeled the left-most through lane as the left turn lane, and associated the through lane with the dedicated left-turn signal head. The problem occurred when the drivers were making a straight-crossing maneuver in the left-most through lane, which had a green-phased light; the adjacent left-turn lane had a red-phased light. The CICAS-V would note the red-phase for the left-turn lane, and warn the driver who was actually in the through lane with a green-phase.

The problem of the incorrect GID was identified by the research team the first time that a false alert was issued. However, since the driver responded calmly to the false alert and proceeded through the intersection appropriately, the incorrect GID was left in place.

This allowed the team to learn more about how drivers respond when receiving a false alert during a green phase. The second and third time this occurred, those drivers also responded in a calm manner, assessed the situation quickly, and proceeded through the intersection. The final driver, however, was very startled by the warning on a green phase, and responded with abrupt braking that, under some conditions, had the potential to result in a rear-end collision with the following vehicle. Of particular importance, a following vehicle both applied the brakes and steered around the test vehicle in order to avoid a collision. Following this event, the correct GID was loaded onto the RSE. This issue is discussed further in the Evaluation of the Study Systems section.

## **2.2 Smart Road Study Results**

As stated previously, a Smart Road test-track study was conducted using the same naturalistic distraction protocol used in Subtask 3.3. This distraction protocol inherently requires more drivers for the study than are planned for analysis, since data loss can occur if the distraction technique is not successful. For this study, 23 drivers who participated in the Pseudo-Naturalistic Study were recruited to participate in the Smart Road test-track study. Of those, 18 were adequately distracted by the task and not looking forward at the time of warning onset. The distribution of these 18 drivers by age and gender is shown in Table 13.

**Table 13 Distribution of drivers by age and gender with date analyzed for the Subtask 3.4 Smart Road Study.**

Age Group	Gender		Total
	Male	Female	
18-30	3	3	6
35-50	2	4	6
55+	3	3	6
<b>Total</b>	8	10	18

To lend context to the results of the Smart Road Study, a comparison will be made between these results and those of the Subtask 3.3 Study 6 (S6). Subtask 3.3 S6 tested the same DVI (the flashing red visual display, an auditory speech warning, and a brake pulse) and used the same naturalistic driving protocol that was used for Subtask 3.4. Subtask 3.4 used the full CICAS-V system and warning algorithm, whereas Subtask 3.3 used a prototype algorithm and a CICAS-V emulator. As such, one goal of the Subtask 3.4 Smart Road Study was to compare compliance rates observed here to those observed in Subtask 3.3 S6 to validate the Subtask 3.3 results using the full CICAS-V.

The number of drivers for whom data was usable was 18, which was the same for both Subtask 3.4 and Subtask 3.3 S6. Recall from the Method section that a driver was considered compliant when he or she stopped the vehicle prior to the “collision zone.” Both the Subtask 3.4 Smart Road Study and the Subtask 3.3 S6 resulted in 17 of 18 drivers making a compliant stop prior to the collision zone (94 percent compliance rate). In each study, the non-compliant driver failed to stop and continued through the intersection. The distribution of compliant drivers by age and gender is presented in Table 14. The violator in Subtask 3.3 S6 was a middle- aged female, whereas the violator from the Subtask 3.4 Smart Road Study was an older male.

**Table 14 Comparing demographics of compliant drivers for Subtask 3.2 SRS and Subtask 3.3 Study 6.**

Subtask 3.4 SR Study	Male	Female	Total
Young	3	3	6
Middle	2	4	6
Old	2	3	5
<b>Total</b>	7	10	17

Subtask 3.3 Study 6	Male	Female	Total
Young	3	3	6
Middle	3	2	5
Old	3	3	6
<b>Total</b>	9	8	17

The parametric data between the two studies is compared in Table 15. The average warning onset Time to Intersection (TTI) in Subtask 3.4 is 2.57s, which is 0.13 s earlier than the preset TTI value in Subtask 3.3 S6. This translated to an average distance to stop bar of 132.17 ft for the Subtask 3.4 Smart Road warnings, compared to 123.2 ft for Subtask 3.3 S6 warnings.

**Table 15 Parametric measures of Subtask 3.4 Smart Road Study and Subtask 3.3 S6.**

Parameter	Subtask 3.4 Smart Road Study		Subtask 3.3 S6	
	Mean	Standard Deviation	Mean	Standard Deviation
Warning TTI	2.57 s	0.11 s	2.44 s	0.02s
Distance to Stop Bar	40.26 m/132.17 ft	3.29 m/10.48 ft	37.55 m/123.2 ft	1.80 m/5.93 ft
Peak Deceleration	0.58 g	0.08 g	0.60 g	0.07 g
Reaction Time	1.01 s	0.36 s	0.74 s	0.14 s

The difference in warning timing resulted in drivers exhibiting slightly lower peak deceleration in Subtask 3.4 (0.58g), compared to Subtask 3.3 (0.60g). The reaction time of the drivers in the Subtask 3.4 Smart Road Study is also longer than the reaction times (time to brake) in the Subtask 3.3 S6. This may be the result of drivers having more time to respond to the warning with the increased TTI and being able to safely stop the vehicle.

The overall results of Subtask 3.3 (Perez et al., in print) suggest that compliance increases with increasing warning distance. Although the Subtask 3.4 warning allowed more distance for the drivers to respond, the same numbers of compliant drivers were observed. In any case, the Smart Road experiment demonstrated that the full CICAS-V system performed at least as well as the system tested in Subtask 3.3.

## 2.3 Post-Drive Questionnaire Results

The post-drive questionnaire results are discussed in this section. Consistent with the questionnaire completed, the results are discussed in terms of whether or not a warning was received by the test participant and in which study (Pseudo Naturalistic vs. Smart Road) it was received. The reader may want to refer to Appendix M to see the number of valid and invalid alerts each driver experienced during the studies.

### 2.3.1 Results for Drivers Who Received a Violation Warning During the Pseudo-Naturalistic Study and, if Participated, the Smart Road Study

Recall from the Method section that drivers who experienced a violation warning during the Pseudo-Naturalistic Study were administered a questionnaire that inquired about their experiences with the DVI modalities (Appendix G). If the driver first drove the Pseudo-Naturalistic route and then went on to complete the Smart Road Study, this questionnaire was administered only once, after the Smart Road Study.

The results of this questionnaire were divided into three groups in order to look for trends that may have occurred due to different driving experiences. For example, drivers who drove with Stop-Controlled Algorithm 1 tended to receive more violation warnings than drivers who drove with Stop-Controlled Algorithm 2, and therefore may have had different impressions of the CICAS-V. Also, drivers who received valid warnings versus invalid warnings may have had different impressions of the CICAS-V. Therefore, the questionnaire responses were divided into three groups: drivers who received valid warnings and drove the vehicle with Stop-Controlled Algorithm 1, drivers who received valid warnings and drove the vehicle with Stop-Controlled Algorithm 2; and, drivers who

received any invalid signalized intersection warnings (there were no invalid stop-controlled intersection warnings). As is the case with any survey, there is always the potential for biases in the drivers' responses. Results are provided in Appendices M, N, and O. Note that responses to similar questions regarding the different modes of the DVI (visual, speech, brake) are grouped on the same graph in order to more easily interpret drivers' opinions on the various DVI modes.

#### *2.3.1.1 Post-drive questionnaire results for drivers who experienced only valid violation warnings while driving with Stop-Controlled Algorithm 1*

Appendix N provides post-drive questionnaire results for drivers who experienced only valid violation warnings while driving with Stop-Controlled Algorithm 1. Of the 14 drivers who received violation warnings, one driver also experienced an invalid warning and therefore was not included in these results. These results reflect the responses of 13 drivers who received 49 valid warnings at stop-controlled intersections. For this reason, only questions relating to the "running stop sign" alert are included in Appendix N. The general trends in the data show that drivers found the alerts useful, effective at communicating a possible violation, and attention getting.

There were also several potential negative trends in responses. More drivers responded that, when receiving a violation warning, they tended to brake without checking for following traffic. Also, drivers tended to find the alert annoying when it was deemed unnecessary. This response is not surprising, and, in part, motivated the change to Stop-Controlled Algorithm 2. Three drivers admitted to intentionally trying to activate the warning system and three drivers said they would have turned the system off if they could. The responses concerning overall satisfaction with the system were spread across the response spectrum.

It is interesting to note that both aspects of the visual DVI, the blue "intersection ahead" icon and red flashing visual alert, were viewed less favorably than the speech alert and brake pulse warning. Several drivers noted, in the open ended comment section, that they did not notice the visual icons. Suggested potential improvement to the visual DVI included a more conspicuous visual display that was a little larger and placed closer to the driver.

#### *2.3.1.2 Post-drive questionnaire results for drivers who experienced only valid violation warnings while driving with Stop-Controlled Algorithm 2*

The results from drivers who experienced Stop-Controlled Algorithm 1 can be compared to those provided by the three drivers who each experienced a single violation warning while driving with Stop-Controlled Algorithm 2. Shown in Appendix O, these responses reflect the opinion of the three drivers who experienced a valid stop-controlled alert while driving the Pseudo-Naturalistic Study route. For this reason, only questions relating to the "running stop sign" alert are included in Appendix O.

These three drivers were issued a warning at the same occluded intersection. The subjective responses from these three drivers were more favorable than those provided by drivers who experienced Stop-Controlled Algorithm 1. This is an expected outcome, since one would expect that drivers who experienced the CICAS-V in the manner it was intended to operate (rare warnings issued only when needed by the driver) would find the



system more agreeable. Overall, drivers were satisfied with the system and recognized that they were in danger of violating the stop sign when they received the warning.

### *2.3.1.3 Post-drive questionnaire results for drivers who experienced an invalid violation warning while driving*

Appendix P provides post-drive questionnaire results for drivers who experienced an invalid violation warning while driving. Six drivers each received one invalid signalized violation warning. The data from one of the drivers were not included in the results because the driver experienced the warning at a location other than the targeted intersection. One of the five represented drivers also received one valid signalized intersection violation warning. Therefore, only the questions inquiring about the “Running Red Light” alert were included since no drivers received a stop-controlled intersection violation warning.

Overall, drivers thought the system was effective and did not rate the system as distracting or annoying. This is likely due to the fact that, even though the alerts were invalid, as the alert frequency was considerably lower than with Stop-Controlled Algorithm 1. Also consistent with responses by drivers who received valid alerts, the red flashing visual alert and the “intersection ahead” icon were viewed less favorably than the speech and brake alerts.

## **2.3.2 Results from Drivers Who Received a Violation Warning During the Smart Road Study Only**

Recall that drivers who participated in the Pseudo-Naturalistic Study and did not experience a violation warning, then participated in the Smart Road Study (in which case they did receive a warning), received the questionnaire shown in Appendix K. The questionnaire inquired about drivers’ impressions of their experiences receiving a violation warning at the Smart Road signalized intersection. Three of the 18 drivers who completed the Smart Road study were not included in the Smart Road questionnaire results as they had completed a different survey. Note that questions regarding the “running stop sign” alert are not included in the graphs since the drivers only experienced the signalized violation warning alert in the Smart Road Study. The responses are shown in Appendix Q.

Overall, the trends reveal very positive impressions of the CICAS-V. Drivers thought the displays were useful, effective, attention-getting, and would increase driving safety. As with the drivers who experienced violation warnings on during the Pseudo-Naturalistic Study, the speech alert and brake pulse warning were viewed most favorably. In the open comments, several drivers said they did not notice the visual portion of the DVI, although, as discussed earlier, this does not necessarily imply the display did not facilitate drawing their attention to the forward scene.

## **2.3.3 Results from Drivers Who Did Not Experience a Violation Warning**

Remember that drivers who completed the Pseudo-Naturalistic Study without receiving a violation warning and did not participate in the Smart Road Study completed the

questionnaire shown in Appendix H. Drivers who completed this questionnaire would not have been drivers who participated in the Smart Road Study. In other words, the only exposure to the CICAS-V for these drivers would have been the opportunity to notice the blue “intersection ahead” icon at equipped intersections. Therefore, this questionnaire contained few questions, most of which asked the driver to rate their experiences with the “intersection ahead” display.

Appendix R provides the results for these drivers. The results are interesting in that there is a trend indicating that the drivers did not find the blue “intersection ahead” icon annoying or distracting; however, these drivers also felt that the visual-only DVI was ineffective in communicating the intended information and not easily detected. Drivers often did not complete the questionnaire, presumably because they did not notice the blue icon. These results are consistent with the other questionnaire results that indicate that drivers often did not notice the blue “intersection ahead” display. Interestingly, many drivers took the time to provide feedback in the final open question on the questionnaire. The comments are provided in Appendix R. Overall, drivers expressed a desire to have the display be more conspicuous.

## **2.4 Evaluation of the Study Systems**

One goal of Subtask 3.4 was to evaluate the CICAS-V and DAS hardware and software performance on live roads in order to demonstrate FOT readiness. However, it should be noted that the CICAS-V software tested during Subtask 3.4 was not the final Phase I release. Version 1.11 of the software was implementable for Subtask 3.4 at the time of testing; however, at the writing of this report, the final Phase I will be Version 1.15. There were several improvements to the software during the releases after 1.11 that would have likely improved the results presented in this section. In particular, as will be discussed shortly, improvements made in the intersection selection method and the wireless protocol updates may have improved the system performance, as shown by tests performed in tasks 10 and 11 (Maile et al., in print-b, in print-a).

Another important note is that the analyses completed in this section relied on the data provided by both the infrastructure and vehicle WSU. The DAS was not equipped with an independent set of sensors to verify this data. As a result, these analyses are somewhat limited in that they assume the data provided by the WSUs are accurate.

### **2.4.1 Evaluate CICAS-V hardware and software**

Two metrics were used to evaluate the performance of the CICAS-V. The first metric is a measure of how often the CICAS-V is fully capable of providing a warning if required. The second metric included a review of the system malfunction log maintained by experimenters during the Subtask 3.4 study.

The DVI status variable was used to determine the first metric. Recall that the DVI status, if operating correctly, was 1) disabled because the vehicle was not within range of an intersection, 2) within range of an intersection and providing the blue “intersection ahead” icon, or 3) within range of an intersection and providing a violation warning. In theory, the DVI should remain in the equipped (blue icon) state throughout the warning

region. If the DVI state became disabled in the warning region, there was the possibility of delaying the alert.

The DVI status can be in the disabled state during the intersection approach for two primary reasons. The first may occur at stop-controlled or signalized intersections when the CICAS-V is not able to place itself on the geometric intersection description (GID). The second primary reason for a disabled icon occurs at signalized intersections when the vehicle does not receive the SPaT or GID message from the signal controller. While these two primary causes could be further investigated to determine the root cause (e.g., poor GPS reception causing the off-GID state), it was beyond the scope of Subtask 3.4 to determine the cause of malfunctions at that level.

The proportion of time the system was ready to provide a warning (DVI in the equipped state) within the warning region was evaluated (the post-processed distance to stop bar was used for this analysis – see section “Validation and Analysis Techniques” for operational definition). The warning region was defined from one meter from the stop bar to 70 meters from the stop bar at stop-controlled intersections and 100 meters from the stop bar at the signalized intersections. The 70 meter and 100 meter upper bounds were determined from the algorithm. From the Stop-Controlled Algorithm 2 and the Signalized Intersection Algorithm tables, the warning distance corresponding to 20 mph (8.9 m/s) over the highest posted speed limit was selected as the upper bound. These regions represent the portion of the intersection approach where warnings were likely to be provided.

In addition, the system was also only evaluated for situations in which the vehicle was traveling at least 10 mph (4.5 m/s). The minimum speed criterion was used to avoid biasing the results due to vehicles that happened to stop in a location where the system was disabled due to a GPS or SPaT outage. Furthermore, none of the algorithms provide warnings at speeds below 10 mph (4.5 m/s).

Overall, the CICAS-V was enabled 96% of the time at either stop-controlled or signalized intersections. The disabled periods lasted from 100 milliseconds up to almost 5 seconds, as will be discussed. At signalized intersections, there were a total of 239 disabled periods spread across 65 of the 87 drivers. At stop-controlled intersections, there were a total of 628 disabled periods spread across 81 of the 87 drivers. Table 16 shows the percent of time the system was enabled as a function of the intersection. Note that a few intersections, such as 19 and 22, exhibited lower enabled time than other sites. The version of the CICAS-V software available for Subtask 3.4 did not perform as well as intended when intersections were near each other. The algorithm used to determine which intersection the vehicle was approaching was primarily based on heading. In certain situations the vehicle heading pointed closer to a nearby intersection on an adjacent roadway than the intersection actually being approached (tended to occur on curved approaches). This resulted in “cross-talking” in which the CICAS-V had difficulty determining which intersection was being approached. The cross-talking problem caused a significant reduction in the enabled time, which necessitated the removal of four stop-controlled intersections at the onset of study, from 14 stop-controlled intersections down to 10. Although not severely impacted, intersections 19

and 22 continued to suffer from some cross-talking (see Appendix E), which likely explains their decreased working time.

**Table 16 Percent of working time of the CICAS-V within the warning region.**

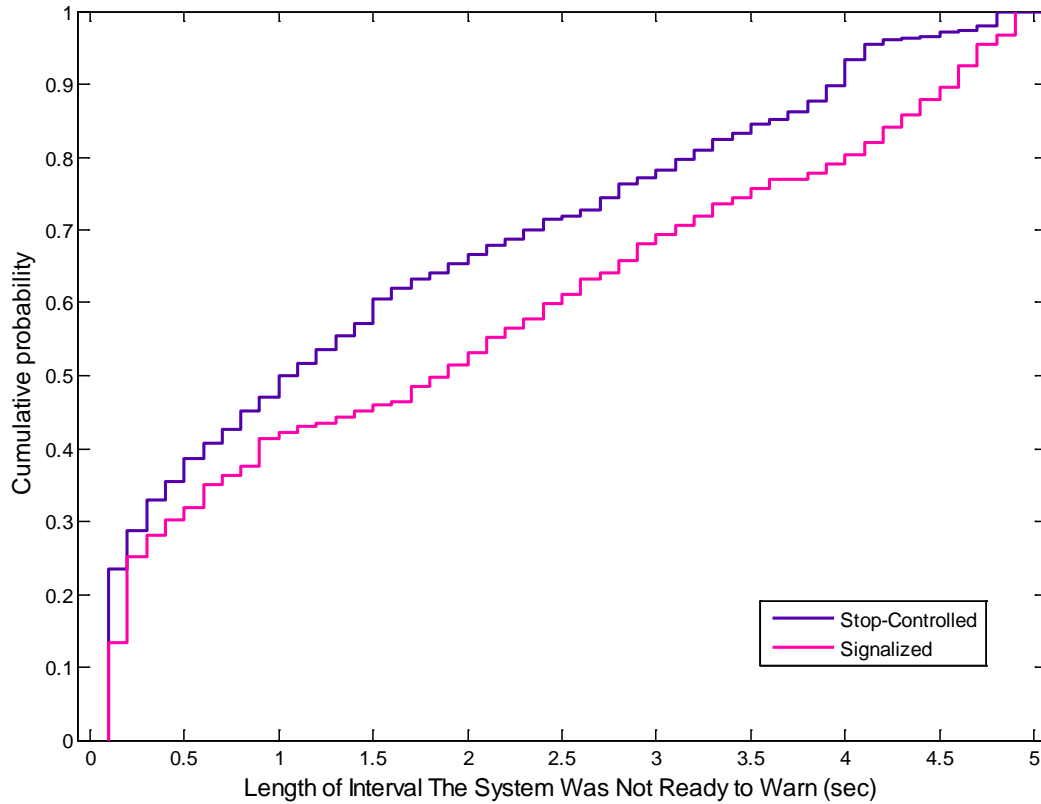
Intersection Type	Intersection ID	Percent of Working Time
Signal	6	96.20
	7	98.09
	8	95.33
Stop	12	95.77
	13	96.45
	15	92.62
	17	95.29
	18	99.62
	19	88.37
	20	99.16
	22	89.88
	23	96.62
25	99.35	

At stop controlled intersections, the disabled periods are nearly always the result of a failure to map-match the vehicle to the GID. Of the time over which the DVI was disabled at stop-controlled intersections, 99% was due to GID map-matching. Interestingly, at signalized intersections, nearly zero of the disabled periods were due to the GID map-matching. This is likely explained by the improved skyline and differential GPS available at the signalized intersections. Most of the outages at signalized intersections (99%) were due to the SPaT messages not being received. The SPaT outages were likely due to the antenna radiation patterns and multipath effects. It may be possible to improve reception by further calibrating the antenna.

It is important to note that instances in which the DVI is only disabled for brief periods (i.e., few hundred milliseconds), will not generally have a large impact on system performance and will not influence the driver’s experience (the blue icon only turned off if the outage lasted more than 400 milliseconds). However, if the DVI is disabled for several seconds, the impact on the CICAS-V effectiveness may be substantial, potentially negating the CICAS-V safety benefit.

To investigate the disabled periods further, the empirical cumulative probability of the disabled length was plotted for stop-controlled and signalized intersections (Figure 17). The figure indicates that over half of the disabled periods at both signalized and stop-controlled intersections were longer than one second. Although there were fewer disabled periods at signalized intersections, the disabled periods typically last longer than at stop-controlled intersections. From these results, it appears that most of these periods have the potential to result in a late warning if the system is momentarily disabled while

the driver happens to violate. In this instance, the warning would be activated when the system becomes enabled.



**Figure 17 Empirical cumulative probability distribution of the length of a disabled DVI period at stop-controlled intersections.**

The second metric used to evaluate system performance was to review the system-issue log maintained by experimenters during Subtask 3.4 (Table 17). The log was maintained during the data collection period to track any system issues that were identified. It included the issue, a brief description, the number of drivers who were affected, and the status of the issue at the time of the of the Subtask 3.4 testing. Most of the problems encountered were addressed with upgrades to the CICAS-V application software.

There are only two outstanding issues. The first is the problem that occurs when an emergency vehicle preempts the signal, which causes the RSE to report incorrect phase information. This is not an issue of the CICAS-V concept, but rather the implementation methods used within a particular signal controller. While this problem is still considered “outstanding” at the time of this writing, a signal controller company is working on a solution that has a very high probability of success. The second problem is with a deficiency in the Netway box during data collection. Recall that the OEM vehicle network provided data such as brake status and velocity to the Netway box. The Netway box, exclusively programmed by each of the OEM, was used to translate OEM-specific

CAN messages to a standard CAN format compatible with the WSU. The Netway was used to simplify the implementation of the WSU into the five OEM vehicles (otherwise five specialized WSU releases would be required).

When the Netway box fails, data is not received by the DAS (or the CICAS-V). It is not a problem of the CICAS-V per se; however, approximately 5 percent of data was lost due to this issue. Therefore, it is a concern that will need to be addressed in order to minimize data loss during an FOT. For the FOT it may be feasible to eliminate the Netway box and provide custom WSU releases for each vehicle platform; particularly if only one platform is selected.

**Table 17 CICAS-V issues log maintained during the 3.4 study.**

<b>Observed Data Collections Issues</b>	<b>Description</b>	<b>Number of Drivers Affected</b>	<b>Status</b>
Violation Warning on Green	Signal Preemption from emergency vehicles causes the RSE to report incorrect phase information	2	<b>Resolution in Process:</b> Signal controller company is working on a solution to output required phase transition information from preempt state
Missing Stop Sign GID's	GID timeout was set to 30 days as default. After 30 days all stop GID's were erased from the OBE memory	5	<b>Resolved:</b> For the purpose of conducting the study, the Stop GID's were reset to timeout after 90 days
Missing Netway Data	DAS recorded Netway variable values of 0 during the start of a trip. Time of missing data ranged from 10 minutes to 75 minutes and could be fixed by restarting the Netway box	9	<b>Unresolved:</b> Unknown cause for drop outs. Appears to be a reliability problem with the Netway box. There is a new version of the Netway used in some of the other OEM vehicles that reportedly do not have this problem.
System Lock up During Drive	The OBE locked up when approaching a stop-controlled intersection prior to receiving messages from an RSE	12	<b>Resolved with Updated Application</b>
Removed 4 Stop Intersections from OBE Memory (14, 16, 21, and 24)	The intersection selection algorithm was not able to identify the appropriate intersection when more than one was within 300m of another. Intersections were removed prior to beginning study	0	<b>Resolved with Updated Application</b>
Extra GID's Back in VTTI Test Vehicles	The removed GID's were accidentally loaded back on the VTTI test cars while OEM's prepared for Task 11 testing	30	<b>Resolved:</b> once discovered, the extra GID's were removed from memory
Inaccurate Signalized GID Information	A signalized GID was found to have lane identification errors that caused signal status errors to occur resulting in issuing a warning during a green phase	5	<b>Resolved:</b> GID was updated and validated

## 2.4.2 Evaluate Vehicle DAS Hardware and Software

The vehicle DAS collected the specified measures throughout the Subtask 3.4 studies. There was one malfunction recorded on the DAS issues log (Table 18) maintained by experimenters throughout Subtask 3.4. This hard drive malfunction caused the video file to be lost for one driver in the Pseudo-Naturalistic Study. This equates to two hours of data lost out of 191 hours, or just over 1 percent data loss.

**Table 18 Vehicle DAS issues log maintained during the Subtask 3.4 studies.**

Observed Data Collections Issues	Description	Number of Hours Affected	Status
Bad video file	Video file was corrupted during collection. Likely cause was a bad sector on the hard drive	2 out of 191 total	<b>Resolved:</b> Replaced hard drive and error never repeated

The vehicle DAS collected 127 variables during Subtask 3.4. A review of the collected variables suggests that some measures are either unavailable or unnecessary. For instance, the variables for tire pressure were not populated, while variables like battery voltage had little utility. Prior to an FOT, the variable list needs to be reviewed to determine which measures should be recorded. Variables that are not desirable should be eliminated from collection to save storage space and simplify the resulting database.

## 2.4.3 Evaluate Intersection DAS Hardware and Software

The intersection DAS collected the specified measures during the Subtask 3.4 Pseudo-Naturalistic Study. There was one malfunction that occurred during the data collection (Table 19), as indicated by the issues log maintained by the experimenters. The system overheated when the DAS was initially installed in a weather-tight, non-vented enclosure, causing the video board to overheat. A redesign of the enclosure to include venting and a fan solved this problem.

**Table 19 Infrastructure DAS issues log maintained during the Subtask 3.4 Pseudo-Naturalistic Study**

Observed Data Collections Issues	Description	Number of Days Affected	Status
Overheating System	The DAS was initially installed in a weather-tight non-vented enclosure. This caused the video board to overheat.	4 days out of 22 total	<b>Resolved:</b> Added fan and venting to the cabinet.

The infrastructure DAS was included in this study to determine if it should be included in the FOT. The primary purpose of the infrastructure DAS for the FOT was to obtain data from surrounding vehicles, especially potential cross traffic, when a warning was issued in the instrumented vehicle. The intent was that this data would be used to determine the benefit of CICAS-V by evaluating if a potential crash was avoided.

Based on our experience in Subtask 3.4, the infrastructure DAS may not represent the most effective method for this type of analysis for two reasons. First, the probability of a CICAS-V warning at a site with an infrastructure DAS may be small. The initial

planning for the FOT indicated that cost and time constraints would only allow a few sites to have the infrastructure DAS. While several warnings may occur over an entire FOT test route, few warnings are likely to occur at any one site. For example, of the 427 crossings at the Peppers Ferry intersection (intersection identification number 8, where the infrastructure DAS was located), there were no valid warnings presented. As a result, no analysis of adjacent vehicles to determine crash risk could be performed.

Secondly, the data collected by the Vehicle DAS may be sufficient for obtaining the data needed for a safety benefit analysis. The test vehicle had front and rear cameras which captured most of the adjacent vehicles for a portion of the intersection approach. If desired, the cameras could be outfitted with wide-angle lenses to increase the time over which adjacent vehicles are visible. If only the presence of vehicles is needed for safety benefits analysis, the cameras may be sufficient for obtaining this data. But, if presence-only data is insufficient, or presence over the entire intersection approach is required, onboard cameras will not provide the necessary information.

However, if it is ultimately determined that detailed trajectories of the surrounding vehicles are required in the FOT, the infrastructure DAS can provide this information. It will be important to evaluate the cost of the infrastructure DAS relative to the expected sample size of the FOT.

### **3 Recommendations and Study Limitations**

Subtask 3.4 was a pilot test to perform the first on-road naive-driver system-level test of the CICAS-V. Drivers were placed into CICAS-V equipped vehicles to navigate a two-hour prescribed route through equipped intersections without an experimenter in the vehicle. To ensure that sufficient data were obtained to understand drivers' impressions of the warning, a subset of the drivers followed the on-road study with a test-track study. Based on the results presented, the following implications may be drawn with further supporting rationale provided below:

- The CICAS-V System is FOT Ready
- CICAS-V Algorithms are FOT Ready
- The Vehicle DAS is FOT Ready
- The Infrastructure DAS is FOT Ready
- Pilot Study Protocols are FOT Ready
- The CICAS-V Appears to Provide a Benefit to the Driver
- Drivers Like the CICAS-V

#### **3.1 The CICAS-V System is FOT Ready**

The on-road and test-track portions of data collection, as well as evaluations provided in other reports (e.g., the Task 11 report by et al., in print-a), indicate that the CICAS-V



system functions reliably and as intended for the purpose of conducting an FOT. The issues that were noted with the system during data collection have already been largely resolved with CICAS-V application software upgrades. The problems that are outstanding at the time of writing this report are not problems with the CICAS-V itself, but rather this initial implementation. First, the invalid warnings that occurred when an emergency vehicle preempted the signal, which caused the RSE to report incorrect phase information, are being addressed by the signal controller company. The occasional failure of the Netway box during data collection is not an issue of the CICAS-V per se; however, it is an issue that would need further attention in order to minimize data loss during an FOT. Approximately five percent of data was lost due to this deficiency. For the FOT, it is likely that the WSU software would be specialized for each vehicle platform making the Netway box unnecessary.

### **3.2 CICAS-V Algorithms are FOT Ready**

The study successfully tested two algorithms for stop-controlled intersections and one algorithm for signalized intersections. Although Stop-Controlled Algorithm 1 was not deemed successful, its successor, Stop-Controlled Algorithm 2, successfully warned three different drivers of an occluded intersection. Signalized Intersection Algorithm 1 provided a valid and timely warning to a driver approaching a light through a phase change.

### **3.3 The Vehicle DAS is FOT Ready**

The Vehicle DAS performed well during the on-road and test-track portions of the study. Although there was a hard drive malfunction during the course of the study, very little data was lost (2 hours out of 191 hours total) due to Vehicle DAS equipment failures. It is recommended that variables that were not useful for the pilot be eliminated from collection to save storage space and simplify the resulting database.

### **3.4 The Infrastructure DAS is FOT Ready**

The Infrastructure DAS also performed well during the study and is ready for an FOT. The bigger issue for an FOT is determining if the benefit of collecting infrastructure DAS data is worth the cost to collect, store, reduce, and analyze the data. The benefit would be measured in terms of the probability that a warning violation would occur at an equipped intersection, providing information that could only be gleaned from an infrastructure DAS. In addition, the Vehicle DAS may be capable of being upgraded to provide sufficient information (e.g., for the purpose of measuring and characterizing cross traffic).

### **3.5 Pilot Study Protocols are FOT Ready**

The protocols, pre-drive questionnaires, and post-drive questionnaires worked well for the pilot study and can be implemented during an FOT.

### **3.6 The CICAS-V Appears to Provide a Benefit to the Driver**

Every driver who was provided with a valid violation warning throughout data collection came to a stop before the intersection box. The valid violation warnings provided from the best performing algorithms, Stop-Controlled Algorithm 2 and the Signalized Intersection Algorithm, are of particular interest since the scenarios mimic those for which the CICAS-V was designed. Those scenarios are an occluded stop-controlled intersection that drivers had trouble detecting, and a signalized intersection with lead traffic going into a phase change. Of course, the results from this study alone cannot provide an accurate cost/benefit trade off, but the results from this study indicate a potential benefit of the system.

### **3.7 Drivers like the CICAS-V**

Subjective data on post-test questionnaires indicate that drivers generally like the CICAS-V. A common critique of the system was the conspicuity of the visual display. Nonetheless, this is a minor critique considering that: 1) the visual display was not designed into the original dash configuration and was added; 2) drivers had little time with the vehicle (two to three hours) to become accustomed to the display; 3) the speech and brake pulse modalities are very effective; and 4) for the purposes of conducting an FOT, the visual display can be viewed as a secondary indicator to the speech and brake pulse warning modes and could be modified to improve conspicuity.

### **3.8 Limitations of the Study**

One shortcoming of the research is that data collection concluded without benefit of testing the final version of the CICAS-V application. As stated, the Subtask 3.4 studies were conducted using Version 1.11 of the software. By the time data collection had ended and the experimenters had given feedback to the CICAS-V developers, Version 1.15 had been developed, reflecting four software upgrades and several incorporated system refinements. Therefore, it is recommended that a small study be conducted prior to an FOT to test the upgraded software.

Also, this study was conducted in the small metropolitan region of Blacksburg, Virginia. In this area, the GPS coverage was adequate for testing the system, the state DOT was very supportive, and the proximity to data collectors was ideal. Alternative locations are likely to provide different and, likely, additional challenges relative to those that were met by the research staff. As such, the trade-offs of alternative locations would need to be carefully considered prior to selecting the final FOT site.

## 4 References

- Doerzaph, Z. R., Neale, V. L., Bowman, J. R., Viita, D. C., and Maile, M. (In Print). *Cooperative Intersection Collision Avoidance System Limited to Stop Sign and Traffic Signal Violations (CICAS-V) Subtask 3.2 Interim Report: Naturalistic Infrastructure-Based Driving Data Collection and Intersection Collision Avoidance Algorithm Development* (Cooperative Agreement No. DTFH61-01-X-00014). Washington, DC: National Highway Traffic Safety Administration.
- Lee, S. E., Perez, M. A., Doerzaph, Z. R., Stone, S. R., Brown, S. B., Neale, V. L., Knipling, R.R., & Holbrook, G.T. (2005). *Task 5 of the Intersection Collision Avoidance - Violation Project: Final Project Report*. Blacksburg: Virginia Tech Transportation Institute.
- Maile, M., Ahmed-Zaid, F., Basnyake, C., Caminiti, L., Kass, S., Losh, M., Lundberg, J., Masselink, D., McGlohon, E., Mudalige, P., Pall C., Peredo, M., Popovic, Z, Stinnett, J., and VanSickle, S. (In Print-a). *Cooperative Intersection Collision Avoidance System Limited to Stop Sign and Traffic Signal Violations (CICAS-V) Task 11 Final Report: Objective Tests*. Washington, DC: National Highway Traffic Safety Administration.
- Maile, M., Ahmed-Zaid, F., Basnyake, C., Caminiti, L., Kass, S., Losh, M., Lundberg, J., Masselink, D., McGlohon, E., Mudalige, P., Pall C., Peredo, M., Stinnett, J., and VanSickle, S. (In Print-b). *Task 10 Final Report: Integration of Subsystems, Building of Prototype Vehicles and Outfitting of Intersections*. (Cooperative Agreement No. DTFH61-01-X-00014). Washington, DC: National Highway Traffic Safety Administration.
- Najm, W.G., Smith, J.D., & Yanagisawa, M. (2007). *Pre-Crash Scenario Typology for Crash Avoidance Research* (Report No. DOT HS 810 767). Washington, D.C.: National Highway Traffic Safety Administration.
- National Highway Transportation Safety Administration. (2006). *Traffic Safety Facts – 2004* (Report No. DOT HS 809 919). Washington, D.C.: National Highway Traffic Safety Administration.
- Neale, V. L., Perez, M. A., Doerzaph, Z. R., & Stone, S. R. (2005). *Intersection Decision Support Final Report*. Charlottesville, VA: Virginia Transportation Research Council.
- Perez, M. A., Neale, V. L., Kiefer, R. J., Viita, D., Wiegand, K., and Maile, M. (In Print). *Cooperative Intersection Collision Avoidance Systems Limited to Stop Sign and Traffic Signal Violations (CICAS-V) Subtask 3.3 Interim Report: Test of Alternative Driver-Vehicle Interfaces on the Smart Road*. (Cooperative Agreement No. DTFH61-01-X-00014). Washington, DC: National Highway Traffic Safety Administration.
- Stone, S., Neale, V. L., Wiegand, K., Doerzaph, Z. R. and Maile, M. (In Print). *Cooperative Intersection Collision Avoidance System Limited to Stop Sign and Traffic Signal Violations (CICAS-V) Task 12 Final Report: Infrastructure and*

*Vehicle DAS Functional Designs.* (Cooperative Agreement No. DTFH61-01-X-00014). Washington, DC: National Highway Traffic Safety Administration.

Sudweeks, J., Neale, V. L., Wiegand, K., Bowman, J., Perez, M. and Maile, M. (In Print). *Cooperative Intersection Collision Avoidance System Limited to Stop Sign and Traffic Signal Violations (CICAS-V) Subtask 3.1 Report: Mining of the 100-Car Naturalistic Database to Determine Factors Related to Intersection Violations and Near Violations.* (Cooperative Agreement No. DTFH61-01-X-00014). Washington, DC: National Highway Traffic Safety Administration.

## 5 Appendices

### Appendix A: Driver Screening Questionnaire

#### Driver Screening Questionnaire

**4. Note to Researcher:**

5. Initial contact between participants and researchers may take place over the phone. If this is the case, read the following Introductory Statement, followed by the questionnaire. Regardless of how contact is made, this questionnaire must be administered verbally before a decision is made regarding suitability for this study. **Do not place any participant information on this questionnaire**, it should only be used to record participant answers. Once eligibility has been determined (i.e., the participant answers comply with all the screening criteria) and you've recorded the participant information on the last page, discard the rest of this questionnaire.

6.

**7. Introductory Statement:**

8. *After prospective participant calls or you call them, use the following script as a guideline in the screening interview.*

9.

10.  
11. Hello, my name is \_\_\_\_\_ and I am a researcher with the Virginia Tech Transportation Institute in Blacksburg, VA. We are currently recruiting people to participate in a research study. The study involves driving an instrumented vehicle on a predetermined route. It will take approximately three (3) hours. Does this sound interesting to you?

12.

**13. If No, thank them for their time and finish the call.**

14.

15.

**16. If Yes:**

17. *First, I would like to collect some information from you to determine if you're eligible. This will take up to 15 minutes of your time.*

18.

**1. Do you have a valid driver's license?**

- Yes
- No

**(STOP and tell them they're not eligible for the study if they answer No)**

**2. How old are you? \_\_\_\_\_**

**(STOP and tell them they're not eligible for the study if they are under 18 years of age)**

**(STOP and tell them they are NOT eligible if they fall in the following age categories: Under 18, 31-34, 51-54)**

**3. Are you authorized to work in the United States? Please note that we are NOT offering employment to you.**

- Yes
- No

**Please explain:\_\_\_\_\_**

**(STOP and tell them they're not eligible for the study if they answer No because they carry a non-working VISA [e.g., F2 Visa])**

**4. Please note that for tax recording purposes, the fiscal and accounting services office at Virginia Tech (also known as the Controller's Office) requires that all participants provide their social security number to receive payment for participation in our studies. You do NOT need to provide it now, but are you willing to provide us with your social security number?**

- Yes
- No

**(Stop and tell them they are not eligible for the study if they are not willing to provide their social security number)**

**5. Are you able to drive an automatic transmission without assistive devices or special equipment?**

- Yes
- No

**(STOP and tell them they're not eligible for the study if they answer No)**

**6. Have you participated in any experiments at the Virginia Tech Transportation Institute? If "yes," please briefly describe the study.**

- Yes \_\_\_\_\_
- No

**(STOP and tell them they're not eligible for the study if they have participated in previous studies involving intersection collision avoidance systems)**

**If they have NOT participated in previous studies involving intersection collision avoidance systems and have NOT experienced a surprise event, please ask:**

**6a. There is a possibility of an additional driving study where you would be driving the instrumented vehicle on the Smart Road for an additional hour. Is this something you may be interested in doing as well?**

- Yes
- No

**7. Have you been convicted of a DUI?**

- Yes
- No

(STOP and tell them they're not eligible for the study if they have been convicted of a DUI)

19.

8. Have you been involved in any accidents within the past 3 years that resulted in injuries? If so, please explain.

- Yes \_\_\_\_\_
- No \_\_\_\_\_

(STOP and tell them they're not eligible if they've caused an accident resulting in injury in the past 3 years)

20.

9. Do you have a history of any of the following? If yes, please explain.

- |   |          |               |
|---|----------|---------------|
| 21. Heart Condition                               | 22. No__ | 23. Yes _____ |
| 24. Stroke  | 25. No__ | 26. Yes _____ |
| 27. Brain tumor                                   | 28. No__ | 29. Yes _____ |
| 30. Head injury                                   | 31. No__ | 32. Yes _____ |
| 33. Neck or back pain or injury                   | 34. No__ | 35. Yes _____ |
| 36. Epileptic seizures                            | 37. No__ | 38. Yes _____ |
| 39. Respiratory disorders                         | 40. No__ | 41. Yes _____ |
| 42. Motion sickness                               | 43. No__ | 44. Yes _____ |
| 45. Inner ear problems                            | 46. No__ | 47. Yes _____ |
| 48. Dizziness, vertigo, or other balance problems | 49. No__ | 50. Yes _____ |
| 51. Diabetes                                      | 52. No__ | 53. Yes _____ |
| 54. Migraine, tension headaches                   | 55. No__ | 56. Yes _____ |

57.

58. (See criterion 11 on next page to determine eligibility if they answer Yes to any of the conditions)

59.

10. (Females only, of course) Are you currently pregnant? *If yes, explain that they cannot participate because the Virginia Tech IRB does not allow pregnant women to participate in this type of driving study.*

- Yes
- No

60.

11. Are you currently taking any medications that may interfere with your driving ability (e.g., medications that may cause drowsiness, medication that may make you dizzy)? If yes, please list them.

- Yes \_\_\_\_\_
- No

**(STOP and tell them they're not eligible if they're taking any substances that may interfere with their driving)**

**12. Do you have normal or corrected to normal hearing and vision? If no, please explain.**

- Yes
- No \_\_\_\_\_

**(STOP and tell them they're not eligible if they report CORRECTED vision lower than 20/40 or uncorrected hearing)**



**62. Criteria for Participation:**

1. *Must hold a valid driver's license.*
2. *Must be 18 years or older.*
3. *Must be eligible for employment in the U.S.*
4. *Must be willing to provide a valid social security number.*
5. *Must be able to drive an automatic transmission without special equipment.*
6. *Must not have been a participant in previous VTTI studies involving intersection collision avoidance systems.*
7. *Must not have been convicted of a DUI.*
8. *Must not have caused an injurious accident in the past three years.*
9. *Must not have lingering effects of back or neck injury or pain. Cannot have lingering effects of heart condition, brain damage from stroke, tumor, head injury, recent concussion, or infection. Cannot have had epileptic seizures within 12 months, respiratory disorders, motion sickness, inner ear problems, dizziness, vertigo, balance problems, diabetes for which insulin is required, chronic migraine or tension headaches.*
10. *Must not be pregnant.*
11. *Cannot currently be taking any substances that may interfere with driving ability (cause drowsiness or impair motor abilities).*
12. *Must have normal (or corrected to normal) hearing and vision.*

**63. *If the Participant is Not Eligible:***

**64. *Unfortunately, you are not eligible to perform the study because \_\_\_\_\_ . Thanks for your time.***

**65. *If the Participant is Eligible:***

*You're eligible to participate in this study. If you verify the following contact information, one of our researchers will contact you to determine a mutually agreeable time for you to complete the study.*

**Information for Screened and Eligible Participant:**

*Screener: Please record this information if the participant is eligible.  
Discard the screening questionnaire after this information has been recorded.*

Name \_\_\_\_\_

Age \_\_\_\_\_

Phone Number \_\_\_\_\_

Best Time/Day to Call \_\_\_\_\_

**Interested in Smart Road session (mark this box ONLY if the participant has expressed interest and has NOT experienced a surprise study)**

Date and Time Scheduled \_\_\_\_\_

## **Appendix B: Informed Consent – Pseudo-Naturalistic**

### **VIRGINIA POLYTECHNIC INSTITUTE AND STATE UNIVERSITY**

#### **Informed Consent for Participants in Research Projects Involving Human Subjects**

Title of Project: CICAS: Pilot Field Operational Test

Investigator(s): Vicki Neale, Zac Doerzaph, Derek Viita, Kendra Wiegand, and Jodi Bowman

#### **I. Purpose of this Research Project**

The purpose of this research project is to investigate new safety devices. We want to find out whether the devices are effective and whether you find them useful. One hundred and ninety two (192) adults will be recruited to participate for this study. Participants will fall within the age ranges of 18-30, 35-50, and over 55. There will be an equal number of males and females.

#### **II. Procedures**

You are being asked to participate in a pseudo-naturalistic driving study. The study involves driving an instrumented vehicle along a pre-determined route. You will be guided along the route by a navigation system, which will give you directions. The vehicle will be equipped with next generation assistive safety devices. In addition, the vehicle will be equipped with a data collection system using an array of sensors and cameras for use in recording a variety of driving measures. During today's session, you will be asked to read and sign this informed consent form, show the experimenter your valid driver's license, fill out questionnaires, and participate in hearing and vision tests. After the forms and tests are completed, you will be shown the instrumentation, navigation, and safety systems in the vehicle. There will be a cell phone in the vehicle in case you need to contact us for any reason. You will be instructed to contact Virginia Tech Transportation Institute (VTTI) if you encounter any difficulties with the vehicle that could be related to the instrumentation system or if you notice any maintenance issues with the system (for example, a camera that comes loose and dangles).

While you are driving the vehicle, we ask that you do the following:

1. Wear your seatbelt at all times.
2. Drive along the pre-determined route.
3. Do not use the radio.
4. Do not allow anyone else to drive the vehicle.
5. Do not wear sunglasses unless absolutely necessary. Sunglasses are recommended if at any time you are suffering from glare problems (e.g., from the

sun shining directly into your face) and cannot see the roadway and surrounding environment.

6. Do not smoke in the vehicle.
7. In the event of equipment malfunctioning or vehicle damage, please notify VTTI.
8. If you are involved in a crash, please follow the instructions listed on the orange envelope located in the glove compartment.
9. At the end of your participation period, please return the vehicle to VTTI.

After you have completed the drive along the pre-determined route, please return the vehicle to VTTI. At this point, you will be asked to complete additional questionnaires about your experience and you will then be compensated for your time. However, if you have been selected to participate in the test-track portion of the study, you will receive additional information after completing the pseudo-naturalistic portion. You will then be escorted to the instrumented vehicle for further instructions. Once you have completed the test track portion of the study, you will be asked to complete the additional questionnaires and will then be compensated for your time.

As a participant in this study, you are requested to perform the following duties:

1. Carefully read the consent form and sign it if you agree to participate.
2. Agree to drive a VTTI vehicle that is equipped with a data acquisition system and experimental assistive safety systems.
3. Agree to drive along the pre-determined route provided by the navigation system.
4. Agree that, if you are involved in a crash, you will follow the instructions on the orange envelope in the glove compartment and contact VTTI so that we can come inspect the data collection system.
5. Agree to notify us if vehicle maintenance is needed. In addition, please do not receive a “jump start” or give a “jump start” to another vehicle.
6. Agree to be the sole driver of the vehicle and not allow others to drive the vehicle.

Your role during this study will be to drive a vehicle on public roads. It is important that you understand that we are not evaluating you in any way. We are collecting information about assistive safety systems and are interested in your opinion about their usefulness.

### **III. Risks**

Caution should be exercised when operating a vehicle with which you are not familiar. Be aware that accidents can happen at any time while driving. As a participant, you may be exposed to the following risks or discomforts by volunteering for this research:

1. The risk of an accident normally present while driving.
2. Any risk present when driving a new and unfamiliar vehicle.

3. While you are driving the vehicle, cameras will videotape you. Due to this fact, we will ask you not to wear sunglasses unless absolutely necessary; however, if at any time you are suffering from glare problems (e.g., from the sun shining directly into your face) and cannot see the roadway and surrounding environment, sunglasses are recommended.

The following precautions will be taken to ensure minimal risk to you:

1. You may decide not to participate at any time.
2. The vehicle is equipped with a driver's side and passenger's side airbag, supplemental restraint system, fire extinguisher and first-aid kit.
3. All data collection equipment is mounted such that, to the greatest extent possible, it does not pose a hazard to you in any foreseeable case.
4. You will be required to wear the lap and shoulder belt restraint system while in the car.

In the event of an accident or injury in an automobile owned or leased by Virginia Tech, the automobile liability coverage for property damage and personal injury is provided. The total policy amount per occurrence is \$2,000,000. This coverage (unless the other party was at fault, which would mean all expense would go to the insurer of the other party's vehicle) would apply in case of an accident for all volunteers and would cover medical expenses up to the policy limit. For example, if you were injured in an automobile owned or leased by Virginia Tech, the cost of transportation to the hospital emergency room would be covered by this policy. Any coverage of the participant is limited to the terms and conditions of the insurance policy.

Participants in a study are considered volunteers, regardless of whether they receive payment for their participation; under Commonwealth of Virginia law, worker's compensation does not apply to volunteers; therefore, if not in the automobile, the participants are responsible for their own medical insurance for bodily injury. Appropriate health insurance is strongly recommended to cover these types of expenses. For example, if you were injured outside of the automobile owned or leased by Virginia Tech, the cost of transportation to the hospital emergency room would be covered by your insurance.

#### **IV. Benefits**

While there are no direct benefits to you from this research, you may find the experiment interesting. No promise or guarantee of benefits is made to encourage you to participate. Participation in this study will contribute to the improvement of future studies concerning advanced vehicle systems.

#### **V. Extent of Anonymity and Confidentiality**

The data gathered in this experiment, including the Health Screening Questionnaire, will be treated with confidentiality. Shortly after participation, your name will be separated from your data. A coding scheme will be employed to identify the data by participant number only (e.g., Participant No. 1). If you choose to do so, you will be allowed to see your data and withdraw the data from the study if you so desire. If you want to base withdrawal of your data on observation of the data, you must ask for an appointment to see the data immediately after you finish your participation. If upon seeing your data you decide to withdraw it from the experiment, the data will be promptly removed and discarded. At no time will the researchers release data identifiable to an individual to anyone other than individuals working on the project without your written consent. VTTI will not turn over the video of your image to its client without your permission. It is possible that the Institutional Review Board (IRB) may view this study's collected data for auditing purposes. The IRB is responsible for the oversight of the protection of human subjects involved in research.

If you are involved in a crash while participating in this study, the data collection equipment in your vehicle will likely capture the events leading up to the event. The data collection equipment SHOULD NOT be given to police officers or any other party. You are under NO LEGAL OBLIGATION to mention participation in this study.

We will do everything we can to keep others from learning about your participation in the research. We may disclose information about you as required by law, in conjunction with a government inquiry, or in litigation or dispute resolution. We cannot resist a demand for information from personnel of the United States Government that is used for auditing or evaluation of federally funded projects or for information that must be disclosed in order to meet the requirements of the federal Food and Drug Administration (FDA).

You should understand that this informed consent does not prevent you or a member of your family from voluntarily releasing information about yourself or your involvement in this research.

This informed consent also does not prevent the researchers from disclosing matters such as child abuse, or subject's threatened violence to self or others. In terms of a vehicle, this could also include items such as driving under the influence of drugs or alcohol or allowing an unlicensed minor to drive the vehicle. If this type of behavior is observed, we reserve the right to remove you from the study and inform the appropriate authorities of what we have observed. In all cases, we will notify you first of the behaviors we have observed prior to removing you from the study or informing others of our observations. If you are removed from the study, you will be compensated for any time already spent in the study, but will receive no further payments.

## **VI. Compensation**

At the end of the study, you will be paid \$25.00 per hour for your participation. This includes the time you are driving the vehicle and the time you spend at VTTI completing

paperwork and filling out questionnaires. If you have driven the entire pre-determined route, you will receive a bonus of \$25.00. If the payment amount you receive is over \$75.00, you will be paid by check. Otherwise, you will be paid in cash.

The vehicle will be provided to you with a sufficient amount of gas to complete the drive along the predetermined route. You are not required to return the vehicle with a full tank of gas. You will, however, be responsible for paying all parking tickets and/or traffic violations issued to the research vehicle during the time the vehicle is in your possession.

### **VII. Freedom to Withdraw**

As a participant in this research, you are free to withdraw at any time without penalty. If you choose to withdraw, please notify VTTI staff immediately. If you choose to withdraw while you are driving the vehicle, please pull the vehicle over to a safe parking area and contact VTTI staff using the cell phone provided to you. Arrangements will be made for VTTI staff to pick you up and bring you back to VTTI. You will be compensated for the portion of time of the study for which you participated. Furthermore, you are free not to answer any question or respond to experimental situations without penalty.

### **VIII. Subject's Responsibilities**

If you voluntarily agree to participate in this study, you will have the following responsibilities:

1. To follow the experimental procedures as well as you can.
  - a) Follow the navigation system directions and drive the instrumented vehicle along the pre-determined route.
2. Inform the experimenter at VTTI if you have difficulties of any type.
3. Wear your seat and lap belt.
4. Abide by the posted speed limits and traffic laws.
5. Abstain from any substances that will impair your ability to drive.
6. Drive the test vehicle in a safe and responsible manner.
7. Do not smoke in the vehicle.
8. Do not allow anyone else to drive the vehicle.
9. Do not use the radio.
10. You are responsible for paying all parking tickets, traffic violations, and tolls issued to the research vehicle during the time the vehicle is in your possession.
11. Do not wear sunglasses unless absolutely necessary. Sunglasses are recommended if at any time you are suffering from glare problems (e.g., from the sun shining directly into your face) and cannot see the roadway and surrounding environment.
12. Do not take the vehicle into any facilities that do not permit video recording devices.
13. In the event of equipment malfunctioning or damage, please notify VTTI.

14. If you are involved in a crash, please follow the instructions listed on the orange envelope located in the glove compartment.

**IX. Participant’s Permissions and acknowledgments**

Check one of the following:

VTTI **has my permission** to provide digital video including my image to the sponsor of this research. I understand that the sponsor will only see the video for research purposes.

VTTI **does not have my permission** to provide digital video including my image to the sponsor of this research. I understand that VTTI will maintain possession of the digital video, and that it will only be used for research purposes.

**X. Subject's Permission**

I have read the Consent Form and conditions of this project. I have had all my questions answered. I hereby acknowledge the above and give my voluntary consent:

\_\_\_\_\_ Date \_\_\_\_\_  
Subject signature

\_\_\_\_\_ Date \_\_\_\_\_  
Witness

Should I have any pertinent questions about this research or its conduct, and research subjects' rights, and whom to contact in the event of a research-related injury to the subject, I may contact:

<u>Investigators</u>	<u>Telephone</u>
Derek Viita	xxx-xxxx
Zac Doerzaph	xxx-xxxx

David M. Moore	xxx-xxxx
Chair, Virginia Tech Institutional Review Board for the Protection of Human Subjects	
Office of Research Compliance	
2000 Kraft Drive, Suite 2000 (0497)	
Blacksburg, VA 24060	



**[NOTE: Subjects must be given a complete copy (or duplicate original) of the signed Informed Consent.]**

## Appendix C: Health Screening Questionnaire

### *Health Screening Questionnaire*

1. Are you in good general health?      Yes    No

If “No”, list any health-related conditions you are experiencing or have experienced in the last year.

---

---

---

2. Have you, in the last 24 hours, experienced any of the following conditions?

Trouble Sleeping	Yes	No
Hangover	Yes	No
Headache	Yes	No
Cold symptoms	Yes	No
Depression	Yes	No
Allergies	Yes	No
Emotional upset	Yes	No

3. Do you have a history of any of the following?

Visual Impairment (including corrective lenses)      Yes    No

(If yes, please describe.)

---

---

---

---

Seizures or other lapses of consciousness      Yes    No

(If yes, please describe.)

---

---

---

---

---

Any disorders similar to the  
above or that would impair  
your driving ability

Yes No

(If yes, please describe.)

---

---

---

---

---

4. List any prescription or non-prescription drugs you are currently taking or have taken in the last 24 hours that may interfere with your ability to drive (e.g., medications that may cause drowsiness, medications that may make you dizzy).

---

---

---

5. List the approximate amount of alcohol (beer, wine, fortified wine, or liquor) you have consumed in the last 24 hours.

---

---

6. Do you smoke?

Yes No

Emergency Contact Information (Optional)

Name: \_\_\_\_\_

Telephone Number: \_\_\_\_\_

---

Signature

---

Date

***For experimenter use:***

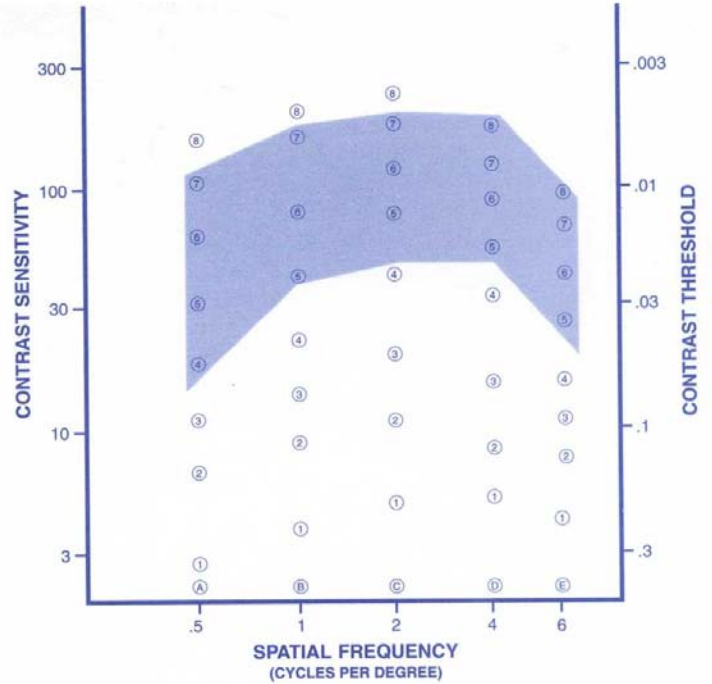
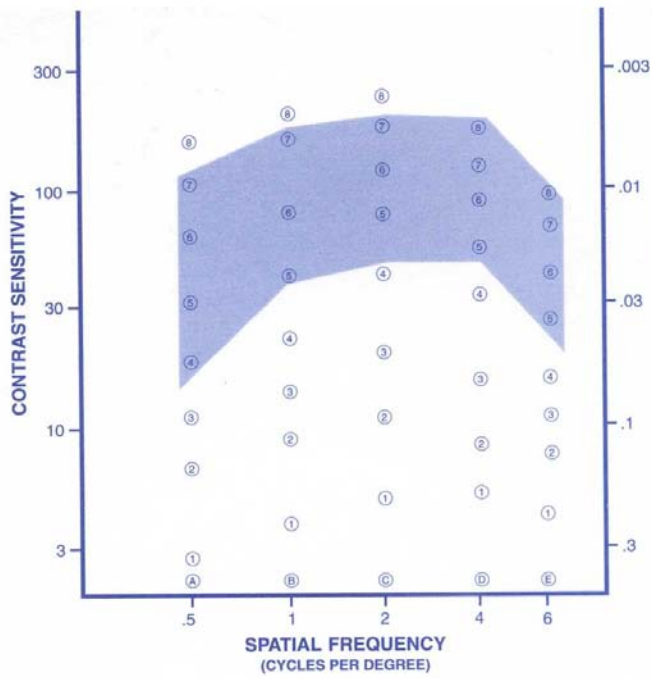
Vision Test (Snellen) \_\_\_\_\_

Color vision \_\_\_\_\_  
\_\_\_\_\_  
\_\_\_\_\_  
\_\_\_\_\_  
\_\_\_\_\_

Contrast Sensitivity Test

Left

Right



Hearing Test

\_\_\_\_\_  
\_\_\_\_\_  
\_\_\_\_\_

## Appendix D: Pre-Drive Questionnaire

### Pre-Drive Questionnaire

1. How long have you had your driver's license? \_\_\_\_\_years
2. Approximately what is your annual mileage? \_\_\_\_\_miles
3. Are you...(circle one)
  - a. Employed
  - b. Student
  - c. Retired
  - d. Unemployed
4. If you are employed, do you drive as part of your work requirement? (circle one)
  - a. Yes
  - b. No
5. What is the make/model/year of your current vehicle?  
Make \_\_\_\_\_  
Model \_\_\_\_\_  
Year \_\_\_\_\_
6. Which type of transmission does your primary vehicle have? (circle one)
  - a. automatic
  - b. manual (stick, straight, standard)
  - c. select shift (automatic with a manual option)
7. Does your vehicle have any of the following (please check all that apply)?
  - Head Up Display
  - Navigation system
  - Voice recognition
  - Adaptive Cruise Control
  - Forward Collision Warning
  - Park aid
  - Rear Vision System (monitor)
  - Blind Spot Alert
  - None of the above

8. Do you have experience using any of the following (please check all that apply)?

- Head Up Display
- Navigation system
- Voice recognition
- Adaptive Cruise Control
- Forward Collision Warning
- Park aid
- Rear Vision System (monitor)
- Blind Spot Alert
- None of the above

9. What percentage of driving trips do you use your cell phone? (circle one)

- a. 0-25%
- b. 26-50%
- c. 51-75%
- d. 76-100%

10. How many times do you use your cell phone in a typical trip? \_\_\_\_\_ times

## Appendix E: Pseudo-Naturalistic Field Test Route Intersections- Aerial and Ground Images

The intersection of Depot Street and Franklin Street (Intersection 6) is a four-way signalized intersection with a traffic light presented to vehicles traveling on both Franklin Street and Depot Street. The Franklin Street eastbound intersection approach has a 35 mph posted speed limit, while the westbound intersection approach has a 25 mph posted speed limit. The Depot Street intersection approach has a 25 mph posted speed limit going southbound and a 35 mph posted speed limit going northbound. An aerial view and ground images of Intersection 6 are presented in Figure 18 and Figure 19, respectively.



**Figure 18 Aerial view of Depot & Franklin intersection.**

[Image is the copyrighted work of Microsoft® and subject to the terms and conditions of the Microsoft® license agreement]



**Figure 19 Ground images from Depot & Franklin intersection.**

The intersection of Franklin Street and Independence Boulevard (Intersection 7) is a four-way signalized intersection with a traffic light presented to vehicles traveling on Independence Boulevard, Elm Street, and both directions on Franklin. The posted speed limits for Franklin Street, Independence Boulevard and Elm Street are 45 mph, 35 mph, and 25 mph, respectively. An aerial view (Figure 20) and ground images (Figure 21) of Intersection 7 are provided below.



**Figure 20 Aerial view Franklin, Elm & Independence intersection.**

[Image is the copyrighted work of Microsoft® and subject to the terms and conditions of the Microsoft® license agreement]



**Figure 21 Ground images from Franklin, Elm & Independence intersection.**



The intersection of Peppers Ferry and Franklin Street (Intersection 8) is a four-way signalized intersection with a traffic light presented to vehicles traveling on Peppers Ferry and Franklin Street. The Peppers Ferry intersection approach has a 35 mph posted speed limit in both westbound and eastbound directions. On Franklin there is a 45 mph posted speed limit in both northbound and southbound directions. An aerial view and ground images of Intersection 8 are presented in Figure 22 and Figure 23, respectively.



**Figure 22 Aerial view of Peppers Ferry (VA-114) & Franklin (Bus460) intersection.**

[Image is the copyrighted work of Microsoft® and subject to the terms and conditions of the Microsoft® license agreement]



**Figure 23 Ground images from Peppers Ferry (VA-114) & Franklin (Bus460) intersection.**

The intersection of Hickok Street and First Street (Intersection 12) is a four-way stop-controlled intersection with a single stop sign for vehicles traveling both directions on Hickok. The speed limit for traffic traveling on both Hickok Street and First Street is 25 mph. An aerial view and ground images of Intersection 12 are presented in Figure 24 and Figure 25, respectively.



**Figure 24 Aerial view of Hickok and First Street intersection.**

[Image is the copyrighted work of Microsoft® and subject to the terms and conditions of the Microsoft® license agreement]



**Figure 25 Ground images of Tranquility Via & Independence intersection**

The intersection of Sheltman Street and College Street (Intersection 13) is a three-way stop-controlled intersection with a single stop sign for vehicles traveling on Sheltman Street. The speed limit for traffic traveling on both Sheltman Street and College Street is 25 mph. An aerial view and ground images of Intersection 13 are presented in Figure 26 and Figure 27, respectively.



**Figure 26 Aerial view of Sheltman & College intersection.**

[Image is the copyrighted work of Microsoft® and subject to the terms and conditions of the Microsoft® license agreement]



**Figure 27 Ground images of Sheltman & College intersection.**

The intersection of Magna Carta Via and Constitution Via (Intersection 15) is a three-way stop-controlled intersection with a single stop sign for vehicles traveling on Magna Carta Via. The speed limit for traffic traveling on both Magna Carta and Constitution is 25 mph. An aerial view and ground images of Intersection 15 are presented in Figure 28 and Figure 29, respectively.



**Figure 28 Aerial view of Magna Carta Via and Constitution Via.**

[Image is the copyrighted work of Microsoft® and subject to the terms and conditions of the Microsoft® license agreement]



**Figure 29 Ground images of Magna Carta Via and Constitution Via.**

The intersection of Constitution Via and Tranquility Via (Intersection 17) is a three-way stop-controlled intersection with a single stop sign for vehicles traveling on Constitution Via. The speed limit for traffic traveling on both Constitution Via and Tranquility Via is 25 mph. An aerial view and ground images of Intersection 17 are presented in and Figure 31, respectively.



**Figure 30 Aerial view of Constitution Via & Tranquility Via intersection.**

[Image is the copyrighted work of Microsoft® and subject to the terms and conditions of the Microsoft® license agreement]



**Figure 31 Ground images of Constitution Via & Tranquility Via intersection.**

The intersection of Tranquility Via and Independence Via (Intersection 18) is a three-way stop-controlled intersection with a single stop sign for vehicles traveling on Tranquility Via. The speed limit for traffic traveling on both Tranquility Via and Independence Via is 25 mph. An aerial view and ground images of Intersection 18 are presented in Figure 32 and Figure 33, respectively.



**Figure 32 Aerial view of Tranquility Via & Independence intersection.**

[Image is the copyrighted work of Microsoft® and subject to the terms and conditions of the Microsoft® license agreement]



**Figure 33 Ground images of Tranquility Via & Independence intersection.**

The intersection of Independence Blvd. and Sapphire Avenue (Intersection 19) is a three-way stop-controlled intersection with a single stop sign for vehicles traveling on Independence Blvd. The speed limit for traffic traveling on both Independence Blvd. and Sapphire Avenue is 25 mph. An aerial view and ground images of Intersection 19 are presented in Figure 34 and Figure 35, respectively.



**Figure 34 Aerial view of Independence & Sapphire intersection.**

[Image is the copyrighted work of Microsoft® and subject to the terms and conditions of the Microsoft® license agreement]



**Figure 35 Ground images of Independence & Sapphire intersection.**



The intersection of Sapphire Avenue and Diamond Avenue (Intersection 20) is a four-way stop-controlled intersection with a single stop sign for vehicles traveling both directions on Sapphire Avenue and Diamond Avenue. The speed limit for traffic traveling on both Sapphire Avenue and Diamond Avenue is 25 mph. An aerial view and ground images of Intersection 20 are presented in Figure 36 and Figure 37, respectively.



**Figure 36 Aerial view of Sapphire & Diamond intersection.**

[Image is the copyrighted work of Microsoft® and subject to the terms and conditions of the Microsoft® license agreement]



**Figure 37 Ground images of Sapphire & Diamond intersection.**

The intersection of Windmill Ridge Road and Cambria (Intersection 22) is a three-way stop-controlled intersection with a single stop sign for vehicles traveling both directions on Windmill Ridge Road and also on Cambria. The speed limit for traffic traveling on both Windmill Ridge Road and Cambria is 25 mph. An aerial view and ground images of Intersection 22 are presented in Figure 38 and Figure 39, respectively.



**Figure 38 Aerial view of Windmill Ridge & Cambria intersection.**

[Image is the copyrighted work of Microsoft® and subject to the terms and conditions of the Microsoft® license agreement]



**Figure 39 Ground images of Windmill Ridge & Cambria intersection.**

The intersection of Juniper Drive and Morning Star Lane (Intersection 23) is a four-way stop-controlled intersection with a single stop sign for vehicles traveling both directions on Juniper Drive. The speed limit for traffic traveling on both Juniper Drive and Morning Star Lane is 25 mph. An aerial view and ground images of Intersection 23 are presented in Figure 40 and Figure 41, respectively.



**Figure 40 Aerial view of Juniper & Morning Star intersection.**

[Image is the copyrighted work of Microsoft® and subject to the terms and conditions of the Microsoft® license agreement]



**Figure 41 Ground images of Juniper & Morning Star intersection.**

The intersection of Market Street and Arbor Drive (Intersection 25) is a four-way stop-controlled intersection with a single stop sign for vehicles traveling both directions on Market Street. The speed limit for traffic traveling on both Market Street and Arbor Drive is 25 mph. An aerial view and ground images of Intersection 25 are presented in Figure 42 and Figure 43, respectively.



**Figure 42 Aerial view of Market & Arbor intersection.**

[Image is the copyrighted work of Microsoft® and subject to the terms and conditions of the Microsoft® license agreement]




**Figure 43 Ground images of Market & Arbor intersection.**






## Appendix F: Route Directions and Mileage

Pictures illustrate intersections that were instrumented for CICAS-V.





### Part A:

1. Leave VTTI parking lot
2. Right onto Transportation Research **0.3 mi**
3. Left onto Industrial Park **0.2 mi**
4. Cross South Main
5. Left onto 460 East Bypass Access Road **2.2 mi**
6. Merge onto 460 East Bypass
7. Exit 4AB, Peppers Ferry/Route 114 Exit **0.3 mi**
8. Curve Right at end of ramp, and merge onto Peppers Ferry **0.4 mi**
9. Left onto 460 Business/North Franklin 




### Part B:





10. Stay on 460 Business for approximately **2.7 miles**
11. Right onto W. Main St. **0.1 mi**
12. Left onto Hickok **0.1 mi**
13. Left onto First St.  **0.1 mi**
14. Left onto North Franklin **0.4 mi**
15. Left onto Depot (second traffic light)  **0.2 mi**
16. Left onto Sheltman **0.2 mi**
17. Left onto College  **0.3 mi**
18. Right onto Depot **203 ft**
19. Right onto N. Franklin  **0.3 mi**
20. Right onto W. Main St. **0.1 mi**
21. Left onto Hickok **0.1 mi**
22. Left onto First St.  **0.1 mi**
23. Left onto N. Franklin **1.2 mi**

### Part E:




24. Left onto Independence Blvd. (4<sup>th</sup> traffic light)  **0.4 mi**
25. Left onto George Edward **0.1 mi**
26. Second Right onto Magna Carta **0.2 mi**
27. Right onto Constitution  **0.2 mi**
28. Straight across Liberty
29. Right onto Tranquility  **0.1 mi**
30. Left onto Independence  **0.4 mi**

### Part F:




31. Left onto Sapphire  **0.2 mi**
32. Right onto Diamond  **0.4 mi**
33. Left onto Windmill **0.1 mi**
34. Straight across Cambria 

- 35. Right onto Juniper **0.3 mi**
- 36. Straight Across Morning Star 
- 37. Right onto Alder **0.12 mi**
- 38. Turn around
- 39. Left onto Juniper **0.3 mi**
- 40. Straight Across Morning Star 
- 41. Left onto Windmill **0.1 mi**
- 42. Straight across Cambria 
- 43. Right onto Diamond **0.4 mi**
- 44. Left onto Sapphire  **0.2 mi**



Part G:

- 45. Right onto Independence **0.5 mi**
- 46. Right onto George Edward **0.1 mi**
- 47. Second Right onto Magna Carta **0.2 mi**
- 48. Right onto Constitution  **0.2 mi**
- 49. Straight across Liberty
- 50. Right onto Tranquility  **0.1 mi**
- 51. Right onto Independence  **0.5 mi**

Part H:

- 52. Left onto North Franklin  **2.3 mi**
- 53. Straight across Peppers Ferry/Rout 114 (intersection by Walgreen's) 
- 54. Right onto Ponderosa **312 ft**
- 55. Right onto Market St. **0.1 mi**
- 56. Right onto Arbor  **377 ft**
- 57. Left onto North Franklin **3.2 mi**

Part I:

- 58. Straight across Peppers Ferry/Route 114 
- 59. Repeat Parts B through H (**Second loop = 13.95 mi**) (**Arbor to Patton = 0.6 mi**)
- 60. Right onto Patton Dr. (Wal-Mart) **0.1 mi**
- 61. Right onto Marshall Dr. **0.2 mi**
- 62. Right onto Peppers Ferry/Route 114 **3.7 mi back to VTTI**
- 63. Straight across North Franklin 
- 64. 460 West Bypass to Exit 5A (Smart Road), and follow signs back to VTTI

## **Appendix G: Post-Drive Questionnaire – Post-Drive Questionnaire for Drivers Who Received a Violation Warning During the Pseudo-Naturalistic Study and, if Participated, the Smart Road Study**

### **Post Driving Questionnaire: Experienced Alert during Pseudo-Naturalistic Driving**

Thank you for taking the time to complete this questionnaire. Your feedback is important to us because it will help us understand how to improve the Intersection Warning System. We are interested in learning your honest opinions about the System and about your experiences driving the research vehicle. The questionnaire should only take about 10-15 minutes of your time. Please note that your answers will be completely confidential.

As you read through the questionnaire you will notice that it has several sections. Each section will ask your opinion about the Intersection Warning System and its three parts: the “Running Red Light” alert, the “Running Stop Sign” alert, and the “Intersection Ahead” display.

#### Questionnaire Sections

- A. Your Overall Impressions of the “Running Red Light” Alert
- B. Your Overall Impressions of the “Running Stop Sign” Alert
- C. Your Experiences Driving the Research Vehicle at Red Lights and Stop Signs
- D. “Running Red Light” Alerts at Traffic Lights
- E. “Running Stop Sign” Alerts at Stop Signs
- F. The “Intersection Ahead” Display
- G. The “Running Red Light/Stop Sign” Display
- H. The Speech Alert
- I. The Brake Pulse Alert
- J. Purchasing the System
- K. Open-ended Question (where we ask you for your suggestions on improving the system)

After reading each statement, please rate how strongly you agree or disagree with it by circling the corresponding number. If you would like to clarify an answer, feel free to write your comments alongside the question.

#### **Example:**

A.) Strawberry ice cream is better than chocolate.

B.)

1	2	3	4	5	6	7
Strongly Disagree						Strongly Agree

**You would circle the “1” if you really liked chocolate ice cream, or you might really like strawberry ice cream. In which case, you would circle the “7.”**

**Section A. Your Overall Impressions of the “Running Red Light” Alert**

This section applies to the Intersection Warning System for Traffic Lights only (not stop signs).

1. The “running red light” alert that let me know that I may be about to run a red light was useful.

1	2	3	4	5	6	7
Strongly Disagree						Strongly Agree

2. The “running red light” alert was effective at communicating that I may be about to run a red light.

1	2	3	4	5	6	7
Strongly Disagree						Strongly Agree

3. The “running red light” alert was effective at getting my attention quickly.

1	2	3	4	5	6	7
Strongly Disagree						Strongly Agree

4. What do you think about the timing of the “running red light”?

1	2	3	4	5	6	7
Too Early			Just Right			Too Late

5. When I received the “running red light” alert, I braked without checking for traffic behind me.

1	2	3	4	5	6	7
Strongly Disagree						Strongly Agree

6. The “running red light” alert was annoying when the alert was unnecessary.

1	2	3	4	5	6	7
Strongly Disagree						Strongly Agree





14. What do you think of the timing of the “running stop sign” alert?

1	2	3	4	5	6	7
Too Early			Just Right			Too Late

15. When I received the “running stop sign” alert, I braked without checking for traffic behind me.

1	2	3	4	5	6	7
Strongly Disagree						Strongly Agree

16. The “running stop sign” alert was annoying when the alert was unnecessary.

1	2	3	4	5	6	7
Strongly Disagree						Strongly Agree

17. I feel the “running stop sign” alert will increase my driving safety.

1	2	3	4	5	6	7
Strongly Disagree						Strongly Agree

18. If I was told that I was allowed to turn the “running stop sign” alert system off, I would have turned it off for the rest of my driving experience.

- Yes
- No

19. Did you ever intentionally activate the “running stop sign” alert?

- Yes
- No

20. Overall, how satisfied were you with the “running stop sign” alert?

1	2	3	4	5	6	7
Not at all Satisfied						Very Satisfied

**Section C. Your Experiences Driving the Research Vehicle at Red Lights and Stop Signs**

21. How many times, if ever, did you run a red light or come close to running a red light while driving the test vehicle?  
\_\_\_\_\_ times (please state a number)
22. How many times, if ever, did you run a stop sign or come close to running a stop sign while driving the test vehicle?  
\_\_\_\_\_ times (please state a number)

**Section D. “Running Red Light” Alerts at Traffic Lights**

23. How many times, if ever, did you get a “running red light” alert while approaching a traffic light that you felt was appropriate?  
\_\_\_\_\_ times (please state a number)
24. How many times, if ever, did you get a “running red light” alert that you felt was not necessary?  
\_\_\_\_\_ times (please state a number)
25. How many times, if ever, did you NOT get a “running red light” alert when you felt one was appropriate?  
\_\_\_\_\_ times (please state a number)
26. How many times, if ever, did you get a “running red light” alert where you could not identify the source of the alert?  
\_\_\_\_\_ times (please state a number)

**Section E. “Running Stop Sign” Alerts at Stop Signs**

- 27. How many times, if ever, did you get a “running stop sign” alert that you felt was appropriate?  
\_\_\_\_\_ times (please state a number)
- 28. How many times, if ever, did you get a “running stop sign” alert that you felt was not necessary?  
\_\_\_\_\_ times (please state a number)
- 29. How many times, if ever, did you NOT get a “running stop sign” alert when you felt one was appropriate?  
\_\_\_\_\_ times (please state a number)
- 30. How many times, if ever, did you get a “running stop sign” alert where you could not identify the source of the alert?  
\_\_\_\_\_ times (please state a number)

---

The next sections address the issue of the location, color, and conspicuity of the warning system itself. The items in these sections will ask your opinions about how easy it was for you to notice and interpret the displays.

**Section F. The “Intersection Ahead” Display**

- 31. The blue “intersection ahead” display was effective in letting me know that the intersection warning system had detected an intersection ahead.

1	2	3	4	5	6	7
Strongly Disagree						Strongly Agree

- 32. The blue “intersection ahead” display was easy to detect.

1	2	3	4	5	6	7
Strongly Disagree						Strongly Agree

- 33. I like the location of the blue “intersection ahead” display.

1	2	3	4	5	6	7
Strongly Disagree						Strongly Agree

34. The size of the blue “intersection ahead” display was appropriate.

1	2	3	4	5	6	7
Strongly Disagree						Strongly Agree

35. The blue “intersection ahead” display was annoying.

1	2	3	4	5	6	7
Strongly Disagree						Strongly Agree

36. The blue “intersection ahead” display was distracting.

1	2	3	4	5	6	7
Strongly Disagree						Strongly Agree

**Section G. The “Running Red Light/Stop Sign” Display**

37. The red flashing alert was effective in letting me know that I may be about to run a red light or stop sign.

1	2	3	4	5	6	7
Strongly Disagree						Strongly Agree

38. The red flashing alert was easy to detect.

1	2	3	4	5	6	7
Strongly Disagree						Strongly Agree

39. I like the location of the red flashing alert.

1	2	3	4	5	6	7
Strongly Disagree						Strongly Agree

40. The red flashing alert was effective at getting my attention quickly.

1	2	3	4	5	6	7
Strongly Disagree						Strongly Agree

41. The red flashing alert was startling.

1	2	3	4	5	6	7
Strongly Disagree						Strongly Agree

42. The red flashing alert was annoying.

1	2	3	4	5	6	7
Strongly Disagree						Strongly Agree

43. The red flashing alert was distracting.

1	2	3	4	5	6	7
Strongly Disagree						Strongly Agree

#### **Section H: The Speech Alert**

44. The speech (“stop sign,” “stop light”) alert was effective in letting me know that I may be about to run a red light or stop sign.

1	2	3	4	5	6	7
Strongly Disagree						Strongly Agree

45. The speech alert was easy to detect.

1	2	3	4	5	6	7
Strongly Disagree						Strongly Agree

46. The speech alert was effective at getting my attention quickly.

1	2	3	4	5	6	7
Strongly Disagree						Strongly Agree

47. The speech alert was startling.

1	2	3	4	5	6	7
Strongly Disagree						Strongly Agree

48. The speech alert was annoying.

1	2	3	4	5	6	7
Strongly Disagree						Strongly Agree

49. The speech alert was distracting.

1	2	3	4	5	6	7
Strongly Disagree						Strongly Agree

**Section I: The Brake Pulse Alert**

50. The brake pulse (vehicle jerk) alert was effective in letting me know that I may be about to run a red light or stop sign.

1	2	3	4	5	6	7
Strongly Disagree						Strongly Agree

51. The brake pulse alert was easy to detect.

1	2	3	4	5	6	7
Strongly Disagree						Strongly Agree

52. The brake pulse alert was effective at getting my attention quickly.

1	2	3	4	5	6	7
Strongly Disagree						Strongly Agree

53. The brake pulse alert was startling.

1	2	3	4	5	6	7
Strongly Disagree						Strongly Agree

54. The brake pulse alert was annoying.

1	2	3	4	5	6	7
Strongly Disagree						Strongly Agree





## Appendix H: Post-Drive Questionnaire for Drivers Who Did Not Experience a Violation Warning

### Post Driving Questionnaire: Did NOT Experience Alert during either driving portion

Thank you for taking the time to complete this questionnaire. Your feedback is important to us because it will help us understand how to improve the Intersection Warning System. We are interested in learning your honest opinions about the System and about your experiences driving the research vehicle. The questionnaire should only take about 5-10 minutes of your time. Please note that your answers will be completely confidential.

As you read through the questionnaire you will notice that it has several sections and will ask your opinion about the Intersection Warning System and its display: the Intersection Ahead display.

#### Questionnaire Sections

- A. Your Experiences Driving the Research Vehicle at Red Lights and Stop Signs
- B. The “Intersection Ahead” Display
- C. Purchasing the System
- D. Open-ended Question (where we ask you for your suggestions on improving the system)

After reading each statement, please rate how strongly you agree or disagree with it by circling the corresponding number. If you would like to clarify an answer, feel free to write your comments alongside the question.

#### **Example:**

A.) Strawberry ice cream is better than chocolate.

1	2	3	4	5	6	7
Strongly Disagree						Strongly Agree

**You would circle the “1” if you really liked chocolate ice cream, or you might really like strawberry ice cream. In which case, you would circle the “7.”**

**Section A: Your Experiences Driving the Research Vehicle at Red Lights and Stop Signs**

1. How many times, if ever, did you run a red light or come close to running a red light while driving with the test vehicle?  
\_\_\_\_\_ times (please state a number)
2. How many times, if ever, did you run a stop sign or come close to running a stop sign while driving with the test vehicle?  
\_\_\_\_\_ times (please state a number)

**Section B. The “Intersection Ahead” Display**

The next section addresses the issue of the location, color, and conspicuity of the warning system itself. The items in this section will ask your opinions about how easy it was for you to notice and interpret the displays.

3. The blue “intersection ahead” display was effective in letting me know that the intersection warning system had detected an intersection ahead?

1	2	3	4	5	6	7
Strongly Disagree						Strongly Agree

4. The blue “intersection ahead” display was easy to detect.

1	2	3	4	5	6	7
Strongly Disagree						Strongly Agree

5. I like the location of the blue “intersection ahead” display.

1	2	3	4	5	6	7
Strongly Disagree						Strongly Agree

6. The size of the blue “intersection ahead” display was appropriate.

1	2	3	4	5	6	7
Strongly Disagree						Strongly Agree

7. The blue “intersection ahead” display was annoying.

1	2	3	4	5	6	7
Strongly Disagree						Strongly Agree

8. The blue “intersection ahead” display was distracting.

1	2	3	4	5	6	7
Strongly Disagree						Strongly Agree

**Section C: Purchasing the System**

9. Cost aside, if you were purchasing a new vehicle, how likely would you be to consider purchasing the intersection warning system?

1	2	3	4	5	6	7
Not at All Likely						Very Likely

10. At what price level might you begin to feel this feature is too expensive to consider purchasing?

\_\_\_\_\_dollars

**Section D: Open-ended question**

11. Do you have any suggestions for improving the intersection warning system?

---

---

---

---

---

---

Thank you for your feedback. Your responses in this questionnaire will help us determine how to improve the Intersection Warning System.

# **Appendix I: Informed Consent – Smart Road**

## **VIRGINIA POLYTECHNIC INSTITUTE AND STATE UNIVERSITY**

### **Informed Consent for Participants in Research Projects Involving Human Subjects**

Title of Project: CICAS: Pilot Field Operational Test

Investigator(s): Vicki Neale, Zac Doerzaph, Derek Viita, Kendra Wiegand, and Jodi Bowman

#### **I. Purpose of this Research Project**

The purpose of this research project is to evaluate in-vehicle devices and identify your comfort level with these devices. Approximately twenty-four (24) adults will be recruited to participate for this study. There will be an equal number of males and females.

#### **II. Procedures**

You have just completed the pseudo-naturalistic driving portion of this study. This next portion involves driving the same instrumented vehicle on the Smart Road.

For this session, you will be asked to read and sign this informed consent form (if you agree to participate). You will then be asked to drive the vehicle on the Smart Road with a trained experimenter and complete some questionnaires about your experience. Shortly after that time, you will receive final payment for participation.

Your role during this study will be to drive a vehicle on the Smart Road. It is important that you understand that we are not evaluating you in any way. We are collecting information about the in-vehicle devices.

#### **III. Risks**

Caution should be exercised when operating a vehicle with which you are not familiar. Be aware that accidents can happen at any time while driving.

As a participant, you may be exposed to the following risks or discomforts by volunteering for this research:

1. The risk of an accident normally present while driving.
2. Any risk present when driving a new and unfamiliar vehicle.
3. While you are driving the vehicle, cameras will videotape you. Due to this fact, we will ask you not to wear sunglasses unless absolutely necessary; however, if at

any time you are suffering from glare problems (e.g., from the sun shining directly into your face) and cannot see the roadway and surrounding environment, sunglasses are recommended.

The following precautions will be taken to ensure minimal risk to you:

1. You may take breaks or decide not to participate at any time.
2. The vehicle is equipped with a driver's side and passenger's side airbag, supplemental restraint system, fire extinguisher, and first-aid kit.
3. All data collection equipment is mounted such that, to the greatest extent possible, it does not pose a hazard to you in any foreseeable case.
4. The experiment will not be run during hazardous road conditions, including wet or icy conditions.
5. You will be required to wear the lap and shoulder belt restraint system while in the car.
6. In the event of a medical emergency, or at your request, VTTI staff will arrange medical transportation to a nearby hospital emergency room. Note that in addition to the in-vehicle experimenter being present, the road and its communications channels are monitored by dispatchers at all times, who can quickly notify the necessary emergency services if required.

In the event of a medical emergency, or at your request, VTTI staff will arrange medical transportation to a nearby hospital emergency room. The cost of this transportation would be covered by whichever insurance policy covers the incident causing the medical emergency (see examples in the next section).

In the event of an accident or injury in an automobile owned or leased by Virginia Tech, the automobile liability coverage for property damage and personal injury is provided. The total policy amount per occurrence is \$2,000,000. This coverage (unless the other party was at fault, which would mean all expense would go to the insurer of the other party's vehicle) would apply in case of an accident for all volunteers and would cover medical expenses up to the policy limit. For example, if you were injured in an automobile owned or leased by Virginia Tech, the cost of transportation to the hospital emergency room would be covered by this policy. Any coverage of the participant is limited to the terms and conditions of the insurance policy.

Participants in a study are considered volunteers, regardless of whether they receive payment for their participation; under Commonwealth of Virginia law, worker's compensation does not apply to volunteers; therefore, if not in the automobile, the participants are responsible for their own medical insurance for bodily injury. Appropriate health insurance is strongly recommended to cover these types of expenses. For example, if you were injured outside of the automobile owned or leased by Virginia Tech, the cost of transportation to the hospital emergency room would be covered by your insurance.

#### **IV. Benefits**

While there are no direct benefits to you from this research, you may find the experiment interesting. No promise or guarantee of benefits is made to encourage you to participate. Participation in this study will contribute to the improvement of future studies concerning advanced vehicle systems.

#### **V. Extent of Anonymity and Confidentiality**

The data gathered in this experiment will be treated with confidentiality. Shortly after participation, your name will be separated from your data. A coding scheme will be employed to identify the data by participant number only (e.g., Participant No. 1). If you choose to do so, you will be allowed to see your data and withdraw the data from the study if you so desire. If you want to base withdrawal of your data on observation of the data, you must ask for an appointment to see the data immediately after you finish your participation. If upon seeing your data you decide to withdraw it from the experiment, the data will be promptly removed and discarded. At no time will the researchers release data identifiable to an individual to anyone other than individuals working on the project without your written consent. VTTI will not turn over the video of your image to its client without your permission. It is possible that the Institutional Review Board (IRB) may view this study's collected data for auditing purposes. The IRB is responsible for the oversight of the protection of human subjects involved in research.

#### **VI. Compensation**

You will be paid \$25.00 per hour for participating in this session, including the time you spend completing paperwork and filling out questionnaires. You will be paid at the end of today's session. Your payment will be in cash, unless you receive more than \$75.00, in which case it will be by check.

#### **VII. Freedom to Withdraw**

As a participant in this research, you are free to withdraw at any time without penalty. If you choose to withdraw, you will be compensated for the portion of time of the study for which you participated. Furthermore, you are free not to answer any question or respond to experimental situations without penalty.

#### **VIII. Subject's Responsibilities**

If you voluntarily agree to participate in this study, you will have the following responsibilities:

1. To follow the experimental procedures as well as you can.

2. To inform the experimenter if you have difficulties of any type.
3. To wear your seat and lap belt.
4. To abide by the posted speed limits and traffic laws.
5. To abstain from any substances that will impair your ability to drive.
6. To drive the test vehicle in a safe and responsible manner.

**X. Participant’s Permissions and acknowledgments**

Check one of the following:

VTTI **has my permission** to provide digital video including my image to the sponsor of this research. I understand that the sponsor will only see the video for research purposes.

VTTI **does not have my permission** to provide digital video including my image to the sponsor of this research. I understand that VTTI will maintain possession of the digital video, and that it will only be used for research purposes.

**X. Subject's Permission**

I have read the Consent Form and conditions of this project. I have had all my questions answered. I hereby acknowledge the above and give my voluntary consent:

\_\_\_\_\_ Date \_\_\_\_\_  
 Subject signature

\_\_\_\_\_ Date \_\_\_\_\_  
 Witness

Should I have any pertinent questions about this research or its conduct, and research subjects' rights, and whom to contact in the event of a research-related injury to the subject, I may contact:

Investigators	
Derek Viita	xxx-xxxx
Zac Doerzaph	xxx-xxxx

David M. Moore  
 Chair, Virginia Tech Institutional Review  
 Board for the Protection of Human Subjects  
 Office of Research Compliance  
 2000 Kraft Drive, Suite 2000 (0497)

Blacksburg, VA 24060

**[NOTE: Subjects must be given a complete copy (or duplicate original) of the signed Informed Consent.]**



## Appendix J: Smart Road Debriefing Form

### VIRGINIA POLYTECHNIC INSTITUTE AND STATE UNIVERSITY

#### Informed Consent for Participants of Investigative Projects Debriefing and Informed Consent for Participants of Investigative Projects

Title of Project: Pilot Field Operational Test

Investigator(s): Vicki Neale, Zac Doerzaph, Derek Viita, Kendra Wiegand, and Jodi Bowman

#### **I. The Purpose of this Research Project**

The true purpose of this research is to evaluate a system which would warn drivers if they are about to run a red light or stop sign. One aspect of the research project deals with how people might respond to such a warning. To do this, we needed to create a situation in which you were presented with the warning while looking away from the forward roadway. If you had been looking directly at the road, you might have seen the light turn red and the data would not have been as useful. There was no “correct” or “incorrect” information in the data that you provided. We are simply evaluating how drivers respond to this situation. All known precautions were taken to ensure your complete safety throughout this session and during the presentation of the scenario. We would like to thank you for your participation in this study, as the results may contribute to future improvements of collision avoidance systems. We would also like to ask that you do not talk about the details of this study to others for at least 8 months after your participation as this may invalidate future data that may be collected.

We again assure you that all data will be treated with complete anonymity. Shortly after participating, your name will be separated from the data. A coding scheme will be employed to identify the data by subject number only (for example, Subject No. 3).

All other aspects of the earlier informed consents you signed, including risks, benefits, safety precautions, and your responsibilities, continue to apply to the remainder of this experiment.

Please check if you give your voluntary consent for your data to be used in this project.

I hereby acknowledge the above.

---

Participant's Signature Date

Should I have any questions about this research or its conduct, I may contact:

Investigators

Derek Viita

xxx-xxxx

Zac Doerzaph

xxx-xxxx

David M. Moore

xxx-xxxx

Chair, Virginia Tech Institutional Review

Board for the Protection of Human Subjects

Office of Research Compliance

2000 Kraft Drive, Suite 2000 (0497)

Blacksburg, VA 24060

## **Appendix K: Post-Drive Questionnaire – Drivers Experienced a Violation Warning During the Smart Road Study Only**

### **Post Driving Questionnaire: Experienced Alert ONLY during Smart Road Portion**

Thank you for taking the time to complete this questionnaire. Your feedback is important to us because it will help us understand how to improve the Intersection Warning System. We are interested in learning your honest opinions about the System and about your experiences driving the research vehicle. The questionnaire should only take about 10-15 minutes of your time. Please note that your answers will be completely confidential.

As you read through the questionnaire you will notice that it has several sections. Each section will ask your opinion about the Intersection Warning System and its two parts: the “Running Red Light” alert and the “Intersection Ahead” display.

### **Questionnaire Sections**

- A. Your Overall Impressions of the “Running Red Light” Alert
- B. Your Experiences Driving the Research Vehicle at Red Lights and Stop Signs
- C. The “Intersection Ahead” Display
- D. The “Running Red Light/Stop Sign” Display
- E. The Speech Alert
- F. The Brake Pulse Alert
- G. Purchasing the System
- H. Open-ended Question (where we ask you for your suggestions on improving the system)

After reading each statement, please rate how strongly you agree or disagree with it by circling the corresponding number. If you would like to clarify an answer, feel free to write your comments alongside the question.

### **Example:**

A.) Strawberry ice cream is better than chocolate.

1	2	3	4	5	6	7
Strongly Disagree						Strongly Agree

**You would circle the “1” if you really liked chocolate ice cream, or you might really like strawberry ice cream. In which case, you would circle the “7.”**

**Section A: Your Overall Impressions of the “Running Red Light” Alert**

1. The “running red light” alert that let me know that I may be about to run a red light would be useful in my everyday driving.

1	2	3	4	5	6	7
Strongly Disagree						Strongly Agree

2. The “running red light” alert was effective at communicating that I may be about to run a red light.

1	2	3	4	5	6	7
Strongly Disagree						Strongly Agree

3. The “running red light” alert was effective at getting my attention quickly.

1	2	3	4	5	6	7
Strongly Disagree						Strongly Agree

4. What did you think about the timing of the “running red light” alert?

1	2	3	4	5	6	7
Too Early			Just Right			Too Late

5. I feel the “running red light” alert will increase my driving safety.

1	2	3	4	5	6	7
Strongly Disagree						Strongly Agree

6. Overall, how satisfied were you with the “running red light” alert?

1	2	3	4	5	6	7
Not at all Satisfied						Very Satisfied

**Section B: Your Experiences Driving the Research Vehicle at Red Lights and Stop Signs**

7. How many times, if ever, did you run a red light or come close to running a red light while driving with the test vehicle?  
\_\_\_\_\_ times (please state a number)
8. How many times, if ever, did you run a stop sign or come close to running a stop sign while driving with the test vehicle?  
\_\_\_\_\_ times (please state a number)

---

The next sections address the issue of the location, color, and conspicuity of the warning system itself. The items in these sections will ask your opinions about how easy it was for you to notice and interpret the displays.

**Section C: The “Intersection Ahead” Display**

9. The blue “intersection ahead” display was effective in letting me know that the intersection warning system had detected an intersection ahead.

1	2	3	4	5	6	7
Strongly Disagree						Strongly Agree

10. The blue “intersection ahead” display was easy to detect.

1	2	3	4	5	6	7
Strongly Disagree						Strongly Agree

11. I like the location of the blue “intersection ahead” display.

1	2	3	4	5	6	7
Strongly Disagree						Strongly Agree

12. The size of the blue “intersection ahead” display was appropriate.

1	2	3	4	5	6	7
Strongly Disagree						Strongly Agree

13. The blue “intersection ahead” display was annoying.

1	2	3	4	5	6	7
Strongly Disagree						Strongly Agree

14. The blue “intersection ahead” display was distracting.

1	2	3	4	5	6	7
Strongly Disagree						Strongly Agree

**Section D: The “Running Red Light/Stop Sign” Display**

15. The red flashing alert was effective in letting me know that I may be about to run a red light or stop sign?

1	2	3	4	5	6	7
Strongly Disagree						Strongly Agree

16. The red flashing alert was easy to detect.

1	2	3	4	5	6	7
Strongly Disagree						Strongly Agree

17. I like the location of the red flashing alert.

1	2	3	4	5	6	7
Strongly Disagree						Strongly Agree

18. The red flashing alert was effective at getting my attention quickly.

1	2	3	4	5	6	7
Strongly Disagree						Strongly Agree

19. The red flashing alert was startling.

1	2	3	4	5	6	7
Strongly Disagree						Strongly Agree

20. The red flashing alert was annoying.

1	2	3	4	5	6	7
Strongly Disagree						Strongly Agree

21. The red flashing alert was distracting.

1	2	3	4	5	6	7
Strongly Disagree						Strongly Agree

**Section E: The Speech Alert**

22. The speech (“stop light”) alert was effective in letting me know that I may be about to run a red light.

1	2	3	4	5	6	7
Strongly Disagree						Strongly Agree

23. The speech alert was easy to detect.

1	2	3	4	5	6	7
Strongly Disagree						Strongly Agree

24. The speech alert was effective at getting my attention quickly.

1	2	3	4	5	6	7
Strongly Disagree						Strongly Agree

25. The speech alert was startling.

1	2	3	4	5	6	7
Strongly Disagree						Strongly Agree

26. The speech alert was annoying.

1	2	3	4	5	6	7
Strongly Disagree						Strongly Agree

27. The speech alert was distracting.

1	2	3	4	5	6	7
Strongly Disagree						Strongly Agree

**Section F: The Brake Pulse Alert**

28. The brake pulse (vehicle jerk) alert was effective in letting me know that I may be about to run a red light.

1	2	3	4	5	6	7
Strongly Disagree						Strongly Agree

29. The brake pulse alert was easy to detect.

1	2	3	4	5	6	7
Strongly Disagree						Strongly Agree

30. The brake pulse alert was effective at getting my attention quickly.

1	2	3	4	5	6	7
Strongly Disagree						Strongly Agree

31. The brake pulse alert was startling.

1	2	3	4	5	6	7
Strongly Disagree						Strongly Agree

32. The brake pulse alert was annoying.

1	2	3	4	5	6	7
Strongly Disagree						Strongly Agree

33. The brake pulse alert was distracting.

1	2	3	4	5	6	7
Strongly Disagree						Strongly Agree



**Section G: Purchasing the System**

34. Cost aside, if you were purchasing a new vehicle, how likely would you be to consider purchasing the intersection warning system?

1	2	3	4	5	6	7
Not at All						Very
Likely						Likely

35. At what price level might you begin to feel this feature is too expensive to consider purchasing?

\_\_\_\_\_dollars

**Section H: Open-ended question**

36. Do you have any suggestions for improving the intersection warning system?

---

---

---

---

---

---

Thank you for your feedback. Your responses in this questionnaire will help us determine how to improve the Intersection Warning System.

## Appendix L: Subtask 3.4 Algorithms

The figure below shows the three algorithms that were tested during Subtask 3.4. The algorithm 641-11 (shown in red) is the signalized algorithm. The original stop-controlled algorithm (“Algorithm 1”) is 232-8 (shown in green) and the new stop-controlled algorithm (“Algorithm 2”) is 741-9 (shown in blue). The numeric naming convention is listed to provide consistency with the Subtask 3.2 report (Doerzaph et al., in print). The line represents when the warning is triggered relative to the velocity of the vehicle and the distance to the stop bar. For example, a vehicle traveling at 15m/s (34 mph) would receive a warning at roughly 60 m (197 ft) from the stop bar using Algorithm 1, 30 m (98 ft) with Algorithm 2, or roughly 40 m (131 ft) with the signalized algorithm. As illustrated in the graph, Algorithm 2 provides the warning when the vehicle is closer to the stop bar than the original stop-controlled algorithm. In comparison with the signalized algorithm, Algorithm 2 triggers the warning closer to the stop bar when the vehicle is traveling at lower speeds and further away from the stop bar at higher speeds.

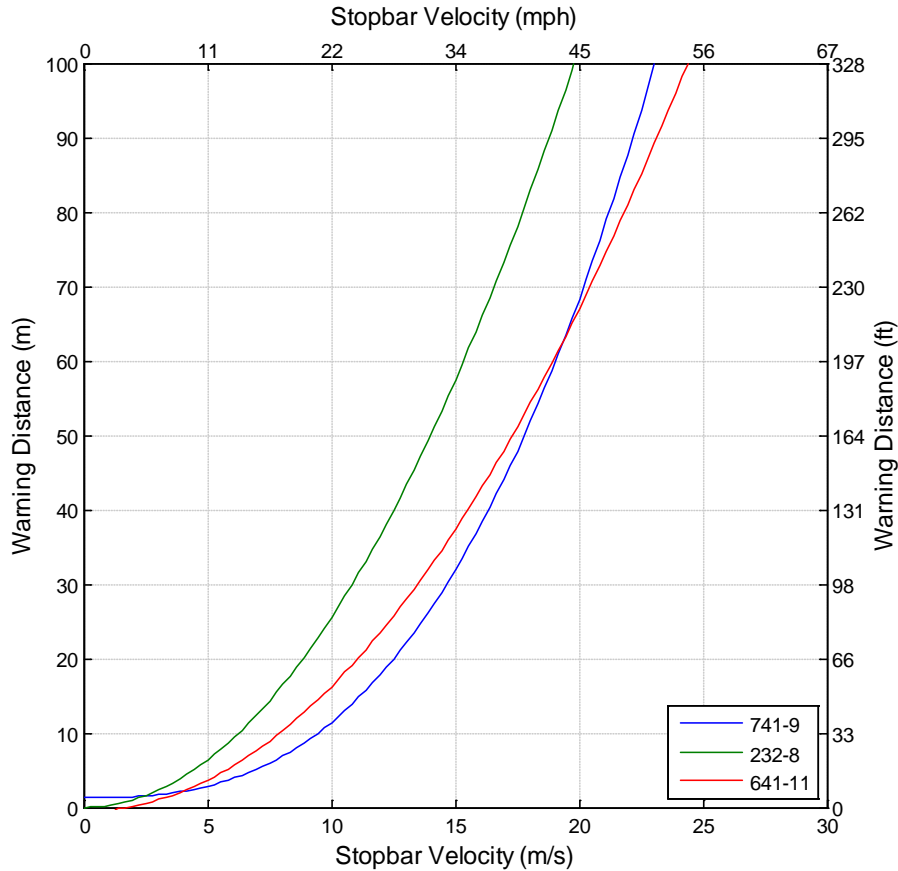


Figure 44 Graphical representation of the Subtask 3.4 algorithms.

## Appendix M: Alerts for Each Driver in the 3.4 Studies

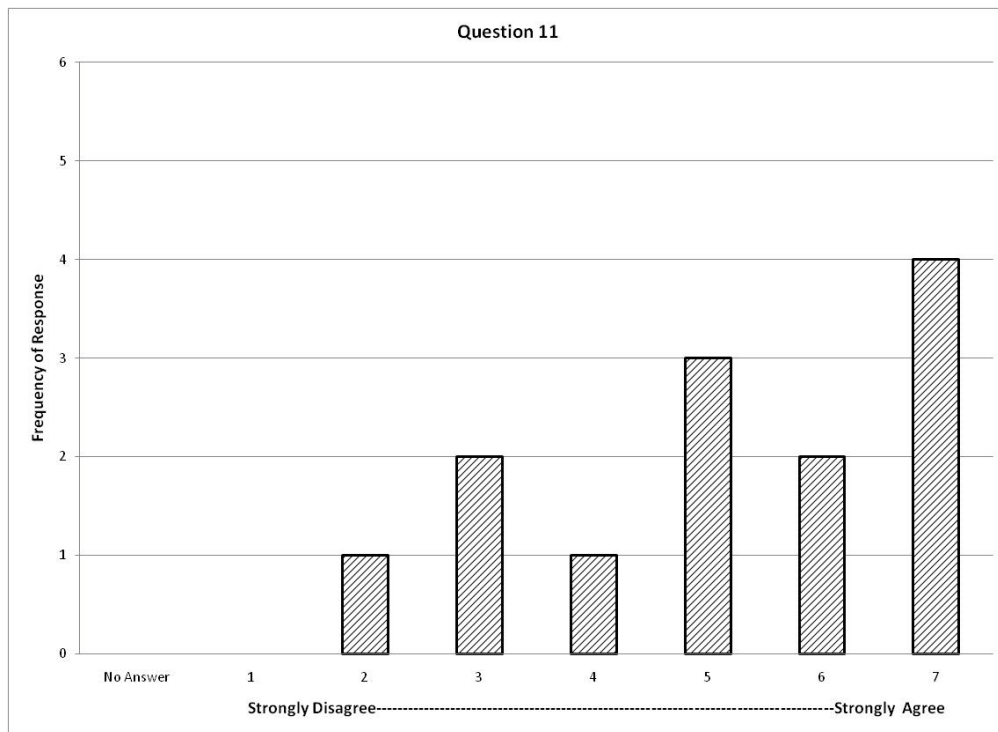
Table 20 The number of valid and invalid alerts by algorithm and driver in the 3.4 studies (Note: A hyphen in a cell means the driver did not experience that option).

Driver_ID	Stop Algorithm 1		Stop Algorithm 2		Signal Algorithm		Smart Road Participant
	Valid	Invalid	Valid	Invalid	Valid	Invalid	
101	13	0	-	-	0	0	NO
102	9	0	-	-	0	0	NO
105	-	-	0	0	0	0	NO
106	-	-	0	0	0	0	YES
107	-	-	0	0	0	0	NO
108	-	-	0	0	0	0	YES
109	-	-	0	0	0	0	NO
110	-	-	0	0	0	1	NO
111	-	-	0	0	0	0	NO
112	-	-	0	0	0	0	NO
113	-	-	0	0	0	0	NO
114	-	-	0	0	0	1	YES
115	-	-	0	0	0	0	YES
116	-	-	1	0	0	0	NO
117	-	-	0	0	0	0	NO
118	-	-	0	0	0	0	NO
119	-	-	0	0	0	0	NO
203	1	0	-	-	0	1	NO
204	-	-	0	0	0	0	NO
205	-	-	0	0	0	0	YES
208	-	-	0	0	0	0	YES
209	-	-	0	0	0	0	NO
210	-	-	0	0	0	0	YES
211	-	-	0	0	0	0	NO
212	-	-	0	0	0	0	YES
213	-	-	0	0	0	0	NO
214	-	-	0	0	0	0	NO
215	-	-	0	0	0	0	NO
216	-	-	0	0	0	1	NO
217	-	-	0	0	0	0	NO
218	-	-	0	0	0	0	NO
219	-	-	0	0	0	0	NO
301	1	0	-	-	0	0	NO
302	-	-	0	0	0	0	NO

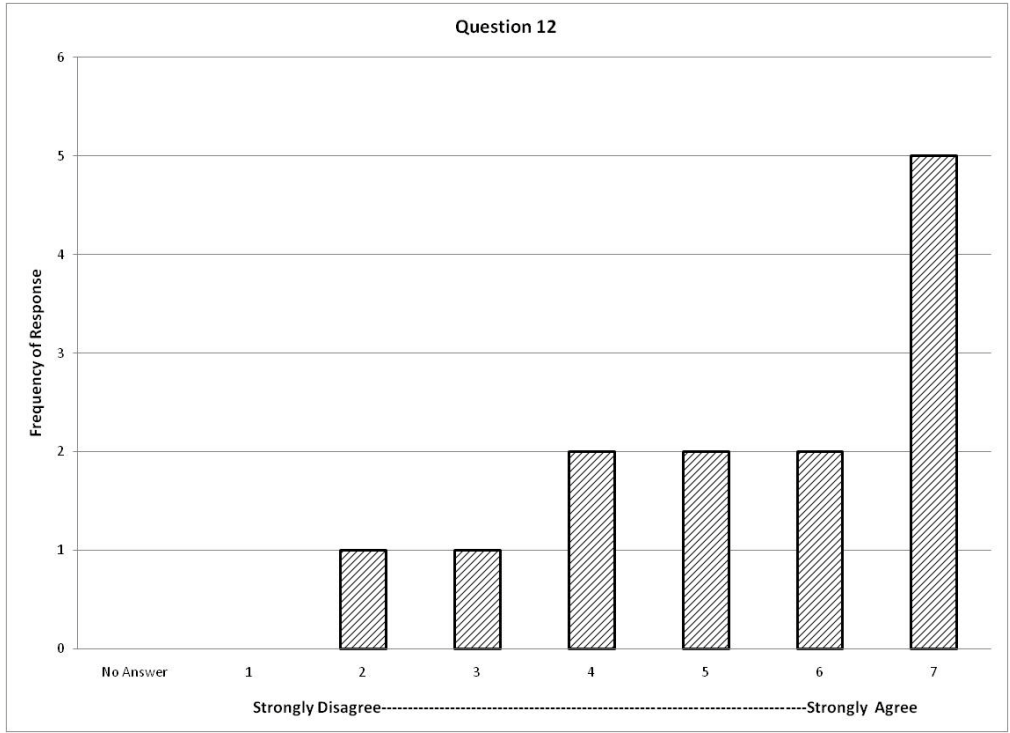
303	-	-	0	0	1	1	NO
304	-	-	0	0	0	0	YES
305	-	-	1	0	0	0	YES
306	-	-	0	0	0	0	NO
307	-	-	0	0	0	0	NO
309	-	-	0	0	0	0	NO
311	-	-	0	0	0	0	YES
312	-	-	0	0	0	0	NO
402	4	0	-	-	0	0	NO
403	2	0	-	-	0	0	NO
404	3	0	-	-	0	0	NO
405	1	0	-	-	0	0	NO
406	-	-	0	0	0	0	NO
407	-	-	0	0	0	0	NO
408	-	-	0	0	0	0	YES
409	-	-	0	0	0	0	YES
410	-	-	0	0	0	0	YES
411	-	-	0	0	0	0	YES
412	-	-	0	0	0	0	NO
413	-	-	0	0	0	0	NO
414	-	-	0	0	0	0	NO
415	-	-	0	0	0	0	NO
501	0	0	-	-	0	0	NO
502	2	0	-	-	0	0	NO
503	1	0	-	-	0	0	NO
504	2	0	-	-	0	0	NO
505	-	-	0	0	0	0	NO
506	-	-	0	0	0	0	NO
507	-	-	0	0	0	0	NO
509	-	-	0	0	0	0	NO
510	-	-	1	0	0	0	NO
511	-	-	0	0	0	0	YES
512	-	-	0	0	0	0	NO
513	-	-	0	0	0	0	YES
514	-	-	0	0	0	0	YES
515	-	-	0	0	0	0	YES
516	-	-	0	0	0	0	NO
601	3	0	-	-	0	0	NO
602	2	0	-	-	0	0	NO
603	6	0	-	-	0	0	NO
605	-	-	0	0	0	0	NO

606	-	-	0	0	0	0	NO
607	-	-	0	0	0	0	YES
608	-	-	0	0	0	0	NO
609	-	-	0	0	0	0	NO
610	-	-	0	0	0	0	NO
611	-	-	0	0	0	0	NO
612	-	-	0	0	0	0	YES
613	-	-	0	0	0	1	NO
614	-	-	0	0	0	0	NO
615	-	-	0	0	0	0	YES
616	-	-	0	0	0	0	YES
617	-	-	0	0	0	0	NO

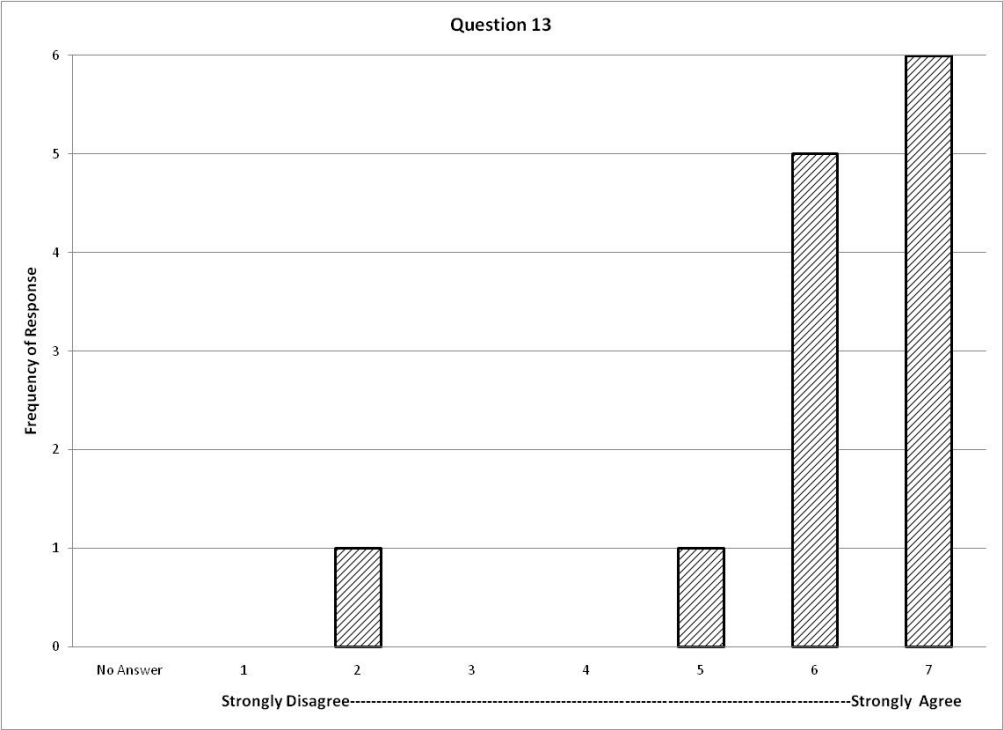
**Appendix N: Post-Drive Questionnaire Results for Drivers Who Experienced a Violation Warning While Driving with Stop-Controlled Algorithm 1**



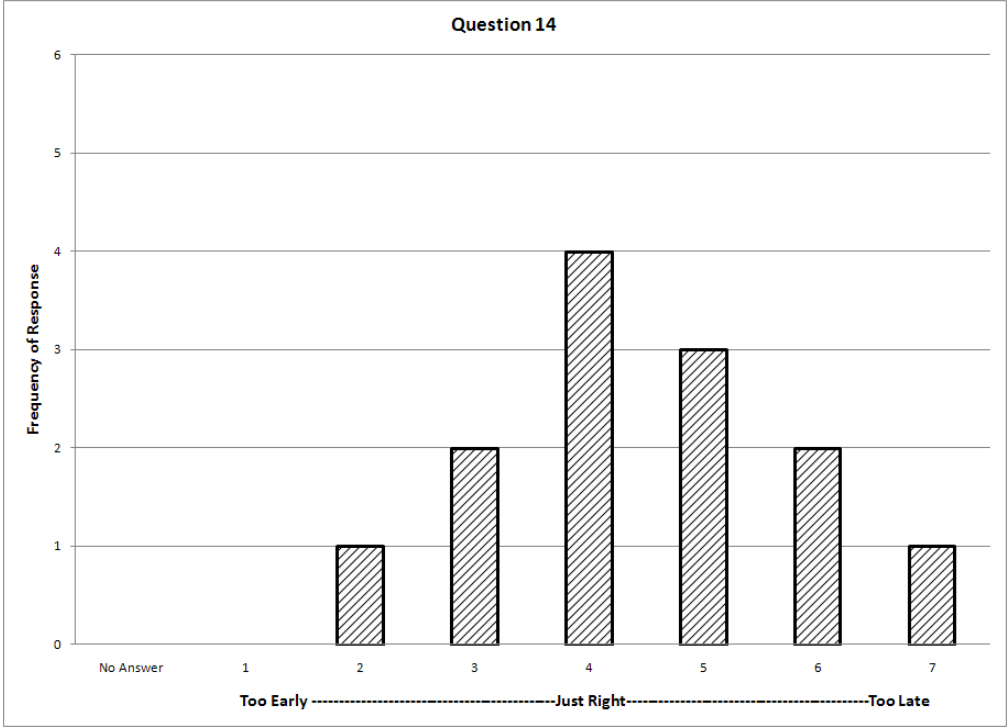
**Figure 45** The “running stop sign” alert that me know that I may be about to run a stop sign was useful.



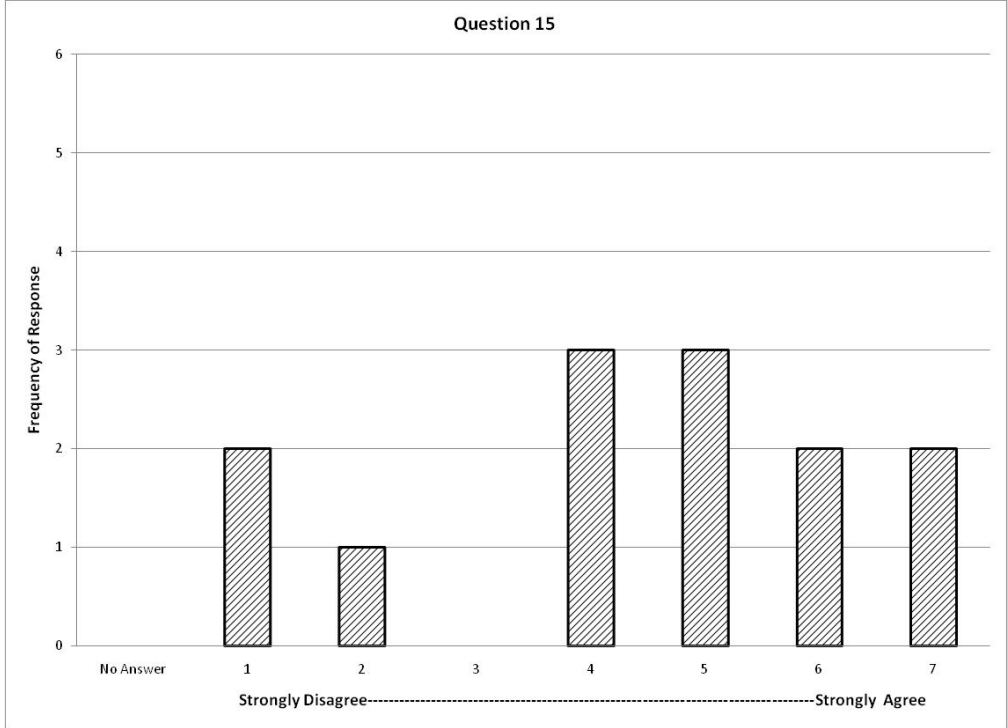
**Figure 46** The “running stop sign” alert was effect at communicating that I may be about to run a stop sign.



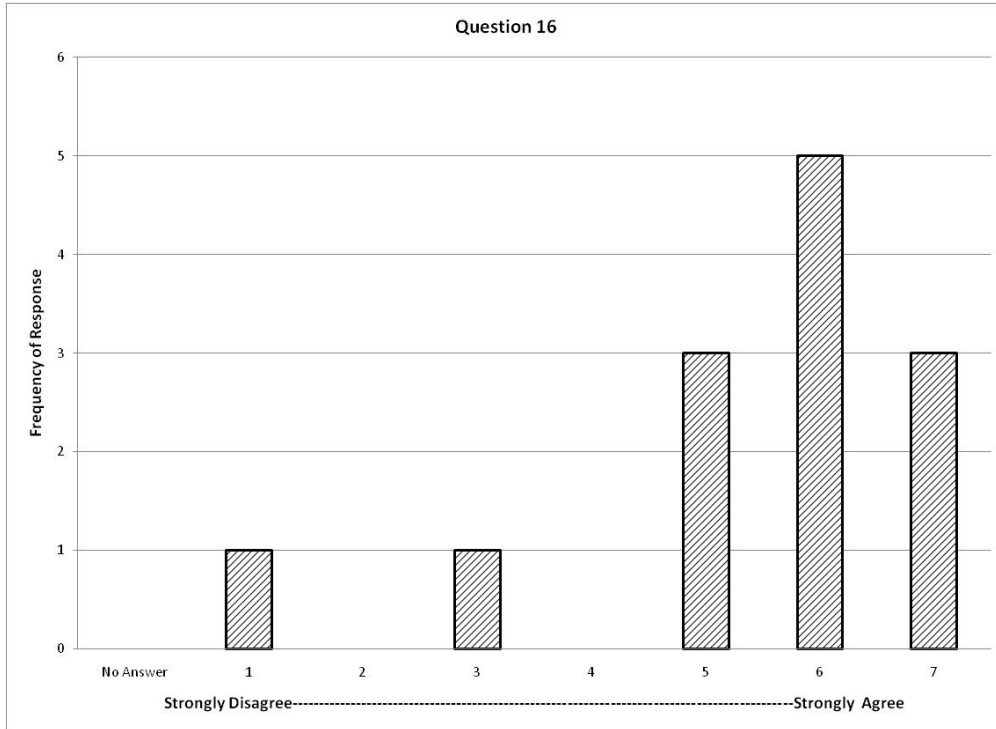
**Figure 47** The “running stop sign” alert was effective at getting my attention quickly.



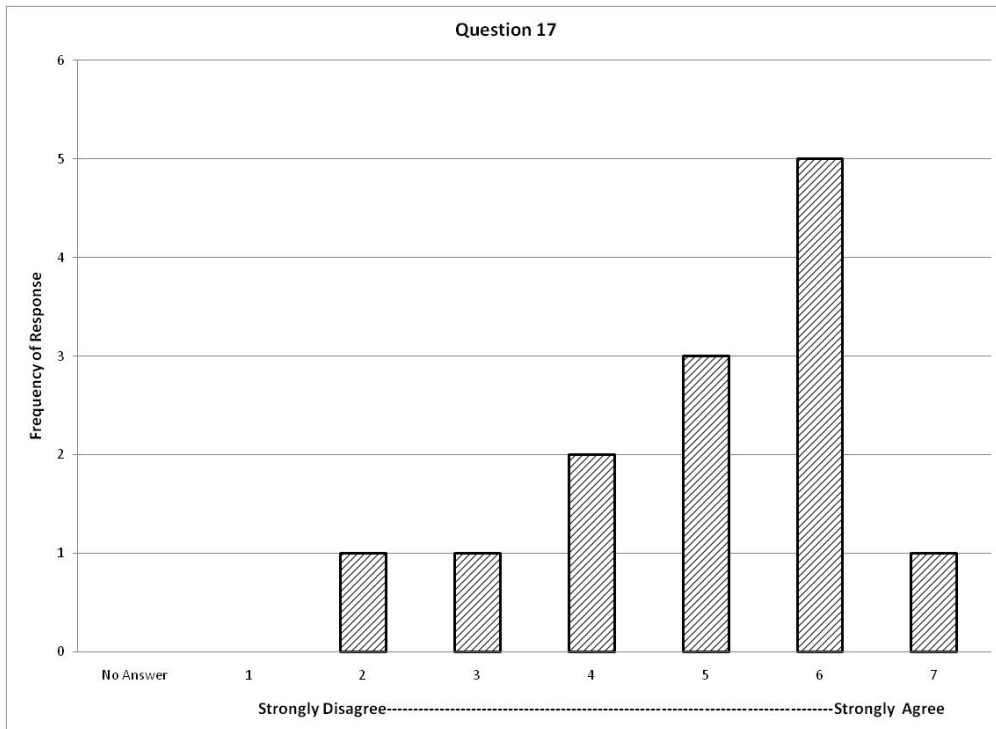
**Figure 48** What do you think of the timing of the “running stop sign” alert?



**Figure 49** When I received the “running stop sign” alert, I braked without checking for traffic behind me.



**Figure 50** The “running stop sign” alert was annoying when the alert was unnecessary.



**Figure 51** I feel the “running stop sign” alert will increase my driving safety.



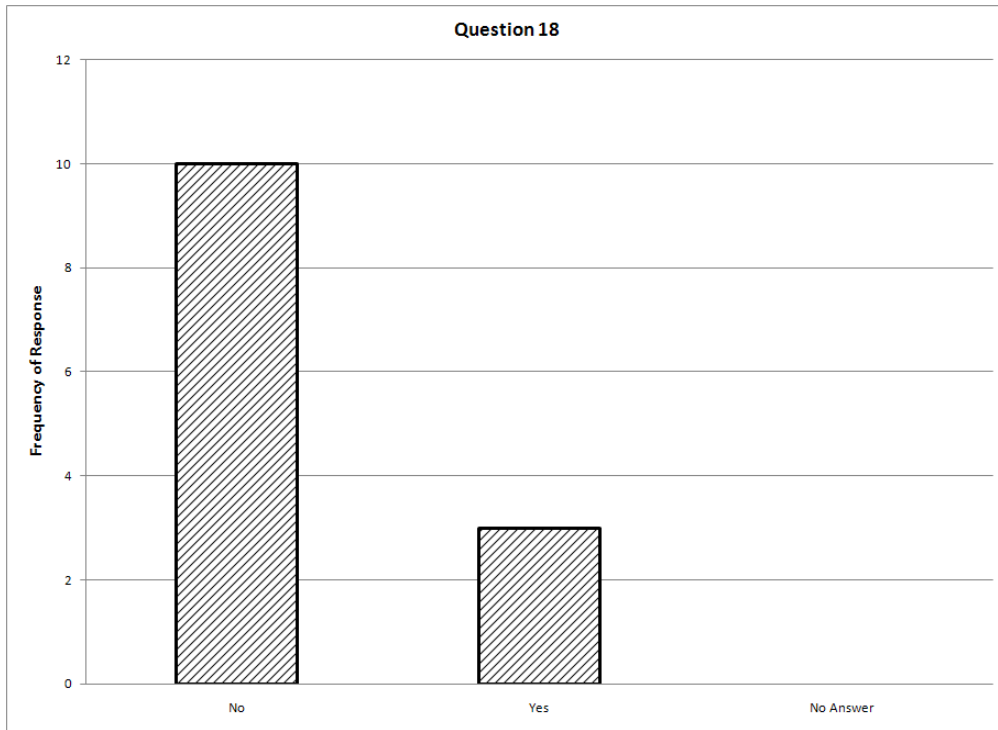


Figure 52 If I was told that I was allowed to turn the “running stop sign” alert system off, I would turned it off the rest of my driving experience.

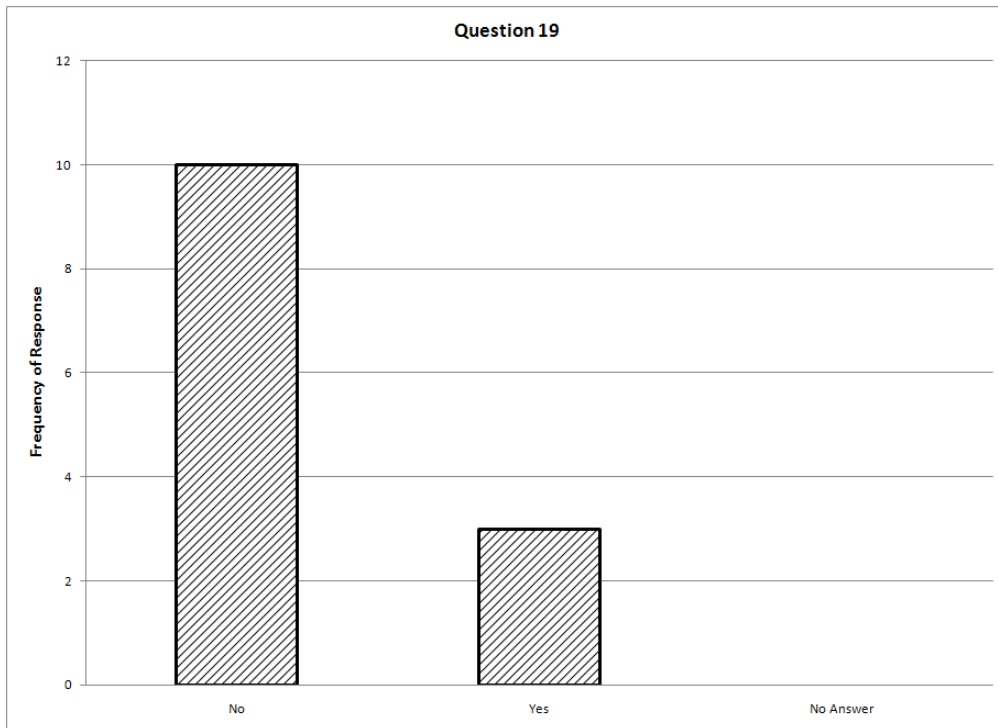
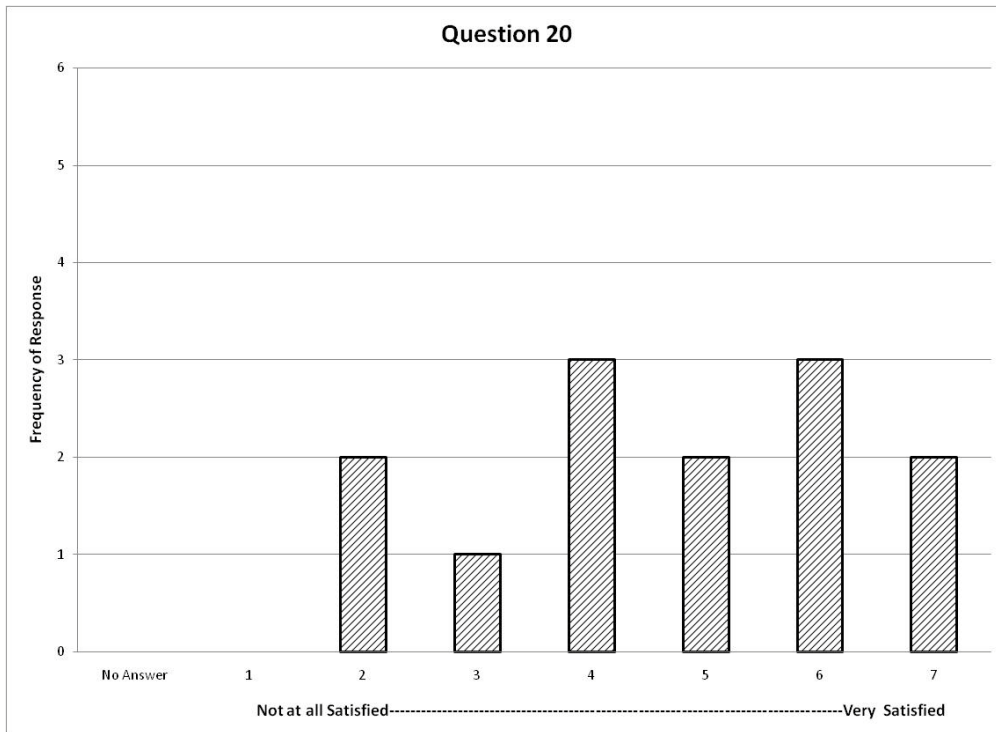
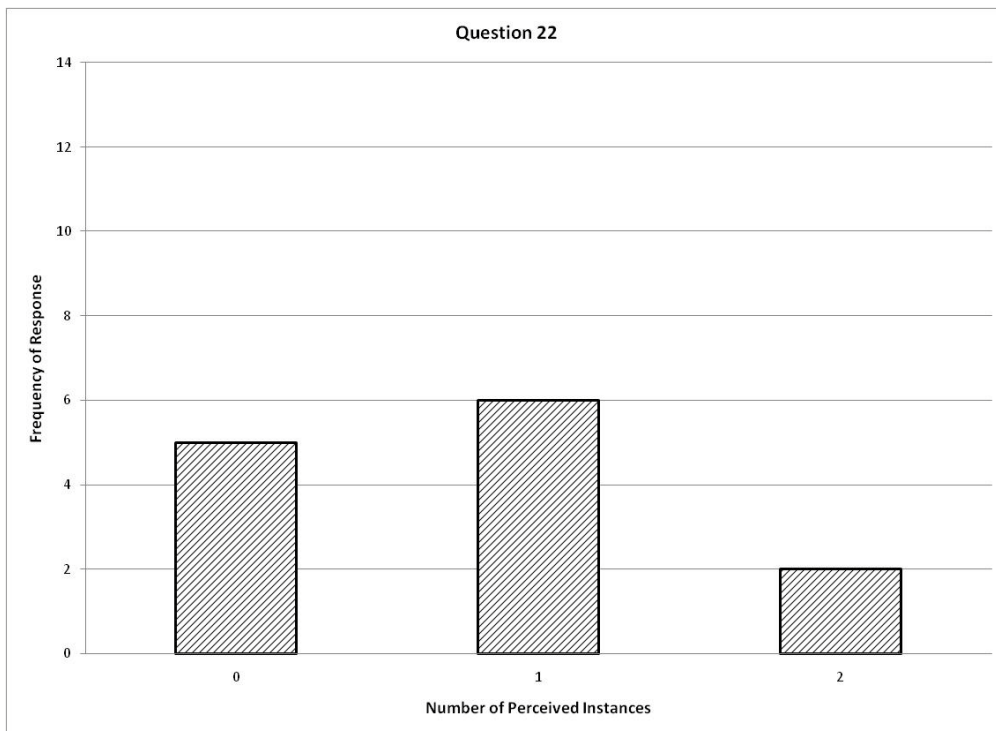


Figure 53 Did you ever intentionally activate the “running stop sign” alert?



**Figure 54 Overall, how satisfied were you with the “running stop sign” alert?**



**Figure 55 How many times did you run a stop sign or come to close to running at stop sign while driving the test vehicle?**

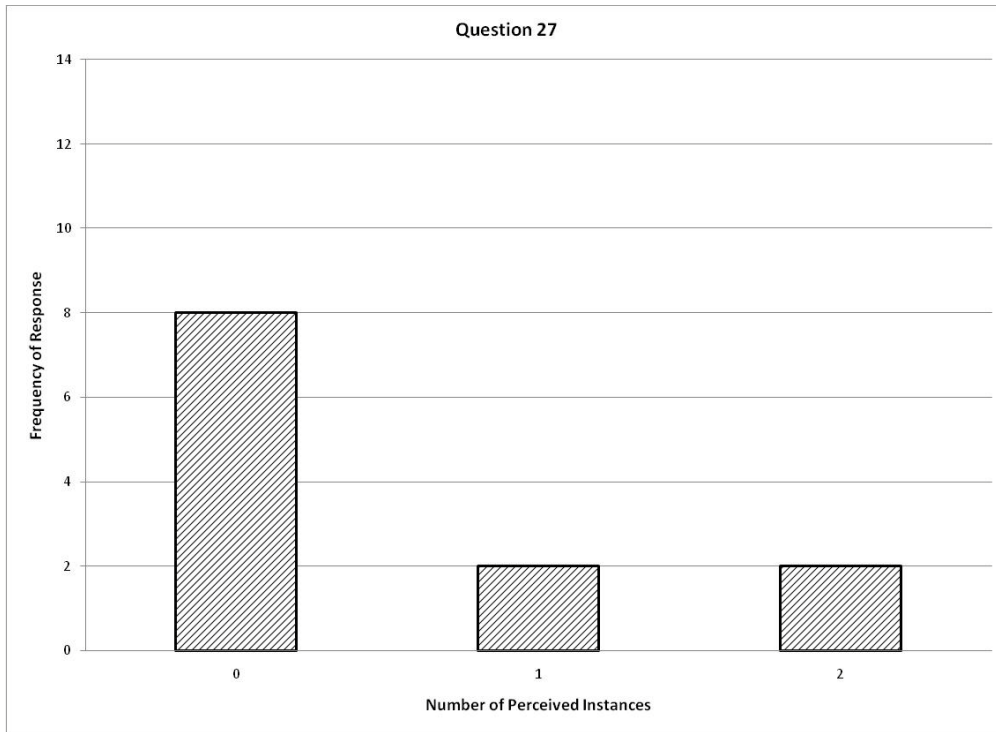


Figure 56 How many times did you get a “running stop sign” alert you felt was appropriate?

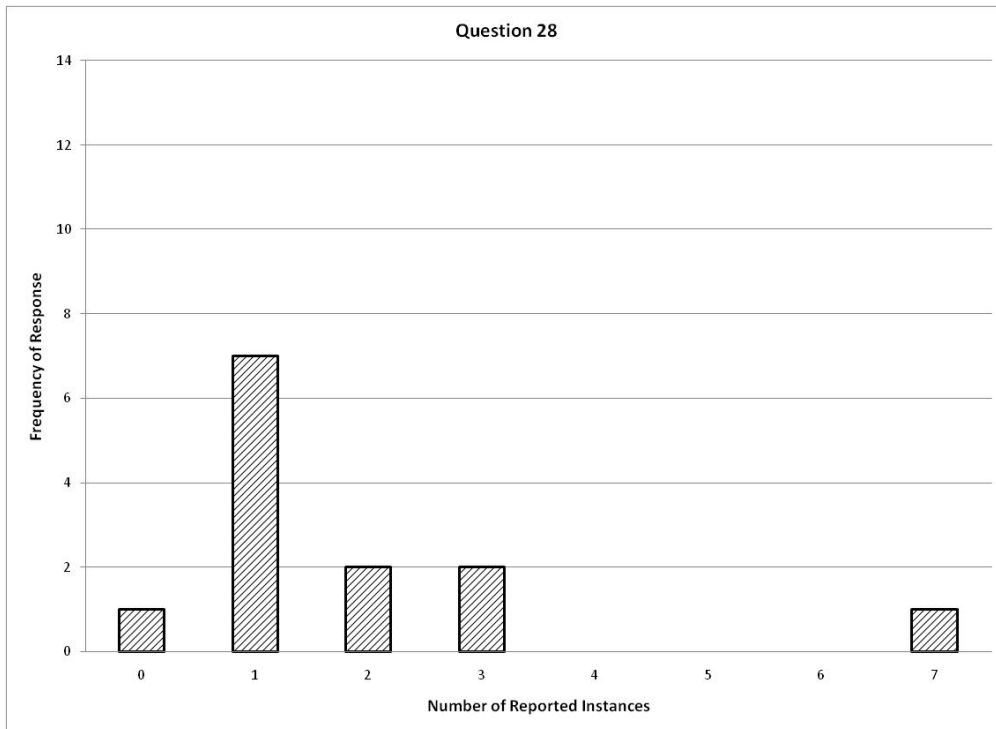
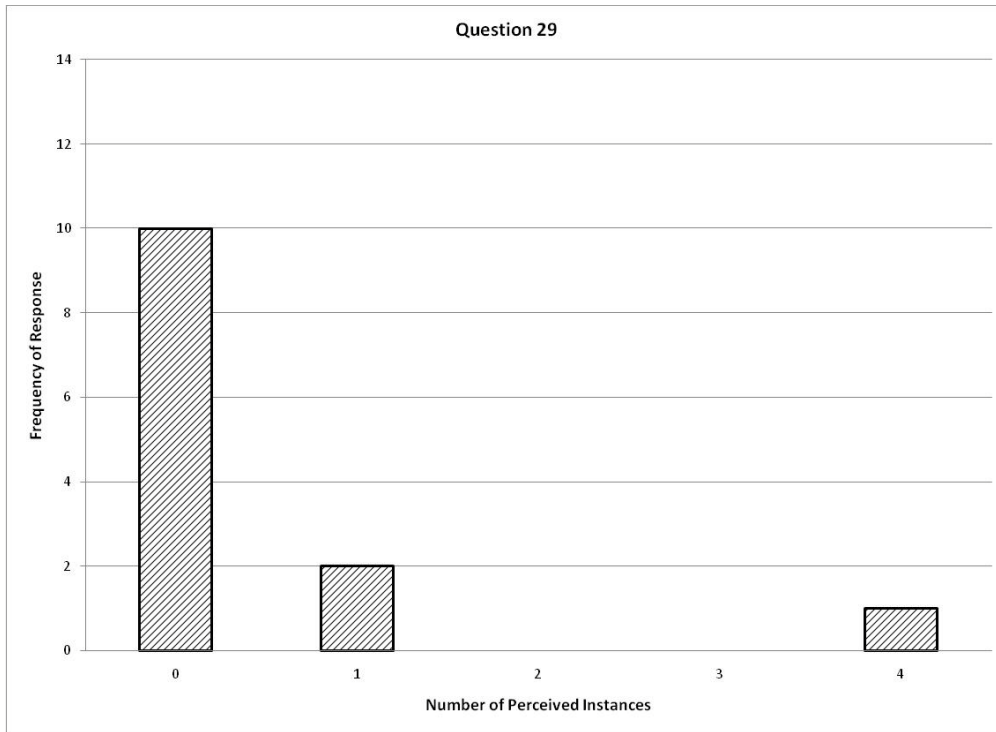
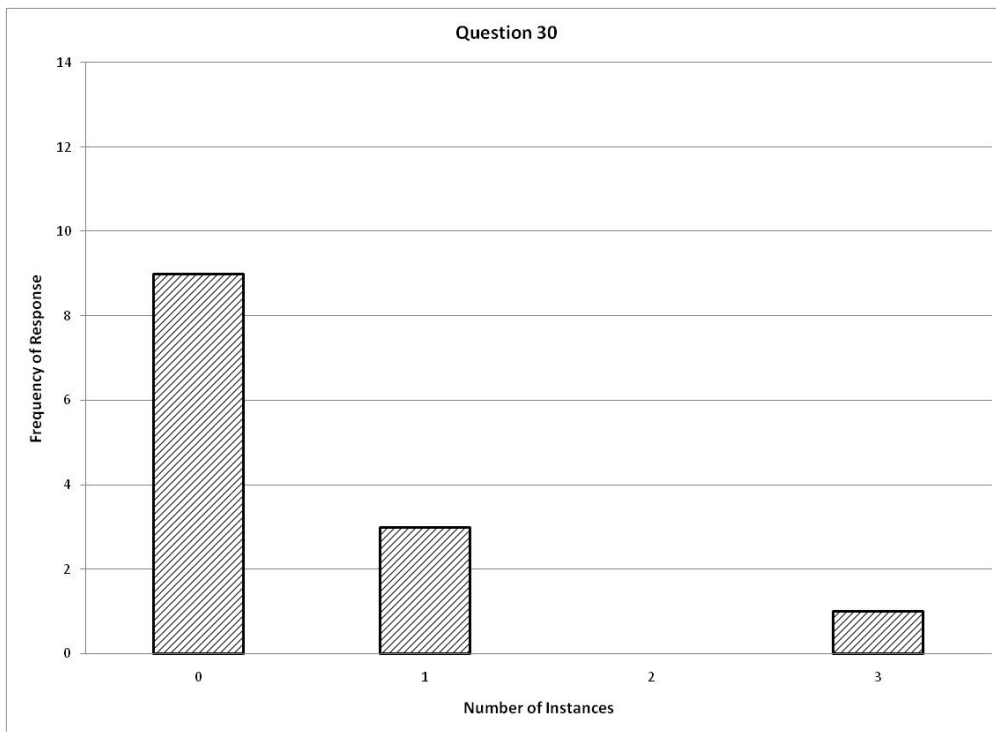


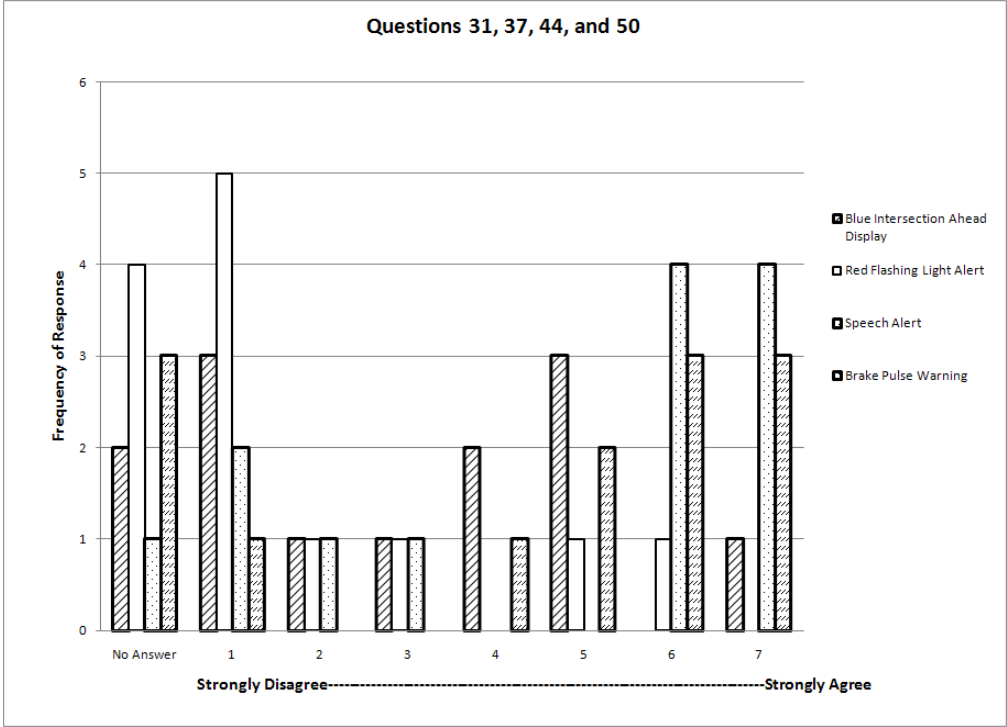
Figure 57 How many times did you get a “running stop sign” alert that you felt was not necessary?



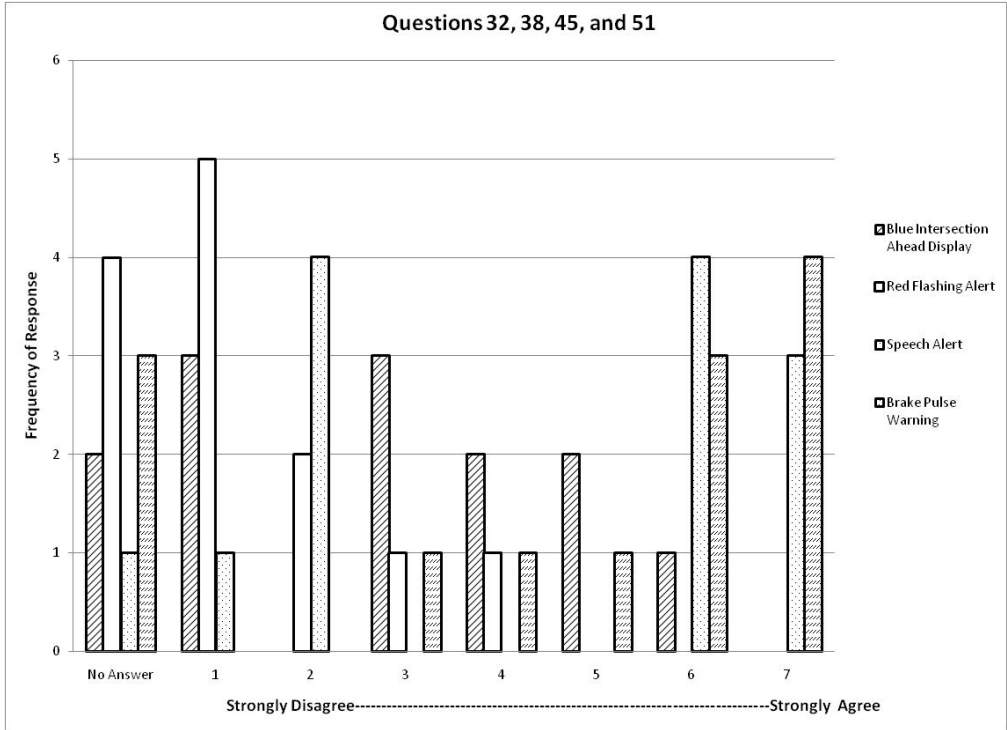
**Figure 58** How many times did you NOT get a “running stop sign” alert when you felt one was appropriate?



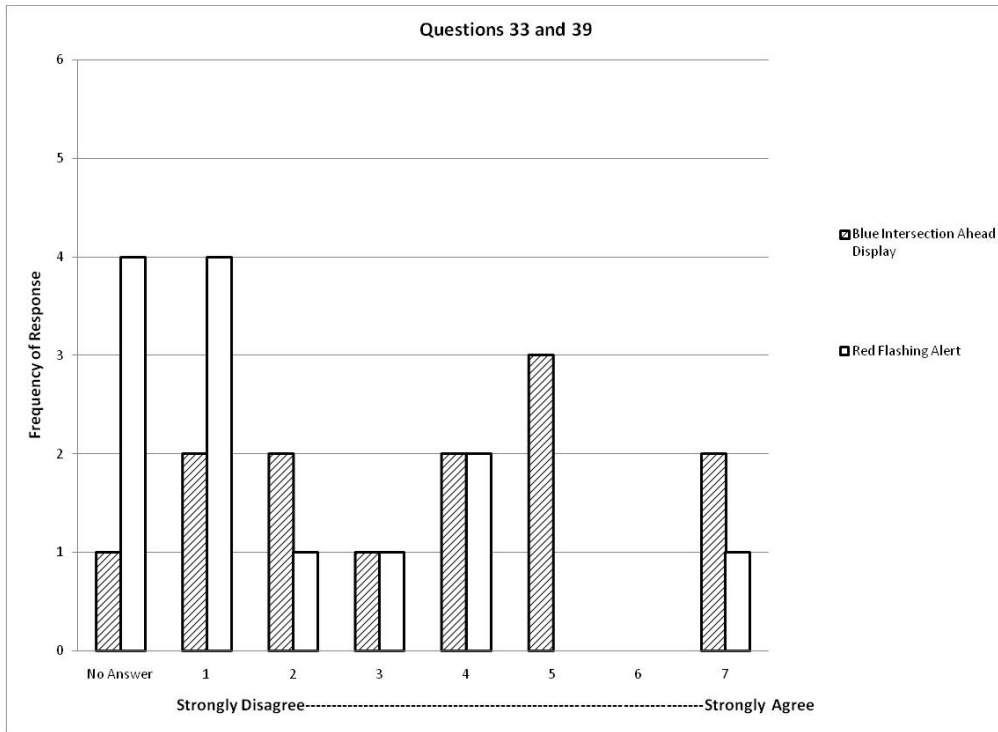
**Figure 59** How many times did you get a “running stop sign” alert where you could not identify the source of the alert?



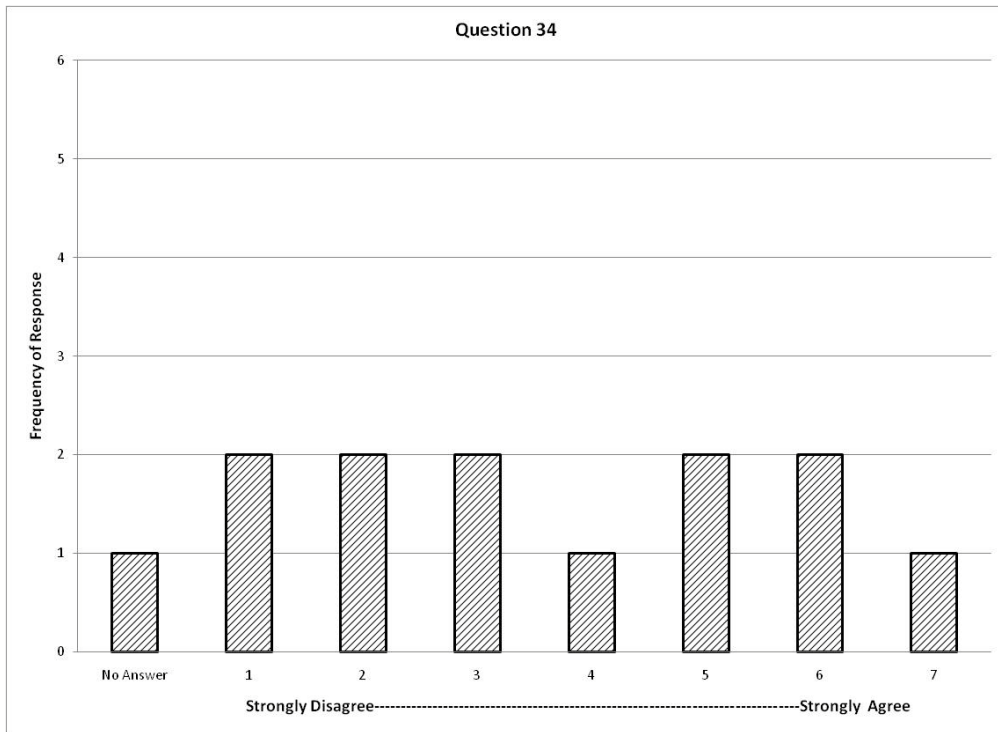
**Figure 60 Effectiveness of the DVI in communicating intended information.**



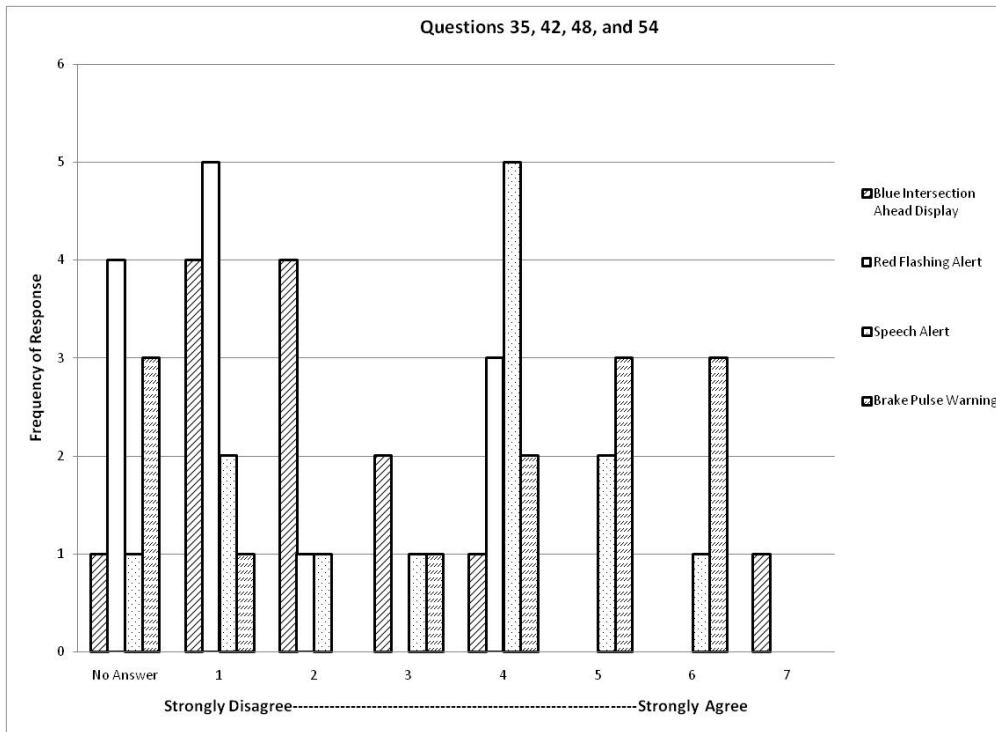
**Figure 61 Ease of detecting the DVI.**



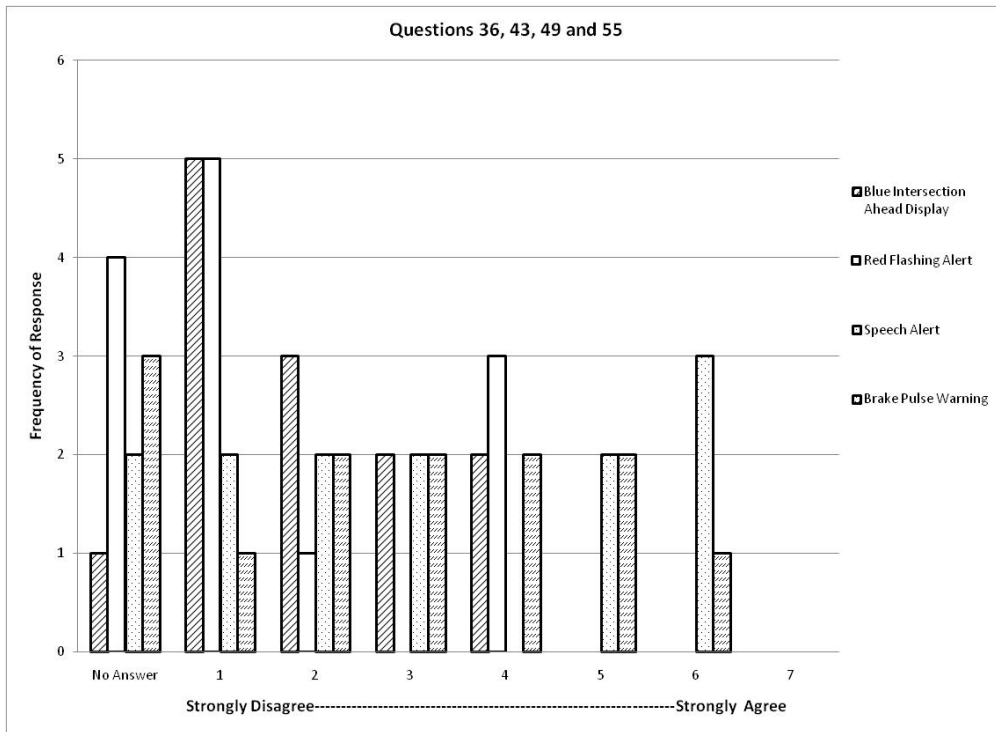
**Figure 62 Location of the visual DVI.**



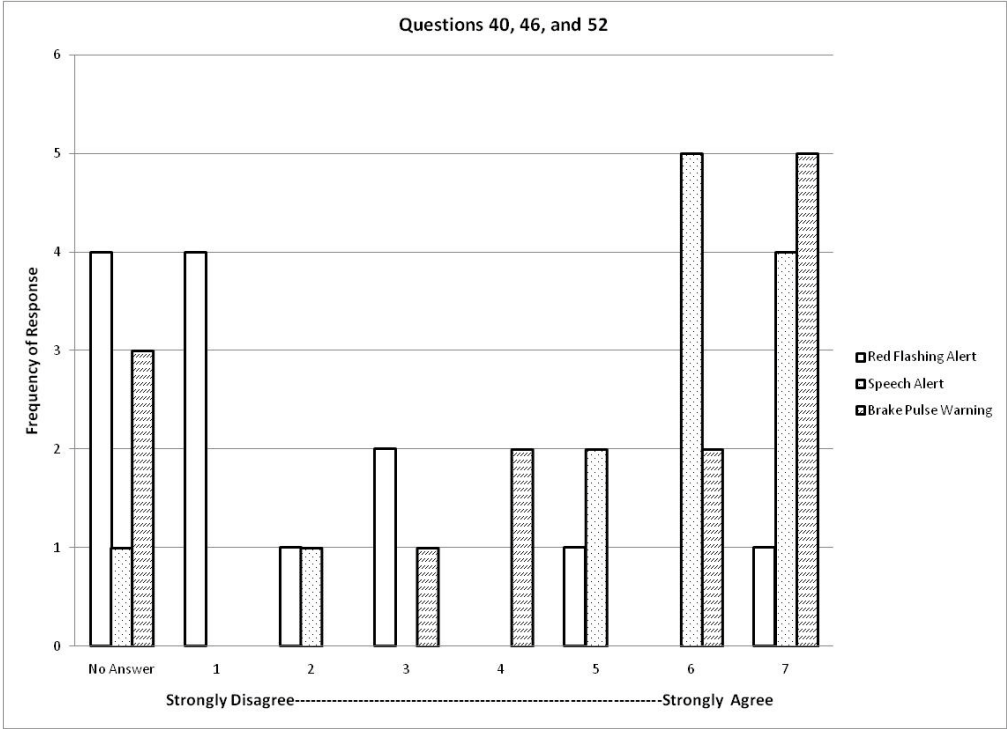
**Figure 63 The size of the “blue intersection ahead” display was appropriate**



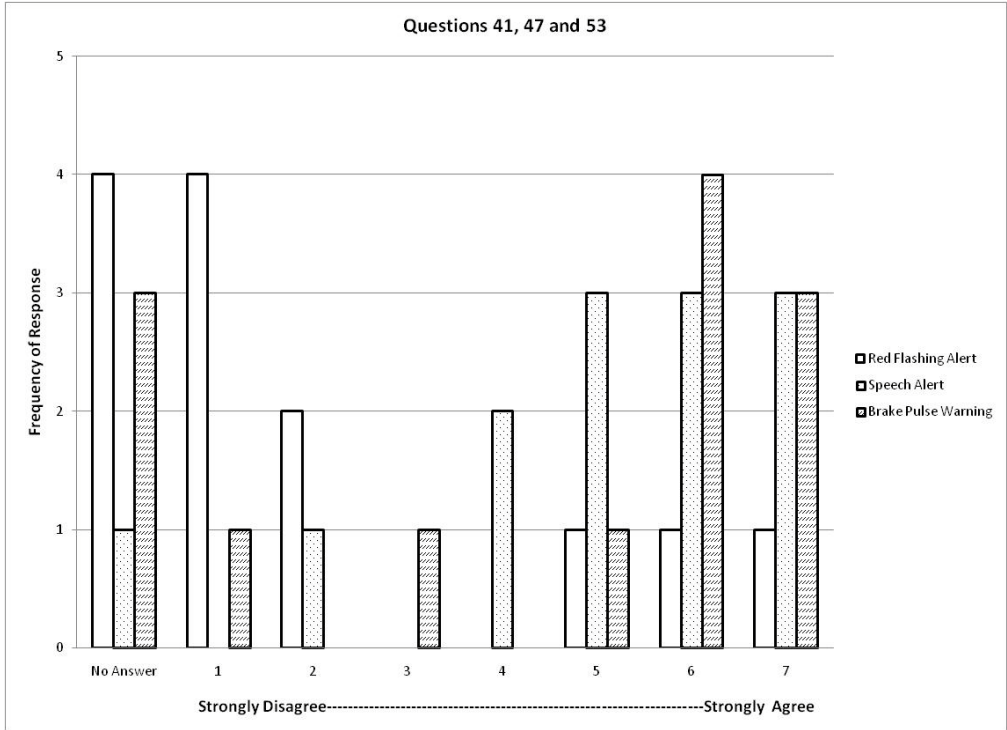
**Figure 64 Annoyance of the DVI.**



**Figure 65 Distractibility of the DVI.**

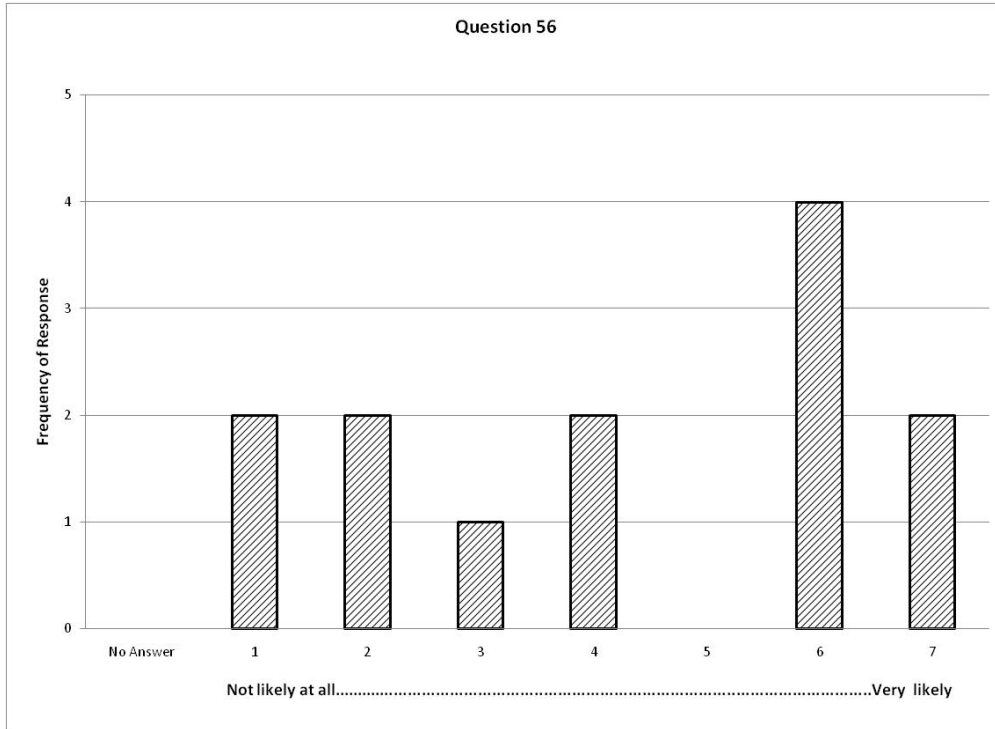


**Figure 66 Effectiveness of the DVI in obtaining driver’s attention.**

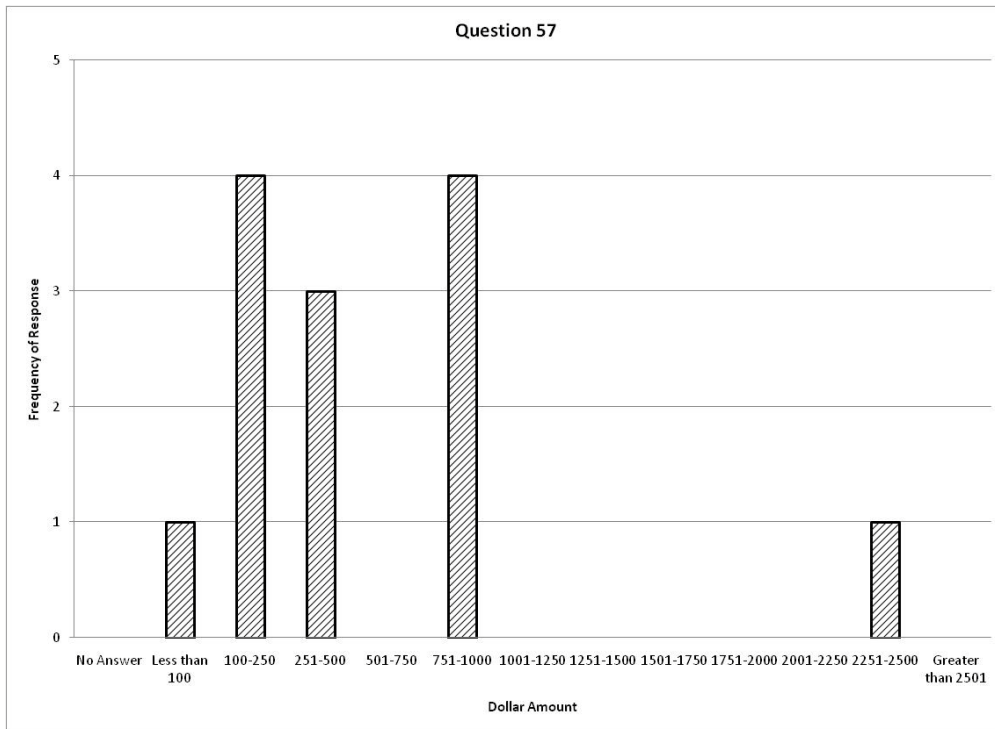


**Figure 67 Startle response to the DVI.**





**Figure 68 Likeliness of purchasing the intersection warning system.**



**Figure 69 Price at which the intersection warning system is considered to be too expensive.**

**Question 58. Do you have any suggestions for improving the intersection warning system that might improve it?**

- I never noticed the red flashing light when I was about to run a stop sign. I never encountered the "running red light" alert. The "running" stop sign seemed inconsistent. When I thought I might do it, it didn't and when I did not think it was necessary it did do it.
- The brake pulse is slightly startling. If the alert lights were projected with the speed on the windshield it would be much more effective.
- Maybe a little brighter display. (After filling out the questionnaire, he said he filled it out wrong by answering questions about a "red light" warning. He said he only received the "stop sign" warning. -Brian)
- "Car did not warn me of a red light," "I did not see a red flashing light."
- Did not encounter 'red light,' "Did not encounter 'intersection ahead' display," "The speech alert was the best part." I think it's good for teens-people just starting to drive maybe, elderly (slowed reaction) but it might startle them and work the opposite way; more so for teens, moms with babies (highly distracted drivers).
- Alerts speaking more clearly. Overall I thought it was a wonderful experience.
- Didn't feel like I got a good test of the system. Only one audio warning "beep beep" turn when I got close to a car making a left turn (that was slow getting out of the travel lane) and one audio that may have said stop or may have just been an unclear monosyllable near a stop sign. I never saw the red warning display.
- Audible alerts are clearly best; brake pulse alert is alarming and annoying. I did not trigger alerts too often since I was driving carefully and anticipating signs/lights. Visual alerts are poor since most people would probably be concentrating vision on upcoming intersections.
- No comment.
- A clearer voice, activated sooner than was my experience- only twice did I hear it.
- No comment.
- I'm impressed with the voice activation, but not crazy about the visual (though I am not sure where else you would put it?), but am sure it's something that you would get used to seeing. It seemed to me that when accelerating on an incline the alarm responded too soon (i.e. didn't give me a chance to get up the hill to the intersection or to the actual stop sign).

- No- good system.

## Appendix O: Post-Drive Questionnaire Results for Drivers Who Experienced a Violation Warning While Driving with Stop-Controlled Algorithm 2

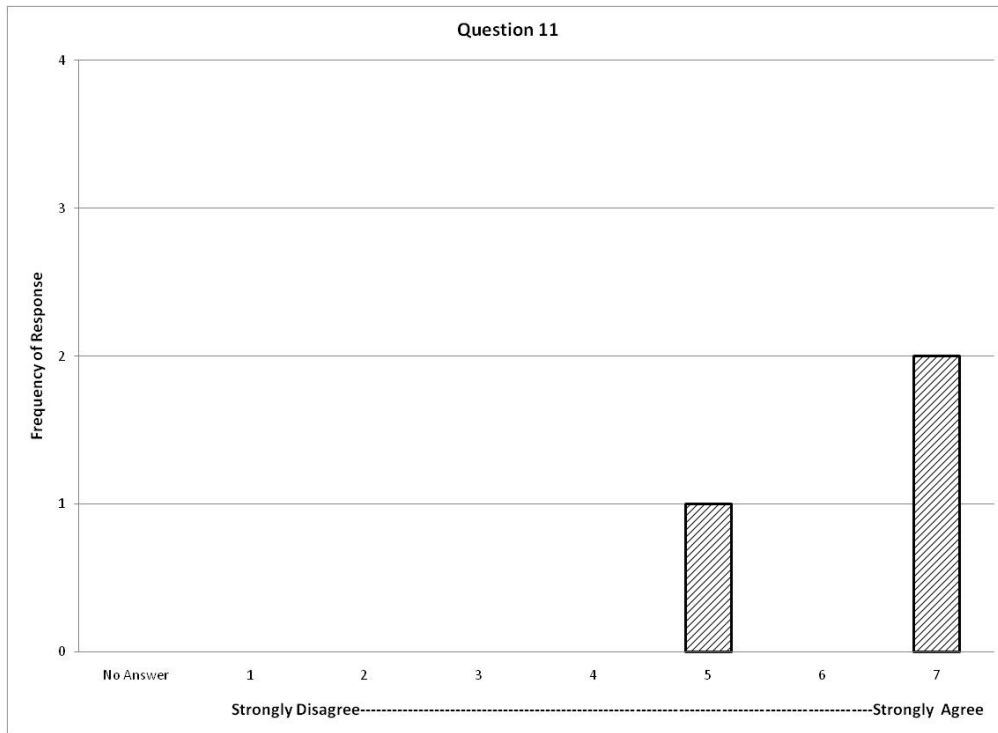
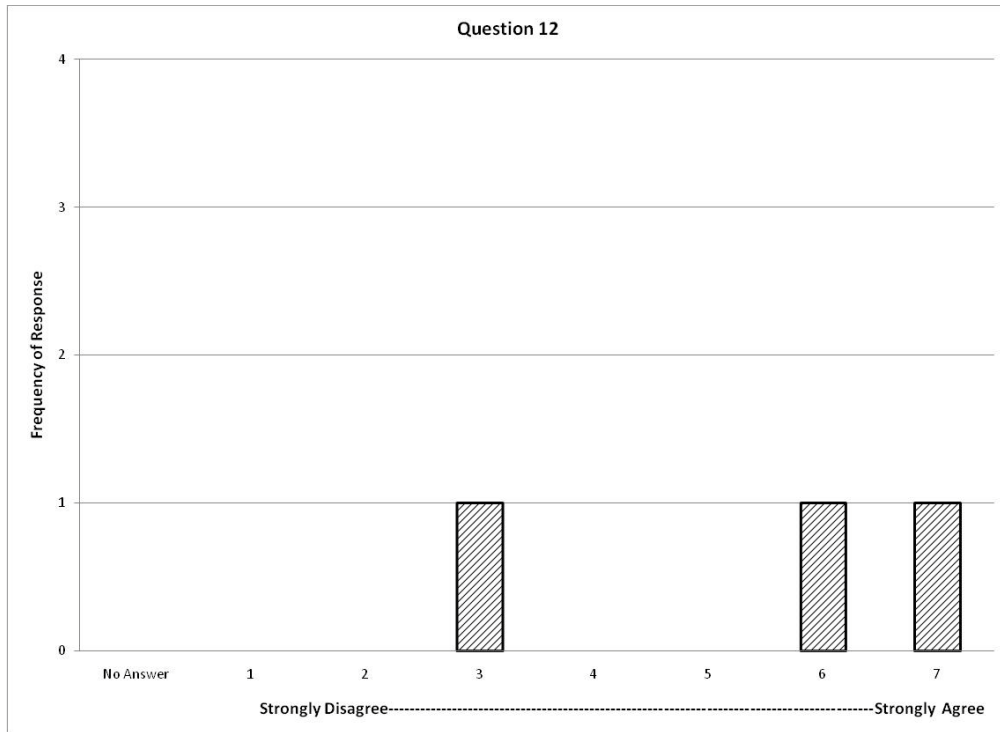
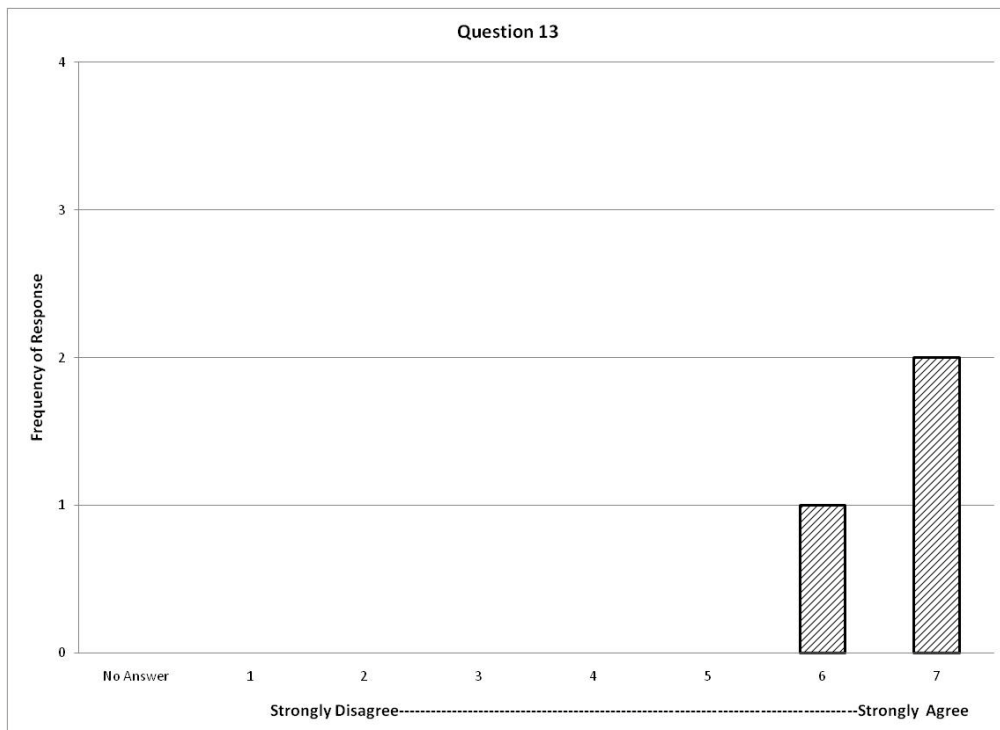


Figure 70 The “running stop sign” alert was useful.



**Figure 71** The “running stop sign” alert was effective in communicating to the driver that he/she may be about to run a stop sign.



**Figure 72** The “running stop sign” alert was effective at getting my attention quickly.

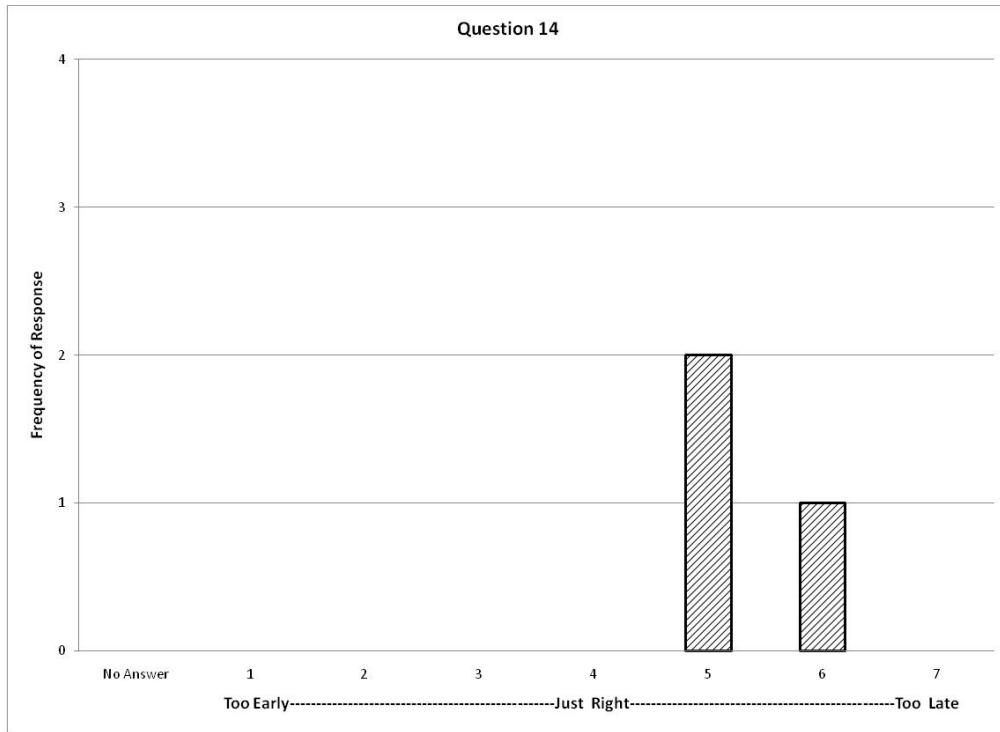


Figure 73 What do you think of the timing of the “running stop sign” alert?

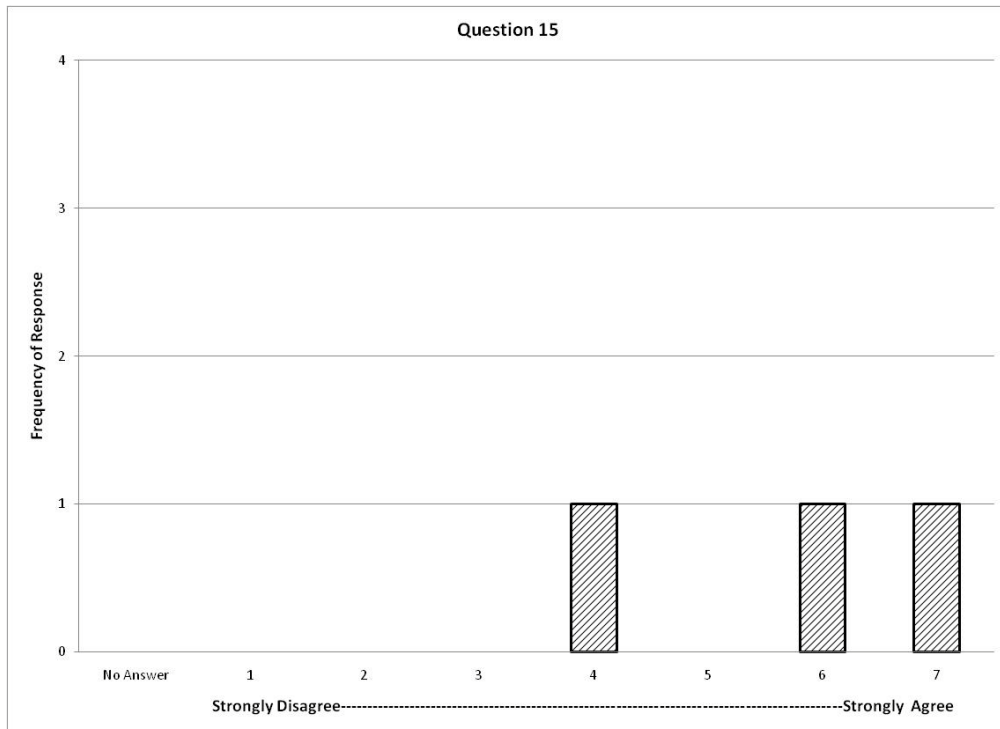
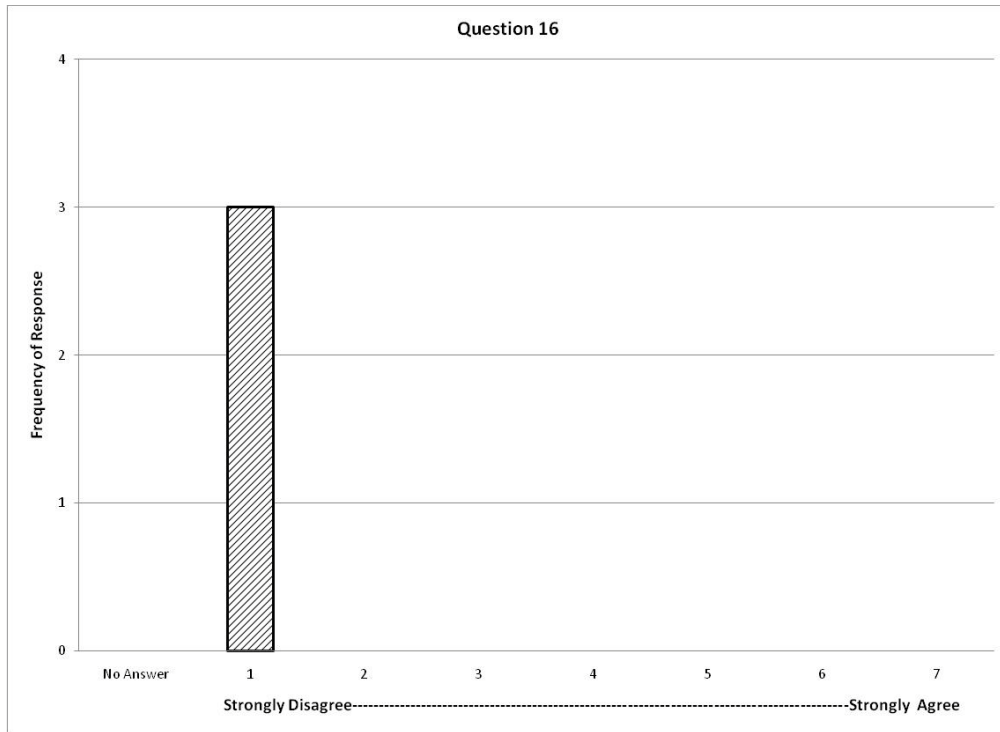
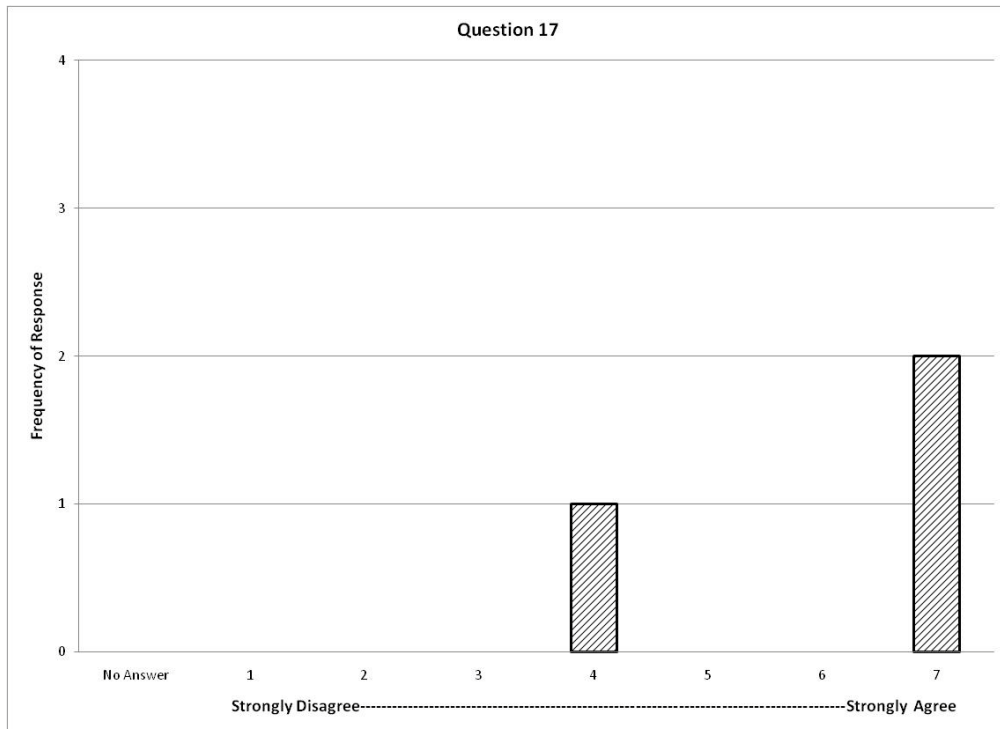


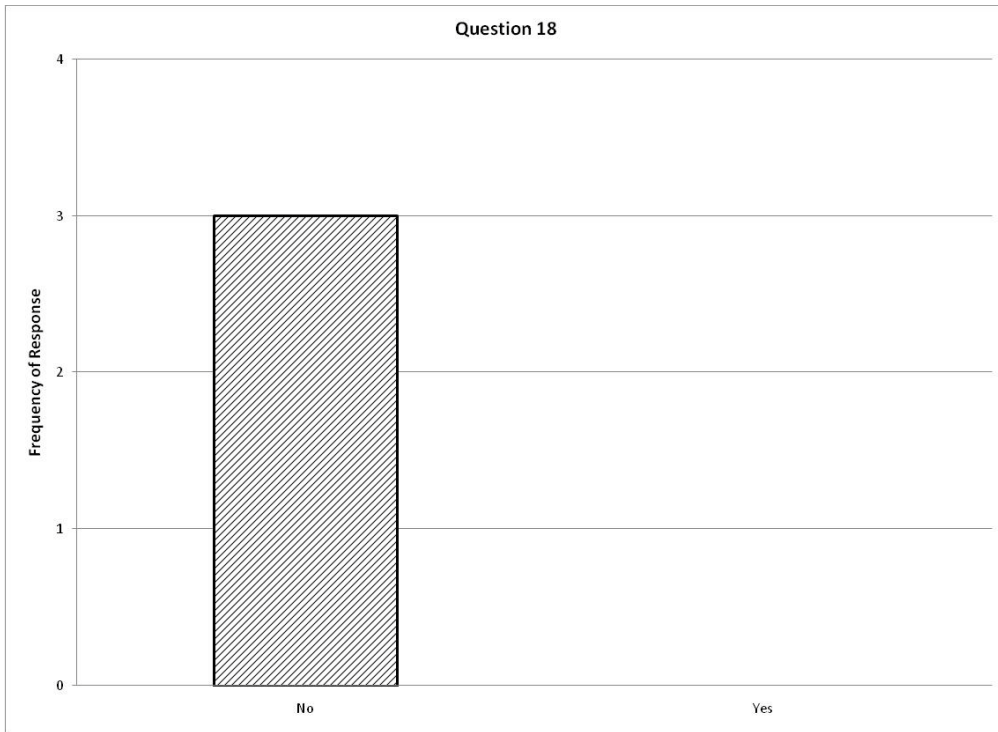
Figure 74 When I received the “running stop sign” alert, I braked without checking for traffic behind me.



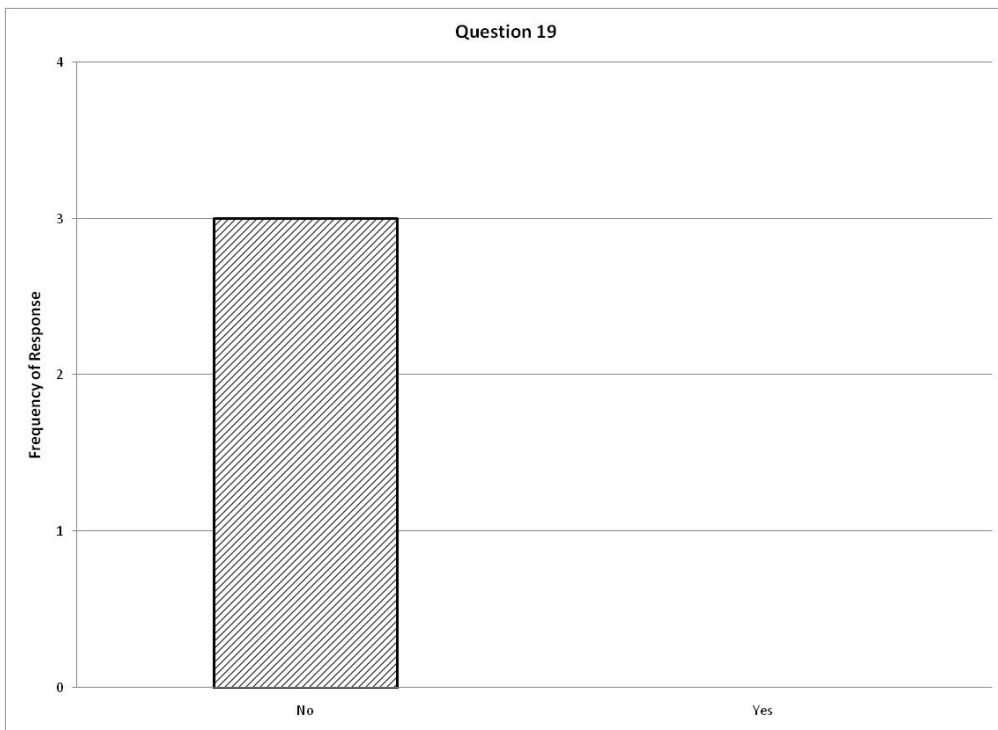
**Figure 75** The “running stop sign” alert was annoying when the alert was unnecessary.



**Figure 76** I feel the “running stop sign” alert will increase my driving safety.



**Figure 77** If I was told I was allowed to turn the “running stop sign” alert system off, I would have turned it off for the rest of my driving experience.



**Figure 78** Did you ever intentionally activate the “running stop sign” alert?



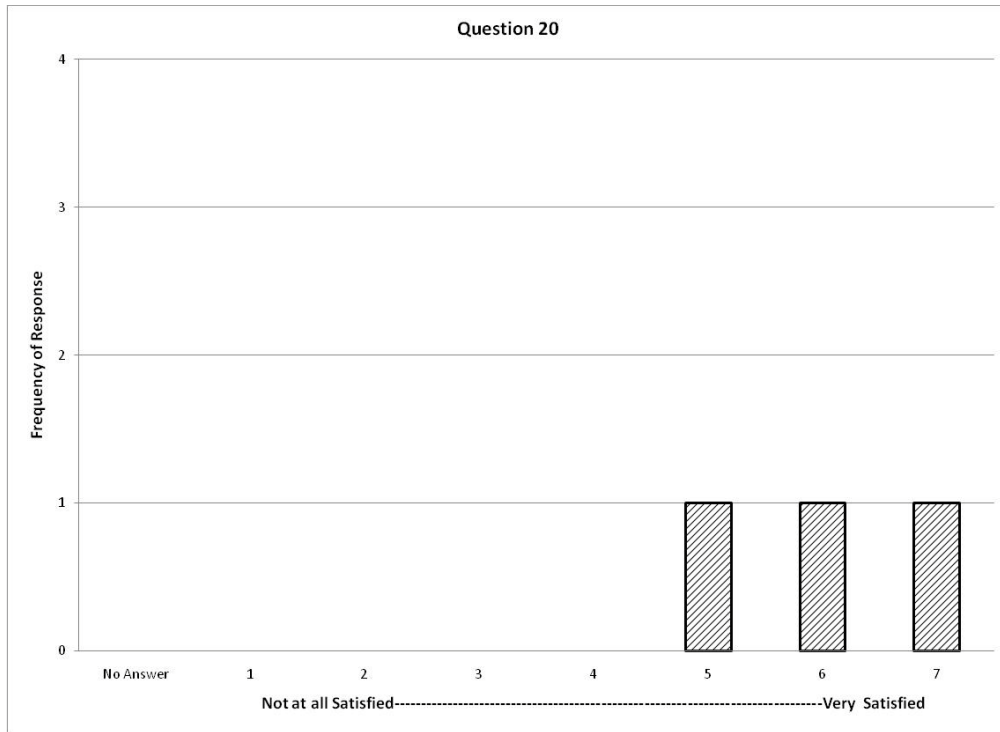


Figure 79 Overall, how satisfied were you with the “running stop sign” alert?

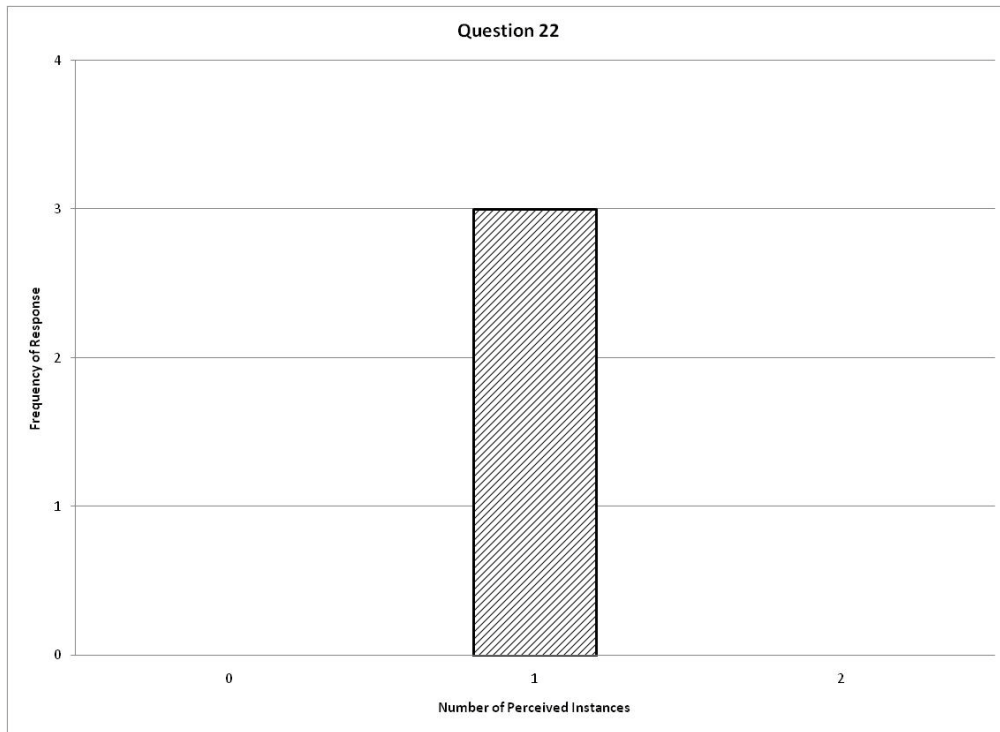
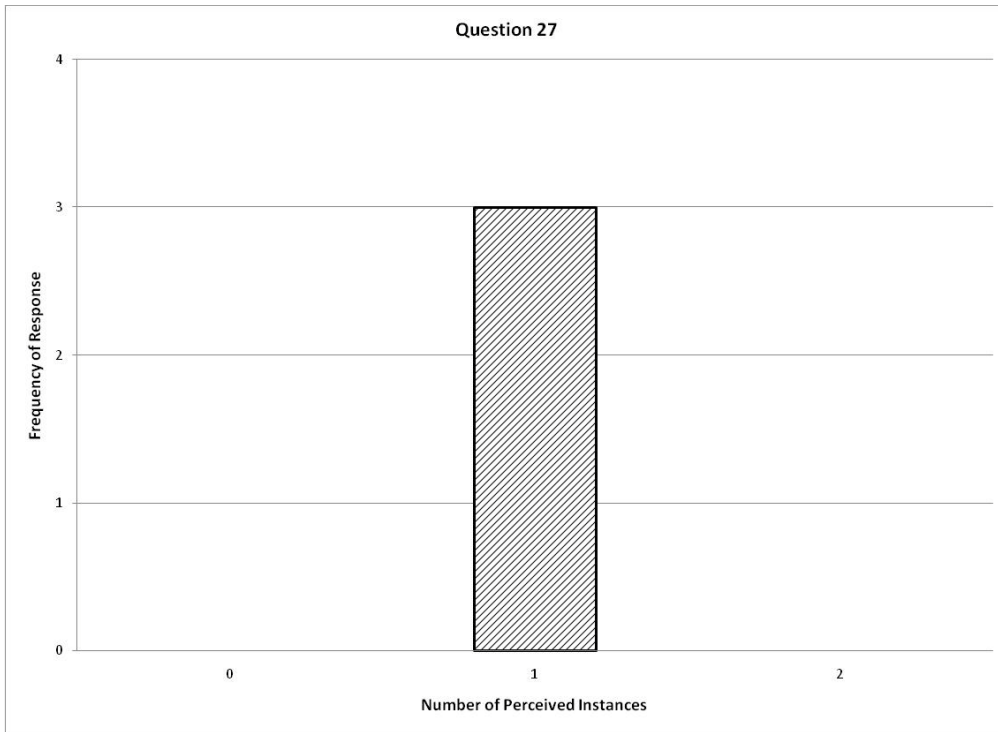
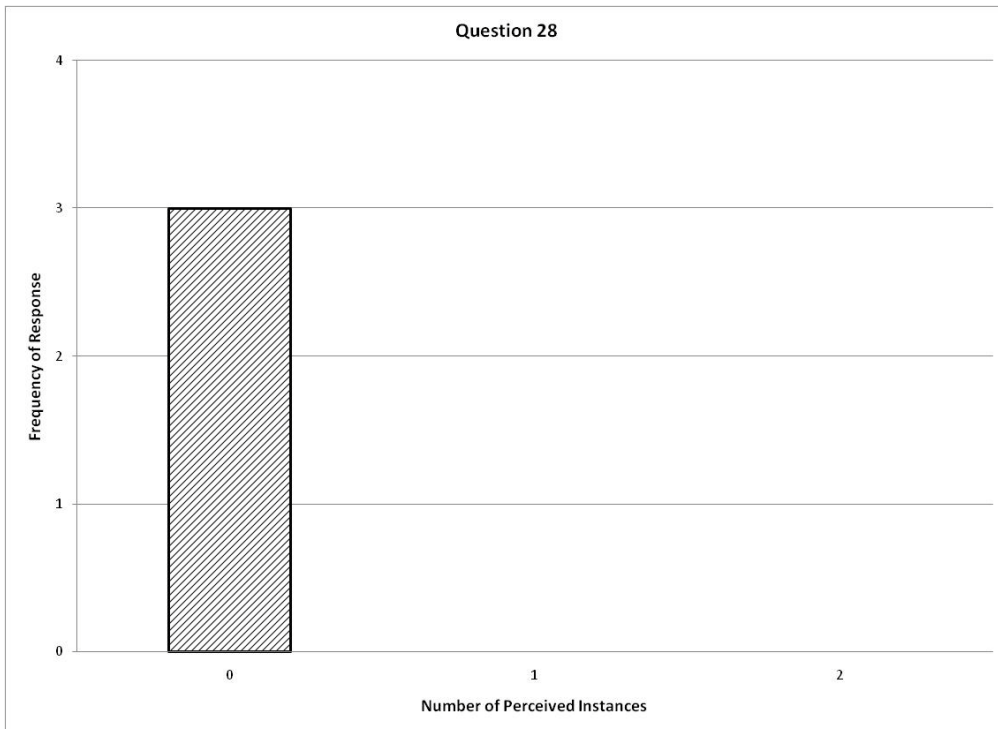


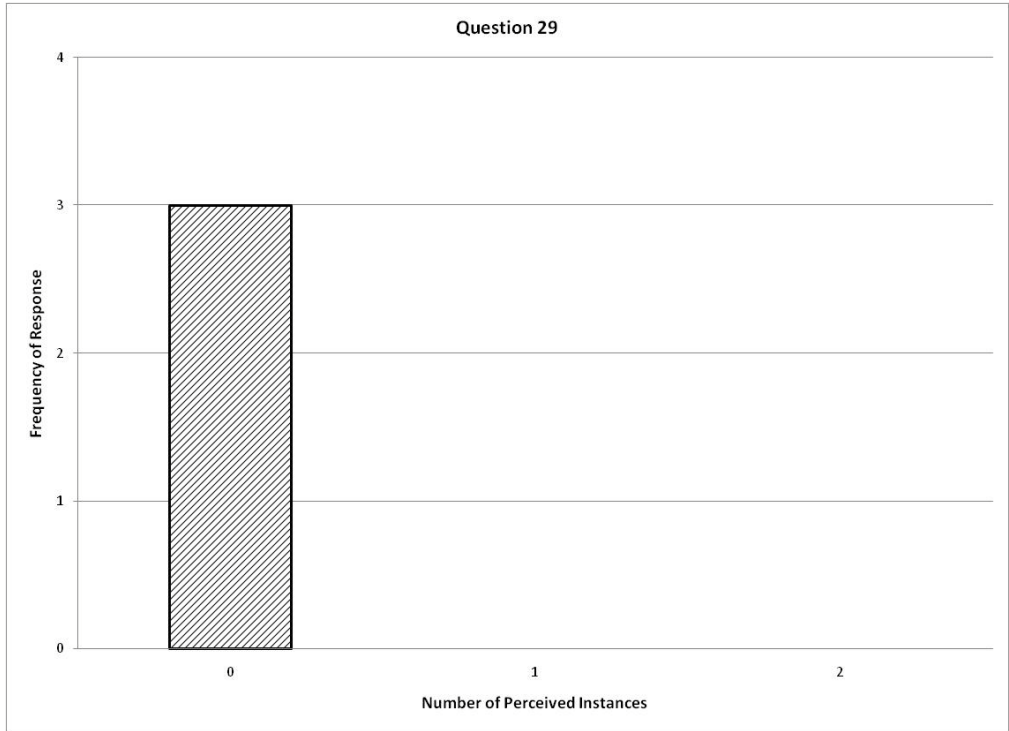
Figure 80 How many times did you run a stop sign or come close to running a stop sign while driving the test vehicle?



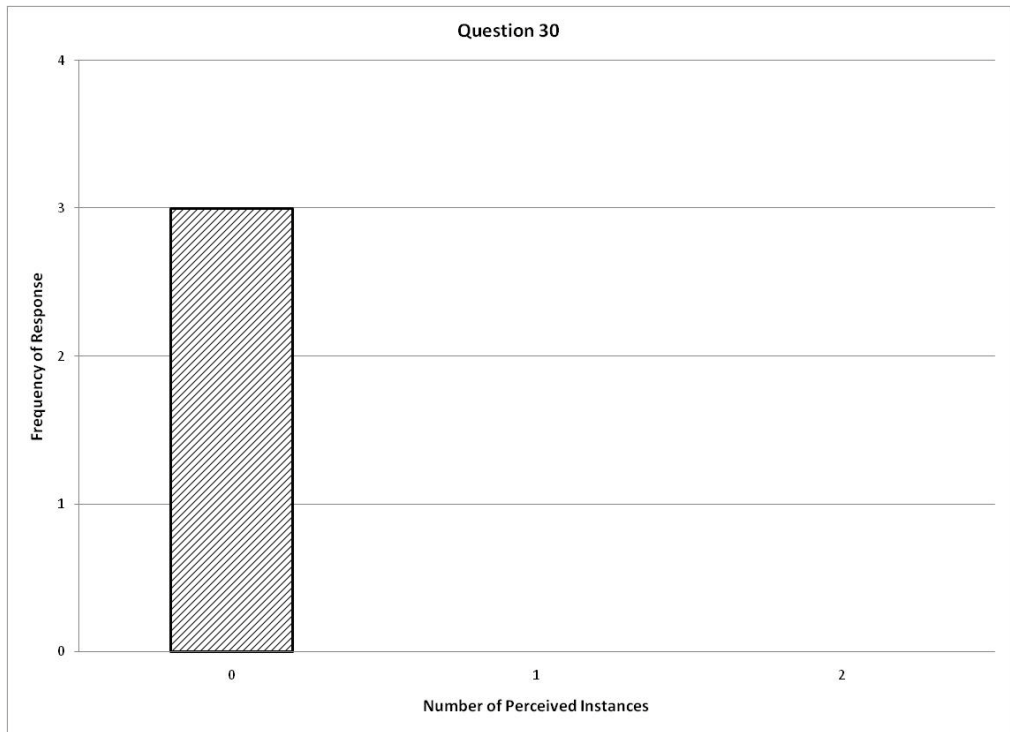
**Figure 81** How many times did you get a “running stop sign” alert that you felt was appropriate?



**Figure 82** How many time did you get a “running stop sign” alert that you felt was not necessary?



**Figure 83** How many times did you NOT get a “running stop sign” alert when you felt one was appropriate?



**Figure 84** How many times did you get a “running stop sign” alert where you could not identify the source of the alert?

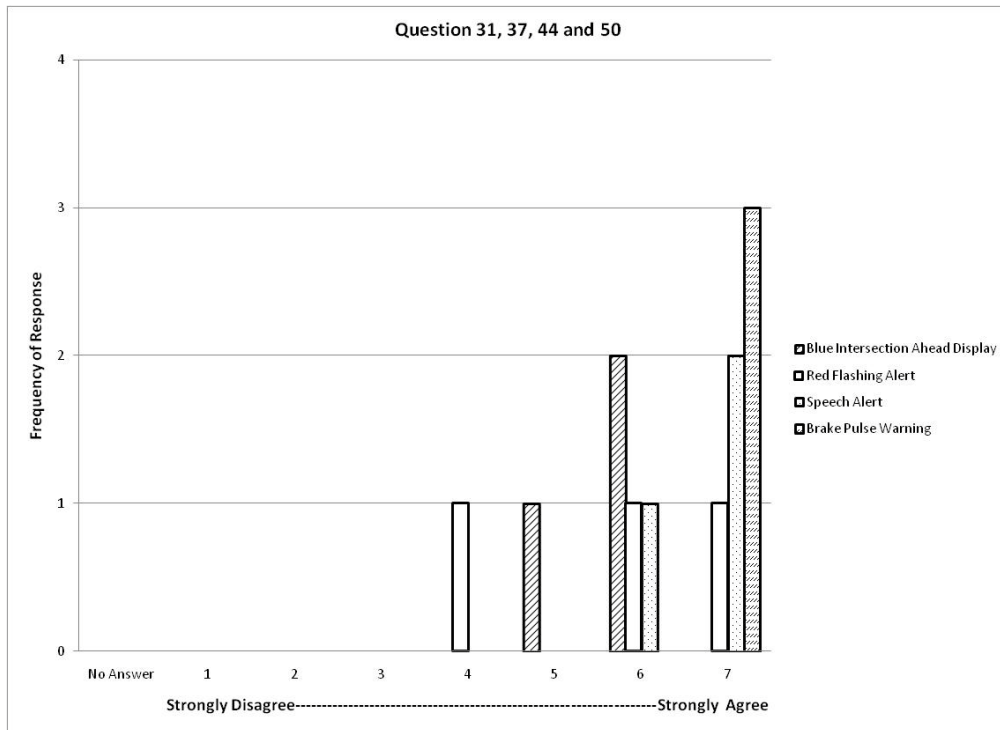


Figure 85 Effectiveness of the DVI in communicating intended information.

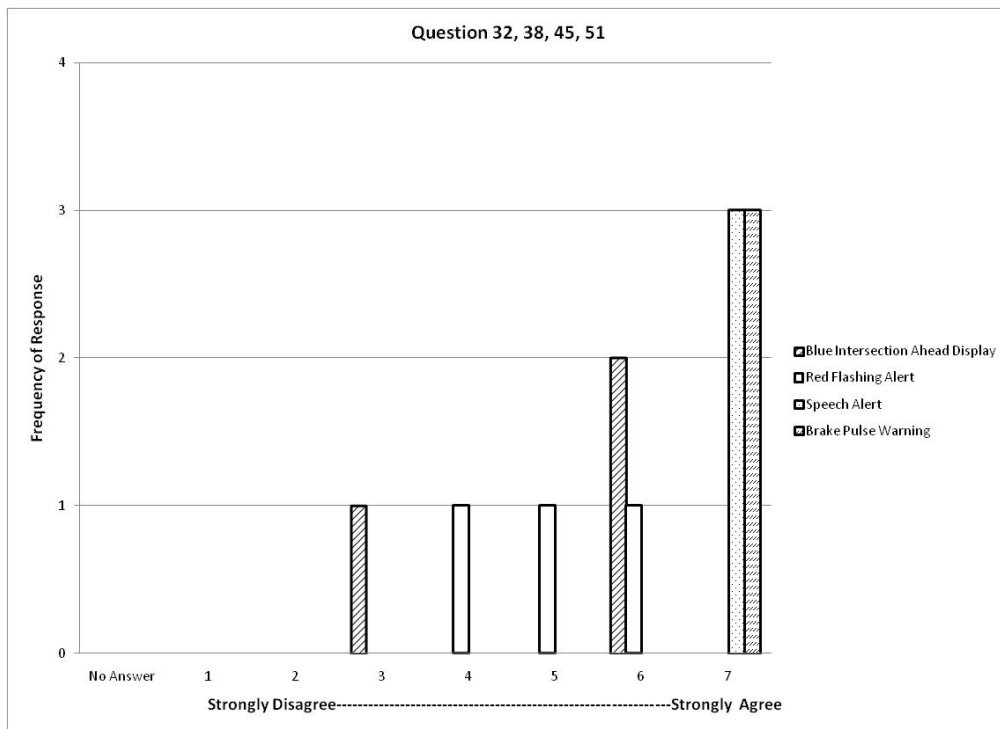


Figure 86 Ease of detecting the DVI.

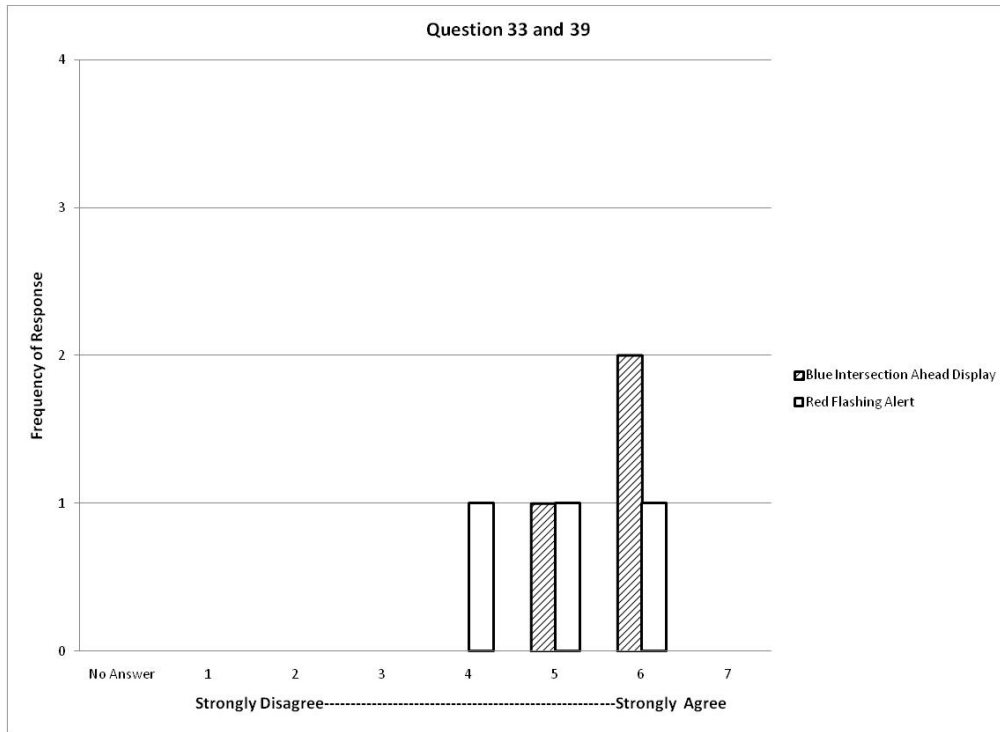


Figure 87 Location of the visual DVI.

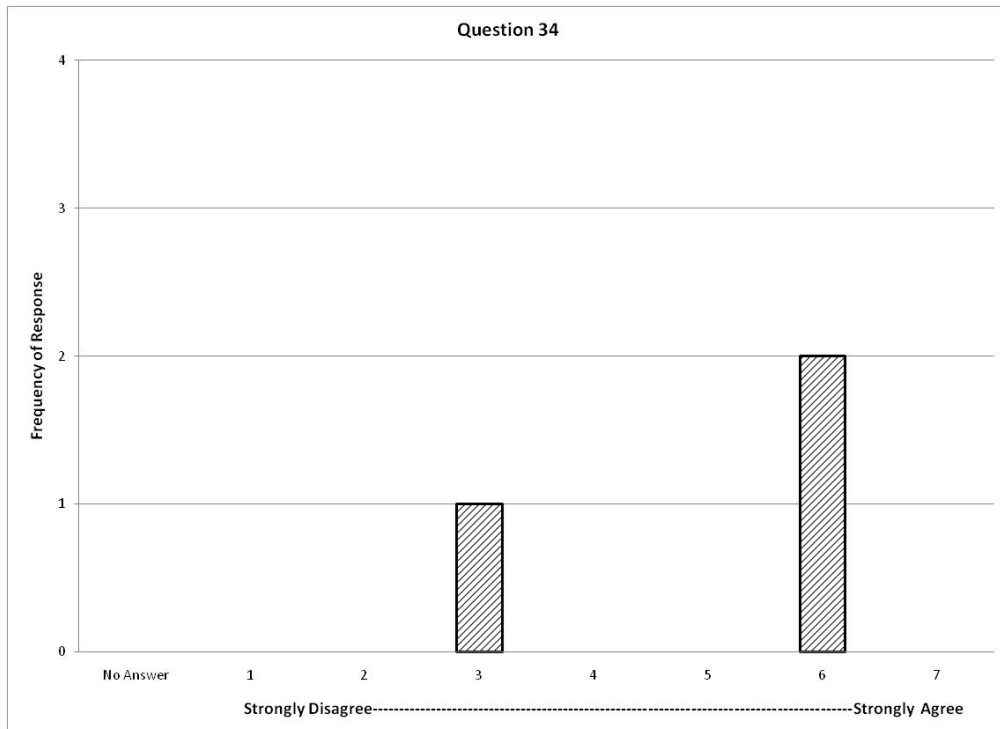


Figure 88 The “blue intersection ahead” display was an appropriate size.

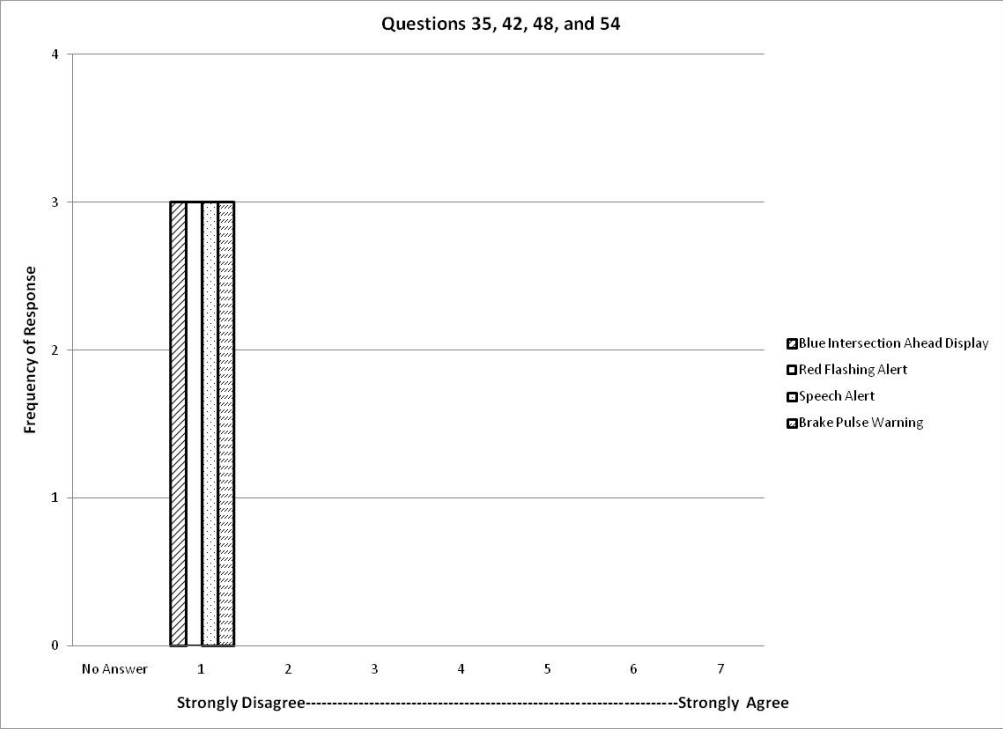


Figure 89 Annoyance of the DVI.

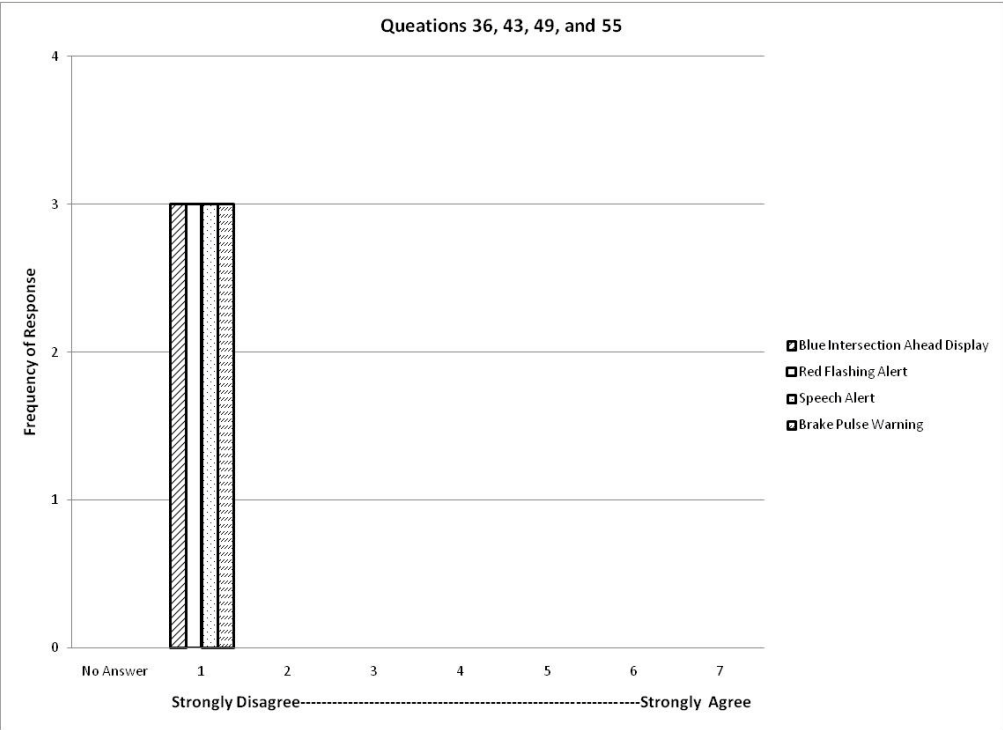
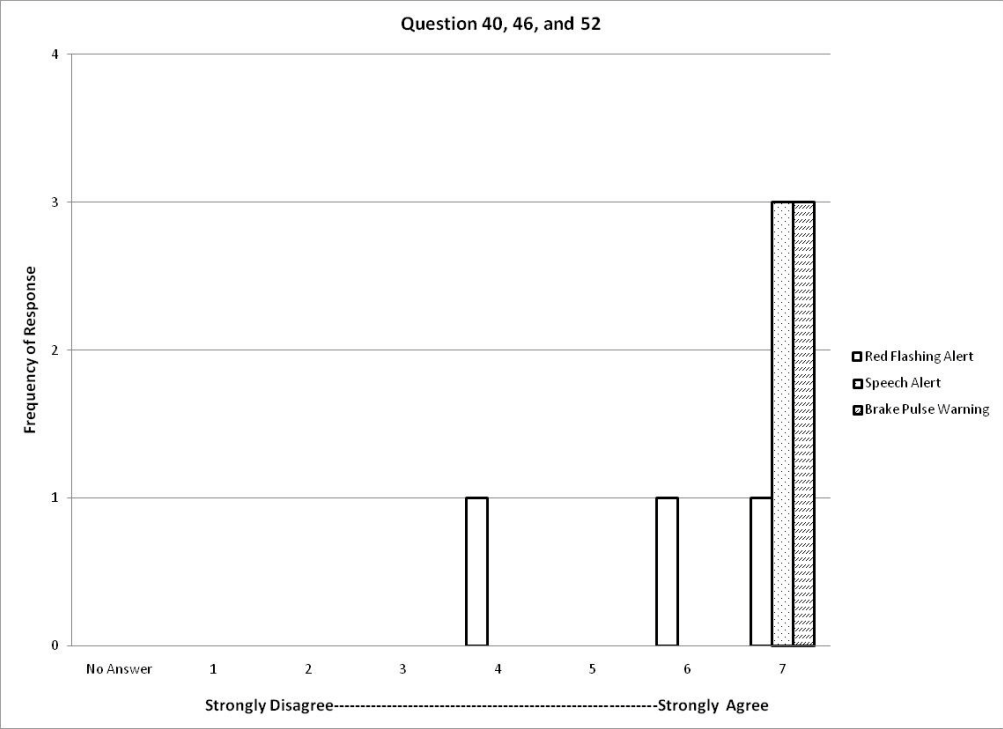
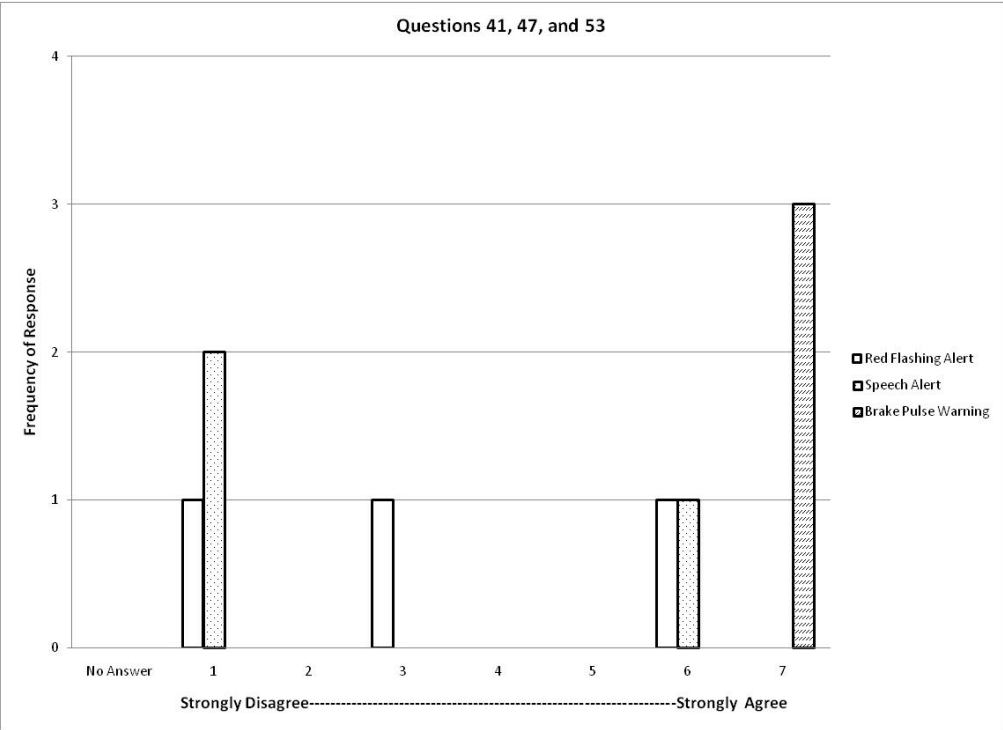


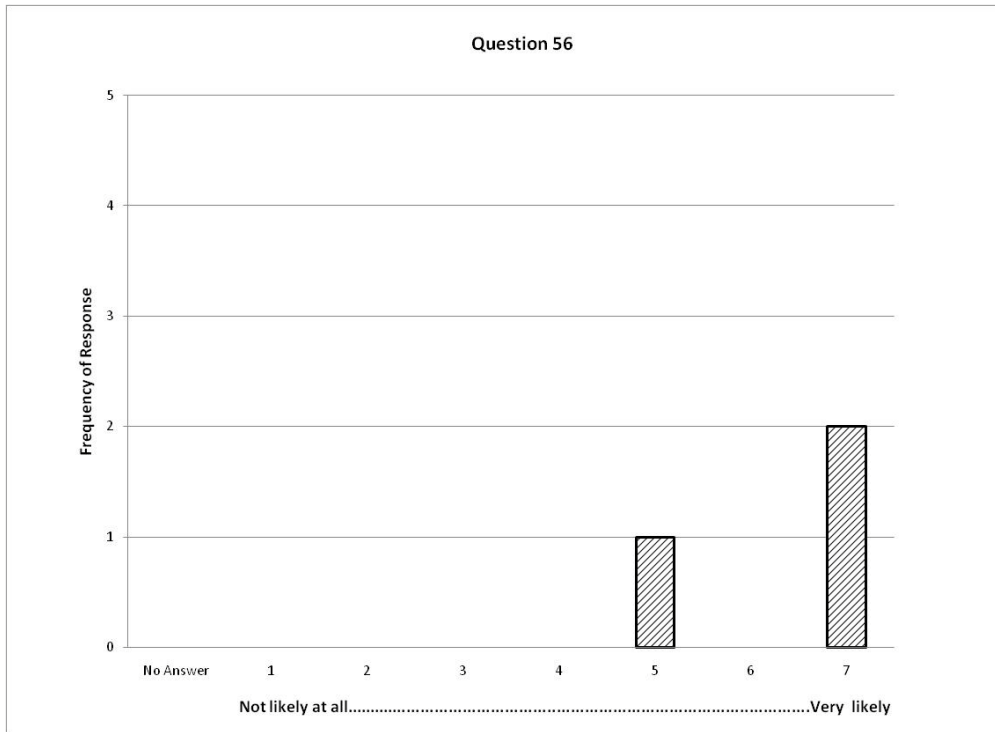
Figure 90 Distractibility of the DVI.



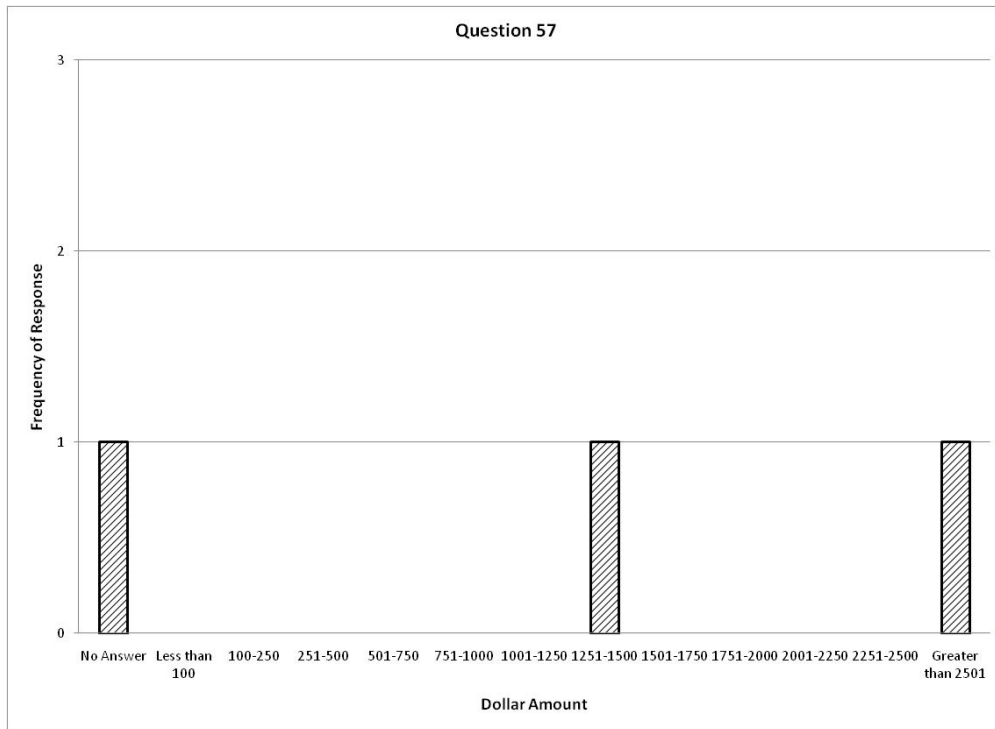
**Figure 91 Effectiveness of the DVI in obtaining the driver’s attention.**



**Figure 92 Startle response of the DVI.**



**Figure 93 Likeliness of purchasing the intersection warning system.**



**Figure 94 Price at which the intersection warning system is considered to be too expensive.**



**Question 58. Do you have any suggestions for improving the intersection warning system that might improve it?**

- The light was ineffective, the brake pulse and auditory was very effective, even startling. Maybe make them a little more forewarning because I definitely looked up to stop. The navigation system was hard to hear over the rain, it definitely wouldn't have been audible over music or windows. The alert system was about the same volume so maybe make it louder or tie it in with music so it accounted for radio or other noises.
- Make the display just a little larger and place it closer to the driver.
- A few directions were quite close to the street that there was a turn.

## Appendix P: Post-Drive Questionnaire Results for Drivers Who Received an Invalid Violation Warning

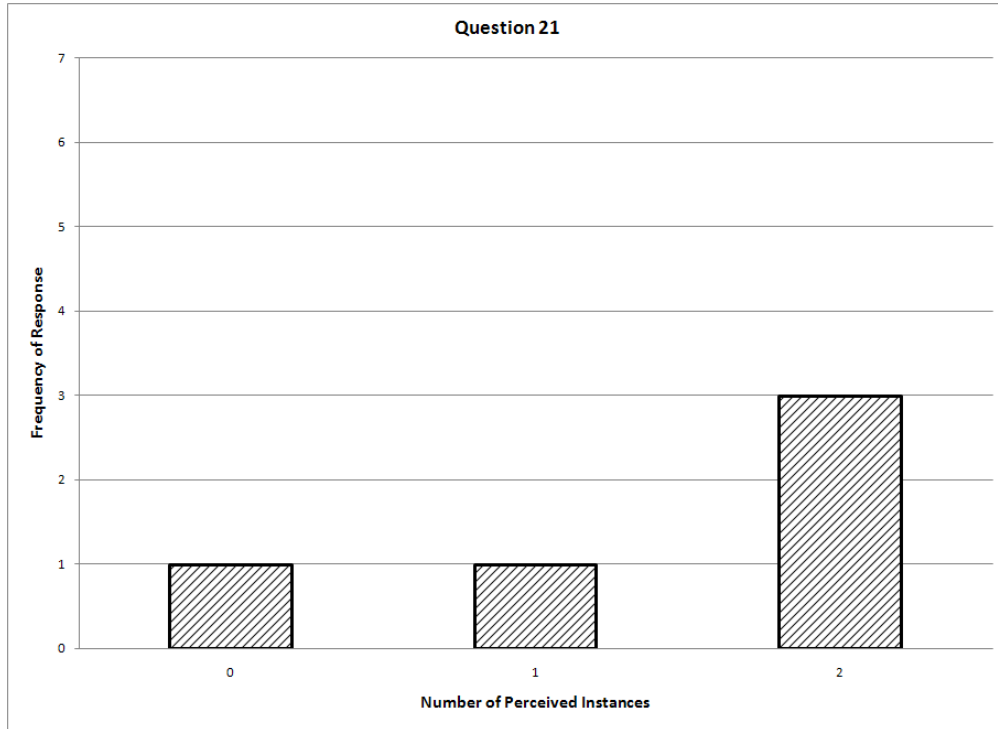
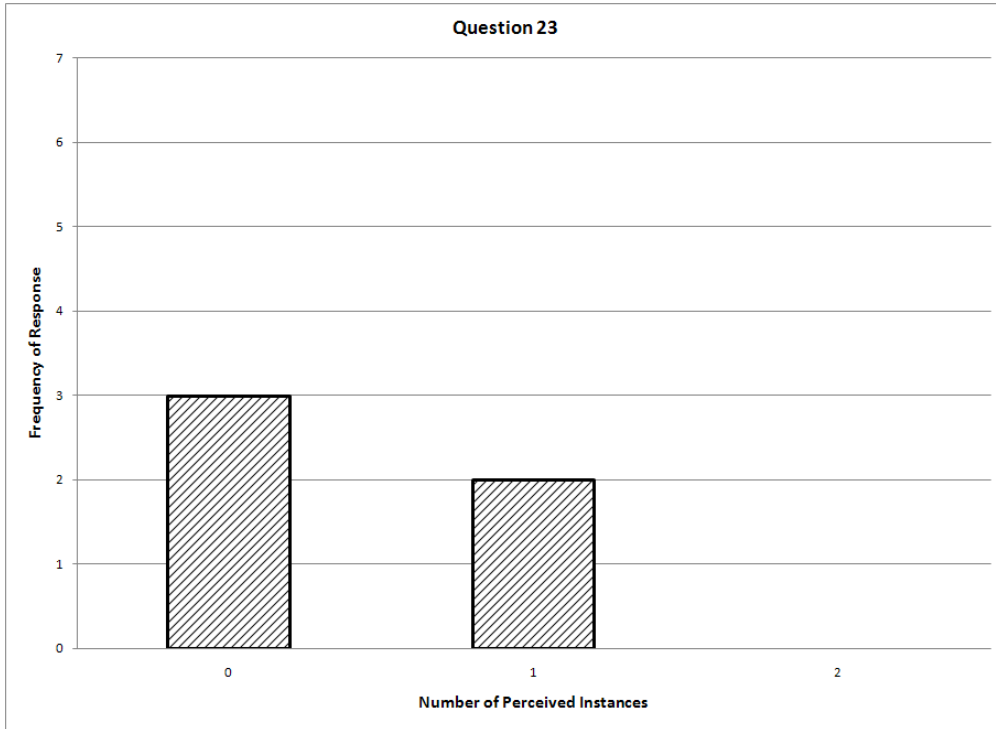
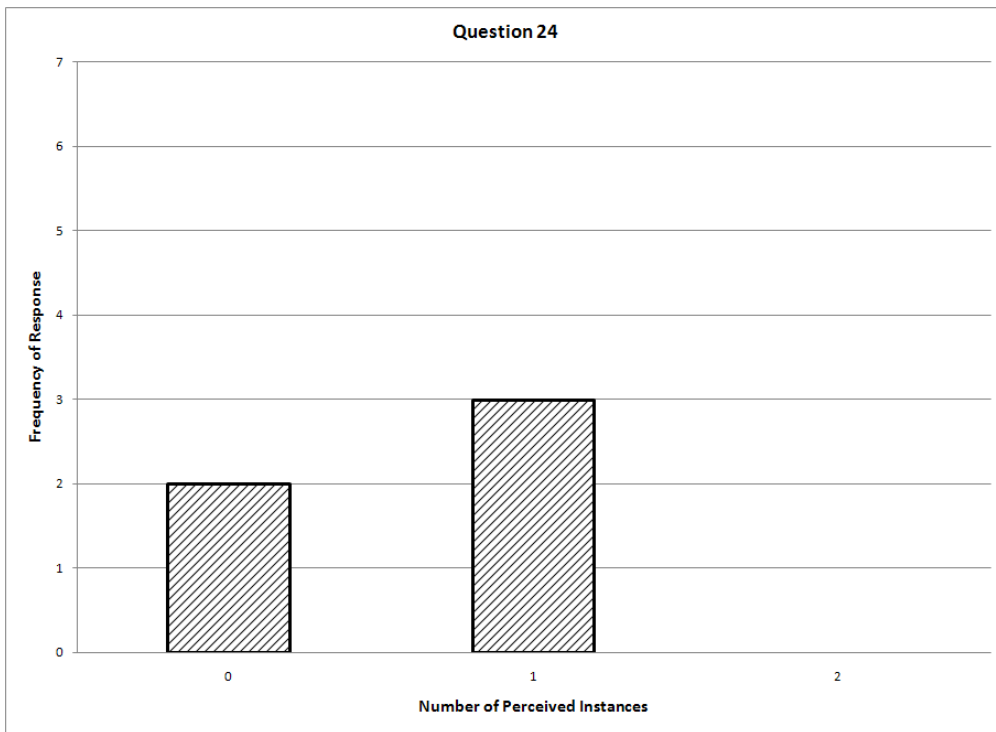


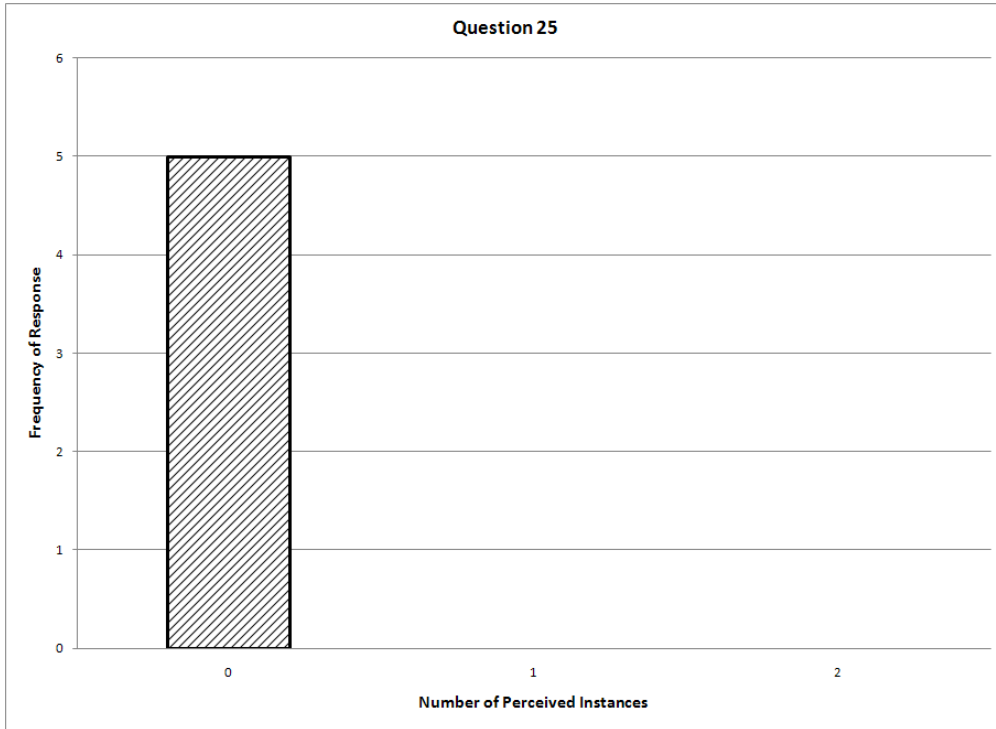
Figure 95 How many times did you run a red light or come close to running a red light while driving the test vehicle?



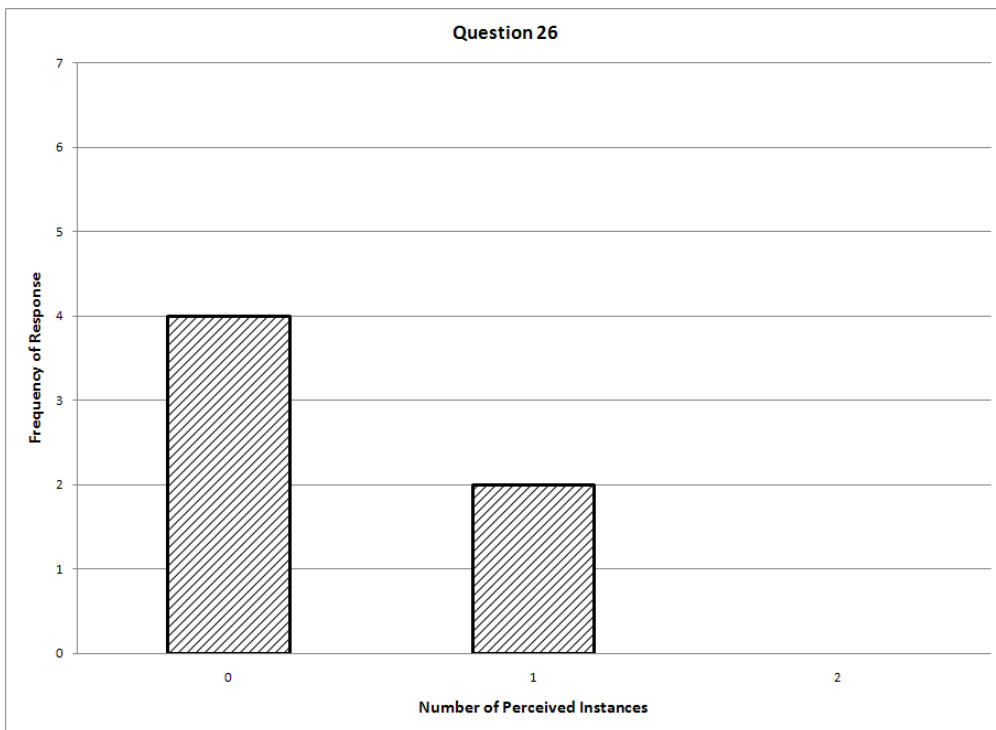
**Figure 96** How many times did you get a “running red light” alert while approaching a traffic light that you felt was appropriate?



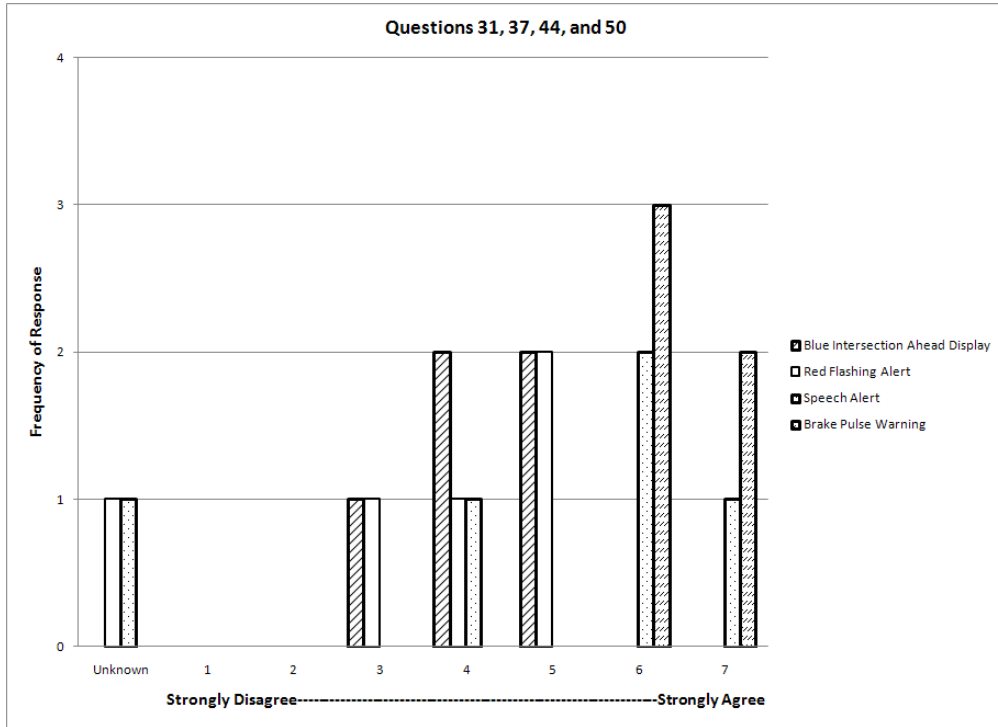
**Figure 97** How many times did you get a “running red light” alert that you felt was not necessary?



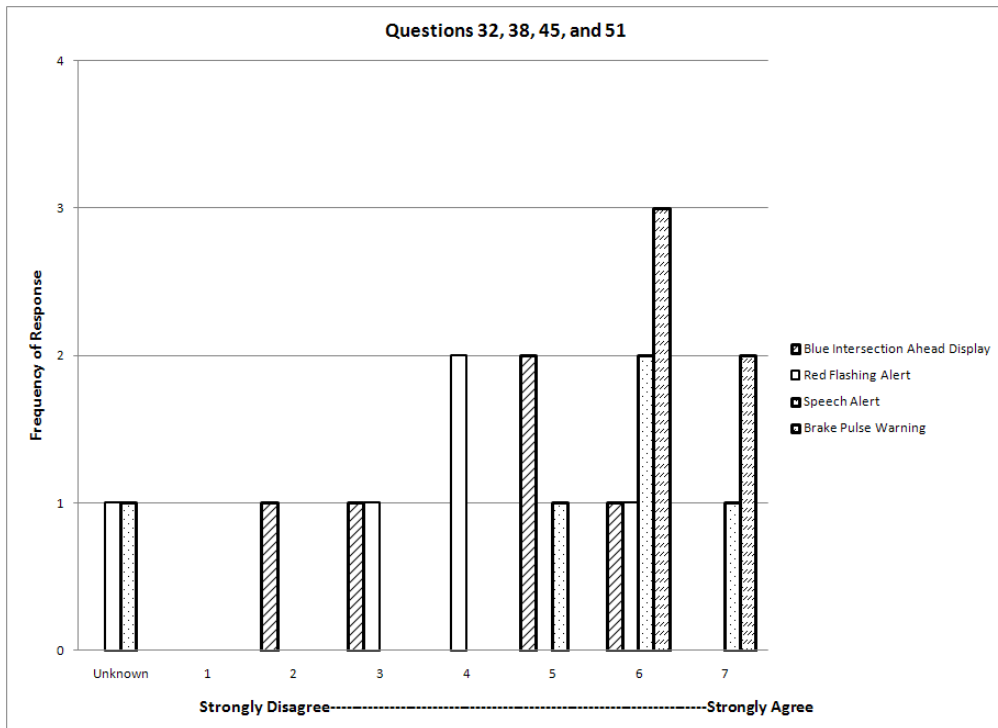
**Figure 98** How many times did you NOT get a “running red light” alert when you felt one was appropriate?



**Figure 99** How many times did you get a “running red light” alert when you could not identify the source of the alert?



**Figure 100 Effectiveness of DVI in communicating intended information.**



**Figure 101 Ease of detecting the DVI.**

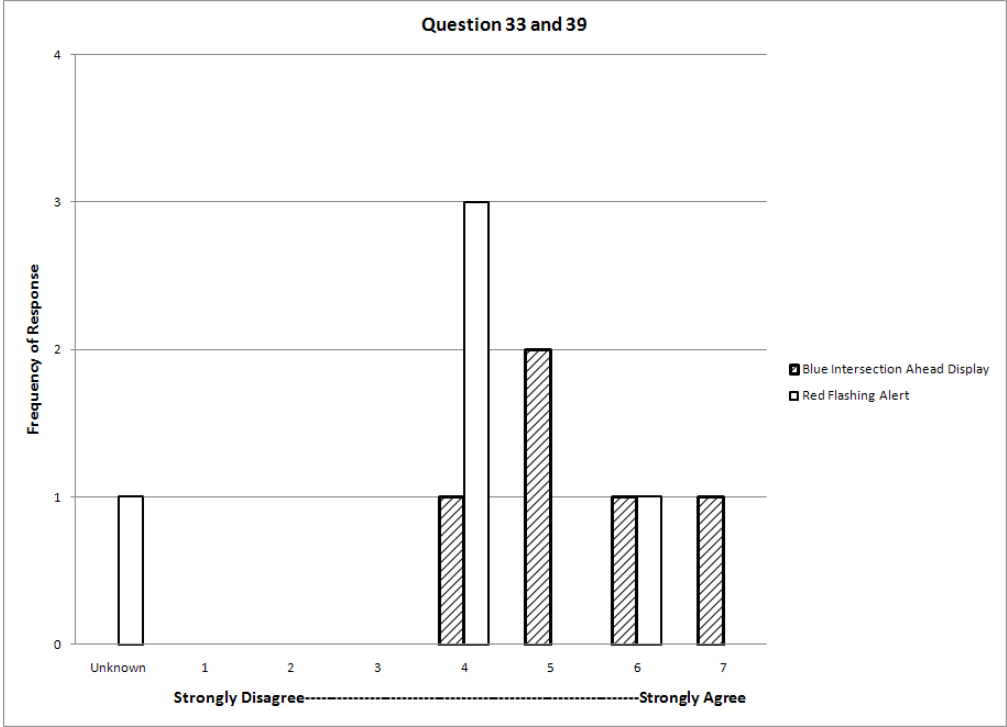


Figure 102 Location of the visual DVI.

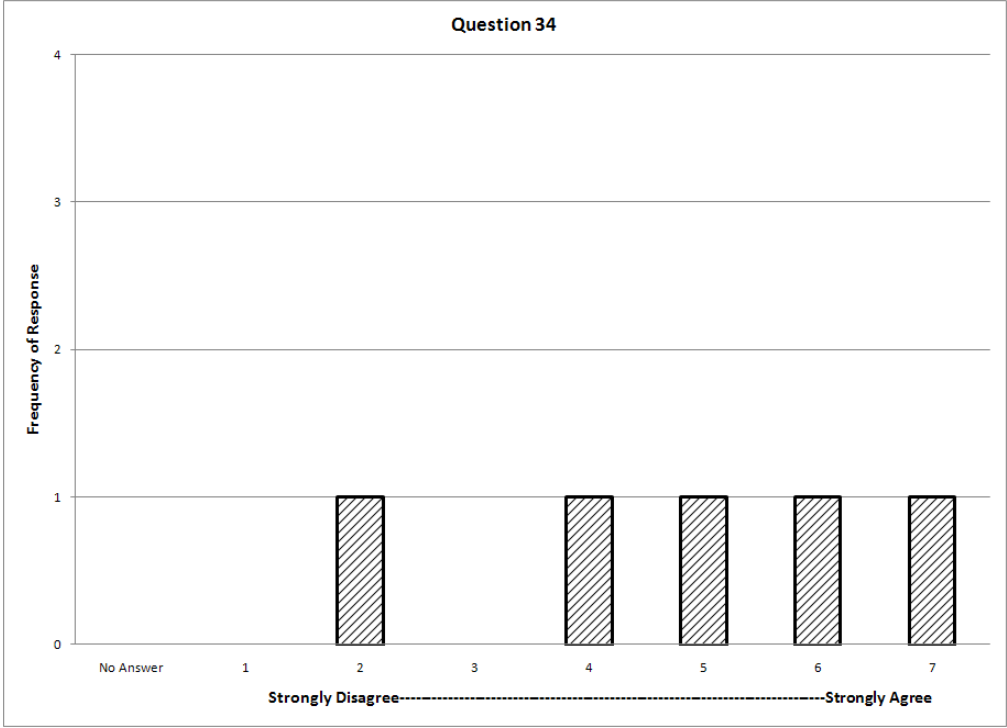
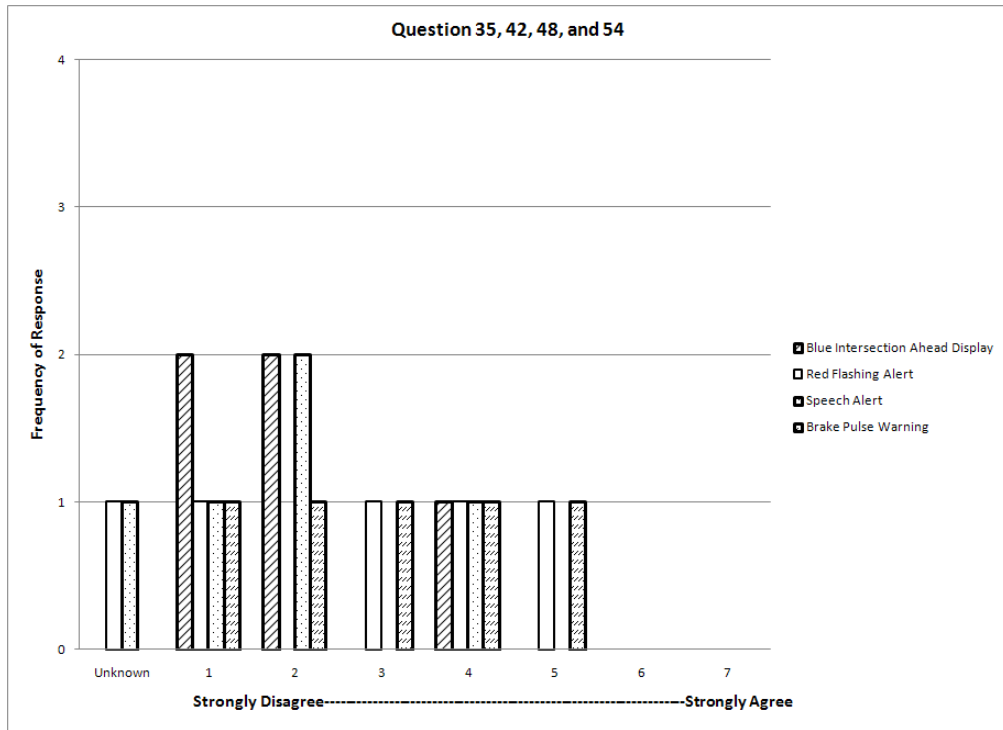
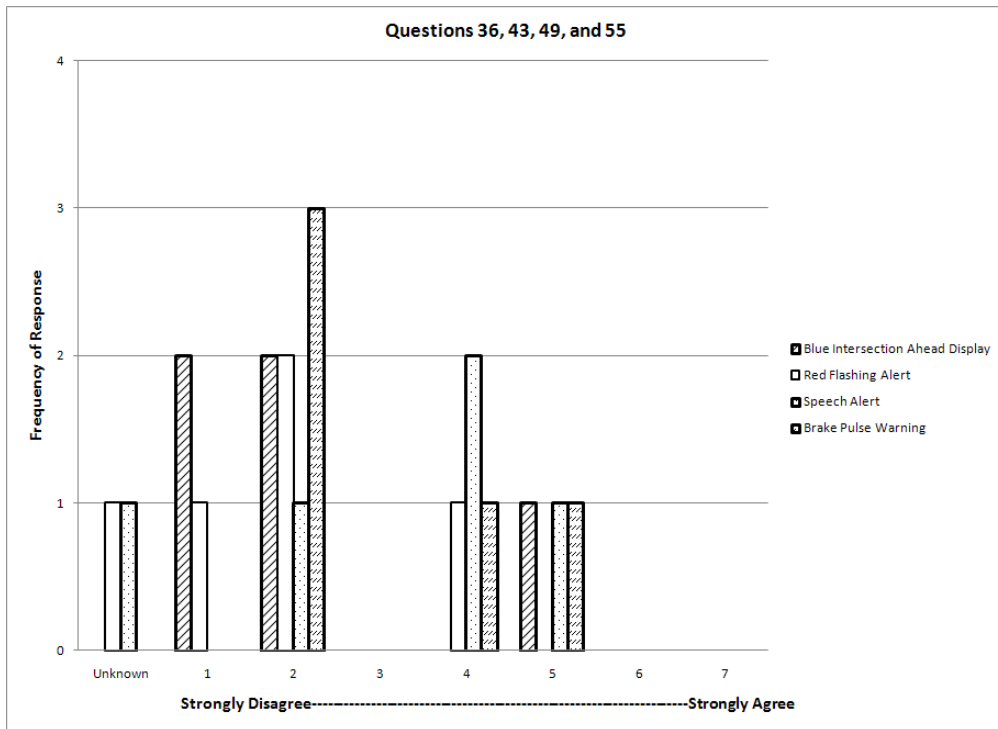


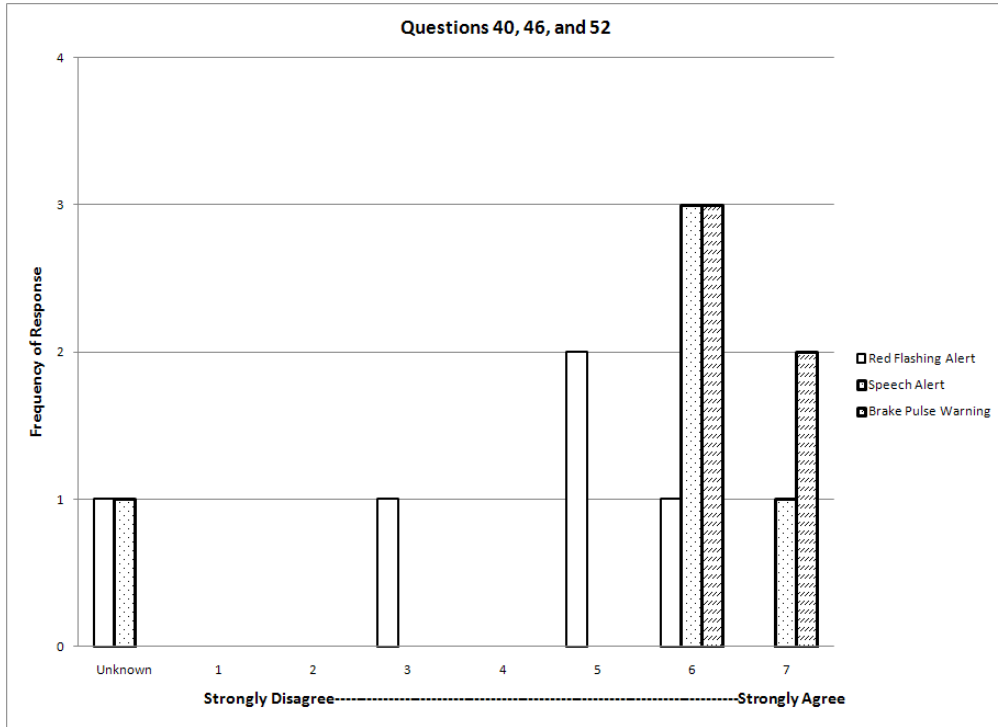
Figure 103 The “blue intersection ahead” display was an appropriate size.



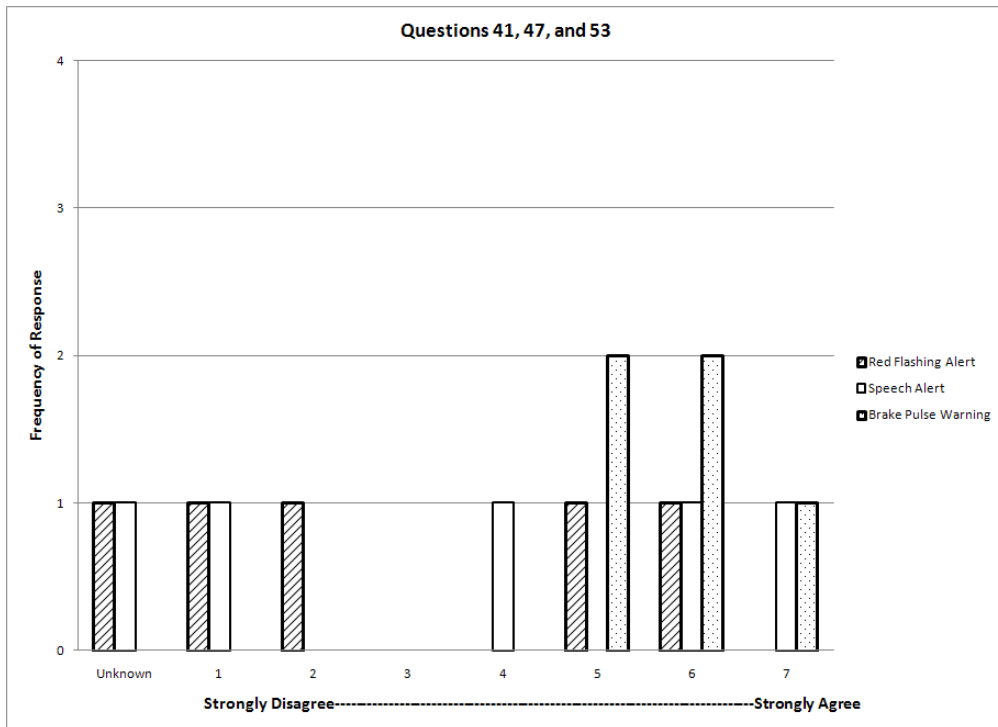
**Figure 104 Annoyance of the DVI.**



**Figure 105 Distractibility of the DVI.**

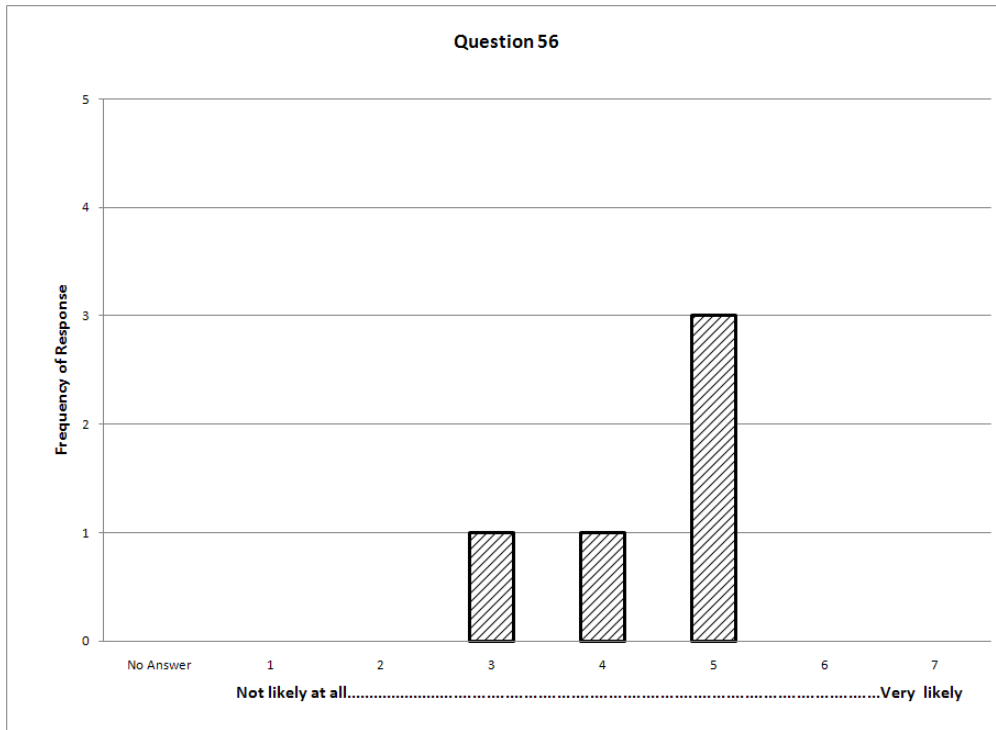


**Figure 106 Effectiveness of DVI in obtaining driver's attention.**

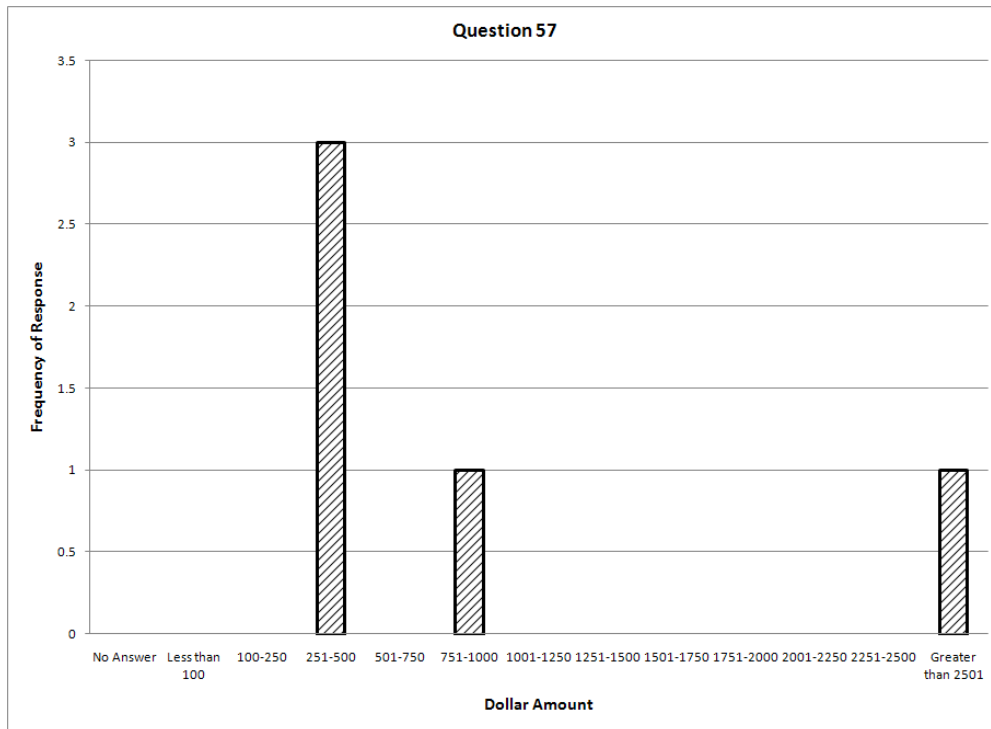


**Figure 107 Startle response of DVI.**





**Figure 108 Likeliness of purchasing the intersection warning system.**



**Figure 109 Price at which the intersection warning system is considered to be too expensive.**

**Question 58. Do you have any suggestions for improving the intersection warning system that might improve it?**

- No comment.
- The blue color of the light letting you know an intersection is ahead is sometimes hard to notice on the black; a brighter color that contrasts more with black might be better.
- I thought the blue intersection warning was little hard to see in the bright daylight-maybe a brighter display would help or color, like green.
- A better display for the approaching intersection. In the bright sun it is difficult to see it. I couldn't understand what the voice said when it was activated -- maybe a clearer description.
- No comment.

## Appendix Q: Post-Drive Questionnaire Results for Drivers Who Experienced a Violation Warning on the Smart Road Only

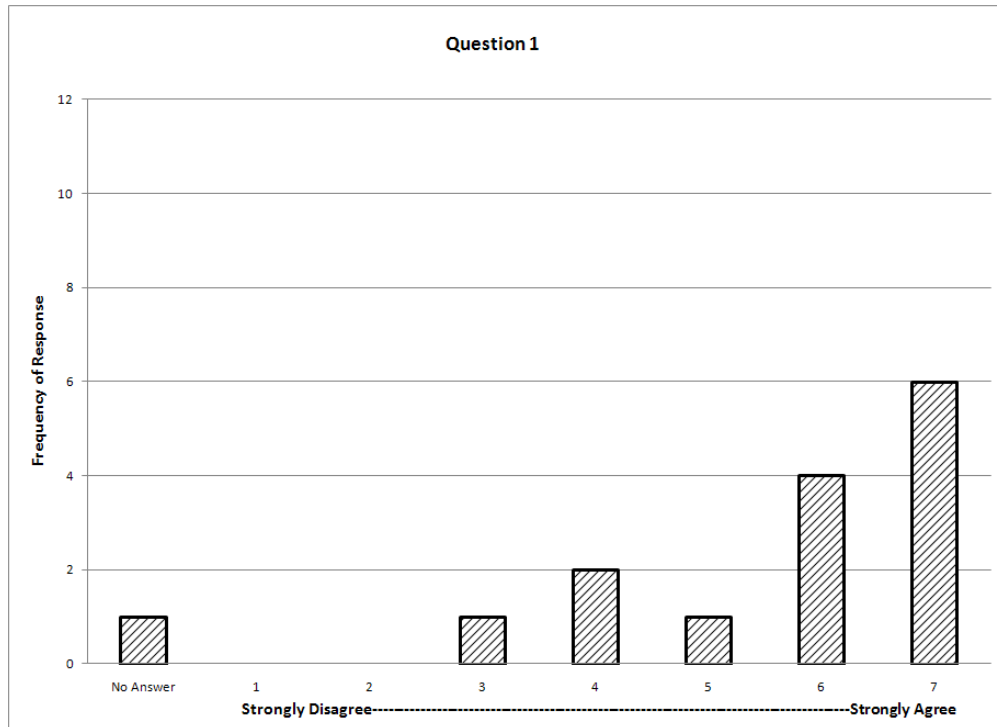
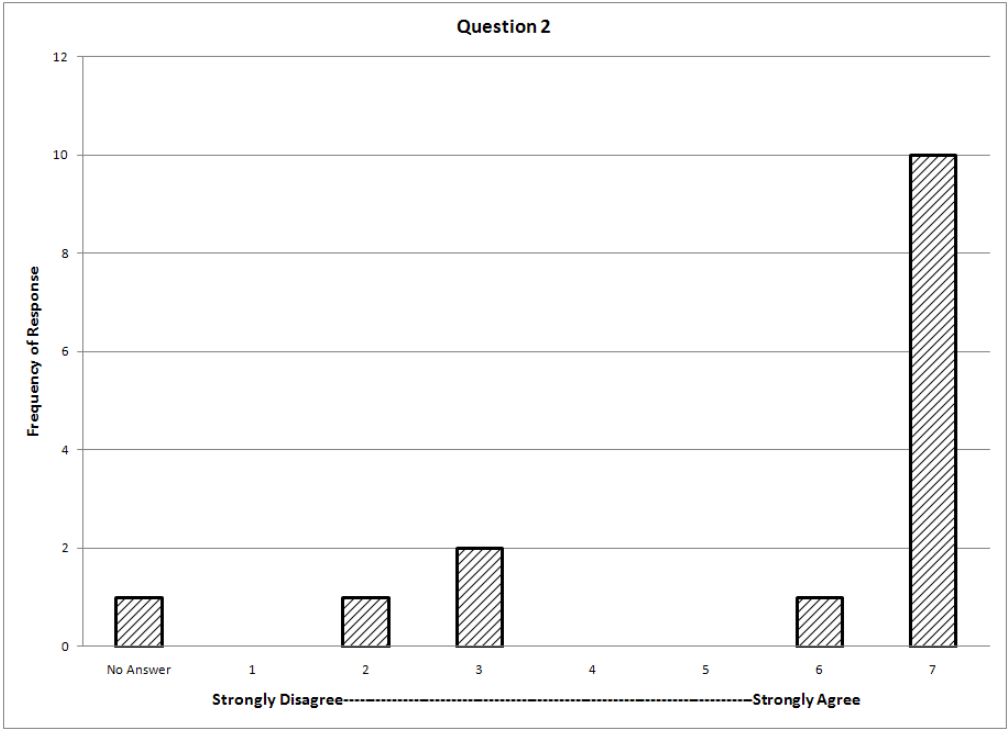
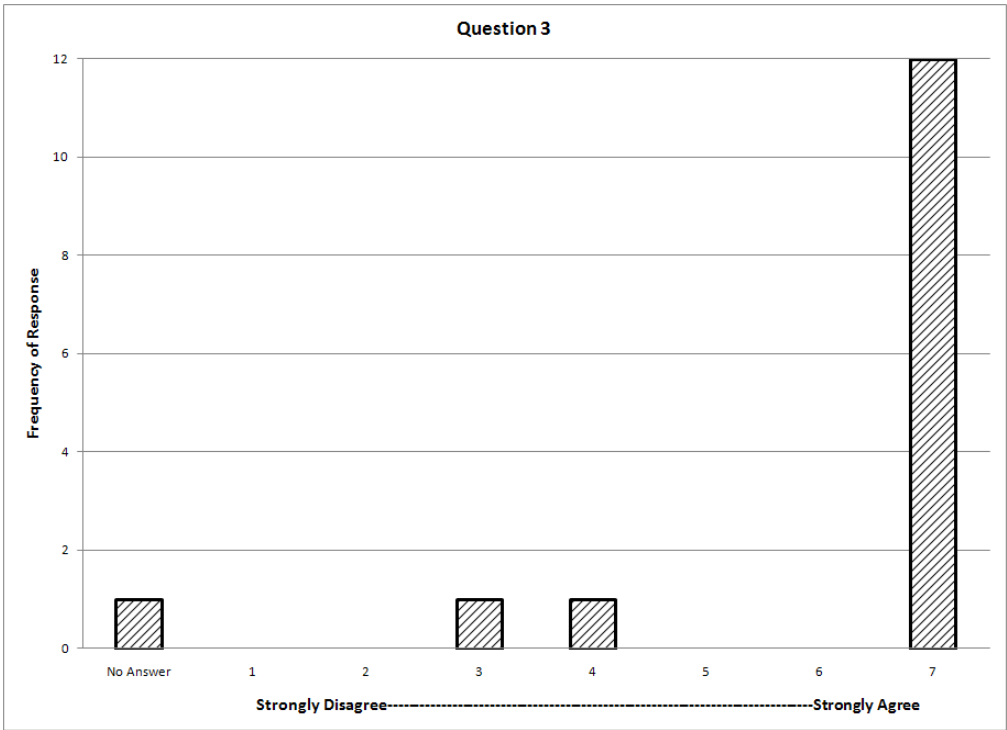


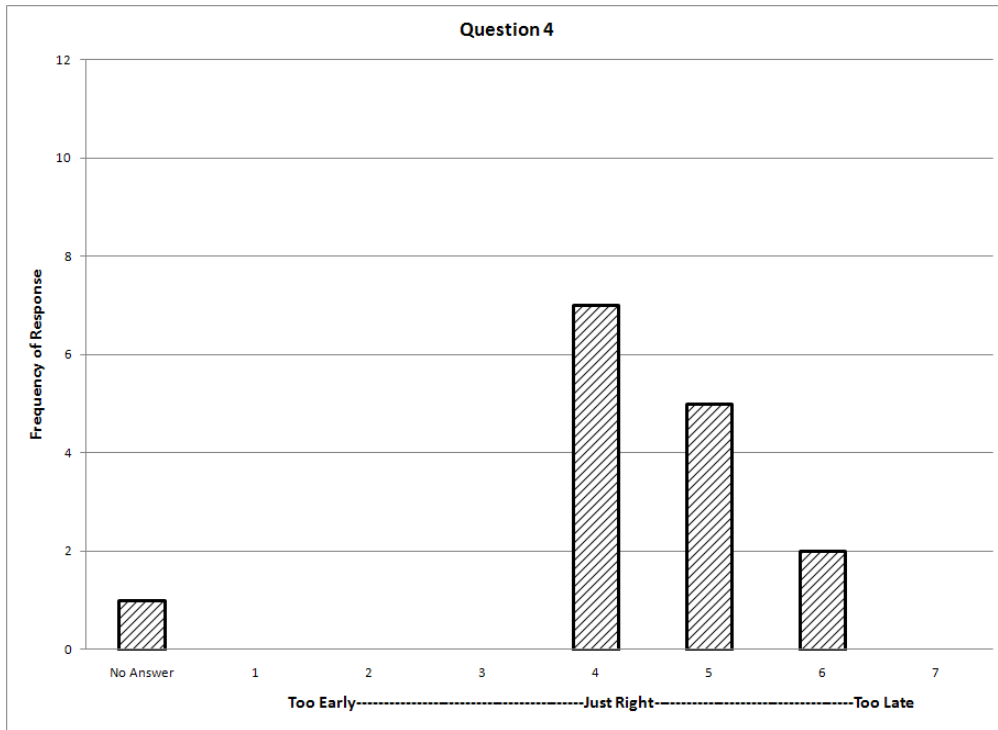
Figure 110 The “running red light” alert that let me know that I may be about to run a right light would be useful in my everyday driving.



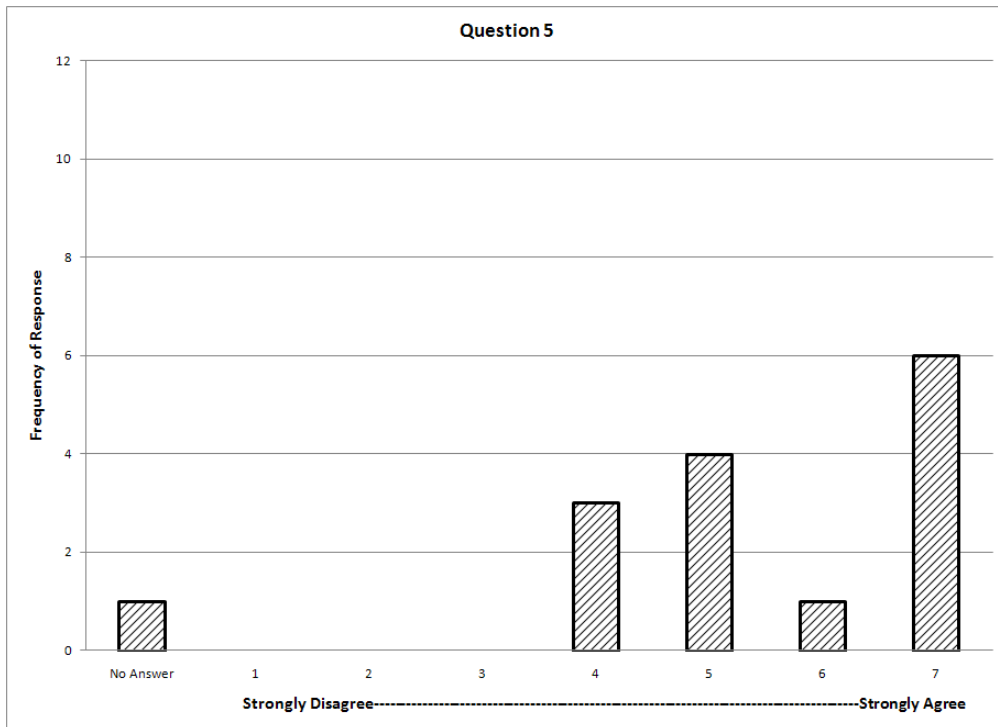
**Figure 111** The “running red light” alert was effective at communicating that I may be about to run a red light.



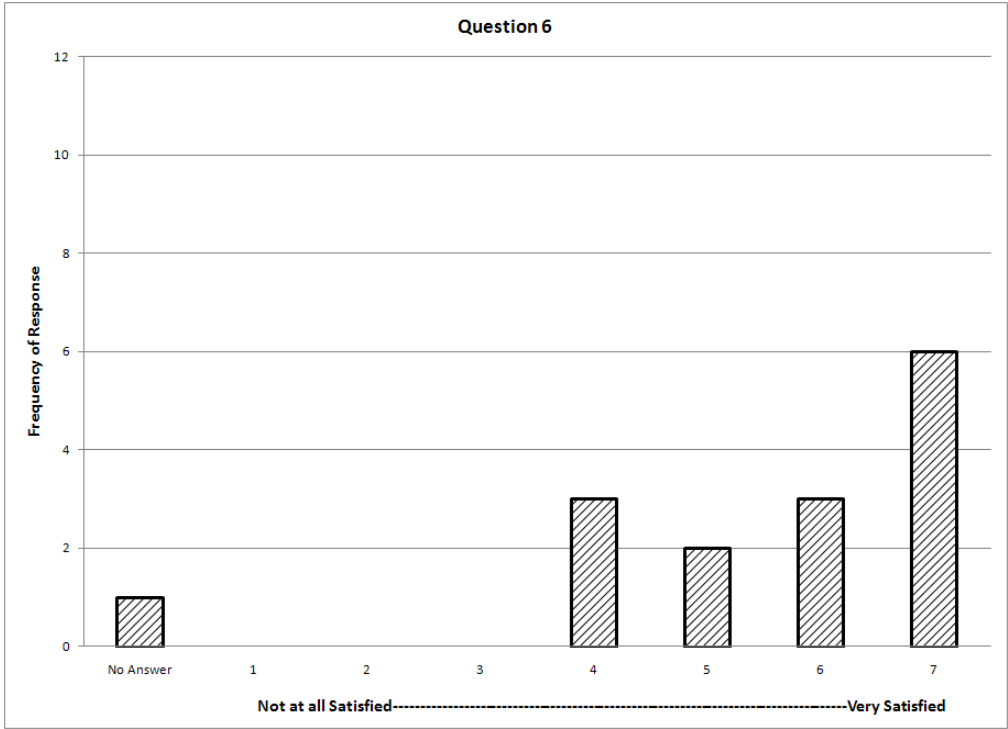
**Figure 112** The “running red light” alert was effective at getting my attention quickly.



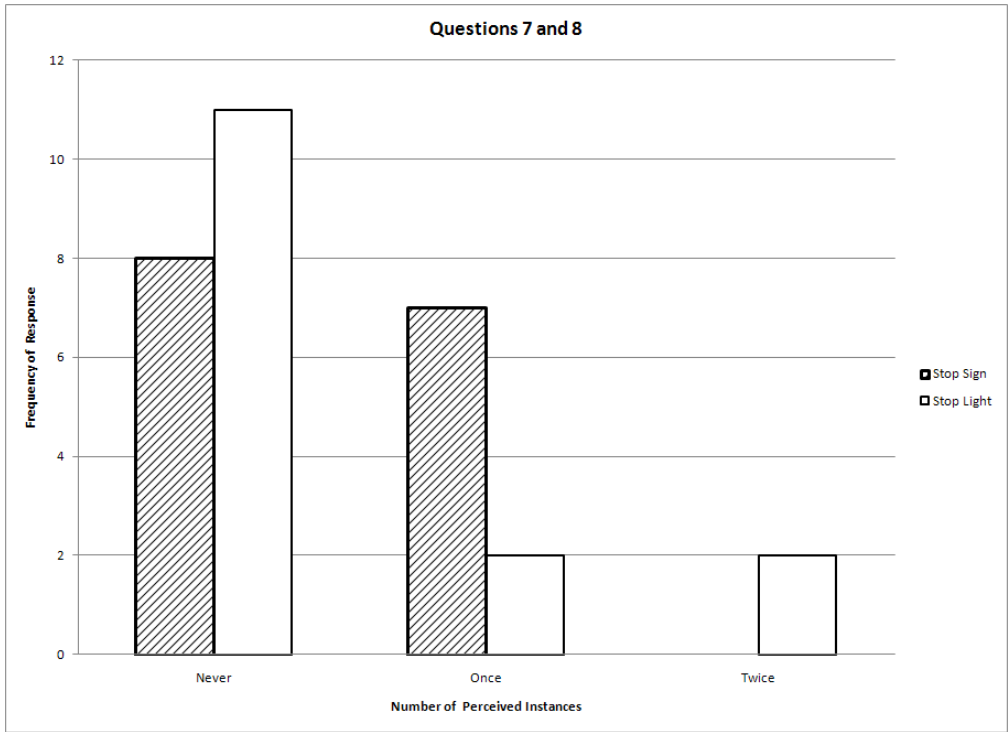
**Figure 113** What do you think of the timing of the “running red light” alert?



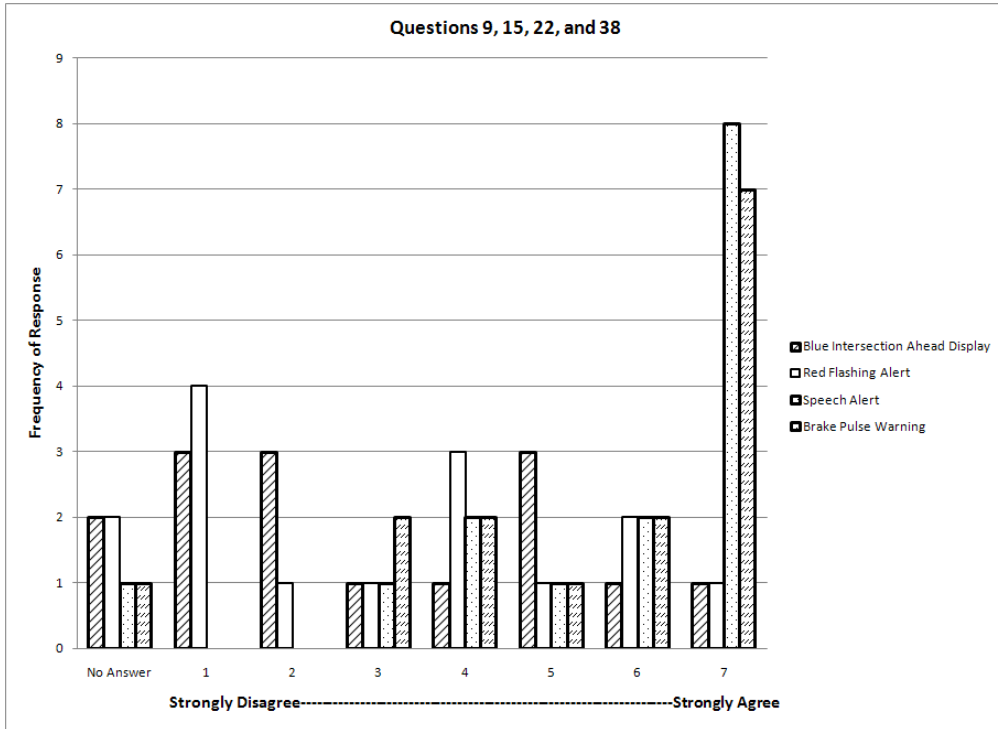
**Figure 114** I feel the “running red light” alert will increase my driving safety.



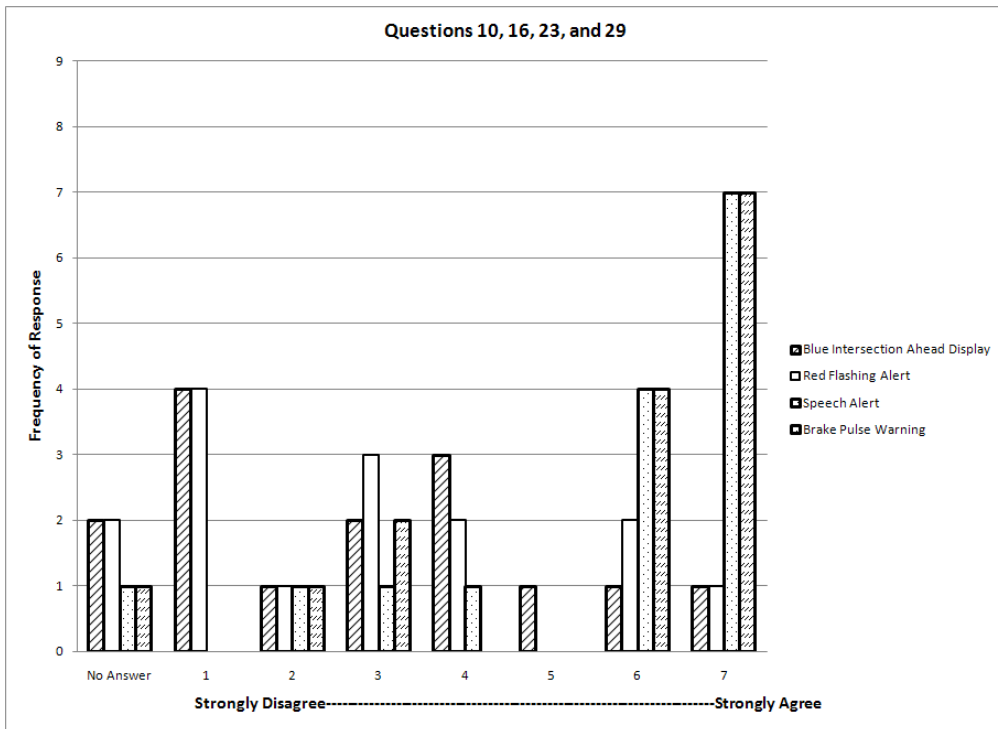
**Figure 115 Overall, how satisfied were you with the “running red light” alert?**



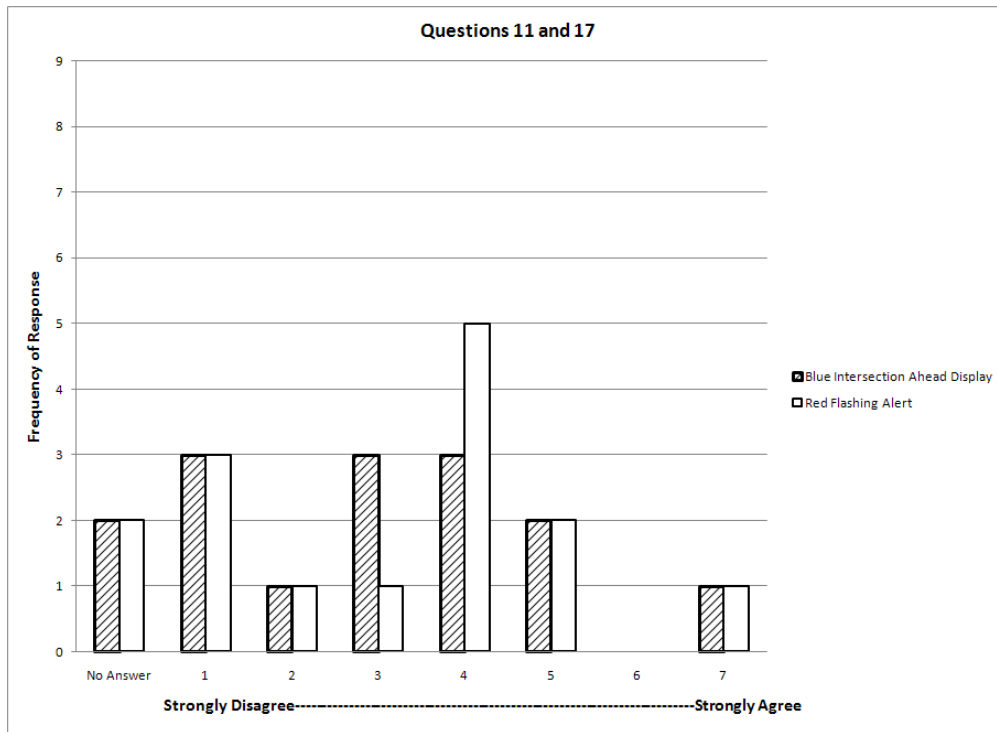
**Figure 116 Almost ran a stop sign or traffic signal.**



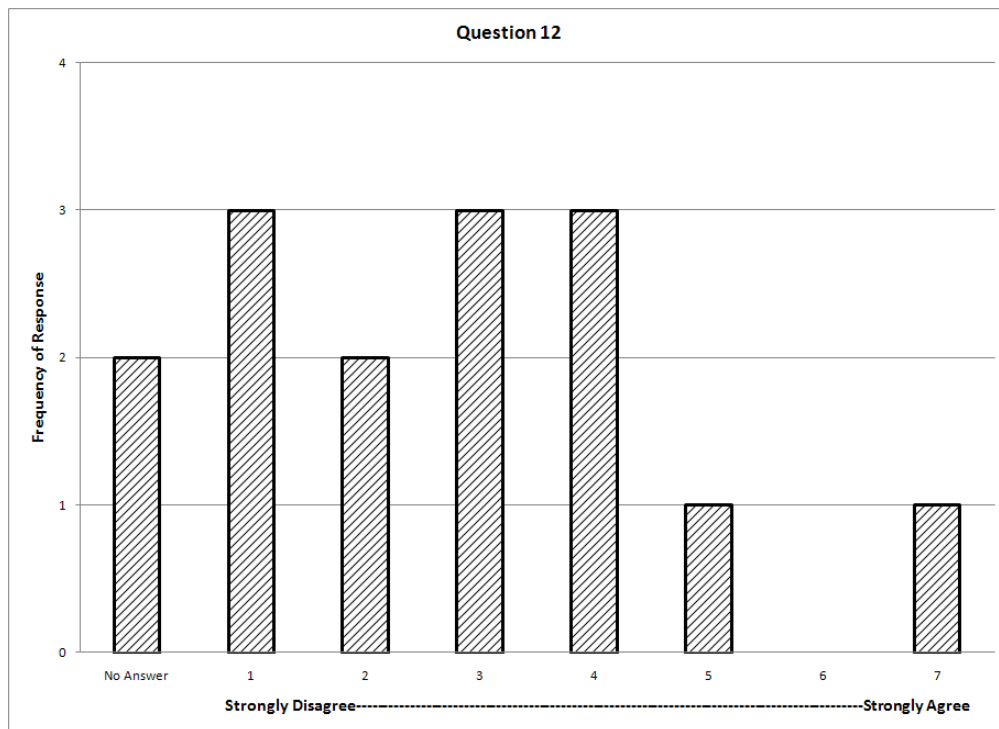
**Figure 117 Effectiveness of DVI in communicating intended information.**



**Figure 118 Ease of detecting the DVI.**

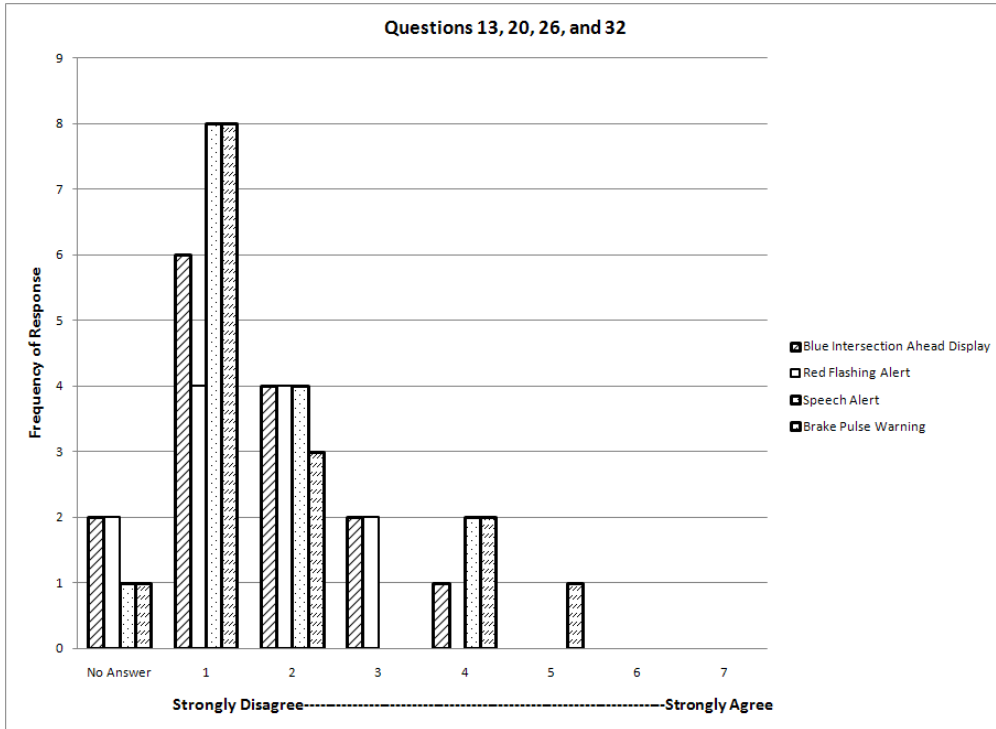


**Figure 119** Location of the visual DVI.

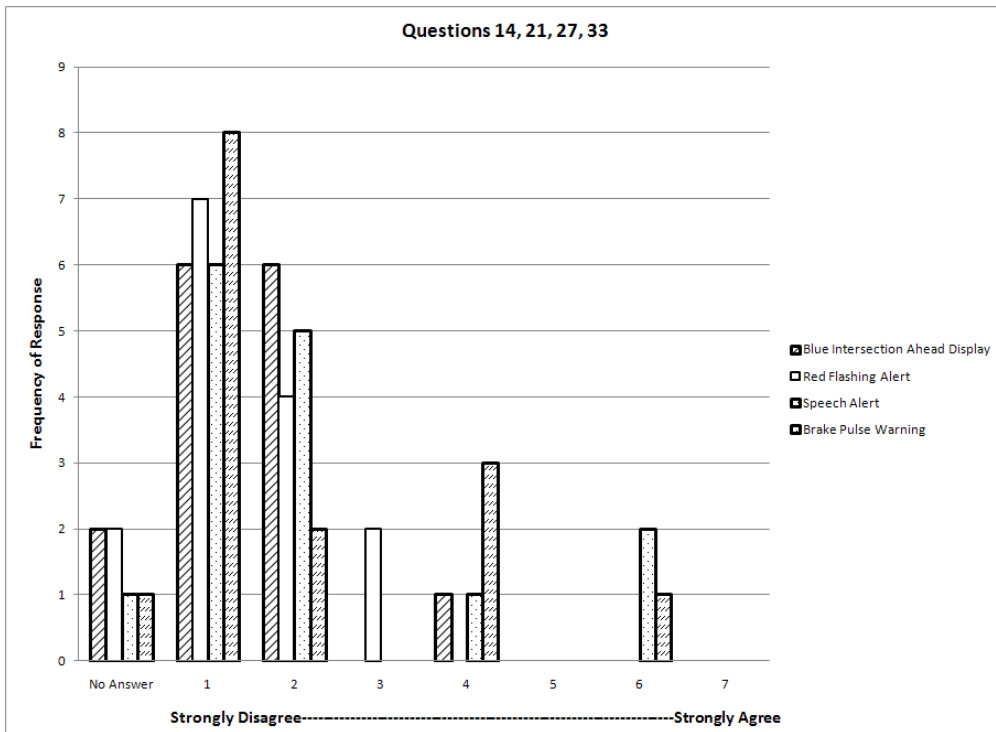


**Figure 120** The size of the blue “intersection ahead” display was appropriate.

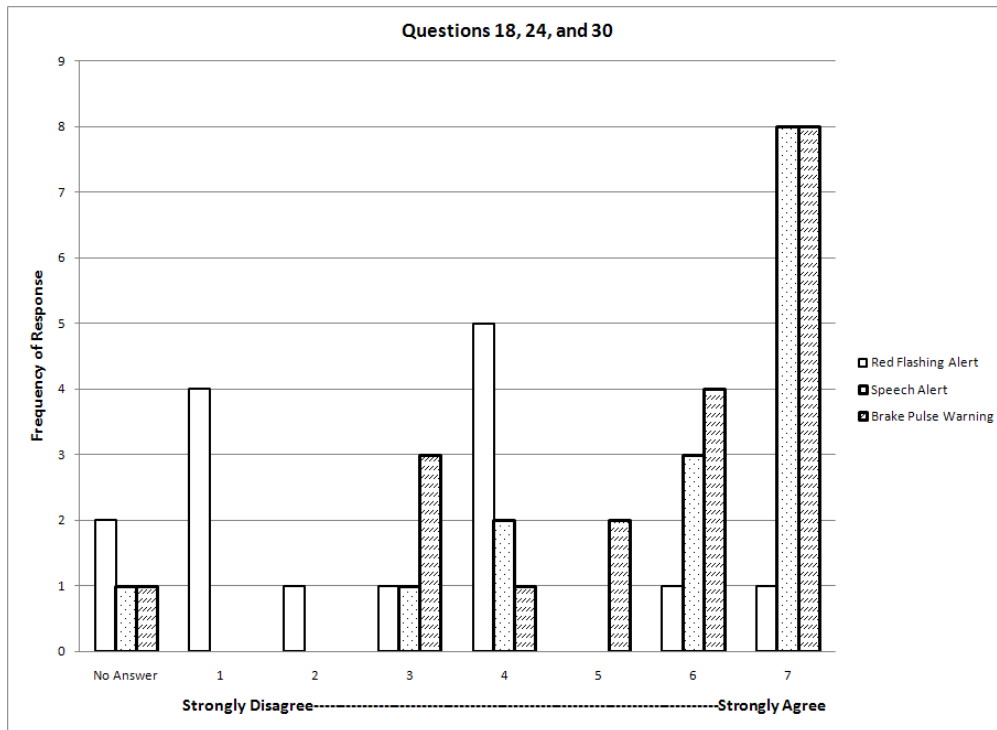




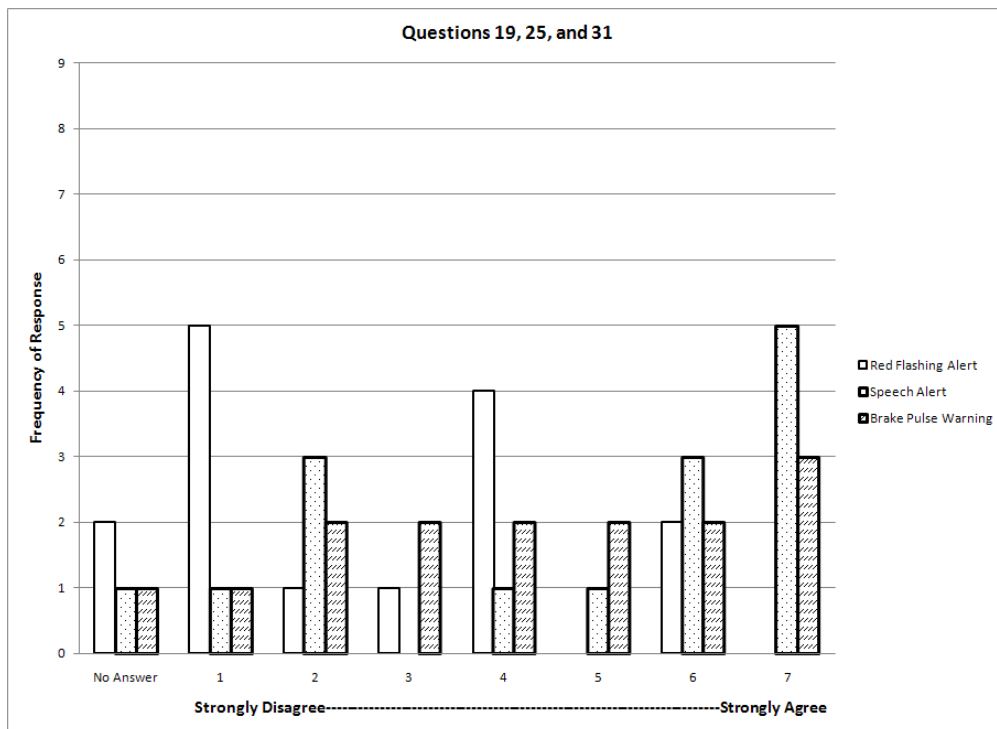
**Figure 121 Annoyance of the DVI.**



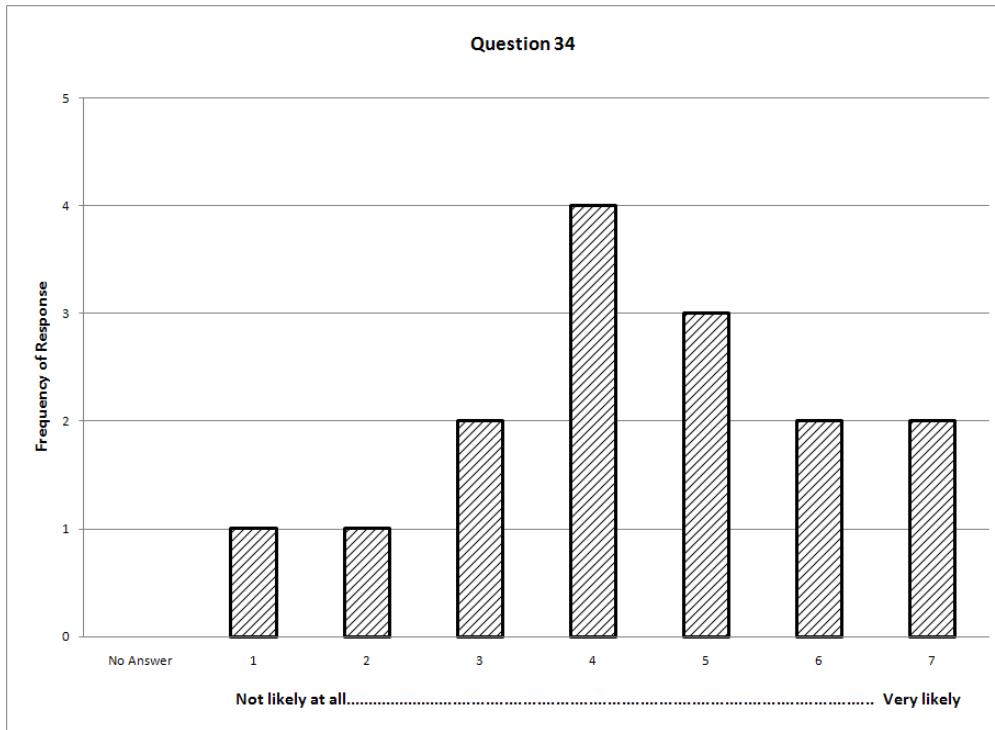
**Figure 122 Distractibility of the DVI.**



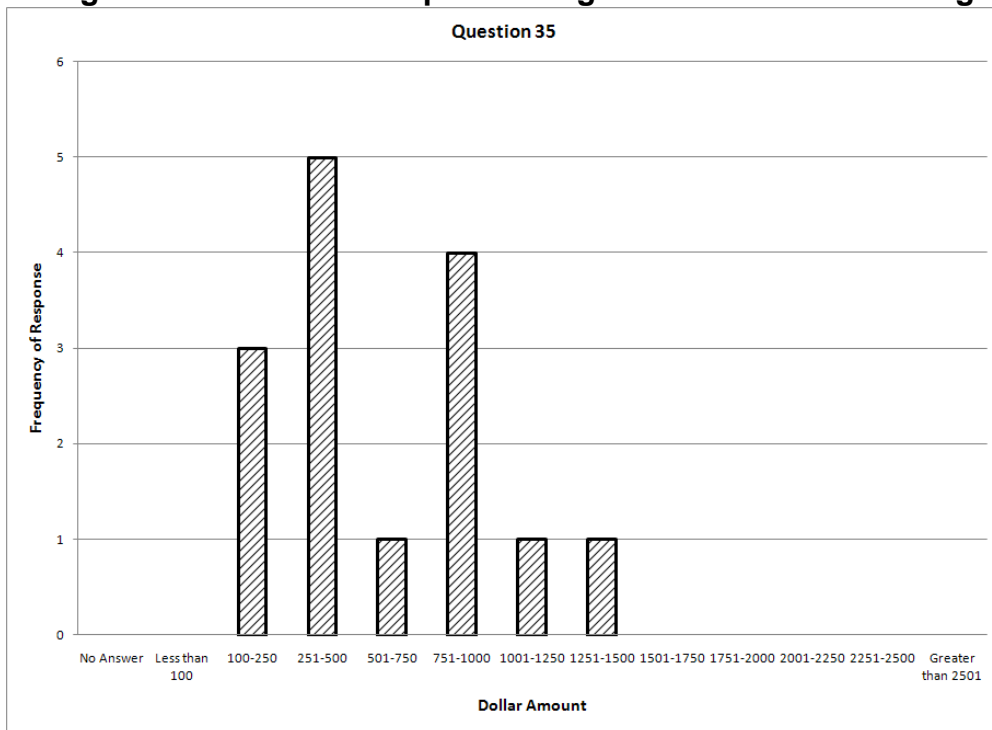
**Figure 123 Effectiveness of the DVI in obtaining driver's attention.**



**Figure 124 Startle response of the DVI.**



**Figure 125 Likeliness of purchasing the intersection warning system.**

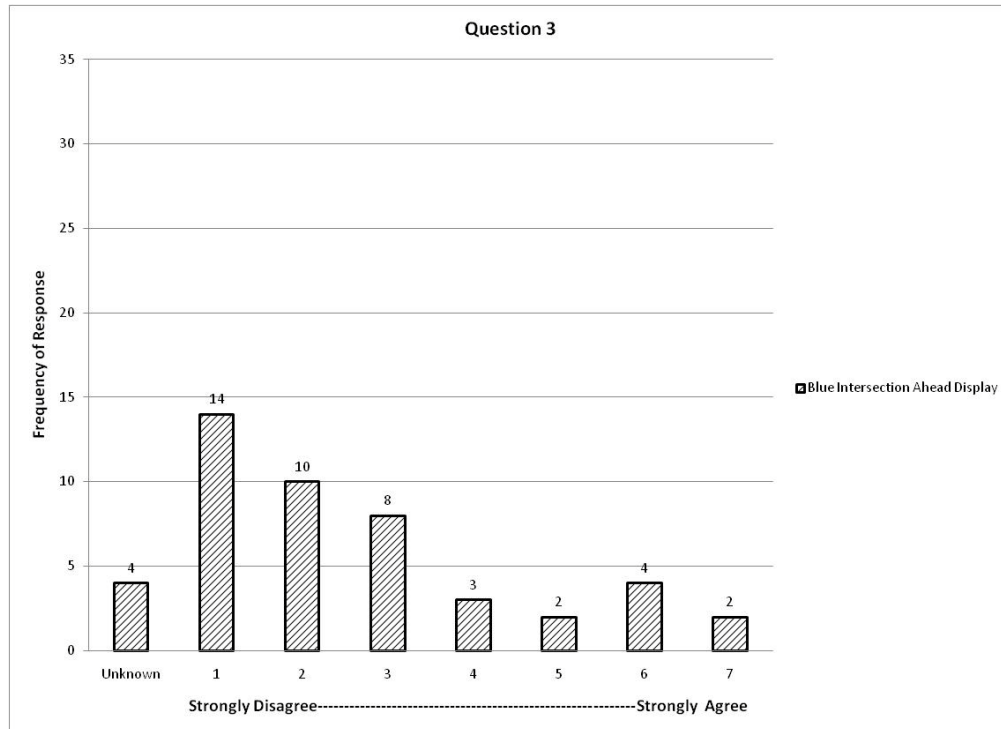


**Figure 126 Price at which the intersection warning system is considered to be too expensive.**

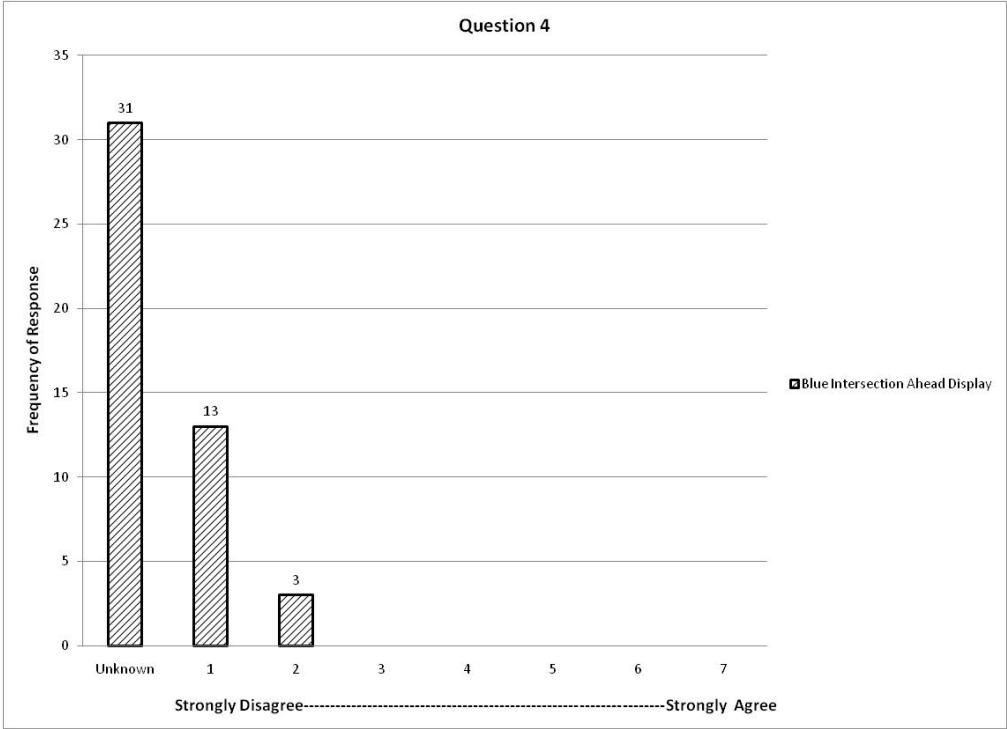
**Question 11. Do you have any suggestions for improving the intersection warning system that might improve it?**

- Increase the size of the display on the dash.
- The "brake jerk" was a little bit too aggressive; maybe something a little less strong would be more comfortable for me. Also, the voice did little in aiding the braking process because it is too long and the car is already stopped by the time it is finished.
- I did not find the 'red' and 'blue' warning lights useful; in actuality, I did not notice them at all. If I were driving at night, I think the lights would have helped me.
- During the trial it seemed to only alert an intersection that was a 4-way intersection. It would also be useful at two way intersections, mainly stop signs, to tell the difference between an actual stop or yield area.
- None.
- I never saw the blue intersection light or the red warning light.
- No comment.
- No comment.
- Not at this time.
- No comment.
- I did not see the intersection ahead display. I did not see the running red light display.
- Did not notice the red light warning.
- Visual warning less obvious than braking and sound.
- No comment.
- Location could be tweaked and compared to the existing "box" to see how a slightly different location would "feel".

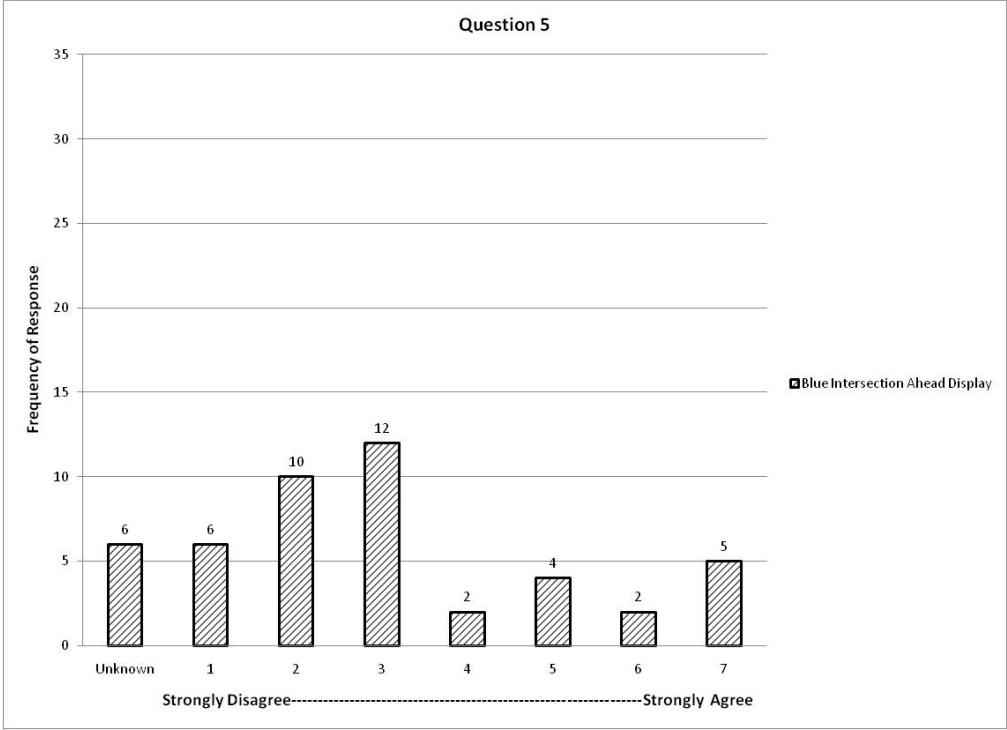
## Appendix R: Post-Drive Questionnaire Results for Drivers Who Did Not Experience a Violation Warning



**Figure 127 The DVI was effective at communicating to me the intended information.**



**Figure 128 Ease of detecting the DVI.**



**Figure 129 Location of the visual DVI.**

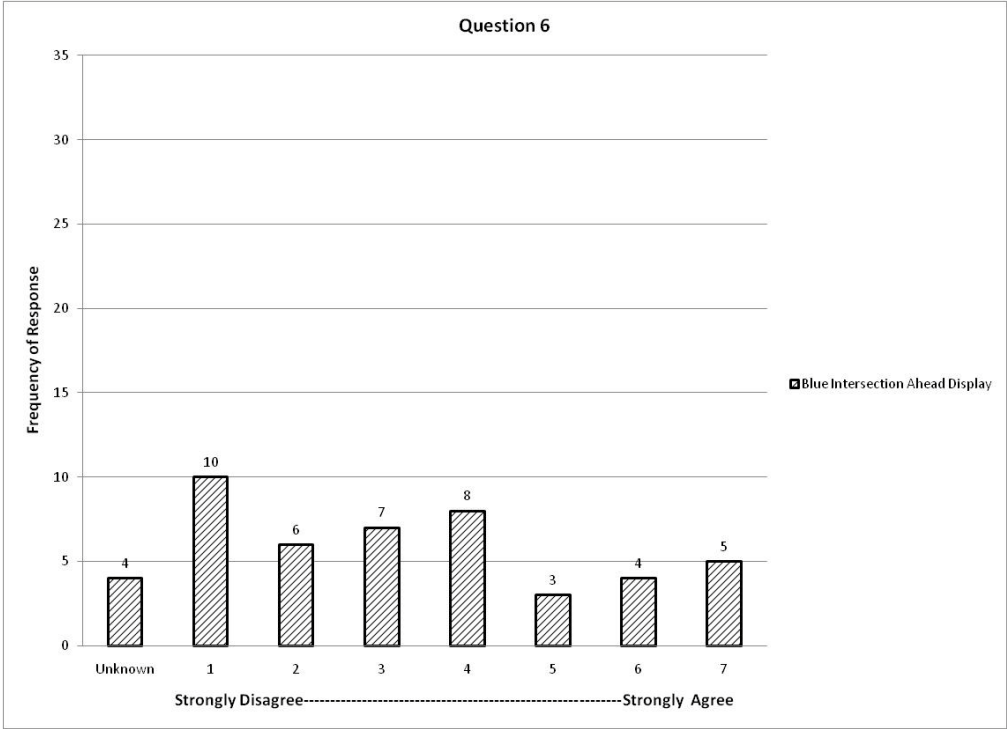


Figure 130 Size of the DVI display.

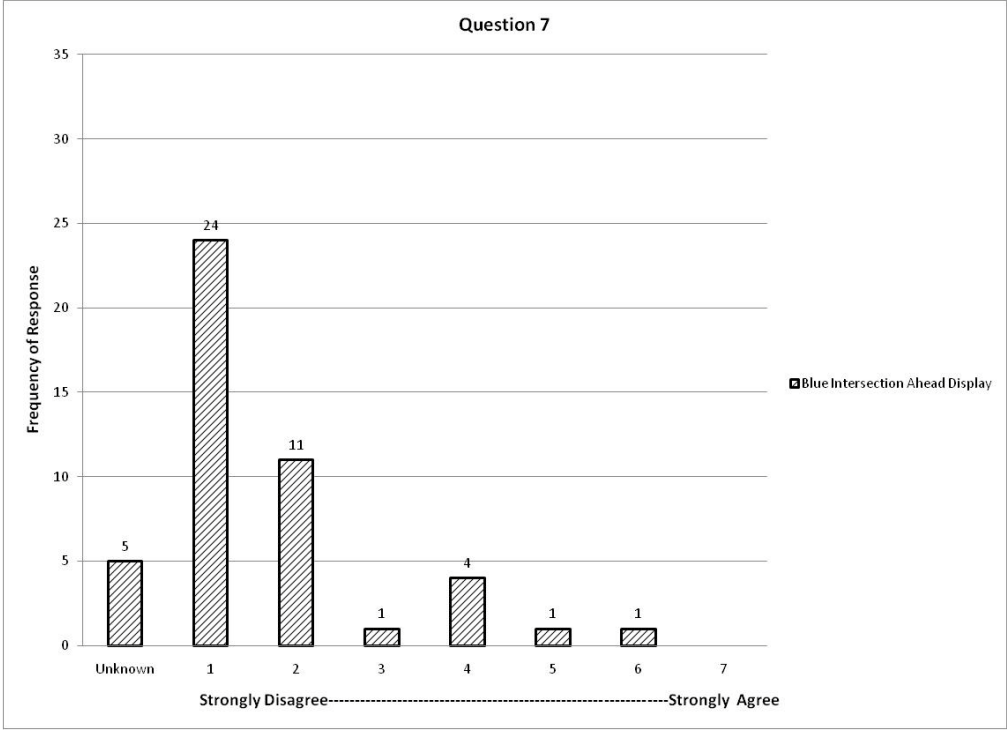
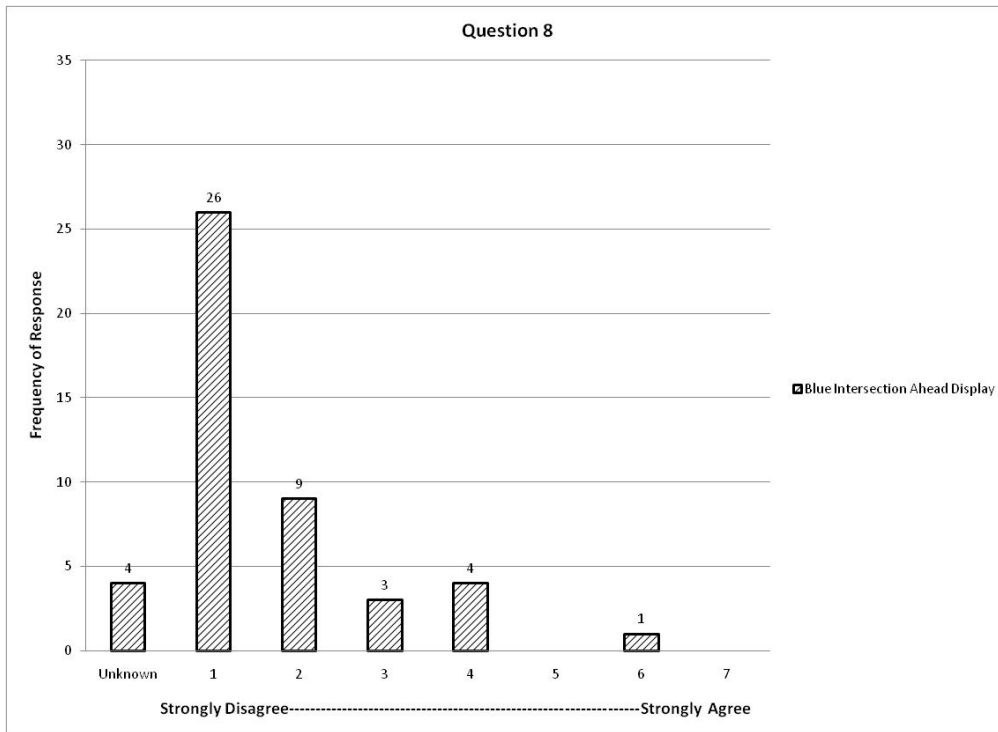
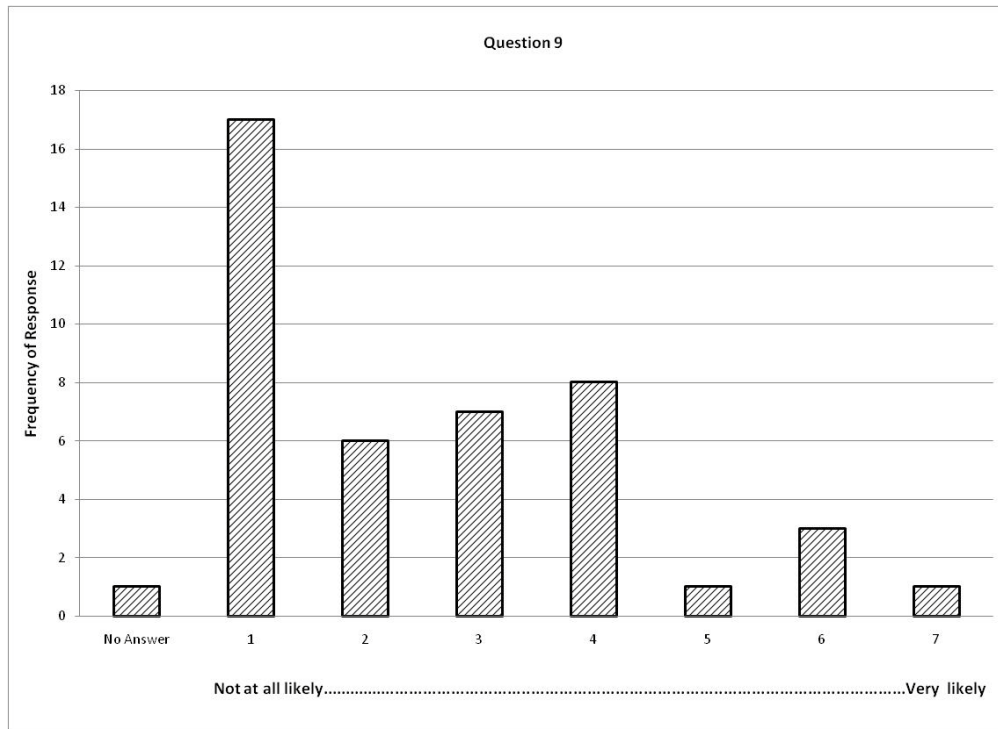


Figure 131 Annoyance of the DVI.

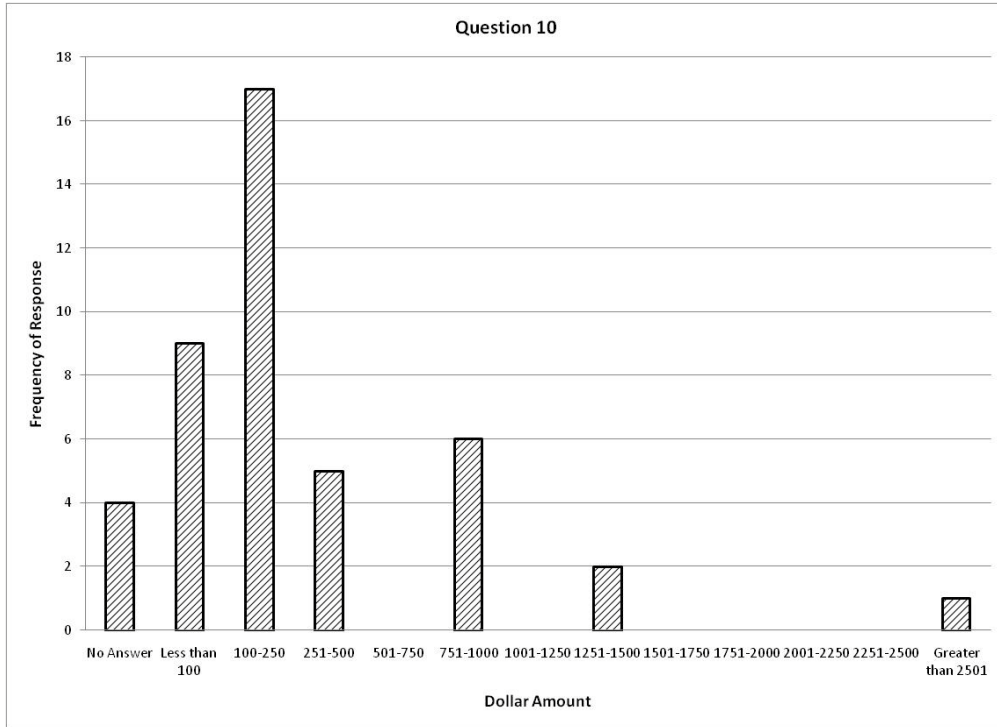


**Figure 132 Distractibility of the DVI.**



**Figure 133 Likelihood of purchasing the intersection warning system.**





**Figure 134 Price at which the intersection warning system is considered to be too expensive.**

**Question 36. Do you have any suggestions for improving the intersection warning system that might improve it?**

- I never saw a blue "intersection ahead" display while driving.
- Unless you happened to glance at it, it wasn't in the greatest place; however, if it were more in front of you, it would potentially take away from your vision of the road. A beep or voice would be helpful.
- Just never noticeable if paying attention to the road; maybe if it were in a different spot. Beeping, however, would be very annoying.
- I would change the color of the light because I could not see when it was on.
- I would find the intersection warning system much more useful if it appeared with the heads up speedometer display, directly on the driver's side windshield. As is, it is just a little out of the way to see.
- It seemed to work fine, but I noticed it didn't go off at one stop sign.
- I didn't even notice the light until more than half way through the drive.

- Possibly move closer to windshield MPH indicator; make slightly bigger icons, sometimes hard to see in certain light.
- A brighter light or a more vivid image that was easier to depict. Many times I had to squint my eyes to see if the blue light was on. Maybe if the sign was with the marked speed on the windshield it would be in a more visual view (more likely to see).
- No, everything was great. (Participant marked N/A, "I didn't see a blue display at any time" on survey)
- Make her speak faster - when the speed limit is faster she's behind at times. I wish I have could the route on display as a backup confirmation
- If it appeared on the windshield, like the speed did, that way you could have the option of having it or not.
- Make the blue light brighter so it's easier to detect.
- No, seems like it works well.
- Make it have sound alerts - I hardly noticed it was even there.
- Landmarks used to supplement the audio (i.e. "turn left onto Sheltman St. after the rescue squad") can be useful, especially when heavy traffic or obscured road signs contribute to possible driver confusion.
- By and large, I didn't notice the system until after coming to a stop. The blue light on a black background is difficult to detect.
- A different color such as yellow or red, maybe orange or bone color.
- No comment. (After participant filled out questionnaire he mentioned he never noticed blue light. He answered the questions as if he had seen blue light because he felt it would have been effective.)
- There needs to be a sound indicator or the warning needs to be closer to the driver's center of vision while driving. Brighter colors would also be an improvement.
- It did not always alert me in time; inconsistent. Red might be a better color; red=stop. A "tone" that you can turn on or off might help in an area where you are not familiar with the streets.
- The intersection warning system needs to be a little larger.

- Although it was pointed out to me in the pre-driving phase, I did not notice it while driving.
- My personal preference is to have nothing on the dashboard. I even found the speed limit I was driving displayed on the windshield distracting. The only location for the intersection warning system to be located, if I were to consider purchasing a car with the option, would be to have it on the dashboard where the speedometer and other regular controls on a car are traditionally found.
- I personally didn't see it or notice it, so I would have to say make it more noticeable.
- I did not notice the system. It was pointed out to me at the beginning but I didn't notice it at all.
- Intersection warning system was not used during drive.
- Since I forgot what the blue display meant, I can't offer any reasonable suggestions.
- None.
- Better explanation of what it does and how it functions, 2) Integrate into heads up display or gage dash system, 3) Add sound option, 4) Make it yellow or orange for alert.
- Change color (red), include tone (low volume), heads-up display rather than dash mounted.
- Not at a deal breaker in buying a car. Voice/verbal warning would be more effective or, better yet, have option to have one on the other (i.e. option to use or not use voice, a blue [button] or both). Some may find voice distracting.
- I think possibly it might be more effective if it were a flashing blue light. I only noticed it occasionally. Probably would be more interested in purchasing if it had actually kept me from running a light!
- No.
- I honestly paid no attention to it and never even noticed it.
- It was not very obvious that it was even working; need to make it stand out more.
- It was so inconspicuous that I never noticed it; in fact, I forgot it was even mentioned before I started driving.

- I was not really attentive to this warning system - due to the bright daylight conditions and the fact that I needed to wear my sunglasses.
- I like the information farther ahead than the warning system or the GPS system...
- I was totally unaware of the existence of the system.
- Unless you happened to glance at it, it wasn't in the greatest place; however, if it were more in front of you it would potentially take away from your vision of the road. A beep or voice would be helpful.
- Perhaps making it a little larger to see.
- Although it was pointed out to me in the pre-driving phase I did not notice it while driving.
- It was not very obvious that it was even working; need to make it stand out more.



U.S. Department of Transportation  
ITS Joint Program Office-HOIT  
1200 New Jersey Avenue, SE  
Washington, DC 20590

Toll-Free "Help Line" 866-367-7487  
[www.its.dot.gov](http://www.its.dot.gov)

FHWA-JPO-10-068



U.S. Department of Transportation  
**Research and Innovative Technology  
Administration**