

**SINGLE MAILBOX INSTALLATION**

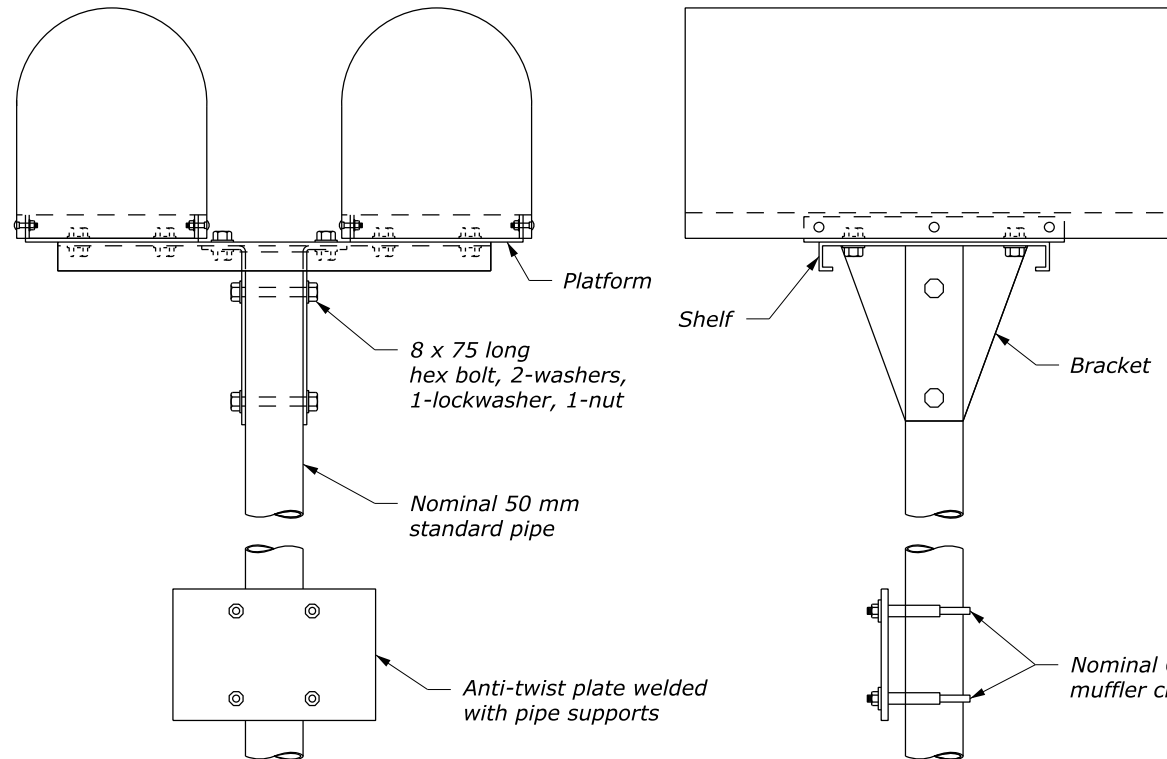

**DOUBLE MAILBOX INSTALLATION**

**NOTE:**

1. Spacing between multiple mailboxes and height of mailbox above ground level are as established by the the U.S. Postal Service. H is usually 1.0 m to 1.2 m.
2. Dimensions without units are millimeters.

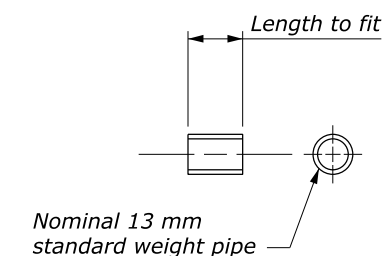

**SPACER**

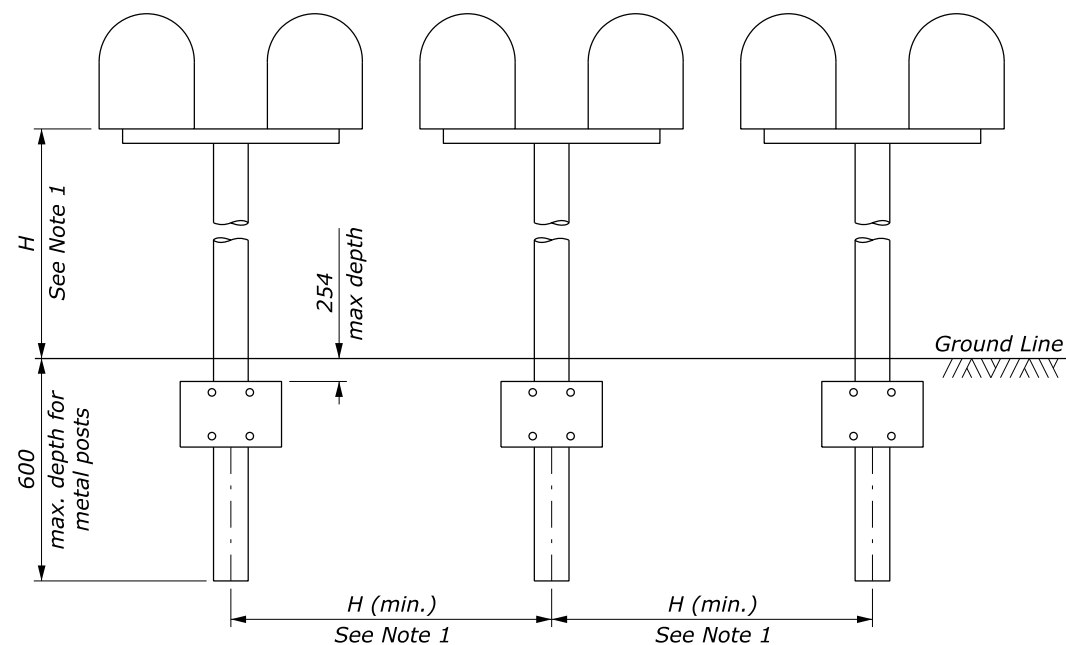

**SPACING FOR MULTIPLE INSTALLATION**

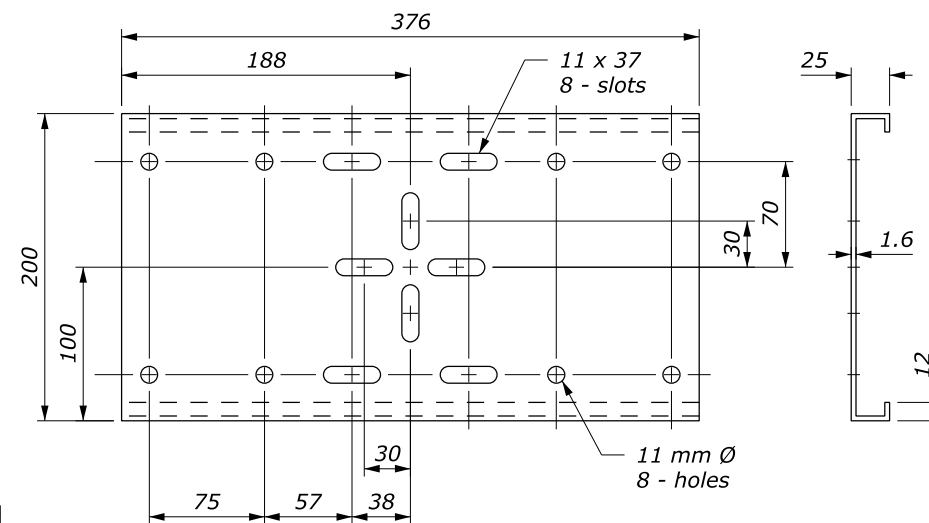

**SHELF**

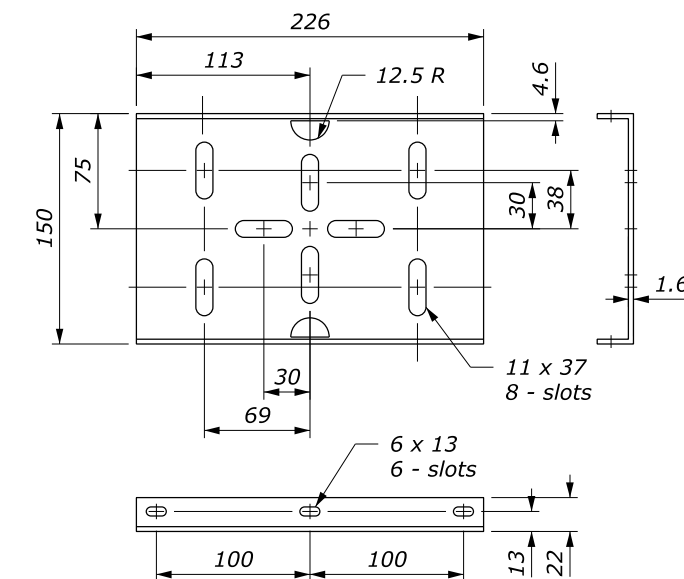

**PLATFORM**

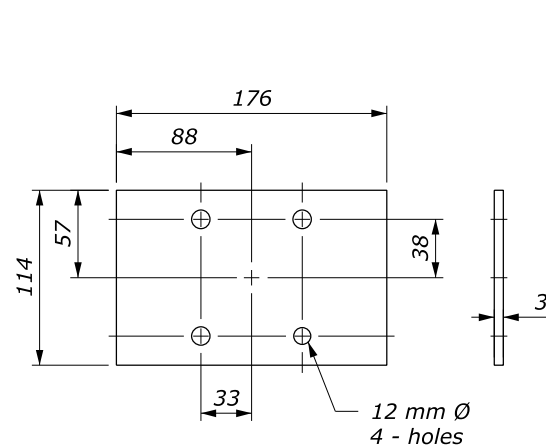

**ANTI-TWIST PLATE**

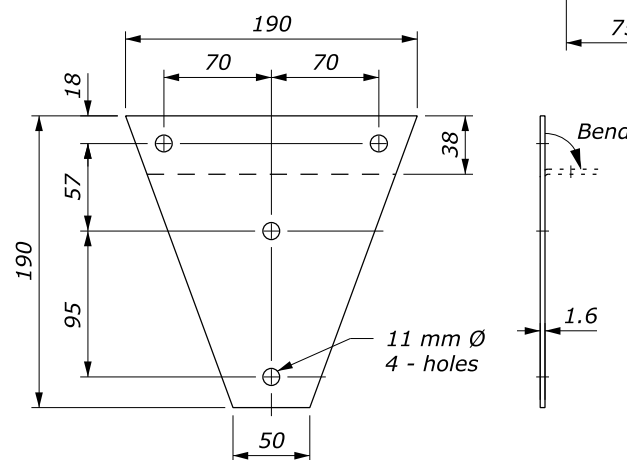

**BRACKET**

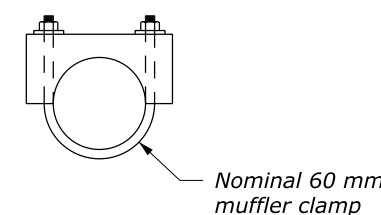

**CLAMP**

NO SCALE

U.S. DEPARTMENT OF TRANSPORTATION FEDERAL HIGHWAY ADMINISTRATION WESTERN FEDERAL LANDS HIGHWAY DIVISION	
METRIC DETAIL	
<b>MAILBOX ASSEMBLY SERIES A</b>	
DETAIL APPROVED FOR USE --/----	DETAIL
REVISED: DRAFT: 11/2014	MW646-2