

**FLEXIBLE PLASTIC POSTS**

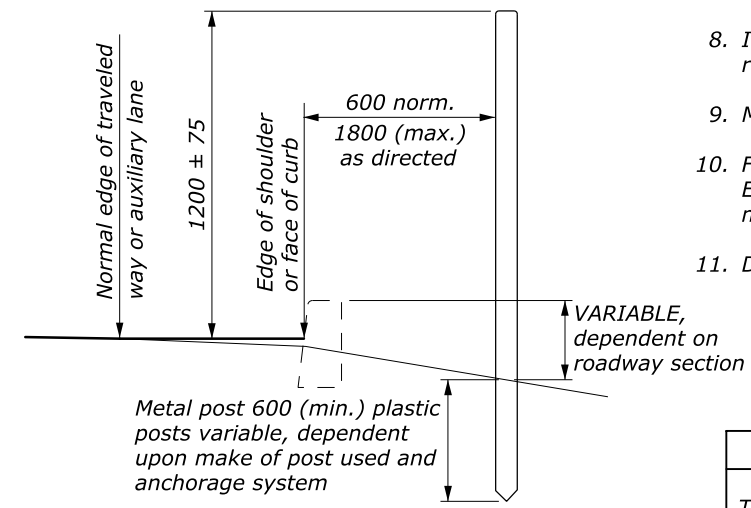
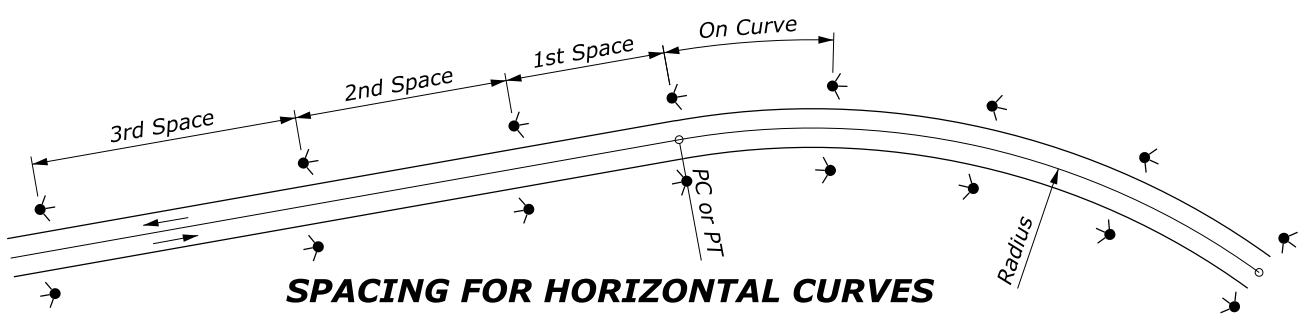

- NOTE:**
- Place delineators nearly opposite each other on horizontal curves.
  - Install all delineators with reflectors facing adjacent on-coming traffic.
  - Install delineators behind the rail at guardrail locations.
  - Offset delineators a minimum distance of 1.2 m in areas of heavy snow removal operations.
  - On roads with less than 500 ADT, use delineators only for situations such as sharp vertical or horizontal curves, or other undesirable geometrics exist.
  - Vary the post spacing up to 1/4 of the spacing shown to clear driveways, cross roads, intersections or ramps. Eliminate the post if the variation is exceeded.
  - When the contract does not provide for the construction of the ultimate pavement, allow for the thickness of base and pavement to be placed later when establishing the elevation of the traffic delineators.
  - If horizontal and vertical curves are combined, use the more restrictive spacing.
  - Measure spacing along the shoulder or face of curb.
  - Furnish hardware in the metric sizes shown. Equivalent US Customary sizes may be used when metric sizes are unavailable.
  - Dimensions without units are millimeters.

REFLECTOR DETAILS			
TYPE	REFLECTOR & TARGET/ POST COLOR	NUMBER OF REFLECTORS	USAGE AND SPACING
W-1	White	1	Max. tangent spacing: 120 m each side
			Intersections (tapers and widening): 30 m
			See Horizontal Curves table for variations
W-2	White	2	Intersection Radius: 3 min. @ 15 m
			Lane Reduction: 3 min @ 30 m

HORIZONTAL CURVES				
RADIUS OF CURVE	SPACING ON EACH SIDE OF ROADWAY IN METERS			
	ON CURVE	IN ADVANCE OF & BEYOND CURVE		
		1st SPACE	2nd SPACE	3rd SPACE
≥ 1750	90	90	90	90
875 to < 1750	70	90	90	90
585 to < 875	50	90	90	90
440 to < 585	40	80	90	90
350 to < 440	35	70	90	90
295 to < 350	30	60	90	90
250 to < 295	30	55	85	90
195 to < 250	25	50	75	90
145 to < 195	20	45	65	90
105 to < 145	20	35	55	90
75 to < 105	15	30	45	90
50 to < 75	10	25	35	75
32 to < 50	10	20	30	55
≤ 32	5	15	20	40

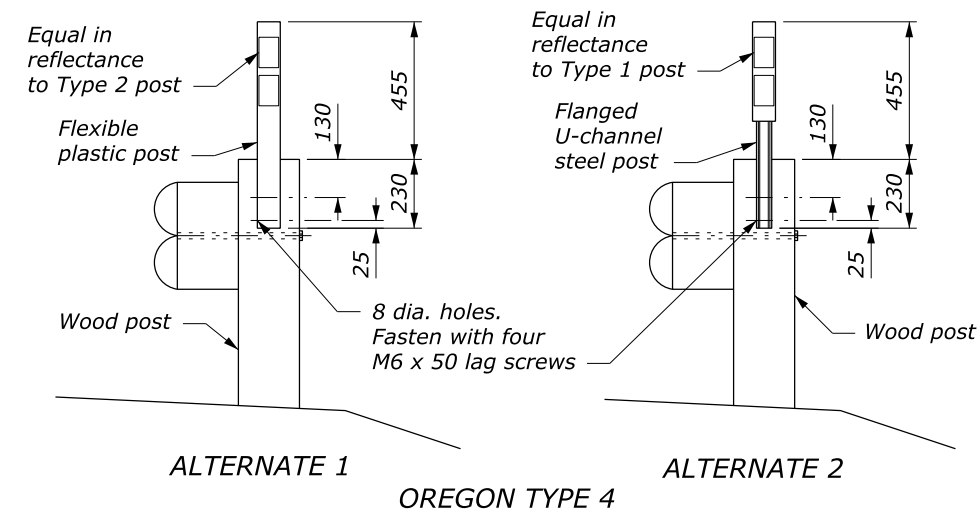

**ALTERNATE 1 ALTERNATE 2 OREGON TYPE 4 PLASTIC OR STEEL POST INSTALLATION WITH BEAM TYPE GUARDRAIL**

U.S. DEPARTMENT OF TRANSPORTATION  
FEDERAL HIGHWAY ADMINISTRATION  
WESTERN FEDERAL LANDS HIGHWAY DIVISION

METRIC DETAIL

**OREGON DELINEATORS**

DETAIL APPROVED FOR USE --/-----  
REVISED: 11/2014

DETAIL MW633-70

NO SCALE